



IntegraHeader™

The Long-Term Chlorine Header Solution



FRP SOLUTIONS MADE SIMPLER™

What's The Problem?

Severe attack on this chlorine header is evidenced by signs of leakage in the nozzle connection area. The connection prematurely failed after the sixth year and therefore limited the lifespan of the system.

Corrosion barrier not sufficient.

Joint leakage caused by poor construction.

Conventional Systems

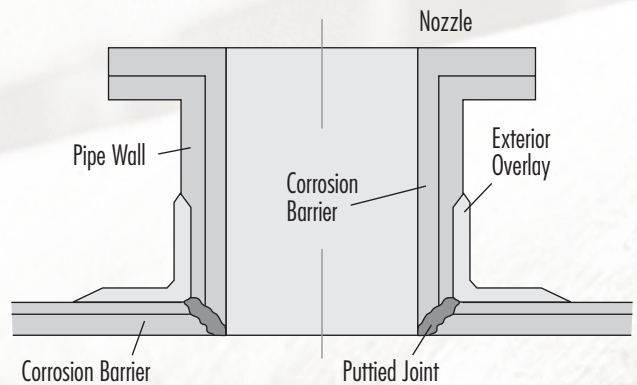

The illustration above represents an old method of attaching nozzles to pipe by filling the interior joint with putty. This nozzle is very susceptible to corrosive attack because vibration, turbulence and flexing at this point will erode the putty out of the joint area, causing the system to fail.

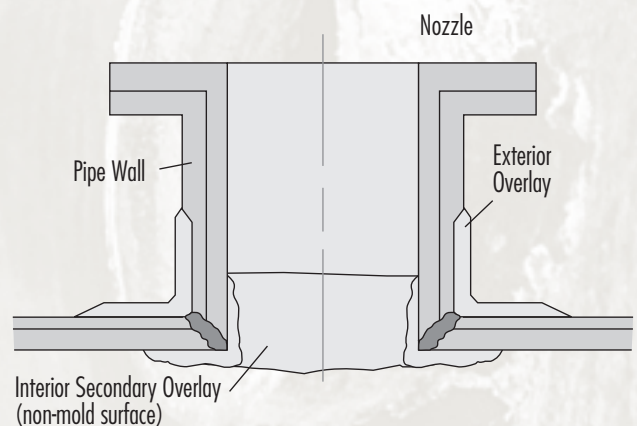

An improvement to the above method is often used for attaching nozzles to pipe by providing an inside overlay corrosion barrier. However, this method still allows for a vulnerable joint. The secondary overlay shown in this illustration does not have the smooth mold finish surface necessary to adequately resist corrosive attack in this area. This weak link will likely be the first area in the header system to yield to attack from corrosion and erosion therefore reducing the life span of the header system.

Corrosion.

Chlorine is one of the harshest and most corrosive chemicals to work with in the chemical process industry. Chlorine manufacturers struggle to find corrosion-resistant materials that can withstand the intense temperatures on a long-term basis. Chlorine's corrosive power will eat through materials that we often think of as indestructible, including stainless steel. The challenge for chlorine producers is to find a material that can slow down the corrosion process and provide long-term reliability.

Plant shutdowns are very costly, especially when they can be delayed by using materials that have the durability to survive the elements of this service environment. For this reason, FRP composites manufactured specifically for chlorine processing have become the leading material to address the problem of corrosion.

Durable joint construction

Limited corrosive attack

The Solution: Innovation with FRP.

Exceeding Industry Expectations.

After more than a decade of use, Fibrex's chlorine IntegraSystems™ are holding up even longer than expected. This system, installed in 1985 with a 250 mil corrosion barrier, didn't require replacement until 11 years later—in May, 1996. But that was the first generation of the Integra-Nozzle™ systems. Even with such encouraging results, Fibrex has doubled the thickness of its corrosion barriers (from 250 to 500 mils) and has updated its award-winning "seamless" technology. As a result, Fibrex IntegraSystems are finding their way into more and more hot, wet chlorine environments. Because they last.

11 Years of Reliability.

The intense attack of chlorine gas to the interior of a header is evident here. Yet this Integra-Nozzle™ connection withstood the attack and allowed this header to reach its maximum service life.

Increasing the Life Span of Your System. Over the past 14 years of supplying FRP to the chlorine industry, Fibrex has seen what is needed and responded by developing FRP pipe and duct with an increased life span.

Fibrex developed an innovative nozzle system called the Integra-Nozzle™. The Integra-Nozzle design reduces the effects of chemical attack at the tee joints in duct/header systems manufactured for wet chlorine gas at over 200 degrees Fahrenheit. Along with the Integra-Nozzle, Fibrex custom manufactures FRP systems with thicker, resin-rich corrosion barriers for increased durability and longer life spans.

Experience and Knowledge.

FRP by itself is not enough. Historically, fiberglass duct components have been assembled into a header system with inadequate assembly procedures and insufficient corrosion barriers. Fibrex fiberglass IntegraSystems however, incorporate thick resin-rich corrosion barriers for superior chemical resistance. Utilizing the unique combination of FRP expertise and chlorine industry experience, Fibrex has demonstrated that FRP can provide a lifespan in the range of 10 to 20 years.



Fibrex IntegraHeader™

FRP Components That Make a Difference

Unflanged



2" – 12" diameter nozzles (flanged or unflanged). Note: nozzle/header diameter ratio must be 3:1 or greater.

Flanged

Minimum 1 1/2" radius to reduce gas flow turbulence and structural stresses.

The Integra-Nozzle™

The Integra-Nozzle is unique because of its smooth, large-radius transition between the header duct and the nozzle branch. This feature offers a significant advantage over conventional nozzle attachments, primarily as a result of its "seamless" resin-rich corrosion barrier. The Integra-Nozzle design eliminates the need for vulnerable fabricated tee joints—traditionally a weak link subject to corrosive attack at cut edges below secondary bonded joints. In contrast, the Integra-Nozzle provides a "seamless" connection and an uninterrupted corrosion barrier, without putty-filled voids.

A typical fiberglass corrosion laminate consists of two distinct layers, the resin-rich corrosion barrier on the inside of the duct and the higher-glass-content structural laminate behind it. The structural laminate is less resistant to corrosion and must be completely protected by the corrosion barrier. This protection has been difficult to achieve using traditional methods of joining component parts together into a header system. The connection joining nozzles and the main header duct has historically failed prematurely due to the interruption of the corrosion barrier at this point, allowing the gas to attack the structural laminate.

Many in the chlorine industry recognized this problem. As a result, Fibrex responded to this need with the Integra-Nozzle, a clear improvement over traditional nozzle-to-header attachments. The Integra-Nozzle, solves several problems at once and provides the following advantages to contribute to longer service life:

- Continuous resin-rich corrosion barrier between inner surfaces of duct and nozzle
- Reduction in the turbulence of the gas flow
- Reduction of physical stresses at the juncture of nozzle and header

The Integra-Joint™

In case that wasn't enough, Fibrex went on to develop the Integra-Joint so that flanged header sections could be provided with the same "seamless" connection between the flanges and the main header duct, eliminating the conventional "butt-and-strap" joint.

The Integra-Joint is a "seamless" connection with a continuous resin-rich corrosion barrier. Although straight joints do not have quite the history of premature failures as nozzle connections, secondary overlays on joint interiors clearly do not resist corrosion as well as the mirror-smooth, resin-rich surface of molded laminate. With the Integra-Joint, flange to header connections are essentially "invisible" to chlorine gas and provide the maximum possible corrosion resistance.

12" – 48" diameter headers. Non-standard sizes available.

0.500" thick resin-rich corrosion barrier is standard. (0.250" thick corrosion barrier is optional for processes operating below 185° F.)

Fire retardant structural laminate



Design Data

	Fixed Headers						Expanding Headers				
	Diameter (in.)	Total Wall Thickness (in.)*	Unit Weight (lb.)	Allowable Vacuum (in. H ₂ O)	Allowable Pressure (psi)	Allowable Span (ft.)	Total Wall Thickness (in.)*	Unit Weight (lb.)	Allowable Vacuum (in. H ₂ O)	Allowable Pressure (psi)	Allowable Span (ft.)
Nozzles	2	0.62	3.00	n/a	180	n/a	0.69	3.48	n/a	285	n/a
	3	0.62	4.14	n/a	120	n/a	0.69	4.77	n/a	190	n/a
	4	0.62	5.28	n/a	90	n/a	0.69	6.05	n/a	143	n/a
	6	0.62	7.56	188.5	60	n/a	0.69	8.62	n/a	95	n/a
	8	0.62	9.98	79.0	44	n/a	0.69	11.35	318.8	70	n/a
Headers	10	0.69	13.92	162.2	56	11.4	0.75	15.35	371.4	74	12.0
	12	0.69	16.48	94.2	47	12.4	0.75	18.17	213.4	62	13.0
	14	0.69	19.05	59.3	40	13.3	0.75	20.99	134.4	53	13.9
	16	0.69	21.62	39.6	35	14.1	0.75	23.80	90.1	47	14.8
	18	0.69	24.19	27.7	31	14.9	0.81	29.07	120.6	51	16.1
	20	0.69	26.76	20.2	28	15.6	0.81	32.14	88.1	46	16.9
	24	0.69	31.89	11.6	24	17.0	0.88	42.01	93.7	47	19.0
	30	0.69	39.60	6.0	19	18.9	0.88	52.08	48.2	38	21.1
	36	0.69	47.30	3.5	16	20.6	0.88	62.15	27.7	32	23.0
	42	0.76	61.15	5.6	19	23.3	0.94	77.46	27.2	31	25.2
	48	0.76	69.73	3.7	16	24.9	0.94	88.28	18.2	28	26.9
	54	0.84	87.52	5.9	19	27.5	1.00	106.05	18.8	28	28.9
	60	0.84	97.10	4.3	17	28.9	1.00	117.61	13.7	25	30.4

- NOTES:
1. Allowable vacuum is based on a 5:1 safety factor with no stiffeners. If greater negative pressures are anticipated, external stiffeners can be added.
 2. Vacuum, pressure and span ratings are based on structural wall only and do not include any consideration of the 0.500" thick corrosion barrier.
 3. Header duct should always have adequate saddle support to avoid point loading.
 4. Allowable spans are based on 0.5" deflection and allow for approximately 1" of condensate in the bottom of the header duct.
 - * 5. Increased wall thickness may be recommended for reasons specific to a particular installation.

Fitting Dimensions

Long Radius 90° Elbow

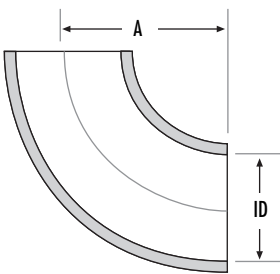

Elbow Dimensions

ID Nominal Diameter	A 90° Elbow	B 45° Elbow
2	4	1-5/8
3	6	2-1/2
4	6	2-1/2
6	9	3-3/4
8	12	5
10	15	6-1/4
12	18	7-1/2
14	21	8-3/4
16	24	10
18	27	11-1/4
20	30	12-1/2
24	36	15
30	45	18-5/8
36	54	22-3/8
42	63	26-1/8
48	72	29-13/16
54	81	33-9/16
60	90	37-1/4

Long Radius 45° Elbow

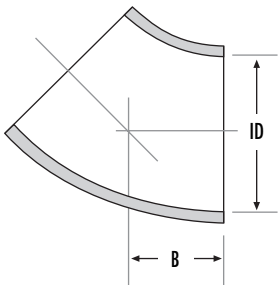

Flanges

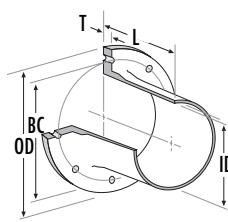

Flange Dimensions

ID Nominal Diameter	OD Outside Diameter	Number of Holes	Diameter of Holes	BC Bolt Circle	T Thickness	L Stub Length
2	6-1/2	4	3/4	4-3/4	3/4	8
3	8	4	3/4	6	3/4	8
4	9-1/2	8	3/4	7-1/2	3/4	8
6	11-1/2	8	7/8	9-1/2	3/4	8
8	14	8	7/8	11-3/4	3/4	8
10	14-3/8	12	7/16	13	3/4	10
12	16-3/8	12	7/16	15	3/4	10
14	18-3/8	12	7/16	17	3/4	10
16	20-3/8	16	7/16	19	1	12
18	22-3/8	16	7/16	21	1	12
20	24-3/8	20	7/16	23	1	12
24	28-3/8	20	7/16	27	1	12
30	34-3/8	28	7/16	33	1	12
36	40-3/8	32	7/16	39	1	12
42	46-3/8	36	7/16	45	1-1/4	16
48	54-3/8	44	9/16	52	1-1/4	16
54	60-3/8	44	9/16	58	1-1/4	16
60	66-3/8	52	9/16	64	1-1/4	16

Reducers

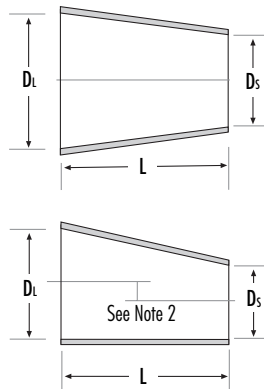

NOTE: Elbows 42" in diameter and larger are mitered construction

- NOTE: 1. Formula for length of reducer:
 $L = 2 - 1/2 (D_1 - D_2)$
 2. Formula for eccentric offset
 $E = \frac{D_1 - D_2}{2}$

NOTE: 2" through 8" diameter nozzle flanges are ANSI B16.5 class 150 drilled hole pattern. 10" through 60" diameter header/duct flanges are NBS PS 15-69 duct flange drilled hole pattern.

System Installation

Since ambient or slightly negative pressures are the norm for chlorine header systems, the IntegraHeader system is more than adequate to handle these conditions. Surrounding structural steel is usually more than adequate to provide appropriate support spans for the header without the need for additional consideration. Expansion is normally accommodated by one of the following two methods:

Expanding Header

The header is allowed to expand with increased temperature. Direction of expansion is controlled by establishing anchor points. The header may be anchored at one end and allowed to grow in the opposite direction or anchored at a mid-point and allowed to grow in both directions. In either case, Fibrex recommends the use of sliding supports with graphite or other anti-friction surfaces to permit

unrestrained axial movement of the header. Guide supports are also provided at appropriate intervals to prevent lateral movement. (See Guide Spacing Table.) The duct connecting the chlorine cells to the header nozzles must have adequate flexibility to accommodate the axial travel of the header nozzles as the header expands.

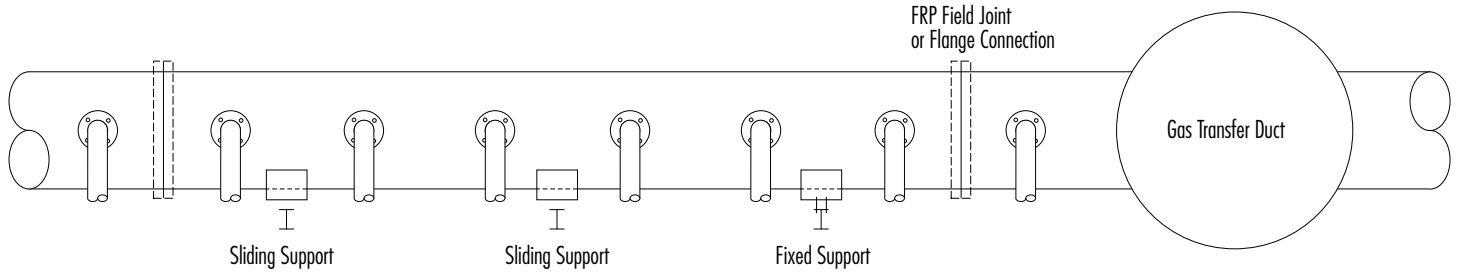

Linear Thermal Expansion

Change in Temperature - Degrees F	10	20	30	40	50	60	70	80	90	100	110	120	130	140	150	160	170	180
Change in Length - Inches per 100 ft.	0.2	0.4	0.5	0.7	0.9	1.1	1.3	1.4	1.6	1.8	2.0	2.2	2.3	2.5	2.7	2.9	3.1	3.2

Guide Spacing

Change in Temperature - Degrees F		10	20	30	40	50	60	70	80	90	100	110	120	130	140	150	160	170	180
Diameter	Wall Thickness																		
10	0.75	91	64	53	46	41	37	34	32	30	29	27	26	25	24	24	23	22	21
12	0.75	108	76	62	54	48	44	41	38	36	34	32	31	30	29	28	27	26	25
14	0.75	124	88	72	62	56	51	47	44	41	39	38	36	35	33	32	31	30	29
16	0.75	141	100	81	71	63	58	53	50	47	45	43	41	39	38	36	35	34	33
18	0.81	158	112	91	79	71	65	60	56	53	50	48	46	44	42	41	40	38	37
20	0.81	175	124	101	87	78	71	66	62	58	55	53	51	49	47	45	44	42	41
24	0.88	209	148	121	104	93	85	79	74	70	66	63	60	58	56	54	52	51	49
30	0.88	259	183	150	130	116	106	98	92	86	82	78	75	72	69	67	65	63	61
36	0.88	309	219	178	155	138	126	117	109	103	98	93	89	86	83	80	77	75	73
42	0.94	359	254	207	179	160	146	136	127	120	113	108	104	99	96	93	90	87	85
48	0.94	409	289	236	204	183	167	155	145	136	129	123	118	113	109	106	102	99	96
54	1.00	459	325	265	230	205	188	174	162	153	145	139	133	127	123	119	115	111	108
60	1.00	510	360	294	255	228	208	193	180	170	161	154	147	141	136	132	127	124	120

Fixed Header

The header is installed with expansion joints. These are located to divide the header into substantially shorter sections, each one of which expands a much smaller incremental amount. This configuration substantially reduces the potential for problems at the connection points between header nozzles and chlorine cells resulting from the axial movement of the header. Supports can be fixed on the structural steel and the header allowed to move axially on the supports.

All supports, whether fixed or sliding, must be adequate to prevent point loading of the header. Several types of supports are available from Fibrex or customer's existing supports can be reviewed for adequacy.

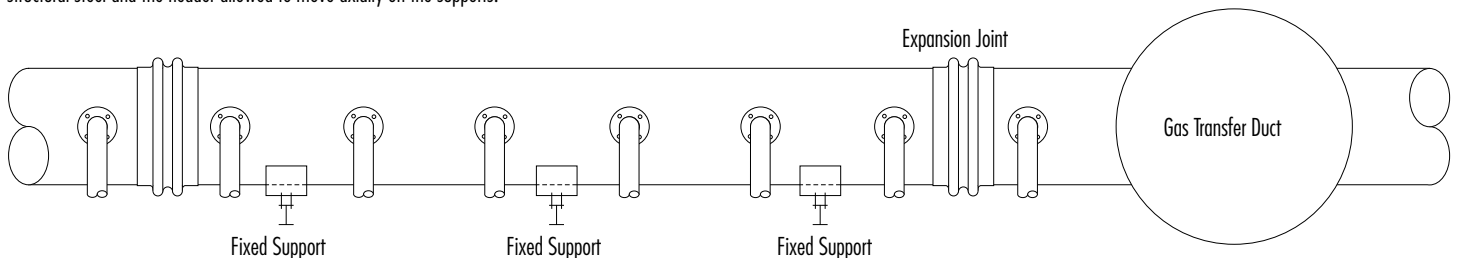

Accessories

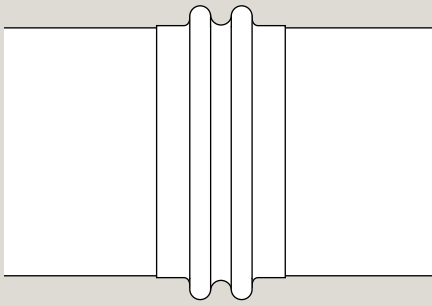

Expansion Joints

Teflon* expansion joints limit the expansion of a header system in multiple sections so that the connection points between header nozzles and chlorine cells line up. This joint will allow for 2" axial expansion in the FRP duct and operates at up to +/- 2" WC pressure and 210 degrees Fahrenheit. The expansion joints are available in all standard nominal sizes, from 4" through 60" diameter.

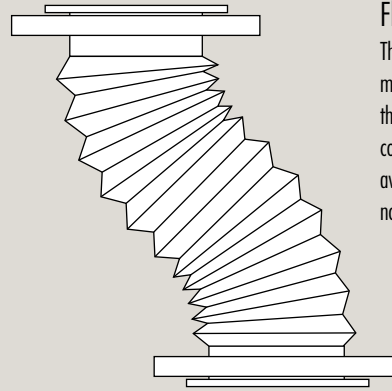

Flexible Connectors

The flexible connectors allow for the misalignment between the chlorine cells and the header nozzles caused by expansion and contraction. PTFE flexible tubing connectors are available with backing flanges in all standard nominal sizes up to 6" diameter.

Fixed Supports

Fixed supports anchor the header system to prevent excessive movement. These supports are not attached to the duct but are provided with a neoprene cushion to ensure full contact between the duct and the support. Each section of duct is typically banded to the center support and allowed to slide axially in the adjacent supports when expanding or contracting. These supports are available in either FRP or painted steel.

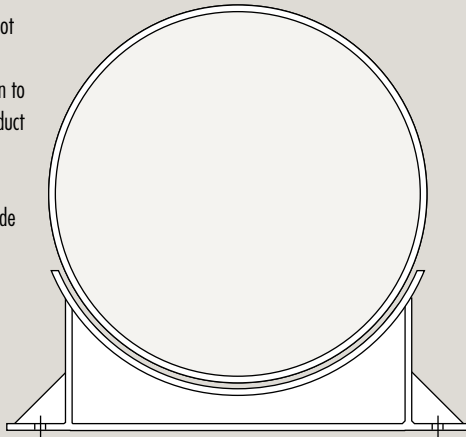

Sliding Supports

FRP sliding supports are designed to accommodate the axial expansion and contraction of a header system that has been anchored in one primary location. These supports utilize integral, anti-friction bearing plates to permit the header to slide easily without imposing point loads or causing abrasion to the FRP duct. To prevent

lateral movement, side plates are used intermittently throughout the system. The supports are manufactured as a permanently attached part of the duct at locations to match the availability of supporting structural steel. Anchor bolt lugs can also be substituted for bearing plates where an occasional fixed support may be required.

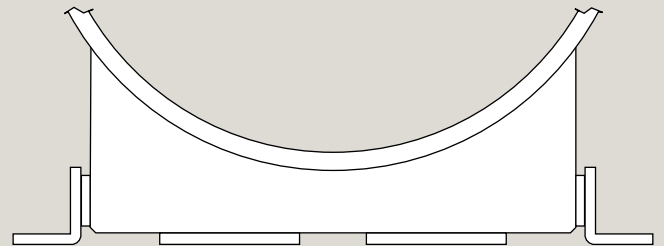

CorrosionProbe™

The CorrosionProbe serves as an indicator of the remaining service life of the chlorine header. This probe allows the corrosive attack on the resin-rich corrosion barrier of the header to be monitored on an ongoing basis. The CorrosionProbe can be manufactured with an identical laminate to the header wall and is easily removed, inspected and replaced during plant outages. For testing alternative resin and laminate systems this probe offers a convenient and cost-effective way to measure the corrosive attack. The CorrosionProbe utilizes standard diameter nozzles and can be placed strategically in a number of locations throughout the system.

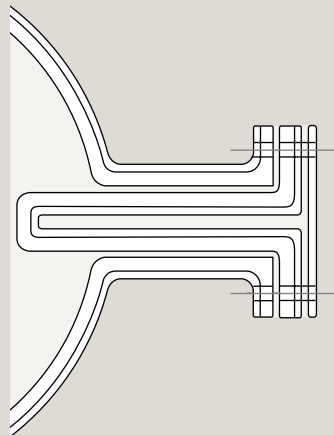

Chlorine Duct Seal Pot

The chlorine duct seal pot captures gas bursts from the system and removes the chlorine in a scrubber before releasing the gas into the air. Seal pots are manufactured utilizing the same highly corrosion-resistant laminate as the chlorine header duct. Standard sizes and configurations are available to meet the capacity requirements of each individual system. They include customized nozzles, manholes and other attachments. All configurations employ a shell flange to permit easy access to the interior of the unit.

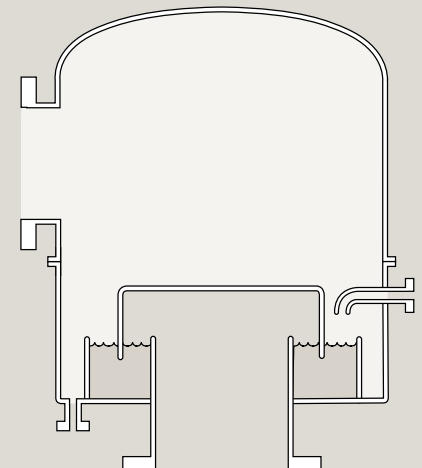

* Teflon is a registered trademark of E.I. DuPont Company.

* CorrosionProbe is a trademark of Fibrex Corporation.

FRP Solutions Made Simpler™

The Fibrex Corrosion-Resistant System

When the first IntegraHeader system was installed in 1985, corrosion barriers were 250 mils thick, half the current standard. Yet even that original IntegraHeader system lasted over a decade. Its reliable service has captured the industry's attention and brought several financial questions into clear perspective.

The first issue settled was the cost-effectiveness of maximum protection. In other words, the price tag of other traditional systems can no longer be taken alone. Related expenses must be added for more frequent maintenance or unexpected replacement. And subsequent "worst-case" scenarios such as demolishing and removing a header and installing a new one require a complete shutdown. Buying a product twice because of premature failure is clearly far more expensive (and more troublesome) than doing it right the first time.

The Fibrex advantage becomes obvious when FRP service life can be extended even in the face of highly corrosive hot chlorine gas. Given the IntegraHeader's outstanding service record, the bottom line will show that design advantages and extra millimeters of protection buy trouble-free time – and save maintenance dollars.



For Every Industrial Piping Need.

Since its start in 1982, Fibrex Corporation has grown to become one of the world's leading manufacturers of FRP pipe and duct solutions for the chlor-alkali, semiconductor, power, pulp & paper, chemical/ petrochemical and metals refining industries.

Fibrex products like the IntegraHeader, "seamless" header system have earned a global reputation for quality, reliability and continuous performance under the harshest industrial environments. All Fibrex materials and products are produced to meet the highest quality standards demanded of chemical producers.



Fibrex has also developed the innovative

IntegraLine™, off-the-shelf standard production pipe with custom corrosion resistance that's simple to specify and select. The Fibrex approach — offering both custom and standard pipe solutions — meets the widest scope of needs.

And because Fibrex understands the industries we serve, Fibrex products are designed to meet the most demanding and specialized conditions at each site. In everything from process vessels and scrubbers to custom pipe, ducts or stacks, Fibrex delivers long-term corrosion solutions and maximum product life.

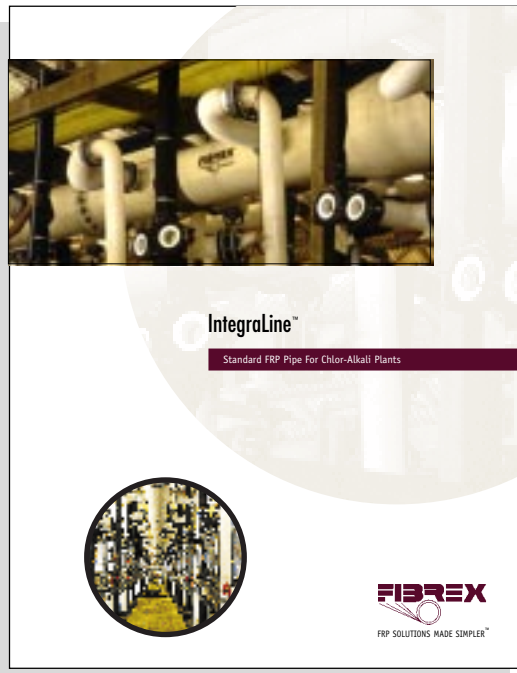

Fibrex Corporation

P.O. Box 428 360.755.9025
401 Sharon Avenue FAX 360.755.9034
Burlington, WA 98233 800.407.5829
USA e-mail: fibrex@fibrex.com
Website: www.fibrex.com/~fibrex

IntegraHeader™ Customers

Occidental Chemical

Delaware City, DE
Tacoma, WA
Ingleside, TX
Convent, LA
Deer Park, TX

Saudi Petrochemical

Jubail, Saudi Arabia

Vulcan Chemical

Wichita, KS

Pioneer Chlor Alkali

Henderson, NV

General Electric

Mt. Vernon, IN
Burkville, AL

Pequiven

El Tablazo, Venezuela

Siam Chemical

Bangpoo, Thailand

Weyerhaeuser

Longview, WA

Elf Atochem

Tacoma, WA
Portland, OR