

TAUNTON'S **Fine**
WoodWorking[®]

Curved-Leg Table

A project plan
for building
a stylish table



©2009 The Taunton Press

For more **FREE**
project plans from
Fine Woodworking

▶ **CLICK HERE NOW**

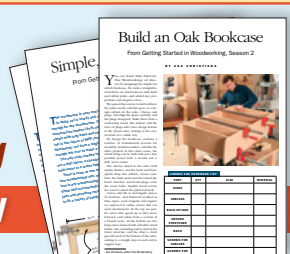

Enjoy our entire site
FREE for 14 days!

450+ videos, 33-year archive,
blogs, and more

▶ **TRY IT NOW**



Curved-Leg Table

BY DON KONDRA

Although I rely heavily on machines to get the job done quickly, I aim to build furniture that looks organic and invites people to touch it. That's why I've turned to using lots of curves in my work. It's true that building swoopy furniture requires more labor than making stick-straight pieces, but I think curves are appealing. And they're also more interesting from a design or construction point of view. Furniture that's square to the world bores me.

Once you get hooked on curves, a whole new world of design opens up. I always make full-sized drawings on newsprint (end rolls) that can be purchased cheaply from the local newspaper. Working from an accurate drawing is the key to finessing the joinery and accurately milling curved parts. To get consistent results and to minimize the amount of handwork required, I also make a router or shaper jig.

I've made several versions of this hall table, and no two were alike. The current version (shown here), with a walnut top and curly maple base, suits me for now. But who knows? The next one might have a different curve or two.

Make templates to draw the curves

The two most prominent features of a hall table are the top and the legs. The top is rectangular with edges that are beveled under. The legs are curved gently and tapered, and the edges are rounded over. To ease the transition from the square, dark top to the curvy, light base, I created a gap (negative space), which makes the top appear to float. The top is secured to a pair of cross braces with four screws.

Whether you wish to copy this plan or use it as a starting point for your own design, the first step is the same: Make a simple jig for drawing smooth curves (see the story and drawings on the facing page), and use the jig to make a drawing template out of 1/4-in. medium-density fiberboard (MDF) or hardboard. That template is then

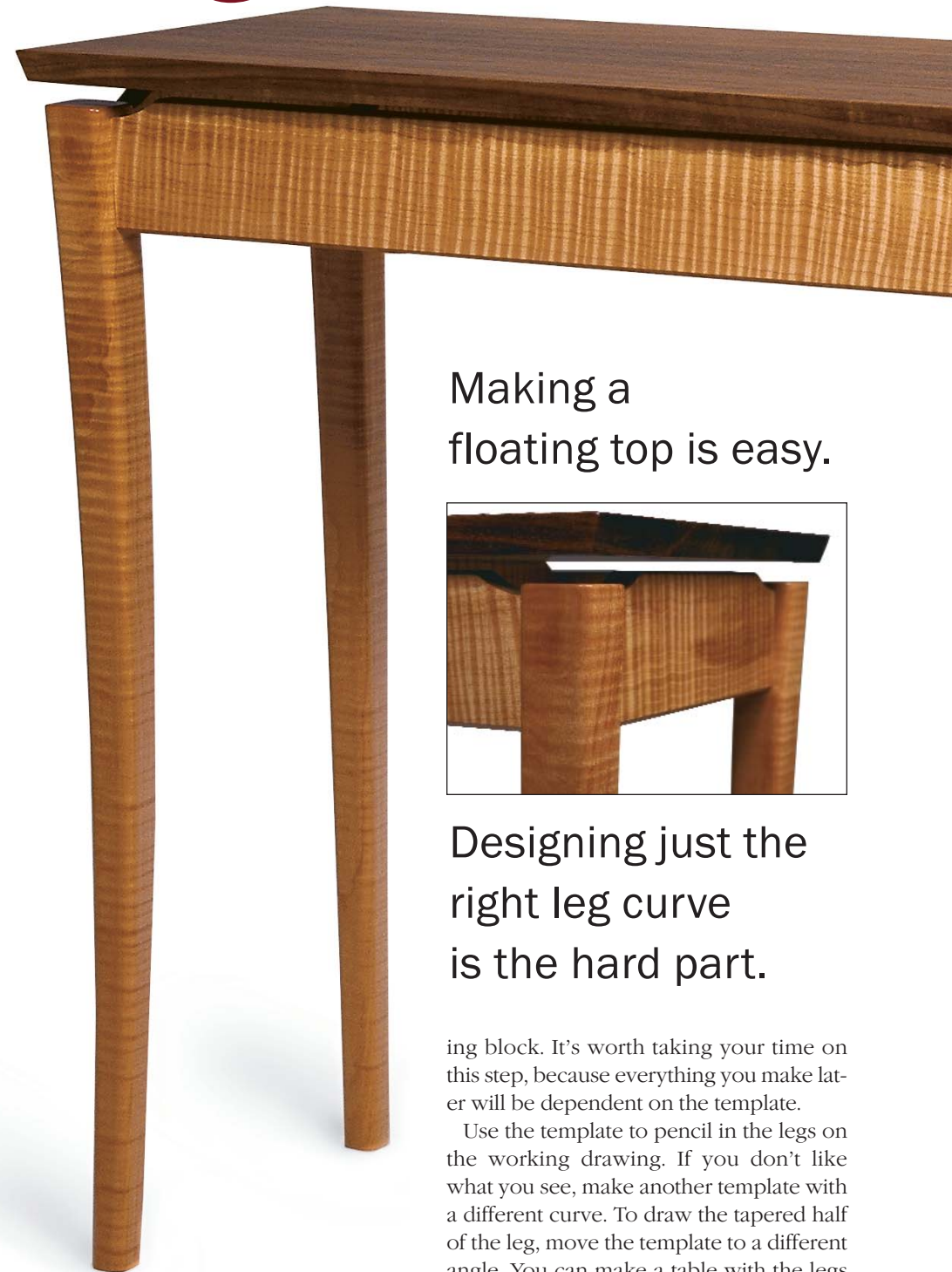

Making a floating top is easy.



Designing just the right leg curve is the hard part.

used to lay out the leg-shaping jig (see the story and drawings on p. 68). The drawing template need only have a convex curve on one side.

Once the curve has been drawn on the MDF, cut the template on the bandsaw and fair the curve using a belt sander or sand-

ing block. It's worth taking your time on this step, because everything you make later will be dependent on the template.

Use the template to pencil in the legs on the working drawing. If you don't like what you see, make another template with a different curve. To draw the tapered half of the leg, move the template to a different angle. You can make a table with the legs splayed out, plumb or tilted inward slightly. I think a table looks best with the outside edges of the legs in a plumb line. Being plumb gives the piece a solid look. This is a personal decision. If the legs are splayed outward, the piece looks pot-bellied, which feels relaxed. If the legs are

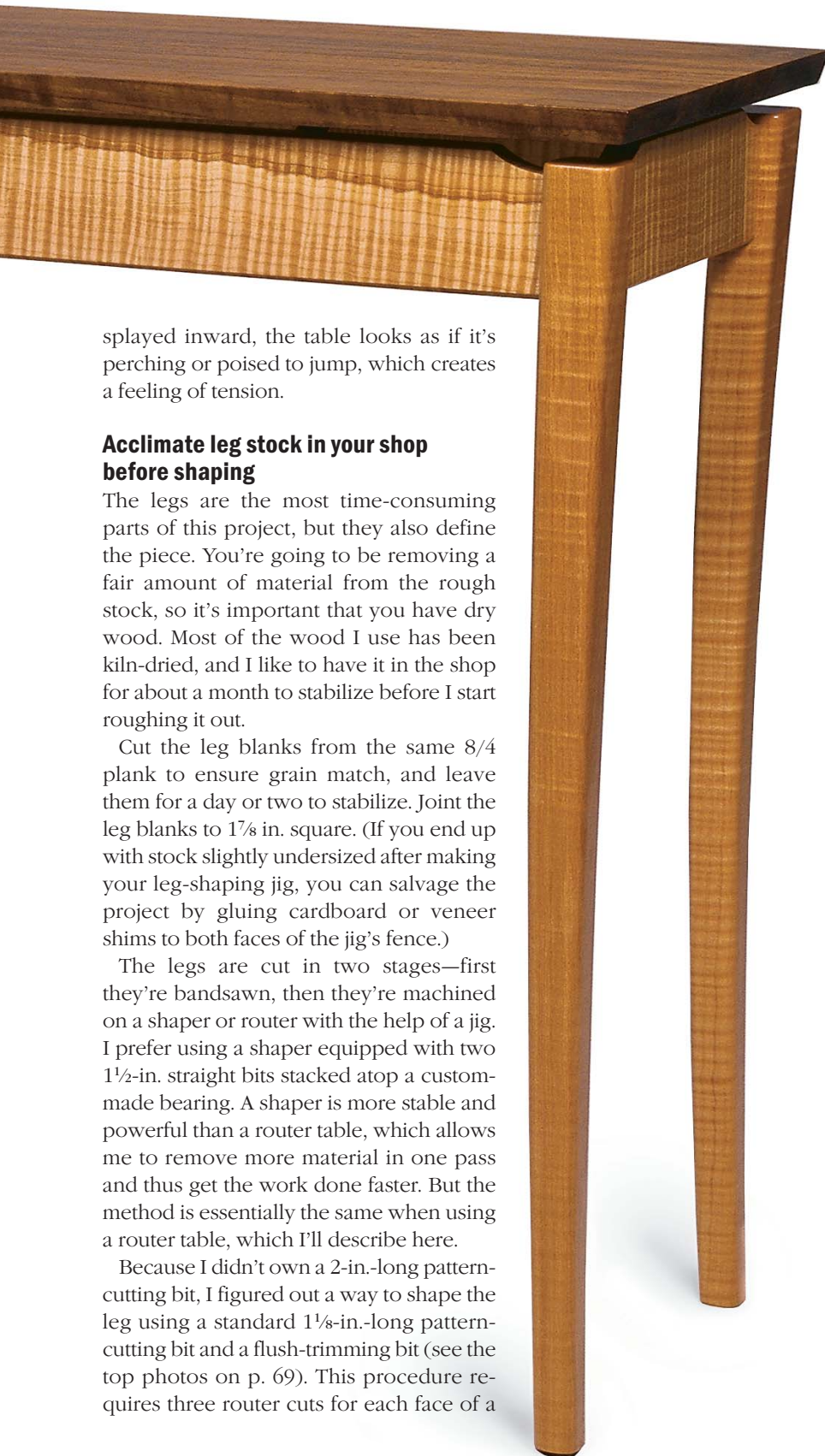

splayed inward, the table looks as if it's perching or poised to jump, which creates a feeling of tension.

Acclimate leg stock in your shop before shaping

The legs are the most time-consuming parts of this project, but they also define the piece. You're going to be removing a fair amount of material from the rough stock, so it's important that you have dry wood. Most of the wood I use has been kiln-dried, and I like to have it in the shop for about a month to stabilize before I start roughing it out.

Cut the leg blanks from the same 8/4 plank to ensure grain match, and leave them for a day or two to stabilize. Joint the leg blanks to 1 7/8 in. square. (If you end up with stock slightly undersized after making your leg-shaping jig, you can salvage the project by gluing cardboard or veneer shims to both faces of the jig's fence.)

The legs are cut in two stages—first they're bandsawn, then they're machined on a shaper or router with the help of a jig. I prefer using a shaper equipped with two 1 1/2-in. straight bits stacked atop a custom-made bearing. A shaper is more stable and powerful than a router table, which allows me to remove more material in one pass and thus get the work done faster. But the method is essentially the same when using a router table, which I'll describe here.

Because I didn't own a 2-in.-long pattern-cutting bit, I figured out a way to shape the leg using a standard 1 1/8-in.-long pattern-cutting bit and a flush-trimming bit (see the top photos on p. 69). This procedure requires three router cuts for each face of a

Drawing smooth curves

Here's an easy way to draw smooth curves using sticks and nails. I used this method to make a drawing template for the curved legs of my hall table. The method isn't new (see *FWW* #28, pp. 14-16), but it's worth repeating. The curve I used for the legs of the hall table was based on a rise of 3/8 in. over a run of 30 in. —D.K.

2. Make another mark 3/8 in. off the center mark.

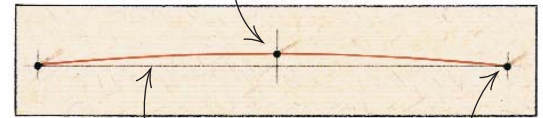

1. Draw a 30-in. line on a piece of 1/4-in. MDF (or hardboard), then mark the center of that line.

3. Drive nails into both ends of the 30-in. mark and at the 3/8-in. mark.

4. Place a straight stick against the 3/8-in. mark and parallel to the straight line.

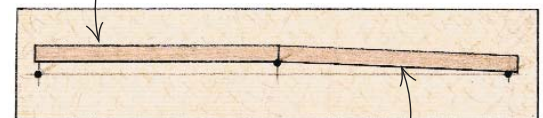

5. Place another stick against the 3/8-in. mark (intersecting the first stick) and at the 30-in. mark. Tack the sticks at that angle. (Or make an adjustable set of sticks by cutting half-lap joints where they meet and hinging them with a bolt and thumbscrew.)

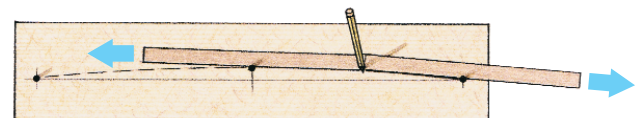

6. To draw the arc, place the sticks against one end nail and the middle nail. Hold a pencil against the intersection of the two sticks and slide the sticks across the nails, letting the pencil drag along. Repeat on the other half of the curve.

A jig for shaping curves

When making curved parts, I prefer using a jig. It speeds up the job and gives me consistent results. The jig is nothing more than a hold-down device connected to a template, which is used in conjunction with a pattern-cutting bit. Use the base of the jig to lay out the curves onto the faces of the leg stock, then bandsaw off the waste. Next, clamp the stock in the jig and make the final cuts. The most efficient way to work is to lay out and cut one face of each leg at a time, then go on to a second side.—D.K.

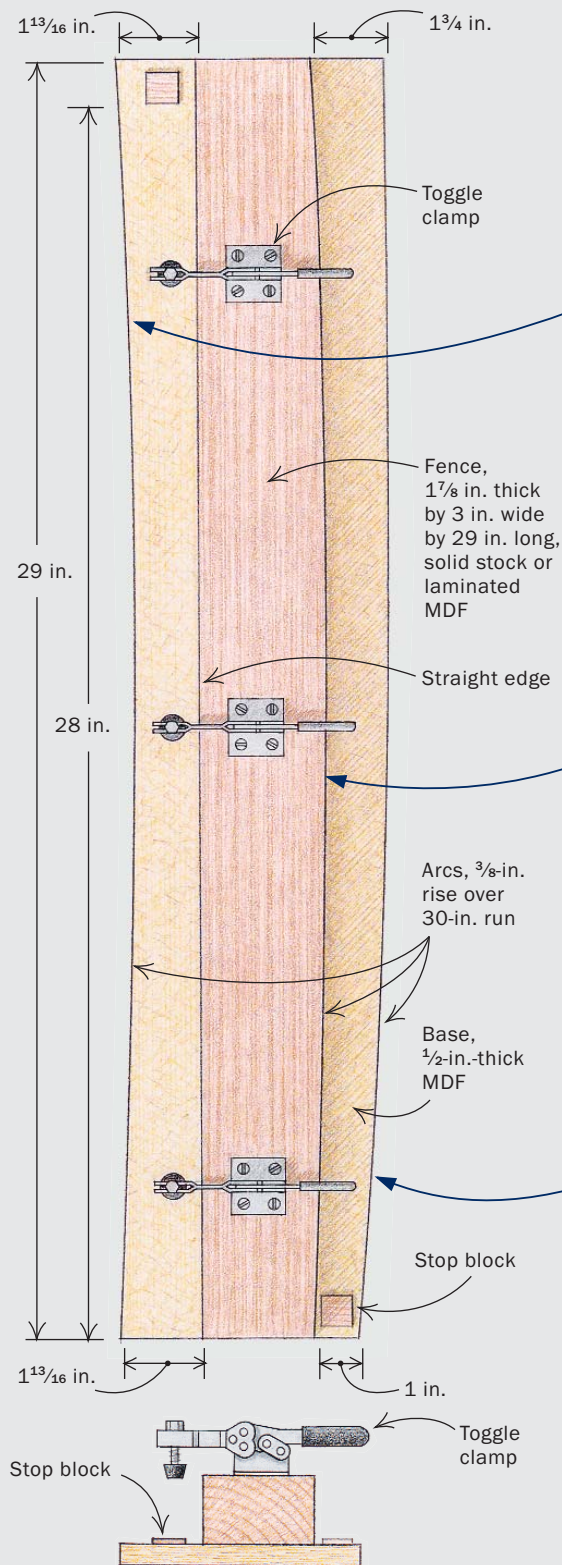

Use the leg template to lay out the jig. Draw a concave curve on a piece of 1/2-in.-thick MDF. Bandsaw the waste and sand the edge fair.



Draw a convex curve on the fence of the jig using the same template. Bandsaw the waste, but don't bother fairing the surface. The curved surface ensures the partially shaped leg will register properly and securely to the jig.

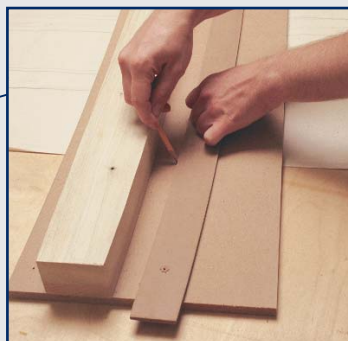

Lay out the convex curve on the base of the jig. Angle the template to create the amount of taper you wish to incorporate into the leg design. Cut and fair the curve.

leg. To cut down on steps, use an extralong pattern-cutting bit (see Sources on p. 71) that will allow you to cut each face in one pass (see the bottom photo on the facing page). You still may need to cut each face in two passes because some routers won't let you raise the collet close enough to the throat of the table.

Place a leg in the nontapered side of the jig and secure it with the toggle clamps. Flip the jig on its side and clamp it in a vise. Using the base of the jig as a template, trace a curve onto the leg. I use a dull pencil, which leaves a fat line that's easy to see when bandsawing. Rotate the leg 90° and repeat. Remove the leg blank and bandsaw off the waste, staying outside of the lines.

Put the leg back in the jig and tighten the clamps. Shape one side. Then flip the leg 90° and shape the other bandsawn face. Complete two faces of all of the legs (see the drawings on the facing page).

Now move to the other side of the jig. Reposition the toggle clamps 180°. Place the concave side of a leg against the curved side of the fence and tighten the toggle clamps. Flip the jig on its side and again use the base of the jig to trace the curves of the last two faces onto the legs. Bandsaw the waste, then finish on the router table or shaper. Use wooden wedges or bandsawn waste to help register the toggle clamps on the legs after the tapers have been cut.

After machining, use a scraper to smooth ridges and tearout. Although you might be tempted to finish shaping the legs, don't round over the corners yet. It's better to mark and cut the mortises for the aprons while the edges of the legs are still crisp.

Cut joints for legs after shaping

Refer to the drawing on p. 70 for the rail measurements and cut your stock to size. You can also use the drawing and a sliding bevel gauge to transfer the angle of the apron pieces where they meet the legs. It's not much of an angle, about 2°.

The leg-to-apron joints can be either mortises and tenons or dowels. Because a hall table generally doesn't take the kind of abuse a dining table is subjected to, the joinery doesn't have to be bombproof, just secure and accurate.

After cutting the joints, use a 3/8-in. roundover bit to soften all four corners of the legs. The top and bottom edges of the rails are chamfered with a 45° router bit, leaving a reveal of about 1/4 in.

Use a pattern-cutting bit and flush-trimming bit ...



Use standard bits to machine the leg. With a 1½-in.-long pattern-cutting bit, you can machine the leg on a router table. First, make one pass with the leg clamped in the jig. Next, remove the leg from the jig and make a second pass, using the machined surface to register the bearing. Finish by using a flush-trimming bit, registering the bearing against an already machined surface.

... or get a bit to do the job in one pass



An easy way to machine the leg. You can remove all of the waste in one pass with an extralong pattern-cutting bit in an inverted router.

A pair of cross braces, attached to the rails, holds the top ¼ in. above the rails. Refer to the drawing on p. 70 for dimensions. Dry-fit the pieces. Once you're sure the parts fit, glue up the side-to-side assemblies. Once they're dry, glue the front and back aprons and cross braces together.

Keep an eye on the overhang

The amount of overhang in a tabletop greatly influences the overall look. Make

the top too long and wide, and you may not even see the apron, which gives you a spindly looking piece of furniture. A top that's too small can have a negative affect as well.

Usually it's best to rough-cut the top, then lay it on the base, varying the overhang on two edges. Stand back and see what it looks like, then take some measurements when you're happy with the look. I settled on an overhang of 7/8 in.,

TWO-SIDED JIG HANDLES CURVES WELL

Cut two adjoining concave faces (A) of leg. Remount clamps and cut remaining faces (B).

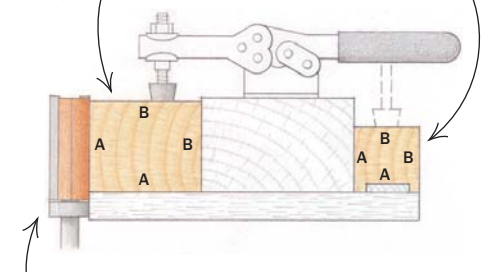

Pattern-cutting bit or shaper cutter with 2-in.-long cutter

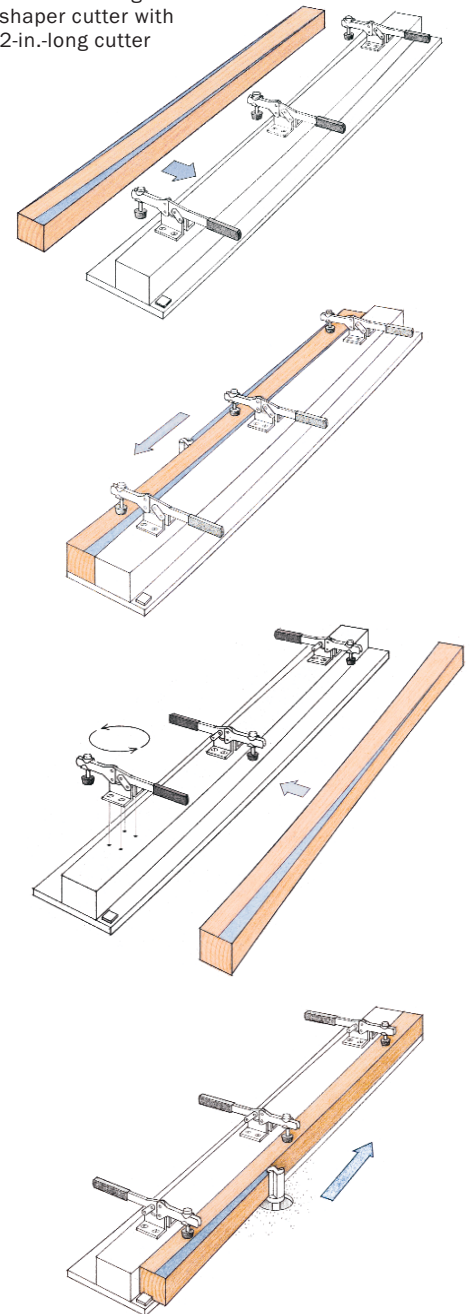
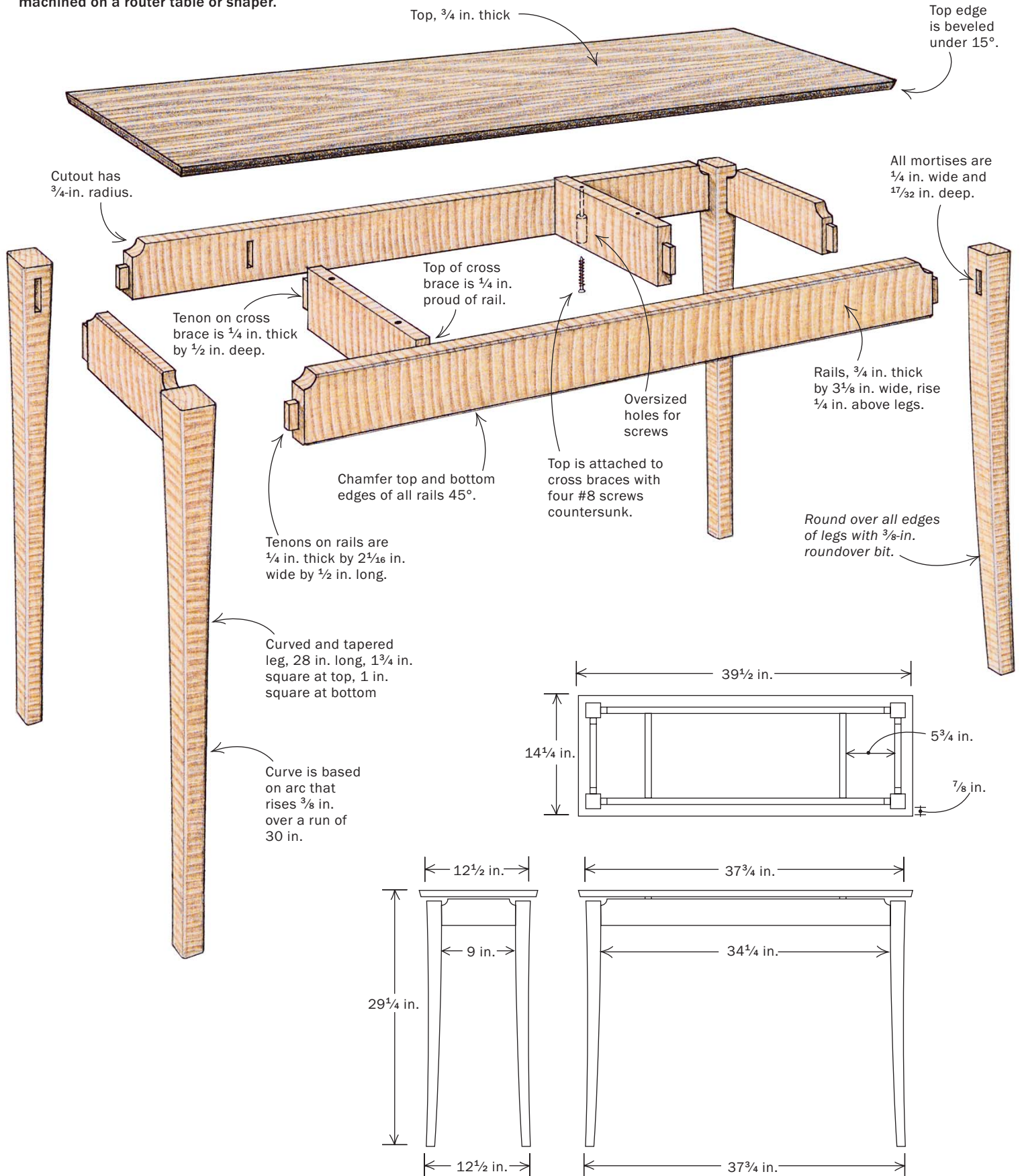

TABLE WITH CURVED, TAPERED LEGS

Legs are rough-cut on the bandsaw, then machined on a router table or shaper.



Balancing a design



A table's footprint affects the look of the piece. The author prefers the symmetry of legs where the outside spread is equal at the top and bottom.



Before cutting the top to final dimensions, rest it on the base. Then, experiment with the amount of overhang that looks right to you. The author settled on an overhang of $\frac{7}{8}$ in. The edge is also beveled under 15° .

measured from the rails. The top is $\frac{3}{4}$ -in.-thick walnut, and all of the edges are beveled under 15° . The top is attached to the cross braces from below with four #8 screws. The holes in the cross braces are oversized to allow the top to shrink and expand without blowing out the base.

No expensive finishing equipment is required

When you have maple with lots of curl, you don't need dyes or stains to bring out

the wood's natural beauty. That's why I used a simple oil/varnish finish that I mixed myself.

My wipe-on finish consists of one part pure tung oil, one part spar varnish, two parts paint thinner and a few drops of Japan drier. Mix only as much as you think you'll use on one project because the drier will age the finish rapidly, even when placed in a sealed jar. For a project of this size, about half a cup (4 oz.) is plenty.

Apply the mixture using a lint-free rag

that's saturated with the finish. The idea is to keep a thin film of finish on the wood, without any drips. I think this works better than applying it heavy, then wiping it down with a dry rag, which leaves too little finish behind.

The finish will be dry to the touch in about 20 minutes. I apply three coats, one a day over a period of three days, rubbing the piece down between coats with a gray Scotch-Brite nylon pad. Wait about three days after the final coat, then give the piece a final polishing with a white Scotch-Brite pad. If the pads leave scratches in the finish, it means your finish is still soft, so wait a day or more. You can fix the scratches by wiping the area with a rag slightly dampened with paint thinner. If you ever need to repair this finish, sand lightly and apply another coat. □

Don Kondra builds custom furniture in Saskatoon, Sask., Canada.

SOURCES FOR ROUTER BITS

RIDGE CARBIDE TOOL CORP. (201-438-8778)

Pattern-Cutting Bit #12-8B-F2. This is a $\frac{1}{2}$ -in. shank, $\frac{3}{4}$ in. dia., 2-in.-long straight carbide bit that comes with a $\frac{3}{4}$ -in. bearing and lock collar slipped over the shank. Cost: \$59

JESADA TOOLS (800-531-5559)

Jesada sells top-bearing kits, and you can make your own custom pattern-cutting bit using a straight bit. The kit consists of an Allen key, bearing and stop collar. A collar and $\frac{3}{4}$ -in. bearing to fit over a $\frac{1}{2}$ -in. shank router bit cost \$14. Jesada also sells router bits.

Safety tip: Be sure that at least 1 in. of the shank is inserted into the router collet.