

Assembly Instruction

OFFICE CHAIR



Carefully unpack and identify each component before beginning assembly. Before you begin, please refer to parts list to make sure that you have all parts. Please take care when assembling the unit and always place the parts on a clean, soft surface.







Get social with us and discover more about our products, tips and exclusive discounts!





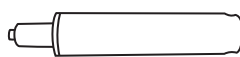

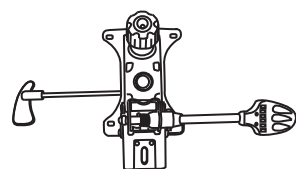
PRE-ASSEMBLY PREPARATION

- **CAUTION:** Assembly will require at least 2 adults. DO NOT use power tools. Please inspect all items BEFORE assembly. If for any reason you need to return this item, please kindly return it in it's original packaging.
- **WARNING!**
 1. DO NOT let any sharp objects touch or rub the surface of the product.
 2. When assembling, do not let children play around the working area.
 3. DO NOT tighten all bolts and screws completely until the entire unit has been assembled and set up.
 4. DO NOT USE if this product become damaged, and/or components are broken or missing.
- **CARE AND CLEANING:** DO NOT scratch or chip the finish. DO NOT use abrasive chemicals for cleaning. Clean with mild soap on a soft rag. Rinse and dry thoroughly.
- **MAINTENANCE:** Please periodically check all fittings and re-tighten as necessary.

PARTS LIST

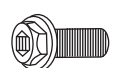
<p>BACKREST (A)</p>  <p>Qty: 1</p>	<p>SEAT (B)</p>  <p>Qty: 1</p>	<p>GAS LIFT (C)</p>  <p>Qty: 1</p>	<p>BASE (D)</p>  <p>Qty: 1</p>
<p>WHEEL (E)</p>  <p>Qty: 5</p>	<p>SEAT PLATE (F)</p>  <p>Qty: 1</p>	<p>BASE CAP (G)</p>  <p>Qty: 1</p>	

HARDWARE LIST

<p>ALLEN SHORT BOLT (H)</p>  <p>1/4" X 7/8"</p> <p>Qty: 4</p>	<p>ALLEN LONG BOLT (I)</p>  <p>M6 x 20MM</p> <p>Qty: 3</p>	<p>BOLT LOCK (J)</p>  <p>Qty: 3</p>	<p>ALLEN WRENCH (K)</p>  <p>Qty: 1</p>
--	---	---	---

STEP 1

Insert the Plastic Cap (G) and Gas Lift (C) to the Five-jaw Base (D), then snap in the Wheels (E) as shown below.

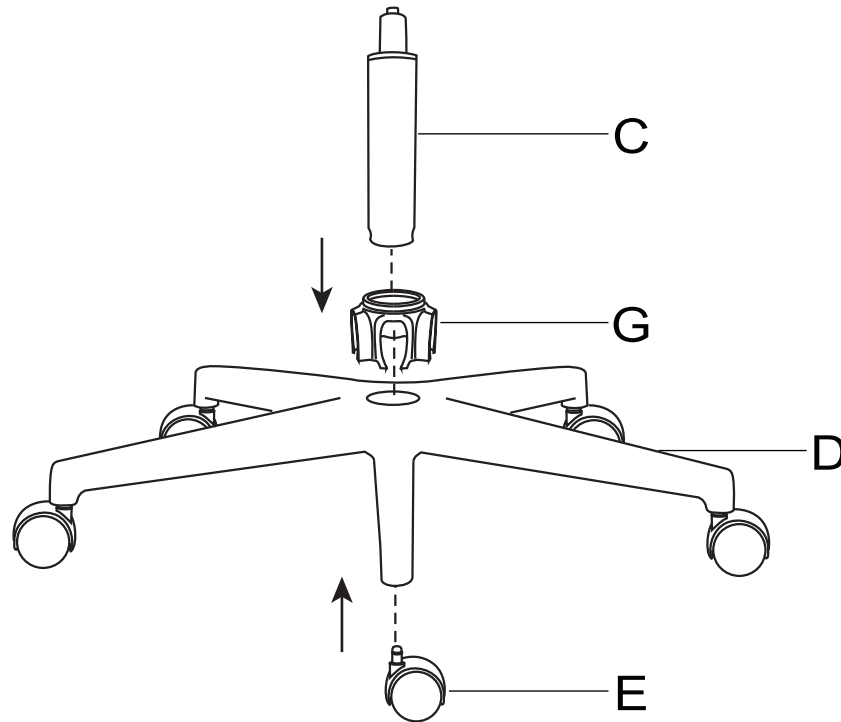

STEP 2

Attach the Seat Plate (F) to the Seat (B) by using Allen Short Bolt (H) and Allen Wrench (K).

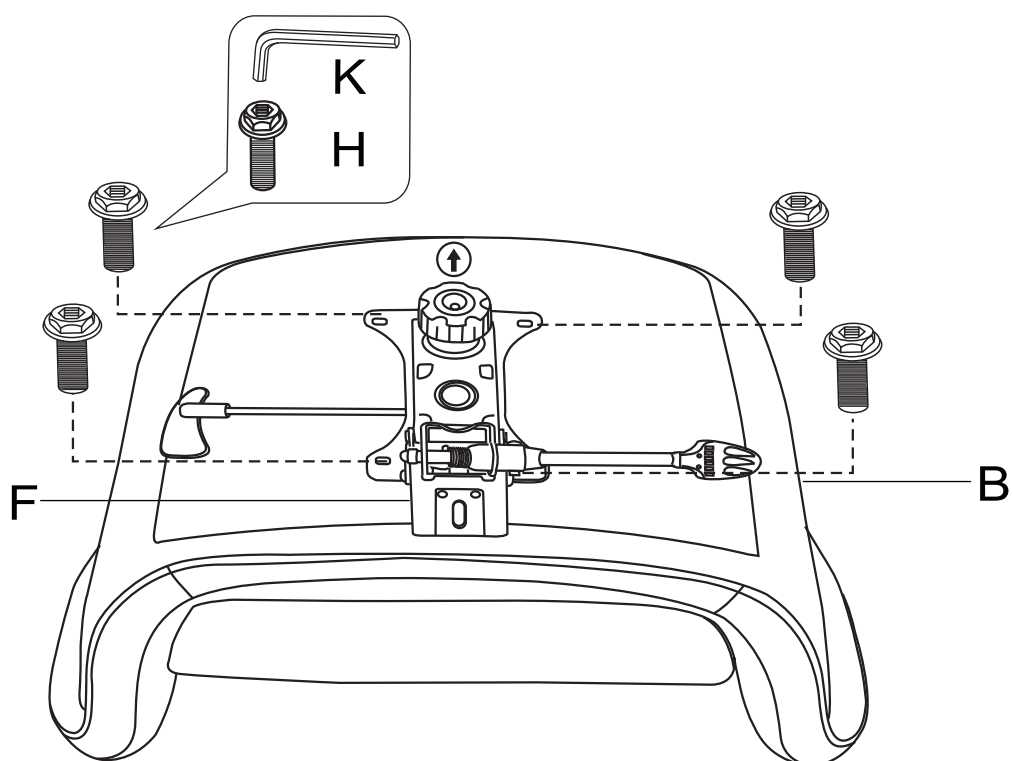

STEP 3

Connect the Backrest (A) and Seat (B) by using Allen Long Bolt (J), Bolt Lock (I) and Allen Wrench (K).

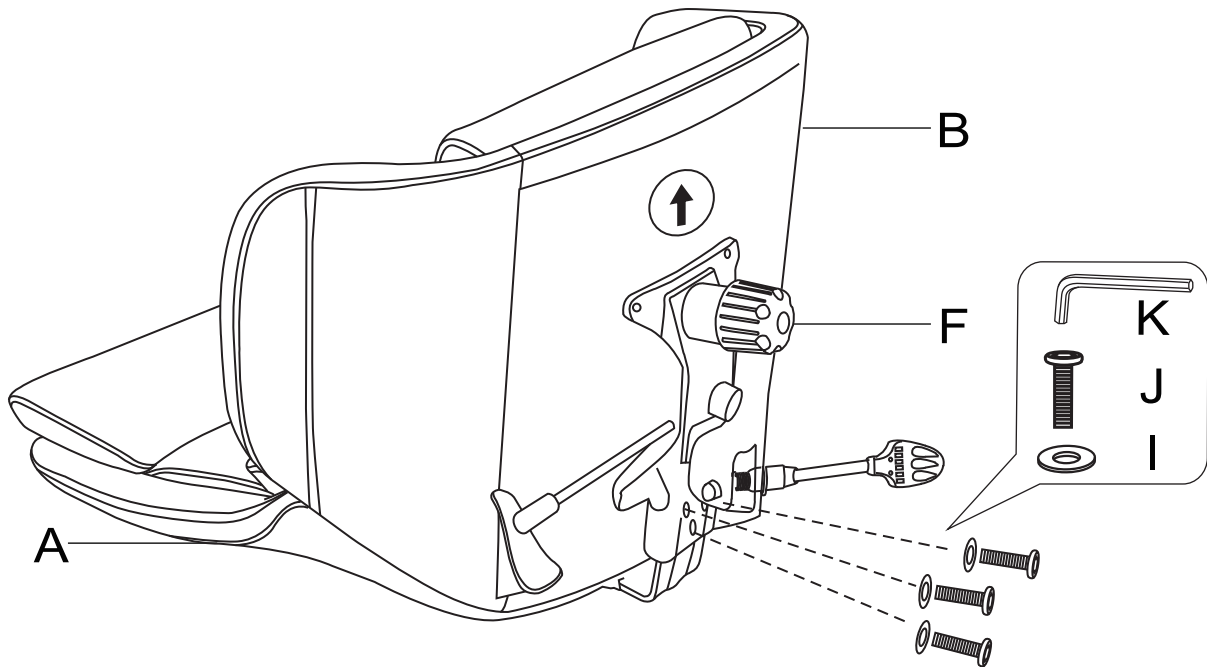

STEP 4

Insert the Gas Lift (C) to the Seat Plate (F) as shown below.

After initial assembly, the product may acclimate to its new environment. Please ensure all screws are still securely tightened.

