

How to build a 3-bin compost system



If you plan on setting up food scrap collection for a group like an apartment complex, a multi-family unit, or a school, you may need the capacity of a three-bin compost system. This scale of system is designed to handle the food scrap outputs associated with larger groups. This design also incorporates additional rodent control and airflow measures like slatted sides and latches to keep the lid closed.

Follow along with our step-by-step instructions to build your community a compost bin that will last for years and provide you with convenient food-scrap disposal and rich organic fertilizer for your garden.

If you think this system is too large for your needs, see our plans for a 2-bin system at <http://www.cvsmd.org/home-composting.html>.

Site preparation tips:

Choose an easily accessible location.

Level the site where the compost bins will be placed. You can use stones to shim up the bin if needed.

IMPORTANT: Make sure the footings are level in both directions or your bin will not work well.

This design has one lid, which may be heavy for some people. If so, you may consider using multiple lids.

Choose an untreated, weather resistant wood such as hemlock, cedar, or locust. You can also seal the wood with a non-toxic wood preservative such as Vermont Natural Coating's Polywhey to protect your bin from the elements and improve its lifespan.

Use whatever materials you have and feel free to re-use old materials.



CENTRAL VERMONT SOLID WASTE MANAGEMENT DISTRICT
137 BARRE STREET, MONTPELIER, VT 05602

Materials

***Wood:**

(10) 2x4s @ 8'

(2) 2x4s @ 12'

(20) 1x4s @ 12'

(2) 1x6s @ 8'

Other Materials:

(1) 36" x 120" piece of tin roofing

(8) stones to help level the bin

Non-toxic wood sealer/preservative (optional)

Hardware:

(1) Large box of 2" decking screws (approx. 5lbs)

(1) Small box of gasketed roofing screws

(4) 3' x 3' pieces of ¼" hardware cloth

(2) 9' x 3' pieces of ¼" hardware cloth

(1) box of ½" heavy duty staples

(4) Hinges

(2) handles

(2) latches

(2) lengths of chain, or cable to hold the lid open. Make sure you get a sturdy chain so it doesn't break!

Tools:

Saw

Drill/Impact driver

Carpenter's square

Stapler

Tape measure

Safety gear (gloves, glasses, ear plugs)

Level

Shovel

**Rough-sawn wood is generally close to the named dimensions, but may vary in thickness and width. Dimensional lumber from a store is smaller, so make sure to adjust your measurements accordingly. For instance, a rough-sawn 2x4 is about 2"x4" whereas a dimensional 2x4 is really 1 ½"x 3 ½".*



Material processing:

Cut and assemble whichever parts you can reasonably move. Examples include building the 3' x 3' dividers, the lid, and cutting the other parts to size for onsite assembly. See illustrations.

Note: When 2x2s are called for, this means a 2x4 cut in half lengthwise.

(2) Divider frames: Fig. 1, 2

- (2) 2x4s @ 36"
- (2) 2x4s @ 33"
- (1) 36"x36" piece of 1/2" hardware cloth
- 2" Screws
- Staples

(2) End Divider frames: (Same as divider frames but with slats on the outside)

- (2) 2x4s @ 36"
- (2) 2x4s @ 33"
- (1) 36"x36" piece of 1/2" hardware cloth
- (7) 1x4s @ 36"

*Make the doors **after** assembling the bins to ensure a good fit.*

(3) Top Doors: Fig. 7a (four slats)

- (4) 1x4s @ 30 3/8"
- (1) 2x2 @ 27 1/8"
- (2) 2x2s @ 14 1/4"
- 2" Screws
- Staples

(3) Bottom Doors: Fig. 7a (five slats)

- (5) 1x4s @ 30 3/8"
- (1) 2x2 @ 27 1/8"
- (2) 2x2s @ 18 1/4"
- 2" Screws
- Staples

(1) Lid: Fig. 11, 12

- (2) 2x4 @ 108"
- (4) 2x4s @ 36"
- (1) 120"x 36" piece of roofing tin (it comes in 10' lengths)
- 2" Screws
- 1" Gasket screws
- (4) Hinges
- (2) Handles
- (2) Latches
- (2) Lengths of chain/cable to hold the lid open

Other pieces to prepare for onsite assembly:

- (4) 1x6s @ 37" for vertical front trim. Fig. 7
- (6) 2x2s @ 36" for internal supports for the door slats Fig. 8
- (9) 1x4s @ 108" for horizontal rear bracing/slats and bottom bracing Fig. 3, 4
- (4) 1x4s @ 29" for bottom bracing



Assemble your four divider frames, then staple hardware cloth across the opening on one side:

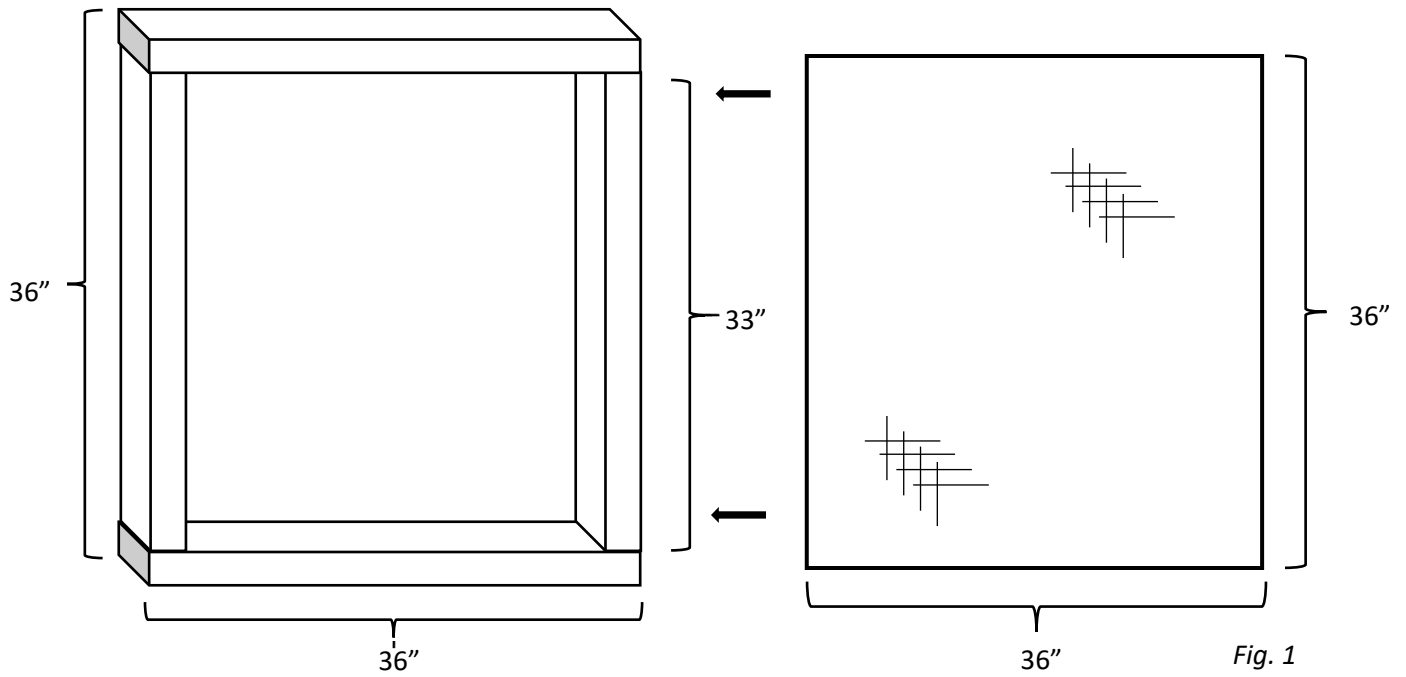

Once you have your divider frames, lay them out with the sides that will end up on the bottom facing up. (see the gray colored sides of the frames in fig. 2)

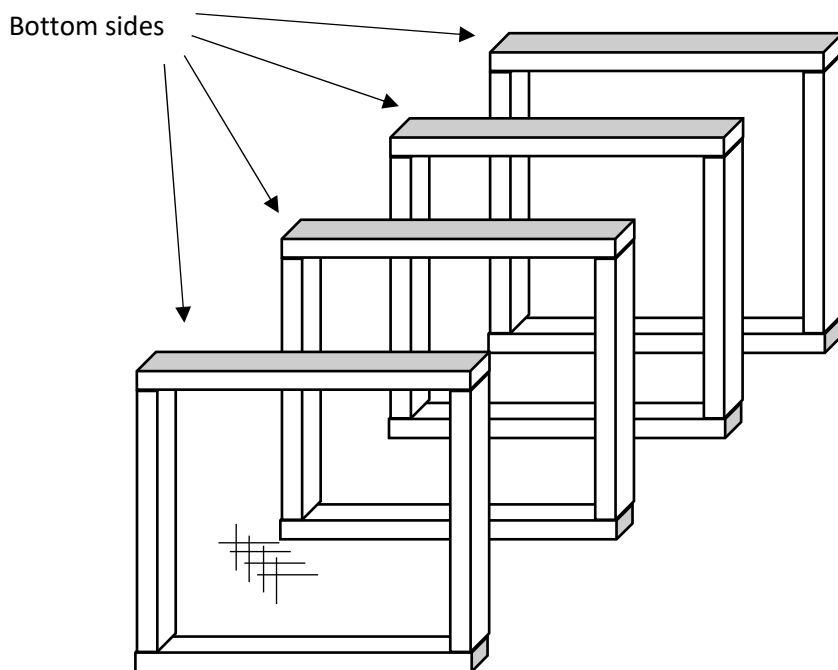

Use two 108" 1x4s to create the frame for the bottom of the bin. Lay them out parallel so that the distance between the outside edges is 36".

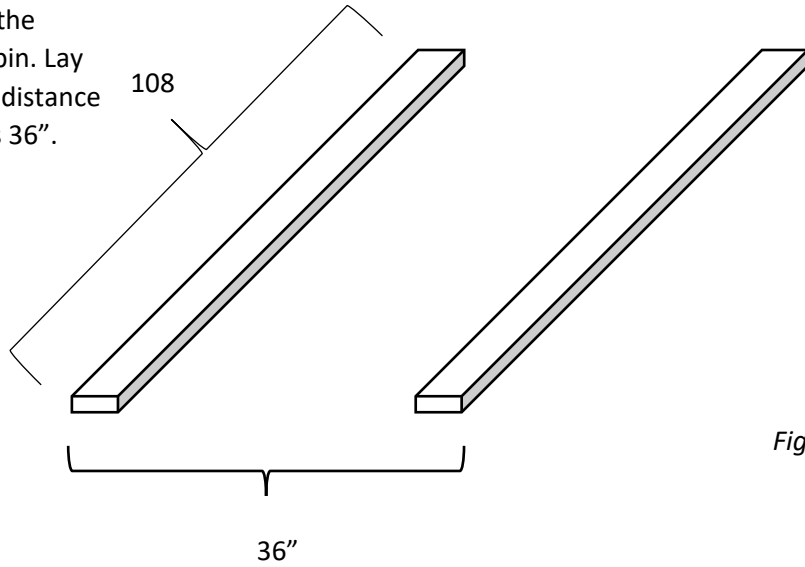

Fig. 3a

Staple a 36" x 108" piece of hardware cloth on to these planks

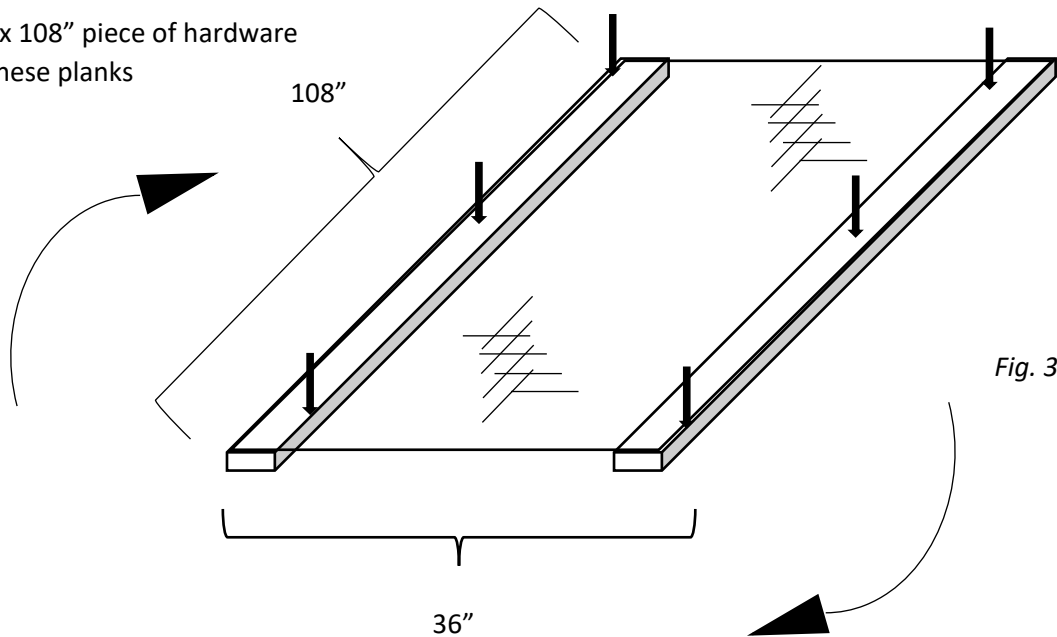
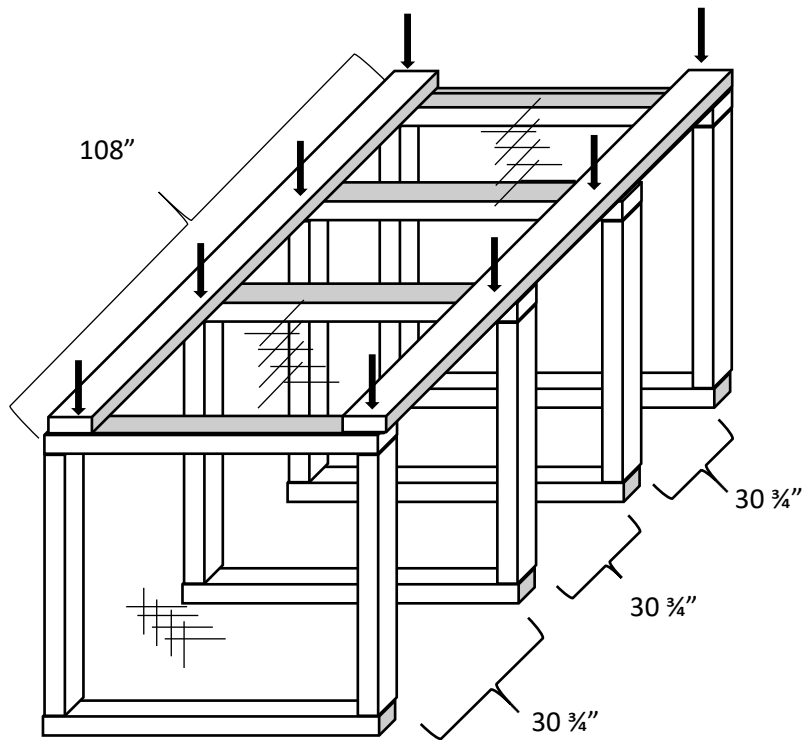

Fig. 3b

Flip this bottom frame over and set it on top of your divider frames before screwing it down with the boards facing out. See fig. 4a





Use screws to attach the bottom frame to the divider frames. The dividers should be evenly spaced along the bottom frame with about 31 5/16" between each frame.

Fig. 4a

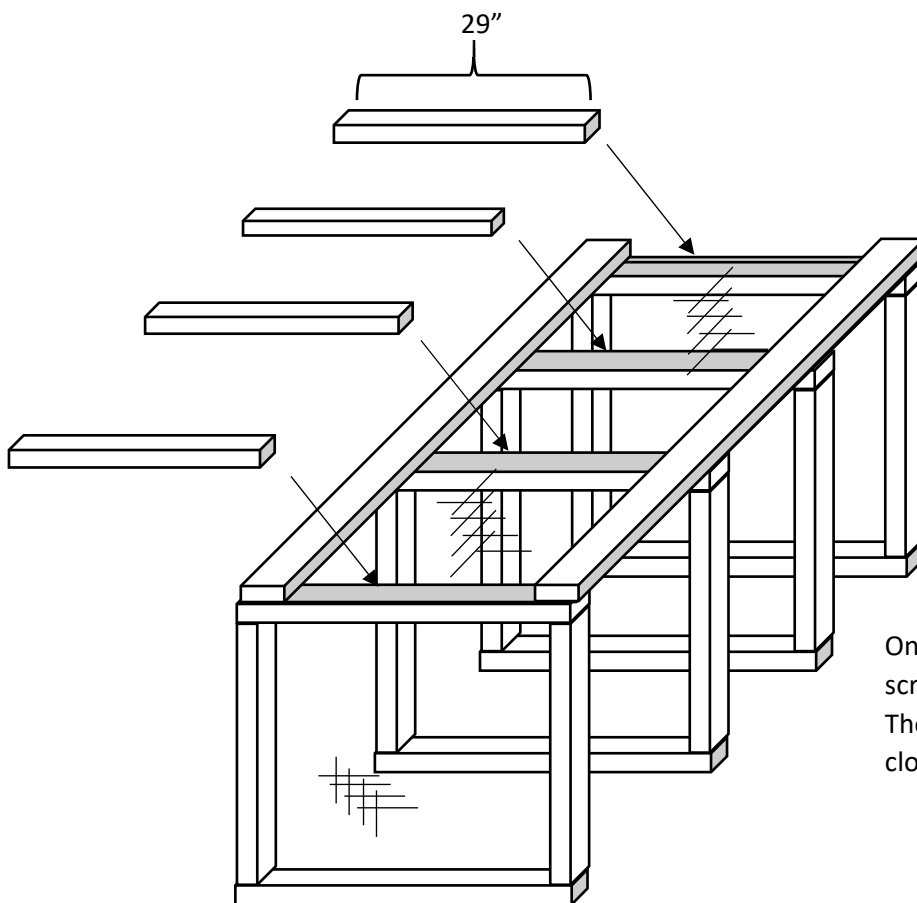

Once the long braces are attached, screw down the 29" bottom braces. These will also secure the hardware cloth on the bottom.

Fig. 4b



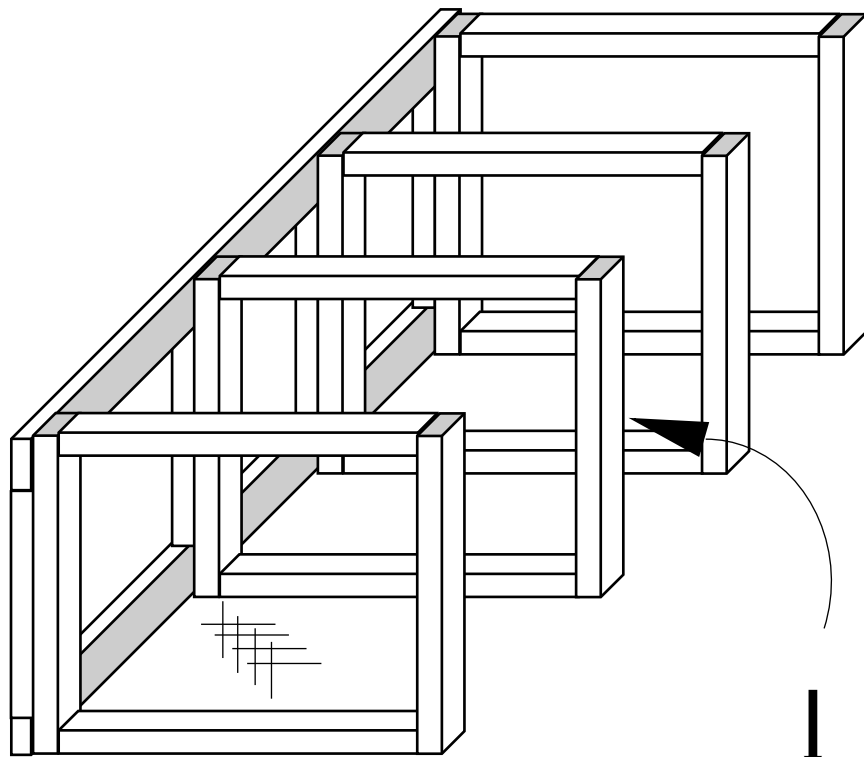

Roll the bin so that the bottom is on one side, then repeat steps 3a-4a to cover the back of the bin with hardware cloth.

Fig. 5a

Once the two end planks are secured, fill in the space between them with five evenly-spaced 1x4 planks 108" long

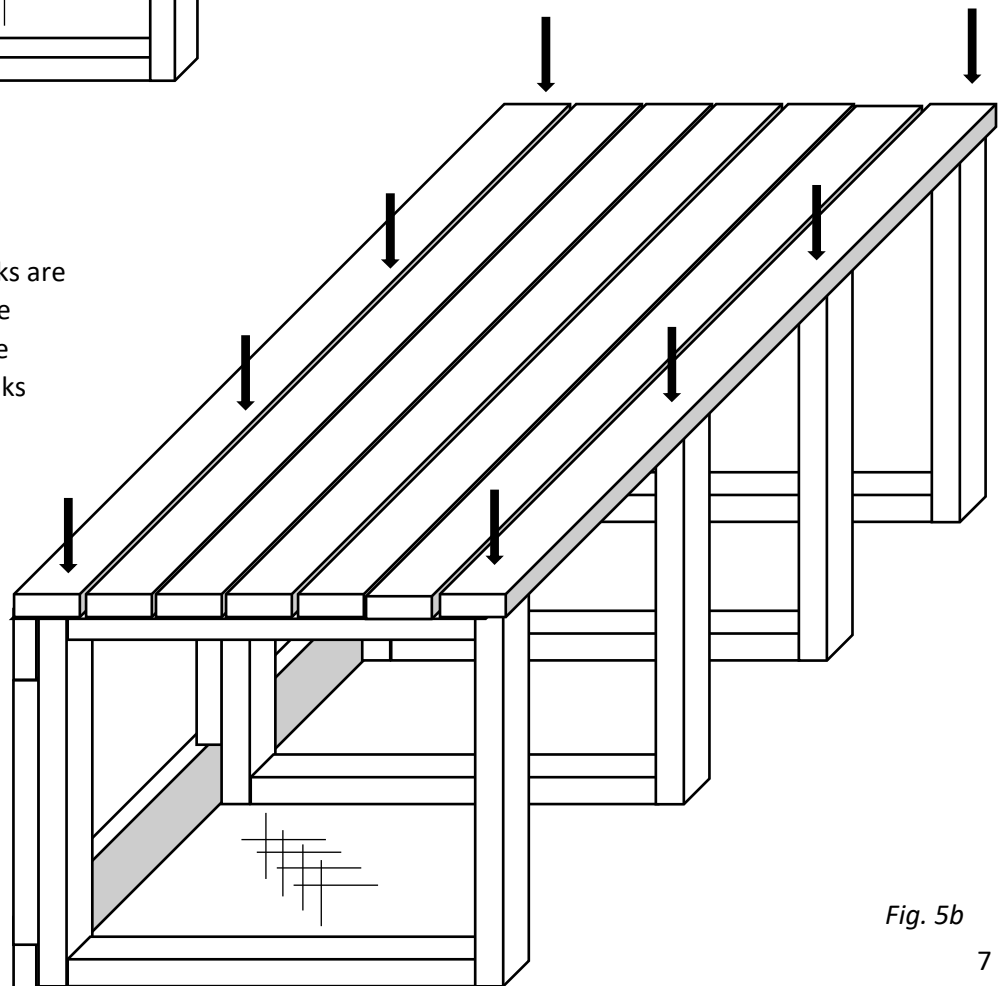
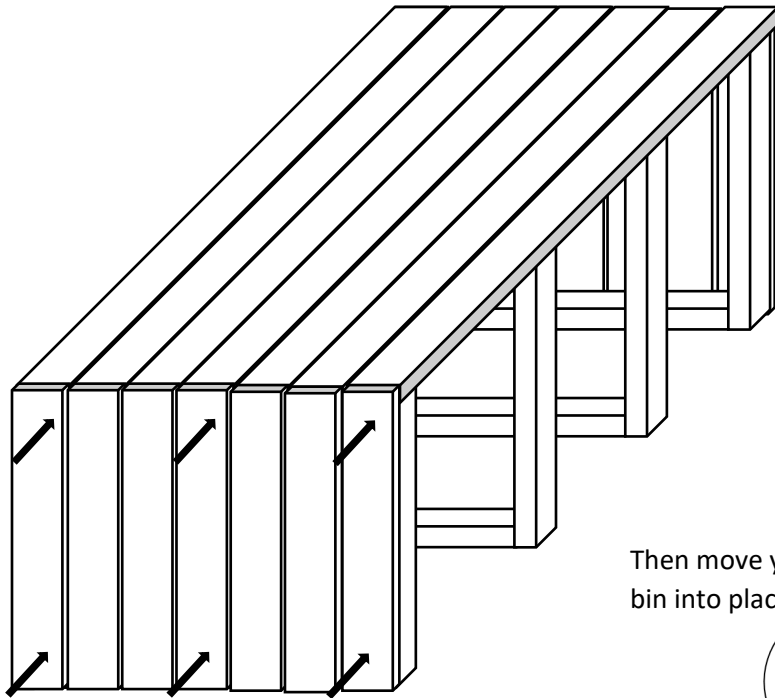

Fig. 5b





Screw on side panels (1x4s @ 36") on both sides, following the same process as Fig. 5b.

Fig. 6a

Then move your bin into place

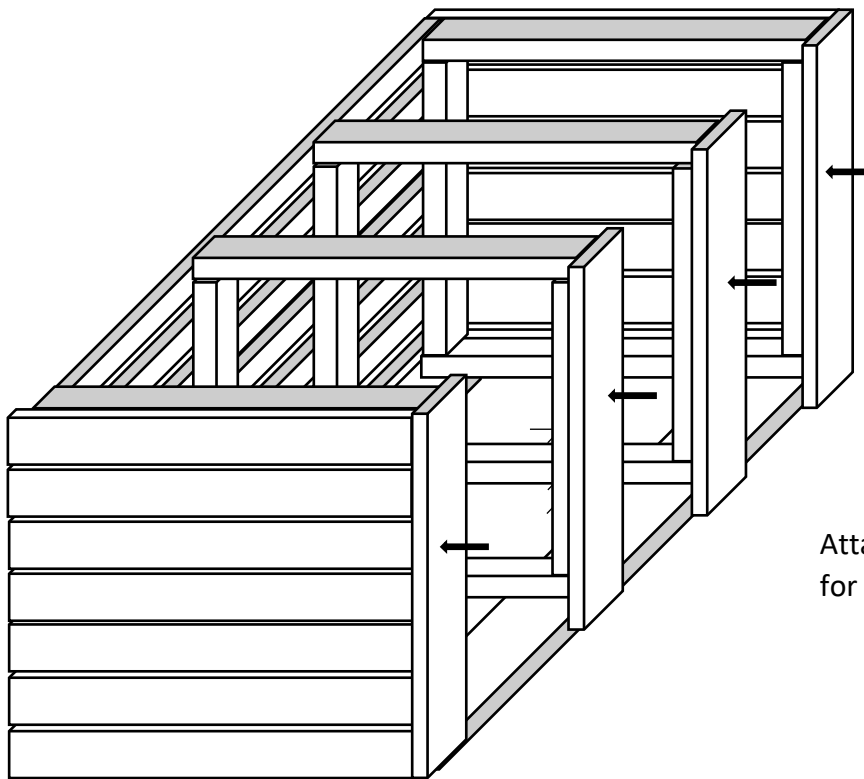
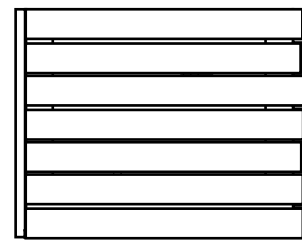

Attach the four 37" 1x6s for the vertical front trim

Fig. 6b



The doors will be made in two pieces so they are sturdy and easy to remove.

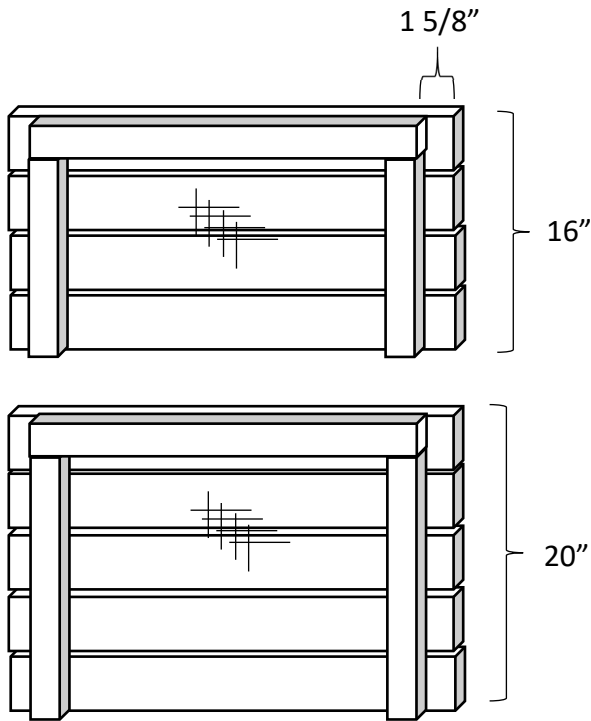

The top door has four slats

The bottom door has five

Fig. 7a

Use 2x4s cut in half lengthwise for the framing, then attach hardware cloth and lock everything in place with evenly spaced slats

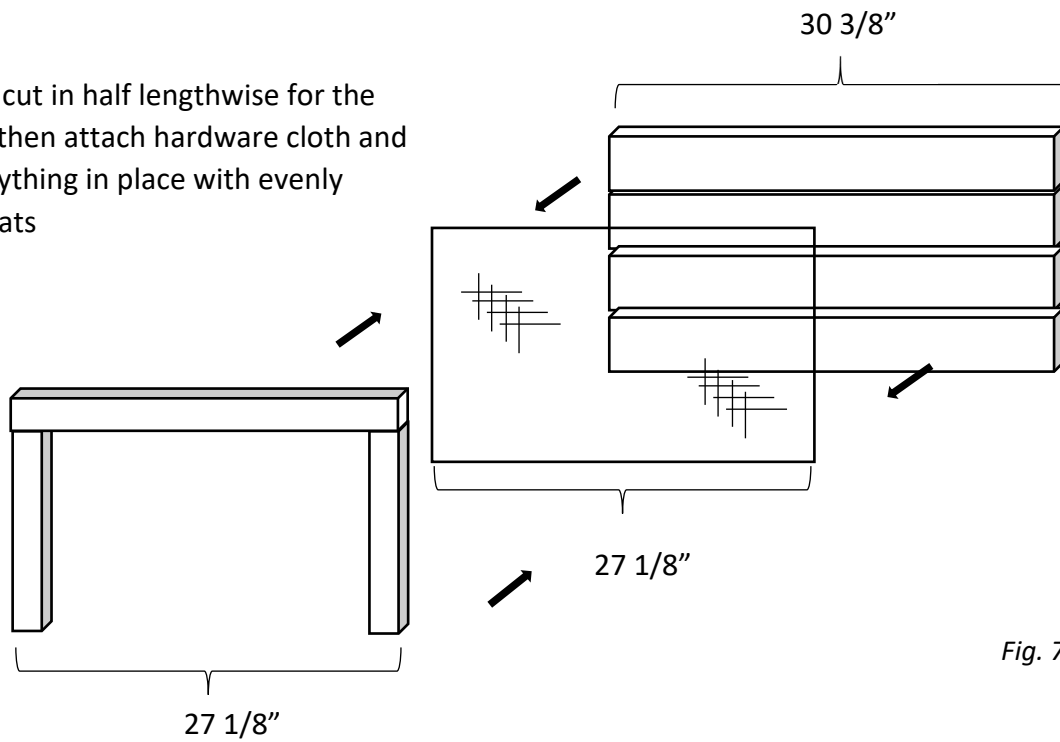

Fig. 7b



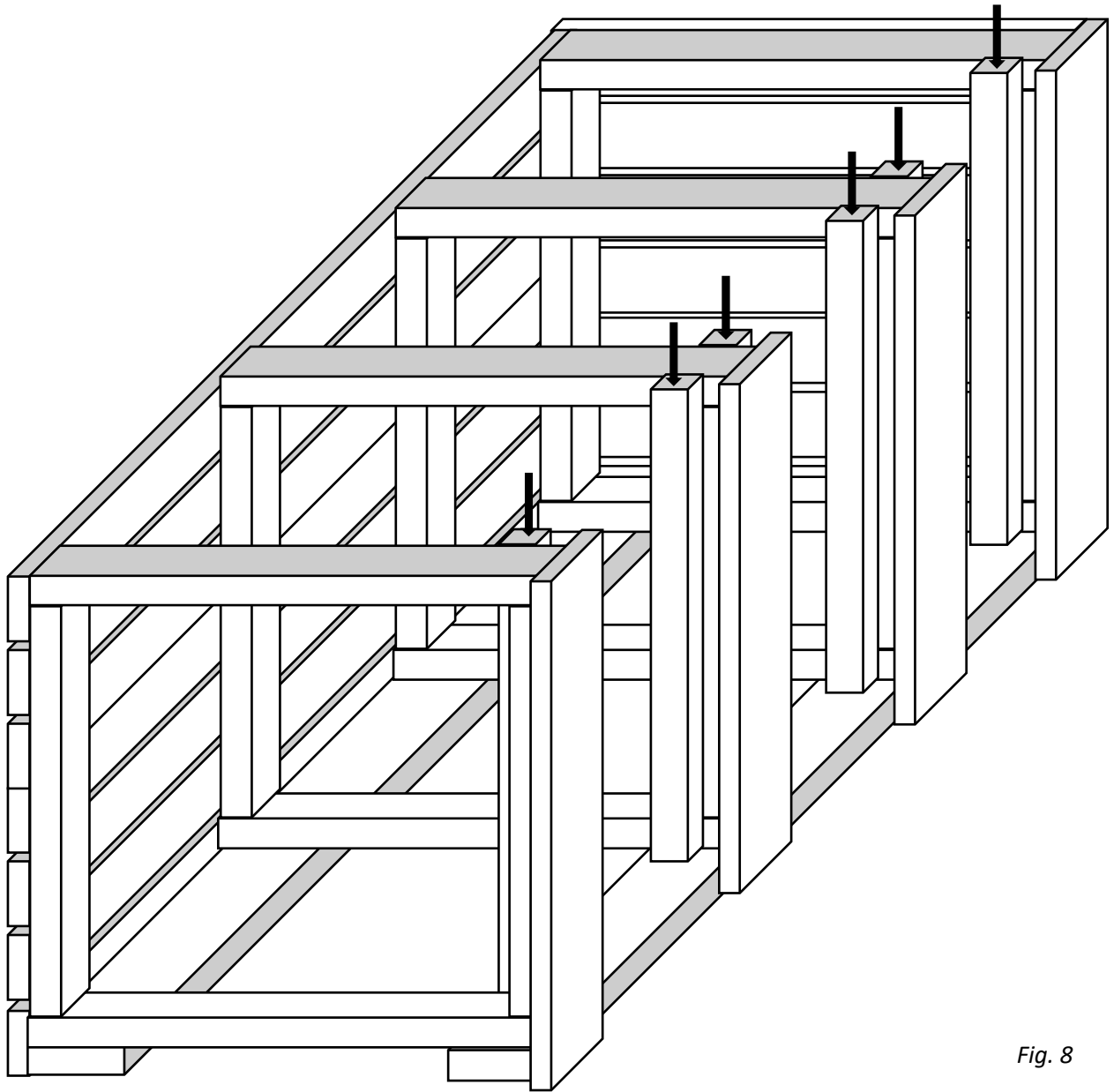

Fig. 8

Use six 36" 2x4s cut in half lengthwise to create backstops for each of the doors. Screw these to the frame inside each of the bins as in Fig. 6c.

Use the doors to space the backstops—the doors should slide in and out easily but still feel secure.



Screw the 2x4 lid frame together, then attach the tin roofing

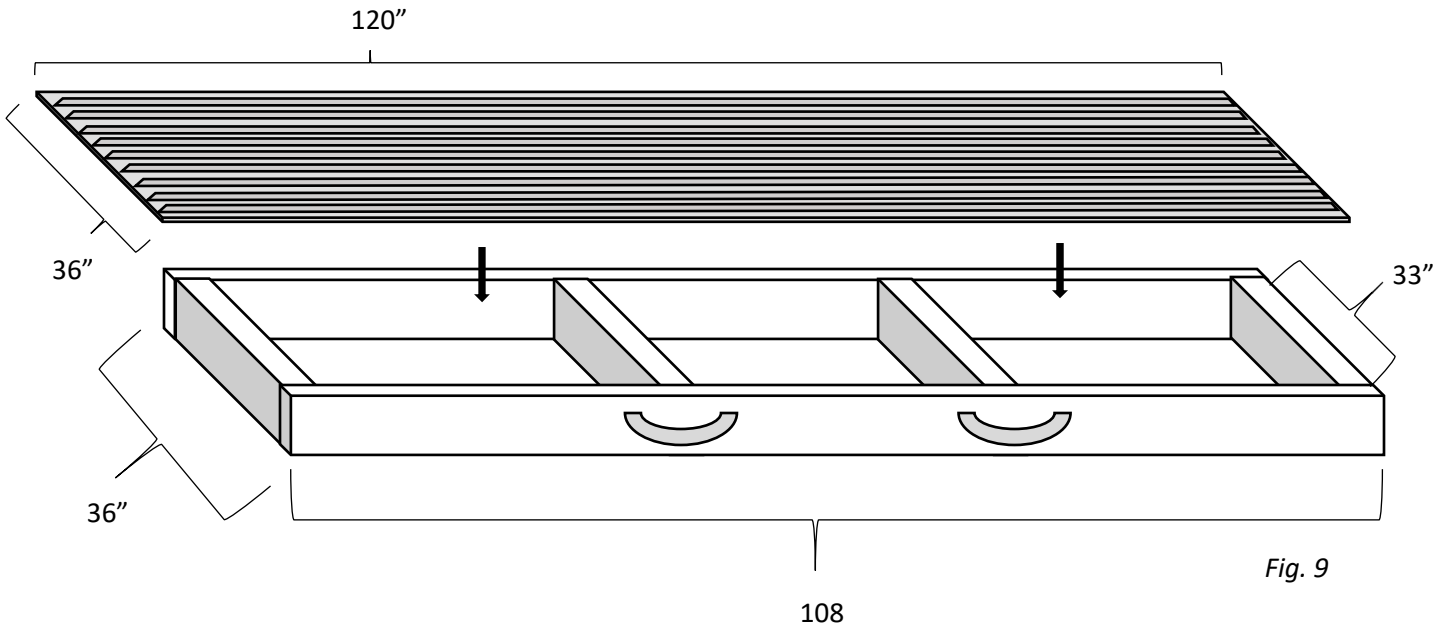

You can then use hinges to attach the roof to the back of the bin. Hinges should be centered on the divider frames for optimal strength.

Handles and latches will make your bin convenient and secure. Handles should be centered on the two middle dividers. Be sure to set up the latches so you can easily disengage them and leave them open for when you open the bin (Fig. 10)

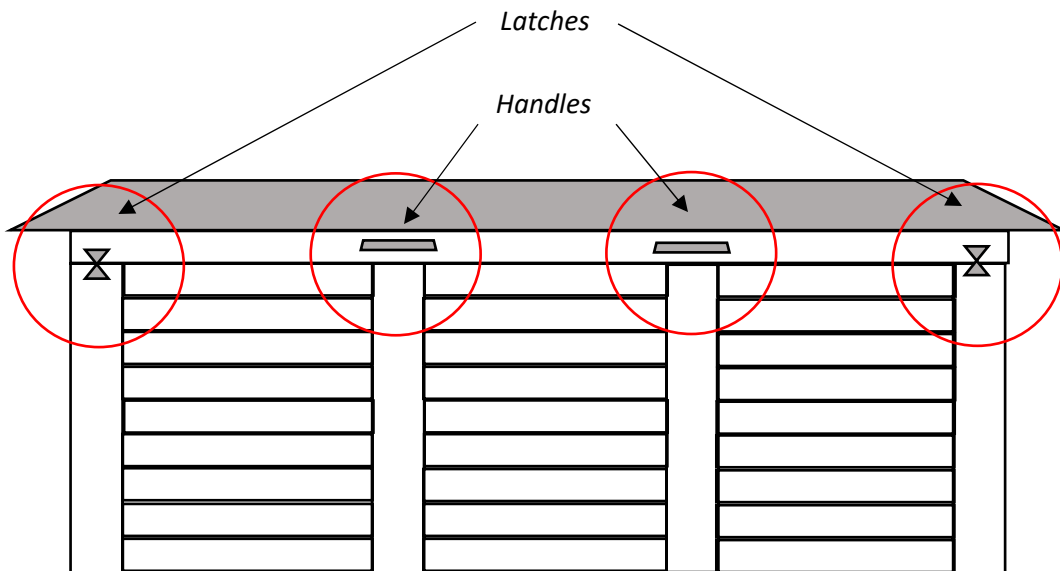

Use a chain or cable (one per side) to stop the bin from opening too far

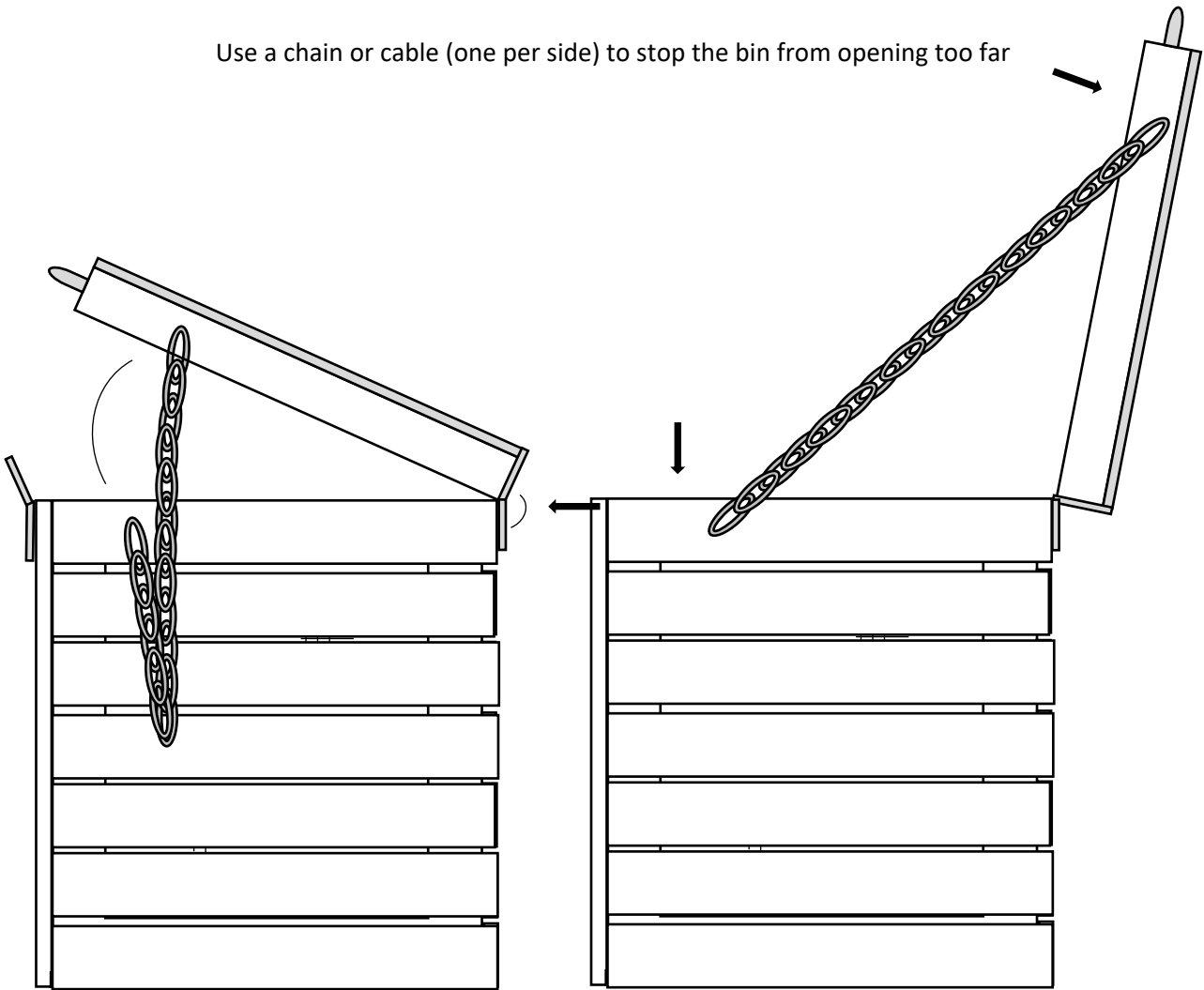

Fig. 11

This bin was designed and built Theron Lay-Sleeper for the residents of Avery Apartments in Barre as part of CVSWMD's community compost program. Please feel free to use and distribute these plans to other groups interested in managing their food scraps better. We hope you enjoy building it and putting your food scraps to their highest and best use. For more information on backyard composting, and other ways to reduce and manage your waste outputs at home, please visit our website at <http://www.cvswmd.org/>

