



Walls Under Existing Manufacturer's Installation Guidelines



Local: 951-369-8777 • Fax: 951-369-0847 • www.cthrusunrooms.com



These instructions are guidelines ONLY. They are not given to be specific to your application. The pieces illustrated are for an OMEGA system and the profiles for an AlphaPlus system may be slightly different in look and connection points. However the principles of installation still apply!

Introduction:

C-Thru recommends that you review this manual thoroughly prior to your installation. These Installation Guidelines should be used as a reference tool during the room construction process. Technical and installation questions can also be addressed the Dealer you purchased the kit from, in this case Home Porch & Patio Kits Inc. (1.844.404.0484 / request@homeporchandpatiokits.com)

C-Thru Industries & Home Porch & Patio Kits Inc are a **“materials only”** supplier. It is the responsibility of the homeowner / installer to make sure that the C-Thru room complies with the requirements of local building codes. C-Thru provides a variety of engineering for permitting purposes. Rooms designed within the scope of these engineering documents meet or exceed the current IBC, IRC and CBC building codes.

BEFORE



AFTER



DEPENDING ON WHICH UNIT YOU HAVE PURCHASED THE PROFILES PICTURED IN THESE GUIDELINES MAY DIFFER SLIGHTLY FROM WHAT YOU RECEIVED.

THESE ARE TO BE CONSIDERED GUIDELINES ONLY AND ARE NOT MEANT TO COVER EVERY FORESEEABLE CIRCUMSTANCE WITHIN A DIY APPLICATION.

ALL CLIENTS OF HOME PORCH & PATIO KITS CAN CALL US ANYTIME, TOLL FREE (1.844.404.0484) WITH YOUR INSTALLATION QUESTIONS. IF WE CAN'T ANSWER THEM, WE WILL FIND SOMEONE WHO CAN!

IT IS HELPFUL TO INCLUDE PICTURES OF YOUR 'QUESTIONS'
request@homeporchandpatiokits.com



The Accomplished

This rating is for those who know their way around a workbench and are familiar with miter saws, reciprocating saws, framing squares, chalk lines, and rivet guns. They are not intimidated by complexity and intuitively understand that ingenuity will be part of solving the inevitable assembly challenges. They are able to read between the lines of instructions, using experience to anticipate solutions to potential roadblocks. They will be able to organize and prioritize a large number of materials and different profiles. They will have the kind of experience and a skill level that has regularly experienced high praise from others on finished projects. This build level will require more time, the ability to research, and a good understanding of tools used in the DIY world. They will have already experienced the pay off in doing these projects and know it to be usually worth it. This build level provides a finished product that should appear professional looking, and none of your friends will believe you did this! This type of job can take between 3 - 7 days, including preparation and clean up, depending on the size of the project and your skill level.

Table of Contents:

Section 1: Tools
Section 2: Job Site Preparations:
Section 3: Material Delivery:
Section 4: Attachment Channels:
Section 5: Bottom Track Installation:
Section 6: Wall Attachment Channel Installation.....
Section 7: Wall Installation.....
Section 8: Door Installation
Section 9: Electrical Wiring.....
Section 10: Final: Details & Clean Up.....
Section 11: Care & Maintenance.....
.....
Appendix A: Part Profiles & Connection Details.....

***Some of the steps given below may not
apply to your specific application!**

Your installation will go smoother when you have the proper tools. Before you begin the installation, please make sure you have the recommended tools and that they are working in a safe and efficient manner.

Power Tools:

- 12" Compound Miter Saw (60-80 Tooth Carbide Blade)
- Worm Drive Circular Saw (24 Tooth Carbide Blade)
- 10" Circular Saw (60-80 Tooth Carbide Blade)
- ½" Hammer Drill
- ½" Hole Shooter
- 14.4 Volt Drill/Driver (Variable Speed, Torque Setting)
- Reciprocating Saw (Sawzall)
- Rotozip Spiral Saw

Miscellaneous Tools:

- Adjustable Framing Square
- Power Strip
- Extension Cord(s)/GFI Pigtail
- Chalk Line
- Putty Blade (1" & 3")
- Measuring Tape (30' & 50')
- Caulking Gun
- Nail Set
- Holster For Cordless Drill
- Gloves
- Safety Goggles
- Tool Box (for misc. fasteners)
- Extrusion Profile Sheet
- Installation Manual
- Shop Vacuum

Drill Bits

- Magnetic Bit Holder w/#2 Phillips Bit
- 2" or 3" Phillips Bit Extension
- Magnetic Nut Setters (1/4", 5/16", 3/8")
- ¼", 9/64", 3/16" Drill Bits
- ¼" Masonry Bit
- 5/8" Wood Boring Bit

Hand Tools:

- Pop Rivet Gun
- 16 Oz. Rubber Mallet
- 16 Oz. Hammer
- Chisel
- Utility Knife
- Flat & Phillips Head Screwdrivers
- Pliers
- Flat Head Vise Grips
- Needle Nose Pliers
- 4' & 2' Level
- Tin Snips
- Step Ladders 4' (a taller ladder may be useful)
- Tool Belt W/Nail Bag
- Chalk & Carpenter's Pencils

Room Foundation:

The C-Thru Modular Walls Layout sheet will list the dimensions of the room. The dimensions needed for the slab or deck are the room dimensions plus min. 1 ½". Thus, if your room dimensions are 10' X 12', the foundation must be a minimum of 10'-6" x 12'-3".

Many potential problems can be eliminated before any construction begins by having a level and square slab or deck. If installing the room on a new concrete slab, it may be necessary to seal the slab. This will help avoid condensation forming within the room. Preferably, the room should be installed on a new slab or deck. A pre-existing slab or deck needs to be in "like new" condition if used. Numerous buckles or cracks in the foundation will make it unsuitable for construction and could contribute to future leaks in an otherwise weather-tight system. Please reference your local building code for the slab, deck, or footing requirements needed to use the C-Thru modular wall system.

Use a 4' level to determine the degree of the foundation's slope. If the foundation is not level and the slope of the slab is less than 1 1/2 inches, then 2" to 3" of solid fill should be ordered at the bottom of each wall module with a glass kick plate to compensate for the slope. If the slab or deck is uneven to a larger degree, a two-stage kick plate or extra solid may be necessary to construct the room. Two-stage kick plates generally have a minimum of 2" of solid below the glass kick plate. Modules with solid kick plates generally provide the most flexibility in dealing with non-level slabs.

The room's foundation must be higher than the grade of the surrounding area to avoid drainage problems. Any water that penetrates the structure of the sunroom will drain out the bottom rails, which are designed to drain water away from the room at connection points. Standing or pooling water next to the sunroom could potentially block and destroy the functionality of the internal weep system.

The general work area must be kept as organized and clean as possible. Make sure the area is free from clutter or debris before the room arrives. Potential obstruction must also be removed. These include trees, bushes, or other greenery that could make the construction of the room difficult. If needed, clean the slab or deck before construction begins. You should try to keep the construction area free from excess material, tools, or debris during all phases of construction.

Preparation of the house walls may also be needed. Examine the attachment "foot print" of the room on the house and identify any elements that may need removal, demolition, adjustment or repair.

The Job Site Preparation Checklist should be used as a checklist to ensure your site is ready for the room's arrival. Once completed, you can begin the installation process.

This section/checklist is given ONLY as a help to the homeowner. As a DIY application these elements are entirely up to the homeowner to assess and carry out in preparation for the Sunroom Installation.

SITE CONDITION

- Yes** **No** Check accessibility - can materials be delivered easily?
- Yes** **No** Are there fences or other interferences which must be removed for access?
- Complete** Check the following for interference:
 - Sprinklers Underground Utilities Air Conditioners
 - Telephone Lines Electrical Meters Exhaust Vents
 - Water Pipes Gas Pipes Meters
- Yes** **No** Check the roof connection, ridge connection, etc.
- Yes** **No** Does the eave or soffit need modifications or repairs?
- Yes** **No** Will the existing gutter and downspouts need to be modified or repaired?
- Yes** **No** Is there existing drainage to connect (French drain, street drain etc.)?
- Complete** Roof type:
 - Shingle Tile Tar/Gravel

FOUNDATION / FLOOR

- Yes** **No** Does the natural slope carry water away from the new foundation?
- Yes** **No** Measure the drops and clearances for cap-overs and slabs (2"-3" min)
- Complete** Can Concrete be poured manually or does the job require a pump?
 - Manual Pump
- Complete** If excavating soil is required, will the dirt be used or hauled out?
 - Used Hauled
- Yes** **No** If a raised floor is specified, is there adequate crawl space?
- Yes** **No** Carefully measure the property drop dimension - are steps/landings required?
- Yes** **No** Are existing steps and landings to code?
- Yes** **No** Determine proper projection of foundation, from house wall or foundation

CONNECTION

- Yes** **No** Are there interferences at the attachment points (doors, windows, etc...)?
- Yes** **No** Verify height connection. Is it adequate for proper connection?
- Yes** **No** Does the eave need to be removed or modified?
- Yes** **No** Does the exterior wall need to be modified (sheetrock, siding, stucco...)?

DEMOLITION

- Yes** **No** Will the existing siding be removed?
- Yes** **No** Is the site clean-up and debris removal included?
- Yes** **No** Any modification to existing wall for opening, doors and windows?
- Yes** **No** Will the existing headers carry the loads of the new openings?

ELECTRICAL CONNECTION

- Yes** **No** Is there enough service at the panel for the new addition? (100 amp recommended, check at main panel)
- Yes** **No** Is there room in the panel for additional breakers or wafers?
- Complete** Can the home run be concealed or will exterior conduit be needed?
 - Concealed Exterior Mounted
- Yes** **No** Determine location of sub-panel, interior wall, exterior wall, closet and how the new home run will be routed. Will it be difficult to run?
(If an exterior run is required, document and obtain sign off from owner)

HVAC (Optional)

- Yes** **No** Is the existing system adequate to support the new addition?
- Yes** **No** Can you connect to the existing ducts/registers?
- Yes** **No** If additional unit is to be installed, check electrical and duct routing.

INTERIOR / EXTERIOR

- Yes** **No** Is painting included in the proposal?
- Yes** **No** Does the owner have matching paint on hand?
- Yes** **No** Will the connecting wall be stripped of siding, etc.?
- Yes** **No** Is drywall included in the proposal?

COMMENTS: _____

The construction process begins when the room arrives to the jobsite. Identifying, organizing, and planning at this stage may save hours on the installation. Use the following checklist during material delivery to help speed along the construction process.

1. If the room is packaged for LTL shipping, make sure you receive all the boxes. A total box count can be found on the bill of lading. Note any missing pieces on the bill of lading. Take pictures of the load upon arrival.
2. Inspect the material for damage. Note any damaged boxes or parts on the bill of lading. Note that the packaging is designed to sustain some abuse during transport. Although the packaging may be damaged, the material inside may be intact.
3. If you do not plan on immediately installing the room, remove some of the packaging for ventilation. See the packing stickers for important maintenance and storage information i.e. **Do not store packaged/unvented vinyl in direct sunlight or at angle so as to prevent the sun from warping or distorting vinyl parts prior to installation of these parts.**
4. When unloading, organize all similar materials together. Place them in a readily accessible area so you can easily select the appropriate materials needed for each step of the installation process.
5. Inventory all the materials that have arrived. You can refer to the C-Thru layout and cut list for the parts. These documents should arrive with your room and will give important information about the particular room being installed. The information includes room dimensions, extrusion cut sizes, and module locations. Keep these documents accessible during all steps of the installation process.
6. The room materials should be placed outside the perimeter of where the room is being built.
7. Be sure to place the material in a hazard-free area, **as damage on the job site is not covered under your warranty and is subject to replacement costs.**
8. Window inserts and screens are shipped within the wall modules. **Remove them from the modules and store in a safe cool location for future installation.**
9. In the unlikely event of an error or missing pieces, contact Home Porch & Patio Kits as soon as possible. Every effort will be made to expedite replacement parts to help avoid job shutdowns.
10. **Figure 01** is an example of a job site in which the materials have been separated, organized and are ready for installation.

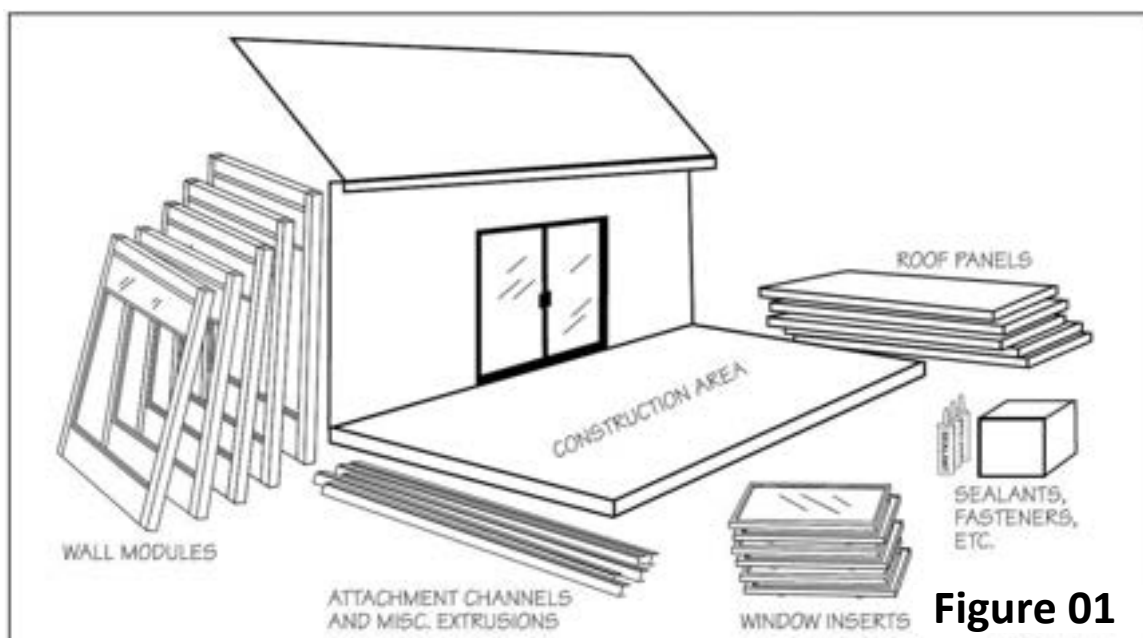

Figure 01

Identifying and Inspecting Materials:

Your room will be attached to the existing structure and foundation with a series of attachment channels. The following is a brief list of the attachment channels needed and the items required for their installation:

1. Bottom Track (**Figure 01**): affixed to the slab or deck. The walls of the sunroom will rest in the bottom tracks.
2. Wall Channel (**Figure 02**): affixed to the existing structure's walls. Used to attach the side walls of the room to the structure.
3. Top Header (**Figure 03**): affixed to the underside of your existing roof line and on top of your wall channel installation.
4. Anchors: When attaching to wood applications, use 3 ea. 14g SST wood screws. When attaching to concrete applications, use Hilti 3/8" Kwik Bolt II or approved equals (refer to ICC-ES Report #4627 for acceptable fasteners substitutes)
5. Sealants: Premium Silicone Caulking.
6. Metal flashing may also be required. Additional flashing may also be needed at the bottom track and wall channel.
7. Carpenter's pencil and chalk line.



Figure 01



Figure 02

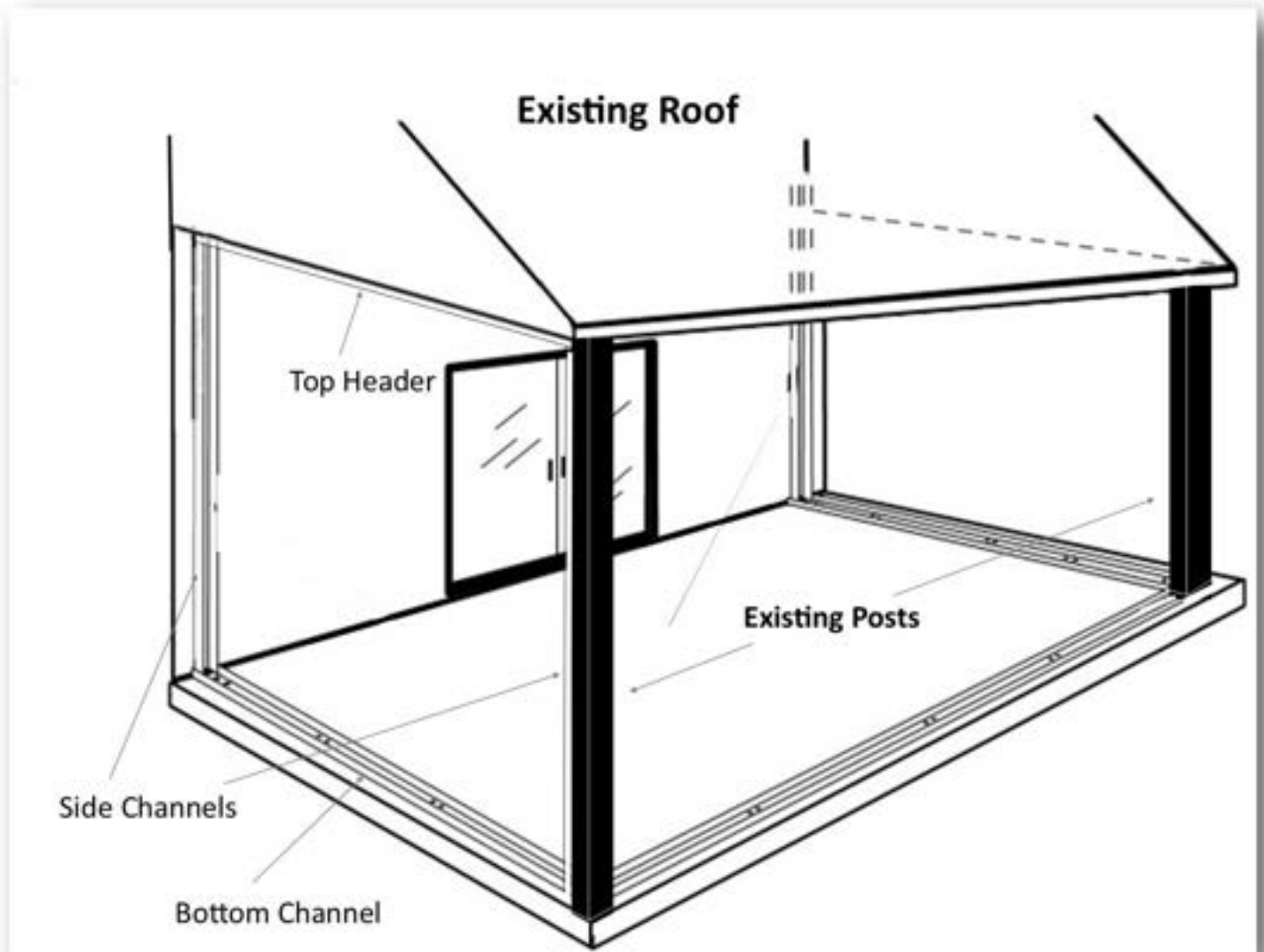

Figure 03

Your profiles may look slightly different than what is pictured to the right.

Once the proper materials have been identified, inspect that they are free from damage. Many of C-Thru's extrusions will contain a screw guide. The screw guide is a line etched into the extrusions that can be used as a guide for fastener placement.

The following is a quick overview of what you will be accomplishing with your materials.



You will start by installing ALL channels, (bottom, side and top header) in all openings in which your modules are to be mounted. Prior to mounting your side channels **choose ONE** of the two side channels, *for each opening*, to rip in half along its entire height (length). You will need secure the inside half to the house wall or post (whichever you have chosen). The second half will be put in place once the last module is put into place.

***The following pictures are given for illustration purposes only;
to help with the concept behind installation.**



Trim the top of the module so it will easily insert into the header track. The total depth from the bottom lip of the header track to the inside stop-lip is about 1 1/8".

Insert top of module into header beam.

Be sure to trim the top of your module **just enough** to allow for the module to swing over the top lip of the bottom channel. This would be a great time to take measurements for the top and bottom fill pieces for this module.

Drop the module in place and push against the wall track.

ONCE ALL MODULES ARE IN PLACE FASTEN THEM DOWN PER NORMAL INSTALL.

Remember... you will be ripping one of your vertical wall channels along its center length, roughly in the middle. You will attach the outer half to your vertical surface and put your last module in place. The remaining half of your vertical channel will be used as a cap, once the last module is in place.

Note: The most important part of any room installation is to make sure the room is square to the house. This is essential in the installation process.

Room wall dimensions and heights can be found on the C-Thru Room layout sheet (your CAD drawing). The wall drawing will show the three sections of the walls **from the perspective of standing outside the room**. Thus, the left wall of the room is found in the upper left corner of the sheet. The wall height listed is the module height. When you receive your modules, you will note they are going to be slightly taller than the tallest indicated wall height on the drawing. All final cuts are to be made at the time of installation. This allows for modifications due to non-square applications and sloping base installations.

The wall projections listed on the sheet are exterior to exterior dimensions and include the measurements of the wall tracks. This should match your wall to post, post to post measurements of each of your existing openings. Use this layout sheet as a reference when placing your tracks and attachment channels.

Cutting the Bottom Track

The bottom tracks for your job will arrive in stock lengths. They will need to be measured for the correct size and cut to length. These measurements can be confirmed on the C-Thru room layout as well as your chalk lines on the foundation. As a general rule, measure twice and cut once!

NOTE: IF YOUR BOTTOM RAILS HAVE WEEPHOLES, MAKE SURE THE WEEP HOLES ARE FACING OUTWARD, PRIOR TO CUTTING THE BOTTOM TRACKS!



Pre-Drilling the Bottom Track

The bottom track will be attached to the foundation using fasteners. Fasteners must be positioned on the bottom track where each module joins the next (module joint mullion). The location & distance between each module joint can be found on the C-Thru room layout sheet (your CAD drawing). Mark the location of each joint on the bottom track. At each module joint, pre-drill two ¼" holes about 3" apart down the center screw line of the bottom tracks as shown in **(Figure 04)**. There is a sealant reservoir on the under portion of the bottom track that separates the interior and exterior half of the bottom track, it looks like a "fin."

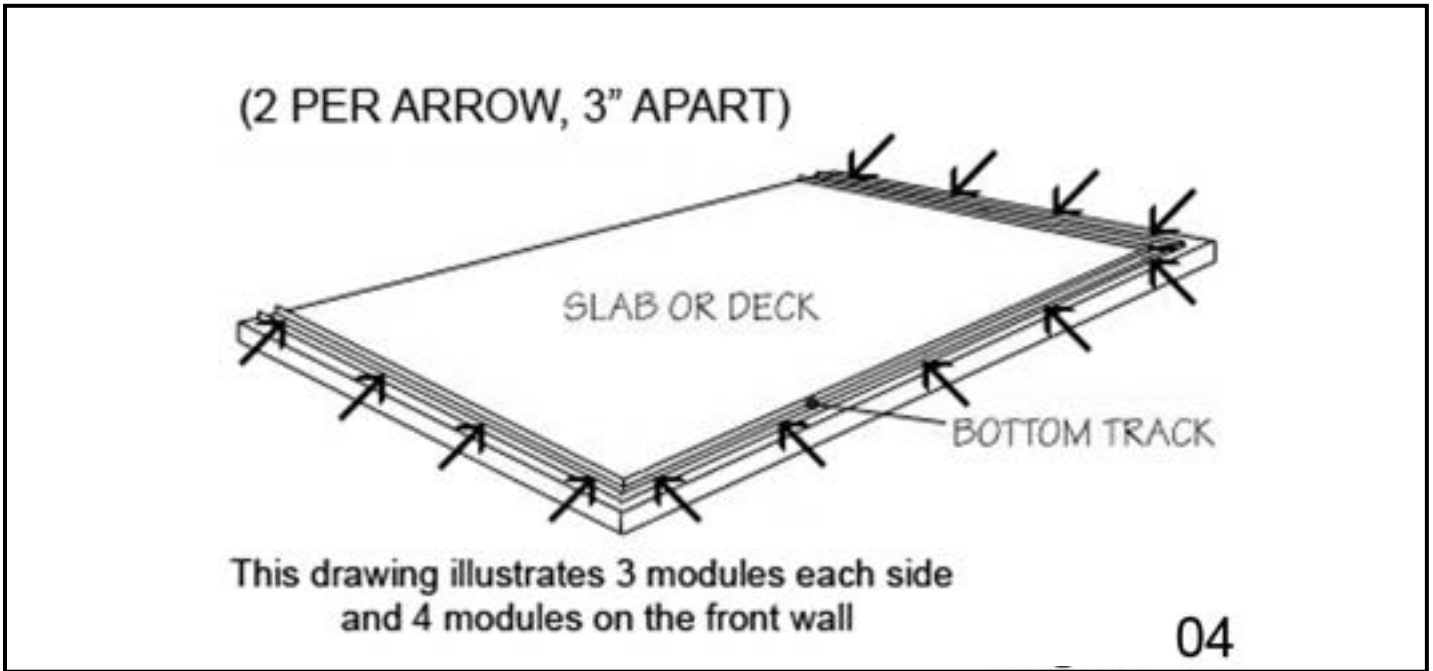

If properly sealed, the sealant reservoir will prevent water from penetrating the room from under the bottom track. You will need to make sure the holes are drilled center of the extrusion. Your bottom track may look slightly different than what is illustrated here. (see Figure 05).

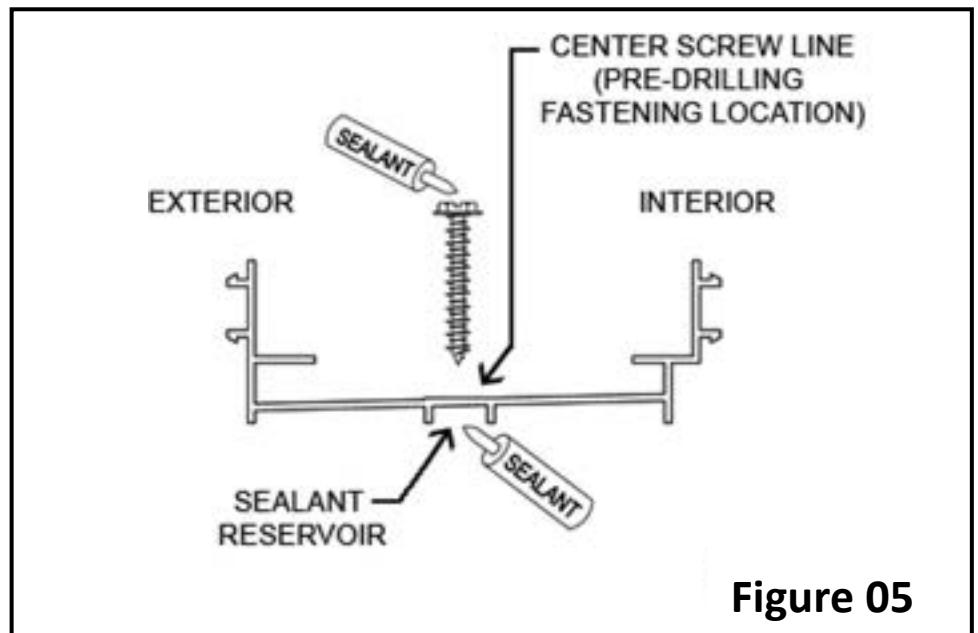

Pre-Drilling the Foundation

Place the outside of the bottom tracks on the foundation and line them up with the chalk lines. First, drill into the foundation with a masonry bit (for concrete) or regular drill bit (for decks) through the first hole that is closest to the house wall in each sidewall bottom track. Temporarily secure each side wall bottom track to the foundation with one lag screw or nail set. This temporary attachment will act as a fixed pivot point to square the bottom track. Once the bottom track is square, drill the remaining foundation holes needed to anchor the bottom track. Once all foundation holes are drilled, remove the bottom track and clear the debris left from the drilling with a broom or shop vacuum.

Note: Use the appropriate bits and fasteners for wood or concrete applications.

<https://www.bing.com/videos/search?q=best+fasteners+for+concrete&docid=608017367916938179&mid=20C1B6FB7E7224AC828720C1B6FB7E7224AC8287&view=detail&FORM=VIRE>

<https://www.bing.com/videos/search?q=best+fasteners+for+concrete&docid=608050061195623247&mid=900EA0F6C2D4F9F4A327900EA0F6C2D4F9F4A327&view=detail&FORM=VIRE>

Sealing and Attaching the Bottom Track

Once the bottom tracks have been cut, pre-drilled, and the foundation holes predrilled, the bottom tracks are ready to be attached to the foundation. Turn the bottom track upside down and run a bead of caulk in the sealant reservoir see **(Figure 06)**. You should also bead over the drill holes you have made. Place the bottom track back next to your chalk line and begin anchoring the bottom track. Remember, the chalk line should line up with the exterior of the bottom track. Seal the corners of the bottom track and the top of the fasteners with silicone sealant as well as any mitered corners.

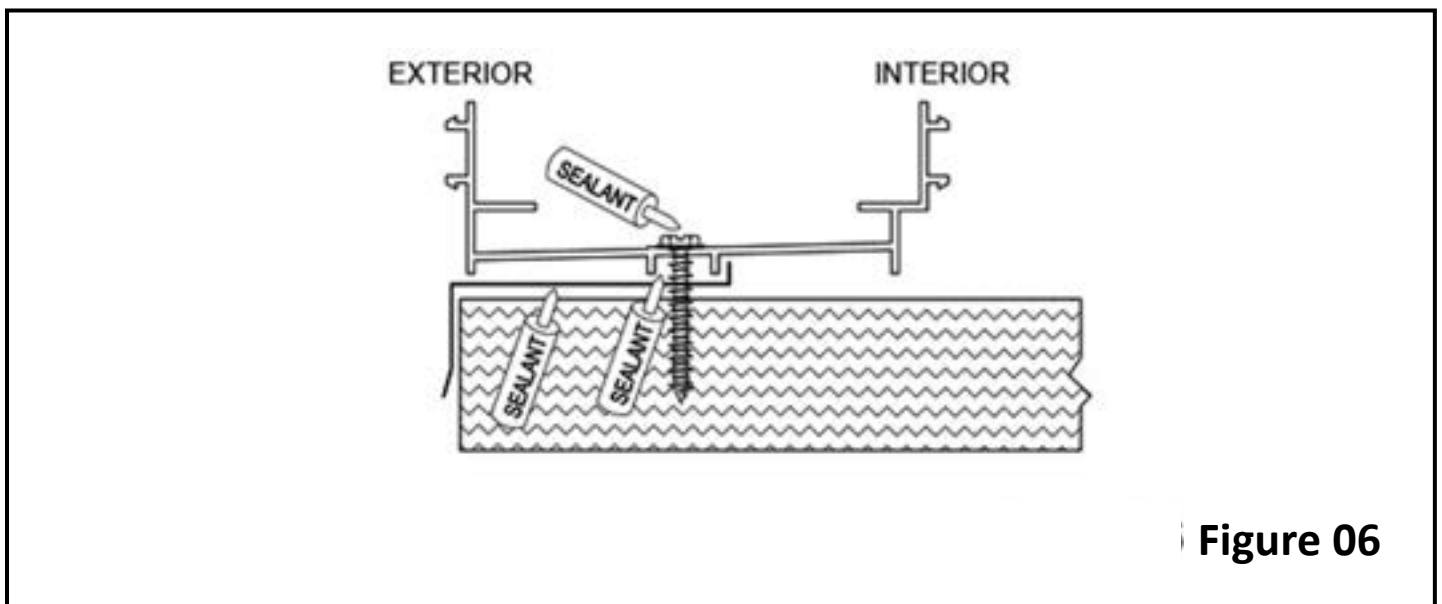

Figure 06

Note: A polyurethane sealant may be substituted to seal bottom tracks to concrete. Wood foundations should be sealed with an "L" metal flashing and silicone **(Figure 06)**.

Cutting and Attaching the Header Beam

After your bottom rails are installed, you will need to attach the header beam. The header beam will arrive in stock lengths and will need to be cut to size. Just as you did for the bottom track, measure the distance from wall to post (post to post) along the underside of the existing roof line. This will be the cut length for the electrical header beam. Cut header beam to length and secure it to the underside of your existing roofline with the appropriate mounting hardware.

After all your modules are in place, use two sheet metal screws at each utility mullion and electrical header beam junction (just like for the bottom track), using the screw guide lines on the header beam.

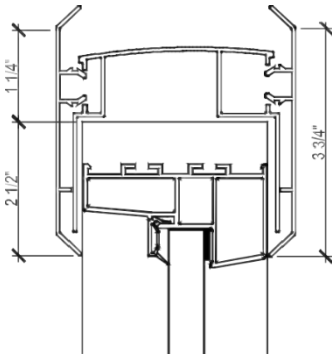

Important: Be sure your chalk lines on the foundation and on the underside of your existing roof line are 'plumb' over top of one another. This will ensure that your wall (post) attachment channels will be installed square in relation to each.

Note:
Make sure once the header clad (OMEGA system only) is snapped into place on rooms with existing roof lines that you trim the top of the cladding to fit snugly up against the roof line.

Measuring and Cutting Wall Attachment Channel

The last attachment channels to be secured are the wall channels to allow you to secure the room sidewalls to the house. Each wall channel will rest on a lip found on the inside of the bottom track and go up to the lip on the inside of the top header. These lips must be taken into consideration when measuring for the wall channel cut lengths (Figure 01).

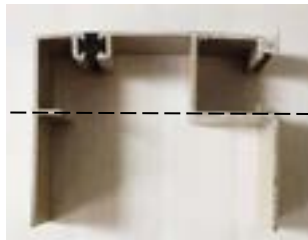

**Header Channel
Alpha Plus
Bottom Channel**

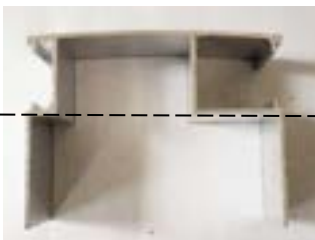

**Header Channel
OMEGA
Bottom Channel**

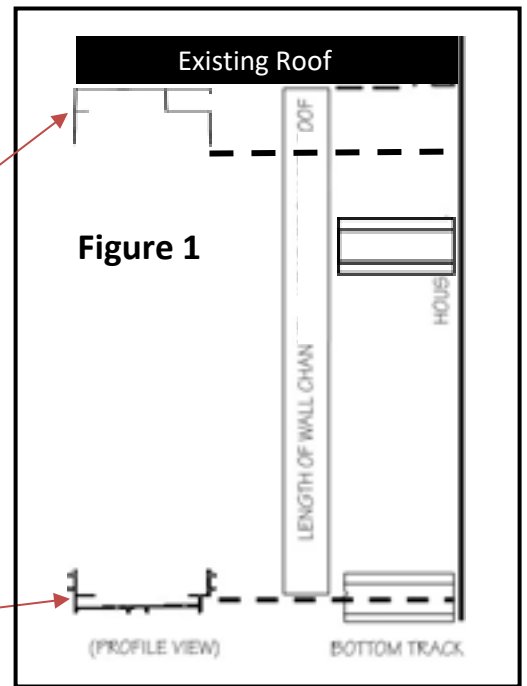
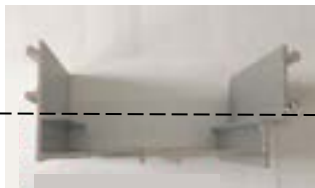

Note: For installations under an existing roof line you will want to rip the length of either the wall channel at the house wall or the wall channel going onto your existing post into 2 pieces. Attach one half of the channel to the wall or post. The remaining half will be put in place after all modules and filler sections are in and serve as a finishing cap.

Checking for Square

Place the wall channel inside the bottom track at the house wall and move the top into place inside the header channel. Make sure this installation is plumb (level) before securing to the house wall or post.

Note: Before attaching wall channel, you will need to remove cladding tits (OMEGA system only) so wall track can slide into the top and bottom tracks.

(Figure 03).

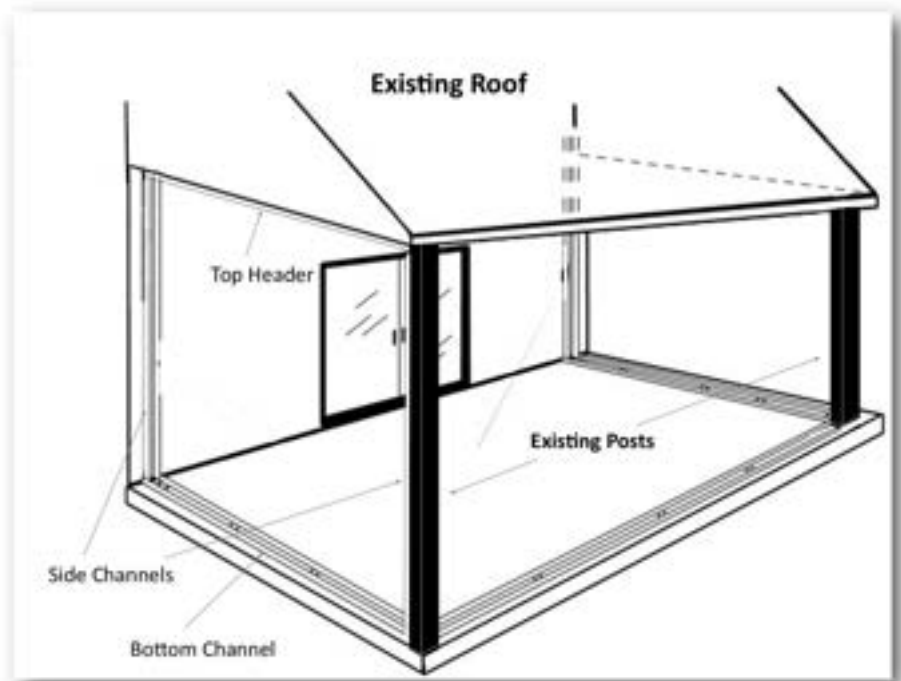

Pre-Drilling, Sealing, and Securing the Wall Channel

Molly bolts will be used to attach the wall channel to the house. Starting at the uppermost end of the wall channel, mark your first location for attachment. Continue to mark fastener locations every 16 inches. Remove the channel and predrill $\frac{1}{4}$ " holes into the wall channel at each mark.

Before bolting, seal the wall channel by placing a bead of sealant center of the back of the extrusion **(Figure 04)**. Use polyurethane or silicone, depending on the material of the house wall.

Note: Expanding plastic plugs may be used to secure the bolts to a stucco wall. *The method and hardware for securing the wall channels to the wall or post is the homeowner's responsibility to assess.*

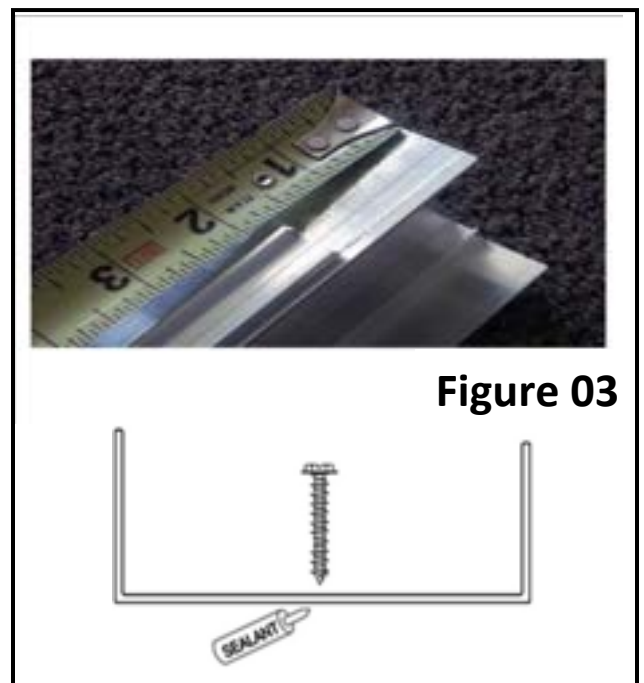
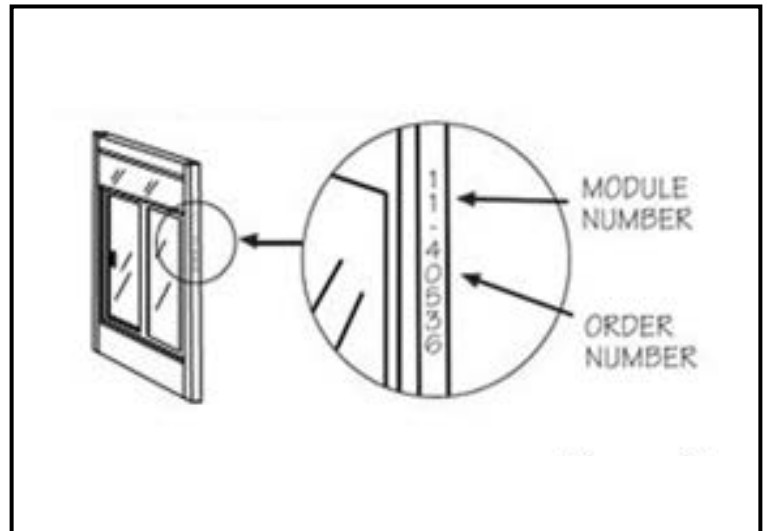

Figure 03

Preparing for Installation

Wall modules for the room are individually numbered and will correspond with the module numbers listed on the C-Thru room layout sheet. The work order number and the module number can be found on the inside web of the mullion for each module (**Figure 01**). Remember that the number 1 module is usually not the first module in the front wall.

Refer back to the room layout sheet for the correct module numbers for the front wall. It is important that you identify which modules go to which walls as module heights and widths will vary.



Note: When putting modules in place, make sure the weep holes are facing outward.

On concrete foundations and deck applications, the foundation may not be level. Place a 4' level on the inside edge of your front wall bottom track to determine if the foundation is level. If there is a slight slope, you will use the solid fill below the window (solid kickplate) or below the glass kickplate to trim to compensating for the slope (**Figure 02**). C-Thru does not recommend this as a norm for sloppy foundation work as this could create problems as the installation continues. If the slope is not uniform, then each module must be cut separately, adding the adjustment for each module cut size to the next module. Not all modules are the same width; therefore, each cut must be made according to the size of the individual module.

Note: It is essential that the window frames and the tops of the modules maintain a continuous level surface. The windows will not operate properly unless the modules and the window frames are level and square. This must be taken into consideration when cutting the solid kick plates to adjust for slopes.

Note: The 2-stage kick plate (glass with solid base trim) gives the ability to install glass kick plates while using an existing out-of-level concrete slab or deck.

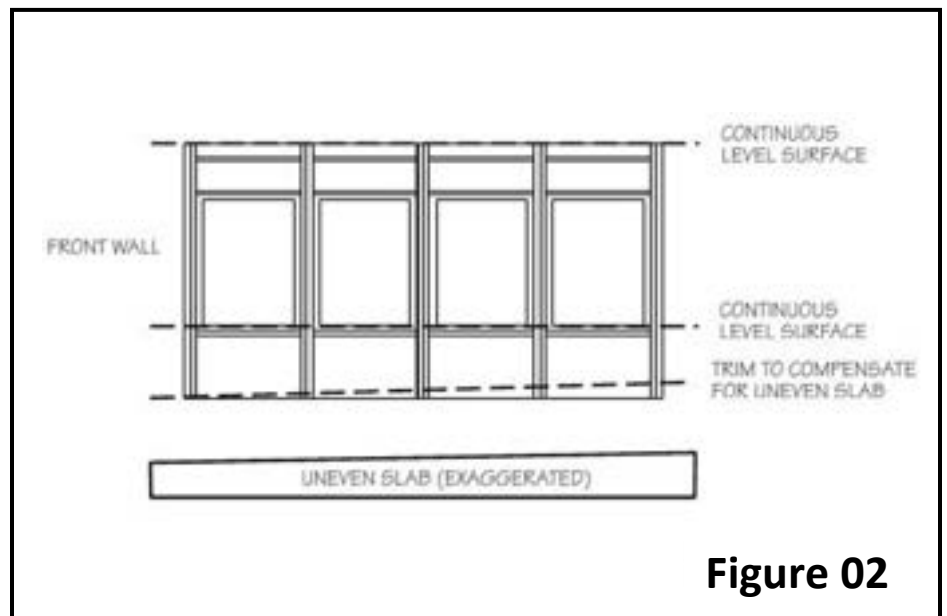

Figure 02

Beginning the Module Installation

Whichever of your openings you have chosen to start with, at this stage, you have determined how your bottom fill will need to be trimmed to compensate for the slope of the slab in that section. In the illustration below, it shows the front wall as a starting point.

All modules will be slightly larger (taller) than is required. Be sure to understand the finished height of each side of each module. If your existing roof line or foundation slopes as you move away from your house wall, the finished measurement on the right side of the module (outside looking in) may be slightly taller than the left.

Your CAD drawing indicates a fill portion against the house wall and/or existing posts. Cut the width of your fill portion and give it the height measured from the lip found on the inside of the bottom track up to the lip on the inside of the top header. Place this fill portion into the top header and swing it toward the bottom channel. It **will not** clear the top lip of the bottom channel. Simply note how much needs to be trimmed in order for it to JUST CLEAR the top lip of the bottom channel. Then drop it into the bottom channel. You will have approximately 1-1/8" of the fill portion sitting in the top header for attaching purposes. DO NOT ATTACH AT THIS TIME. Simply slide the fill portion up into the wall channel for now.

Do the same operation, as described above, with all your modules. The finished module will easily insert into the header track. The total depth from the bottom lip of the header track to the inside stop-lip is about 1 1/8".

Insert top of the first module (without the window inserts) into header beam. As described above, be sure to trim the top of your module **just enough** to allow for the module to swing over the top lip of the bottom channel. **This would be a great time to take measurements for the top and bottom fill pieces for this module.**

Drop the module in place and push against the fill you started with at the wall/post track. We do not suggest screwing the module into place at this time. This will allow for small adjustments, should they become necessary. In the event that the kick plate catches the lip of the bottom track, use a putty knife to slide it in (silicon spray can be used to help allow the modules to slide into place). Do not fasten the module at this point to allow for adjustability for additional modules.

Some modules will be connected by simple H channels. They **may** even already be connected to the module on one or more sides. Often they are sent in stock lengths for you to cut to size on site. Other modules will have connections that form the utility mullion which can be used to run electrical to plugs and light switches for your new room. One side of the module connection will have a male fitting and the next module will have a female fitting. Always consult an electrician when considering electrical installations.

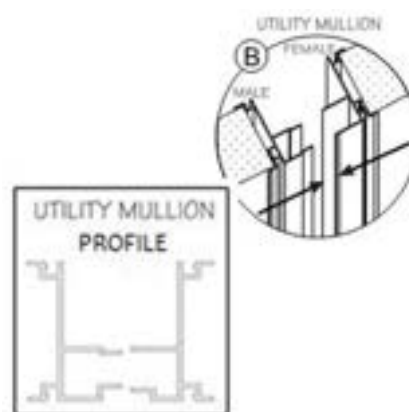
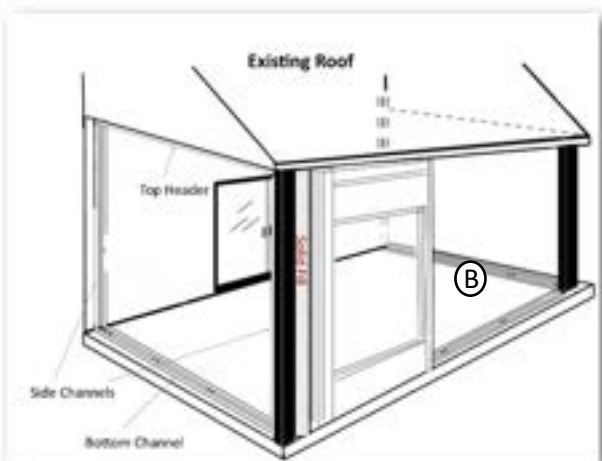

Tip: A helper may be useful at this point to hold the modules up. You may also support the front wall with a temporary rafter.

Installing the Second and Subsequent Modules

The next module will slide in identically as the first. Each wall module contains a male utility mullion extrusion on one side and a female utility mullion extrusion on the other side (**Figure 03, Detail "B"**). Utility mullion males and females are designated on the C-Thru room layout sheets with UM and UF. These two extrusions mate to form a complete utility mullion between each module. Exceptions may occur at the house wall, next to solid, or corners where a regular female extrusion may be found. Female extrusions are identified with an F on the room layout sheet. Once in the track, a soft mallet may be used to nudge the second module to interlock with the first (**silicone lubricant may be helpful**). Continue as needed to assemble the front wall. Place all of the modules in the front wall without fastening them.

Note: The front wall will need to be aligned so the end modules line up with the inside corners of the sidewall bottom track.

IMPORTANT! THE MODULES AND THE WINDOW FRAMES MUST BE PERFECTLY LEVEL AND PLUMB IN ORDER FOR THE WINDOWS TO OPERATE PROPERLY. BEFORE PROCEEDING, TEST EACH MODULE WITH THE WINDOW SASHES TO MAKE SURE THE WINDOWS FIT AND LOCK PROPERLY.

Fastening the Wall Modules Together

You will be attaching the modules together by the utility mullions affixed on either end of each module. Be sure to mate a male and female utility mullion together for a proper fit. For the Omega (vinyl) system, snap in several scrap pieces of utility mullion cladding on both sides of the utility mullions to temporarily hold the width of the mullion. A sheet metal screw or Pop rivet will be needed every 24" to attach both sides of the utility mullion together. Use #8 x 1/2" tek screws (**Figure 04**). Vinyl cladding will be added on top of the utility mullion during any electrical wiring installation section of this manual.

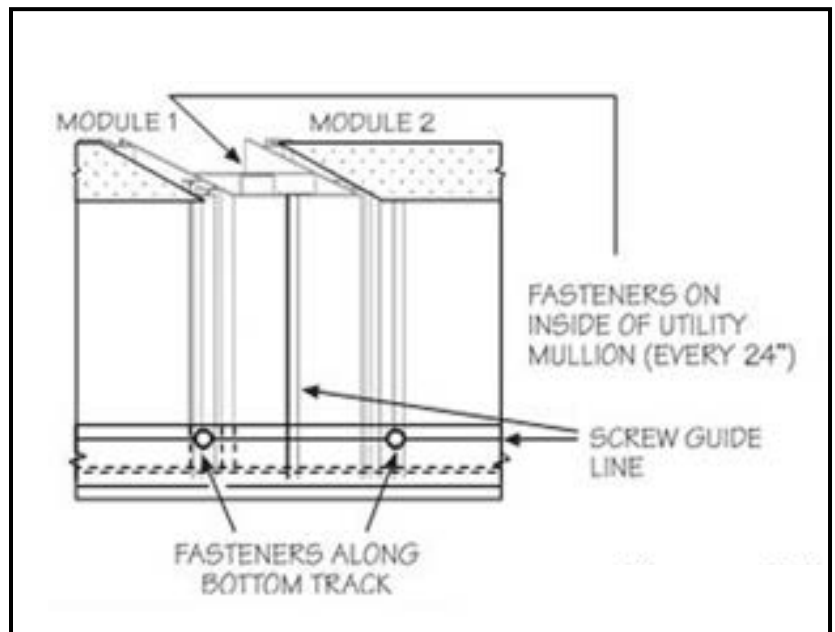

Fastening the Wall Modules to the Bottom Track

The modules will be fastened with #8 x 1/2" tek screws at the base where the vertical mullions and bottom track intersect. Use the guide line (**Figure 04**) in the bottom track to place the screws. Fasten two sheet metal screws per utility mullion connection at the base on the room's exterior.

Adding Solid Fill

The C-Thru Room Layout Sheet will note solid fill or window modules on the corners of the front wall. If the front wall requires solid fill, refer to the layout for the cut size of the solid fill. You can double check this measurement by measuring from the inside of the "H" channel of the module to the inside corner of the bottom track for the width, and the height of the module for the height (both sides may be slightly different to account for the slope of the foundation). Cut the solid material and place it on the sides of the front wall.

Door Installation:

Note: C-Thru offers three types of doors: pedestrian (single), French (double), and sliding doors (**Figure 01**). The pedestrian and French doors have similar installation procedures. Refer to section 11B for the sliding door installation.

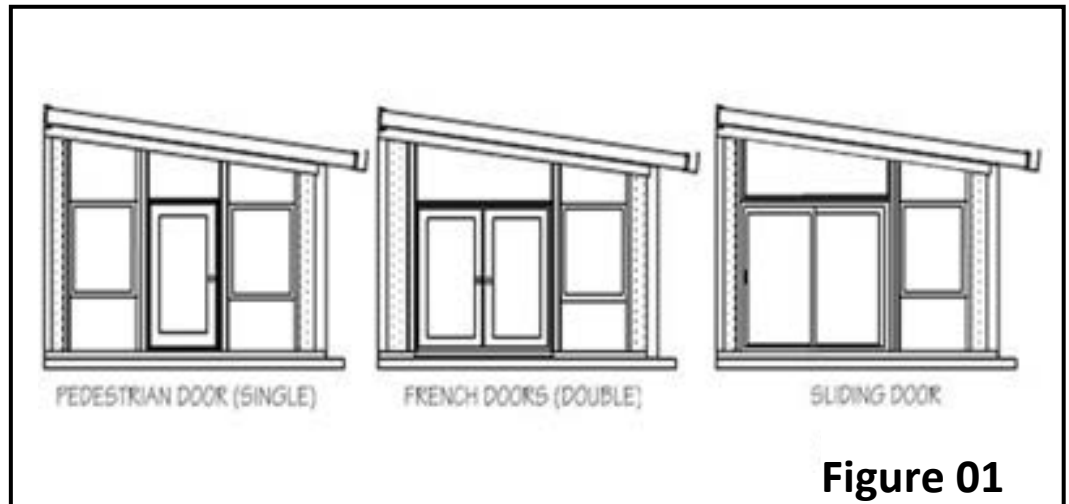

Figure 01

Assembling the French Doorjamb

The French doorjamb will arrive in four pre-cut sections: vertical doorjamb (2 pieces), horizontal doorjamb, and threshold. The horizontal and vertical jambs are miter-cut at 45-degrees and will be joined together with two "L" brackets per corner. Use a mallet to press-fit the "L" brackets on the horizontal doorjamb. Mate the vertical doorjambs with the horizontal pieces until they form a tight seam at their juncture (**Figure 02**).

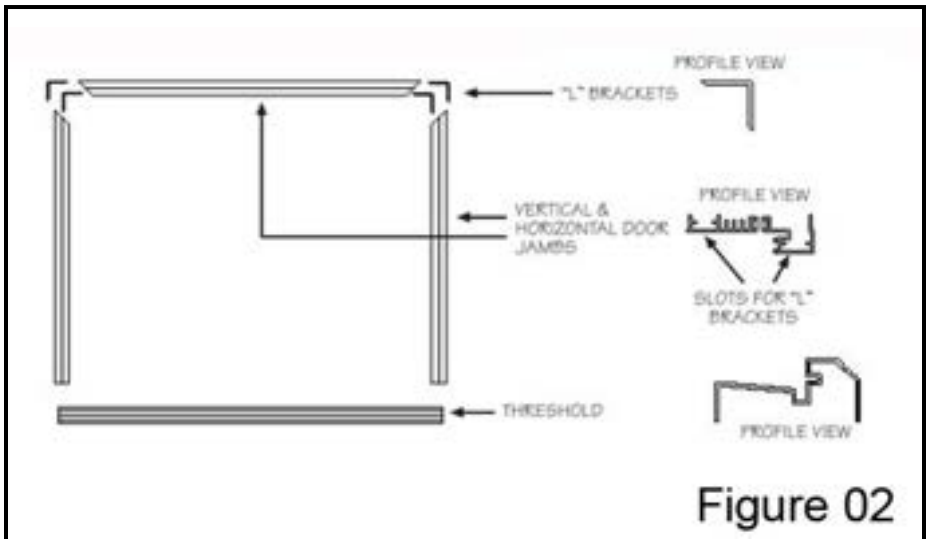

Figure 02

Tip: Punch door jamb and L bracket with a flat blade screw driver, this will lock the jambs together and prevent them from moving apart.

Adding a Female Extrusion above the Doorjamb

A female extrusion will be used for the transition between the top doorjamb and the transom. Measure the width of the assembled doorjamb. Deduct 3/4" from this length and cut a section of female extrusion to this length. Center this female extrusion on top of the door jamb. Do not fasten the female extrusion yet.

Installing the Threshold

Note: The bump-out on the threshold must be notched on both ends to accept the bump-outs on the vertical door jambs (**Figure 03**). Place the bottom threshold in the bottom track, make sure it is level, and fasten it to the bottom track with #8 x 1/2" tek screws.

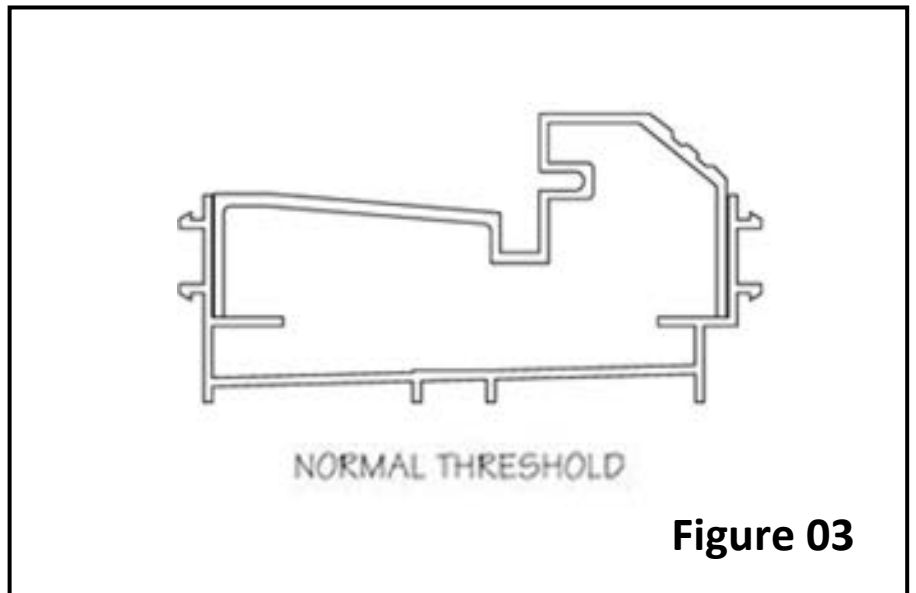

Figure 03

Note: The threshold by design, can compensate for some out of levelness of the slab/ deck.

Installing the First Utility Mullion

A complete utility mullion will be secured to each side of the doorframe. Determine the location of the doorframe on the C-Thru room layout sheet and mark the opening on the bottom track. The C-Thru room layout sheet will also note which side the utility mullion male (UM) and female (UF) piece should be attached. At each end of the opening, measure from the inside lip of the bottom track to the bottom of the roof rafter and subtract 1/4" for the C-bracket. This will be the length of each utility mullion. Cut each utility mullion to the proper length. Making sure it is level, fasten one utility mullion to the C-bracket and the bottom track. Insert the assembled doorframe into the opening.

Note: If the wall modules have already been assembled, they may have half of a utility mullion already attached to each module. Complete the utility mullion by attaching a male or female utility mullion to the other side to complete the mated utility mullion. See the C-Thru room layout sheet for proper U/M and U/F locations.

Completing the Transom

Please refer to the appropriate side wall section of this manual to place glass transoms, glass trapezoids or solid fill above the doorframe.

Installing the Second Utility Mullion and Securing the Doorframe.

Place the second utility mullion on the opposite side and slide the doorframe into the opening. Make sure it is level. Fasten the utility mullion to the C-bracket and the bottom track. Making sure that the doorframe is level, secure it to the utility mullions with Pop rivets or #8 x 1/2" tek screws spaced every 16".

Installing the Adjustable Hinge Channel

Cut the hinge channel to the length of the door and attach it to the door jamb using #12 x 1/2" tek screws.

Installing the Door(s)

Slide the door into the hinge channel, and place the door in the "closed" position. Make sure the gap around sides and the top of the door is even. Place shims underneath the door until the top of the door is spaced approximately 3/8" from the door jamb. For French doors, leave a gap to account for the astragal that will be placed on the non-operable door. Secure the hinge channel to the door on both sides with Pop rivets or #8 x 1/2" tek screws spaced every 16". Repeat this process for the other door as necessary for double pedestrian door installations. See **(Figure 04)** for the completed door attachment.

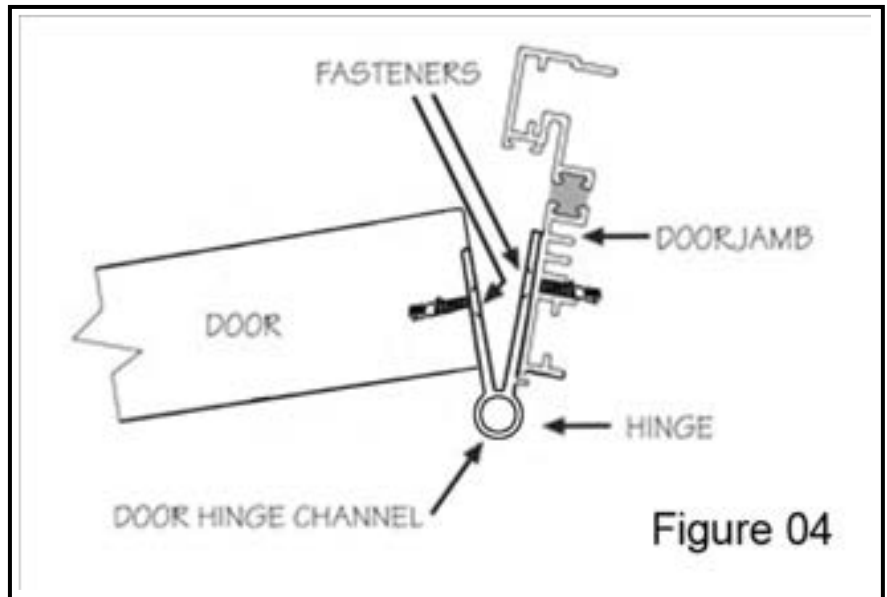

Installing the Bottom Adjustment Channel

Measure from the edge of the door to the edge of the hinge channel, and cut a section of hinge channel to this length. Place it onto the bottom of the door. This will be the bottom adjustment channel. Close the door, and slide this channel down until there is a 3/8" gap between the bottom adjustment channel and the threshold **(Figure 05)**. Fasten this channel into place.

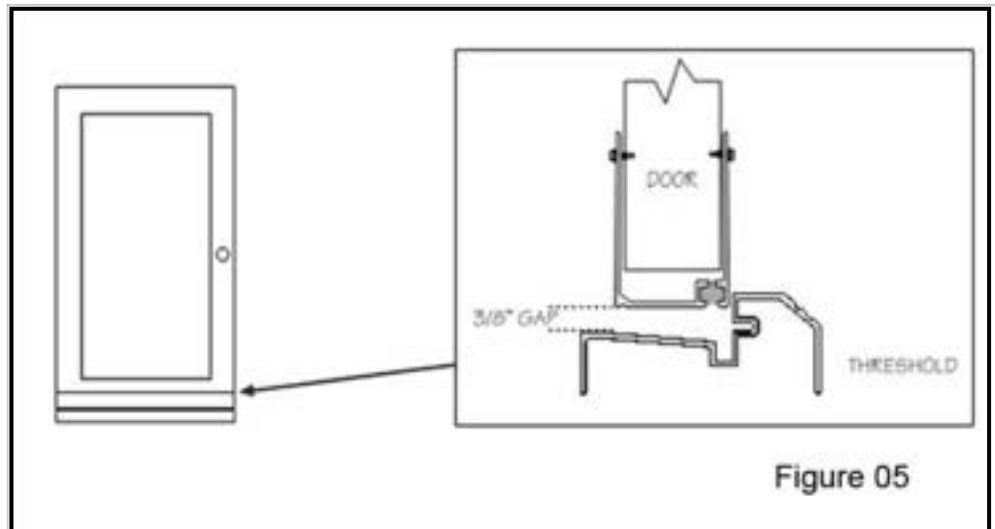

Note: For level or near level slab/ deck the threshold can be adjusted to eliminate the need for a bottom door adjustment channel.

Installing the Locking Astragal (French Doors Only)

The astragal is the unit that locks the fixed door in place with a set of pins. It is secured to the locked side of the two doors. Remove the rubber caps from both ends. Cut a 1" tall by 1-1/4" deep notch on the back section of the astragal on both the top and the bottom so it will fit around the raised section of the doorjamb and the threshold when the door is closed (**Figure 06**). Attach the astragal to the door with #8 x 3/4" tek screws every 16". With the door in the "closed" position, slide the locking pins up to the door jamb and down to the threshold. Mark these two locations and drill a 1/4" hole where the pins will slide into place securing the door.

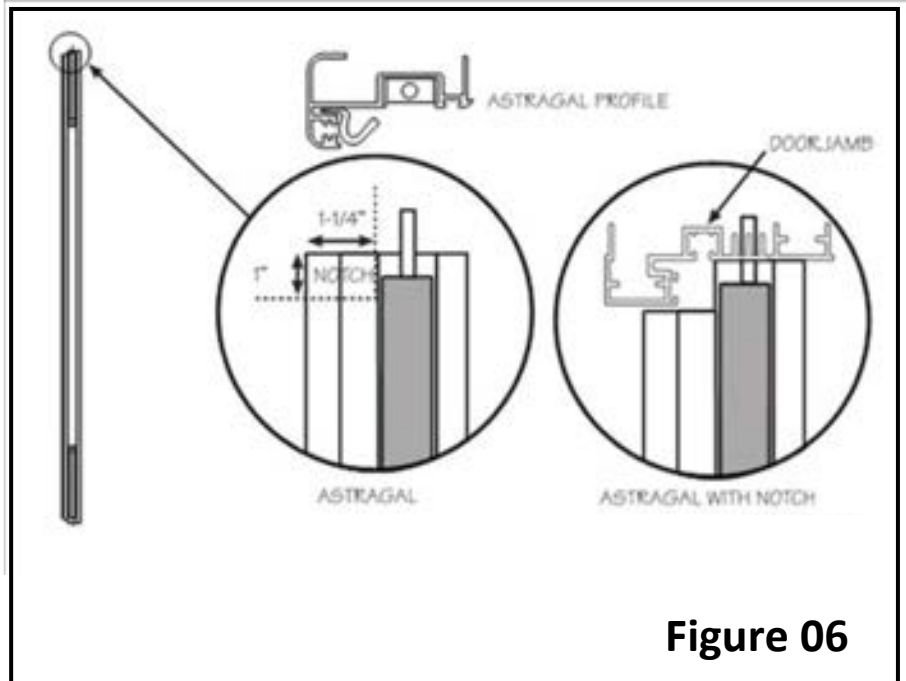

Figure 06

Installing Door Hardware

Install the door hardware and the striker plate per the instructions included with the door hardware.

Note: For French doors, install the striker plate on the fixed door. Install the dummy handle on the outside of the fixed door.

Installing Weather- Stripping

The doorjamb, threshold, and astragal have a small groove that accepts weatherstripping. Insert the weatherstripping into this groove to ensure a weather tight seal (**Figure 07**).

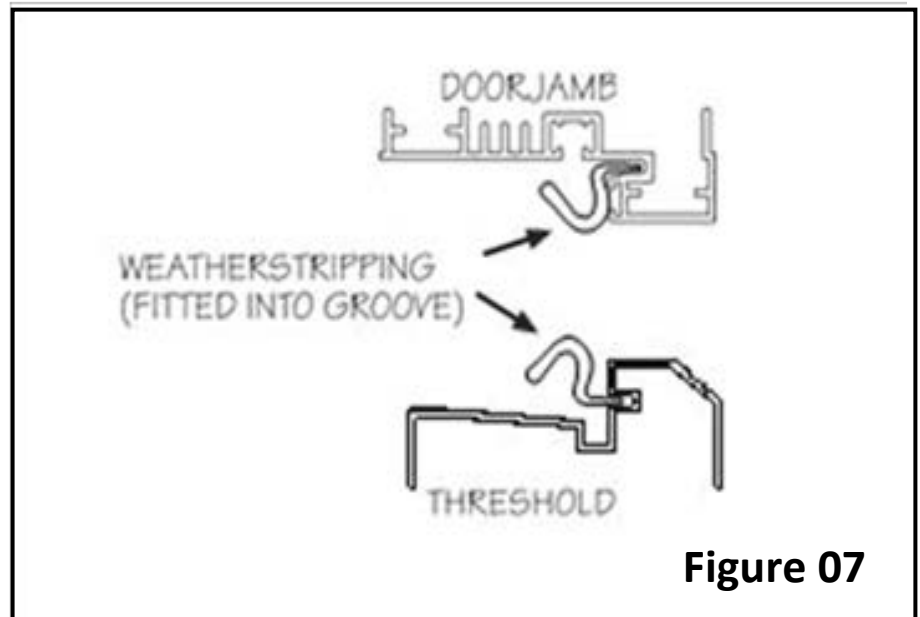

Figure 07

Sliding Door Installation

Note: The sliding door frame will arrive assembled.

Installing the First Utility Mullion

A complete utility mullion will be secured to each side of the sliding door frame. Determine the location of the door frame on the C-Thru room layout sheet and mark the opening on the bottom track. The C-Thru room layout sheet will also note which side the utility mullion male (UM) and female (UF) piece should be attached. At each end of the opening, measure from the inside lip of the bottom track to the bottom of the roof rafter, subtract $\frac{1}{4}$ " for the C-bracket. This will be the length of each utility mullion. Cut each utility mullion to the proper length. Making sure it is level fasten one utility mullion to the C-bracket and the bottom track.

Note: If the wall modules have already been assembled, they may have half of a utility mullion already attached to each module. Complete the utility mullion by attaching a male or female utility mullion to the other side. See the C-Thru room layout sheet for proper UM and UF locations. The opening for the vinyl door should be $\frac{1}{8}$ " larger than the door frame (approximately 71-5/8"). Plumb and secure the mullions on either side of the opening. Take diagonal measurements to make sure before the opening.

Raising or Lowering the Threshold

A female extrusion must be placed on the bottom track to raise door above bottom track clads and allow for adjustment with non-level slabs/decks.

Trim the female extrusion to the length of the opening and fasten it to the bottom track with #8 x 1/2" tek screws every 18". See **(Figure 08)**.

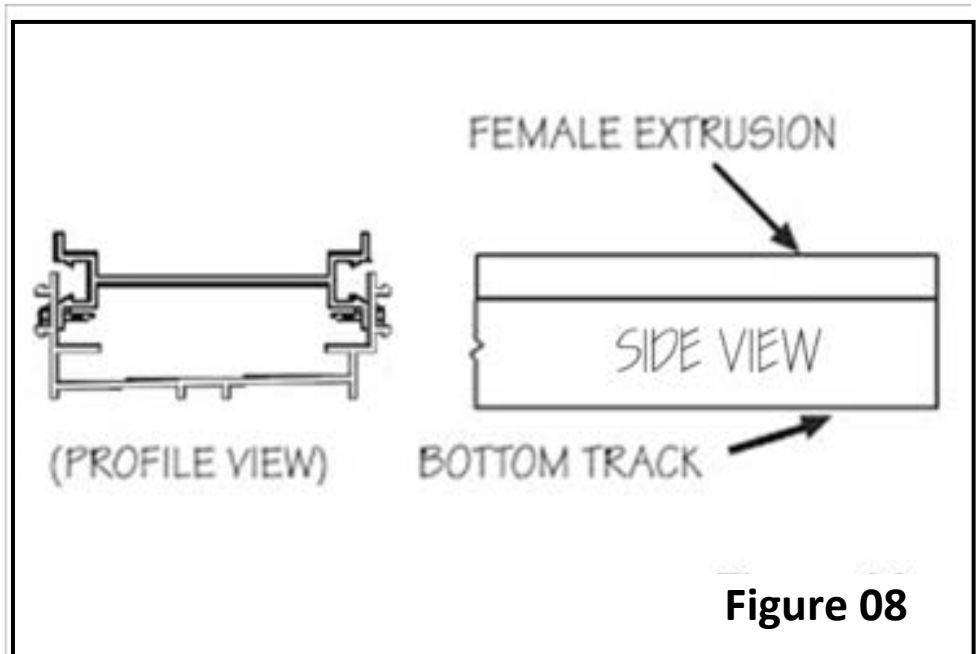

Figure 08

Tip: If slope is greater than $\frac{3}{4}$ " use solid fill below female & trim to level. Also, to prevent the threshold entry from being too high, locate the opening side of the door on the high side of the slope.

Tip: In extreme circumstances (such as city code or customer request), it may be necessary to lower the height of the door threshold. Mark the position of the sliding door on the bottom track, and cut a notch in the bottom track (as illustrated), so door is resting on horizontal legs. You will not need to use the female in this situation (**Figure 09**).

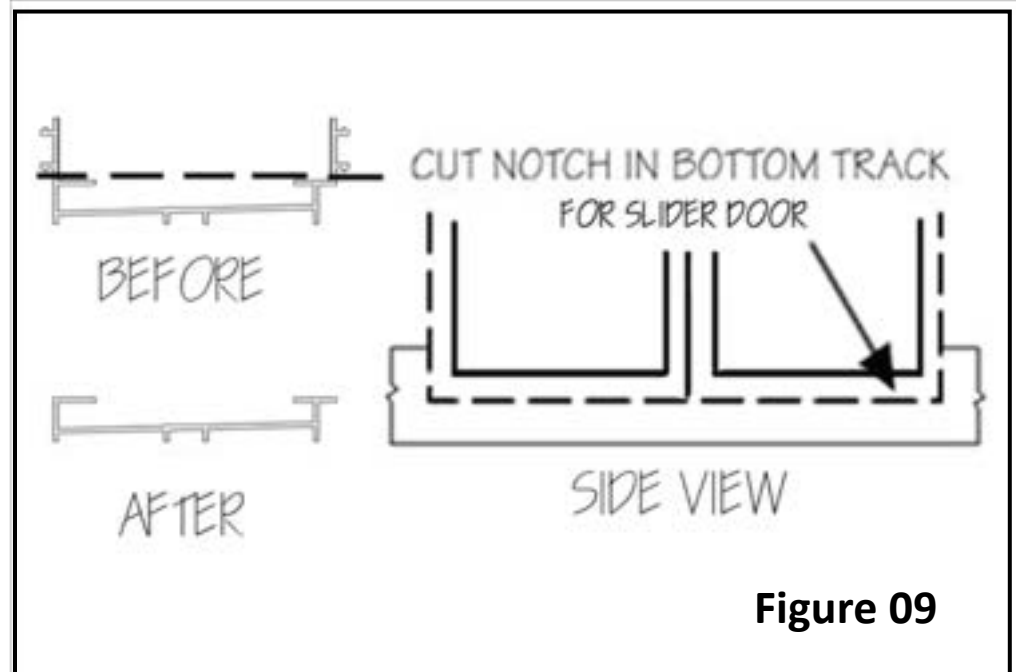

Figure 09

Installing the Sliding Door Frame

Note: Installing the unit "upside down" will change the direction of the door opening. Place the sliding door frame into the door frame from the outside of the room. Make sure it is square and level. Pre-drill 3/8" pilot holes through the **First Layer** of the door frame. See (**Figure 10A**).

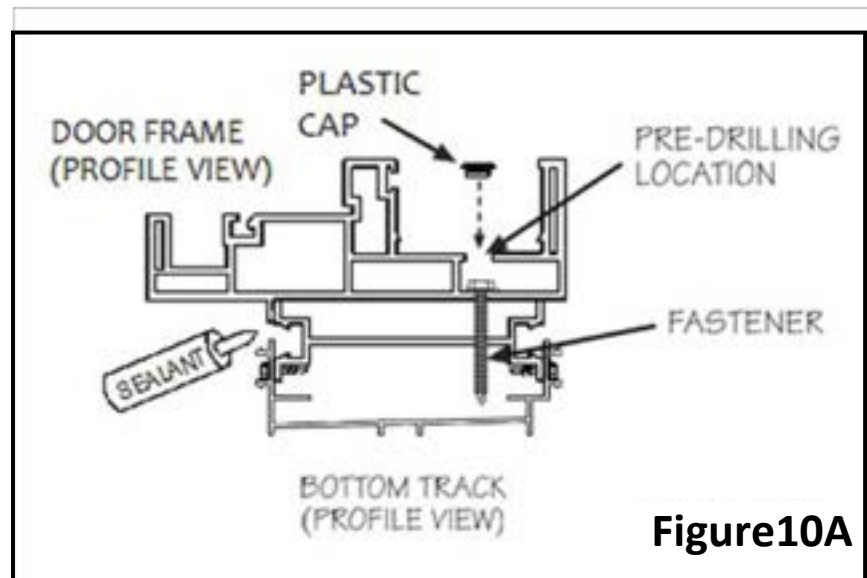

Figure10A

Note: Do Not Drill Thru The Entire Door Frame.

Fasten the door frame to the side mullions, top channel, female and the bottom track approximately every 18" using #8 x 1" tek screws. Plug the hole with the supplied plastic caps.

Adding a Female H Extrusion above the Sliding Door

An "H" channel will be used for the transition between the top of the sliding door and the transom. Measure the width of the opening and cut a section of "H" channel to this length. Fasten this piece to the top of the sliding door frame as in **Section 15B-3**.

Placing the Door Track and Threshold

The door track and threshold will need to be snapped into place in the bottom of the sliding door frame. Refer to **(Figure 10B)** for the correct placement of each piece.

Installing the Operable Door Panel

Note: The sliding door contains two adjustable rollers on the top and the bottom of the door. These rollers are adjusted by the screws located on the sides of the door.

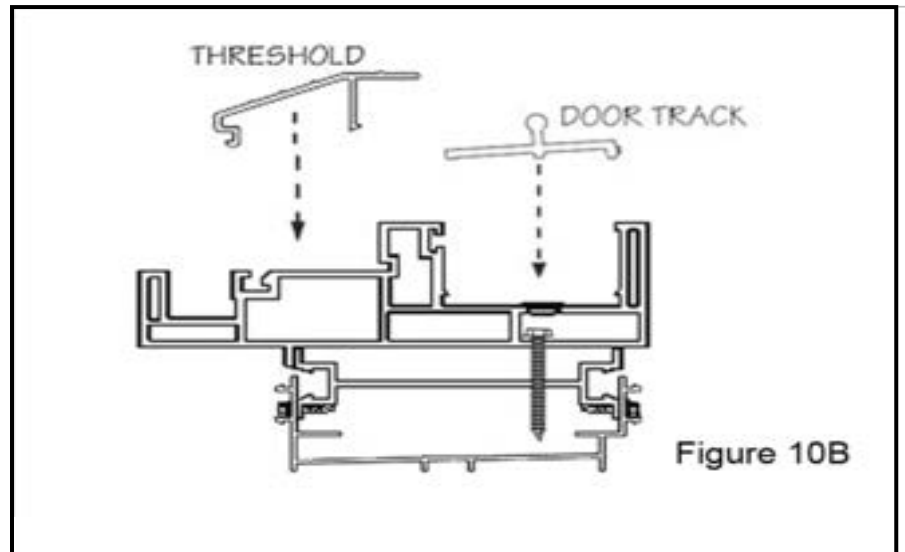

Note: The sliding door is punched on one side to accept the door handle and locking hardware. Make sure this side will sit next to the door frame when the door is closed.

Adjust the rollers on the bottom of the door so they protrude 1/4" from the frame. From the inside of the room, lift the door up, into the top of the door frame and down into the bottom of the door frame. The rollers should rest on the door track. Adjust the bottom rollers again so that the door is plumb and it operates smoothly. Adjust the top rollers so that they rest snugly against the top of the door frame. Install the door hardware per the instructions supplied with the kit.

Electrical

Note: In many areas, the electrical must be installed by a certified electrician. Please consult your local building department for rules and regulations regarding the installation of electrical.

Note: The electrical wires can be fed through the electrical header beam, utility mullions, roof attachment channel and roof rafters.

Routing the Main Electrical Source

The main electrical source will enter the sunroom at the right or left side wall channel at the house wall. You may choose to tap into an existing electrical source on the house wall or run conduit to the electric box and create a new circuit **(Figure 01)**. Please follow the requirements of your local building department.

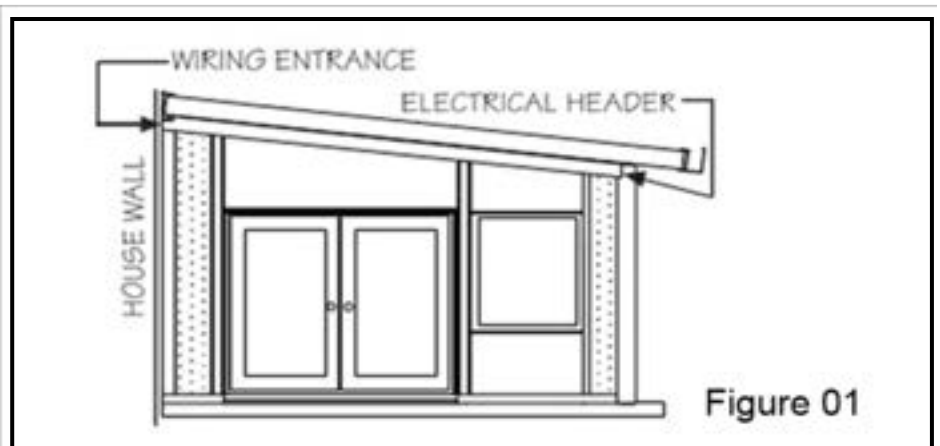

IMPORTANT! DO NOT ACTIVATE THIS CIRCUIT UNTIL ALL OF THE ELECTRICAL CONNECTIONS HAVE BEEN MADE. CONTACT WITH A LIVE ELECTRICAL WIRE MAY RESULT IN SEVERE INJURY OR DEATH.

Mounting the Interior Electrical Boxes

Note: All interior electrical boxes will be placed inside the channels of the utility mullions.

Note the location of all electrical switches and outlets on the C-Thru room layout sheet. Place an electrical box (J-box) in the utility mullion channel. If there is a screw or rivet in this location, remove it. Fasten the J-box to the utility mullion with four #8 x 1/2" tek screws (**Figure 02**). If you removed a rivet or tek screw in the utility mullion, add one above and below the J- box. Repeat this process for every outlet or switch in the sunroom.

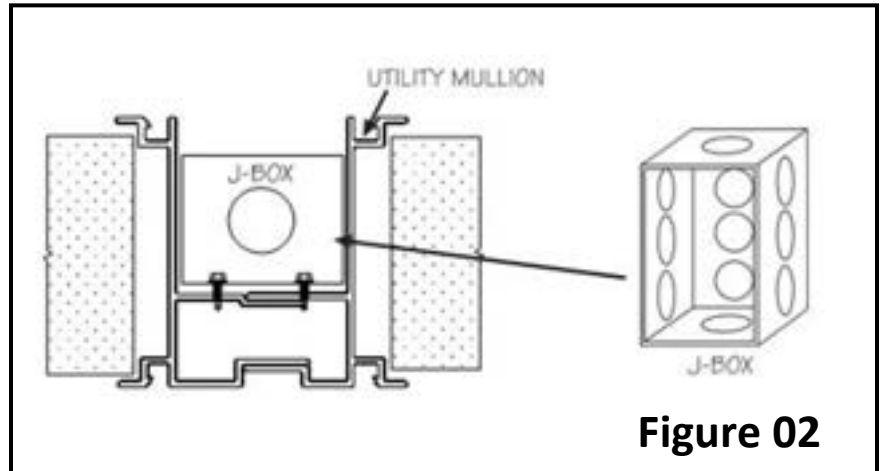

Note: Each electrical box requires a threaded chase nipple or plastic insert where the wire will be threaded into the box.

Note: If a fan/light is to be installed in the room ceiling, a junction box will be needed on the roof rafter that the fan will be located on. Follow the same procedure described above.

Chase Nipple/Plug Installation

A threaded chase nipple or plug must be used at every wiring junction of the sunroom's structural components such as between a utility mullion and the electrical header beam. Check your local building code for requirements. Drill a 7/8" hole into the header beam (from the underside) that will act as a junction between the utility mullion and the electrical header beam. With a locknut threaded on one end, slide a 1-1/2" x 3/4" chase nipple through the hole. Secure the top of the chase nipple with a locknut (**Figure 03**).

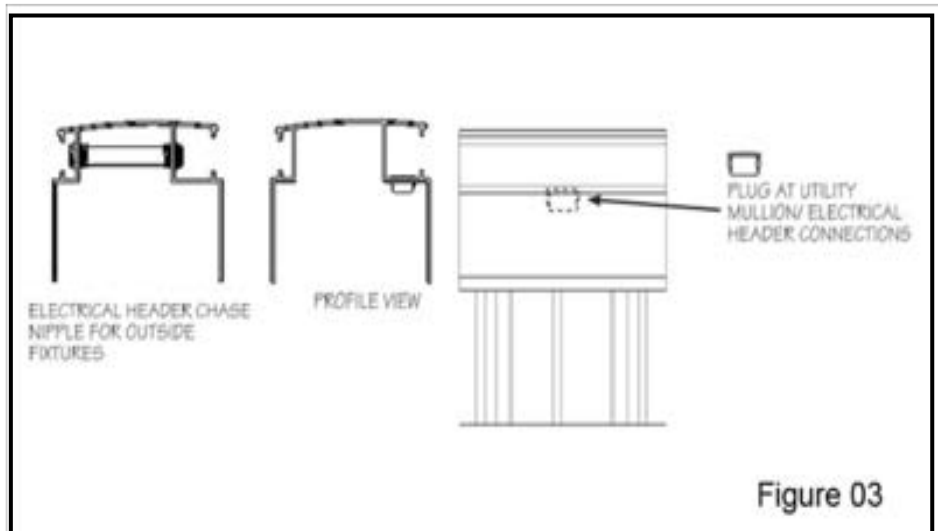

Installing Wiring

Thread the wiring to all of the switches, outlets, and fixtures, according to the desired operation of the electrical system. Use 12 or 14 gauge single strand solid Romex wiring. Check with your local Building Department to make sure they approve this method.

Note: For fan beam wiring, thread the wiring through the roof attachment channel to the roof rafter.

Installing Vinyl Utility Mullion Cladding

The vinyl cladding will cover the utility mullion channels on the inside and outside of the room. Measure from the bottom track to the header beam, and cut the vinyl cladding to length. Make sure the cuts conform to the angles of the header beam. Mark the location of each electrical J-box. Snap the vinyl cladding into place with a soft mallet.

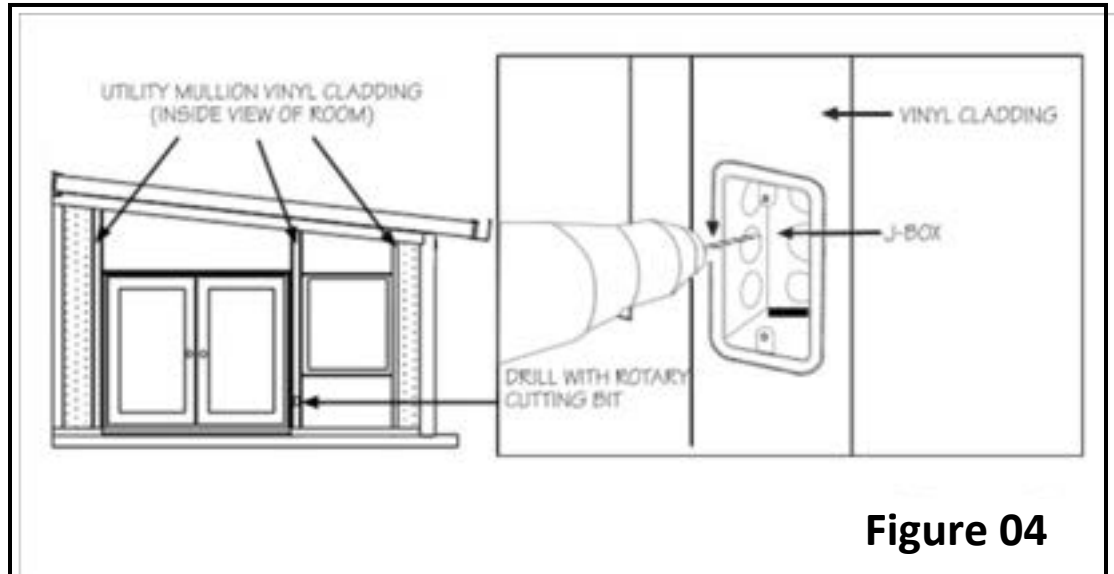

Figure 04

Use a rotary cutting tool (or a rotary cutting bit on a drill) to cut the openings for the electrical boxes. Simply insert the cutting tool through the vinyl cladding and follow the drill bit along the inside of the J-box (**Figure 04**).

Installing Electrical Switches and Outlets

The first outlet on the electrical circuit in the sunroom must have a Ground Fault Circuit Interrupter (GFCI) type outlet. Make the electrical connections to all of the outlets, switches, and fixtures.

Mounting Outside Fixtures and Outlets (Optional)

Outside electrical fixtures will be surface mounted to the exterior of a utility mullion. Depending on the location of the fixture, drill a 7/8" hole through the center of the utility mullion or the top of the header beam. The cladding or snap cover may have to be temporarily removed to drill this hole. With a locknut threaded on one end, slide a 2" x 3/4" chase nipple through the hole. Secure the exterior electrical box to the chase nipple with a locknut. A weatherproof exterior outlet is available from C-Thru.

**For Omega Wall System Clad Installation Tips And Instructions –
See Room Clad Installation Guidelines Manual**

At this point, your new room should be nearly complete. The only remaining steps are installing your window sashes and screens. In addition, it is time to give your new room a good wipe down. Wash the windows and sweep the floor. Wipe the ceiling and walls down of dust and debris. You may also use a leaf blower, shop vac, or vacuum cleaner with attachments to clean.

Installing Window Sashes

Group your window sashes in like sizes (small, medium, and large). Start installing sashes from the inside of room by lifting the sash up and into the center track of the window header and down into the center track of the sill. **Note:** The direction of the sash interlock must be facing in and center for window sashes to interlock properly.

Window Adjustment

The windows may need some slight adjustments to open and close smoothly. The vinyl windows have brass rollers on the bottom of each sash. Pop out the roller with a screwdriver and move it to the alternate location in the plastic clip if necessary.

Installing the Screens

Install your screens from the outside of the room. Lift screens up and into window header and down into the sill. Repeat this procedure for all of the window screens.

Installing Weep Hole Covers

The openings in the bottom track and the window frames contain punched openings that accept weep hole covers. Find the appropriate sized weep hole covers and press-fit them into these openings.

The following are some points of interest that should be reviewed with the homeowner upon completion of the sunroom:

1. Clean your room both outside and inside using mild household cleaning solutions. This should be done on a regular basis to maintain its luster.
2. Periodically check flashing and caulking. The caulking sealants need to be cut away and re-caulked as needed to maintain a leak-free room. Silicone Tape is also available to seal the roof seams.
3. Gutters need to be checked for debris and cleaned regularly.
4. Do not allow sprinklers, down spouts, or fountains to spray the walls for a prolonged period of time as sediments and minerals may deteriorate materials or impede the integrated drainage systems.
5. Do not paint the sunroom as it will null and void the warranty. Review the warranty with the homeowner, for more details see the warranty card.
6. For the operable windows and doors, be sure to vacuum the tracks out and thoroughly wipe down with a damp rag and occasionally lubricate wheel housings with silicone spray to keep them free from debris and operating correctly.

Warning





Under NO circumstances should you use acid tone or any type of solvent cleaner on the vinyl. This may damage the UV coating.

ALL PRODUCT FASTENERS

NOTE: Some of the profiles shown in Appendix A have slightly changed in both the Alpha Plus and OMEGA style sunrooms.

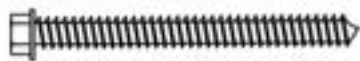
- If your profiles look slightly different than what is pictured below, that is okay! You have the right material!
- For example, the Alpha Plus Sunroom system now has ‘single piece’ corners. The OMEGA Sunroom still has the “two piece’ finishing corner materials. This is explained & pictured in the guidelines above.

Weatherguard Roof Fasteners

- | | |
|---|--|
|  | — 1. 1/4" Panhead Screw x 3"
Roof Attachment Channel To House |
|  | — 2. 1/8" Machine Screw W/Washer x 4", 5", 7"
Insulated Roof Panel to Wall Header Or Beam |
|  | — 3. 1/2" Rivet x 1 3/4"
Misc. Detail Areas - All Purpose |
|  | — 4. 1/4" Self-Tap Screw x 1"
Insulated Roof Panel To Attachment Channel |
|  | — 5. 1/4" Tek Screw x 1/2"
Misc. Detail Areas - All Purpose |

Wall Fasteners

- | | |
|---|--|
|  | — 1. 3/8" Hilti Kwik Bolt x 3"
Bottom Track to Wood Deck |
|  | — 2. 1/2" Self-Tap Screw x 1 1/2"
Bottom Track to Cement Slab |
|  | — 3. Plastic Expansion Plug
Plug For Wall Track To House Wall |
|  | — 4. 1/2" Self-Tap Screw x 1 1/2"
Wall Track To House Wall |
|  | — 5. 1/2" Rivet x 1 3/4"
Misc. Detail Areas - All Purpose |
|  | — 6. 1/4" Tek Screw x 1/2"
Bottom / Top Track / Corners & Wall Tracks To Mullions |



C-Thru Industries
 1477 Davril Circle
 Corona, CA 92880
 PH: (951) 369-8777 / (800) 287-2846
 Fax: (951) 369-0847
 www.c-thru.com

COMPONENT PROFILES - ALPHA WALL SYSTEM



1 Utility Mullion
Part # A3UMPM20



2 Female H Mullion
Part # A3FHM20

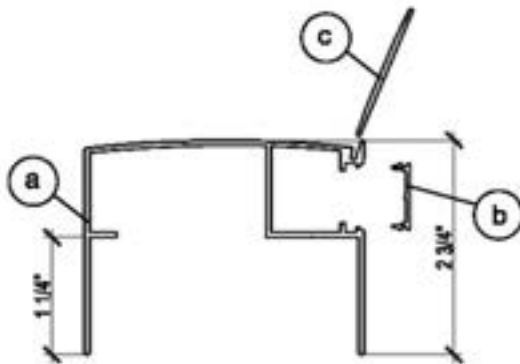

3 Header Beam W/Cap
a. Header Beam - Part # A3HEAD20W
b. Beauty Cap - Part # 2033 (A or W) - 16
c. Shadowline Extender - Part # DS-150 (50PK or 50PKA)



4 Bottom, Top & Wall Track
Part # AEBOTT20

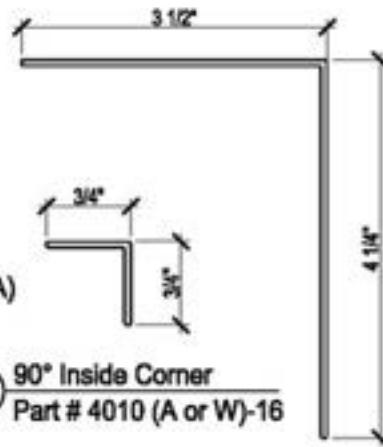

5 90° Inside Corner
Part # 4010 (A or W)-16

6 90° Outside Corner
Part # 4-2030 (A or W)-24



C-Thru Industries
1477 Davril Circle
Corona, CA 92880
PH: (951) 369-8777 / (800) 287-2846
Fax: (951) 369-0847
www.c-thru.com

COMPONENT PROFILES - OMEGA WALL SYSTEM

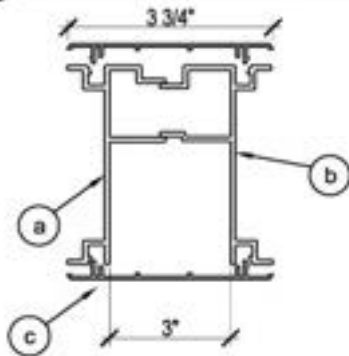

1 Utility Mullion W/ Clads
 a. Female Utility Mullion, Part # 4-2020M-24
 b. Male Utility Mullion, Part # 4-2019-24-M
 c. Clad, Part # VNL-4-2020-24 (A or W)

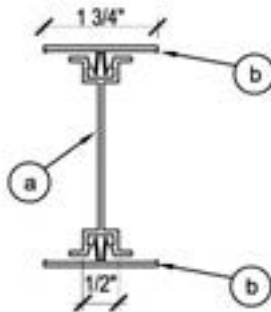

2 Female W/ Clads
 a. Female, Part # 4-4041-24 M
 b. Clad, Part # 4-4076M-24

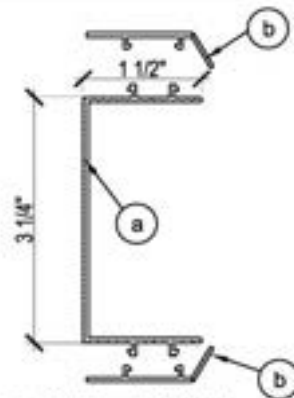

3 Wall Track W/Clads
 a. Wall Track, Part # ALE4-4034M-20 (A or W)
 b. Clad, Part # VNL4-148-24 (A or W)

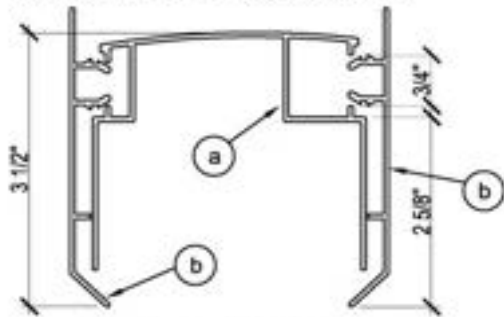

4 Header Beam W/ Clads
 a. Header Beam, Part # 4-2021-24-M
 b. Clad, Part # VNL-4-147-24-(A or W)

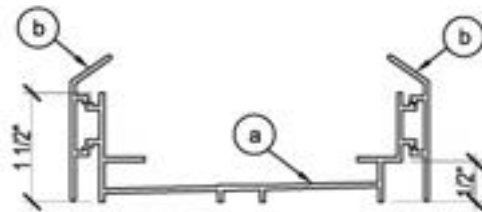

5 Bottom Track W/ Clads
 a. Bottom Track, Part # 4-2005-24 ANO
 b. Clad, Part # VNL-4-148-24-(A or W)

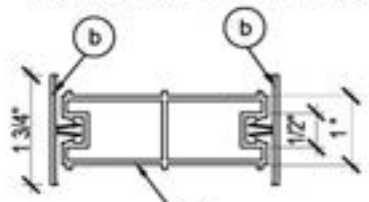

6 Sill Stiffener
 a. Sill Stiffener, Part # ALE4-4076M-24
 b. Sill Stiffener Clad, Part # VNL-4-154-24 (A or W)

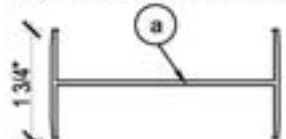

7 Vinyl 'H'
 a. Vinyl 'H', Part # VNL-UVO1 (A or W)

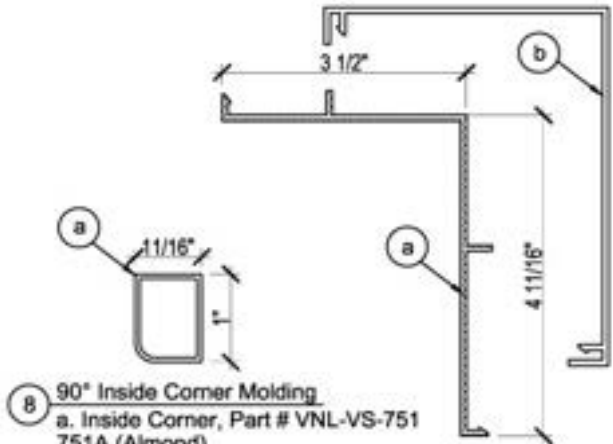

8 90° Inside Corner Molding
 a. Inside Corner, Part # VNL-VS-751 751A (Almond)

9 90° Outside Corner
 a. Outside Corner, Part # 4-2030M (A or W)-24
 b. Clad, Part # VNL4-2030 (A or W)-24

Wall Extrusions:



C-Thru Industries
 1477 Davril Circle
 Corona, CA 92880
 PH: (951) 369-8777 / (800) 287-2846
 Fax: (951) 369-0847
 www.c-thru.com

ASSEMBLY GAINS - OMEGA & ALPHA WALL SYSTEM

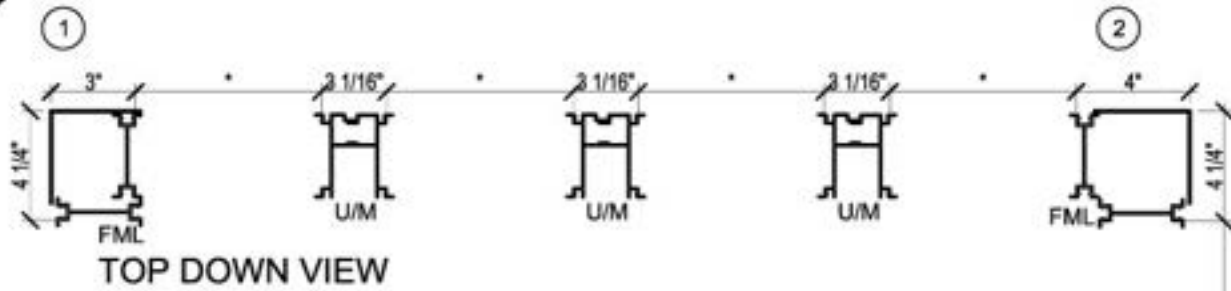

* Windows, Doors & Solids Widths

24" Window	23 1/8"
36" Window	36 3/8"
42" Window	39 5/8"
48" Window	45 5/8"
54" Window	54 3/8"
36" Pedestrian Door	38"
72" French Doors	74 3/4"
72" Sliding Door	71 1/2"
96" Sliding Door	96 1/4"

U/M= Utility Mullion
 FML= Regular Female
 W/T= Wall Track

- ① Fully Compressed Corners
- ② Non-Compressed Corners

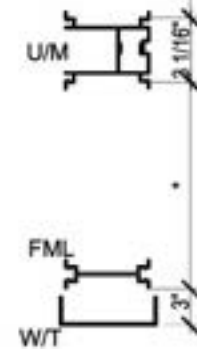

Roof Thickness
 + Slope
 = Top Attachment Height

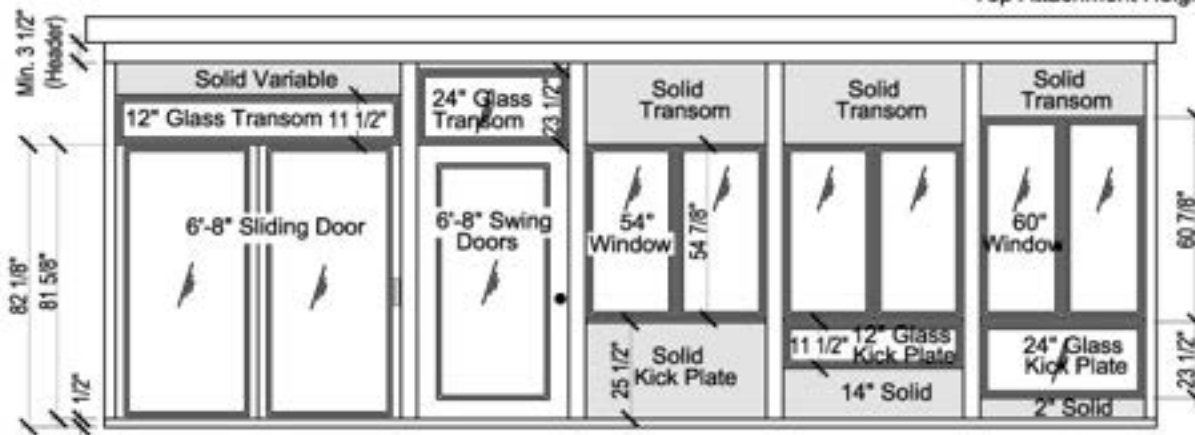

Side View

Wall Dimensions:



C-Thru Industries
 1477 Davril Circle
 Corona, CA 92880
 PH: (951) 369-8777 / (800) 287-2846
 Fax: (951) 369-0847
 www.c-thru.com

Notes: _____

Full C-Thru Product Line



-Straight Eave Sunroom-



-Walls Under Existing-



-Studio Patio Sunroom-



-Gabled Garden Room-



-Curved Eave Sunroom-



-Conservatories-



C-Thru Sunrooms & Windows

All contents and images are copyright 2005-2023 C-Thru Industries. WeatherGuard, Omega, SmartGlass, TuffCore, Duralite & C-Thru are registered trademarks of C-Thru Industries.

Phone: 800-287-2846 • Local: 951-369-8777 • Fax: 951-369-0847 • www.cthrusunrooms.com