



SPECIFICATION FOR TFT LCD MODULE

CUSTOMER : _____

CUSTOMER MODULE : _____

HL MODEL : HG101WU065

Preliminary Specification

Final Specification

Customer Confirmation column:

Approved by : _____ Dept. : _____ Data : _____

Please return one of the copies of the specification with your signature to us within two weeks after you receive this document. If it is not returned, we will assume that you agree to the entire contents of this specification document.

Designed by	Checked by	Approved by



Contents

No.	Items	Page
1.0	General Description	3
2.0	Absolute Maximum Ratings	5
3.0	Electrical Specifications	6
4.0	Optical Specifications	13
5.0	Reliability Test	17
6.0	Packing Information	18
7.0	Handling & Cautions	19
8.0	Appendix	22



1.0 GENERAL DESCRIPTION

1.1 Introduction

HG101WU065 is a color active matrix TFT LCD FOB using amorphous silicon TFT 's (Thin Film Transistors) as an active switching devices. This module has a 10.1 inch diagonally measured active area with WUXGA resolutions (1920 horizontal by 1200 vertical pixel array). Each pixel is divided into RED, GREEN, BLUE dots which are arranged in vertical stripe and this module can display 16.7M colors.

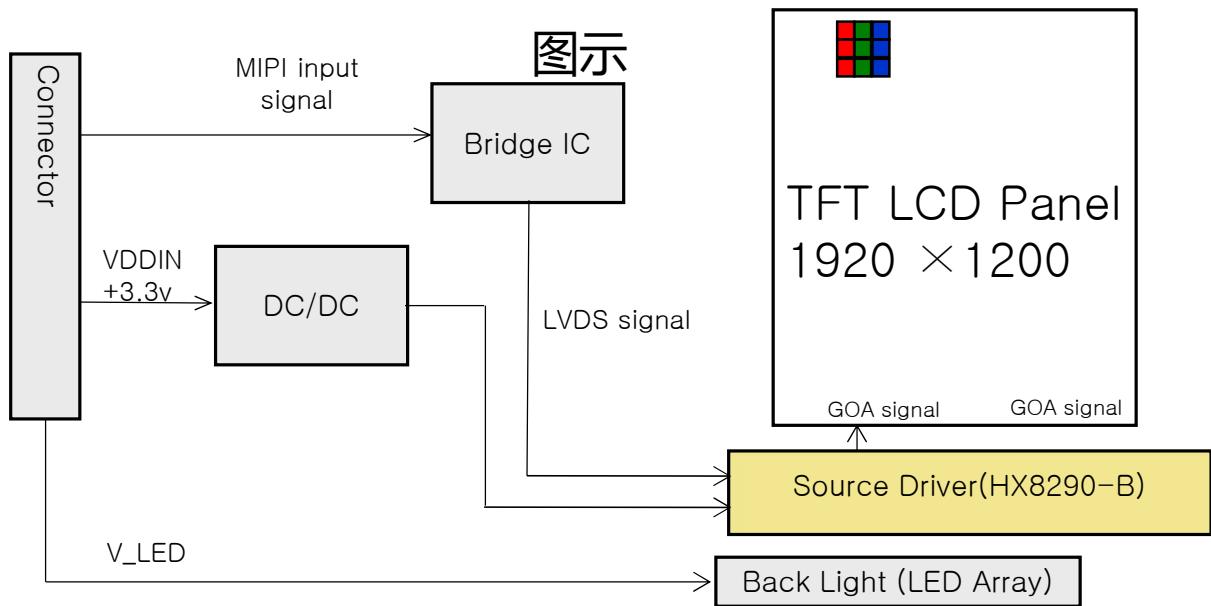

1.2 Features

- MIPI Interface;
- 8bit display 16.7M colors
- High contrast ratio and Transmittance



1.3 Application

- G Industrial

1.4 General Specification

The followings are general specifications at the HG101WU065.

<Table 1. LCD Module Specifications>

Parameter	Specification	Unit	Remarks
Active Area	216.8064(H)*135.504(V)	mm	
Number Of Pixels	1920(H)×1200(V)	pixels	
Pixel Pitch	0.03764(H)×RGB×0.11292(V)	mm	
Pixel Arrangement	Pixels RGB stripe arrangement		
Display Mode	Normally Black		
Display Colors	16.7M(8bit)	colors	
Surface Treatment	HC		
Contrast Ratio	900:1(typ.)		
Viewing Angle(CR>10)	80/80/80/80(typ.)		
Response Time	30(typ.)/35(max.)	ms	
Color Gamut	72%NTSC		@BOE BLU
Power Consumption	BLU:3.73(Typ.)	W	
Outline Dimension	228.3(H)*149.05.(V)*2.7(typ)(5.05max.)	mm	



2.0 ABSOLUTE MAXIMUM RATINGS

The followings are maximum values which, if exceed, may cause faulty operation or damage to the unit.

< Table 2. Absolute Maximum Ratings >

Parameter		Symbol	Min.	Max.	Unit	Remarks
Power Supply	LCD Module	VDD	VSS-0.3	3.6	V	Ta = 25 °C
Operating Temperature		T _{OP}	-20	+70	°C	
Storage Temperature		T _{ST}	-30	+80	°C	
Operating Ambient Humidity		Hop	10	90	%RH	
Storage Humidity		Hst	10	90	%RH	

3.0 ELECTRICAL SPECIFICATIONS

3.1 TFT LCD Module

< Table 3. LCD Module Electrical specifications > [Ta =25±2 °C]

Parameter	Symbol	Values			Unit	Notes	
		Min.	Typ.	Max.			
Power Supply Voltage	VDD	3.0	3.3	3.6	V		
	VRP			300	mV	Ripple	
Power Supply Current	IDD	-	300	360	mA	Note 1	
Power Consumption	PLCD	-	1	1.2	W		
Rush current	IRUSH	-	-	3.0	A	Note 2	
CMOS Interface	Input Voltage	VIH	2.7		3.3	V	
		VIL	0		0.5	V	
	Output Voltage	VOH	2.7		3.3	V	
		VOL	0		0.5	V	

Notes : 1. The supply voltage is measured and specified at the interface connector of LCM.
 The current draw and power consumption specified is for VDD=3.3V, Frame rate f_v and Clock frequency = 490MHz. Test Pattern of power supply current

a) Typ : Mosaic 8 x 6 Pattern(L0/L255)

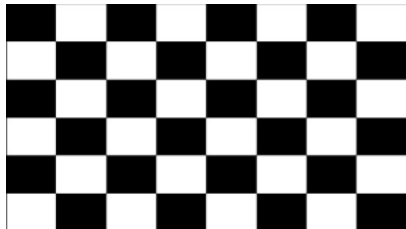

b) Max : skip subPixel(L255)

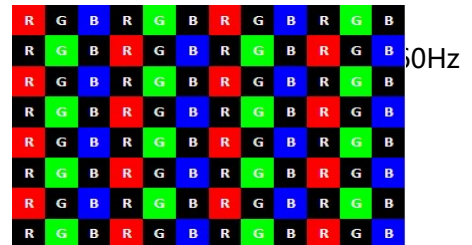

2. The duration of rush current is about 2ms and rising time of Power Input is 1ms(min)



3.2 Back-Light Unit

Table 4. LED Driver Electrical Specifications >

Parameter		Values			Unit	Notes
		Min.	Typ.	Max.		
LED Forward Voltage	V_F	-	-	3.0	V	Note 1 (8pcs Serial 6pcs Parallel.)
LED Forward Current	I_F	-	22	-	mA	
Power Consumption	P_{LED}	-	3.73	-	W	
LED Quantity	-	-	48	-	EA	
LED Life Time	N/A	15000	-	-	Hrs	$I_F=22mA$ Note 2

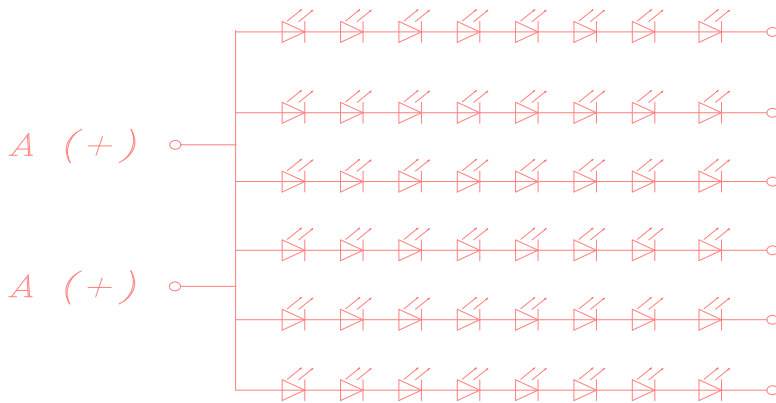

$$I_f = 120mA, V_f = 25.6V, L_v = 400cd/m^2$$

Notes : 1. Power supply voltage 25.6V for LED Driver

Calculator Value for reference $I_F \times V_F \times 48 / 85\%(\text{ efficiency}) = P_{LED}$

2. The LED Life-time define as the estimated time to 50% degradation of initial luminous.



3.2 INPUT TERMINAL PIN ASSIGNMENT

This LCD employs one interface connections, a 34 pin connector is used for the LCD module electronics interface.

3.2.1 Pin assignment for LCD module

Connector : FH34SRJ-34S-0.5SH(50) (HRS) or equivalent

< Table4. Pin Assignment for LCD Module Connector >

Pin No.	Symbol	Description	I/O
1	VLEDIN	LED POWER SUPPLY	P
2	VLEDIN	LED POWER SUPPLY	P
3	VLEDIN	LED POWER SUPPLY	P
4	I2C_SDA	OTP_SDA	I
5	I2C_SCL	OTP_SCL	I
6	AGING	H,BIST;L NORMAL mode;	I
7	ID	ID Pin (1.8V拉高或拉低)	I
8	ADDR	1.8V拉高或拉低(预留)	I
9	GND	Power Ground	P
10	GND	Power Ground	P
11	GND	Power Ground	P
12	DSI_D3N	MIPI data pair 3 negative signal	I
13	DSI_D3P	MIPI data pair 3 positive signal	I
14	GND	Power Ground	P
15	DSI_D0N	MIPI data pair 0 negative signal	I
16	DSI_D0P	MIPI data pair 0 positive signal	I
17	GND	Power Ground	P
18	DSI_CLKN	MIPI data pair CLK negative signal	I
19	DSI_CLKP	MIPI data pair CLK positive signal	I
20	GND	Power Ground	P



Pin No.	Symbol	Description	I/O
21	DSI_D1N	MIPI data pair 1 negative signal	I
22	DSI_D1P	MIPI data pair 1 positive signal	I
23	GND	Power Ground	P
24	DSI_D2N	MIPI data pair 2 negative signal	I
25	DSI_D2P	MIPI data pair 2 positive signal	I
26	GND	Power Ground	P
27	STBYB	Timing control(3.3V)	I
28	SCL	SCL for EEPROM IC (1.8V)	
29	SDA	SDA for Bridge IC (1.8V)	
30	LED_PWM	Backlight LED Driver PWM (1.8V)	
31	LED_EN	LED_EN	
32	VDD_OTP	OTP Power supply VDD OTP=8.6V	
33	VDDIN	3.3V	P
34	VDDIN	3.3V	P

3.3 Interface timing Parameter and AC/DC Parameter

The HG101WU065 is operated by the DE only

< Table5. MIPI Timing Parameter >

ITEM		SYMBOL	min	typ	max	UNIT	
LCD	Frame Rate	-	-	60	-	Hz	
	Pixels Rate	-	150.0	150.0	159.9	MHz	
Timing	Mipi CLK	Frequency	fCLK	490	490	498	MHz
		Period	Tclk	2.01	2.04	2.04	ns
	Horizontal	Horizontal total time	tHP	1946	1946	1951	t _{CLK}
		Horizontal Active time	tHadr	1920			t _{CLK}
		Horizontal Pulse Width	tHsync	1	1	1	t _{CLK}
		Horizontal Back Porch	tHBP	32	32	32	t _{CLK}
		Horizontal Front Porch	tHFP	110	110	133	t _{CLK}
	Vertical	Vertical total time	tvp	1343	1343	1366	t _H
		Vertical Active time	tVadr	1200			t _H
		Vertical Pulse Width	tVsync	1	1	1	t _H
		Vertical Back Porch	tVBP	14	14	14	t _H
		Vertical Front Porch	tVFP	11	11	16	t _H
	Bit Rate		TX SPD (MBPS)	980	980	995	Mbps
	Lane			-	4	-	Lane

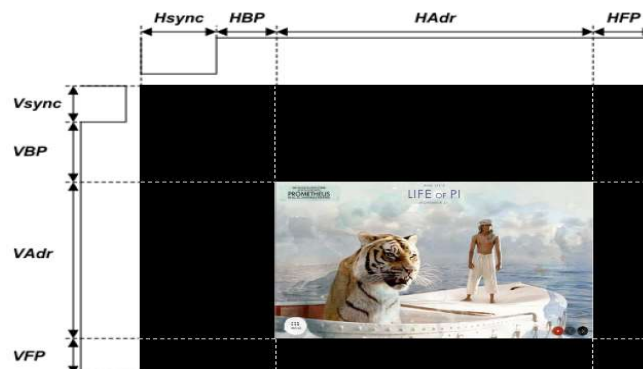



3.4 Power Sequence

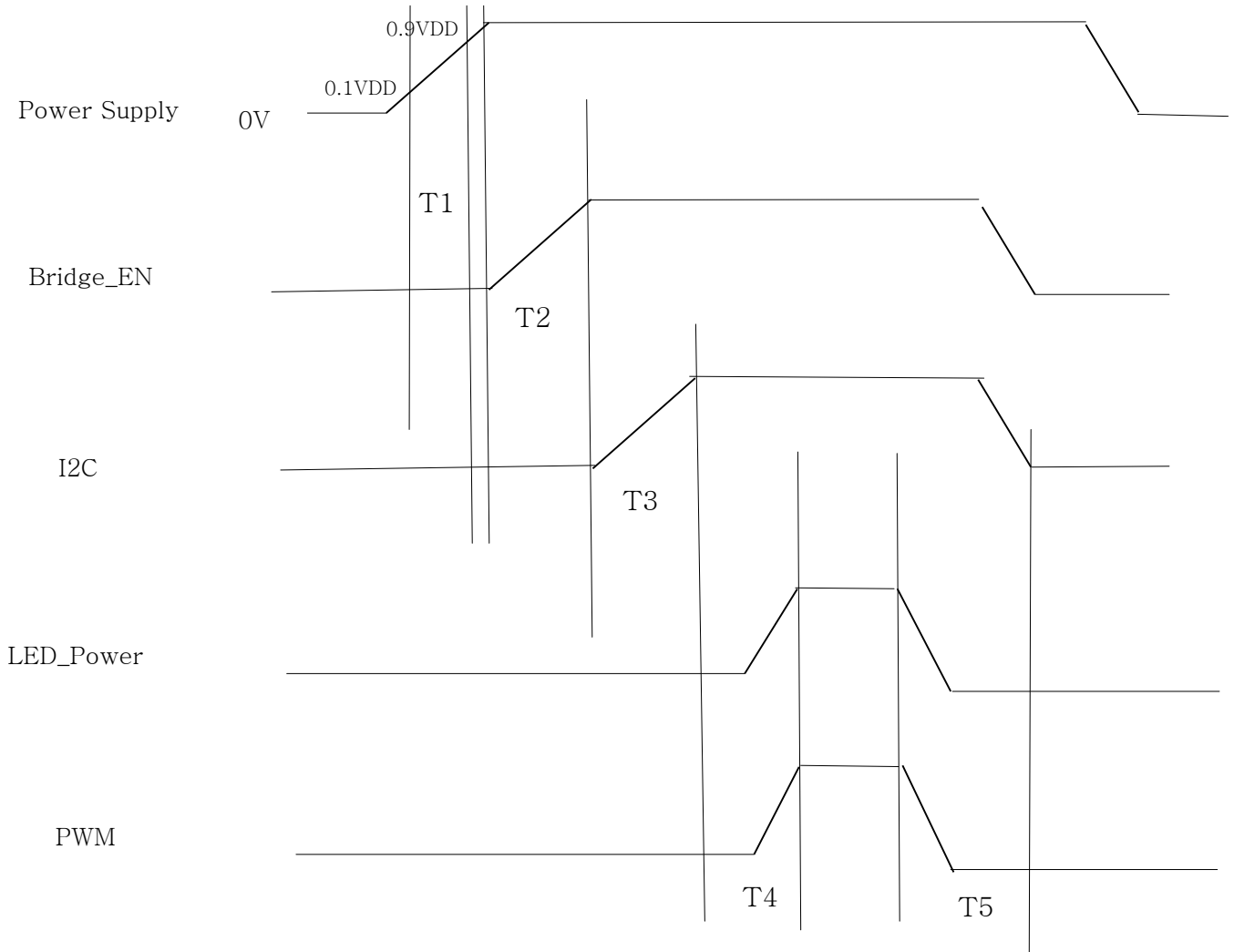

$0.5 \text{ ms} \leq T1 \leq 10 \text{ ms}$

T2:10ms

T3:10ms

$200\text{ms} \leq T4$

$200\text{ms} \leq T5$



3.4 Power Sequence

INITIALIZATION SEQUENCE NUMBER	INITIALIZATION SEQUENCE DESCRIPTION
Init seq 1	Power on
Init seq 2	After power is applied and stable, the DSI CLK lanes MUST be in HS state and the DSI data lanes MUST be driven to LP11 state
Init seq 3	Set EN pin to Low
Wait 10 ms ⁽¹⁾	
Init seq 4	Tie EN pin to High
Wait 10 ms ⁽¹⁾	
Init seq 5	Initialize all CSR registers to their appropriate values based on the implementation (The SN65DSI8x is not functional until the CSR registers are initialized)
Init seq 6	Set the PLL_EN bit (CSR 0x0D.0)
Wait 10 ms ⁽¹⁾	
Init seq 7	Set the SOFT_RESET bit (CSR 0x09.0)
Wait 10 ms ⁽¹⁾	
Init seq 8	Change DSI data lanes to HS state and start DSI video stream
Wait 5 ms ⁽¹⁾	
Init seq 9	Read back all registers and confirm they were correctly written
Init seq 10	Write 0xFF to CSR 0xE5 and CSR 0xE6 to clear the error registers
Wait 1 ms ⁽¹⁾	
Init seq 11	Read CSR 0xE5 and CSR 0xE6. If CSR 0xE5 and CSR 0xE6 != 0x00, then go back to step #2 and re-initialize

(1) Minimum recommended delay. It is fine to exceed these.

注：1) CSR registers, PLL_EN,SOFT_RESET都是寄存器，上电时需要通过I2C配置。Data的状态由处理器进行控制。

2) Sequence 9,10,11，这些是IC监测到错误后重新启动时的初始化流程，如果需要可以不设置。

3) 背光PWM时序需与LED_Power同时上电。



4.0 OPTICAL SPECIFICATIONS

4.1 Overview

The test of optical specifications shall be measured in a dark room (ambient luminance ≤ 1 lux and temperature = $25 \pm 2^\circ\text{C}$) with the equipment of Luminance meter system (Gonio meter system and TOPCON BM-5) and test unit shall be located at an approximate distance 50cm from the LCD surface at a viewing angle of θ and Φ equal to 0° . We refer to $\theta=0$ ($=\theta_3$) as the 3 o' clock direction (the "right"), $\theta=90$ ($=\theta_{12}$) as the 12 O' clock direction ("upward"), $\theta=180$ ($=\theta_9$) as the 9 O' clock direction ("left") and $\theta=270$ ($=\theta_6$) as the 6 O' clock direction ("bottom"). While scanning θ and/or Φ , the center of the measuring spot on the Display surface shall stay fixed.

4.2 Optical Specifications < Table9. Optical Table >

Item	Symbol	Condition	Min	Typ.	Max	Unit	Note
Viewing Angle	θ_L	$Cr \geq 10$	70	80	--	deg	<u>Note 1</u>
	θ_R		70	80	--		
	ψ_T		70	80	--		
	ψ_B		70	80	--		
Contrast Ratio	Cr	$\theta=0^\circ$	700	900		-	<u>Note 2</u>
Response Time	Tr+Tf	$FF=0^\circ$	--	30	35	ms	<u>Note 3</u>
Color Coordinate of CIE1931	Rx	$\theta=0^\circ$	-0.03	0.644	+0.03	-	<u>@BOE BLU Note 4</u>
	Ry			0.344			
	Gx			0.315			
	Gy			0.632			
	Bx			0.157			
	By			0.054			
	Wx			0.310			
	Wy			0.330			
NTSC Ratio	NTSC	CIE1931	--	72	--	%	<u>@BOE BLU Note 5</u>
Polarization Direction of Front Polarizer	PdF	-		0		deg	<u>Absorption axis Note 6</u>
Polarization Direction of Rear Polarizer	PdR			90		deg	
Luminance of White	Y_w	$\theta=0^\circ$	-	400	-	cd/m^2	<u>Note 7</u>
Brightness Uniformity	ΔBp	$\theta=0^\circ$	75	80	-	%	<u>Note 8</u>

**Note 1: The definition of Viewing Angle**

Refer to the graph below marked by θ and ϕ .

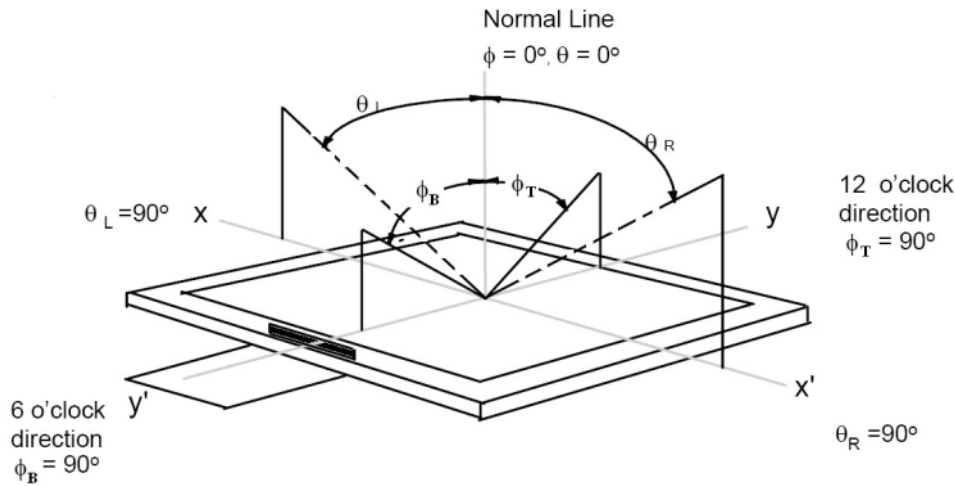
**Note 2: The definition of Contrast Ratio**

$$\text{Contrast Ratio (CR)} = \frac{\text{Luminance When LCD is at "White" state}}{\text{Luminance When LCD is at "Black" state}}$$

(Contrast Ratio is measured in optimum common electrode voltage)

Note 3: Definition of Response time. (Test LCD using RD80S or similar equipments):

The output sign also photo detector are measured when the input sign also are changed from "black" to "white" (Voltage falling time) and from "white" to "black" (Voltage rising time), respectively. The response time is defined as the time interval between the 10% and 90% of amplitudes. Refer to figures below.

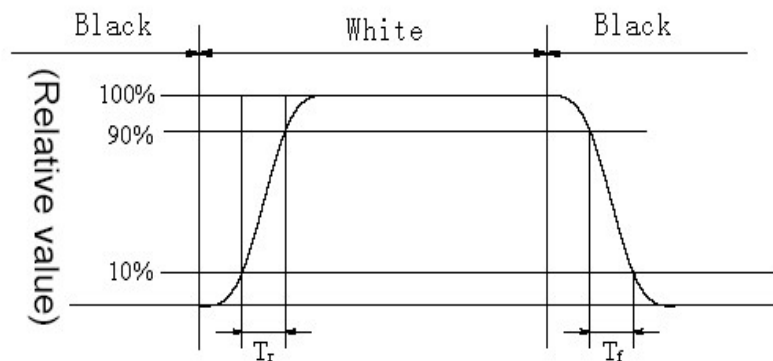
**Note 4: Color Coordinates of CIE 1931**

The test condition is at ILED=20mA and measured on the surface of LCD module at 25°C.

Measurement equipment: CS2000 or similar equipments

The Color Coordinate (CIE 1931) is the measurement of the center of the display shown in below figure.



Note 5: Definition of Color of CIE Coordinate and NTSC Ratio.

$$S = \frac{\text{area of RGB triangle}}{\text{area of NTSC triangle}} \times 100\%$$

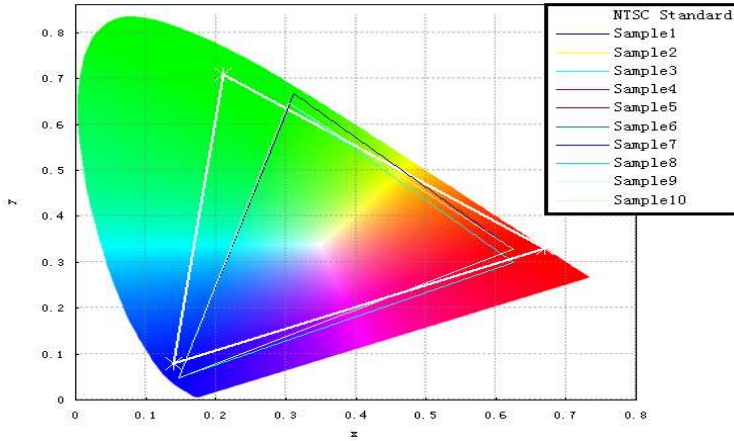

Note 6: Polarization Direction Definition

- Viewing direction is normal user viewing direction which is vertical to the display surface
- The polarizer which is closer to viewer is defined as Front Polarizer
- The polarizer which is on the rear side of viewer is defined as Rear Polarizer
- The X axis is defined as parallel line to top & bottom sidelines of the Active Area
- PdF which is marked in blue arrow is polarization degree of Front polarizer
- PdR which is marked in red arrow is polarization degree of Back polarizer
- The polarization degree parameter must be indicated in range of 0deg to 180deg according to above definition

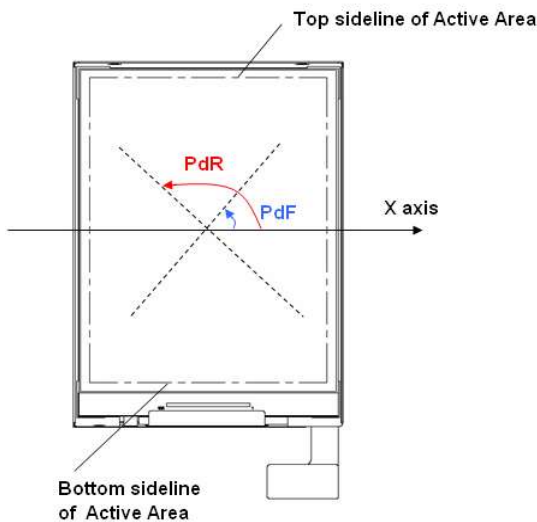



Note7:Luminance measurement

The test condition is at ILED=22mA and measured on the surface of LCD module at 25°C.

- The data are measured after LEDs are lighted on for more than 9 minutes and LCM displays are fully white. The brightness is the value of center measured spots. Measurement equipment LMS OTS or similar equipments(Field of view:1deg,Distance:50cm)
- Measuring surroundings: Dark room.
- Measuring temperature: Ta=25°C.
- Adjust operating voltage to get optimum contrast at the center of the display.
- Measured value at the center point of LCD panel must be after more than 5 minutes while backlight turning on.

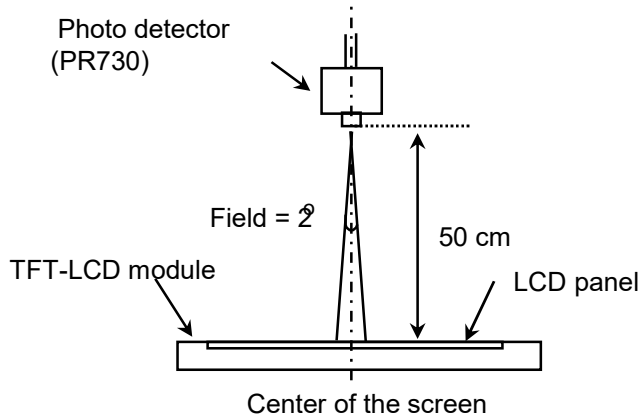

Optical characteristics measurement setup

Note8:Uniformity

- The test condition is at ILED=22mA and measured on the surface of LCD module at 25°C.
- Measurement equipment:LMS OTS or similar equipments
- The luminance uniformity is calculated by using following formula:
 - $\Delta Bp = Bp (\text{Min.}) / Bp (\text{Max.}) \times 100 (\%)$
 - Bp (Max.) = Maximum brightness in 9 measured spots
 - Bp (Min.) = Minimum brightness in 9 measured spots.

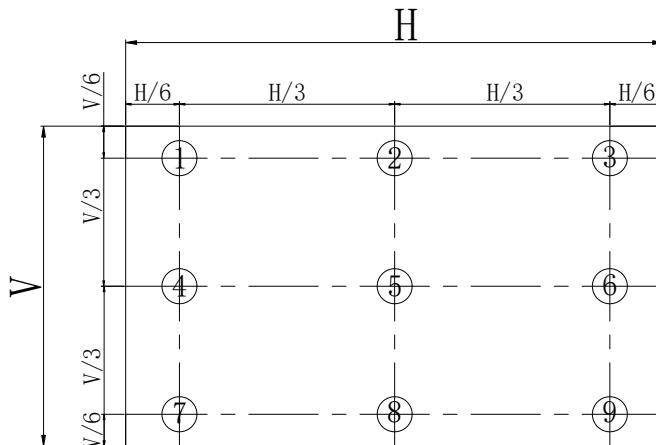



5.0 RELIABILITY TEST

The Reliability test items and its conditions are shown in below.

<Table 10. Reliability Test Parameters >

No	Test Items	Conditions
1	High temperature storage test	80°C 240hr
2	Low temperature storage test	-30°C 240hr
3	Low temperature operation test	-20°C 240hr
4	High temperature operation test	70°C 240hr
5	High temperature & high humidity (operation test)	60°C 90%RH 240hr
6	Thermal Shock Test	-40°C~85°C 0.5hr/cycle 100cycle
7		
8		
9		
10		
...		



6.0 PACKING INFORMATION(产品形态: MDL)

Packing procedure:

- 将 2pcs LCM 平放入Tray,
下部PE 垫片
CF 侧向上放置;

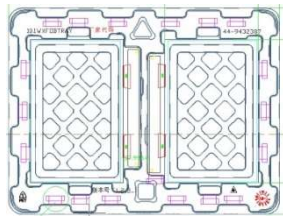

Tray

- 将**22pcs PET Tray** 平放入**Shielding Bag**, 顶部为空**Tray**
进行抽真空处理;
- **Tray** 无需区分旋转码放

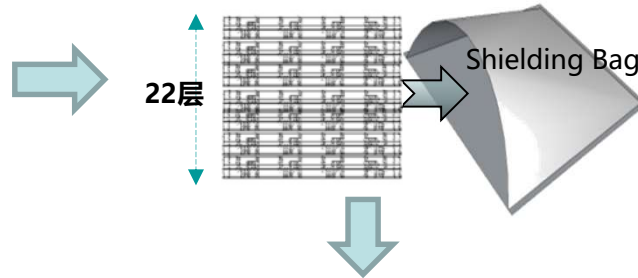

- 每个**Pallet**上放**3层Box**,
1层4箱
- **Pallet** 缠绕膜包装
- **756pcs / Pallet**

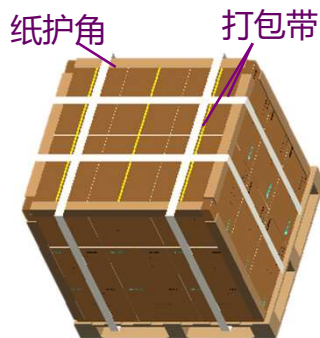

- 将**PET Tray**堆码后平放入**Inner Box**
上下放置**EPE Board**
- 容量: **42pcs/Inner Box**

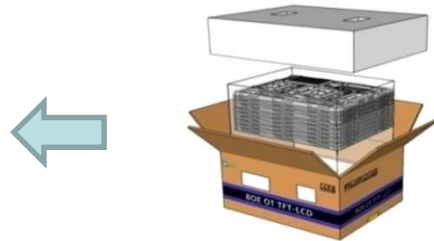



7.0 Handling & Cautions

7.1 Mounting Method

- The panel of the LCD consists of two thin glasses with polarizers which easily get damaged. So extreme care should be taken when handling the LCD.
- Excessive stress or pressure on the glass of the LCD should be avoided. Care must be taken to insure that no torsional or compressive forces are applied to the LCD unit when it is mounted.
- If the customer's set presses the main parts of the LCD, the LCD may show the abnormal display. But this phenomenon does not mean the malfunction of the LCD and should be pressed by the way of mutual agreement.
- To determine the optimum mounting angle, refer to the viewing angle range in the specification for each model.
- Mount a LCD module with the specified mounting parts.

7.2 Caution of LCD Handling and Cleaning

- Since the LCD is made of glass, do not apply strong mechanical impact or static load onto it. Handling with care since shock, vibration, and careless handling may seriously affect the product. If it falls from a high place or receives a strong shock, the glass may be broken.
- The polarizers on the surface of panel are made from organic substances. Be very careful for chemicals not to touch the polarizers or it leads the polarizers to be deteriorated.
- If the use of a chemical is unavoidable, use soft cloth with solvent (recommended below) to clean the LCD's surface with wipe lightly.
 - IPA(Isopropyl Alcohol), Ethyl Alcohol, Trichlorotrifluoroethane
- Do not wipe the LCD's surface with dry or hard materials that will damage the polarizers and others. Do not use the following solvent.
 - Water, Ketone, Aromatics
- It is recommended that the LCD be handled with soft gloves during assembly, etc. The polarizers on the LCD's surface are vulnerable to scratch and thus to be damaged by sharp particles.
- Do not drop water or any chemicals onto the LCD's surface.
- A protective film is supplied on the LCD and should be left in place until the LCD is required for operation.
- The ITO pad area needs special careful caution because it could be easily corroded. Do not contact the ITO pad area with HCFC, Soldering flux, Chlorine, Sulfur, saliva or fingerprint. To prevent the ITO corrosion, customers are recommended that the ITO area would be covered by UV or silicon.



7.3 Caution Against Static Charge

- The LCD modules use C-MOS LSI drivers, so customers are recommended that any unused input terminal would be connected to Vdd or Vss, do not input any signals before power is turn on, and ground you body, work/assembly area, assembly equipments to protect against static electricity.
- Remove the protective film slowly, keeping the removing direction approximate 30-degree not vertical from panel surface, If possible, under ESD control device like ion blower, and the humidity of working room should be kept over 50%RH to reduce the risk of static charge.
- Avoid the use work clothing made of synthetic fibers. We recommend cotton clothing or other conductivity-treated fibers.
- In handling the LCD, wear non-charged material gloves. And the conducting wrist to the earth and the conducting shoes to the earth are necessary.

7.4 Caution For operation

- It is indispensable to drive the LCD within the specified voltage limit since the higher Voltage than the limit causes the shorter LCD's life. An electro-chemical reaction due to DC causes undesirable deterioration of the LCD so that the use of DC drive should avoid.
- Do not connect or disconnect the LCD to or from the system when power is on.
- Never use the LCD under abnormal conditions of high temperature and high humidity.
- When expose to drastic fluctuation of temperature (hot to cold or cold to hot) ,the LCD may be affected; Specifically, drastic temperature fluctuation from cold to hot ,produces dew on the LCD's surface which may affect the operation of the polarizer and the LCD.
- Response time will be extremely delayed at lower temperature than the operating temperature range and on the other hand at higher temperature LCD may turn black at temperature above its operational range. However those phenomena do not mean malfunction or out of order with the LCD. The LCD will revert to normal operation once the temperature returns to the recommended temperature range for normal operation.
- Do not display the fixed pattern for a long time because it may develop image sticking due to the LCD structure. If the screen is displayed with fixed pattern, use a screen saver.



7.5 Packaging

- Modules use LCD element, and must be treated as such.
 - Avoid intense shock and falls from a height.
 - To prevent modules from degradation, do not operate or store them exposed directly to sunshine or high temperature/humidity for long periods.

7.6 Storage

- A slight dew depositing on terminals is a cause for electro-chemical reaction resulting in terminal open circuit. Relative humidity of the environment should therefore be kept below 60%RH.
- Original protective film should be used on LCD' s surface (polarizer). Adhesive type protective film should be avoided, because it may change color and/or properties of the polarizers.
- Do not store the LCD near organic solvents or corrosive gasses.
- Keep the LCD safe from vibration, shock and pressure.
- Black or white air-bubbles may be produced if the LCD is stored for long time in the lower temperature or mechanical shocks are applied onto the LCD.
- In the case of storing for a long period of time for the purpose or replacement use, the following ways are recommended.
 - Store in a polyethylene bag with sealed so as not to enter fresh air outside in it.
 - Store in a dark place where neither exposure to direct sunlight nor light is.
 - Keep temperature in the specified storage temperature range.
 - Store with no touch on polarizer surface by the anything else. If possible, store the LCD in the packaging situation LCD when it was delivered.

7.7 Safety

- For the crash damaged or unnecessary LCD, it is recommended to wash off liquid crystal by either of solvents such as acetone and ethanol an should be burned up later.
- In the case the LCD is broken, watch out whether liquid crystal leaks out or not. If your hands touch the liquid crystal, wash your hands cleanly with water an soap as soon as possible.
- If you should swallow the liquid crystal, first, wash your mouth thoroughly with water, then drink a lot of water and induce vomiting, and then, consult a physician.
- If the liquid crystal should get in your eyes, flush your eyes with running water for at least fifteen minutes.
- If the liquid crystal touches your skin or clothes, remove it and wash the affected part of your skin or clothes with soap and running water.



Mechanical Drawing

Drawing Attachment: Back

