

ICAO Standards

Holding Position Markings and Mandatory Instruction Signs

ICAO Annex 14, 5th Edition Aerodrome Design and Operations



Federal Aviation Administration
U.S. Department of Transportation

May 2016

ICAO Standards

This PowerPoint presentation reviews ICAO Annex 14 standards for holding position markings and mandatory instruction signs. A second presentation on ICAO Information Signs is a supplement to this presentation.

ICAO Standards

The Topics addressed in this PowerPoint presentation include:

Runway-Holding Position Markings
Intermediate Holding Position Markings
ICAO Sign Characteristics
Mandatory Instruction Signs
Mandatory Instruction Marking
Road-Holding Positions
Related FAA Standards

This presentation can be printed and used as a reference on ICAO standards.

ICAO Standards

The ICAO standards are in orange text blocks.

Sample

ICAO 3.11.3 – A runway-holding position shall be established on a taxiway if the location or alignment of the taxiway is such that a taxiing aircraft or vehicle can infringe an obstacle limitation surface or interfere with the operation of radio navigation aids.

Additional comments are in yellow text blocks.

Sample

The FAA requires that all runway-holding position markings be double size to increase conspicuity of the runway-holding position.

Table 1.1. Airport Reference Code

Table 1-1. Aerodrome reference code
(see 1.4.2 to 1.4.4)

Code element 1		Code element 2		
Code number (1)	Aeroplane reference field length (2)	Code letter (3)	Wing span (4)	Outer main gear wheel span ^a (5)
1	Less than 800 m	A	Up to but not including 15 m	Up to but not including 4.5 m
2	800 m up to but not including 1 200 m	B	15 m up to but not including 24 m	4.5 m up to but not including 6 m
3	1 200 m up to but not including 1 800 m	C	24 m up to but not including 36 m	6 m up to but not including 9 m
4	1 800 m and over	D	36 m up to but not including 52 m	9 m up to but not including 14 m
		E	52 m up to but not including 65 m	9 m up to but not including 14 m
		F	65 m up to but not including 80 m	14 m up to but not including 16 m

International airports will generally be Code number 3 or 4.

a. Distance between the outside edges of the main gear wheels.

Students need to be aware of the Aerodrome Reference Code. ICAO standards reference the code number for slightly different requirements based on the length of the runway.

Holding Position Markings

•Runway-Holding Position Marking

ICAO 3.12.2 – A runway-holding position or positions shall be established:

- a) on the taxiway, at the intersection of a taxiway and a runway; and**
- b) at an intersection of a runway with another runway when the former runway is part of a standard taxi-route.**

ICAO 3.12.3 – A runway-holding position shall be established on a taxiway if the location or alignment of the taxiway is such that a taxiing aircraft or vehicle can infringe an obstacle limitation surface or interfere with the operation of radio navigation aids.

Holding Position Markings

•Runway-Holding Position Marking

Basically, a runway-holding position is required to protect aircraft landing or taking-off on a runway. The runway-holding positions are located to keep vehicles and aircraft out of the runway obstacle free zone, approach surface and ILS critical areas.

Obstacle free zones provide a clear area around a runway in case an aircraft inadvertently leaves the runway pavement.

ILS critical areas are protected to prevent aircraft or vehicles from distorting the ILS signal while an aircraft is making an ILS approach during low visibility conditions. An ILS signal distorted by an aircraft or vehicle can cause an aircraft on approach to be off the runway alignment or glide angle. During low visibility conditions, a pilot may not have time to correct his approach when the runway becomes visible.

Holding Position Markings

•Runway-Holding Position Marking

Table 3-2. Minimum distance from the runway centre line to a holding bay, runway-holding position or road-holding position

Type of runway	Code number			
	1	2	3	4
Non-instrument	30 m	40 m	75 m	75 m
Non-precision approach	40 m	40 m	75 m	75 m
Precision approach category I	60 m ^b	60 m ^b	90 m ^{a,b}	90 m ^{a,b,c}
Precision approach categories II and III	–	–	90 m ^{a,b}	90 m ^{a,b,c}
Take-off runway	30 m	40 m	75 m	75 m

ICAO 3.12.6 – The distance between a holding bay, runway-holding position established at a taxiway/runway intersection or road-holding position and the centre line of a runway shall be in accordance with Table 3-2 and, in the case of a precision approach runway, such that a holding aircraft or vehicle will not interfere with the operation of radio navigation aids.

Holding Position Markings

•Runway-Holding Position Marking

ICAO 3.12.7 Recommendation. – At elevations greater than 700 m (2300') the distance of 90 m specified in Table 3-2 for a precision approach runway code number 4 should be increased as follows:

- (a) up to an elevation of 2000 m (6600'); 1 m for every 100 m (330') in excess of 700 m (2300');**
- (b) Elevation in excess of 2000 m (6600') and up to 4000 m (13320'); 13 m plus 1.5 m for every 100 m (330') in excess of 2000 m (6600'); and**
- (c) Elevation in excess of 4000 m (13320') and up to 5000 m (16650'); 43 m plus 2 m for every 100 m (330') in excess of 4000 m (13320').**

ICAO 3.12.8 Recommendation. – If a holding bay, runway-holding position or road-holding position for a precision approach runway code number 4 is at a greater elevation compared to the threshold, the distance of 90 m or 107.5 m, as appropriate, specified in Table 3-2 should be further increased 5 m for every metre the bay or position is higher than the threshold.

Holding Position Markings

•Runway-Holding Position Marking

ICAO 3.12.9 – The location of a runway-holding position established in accordance with 3.12.3 shall be such that a holding aircraft or vehicle will not infringe the obstacle free zone, approach surface, take-off climb surface or ILS/MLS critical/sensitive area or interfere with the operation of radio navigation aids.

Holding Position Markings

•Runway-Holding Position Marking

ICAO 5.2.10.1 – A runway-holding position marking shall be displayed along a runway-holding position.

ICAO 5.2.10.2 – At an intersection of a taxiway and a non-instrument, non-precision approach or take-off runway, the runway-holding position marking shall be shown in Figure 5-6, pattern A.

RUNWAY-HOLDING POSITION MARKING

PATTERN A:
4 lines and
3 spaces at
0.15 m each

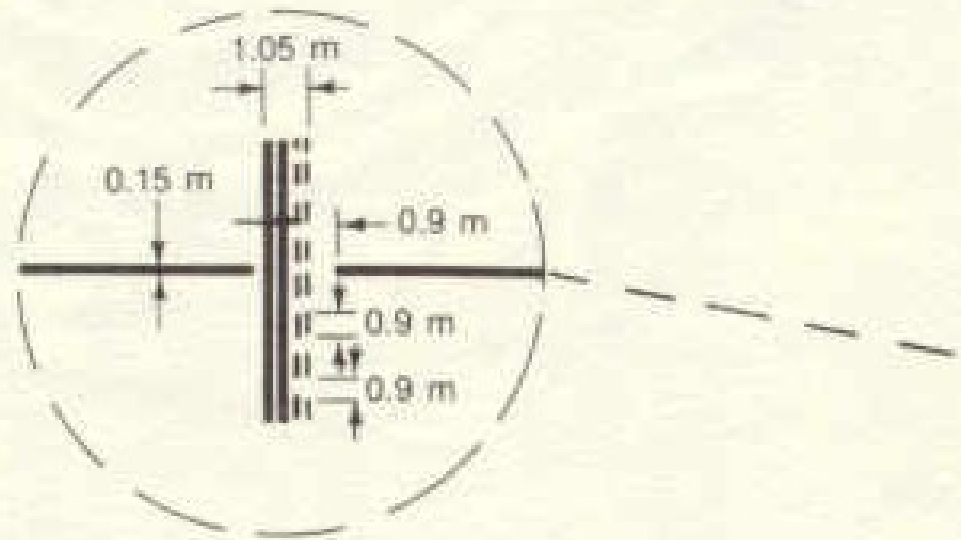

Pattern "A" runway
holding position
marking.

B1 15R - 33L

15R - 33L B1

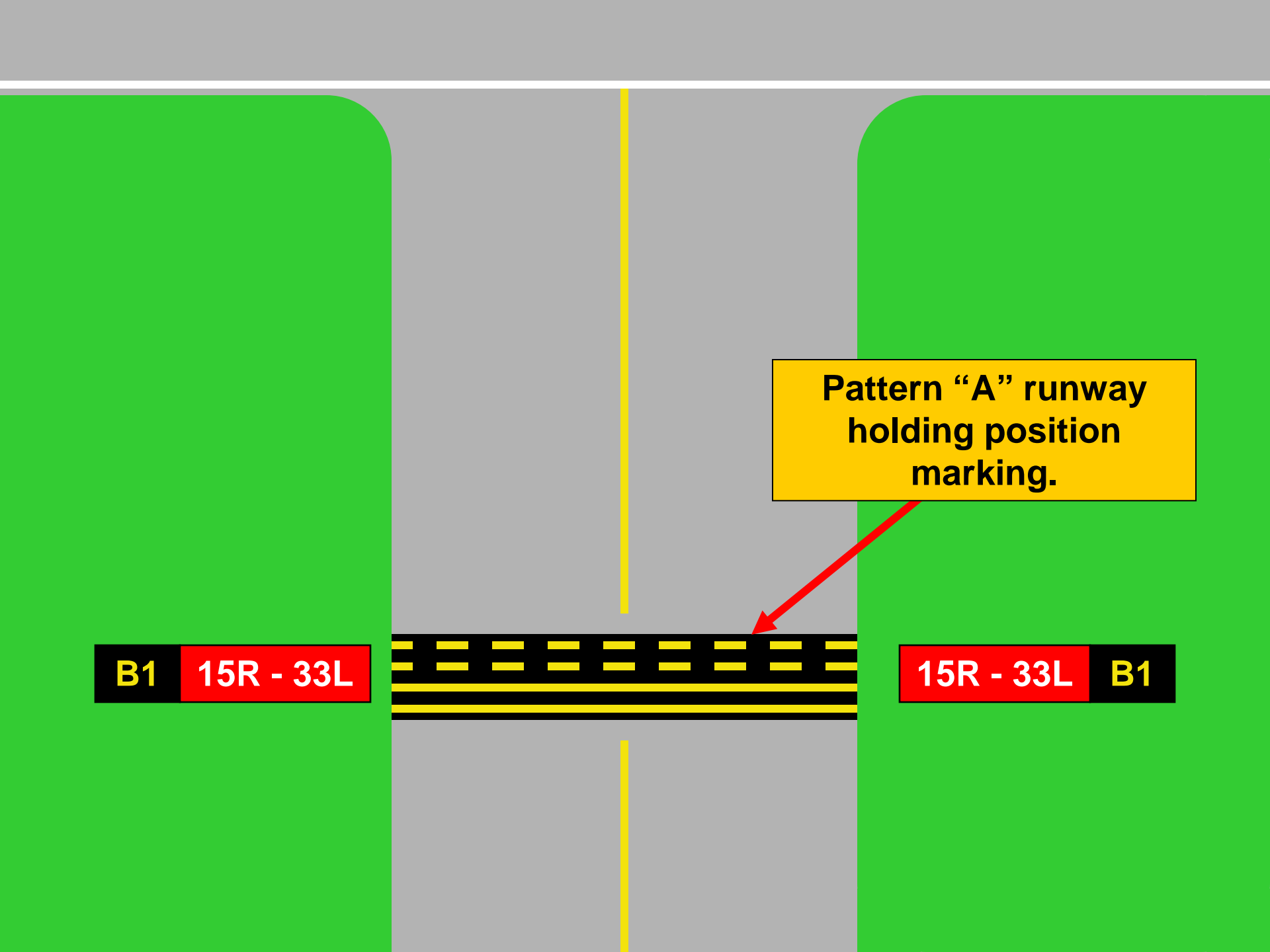

Holding Position Markings

•Runway-Holding Position Marking

ICAO 5.2.10.3 – Where a single runway-holding position is provided at an intersection of a taxiway and a precision approach category I, II or III runway, the runway-holding position marking shall be as shown in Figure 5-6, pattern “A”. Where two or three runway-holding positions are provided at such an intersection, the runway-holding position marking closer (closest) to the runway shall be shown in Figure 5-6, pattern “A” and the markings farther from the runway shall be as shown in Figure 5-6, pattern “B”.

PATTERN B:
2 lines at
0.3 m each
1 space at
0.6 m

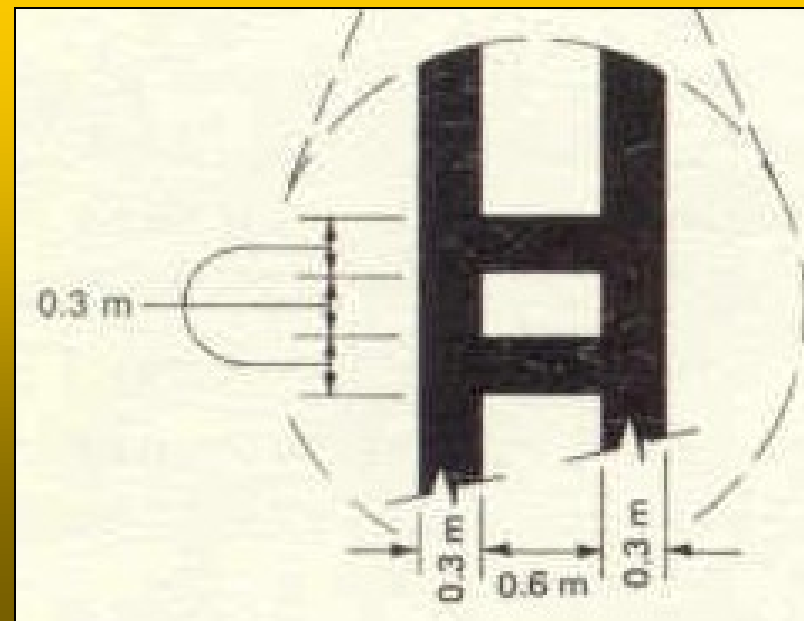
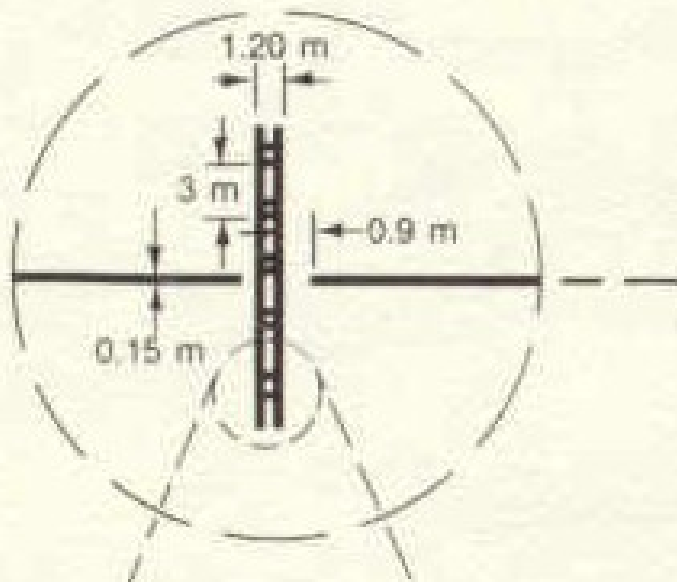

A1 33L

33L A1

**Pattern "A" runway
holding position
marking.**

33L CAT III

33L CAT III

**Pattern "B" runway
holding position
marking.**

Example of a runway-holding position and a CAT III critical area holding position at the takeoff end.

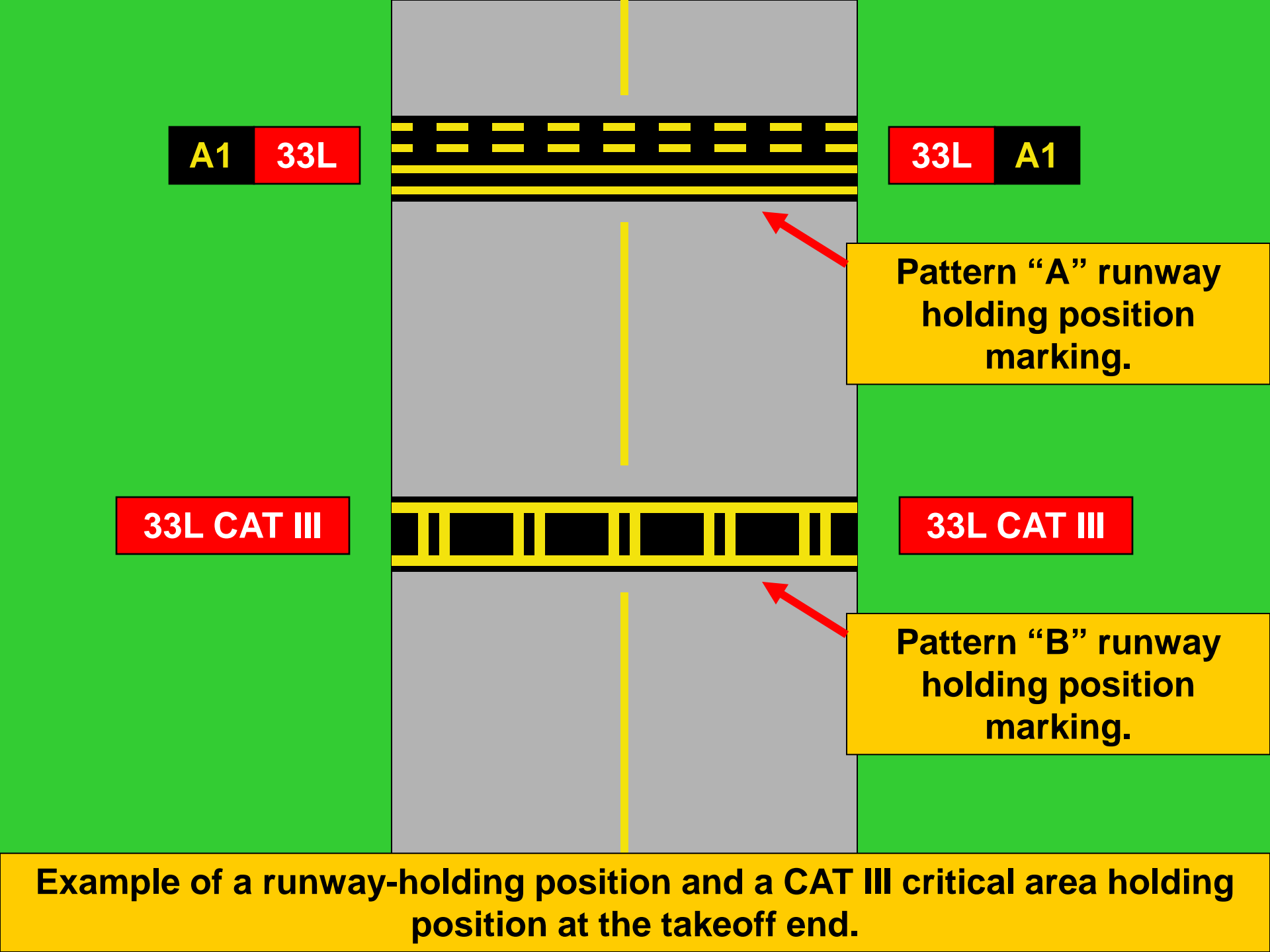

Holding Position Markings

•Runway-Holding Position Marking

ICAO 5.2.10.5 Recommendation. – *Where increased conspicuity of the runway-holding position is required, the runway-holding position marking should be as shown in Figure 5-7, pattern A or pattern B, as appropriate.*

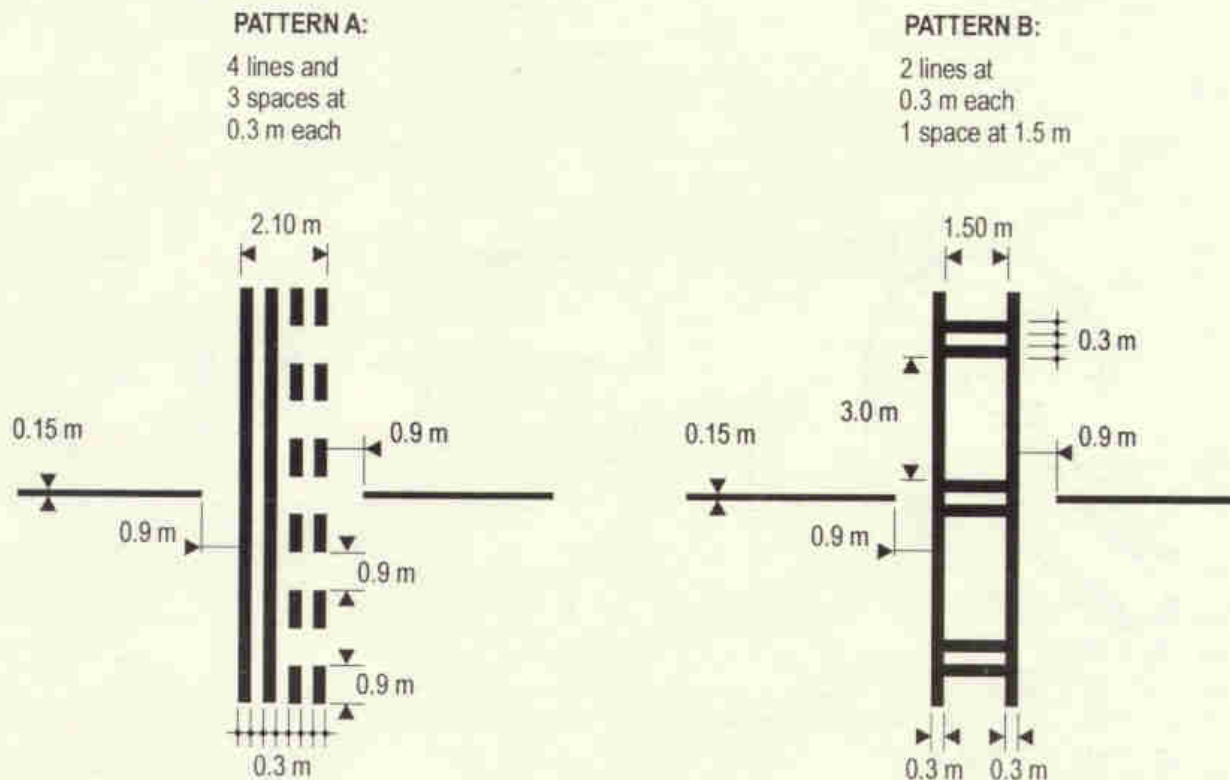

The dimensions in Figure 5-7 are double the size of the dimensions in Figure 5-6.

Figure 5-7. Runway-holding position markings

Holding Position Markings

•Runway-Holding Position Marking



ICAO 5.2.1.7 Recommendation. – *At aerodromes where operations take place at night, pavement markings should be made with reflective materials designed to enhance the visibility of the markings.*

FAA Standard – Holding Position Markings



Old Size



The FAA requires that all holding position markings be double size (0.3 m) to increase conspicuity of the runway-holding position.

FAA Standard – Holding Position Markings



The FAA requires that holding position markings be highlighted in black on light colored pavement to increase conspicuity of the runway-holding position.

FAA Standard – Holding Position Markings



The FAA also requires that holding position markings be glass beaded to increase conspicuity of the runway-holding position at night.

FAA Standard – Holding Position Markings



ILS holding position markings are also required to be double size, glass beaded and highlighted in black on light colored pavement to increase conspicuity.

Holding Position Markings

•Runway-Holding Position Marking on Runways

ICAO 5.2.10.7 – The runway-holding position marking displayed at a runway/runway intersection shall be perpendicular to the center line of the runway forming part of the standard taxi-route. The pattern of the marking shall be as shown in Figure 5-7, pattern A.

15R - 33L



15R - 33L

The larger pattern "A" runway-holding position marking with 0.3 m lines and spaces must be used on a runway.

ICAO 5.2.10.6 Recommendation. – Where a pattern B runway-holding position marking is located on an area where it would exceed 60 m in length, the term “CAT II” or “CAT III” as appropriate should be marked on the surface at the ends of the runway-holding position marking and at equal intervals of 45 m maximum between successive marks. The letters should be not less than 1.8 m high and should be placed not more than 0.9 m beyond the holding position marking.

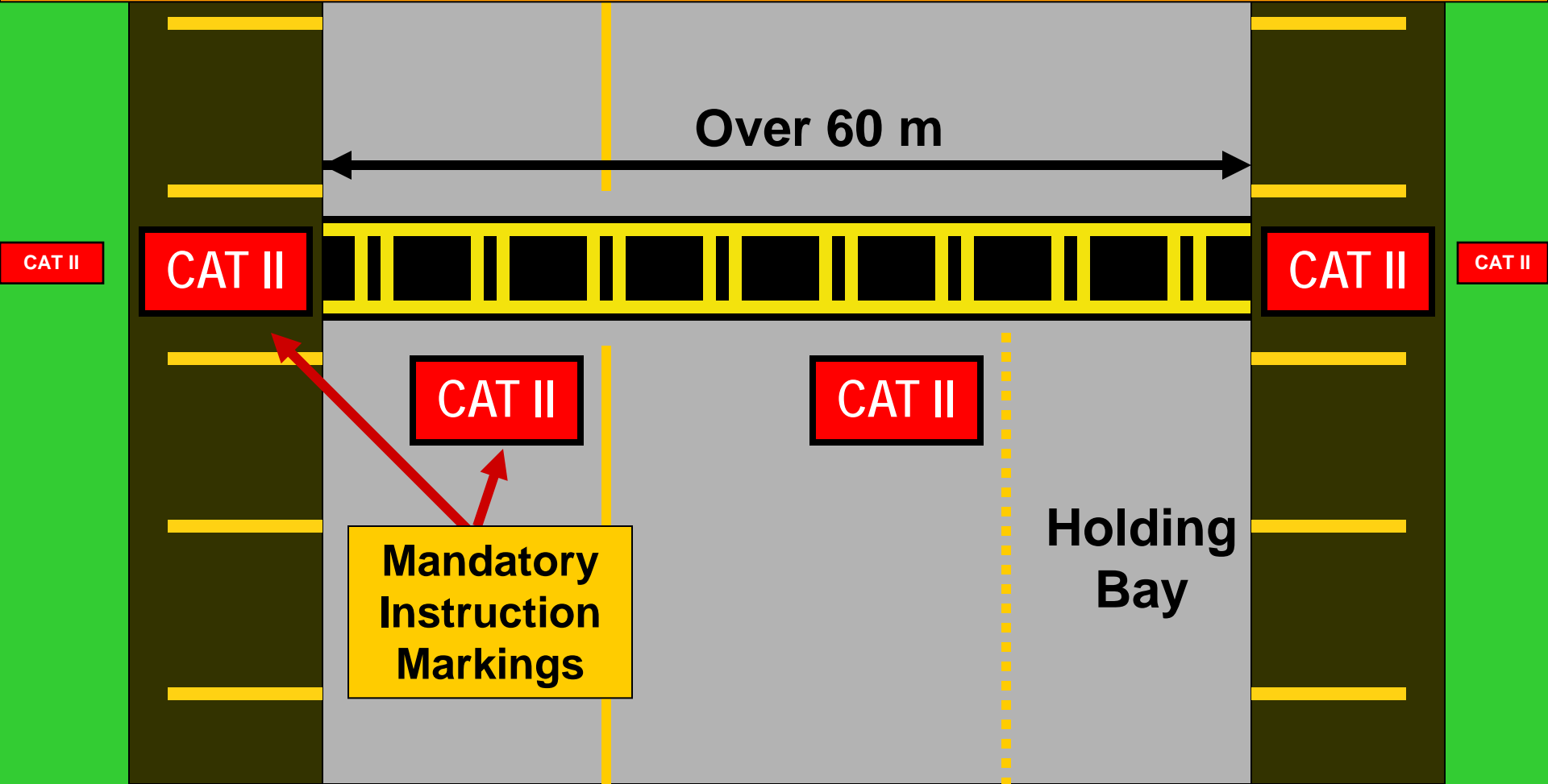

The taxiway centre line marking is interrupted for the runway-holding position marking by 0.9 m on either side, as shown in Figure 5-6.

B1 **15R - 33L**



15R - 33L **B1**

Holding Position Markings

• Intermediate Holding Position Marking



ICAO 5.2.11.1 Recommendation. - *An intermediate holding position marking should be displayed along an intermediate holding position.*

Holding Position Markings

• Intermediate Holding Position Marking

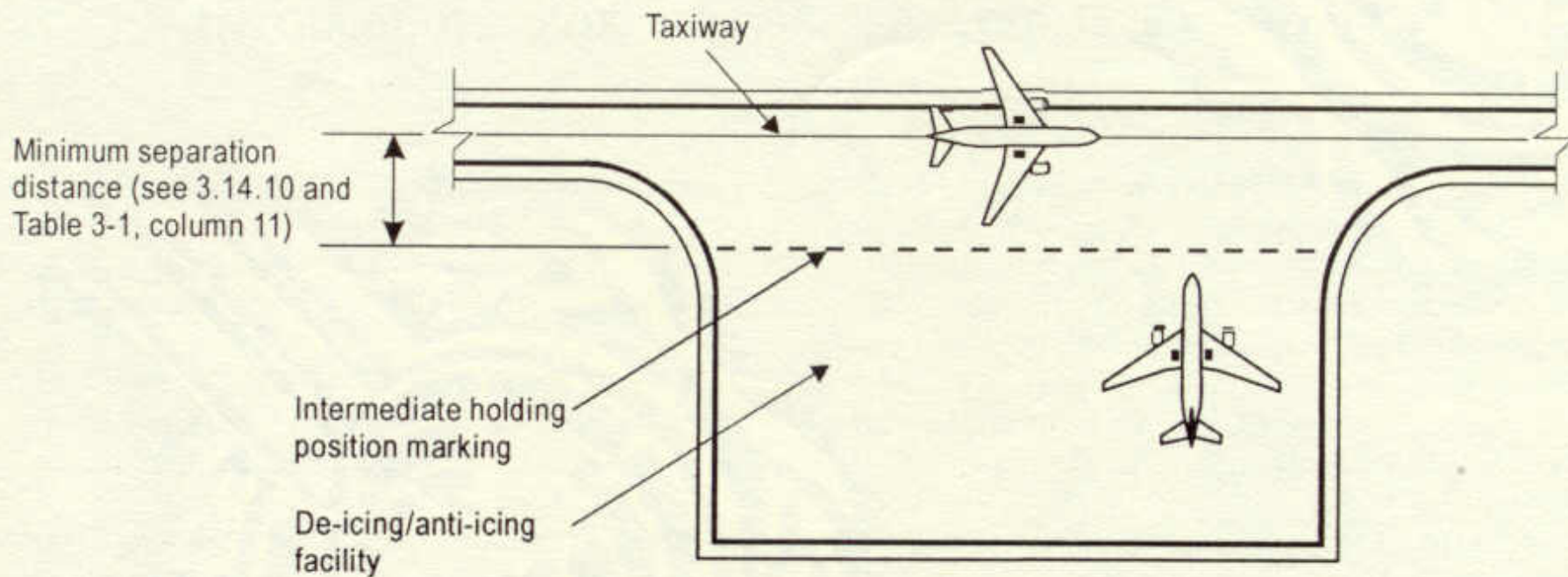
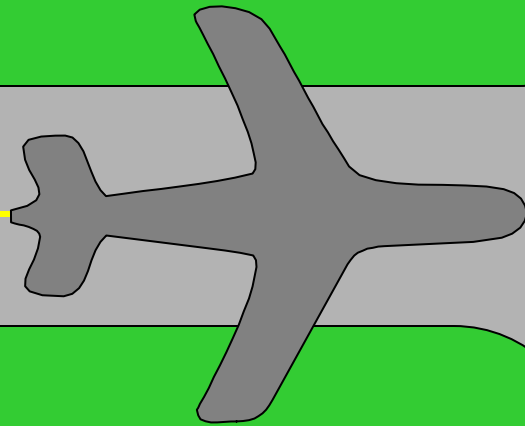

Figure 3.3. Minimum separation distance on a de-icing/anti-icing facility

ICAO 5.2.11.2 Recommendation. - *An intermediate holding position marking should be displayed at the exit boundary of a remote de-icing/anti-icing facility adjoining a taxiway.*

Holding Position Markings

• Intermediate Holding Position Marking



ICAO 5.2.11.3 – Where an intermediate holding position marking is displayed at an intersection of two paved taxiways, it shall be located across the taxiway at sufficient distance from the near edge of the intersecting taxiway to ensure safe clearance between taxiing aircraft. It shall be coincident with a stop bar or intermediate holding position lights, where provided.

Holding Position Markings

• Intermediate Holding Position Marking

INTERMEDIATE HOLDING POSITION MARKING

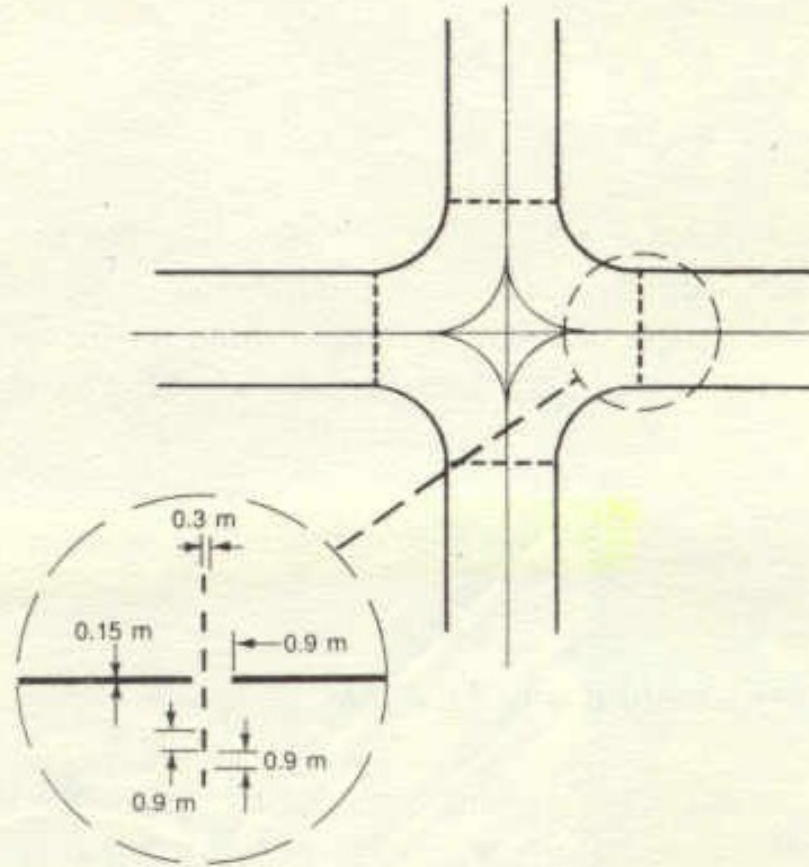

ICAO 5.2.11.5 – An intermediate holding position marking shall consist of a single broken line as shown in Figure 5-6.

ICAO 5.2.11.4 – The distance between an intermediate holding position marking at the exit boundary of a remote de-icing/anti-icing facility and the centerline of the adjoining taxiway shall not be less than the dimensions specified in Table 3-1, column 11.

Table 3-1. Taxiway minimum separation distances

Code letter	Distance between taxiway centre line and runway centre line (metres)								Taxiway centre line to taxiway centre line (metres)	Taxiway, other than aircraft stand taxilane, centre line to object (metres)	Aircraft stand taxilane centre line to object (metres)
	Instrument runways				Non-instrument runways						
	Code number				Code number						
(1)	(2)	(3)	(4)	(5)	(6)	(7)	(8)	(9)	(10)	(11)	(12)
A	82.5	82.5	–	–	37.5	47.5	–	–	23.75	16.25	12
B	87	87	–	–	42	52	–	–	33.5	21.5	16.5
C	–	–	168	–	–	–	93	–	44	26	24.5
D	–	–	176	176	–	–	101	101	66.5	40.5	36
E	–	–	–	182.5	–	–	–	107.5	80	47.5	42.5
F	–	–	–	190	–	–	–	115	97.5	57.5	50.5

Note 1.— The separation distances shown in columns (2) to (9) represent ordinary combinations of runways and taxiways. The basis for development of these distances is given in the Aerodrome Design Manual, Part 2.

Note 2.— The distances in columns (2) to (9) do not guarantee sufficient clearance behind a holding aeroplane to permit the passing of another aeroplane on a parallel taxiway. See the Aerodrome Design Manual, Part 2.

Holding Position Markings

• Intermediate Holding Position Marking



Intermediate holding positions are designated positions intended for traffic control at which taxiing aircraft and vehicles shall stop and hold until further cleared to proceed, when so instructed by the aerodrome control tower. In the U.S., aircraft and vehicles only stop at intermediate holding positions when instructed by ATC.

Review of Holding Position Markings

What type is this runway-holding position marking?

Answer: Pattern "A".

B1 15R - 33L



15R - 33L B1

Answer: 0.9 m

What distance is the taxiway centre line marking interrupted for the runway-holding position marking?



What type of holding position marking is shown in this photo?

Answer: Intermediate Holding Position Marking.

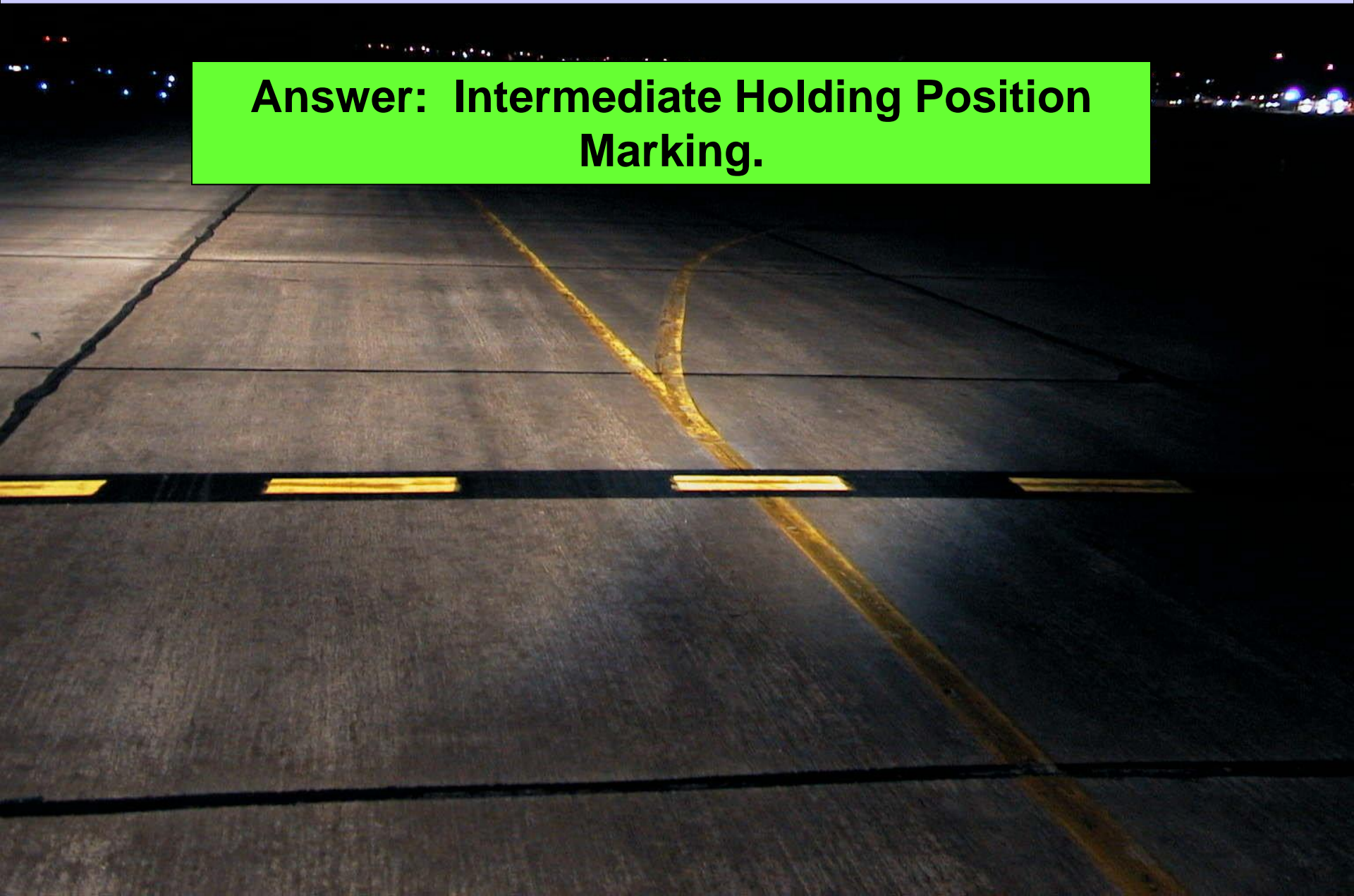

In this photo, is the runway for this runway-holding position marking in front or behind?

Answer: Behind. The dashed side of the runway-holding position marking is on the runway side.



What type is this runway-holding position marking?

Answer: Pattern "B" to protect an ILS critical area .



ICAO Signs - General

ICAO 5.4.1.1 - Signs shall be provided to convey a mandatory instruction, information on specific location or destination on a movement area or to provide information to meet Surface Movement Guidance & Control System (SMGCS) requirements in ICAO 9.8.



ICAO Signs - Characteristics

5.4.1.3 - Signs shall be frangible. Those located near a runway or taxiway shall be sufficiently low to preserve clearance for propellers and the engine pods of jet aircraft. The installed height of the sign shall not exceed the dimensions shown in the appropriate column of Table 5-4, Annex 14.

Table 5-4. Location distances for taxiing guidance signs including runway exit signs

Code number	Legend	Sign height (mm)		Perpendicular distance from defined taxiway pavement edge to near side of sign	Perpendicular distance from defined runway pavement edge to near side of sign
		Face (min.)	Installed (max.)		
1 or 2	200	400	700	5-11 m	3-10 m
1 or 2	300	600	900	5-11 m	3-10 m
3 or 4	300	600	900	11-21 m	8-15 m
3 or 4	400	800	1 100	11-21 m	8-15 m

ICAO Signs - Characteristics

5.4.1.4 – Signs shall be rectangular, as shown in Figure 5-28 and Figure 5-29 with the longer side horizontal.

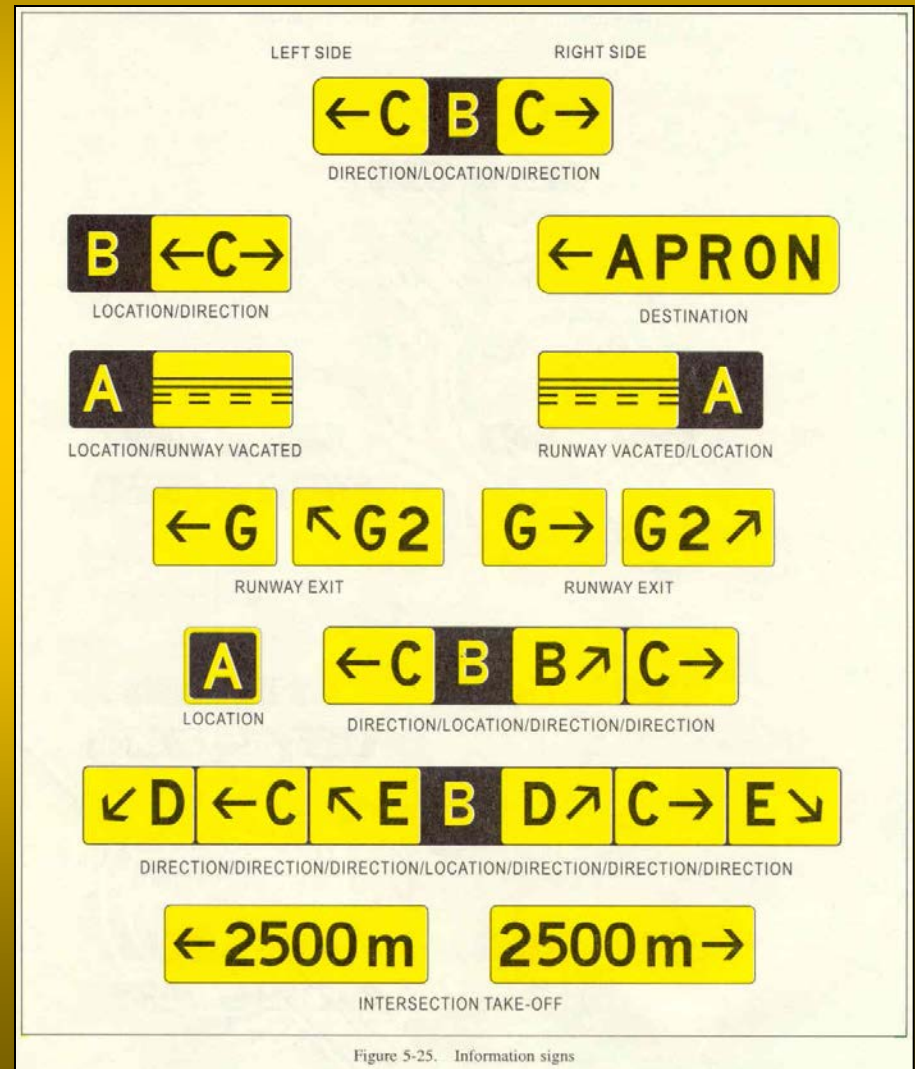
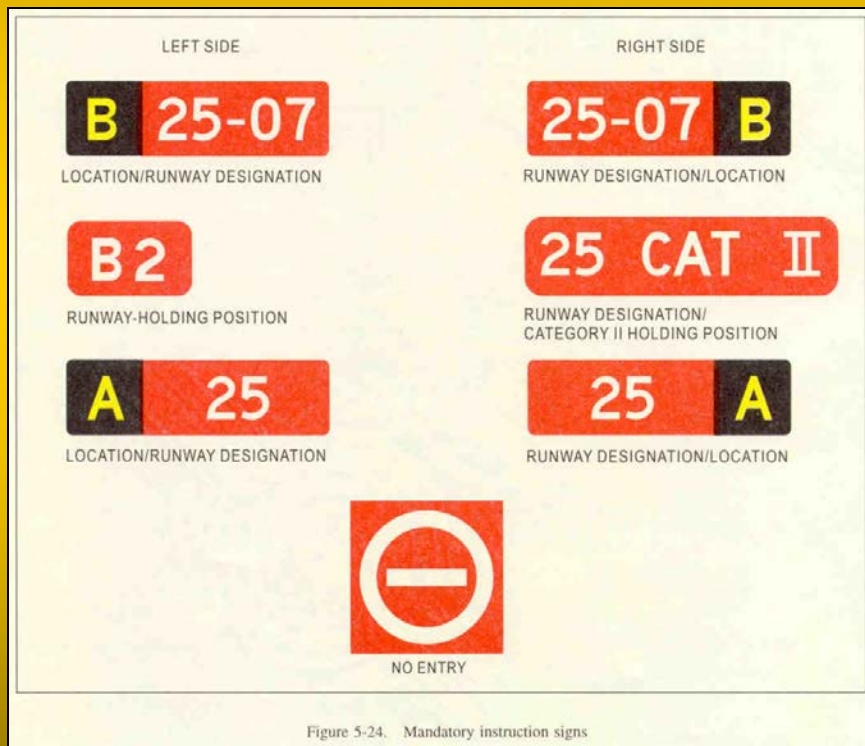

ICAO Signs - Characteristics

5.4.1.5 – The only signs on the movement area utilizing red shall be mandatory instruction signs.



ICAO Signs - Characteristics

5.4.1.6 – The inscriptions on a sign shall be in accordance with the provisions of Appendix 4. (ICAO Annex 14)

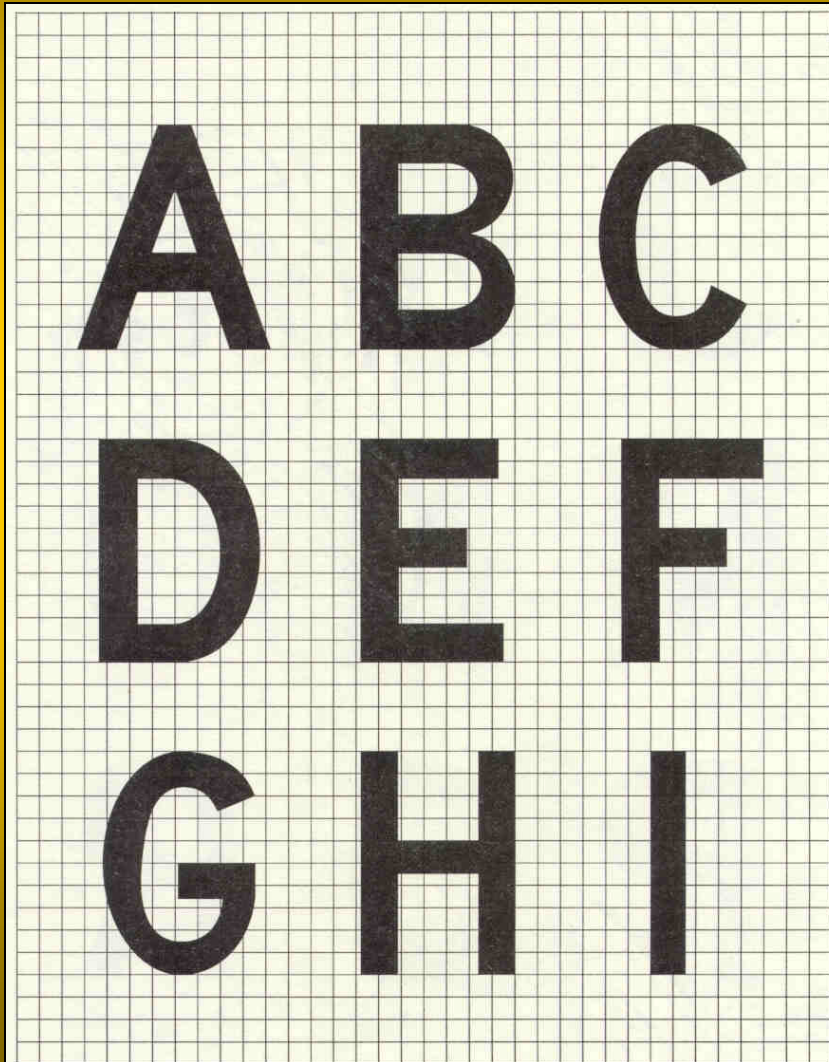

Figure 4.2 Forms of characters

ICAO Signs - Characteristics

5.4.1.7 – Signs shall be illuminated in accordance with the provisions of Appendix 4 when intended for use:

- a) in runway visual range conditions less than a value of 800 m; or
- b) at night in association with instrument runways; or
- c) at night in association with non-instrument runways where the code number is 3 or 4.



ICAO Signs - Characteristics

5.4.1.8 – Signs shall be retroreflective and/or illuminated in accordance with the provisions of Appendix 4 when intended for use at night in association with a non-instrument runways where the code number is 1 or 2.



ICAO Signs - Characteristics

ICAO Annex 14, Appendix 4 – *Requirements Concerning Design of Taxiing Guidance Signs*, contains additional requirements for sign characteristics.

APPENDIX 4. REQUIREMENTS CONCERNING DESIGN OF TAXIING GUIDANCE SIGNS

Note.— See Chapter 5, Section 5.4 for specifications on the application, location and characteristics of signs.

1. Inscription heights shall conform to the following tabulation.

Runway code number	Minimum character height		
	Mandatory instruction sign	Information sign	
		Runway exit and runway vacated signs	Other signs
1 or 2	300 mm	300 mm	200 mm
3 or 4	400 mm	400 mm	300 mm

Note.— Where a taxiway location sign is installed in conjunction with a runway designation sign (see 5.4.3.22), the character size shall be that specified for mandatory instruction

b) Where operations are conducted in accordance with 5.4.1.7 b) and c) and 5.4.1.8, average sign luminance shall be at least:

Red	10 cd/m ²
Yellow	50 cd/m ²
White	100 cd/m ²

Note.— In runway visual range conditions less than a value of 400 m, there will be some degradation in the performance of signs.

5. The luminance ratio between red and white elements of a mandatory sign shall be between 1:5 and 1:10.

6. The average luminance of the sign is calculated by establishing grid points as shown in Figure 4.1 and using the luminance values measured at all grid points located within the rectangle representing the sign.

ICAO Signs - Characteristics

5.4.1.9 – A variable message sign shall show a blank face when not in use.

5.4.1.10 – In case of failure, a variable message sign shall not provide information that could lead to unsafe action from a pilot or a vehicle driver.

ICAO Signs - Characteristics



In the U.S, signs are constructed to be double sided so sign panels can be installed on both sides of the sign.

Types of ICAO Signs

1. Mandatory Instruction Signs

- Runway designation signs
- Cat I, II, III holding position signs
- Runway holding position signs
- Road holding position signs
- No entry signs

2. Information Signs

- Direction signs
- Location signs
- Destination signs
- Runway exit signs
- Runway vacated signs
- Intersection take-off signs

Mandatory Instruction Signs

ICAO 5.4.2.1 – A mandatory instruction sign shall be provided to identify a location beyond which an aircraft taxiing or vehicle shall not proceed unless authorized by the airport control tower.

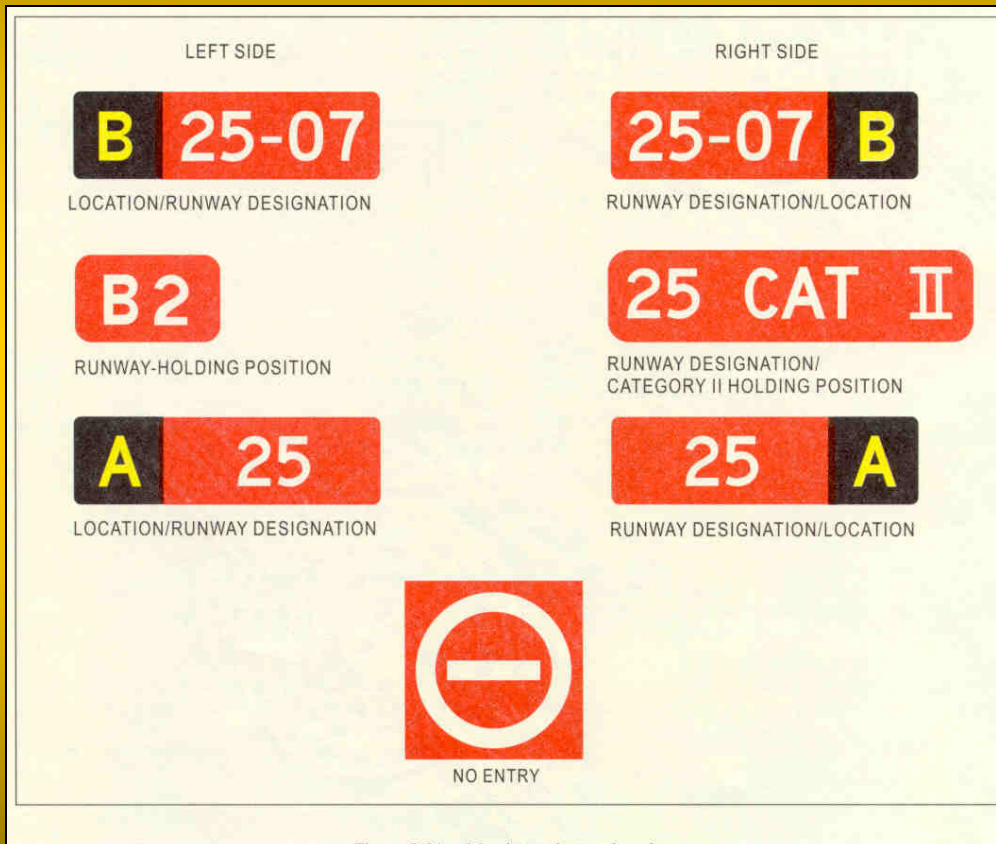
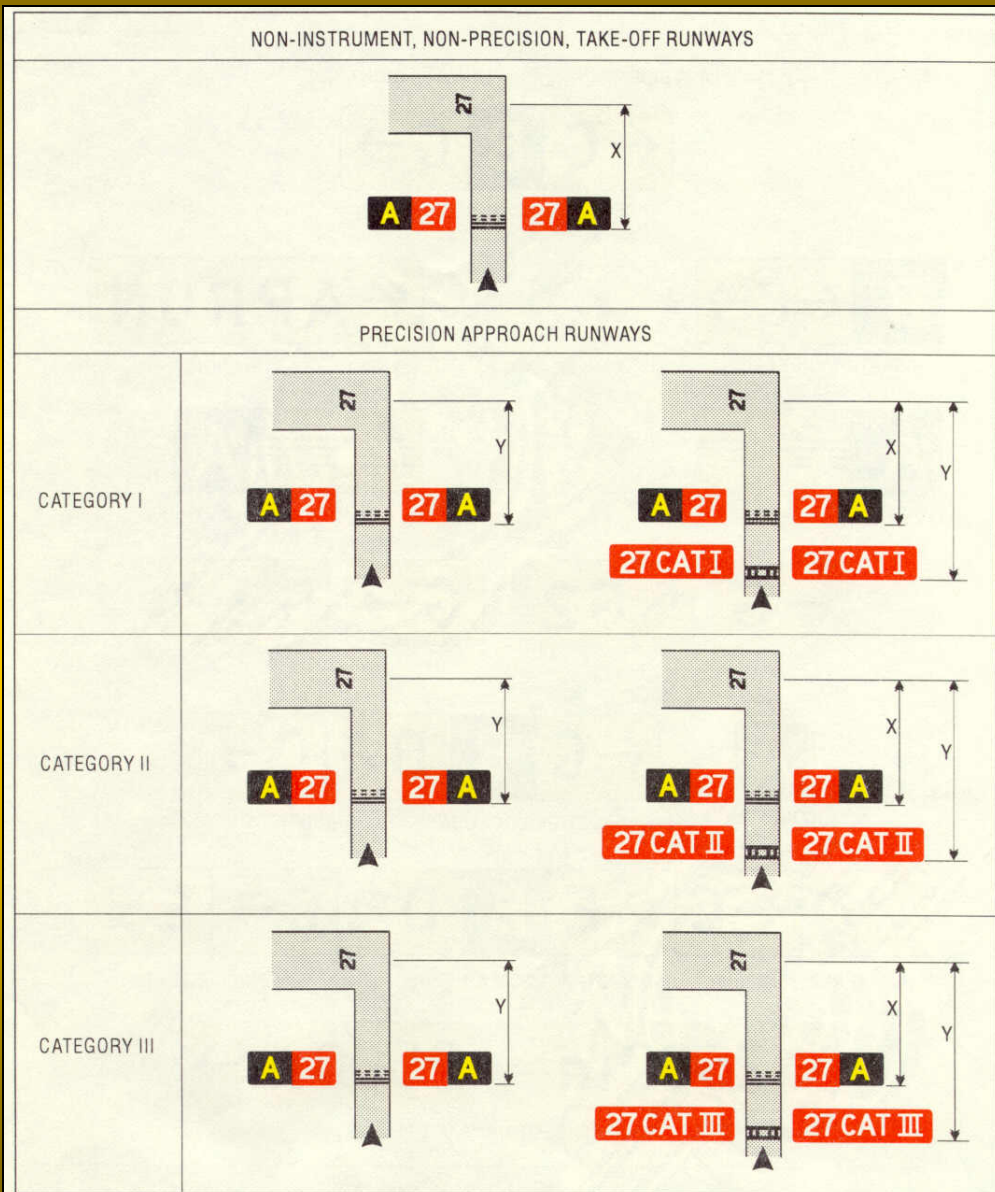

Figure 5-28

Note. – See Figure 5-28 for pictorial representation of mandatory instruction signs and Figure 5-30 for examples of locating signs at taxiway/runway intersections.

Mandatory Instruction Signs



Note: Distance X is established in accordance with Table 3-2. Distance Y is established at the edge of the ILS/MLS critical/sensitive area.

Figure 5-26. Examples of sign positions at taxiway/runway intersections

Figure 5-30

Mandatory Instruction Signs

ICAO 5.4.2.2 – Mandatory instruction signs shall include runway designation signs, category I, II or III holding position signs, runway-holding position signs, road-holding position signs and NO ENTRY signs.

B1 15R - 33L

Runway designation sign on a taxiway

15R - 33L

Runway designation sign on a runway

33L CAT III

Category III holding position sign

B2

Runway-holding position sign on a taxiway



NO ENTRY sign

ICAO 5.4.2.12 – A mandatory instruction sign shall consist of an inscription in white on a red background.

Mandatory Instruction Signs

•Runway Designation Signs at taxiway/runway intersections

These signs identify runway-holding positions on taxiways at runway intersections.

Location Sign



Take-off End



ICAO 5.4.2.13 - The inscription on a runway designation sign shall consist of the runway designations of the intersecting runway properly oriented with respect to the viewing position of the sign, except that a runway designation sign installed in the vicinity of a runway extremity may show the runway designation of the concerned runway extremity only.

← Runway 32R

Runway 14L →

Pattern "A" runway holding position marking.

C1

32R - 14L

32R - 14L

C1

ICAO 5.4.2.8 – A runway designation sign at a taxiway/runway intersection or a runway/runway intersection shall be located on each side of the runway-holding position marking facing the direction of approach to the runway.

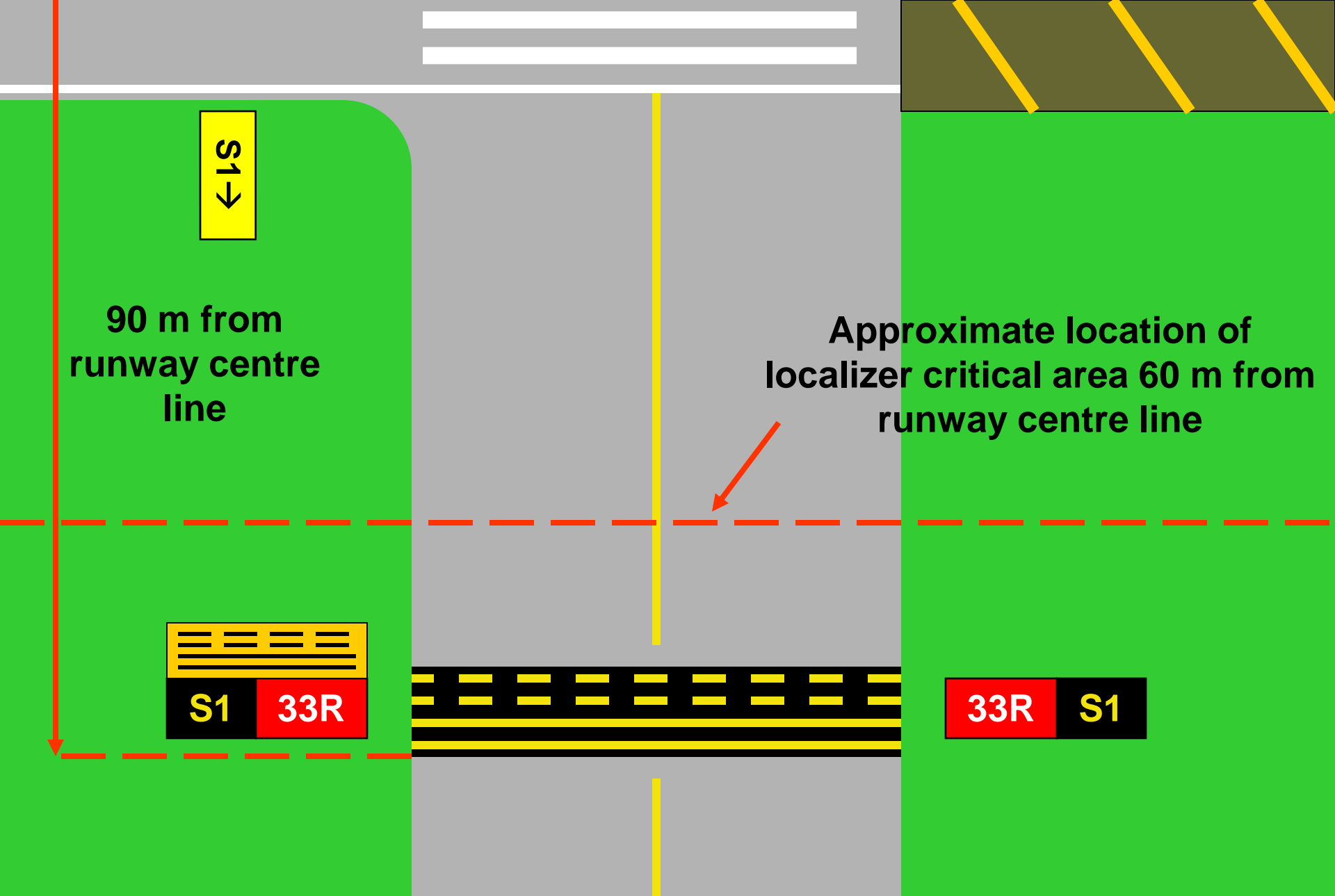

The runway designation sign installed at the runway extremity may only show the runway designation of the concerned runway extremity only.

ICAO 5.4.3.10 – A location sign shall be provided in conjunction with a runway designation sign, except at a runway/runway intersection.

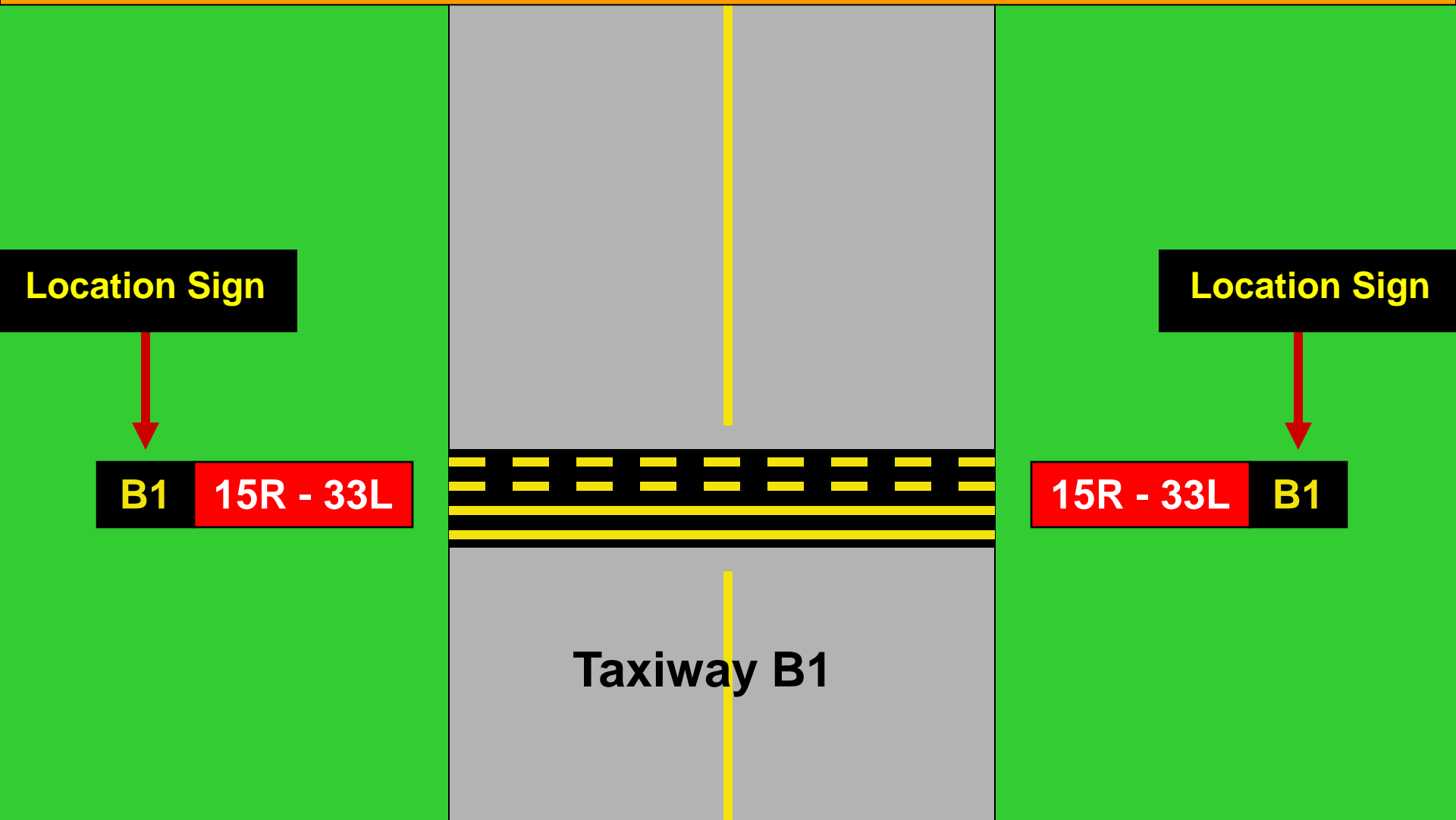

ICAO 5.4.3.21 – A taxiway location sign installed in conjunction with a runway designation sign shall be positioned outboard of the runway designation sign.

ICAO Table 3-2 (Top portion)

Table 3-2. **Minimum** distance from the runway centre line to a holding bay, runway-holding position or road-holding position

Type of runway	Code number			
	1	2	3	4
Non-instrument	30 m	40 m	75 m	75 m
Non-precision approach	40 m	40 m	75 m	75 m
Precision approach category I	60 m ^b	60 m ^b	90 m ^{a,b}	90 m ^{a,b,c}
Precision approach categories II and III	–	–	90 m ^{a,b}	90 m ^{a,b,c}
Take-off runway	30 m	40 m	75 m	75 m

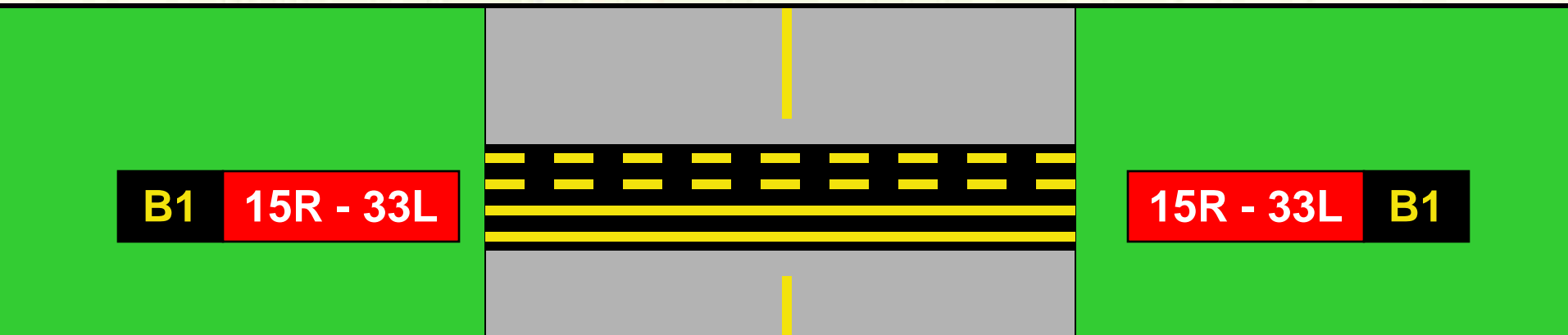

ICAO 3.12.6 – The distance between a runway-holding position established at a taxiway/runway intersection and the centre line of a runway shall be in accordance with Table 3-2 and, in the case of a precision approach runway, such that a holding aircraft or vehicle will not interfere with the operation of radio navigation aids.

ICAO Table 3-2

Table 3-2. Minimum distance from the runway centre line to a holding bay, runway-holding position or road-holding position

Type of runway	Code number			
	1	2	3	4
Non-instrument	30 m	40 m	75 m	75 m
Non-precision approach	40 m	40 m	75 m	75 m
Precision approach category I	60 m ^b	60 m ^b	90 m ^{a,b}	90 m ^{a,b,c}
Precision approach categories II and III	—	—	90 m ^{a,b}	90 m ^{a,b,c}
Take-off runway	30 m	40 m	75 m	75 m

- a. If a holding bay, runway-holding position or road-holding position is at a lower elevation compared to the threshold, the distance may be decreased 5 m for every metre the bay or holding position is lower than the threshold, contingent upon not infringing the inner transitional surface.
- b. This distance may need to be increased to avoid interference with radio navigation aids, particularly the glide path and localizer facilities. Information on critical and sensitive areas of ILS and MLS is contained in Annex 10, Volume I, Attachments C and G to Part I, respectively (see also 3.11.6).

Note 1.— The distance of 90 m for code number 3 or 4 is based on an aircraft with a tail height of 20 m, a distance from the nose to the highest part of the tail of 52.7 m and a nose height of 10 m holding at an angle of 45° or more with respect to the runway centre line, being clear of the obstacle free zone and not accountable for the calculation of OCA/H.

Note 2.— The distance of 60 m for code number 2 is based on an aircraft with a tail height of 8 m, a distance from the nose to the highest part of the tail of 24.6 m and a nose height of 5.2 m holding at an angle of 45° or more with respect to the runway centre line, being clear of the obstacle free zone.

- c. Where the code letter is F, this distance should be 107.5 m.

Note.— The distance of 107.5 m for code number 4 where the code letter is F is based on an aircraft with a tail height of 24 m, a distance from the nose to the highest part of the tail of 62.2 m and a nose height of 10 m holding at an angle of 45° or more with respect to the runway centre line, being clear of the obstacle free zone.

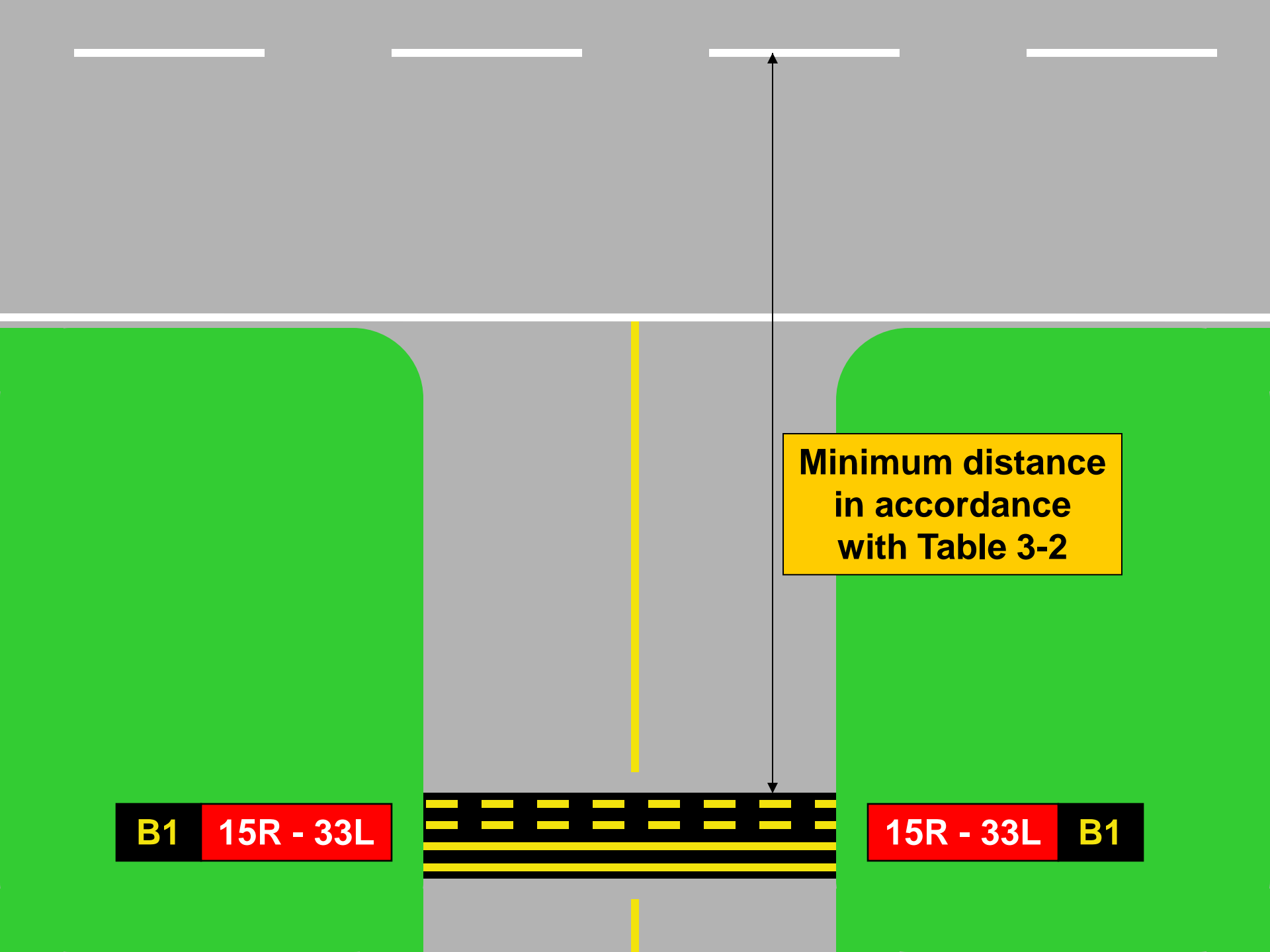

**Minimum distance
in accordance
with Table 3-2**

B1

15R - 33L

15R - 33L

B1

For Rapid Exit Taxiways, the minimum distance for locating the runway-holding position is measured perpendicular from the runway centre line to the nearest edge of the runway-holding position marking.

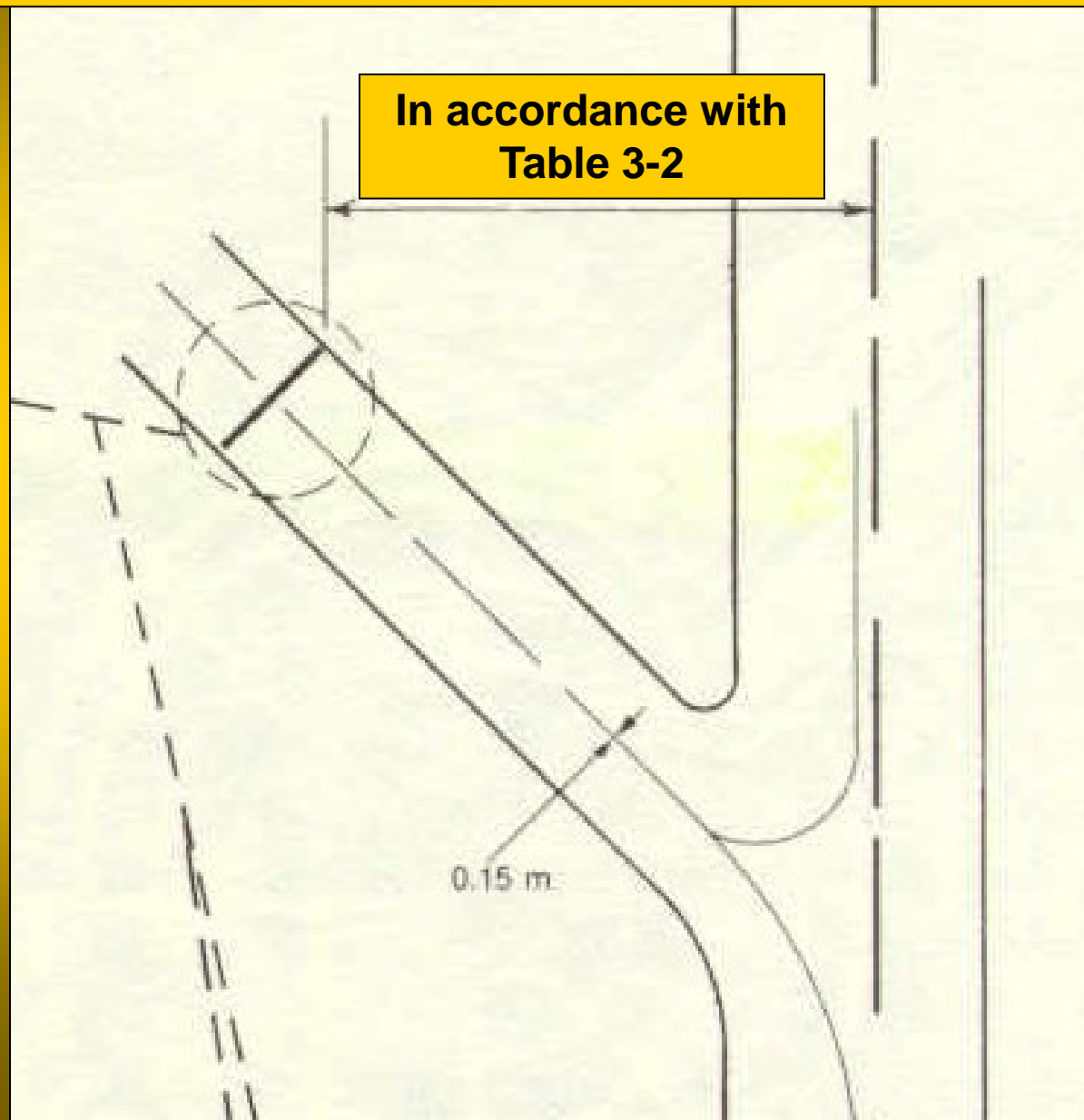

Mandatory Instruction Signs

•Runway Designation Signs at a runway/runway intersection

These signs identify runway intersections when a runway is part of a standard taxi-route.



ICAO 3.12.2 – A runway-holding position or positions shall be established:

b) at an intersection of a runway with another runway when the former runway is part of a standard taxi-route.

Mandatory Instruction Signs

- Runway Designation Signs at a runway/runway intersection



2nd runway
designation
sign

Where a runway is part of a standard taxi-route, a pattern “A” runway-holding position marking is installed along with runway designation signs on both sides of the runway.

This an example of a runway-holding position established on a runway where the runway is a standard taxi-route. Pilots must taxi on Runway 35 to take-off on Runway 30 because there is no direct taxiway access to Runway 30.

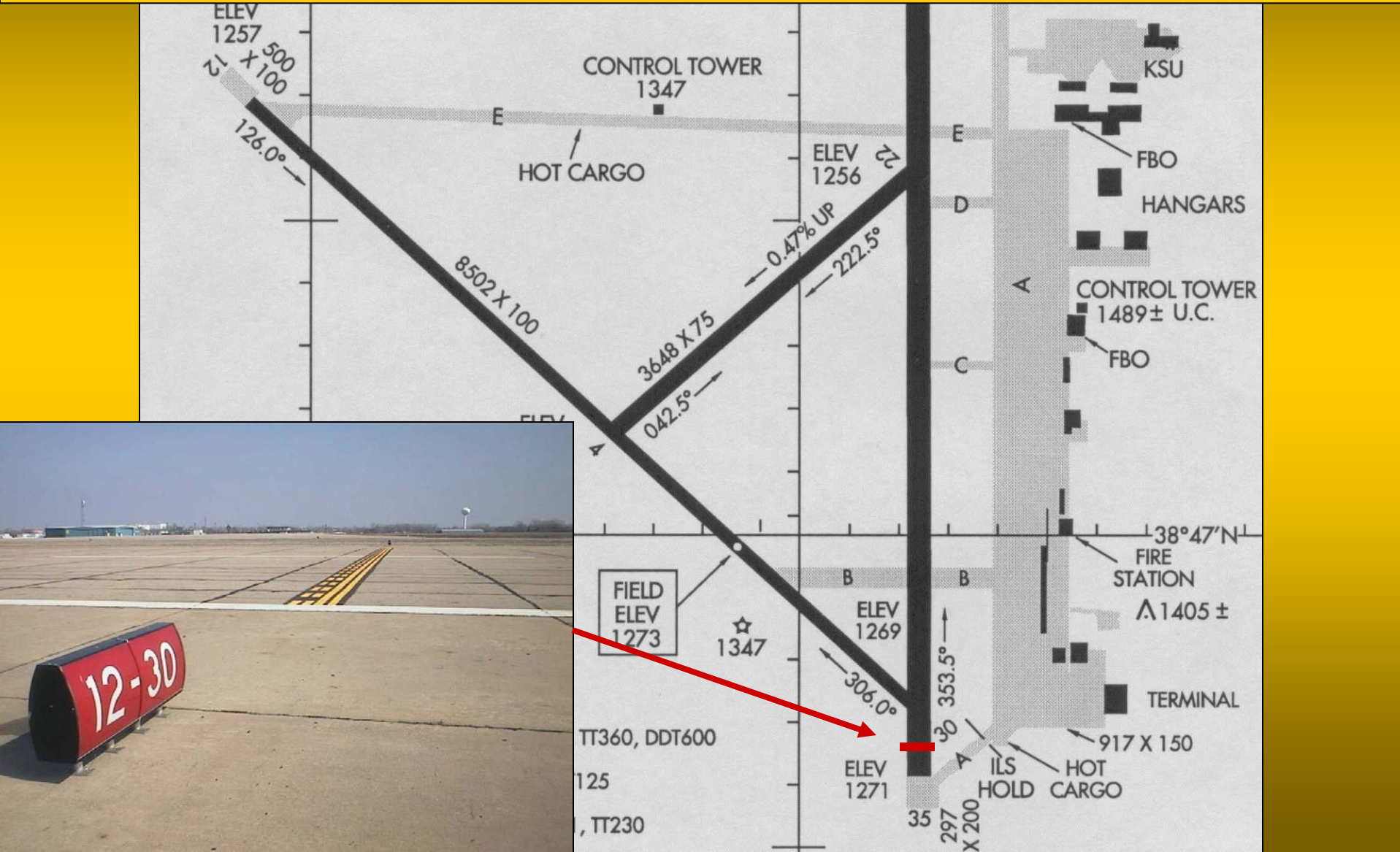

Mandatory Instruction Signs

•Runway Designation Signs at a runway/runway intersection

15R - 33L

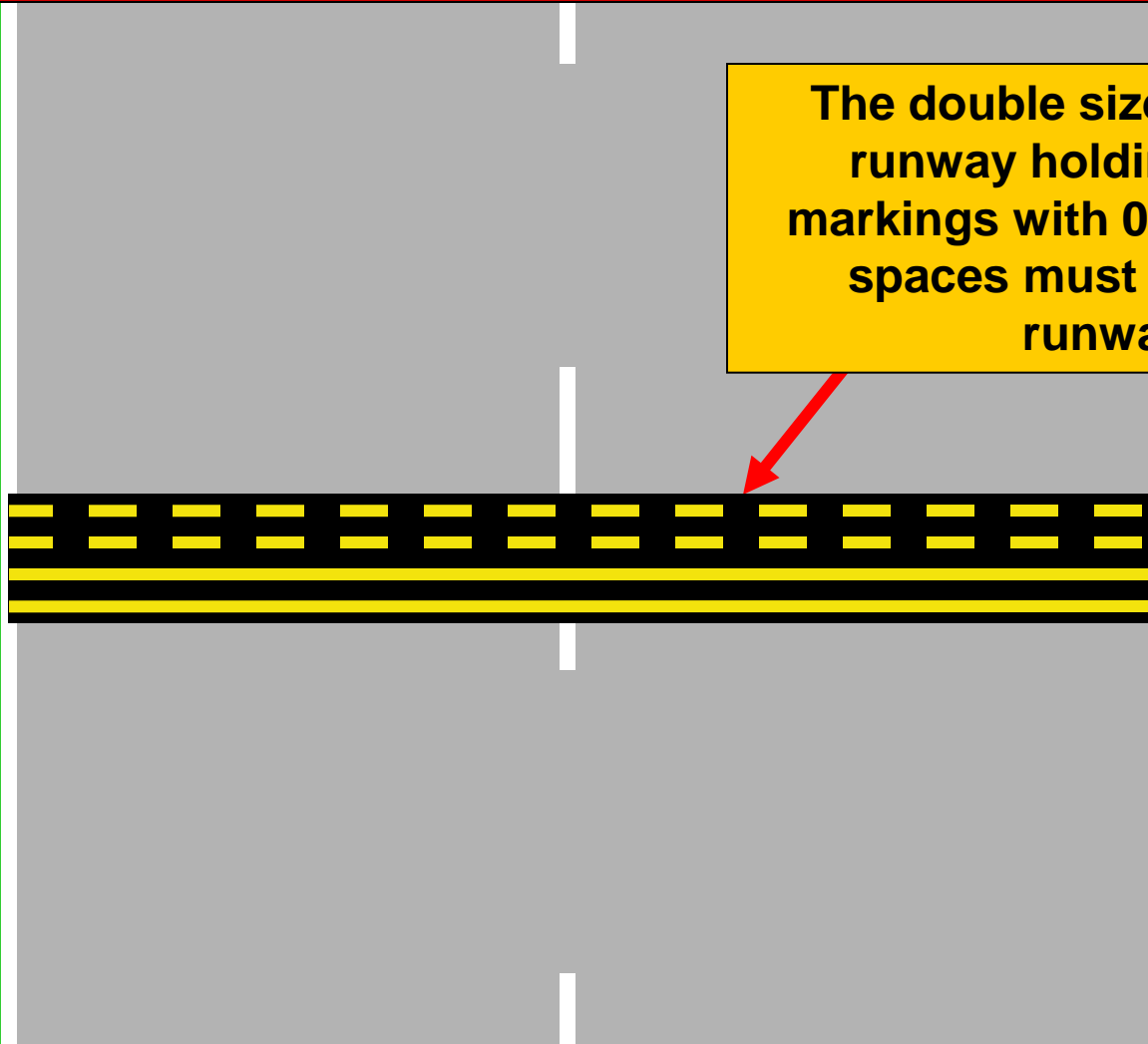

The double size Pattern "A" runway holding position markings with 0.3 m lines and spaces must be used on runways.

15R - 33L

Location signs are not included with runway designation signs at runway/runway intersections.

FAA Standard – Holding Position Signs

In the U.S., runway designation signs are called runway holding position signs.



FAA standards only require one holding position sign on the left side for typical intersections. Otherwise, FAA standards are similar to ICAO.

FAA Standard – Holding Position Signs



However, a 2nd runway holding position sign is required on the right side at intersections over 150 feet, converging intersections, where the holding position is close to the parallel taxiway and at complex intersections where there has been a history of pilots failing to hold.

Mandatory Instruction Signs

•Category I, II, III Signs

These signs identify holding positions for ILS critical areas.



33L CAT III

ICAO 5.4.2.14 – The inscription on a category I, II, III or joint II/III holding position sign shall consist of the runway designator followed by CAT I, CAT II, CAT III or CAT II/III, as appropriate.

Example of a runway-holding position and CAT III critical area holding position at the takeoff end.

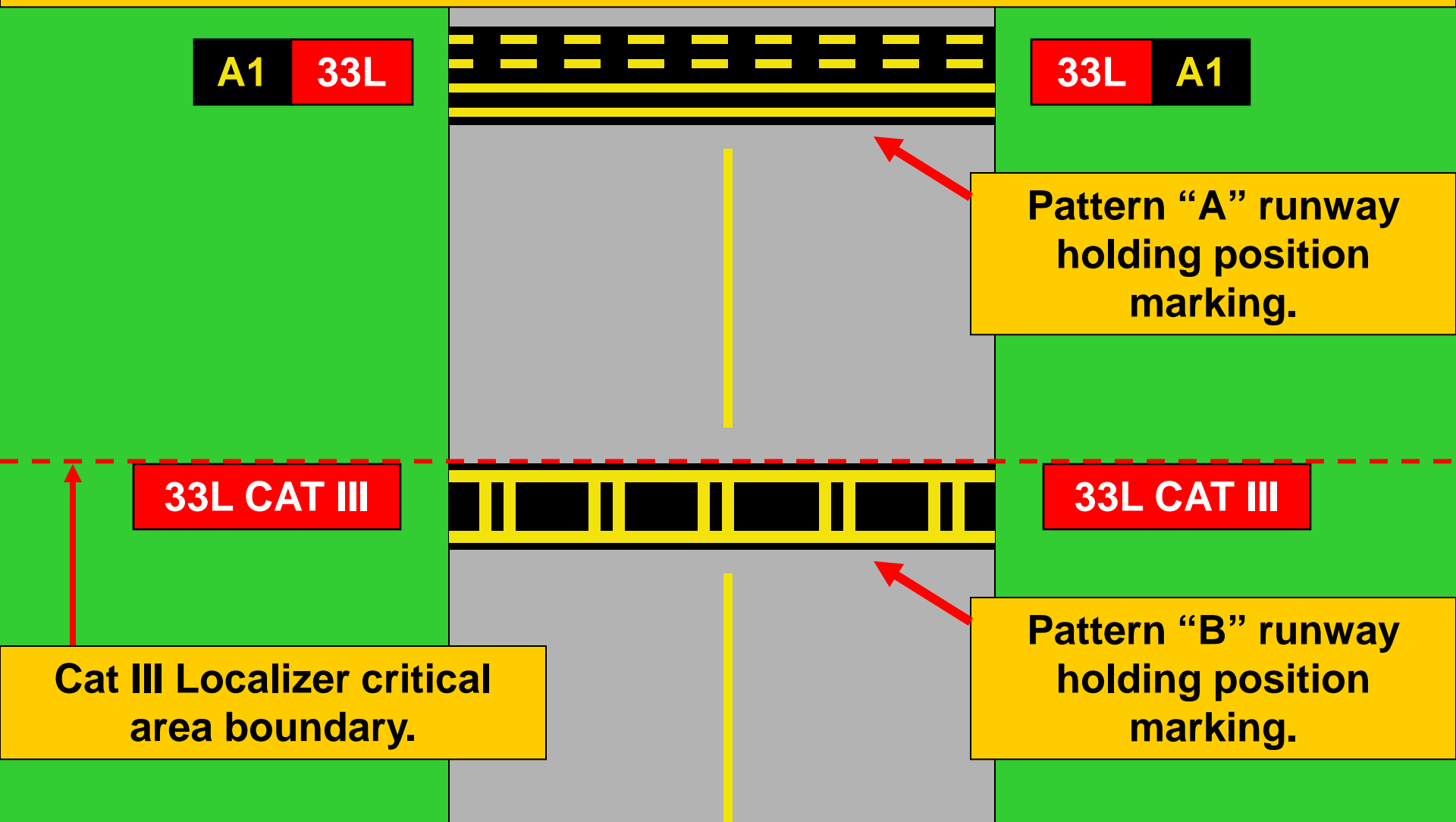

Pattern "A" runway holding position marking.

Pattern "B" runway holding position marking.

Cat III Localizer critical area boundary.

ICAO 5.4.2.9 – A category I, II, or III holding position sign shall be located on each side of the runway-holding position marking facing the direction of the approach to the critical area.

Example of an ILS critical area for a Localizer

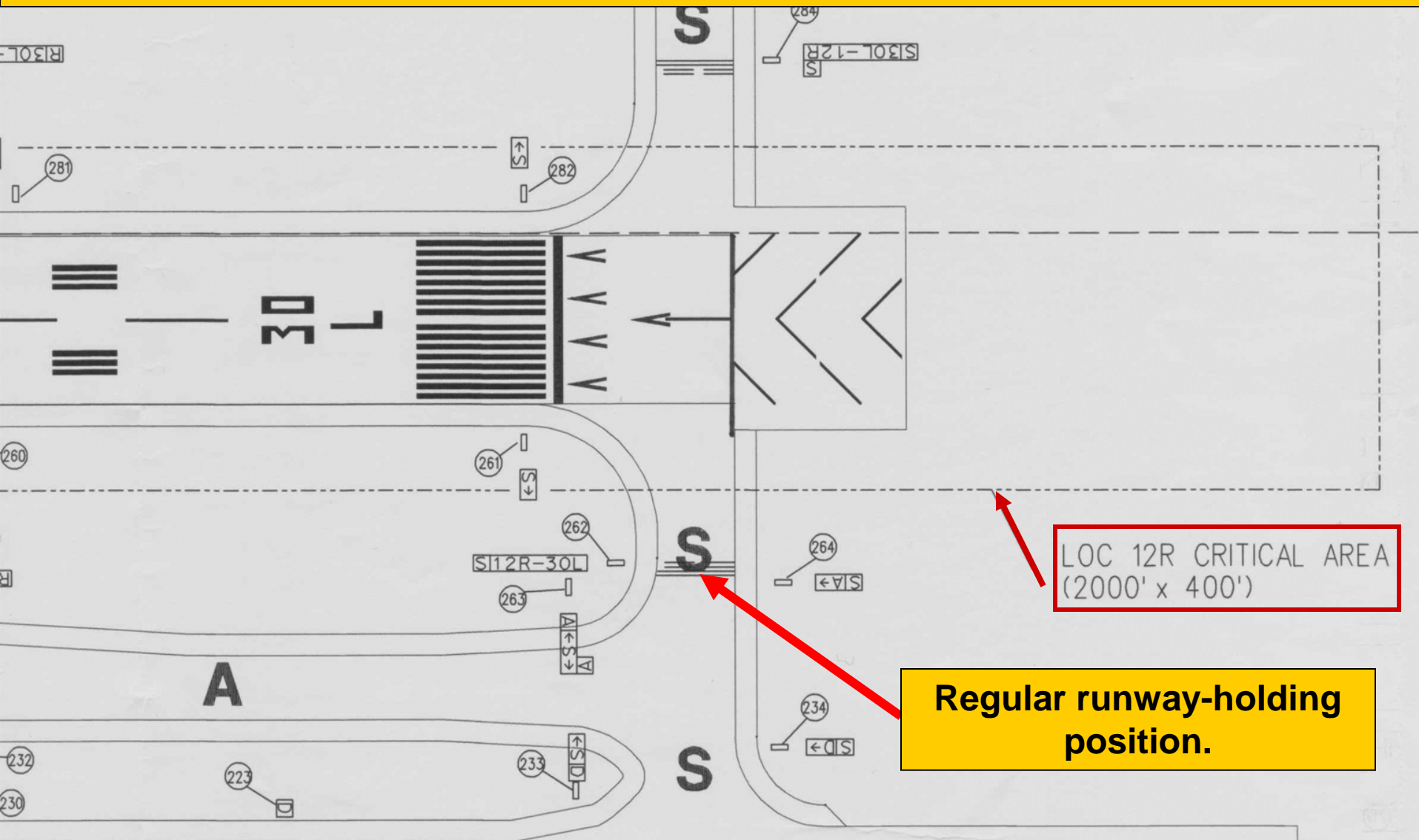

Regular runway-holding position.

LOC 12R CRITICAL AREA
(2000' x 400')

The typical localizer critical area extends 60 m from the runway centre line and is normally protected by the runway-holding position. An ILS holding position is usually not necessary for a localizer critical area.

Example of an ILS critical area for a Glide Slope



ILS Glide Slope

When a glide slope is located between the runway and parallel taxiway, an ILS critical area holding position is normally needed.

Example of an ILS critical area for a Glide Slope

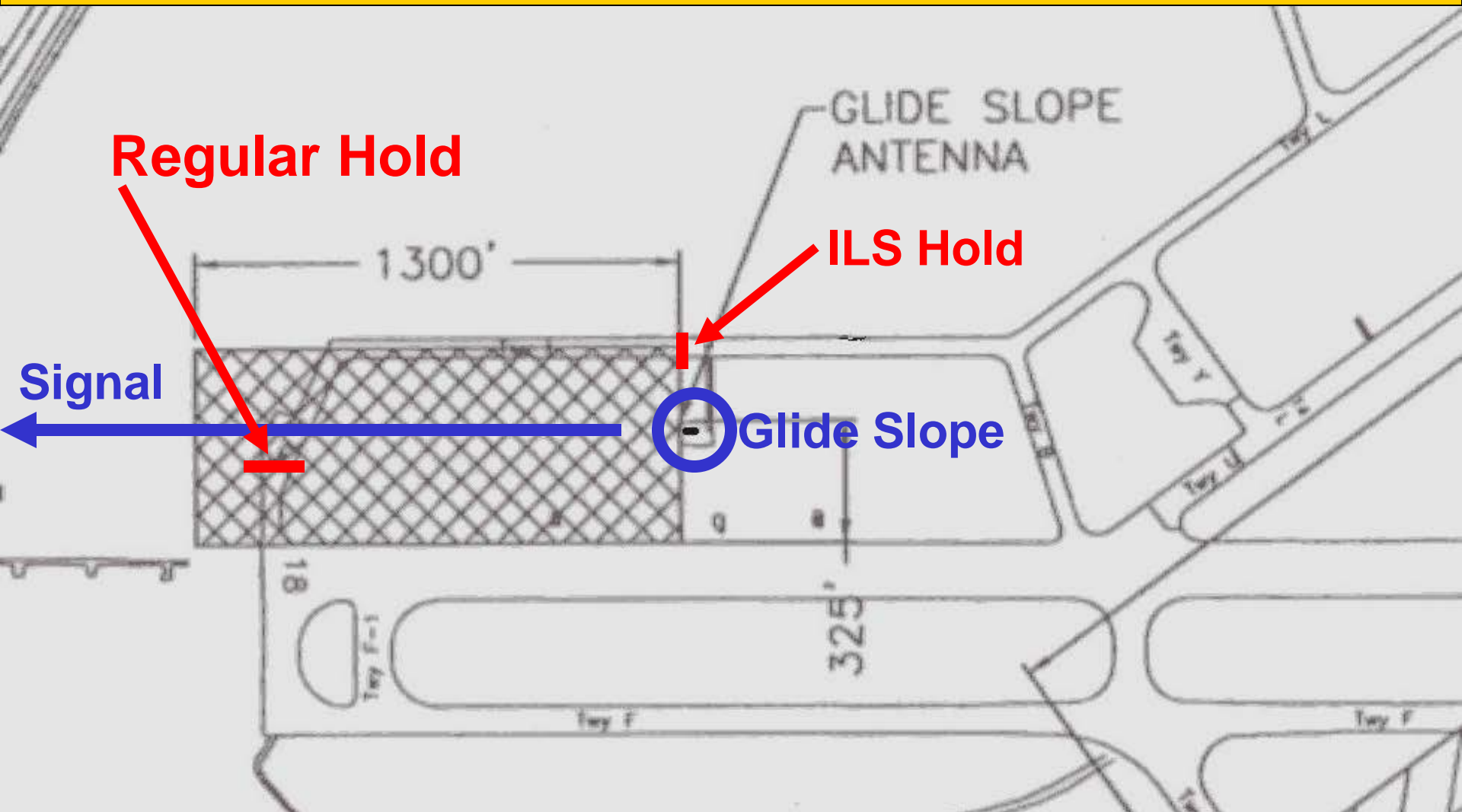

The glide slope is normally located on the opposite side of the runway from the parallel taxiway. However, if there is a parallel taxiway on both sides of the runway, the glide slope must be located between the runway and parallel taxiway.

Example of an ILS critical area for a Glide Slope

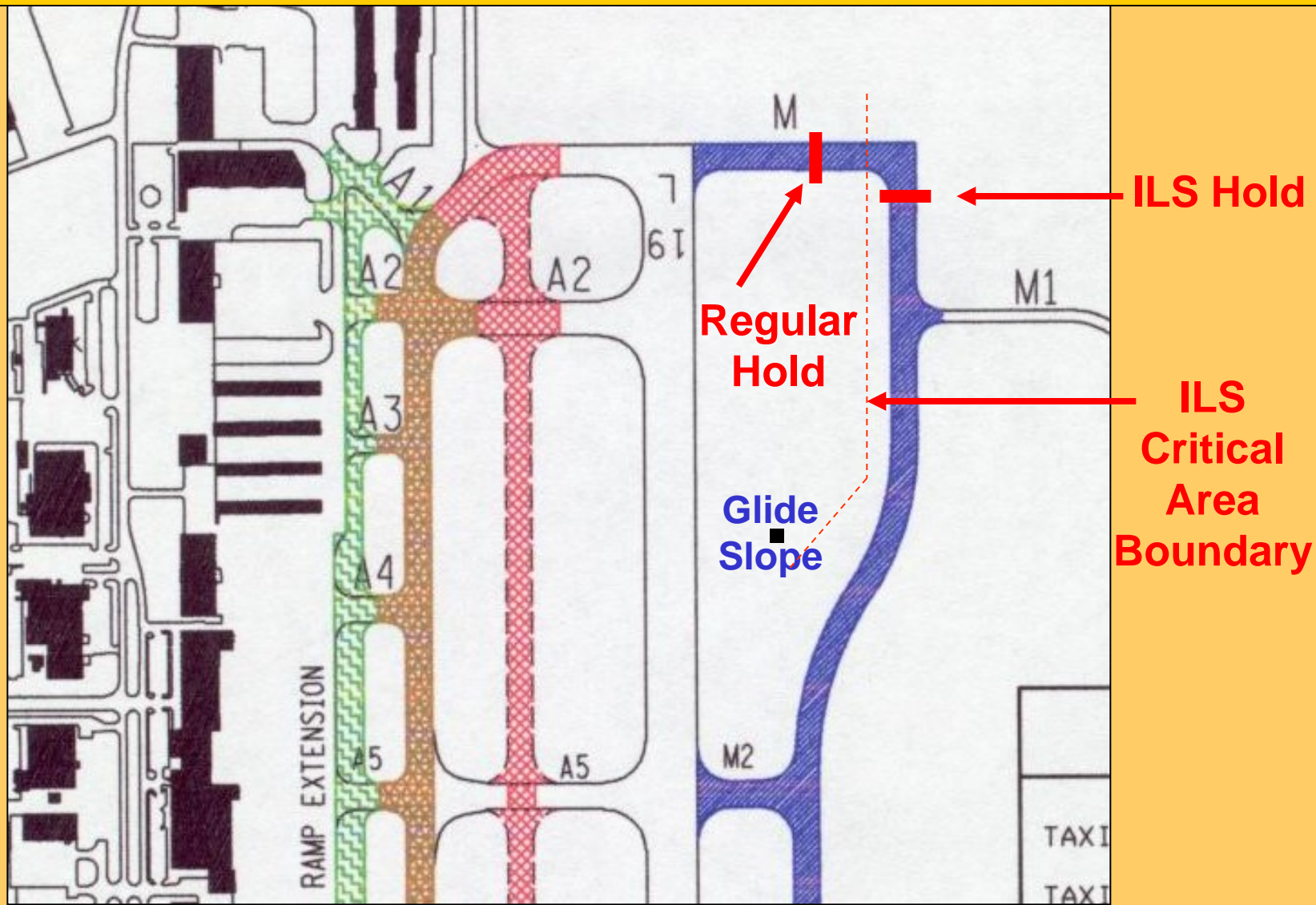

Where a taxiway curves out around the Glide Slope, the ILS hold may be located just prior to the taxiway corner for better visibility to approaching pilots.

FAA Standard – ILS Holding Position Signs



FAA ILS critical area signs state “ILS” rather than “CAT I, II or III”.

Mandatory Instruction Signs

•Runway-Holding Position Signs

These signs identify a holding position on a taxiway for a runway approach or ILS critical area for a runway where the taxiway is not connected to the runway.



ICAO 5.4.2.16 – The inscription on a runway-holding position sign at a runway-holding position established in accordance with 3.12.3 shall consist of the taxiway designation and a number.

Mandatory Instruction Signs

•Runway-Holding Position Signs



Example of a runway-holding position sign on Taxiway W.

ICAO 5.4.2.11 – A runway-holding position sign shall be located on each side of the runway-holding position establish in accordance with 3.12.3, facing the approach to the obstacle limitation surface or ILS/MLS critical/sensitive area, as appropriate.

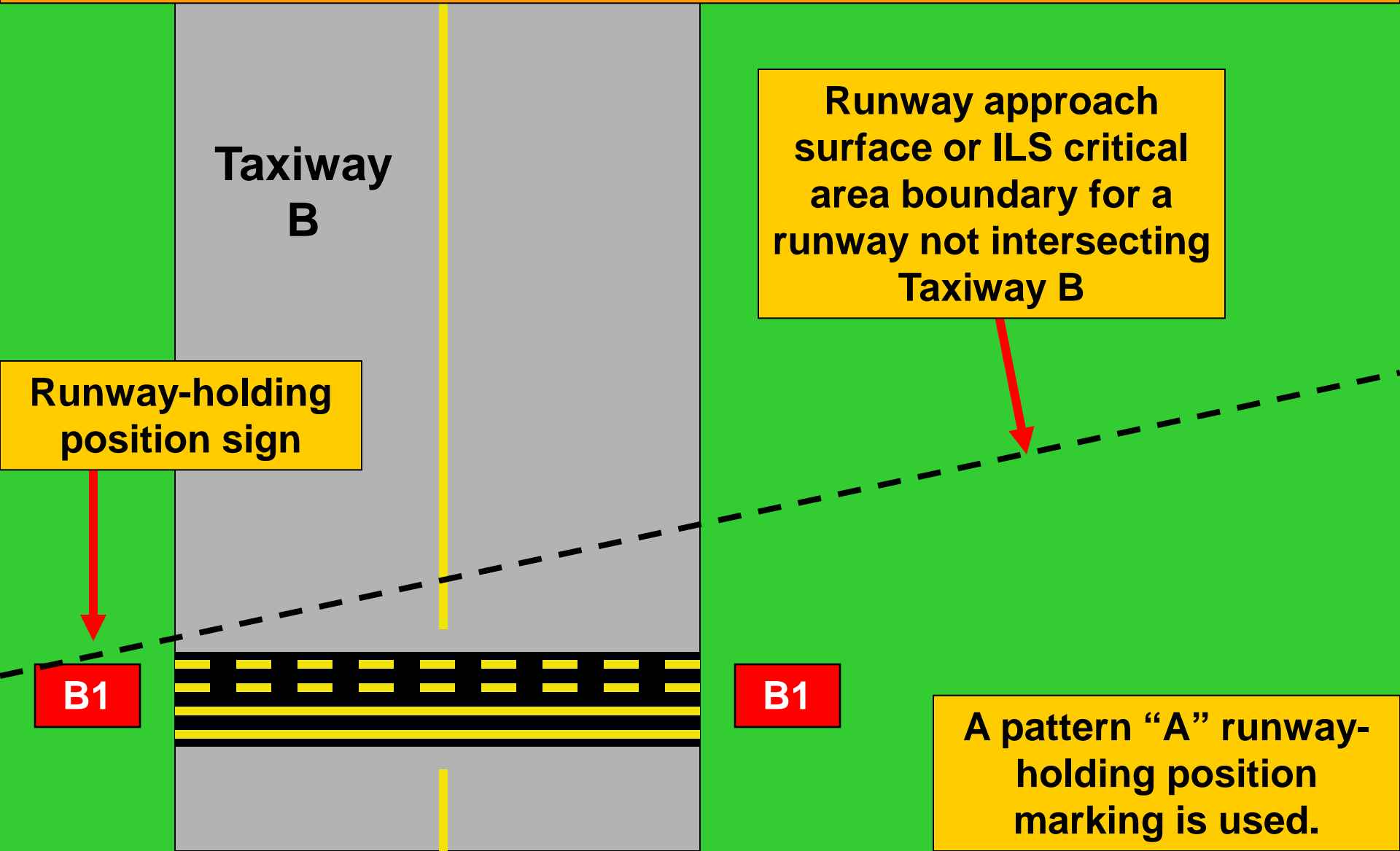

•Runway-Holding Position Signs

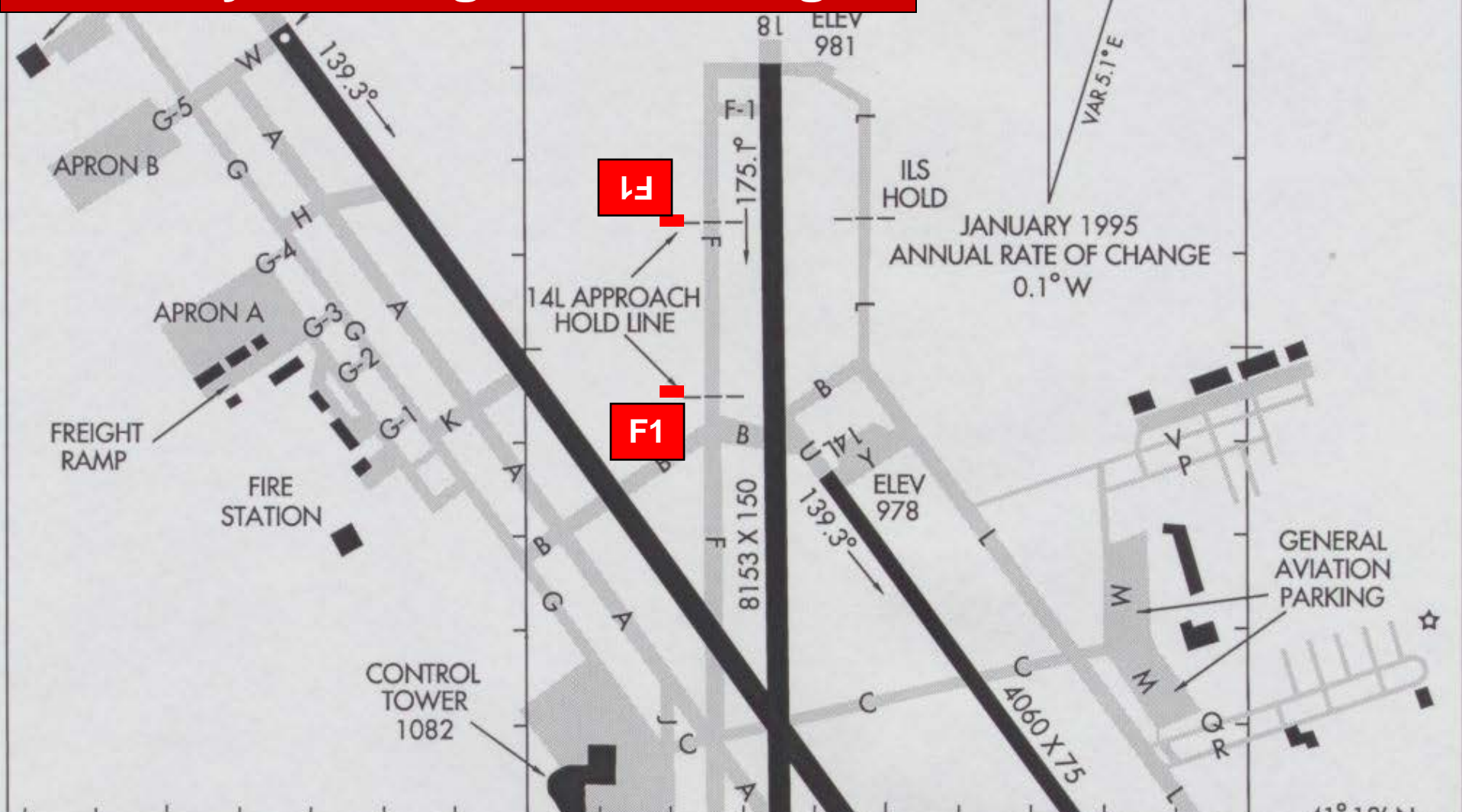

ICAO 3.12.3 – A runway-holding position shall be established on a taxiway if the location or alignment of the taxiway is such that a taxiing aircraft or vehicle can infringe an obstacle limitation surface or interfere with the operation of radio navigation aids.

FAA Standard - Runway Approach Hold Sign



Approach holding position signs are used in the U.S. to protect the approach surface to a runway.

FAA Standard - Runway Approach Hold Sign

ICAO sign to protect a
runway approach surface

F1



Mandatory Instruction Signs

•No Entry Signs

These signs identify areas where entry is prohibited. Usually used on service roads and closed taxiways.



ICAO 5.4.2.7 – A NO ENTRY sign shall be provided when entry into an area is prohibited.

ICAO 5.4.2.10 – A NO ENTRY sign shall be located at the beginning of the area to which entrance is prohibited on each side of the taxiway as viewed by the pilot.

Mandatory Instruction Signs

•No Entry Signs

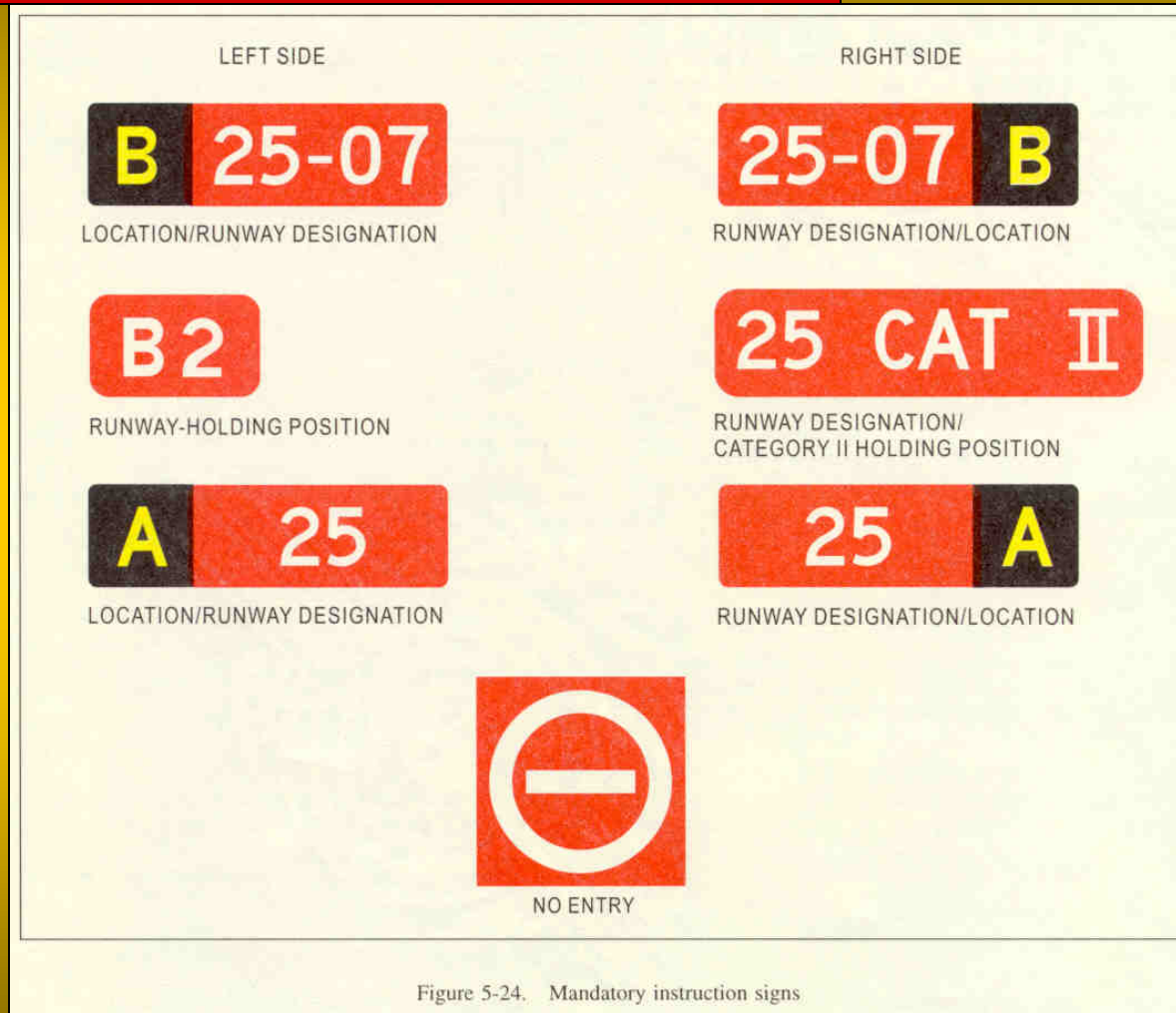

ICAO 5.4.2.15 – The inscription on a NO ENTRY sign shall be in accordance with Figure 5-28.

Mandatory Instruction Signs

•No Entry Signs

A yellow cross is also used to mark the closed pavement, or a service road as in this case.



Mandatory Instruction Signs

•No Entry Signs

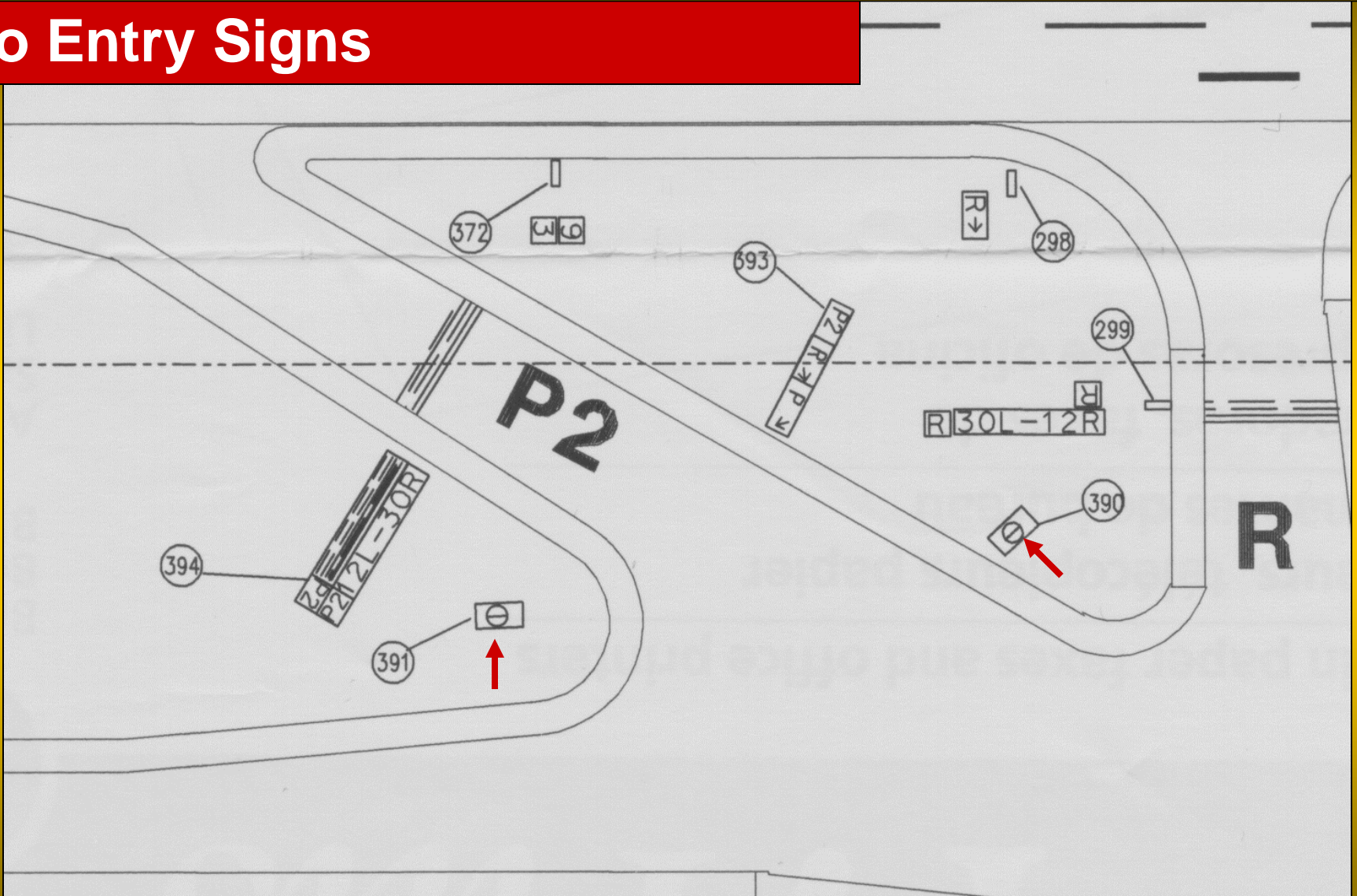

No Entry signs may also be installed at the entrance to a one-way taxiway, such as a rapid exit taxiway.

Mandatory Instruction Signs

•No Entry Signs

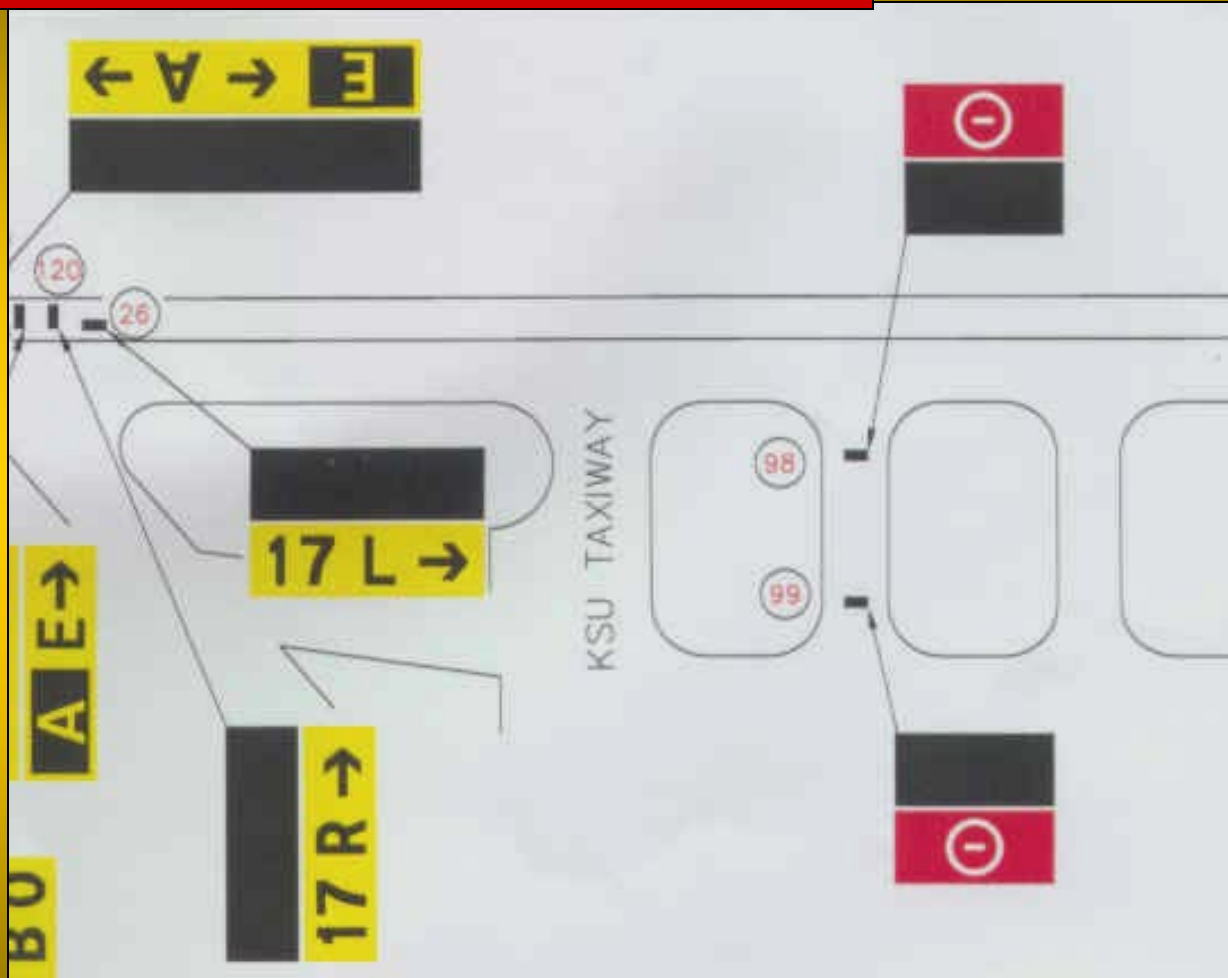

Another option to consider is installing a NO ENTRY sign in the middle of the entrance to a closed area. The NO ENTRY sign serves as a barricade in this situation. ICAO standards do not address this situation.

FAA Standard – NO ENTRY Sign



FAA standards for No Entry signs are similar to ICAO.

Mandatory Instruction Marking



ICAO 5.2.16.1 – Where it is impracticable to install a mandatory instruction sign in accordance with 5.4.2.1, a mandatory instruction marking shall be provided on the surface of the pavement.

Mandatory Instruction Marking



A mandatory instruction marking is installed at this location because the intersection configuration does not allow for a runway designation sign to be installed on the left side of the runway-holding position.

Mandatory Instruction Marking

ICAO 5.2.16.2 Recommendation. – *Where operationally required, such as on taxiways exceeding 60 m in width, a mandatory instruction sign should be supplemented by a mandatory instruction marking.*

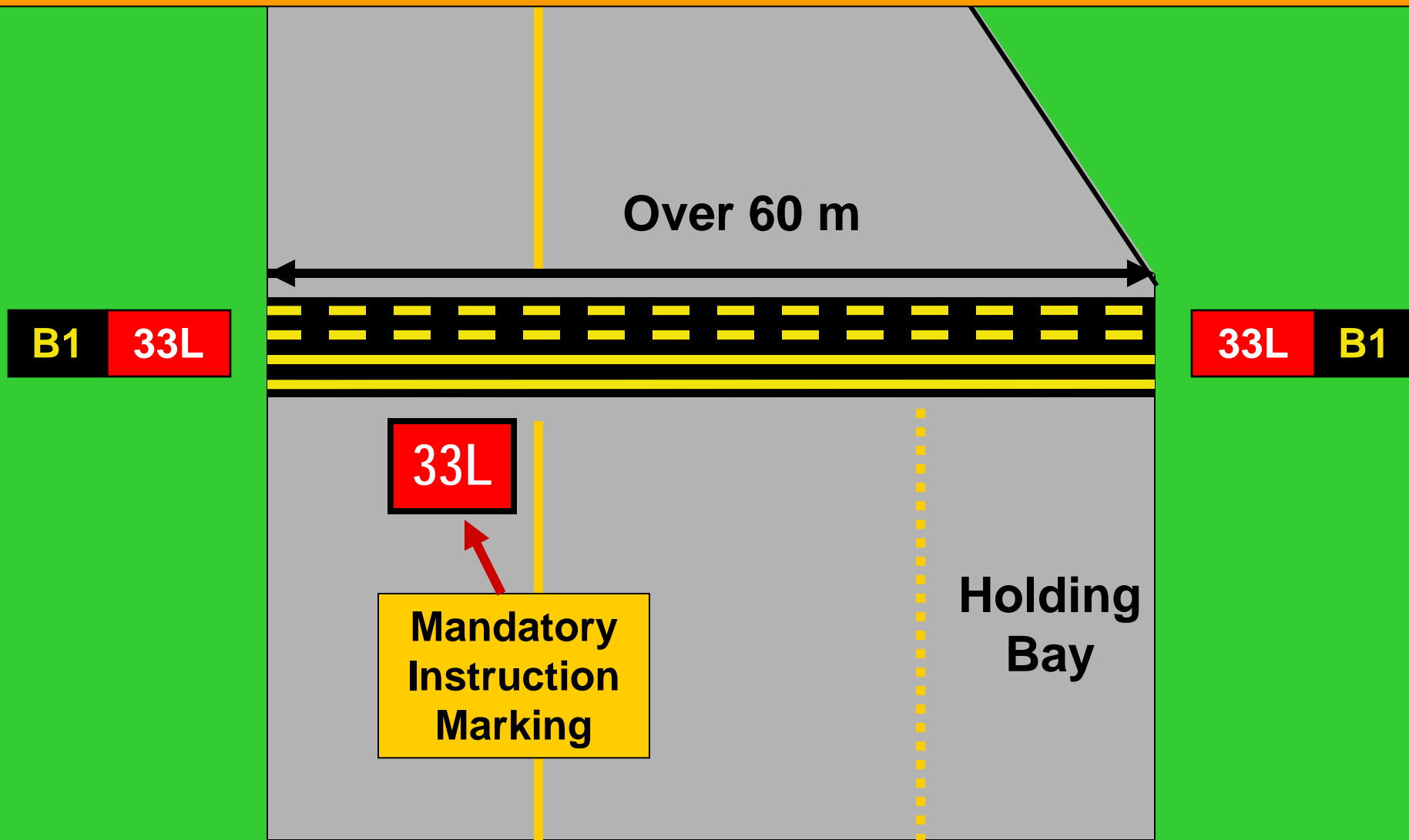

Mandatory Instruction Marking

ICAO 5.2.16.3 – The mandatory instruction marking shall be located on the left-hand side of the taxiway centre line marking and on the holding side of the runway-holding position marking as shown in Figure 5-9. The distance between the nearest edge of the marking and the runway-holding position marking or the taxiway centre line marking shall be not less than 1 m.



Figure 5-9. Mandatory Instruction Marking

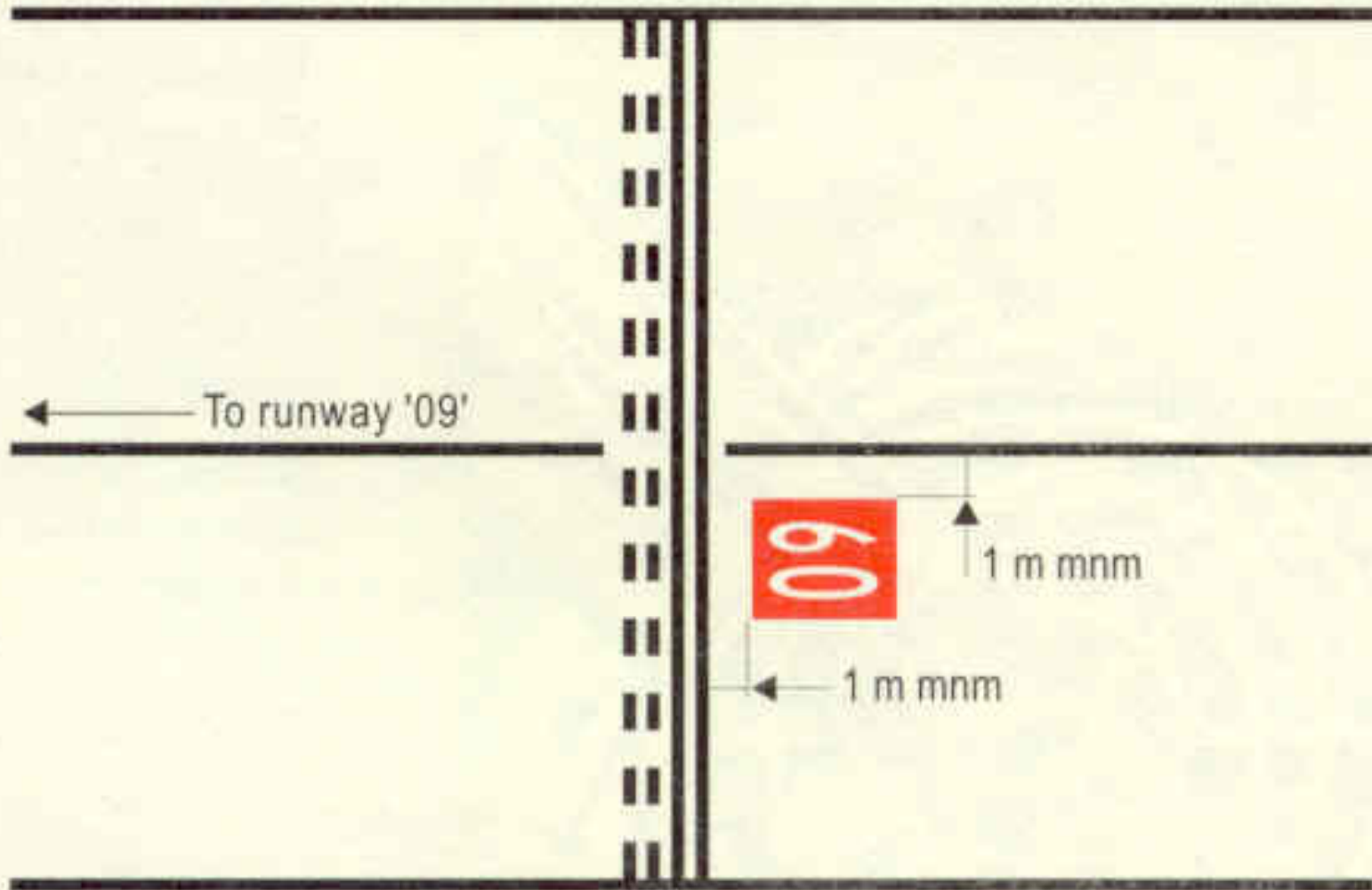

Figure 5-9. Mandatory instruction marking

Mandatory Instruction Marking

ICAO 5.2.16.4 Recommendation. – *Except where operationally required, a mandatory instruction marking should not be located on a runway.*



This is an example of “operationally required”. A mandatory instruction marking is installed at this runway location because the runway is a designated taxi route to the takeoff end of Runway 12L, and there has been a history of pilots failing to hold short of 12L at this location. The problems of pilots failing to hold short at this location have not occurred after this mandatory instruction marking was installed.

Mandatory Instruction Marking

ICAO 5.2.16.5 – A mandatory instruction marking shall consist of an inscription in white on a red background. Except for a NO ENTRY marking, the inscription shall provide information identical to that of the associated mandatory instruction sign.

Note: ICAO 5.2.16.5 states that “for a NO ENTRY marking, the inscription shall provide information identical to that of the associated mandatory instruction sign.” This conflicts with ICAO 5.2.16.6. (See next slide)



NO ENTRY

Figure 5-24. Mandatory instruction signs

Mandatory Instruction Marking



ICAO 5.2.16.6 – A NO ENTRY marking shall consist of an inscription in white reading NO ENTRY on a red background.

Mandatory Instruction Marking

ICAO 5.2.16.7 – Where there is insufficient contrast between the marking and the pavement surface, the mandatory instruction marking shall include an appropriate border, preferably white or black.



A white border would be used on new asphalt pavement.

Mandatory Instruction Marking

ICAO 5.2.15.8 Recommendation. – *The character height should be 4 m. The inscription should be in the form and proportions shown in Appendix 3.*

Annex 14 — Aerodromes

Volume I



ICAO Annex 14, Appendix 3

Mandatory Instruction Marking

ICAO 5.2.16.9 Recommendation. – *The background should be rectangular and extend a minimum of 0.5 m laterally and vertically beyond the extremities of the inscription.*



FAA Standard – Surface Painted Holding Position Sign

In the U.S. these markings are called surface painted holding position signs.



This is an example of a mandatory instruction marking installed on a wide taxiway at a U.S. airport. Mandatory instruction markings at U.S. airports are commonly used at “problem” intersections where there has been a history of pilots failing to hold short of a runway. Mandatory instruction markings enhance the visibility of the runway-holding position and are an excellent runway incursion prevention measure.

Review of Mandatory Instruction Signs

What type of mandatory instruction sign is shown in this photo?

Answer: Runway designation sign on a taxiway.



What type of mandatory instruction sign is shown in this photo?

Answer: Runway designation sign on a runway.



Which side of the taxiway is this runway designation sign located?

Answer: Right side. Location signs are installed outboard of the runway designation sign.



12R-30L

B1

A ILS CAT I

B 12L-30R

C 33L CAT III

D B1 12L-30R

E B2

F A

Answer: "C". The "33L CAT III" mandatory instruction sign is installed with a Pattern "B" runway-holding position marking.

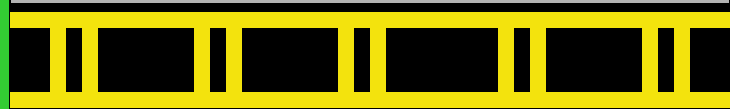

Which mandatory instruction sign is appropriate for this holding position marking? A-B-C-D-E or F?

The minimum set back distance for the runway-holding position marking is measured from the runway edge. True or False?

Answer: False. The minimum distance for the runway-holding position marking is measured from the runway centre line.

B1 **15R - 33L**

15R - 33L **B1**

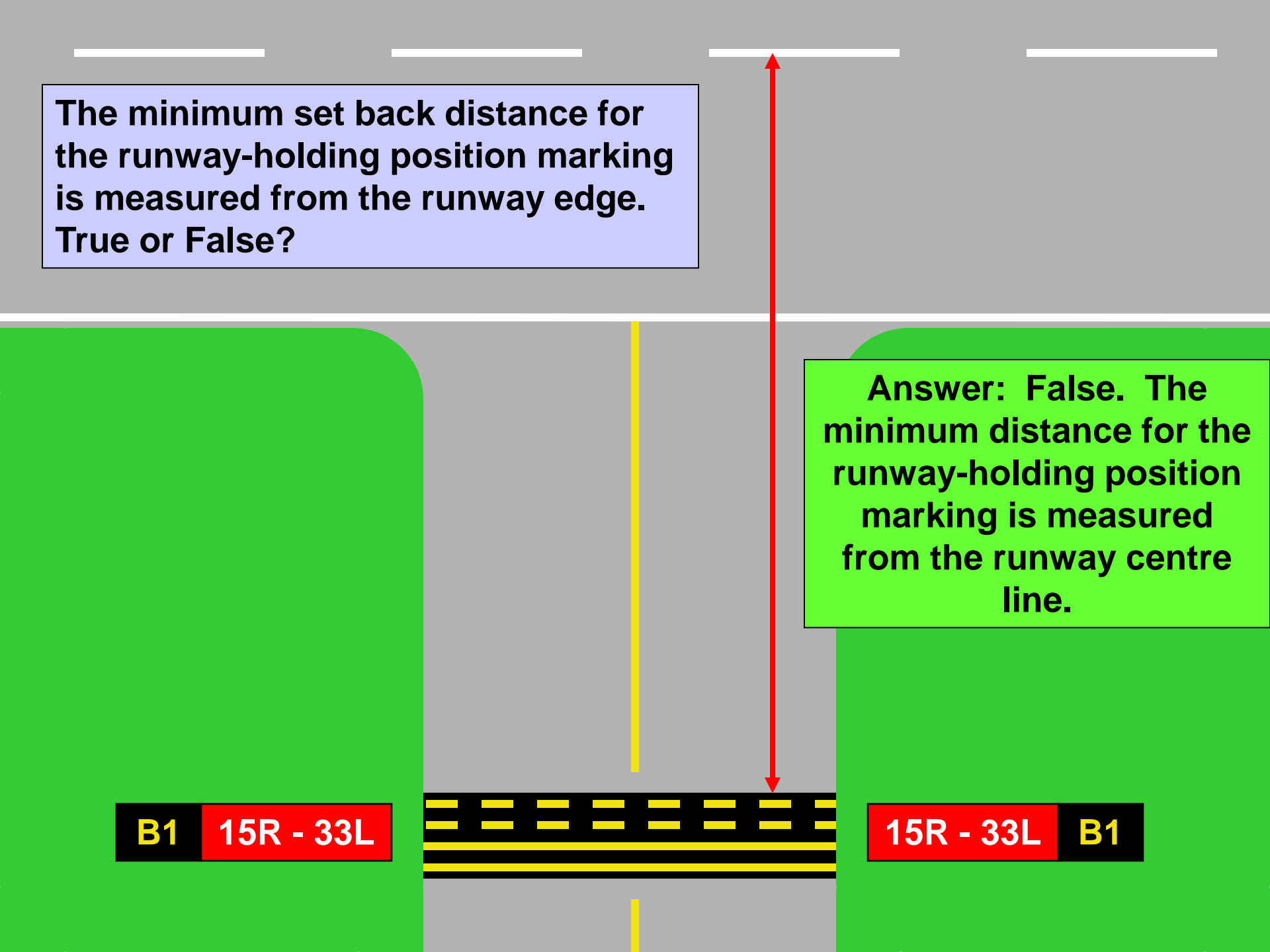

What type of mandatory instruction sign is this sign?



Answer: Runway–Holding Position Sign.

These signs are used to identify a runway-holding position on a taxiway for a runway approach or an ILS critical area for a runway that is not physically connected with the taxiway.

Does the “NO ENTRY” sign apply to vehicles?



Answer: No. The No Entry signs are often installed at the entrance to a service road to prevent pilots from taxiing on the service road.

Is this runway designation sign correct?

Answer: No. There is no such runway as 37.



Road-Holding Positions



Road-holding positions need to be established on any service road that enters a runway strip or runway end safety area to prevent vehicles from inadvertently entering an active runway without ATC clearance.

Road-Holding Positions



ICAO 3.12.5 – A road-holding position shall be established at an intersection of a road with a runway.

ICAO 5.2.15.1 – A road-holding position marking shall be provided at all road entrances to a runway.

Road-Holding Positions



A road-holding position marking would not be expected on a non-paved road.

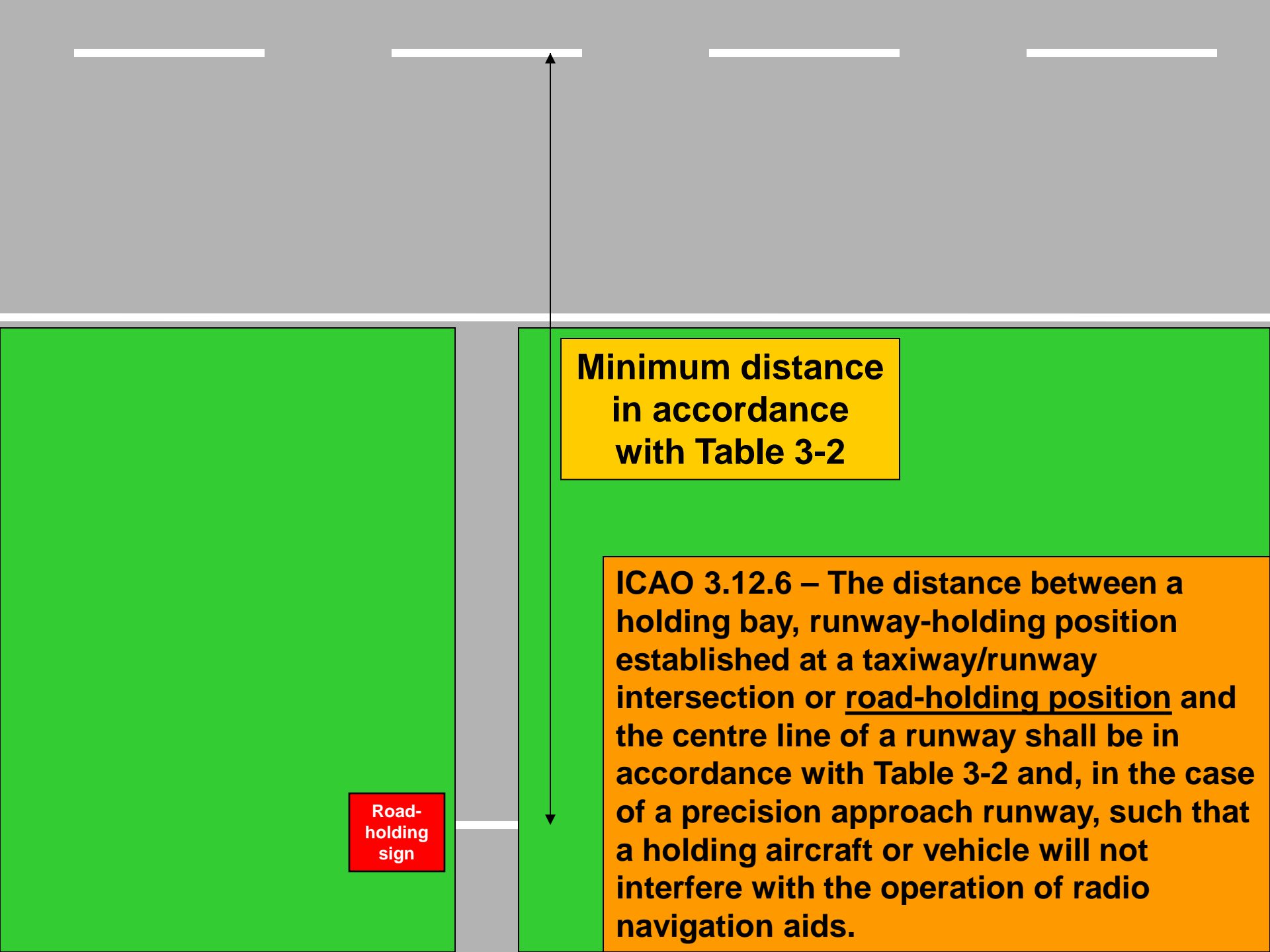

**Minimum distance
in accordance
with Table 3-2**

**Road-
holding
sign**

ICAO 3.12.6 – The distance between a holding bay, runway-holding position established at a taxiway/runway intersection or road-holding position and the centre line of a runway shall be in accordance with Table 3-2 and, in the case of a precision approach runway, such that a holding aircraft or vehicle will not interfere with the operation of radio navigation aids.

Road-Holding Positions

Localizer



A road-holding position is also needed where a serviced road enters an ILS critical area.

Road-Holding Positions



A road-holding position is needed 300 m off the ends of a runway where a road along the approach lights enters the runway end safety area.

Road-Holding Positions



A road-holding position would also be needed where a service road crosses through the runway end safety area.

Road-Holding Positions



A road-holding position should be established where a service road crosses a taxiway. The road holding position should be at least 60 m from the centre line of the taxiway where the code number is 3 or 4 to provide adequate wing tip clearance.

Road-Holding Positions

• Road-Holding Position Marking

ICAO 5.2.15.2 – A road-holding position marking shall be located across the road at the holding position.

FAA Standards: The FAA standards for a road-holding position marking is a two foot wide white bar.



ICAO 5.2.15.3 – A road-holding position marking shall be in accordance with the local road traffic regulations.

Road-Holding Positions

•Road-Holding Position Signs

ICAO 5.4.7.1 – A road-holding position sign shall be provided at all road entrances to a runway.



ICAO 5.4.7.2 – The road-holding position sign shall be located 1.5 m from one edge of the road (left or right as appropriate to local traffic regulations) at the holding position.

Road-Holding Positions

•Road-Holding Position Signs

ICAO 5.4.7.3 – A road-holding position sign shall consist of an inscription in white on a red background.

ICAO 5.4.7.4 – The inscription on a road-holding position sign shall be in the national language, be in conformity with the local traffic regulations and include the following:

- a) a requirement to stop; and**
- b) where appropriate:**
 - 1) a requirement to obtain ATC clearance; and**
 - 2) location designator.**

ICAO 5.4.7.5 – A road-holding position sign intended for night use shall be retroreflective or illuminated.

Road-Holding Positions

•Road-Holding Position Signs



Examples of road-holding signs used in the U.S.

FAA Standard – Road Holding Positions



In the U.S., not all road-holding positions require ATC clearance to proceed. At many major airports, ATC is too busy to handle clearance for ground vehicles to cross runway end safety areas. Airport ground vehicle procedures at these airports require vehicle operators to stop and check for aircraft using the runway before proceeding.

FAA Standard – Road Holding Positions



The FAA strongly encourages airport operators to construct service roads outside of runway safety areas if at all possible. Service roads in some situations are funded by the FAA to reduce runway crossings by vehicles at busy airports.

Road-Holding Positions

•Road-Holding Position Lights

ICAO 5.3.26.1 – A road-holding position light shall be provided at each road-holding position serving a runway when it is intended that the runway will be used in runway visual range conditions less than a value of 350 m.

ICAO 5.3.26.2 Recommendation. – A road-holding position light should be provided at each road-holding position serving a runway when it is intended that the runway will be used in runway visual range conditions of values between 350 m and 550 m.

ICAO 5.3.26.3 – A road-holding position light shall be located adjacent to the holding position marking 1.5 m (\pm 0.5 m) from one edge of the road, i.e. left or right as appropriate to the local traffic regulations.

Note. – See 9.9 for mass and height limitations and frangibility requirements of navigational aids located on runway strips.

Road-Holding Positions

•Road-Holding Position Lights

ICAO 5.3.26.4 – The road-holding position light shall comprise:

- a) a controllable red (stop)/green (go) traffic light; or**
- b) a flashing-red light.**

Note. – It is intended that the lights specified in sub-paragraph a) be controlled by the the air traffic services.

ICAO 5.3.26.5 – The road-holding position light beam shall be unidirectional and aligned so as to be visible to the driver of a vehicle approaching the holding position.

Road-Holding Positions

• Road-Holding Position Lights



Example of a road-holding position lights.

Road-Holding Positions

•Road-Holding Position Lights

ICAO 5.3.26.6 – The intensity of the light beam shall be adequate for the conditions of visibility and ambient light in which the use of the holding position is intended, but shall not dazzle the driver.

Note. – The commonly used traffic lights are likely to meet the requirements in 5.3.26.5 and 5.3.26.6.

ICAO 5.3.26.7 – The flash frequency of the flashing-red light shall be between 30 and 60 per minute.

FAA Requirements for Road-Holding Positions

Part 139 Requirements: In the U.S. the FAA does not have a specific requirement in 139.329 for road holding signs. The FAA requires airport operators to establish procedures for safe ground vehicle operations. Airport operators are strongly encouraged to have road-holding signs installed as part of their safe ground vehicle procedures.

FAA Standards: The FAA does not have standards for road-holding signs. The colors and size of the signs are at the discretion of the airport operator. However, most of the road-holding signs in the U.S. are red and white to match the mandatory instruction sign colors.

Road-Holding Lights: The FAA does not require road-holding position lights at SMGCS airports. However, if there was a problem with vehicle operators having difficulty observing a certain road-holding position during low visibility conditions, the FAA would recommend that road-holding position lights be installed.

**End of ICAO Standards for
Holding Position Markings
and Mandatory Instruction
Signs**