

AP2128

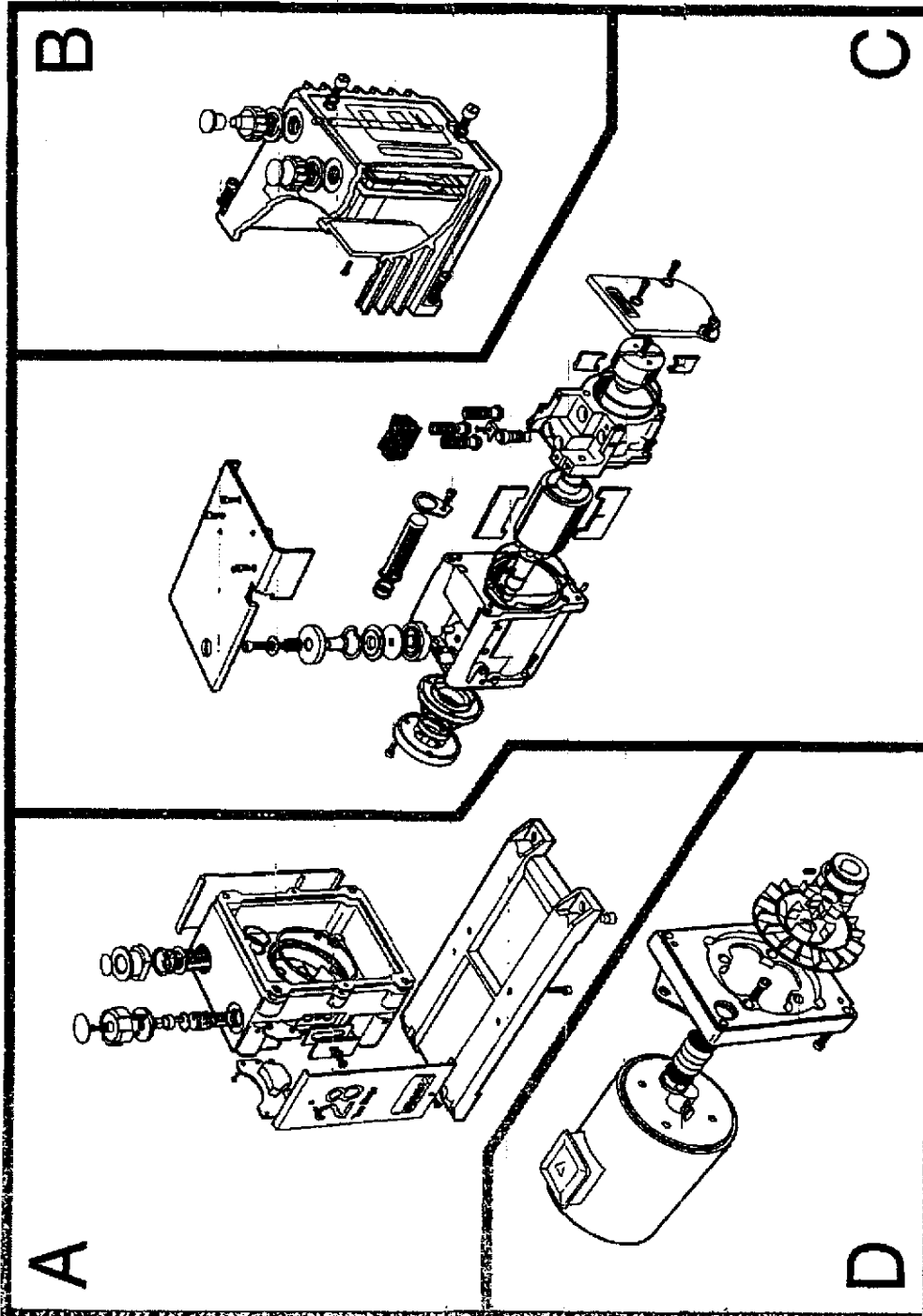

A. Adaptor sub-assembly  
B. Oil box sub-assembly  
C. High and low vacuum stator sub-assembly  
D. Motor and adaptor plate sub-assembly

Figure 1 - Major sub-assemblies

(A) Adaptor sub-assembly

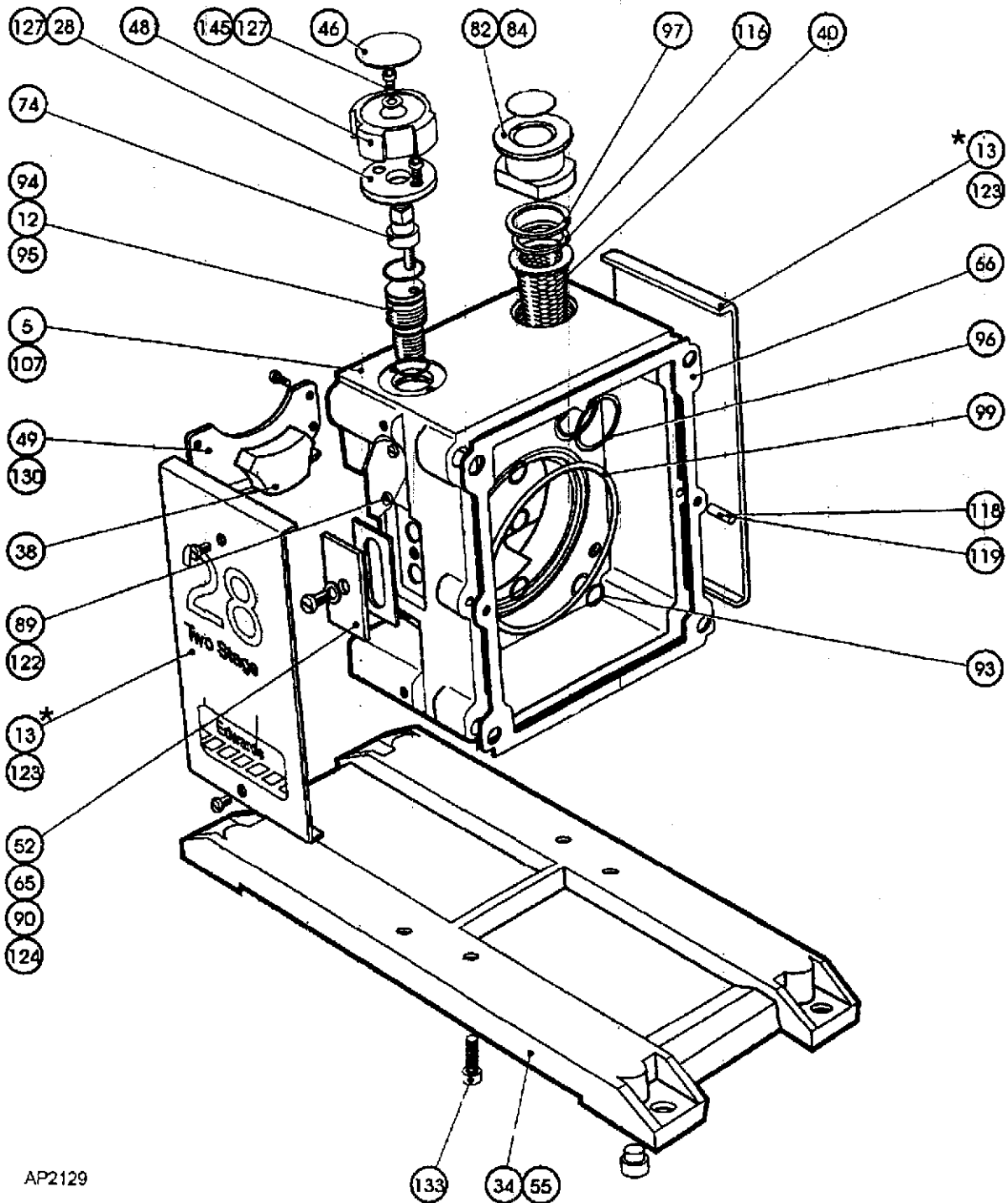

AP2129

\* See Table 2 for alternative side panels

Figure 2 - Adaptor sub-assembly

ITEM	DESCRIPTION	ITEM No	Qty	Kit No.(s)
5	Adaptor	A37301001	1	
12	Ballast piston	A37301010	1	
*13	Side panel(28) - 50Hz model	A37301011	2	
*13	Side panel(30) - 60Hz model	A37401011	2	
28	Bearing plate	A20514001	1	
34	Base plate	A20499026	1	
38	Felt pad	A22302017	1	
40	Inlet filter	A22305037	1	
46	Ballast insert	A25908034	1	
48	Ballast knob	A25908038	1	
49	Clamp plate	A25908041	1	
52	Blanking plate	A25942010	1	
55	Isolator rubber	A26501031	4	
65	Gasket		1	2
66	Oil box gasket		1	2
74	Ballast spindle	A34301023	1	
82	Adaptor NW25 x 1" BSP	C10501203	1	
84	Protective cover	D32201071	1	
89	Dowty seal		1	2
90	Dowty seal		1	2
93	'O' ring		4	2
94	'O' ring		1	2
95	'O' ring		1	2
96	'O' ring	H02120068	1	
97	'O' ring		1	2
99	'O' ring		1	2
107	Hollow taper pressure plug - 1/4" BSP	H03517003	1	
116	Circlip	212081133	1	
118	R. pin lgt dty. ms. nt. Ø5x16mm lg	212170132	2	
119	R. pin lgt dty. ss. Ø5x16mm lg.	212174132	2	
122	Ch sl screw, M5 x 8 (ms ni)		1	
123	Pan sl screw, M5 x 8 (ms ni)		4	
124	Pan sl screw, M8 x 20 (ms ni)		1	
127	Cap ht screw, M4 x 12 (nt)		3	
130	Cap ht screw, M5 x 10 (nt)		2	
133	Cap ht screw, M8 x 20 (nt)		4	
145	Washer, large M6 (ms ni)		1	

Table 3 Adaptor sub-assembly items

(B) Oil box sub-assembly

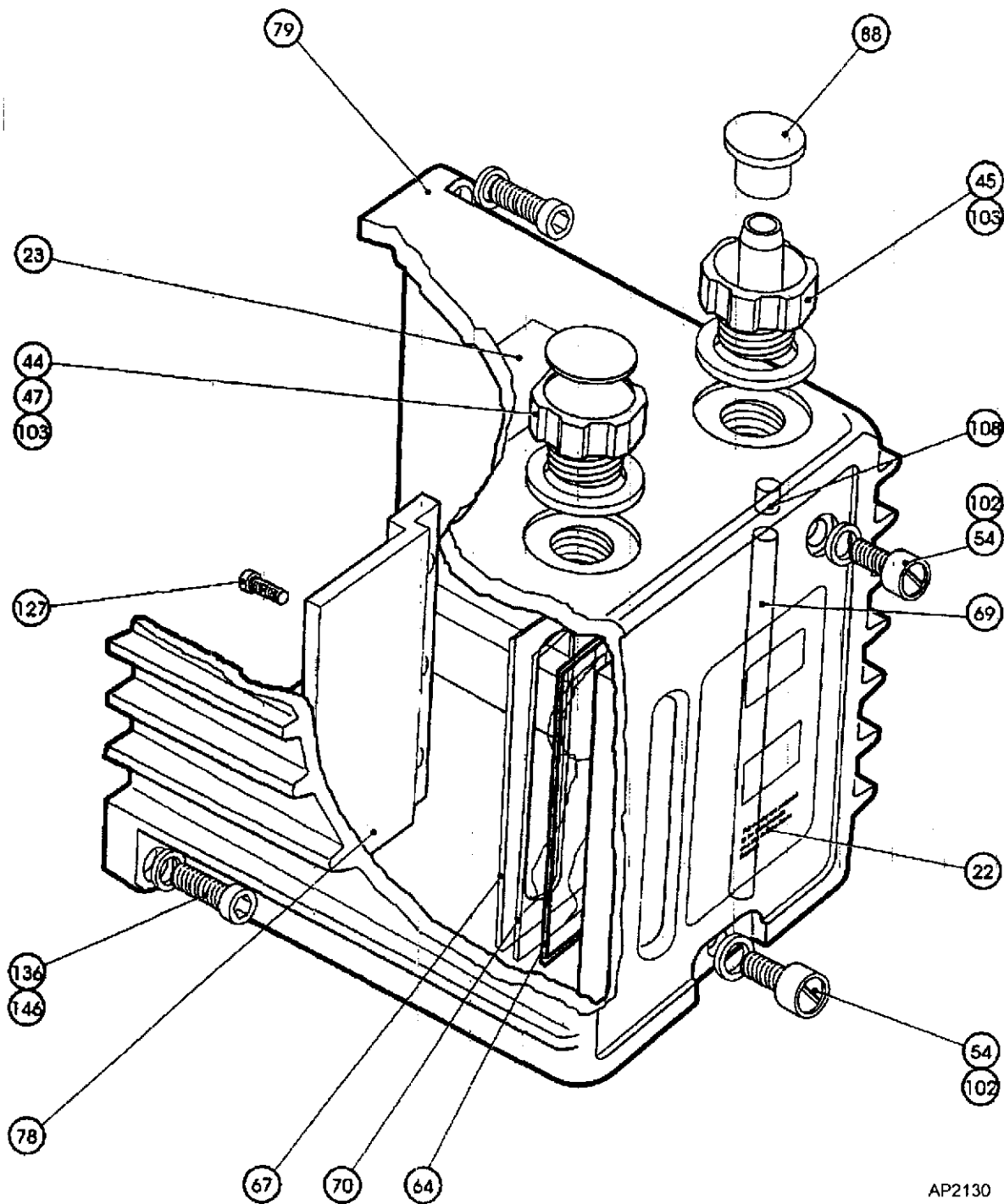

AP2130

Figure 3 - Oil box sub-assembly

ITEM	DESCRIPTION	ITEM No	Qty	Kit No.(s)
22	Label	A20001065	1	
36	Hazard warning label	A20001084	1	
44	Filter plug - 3/4" BSP	A25908027	1	
45	Nozzle - _ 15 tube x 3/4" BSP	A25908029	1	
47	Filter plug insert	A25908035	1	
54	Plug-1/8" BSP	A26002027	2	
64	Seal		1	2
67	Gasket		1	2
69	Drain tube	A27858001	1	
70	Sight glass	A29201010	1	
78	Sight glass clamp	A25908059	1	
79	Oilbox	A36301011	1	
88	Redcap-AQ330-13	H01503013	1	
102	'O' ring		2	2
103	'O' ring	H02125026	2	
108	Hollow taper pressure plug 1/8" BSP	H03517004	1	
127	Cap ht screw, M4x 12 (nt)		6	
136	Cap ht screw M8 x 40 (nt)		4	
146	Washer, s.coil sq. M8 (ms nt)		4	

Table 4 - Oil box sub-assembly items

(C) High and low vacuum stator sub-assembly

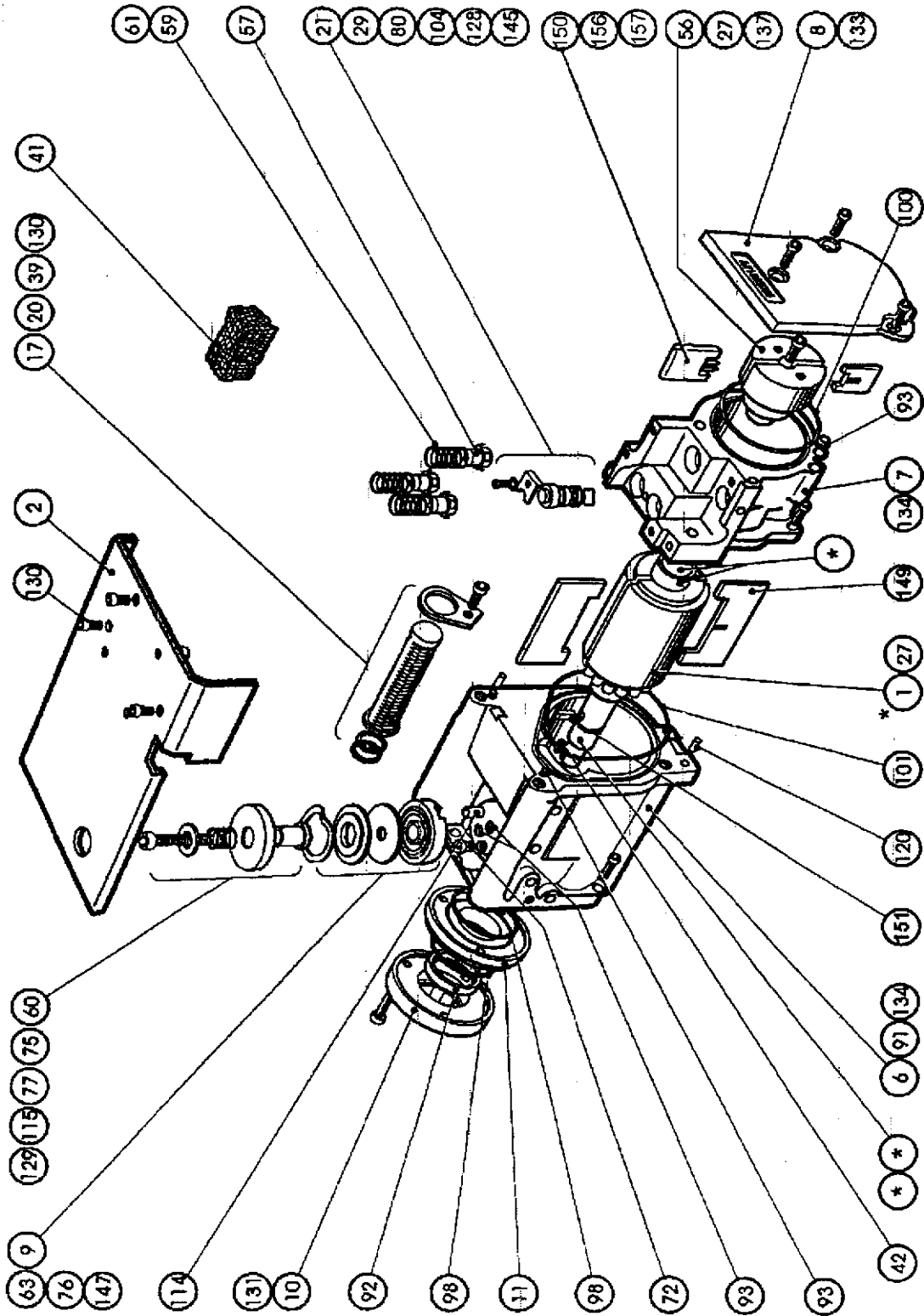

AP2131

Figure 4 - High and low vacuum stator sub-assembly

\* See Table 5a

ITEM	DESCRIPTION	ITEM No	Qty	Kit No.(s)
1	H.V. rotor assy.	A26401073	1	
2	Baffle plate assy.	A37301005	1	
6	H.V. stator	A37301030	1	
7	L.V. stator	A37301031	1	
8	Rear cover	A37301004	1	
9	Distributor body	A25908058	1	
10	Seal carrier	A37301008	1	
11	Oil pump housing	A37301009	1	
17	Filter seal		2	2
20	Filter clamp	A11101054	1	
21	Ballast valve	A25908117	1	
27	Roller bearing	A20404011	2	
29	Ballast clamp	A20528001	1	
39	Oil filter		1	2
41	Knitmesh	A22305052	1	
42	Key 6 x 6 x 27 rd ends	A24301014	1	
56	Low vac. Rotor	A26401071	1	
57	Valve pad		3	2
59	Exhaust valve spring		1	2
60	Distributor spring		1	2
61	Valve spring		2	2
63	Distributor rubber		1	2
72	Relief valve assy.	A37301018	1	
75	Distributor sleeve	A37301022	1	
76	Distributor weight	A34301037	1	
77	Distributor cap	A34301038	1	
80	Ballast plug	A37101022	1	
91	Oil seal - 30 x 40 x 7mm		1	2
92	Oil seal UID poss. action		1	2
93	'O' ring		5	2
98	'O' ring		2	2
100	'O' ring		1	2
101	'O' ring		1	2
104	'O' ring		2	2
114	Springpin-1/4" x 1/2"	211174099	1	
115	Washer. large 2BA (ms ni)	211814057	1	
120	D.pin p'llel. ms. nt. _ 8 x 20	212211040	2	
128	Cap ht screw, M 4x 16 (nt)		1	
129	Cap ht screw, M4 x 35 (nt)		1	
130	Cap ht screw, M5 x 10 (nt)		4	
131	Cap ht screw, M5 x 30 (nt)		3	
133	Cap ht screw, M8 x 20 (nt)		3	
134	Cap ht screw, M8 x 25 (nt)		6	
137	Cap ht screw, M10 x 25 (nt)		1	
145	Washer large M4 (ms.ni)		1	
147	Washer, waved		1	2
149	High vac. Blade	A20402622	2	
150	Low vac. Blade	A20402640	2	
151	Oil pump blade	A20402538	1	
156	Spring		2	1
157	Pin		2	1

Table 5 - High and low vacuum stator sub-assembly items

**Figure 4a - HV rotor assembly**

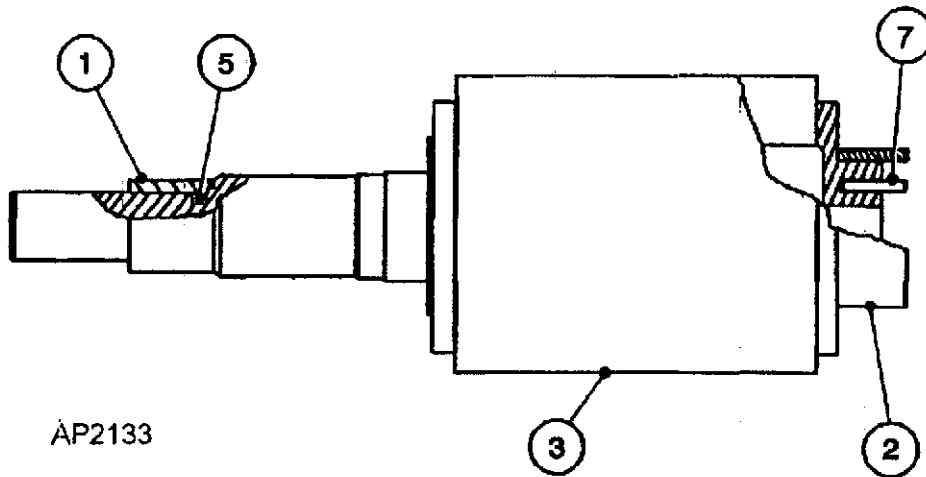

Figure 4a - HV rotor assembly

ITEM	DESCRIPTION	ITEM No	Qty	Kit No.(s)
1	Sleeve - 20 x 25 x 20	A20405024	1	
2	Sleeve - 30 x 35 x 20	A20405008	1	
3	HV rotor	A26401072	1	
5	'O' ring	H02120015	1	
7	Spring pin - Ø4 x 18	212170758	1	

Note: Item Numbers in Table 5a refer to GA A2640173 only

Table 5a - HV rotor assembly items



(D) Motor and adaptor plate sub-assembly

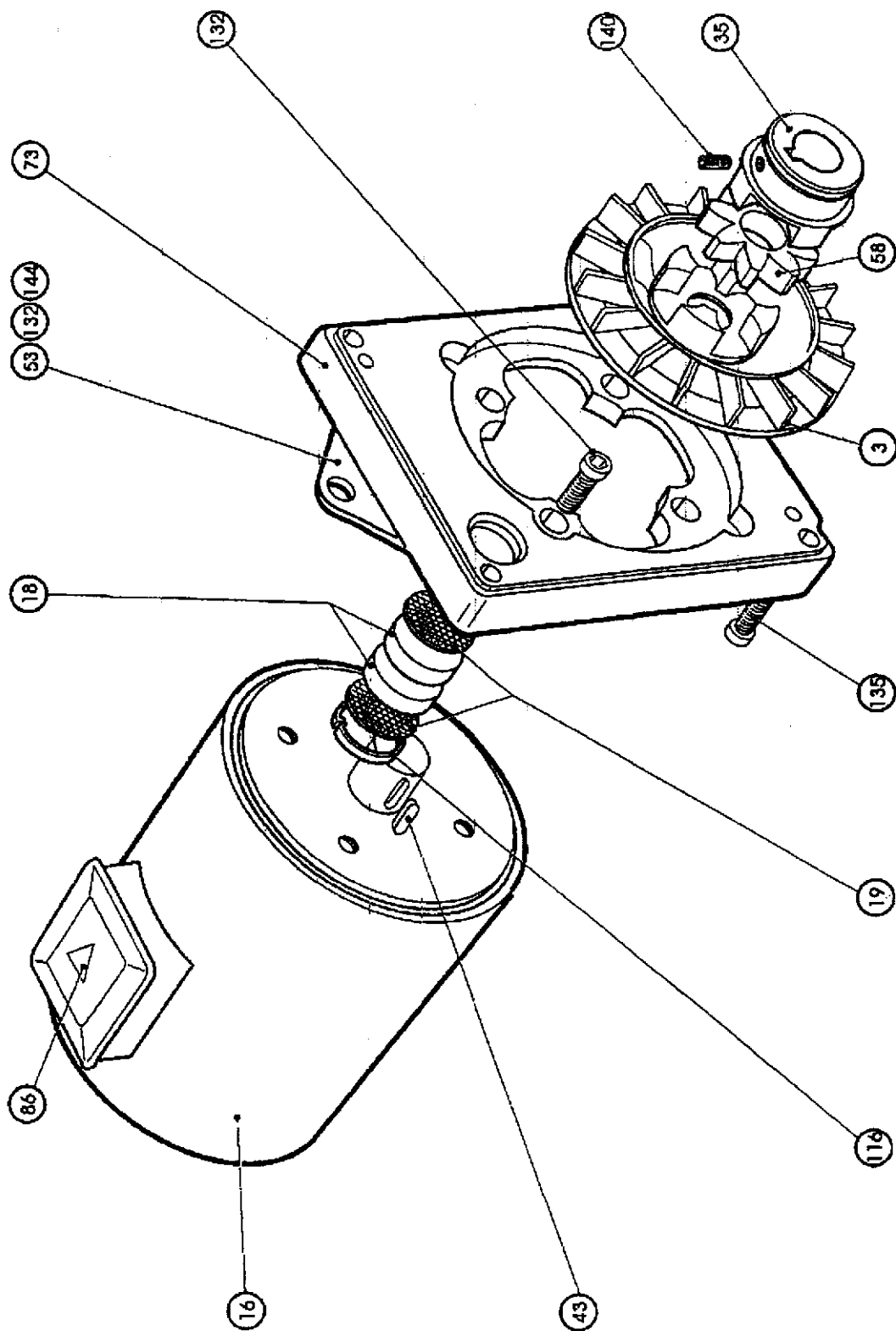

Figure 5 - Motor and adaptor plate sub-assembly

ITEM	DESCRIPTION	ITEM No	Qty	Kit No.(s)
3	Coupling and fan assy.(UK)	A37301012	1	
16	Motor - see pump data table 2	0.75/0.90kW	1	
18	Gas Ballast filter pad		2	2
19	Gas Ballast gauze		2	2
35	Coupling boss (UK)	A21071046	1	
43	Key 6 x 6, 7mm lg.	A24301015	1	
53	Lifting plate	A25971017	1	
58	Coupling element	A26501032	1	
73	Motor plate	A34301012	1	
86	Warning label	E20001063	1	
116	Circlip	212081133	1	
132	Cap ht screw, M6 x 20 (nt)		6	
135	Cap Ht screw, M8 x 30 (nt)		4	
140	Set hx knrld screw, M6 x 12 (ms. nt)		1	
144	Washer. M6 (ms ni)		2	

Table 6 - Motor and adaptor plate sub-assembly items

#### 4 BLADE KITS

The blade Kit (A37301135) is detailed in Table 7.

Code No.	DESCRIPTION	QTY.
A37301132	Blade H.V. (2 blade pack)	1
A37301140	Blade L.V. (2 blade pack)	1
A20402538	Oil pump blade	1
A00906077	Spring	2
A29203003	Pin	2

Table 7 - Kit 1 - E2M28 Blade Kit items

## 5 CLEAN AND OVERHAUL KIT

The Clean and Overhaul Kit (A37301131) is detailed below in Table 8.

CODE No.	DESCRIPTION	QTY.
A37301026	Fitting pack	1
A01403030	Filter seal	2
A02308043	Gas ballast filter	2
A02308044	Gas ballast gauze	2
A11301045	Gas ballast valve	1
A22305008	Oil filter assy	1
A26501029	Valve pad	3
A26501032	Coupling element	1
A27102041	Exhaust spring	1
A27102032	Distributor spring	1
A27102033	Valve spring HV	2
A27159430	Distributor rubber	1
A27159530	Seal (Nitrile)	1
A27159532	Gasket	1
A27159635	Oil box gasket	1
A27159638	Sight glass gasket	1
H02104012	Dowty seal	1
H02104030	Dowty seal	1
H02109064	Inner shaft seal	1
H02109094	Outer shaft simrit seal	1
H02120028	'O' ring	9
H02122035	Gas ballast 'O' ring	1
H02122037	Gas ballast 'O' ring	1
H02122038	'O' ring	1
H02120072	Inlet 'O' ring	1
H02120078	'O' ring	2
H02120085	'O' ring	1
H02120087	'O' ring	1
H02124145	Dowty 'O' ring	1
H02122009	'O' ring	2
H02126026	'O' ring	2
H02126116	'O' ring	2
218990201	Waved washer	1
A20001293	Exhaust warning label	1

Table 8 - Kit 2 - E2M28 Overhaul Kit items

## CLEAN AND OVERHAUL KIT FOR E2M28

A373-01-131

PUMP ITEM NUMBER	DESCRIPTION	QUANTITY	PART NUMBER	SIZE/mm AND FEATURE (IF APPLICABLE) L x DIAM x WIDTH; * = INSIDE DIAM (X)=NO. OF COILS
------------------	-------------	----------	-------------	---

14	FITTING PACK			
17	FILTER SEAL	2	A014-03-030	28.8 x 3.2
18	GAS BALLAST FILTER	2	A023-08-043	
19	GAS BALLAST GAUZE	2	A023-08-044	
21	GAS BALLAST VALVE	1	A113-01-045	
39	OIL FILTER ASSEMBLY	1	A223-05-008	
57	VALVE PAD	3	A265-01-029	
58	COUPLING ELEMENT	1	A265-01-032	
59	EXHAUST SPRING	1	A271-02-041	28 x 9 * (14)
60	DISTRIBUTOR SPRING	1	A271-02-032	14.0 x 10.3 * (5)
61	VALVE SPRING H.V.	2	A271-02-033	30 x 9 * (10)
63	DISTRIBUTOR RUBBER	1	A271-59-430	
64	SEAL (NITRILE)	1	A271-59-530	111 x 29 x 2
65	GASKET	1	A271-59-532	
66	OIL BOX GASKET	1	A271-59-635	
67	SIGHT GLASS GASKET	1	A271-59-638	
89	DOWTY SEAL	1	H021-04-012	2BA
90	DOWTY SEAL	1	H021-04-030	
91	INNER SHAFT SEAL	1	H021-09-064	30 x 40 x 7 (VITON)
92	OUTER SHAFT SIMRIT SEAL	1	H021-09-094	25.0 x 35.0 x 5.8 (VITON)
93	O-RING	9	H021-20-028	6.6 x 2.4
94	GAS BALLAST O-RING	1	H021-22-035	13.6 x 2.4 (VITON)
95	GAS BALLAST O-RING	1	H021-22-037	15.6 x 2.4 (VITON)
96	O-RING	1	H021-22-038	
97	INLET O-RING	1	H021-20-072	35.5 x 3.0
98	O-RING	2	H021-20-078	44.5 x 3.0
99	O-RING	1	H021-20-085	79.5 x 3.0
100	O-RING	1	H021-20-087	89.5 x 3.0
101	DOWTY O-RING	1	H021-24-145	
102	O-RING	2	H021-22-009	11.1 x 1.6
103	O-RING	2	H021-26-026	28.2 x 3.5 (VITON)
104	O-RING	2	H021-26-116	7.9 x 2.6 (VITON)
147	WAVED WASHER	1	2189-90-201	

## BLADE KIT FOR E2M28

A373-01-130

PUMP ITEM NUMBER	DESCRIPTION	QUANTITY	PART NUMBER
------------------	-------------	----------	-------------

24	BLADE H.V.	2	A204-02-153
25	BLADE L.V.	2	A204-02-155
26	OIL PUMP BLADE	1	A204-02-157