



TIC Instrument Controllers	126
Profibus Communications Module	128
ADC Active Digital Controllers	130
APG100 Active Pirani Vacuum Gauge	132
APGX-H Active Linear Convection Gauges	134
ATC Active Thermocouple Gauge	136
ASG Active Strain Gauge	138
AIM Active Inverted Magnetron Gauge	140
WRG Active Wide Range Gauge	142
AIGX Active Ion Gauge	144
IGC Ion Gauge Controller	146
Barocel® Vacuum / Pressure Transducers	148
Model 1575 Pressure Display	151
CG16K Capsule Dial Gauge	153
IS16K Vacuum Interlock Switch	154
VS16K Adjustable Vacuum Switch	155

Vacuum Measurement and Control Systems

The Edwards range of instruments offers:

- Measurement over the range 2000 to 10^{-11} mbar
- Advanced microprocessor based controllers
- Calibration of instruments to UK national standards

Selecting Your Vacuum Gauge

Edwards offers a wide choice of vacuum measurement and control products – from dial gauges to microprocessor based gauge controllers. Within each product range, there is a family of models designed to meet the widest user specification.

The first step in selecting the right gauge to meet your application is to decide the range of pressures that you want to measure at each of your measuring points. The chart below indicates the broad pressure ranges covered by the spectrum of Edwards instruments: use this chart as a primary guide to the choice of gauge head.

The second step is to establish your requirement for the output of the pressure measurement. If you simply want an indication that a certain level of vacuum has been reached (for example, to open a valve or start a process), then a vacuum switch or Active gauge head alone may be appropriate. If you want to display the pressure locally, then a dial gauge may be suitable. If you need the pressure display to be remote from the measurement point (for example, in a control panel) then select the TIC Instrument Controller or Active Digital Controller, depending on the features you require. (You will also need to select appropriate gauge head(s) to accompany these displays and controllers.) If your control system (such as a PLC, PC or dedicated microprocessor controller) needs to know the pressure to make sequence decisions but you do not need a separate vacuum display, then you can use an Active gauge head as a stand-alone transducer connected to an appropriate power supply and control system analog input.

Thirdly, you need to select a gauge suitable for the process gases and constructed to withstand exposure to the external environment of your vacuum system. Consider both whether the gauge will survive in the process and also whether the process gases will effect the gauge's measurement. For example, the measurement made by mechanical gauges (vacuum switches, dial gauges, strain gauges and capacitance manometers) is not affected by gas composition, whereas that made by other types of gauges is gas dependent.

Calibration for Different Gases

All of our gauge heads are calibrated for dry nitrogen; the calibration for dry air is the same. If you use thermal conductivity or ionization gauges with gases other than nitrogen or air, you may need to apply a gas correction factor for an accurate indication of your system pressure. Please contact us if you need more information.

Gauge Head Installation

How you install the gauge head into your vacuum system will affect the accuracy and reliability of your pressure measurement. For best performance we recommend that you:

- Connect the gauge head to your vacuum system with a straight, short branch pipe. This pipe should have an internal diameter no less than that of the gauge tube itself. Long, narrow or angled connections can cause a significant measurement error. Note that the indicated pressure may be higher or lower than the actual pressure.
- Connect the gauge head as close as possible to the point where you want to measure the system pressure.
- Orientate the gauge head so that it is vertical, with the connection to the vacuum system at its base. This prevents debris falling into the gauge.

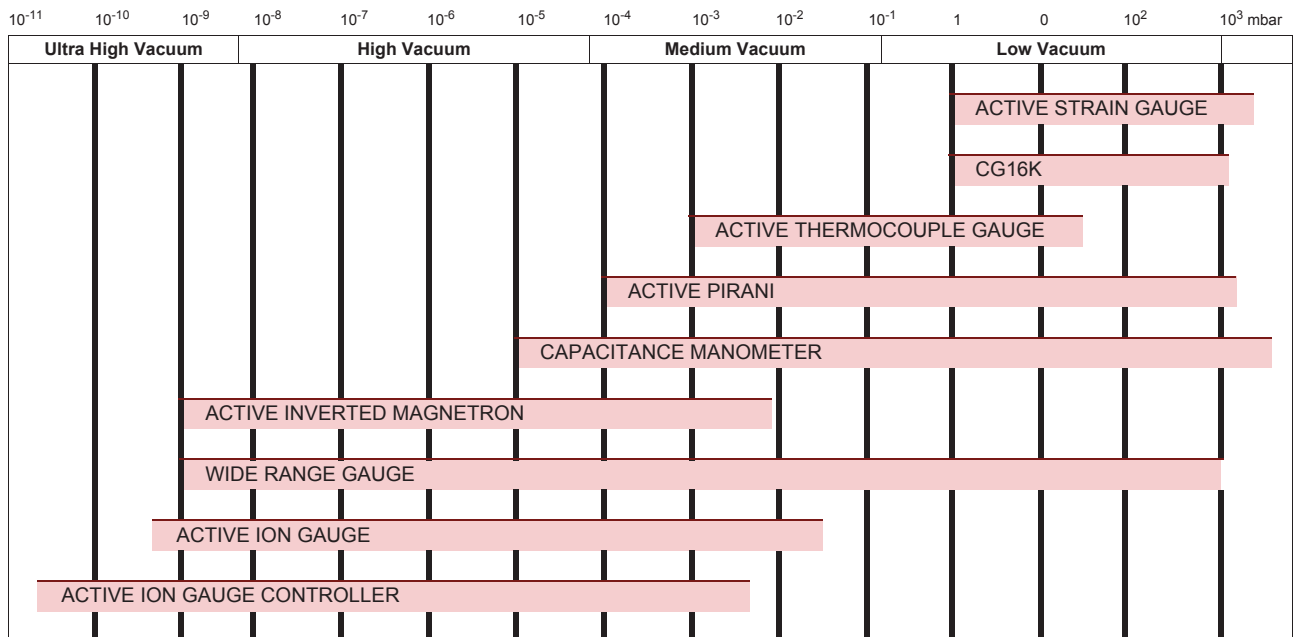

The Active Gauge Concept



- Operate from standard power supplies for simple installation
- Gauge type identification signal and common 0-10 V d.c. output
- Cable lengths of up to 100 m for remote operation
- Range of microprocessor based controllers
- The Active gauge range with TIC Instrument Controller give continuous measurement from 2000 mbar to 10^{-11} mbar
- Low cost analog and digital displays and controllers available

Edwards Active vacuum gauges and controllers give unrivalled performance, flexibility and ease of use. Traditionally, vacuum gauges consisted of a sensing element and a separate display/controller. With Edwards' Active gauges, the functions that are specific to the gauge type (such as signal conditioning and specialized power supplies) have been moved from the dedicated controller and incorporated in the head itself. Now the gauge head can be used as a stand-alone transducer: it requires only a simple power supply and it provides a 2 to 10 V output. Alternatively, you can connect the gauges to a Edwards display or universal controller: these will accept all gauge types in any combination for the most flexible solution.

The Active Gauge Range

Active Pirani Gauge A range of Pirani gauges including linear measuring from above atmospheric pressure to 10^{-4} mbar, with integral set-point for OEM use.

Active Ion Gauge A new range of small self-contained Active ion gauges with a measuring range from 5×10^{-2} to 5×10^{-10} Torr. The gauges incorporate degas, automatic emission current switching, automatic filament protection, a push button adjustable set point and status indicating LED.

Active Inverted Magnetron Operating through the range 10^{-2} mbar to 10^{-9} mbar, with integral set-point for OEM use. A low external magnetic active field version is available.

Active Wide Range Gauge A range of gauges measuring from atmosphere to 10^{-9} mbar with a linear output and integral set-point for OEM use. A low external magnetic field version is available.

Active Thermocouple Gauge A range of gauges measuring from atmosphere to 10^{-3} mbar, with integral set-point for OEM use and LED indication of vacuum status.

Active Strain Gauge A range of strain gauges measuring from 2000 mbar to 1 mbar. This type of gauge is extremely rugged and offers accurate, gas independent measurement.

Ion Gauge Controller The Ion Gauge Controller can operate one or two ion gauge tubes, as well as a high pressure interlocking gauge. It has a measurement range of 5×10^{-3} to 2×10^{-11} mbar, with 3 levels of emission current and electron bombardment type degas.

Barocel Capacitance Manometers

The Barocel manometers provide high accuracy, high stability, gas independent pressure measurement making them ideal for a wide range of industrial process, research and calibration applications. Their Inconel/Monel construction means that they can also be used with corrosive and radioactive gases.

- Accuracy 0.15% of reading
- True total pressure measurement, independent of gas species
- Very high corrosion resistance
- Fast response
- Wide range, 4 decade range with single head
- Temperature controlled manometers from 45 to 123 °C
- Excellent stability
- Full scale ranges from 1 mbar to 1000 mbar (0.05 Torr to 1000 Torr)

Active Controllers and Displays

The Edwards Active range of gauges can operate as stand-alone pressure transducers requiring only a simple power supply and providing a 2 to 10 V analog output. If you need a complete vacuum measuring and display system, we also offer a range of controllers and displays.

Our displays and controllers are designed for maximum flexibility and ease of use. The range is suitable for bench-top or panel mounting and options include RS232 interfacing.

TIC Instrument Controller A compact instrument controller with a large clear graphical display, an intuitive user interface and serial communications providing full remote control and data logging functions for one or more TIC systems via a new Windows™ based PC program.

The controller supports, automatically recognises and controls up to six gauges from the Edwards range (including IGC and up to three Barocels), with coverage from 2000 to 6.6×10^{-10} mbar. Low pressure gauges may be controlled and protected by high pressure gauges and there are open collector set point outputs. An optional relay box uses these outputs to control mains changeover relays.

The TIC instrument controller may be either rack or bench mounted and provides a useful hub for the flexible operation of a wide range of vacuum system configurations.

Active Digital Controller The Edwards Active Digital Controller (ADC) is a compact single gauge controller and display. It features a bright LED display and simple push-button controls. The ADC automatically recognises compatible Edwards gauges, loads the appropriate look-up table and displays the pressure in commonly used vacuum units. The ADC is available in standard and enhanced versions. The standard controller displays the pressure measured by a single active gauge. The enhanced controller supports two similar gauges – it has two variable hysteresis set-points which are linked to 48 V d.c. 1 A changeover relays and two 0-10 V d.c. analog outputs. To aid system integration, the enhanced controller is provided with an RS232 interface.

When combined with a suitable gauge, such as the Edwards APGX-H Convection Pirani or Wide Range Gauge (WRG), the ADC represents a cost effective means of monitoring and controlling process vacuum in a broad range of applications.

Other Instruments

In addition to the range of Active gauges, Edwards offers a variety of more traditional vacuum measurement and control products.

Our simple dial gauges provide rugged, local indication of pressures from atmosphere to 1 mbar and are ideal for vacuum chambers in an industrial environment. Vacuum switches, with high current ratings, give a simple method of directly controlling loads without the need for additional relays or power supplies.

Gauge Calibration Service

All Edwards gauges may either be supplied with a calibration certificate or re-calibrated by request.

- Provides certificate of calibration traceable to National Standards which meets ISO9000 requirements worldwide
- Service available for both new and returned instruments
- Transducers calibrated separately or with display/controller

As a leading manufacturer of vacuum instruments, Edwards offers an expert calibration and repair service with 25 years of experience. Other manufacturers' vacuum instruments including Helium leaks are also covered. The instruments are calibrated with dry nitrogen; for calibration with other gases or at specific pressures, please consult Edwards. The option of calibration figures before and after adjustments and repairs is also available.

The range of instruments include:

- Active gauges, displays and controllers. Note that Active gauges can be calibrated on their own, with a display or with a controller.
- Capacitance manometers. Note that some types of manometers can be calibrated as stand-alone instruments, with a controller or with a pressure monitor, for example the TIC Instrument Controller.
- Helium quartz leaks for mass spectrometer leak detectors.

Contact Edwards for details.

TIC Instrument Controller



The TIC Instrument Controller provides compact control with a large, clear graphical display, an intuitive user interface and serial communications. The supplied Windows™-based PC program provides full remote setup, control and data logging functions via the RS232 interface.

Three TIC Instrument Controllers are available; the three head and six head versions can accommodate 3 or 6 active gauges including the Active Ion Gauge Controller (ebeam version). The six head capman version can accept upto three Edwards Barocel Capacitance Manometers..

4 Features & Benefits

Page
126

- TIC automatically recognizes and controls active gauges including APG100 Pirani, convection, thermocouple, strain, inverted magnetron, wide range and active ion gauges. To enable complete integration into PC and PLC controlled processes, all TIC variants include RS232 and RS485 interface.
- TIC has six pressure related set points, which operate open collector outputs rated at 24 V d.c. 50 mA. Using the optional relay boxes, these may be linked to 250 V a.c. changeover relays to provide a useful accessory control capability. All relay boxes include a logic bypass facility for further system integration.
- In most instances, TIC systems may be simply and quickly configured using the range of standard cables on offer, there is therefore no need for the customer to prepare loom assemblies or relay boxes and special interfaces.
- TIC includes lookup tables for a range of commonly encountered process gasses (N₂, He, Ar, CO₂, Kr & Ne). Selecting the appropriate gas enables direct readout of the correct pressure without the need to apply conversion factors.
- TIC is packaged in a compact case and may be panel or rack (1/4 19 inch rack 3U) mounted. With the addition of the bezel it becomes an attractive bench-top instrument. The large 128 x 64 pixel backlit graphics LCD and mobile phone style menu system simplifies programing and with a choice of summary screens excellent visibility of displayed parameters is assured.

Dimensions

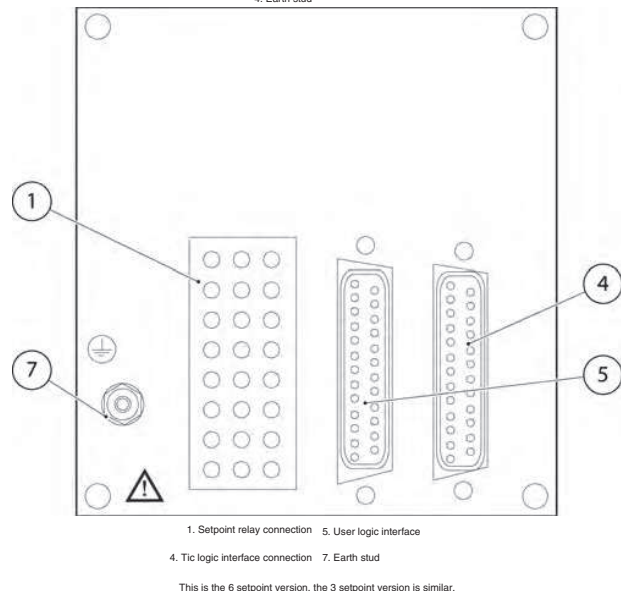
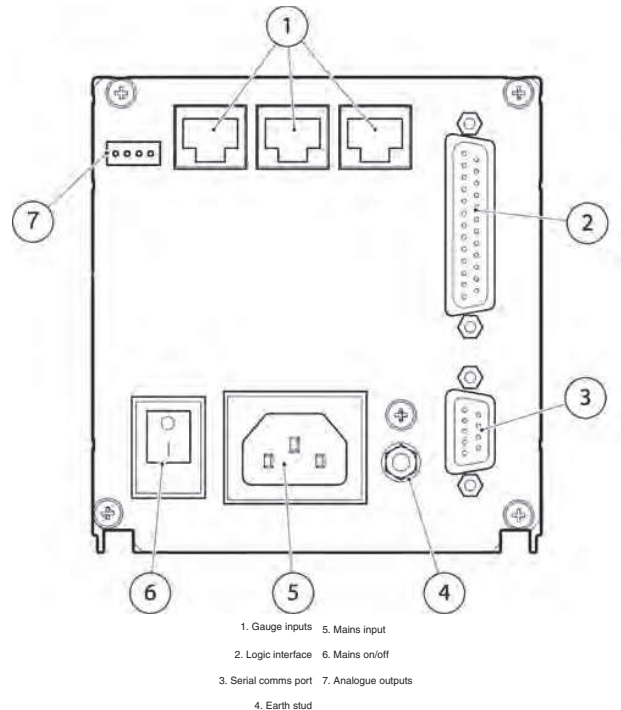

Technical Data

Electrical Data

Connector type	CEE/IEC 320
Electrical supply	90 to 264 V AC, 47 to 63 Hz
Power consumption	3 head TIC 55 VA. 6 Head TIC 160 VA

Fuse
The unit is self-protecting and has no user replaceable fuse. The unit will recover once any overload is removed.

Earth stud M4

Operating And Storage Data

Ambient operating temperature range	0 °C to 40 °C (measured underneath TIC)
Maximum ambient operating humidity	Max 90% RH non-condensing at 40 °C
Maximum operating altitude	3000 m max
IP rating	20
IEC rated pollution degree	2

Mechanical Data

Weight 1.7 Kg

Interfaces

Analogue output	0-10 V DC – one for each gauge The TIC has two built-in communications protocols, RS232 and RS485. These may be used either to interface to a PLC or, using the Windows™ PC software package supplied, connected to a PC for full monitoring and control of a TIC system.
Serial Interface	
Set-points	6 set-point (open collector) rated at 24V DC 50 mA can be assigned to any gauge. Use directly or in conjunction with TIC relay boxes.

Capacitance manometer compatability – 6 head capman versions only
3 x 600 or 622 series Barocel
2 x 655 series Barocel
1 x 658 series Barocel
For more information, contact Edwards.

Ordering Information

Product Description	Order No.
TIC Instrument Controller 3 Head RS232/RS485	D39700000
TIC Instrument Controller 3 Head RS232/RS485 Certified	D3970000C
TIC Instrument Controller 6 Head RS232/RS485	D39701000
TIC Instrument Controller 6 Head Capman	D39702000
TIC Instrument Controller 6 Head RS232/RS485 Certified	D3970100C
TIC Instrument Controller 6 Head Capman Certified	D3970200C
Accessories & Spares	Order No.
0.5M Active Gauge Cable	D40001005
100M Active Gauge Cable Assembly	D40001999
10M Active Gauge Cable	D40001100
15M Active Gauge Cable	D40001150
1M Active Gauge Cable	D40001010
25M Active Gauge Cable	D40001250
3M Active Gauge Cable	D40001030
50M Active Gauge Cable	D40001500
5M Active Gauge Cable	D40001050
Linecord 2M North Euro Plug	D40013030
Linecord 2M UK Plug	D40013025
Linecord 2m With US Plug	D40013120
TIC front bezel kit	D39700803
TIC Logic Interface Cable 2m	D39700833
TIC Relay Box Instruments (3 x 3A, 250V)	D39700804
TIC Relay box instruments (6 x 5 A, 250 V)	D39701804
TIC RS232 Interface Cable 2m	D39700834

Profibus Communications Module



Manufacturers, laboratories and research establishments are converting to fieldbus to take advantage of the reduced cabling and network equipment costs.

Edwards offers a compact, Din rail mountable module to allow Profibus protocol communications with the TIC Turbo and Instrument Controllers, or directly with Edwards DX turbo pumps.

The TIC is a versatile, advanced system controller capable of controlling a series of vacuum pumps and up to three Edwards Active vacuum gauges. The addition of the Profibus module allows full advantage to be taken of digital multi-drop communications.

4 Features & Benefits

Page
128

- Full Profibus International Accreditation
- Din Rail Or Rack Mounting
- Wide Operating Voltage Range 9 - 52 V
- Simple Set-up
- Field Software Upgrades Available

Dimensions

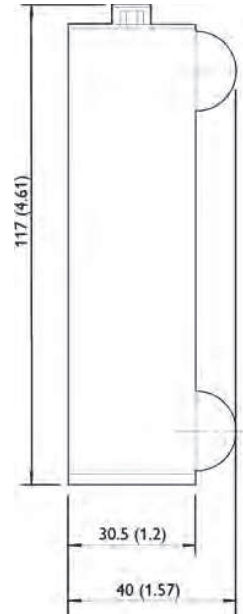

Technical Data

Electrical Data

Electrical supply	
TIC Profibus module	9 - 52 V DC 5W (switch on surge 500 mA)
Ambient operating temperature	0 to 40 ° C
Ambient storage temperature	-30 to 70° C
Max ambient operating humidity	90% RH non-condensing
Max operating altitude	2000 m
IP rating	IP30 - indoor use only
Mass	0.28 kg

Connectors

DC power connector (supplied)	2-way receptacle. Mating part is cable mount terminal block (supplied). Suitable parts include: Phoenix MSTBV 2.5/2-G-5.08;Weidmuller BLZ 5.08/2; Amp796634-2; IMO 21.950/2
Profibus connector	
Connector type	9-way sub-miniature "D" type socket
Profibus data signals	Electrically compliant with RS485 specification isolated from chassis
Profibus power supply	10 mA supply (protected for external terminator resistors if required)
Chassis	For Profibus cable screen convention
Repeater control signal	Digital signal, nominally 0-5 V but with series 340 ohm resistor. High = module transmitting. Low = receiving or idle
RS232 connector TIC version	9-way sub-miniature "D" type plug
RS232 protocol	9600 baud, 1 stop bit, 8 data bits, no parity
RS232 protocol	9600 baud, 1 stop bit, 8 data bits, no parity

Cables

Profibus cable	Should be screened and comply with EN50170
RS232 cable TIC version	15 m max. Screening not required.
DX pump connection	Connection must be either direct to the DX pump flying lead or a Edwards DX pump extension cable.

Ordering Information

Product Description	Order No.
TIC Profibus Communications Module	D39750000
DX Pump Profibus Communications Module	D39751000

ADC Active Digital Controller



The Edwards Active Digital Controller (ADC) is a compact single gauge controller and display. It features a bright LED display and simple push-button controls. The ADC automatically recognizes compatible Edwards gauges, loads the appropriate look-up table and displays the pressure in commonly used vacuum units.

Two versions are available; the standard ADC simply displays the pressure in choice of units, and the enhanced ADC includes a second gauge connection, two set-point relays, two analogue outputs and an RS232 interface.

New for 2011, the ADC mk2 enhanced controller can now support 2 different gauges e.g. APG100 and AIM.

4 Features & Benefits

Page
130

- Plug and measure operation means you simply plug in the mains supply, connect the gauge and ADC displays the measured pressure
- The ADC supports Edwards gauges with a total measuring range of 2000 to 1×10^{-9} mbar (1500 to 7.5×10^{-10} Torr)
- Bright LED display gives clear, long distance readability
- The ADC displays units in mbar, Torr, Pascal or Volts
- Small 1/8 DIN enclosure, may be panel or bench mounted

Dimensions

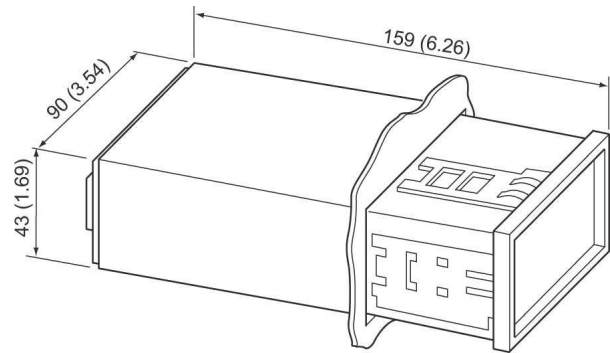

Technical Data

Active gauge compatibility	
Standard	APG100, APG-L, APG-MP, APG-M, APGX-H, APGX-L, WRG
Enhanced	Up to two identical gauges from the standard version plus AIM-X, AIM-S & ASG
Display	High brightness green LED display (0.47 inch high)
Electrical supply	Units - mbar/Torr/Pa/Volts
Dimensional Data	100 to 240V AC 47 to 63 Hz
Panel cut-out	$92^{+0.8} \times 45^{+0.6} \text{ mm}$ (3.62inch x 1.77 inch) to DIN43700
Panel thickness	1.5mm (0.06 inch) Min
Weight	0.33Kg
Operating and storage data	
Operating temperature	+0 to +40°C
Storage temperature	-30 to +70°C
Max ambient operating humidity	90% RH non condensing at 40°C
Standards	
Electrical safety	BS EN 61010-1 2001
Electrical noise immunity	BS EN 61326 (Industrial location, class B emissions)
Flame retardant case materials	UL94 V1
Enclosure rating	IP40
Enhanced features	
Two analogue output	0-10V d.c.
Two set-point relays, volt free single pole change-over	1A at 48V d.c. / 2A at 24V d.c.
Serial output	RS232

Ordering Information

Product Description	Order No.
ADC Standard	D39590000
ADC mk2 Enhanced	D39591500
ADC Standard certified	D3959000C
ADC mk2 Enhanced certified	D3959150C
Accessories & Spares	Order No.
0.5M Active Gauge Cable	D40001005
100M Active Gauge Cable Assembly	D40001999
10M Active Gauge Cable	D40001100
15M Active Gauge Cable	D40001150
1M Active Gauge Cable	D40001010
25M Active Gauge Cable	D40001250
3M Active Gauge Cable	D40001030
50M Active Gauge Cable	D40001500
5M Active Gauge Cable	D40001050
Linecord 2M North Euro Plug	D40013030
Linecord 2M UK Plug	D40013025
Linecord 2m With US Plug	D40013120
TIC RS232 Interface Cable 2m	D39700834

APG100 Active Pirani Vacuum Gauge



Features include compact size for easy installation, a linear output, and a replaceable sensor tube. The new gauges are compatible with all Edwards TIC instrument controllers and other active gauge controllers and displays. They are also CSA, C/US approved as well as fully RoHS compliant due to their lead-free construction.

4 Features & Benefits

Page 132

- Cable connections and gauge adjustment conveniently located, thereby minimizing the space envelope required for access
- Sensor tube can be baked to 150 °C
- Adjustable set-point for simple process control and interlocking
- Remote calibration possible
- CSA, C/US approved

Performance Curves

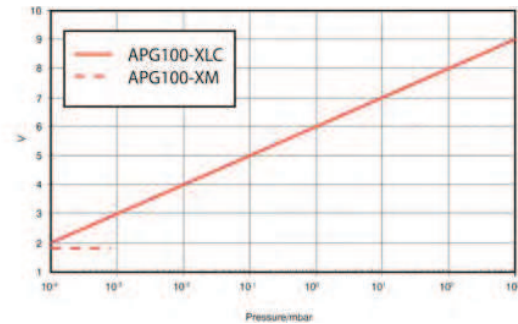

Dimensions

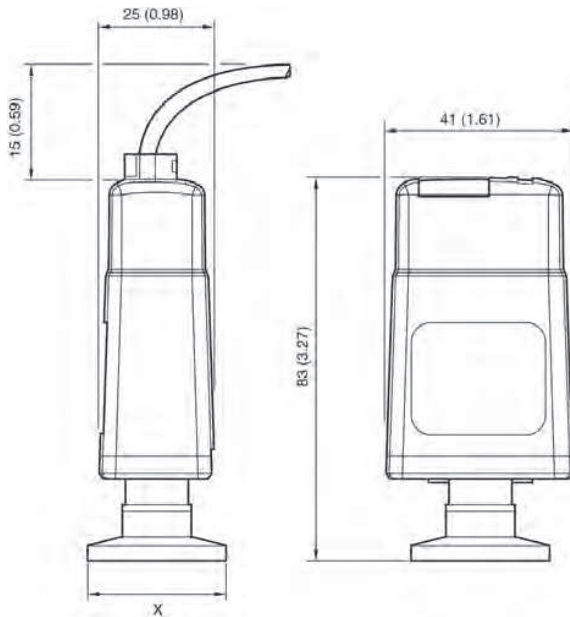

Flange X
 NW16 30 mm (1.18 inch)
 NW25 40 mm (1.57 inch)

Ordering Information

Product Description	Order No.
APG100-XM, NW16	D02601000
APG100-XM, NW25	D02602000
APG100-XLC, corrosion resistant, NW16	D02603000
APG100-XLC, corrosion resistant, NW25	D02604000
APG100-XM, NW16, Certified	D0260100C
APG100-XM, NW25, Certified	D0260200C
APG100-XLC, NW16, Certified	D0260300C
APG100-XLC, NW25, Certified	D0260400C
Accessories & Spares	Order No.
Spare APG100-XLC electronics module	D02603800
Spare APG100-XM electronics module	D02601800
Spare mesh filter for APG100 pack of 5	D02601805
Spare sensor for APG100-XLC NW16 flange	D02603801
Spare sensor for APG100-XLC NW25 flange	D02604801
Spare sensor for APG100-XM NW16 flange	D02601801
Spare sensor for APG100-XM NW25 flange	D02602801

Technical Data

Mass	85 g
Internal volume	5 cm ³
Enclosure rating	IP40
Measurement range (APG100-XM)	Atmosphere to 10 ⁻³ mbar
Measurement range (APG100-XLC)	Atmosphere to 10 ⁻⁴ mbar
Accuracy (APG100-XM)	Typically +/- 15% at <100 mbar
Accuracy (APG100-XLC)	Typically +/- 15% at <10 mbar
Maximum over-pressure	10 bar absolute
Operating temp range	5° to 60° C
Storage temp range	-30° to 70° C
Bake-out with no electronics	150 °C
Humidity	80% RH up to 31 °C decreasing linearly to 50% RH at 40 °C and above
Maximum altitude	3000 m
Filament temperature	100 °C above ambient
Electrical supply voltage	15 to 30 V d.c. nominal 13.5 V d.c. minimum 32 V d.c. maximum
Power consumption	1 W
Output signal	0 to 10 V d.c. nominal
Set-point – open collector transistor	
Rating	30 V d.c. 100 mA
Range of set-point	1.8 to 9.2 V dc
Fixed hysteresis	500 mV (1/2 decade)
Level setting resolution	6 mV

APGX-H Active Linear Convection Gauge



Edwards Linear Convection Vacuum Gauge has a wide measuring range from 1333 to 3×10^{-4} mbar (1000 to 2.3×10^{-4} Torr). The use of convection technology ensures accuracy and sensitivity are maintained to the top of the range.

The gauge is compact and may be mounted in any orientation, simplifying installation where space is limited. The gauge incorporates a setpoint and two LEDs, which indicate setpoint and gauge status.

4 Features & Benefits

Page 134

- Wide Measuring Range 1333 to 3×10^{-4} mbar (1000 to 2.3×10^{-4} Torr)
- Use of convection technology ensures consistent measuring accuracy (typically $\pm 15\%$) and repeatability ($\pm 5\%$) to top of range
- Reduced Cost of Ownership
- Replaceable tubes are available
- CSA, C/US Approved

Dimensions

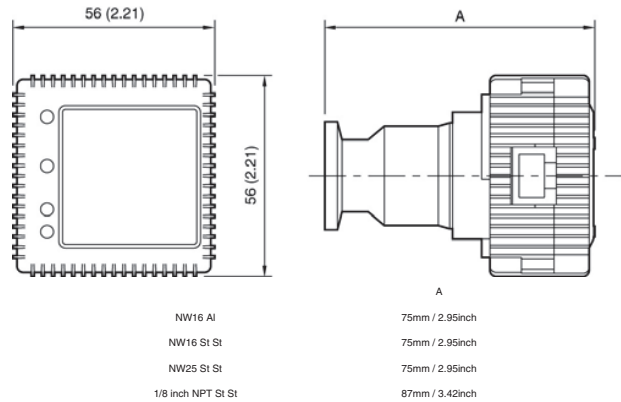

Performance Curves

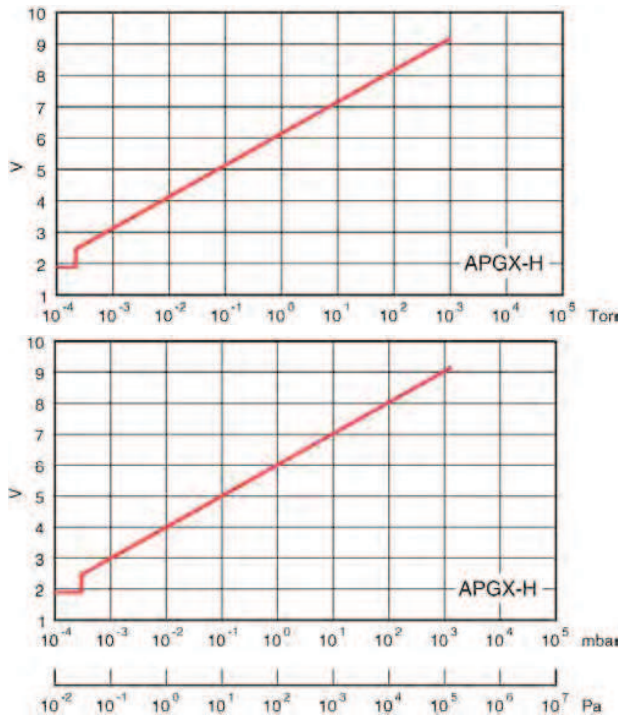

Technical Data

Pressure range	1333 to 3×10^{-4} mbar (1000 to 2.3×10^{-4} Torr)
Power supply	14.5 to 30 V DC
Power consumption	1.5 W maximum
Accuracy	$\pm 15\%$ of reading $\pm 3 \times 10^{-4}$ mbar
Repeatability	$\pm 5\%$ of reading
Resolution	6mV increments
Response time	< 100 ms
Maximum overpressure	10 bar absolute (145 psia)
Adjustments	Set vacuum and set atmosphere. To allow for variations in barometric pressure, atmosphere may be set in the range 700 to 1100 mbar (525 to 825 Torr).
Setpoints† (open collector transistor)	Range of setpoint 1.8 to 9.3 V Rating 30 V DC 100 mA Fixed hysteresis (1/2 decade) 500 mV

† The setpoint output will be turned off if an error is detected. For further information, please contact Edwards.

Ordering Information

Product Description	Order No.
APGX-H-NW16, aluminium	D02391000
APGX-H-NW25 ST/ST	D02392000
APGX-H-NW16 ST/ST	D02395000
APGX-H 1/8" NPT ST/ST	D02396000
APGX-H-NW16 Aluminium, certified	D0239100C
APGX-H-NW16 ST/ST, certified	D0239500C
APGX-H-NW25 ST/ST, certified	D0239200C
APGX-H 1/8" NPT ST/ST, certified	D0239600C
Accessories & Spares	Order No.
0.5M Active Gauge Cable	D40001005
100M Active Gauge Cable Assembly	D40001999
10M Active Gauge Cable	D40001100
15M Active Gauge Cable	D40001150
1M Active Gauge Cable	D40001010
25M Active Gauge Cable	D40001250
3M Active Gauge Cable	D40001030
50M Active Gauge Cable	D40001500
5M Active Gauge Cable	D40001050
AGC EPROM Upgrade Kit	D38660800
APGX-H Electronics Module	D02391800
APGX-H Filter Pack 5 (not NPT version)	D02391805
NW16 AL TUBE APGX-H SPARE	D02391801
NW16 STST TUBE APGX-H	D02395801
NW25 STS TUBE APGX-H SPARE	D02392801
Spare Tube 1/8" NPT ST/ST	D02396801

ATC Active Thermocouple Gauge



The Edwards Active Thermocouple (ATC-E) gauges mount directly on either the ATC-D or ATC-M thermocouple tubes to form a compact, stand-alone transducer.

The ATC-E electronics module drives both medium and low pressure gauge tubes. These gauges offer a cost effective measuring solution for higher pressures.

4 Features & Benefits

Page
136

- Drive electronics mount directly on the gauge tube which simplifies the system design and saves valuable rack space
- Wide range, regulated, internal power supply runs from standard d.c. power supplies from +13.5 to +36 V and is tolerant to voltage fluctuations
- Standard analog outputs of 0 to +10 V d.c. and gauge identifier allows for easy interface with a computer or PLC and provides fault output indication
- Adjustable set-point with vacuum status LED can be used for process control and interlocking and includes a digital vacuum status signal with set-point level ready visually
- Low output impedance and integral Faraday shield provides a high level of noise immunity and permits long cable runs of up to 100 meters

Dimensions

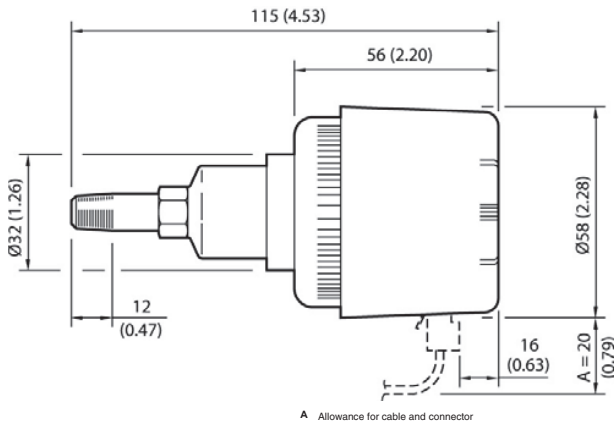

Applications

Active thermocouple gauges are ideally suited to applications where a simple rugged gauge is required to measure higher pressures.

Performance Curves

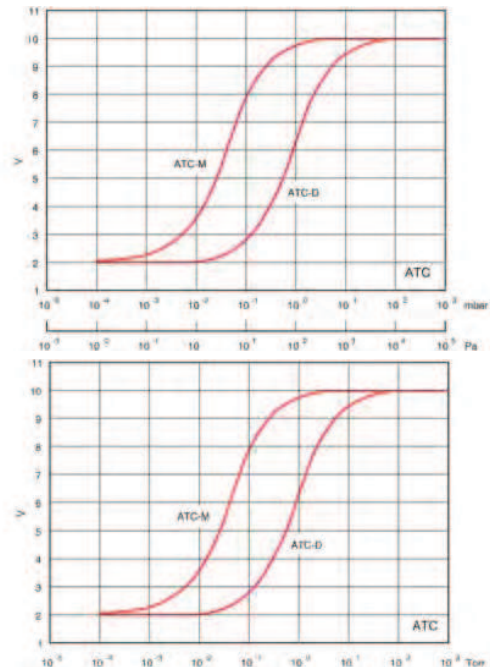

Technical Data

ATC-E Electronics Module

Power supply	+13.5 to +36 V d.c. (max 1 V ripple)
Power consumption	0.54W maximum
Output signal	
Operating	2 to 10 V d.c.
Fault output	0 to 2 V d.c., 10 to 13.5 V d.c.
Output impedance	0.1 ohms
Minimum load	10 k ohms

Tube Type Selection

Adjustments	Adjust set point visually via potentiometer
Set point	Open collector transistor
Range of set point	2 to 85 full scale voltage
Fixed hysteresis	12 full scale voltage
Level setting	±2 full scale voltage
Rating	40 V d.c., 100 mA maximum
Temperature range	
Operating	+5 to +60 °C
Storage	0 to +70 °C
Weight	110 g
External interface connector	8 way FCC68 / RJ45 socket

ATC-D, ATC-M gauge tubes

Pressure range	
ATC-D	50 to 5×10^{-2} Torr 65 to 6.5×10^{-2} mbar
ATC-M	1 to 1×10^{-3} Torr 1.3 to 1.3×10^{-3} mbar
Maximum overpressure	
ATC-D	10 bar absolute
ATC-M	3.4 bar absolute
Weight	55 g
Internal volume	
ATC-D	1 cm^3
ATC-M	8 cm^3

For more information, contact Edwards.

Ordering Information

Product Description	Order No.
ATC-E Electronics module	D35108000
ATC-D 1/8 inch NPT gauge tube	D35512000
ATC-M 1/8 inch NPT gauge tubes	D35513000
Accessories & Spares	Order No.
0.5M Active Gauge Cable	D40001005
100M Active Gauge Cable Assembly	D40001999
10M Active Gauge Cable	D40001100
15M Active Gauge Cable	D40001150
1M Active Gauge Cable	D40001010
25M Active Gauge Cable	D40001250
3M Active Gauge Cable	D40001030
50M Active Gauge Cable	D40001500
5M Active Gauge Cable	D40001050
NW10 Adapter Pipe 1/8NPT Female S/S	C10501072
Surge Protector Box	D40006000

ASG Active Strain Gauge



The Edwards Active Strain Gauge (ASG) is a rugged, corrosion resistant diaphragm gauge which provides accurate, gas independent measurement from 2000 mbar to 1 mbar. It can be used as a stand-alone transducer allowing OEMs and system builders to develop low cost, flexible solutions to their vacuum instrumentation needs. Alternatively, it can be connected to the TIC Instrument Controller where it can be combined with many other sensor types to provide a complete vacuum instrument solution.

Note: ASG adaptor cable supplied separately. This cable must be used with TIC, AGC, ADC & ADD.

4 Features & Benefits

Page
138

- Drive electronics combined in the gauge head which simplifies system design and saves valuable rack space
- Wide range, regulated internal power supply which runs from standard d.c. power supplies of +13.5 to +36 V and is tolerant to voltage fluctuations
- Standard analog output of 0 to 10 V d.c. which is easy to interface with a computer or PLC
- High accuracy and stability. Accuracy of ± 0.2 full scale and stability 0.2 full scale
- Corrosion resistant, rugged design where the only material exposed to vacuum is stainless steel 316

Dimensions

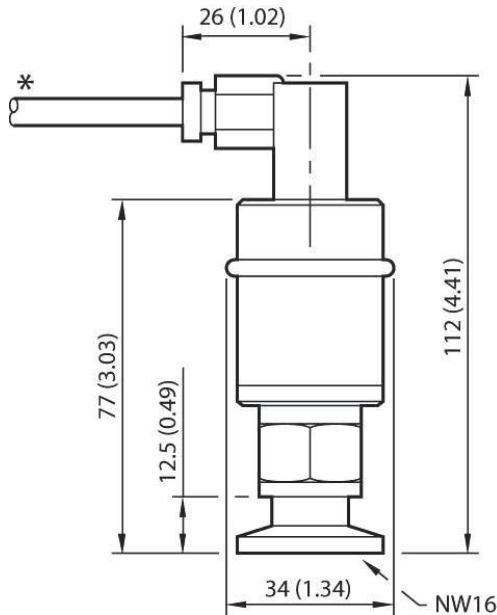

Applications

Active strain gauges are an excellent choice where accurate, gas independent, measurement of pressures around atmosphere are required, making them ideal for applications such as load locks.

It can be used as a stand-alone transducer allowing OEMs and system builders to develop low cost, flexible solutions to their vacuum instrumentation needs. Alternatively, it can be connected to the TIC Instrument Controller where it can be combined with many other sensor types to provide a complete vacuum instrument solution.

Performance Curves

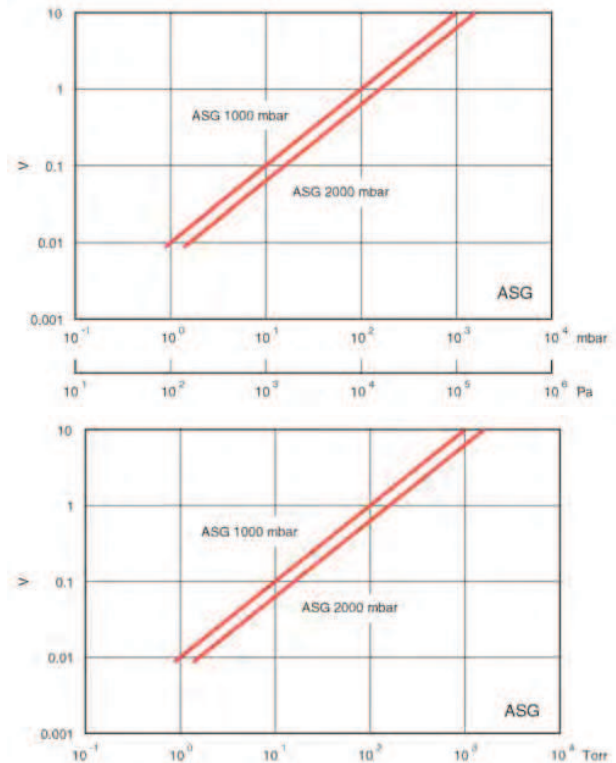

Technical Data

Full scale pressure range	1000 mbar
Accuracy	±0.2 full scale
Stability	0.2 full scale
Temperature coefficient	0.05 full scale per °C
Power supply	+13.5 to +36 V d.c.
Power consumption	0.4 W
Output signal	
Operating	0 to 10 V d.c. linear
Output impedance	>200 ohms
Minimum load	50 k ohms
Response speed	5 msec
Adjustments	Set full scale and set zero
Temperature range	
Compensated	+10 to +50 °C
Operating	-20 to +90 °C
Materials exposed to vacuum	Stainless steel 316
Internal volume	1.25 cm ³
Weight	120g
Electrical connector	Miniature 4 pin Din
Vacuum fitting	1/8 Inch NPT
Standards	
Overall design	EN 61010-1
Electromagnetic compatibility	EN 61326 (Class B Emissions)
Enclosure rating	IP65

Ordering Information

Product Description	Order No.
ASG 1/8 Inch NPT, 1000 mbar	D35725000
ASG NW16, 1000 mbar	D35726000
ASG NW16, 2000 mbar	D35728000
ASG 1/8 Inch NPT, 2000 mbar	D35727000
ASG 1/8 Inch NPT, 1000 mbar + calibration certificate	D3572500C
ASG NW16, 1000 mbar + calibration certificate	D3572600C
ASG 1/8 Inch NPT, 2000 mbar + calibration certificate	D3572700C
ASG NW16, 2000 mbar + calibration certificate	D3572800C
Accessories & Spares	Order No.
0.5M Active Gauge Cable	D40001005
100M Active Gauge Cable Assembly	D40001999
10M Active Gauge Cable	D40001100
15M Active Gauge Cable	D40001150
1M Active Gauge Cable	D40001010
25M Active Gauge Cable	D40001250
3M Active Gauge Cable	D40001030
50M Active Gauge Cable	D40001500
5M Active Gauge Cable	D40001050
Adapter Cable AGC-ASG	D40003060
Surge Protector Box	D40006000

AIM-X Active Inverted Magnetron Gauge



The Edwards Active Inverted Magnetron Gauges (AIM) combine the gauge-head and controller in one compact Active unit. These gauges have proved to be rugged and reliable in a wide range of applications ranging from scientific instruments to industrial processes.

This gauge features a linear output for easy integration with a computer or PLC.

4 Features & Benefits

Page
140

- Drive electronics combined in the gauge head which reduces the system cost and saves valuable rack space
- Low output impedance and integral Faraday shield provides high level of noise immunity and permits long cable runs (up to 100 m)
- Low magnetic field version - XL - for sensitive applications e.g. mass spectrometry and electron microscopy.
- Interchangeable body tube allows for rapid tube replacement without pre-calibration
- CSA, C/US approved

Dimensions

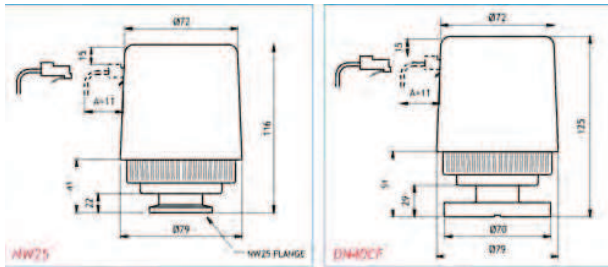

Applications

All vacuum applications requiring rugged and reliable pressure indication in the range 1×10^{-2} to 1×10^{-9} mbar. Typical processes range from general vacuum through industrial coaters and furnaces to scientific instruments and semicon.

Performance Curves

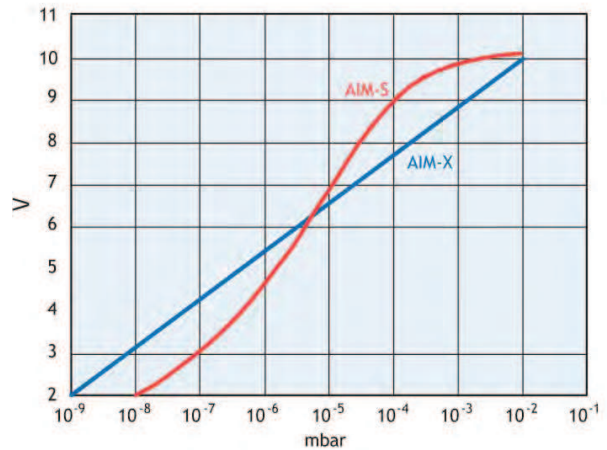

Technical Data

Pressure Range	
AIM-X	10 ⁻² to 10 ⁻⁹ mbar
Accuracy*	Typically ±30%
Maximum overpressure	10 bar absolute (145 psi)
Power supply	+13.5 to +36 V DC (max 1 V ripple)
Power consumption	2 W Maximum
Output signal	2 to 10 V DC
Set point	Open collector transistor
Maximum voltage	40V DC
Current	100 mA max
Temperature range	
Operating	+5 to +60°C
Storage	+0 to +70°C
Materials exposed to vacuum	
NW25 versions	Stainless steel 304 & 306 & 347, fluoroelastomer, glass
Internal volume	26 cm ³
Weight	0.81 kg
External interface connector	8-way FCC68/RJ45 socket
Vacuum fitting	NW25
Standards	
Electronic design	EN 61010-1
Electromagnetic compatibility	EN 61326 (Class B Emissions)
Flame retardant casing	UL94
Enclosure rating	IP40

*Accuracy is reduced at the limits of the measuring range

Ordering Information

Product Description	Order No.
AIM-X-NW25	D14642000
AIM-X-DN40CF	D14662000
AIM-X-NW25, Certified	D1464200C
AIM-X-DN40CF, Certified	D1466200C
AIM-XL-NW25	D14645000
AIM-XL-DN40CF	D14665000
AIM-XL-NW25, Certified	D1464500C
AIM-XL-DN40CF, Certified	D1466500C
Accessories & Spares	Order No.
0.5M Active Gauge Cable	D40001005
100M Active Gauge Cable Assembly	D40001999
10M Active Gauge Cable	D40001100
15M Active Gauge Cable	D40001150
1M Active Gauge Cable	D40001010
25M Active Gauge Cable	D40001250
3M Active Gauge Cable	D40001030
50M Active Gauge Cable	D40001500
5M Active Gauge Cable	D40001050
Aim Body Tube Assy - NW25	D14545801
Aim Body Tube Assy DN40CF	D14661801
AIM-X Elect & Mag Housing	D14642800
NW25 Centering Ring 3D Baffle Viton	D02110000
Spares Kit Aim Body Tube	D14545802
Spares Kit Aim Body Tube DN40CF	D14661802
Surge Protector Box	D40006000

WRG-S Active Wide Range Gauge



The Wide Range Gauge (WRG) family offers the capability of single port pressure measurement in the range atmosphere to 10^{-9} mbar with a linear output. Its a compact solution, halving the space and connectivity hardware requirement, which can be all important in many applications. The WRG has many novel features, including a new patented striker, pushbutton calibration and set point controls and comprehensive diagnostics. The WRG is a cost-effective vacuum management solution when used either with a Edwards controller or directly integrated into the system controls.

4 Features & Benefits

Page
142

- Microprocessor signal processing gives seamless transition between Pirani and magnetron outputs as well as linear output (log pressure scale)
- D-type version including cable strain relief and enhanced ingress protection - IP44
- Low magnetic field version (SL) available for sensitive applications e.g. mass spectrometry and electron microscopy
- Easily programmed set point covering entire measuring range
- Magnetron uses an advanced patented technique for highly reliable striking, even at high vacuum or in relatively contaminated conditions

Dimensions

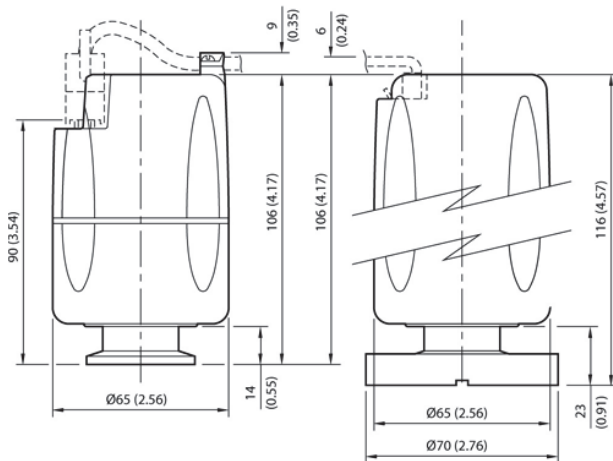

Applications

Any vacuum system where there is a need to measure pressure over a wide range. The WRG with an AGD represents a very simple and cost effective means of achieving this.

The linear output and equation make WRG's an attractive option for industrial OEM's where the gauge may be directly integrated into the process controller.

Performance Curves

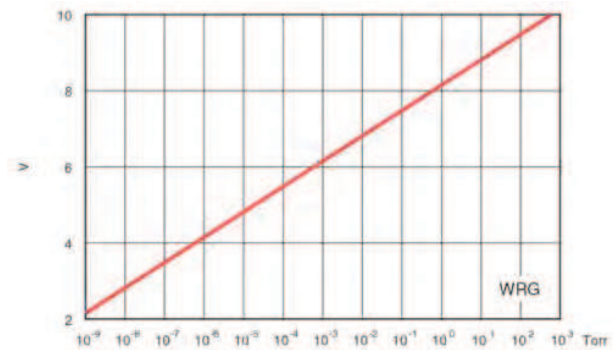
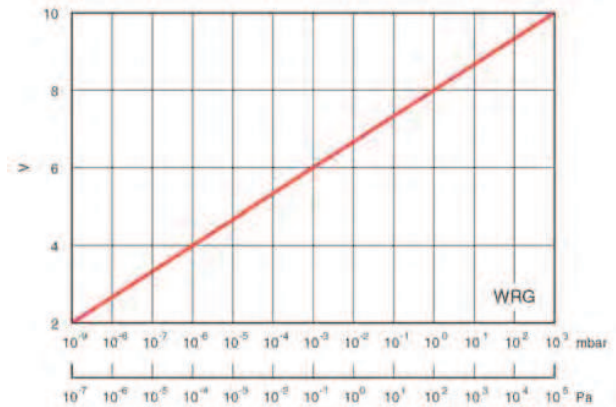

Technical Data

Pressure range	Atmosphere to 10^{-9} mbar/Torr
Accuracy *	Typically $\pm 15\%$ <100 mbar and $\pm 30\%$ < 10^{-3} mbar
Maximum over pressure	6 bar absolute (87 psia)
Power supply	+14.5 to +36 V d.c.
Power consumption	2 W maximum
Output signal	1.8 to 10.2 V d.c.
Adjustments	Atmosphere and setpoint
Set point	Open collector transistor
Maximum voltage	40 V d.c.
Current	100 mA maximum
Temperature range	
Operating	+5 to +60°C
Storage	0 to +70 °C
Materials exposed to vacuum (Both NW and CF versions)	Stainless steel (AISI 304, 316, 321, 347), Fluoroelastomer, soda lime glass, Tungsten, trace of Nickel and Nickel Iron
Internal volume	26 cm ³
Weight	0.8 kg
External interface connector	8-way FCC68 / RJ45 Socket
Interface cables	Use range of active gauge cables
Standards	
Electronic design	EN 61010-1
Electromagnetic compatibility	EN 61326 Industrial Location, Class B emissions
Flame retardant casing	UL94 (V0)
Enclosure rating	IP40
Pin allocation **	
1. Power supply positive	5. Signal common
2. Power supply common	6. Set-point output
3. Gauge output	7. Atmosphere calibration
4. Gauge identification	8. Not connected

* Accuracy is reduced at the limits of the measuring range.

** Not shown on diagram

Ordering Information

Product Description	Order No.
WRG-S-NW25	D14701000
WRG-S-DN40CF	D14703000
WRG-S-NW25, Certified	D1470100C
WRG-S-DN40CF, Certified	D1470300C
WRG-D-NW25	D14702000
WRG-SL-NW25	D14711000
WRG-SL-NW25, Certified	D1471100C
Accessories & Spares	Order No.
0.5M Active Gauge Cable	D40001005
100M Active Gauge Cable Assembly	D40001999
10M Active Gauge Cable	D40001100
15M Active Gauge Cable	D40001150
1M Active Gauge Cable	D40001010
25M Active Gauge Cable	D40001250
3M Active Gauge Cable	D40001030
50M Active Gauge Cable	D40001500
5M Active Gauge Cable	D40001050
NW25 Centering Ring 3D Baffle Viton	D02110000
Spares Kit WRG Electrode Assy	D14701802
Spares Kit WRG Full Body Tube	D14701804
Spares Kit WRG Pirani Tube	D14701803
Surge Protector Box	D40006000
WRG Body Tube Assy DN40CF	D14703801
WRG Body Tube Assy NW25	D14701801
WRG D Adapter Cable 9-Way D/Fcc68	D40003100
WRG-D Elect & Mag Housing NW25	D14702800
WRG-S Elect & Mag Housing NW25	D14701800
WRG-SL Elect & Mag Housing NW25	D14711800

AIGX Active Ion Gauge



A compact Active ion gauge with dual yttria coated iridium filaments, a wide measuring range from 6.6×10^{-2} to 6.6×10^{-10} mbar (5×10^{-2} to 5×10^{-10} Torr) and a 1 Volt/decade linear output.

The new AIGX gauge from Edwards incorporates all the benefits of the industry standard Active gauging concept, with integral electronics and replaceable tube. The gauge has a degas facility and includes features to protect and extend the life of the filaments. The AIGX benefits from extremely low emissions of charged particles, which makes it an excellent choice for processes where background noise is undesirable.

4 Features & Benefits

Page 144

- Full 8-decade measurement capability, to 6.6×10^{-10} mbar (5×10^{-10} Torr).
- Two versions available, each with three vacuum coupling variants:
- 'D' versions have a 9-pin 'D' connector and standard interface;
- Up to a thirty-fold reduction in charged particle process contamination compared to leading competitors.
- Automatic filament protection against switching on at atmosphere and running or degassing at high pressure.

Performance Curves

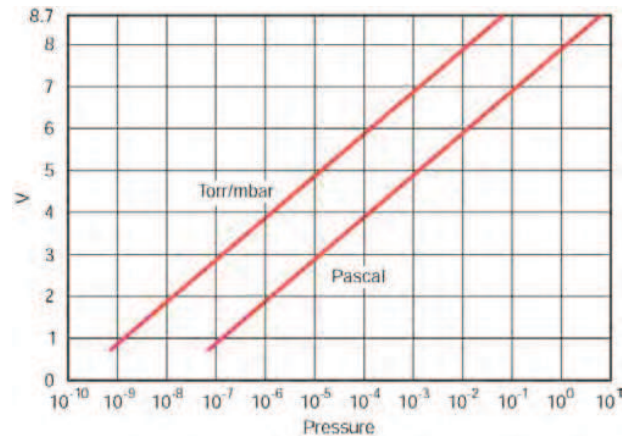

Dimensions

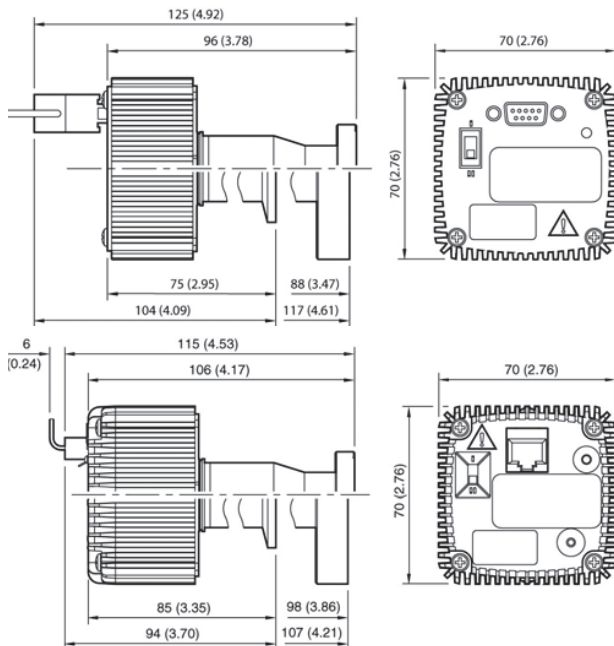

Technical Data

Pressure range	6.6×10^{-2} to 6.6×10^{-10} mbar (5×10^{-2} to 5×10^{-10} Torr)
Power supply	+14.5 to +30.0 V d.c.
Power consumption	Normal operation: 7W (Max), Degas: 14W (Max)
Output signal	Linear, 1 Volt / decade
Response time	1.33×10^{-8} mbar ($>10^{-8}$ Torr) ~ 100 ms 1.33×10^{-8} mbar ($<10^{-8}$ Torr) ~ 2 s
Maximum voltage	30 V d.c.
Maximum current	100 mA max
Temperature range	
Operating temperature	0 to +40 °C
Storage temperature	-30 to +70 °C

For more information, contact Edwards.

Ordering Information

Product Description	Order No.
AIGX-D-NW25	D04860000
AIGX-D-DN16CF	D04861000
AIGX-D-DN40CF	D04862000
AIGX-D-NW25 + calibration certificate	D0486000C
AIGX-D-DN16CF + calibration certificate	D0486100C
AIGX-D-DN40CF + calibration certificate	D0486200C
AIGX-S-NW25 + calibration certificate	D0485000C
AIGX-S-DN16CF + calibration certificate	D0485100C
AIGX-S-DN16CF	D04851000
AIGX-S-DN40CF	D04852000
AIGX-S-DN40CF + calibration certificate	D0485200C
AIGX-S-NW25	D04850000
Accessories & Spares	Order No.
0.5M Active Gauge Cable	D40001005
10M Active Gauge Cable	D40001100
1M Active Gauge Cable	D40001010
3M Active Gauge Cable	D40001030
5M Active Gauge Cable	D40001050
AIGX Fuses Spare Pk5	D04850805
AIGX Tube DN40CF	D04852801
AIGX Tube Spare DN16CF	D04851801
AIGX Tube Spare NW25	D04850801
AIGX-D Electronics Module SP	D04860800
AIGX-S Electronics Module SP	D04850800
DN16CF/1.33 Annealed Copper Gasket Pk 5	C10001270
DN16CF/1.33 Nut & Bolt & Washer M4 Pk 25	C10001630
DN40CF/2.75 Annealed Copper Gasket Pk 5	C10005270
DN40CF/2.75 Nut & Bolt & Washer M6 Pk 25	C10005630
NW25 Trapped O Ring Viton	C10514490

IGC Ion Gauge Controller



The Edwards Ion Gauge Controller (IGC) provides all the power, control and signal conditioning required to run one or two ion gauge heads. When connected to a Edwards TIC Instrument Controller the user has full control of the ion gauge functions from the TIC front panel. This includes features such as automatic emission current selection and interlock with other gauge types.

Alternatively the IGC PCSP (Parallel Command and Station Port) version can be linked directly to a control system such as a PLC to give the OEM or system builder direct access to control inputs and signal outputs.

4 Features & Benefits

Page
146

- Wide measurement range with electron beam degas versions offering 5×10^{-3} to 2×10^{-11} mbar
- Selection of heads available with the choice of electron beam degas, nude or glass encapsulated, tungsten or thoriated iridium filaments
- Flexible cabling system with ion gauge cables which are available in 2 and 3 m lengths including bakeable versions. Active gauge cables to link IGC and TIC Instrument Controller are available in lengths up to 100 m.
- Vacuum interlock through an auxiliary high pressure gauge to protect the ion gauge from accidental operation at high pressure. It can be interlocked through an Active Pirani or thermocouple gauge connected to the IGC or TIC Instrument Controller.
- Ratiomatic measurement system giving improved measurement accuracy and allowing soft start on filament power-up which gives an added degree of filament protection

Dimensions

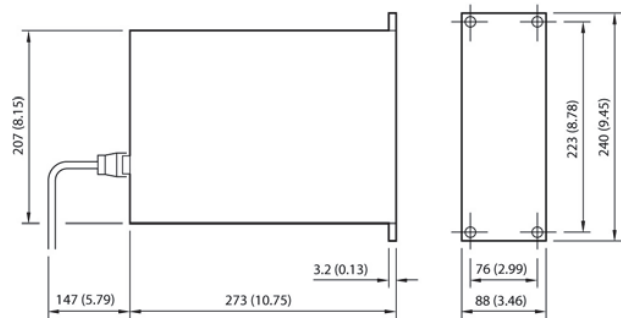

Technical Data

Power supply	
Input voltage range	90 to 265 V a.c.
Input frequency range	45 to 70 Hz
Mains supply socket	IEC 320
Temperature range	
Operating	10 to 50 °C
Storage	-20 to +70 °C
Relative humidity (non condensing)	10 to 90
Standards	
Electronic design	EN 61010-1
Electromagnetic compatibility	EN 61326 (Class B Emissions)
Enclosure rating	IP20
Pressure range	
Electron beam degas (EBEAM)	5 x 10 ⁻³ to 2 x 10 ⁻¹¹ mbar
Output signal	
Electron beam degas (EBEAM)	1 to 10 V d.c. logarithmic
Emission current	0.1, 1.0 or 10 mA (selectable)
Filament power supply	
Voltage	8 V d.c. max
Current	5 A max
Power	40 W max
Degas power	
Electron beam (EBEAM)	60 W max (adjustable)
PCSP interface	Active low (less than 3 V) with internal pull up resistors (150 k W) to 28 V
Connections	
PCSP interface socket	15 way female D-type
TIC interface socket plus	8 way FCC68 / RJ45 socket
Auxiliary gauge socket	8 way FCC68 / RJ45 socket
Ion gauge socket	7 way circular multipole
Dimensions	
Without rack mounting kit	203 x 87 x 273 mm
With rack mounting kit	Half 19" rack, 2U
Weight	1.8 kg

Note: 2 head versions of the IGC will only drive one head at a time

Ordering Information

Product Description	Order No.
IGC EBEAM, 2 Head, PCSP	D04846000
IGC EBEAM, 2 Head	D04847000
Accessories & Spares	Order No.
Half 19 Rack Blanking Kit	D04830301
Half 19 Rack Joining Kit	D04830302
IG Tube Ebeam DN40CF Thoria	D02999390
IG Tube Ebeam DN40CF Tungsten	D02999380
IG Tube I2R 1 Port Thoria	D02998110
IG Tube I2R 1 Port Tungsten	D02998070
IG Tube I2R 2 3/4 CF Thoria	D02998170
IG Tube I2R 3/4 Port Thoria	D02998040
IG Tube I2R 3/4 Port Tungsten	D02998010
IG Tube I2R DN40CF Tungsten	D02998140
IG Tube Nude I2R DN40CF Thoria	D02998390
IG Tube Nude I2R DN40CF Tungsten	D02998380
Ion Gauge Cable EBEAM (Nude) 2m	D04847060
Ion Gauge Cable EBEAM (Nude) 3m	D04847100
Ion Gauge Cable I2R (Glass) 1.8m	D04831060
Ion Gauge Cable I2R (Glass) 3m	D04831100
Ion Gauge Cable I2R (Nude) 1.8m	D04846060
Ion Gauge Cable I2R (Nude) 3m	D04846100
Linecord 2M North Euro Plug	D40013030
Linecord 2M UK Plug	D40013025
Linecord 2m With US Plug	D40013120
Rack Mounting Kit For IGC	D04830300

Model 600 Barocel®



The Model 600 Barocel transducer is an advanced design capacitance manometer which uses advanced technology to improve zero stability after temperature excursions or pressure overloads. An integral vacuum reference of all-welded construction contains gettering material to ensure long-term stability.

In vacuum systems, the Model 600 Barocel transducer is the ideal replacement for McLeod, Pirani, or thermocouple gauges. Since pressure is sensed by electrically measuring pressure-induced displacement of a thin metal membrane, calibration accuracy is unaffected by the chemical composition of input media.

4 Features & Benefits

Page
148

- High accuracy of 0.15 of reading
- High resolution of 0.01 full scale
- Unaffected by overpressure. Repeats within 0.01 full scale after being exposed to 2.4 bar (35 psia)
- True total pressure reading independent of gas composition
- High level output of 0-10 volts d.c. full scale, linear with pressure

Technical Data

Accuracy	±(0.15 of reading + 0.01 of full scale)
Resolution	Better than ± 0.01 full scale
Operating temperature	0 – 65 °C
Temperature effect on zero	<0.005 full scale/°C
Temperature effect on sensitivity	<0.02 reading/ °C
Overpressure without damage	1.25 x full scale range or 2.4 bar (35 psia), whichever is greatest
Overpressure effect	Repeats within 0.01 full scale after 2.4 bar (35 psia) absolute exposure
Materials exposes to process	Inconel and Monel
Internal volume	8.3 cm ³ (includes ½" dia tube)
Time constant	8 msec
Output signal	0-10 V d.c. linear with pressure
Power requirements	±15 V d.c ±5 regulated to ±1 at 30 mA
Weight	0.7 kg (1.5 lb)
Standards	
Electronic design	EN 61010-1
Electromagnetic compatibility	EN 61326 Industrial location (Class A Emissions)

Ranges to 10000 Torr also available
0.5 of reading also available

Dimensions

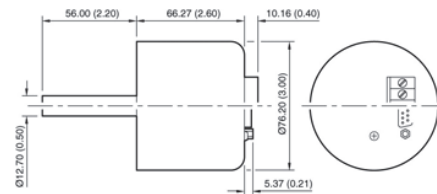

Ordering Information

Connector type
D 15-pin "D"

Pressure range
2 210
3 100
4 1000

Pressure units
1 Torr
2 mbar
P Pascal

Vacuum fitting
1 1/2 inch OD tube
3 1.33 inch Mini ConFlat® 1
6 8 VCR
7 8 VCO
8 NW16

W 6 D 0 - - 1 1

* ConFlat® is a trade mark of Varian, Inc.

Model 622 Barocel®

The Model 622 Bakeable Barocel is an adaptation of the field-proven Model 600 vacuum/pressure transducer, the signal conditioning electronic components are separated from the sensor, allowing it to be operated at 200 °C as required by some applications.

The sensor employs the same high performance features found in the Model 600.

For more information, please contact Edwards or refer to the Documentation tab.



Features & Benefits

- Sensor bakeable and operable to 200 °C
- Fully temperature compensated
- High accuracy of 0.15 of reading
- High resolution which is better than 0.01 full scale
- Stable zero reference

Dimensions

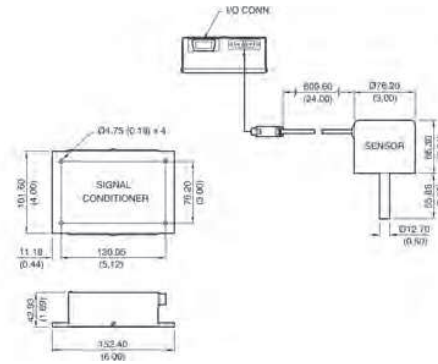

Technical Data

Pressure range	0-10 Torr
Accuracy	±(0.15 of reading + 0.01 of full scale)
Resolution	Better than ± 0.01 full scale
Operating temperature	
Sensor	0 – 200 °C
Signal conditioner	0 – 65 °C
Temperature effect on zero	<0.005 full scale/°C
Temperature effect on sensitivity	<0.02 reading/ °C
Overpressure without damage	1.25 x full scale range or 2.4 bar (35 psia), whichever is greatest
Overpressure effect	Repeats within 0.01 full scale after 2.4 bar (35 psia) absolute exposure
Materials exposes to process	Inconel and Monel
Internal volume	8.3 cm ³ (includes ½" dia tube)
Time constant	8 msec
Output signal	0-10 V d.c. linear with pressure
Power requirements	±15 V d.c ±5 regulated to ±1 at 30 mA
Weight	1.3 kg (2.9 lb)
Standards	
Electronic design	EN 61010-1
Electromagnetic compatibility	EN 61326 Industrial location (Class A Emissions)

Ranges to 10000 Torr also available
0.5 of reading also available

Ordering Information

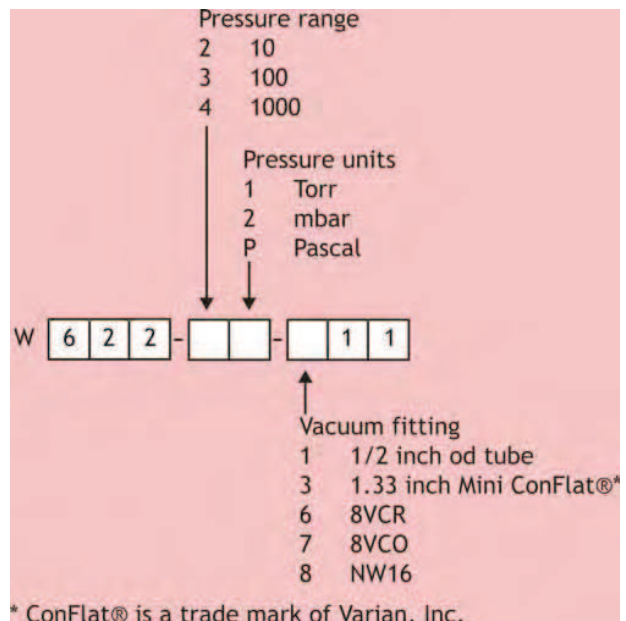

Model 1575 Pressure Display

The Model 1575 Pressure Display is a low cost, microprocessor based, digital display and set-point controller for the Barocel 600, 622 and 655 capacitance manometers. The Model 1575 incorporates power supply, digital display, four user-selectable set-points, along with analog outputs in a compact 1/8 DIN package.



Features & Benefits

- Push button or remote zero adjustment
- Push button full scale calibration
- There are four user programmable solid-state, open collector set-points; two high and two low. The hysteresis band associated with each set-point can also be adjusted to meet system requirements.
- Easy to read LED display
- Optional RS232 output

Ordering Information

Product Description	Order No.
Model 1575, Analog Output, 115V	W60810000
Model 1575, Analog Output, 230V	W60820000
Model 1575, RS232 Output, 230V	W60820004
Model 1575, RS232 Output, 115V	W60810004
Accessories & Spares	Order No.
Cable 1800 To 600 Length 15'	W18997005
Cable 1800 To 655 Length 15'	W18992005
Cable 622 Barocel 1501C/1575	W18999005
Linecord 2M North Euro Plug	D40013030
Linecord 2M UK Plug	D40013025
Linecord 2m With US Plug	D40013120

Technical Data

Signal input	± 10 V d.c.
d.c. output	Transducer input signal
A/D resolution	± 25000 counts
Accuracy ¹	± 0.005% of reading ± 2 counts
Full scale temperature coefficient	20 ppm/ °C
Zero temperature coefficient	.001 ppm/ °C
Zero suppression	± 100% of full scale
Transducer supply	±15 V d.c. at 250 mA (maximum)
Electrical supply (50 - 60 Hz)	
Standard	230 V ac ± 10%
Optional	115 V ac ± 10%
Set-points (4 open collector transistors)	
Voltage (maximum)	50 V
Current (maximum)	100 mA
Hysteresis (both set-points)	0 - 99 counts
Control status	LEDs indicate controls actuated
Temperature range	
Operation	+0 to +55 °C
Storage	-40 to +85 °C
Warm-up time (at 25 °C)	30 minutes
Standards	
Electronic design	EN 61010-1
Electromagnetic compatibility	EN 61326 Industrial Location, Class A Emissions
List of compatible transducers	
Barocels	600, 622, 655

CG16K dial gauge

Edwards CG16K capsule dial gauges are barometrically compensated with NW flange fittings. Designed to cover the range of 0 to 1040 mbar, these robust gauges provide accurate, repeatable performance even at low pressures making them equally suited for non-corrosive process plant or for laboratory applications. Fitting is simple: the gauges can be mounted direct or panel mounted using the kit supplied.



Features & Benefits

- Reading independent of gas type
- Accurate to ± 2 of full scale
- Barometrically independent
- Pipeline or panel mounting
- Easy to read linear scale

Dimensions

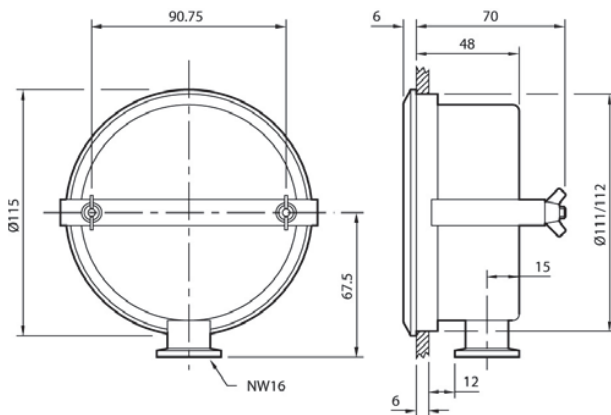

Applications

- Backfilling
- Portable equipment
- Degassing
- Refrigeration
- Flammable vapors

Ordering Information

Product Description	Order No.
CG16K, 0-1040 mbar	D35610000
CG16K, 0-125 mbar	D35611000
CG16K, 0-50 mbar	D35612000
CG16K, 0-25 mbar	D35613000
CG16K, 0-760 Torr	D35630000
CG16K, 0-100 Torr	D35631000
CG16K, 0-40 Torr	D35632000
CG16K, 0-20 Torr	D35633000
CG16K, 0-1040 mbar + calibration certificate	D3561000C
CG16K, 0-125 mbar + calibration certificate	D3561100C
CG16K, 0-50 mbar + calibration certificate	D3561200C
CG16K, 0-25 mbar + calibration certificate	D3561300C
CG16K, 0-760 Torr + calibration certificate	D3563000C
CG16K, 0-100 Torr + calibration certificate	D3563100C
CG16K, 0-40 Torr + calibration certificate	D3563200C
CG16K, 0-20 Torr + calibration certificate	D3563300C

Technical Data

Range	0-1040 mbar, 0-760 Torr 0-125 mbar, 0.100 Torr 0-50 mbar, 0-40 Torr 0-25 mbar, 0-20 Torr
Accuracy	± 2 of full scale deflection
Maximum applied pressure	
25 mbar version	1 bar absolute, 0 bar gauge
Other versions	2 bar absolute, 1 bar gauge
Weight	1 kg
Vacuum connection	NW16 Flange
Accessories supplied	Clamp and studs for panel mounting

IS16K Vacuum Interlock Switch



The IS16K vacuum interlock switch is designed to safeguard the operator by ensuring that electrical circuits in the vacuum chamber do not remain energized when the system is let up to atmosphere.

Typical applications include interlocking of the HT cleaning or process circuits on thin film deposition and vacuum systems.

The IS16K is high vacuum compatible and corrosion resistant, with all wetted parts made from stainless steel. A high current rating allows direct switching of loads without additional relays or external power supplies.

4 Features & Benefits

Page
154

- Single non-adjustable set-point, cannot be tampered with
- Positive break switch
- Rapid contact separation, prevents arcing
- Breaks circuit directly, no relays required
- Corrosion resistant materials exposed to vacuum

Dimensions

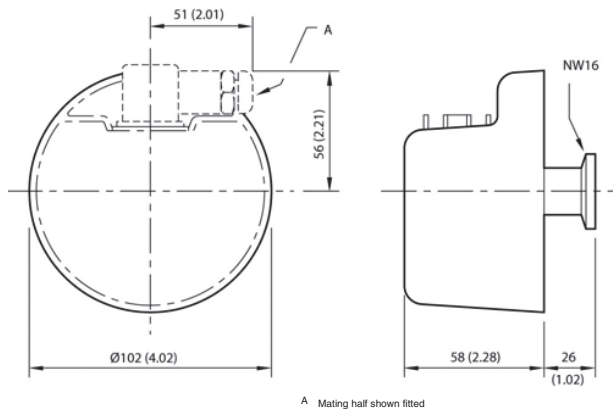

Applications

- Furnaces
- TV tube manufacture
- Laboratories
- Tank units
- Packaging

Ordering Information

Product Description	Order No.
IS16K Vacuum Interlock Switch	D05914000

Technical Data

Fixed set-point	640 \pm 120 mbar*
Maximum switching differential	100 mbar
Maximum working pressure	1 bar gauge (2 bar absolute)
Electrical rating	10 A resistive, 5 A inductive at 250 V a.c.
Electrical connection plug	Type 283 mPm
Internal volume	7 cm ³
Materials in vacuum	Stainless steel
Leak rate	<1 x 10 ⁻⁹ mbar l s ⁻¹
Enclosure classification	IP52
Weight	0.7 kg
Vacuum connection	NW16
Accessories supplied	Mating electrical socket type 183 mPm

* Set point varies with barometric pressure

VS16K Adjustable Vacuum Switch

The VS16K is a general purpose vacuum switch with a user adjustable set-point and small switching differential. This diaphragm operated vacuum switch is high vacuum compatible and corrosion resistant with all wetted parts made from stainless steel. A high current rating allows direct switching of loads without additional relays or external power supplies.

This switch should not be used for safety critical applications. For many interlock applications the Edwards IS16K may be more suitable.



Features & Benefits

- Set-point range 30-1000 mbar
- User adjustable
- Reproducible
- Changeover contacts for normally open or normally closed operation
- Switch point independent of gas composition

Dimensions

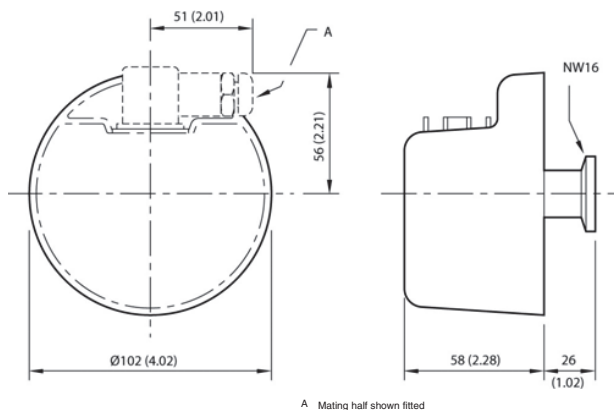

Applications

- Furnaces
- TV tube manufacture
- Laboratories
- Tank units
- Packaging

Ordering Information

Product Description	Order No.
VS16K Adjustable Vacuum Switch	D05915000

Technical Data

Range of adjustment	30 to 1000 mbar
Maximum switching differential	30 mbar
Maximum working pressure	1 bar gauge (2 bar absolute)
Electrical rating	10 A resistive, 5 A inductive at 250 V a.c.
Electrical connection plug	Type 283 mPm
Internal volume	7 cm ³
Materials in vacuum	Stainless steel
Leak rate	<1 x 10 ⁻⁹ mbar l s ⁻¹
Enclosure classification	IP52
Weight	0.7 kg
Vacuum connection	NW16
Accessories supplied	Mating electrical socket type 183 mPm

Set-point varies with barometric pressure