



AGILENT TURBO PUMPS

2-5	Introduction
6-7	Molecular Drag Technology
8-9	Agilent Floating Suspension
10-11	Turbo Pump Technology
12-13	Turbo Pump Technology for Instrumentation
14-17	Typical Applications
18-45	Turbo Pump Models
46	Accessories
47-49	Technical Notes
50-52	Service and Support Plans



Agilent Technologies

INTRODUCTION

The Agilent Advantage

A complete family of Turbo Pumps including the innovative break-through TwisTorr FS pumps.

- Agilent turbo pumps are designed for reliability and optimum performance in real world applications to meet highest quality standard
- Our pump range also includes integrated pumping systems, multiflow pump solutions for scientific instruments, and dedicated solutions for vibration-sensitive applications in nanotechnologies



2015 • Agilent expands the TwisTorr family with the new 84 FS

2013 • Agilent launches the TwisTorr 304 FS with Floating Suspension, the patented innovative, most reliable and high performing 300 l/s pump in the market

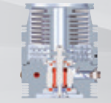

2010 • Agilent Technologies, having acquired Varian, presents the new TwisTorr molecular drag technology based on its well-known hybrid Turbo Molecular Pump design, introducing a spiral drag section that achieves unmatched performance in both pumping speed and compression ratio in the most compact space available. New state-of-the-art electronics complete this industry leading Turbomolecular Pump innovation



2004 • Varian develops a dedicated range of SEM products that meets the most stringent requirements of the industry



2003 • With the Turbo-V 2K-G Varian, now Agilent, introduces a fully integrated Turbo pumping system



1996 • Introduction by Varian of microprocessor-based on-board controller units: Navigator line, for computer driven plug-and-pump operation



1991 • Varian introduces a new hybrid type Turbo Molecular Pump: one monolithic rotor provides both high speed (Turbo stages) and high foreline tolerance (MacroTorr stages)
• Use of ceramic ball bearings with life-time lubrication using a proprietary dry solid lubricant



1986 • Varian begins collaboration with Elettrorava for turbomolecular pump technology and know-how transfer



Turbopump Operating Principles

Turbomolecular pumps consist of a series of bladed impellers rotating at high speed and fixed bladed stators. These impellers and stators are alternately spaced and are inclined in opposite directions.

The pumping action is based on momentum transfer from the fast moving impeller surface to the gas molecules. The speed of the moving surface must be as high as possible to achieve optimum pumping efficiency in terms of pumping speed and compression ratio. When this mechanism takes place several times in a pump a pumping action is created. The sequence of alternating rotors and stators typical of a conventional

turbomolecular pump develops the compression ratio. Turbomolecular drag pumps operate according to the same principle, but with a different geometry in the pumping stages. Gas molecules collide against a fast moving wall and are dragged into a channel toward the high pressure region. Conventional turbomolecular pumps have high pumping speed but low compression ratio at foreline pressures higher than 10^{-1} mbar. Molecular drag pumps have low pumping speed but high compression ratios up to foreline pressures of more than 20 mbar. When the two types of stages are combined together in one pump, extended operational pressure ranges can be achieved.

TURBO PUMPS

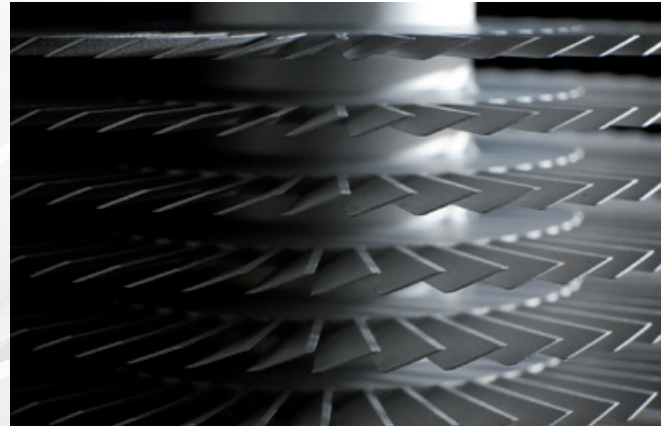

Turbomolecular Pump Parameters and Definitions

Throughput

“Throughput” is the flow rate of pumped gas through the turbomolecular pump (and foreline pump).

Throughput (Q) is measured in mbar l/s 1/60 standard cm³/min. The maximum throughput a pumping system can handle is, in general, dependent upon the size of its foreline pump rather than the turbomolecular pump.

Pumping Speed

“Pumping speed” (S) (volumetric flow rate) of a turbomolecular pump is the ratio between throughput and inlet pressure (foreline pump size must be the recommended one as a minimum).

$$S = Q / p$$

The pumping speed of a turbomolecular pump is constant over a wide pressure range and depends upon geometric factors such as diameter and rotational speed. For most turbomolecular pumps, pumping speed is nearly independent from gas species (molecular weight).

Compression Ratio

“Compression Ratio” is the ratio between foreline (partial) pressure and inlet (partial) pressure for a given process gas, measured in “zero flow” conditions (performed by injecting the process gas in the pump foreline while the high vacuum port is blanked off).

Compression ratio is generally indicated with the letter “K”. In technical specifications of turbomolecular pumps, it is the maximum attainable value of K (at low foreline pressure).

Compression ratio is, in fact, a function of the foreline pressure as shown in Figure 1.

Compression ratio decays at high pressure depending on turbomolecular pump configuration (the number of molecular stages) and/or power limitations that slow down the rotor (gas friction increases with pressure).



INTRODUCTION

The maximum compression ratio is strongly influenced by gas species: it is an exponential function of the molecular weight of the pumped gas (compression ratio is considerably lower for light gases).

Pumping Speed and Pressure Ratio

The pressure ratio between foreline and inlet pressures in each operational situation is indicated by "Rp". This is, in general, equal to pumping speed ratio

$$R_p = p_{foreline} / p_{inlet} = S_{eff} / S_{foreline}$$

where S_{eff} is the effective pumping speed, and $S_{foreline}$ is the pumping speed of the foreline pump.

In fact

$$Q = S_{eff} p_{inlet} = S_{foreline} p_{foreline}$$

therefore

$$S_{eff} / S_{foreline} = p_{foreline} / p_{inlet}$$

The pumping speed of a turbomolecular pump is minimally affected by pressure ratio (and foreline pump size) in most common operational conditions (when pressure ratio is much smaller than K).

Generally, however, the effective pumping speed " S_{eff} " is a linear function of the pressure ratio " R_p " as shown in Figure 2 (and therefore is also dependent upon the size of the backing pump).

S_{eff} reaches its maximum value "S" (nominal pumping speed) when " R_p " equals unity, and it is zero when the pressure ratio R_p has reached its maximum value "K".

This linear dependence can be expressed by the following relationship:

$$S_{eff} = S / (1 - 1 / K + S / S_{foreline}K) \tag{1}$$

As it can be seen:

when

$$K \gg S / S_{foreline}$$

and

$$K \gg 1$$

then

$$S_{eff} \cong S$$

when

$$K \cong 1$$

then

$$S_{eff} = S_{foreline}$$

The above formula (1) must be used to evaluate pumping speed when operating at high pressure, especially with light gases (low K).

Base Pressure

The base pressure of a turbomolecular pump is the equilibrium pressure between outgassing of pump surfaces exposed to high vacuum, including test dome, and the pumping speed of the pump.

$$p_{base} = Q_{outgas} / S_{eff}$$

In the case of ultimate operational pressure, as specified by norms, the pressure is measured after 48 hours bakeout of pump and dome (provided with metal gasket); therefore the prevailing outgassing product is H₂ and equilibrium is reached with hydrogen pumping speed.

$$p_{base} = Q_{H_2} / S_{effH_2}$$

When foreline pumps with relatively high base pressures are used, base pressure is sometimes limited by the compression ratio for H₂O (or N₂).

$$p_{base} = p_{forelineH_2O} / K_{H_2O}$$

Figure 1 - Compression Ratio vs Foreline Pressure

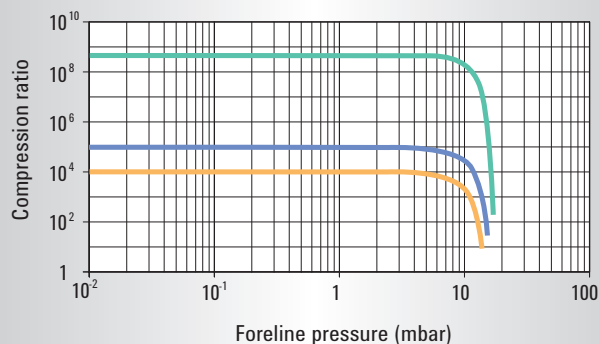

— Nitrogen — Helium — Hydrogen

Figure 2 - Pumping Speed vs Inlet Pressure

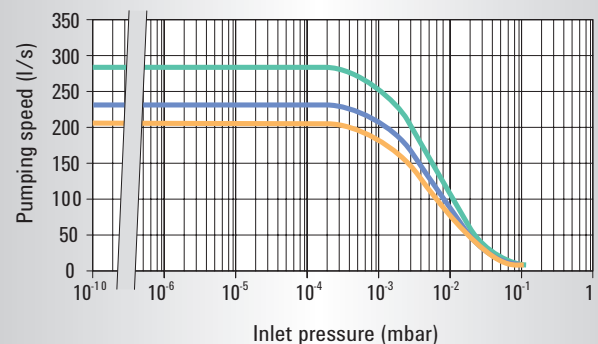

— Nitrogen — Helium — Hydrogen



Pump Selection

How to Select a Turbo-V Pump

The right choice of a turbomolecular pump depends on the application; as a general rule we can reduce the choice to two types of use:

UHV (no gas flow) operations and Process Gas flow operations.

– UHV (no gas flow) operations.

The former case includes most cases in which the turbomolecular pump is employed to create vacuum in systems where the gas load is mainly produced by outgassing. In this application the choice is typically based on the desired base pressure within a desired time as a function of the foreseen outgassing rate, i.e.

$$S_{\text{eff}} = Q / p$$

where:

- p is the desired base pressure (mbar)
- Q is the total outgassing rate at the desired time (mbar l/s)
- S_{eff} is the effective pumping speed

– Process Gas flow operations.

The second case relates to all operations where process gases must be used. The main parameters are therefore the desired operation pressure and the process gas flow

$$S_{\text{eff}} = Q' / p'$$

where Q' is the total gas flow and p' is the operating pressure.

How to Select the Backing Pump of a Turbomolecular Pump

The selection of a backing pump should be based analyzing two requirements of the vacuum system:

- a. the roughing time
 - b. the minimum recommended backing pump of the turbo
- a. Roughing: once the desired roughing time is established, the size of the forepump can be determined through the following formula:

$$S_{\text{foreline}} = (V / t) \ln (p_0 / p_1)$$

where

- S_{foreline} is the pumping speed of the roughing pump (l/min)
- V is the volume of the chamber to be evacuated (l)
- t is the desired roughing time (min)
- p_0 is the starting pressure (mbar)
- p_1 is the end pressure (mbar)

When using a foreline pump much larger than the recommended size, a by-pass line might be necessary to achieve calculated roughing time.

- b. Backing: the backing pump must be big enough to achieve an effective pumping speed as close as possible to the nominal speed.

$$p_{\text{foreline}} = Q / S_{\text{foreline}}$$

where

- S_{foreline} is the pumping speed of the foreline pump
 - Q is the gas load
 - p is the operating foreline pressure
- It should be noted that Q is the total gas load on the pump and includes process gases and turbo purge gases when used. The size of the backing pump can be calculated according to the following rule:

$$S_{\text{foreline}} \geq 20S / K$$

where

- S is the pumping speed of the turbopump
- S_{foreline} is the pumping speed of the backing pump
- K is the maximum compression ratio of the turbopump for a given gas (i.e.: process gas) at the operating foreline pressure.

The pumping speed of the backing pump should be the higher of the two values calculated as above (roughing and backing). Finally, it is possible to use a dry pump (scroll or diaphragm) for hydrocarbon-free operation when pumps of the MacroTorr type are used.

MOLECULAR-DRAG TECHNOLOGY

Drag Technology allows higher foreline pressure, higher efficiency and smaller backing pump in a very compact design. Agilent solutions are designed using state of the art, proprietary numerical modeling. We offer optimized solutions for:

- Pumps with high compression ratio for UHV applications requiring lowest base pressure
- Pumps with high pressure differential for high throughput
- Pumps with high discharge pressure allowing downsizing of the complete vacuum system

Agilent developed two innovative molecular drag stages technological platforms: TwisTorr and MacroTorr.

AGILENT TWISTORR TECHNOLOGY*

- Pumping effect is created by a spinning rotor disk which transfers momentum to gas molecules
- Gas molecules are forced to follow spiral groove design on the stator. The specific design of the channel ensures constant local pumping speed and avoids reverse pressure gradients, minimizing power consumption

(*) US Patents applications 12/343961 and 12/343980, 24 Dec. 2008.

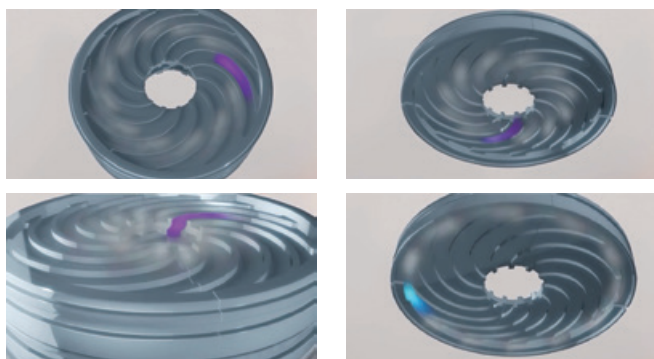

Centripetal pumping action

Lower surface area of rotating disk transfers momentum to gas molecules.

Spiral groove design on the upper section of the TwisTorr stator causes a **centripetal** pumping action).

Centrifugal pumping action

Upper surface area of rotating disk transfers momentum to gas molecules.

Spiral groove design on the lower section of the TwisTorr stator causes a **centrifugal** pumping action.

Loading Edge Performance

- The TwisTorr Pumps offer the highest pumping speed in their category for all gases
- The state of the art TwisTorr technology also achieves the highest compression ratios for light gases in a commercially available Turbo Molecular Pump
- Besides offering the highest performance, average power consumption results particularly low

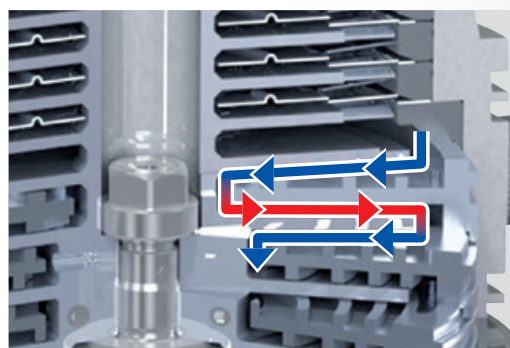

Gas flow in centripetal and centrifugal direction through TwisTorr channels

Space Saving Design

- Our rotor is based on the proven Agilent monolithic rotor design which positions the TwisTorr Stator between two smooth spinning disks and therefore exploits the pumping action by both disk surfaces in series
- The double-sided spiral groove design on the TwisTorr stators combines centripetal and centrifugal pumping action in series, greatly compacting the size of the drag section

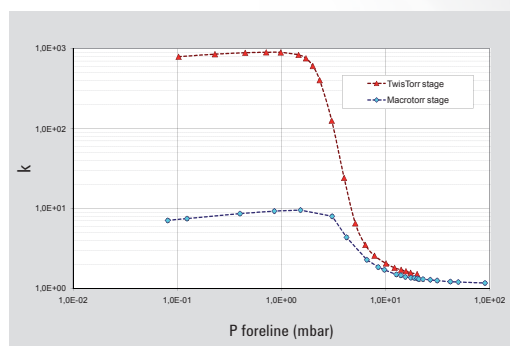

Compression Ratio

- Compression ratio for N₂ of a single TwisTorr stage can increase up to a factor of 100 with respect to a conventional stage of the same space and rotor speed, providing exceptional foreline tolerance and pumping speed

TURBO PUMPS

TwisTorr Technology in Agilent Turbo Pumps



Turbo section: turbo stators



Turbo section: aluminum rotor with turbo stages designed to optimize pumping speed for light gases



Drag section: New TwisTorr technology TwisTorr drag stages (spiral channels) designed for high compression ratio performances

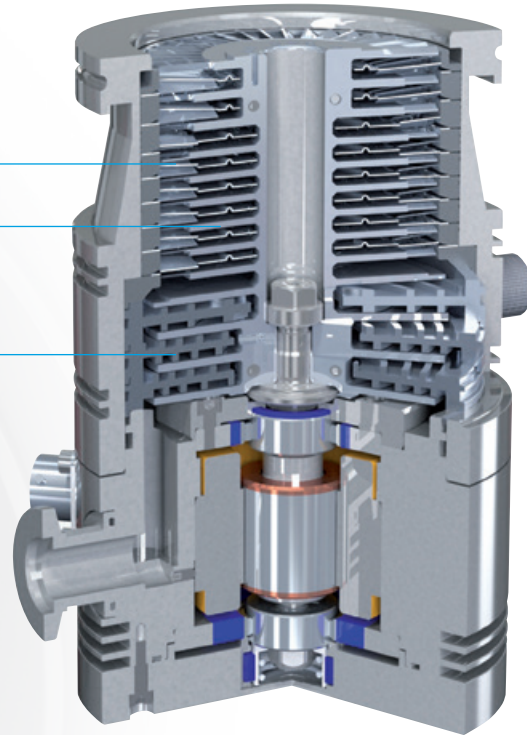

Turbo Pumps

AGILENT MACROTORR TECHNOLOGY

The MacroTorr Concept

Agilent patented MacroTorr design is based on the idea of replacing (rather than adding) molecular impeller disks to some turbo bladed stages.

The molecular impellers consist of a disk rotating in a channel in which the inlet and outlet are divided by a wall. The cross section of the channels decreases from the top to the bottom of the pump (from high vacuum to low vacuum or from the low pressure to the high pressure zone).

Gas molecules gain momentum after each collision with the moving surface of the impeller. The gas is then forced to pass through a hole to the next stage due to the wall.

The result is a product that, with the same dimensions as a conventional turbopump, provides: high compression ratios for light gases and high compression ratios at high foreline pressure. This allows the use of a very small mechanical pump while maintaining a low inlet pressure, or the use of a dry pump, for an oil free environment, and high throughput capacity at inlet pressures greater than 10^{-3} mbar.

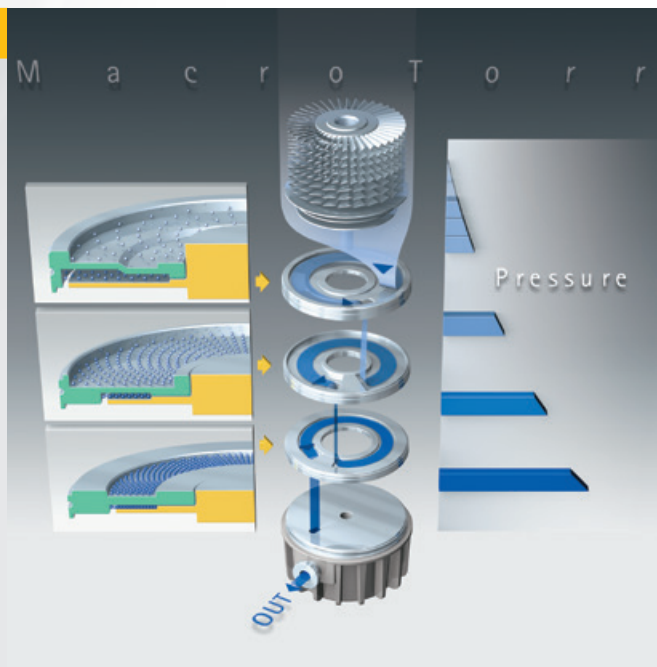

FLOATING SUSPENSION

AGILENT FLOATING SUSPENSION

The Turbomolecular pumps' rotor rotates at very high speed to provide the necessary pumping effect. In that operative mode there are several crucial parameters to be rigorously controlled and managed:

- radial positioning
- axial alignment
- bearings axial pre-load

Agilent designed a patented innovative suspension technology that gives to Agilent Turbo Pumps the best dynamic behaviour, resulting in low noise, low vibration, longer bearings' life, and exceptional stability over time.

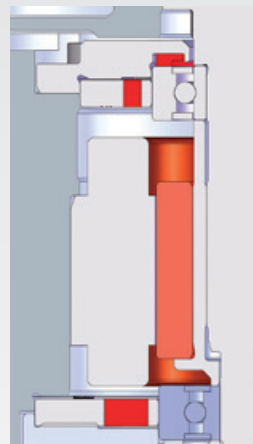
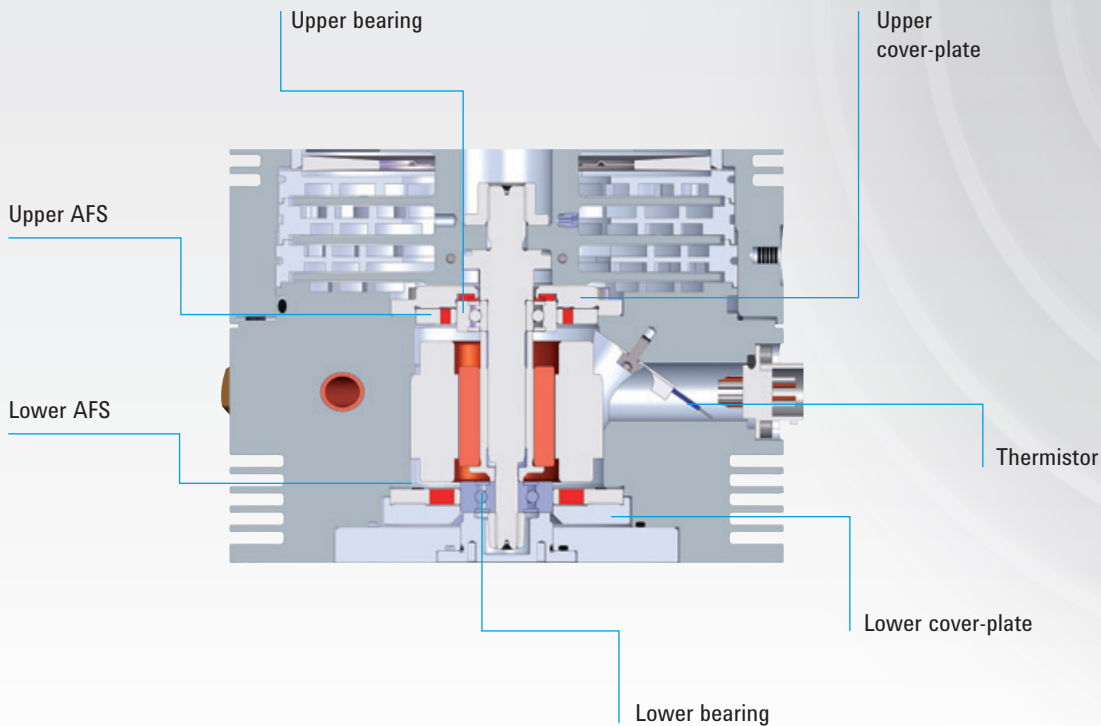

Mechanical Design

SST shaft screwed on Al rotor to provide rotor stability (bending effect, behaviour under external shock loads)
Agilent Floating Suspensions (AFS)

- AFS geometrical precision to guarantee bearing alignment
- Designed radial stillness to optimize rotor dynamic behaviour and acoustic noise
- Lower AFS acts as an axial spring to provide bearing's constant preload and rotor axial positioning
- Thermal stability
- Vibration stability over time

TURBO PUMPS

To ensure

- Low vibration and acoustical noise
- Optimal working conditions for the bearings, extended operating life
- Exceptional stability for the very demanding SEM application

- AFS geometrical precision guarantees perfect bearings alignment
- Designed radial and axial stiffness, optimized rotor dynamic behaviour and acoustic noise
- Lower AFS acts as an axial spring providing bearing's preload and rotor axial positioning
- Thermal stability



TwisTorr 304 FS



TwisTorr 84 FS

Lower AFS

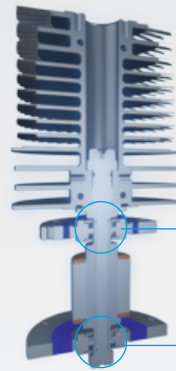
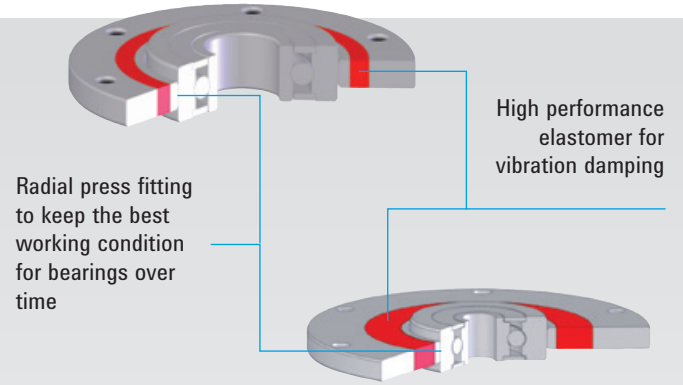
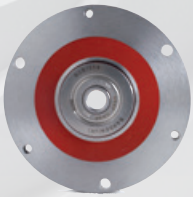

Perfect bearing alignment

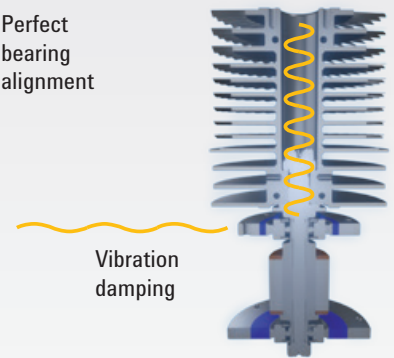

Vibration damping

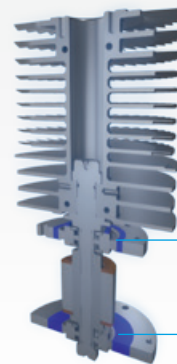

Thermal stability

Optimized rotor dynamic behaviour

TwisTorr 84 FS

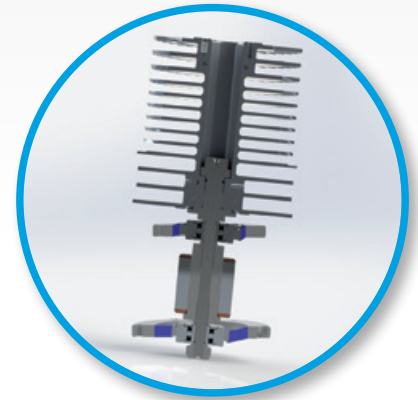

TURBO PUMP TECHNOLOGY

Wide Pumping Speed Range: 80 to 2,200 l/s

Agilent offers a complete range of turbomolecular pumps, to cover all applications and market segments.



Controllers

- Various configurations available to match each application's requirements
- Rack type display controllers, to match your existing system architecture
- Low voltage - PCB units, to fully integrate turbopump electronics into your system's electronics
- Navigator on board controllers, for plug-and-pump operation driven by the computer of your system
- Truly integrated electronics, completely embedded in the pump body



Molecular Drag Technology & Pumping Efficiency

- MacroTorr and TwisTorr technologies allow higher foreline pressure, higher efficiency and smaller backing pump, in a very compact design
- Agilent R&D Team has the capability to optimize the pump performances for different applications

TURBO PUMPS



Controller and T-plus SW

- T-plus Software runs on a PC or laptop and is an effective operation and trouble shooting interface
- It enables complete remote control of the pump
- It is available for all controllers, when equipped with serial port, for data logging and displaying



Ceramic Ball Bearings

- Agilent was the first to introduce permanently lubricated ceramic ball bearings in turbomolecular pumps in 1992
- From there, bearings' quality and reliability have dramatically improved
- Now typical MTTF well exceeds 200,000 hours



Application Specific Solutions for SEM

A complete line of turbo pumps dedicated to Electron Microscopy. (See page 12-13)



Oil Free - Permanent Lubrication

- Permanent lubrication is possible thanks to the extremely low vapor pressure of the solid lubricant
- This solution allows pump operation in any position
- No maintenance, no oil, no refill and most important no contamination



Thermal Efficiency & Temperature Control

- The correct design of pumping stages, motor and electronics allows low heat dissipation and low power consumption
- Total temperature control within the pump is important for reliable long-term operation. All our pumps are equipped with at least one temperature sensor
- Controllers manage temperature information related to other operational parameters, for an evenly distributed and controlled temperature within the pump
- These, in combination with efficient air and water cooling systems, are key factors for reliability, in any application



Rotor

- Suspension axial/radial perfect positioning
- Vibration damping
- Correct bearing pre-load

TURBO PUMP TECHNOLOGY FOR INSTRUMENTATION

The Agilent Advantage: Masters in Mass Spec and Nanotechnology

As the leading Ultra-High Vacuum products supplier, Agilent Technologies has long been working with all MS, SEM and TEM manufacturers, providing application specific solutions.

Today Agilent is the only company able to offer a complete and dedicated range of MS and SEM products, including primary pumps, turbomolecular pumps, ion getter pumps, and vacuum measurement, that meet the most stringent requirements of the industry.

Turbo-V SEM versions are available on request; please ask Agilent for technical details.

Vacuum for SEM: basic requirements

- Vacuum in the gun and sample chamber must be particle-free and oil-free
- **No Vibrations**
- **No Resonances**
- **No** Magnetic stray fields from both IGP and TMPs
- **No** Electric noise from power supplies
- **Fastest** Pumpdown cycles
- Pressure levels stable and controlled
- Maximum Uptime
- Fast, worldwide Service Support

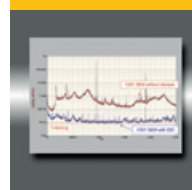

Superior Vibration Isolation System

- Lower vibrations than Mag-Lev!
- Certified Computer Aided Balancing, thanks to suspended benches with special high sensitivity accelerometers



Foreline Pressure up to 15 mbar

- Ideal to minimize forepump size (i.e. IDP-3 Dry Scroll Pump, DS 42 Rotary Vane Pump), resulting in the lowest cost of ownership

TURBO PUMPS

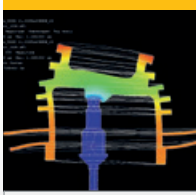

Improved Roto Dynamics

- Designed to avoid internal mechanical resonances
- Agilent SEM turbopumps are designed to minimize vibration sources, and have a very stable vibration profile



Enhanced Electronic Controllers

- Universal voltages
- Integrated Vent valve command, adjustable valve delay and opening time
- Pressure gauge reading
- Integrated Profibus



Monolithic Rotor

Mounting in any position, with no limitations.

- Rugged design
- Light weight
- Air inrush proof
- Earthquake proof

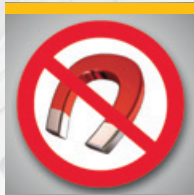

Magnets Free Design

- Lowest Magnetic Signature in the industry
- Best to work very close to ebeams
- No need for magnetic shields



Integrated Double Dampers

- Agilent developed special Integrated Double Dampers for the most demanding SEM applications
- Damping factor up to 1400X (Radial, at unbalance level, with IDD100 ISOK): better than Mag-Lev!
- Best SEM image resolution

AGILENT TURBO PUMPS TYPICAL APPLICATIONS

Research and Development Particle Accelerators

- Turbomolecular pumps are widely used in High Energy Physics, Fusion Technology and general UHV research. Synchrotron Light Sources, Particle Accelerator Rings, UHV Laboratory research, and Fusion reactors need extremely clean, reliable and cost effective HV and UHV.F Maintenance-free pumps are specifically required, because most pumps are not easily accessible.
- Agilent turbomolecular pumps are designed to offer unmatched reliability, performance and cleanliness for these applications. Ceramic bearing pumps, thanks to their reduced rolling friction, low stress and high thermal stability compared to conventional bearings, deliver longer operating life. Ultra low vapor pressure solid lubricant eliminates the need for maintenance and assures clean operation under any operating conditions.
- Furthermore, in contrast to most of the other pumps, all Agilent turbopumps have both the upper and the lower bearing in the rough vacuum side and not exposed to UHV, further reducing the possibility of contamination - even in case of misuse.

- The patented TwisTorr stages provide the highest speed and compression ratio in the smallest footprint; furthermore all Agilent turbopumps can truly be mounted in any orientation, from vertical to horizontal to upside down, aiding system design in the most stringent space requirements.
- Agilent turbopumps can operate at higher foreline pressures, allowing the use of dry roughing pumps, thus providing a completely clean, oil-free compact and cost effective pumping package.
- Whenever a large amount of gas has to be pumped and higher throughput is needed, the combination of TwisTorr pumps and TriScroll dry pumps is the state-of-the-art solution. All Agilent turbopumps have integrated or on board controller versions allowing easy plug and pump operation, or a rack-mounted controller for applications where the electronics need to be remotely placed (i.e. radioactive environments).

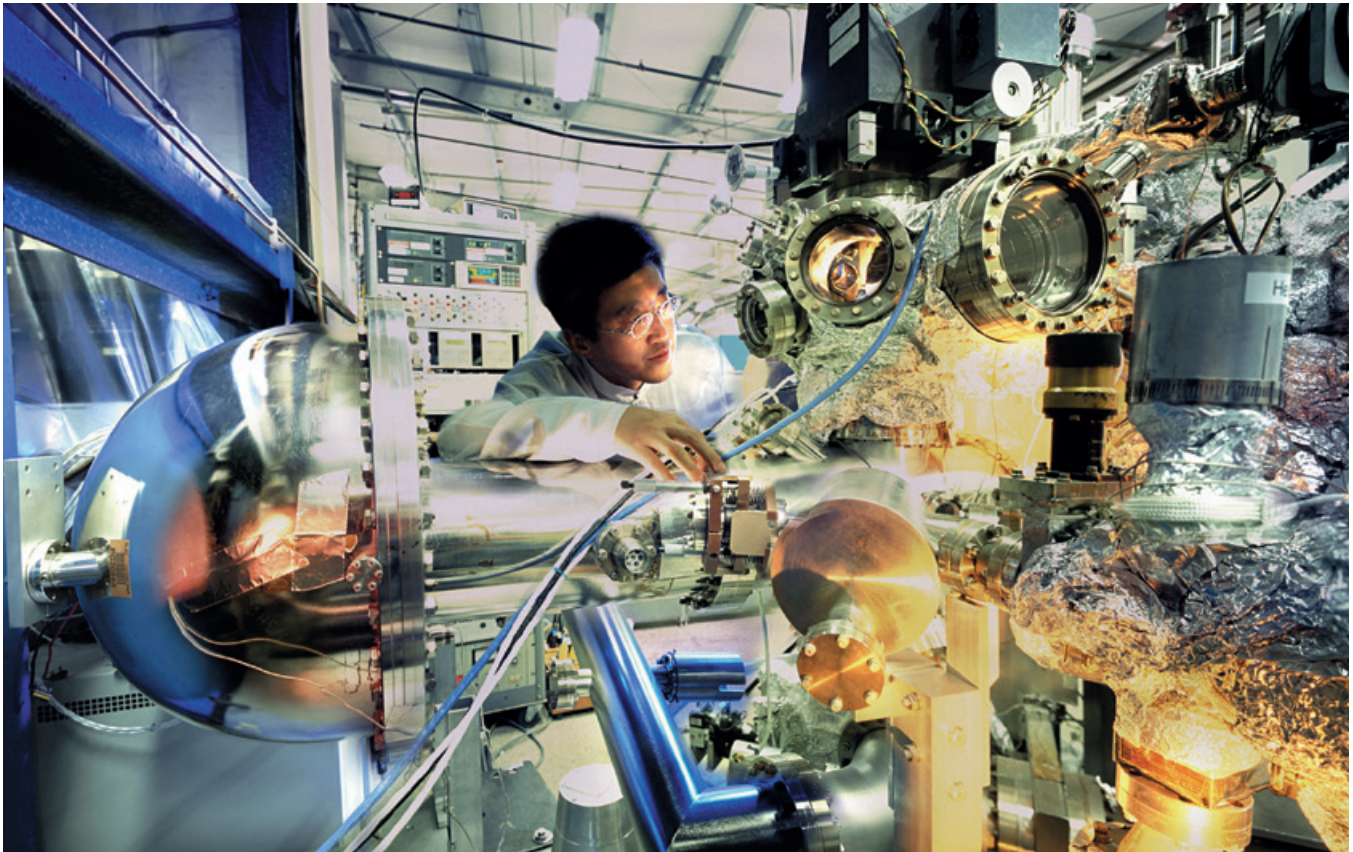

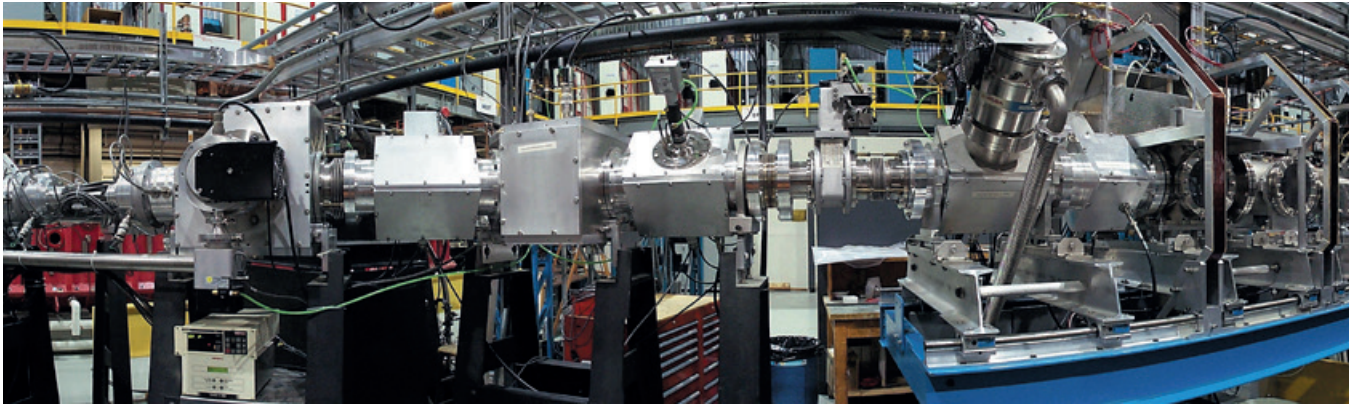

Courtesy TRIUMF-ISAC.

Instrumentation

Electron Microscopy (SEM, TEM), Focused Ion-beam Systems (FIB) and Surface Analysis

- Modern focused-beam systems such as SEM's, TEM's and FIB's utilize columns that project electrons or ions onto microscopic samples for detailed analysis. End users analyze all types of substances from organic compounds to semiconductor wafers. In the Semiconductor industry, in particular, they require more sensitivity for better sample resolution. Another key requirement is high sample throughput in order to lower the cost of ownership of these instruments.
- Based on these requirements, the demand for high performance vacuum pumps is greater than ever. Agilent offers a full range of high and ultra-high vacuum pumps designed especially for the demanding requirements of SEM's, TEM's and surface analysis systems (Agilent has a full range of ion pumps, which are key products for this application; please see ion pump section).
- Turbo molecular pumps are also a key component in modern focused-beam systems because they offer fast, oil-free air evacuation of large sample chambers (oil-free operation is a key requirement of many modern analysis applications such as semiconductor manufacturing). From Agilent's full range of turbo pumps, the focused-beam system designer can choose a pump size that offers the best chamber evacuation time with the best cost of ownership and compact size for use in limited space situations.
- Agilent has a full line of customized, low vibration turbo pumps for the most sensitive microscopy applications. Finally, Agilent has a full range of integrated pump controllers that offer the highest control flexibility with near zero electromagnetic noise generation.
- **Agilent offers a full range of application specific designed SEM turbo pumps including 80 l/s, 300 l/s, 550 l/s, 700 l/s and 1000 l/s speeds.**

All of Agilent's SEM turbo pumps designs can be verified in Agilent's application lab. Finally, each SEM turbo pump is tested in production before being shipped to the customer.

Mass Spectrometry

MS is our core business and has become a fundamental analytical tool in many industries. Thanks to advances in electronics, instrument designers can implement cost-effective, high-performance analytical power in a cost-effective, easy-to-use system.

These developments require advanced vacuum systems that are characterized by multi-chamber, high throughput designs on the high quality instruments.

These requirements, in turn, demand cost-effective, high performance vacuum pumps.

Agilent offers a full line of pumps and controllers that meet the most challenging vacuum requirements and are optimized for the specific requirements of modern mass spectrometry systems.



Agilent Split Flow Turbo Pumps

AGILENT TURBO PUMPS TYPICAL APPLICATIONS

Agilent can further customize its pumps by providing multi-inlet pumping systems that are compact and reliable. A few common application examples for mass spectrometry are listed below:

- **GC-MS**

Gas Chromatograph Mass Spectrometers typically use one vacuum chamber in relatively low gas load environments and an intermediate vacuum interface to analyze inorganic samples.

The Agilent Turbo-V 81 with printed circuit board controller (PCB) is a very cost-effective solution for this common analytical technique. The V 301 Navigator offers a compact, cost-effective solution for larger instrument designs.

- **LC-MS**

Liquid Chromatograph Mass Spectrometers typically include multi-chamber, high throughput vacuum systems.

Agilent's turbomolecular pumps are designed for high throughput operation with air cooling – an important benefit for maintaining a compact system. They are also available in several split flow versions to increase their utility and performance in this application.

The integrated controller provides a high level of control function in a small package.

- **ICP-MS**

Inductively Coupled Plasma-MS systems have a wide range of vacuum requirements. Many systems can use heavy carrier gases such as argon, while collision cell designs use helium.

Agilent turbopumps have a high efficiency motor and TwisTorr or MacroTorr drag stages to reduce heat production under gas load. These features allow to pump high levels of argon. Integrated or on board controllers assure compact package.

- **TOF**

Time Of Flight systems are becoming very important analytical tools in drug discovery and proteomics. Vacuum requirements vary, although small size is often an important consideration.

Agilent turbopump and controller package provides the TOF designer with a high degree of flexibility with regard to high throughput, efficient heat dissipation and compact size.

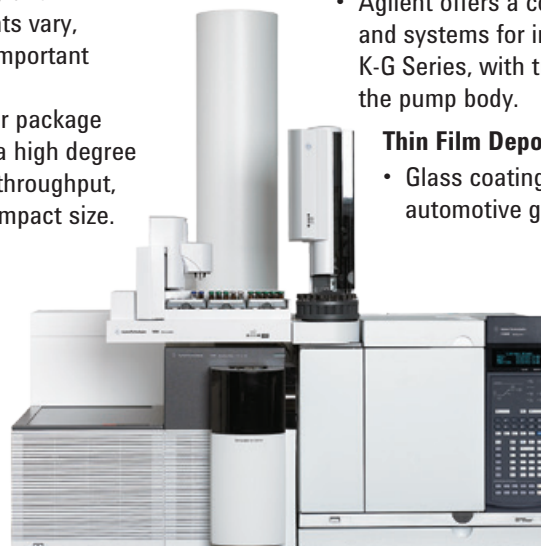

Industrial Vacuum Processing

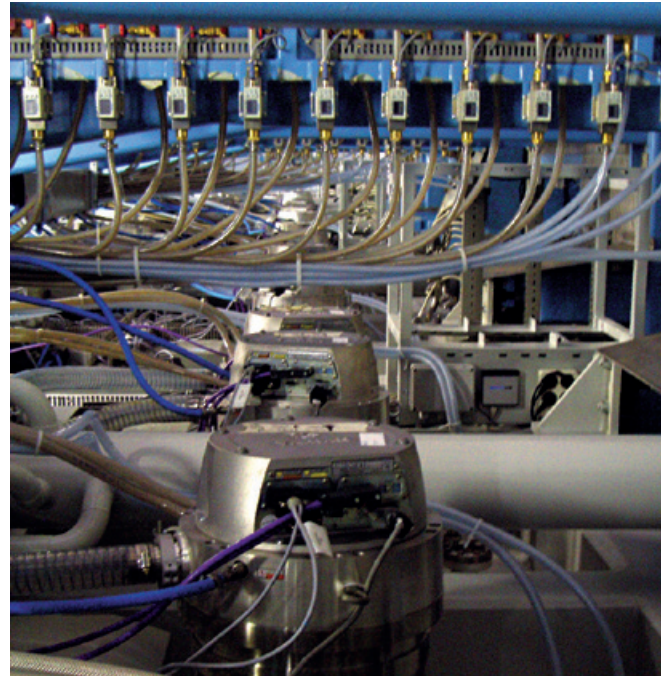

Agilent Turbo-V 2K-G in Thin Film Deposition application.

- In a wide range of industries, from glass coating to medical equipment, manufacturers share a need for robust, reliable, production-friendly vacuum technologies.
- Focusing on the total cost of ownership, Agilent continues to deliver innovative vacuum solutions that maximize throughput, tolerate varying operating conditions, and simplify maintenance, helping to assure maximum uptime and efficiency.
- Turbo-V pumps, designed to withstand heavy industrial use, can handle high gas loads and will recover quickly from accidental air in-rushes.
- Agilent offers a comprehensive range of vacuum pumps and systems for industrial uses, including the new Turbo-V K-G Series, with truly integrated electronics embedded in the pump body.

Thin Film Deposition

- Glass coating equipment (architectural glass, automotive glass, flat panel display substrates)

TURBO PUMPS

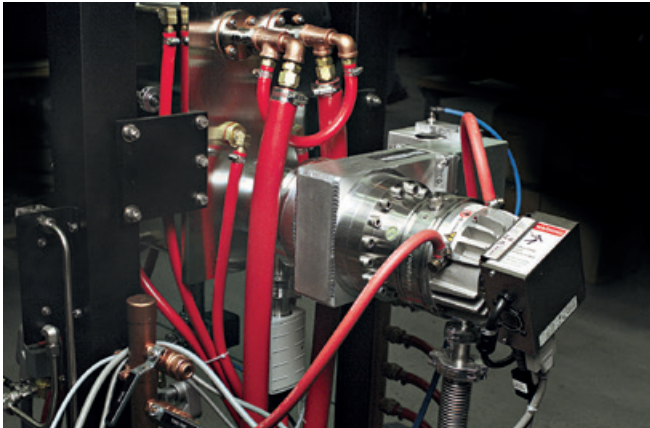

Courtesy Centorr.

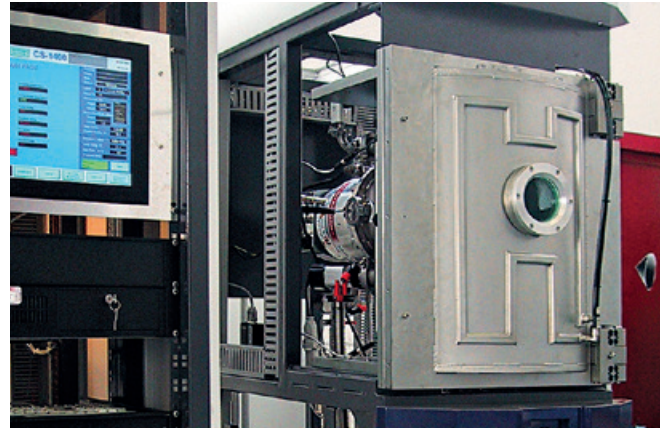

Courtesy Optovac Vacuum Coating Systems.

- Thin film solar cells production (photo-voltaic)
- Optical data media (Compact Discs, Digital Versatile Discs, Magneto Optical Discs)
- Magnetic storage media (hard discs, read heads)
- Surface treatments used for Tribological and Wear coatings
- Functional and Decorative coatings, including Metallization
- Optical coating (ophthalmic, precision opto-electronics)
- Roll/Web coating on films or foils
- PVD and other Plasma Process systems requiring high gas load

Device Processing:

- TV & Monitor picture tube manufacture
- Evacuation of lamps (motorway lighting, beamers)
- X-Ray tubes & electron devices
- Medical accelerator tubes
- Lasers

General Industrial Processes:

- Vacuum furnaces / Brazing
- Electron beam welding

Dedicated Solutions for Thin Film Deposition

- In single chamber batch systems, multiple chamber systems, with load locks, or large inline continuous systems, Agilent has the right turbo pump for your process requirements. What really differentiates Agilent is the expertise of its applications, support and custom system design staff to integrate vacuum pumps into optimized vacuum solutions.

The Turbo-V K-G Series Systems

- Application-specific pumping solutions designed for thin film deposition equipment: the first fully integrated approach for maximum system productivity and uptime.
 - high pumping speed and high gas throughput
 - truly integrated power supply (Protection Class IP 54), resulting in compact size and ease of system integration



- capability to create differentiated partial pressures where needed
- maximum throughput capacity at stable operation pressure
- ceramic ball bearings, oil-free, contamination-free, no preventive maintenance, make the pump mountable in any position
- extremely low vibration and noise for sensitive applications
- water cooling (water compatibility up to 35 °C) allows long service life of electronic components
- permanent monitoring system integrated in the electronic device, and built-in self-diagnostics capability, in combination with our tailored service & support plans offers a unique solution for TFD applications.

AGILENT TURBO PUMPS MODELS

		TwisTorr 84 FS		TwisTorr 304 FS		Turbo-V 551 Navigator	
Pump specification		DN 40	DN 63	DN 100	DN 160	DN 100	DN 160
Pumping speed, l/s	Nitrogen	49	67	250	250	350	550
	Helium	38	63	255	255	450	600
	Hydrogen	36	53	220	220	450	510
	Argon	44	66	250	250		
Compression ratio	Nitrogen	$\geq 1 \times 10^{11}$		$> 1 \times 10^{11}$		$> 1 \times 10^9$	
	Helium	2×10^6		$> 1 \times 10^8$		1×10^7	
	Hydrogen	5×10^4		1.5×10^6		1×10^6	
	Argon	$> 1 \times 10^{11}$		$> 1 \times 10^{11}$			
Base pressure, mbar	With recommended mechanical pump	$< 5 \times 10^{-10}$		$< 1 \times 10^{-10}$		$< 1 \times 10^{-10}$	
	With recommended dry pump					$< 1 \times 10^{-10}$	
Startup time, min		< 2		< 3		< 5	
Rotational speed, rpm		81,000		60,000		42,000	
Recommended forepump	Mechanical pump	DS 42, DS 102		DS 102		DS 302	
	Dry pump	SH-110, IDP-3		SH-110		IDP-15	
Inlet flange, nominal diameter	Klamp flange, mm	40	—	—	—	—	—
	ConFlat, mm (inches OD)	35 (2.75)	63 (4.5)	100 (6)	160 (8)	100 (6)	160 (8)
	ISO clamp style, mm	—	63	100	160	—	160
	ISO-F bolted, mm	—	—	—	—	—	160-F bolted
Foreline flange, nominal diameter	Klamp flange	NW16		NW16 (NW25 optional)		NW25	
SEM version available on request		—		—		•	
Controllers	Rack controller	•		•		•	
	Navigator on board contr.	•		•		•	
	Integrated electronics	—		—		—	
	PCB controller	•		—		—	



TURBO PUMPS

Turbo-V 701 Navigator	Turbo-V 1001 Navigator			Turbo-V 2300 TwisTorr	Turbo-V 1K-G		Turbo-V 2K-G System	Turbo-V 3K-G System
DN 200	DN 160	DN 200	DN 250	DN 250	DN 160	DN 200	DN 250	DN 250
690 620 510	790 820 860	950 870 900	1,050 900 920	2,050 1,800 1,500	810 950 680 750	1,080 1,150 730 1,040	1,600	2,200
1×10^9 1×10^7 1×10^6	1×10^9 1×10^7 1×10^6			$>8 \times 10^8$ 8×10^5 4×10^4	$>5 \times 10^7$ $>4 \times 10^4$ 1.5×10^4 $>5 \times 10^8$		3×10^5	$>1 \times 10^7$
$<1 \times 10^{-10}$ $<1 \times 10^{-10}$	$<1 \times 10^{-10}$ $<1 \times 10^{-10}$			10^{-10}	$<1 \times 10^{-10}$ $<1 \times 10^{-10}$		$<1 \times 10^{-8}$ $<1 \times 10^{-8}$	$<1 \times 10^{-9}$ $<1 \times 10^{-9}$
< 5	< 4			< 6	< 5		< 7	< 6
42,000	38,000			33,300	45,660		33,000	31,800
DS 302 IDP-15	DS 402 IDP-15			DS 602 TS600	$>20 \text{ m}^3/\text{h}$	$>36 \text{ m}^3/\text{h}$	$>40 \text{ m}^3/\text{h}$	$>60 \text{ m}^3/\text{h}$
– 200 (10) 200 200-F bolted	– 160 –	– 200 (10) 200 200-F bolted	– – 250 250-F bolted	– 250 (12) – 250-F bolted	– – – 160-F	– – – 200-F	– – – 250-F bolted	– – – 250-F bolted
NW25	NW40			NW40	NW25	NW40	NW40	NW40
•	•			–	–		–	–
• • – –	• • – –			• – – –	• • – –		– – • –	– – • –

Turbo Pumps



AGILENT TURBO PUMP MODELS

▶ Agilent TwisTorr 84 FS

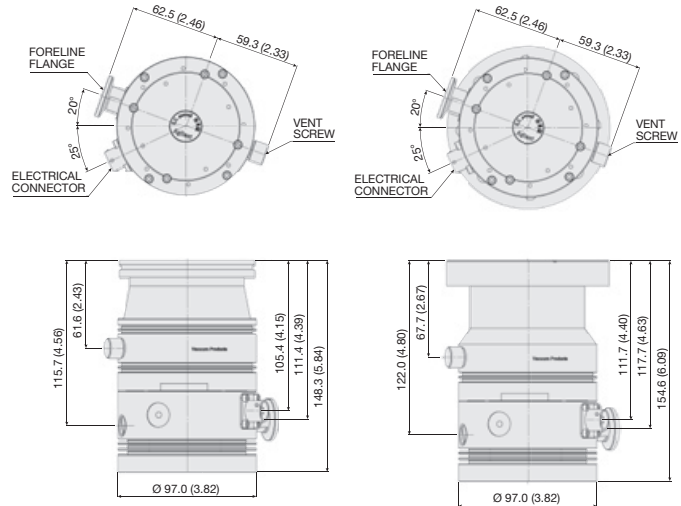

Dimensions: millimeters (inches)

Technical Specifications

Pumping speed (l/s)					
With CFF 4 ½" or ISO 63:	N ₂ : 67 l/s	He: 63 l/s	H ₂ : 53 l/s	Ar: 66 l/s	
With CFF 2 ¾":	N ₂ : 56 l/s	He: 46 l/s	H ₂ : 40 l/s	Ar: 57 l/s	
With KF 40:	N ₂ : 49 l/s	He: 38 l/s	H ₂ : 36 l/s	Ar: 44 l/s	
Gas throughput at full rotational speed (with recommended forepump)					
Air cooling (35 °C)		N ₂ : 100 sccm	Ar: 70 sccm		
Water cooling (25 °C, 65 l/h)		N ₂ : 100 sccm	Ar: 70 sccm		
Compression ratio	N ₂ : ≥1 x 10 ¹¹	He: 2 x 10 ⁶	H ₂ : 5 x 10 ⁴	Ar: >1 x 10 ¹¹	
Base pressure with recommended forepump (5 m³/h)		< 5 ⁻¹⁰ mbar (< 3.75 x 10 ⁻¹⁰ Torr)			
Inlet flange		CFF 4 ½" O.D.	ISO 63		
		CFF 2 ¾" O.D.	KF 40		
Foreline flange		KF 16 NW			
Rotational speed		81000 rpm (1350 Hz driving frequency)			
Start-up time		< 2 minutes			
Recommended forepump		Mechanical: Agilent DS 42 – DS 102 Dry pump: Agilent IDP-3, SH 110			
Operating position		Any			
Operating ambient temperature		+5 °C to +35 °C			
Relative humidity of air		0 - 90 % (not condensing)			
Bakeout temperature		80 °C at inlet flange max. (ISO flange) 120 °C at inlet flange max. (CFF flange)			
Lubricant		Permanent lubrication			
Cooling requirements	Air Cooling:	Air flow temperature +5 °C to +35 °C			
	Water Cooling:	Cooling water temperature: +15 °C to +25 °C			
		Minimum flow: 65 l/h (0.30 GPM)			
		Pressure: 2 to 4 bar (45 to 75 psi)			
Bakeout temperature		120 °C at inlet flange max. (CF flange) 80 °C at inlet flange max. (ISO flange)			
Noise pressure level (at 1 mt at full speed)		40 dB(A) *			
Storage temperature		-40 °C to +70 °C			
Max altitude		3000 m			
Certifications		CE, C-CSA-US, RoHS compliant as per 2011/65/UE			
Weight kg (lbs)	Pump ISO 63:	Pump CFF 4 ½" :	Pump CFF 2 ¾" :	Pump KF 40:	
	2.5 (5.5)	3.5 (7.7)	3.34 (7.35)	2.37 (5.22)	

* Average value ± 4 dB(A) std deviation

TURBO PUMPS

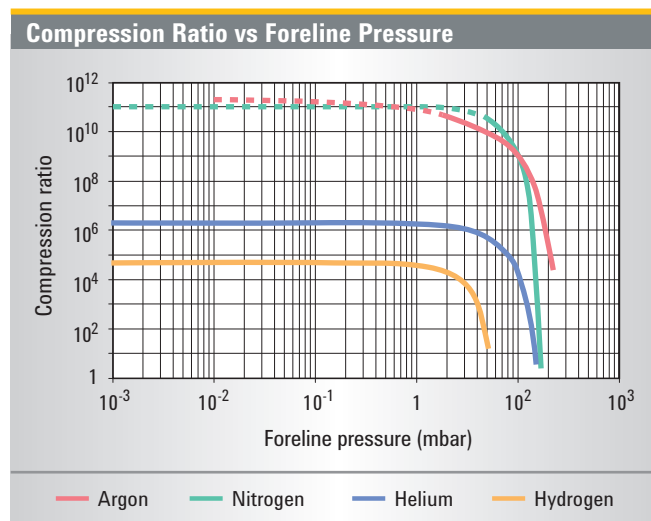
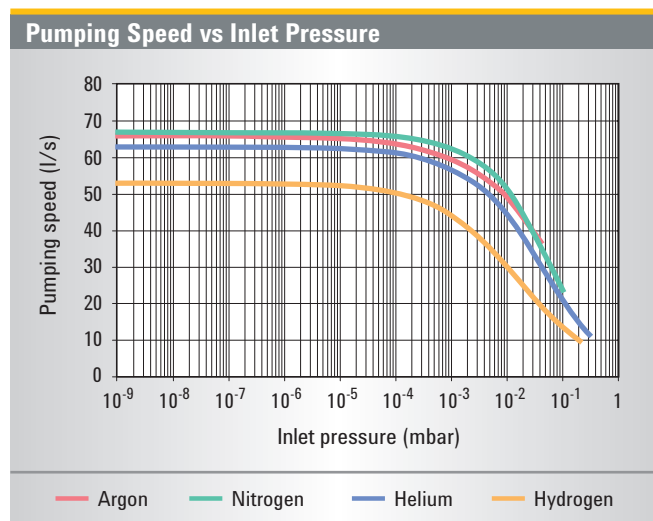

Ordering Information

Pumps	Part Number
TwisTorr 84FS ISO63	X3502-64000
TwisTorr 84FS KF40	X3502-64001
TwisTorr 84FS CFF 4 ½"	X3502-64002
TwisTorr 84FS CFF 2 ¾"	X3502-64003
Controllers	Part Number
TwisTorr 84FS AG Rack controller RS232/485	X3508-64001
TwisTorr 84FS AG Rack controller Profibus	X3508-64002
TwisTorr 84FS on-board controller 110/220 V	X3509-64000
TwisTorr 84FS on-board controller 24 V	X3509-64001
TwisTorr 84FS PCB Controller	X3510-64000
Accessories	Part Number
Cables	
Mains cable NEMA plug, 3 m long	969-9958
Mains cable European plug, 3 m long	969-9957
Serial cable and T-plus software	969-9883
PCB cable	969-9869
Pump extension cable (3 m)	969-9942
Extension cable 5 m	969-9942M007
Extension cable 10 m	969-9942M006
Extension cable 15 m	969-9942M005
Extension cable 20 m	969-9942M004
Inlet screen	
Inlet screen ISO 63	X3502-68001
Inlet screen CFF 4 ½"	X3502-68000
Inlet screen, KF 40	969-9309
Inlet screen CFF 2 ¾"	969-9328
Cooling	
Metal Water Cooling Kit	X3502-68002
Plastic Water cooling kit	X3502-68003
Air cooling kit (0,5 m cable)	969-9290
Air cooling kit extension cable (5 m)	969-9940

Accessories	Part Number
Vibration isolator	
Vibration isolator ISO 63	969-9375
Vibration isolator CFF 4 ½"	969-9376
Venting	
Vent Valve N.O. 0,5 mm orifice (0,5 m cable)	969-9844
Vent Valve extension cable (5 m)	969-9941
Vent Valve extension cable (10 m)	969-9941M003
Vent Valve extension cable (15 m)	969-9941M001
Vent Valve extension cable (20 m)	969-9941M005
Vent Screw M5	X3502-68005
Vent Adapter kit M5-M8	X1699-64039
Purge	
Purge Screw	X3502-68004
Purge valve 10 SCCM NW16KF - M12	969-9239
Purge valve 10 SCCM ¼ Swagelok - M12	969-9240
Purge valve 20 SCCM NW16KF - M12	969-9241
Purge valve 20 SCCM ¼ Swagelok - M12	969-9242
Purge valve 10 SCCM ¼ Swagelok - ¼ Swagelok	969-9232
Purge valve 20 SCCM ¼ Swagelok - ¼ Swagelok	969-9236
Mounting	
Controller side mounting bracket	X3502-68006
CFF 4 ½" mounting kit	X3502-68007
Metric screws kit	X3502-68008
American screws kit	X3502-68009
Active Gauges	
FRG 700 Full Range Gauge	Ask Agilent for details
PVG 500 Pirani Vacuum Gauge	Ask Agilent for details
PCG 750 Pirani Capacitance Gauge	Ask Agilent for details
CDG-500 Capacitance Diaphragm Gauge	Ask Agilent for details

AGILENT TURBO PUMP CONTROLLERS

▶ Agilent TwisTorr 84 FS AG Navigator On-board Controller

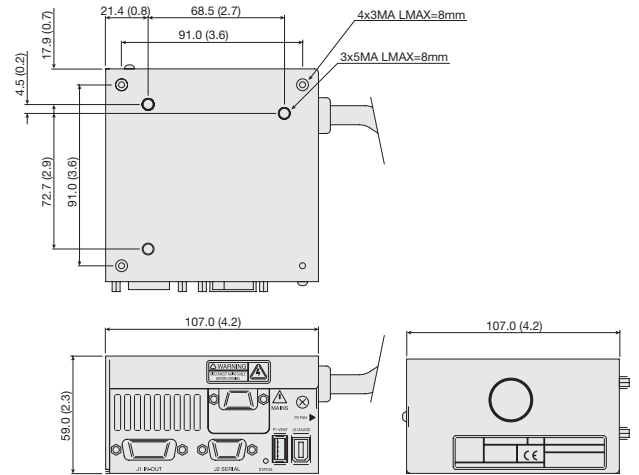

Dimensions: millimeters (inches)

The TwisTorr 84 FS AG Navigator On-board controller is a solid-state frequency converter with the following features:

- Drives the TwisTorr 84 FS pumps
- Powers the pump cooling fan
- Drives the vent valve
- Provides and acquires the pressure of the wide range gauge.
- Remote I/Os compatible with the previous version
- Navigator default serial compatible with the previous RS 232 and 485 version
- Able to operate with Active Gauges (Full Range Gauge FRG-700 and FRG-702)

The dedicated controller is a solid-state frequency converter which is driven by a single chip microcomputer and consists of two PCBs which include power supply and 3-phase output, analog and input/output section, microprocessor and digital

Technical Specifications

Input voltages:	
Navigator controller, 24 Vdc	24 Vdc ±10%
Navigator controller, 100/240 Vac	100 ÷ 240 Vac ±10%
Input power:	
Navigator controller, 24 Vdc	80 W
Navigator controller, 100/240 Vac	180 VA
Input frequency:	
Navigator controller, 100/240 Vac	50 to 60 Hz ±5%
Fuse	
	2 x T4 A 250 V
Output voltage	
	60 Vac
Output frequency	
	1350 Hz
Output power:	
Navigator controller, 24 Vdc	50 W
Navigator controller, 100/240 Vac	70 W (ramp), 50 W (Normal and Autotuning)
Operating temperature	
	+5 ÷ +45 °C 0 – 90% (Not condensing)
Storage temperature	
	-20 °C to +70 °C 0 – 95%

section. The power supply, together with the 3-phase output, converts the single phase AC mains supply or 24Vdc supply into a 3-phase, low voltage, medium frequency output which is required to power the pump. The controller can be operated by a remote host computer via the serial connection. A Windows-based software is available (optional). The TwisTorr 84 FS AG Navigator controller can be mounted on board, on the bottom of the TwisTorr 84 FS pumps.

Ordering Information

Description	Weight kg (lbs)	Part Number
Controllers		
TwisTorr 84FS on-board controller* 110/220 V	0.3 (0.66)	X3509-64000
TwisTorr 84FS on-board controller* 24 V	0.3 (0.66)	X3509-64001

* Order power cable separately

Cables		
Mains cable NEMA Plug, 3 m long		969-9958
Mains cable European Plug, 3 m long		969-9957
Serial cable and T-Plus Software		969-9883

Active Gauges		
FRG-700 Pirani/IMG Combination Gauge, KF25		FRG700KF25
FRG-700 Pirani/IMG Combination Gauge, DN40 CF		FRG700CF35
FRG-702 Pirani/IMG Combination Gauge, KF25 All metal - bakeable		FRG702KF25
FRG-702 Pirani/IMG Combination Gauge, DN40 CF All metal - bakeable		FRG702CF35
Gauge connection cable to AG rack controller - 3 m		9699960
Gauge connection cable to AG rack controller - 5 m		9699961

NOTE • For other Active Gauges models please ask Agilent for details

▶ Agilent TwisTorr 84 FS-AG Rack Controller

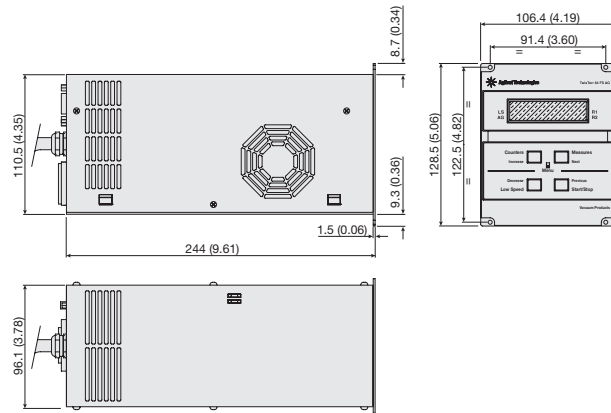

Dimensions: millimeters (inches)

The TwisTorr 84 FS-AG Rack controller is a microprocessor-controlled frequency converter with new, enhanced features that allow greater control and communication capabilities. This compact, ¼ rack unit is designed for full worldwide compatibility, for vent valve control, active gauge pressure reading and pump operation parameters control, as well as for self diagnostic and protection features.

• Universal Voltage

Controller able to auto set according to the input voltage, providing flexibility for easy installation worldwide

• RS-232/485 Communication Protocols and Profibus (Options)

- Allows the pump to be interfaced with the system controls
- Enables the pump to be operated via PC with T-Plus software
- Helps development of own customer software

• Stop Speed Reading (SSR)

- Continues pump speed reading after the stop command
- Allows monitoring the pump in slow down ramp and shut down time

• N.O. and N.C. Vent Valve Drive

- Valve delay and opening time adjustable
- Vent valve driven by controller automatically or by serial line
- Opening time control through SSR function

Technical Specifications

Input	100 ÷ 240 Vac 50/60 Hz
Maximum input power	210 VA
Output voltage	76 Vac
Output frequency	1,350 Hz
Nominal output power	100 W
Operating temperature	+5 °C to +45 °C
Storage temperature	-20 °C to +70 °C

• Active Gauge Pressure Reading Capability

- Able to operate with Active Gauges (Full Range Gauge FRG-700 and FRG-702)
- Provides accurate pressure measurements from atm down to 10⁻⁹ mbar
- Rack mounted control electronics no longer necessary, with simple +24 Vdc power connector
- Proven inverted magnetron design
- Rapid start even in high-vacuum conditions

Ordering Information

Description	Weight kg (lbs)	Part Number
Controller		
TwisTorr 84FS AG Rack controller* RS232/485	1.7 (3.2)	X3508-64001
TwisTorr 84FS AG Rack controller* Profibus	1.7 (3.2)	X3508-64002

* Order power cable separately

Cables

Mains cable NEMA Plug, 3 m long	969-9958
Mains cable European Plug, 3 m long	969-9957
Serial cable and T-Plus Software	969-9883

Active Gauges

FRG-700 Pirani/IMG Combination Gauge, KF25	FRG700KF25
FRG-700 Pirani/IMG Combination Gauge, DN40 CF	FRG700CF35
FRG-702 Pirani/IMG Combination Gauge, KF25 All metal - bakeable	FRG702KF25
FRG-702 Pirani/IMG Combination Gauge, DN40 CF All metal - bakeable	FRG702CF35
Gauge connection cable to AG rack controller - 3 m	9699960
Gauge connection cable to AG rack controller - 5 m	9699961

NOTE • For other Active Gauges models please ask Agilent for details

AGILENT TURBO PUMP MODELS

▶ Agilent TwisTorr 304 FS

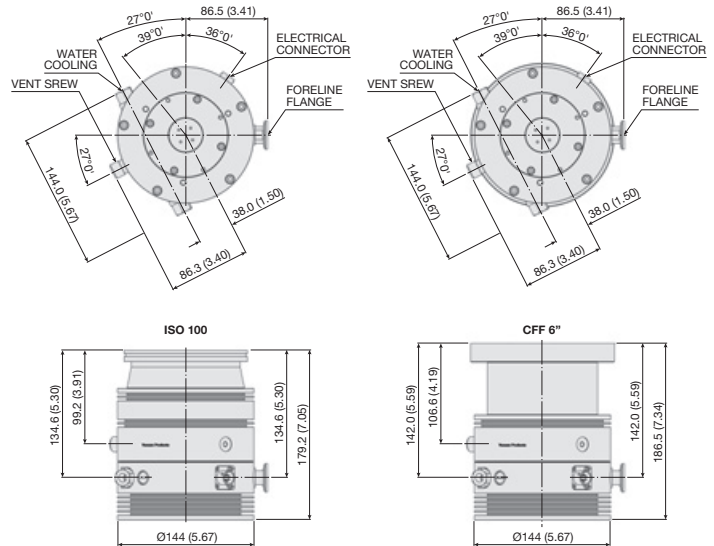

Dimensions: millimeters (inches)

Technical Specifications

Pumping speed (l/s)				
With CFF 6" or ISO 100:	N ₂ : 250 l/s	He: 255 l/s	H ₂ : 220 l/s	Ar: 250 l/s
With CFF 8" or ISO 160:	N ₂ : 250 l/s	He: 255 l/s	H ₂ : 220 l/s	Ar: 250 l/s
Gas throughput at full rotational speed (with recommended forepump)				
Ambient Temp. (25 °C)		N ₂ : 170 sccm	Ar: 110 sccm	
Water Temp. (25 °C, 50 l/h)		N ₂ : 170 sccm	Ar: 110 sccm	
Compression ratio & Foreline tolerance	N ₂ : > 1 x 10 ¹¹ N ₂ : >10 mbar	He: > 1 x 10 ⁸ He: >10 mbar	H ₂ : 1.5 x 10 ⁶ H ₂ : >4 mbar	Ar: > 1 x 10 ¹¹ Ar: >10 mbar
Base pressure with recommended forepump (5 m³/h)	< 1 x 10 ⁻¹⁰ mbar (< 1 x 10 ⁻¹⁰ Torr)			
Inlet flange	CFF 8" O.D.		ISO 160	
	CFF 6" O.D.		ISO 100	
Foreline flange	KF16 NW (KF25 - optional)			
Rotational speed	60000 rpm (1010 Hz driving frequency)			
Start-up time	< 3 minutes			
Recommended forepump	Mechanical: Agilent DS 102 Dry pump: Agilent SH-110			
Operating position	Any			
Operating ambient temperature	+5 °C to +35 °C			
Relative humidity of air	0 - 90 % (not condensing)			
Bakeout temperature	80 °C at inlet flange max. (ISO flange) 120 °C at inlet flange max. (CFF flange)			
Lubricant	Permanent lubrication			
Cooling requirements	Forced air (5- 35 °C ambient temperature) Water (mandatory if ambient temperature > 35 °C)			
Coolant water	Minimum flow: 50 l/h (0.89 GPM)	Temperature: +15 °C to +30 °C	Pressure: 3 to 5 bar (45 to 75 psi)	
Noise pressure level	< 50 dB(A) at 1 meter			
Storage temperature	-40 °C to +70 °C			
Max altitude	3000 m			
Weight kg (lbs)	Pump ISO 100: 5.5 kg (12.3)	Pump CFF 6": 7.5 kg (16.5)	Pump ISO 160: 5.7 kg (12.6)	Pump CFF 8": 9.7 kg (20.9)

TURBO PUMPS

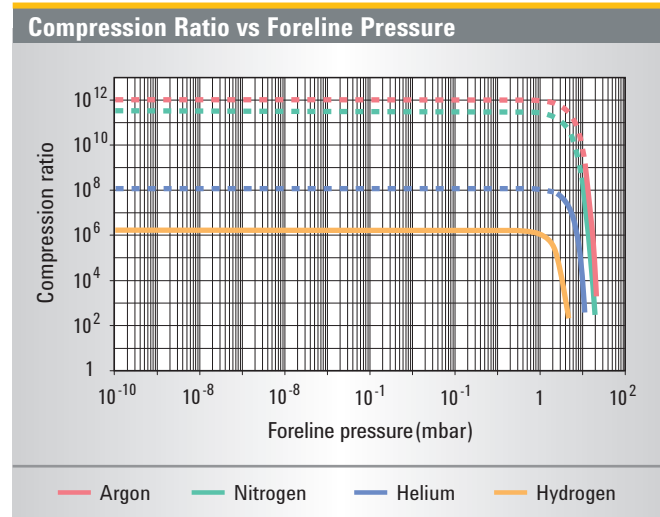
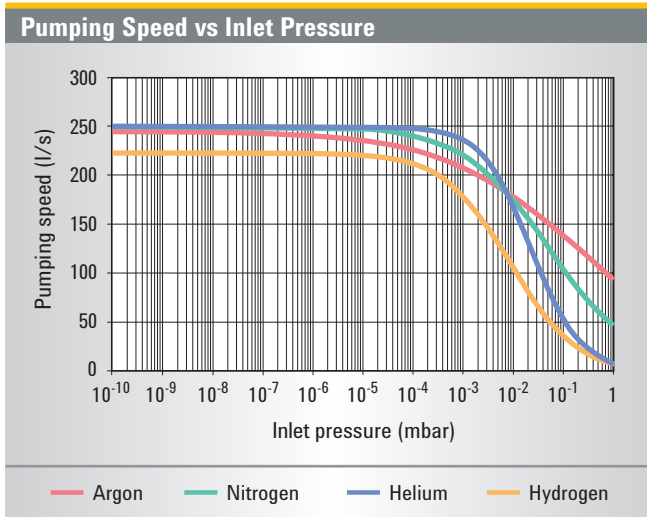

Ordering Information

Pumps	Part Number
TwisTorr 304 FS ISO100 water cooling	X3500-64000
TwisTorr 304 FS CFF 6" water cooling	X3500-64001
TwisTorr 304 FS ISO160 water cooling	X3500-64002
TwisTorr 304 FS CFF 8" water cooling	X3500-64003
TwisTorr 304 FS ISO100 air cooling	X3500-64004
TwisTorr 304 FS CFF 6" air cooling	X3500-64005
TwisTorr 304 FS ISO160 air cooling	X3500-64006
TwisTorr 304 FS CFF 8" air cooling	X3500-64007
TwisTorr 304 FS ISO100 SF water cooling	X3500-64010

Controllers	Part Number
TwisTorr 304 FS AG Rack controller with RS 232/485	X3506-64002
TwisTorr 304 FS AG Rack controller with Profibus	X3506-64003
TwisTorr 304 FS on board controller 24 Vdc	X3507-64002
TwisTorr 304 FS on board controller 100-240 Vac	X3507-64003

Accessories	Part Number
Cables	
Mains cable NEMA plug, 3 m long	9699958
Mains cable European plug, 3 m long	9699957
Serial cable and T-plus Software	9699883
Extension cable 5 m	969-9942M007
Extension cable 10 m	969-9942M006
Extension cable 15 m	969-9942M005
Extension cable 20 m	969-9942M004

Inlet screen	Part Number
Inlet Screen ISO100	X3500-68000
Inlet Screen CFF 6"	9699302
Inlet Screen ISO160	X3500-68001
Inlet Screen CFF 8"	9699304

Accessories	Part Number
Cooling	
Water cooling kit	9699337
Plastic water cooling kit	9699347
Air cooling kit for On board controller	X3500-68010
Fan extension cable for On board controller	9699949
Air cooling kit for rack AG controller	X3500-68011
Fan extension cable for rack AG controller	9699940
Vibration isolator	
Vibration isolator ISO 100	9699344
Vibration isolator CF 6"	9699334
Vibration isolator ISO 160	9699345
Vibration isolator CF 8"	9699335
Vibration isolator ISO 100 IDX	9699396
Vent flange, NW 10 KF / M8	9699108

Venting	Part Number
Delay vent valve 1.2 mm orifice	X3505-68000
Delay vent valve 0.5 mm orifice	X3505-68001
Vent valve N.O. for rack AG controller (0.5 mm)	9699844
Vent valve for on-board controller (1.2 mm)	9699834
Vent valve for on-board controller (0.5 mm)	9699834M006

Purge	Part Number
Purge valve 10 SCCM NW16KF - M12	9699239
Purge valve 10 SCCM ¼ Swagelok - M12	9699240
Purge valve 20 SCCM NW16KF - M12	9699241
Purge valve 20 SCCM ¼ Swagelok - M12	9699242
Purge valve 10 SCCM ¼ Swagelok - ¼ Swagelok	9699232
Purge valve 20 SCCM ¼ Swagelok - ¼ Swagelok	9699236

Mounting	Part Number
Bracket for On board controller side mounting	X3500-68012
Foreline flange KF25	X3500-68002

Active Gauges	Part Number
FRG 700 Full Range Gauge	Ask Agilent for details
PVG 500 Pirani Vacuum Gauge	Ask Agilent for details
PCG 750 Pirani Capacitance Gauge	Ask Agilent for details
CDG-500 Capacitance Diaphragm Gauge	Ask Agilent for details

AGILENT TURBO PUMP CONTROLLERS

► Agilent TwisTorr 304 FS on board Controller



120/220 V controller front panel

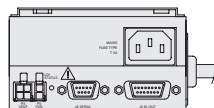

24 V controller front panel

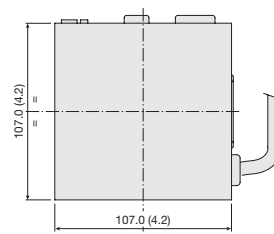
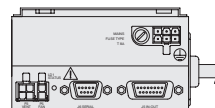

Dimensions: millimeters (inches)

The TwisTorr 304 FS on board controllers are microprocessor-controlled frequency converters, fully controllable through PC software, with self-diagnostic and protection features that ensure the highest degree of reliability.

They can be mounted on board, either on the bottom or on the side of the pump, offering outstanding flexibility and simplicity.

Technical Specifications

Input voltages:	
On board controller, 24 Vdc	24 Vdc \pm 10%
On board controller, 120/220 Vac	100/120/220/240 Volt, 1 phase, 50/60 Hz
Maximum input power:	
100-240 controller, 24 Vdc	200 W
100-240 controller, 120/220 Vac	300 VA
Output voltage	75 Vac, 3 phase
Output frequency	963 Hz
Nominal power	150 W
Start-up power	150 W
Operating temperature	0 °C to +40 °C
Storage temperature	20 °C to +70 °C

Ordering Information

Description	Weight kg (lbs)	Part Number
Controllers		
TwisTorr 304 FS on board controller* 24 Vdc	0.3 (0.66)	X3507-64002
TwisTorr 304 FS on board controller* 100-240 Vac	0.3 (0.66)	X3507-64003
* Order power cable separately		
Cables		
Mains cable NEMA Plug, 3 m long		969-9958
Mains cable European Plug, 3 m long		969-9957
Serial cable and T-Plus Software		969-9883

TURBO PUMPS

► Agilent TwisTorr 304 FS AG Rack Controller

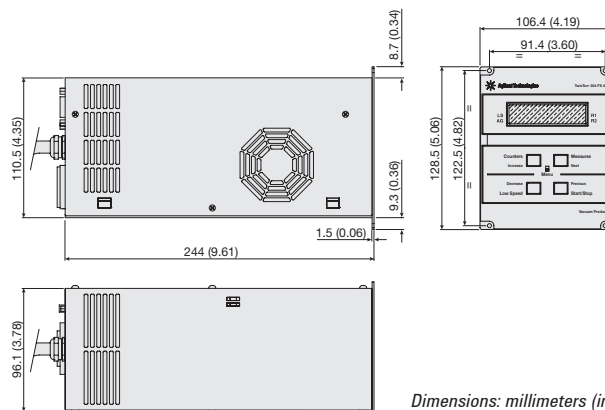

The TwisTorr 304 FS AG Rack controller is a microprocessor-controlled frequency converter with new, enhanced features that allow greater control and communication capabilities. This compact, ¼ rack unit is designed for full worldwide compatibility, for vent valve control, active gauge pressure reading and pump operation parameters control, as well as for self diagnostic and protection features.

• Universal Voltage

Controller able to auto set according to the input voltage, providing flexibility for easy installation worldwide

• RS-232/485 Communication Protocols and Profibus (Options)

- Allows the pump to be interfaced with the system controls
- Enables the pump to be operated via PC with T-Plus software
- Helps development of own customer software

• Stop Speed Reading (SSR)

- Continues pump speed reading after the stop command.
- Allows monitoring the pump in slow down ramp and shut down time

• N.O. and N.C. Vent Valve Drive

- Valve delay and opening time adjustable
- Vent valve driven by controller automatically or by serial line
- Opening time control through SSR function

Technical Specifications

Input	100 ÷ 240 Vac 50/60 Hz
Maximum input power	300 VA
Output voltage	75 Vac
Output frequency	963 Hz
Nominal output power	150 W
Operating temperature	+5 °C to +45 °C
Storage temperature	-20 °C to +70 °C

• Active Gauge Pressure Reading Capability

- Able to operate with Active Gauges (IM-500, Full Range Gauge FRG-700 and FRG-702)
- Provides accurate pressure measurements from atm down to 10⁻⁹ mbar
- Rack mounted control electronics no longer necessary, with simple +24 Vdc power connector
- Proven inverted magnetron design
- Rapid start even in high-vacuum conditions

Ordering Information

Description	Weight kg (lbs)	Part Number
Controllers		
TwisTorr 304 FS AG Rack controller* with RS 232/485	1.7 (3.2)	X3506-64002
TwisTorr 304 FS AG Rack controller* with Profibus	1.7 (3.2)	X3506-64003
* Order power cable separately		
Cables		
Mains cable NEMA Plug, 3 m long		969-9958
Mains cable European Plug, 3 m long		969-9957
Serial cable and T-Plus Software		969-9883

Active Gauges

PVG-500 Pirani, KF16	PVG500KF16
PVG-500 Pirani Tungsten filament, KF16	PVG500KF16S
FRG-700 Pirani/IMG Combination Gauge, KF25	FRG700KF25
FRG-700 Pirani/IMG Combination Gauge, DN40 CF	FRG700CF35
FRG-702 Pirani/IMG Combination Gauge, KF25 All metal - bakeable	FRG702KF25
FRG-702 Pirani/IMG Combination Gauge, DN40 CF All metal - bakeable	FRG702CF35
PCG-750 Pirani/CDG Combination Gauge (Tungsten), KF16	PCG750KF16
Gauge connection cable to AG rack controller - 3 m	9699960
Gauge connection cable to AG rack controller - 5 m	9699961

NOTE • For other Active Gauges models please ask Agilent for details

AGILENT TURBO PUMP MODELS

▶ Agilent Turbo-V 551 Navigator

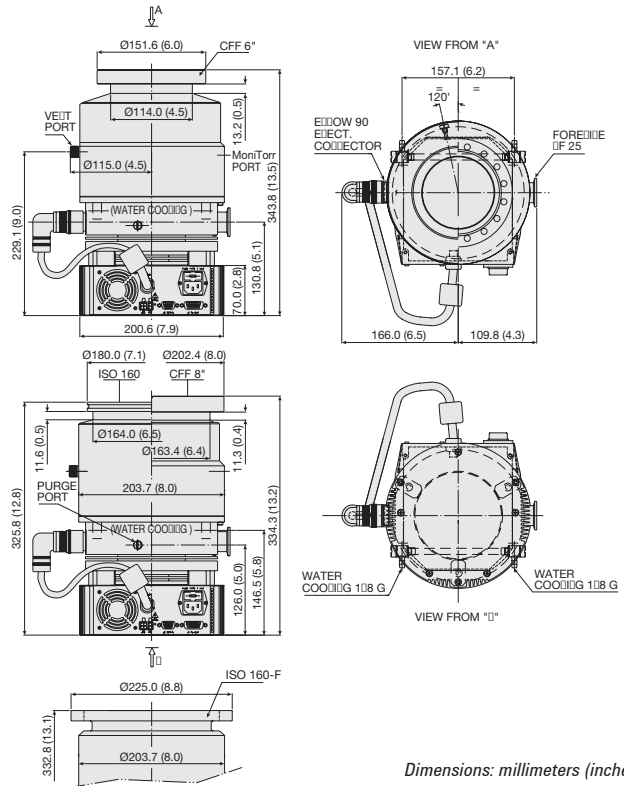

Dimensions: millimeters (inches)

Technical Specifications

Pumping speed (with inlet screen)			
CFF 6":	N ₂ : 350 l/s	He: 450 l/s	H ₂ : 450 l/s
CFF 8" or ISO 160:	N ₂ : 550 l/s	He: 600 l/s	H ₂ : 510 l/s
Compression ratio	N ₂ : 1 x 10 ⁹	He: 1 x 10 ⁷	H ₂ : 1 x 10 ⁶
Base pressure* (with minimum recommended forepump)	<1 x 10 ⁻¹⁰ mbar (< 1 x 10 ⁻¹⁰ Torr)		
Inlet flange	CFF 6"	ISO 160	
	CFF 8"	ISO 160-F bolted	
Foreline flange	KF 25		
Rotational speed	42,000 rpm		
Start-up time	<5 minutes		
Recommended forepump	Mechanical: Agilent DS 302 Dry scroll: Agilent TS300, IDP-15		
Operating position	Any		
Cooling requirements	Natural air convection Water optional (use water with electrical conductivity ≤ 500 µS/cm)		
Bakeout temperature	120 °C at inlet flange max. (CF flange) 80 °C at inlet flange max. (ISO flange)		
Vibration level (displacement)	<0.01 µm at inlet flange		
Weight kg (lbs)	ISO flange 19.4 (43.0) CF flange 23.4 (51.6) CF and ISO bolted flange 23.4 (51.6)		

* According to PNEUROP 5608.

SEM version available on request

TURBO PUMPS

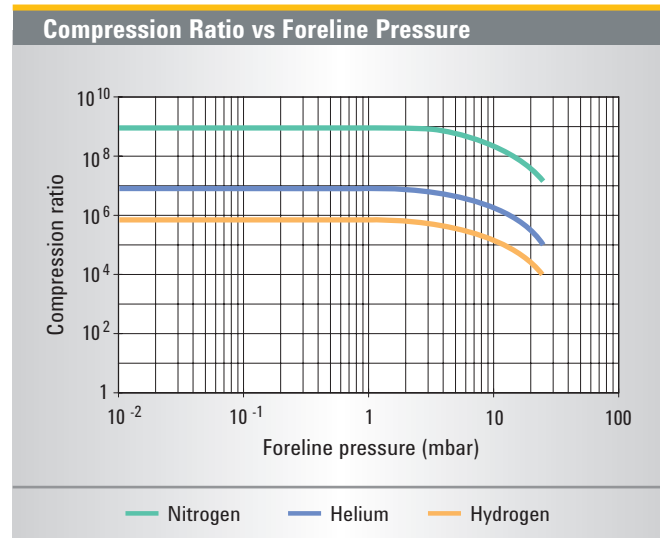
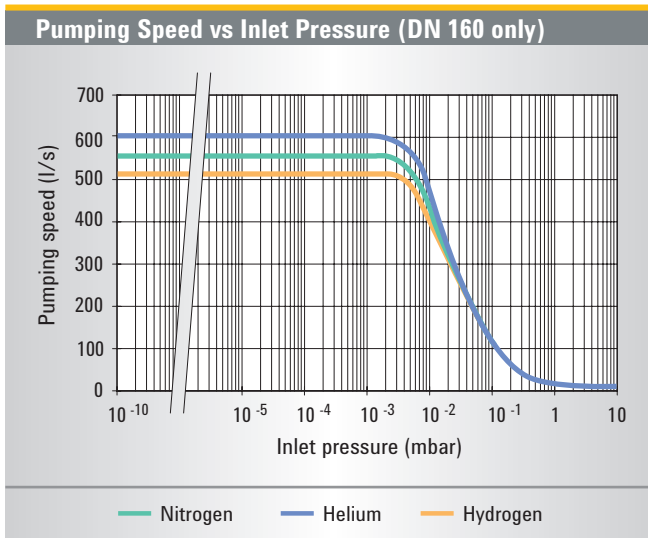

Ordering Information

Description	Weight kg (lbs)	Part Number
Complete Systems		
Turbo-V 551 Navigator complete system, ISO 160 flange	19.4 (43.0)	9698832
Turbo-V 551 Navigator complete system, ISO 160-F bolted flange	23.4 (51.6)	9698842
Turbo-V 551 Navigator complete system, 6" CF flange	23.4 (51.6)	9698835
Turbo-V 551 Navigator complete system, 8" CF flange	23.4 (51.6)	9698833
<i>Complete system includes: Pump, Inlet screen, Controller mounted on the bottom, 2 Mains cables (NEMA plug and European plug).</i>		
Pumps		
Turbo-V 551 Navigator pump, ISO 160 flange	16.0 (35.0)	9698922
Turbo-V 551 Navigator pump, ISO 160-F bolted flange	22.0 (49.0)	9698944
Turbo-V 551 Navigator pump, 6" CF flange	22.0 (49.0)	9698925
Turbo-V 551 Navigator pump, 8" CF flange	22.0 (49.0)	9698923
Controllers		
Turbo-V 551 Navigator controller 120/220 V - 50/60 Hz	3.0 (6.0)	9698976
Turbo-V 551 Rack controller, 100-240 V	15.7 (35.0)	X3501-64001

Description	Weight kg (lbs)	Part Number
Accessories		
Mains cable NEMA plug, 3 m long		9699958
Mains cable European plug, 3 m long		9699957
Serial cable and T-plus Software <i>(previous release Navigator 2.2 included in the CD)</i>		9699883
Inlet screen DN 100		9699302
Inlet screen DN 160		9699304
Water cooling kit		9699337
Plastic water cooling kit		9699347
Air cooling kit for use with Navigator controller		9699339
Air cooling kit for use with standard rack controller, 24 V		X3501-68001
Bracket for Navigator controller side mouting		9699349
Vibration damper CFF 6"	3.0 (7.0)	9699334
Vibration damper ISO 160	4.0 (9.0)	9699345
Vibration damper CFF 8"	4.0 (9.0)	9699335
Vent flange, NW 10 KF / M8		9699108
Vent valve kit for standard rack controller, 24 V		X3501-68002
Vent valve for Navigator controller		9699834
Purge valve 10 SCCM NW16KF - M12		9699239
Purge valve 10 SCCM ¼ Swagelok - M12		9699240

AGILENT TURBO PUMP MODELS

▶ Agilent Turbo-V 701 Navigator

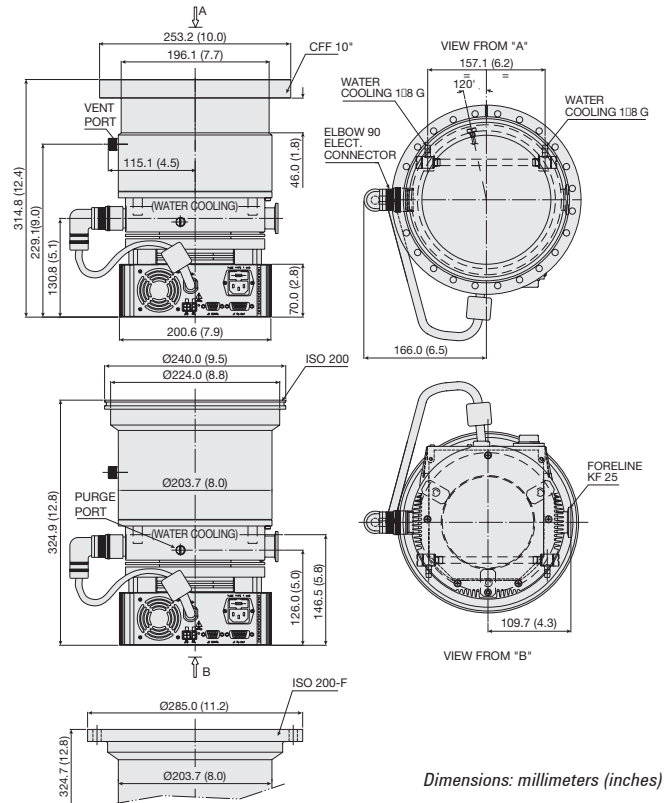

Dimensions: millimeters (inches)

Technical Specifications

Pumping speed (with inlet screen) CFF 10" or ISO 200:	N ₂ : 690 l/s	He: 620 l/s	H ₂ : 510 l/s
Compression ratio	N ₂ : 1 x 10 ⁹	He: 1 x 10 ⁷	H ₂ : 1 x 10 ⁶
Base pressure * (with minimum recommended forepump)	<1 x 10 ⁻¹⁰ mbar (< 1 x 10 ⁻¹⁰ Torr)		
Inlet flange	CFF 10"	ISO 200	ISO 200-F bolted
Foreline flange	KF 25		
Rotational speed	42,000 rpm		
Start-up time	<5 minutes		
Recommended forepump	Mechanical: Agilent DS 402 Dry scroll: Agilent TS300, IDP-15		
Operating position	Any		
Cooling requirements	Natural air convection Water optional (use water with electrical conductivity ≤ 500 μS/cm)		
Bakeout temperature	120 °C at inlet flange max. (CF flange) 80 °C at inlet flange max. (ISO flange)		
Vibration level (displacement)	<0.01 μm at inlet flange		
Weight kg (lbs)	ISO flange 19.4 (43.0) CF flange 25.5 (54.2) CF and ISO bolted flange 25.5 (54.2)		

* According to PNEUROP 5608.

SEM version available on request

TURBO PUMPS

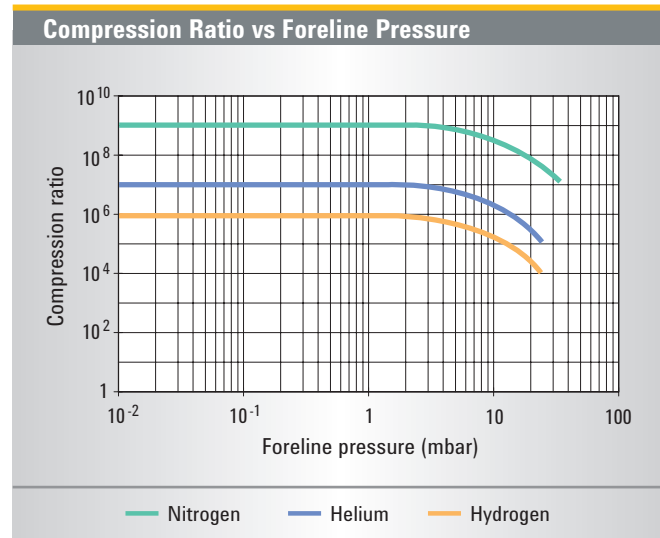
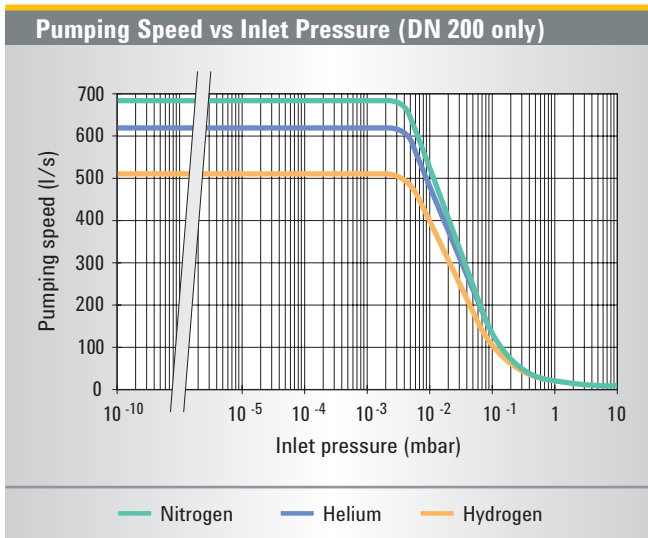

Ordering Information

Description	Weight kg (lbs)	Part Number
Complete Systems		
Turbo-V 701 Navigator complete system, ISO 200 flange	19.0 (43.0)	9698836
Turbo-V 701 Navigator complete system, ISO 200-F bolted flange	25.0 (56.0)	9698843
Turbo-V 701 Navigator complete system, 10" CF flange	25.0 (56.0)	9698837
<i>Complete system includes: Pump, Inlet screen, Controller mounted on the bottom, 2 Mains cables (NEMA plug and European plug).</i>		
Pumps		
Turbo-V 701 Navigator pump, ISO 200	16.0 (35.0)	9698926
Turbo-V 701 Navigator pump, ISO 200-F bolted	22.0 (49.0)	9698945
Turbo-V 701 Navigator pump, 10" CFF	22.0 (49.0)	9698927
Controllers		
Turbo-V 701 Navigator controller 120/220 V - 50/60 Hz	3.0 (6.0)	9698977
Turbo-V 701 Rack controller, 100-240 V	16.0 (35.0)	X3501-64002
Accessories		
Mains cable NEMA plug, 3 m long		9699958
Mains cable European plug, 3 m long		9699957
Serial cable and T-plus Software (previous release Navigator 2.2 included in the CD)		9699883
Inlet screen DN 200		9699316
Water cooling kit		9699337
Plastic water cooling kit		9699347
Air cooling kit for use with Navigator controller		9699339
Air cooling kit for use with standard rack controller, 24 V		X3501-68001
Bracket for Navigator controller side mounting		9699349
Vibration damper, ISO 200	5.0 (10.0)	9699346
Vibration damper, CFF 10"	5.0 (10.0)	9699336
Vent flange, NW 10 KF / M8		9699108
Vent valve kit for standard rack controller		X3501-68002
Vent valve for Navigator controller		9699834
Purge valve 10 SCCM NW16KF – M12		9699239
Purge valve 10 SCCM ¼ Swagelok – M12		9699240

AGILENT TURBO PUMP CONTROLLERS

▶ Agilent Turbo-V 551 and 701 Navigator Controllers

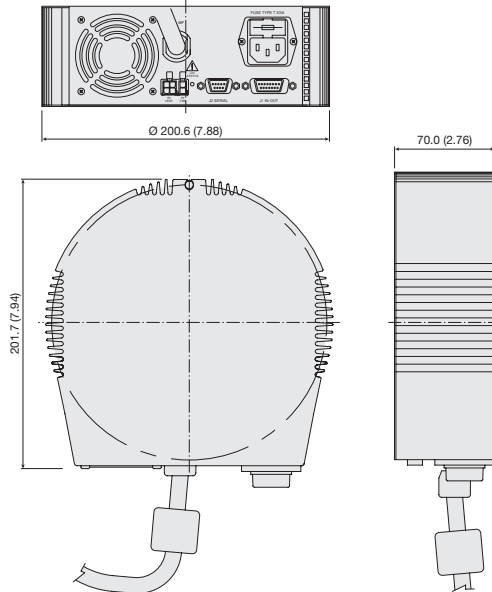

Dimensions: millimeters (inches)

The Turbo-V 551 and 701 Navigator controllers are microprocessor-controlled frequency converters, fully controllable through PC software, with self-diagnostic and protection features that ensure the highest degree of reliability. They can be mounted on board, either on the bottom or on the side of the pump, offering outstanding flexibility and simplicity.

Technical Specifications

Input voltages	100/120/220/240 VAC 50/60 Hz, 1 ph
Maximum input power	640 VA
Output voltage	54 VAC, 3 ph
Output frequency	714 Hz
Operating temperature	0 °C to +40 °C
Storage temperature	-20 °C to +70 °C

Ordering Information

Description	Weight kg (lbs)	Part Number
Controllers		
Turbo-V551 Navigator controller 120/220 V - 50/60 Hz	3.0 (6.0)	9698976
Turbo-V701 Navigator controller 120/220 V - 50/60 Hz	3.0 (6.0)	9698977
Accessories		
Mains cable NEMA plug, 3 m long		9699958
Mains cable European plug, 3 m long		9699957
Serial cable and T-plus Software <i>(previous release Navigator 2.2 included in the CD)</i>		9699883
External "TMP Profibus gateway"		9699261

TURBO PUMPS

▶ Agilent Turbo-V 551 and 701 Rack Controllers

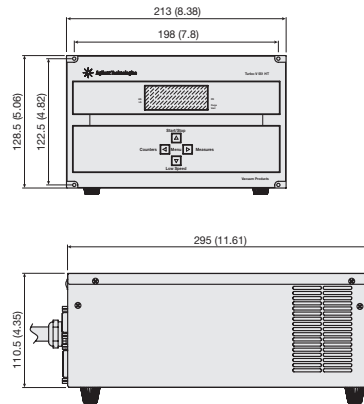

Dimensions: millimeters (inches)

These controllers are microprocessor-controlled frequency converters with self diagnostic and protection features that ensure the highest degree of reliability. The compact, ½ rack unit has a multifunction alphanumeric display for pump status and error code diagnostics. The front panel has a two-line dot matrix LCD display with back lighting. It displays rotational speed as the pump starts up and indicates when full speed is reached. At any time during the operation of the pump, the speed, current, power, and bearing temperature can be displayed. Additionally, the microprocessor acts as a pump

cycle log, and can display the number of vacuum cycles, the cycle time for the current cycle, and the total operating hours on the pump. Remote operation can be accomplished with logic level contact closures and with optional computer interfaces.

PCB controllers are available. Please contact Agilent for details.

Technical Specifications

Input voltages	100-240 V 1 ph, 50/60 Hz
Maximum input power	800 VA
Output frequency	700 Hz
Maximum output power*	
V 501:	320 W
V 701:	350 W
Startup power	430 W
Operating temperature	+5 °C to +45 °C
Storage temperature	-20 °C to +70 °C

* Data valid for nitrogen.

Ordering Information

Description	Weight kg (lbs)	Part Number
Controllers		
Turbo-V 551 Rack controller with RS 232/485, 120-220 V	15.7 (35.0)	X3501-64001
Turbo-V 701 Rack controller with RS 232/485, 120-220 V	15.7 (35.0)	X3501-64002
Accessories		
J1 input mating connector		9699853
P6 and P7 mating plug		9699854
Mains cable (European plug, 3 m long)		9699957
Mains cable (American plug, 120 V, 3 m long)		9699958
Options		
P2 output mating connector		9699852
Rack adapter for controller		9699191
Controller to pump extension cable (3 m extension) for Turbo-V 551, 701	1.0 (2.0)	9699948
Controller to pump extension cable (5 m extension) for Turbo-V 551, 701	2.0 (4.0)	9699948M001
Controller to pump extension cable (20 m extension) for Turbo-V 551, 701	4.0 (8.0)	9699948M002

AGILENT TURBO PUMP MODELS

▶ Agilent Turbo-V 1001 Navigator

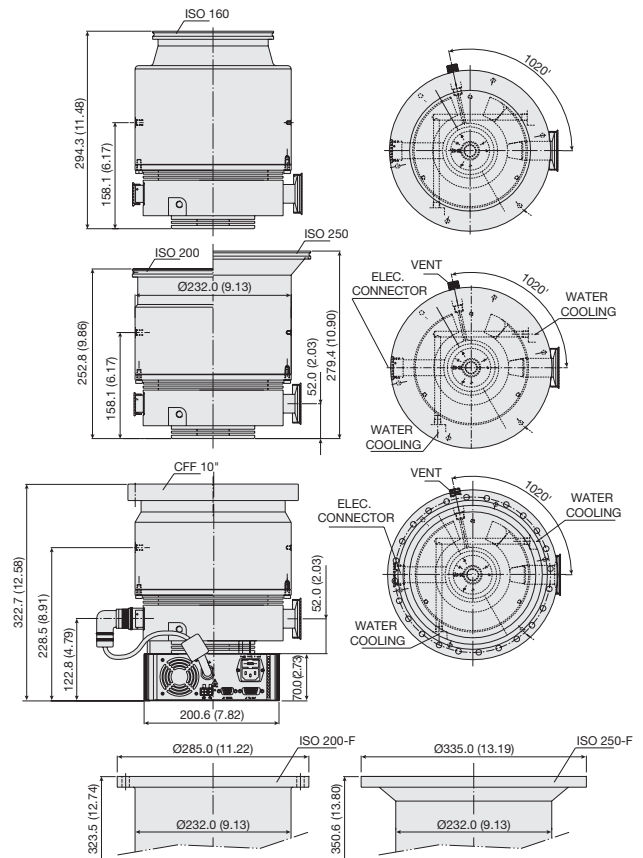

Dimensions: millimeters (inches)

Technical Specifications

Pumping speed:	ISO 160:	N ₂ : 790 l/s	He: 820 l/s	H ₂ : 860 l/s		
	CFF 10" or ISO 200:	N ₂ : 950 l/s	He: 870 l/s	H ₂ : 900 l/s		
	ISO 250:	N ₂ : 1,050 l/s	He: 900 l/s	H ₂ : 920 l/s		
Compression ratio:	ISO 160	N ₂ : 1 x 10 ⁹	He: 1 x 10 ⁷	H ₂ : 1 x 10 ⁶		
	CFF 10"/ISO 200 - ISO 250	N ₂ : 1 x 10 ⁹	He: 1 x 10 ⁷	H ₂ : 1 x 10 ⁶		
Base pressure* (with recommended forepump)	<1 x 10 ⁻¹⁰ mbar (< 1 x 10 ⁻¹⁰ Torr)					
Inlet flange	ISO 160	ISO 200	ISO 200-F bolted	CFF 10"	ISO 250	ISO 250-F bolted
Foreline flange	KF 40					
Rotational speed	38,000 rpm					
Start-up time	<4 minutes					
Recommended forepump	Mechanical: Agilent DS 402 Dry scroll: Agilent TS300, IDP-15					
Operating position	Any					
Cooling requirements	Forced air or water					
Bakeout temperature	120 °C at inlet flange max. (CF flange)					
	80 °C at inlet flange max. (ISO flange)					
Vibration level (displacement)	< 0.01 µm at inlet flange					
Weight kg (lbs):	ISO 160 flange					19 (41.8)
	ISO 200 flange					19.4 (43.0)
	CF 10" flange					25.5 (54.2)
	ISO 250 flange					21.2 (46.6)
	ISO 200-F and 250-F bolted flange, CF 10" flange					25.5 (54.2)

* According to standard DIN 28 428.

available with On-board Navigator controller, ½ Rack controller or PCB controller;
for information on controllers see also following pages.

SEM version available on request

TURBO PUMPS

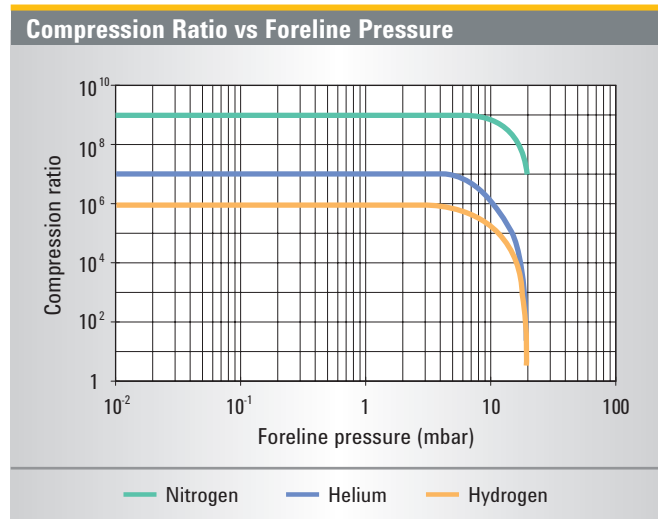
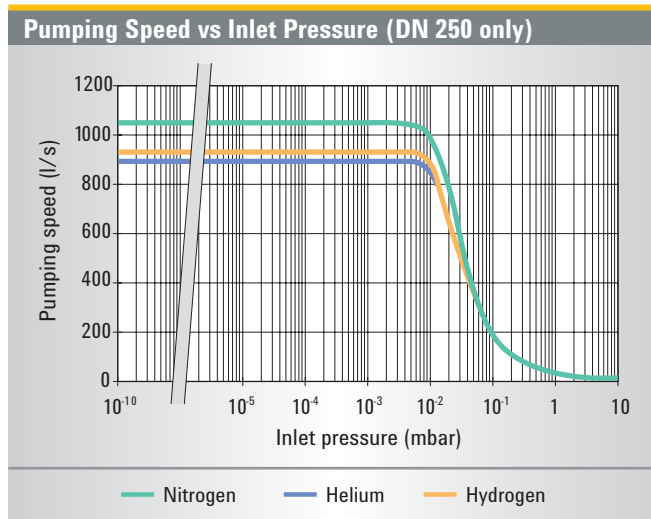

Ordering Information

Description	Weight kg (lbs)	Part Number
Complete Systems		
Turbo-V 1001 Navigator complete system, ISO 160 flange	24.4 (53.8)	9698840
Turbo-V 1001 Navigator complete system, ISO 200 flange	24.8 (55.0)	9698838
Turbo-V 1001 Navigator complete system, ISO 200-F bolted flange	30.9 (66.2)	9698844
Turbo-V 1001 Navigator complete system, 10" CF flange	30.9 (66.2)	9698839
Turbo-V 1001 Navigator complete system, ISO 250 flange	26.6 (58.6)	9698841
Turbo-V 1001 Navigator complete system, ISO 250-F bolted flange	30.9 (66.2)	9698845
<i>Complete system includes: Pump, Inlet screen, Controller mounted on the bottom, 2 Mains cables (NEMA plug and European plug).</i>		
Pumps		
Turbo-V 1001 Navigator pump, ISO 160 flange	19.0 (41.8)	9698933
Turbo-V 1001 Navigator pump, ISO 200 flange	19.4 (43.0)	9698931
Turbo-V 1001 Navigator pump, ISO 200-F bolted flange	25.5 (54.2)	9698946
Turbo-V 1001 Navigator pump, 8" CF flange	25.5 (54.2)	9698932M003
Turbo-V 1001 Navigator pump, 10" CF flange	25.5 (54.2)	9698932
Turbo-V 1001 Navigator pump, ISO 250 flange	21.2 (46.6)	9698934
Turbo-V 1001 Navigator pump, ISO 250-F bolted flange	25.5 (54.2)	9698947
Controllers (See following pages for specifications)		
Turbo-V 1001 Navigator controller 120/220 V - 50/60 Hz	5.4 (12.0)	9698978
Turbo-V 1001 Rack controller, 100-240 V	15.7 (35.0)	X3501-64003

Description	Weight kg (lbs)	Part Number
Pump Accessories		
Mains cable NEMA plug, 3 m long		9699958
Mains cable European plug, 3 m long		9699957
Serial cable and T-plus Software <i>(previous release Navigator 2.2 included in the CD)</i>		9699883
Inlet screen DN 160		9699304
Inlet screen DN 200		9699316
Inlet screen DN 250		9699350
Water cooling kit		9699337
Plastic water cooling kit		9699347
Air cooling kit for use with Navigator controller		9699297
Air cooling kit for use with standard rack controller		X3501-68001
Bracket for Navigator controller side mouting		9699298
Vibration damper ISO 160	4.0 (9.0)	9699345
Vibration damper, ISO 200	5.0 (10.0)	9699346
Vibration damper, CFF 10"	5.0 (10.0)	9699336
Vent flange, NW 10 KF / M8		9699108
Vent device with adjustable delay time for standard rack controller		9699831
Vent valve for standard rack controller		X3501-68002
Vent valve for Navigator controller		9699834
Purge valve 10 SCCM NW16KF – M12		9699239
Purge valve 10 SCCM ¼ Swagelok – M12		9699240
Purge valve 20 SCCM NW16KF - M12		9699241
Purge valve 20 SCCM ¼ Swagelok – M12		9699242
Purge valve 10 SCCM ¼ Swagelok ¼ Swagelok		9699232
Purge Valve 20 SCCM ¼ Swagelok ¼ Swagelok		9699236

Turbo Pumps

AGILENT TURBO PUMP CONTROLLERS

▶ Agilent Turbo-V 1001 Navigator Controller



The Turbo-V 1001 Navigator controllers are microprocessor-controlled frequency converters, fully controllable through PC software, with self-diagnostic and protection features that ensure the highest degree of reliability. They can be mounted on board, either on the bottom or on the side of the pump, offering outstanding flexibility and simplicity.

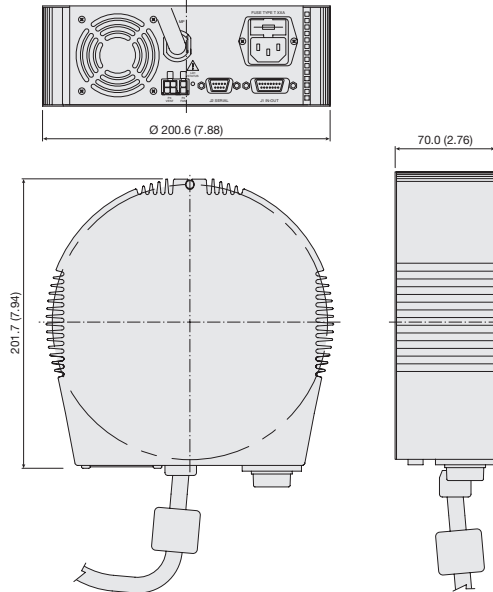

Dimensions: millimeters (inches)

Technical Specifications

Input voltages	100/120/220/240 VAC
	50/60 Hz, 1 ph
Maximum input power	850 VA
Output voltage	54 VAC, 3 ph
Output frequency	640 Hz
Operating temperature	0 °C to +40 °C
Storage temperature	-20 °C to +70 °C

Ordering Information

Description	Weight kg (lbs)	Part Number
Controllers		
Turbo-V 1001 Navigator controller 120/220 V - 50/60 Hz	3.0 (6.0)	9698978
Accessories		
Mains cable NEMA plug, 3 m long	0.5 (1.0)	9699958
Mains cable European plug, 3 m long	0.5 (1.0)	9699957
Serial cable and T-plus Software <i>(previous release Navigator 2.2 included in the CD)</i>	0.5 (1.0)	9699883
External "TMP Profibus gateway"	0.4 (0.8)	9699261

TURBO PUMPS

► Agilent Turbo-V 1001 Rack Controller

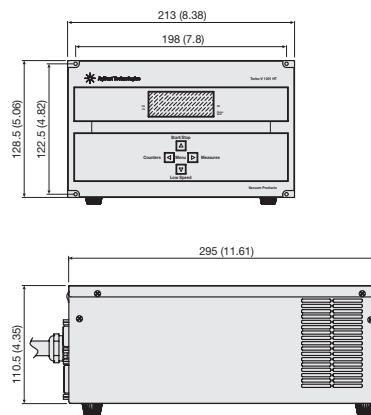

Dimensions: millimeters (inches)

These controllers are microprocessor-controlled frequency converters with self diagnostic and protection features that ensure the highest degree of reliability. The compact, ½ rack unit has a multifunction alphanumeric display for pump status and error code diagnostics. The front panel has a two-line dot matrix LCD display with back lighting. It displays rotational speed as the pump starts up and indicates when full speed is reached. At any time during the operation of the pump, the speed, current, power, and bearing temperature can be displayed. Additionally, the microprocessor acts as a pump

cycle log, and can display the number of vacuum cycles, the cycle time for the current cycle, and the total operating hours on the pump. Remote operation can be accomplished with logic level contact closures and with optional computer interfaces.

PCB controllers are available. Please contact Agilent for details.

Technical Specifications

Input voltages	100-240 V 1 ph, 50/60 Hz
Maximum input power	800 VA
Output voltage	56 VAC, 3 ph
Output frequency	633 Hz
Maximum output power*	450 W
Startup power	450 W
Operating temperature	+5 °C to +45 °C
Storage temperature	-20 °C to +70 °C

* Data valid for nitrogen.

Ordering Information

Description	Weight kg (lbs)	Part Number
Controller		
Turbo-V 1001 Rack controller, 100-240 V	15.7 (35.0)	X3501-64003
Accessories		
Mains cable (European plug, 3 m long)		9699957
Mains cable (American plug, 120 V, 3 m long)		9699958
Options		
Rack adapter for controller	2.0 (4.0)	9699191
Controller to pump extension cable (5 m extension) for Turbo-V 1001	1.0 (2.0)	9699948M001
Controller to pump extension cable (12 m extension) for Turbo-V 1001	2.0 (4.0)	9699951S029
Controller to pump extension cable (20 m extension) for Turbo-V 1001	4.0 (8.0)	9699948M002
External "TMP Profibus gateway"	0.4 (0.8)	9699261

AGILENT TURBO PUMP MODELS

▶ Agilent Turbo-V 2300 TwisTorr Rack

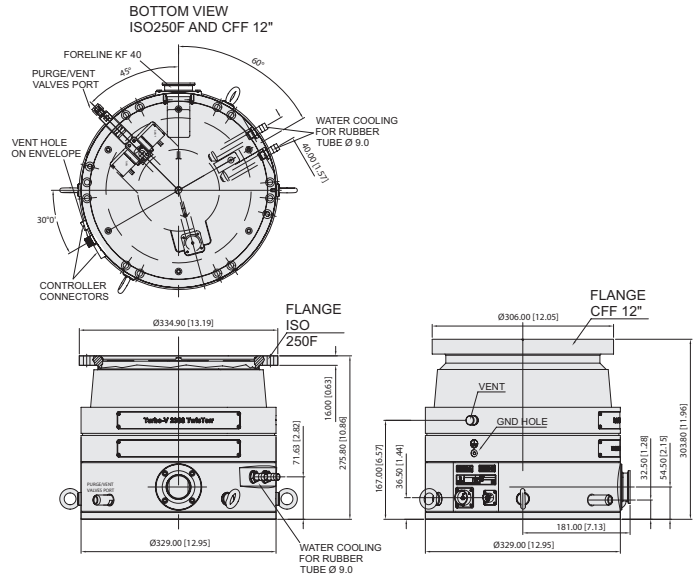

Technical Specifications

Vacuum Performances

Pumping speed for N ₂ (*)	2050 l/s
Pumping speed for He (*)	1800 l/s
Pumping speed for H ₂ (*)	1500 l/s
Compression ratio for N ₂	>8 x 10 ⁸
Compression ratio for He	8 x 10 ⁵
Compression ratio for H ₂	4 x 10 ⁴
Base pressure* (with recommended forepump)	10 ⁻¹⁰ mbar (7.5 x 10 ⁻¹¹ Torr) (**)
Max foreline pressure for N ₂	4 mbar
Inlet Flange	ISO 250F, CFF 12" O.D.
Foreline flange	KF 40 NW

Other

Nominal rotational speed	33300 rpm
Start-up time without gas load and with the recommended forepump	< 6 minutes
Minimum recommended forepump	TriScroll 600
Operational position	Vertical/Upside down
Operating ambient temperature	+5 °C to +35 °C
Bakeout temperature	120 °C (CFF), 80 °C (ISO)
Max rotor temperature	120 °C
Vibration level (displacement)	< 0.01 µm at inlet flange
Lubricant	Permanent lubrication
Cooling requirements	Water
Coolant water	Recommended flow: 200 l/h Temperature: +15 °C to +30 °C Pressure: 3 to 5 bar (45 to 75 psi)
Noise level	<60 dB(A) at 1 meter
Storage temperature	-20 °C to +70 °C
Environment protection	IP54
Weight	ISO 250: 54.2 kg (119.5 lbs) CFF 12": 55.3 kg (121.9 lbs)

(*): WITHOUT INLET SCREEN

(**): According to standard DIN 28 428, the base pressure is that measured in a leak-free test dome, 48 hours after the completion of test dome bake-out, with a Turbopump fitted with a CFF flange and using the recommended pre-vacuum pump

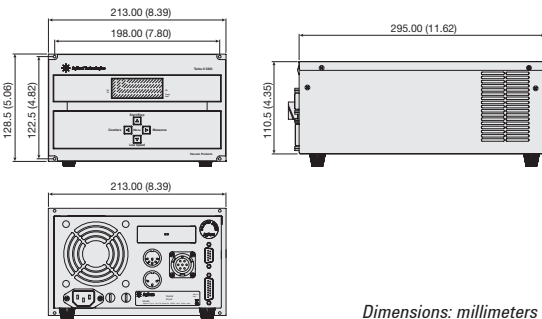

Dimensions: millimeters (inches)

Controller Specifications

Input voltages	100-120 VAC, 220-240 Vac, 1-phase
Input frequency	50 - 60 Hz
Maximum input power	1300 VA
Output voltage	64 Vac
Output frequency	555 Hz
Output Power starting	560 W maximum
Output Power normal	450 W maximum
Weight (both models)	12.5 kg (28 lbs)
Installation category	II
Pollution degree	2

TURBO PUMPS

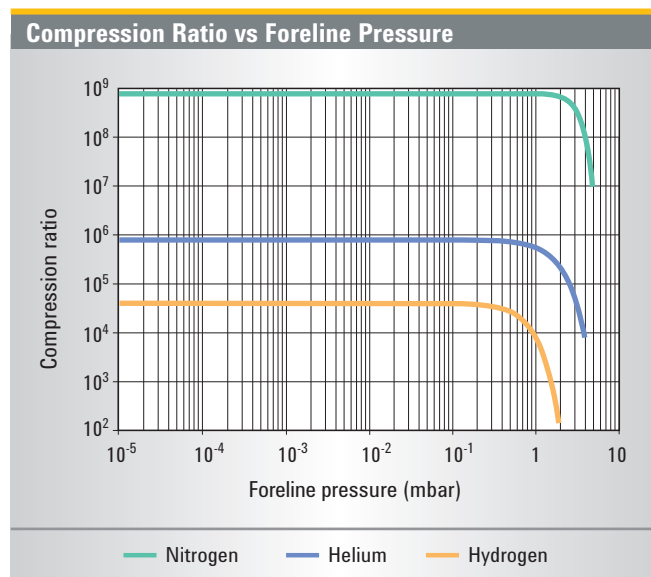
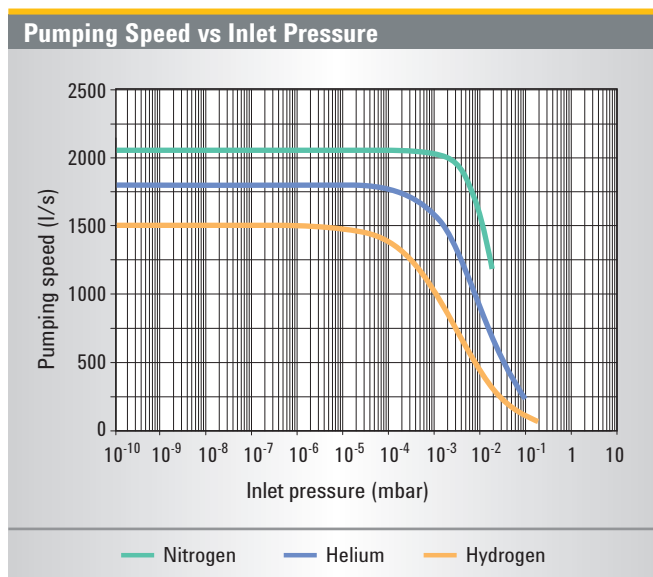

Ordering Information

Pump	Part Number
Agilent Turbo-V 2300 TwisTorr ISO250F Rack	9696000
Agilent Turbo-V 2300 TwisTorr CFF12" OD Rack	9696001

Controllers*

Agilent Turbo-V 2300 Rack controller, 100-240 V	X3501-64004
Agilent Turbo-V 2300 Pump-Controller Cable kit, 5 m, for pump and vent valve operation	X3501-68003

(*): Please note that rack controllers do not include the Pump-Controller Cable Kit

Accessories

Mains cable NEMA Plug, 3 m long	9699958
Mains cable European Plug, 3 m long	9699957
Center-ring ISO 250	9699144
Inlet screen DIN ISO 250 // CFF12" AISI	9699350
Water cooling kit for 6x8 (IDxOD) flexible tube	9699348
Water cooling kit for 3/8 in. ID flexible tube	9699338

AGILENT TURBO PUMP MODELS

▶ Agilent Turbo-V 1K-G

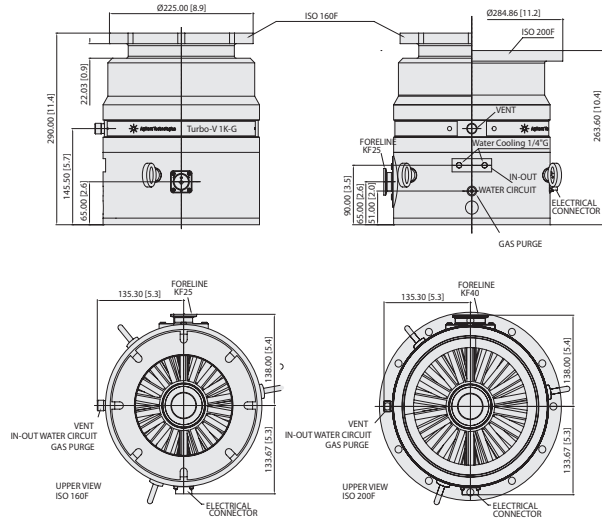

Dimensions: millimeters (inches)

Turbo-V 1K-G

- Application-specific pumping solution designed for thin film deposition equipment
- High pumping speed and high gas throughput
- Rugged design and highly efficient cooling system for continuous operation
- Gas Purge for bearings protection

Advanced Electronics

- Rack type or Navigator on board controllers
- Versatile electronics interface with easy to use control Software
- Analog I/O signals and RS232 / RS485 interface as standard Agilent Profibus interface as option

Technical Specifications

Pumping speed:	ISO 160:	Ar: 750 l/s	N ₂ : 810 l/s	He: 950 l/s	H ₂ : 680 l/s
	ISO 200:	Ar: 1,040 l/s	N ₂ : 1,080 l/s	He: 1,150 l/s	H ₂ : 730 l/s
Compression ratio:		Ar: > 5 x 10 ⁸	N ₂ : > 5 x 10 ⁷	He: > 4 x 10 ⁴	H ₂ : 1.5 x 10 ⁴
Base pressure* (with recommended forepump)	< 1 x 10 ⁻¹⁰ mbar				
Inlet flange	ISO 160 F, ISO 200 F				
Foreline flange	ISO 160:	KF 25 NW			
	ISO 200:	KF 40 NW			
Nominal rotational speed	45,500 rpm				
Start-up time	< 5 minutes				
Minimum recommended forepump	> 20 m ³ /h (TriScroll 600, DS 602)				
Operating position	Any				
Operating ambient temperature	+5 °C to +35 °C				
Bakeout temperature	80 °C at inlet flange max. (ISO flange)				
Vibration level (displacement)	< 0.01 μm at inlet flange				
Cooling requirements	Water				
Power supply	Input voltage: 100-240 Vac	Input freq.: 50 - 60 Hz	Max input power: 600 VA	Stand-by power: 30 to 35 W	
	Max operating power: 400 W using Nitrogen and lighter gases (water cooling setting) 260 W using Argon (air cooling setting)				
Protection fuse (Navigator controller)	1 x 6.3 A				
Serial communication (Navigator Kit)	RS232 cable with a 9-pin D type male connector and a 9-pin D type female connector, and Navigator software (optional)				
Storage temperature	-20 °C to +70 °C				
Weight	26.8 kg (59.1 lbs)				

* According to standard DIN 28 428.

TURBO PUMPS

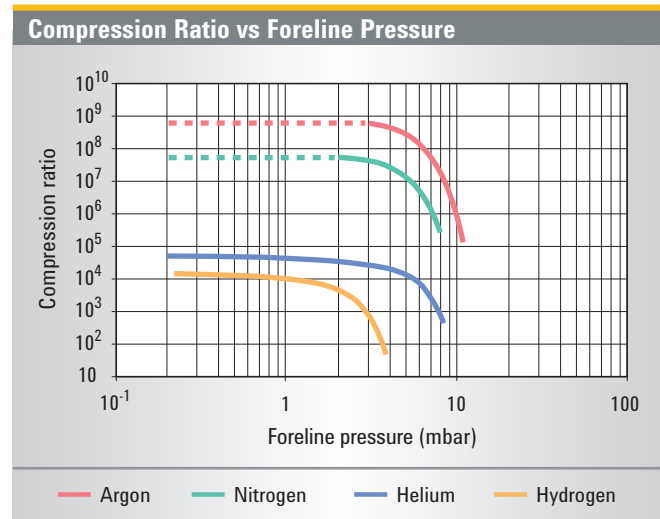
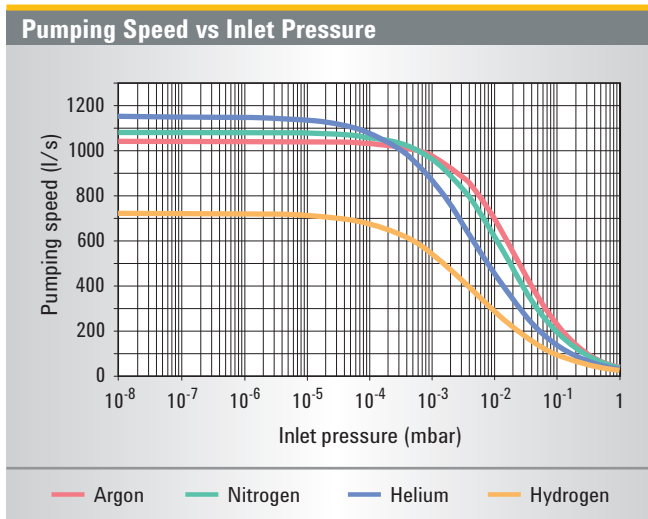

Ordering Information

Description	Part Number
Pumping Systems	
Turbo-V 1K-G ISO160 F	8698961R002
Turbo-V 1K-G ISO200 F	8698962R001
Controllers	
Turbo-V 1K-G Navigator controller, 120-220 V	9698978M005
Turbo-V 1K-G Rack controller, 100-240 V	X3501-64005
Accessories	
Mains cable NEMA Plug, 3 m long	9699958
Mains cable European Plug, 3 m long	9699957
Serial cable and Navigator Software	9699883
Inlet screen ISO 160	9699304
Inlet screen ISO 200	9699316
Water cooling kit (hose tail G ¼)	9699825
Water cooling kit (Inox G ¼)	9699826
Vent flange, NW 10 KF / M8	9699108
Vent device with adjustable delay time for standard rack controller	9699831
Vent valve for standard rack controller	X3501-68002
Vent valve for Navigator controller	9699834
Purge valve KF16-M12 20 SCCM	9699241
Purge valve 7/16-M12 20 SCCM	9699242
Recommended Forepump	
Rotary Vane pump DS 602, with 1 ph, worldwide motor	9499335
Rotary Vane pump DS 602, with 3 ph, worldwide motor	9499336
Rotary Vane pump HS 452, with 1 ph, worldwide motor	9499360
Rotary Vane pump HS 652, with 1 ph, worldwide motor	9499365
Dry pump TriScroll 600, with 1 ph, worldwide motor	PTS06001UNIV
Dry pump TriScroll 600, with 3 ph, worldwide motor	PTS06003UNIV
Dry pump TriScroll 600 inverter, with 1 ph, worldwide motor	PTS06001INV

AGILENT TURBO PUMP MODELS

▶ Agilent Turbo-V 2K-G System

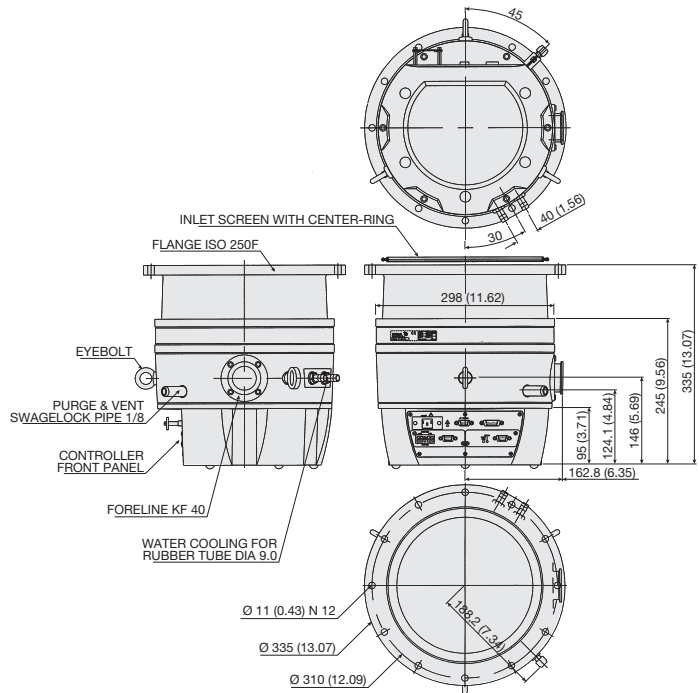

Dimensions: millimeters (inches)

Turbo-V 2K-G System

- The first application-specific pumping solution designed for thin film deposition equipment
- The highest performing, most compact unit available
- The first fully integrated approach for maximum system productivity and uptime

The System Interface

- Integrated package includes Turbo Molecular Pump, Drive Electronics, Power Supply, Purge Gas and Communication
- Versatile electronics interface with easy to use control Software
- Analog I/O signals and RS232 / RS485 interface as standard Agilent Profibus interface as option

Technical Specifications

Pumping speed		N ₂ : 1600 l/s
Compression ratio		N ₂ : 3 x 10 ⁵
Base pressure* (with recommended forepump)		< 1 x 10 ⁻⁸ mbar
Inlet flange		ISO 250 F
Foreline flange		KF 40 NW
Nominal rotational speed		33,000 rpm
Start-up time		<7 minutes
Recommended forepump		> 40 m ³ /h
Operating position		Any
Operating ambient temperature		+5 °C to +40 °C
Power supply	Input voltage	100 - 240 Vac
	Input freq.	50 - 60 Hz
Communication Interface	Analogue I/O	Standard
	RS232 / RS485	Standard
	Profibus	Optional
Dimensions	Height	335 mm (13.18 in.)
	Diameter	335 mm (13.18 in.)
	Weight	35 kg (77 lbs)

* According to standard DIN 28 428.

TURBO PUMPS

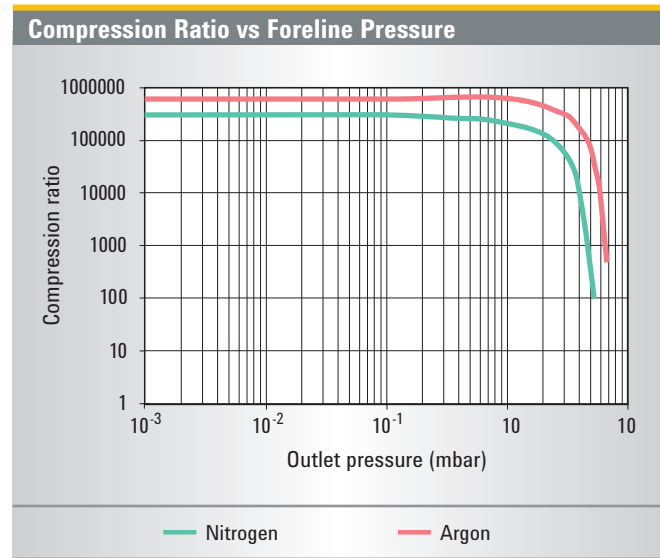
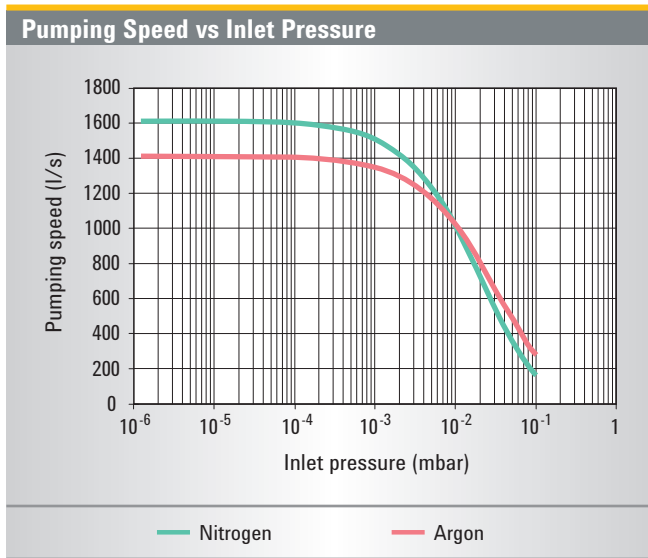

Ordering Information

Description	Part Number
Pumping Systems (*)	
Turbo-V 2K-G system with MoniTorr	9698871
Turbo-V 2K-G system with Profibus and MoniTorr	9698873
(*) Pumping Systems include Pump with 230 V Integrated Electronics, water hose connection, Inlet Screen with center-ring and pre-installed IP54 Mating Connectors. Both standard models can be equipped with Agilent's MoniTorr device on request. Also 120 Vac units available on request.	
Accessories	
Mains cable NEMA Plug, 3 m long	9699958
Mains cable European Plug, 3 m long	9699957
T-Plus Software and serial cable	9699883
Water cooling kit for 6x8 (IDxOD) flexible tube	9699348
Water cooling kit for 3/8 in.ID flexible tube	9699338
Turbo-V remote cable	9699945
Turbo-V remote panel	9698850
Spare Parts	
IP54 proof mating connectors	9699958
Inlet screen ISO 250 with center ring	9699138
Water hoses	9699825

AGILENT TURBO PUMP MODELS

▶ Agilent Turbo-V 3K-G System

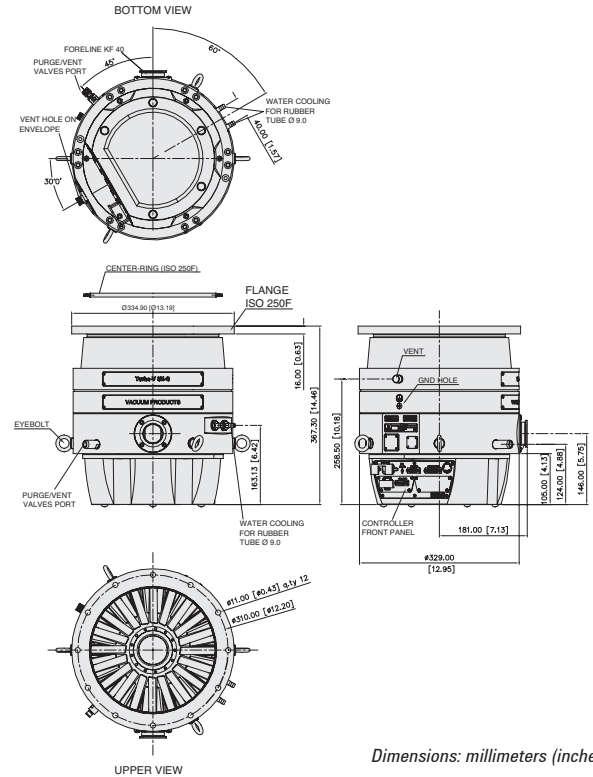

Dimensions: millimeters (inches)

The Only Truly “Integrated” System in the Market

The Turbo-V 3K-G: an advanced solution for Thin Film applications

- Fully integrated system with on board waterproof power supply
- Vent/purge valves control capability
- Integrated diagnostics
- Multiple interfaced capability
- Lowest power absorption

Best Footprint to Performance Ratio

- The highest Argon pumping speed (2050 l/s) for its size allows uniform deposition rates at high substrate throughput
- Highest pumping speed in its class: 2200 l/s for Nitrogen
- Throughput: over 1400 sccm for Nitrogen
- The all-turbo, more compact rotor design delivers highest performance with the smallest footprint

Technical Specifications

Pumping speed	N ₂ : 2200 l/s	He: 1900 l/s	Ar: 2050 l/s
Compression ratio	N ₂ : > 1 x 10 ⁷	He: 6 x 10 ³	Ar: > 1 x 10 ⁸
Base pressure* (with recommended forepump)	< 1 x 10 ⁻⁸ mbar		
Inlet flange	ISO 250 F		
Foreline flange	KF 40 NW		
Nominal rotational speed	31,800 rpm		
Start-up time without gas load and with the recommended forepump	< 6 minutes		
Foreline pressure	< 0.5 mbar		
Minimum recommended forepump	> 60 m ³ /h (depending on gasflow requirements)		
Operating position	Any		
Cooling requirements	Water		
Weight (ISO 250)	52 kg (114.63 lbs)		

* According to standard DIN 28 428.

TURBO PUMPS

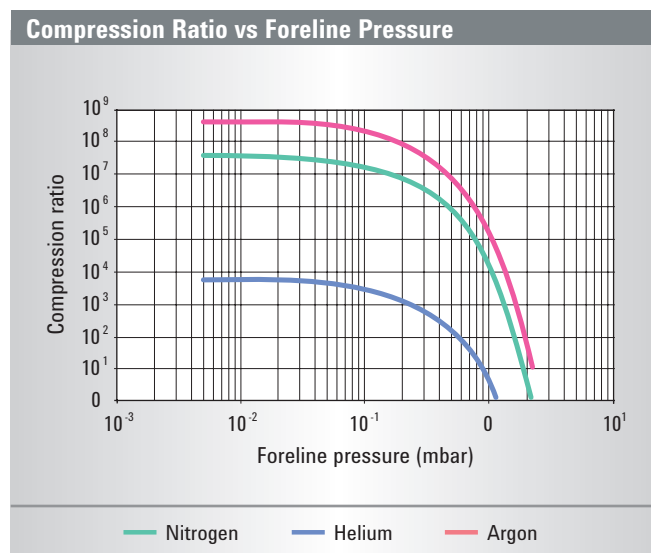
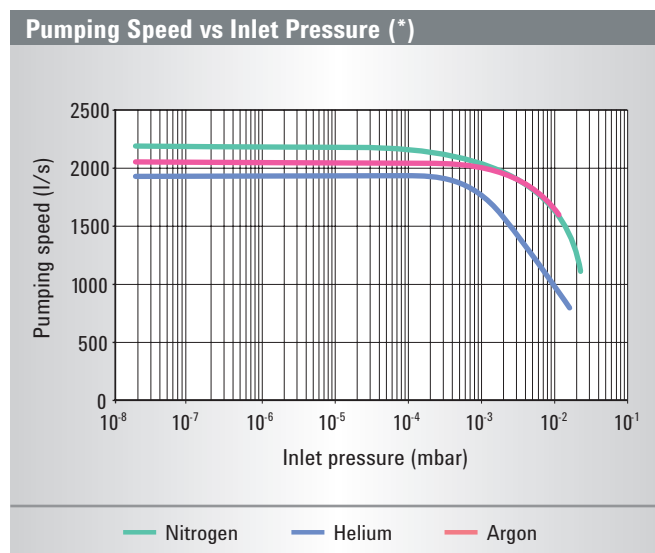

(*) Measured with a 60 m³/h forepump.

Ordering Information

Description	Part Number
Pumping Systems (*)	
Turbo-V 3K-G ISO 250 F System with integrated purge/vent device	9698888
Turbo-V 3K-G ISO 250 F System with Profibus and integrated purge/vent device	9698889
(*) Pumping Systems include Pump with 230 V Integrated Electronics, Inlet Screen installed on the pump, separate center-ring and pre-installed IP54 Mating Connectors. Both standard models can be equipped with Agilent's MoniTorr device on request. Also 120 Vac units available on request.	
Accessories	
Mains cable NEMA Plug, 3 m long	9699958
Mains cable European Plug, 3 m long	9699957
T-Plus Software and serial cable	9699883
Water cooling kit for 6x8 (IDxOD) flexible tube	9699348
Water cooling kit for 3/8 in.ID flexible tube	9699338
Spare Parts	
IP54 proof mating connectors	9699960
Inlet screen ISO 250	9699350
O-ring and center ring ISO250	9699144

AGILENT TURBO PUMP ACCESSORIES

Inlet Screens

To prevent any possible damage to the pump blades caused by particles falling into the pump, an inlet screen is available as an accessory. The inlet screen is a curved stainless steel mesh. It provides protection against debris larger than 0.7 to 3 mm (depending on the model), while reducing the pumping speed by only about 10%.

For ordering information, see individual pumps.

Air Cooling Kits

A fan is provided as an option for applications requiring forced air flow. The fan is easily installed using the included installation kit.

The air cooling kit for the Turbo-V 81's can be mounted beside or underneath the pump body. The fans for all the other pump models can be installed in a side location only. The maximum allowable ambient temperature for an effective cooling action is 30 °C. To meet the air flow rate specifications, care must be taken not to restrict or cover the space around the fan so that air can flow freely. The operation of the cooling fan is controlled by the Turbo controller.

For ordering information, see individual controllers.

Water Cooling Kits

A water cooling kit is provided to cool the pump when operating at high inlet or high exhaust pressures. The cooling water can be supplied by an open circuit with drainage or a closed-loop refrigerated system.

Care must be taken to secure the tubes to ensure that they do not detach during operation. Four different kits with various tube sizes are available (refer to the following table).

Tube Size	Material	Screw Thread	Part Number
4 x 6 mm (ID x OD)	Plastic	¼ BSP	9699347
6 x 8 mm (ID x OD)	Plastic	¼ BSP	9699348
¼" ID	SST	¼ BSP	9699337
⅜" ID	SST	¼ BSP	9699338

For ordering information, see individual pumps.

Vibration Dampers

Highly sensitive equipment such as an electron microscope and certain analytical instruments require extremely low vibration amplitudes. The dampers reduce turbopump vibration

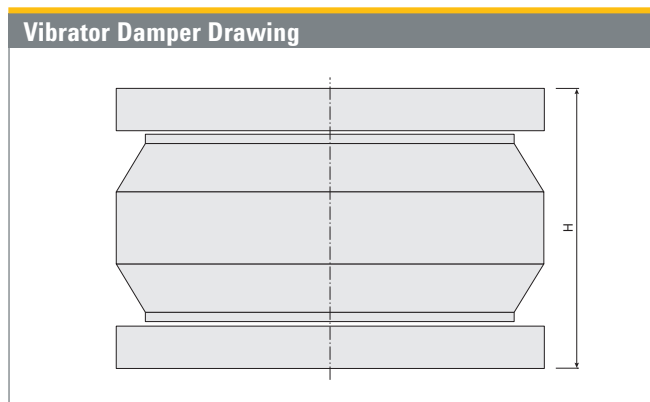

amplitude by at least a factor of 10 at their main frequencies. They are available up to a size of 200 mm (ISO 200 or CFF 10" O.D.). To effectively decouple the equipment from the pump, the vibration damper must be installed between the connecting flanges.

For ordering information, see individual pumps.

	H (mm)	H (inches)
Vibration Damper 4 ½" CF	96.5	3.80
Vibration Damper 6" CF	101	3.97
Vibration Damper 8" CF	110	4.33
Vibration Damper 10" CF	113	4.45
Vibration Damper 63 ISO	84	3.31
Vibration Damper 100 ISO	84	3.31
Vibration Damper 160 ISO	88	3.46
Vibration Damper 200 ISO	88	3.46

Turbo Vent Valve

The Turbo Vent Valve, consisting of a control unit and a valve, is a complete unit for automatic venting of the Turbo pump when it is switched off or during a power failure. The valve is a normally open, electromagnetically-actuated valve with a filter on the air inlet. The control unit is powered by the Turbo controller and is provided with a fixed delay time of about 5 seconds to avoid undesired venting during a temporary power failure and to allow closure of the system valves before venting.

For ordering information, see individual controllers.

Turbo Vent Device

To control the venting of the Turbo pumps when they are switched off or during a power failure, a vent device is offered. The Turbo vent device consists of a normally closed valve and a control unit. The valve is electromagnetically-actuated and has a filter on the air-inlet. The control unit is powered by the Turbo controller and has a built-in battery backup. Delay and venting times are adjustable up to 36 minutes to optimize the venting conditions for each application.

For ordering information, see individual controllers.

Handheld Terminal

The handheld terminal is a remote control display for use with V 81 series Turbo pumps when connected to a controller without a front panel. It consists of an LCD alphanumeric display and keyboard which provide useful real time indications of the operating conditions and parameters of the turbopump.

Moreover, it allows the reprogramming of the controller parameters and troubleshooting of the pump and controller. The handheld terminal is connected to and powered from the Turbo-V controller through a 1.5 meter cable.

For ordering information, please call your local Agilent Office.

Purge Valve

To protect the bearings of a turbomolecular pump used with aggressive process gases, a measured supply of inert gas (N₂, Ar) must flow into the pump body around the upper bearing toward the fore-vacuum line. The Agilent fixed orifice purge valve is calibrated for nitrogen to provide the correct gas flow to safely operate Turbo pumps. For ordering information, see individual pumps.

Vibration Level

Thanks to low vibration, focused design, and computer assisted balancing tools, today turbomolecular pumps generate very low levels of mechanical vibration. This is mainly a result of the numerical modeling of the pump rotodynamics (see Figure 1) and a specific vibration damping system already built into the pump structure. Thanks to both design features, today ceramic ball bearings pumps are standard even in very high vibration applications like SEM and Metrology Tools.

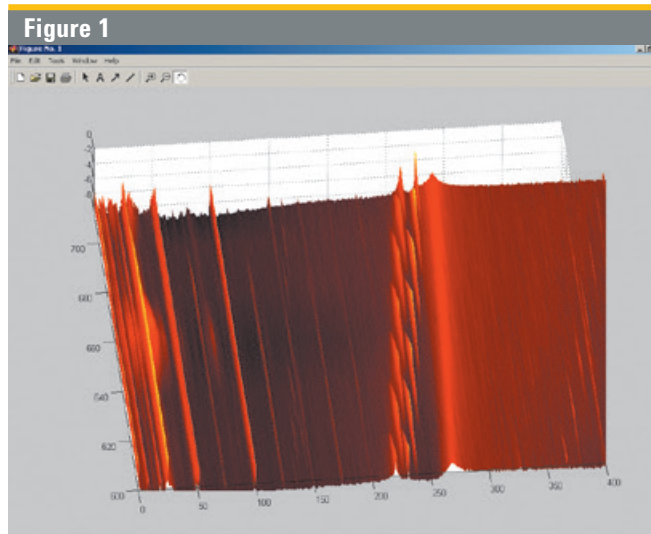

A typical vibration spectrum of a turbomolecular pump can be seen in Figure 2:

Possible sources of vibration in a turbomolecular pump are unbalanced rotor, high frequency motor or bearings. Rotor unbalance can be reduced to a very low level through dynamic balancing, which minimizes forces caused by a nonsymmetric distribution of masses in relation to the rotational axis. As an order of magnitude, the radial displacement on the pump HV flange after balancing can be as low as 0.001 μm .

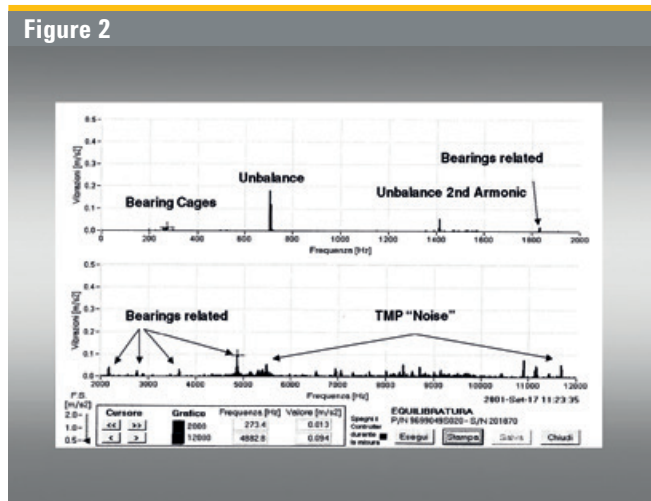

The vibrations from a high frequency motor are caused by electromagnetic interactions between the motor stator and rotor: their characteristic frequencies are multiples of the motor driving frequency. Also, the rotor supports generate both white noise and vibrations at specific frequencies of the bearings' moving parts (cage, balls and rotating ring, usually the inner one).

In general, the vibrations caused by an electric motor or bearing are even lower than those caused by unbalance. They may be relevant in the case of bearing damage or because of excitation of a natural resonant frequency of the system connected to the pump. In the second case, the system structure should be modified by adding mass, changing the stiffness and/or inserting a vibration damper between pump and system.

Operation in Presence of Magnetic Fields

Magnetic fields induce eddy currents in the turbomolecular pump rotor that tend to oppose its rotation. As a consequence the power delivered to the electrical motor is increased.

Since the pump rotor is not in contact with the stator, all the heat generated by the eddy currents must be dissipated by radiation, so the rotor can be overheated even if the static parts remain cool.

According to our tests, the maximum magnetic field that our pumps can tolerate is:

- 50 Gauss in the transversal direction
- 100 Gauss in the axial direction

In these cases, a power increase to the motor can be expected. If the magnetic field is greater than the above values a shield must be used in order to have a residual magnetic field around the pump below the value specified.

Please contact Agilent for more details.

Turbomolecular Pump Bearings and Lubrication System

The Turbo-V pumps incorporate Agilent's innovative ceramic bearing design with a proprietary ultra-low vapor pressure solid lubricant, which enables these pumps to provide a long service life and a high degree of cleanliness under most operating conditions. This lubrication system is a superior feature of Agilent Technology and guarantees no contamination of the vacuum system, especially when compared to other oil-lubricated turbomolecular pumps (See figures 3-4).

The ceramic bearings utilize balls made of silicon nitride, a polycrystalline material with an amorphous intergranular binder base that offers the following advantages:

Hardness

This is a critical aspect of bearing design, and it closely relates to bearing performance and reliability. The silicon nitride material used in Agilent's Turbo-V bearing system is twice as hard as conventional steel providing dramatic improvement in wear resistance while minimizing the effects of surface contact and stress.

AGILENT TURBO PUMP TECHNICAL NOTES

Figure 3 - Typical Competitor Pump

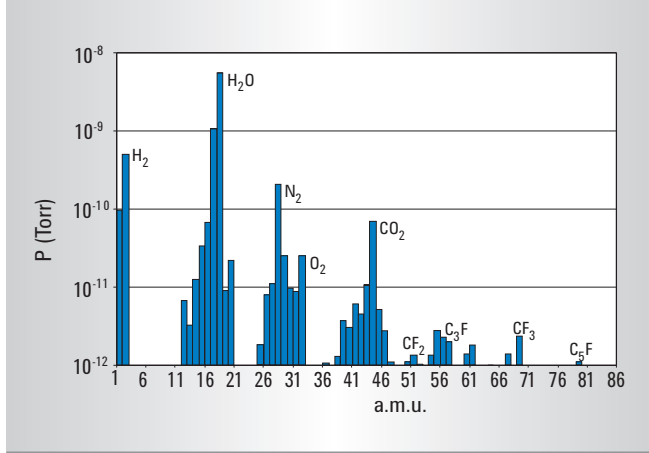
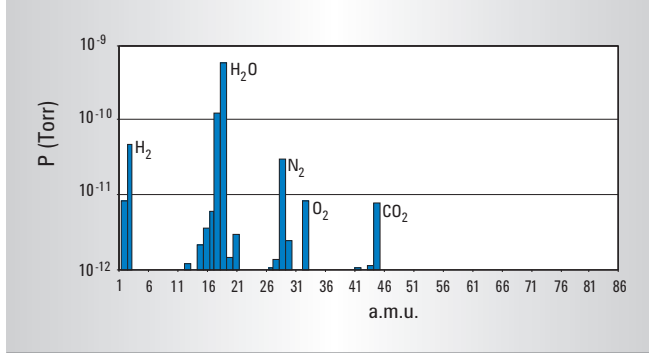

Figure 4 - Typical Agilent Pump



Weight

Silicon nitride is 40% less dense than conventional steels, which helps to reduce centrifugal loading and stress levels at high rotational speeds, especially in the bearing race area.

Friction

Silicon nitride's low coefficient of friction enhances wear resistance and adds to the bearing's operational life.

Thermal Stability

With its low thermal expansion coefficient, the silicon nitride bearing material ensures that tight tolerances and mating component fit will be maintained over an extremely wide temperature range. In addition, silicon nitride has an outstanding resistance to fracture by thermal shock.

Chemical Stability

Silicon nitride is virtually inert.

Another feature of the Turbo-V bearing system is its proprietary lubricant which has an extremely low vapor pressure and is virtually hydrocarbon free. The use of this lubricant in the permanently sealed bearing system ensures clean, reliable operation without the need for any maintenance whatsoever.

Agilent T-plus

Agilent T-plus (Turbo Pumps Linked User Software) is the new communication, control and monitoring software for Agilent Turbomolecular Pumps and all other Agilent products featuring the Agilent Window Serial Protocol.

With T-plus, you can simultaneously drive and control one or more Turbo Pumps, connected to a PC through an RS232 or an RS485 serial communication.

Automatic identification of the connected Pumps, description of each command always on screen, and User Interface adaptable to the Pump Status are only some of the new features developed to make the approach to pump settings easy and to reduce the number of steps during pump configuration.

Moreover, special care is given to the GUI (Graphical User Interface), to reproduce the environment of well-known User Interfaces (such as Microsoft Windows applications), to obtain a real User Friendly tool, and to reduce the user learning time. T-plus software features several options like Data Logging, Chart Representation and Network Configuration, to help you configure your Vacuum devices quickly, and to check your vacuum system status at any time.

Exhaustive online Help is also included, providing the user with a complete, easy to learn system, tailored to customer requirements.

The previous software release Navigator 2.2 is included in the T-plus CD.

Figure 5

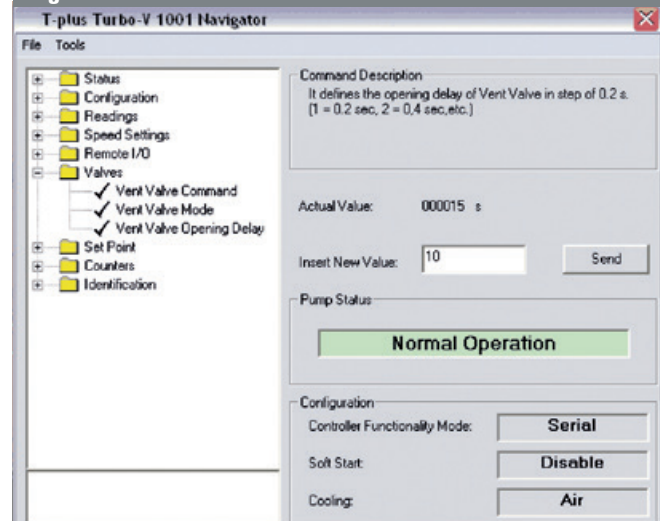

CE/CSA, EMC Electrical Specifications Compliance

Compliance to these norms guarantees that there are no limits on the use of the controllers and turbopumps in every type of ambient, and that their use doesn't create any kind of disturbance to electronic units connected to the same line.

Agilent's new generation of Turbo controllers comply with the limits given by the following norms:

EN 55011 Class A group 1

EN 61000/3/2

EN 61000/3/3

EN 61000/4/2

EN 61000/4/3

EN 61000/4/4

EN 61010-1

UNI EN 291-1

UNI EN 292-2

EN 1012-2

AGILENT TURBO PUMP SERVICE AND SUPPORT PLANS

Agilent Vacuum Products offers one of the most comprehensive service and support plans in the industry. As a worldwide, first class company we strive to offer added value to our Customers wherever they may be located. Excellence in Service and Support is a key factor in added value. Support can be accomplished with qualified Engineers and an appropriate logistic infrastructure. Technical skills and infrastructure are two areas where we are continuously making medium and long-term investments. Our daily customer support philosophy is focused on two important factors: fast response and no hassle. This philosophy translates to the following sections of our Turbo Pump Service and Support Plan:

- **Worldwide Parts Sourcing Plan:**
Three Progressive Levels of Support
- **Technical Assistance:** Customer Support, Application Support, Application Training

Agilent Vacuum **Products is committed** to providing our Customers with the most comprehensive service plans possible.

The following pages detail the standard sections of our Turbo Pump Service and Support Plan. For more information, or if you have a need for customized solutions, please contact your Agilent representative.

Often, excellent products are not enough: Agilent’s constant presence with Customer Service as a responsive partner is what really makes a difference.

Worldwide Parts Sourcing Plan

- **Repair Program**
Agilent products offer unmatched reliability, performance and cleanliness. Production requirements, however, inevitably create, over time, the need for maintenance and repair. Timely repair at Agilent will keep your products performing at an outstanding level all the time.

- **Advanced Exchange Program**

To maximize uptime, and for those occasions where time is essential, Agilent offers exchange units for advance shipment.

Exchange units are fully remanufactured to the same strict standards as new products. They are kept in stock in North America, Europe, China, Japan, Korea, Singapore, Taiwan and India.

As soon as requested, your Exchange unit can be shipped for overnight delivery. This efficiency is due to our logistic infrastructure and is the result of excellent teamwork among our Service and Customer Service Teams!

The Exchange and Repair Programs are available worldwide and allow global OEMs and End-Users consistent delivery time, value pricing, consistent part numbers, and simple order processing procedures.

- **Upgrade Program**

The Upgrade Program is designed for customers who need to replace an Agilent (formerly Varian) product at the end of its life, or of old technology, with a newest technology product.



TURBO PUMPS

The Upgrade Program includes proactive technical installation support, by telephone and full 12-month warranty.

Agilent's Turbo pump Upgrade Program provides a customer with the same outstanding support delivered with our service programs, including:

- RMA# tracking
- Replacement with remanufactured pump of the newest technology
- Advance replacement
- 24-hour expedited order management
- WEB on-line order status & shipment tracking
- **End User Extended Warranty**

The End User Extended Warranty is a Service Agreement that provides coverage extension beyond the standard 12 months warranty of a product. It extends for additional 12 months the coverage from failures due to defects in material and workmanship.

By extending the warranty of purchased products, post-sales satisfaction is guaranteed. This is the result of the relevant cost decrease while cost predictability is increased.

The End User Extended Warranty has been designed to cover the needs of the End User Market:

- General Purpose Vacuum applications.
- High Energy Physics Ultra High Vacuum applications.

Ordering Information for End User Extended Warranty

General Purpose Vacuum Applications	Part Number
Extd. Warranty 12M Turbo 80 l/s class	EW81
Extd. Warranty 12M Turbo 300 l/s class	EW300
Extd. Warranty 12M Turbo 700 l/s class	EW700
Extd. Warranty 12M Turbo 1000 l/s class	EW1000
Extd. Warranty 12M Turbo TV1KG	EWTV1KG
Extd. Warranty 12M Turbo TV2KG	EWTV2KG
Extd. Warranty 12M Turbo TV3KG	EWTV3KG
Extd. Warranty 12M Turbo (other config.)	EW969TMP
High Energy Physics UHV Applications	Part Number
Extd. Warranty HEP 12M Turbo 80 l/s class	EW969TV81
Extd. Warranty HEP 12M Turbo 300 l/s class	EW969TV301
Extd. Warranty HEP 12M Turbo 700 l/s class	EW969TV701
Extd. Warranty HEP 12M Turbo 1000 l/s class	EW969TV1001
Extd. Warranty HEP 12M Turbo V2300	EW969TV2300
Extd. Warranty 12M Turbo (other config.)	EW969TMP

• Cleaning Service

Agilent offers a cleaning service in cases where a turbo pump may have been exposed to chemically hazardous materials.

This service is available worldwide and allows global OEMs and End-Users consistent delivery time, pricing, part numbers, and order processing procedures.

Ordering Information for Agilent's Cleaning Service

Turbo-V Pump Size	Part Number
From V 60 to TwisTorr 304 FS	TURBOCLEAN1
From V 450 to V 701 Navigator	TURBOCLEAN2
From V 1000 to 3K-G / 2300 TwisTorr	TURBOCLEAN3

AGILENT TURBO PUMP SERVICE AND SUPPORT PLANS

Technical Assistance

As an Agilent Customer, you can rely on an attentive and professional support staff, dedicated to providing you with the easiest and most personalized service solution possible.

Customer Support

- Our toll-free lines, with mother tongue Technical Support Engineers at worldwide locations, allow us to provide you with quick responses to your needs.
- All issues are entered into our data-base, and become available to all Agilent's Technical Support Centers and to our R&D Departments for possible product improvements.

Americas

North America: Toll-Free +1 800-882-7426
Fax +1 781-860-5437

Central and South America: Tel. +1 781-861-7200
Fax +1 781-860-5437

Asia

Japan: Toll-Free +81 120-477-111
Fax +81 120-565-154

Korea: Toll-Free 080 222 2452
Fax +82 (0) 2 3452 3947

China: Beijing Office Toll-Free 800 820 3278
Fax +86 (0)10 64392765

Shanghai Office Toll-Free 800 820 3278
Fax +86 (0)21 66285169

Guangzhou Office Toll-Free 800 820 3278
Fax +86 (0)20 86695861

Shenzhen Office Toll-Free 800 820 3278
Fax +86(0)755 82763182

Taiwan: Toll-Free 0800-018-768

Singapore: Toll-Free 1 800 2762622
Fax +65 6754 0574

Malaysia: Toll-Free 1 800 880 805
Fax +60 3 6733 8121

India North & East Zone Toll-Free 18001801517
Fax +91 11 46237105

West Zone Toll-Free: 18001801517
Fax +91 22 30648250

South Zone Toll-Free: 18001801517
Fax +91 80 40148991

Europe and Israel

Austria, Belgium, Finland, France, Germany, Holland, Ireland, Israel (*), Italy, Portugal, Spain, Switzerland, UK:
Toll-Free 00-800-234-234-00
Toll-Free-Fax 00-800-345-345-00

(*) From Israel dial 012 instead of initial 00

Other Countries Tel. +39 011-9979-369
Fax +39 011-9979-330



Application Support - Application Training

- Our Application Engineers can bring Agilent's expertise in vacuum technology to our customers
- Application Support is a project-based activity where our experts assist you solving the application issues that might arise pre-sales or post-sales
- By designing solutions that meet customer needs, Agilent aims at creating a positive and synergetic relationship with customers
- Our experts keep you up-to-date on industrial and scientific vacuum applications with the goal of optimizing the use of our products on your system