

Thermal Products

Section Six

6

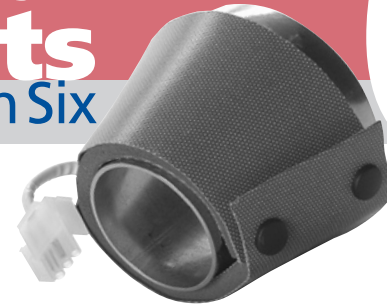

6.1	General Information	160
6.2	Designing Heated Systems	163
6.3	Heater Jackets & Insulators	164
6.4	Gas Line Heaters & Insulators	168
6.5	HCS-Series Heaters & Insulators	169
6.6	Controllers, Thermostats & Accessories	170



Nor-Cal Products, Inc.
 1967 South Oregon Street
 Yreka, California, 96097 USA
 Tel: **800-824-4166**
 or 530-842-4457
 Fax: 530-842-9130
www.n-c.com

Bay Area
 2161 O'Toole Avenue #40
 San Jose, CA 95131 USA
 Tel: **800-824-4166**
 or 530-842-4457
 Fax: 530-842-9130

Europe
 Anna-Vandenhoeck-Ring 44
 37081 Göttingen, Germany
 Tel: **+49 551 99963-0**
 Fax: +49 6441 802-1202

Republic of Korea
 Gadong 2nd Floor, 531-8 Gajang-ro
 Osan-si, Gyeonggi-do,
 South Korea, 18103
 Republic of Korea
 Tel: **+82 31 8003-1341**
 Fax: +82 31 8003-1342

Asia-Pacific
 Serangoon Garden
 P. O. Box 428
 Singapore 915531
 Tel: **+65-6634-1228**

1/2 Inch Thick Heater Jackets

For heating applications where external temperatures are of concern, 1/2 inch thick insulated heater jackets are now available as a standard product. These jackets maintain a lower external temperature than the traditional 1/4 inch heater jackets.

Electronic Thermostat Option

As an option, we offer electronic thermostats for fixed set-point thermal applications. These devices have an extended life (up to 10 times or more) than standard thermostat life. In addition, temperature variations are typically $\pm 3^\circ\text{C}$, a major improvement over typical thermostats' $\pm 15^\circ\text{C}$. Our electronic thermostats include a thermocouple sensor and power switch compactly integrated into the heater's power cable. A single thermostat may be attached to several heater jackets on the same line to reduce system costs. Call for more details.

All dimensions are called out in inches unless otherwise noted

Heater jackets, controllers and accessories reduce build-up of semiconductor process by-products in valves and other exhaust line components, while reducing particle generation and system downtime. Uniform line heating will minimize condensation and particle build-up in gas delivery and pump lines. Condensation and particle build-up will begin when temperatures and/or pressure falls below vapor phase. (See diagrams next page)

Heater Jackets

Silicone rubber modular heater jackets and insulators are available in 1/4 or 1/2 inch thicknesses. Straight lengths are available from 2 to 36 inches. Trimmable heater jackets (-T) allow up to one inch to be trimmed off for custom test ports and odd lengths. Elbows, conical reducers and tees are available to accommodate tube ODs up to 4 inches. These can be used in combination with controllers, sensors or thermostats to apply and regulate heat to the most complex line designs, optimizing system performance.

Controllers

Nor-Cal Products offers a variety of temperature control options. Up to 32 zone, full process control is possible with front panel console controllers which feature set points



and alarms. PC control is available on select controllers using standard software programs. Thermostat control, thermal fuses, up-to-temperature sensors, etc. are available on request.

Gas Line Heaters

Nor-Cal's upstream gas line heaters and insulators offer quick delivery from stock for heating gas delivery lines, such as BCl_3 and WF_6 . They are made from silicone rubber heater material insulated with 1/4 inch closed cell silicone rubber sponge and feature quick ON/OFF installation with

snap closures. Heaters can be linked/daisy chained to a maximum of 10 amps. Insulators trim-to-fit to insure 100% line coverage. UL Listed.

Valve Heaters

Nor-Cal Products entire selection of isolation and pressure control valves can be provided with silicone foam or fiberglass insulated heater jackets to reduce resident time of corrosives or particle build-up in semiconductor and other applications.

Please call for more information.

High Temperature Cloth Heater Jackets

We offer a complete line of high-temp cloth heater jackets and insulators. Heating elements are helical wound resistive wire on a fiberglass core to allow the wire to expand during thermal cycling with minimal metal fatigue. Jackets with fiberglass insulation and fiberglass based cloth can attain temperatures up to 482°C . Various insulation types and thicknesses can be provided to meet specific requirements.

A major benefit of cloth heater jackets is their durability and ease of removal/reinstallation for system cleaning and maintenance. Nor-Cal Products cloth heater jackets are sewn for an exact fit upon the piece to be heated or insulated.

Custom Heaters

The experience gained designing heaters for our standard products has allowed us to provide thermal components for special applications. We have drawn from a number of heating technologies (silicon, fiberglass, cartridge, strip, band, tubular and thick film) in order to provide the most cost-effective solutions. Custom components include heated traps, Kapton and tube internal vacuum chamber heaters, gas delivery systems, ion pump heaters and others. Custom heater jackets for specific agency compliance, (i.e. CE, NEC 427, Semi S2-93) are also available.



Custom high temperature valve heater jacket

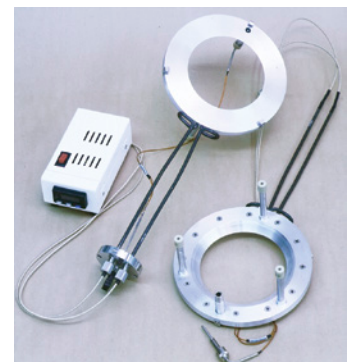

Heated annular rings with PID controller for plasma chamber

Download our Downstream Solutions Worksheet at www.n-c.com/downstreamsolutions to assist in calculating payback as a result of increased tool utilization, and decreased maintenance costs.

The Benefits of Heating Vacuum Lines

Many semiconductor processes are carried out in vacuum chambers with internal temperatures in the 700°C range. Process by-products exit the chamber in vapor phase, but sublimate in the foreline and vacuum pump exhaust when gas temperatures drop sufficiently for them to form solids. The resultant buildup can increase wafer defects from particle back streaming, reduce throughput of vacuum lines, impede the function of throttle valves and isolation valves, damage some dry pumps and reduce the efficiency of the scrubber. This buildup can be reduced or eliminated by heating vacuum lines and associated components from the chamber to the scrubber, or by using a combination of heaters and foreline traps, which collect the by-products, preventing them from continuing downstream. Heated lines are a common occurrence on semiconductor equipment and in the subfab.

Heating Requirements

Thermal mass, thermal conductivity, desired ramp time, ambient temperature and gas temperature are a few of the factors that effect the design of the thermal system. Stainless steel is a relatively poor thermal conductor (approximately 1/12 that of aluminum) and requires heat to be applied uniformly to avoid cold spots. Even when insulated, the temperature of unheated stainless steel vacuum lines will drop significantly in a matter of inches. Care should be taken to increase the watt density of heaters for heavier components, such as gate valves, especially if they are connected in series with heaters for components with dissimilar masses. Zoning of components with similar thermal masses is even better. It is important to characterize the system for internal as well as external temperature loads.

Heating Element Construction

Heating elements are helical wound resistive wire on a fiberglass core. This allows the wire to expand during thermal cycling with minimal metal fatigue. Jackets with fiberglass insulation and fiberglass based cloth can attain temperatures up to 450°C. The silicone used by Nor-Cal is UL listed to 220°C. Life testing indicates a half life of 25 years with 150°C continual operation. Fiberglass reinforced silicone encapsulates the heater element, while the insulation is silicone foam in various thicknesses. Nor-Cal Products silicone jackets are trimmed, allowing greater flexibility during installation, and have been tested to have Class 100 clean room compatibility.

Temperature Control

The two most common methods of controlling temperature are snap action thermostats and proportional integral derivative (PID) controllers. Although the lowest cost initially, thermostats create the highest three year operating cost due to heater failure caused by high temperature excursions. Thermostats are typically UL rated for 100,000 cycles, which can equate to as little as one year of continual operation. PID control maintains the temperature within 2°C of the specified setpoint, eliminating high temperature excursions, and extending heater life by up to ten times. Additionally, controllers allow the operator to change setpoints, ramp temperatures, set alarm parameters and monitor system performance from outside the subfab via RS232 or RS485 connection.

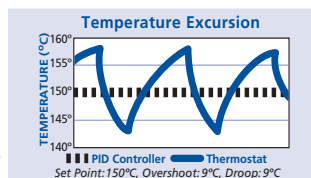

High Temp Protection

Several methods of protecting heater jackets from reaching unsafe temperatures in the event of controller malfunction are available. The jacket's watt density can be limited, also limiting the heater's ability to regulate temperature in the event of high thermal loads. A thermal fuse, which cannot be reset or replaced, can open the circuit to the heater element at a specified temperature. However, that temperature degrades by as much as 30°C during the life of the thermal fuse in one year and must be taken into account to avoid premature failure of the heater. High limit cut-offs are similar to thermal fuses, but can be reset automatically or manually and are available in a wide temperature range with an accuracy of ±10°C of the specified temperature limit with no degradation. Safety limit controllers use thermocouples or resistance temperature detectors (RTDs) to monitor temperature. Extremely accurate, they are available with preset or adjustable temperatures and can control a variety of cut-off devices and/or alarms.

Semiconductor Applications

Many semiconductor processes benefit from heated foreline and exhaust lines. Silicon nitride and LPCVD/TEOS and aluminum or tungsten metal etch are the most common processes requiring heated pump lines.

Typical Pumpline Configurations

Refer to diagram at right

1. Heated foreline to pump and exhaust line to scrubber. No trap
2. Heated foreline to trap before pump
3. Heated foreline to pump and heated exhaust to trap after pump
4. Heated foreline to foreline trap

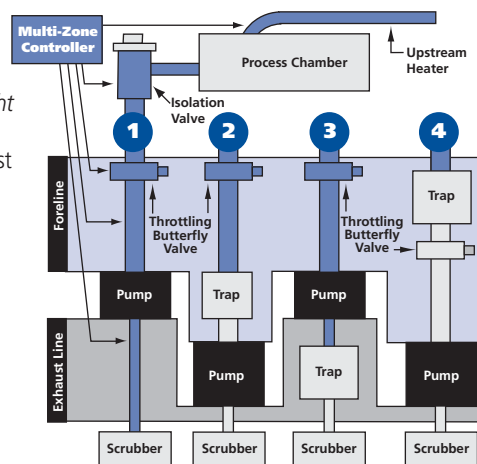

Silicon Nitride & LPCVD/TEOS

For silicon nitride LPCVD, heating the line over 110°C from the process to the dry-pump can greatly reduce the amount of solids which build up in the line. LPCVD/TEOS lines should be heated to 150°C. This extends PM intervals and reduces wafer defects in the process chamber by up to 10 times.

Preventative maintenance schedules can be extended several times, meaning larger numbers of runs between line cleaning. The heated foreline will no longer catch the majority of the condensable by-products, which can sublimate in the pump. For most applications, it is highly recommended that the dry-pump is protected by a foreline trap upstream from the pump (reference 2 and 4 on chart above). Nor-Cal offers standard and custom water-cooled, particulate, and multi-stage foreline traps for most semiconductor applications. See Section 5 - Foreline Traps for more information

Aluminum or Tungsten Metal Etch

When heating lines for metal etch applications, keeping the lines above 90°C can greatly reduce the metal and salt build-up. This minimizes wafer defects and extends preventative maintenance schedules. For metal etch, heating both the foreline from the process tool to the pump, and the pump exhaust line to the scrubber will yield the best results. (Reference 1 on chart above) Heating other components, such as pump mufflers, is also beneficial and helps to reduce downtime.

Variations in process equipment, process parameters and component temperature ratings will dictate different system solutions. Always review equipment specifications and process parameters before determining temperature specifications and heated line design. Failure to follow the required specifications and parameters could result in equipment damage or undesired process results.

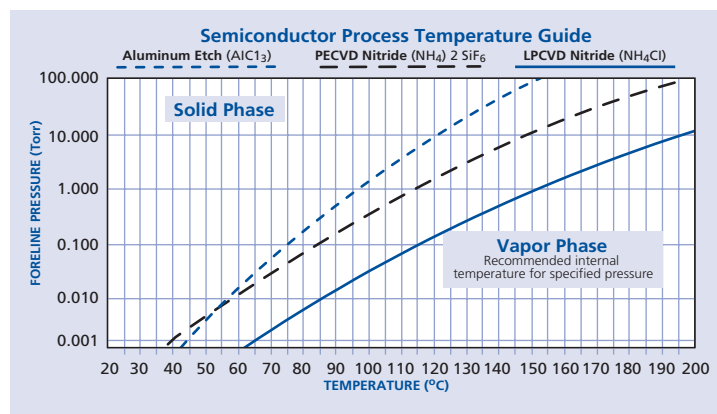

Thermal Products

General Information

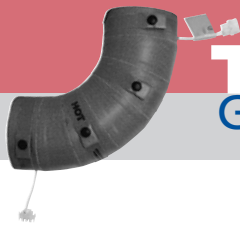

SPECIFICATIONS

Materials

- Heater jacket:** Reinforced silicone rubber fabric
- Insulator:** 1/4 or 1/2 inch thick closed-cell silicone rubber foam
- Fasteners:** 1/2 inch diameter metal snaps with nylon cover standard

Electrical

- Watt density:**
 - 1 to 2 inch diameter: 1.5 W/in²
 - 3 to 4 inch diameter: 1.25 W/in²
- Voltage:** 120V or 208V standard, other voltages available
- Power leads:** 4 inch long #18 AWG, UL 180/CSA 10A rated
- Connectors:** Positive locking Mate-N-Lok

Temperature range: ≤ 200°C

Need to heat a line in a hurry? Nor-Cal Products maintains a large inventory of heaters for 1 1/2, 2 and 4 inch tubing, elbows and flanges. Standard voltage is 120V. Nearly all heaters are available with 208V at no extra charge, replace “-3” with “-2” in model number. Other voltages are available. Elbow and tee heaters fit both tube ending and flanged style weld fittings. Custom heaters for valves and other components are also available.

Features

- Even heating up to 200°C
- High temperature cloth heaters for heating up to 450°C
- Easy on/off with reclosable fasteners
- Trimmable, tight contact fit
- 1/4 or 1/2 inch thick closed cell silicone rubber
- 1/4 to 2 inch fiberglass based insulation for cloth heaters
- 120V or 208V standard, 208V available at no charge, replace “-3” with “-2” in model number, other voltages are also available
- Heaters are interconnectable up to a 10A circuit
- Integrates with standard controllers
- Built-in insulation with insulated lead wires
- UL recognized construction
- One year warranty



Benefits

- Reduced system downtime
- Improved heat transfer minimizing cold spots
- Clean room compatible
- Combine standard parts to cover custom lines
- Adjustable temperatures
- Modular heating system



Thermocouple pocket is built-in to all straight length heaters three inch long and greater. Shown with optional thermocouple installed.

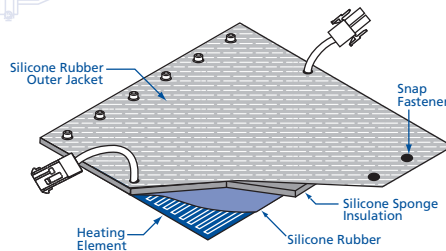

All trimmable jackets allow for up to one inch of insulation to be removed. This allows you to cover almost any line completely.

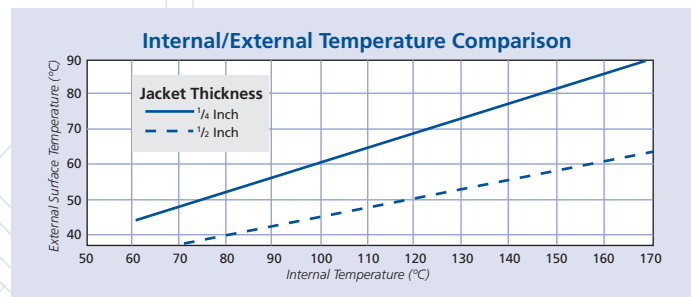

Self-adhesive kapton thermocouples are available for heaters without thermocouple pockets.

To achieve the optimal benefit from your Nor-Cal Products heating system, maximum heated coverage is needed. Measurement of the vacuum line is necessary to accomplish this. Contact your Nor-Cal Products representative for assistance.

Line Measurement

Use the following guidelines to develop an approximate measurement to use for component selection and control zone layout.

NOTE: To measure quickly, work from one end of the line to the other. Measure one component at a time. Component drawings are not necessary if detailed measurement notes are taken.

DIAMETER: Verify the line diameter by measuring the circumference of a common straight section within the line.

DIAMETER	CIRCUMFERENCE
1.50"	4.71"
2.00"	6.28"
3.00"	9.42"
4.00"	12.57"

STRAIGHT SECTIONS:

Measure the straight section length by referencing the backside of the flange or the centerline of the weld fitting.

45° and 90° ELBOWS:

Measure the "L" dimension from the backside of the flange to the centerline of the opposing leg. Refer to specific heater drawings located in this catalog.

TEE: Measure the "L" dimension.

FLEXIBLE SECTIONS: Measure the bellows OD and the length. (See specific heater drawing.)

Note: The length must be measured under compression with full vacuum pulled. If there is a noticeable "twisting" on the flexible section, adjustment of the line may be needed for proper heater installation.

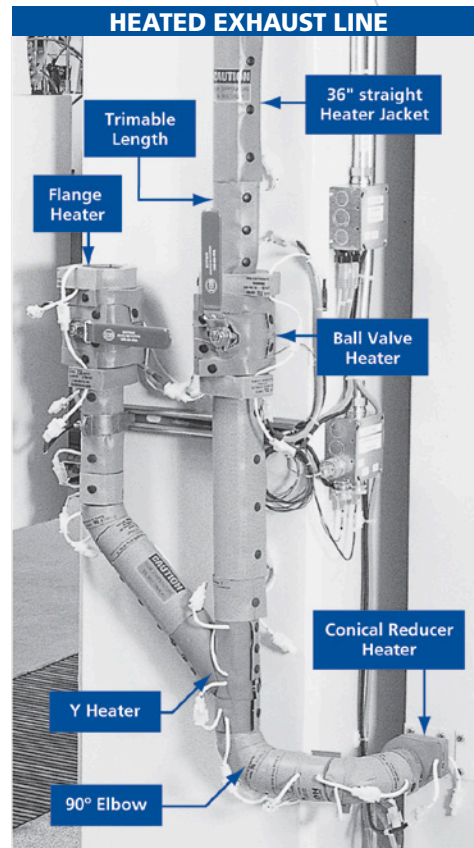
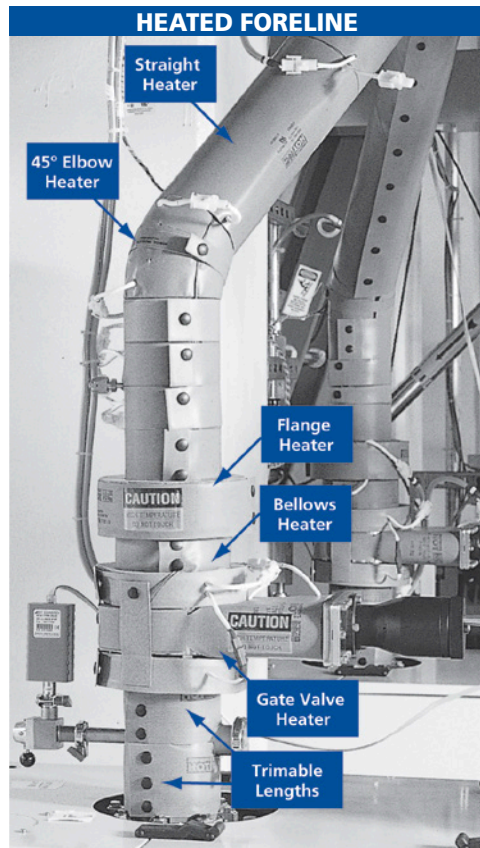

FLANGES:

Note flange types and measure.

VALVES and OTHER SHAPES:

Nor-Cal Products offers a large selection of existing heater designs for valves, reducers and other components. Note manufacturer, size and model number.

Download the
**Thermal Products
Worksheet**
from
www.n-c.com

Heater Jacket Selection

After measuring your system using the instructions on the facing page, choose the heater segments you will need from this product guide. List the model numbers with your notes. Trimmable heaters solve the problem of odd straight section lengths. For example, for a 14 1/2 inch section, combine a 12 inch trimmable and a 3 inch heater. The 12 inch heater can be cut to a minimum of 11 inches. Cut 1/2 inch from the 12 inch heater to make a 11 1/2 inch length. Place cut edge towards the 3 inch heater to maximize temperature uniformity.

Zone Layout and Heater Installation

Connect heaters end-to-end in order to form a larger single circuit which then can be controlled as one "zone." A single line may contain multiple zones, depending on the length and the complexity. Use the following rules of thumb when grouping sets of heaters into zones.

- Maximum amperage per zone is 10 amps, or 1200 watts. Use the part number list to calculate the total wattage of your line. Dividing by 1080 will give you the approximate number of zones required.
- Split zones at natural break points, such as at a flange, elbow or valve.
- Each component, such as a gate valve, needs a separate control circuit due to the difference in thermal mass between the component and the tubing.
- Place temperature sensors (*thermocouples*) in straight heaters three inches or longer. These heaters have a built-in thermocouple pocket for easy installation. Self-adhesive Kapton thermocouples are available for heaters without pockets.
- Remove labels and residual glue with methanol or another solvent before attaching the heater jacket. Operating the heater on a component with a label can cause discoloration or scorching of the jacket and may cause the label to ignite and damage the heater.
- When choosing where to place the thermocouples for each zone, start at the process tool, placing the first thermocouple two to four feet from the outlet of the process.
- The jacket should fit tightly for optimum heat transfer. Loose areas can draw higher wattage and damage the insulation and/or heater element. **Note:** Heater must be attached to the component when in operation.
- **Do not immerse the heaters in water or cleaning solutions.**

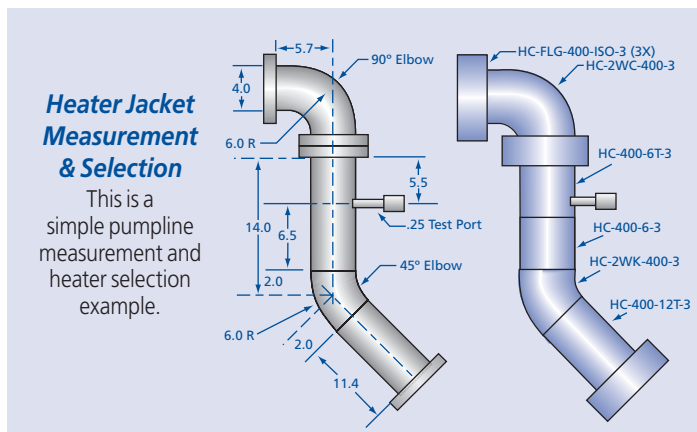

SPECIFICATIONS

Materials

- Heater jacket: Reinforced silicone rubber fabric
- Insulator: 1/4 or 1/2 inch thick closed-cell silicone rubber foam
- Fasteners: 1/2 inch diameter metal snaps with nylon cover standard

Electrical

- Watt density:
 - 1 to 2 inch diameter: 1.5 W/in²
 - 3 to 4 inch diameter: 1.25 W/in²
- Voltage: 120V or 208V standard, other voltages available
- Power leads: 4 inch long #18 AWG, UL 1180/CSA 10A rated
- Connectors: Positive locking Mate-N-Lok

Temperature range: ≤200°C

Installation of Nor-Cal Products' modular heaters help produce consistent process yields by reducing the build-up of by-products in valves and other exhaust line components. Even line heating minimizes cold spots, greatly reducing particle generation - the cause of most unscheduled maintenance downtime. See page 160-163 for more information on heated lines.



1/4" Thick Heater Jackets – 1 1/2" Tube OD

MODEL NUMBER	WATTS* 120 or 208V	POCKET Thermocouple	TRIMMABLE	LENGTH L
HC-150-2-3	14			2
HC-150-2T-3	7**		✓	2
HC-150-3-3	22	✓		3
HC-150-3T-3	14	✓	✓	3
HC-150-4-3	29	✓		4
HC-150-4T-3	22	✓	✓	4
HC-150-5-3	36	✓		5
HC-150-5T-3	29	✓	✓	5
HC-150-6-3	43	✓		6
HC-150-6T-3	36	✓	✓	6
HC-150-12-3	85	✓		12
HC-150-12T-3	78	✓	✓	12
HC-150-18-3	128	✓		18
HC-150-24-3	170	✓		24
HC-150-24T-3	163	✓	✓	24
HC-150-30-3	213	✓		30
HC-150-36-3	255	✓		36
HC-150-36T-3	248	✓	✓	36

* For 208V heaters replace the "-3" with "-2" at the end of the model number.
** 208V is not available.

1/4" Thick Heater Jackets – 2" Tube OD

MODEL NUMBER	WATTS* 120 or 208V	POCKET Thermocouple	TRIMMABLE	LENGTH L
HC-200-2-3	19			2
HC-200-2T-3	10		✓	2
HC-200-3-3	29	✓		3
HC-200-3T-3	19	✓	✓	3
HC-200-4-3	38	✓		4
HC-200-4T-3	29	✓	✓	4
HC-200-5-3	48	✓		5
HC-200-5T-3	38	✓	✓	5
HC-200-6-3	57	✓		6
HC-200-6T-3	47	✓	✓	6
HC-200-7T-3	57	✓	✓	7
HC-200-8T-3	68	✓	✓	8
HC-200-9T-3	75	✓	✓	9
HC-200-10T-3	85	✓	✓	10
HC-200-11T-3	95	✓	✓	11
HC-200-12-3	114	✓		12
HC-200-12T-3	104	✓	✓	12
HC-200-18-3	170	✓		18
HC-200-24-3	227	✓		24
HC-200-24T-3	217	✓	✓	24
HC-200-30-3	283	✓		30
HC-200-36-3	340	✓		36
HC-200-36T-3	330	✓	✓	36

* For 208V heaters replace the "-3" with "-2" at the end of the model number.

1/2" Thick Heater Jackets – 1 1/2" Tube OD

MODEL NUMBER	WATTS* 120 or 208V	POCKET Thermocouple	TRIMMABLE	LENGTH L
HC2-150-2-3	14			2
HC2-150-2T-3	7**		✓	2
HC2-150-3-3	22	✓		3
HC2-150-3T-3	14	✓	✓	3
HC2-150-4-3	29	✓		4
HC2-150-4T-3	22	✓	✓	4
HC2-150-5-3	36	✓		5
HC2-150-5T-3	29	✓	✓	5
HC2-150-6-3	43	✓		6
HC2-150-6T-3	36	✓	✓	6
HC2-150-12-3	85	✓		12
HC2-150-12T-3	78	✓	✓	12
HC2-150-18-3	128	✓		18
HC2-150-24-3	170	✓		24
HC2-150-24T-3	163	✓	✓	24
HC2-150-30-3	213	✓		30
HC2-150-36-3	255	✓		36
HC2-150-36T-3	248	✓	✓	36

* For 208V heaters replace the "-3" with "-2" at the end of the model number.
** 208V is not available.

1/2" Thick Heater Jackets – 2" Tube OD

MODEL NUMBER	WATTS* 120 or 208V	POCKET Thermocouple	TRIMMABLE	LENGTH L
HC2-200-2-3	19			2
HC2-200-2T-3	10		✓	2
HC2-200-3-3	29	✓		3
HC2-200-3T-3	19	✓	✓	3
HC2-200-4-3	38	✓		4
HC2-200-4T-3	29	✓	✓	4
HC2-200-5-3	48	✓		5
HC2-200-5T-3	38	✓	✓	5
HC2-200-6-3	57	✓		6
HC2-200-6T-3	47	✓	✓	6
HC2-200-7T-3	57	✓	✓	7
HC2-200-8T-3	68	✓	✓	8
HC2-200-9T-3	75	✓	✓	9
HC2-200-10T-3	85	✓	✓	10
HC2-200-11T-3	95	✓	✓	11
HC2-200-12-3	114	✓		12
HC2-200-12T-3	104	✓	✓	12
HC2-200-18-3	170	✓		18
HC2-200-24-3	227	✓		24
HC2-200-24T-3	217	✓	✓	24
HC2-200-30-3	283	✓		30
HC2-200-36-3	340	✓		36
HC2-200-36T-3	330	✓	✓	36

* For 208V heaters replace the "-3" with "-2" at the end of the model number.

SPECIFICATIONS

Materials

Heater jacket:
Reinforced silicone rubber fabric
Insulator: 1/4 or 1/2 inch thick closed-cell silicone rubber foam
Fasteners: 1/2 inch diameter metal snaps with nylon cover standard

Electrical

Watt density:
1 to 2 inch diameter: 1.5 W/in²
3 to 4 inch diameter: 1.25 W/in²
Voltage: 120V or 208V standard, other voltages available
Power leads: 4 inch long #18 AWG, UL1180/CSA 10A rated
Connectors: Positive locking Mate-N-Lok

Temperature range: ≤200°C

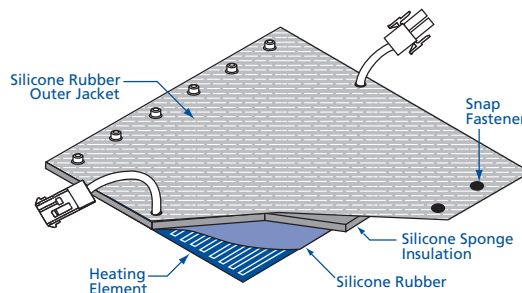
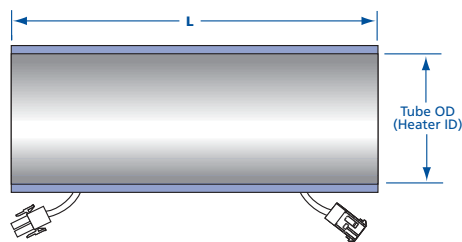

1/4" Thick Heater Jackets - 3" Tube OD

MODEL NUMBER	WATTS* 120 or 208V	POCKET Thermocouple	TRIMMABLE	LENGTH L
HC-300-2-3	24			2
HC-300-2T-3	12		✓	2
HC-300-3-3	36	✓		3
HC-300-3T-3	24	✓	✓	3
HC-300-4-3	48	✓		4
HC-300-4T-3	36	✓	✓	4
HC-300-5-3	59	✓		5
HC-300-5T-3	48	✓	✓	5
HC-300-6-3	71	✓		6
HC-300-6T-3	59	✓	✓	6
HC-300-12-3	141	✓		12
HC-300-12T-3	129	✓	✓	12
HC-300-18-3	213	✓		18
HC-300-24-3	283	✓		24
HC-300-24T-3	271	✓	✓	24
HC-300-30-3	354	✓		30
HC-300-36-3	425	✓		36
HC-300-36T-3	413	✓	✓	36

* For 208V heaters replace the "-3" with "-2" at the end of the model number.

1/2" Thick Heater Jackets - 3" Tube OD

MODEL NUMBER	WATTS* 120 or 208V	POCKET Thermocouple	TRIMMABLE	LENGTH L
HC2-300-2-3	24			2
HC2-300-2T-3	12		✓	2
HC2-300-3-3	36	✓		3
HC2-300-3T-3	24	✓	✓	3
HC2-300-4-3	48	✓		4
HC2-300-4T-3	36	✓	✓	4
HC2-300-5-3	59	✓		5
HC2-300-5T-3	48	✓	✓	5
HC2-300-6-3	71	✓		6
HC2-300-6T-3	59	✓	✓	6
HC2-300-12-3	141	✓		12
HC2-300-12T-3	129	✓	✓	12
HC2-300-18-3	213	✓		18
HC2-300-24-3	283	✓		24
HC2-300-24T-3	271	✓	✓	24
HC2-300-30-3	354	✓		30
HC2-300-36-3	425	✓		36
HC2-300-36T-3	413	✓	✓	36

* For 208V heaters replace the "-3" with "-2" at the end of the model number.

1/4" Thick Heater Jackets - 4" Tube OD

MODEL NUMBER	WATTS* 120 or 208V	POCKET Thermocouple	TRIMMABLE	LENGTH L
HC-400-2-3	32			2
HC-400-2T-3	16		✓	2
HC-400-3-3	48	✓		3
HC-400-3T-3	32	✓	✓	3
HC-400-4-3	63	✓		4
HC-400-4T-3	48	✓	✓	4
HC-400-5-3	79	✓		5
HC-400-5T-3	63	✓	✓	5
HC-400-6-3	95	✓		6
HC-400-6T-3	79	✓	✓	6
HC-400-7T-3	95	✓	✓	7
HC-400-8T-3	114	✓	✓	8
HC-400-9T-3	130	✓	✓	9
HC-400-10T-3	146	✓	✓	10
HC-400-11T-3	157	✓	✓	11
HC-400-12-3	189	✓		12
HC-400-12T-3	173	✓	✓	12
HC-400-18-3	283	✓		18
HC-400-24-3	377	✓		24
HC-400-24T-3	361	✓	✓	24
HC-400-30-3	472	✓		30
HC-400-36-3	566	✓		36
HC-400-36T-3	550	✓	✓	36

* For 208V heaters replace the "-3" with "-2" at the end of the model number.

1/2" Thick Heater Jackets - 4" Tube OD

MODEL NUMBER	WATTS* 120 or 208V	POCKET Thermocouple	TRIMMABLE	LENGTH L
HC2-400-2-3	32			2
HC2-400-2T-3	16		✓	2
HC2-400-3-3	48	✓		3
HC2-400-3T-3	32	✓	✓	3
HC2-400-4-3	63	✓		4
HC2-400-4T-3	48	✓	✓	4
HC2-400-5-3	79	✓		5
HC2-400-5T-3	63	✓	✓	5
HC2-400-6-3	95	✓		6
HC2-400-6T-3	79	✓	✓	6
HC2-400-7T-3	95	✓	✓	7
HC2-400-8T-3	114	✓	✓	8
HC2-400-9T-3	130	✓	✓	9
HC2-400-10T-3	146	✓	✓	10
HC2-400-11T-3	157	✓	✓	11
HC2-400-12-3	189	✓		12
HC2-400-12T-3	173	✓	✓	12
HC2-400-18-3	283	✓		18
HC2-400-24-3	377	✓		24
HC2-400-24T-3	361	✓	✓	24
HC2-400-30-3	472	✓		30
HC2-400-36-3	566	✓		36
HC2-400-36T-3	550	✓	✓	36

* For 208V heaters replace the "-3" with "-2" at the end of the model number.

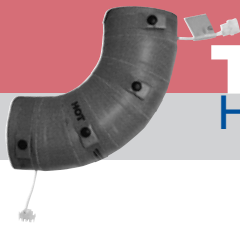

SPECIFICATIONS

Materials

- Heater jacket: Reinforced silicone rubber fabric
- Insulator: 1/4 or 1/2 inch thick closed-cell silicone rubber foam
- Fasteners: 1/2 inch diameter metal snaps with nylon cover standard

Fit: Formed elbows and tees fit weld fittings and flanged style tubing

Electrical

- Watt density:
 - 1 to 2 inch diameter: 1.5 W/in²
 - 3 to 4 inch diameter: 1.25 W/in²
- Voltage: 120V or 208V standard, other voltages available
- Power leads: 4 inch long #18 AWG, UL 1180/CSA 10A rated
- Connectors: Positive locking Mate-N-Lok

Temperature range: ≤200°C

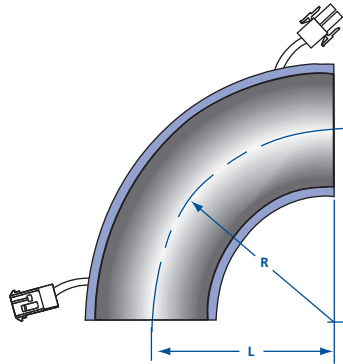

1/4" Thick Heater Jackets – 90° Radius Elbow

MODEL NUMBER	TANGENT	TUBE OD
HC-2WC-150-3		1 1/2
HC-2WC-150HW-3	✓	1 1/2
HC-2WC-200-3		2
HC-2WC-200HW-3	✓	2
HC-2WC-300-3		3
HC-2WC-300HW-3	✓	3
HC-2WC-400-3		4

1/2" Thick Heater Jackets – 90° Radius Elbow

MODEL NUMBER	TANGENT	TUBE OD	LENGTH L	RADIUS R	WATTS* 120 or 240V
HC2-2WC-150-3		1 1/2	2.00	2.25	25
HC2-2WC-150HW-3	✓	1 1/2	2.68	2.25	36
HC2-2WC-200-3		2	2.75	3.00	45
HC2-2WC-200HW-3	✓	2	3.81	3.00	65
HC2-2WC-300-3		3	4.00	4.50	93
HC2-2WC-300HW-3	✓	3	5.81	4.50	141
HC2-2WC-400-3		4	5.50	6.00	149
HC2-2WC-400HW-3	✓	4	7.81	6.00	217

* For 208V heaters replace the "3" with "2" at the end of the model number.

SPECIFICATIONS

Materials

- Heater jacket: Reinforced silicone rubber fabric
- Insulator: 1/4 or 1/2 inch thick closed-cell silicone rubber foam
- Fasteners: 1/2 inch diameter metal snaps with nylon cover standard

Fit: Formed elbows and tees fit weld fittings and flange style tubing

Electrical

- Watt density:
 - 1 to 2 inch diameter: 1.5 W/in²
 - 3 to 4 inch diameter: 1.25 W/in²
- Voltage: 120V or 208V standard, other voltages available
- Power leads: 4 inch long #18 AWG, UL 1180/CSA 10A rated
- Connectors: Positive locking Mate-N-Lok

Temperature range: ≤200°C

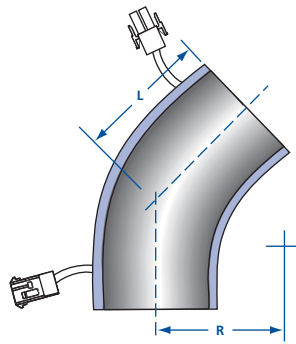

1/4" Thick Heater Jackets – 45° Radius Elbow

MODEL NUMBER	TANGENT	TUBE OD	LENGTH L	RADIUS R	WATTS* 120 or 240V
HC-2WK-150-3		1 1/2	0.69	2.25	13
HC-2KL-150HW-3	✓	1 1/2	1.38	2.25	23
HC-2WK-200-3		2	1.00	3.00	23
HC-2KL-200HW-3	✓	2	2.06	3.00	44
HC-2WK-300-3		3	1.37	4.50	47
HC-2KL-300HW-3	✓	3	3.18	4.50	95
HC-2WK-400-3		4	2.00	6.00	70
HC-2KL-400HW-3	✓	4	4.31	6.00	148

* For 208V heaters replace the "3" with "2" at the end of the model number.

1/2" Thick Heater Jackets – 45° Radius Elbow

MODEL NUMBER	TANGENT	TUBE OD	LENGTH L	RADIUS R	WATTS* 120 or 240V
HC2-2WK-150-3		1 1/2	0.69	2.25	13
HC2-2KL-150HW-3	✓	1 1/2	1.38	2.25	23
HC2-2WK-200-3		2	1.00	3.00	23
HC2-2KL-200HW-3	✓	2	2.06	3.00	44
HC2-2WK-300-3		3	1.37	4.50	47
HC2-2KL-300HW-3	✓	3	3.18	4.50	95
HC2-2WK-400-3		4	2.00	6.00	70
HC2-2KL-400HW-3	✓	4	4.31	6.00	148

* For 208V heaters replace the "3" with "2" at the end of the model number.

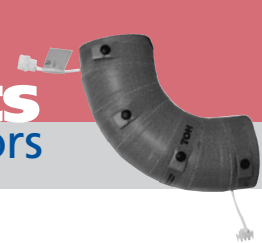

Tee Heater Jackets

MODEL NUMBER	THICKNESS	TUBE OD	LENGTH L	WATTS* 120 or 240V
HC-7W-150-3	1/4	1 1/2	2	37
HC2-7W-150-3	1/2	1 1/2	2	37
HC-7W-200-3	1/4	2	2 3/4	69
HC2-7W-200-3	1/2	2	2 3/4	69
HC-7W-300-3	1/4	3	3	99
HC2-7W-300-3	1/2	3	3	99
HC-7W-400-3	1/4	4	3 5/8	140
HC2-7W-400-3	1/2	4	3 5/8	140

* For 208V heaters replace the "-3" with "-2" at the end of the model number.

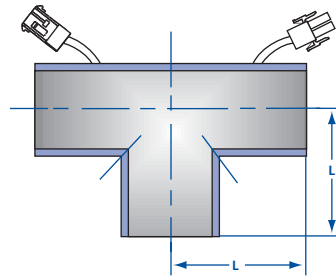

SPECIFICATIONS

Materials

Heater jacket: Reinforced silicone rubber fabric
 Insulator: 1/4 or 1/2 inch thick closed-cell silicone rubber foam
 Fasteners: 1/2 inch diameter metal snaps with nylon cover standard

Electrical

Watt density:
 1 to 2 inch diameter: 1.5 W/in²
 3 to 4 inch diameter: 1.25 W/in²
 Voltage: 120V or 208V standard, other voltages available
 Power leads: 4 inch long #18 AWG, UL 1180/CSA 10A rated
 Connectors: Positive locking Mate-N-Lok

Temperature range: $\leq 200^{\circ}\text{C}$

Conical Heater Jackets

MODEL NUMBER	THICKNESS	A	B	LENGTH L	WATTS* @ 120V
HC-200-150-3	1/4	1 1/2	2	1 3/8	12
HC2-200-150-3	1/2	1 1/2	2	1 3/8	12
HC-300-200-3	1/4	2	3	2 7/16	24
HC2-300-200-3	1/2	2	3	2 7/16	24
HC-400-200-3	1/4	2	4	2 5/8	31
HC2-400-200-3	1/2	2	4	2 5/8	31
HC-400-300-3	1/4	3	4	2 5/8	36
HC2-400-300-3	1/2	3	4	2 5/8	36

* For 208V heaters replace the "-3" with "-2" at the end of the model number.

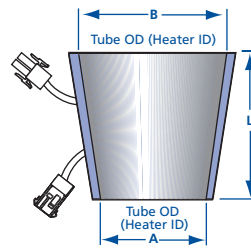

NW & ISO Flange Heater Jackets

MODEL NUMBER	THICKNESS	FLANGE TYPE	NOMINAL TUBE OD	WATTS* @ 120V
HC-FLG-150-NW-3	1/4	NW-40	1 1/2	10
HC2-FLG-150-NW-3	1/2	NW-40	1 1/2	10
HC-FLG-200-NW-3	1/4	NW-50	2	15
HC2-FLG-200-NW-3	1/2	NW-50	2	15
HC-FLG-300-ISO-3	1/4	ISO-80	3	35
HC2-FLG-300-ISO-3	1/2	ISO-80	3	35
HC-FLG-400-ISO-3	1/4	ISO-100	4	82
HC2-FLG-400-ISO-3	1/2	ISO-100	4	82

* For 208V heaters replace the "-3" with "-2" at the end of the model number.



NW & ISO Flange Insulators

MODEL NUMBER	THICKNESS	FLANGE TYPE	NOMINAL TUBE OD
HI-FLG-100-NW-1	1/4	NW-25	1
HI-FLG-150-NW-1	1/4	NW-40	1 1/2
HI2-FLG-150-NW-1	1/2	NW-40	1 1/2
HI-FLG-200-NW-1	1/4	NW-50	2
HI2-FLG-200-NW-1	1/2	NW-50	2
HI-FLG-300-ISO-1	1/4	ISO-80	3
HI2-FLG-300-ISO-1	1/2	ISO-80	3
HI-FLG-400-ISO-1	1/4	ISO-100	4
HI2-FLG-400-ISO-1	1/2	ISO-100	4

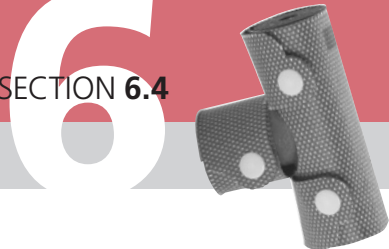

Thermal Products

Gas Line Heaters & Insulators

SPECIFICATIONS

Materials

Heater and jacket: Reinforced silicone rubber fabric

Color: Orange

Insulation: 1/4 inch thick closed-cell silicone rubber foam

Fasteners: Nylon snap

Electrical

Watt density: 2.5 W/in² typical

Voltage: 120V standard

Power leads: 3 inch long #18 AWG,

UL 1180/CSA 10A rated

Connectors: Positive locking Mate-N-Lok

Temperature range: ≤200°C

Thermocouples: #30 AWG, Type J, PTFE insulated

Nor-Cal Products upstream gas line heaters and insulators offer quick delivery from stock for heating gas delivery lines, such as BC13 and WF6. They are made from silicone rubber heater material insulated with 1/4 inch closed cell silicone rubber sponge and feature quick ON/OFF installation with snap closures. Heaters can be linked/daisy chained to a maximum of 10 amps. Lead pair extends 3 inches past each end of the heaters. Insulators trim-to-fit to insure 100% line coverage. Flexible elbow heaters fit most radius elbows. Meets UL94HB flammability requirements. UL Listed.

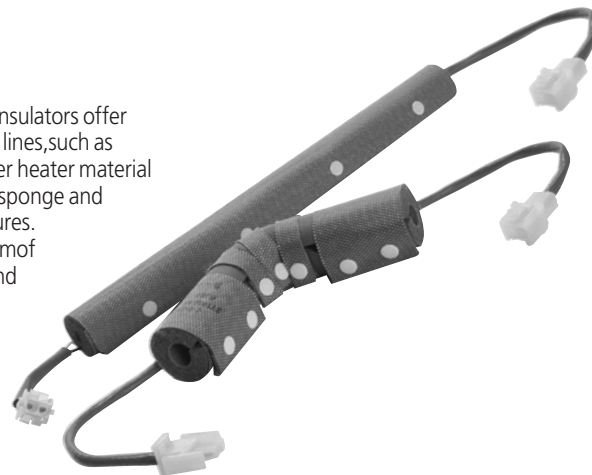

Gas Line Heaters - 1/4" Tube OD

MODEL NUMBER	TYPE	TYPE J Thermocouple	LENGTH	WATTS @ 120V
HC-025-6-1	Straight		6	12
HC-025-6-TC-1	Straight	✓	6	12
HC-025-9-1	Straight		9	18
HC-025-9-TC-1	Straight	✓	9	18
HC-025-12-1	Straight		12	24
HC-025-12-TC-1	Straight	✓	12	24
HC-025-18-1	Straight		18	36
HC-025-18-TC-1	Straight	✓	18	36
HC-025-24-1	Straight		24	48
HC-025-24-TC-1	Straight	✓	24	48
HC-025-36-1	Straight		36	72
HC-025-36-TC-1	Straight	✓	36	72

Gas Line Heater Elbows - 1/4" Tube OD

MODEL NUMBER	TANGENTS	LENGTH	WATTS @ 120V
HC-025-2WC-1-1	Two 1 inch	6	12
HC-025-2WC-5-1	One 5 inch	9	18

Gas Line Heaters - 1/2" Tube OD

MODEL NUMBER	TYPE	TYPE J Thermocouple	LENGTH	WATTS @ 120V
HC-050-6-1	Straight		6	24
HC-050-6-TC-1	Straight	✓	6	24
HC-050-9-1	Straight		9	36
HC-050-9-TC-1	Straight	✓	9	36
HC-050-12-1	Straight		12	48
HC-050-12-TC-1	Straight	✓	12	48
HC-050-18-1	Straight		18	72
HC-050-18-TC-1	Straight	✓	18	72
HC-050-24-1	Straight		24	96
HC-050-24-TC-1	Straight	✓	24	96
HC-050-36-1	Straight		36	144
HC-050-36-TC-1	Straight	✓	36	144

Gas Line Insulators - 1/4" Tube OD

MODEL NUMBER	TYPE	TRIMMABLE	TUBE OD
HI-025-18T	18 inch straight length	✓	1/4
HI-025-7W-M	Micro-tee		1/4
HI-025-2WC-M	Micro-elbow		1/4

Gas Line Insulators - 1/2" Tube OD

MODEL NUMBER	TYPE	TRIMMABLE	TUBE OD
HI-050-18T	18 inch straight length	4	1/2
HI-050-7W-M	Micro-tee		1/2
HI-050-2WC-M	Micro-elbow		1/2

Warning: Upstream gas line heater jackets are not designed for hazardous or outdoor locations. They are not designed for total or partial immersion and should only be installed on grounded metallic tubing systems or GFI protected circuit.



HCS-Series Heaters (1/4" and 1/2" OD Tube)

MODEL NUMBER	TUBE OD	MINIMUM LENGTH	MAXIMUM LENGTH	WATTS@120V
HCS-025-8-1*	1/4	8	10	12
HCS-025-11-1*	1/4	11	14.5	17
HCS-025-15-1	1/4	15	19	22
HCS-025-19-1	1/4	19	24	28
HCS-025-24-1	1/4	24	30.5	36
HCS-025-31-1	1/4	31	40	47
HCS-025-40-1	1/4	40	51	60
HCS-025-50-1	1/4	50	64	76
HCS-025-60-1	1/4	60	76.5	90
HCS-050-7-1*	1/2	7	10	17
HCS-050-10-1*	1/2	10	15	25
HCS-050-14-1	1/2	14	21	35
HCS-050-19-1	1/2	19	29.5	49
HCS-050-25-1	1/2	25	38.5	64
HCS-050-31-1	1/2	31	47.5	79
HCS-050-39-1	1/2	39	59.5	99
HCS-050-50-1	1/2	50	74	123
HCS-050-60-1	1/2	60	92.5	154

* Note: 240V not available in these sizes.
(240V heaters can be ordered by changing the last "-1" to "-2")

SPECIFICATIONS

Materials

Color: Orange
Heater: Spiral formed reinforced silicone rubber fabric

Electrical

Watt density:
Max. 2.0 W/in² at 100% coverage, 80% coverage recommended
Voltage: 120V or 240V*
Leads: 12" long pair located on one end, #18 AWG, UL 1180/CSA 10A rated
Connectors: Positive locking AMP Mate-N-Lok

Temperature range: ≤200°C

HCS-Series Insulators (3/8" Thick Insulation)

MODEL NUMBER	DESCRIPTION
HIS-025-18	INS,1/4" Spiral Wrap,18" Long
HIS-025-2WC-M	INS,1/4" Spiral Wrap,Micro Elbow
HIS-025-7W-M	INS,1/4" Spiral Wrap,Micro Tee
HIS-025-VCR	INS,1/4" Spiral Wrap,VCR Union
HIS-038-18	INS,3/8" Spiral Wrap,18" Long
HIS-038-2WC-M	INS,3/8" Spiral Wrap,Micro Elbow
HIS-038-7W-M	INS,3/8" Spiral Wrap,Micro Tee
HIS-038-VCR	INS,3/8" Spiral Wrap,VCR Union
HIS-050-18	INS,1/2" Spiral Wrap,18" Long
HIS-050-2WC-M	INS,1/2" Spiral Wrap,Micro Elbow
HIS-050-7W-M	INS,1/2" Spiral Wrap,Micro Tee
HIS-050-VCR	INS,1/2" Spiral Wrap,VCR Union

SPECIFICATIONS

Materials

Color: Insulation and outer jacket – orange
Insulator: 3/8" thick closed cell silicone rubber

Fasteners: Cleanroom straps

Temperature range: ≤200°C

Nor-Cal Products is your source for temperature controllers. Full thermal control of the process is available through front panel controls including set points and alarms. Timers and digital readouts are standard on some models. Enclosures are either Nema 4, 4x or 12. Most controllers are RS232/485 compatible. Choose from 1, 2, 4 and 8 zone controllers. Line voltage is from 100V to 240V. Custom voltages and zoning is available on request. PC control using standard software programs is available. Nor-Cal Products heater controllers come with a three year warranty.

The Effect of Temperature Excursion on Heater Life

PID Controllers result in temperature control accuracy of $\pm 2^\circ\text{C}$, and extend heater element life by up to 10 times. Although the lowest cost initially, thermostats create the highest 3 year operating cost due to heater failure caused by temperature excursions. (See chart below) Although the highest cost initially, PID controllers with SCR Burst Firing create the lowest 3 year operating cost due to its ability to eliminate temperature excursions. This can extend heater life up to 10 times.

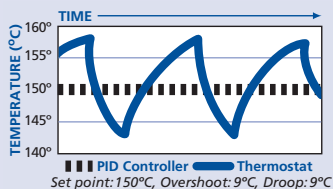

Heater Controllers

HC-SD series digital indicating, microprocessor-based heater controllers are available with a single temperature sensor input from a thermocouple or RTD sensor, and control outputs for one, two and four zones. These low-cost, self contained controllers feature a programmable alarm, small panel footprint and operate at $\pm 0.25\%$ accuracy. The outputs may operate in a variety of modes including: heat, alarm and timer. The countdown timer function operates in a choice of delay-ON, delay-OFF, signal-ON or signal-OFF modes. Front panel lock capability rounds out the feature set. Other features include EIA-485 Modbus serial communication, 1/32 DIN package, Nema 4x control console and a universal power supply.

Controllers

MODEL NUMBER	VOLTAGE	MAX. AMP OUTPUT / ZONE	ZONES	AC PLUG
HC-SDC15-1-1	120V	10	1	Straight blade
HC-SDC15-1-2	208-240V	10	1	Schuko
HC-SDC15-2-1	120V	5	2	Straight blade
HC-SDC15-2-2	208-240V	5	2	Schuko

Electronic Thermostats

Nor-Cal Products offers UL recognized electronic thermostats for fixed set-point thermal applications. Electronic thermostats replace the thermocouple/controller assembly on a heater with a single device attached to the heater jacket. These devices have an extended life of over 10 times the standard thermostat life. In addition, temperature variations are typically $\pm 3^\circ\text{C}$, a major improvement over typical thermostats' $\pm 15^\circ\text{C}$. These thermostats include a thermocouple sensor and power switching compactly integrated into the heater's power cable. A single thermostat may be attached to several heater jackets on the same line to reduce system costs. They are preprogrammed with the thermal set point you request. Call for more details.



Thermocouples & Cables

MODEL NUMBER	DESCRIPTION*	LENGTH IN FEET
HC-TC-K-1	K-type with one foot lead and mini-connector	1
HC-TC-K-8	K-type with eight foot lead and mini-connector	8
HC-TC-K-KAP-8	K-type kapton with eight foot lead and mini-connector	8
HC-TC-CRD-K-6	K-type thermocouple extension cable with connectors	6
HC-TC-CRD-K-10	K-type thermocouple extension cable with connectors	10
HC-TC-CRD-K-25	K-type thermocouple extension cable with connectors	25

*Most items available in various lengths and in J-type also. Call for pricing and information.

Control Cables and Accessories

MODEL NUMBER	DESCRIPTION	LENGTH IN FEET
HC-PLG	Termination for end of last heater, 2 prong MNL plug	-
HC-PLG-2C	Termination for end of last heater, 2 prong MNL cap	-
HC-PLG-3C	Termination for end of last heater, 3 prong MNL cap	-
HC-PLG-3P	Termination for end of last heater, 3 prong MNL plug	-
HC-PCRD-6	SD3 controller to heater or 2 circuit MNL extension, 2 circuit plug, 2 circuit cap	6
HC-PCRD-6-3	SD3 controller to heater, 2 circuit plug, 3 circuit MNL cap	6
HC-PCRD-6-3B	SD3 controller to cloth heater, 2 circuit plug, 3 circuit MNL cap, center ground	6
HC-PCRD-CPC-6-2	SDC15 controller to heater, CPC, 2 circuit MNL cap	6
HC-PCRD-CPC-6-3	SDC15 controller to heater, CPC, 3 circuit MNL cap	6
HC-PCRD-CPC-6-3B	SDC15 controller to cloth heater, CPC, 3 circuit MNL cap, center ground	6
HT-CRD-6-2P	120V straight wall to 2 circuit MNL plug	6
HT-CRD-6-3P	120V straight wall to 3 circuit MNL plug (GNV heater)	6

