

# DRY PUMPS AND SYSTEMS FOR HAZARDOUS APPLICATIONS

## MORE THAN PUMPS, COMPLETE VACUUM SOLUTIONS

---

CXS Chemical Dry Pumps	233
CDX Dry Vacuum Pumps	239
EDP Chemical Dry Pumps	244

- EDP Chemical Dry Pumps and Systems
- CXS Chemical Dry Pumps and Systems
- CDX1000 Dry Vacuum Pumps

Edwards is a market leader in dry pump technology and pioneer of dry vacuum for the chemical process, pharmaceutical and fine chemical industries.

### Why Dry?

Dry running pumps have no oil, steam or water in the process volume. This eliminates, at source, the pollution traditionally associated with wet sealed vacuum systems and provides cost and materials handling benefits as the sealing medium does not have to be replenished:

- No contamination of the process stream
- No polluted effluent
- No messy oil drums
- Improved processing with reduced down time
- Lower utility and consumable costs

The proven and rugged non contacting designs, both screw and reverse claw mechanisms, include the ability to control pump body and internal gas temperatures allowing a comprehensive range of solvents, flammables and corrosives to be pumped. Systemised variants address the EU's explosive atmospheres (ATEX) directive for Category (Zone 0) T4 operation. The mechanisms are both highly tolerant to liquids and particles in the gas stream and are suitable for many applications including:

- Distillation
- Drying
- Evaporation and crystallisation
- Filter/dryers
- Solvent recovery
- Reactor service
- House/Central vacuum

Applications Engineering is a core competence and Edwards are able to offer a comprehensive solutions package that includes:

- Process design
- Equipment specification and selection
- Safety and operating procedures
- Vacuum system and control integration
- Commissioning advice

Edwards have a full range of dry pumps with a set of characteristics suited to most applications.

### EDP Chemical Dry Pumps and Systems

In the early 1980's, the EDP range pioneered the use of environmentally friendly dry vacuum pumps in the Chemical Process Industries. Based on the award-winning reverse claw mechanism this pump range has been designed and tested with reliability and safety in mind. With a large global installed base, the EDP model has been tried and tested over many years on its long life and easy maintenance and on its ability to pump flammable gases safely, to pump corrosive gases without corroding and to handle liquid or particulate carry over.

We offer a range of four pumps with 80-400 m<sup>3</sup>h<sup>-1</sup> capacity and ultimate vacuums of below 1 mbar.

### CXS Chemical Dry Pumps and Systems

CXS is Edwards most advanced chemical dry pump incorporating our many years of experience while adding more features and benefits designed to address the increased requirements coming from the CPI market. The patented screw technology delivers excellent liquid and solids handling and pumps corrosive vapours without deterioration.

CXS features an integral 'hazardous area' controller which allows for start-up and shut down procedures, pressure control, solvent flushing and multiple communications options. The integral PID pressure control with inverter delivers flexible process control and communications options for full monitoring of process parameters. The CXS lowers cost of ownership with low use of power and other utilities and stand by operation between processes. The CXS lowers maintenance bills with up to 5 years between services. The CXS lowers noise level < 64dB(A) for quieter operation. CXS is available now in two models 160 and 250 m<sup>3</sup>h<sup>-1</sup>, with 10<sup>-3</sup> mbar ultimate.

### CDX Dry Vacuum Pumps

CDX1000 is the pump optimised for processes requiring large pumping speeds, delivering a 900 m<sup>3</sup>h<sup>-1</sup> pumping speed and an ultimate vacuum of 0.005 mbar. Installed mainly in continuous, large, high throughput environments, this pump has been designed to withstand process malfunctions and to minimise down time from line maintenance to overhaul.

# CXS CHEMICAL DRY PUMP

## SIMPLY RELIABLE



Edwards is synonymous with vacuum. Having over 90 years experience and over 150,000 dry pumps installed worldwide, our high quality products and application know-how are renowned in the world of vacuum technology. CXS is Edwards most advanced chemical dry pump featuring tapered-screw technology for exceptional energy efficiency and performance. It offers high reliability and effluent-free pumping even in the most difficult of harsh chemical and pharmaceutical processing applications. The CXS pumps up to one litre of liquid per minute continuously or up to 25 litre-slugs without stopping, and provides an ultimate vacuum down to  $10^{-2}$  mbar. CXS is available in two sizes, with capacities of  $160 \text{ m}^3\text{h}^{-1}$  and  $250 \text{ m}^3\text{h}^{-1}$ .



### Features and Benefits

- **Environmental**
  - No oil disposal.
  - No oil emissions into atmosphere.
- **Performance**
  - Very stable pumping speed gives repeatability to processes.
  - Continuous pumping at atmosphere.
  - Ability to handle particulates.
  - Dry eliminates back-streaming, thus protecting reactive alloys from contamination.
- **Safety**
  - Unobtrusive noise levels.
  - No unsightly oil spills.
  - No hazardous oil vapours.

Hazardous area ATEX certification for T4 and IIB3 gas groups.

### Applications

- Drying
- Degassing
- Deodorisation
- Distillation
- Solvent recovery

### Pump Range

#### CXS160

- CXS160
- CXS160/1200

#### CXS250

- CXS250
- CXS250/1200
- CXS250/2600



# Performance Curves

## CXS160 Dry Pump

### CXS160



<b>Maximum pumping speed</b>
160 m <sup>3</sup> h <sup>-1</sup>
95 ft <sup>3</sup> min <sup>-1</sup>
<b>Capacity at 10 mbar (7.5 Torr)</b>
132 m <sup>3</sup> h <sup>-1</sup>
78 ft <sup>3</sup> min <sup>-1</sup>
<b>Ultimate vacuum</b>
< 0.02 mbar
< 0.015 Torr

### Ordering information

Product description	Order no:
CXS160 ATEX CAT2 T3 Light Duty	CS2560000000
CXS160 ATEX CAT2 T3 Medium Duty +	CS2561005000
CXS160/EH1200 ATEX CAT2 Light Duty	CS6560000000
CXS160/EH1200 ATEX CAT2 Medium Duty +	CS6561005000

- Light Duty includes Shaft Seal Purges (SSP) only for clean applications
- Medium Duty + includes SSP, gas ballast, inlet purge, solvent flush and exhaust pressure monitoring for harsh processes.

The above products are our standard offering.

A comprehensive 'matrix' of CXS products are available including the following:

- Containment safety ATEX CAT2 products with integral Flame Arrestors
- Fully systemised ATEX CAT 1 external/CAT2 external products
- T160 and T4 products

Please consult your Edwards Sales or Applications specialist for assistance with the correct product selection.

### CXS160 Performance Curve

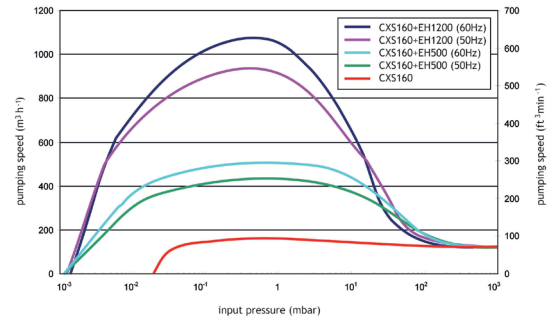

## CX250 Performance Curve

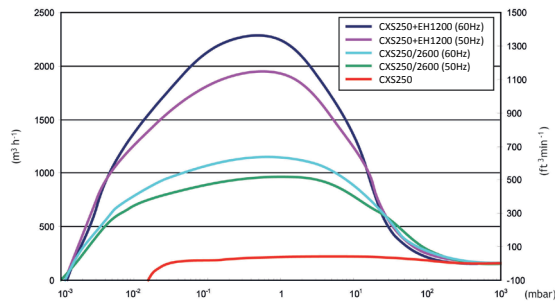

## Maximum pumping speed

250 m<sup>3</sup>h<sup>-1</sup>148 ft<sup>3</sup>min<sup>-1</sup>

## Capacity at 10 mbar (7.5 Torr)

230 m<sup>3</sup>h<sup>-1</sup>135 ft<sup>3</sup>min<sup>-1</sup>

## Ultimate vacuum

&lt; 0.015 mbar

&lt; 0.011 Torr



## Ordering information

Product description	Order no:
CX250 ATEX CAT2 T3 Light Duty	CS956000000
CX250 ATEX CAT2 T3 Medium Duty +	CS9561005000
CX250/EH1200 ATEX CAT2 T3 Light Duty	CS8560000000
CX250/EH1200 ATEX CAT2 T3 Medium Duty +	CS8561005000
CX250/EH2600 ATEX CAT2 T3 Light Duty	CSD560000000

- Light Duty includes Shaft Seal Purges (SSP) only for clean applications
- Medium Duty + includes SSP, gas ballast, inlet purge, solvent flush and exhaust pressure monitoring for harsh processes.

The above products are our standard offering.

A comprehensive 'matrix' of CXS products are available including the following:

- Containment safety ATEX CAT2 products with integral Flame Arrestors
- Fully systemised ATEX CAT 1 external/CAT2 external products
- T160 and T4 products

Please consult your Edwards Sales or Applications specialist for assistance with the correct product selection.



# Dimensions

## Standard CXS pump

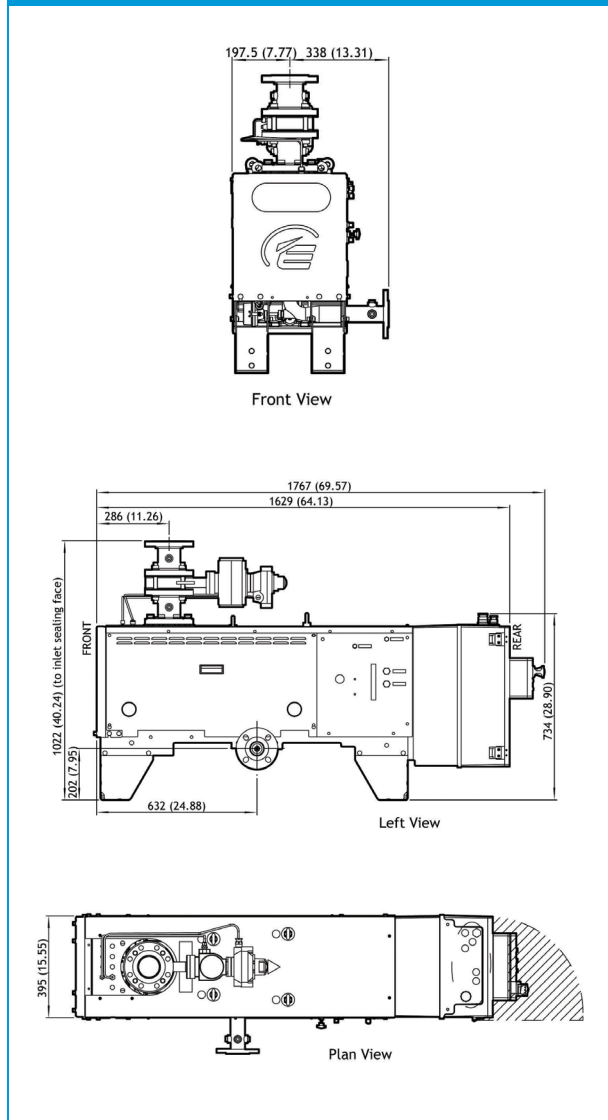

## CXS with booster combination

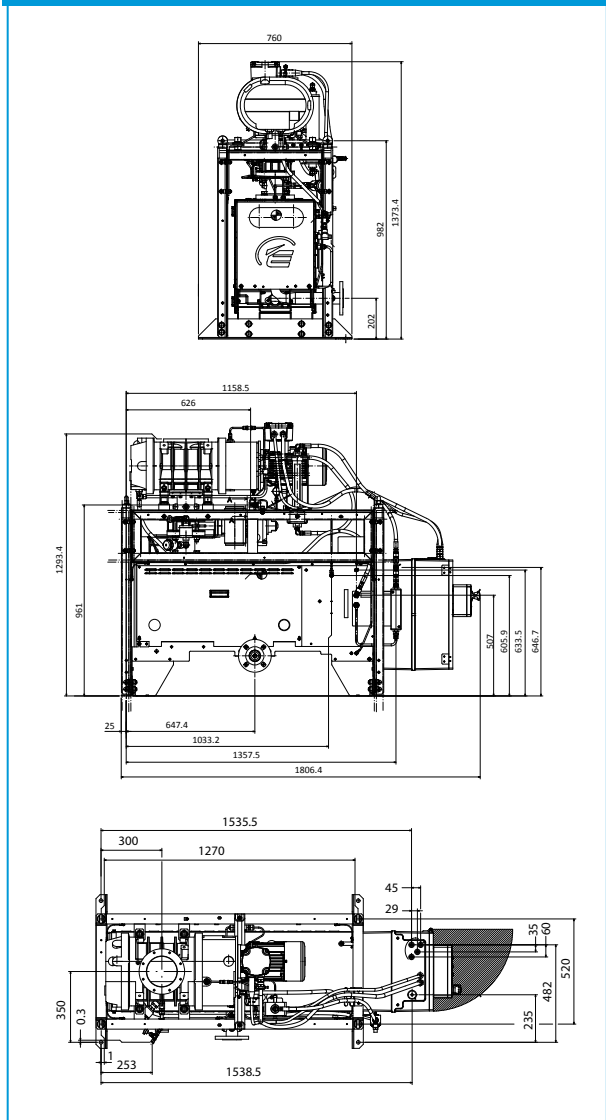

## Pump view



## Pump view



This example shown is for a CXS160 or CXS250 with an EH1200 booster.

# Technical Data

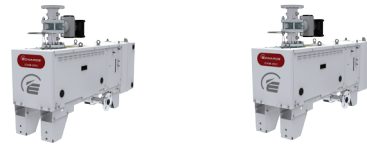

Specification	Units	CXS160	CXS250
Maximum pumping speed	m <sup>3</sup> h <sup>-1</sup> /ft <sup>3</sup> min <sup>-1</sup>	160/95	250/148
Capacity at 10 mbar (7.5 Torr)	m <sup>3</sup> h <sup>-1</sup> /ft <sup>3</sup> min <sup>-1</sup>	132/78	230/135
Ultimate vacuum	mbar/Torr	< 0.02/< 0.015	< 0.015/< 0.011
Maximum back pressure – standard	mbar/psig		1,200/2.7
Power consumption at 10 mbar (7.5 Torr)	kW/hp	3.6/4.8	3.8/5.1
Standard motor (380-460V ±10%, 3 ph, 50/60 Hz)	kW/hp		7.5/10
Cooling water flow rate, (adjustable)	lmin <sup>-1</sup> /gal min <sup>-1</sup>		4-10/1.1-2.6
Cooling water temperature*	°C/F		5-35*/41-95*
Maximum cooling water supply pressure	barg/psig		6.9/100
Cooling water supply differential pressure*	bar/psi		0.6-1.7/9-25
Seal purge flow (maximum)	std l min <sup>-1</sup> /std ft <sup>3</sup> min <sup>-1</sup>		12/0.424
Seal purge supply pressure, (minimum – maximum)	barg/psig		2.5-6.9/36-100
Noise (maximum) with silencer	dB(A)		64
Weight (with frame and standard motor)	kg/lbs		470/1,034
Process connection, inlet	ANSI/DIN		3"/DN80
Process connection, outlet	ANSI/DIN		2"/DN50

\* Data for T3. Contact Edwards for T160 and T4 options



# Service, Spares and Accessories

## CXS Accessories

Product description	Order no:
Exhaust manual isolation valve kit	M52808600
Solvent flush assembly	M52808300
Exhaust silencer assembly	M52808550
Water pump assembly	M52809300
CXS Exhaust temperature transmitter accessory kit	M52809280
CXS Inlet pressure transmitter	M52809200
CXS Gas purge flow meter accessory kit	M52805170
CXS Inlet pressure indicator accessory kit	M52808460
CXS Exhaust pressure indicator accessory kit	M52808480
CXS Inlet temperature indicator accessory kit	M52809160
CXS Exhaust temperature indicator accessory kit	M52809170

## Service

Edwards products, spares and accessories are available from Edwards companies in Belgium, Brazil, China, France, Germany, Israel, Italy, Japan, Korea, Singapore, United Kingdom, U.S.A. and a worldwide network of distributors. The majority of these centres employ Service Engineers who have undergone comprehensive Edwards training courses. Order spare parts and accessories from your nearest Edwards company or distributor.

When you order, please state for each part required:

- Model and item number of your equipment.
- Serial number (if any).
- Item number and description of the part.



# CDX DRY VACUUM PUMP

## MORE THAN PUMPS, COMPLETE VACUUM SOLUTIONS

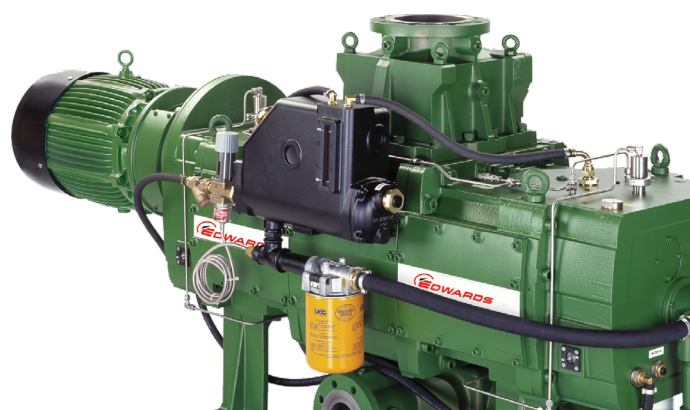

Edwards CDX1000 represents the latest generation of dry pump technology. The CDX1000 is a double-ended screw mechanism for the chemical process, pharmaceutical and petrochemical industries. This innovative technology leverages Edwards latest manufacturing and design philosophies. The CDX1000 is suited to larger processes where repeatability and reliability are key. Technologies and manufacturing techniques have been carefully selected to produce a robust, high performance machine that is simple to operate and maintain.



### Features and Benefits

- **Performance**
  - Continuous from atmosphere to ultimate.
  - Excellent temperature control.
  - Large liquid slug capability.
- **Environment**
  - No effluent generated.
  - Dry running mechanism.
  - Efficient solvent recovery.
  - Low power.
- **Maintenance**
  - On-site seal and bearing change.
  - Flushable with water, solvent or steam.
  - Low rotational speed.
  - Cooled and filtered oil.
  - Integral accessory modules.
- **Simplicity**
  - Low parts count.
  - Balanced rotor design.
  - No compression plate.
  - Industry standard motors.

### Applications

- Processes.
- Distillation.
- Drying.
- Evaporation/Crystallisation.
- Solvent/Vapour Recovery.

### Pump Range

- CDX
- CDX1000



# Performance Curves

## CDX1000 Dry Vacuum Pump

### CDX1000



#### Maximum pumping speed

900 m<sup>3</sup>h<sup>-1</sup>

530 ft<sup>3</sup>min<sup>-1</sup>

#### Ultimate vacuum

5 x 10<sup>-3</sup> mbar

4 x 10<sup>-3</sup> Torr

### CDX1000 Performance Curve

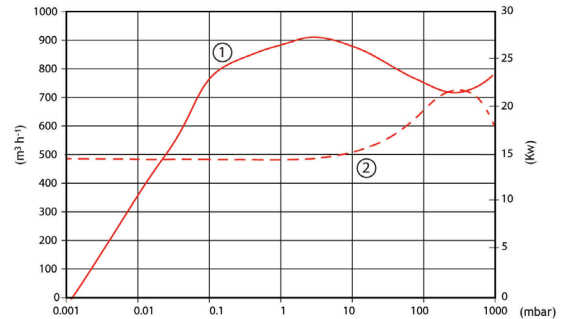

### Ordering information

Product description	Order no:
CDX1000, 30 kW, 50 Hz, flame proof with integral flame arrestors	A70801985
CDX1000 Dry vacuum pump, 30 kW, 50 Hz, flame proof (without integral flame arrestors)	A70802985
CDX1000 Dry vacuum pump, 40 HP, 60 Hz, flame proof with integral flame arrestors	A70811985
CDX1000 Dry vacuum pump, 40 HP, 60 Hz, flame proof (without integral flame arrestors)	A70812985

1 Power

2 Speed

# Dimensions

## CDX dimensions

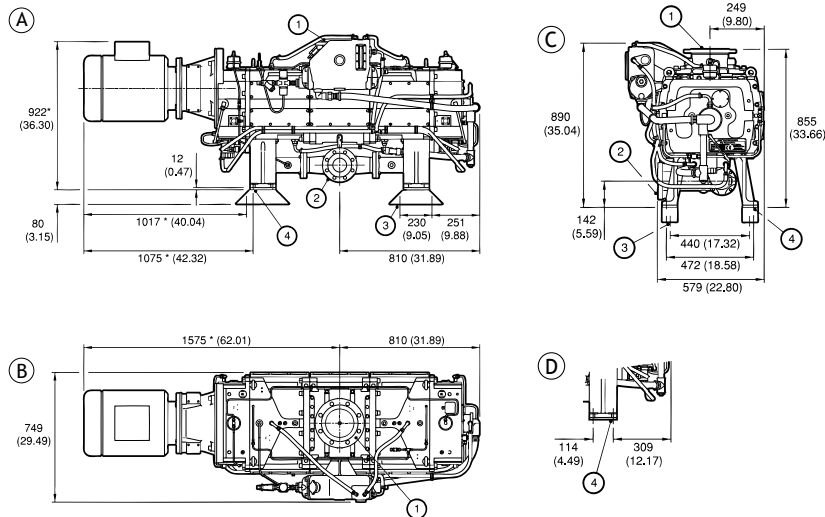

Note: this diagram shows a CDX with integral flame arrestors.

A	Side view	1	Pump inlet
B	Plan view	2	Pump outlet
C	End view	3	Fixing-holes: Ø18 mm (0.71 inch), 2 holes on each mounting foot
D	Front fixing dimensions with mounting feet removed	4	Fixing-holes: Ø17 mm (0.67 inch), 2 holes on each mounting bracket

# Technical data



	Units	CDX1000
Maximum pumping speed	m <sup>3</sup> h <sup>-1</sup>	900
	ft <sup>3</sup> min <sup>-1</sup>	530
Capacity at 10 mbar (7.5 Torr)	m <sup>3</sup> h <sup>-1</sup>	900
	ft <sup>3</sup> min <sup>-1</sup>	530
Ultimate vacuum	mbar	5 x 10 <sup>-3</sup>
	Torr	4 x 10 <sup>-3</sup>
Maximum back pressure – standard (optional*)	mbarA	1150
	psig	2.0
Power consumption at 10 mbar (7.5 Torr)	kW	17.1
	Hp	23.2
Standard motor (380-400 V, 3 ph, 50 Hz)	kW	30
Standard motor (200-460 V, 3 ph, 60 Hz)	hp	40
Cooling water flow rate (adjustable)	lmin <sup>-1</sup>	10-20
	gal min <sup>-1</sup>	2.64-5.28
Cooling water supply temperature range	°C/°F	5-35/41-95
Cooling water supply pressure	barg	2-10
	psig	29-145
Seal purge flow (maximum), regulated to 0.3-0.5 barg, (5-7 psig)	lmin <sup>-1</sup>	24
	ft <sup>3</sup> min <sup>-1</sup>	0.85
Seal purge supply pressure (minimum-maximum)	barg	2-10
	psig	29-145
Noise (max. with exhaust silencer)	dB(A)	82
Weight (with frame and standard motor)	kg	1710
	lbs	3765
Process connection, inlet	ANSI/DN150	6"
Process connection, outlet	ANSI/DN80	3"



## Systemisation

Because no two installations are identical, Edwards offers a custom systemisation design and build service, exactly matched to customer needs, using pre-engineered modules together with an extensive CAD capability. This also allows subsequent expansion or reconfiguration. A wide range of modules is available, including:

- EH\* and HV mechanical booster pumps
- Condensers
- Receivers
- Knockout pots
- Dust filters
- Solvent purging
- Flame arrestors
- Isolation and throttle control valves
- Instrumentation
- Silencers
- Inverter drives and pressure controls
- Electrical control panels
- Air blast closed-loop cooling
- Base skids

The requirement for these or other accessories is clarified through expert applications engineering.

Work can be carried out to a customer's specifications, or to local or industry standard codes and practices. Full documentation is provided, and full certification can be obtained if necessary.

\*Edwards EH Series boosters feature our unique hydrokinetic drive which provides significant cost and performance advantages over direct drive machines. The hydrokinetic drive removes any need for pressure sensors or bypass lines or inverters, and allows the booster to run from atmospheric pressure to ultimate vacuum, giving faster pump-down and more flexible operation with less maintenance.

## Systemisation to match your process

### CDX1000 + HV8000 booster combination

- Pre-engineered modules
- Customised systems
- Tailored applications support to match performance to process

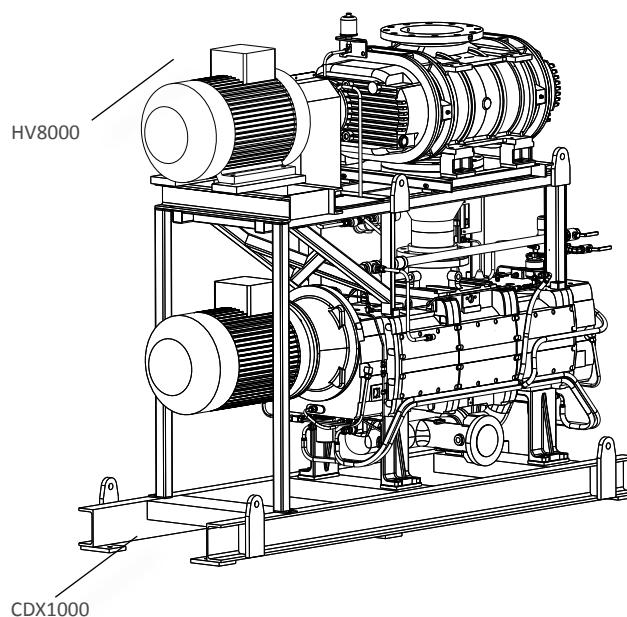

# Service, Spares and Accessories

## Flame Arrestor Kit

Product description	Order no:
Flame Arrestor replacement kit (inlet)	A70801810
Flame Arrestor replacement kit (outlet)	A70801811
Flame Arrestor tooling kit	A70801812
Flame Arrestor cleaning kit	A70801808

## Replacement Kit

Product description	Order no:
Air bleed filter replacement kit	A70901801
Bearing and seal replacement kit	A70801805
Oil pump replacement kit	A70801806

## Kit

Product description	Order no:
Routine maintenance kit	A70801800
Heat exchanger cleaning kit	A70801801
Cooling system overhaul kit	A70801802
Motor fitting kit	A70801803
Drive coupling kit	A70801804
Strip and rebuild kit	A70801807
Hoses kit	A70801809

## Mobil SHC 629 Oil

Product description	Order no:
Mobil SHC 629 oil: 4 litres (1.06 US gal)	H11023011

## Coolant

Product description	Order no:
Container of coolant*	
* 0.9 litres (0.24 US gal) as supplied, 2.0 litres (0.53 US gal) when diluted.	H12810003

Note: You will need 25 containers of coolant to completely fill a pump with coolant

## Service

Edwards products, spares and accessories are available from Edwards companies in Belgium, Brazil, China, France, Germany, Israel, Italy, Japan, Korea, Singapore, United Kingdom, U.S.A. and a worldwide network of distributors. The majority of these centres employ Service Engineers who have undergone comprehensive Edwards training courses. Order spare parts and accessories from your nearest Edwards company or distributor.

When you order, please state for each part required:

- Model and item number of your equipment.
- Serial number (if any).
- Item number and description of the part.

# EDP CHEMICAL DRY PUMP

## MORE THAN PUMPS, COMPLETE VACUUM SOLUTIONS

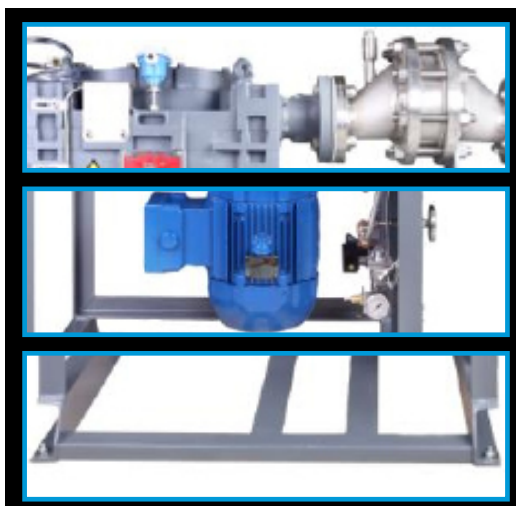

EDP pumps are based on Edwards' oil-free, non-contacting, award-winning, reverse claw mechanism. They provide consistent vacuum at high efficiencies and low costs of ownership. Dry pumps completely eliminate all problems of process contamination and creation of polluted effluent, which are experienced with traditional wet vacuum pump technologies.



### Features and Benefits

- Staged compression for optimum temperature profile within the pump and no requirement for cooling gas injection.
- Inherently free draining.
- Able to handle liquid or particulate carry-over.
- Short gas path eliminates particulate build-up and corrosion – Edwards' patented design.
- Can flush with solvents, water or steam
- No internal valves to block or corrode and no interstage condensers to create potential for corrosion.
- Simple robust construction with ample power ensures reliable operation even during process upsets.
- Non-contacting mechanisms gives long life and high reliability.
- Pump flammable gases safely.
- Pump corrosive gases without corroding.
- Designed for long life and easy maintenance.
- Minimum of 25 years life expectancy.
- Lower cost of ownership.

### Applications

- Drying
- Distillation
- Reactor service
- Solvent recovery
- House/central vacuum

### Pump Range

#### EDP

- EDP80
- EDP160
- EDP250
- EDP400

# Performance Curves

## EDP80 Chemical Dry Pump

### EDP80



#### Peak speed

50 Hz	83 m <sup>3</sup> h <sup>-1</sup> /49 ft <sup>3</sup> min <sup>-1</sup>
60 Hz	102 m <sup>3</sup> h <sup>-1</sup> /60 ft <sup>3</sup> min <sup>-1</sup>

#### Ultimate Vacuum

50 Hz	0.5 mbar/0.4 Torr
60 Hz	0.2 mbar/0.2 Torr

### Ordering information

Product description	Order no:
EDP80 50 Hz	A70545008
EDP80 60 Hz	A70545008

### EDP80 Performance Curve

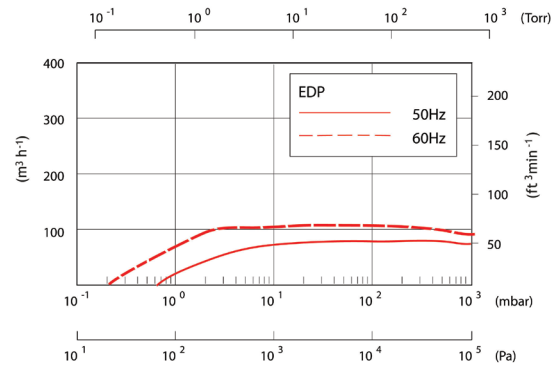

## EDP160 Chemical Dry Pump

### EDP160



#### Peak speed

50 Hz	163 m <sup>3</sup> h <sup>-1</sup> /96 ft <sup>3</sup> min <sup>-1</sup>
60 Hz	202 m <sup>3</sup> h <sup>-1</sup> /119 ft <sup>3</sup> min <sup>-1</sup>

#### Ultimate Vacuum

50 Hz	0.5 mbar/0.4 Torr
60 Hz	0.2 mbar/0.2 Torr

### Ordering information

Product description	Order no:
EDP160 50 Hz	A70544008
EDP160 60 Hz	A70544008

### EDP160 Performance Curve

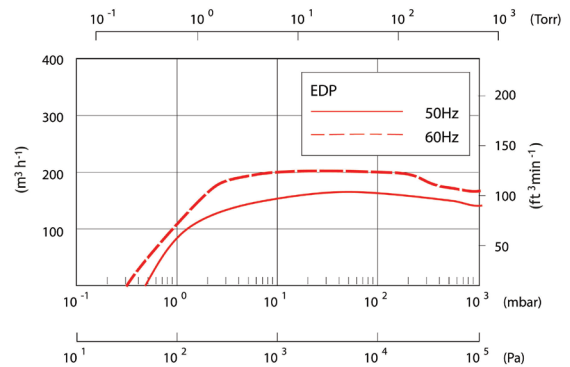

## EDP250 Chemical Dry Pump

### EDP250 Performance Curve

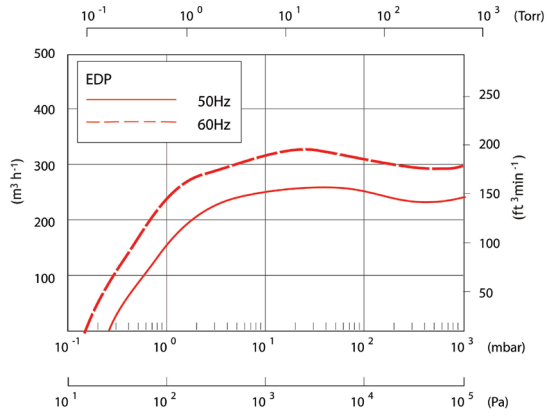

### EDP250

#### Peak speed

50 Hz	260 m <sup>3</sup> h <sup>-1</sup> /320 ft <sup>3</sup> min <sup>-1</sup>
60 Hz	153 m <sup>3</sup> h <sup>-1</sup> /188 ft <sup>3</sup> min <sup>-1</sup>

#### Ultimate Vacuum

50 Hz	0.5 mbar/0.4 Torr
60 Hz	0.2 mbar/0.2 Torr



### Ordering information

Product description	Order no:
EDP250 50 Hz	A70543008
EDP250 60 Hz	A70543008

## EDP400 Chemical Dry Pump

### EDP400 Performance Curve

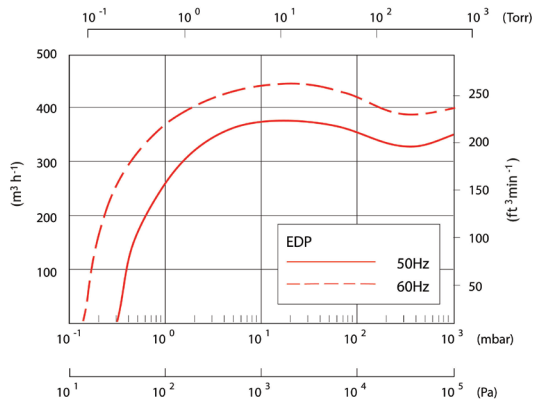

### EDP400

#### Peak speed

50 Hz	377 m <sup>3</sup> h <sup>-1</sup> /222 ft <sup>3</sup> min <sup>-1</sup>
60 Hz	427 m <sup>3</sup> h <sup>-1</sup> /251 ft <sup>3</sup> min <sup>-1</sup>

#### Ultimate Vacuum

50 Hz	0.4 mbar/0.3 Torr
60 Hz	0.2 mbar/0.2 Torr



### Ordering information

Product description	Order no:
EDP400 50 Hz	A70542008
EDP400 60 Hz	A70541008



# Dimensions

## EDP dimension

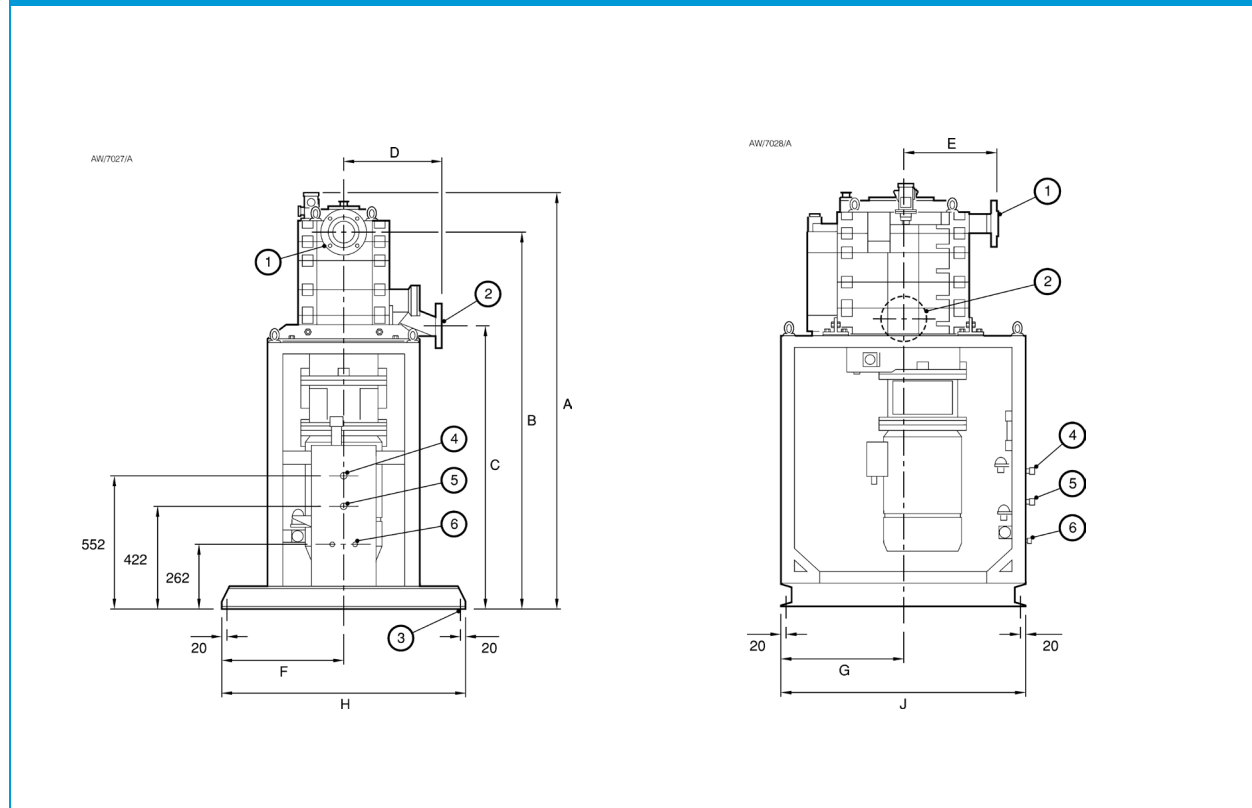

Key	EDP80	EDP160	EDP250	EDP400 50 Hz	EDP400 60 Hz	
A	1423 (56.0)	1458 (57.4)	1681 (66.2)	1730 (68.1)	1721 (67.8)	1 Pump inlet
B	1254 (49.4)	1289 (50.7)	1514 (59.6)	1562 (61.5)	1549 (61.0)	2 Pump outlet
C	974 (38.3)	974 (38.3)	1148 (45.2)	1148 (45.2)	1149 (45.2)	3 Fixing hole: $\varnothing 18$ mm (4 off)
D	353 (13.9)	353 (13.9)	377 (14.8)	377 (14.8)	349 (13.7)	4 Cooling water outlet connection
E	443 (17.4)	448 (17.6)	359 (14.1)	359 (14.1)	362 (14.3)	5 Cooling water inlet connection
F	350 (13.8)	350 (13.8)	500 (19.7)	500 (19.7)	476 (18.7)	6 Nitrogen supply inlet connection
G	350 (13.8)	350 (13.8)	475 (18.7)	475 (18.7)	476 (18.7)	
H	700 (27.6)	700 (27.6)	1000 (39.4)	1000 (39.4)	997 (39.3)	
J	850 (33.5)	850 (33.5)	950 (37.4)	950 (37.4)	946 (37.2)	



## Technical Data



	Units	EDP80		EDP160	
		50 Hz	60 Hz	50 Hz	60 Hz
Maximum pumping speed	m <sup>3</sup> h <sup>-1</sup> /ft <sup>3</sup> min <sup>-1</sup>	83/49	102/60	163/96	202/119
Capacity at 10 mbar (7.5 Torr)	m <sup>3</sup> h <sup>-1</sup> /ft <sup>3</sup> min <sup>-1</sup>	75/44	102/60	153/90	198/117
Ultimate vacuum	mbar/Torr	0.5/0.4	0.3/0.2	0.5/0.4	0.3/0.2
Maximum back pressure – standard (optional*)	mbar/psig	1150 (1300*)/2.2 (4.4*)			
Power consumption at 10 mbar (7.5 Torr)	kW/hp	3.3/4.4	4.0/5.4	4.9/6.6	
Standard motor (380-400 V, 3 ph, 50 Hz)	kW/hp	5.5/7.5		7.5/10.0	11.0/15.0
Cooling water flow rate, (adjustable)	l min <sup>-1</sup> /gal min <sup>-1</sup>	1-8/0.3-2.1	1-10/0.3-2.6	1-8/0.3-2.1	1-10/0.3-2.6
Cooling water supply pressure	barg/psig	2-10/29-145			
Seal purge flow (maximum), regulated to 0.3-0.5 barg, (5-7 psig)	lmin <sup>-1</sup> /ft <sup>3</sup> min <sup>-1</sup>	20/0.7			
Seal purge supply pressure, (minimum – maximum)	barg/psig	2-10/29-145			
Noise (max. with exhaust silencer)	psig	73		77	78
Weight (with frame and standard motor)	kg/lbs	648/1429	650/1433	747/1647	756/1667
Process connection, inlet		2"/DN50		3"/DN80	
Process connection, outlet		1.5"/DN40			
Pumping mechanism		3 stage reversed claw			



	Units	EDP250		EDP400	
		50 Hz	60 Hz	50 Hz	60 Hz
Maximum pumping speed	m <sup>3</sup> h <sup>-1</sup> /ft <sup>3</sup> min <sup>-1</sup>	260/153	320/188	377/222	427/251
Capacity at 10 mbar (7.5 Torr)	m <sup>3</sup> h <sup>-1</sup> /ft <sup>3</sup> min <sup>-1</sup>	255/150	315/185	377/222	422/248
Ultimate vacuum	mbar/Torr	0.5/0.4	0.2/0.2	0.4/0.3	0.2/0.2
Maximum back pressure – standard (optional*)	mbar/psig	1150 (1300*)/2.2 (4.4*)			
Power consumption at 10 mbar (7.5 Torr)	kW/hp	6.0/8.0		7.0/9.4	
Standard motor (380-400 V, 3 ph, 50 Hz)	kW/hp	11.0/15.0	15.0/20.0	18.5/25.0	25.0/30.0
Cooling water flow rate, (adjustable)	lmin <sup>-1</sup> /gal min <sup>-1</sup>	1-10/0.3-2.6	1-10/0.3-2.7	1-10/0.3-2.6	1-10/0.3-2.7
Cooling water supply pressure	barg/psig	2-10/29-145			
Seal purge flow (maximum), regulated to 0.3-0.5 barg, (5-7 psig)	lmin <sup>-1</sup> /ft <sup>3</sup> min <sup>-1</sup>	20/0.7			
Seal purge supply pressure, (minimum-maximum)	barg/psig	2-10/29-145			
Noise (max. with exhaust silencer)	psig	739		82	
Weight (with frame and standard motor)	kg/lbs	848/1870	860/1909	918/2024	960/2116
Process connection, inlet		3"/DN80			
Process connection, outlet		2"/DN50			
Pumping mechanism		3 stage reversed claw			