



Nor-Cal Products
NC
by PFEIFFER VACUUM



Nor-Cal Products

where technology takes shape

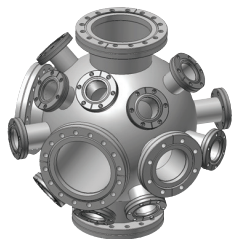
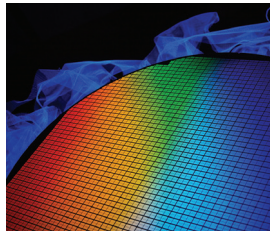
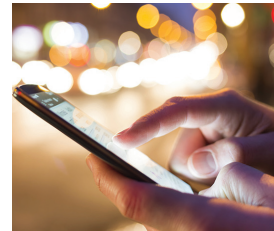
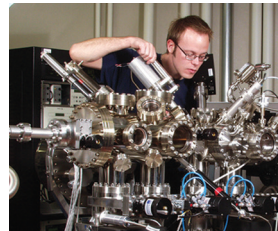
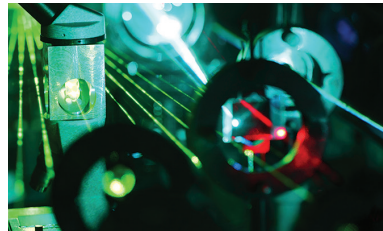

vacuum products catalog

Sample Transfer & Manipulation

Section Nine

9



9.1	General Information	188
9.2	Sample Transfer System & Load Lock Chamber	190
9.3	Add-A-Doors	191
9.4	Manipulators, Stages & Translators	192
9.5	Utility Hat & Alignment Gimbals	194
9.6	Motion Feedthroughs	195
9.7	Wobble Sticks	200

Nor-Cal Products

 by PFEIFFER VACUUM



Nor-Cal Products, Inc.
 1967 South Oregon St.
 Yreka, CA 96097 USA
 Tel: **800-824-4166**
 or 530-842-4457
 Fax: 530-842-9130
www.n-c.com

Sales Office
 3375 Scott Blvd., Ste. 100
 Santa Clara, CA 95054, USA
 Tel: **408-980-8992**
 Fax: 408-980-8947

Nor-Cal Europe Ltd.
 Suite D, Dittons Engineering Park
 Dittons Road
 Polegate BN26 6HY
 United Kingdom
 Tel: **+44(0)1323 810854**
www.nor-cal.eu

Nor-Cal Korea
 Gadong 2nd Floor, 531-8 Gajang-ro
 Osan-si, Gyeonggi-do,
 South Korea, 18103
 Republic of Korea
 Tel: **+82(0)31-222-6086**
 Fax: +82(0)31-8003-1342

**Nor-Cal Products
 Asia Pacific Pte. Ltd.**
 Serangoon Garden
 P. O. Box 428
 Singapore 915531
 Tel: **+65 6634-1228**
 Fax: +65 6634-1008

Sample Transfer & Manipulation

General Information

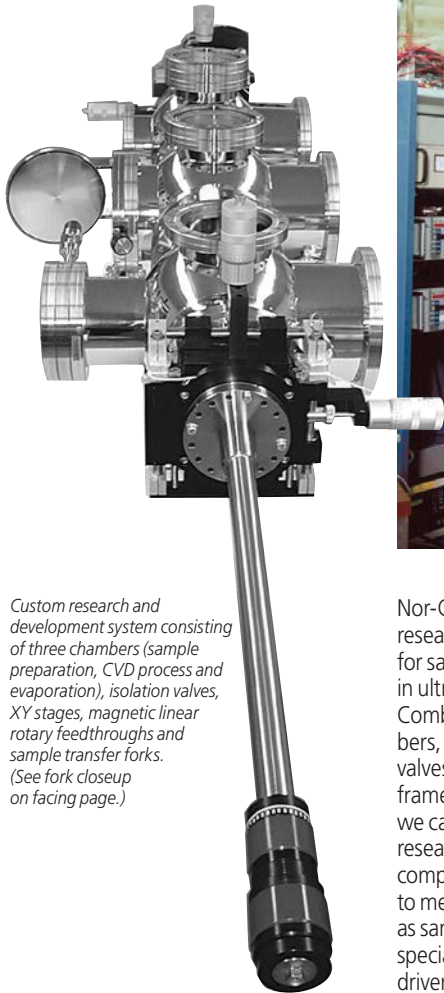

Custom research and development system consisting of three chambers (sample preparation, CVD process and evaporation), isolation valves, XY stages, magnetic linear rotary feedthroughs and sample transfer forks. (See fork closeup on facing page.)

Most sample transfer/manipulation devices include a 5 year warranty, depending on the specific product type. 5 year warranty not available in all territories.

Contact the factory for details.

All dimensions are in inches (mm) & weights are in pounds (kg), unless otherwise noted.

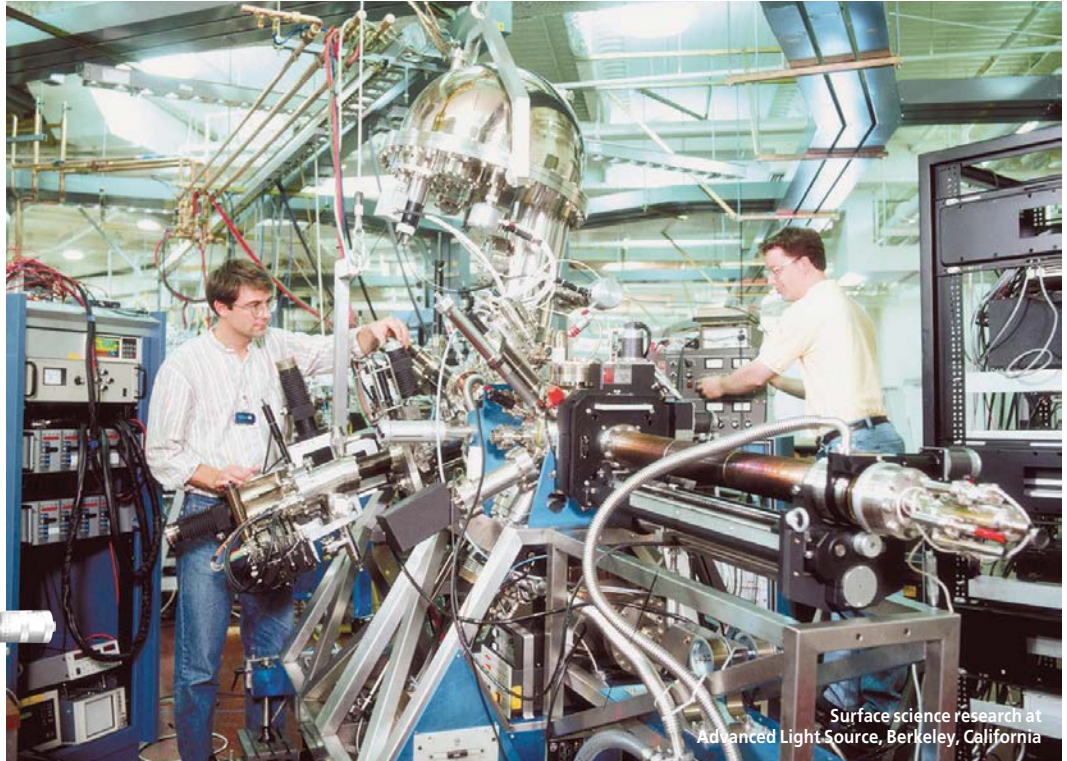

Nor-Cal Products offers the researcher complimentary devices for sample transfer and positioning in ultra-high vacuum systems. Combined with our vacuum chambers, load locks, gate valves, all-metal valves, feedthroughs, viewports, frames and roughing accessories, we can provide a complete turn-key research system. Each standard component can readily be customized to meet specific requirements, such as sample heating and cooling, special lengths or stepper motor drivers. Our sample transfer and manipulation devices are made from the highest quality materials and lubricants to withstand repeated UHV bakeouts.

When selecting a sample handling system, consideration must be given to its operation with goniometers and precision gearboxes. These devices typically require that the sample be solidly held and moved in a precise way. The sample platen must be docked to a goniometer so as not to limit the degrees of freedom or degrade the goniometer's resolution.

Selecting a Sample Transfer System

The following list contains some of the many factors that influence the selection of a sample transfer system, which vary by application.

- Sample motion requirements
- Heating requirements
- Cooling requirements
- Sample size
- Size of chamber tubulations available
- Geometry of the chambers relative to manipulators and type of transfer translator and load-lock
- Motion available for actuation
- Compatibility with existing or planned equipment
- Ease and reliability of operation

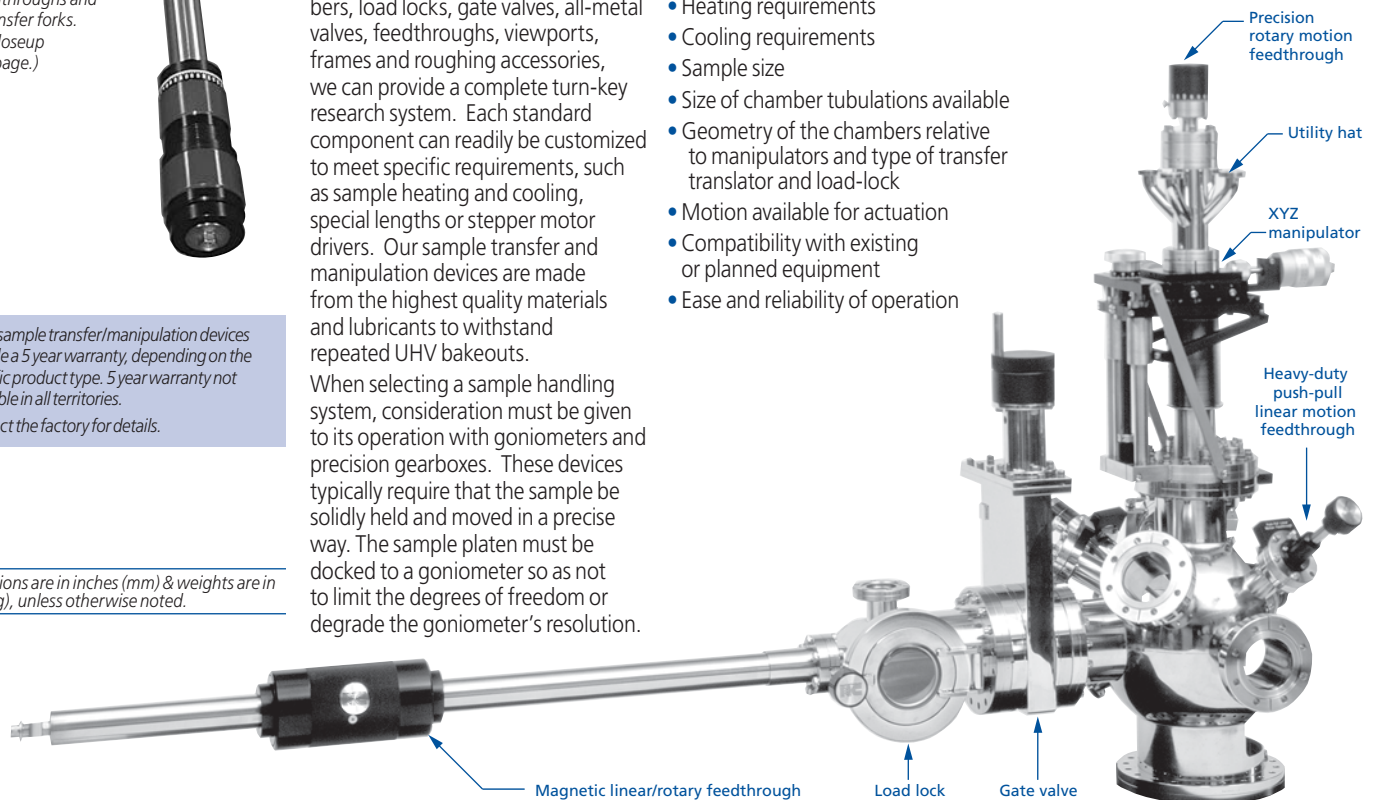

Precision rotary motion feedthrough

Utility hat

XYZ manipulator

Heavy-duty push-pull linear motion feedthrough

Magnetic linear/rotary feedthrough

Load lock

Gate valve

XYZ Manipulator

The XYZ manipulator is a 3-axis (X,Y,Z) positioning device which is typically mounted outside the vacuum chamber for most applications. A welded bellows provides a flexible vacuum curtain. The X axis passes in front of the vertical, mechanical structure, or "backframe," with the Y axis moving to and away from the backframe. The Z axis is perpendicular to the X and Y axes and moves up and down directly against the vacuum pressure differential. The polar axis is the same as the Z axis.

The limit of X and Y travel is normally a circular pattern with range indicated as a vector sum. This means a $\pm .50$ inch (12.7mm) range of X and Y allows the polar axis to be moved anywhere inside a 1.00 inch (25.4mm) diameter circle. The sum of the X and Y vectors is limited to .50 inch (12.7mm). Square pattern XY stages are available as options on some models.

Z Translator

A translator is a single axis positioning device, utilizing a bellows as a vacuum seal. Referred to as a "Z only" stage, this axis is normally perpendicular to the chamber. This causes the Z axis to work directly against the force from the pressure differential.

XY Stage

The XY stage provides the X and Y axes only. No Z motion is available.

Polar Rotation

The polar axis is the same as the Z axis. Rotation about the polar axis is commonly achieved by mounting a rotary feedthrough at the center of the traveling flange of a manipulator or translator. This degree of freedom can also be achieved with a differentially pumped rotary seal.

Azimuthal Axis

The azimuthal axis is perpendicular to the polar axis. Sample azimuthal rotation refers to rotation of the sample about an axis normal to the sample face and perpendicular to the polar axis.

Flip Motion

Flip motion is the changing of an axis normal to the sample face from parallel (or coaxial) to the polar axis to coaxial with the azimuthal axis. The range of this change of axis may be 90°, 180° or full 360°.

Tilt Motion

Tilt refers to changing the polar axis with respect to the X, Y and Z axes. This is usually done at the traveling flange of a 3-axis manipulator or other exterior mounting stage. Tilt range is often limited by the bellows ID and the OD of the probe passing through the bellows. The maximum angle practical is about $\pm 7^\circ$. When used in this manner, translation in X, Y and (slightly) Z will occur with adjustment of the tilt angle. Tilt stages are available in single or dual axis units.

Sample Transfer & Heating

Sample transfer may reduce heating performance at high temperatures. The ideal transfer system for heating the sample to the highest temperatures should use thin sample plates made of appropriate material placed as close to the heater as possible. Thick, high mass, sample plates reduce thermal response and lower peak heating temperatures.

Sample Transfer & Cooling

Sample transfer may reduce cooling performance at low temperatures. The ideal transfer system for cooling the sample to the lowest temperatures should use thin, highly conductive, sample plates that contact the dewar with a large surface area. Thick, high mass, sample plates reduce thermal response and reduce peak cooling performance.

Transfer Components

Sample Platen - the transferable plate that holds the sample

Sample Fork - attaches to a transfer arm from the load-lock and holds the sample platen

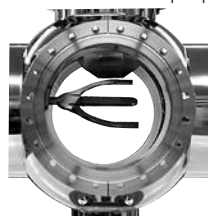

Sample transfer fork

Sample Dock - attaches to a work station (manipulator) and holds the platen for processing or positioning the sample

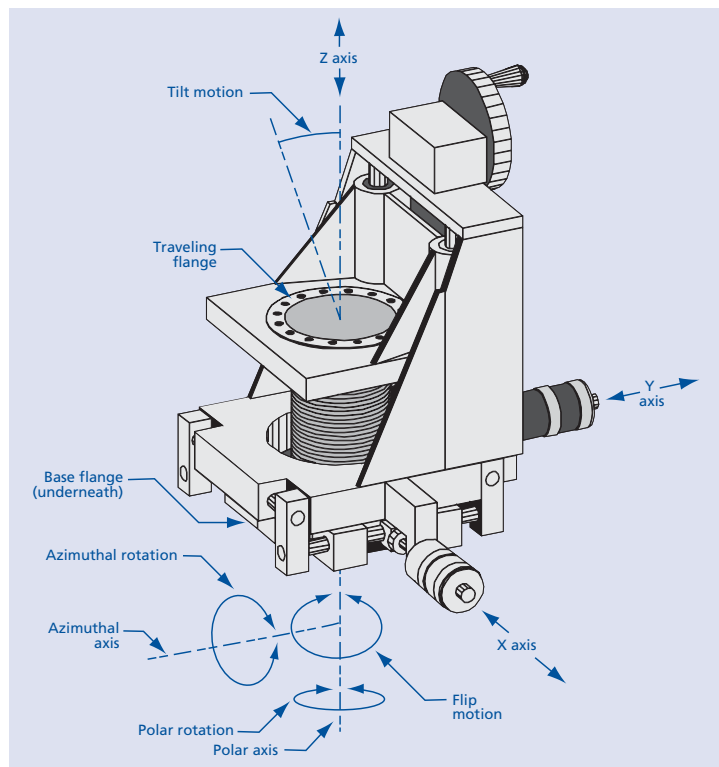

Fork & Dock Configurations

Axial Fork - a sample fork with the plane of the sample platen face orthogonal to the axis of the transfer arm on which the fork is mounted

Radial Fork - a sample fork with the plane of the sample platen face parallel to the axis of the transfer arm on which the fork is mounted

Axial Dock - a sample dock with the plane of the sample platen face orthogonal to the axis of the manipulator on which the dock is mounted

Radial Dock - a sample dock with the plane of the sample platen face parallel to the axis of the manipulator to which the dock is mounted.

Bolt Pattern Orientation

Our components are manufactured with the primary axis straddling adjacent bolt holes on the mounting flange (American standard). Most components can be furnished with the axis passing through a bolt hole axis (European standard) on request. Some equipment is field adjustable.

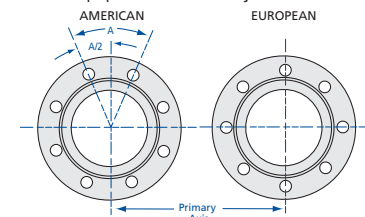

Types of Motion Used for Transfer Actuation

Linear Motion - linear sample motion along any axis

Rotary Motion - rotary sample motion about any axis

Tilt Motion - angular positioning movement of the horizontal or orthogonal axis. The weight of the sample, plate, fork and translator can cause deflection that misaligns the axis of transfer. A tilt stage can be used to re-align the axis to enable a transfer

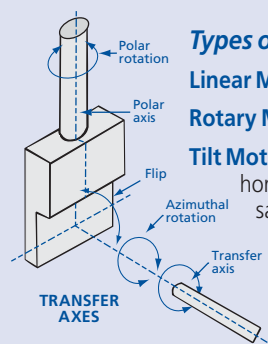

Sample Transfer & Manipulation

Sample Transfer System & Load Lock Chamber

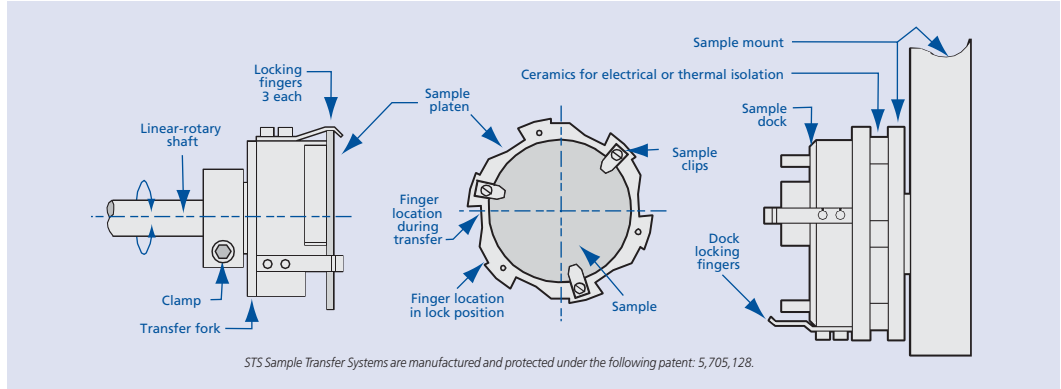
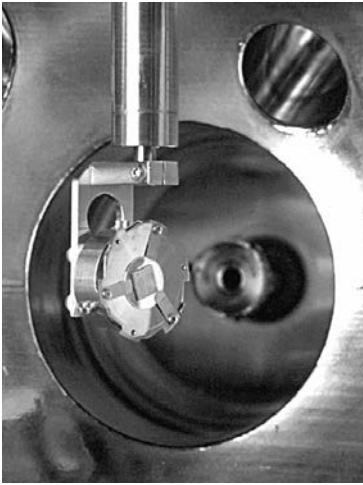

Sample Transfer System

This sample transfer system uses thin (.040 inch) sample plates with six sawtooth shaped ramps, profiled on the plate's edge. The sample transfer probe is fitted with a fork consisting of three tab-shaped spring fingers positioned radially on a barrel. The sample plate locks on to the fork by rotating the fork's fingers over three of the six ramps. When the fork is rotated, the locking fingers slide up the ramps to stops. The plate is gripped by the spring fingers, holding it tight to the barrel of the fork.

Transferring the sample from the probe fork to a manipulator sample dock is done with a rotary motion. The dock has the same type of locking fingers as the fork. The plate is mated to the dock by orienting it so that the three unused ramps can receive the dock's fingers. Rotating the fork releases the plate at the same time the fingers on the dock grip and lock the plate to the manipulator. This rotary movement makes a smooth sample transfer from the fork to dock and back again.

Nor-Cal Products sample transfer system allows easy, forgiving sample transfer from a rotary/linear feedthrough to the sample dock mounted inside the chamber. Systems are available for sample sizes ranging from 1/2 inch (12.7mm) to 3 inches (76.2mm). Each system includes a dock assembly custom fitted to place the sample on target in your particular chamber, a transfer fork assembly which mounts to a rotary/linear device and two stainless steel sample plates. Molybdenum sample plates are also available. Call for details and pricing.

Features

- Fast thermal response and greater extremes
- Larger samples may be introduced through smaller ID plumbing
- Excellent sample plane repeatability
- Adapts to most goniometers and precision gearboxes
- Excellent performance for direct and indirect cooling
- Transferable thermocouple, optional
- Transferable intrinsic direct heating
- Five-year guarantee

MODEL NUMBER	SAMPLE OD	MINIMUM PORT OD
STS-050	1/2 (12.7)	1 1/2 (38.1)
STS-100	1 (25.4)	1 1/2 (38.1)
STS-200	2 (50.8)	2 1/2 (63.5)
STS-300	3 (76.2)	4 (101.6)

Load Lock Chamber

Load lock chambers are an efficient means to introduce a sample into a vacuum chamber without impacting the main chamber vacuum. Load Locks are provided with a six inch CF flange for mounting to the gate valve, a six inch Add-A-Door with 7056 glass viewport, a 2 3/4 inch (70mm) CF flange for attachment of the linear feedthrough, and two 2 3/4 inch (70mm) CF flanges for pumping and gauges. Standard finish is electropolished. Custom sizes and configurations are readily available. Call for pricing.

MODEL NUMBER
LL-600-ADV-150-3

SPECIFICATIONS

Construction
Flanges: 304 stainless steel
Body: 304 stainless steel
Viewport: 7056 glass
O-ring: FKM

Temperature range: -20°C to 200°C

Vacuum range: $\geq 10^{-8}$ mbar (High vacuum)

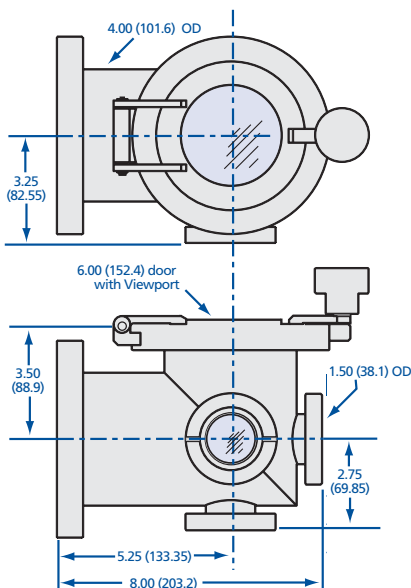

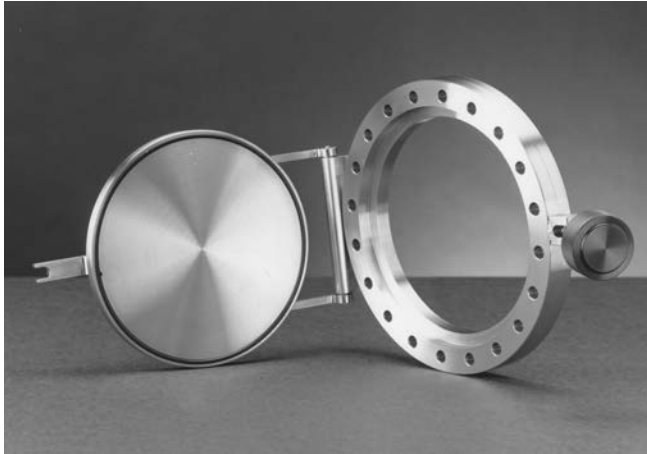
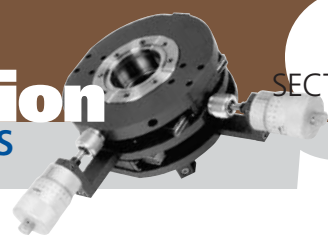

An Add-A-Door can provide easy access to a vacuum system when elastomer seals are acceptable. The hinged, FKM sealed door is quickly bolted to an existing CF (Conflat style) flanged chamber port. The door is opened easily by turning a knurled knob. These doors are available for 2³/₄ to 10 inch (70 to 254mm) OD flanges with a solid metal door or with a viewport. The standard finish is electropolish. Custom sizes can be supplied upon request.

SPECIFICATIONS

Construction

Body: 304 stainless steel
 Flange: 2³/₄ to 10 inch (70 to 254mm) CF
 Door: Blank, 7056 glass, or fused silica
 O-ring: FKM standard

Temperature range: -20°C to 200°C

Vacuum range: ≥ 10⁻⁸ mbar (High vacuum)

Add-A-Doors

MODEL NUMBER	FLANGE TYPE	A	B
AD-275	2.75 CF	1.380 (35.05)	0.500 (12.70)
AD-450	4.50 CF	2.435 (61.85)	0.687 (17.45)
AD-600	6.00 CF	3.917 (99.49)	0.781 (19.84)
AD-800	8.00 CF	5.875 (149.23)	0.875 (22.23)
AD-1000	10.00 CF	7.875 (200.03)	0.968 (24.59)

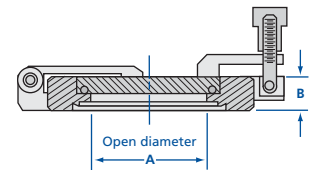

Add-A-Doors with Viewport – 7056 Glass

MODEL NUMBER	FLANGE TYPE	A	B	C
ADV-450	4.50 CF	2.435 (61.85)	0.687 (17.45)	1.49 (37.85)
ADV-600	6.00 CF	3.917 (99.49)	0.781 (19.84)	2.65 (67.31)
ADV-800	8.00 CF	5.875 (149.23)	0.875 (22.23)	3.88 (98.55)
ADV-1000	10.00 CF	7.875 (200.03)	0.968 (24.59)	5.60 (142.24)

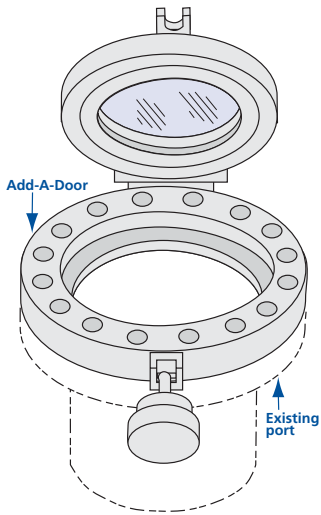
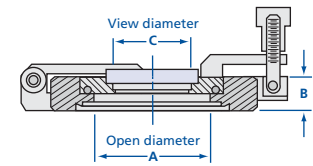

Add-A-Doors with Viewport – Fused Silica

MODEL NUMBER	FLANGE TYPE	A	B	C
ADVQ-450	4.50 CF	2.435 (61.85)	0.687 (17.45)	1.40 (35.56)
ADVQ-600	6.00 CF	3.917 (99.49)	0.781 (19.84)	2.69 (68.33)
ADVQ-800	8.00 CF	5.875 (149.23)	0.875 (22.23)	3.88 (98.55)
ADVQ-1000	10.00 CF	7.875 (200.03)	0.968 (24.59)	5.38 (136.65)

Viewport Optical Transmission Curves

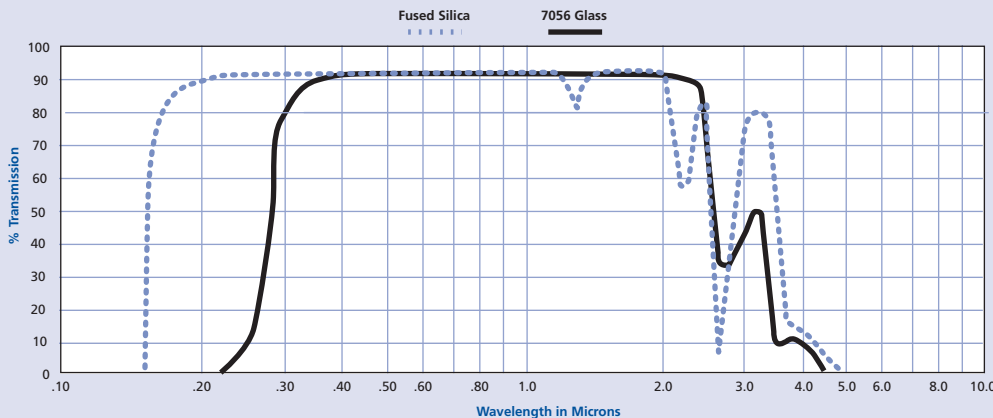

All dimensions are in inches (mm) & weights are in pounds (kg), unless otherwise noted.



Sample Transfer & Manipulation

Manipulators, Stages & Translators

SPECIFICATIONS

- Construction**
 Bellows: 1 7/8 inch (47.63mm) ID
 Base flange: 6 inch (152.4mm) CF, clearance holes with 5 mini flanges
 Traveling flange: 2 3/4 inch (69.85mm) CF, tapped holes
 Guide rods: Dual 3/4 inch (19.05mm) OD hardened stainless steel
 Stage: Aluminum
- Motion**
 XY travel: ± 1/2 inch (12.7mm), circular pattern, pre-loaded large drum micrometer stage coupling with .0001 inch (.003) divisions
 Z travel: 2 inch (50.8mm), Acme drive with 2 inch (50.8mm) diameter drive knob (0.10 inch (2.54mm) per turn)
- Operating orientation:** Any; maximum payload 10lbs (4.54kg) when horizontally mounted
- Temperature**
 Maximum bakeout: 150°C, fully assembled
 Operating: 20°C (ambient)
- Vacuum range:** ≥ 10⁻¹⁰ mbar (UHV)
- Options:** Support tube

XYZ Precision Manipulator

The PMXYZ manipulator provides high precision positioning at a minimum cost. It features precision pre-loaded cross-roller stage control with pre-loaded micrometer-to-stage coupling. The X-Y guide system is made of hardened carbon steel. Support tube option includes a 3/4 inch (19.05) OD tube and end bearing support. This increases rigidity on longer rotary shafts.

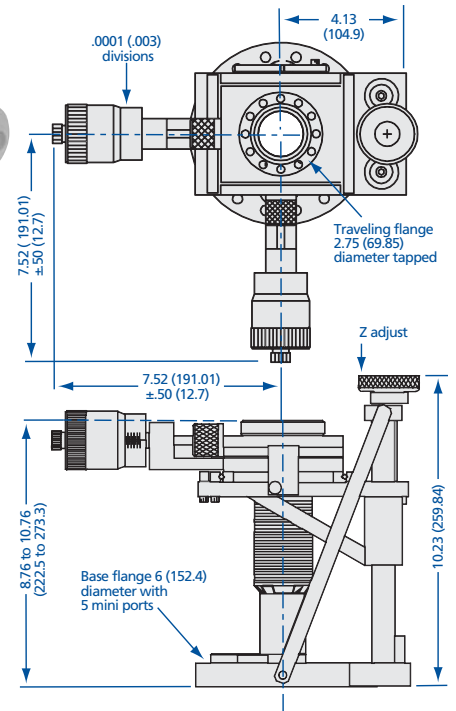
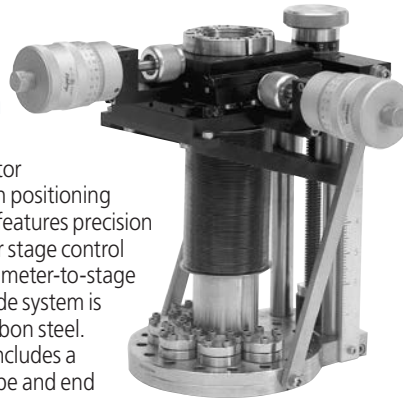

MODEL NUMBER	DESCRIPTION
PMXYZ-600-1.87-2	XYZ manipulator
-ST.25	1/4 inch (6.35) rotary shaft support tube*
-ST.38	3/8 inch (9.53) rotary shaft support tube*

*Note: Add support tube option model number to the manipulator's model number. Example: PMXYZ-600-1.87-2-ST.38

XY Stages with Bellows

XY stages are used to provide precise two-axis sample transfer positioning.

SPECIFICATIONS

- Construction**
 Bellows: Edge welded stainless steel
 Base flange: CF, clearance holes
 Traveling flange: CF, tapped holes
 Way bearings: Precision linear
- Motion**
 XY travel: ± 1/2 to 1 inch (12.7 to 25.4mm), circular pattern, pre-loaded large drum micrometer stage coupling with 0.0001 inch (.003mm) divisions
- Operating orientation:** Any; maximum payload 10 lbs (4.54kg) when horizontally mounted
- Temperature**
 Maximum bakeout: 150°C, fully assembled
 Operating: 20°C (ambient)
- Vacuum range:** ≥ 10⁻¹⁰ mbar (UHV)

MODEL NUMBER	FLANGE TYPE	BELLOWS ID	XY TRAVEL	A	B	C	D	E
PMXY-275-139-1	2 3/4 CF	1.39 (35.31)	± 1/2 (12.07)	7.386 (187.60)	5.000 (127.00)	5.000 (127.00)	4.100 (104.14)	7.386 (187.60)
PMXY-450-200-1	4 1/2 CF	2.00 (50.80)	± 1/2 (12.07)	9.250 (234.95)	7.750 (196.85)	7.750 (196.85)	5.400 (137.16)	9.250 (234.95)
PMXY-450-250-1	4 1/2 CF	2.50 (63.50)	± 1/2 (12.07)	9.250 (234.95)	7.750 (196.85)	7.750 (196.85)	5.400 (137.16)	9.250 (234.95)
PMXY-450-250-2	4 1/2 CF	2.50 (63.50)	± 1 (25.40)	9.250 (234.95)	7.750 (196.85)	7.750 (196.85)	5.400 (137.16)	9.250 (234.95)
PMXY-600-300-1	6 CF	3.00 (76.20)	± 1/2 (12.07)	11.960 (303.78)	9.875 (250.83)	9.312 (236.52)	6.530 (165.86)	11.087 (281.61)
PMXY-600-300-2	6 CF	3.00 (76.20)	± 1 (25.40)	11.960 (303.78)	9.875 (250.83)	9.312 (236.52)	6.530 (165.86)	11.087 (281.61)
PMXY-600-400-1	6 CF	4.00 (101.60)	± 1/2 (12.07)	11.960 (303.78)	9.875 (250.83)	9.312 (236.52)	6.530 (165.85)	11.087 (281.61)
PMXY-600-400-2	6 CF	4.00 (101.60)	± 1 (25.40)	11.960 (303.78)	9.875 (250.83)	9.312 (236.52)	6.530 (165.86)	11.087 (281.61)

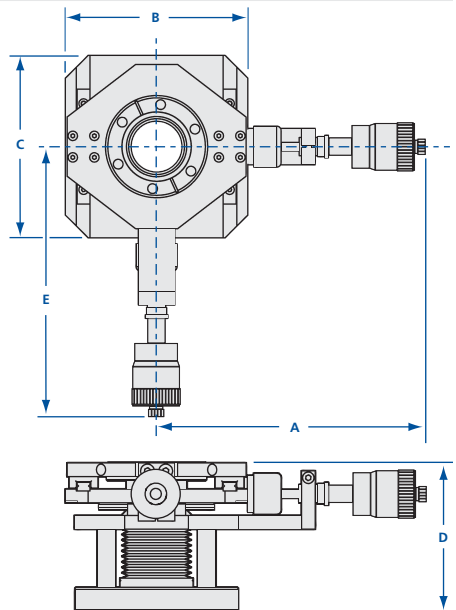

All dimensions are in inches (mm) & weights are in pounds (kg), unless otherwise noted.

Sample Transfer & Manipulation

Manipulators, Stages & Translators



Z-Translators

Nor-Cal Products Z Translators feature a compact, yet stable, linear motion design suitable for a variety of applications including use with our differentially pumped rotary seals. Z Translators may also be used with feedthrough utility hats and rotary motion feedthroughs.

MODEL NUMBER	DIAGRAM	TRAVELING FLANGE	BELLOWS ID	Z STROKE	BASE FLANGE	A	B	C	MIN.-MAX. D & E
MZ-275-153-2	A	2 ³ / ₄ (70)	1.53 (38.86)	2	2 ³ / ₄ (69.85)	3.060 (77.72)	6.94 (176.28)	1.750 (44.45)	Call
MZ-275-153-4	A	2 ³ / ₄ (70)	1.53 (38.86)	4	2 ³ / ₄ (69.85)	3.060 (77.72)	6.94 (176.28)	1.750 (44.45)	Call
MZ-275-153-6	A	2 ³ / ₄ (70)	1.53 (38.86)	6	2 ³ / ₄ (69.85)	3.060 (77.72)	6.94 (176.28)	1.750 (44.45)	Call
MZ-450-188-2	A	2 ³ / ₄ (70)	1.88 (47.75)	2	4 ¹ / ₂ (114.3)	3.250 (82.55)	6.94 (176.28)	1.750 (44.45)	Call
MZ-450-188-4	A	2 ³ / ₄ (70)	1.88 (47.75)	4	4 ¹ / ₂ (114.3)	3.250 (82.55)	6.94 (176.28)	1.750 (44.45)	Call
MZ-450-188-6	A	2 ³ / ₄ (70)	1.88 (47.75)	6	4 ¹ / ₂ (114.3)	3.250 (82.55)	6.94 (176.28)	1.750 (44.45)	Call
MZ-450-250-2	A	4 ¹ / ₂ (114)	2.50 (63.50)	2	4 ¹ / ₂ (114.3)	3.250 (82.55)	6.94 (176.28)	1.750 (44.45)	Call
MZ-450-250-4	A	4 ¹ / ₂ (114)	2.50 (63.50)	4	4 ¹ / ₂ (114.3)	3.250 (82.55)	6.94 (176.28)	1.750 (44.45)	Call
MZ-450-250-6	A	4 ¹ / ₂ (114)	2.50 (63.50)	6	4 ¹ / ₂ (114.3)	3.250 (82.55)	6.94 (176.28)	1.750 (44.45)	Call
MZ-600-300-2	B	6 (152.40)	3.00 (76.20)	2	6 (152.40)	12.125 (307.98)	-	6.426 (163.22)	Call
MZ-600-300-4	B	6 (152.40)	3.00 (76.20)	4	6 (152.40)	12.125 (307.98)	-	6.426 (163.22)	Call
MZ-600-300-6	B	6 (152.40)	3.00 (76.20)	6	6 (152.40)	12.125 (307.98)	-	6.426 (163.22)	Call
MZ-600-400-2	B	6 (152.40)	4.00 (101.60)	2	6 (152.40)	12.125 (307.98)	-	6.426 (163.22)	Call
MZ-600-400-4	B	6 (152.40)	4.00 (101.60)	4	6 (152.40)	12.125 (307.98)	-	6.426 (163.22)	Call
MZ-600-400-6	B	6 (152.40)	4.00 (101.60)	6	6 (152.40)	12.125 (307.98)	-	6.426 (163.22)	Call

SPECIFICATIONS

Construction
 Bellows: 1.04 to 4 inch (26.42 to 101.6mm) ID edge welded stainless steel
 Base flange: 2³/₄ to 6 inch (70 to 152.4mm) CF, clearance holes
 Traveling flange: 2³/₄ to 6 inch (70 to 152.4mm) CF, tapped holes
 Guide rods: Dual 3⁴/₁₆ inch (19.05mm) OD hardened stainless steel
 Stage: Aluminum

Motion: 2 to 6 inches (50.8 to 152.4mm) Z travel, Acme drive with position indicator scale

Operating orientation: Any

Temperature
 Maximum bakeout: 150°C, fully assembled
 Operating: 20°C (ambient)

Vacuum range: ≥ 10⁻¹⁰ mbar (UHV)

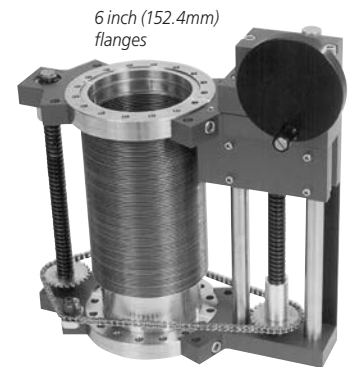
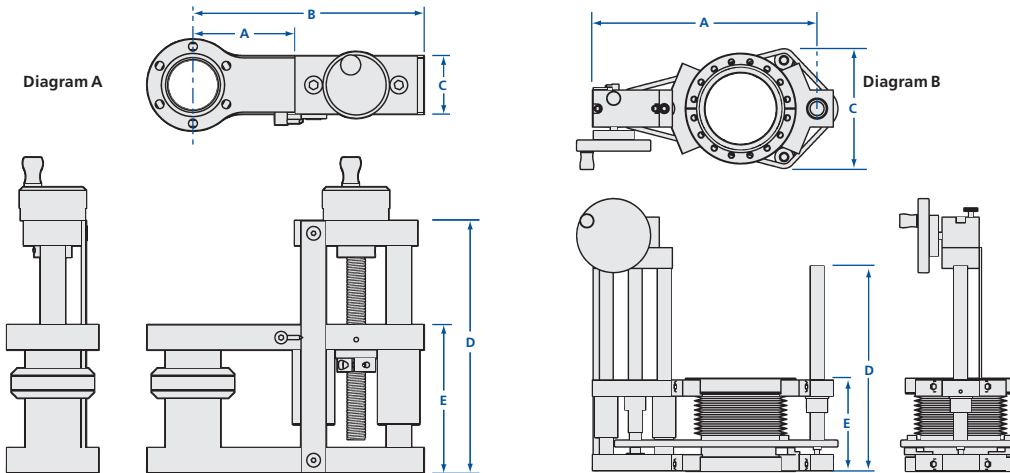

Linear Motion Thimbles

The compact design and reliable operation of these linear motion thimbles allows precision linear probe positioning to distances up to 2 inches (50.8mm). Features include a clear bore design with a stainless steel welded bellows. The anodized aluminum collar is threaded to perform linear movement.

MODEL NUMBER	NOMINAL OD A	MINIMUM - MAXIMUM B	ID
LMT-133	1 ³ / ₄ (44.45)	1.800 - 2.800 (45.72 - 71.12)	0.54 (13.72)
LMT-275	3 ¹ / ₄ (82.55)	3.060 - 5.060 (77.72 - 128.52)	1.43 (36.32)

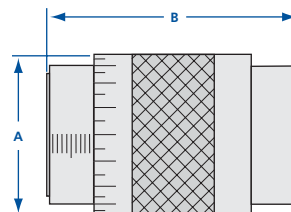

SPECIFICATIONS

Construction
 Bellows: 0.54 or 1.43 inch (13.72 or 36.32mm) ID stainless steel
 Flanges: 1¹/₃ or 2³/₄ inch (34 or 70mm) CF, tapped holes
 Collar: Anodized aluminum

Motion: Up to 2 inches (50.8mm) linear movement, 360° graduations laser engraved on the collar

Temperature range: -20°C to 350°C

Vacuum range: ≥ 10⁻¹⁰ mbar (UHV)



Sample Transfer & Manipulation

Utility Hat & Alignment Gimbals

SPECIFICATIONS

- Construction**
 - Material: 304 stainless steel
 - Flanges: CF, tapped and clearance holes see diagram for details
 - Finish: Electropolished
- Operating orientation:** Any
- Temperature range:** -200°C to 450°C
- Vacuum range:** $\geq 10^{-10}$ mbar (UHV)

Utility Hat

Feedthroughs can be mounted to the base flange of the XYZ Manipulator or to a utility hat. A utility hat is the preferred method when X-Y movements of the sample will cause excessive flexing and abrading of utility lines in vacuum. The utility hat can be mounted between the precision rotary feedthrough and the traveling flange on top of the XYZ to provide X-Y movement of utility lines with the sample. Additionally, the utility hat can be used on top of a differentially pumped rotary seal to allow 360° polar rotation of utility lines along with the sample. (See photo next page.) The standard utility hat comes with a 1 $\frac{3}{4}$ inch (44.45mm) tube, two 2 $\frac{3}{4}$ inch (69.85mm) CF flanges and four 1 $\frac{1}{3}$ inch (34mm) CF ports for mounting feedthroughs. Standard finish is electropolish. Custom sizes can be supplied upon request.

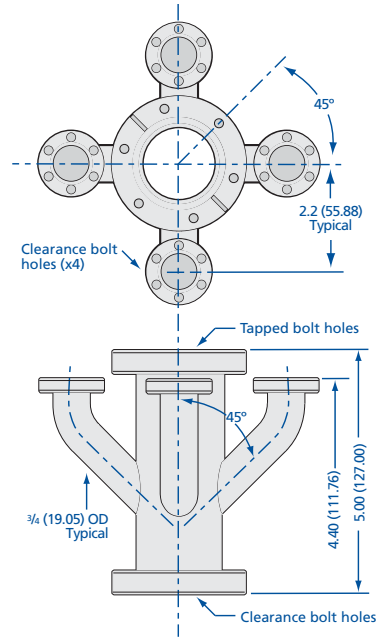

MODEL NUMBER
UH-175-2-133-4

SPECIFICATIONS

- Construction**
 - Bellows: 1 $\frac{1}{2}$ inch (38.1mm) ID stainless steel
 - Flanges: 2 $\frac{3}{4}$ inch (70mm) CF, tapped holes
 - Pivots: Roller bearing
- Motion:** $\pm 5^\circ$ XY adjustment range, knurled knob adjustment
- Operating orientation:** Any
- Temperature**
 - Maximum bakeout: 200°C
 - Operating: 20°C (ambient)
- Vacuum range:** $\geq 10^{-10}$ mbar (UHV)
- Options:** Micrometers "-M1" and "-M2"

Alignment Gimbals

Alignment gimbals allow a precise angle alignment to be established (and repeated) between two flanges. When the base flange of a gimbal is attached to the chamber flange (or traveling stage of a positioning device) and a probe is attached to the tilting flange, probe angle and tip position can be changed. Alignment gimbals were designed as an inexpensive method to align docking systems and actuate sample transfers. Gimbals cantilever the (horizontal) load when the linear feedthrough flange and the load lock are horizontally mounted and can also compensate for droop in long horizontal mounted linear feedthrough probes. Single axis alignment gimbals are also available. Call for pricing and availability.

MODEL NUMBER	DESCRIPTION
AG-275-150	Knurled knob adjustment on both axes
AG-275-150-M1	Micrometer adjustment on one axis, knurled knob on the other axis
AG-275-150-M2	Micrometer adjustment on both axes

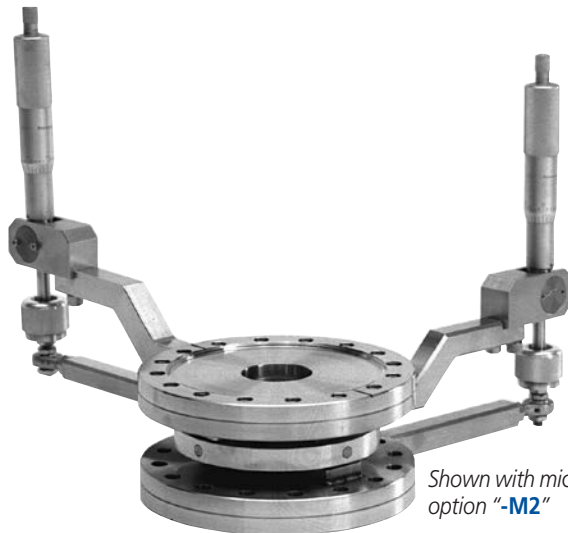

Shown with micrometer option "-M2"

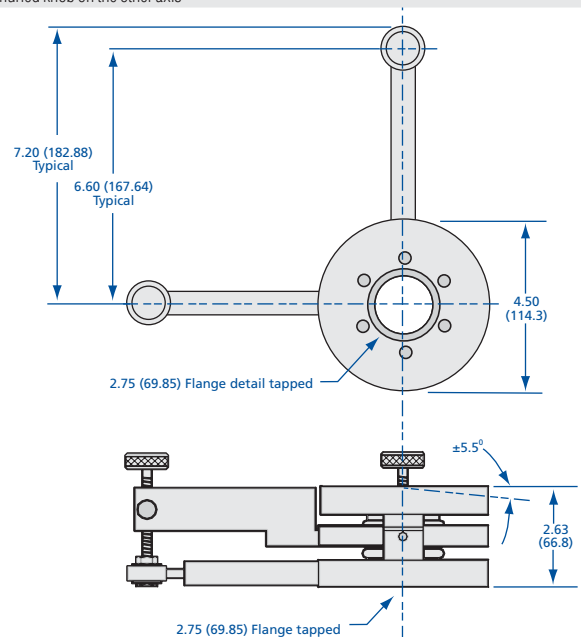

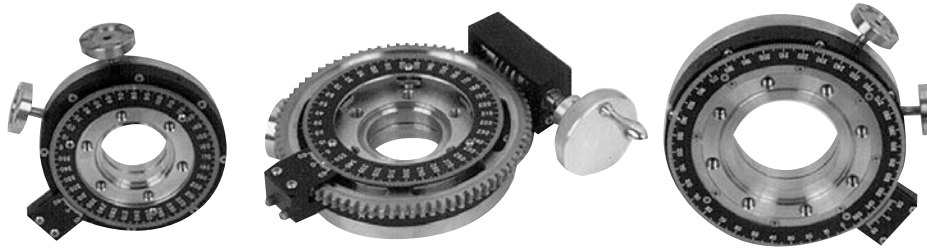
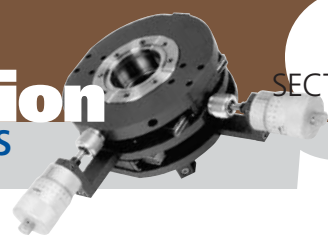

Differentially Pumped Rotary Seals

Differentially pumped rotary seals provide 360° of continuous rotation through the vacuum wall of a UHV system. They have two stages of differential pumping isolated by graphite-impregnated, expanded, PTFE seals on special sealing surfaces. A pre-loaded ball bearing set accurately controls the rotating stage position, allowing the unit to be successfully used with manipulators and other precision positioning devices. For easier and more accurate angle adjustment, a worm drive fine adjust option is available. Rotary seals are also available with an anti-backlash stepping or synchronous motor drive. Sizes up to 4 inch (101.6mm) ID are standard, while larger sizes are available on request.

SPECIFICATIONS

- Construction**
Flanges: CF, tapped holes, one rotational and one stationary
T-wrench included for adjustment
- Motor:** 360° rotation, two stage, differentially pumped with 360° vernier scale
- Operating orientation:** Any
- Temperature**
Maximum bakeout: 150°C
Operating: 20°C (ambient)
- Vacuum range:** $\geq 10^{-11}$ mbar (UHV)
- Readability:** Standard scale 1.0°, mechanical counter 0.1°, micro stepped motor drive required for maximum resolution
- Options:** Fine adjust worm drive "-W"; digital counters, stepper motors and other sizes available

MODEL NUMBER	ID	NOMINAL OD	A	B	C	D	E	F	G	H	VERTICAL PAYLOAD*	HORIZONTAL PAYLOAD*
RS-150	1.53 (38.86)	2 ³ / ₄ (69.85)	4.50 (114.30)	2.99 (75.95)	1.00 (25.40)	3.18 (80.77)	2.75 (69.85)	0.49 (12.45)	0.13 (3.30)	60°	54 (24.3)	30 (13.5)
RS-150-W	1.53 (38.86)	2 ³ / ₄ (69.85)	5.13 (130.30)	3.38 (85.85)	1.00 (25.40)	4.95 (125.73)	2.75 (69.85)	0.49 (12.45)	0.37 (9.40)	60°	54 (24.3)	30 (13.5)
RS-250	2.53 (64.26)	4 ¹ / ₂ (114.3)	5.75 (146.05)	3.64 (92.46)	1.36 (34.54)	3.58 (90.93)	4.50 (114.30)	0.49 (12.45)	0.03 (0.76)	45°	90 (40.5)	38 (17.1)
RS-250-W	2.53 (64.26)	4 ¹ / ₂ (114.30)	6.38 (162.05)	4.20 (106.68)	1.36 (34.54)	6.11 (155.19)	4.50 (114.30)	0.49 (12.45)	0.41 (10.41)	45°	90 (40.5)	38 (17.1)
RS-400	4.03 (102.36)	6 (152.40)	7.75 (196.85)	4.57 (116.08)	1.68 (42.67)	4.34 (110.24)	6.02 (152.91)	0.37 (9.40)	0.06 (1.52)	45°	144 (64.8)	66 (29.7)
RS-400-W	4.03 (102.36)	6 (152.40)	8.50 (215.90)	8.25 (209.55)	1.68 (42.67)	9.28 (235.71)	6.02 (152.91)	0.37 (9.40)	0.54 (13.72)	45°	144 (64.8)	66 (29.7)

*Note: Standard maximum payloads with center of gravity within 10% of the RS ID from the RS centerline when vertical, within one ID of the RS from the RS flange face when horizontal, and certain other size restrictions are met – consult factory.

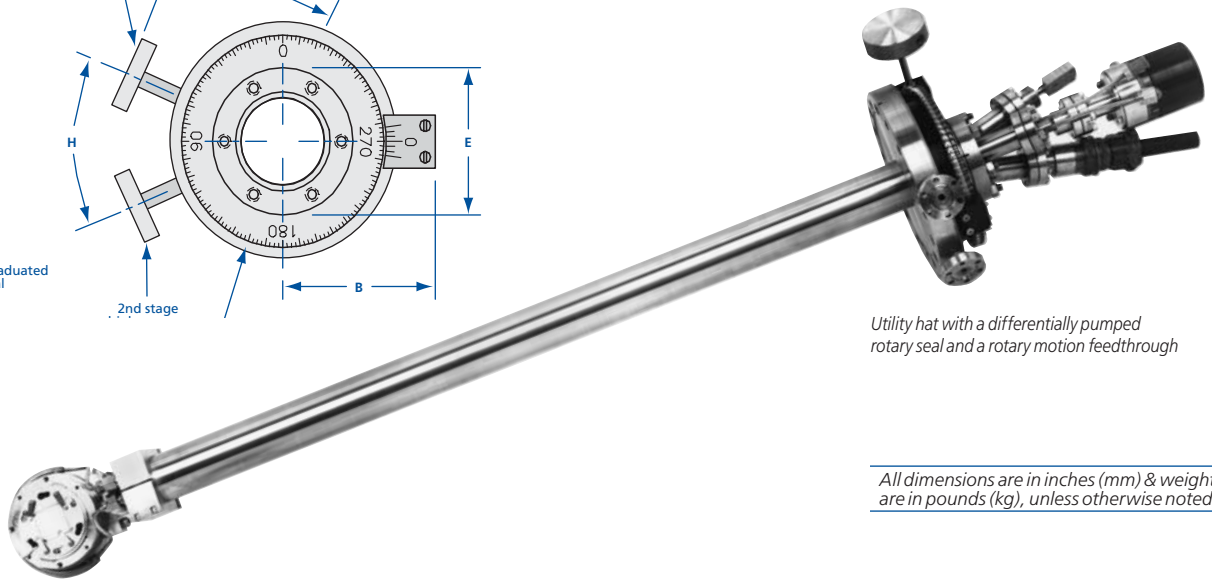
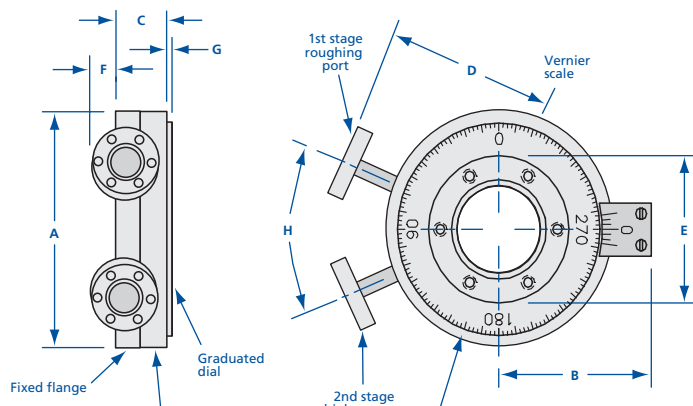

Utility hat with a differentially pumped rotary seal and a rotary motion feedthrough

All dimensions are in inches (mm) & weights are in pounds (kg), unless otherwise noted.

Motorized Rare Earth Magnetic Rotary Motion Feedthrough

The rare earth magnetic series rotary drives are designed to provide exceptional, long life performance. They are UHV compatible and are an excellent option to conventional bellows sealed and other rotary devices. They can be adapted to pulsed laser deposition (PLD) target clogging and continuous rotation of targets and substrates, as well as applications that require small profiles and high performance. There are no sliding seals or magnets in vacuum and stray magnetic fields are virtually nonexistent. The in-vacuum armature is made of paramagnetic materials with stainless steel and silicon nitride bearings and is capable of repeated bake-out to 200°C with magnets removed. Out-of-vacuum bearings are accessible for lubrication and the magnet drive is easily removable.

SPECIFICATIONS

Construction

Mounting flange: 2³/₄ (70mm) CF, clearance holes
 Rotary probe: 3/8 inch (9.53mm)
 Drive: Motor drive with controller, manual drive knob with position lock
 Bearings: 4,000,000 revolutions before service

Motion: 360° continuous with variable speed

Operating orientation: Any

Temperature

Maximum bakeout: 200°C, with drive removed
 Operating: 20°C (ambient)

Vacuum range: ≥ 10⁻¹⁰ mbar (UHV)

Torque

Motor: 50 ounce-inches (.353 Nm)
 Feedthrough: 150 ounce-inches (1.059 Nm)

Speed: 5 to 95 RPM

Options: Higher torque motors, different speed ranges

MODEL NUMBER	FLANGE TYPE	SHAFT OD	SHAFT LENGTH
MRRE-275-038	2.75 CF	0.375 (9.53)	2.75 (69.85)

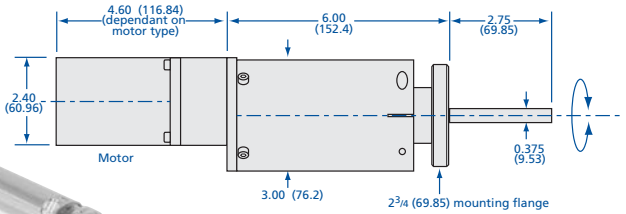

1/4 Inch Precision Rotary Motion Feedthroughs

Precision rotary feedthroughs provide 360° continuous rotation and may be used to define a polar axis for a sample or probe or to actuate a mechanical device, such as a shutter, inside the vacuum chamber. Typically used for polar rotation on top of an XYZ manipulator.

SPECIFICATIONS

Construction

Mounting flange: 1¹/₂ or 2³/₄ (34 or 70mm) CF, clearance holes
 Rotary shaft: 1/4 inch (6.35mm)
 Drive: Manually actuated
 Attachment: 8-32 tapped hole

Motion: 360° continuous, with 360° graduations on knob and locking screw

Operating orientation: Any

Temperature range: -20°C to 150°C

Vacuum range: ≥ 10⁻¹⁰ mbar (UHV)

Torque: 50 ounce-inches (.353 Nm)

Options: Tapped holes, special lengths

MODEL NUMBER	FLANGE TYPE	SHAFT OD	SHAFT LENGTH
PRM-133	1.33 CF	0.25 (6.35)	3.26 (82.80)
PRM-275	2.75 CF	0.25 (6.35)	3.26 (82.80)

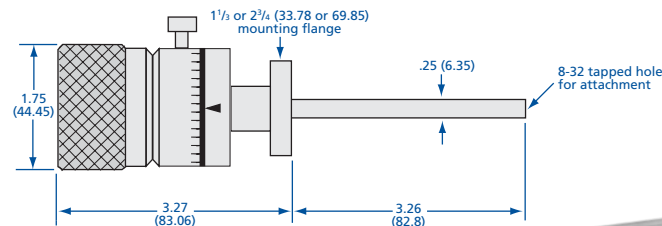

SPECIFICATIONS

Construction

Bellows: Welded stainless steel
 Mounting flange: 2³/₄ (70mm) CF, clearance holes
 Rotary shaft: 3/8 inch (9.53mm)
 Drive: Manually actuated

Motion: 360° continuous, 0.10° resolution (1° graduations on dial), maximum run-out 0.005 inches (.13mm)

Operating orientation: Any

Temperature

Maximum bakeout: 200°C
 Operating: 20°C (ambient)

Vacuum range: ≥ 10⁻¹⁰ mbar (UHV)

Torque: 1,100 ounce-inches (7.768 Nm)

Options: Custom shaft lengths: 9 to 23 inches (228.6 to 584.2mm). Change model number suffix "-24" Additional charges will apply. Example: PRM-275-038-12 (indicates 12 inch (304.8mm) shaft), field-mountable shaft extensions, fine adjust and motor drives

3/8 Inch Precision Rotary Motion Feedthrough

Precision rotary feedthroughs are commonly used to define a polar axis for a sample or probe. They provide 360° continuous rotation and are mounted on top of XYZ manipulators and other stages. They are also used separately where precision angular orientation is needed.

MODEL NUMBER	FLANGE TYPE	SHAFT OD	SHAFT LENGTH
PRM-275-038-24	2.75 CF	3/8 (9.53)	24.00 (609.60)

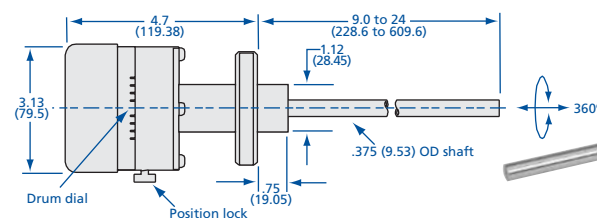



Pneumatically Actuated Linear Motion Feedthrough

Commonly used as positioning devices for shutters and beam stoppers.

MODEL NUMBER	FLANGE TYPE	SHAFT OD	TRAVEL
ALM-133-2	1.33 CF	0.25 (6.35)	2 (50.80)
ALM-133-4	1.33 CF	0.25 (6.35)	4 (101.60)

ACV-24 Solenoid

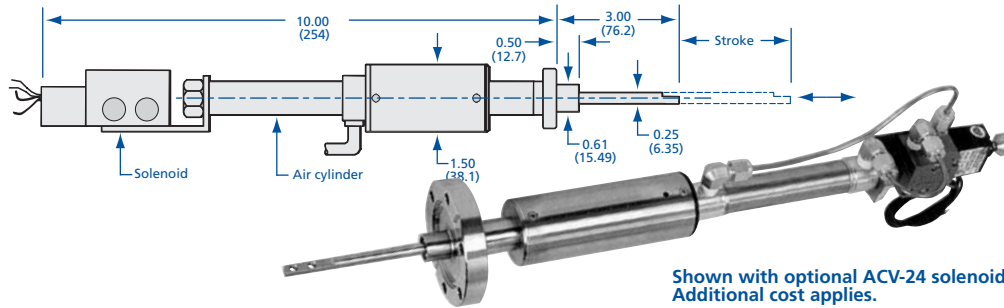

Shown with optional ACV-24 solenoid. Additional cost applies.

SPECIFICATIONS

Construction
 Bellows: Welded stainless steel, sealed
 Mounting flange: 1 1/3 (34mm) CF, clearance holes
 Linear probe: 1/4 inch (6.35mm) OD
 Cylinder: 3/4 inch (19.05mm) ID
 Bushing: Macor

Motion
 Linear: 2 to 4 inch (50.8 to 101.6mm) travel, pneumatically actuated
 Operating air pressure: 50 to 150 psi

Operating orientation: Any

Temperature
 Maximum bakeout: 200°C
 Operating: 20°C (ambient)

Vacuum range: ≥ 10⁻¹⁰ mbar (UHV)

Options: 2 3/4 inch (69.85) OD flange, solenoid 24VDC or per customer requirements

Heavy-Duty Push-Pull Linear Motion Feedthroughs

Manually operated linear motion positioning device designed for UHV applications.

MODEL NUMBER	FLANGE TYPE	TRAVEL	MINIMUM – MAXIMUM A	B
HLM-275-2	2.75 CF	2 (50.80)	1.1 - 3.1 (27.94 - 78.74)	6.75 (171.45)
HLM-275-3	2.75 CF	3 (76.20)	1.4 - 4.4 (35.56 - 111.76)	8.07 (204.98)
HLM-275-4	2.75 CF	4 (101.60)	1.7 - 5.7 (43.18 - 144.78)	9.38 (238.25)

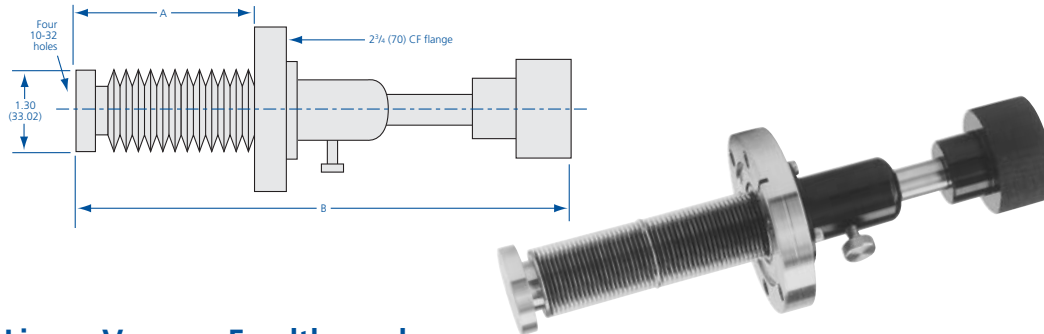

Linear Vacuum Feedthrough

Manually operated linear motion positioning device with rotary actuation.

MODEL NUMBER	FLANGE TYPE	LINEAR TRAVEL	SHAFT OD
RLM-133-2	1.33 CF	2 (50.80)	0.25 (6.35)
RLM-133-4	1.33 CF	4 (101.60)	0.25 (6.35)
RLM-275-2	2.75 CF	2 (50.80)	0.25 (6.35)
RLM-275-4	2.75 CF	4 (101.60)	0.25 (6.35)

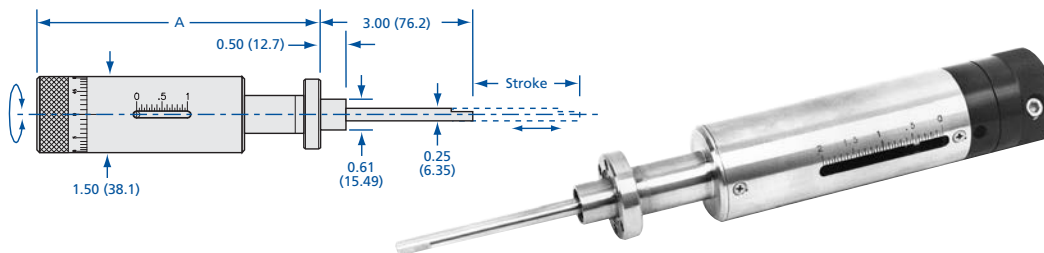

SPECIFICATIONS

Construction
 Bellows: Welded stainless steel, sealed
 Mounting flange: 1 1/3 or 2 3/4 (34 or 70mm) CF, clearance holes
 Linear shaft: 1/4 inch (6.35mm) OD
 Drive: All ball bearing

Motion: 2 or 4 inch (50.8 or 101.6mm) linear travel, 20 turns/inch (25.4) rotary actuation, position indicator

Operating orientation: Any

Temperature
 Maximum bakeout: 200°C
 Operating: 20°C (ambient)

Vacuum range: ≥ 10⁻¹⁰ mbar (UHV)

Options: Longer strokes

All dimensions are in inches (mm) & weights are in pounds (kg), unless otherwise noted.

SPECIFICATIONS

Construction

Mounting flange: 2³/₄ (70mm) CF, clearance holes
 Probe: 1/2 inch (12.7mm) OD stainless steel tubular probe
 Drive: Removable neodymium iron boron magnet
 Bearings: 8 stainless steel

Motion

Linear: 24 and 36 inch (609.6 and 914.4mm), adjustable stops
 Rotary: 360° continuous rotation, with 0° to 360° indication

Operating orientation: Horizontal

Maximum temperature: 200°C with drive removed

Vacuum range: $\geq 10^{-10}$ mbar (UHV)

Linear force: 4 pounds (1.8 kg)

Torque: 150 ounce-inches (1.059 Nm)

Options: Light-touch magnet (-LT)

Magnetic Linear/Rotary Feedthrough

Magnetically coupled feedthroughs offer exceptional linear/rotary motion for short to medium stroke sample introduction and transfer of light loads. The standard magnetic driver package provides more than 150 ounce-inches (1.059 Nm) of torque and four pounds of linear force. The inside traveler has no magnets, but it is made of magnetically permeable material.

LIGHT-TOUCH MAGNET ASSEMBLY OPTION (-LT)

- Utilizes dynamically loaded full-bearing support to increase tactile feedback
- Heavy-duty linear magnet driver increases linear force to 15 pounds (6.75 kg)

MODEL NUMBER	DESCRIPTION
MLR-275-050-24	24 inch (609.6) stroke
MLR-275-050-36	36 inch (914.4) stroke
-LT	Light-touch magnet assembly option (Add -LT to the model number)

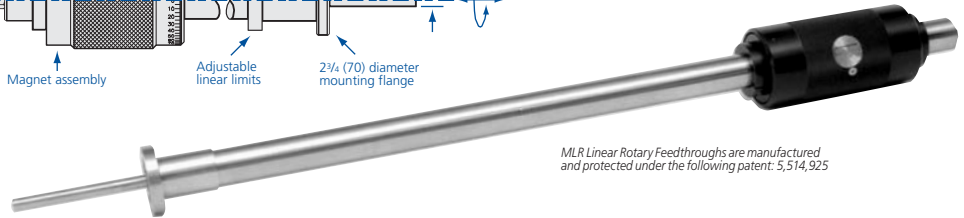
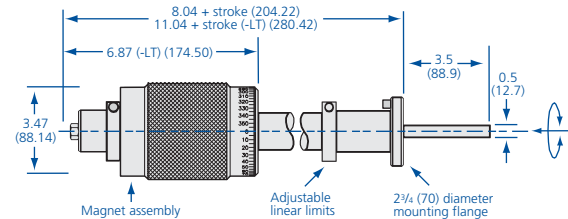

MLR Linear Rotary Feedthroughs are manufactured and protected under the following patent: 5,514,925

SPECIFICATIONS

Construction

Mounting flange: 2³/₄ (70mm) CF, clearance holes
 Linear shaft: 3/4 inch (19.05mm)
 Rotary probe: 1/4 inch (6.35mm)
 Drive: Removable neodymium iron boron magnet
 Bearings: Precision internal guide

Motion

Linear: Up to 48 inch (1219.2mm)
 Rotary: 360° continuous

Operating orientation: Horizontal

Temperature

Maximum bakeout: 200°C, drive removed
 Operating: 20°C (ambient)

Vacuum range: $\geq 10^{-10}$ mbar (UHV)

Linear force: 15 pounds (6.75 kg)

Torque: 150 ounce-inches (1.059 Nm)

Options: Soft-touch magnet (-ST)

Coaxial Magnetic Linear/Rotary Feedthrough

Magnetically-coupled linear/rotary feedthroughs offer unparalleled smooth rotary motion for medium to long stroke sample introduction and transfer of light loads. The coaxial design features a 3/4 inch (19.05mm) linear support tube with rotary bearing in the tip to guide the 1/4 inch (6.35mm) rotary probe. In addition to rotary motion, the design includes a linear driver, for additional axial force and tactile feedback.

SOFT-TOUCH MAGNET ASSEMBLY OPTION (-ST)

- Soft touch magnet assembly utilizes dynamically loaded full-bearing support to increase tactile feedback.

MODEL NUMBER	DESCRIPTION
MLRC-275-36	36 inch (914.4) stroke
MLRC-275-42	42 inch (1066.8) stroke
MLRC-275-48	48 inch (1219.2) stroke
-ST	Soft-touch magnet assembly option (Add -ST to model number)

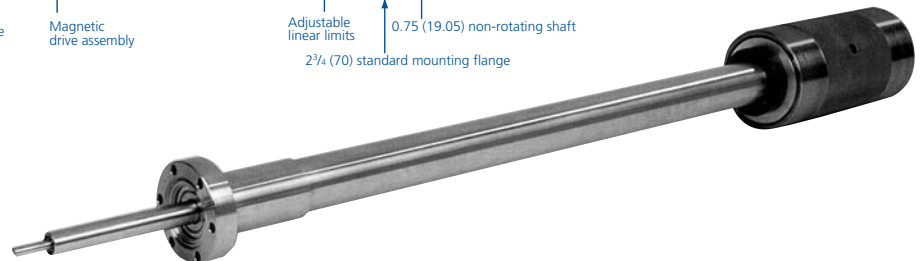
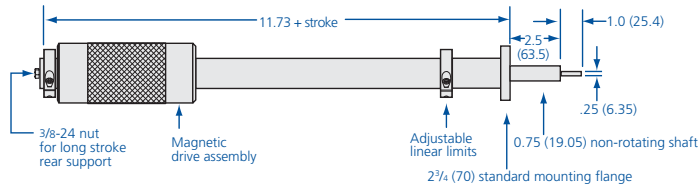

All dimensions are in inches (mm) & weights are in pounds (kg), unless otherwise noted.



Differentially Pumped Linear/Rotary Motion Feedthrough

MODEL NUMBER	SEAL	DESCRIPTION	MAXIMUM A
OLR-275-10	FKM	Manually operated, for medium vacuum applications	15.20 (386.08)

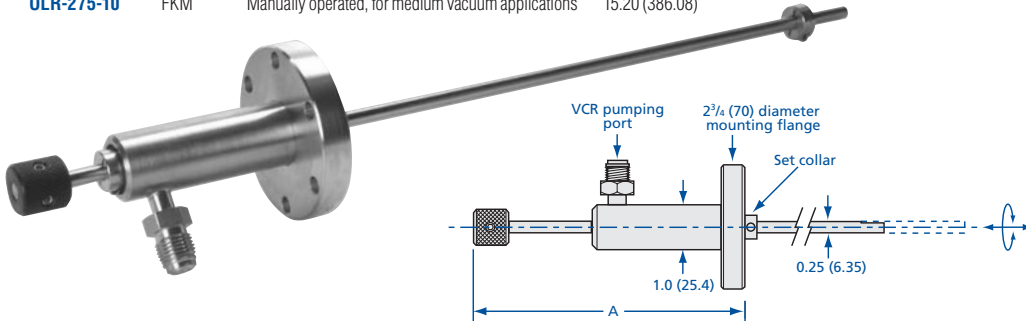

SPECIFICATIONS

Construction
 Feedthrough: stainless steel
 Mounting flange: 2³/₄ (70mm) CF, clearance holes
 Probe: 1/4 inch (6.35mm) OD
 Seal: Differentially pumped FKM O-ring
 Body insert: PTFE

Motion

Linear: 10 inch (254mm), clamp type stop collar
 Other lengths available on request.
 Rotary: 360° continuous rotation

Operating orientation: Any

Temperature range: -20°C to 150°C

Vacuum range: ≥ 10⁻⁵ mbar (Medium vacuum)

Precision Linear/Rotary Motion Feedthrough

MODEL NUMBER	DESCRIPTION	STROKE
PLR-275-050	Stand-alone device or used when coupled with a gearbox to control polar and azimuthal rotation of a sample	1/2 (12.70)

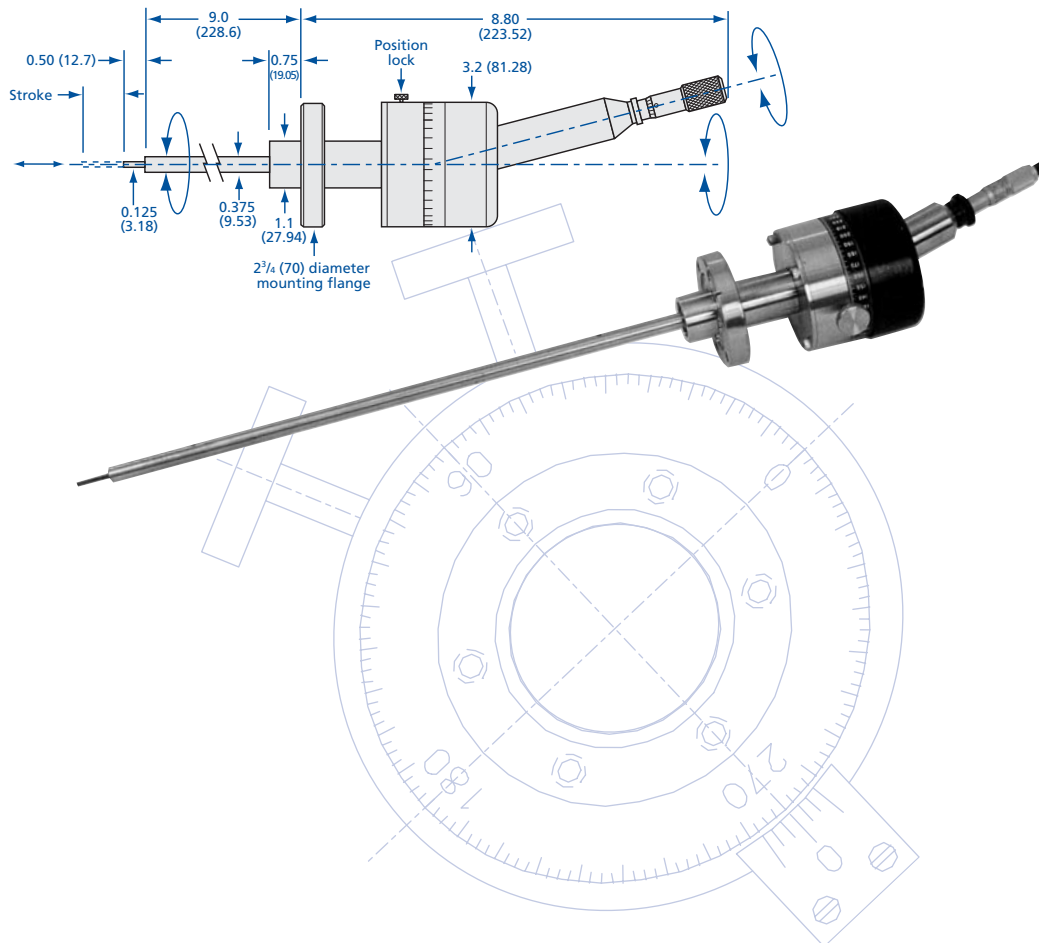

SPECIFICATIONS

Construction
 Mounting flange: 2³/₄ (70mm) CF, clearance holes
 Linear probe: 1/8 inch (3.18mm) OD
 Rotary tube: 3/8 inch (9.53mm) OD, 9 inch (228.6mm) length
 Bearings: Precision internal guide

Motion

Linear: 1/2 inch (12.7mm), micrometer adjusted
 Rotary: 360° continuous, 0.1° resolution in 1.0° graduations with position lock

Operating orientation: Any

Temperature

Maximum bakeout: 200°C
 Operating: 20°C (ambient)

Vacuum range: ≥ 10⁻⁸ mbar (UHV)

All dimensions are in inches (mm) & weights are in pounds (kg), unless otherwise noted.



Sample Transfer & Manipulation

Wobble Sticks

Wobble Sticks

WBL wobble sticks offer a simple means of positioning samples in vacuum by permitting Z-axis and tilt movements. All stainless steel construction designed for use in high vacuum or UHV environments.

SPECIFICATIONS

Construction
 Bellows: Welded stainless steel
 Mounting flange: CF or NW
 Shaft OD: 1/8 or 1/4 inch (3.18 or 6.35mm)
 Drive: Manually actuated

Motion: ±22° or ±30° tilt

Operating orientation: Any

Temperature range
 Metal seal: 450°C
 Elastomer seal: 200°C

Vacuum range
 Metal seal: ≥ 10⁻¹⁰mbar (UHV)
 Elastomer seal: ≥ 10⁻⁸mbar (High Vacuum)

MODEL NUMBER	FLANGE TYPE	FLEX ANGLE*	A	B	MIN. - MAX. C
WBL-133	1.33 CF	±22°	6 (152.40)	0.12 (3.05)	3 - 3 1/2 (76.20 - 88.90)
WBL-275	2.75 CF	±30°	10 (254.00)	0.25 (6.35)	3 3/4 - 6 (95.25 - 152.40)
WBL-NW-16	NW-16	±22°	6 (152.40)	0.12 (3.05)	3 - 3 1/2 (76.20 - 88.90)
WBL-NW-40	NW-40	±30°	10 (254.00)	0.25 (6.35)	3 3/4 - 6 (95.25 - 152.40)

* Mating flange may restrict flexible angle

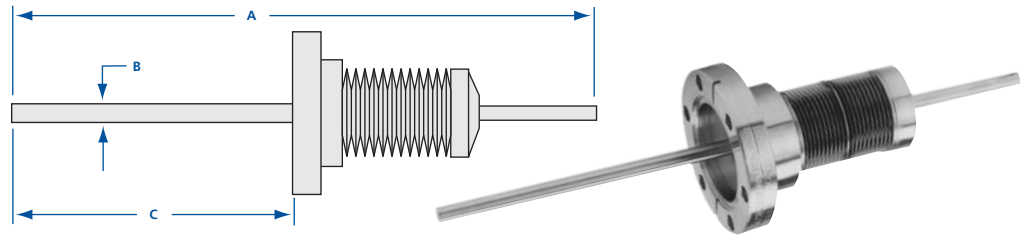

Rotary Wobble Sticks

RWS wobble sticks provide Z-axis, polar rotation, and polar axis tilt to allow tip positioning inside a vacuum chamber. They offer an inexpensive alternative for sample introduction and manipulation.

SPECIFICATIONS

Construction
 Bellows: Welded stainless steel, independent for Z and theta
 Mounting flange: 2 3/4 (70mm) CF, clearance holes
 Tip: Pre-fitted with hook
 Drive: Manually actuated

Motion
 Rotary: 360° probe rotation via rotary motion feedthrough
 Linear: 4 or 8 inch (101.6 or 203.2mm) stroke
 Tilt: ±22°

Operating orientation: Any

Temperature
 Maximum bakeout: 200°C
 Operating: 20°C (ambient)

Vacuum range: ≥ 10⁻¹⁰mbar (UHV)

Options: Single-jaw pincer (add "-PS" to model number), double-jaw and other pincers upon request

MODEL NUMBER	FLANGE TYPE	FLEX ANGLE*	Z STROKE
RWS-275-4	2.75 CF	±22°	4 (101.60)
RWS-275-8	2.75 CF	±22°	8 (203.20)

-PS Single Jaw Pincer Option Add **-PS** to model number

* Mating flange may restrict flexible angle

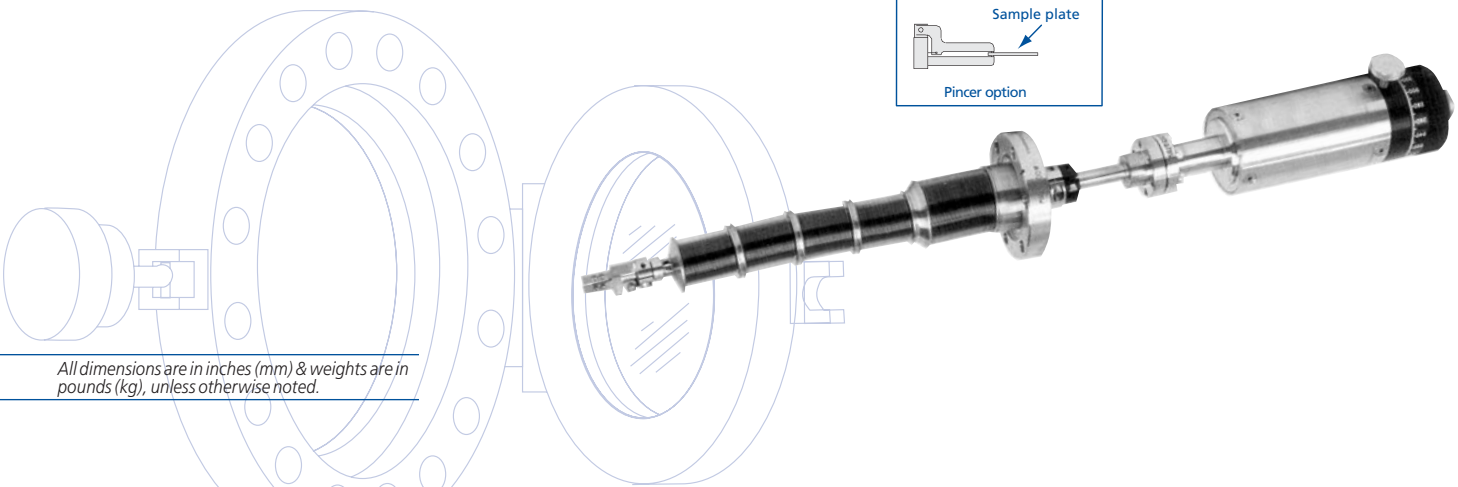
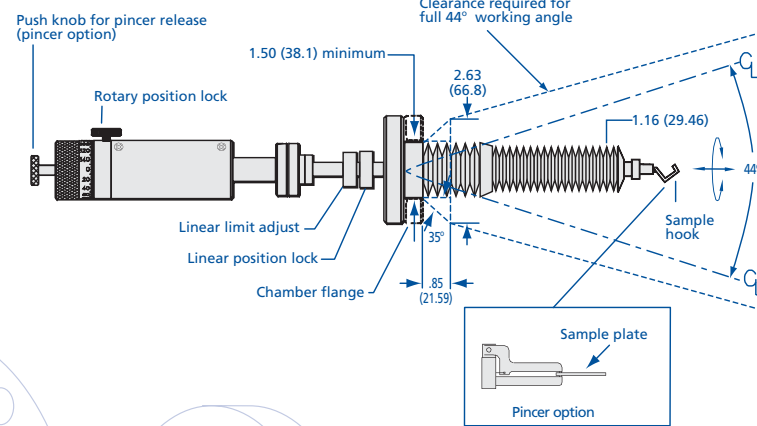

All dimensions are in inches (mm) & weights are in pounds (kg), unless otherwise noted.

Order Information

Regional Sales Contacts

Nor-Cal Products



by PFEIFFER VACUUM

Manufacturing & Corporate Global Headquarters

1967 South Oregon Street, Yreka, CA 96097

Phone: 530-842-4457 | Toll Free: 800-824-4166 | Fax: 530-842-9189

Silicon Valley Sales & Applications Office

3375 Scott Blvd., Suite 100, Santa Clara, CA 95054

Phone: 408-980-8992 | Fax: 408-980-8947 | E-mail: ncsales@n-c.com

DIRECT SALES:

www.n-c.com | 1-800-824-4166 | ncsales@n-c.com

Locate your
sales representative
at
www.n-c.com/sales
or call
800-824-4166
for assistance

Send drawings
and quote
requests to
ncsales@n-c.com

Follow us on
LinkedIn

Sylvie Bouhier

*European
Regional Sales Manager*

Ph: +44 (0)799 057 1405
sbouhier@nor-cal.eu

Nor-Cal Products, Europe

Suite D, Dittons Engineering Park
Dittons Road, Polegate BN26 6HY
United Kingdom

Ph: +44 (0)1323 810 854

www.nor-cal.eu

Lena Tan

*Asia-Pacific
Regional Sales Manager*

Ph: +65 6634-1228
sales@n-c.asia

Nor-Cal Products, Asia Pacific

2 Ang Mo Kio Street 64 #01-03A
ECON Industrial Building
Singapore 569084

MAILING ADDRESS:

Nor-Cal Products, Asia Pacific

Serangoon Garden
P. O. Box 428
Singapore 915531

IT Jang

*South Korea
Regional Sales Manager*

Ph: +82-10-7554-0117
itjang@n-c.com

Nor-Cal Products, South Korea

Gadong 2nd Floor, 531-8 Gajang-ro,
Osan-si, Gyeonggi-do,
South Korea, 18103
Republic of Korea

Ph: +82-31-8003-1341

Fax: +82-31-8003-1342

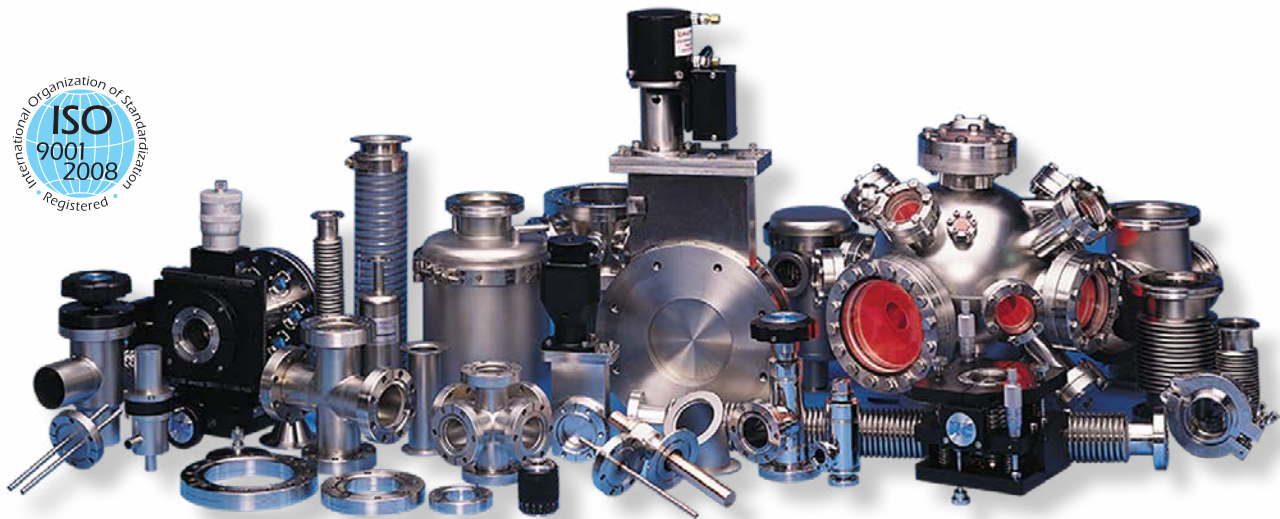

Terms & Conditions of Sale

Payment terms are net 30 days from the date of the invoice once credit has been approved. Otherwise, C.O.D. Most major credit cards are accepted.

If payment in full is not received within 30 days, a 1.5% per month late charge may be added to the unpaid balance. Discounts may be revoked if an account is not paid within these terms.

MINIMUM ORDERS: The minimum domestic order is \$40. The minimum international order is \$100.00.

QUANTITY PRICING:

Quantity pricing is valid on single shipments only.

AVAILABILITY: Our inventory is updated automatically, but there is always a possibility that an item may be unavailable or sold-out. If this occurs, customers are notified as soon as possible and alternative options are offered if available.

PACKAGING: The factory will determine the most cost effective method to package items for shipment. A \$5.00 USD per cardboard box charge will be applied to all orders with a maximum charge of \$25.00 USD per shipment. Large products requiring a wooden crate will be charged an amount consistent with the fabrication of the necessary crate.

FOB POINT: All orders ship FOB Yreka from 1967 S. Oregon, Yreka, California, 96097, USA unless quoted otherwise.

LOST OR DAMAGED ITEMS: Nor-Cal does not assume responsibility for items lost or damaged in transit, or for any direct or indirect damages incurred. Shipping damages are to be handled by the customer. Nor-Cal will provide the tracking number and contact information for the shipping company as needed. All items are purchased at the customer's risk.

EXPORTED COMMODITIES: US Export administration Regulations must be followed. Diversion contrary to US Law is prohibited.

Pricing & Dimensions

In order to meet the changing needs of our customers we periodically make design revisions in our standard product line. As a result, the dimensions, pricing and specifications are subject to change without notice. International pricing may also vary.

SPECIAL TOOLING: Products ordered to non-standard specifications should state specification requirements in detail. Fee for special tooling may apply. On request, test report(s) and/or certification(s) can be supplied at additional cost.

Discounts

OEM and quantity discounts are available to qualified customers.

Return Policy

An RMA (Return Materials Authorization) number must be obtained from Nor-Cal Products before returning any merchandise. The RMA form can be found under SUPPORT in the footer of pages at www.n-c.com. To expedite the assignment of an RMA number, complete the form online and submit online. You may also print and email the completed form to rma@n-c.com or fax to the attention of the RMA Coordinator at 866-640-9012.

- Nor-Cal Products reserves the right to refuse the return of non-stocked items. A twenty-five (25) percent restocking fee may be charged.
- Nor-Cal Products shall incur no liability for damage, shortages or other cause alleged to have occurred at, or prior to, delivery to the carrier unless buyer shall have entered full details thereof on its receipt to the carrier. Products over 60 days old from the date of shipment will not be accepted for return.
- Nor-Cal Products must be allowed time to investigate all returns.

Cancellations & Rescheduling

Any request by customers to reschedule or cancel in total or part of any purchase order must be approved at the sole discretion of Nor-Cal Products and shall be subject to the following conditions. Nor-Cal must receive written notice of Request for Cancellation or Reschedule, stating the reasons therefore.

Customer shall be liable for payment of the following charges to Nor-Cal in the event of Cancellation or Reschedule.

- For all charges incurred (including overhead, G&A, and profit) prior to the date that notice of cancellation is received by Nor-Cal for all parts peculiar to customer's requirements. Upon payment by the customer of these charges, such parts become the property of customer, Nor-Cal will store said parts for a reasonable period of time pending the receipt of customer's instructions for disposition. Such storage is at customer's risk and may be subject to storage charges if stored by Nor-Cal for longer than 30 days from the cancellation date; plus
- Charges to convert modified standard parts for return to Nor-Cal's inventory; plus
- A restocking charge of twenty (25) percent of the purchase price of the cancelled item.

Warranty Products manufactured by Nor-Cal Products are warranted against defects in material and workmanship for a period of twelve (12) months from the date of shipment from Nor-Cal Products to the buyer. Any modification to the product by the buyer or their agent voids this warranty. Liability under this warranty is expressly limited to the replacement or repair (at Nor-Cal Products' option) of defective parts. Nor-Cal Products may at any time discharge its warranty as to any of its products by refunding the purchase price and taking back the products. This warranty applies only to parts manufactured and labor provided by Nor-Cal Products under valid warranty claims received by Nor-Cal Products within the applicable warranty period and shall be subject to the terms and conditions hereof.

- Expendable items such as tubes, heaters, sources, bellows, etc., by their nature, may not function for one year; if such items fail to give reasonable service for a reasonable period of time, as determined solely by Nor-Cal Products, they will be repaired or replaced by Nor-Cal Products at its election.
- All warranty replacement or repair of parts shall be limited to equipment malfunctions which, in the sole opinion of Nor-Cal Products, are due or traceable to defects in original materials or workmanship. Malfunctions caused by abuse or neglect of the equipment are expressly not covered by this warranty. Nor-Cal Products expressly disclaims responsibility for any loss or damage caused by the use of its products other than in accordance with proper operating and safety procedures. Reasonable care must be taken by the user to avoid hazards.
- The buyer shall give Nor-Cal Products prompt notice of any claim under this warranty. If Nor-Cal Products, in its sole discretion, determines that the product does not conform to this warranty, Nor-Cal Products shall replace or repair the product free of charge. If such replacement or repair is not feasible, Nor-Cal Products may, at its sole option, refund the purchase price.
- In-warranty repaired or replacement parts are warranted only for the remaining unexpired portion of the original warranty period applicable to the parts which have been repaired or replaced.
- After the expiration of the applicable warranty period, the buyer shall be charged at Nor-Cal Products' then current prices for parts and labor plus transportation.
- Except as stated herein, Nor-Cal Products makes no warranty, expressed or implied (either in fact or operation of law), statutory or otherwise: and, except as stated herein, Nor-Cal Products shall have no liability for special or consequential damages of any kind or from any cause arising out of the sale, installation, or use of any of its products. Statements made by any person, including representatives of Nor-Cal Products, which are inconsistent or in conflict with the terms of this warranty shall not be binding upon Nor-Cal unless reduced to writing and approved by an officer of Nor-Cal Products.
- This warranty shall not extend to any product, that in Nor-Cal Products' judgment, has been affected by damage or wear resulting from operations performed after the sale, or misuse, abrasion, negligence, accident, tampering, faulty installation, inadequate maintenance, damage or casualty.

DISCLAIMER OF WARRANTY: NOR-CAL MAKES NO WARRANTIES WITH RESPECT TO THIS SALE, WHETHER EXPRESSED OR IMPLIED, EXCEPT AS STATED HEREIN, NOR-CAL PRODUCTS MAKES NO WARRANTY OF MERCHANTABILITY OR FITNESS FOR A PARTICULAR PURPOSE.

LIMITATION OF REMEDY AND DAMAGES: THE EXCLUSIVE REMEDY OF THE BUYER WITH RESPECT TO THE TRANSACTIONS CONTEMPLATED HEREIN SHALL BE THE REPLACEMENT OR REPAIR OF SAID PRODUCTS, OR THE RETURN OF THE PURCHASE PRICE, AS SET FORTH UNDER "WARRANTY".

EXCEPT AS HEREIN PROVIDED, EVERY FORM OF LIABILITY FOR DIRECT OR CONSEQUENTIAL DAMAGE FOR LOSS, ARISING FROM CONTRACT, TORT OR OTHERWISE, IS EXPRESSLY EXCLUDED AND DENIED, INCLUDING WITHOUT LIMITATION, LOSS OR DAMAGES TO BUILDINGS, CONTENTS, PRODUCTS OR PERSONS.

Order Information

Patents & Trademarks

Nor-Cal Products, Inc. patents and trademarks:

Genesis Modular Valves are manufactured under patent number 6289932
Intellisys Pressure Control Products are manufactured under patent number 6612331
Genesis is a trademark of Nor-Cal Products, Inc.
Intellisys is a registered trademark of Nor-Cal Products, Inc.

Other registered patents and trademarks:

Magnetic Linear/Rotary Feedthroughs are manufactured under patent number 5514925
Sample Transfer Systems are manufactured under patent number 5705128
Alumel is a registered trademark of Concept Alloys, Inc.
Cajon is a registered trademark of Swagelok Company
Chemraz is a registered trademark of Greene Tweed Company
Chromel is a registered trademark of Concept Alloys, Inc.
ConFlat is a registered trademark of Varian Associates Corp.
DeviceNet is a trademark of the Open DeviceNet Vendor Association (ODVA)
Dupra is a registered trademark of Daikin Industries, Ltd.
Ethernet is a trademark of Xerox Corporation
EVAC-CeFix is a registered trademark of EVAC AG
Inconel is a registered trademark of Special Metals Corp.
KF is a registered trademark of Leybold Vacuum Products Inc.
Kalrez is a registered trademark of DuPont Dow Elastomers
Kovar is a registered trademark of CRS Holdings Inc.
Macor is a registered trademark of Corning, Inc.
Microdot is a registered trademark of Tyco Electronics Corp.
Modbus is a registered trademark of Schneider Electric USA Inc.
Omicron is a registered trademark of Omicron Electric GmbH
Pendurroll is a patented technology of V-Tex Corporation
Perlast is a registered trademark of Precision Polymer Engineering LTD.
SolidWorks is a registered trademark of Dassault Systèmes SolidWorks Corp.
Swagelok is a registered trademark of Swagelok Company
UL is a registered trademark of Underwriters Laboratories, Inc.
VCR is a registered trademark of Swagelok Company
Windows is a registered trademark of Microsoft Corporation

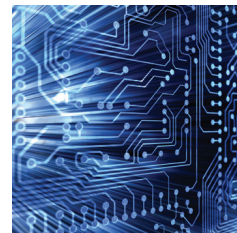
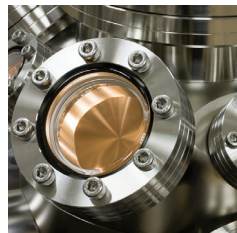
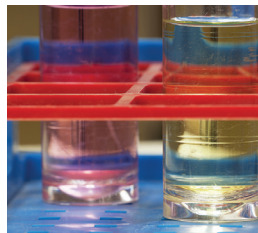

Nor-Cal Products



by PFEIFFER VACUUM

Nor-Cal Products, Inc.
1967 South Oregon Street
Yreka, California 96097
800-824-4166 or 530-842-4457
Fax: 530-841-9189
www.n-c.com