

Agilent TPS-compact

User Manual



Notices

Manual Part Number

87-901-010-01
Edition L.00, April 2022

Copyright

© Agilent Technologies, Inc. 2022

No part of this manual may be reproduced in any form or by any means (including electronic storage and retrieval or translation into a foreign language) without prior agreement and written consent from Agilent Technologies, Inc. as governed by United States and international copyright laws.

Agilent Technologies Italia S.p.A.
Vacuum Products Division
Via F.lli Varian, 54
10040 Leini (TO)
ITALY

www.agilent.com

Instrument Manufacturing

Manufactured by Agilent Technologies Italia S.p.A., Vacuum Products Division
Via F.lli Varian, 54, 10040 Leini (TO),
ITALY

Printed in Italy

Operating Temperature

Operating Temperature: + 5 °C to + 35 °C
Storage Temperature: - 20 °C to + 60 °C

Warranty

The material contained in this document is provided "as is," and is subject to being changed, without notice, in future editions. Further, to the maximum extent permitted by applicable law, Agilent disclaims all warranties, either express or implied, with regard to this manual and any information contained herein, including but not limited to the implied warranties of merchantability and fitness for a particular purpose. Agilent shall not be liable for errors or for incidental or consequential damages in connection with the furnishing, use, or performance of this document or of any information contained herein. Should Agilent and the user have a separate written agreement with warranty terms covering the material in this document that conflict with these terms, the warranty terms in the separate agreement shall control.

Technology Licenses

The hardware and/or software described in this document are furnished under a license and may be used or copied only in accordance with the terms of such license.

Restricted Rights Legend

U.S. Government Restricted Rights. Software and technical data rights granted to the federal government include only those rights customarily provided to end user customers. Agilent provides this customary commercial license in Software and technical data pursuant to FAR 12.211 (Technical Data) and 12.212 (Computer Software) and, for the Department of Defense, DFARS 252.227-7015 (Technical Data - Commercial Items) and DFARS 227.7202-3 (Rights in Commercial Computer Software or Computer Software Documentation).

Safety Notices

CAUTION

A **CAUTION** notice denotes a hazard. It calls attention to an operating procedure, practice, or the like that, if not correctly performed or adhered to, could result in damage to the product or loss of important data. Do not proceed beyond a **CAUTION** notice until the indicated conditions are fully understood and met.

WARNING

A **WARNING** notice denotes a hazard. It calls attention to an operating procedure, practice, or the like that, if not correctly performed or adhered to, could result in personal injury or death. Do not proceed beyond a **WARNING** notice until the indicated conditions are fully understood and met.

Contents

1 Istruzioni per l'uso	13
Informazioni su questo manuale	14
Validità	14
Definizioni e terminologia	15
Definizione di Attenzione, Avvertenza e Nota	15
Simboli di avvertenza	16
Sicurezza	18
Uso corretto	18
Uso improprio	19
Attrezzatura di protezione	20
Linee guida di sicurezza per pompe turbomolecolari	21
Trasporto & Immagazzinamento	22
Descrizione del prodotto	23
Installazione	24
Preparazione per l'installazione	24
Set-up	25
Fissaggio del TPS-compact	26
Collegamento della flangia per alto vuoto	28
Installazione della flangia ISO-K	29
Installazione della flangia ConFlat	30
Avvio e funzionamento del TPS-compact	31
Soft Start	32
Arresto del TPS-compact	33
Arresto di emergenza	33

Contents

Manutenzione	34
Vita del rotore	34
Pulizia	34
Smaltimento	35
Servizio Post Vendita	36
2 Betriebsanleitung	37
Informationen über diese Betriebsanleitung	38
Gültigkeit	38
Definitionen und Terminologie	39
Definition von Vorsicht, Warnung und Hinweis	39
Warnsymbole	40
Sicherheit	42
Sachgemäße Verwendung	42
Unsachgemäße Anwendung	43
Schutzausrüstung	44
Sicherheitsrichtlinie für Turbomolekularpumpen	45
Transport und Lagerung	46
Produktbeschreibung	47
Installation	48
Vorbereitung zum Einbau	48
Einrichten	49
Montage von TPS-compact	50
Anschluss des Hochvakuumflansches	52
Installation des ISO-K-Flansches	53
Installation des ConFlat-Flansches	54
Inbetriebnahme und Betrieb des TPS-compact	55

Contents

Sanftanlauf	56
Stoppen von Modell TPS-compact	57
Not-Aus	57
Wartung	58
Rotordauer	58
Reinigung	58
Entsorgung	59
Service	60
3 Mode d'emploi	61
À propos de ce manuel	62
Validité	62
Définitions et terminologie	63
Signification des messages d'attention, d'avertissement et des notes	63
Symboles d'avertissement	64
Sécurité	66
Utilisation appropriée	66
Utilisation inappropriée	67
Équipements de protection individuelle	68
Consignes de sécurité pour les pompes turbomoléculaires	69
Transport et entreposage	70
Description du produit	71
Installation	72
Préparation pour l'installation	72
Configuration	73
Montage du TPS-compact	74
Raccordement de la bride à vide élevé	76

Contents

Installation de la bride ISO-K	77
Installation de la bride ConFlat	78
Démarrage et utilisation du TPS-compact	79
Démarrage progressif	80
Arrêt du TPS-compact	81
Arrêt d'urgence	81
Entretien	82
Durée de vie du rotor	82
Nettoyage	82
Élimination	83
Service	84
4 Instrucciones de uso	85
Acerca del manual	86
Validez	86
Definiciones y terminología	87
Definición de Precaución, Advertencia y Nota	87
Símbolos de advertencia	88
Seguridad	90
Uso correcto	90
Uso incorrecto	91
Equipo de protección	92
Pautas de seguridad para bombas turbomoleculares	93
Transporte y almacenamiento	94
Descripción del producto	95
Instalación	96
Preparación para instalación	96

Contents

Puesta en marcha	97
Montaje de TPS-compact	98
Conexión de la brida de alto vaciado	100
Instalación de la brida ISO-K	101
Instalación de la brida ConFlat	102
Puesta en marcha y funcionamiento de TPS-compact	103
Arranque suave	104
Parada del TPS-compact	105
Parada de emergencia	105
Mantenimiento	106
Vida del rotor	106
Limpieza	106
Eliminación	107
Servicio	108
5 使用说明	109
关于本手册	110
有效性	110
定义与术语	111
小心、警告和注意的定义	111
警告符号	112
安全	114
正确使用	114
使用不当	115
防护设备	116
涡轮分子泵安全指南	117

Contents

运输及存储	118
产品描述	119
安装	120
安装准备	120
设置	121
TPS-compact 的安装	122
高真空法兰的连接	124
ISO-K 法兰的安装	125
ConFlat 法兰的安装	126
TPS-compact 的启动和运行	127
慢启动	128
停止 TPS-compact	129
紧急停止	129
维护	130
转子寿命	130
清洁	130
处置	131
服务	132
6 取扱説明書	133
この説明書について	134
有効期	134

Contents

定義と用語	135
警告・注意・注の定義	135
警告の記号	136
安全性	138
適切な使用	138
不適切な使用	139
保護用装備	140
ターボ分子ポンプ用安全ガイドライン	141
輸送と保管	142
製品説明	143
取り付け	144
取り付けの準備	144
セットアップ	145
TPS-compact 実装	146
高真空フランジの接続	148
ISO-K フランジの取り付け	149
ConFlat フランジの取り付け	150
TPS-compact コンパクトの起動と操作	151
ソフトスタート	152
TPS-compact コンパクトを停止する	153
非常停止	153
メンテナンス	154
ローターの寿命	154
クリーニング	154
処分	155
サービス	156

Contents

7	Instructions for Use	157
	About this manual	158
	Validity	158
	Definitions and terminology	159
	Definition of Caution, Warning and Note	159
	Warning Symbols	160
	Safety	162
	Proper use	162
	Improper use	163
	Protective equipment	164
	Safety guideline for Turbomolecular Pumps	165
	Transport & Storage	166
	Product description	167
	Installation	168
	Preparation for installation	168
	Set-up	169
	TPS-compact Mounting	170
	Connection of the High Vacuum Flange	172
	Installation of ISO-K Flange	173
	Installation of ConFlat Flange	174
	Startup and Operation of the TPS-compact	175
	Soft Start	176
	Stopping the TPS-compact	177
	Emergency stop	177
	Maintenance	178
	Rotor life	178

Contents

Cleaning	178
Disposal	179
Service	180
8 Technical Information	181
Description of the TPS-compact	182
Turbopump Description	184
Controller Description	184
Control Panel Description	185
Scroll Pump Description	186
Technical specification	187
TPS-compact Outline	189
Inlet screen installation	192
High Vacuum Flange Connection Configurations	195
ASDF – Adaptive Scroll Driving Firmware	196
Gas Ballast	198
Interconnections	200
Input Power Connector	200
P3 – Vent	200
Gauge Connector	201
Pressure Display Module	202
J5 – In-Out	203
Signal Description	204
How to Connect the Open Collector Input of the Controller	209
How to Connect the Outputs of the Controller	212
J6 – Serial	212

Contents

RS 232/RS 485 Communication Description	214
Communication Format	214
Serial Communication Descriptions	216
Window Protocol	217
Description	217
Communication Format	217
Communication Protocol	217
Examples	220
Window Meanings	223
Service Options	226
Tip-Seal Replacement	227
To Remove the Worn Tip-Seals	228
To Install the new Seals and O-Rings	229
To test the Pumping System	230
Troubleshooting Chart	231
Accessories and Spare Parts	232

1

Istruzioni per l'uso

Informazioni su questo manuale	14
Validità	14
Definizioni e terminologia	15
Definizione di Attenzione, Avvertenza e Nota	15
Simboli di avvertenza	16
Sicurezza	18
Uso corretto	18
Uso improprio	19
Attrezzatura di protezione	20
Linee guida di sicurezza per pompe turbomolecolari	21
Trasporto & Immagazzinamento	22
Descrizione del prodotto	23
Installazione	24
Preparazione per l'installazione	24
Set-up	25
Fissaggio del TPS-compact	26
Collegamento della flangia per alto vuoto	28
Installazione della flangia ISO-K	29
Installazione della flangia ConFlat	30
Avvio e funzionamento del TPS-compact	31
Soft Start	32
Arresto del TPS-compact	33
Arresto di emergenza	33
Manutenzione	34
Vita del rotore	34
Pulizia	34
Smaltimento	35
Servizio Post Vendita	36

Informazioni su questo manuale

Validità

Questo manuale elenca le istruzioni per gli utenti del TPS-compact, con particolare riferimento alle nozioni relative a sicurezza, funzionamento e manutenzione di primo livello, limitatamente alle operazioni di manutenzione di cui l'utente è responsabile.

Le operazioni di manutenzione, illustrate nelle sezioni specifiche, con disposizioni specifiche relative al livello più elevato di manutenzione (personale appositamente addestrato per le operazioni di manutenzione) non devono essere eseguite dall'utente.

Per una corretta installazione e avvio/arresto, consultare il paragrafo "Installazione". Per un uso tecnico più dettagliato, consultare il capitolo "Technical Information".

NOTA

- 1 Questo manuale contiene informazioni utili affinché tutto il personale che utilizza il TPS-compact possa utilizzarlo in sicurezza e garantire la perfetta efficienza, per tutta la sua durata.
 - 2 Conservare questo manuale, insieme a tutte le pubblicazioni ad esso correlate, in un luogo accessibile, conosciuto da tutti gli operatori/personale di manutenzione.
-

Definizioni e terminologia

Definizione di Attenzione, Avvertenza e Nota

Alcuni riferimenti importanti di questo manuale sono evidenziati e incorniciati in colori contrastanti.

ATTENZIONE

I messaggi di attenzione sono visualizzati prima di procedure che, se non osservate, potrebbero causare danni all'apparecchiatura.

AVVERTENZA



I messaggi di avvertenza attirano l'attenzione dell'operatore su una procedura o una pratica specifica che, se non eseguita in modo corretto, potrebbe provocare gravi lesioni personali.

NOTA

Le note contengono informazioni importanti e forniscono maggiori dettagli su passaggi specifici.

Simboli di avvertenza

Di seguito si riporta un elenco di simboli che vengono visualizzati insieme agli avvisi del TPS-compact. Viene mostrato anche il pericolo che descrivono.

Un simbolo triangolare indica un'avvertenza. I significati dei simboli che possono apparire accanto alle avvertenze nella documentazione o sullo strumento stesso sono i seguenti:



Messa a terra protettiva



Non toccare



Dichiarazione
Europea
di Conformità



Pericolo generico



Presenza di tensioni
pericolose



Presenza di superfici
surriscaldate



Sito di produzione



Spegnimento



Accensione

RoHS

Certificazione Restrizioni
Sostanze Pericolose

**UK
CA**

Marcatura UK CA

Istruzioni per l'uso

Il seguente simbolo può essere usato sulle etichette di avvertenza attaccate allo strumento. Quando viene visualizzato questo simbolo, consultare il relativo manuale operativo o di manutenzione per la procedura corretta a cui fa riferimento tale etichetta di avvertenza.



I seguenti simboli appaiono sullo strumento per vostra informazione.

	Pericolo generico
	Certificazione CE
	Certificazione CSA
	Certificazione RoHS China
	Rifiuti di Apparecchiature Elettriche ed Elettroniche
	Marchatura UK CA

Sicurezza

Questa sezione contiene le informazioni, prescritte dalla Direttiva Macchine 2006/42/CE, che sono essenziali per la conformità e il rispetto delle norme di sicurezza sia in generale che in relazione all'uso specifico della macchina.

La mancata osservanza di queste istruzioni e delle altre istruzioni contenute nel presente manuale può rendere inefficaci le condizioni di sicurezza previste in fase di progettazione e causare incidenti a chi utilizza la macchina.

Agilent Technologies declina ogni responsabilità per danni alla macchina o per la sicurezza fisica dell'operatore o di terzi, derivanti dal mancato rispetto delle norme di sicurezza indicate nella documentazione tecnica.

Uso corretto

Questo manuale contiene importanti avvertenze e istruzioni di sicurezza da osservare affinché l'unità funzioni in sicurezza.

Il prodotto descritto in questo manuale è destinato esclusivamente all'ambito specificato nelle istruzioni. Il manuale fornisce inoltre indicazioni relative ai requisiti essenziali per l'applicazione e il funzionamento del prodotto, nonché le misure di sicurezza che possono essere adottate per garantire un funzionamento regolare. Agilent Technologies non fornisce alcuna garanzia né si assume alcuna responsabilità per applicazioni diverse da quelle descritte nel presente manuale o in cui i requisiti essenziali e le misure di sicurezza non siano rispettati. Il prodotto deve essere utilizzato solo da personale qualificato in grado di adottare le misure di sicurezza necessarie in condizioni che non causano danni o lesioni.

Gli accessori e le attrezzature utilizzati con il prodotto devono essere forniti o approvati da Agilent Technologies.

Qualsiasi operazione di regolazione o manutenzione deve essere eseguita da un tecnico professionista informato dei rischi.

Le riparazioni sul prodotto devono essere eseguite esclusivamente da personale autorizzato Agilent.

Istruzioni per l'uso

Uso improprio

Agilent Technologies declina ogni responsabilità derivante dall'uso improprio del TPS-compact.

L'uso improprio comporterà la perdita di tutti i reclami per responsabilità e garanzie. L'uso improprio è definito come:

- installazione della pompa con materiale di montaggio non specificato
- pompaggio di gas corrosivi e ossidanti
- pompaggio di gas esplosivi
- pompaggio di vapori condensanti
- pompaggio di liquidi
- pompaggio di polvere
- funzionamento con un eccessivo flusso di gas
- funzionamento con pressioni improprie per l'alto vuoto
- funzionamento con modalità gas selezionata diversa dal gas effettivamente utilizzato
- funzionamento con elevati livelli di apporto termico
- funzionamento in elevati campi magnetici impropri
- procedura di vent con flussi elevati
- utilizzo della pompa da vuoto per generare pressione
- funzionamento del dispositivo in aree con radiazioni ionizzanti
- funzionamento in aree potenzialmente esplosive
- utilizzo del sistema in un ambiente nel quale stress e vibrazioni portano a shock o forze ricorrenti e/o periodiche.

Attrezzatura di protezione

L'attrezzatura di protezione degli operatori che stanno operando o eseguendo la manutenzione del sistema di pompaggio deve essere sempre adeguata al tipo di operazione da eseguire. Inoltre, deve soddisfare i requisiti di sicurezza della legislazione in vigore nel paese in cui viene utilizzata la macchina.

In generale, l'operatore deve indossare scarpe antinfortunistiche durante la manipolazione del TPS e durante l'installazione.

AVVERTENZA

Pericolo per la salute a causa di sostanze pericolose durante la manutenzione o l'installazione.



- A seconda della peculiarità del processo, le pompe per vuoto, i componenti o i fluidi di funzionamento possono essere contaminati da sostanze tossiche, reattive o radioattive.
- Indossare attrezzatura di protezione adeguata durante la manutenzione e le riparazioni o in caso di reinstallazione.

AVVERTENZA

Rischio di lesioni dovute alla caduta di oggetti



Durante il trasporto manuale delle pompe per vuoto, sussiste il pericolo che i carichi scivolino e cadano.

- Trasportare pompe per vuoto di piccole e medie dimensioni a due mani.
- Qualsiasi attrezzatura più pesante di 20 kg deve essere trasportata utilizzando un dispositivo di sollevamento adatto.
- Indossare scarpe antinfortunistiche con puntale in acciaio secondo la direttiva EN 347.

ATTENZIONE



Rischio di lesioni a causa di spigoli vivi

- Prima di riparare la pompa o prima di qualsiasi azione di montaggio/smontaggio della pompa del sistema, attendere l'arresto completo della pompa.
- Non operare direttamente all'interno della pompa.
- Se necessario, indossare guanti protettivi secondo la EN 420.

Linee guida di sicurezza per pompe turbomolecolari

Le pompe turbomolecolari descritte nel seguente manuale contengono una grande quantità di energia cinetica dovuta all'elevata velocità di rotazione in combinazione con la massa specifica dei loro rotori.

In caso di malfunzionamento di una parte meccanica della pompa, l'energia di rotazione può essere rilasciata a qualunque cosa sulla quale la pompa sia fissata (vedere sezione "Installazione della flangia ConFlat e ISO-K").

AVVERTENZA



Per evitare danni alle apparecchiature e per prevenire lesioni al personale operativo, è necessario seguire scrupolosamente le istruzioni di installazione fornite nel presente manuale!

AVVERTENZA



Quando la pompa viene utilizzata per il pompaggio di gas tossici, infiammabili o radioattivi, seguire le appropriate procedure tipiche di ciascun gas. La pompa è progettata per un elevato trasferimento di N₂, Ar e gas leggeri. Nel caso in cui ci fosse la necessità di pompare gas più pesanti di Ar, rivolgersi al supporto tecnico Agilent per informazioni.

Il dispositivo TPS-compact non è idoneo all'uso in presenza di gas aggressivi, corrosivi o esplosivi.

Trasporto & Immagazzinamento

Al fine di garantire il massimo livello di prestazioni e affidabilità delle pompe turbomolecolari Agilent, è necessario seguire le seguenti linee guida per evitare la condensa.

- durante il trasporto, lo spostamento e l'immagazzinamento delle pompe non devono essere superate le seguenti condizioni ambientali:
 - temperatura: fare riferimento ai manuali dei singoli componenti del TPS
 - umidità relativa: fare riferimento ai manuali dei singoli componenti del TPS
- le pompe turbomolecolari devono essere sempre avviate in modalità Soft Start quando vengono ricevute e utilizzate per la prima volta dal cliente.
- le pompe turbomolecolari devono essere sempre avviate in modalità Soft Start dopo un periodo di inattività della pompa di 60 giorni.

ATTENZIONE

Se per qualsiasi motivo viene superato il periodo di immagazzinamento, la pompa deve essere restituita alla fabbrica. Per informazioni, contattare l'ufficio Vendite o il servizio assistenza clienti Agilent Vacuum.

AVVERTENZA



Maneggiare con estrema cautela i componenti pesanti. Si raccomanda di sollevarli in due persone.

L'inosservanza del sollevamento in due persone può causare lesioni personali.

Descrizione del prodotto

Questa attrezzatura è destinata all'uso professionale e deve essere utilizzata da professionisti.

Il TPS-compact è un sistema integrato costituito da una pompa turbomolecolare (TwisTorr 74 FS, Twistorr 305 FS) per applicazioni di alto e ultra alto vuoto integrata dal relativo controller e dalla pompa primaria. Il sistema è capace di pompare qualsiasi tipo di gas o di composto gassoso, ma non è adatto per il pompaggio di liquidi o di particelle solide.

L'azione di pompaggio si ottiene attraverso una turbina ad alta velocità (max. 70000 rpm) azionata da un motore elettrico ad alte prestazioni.

È privo di agenti contaminanti e, quindi, è adatto per applicazioni che richiedono un vuoto "pulito".

Il TPS-compact ha inoltre dei connettori ausiliari tramite i quali è possibile pilotarlo da remoto tramite un computer host collegato tramite linea seriale.

Informazioni dettagliate sono fornite nella sezione "Technical Information".

Installazione

Preparazione per l'installazione

Il TPS-compact viene fornito in un imballo protettivo speciale; se sono presenti segni di danni, che potrebbero essersi verificati durante il trasporto, contattare l'ufficio vendite locale.

Evitare impatti improvvisi sul TPS-compact in seguito alla caduta del sistema.

Fare attenzione a conservare la confezione per riutilizzarla in caso di immagazzinamento per un lungo periodo di tempo o in caso di spedizione.

Non gettare i materiali di imballaggio in modo non autorizzato. Il materiale è riciclabile al 100% ed è conforme alla Direttiva CEE 94/62 e successive modifiche.

ATTENZIONE Per evitare problemi di degasamento, non usare le mani nude per maneggiare i componenti che saranno esposti al vuoto. Usare sempre guanti o altre protezioni appropriate.



Figura 1

NOTA

La normale esposizione all'ambiente non può danneggiare il TPS-compact. Tuttavia, si consiglia di tenerlo sigillato nella sua busta di plastica fino a quando non viene installato nel sistema, evitando così qualsiasi forma di inquinamento da polvere.

Set-up

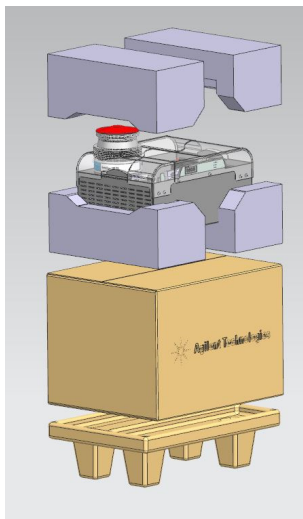
ATTENZIONE Non rimuovere l'adesivo e il cappuccio protettivo fino a quando non si è pronti per installare la turbopompa sul sistema.



Figura 2

Installare questo dispositivo solo in ambienti chiusi e non utilizzare il sistema in un ambiente esposto ad agenti atmosferici (pioggia, ghiaccio, neve), polvere, gas aggressivi o in ambienti esplosivi o ad alto rischio di incendio.

Durante il funzionamento è necessario rispettare le seguenti condizioni ambientali per evitare la condensa:

- pressione massima: 2 bar oltre la pressione atmosferica
- temperatura: fare riferimento ai manuali dei singoli componenti del TPS-compact
- umidità relativa: fare riferimento ai manuali dei singoli componenti del TPS-compact.

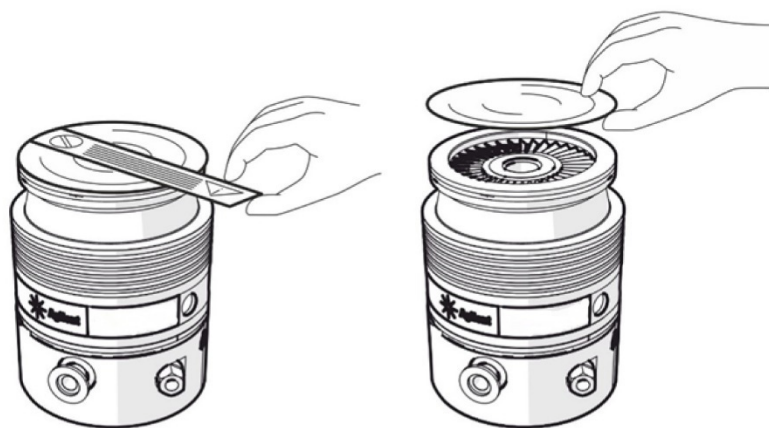
In presenza di campi magnetici, il sistema deve essere protetto usando uno schermo per campi magnetici.

Fissaggio del TPS-compact

AVVERTENZA



La mancata osservanza di queste istruzioni di installazione potrebbe comportare il distacco della pompa dal sistema in caso di guasto del rotore, con conseguenti danni materiali o lesioni gravi o mortali.

Il TPS-compact può essere installata solo in posizione verticale.

Fissare il TPS-compact in una posizione stabile, montando la flangia di ingresso della turbopompa sulla controflangia del sistema.

La turbopompa con flangia di ingresso ConFlat e ISO K deve essere fissata alla camera del vuoto mediante l'apposito hardware Agilent.

Per ulteriori dettagli consultare la sezione "Installazione di ConFlat e ISO K".

Cavo di alimentazione: il cavo adatto al collegamento elettrico è un cavo a 3 conduttori (Fase+Neutro+Terra). La sezione del cavo deve essere almeno di 0,75 mm² (AWG18).

ATTENZIONE

Il TPS-compact non può essere fissato tramite la sua base, nè tramite altre flange che non siano di inlet.

AVVERTENZA



Il Sistema deve essere installato in modo da permettere una facile interruzione dell'alimentazione.

ATTENZIONE

Al fine di permettere un'adeguata circolazione dell'aria, assicurare uno spazio libero intorno al sistema di minimo 20 cm e non coprire o ridurre lo spazio tra la base del TPS-compact ed il suo piano di appoggio.

Istruzioni per l'uso

Per l'installazione degli accessori opzionali, vedere "Technical Information".

In questo paragrafo sono riportate le principali procedure operative.

Prima di usare il sistema verificare che tutti i collegamenti elettrici e pneumatici siano stati realizzati correttamente. Durante l'eventuale riscaldamento della camera da vuoto, la temperatura sulla flangia di ingresso non deve essere superiore a 120 °C con flangiatura ConFlat e a 80 °C con flangiatura ISO.

AVVERTENZA



Non far funzionare mai il sistema di pompaggio se la flangia di ingresso non è collegata alla camera da vuoto o non è chiusa con la flangia di chiusura.

AVVERTENZA



Non toccare la turbopompa e i suoi eventuali accessori durante le operazioni di riscaldamento. L'elevata temperatura può causare lesioni alle persone.

AVVERTENZA



Evitare urti o spostamenti della turbopompa quando è in funzione. I cuscinetti potrebbero danneggiarsi e potrebbero verificarsi danni alle persone o alle cose.

ATTENZIONE

Quando si introduce un flusso d'aria dal vent, utilizzare gas inerte esente da polvere, particelle o umidità (es. Azoto). La pressione di ingresso attraverso l'apposita porta deve essere inferiore a 2 bar (oltre la pressione atmosferica).

AVVERTENZA



Non utilizzare il sistema di pompaggio in presenza di gas esplosivi, tossici, infiammabili o radioattivi.

Collegamento della flangia per alto vuoto

Se il rotore si arresta improvvisamente, la coppia risultante deve essere assorbita dall'hardware che fissa la flangia dell'alto vuoto.

I bulloni o l'hardware devono soddisfare le specifiche seguenti.

AVVERTENZA



È obbligatorio collegare la pompa in modo tale da resistere alla coppia specificata nella sezione "Fissaggio del TPS-compact". In particolare, prestare attenzione al design dei morsetti, al materiale dei morsetti e ai bulloni e alla coppia di fissaggio dei bulloni. Utilizzare solo morsetti (o bulloni) di classe ad alta resistenza $\geq 8,8$.

AVVERTENZA



Se la pompa viene fissata su una camera da vuoto con flange diverse da quelle consigliate da Agilent, esiste la possibilità che il TPS ruoti e si distacchi nel caso in cui il rotore si arresti improvvisamente. La combinazione di diversi tipi di flangia non è consentita. Agilent non si assume alcuna responsabilità per tutti i danni derivanti da un fissaggio improprio.

Installazione della flangia ISO-K

Per i collegamenti della flangia ISO-K, fissare le due flange con i morsetti modello IC63250DCMZ o equivalenti, come mostrato nella figura seguente (è possibile utilizzare facoltativamente uno schermo protettivo).



Figura 3

Utilizzare il numero richiesto di morsetti artiglio:

- 4 per la flangia ISO 63
- 4 per la flangia ISO 100
- 4 per la flangia ISO 160

Stringere i bulloni con una coppia di 22 Nm

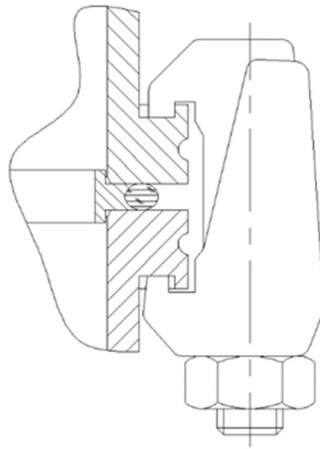
Installazione della flangia ConFlat

Per i collegamenti delle flange ConFlat, fissare le due flange con le viti come mostrato nella figura seguente (è possibile utilizzare facoltativamente uno schermo protettivo).



Figura 4

Utilizzare il numero richiesto di viti:

- 16 per CFF 6"
- 20 per CFF 8"

Collegare le unità e serrare a turno ciascuna vite. Ripetere il serraggio sequenziale fino a quando le facce della flangia si incontrano. Stringere le viti con una coppia di 20 Nm. Per la flangia ConFlat consigliamo solo l'uso di bulloni in acciaio ad alta resistenza. Per facilitare il montaggio e lo smontaggio, è facoltativo applicare il lubrificante Felpro C-100 ad alta temperatura per le filettature delle viti che sporgono dalla flangia e tra i dadi e la flangia.

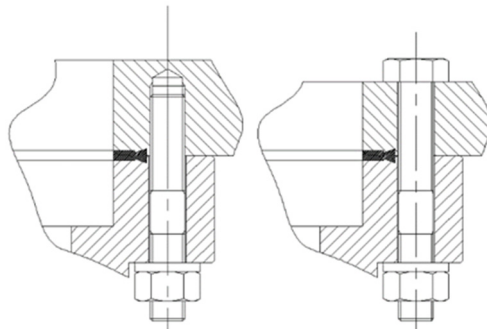
In alcuni casi, i collegamenti possono essere effettuati solo con il bullone nella parte inferiore.

ATTENZIONE

Prestare attenzione quando si serrano dadi e bulloni per evitare di creare ammaccature sull'involucro della pompa turbomolecolare.

Avvio e funzionamento del TPS-compact

Verificare la tensione d'ingresso riportata sull'etichetta Agilent incollata allo chassis dell'unità elettronica del sistema.

Per accendere il TPS-compact è sufficiente fornire la tensione di alimentazione e mettere in posizione ON l'interruttore esterno. Il controller incorporato riconosce automaticamente la presenza dell'alimentazione ed avvia la pompa.

AVVERTENZA



L'avvio iniziale della pompa TwisTorr 305 FS sarà in modalità "SOFT START"; per informazioni dettagliate su questa modalità consultare la sezione dedicata.

Il LED blu "STATUS" posto sul pannello posteriore della base del TPS-compact indica, con la frequenza del suo lampeggio, le condizioni operative del sistema:

- acceso fisso: la pompa è in rotazione normale;
- lampeggiante lentamente (periodo di circa 400 ms): il sistema è in stato di rampa, o di frenata, o di Stop;
- lampeggiante velocemente (periodo di circa 200 ms): condizione di errore.

Per una descrizione dettagliata del pannello di controllo del TPS-compact vedere l'appendice "Technical Information".

Soft Start

AVVERTENZA



Per garantire una corretta lubrificazione dei cuscinetti della pompa, al primo avvio, la pompa deve essere avviata in modalità "Soft Start".

Questa modalità di avviamento (Soft Start) garantisce un incremento progressivo della velocità fino alla massima velocità e consente una corretta lubrificazione dei cuscinetti.

L'unità di controllo collegata alla pompa è già predisposta di default in modalità Soft Start per il funzionamento della pompa (solo al primo avviamento dell'unità di controllo).

In caso di utilizzo di una pompa nuova con un'unità di controllo usata, ricordarsi di impostare manualmente la modalità soft start.

La modalità di avvio graduale richiederà più tempo rispetto all'avvio standard; l'utente deve attendere che la pompa sia completamente a regime prima di arrestarla.

Dopo il primo avvio, la centralina non riavvia la pompa in modalità soft start.

NOTA

Dopo un lungo periodo di inattività (60 giorni o più), al fine di consentire nuovamente la corretta redistribuzione del grasso presente nei cuscinetti, è necessario riavviare la pompa tramite la modalità Soft Start.

AVVERTENZA



Fare riferimento ai relativi manuali di istruzioni del controller al fine di trovare l'insieme appropriato di istruzioni per attivare la modalità Soft Start (Remoto: Capitolo Informazioni tecniche - Collegamento del controller e significati delle finestre; A bordo: Capitolo Informazioni tecniche - Interconnessioni e significati delle finestre).

Arresto del TPS-compact

Per arrestare il TPS-compact è sufficiente mettere in posizione OFF l'interruttore esterno. Il controller incorporato arresta immediatamente il sistema di pompaggio.

AVVERTENZA



Prima di eseguire qualsiasi intervento sul sistema, scollegarlo dall'alimentazione, sfiatare la pompa tramite la valvola di vent, attendere che il rotore sia completamente fermo e attendere che la temperatura superficiale della pompa sia inferiore a 50° C.

Arresto di emergenza

Per arrestare in condizioni di emergenza il TPS-compact occorre staccare il cavo di alimentazione dalla presa di rete, o spostare l'interruttore esterno in posizione OFF.

AVVERTENZA



Questa modalità deve essere utilizzata solo in caso di emergenza. L'uso di questa modalità di arresto potrebbe causare guasti e/o danni alla pompa. L'uso improprio di questa modalità di arresto potrebbe invalidare la garanzia.

Manutenzione

Il TPS-compact non richiede manutenzione (ad eccezione della sostituzione del Tip- seal). Qualsiasi lavoro deve essere eseguito da personale autorizzato.

In caso di guasto è possibile usufruire del servizio di riparazione Agilent.

Se è necessario smaltire un pezzo, assicurarsi che vengano seguite le normative locali per lo smaltimento appropriato.

Vita del rotore

La resistenza alla fatica del rotore della pompa turbomolecolare dipende dalla dimensione della pompa stessa. Far riferimento allo specifico manuale della pompa turbomolecolare per il valore corretto (numero di cicli di rampa da arresto a piena velocità e ritorno a fine corsa) oppure contattare il servizio assistenza clienti per ulteriori informazioni.

Pulizia

La superficie esterna del TPS può essere pulita solo con un detergente delicato.

Smaltimento

Significato del logo "WEEE" presente sulle etichette.

Il simbolo qui sotto riportato è applicato in ottemperanza alla direttiva CE denominata "WEEE".

Questo simbolo (valido solo per i paesi della Comunità Europea) indica che il prodotto sul quale è applicato, NON deve essere smaltito insieme ai comuni rifiuti domestici o industriali, ma deve essere avviato ad un sistema di raccolta differenziata. Si invita pertanto l'utente finale a contattare il fornitore del dispositivo, sia esso la casa madre o un rivenditore, per avviare il processo di raccolta e smaltimento, dopo opportuna verifica dei termini e condizioni contrattuali di vendita.



Figura 5 Logo "WEEE"

Per maggiori informazioni consultare:

<http://www.agilent.com/environment/product/index.shtml>

Servizio Post Vendita

Nel caso in cui un cliente necessiti di un servizio di sostituzione o riparazione avanzato, si prega di contattare il distributore locale o spedire direttamente a:

vpt-customer@agilent.com

vpl-customer@agilent.com

È necessario completare il modulo "Request for Return" per restituire il prodotto ad Agilent per l'assistenza (fornito alla fine di questo manuale).

2

Betriebsanleitung

Informationen über diese Betriebsanleitung	38
Gültigkeit	38
Definitionen und Terminologie	39
Definition von Vorsicht, Warnung und Hinweis	39
Warnsymbole	40
Sicherheit	42
Sachgemäße Verwendung	42
Unsachgemäße Anwendung	43
Schutzausrüstung	44
Sicherheitsrichtlinie für Turbomolekularpumpen	45
Transport und Lagerung	46
Produktbeschreibung	47
Installation	48
Vorbereitung zum Einbau	48
Einrichten	49
Montage von TPS-compact	50
Anschluss des Hochvakuumflansches	52
Installation des ISO-K-Flansches	53
Installation des ConFlat-Flansches	54
Inbetriebnahme und Betrieb des TPS-compact	55
Sanftanlauf	56
Stoppen von Modell TPS-compact	57
Not-Aus	57
Wartung	58
Rotordauer	58
Reinigung	58
Entsorgung	59
Service	60

Informationen über diese Betriebsanleitung

Gültigkeit

Diese Betriebsanleitung enthält die Anweisungen für die Benutzer der TPS-compact mit besonderer Bezugnahme auf die Begriffe für Sicherheit, Betrieb und Wartung auf der ersten Ebene, auf die Wartungsarbeiten beschränkt, für die der Benutzer verantwortlich ist.

Die in den spezifischen Abschnitten dargestellten Wartungsarbeiten mit spezifischen Verordnungen hinsichtlich der höheren Wartungsebene (entsprechend geschultes Personal für die Wartungsarbeiten) dürfen nicht durch den Benutzer ausgeführt werden.

Für eine korrekte Installation und Start/Stop der Absatz „Installation“ konsultieren. Für eine detailliertere technische Verwendung das Kapitel „Technical Information“ konsultieren.

HINWEIS

- 1** Diese Betriebsanleitung enthält nützliche Informationen, damit das gesamte Personal, das die TPS-compact verwendet, diese in Sicherheit verwenden und die perfekte Funktionstüchtigkeit für ihre gesamte Betriebsdauer garantieren kann.
- 2** Diese Betriebsanleitung muss zusammen mit allen mit dieser zusammenhängenden Veröffentlichungen an einem zugänglichen Ort, der allen Bedienern/Wartungspersonal bekannt ist, aufbewahrt werden.

Definitionen und Terminologie

Definition von Vorsicht, Warnung und Hinweis

Einige wichtige Bezüge dieser Betriebsanleitung werden durch Kontrastfarben hervorgehoben und eingerahmt.

VORSICHT

Die Vorsichtshinweise werden vor Verfahren angezeigt, die Schäden am Gerät verursachen könnten, wenn sie nicht beachtet werden.

WARNUNG



Die Warnhinweise lenken die Aufmerksamkeit des Bedieners auf ein Verfahren oder einen spezifischen Vorgang, der schwere Verletzungen von Personen zur Folge haben könnte, wenn er nicht korrekt ausgeführt wird.

HINWEIS

Die Hinweise enthalten wichtige Informationen und liefern weitere Details über spezifische Arbeitsschritte.

Warnsymbole

Das Folgende ist eine Liste von Symbolen, die in Verbindung mit den Warnungen auf dem TPS-compact angezeigt werden. Die von ihnen beschriebene Gefahr wird ebenfalls angezeigt.

Ein dreieckiges Symbol weist auf eine Warnung hin. Die Bedeutung der Symbole, die neben Warnhinweisen in der Dokumentation oder auf dem Gerät selbst erscheinen können, ist wie folgt:



Schutzerdungsanschluss



Nicht berühren



Europäische
Konformitätserklärung



Allgemeine Gefahr



Hochspannung



Heiße Oberflächen



Herstellungsbetrieb



Ausschalten



Einschalten

RoHS

Beschränkung
gefährlicher Stoffe

**UK
CA**

UK CA-Kennzeichnung

Betriebsanleitung

Das folgende Symbol kann auf am Gerät angebrachten Warnschildern verwendet werden. Wenn Sie dieses Symbol sehen, finden Sie in der jeweiligen Betriebs- oder Wartungsanleitung das richtige Verfahren, auf das sich dieses Warnschild bezieht.



Die folgenden Symbole werden zu Ihrer Information auf dem Instrument angezeigt.

	Allgemeine Gefahr
	CE-Zertifizierung
	CSA-Zertifizierung
	RoHS-Chinazertifizierung
	Elektro- und Elektronikaltgeräte
	UK CA-Kennzeichnung

Sicherheit

Dieser Abschnitt enthält die in der Maschinenrichtlinie 2006/42/EG vorgeschriebenen Informationen, die für die Einhaltung der Sicherheitsbestimmungen im Allgemeinen und in Bezug auf den spezifischen Einsatz der Maschine von wesentlicher Bedeutung sind.

Die Nichtbeachtung dieser Anweisungen und der anderen in diesem Handbuch enthaltenen Anweisungen kann die in der Konstruktionsphase vorgesehenen Sicherheitsbedingungen ineffizient machen und Unfälle bei den Bedienern der Maschine verursachen.

Agilent Technologies lehnt jede Verantwortung für Schäden an der Maschine oder für die physische Sicherheit des Bedieners oder Dritter ab, die sich aus der Nichtbeachtung der in den technischen Unterlagen angegebenen Sicherheitsregeln ergeben.

Sachgemäße Verwendung

Dieses Handbuch enthält wichtige Warnungen und Sicherheitshinweise, die beachtet werden müssen, damit das Gerät sicher funktioniert.

Das in dieser Anleitung beschriebene Produkt ist ausschließlich für den in der Anleitung angegebenen Anwendungsbereich bestimmt. Das Handbuch enthält auch Angaben zu den grundlegenden Anforderungen für die Anwendung und den Betrieb des Produkts sowie zu den Sicherheitsmaßnahmen, die zur Gewährleistung eines regelmäßigen Betriebs ergriffen werden können. Agilent Technologies übernimmt keine Garantie oder Verantwortung für Anwendungen, die nicht in diesem Handbuch beschrieben sind oder bei denen die grundlegenden Anforderungen und Sicherheitsmaßnahmen nicht eingehalten werden.

Das Produkt darf nur von qualifiziertem Personal verwendet werden, das in der Lage ist, die erforderlichen Sicherheitsmaßnahmen unter Bedingungen zu treffen, die keine Schäden oder Verletzungen verursachen. Alle mit dem Produkt verwendeten Zubehörteile und Geräte müssen von Agilent Technologies geliefert oder genehmigt werden.

Einstellungs- oder Wartungsarbeiten müssen von einem Fachmann durchgeführt werden, der über die Risiken informiert ist.

Reparaturen am Produkt dürfen ausschließlich von Agilent-autorisiertem Personal durchgeführt werden.

Unsachgemäße Anwendung

Agilent Technologies lehnt jede Verantwortung ab, die sich aus der unsachgemäßen Benutzung vom TPS-Compact ergibt.

Bei unsachgemäßer Verwendung verfallen alle Haftungs- und Gewährleistungsansprüche. Unsachgemäße Verwendung ist definiert als.

- Installation der Pumpe mit nicht spezifiziertem Befestigungsmaterial
- Pumpen von ätzenden und oxidierenden Gasen
- Pumpen von explosiven Gasen
- Pumpen von kondensierenden Dämpfen
- Pumpen von Flüssigkeiten
- Pumpen von Pulver
- Betrieb mit unzulässig hohem Gasdurchsatz
- Betrieb mit ungeeignetem Hochvakuumdruck
- Betrieb mit gewählter Gasart, die sich vom tatsächlich verwendeten Gas unterscheidet
- Betrieb mit hohem Wärmeeintrag
- Betrieb in unzulässig hohen Magnetfeldern
- Entlüften mit ungeeignet hohen Entlüftungsraten
- Verwendung der Vakuumpumpe zur Druckerzeugung
- Betrieb des Gerätes in Bereichen mit ionisierender Strahlung
- Betrieb in explosionsgefährdeten Bereichen
- Einsatz des Systems in einer Umgebung, in der Belastungen und Vibrationen zu periodisch wiederkehrenden Stößen führen.

Schutzausrüstung

Die Schutzausrüstung der Bediener, die das Pumpensystem bedienen oder warten, muss immer für die Art des auszuführenden Vorgangs geeignet sein. Darüber hinaus muss es den Sicherheitsanforderungen der in dem Land, in dem die Maschine verwendet wird, geltenden Rechtsvorschriften entsprechen.

Im Allgemeinen muss der Bediener beim Umgang mit dem TPS-compact und während der Installation Unfallverhütungsschuhe tragen.

WARNUNG

Gesundheitsgefahr durch gefährliche Stoffe bei Wartung oder Installation.



- Vakuumpumpen, Komponenten oder Betriebsflüssigkeiten können je nach Prozessbesonderheit mit giftigen, reaktiven oder radioaktiven Stoffen verunreinigt sein.
- Tragen Sie bei Wartungs- und Reparaturarbeiten oder bei einer erneuten Installation angemessene Schutzausrüstung.

WARNUNG

Verletzungsgefahr durch herunterfallende Gegenstände



Beim Transport von Vakuumpumpen von Hand besteht die Gefahr, dass Lasten verrutschen und herunterfallen.

- Tragen Sie kleine und mittlere Vakuumpumpen mit zwei Händen.
- Alle Geräte, die schwerer als 20 kg sind, sollten mit einer geeigneten Hebevorrichtung transportiert werden.
- Sicherheitsschuhe mit Stahlkappe gemäß Richtlinie EN 347 tragen.

VORSICHT



Verletzungsgefahr durch scharfe Kanten

- Warten Sie vor der Wartung der Pumpe oder vor dem Ein- und Ausbau der Pumpe vom System bis zum vollständigen Stillstand der Pumpe.
- Nicht direkt im Hochvakuumflansch betreiben.
- Gegebenenfalls Schutzhandschuhe nach EN 420 tragen.

Sicherheitsrichtlinie für Turbomolekularpumpen

Turbomolekularpumpen, wie sie in der folgenden Betriebsanleitung beschrieben sind, enthalten aufgrund der hohen Drehzahl in Kombination mit der spezifischen Masse ihrer Rotoren eine große Menge kinetischer Energie.

Bei einer Funktionsstörung eines mechanischen Teils der Pumpe kann die Rotationsenergie an alle Stellen abgegeben werden, an denen die Pumpe befestigt ist (siehe Abschnitte "Installation des ConFlat-Flansches" und "Installation des ISO-K-Flansche").

WARNUNG



Um Geräteschäden und Verletzungen des Bedienpersonals zu vermeiden, sind die in diesem Handbuch enthaltenen Installationsanweisungen unbedingt zu beachten!

WARNUNG



Wird die Pumpe zum Pumpen von giftigen, brennbaren oder radioaktiven Gasen verwendet, die entsprechenden Verfahren für das jeweilige Gas befolgen. Die Pumpe ist entworfen worden, um Stickstoff, Argon und leichtere Gase zu pumpen. Sollte die Notwendigkeit bestehen, schwereres Gas als Argon pumpen zu müssen, wenden Sie sich bitte für Informationen an den Technischen Kundendienst der Agilent.

Das TPS-Compact ist nicht für den Einsatz in Umgebungen mit aggressiven, korrosiven oder explosiven Gasen bestimmt.

Transport und Lagerung

Um die maximale Leistung und Zuverlässigkeit von Agilent Turbomolekularpumpen zu gewährleisten, müssen die folgenden Richtlinien beachtet werden, um Kondensation zu vermeiden:

- Während des Transports, der Handhabung und der Einlagerung der Pumpen dürfen die folgenden Grenzwerte nicht überschritten werden:
 - Temperatur: siehe die Handbücher der einzelnen Komponenten des TPS-compact.
 - Relative Feuchtigkeit: siehe die Handbücher der einzelnen Komponenten des TPS-compact.
- Der Kunde hat die Turbomolekularpumpen nach dem Empfang bei Erstinbetriebnahme stets im Modus Soft-Start ingangzusetzen.
- Die Turbomolekularpumpen müssen nach einer gewissen Zeit von 60 Tage von Inaktivität der Pumpe immer sanft gestartet werden.

VORSICHT

Wenn aus irgendeinem Grund die Haltbarkeitsdauer überschritten wird, muss die Pumpe an das Werk zurückgeschickt werden. Bitte wenden Sie sich an den lokalen Agilent Vacuum Vertriebs- und Servicevertreter, um weitere Informationen zu erhalten.

WARNUNG



Seien Sie bei der Handhabung schwerer Teile äußerst vorsichtig. Es ist ratsam, das Gerät zu zweit anzuheben.

Erfolgt das Anheben nicht unter Einsatz von zwei Personen, kann dies zu Verletzungen führen.

Produktbeschreibung

Dieses Gerät ist für den professionellen Gebrauch und für den professionellen Gebrauch bestimmt.

Modell TPS-compact ist ein integriertes System, das aus einer Turbomolekularpumpe (TwisTorr 74 FS, Twistorr 305 FS) für Hoch- und Höchstvakuum-anwendungen, integriert mit einem entsprechenden Controller und der Primärpumpe, besteht. Das System eignet sich für die Förderung aller Arten von Gasen oder gashaltigen Gemischen, nicht jedoch für die Förderung von Flüssigkeiten oder Festpartikeln.

Die Pumpwirkung wird durch eine Hochgeschwindigkeitsturbine (max. 70000 U/min) erzielt, die von einem Hochleistungselektromotor angetrieben wird.

Modell TPS-compact verfügt des weiteren über Zusatzanschlüsse, über die Vorrichtung von einem Host Computer über eine serielle Leitung gesteuert werden kann.

Detaillierte Informationen entnehmen Sie dem Abschnitt „Technische Informationen“.

Installation

Vorbereitung zum Einbau

TPS-compact wird in einer speziellen Schutzverpackung geliefert. Wenden Sie sich an Ihr lokales Verkaufsbüro, wenn dies Anzeichen von Schäden zeigt, die während des Transports aufgetreten sein können.

Vermeiden Sie plötzliche Stöße auf den TPS-compact, die durch Herunterfallen verursacht werden können. Bewahren Sie den Verpackungskarton auf, um ihn bei längerer Lagerung oder beim Versand wieder verwenden zu können.

Entsorgen Sie das Verpackungsmaterial nicht auf unbefugte Weise. Das Material ist zu 100% recycelbar und entspricht der EG-Richtlinie 94/62 und nachfolgenden Änderungen.

VORSICHT

Um Ausgasungsprobleme zu vermeiden, verwenden Sie keine bloßen Hände, um Bauteile zu handhaben, die Vakuum ausgesetzt sind. Verwenden Sie immer Handschuhe oder einen anderen geeigneten Schutz.



Abbildung 6

HINWEIS

Normale Umwelteinflüsse können den TPS-compact nicht beschädigen. Trotzdem ist es ratsam, es bis zum Einbau in das System in der Plastiktüte aufzubewahren, um jegliche Verschmutzung durch Staub zu vermeiden.

Einrichten

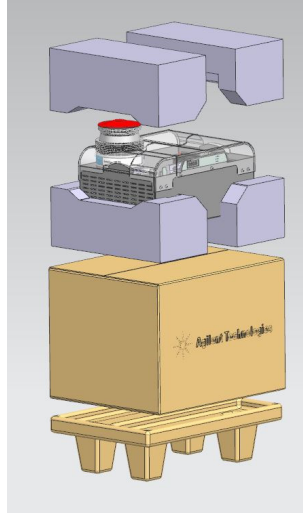
VORSICHT

Entfernen Sie den Klebstoff und die Schutzkappe erst, wenn Sie bereit sind, die Turbopumpe am System zu installieren.



Abbildung 7

Stellen Sie das Gerät nur in Innenräumen auf und verwenden Sie die Pumpe nicht in Umgebungen, die Witterungseinflüssen (Regen, Eis, Schnee), Staub, aggressiven Gasen oder explosionsgefährdeten Umgebungen ausgesetzt sind.

Während des Betriebs müssen folgende Umgebungsbedingungen eingehalten werden, um Kondensation zu vermeiden:

- Maximaler Druck: 2 bar über dem atmosphärischen Druck
- Temperatur: siehe die Handbücher der einzelnen Komponenten des TPS
- Relative Luftfeuchtigkeit: siehe die Handbücher der einzelnen Komponenten des TPS.

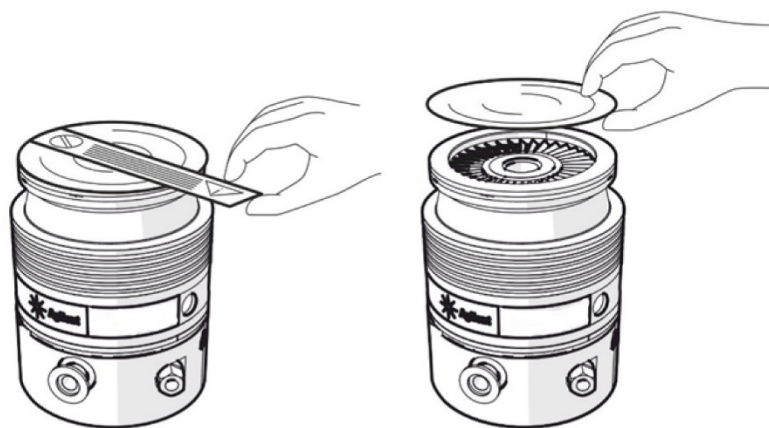
Bei Vorhandensein von elektromagnetischen Feldern ist das Pumpensystem die Pumpe entsprechend abzuschirmen.

Montage von TPS-compact

WARNUNG



Die Nichtbeachtung dieser Installationsanweisungen kann dazu führen, dass sich die Pumpe bei einem Rotorausfall vom System löst, was zu Sachschäden oder schweren oder tödlichen Verletzungen führen kann.

TPS-compact kann nur in vertikaler Position installiert werden.

Befestigen Sie den TPS-compact in einer stabilen Position und montieren Sie den Einlassflansch der Turbopumpe am Gegenflansch des Systems.

Die Turbopumpe mit ConFlat- und ISO K-Einlassflansch muss mit den entsprechenden Agilent-Teilen an der Vakuumkammer befestigt werden.

Weitere Einzelheiten entnehmen Sie dem Abschnitt „Installation von ConFlat und ISO K“.

Versorgungskabel: Das Kabel für den Stromanschluss ist dreidrig (stromführendes Kabel + Neutralleiter + Masse). Der Kabelquerschnitt muss mindestens $0,75 \text{ mm}^2$ betragen (AWG18).

VORSICHT

TPS-compact kann weder über ihren Sockel noch über andere Flansche als die Einlassflansche befestigt werden.

WARNUNG



Das System muss so installiert werden, dass die Stromversorgung schnell abgeschaltet werden kann.

VORSICHT

Für eine gute Luftzirkulation ist ein Freiraum von mindestens 20 cm um die Anlage herum sicherzustellen und der Abstand zwischen dem Unterbau des TPS-compact und seiner Auflagefläche darf nicht verdeckt sein oder verringert werden.

Betriebsanleitung

Für die Installation der Optionsteile siehe im Anhang "Technical Information".
In diesem Abschnitt werden die wichtigsten Betriebsvorgänge erläutert.

Vor Benutzung des Systems sind alle elektrischen und pneumatischen Anschlüsse auszuführen. Während der eventuellen Aufheizung der Vakuumkammer darf die Temperatur am Eingangsflansch bei einem ConFlat-Flansch nicht über 120°C und bei einem ISO-Flansch nicht über 80 °C steigen.

WARNUNG



Das Pumpensystem darf nicht in Betrieb genommen werden, wenn der Eingangsflansch nicht an die Vakuumkammer angeschlossen oder nicht mit dem Verschlußflansch verschlossen ist.

WARNUNG



Während des Aufheizens dürfen weder die Pumpe noch eventuelle heiße Zubehörteile berührt werden. Es besteht Verbrennungsgefahr.

WARNUNG



Die Turbopumpe darf während des Betriebes keinen Stößen oder ruckartigen Bewegungen ausgesetzt werden. Die Lager könnten beschädigt werden und Personen oder Gegenständen Schaden zugefügt werden.

VORSICHT

Für die Belüftung der Pumpe staub-, partikel- und feuchtigkeitsfreies Inertgas (z.B. Stickstoff) verwenden. Der Eingangsdruck am Belüftungsanschluß soll unter 2 bar (über dem atmosphärischen Druck) betragen.

WARNUNG



Verwenden Sie das Pumpensystem nicht in der Nähe von explosiven, giftigen, brennbaren oder radioaktiven Gasen.

Anschluss des Hochvakuumflansches

Wenn der Rotor plötzlich stoppt, muss das resultierende Drehmoment von der Befestigung des Hochvakuumflansches aufgenommen werden.

Schrauben oder Kleinteile müssen den unten angegebenen Spezifikationen entsprechen.

WARNUNG



Die Pumpe muss so angeschlossen werden, dass sie dem im Abschnitt „Montage von TPS-compact“ angegebenen Drehmoment standhält. Achten Sie insbesondere auf die Ausführung der Klemmen, das Material der Klemmen und Schrauben und den Anzugmoment der Schrauben.

Verwenden Sie nur Klemmen (oder Schrauben) mit hohem Widerstand ≥ 8.8 .

WARNUNG



Wenn die Pumpe an einer Vakuumkammer mit Flanschen befestigt ist, die von den von Agilent empfohlenen Flanschen abweichen, besteht die Möglichkeit, dass sich der TPS-compact dreht oder abreißt, falls der Rotor plötzlich stoppt. Die Kombination verschiedener Flanschtypen ist nicht zulässig. Agilent übernimmt keine Haftung für alle Schäden, die durch unsachgemäße Befestigung entstehen.

Installation des ISO-K-Flansches

Befestigen Sie bei ISO-K-Flanschverbindungen die beiden Flansche mit den Klemmen Modell IC63250DCMZ oder einem gleichwertigen Element, wie in der folgenden Abbildung dargestellt (optional kann ein Schutzgitter verwendet werden).



Abbildung 8

Verwenden Sie die erforderliche Anzahl von Klauenklemmen:

- 4 für ISO 63 Flansch
- 4 für ISO 100 Flansch
- 4 für ISO 160 Flansch

Ziehen Sie die Schrauben mit einem Drehmoment von 22 Nm an.

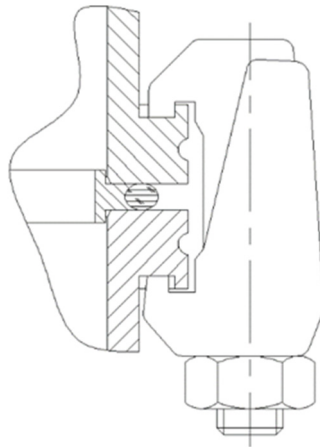
Installation des ConFlat-Flansches

Befestigen Sie bei ConFlat-Flanschverbindungen die beiden Flansche mit den Schrauben wie in der folgenden Abbildung gezeigt (optional kann ein Schutzgitter verwendet werden).



Abbildung 9

Verwenden Sie die erforderliche Anzahl von Schrauben:

- 16 for CFF 6"
- 20 for CFF 8"

Befestigen Sie die Einheiten und ziehen Sie jede Schraube der Reihe nach an. Wiederholen Sie das sequenzielle Anziehen, bis die Flanschflächen einander anschlagen. Ziehen Sie die Schrauben mit einem Drehmoment von 20 Nm an. Für ConFlat-Flansche empfehlen wir nur die Verwendung von hochfesten Stahlschrauben.

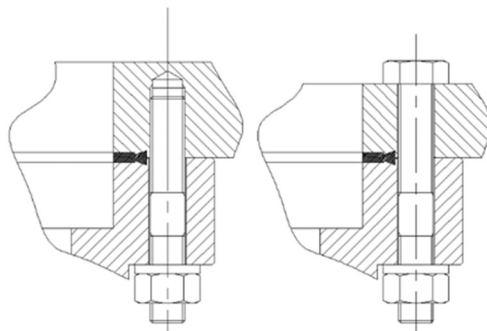
Um die Montage und Demontage zu erleichtern, kann optional Felpro C-100 Hochtemperaturschmiermittel auf, die aus dem Flansch und zwischen den Muttern und dem Flansch herausragenden Schraubengewinde aufgetragen werden. In einigen Fällen können die Verbindungen nur mit dem Bolzen in der unteren Seite hergestellt werden.

VORSICHT

Gehen Sie beim Anziehen der Schrauben und Muttern vorsichtig vor, um Dellen am Turbomolekularpumpengehäuse zu vermeiden.

Inbetriebnahme und Betrieb des TPS-compact

Die Eingangsspannung auf der Etiketle Agilent am Gehäuse der Elektronik des Systems prüfen.

Zur Einschaltung des TPS-compact ist der Netzstecker anzuschließen und der externe Schalter auf die Schaltstellung ON zu stellen. Der eingebaute Controller erfaßt automatisch das Anliegen der Spannung und startet die Pumpe.

WARNUNG



Der erste Start der Pumpe TwisTorr 305 FS erfolgt im „Sanftanlauf“-Modus. Ausführliche Informationen zu diesem Modus finden Sie im entsprechenden Abschnitt.

Die blauen LEDs „STATUS“ an der Bodenplatte von Modell TPS-compact gibt mit der Häufigkeit ihres Blinkens die Betriebsbedingungen des System an:

- Daueranzeige: Die Pumpe befindet sich im normalen Betrieb;
- Langsame Blinkanzeige (ca. 400 ms): das System befindet sich entweder im Status Rampe, Abbremsung, Stopp oder „Waiting for Interlock“;
- Schnelle Blinkanzeige (ca. 200 ms): Fehlerstatus.

Für eine detaillierte Erläuterung der Bedienblende des TPS-compact siehe im Anhang "Technical Information".

Sanftanlauf

WARNUNG



Um eine ordnungsgemäße Schmierung der Lager der Pumpe zu gewährleisten, muss die Pumpe beim ersten Hochfahren im Modus „Sanftanlauf“ gestartet werden.

Diese Anlaufart (Soft Start) sorgt für ein gleichmäßiges Anlaufen der Pumpe und ermöglicht eine ordnungsgemäße Schmierung der Lager.

Die an die Pumpe angeschlossene Steuereinheit ist bereits standardmäßig für den Betrieb der Pumpe eingerichtet (nur bei der ersten Inbetriebnahme der Steuereinheit). Bei Verwendung einer neuen Pumpe mit einer gebrauchten Steuereinheit denken Sie daran, den Softstartmodus manuell einzustellen.

Der Softstart-Modus dauert im Vergleich zum Standardstart länger. Der Benutzer muss warten, bis die Pumpe vollständig die Geschwindigkeit erreicht hat, bevor er die Pumpe anhält.

Nach dem ersten Start wird die Pumpe von der Steuereinheit nicht mehr im Softstartmodus gestartet.

HINWEIS

Nach längerer Inaktivität (60 Tage oder länger) muss die Pumpe über den Softstart-Modus erneut gestartet werden, damit das in den Lagern vorhandene Fett wieder richtig verteilt wird.

WARNUNG



Informationen zum Aktivieren der Softstart-Modalität finden Sie in den entsprechenden Bedienungsanleitungen des Controllers. (Fern: Kapitel Technische Informationen - Bedeutungen von Steuerungsanschluss und Fenstern; On Board: Kapitel Technische Informationen - Bedeutungen von Verriegelungen und Fenstern).

Stoppen von Modell TPS-compact

Zur Stillsetzung des TPS-compact ist der externe Schalter auf die Schaltstellung OFF zu schalten. Der eingebaute Controller sorgt für den sofortigen Stopp des Pumpensystems.

WARNUNG



Bevor Sie Arbeiten an der Anlage ausführen, trennen Sie diese von der Stromversorgung, entlüften Sie die Pumpe mit dem Entlüftungsventil, warten Sie, bis der Rotor vollständig stillsteht und bis die Oberflächentemperatur der Pumpe unter 50° C liegt.

Not-Aus

Zur Notstillsetzung des TPS-compact ist der Netzstecker zu ziehen oder der externe Schalter auf die Schaltstellung OFF zu schalten.

WARNUNG



Diese Betriebsart ist nur im Notfall zu verwenden. Die Verwendung dieses Stoppmodus kann zu Fehlern und/oder Schäden an der Pumpe führen. Die unsachgemäße Verwendung dieses Stoppmodus kann zum Erlöschen der Garantie führen.

Wartung

Die TPS-compact ist wartungsfrei (außer der Austausch des Tip-seal). Alle Arbeiten müssen von autorisiertem Personal durchgeführt werden.

Bei Defekten kann der Agilent Service.

Wenn ein System verschrottet werden muss, stellen Sie sicher, dass die örtlichen Vorschriften für eine angemessene Entsorgung befolgt werden.

Rotordauer

Die Dauerlastfestigkeit des Rotors der Turbomolekularpumpe hängt stark von der Pumpengröße ab. Den zutreffenden Wert sehen Sie bitte in der Anleitung der jeweiligen Pumpe (Anzahl der Hochlaufzyklen vom Stillstand auf volle Drehzahl und zurück auf Stillstand). Als Vorsichtsmaßnahme empfiehlt Agilent unter Berücksichtigung der typischen Verwendung der Pumpe und unter Berücksichtigung der Sicherheitsgrenzen, das System nach 17 Jahren Nutzung zur Wartung einzusenden.

Reinigung

Die Außenfläche des TPS-compact darf nur mit einem milden Reinigungsmittel gereinigt werden.

Entsorgung

Bedeutung des „WEEE“ Logos auf den Schildern.

Das folgende Symbol ist in Übereinstimmung mit der EG-Richtlinie WEEE (Waste Electrical and Electronic Equipment) angebracht.

Dieses Symbol (nur in den EU-Ländern gültig) zeigt an, dass das betreffende Produkt NICHT zusammen mit Haushalts- oder Industriemüll entsorgt werden darf, sondern einem speziellen Sammelsystem zugeführt werden muss. Der Endabnehmer sollte daher den Lieferanten des Geräts - d. h. die Muttergesellschaft oder den Wiederverkäufer - kontaktieren, um den Entsorgungsprozess zu starten, nachdem er die Verkaufsbedingungen geprüft hat.



Abbildung 10 Logo „WEEE“

Für weitere Informationen siehe:

<http://www.agilent.com/environment/product/index.shtml>

Service

Sollte ein Kunde einen erweiterten Austausch- oder Reparaturservice benötigen, wenden Sie sich bitte an den örtlichen Händler oder direkt an die Email-Adresse

vpt-customer@agilent.com

vpl-customer@agilent.com

Das Ausfüllen des "Request for Return" formulars ist erforderlich, um die Pumpe zur Wartung an Agilent zurückzusenden (am Ende dieses Handbuchs angegeben).

3

Mode d'emploi

À propos de ce manuel	62
Validité	62
Définitions et terminologie	63
Signification des messages d'attention, d'avertissement et des notes	63
Symboles d'avertissement	64
Sécurité	66
Utilisation appropriée	66
Utilisation inappropriée	67
Équipements de protection individuelle	68
Consignes de sécurité pour les pompes turbomoléculaires	69
Transport et entreposage	70
Description du produit	71
Installation	72
Préparation pour l'installation	72
Configuration	73
Montage du TPS-compact	74
Raccordement de la bride à vide élevé	76
Installation de la bride ISO-K	77
Installation de la bride ConFlat	78
Démarrage et utilisation du TPS-compact	79
Démarrage progressif	80
Arrêt du TPS-compact	81
Arrêt d'urgence	81
Entretien	82
Durée de vie du rotor	82
Nettoyage	82
Élimination	83
Service	84

À propos de ce manuel

Validité

Le présent manuel contient les instructions destinées aux utilisateurs du TPS-compact, notamment celles relatives à la sécurité, au fonctionnement et à la maintenance de premier niveau, dans la limite des activités de maintenance incombant à l'utilisateur.

Les opérations de maintenance décrites dans des paragraphes spécifiques qui contiennent des dispositions relevant d'un niveau de maintenance plus élevé (personnel spécialement formé aux opérations de maintenance) ne doivent pas être effectuées par l'utilisateur.

Pour une installation et une mise en marche/arrêt correctes, consultez le paragraphe « Installation ». Pour une utilisation technologique plus détaillée, consultez le chapitre « Technical Information ».

NOTE

- 1 Ce manuel contient des informations utiles pour que l'ensemble du personnel puisse utiliser le TPS-compact en toute sécurité et pour garantir un fonctionnement parfait pendant toute sa durée de vie.
 - 2 Veuillez conserver ce manuel et tous les documents connexes dans un lieu accessible connu de tous les opérateurs et du personnel de maintenance.
-

Définitions et terminologie

Signification des messages d'attention, d'avertissement et des notes

Dans ce manuel, certaines informations importantes sont surlignées et encadrées avec des couleurs voyantes.

ATTENTION

Les messages d'attention sont affichés au début de procédures qui, si elles ne sont pas respectées, peuvent entraîner des dommages aux équipements.

AVERTISSEMENT



Les messages d'avertissement attirent l'attention de l'opérateur sur une procédure ou une pratique particulière qui, si elle n'est pas effectuée correctement, peut entraîner de graves blessures.

NOTE

Les remarques contiennent des informations importantes et fournissent des précisions sur certains passages particuliers.

Symboles d'avertissement

Voici une liste de symboles qui apparaissent en conjonction avec les avertissements sur le TPS-compact. Le danger qu'ils décrivent est également illustré. Le symbole triangulaire indique un avertissement. Les significations des symboles qui peuvent apparaître à côté des avertissements dans la documentation ou sur l'appareil lui-même sont les suivantes.



Borne de mise à la terre de protection



Ne pas toucher



Déclaration européenne de conformité



Danger générique



Tensions dangereuses



Surfaces chaudes



Site de fabrication



Mise hors tension



Mise sous tension

RoHS

Restriction de la certification des substances dangereuses









Marquage UK CA

Mode d'emploi

Le symbole suivant peut être utilisé sur les étiquettes d'avertissement apposées sur l'appareil. Lorsque vous voyez ce symbole, reportez-vous au manuel d'utilisation ou d'entretien correspondant pour connaître la procédure correcte visée par cette étiquette d'avertissement.



Les symboles suivants apparaissent sur l'appareil pour votre information.

	Danger générique
	Certification CE
	Certification CSA
	Certification RoHS Chine
	Déchets d'équipements électriques et électroniques
	Marquage UK CA

Sécurité

Cette section contient les informations prescrites par la directive Machines 2006/42/CE, qui est essentielle à la conformité et au respect des règles de sécurité en général ainsi qu'à l'utilisation spécifique de la machine.

Le non-respect de ces instructions et des autres instructions contenues dans le présent manuel peut rendre inefficaces les conditions de sécurité prévues dans la phase de conception et causer des accidents à ceux qui utilisent la machine.

Agilent Technologies décline toute responsabilité pour les dommages causés à la machine ou pour la sécurité physique de l'opérateur ou des tiers résultant du non-respect des règles de sécurité indiquées dans la documentation technique.

Utilisation appropriée

Le présent manuel contient des avertissements importants et des instructions de sécurité à respecter pour que l'appareil puisse fonctionner en toute sécurité.

Le produit décrit dans le présent manuel est destiné exclusivement au domaine d'application spécifié dans les instructions. Le manuel fournit également des indications concernant les exigences essentielles pour l'application et le fonctionnement du produit ainsi que les mesures de sécurité qui peuvent être adoptées pour garantir un fonctionnement régulier. Agilent Technologies ne fournit aucune garantie ou n'assume aucune responsabilité pour des applications autres que celles décrites dans le présent manuel ou dans lesquelles les exigences essentielles et les mesures de sécurité ne sont pas respectées.

Le produit ne doit être utilisé que par un personnel qualifié capable de prendre les mesures de sécurité nécessaires dans des conditions qui ne causent pas de dommages ou de blessures. Tous les accessoires et équipements utilisés avec le produit doivent être fournis ou approuvés par Agilent Technologies.

Toute opération de réglage ou de maintenance doit être effectuée par un technicien professionnel informé des risques.

Les réparations du produit doivent être effectuées exclusivement par le personnel autorisé d'Agilent.

Utilisation inappropriée

Agilent Technologies décline toute responsabilité en raison de l'utilisation inappropriée du TPS-compact.

Une utilisation inappropriée entraînera l'annulation de toutes les créances et garanties.

Une utilisation inappropriée est définie comme suit :

- installation de la pompe avec un matériau de montage non spécifié ;
- pompage des gaz corrosifs et oxydants ;
pompage des gaz explosifs ;
- pompage des vapeurs de condensation ;
- pompage des liquides ;
- pompage de la poussière ;
- fonctionnement avec débit de gaz élevé ;
- fonctionnement avec des pressions de vide élevées ;
- fonctionnement avec la modalité de gaz sélectionnée différente du gaz réellement utilisé ;
- fonctionnement avec des apports calorifiques élevés ;
- fonctionnement dans des champs magnétiques élevés incorrects ;
- évacuation avec des taux d'évacuation élevés inappropriés ;
- utilisation de la pompe à vide pour générer de la pression ;
- fonctionnement de l'appareil dans les zones à rayonnement ionisant ;
- fonctionnement dans des zones potentiellement explosives ;
- Utilisation du système dans un environnement où les contraintes et les vibrations similaires à des chocs ou des forces périodiques.

Équipements de protection individuelle

Les équipements de protection individuelle des opérateurs qui utilisent ou entretiennent le système de pompage doivent toujours être appropriés au type d'opération à effectuer. De plus, ils doivent satisfaire aux exigences de sécurité de la réglementation en vigueur dans le pays d'utilisation de l'appareil.

En règle générale, l'opérateur doit porter des chaussures de sécurité pendant la manipulation du TPS-compact et pendant son installation.

AVERTISSEMENT

Danger pour la santé en raison de la présence de substances dangereuses pendant la maintenance ou l'installation.



- En fonction des caractéristiques du processus, les pompes à vide, les composants ou les fluides de fonctionnement peuvent être contaminés par des substances toxiques, réactives ou radioactives.
- Portez des équipements de protection individuelle appropriés pendant la maintenance, les opérations de réparation ou de réinstallation.

AVERTISSEMENT

Risques de blessure dus à la chute d'objets



Pendant le transport manuel des pompes à vide, il existe un risque de glissement et de chute de la charge.

- Transportez les pompes à vide de petite et moyenne dimension avec les deux mains.
- Tout objet de plus de 20 kg doit être transporté à l'aide d'un moyen de levage adapté.
- Portez des chaussures de sécurité à pointes en acier conformes à la directive EN 347.

ATTENTION



Risques de blessures par des arêtes vives ou tranchantes

- Avant de réparer la pompe et avant toute opération de montage/démontage de la pompe du système, attendez qu'elle soit complètement arrêtée.
- N'intervenez pas directement à l'intérieur de la pompe.
- Si nécessaire, portez des gants de protection conformes à la directive EN 420.

Consignes de sécurité pour les pompes turbomoléculaires

Les pompes turbomoléculaires décrites dans le manuel d'utilisation suivant contiennent une grande quantité d'énergie cinétique en raison de la vitesse de rotation élevée en combinaison avec la masse spécifique de leurs rotors.

En cas de dysfonctionnement d'une partie mécanique de la pompe, l'énergie de rotation peut être libérée sur la pompe à laquelle elle est fixée (voir la section « Installation de la bride ConFlat » et « Installation de la bride ISO-K »).

AVERTISSEMENT



Pour éviter d'endommager les équipements et prévenir les risques de blessure des opérateurs, respectez rigoureusement les instructions d'installation fournies dans le présent manuel.

AVERTISSEMENT



Quand la pompe est utilisée pour le pompage de gaz toxiques, inflammables ou radioactifs, respectez les procédures spécifiques à chaque gaz. La pompe est conçue pour pomper de l'azote, de l'argon et des gaz plus légers. En cas de nécessité de pomper des gaz plus lourds que l'argon, veuillez prendre contact avec l'assistance technique de Agilent pour plus d'informations.

Le TPS-compact n'a pas été conçu pour être utilisé en présence de gaz agressifs, corrosifs ou explosifs.

Transport et entreposage

Afin de garantir le niveau maximal de performance et de fiabilité des pompes turbomoléculaires Agilent, les directives suivantes doivent être respectées pour éviter la condensation :

- Le transport, la manutention et le stockage des pompes, doivent impérativement avoir lieu dans les conditions ambiantes suivantes :
 - température: consulter les manuels des composants du TPS-compact ;
 - humidité relative: consulter les manuels des composants du TPS-compact.
- A la première utilisation, les pompes turbomoléculaires doivent toujours être mises en marche en mode soft-Start.
- les pompes turbomoléculaires doivent toujours être démarrées progressivement après une période d'inactivité de 60 jours de la pompe.

ATTENTION

Si, pour une raison quelconque, la durée de conservation est dépassée, la pompe doit être retournée à l'usine. Contacter le représentant local Agilent Vacuum Sales and Service pour plus d'informations.

AVERTISSEMENT



Faire très attention lors de la manutention de pièces lourdes. Le recours à deux personnes pour effectuer le levage est recommandé.

L'absence de recours à deux personnes pour effectuer le levage peut se solder par des blessures

Description du produit

Cet équipement est destiné à un usage professionnel et doit être utilisé par des professionnels.

Le TPS-compact est un système intégré, constitué d'une pompe turbomoléculaire (TwisTorr 74 FS, Twistorr 305 FS) conçue pour des applications de vide poussé et ultrapoussé et dotée d'un contrôleur et d'une pompe primaire. Le système est à même de pomper tous les types de gaz et de composés gazeux mais il n'est pas adapté au pompage de liquides ou de particules solides.

L'action de pompage est obtenue par une turbine à grande vitesse (max. 70000 tr/m) entraînée par un moteur électrique à haute performance.

La pompe est exempte d'agents contaminants et, par conséquent, adaptée aux applications nécessitant un vide « pur ».

Le TPS-compact est en outre doté de connecteurs auxiliaires permettant de le piloter à distance à l'aide d'un ordinateur host connecté par ligne série.

Des informations détaillées sont fournies dans section « Technical Information ».

Installation

Préparation pour l'installation

TPS-compact est fourni dans un emballage de protection spécial. Si l'on constate des marques de dommages pouvant s'être produits pendant le transport, contacter aussitôt le bureau de vente local.

Éviter les impacts soudains sur le TPS-compact qui seraient causés par la chute. Veiller à entretenir le carton d'emballage afin de le réutiliser en cas de stockage de longue durée ou d'expédition.

Ne pas jeter les matériaux d'emballage sans autorisation. Le matériel est recyclable à 100 % et est conforme à la directive 94/62 de la CEE et aux modifications ultérieures.

ATTENTION

Afin de prévenir les problèmes de dégazage, ne pas utiliser les mains nues pour manipuler les composants qui seront exposés au vide. Toujours porter des gants ou une autre protection adaptée.

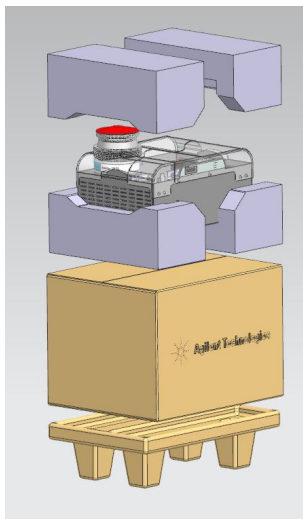

Figure 11

NOTE

L'exposition normale à l'environnement ne peut pas endommager le TPS-compact. Néanmoins, il est conseillé de garder le produit scellé dans son sac plastique jusqu'à ce qu'il soit installé dans le système, empêchant ainsi toute forme de pollution par la poussière.

Configuration

ATTENTION

Ne pas retirer l'adhésif et le capuchon de protection avant d'être prêt à installer la turbopompe sur le système.

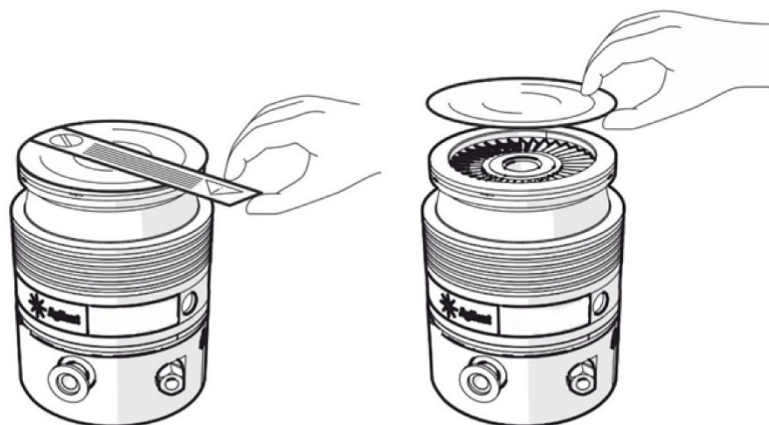

Figure 12

Installer ce dispositif à l'intérieur seulement, et ne pas utiliser la pompe dans un environnement exposé à des agents atmosphériques (pluie, glace, neige), de la poussière, des gaz agressifs, ou dans des environnements explosifs ou présentant un risque élevé d'incendie.

Pendant l'exploitation, les conditions environnementales suivantes doivent être respectées afin d'éviter la condensation :

- pression max. : 2 bars au-delà de la pression atmosphérique
- température : consulter les manuels des composants du TPS-compact
- humidité relative : consulter les manuels des composants du TPS-compact

En présence de champs magnétiques, le système de pompage doit être protégée à l'aide d'écrans appropriés.

Montage du TPS-compact

AVERTISSEMENT



Le non-respect de ces instructions d'installation peut entraîner le détachement de la pompe du système en cas de défaillance du rotor, ce qui peut causer des dommages matériels, corporels ou la mort.

Le TPS-compact ne peut être installé qu'en position verticale.

Fixer le TPS-compact dans une position stable, en montant la bride d'entrée de la turbopompe sur la contre-bride du système.

La turbopompe avec bride d'entrée ConFlat et ISO K doit être fixée à la chambre à vide au moyen du matériel Agilent approprié.

Pour plus de détails, voir la section « Installation de la ConFlat et de l'ISO K ».

Câble d'alimentation : le câble destiné au raccordement électrique doit avoir trois conducteurs (Phase+Neutre+Terre). La section du câble doit être de 0,75 mm² minimum (AWG18).

ATTENTION

Le TPS-compact ne peut pas être fixé par sa base ni par des brides autres que celles d'entrée.

AVERTISSEMENT



Le système doit être installé de manière à permettre une interruption facile de l'alimentation.

ATTENTION

Pour permettre à l'air de circuler correctement, laisser un espace libre d'au moins 20 cm tout autour du système et ne pas couvrir ni réduire l'espace entre la base du TPS-compact et son plan d'appui.

Mode d'emploi

Pour l'installation des accessoires en option, se reporter à "Technical Information".
Ce paragraphe présente les principales procédures opérationnelles.
Avant d'utiliser le système, effectuer tous les branchements électriques et pneumatiques. Pendant le chauffage éventuel de la chambre à vide, la température de la bride d'entrée ne doit pas dépasser 120°C en cas de bridage ConFlat et 80°C en cas de bridage ISO.

AVERTISSEMENT



Ne jamais faire fonctionner le système de pompage si la bride d'entrée n'est pas reliée à la chambre à vide ou si elle n'est pas fermée avec la bride de fermeture.

AVERTISSEMENT



Éviter de toucher la turbopompe ainsi que ses accessoires éventuels pendant les opérations de chauffage. La température élevée peut être à l'origine de lésions graves.

AVERTISSEMENT



Éviter tout choc ou déplacement de la turbopompe lorsqu'elle est en marche. Cela pourrait endommager les paliers et provoquer de graves dommages aux personnes et aux choses.

ATTENTION

Pour le "refoulement à l'air" de la pompe, utiliser un gaz inerte dépourvu de poussière, particules ou humidité (Ex. azote). La pression d'entrée à travers la porte prévue à cet effet doit être inférieure à 2 bars (au-delà de la pression atmosphérique).

AVERTISSEMENT



Ne pas utiliser le système de pompage en présence de gaz explosifs, toxiques, inflammables ou radioactifs.

Raccordement de la bride à vide élevé

Si le rotor s'arrête soudainement, le couple résultant doit être absorbé par le matériel de fixation de la bride à vide élevé.

Les boulons ou le matériel doivent être conformes aux spécifications ci-dessous.

AVERTISSEMENT



Il est obligatoire de raccorder la pompe de manière à résister au couple spécifié dans la section «Montage du TPS-compact». Porter une attention particulière à la conception des colliers, au matériau des colliers et des boulons et au couple de fixation des boulons. Utiliser uniquement des colliers (ou boulons) de classe haute résistance ≥ 8.8 .

AVERTISSEMENT



Si la pompe est fixée sur une chambre à vide avec des brides différentes de celles recommandées par Agilent, le TPS-compact risque de se tordre ou de se déchirer en cas d'arrêt soudain du rotor. La combinaison de différents types de brides n'est pas autorisée. Agilent n'acceptera aucune responsabilité pour tous les dommages résultant d'une mauvaise fixation.

Installation de la bride ISO-K

Pour les raccords à brides ISO-K, fixer les deux brides avec les attaches modèle IC63250DCMZ ou équivalent, comme indiqué dans la figure suivante (un écran de protection peut être utilisé en option).

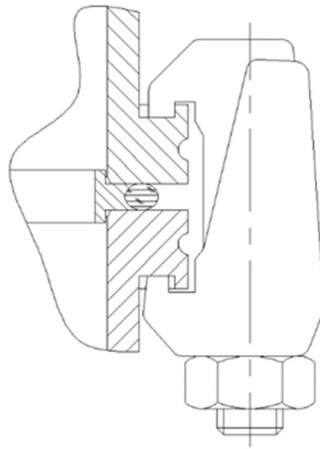

Figure 13

Utiliser le nombre requis de brides de serrage :

- 4 pour la bride ISO 63
- 4 pour la bride ISO 100
- 4 pour la bride ISO 160

Serrez les boulons au couple de 22 Nm.

Installation de la bride ConFlat

Pour les raccords à bride ConFlat, fixer les deux brides avec les vis comme indiqué dans la figure suivante (un écran de protection peut être utilisé en option).

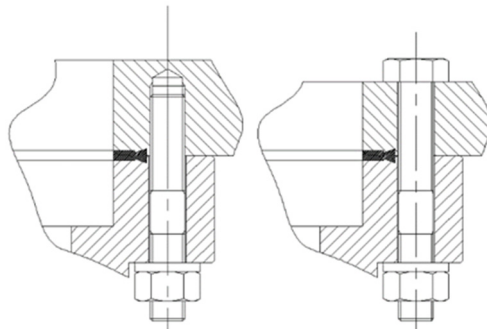

Figure 14

Utiliser le nombre requis de vis :

- 16 pour CFF 6"
- 20 pour CFF 8"

Fixer les unités et serrer chaque vis à tour de rôle. Répéter le serrage séquentiel jusqu'à ce que les faces de la bride se rencontrent. Serrer les vis à un couple de 20 Nm.

Pour la bride ConFlat, nous recommandons l'utilisation de boulons en acier à haute résistance uniquement.

Pour faciliter l'assemblage et le démontage, vous avez la possibilité d'appliquer du lubrifiant à haute température Felpro C-100 sur les filetages de vis dépassant de la bride et entre les écrous et la bride.

Dans certains cas, les raccordements peuvent être faits seulement avec le boulon dans le côté inférieur.

ATTENTION

Faire preuve de prudence lors du serrage des écrous et des boulons pour éviter de créer des bosselures sur le boîtier de la pompe turbomoléculaire.

Démarrage et utilisation du TPS-compact

Vérifiez la tension d'alimentation indiquée sur l'étiquette Agilent collée sur le châssis de l'unité électronique du système.

Pour allumer le TPS-compact via les contrôleurs embarqués ou les contrôleurs distants, raccorder la pompe au contrôleur, fournir au contrôleur la tension d'alimentation appropriée, puis activer les signaux « START » (Démarrer) et « INTERLOCK » (Verrouiller) (qui sont situés sur l'interface du contrôleur). Une fois ces signaux reconnus, le contrôleur démarre la pompe.

AVERTISSEMENT



Le démarrage initial de la pompe TwisTorr 305 FS sera en mode « Démarrage progressif » ; pour plus d'informations sur ce mode, reportez-vous à la section dédiée.

La LED bleu "STATUS" placée sur le panneau arrière de la base du TPS-compact indique, par sa fréquence de clignotement, les conditions opérationnelles du système :

- allumée fixe: la pompe est en rotation normale ;
- clignote lentement (période d'environ 400 ms): le système est en état de rampe, de freinage, de stop ou d'attente interlock ;
- clignote rapidement (période d'environ 200 ms): condition d'erreur.

Pour une description détaillée du panneau de contrôle du TPS-compact, consulter l'appendice "Technical Information".

Démarrage progressif

AVERTISSEMENT



Pour s'assurer que les roulements sont correctement lubrifiés, la pompe doit être démarrée en mode « démarrage progressif » (Soft Start) lors du premier démarrage.

Cette modalité de démarrage (Démarrage progressif) assure une montée en douceur de la vitesse de la pompe et permet une bonne lubrification des roulements.

L'unité de commande qui est connectée à la pompe est déjà configurée par défaut pour faire fonctionner la pompe (uniquement lors de la première mise en service de l'unité de commande).

En cas d'utilisation d'une nouvelle pompe avec une unité de commande usagée, n'oubliez pas de régler manuellement le mode de démarrage progressif.

Le mode Démarrage progressif prend plus de temps que le mode Démarrage standard ; l'utilisateur doit attendre que la pompe atteigne complètement sa vitesse avant de l'arrêter.

Après le premier démarrage, la pompe ne sera plus démarrée en mode Démarrage progressif par l'unité de commande.

NOTE

Après une longue période d'inactivité (60 jours ou plus), afin de permettre à nouveau la redistribution correcte de la graisse présente dans les roulements, il est nécessaire de redémarrer la pompe en mode Démarrage progressif.

AVERTISSEMENT



Veillez consulter les modes d'emploi en question du contrôleur pour trouver l'ensemble des instructions approprié pour activer la modalité de démarrage progressif (À distance : Chapitre Informations techniques – Connexion du contrôleur et significations des fenêtres ; Embarqué : Chapitre Informations techniques – Interconnexions et significations des fenêtres).

Arrêt du TPS-compact

Pour arrêter le TPS-compact, il suffit de placer l'interrupteur extérieur sur OFF. Le contrôleur incorporé arrête immédiatement le système de pompage.

AVERTISSEMENT



Avant d'effectuer des travaux sur le système, le mettre hors tension, purger la pompe avec la valve de purge, attendre que le rotor soit complètement arrêté et que la température de surface de la pompe soit inférieure à 50 °C.

Arrêt d'urgence

Pour arrêter le TPS-compact en condition d'urgence, débrancher le cordon d'alimentation de la prise ou placer l'interrupteur extérieur sur OFF.

AVERTISSEMENT



Ce mode ne doit être utilisé qu'en cas d'urgence. L'utilisation de ce mode d'arrêt peut entraîner des défauts et/ou des dommages à la pompe. Une utilisation inappropriée de ce mode d'arrêt pourrait annuler la garantie.

Entretien

Le TPS-compact ne nécessite aucun entretien (à l'exception du remplacement du Tip-seal). Tout travail doit être effectué par un personnel autorisé.

En cas de panne, il est possible de bénéficier du service réparations Agilent.

Si un système doit être mis au rebut, s'assurer que les réglementations locales sont respectées pour une mise au rebut appropriée.

Durée de vie du rotor

La résistance à la fatigue du rotor de la pompe turbomoléculaire dépend fortement de la taille de la pompe. Se référer au manuel spécifique de la pompe pour la valeur correcte (nombre de cycles de montée de l'arrêt à la pleine vitesse et retour à l'arrêt). Par mesure de précaution, compte tenu de l'utilisation typique de la pompe et des limites de sécurité, Agilent recommande de la remettre en service après 17 ans d'utilisation pour l'entretien.

Nettoyage

La surface extérieure du TPS-compact ne peut être nettoyée qu'avec un détergent doux.

Élimination

Signification du logo « DEEE » présent sur les étiquettes.

Le symbole représenté ci-dessous est apposé conformément à la directive CE dite « DEEE ».

Ce symbole (valable uniquement pour les pays de la Communauté européenne) indique que le produit sur lequel il est apposé NE DOIT PAS être éliminé avec des déchets ménagers ou industriels communs mais qu'il doit être confié à un centre de collecte sélective. L'utilisateur est donc invité à contacter le fournisseur du produit, qu'il s'agisse du fabricant ou d'un revendeur, pour donner lieu au processus de collecte et d'élimination, après avoir vérifié les conditions générales de vente.



Figure 15 Logo « DEEE »

Pour plus de précisions, veuillez consulter :

<http://www.agilent.com/environment/product/index.shtml>

Mode d'emploi

Service

Si, vous, le client avez besoin d'un service d'échange ou de réparation avancé, veuillez contacter le distributeur local ou directement par courrier à:

vpt-customer@agilent.com

vpl-customer@agilent.com

Vous devez remplir le formulaire de "Request for Return" pour retourner votre pompe à Agilent pour l'entretien (fourni à la fin du présent manuel).

4 Instrucciones de uso

Acerca del manual	86
Validez	86
Definiciones y terminología	87
Definición de Precaución, Advertencia y Nota	87
Símbolos de advertencia	88
Seguridad	90
Uso correcto	90
Uso incorrecto	91
Equipo de protección	92
Pautas de seguridad para bombas turbomoleculares	93
Transporte y almacenamiento	94
Descripción del producto	95
Instalación	96
Preparación para instalación	96
Puesta en marcha	97
Montaje de TPS-compact	98
Conexión de la brida de alto vaciado	100
Instalación de la brida ISO-K	101
Instalación de la brida ConFlat	102
Puesta en marcha y funcionamiento de TPS-compact	103
Arranque suave	104
Parada del TPS-compact	105
Parada de emergencia	105
Mantenimiento	106
Vida del rotor	106
Limpieza	106
Eliminación	107
Servicio	108

Acerca del manual

Validez

Este manual enumera las instrucciones para los usuarios de la bomba TPS-compact, con particular referencia a la información relacionada con la seguridad, la operación y el mantenimiento de primer nivel que está limitado a las operaciones de mantenimiento que son responsabilidad del usuario.

Las operaciones de mantenimiento, ilustradas en las secciones particulares, con disposiciones específicas relacionadas con el nivel más elevado de mantenimiento (personal específicamente capacitado para las operaciones de mantenimiento) no deben ser realizadas por el usuario.

Para una instalación y arranque/parada correctos, consulte el párrafo "Instalación".

Para una instalación y un encendido/apagado correctos, consulte la sección "Technical Information".

NOTA

- 1 Este manual contiene información útil para que todo el personal que utilice la bomba TPS-compact pueda operarla de manera segura y garantizar un rendimiento perfecto, durante toda su vida útil.
- 2 Guarde este manual, junto con todas las publicaciones relacionadas, en un lugar conocido y accesible para todos los operadores/personal de mantenimiento.

Definiciones y terminología

Definición de Precaución, Advertencia y Nota

Algunas referencias importantes de este manual están resaltadas y enmarcadas en color contrastante.

PRECAUCIÓN

Los mensajes de precaución se muestran antes de los procedimientos que, si no se respetan, pueden causar daños al equipo.

ADVERTENCIA



Los mensajes de advertencia llaman la atención del operador sobre un procedimiento o práctica específica que, si no se realiza correctamente, puede causar lesiones personales graves.

NOTA

Las notas están previstas para llamar la atención sobre información importante y proporcionar más detalles en relación con pasos específicos.

Símbolos de advertencia

La siguiente es una lista de los símbolos que aparecen en conjunto con las advertencias en la bomba TPS-compact. También se muestra el peligro que describen.

Un símbolo triangular indica una advertencia. Los significados de los símbolos que pueden aparecer junto a las advertencias en la documentación son los siguientes:



Terminal protectora de tierra



No tocar



Declaración Europea de Conformidad



Peligro genérico



Voltajes peligrosos



Superficie caliente



Lugar de fabricación



Apagado



Encendido

RoHS

Certificación de Restricción de Sustancias Peligrosas

**UK
CA**

Marca UK CA

Instrucciones de uso

El siguiente símbolo podría utilizarle en las etiquetas de advertencia fijadas al instrumento. Cuando vea este símbolo, consulte la operación relevante o el manual de servicio para el procedimiento referido por dicha etiqueta de advertencia.



Los siguientes símbolos aparecen en el instrumento para su información.

	Peligro genérico
	Certificación CE
	Certificación CSA
	Certificación China RoHS
	Equipo de Desecho Eléctrico y Electrónico
	Marca UK CA

Seguridad

La presente sección contiene la información, prescrita por la Directiva de Maquinario 2006/42/EC, que es esencial para el cumplimiento y seguimiento de las normativas de seguridad, tanto generales como en relación con el uso específico de la máquina.

El incumplimiento de las presentes instrucciones y las otras instrucciones en el presente manual pueden hacer que las condiciones de seguridad previstas en la fase de diseño sean ineficaces y causen accidentes a los que operen la maquinaria.

Agilent Technologies niega cualquier responsabilidad por daños a la máquina o la seguridad física del operario o terceras partes derivados del incumplimiento de las reglas de seguridad indicadas en la documentación técnica.

Uso correcto

El presente manual contiene advertencias importantes e instrucciones de seguridad a cumplir para que la unidad funcione de manera segura.

El producto descrito en el presente manual está destinado exclusivamente al área de aplicación especificado en las instrucciones. El manual también proporciona indicaciones acerca de los requisitos esenciales para la aplicación y funcionamiento del producto, así como las medidas de seguridad que pueden ser adoptadas para garantizar el funcionamiento regular. Agilent Technologies no proporciona ninguna garantía ni asume ninguna responsabilidad por aplicaciones que no sean las descritas en el presente manual, o en las que no se respeten los requisitos y medidas de seguridad esenciales.

El producto solo puede ser utilizado por personal cualificado que pueda tomar las medidas de seguridad necesarias bajo condiciones que no causen daños o lesiones. Cualquier accesorio y equipo utilizado con el producto debe ser proporcionado o aprobado por Agilent Technologies.

Cualquier ajuste u operación de mantenimiento debe ser realizada por un técnico profesional informado sobre los riesgos.

Las reparaciones del producto deberán ser realizadas exclusivamente por personal autorizado por Agilent.

Uso incorrecto

Agilent Technologies niega cualquier responsabilidad derivada del uso incorrecto del TPS-compact.

El uso incorrecto anulará todas las reclamaciones por responsabilidad y garantías.

El uso incorrecto se define como:

- instalación de la bomba con el material de montaje incorrecto
- bombear gases corrosivos u oxidantes sin el flujo de purga adecuado
- bombear gases explosivos
- bombear vapores condensantes
- bombear líquidos
- bombear polvo
- funcionamiento con capacidad de gas alta incorrecta
- funcionamiento con presiones de pre-vaciado altas incorrectas
- funcionamiento con modalidad de gas seleccionada diferente del gas utilizado
- funcionamiento con altos niveles de aporte de calor
- funcionamiento en campos magnéticos altos incorrectos
- descargar con velocidad de descarga alta incorrecta
- uso de la bomba de vacío para generar presión
- funcionamiento del dispositivo en zonas con radiación ionizante
- funcionamiento en zonas potencialmente explosivas
- Uso en entornos en los que factores como el estrés y las vibraciones son similares a impactos o fuerzas periódicas.

Equipo de protección

El equipo de protección de los operadores que usan la bomba o realizan su mantenimiento siempre debe ser adecuado para el tipo de operación que realizan. Además, debe cumplir con los requisitos de seguridad de la legislación vigente en el país en donde se utiliza el equipo.

En general, el operador debe usar zapatos antiaccidentes durante la instalación y manipulación de la bomba TPS-compact.

ADVERTENCIA Peligro para la salud debido a la presencia de sustancias peligrosas durante el mantenimiento o la instalación.



- Dependiendo de la peculiaridad del proceso, las bombas de vacío, los componentes o los fluidos de funcionamiento pueden estar contaminados con sustancias tóxicas, reactivas o radioactivas.
- Use el equipo de protección adecuado durante el mantenimiento y las reparaciones o en caso de volver a instalar el equipo.

ADVERTENCIA Riesgo de lesiones debido a la caída de objetos



Cuando se transportan las bombas de vacío manualmente, existe el peligro de que las cargas se resbalen y caigan.

- Traslade las bombas de vacío de tamaño pequeño y mediano con las dos manos.
- Todo equipo de más de 20 kilos de peso debe ser transportado con un dispositivo de elevación adecuado.
- Use zapatos de seguridad con puntera de acero que cumplan con la Directiva EN 347.

PRECAUCIÓN



Riesgo de lesiones debido a la presencia de cantos vivos

- Antes de realizar el servicio técnico o antes del montaje/desmontaje de la bomba del sistema, espere a que la bomba se detenga por completo.
- No trabaje directamente dentro de la brida de alto vacío.
- Si es necesario, use guantes de protección que cumplan con la norma EN 420.

Pautas de seguridad para bombas turbomoleculares

Las bombas turbomoleculares, como se describen en el siguiente manual de funcionamiento, contienen una gran cantidad de energía cinética debido a la alta velocidad de rotación en combinación con la masa específica de sus rotores.

En caso de avería de una parte mecánica de la bomba, la energía de rotación podría pasarse a lo que esté fijada la bomba (consulte la sección "Instalación de la brida ISO-K" y "Instalación de la brida ConFlat y ISO-K").

ADVERTENCIA



Para evitar daños al equipo y prevenir lesiones al personal operativo, se deben cumplir estrictamente las instrucciones de instalación indicadas en este manual.

ADVERTENCIA



Cuando la bomba se utiliza para bombear gases tóxicos, inflamables o radiactivos, seguir los procedimientos adecuados, típicos para cada gas. La bomba está diseñada para bombear Nitrógeno, Argón y gases más livianos. En caso de que surja la necesidad de bombear gases más pesados que el Argón, se solicita contactar con la Asistencia Técnica de Agilent para obtener información.

El dispositivo TPS-compact no es adecuado al uso en presencia de gases agresivos, corrosivos o explosivos.

Transporte y almacenamiento

Para garantizar el máximo nivel de rendimiento y fiabilidad de las bombas turbomoleculares de Agilent, las siguientes pautas deben seguirse para evitar la condensación.

- durante el transporte, desplazamiento y almacenamiento de las bombas no deberán superarse las siguientes condiciones ambientales:
 - temperatura: consultar los manuales de cada componente del TPS-compact;
 - humedad relativa: consultar los manuales de cada componente del TPS-compact.
- el cliente deberá activar siempre las bombas turbomoleculares en modalidad Soft-Start al recibirlas y ponerlas en funcionamiento por primera vez;
- las bombas turbomoleculares deben iniciarse con arranque suave siempre después de un período de 60 días de inactividad de la bomba.

PRECAUCIÓN

Si, por cualquier motivo, la vida útil es excedida, la bomba deberá ser devuelta a la fábrica. Por favor, contacte con el representante local de Ventas y Servicios de Vacío de Agilent para más información.

ADVERTENCIA

Manejar los componentes pesados con extrema precaución.



Se aconseja que las maniobras de elevación sean efectuadas por dos operadores, de lo contrario existe el riesgo de lesiones personales.

Descripción del producto

Este equipo está destinado a uso profesional y deberá ser utilizado por profesionales.

El TPS-compact es un sistema integrado compuesto por una bomba turbomolecular (TwisTorr 74 FS, Twistorr 305 FS) para aplicaciones de alto y ultra alto vacío integrada por el respectivo controlador y la bomba primaria. El sistema puede bombear cualquier tipo de gas o de composición gaseosa, pero no es adecuado para bombear líquidos o partículas sólidas.

La acción de bombeado se obtiene a través de una turbina de alta velocidad (max. 70000 rpm) impulsada por un motor eléctrico de alto rendimiento. Está libre de agentes contaminantes y, por tanto, es adecuada para aplicaciones que requieran un vacío "limpio".

El TPS-compact posee conectores auxiliares con los que se puede pilotarlo a distancia mediante un ordenador host conectado a través de línea serial.

Puede encontrar información detallada en la sección "Technical Information".

Instalación

Preparación para instalación

El TPS-compact se proporciona con un embalaje protector especial. Si esta muestra signos de daños que puedan haber ocurrido durante el transporte, contacte con su oficina de ventas local.

Evite impactos repentinos al TPS-compact que podrían ser causados al dejarla caer. Tenga cuidado de guardar la caja de embalaje para reutilizarla en caso de almacenamiento durante largos períodos de tiempo o en caso de envío.

No tire los materiales de embalaje de manera no autorizada. El material es 100% reciclable y cumple con la Directiva EEC 94/62 y modificaciones posteriores.

PRECAUCIÓN

Para evitar problemas de liberación de gases, no utilice las manos para manejar los componentes que estén expuestos a la bomba. Utilice guantes u otra protección adecuada siempre.

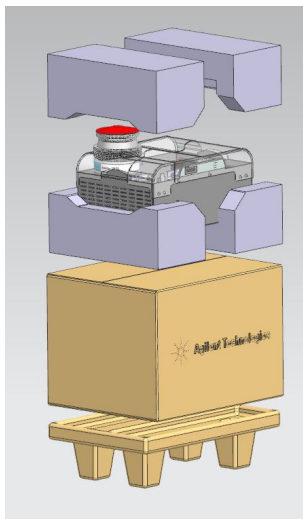

Figure 16

NOTA

La exposición normal al ambiente no puede dañar el TPS-compact. Sin embargo, es aconsejable mantenerla sellada en su bolsa de plástico hasta que esté instalada en el sistema, evitando así cualquier forma de contaminación por polvo.

Puesta en marcha

PRECAUCIÓN No extraiga la tapa adhesiva y protectora hasta que esté preparado para instalar la turbobomba en el sistema.



Figura 17

Instale este dispositivo solo en interiores y no utilice la bomba en un ambiente expuesto a agentes atmosféricos (lluvia, hielo, nieve), polvo, gases agresivos o en ambientes explosivos o con un alto riesgo de incendio.

Durante el funcionamiento, las siguientes condiciones ambientales deben cumplirse para evitar la condensación:

- presión máxima: 2 bares por encima de la presión atmosférica
- temperatura: consultar los manuales de cada componente del TPS-compact
- humedad relativa: consultar los manuales de cada componente del TPS-compact.

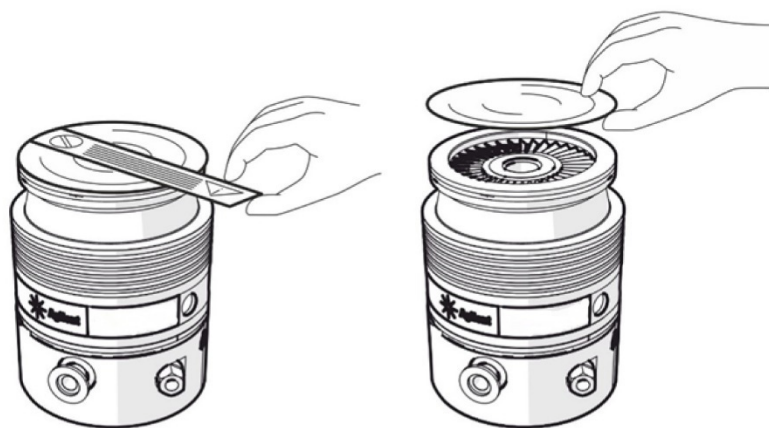
Cuando existan campos electromagnéticos, el sistema de bombeo ha de protegerse mediante pantallas adecuadas.

Montaje de TPS-compact

ADVERTENCIA



El incumplimiento de las presentes instrucciones podría causar que la bomba se desprege del sistema en el caso de un fallo del rotor, lo que podría causar daños a la propiedad o lesiones graves o la muerte.

El TPS-compact solo se puede instalar en posición vertical.

Fije el TPS-compact en una posición estable, montando la brida de entrada de la turbobomba en el sistema de la contrabrida.

La turbobomba con brida de entrada ConFlat e ISO K debe estar fijada a la cámara de vacío mediante las herramientas adecuadas de Agilent. Para más detalles consulte la sección "Installation of ConFlat and ISO K".

Cable de alimentación: el cable adecuado para la conexión eléctrica es un cable de tres conductores (Fase+Neutro+Tierra). El cable debe tener una sección de al menos 0,75 mm² (AWG18).

PRECAUCIÓN

El TPS-compact no puede ser fijado mediante su base, ni mediante otras bridas que no sean de inlet.

ADVERTENCIA



Instalar el sistema de modo que se pueda interrumpir fácilmente la alimentación.

PRECAUCIÓN

Para permitir una correcta circulación del aire, asegure un espacio libre alrededor del sistema de al menos 20 cm y no cubra ni reduzca el espacio entre la base del TPS-compact y su superficie de apoyo.

Instrucciones de uso

Para instalar los accesorios opcionales, véase "Technical Information".
En este apartado se citan los procedimientos operativos principales.
Antes de usar el sistema realizar todas las conexiones eléctricas y neumáticas.
Durante el posible calentamiento de la cámara de vacío, la temperatura de la brida de entrada no ha de ser superior a 120 °C con una fijación con brida ConFlat y a 80 °C con una fijación con brida ISO.

ADVERTENCIA



No hacer funcionar nunca el sistema de bombeo si la brida de entrada no está conectada a la cámara de vacío o no está cerrada con la brida de cierre.

ADVERTENCIA



No tocar la turbobomba y sus posibles accesorios durante las operaciones de calentamiento. La alta temperatura puede provocar lesiones a las personas.

ADVERTENCIA



Evitar los golpes o bruscos desplazamientos de la turbobomba cuando está en marcha. Los rodamientos se podrían dañar y se podrían verificar daños a las personas o a las cosas.

PRECAUCIÓN

Para el "envío al aire" de la bomba utilizar gas inerte exento de polvo, partículas y humedad (por ej.: nitrógeno). La presión de entrada a través de la respectiva puerta debe ser inferior a 2 bares (por encima de la presión atmosférica).

ADVERTENCIA



No utilice el sistema de bombeo en presencia de gases explosivos, tóxicos, inflamables o radiactivos.

Conexión de la brida de alto vaciado

Si el rotor se detiene de repente, la torsión resultante debe ser absorbida por las herramientas que fijan la brida de vacío alto.

Los tornillos y herramientas deben cumplir la siguiente especificación.

ADVERTENCIA



Es obligatorio conecta la bomba de manera que pueda soportar la torsión especificada en la sección "Montaje de TPS-compact". Preste especial atención al diseño de la pinza, los materiales de las pinzas y tornillos y la torsión de fijación del tornillo.

Utilice solo pinzas (o tornillos) de clase de resistencia alta ≥ 8.8 .

ADVERTENCIA



Si la bomba está fijada a una cámara de vacío con bridas diferentes a las recomendadas por Agilent, es posible que el TPS-compact se tuerza o se rompa si el rotor se detiene de repente. La combinación de diferentes tipos de bridas no está permitida. Agilent no aceptará ninguna responsabilidad por daños resultantes de una sujeción incorrecta.

Instalación de la brida ISO-K

Para las conexiones de brida ISO-K, sujete las dos bridas con el modelo de pinzas IC63250DCMZ o equivalente, como se muestra en la figura siguiente (se puede utilizar una pantalla de protección opcionalmente).



Figura 18

Utilice el número de pinzas de garra requerido:

- 4 para brida ISO 63
- 4 para brida ISO 100
- 4 para brida ISO 160

Ajustar los tornillos con un par de 22 Nm.

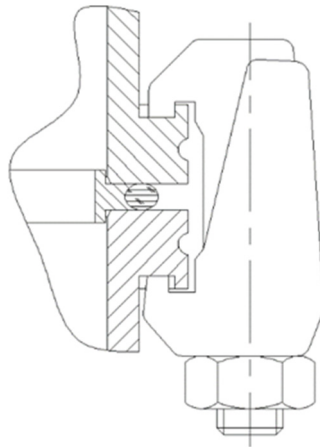
Instalación de la brida ConFlat

Per i collegamenti delle flange ConFlat, fissare le due flange con le viti come mostrato nella figura seguente (è possibile utilizzare facoltativamente uno schermo protettivo).



Figura 19

Utilice el número de tornillos requerido:

- 16 para CFF 6"
- 20 para CFF 8"

Fije las unidades y apriete cada tornillo a su vez. Vuelva a apretar en secuencia hasta que las caras de la brida se encuentren. Apriete los tornillos con una torsión de 20 Nm. Para la brida ConFlat le recomendamos que use solo tornillos de acero de alta resistencia.

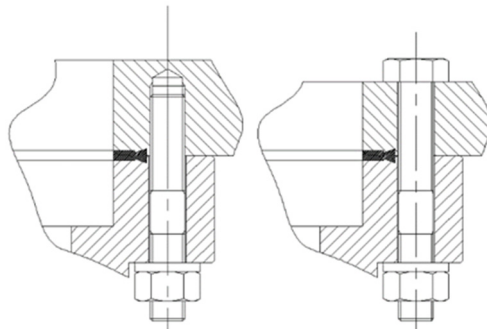
Para facilitar el montaje y desmontaje es opcional aplicar lubricante de alta temperatura.

Felpro C-100 a las roscas de los tornillos que sobresalgan de la brida y entre las roscas y la brida.

En algunos casos, las conexiones solo pueden hacerse con el tornillo en la cara inferior.

PRECAUCIÓN

Tenga cuidado cuando apriete las tuercas y tornillos para evitar abollar la carcasa de la bomba turbomolecular

Puesta en marcha y funcionamiento de TPS-compact

Controlar la tensión de entrada presente en la etiqueta Agilent fijada al chasis de la unidad electrónica del sistema.

Para encender el TPS-compact a través de los controladores abordo o los mandos a distancia, conecte la bomba al controlador, proporcione la tensión de alimentación correcta al controlador y actúe en las señales "START" e "INTERLOCK" (situadas en la interfaz del controlador).

ADVERTENCIA



El arranque inicial de la bomba TwisTorr 305 FS estará en modo "Arranque suave"; para más información sobre este modo, consulte la sección dedicada.

El LED azul "STATUS" situado en el panel trasero de la base del TPS-compact indica, con la frecuencia de su parpadeo, las condiciones operativas del sistema:

- encendido fijo: la bomba está en rotación normal;
- parpadea lentamente (período de 400 ms aproximadamente): el sistema está en estado de rampa, o de frenado, o de stop;
- parpadea rápidamente (período de 200 ms aproximadamente): situación de error.

Una descripción detallada del panel de control del TPS-compact aparece en la sección "Technical Information".

Arranque suave

ADVERTENCIA



Para asegurar la lubricación correcta de los cojinetes de la bomba, en la primera aceleración, la bomba debe iniciarse en modo de arranque suave.

Esta modalidad de inicio (Arranque Suave) asegura que la bomba alcanza la velocidad de manera uniforme y permite una lubricación adecuada de los cojinetes.

La unidad de control conectada a la bomba ya está configurada por defecto para hacer funcionar la bomba (sólo en la primera puesta en marcha de la unidad de control). En caso de utilizar una bomba nueva con una unidad de control usada, recuerde configurar manualmente el modo de arranque suave.

El modo de arranque suave tardará más tiempo comparado con el arranque normal; el usuario debe esperar a que la bomba haya alcanzado la velocidad completamente antes de detener la bomba.

Después del primer arranque, la unidad de control no iniciará la bomba en el modo de arranque suave de nuevo.

NOTA

Después de un periodo de inactividad largo (60 días o más), para permitir de nuevo la redistribución correcta de la grasa presente en los cojinetes, es necesario arrancar la bomba mediante el modo de arranque suave de nuevo.

ADVERTENCIA



Consulte los manuales de instrucción correspondientes del controlador para encontrar las instrucciones adecuadas para activar el modo de arranque suave (Remote: Chapter Technical Information – Controller Connection & Window Meanings ; On Board: Chapter Technical Information – Interconnections & Window Meanings).

Parada del TPS-compact

Para detener el TPS-compact basta disponer el interruptor externo en posición OFF. El controlador incorporado detiene inmediatamente el sistema de bombeo.

ADVERTENCIA



Antes de realizar cualquier trabajo en el sistema, desconecte de la fuente de alimentación, descargue la bomba con la válvula de descarga, espere hasta que el rotor esté completamente detenido y espere hasta que la temperatura de la superficie de la bomba esté por debajo de 50°C.

Parada de emergencia

La parada de emergencia puede conseguirse extrayendo la fuente de alimentación.

ADVERTENCIA



Este modo debe ser utilizada solo en caso de emergencia. El uso de este modo de parada podría llevar a fallos y/o daños en la bomba. El uso indebido de este modo de parada podría anular la garantía.

Mantenimiento

El TPS-compact no requiere ningún mantenimiento (a excepción de la sustitución del Tip-seal). Cualquier trabajo debe ser realizado por personal autorizado.

En caso de avería se podrá utilizar el servicio de reparación Agilent.

Si un sistema debe ser descartado, asegúrese de que se cumplen las normativas locales para la eliminación adecuada.

Vida del rotor

La resistencia a la fatiga del rotor de la bomba turbomolecular depende en gran medida del tamaño de la bomba. Consulte el manual específico de la bomba para conocer el valor correcto (número de ciclos de aceleración desde la parada a la velocidad máxima y de regreso a la parada). Como medida de precaución, considerando el uso típico de la bomba y teniendo en cuenta los límites de seguridad, Agilent recomienda devolver el sistema después de 17 años de uso para mantenimiento.

Limpieza

La superficie exterior de la superficie exterior del TPS-compact puede ser limpiada con detergente suave solamente puede ser limpiada con detergente suave solamente.

Eliminación

Significado del logo "WEEE" que se encuentra en las etiquetas.

El siguiente símbolo se aplica de acuerdo con la Directiva WEEE (Residuos de Aparatos Eléctricos y Electrónicos, por sus siglas en inglés) de la CE.

Este símbolo (válido solo en los países de la Comunidad Europea) indica que el producto en el que se aplica NO debe desecharse con la basura doméstica o industrial común, sino que debe enviarse a un sistema de recolección diferenciada. Se invita al usuario final a comunicarse con el proveedor del dispositivo, ya sea directamente con la Casa Matriz o con un revendedor, para iniciar el proceso de recolección y eliminación después de verificar las condiciones contractuales de venta.



Figura 20 Logotipo "WEEE"

Para más información, consulte:

<http://www.agilent.com/environment/product/index.shtml>

Servicio

Si un cliente necesita un servicio de intercambio avanzado o reparación, contacte con un distribuidor local o contacte por correo a:

vpt-customer-care@agilent.com

vpl-customer-care@agilent.com

Es obligatorio completar la "Request for Return" para devolver su bomba a Agilent para mantenimiento (proporcionada al final del presente manual).

5

使用说明

关于本手册	110
有效性	110
定义与术语	111
小心、警告和注意的定义	111
警告符号	112
安全	114
正确使用	114
使用不当	115
防护设备	116
涡轮分子泵安全指南	117
运输及存储	118
产品描述	119
安装	120
安装准备	120
设置	121
TPS-compact 的安装	122
高真空法兰的连接	124
ISO-K 法兰的安装	125
ConFlat 法兰的安装	126
TPS-compact 的启动和运行	127
慢启动	128
停止 TPS-compact	129
紧急停止	129
维护	130
转子寿命	130
清洁	130
处置	131
服务	132

关于本手册

有效性

本手册列出 TPS-compact 用户说明，特别注意与安全、操作和一级维护有关的注意事项，受用户负责的维护操作限制。

维护操作在特定章节中说明，对于更高等级的维护设有具体规定（接受过维护操作专门培训的人员），用户不得执行此类操作。

有关正确的安装和启动/停止，请参阅“安装”章节。

要正确安装和启动/停止，请参考“Technical Information”章节。

注意

- 1 本手册包含有用信息，确保所有使用 TPS-compact 的人员可以安全操作，在设备整个寿命期内发挥完美效率。
- 2 将本手册和所有相关出版物放在所有操作员、维护人员方便访问的位置。

定义与术语

小心、警告和注意的定义

本手册的一些重要参考内容用背景色突出显示。

小心

程序开始前，提示小心消息，如果不遵守过程指示，可能导致设备损坏。

警告



警告消息提醒操作员注意特定过程或做法，如果执行错误，可能导致人员重伤。

注意

注意旨在让人注意重要信息，提供具体步骤的更多详细信息。

警告符号

以下是在 TPS-compact 上与警告一起显示的符号列表。还显示了这些符号所指的危险。

三角形符号表示警告。在文档或仪器警告旁边可能出现的符号含义如下：



保护接地端子



请勿触摸



欧洲符合性声明



一般危险



表示危险电压



表面较热



生产现场



电源关闭



电源开启

RoHS

有害物质认证限制



UK CA 打標

使用说明

以下符号可用作附在仪器上的警告标签。当您看到此符号时，请参阅相关操作或维修手册，了解该警告标签所指的正确操作过程。



以下符号会出现在仪器上供您参考。

	一般危险
	CE认证
	CSA 认证
	RoHS中国认证
	废弃电气和电子设备
	UK CA 打標

安全

本节包含机械指令 2006/42/EC 规定的信息，这些信息对于遵守常规安全法规以及机器特定用途相关安全法规至关重要。

不遵守这些说明或本手册的其他说明，将导致设计阶段设想的安全条件无效，操作员可能发生事故。

对于不遵守技术文档中的安全规定而导致的机器损坏或者操作员或第三方人身伤害，Agilent Technologies 不承担任何责任。

正确使用

本手册包含机器安全工作需要遵守的重要警告和安全说明。

本手册所述产品仅用于本手册指定的应用领域。手册还规定了产品应用和操作基本要求相关的说明，以及可确保正常运行的安全措施。对于将产品用于非本手册介绍的用途或者产品使用过程中不遵守基本要求和安全措施，Agilent Technologies 不承担任何责任。

必须由能够采取必要安全措施，不会导致损坏或受伤的具备资质人员使用产品。产品的配套配件和设备必须由 Agilent Technologies 提供或授权使用。

必须由了解相关风险的专业技术人员执行任何调整或维护操作。

必须由 Agilent 授权人员执行产品维修。

使用不当

对于因不正确使用 TPS-compact 而造成的任何后果，安捷伦科技公司 (Agilent Technologies) 不承担任何责任。

使用不当将导致所有责任保证和索赔保证失效。使用不当的定义为：

- 使用未指定的安装材料安装泵
- 泵送氧化性、腐蚀性气体，但没有适当的废液排空
- 泵送爆炸气体
- 泵送冷凝蒸汽
- 泵送液体
- 泵送粉尘
- 气体产量过高的情况下作业
- 前真空压力过高的情况下作业
- 使用与实际使用的气体不同的选定气体方式进行操作
- 高热输入运行
- 磁场过高的情况下作业
- 使用过高的通风速率进行通风
- 使用真空泵来产生压力
- 在电离辐射区域运行设备
- 在潜在爆炸区作业
- 明知系统会受其影响，依然在应力和振动导致周期性重复出现冲击和力作用的环境中
使用系统。

防护设备

进行或执行泵送系统维护的操作员必须始终使用适合操作类型的防护设备。

此外，它必须符合使用机器所在国家的现行立法安全要求。

通常，操作员在操作TPS-compact时和安装过程中必须穿防事故鞋。

警告

维护或安装时危险物质导致的健康危险。



- 根据流程特性，真空泵、组件或工作流体可能被有毒、反应性或放射性物质污染。
- 维护维修或重新安装时，穿戴合适防护设备。

警告

掉落物体导致受伤的风险

手动运输真空泵时，存在重物滑动和掉落的风险。



- 双手搬运中小型真空泵。
- 如果设备重量超过 20 kg，应使用合适的起吊设备运输。
- 穿着符合指令 EN 347，并带有铁鞋头的安全鞋。

小心



锋利边缘导致受伤的风险

涡轮泵的转子和定子盘具有非常锋利的边缘



- 在维修泵之前，或在泵从系统中执行任何安装/拆卸操作之前，等待泵完全停止。
- 不要直接在高真空法兰内操作。
- 如有必要，请按照 EN 420 佩戴防护手套。

涡轮分子泵安全指南

以下操作手册中描述的涡轮分子泵包含大量动能，因为旋转速度高，加上转子拥有特定质量。

在泵的机械部件发生故障的情况下，旋转能量可能会释放到泵所固定的任何位置（见段落“ConFlat 法兰的安装”“ISO-K 法兰的安装”）。

警告



为避免损坏设备并防止操作人员受伤，应严格遵守本手册中提供的安装说明！

警告



当使用泵抽吸有毒、易燃或放射性气体时，请遵循每种气体处理所需的程序。该泵旨在泵送高吞吐量的 **N₂ Ar** 和较轻的气体。如果您需要泵送比氩气 **Ar** 重的气体，请联系安捷伦技术支持以获取信息。

TPS-compact 不适用于存在侵略性、腐蚀性或爆炸性气体的环境。

运输及存储

为了保证安捷伦涡轮分子泵的最高性能和可靠性，必须遵循以下准则以避免出现冷凝的情况。

- 运输、移动和存储泵时，不应超出以下环境条件：
 - 温度范围：参考单个TPS-compact组件手册
 - 相对湿度范围：参考单个TPS-compact组件手册
- 涡轮分子泵在首次由客户接收和操作时必须进行慢启动。
- 涡轮分子泵必须在泵处于非活动状态的 60天月后进行慢启动。

小心

如果由于任何原因超过保质期，必须将泵退回工厂。请联系当地的安捷伦真空销售和服务代表以了解相关信息。

警告



处理重部件时要格外小心。建议两人一起将其抬起。

如果未在两人一起抬起的情况下进行操作，可能会导致人身伤害。

产品描述

TPS-compact 是一款涡轮分子泵，适用于高真空和超高真空应用，能够泵送任何类型的非腐蚀性和氧化性气体或气体化合物。

TPS-compact 是一个带有涡轮分子泵的集成系统（TwisTorr 74 FS、Twistorr 305 FS）适用于与其相关控制器及其主泵相关的高真空和超高真空应用。该系统可以泵送任何类型的氣體或氣體化合物。不適用於泵送液體或固體顆粒。

泵送作用通过由高性能电机驱动的高速涡轮（最大 70000 rpm）获得。它不含污染物，因此适用于需要“清洁”真空的应用。

TPS-compact 还具有辅助连接器，通过它可以 通过主机远程驱动它 通过串行线连接。

详细信息可参考“技术信息”章节。

安装

安装准备

TPS-compact 具有特殊的保护包装。如果表现出在运输过程中可能发生损坏的迹象，请联系您当地的销售办事处。

避免因放下 TPS-compact 造成突然撞击。请注意保存好包装盒，以便在存放时间过长或运输时重复使用。

请勿以未经授权的方式处理包装材料。该材料是100%可回收的，符合EEC指令 94/62号和随后颁布的修正案。

小心

为防止出现脱气问题，请勿赤手操作 会暴露在真空中的组件。始终使用手套或其他适当的保护措施。



图 21

注意

正常暴露于环境中不会损坏 TPS-compact。不过，还是建议将其密封在塑料袋中，直到安装到系统中为止，从而防止灰尘对其造成任何形式的污染。

设置

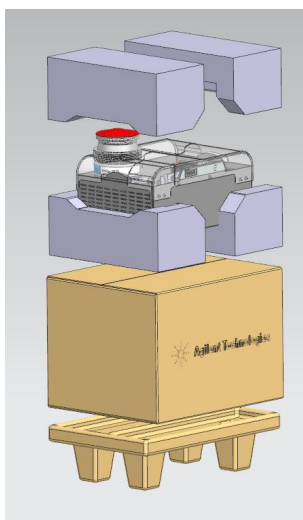
小心

在准备好将涡轮泵安装到系统中之前，请勿拆下粘合剂和保护盖。



图 22

仅将本设备安装在室内，请勿在暴露于大气物质（雨、冰、雪）、灰尘、腐蚀性气体或爆炸性环境或高火灾风险的环境中使用泵。

在操作过程中，必须遵守以下环境条件，以避免冷凝：

- 最大压力：高于大气压 2 bar
- 温度：参考单个TPS-compact组件手册
- 湿度范围：参考单个TPS-compact组件手册。

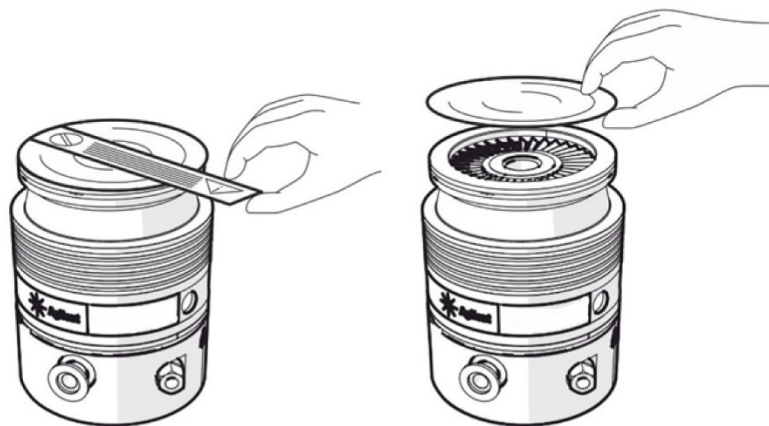
在存在磁场的情况下，必须使用铁磁屏蔽来保护泵送系统。

TPS-compact 的安装

警告



如果不遵守这些安装说明可能会导致泵在转子发生故障时与系统分离，从而导致财产损失或严重伤害或死亡。

TPS-compact 只能安装在垂直位置。

TPS-compact 可安装在任何位置。将 TPS-compact 固定在稳定位置，将涡轮泵的进气法兰安装到系统对接法兰上。

带有 ConFlat 和 ISO K 入口法兰的涡轮泵必须通过适当的安捷伦硬件固定在真空室上。

有关详细信息，请参阅“ConFlat 和 ISO K 的安装”章节。

电源线：正确的电线电缆是三芯 (Ph+N+Earth) 电缆。电线截面必须至少为 0.75 mm^2 (AWG18)。

小心

TPS-compact 不能通过其底座或其他非入口法兰固定。

警告



系统必须以能够轻松中断线路电压的方式进行安装

小心

为了保证适当的空气流通，请确保系统周围至少有 **20 厘米** 的自由空间，并且不要覆盖或减少 **TPS-compact** 底座与其支撑平面之间的空间。

使用说明

有关可选附件的安装，请参见“技术信息”章节。

本段详细介绍了基本操作程序。

在使用系统之前，进行所有电气和气动连接。在加热真空室时，入口法兰的温度不得超过 120° C（使用 ConFlat 法兰）和 80° C（使用 ISO 法兰）

警告



当涡轮进气法兰未连接到真空室或未封闭时，切勿使用泵系统。

警告



请勿在加热过程中接触涡轮分子泵或其任何附件。高温可能会导致灼伤

警告



避免泵在运行时受到冲击或发生剧烈运动。轴承可能会损坏，并可能对人体或物品造成损害。

小心

使用不含灰尘、颗粒或湿气的惰性气体（如氮气）为泵排气。排气口的压力必须小于 2 bar（高于大气压）

警告



不要在存在爆炸性、有毒、易燃或放射性氣體的情況下使用泵系統。

高真空法兰的连接

如果转子突然停止，则必须通过紧固高真空法兰的硬件来吸收产生的扭矩。
螺栓或硬件必须符合以下规格。

警告



必须以能够承受“**TPS-compact** 的安装”部分中指定的扭矩的方式连接泵。
特别注意卡箍的设计、卡箍和螺栓的材料和螺栓固定扭矩

仅使用高电阻级夹具（或螺栓） = 8.8。

警告



如果泵固定在真空室上，其法兰与安捷伦推荐的法兰不同，则转子突然停止时，TPS-compact 将会有 扭曲或撕裂的可能性。不允许将不同法兰类型组合使用。安捷伦对因紧固不当造成的所有损害不承担任何责任。

ISO-K 法兰的安装

对于ISO-K法兰连接，请使用下图所示的IC63250DCMZ型夹具或等效夹具固定两个法兰（可选使用保护屏）。



图 23

使用所需数量的夹钳：

- 4 表示 ISO 63 法兰
- 4 表示 ISO 100 法兰
- 4 表示 ISO 160 法兰

用22 Nm的扭矩拧紧螺栓

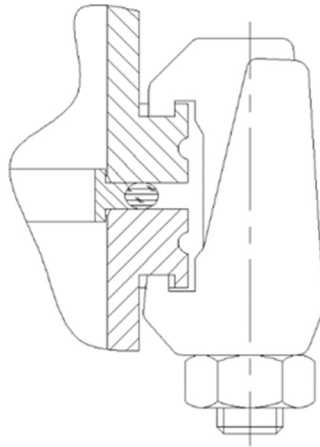
ConFlat 法兰的安装

对于ConFlat法兰连接，请如下图所示用螺钉固定两个法兰（可以选择使用保护屏）。



图 24

使用所需数量的螺钉：

- 16 表示CFF 6"
- 20 表示 CFF 8"

连接装置并依次**拧紧**每个螺钉。重复**顺序拧紧**，直到法兰面相重合。以 20 Nm 的扭矩**拧紧**螺钉。

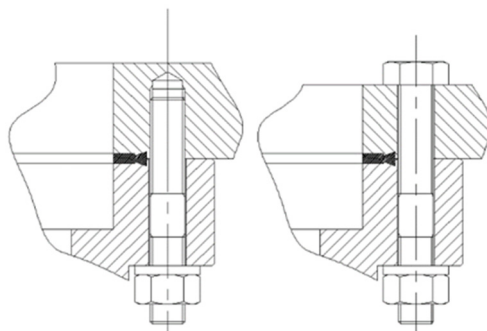
对于 ConFlat 法兰，我们建议仅使用**高强度钢螺栓**。

为了便于**组装和拆卸**，可以**选择**将Felpro C-100**高温润滑剂**涂在**法兰突出的螺母上**以及**螺母与法兰之间的螺纹上**。

在某些情况下，只能使用**下侧的螺栓**进行连接。

小心

拧紧螺母和螺栓时要小心，以免在涡轮分子泵壳上产生凹痕。

TPS-compact 的启动和运行

检查粘贴在 Agilent 标签上的输入电压 到系统电子单元的底盘。

如要启动TPS-compact，只需提供主电源、再将外部开关移到ON位置就可以了。集成控制器会自动识别主电源并启动泵。

警告



TwisTorr 305 FS 泵的初始启动将处于“软启动”模式；有关此模式的详细信息，请参阅其专用章节。

位于TPS-compact底座后面板上的蓝色LED灯“STATUS”以其闪烁频率指示系统运行状况:

- 无闪烁：泵正常旋转；
- 慢闪（周期约400 ms）：系统处于斜坡、制动、停止或“等待联锁”的状态；
- 快速闪烁（周期约200 ms）：错误状态。

有关TPS-compact控制面板的详细说明，请参见附录的“技术信息”章节。

慢启动

警告



为确保泵轴承的正确润滑，在第一次加速时，泵必须在“慢启动”模式下启动。

这种启动方式（慢启动）可确保泵平稳地达到转速，并对轴承进行适当的润滑。

连接到泵的控制单元具有运行泵的默认设置（仅在第一次启动控制单元时）。

如果将新泵与使用过的控制单元一起使用，请记住手动设置慢启动模式。

与标准启动相比，慢启动模式需要更长的时间；用户必须等待泵完全达到转速，然后才能停止泵。

第一次启动后，控制单元不会再次在慢启动模式下启动泵。

注意

长时间不活动（60 天或更长时间）后，为了再次正确重新分配轴承中的润滑脂，有必要通过慢启动模式再次启动泵。

警告



请参阅控制器的相关说明手册，以找到激活“慢启动”模式的适当说明集（远程：技术信息-控制器连接和窗口含义的章节；板载：技术信息-互连和窗口含义的章节）。

停止 TPS-compact

如要关闭TPS-compact，将外部开关移到OFF位置就可以了。集成控制器会立即停止泵送系统。。

警告



在对系统进行任何操作之前，将其从电源断开，用排气阀向泵排气，在转子完全停止后，等待泵的表面温度降低到 50°C 以下。

紧急停止

如要在紧急情况下立即停止TPS-compact，必须从电源插头上拔下电源线或将外部开关移至OFF位置。

警告



此模式仅在紧急情况下使用。使用此停止模式可能导致泵出现故障和/或损坏。不正确使用此停止模式可能会使保修失效。

维护

TPS-compact 不需要任何维护（除了更换尖端密封件）。任何工作必须由授权人员进行。

如果出现故障，请联系您当地的安捷伦服务中心。

如果需要废除系统，请确保在遵守当地法规的情况下进行适当处置。

转子寿命

渦輪分子泵轉子的抗疲勞性在很大程度上取決於泵的尺吋。有關正確值（從停止到全速再到停止的加速循環數），請參閱特定的泵手冊。

考慮到泵的通常使用情況以及安全限制，作為預防措施，安捷倫建議在使用 17 年後退回泵以進行維護。

清潔

TPS-compact 的外表面只能用溫和的清潔劑清潔。

处置

标签中的“WEEE”徽标含义。

按照 EC WEEE（废电子电气设备）指令应用以下符号。

此符号（仅在欧盟国家有效）表示所适用产品不得与家庭或工业垃圾一起处置，必须送至专门废弃物回收系统。因此，欢迎最终用户联系设备供应商（无论是母公司还是零售商），在检查销售合同条款后启动回收和处置流程。



图 25 “WEEE” 徽标

有关更多信息，请参考：

<http://www.agilent.com/environment/product/index.shtml>

使用说明

服务

如果客户需要高级替换或维修服务，请联系当地经销商或直接发送邮件至

vpt-customer@agilent.com

vpl-customer@agilent.com

需要填写“Request for Return”表才能将泵退回到 Agilent 维修部门（在本手册末尾会提供）。

6

取扱説明書

この説明書について	134
有効期	134
定義と用語	135
警告・注意・注の定義	135
警告の記号	136
安全性	138
適切な使用	138
不適切な使用	139
保護用装備	140
ターボ分子ポンプ用安全ガイドライン	141
輸送と保管	142
製品説明	143
取り付け	144
取り付けの準備	144
セットアップ	145
TPS-compact 実装	146
高真空フランジの接続	148
ISO-K フランジの取り付け	149
ConFlat フランジの取り付け	150
TPS-compact コンパクトの起動と操作	151
ソフトスタート	152
TPS-compact コンパクトを停止する	153
非常停止	153
メンテナンス	154
ローターの寿命	154
クリーニング	154
処分	155
サービス	156

この説明書について

有効期

本説明書には、特に安全、操作手順およびユーザーに必要なメンテナンス手順のみの簡易メンテナンスに関連する考え方を参考に、TPS-compact の使用方法をユーザーに説明します。

高度なメンテナンス（メンテナンス手順の個別訓練を受けた人員）に関連した各条項とあわせて、各セクションで説明するメンテナンス手順は、ユーザーは行わないでください。

正しい取り付けと起動/停止については、「取り付け」の章をご確認ください。

正しい取付および始動/停止については、「Technical Information」セクションを参照してください。

注

- 1 本説明書には、TPS-compact を使用する人員がすべて安全に使用でき、また機器使用寿命中に効率よく使用できるのに、役立つ情報が記載されています。
- 2 本説明書は、関連するすべての刊行物とあわせて、オペレータ/メンテナンス要員に分かりやすい、取り扱いしやすい場所に保管してください。

定義と用語

警告・注意・注の定義

このマニュアルのいくつかの重要な参照部は、対比色でハイライトされ枠で囲ってあります。

注意

「注意」のメッセージは、もし監視されていない場合に装置に損害が生じる可能性を示しています。

警告



「警告」のメッセージは、もし正しく操作されない場合に、重大な人身障害につながる可能性がある特定の操作や実行への操作者の注意の必要性を示しています。

注

「注」は、重要な情報への注意喚起と特定の工程に関してのより詳細な情報を提供しています。

警告の記号

下記は、TPS-compact上の警告と併せて表示される記号のリストです。危険性の説明も記載されています。

三角の記号は警告を示しています。説明書内または装置上の警告記号と共に示される記号の意味は下記の通りです：



保護接地端子



触らないでください



CE適合宣言書



包括的な危険



危険な電圧



高温の表面



製造所



電源オフ



電源オン



EU RoHS指令認証



UK CAマーキング

取扱説明書

下記の記号は、装置に貼り付けられた警告ラベル上に使用されることがあります。もしこの記号を目視した場合、その警告ラベルに関する正しい工程のために、関連する操作またはサービスマニュアルを参照してください。



参考情報として、下記の記号は装置上に示されます。

	包括的な危険
	CE認証
	CSA 認証
	中国RoHS 指令認証
	廃電気・電子製品に関するEU WEEE指令
	UK CAマーキング

安全性

このセクションは、一般的、かつ機械の特定の使用に関する安全規定の遵守と監督に必須である機械指令（Machinery Directive 2006 / 42/ EC）の情報を含みません。

これらの指示とこのマニュアル内のその他の指示に従わなかった場合、設計時に予測された安全状態が非効率に損なわれ、機械を操作する者へ事故が生じる可能性があります。

アジレント・テクノロジー株式会社は、技術的な参照書に示された安全規定の不順守により派生した、機械または操作者もしくは第三者の身体的安全への損害・損傷の責任を全て拒否します。

適切な使用

このマニュアルは、装置一式が安全に機能するために遵守されるべき重要な警告と安全の手引きを含みます。

このマニュアルに説明されている製品は、説明書に特記されている分野への活用に限定した目的のものです。マニュアルはまた、製品の活用と操作に必須の要件に関する指示と標準の操作を保証するために適用される安全対策を提供します。アジレント・テクノロジー株式会社は、このマニュアル内説明されているもの以外の適用、または必須の要件や安全対策に注意が払われていない場合にいかなる保証も提供せず、またはいかなる責任も負いません。

製品は、損傷や怪我を生じさせない状況下において必要な安全対策を講じることができる有資格者のみ使用することができます。製品と共に使用されたいかなる付属品や機器も、アジレント・テクノロジー株式会社により共有もしくは承認されたものでなければなりません。

いかなる調整またはメンテナンスの操作は、リスクについて承知している専門家の技術者により実行されなければなりません。

製品の修理は、専らアジレント・テクノロジー株式会社により行われなければなりません。

不適切な使用

Agilent Technologiesは、TPS-compactコンパクトの不適切な使用に起因する責任を負いません。

不適切な使用は、責任と保証への全ての請求権が喪失します。不適切な使用は下記の通り定義されます：

- 不特定の取り付け用具を使用したポンプの取り付け
- 適切な廃棄フローの排出なしに、酸化性ガス、腐食性ガスを汲み上げること
- 爆発性のガスをポンプすること
- 凝縮した蒸気をポンプすること
- 液体をポンプすること
- 粉末をポンプすること
- 不適切な高ガス量での操作
- 不適切な高圧補助真空での操作
- 実際に使用されるガスのもとは異なる選択されたガスのモダリティでの操作
- 高レベルの入熱での操作
- 不適切な高い磁界での操作
- 不敵な高い通気率での通気
- 圧力を生じさせるための真空ポンプの使用
- 電離放射線の範囲内での機器の操作
- 潜在的に爆発性がある範囲での操作
- 圧力と振動が、システムに影響を与える定期的に繰り返される衝撃と力につながる環境でシステムを使用すること

保護用装備

ポンプシステムのメンテナンスを操作または実行している操作者の保護装置は、実行される操作タイプに常に適切なものでなければなりません。

更に、それは機械が使用される該当国の法律に準拠する安全上の必要条件に従うものでなければなりません。一般的に。

一般的に、操作者は TPS-compact を操作している時や取り付けの時に事故防止の靴を着用しなくてはなりません。

警告

メンテナンスまたは取り付け時に、有害物質による健康への危険。



- 過程の異常な点により、真空ポンプ、構成部分、または操作液は、有害物質、反応性物質、もしくは放射性物質に汚染される場合があります。
- メンテナンスや修理、もしくは再度取り付け時には適切で十分な保護装備を着用してください。

警告

装置の落下による損傷のリスク。



- 真空ポンプを手で運搬する場合、荷重が滑り落ちる危険があります。
- 両手で小型・中型の真空ポンプを運んでください。
 - 20 kg 以上のいかなる装置も、適切なリフトの機器を使用して運搬されなければなりません。
 - 指令 EN 347 にしたがって、爪先が鋼製の安全長靴を着用してください。

注意



鋭い縁による損傷のリスク。

ターボポンプのローターと固定子ディスクは、縁が非常に鋭くなっています。

- ポンプを修理する前、またはシステムからポンプのいかなる取り付け/取り外しをする前に、ポンプの完全な静止をお待ちください。
- 高真空フランジ内で直接操作しないでください。
- 必要に応じて、指令 EN 420 に従った保護手袋を着用してください。

ターボ分子ポンプ用安全ガイドライン

下記の操作マニュアルに説明されるターボ分子ポンプは、それらローターの特定の質量との組み合わせで高回転速度により大量の運動エネルギーを含有します。ポンプの機械的な部分の機能不良の場合、回転エネルギーはポンプが固定されているどの部分へも放出されています（セクションを参照 “ConFlatフランジの取り付け” と “SO-K フランジの取り付け”（セクションを参照 “ConFlatフランジの取り付け” と “ISO-K フランジの取り付け”））。

警告



装置の損傷と操作者の怪我を避けるために、このマニュアルに記載された取り付けの指示に厳密に従ってください！

警告



有毒ガス、可燃性ガス、または放射性ガスをポンプするためにポンプを使用する場合は、各ガス処理に必要な手順に従ってください。ポンプは、**N₂ Ar** とより軽いガスの高スループットをポンプするように設計されています。**Ar** より重いガスをポンプする必要がある場合は、詳細情報に関して Agilent の技術サポートへお問い合わせください。

TPS-compact コンパクトは、侵襲性、腐食性、または爆発性のガスが存在する環境での使用を想定していません。

輸送と保管

アジレントのターボ分子ポンプの最大レベルの性能と責任を保証するため、凝縮を避けるために下記のガイドラインに従わなければなりません：

- ポンプを輸送、移動、保存する時は、下記の環境仕様を超過してはいけません：
 - 温度範囲：単一TPS-compactコンポーネントのマニュアルを参照してください
 - 相対湿度範囲：単一TPS-compactコンポーネントのマニュアルを参照してください
- お客様がポンプを受け取ってから最初に操作する際には、ターボ分子ポンプは常にゆっくりと開始されなければなりません。
- ポンプを60日間以上使用していない場合、ターボ分子ポンプは常にゆっくりと開始されなければなりません。

注意

もしいかなる理由により保存可能期間を超過した場合、ポンプは工場へ返送されなければなりません。アジレントの現地の販売者やサービス担当者へ情報をお問い合わせください。

警告



重い部品の取り扱いには細心の注意を払ってください。持ち上げる場合は、2人で行うことを推奨します。

2人で持ち上げない場合、怪我をする可能性があります。

製品説明

この装置は専門家の使用向けで専門家により使用されることを対象としています。

TPS-compactは、ターボ分子ポンプを備えた統合システムです (TwisTorr 74 FS、Twistorr 305 FS) 関連するコントローラーとプライマリポンプに関連する高真空および超高真空アプリケーション用。このシステムは、あらゆるタイプのガスまたはガス化合物をポンプで送ることができます。液体や固体粒子のポンピングには適していません。

ポンプの動作は、高性能電子モータにより駆動し高速タービン (最大70000 rpm) により得られます。

汚染物質がなく、ゆえに「清潔な」真空を必要とする活用に最適です。

TPS-compactには、シリアル回線を介して接続されたホストコンピュータを使用してリモートサイトから制御される補助コネクタが装備されています。

より詳細な情報は、「技術的情報」のセクションに記載されています。

取り付け

取り付けの準備

TPS-compactは、特別に保護された梱包により供給されます。もしこれに輸送中に発生した可能性のある損傷の跡がある場合、現地の販売営業所へお問い合わせください。

落下等によるTPS-compactへの突然の衝撃は避けてください。長期間の保存または輸送の場合のために、梱包ボックスを保持するようにご注意ください。

許可されていない方法で梱包材料を破棄しないでください。材料は100%リサイクルが可能で、EEC指令94/62とそれに準ずる改正を遵守しています。

注意

ガス放出の問題を避けるために、真空中に露出される構成部を素手で取り扱わないでください。常に手袋やその他適切な保護製品をご使用ください。ガス放出の問題を防ぐために、真空中にさらされるコンポーネントを素手で取り扱わないでください。常に手袋やその他の適切な保護具を使用してください。



图 26

注

通常環境への露出は、TPS-compactを損傷しません。しかしながら、ちり・ホコリによるいかなる種類の汚染を防ぐので、システムに取り付けられるまでビニールの袋に密閉して保管することが推奨されます。

セットアップ

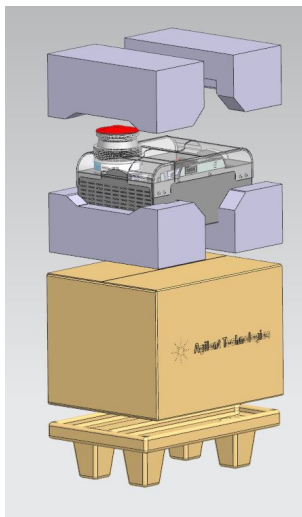
注意

システムヘターボポンプを取り付ける準備ができるまで、粘着材と保護キャップを取り外さないでください。



図 27

この機器は屋内でのみ取り付けてください。また、ポンプを大気物質（雨、氷、雪）、ちり・ホコリ、侵略的ガスなどに露出する環境、または爆発の可能性がある環境、または燃えやすい環境下では使用しないでください。

操作中、凝縮をさけるために下記の環境状況は遵守されなければいけません：

- 最大圧力：大気圧より2バール上
- 温度：単一TPS-compactコンポーネントのマニュアルを参照してください
- 相対湿度：単一TPS-compactコンポーネントのマニュアルを参照してください

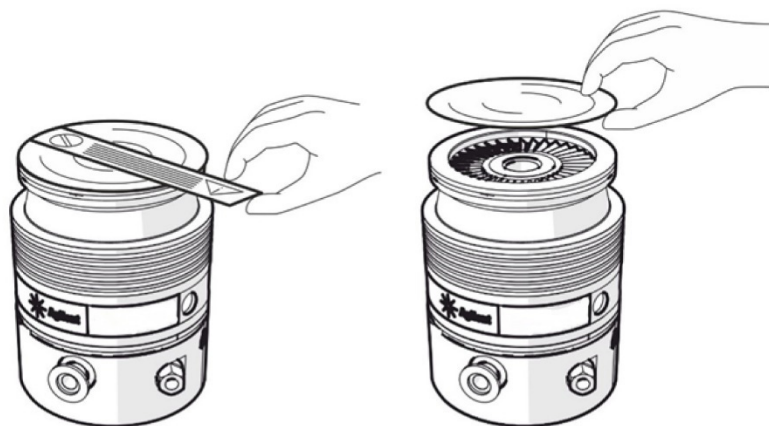
磁場が存在する環境下では、ポンプシステムは強磁性シールドを使用して保護する必要があります。

TPS-compact 実装

警告



これらの取り付け説明が遵守されなかった場合、ローターの故障の際にシステムからのポンプの分離を引き起こし、それにより土地建物が損害を受けるか、重大な損傷や死亡事故につながる可能性があります。

TPS-compactは、垂直位置にのみ取り付けすることができます。

TPS-compactを安定した位置に固定し、ターボポンプのインレットフランジをシステムのカウンターフランジに取り付けます。

ConFlat と ISO K 吸気フランジのターボポンプは、適切なアジレントのハードウェアを用いて真空チェンバーへ固定されなければなりません。

更なる詳細は、「ConFlatとISO Kの取り付け」セクションをご覧ください。

電源コード：電気配線用の正しいケーブルは、3線（Ph + N + Earth）ケーブルです。線の部分は、少なくとも0.75 mm² (AWG18) する必要があります。

注意

TPS-compact は、その基部またはインレットではない他のフランジを介して固定することはできません。

警告



システムは、線間電圧を簡単に遮断できるように設置する必要があります。

注意

適切な空気循環を可能にするために、システムの周囲全体に最低 **20 cm** の空きスペースを確保し、**TPS-compact** の土台とその支持平面の間のスペースを覆ったり縮小しないでください。

取扱説明書

オプションの付属品の取り付けについては、「技術情報」を参照してください。

この段落では、基本的な操作手順について詳しく説明します。

システムを使用する前には、すべての電気空気圧接続を行ってください。真空チャンバーを加熱している間、インレットフランジの温度は、ConFlatフランジで120° C、ISOフランジで80° Cを超えてはいけません。

警告



ターボインレットフランジが真空チャンバーに接続されていないか、または空になっていない場合は、ポンプシステムを使用しないでください。

警告



加熱プロセス中は、ターボポンプまたはその付属品に触れないでください。高温により火傷する可能性があります。

警告



操作中のポンプは、衝撃や激しい動きを避けてください。ベアリングが破損したり、人への損傷や物が破損したりする可能性があります。

注意

ポンプに放出するには、ほこり、粒子、または湿気（窒素など）のない不活性ガスを使用してください。ベントポートの圧力は2バール未満（大気圧以上）でなければいけません。

警告



爆発性、有毒、可燃性、または放射性ガスの存在下でポンプシステムを使用しないでください。

高真空フランジの接続

もしローターが突然停止した場合、結果として生じるトルクは高真空フランジを留めているハードウェアにより吸収されなければいけません。

ボルトまたはハードウェアは下記の仕様に適合していなければいけません。

警告



必ず「使用の説明」セクションに指定されているトルクに耐える方法でポンプを接続しなくてはなりません。特に、クランプのデザイン、材料、ボルト、ボルトの固定トルクに注意してください。

“TPS-compact 実装”のセクションで指定されたトルクに耐えられるようにポンプを接続する必要があります。特にクランプの設計、クランプとボルトの材質、ボルトの固定トルクに注意してください。

高い耐荷重性クラスのクランプ（またはボルト）を使用してください
≥ 8.8。

警告



もしポンプが、アジレントが推奨するものとは異なるフランジで真空チェンバー上に締め付けられた場合、ローターが突然停止した際にTPS-compact がねじ曲がるまたは引き裂かれる可能性があります。異なるフランジタイプの組み合わせは禁止されています。アジレントは不適切な締め付けにより生じた全ての損害・損傷にいかなる責任も負いません。

ISO-K フランジの取り付け

ISO-K フランジの接続には、下記の図に示される通り、クランプのモデル IC63250DCMZ または同等のもので2つのフランジを固定します（オプションとして保護スクリーンを使用できます）。



図 28

必要な個数のクロークランプを使用してください：

- ISO 63 フランジ - 4個
- ISO 100 フランジ - 4個
- ISO 160 フランジ - 4個

22 Nmのトルクでボルトを締めます。

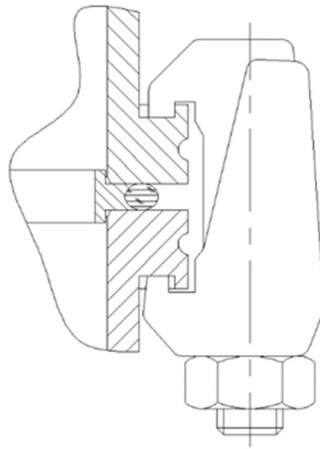
ConFlat フランジの取り付け

ConFlat フランジの接続には、下記の図に示される通り、2つのフランジをネジで固定します（オプションとして保護スクリーンを使用できます）。



図 29

必要な個数のネジを使用してください：

- CFF 6” - 16個
- CFF 8” - 20個

ユニットをくっつけ、交互に各ネジを締めます。フランジの面が合うまで引き続き締め付けを繰り返します。20 Nm のトルクでネジを締めます。

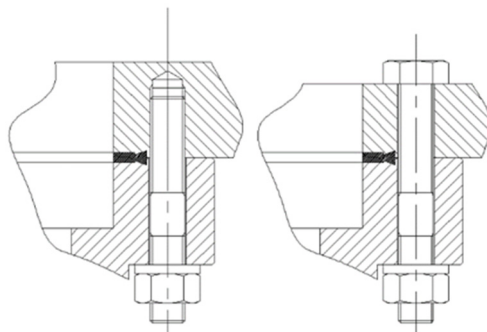
ConFlatフランジには、当社は高強度のスチールボルトのみを使用することを推奨します。

組み立てと解体を円滑にするため、オプションとしてFelpro C-100 高温潤滑剤をフランジから突き出ているネジ山と、ナットとフランジの間へ注入できます。場合によっては、下側ではボルトでのみ接続できます。

注意

ターボ分子ポンプのケーシングにへこみが生じないように、ナットとボルトを締めるときは注意してください。

TPS-compact コンパクトの起動と操作

システム電子ユニットのケースに貼られているAgilentラベルのシステム電圧を確認します。

TPS-compactコンパクトをオンに切り替えるには、主電源を供給してから、外部のスイッチをオンの位置に動かすだけで十分です。統合コントローラーは、主電源の存在を自動的に認識し、ポンプを起動します。

警告



TwisTorr 305 FS ポンプの最初の起動は「ソフトスタート」モードになります；このモードの詳細については、該当するセクションを参照してください。

TPS-compactコンパクトベースのリアパネルに表示される青色のLED「状態」は、点滅する頻度でシステムの動作状態を示します：

- 点滅がない：ポンプは正常に回転しています；
- ゆっくりと点滅 (約400ミリ秒の間隔)：システムがランプ中、ブレーキ中、停止中、または「インターロックを待機中」の状態です；
- 速く点滅 (約200ミリ秒の間隔)：エラー状態。

TPS-compact コンパクトのコントロールパネルの詳細説明については、付録「技術情報」を参照してください。

ソフトスタート

警告



最初のランプアップの際に、ポンプの軸受の適切な潤滑油を確保するには、ポンプは「ソフトモード」で開始されなければなりません。

この開始モダリティ（ソフトスタート）は、ポンプの速度を円滑にし、軸受の適切な潤滑を可能にします。

ポンプに接続されているコントロールユニットは、既にデフォルトによりポンプを作動するようセットアップされています。

（初回コントロールユニットの起動のみ）。

使用済みのコントロールユニットで新しいポンプを使用する場合には、手動でソフトスタートモードを設定することを忘れないでください。

ソフトスタートモードは、標準の起動開始よりも時間がかかります；使用者は、ポンプを停止する前にはポンプが最大速度になるまで待たなければなりません。

初回の開始後は、ポンプは再度コントロールユニットによるソフトスタートモードにはなりません。

注

長期間の不稼働状態（60 日間またはそれ以上）の後、軸受に残存している潤滑油の適切な再分配を可能するには、再度ソフトスタートモードでポンプを開始する必要があります。

警告



「ソフトスタート」モダリティを有効にする一連の適切な使用方法を探すには、コントローラーの関連する説明マニュアルを参照してください（リモートについて：技術的情報の章 - コントローラー接続 & ウィンドウの意味；搭載について；技術的情報の章 - 相互接続 & ウィンドウの意味）。

TPS-compact コンパクトを停止する

TPS-compactコンパクトをオフにするには、外部のスイッチをオフの位置に動かすだけで十分です。統合コントローラーは、ポンプシステムを即座に停止します。

警告



システム上でいかなる動作を実行する前に、電源供給を切り、通気弁でポンプを通気し、ローターが完全に停止して待ちポンプの表面温度が 50° C 以下になるまで待ってください。

非常停止

緊急時にTPS-compactコンパクトをただちに停止するには、電源ケーブルを主電源プラグから抜くか、または外部のスイッチをオフの位置に動かす必要があります。

警告



これは緊急時にのみ使用されるべきモードです。この停止モードの使用は、ポンプに障害及び/または損害が生じる可能性があります。この停止モードの不適切な使用は、保証が無効となりえます。

メンテナンス

TPS-compact はいかなるメンテナンスも必要ではありません（チップシールの交換を除く）。いかなる作業も有資格者によって実施されなければなりません

もしシステムを廃棄する必要がある場合、適切な破棄のために現地の条例に従うようご確認ください。

ローターの寿命

ターボ分子ポンプローターの耐疲労性は、ポンプのサイズに強く依存します。正しい値（停止から全速力へのランプアップおよび停止への復帰のサイクル数）については、特定のポンプのマニュアルを参照してください。

予防措置として、典型的なポンプの使用と安全制限を考慮に入れると、アジレントは17年間の使用後にメンテナンスのためポンプを返品することを推奨します。

クリーニング

TPS-compactコンパクトの外面は、中性洗剤のみ使用して掃除できます。

処分

ラベルに記載の“WEEE” ロゴの意味。

下記の記号は、EC WEEE（電気電子機器廃棄物）指令にしたがって適用されます。

この記号（EC 諸国内のみで有効）は、この記号が適用される製品は、通常の家
庭ゴミとあわせて処分してはいけないこと、また個別廃棄物回収システムに送付
しなければならないことを表します。そのため、エンドユーザーは、親会社か小
売業者かに関係なく、当該機器のサプライヤに連絡の上、契約上の販売条件の確
認後、回収および処分プロセスを開始することが求められます。



図 30 ロゴ“WEEE”

詳細は、下記サイトを参照してください。

<http://www.agilent.com/environment/product/index.shtml>

サービス

お客様が最新交換サービスまたは修理サービスが必要な場合は、現地代理店もしくは下記まで直接ご連絡ください：

vpt-customer@agilent.com

vpl-customer@agilent.com

“Request for Return”の申請の完了には、サービス提供のためにお客様のポンプをAgilentへ返送する必要があります。（このマニュアルの最後に提供されています）。

7

Instructions for Use

About this manual	158
Validity	158
Definitions and terminology	159
Definition of Caution, Warning and Note	159
Warning Symbols	160
Safety	162
Proper use	162
Improper use	163
Protective equipment	164
Safety guideline for Turbomolecular Pumps	165
Transport & Storage	166
Product description	167
Installation	168
Preparation for installation	168
Set-up	169
TPS-compact Mounting	170
Connection of the High Vacuum Flange	172
Installation of ISO-K Flange	173
Installation of ConFlat Flange	174
Startup and Operation of the TPS-compact	175
Soft Start	176
Stopping the TPS-compact	177
Emergency stop	177
Maintenance	178
Rotor life	178
Cleaning	178
Disposal	179
Service	180

About this manual

Validity

This manual lists the instructions for the users of the TPS-compact, with particular reference to the notions relating to safety, operation and first level maintenance, limited to maintenance operations for which the user is responsible.

The maintenance operations, illustrated in the specific sections, with specific provisions relating to the higher level of maintenance (personnel specifically trained for maintenance operations) must not be carried out by the user.

For a correct installation and start/stop, please refer to "Installation" section.

Detailed information is supplied in the "Technical Information" section.

NOTE

- 1 This manual contains useful information so that all personnel using the TPS-compact can operate it safely and guarantee perfect efficiency, for its entire life span.
 - 2 Keep this manual, together with all the related publications, in an accessible place known to all operators/maintenance personnel.
-

Definitions and terminology

Definition of Caution, Warning and Note

Some important references of this manual are highlighted and framed in contrasting color.

CAUTION

Caution messages are displayed before procedures which, if not observed, could cause damage to the equipment.

WARNING



Warning messages draw the operator's attention to a specific procedure or practice which, if not performed correctly, could result in serious personal injury.

NOTE

Notes are intended to call attention to important information and provide more detail regarding specific steps.

Warning Symbols

The following is a list of symbols that appear in conjunction with warnings on the TPS-compact. The hazard they describe is also shown.

A triangular symbol indicates a warning. The meanings of the symbols that may appear alongside warnings in the documentation are as follows:



Protective Ground Terminal



Do Not Touch



European Declaration of Conformity



Generic hazard



Dangerous voltages



Hot surfaces



Manufacturing Site



Power OFF



Power ON



Restriction of Hazardous Substances certification



UK CA Marking

Instructions for Use

The following symbol may be used on warning labels attached to the instrument. When you see this symbol, refer to the relevant operation or service manual for the correct procedure referred to by that warning label.



The following symbols appear on the instrument for your information.

	Generic hazard
	CE certification
	CSA certification
	RoHS China certification
	Waste Electrical and Electronic Equipment
	UK CA Marking

Safety

This section contains the information, prescribed by the Machinery Directive 2006/42/EC, which is essential for the compliance and observance of the safety regulations both generally and in relation to the specific use of the machine.

Failure to comply with these instructions and the other instructions contained in this manual may render the safety conditions envisaged in the design phase inefficient and cause accidents to those operating the machine.

Agilent Technologies declines all responsibility for damage to the machine or for the physical safety of the operator or third parties deriving from the non-observance of the safety rules indicated in the technical documentation.

Proper use

This manual contains important warnings and safety instructions to be observed in order for the unit to work safely.

The product described in this manual is intended exclusively for the area of application specified in the instructions. The manual also provides indications regarding the essential requirements for the application and operation of the product as well as the safety measures that can be adopted to guarantee regular operation. Agilent Technologies does not provide any guarantee or assume any responsibility for applications other than those described in this manual or in which the essential requirements and safety measures are not respected.

The product must only be used by qualified personnel who are able to take the necessary safety measures under conditions that do not cause damage or injury. Any accessories and equipment used with the product must be supplied or approved by Agilent Technologies.

Any adjustment or maintenance operation must be performed by a professional technician informed about the risks.

Repairs on the product must be carried out exclusively by Agilent authorized personnel.

Improper use

Agilent Technologies declines all responsibility, deriving from the improper use of the TPS-compact.

Improper use will cause all claims for liability and warranties to be forfeited. Improper use is defined as:

- installation of the pump with unspecified mounting material
- pumping corrosive and oxidizing gases
- pumping of explosive gases
- pumping of condensing vapors
- pumping of liquids
- pumping dust
- operation with improper high gas throughput
- operation with improper high fore-vacuum pressures
- operation with selected gas modality different from the gas actually used
- operation with high levels of heat input
- operation in improper high magnetic fields
- venting with improper high venting rates
- use of the vacuum pump to generate pressure
- operation of the device in areas with ionizing radiation
- operation in potentially explosive areas
- using the system in an environment where stresses and vibrations lead to periodically reoccurring shocks and forces.

Protective equipment

The protective equipment of the operators who are operating or executing the maintenance of the pumping system must always be adequate for the type of operation being executed. Furthermore, it must comply with the safety requirements of the legislation in force in the country in which the machine is used.

In general, the operator must wear accident-prevention shoes while handling the TPS-compact and during installation.

WARNING

Danger to health by hazardous substances during maintenance or installation.



- Depending on the process peculiarity, vacuum pumps, components or operating fluids can be contaminated by toxic, reactive or radioactive substances.
- Wear adequate protective equipment during maintenance and repairs or in case of reinstallation.

WARNING

Risk of injury through falling objects



When transporting vacuum pumps by hand, there is a danger through loads slipping and falling down.

- Carry small and mid-size vacuum pumps two-handed.
- Any equipment heavier than 20 kg should be transported using a suitable lifting device.
- Wear safety shoes with steel toe cap according to directive EN 347.

Instructions for Use

CAUTION



Risk of injury through sharp edges

- Before servicing the pump or before any mounting/ dismantling action of the pump from the system, wait for the complete standstill of the pump.
- Do not operate directly inside the high vacuum flange.
- If necessary, wear protective gloves according to EN 420.

Safety guideline for Turbomolecular Pumps

Turbomolecular pumps as described in the following operating manual contain a large amount of kinetic energy due to the high Rotation Speed in combination with the specific mass of their rotors.

In case of malfunctioning of a mechanical part of the pump the rotational energy may be released to whatever the pump is fixed to (see "Installation of ConFlat Flange" and "Installation of ISO-K Flange" sections).

WARNING



To avoid damage to equipment and to prevent injuries to operating personnel the installation instructions as given in this manual should be strictly followed!

WARNING



When employing the pump for pumping toxic, flammable, or radioactive gases, please follow the required procedures for each gas disposal. The pump is designed to pump high throughput of N₂, Ar and lighter gas. Should you need to pump gases heavier than Ar, please contact Agilent technical support for informations.

The TPS-compact is not intended to be used in presence of aggressive, corrosive or explosive gases.

Transport & Storage

In order to guarantee the maximum level of performance and reliability of Agilent Turbomolecular pumps, the following guidelines must be followed to avoid condensation.

- when shipping, moving and storing pumps, the following environmental specifications should not be exceeded:
 - temperature range: refer to the manuals of the single TPS-compact component.
 - relative humidity range: refer to the manuals of the single TPS-compact component.
- the turbomolecular pumps must be always soft-started when received and operated for the first time by the customer.
- the turbomolecular pumps must be always soft-started after a period of 60 days of inactivity of the pump.

CAUTION

If for any reason the shelf life time is exceeded, the pump has to be returned to the factory. Please contact the local Agilent Vacuum Sales and Service representative for information.

WARNING



Use extreme caution handling heavy parts. A two person lift is recommended.

Failure to perform a two person lift may result in personal injury.

Product description

This equipment is intended for professional use and to be used by professionals.

The TPS-compact is an integrated system with a turbomolecular pump (TwisTorr 74 FS, Twistorr 305 FS) for high and ultra-high vacuum applications associated with its relevant controller and its primary pump. The system can pump any type of gas or gas compound. It is not suitable for pumping liquids or solid particles.

The pumping action is obtained through a high speed turbine (max. 70000 rpm) driven by a high-performance electric motor.

It is free of contaminating agents and, therefore, is suitable for applications requiring a "clean" vacuum.

The TPS-compact is equipped with auxiliary connectors to be controlled from a remote site by means of an host computer connected through a serial line.

Detailed information is supplied in the "Technical Information" section.

Installation

Preparation for installation

The TPS-compact is supplied in a special protective packaging. If this shows signs of damage which may have occurred during transport, contact your local sales office. Avoid sudden impacts to the TPS-compact that would be caused by dropping it. Be aware to maintain the packaging box in order to reuse it in case of storage for a long period of time or in case of shipping.

Do not dispose of the packing materials in an unauthorized manner. The material is 100% recyclable and complies with EEC Directive 94/62 and subsequent amendments.

CAUTION

In order to prevent outgassing problems, do not use bare hands to handle components which will be exposed to vacuum. Always use gloves or other appropriate protection.

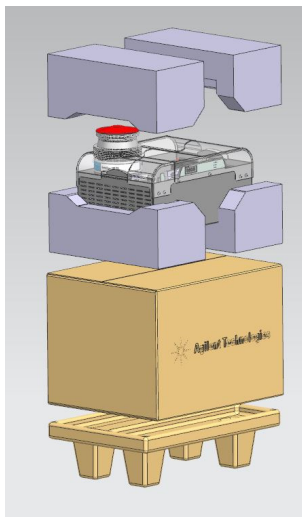

Figure 31

NOTE

Normal exposure to the environment cannot damage the TPS-compact. Nevertheless, it is advisable to keep it closed until it is installed in the system, thus preventing any form of pollution by dust.

Set-up

CAUTION

Do not remove the adhesive and protective cap until you are ready to install the turbopump to the system.

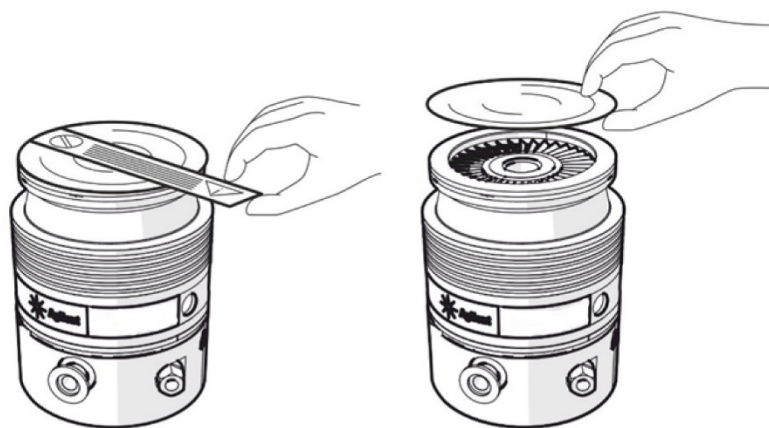

Figure 32

Install this device indoors only, and do not use the system in an environment exposed to atmospheric agents (rain, ice, snow), dust, aggressive gases, or in explosive environments or those with a high fire risk.

During operation, the following environmental conditions must be complied with in order to avoid condensation:

- maximum ambient pressure: 2 bar above atmospheric pressure
- temperature: refer to the manuals of the single TPS-compact components
- relative humidity: refer to the manuals of the single TPS-compact components.

In the presence of magnetic fields the pumping system must be protected using a ferromagnetic shield.

TPS-compact Mounting

WARNING



Failure to comply with these installation instructions could result in the pump detaching from the system in the event of a rotor failure, which could cause property damage or serious injury or death.

The TPS-compact can be installed in vertical position only.

Fix the TPS-compact in a stable position, mounting the inlet flange of the turbopump to the system counter-flange.

The turbopump with ConFlat and ISO K inlet flange must be fixed to the vacuum chamber by means of the appropriate Agilent hardware.

For further details see the “Installation of ConFlat and ISO K” section.

Power supply cord: The correct cable for electrical wiring is a three wires (Ph+N+Earth) cable. The wire section has to be at least 0.75 mm² (AWG18).

CAUTION

The TPS-compact cannot be fixed by means of its base or through other flanges that are not inlet.

WARNING



The System must be installed in a way that allows an easy interruption of the line voltage.

CAUTION

To allow proper air circulation assure a free space all around the system at minimum of 20 cm and do not cover or reduce the space between the base of TPS-compact and its support plane.

Instructions for Use

For installation of optional accessories, see "Technical Information".

This paragraph details the fundamental operating procedures.

Make all electrical pneumatic connections before the use of the system. While heating the vacuum chamber, the temperature of the inlet flange must not exceed 120 °C with ConFlat flanging and 80 °C with ISO flanging.

WARNING



Never use the pumping system when the turbo inlet flange is not connected to the vacuum chamber or is not blanked.

WARNING



Do not touch the turbopump or any of its accessories during the heating process. The high temperatures may cause burns.

WARNING



Avoid impacts or harsh movements of the pump when in operation. The bearings may become damaged and damages to the persons or the things could be taken place.

CAUTION!

Use inert gas free from dust, particles or humidity (like Nitrogen) for venting the pump. The pressure at the vent port must be less than 2 bar (above atmospheric pressure).

WARNING!



Do not use the pumping system in presence of explosive, toxic, flammable or radioactive gases.

Connection of the High Vacuum Flange

If the rotor stops suddenly, the resulting torque must be absorbed by the hardware fastening the high vacuum flange.

Bolts or hardware must meet the specification below.

WARNING



It is mandatory to connect the pump in such a way to withstand the torque specified in the "TPS-compact Mounting" section. Specifically pay attention to clamp design, material of clamps and bolts and bolt fixing torque.

Use only high resistance class clamps (or bolts) ≥ 8.8 .

WARNING



If the pump is fastened on a vacuum chamber with flanges different from those recommended by Agilent, there is the chance of the TPS-compact twisting or tearing-off in case the rotor suddenly stops. The combination of different flange types is not allowed. Agilent will not accept any liability for all damages resulting from improper fastening.

Installation of ISO-K Flange

For ISO-K flange connections, fix the two flanges with the clamps model IC63250DCMZ or equivalent, as shown in the following figure (a protective screen can optionally be used).

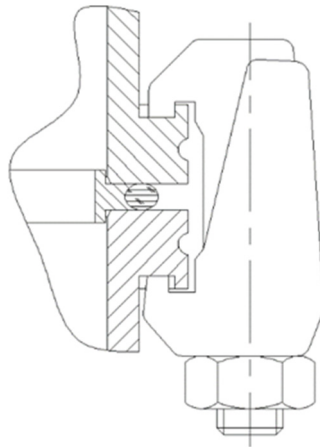

Figure 33

Use the required number of claw clamps:

- 4 for ISO 63 flange
- 4 for ISO 100 flange
- 4 for ISO 160 flange

Tighten the bolts with a torque of 22 Nm.

Installation of ConFlat Flange

For ConFlat flange connections, fix the two flanges with the screws as shown in the following figure (a protective screen can optionally be used).

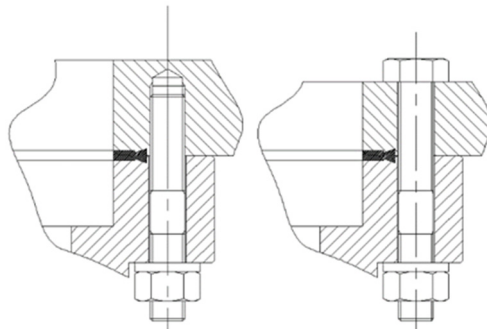

Figure 34

Use the required number of screws:

- 16 for CFF 6"
- 20 for CFF 8"

Attach the units and tighten each screw in turn. Repeat the sequential tightening until the flange faces meet. Tighten the screws with a torque of 20 Nm.

For ConFlat flange we recommend the usage of high strength steel bolts only.

To facilitate assembly and dismantling, it is optional to apply

Felpro C-100 high temperature lubricant to the screw threads protruding from the flange and between the nuts and flange.

In some cases, the connections can be made only with the bolt in the lower side.

CAUTION!

Be careful when tightening nuts and bolts to avoid creating dents on the turbomolecular pump casing.

Startup and Operation of the TPS-compact

Check the system voltage on the Agilent label stuck on the system electronic units case.

To switch on the TPS-compact it is sufficient to supply the mains and then move the external switch to ON position. The integrated controller automatically recognizes the mains presence and start up the pump.

WARNING



The initial startup of the pump TwisTorr 305 FS will be in "SOFT START" mode; for detailed information on this mode refer to the dedicated section.

The blue LED "STATUS" located on the TPS-compact base rear panel indicates with its flashing frequency the system operating conditions:

- with no flashing: the pump is normally rotating;
- slowly flashing (period of about 400 ms): the system is in ramp, or in braking, or in Stop;
- fast flashing (period of about 200 ms): error condition.

See the appendix "Technical Information" for a detailed description of the TPS-compact control panel.

Soft Start

WARNING



To ensure proper lubrication of the bearings the pump, at the first ramp-up, the pump has to be started in “soft start” mode.

This starting modality (Soft Start) ensures a smooth up to speed of the pump and it allows a proper lubrication of the bearings.

The control unit which is connected to the pump is already set-up by default to run the pump (only at the first control unit start-up). In case of use of a new pump with an used control unit, remember to set manually the soft start mode.

The soft start mode will take a longer time compared to the standard start-up; the user must wait that the pump is completely up to speed before stopping the pump.

After the first start, the pump won't be started in soft start mode again by the control unit.

NOTE

After 60 days or more of inactivity, in order to allow again the correct redistribution of the grease present in the bearings, it is necessary to start the pump via soft start mode again.

WARNING



Please refer to the controller's relevant instruction manuals in order to find the appropriate set of instructions to activate the “soft start” modality (Remote: Chapter Technical Information – Controller Connection & Window Meanings ; On Board: Chapter Technical Information – Interconnections & Window Meanings).

Stopping the TPS-compact

To switch off the TPS-compact it is sufficient to move the external switch to OFF position. The integrated controller immediately stops the pumping system.

WARNING



Before carrying out any work on the system, disconnect it from the power supply, vent the pump with the vent valve, wait until the rotor is completely stopped and wait until the surface temperature of the pump is below 50° C.

Emergency stop

To immediately stop the TPS-compact in an emergency condition it is necessary to remove the supply cable from the mains plug or moving the external switch to OFF position.

WARNING



This mode is to be used only in an emergency. The use of this stop mode could lead to faults and/or damages at the pump. Improper use of this stop mode could void the warranty.

Maintenance

The TPS-compact does not require any maintenance (except Tip-seal replacement). Any work must be carried out by authorized personnel.

In the case of breakdown, contact your local Agilent service center.

If a system needs to be scrapped, ensure that local regulations are followed for appropriate disposal.

Rotor life

The fatigue resistance of the turbomolecular pump rotor strongly depends on pump size. Refer to the specific pump manual for correct value (number of cycles of ramp up from stop to full speed and back to stop). As a precautionary measure, considering the typical usage of the pump and taking into account safety limits, Agilent recommends to return the system after 17 years of use for maintenance.

Cleaning

The exterior surface of the TPS-compact may be cleaned with mild detergent only.

Disposal

Meaning of the "WEEE" logo found in labels.

The following symbol is applied in accordance with the EC WEEE (Waste Electrical and Electronic Equipment) Directive.

This symbol (valid only in countries of the European Community) indicates that the product it applies to must NOT be disposed of together with ordinary domestic or industrial waste but must be sent to a differentiated waste collection system. The end user is therefore invited to contact the supplier of the device, whether the Parent Company or a retailer, to initiate the collection and disposal process after checking the contractual terms and conditions of sale.



Figure 35 Logo "WEEE"

For more information refer to:

<http://www.agilent.com/environment/product/index.shtml>

Service

Should a customer need an advanced exchange or repair service, please contact local distributor or directly mail to

vpt-customer@agilent.com

vpl-customer@agilent.com

Completion of the "Request for Return" form is required to return your pump to Agilent for service (provided at the end of this manual).

8 Technical Information

Description of the TPS-compact	182
Turbopump Description	184
Controller Description	184
Control Panel Description	185
Scroll Pump Description	186
Technical specification	187
TPS-compact Outline	189
Inlet screen installation	192
High Vacuum Flange Connection Configurations	195
ASDF – Adaptive Scroll Driving Firmware	196
Gas Ballast	198
Interconnections	200
Input Power Connector	200
P3 – Vent	200
Gauge Connector	201
Pressure Display Module	202
J5 – In-Out	203
Signal Description	204
How to Connect the Open Collector Input of the Controller	209
How to Connect the Outputs of the Controller	212
J6 – Serial	212
RS 232/RS 485 Communication Description	214
Communication Format	214
Serial Communication Descriptions	216
Window Protocol	217
Description	217
Communication Format	217
Communication Protocol	217
Examples	220
Window Meanings	223
Service Options	226
Tip-Seal Replacement	227
To Remove the Worn Tip-Seals	228
To Install the new Seals and O-Rings	229
To test the Pumping System	230
Troubleshooting Chart	231
Accessories and Spare Parts	232

Description of the TPS-compact

The TPS-compact pumping system consists of a pump with an integrated controller and a forepump and is available in twenty-four models which differ in the TPM size, high vacuum flange and voltage. The models are:

Table 1

P/N	TMP	Flange	Foreline	Voltage
X3583-64000	74 FS	KF40	3.6 m3/h Scroll	115V 60Hz
X3583-64001	74 FS	CFF 2.75	3.6 m3/h Scroll	115V 60Hz
X3583-64002	74 FS	ISO63	3.6 m3/h Scroll	115V 60Hz
X3583-64003	74 FS	CFF 4.5	3.6 m3/h Scroll	115V 60Hz
X3583-64004	74 FS	KF40	3.0m3/h Scroll	230V 50-60Hz
X3583-64005	74 FS	CFF 2.75	3.0m3/h Scroll	230V 50-60Hz
X3583-64006	74 FS	ISO63	3.0m3/h Scroll	230V 50-60Hz
X3583-64007	74 FS	CFF 4.5	3.0m3/h Scroll	230V 50-60Hz
X3583-64008	74 FS	KF40	3.6 m3/h Scroll	100V 50-60Hz
X3583-64009	74 FS	CFF 2.75	3.6 m3/h Scroll	100V 50-60Hz
X3583-64010	74 FS	ISO63	3.6 m3/h Scroll	100V 50-60Hz
X3583-64011	74 FS	CFF 4.5	3.6 m3/h Scroll	100V 50-60Hz
X3582-64000	305 FS	ISO100	3.6 m3/h Scroll	115V 60Hz
X3582-64001	305 FS	CFF6	3.6 m3/h Scroll	115V 60Hz
X3582-64002	305 FS	ISO160	3.6 m3/h Scroll	115V 60Hz
X3582-64003	305 FS	CFF8	3.6 m3/h Scroll	115V 60Hz
X3582-64004	305 FS	ISO100	3.0m3/h Scroll	230V 50-60Hz
X3582-64005	305 FS	CFF6	3.0m3/h Scroll	230V 50-60Hz
X3582-64006	305 FS	ISO160	3.0m3/h Scroll	230V 50-60Hz
X3582-64007	305 FS	CFF8	3.0m3/h Scroll	230V 50-60Hz
X3582-64008	305 FS	ISO100	3.6 m3/h Scroll	100V 50-60Hz
X3582-64009	305 FS	CFF6	3.6 m3/h Scroll	100V 50-60Hz
X3582-64010	305 FS	ISO160	3.6 m3/h Scroll	100V 50-60Hz
X3582-64011	305 FS	CFF8	3.6 m3/h Scroll	100V 50-60Hz

Technical Information

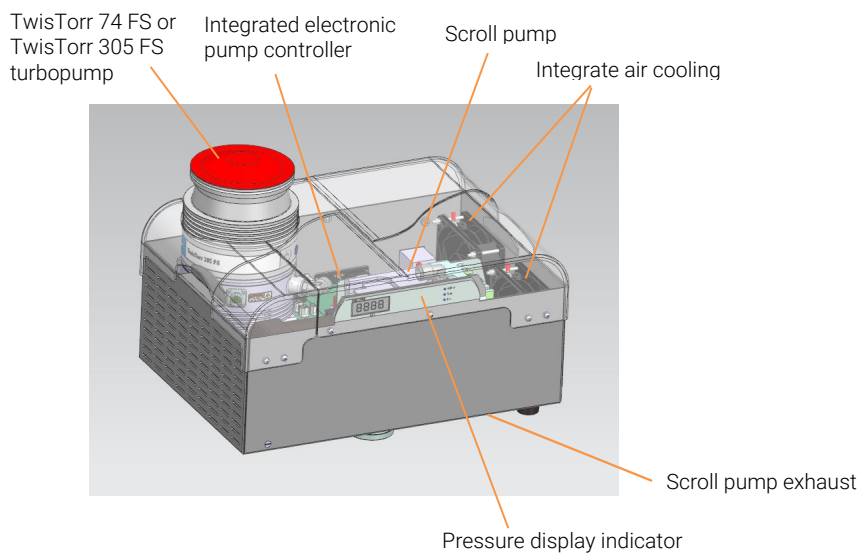

Figure 36

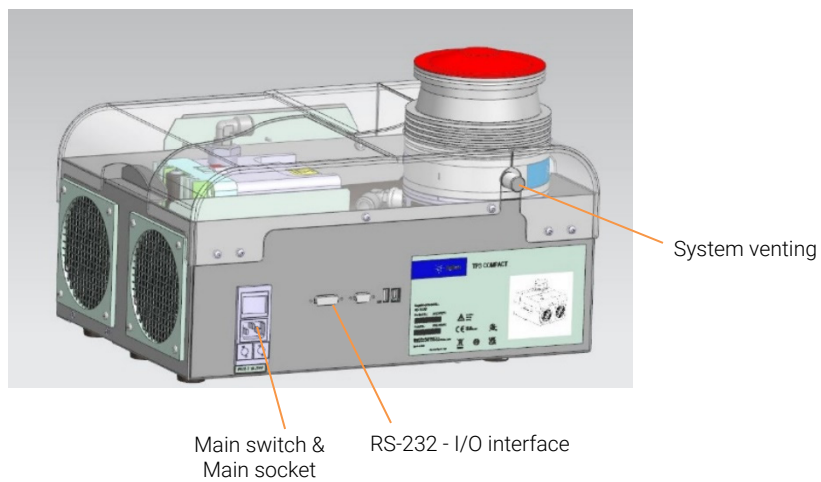

Figure 37

Technical Information

Turbopump Description

The turbopump consists of a high frequency motor driving a turbine fitted with many bladed stages and Twistorr drag stages. The turbine rotates in an anticlockwise direction when viewed from the high vacuum flange end.

The turbine is made of high-strength, light aluminium alloy, and is machined from a single block of aluminium. The Twistorr stages are in the form of discs.

The turbine rotor is supported by permanently lubricated high precision ceramic ball bearings installed on the forevacuum side of the pump.

The static blades of the stator are fabricated in stainless steel. These are supported and accurately positioned by spacer rings.

The TwisTorr stators are in the form of selfpositioning machined disks. On each disk there are parallel spiral pumping channels designed to pump in centrifugal direction on one side and in centripetal direction on the other side. These are made of aluminium alloy.

During normal operation, the motor functions with a power feed at 54 Vac three-phase at 1167 Hz (74 FS) or 1010 Hz (305 FS). To reduce losses during start-up to a minimum, the frequency increases according to a ramp with a higher initial voltage/frequency ratio.

A thermistor sensor is mounted near the upper bearing to prevent the pump from overheating. The pump is balanced after assembly with a low residual unbalance amplitude.

Controller Description

The integrated controller is a solid-state frequency converter which is driven by a single chip micro-computer and is composed of a PCB which includes a power supply with a 3-phase AC output, analog and input/output section, microprocessor and digital section. The controller recognizes the mains presence and converts the single phase AC mains supply into a 3-phase, medium frequency output which is required to power the pump.

The controller can be operated by a remote host computer via the serial connection.

Control Panel Description

The following picture shows the TPS-compact control panel; the associated table lists the available commands. For a detailed description see the following paragraphs.

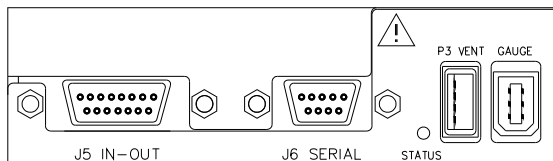

Figure 38

Table 2

Control name	Description
J5 IN-OUT	Input-output connector to remote control the TPS-compact
J6 SERIAL	Serial input-output connector to control the TPS-compact via an RS 232 or RS 485 connection
STATUS	Blue LED to show the system operating condition
P3 VENT	Connector to control the optional vent valve
GAUGE	Connector to control external active gauge
ON-OFF switch (not shown in the picture)	It is located on the rear side of the system. It is the power supply switch.

Technical Information

Scroll Pump Description

The TPS-compact internal scroll creates vacuum using a simple dual scroll mechanism in which one of the nested scrolls orbits about the other, creating moving zones of captured gas.

Gas enters the scroll set at the perimeter and is displaced and compressed toward the center hub where it is exhausted.



Figure 39

CAUTION!

Scroll Pump exhaust connection: To avoid overheating the Scroll pump, do not restrict the exhaust flow with long lengths of small diameter tubing.

Technical specification

The following tables list the main technical data of the TPS-compact.

Table 3 TPS-compact Technical Specification

Characteristic	305 FS	74 FS
Pumping speed	N ₂ : 250 l/s He 255 l/s Ar 250 l/s	N ₂ : 48 l/s (with inlet screen) He: 44 l/s (with inlet screen) H ₂ : 32 l/s (with inlet screen)
Base pressure*	<1.0 ⁻⁹ mbar <7.5 ⁻¹⁰ Torr	1x10 ⁻⁹ mbar 7.5x10 ⁻¹⁰ Torr
Inlet flange	ISO 100, ISO 160, CFF 6, CFF 8	KF 40, ISO 63, CFF 2.75, CFF 4.5
Rotational speed	60600 rpm (1010 Hz driving frequency)	70000 rpm
Start-up time	350 sec (it can be longer in case of soft start active)	144 s
Operating position	Vertical	
Operating ambient temperature	+ 5 °C to + 35 °C	
Bakeout temperature	100 °C at inlet flange max (CF flange) 75 °C at inlet flange max (ISO flange)	120 °C at inlet flange max. (CF flange) 80 °C at inlet flange max. (ISO flange)
Noise level	55.4 dB(A) at 1 meter	51.5 dB (A) at 1 meter
Lubricant	permanent lubrication	
Power supply (Line type): Input voltage and frequency:	100 Vac 50/60 Hz 115 Vac 60 Hz 200–230 Vac 50 – 60 Hz	
Max input power:	650 VA	
Protection fuse Type Time Delayed	115 Vac: 5 A 230 Vac: 3 A 100 Vac: 5 A	115 Vac: 4 A 230 Vac: 2.5 A 100 Vac: 4 A
Compliance with:	EN 55011 (Class A Group 1) EN 61326-1 EN 61010-1 EN 1012-2 EN 12100	

* According to standard DIN 28 428, the base pressure is that measured in a leakfree test dome, 48 hours after the completion of test dome bake-out, with a Turbopump fitted with a ConFlat flange.

Technical Information

Table 3 TPS-compact Technical Specification - Continued

Characteristic	305 FS	74 FS
Indoor Use		Only
Max Altitude		2000m
Installation category		II
Pollution degree		2
Power cable		115 Vac: US plug 3 meters long 230 Vac: EU or UK plug 3 meters long
Serial communication		RS232 and RS485 interface
Storage temperature		-20°C to + 60°C
Weight kg (lbs)	20.1 (44.3)	16.7 (36.8)

NOTE

When the TPS-compact has been stored at a temperature less than 5 °C, wait until the TPS-compact has reached the above mentioned temperature before switch the system on.

TPS-compact Outline

The following figure shows the TPS-compact outline. Dimensions are in mm.

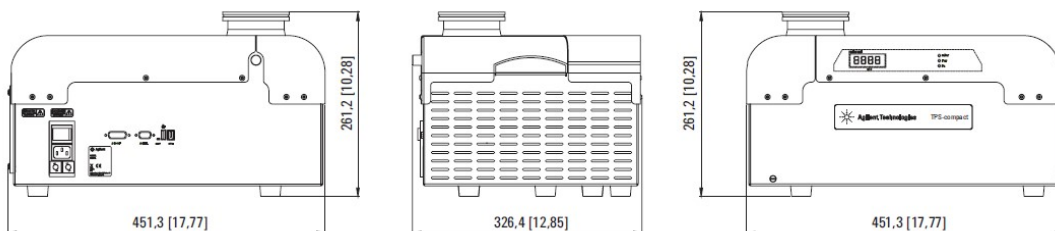

74 FS

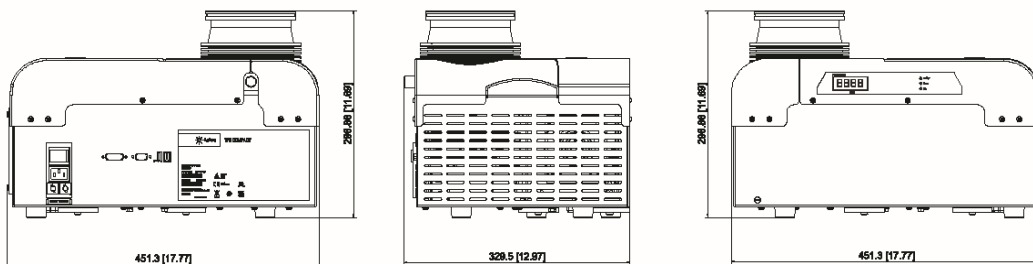

305 FS

Dimensions: millimeters (inches)

Figure 40

Technical Information

TPS-compact equipped with 305 FS: Pumping speed for Nitrogen.

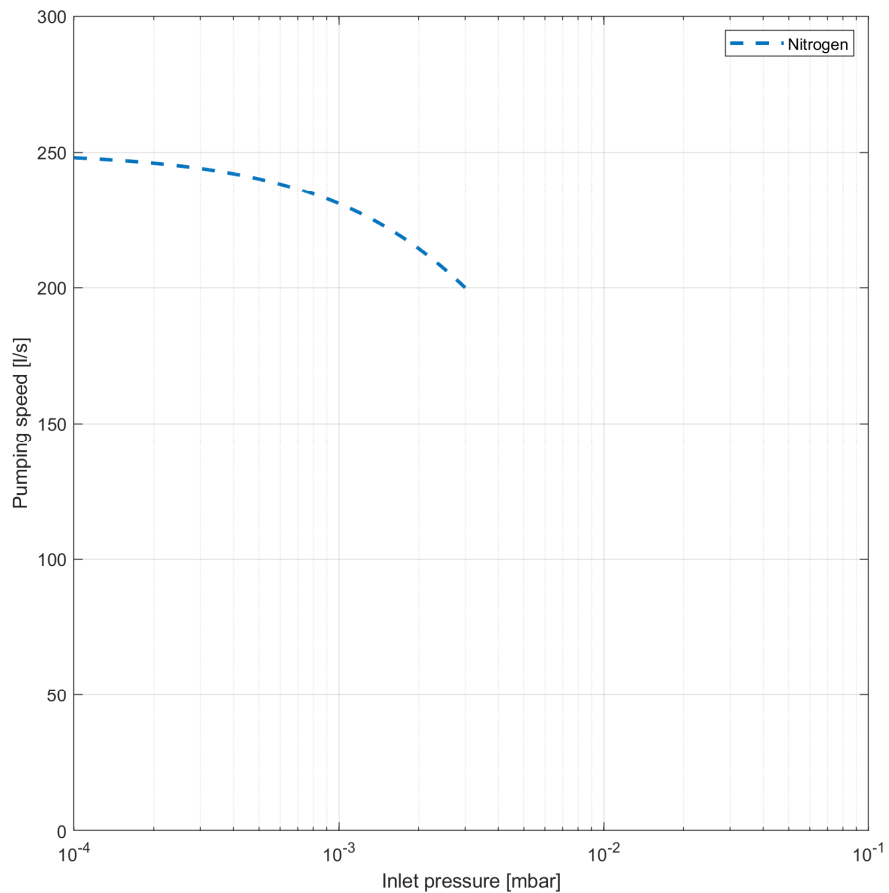

Figure 41 Graph of pumping speed vs inlet pressure at full speed (1010Hz driving freq.)

Technical Information

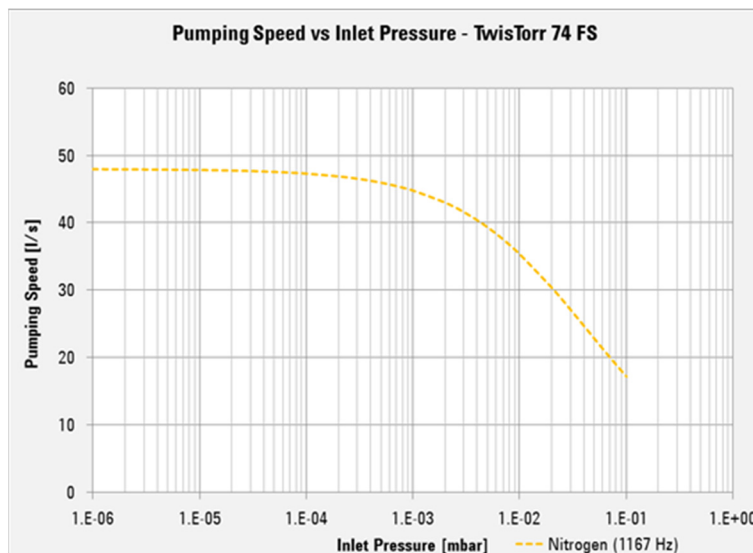

Figure 42 Graph of pumping speed vs inlet pressure

TPS-compact 305 FS: 15l pumpdown

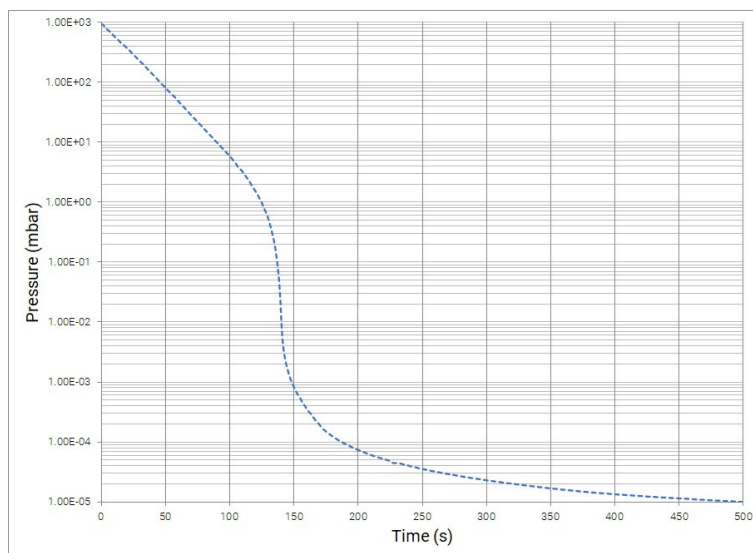

Figure 43 Graph of pressure vs time (w/o soft start)*

* Measurement obtained using both capacitive and UHV gauges Shape of curve in the range 1.0E-3 mbar – 1.0E-5 mbar is strongly affected by the type of gauge used and its accuracy.

Technical Information

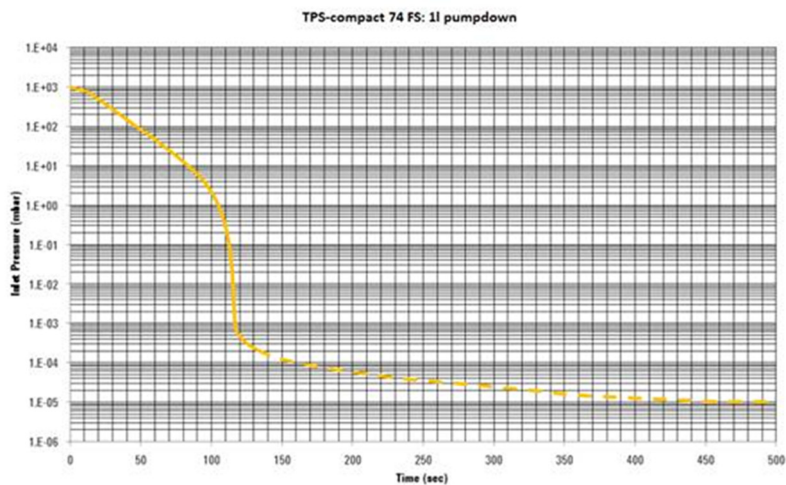

Figure 44 Graph of pressure vs time (with a pumpdown volume of 1 litre)

Inlet screen installation

Installing the inlet screen will reduce the pumping speed of heavy gases (i.e. Argon, Nitrogen) of about 25% while for lighter gases (i.e. Helium and Hydrogen) the amount is of about 10%.

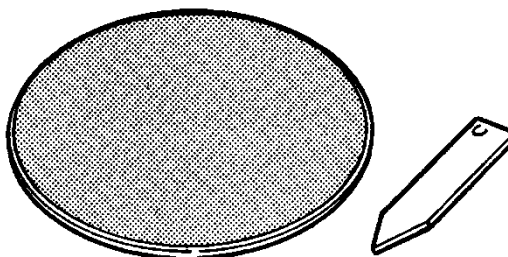

Figure 45

Technical Information

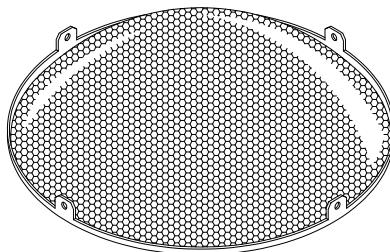

Figure 46

The inlet screens mod. 9699300, 9699309, 9699302 and 9699303 prevent the blades of the pump from being damaged by debris greater than 0.7 mm diameter.

The inlet screen is fitted in the upper part of the pump, as shown in the figure.

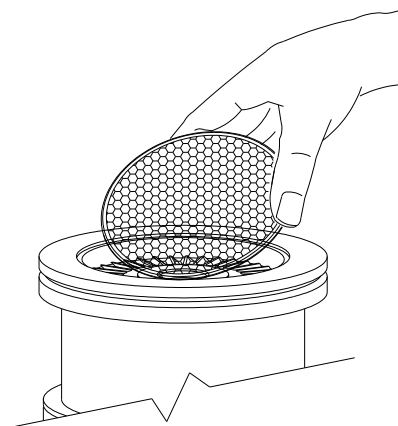

Figure 47

Technical Information

The screen can be mounted on each pump.

The screen can be removed as shown in the following figure.

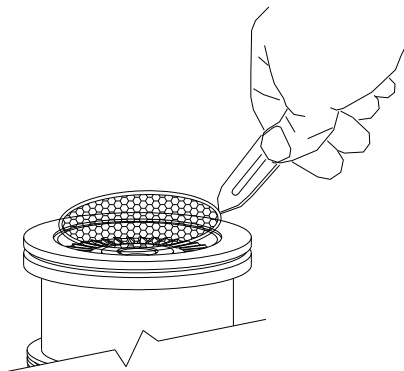

Figure 48

High Vacuum Flange Connection Configurations

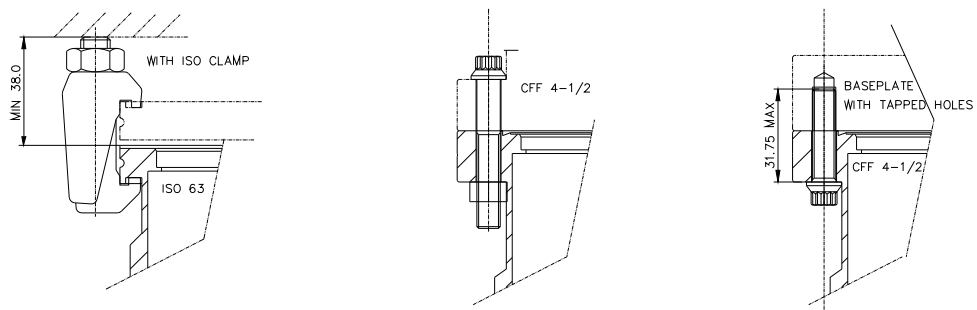

Figure 49

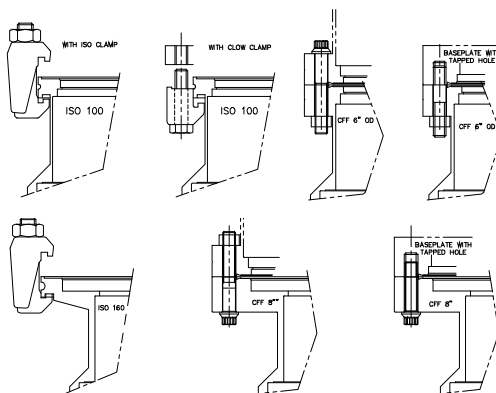

Figure 50

ASDF – Adaptive Scroll Driving Firmware

TPS-compact implements a function that safeguards the life of the scroll pump Tip-seal. The function is described in the diagram below where P is the turbomolecular pump power.

Inlet gas load is monitored measuring the turbomolecular absorbed power. A power threshold P_{TMP}^{OFF} is defined and if the turbomolecular power is below the P_{TMP}^{OFF} , then the foreline separation electromagnetic valve is closed and integrated scroll pump is switched off. Since the turbomolecular pump temporarily works without a backing pump, the power necessary to maintain a stable inlet pressure tends to increase. When the absorbed power exceeds the threshold power P_{TMP}^{ON} , then the integrated scroll pump is switched on and the separation electromagnetic valve is re-opened. So, the ASDF is able to extend the scroll Tip-seal life.

NOTE

A slight variation in turbomolecular pump inlet pressure can be detected; this variation is a normal response of the TPS-compact to primary pump shutdown.

By disabling this function, the scroll remains in operation as long as the customer does not switch off the entire system.

By disabling this function, warranty does not cover the short tip seal life.

To disable this function, put a jumper between pins 3-9 and 4-15 on I/O connector of Turbo controller:

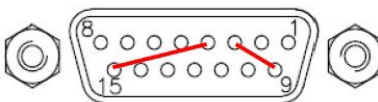

This signal is no more used for interlock, it's now dedicated to disable/enable the adaptive driving firmware.

Technical Information

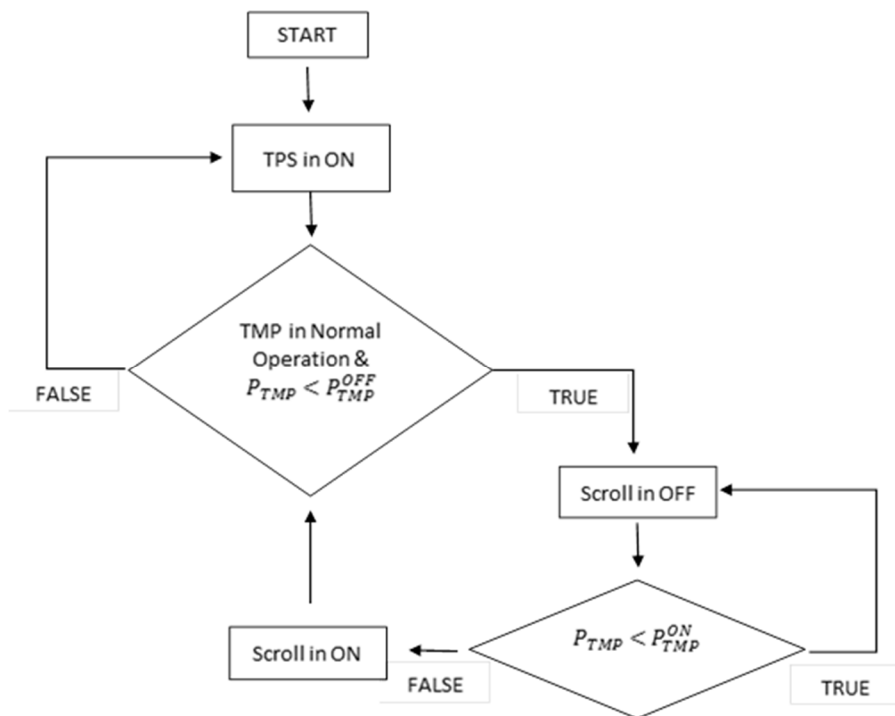

Figure 51

Gas Ballast

The TPS-compact packaging includes a standard gas ballast kit (P/N IDP3GBKIT) that can be used to prevent water and other condensates from accumulating within the foreline pump. The standard configuration has a seal screw installed in the 1/4-20 thread in the top of the exhaust manifold. This configuration can be used for dry applications. When appreciable amounts of water, solvents, etc., are being pumped, remove the seal screw and replace it with the provided adapter and 1/8" NPT sintered filter plug.

WARNING



Before install gas ballast adapter remove the power supply cable.

- 1 Disconnect the TPS-compact from electrical power.
- 2 Unlock the scroll pump support by unscrewing the screws.

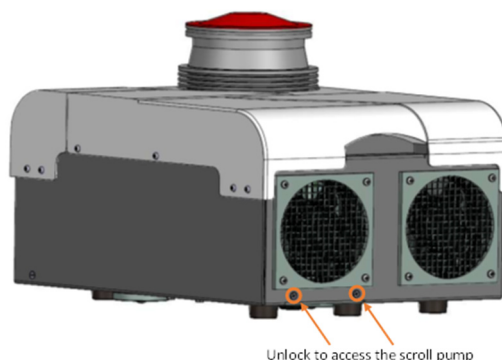

Figure 52

- 3 Lift the TPS-compact in order to access the Scroll pump site.

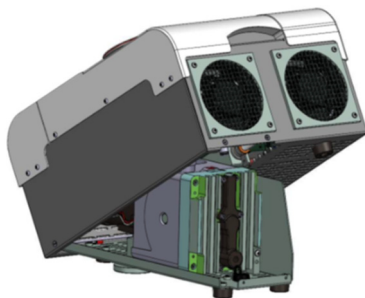

Figure 53

Technical Information

- 4 Unscrew seal screw and install provided gas ballast adapter and 1/8" NPT sintered filter plug.

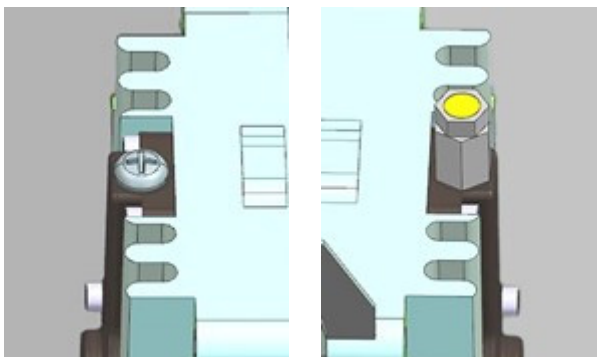

Figure 54

- 5 Lock the scroll pump support by screwing the screws.

CAUTION

Be careful during pump support closing to prevent damage to system components (vacuum pipes and connectors).

NOTES

- During the operation of the gas ballast feature the noise may increase.
- There is not a predefined amount of time to let the gas ballast open: it depends on the amount of moisture trapped in the system.

CAUTION

Do not exceed 2.8 Nm of torque when installing the adapter into the manifold.

For more details about gas ballast refer to the manuals of the single TPS-compact components.

CAUTION

Use the provided adapter and 1/8" NPT sintered filter plug in order to avoid dust entrance.

CAUTION

The gas ballast must be sealed whenever pumping any gas not intended to be vented to atmosphere.

Interconnections

Input Power Connector

The following figure shows the input power connector.

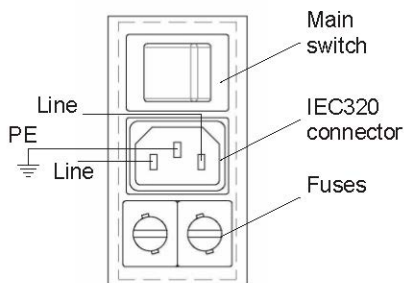

Figure 55

P3 – Vent

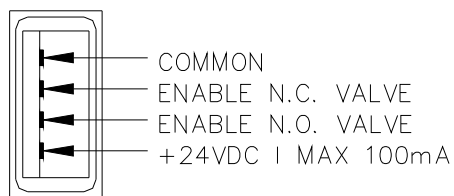

Figure 56

This is a dedicated 24 Vdc connector to control the optional vent valve (available on request).

The vent valve can be driven by controller automatically or by serial line.

Technical Information

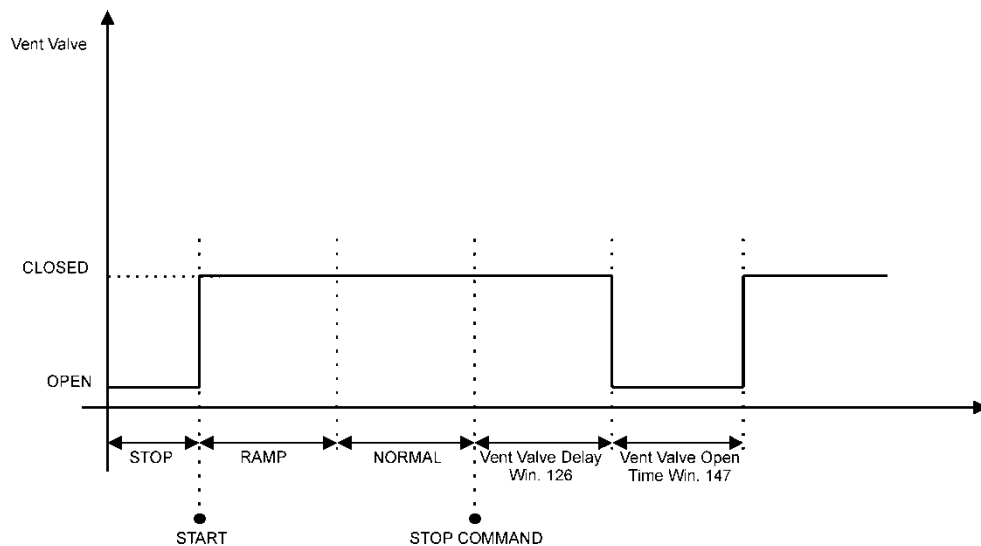

Figure 57

Gauge Connector

TPS-compact is equipped with new generation gauge reading card able to drive/read a Agilent Full Range Gauge FRG-700.

The FRG-700 Full Range Gauge is a combined technologies gauge (Inverted Magnetron plus Pirani Gauge).

FRG-700 measure from 5×10^{-9} mbar to atmosphere (3.8×10^{-9} Torr to atmosphere) and its temperature range goes from 5 °C to 55 °C [41 °-131 °F].

Pressure data is available on three independent reading channels:

- 6** On-board display (data expressed in mbar, Torr or Pa) – (see Pressure Display Module picture).
- 7** Serial communication line (Win 224).
- 8** Analogical output.

Technical Information

Pressure gauge can be connected/disconnected from the TPS-compact during normal operation

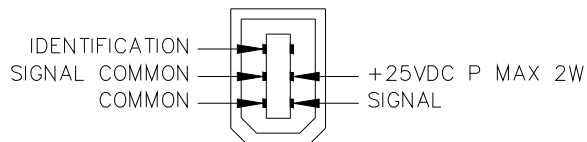

Figure 58 Gauge Connector

Pressure Display Module



Figure 59 Pressure display module

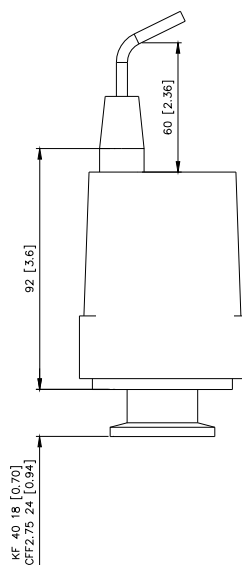

Figure 60 FRG-700 gauge dimension

Technical Information

J5 – In-Out

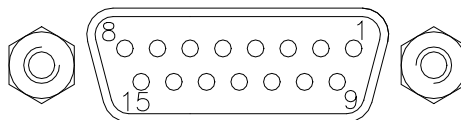

Figure 61

This connector carries all the input and output signals to remote control the TPS-compact.

It is a 15-pins D type connector; the available signals are detailed in the table, the following paragraphs describe the signal characteristics and use.

Table 4

Pin N.	Signal name	Input/Output
1	START/STOP (+)	IN
2	START/STOP (-)	IN
3	ADAPTIVE SCROLL DRIVING DISABLE (+)	IN
4	ADAPTIVE SCROLL DRIVING DISABLE (-)	IN
5	SPEED SETTING (+)	IN
6	SPEED SETTING (-)	IN
7	SOFT START (+)	IN
8	SOFT START (-)	IN
9	+24 Vdc I _{max} = 30 mA	OUT
10	NORMAL OUTPUT (relay contact) V _{max} = 125V I _{max} = 200 mA	OUT
11	PROGRAMMABLE SET POINT	OUT
12	NORMAL OUTPUT (relay contact)	OUT
13	FAULT OUTPUT	OUT
14	PROGRAMMABLE ANALOG SIGNAL (+)	OUT
15	<ul style="list-style-type: none">GROUNDPROGRAMMABLE ANALOG SIGNAL (-)	OUT

Signal Description

START/STOP: input signal to start or stop the pump. Without the supplied cover connector the turbomolecular pump automatically starts, if you want to stop the turbo-pump from outside, you have to connect the START/STOP (+) signal to the +24 Vdc pin and the START/STOP (-) signal to the GROUND pin (this is the default configuration of the cover connector).

ADAPTIVE SCROLL DRIVING DISABLE: Input signal to disable Adaptive Scroll Driving function. With the supplied mating connector the Adaptive Scroll Driving Disable (+) input is connected to the +24Vdc pin and the Adaptive Scroll Driving Disable (-) input is connected to GROUND pin; in this condition the Adaptive Scroll Driving function is disabled.

SOFT START: this input is used to provide a "soft start" to the pump; in this condition the ramp-up time could be up to 20 min.

SPEED SETTING: PWM input signal to set the pump speed. The PWM signal characteristics must be the following:

- frequency: 100 Hz +/-20 %
- amplitude: 24 V max
- duty cycle range: from 25 % to 75 %
- corresponding to a pump speed from 1100Hz to 1167Hz (see the following diagram).

Technical Information

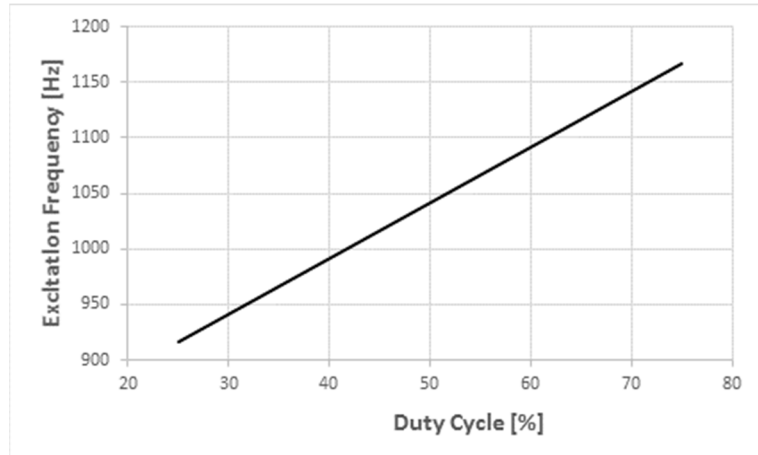

Figure 62

PROGRAMMABLE ANALOG SIGNAL: this output signal is a voltage (from 0 to 10 Vdc) proportional to a reference quantity (frequency or power or Temperature or Pressure) set by the user. The de-fault setting is the frequency (see the following example diagram).

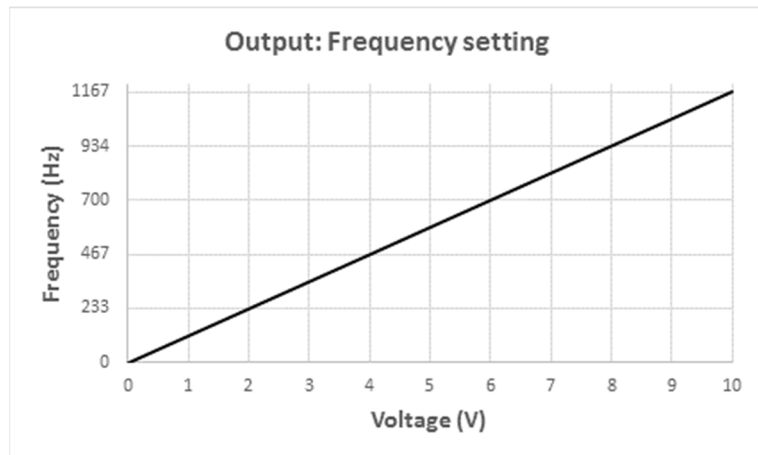

Figure 63

Technical Information

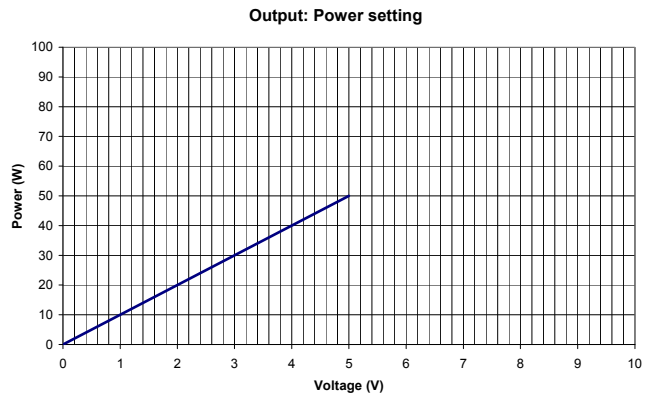

Figure 64

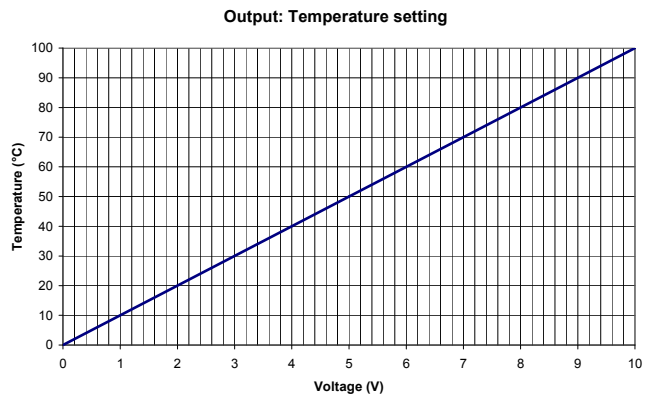

Figure 65

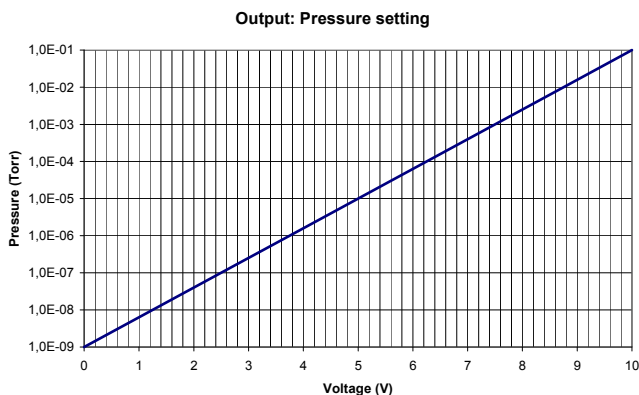

Figure 66

FAULT: this open collector output signal is ON when a system fault condition is detected.

PROGRAMMABLE SET POINT: this open collector output signal is enabled when the reference quantity chosen (frequency, power or time or pressure or normal) is higher than the set threshold. The signal can be "high level active" (that is the output is normally OFF and becomes ON when activated), or "low level active" (that is the output is normally ON and becomes OFF when activated). Moreover, if the reference quantity is the frequency or the power or pressure drawn, it is possible to set the hysteresis (in % of the threshold value) to avoid bouncing.

For example:

- reference quantity: frequency
- threshold: 867 Hz
- hysteresis: 2 %
- activation type: "high level"

Technical Information

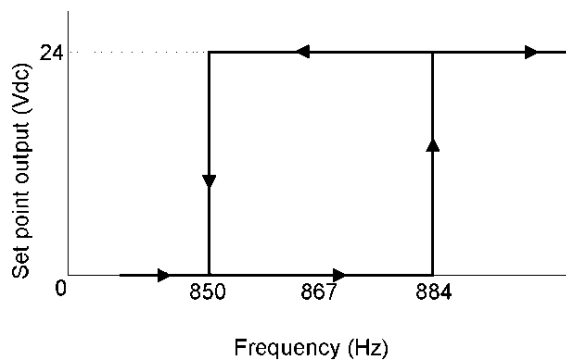

Figure 67

It is possible to delay the set point checking for a programmable delay time.

The PROGRAMMABLE SET POINT signal has the following default settings:

- reference quantity: frequency
- threshold: 867 Hz
- hysteresis: 2 %
- activation type: high level
- delay time: 0 second

NOTE

The A-Plus Software (optional) allows the operator to set all the programmable feature.

How to Connect the Open Collector Input of the Controller

Here below there are the typical connections of the open collector input of TPS-compact to an external system. Two cases are considered:

- 1 the customer supplies the 24 Vdc.
- 2 the customer does not supply the 24 Vdc.

Please note that on the connector a 24 Vdc, 30 mA, a GROUND signal and the open collector pin are available.

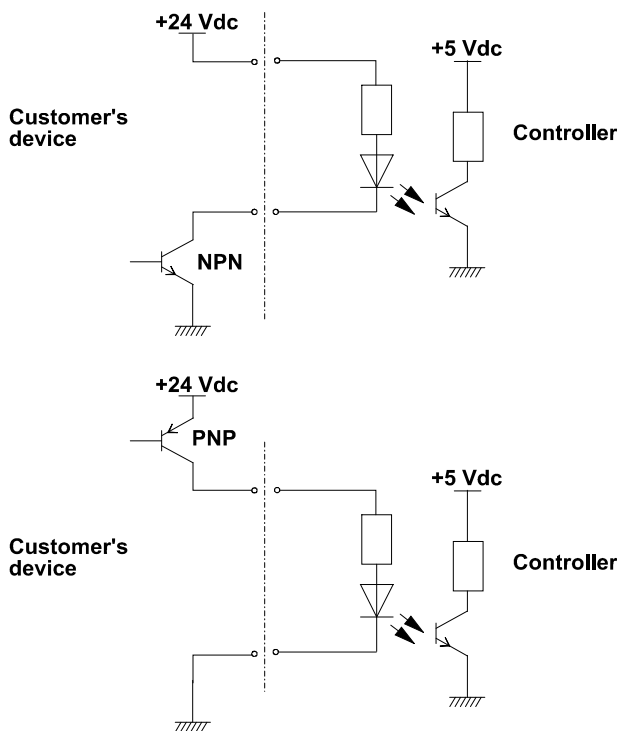

Figure 68 Case 1

Technical Information

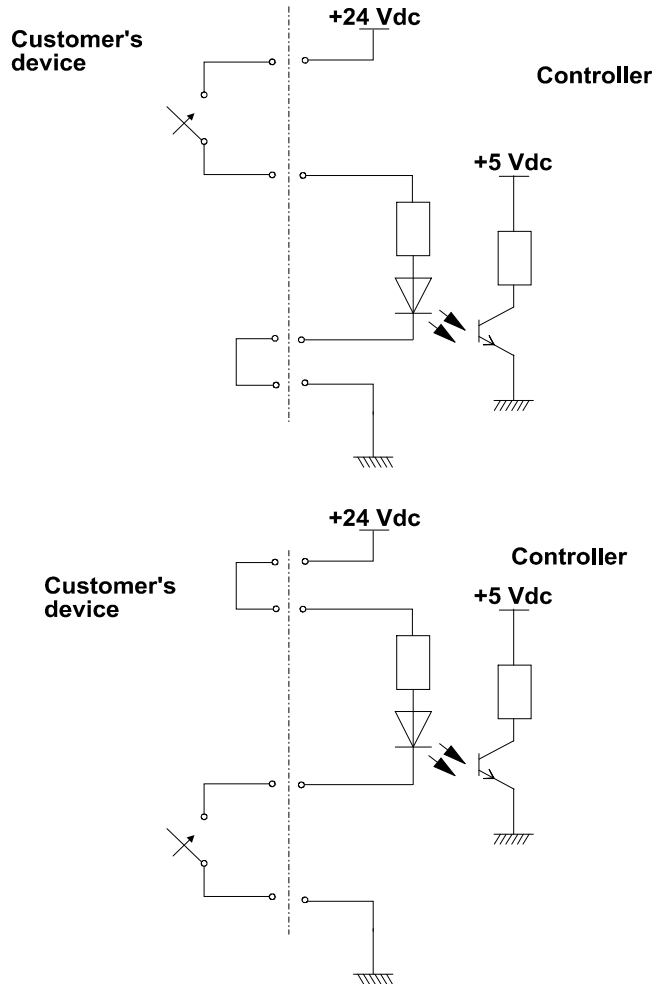

Figure 69 Case 2 with relay utilisation

Technical Information

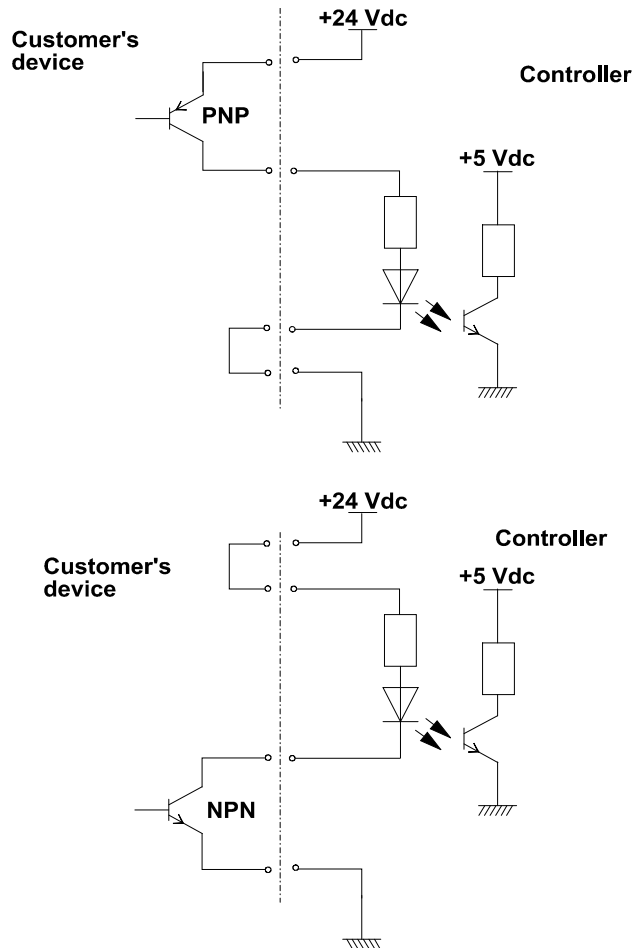

Figure 70 Case 2 with transistor utilisation

Technical Information

How to Connect the Outputs of the Controller

The following figure shows a typical logic output connection (relay coil) but any other device may be connected e.g. a LED, a computer, etc., and the related simplified circuit of the controller. The figure example refers to the programmable set point signal on pins 11 and 9.

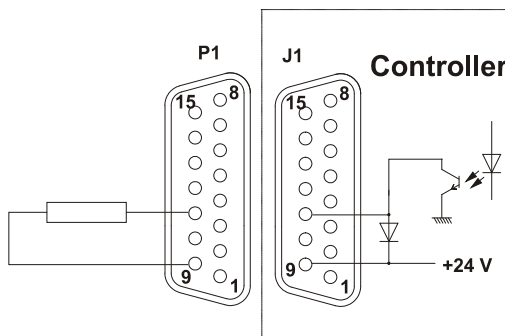

Figure 71 Typical output connection 1

J6 – Serial

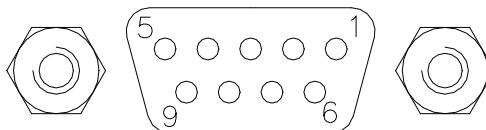

Figure 72

This is a 9 pin D-type serial input/output connector to control via an RS 232 or RS 485 connection the TPS-compact.

Technical Information

Table 5

P/N	Signal name
1	+5 V (OUT)
2	TX (RS232)
3	RX (RS232)
4	Not used
5	GND
6	A + (RS485)
7	Not used
8	B - (RS485)
9	Not used

A serial communication kit with a serial cable and the A-Plus Software is available (optional).

RS 232/RS 485 Communication Description

Both the RS 232 and the RS 485 interfaces are available on the connector J6.

The communication protocol is the same (see the structure below), but only the RS 485 manages the address field. Therefore to enable the RS 485 is necessary to select the type of communication as well as the device address by means of the software.

Communication Format

- 8 data bit
- no parity
- 1 stop bit
- baud rate: 600/1200/2400/4800/9600 programmable.

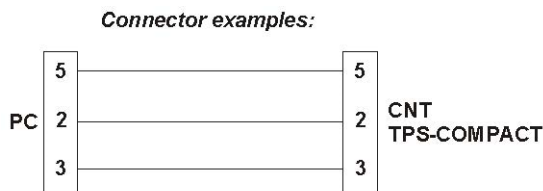

Figure 73 RS 232 Connection

Technical Information

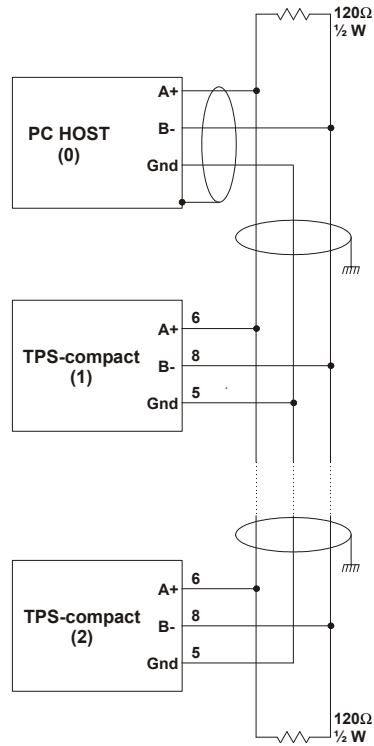

Figure 74 RS 485 Connection

Technical Information

The communication port mating connector is supplied with the RS232 PCB (AMP/Cannon or equivalent 15-pin "D" type male connector).

For example, the Transmit data signal from controller (pin 2) must be connected to the host computer's receive data line (pin 2) and vice versa. Consult the host computer's instruction manual for its serial port connections

NOTE

Agilent cannot guarantee compliance with FCC regulations for radiated emissions unless all external wiring is shielded, with the shield being terminated to the metal shroud on the 0-subconnector. The cable should be secured to the connector with screws.

Serial Communication Descriptions

This unit can communicate by two different protocols:

- protocol (old system) "letter"
- "Window" protocol (new system).

These two protocols can be used as well with 232 or 485 media.

NOTE

Please use "Window" protocol for new development.

Window Protocol

Description

Communication Format

- 8 data bit
- no parity
- 1 stop bit
- baud rate: 600/1200/2400/4800/9600 programmable

Communication Protocol

The communication protocol is a MASTER/SLAVE type where:

- Host = MASTER
- Controller = SLAVE

The communication is performed in the following way:

- 1** the host (MASTER) send a MESSAGE + CRC to the controller (SLAVE);
- 2** the controller answer with an ANSWER + CRC to the host.

The MESSAGE is a string with the following format:

<STX>+<ADDR>+<WIN>+<COM>+<DATA>+<ETX>+<CRC>

Where:

NOTE

When a data is indicated between two quotes ('...') it means that the indicated data is the corresponding ASCII character.

Technical Information

- <STX> (Start of transmission) = 0x02
- <ADDR> (Unit address) = 0x80 (for RS 232)
<ADDR> (Unit address) = 0x80 + device number (0 to 31)
(for RS 485)
- <WIN> (Window) = a string of 3 numeric character indicating the window number (from '000' to '999'); for the meaning of each window see the relevant paragraph.
- <COM> (Command) = 0x30 to read the window, 0x31 to write into the window
- <DATA> = an alphanumeric ASCII string with the data to be written into the window. In case of a reading command this field is not present.

The field length is variable according to the data type as per the following table:

Table 6

Data Type	Field Length	Valid Characters
Logic (L)	1	'0' = OFF '1' = ON
Numeric (N)	6	'0', '1', '2' ... '9' right justified with '0'
Alphanumeric (A)	10	from blank to '_' (ASCII)

- <ETX> (End of transmission) = 0x03
- <CRC> = XOR of all characters subsequent to <STX> and including the <ETX> terminator. The value is hexadecimal coded and indicated by two ASCII character.

The addressed SLAVE will respond with an ANSWER whose structure depends from the MESSAGE type. When the MESSAGE is a reading command, the SLAVE will respond transmitting a string with the same structure of the MESSAGE.

NOTE

Using the RS 485 interface, the message structure remains identical to the one used for the RS 232 interface, the only difference being that the value assigned to the ADDRESS <ADDR>.

Technical Information

The controller can answers with the following response types:

Table 7

Response Type	Response Length	Response Value	Description
Logic	1 byte	-	After a read instruction of a logic window
Numeric	6 bytes	-	After a read instruction of a numeric window
Alphanumeric	10 bytes	-	After a read instruction of an alphanumeric window
ACK	1 byte	(0x6)	The command execution has been successfully completed
NACK	1 byte	(0x15)	The command execution has been failed
Unknown Window	1 byte	(0x32)	The specified window in the command is not a valid window
Data Type Error	1 byte	(0x33)	The data type specified in the command (Logic, Numeric or Alphanumeric) is not accorded with the specified Window
Out of Range	1 byte	(0x34)	The value expressed during a write command is out of range value of the specified window
Win Disabled	1 byte	(0x35)	The specified window is Read Only or temporarily disabled (for example) you can't write the Soft Start when the Pump is running)

Examples

Command: START

Source: PC

Destination: Controller

02	80	30	30	30	31	31	03	42	33
STX	ADDR	WINDOW			WR	ON	ETX	CRC	

Source: Controller

Destination: PC

02	80	06	03	38	35
STX	ADDR	ACK	ETX	CRC	

Command: STOP

Source: PC

Destination: Controller

02	80	30	30	30	31	30	03	42	32
STX	ADDR	WINDOW			WR	OFF	ETX	CRC	

Source: Controller

Destination: PC

02	80	06	03	38	35
STX	ADDR	ACK	ETX	CRC	

Technical Information

Command: SOFT-START (ON)

Source: PC

Destination: Controller

02	80	31	30	30	31	31	03	42	32
STX	ADDR	WINDOW			WR	ON	ETX	CRC	

Source: Controller

Destination: PC

02	80	06	03	38	35
STX	ADDR	ACK	ETX	CRC	

Command: SOFT-START (OFF)

Source: PC

Destination: Controller

02	80	31	30	30	31	30	03	42	33
STX	ADDR	WINDOW			WR	OFF	ETX	CRC	

Source: Controller

Destination: PC

02	80	06	03	38	35
STX	ADDR	ACK	ETX	CRC	

Technical Information

Command: READ PUMP STATUS

Source: PC

Destination: Controller (with address = 3)

02	83	32	30	3	30	03	38	37
STX	ADDR	WINDOW			RD	ETX	CRC	

Source: Controller (with address = 3 in stop status)

Destination: PC

02	83	32	30	35	30	30	30	30	30	30	03	38	37
STX	ADDR	WINDOW			DATA (STATUS)						ETX	CRC	

Command: REAL SERIAL TYPE

Source: PC

Destination: Controller (with address = 3 in 485 mode)

02	83	35	30	34	30	03	38	31
STX	ADDR	WINDOW			RD	ETX	CRC	

Source: Controller

Destination: PC

02	83	35	30	34	30	31	03	42	30
STX	ADDR	WINDOW			RD	DATA	ETX	CRC	

Window Meanings

N.	Read/Write	Data Type	Description	Admitted Values
000	R/W	L	Start/Stop (in remote/ mode the window is a read only)	Start = 1 Stop = 0
001	R/W	L	Low Speed Activation (in remote/ mode the window is a read only)	No = 0 Yes = 1 (default = 0)
008	R/W	L	Remote or Serial configuration	Remote = 1 Serial = 0 (default = 1)
100	R/W	L	Soft Start (write only in Stop condition)	YES = 1 NO = 0
101	R/W	N	R1 Set Point type	0 = Frequency 1 = Power 2 = Time 3 = Normal 4 = Pressure (default = 0)
102	R/W	N	R1 Set Point valve (expressed in Hz, W or s)	(default = 867)
103	R/W	N	Set Point delay: time between the pump start and the set point check (seconds)	0 to 999999 (default = 0)
104	R/W	L	Set Point signal activation type: the signal can be "high level active" or "low level active"	0 = high level active 1 = low level active (default = 0)
105	R/W	N	Set point hysteresis (in % of value)	0 to 100 (default = 2)
107	R/W	L	Active Stop (write only in stop)	0 = NO 1 = YES (default = 0)
108	R/W	N	Baud rate	600 = 0 1200 = 1 2400 = 2 4800 = 3 9600 = 4 (default = 4)
111	R/W	L	Analog output type: output voltage signal proportional to frequency or power	0 = frequency 1 = power (default = 1) 2 = Pump temperature 3 = Pressure
117	R/W	N	Low Speed frequency (Hz)	1100 to "Maximum rotational frequency" (win 120) (default = 1100)

Technical Information

N.	Read/ Write	Data Type	Description	Admitted Values	
				For 74 FS	For 305 FS
120	R/W	N	Rotational frequency setting (Hz)	1100 to 1167 (default = 1167)	700 to 1010 (default = 1010)
122	R/W	L	Set vent valve on/off	0 = Closed 1 = Open (default = 1)	
125	R/W	L	Set the vent valve operation	Automatic = 0 (see note 1.) On command = 1 (see note 2.)	
126	R/W	N	Vent valve opening delay (expressed in 0.2 sec)	0 to 65535 (corresponding to 0 to 13107 sec) (default = 15)	
147	R/W	N	Vent open time	0 = infinite 1 bit = 0.2 sec 1 to 65535	
155	R	N	Power limit applied	155	
157	R/W	N	Gas load type Select the gas load to the pump	Ø = N ² 1 = Ar	
162	R/W	A	R1 Set Point Pressure Valve Valid if Win. 101 = 4 Format X.X E. XX Where X = 0 to 9 s = + or -		
163	R/W	N	Pressure unit of measure	0 = mBar 1 = Pa 2 = Torr	
167	R/W	A	Stop speed reading Activates / deactivates the pump speed reading after Stop command	0 = disable 1 = enable	
200	R	N	Pump current in mA dc		
201	R	N	Pump voltage in Vdc		
206	R	N	Error code	Bit description: see the following figure	
216	R	N	Controller Air Temperature (°C).		
224	R	A	Pressure reading Format = X.X E XX		
226	R	N	Rotation Frequency (rpm)		
300	R	N	Cycle time in minutes (zeroed by the reset command)	0 to 999999	
301	R	N	Cycle number (zeroed by the reset command)	0 to 9999	
302	R	N	Pump life in hours (zeroed by the reset command)	0 to 999999	
310 to 347			Reserved to Agilent service		

Technical Information

N.	Read/Write	Data Type	Description	Admitted Values
358	R/W	N	Tip-seal life (R) Tip-seal life reset (W)	0 = reset
406	R	A	Program Listing Code	"XXXXXXXXXX"
407	R	A	Parameter Listing Code	"XXXXXXXXXX"
500	Reserved to Agilent service			
503	R/W	N	RS 485 address	0 to 31 (default = 0)
504	R/W	L	Serial type select	0 = RS 232
724	R/W	N	Run Up time (minutes)	0.30 15
725	R/W	L	Run Up time control	On = 1 1 Off = 0

NOTE

- 1 Automatic means that when the controller stops, the vent valve is opened with a delay defined by window n. 126; when the controller starts, the vent valve is immediately closed.
- 2 On command means that the vent valve is opened or closed by means of window n. 122.
- 3 These commands remove the pump motor supply for a short time. If they are used continuously, they can cause the pump stopping.

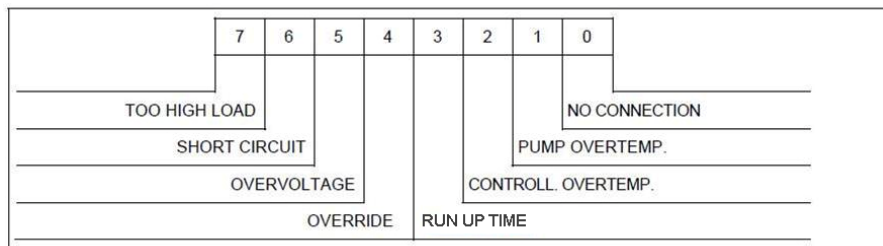

Figure 75 Windows N. 206 Bit Description

Service Options

Agilent pumping systems will provide many years of trouble-free operation if the maintenance procedures are observed.

Pumping System cleaning and internal scroll pump tip seal replacement are recommended when Pumping System TMP adsorbed current (with blanked inlet flange) has risen to an unacceptably high level (>500 mA) or when the message "TIP-SEAL SERV" appears on the TPS-compact front side display.

The warning message appears after 5000 h of operation.

If your TPS-compact exhibits humming or grinding noises from the scroll pump, a major overhaul should be done by Agilent Vacuum Technologies.

The parts needed for Tip-Seal replacement on the internal scroll pump are available in the kit described in Orderable parts Table. This kit contains seals and O-rings, and can be obtained from your Agilent dealer.

Tip-Seal Replacement

WARNING

Before replace Tip-Seals remove the power supply cable.



The parts and tools required to replace Tip-Seals are listed below:

- Tip-Seal Replacement Kit P/N IDP3TS
- 4 mm Allen wrench
- Razor blade or side-cutting pliers
- Compressed air (optional)

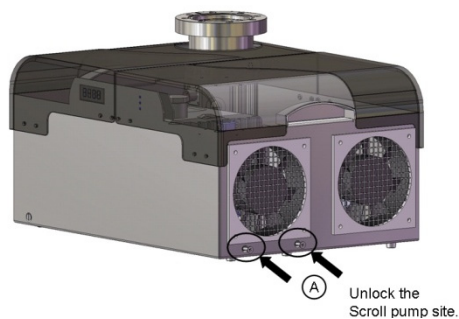

Figure 76 Tip-Seal replacement - Figure A

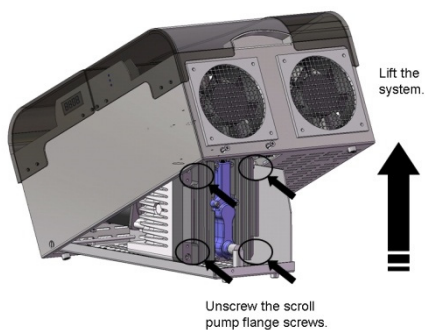

Figure 77 Tip-Seal replacement - Figure B

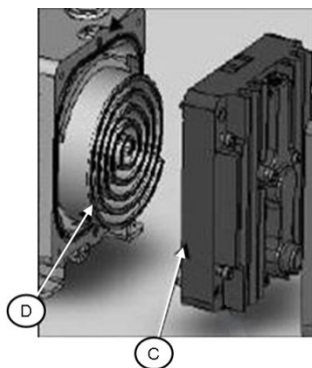

Figure 78 Tip-Seal replacement - Figure C

To Remove the Worn Tip-Seals

Disconnect the TPS-compact from electrical power.

Unlock the scroll pump support by unscrewing the screws (A) (see the “Tip-Seal replacement - Figure A”)

- 1** Lift the TPS-compact in order to access the Scroll pump site (you’ll hear a “click” noise as soon as the upper part of TPS-compact is locked).
- 2** Remove (4) M5 socket head bolts (B).
- 3** Remove the outboard housing axially off the frame (C).
- 4** Remove and discard the worn tip seals (D) and the main O-ring.
- 5** If compressed air is available, blow any remaining seal debris off the scroll parts. If seal debris is attached to the sides, use a razor or Exacto knife to scrape the debris off.

To Install the new Seals and O-Rings

- 1** Unpack the Tip-Seals. Two tip seals are provided in the kit; one fits the orbiting scroll and the other fits the out-board housing scroll.
- 2** Install the correct tip seal into the groove of the orbiting scroll by:
 - a** Facing the white plastic surface upwards and inserting the foam backing into the groove. Start from the center and work outward.
 - b** Cutting the tip seal off about 1/8" (3 mm) from the outer end of the groove.
- 3** Install the correct tip seal into the groove of the outboard housing scroll as in step 3.
- 4** Place the new main O-ring into the groove in the frame.
- 5** Ensure that the groove is clean.
- 6** Ensure the sealing face of the outboard housing is clean. Carefully replace the outboard housing by lining up the locating pins. Ensure the tip seal has not fallen out of its groove.
- 7** Reinstall (4) M5 bolts (B) and torque the (4) M5 bolts to 5.6 Nm (50 in-lb).
- 8** Unlock the upper part of TPS-compact by sliding the small lever you can find on the bottom side of TPS-compact.
- 9** Reconnect the TPS-compact to the electrical power mains.

Technical Information

- 10 Disable the "TIP-SEAL SERV" warning message by serial interface. To disable the Tip-seal Service message you have to reset the Tip-seal hour-meter (Win 358). Write a "0" on the window 358. The message will be showed again after 5000 h of operation. To check the Tip-seal life you have just to read the Win 358.

Tip Seal Life Reset using A-plus

The screenshot shows a sequence of three windows in a software interface:

- Top window:** A dark blue header with the text "Add new parameter".
- Middle window:** A dark blue header with the text "Enter unknown window". Below the header are three input fields: "Window number:" with the value "538", "Description:" with the value "reset", and "Type:" with radio buttons for "boolean", "numeric" (which is selected), and "string". At the bottom are "OK" and "CANCEL" buttons.
- Bottom window:** A dark blue header with a dropdown arrow and the text "Unknown Windows". Below the header is a list item "reset" with a list icon and an eye icon to its right. Below the list is a highlighted row with the text "538 (reset): reset" and "Value: TIMEOUT". At the bottom is an input field containing "0" and a "WRITE VALUE" button.

To test the Pumping System

- 1 Run the TPS-compact for about 5 seconds. Verify that the front fan is running. If you hear loud noises from the Scroll pump this indicates that the tip seal or main O-ring are possibly out of place.
- 2 Disassemble and repair as necessary.
- 3 The pump is now ready to return to service.

NOTE

Newly installed tip seals may require several hours of run time to seat properly and enable the pump to meet speed and base pressure specifications.

Troubleshooting Chart

Table 8

Problem	Possible Causes	Corrective Actions
TMP doesn't reach NORMAL OPERATION	Scroll Pump motor thermal protector open.	Allow motor to cool. Identify cause of overload.
	Vacuum system leak.	Locate and repair leak.
System will not start	Excessive voltage drop.	Check size and length of cable.
	Fuses burnt-out.	Check fuses and if necessary replace.
Poor ultimate pressure	Vacuum system leak.	Locate and repair leak.
	Water in TPS-compact.	Flush the system with air (use provided IDP3GBKIT) or dry nitrogen.
	Water vapour in TPS-compact.	Flush the system with air (use provided IDP3GBKIT) or dry nitrogen. Install trap or filter.
	Scroll Pump seals worn out.	Replace tip seals.
Hammering noise	Poor conductance to TPS-compact.	Replumb with shorter and/or larger diameter tubing.
	Scroll pump overheated.	Check ventilation to TPS-compact. Check ambient temperature.
Internal Scroll Pump runs intermittently	Debris in Scroll pump.	Flush the TPS-compact. Disassemble pump and inspect.
	Motor thermal protector is cycling open and closed.*	Allow the scroll motor to cool. Identify the cause of the overload.
Overtemperature	Fans clogged or not spinning, problems with turbomolecular pump.	Check if the rotor freely rotates.

- * The internal Scroll Pump is equipped with an auto-reset thermal motor protector. This protector automatically shuts down the pump when it detects an overload condition, and automatically restarts the pump when the motor has cooled to within an acceptable temperature range.

CAUTION

Overtemperature:
To prevent damage to the pump when the temperature exceeds 60 °C, the sensor automatically cuts off the power supply.

Accessories and Spare Parts

Table 9 Accessories and spare parts

TPS-compact	74 FS KF40	74 FS CFF 2.75"	74 FS ISO 63	74 FS CFF 4.5"
115 V	X3583-64000	X3583-64001	X3583-64002	X3583-64003
230 V	X3583-64004	X3583-64005	X3583-64006	X3583-64007
100 V	X3583-64008	X3583-64009	X3583-64010	X3583-64011
Accessories				
DIY Full Range Gauge Kit	9699190	9699199	9699192	9699193
Wheels accessory kit	9698233	9698233	9698233	9698233
Mains cable NEMA plug [3m]	9699958	9699958	9699958	9699958
Mains cable EU plug [3m]	9699957	9699957	9699957	9699957
Inlet screen	9699309	9699328	9699300	9699300
FRG-700 3 m cable	9699960	9699960	9699960	9699960
FRG-700 5 m cable	9699961	9699961	9699961	9699961
Serial cable	9699883	9699883	9699883	9699883
Tip-seal replacement kit	IDP3TS	IDP3TS	IDP3TS	IDP3TS
Vent Valve N.O. 0.5 mm orifice	9699844M005	9699844M005	9699844M005	9699844M005
Mains Cable China Plug	8121-0723	8121-0723	8121-0723	8121-0723
Power cable IEC320 (3 m long)	9499399	9499399	9499399	9499399
Breather vent with adapter	IDP3GBKIT	IDP3GBKIT	IDP3GBKIT	IDP3GBKIT

Technical Information

Table 9 Accessories and spare parts (continued)

TPS-compact	305 FS ISO 100	305 FS CFF 6"	305 FS ISO 160	305 FS CFF 8"
115 V	X3582-64000	X3582-64001	X3582-64002	X3582-64003
230 V	X3582-64004	X3582-64005	X3582-64006	X3582-64007
100 V	X3582-64008	X3582-64009	X3582-64010	X3582-64011
Accessories				
DIY Full Range Gauge Kit	9699194	9699201	9699195	9699202
Wheels accessory kit	9698233	9698233	9698233	9698233
Mains cable NEMA plug [3m]	9699958	9699958	9699958	9699958
Mains cable EU plug [3m]	9699957	9699957	9699957	9699957
Inlet screen	9699302	9699302	9699304	9699304
FRG-700 3 m cable	9699960	9699960	9699960	9699960
FRG-700 5 m cable	9699961	9699961	9699961	9699961
Serial cable	9699883	9699883	9699883	9699883
Tip-seal replacement kit	IDP3TS	IDP3TS	IDP3TS	IDP3TS
Breather vent with adapter	IDP3GBKIT	IDP3GBKIT	IDP3GBKIT	IDP3GBKIT
Vent Valve N.O. 0.5 mm orifice	9699844M005	9699844M005	9699844M005	9699844M005
Mains Cable				
China Plug	8121-0723	8121-0723	8121-0723	8121-0723

For a complete overview of Agilent's extensive product lines, please refer to the Agilent catalog.



Vacuum Products Division

Dear Customer,

Thank you for purchasing an Agilent vacuum product. At Agilent Vacuum Products Division we make every effort to ensure that you will be satisfied with the product and/or service you have purchased.

As part of our Continuous Improvement effort, we ask that you report to us any problem you may have had with the purchase or operation of our products. On the back side you find a Corrective Action request form that you may fill out in the first part and return to us.

This form is intended to supplement normal lines of communications and to resolve problems that existing systems are not addressing in an adequate or timely manner.

Upon receipt of your Corrective Action Request we will determine the Root Cause of the problem and take the necessary actions to eliminate it. You will be contacted by one of our employees who will review the problem with you and update you, with the second part of the same form, on our actions.

Your business is very important to us. Please, take the time and let us know how we can improve.

Sincerely,

A handwritten signature in black ink, appearing to read "Giampaolo LEVI".

Giampaolo LEVI

*Vice President and General Manager
Agilent Vacuum Products Division*

Note: Fax or mail the Customer Request for Action (see backside page) to Agilent Vacuum Products Division (Torino) – Quality Assurance or to your nearest Agilent representative for onward transmission to the same address.

CUSTOMER REQUEST FOR CORRECTIVE / PREVENTIVE / IMPROVEMENT ACTION

TO: AGILENT VACUUM PRODUCTS DIVISION TORINO – QUALITY ASSURANCE FAX

N°: XXXX-011-9979350

ADDRESS: AGILENT TECHNOLOGIES ITALIA S.p.A. – Vacuum Products Division –

Via F.Ili Varian, 54 – 10040 Leini (TO) – Italy

E-MAIL: vpd-qualityassurance_pdl-ext@agilent.com

NAME	COMPANY	FUNCTION
<p>ADDRESS:</p> <p>TEL. N° : FAX N° :</p> <p>E-MAIL:</p>		
<p>PROBLEM / SUGGESTION :</p> <p>REFERENCE INFORMATION (model n°, serial n°, ordering information, time to failure after installation, etc.):</p> <p style="text-align: right;">DATE</p>		
<p>CORRECTIVE ACTION PLAN / ACTUATION (by AGILENT VPD)</p>		<p>LOG N°</p>

XXX = Code for dialing Italy from your country (es. 01139 from USA; 00139 from Japan, etc.)



**Vacuum Products Division
Instructions for returning products**

Dear Customer,

Please follow these instructions whenever one of our products needs to be returned.

Complete the attached **Request for Return form** and send it to Agilent Technologies (see below), taking particular care to include the completed **Health and Safety** declaration Section. No work can be started on your unit until we receive a completed copy of this form.

After evaluating the information, Agilent Technologies will provide you with a **Return Authorization (RA) number** via email or fax, as requested. Note: Depending on the type of return, a Purchase Order may be required at the time the **Request for Return** is submitted. We will quote any necessary services (evaluation, repair, special cleaning, eg).

Product preparation

- Remove all accessories from the core product (e.g. inlet screens, vent valves).
- Prior to shipment and if applicable for your product, drain any oils or other liquids, purge or flush all gasses, and wipe off any excess residue.
- If ordering an Advance Exchange product, please use the packaging from the Advance Exchange to return the defective product.
- Seal the product in a plastic bag, and package product carefully to avoid damage in transit. You are responsible for loss or damage in transit.
- Include a copy of the Health and Safety Declaration in the shipping documentation on the outside of the shipping box of your returning product.
- Clearly label package with RA number. Using the shipping label provided will ensure the proper address and RA number are on the package. Packages shipped to Agilent without a RA clearly written on the outside cannot be accepted and will be returned.
- Return only products for which the RA was issued.

Shipping

- Ship to the location specified on the printable label, which will be sent, along with the RA number, as soon as we have received all of the required information. Customer is responsible for freight charges on returning product.
- Return shipments must comply with all applicable Shipping Regulations (IATA, DOT, ADR, etc.) and carrier requirements.

RETURN THE COMPLETED REQUEST FOR RETURN FORM TO YOUR NEAREST LOCATION:

EUROPE:

Fax: 00 39 011 9979 330
Fax Free: 00 800 345 345 00
Toll Free: 00 800 234 234 00

vpt-customer@agilent.com

NORTH AMERICA:

Fax: 1 781 860 9252
Toll Free: 800 882 7426

vpl-ra@agilent.com

PACIFIC RIM:

please visit our website for individual
office information

<http://www.agilent.com>



TERMS AND CONDITIONS

Please read the terms and conditions below as they apply to all returns and are in addition to the Agilent Technologies Vacuum Product Division – Products and Services Terms of Sale.

- Unless otherwise pre-negotiated, customer is responsible for the freight charges for the returning product. Return shipments must comply with all applicable **Shipping Regulations** (IATA, DOT, etc.) and carrier requirements.
- Agilent Technologies is not responsible for returning customer provided packaging or containers.
- Customers receiving an Advance Exchange product agree to return the defective, rebuildable part to Agilent Technologies **within 15 business days**. Failure to do so, or returning a non-rebuildable part (crashed), will result in an invoice for the non-returned/non-rebuildable part.
- Returns for credit toward the purchase of new or refurbished Products are subject to prior Agilent approval and may incur a restocking fee. Please reference the original purchase order number.
- Units returned for evaluation will be evaluated, and a quote for repair will be issued. If you choose to have the unit repaired, the cost of the evaluation will be deducted from the final repair pricing. A Purchase Order for the final repair price should be issued within 3 weeks of quotation date. Units without a Purchase Order for repair will be returned to the customer, and the evaluation fee will be invoiced.
- Products returned that have not been drained from oil will be disposed.
- A Special Cleaning fee will apply to all exposed products
- If requesting a calibration service, units must be functionally capable of being calibrated.



Vacuum Products Division
Request for Return Form

Customer information
Company :
Address:
Contact Name:
Tel:
Fax:
Email:

Equipment
Product description
Agilent PartNo
Agilent Serial No
Original Purchasing Reference
Failure description
Type of process (for which the equipment was used)

Type of return
Non Billable
Billable
New PO # (hard copy must be submitted with this form):
Exchange
Repair
Upgrade
Consignment/Demo
Calibration
Evaluation
Return for Credit

Health and safety
Substances (please refer to MSDS forms)
The product has been exposed to the following substances:
Trade name
Chemical name
Chemical Symbol
CAS Number
Toxic
Harmful
Corrosive
Reactive
Flammable
Explosive (*)
Radioactive (*)
Biological (*)
Oxidizing
Sensitizer
Other dangerous substances

Goods preparation
If you have replied YES to one of the above questions. Has the product been purged?
If yes, which cleaning agent/method:
Has the product been drained from oil?
I confirm to place this declaration on the outside of the shipping box.

I declare that the above information is true and complete to the best of my knowledge and belief.
I understand and agree to the terms and conditions on page 2 of this document.
Name:
Position:
Date:
Authorized Signature:

NOTE: If a product is received at Agilent which is contaminated with a toxic or hazardous material that was not disclosed, the customer will be held responsible for all costs incurred to ensure the safe handling of the product, and is liable for any harm or injury to Agilent employees as well as to any third party occurring as a result of exposure to toxic or hazardous materials present in the product.

Agilent Vacuum Products Division/Sales and Service Offices

United States

Agilent Technologies

121 Hartwell Avenue
Lexington, MA 02421 - USA
Ph. +1 781 861 7200
Fax: +1 781 860 5437
Toll-Free: +1 800 882 7426
vpl-customer@agilent.com

Netherlands

Agilent Technologies Netherlands B.V.

Customer Contact Center
Laan van Langerhuize 1, toren A-8
1186 DS Amstelveen
Tel. +31 020 547 2600
Fax +31 020 654 5748
customer@agilent.com

Belgium

Agilent Technologies Belgium S.A./N.V.

Customer Contact Center
Pegasus Park
De Kleetlaan 12A bus 12
B-1831 Diegem
Tel. +32 2 404 92 22
Fax +32 2 626 46 30
customer@agilent.com

Brazil

Agilent Technologies Brasil

Avenida Marcos Penteado de Ulhoa
Rodrigues, 939 - 6° andar
Castelo Branco Office Park
Torre Jacarandá - Tamboré
Barueri, Sao Paulo CEP: 06460-040
Toll free: 0800 728 1405

China

Agilent Technologies (China) Co. Ltd

No.3, Wang Jing Bei Lu, Chao Yang District
Beijing, 100102, China
Tel: +86 (0)10 64397888
Fax: +86 (0)10 64392765
Toll free: 400 8206778 (mobile)
Toll free: 800 8206778 (landline)
vacuum.cnmarketing@agilent.com
vpc-customerservice@agilent.com

France

Agilent Technologies
Parc Technopolis - Z.A. de Courtaboeuf
3, avenue du Canada - CS 90263
91978 Les Ulis cedex, France
Tel: +33 (0) 1 64 53 61 15
Fax: +33 (0) 1 64 53 50 01
vpf.sales@agilent.com

Southeast Asia

Agilent Technologies Sales Sdn Bhd

Unit 201, Level 2 uptown 2,
2 Jalan SS21/37, Damansara Uptown
47400 Petaling Jaya, Selangor, Malaysia
Ph. +603 7712 6181
Fax: +603 7727 1239
Toll free: 1 800 880 805
vps-customerservice@agilent.com

India (Sales)

Agilent Technologies India Pvt. Ltd.

Unit Nos 110- 116, & Part of 101 & 109
First Floor, Splendor Forum,
Plot No.-3, District Centre, Jasola
New Delhi-110025
Ph. +91 11 4623 7100
Fax: +91 4623 7105
Toll Free: 1 800 180 1517

Italy

Agilent Technologies Italia S.p.A.

Via F.lli Varian, 54
10040 Leini, (Torino) - Italy
Tel: +39 011 9979 111
Fax: +39 011 9979 350
Toll free: 00 800 234 234 00
vpt-customerservice@agilent.com

Japan

Agilent Technologies Japan, Ltd.

9-1 Takakura-cho Hachioji-city,
Tokyo, Japan
Tel.: +81- 3-5232-1253
Fax: +81-120-565-154
Toll-Free: +81-120-477-111
jp-vvt-sales.pdl-ext@agilent.com

Singapore

Agilent Technologies Singapore Pte. Ltd.

1 Yishun Avenue 7,
Singapore 768923
Tel : (65) 6215 8045
Fax : (65) 6754 0574
Toll free: 1 800 2762622
vps-customerservice@agilent.com

Korea

Agilent Technologies Korea, Ltd.

Ilshin Building 4F
Yongsan-gu Hannam-daero
Seoul Korea 04418
Tel: +82 (0)2 2194 9449
Fax: +82 (0)2 2194 9853
Toll free: 080 222 2452
vpc-customerservice@agilent.com

UK and Ireland

Agilent Technologies LDA UK Limited

Lakeside Cheadle Royal Business Park
Cheadle, Cheshire SK8 3GR,
United Kingdom
Ph. +44 01865291570
Fax +44 01865291571
Toll free: 00 800 234 234 00
Toll free fax: 00 800 345 345 00
vpt-customer@agilent.com

© Agilent Technologies, Inc. 2021
02/2021

India (Service)

Agilent Technologies India Pvt. Ltd.
C-Block, RMZ Centennial Plot Number- 8A, 8B, 8C,
8D,
Doddanakundi Industrial Area, ITPL Road,
Mahadevapura Post, Bangalore- 560048
Ph. +91 80 40614000
Fax: +91 80 40148991

Taiwan

Agilent Technologies Taiwan Limited

No. 20 Gao-shuang Road, Ping-zhen Dist
Tao-Yuan City
32450 Taiwan, R.O.C.
Tel: +886 3 4959004
Toll free: 0800 018 768
vpw-customerservice@agilent.com

Germany and Austria

Agilent Technologies Sales & Services GmbH & Co. KG

Lyoner Str. 20
60 528 Frankfurt am Main
GERMANY
Tel: +49 69 6773 43 2230
Fax: +49 69 6773 43 2250

Mexico

Agilent Technologies

Concepcion Beistegui No 109
Col Del Valle
C.P. 03100 – Mexico, D.F.
Tel.: +52 5 523 9465
Fax: +52 5 523 9472

Other Countries

Agilent Technologies Italia S.p.A.

Via F.lli Varian, 54
10040 Leini, (Torino) - Italy
Tel.: +39 011 997 9111
Fax: +39 011 997 9350
Toll-Free: 00 800 234 234 00
vpt-customer@agilent.com

Customer Support & Service

NORTH AMERICA:

Toll Free: 800 882 7426
vpl-ra@agilent.com
Lexington-service@agilent.com

EUROPE:

Toll Free: 00 800 234 234 00
vpt-customer@agilent.com

PACIFIC RIM:

please visit our website for individual office
information
<http://www.agilent.com/chem/vacuum>

Worldwide Web Site, Catalog and Order On- line:

www.agilent.com/chem/vacuum
Representatives in most countries

In This Book

The manual describes the following:

- Istruzioni per l'uso
- Bedienungshandbuch
- Notice de mode d'emploi
- Manual de instrucciones
- 用户手册
- ユーザーマニュアル
- Instruction for Use
- Technical information

www.agilent.com

© Agilent Technologies, Inc. 2022

Edition L.00, 04/22



87-901-010-01

