

32 PROPANE



Packaged under pressure, propane gas presents three hazards if misused:

1. High flammability and explosive potential
2. Displacement of breathable air in confined spaces (also, being heavier than air, propane will collect in low areas)
3. Contact injury from accidental exposure to a substance under high pressure.

We will not cover the use of propane in the roofing industry.

Physical Characteristics

Propane or liquefied petroleum gas (LPG) is a by-product of petroleum or natural gas refining which is packaged under pressure in cylinders. In its stored state it is a liquid but is released from the cylinder or tank in a gaseous form. The boiling point of propane, the point at which the liquid converts to a gas, is -42.2°C (-44°F). If the surrounding air temperature is above this, gas will form in the upper part of the cylinder (Figure 32-1).

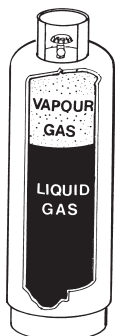
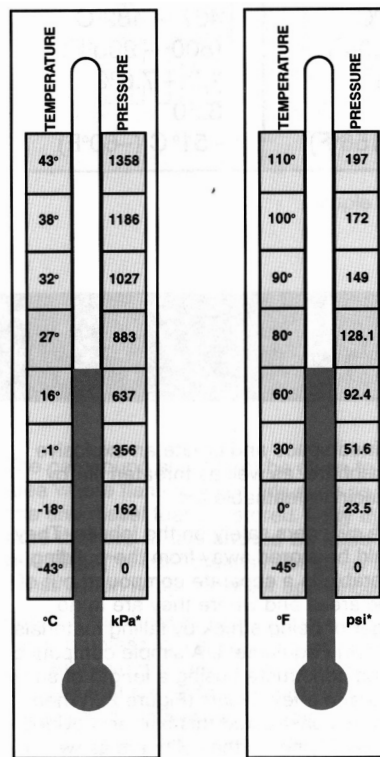

Figure 32-1: Cutaway View of Vapour Withdrawal Propane Cylinder

The pressure within the container is variable depending on the temperature to which the container is exposed (Table 32-1). The pressure increases as the temperature rises, causing expansion of the liquid. For this reason containers are never fully charged with liquid, but have a vapour space at the top of the tank to allow for normal expansion.

Table 32-1: Temperature/Pressure Variables



*kilopascals

*pounds per square inch

Source: CSA Standard B149.2-M80

Should the temperature rise above safe limits, a relief valve will open to allow release of the gas in a measured amount. This release is generally over in seconds. The valve reseals and remains closed until the pressure builds up again. Cylinder relief valves are set at 2585.5 kPa (375 lb per square inch).

Propane is packaged in a number of cylinder types and sizes to meet a variety of applications:

- 100-lb cylinders for construction heaters, roofing kettles, and other appliances that consume large amounts of fuel. They are called 100-lb cylinders because they are charged with 100-lb of liquid at the propane plant.
- 20-lb cylinders for oxypropane welding set-ups. (This is a familiar size that will be used on such appliances as household gas barbecues.)
- 10 and 20-lb cylinders for soldering work.
- 14-oz. throwaway containers for various hand-held torch applications.

Propane can be easily compressed from a gaseous to a liquid state in small cylinders, making it very portable. When the liquid converts back to a gas, it expands 270 times in volume. Compared to natural gas, propane has a heating value that is 2.5 times greater. One cubic foot of propane converts to 2,500 BTUs, while one cubic foot of natural gas converts to only 1,000 BTUs. This explains why so much energy (BTUs) can be contained in a small cylinder, making it a very convenient fuel for the contractor.

But the high-energy value of propane also makes it very dangerous to handle. It only takes a tiny leak to form an explosive gas/air mixture.

The high flammability of propane can be seen by comparing its ignition characteristics with those of gasoline (Table 32-2).

Table 32-2: Ignition Points of Gasoline vs. Propane

	Propane	Gasoline
Minimum ignition temperature range	493° - 549°C (920° - 1020°F)	427° - 482°C (800° - 900°F)
Flammability limits in air	2.4 - 9.5%	1.3 - 7.5%
Vapour density (air=1)	1.52	3.50
Minimum flash point	-104°C (-156°F)	-51°C (-60°F)

When you consider that the heat from a lighted cigarette ranges between 1000°F and 1600°F, and that a lighted match produces 2000°F, all that is necessary for combustion is a sufficient quantity of propane gas mixed with air. This is why safety procedures must be followed—so that a very efficient energy source does not become a hazard to workers.

Safe Handling of Cylinders

In construction, most propane applications dispense the fuel in a vapour form. For this reason, it is essential that portable cylinders be transported, stored, and used in an upright position. Propane liquid must never come in contact with the cylinder relief valve. If liquid escapes through the valve, large volumes of gas will be released. This release can also cause pooling of propane in the storage area, which is an invisible fire and explosion hazard for workers.

The simplest way to avoid the problem is to fasten cylinders in an upright position with rope, wire, or other means. When transporting by truck, take extra care to keep cylinders upright and stationary. Cylinders should not be transported in an automobile trunk or in a closed van, especially in the horizontal position. Escaping gas can collect in a confined space and create an explosive atmosphere, as well as threaten life by displacing breathable air.

Store cylinders safely on the jobsite. Only one day's supply is permitted to be connected to the heater or propane-fueled device. Additional cylinders should be stored in a separate compound out of traffic areas and where they are in no danger of being struck by falling materials or moving equipment.

A simple compound can be constructed using a length of snow fence and a few T-bars (Figure 32-2). When properly constructed, this barrier provides a means of tying up the cylinders as well as controlling stock. Store empty cylinders on one side of the compound and full cylinders on the other. Don't mix the cylinders. Secure cylinders together to prevent them from falling over.

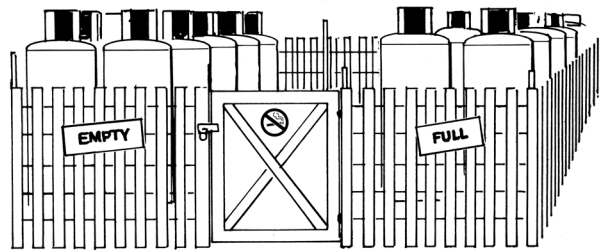

Figure 32-2: Secure On-site Propane Storage

The compound should not be close to an area where flammable liquids such as gasoline and diesel fuel are stored. **Only cylinders that are in use should be inside a building.** (“In use” means hooked up to a construction heater or other appliance.)

Do not locate cylinders in stairwells and hallways. Leaking gas or the outbreak of fire can block exits and prevent escape.

When moving cylinders of gas around the jobsite, remember the following precautions:

- Never hoist propane cylinders by using a sling. It is prohibited under O. Reg 213/91, s. 122(2).
- Never hook onto the protective collar around the valve.
- Keep cylinders away from heat sources.
- Keep cylinders upright. Use a hand cart to move cylinders (Figure 32-3). Never roll cylinders.
- Use a hoisting cradle to move cylinders from one level to another (Figure 32-4). During transport with a hoisting cradle, secure cylinders with a rope or chain to prevent them from falling over.



Figure 32-3: Moving Cylinders with a Hard Cart

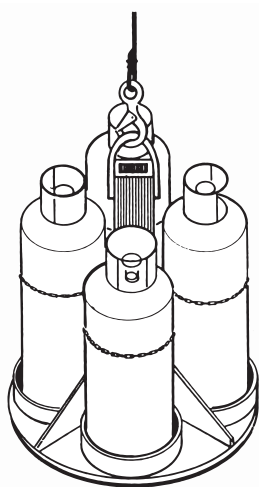

Figure 32-4: Moving Cylinders with a Hoisting Cradle

Heaters

You must have adequate training before you can hook up and light a propane-fired heater. A record of training (ROT) recognized by the Technical Standards and Safety Authority (TSSA) is acceptable if you are demonstrating proper procedures.

When working near construction heaters, take the following precautions.

- All connections must be made by a competent worker holding a valid ROT who can inspect the burner, controls, regulator, and hose for defects. Repair or replace any damaged parts. **Gas-burning equipment should only be repaired by licensed service personnel.**
- Make sure all hose and valve connections are clean.
- Use fitting wrenches to make connections. Don't use adjustable pipe wrenches.
- Cylinders should be secured and kept at least 10 feet away from the heaters. The cylinder should be placed well clear of any heat source and never at the flame end of a heater. Hose length must be between 15 feet and 75 feet (Figure 32-5).

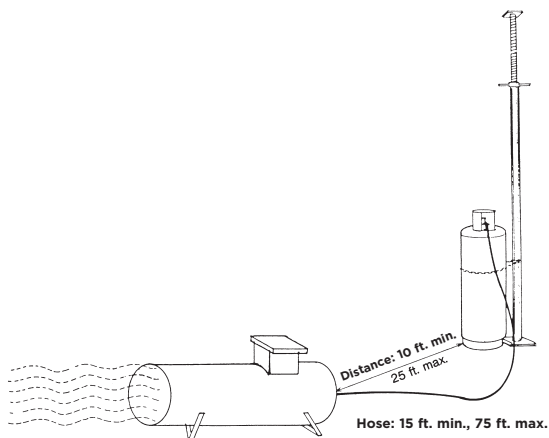

Figure 32-5: Proper Set-Up of Propane Cylinder and Heater

- Secure the cylinder by tying or wiring it to a column or other upright. Keep cylinders out of traffic areas where they may be knocked over.
- Keep heaters away from flammable materials. The heat from a burner is effective well past the tip.
- Have a 4A40BC fire extinguisher on hand before lighting the heater.
- Cylinder valves in use must be fully opened and check for leaks with soapy water (Figure 32-6) or a leak detector. Sometimes you may notice a gas odour or frost appearing on a fitting, but these signs are not always reliable. If a leak is detected, shut off the cylinder valve and make corrections. Fully close valves when not in use.

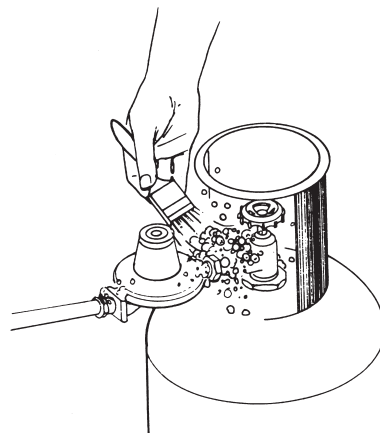

Figure 32-6: Use Soap to Test for Leaks

- Watch for a drop in pressure or reduced flame efficiency. This indicates that gas is being withdrawn too quickly, and may require additional cylinders to be hooked up in manifold. Never apply heat to the cylinder.
- If cylinders must be manifolded, use no more than three 100-pound cylinders (Figure 32-7). If other heaters with manifolded cylinders are to be operated in the same area, they must be at least fifty feet away or be separated by a firewall.

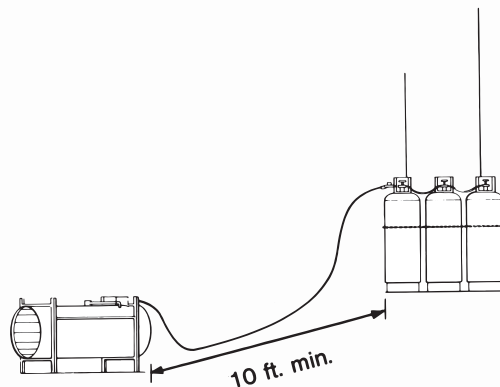

Figure 32-7: Typical Manifold Set-Up

- Remember that propane is heavier than air and will collect in low areas such as trenches, pits, and basements where it can create a flammable or explosive situation (Figure 32-8).

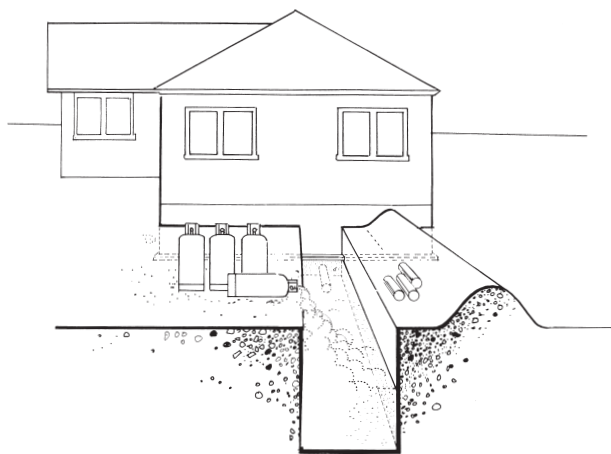

Figure 32-8: Propane Can Collect in Low-lying Areas

- Never attempt to tie down, defeat, or bypass safety devices on a construction heater. If the heater is defective, replace it. If the heater is inadequate, get extra heaters or replace it with a larger one.
- If the flame goes out, act with caution. Shut off the gas supply, then determine whether escaped gas is concentrated in the area. Because of its strong odour, you can usually smell propane. However, in a confined space, test with a gas detection device. If escaped gas is detected or even suspected, ventilate and purge the area thoroughly before relighting the unit.

Warning: If the heater is in a confined or low-lying area, escaped gas can accumulate. Never attempt to relight. Notify your supervisor or certified operator.

- Never expose any part of your skin to liquid propane. Propane under pressure is extremely cold and can cause frostbite.
- Don't allow propane gas to saturate your clothing. A highly flammable situation can remain for some time after the exposure. Saturated clothing should be removed and aired outside.
- Never operate heaters without adequate ventilation. Do not block or restrict openings meant to ventilate emission gasses.
- Take special care when ambient air temperature falls below -25°C . In the winter, propane can flow more slowly. When the ambient air becomes colder, it can reduce flame efficiency and additional propane tanks may be required.
- NEVER use propane-powered equipment without a safety device that stops propane fuel from flowing when it senses the flame has gone out. The natural cooling effect that occurs at shut-off valves can freeze a propane supply line temporarily, which will stop the supply of fuel and cause the flame to go out. If there is no safety device, propane will flow into the area when the ambient temperature of the hose increases and create an explosion hazard.

Bulk Tanks

Propane construction heaters that operate from a central bulk storage tank are common on large construction projects. This type of installation takes planning and close consultation between contractor and gas supplier to select a safe, convenient tank storage area that will not interfere with onsite traffic and materials handling, nor infringe on property line clearance requirements.

The bulk tank and feed lines are installed by licensed service personnel, but hooking up the heaters is generally left to the construction heater operator. The feed lines are usually well provided with hook-up points called station valves. They consist of a shut-off and a connection point for a flexible hose. Similar safety precautions also apply here.

- Check for leaks at the hook-up point after installing a flexible heater line.
- Flexible hose lengths should never exceed 75 feet between heater and station valve.

Welding and Cutting

In recent years, propane has become a popular energy source in open flame welding and cutting. Combined with oxygen in a manner similar to oxyacetylene welding, it provides a gas mix that is considered much more stable by many users.

While welding cylinders are generally smaller than cylinders used for construction heaters, they should be treated with the same care.

- Fittings should be clean and free of grease before hooking up.
- Use fitting wrenches avoid damaging parts.
- Cylinders must be in an upright position at all times, kept in a suitable cradle when in use, and preferably tied upright to prevent tipping over (Figure 32-9).
- A fire extinguisher (4A40BC minimum) should be kept close when using any torch.
- Regulators should be removed and stored in a protective case when not in use, along with hoses and torches.
- Consult manufacturer's handbook for oxypropane regulator settings. They are very different from oxyacetylene settings. (Refer to Chapter 41.)

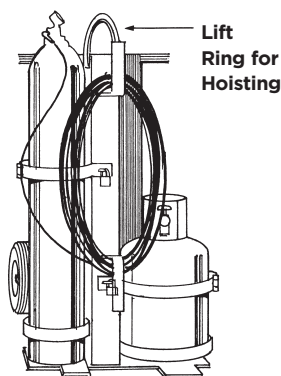

Figure 32-9: Oxypropane Welding Cart