

Rosemount™ 3144P Temperature Transmitter

with Rosemount X-well™ Technology



For every responsibility you have, you are confronted with a number of challenges. You have aggressive production and quality targets, but inaccurate or unavailable temperature measurements create unscheduled downtime and off-spec products. Loops may be running in manual because you don't trust your temperature measurement, requiring the attention of your maintenance staff and costing money in lost production. Additionally, improving safety and complying with government and company regulations is made more difficult when you don't have the information or tools needed to prove your compliance.

That's why companies are coming to Emerson™ – because they know they need reliable measurements and visibility into their temperature measurements in order to address these challenges and achieve their business objectives. With the Rosemount 3144P Transmitter, you gain greater visibility into your temperature processes so you can improve safety, comply with regulations, make the most of your limited resources, and reach your production and quality targets. By leveraging Rosemount X-well Technology, advanced diagnostic capabilities and the unparalleled reliability and accuracy of the transmitter, you can minimize off-spec product, reduce maintenance and downtime, improve the usage of your limited resources, and meet regulatory demands.

Rosemount 3144P Temperature Transmitter

Rosemount X-well Technology provides a Complete Point Solution™ for accurately measuring process temperature in monitoring applications without the requirement of a thermowell or process penetration.

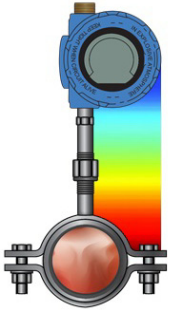

- Simplify temperature measurement point specification, installation and maintenance, and eliminate possible leak points.
- Calculates a repeatable and accurate process temperature measurement via an in-transmitter thermal conductivity algorithm.
- Measures pipe surface and ambient temperature, and utilizes the thermal conductivity properties of the installation and process piping in order to provide an accurate process measurement.

Industry-leading temperature transmitter delivers unmatched field reliability and innovative process measurement solutions

- Superior accuracy and stability
- Dual and single sensor capability with universal sensor inputs (RTD, T/C, mV, ohms)
- Comprehensive sensor and process diagnostics offering
- SIL3 Capable: IEC 61508 certified by an accredited 3rd party agency for use in safety instrumented systems up to SIL 3 (minimum requirement of single use [1oo1] for SIL 2 and redundant use [1oo2] for SIL 3)
- Dual-compartment housing
- Large LCD display
- 4–20 mA /HART® with selectable revisions (5 and 7)
- FOUNDATION™ Fieldbus, compliant to ITK 6.0 and NE107 standards



Content

Rosemount 3144P Temperature Transmitter	2	Product certification	18
Specifications	10	Dimensional drawings	24

Improve efficiency with best-in-class product specifications and capabilities

- Reduce maintenance and improve performance with industry leading accuracy and stability.
- Improve measurement accuracy by 75 percent with transmitter-sensor matching.
- Ensure process health with system alerts and easy to use device dashboards.
- Easily check device status and values on local LCD display with large percent range graph.
- Achieve high reliability and installation ease with the industry's most rugged dual compartment design.



Optimize measurement reliability with diagnostics designed for any protocol on any host system

- Thermocouple degradation diagnostic monitors the health of a thermocouple loop, enabling preventative maintenance.
- Minimum and maximum temperature tracking tracks and records temperature extremes of the process sensors and the ambient environment.
- Sensor drift alert detects sensor drift and alerts the user.
- The Hot Backup™ feature provides temperature measurement redundancy.

Explore the benefits of a Complete Point Solution from Emerson

- An “Assemble To Sensor” option enables Emerson to provide a complete point temperature solution, delivering an installation-ready transmitter and sensor assembly.
- Emerson offers a selection of RTDs, thermocouples, and thermowells that bring superior durability and Rosemount reliability to temperature sensing, complementing the Rosemount Transmitter portfolio.

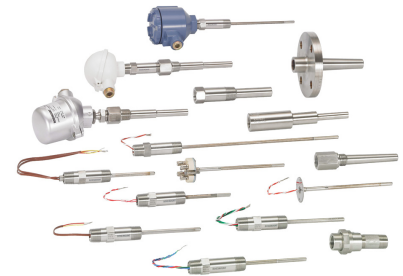

Experience global consistency and local support from numerous worldwide Emerson manufacturing sites



- World-class manufacturing provides globally consistent product from every factory and the capacity to fulfill the needs of any project, large or small.
- Experienced instrumentation consultants help select the right product for any temperature application and advise on best installation practices.
- An extensive global network of Emerson service and support personnel can be on-site when and where they are needed.
- Make wireless installation and configuration easy with the Smart Wireless Gateway.

Looking for a wireless temperature solution? For wireless applications that require superior performance and unmatched reliability, consider the **Rosemount 648 Wireless Temperature Transmitter**.

Ordering Information

Rosemount 3144P Temperature Transmitter



The industry-leading Rosemount 3144P Single Point Temperature Transmitter delivers unmatched field reliability and innovative process measurement solutions and diagnostics

Transmitter features include:

- Temperature measurement assembly with Rosemount X-well Technology (option code PT)
- Dual and single sensor input capabilities
- Transmitter-sensor matching (option code C2)
- Integral transient protector (option code T1)
- IEC 61508 Safety Certificate of Compliance (option code QT)
- Advanced sensor and process diagnostics (option codes D01 and DA1)
- Large, easy to read LCD display (option code M5)
- “Assemble to Sensor” option (option code XA)

Specification and selection of product materials, options, or components must be made by the purchaser of the equipment. See [page 10](#) for more information on material selection. When ordering Rosemount X-well Technology, specific option codes are required. See [Table 2](#) and [3](#) for more information.

Table 1. Rosemount 3144P Temperature Transmitter Ordering Information

The starred offerings (★) represent the most common options and should be selected for best delivery. The non-starred offerings are subject to additional delivery lead time.

Model	Product description		
3144P	Temperature transmitter		
Housing style		Material	Conduit entry size
D1	Field mount housing, dual-compartment housing	Aluminum	1/2–14-in. NPT ★
D2	Field mount housing, dual-compartment housing	Aluminum	M20 × 1,5 (CM20) ★
D3	Field mount housing, dual-compartment housing	Aluminum	PG 13.5 (PG11) ★
D4	Field mount housing, dual-compartment housing	Aluminum	JIS G 1/2 ★
D5	Field mount housing, dual-compartment housing	Stainless steel	1/2–14-in. NPT ★
D6	Field mount housing, dual-compartment housing	Stainless steel	M20 × 1,5 (CM20) ★
D7	Field mount housing, dual-compartment housing	Stainless steel	PG 13.5 (PG11) ★
D8	Field mount housing, dual-compartment housing	Stainless steel	JIS G 1/2 ★
Transmitter output			
A	4–20 mA with digital signal based on HART Protocol		★
F	FOUNDATION Fieldbus digital signal (includes three AI function block and backup link active scheduler)		★
Measurement configuration			
1	Single-sensor input		★
2	Dual-sensor input		★

Table 1. Rosemount 3144P Temperature Transmitter Ordering Information

The starred offerings (★) represent the most common options and should be selected for best delivery. The non-starred offerings are subject to additional delivery lead time.

Product Certificates		
NA	No Approval	★
E5	FM Explosion-proof, Dust Ignition-Proof, and Non-incendive approval	★
I5 ⁽¹⁾	FM Intrinsically Safe and Non-incendive (includes standard IS and FISCO for Fieldbus units)	★
K5 ⁽¹⁾	FM IS, Non-incendive and Explosion-proof combo (includes standard IS and FISCO for Fieldbus units)	★
KB ⁽¹⁾	FM and CSA IS, Explosion-proof, and Non-incendive combo (includes standard IS and FISCO for FF units)	★
I6 ⁽¹⁾	CSA Intrinsically Safe/FISCO and Division 2 (includes standard IS and FISCO for Fieldbus units)	★
K6 ⁽¹⁾	CSA IS, FISCO Division 2 and Explosion-proof combo (includes standard IS, FISCO for Fieldbus units)	★
E1	ATEX Flameproof approval	★
N1	ATEX type n approval	★
I1 ⁽¹⁾	ATEX intrinsic safety approval (includes standard IS and FISCO for Fieldbus units)	★
K1 ⁽¹⁾	ATEX IS, Flameproof, Dust Ignition-Proof and type n combo (includes standard IS and FISCO for Fieldbus units)	★
ND	ATEX Dust Ignition-Proof approval	★
KA ⁽¹⁾	ATEX/CSA intrinsic safety, Explosion-proof combo (includes standard IS and FISCO for Fieldbus units)	★
E7	IECEx Flameproof approval	★
N7	IECEx Type 'n' approval	★
I7 ⁽¹⁾⁽²⁾	IECEx Intrinsic Safety	★
K7 ⁽¹⁾⁽²⁾	IECEx Intrinsic Safety, Flameproof, Dust Ignition-Proof and Type n combination	★
E2 ⁽²⁾	INMETRO Flameproof	★
I2 ⁽²⁾	INMETRO Intrinsic safety	★
E4 ⁽²⁾	TIIS Flameproof approval	★
E3 ⁽²⁾	NEPSI Flameproof approval	★
I3 ⁽¹⁾⁽²⁾	NEPSI Intrinsic safety	★
N3	NEPSI Type n	★
KM	Technical Regulations Customs Union (EAC) Flameproof, Intrinsic Safety	★
IM	Technical Regulations Customs Union (EAC) Intrinsic Safety	★
EM	Technical Regulations Customs Union (EAC) Flameproof	★

Options (include with selected model number)

PlantWeb™ control functionality		
A01	FOUNDATION Fieldbus advanced control function block suite	★
PlantWeb advanced diagnostic functionality		
D01	FOUNDATION Fieldbus sensor and process diagnostic suite: thermocouple diagnostic, min/max tracking	★
DA1	HART sensor and process diagnostic suite: thermocouple diagnostic, min/max tracking	★

Table 1. Rosemount 3144P Temperature Transmitter Ordering Information

The starred offerings (★) represent the most common options and should be selected for best delivery. The non-starred offerings are subject to additional delivery lead time.

Enhanced performance		
PT ⁽³⁾	Temperature measurement assembly with Rosemount X-well Technology	★
P8 ⁽⁴⁾	Enhanced transmitter accuracy	★
Mounting bracket		
B4	“U” mounting bracket for 2-in. pipe mounting - All SST	★
B5	“L” mounting bracket for 2-in. pipe or panel mounting - All SST	★
Display		
M5	LCD display	★
External ground		
G1	External ground lug assembly	★
Transient protector		
T1	Integral transient protector	★
Software configuration		
C1	Custom configuration of date, descriptor and message (requires Configuration Data Sheet with order)	★
Line filter⁽³⁾		
F5	50 Hz Line voltage filter	★
Alarm level configuration⁽³⁾		
A1	NAMUR alarm and saturation levels, high alarm	★
CN	NAMUR alarm and saturation levels, low alarm	★
Low alarm		
C8	Low alarm (standard Rosemount alarm and saturation values)	★
Sensor trim		
C2	Transmitter-sensor matching – trim to PT100 RTD calibration schedule (Callendar-Van Dusen constants)	★
C7	Trim to non-standard sensor (special sensor–customer must provide sensor information)	
5-point calibration		
C4	5-Point calibration (requires the Q4 option code to generate a calibration certificate)	★
Calibration certification		
Q4	Calibration certificate (3-point calibration)	★
QG	Calibration certificate and GOST verification certificate	★
QP	Calibration certificate and tamper evident seal	★
Dual-input custom configuration (only with measurement type option code 2)		
U1	Hot Backup	★
U2 ⁽³⁾	Average temperature with hot backup and sensor drift alert – warning mode	★

Table 1. Rosemount 3144P Temperature Transmitter Ordering Information

The starred offerings (★) represent the most common options and should be selected for best delivery. The non-starred offerings are subject to additional delivery lead time.

U3 ⁽³⁾	Average temperature with hot backup and sensor drift alert – alarm mode	★
U5	Differential temperature	★
U6	Average temperature	★
Dual-input custom configuration (only with measurement type option code 2)		
U7	First good temperature	★
U4	Two independent sensors	
Custody transfer⁽³⁾		
D3	Custody transfer approval (Canada)	
D4	MID custody transfer (Europe)	
Quality certification for safety		
QS	Prior-use certificate of FMEDA data (HART only)	★
QT	Safety-certified to IEC 61508 with certificate of FMEDA data (HART only)	★
Shipboard certification		
SBS	American Bureau of Shipping (ABS) type approval	★
SBV	Bureau Veritas (BV) type approval	★
SDN	Det Norske Veritas (DNV) type approval	★
SLL	Lloyd's Register (LR) type approval	★
Conduit electrical connector⁽⁵⁾		
GE	M12, 4-pin, male connector (eurofast®)	★
GM	A size mini, 4-pin, male connector (minifast®)	★
HART revision configuration		
HR7	Configured for HART Revision 7	★
Assemble to options		
XA	Sensor specified separately and assembled to transmitter	★
Extended product warranty		
WR3	3-year limited warranty	★
WR5	5-year limited warranty	★
Typical model number: 3144P D1 A 1 E5 B4 M5		

1. When IS approval is ordered on a FOUNDATION Fieldbus, both standard IS and FISCO IS approvals apply. The device label is marked appropriately.
2. Consult factory for availability when ordering with HART or FOUNDATION Fieldbus models.
3. Not available with FOUNDATION Fieldbus models.
4. Enhanced accuracy only applies to RTDs, however the option can be ordered with any sensor type.
5. Available with Intrinsically Safe approvals only. For FM Intrinsically Safe or non-incendive approval (option code I5), install in accordance with Rosemount drawing 03151-1009 to maintain 4X rating.

How to order Rosemount X-well Technology

Rosemount X-well Technology is for temperature monitoring applications and is not intended for control or safety applications. It is available in the Rosemount 3144P Transmitter in a factory assembled direct mount configuration with a Rosemount 0085 Pipe Clamp Sensor. It cannot be used in a remote mount configuration. Rosemount X-well Technology will only work as specified with factory supplied and assembled Rosemount 0085 Sensor silver tipped single element sensor with an 80 mm extension length. It will not work as specified if used with other sensors.

Table 2. Rosemount 3144P X-well Technology Option Code Requirements

Code	Description
D1–D4	Aluminum field mount housing
PT	Temperature measurement assembled with Rosemount X-well Technology
A	4–20 mA with digital signal based on HART Protocol
XA	Sensor specified separately and assembled to transmitter
C1	Custom configuration of date, descriptor, message, and wireless parameters (requires Configuration Data Sheet with order)
HR7	Configured for HART Revision 7

Table 3. Rosemount 0085 Pipe Clamp Sensor Option Code Requirements for Use with X-well Technology

Code	Description
N	No connection head
3	Sensor connection
P1	Sensor type
J	Extension type
0080	Extension length
XA	Assemble sensor to specific temperature transmitter

Rosemount X-well assemblies are available in most Rosemount 0085 Pipe Clamp Sensor diameter sizes.

**Typical model number of the assembly: 3144P D 1A 1 NA M5 PT C1 XA
0085 N 3 P1 J 0080 C 0169 N XA**

Specifications

HART and FOUNDATION Fieldbus

Functional specifications

Inputs

User-selectable. See [Table 4 on page 11](#) for sensor options.

Output

2-wire device with either 4–20 mA/HART, linear with temperature or input, or completely digital output with FOUNDATION Fieldbus communication (ITK 6.0.1 compliant).

Isolation

Input/output isolation specified to 500 Vdc (500 Vrms 707 V peak) at 50/60 Hz.

Humidity limits

0–99 percent relative humidity.

Update time

Approximately 0.5 second for a single sensor (one second for dual sensors).

Physical specifications

Material selection

Emerson provides a variety of Rosemount product with various product options and configurations including materials of construction that can be expected to perform well in a wide range of applications. The Rosemount product information presented is intended as a guide for the purchaser to make an appropriate selection for the application. It is the purchaser's sole responsibility to make a careful analysis of all process parameters (such as all chemical components, temperature, pressure, flow rate, abrasives, contaminants, etc.), when specifying product, materials, options and components for the particular application. Emerson is not in a position to evaluate or guarantee the compatibility of the process fluid or other process parameters with the product, options, configuration or materials of construction selected.

Conformance to specification ($\pm 3\sigma$ [Sigma])

Technology leadership, advanced manufacturing techniques, and statistical process control ensure specification conformance to at least $\pm 3\sigma$.

Conduit connections

The standard field mount housing has 1/2–14-in. NPT conduit entries. Additional conduit entry types are available, including PG13.5 (PG11), M20 × 1.5 (CM20), or JIS G 1/2. When any of these additional entry types are ordered, adapters are placed in the standard field housing so these alternative conduit types fit correctly. See “[Dimensional drawings](#)” on [page 24](#) for dimensions.

Materials of construction

Electronics housing

Low-copper aluminum or CF-8M (cast version of 316 stainless steel)

Paint

Polyurethane

Cover O-rings

Buna-N

Mounting

Transmitters may be attached directly to the sensor. Optional mounting brackets (codes B4 and B5) allow for remote mounting. See “[Mounting Configurations with Optional Mounting Bracket](#)” on [page 26](#).

Weight⁽¹⁾

Aluminum	Stainless steel
3.1 lb (1.4 kg)	7.8 lb (3.5 kg)

Enclosure ratings

Type 4X

IP66 and IP68

Stability

- RTDs: - $\pm 0.1\%$ of reading or 0.1 °C, whichever is greater, for 24 months.
- Thermocouples: - $\pm 0.1\%$ of reading or 0.1 °C, whichever is greater, for 12 months.

Five year stability

- RTDs: - $\pm 0.25\%$ of reading or 0.25 °C, whichever is greater, for five years.
- Thermocouples: - $\pm 0.5\%$ of reading or 0.5 °C, whichever is greater, for five years.

1. Add 0.5-lb. (0.2 kg) for local display or 1.0 lb. (0.5 kg) for bracket options.

Vibration effect

Tested to the following with no effect on performance per IEC 60770-1, 1999:

Frequency	Acceleration
10–60 Hz	0.21 mm peak displacement
60–2000 Hz	3 g

Self calibration

The analog-to-digital measurement circuitry automatically self-calibrates for each temperature update by comparing the dynamic measurement to extremely stable and accurate internal reference elements.

RFI effect

Worst case RFI effect is equivalent to the transmitter’s nominal accuracy specification, according to [Table 4 on page 11](#), when tested in accordance with IEC 61000-4-3, 30 V/m (HART)/20 V/m (HART T/C) /10 V/m (FOUNDATION Fieldbus), 80 to 1000 MHz, with unshielded cable.

CE electromagnetic compatibility compliance testing

The Rosemount 3144P meets or exceeds all requirements listed under IEC 61326: 2006.

External ground screw assembly

The external ground screw assembly can be ordered by specifying code G1. However, some approvals include the ground screw assembly in the transmitter shipment, hence it is not necessary to order code G1. The table below identifies which approval options include the external ground screw assembly.

Approval type	External ground screw assembly included?(1)
E5, I1, I2, I5, I6, I7, K5, K6, KB, NA	No–Order option code G1
E1, E2, E3, E4, E7, K1, K7, KA, N1, N7, ND, NF	Yes

1. The parts contained with the G1 option are included with the Integral Protector option code T1. When ordering T1, the G1 option code does not need to be ordered separately.

Hardware tag

- No charge
- Two lines of 28 characters (56 characters total)
- Tags are stainless steel
- Permanently attached to transmitter
- Character height is 1/16-in. (1.6 mm)
- A wire-on tag is available upon request. Five lines of 12 characters (60 characters total)

Software tag

- HART transmitter can store up to eight characters in HART 5 mode and 32 characters in HART 7 mode. FOUNDATION Fieldbus transmitters can store up to 32 characters.
- Can be ordered with different software and hardware tags.
- If no software tag characters are specified, the first eight characters of the hardware tag are the default.

Table 4. Transmitter Accuracy

Sensor options	Sensor reference	Input ranges		Minimum span(1)		Digital accuracy(2)		Enhanced accuracy(3)	D/A accuracy(4)(5)
		°C	°F	°C	°F	°C	°F	°C	
2-, 3-, 4-wire RTDs									
Pt 100 (α = 0.00385)	IEC 751	-200 to 850	-328 to 1562	10	18	± 0.10	± 0.18	± 0.08	±0.02% of span
Rosemount X-well Pt 100 (α = 0.00385)	IEC 751	-50 to 300	-58 to 572	10	18	±0.29	±0.52	N/A	±0.02% of span
Pt 200 (α = 0.00385)	IEC 751	-200 to 850	-328 to 1562	10	18	± 0.22	± 0.40	± 0.176	±0.02% of span
Pt 500 (α = 0.00385)	IEC 751	-200 to 850	-328 to 1562	10	18	± 0.14	± 0.25	± 0.112	±0.02% of span
Pt 1000 (α = 0.00385)	IEC 751	-200 to 300	-328 to 572	10	18	± 0.10	± 0.18	± 0.08	±0.02% of span
Pt 100 (α = 0.003916)	JIS 1604	-200 to 645	-328 to 1193	10	18	± 0.10	± 0.18	± 0.08	±0.02% of span
Pt 200 (α = 0.003916)	JIS 1604	-200 to 645	-328 to 1193	10	18	± 0.22	± 0.40	± 0.176	±0.02% of span
Ni 120	Edison Curve No. 7	-70 to 300	-94 to 572	10	18	± 0.08	± 0.14	± 0.064	±0.02% of span
Cu 10	Edison Copper Winding No. 15	-50 to 250	-58 to 482	10	18	±1.00	± 1.80	± 0.8	±0.02% of span
Pt 50 (α=0.00391)	GOST 6651-94	-200 to 550	-328 to 1022	10	18	±0.20	±0.36	± 0.16	±0.02% of span

Table 4. Transmitter Accuracy

Sensor options	Sensor reference	Input ranges		Minimum span ⁽¹⁾		Digital accuracy ⁽²⁾		Enhanced accuracy ⁽³⁾	D/A accuracy ⁽⁴⁾⁽⁵⁾
		°C	°F	°C	°F	°C	°F	°C	
2-, 3-, 4-wire RTDs									
Pt 100 ($\alpha=0.00391$)	GOST 6651-94	-200 to 550	-328 to 1022	10	18	±0.10	±0.18	± 0.08	±0.02% of span
Cu 50 ($\alpha=0.00426$)	GOST 6651-94	-50 to 200	-58 to 392	10	18	±0.34	±0.61	± 0.272	±0.02% of span
Cu 50 ($\alpha=0.00428$)	GOST 6651-94	-185 to 200	-301 to 392	10	18	±0.34	±0.61	± 0.272	±0.02% of span
Cu 100 ($\alpha=0.00426$)	GOST 6651-94	-50 to 200	-58 to 392	10	18	±0.17	±0.31	± 0.136	±0.02% of span
Cu 100 ($\alpha=0.00428$)	GOST 6651-94	-185 to 200	-301 to 392	10	18	±0.17	±0.31	± 0.136	±0.02% of span
Thermocouples⁽⁶⁾									
Type B ⁽⁷⁾	NIST monograph 175, IEC 584	100 to 1820	212 to 3308	25	45	± 0.75	± 1.35	N/A	±0.02% of span
Type E	NIST monograph 175, IEC 584	-50 to 1000	-58 to 1832	25	45	± 0.20	± 0.36	N/A	±0.02% of span
Type J	NIST monograph 175, IEC 584	-180 to 760	-292 to 1400	25	45	± 0.25	± 0.45	N/A	±0.02% of span
Type K ⁽⁸⁾	NIST monograph 175, IEC 584	-180 to 1372	-292 to 2501	25	45	± 0.25	± 0.45	N/A	±0.02% of span
Type N	NIST monograph 175, IEC 584	-200 to 1300	-328 to 2372	25	45	± 0.40	± 0.72	N/A	±0.02% of span
Type R	NIST monograph 175, IEC 584	0 to 1768	32 to 3214	25	45	± 0.60	± 1.08	N/A	±0.02% of span
Type S	NIST monograph 175, IEC 584	0 to 1768	32 to 3214	25	45	± 0.50	± 0.90	N/A	±0.02% of span
Type T	NIST monograph 175, IEC 584	-200 to 400	-328 to 752	25	45	± 0.25	± 0.45	N/A	±0.02% of span
DIN Type L	DIN 43710	-200 to 900	-328 to 1652	25	45	± 0.35	± 0.63	N/A	±0.02% of span
DIN Type U	DIN 43710	-200 to 600	-328 to 1112	25	45	± 0.35	± 0.63	N/A	±0.02% of span
Type W5Re/W26Re	ASTM E 988-96	0 to 2000	32 to 3632	25	45	± 0.70	± 1.26	N/A	±0.02% of span
GOST Type L	GOST R 8.585-2001	-200 to 800	-392 to 1472	25	45	± 0.25	± 0.45	N/A	±0.02% of span
Other input types									
Millivolt input		-10 to 100 mV		3 mV		±0.015 mV		N/A	±0.02% of span
2-, 3-, 4-wire Ohm Input		0 to 2000 ohms		20 ohm		±0.35 ohm		N/A	±0.02% of span

1. No minimum or maximum span restrictions within the input ranges. Recommended minimum span will hold noise within accuracy specification with damping at zero seconds.
2. Digital accuracy: digital output can be accessed by the Field Communicator.
3. Enhanced accuracy can be ordered using the P8 Model Code.
4. Total Analog accuracy is the sum of digital and D/A accuracies.
5. Applies to HART/4-20 mA devices.
6. Total digital accuracy for thermocouple measurement: sum of digital accuracy +0.25 °C (0.45 °F) (cold junction accuracy).
7. Digital accuracy for NIST Type B is ±3.0 °C (±5.4 °F) from 100 to 300 °C (212 to 572 °F).
8. Digital accuracy for NIST Type K is ±0.50 °C (±0.9 °F) from -180 to -90 °C (-292 to -130 °F).

Reference accuracy example (HART Protocol only)

When using a Pt 100 ($\alpha = 0.00385$) sensor input with a zero to 100 °C span: Digital Accuracy would be ± 0.10 °C, D/A accuracy would be $\pm 0.02\%$ of 100 °C or ± 0.02 °C, Total = ± 0.12 °C.

Differential capability exists between any two sensor types (dual-sensor option)

For all differential configurations, the input range is X to Y where:

- X = Sensor 1 minimum – Sensor 2 maximum and
- Y = Sensor 1 maximum – Sensor 2 minimum

Digital accuracy for differential configurations (dual-sensor option, HART Protocol only)

- Sensor types are similar (e.g., both RTDs or both T/Cs): Digital Accuracy = 1.5 times worst case accuracy of either sensor type
- Sensor types are dissimilar (e.g., one RTD, one T/C): Digital accuracy = Sensor 1 accuracy + Sensor 2 accuracy

Ambient temperature effect

Transmitters may be installed in locations where the ambient temperature is between –40 and 85 °C (–40 and 185 °F). To maintain excellent accuracy performance, each transmitter is individually characterized over this ambient temperature range at the factory.

Table 5. Ambient Temperature Effect on Digital Accuracy

Sensor options	Sensor reference	Effect per 1.0 °C (1.8 °F) change in ambient ⁽¹⁾⁽²⁾	Input temperature (T)	D/A effect ⁽³⁾
2-, 3-, or 4-wire RTDs				
Pt 100 ($\alpha = 0.00385$)	IEC 751	0.0015 °C (0.0027 °F)	Entire sensor input range	0.001% of span
Rosemount X-well Pt 100 ($\alpha = 0.00385$)	IEC 751	0.0058 °C (0.0104 °F)	Entire sensor input range	0.001% of span
Pt 200 ($\alpha = 0.00385$)	IEC 751	0.0023 °C (0.00414 °F)	Entire sensor input range	0.001% of span
Pt 500 ($\alpha = 0.00385$)	IEC 751	0.0015 °C (0.0027 °F)	Entire sensor input range	0.001% of span
Pt 1000 ($\alpha = 0.00385$)	IEC 751	0.0015 °C (0.0027 °F)	Entire sensor input range	0.001% of span
Pt 100 ($\alpha = 0.003916$)	JIS 1604	0.0015 °C (0.0027 °F)	Entire sensor input range	0.001% of span
Pt 200 ($\alpha = 0.003916$)	JIS 1604	0.0023 °C (0.00414 °F)	Entire sensor input range	0.001% of span
Ni 120	Edison curve no. 7	0.0010 °C (0.0018 °F)	Entire sensor input range	0.001% of span
Cu 10	Edison copper winding no. 15	0.015 °C (0.027 °F)	Entire sensor input range	0.001% of span
Pt 50 ($\alpha = 0.00391$)	GOST 6651-94	0.003 °C (0.0054 °F)	Entire sensor input range	0.001% of span
Pt 100 ($\alpha = 0.00391$)	GOST 6651-94	0.0015 °C (0.0027 °F)	Entire sensor input range	0.001% of span
Cu 50 ($\alpha = 0.00426$)	GOST 6651-94	0.003 °C (0.0054 °F)	Entire sensor input range	0.001% of span
Cu 50 ($\alpha = 0.00428$)	GOST 6651-94	0.003 °C (0.0054 °F)	Entire sensor input range	0.001% of span
Cu 100 ($\alpha = 0.00426$)	GOST 6651-94	0.0015 °C (0.0027 °F)	Entire sensor input range	0.001% of span
Cu 100 ($\alpha = 0.00428$)	GOST 6651-94	0.0015 °C (0.0027 °F)	Entire sensor input range	0.001% of span
Thermocouples				
Type B	NIST monograph 175, IEC 584	0.014 °C 0.029 °C – 0.0021% of (T – 300) 0.046 °C – 0.0086% of (T – 100)	T ≥ 1000 °C 300 °C ≤ T < 1000 °C 100 °C ≤ T < 300 °C	0.001% of span
Type E	NIST monograph 175, IEC 584	0.004 °C + 0.00043% of T	N/A	0.001% of span
Type J	NIST monograph 175, IEC 584	0.004 °C + 0.00029% of T 0.004 °C + 0.0020% of abs. val. T	T ≥ 0 °C T < 0 °C	0.001% of span
Type K	NIST monograph 175, IEC 584	0.005 °C + 0.00054% of T 0.005 °C + 0.0020% of abs. val. T	T ≥ 0 °C T < 0 °C	0.001% of span
Type N	NIST monograph 175, IEC 584	0.005 °C + 0.00036% of T	All	0.001% of span
Types R	NIST monograph 175, IEC 584	0.015 °C 0.021 °C – 0.0032% of T	T ≥ 200 °C T < 200 °C	0.001% of span

Table 5. Ambient Temperature Effect on Digital Accuracy

Thermocouples				
Types S	NIST monograph 175, IEC 584	0.015 °C 0.021 °C – 0.0032% of T	T ≥ 200 °C T < 200 °C	0.001% of span
Type T	NIST monograph 175, IEC 584	0.005 °C 0.005 °C + 0.0036% of abs. val. T	T ≥ 0 °C T < 0 °C	0.001% of span
DIN Type L	DIN 43710	0.0054 °C + 0.00029% of R 0.0054 °C + 0.0025% of abs. val. T	T ≥ 0 °C T < 0 °C	0.001% of span
DIN Type U	DIN 43710	0.0064 °C 0.0064 °C + 0.0043% of abs. val. T	T ≥ 0 °C T < 0 °C	0.001% of span
Type W5Re/W26Re	ASTM E 988-96	0.016 °C 0.023 °C + 0.0036% of T	T ≥ 200 °C T < 200 °C	0.001% of span
GOST Type L	GOST R 8.585–2001	0.005 > 0 °C 0.005 - 0.003% < 0 °C	N/A	0.001% of span
Other input types				
Millivolt Input		0.00025 mV	Entire sensor input range	0.001% of span
2-, 3-, 4-wire Ohm Input		0.007 Ω	Entire sensor input range	0.001% of span

1. Change in ambient is in reference to the calibration temperature of the transmitter (20 °C [68 °F]).
2. Ambient temperature effect specification valid over minimum temperature span of 28 °C (50 °F).
3. Applies to HART/4–20 mA devices.

Process temperature effects

Table 6. Ambient and Process Temperature Difference Effect on Digital Accuracy

Sensor option	Sensor reference	Effects per 1.0 °C (1.8 °F) difference in ambient and process temperature ⁽¹⁾	Input temperature (T)
Rosemount X-well Pt 100 (α = 0.00385)	IEC 751	± 0.01 °C (0.018 °F)	Entire sensor input range

1. Valid under steady state process and ambient conditions.

Temperature effects example

When using a Pt 100 (α = 0.00385) sensor input with a 0 to 100 °C span at 30 °C ambient temperature, the following statements would be true:

Digital temp effects

- $0.0015 \frac{^{\circ}\text{C}}{^{\circ}\text{C}} \times (30 - 20 \text{ }^{\circ}\text{C}) = 0.015 \text{ }^{\circ}\text{C}$

D/A effects (HART/4–20 mA only)

- $[0.001\%/^{\circ}\text{C of span}] \times 100 \text{ }^{\circ}\text{C} \times |(30 - 20^{\circ}\text{C})| = \text{ }^{\circ}\text{C DA effect}$

- $[0.001\%/^{\circ}\text{C} \times 100] \times |(30 - 20)| = 0.001^{\circ}\text{C}$

Worst case error

- Digital + D/A + Digital temp effects + D/A effects = $0.10 \text{ }^{\circ}\text{C} + 0.02 \text{ }^{\circ}\text{C} + 0.015 \text{ }^{\circ}\text{C} + 0.01 \text{ }^{\circ}\text{C} = 0.145 \text{ }^{\circ}\text{C}$

Total probable error

- $\sqrt{0.10^2 + 0.02^2 + 0.015^2 + 0.01^2} = 0.10 \text{ }^{\circ}\text{C}$

Rosemount X-well temperature effects example

When using Rosemount X-well Technology at 30 °C ambient temperature and 100 °C process temperature:

- Digital ambient temperature effects:

- $0.0058 \text{ }^{\circ}\text{C} \times (30 - 20) = .058 \text{ }^{\circ}\text{C}$

- Process temperature effects: $0.01 \text{ }^{\circ}\text{C} \times (100 - 30) = .70 \text{ }^{\circ}\text{C}$

- Worst case error: Digital accuracy + Digital ambient temperature effects + Process temperature effects = $0.29 \text{ }^{\circ}\text{C} + 0.058 \text{ }^{\circ}\text{C} + 0.70 \text{ }^{\circ}\text{C} = 1.05 \text{ }^{\circ}\text{C}$

- Total probable error: $\sqrt{0.29^2 + 0.058^2 + 0.70^2} = 0.76 \text{ }^{\circ}\text{C}$

HART/4–20 mA specifications

Power supply

External power supply required. Transmitters operate on 12.0 to 42.4 Vdc transmitter terminal voltage (with 250 ohm load, 18.1 Vdc power supply voltage is required). Transmitter power terminals rated to 42.4 Vdc.

Wiring diagram

See [Figure 7 on page 27](#).

Alarms

Custom factory configurations of alarm and saturation levels are available for valid values with option code C1. These values can also be configured in the field using a Field Communicator.

Transient protection (option code T1)

The transient protector helps to prevent damage to the transmitter from transients induced on the loop wiring by lightning, welding, heavy electrical equipment, or switch gears. The transient protection electronics are contained in an add-on assembly that attaches to the standard transmitter terminal block. The external ground lug assembly (code G1) is included with the transient protector. The transient protector has been tested per the following standard:

- IEEE C62.41-1991 (IEEE 587)/location categories B3.
6 kV/3 kA peak (1.2 × 50 μS Wave 8 × 20 μS combination wave) 6 kV/0.5 kA peak (100 kHz ring wave)
EFT, 4 kV peak, 2.5 kHz, 5 × 50 nS
- Loop resistance added by protector: 22 ohms max.
- Nominal clamping voltages: 90 V (common mode), 77 V (normal mode)

Local display

Optional five-digit LCD display includes 0–100% bar graph. Digits are 0.4 inches (8 mm) high. Display options include engineering units (°F, °C, °R, K, ohms, and millivolts), percent, and milliamperes. The display can also be set to alternate between engineering units/milliamperes, Sensor 1/Sensor 2, Sensor 1/Sensor 2/Differential Temperature, and Sensor 1/Sensor2/Average Temperature. All display options, including the decimal point, may be reconfigured in the field using a Field Communicator or AMS Device Manager.

Turn-on time

Performance within specifications is achieved less than six seconds after power is applied to the transmitter when the damping value is set to zero seconds.

Power supply effect

Less than ±0.005% of span per volt.

SIS safety transmitter failure values

IEC 61508 Safety Certified SIL 2 and SIL 3 Claim Limit

- Safety accuracy: Span ≥ 100 °C: ±2% of process variable span
- Span < 100 °C: ±2 °C
- Safety response time: five seconds
- Safety specifications and FMEDA report available at Emerson.com/Rosemount/Safety
- Software suitable for SIL3 applications

Table 7. Temperature Limits

Description	Operating limit	Storage limit
Without LCD display	-40 to 185 °F -40 to 85 °C	-76 to 250 °F -60 to 120 °C
With LCD display ⁽¹⁾	-40 to 185 °F -40 to 85 °C	-76 to 185 °F -60 to 85 °C

1. LCD display may not be readable and LCD display updates will be slower at temperatures below -4 °F (-20 °C).

Field Communicator connections

Field Communicator connections are permanently fixed to power/signal block.

Failure mode

The Rosemount 3144P features software and hardware failure mode detection. An independent circuit is designed to provide backup alarm output if the microprocessor hardware or software fails.

The alarm level is user-selectable using the failure mode switch. If failure occurs, the position of the hardware switch determines the direction in which the output is driven (HIGH or LOW). The switch feeds into the digital-to-analog (D/A) converter, which drives the proper alarm output even if the microprocessor fails. The values at which the transmitter drives its output in failure mode depends on whether it is configured to standard, or NAMUR-compliant (NAMUR recommendation NE 43) operation. The values for standard and NAMUR-compliant operation are as follows:

Table 8. Operation Parameters

	Standard ⁽¹⁾	NAMUR-compliant ⁽¹⁾
Linear output	3.9 ≤ I ≤ 20.5	3.8 ≤ I ≤ 20.5
Fail high	21.75 ≤ I ≤ 23 (default)	21.5 ≤ I ≤ 23 (default)
Fail low	I ≤ 3.75	I ≤ 3.6

1. Measured in milliamperes.

Load limitations

Maximum load = $40.8 \times (\text{supply voltage} - 12.0)$ ⁽¹⁾

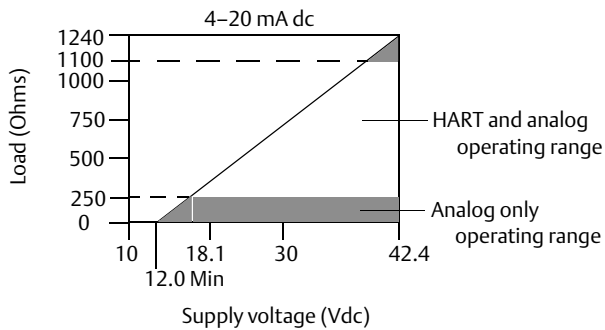

1. Without transient protection (optional).

Note

HART communication requires a loop resistance between 250 and 1100 ohms. Do not communicate with the transmitter when power is below 12 Vdc at the transmitter terminals.

FOUNDATION Fieldbus specifications

Fieldbus Foundation device registration

Device tested and registered to ITK 6.0.1

Power supply

Powered over FOUNDATION Fieldbus with standard Fieldbus power supplies. Transmitters operate on 9.0 to 32.0 Vdc, 12 mA maximum. Transmitter power terminals are rated to 42.4 Vdc.

Wiring diagram

See [Figure 8 on page 28](#).

Alarms

The AI function block allows the user to configure the alarms to HIGH-HIGH, HIGH, LOW, or LOW-LOW with a variety of priority levels and hysteresis settings.

Transient protection (option code T1)

The transient protector helps to prevent damage to the transmitter from transients induced on the loop wiring by lightning, welding, heavy electrical equipment, or switch gears. The transient protection electronics are contained in an add-on assembly that attaches to the standard transmitter terminal block. The transient terminal block is not polarity insensitive. The transient protector has been tested to the following standard:

- IEEE C62.41-1991 (IEEE 587)/Location Categories B3.
 - 6 kV/3 kA peak ($1.2 \times 50 \mu\text{S}$ Wave $8 \times 20 \mu\text{S}$ Combination Wave)
 - 6 kV/0.5 kA peak (100 kHz Ring Wave)
 - EFT, 4 kV peak, 2.5kHz, $5 \times 50\text{nS}$

- Loop resistance added by protector: 22 ohms maximum
- Nominal clamping voltages: 90 V (common mode), 77 V (normal mode)

Diagnostics suite for FOUNDATION Fieldbus (option code D01)

The Rosemount 3144P Diagnostics Suite for FOUNDATION Fieldbus provides advanced functionality in the form of Statistical Process Monitoring (SPM), a thermocouple diagnostic, and sensor drift alert. SPM technology calculates the mean and standard deviation of the process variable and makes them available to the user. This may be used to detect abnormal process situations.

The thermocouple diagnostic enables the transmitter to measure and monitor the resistance of thermocouple loops in order to detect drift or changing wiring connections.

Sensor drift alert allows the user to monitor the difference in measurement between two sensors installed in one process point. A change in this differential value may indicate drifting sensors.

Local display

Displays all DS_65 measurements in the Transducer and Function Blocks including Sensor 1, Sensor 2, differential, and terminal temperatures. The display alternates up to four selected items. The meter can display up to five digits in engineering units ($^{\circ}\text{F}$, $^{\circ}\text{C}$, $^{\circ}\text{R}$, K, Ω , and millivolts). Display settings are configured at the factory according to the transmitter configuration (standard or custom). These settings can be reconfigured in the field using a Field Communicator or DeltaV™. In addition, the LCD display provides the ability to display DS_65 parameters from other devices. In addition to the configuration of the meter, sensor diagnostic data is displayed. If the measurement status is *Good*, the measured value is shown. If the measurement status is *Uncertain*, the status indicating uncertain is shown in addition to the measured value. If the measurement status is *Bad*, the reason for the bad measurement is shown.

Note

When ordering a spare electronics module assembly, the LCD display transducer block will display the default parameter.

Turn-on time

Performance within specifications is achieved less than 20 seconds after power is applied to the transmitter when the damping value is set to 0 seconds.

Status

The device is compliant to NAMUR NE 107, ensuring consistent, reliable and standardized device diagnostic information.

The new standard is designed to improve the way device status and diagnostic information is communicated to operators and maintenance personnel in order to increase productivity and reduce costs.

If self-diagnostics detect a sensor burnout or a transmitter failure, the status of the measurement will be updated accordingly. The status may also send the PID output to a safe value.

FOUNDATION Fieldbus parameters

Schedule entries	25 (max.)
Links	30 (max.)
Virtual Communications Relationships (VCR)	20 (max.)

Backup Link Active Scheduler (LAS)

The transmitter is classified as a device link master, which means it can function as a LAS if the current link master device fails or is removed from the segment. The host or other configuration tool is used to download the schedule for the application to the link master device. In the absence of a primary link master, the transmitter will claim the LAS and provide permanent control for the H1 segment.

Function blocks

- All blocks will ship with unique block names, e.g. AI_1400_XXXX.
- All blocks shall be instantiated to avoid invalid defaults.
- All Rosemount 3144P FF have parameter COMPATIBILITY_REV for backward compatibility.
- Parameters will be initialized to common values for easier bench configuration.
- All default block tags are less than or equal to 16 characters in length to avoid inconvenience of apparently identical tags.
- Default block tags include underscores, “_”, instead of whitespaces for easier configuration.

Resource block

- Contains physical transmitter information including available memory, manufacture identification, device type, software tag, and unique identification.
- PlantWeb Alerts enable the full power of the PW digital architecture by diagnosing instrumentation issues, communicating the details, and recommending a solution.

Transducer block

- Contains the actual temperature measurement data, including sensor 1, sensor 2, and terminal temperature.
- Includes information about sensor type and configuration, engineering units, linearization, range, damping, and diagnostics.
- Device Revision 3 and above includes Hot Backup functionality in the transducer block.

LCD display block (when an LCD display is used)

- Configures the local display.

Analog input (AI)

- Processes the measurement and makes it available on the Fieldbus segment.
- Allows filtering, engineering unit, and alarm changes.
- All devices ship with the AI blocks scheduled, meaning no configuration is needed if the factory default channels are used.

PID block (provides control functionality)

- Performs single loop, cascade, or feedforward control in the field.

Block	Execution time
Resource	N/A
Transducer	N/A
LCD display block	N/A
Advanced diagnostics	N/A
Analog input 1, 2, 3, 4	60 milliseconds
PID 1 and 2 with autotune	90 milliseconds
Input selector	65 milliseconds
Signal characterizer	60 milliseconds
Arithmetic	60 milliseconds
Output splitter	60 milliseconds

Product certification

1.15

European Directive Information

A copy of the EU Declaration of Conformity can be found at the end of the Quick Start Guide. The most recent revision of the EU Declaration of Conformity can be found at Emerson.com/Rosemount.

Ordinary Location Certification

As standard, the transmitter has been examined and tested to determine that the design meets the basic electrical, mechanical, and fire protection requirements by a nationally recognized test laboratory (NRTL) as accredited by the Federal Occupational Safety and Health Administration (OSHA).

North America

- E5** FM Explosionproof, Dust-Ignitionproof, and Nonincendive
Certificate: FM16US0202X
Standards: FM Class 3600: 2011, FM Class 3611: 2004, FM Class 3615: 2006, FM Class 3810: 2005, NEMA-250: 1991, ANSI/ISA 60079-0: 2009, ANSI/ISA 60079-11: 2009
Markings: XP CL I, DIV 1, GP A, B, C, D; T5($-50^{\circ}\text{C} \leq T_a \leq +85^{\circ}\text{C}$); DIP CL II/III, DIV 1, GP E, F, G; T5($-50^{\circ}\text{C} \leq T_a \leq +75^{\circ}\text{C}$); T6($-50^{\circ}\text{C} \leq T_a \leq +60^{\circ}\text{C}$); when installed per Rosemount drawing 03144-0320; NI CL I, DIV 2, GP A, B, C, D; T5($-60^{\circ}\text{C} \leq T_a \leq +75^{\circ}\text{C}$); T6($-60^{\circ}\text{C} \leq T_a \leq +50^{\circ}\text{C}$); when installed per Rosemount drawing 03144-0321, 03144-5075
- I5** FM Intrinsic Safety and Nonincendive
Certificate: FM16US0202X
Standards: FM Class 3600: 2011, FM Class 3610: 2010, FM Class 3611: 2004, FM Class 3810: 2005, NEMA-250: 1991, ANSI/ISA 60079-0: 2009, ANSI/ISA 60079-11: 2009
Markings: IS CL I / II / III, DIV 1, GP A, B, C, D, E, F, G; T4($-60^{\circ}\text{C} \leq T_a \leq +60^{\circ}\text{C}$); IS [Entity] CL I, Zone 0, AEx ia IIC T4($-60^{\circ}\text{C} \leq T_a \leq +60^{\circ}\text{C}$); NI CL I, DIV 2, GP A, B, C, D; T5($-60^{\circ}\text{C} \leq T_a \leq +75^{\circ}\text{C}$); T6($-60^{\circ}\text{C} \leq T_a \leq +50^{\circ}\text{C}$); when installed per Rosemount drawing 03144-0321, 03144-5075
- I6** CSA Intrinsic Safety and Division 2
Certificate: 1242650
Standards: CAN/CSA C22.2 No. 0-M91 (R2001), CAN/CSA-C22.2 No. 94-M91, CSA Std C22.2 No. 142-M1987, CAN/CSA-C22.2 No. 157-92, CSA Std C22.2 No. 213-M1987

Markings: Intrinsically Safe for Class I Groups A, B, C, D; Class II, Groups E, F, G; Class III;
[HART only zone markings]: Intrinsically Safe for Class I Zone 0 Group IIC; T4($-50^{\circ}\text{C} \leq T_a \leq +60^{\circ}\text{C}$); Type 4X; Suitable for Class I, Div. 2, Groups A, B, C, D;
[HART only zone markings]: Suitable for Class I Zone 2 Group IIC; T6($-60^{\circ}\text{C} \leq T_a \leq +60^{\circ}\text{C}$); T5($-60^{\circ}\text{C} \leq T_a \leq +85^{\circ}\text{C}$); when installed per Rosemount drawing 03144-5076

- K6** CSA Explosionproof, Intrinsic Safety and Division 2
Certificate: 1242650
Standards: CAN/CSA C22.2 No. 0-M91 (R2001), CSA Std C22.2 No. 30-M1986; CAN/CSA-C22.2 No. 94-M91, CSA Std C22.2 No. 142-M1987, CAN/CSA-C22.2 No. 157-92, CSA Std C22.2 No. 213-M1987
Markings: Explosionproof for Class I, Groups A, B, C, D Class II, Groups E, F, G; Class III
[HART only zone markings]: Suitable for Class I Zone 1 Group IIC; Intrinsically Safe for Class I Groups A, B, C, D; Class II, Groups E, F, G; Class III;
[HART only zone markings]: Suitable for Class I Zone 0 Group IIC; T4($-50^{\circ}\text{C} \leq T_a \leq +60^{\circ}\text{C}$); Type 4X; Suitable for Class I, Div. 2, Groups A, B, C, D; [HART only zone markings]: Suitable for Class I Zone 2 Group IIC; T6($-60^{\circ}\text{C} \leq T_a \leq +60^{\circ}\text{C}$); T5($-60^{\circ}\text{C} \leq T_a \leq +85^{\circ}\text{C}$); when installed per Rosemount drawing 03144-5076

Europe

- E1** ATEX Flameproof
Certificate: FM12ATEX0065X
Standards: EN 60079-0: 2012, EN 60079-1: 2007, EN 60529:1991 +A1:2000
Markings:  II 2 G Ex d IIC T6...T1 Gb, T6($-50^{\circ}\text{C} \leq T_a \leq +40^{\circ}\text{C}$), T5...T1($-50^{\circ}\text{C} \leq T_a \leq +60^{\circ}\text{C}$)

See [Table 12](#) at the end of the Product Certifications section for Process Temperatures.

Special Conditions for Safe Use (X):

1. See certificate for ambient temperature range.
2. The non-metallic label may store an electrostatic charge and become a source of ignition in Group III environments.
3. Guard the LCD display cover against impact energies greater than 4 joules.
4. Flameproof joints are not intended for repair.

5. A suitable certified Ex d or Ex tb enclosure is required to be connected to temperature probes with Enclosure option "N".
6. Care shall be taken by the end user to ensure that the external surface temperature on the equipment and the neck of DIN Style Sensor probe does not exceed 130 °C.
7. Non-Standard Paint options may cause risk from electrostatic discharge. Avoid installations that cause electrostatic build-up on painted surfaces, and only clean the painted surfaces with a damp cloth. If paint is ordered through a special option code, contact the manufacturer for more information.

I1 ATEX Intrinsic Safety

Certificate: BAS01ATEX1431X [HART];
Baseefa03ATEX0708X [Fieldbus];
Standards: EN 60079-0:2012; EN 60079-11:2012
Markings: HART: Ⓢ II 1 G Ex ia IIC T5/T6 Ga;
T6(-60 °C ≤ T_a ≤ +50 °C), T5(-60 °C ≤ T_a ≤ +75 °C)
Fieldbus: Ⓢ II 1 G Ex ia IIC T4 Ga;
T4(-60 °C ≤ T_a ≤ +60 °C)

See [Table 13](#) at the end of the Product Certifications section for Entity Parameters.

Special Conditions for Safe Use (X):

1. When fitted with the transient terminal options, the equipment is not capable of passing the 500 V insulation test. This must be taken into account during installation.
2. The enclosure may be made from aluminum alloy with a protective polyurethane paint finish; however, care should be taken to protect it from impact or abrasion when located in Zone 0.

N1 ATEX Type n

Certificate: BAS01ATEX3432X [HART];
Baseefa03ATEX0709X [Fieldbus]
Standards: EN 60079-0:2012, EN 60079-15:2010
Markings: HART: Ⓢ II 3 G Ex nA IIC T5/T6 Gc;
T6(-40 °C ≤ T_a ≤ +50 °C), T5(-40 °C ≤ T_a ≤ +75 °C)
Fieldbus: Ⓢ II 3 G Ex nA IIC T5 Gc;
T5(-40 °C ≤ T_a ≤ +75 °C)

Special Conditions for Safe Use (X):

1. When fitted with the transient terminal options, the equipment is not capable of withstanding the 500 V electrical strength test as defined in clause 6.5.1 of EN 60079-15: 2010. This must be taken into account during installation.

ND ATEX Dust

Certificate: FM12ATEX0065X
Standards: EN 60079-0: 2012, EN 60079-31: 2009,
EN 60529:1991 +A1:2000
Markings: Ⓢ II 2 D Ex tb IIIC T130 °C Db,
(-40 °C ≤ T_a ≤ +70 °C); IP66

See [Table 12](#) at the end of the Product Certifications section for Process Temperatures

Special Conditions for Safe Use (X):

1. See certificate for ambient temperature range.
2. The non-metallic label may store an electrostatic charge and become a source of ignition in Group III environments.
3. Guard the LCD display cover against impact energies greater than 4 joules.
4. Flameproof joints are not intended for repair.
5. A suitable certified Ex d or Ex tb enclosure is required to be connected to temperature probes with Enclosure option "N".
6. Care shall be taken by the end user to ensure that the external surface temperature on the equipment and the neck of DIN Style Sensor probe does not exceed 130 °C.
7. Non-Standard Paint options may cause risk from electrostatic discharge. Avoid installations that cause electrostatic build-up on painted surfaces, and only clean the painted surfaces with a damp cloth. If paint is ordered through a special option code, contact the manufacturer for more information.

International**E7** IECEx Flameproof

Certificate: IECEx FMG 12.0022X
Standards: IEC 60079-0:2011, IEC 60079-1:2007-04, IEC
60079-31:2008
Markings: Ex d IIC T6...T1 Gb, T6(-50 °C ≤ T_a ≤ +40 °C),
T5...T1(-50 °C ≤ T_a ≤ +60 °C)
Ex tb IIIC T130 °C Db, (-40 °C ≤ T_a ≤ +70 °C);
IP66

See [Table 12](#) at the end of the Product Certifications section for Process Temperatures

Special Conditions for Safe Use (X):

1. See certificate for ambient temperature range.
2. The non-metallic label may store an electrostatic charge and become a source of ignition in Group III environments.
3. Guard the LCD display cover against impact energies greater than 4 joules.
4. Flameproof joints are not intended for repair.
5. A suitable certified Ex d or Ex tb enclosure is required to be connected to temperature probes with Enclosure option "N".

6. Care shall be taken by the end user to ensure that the external surface temperature on the equipment and the neck of DIN Style Sensor probe does not exceed 130 °C.
7. Non-Standard Paint options may cause risk from electrostatic discharge. Avoid installations that cause electrostatic build-up on painted surfaces, and only clean the painted surfaces with a damp cloth. If paint is ordered through a special option code, contact the manufacturer for more information.

I7 IECEx Intrinsic Safety

Certificate: IECEx BAS 07.0002X [HART]; IECEx BAS 07.0004X [Fieldbus]
 Standards: IEC 60079-0:2011; IEC 60079-11:2011;
 Markings: HART: Ex ia IIC T5/T6 Ga; T6(-60 °C ≤ T_a ≤ +50 °C), T5(-60 °C ≤ T_a ≤ +75 °C)
 Fieldbus: Ex ia IIC T4 Ga; T4(-60 °C ≤ T_a ≤ +60 °C)

See [Table 13](#) at the end of the Product Certifications section for Entity Parameters

Special Conditions for Safe Use (X):

1. When fitted with the transient terminal options, the apparatus is not capable of withstanding the 500 V electrical strength test as defined in Clause 6.3.13 of IEC 60079-11:2011. This must be taken into account during installation.
2. The enclosure may be made from aluminum alloy with a protective polyurethane paint finish; however, care should be taken to protect it from impact or abrasion when located in Zone 0.

N7 IECEx Type n

Certificate: IECEx BAS 07.0003X [HART]; IECEx BAS 07.0005X [Fieldbus]
 Standards: IEC 60079-0:2011, IEC 60079-15:2010
 Markings: HART: Ex nA IIC T5/T6 Gc; T6(-40 °C ≤ T_a ≤ +50 °C), T5(-40 °C ≤ T_a ≤ +75 °C);
 Fieldbus: Ex nA IIC T5 Gc; T5(-40 °C ≤ T_a ≤ +75 °C)

Brazil**E2** INMETRO Flameproof and Dust

Certificate: UL-BR 13.0535X
 Standards: ABNT NBR IEC 60079-0:2008 + corrigendum 1:2011, ABNT NBR IEC 60079-1:2009 + corrigendum 1:2011, ABNT NBR IEC 60079-31:2011
 Markings: Ex d IIC T6...T1* Gb;
 T6...T1*: (-50 °C ≤ T_a ≤ +40 °C);
 T5...T1*: (-50 °C ≤ T_a ≤ +60 °C) Ex tb IIIC
 T130°C; IP66; (-40 °C ≤ T_a ≤ +70 °C)

Special Conditions for Safe Use (X):

1. See product description for ambient temperature limits and process temperature limits.
2. The non-metallic label may store an electrostatic charge and become a source of ignition in Group III environments.
3. Guard the LCD display cover against impact energies greater than 4 joules.
4. Consult the manufacturer if dimensional information on the flameproof joints is necessary.

I2 INMETRO Intrinsic Safety [HART]

Certificate: UL-BR 15.0088X
 Standards: ABNT NBR IEC 60079-0:2008 + Errata 1:2011, ABNT NBR IEC 60079-11:2009
 Markings: Ex ia IIC T6 Ga (-60 °C ≤ T_a ≤ 50 °C), Ex ia IIC T5 Ga (-60 °C < T_a < 75 °C)

See [Table 13](#) at the end of the Product Certifications section for Entity Parameters

Special Conditions for Safe Use (X):

1. When fitted with the transient terminal options, the equipment is not capable of withstanding the 500 V electrical strength test as defined in ABNT NBR IEC60079-11. This must be taken into account during installation.
2. The enclosure may be made from aluminum alloy with a protective polyurethane paint finish; however, care should be taken to protect it from impact and abrasion when located in areas that require EPL Ga (Zone 0).

INMETRO Intrinsic Safety [Fieldbus/FISCO]
 Certificate: UL-BR 15.0030X
 Standards: ABNT NBR IEC 60079-0:2008 + Errata 1:2011, ABNT NBR IEC 60079-11:2009
 Markings: Ex ia IIC T4 Ga (-60 °C < T_a < 60 °C)

See [Table 13](#) at the end of the Product Certifications section for Entity Parameters

Special Conditions for Safe Use (X):

1. When mounted with the terminal options with transient protection, the equipment is not capable of withstanding the dielectric strength test with 500 V as defined in ABNT NBR IEC 60079-11. This feature should be taken into account during installation.
2. The enclosure may be made from aluminum alloy with a protective polyurethane paint finish; however, care should be taken to protect it from impact and abrasion when located in areas that require EPL Ga (Zone 0).

China

E3 China Flameproof

Certificate: GYJ16.1339X
 Standards: GB3836.1-2010, GB3836.2-2010,
 Markings: Ex d IIC T6 Gb

Special Conditions of Use (X):

1. Symbol “X” is used to denote specific conditions of use: For information on the dimensions of the flameproof joints the manufacturer shall be contacted. This shall be mentioned in the manual.
2. Relation between T code and ambient temperature range is:

T code	Ambient temperature
T6	$-50\text{ °C} \leq T_a \leq +40\text{ °C}$
T5...T1	$-50\text{ °C} \leq T_a \leq +60\text{ °C}$

3. The earth connection facility in the enclosure should be connected reliably.
4. During installation, there should be no mixture harmful to flameproof housing.
5. During installation in hazardous location. Cable glands, conduits and blanking plugs, certified by state-appointed inspection bodies with Ex d IIC Gb degree, should be used.
6. During installation, use and maintenance in explosive gas atmospheres, observe the warning “Do not open when energized”.
7. End users is not permitted to change any components insides, but to settle the problem in conjunction with manufacturer to avoid damage to the product.
8. When installation, use and maintenance of this product, observe following standards:
 GB3836.13-2013 “Electrical apparatus for explosive gas atmospheres Part 13: Repair and overhaul for apparatus used in explosive gas atmospheres”
 GB3836.15-2000 “Electrical apparatus for explosive gas atmospheres Part 15: Electrical installations in hazardous area (other than mines)”
 GB3836.16-2006 “Electrical apparatus for explosive gas atmospheres Part 16: Inspection and maintenance of electrical installation (other than mines)”
 GB50257-2014 “Code for construction and acceptance of electric device for explosion atmospheres and fire hazard electrical equipment installation engineering”.

I3 China Intrinsic Safety

Certificate: GYJ16.1338X
 Standards: GB3836.1-2010, GB3836.4-2010,
 GB3836.20-2010
 Markings: Ex ia IIC T4/T5/T6 Ga

Special Conditions for Safe Use (X):

1. Symbol “X” is used to denote specific conditions of use:
 - a. The enclosure may contain light metal, attention should be taken to avoid ignition hazard due to impact or friction when used in Zone 0.
 - b. When fitted with the “Transient Terminal Option”, this apparatus is not capable of withstanding the 500V r.m.s. insulation test required by Clause 6.3.12 of GB3836.4-2010.
2. Relation between T code and ambient temperature range is:

Output	T Code	Ambient temperature
HART	T6	$-60\text{ °C} \leq T_a \leq +50\text{ °C}$
	T5	$-60\text{ °C} \leq T_a \leq +75\text{ °C}$
Fieldbus	T4	$-60\text{ °C} \leq T_a \leq +60\text{ °C}$

3. Parameters:

Table 9. Power/Loop Terminals (+ and -)

Output	Maximum input voltage: U_i (V)	Maximum input current: I_i (mA)	Maximum input power: P_i (W)	Maximum internal parameters:	
				C_i (nF)	L_i (μ H)
HART	30	300	1	5	0
Fieldbus	30	300	1.3	2.1	0

Table 10. Sensor Terminal (1 to 5)

Output	Maximum input voltage: U_o (V)	Maximum input current: I_o (mA)	Maximum input power: P_o (W)	Maximum Internal Parameters:	
				C_i (nF)	L_i (μ H)
HART	13.6	56	0.19	78	0
Fieldbus	13.9	23	0.079	7.7	0

Table 11. Load Connected to Sensor Terminals (1 to 5)

Output	Group	Maximum external parameters:	
		C_o (μ F)	L_o (mH)
HART	IIC	0.74	11.7
	IIB	5.12	44
	IIA	18.52	94
Fieldbus	IIC	0.73	30.2
	IIB	4.8	110.9
	IIA	17.69	231.2

Temperature transmitters comply to the requirements for FISCO field devices specified in GB3836.19-2010. FISCO parameters are as follows:

Maximum input voltage: U_i (V)	Maximum input current: I_i (mA)	Maximum input power: P_i (W)	Maximum internal parameters:	
			C_i (nF)	L_i (μ H)
17.5	380	5.32	2.1	0

- The product should be used with Ex-certified associated apparatus to establish explosion protection system that can be used in explosive gas atmospheres. Wiring and terminals should comply with the instruction manual of the product and associated apparatus.
- The cables between this product and associated apparatus should be shielded cables (the cables must have insulated shield). The shielded has to be grounded reliably in non-hazardous area.
- End users are not permitted to change any components insides, but to settle the problem in conjunction with manufacturer to avoid damage to the product.
- When installation, use and maintenance of this product, observe following standards:
GB3836.13-2013 “Electrical apparatus for explosive gas atmospheres Part 13: Repair and overhaul for apparatus used in explosive gas atmospheres”
GB3836.15-2000 “Electrical apparatus for explosive gas atmospheres Part 15: Electrical installations in hazardous area (other than mines)”
GB3836.16-2006 “Electrical apparatus for explosive gas atmospheres Part 16: Inspection and maintenance of electrical installation (other than mines)”
GB3836.18-2010 “Explosive atmospheres Part 18: Intrinsically safe system”
GB50257-2014 “Code for construction and acceptance of electric device for explosion atmospheres and fire hazard electrical equipment installation engineering”

N3 China Type n
Certificate: GY15.1087X [Fieldbus]; GY15.1088X [HART]
Standards: GB3836.1-2010, GB3836.8-2003
Markings: Ex nA nL IIC T5 Gc [Fieldbus];
Ex nA nL IIC T5/T6 GC [HART]

Output	T code	Ambient temperature
Fieldbus	T5	$-40\text{ }^\circ\text{C} \leq T_a \leq +75\text{ }^\circ\text{C}$
HART	T6	$-40\text{ }^\circ\text{C} \leq T_a \leq +50\text{ }^\circ\text{C}$
	T5	$-40\text{ }^\circ\text{C} \leq T_a \leq +75\text{ }^\circ\text{C}$

Special Conditions for Safe Use (X):

- See certificate for special conditions of use.
- Max Input Voltage: 42.4 VDC [Fieldbus]; 55 VDC [HART]
- When installation, use and maintenance of this product, observe following standards:
GB3836.13-1997 “Electrical apparatus for explosive gas atmospheres Part 13: Repair and overhaul for apparatus used in explosive gas atmospheres”
GB3836.15-2000 “Electrical apparatus for explosive gas atmospheres Part 15: Electrical installations in hazardous area (other than mines)”
GB3836.6-2006 “Electrical apparatus for explosive gas atmospheres Part 16: Inspection and maintenance of electrical installation (other than mines)”
GB50257-1996 “Code for construction and acceptance of electric device for explosion atmospheres and fire hazard electrical equipment installation engineering”

EAC – Belarus, Kazakhstan, Russia

EM Technical Regulation Customs Union (EAC) Flameproof
Certificate: RU C-US.GB05.B.00289
Markings: 1Ex d IIC T6...T1 Gb X

Special Condition for Safe Use (X):

- See certificate for special conditions.

IM Technical Regulation Customs Union (EAC) Intrinsic Safety
Certificate: RU C-US.GB05.B.00289
Markings: [HART]: 0Ex ia IIC T5, T6 Ga X;
[Fieldbus/PROFIBUS®]: 0Ex ia IIC T4 Ga X

Special Condition for Safe Use (X):

- See certificate for special conditions.

Japan

E4 TIIS Flameproof
Certificate: TC21038, TC21039
Markings: Ex d IIC T5 ($-20\text{ }^\circ\text{C} \leq T_a \leq +60\text{ }^\circ\text{C}$)

Certificate: TC16127, TC16128, TC16129, TC16130
Markings: Ex d IIB T4 ($-20\text{ }^\circ\text{C} \leq T_a \leq +55\text{ }^\circ\text{C}$)

Combinations

- K1** Combination of E1, I1, N1, and ND
- K2** Combination of E2 and I2
- K5** Combination of E5 and I5
- K7** Combination of E7, I7, N7
- KA** Combination of K1 and K6
- KB** Combination of K5, I6, and K6
- KM** Combination of EM and IM

Tables

Table 12. Process Temperatures

		T6	T5	T4	T3	T2	T1	T130	
Max ambient		+40 °C	+60 °C	+60 °C	+60 °C	+60 °C	+60 °C	+70 °C	
Transmitter with LCD display									
Sensor extension	0-in.	55 °C	70 °C	95 °C	95 °C	95 °C	95 °C	95 °C	
	3-in.	55 °C	70 °C	100 °C	100 °C	100 °C	100 °C	100 °C	
	6-in.	60 °C	70 °C	100 °C	100 °C	100 °C	100 °C	100 °C	
	9-in.	65 °C	75 °C	110 °C	110 °C	110 °C	110 °C	110 °C	
	Transmitter without LCD display								
	0-in.	55 °C	70 °C	100 °C	170 °C	280 °C	440 °C	100 °C	
	3-in.	55 °C	70 °C	110 °C	190 °C	300 °C	450 °C	110 °C	
	6-in.	60 °C	70 °C	120 °C	200 °C	300 °C	450 °C	110 °C	
9-in.	65 °C	75 °C	130 °C	200 °C	300 °C	450 °C	120 °C		

Table 13. Entity Parameters

Parameters	HART	Fieldbus/PROFIBUS	FISCO
Voltage U_i (V)	30	30	17.5
Current I_i (mA)	300	300	380
Power P_i (W)	1	1.3	5.32
Capacitance C_i (nF)	5	2.1	2.1
Inductance L_i (mH)	0	0	0

Additional Certifications

SBS American Bureau of Shipping (ABS) Type Approval
 Certificate: 02-HS289101-4-PDA
 Intended Use: Measurement of temperature for marine and offshore applications.

SBV Bureau Veritas (BV) Type Approval
 Certificate: 23154
 Requirements: Bureau Veritas Rules for the Classification of Steel Ships
 Application: Class notations: AUT-UMS, AUT-CCS, AUT-PORT and AUT-IMS; Temperature transmitter type 3144P cannot be installed on diesel engines

SDN Det Norske Veritas (DNV) Type Approval
 Certificate: A-14184
 Intended Use: Det Norske Veritas' Rules for Classification of Ships, High Speed and Light Craft and Det Norske Veritas' Offshore Standards

Application:

Location classes	
Temperature	D
Humidity	B
Vibration	A
EMC	A
Enclosure	D

SLL Lloyds Register (LR) Type Approval
 Certificate: 11/60002
 Application: Environmental categories ENV1, ENV2, ENV3, and ENV5

Dimensional drawings

Figure 1. Transmitter Exploded View

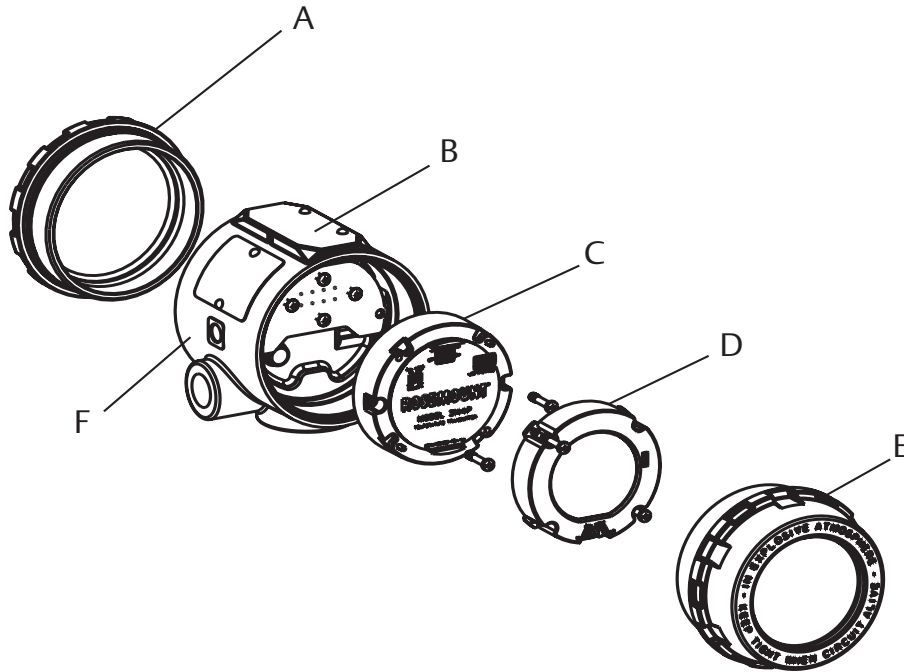

- A. Housing with permanent terminal block
- B. Cover with wiring diagram label
- C. Nameplate

- D. Electronic module
- E. LCD display
- F. Display cover

Figure 2. Switch Location and LCD Display Faceplate

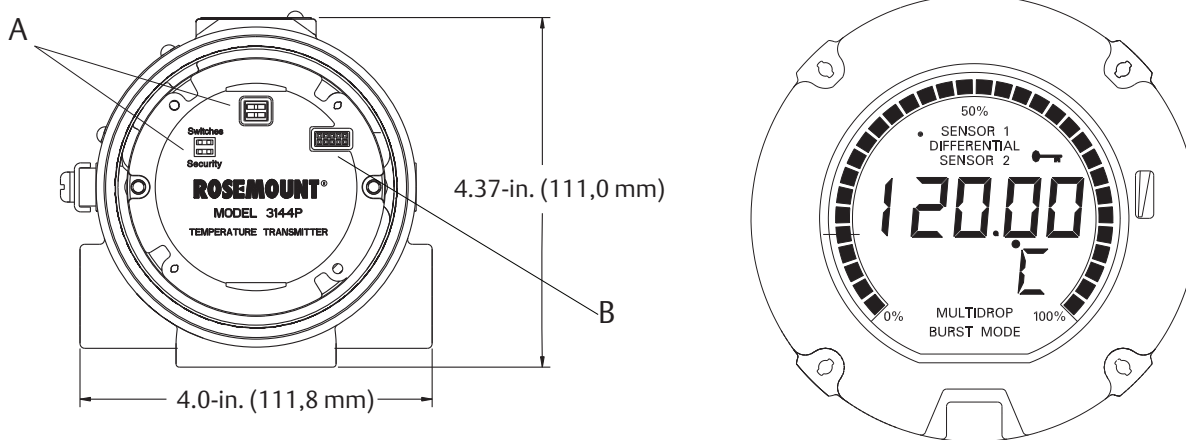

- A. Switches⁽¹⁾

- B. LCD display connector

Dimensions are in inches (millimeters).

1. Alarm and write protect (HART), simulate and write protect (FOUNDATION Fieldbus).

Figure 3. Transmitter

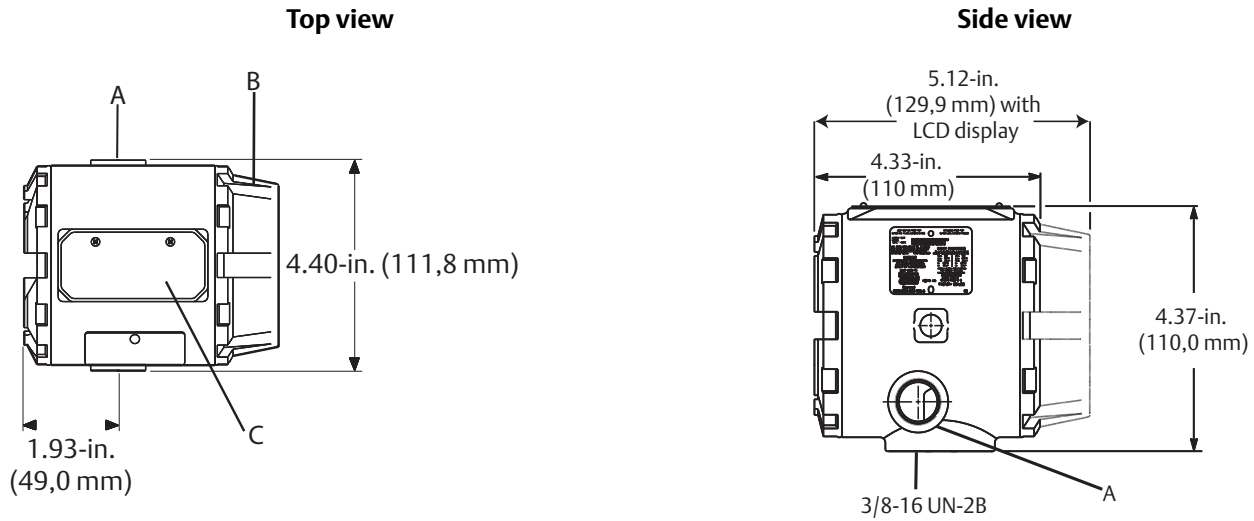

- A. Conduit entry
- B. Display cover
- C. Nameplate

Dimensions are in inches (millimeters).

Figure 4. Transmitter for Conduits with M20 × 1.5, PG 13.5 Entries

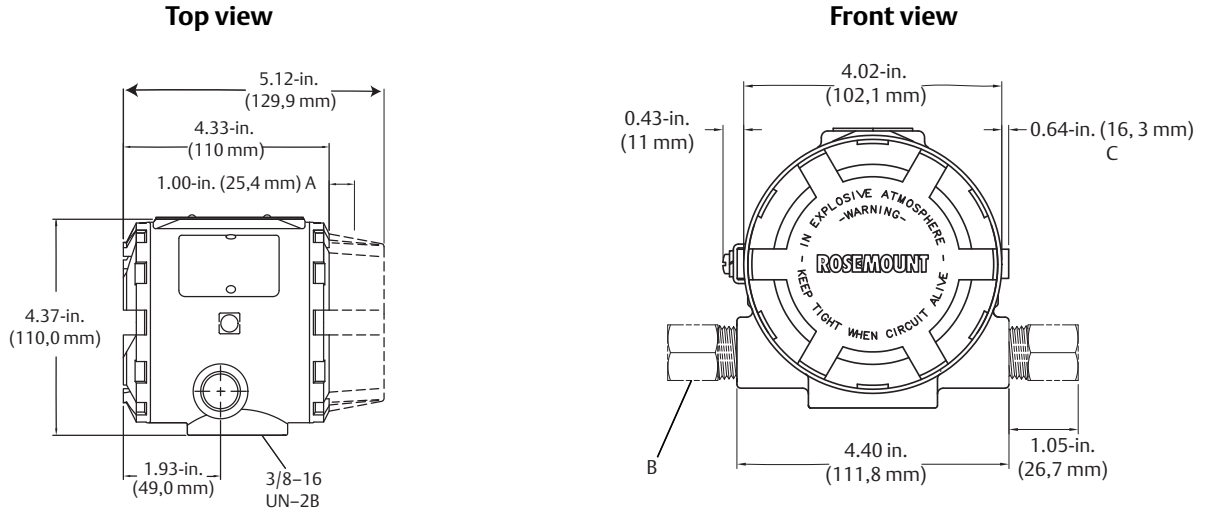

- A. Clearance required to remove cover
- B. Adapters for M20 × 1.5, PG 13.5
- C. Explosion/flame proof clamp (option code dependent)

Dimensions are in inches (millimeters).

Figure 5. Mounting Configurations with Optional Mounting Bracket

Pipe mounting

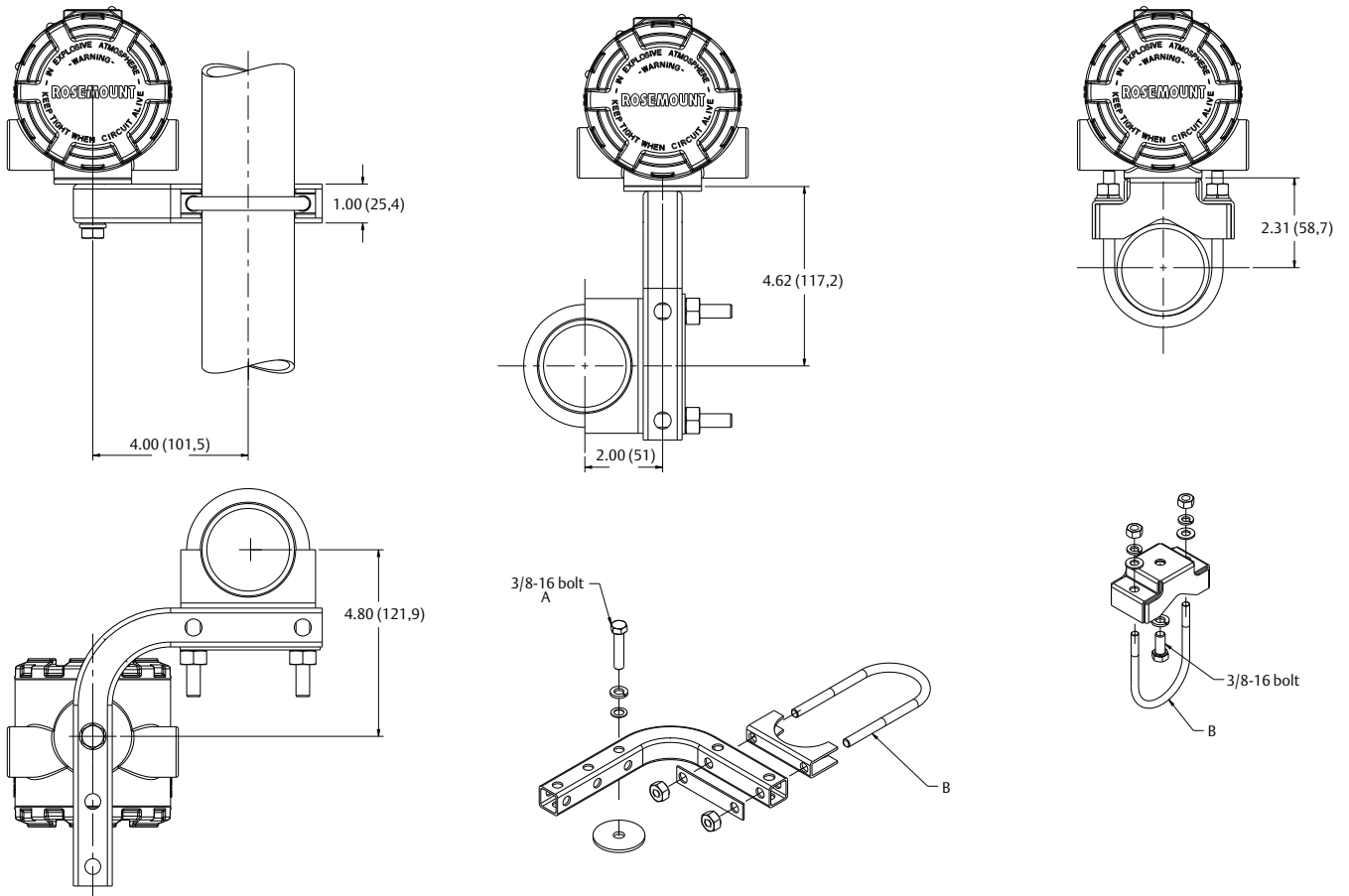

- A. For transmitter mounting
 - B. 2-in. U-bolt for pipe mounting
- Dimensions are in inches (millimeters).

Figure 6. Rosemount X-well Assembly

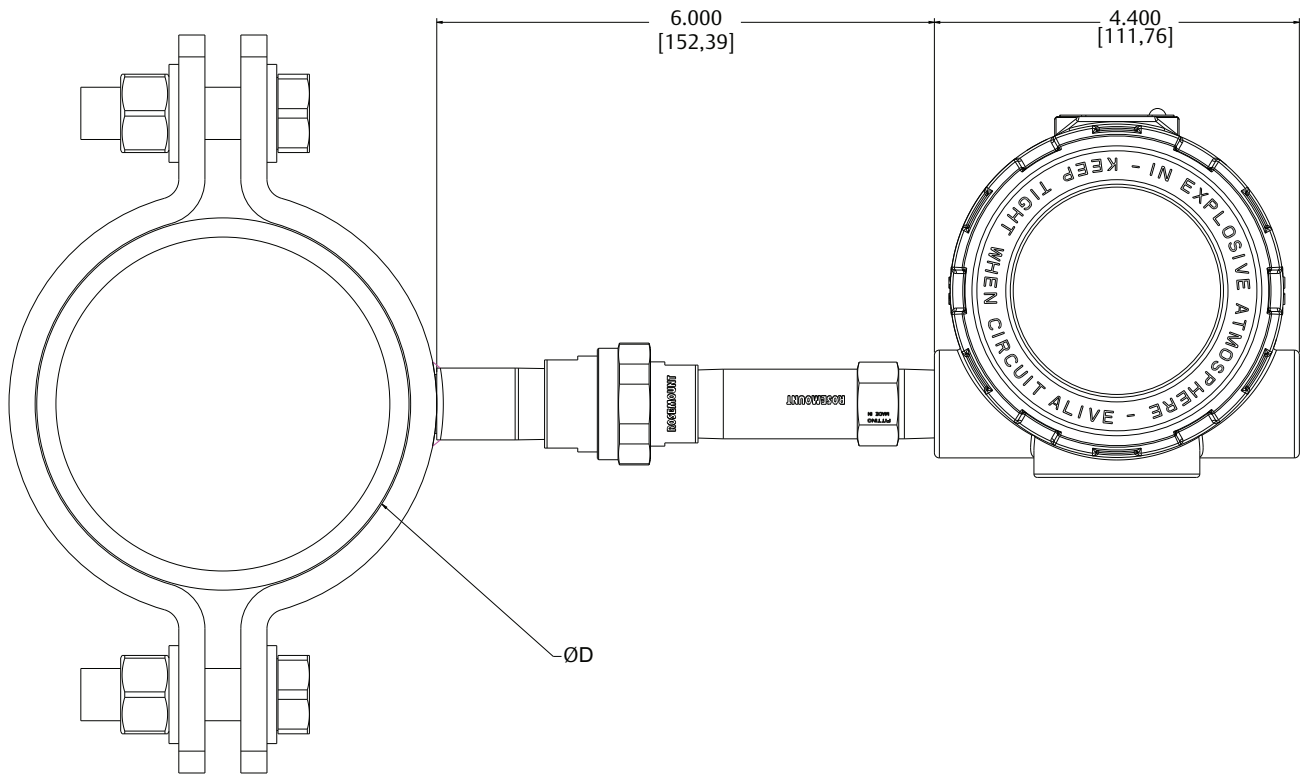
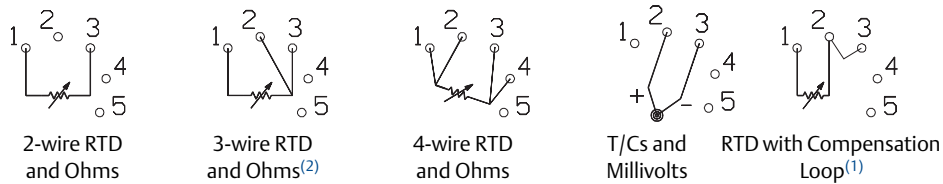
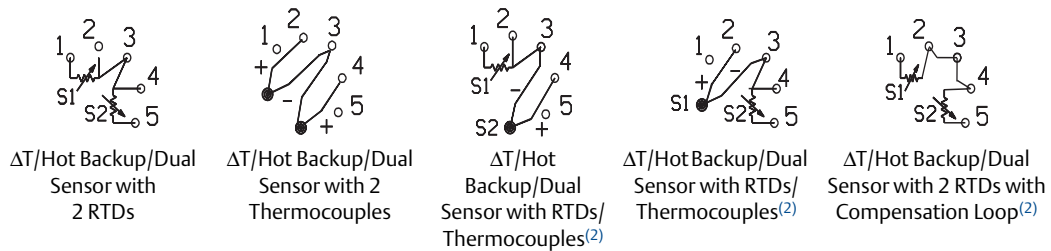

Figure 7. HART/4–20 mA

Rosemount 3144P single-sensor connections



Rosemount 3144P dual-sensor connections



1. Transmitter must be configured for a 3-wire RTD in order to recognize an RTD with a compensation loop.
2. Emerson provides 4-wire sensors for all single-element RTDs. Use these RTDs in 2-wire or 3-wire configurations by leaving the unneeded leads disconnected and insulated with electrical tape.

Figure 8. FOUNDATION Fieldbus

Rosemount 3144P single-sensor connections

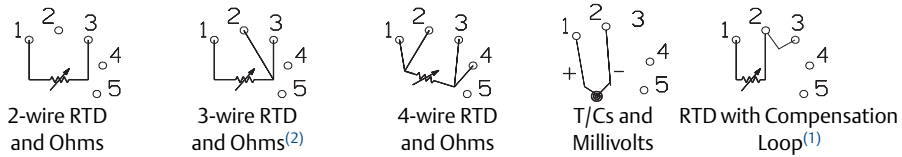

Rosemount 3144P dual-sensor connections

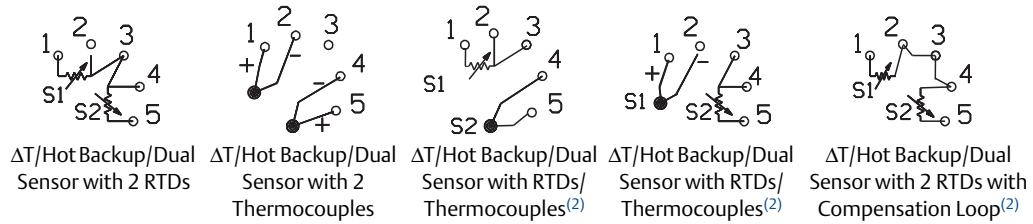

1. Transmitter must be configured for a 3-wire RTD in order to recognize an RTD with a compensation loop.
2. Emerson provides 4-wire sensors for all single-element RTDs. Use these RTDs in 2-wire or 3-wire configurations by leaving the unneeded leads disconnected and insulated with electrical tape.

Standard configuration

Both standard and custom configuration settings may be changed. Unless specified, the transmitter will be shipped as follows:

Standard configuration	
4 mA value/lower range (HART/4–20 mA) measurement point LO (FOUNDATION Fieldbus)	0 °C
20 mA value/upper range (HART/4–20 mA) measurement point HI (FOUNDATION Fieldbus)	100 °C
Damping	5 seconds
Output	Linear with temperature
Failure mode (HART/4–20 mA)	High
Line voltage filter	60 Hz
Software tag	See “Software tag” on page 11
Optional integral display	Units and mA/sensor 1 units
Single-sensor option	
Sensor type	4-wire, Pt 100 $\alpha = 0.00385$ RTD
Primary variable (HART/4–20 mA) AI 1400 (FOUNDATION Fieldbus)	Sensor 1
Secondary variable AI 1600 (FOUNDATION Fieldbus)	Terminal temperature
Tertiary variable	Not used
Quaternary variable	Not used
Dual-sensor option	
Sensor type	Two 3-wire, Pt 100 $\alpha = 0.00385$ RTD
Primary variable (HART/4–20 mA) AI 1400 (FOUNDATION Fieldbus)	Sensor 1
Secondary variable AI 1500 (FOUNDATION Fieldbus)	Sensor 2
Tertiary variable AI 1600 (FOUNDATION Fieldbus)	Terminal temperature
Quaternary variable	Not used

Custom configuration

The Rosemount 3144P can be ordered with custom configuration. The table below lists the requirements necessary to specify a custom configuration.

Option code	Requirements/specification
C1: Factory data ⁽¹⁾	Date: day/month/year Descriptor: 16 alphanumeric character Message: 32 alphanumeric character Custom alarm levels can be specified for configuration at the factory. Rosemount X-well specific information: pipe material, pipe schedule, line size
C2: Transmitter-sensor matching	The Rosemount 3144P Transmitter is designed to accept Callendar-van Dusen constants from a calibrated RTD schedule and generate a custom curve to match any specific sensor curve. Specify a Series 68, 65, or 78 RTD sensor on the order with a special characterization curve (V or X8Q4 option). These constants will be programmed into the transmitter when this option is selected.
C4: Five point calibration	Will include five-point calibration at 0, 25, 50, 75, and 100% analog and digital output points. Use with option code Q4 to obtain a Calibration Certificate.
C7: Special sensor	Used for non-standard sensor, adding a special sensor or expanding input. Customer must supply the non-standard sensor information. Additional special curve will be added to sensor curve input choices.
A1: NAMUR-compliant, high alarm	Analog output levels compliant with NAMUR. Alarm is set to fail high.
CN: NAMUR-compliant, low alarm	Analog output levels compliant with NAMUR. Alarm is set to fail low.
C8: Low alarm	Analog output levels compliant with Rosemount standard. Alarm is set to fail low.
F5: 50 Hz Line voltage filter	Calibrated to 50 Hz line voltage filter.

1. CDS required.

To custom configure the Rosemount 3144P Transmitter with the dual-sensor option transmitter for one of the applications described below, indicate the appropriate option code in the model number. If a sensor type is not specified, the transmitter will be configured for two 3-wire Pt 100 ($\alpha = 0.00385$) RTDs if any of the following option codes are selected.

Option code U1: Hot Backup	
Primary usage	Primary usage sets the transmitter to automatically use sensor 2 as the primary input if sensor 1 fails. Switching from sensor 1 to sensor 2 is accomplished without any effect on the analog signal. A digital alert will be sent in the event of a failed sensor.
Primary variable	1st good
Secondary variable	Sensor 1
Tertiary variable	Sensor 2
Quaternary variable	Terminal temperature

Option code U2: average temperature with Hot Backup and sensor drift alert—warning mode	
Primary usage	Critical applications, such as safety interlocks and control loops. Outputs the average of two measurements and sends a digital alert if temperature difference exceeds the set maximum differential (Sensor Drift Alert – warning mode). If a sensor fails, an alert will be sent digitally and the primary variable will be reported as the remaining good sensor value.
Primary variable	Sensor average
Secondary variable	Sensor 1
Tertiary variable	Sensor 2
Quaternary variable	Terminal temperature

Option code u3: average temperature with Hot Backup and sensor drift alert—alarm mode	
Primary usage	Critical applications, such as safety interlocks and control loops. Outputs the average of two measurements and sets the analog output into alarm if temperature difference exceeds the set maximum differential (sensor drift alert – alarm mode). If a sensor fails, an alert will be sent digitally and the primary variable will be reported as the remaining good sensor value.
Primary variable	Sensor average
Secondary variable	Sensor 1
Tertiary variable	Sensor 2
Quaternary variable	Terminal temperature

Option code U4: two independent sensors	
Primary usage	Used in non-critical applications where the digital output is used to measure two separate process temperatures.
Primary variable	Sensor 1
Secondary variable	Sensor 2
Tertiary variable	Terminal temperature
Quaternary variable	Not used

Option code U5: differential temperature	
Primary usage	The differential temperature of two process temperatures is configured as the primary variable. If the temperature difference exceeds the maximum differential, the analog output will go into alarm. Primary Variable will be reported as a bad sensor value.
Primary variable	Differential temperature
Secondary variable	Sensor 1
Tertiary variable	Sensor 2
Quaternary variable	Terminal temperature

Option code U6: average temperature	
Primary usage	When average measurement of two different process temperatures is required. If a sensor fails, the analog output will go into alarm and the primary variable will report the measurement of the remaining good sensor.
Primary variable	Sensor average
Secondary variable	Sensor 1
Tertiary variable	Sensor 2
Quaternary variable	Terminal temperature

Global Headquarters

Emerson Automation Solutions

6021 Innovation Blvd.
Shakopee, MN 55379, USA
+1 800 999 9307 or +1 952 906 8888
+1 952 949 7001
RFQ.RMD-RCC@Emerson.com

North America Regional Office

Emerson Automation Solutions

8200 Market Blvd.
Chanhassen, MN 55317, USA
+1 800 999 9307 or +1 952 906 8888
+1 952 949 7001
RMT-NA.RCCRFQ@Emerson.com

Latin America Regional Office

Emerson Automation Solutions

1300 Concord Terrace, Suite 400
Sunrise, FL 33323, USA
+1 954 846 5030
+1 954 846 5121
RFQ.RMD-RCC@Emerson.com

Europe Regional Office

Emerson Automation Solutions Europe GmbH

Neuhofstrasse 19a P.O. Box 1046
CH 6340 Baar
Switzerland
+41 (0) 41 768 6111
+41 (0) 41 768 6300
RFQ.RMD-RCC@Emerson.com

Asia Pacific Regional Office

Emerson Automation Solutions Asia Pacific Pte Ltd

1 Pandan Crescent
Singapore 128461
+65 6777 8211
+65 6777 0947
Enquiries@AP.Emerson.com

Middle East and Africa Regional Office

Emerson Automation Solutions

Emerson FZE P.O. Box 17033
Jebel Ali Free Zone - South 2
Dubai, United Arab Emirates
+971 4 8118100
+971 4 8865465
RFQ.RMTMEA@Emerson.com

 [Linkedin.com/company/Emerson-Automation-Solutions](https://www.linkedin.com/company/Emerson-Automation-Solutions)

 [Twitter.com/Rosemount_News](https://twitter.com/Rosemount_News)

 [Facebook.com/Rosemount](https://www.facebook.com/Rosemount)

 [Youtube.com/user/RosemountMeasurement](https://www.youtube.com/user/RosemountMeasurement)

 [Google.com/+RosemountMeasurement](https://www.google.com/+RosemountMeasurement)

Standard Terms and Conditions of Sale can be found on the [Terms and Conditions of Sale page](#).

The Emerson logo is a trademark and service mark of Emerson Electric Co. DeltaV, PlantWeb, Hot Backup, Complete Point Solution, Rosemount X-well Technology, Rosemount, and Rosemount logotype are trademarks of Emerson.

HART is a registered trademark of FieldComm Group.
FOUNDATION Fieldbus is a trademark of FieldComm Group.
PROFIBUS is a registered trademark of PROFINET International (PI).
eurofast and minifast are registered trademarks of TURCK
All other marks are the property of their respective owners.
© 2017 Emerson. All rights reserved.