



**AQUARIUS**  
WAVES

*Kelvinator*

White-Westinghouse®

# ILLUSTRATED PARTS BREAKDOWN

## WATER COOLER MODELS

P8AM-100 PAM-001

P8AMSL-100



### SPECIFICATIONS

**MODEL: P8AM-100, P8AMS-100**

Voltage .....115 VAC ±10%/1PH/60Hz  
 Size (Approx).....27" H., 20-1/4" W., 20-1/2" D.  
 Shipping Weight (Approx).....59 lbs.  
 Cold Water Capacity (GPH)\* .....8  
 Compressor (HP) .....1/5  
 Compressor (Amps) (Full Load) .....4.6  
 Refrigerant .....R-134A  
 Refrigerant Charge.....3.875 oz. (110 grams)

**MODEL: PAM-001, PAMS-001**

Size (Approx) .....27" H., 20-1/4" W., 20-1/2" D.  
 Shipping Weight (Approx).....37 lbs.

\* A.R.I. Rating: Room Temperature 90°F; Supply Water Temperature 80°F; Drinking Water Temperature 50°F. Based on standard test procedures.

Specifications subject to change without notice.

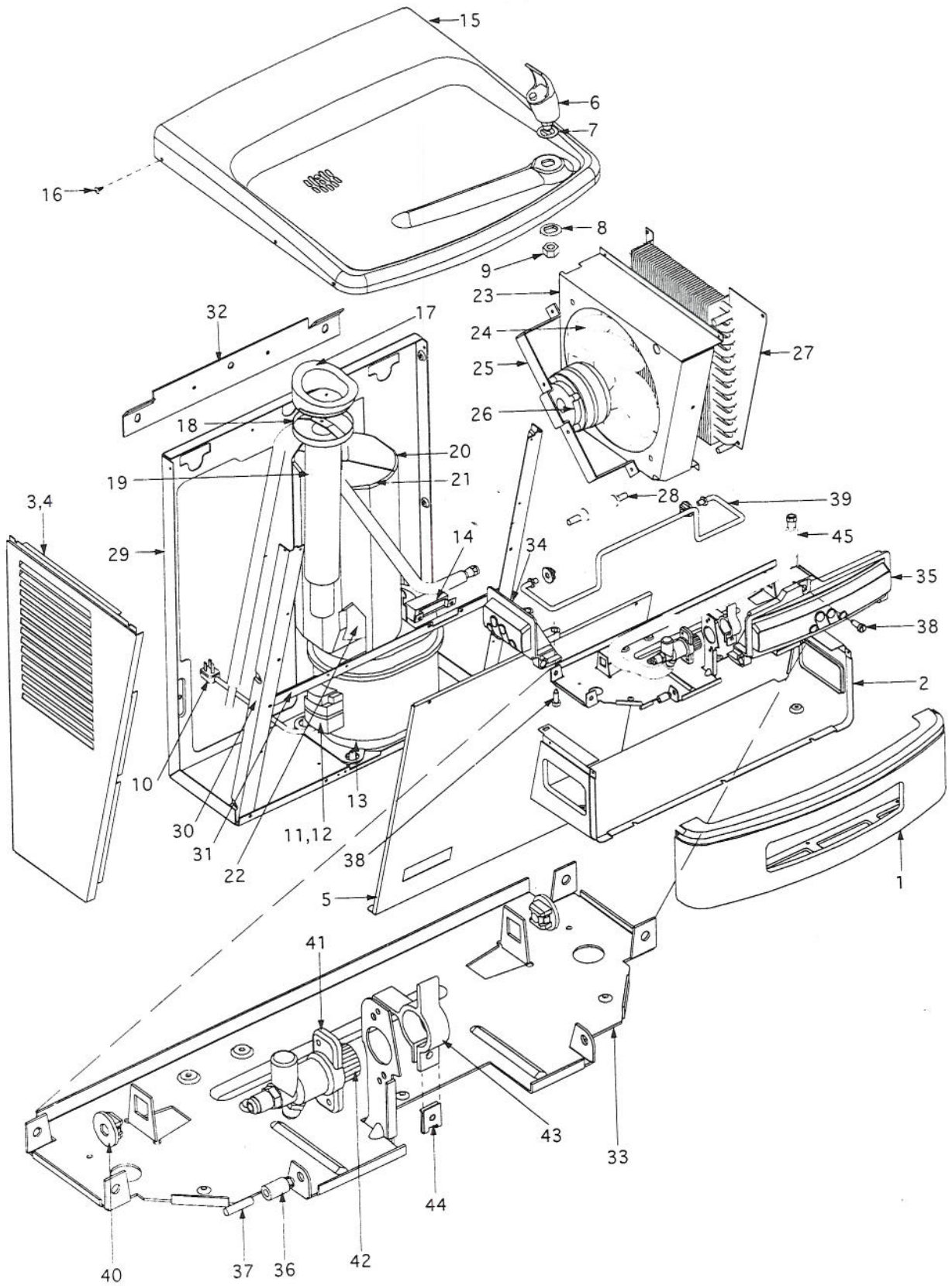



# PARTS LIST

ITEM NO.	DESCRIPTION	P8AM-100	PAM-001	P8AMS-100	PAMS-001
1	Front Nose, Sandstone	031754-006	031754-006	031754-006	031754-006
	Front Nose, Greystone	031754-005	031754-005	031754-005	031754-005
	Front Nose, Stainless	031754-007	031754-007	031754-007	031754-007
	Front Nose, Painted (tan)	031754-008	031754-008	031754-008	031754-008
2	Housing, Middle Sandstone	031753-002	031753-002	031753-102	031753-102
	Housing, Middle Greystone	031753-001	031753-001	031753-101	031753-101
	Housing, Middle Stainless	031753-003	031753-003	031753-103	031753-103
	Housing, Middle Painted (tan)	031753-005	031753-005	031753-105	031753-105
3	Panel, Side Left Sandstone	031751-002	031751-002	031751-102	031751-002
	Panel, Side Left Greystone	031751-001	031751-001	031751-101	031751-001
	Panel, Side Left Stainless	031751-003	031751-003	031751-103	031751-003
	Panel, Side Left Painted (tan)	031751-005	031751-005	031751-105	031751-005
4	Panel, Side Right Sandstone	031750-002	031750-002	031750-002	031750-102
	Panel, Side Right Greystone	031750-001	031750-001	031750-001	031750-101
	Panel, Side Right Stainless	031750-003	031750-003	031750-003	031750-103
	Panel, Side Right Painted (tan)	031750-005	031750-005	031750-005	031750-105
5	Panel, Front Sandstone	031752-002	031752-002	031752-002	031752-002
	Panel, Front Greystone	031752-001	031752-001	031752-001	031752-001
	Panel, Front Stainless	031752-003	031752-003	031752-003	031752-003
	Panel, Front Painted (tan)	031752-005	031752-005	031752-005	031752-005
6	Bubbler Valve	031760-003	031760-003	031760-003	031760-003
	Nozzle Assembly	030029-005	030029-005	030029-005	030029-005
7	Gasket	028706-031	028706-031	028706-031	028706-031
8	Washer, Undertop	028706-030	028706-030	028706-030	028706-030
9	Nut	026824-019	026824-019	026824-019	026824-019
10	Cord Assy, Power Supply	026540-040	---	026540-040	---
11	Overload, MRP26ALL-69	031697-001	---	031697-001	---
12	Relay, 9660-043-166	031698-001	---	031698-001	---
13	Compressor Assembly (includes 11 & 12)	032124-001	---	032124-001	---
14	Control, Cold	027040-007	---	027040-007	---
15	Top	031714-001	031714-001	031714-001	031714-001
16	Screw, Torx Hd	031875-005	031875-005	031875-005	031875-005
17	Gasket, Waste	031756-001	031756-001	031756-001	031756-001
18	Waste Assy, Insulated	032126-001	032126-001	---	---
18	Waste Assy	---	---	031892-002	031892-003
19	Insulation, Waste Assy	031497-006	031497-006	031497-005	031497-004
20	Insulation, Cooling Tank R/H	031898-001	---	031898-001	---
21	Insulation, Cooling Tank L/H	031899-001	---	031899-001	---
22	Cooling Tank Assy, Insulated	031775-002	---	031775-002	---
23	Shroud, Fan	031767-001	---	031767-001	---
24	Blade, Fan	024033	---	024033	---
25	Bracket, Fan Motor	026969	---	026969	---
26	Motor, Fan	027354-026	---	027354-026	---
27	Condenser	031766-001	---	031766-001	---
28	Drier, Refrigerant	031593-003	---	031593-003	---
29	Frame, Back/Bottom	031747-001	031747-001	031747-001	031747-002
30	Strut, Support	031748-001	031748-001	031748-001	031748-001
31	Angle, Cross Brace	031772-001	031772-001	031772-001	031772-001
32	Hanger Bracket	031363-002	031363-002	031363-002	031363-002
33	Shelf, Activation	031853-001	031853-001	031853-001	031853-001
34	Push Button Assy, R/H	031951-001	031951-001	---	---
	Push Button Assy, L/H	031951-002	031951-002	---	---
35	Push Button, Front	031763-001	031763-001	031763-001	031763-001
36	Body, Push Rivet	031856-001	031856-001	031856-001	031856-001
37	Rivet, Push	031859-001	031859-001	031859-001	031859-001
38	Screw, Adjust	031858-001	031858-001	031858-001	031858-001
39	Rod, Activation	031854-002	031854-002	---	---
40	Bushing, Rod	031857-002	031857-002	---	---
41	Valve Body	032045-002	032045-002	032045-002	032045-002
42	Stem Assy	031759-001	031759-001	031759-001	031759-001
43	Wheel Arm, Valve	031765-001	031765-001	031765-001	031765-001
44	Clip, U Type	030409-002	030409-002	030409-002	030409-002
45	Tube Assy, Valve to Bubbler	031739-002	031739-002	031739-002	031739-002
<b>Items Not Shown</b>					
	Heat Exchanger Assy	031869-001	---	031869-001	---
	Brace Panel (PAM)	---	032102-001	---	032102-002
	Tube Assy, Water Supply (PAM)	---	032041-001	---	032041-002
	Tube, Supply Extension	---	---	---	032312-001
	Waste T.	---	---	---	019733
	Tube, Waste Extension	---	---	---	018066-008
	Waste Arm	---	---	---	029611-003

## ELECTRICAL DIAGRAM

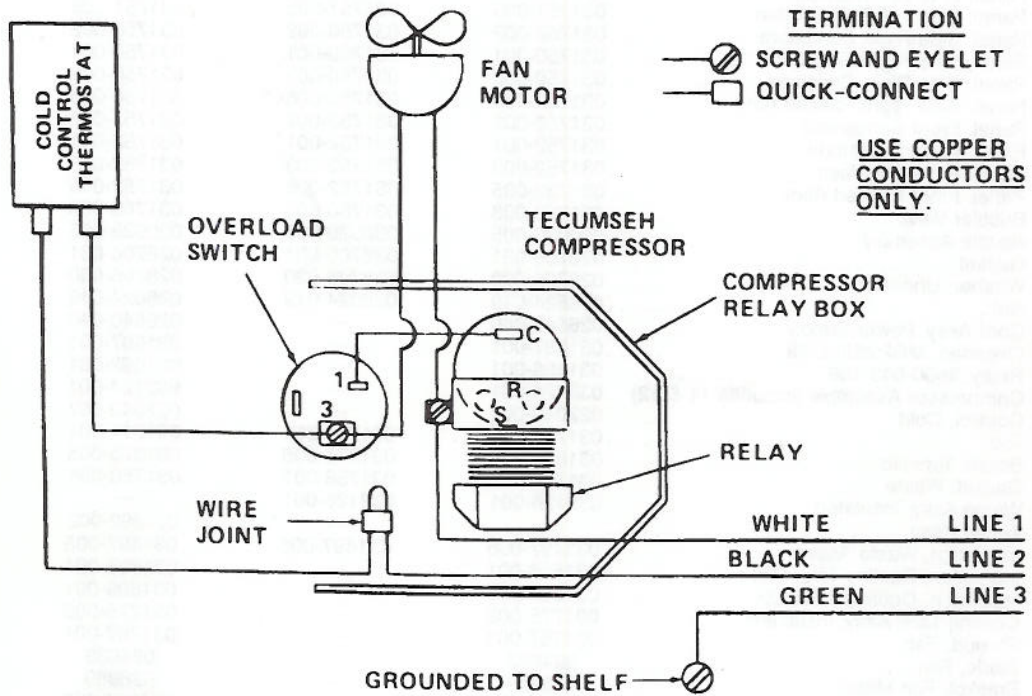

**USED ON MODELS:**  
**P8AM-100**  
**P8AMS-100**

OASIS® & AQUARIUS® are registered trademarks of EBCO Manufacturing Company  
 The trademarks Kelvinator® and White-Westinghouse® are used under license from White Consolidated Industries, Inc.

**EBCO® MANUFACTURING COMPANY**

265 N. Hamilton Rd. • P.O. Box 13150 • Columbus, OH 43213-0150 • 614/861-1350 • Fax: 614/861-5017

Printed in U.S.A.

Copyright 1998 EBCO Manufacturing Co.