

Eliminator

Torsion Axles

Congratulations on the purchase of your new trailer. This trailer manufacturer has chosen the Tie Down Engineering Eliminator Torsion Axle for your trailer's suspension requirements. There are several important facts in using your new trailer with the Eliminator Torsion Axle.

Four cords inside the axle housing handle suspension travel and shock absorption. As the wheel moves up or down, the rubber cords compress, offering a progressive rate of resistance. Benefits to this system are: Independent suspension, each wheel acts independently for a smoother ride. Trailer rigidity, the axle is bolted to the trailer frame. This acts as an additional cross member which stiffens the frame, reducing flex in cross winds and rough roads. Progressive "spring" rate, small bumps are handled by a soft initial rate, while larger bumps use a stiffer rate. This makes for a smoother ride over all types of roads.

Corrosion resistance: Each Eliminator torsion axle tube is galvanized inside and out. Since there is no metal-to-metal contact as with springs, bare metal is not exposed that promotes corrosion. The torsion arms are available with E-coat or with hot dip galvanizing. Longer life with fewer problems. **Reduced un-sprung weight:** The Eliminator torsion axle tube is bolted to the frame. The moving parts are reduced, lowering the weight that the "spring action" must move. This results in a smoother shock action.

Stainless Steel Wear Sleeves: Rear oil seals ride on stainless steel sleeves on the 3500 series and 5000/6000 series axles. This reduces the chance of worn seals due to corrosion build up on the spindle surface where the oil seal meets the spindle surface. Backing Plates are built into the casting design of the torsion arms. All surfaces are machined to assure that the backing plate and spindle are "square" to each other. This assures a better fitting brake assembly.

The Eliminator Torsion Axle has an industry first with its removable spindle. Gone are the days of sitting by the side of the road when the spindle is damaged due to extreme bearing failure or an accident. Available from your trailer manufacturer or dealer is a spare tire-hub-spindle carrier that replaces the old style spare tire carrier. This gives you great peace of mind by having a spare tire, a spare hub with bearings and grease and something no one else offers, a spare spindle that can be removed with standard tools.

Road Side Repairs

When required, you have several options when confronted with a flat tire, bearing failure or spindle damage. Flat tires should be handled like any other trailer tire change. Make sure trailer is on level or near level ground. Loosen lug nuts on wheel. Use jack on trailer frame to elevate tire in order to place spare tire on the hub. Make sure all lug nuts are securely tightened before moving trailer. Re-check lug nuts after several miles to make sure they are tight. Bearing failure is usually discovered by a loud grinding noise or wheel wobble. If there is obvious bearing damage, jack up the

trailer to remove the tire. Remove the dust cap with a hammer by striking at the edge, rotating the hub to strike different sides until the dust cap is removed. The castle nut that holds the hub on has a "tang" washer to keep it from coming off. Bend or straighten the tab so that the nut will come off. Remove the hub and inspect the spindle for damage. If none is detected, wipe the spindle clean and replace the damaged hub with a pre-greased spare. The washer and castle nut are replaced. Tighten the nut until it is tight with obvious friction on the bearings. Back off nut 1/4 turn to allow fluid bearing movement Re-lock the castle nut with the unused tang on the washer. Replace tire and secure with lug nuts.

Spindle failure is usually defined as damage to the spindle causing excessive worn spots in the bearing surfaces or damage due to an accident. Follow the instructions for hub removal or replace the entire spindle and hub combination by removing the cotter key and castle nut on the backside of the spindle. Hit the backside of the spindle with a heavy hammer to dislodge the spindle. Place the replacement spindle in the torsion arm. Place washer and nut on spindle and tighten with 100 ft. lbs of torque. Replace hub and or wheel as discussed above.

Always re-check all work performed when you return to a safe area.

Torsion Axle Maintenance

Torsion axles do not require any regular maintenance, unlike springs that need constant review for worn or loose parts. Spring axles must be checked regularly to make sure the spring surfaces are not corroded, creating a weak point in the suspension.

It is always a good idea to tow any trailer in a level position with the load balanced over the axle or axles. Torsion axles require that the trailer be towed level. On multi axle torsion axle trailers, excessive tire wear will occur from the coupler being too high or too low. Trailers with two or more torsion axles do not have a self-leveling or load balancing feature.

If the hitch/coupler/actuator position is too high, too much load will be transferred to the rear axle. If the hitch/coupler/actuator is too low, too much load will be placed on the front axle.

Either situation will create excessive tire wear and loss of braking power. Excessive tire or brake wear due to the trailer being towed improperly is not covered under manufacturer's warranty programs.

WARNING

Improper hitch height may overload the front or rear axle on your trailer and could result in tire, wheel or bearing failure. Serious injury or property damage can result from such failure.

Correct Towing Positions for Torsion Axles

Correct Level

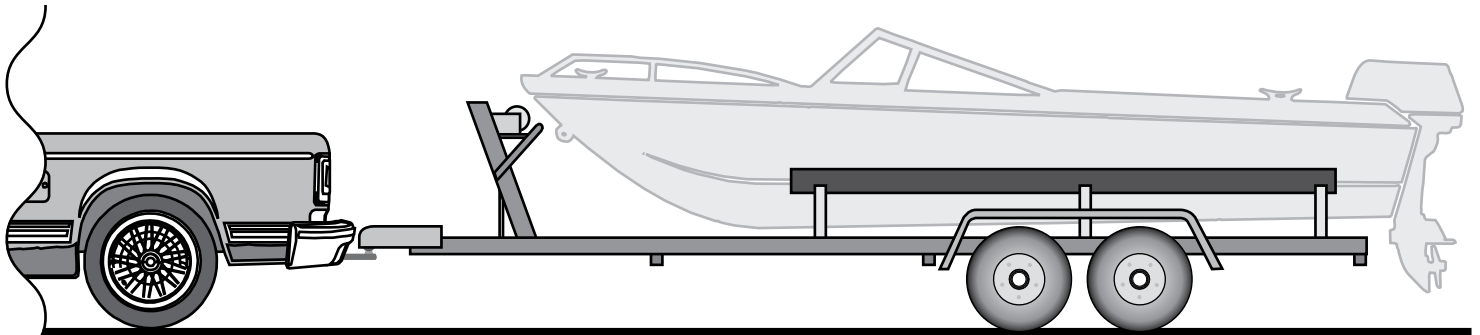

Trailer is level, note position of the tires

Hitch Too High

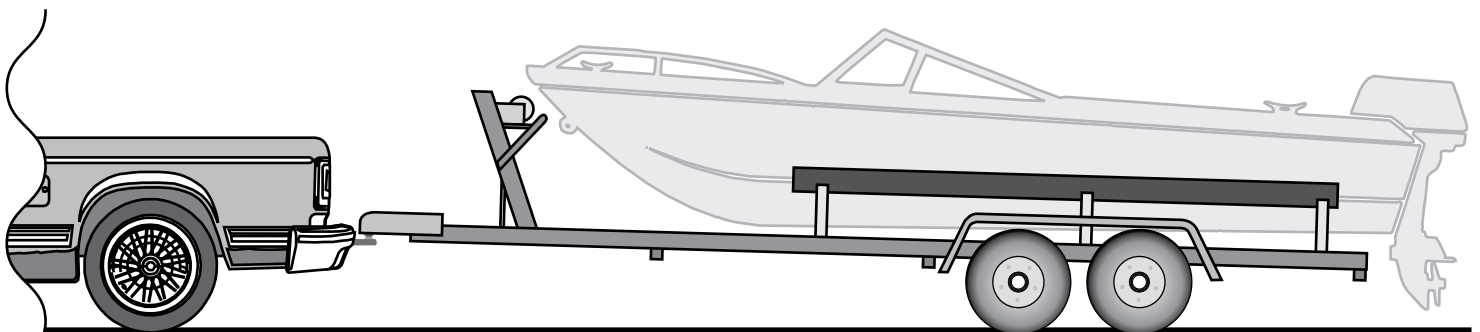

Trailer is not level, note that most of the load is on the rear axle

Hitch Too Low

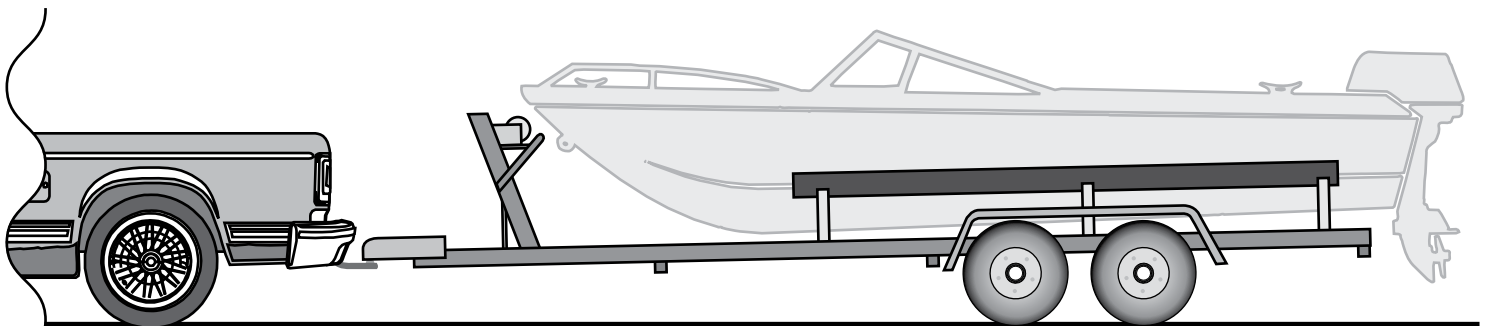

Trailer is not level, note that most of the load is on the front axle



Eliminator

Torsion Axles

with Quick Change Spindles

The Eliminator Torsion Axle has an industry first with its removable spindle. Gone are the days of sitting by the side of the road when the spindle is damaged due to extreme bearing failure or due to an accident.

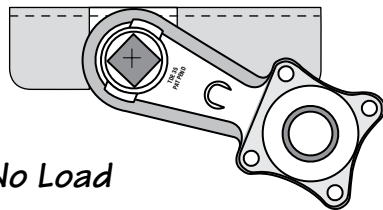
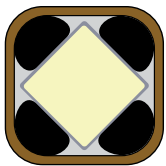
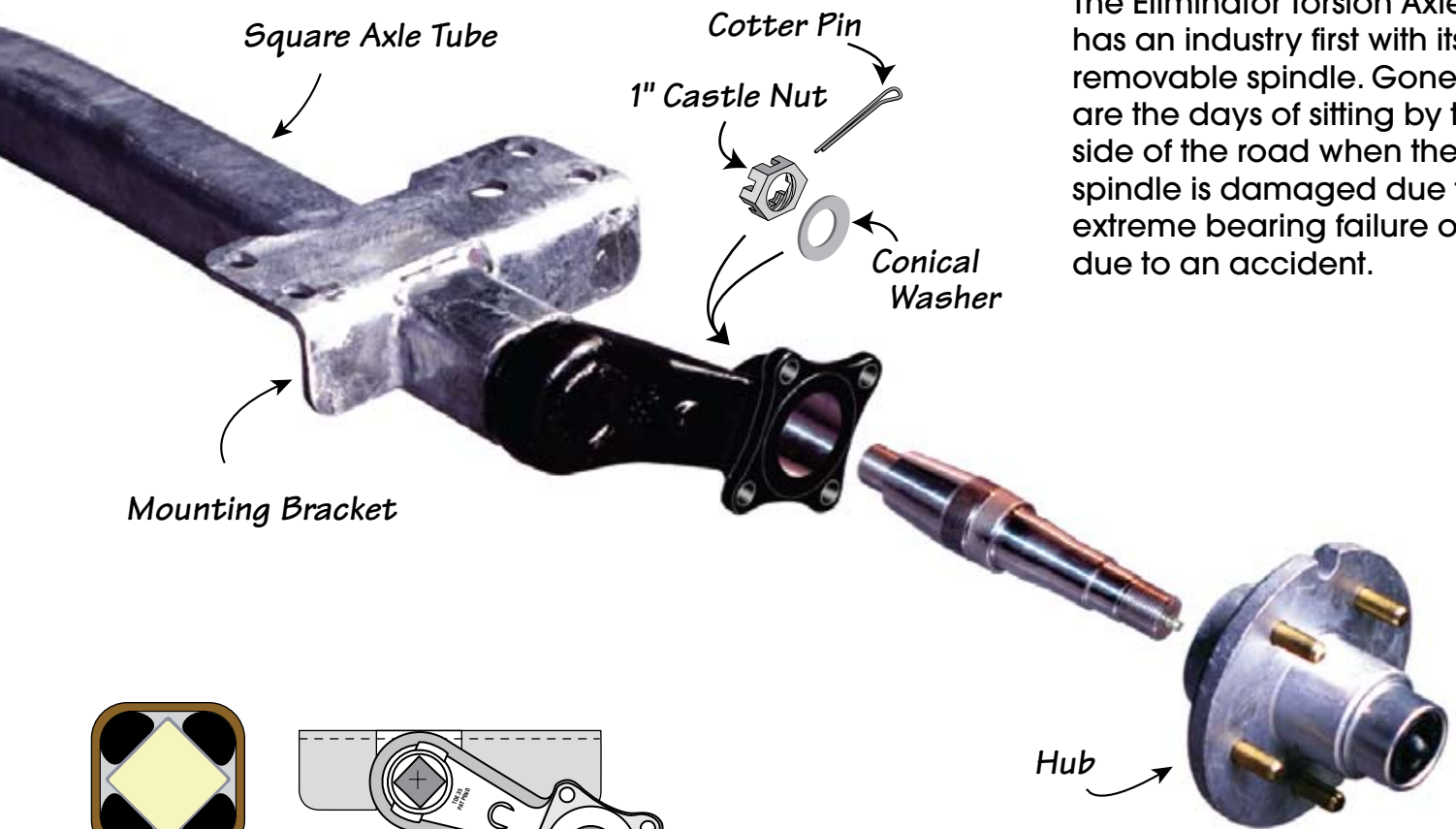

No Load

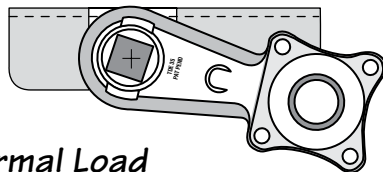

Normal Load

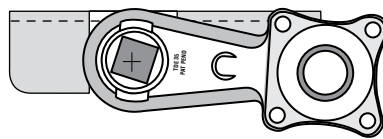

Heavy Shock

Tools required to change spindle:

- 1-1/2" Wrench
- Pliers
- Heavy Hammer
- Lug Wrench
- Jack & Jack Stand

