



MAXMADE LIMITED

Coldroom & Cleanroom
Accessories



Coldroom & Cleanroom Accessories



Maxmade Limited have been supplying the Clean Room and Temperature Controlled Building Industry since 1973. Initially only supplying specialist ceiling support systems and sheet metal fabrications.

Since this time, the company has gained a wealth of experience, and has developed its range of products to meet the new demands of this industry, and that of the Food Preparation Industry, including wall and door protection systems, wall and ceiling cladding systems and also supplying quality fixings and sealants to help complete the job.

A working solution

Maxmade Limited stocks a large range of cold and clean room accessories that compliment its hygienic cladding range, as well as for use with composite panel temperature controlled buildings. These include

- Coves
- Cove end caps and corners
- Skirting
- Skirting end caps and corners.
- Dunnage / Bump rails
- Channels
- Angles
- Nylon bolts and washers
- Vision panels
- Hygienic Cladding sheets and planks.

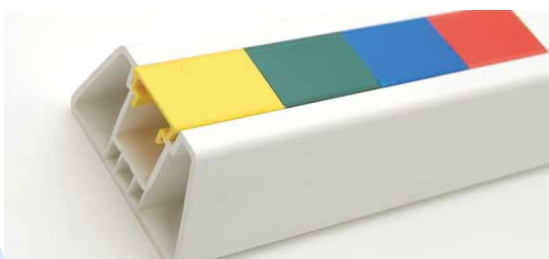
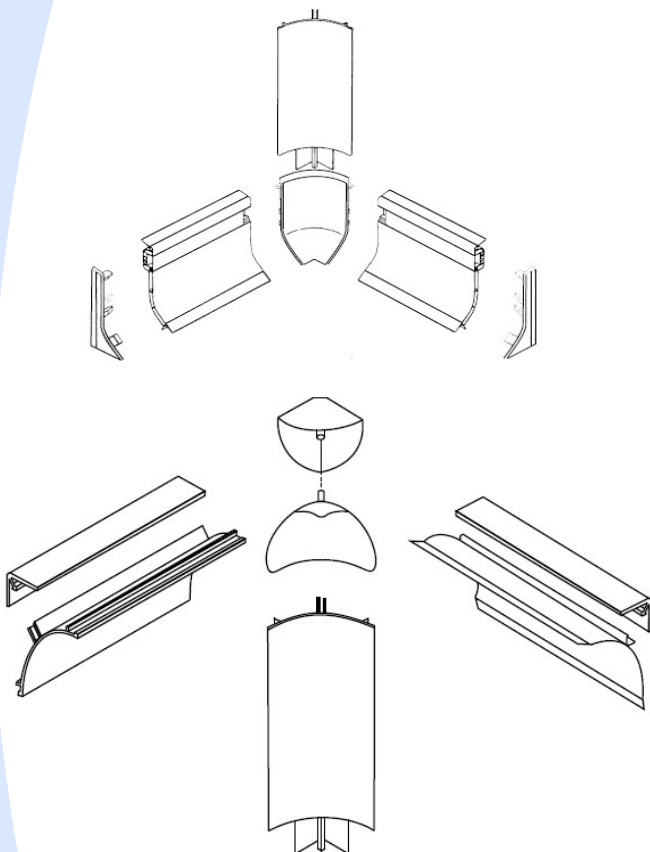

Contact our sales team for more information on any of our range of products.



Hemmings Way, Off Stoney Lane,
Rainhill, Prescot, Merseyside L35 9ND
www.maxmade.com sales@maxmade.com
Telephone: 0151 430 9797
Fax: 0151 493 1320

Coving Range

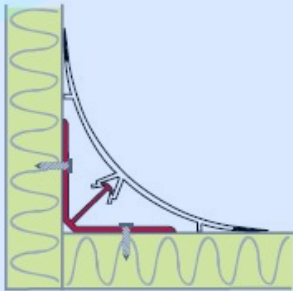

COVING:

Our two part coving gives a quality finish to the wall to wall and wall to ceiling joints. A robust aluminium backer is used to hold the PVC cove, giving you a visually pleasing finish with a easy cleanable corner as required by food and chemical buildings regulations.

The 2 part coving comes in three sizes, some of which have ancillary items such as end caps and corners. The Backer section is extruded aluminium. The front cove is a prime grade pvc in white.

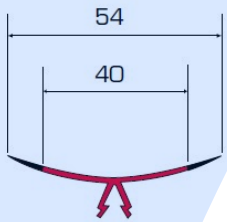

Small:

The EX40 Flexi-edged 2 part cove is available in 4 mtr lengths. This section comes with internal three way corners, external two way corners and end caps ancillary parts.

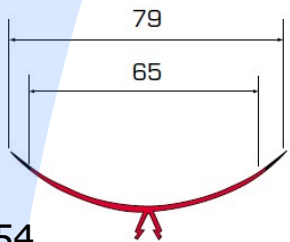

EX54

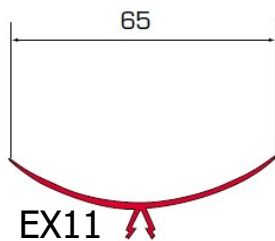

EX11

Medium:

The EX54 Flexi-edged, and EX11 Rigid-edge 2 part cove is available in 4 mtr lengths. This section only comes with internal three way corners.

Large:

The EX14 Flexi-edged 2 part cove is the largest section, available in 4 mtr lengths. This section comes with internal three way corners, external two way corners and end caps ancillary parts.

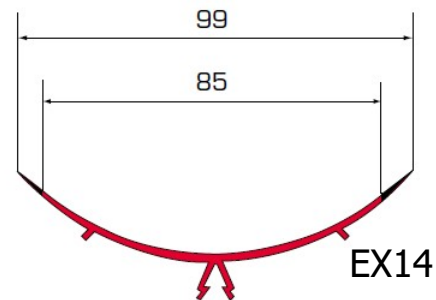

EX14

Contact our sales team for more information on any of our range of products.

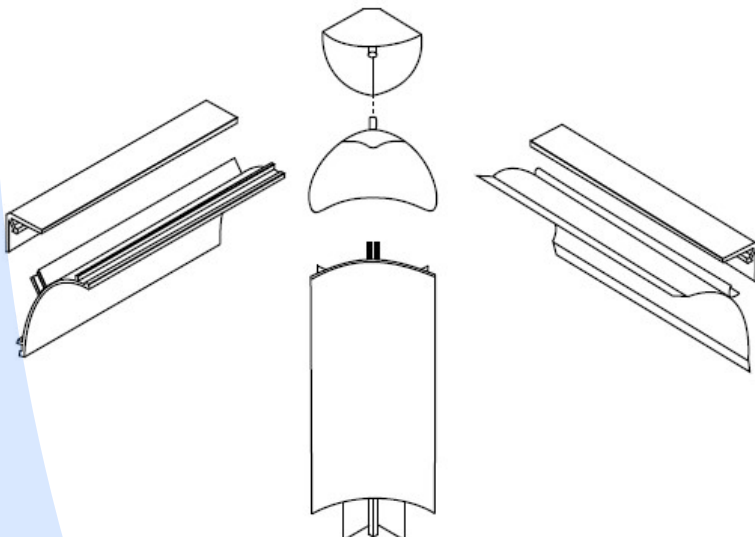

Hemmings Way, Off Stoney Lane,
Rainhill, Prescot, Merseyside L35 9ND
www.maxmade.com sales@maxmade.com
Telephone: 0151 430 9797
Fax: 0151 493 1320

Aluminium Coving Range

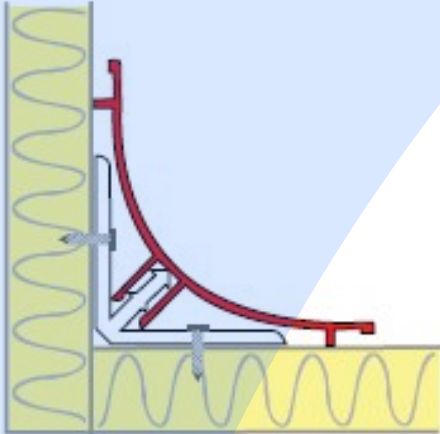

ALUMINIUM COVING:

Our two part coving gives a quality finish to the wall to wall and the wall to ceiling joints. A robust aluminium backer is used to hold the RAL 9010 white powder coated aluminium cove, giving you a visually pleasing finish with an easy to clean corner as required by food and chemical regulations.

The 2 part coving comes in two sizes. The large cove comes with a 3 way internal corners to suit.

Large:

The ANGALU 01 is available in 4 mtr lengths. This section comes with internal three way corners, and is used with the H40 aluminium backer section.

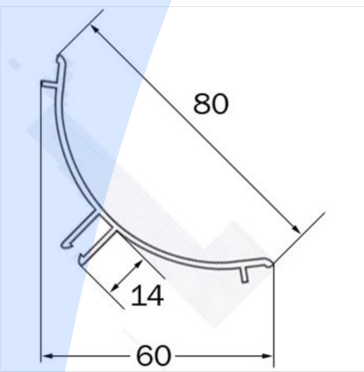

Small:

The ANGALU 01 is available in 4 mtr lengths. This section is used with the H30 aluminium backer section.

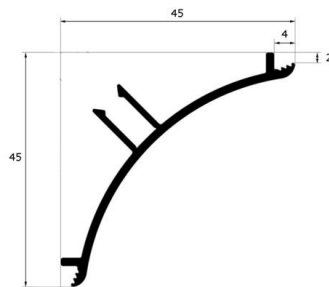

Birds beak:

An anodised aluminium birds beak is available for resin floors, as the profile shown. Birds beak are manufactured to size in stainless steel, aluminium or food safe laminates steels.

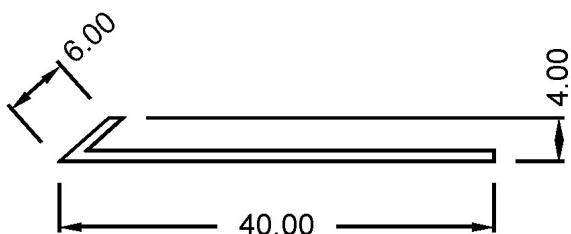

Contact our sales team for more information on any of our range of products.



MAXMADE LIMITED

Hemmings Way, Off Stoney Lane,
Rainhill, Prescot, Merseyside L35 9ND
www.maxmade.com sales@maxmade.com
Telephone: 0151 430 9797
Fax: 0151 493 1320

Channel & Angle Range

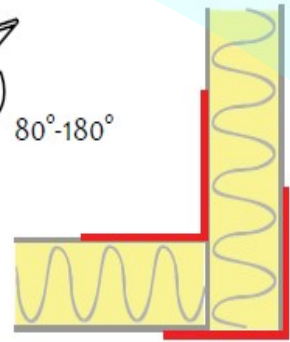
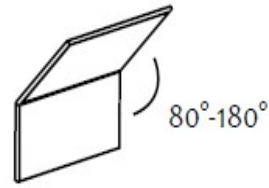
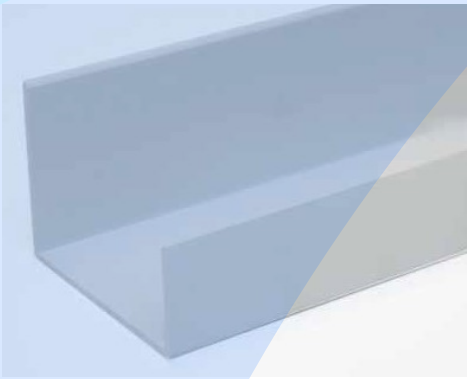

CHANNEL AND ANGLE:

White UV stabilised PVC channel and angles are available in a number of sizes, all 4 mtr long.

Ref	Size A	Size B	Size C	Length
EX.68	50 mm	50 mm	30 mm	4 lm
EX.65	50 mm	75 mm	30 mm	4 lm
EX.66	50 mm	80 mm	30 mm	4 lm
EX.67	50 mm	100 mm	30 mm	4 lm

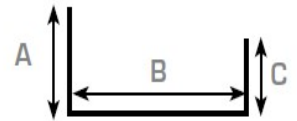

Ref	Size A	Size B	Thickness	Length
EX.113	50 mm	50 mm	1,4 mm	4 lm
EX.114	60 mm	60 mm	2 mm	4 lm
EX.115	50 mm	100 mm	2 mm	4 lm

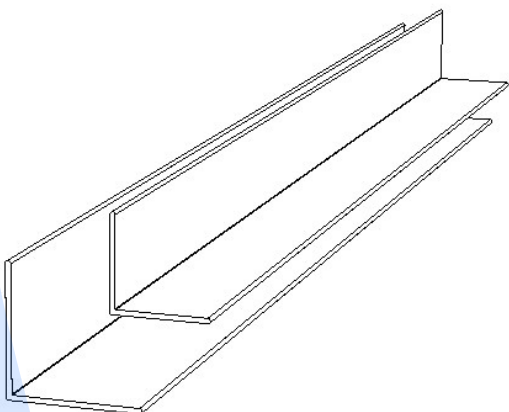
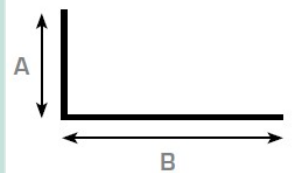

Flexible Angle Profile:

Comes in 50x50 and 80x80 wide sections in 4mtr lengths

Aluminium Angle Profile:

Available in 2mm thick 50x50 and 3mm 38x38 wide sections in 5mtr lengths. These are available either mill finish or white powder coated.

Skirting Trims

SKIRTING:

Made from prime pvc, the skirting sections are in either white or black. They are supplied in 4 mtr lengths.

The double skinned skirting system works in conjunction with the two part coves to give a aesthetically, but functional finish to wall to floor joints.

For the EX15 and EX80 Skirting range a series of ancillary sections are available.

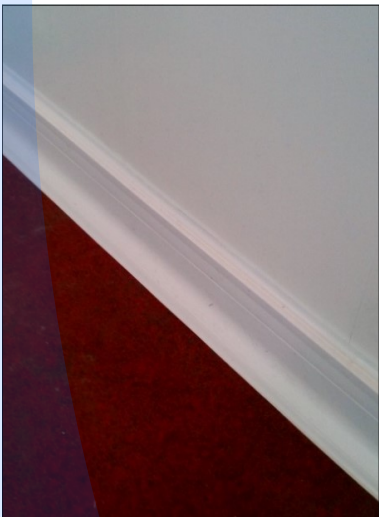
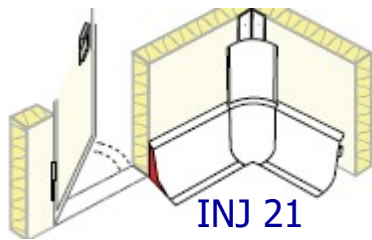
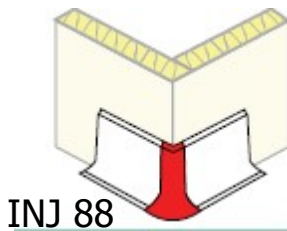
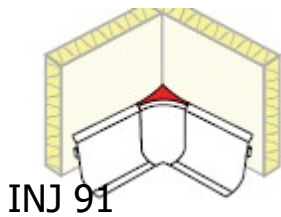
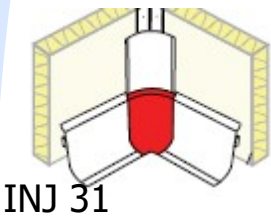
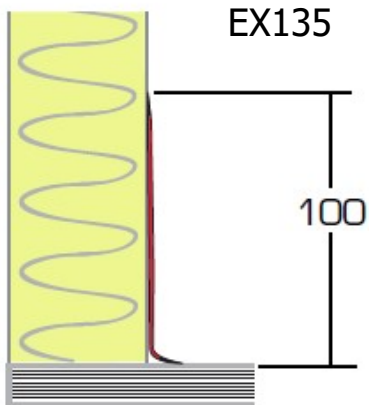
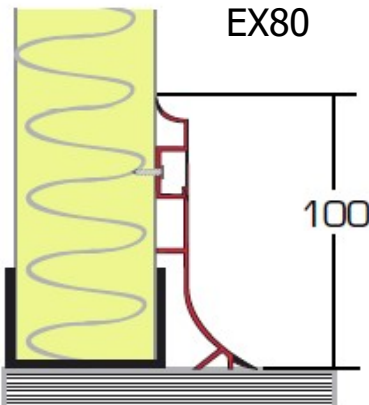
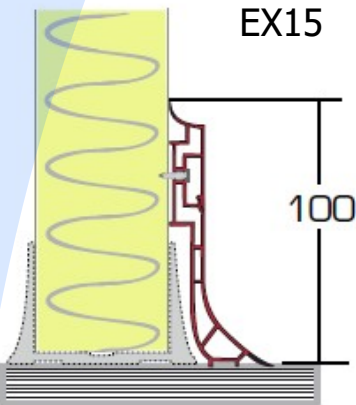
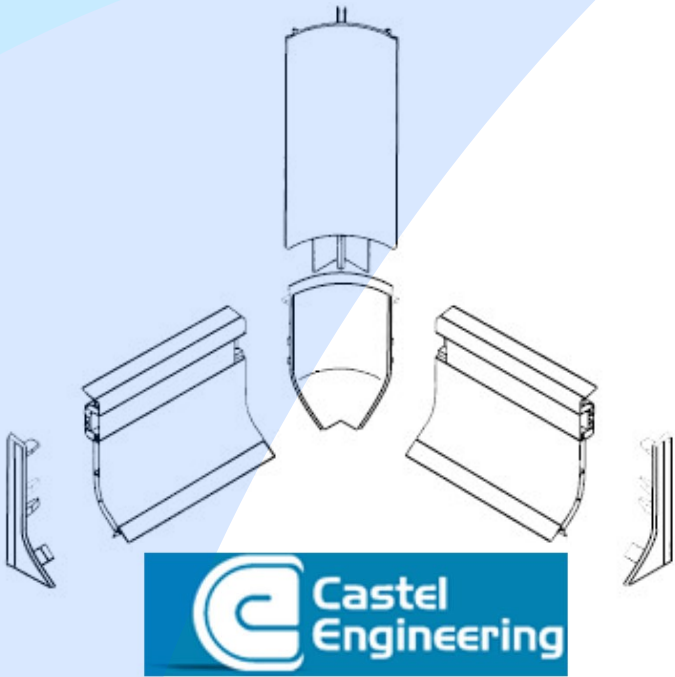

Contact our sales team for more information on any of our range of products.



Hemmings Way, Off Stoney Lane,
 Rainhill, Prescot, Merseyside L35 9ND
www.maxmade.com sales@maxmade.com
 Telephone: 0151 430 9797
 Fax: 0151 493 1320

Wall Protection Trims



BUMP RAILS:

Two types are available in PVC, both are available in 4mtr lengths. With a selection of corners and stop ends. Coloured inserts or strips are available to highlight different risk areas.

Heavy Duty:

The EX81-82 is available in 4 mtr lengths. This section comes with external corners and end caps., and coloured inserts also in 4 mtr lengths.

Ref	Size A	Size B	Length
EX.81-82	40 mm	70 mm	4 lm

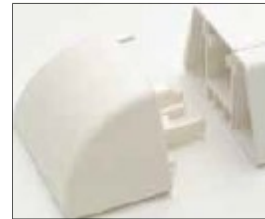
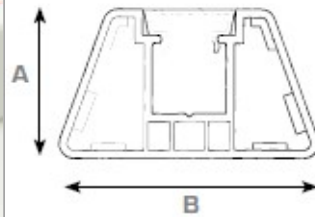

INJ 296



INJ 334

Light Duty:

The EX20-21 bump rail is available in 4 mtr lengths. This section comes with internal and external two way corners and end caps ancillary parts.

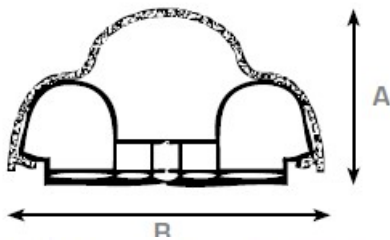

Ref	Size A	Size B	Length
EX.20-21	47 mm	90 mm	4 lm

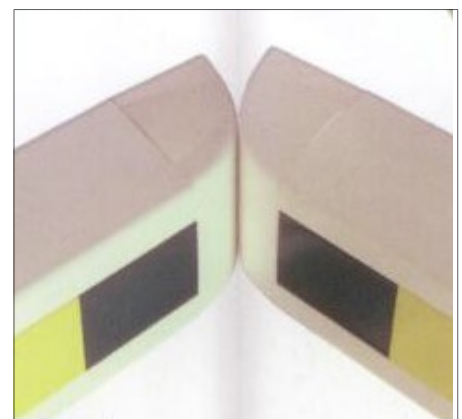

INJ A75

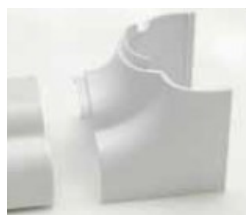

INJ 75



INJ 58



Nylon Bolts & Fixings

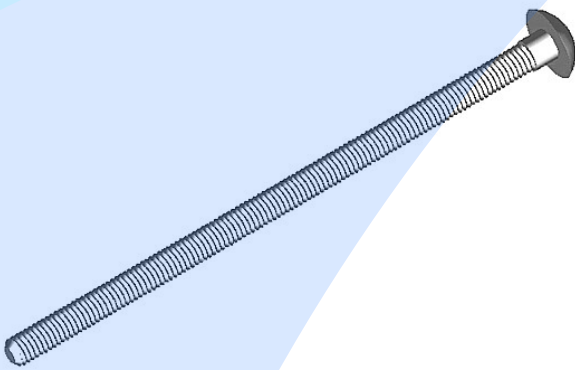

NYLON BUFFALO BOLTS:

Maxmade Limited hold in stock M12 Nylon Bolts. One of the strongest grades of engineering plastic.

Bolts are kept in 150mm, 200mm 250mm and 300mm lengths.

Other diameters and lengths are available to order.

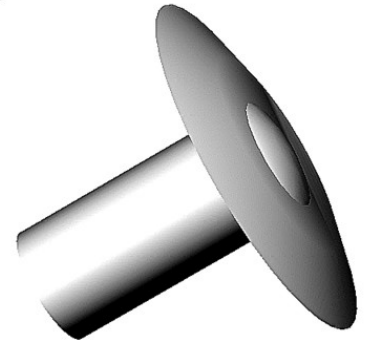
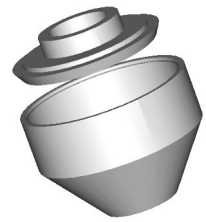
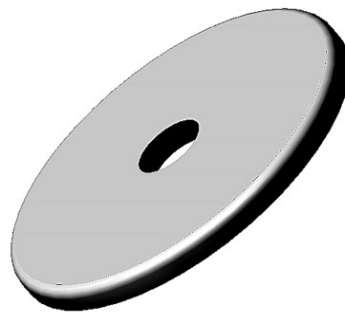
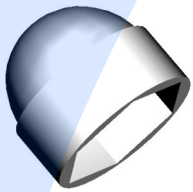

NYLON NUTS AND WASHERS:

For use with the M12 Nylon Buffalo Bolts, 75 and 50mm dia washers, along with M12 Washer faced nuts, and push on nut covers are available.

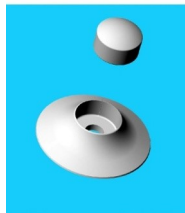
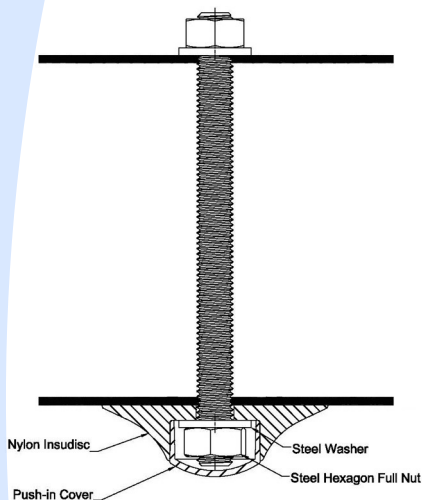

Designed for use with metal fixings, the "Chinese hat" washer has a metal internal captured nut, that allows the washer to screw directly to the stud. (M10 only).

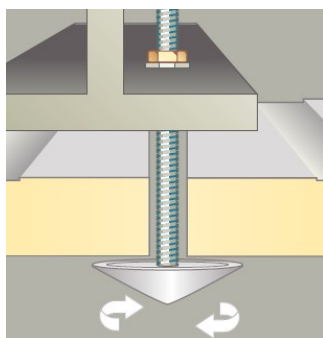

Special washers:

Designed for use with metal fixings, the Insudiscs offer strong support for ceiling and wall panels. The plug cap gives a neat, hygienic and clean finish.

Available for M10 and M12 bolts.

Contact our sales team for more information on any of our range of products.



Hemmings Way, Off Stoney Lane,
Rainhill, Prescot, Merseyside L35 9ND
www.maxmade.com sales@maxmade.com
Telephone: 0151 430 9797
Fax: 0151 493 1320