



**CITY OF MILWAUKIE, OREGON**

# **CAPITAL IMPROVEMENT PLAN**

*Fiscal Years 2021-2026*

# TABLE OF CONTENTS

Message from the City Manager .....	1
Document Guide .....	2
Standard Abbreviations .....	3
CIP Overview .....	4
Summary Information .....	5
Multi-Document Transparency .....	6
CIP Process .....	7
<b>Chapter 1: Infrastructure</b>	
Funding Overview .....	9
Water .....	17
Wastewater .....	18
Stormwater .....	19
Transportation (SAFE, SSMP, Gas Tax) .....	20–22
Project Summaries .....	23–63
<b>Chapter 2: Operational Facilities &amp; Equipment</b>	
Narratives, Funding Tables, Project/Purchase Summaries .....	65
Facilities .....	66
City Hall .....	66
Utility .....	66
Fleet.....	67
Information Technology .....	67
Project Summaries .....	68–74
<b>Chapter 3: Community Development</b>	
Narrative & Fund Table .....	75
Project Summaries .....	76–77
<b>Chapter 4: Unfunded</b>	
Narrative .....	79
Fund Table.....	80–81
Project Summaries .....	82–93
<b>Appendix</b>	
Project Elements .....	95–99
Transportation Projects Map .....	100
SAFE Projects Map .....	101
SSMP Projects Map .....	102
Stormwater Projects Map .....	103
Wastewater Projects Map .....	104
Water Projects Map .....	105
<b>Contact Information.....</b>	<b>107</b>



# MESSAGE FROM THE CITY MANAGER

The enclosed Capital Improvement Plan (CIP) has been developed to fulfill several council and community goals. With it, the city intends to invest substantial utility and general fund dollars to improve our city’s sewer, storm, water and streets infrastructure over the next five years. For city staff, development of the CIP involves reviewing projects from our master plans, identifying how those projects interrelate across various funds and sorting them by year according to priority and fund availability. It’s a complex and lengthy exercise that has become even more vital in recent years as the number of city and private development projects increase.

*Despite the uncertain times in which we find ourselves, the city intends to keep forging ahead with aggressive investments in the city infrastructure.*

The last two years marked a period of intense growth for Milwaukie. Our last CIP included the construction of the new Ledding Library, replacement of the Kellogg/Milwaukie Bay Park Bridge, construction of the meandering path in Kronberg Park, reconstruction of South Downtown and creation of the city’s first festival street. This was in addition to kicking off the city’s Safe Access for Everyone (SAFE) program, where we designed and constructed our first two critical Safe Routes to Schools. SAFE’s goal is to build 27.9 miles of sidewalk and 900 ADA ramps in nine years and we have seven years remaining.

Accelerating SAFE from a 25-year to a nine-year program triggered two major actions that impacted the rest of the CIP. First, the city bonded our initial tranche of funding using SAFE, SSMP and Gas Tax dollars. Second, we integrated our projects to ensure that we only cut into city streets once every five years. This means coordinating projects and funding to assure that sewer and water pipes that are nearing their end of life are constructed now to reduce future impacts to our newly developed streets and sidewalks. We have also worked to assure that planned developments and other agencies install their infrastructure prior to paving. In previous versions of the CIP you would find projects divided out by fund type, but for the reason described above, this CIP shows bundled projects that have been integrated across funds to maximize project funding, minimize disturbance and facilitate efficient delivery.

Despite the uncertain times in which we find ourselves, the city intends to keep forging ahead with aggressive investments in the city infrastructure. We are seeing exceptionally low bond rates and may see a dip in construction costs. In Fiscal Year 2020 the city expended just over \$9,000,000 on sidewalk, bridge, paving, water, wastewater and stormwater projects. In FY 2021 this will jump to nearly \$16,000,000 and \$14,000,000 in FY 2022. This will complete the phase 1 priority projects in SAFE and keep us on pace to complete the program in nine years. To maintain this schedule, however, the city will need to issue bonds again late in FY 2022. We won’t know for some time what the true fiscal impacts of COVID-19 will be to our utility funds. Therefore, we’ll continue to chart a path towards FY 2022 with the best information available and change course as needed to address fiscal constraints.

I would like to personally thank the people of Milwaukie for supporting investments in infrastructure and for working with us project by project to improve our city. You are helping us build a network of safe and reliable infrastructure that will serve this community for decades to come.

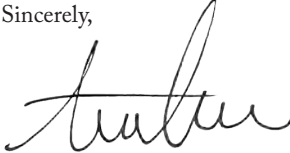
Sincerely,  

Ann Ober  
Milwaukie City Manager

# DOCUMENT GUIDE

This Capital Improvement Plan document provides detailed descriptions about projects organized by fund. Each fund section begins with a summary overview of the function of the fund followed by funding and project information. Summary tables and graphs highlight the capital projects within each fund. Following the summary sections are detailed breakdowns of each project, along with project schedules, cost estimates, and operating budget impacts. Summary information of all capital projects sorted by fund, funding source, and funding status are included as appendices to this document.

The project title and description explain the details and need for each project.



Where the project originated (see abbreviation list on opposite page).

## DOGWOOD PARK IMPROVEMENTS

Capital projects constructed in South Downtown throughout 2018 and 2019 created a new plaza adjacent to the park and the addition of a retaining wall at the southern end as Main Street passes under the railroad overcrossing. Construction staging also took place in the park. Through a joint planning project with NCPRD, a framework plan is being created to help integrate Dogwood Park into the new built environment in South Downtown along with the Coho Point development site to the north.

The estimated total project cost is \$245,000.

**Operating Budget Impact:** Unknown  
**Source:** DRFP, URAP  
**Submitted by:** City Manager's Office

Describes the outcome of the project on the operating budget of each fund.

The requesting department(s).

	FY 2021	FY 2022	FY 2023	FY 2024	FY 2025	FY 2026	TOTAL
<b>Funding Source:</b>							
General Fund	\$10,000						\$10,000
Metro Parks Bond - Local Share Allocation	\$60,000						\$60,000
<b>TOTAL FUNDING</b>	<b>\$70,000</b>						<b>\$70,000</b>

This indicates whether the project is funded or unfunded, the funding source, and the cost for each scheduled project year.

# ABBREVIATIONS

<b>ADA</b>	Americans with Disabilities Act	<b>LIDA</b>	Low Impact Development Approach
<b>BPAP</b>	Bicycle and Pedestrian Accessibility Program	<b>MH</b>	Manhole
<b>CCSD</b>	Clackamas County Service District #1	<b>NMIA(P)</b>	North Milwaukie Industrial Area (Plan)
<b>CCTV</b>	Closed Circuit Television	<b>ODOT</b>	Oregon Department of Transportation
<b>CD</b>	Community Development Department	<b>PCC</b>	Precision Castparts Corporation
<b>CDBG</b>	Capital Development Block Grant	<b>PCI</b>	Pavement Condition Index
<b>CIP</b>	Capital Improvement Plan	<b>PSB</b>	Public Safety Building
<b>CMLUTP</b>	Central Milwaukie Land Use and Transportation Plan	<b>PW</b>	Public Works Department
<b>CMTF</b>	Central Milwaukie Transportation Plan	<b>RFFA</b>	Regional Flexible Funding Allocation
<b>CMU</b>	Concrete Masonry Unit	<b>ROW</b>	Right-of-Way
<b>CNG</b>	Compressed Natural Gas	<b>RRFB</b>	Rectangular Rapid Flash Beacon
<b>CO</b>	Cleanout	<b>RTP</b>	Regional Transportation Plan
<b>CRW</b>	Clackamas River Water	<b>SAFE</b>	Safe Access for Everyone
<b>CUAB</b>	Citizens Utility Advisory Board	<b>SCADA</b>	Supervisory Control and Data Acquisition
<b>DEQ</b>	Department of Environmental Quality	<b>SDC</b>	System Development Charges
<b>DRFP</b>	Milwaukie Downtown and Riverfront Land Use Framework Plan	<b>SSMP</b>	Street Surface Maintenance Program
<b>EV</b>	Electric Vehicle	<b>SWMP</b>	Storm Water Master Plan
<b>FEMA</b>	Federal Emergency Management Agency	<b>TSP</b>	Transportation System Plan
<b>FILOC</b>	Fee in Lieu of Construction	<b>TSAP</b>	Tacoma Station Area Plan
<b>FRA</b>	Federal Railroad Administration	<b>UD</b>	Brand of Truck
<b>FY</b>	Fiscal Year	<b>UGMA</b>	Urban Growth Management Area
<b>GIS</b>	Geographic Information System	<b>UIC</b>	Underground Injection Control
<b>GMC</b>	Brand of Truck	<b>UPRR</b>	Union Pacific Rail Road
<b>GPM</b>	Gallons per Minute	<b>URA(P)</b>	Urban Renewal Area (Plan)
<b>HDPE</b>	High-Density Polyethylene	<b>WPCF</b>	Water Pollution Control Facility
<b>HMA</b>	Hazard Mitigation Assistance	<b>WMP</b>	Water Master Plan
<b>JCB</b>	Johnson Creek Boulevard Building	<b>WSI</b>	Water System Improvements
		<b>WWMP</b>	Waste Water Master Plan

# CAPITAL IMPROVEMENT PLAN OVERVIEW

The Capital Improvement Plan (CIP) establishes guidance and planning for the City of Milwaukie's capital investments in fleet, facilities and infrastructure. At the foundation of the CIP are the city's Master Plan documents (Water, Sewer, Storm, Transportation, and Parks), which are an extension of the city's Comprehensive Plan. These master plans illustrate the long-term needs and goals of each department as defined by community input, advisory groups, expert consultants, and city staff. Planning commission and city council goals, operational (i.e. service delivery) needs, and regulatory requirements further refine and shape the CIP.

Projects within the CIP are prioritized and matched with projections of future revenues. Inclusion of a project within this document does not necessarily reflect a budgeted spending commitment, but instead reflects anticipated priority at this point in time based on estimated future revenues. Current revenues are not enough to keep up with all the capital needs of the city and as such, some projects are shown as unfunded or partially funded in the CIP. Additionally, there are restrictions related to where the funds may be spent on many revenue sources.

A capital expenditure is defined by the city using the following two criteria: relatively high monetary value (\$10,000 or greater), and a long asset life (1 or more years of useful life), excluding the cost of normal maintenance and repairs that do not add to the value of the asset or partially extend the asset's life.

The CIP is intended as a method of communication with citizens, businesses, advisory groups, the planning commission, and city council. It gives the public the opportunity to see the city's proposed plans for the future and provide feedback to the city council and city staff.

The goal of this Capital Improvement Plan is to provide the maximum sustainable level of priority capital investment to deliver outcomes that are of the highest importance to our citizens and provide for a healthy, safe, active, efficient, and optimized community with excellent livability and quality of life.

## FACTORS IN EVALUATING CIP PROJECTS

- Master planning documents
- City council & planning commission goals
- Operational needs
- Regulatory requirements
- Fiscal impacts
- Health, safety, and environmental effects
- Community economic effects
- Feasibility, including public support and disruption
- Implications of deferring the project
- Coordination and advantages of joint projects

# FUNDING SUMMARY INFORMATION

FUND	FY 2021	FY 2022	FY 2023	FY 2024	FY 2025	FY 2026	TOTAL
General	\$ 1,086,000	1,652,000	260,000	240,000	150,000	150,000	3,538,000
City Hall	—	120,000	1,200,000	—	—	—	1,320,000
System Devp Charges	1,108,000	831,000	500,000	269,000	147,000	—	2,855,000
Transportation	7,660,000	6,587,000	7,013,000	4,972,000	6,581,000	2,009,000	34,822,000
Water	2,432,000	2,223,000	2,324,000	3,065,000	1,543,000	272,000	11,859,000
Wastewater	2,029,000	1,363,000	1,593,000	1,653,000	1,998,000	50,000	8,686,000
Stormwater	3,853,000	3,109,000	3,752,000	534,000	2,948,000	1,545,000	15,741,000
<b>CITY-WIDE TOTALS</b>	<b>\$ 18,168,000</b>	<b>15,885,000</b>	<b>16,642,000</b>	<b>10,733,000</b>	<b>13,367,000</b>	<b>4,026,000</b>	<b>78,821,000</b>

Total Capital Improvement Program Cost

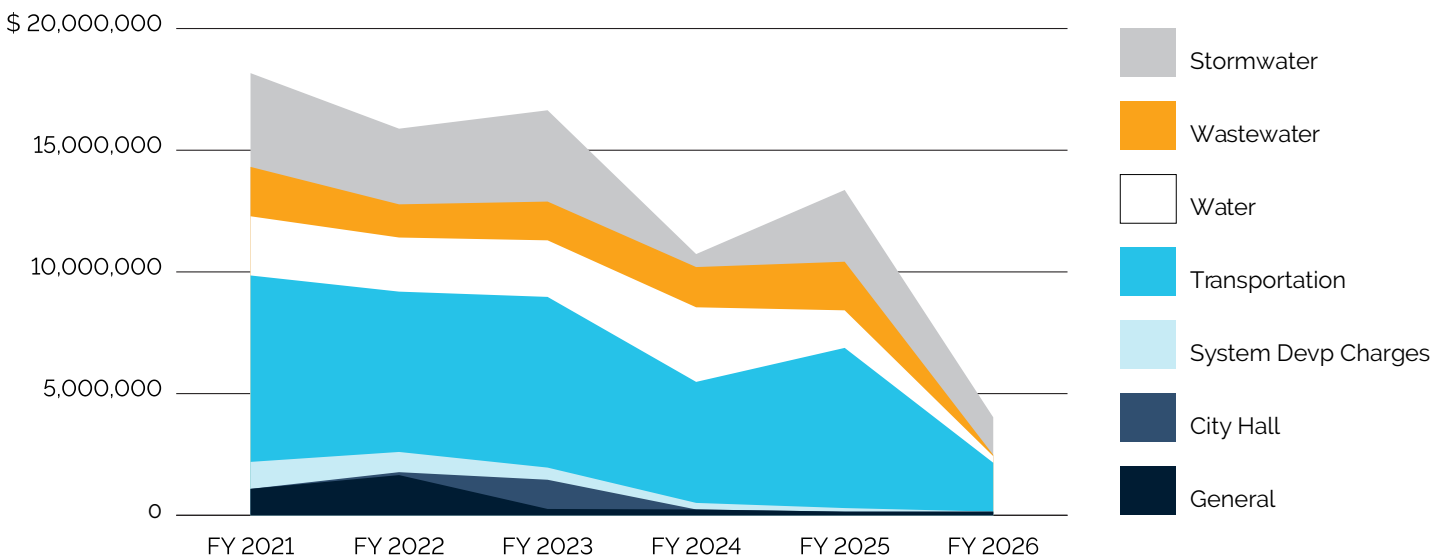

## FUNDING FOR CAPITAL PROJECTS COMES FROM FOUR DISTINCT SOURCES

- FEES:** including utility rates, franchise utility fees, state gas tax and vehicle registration fees, interest income, streets/parks fees, and property taxes.
- BONDS**
- GRANTS AND INTERGOVERNMENTAL:** from outside agencies such as ODOT, Metro, Clackamas County, DEQ, CDBG, Oregon Parks, and the Oregon Marine Board.
- DEVELOPMENT:** funds paid by new development to cover the cost of the development's impact to the systems either by their request or as a condition of development.



# MULTI-DOCUMENT TRANSPARENCY

The City of Milwaukie recognizes that the projects included in the Capital Improvement Plan represent a significant amount of public monies and it is the City's intention to present this information across several documents to ensure that projects are clearly understood and accounted for in financial forecasts, budgets, capital improvement plans, and master plans.

Multi-document transparency means that a capital project necessitated by a master plan will be included in the CIP document and then planned for in the forecast document. Funding for the project will then be included in the budget document and the expense will be recorded in quarterly and annual financial reports.

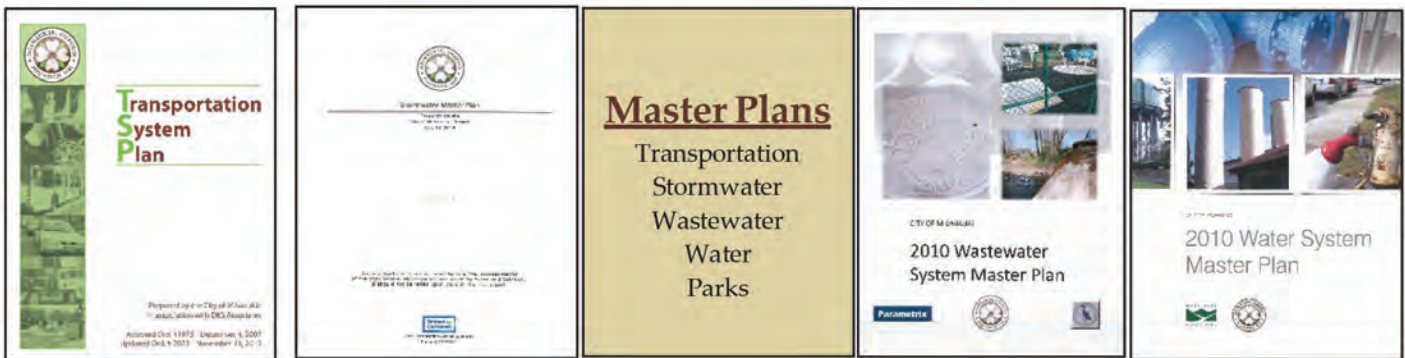

## FINANCIAL REPORTING

Projects funded within the CIP are reported as "Capital Outlay" in financial forecasts, budgets, quarterly reports, and annual reports. This line item corresponds with the annual funded totals shown in this Capital Improvement Plan (CIP).

The adoption of this CIP document provides the baseline for Capital Outlay that will be included in future budget documents for the Budget Committee to review, consider, and approve, and for the City Council to formally adopt.

City of Milwaukie		Stormwater Fund (amounts in thousands)										
		ACTUALS					Current Year	PROJECTED				
		FY13	FY14	FY15	FY16	FY17	Estimated FY18	+1 FY19	+2 FY20	+3 FY21	+4 FY22	+5 FY23
<b>Resources</b>												
Beginning fund balance		\$ 1,416	\$ 1,895	\$ 2,527	\$ 3,390	\$ 2,952	\$ 3,774	\$ 2,969	\$ 2,883	991	1,261	1,557
Stormwater fee - base		1,971	2,205	2,572	2,933	3,357	3,357	3,830	4,370	4,982	5,670	6,277
Stormwater fee - rate increases		-	-	-	-	-	473	540	612	688	607	-
Miscellaneous		21	7	9	29	62	64	65	67	69	71	73
Fees in Lieu of Construction (FILOC)		-	-	-	-	-	-	120	-	-	-	-
Total revenues		1,992	2,212	2,581	2,962	3,419	3,894	4,556	5,049	5,739	6,348	6,350
<b>Total Resources</b>		<b>\$ 3,408</b>	<b>\$ 4,107</b>	<b>\$ 5,108</b>	<b>\$ 6,352</b>	<b>\$ 6,371</b>	<b>\$ 7,668</b>	<b>\$ 7,525</b>	<b>\$ 7,932</b>	<b>6,730</b>	<b>7,609</b>	<b>7,907</b>
<b>Requirements</b>												
Personnel Services		\$ 423	422	483	484	560	738	778	846	883	939	981
Materials & services (base)		108	95	118	139	145	216	229	232	239	246	253
M&S (Franchise Fee to Streets)		156	178	205	234	269	310	350	400	460	510	510
Transfers to other funds		740	760	905	965	1,020	1,060	1,296	1,348	1,392	1,427	1,463
Capital outlay		-	-	-	-	-	-	-	-	-	-	-
Scheduled capital projects		83	125	7	1,578	375	2,146	1,961	4,115	2,400	2,890	2,715
Unfunded CIP		3	-	-	-	-	-	-	-	-	-	-
Other		-	-	-	-	-	-	28	-	10	-	10
Additions (vehicles & equip)		-	-	-	-	229	229	-	-	85	40	31
Total expenditures		1,513	1,580	1,718	3,400	2,598	4,699	4,642	6,941	5,469	6,052	5,963
Ending Fund Balance		-	-	-	-	-	-	-	-	-	-	-
Policy requirement (25%)		360	360	430	460	500	480	560	610	640	680	700
Reserve for vehicle replacement		50	100	100	100	100	100	100	100	100	100	100
Over (under) policy/reserves		1,485	2,067	2,860	2,392	3,174	2,389	2,223	281	521	777	1,144
Total ending fund balance		1,895	2,527	3,390	2,952	3,774	2,969	2,882.60	991	1,261	1,557	1,944
<b>Total Requirements</b>		<b>\$ 3,408</b>	<b>\$ 4,107</b>	<b>\$ 5,108</b>	<b>\$ 6,352</b>	<b>\$ 6,372</b>	<b>\$ 7,668</b>	<b>\$ 7,525</b>	<b>\$ 7,932</b>	<b>6,730</b>	<b>7,609</b>	<b>7,907</b>

# THE PROCESS OF A CIP PROJECT

**Question:**

*How does a project get placed on the Capital Improvement Plan?*

**Answer:**

*Community Engagement is the cornerstone of the Capital Improvement Plan. Projects are vetted through a multi-step process (see below) that includes public comment at several stages to ensure that projects meet the community's needs, in addition to expert analyses during plan development. Projects do not begin until funding has been confirmed, approved and adopted into the City's biennial budget.*

## PROJECT START

A project is first considered as part of the master planning process. Staff, with the assistance of expert consultants and Citizen Advisory Group members, drafts Master Plans for community consideration.

Master Plans are subject to several community meetings where citizens are invited to review the plan scope and corresponding capital projects required to fulfill the plan.

Planning Commission reviews Master Plans and takes citizen comments. The Planning Commission carefully considers the community vision when determining whether to recommend a Master Plan.

City council then reviews Master Plans and adopts them. Once adopted, a Master Plan becomes the guiding document for that city function and the associated project list required to fulfill the Master Plan.

Staff reviews other council adopted plans such as individual Parks Master Plans, Greenway Plans and other similar documents for inclusion in the CIP.

Staff tracks citizen input, regulatory requirements and infrastructure needs to refine the list of capital needs and the prioritization of projects within the CIP.

Budget committee reviews and recommends revisions as part of the biennial budget process. City council adopts the CIP with the biennial budget.

As projects commence, public outreach efforts will focus on impacted neighbors to ensure that project work meets the needs of the community within the adopted council plan and has a minimal impact on services and the community. The city's website is the primary communications vehicle.

## PROJECT COMPLETION



# CHAPTER 1 INFRASTRUCTURE

## FUNDING OVERVIEW

The tables on pages 10–16 list projects that are funded with the following sources. Most of the sources are constrained, meaning that they can only be used for a specific function like expanding the system's capacity, paving streets, or building sidewalk or bicycle facilities. The funds also flow into Milwaukie from a variety of sources, most of which are tax based and administered through different levels of government and mechanisms.

### TRANSPORTATION

**SAFE:** Safe Access for Everyone (SAFE) is the city's program to improve safety for people walking, biking and more. SAFE calls for upgrading the city's network of connections, such as sidewalks, ramps and crossings to fill network gaps, replace portions that don't meet Americans with Disabilities Act (ADA) standards, and remove barriers for people to get where they need to go safely. The SAFE fee is collected as a part of city utility bills and the amount is based on the way the property is utilized.

**SSMP:** City Council adopted the Street Surface Maintenance Program (SSMP) in 2006 and established a fee to improve and maintain the state of Milwaukie's streets. The engineering department maintains a database of overall Pavement Condition Index (PCI) for all city streets. The database is updated each year to include all constructed or reconstructed projects. A newly paved street has a PCI of 100. The original SSMP goal was to obtain an average PCI value of 75 for arterial and collector streets. In 2016, the Citizens Utility Advisory Board (CUAB) approved incorporating residential streets into the SSMP. The city street network has approximately 148 miles of roadway. The SSMP fee is collected as part of city utility bills and the amount is based on the way the property is utilized.

**Gas Tax:** State gas taxes are collected by the state. The state retains 50 percent of funds and then distributes the remainder to counties and cities in a 30 / 20 split. State gas tax funds must be spent on improvements to roads and cannot be used for trails or other improvements outside of road right-of-way.

**Grants (state and federal):** The city regularly applies for grants to fund transportation projects. During the time period covered by this CIP, the city will be utilizing federal and state funds awarded by Metro Regional government and the Oregon Department of Transportation (ODOT).

**Transportation System Development Charges:** Transportation system development charges (SDC) are calculated based on the expected impact of new development to the transportation system. SDCs can be used to expand the transportation system but cannot be used for ongoing maintenance.

**Vehicle Registration Fees:** Clackamas County began collecting vehicle registration fees in late 2019. A portion of the funding collected, based on population, is provided directly to the city to maintain or invest in city projects. These funds are constrained by the same limitations as the state gas tax and therefore must be used on roads.

### WATER

**Usage Charges:** The city periodically conducts rate studies to determine its revenue requirements for operations and capital improvements related to its water system. The most recent study was completed and recommendations adopted by City Council in May 2019. The services are billed monthly and for each water customer there is a fixed charge based on meter size and a usage fee based on 100 cubic feet of water (CCF).

**SDCs:** The SDC is a onetime fee imposed on new development at the time of development. The fee is intended to recover a fair share of the costs of existing and planned facilities that provide capacity to serve growth. The water SDC is the sum of the reimbursement fee and improvement fee.

### WASTEWATER

The city periodically conducts rate studies to determine its revenue requirements for operations and capital improvements related to its wastewater system. The most recent study was completed and recommendations adopted by City Council in May 2019. The services are billed monthly and for each wastewater customer there is a fixed charge based on meter size, a usage fee based on 100 ccf based on the winter average usage and a treatment fee based on an equivalent dwelling unit (EDU).

**SDCs:** The SDCs is a onetime fee imposed on new development at the time of development. The fee is intended to recover a fair share of the costs of existing and planned facilities that provide capacity to serve growth. The wastewater SDC is the sum of the reimbursement fee and the improvement fee adjusted by an administrative cost recovery factor.

### STORMWATER

The city periodically conducts rate studies to determine its revenue requirements for operations and capital improvements related to its stormwater system. The most recent study was completed, and recommendations adopted by City Council in 2014. The services are billed monthly and single family residential customers are billed a flat fee. Commercial customers fees are calculated based on the amount impervious surface area.

The system development charges (SDC) are a one-time fee imposed on new growth and increased development to recover the cost of system facilities needed to serve that growth. The fee is intended to recover a fair share of the costs of existing and planned facilities that provide capacity to serve growth. The water SDC is the sum of the reimbursement fee and improvement fee. One stormwater unit represents the stormwater service needs of an average single-family residence.

PAGE	PROJECT	FUND	FY	FY 2021	FY 2022	FY 2023	FY 2024	FY 2025	FY 2026	TOTAL
23	22nd Avenue & River Road SAFE Improvements	SAFE	2021	434,000	265,000					699,000
		SSMP	2021	232,000	155,000					387,000
		Stormwater	2021	159,000	106,000					265,000
		Water	2021	292,000	195,000					487,000
		Wastewater	2021	18,000						18,000
<b>22ND AVE &amp; RIVER ROAD TOTALS</b>				<b>1,135,000</b>	<b>721,000</b>					<b>1,856,000</b>
24	42nd Avenue & 43rd Avenue Improvements	SAFE	2021	397,000	382,000					779,000
		SSMP	2021	79,000	71,000					150,000
		Stormwater	2021	275,000	257,000					532,000
		Transportation	2021	541,000	492,000					1,033,000
		Water	2021	50,000						50,000
		Wastewater	2021	335,000						335,000
<b>42ND AVE &amp; 43RD AVE IMPROVEMENTS TOTALS</b>				<b>1,677,000</b>	<b>1,202,000</b>					<b>2,879,000</b>
25	Downtown Curbs (Main Street at Monroe Street)	Transportation	2021	15,000						15,000
25	FRA Quiet Zone Study	Transportation	2021	15,000						15,000
26	Kronberg Park Stormwater Improvements	Stormwater	2021	100,000						100,000
27	Lake Road Improvements	FILOC/Other	2021	127,000						127,000
		SAFE	2021	720,000						720,000
		SSMP	2021	1,407,000						1,407,000
		Transportation	2021	531,000						531,000
		Stormwater	2021	650,000						650,000
		Wastewater	2021	86,000						86,000
<b>LAKE ROAD IMPROVEMENTS TOTALS</b>				<b>3,521,000</b>						<b>3,521,000</b>
28	Linwood Avenue SAFE Improvements	SAFE	2021	626,000	426,000					1,052,000
		Stormwater	2021	492,000	328,000					820,000
		Transportation	2021	319,000	213,000					532,000
		ODOT SRTS Grant	2021	691,000	461,000					1,152,000
<b>LINWOOD AVENUE SAFE IMPROVEMENTS TOTALS</b>				<b>2,128,000</b>	<b>1,428,000</b>					<b>3,556,000</b>

PAGE	PROJECT	FUND	FY	FY 2021	FY 2022	FY 2023	FY 2024	FY 2025	FY 2026	TOTAL
29	McBrod Avenue Improvements	SSMP	2021	464,000						464,000
		Transportation	2021	370,000						370,000
		Stormwater	2021	20,000						20,000
		Wastewater	2021	4,000						4,000
		Water	2021	59,000						59,000
<b>McBROD AVENUE IMPROVEMENTS TOTALS</b>				<b>917,000</b>						<b>917,000</b>
30	Meek Street Improvements, South Phase	Stormwater	2021	400,000						400,000
30	Request for Service Fund	SAFE	2021	50,000	50,000					100,000
31	SAFE & SSMP FY 2021 Improvements	FILOC/Other	2021	41,000	41,000					82,000
		SAFE	2021	416,000	376,000					792,000
		SSMP	2021	339,000	339,000					678,000
		Stormwater	2021	2,000	2,000					4,000
		Transportation	2021	17,000	17,000					34,000
		Wastewater	2021	360,000						360,000
		Wastewater SDC	2021	180,000						180,000
<b>SAFE &amp; SSMP FY 2021 IMPROVEMENTS TOTALS</b>				<b>1,355,000</b>	<b>775,000</b>					<b>2,130,000</b>
32	SCADA Design & Construction	Water	2021	935,000						935,000
		Wastewater	2021	530,000	105,000					635,000
<b>SCADA DESIGN AND CONSTRUCTION TOTALS</b>				<b>1,465,000</b>	<b>105,000</b>					<b>1,570,000</b>
33	Signal Upgrades	Transportation	2021	100,000						100,000
34	Wastewater System Master Plan	Wastewater	2021	65,000						65,000
		Wastewater SDC	2021	135,000						135,000
<b>WASTEWATER SYSTEM MASTER PLAN TOTALS</b>				<b>200,000</b>						<b>200,000</b>
35	Wastewater System Improvements FY 2021	Wastewater	2021	466,000						466,000
<b>WASTEWATER SYSTEM IMPROVEMENTS FY 2021</b>				<b>466,000</b>						<b>466,000</b>
36	Water System Master Plan	Water	2021	120,000						120,000
		Water SDC	2021	116,000						116,000
<b>WATER MASTER PLAN TOTALS</b>				<b>236,000</b>						<b>236,000</b>

PAGE	PROJECT	FUND	FY	FY 2021	FY 2022	FY 2023	FY 2024	FY 2025	FY 2026	TOTAL
37	Well #5 Reconditioning	Water	2021	170,000						<b>170,000</b>
38	Well #2 Rehabilitation & Relocation	Water	2021	545,000						<b>545,000</b>
39	Ardenwald North Improvements	SAFE	2022	30,000	669,000					<b>699,000</b>
		SSMP	2022		313,000					<b>313,000</b>
		Stormwater	2022		160,000					<b>160,000</b>
		Wastewater	2022		476,000					<b>476,000</b>
		Water	2022	50,000	854,000					<b>904,000</b>
	<b>ARDENWALD NORTH IMPROVEMENTS TOTALS</b>			<b>80,000</b>	<b>2,472,000</b>					<b>2,552,000</b>
40	Downtown Public Area Requirements	Transportation	2022		500,000					<b>500,000</b>
41	Harvey Street Improvements	SAFE	2022	30,000	503,000					<b>533,000</b>
		SSMP	2022	50,000	700,000					<b>750,000</b>
		Stormwater	2022		336,000					<b>336,000</b>
		Transportation	2022		341,000					<b>341,000</b>
		Wastewater	2022		5,000					<b>5,000</b>
		Water	2022		983,000					<b>983,000</b>
	<b>HARVEY STREET IMPROVEMENTS TOTALS</b>			<b>80,000</b>	<b>2,868,000</b>					<b>2,948,000</b>
42	Meek St Improvements, North Phase	Stormwater	2021	1,390,000	1,504,000	1,500,000				<b>4,394,000</b>
		Stormwater SDC	2021		180,000					<b>180,000</b>
	<b>MEEK STREET IMPROVEMENTS, NORTH PHASE</b>			<b>1,390,000</b>	<b>1,684,000</b>	<b>1,500,000</b>				<b>4,574,000</b>
42	Transportation Systems Plan Update	Transportation SDC	2022		100,000	250,000				<b>350,000</b>
43	Milwaukie/El Puente SRTS Improvements	SAFE	2023	100,000	190,000	2,054,000				<b>2,344,000</b>
		SSMP	2023	30,000	64,000	669,000				<b>763,000</b>
		Stormwater	2023	100,000	166,000	1,882,000				<b>2,148,000</b>
		Wastewater SDC	2023		220,000					<b>220,000</b>
		Wastewater	2023		37,000	265,000				<b>302,000</b>
		Water	2023	20,000	21,000	290,000				<b>331,000</b>
	<b>MILWAUKIE / EL PUENTE SRTS PROJECT TOTALS</b>			<b>250,000</b>	<b>698,000</b>	<b>5,160,000</b>				<b>6,108,000</b>

PAGE	PROJECT	FUND	FY	FY 2021	FY 2022	FY 2023	FY 2024	FY 2025	FY 2026	TOTAL
44	King Road Improvements	SAFE	2023		80,000	2,257,000				2,337,000
		SSMP	2023		20,000	475,000				495,000
		Stormwater	2023			18,000				18,000
<b>KING ROAD IMPROVEMENTS TOTALS</b>					<b>100,000</b>	<b>2,750,000</b>				<b>2,850,000</b>
45	Logus Road & 40th Avenue Improvements	SAFE	2022		15,000	387,000				402,000
		SSMP	2022		10,000	254,000				264,000
		Wastewater	2022		5,000	144,000				149,000
		Water	2022		10,000	262,000				272,000
<b>LOGUS ROAD &amp; 40TH AVE IMPROVEMENTS TOTALS</b>					<b>40,000</b>	<b>1,047,000</b>				<b>1,087,000</b>
46	Monroe Street Greenway Improvements	Metro RFFA	2023			1,930,000	1,930,000			3,860,000
		ODOT Grant	2023			1,550,000	1,550,000			3,100,000
		SAFE	2023		400,000					400,000
		Transportation SDC	2023	677,000	81,000					758,000
<b>MONROE ST GREENWAY IMPROVEMENTS TOTALS</b>					<b>677,000</b>	<b>481,000</b>	<b>3,480,000</b>	<b>3,480,000</b>		<b>8,118,000</b>
47	Stanley Reservoir Design & Construction (Well #6)	Water	2023	35,000		1,335,000	1,335,000			2,705,000
<b>STANLEY RESERVOIR DESIGN &amp; CONSTRUCTION TOTALS</b>					<b>35,000</b>		<b>1,335,000</b>	<b>1,335,000</b>		<b>2,705,000</b>
48	System Development Charges Rate Study	Transportation SDC	2023			50,000				50,000
48	Wastewater System Improvements FY 2023	Wastewater	2023			491,000				491,000
49	Waverly South Improvements	SAFE	2023		20,000	278,000				298,000
		SSMP	2023		20,000	302,000				322,000
		Wastewater	2023			91,000				91,000
		Water	2023			115,000				115,000
<b>WAVERLY SOUTH IMPROVEMENTS TOTALS</b>					<b>40,000</b>	<b>786,000</b>				<b>826,000</b>



PAGE	PROJECT	FUND	FY	FY 2021	FY 2022	FY 2023	FY 2024	FY 2025	FY 2026	TOTAL	
50	Well #4 Reconditioning	Water	2023			60,000				60,000	
50	Well #7 Reconditioning	Water	2023			60,000				60,000	
51	Ardenwald South Improvements	SAFE	2024				1,527,000			1,527,000	
		SSMP	2024				404,000			404,000	
		Stormwater	2024				40,000			40,000	
		Water	2024				832,000			832,000	
<b>ARDENWALD SOUTH IMPROVEMENTS TOTALS</b>							<b>2,803,000</b>			<b>2,803,000</b>	
52	CRW Intertie	Water	2024				112,000			112,000	
52	International Way Improvements	SAFE	2024				2,122,000			2,122,000	
		SSMP	2024				679,000			679,000	
		Stormwater	2024				174,000			174,000	
		Wastewater	2024				144,000			144,000	
		Water	2024				277,000			277,000	
<b>INTERNATIONAL WAY IMPROVEMENTS TOTALS</b>							<b>3,396,000</b>			<b>3,396,000</b>	
53	Monroe Street Pipe Extension	Water	2024				321,000			321,000	
53	Mullan Street Pipe Extension	Water	2024				88,000			88,000	
53	Waverly Heights Sewer System Reconfiguration	Wastewater	2024			400,000	1,394,000	1,294,000		3,088,000	
		Wastewater SDC	2024				169,000	147,000		316,000	
<b>WAVERLY HEIGHTS SEWER SYSTEM RECONFIGURATION TOTALS</b>							<b>400,000</b>	<b>1,563,000</b>	<b>1,441,000</b>		<b>3,404,000</b>
54	Lewelling North SAFE & SSMP	SAFE	2025					1,569,000		1,569,000	
		SSMP	2025						213,000	213,000	
<b>LEWELLING NORTH SAFE &amp; SSMP TOTALS</b>									<b>1,782,000</b>	<b>1,782,000</b>	

PAGE	PROJECT	FUND	FY	FY 2021	FY 2022	FY 2023	FY 2024	FY 2025	FY 2026	TOTAL
55	North Milwaukie Improvements	SAFE	2025					2,179,000		2,179,000
		SSMP	2025					929,000		929,000
		Stormwater	2025					641,000		641,000
		Transportation	2025					96,000		96,000
		Wastewater	2025					465,000		465,000
<b>NORTH MILWAUKIE IMPROVEMENTS TOTALS</b>								<b>4,310,000</b>		<b>4,310,000</b>
56	SAFE & SSMP FY 2025 Improvements - Park/Lloyd/Stanley	SAFE	2025					918,000		918,000
		SSMP	2025					512,000		512,000
		Wastewater	2025					139,000		139,000
		Water	2025					1,128,000		1,128,000
<b>SAFE &amp; SSMP FY 2025 IMPROVEMENTS PARK/LLOYD/STANLEY TOTALS</b>								<b>2,697,000</b>		<b>2,697,000</b>
57	Stormwater Quality Facilities FY 2025	Stormwater	2025					1,482,000		1,482,000
58	Well #8 Rehabilitation	Water	2025					200,000		200,000
58	Oatfield Road & Shell Lane Improvements	SAFE	2026						432,000	432,000
		SSMP	2026						512,000	512,000
		Stormwater	2026						297,000	297,000
		Transportation	2026						644,000	644,000
		Water	2026						72,000	72,000
<b>OATFIELD ROAD &amp; SHELL LANE IMPROVEMENTS TOTALS</b>								<b>1,957,000</b>		<b>1,957,000</b>
59	Pipe Replacements: Plum/Apple Street & Hemlock Street	Stormwater	2026						1,248,000	1,248,000
59	SAFE & SSMP FY 2026 Improvements - 51st Avenue/Rockwood	SAFE	2026						TBD	
		SSMP	2026						TBD	
<b>SAFE &amp; SSMP FY 2026 - 51ST AVE/ROCKWOOD</b>										
60	Sparrow Street Improvements	SAFE	2026						221,000	221,000
		SSMP	2026						35,000	35,000
<b>SPARROW STREET IMPROVEMENTS TOTALS</b>									<b>256,000</b>	<b>256,000</b>

PAGE	PROJECT	FUND	FY	FY 2021	FY 2022	FY 2023	FY 2024	FY 2025	FY 2026	TOTAL
60	Well #2 Building Upgrades	Water	2026						100,000	<b>100,000</b>
73	Vehicle Purchases	Stormwater		15,000		102,000	70,000	575,000		<b>762,000</b>
73	Vehicle Purchases	Transportation		15,000		162,000	75,000			<b>252,000</b>
73	Vehicle Purchases	Wastewater		15,000	635,000	102,000	15,000			<b>767,000</b>
73	Vehicle Purchases	Water		56,000	60,000	102,000	115,000			<b>333,000</b>
61	Lift Station Pump & SCADA Controls Replacement	Wastewater		100,000	50,000	50,000	50,000	50,000		<b>300,000</b>
61	Stormwater Capital Maintenance Program	Stormwater		250,000	250,000	250,000	250,000	250,000		<b>1,250,000</b>
62	Transportation Maintenance (Crack Seal/Slurry Seal)	SSMP		15,000	15,000	15,000	15,000	15,000	15,000	<b>90,000</b>
		Transportation		150,000	150,000	150,000	150,000	150,000	150,000	<b>900,000</b>
		<b>TRANSPORTATION CAPITAL MAINTENANCE PROGRAM TOTALS</b>		<b>165,000</b>	<b>165,000</b>	<b>165,000</b>	<b>165,000</b>	<b>165,000</b>	<b>165,000</b>	<b>990,000</b>
62	Wastewater Capital Maintenance Program	Wastewater		50,000	50,000	50,000	50,000	50,000	50,000	<b>300,000</b>
63	Water Capital Maintenance Program	Water		100,000	100,000	100,000	100,000	100,000	100,000	<b>600,000</b>
				<b>32,741,000</b>	<b>25,540,000</b>	<b>32,692,000</b>	<b>24,440,000</b>	<b>20,360,000</b>	<b>5,774,000</b>	<b>141,547,000</b>

WATER SUMMARY

PAGE	PROJECT NAME	FY 2021	FY 2022	FY 2023	FY 2024	FY 2025	FY 2026	TOTAL
73	Water Vehicle Purchases	\$ 56,000	60,000	102,000		115,000		\$ 333,000
<b>VEHICLES &amp; EQUIPMENT SUBTOTAL</b>		<b>\$ 56,000</b>	<b>60,000</b>	<b>102,000</b>		<b>115,000</b>		<b>\$ 333,000</b>

PAGE	PROJECT NAME	FY 2021	FY 2022	FY 2023	FY 2024	FY 2025	FY 2026	TOTAL
63	Water Capital Maintenance Program	\$ 100,000	100,000	100,000	100,000	100,000	100,000	\$ 600,000
23	22nd Avenue & River Road SAFE Improvements	292,000	195,000					487,000
24	42nd Avenue & 43rd Avenue Improvements	50,000						50,000
29	McBrod Avenue Improvements	59,000						59,000
32	SCADA Design & Construction	935,000						935,000
36	Water System Master Plan	120,000						120,000
37	Well #5 Reconditioning	170,000						170,000
38	Well #2 Rehabilitation & Relocation	545,000						545,000
39	Ardenwald North Improvements	50,000	854,000					904,000
41	Harvey Street Improvements		983,000					983,000
45	Logus Road & 40th Avenue Improvements		10,000	262,000				272,000
43	Milwaukie / El Puente SRTS Improvements	20,000	21,000	290,000				331,000
50	Well #4 Reconditioning			60,000				60,000
50	Well #7 Reconditioning			60,000				60,000
49	Waverly South Improvements			115,000				115,000
51	Ardenwald South Improvements				832,000			832,000
52	CRW Intertie				112,000			112,000
52	International Way Improvements				277,000			277,000
53	Monroe Street Pipe Extension				321,000			321,000
53	Mullan Street Pipe Extension				88,000			88,000
47	Stanley Reservoir Design & Construction (Well #6)	35,000		1,335,000	1,335,000			2,705,000
55	SAFE & SSMP FY 2025 Improvements - Park/Lloyd/Stanley					1,128,000		1,128,000
58	Well #8 Rehabilitation					200,000		200,000
58	Oatfield Road & Shell Lane Improvements						72,000	72,000
60	Well #2 Building Upgrades						100,000	100,000
<b>INFRASTRUCTURE SUBTOTAL</b>		<b>\$ 2,376,000</b>	<b>2,163,000</b>	<b>2,222,000</b>	<b>3,065,000</b>	<b>1,428,000</b>	<b>272,000</b>	<b>\$ 11,526,000</b>
<b>WATER FUND TOTAL</b>		<b>\$ 2,432,000</b>	<b>2,223,000</b>	<b>2,324,000</b>	<b>3,065,000</b>	<b>1,543,000</b>	<b>272,000</b>	<b>\$ 11,859,000</b>

PAGE	PROJECT NAME	FY 2021	FY 2022	FY 2023	FY 2024	FY 2025	FY 2026	TOTAL
36	Water System Master Plan	116,000						116,000
<b>WATER SDC FUND TOTAL</b>		<b>\$ 116,000</b>						<b>\$ 116,000</b>

## WASTEWATER SUMMARY

PAGE	PROJECT NAME	FY 2021	FY 2022	FY 2023	FY 2024	FY 2025	FY 2026	TOTAL
73	Wastewater Vehicle Purchases	\$ 15,000	635,000	102,000	15,000			\$ 767,000
61	Lift Station Pump & SCADA Controls Replacement	100,000	50,000	50,000	50,000	50,000		300,000
<b>VEHICLES &amp; EQUIPMENT SUBTOTAL</b>		<b>\$ 115,000</b>	<b>685,000</b>	<b>152,000</b>	<b>65,000</b>	<b>50,000</b>		<b>\$ 1,067,000</b>
PAGE	PROJECT NAME	FY 2021	FY 2022	FY 2023	FY 2024	FY 2025	FY 2026	TOTAL
62	Wastewater Capital Maintenance Program	\$ 50,000	50,000	50,000	50,000	50,000	50,000	\$ 300,000
23	22nd Avenue & River Road SAFE Improvements	18,000						18,000
24	42nd Avenue & 43rd Avenue Improvements	335,000						335,000
27	Lake Road Improvements	86,000						86,000
29	McBrod Avenue Improvements	4,000						4,000
31	SAFE & SSMP FY 2021 Improvements	360,000						360,000
32	SCADA Design & Construction	530,000	105,000					635,000
34	Wastewater System Master Plan	65,000						65,000
35	Wastewater System Improvements FY 2021	466,000						466,000
39	Ardenwald North Improvements		476,000					476,000
41	Harvey Street Improvements		5,000					5,000
45	Logus Road & 40th Avenue Improvements		5,000	144,000				149,000
48	Wastewater System Improvements FY 2023			491,000				491,000
43	Milwaukie / El Puente SRTS Improvements		37,000	265,000				302,000
49	Waverly South Improvements			91,000				91,000
52	International Way Improvements				277,000			277,000
53	Waverly Heights Sewer System Reconfiguration			400,000	1,394,000	1,294,000		3,088,000
55	North Milwaukie Improvements					465,000		465,000
55	SAFE & SSMP FY 2025 Improvements - Park/Lloyd/Stanley					139,000		139,000
<b>INFRASTRUCTURE SUBTOTAL</b>		<b>\$ 1,914,000</b>	<b>678,000</b>	<b>1,441,000</b>	<b>1,588,000</b>	<b>1,948,000</b>	<b>50,000</b>	<b>\$ 7,619,000</b>
<b>WASTEWATER FUND TOTAL</b>		<b>\$ 2,029,000</b>	<b>1,363,000</b>	<b>1,593,000</b>	<b>1,653,000</b>	<b>1,998,000</b>	<b>50,000</b>	<b>\$ 8,686,000</b>
PAGE	PROJECT NAME	FY 2021	FY 2022	FY 2023	FY 2024	FY 2025	FY 2026	TOTAL
31	SAFE & SSMP FY 2021 Improvements	\$ 180,000						\$ 180,000
34	Wastewater System Master Plan	135,000						135,000
43	Milwaukie / El Puente SRTS Improvements		220,000					220,000
53	Waverly Heights Sewer System Reconfiguration				169,000	147,000		316,000
<b>WASTEWATER SDC FUND TOTAL</b>		<b>\$ 315,000</b>	<b>220,000</b>		<b>169,000</b>	<b>147,000</b>		<b>\$ 851,000</b>

STORMWATER SUMMARY

PAGE	PROJECT NAME	FY 2021	FY 2022	FY 2023	FY 2024	FY 2025	FY 2026	TOTAL
73	Stormwater Vehicle Purchases	\$ 15,000		102,000	70,000	575,000		\$ 762,000
<b>VEHICLES &amp; EQUIPMENT SUBTOTAL</b>		<b>\$ 15,000</b>		<b>102,000</b>	<b>70,000</b>	<b>575,000</b>		<b>\$ 762,000</b>

PAGE	PROJECT NAME	FY 2021	FY 2022	FY 2023	FY 2024	FY 2025	FY 2026	TOTAL
61	Stormwater Capital Maintenance Program	\$ 250,000	250,000	250,000	250,000	250,000		\$ 1,250,000
23	22nd Avenue & River Road SAFE Improvements	159,000	106,000					265,000
24	42nd Avenue & 43rd Avenue Improvements	275,000	257,000					532,000
26	Kronberg Park Stormwater Improvements	100,000	-					100,000
27	Lake Road Improvements	650,000	-					650,000
28	Linwood Avenue SAFE Improvements	492,000	328,000					820,000
29	McBrod Avenue Improvements	20,000						20,000
30	Meek Street Improvements, South Phase	400,000	-					400,000
42	Meek Street Improvements, North Phase	1,390,000	1,504,000	1,500,000				4,394,000
31	SAFE & SSMP FY 2021 Improvements	2,000	2,000					4,000
39	Ardenwald North Improvements		160,000					160,000
41	Harvey Street Improvements		336,000					336,000
43	Milwaukie / El Puente SRTS Improvements	100,000	166,000	1,882,000				2,148,000
44	King Road Improvements			18,000				18,000
51	Ardenwald South Improvements				40,000			40,000
52	International Way Improvements				174,000			174,000
55	North Milwaukie Improvements					641,000		641,000
57	Stormwater Quality Facilities FY 2025					1,482,000		1,482,000
58	Oatfield Road & Shell Lane Improvements						297,000	297,000
59	Pipe Replacements: Plum/Apple Street and Hemlock Street						1,248,000	1,248,000

<b>INFRASTRUCTURE SUBTOTAL</b>	<b>\$ 3,838,000</b>	<b>3,109,000</b>	<b>3,650,000</b>	<b>464,000</b>	<b>2,373,000</b>	<b>1,545,000</b>	<b>\$ 14,979,000</b>
--------------------------------	---------------------	------------------	------------------	----------------	------------------	------------------	----------------------

<b>STORMWATER FUND TOTAL</b>	<b>3,853,000</b>	<b>3,109,000</b>	<b>3,752,000</b>	<b>534,000</b>	<b>2,948,000</b>	<b>1,545,000</b>	<b>\$ 15,741,000</b>
------------------------------	------------------	------------------	------------------	----------------	------------------	------------------	----------------------

PAGE	PROJECT NAME	FY 2021	FY 2022	FY 2023	FY 2024	FY 2025	FY 2026	TOTAL
42	Meek Street Improvements, North Phase	\$	180,000					\$ 180,000
47	Stormwater Master Plan			200,000	100,000			300,000
<b>STORMWATER SDC FUND TOTAL</b>		<b>\$</b>	<b>180,000</b>	<b>200,000</b>	<b>100,000</b>			<b>\$ 480,000</b>

## TRANSPORTATION SUMMARY

PAGE	PROJECT NAME	FY 2021	FY 2022	FY 2023	FY 2024	FY 2025	FY 2026	TOTAL
73	Transportation Vehicle Purchases	\$ 15,000		162,000	75,000			\$ 252,000
<b>VEHICLES &amp; EQUIPMENT SUBTOTAL</b>		<b>\$ 15,000</b>		<b>162,000</b>	<b>75,000</b>			<b>\$ 252,000</b>

PAGE	PROJECT NAME	FY 2021	FY 2022	FY 2023	FY 2024	FY 2025	FY 2026	TOTAL
62	Transportation Maintenance (Crack Seal/Slurry Seal)	\$ 150,000	150,000	150,000	150,000	150,000	150,000	\$ 900,000
24	42nd Avenue & 43rd Avenue Improvements	541,000	492,000					1,033,000
25	Downtown Curb Improvements	15,000						15,000
27	Lake Road Improvements	531,000						531,000
28	Linwood Avenue SAFE Improvements	319,000	213,000					532,000
29	McBrod Avenue Improvements	370,000						370,000
31	SAFE & SSMP FY 2021 Improvements	17,000	17,000					34,000
33	Signal Upgrades	100,000						100,000
25	FRA Quiet Zone Study	15,000						15,000
40	Downtown Public Area Requirements		250,000					250,000
41	Harvey Street Improvements		341,000					341,000
54	North Milwaukie Improvements					96,000		96,000
57	Oatfield Road & Shell Lane Improvements						644,000	644,000
<b>INFRASTRUCTURE SUBTOTAL</b>		<b>\$ 2,058,000</b>	<b>1,463,000</b>	<b>150,000</b>	<b>150,000</b>	<b>246,000</b>	<b>794,000</b>	<b>\$ 4,861,000</b>

PAGE	PROJECT NAME	FY 2021	FY 2022	FY 2023	FY 2024	FY 2025	FY 2026	TOTAL
27	Lake Road Improvements	\$ 127,000						\$ 127,000
31	SAFE & SSMP FY 2021 Improvements	41,000	41,000					82,000
<b>FILOC SUBTOTAL</b>		<b>\$ 168,000</b>	<b>41,000</b>					<b>\$ 209,000</b>
<b>TRANSPORTATION FUND TOTAL</b>		<b>\$ 2,241,000</b>	<b>1,504,000</b>	<b>312,000</b>	<b>225,000</b>	<b>246,000</b>	<b>794,000</b>	<b>\$ 5,322,000</b>

PAGE	PROJECT NAME	FY 2021	FY 2022	FY 2023	FY 2024	FY 2025	FY 2026	TOTAL
42	Transportation Systems Plan Update	\$	100,000	250,000				\$ 350,000
40	Downtown Public Area Requirements		250,000					250,000
46	Monroe Street Greenway Improvements	677,000	81,000					758,000
48	System Development Charges Rate Study			50,000				50,000
<b>TRANSPORTATION SDC FUND TOTAL</b>		<b>\$ 677,000</b>	<b>431,000</b>	<b>300,000</b>				<b>\$ 1,408,000</b>

SSMP SUMMARY

PAGE	PROJECT NAME	FY 2021	FY 2022	FY 2023	FY 2024	FY 2025	FY 2026	TOTAL
62	Transportation Maintenance (Crack Seal/Slurry Seal)	\$ 15,000	15,000	15,000	15,000	15,000	15,000	\$ 90,000
23	22nd Avenue & River Road SAFE Improvements	232,000	155,000					387,000
24	42nd Avenue & 43rd Avenue Improvements	79,000	71,000					150,000
27	Lake Road Improvements	1,407,000	-					1,407,000
29	McBrod Avenue Improvements	464,000	-					464,000
31	SAFE & SSMP FY 2021 Improvements	339,000	339,000					678,000
39	Ardenwald North Improvements		313,000					313,000
41	Harvey Street Improvements	50,000	700,000					750,000
45	Logus Road & 40th Avenue Improvements		10,000	254,000				264,000
43	Milwaukie / El Puente SRTS Improvements	30,000	64,000	669,000				763,000
44	King Road Improvements		20,000	475,000				495,000
49	Waverly South Improvements		20,000	302,000				322,000
51	Ardenwald South Improvements				404,000			404,000
52	International Way Improvements				679,000			679,000
54	Lewelling North SAFE & SSMP					213,000		213,000
55	North Milwaukie Improvements					929,000		929,000
56	SAFE & SSMP FY 2025 Improvements - Park/Lloyd/Stanley					512,000		512,000
58	Oatfield Road & Shell Lane Improvements						512,000	512,000
59	SAFE & SSMP FY 2026 Improvements - 51st Ave/Rockwood						TBD	TBD
60	Sparrow Street Improvements						35,000	35,000
<b>SSMP FUND TOTAL</b>		<b>\$ 2,616,000</b>	<b>1,707,000</b>	<b>1,715,000</b>	<b>1,098,000</b>	<b>1,669,000</b>	<b>562,000</b>	<b>\$ 9,367,000</b>



## SAFE SUMMARY

PAGE	PROJECT NAME	FY 2021	FY 2022	FY 2023	FY 2024	FY 2025	FY 2026	TOTAL
23	22nd Avenue & River Road SAFE Improvements	\$ 434,000	265,000					\$ 699,000
24	42nd Avenue & 43rd Avenue Improvements	397,000	382,000					779,000
27	Lake Road Improvements	720,000	-					720,000
28	Linwood Avenue SAFE Improvements	626,000	426,000					1,052,000
30	Request for Service Fund	50,000	50,000					100,000
31	SAFE & SSMP FY 2021 Improvements	416,000	376,000					792,000
39	Ardenwald North Improvements	30,000	669,000					699,000
41	Harvey Street Improvements	30,000	503,000					533,000
45	Logus Road & 40th Avenue Improvements		15,000	387,000				402,000
43	Milwaukie / El Puente SRTS Improvements	100,000	190,000	2,054,000				2,344,000
44	King Road Improvements		80,000	2,257,000				2,337,000
46	Monroe Street Greenway Improvements		400,000	-				400,000
49	Waverly South Improvements		20,000	278,000				298,000
51	Ardenwald South Improvements				1,527,000			1,527,000
52	International Way Improvements				2,122,000			2,122,000
54	Lewelling North SAFE & SSMP					1,569,000		1,569,000
55	North Milwaukie Improvements					2,179,000		2,179,000
55	SAFE & SSMP FY 2025 Improvements - Park/Lloyd/Stanley					918,000		918,000
58	Oatfield Road & Shell Lane Improvements						432,000	432,000
59	SAFE & SSMP FY 2026 Improvements - 51st Ave/Rockwood						TBD	TBD
60	Sparrow Street Improvements						221,000	221,000
<b>SAFE FUND TOTAL</b>		<b>\$ 2,803,000</b>	<b>3,376,000</b>	<b>4,976,000</b>	<b>3,649,000</b>	<b>4,666,000</b>	<b>653,000</b>	<b>\$ 20,123,000</b>

## ODOT GRANT SUMMARY

PAGE	PROJECT NAME	FY 2021	FY 2022	FY 2023	FY 2024	FY 2025	FY 2026	TOTAL
46	Monroe Street Greenway Improvements	\$		1,550,000	1,550,000			\$ 3,100,000
28	Linwood Avenue SAFE Improvements	691,000	461,000					1,152,000
<b>ODOT GRANT SUBTOTAL</b>		<b>\$ 691,000</b>	<b>461,000</b>	<b>1,550,000</b>	<b>1,550,000</b>			<b>\$ 4,252,000</b>

## METRO RFFA SUMMARY

PAGE	PROJECT NAME	FY 2021	FY 2022	FY 2023	FY 2024	FY 2025	FY 2026	TOTAL
46	Monroe Street Greenway Improvements	\$		1,930,000	1,930,000			\$ 3,860,000
<b>METRO RFFA SUBTOTAL</b>		<b>\$</b>		<b>1,930,000</b>	<b>1,930,000</b>			<b>\$ 3,860,000</b>



## 22ND AVENUE & RIVER ROAD SAFE IMPROVEMENTS

*McLoughlin Boulevard to Southern City Limits*

### SAFE IMPROVEMENTS

Sidewalk, roadway, and stormwater construction and improvements on 22nd Avenue and River Road from McLoughlin Boulevard to southern city limits.

### WATER SYSTEM IMPROVEMENTS

Sparrow Street Vault Updates will consist of replacing the vault top at Sparrow Street and River Road that houses one of the four pressure regulators that manages water pressure between Zones 1 and 2. The existing concrete vault opening is too small to facilitate proper confined space entry and egress.

River Road Pressure Boundary Reconfiguration consists of conducting a comprehensive inspection to reconfigure a portion of the southwest corridor of Pressure Zone 1 so that it is served by Pressure Zone 2. This includes connection verification between Miramonte Lodge Apartments to River Road, and isolation of the 6-inch diameter pipeline along 22nd Avenue from Zone 1.

**Operating Budget Impact:** This project will potentially increase ongoing operational needs due to the addition of new infrastructure (sidewalk and pavement). However, operational needs for water infrastructure will be reduced as a result of this project.

**Source:** SAFE, SSMP, Public Works Maintenance

**Submitted by:** Engineering, Public Works

	FY 2021	FY 2022	FY 2023	FY 2024	FY 2025	FY 2026	TOTAL
<b>Capital Cost:</b>							
Planning, Engineering, Design	\$36,000						\$36,000
Land/ROW Acquisition							n/a
Construction	\$1,099,000	\$721,000					\$1,820,000
<b>TOTAL EST. CAPITAL COST</b>	<b>\$1,135,000</b>	<b>\$721,000</b>					<b>\$1,856,000</b>
<b>Funding Source:</b>							
SAFE	\$434,000	\$265,000					\$699,000
SSMP	\$232,000	\$155,000					\$387,000
Stormwater	\$159,000	\$106,000					\$265,000
Wastewater	\$18,000						\$18,000
Water	\$292,000	\$195,000					\$487,000
<b>TOTAL FUNDING</b>	<b>\$1,135,000</b>	<b>\$721,000</b>					<b>\$1,856,000</b>



## 42ND AVENUE & 43RD AVENUE IMPROVEMENTS

*King Road to Howe Street, Rockwood Street to Covell Street, Harvey Street to Johnson Creek Boulevard*

**42nd Ave SAFE Improvements:** Sidewalk replacement and improvements, ADA barrier removal, pavement patching, and bike lane sharrow markings.

**42nd Ave Wastewater System Improvements (Fieldcrest Street to Olsen Street):** Repair to fix multiple bellies and sags in the mainline. Includes reconnection of services. MH 1055 – 1054: Length 254.6', Upstream depth 15.7', Downstream depth 19.7', Number of services 5, Diameter 12"

**42nd Ave Water System Improvements (42nd Avenue – Harvey Street to Howe Street and Harvey Street – 40th Avenue to 42nd Avenue):** Abandon existing 4-inch main, provide reconnection of 15-20 services from the 4-inch to the 12-inch main, and connection of hydrants to the 12-inch main for improved fire flow.

**43rd SAFE/SSMP Improvements:** Construct multi-use path (west) and sidewalk (east) and curb on both sides of street. Reconstruct pavement.

**43rd Ave Stormwater System Improvements:** Construct stormwater management facilities adjacent to street.

**43rd Avenue Wastewater System Improvements (Covell Street to Rockwood Street):** To address significant bellies in the mainline and will include reconnection of services. A 36-inch stormwater mainline is in close proximity to the sewer mainline and will require adjustment. MH 1058 – 1057: Length 321', Upstream depth 15.42', Downstream depth 16', Number of services 7, diameter 12"

**Howe Street SAFE:** Construct new sidewalks on both sides of street, add curbs, and perform pavement repair.

**Operating Budget Impact:** This project will potentially increase ongoing operational needs due to the addition of new infrastructure (sidewalk and pavement). However, operational needs for the wastewater main will be reduced as a result of this project.

**Source:** TSP, SSMP, SAFE, RTP, WMP, Public Works Maintenance **Submitted by:** Engineering, Public Works

	FY 2021	FY 2022	FY 2023	FY 2024	FY 2025	FY 2026	TOTAL
<b>Capital Cost:</b>							
Planning, Engineering, Design	\$121,000						\$121,000
Land/ROW Acquisition							n/a
Construction	\$1,556,000	\$1,202,000					\$2,758,000
<b>TOTAL EST. CAPITAL COST</b>	<b>\$1,677,000</b>	<b>\$1,202,000</b>					<b>\$2,879,000</b>
<b>Funding Source:</b>							
SAFE	\$397,000	\$381,000					\$778,000
SSMP	\$79,000	\$71,000					\$150,000
Stormwater	\$275,000	\$257,000					\$532,000
Transportation	\$541,000	\$492,000					\$1,033,000
Wastewater	\$335,000						\$335,000
Water	\$50,000						\$50,000
<b>TOTAL FUNDING</b>	<b>\$1,677,000</b>	<b>\$1,202,000</b>					<b>\$2,879,000</b>

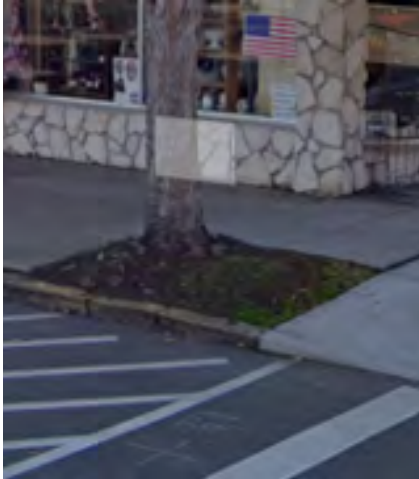

### DOWNTOWN CURBS

#### Main Street at Monroe Street

The city will be rebuilding a section of a downtown curb and restriping several parking stalls to help accommodate a sidewalk repair project needed for ADA accessibility.

**Operating Budget Impact:** *Unknown*

**Source:** *Engineering*

**Submitted by:** *Engineering*

	FY 2021	FY 2022	FY 2023	FY 2024	FY 2025	FY 2026	TOTAL
<b>Capital Cost:</b>							
Planning, Engineering, Design							n/a
Land/ROW Acquisition							n/a
Construction	\$15,000						\$15,000
<b>TOTAL EST. CAPITAL COST</b>	<b>\$15,000</b>						<b>\$15,000</b>
<b>Funding Source:</b>							
Transportation	\$15,000						\$15,000
<b>TOTAL FUNDING</b>	<b>\$15,000</b>						<b>\$15,000</b>



### FRA QUIET ZONE STUDY

In 2014/15 the city worked with the Federal Railroad Administration (FRA) to establish eight rail/street crossing quiet zones within Milwaukie. As part of this program, every five years the FRA requires updates to indicate that these quiet zone crossings continue to provide an adequate level of safety. These studies will provide traffic counts and other information as required by the FRA.

**Operating Budget Impact:** *None*

**Source:** *Federal Railroad Administration*

**Submitted by:** *Engineering*

	FY 2021	FY 2022	FY 2023	FY 2024	FY 2025	FY 2026	TOTAL
<b>Funding Source:</b>							
Transportation	\$15,000						\$15,000
<b>TOTAL FUNDING</b>	<b>\$15,000</b>						<b>\$15,000</b>



## KRONBERG PARK STORMWATER IMPROVEMENTS

A final piece of stormwater work is needed to treat the runoff from the multiuse pathway improvements completed in 2019/20.

**Operating Budget Impact:** NCPRD will maintain Kronberg Park.

**Source:** Kronberg Master Plan

**Submitted by:** Engineering

	FY 2021	FY 2022	FY 2023	FY 2024	FY 2025	FY 2026	TOTAL
<b>Capital Cost:</b>							
Planning, Engineering, Design							n/a
Land/ROW Acquisition							n/a
Construction	\$100,000						\$100,000
<b>TOTAL EST. CAPITAL COST</b>	<b>\$100,000</b>						<b>\$2,879,000</b>
<b>Funding Source:</b>							
Stormwater	\$100,000						\$100,000
<b>TOTAL FUNDING</b>	<b>\$100,000</b>						<b>\$100,000</b>



## LAKE ROAD IMPROVEMENTS

### 21st Avenue to Guilford Drive

Lake Road will be widened and reconstructed between the southeast end of 21st Avenue and Guilford Drive. Project will include new curb and gutter on both sides of the roadway, new bike lanes between 21st Avenue and Oatfield Road/34th Avenue, new signals on the north side of Lake Road at the Oatfield Road/34th Avenue intersection, sidewalk repairs and new ADA ramps where needed.

**Stormwater System Improvements:** A few stormwater quality planters will be installed with the project. Most of the stormwater treatment will be handled by installation of pervious asphalt.

**32nd Avenue Sewer Repair:** Fix known roots that have penetrated the mainline at joints and service connections. Install manhole at midway point of mainline to ease maintenance. Project will include reconnection of services. MH 2184 – 2149: Length 414.5', Upstream depth 8.5', Downstream 16.33', Number of services 8, Diameter 8"

**Operating Budget Impact:** *This project will potentially increase ongoing operational needs due to the addition of new infrastructure (sidewalk and pavement). However, operational needs for sewer infrastructure will be reduced as a result of this project.*

**Source:** SSMP, Public Works Maintenance

**Submitted by:** Engineering, Public Works

	FY 2021	FY 2022	FY 2023	FY 2024	FY 2025	FY 2026	TOTAL
<b>Capital Cost:</b>							
Planning, Engineering, Design							n/a
Land/ROW Acquisition							n/a
Construction	\$3,521,000						\$3,521,000
<b>TOTAL EST. CAPITAL COST</b>	<b>\$3,521,000</b>						<b>\$3,521,000</b>
<b>Funding Source:</b>							
SAFE	\$720,000						\$720,000
SSMP	\$1,407,000						\$1,407,000
Transportation	\$531,000						\$531,000
FILOC	\$127,000						\$127,000
Stormwater	\$650,000						\$650,000
Wastewater	\$86,000						\$86,000
<b>TOTAL FUNDING</b>	<b>\$3,521,000</b>						<b>\$3,521,000</b>



## LINWOOD AVENUE SAFE IMPROVEMENTS

### Monroe Street to Harmony Road

**SAFE Improvements:** Construct off-street, multiuse paths for pedestrian/bicycle use on both sides of Linwood Avenue from Monroe Street to Cedarcrest Drive. Overall, the street will be narrowed to include two 12-foot travel lanes. Enhanced pedestrian crossings will be installed at the Linwood/ Sojourner Elementary School driveway and at Furnberg Street.

**Stormwater System Improvements:** Stormwater management facilities will be built in the right-of-way.

**Operating Budget Impact:** This project will potentially increase ongoing operational needs due to the addition of new infrastructure.

**Source:** SAFE, TSP, SWMP, RTP

**Submitted by:** Engineering, Public Works

	FY 2021	FY 2022	FY 2023	FY 2024	FY 2025	FY 2026	TOTAL
<b>Capital Cost:</b>							
Planning, Engineering, Design	\$26,000	\$26,000					\$52,000
Land/ROW Acquisition							n/a
Construction	\$2,102,000	\$1,402,000					\$3,504,000
<b>TOTAL EST. CAPITAL COST</b>	<b>\$2,128,000</b>	<b>\$1,428,000</b>					<b>\$3,556,000</b>
<b>Funding Source:</b>							
SAFE	\$626,000	\$426,000					\$1,052,000
Stormwater	\$492,000	\$328,000					\$820,000
Transportation	\$319,000	\$213,000					\$532,000
ODOT SRTS Grant	\$691,000	\$461,000					\$1,152,000
<b>TOTAL FUNDING</b>	<b>\$2,128,000</b>	<b>\$1,428,000</b>					<b>\$3,556,000</b>



## McBROD AVENUE IMPROVEMENTS

### Ochoco Street to 17th Avenue

**SSMP Improvements:** Reconstruct asphalt roadway surface, construct ADA-accessible sidewalk along the east side of the roadway, and complete rail crossing upgrades.

**Stormwater System Improvements:** Install new, upsized G2 inlets with sumps reduce undersized inlets and space between inlets. Roadway reconstruction triggers stormwater and water quality facilities to be installed via tree boxes near existing stormwater outfalls and proprietary cartridge filters within the G2 inlets.

**Wastewater System Improvements:** Replace failing sections of the wastewater system. MH 1121 – 1120: Length 233', Upstream depth 4.84', Downstream depth 8.75', Number of services, Diameter 12"

**Water System Improvements:** Replace 2,850 feet of existing lead joint water main with 8-inch and 10-inch ductile iron main to reduce high level of maintenance of lead joint water mains. Project will include replacing service lines, installation of 10 new fire hydrants and two water sample stations, and replacing water meters and boxes as needed.

**Operating Budget Impact:** This project will potentially increase ongoing operational needs due to the addition of new infrastructure. However, pipe repairs and replacements will reduce operating expenditures due to the reduction of maintenance issues.

**Source:** NMIA, SSMP, WMP, RTP

**Submitted by:** Engineering, Public Works

	FY 2021	FY 2022	FY 2023	FY 2024	FY 2025	FY 2026	TOTAL
<b>Capital Cost:</b>							
Planning, Engineering, Design							n/a
Land/ROW Acquisition							n/a
Construction	\$917,000						\$917,000
<b>TOTAL EST. CAPITAL COST</b>	<b>\$917,000</b>						<b>\$917,000</b>
<b>Funding Source:</b>							
SSMP	\$464,000						\$464,000
Transportation	\$370,000						\$370,000
Stormwater	\$20,000						\$20,000
Wastewater	\$4,000						\$4,000
Water	\$59,000						\$59,000
<b>TOTAL FUNDING</b>	<b>\$917,000</b>						<b>\$917,000</b>





## MEEK STREET IMPROVEMENTS, SOUTH PHASE

### Meek Street to Monroe Street

The Meek Street Pipeline project will alleviate flooding in the Harrison Street stormwater system. The project has been separated into two phases south and north, to address immediate stormwater overcapacity issues, advance the construction schedule, and minimize construction impacts.

**South Phase:**

- Construction of approximately 2,500-lf of storm drainage mainline from Meek Street to 37th Avenue and Monroe Street
- One stormwater detention facility at Oak Street
- A temporary connection to Harrison Street system until the design of the north phase of the project is complete

**Operating Budget Impact:** This project will increase operating expenditures due to the added expense of maintaining the additional pipe and detention ponds. However, this project will also reduce the amount of emergency maintenance on Harrison Street due to flooding caused by its undersized system.

**Source:** SWMP

**Submitted by:** Engineering

	FY 2021	FY 2022	FY 2023	FY 2024	FY 2025	FY 2026	TOTAL
<b>Funding Source:</b>							
Stormwater	\$400,000						\$400,000
<b>TOTAL FUNDING</b>	<b>\$400,000</b>						<b>\$400,000</b>



## REQUEST FOR SERVICE FUND

### SAFE Program

The Bike and Pedestrian Accessibility Plan, later renamed the SAFE program, called for the creation of a request for service fund to respond to ADA and traffic safety issues identified by the public. Requests for service are reviewed by the Public Safety Advisory Committee. Staff will work with PSAC and council to determine ongoing funding levels prior to adoption of the FY 23/24 biennium budget.

**Operating Budget Impact:** Unknown

**Source:** SAFE

**Submitted by:** Engineering

	FY 2021	FY 2022	FY 2023	FY 2024	FY 2025	FY 2026	TOTAL
<b>Capital Cost:</b>							
Planning, Engineering, Design							n/a
Land/ROW Acquisition							n/a
Construction	\$50,000	\$50,000					\$100,000
<b>TOTAL EST. CAPITAL COST</b>	<b>\$50,000</b>	<b>\$50,000</b>					<b>\$100,000</b>
<b>Funding Source:</b>							
SAFE	\$50,000	\$50,000					\$100,000
<b>TOTAL FUNDING</b>	<b>\$50,000</b>	<b>\$50,000</b>					<b>\$100,000</b>



### SAFE & SSMP FY 2021 IMPROVEMENTS

#### Home Avenue, Edison Street, Wood Avenue

##### SAFE & SSMP IMPROVEMENTS

**Home Avenue:** Construct continuous ADA-compliant sidewalk along the west side of Home Avenue and reconstruct surface of asphalt paving from King Road to Railroad Avenue.

**Edison Street:** Construct a continuous sidewalk on the north side of Edison Street from Highway 224 to 35th Avenue. Project will include asphalt pavement reconstruction from 35th Avenue to 37th Avenue.

**Wood Avenue:** Water work on Wood Avenue between Park Street to Monroe Street may be needed. If so, funding will be provided from the Water Maintenance Fund.

**Wastewater System Improvements:** This project will include the Home Avenue and Monroe Street Lift Capacity Upgrade which will upsize the capacity of the sewer mainline to alleviate surcharging of the mainline from Lift Station S3. The concrete liner is failing in the steel mainline causing structural issues within the pipe.

MH 3311 – 3310: Length 301.3', Depth upstream 19.6', Depth downstream 20.70', Number of services 8

MH 3305 – 3159: Length 251.9', Depth upstream 26.92', Depth downstream 25.60', Number of services 1

MH 3310 – 3161: Length 360.3', Depth upstream 20.7', Depth downstream 27.25', Number of services 4

MH 3161 – 3160: Length 231.1', Depth upstream 27.25', Depth downstream 26.25', Number of services 1

MH 3160 – 3305: Length 44', Depth upstream 26.25', 26', Depth downstream 26', Number of services 0

**Operating Budget Impact:** This project will potentially increase ongoing operational needs due to the addition of new infrastructure.

**Source:** SAFE, SSMP, WWMP

**Submitted by:** Engineering, Public Works

	FY 2021	FY 2022	FY 2023	FY 2024	FY 2025	FY 2026	TOTAL
<b>Capital Cost:</b>							
Planning, Engineering, Design	\$40,000						\$40,000
Land/ROW Acquisition							n/a
Construction	\$1,315,000	\$775,000					\$2,090,000
<b>TOTAL EST. CAPITAL COST</b>	<b>\$1,355,000</b>	<b>\$775,000</b>					<b>\$2,130,000</b>
<b>Funding Source:</b>							
SAFE	\$416,000	\$376,000					\$792,000
SSMP	\$339,000	\$339,000					\$678,000
FILOC	\$41,000	\$41,000					\$82,000
Stormwater	\$2,000	\$2,000					\$4,000
Transportation	\$17,000	\$17,000					\$34,000
Wastewater	\$360,000						\$360,000
Wastewater SDC	\$180,000						\$180,000
<b>TOTAL FUNDING</b>	<b>\$1,355,000</b>	<b>\$775,000</b>					<b>\$2,130,000</b>

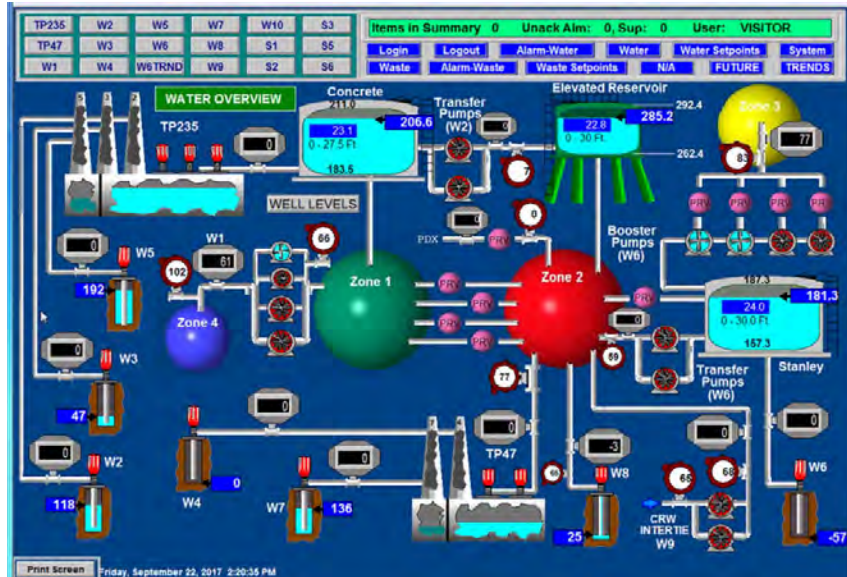

### SCADA DESIGN & CONSTRUCTION

Supervisory Control and Data Acquisition (SCADA) is a system for remote monitoring and control. The last system installed for the City of Milwaukie was in 1998 but advances in technology and communication have made the city’s current system obsolete and difficult to maintain. A goal for an updated system is to maintain the highest possible system security and system integrity while improving site security, control capabilities, data acquisition, and a simplified user interface. The cost will be shared between the Water and Wastewater funds.

**THE KEY ELEMENTS OF THE PROJECT ARE:**

**Modernization:** Implementation of modern technology will minimize support requirements, system administration, and improve maintenance support.

**Best Practices:** Undertaking this upgrade provides the utility with other improvements that can be realized by incorporating best practices for control industry system implementation.

**Cybersecurity:** Ensures security is implemented as part of any SCADA system addition or modification.

Project design began in Spring 2020. Estimated project costs are:

- Design and integration: \$470,000
- Field automation construction: \$400,000
- Communications infrastructure: \$240,000
- Network architecture infrastructure: \$200,000
- Construction management: \$175,000

**Operating Budget Impact:** This project would decrease ongoing operational needs by restoring infrastructure to good condition.

**Source:** Public Works Maintenance **Submitted by:** Public Works

	FY 2021	FY 2022	FY 2023	FY 2024	FY 2025	FY 2026	TOTAL
<b>Capital Cost:</b>							
Planning, Engineering, Design	\$470,000						\$470,000
Land/ROW Acquisition							n/a
Construction	\$995,000	\$105,000					\$1,100,000
<b>TOTAL EST. CAPITAL COST</b>	<b>\$1,570,000</b>	<b>\$105,000</b>					<b>\$1,570,000</b>
<b>Funding Source:</b>							
Water	\$935,000						\$935,000
Wastewater	\$530,000	\$105,000					\$635,000
<b>TOTAL FUNDING</b>	<b>\$1,570,000</b>	<b>\$105,000</b>					<b>\$1,570,000</b>



### SIGNAL UPGRADES

The City of Milwaukie contracts with Clackamas County to install and maintain traffic signals within the city. Several signals need to be upgraded to meet standards required for ongoing maintenance. City staff will work with the county to identify the highest priority locations and seek out opportunities to leverage additional funding sources.

- Operating Budget Impact:** *Unknown*
- Source:** *Public Works Maintenance*
- Submitted by:** *Engineering*

	FY 2021	FY 2022	FY 2023	FY 2024	FY 2025	FY 2026	TOTAL
<b>Capital Cost:</b>							
Planning, Engineering, Design							n/a
Land/ROW Acquisition							n/a
Construction	\$100,000						\$100,000
<b>TOTAL EST. CAPITAL COST</b>	<b>\$100,000</b>						<b>\$100,000</b>
<b>Funding Source:</b>							
Transportation	\$100,000						\$100,000
<b>TOTAL FUNDING</b>	<b>\$100,000</b>						<b>\$100,000</b>



## WASTEWATER SYSTEM MASTER PLAN

The city's Wastewater System Master Plan was last updated in 2010. Since then there have been land use changes, new business and residential development, and plans for expanding the city's limits. Through effective master planning and modeling, the city will be able to determine the condition of its current wastewater system, organize future capital improvement projects to fix system deficiencies, plan for future growth, sustainability and resiliency, and investigate the applicability of current industry technology. The updated plan will guide capital expenditures for the system and furnish guidance on operational issues and future wastewater rate structures.

**The Master Plan will:**

1. Evaluate and summarize the existing wastewater system and key facilities and future conditions, inventory the existing system, review current and projected population, service area boundaries and land use and zoning.
2. Develop wastewater capacity projections for several scenarios, to include buildout, annexation of Dual Interest Areas, and annexation of the UGMA.
3. Consider and evaluate opportunities for wastewater reuse in the North Milwaukie Innovation Area (NMIA).
4. Develop performance and operational criteria under which the wastewater system will be analyzed and future facilities will be formulated.
5. Develop and calibrate a new wastewater collection system hydraulic model, model buildout scenarios.
6. Evaluate the existing wastewater system for seismic resiliency and provide potential solutions.
7. Develop a prioritized capital improvement for recommended existing and future wastewater system facilities and an analysis of potential funding.

**Operating Budget Impact:** *Unknown*

**Source:** *Public Works*

**Submitted by:** *Public Works*

	FY 2021	FY 2022	FY 2023	FY 2024	FY 2025	FY 2026	TOTAL
<b>Funding Source:</b>							
Wastewater		\$65,000					\$65,000
Wastewater SDC		\$135,000					\$135,000
<b>TOTAL FUNDING</b>		<b>\$200,000</b>					<b>\$200,000</b>



### WASTEWATER SYSTEM IMPROVEMENTS FY 2021

*37th Avenue, Kent Street, Rio Vista Street, Washington Street*

**37th Avenue Sewer Repair:** To ease maintenance on the mainline. The mainline has extensive mortar in joints that results in debris buildup and difficulty in camera scoping. Installation of a manhole midway will be included. MH 2115 – 2108: Length 516', Depth upstream 7.33', Depth downstream 10.33'; Number of services 11; Diameter 8"

**Kent Street Sewer Repair:** Full replacement recommended to address bellies and sags in the mainline which cause debris to sit in the mainline. Replacement will also relieve the upstream line. MH 3482 – 3481: Length 275.3', Depth upstream 7.42', Depth downstream 14.83'; Number of services 6, Diameter 8"

**Rio Vista Street Sewer Repair:** Full replacement recommended to address root infiltration in the mainline. MH 3094 – 3093: Length 298.1', Upstream depth 9.17', Downstream depth 9.42', Number of services 10, Diameter 8"

**Washington Street Sewer Repair:** Full replacement recommended to address the heavily deteriorated line with root intrusion, holes, and a belly. Installation of a manhole midway will be included. MH 3043 – 3042: Length 554.7', Upstream depth 9.25', Downstream depth 8.92', Number of services 20, Diameter 8"

Reconnection of services and pavement patching along the replaced lines will be included in all projects.

**Operating Budget Impact:** *This project would decrease ongoing operational needs by restoring infrastructure to good condition.*

**Source:** *Public Works Maintenance*

**Submitted by:** *Public Works*

	FY 2021	FY 2022	FY 2023	FY 2024	FY 2025	FY 2026	TOTAL
<b>Capital Cost:</b>							
Planning, Engineering, Design							n/a
Land/ROW Acquisition							n/a
Construction	\$466,000						\$466,000
<b>TOTAL EST. CAPITAL COST</b>	<b>\$466,000</b>						<b>\$466,000</b>
<b>Funding Source:</b>							
Wastewater	\$466,000						\$466,000
<b>TOTAL FUNDING</b>	<b>\$466,000</b>						<b>\$466,000</b>



**WATER SYSTEM MASTER PLAN**

The Master Plan will identify strategies for maintaining adequate water supplies and service levels for the community. The updated plan will guide capital expenditures for the system and furnish guidance on operational issues and future water rate structures.

**The Master Plan will:**

1. Evaluate and summarize the existing water system and key facilities.
2. Develop water demand projections for several scenarios, to include buildout, annexation of Dual Interest Areas, and annexation of the UGMA.
3. Evaluate existing and future water supplies to develop a strategy for the city to meet existing and future water demand needs.
4. Develop performance and operational criteria under which the water system will be analyzed and future facilities will be formulated.
5. Develop and calibrate a new water distribution system hydraulic model, model buildout scenarios and provide recommendations for optimal pressure management.
6. Evaluate existing and buildout water system conditions to identify the city's water distribution system facility needs.
7. Evaluate the existing water system for seismic and climate resiliency and provide potential solutions.
8. Develop a prioritized capital improvement for recommended existing and future water system facilities and an analysis of potential funding.
9. Update the System Development Charge Rate.

**Operating Budget Impact:** *Unknown*

**Source:** *Public Works*

**Submitted by:** *Public Works*

	FY 2021	FY 2022	FY 2023	FY 2024	FY 2025	FY 2026	TOTAL
<b>Funding Source:</b>							
Water		\$120,000					\$120,000
Water SDC		\$116,000					\$116,000
<b>TOTAL FUNDING</b>		<b>\$236,000</b>					<b>\$236,000</b>



### WELL #5 RECONDITIONING

Water wells require regular maintenance to ensure adequate water flow and continued drinking water safety, and should be professionally inspected by a water well contractor every 10 years. As a well ages, the rate at which water may be pumped (commonly referred to as well yield, flow, or performance) tends to decrease. Reduced well yield over time can be related to changes in the water well itself including: incrustation from mineral deposits, bio-fouling by the growth of microorganisms, physical plugging of “aquifer” (the saturated layer of sand, gravel, or rock through which water is transmitted) by sediment, sand pumping, well screen or casing corrosion, and pump damage.

Well #5 is located north of the intersection of Harvey Street and 40th Avenue, adjacent to the Elevated Storage Reservoir and is part of the Well #2, #3, and #5 well field. It pumps approximately 605 gpm directly into Tower #5 at the TP 235 site. This project consists of repairing the existing building which is in a failing condition, replacing and upgrading the electrical panel and motor start, inspecting and reconditioning the well, and replacing the buried sand particle separator.

**Operating Budget Impact:** None

**Source:** WMP

**Submitted by:** Public Works

	FY 2021	FY 2022	FY 2023	FY 2024	FY 2025	FY 2026	TOTAL
<b>Capital Cost:</b>							
Planning, Engineering, Design							n/a
Land/ROW Acquisition							n/a
Construction	\$170,000						\$170,000
<b>TOTAL EST. CAPITAL COST</b>	<b>\$170,000</b>						<b>\$170,000</b>
<b>Funding Source:</b>							
Water	\$170,000						\$170,000
<b>TOTAL FUNDING</b>	<b>\$170,000</b>						<b>\$170,000</b>





### WELL #2 REHABILITATION & RELOCATION

Well #2 was installed in 1936 and was overhauled in early 2016. It's part of the Well #2/#3/#5 well field and is expected to deliver a minimum of 380 gpm (about 10% of current total city capacity) based on past production, and pumps directly into treatment plant 2/3/5 with its operation regulated by the water level in the Concrete Storage Reservoir. A video inspection revealed a split in the casing several feet long and is opening inward like a can with a tear. The casing is cracked with 6-inch gaps at a depth of 220 feet in the 300 feet deep well. It has been determined that based on the video log, the condition of the casing, the deterioration in general, and the overall loss of strength of the casing that an in-place repair would not be successful. Based on this evaluation it was determined by Public Works Staff that the condition of Well #2 as well as the importance of Well #2 as a source that repair/replacement of Well #2 should take precedence over the rehabilitation of Well #8. Currently, the well remains in use, but at a reduced pumping capacity. Public Works has hired Tetra Tech to provide design services at a cost of \$198,213. The current estimate for reconstruction of Well #2 is approximately \$750,000. It is expected that this project will include consultant construction engineering services at an approximate cost of \$150,000.

**Operating Budget Impact:** Minor impact to operating costs as the current well would be replaced with similar operational and maintenance costs.

**Source:** Public Works Maintenance

**Submitted by:** Public Works

	FY 2021	FY 2022	FY 2023	FY 2024	FY 2025	FY 2026	TOTAL
<b>Capital Cost:</b>							
Planning, Engineering, Design							n/a
Land/ROW Acquisition							n/a
Construction	\$545,000						\$545,000
<b>TOTAL EST. CAPITAL COST</b>	<b>\$545,000</b>						<b>\$545,000</b>
<b>Funding Source:</b>							
Water	\$545,000						\$545,000
<b>TOTAL FUNDING</b>	<b>\$545,000</b>						<b>\$545,000</b>



## ARDENWALD NORTH IMPROVEMENTS

### SAFE & SSMP IMPROVEMENTS

**28th Avenue & Van Water Street:** Fill in sidewalk gaps, replace portions of existing sidewalk, and reconstruct the asphalt surface with new overlay from the Springwater Corridor to 32nd Avenue.

**32nd Avenue:** Replace portions of existing sidewalk, remove barriers, and reconstruct asphalt surface with new overlay from Van Water Street to Roswell Street.

**Roswell Street:** Fill in sidewalk gaps, remove ADA barriers, and reconstruct asphalt surface from 32nd Avenue to Rockvorst Street.

**Stormwater Improvements:** Replace stormwater system with 12-inch PVC, install 5 G2 catch basins, and 2 manholes at each mid-block for improved access. Van Water Street (29th Avenue to 31st Avenue).

**Water System Improvements:** Replace and upsize existing cast iron 4-inch water main to 8-inch ductile iron pipe to improve fire flows in the neighborhood. New mains will connect to existing 8-inch water main. The project will include the replacement of existing valves, and reconnection of existing water services and hydrants along the length of the pipes, 29th Avenue, 30th Avenue, 31st Avenue (Roswell Street to Van Water Street), and Roswell Street (29th Avenue to 32nd Avenue).

**Wastewater System Improvements:** Address multiple bellies and root intrusion to reduce debris buildup. Additional manholes will be installed where needed to ease maintenance issues. Full line replacement is recommended, and will include reconnection of services along the replaced line.

*28th Avenue (Roswell Street to Van Water Street):*

28th Avenue: MH 1212 – 1211: Length 415', Upstream depth 15', Downstream depth 11.4', Number of services 14, Diameter 8"

*Van Water Street:*

MH 1213 – 1212: Length 411.4', Upstream depth 16', Downstream depth 15', Number of services 14, Diameter 8"

*29th Avenue (South of Van Water Street):*

MH 1222 – 1220: Length 341.2', Upstream depth 12', Downstream depth 8.25', Number of services 10, Diameter 8"

*31st Avenue (North of Roswell Street):*

MH 1910 – 1200: Length 374.3', Upstream depth 11.5', Downstream depth 15.2', Number of services 13, Diameter 8"

**Operating Budget Impact:** *The paving projects could potentially increase ongoing operational needs due to the addition of new infrastructure. However, the pipe replacements would decrease ongoing operational needs by restoring infrastructure to good condition.*

**Source:** SAFE, SSMP, WMP, Public Works Maintenance

**Submitted by:** Engineering, Public Works

	FY 2021	FY 2022	FY 2023	FY 2024	FY 2025	FY 2026	TOTAL
<b>Capital Cost:</b>							
Planning, Engineering, Design	\$80,000						\$80,000
Land/ROW Acquisition							n/a
Construction		\$2,472,000					\$2,472,000
<b>TOTAL EST. CAPITAL COST</b>	<b>\$80,000</b>	<b>\$2,472,000</b>					<b>\$2,552,000</b>
<b>Funding Source:</b>							
SAFE	\$30,000	\$669,000					\$699,000
SSMP		\$313,000					\$313,000
Stormwater		\$160,000					\$160,000
Wastewater		\$476,000					\$476,000
Water	\$50,000	\$854,000					\$904,000
<b>TOTAL FUNDING</b>	<b>\$80,000</b>	<b>\$2,472,000</b>					<b>\$2,552,000</b>



## DOWNTOWN PUBLIC AREA REQUIREMENTS

### Washington Street and Main Street.

Construction of sidewalk and frontage improvements related to the Coho Point Private/Public Development at the corner of Washington Street and Main Street.

**Operating Budget Impact:** *Unknown*

**Source:** *Private/Public Development*

**Submitted by:** *Engineering*

	FY 2021	FY 2022	FY 2023	FY 2024	FY 2025	FY 2026	TOTAL
<b>Capital Cost:</b>							
Planning, Engineering, Design							n/a
Land/ROW Acquisition							n/a
Construction		\$500,000					\$500,000
<b>TOTAL EST. CAPITAL COST</b>		<b>\$500,000</b>					<b>\$500,000</b>
<b>Funding Source:</b>							
Transportation SDC		\$250,000					\$250,000
Transportation		\$250,000					\$250,000
<b>TOTAL FUNDING</b>		<b>\$500,000</b>					<b>\$500,000</b>



## HARVEY STREET IMPROVEMENTS

*32nd Avenue to 42nd Avenue, 33rd Avenue and 36th Avenue*

**Harvey Street SAFE/SSMP:** Fill in sidewalk gaps on both sides of street, replace portions of existing sidewalk, and remove ADA barriers. Reconstruct roadway surface, install traffic calming improvements, and improve bicycle connections.

**Water System Improvements:** Projects will include replacement of existing valves and reconnection of existing water services.

*Harvey Street:* Replace approximately 2,500 feet and upsize various sections of 4-inch and 6-inch cast iron water main to 8-inch ductile iron pipe to improve fire flows and water quality in the neighborhood.

*33rd Avenue:* Replace approximately 470 feet and upsize the existing 4-inch water main to 8-inch ductile iron pipe to improve fire flows in the neighborhood. The new main will connect to the 12-inch water main on Harvey Street.

*36th Avenue:* Replace approximately 600 feet and upsize the existing 4-inch and 6-inch water main to 8-inch ductile iron pipe to improve fire flows in the neighborhood and may include the proper abandonment of the 2-inch line on Sherry Lane. The new main will connect to the 12-inch main on Harvey Street.

**Stormwater System Improvements:** Roadway reconstruction triggers stormwater treatments which will include 4,000 sq ft of vegetated stormwater planters within the right-of-way.

**Wastewater System Improvements:** Provide pipe stub out to right-of-way to Willamette Townhouse Apartments.

**Operating Budget Impact:** *This project will potentially increase ongoing operational needs due to the addition of new infrastructure. However, pipe repairs and replacements will reduce operating expenditures due to the reduction of maintenance issues.*

**Source:** BPAP, SSMP, RTP, TSP, WMP

**Submitted by:** Engineering, Public Works

	FY 2021	FY 2022	FY 2023	FY 2024	FY 2025	FY 2026	TOTAL
<b>Capital Cost:</b>							
Planning, Engineering, Design	\$80,000						\$80,000
Land/ROW Acquisition							n/a
Construction		\$2,868,000					\$2,868,000
<b>TOTAL EST. CAPITAL COST</b>	<b>\$80,000</b>	<b>\$2,868,000</b>					<b>\$2,948,000</b>
<b>Funding Source:</b>							
SAFE	\$30,000	\$503,000					\$533,000
SSMP	\$50,000	\$700,000					\$750,000
Stormwater		\$336,000					\$336,000
Transportation		\$341,000					\$341,000
Wastewater		\$5,000					\$5,000
Water		\$983,000					\$983,000
<b>TOTAL FUNDING</b>	<b>\$80,000</b>	<b>\$2,868,000</b>					<b>\$2,948,000</b>



## MEEK STREET IMPROVEMENTS, NORTH PHASE

### Boyd Street to Meek Street

The Meek Street Pipeline project will alleviate flooding in the Harrison Street stormwater system. The project has been separated into two phases south and north, to address immediate stormwater overcapacity issues, advance the construction schedule, and minimize construction impacts.

**North Phase:** The North Phase project will route stormwater north to discharge at the existing Roswell Pond Open Space and ultimately into Johnson Creek.

**Operating Budget Impact:** This project will increase operating expenditures due to the added expense of maintaining the additional pipe and detention ponds. However, this project will also reduce the amount of emergency maintenance on Harrison Street due to flooding caused by its undersized system.

**Source:** SWMP

**Submitted by:** Engineering

	FY 2021	FY 2022	FY 2023	FY 2024	FY 2025	FY 2026	TOTAL
<b>Capital Cost:</b>							
Planning, Engineering, Design	\$327,000						\$327,000
Land/ROW Acquisition							n/a
Construction	\$1,063,000	\$1,064,000	\$1,500,000				\$4,247,000
<b>TOTAL EST. CAPITAL COST</b>	<b>\$1,390,000</b>	<b>\$1,064,000</b>	<b>\$1,500,000</b>				<b>\$4,574,000</b>
<b>Funding Source:</b>							
Stormwater	\$1,390,000	\$1,504,000	\$1,500,000				\$4,394,000
Stormwater SDC		\$180,000					\$180,000
<b>TOTAL FUNDING</b>	<b>\$1,390,000</b>	<b>\$1,684,000</b>	<b>\$1,500,000</b>				<b>\$4,574,000</b>



## Transportation System Plan

## TRANSPORTATION SYSTEM PLAN UPDATE

A city typically reviews and updates its Transportation System Plan (TSP) every 10 years; Milwaukie's TSP was last updated in 2013. The TSP will be guided by the city's updated comprehensive plan which is slated for adoption in FY 2021. The TSP is the city's long-term plan for transportation improvements to accommodate growth forecasts and projections. Projects identified in it are implemented through our Capital Improvement Plan. Updating the TSP fulfills the State of Oregon Transportation Planning Rule requirements for comprehensive transportation planning.

**Operating Budget Impact:** Unknown

**Source:** TSP, Public Works

**Submitted by:** Engineering, Public Works, Planning

	FY 2021	FY 2022	FY 2023	FY 2024	FY 2025	FY 2026	TOTAL
<b>Funding Source:</b>							
Transportation SDC		\$100,000	\$250,000				\$350,000
<b>TOTAL FUNDING</b>		<b>\$100,000</b>	<b>\$250,000</b>				<b>\$350,000</b>



## MILWAUKIE / EL PUENTE ELEMENTARY SAFE ROUTES TO SCHOOL IMPROVEMENTS

*From McLoughlin Boulevard to Edison Street*

### SAFE/SSMP IMPROVEMENTS

**26th Avenue:** Fill in sidewalk gaps on the street, and grind and pave new overlay to the street surface from Lake Road to Lake Village Apartments.

**27th Avenue:** Replace portions of existing sidewalk, remove ADA barriers, and grind and pave a new overlay to the street surface from Lake Road to Washington Street.

**Oak Street:** Replace portions of existing sidewalk and repair or reconstruct asphalt pavement from Washington Street to Monroe Street.

**Washington Street:** Fill in sidewalk gaps on both sides of the street, replace portions of existing sidewalk, remove ADA barriers, and reconstruct asphalt pavement from McLoughlin Boulevard to 35th Avenue. May require relocation of water and stormwater utilities in addition to construction of new water quality facilities.

**Washington Street Sewer Replacement:** Replace sewer main from 34th Avenue to Sellwood Street. Both replacements would include service reconnection along the length of the pipe.

MH 2227 – 2226, Length 313', Depth upstream 12.58', Depth downstream 13.25', Number of services 7, Diameter 10". This project is required to address intruding roots and seal material which cause debris build-up requiring regular clearing.

MH 2228 – 2227, Length 462.9', Depth 7.33', Upstream 12.58', Downstream number of services 19, Diameter 10". This project is required to address intruding roots and add a manhole in the middle of the line to ease maintenance issues.

**Washington Street Storm Pipe Replacement - Phase II:** Replace undersized storm pipe in Washington Street.

**Operating Budget Impact:** *The paving projects could potentially increase ongoing operational needs due to the addition of new infrastructure. However, the wastewater replacements would decrease ongoing operational needs by restoring infrastructure to good condition.*

**Source:** SAFE, SSMP, Public Works Maintenance

**Submitted by:** Engineering, Public Works

	FY 2021	FY 2022	FY 2023	FY 2024	FY 2025	FY 2026	TOTAL
<b>Capital Cost:</b>							
Planning, Engineering, Design	\$250,000	\$478,000	\$184,000				\$912,000
Land/ROW Acquisition							n/a
Construction		\$220,000	\$4,976,000				\$5,196,000
<b>TOTAL EST. CAPITAL COST</b>	<b>\$250,000</b>	<b>\$698,000</b>	<b>\$5,160,000</b>				<b>\$6,108,000</b>
<b>Funding Source:</b>							
SAFE	\$100,000	\$190,000	\$2,054,000				\$2,344,000
SSMP	\$30,000	\$64,000	\$669,000				\$763,000
Stormwater	\$100,000	\$166,000	\$1,882,000				\$2,148,000
Wastewater		\$37,000	\$265,000				\$302,000
Wastewater SDC		\$220,000					\$220,000
Water	\$20,000	\$21,000	\$290,000				\$331,000
<b>TOTAL FUNDING</b>	<b>\$250,000</b>	<b>\$698,000</b>	<b>\$5,160,000</b>				<b>\$6,108,000</b>



## KING ROAD IMPROVEMENTS

### 40th Avenue to Linwood Avenue

**SAFE/SSMP Improvements:** Fill in sidewalk gaps on both sides of street, replace portions of existing sidewalk, remove ADA barriers, and overlay or reconstruct roadway surface from 40th Avenue to Linwood Avenue.

**Stormwater System Improvements:** Addition of a catch basin and sedimentation manhole tied to a current UIC to relieve flooding and possible property damage at 6011 SE King Road.

**Operating Budget Impact:** This project will potentially increase ongoing operational needs due to the addition of new infrastructure (sidewalk and pavement).

**Source:** SAFE, SSMP

**Submitted by:** Engineering

	FY 2021	FY 2022	FY 2023	FY 2024	FY 2025	FY 2026	TOTAL
<b>Capital Cost:</b>							
Planning, Engineering, Design		\$100,000					\$100,000
Land/ROW Acquisition							n/a
Construction			\$2,750,000				\$2,750,000
<b>TOTAL EST. CAPITAL COST</b>		<b>\$100,000</b>	<b>\$2,750,000</b>				<b>\$2,850,000</b>
<b>Funding Source:</b>							
SAFE		\$80,000	\$2,257,000				\$2,337,000
SSMP		\$20,000	\$475,000				\$495,000
Stormwater			\$18,000				\$18,000
<b>TOTAL FUNDING</b>		<b>\$100,000</b>	<b>\$2,750,000</b>				<b>\$2,850,000</b>



### LOGUS ROAD & 40TH AVENUE IMPROVEMENTS

40th Avenue, Logus Road, 42nd Avenue, 38th Avenue, Drake Street & 38th Avenue, 45th Court

#### SAFE/SSMP IMPROVEMENTS

40th Avenue: Reconstruct roadway surface on 40th Avenue from Harvey Street to King Road.

Logus Road: Fill in sidewalk gaps, replace portions of existing sidewalk, remove barriers, and reconstruct roadway surface on Logus Road from 43rd Avenue to 49th Avenue.

#### SSMP IMPROVEMENTS

42nd Avenue: Reconstruct roadway surface on 42nd Avenue from Monroe Street to King Road.

#### WASTEWATER SYSTEM IMPROVEMENTS

38th Avenue Repair: Replacement recommended to address holes and a significant belly in the mainline that holds debris requiring quarterly flushing. The line also has two poorly constructed point repairs. MH 2120 – 2118: Length 253.6', Depth upstream 5.92', Depth downstream 5.67', Number of services 9, Diameter 8"

45th Court Repair: Repair of a failing upstream manhole which must be flushed regularly to clear debris build-up that blocks a service lateral. MH 3503 – 3316: Length 149.5', Depth upstream 8.5', Depth downstream 12.92', Number of services 3, Diameter 6"

#### WATER SYSTEM IMPROVEMENTS

Drake Street & 38th Avenue: Replace approximately 800 feet, upsize the existing cast iron 4-inch water main to 8-inch to improve fire flows in the neighborhood, and connect to the 8-inch water main on 40th Avenue. The project will include replacement of existing valves, reconnection of existing water services and hydrants, and pavement patching along the length of the pipe.

**Operating Budget Impact:** This project would decrease ongoing operational needs by restoring infrastructure to good condition.

**Source:** WMP, SSMP, Public Works Maintenance **Submitted by:** Engineering, Public Works

	FY 2021	FY 2022	FY 2023	FY 2024	FY 2025	FY 2026	TOTAL
<b>Capital Cost:</b>							
Planning, Engineering, Design		\$40,000					\$40,000
Land/ROW Acquisition							n/a
Construction			\$1,047,000				\$1,047,000
<b>TOTAL EST. CAPITAL COST</b>		<b>\$40,000</b>	<b>\$1,047,000</b>				<b>\$1,087,000</b>
<b>Funding Source:</b>							
SAFE		\$15,000	\$387,000				\$402,000
SSMP		\$10,000	\$254,000				\$264,000
Wastewater		\$5,000	\$144,000				\$149,000
Water		\$10,000	\$262,000				\$272,000
<b>TOTAL FUNDING</b>		<b>\$40,000</b>	<b>\$1,047,000</b>				<b>\$1,087,000</b>



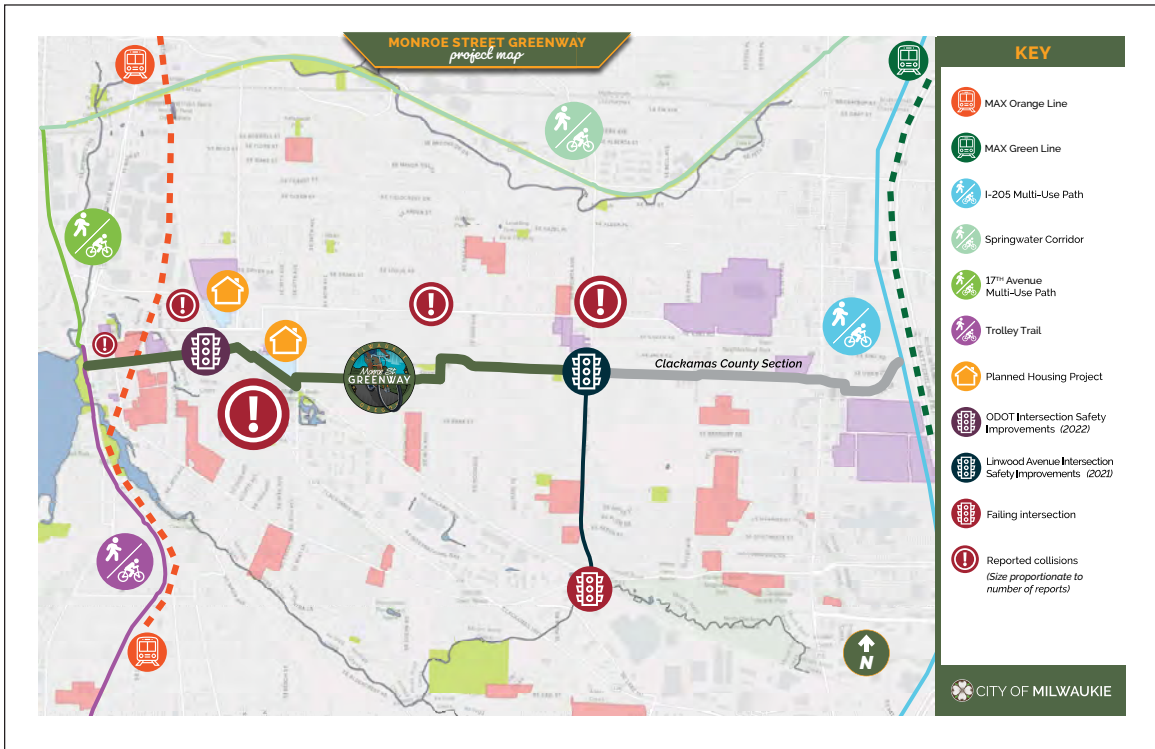

## MONROE STREET GREENWAY IMPROVEMENTS

The Monroe Greenway will provide key east-west bicycle and pedestrian connection through the city, with connections to the future 29th Avenue Greenway and Railroad Avenue Trail. It will also provide for a key Safe Route to School for Milwaukie High School and a connection with Central Milwaukie businesses. Phase 1 improvements for the Monroe Street Greenway will implement the design concepts developed with a Regional Flexible Fund Grant and ODOT Safety Leverage funds. Treatments will include lane striping, signage, and application of sharrows.

**SAFE/SSMP Improvements:** Replace portions of existing sidewalk, remove barriers, and construct new surface overlay from 25th Avenue to 28th Avenue.

**Operating Budget Impact:** Potential increase to ongoing operational needs due to the addition of new infrastructure. However, the pipe replacements would decrease ongoing operational needs by restoring infrastructure to good condition.

**Source:** Monroe Street Neighborhood Greenway Concept Plan, CMLUTP, URAP, TSP, RTP (#10099), Public Works Maintenance

**Submitted by:** Community Development, Engineering, Public Works

	FY 2021	FY 2022	FY 2023	FY 2024	FY 2025	FY 2026	TOTAL
<b>Capital Cost:</b>							
Planning, Engineering, Design	\$577,000	\$327,000					\$904,000
Land/ROW Acquisition		\$110,000					\$110,000
Construction			\$3,480,000	\$3,480,000			\$6,960,000
<b>TOTAL EST. CAPITAL COST</b>	<b>\$577,000</b>	<b>\$437,000</b>	<b>\$3,480,000</b>	<b>\$3,480,000</b>			<b>\$7,974,000</b>
<b>Funding Source:</b>							
SAFE		\$400,000					\$400,000
Transportation SDC	\$677,000	\$81,000					\$758,000
Metro RFFA			\$1,930,000	\$1,930,000			\$3,860,000
ODOT Safety Leverage			\$1,550,000	\$1,550,000			\$3,100,000
<b>TOTAL FUNDING</b>	<b>\$677,000</b>	<b>\$481,000</b>	<b>\$3,480,000</b>	<b>\$3,480,000</b>			<b>\$8,118,000</b>



## STANLEY RESERVOIR DESIGN & CONSTRUCTION (WELL #6)

### WATER WELL NO. 6: STORAGE TANK MAINTENANCE

The Stanley Reservoir is a 3.0 MG at-grade welded steel tank constructed in 1970 and is supplied directly from Well #6 on the same site. The coating system on the exterior has failed and large pieces of exterior coating is peeling. The project consists of abrasive blasting the exterior to a near white blast (SP-10) and then coating with a three-coat zinc, epoxy, stripe coat with urethane finish. Due to lead paint on the exterior, the project will require a full containment tent using shrink wrap plastic with scaffolding access around and over the top. The interior of the tank will be coated with a three-coat epoxy system as well. The project will include the installation of a seismic valve and seismic upgrades to roof rafter systems.

**Operating Budget Impact:** *The project will not increase operating expenditures.*

**Source:** *WMP*

**Submitted by:** *Public Works*

	FY 2021	FY 2022	FY 2023	FY 2024	FY 2025	FY 2026	TOTAL
<b>Capital Cost:</b>							
Planning, Engineering, Design	\$35,000						\$35,000
Land/ROW Acquisition							n/a
Construction			\$1,335,000	\$1,335,000			\$2,670,000
<b>TOTAL EST. CAPITAL COST</b>	<b>\$35,000</b>		<b>\$1,335,000</b>	<b>\$1,335,000</b>			<b>\$2,705,000</b>
<b>Funding Source:</b>							
Water	\$35,000		\$1,335,000	\$1,335,000			\$2,705,000
<b>TOTAL FUNDING</b>	<b>\$35,000</b>		<b>\$1,335,000</b>	<b>\$1,335,000</b>			<b>\$2,705,000</b>



## Stormwater Master Plan

Prepared for the  
City of Milwaukie, Oregon  
January 2014

## STORMWATER MASTER PLAN

The Master Plan will identify strategies for maintaining adequate maintenance levels for the community. The updated plan will guide capital expenditures for the system and furnish guidance on operational issues and future stormwater rate structures.

**The Master Plan will:**

1. Evaluate and summarize the existing stormwater system and key facilities.
2. Develop demand projections for several scenarios, to include buildout, annexation of Dual Interest Areas, and annexation of the UGMA.
3. Evaluate existing and future demands to develop a strategy for the City to meet existing and future stormwater management demand needs.
4. Develop performance and operational criteria under which the stormwater system will be analyzed and future facilities will be formulated.
5. Evaluate the existing stormwater management system for seismic and climate resiliency and provide potential solutions.
6. Develop a prioritized capital improvement for recommended existing and future stormwater system facilities and an analysis of potential funding.
7. Update the System Development Charge Rate.

**Operating Budget Impact:** *Unknown* **Source:** *Public Works* **Submitted by:** *Public Works*

	FY 2021	FY 2022	FY 2023	FY 2024	FY 2025	FY 2026	TOTAL
<b>Funding Source:</b>							
Stormwater SDC			\$200,000	\$100,000			\$300,000
<b>TOTAL FUNDING</b>			<b>\$200,000</b>	<b>\$100,000</b>			<b>\$300,000</b>

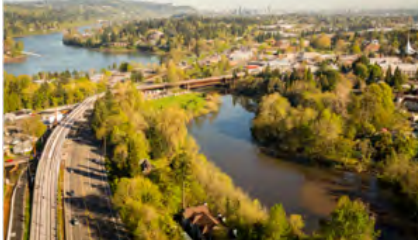

### SYSTEM DEVELOPMENT CHARGE RATE STUDY

Following the update to the city's Transportation System Plan (TSP), a System Development Charge (SDC) Rate Study will be performed to determine the transportation SDC amounts needed to construct the capacity improvements recommended in the TSP.

**Operating Budget Impact:** Unknown **Source:** Engineering, Public Works

**Submitted by:** Engineering, Public Works

	FY 2021	FY 2022	FY 2023	FY 2024	FY 2025	FY 2026	TOTAL
<b>Funding Source:</b>							
Transportation SDC			\$50,000				\$50,000
<b>TOTAL FUNDING</b>			<b>\$50,000</b>				<b>\$50,000</b>



### WASTEWATER SYSTEM IMPROVEMENTS FY 2023

*26th Avenue, 34th Avenue, 37th Avenue at Marketplace, 37th Avenue at Monroe Street, Lake Village Apartments, River Road*

**26th Avenue Sewer Repair:** To address a belly in the mainline and to reduce debris buildup. MH 4008 – 4007: Length 36.1', Upstream depth 7.6', Downstream depth 10', Number of services 0, Diameter 8"

**34th Avenue Sewer Replacement:** To address intrusion of seal material and multiple cracks and fractures that impact the integrity of the mainline. CO 2344 – 2018: Length 257', Upstream depth CO', Downstream depth 10', Number of services 6, Diameter 8"

**37th Avenue (Marketplace) Sewer Replacement:** To fix bellies in the mainline that collect grease from primarily the Milwaukie Marketplace. The downstream manhole can be eliminated and tie into the next 20 feet away. MH 3512 – 3511: Length 324.95', Upstream depth 8.42', Downstream depth 10.17', Number of services 1, Diameter 8"

**37th Avenue (at Monroe Street) Sewer Replacement:** To repair root intrusion into the main from mainline joints and lateral connections. MH 2075 – 2070: Length 263', Upstream depth 8.9', Downstream depth 9.5', Number of services 8, Diameter 8"

**Lake Village Apartments Sewer Replacement:** Construct 350 ft of 8-inch sanitary sewer line and associated manholes with a new alignment that would bypass lines currently located under the apartment complex and address access and maintenance issues.

**River Road Sewer Repair:** To address known inflow and infiltration (I&I) issues. The joints and lateral connections of the sewer mainline are failing and ground water is infiltrating. Eliminating the I&I will relieve the Kellogg Creek Waste Treatment Plant, reduce capacity issues, and maintain a good water-tight mainline. Medium infiltration 1-5 gallons a minute. This project may be eligible for a 10% cost share from CCSD#1 since it is a project designed to reduce I&I within the city. The project will be evaluated by CCSD#1 for its impact on I&I. CIPP is recommended for the mainline. MH 5052 – 5051: Length 304.0', Upstream depth 6.4', Downstream depth 6.2', Number of services 7, Diameter 8"

Reconnection of services and pavement patching along the replacement lines will be included in all projects.

**Operating Budget Impact:** This project would decrease ongoing operational needs by restoring infrastructure to good condition.

**Source:** WWMP, Public Works Maintenance **Submitted by:** Public Works

	FY 2021	FY 2022	FY 2023	FY 2024	FY 2025	FY 2026	TOTAL
<b>Capital Cost:</b>							
Planning, Engineering, Design							n/a
Land/ROW Acquisition							n/a
Construction			\$491,000				\$491,000
<b>TOTAL EST. CAPITAL COST</b>			<b>\$491,000</b>				<b>\$491,000</b>
<b>Funding Source:</b>							
Wastewater			\$491,000				\$491,000
<b>TOTAL FUNDING</b>			<b>\$491,000</b>				<b>\$491,000</b>

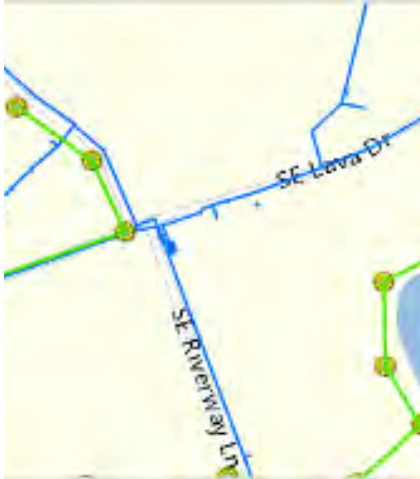

### WAVERLY SOUTH IMPROVEMENTS

*Lave Drive, Waverly Court, Riverway Lane*

**Lava Drive & Waverly Court SAFE/SSMP:** Fill in sidewalk gaps on both sides of the streets, replace portions of sidewalk, overlay surface on Lava Drive and reconstruct asphalt surface on Waverly Court, from 17th Avenue to Highlands Apartments Entrance.

**Riverway Lane Sewer Repair:** Fix heavy root intrusion in portions of the mainline. Mainline is a trunk line and collects from the Waverly area, and a manhole installation at 153 feet would allow access to a private sewer mainline for 3 homes. Project could use a pipeburst method and would include reconnection of services. MH 1087 – 1086: Length 220.6'; Upstream depth 10'; Downstream depth 11.5'; Number of services 2, Diameter 10'

**Riverway Lane Water Line Replacement:** Replace the existing 2-inch water line with a 6-inch ductile iron pipe water main to address hydraulic, structural, and water quality issues. This project may require an additional easement and will include reconnection of services and hydrants.

**Operating Budget Impact:** *The paving projects could potentially increase ongoing operational needs due to the addition of new infrastructure. However, the pipe replacements would decrease ongoing operational needs by restoring infrastructure to good condition.*

**Source:** WWMP, WMP

**Submitted by:** Engineering, Public Works

	FY 2021	FY 2022	FY 2023	FY 2024	FY 2025	FY 2026	TOTAL
<b>Capital Cost:</b>							
Planning, Engineering, Design		\$40,000					\$40,000
Land/ROW Acquisition							n/a
Construction			\$786,000				\$786,000
<b>TOTAL EST. CAPITAL COST</b>		<b>\$40,000</b>	<b>\$786,000</b>				<b>\$826,000</b>
<b>Funding Source:</b>							
SAFE		\$20,000	\$278,000				\$298,000
SSMP		\$20,000	\$302,000				\$322,000
Wastewater			\$91,000				\$91,000
Water			\$115,000				\$115,000
<b>TOTAL FUNDING</b>		<b>\$40,000</b>	<b>\$786,000</b>				<b>\$826,000</b>



### WELL #4 RECONDITIONING

Water wells require regular maintenance to ensure adequate water flow and continued drinking water safety, and should be professionally inspected by a water well contractor every 10 years. As a well ages, the rate at which water may be pumped (commonly referred to as well yield, flow, or performance) tends to decrease. Reduced well yield over time can be related to changes in the water well itself including: incrustation from mineral deposits, bio-fouling by the growth of microorganisms, physical plugging of "aquifer" (the saturated layer of sand, gravel, or rock through which water is transmitted) by sediment, sand pumping, well screen or casing corrosion, and pump damage.

Well #4 is located at the intersection of Monroe Street, Railroad Avenue, and Oak Street adjacent to Water Treatment Plant 47. It pumps approximately 605 gpm directly into Tower #4 at the TP 47 site. This project consists of inspecting by video, disinfecting, and reconditioning the well.

**Operating Budget Impact:** None **Source:** Public Works Maintenance **Submitted by:** Public Works

	FY 2021	FY 2022	FY 2023	FY 2024	FY 2025	FY 2026	TOTAL
<b>Capital Cost:</b>							
Planning, Engineering, Design							n/a
Land/ROW Acquisition							n/a
Construction			\$60,000				\$60,000
<b>TOTAL EST. CAPITAL COST</b>			<b>\$60,000</b>				<b>\$60,000</b>
<b>Funding Source:</b>							
Water			\$60,000				\$60,000
<b>TOTAL FUNDING</b>			<b>\$60,000</b>				<b>\$60,000</b>



### WELL #7 RECONDITIONING

Water wells require regular maintenance to ensure adequate water flow and continued drinking water safety, and should be professionally inspected by a water well contractor every 10 years. As a well ages, the rate at which water may be pumped (commonly referred to as the well yield, flow, or performance) tends to decrease. Reduced well yield over time can be related to changes in the well itself including: incrustation from mineral deposits, bio-fouling by the growth of microorganisms, physical plugging of "aquifer" (the saturated layer of sand, gravel, or rock through which water is transmitted) by sediment, sand pumping, well screen or casing corrosion, and pump damage.

Well #7 is located near the intersection of Washington Street and 37th Avenue, and pumps approximately 1,120 gpm directly into Tower at Treatment Plant 47. Well #7 has a sand separator and onsite back-up generator. This project consists of inspecting by video, disinfecting, and reconditioning the well, pump motor, and pump as necessary.

**Operating Budget Impact:** None **Source:** Public Works Maintenance **Submitted by:** Public Works

	FY 2021	FY 2022	FY 2023	FY 2024	FY 2025	FY 2026	TOTAL
<b>Capital Cost:</b>							
Planning, Engineering, Design							n/a
Land/ROW Acquisition							n/a
Construction			\$60,000				\$60,000
<b>TOTAL EST. CAPITAL COST</b>			<b>\$60,000</b>				<b>\$60,000</b>
<b>Funding Source:</b>							
Water			\$60,000				\$60,000
<b>TOTAL FUNDING</b>			<b>\$60,000</b>				<b>\$60,000</b>



## ARDENWALD SOUTH IMPROVEMENTS

### SAFE & SSMP IMPROVEMENTS

**32nd Avenue:** Replace portions of existing sidewalk, remove ADA barriers, and reconstruct asphalt surface with new overlay from Roswell Street to Oak Street.

**Balfour Street:** Add sidewalk from 32nd Avenue to Balfour Park and reconstruct asphalt surface from 32nd Avenue to street terminus.

**Water System Improvements:** Replace and upsize existing 4-inch cast iron water main to 8-inch ductile iron pipe to improve fire flows in the neighborhood. New mains will connect to existing 8-inch water main. The project will include the replacement of existing valves, reconnection of existing water services and hydrants along the length of the pipes.

32nd Avenue Water (Kelvin Street to Filbert Street), Llewellyn Street (32nd Avenue to 34th Avenue), Malcolm Street (32nd Avenue to 29th Avenue).

**Operating Budget Impact:** The paving projects could potentially increase ongoing operational needs due to the addition of new infrastructure. However, the pipe replacements would decrease ongoing operational needs by restoring infrastructure to good condition.

**Source:** SAFE, SSMP, WMP, Public Works Maintenance

**Submitted by:** Engineering, Public Works

	FY 2021	FY 2022	FY 2023	FY 2024	FY 2025	FY 2026	TOTAL
<b>Funding Source:</b>							
SAFE				\$1,527,000			\$1,527,000
SSMP				\$404,000			\$404,000
Stormwater				\$40,000			\$40,000
Water				\$832,000			\$832,000
<b>TOTAL FUNDING</b>				<b>\$2,803,000</b>			<b>\$2,803,000</b>



### CRW INTERTIE

Emergency interties are maintained with the City of Portland and Clackamas River Water (CRW). The CRW Intertie is located at 7001 SE Harmony Road. Pumping capacity for this intertie is approximately 700 gpm in either direction and can pump into and out of city Pressure Zone 2. This project includes electrical upgrades, new motor controls, and installation of a new variable frequency drive (VFD). This project includes approximately \$27,500 in engineering expenses.

**Operating Budget Impact:** *Unknown*

**Source:** *Public Works Maintenance*

**Submitted by:** *Public Works*

	FY 2021	FY 2022	FY 2023	FY 2024	FY 2025	FY 2026	TOTAL
<b>Funding Source:</b>							
Water				\$112,000			\$112,000
<b>TOTAL FUNDING</b>				<b>\$112,000</b>			<b>\$112,000</b>



### INTERNATIONAL WAY IMPROVEMENTS

#### 37th Avenue to Lake Road

**International Way SAFE/SSMP:** Fill in sidewalk gaps on both sides of the street, remove barriers, construct bicycle facility improvements, replace asphalt roadway surface from 37th Avenue to Lake Road.

**International Way & Wister Street Underground Storage:** Construct underground storage within piped storm system and install upsized pipe within existing system to eliminate potential flooding.

**International Way Sewer Replacement:** To address two significant bellies (211'-260' and 330'-340'), which create debris buildup that can go septic. Two plumber laterals may need grease traps. Replacement should be during dry season due to ground water issues and may require dewatering. MH 3033 - 3032: Length 354.2', Upstream depth 10.5', Downstream depth 11.5', Number of services 3, Diameter 12"

**International Way Pipe Extension:** Install of 820 feet of 12-inch ductile iron water main from Freeman Way to Mallard Way to tie together the entire length of International Way which would provide increased water flow capacity coupled with improved water quality. Project will include installation of a three-valve cluster fire hydrant at the midpoint to provide for proper unidirectional flushing and installation of a sample station at the northwest end of the new main. Accommodation of storm or wastewater systems may be necessary to accept large water volumes during flushing activities. Replacement of existing valves and reconnection of water services and hydrants will be included.

**Mallard Street SAFE:** Construct sidewalk from International Way to the Mallard Bridge.

**Operating Budget Impact:** *This project will potentially increase ongoing operational needs due to the addition of new infrastructure. However, pipe repairs and replacements will reduce operating expenditures due to the reduction of maintenance issues.*

**Source:** *SAFE, SSMP, RTP, Public Works Maintenance*

**Submitted by:** *Engineering, Public Works*

	FY 2021	FY 2022	FY 2023	FY 2024	FY 2025	FY 2026	TOTAL
<b>Funding Source:</b>							
SAFE				\$2,122,000			\$2,122,000
SSMP				\$679,000			\$679,000
Stormwater				\$174,000			\$174,000
Wastewater				\$144,000			\$144,000
Water				\$277,000			\$277,000
<b>TOTAL FUNDING</b>				<b>\$3,396,000</b>			<b>\$3,396,000</b>



### MONROE STREET WATER PIPE EXTENSION

#### Linwood Avenue to 66th Avenue

This project will extend an 8-inch water main east from Linwood Avenue, down Monroe Street, then south on 66th Avenue to connect to the existing 6-inch water main located there. This project will provide redundancy in the system and improve fire flows in this area.

**Operating Budget Impact:** Project will add minimal additional maintenance cost.

**Source:** WMP **Submitted by:** Engineering, Public Works

	FY 2021	FY 2022	FY 2023	FY 2024	FY 2025	FY 2026	TOTAL
<b>Funding Source:</b>							
Water				\$321,000			\$321,000
<b>TOTAL FUNDING</b>				<b>\$321,000</b>			<b>\$321,000</b>



### MULLAN STREET PIPE EXTENSION

This project consists of water line installation at the west portion of Mullan Street, connecting to the 6-inch on 51st Avenue and then to the new 6-inch pipe that was installed in 2015 on the east end of Mullan Street, off 54th Court. This project will address hydraulic, structural, and water quality issues as well as loop the system. The project will include the installation of an Eclipse 88 sample station, replacement of existing valves, reconnection of existing water services and hydrants, and pavement patching along the length of the pipe.

**Operating Budget Impact:** This project is anticipated to reduce operating expenditures due to the reduction of water quality flushing that would be needed.

**Source:** Public Works **Submitted by:** Public Works

	FY 2021	FY 2022	FY 2023	FY 2024	FY 2025	FY 2026	TOTAL
<b>Funding Source:</b>							
Water				\$88,000			\$88,000
<b>TOTAL FUNDING</b>				<b>\$88,000</b>			<b>\$88,000</b>



### WAVERLY HEIGHTS SEWER SYSTEM RECONFIGURATION

Replace and reconfigure the aging wastewater system within the Waverly Heights area of northwest Milwaukie. The 2010 Wastewater System Master Plan proposes five design alternatives. Design for the appropriate solution for the neighborhood’s sewer system will occur in Fiscal Year 2023 and construction will follow in Fiscal Years 2024 and 2025.

It is proposed to complete this project through an alternative delivery method. This would allow the project to evaluate the use of multiple construction methods and value engineer options with contractor and design team which will be managed by city staff.

**Operating Budget Impact:** This project will not increase operating expenditures. It will help solve a major maintenance issue for the city and will reduce infiltration and inflow into the system.

**Source:** Wastewater Master Plan **Submitted by:** Public Works

	FY 2021	FY 2022	FY 2023	FY 2024	FY 2025	FY 2026	TOTAL
<b>Funding Source:</b>							
Wastewater			\$400,000	\$1,394,000	\$1,294,000		\$3,088,000
Wastewater SDC				\$169,000	\$147,000		\$316,000
<b>TOTAL FUNDING</b>			<b>\$400,000</b>	<b>\$1,563,000</b>	<b>\$1,441,000</b>		<b>\$3,404,000</b>





## LEWELLING NORTH SAFE & SSMP

*Brookside Drive, Winsor Drive, Mason Lane*

### SAFE & SSMP IMPROVEMENTS

*Brookside Drive & Winsor Drive:* Fill in sidewalk gaps on both sides of the street, remove barriers, and repair or reconstruct roadway surface between Johnson Creek Boulevard and Willow Street.

*Mason Lane Improvements:* Add new sidewalk and provide new overlay to roadway surface between 42nd Avenue and Regents Drive.

**Operating Budget Impact:** *The project will potentially increase ongoing operational needs due to the addition of new infrastructure.*

**Source:** SAFE, SSMP

**Submitted by:** Engineering

	FY 2021	FY 2022	FY 2023	FY 2024	FY 2025	FY 2026	TOTAL
<b>Funding Source:</b>							
SAFE					\$1,569,000		\$1,569,000
SSMP					\$213,000		\$213,000
<b>TOTAL FUNDING</b>					<b>\$1,782,000</b>		<b>\$1,782,000</b>



## NORTH MILWAUKIE IMPROVEMENTS

### SAFE/SSMP IMPROVEMENTS

**Main Street:** Fill in sidewalk gaps, replace portions of existing sidewalk, remove ADA barriers, and reconstruct asphalt pavement surface from Harrison Street to Ochoco Street/McLoughlin Boulevard.

**Mailwell Drive:** Construct continuous 6 feet-wide curbside ADA-compliant sidewalk on the north side of Mailwell Drive from Main Street to UPRR; construct new curbs where none are present; and reconstruct asphalt roadway from Main Street to UPRR.

### WASTEWATER SYSTEM IMPROVEMENTS

**Main Street Sewer Replacement:** Sewer replacement to address multiple holes and fractures in the mainline, as well as significant buildup of fats, oils, and grease (FOG). An additional manhole will be installed due to the length of the line. MH 1157 – 1156: Length 445'; Upstream depth 4.83'; Downstream depth 5.33'; Number of services 13, Diameter 8"

### MAIN STREET STORM IMPROVEMENTS PHASE II

Repair and/or replace the existing storm system that is located on private property and under buildings between Main Street and Omark Drive at Milport Road.

**Mailwell Drive Sewer Repair:** Repair to eliminate known inflow and infiltration (I/I), including those at the Kellogg Creek Waste Treatment Plant; replacing the existing 8-inch concrete pipe; installing one manhole to ease maintenance. Reconnect five existing services. May be eligible for a 10% costshare from CCSD#1. MH 1166 – 1029: Length 403.2'; Upstream depth 8'; Downstream depth 9.33'; Number of services 5, Diameter 8"

**Hannah Harvester Sewer Replacement:** Sewer replacement to fix a significant belly in the last 90 feet of the line. The line has heavy flow use, therefore the project will require bypass pumping. MH 1575 – 1144: Length 143.2'; Upstream depth 9.5'; Downstream depth 10'; Number of services 0, Diameter 8"

**17th Avenue Sewer Repair:** CIPP or line replacement due to substantial cracks and fractures that threaten the structural integrity of the mainline. MH – 1133 Length 233.4'; Upstream depth 4'; Downstream depth 5.42'; Number of services 2, Diameter 6"

**Roswell Street Sewer Repair:** CIPP repair or full replacement to eliminate known I/I issues to reduce groundwater, including those at the Kellogg Creek Treatment Plant. Removal of not-in-use laterals recommended. May be eligible for a 10% costshare from CCSD#1. MH 1204 – 1203: Length 362.8'; Upstream depth 8.83'; Downstream depth 8.33'; Number of services 8, Diameter 8"

**Stubb Street Sewer Repair:** CIPP repair or full replacement to eliminate known I/I issues, including those at the Kellogg Creek Treatment Plant. Removal of not-in-use laterals recommended. May be eligible for a 10% costshare from CCSD#1. MH 1192 – 1034: Length 367.7'; Upstream depth 5.5'; Downstream depth 5.4'; Number of services 9, Diameter 8"

**Operating Budget Impact:** Paving projects could potentially increase ongoing operational needs due to the addition of new infrastructure. However, pipe replacement would decrease ongoing operational needs by restoring infrastructure to good condition.

**Source:** SAFE, SSMP, Public Works Maintenance

**Submitted by:** Engineering

	FY 2021	FY 2022	FY 2023	FY 2024	FY 2025	FY 2026	TOTAL
<b>Funding Source:</b>							
SAFE					\$2,179,000		\$2,179,000
SSMP					\$929,000		\$929,000
Stormwater					\$641,000		\$641,000
Transportation					\$96,000		\$96,000
Wastewater					\$465,000		\$465,000
<b>TOTAL FUNDING</b>					<b>\$4,310,000</b>		<b>\$4,310,000</b>



### SAFE & SSMP FY 2025 IMPROVEMENTS

*Park Street, Lloyd Street, Beckman Avenue, Stanley Avenue*

**Park Street & Lloyd Street SAFE/SSMP Improvements:** Fill in sidewalk gaps on the street, replace portions of existing sidewalk, remove ADA barriers, and reconstruct asphalt surface from Home Avenue on Park Street, Beckman Avenue, Beckman Terrace, 56th Avenue, and Lloyd Street to Stanley Avenue.

**Stanley Avenue SSMP Improvements:** Reconstruct asphalt surface from Railroad Avenue to Lloyd Street.

**Water System Improvements:** Replace and upsize existing cast iron water mains to improve fire flows in the neighborhood. The project will include replacement of existing valves, and reconnection of existing water services and hydrants.

*Beckman Avenue:* Upsize from 6-inch water main to 8-inch; connect to the 12-inch main on Railroad Avenue and the 6-inch main on Park Street.

*Park Street:* Upsize from 6-inch to 8-inch; connect to 8-inch main on Home Avenue and 6-inch main or proposed 8-inch main on Beckman Street.

**Beckman Avenue Sewer Replacement:** Address multiple bellies in the mainline that can cause backup and property damage and install new manhole to ease maintenance. Full replacement is recommended and will include reconnection of services along replaced line. MH 3212 – 3211: Length 401.2'; Upstream depth 10.25'; Downstream depth 9.42'; Number of services 11, Diameter 8"

**Operating Budget Impact:** *The paving projects could potentially increase ongoing operational needs due to the addition of new infrastructure. However, pipe replacements would decrease ongoing operational needs by restoring infrastructure to good condition.*

**Source:** SAFE, SSMP, WMP, Public Works Maintenance **Submitted by:** Engineering

	FY 2021	FY 2022	FY 2023	FY 2024	FY 2025	FY 2026	TOTAL
<b>Funding Source:</b>							
SAFE					\$918,000		\$918,000
SSMP					\$512,000		\$512,000
Wastewater					\$139,000		\$139,000
Water					\$1,128,000		\$1,128,000
<b>TOTAL FUNDING</b>					<b>\$2,697,000</b>		<b>\$2,697,000</b>



**STORMWATER QUALITY FACILITIES FY 2025**

*36th Avenue, 47th Avenue/Llewellyn Street, 55th Avenue/Monroe Street, 42nd Avenue, Stanley Avenue/Willow Street, Winworth Court*

**36th Avenue UIC/LIDA:** Construct water quality facilities to collect and treat stormwater on 36th Avenue between Harvey Street and King Road prior to infiltration. The area is prone to flooding.

**47th Avenue & Llewellyn Street:** Install new underground injection control devices, raingardens, and associated inlets at the intersection of 47th Avenue and Llewellyn Street. This intersection routinely floods because the existing UIC is under capacity. There is approximately 70,070 sq. ft. of impervious surface contributing to this UIC. It is expected that the project will require the installation of five additional UICs to accommodate the contributing impervious area. Each UIC is assumed to be 48-inches in diameter and 20 feet deep.

**55th Avenue & Monroe Street:** Install new underground injection control devices or raingardens on 55th Avenue and Monroe Street. This intersection routinely floods because the existing infrastructure is under capacity. This project includes the construction of additional 125 feet of soakage trench to be installed near the catch basins.

**42nd Avenue & Railroad Avenue:** Construct a water quality facility at 42nd Avenue and Railroad Avenue to treat the 42nd Avenue and Railroad Avenue storm basins.

**Stanley-Willow UIC Decommissioning (Hazel Place to Hill Street):** Decommission two substandard drywells along Stanley Avenue and construct new storm pipe on Stanley Avenue from Hill Street to Ball-Michel Park. Replace current system with two new G2 catch basins on Willow Street, with a sedimentation manhole between the two, and install 425 feet of new 12-inch HDPE piping from Hill Street to an outfall in Ball-Michel Park. The project also includes planting of approximately 2,000 sq. ft. of native vegetation on the bottom of the stormwater facility at Ball-Michel Park.

**Winworth Court Stormwater Repair:** Install UIC to alleviate flooding issues that have potential to cause property damage. Current pipe size 12-inch, Catch basins 32101 and 32103 tied to UIC numbers 34055 and 34054.

**Operating Budget Impact:** *This project will reduce operating expenditures because stormwater crews are routinely called to this area to help alleviate flooding.*

**Source:** *Public Works*

**Submitted by:** *Public Works Maintenance*

	FY 2021	FY 2022	FY 2023	FY 2024	FY 2025	FY 2026	TOTAL
<b>Funding Source:</b>							
Stormwater					\$1,482,000		\$1,482,000
<b>TOTAL FUNDING</b>					<b>\$1,482,000</b>		<b>\$1,482,000</b>



### WELL #8 REHABILITATION

5393 SE Lake Road

Well #8 pumps between 300 and 700 gpm directly into the Zone 2 distribution system and has an active water right certified through the Oregon Water Resources Department of 727 gpm. The well water is treated with chlorine which is injected upstream of the buried chlorine contact tank. The well is experiencing issues with excessive iron in the water it is drawing. Workable solutions include relocating the well and this project provides funding to explore the viability of siting Well #8 at a new location. Construction of the new location will require a sand separator and onsite backup generation.

**Operating Budget Impact:** *Unknown*

**Source:** *Public Works Maintenance*

**Submitted by:** *Public Works*

	FY 2021	FY 2022	FY 2023	FY 2024	FY 2025	FY 2026	TOTAL
<b>Funding Source:</b>							
Water					\$200,000		\$200,000
<b>TOTAL FUNDING</b>					<b>\$200,000</b>		<b>\$200,000</b>



### OATFIELD ROAD & SHELL LANE IMPROVEMENTS

Lake Road to Kellogg Creek Bridge; Lake Road to Licyntra Lane

**Oatfield Road:** Fill in sidewalk gaps on both sides of street, remove barriers, fill in gaps in bicycle network, add bike lanes, resurface street, and add stormwater and water quality facilities.

**Shell Lane (Lake Road to Licyntra Lane):** SSMP–Reconstruction asphalt surface. Water project will consist of water line installments on the south portion of Shell Lane to connect to the 6-inch main on Licyntra Lane which will address hydraulic, structural, and water quality issues as well as loop the system.

**Operating Budget Impact:** *This project will potentially increase operational needs due to the addition of new infrastructure.*

**Source:** *SAFE, TSP, RTP*

**Submitted by:** *Engineering*

	FY 2021	FY 2022	FY 2023	FY 2024	FY 2025	FY 2026	TOTAL
<b>Funding Source:</b>							
SAFE						\$432,000	\$432,000
SSMP						\$512,000	\$512,000
Stormwater						\$297,000	\$297,000
Transportation						\$644,000	\$644,000
Water						\$72,000	\$72,000
<b>TOTAL FUNDING</b>						<b>\$1,957,000</b>	<b>\$1,957,000</b>

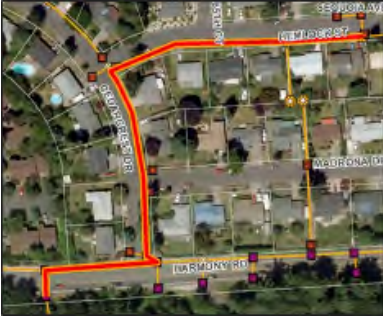

### PIPE REPLACEMENTS

#### Plum Street/Apple Street and Hemlock Street

**Plum Street & Apple Street:** This project will install new 12-inch stormwater pipe from the intersection of Plum and Apple Streets to the intersection of Juniper and Aspen Streets. This project will provide increased capacity to alleviate local flooding problems. The project includes approximately 780 feet of new 12-inch pipe.

**Hemlock Street:** This project will replace existing stormwater pipe on Hemlock Street and Cedarcrest Drive. The existing pipe is undersized and currently floods in heavy rain events. This project will replace and realign piping along a portion of Cedarcrest Drive from Hemlock Street to Harmony Road and will abandon the existing 15-inch pipe between Hemlock Street and Harmony Road.

**Operating Budget Impact:** Since this project replaces existing undersized pipe, there will be a net reduction in operating expenditures because stormwater crews are routinely called to this area to help alleviate flooding.

**Source:** SWMP

**Submitted by:** Public Works, Engineering

	FY 2021	FY 2022	FY 2023	FY 2024	FY 2025	FY 2026	TOTAL
<b>Funding Source:</b>							
Stormwater						\$1,248,000	\$1,248,000
<b>TOTAL FUNDING</b>						<b>\$1,248,000</b>	<b>\$1,248,000</b>



### SAFE & SSMP FY 2026 IMPROVEMENTS - 51ST AVENUE/ROCKWOOD

#### 43rd Avenue, 49th Avenue, 51st Avenue, Rockwood Street, Willow Street

**43rd Avenue SAFE/SSMP Improvements:** Construct new sidewalk and curb on both sides of the street, replace portions of existing sidewalk, and remove barriers. Reconstruct roadway surface on 43rd Avenue from Howe Street to Covell Street, and on Covell Street.

**49th Avenue SAFE/SSMP Improvements:** Fill in sidewalk gaps on both sides of the street, remove barriers, and reconstruct roadway surface from King Road to Logus Road.

**51st Avenue SAFE/SSMP Improvements:** Add new ADA-accessible sidewalk and reconstruct roadway surface from Logus Road to Winworth Court.

**Rockwood Street – Willow Street SAFE Improvements:** Fill in sidewalk gaps on both sides of the street and remove barriers on Rockwood Street from 43rd Avenue to 49th Avenue and on Willow Street from Winworth Court to Stanley Avenue. Pave Willow Street path between 49th Avenue and Winworth Court.

**Operating Budget Impact:** This project will potentially increase ongoing operational needs due to the addition of new infrastructure (sidewalk and pavement).

**Source:** SAFE, SSMP, Public Works Maintenance

**Submitted by:** Engineering, Public Works

	FY 2021	FY 2022	FY 2023	FY 2024	FY 2025	FY 2026	TOTAL
<b>Funding Source:</b>							
SAFE						TBD	TBD
SSMP						TBD	TBD
<b>TOTAL FUNDING</b>						<b>TBD</b>	<b>TBD</b>



### SPARROW STREET IMPROVEMENTS

#### 22nd Avenue to the Trolley Trail

Construct sidewalks, and add pedestrian and bicycle crossing between River Road and 25th Avenue. Reconstruct or overlay roadway surface between 22nd Avenue and River Road, and between 25th Avenue and 26th Avenue.

**Operating Budget Impact:** This project would increase ongoing operational needs due to the addition of new infrastructure.

**Source:** SAFE, SWMP

**Submitted by:** Engineering

	FY 2021	FY 2022	FY 2023	FY 2024	FY 2025	FY 2026	TOTAL
<b>Funding Source:</b>							
SAFE						\$221,000	\$221,000
SSMP						\$35,000	\$35,000
<b>TOTAL FUNDING</b>						<b>\$256,000</b>	<b>\$256,000</b>



### WELL #2 BUILDING UPGRADES

Evaluate, develop, and design building upgrades, roof replacement, and seismic upgrades as needed to the 40th Avenue and Harvey Street water facility.

**Operating Budget Impact:** Unknown

**Source:** Public Works Maintenance

**Submitted by:** Public Works

	FY 2021	FY 2022	FY 2023	FY 2024	FY 2025	FY 2026	TOTAL
<b>Funding Source:</b>							
Water						\$100,000	\$100,000
<b>TOTAL FUNDING</b>						<b>\$100,000</b>	<b>\$100,000</b>

### LIFT STATION PUMP & SCADA CONTROLS REPLACEMENT



A program that replaces the city's lift station pumps and SCADA controls prior to failures and/or service interruptions.

**Operating Budget Impact:** Complete preventative maintenance in advance of emergency repairs should reduce the possibility of sewer back up, claims against the city, and reduce operating expenditures.

**Source:** Public Works Maintenance

**Submitted by:** Public Works

	FY 2021	FY 2022	FY 2023	FY 2024	FY 2025	FY 2026	TOTAL
<b>Funding Source:</b>							
Wastewater	\$100,000	\$50,000	\$50,000	\$50,000	\$50,000		\$300,000
<b>TOTAL FUNDING</b>	<b>\$100,000</b>	<b>\$50,000</b>	<b>\$50,000</b>	<b>\$50,000</b>	<b>\$50,000</b>		<b>\$300,000</b>



### STORMWATER CAPITAL MAINTENANCE PROGRAM

This yearly project will begin to replace Milwaukee's aging stormwater infrastructure. To complete replacement of the City's system on a 75-year cycle per the 2014 Stormwater Master plan requires \$250,000/year. Current funding does not meet planned future replacement costs.

**Operating Budget Impact:** This project will reduce the operating expenditures by upgrading materials which will require less maintenance.

**Source:** SWMP, Public Works Maintenance

**Submitted by:** Public Works

	FY 2021	FY 2022	FY 2023	FY 2024	FY 2025	FY 2026	TOTAL
<b>Funding Source:</b>							
Stormwater	\$250,000	\$250,000	\$250,000	\$250,000	\$250,000		\$1,250,000
<b>TOTAL FUNDING</b>	<b>\$250,000</b>	<b>\$250,000</b>	<b>\$250,000</b>	<b>\$250,000</b>	<b>\$250,000</b>		<b>\$1,250,000</b>





## TRANSPORTATION MAINTENANCE

### Crack Seal / Slurry Seal

**Slurry Seal Program:** Treat street surface in “good” condition prior to the need for grind and inlay/overlay. By surface sealing worn asphalt, the life of streets can be prolonged.

**Crack Seal Program:** Provides protection to roadways from possible damage due to water within cracks that form as part of the natural process by sealing them before more expensive measures are required.

**Operating Budget Impact:** This project will reduce maintenance operating expenditures by providing a short-term wearing course on the streets and reduce the potential for potholes and surface cracking.

**Source:** SSMP, Public Works Maintenance

**Submitted by:** Public Works

	FY 2021	FY 2022	FY 2023	FY 2024	FY 2025	FY 2026	TOTAL
<b>Funding Source:</b>							
SSMP	\$15,000	\$15,000	\$15,000	\$15,000	\$15,000	\$15,000	\$90,000
Transportation	\$150,000	\$150,000	\$150,000	\$150,000	\$150,000	\$150,000	\$900,000
<b>TOTAL FUNDING</b>	<b>\$165,000</b>	<b>\$165,000</b>	<b>\$165,000</b>	<b>\$165,000</b>	<b>\$165,000</b>	<b>\$165,000</b>	<b>\$990,000</b>



## WASTEWATER CAPITAL MAINTENANCE PROGRAM

Projects under this program consist of repair of pipe where structural conditions exist or lining is necessary to prevent groundwater infiltration and/or stormwater inflow. Projects are identified based on routine system monitoring.

**Operating Budget Impact:** Regular maintenance will reduce operating expenditures.

**Source:** Public Works Maintenance

**Submitted by:** Public Works

	FY 2021	FY 2022	FY 2023	FY 2024	FY 2025	FY 2026	TOTAL
<b>Funding Source:</b>							
Wastewater	\$50,000	\$50,000	\$50,000	\$50,000	\$50,000	\$50,000	\$300,000
<b>TOTAL FUNDING</b>	<b>\$50,000</b>	<b>\$50,000</b>	<b>\$50,000</b>	<b>\$50,000</b>	<b>\$50,000</b>	<b>\$50,000</b>	<b>\$300,000</b>



### WATER CAPITAL MAINTENANCE PROGRAM

Projects under this program consist of repair or replacement of small segments of water main due to structure failure or breaks. Projects are identified based on routine system monitoring for leaks.

**Operating Budget Impact:** Regular maintenance will reduce operating expenditures.

**Source:** Public Works Maintenance

**Submitted by:** Public Works

	FY 2021	FY 2022	FY 2023	FY 2024	FY 2025	FY 2026	TOTAL
<b>Funding Source:</b>							
Water	\$100,000	\$100,000	\$100,000	\$100,000	\$100,000	\$100,000	\$600,000
<b>TOTAL FUNDING</b>	<b>\$100,000</b>	<b>\$100,000</b>	<b>\$100,000</b>	<b>\$100,000</b>	<b>\$100,000</b>	<b>\$100,000</b>	<b>\$600,000</b>



# CHAPTER 2 OPERATIONAL FACILITIES AND EQUIPMENT

The projects and capital needs within this chapter are necessary to keep the existing city facilities and operational needs maintained and up to date. Projects within this chapter include facility improvements, vehicle replacements, information technology upgrades, and other enhancements necessary to extend the useful life of existing city facilities and equipment.

## OVERVIEW

The General Fund is the main operating fund of the city. It accounts for and reports all financial resources not accounted for and reported in another fund.

### THE CITY'S GENERAL FUN ACCOUNTS FOR THE FOLLOWING DEPARTMENTS

- City Council
- City Manager
- Community Development
- Public Works Administration
- Engineering
- Facilities Management
- Finance
- Fleet Services
- Human Resources
- Municipal Court
- Information System Technology
- Planning
- Code Enforcement
- Public Access Studio
- City Recorder
- Police Department
- Nondepartmental

Ongoing revenue sources for the General Fund are property taxes, reimbursement charges for services to other funds, intergovernmental revenues, franchise fees, fines and forfeitures, licenses and permits, and miscellaneous income. The General Fund also may anticipate debt proceeds.

The General Fund expenditures consist of Personnel Service to support the budgeted full-time equivalents (FTEs), Materials and Services, Debt Service, and Capital Outlay across the 17 departments listed above.

General Fund Capital Improvement Program Cost

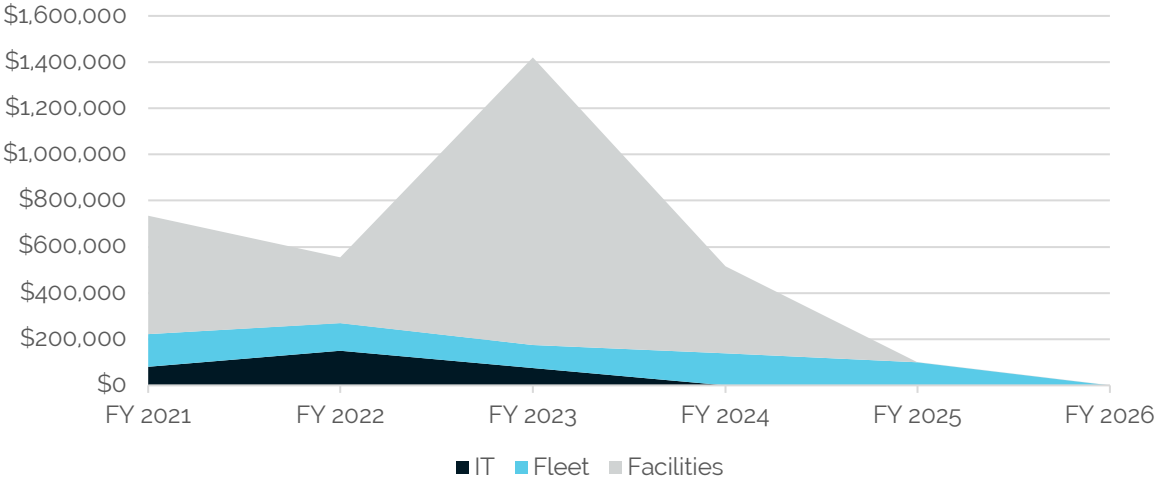

## FACILITIES SUMMARY

PAGE	PROJECT NAME	FY 2021	FY 2022	FY 2023	FY 2024	FY 2025	FY 2026	TOTAL
68	Community Development Roof Paint	\$ 140,000						\$ 140,000
68	Johnson Creek Campus Fuel Tank Removal	100,000						100,000
68	Public Safety Building Seismic Retrofit Design	175,000						175,000
69	Badge Reader Installation		40,000					40,000
69	Citywide Security System Panel Upgrade		35,000					35,000
69	Harvey Street Campus Fiber Ring Connection		15,000					15,000
70	Harvey Street Campus Storage Building Roof Repair		50,000					50,000
70	Johnson Creek Campus Diesel Tank Installation		40,000					40,000
70	Public Safety Building Security System Server		60,000					60,000
71	Public Safety Building South Entrance Door Replacement		25,000					25,000
71	Public Safety Building Exterior Paint			35,000				35,000
<b>GENERAL FUND FACILITIES TOTAL</b>		<b>\$ 415,000</b>	<b>265,000</b>	<b>35,000</b>				<b>\$ 715,000</b>

## CITY HALL SUMMARY

PAGE	PROJECT NAME	FY 2021	FY 2022	FY 2023	FY 2024	FY 2025	FY 2026	TOTAL
72	Art in Public Places		100,000					100,000
72	New City Hall Window Seals		20,000					20,000
72	New City Hall Remodel			1,200,000				1,200,000
<b>CITY HALL FUND TOTAL</b>		<b>\$</b>	<b>120,000</b>	<b>1,200,000</b>				<b>\$ 1,320,000</b>

## UTILITY FUND SUMMARY

PAGE	PROJECT NAME	FY 2021	FY 2022	FY 2023	FY 2024	FY 2025	FY 2026	TOTAL
72	Community Development Building Remodel			10,000				10,000
72	Johnson Creek Campus Solar Array Installation				375,000			375,000
<b>UTILITY FUND TOTAL</b>		<b>\$</b>		<b>10,000</b>	<b>375,000</b>			<b>\$ 385,000</b>

## FLEET SUMMARY

PAGE	PROJECT NAME	FY 2021	FY 2022	FY 2023	FY 2024	FY 2025	FY 2026	TOTAL
73	Dept Vehicles - Police Dept	\$ 141,000	100,000	100,000	150,000	100,000	100,000	\$ 691,000
73	Dept Vehicles - City Manager	20,000						20,000
73	Dept Vehicles - Comm Devp		20,000					20,000
73	Dept Vehicles - Engineering				40,000			40,000
<b>FLEET TOTAL</b>		<b>\$ 161,000</b>	<b>120,000</b>	<b>100,000</b>	<b>190,000</b>	<b>100,000</b>	<b>100,000</b>	<b>\$ 771,000</b>

## IT SUMMARY

PAGE	PROJECT NAME	FY 2021	FY 2022	FY 2023	FY 2024	FY 2025	FY 2026	TOTAL
74	Camera & Data Backup Storage Replacement	\$ 80,000	80,000					\$ 160,000
74	Server Replacement		70,000					70,000
74	Firewall Replacement			75,000				75,000
<b>IT TOTAL</b>		<b>\$ 80,000</b>	<b>150,000</b>	<b>75,000</b>				<b>\$ 305,000</b>



### COMMUNITY DEVELOPMENT BUILDING ROOF PAINT

The Community Development and Fleet building roof at the Johnson Creek Campus is approaching 25 years old. It will be repainted, providing another 15 years of serviceable life.

**Operating Budget Impact:** None Identified  
**Source:** Facilities Maintenance  
**Submitted by:** Facilities

	FY 2021	FY 2022	FY 2023	FY 2024	FY 2025	FY 2026	TOTAL
<b>Funding Source:</b>							
General Fund - Facilities	\$140,000						\$140,000
<b>TOTAL FUNDING</b>	<b>\$140,000</b>						<b>\$140,000</b>



### JOHNSON CREEK CAMPUS FUEL TANK REMOVAL

The underground fuel tanks at the Johnson Creek Campus were installed in 1990 and are approaching the end of their useful life. The infrastructure and insurance needed to maintain the tanks are expensive. The tanks will be removed and city vehicles will be fueled at the 32nd Avenue and Harrison Street gas station.

**Operating Budget Impact:** None Identified  
**Source:** Facilities Maintenance  
**Submitted by:** Facilities

	FY 2021	FY 2022	FY 2023	FY 2024	FY 2025	FY 2026	TOTAL
<b>Funding Source:</b>							
General Fund - Facilities	\$100,000						\$100,000
<b>TOTAL FUNDING</b>	<b>\$100,000</b>						<b>\$100,000</b>



### PUBLIC SAFETY BUILDING SEISMIC RETROFIT DESIGN

The Public Safety Building (PSB) is designated as an Emergency Operations Center (EOC), and is required to meet certain seismic requirements. Due to the building's odd shape, seismic assessment and design will not be straightforward and will need to have a more detailed assessment and design performed.

**Operating Budget Impact:** None Identified  
**Source:** Facilities Maintenance  
**Submitted by:** Facilities

	FY 2021	FY 2022	FY 2023	FY 2024	FY 2025	FY 2026	TOTAL
<b>Funding Source:</b>							
General Fund - Facilities	\$175,000						\$175,000
<b>TOTAL FUNDING</b>	<b>\$175,000</b>						<b>\$175,000</b>



### BADGE READER INSTALLATION

Badge reader installation or replacement is required at a number of city facility doors.

- Operating Budget Impact:** None Identified
- Source:** General Fund
- Submitted by:** Facilities

	FY 2021	FY 2022	FY 2023	FY 2024	FY 2025	FY 2026	TOTAL
<b>Funding Source:</b>							
General Fund - Facilities		\$40,000					\$40,000
<b>TOTAL FUNDING</b>		<b>\$40,000</b>					<b>\$40,000</b>



### CITYWIDE SECURITY SYSTEM PANEL UPGRADE

The local panels that support the badge readers and communicate with the central server are out of date and require replacement. Upgrading panels will provide improved functionality and features, including the ability to unlock a door for after hours meetings.

- Operating Budget Impact:** None Identified
- Source:** Facilities Maintenance
- Submitted by:** Facilities

	FY 2021	FY 2022	FY 2023	FY 2024	FY 2025	FY 2026	TOTAL
<b>Funding Source:</b>							
General Fund - Facilities		\$35,000					\$35,000
<b>TOTAL FUNDING</b>		<b>\$35,000</b>					<b>\$35,000</b>



### HARVEY STREET CAMPUS FIBER RING CONNECTION

A fiber connection at the Harvey Street Campus would provide secure internet access as well as support the SCADA water system monitoring equipment.

- Operating Budget Impact:** None Identified
- Source:** Facilities Maintenance
- Submitted by:** Facilities

	FY 2021	FY 2022	FY 2023	FY 2024	FY 2025	FY 2026	TOTAL
<b>Funding Source:</b>							
General Fund - Facilities		\$15,000					\$15,000
<b>TOTAL FUNDING</b>		<b>\$15,000</b>					<b>\$15,000</b>





### HARVEY STREET CAMPUS STORAGE BUILDING ROOF REPAIR

The west building at the Harvey Street Campus roof is leaking and at the end of its useful life. A new membrane will be applied and should last approximately 15 years.

**Operating Budget Impact:** None Identified

**Source:** Facilities Maintenance

**Submitted by:** Facilities

	FY 2021	FY 2022	FY 2023	FY 2024	FY 2025	FY 2026	TOTAL
<b>Funding Source:</b>							
General Fund - Facilities		\$50,000					\$50,000
<b>TOTAL FUNDING</b>		<b>\$50,000</b>					<b>\$50,000</b>



### JOHNSON CREEK CAMPUS DIESEL TANK INSTALLATION

The large underground fuel tanks at the Johnson Creek campus will be decommissioned. A small aboveground diesel tank for fueling off-road equipment will be installed.

**Operating Budget Impact:** None Identified

**Source:** Facilities Maintenance

**Submitted by:** Facilities

	FY 2021	FY 2022	FY 2023	FY 2024	FY 2025	FY 2026	TOTAL
<b>Funding Source:</b>							
General Fund - Facilities		\$40,000					\$40,000
<b>TOTAL FUNDING</b>		<b>\$40,000</b>					<b>\$40,000</b>

### PUBLIC SAFETY BUILDING SECURITY SYSTEM SERVER



The security system server at the Public Safety Building is outdated, insufficient for current needs, and requires replacement. The server serves as storage for city security cameras as well as for critical interview room camera footage.

**Operating Budget Impact:** None Identified

**Source:** Facilities Maintenance

**Submitted by:** Facilities

	FY 2021	FY 2022	FY 2023	FY 2024	FY 2025	FY 2026	TOTAL
<b>Funding Source:</b>							
General Fund - Facilities		\$60,000					\$60,000
<b>TOTAL FUNDING</b>		<b>\$60,000</b>					<b>\$60,000</b>



### PUBLIC SAFETY BUILDING SOUTH ENTRANCE DOOR REPLACEMENT

The Public Safety Building entrance doors closest to the community room are in disrepair, as are a few windows in the community room.

- Operating Budget Impact:** None identified
- Source:** Facilities Maintenance
- Submitted by:** Facilities

	FY 2021	FY 2022	FY 2023	FY 2024	FY 2025	FY 2026	TOTAL
<b>Funding Source:</b>							
General Fund - Facilities		\$25,000					\$25,000
<b>TOTAL FUNDING</b>		<b>\$25,000</b>					<b>\$25,000</b>

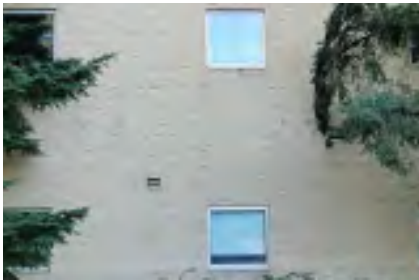

### PUBLIC SAFETY BUILDING EXTERIOR PAINT

The exterior walls of the Public Safety Building will require painting in 2023.

- Operating Budget Impact:** None Identified
- Source:** Facilities Maintenance
- Submitted by:** Facilities

	FY 2021	FY 2022	FY 2023	FY 2024	FY 2025	FY 2026	TOTAL
<b>Funding Source:</b>							
General Fund - Facilities			\$35,000				\$35,000
<b>TOTAL FUNDING</b>			<b>\$35,000</b>				<b>\$35,000</b>



### NEW CITY HALL WINDOW SEALS

The new City Hall building will require the window seals on the west side be replaced, which will involve hiring a contractor to address the seals from the outside.

- Operating Budget Impact:** None Identified
- Source:** Facilities Maintenance
- Submitted by:** Facilities

	FY 2021	FY 2022	FY 2023	FY 2024	FY 2025	FY 2026	TOTAL
<b>Funding Source:</b>							
City Hall Fund		\$20,000					\$20,000
<b>TOTAL FUNDING</b>		<b>\$20,000</b>					<b>\$20,000</b>



### NEW CITY HALL REMODEL

The city hall building requires interior work to meet the needs of the city. The scope primarily involves adding a council chambers, reception and permitting areas, security measures, and compatibility upgrades to the HVAC system.

**Operating Budget Impact:** None Identified

**Source:** Facilities Maintenance

**Submitted by:** Facilities

	FY 2021	FY 2022	FY 2023	FY 2024	FY 2025	FY 2026	TOTAL
<b>Funding Source:</b>							
City Hall Fund - Art in Public Places		\$100,000					\$100,000
City Hall Fund			\$1,200,000				\$1,200,000
<b>TOTAL FUNDING</b>		<b>\$100,000</b>	<b>\$1,200,000</b>				<b>\$1,300,000</b>



### JOHNSON CREEK CAMPUS BUILDING REMODEL

The building at the Johnson Creek Campus is due for repainting, carpet replacement, and workstation and public-facing adjustments.

**Operating Budget Impact:** None Identified

**Source:** Facilities Maintenance

**Submitted by:** Facilities

	FY 2021	FY 2022	FY 2023	FY 2024	FY 2025	FY 2026	TOTAL
<b>Funding Source:</b>							
General Fund - Facilities			\$10,000				\$10,000
<b>TOTAL FUNDING</b>			<b>\$10,000</b>				<b>\$10,000</b>



### JOHNSON CREEK CAMPUS SOLAR ARRAY INSTALLATION

Installation of a solar array at the Johnson Creek Campus to offset energy usage and further the city's decarbonization goals. It's anticipated that this will be a roof top installation and will take advantage of the open roof space at the campus.

**Operating Budget Impact:** Unknown

**Source:** Facilities

**Submitted by:** Facilities

	FY 2021	FY 2022	FY 2023	FY 2024	FY 2025	FY 2026	TOTAL
<b>Funding Source:</b>							
General Fund - Facilities				\$375,000			\$375,000
<b>TOTAL FUNDING</b>				<b>\$375,000</b>			<b>\$375,000</b>

## VEHICLE PURCHASES

The Public Works Fleet Division works constantly to ensure the profile of the fleet matches the needs, goals, and budgetary restrictions of the organization. The fleet needs to be right-sized as well as regularly evaluated for reduction or addition. Vehicles are examined through a number of filters to establish need:

- *Is the vehicle near the end of its useful life (typically 8-10 years or 100,000 miles)?*
- *How many miles per year does the vehicle travel? Is it low-use and could it be combined with another vehicle?*
- *What is the condition of the vehicle? Are repair costs anticipated? Is the vehicle value approaching 30% of residual value?*
- *Does the vehicle serve a critical function (snowplow, emergency response, etc.)?*
- *Is the vehicle task-specific? Could the function be subcontracted at a lower cost than the purchase and maintenance of a vehicle?*
- *Is it a passenger or light-duty vehicle that could be replaced with an EV or hybrid?*

Police Department includes three vehicle replacements at \$100,000 per year. FY 2021 includes an outstanding Purchase Order from FY 2020.

City Manager Department and Community Development Department includes \$20,000 in relation to the community engagement goal and site inspection/visits, respectively.

Public Works vehicle purchases include both Division-specific equipment as well as shared utility vehicles.

### FY 2021

- Utility shared 1-ton dump truck – \$60,000. Vehicle is 20 years old. Used for hauling excavation materials, rock for repairs, leaf debris, and equipment.
- PHEV Van for the Cross-Connection Specialist position –\$41,000. Vehicle was ordered but unavailable for delivery in FY 2020.
- PHEV Van for the Police Department – \$41,000. In addition to the \$150,000/year budget, as it was ordered but unavailable for delivery in FY 2020.

### FY 2022

- Utility wastewater service truck – \$60,000. Vehicle is 10 years old with 73k miles.
- Utility water chase truck – \$60,000. Vehicle is 10 years old with 50k miles.



- Utility wastewater VacCon truck – \$575,000. A 2008 vehicle that is heavily used. Maintenance on this vehicle is very expensive and it does not meet current diesel emission standards.
- General Fund CD staff vehicle – \$20,000. Vehicle is 2007, will convert to EV.

### FY 2023

- Utility shared 5-yard dump truck and plow – \$140,000. Vehicle is approaching 30 years old and does not meet current diesel standards. Used for moving spoils, materials to and from job sites, and plowing snow.
- Utility shared 5-yard dump truck and plow – \$140,000. Vehicle is approaching 30 years old and does not meet current diesel standards. Used for moving spoils, materials to and from job sites, and plowing snow.
- Utility shared backhoe – \$125,000
- Utility streets utility 2 truck – \$60,000

### FY 2024

- Utility water chase truck – \$40,000
- Utility streets sign shop truck – \$60,000
- Utility water van – \$60,000
- Utility stormwater utility crane truck – \$55,000
- Utility shared flatbed – \$60,000
- General Fund Engineering vehicle – \$40,000

### FY 2025

- Utility Stormwater Vactor Truck – \$575,000.
- A 2012 vehicle that is heavily used. Maintenance on this vehicle is very expensive.

**Operating Budget Impact:** General Maintenance

**Source:** Fleet Maintenance **Submitted by:** Fleet & Facilities

	FY 2021	FY 2022	FY 2023	FY 2024	FY 2025	FY 2026	TOTAL
<b>Funding Source:</b>							
General Fund	\$161,000	\$120,000	\$100,000	\$140,000	\$100,000		\$621,000
Stormwater	\$15,000		\$102,000	\$70,000	\$575,000		\$762,000
Transportation	\$15,000		\$162,000	\$75,000			\$252,000
Wastewater	\$15,000	\$635,000	\$102,000	\$15,000			\$767,000
Water	\$56,000	\$60,000	\$102,000	\$115,000			\$333,000
<b>TOTAL FUNDING</b>	<b>\$262,000</b>	<b>\$815,000</b>	<b>\$568,000</b>	<b>\$415,000</b>	<b>\$675,000</b>		<b>\$2,735,000</b>



### CAMERA & DATA BACKUP STORAGE REPLACEMENT

Lifecycle replacement of storage for cameras and data backup.

**Operating Budget Impact:** Annual support and maintenance of 10% of purchase cost.

**Source:** Information Technology

**Submitted by:** Information Technology

	FY 2021	FY 2022	FY 2023	FY 2024	FY 2025	FY 2026	TOTAL
<b>Funding Source:</b>							
General Fund - IT	\$80,000	\$80,000					\$160,000
<b>TOTAL FUNDING</b>	<b>\$80,000</b>	<b>\$80,000</b>					<b>\$160,000</b>

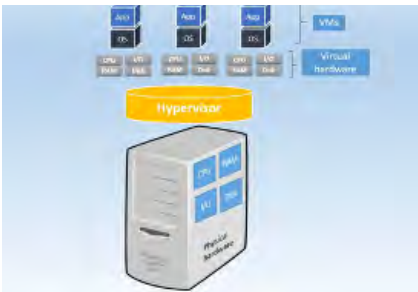

### SERVER REPLACEMENT

Servers are more than eight years old and due for lifecycle replacement.

**Operating Budget Impact:** None Identified

**Source:** Information Technology

**Submitted by:** Information Technology

	FY 2021	FY 2022	FY 2023	FY 2024	FY 2025	FY 2026	TOTAL
<b>Funding Source:</b>							
General Fund - IT		\$70,000					\$70,000
<b>TOTAL FUNDING</b>		<b>\$70,000</b>					<b>\$70,000</b>



### FIREWALL REPLACEMENT

A firewall is a network security device that monitors incoming and outgoing network traffic and decides whether to allow or block specific traffic based on a defined set of security rules.

Firewalls are a first line of defense in network security. They establish a barrier between secured and controlled internal networks that can be trusted and untrusted outside networks, such as the Internet.

Current firewalls have been in place for seven years by the replacement date and are scheduled for life cycle replacement.

**Operating Budget Impact:** None

**Source:** Information Technology

**Submitted by:** Information Technology

	FY 2021	FY 2022	FY 2023	FY 2024	FY 2025	FY 2026	TOTAL
<b>Funding Source:</b>							
General Fund - IT			\$75,000				\$75,000
<b>TOTAL FUNDING</b>			<b>\$75,000</b>				<b>\$75,000</b>

# CHAPTER 3

## COMMUNITY DEVELOPMENT

The Community Development Capital Improvement Plan identifies infrastructure improvements and other amenities that enhance the livability of the community. Projects within the chapter include parks, new community facilities, economic development, and urban renewal needs. Many of the capital improvement projects listed are in response to the growing demands of the community in housing, community, and economic development. With the 2016 passing of the Urban Renewal Plan the area parks, downtown and central Milwaukie infrastructure, wayfinding, and downtown enhancements will provide for a more walkable, accessible, and livable community.

### COMMUNITY DEVELOPMENT SUMMARY

PAGE	PROJECT NAME	FY 2020	FY 2021	FY 2022	FY 2023	FY 2024	FY 2025	TOTAL
76	Dogwood Park Improvements	\$ 10,000						10,000
76	Scott Park Master Plan & Implementation	60,000						60,000
77	Milwaukie Bay Park Final Design Implementation	250,000						250,000
77	Landbanking	50,000	50,000	50,000	50,000	50,000	50,000	300,000
<b>COMMUNITY DEVELOPMENT TOTAL BEFORE GRANTS</b>		<b>\$ 370,000</b>	<b>50,000</b>	<b>50,000</b>	<b>50,000</b>	<b>50,000</b>	<b>50,000</b>	<b>\$ 620,000</b>

### METRO BOND SUMMARY

PAGE	PROJECT NAME	FY 2021	FY 2022	FY 2023	FY 2024	FY 2025	FY 2026	TOTAL
76	Dogwood Park Improvements	\$ 60,000						60,000
76	Scott Park Master Plan & Implementation		317,000					317,000
77	Milwaukie Bay Park Final Design Implementation		750,000					750,000
<b>METRO BOND TOTAL</b>		<b>\$ 60,000</b>	<b>1,067,000</b>					<b>\$ 1,127,000</b>

<b>COMMUNITY DEVELOPMENT TOTAL</b>		<b>\$ 430,000</b>	<b>1,117,000</b>	<b>50,000</b>	<b>50,000</b>	<b>50,000</b>	<b>50,000</b>	<b>\$ 1,747,000</b>
------------------------------------	--	-------------------	------------------	---------------	---------------	---------------	---------------	---------------------



### DOGWOOD PARK IMPROVEMENTS

Capital projects constructed in South Downtown throughout 2018 and 2019 created a new plaza adjacent to the park and the addition of a retaining wall at the southern end as Main Street passes under the railroad overcrossing. Construction staging also took place in the park. Through a joint planning project with NCPRD, a framework plan is being created to help integrate Dogwood Park into the new built environment in South Downtown along with the Coho Point development site to the north.

The estimated total project cost is \$245,000.

**Operating Budget Impact:** *Unknown*

**Source:** *DRFP, URAP*

**Submitted by:** *City Manager's Office*

	FY 2021	FY 2022	FY 2023	FY 2024	FY 2025	FY 2026	TOTAL
<b>Funding Source:</b>							
General Fund	\$10,000						\$10,000
Metro Parks Bond - Local Share Allocation	\$60,000						\$60,000
<b>TOTAL FUNDING</b>	<b>\$70,000</b>						<b>\$70,000</b>



### SCOTT PARK MASTER PLAN & IMPLEMENTATION

This project would fund the improvements to Scott Park identified in a revised Master Plan. The Master Plan update is funded by the North Clackamas Parks and Recreation District.

The estimated project cost is approximately \$580,000. The city anticipates working with NCPRD on grant funding to help round out the budget after the master plan update is complete.

**Operating Budget Impact:** *Unknown*

**Source:** *DRFP, Grants*

**Submitted by:** *Community Development, Planning*

	FY 2021	FY 2022	FY 2023	FY 2024	FY 2025	FY 2026	TOTAL
<b>Funding Source:</b>							
General Fund	\$60,000						\$60,000
Metro Parks Bond - Local Share Allocation		\$317,000					\$317,000
<b>TOTAL FUNDING</b>	<b>\$60,000</b>	<b>\$317,000</b>					<b>\$377,000</b>



## MILWAUKIE BAY PARK

### Final Design Implementation

Implementation of North Clackamas Parks and Recreation District's (NCPRD) final design of Milwaukie Bay Park.

The total estimated project cost is nearly \$9,693,000. The majority of project funding will come from grants secured by NCPRD, parks SDCs collected by the district and local share funds rprovided via Metro's regional parks bond.

**Operating Budget Impact:** The project will increase the park's operating expenses.

**Source:** DRFP, Grants

**Submitted by:** Community Development, Engineering, Public Works, City Manager

	FY 2021	FY 2022	FY 2023	FY 2024	FY 2025	FY 2026	TOTAL
<b>Funding Source:</b>							
General Fund	\$250,000						\$250,000
Metro Parks Bond - Local Share Allocation		\$750,000					\$750,000
<b>TOTAL FUNDING</b>	<b>\$250,000</b>	<b>\$750,000</b>					<b>\$1,000,000</b>



## LAND BANKING

### Affordable Housing

Opportunity Site funding for acquisition and development of city owned land for the purpose of building affordable housing.

**Operating Budget Impact:** Land acquisition may add additional costs associated with maintenance.

**Source:** General Fund

**Submitted by:** Community Development

	FY 2021	FY 2022	FY 2023	FY 2024	FY 2025	FY 2026	TOTAL
<b>Funding Source:</b>							
General Fund	\$50,000	\$50,000					\$100,000
<b>TOTAL FUNDING</b>	<b>\$50,000</b>	<b>\$50,000</b>					<b>\$100,000</b>





# CHAPTER 4

## UNFUNDED

*The unfunded chapter includes projects from city plans that do not have identified resources at this time. We include unfunded projects in the CIP to help inform future grant applications and inform discussions about funding allocations through sources not currently available to the city. At this time, funds that may become available for capital projects over the FY 21-26 include urban renewal bonds, state or federal infrastructure stimulus and competitive grants.*

*A number of projects programmed for FY 23 through FY 26 assume issuing bonds in late FY 22. Should those bonds fail to materialize, or other significant reductions in funding occur after adoption of the budget, projects will need to be deferred or defunded until resources can be identified.*



## UNFUNDED SUMMARY

PAGE	POTENTIAL FUNDING SOURCE	PROJECT NAME	ESTIMATED COST (2016 COST)
82	URA	29 <sup>th</sup> Avenue Bicycle/Pedestrian Connection	3,000,000
82	Transportation	29 <sup>th</sup> Avenue Bicycle/Pedestrian Connection	400,000
82	SAFE	37 <sup>th</sup> Avenue Pedestrian Improvements (Lake Road to Harrison Street)	240,600
82	Transportation	37 <sup>th</sup> Avenue Pedestrian Improvements (Lake Road to Harrison Street)	212,000
82	SSMP	37 <sup>th</sup> Avenue Pedestrian Improvements (Lake Road to Harrison Street)	91,800
83	URA (CD)	Central Milwaukie Transit Improvements	500,000
83	URA (CD)	Downtown and Central Milwaukie Enhancements	1,300,000
84	Transportation	Downtown Parking Solutions	4,163,000
84	URA	Downtown Parking Solutions	10,500,000
84	Unfunded (CD)	Fiber Optic Service	TBD
84	Transportation	Harrison Street Capacity Improvements (32 <sup>nd</sup> Avenue to 42 <sup>nd</sup> Avenue)	3,769,000
85	Transportation	Hwy 224 & Hwy 99 Improvements	4,008,000
85	URA	Hwy 224 & Hwy 99 Improvements	5,000,000
85	Safe	Island Station Neighborhood Greenway	357,600
85	Transportation	Island Station Neighborhood Greenway	2,714,000
72	Unfunded (F&F)	JCB Campus Solar Array	375,000
86	Transportation (CD)	Kellogg Creek Dam Removal/Hwy 99 Underpass	8,900,000
86	URA (CD)	Kellogg Creek Dam Removal/Hwy 99 Underpass	1,000,000
86	Unfunded (CD)	Kellogg Creek Dam Removal/Hwy 99 Underpass	551,000
86	SAFE	Lake Road SAFE Improvements (Where Else Lane to Railroad Ave)	215,400
86	Transportation	Lake Road SAFE Improvements (Where Else Lane to Railroad Ave)	1,298,600
86	Transportation	Lake Road/Harmony Road Intersection	21,260,000
86	SAFE	Lake Road/Harmony Road Intersection	350,000
87	LID/URA/Grants	McBrod Avenue Green Street	3,762,000
87	Transportation	Milwaukie Bay Park Trail Improvements	TBD
88	General Fund/UR/LID/MTIP/CIP (CD)	NMIA Branding and Wayfinding	750,000

PAGE	POTENTIAL FUNDING SOURCE	PROJECT NAME	ESTIMATED COST (2016 COST)
88	General Fund/Grants (CD)	NMIA District Gateway Improvements	TBD
89	Transportation	NMIA Intersection Improvements	2,261,000
90	Unfunded (CD)	NMIA Johnson Creek to Milwaukie Bay Park Greenway Connection	TBD
89	Transportation	NMIA McLoughlin Green Street Demonstration	20,726,000
90	Grants/UR/Private	NMIA Sewer Mining District/Treatment Plant	7,500,000
90	Transportation	Oak Street/34 <sup>th</sup> Avenue Connection	106,000
91	Transportation	Ochoco Street/Roswell Street Connection (NMIA)	TBD
68	Unfunded (F&F)	Public Safety Building Seismic Retrofit	1,000,000
91	SAFE	Railroad Avenue Bicycle/Pedestrian Overpass	226,000
91	Transportation	Railroad Avenue Bicycle/Pedestrian Overpass	2,736,000
87	Transportation	Riverfront Trail Improvements (AKA Kellogg Creek Trail Improvements; Milwaukie Bay Park to 19 <sup>th</sup> Avenue)	87,000
92	Transportation	Springwater Corridor Connection Improvements	7,994,200
93	TGM Grant	Stanley Avenue Neighborhood Greenway	200,000
93	SAFE	Stanley Avenue Neighborhood Greenway	483,000
93	Transportation	Stanley Avenue Neighborhood Greenway	6,449,000
93	URA (CD)	Wayfinding Phase 2 & 3 Final Implementation	200,000
<b>UNFUNDED TOTAL</b>			<b>131,686,200</b>



## 29TH AVENUE BICYCLE/PEDESTRIAN CONNECTION

### 29th Avenue to Railroad Avenue

Provide bicycle and pedestrian connections from 29th Avenue to the Railroad Avenue multiuse path, including:

- A north/south bicycle and pedestrian connection through the Murphy site that connects to 29th Avenue;
- Pedestrian/bicycle treatments on Campbell Street and Railroad Avenue between Monroe Street and Harrison Street. This is the natural direct bicycle connection between the two Central Milwaukie opportunity sites – the Murphy Site and the McFarland Site;
- A bicycle crossing on Harrison Street between Campbell Street and 31st Avenue; and
- A multiuse trail from Oak Street to 37th Avenue connecting the Railroad Avenue multiuse path with the Monroe Street Greenway and the 29th Avenue Greenway.

Exact locations to be determined by future development and a planning project that will take place in FY 2021.

**Operating Budget Impact:** *This project would increase operational expenses by increasing infrastructure.*

**Source:** TSP, CMLUTP, URAP

**Submitted by:** Community Development, Engineering, Planning

**Status:** Unfunded **Potential Funding Sources:** Transportation, Urban Renewal Area

**Estimated Capital Cost:** \$3,400,000



## 37TH AVENUE IMPROVEMENTS

### Harrison Street to International Way

Fill in sidewalk gaps on both sides of the street, replace portions of existing sidewalk, and remove barriers between Harrison Street and International Way. Complete a roadway overlay between International Way and Railroad Avenue, and between Monroe Street to Harrison Street.

**Operating Budget Impact:** *This project will potentially increase ongoing operational needs due to the addition of new infrastructure.*

**Source:** SAFE, SSMP, BPAP, TSP, RTP (#10096)

**Submitted by:** Engineering

**Status:** Unfunded

**Potential Funding Sources:** SAFE, SSMP, Transportation (State Gas Tax)

**Estimated Capital Cost:** \$550,000



### CENTRAL MILWAUKIE TRANSIT STOP IMPROVEMENTS

This project would provide transit shelters as sites are developed and ensure excellent transit service to Central Milwaukie. It would also add Transit Tracker and LED lighting units at main stops along bus routes.

**Operating Budget Impact:** None. Anticipated to be owned and maintained by TriMet under an IGA.

**Source:** URAP

**Submitted by:** Community Development, Planning

**Status:** Unfunded

**Potential Funding Sources:** Urban Renewal Area

**Estimated Capital Cost:** \$500,000



### DOWNTOWN AND CENTRAL MILWAUKIE ENHANCEMENTS

This project would focus on design, planning, and capital projects related to the downtown Main Street corridor and Central Milwaukie to provide improved access to opportunity sites, gateway/entryway improvements, (banners, flower baskets, etc.), and pedestrian amenities.

**Operating Budget Impact:** This project will potentially increase ongoing operational needs due to the addition of new infrastructure.

**Source:** URAP, TSP

**Submitted by:** Community Development, Planning

**Status:** Unfunded

**Potential Funding Sources:** Urban Renewal Area

**Estimated Capital Cost:** \$1,300,000



## DOWNTOWN PARKING SOLUTIONS

Implement parking management strategy for the downtown including parking meters, signage, enforcement, and potentially assistance in the development of structured parking as part of a larger mixed-use development that would service downtown uses. Construct 3- to 4-story public parking structure with retail at ground floor for visitor/employee parking. The purpose is to expand off-street parking supply downtown.

**Operating Budget Impact:** *The project would increase operational expenses by adding infrastructure.*

**Source:** TSP, RTP (#11175)

**Submitted by:** Community Development, Engineering

**Status:** Unfunded

**Potential Funding Sources:** Transportation, Urban Renewal Area

**Estimated Capital Cost:** \$14,663,000



## FIBER OPTIC SERVICE

### *NMIA and Downtown Milwaukie*

Extend high speed fiber optic service to the NMIA and Downtown Milwaukie as funding becomes available. Clackamas County's Economic Development division oversees the implementation funding for Dark Fiber and staff will work with them on funding allocation and grant writing.

**Operating Budget Impact:** *The project will potentially increase ongoing operational needs due to the addition of new infrastructure.*

**Source:** NMIA

**Submitted by:** Community Development

**Status:** Unfunded

**Potential Funding Sources:** TBD

**Estimated Capital Cost:** TBD



## HARRISON STREET CAPACITY IMPROVEMENTS

### *McLoughlin Boulevard to 42nd Avenue*

Widen to standard three lane cross-section with bike lanes, filling in last portion of on-street bike lanes along one of the City's principle arterials.

**Operating Budget Impact:** *This project will potentially increase ongoing operational needs due to the addition of new infrastructure.*

**Source:** Engineering

**Submitted by:** Engineering

**Status:** Unfunded

**Potential Funding Sources:** Transportation

**Estimated Capital Cost:** \$4,300,000



## HWY 224 & HWY 99E IMPROVEMENTS

### PLANNING

#### HWY 224 & HWY 99E REFINEMENT PLAN

Conduct refinement study to establish alternative mobility targets for Hwy 224 and McLoughlin Boulevard (Hwy 99) for locations not meeting applicable state targets, and explore ways to minimize barrier effect and improve pedestrian, auto, and freight mobility.

#### HWY 224 UPGRADES

*Pedestrian Improvements at Hwy 224:* This project will reconfigure the intersections of Harrison Street, Oak Street, 37th Avenue, and Freeman Way at Hwy 224 by adding left turn lanes and protected signal phasing on the local streets together with reconfiguring the intersections as needed to improve overall intersection functioning.

#### HWY 99 UPGRADES

*East Sidewalk Improvements:* Improve the east sidewalk from north of Harrison Street to Hwy 224. These improvements are to enhance pedestrian safety and signal visitors that they are entering downtown.

*Sidewalks from Harrison Street to UPRR:* Address gaps in pedestrian system and improve connection between downtown and Milwaukie Bay Park. Provide grade-separated crossing.

*Crosswalk/Intersection Upgrades:* Improve all existing crossings of McLoughlin Boulevard, using better signage, extended crossing times, and distinctive crosswalk paving. Construct improvements

at Harrison Street, Monroe Street, Jackson Street, Jefferson Street, and Washington Street to enhance bike/pedestrian crossings to the Trolley Trail and Milwaukie Bay Park.

*Intersection improvements at McLoughlin Boulevard and River Road:* Consolidate a single access point for the area at Bluebird Street with full intersection treatment and signalization or add second northbound left-turn lane at River Road to reduce congestion and improve safety.

Construct multiuse walkway from McLoughlin Boulevard to Kronberg Park Multiuse Path south of UPRR to complete pedestrian connection.

**Operating Budget Impact:** Unknown

**Source:** TSP, RTP (#11620, #11537, #10098, #11539, #11623), URAP, DRDP

**Submitted by:** Engineering

**Status:** Unfunded

**Potential Funding Sources:** Transportation, Urban Renewal Area

**Estimated Capital Cost:** \$9,008,000



## ISLAND STATION NEIGHBORHOOD GREENWAY

### 19th Avenue and Sparrow Street

Designate 19th Avenue and Sparrow Street as a neighborhood greenway and install traffic-calming improvements, utilizing a woonerf design together with typical traffic calming features, designated path and on street measures connecting the south end of Kellogg Creek Trail with the Trolley Trail via 19th Avenue and Sparrow Streets. Some work will be completed in 2021 with the River Road/22nd Avenue SAFE/SSMP project.

**Operating Budget Impact:** The project will potentially increase ongoing operational needs due to the addition of new infrastructure.

**Source:** TSP, RTP (#11622)

**Submitted by:** Engineering

**Status:** Unfunded

**Potential Funding Sources:** SAFE, Transportation

**Estimated Capital Cost:** \$3,071,600





## KELLOGG CREEK DAM REMOVAL & HWY 99 UNDERPASS

Revise or replace Hwy 99E bridge over Kellogg Creek, remove dam, restore fish passage and habitat. Construct bike/pedestrian undercrossing between Dogwood Park and Milwaukie Bay Park. This is a project in partnership with ODOT. The purpose is to reestablish fish migration into Kellogg Creek and to establish safer bicycle and pedestrian connection between downtown, the light rail station with Milwaukie Bay Park and the Trolley Trail.

**Operating Budget Impact:** *Unknown impact due to ODOT/city partnership and the need for an IGA in the future.*

**Source:** DRFP, TSP, RTP (#10101), URAP

**Submitted by:** Community Development, Engineering, Planning

**Status:** Unfunded

**Potential Funding Sources:** Transportation, Urban Renewal

**Estimated Capital Cost:** \$10,500,000



## LAKE ROAD SAFE IMPROVEMENTS

*Where Else Lane to Harmony Road/Railroad Avenue*

Fill in sidewalk gaps on both sides of street, widen to provide for standard three-way cross-section west of Hwy 224, fill in gaps in existing bicycle network with bike lanes, provide intersection improvements, and ADA ramps.

**Operating Budget Impact:** *This project will potentially increase ongoing operational needs due to the addition of new infrastructure.*

**Source:** BPAP, TSP, RTP (#10094)

**Submitted by:** Engineering

**Status:** Unfunded

**Potential Funding Sources:** SAFE, Transportation

**Estimated Capital Cost:** \$1,514,000

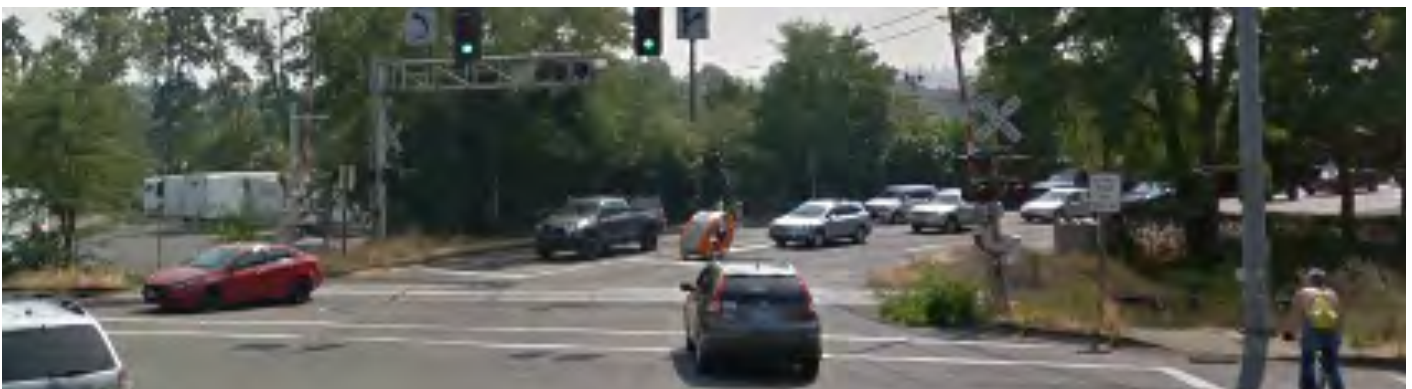

## LAKE ROAD/HARMONY ROAD/RAILROAD AVENUE INTERSECTION

Railroad crossing and intersection improvements based on further study of intersection operations, including bicycle and pedestrian facilities to be undertaken jointly by the City of Milwaukie and Clackamas County.

**Operating Budget Impact:** *This project will potentially increase ongoing operational needs due to the addition of new infrastructure.*

**Source:** RTP (#10000) **Submitted by:** Engineering, Clackamas County

**Status:** Unfunded **Potential Funding Sources:** SAFE, Transportation **Estimated Capital Cost:** \$21,610,000



### McBROD AVENUE GREEN STREET DEMONSTRATION PROJECT

Develop McBrod Avenue as a demonstration project that integrates green street/shared facility approaches to treat both right-of-way and adjacent development. Project would include continuous at-grade rail line, required reconstruction of existing rail infrastructure, together with the construction of an activated area between the rail line and the buildings.

**Operating Budget Impact:** Unknown rail impact.

**Source:** NMIA

**Submitted by:** Community Development

**Status:** Unfunded

**Potential Funding Sources:** Grants, Local Improvement District, Urban Renewal

**Estimated Capital Cost:** \$3,762,000



### MILWAUKIE BAY PARK TRAIL IMPROVEMENTS

Milwaukie Bay Park to 19th Avenue

Construct trail improvements to create an ADA-accessible path from the Milwaukie Bay Park to 19th Avenue.

**Operating Budget Impact:** None

**Source:** BPAP, ADA

**Submitted by:** Engineering

**Status:** Unfunded

**Potential Funding Sources:** Transportation

**Estimated Capital Cost:** TBD



### RIVERFRONT TRAIL IMPROVEMENTS (AKA KELLOGG CREEK TRAIL IMPROVEMENTS)

Milwaukie Bay Park to 19th Avenue

Construct trail improvements to create an ADA-accessible path from the Milwaukie Bay Park to 19th Avenue.

**Operating Budget Impact:** None

**Source:** BPAP, ADA

**Submitted by:** Engineering

**Status:** Unfunded

**Potential Funding Sources:** Transportation

**Estimated Capital Cost:** \$87,000



## NMIA BRANDING AND WAYFINDING

### North Milwaukie Innovation Area (NMIA)

Develop a wayfinding and branding strategy that builds upon the historic industrial, rail, and natural resources of the NMIA, and focuses on businesses that encourage transit use, pedestrian, and bicycling as modes of travel to seek funding for implementation via CIP. Potential wayfinding sections would include McLoughlin Boulevard, Ochoco Street, Mailwell Drive, Main Street, Tacoma Street, McBrod Avenue, Frontage Street, and others following intersection improvements.

**Operating Budget Impact:** Project would have a minor increase to ongoing sign maintenance operations.

**Source:** NMIA Plan

**Submitted by:** Community Development, Public Works

**Status:** Unfunded

**Potential Funding Sources:** General Fund, Urban Renewal, Local Improvement District (LID), Metropolitan Transportation Improvement Program (MTIP), Capital Improvement

**Estimated Capital Cost:** \$750,000

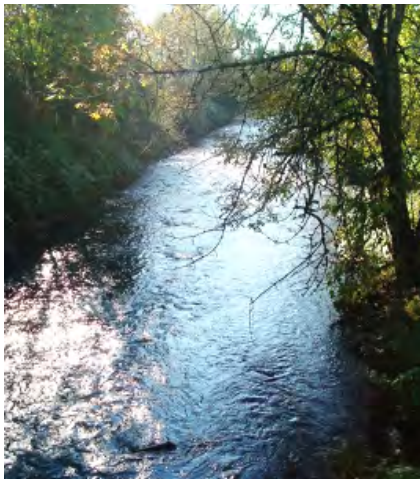

## NMIA DISTRICT GATEWAY IMPROVEMENTS

### North Milwaukie Innovation Area

Identify landscape and streetscape enhancements that help address flooding and enhance key gateways to the NMIA District and near significant public use areas such as Johnson Creek.

**Operating Budget Impact:** Unknown

**Source:** NMIA Plan

**Submitted by:** Community Development, Planning

**Status:** Unfunded

**Potential Funding Sources:** General Fund, Grants

**Estimated Capital Cost:** TBD



## NMIA INTERSECTION IMPROVEMENTS

Reduce congestion, improve accessibility for freight, and improve safety through signage and intersection improvements in the North Milwaukie Innovation Area:

- Establish signage for trucks and improve intersection at McLoughlin Boulevard and Ochoco Street.
- Upgrade intersection turning radii to better accommodate freight movements at Main Street and Mailwell Drive.
- Prohibit left turn movement from 17th Avenue to northbound McLoughlin Boulevard at 17th Avenue and McLoughlin Boulevard.

**Operating Budget Impact:** No applicable increase in operating expenses.

**Source:** TSP, NMIA Plan

**Submitted by:** Engineering

**Status:** Unfunded

**Potential Funding Sources:** Transportation

**Estimated Capital Cost:** \$2,261,000

## NMIA McLOUGHLIN BOULEVARD GREEN STREET DEMONSTRATION

[Downtown Milwaukie to Springwater Corridor Bridge](#)



Partner with ODOT to develop a green street demonstration project for McLoughlin Boulevard between Downtown Milwaukie and the Springwater Corridor Pedestrian Bridge.

**Operating Budget Impact:** Unknown

**Source:** NMIA Plan

**Submitted by:** Community Development, Planning, Engineering, Public Works

**Status:** Unfunded

**Potential Funding Sources:** Transportation

**Estimated Capital Cost:** \$20,726,000



### NMIA JOHNSON CREEK TO MILWAUKIE BAY PARK GREENWAY CONNECTION

#### *North Milwaukie Innovation Area (NMIA) to Milwaukie Bay Park*

Connect Johnson Creek Park to Milwaukie Bay Park via a greenway trail along Johnson Creek and McBrod Avenue. The trail would terminate at the multiuse path along 17th Avenue.

**Operating Budget Impact:** Project would increase maintenance requirements with the addition of a new multiuse facility.

**Source:** NMIA Plan

**Submitted by:** Community Development, Planning

**Status:** Unfunded

**Potential Funding Sources:** TBD

**Estimated Capital Cost:** TBD



### NMIA SEWER MINING DISTRICT

Create a sewer mining district that connects to the sewer main line at the southwest corner of the North Milwaukie Innovation Area to reduce wastewater flow to the city main treatment system. The project would include a treatment plant and distribution system to return treated water to customers for use in non-potable applications.

**Operating Budget Impact:** This project would have a significant impact on maintenance operations by the addition of a treatment plant and a separated distribution system for the NMIA. Additional staff and equipment would need to be hired by the city.

**Source:** NMIA Plan

**Submitted by:** Community Development, Public Works

**Status:** Unfunded

**Potential Funding Sources:** Grants, Urban Renewal, Private Business Funding

**Estimated Capital Cost:** \$7,500,000

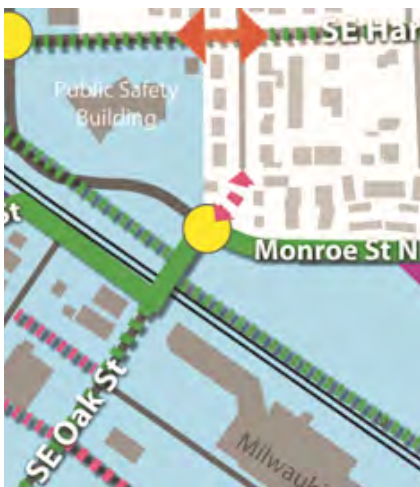

### OAK STREET & 34TH AVENUE CONNECTION

Provide a pedestrian and bicycle connection between Monroe Street and 34th Avenue, including access for a nearby residential neighborhood.

**Operating Budget Impact:** This project will increase operational expenses with construction of new infrastructure.

**Source:** TSP, CMLUTP

**Submitted by:** Community Development, Engineering

**Status:** Unfunded

**Potential Funding Sources:** Transportation

**Estimated Capital Cost:** \$106,000



### OCHOCO STREET/ROSWELL STREET CONNECTION (NMIA)

Extend bicycle and pedestrian connections along Ochoco Street to Roswell Street across the railroad tracks to improve connectivity and circulation to/from the project area.

**Operating Budget Impact:** This project constructs a new bridge and supporting infrastructure, increasing operational expenses.

**Source:** NMIA Plan

**Submitted by:** Community Development, Planning, Engineering, Public Works

**Status:** Unfunded

**Potential Funding Sources:** Transportation

**Estimated Capital Cost:** TBD

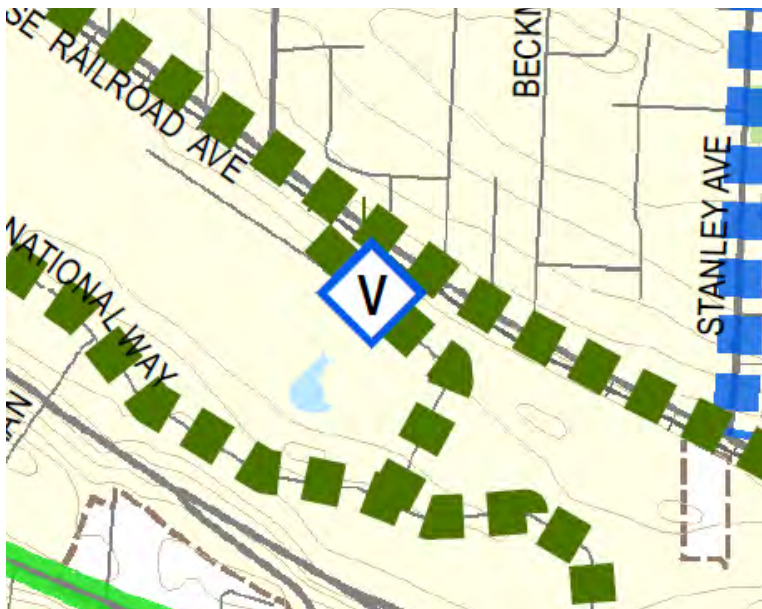

### RAILROAD AVENUE BICYCLE/PEDESTRIAN OVERPASS

*Railroad Avenue and International Way*

Establish a dedicated bicycle and pedestrian connection across Railroad Avenue and the railroad tracks that connects Railroad Avenue with International Way and connections to transit. The purpose of this project is to improve north-south bicycle and pedestrian connections, and enhance the accessibility to transit, and the Milwaukie Business Employment area.

**Operating Budget Impact:** Project would add infrastructure by constructing a new multiuse path.

**Source:** TSP, RTP (#11533), SAFE

**Submitted by:** Engineering

**Status:** Unfunded

**Potential Funding Sources:** SAFE, Transportation

**Estimated Capital Cost:** \$2,962,000



## SPRINGWATER CORRIDOR CONNECTIONS IMPROVEMENTS

### Springwater Corridor to Tacoma Station Area

Enhance bicycle and pedestrian facilities within residential neighborhood and establish bicycle and pedestrian connections from Springwater Corridor Trail to Tacoma Station Area.

- Improved connection from Springwater Trail to Pendleton Site (Ramps) – Construct ramps to improve existing connection of Springwater Trail to Pendleton site at Clatsop Street.
- Improved connection from Springwater Trail to Pendleton Site (Widened Undercrossing) – Widen existing undercrossing to improve connection of Springwater Trail to Pendleton site at Clatsop Street.
- Improved connection from Springwater Trail to Pendleton Site (Tunnel) – Construct tunnel under Springwater Trail to improve connection to Pendleton site at Clatsop Street.
- Improved connection from Springwater Trail to McLoughlin Boulevard – Construct stairs or other facility to connect Springwater Trail to west side of McLoughlin Boulevard.
- Bicycle/Pedestrian Improvements to Main Street – Construct multiuse path or other improved bike/ped facilities to Main Street to provide safer connection between downtown Milwaukie and Tacoma Station.
- Bicycle/Pedestrian connection over Johnson Creek – Construct bike/ped bridge over Johnson Creek along Clatsop Street at 23rd Avenue to connect Tacoma Station area with adjacent neighborhood.
- Improved Bicycle/Pedestrian connections on West Side of Tacoma Station Area – Improve bike/ped connections to adjacent neighborhood to west of Tacoma Station area at Ochoco Street and Milport Road.

**Operating Budget Impact:** *This project will potentially increase ongoing operational needs due to the addition of new infrastructure.*

**Source:** TSP, RTP (#11174), NMIA Plan

**Submitted by:** Engineering

**Status:** Unfunded

**Potential Funding Sources:** Transportation

**Estimated Capital Cost:** \$7,994,200



### STANLEY AVENUE NEIGHBORHOOD GREENWAY

Fill in sidewalk gaps on both sides of street, provide for bicycles with design to accommodate a neighborhood greenway, and install traffic-calming improvements. Project needs planning effort to determine desired design concept.

**Operating Budget Impact:** *Unknown*

**Source:** *TSP, RTP (#10094)*

**Submitted by:** *Engineering*

**Status:** *Unfunded*

**Potential Funding Sources:** *TGM Grant, SAFE, Transportation*

**Estimated Capital Cost:** *\$7,132,000*



### WAYFINDING PHASE 2 & 3 FINAL IMPLEMENTATION

*Downtown Gateway, Wayfinding, and Interpretive Heritage Plaques*

Fund the full implementation of Phases 2 and 3 of the downtown Wayfinding Systems Plan, including the installation of gateway/entryway signage at the north and south entrances to downtown along McLoughlin Boulevard such as plantings, lighting, and related improvements to draw more traffic off of McLoughlin Boulevard and into the downtown area. Wayfinding signage in the downtown will include kiosks to aid residents and visitors in exploring Milwaukie by providing easy access to cultural and recreational opportunities within an area that can be easily accessed by foot, bicycle, and transit. This project would also fund the installation of interpretive heritage plaques.

**Operating Budget Impact:** *This project would create a minor increase to ongoing sign maintenance operations.*

**Source:** *URAP, DRFP*

**Submitted by:** *Community Development, Planning*

**Status:** *Unfunded*

**Potential Funding Sources:** *Urban Renewal, Undesignated*

**Estimated Capital Cost:** *\$200,000*





PROJECT ELEMENT	PROJECT NAME	PAGE
<b>TRANSPORTATION</b>		
22 <sup>nd</sup> Avenue SAFE (McLoughlin Boulevard to Sparrow Street)	22 <sup>nd</sup> Avenue & River Road SAFE Improvements	23
22 <sup>nd</sup> Avenue SSMP (McLoughlin Boulevard to Sparrow Street)	22 <sup>nd</sup> Avenue & River Road SAFE Improvements	23
23 <sup>rd</sup> Avenue & Willard Street (Lake Road to 27 <sup>th</sup> Avenue)	Lake Road Improvements	27
26 <sup>th</sup> Avenue SAFE (Lake Road to Lake Village Apartments)	Milwaukie / El Puente SRTS Improvements	43
26 <sup>th</sup> Avenue SSMP (Lake Road to Lake Village Apartments)	Milwaukie / El Puente SRTS Improvements	43
27 <sup>th</sup> Avenue SAFE (Lake Road to Washington Street)	Milwaukie / El Puente SRTS Improvements	43
27 <sup>th</sup> Avenue SSMP (Lake Road to Washington Street)	Milwaukie / El Puente SRTS Improvements	43
28 <sup>th</sup> Avenue & Van Water Street SAFE (Springwater Trail to 32 <sup>nd</sup> Avenue)	Ardenwald North Improvements	39
28 <sup>th</sup> Avenue & Van Water Street SSMP (Springwater Trail to 32 <sup>nd</sup> Avenue)	Ardenwald North Improvements	39
32 <sup>nd</sup> Avenue SAFE (Van Water Street to Roswell Street)	Ardenwald North Improvements	39
32 <sup>nd</sup> Avenue SSMP (Van Water Street to Roswell Street)	Ardenwald North Improvements	39
32 <sup>nd</sup> Avenue SAFE (Roswell Street to Railroad Avenue)	Ardenwald South Improvements	51
32 <sup>nd</sup> Avenue SSMP (Roswell Street to Railroad Avenue)	Ardenwald South Improvements	51
40 <sup>th</sup> Avenue SSMP (Harvey Street to King Road)	Logus Road & 40 <sup>th</sup> Avenue Improvements	45
42 <sup>nd</sup> Avenue SAFE (Johnson Creek Boulevard to Harvey Street)	42 <sup>nd</sup> Avenue & 43 <sup>rd</sup> Avenue Improvements	24
42 <sup>nd</sup> Avenue SSMP (Monroe Street to King Road)	Logus Road & 40 <sup>th</sup> Avenue Improvements	45
43 <sup>rd</sup> Avenue SAFE (Howe Street to Covell Street, Covell Street)	SAFE & SSMP FY 2026 Improvements	59
43 <sup>rd</sup> Avenue SAFE (King Road to Howe Street, Howe Street)	42 <sup>nd</sup> Avenue & 43 <sup>rd</sup> Avenue Improvements	24
43 <sup>rd</sup> Avenue SSMP (King Road to Howe Street, Howe Street)	42 <sup>nd</sup> Avenue & 43 <sup>rd</sup> Avenue Improvements	24
43 <sup>rd</sup> Avenue SSMP (Howe Street to Covell Street, Covell Street)	SAFE & SSMP FY 2026 Improvements	59
49 <sup>th</sup> Avenue SAFE (King Road to Logus Road)	SAFE & SSMP FY 2026 Improvements	59
49 <sup>th</sup> Avenue SSMP (King Road to Logus Road)	SAFE & SSMP FY 2026 Improvements	59
51 <sup>st</sup> Avenue SAFE (Logus Road to Winworth Court)	SAFE & SSMP FY 2026 Improvements	59
51 <sup>st</sup> Avenue SSMP (Logus Road to Winworth Court)	SAFE & SSMP FY 2026 Improvements	59
Balfour Street SAFE (32 <sup>nd</sup> Avenue to Balfour Park)	Ardenwald South Improvements	51
Balfour Street SSMP (32 <sup>nd</sup> Avenue to Balfour Park)	Ardenwald South Improvements	51
Brookside Drive & Winsor Drive SAFE (Johnson Creek Blvd to Willow Street)	Lewelling North SAFE & SSMP	54
Brookside Drive & Winsor Drive SSMP (Johnson Creek Blvd to Willow Street)	Lewelling North SAFE & SSMP	54
Downtown Curbs (Main Street at Monroe Street)	Downtown Curbs	25
Downtown Public Area Requirements (Main Street & Washington Street)	Downtown Public Area Requirements	40
Edison Street SAFE (Hwy 224 to 35 <sup>th</sup> Avenue)	SAFE & SSMP FY 2021 Improvements	31
Edison Street SSMP (Hwy 224 to 35 <sup>th</sup> Avenue)	SAFE & SSMP FY 2021 Improvements	31
FRA Quiet Zone Study	FRA Quiet Zone Study	25
Harvey Street SAFE (32 <sup>nd</sup> Avenue to 42 <sup>nd</sup> Avenue)	Harvey Street Improvements	41
Harvey Street SSMP (32 <sup>nd</sup> Avenue to 42 <sup>nd</sup> Avenue)	Harvey Street Improvements	41
Home Avenue SAFE (King Road to Railroad Avenue)	SAFE & SSMP FY 2021 Improvements	31
Home Avenue SSMP (King Road to Railroad Avenue)	SAFE & SSMP FY 2021 Improvements	31
Howe Street SAFE (42 <sup>nd</sup> Avenue to 43 <sup>rd</sup> Avenue)	42 <sup>nd</sup> Avenue & 43 <sup>rd</sup> Avenue Improvements	24

PROJECT ELEMENT	PROJECT NAME	PAGE
International Way SAFE (Freeman Way/37 <sup>th</sup> Avenue to Lake Road)	International Way Improvements	52
International Way SSMP (Freeman Way/37 <sup>th</sup> Avenue to Lake Road)	International Way Improvements	52
King Road SAFE (40 <sup>th</sup> Avenue to Linwood Avenue)	King Road Improvements	44
King Road SSMP (40 <sup>th</sup> Avenue to Linwood Avenue)	King Road Improvements	44
Lake Road SAFE (23 <sup>rd</sup> Avenue to 37 <sup>th</sup> Avenue)	Lake Road Improvements	27
Lake Road SSMP (23 <sup>rd</sup> Avenue to 37 <sup>th</sup> Avenue)	Lake Road Improvements	27
Lava Drive & Waverly Court SAFE (17 <sup>th</sup> Avenue to Highlands Apartments)	Waverly South Improvements	49
Lava Drive & Waverly Court SSMP (17 <sup>th</sup> Avenue to Highlands Apartments)	Waverly South Improvements	49
Linwood Avenue SAFE (Monroe Street to Harmony Road)	Linwood Avenue SAFE Improvements	28
Logus Road SAFE (43 <sup>rd</sup> Avenue to 49 <sup>th</sup> Avenue)	Logus Road & 40 <sup>th</sup> Avenue Improvements	45
Logus Road SSMP (43 <sup>rd</sup> Avenue to 49 <sup>th</sup> Avenue)	Logus Road & 40 <sup>th</sup> Avenue Improvements	45
Mailwell Drive SAFE (Main Street to UPRR)	North Milwaukie Improvements	55
Mailwell Drive SSMP (Main Street to UPRR)	North Milwaukie Improvements	55
Main Street to Ochoco Street SAFE (Harrison Street to McLoughlin Blvd)	North Milwaukie Improvements	55
Main Street to Ochoco Street SSMP (Harrison Street to McLoughlin Blvd)	North Milwaukie Improvements	55
Mallard Street SAFE (International Way to Mallard Bridge)	International Way Improvements	52
Mason Lane SAFE (42 <sup>nd</sup> Avenue to Regents Drive)	Lewelling North SAFE & SSMP	54
Mason Lane SSMP (42 <sup>nd</sup> Avenue to Regents Drive)	Lewelling North SAFE & SSMP	54
McBrod Avenue SSMP (17 <sup>th</sup> Avenue to Ochoco Street)	McBrod Avenue Improvements	29
Monroe Street Neighborhood Greenway	Monroe Street Greenway Improvements	46
Monroe Street SAFE (25 <sup>th</sup> Avenue to 28 <sup>th</sup> Avenue)	Monroe Street Greenway Improvements	46
Oak Street SAFE (Washington Street to Monroe Street)	Milwaukie / El Puente SRTS Improvements	43
Oak Street SSMP (Washington Street to Monroe Street)	Milwaukie / El Puente SRTS Improvements	43
Oatfield Road SAFE (Lake Road to Kellogg Bridge)	Oatfield Road & Shell Lane Improvements	58
Oatfield Road SSMP (Lake Road to Kellogg Bridge)	Oatfield Road & Shell Lane Improvements	58
Park Street & Lloyd Street SAFE (Home Avenue to Stanley Avenue)	SAFE & SSMP FY 2025 Improvements	56
Park Street & Lloyd Street SSMP (Home Avenue to Stanley Avenue)	SAFE & SSMP FY 2025 Improvements	56
Request for Service Fund	Request for Service Fund	30
River Road SAFE (McLoughlin Boulevard to city limits)	22 <sup>nd</sup> Avenue & River Road SAFE Improvements	23
River Road SSMP (McLoughlin Boulevard to city limits)	22 <sup>nd</sup> Avenue & River Road SAFE Improvements	23
Rockwood Street & Willow Street SAFE (43 <sup>rd</sup> Avenue to Stanley Avenue)	SAFE & SSMP FY 2026 Improvements	59
Roswell Street SAFE (32 <sup>nd</sup> Avenue to Rockvorst Street)	Ardenwald North Improvements	39
Roswell Street SSMP (32 <sup>nd</sup> Avenue to Rockvorst Street)	Ardenwald North Improvements	39
Shell Lane SSMP (Licyntra Lane to Shell Lane)	Oatfield Road & Shell Lane Improvements	58
Signal Upgrades	Signal Upgrades	33
Sparrow Street SAFE (22 <sup>nd</sup> Avenue to Trolley Trail)	Sparrow Street Improvements	60
Sparrow Street SSMP (22 <sup>nd</sup> Avenue to Trolley Trail)	Sparrow Street Improvements	60
Stanley Avenue SSMP (Railroad Avenue to Lloyd Street)	SAFE & SSMP FY 2025 Improvements	56
System Development Charge Rate Study	System Development Charge Rate Study	48



PROJECT ELEMENT	PROJECT NAME	PAGE
Transportation Maintenance – Crack Seal	Transportation Maintenance	62
Transportation Maintenance – Slurry Seal	Transportation Maintenance	62
Transportation System Plan Update	Transportation System Plan Update	42
Vehicle Purchases – Transportation	Vehicle Purchases	73
Washington Street SAFE (McLoughlin Boulevard to Edison Street)	Milwaukie / El Puente SRTS Improvements	43
Washington Street SSMP (McLoughlin Boulevard to Edison Street)	Milwaukie / El Puente SRTS Improvements	43
Wood Avenue SSMP (Monroe Street to Railroad Avenue)	SAFE & SSMP FY 2021 Improvements	31
<b>STORMWATER</b>		
22 <sup>nd</sup> Avenue & River Road SAFE/SSMP Improvements	22 <sup>nd</sup> Avenue & River Road SAFE Improvements	23
36 <sup>th</sup> Avenue Stormwater Improvements	Stormwater Quality Facilities FY 2025	57
42 <sup>nd</sup> Avenue & Railroad Avenue Water Quality Facility	Stormwater Quality Facilities FY 2025	57
43 <sup>rd</sup> Avenue SAFE/SSMP Improvements	42 <sup>nd</sup> Avenue & 43 <sup>rd</sup> Avenue Improvements	24
47 <sup>th</sup> Avenue & Llewellyn Street Raingardens	Stormwater Quality Facilities FY 2025	57
55 <sup>th</sup> Avenue & Monroe Street Raingardens	Stormwater Quality Facilities FY 2025	57
Balfour Street SAFE/SSMP Improvements	Ardenwald South Improvements	51
Edison Street SAFE/SSMP Improvements	SAFE & SSMP FY 2021 Improvements	31
Harvey Street Improvements	Harvey Street Improvements	41
Hemlock Street Pipe Replacement	Pipe Replacements	59
International Way & Wister Street Underground Storage	International Way Improvements	52
King Road Stormwater Improvements (6011 SE King Road)	King Road Improvements	44
Kronberg Park Stormwater Improvements	Kronberg Park Stormwater Improvements	26
Lake Road SAFE/SSMP Improvements	Lake Road Improvements	27
Linwood Elementary Pipe Replacement	Linwood Avenue SAFE Improvements	28
Mailwell Drive SAFE/SSMP Improvements	North Milwaukie Improvements	55
Main Street Stormwater Improvements, Phase II	North Milwaukie Improvements	55
McBrod Avenue Stormwater Improvements	McBrod Avenue Improvements	29
Meek Street Improvements, North Phase	Meek Street Improvements, North Phase	42
Meek Street Improvements, South Phase	Meek Street Improvements, South Phase	30
Oatfield Road SAFE/SSMP Improvements	Oatfield Road & Shell Lane Improvements	58
Plum Street & Apple Street Pipe Replacement	Pipe Replacements	59
Stanley-Willow UIC Decommissioning	Stormwater Quality Facilities FY 2025	57
Stormwater Capital Maintenance Program	Stormwater Capital Maintenance Program	61
Stormwater Master Plan	Stormwater Master Plan	47
Van Water Street Stormwater Improvements	Ardenwald North Improvements	39
Vehicle Purchases – Stormwater	Vehicle Purchases	73
Washington Street Pipe Replacement, Phase I & II	Milwaukie / El Puente SRTS Improvements	43
Winworth Court Repair	Stormwater Quality Facilities FY 2025	57

PROJECT ELEMENT	PROJECT NAME	PAGE
<b>WASTEWATER</b>		
17 <sup>th</sup> Avenue CIPP Sewer Repair	North Milwaukie Improvements	55
22 <sup>nd</sup> Avenue & River Road SAFE Improvements	22 <sup>nd</sup> Avenue & River Road SAFE Improvements	23
26 <sup>th</sup> Avenue Sewer Repair	Wastewater System Improvements FY 2023	48
28 <sup>th</sup> Avenue Sewer Repair	Ardenwald North Improvements	39
29 <sup>th</sup> Avenue Sewer Repair	Ardenwald North Improvements	39
31 <sup>st</sup> Avenue Sewer Repair	Ardenwald North Improvements	39
32 <sup>nd</sup> Avenue Sewer Repair, North of Lake Road	Lake Road Improvements	27
34 <sup>th</sup> Avenue Sewer Repair	Wastewater System Improvements FY 2023	48
37 <sup>th</sup> Avenue Sewer Repair, Marketplace	Wastewater System Improvements FY 2023	48
37 <sup>th</sup> Avenue Sewer Repair, Monroe Street to Jackson Street	Wastewater System Improvements FY 2023	48
37 <sup>th</sup> Avenue Sewer Repair, North of King Road	Wastewater System Improvements FY 2021	35
38 <sup>th</sup> Avenue Sewer Repair	Logus Road & 40 <sup>th</sup> Avenue Improvements	45
42 <sup>nd</sup> Avenue Sewer Repair, Fieldcrest Street to Olsen Road	42 <sup>nd</sup> Avenue & 43 <sup>rd</sup> Avenue Improvements	24
43 <sup>rd</sup> Avenue Sewer Repair	42 <sup>nd</sup> Avenue & 43 <sup>rd</sup> Avenue Improvements	24
45 <sup>th</sup> Court Sewer Repair	Logus Road & 40 <sup>th</sup> Avenue Improvements	45
Beckman Avenue Sewer Repair	SAFE & SSMP FY 2025 Improvements	56
Hanna Harvester Street Sewer Repair	North Milwaukie Improvements	55
Home Avenue Lift Capacity Upgrade	SAFE & SSMP FY 2021 Improvements	31
International Way Sewer Repair	International Way Improvements	52
Kent Street Sewer Repair, at 60 <sup>th</sup> Avenue	Wastewater System Improvements FY 2021	35
Lake Village Apartments Sewer Replacement	Wastewater System Improvements FY 2023	48
Lift Station Pump Replacement	Lift Station Pump & SCADA Controls Replacement	61
Mailwell Drive I & I Repair	North Milwaukie Improvements	55
Main Street Sewer Repair (Credit Union)	North Milwaukie Improvements	55
McBrod Ave Paving SSMP	McBrod Avenue Improvements	29
Rio Vista Street Repair	Wastewater System Improvements FY 2021	35
River Road Sewer Repair	Wastewater System Improvements FY 2023	48
Riverway Lane Sewer Repair	Waverly South Improvements	49
Roswell Street CIPP Sewer Repair	North Milwaukie Improvements	55
SCADA Design & Construction	SCADA Design & Construction	32
Stubb Street CIPP/I&I Sewer Repair	North Milwaukie Improvements	55
Van Water Street Sewer Repair	Ardenwald North Improvements	39
Vehicle Purchases – Wastewater	Vehicle Purchases	73
Washington Street Sewer Repair, 37 <sup>th</sup> Avenue to 40 <sup>th</sup> Avenue	Wastewater System Improvements FY 2021	35
Washington Street Sewer Replacement, 34 <sup>th</sup> Avenue to Sellwood Street	Milwaukie / El Puente SRTS Improvements	43
Wastewater Capital Maintenance Program	Wastewater Capital Maintenance Program	62
Wastewater System Master Plan	Wastewater System Master Plan	34
Waverly Heights Sewer System Reconfiguration	Waverly Heights Sewer System Reconfiguration	53
Willamette Townhouse Apartments stub-out	Harvey Street Improvements	41

PROJECT ELEMENT	PROJECT NAME	PAGE
<b>WATER</b>		
CRW Intertie	CRW Intertie	52
Edison Street SAFE/SSMP Improvements	SAFE & SSMP FY 2021 Improvements	31
International Way Pipe Extension	International Way Improvements	52
McBrod Avenue Water System Improvements	McBrod Avenue Improvements	29
Monroe Street Pipe Extension, Linwood Avenue to 66 <sup>th</sup> Avenue	Monroe Street Water Pipe Extension	53
Mullan Street Pipe Extension	Mullan Street Pipe Extension	53
River Road Pressure Boundary Reconfiguration	22 <sup>nd</sup> Avenue & River Road SAFE Improvements	23
Riverway Lane Water Line Replacement	Waverly South Improvements	49
SCADA Design & Construction	SCADA Design & Construction	32
Sparrow Street Vault Upgrade	22 <sup>nd</sup> Avenue & River Road SAFE Improvements	23
Stanley Reservoir Design & Construction	Stanley Reservoir Design & Construction (Well #6)	47
Vehicle Purchases – Water	Vehicle Purchases	73
Washington Street Water Improvements	Milwaukie / El Puente SRTS Improvements	43
Water Capital Maintenance Program	Water Capital Maintenance Program	63
Water System Master Plan	Water System Master Plan	36
Well #2 Building Upgrades	Well #2 Building Upgrades	60
Well #2 Rehabilitation & Relocation	Well #2 Rehabilitation & Relocation	38
Well #4 Reconditioning	Well #4 Reconditioning	50
Well #5 Recondition & Building Repair	Well #5 Recondition & Building Repair	37
Well #7 Reconditioning	Well #7 Reconditioning	50
Well #8 Rehabilitation	Well #8 Rehabilitation	58
WSI – 29 <sup>th</sup> Avenue, 30 <sup>th</sup> Avenue, 31 <sup>st</sup> Avenue	Ardenwald North Improvements	39
WSI – 42 <sup>nd</sup> Avenue	42 <sup>nd</sup> Avenue & 43 <sup>rd</sup> Avenue Improvements	24
WSI – Beckman Avenue, Park Street	SAFE & SSMP FY 2025 Improvements	56
WSI – Drake Street & 38 <sup>th</sup> Avenue Replacement	Logus Road & 40 <sup>th</sup> Avenue Improvements	45
WSI – Harvey Street, 33 <sup>rd</sup> Avenue, 36 <sup>th</sup> Avenue	Harvey Street Improvements	41
WSI - Malcolm Street, Llewellyn Street, 32 <sup>nd</sup> Avenue	Ardenwald South Improvements	51
WSI – Shell Lane to Licyntra Lane	Oatfield Road & Shell Lane Improvements	58

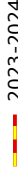

## Milwaukie CIP - Transportation

-  City of Milwaukie
  -  2021
  -  2022
  -  2023-2024
- FRA Quiet Zone Study  
Downtown Curb Improvements  
Downtown Public Area Requirements  
Monroe Street Greenway Improvements

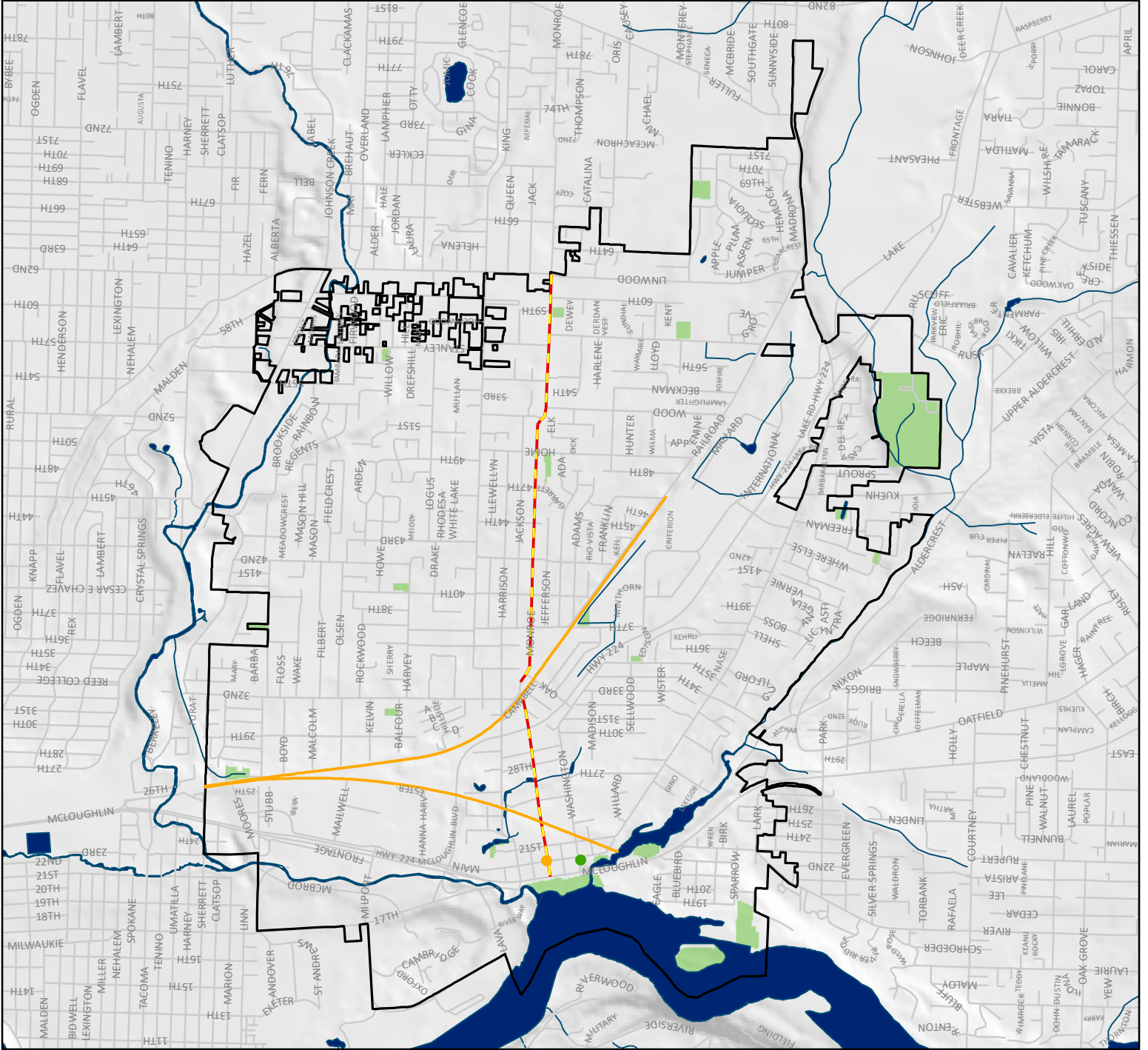

Data Sources: City of Milwaukie GIS, Clackamas County GIS, Metro Data Resource Center  
Date: Tuesday, June 9, 2020

The information depicted on this map is for general reference only. The City of Milwaukie cannot accept any responsibility for errors, omissions or positional accuracy. There are no warranties, expressed or implied, including the warranty of merchantability or fitness for a particular purpose, accompanying this product. However, notification of errors would be appreciated.

GIS Coordinator  
City of Milwaukie  
610 S. Main Street, 2nd Floor  
Milwaukie, OR 97266  
(503) 786-7687

## Milwaukee CIP - SAFE

City of Milwaukee

2021

22nd Avenue & River Road SAFE Improvements

42nd Avenue & 43rd Avenue Improvements

Lake Road Improvements 2020

Linwood Avenue SAFE Improvements

SAFE & SSMP FY 2021 Improvements

2022

Ardenwald North Improvements

Harvey Street Improvements

2023

El Puente Safe Routes to School

King Road Improvements

Logus Road & 40th Avenue Improvements

Monroe Street Greenway Improvements

Waverly South Improvements

2024

Ardenwald South Improvements

International Way Improvements

2025

North Milwaukee Improvements

SAFE & SSMP FY 2025 Improvements

SAFE & SSMP FY 2025 Improvements - Lewelling North

2026

Oatfield Road & Shell Lane Improvements

SAFE & SSMP FY 2026 Improvements

Sparrow Street Improvements

Data Sources: City of Milwaukee GIS, Clarkamas County GIS, Metro Data Resource Center

Date: Tuesday, June 9, 2020

The information depicted on this map is for general reference only. The City of Milwaukee cannot accept any responsibility for errors, omissions or positional accuracy. There are no warranties, expressed or implied, including the warranty of merchantability or fitness for a particular purpose, accompanying this product. However, notification of errors would be appreciated.

GIS Coordinator  
 City of Milwaukee  
 610 S. Milwaukee Blvd.  
 Milwaukee, WI 53206  
 (503) 786-7887

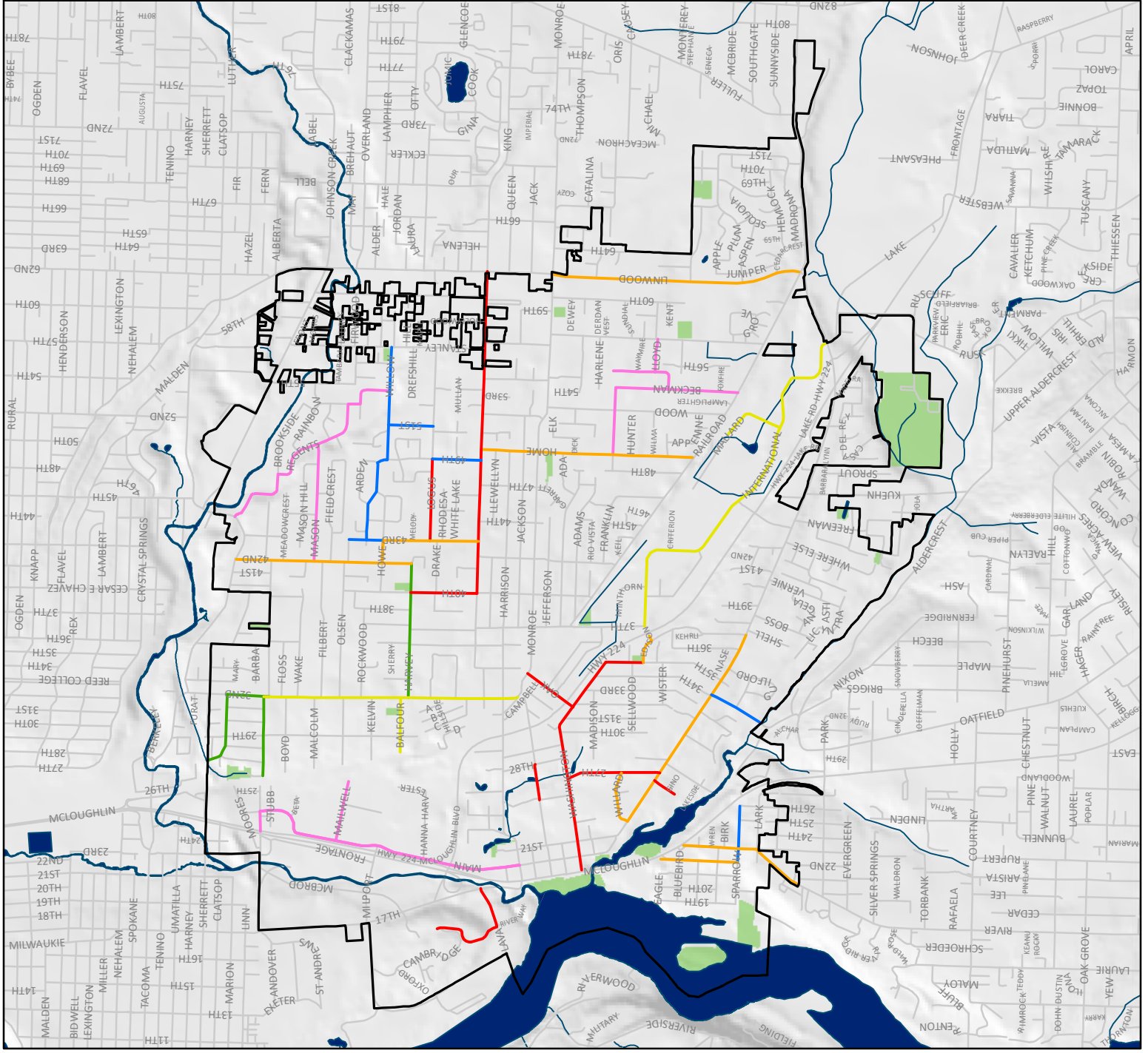



## Milwaukie CIP - SSMP

City of Milwaukee

2021

22nd Avenue & River Road SAFE Improvements

42nd Avenue & 43rd Avenue Improvements

Lake Road Improvements 2020

McBrod Avenue Improvements

SAFE & SSMP FY 2021 Improvements

2022

Ardenwald North Improvements

Harvey Street Improvements

2023

El Puente Safe Routes to School

King Road Improvements

Logus Road & 40th Avenue Improvements

Waverly South Improvements

2024

Ardenwald South Improvements

International Way Improvements

2025

North Milwaukee Improvements

SAFE & SSMP FY 2025 Improvements - Lewelling North

SAFE & SSMP FY 2025 Improvements

2026

Oatfield Road & Shell Lane Improvements

SAFE & SSMP FY 2026 Improvement

Sparrow Street Improvements

Data Sources: City of Milwaukee GIS, Clackamas County GIS, Metro Data Resource Center

Date: Tuesday, June 9, 2020

The information depicted on this map is for general reference only. The City of Milwaukee cannot accept any responsibility for errors, omissions or positional accuracy. There are no warranties, expressed or implied, including the warranty of merchantability or fitness for a particular purpose, accompanying this product. However, notification of errors would be appreciated.

GIS Coordinator  
 City of Milwaukee  
 6101 S. Milwaukie Blvd.  
 Milwaukie, OR 97266  
 (503) 786-7687

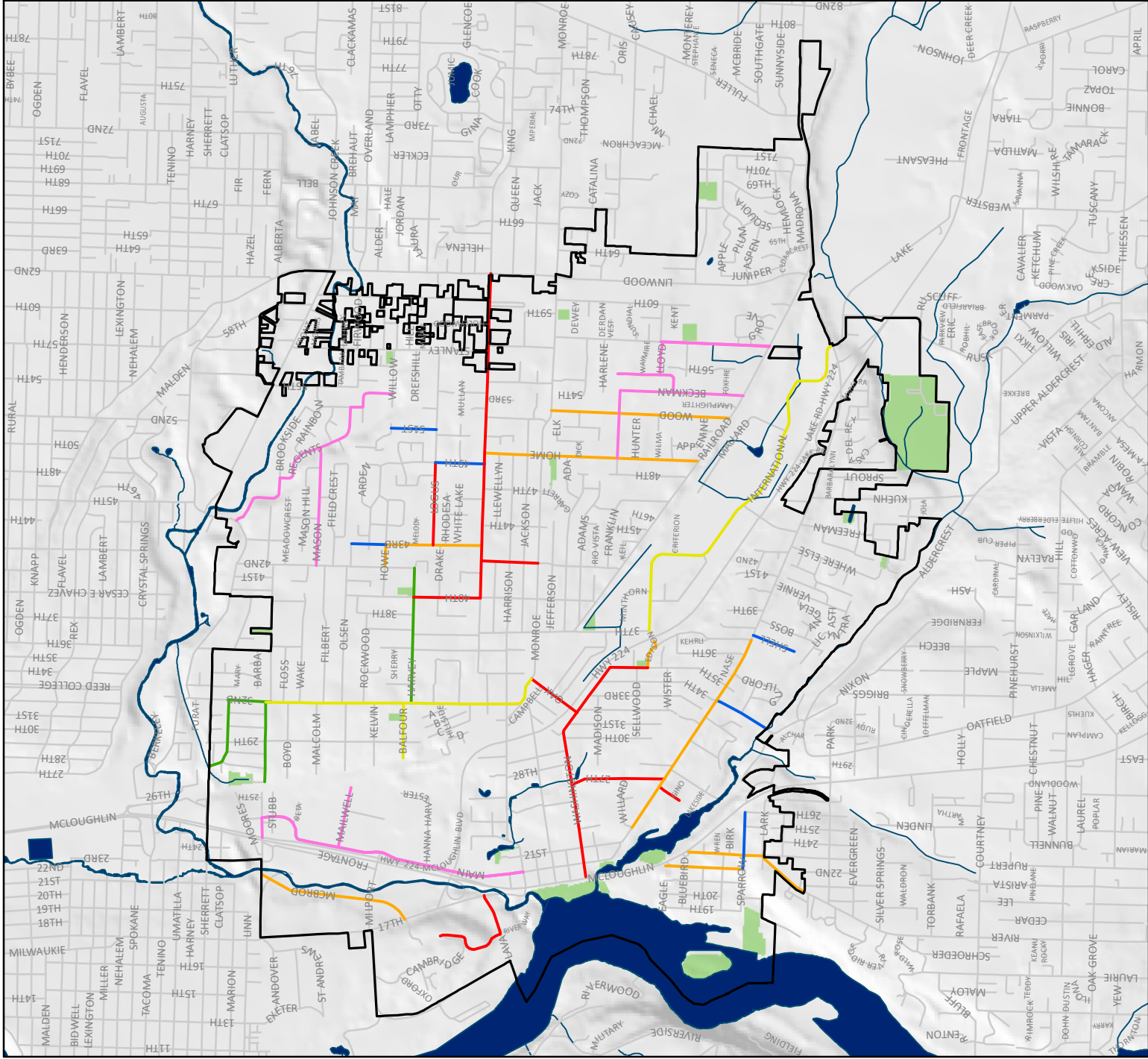



# CITY OF MILWAUKIE

## Milwaukie CIP - Stormwater

City of Milwaukie

2021

22nd Avenue & River Road SAFE Improvements

42nd Avenue & 43rd Avenue Improvements

Kronberg Park Stormwater Improvements

Lake Road Improvements 2020

Linwood Avenue SAFE Improvements

McBrod Avenue Improvements

SAFE & SSMP FY 2021 Improvements

Linwood Avenue SAFE Improvements

Meek Street Improvements, South Phase

2022

Ardenwald North Improvements

Harvey Street Improvements

Meek Street Improvements, North Phase

2023

El Puento Safe Routes to School Improvements

King Road Improvements

2024

Ardenwald South Improvements

International Way Improvements

2025

North Milwaukie Improvements

Stormwater Quality Facilities FY 2025

2026

Outfield Road & Shell Lane Improvements

Pipe Replacements: Plum/Apple Street and Hemlock Street

Data Sources: City of Milwaukie GIS, Clackamas County GIS, Metro Data Resource Center

Date: Friday, June 5, 2020

The information depicted on this map is for general reference only. The City of Milwaukie cannot accept any responsibility for errors, omissions or positional accuracy. There are no warranties, expressed or implied, including the warranty of merchantability or fitness for a particular purpose, accompanying this product. However, notification of errors would be appreciated.

GIS Coordinator  
City of Milwaukie  
6101 S. Milwaukie Blvd.  
Milwaukie, OR 97126-0606  
(503) 786-7687

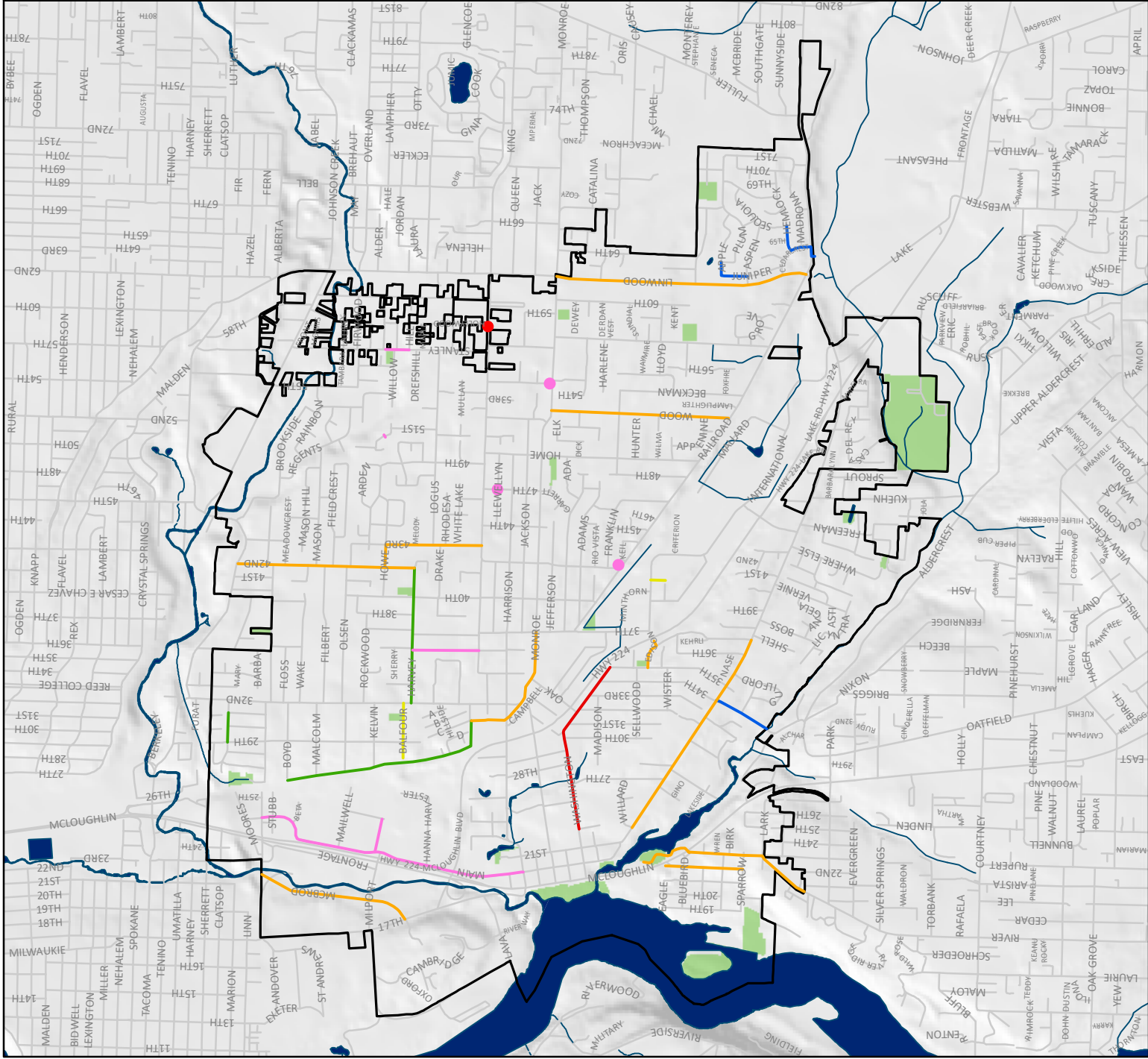

# CITY OF MILWAUKIE

## Milwaukie CIP - Wastewater

City of Milwaukie

2021

22nd Avenue & River Road SAFE Improvements

42nd Avenue & 43rd Avenue Improvements

Lake Road Improvements 2020

McBrod Avenue Improvements

SAFE & SSMP FY 2021 Improvements

Wastewater System Improvements FY 2021

2022

Ardenwald North Improvements

Harvey Street Improvements

2023

EI Puente Safe Routes to School Improvements

Logus Road & 40th Avenue Improvements

Wastewater System Improvements FY 2023

Waverly South Improvements

2024

International Way Improvements

Waverly Heights Sewer System Reconfiguration

2025

North Milwaukie Improvements

SAFE & SSMP FY 2025 Improvements

Data Sources: City of Milwaukie GIS, Clackamas County GIS, Metro Data Resource Center

Date: Tuesday, June 9, 2020

The information depicted on this map is for general reference only. The City of Milwaukie cannot accept any responsibility for errors, omissions or positional accuracy. There are no warranties, expressed or implied, including the warranty of merchantability or fitness for a particular purpose, accompanying this product. However, notification of errors would be appreciated.

GIS Coordinator  
City of Milwaukie  
610 S. Main Street, 2nd Fl.  
Milwaukie, OR 97126  
(503) 786-7687

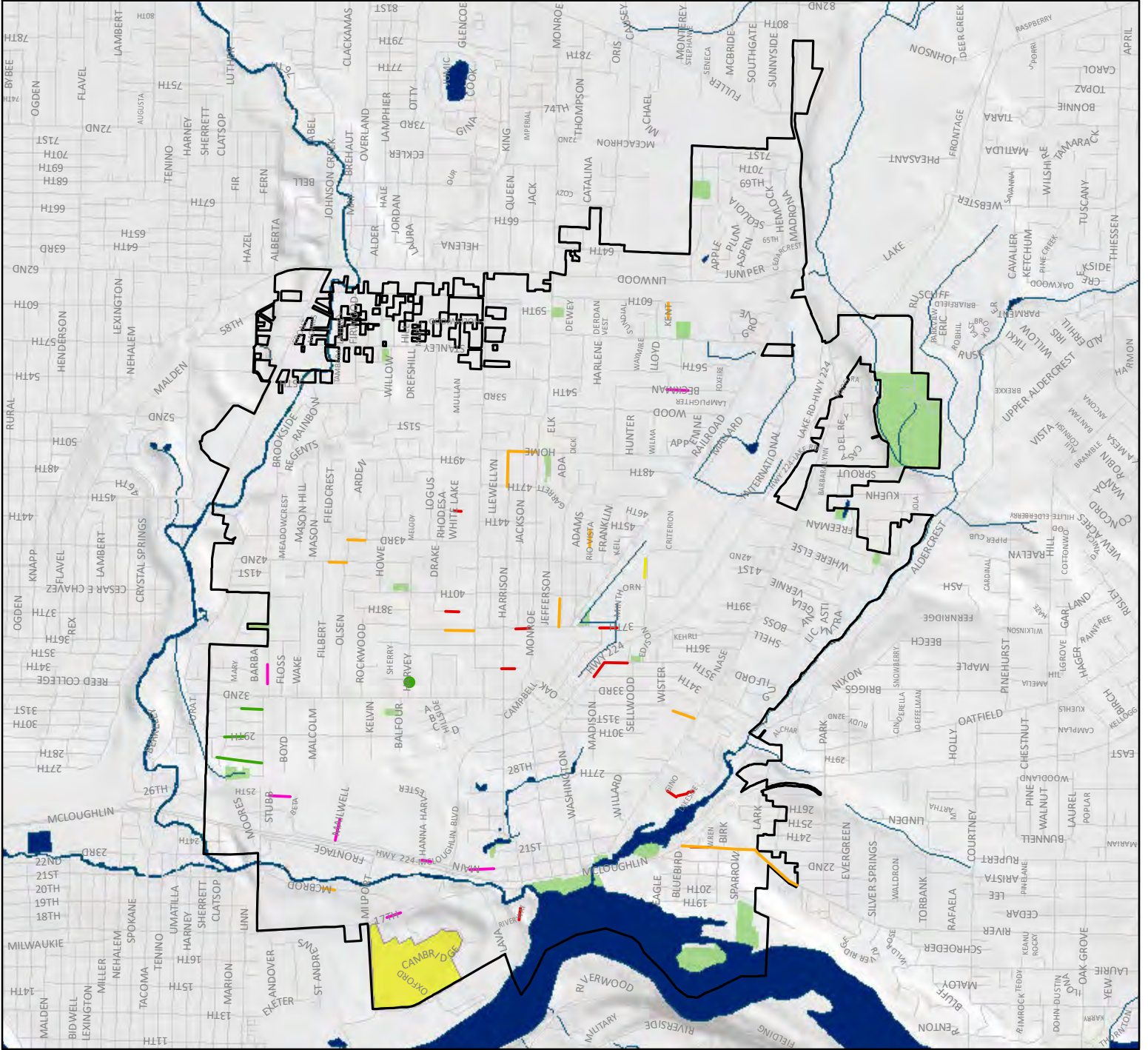



## Milwaukie CIP - Water

City of Milwaukie

2021

22nd Avenue & River Road SAFE Improvements

42nd Avenue & 43rd Avenue Improvements

McBrod Avenue Improvements

Well #2 Rehabilitation & Relocation

Well #5 Reconditioning & Building Repair

2022

Ardenwald North Improvements

Harvey Street Improvements

2023

El Puente Safe Routes to School Improvements

Logus Road & 40th Avenue Improvements

Waverly South Improvements

Stanley Reservoir Design and Construction Well #6

Well #4 Reconditioning

Well #7 Reconditioning

2024

Ardenwald South Improvements

CRW Intertie

International Way Improvements

Monroe Street Pipe Extension

Mullan Street Pipe Extension

2025

SAFE & SSMP FY 2025 Improvements

Well #8 Rehabilitation

2026

Oatfield Road & Shell Lane Improvements

Well #2 Building Upgrades

Date: Tuesday, June 9, 2020

GIS Coordinator

City of Milwaukie  
610 S. Milwaukie Blvd.  
Milwaukie, OR 97126  
(503) 786-7887

City of Milwaukie  
610 S. Milwaukie Blvd.  
Milwaukie, OR 97126  
(503) 786-7887

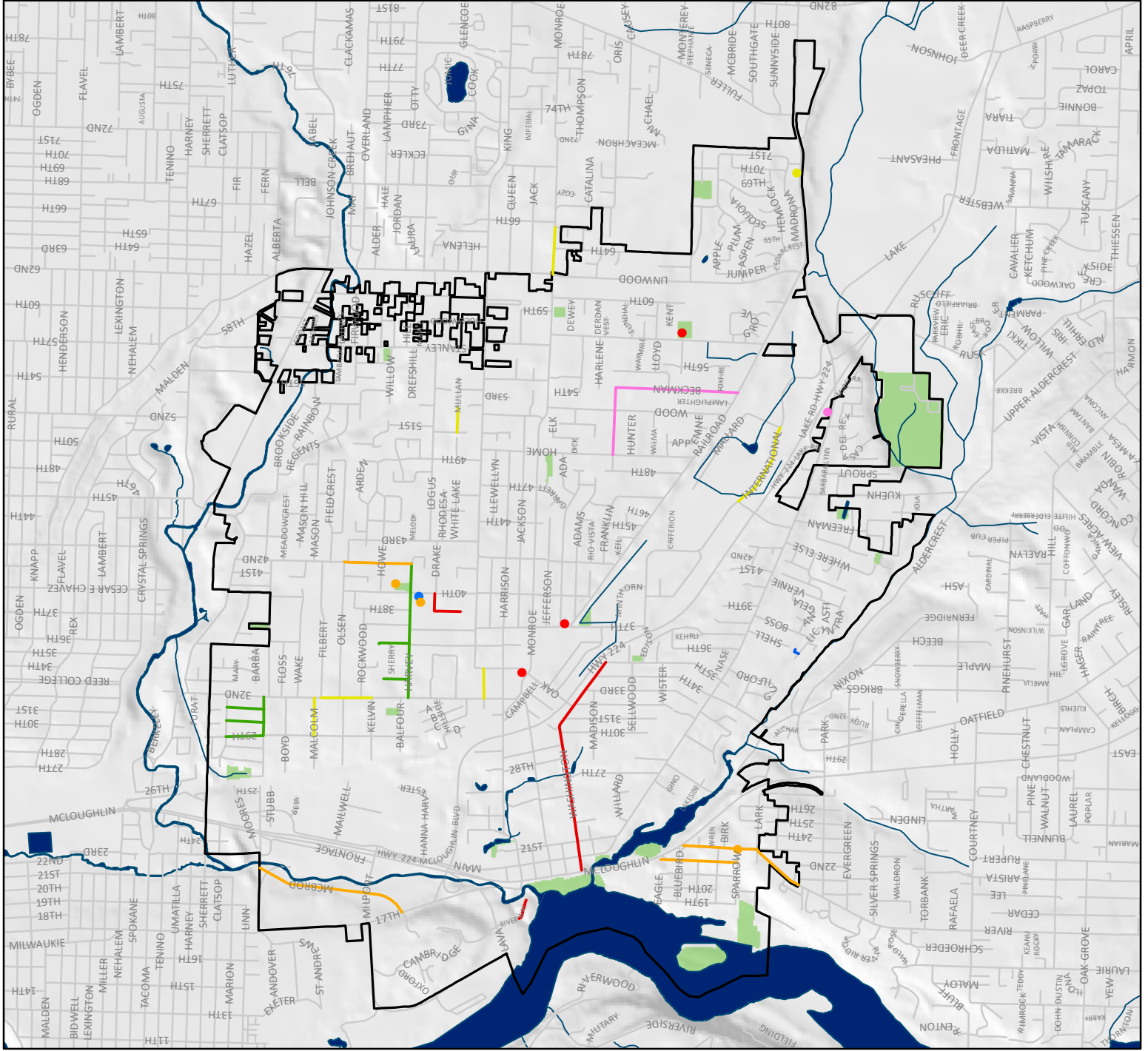



**Special thanks to:**

Steve Adams, Leila Aman, Bonnie Dennis, Damien Farwell, Jennifer Garbely, Shane Hart, Nick Lindekugel, Alicia Martin, Ronelle Sears, Peter Passarelli and Julie Rea.

**Citizens Utility Advisory Board**

Joel Bergman  
Laura Hanna  
Edward Simmons  
Jacob Stetson

**Public Safety Advisory Board**

Regis Niggemann, Chair, (Linwood)  
Lance Lindahl, Vice Chair (Ardenwald-Johnson Creek)  
Nicole Perry, Member At-Large (Linwood)  
Beth Platte, Member (Lewelling)  
Tony Lewis, Secretary (Lake Road)  
Lori Dorman, Member (Historic Milwaukie)  
Pam Denham, Member (Island Station)  
Rob Reynolds, Member (Hector-Campbell)  
Jay Panagos, Member At-Large (Unincorporated)  
Christina Cole, Member At-Large (Linwood)