

BULLDOG 65 Hydraulic Steelworker

Name and Address:

**MUBEA SYSTEME
EXPORT DEPARTMENT
HOGESCHUURSTRAAT 2
B-8850 ARDOOIE
BELGIUM**

**MUBEA SYSTEME GmbH
Viersenerstraße 3
D-47929 GREFRATH
Germany**

Year of Manufacture:

Model Type: **BULLDOG 65 HYDRAULIC STEELWORKER**

Serial Number:
(Note: last 2 digits represent year of manufacture)

Weight of Machine: **2375 lb NETT**

BULLDOG 65 Hydraulic Steelworker

MUBEA SYSTEME BULLDOG 65 HYDRAULIC STEELWORKER

This MUBEA SYSTEME Steelworker has been developed to give you, the user, a reliable long service - low maintenance machine tool.

These machines are capable of performing five basic functions, with the facility to add various additional tooling arrangements to complement the fully universal aspects of the Steelworker.

These instructions give general guide lines for the use of the Steelworker, commissioning, operating and maintenance, and should be carefully studied by the installation engineer and operator before the machine is put into operation.

Any assistance regarding the machines, should first be sought from the supplier or agent:

MUBEA SYSTEME

PINNEY

MACHINERY & SUPPLY, INC.

7053 PRODUCTION COURT - FLORENCE, KY 41042

PHONE (606) 727-6499 FAX (606) 342-2523

TOLL FREE 800-255-5698

BULLDOG 65 Hydraulic Steelworker

INDEX

1 SAFETY NOTES FOR MUBEA SYSTEME STEELWORKERS	1
2 BRIEF SPECIFICATIONS	2
2.1 MEASUREMENTS	2
2.2 CAPACITIES	2
2.3 STANDARD EQUIPMENT SUPPLIED WITH MACHINE	2
3 BRIEF DESCRIPTION OF MACHINE	4
3.1 PUNCHING	4
3.2 SHEARING	4
3.3 ANGLE CUTTING	4
3.4 SECTION CUTTING	4
3.5 NOTCHING	4
3.6 FURTHER INFORMATION	5
3.7 SAFETY POINTS	6
3.8 OVERLOADING	6
3.9 WARNINGS AND DANGERS	6
3.10 OPERATING MODE SWITCH	7
4 PUNCHING WORK STATION	8
4.1 GENERAL DESCRIPTION	8
4.2 PUNCH TOOLING	9
4.3 PUNCH TOOLING - GENERAL GUIDES	9
4.4 PUNCH AND DIE LUBRICATION	10
4.5 PUNCHING CAPACITY	11
4.6 BAR BENDING FACILITY AT PUNCHING STATION	13
4.7 STANDARD PUNCH TOOLING	14
4.8 TYPICAL APPLICATIONS	16
4.9 FLANGE PUNCHING	16
5 SHEARING STATION	17
5.1 DESCRIPTION	17
5.2 SHEAR TOOLING - GENERAL GUIDES	17
5.3 SHEAR BLADES	18
6 ANGLE CUTTING	19
6.1 DESCRIPTION	19
6.2 ANGLE TOOLING - GENERAL GUIDES	20
6.3 GRINDING OF CHANNEL INSERT BLADES	21
6.4 GRINDING OF JOIST INSERT BLADE	22

BULLDOG 65 Hydraulic Steelworker

7 SECTION CUTTING	23
7.1 DESCRIPTION	23
7.2 SECTION TOOLING - GENERAL GUIDES	24
8 NOTCHING STATION	25
8.1 DESCRIPTION	25
8.2 NOTCHING TOOLING - GENERAL GUIDES	25
8.3 RECTANGULAR NOTCH TOOLING ARRANGEMENT	26
9 FURTHER INFORMATION	27
9.1 CAPACITIES	27
9.2 SPECIFICATION	28
9.3 ADDITIONAL TOOLING	28
9.4 STROKE ADJUSTMENT	29
9.5 HYDRAULIC SYSTEM	30
9.6 CLEANING	30
9.7 REGULAR MAINTENANCE	30
9.8 HYDRAULIC FLUID	31
9.9 OILING LUBRICANT	31
9.10 MACHINE ARM ADJUSTMENT	32
9.11 PARTS LIST	33
10 CIRCUITS	36
10.1 HYDRAULIC CIRCUIT	36
10.2 ELECTRICAL CIRCUIT	38
11 SPECIAL TOOLING	39
11.1 90° VEE NOTCH TOOLING ARRANGEMENT	39
11.2 WEB PUNCHING ARRANGEMENT FOR 'I' & 'U' SECTIONS	39
11.3 LARGE HOLE PUNCHING	40
11.4 BAR BENDING UNIT	41
12 MANUAL APPENDIX	42
12.1 MITRING ANGLE 45 DEGREES ON BULLDOG MACHINES	42

BULLDOG 65 Hydraulic Steelworker

1 SAFETY NOTES FOR MUBEA SYSTEME STEELWORKERS

In this manual particular references are made regarding aspects of safety and the notes below are intended as a summary to highlight the main areas for your attention.

The machine should be positioned so that the operator has sufficient room to work having regard for the long lengths of material which may be punched or cropped. Electrical supply should be by overhead cable to avoid possible damage.

It should be considered if additional equipment will be required to safely handle long or heavy items being processed.

Any person who will use the machine should be given adequate instruction on the operation and safety aspects of the machine. Extra copies of this manual are available from the manufacturer.

In addition it should be established which persons shall be responsible for the changing and setting of tools and blades and these persons given a more detailed instruction.

Mubea Systeme machines are supplied complete with various guards and barriers as standard equipment which provide a generally accepted level of guarding when the machine is used for the purpose for which it was designed.

1. The main areas of deviation from design criteria would probably be:
2. The use of materials other than mild steel (65.000lbs.)
3. The incorrect use of material hold-downs
4. The punching, cropping or notching of small items
(as this would encourage the operator place fingers or hands into danger area).

If at any time additional tooling or equipment is fitted to the machine the question of adequate guarding must be reviewed and the advice of the manufacturer sought if necessary.

All maintenance should be carried out by suitably qualified personnel and particular attention must be paid to the correct setting and alignment of punches and dies, blades and other tools.

BULLDOG 65 Hydraulic Steelworker

2 BRIEF SPECIFICATIONS

The machine has been developed to perform five basic functions:
Punching, Flat Bar Shearing, Notching, Angle and Section Cutting.

2.1 MEASUREMENTS (Full details, see page 26-27.)

Length x Width x Height	59 ¹ / ₂ " x 23 ¹ / ₄ " x 62" (+ 4" lifting eye)
Die Height from floor	37"
Shear Support from floor	37"
Angle Support from floor	44 ³ / ₄ "
Notch Height from floor	37"

2.2 CAPACITIES (Full details, see page 26-27.)

Punching	1 ¹ / ₄ ' x 15 ¹ / ₃₂ " or 1 ¹ / ₁₆ ' x 5 ¹ / ₈ "
Shearing	8 x 3 ⁴ / ₄ " or 12 x 5 ¹ / ₈ "
Angle Cutting	4 ³ / ₄ " x 1 ¹ / ₂ ", 5 ¹ / ₈ " x 1 ¹ / ₂ " with modified blade
Section Cutting	1 ⁹ / ₁₆ " Round, 1 ³ / ₈ " Square
Notching	3 ¹ / ₈ " Thickness

(All capacities are based on materials of 65,000 lbs. Tensile Strength.)

Punch Pressure	65 Tons
----------------	---------

2.3 STANDARD EQUIPMENT SUPPLIED WITH MACHINE

Punch Bolster	BULLDOG 65-319
Shear Blade (1 set mounted)	3409 & 3309
Angle Blades (1 set mounted)	3549 & 3550 (Arm), 3548 & 3547 (Body)
Section Blades (1 pair mounted)	3427 & 3428
Notch Punch & Dies (1 set mounted)	Punch H1 Ø9 ¹ / ₁₆ " and die H1 Ø19 ¹ / ₃₂ "
Notch Bolster	3315

BULLDOG 65 Hydraulic Steelworker

-
- **Tool Kit comprising:**
- Allen Key 4, 5, 6, 8, 10, 12, 14, 17mm
- 19 and 24mm Open-Ended Spanner

BULLDOG 65 Hydraulic Steelworker

3 BRIEF DESCRIPTION OF MACHINE

3.1 PUNCHING (For details see pages 8-15)

The punching unit is fitted with a quick-change device for punches and dies. Changes are made quickly and without a problem, and require no additional devices.

3.2 SHEARING (For details see page 16-17)

The shearing unit is fitted with a simple robust hold-down which is adjustable to any thickness of material within the cutting capacity of the machine. A shear feed table with adjustable guides is fitted to allow the accurate feeding of materials. The guide can be adjusted to allow mitre cutting up to 45 degrees for flat bars or to trim the flanges of angle sections previously cut at the angle cutting station.

3.3 ANGLE CUTTING (For details see page 18-21)

This station provides large capacity angle cutting at 90 degrees and lighter angle cutting at 45 degrees. Angles between 45 and 90 degrees can be achieved by first cutting at 90 degrees and then flange trimming to the required angle in the shearing station. The hold-down supports the material thus ensuring a true cut.

3.4 SECTION CUTTING (For details see pages 22-23)

The machines are fitted as standard with blades for cutting round and square bars. With extra equipment, the machines are able to cut, in this aperture, Channels, Joists and Tee Sections. The blades are retained by simple clamps, allowing easy changes without the need for elaborate setting.

3.5 NOTCHING (For details see page 24-25)

The notching station is fitted as standard with a rectangular unit and notch table with adjustable back stops allowing repetitive positioning. Extra equipment is available for narrow widths or vee notching of angles up to 90 degrees vee; units are also available for bar end shaping applications.

BULLDOG 65 Hydraulic Steelworker

3.6 FURTHER INFORMATION

3.6.1 System Pressure

To check any operational loadings, a pressure gauge can be fitted at the manifold position. The max. system pressure has been set at the works to 234 bar (3500 P. S. I.) which is below the max. continuous working pressure of the pump, thereby giving increased reliability.

3.6.2 Cleaning

On arrival, all anti-corrosion lacquer should be removed from the machined bright parts with petroleum solvent. When the machine is operational, all visible working parts should be regularly cleaned of foreign matter, thus preventing excessive wear and possible failure.

3.6.3 Lifting

The machine is supplied with a lifting eye, mounted on top of the machine. All lifting and manoeuvring should be carried out using this eye along with a suitably rated chain or sling. The eye can be removed if desired after final siting of the machine but hole should be blanked off.

DO NOT USE SLINGS UNDER MACHINE!

3.6.4 Installing

Locate the machine on a solid foundation allowing sufficient area all round for easy working and maintenance. The machine may be used free standing, but bolting to the foundation is recommended. With the machine mounted directly on the floor - this gives a comfortable working height.

3.6.5 Electrical Supply

Input wires should arrive at the machine via suitably protected underground supply directly into the electrics box in the base of the machine. As an alternative by overhead supply to the top of the machine and routed inside the top guard and hydraulic pipe trunking to the electrics box. A 30 amp isolating switch, fuse and appropriate cable should be used for mains supply connection. The circuit provides protection against sustained over-load and phase failure. Should the machine cut out during an operation or whilst running, the cause of the problem should be investigated to prevent re-occurrence.

IMPORTANT

Motor rotation MUST be as arrow on motor fan end cover!

This machine will not operate if the motor is running in the wrong direction. It must be stressed however that the motor must not be allowed to run in the wrong direction for more than a few seconds, as this will cause seizure of the pump. To check motor direction start and stop motor with foot on footswitch if machine does not operate reverse two of the incoming 3 phase connections.

BULLDOG 65 Hydraulic Steelworker

3.7 SAFETY POINTS

- All adjustments, setting, change of tooling and maintenance must be carried out by a suitable qualified engineer in accordance with the manufacturers instructions.
- Remove off-cuts, slugs and any other waste from around the machine before leaving the work station.
- The operator should check all tooling is in good condition before operating machine.
- All stations should be checked for obstructions.
- Heavy work should be supported by a sound work steady.
- The machine should never be left running while unattended.
- When leaving, the machine **MUST** be switched off.

3.8 OVERLOADING

In the event of an accidental overload to the hydraulic circuit, the oil will be diverted direct back to the tank via a relief valve, until the overload condition is removed.

IT MUST BE STRESSED HOWEVER IT IS NOT ADVISABLE TO EXCEED THE CAPACITY OF THE MACHINE USING RELIEF VALVE AS A SAFETY VALVE.

3.9 WARNINGS AND DANGERS

Any point of the machine painted RED should be treated as a danger area. Operators should be instructed not to extend any finger or limbs into or beyond the vicinity of the warning labels. Any guards or hold downs removed for maintenance or adjustments **MUST** be replaced before the machine is put back in service.

BULLDOG 65 Hydraulic Steelworker

3.10 OPERATING MODE SWITCH

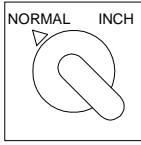

The Operating Mode Switch has two positions - **NORMAL** and **INCH**. With the switch set to **INCH** all work stations are in the slow speed Inching Mode.

3.10.1 Inching Positon

In Inching position the arm will travel down slowly when footswitch is fully depressed. The arm will remain in any position when foot is removed. Turn switch to **NORMAL** to return arm to top of stroke. All tool setting and adjusting and setting of stroke limit switches should be done in the Inching position.

3.10.2 Normal Operating

With Selector Switch to **NORMAL** the arm will travel down at operating speed when footswitch is fully depressed and will return to top of stroke when foot is completely removed.

The footswitch does however have three “positions” giving the very useful facility that after bringing the arm down by full depression of switch, the arm may be held in any position of the stroke by raising the foot to the mid-position. Remove foot and arm will return to top position.

3.10.3 Punch and Die Alignment

Should be checked before using, and **MUST** be checked after punch and die changes have been made.

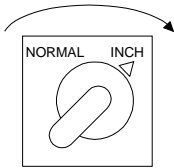

To check alignment switch mode of operation **INCH**, then inch the punch down by fully depressing the footswitch. Care must be taken as the punch approaches the die, if misalignment is apparent remove foot from switch.

To align punch and die release bolster fixing screws, operate the foot switch with care, aligning the bolster containing the die to the punch, the punch will stay in the down position. Centralise the die clearance around the punch, clamp the bolster in position, tighten die retaining screw, check die maintains in the central position after clamping. Return punch to top position by switching back to run position.

BULLDOG 65 Hydraulic Steelworker

4 PUNCHING WORK STATION

4.1 GENERAL DESCRIPTION

The punch station is a particular well equipped station. It offers many features normally associated with much larger machines.

The large punch bed area is designed to give a very wide range of punching applications, including overhang work in small channel sections. The punch table is particularly useful when the side and back stops are set for small repetitive work. This coupled with a finely adjusted stroke length gives a very productive machine. The table is assembled in two parts of which the front is removable for flange punching.

The punch is retained by means of a quick-change device. Changes are quickly and without problem and require no additional devices. The die is retained in the bolster by a set screw, ensure the screw locates correctly on the machined flat on the die when shaped punches and dies are being aligned.

The punch stripper plate must be correctly adjusted allowing sufficient clearance for placing and removal of material, but must NOT restrict the punch stroke, ensure the bottom stroke limit switch is correctly adjusted. Punch holes with sufficient material around the hole so that contact will be made on both sides of the stripper plate. Stripping forces can be severe and unbalanced stripping forces, due to contact on one side stripper, may cause punch breakages. When using stripper fingers for oversize holes or irregular shapes position and adjust fingers equally so as to avoid unbalanced stripping loads.

Additional tooling in this versatile work station can provide bar bending, corner notching, tube notching and general die-set work.

**WHEN ORDERING REPLACEMENT PUNCHES AND DIES, ALWAYS
QUOTE - MODEL, TYPE AND SERIAL NUMBER OF MACHINE.**

BULLDOG 65 Hydraulic Steelworker

4.2 PUNCH TOOLING

The Punch and Die should be checked for alignment, prior to punching any material.

4.2.1 Tooling Changes

Punch: With quick-change device. No need of additional devices.

Die: To change die, slacken set screw in side of bolster, remove die and replace with new die, retighten set screw.

After replacing punches and dies, it is important that they are correctly aligned. See page 6 for alignment procedure under the heading 'Safety Points'. Extra care must be taken when fitting square or shaped punches that they are correctly aligned before operating machine.

4.3 PUNCH TOOLING - GENERAL GUIDES

1. The punch stripper plate must be adjusted correctly with sufficient clearance to allow positioning and removal of the material being punched.
2. Punch holes with sufficient material around the hole so contact is made on both sides of the stripper plate. Stripping forces can be severe. Unbalanced stripping forces may cause punch breakage.
3. Liberal oiling of the punch will considerably lengthen the life of the punch and die and also help reduce the stripping forces.
4. The quality of the hole (or blank) is an immediate indication of the condition of the punch and die.
5. Do not punch material thicker than the punch diameter, this overloads the punch and can result in breakage.
6. Punch full and complete holes, do not punch partial holes unless tooling is specifically designed to do so.
7. When punching small items (i.e. small pieces of plate, bar etc) these items **MUST** be placed and extracted with suitable handling aids, extra guarding may be required too ensure operator safety.
8. Stay within the rated capacity of the machine.

BULLDOG 65 Hydraulic Steelworker

4.4 PUNCH AND DIE LUBRICATION

It is recommended that one of the following oils is applied by brush to the punch and die or both sides of the material being punched.

SHELL	- GARIA 927
B. P.	- SERVORA 68
CASTROL	- ILOBROACH 219
DUCKHAMS	- ADFORNOL EP7

Die clearance: It is normal practice to aim for a clearance of 10% material thickness.

Whether clearance is added to the size of the die or deducted from the size of the punch, depends on the nature of the work. When holes of a given size are required the punch is made to size and the die is made larger. Conversely, when blanks of a given size are required the die is made to size and the punch smaller.

Special clearance dies for thin sheet and plate punching, or size dies and special clearance punches can be supplied to order.

BULLDOG 65 Hydraulic Steelworker

4.5 PUNCHING CAPACITY

The graph shows the punch capacity curves for the BULLDOG 65 and BULLDOG 50 machines. As an example it can be seen to punch material 15mm ($\frac{5}{8}$ "') thick, the maximum diameter is 22mm ($\frac{7}{8}$ "') on the BULLDOG 50 and the maximum diameter on the BULLDOG 65 is 28mm ($1\frac{1}{16}$ "). As an alternative it is possible to calculate a capacity by using the machine constant. By dividing the machine constant by the material thickness will give the maximum diameter through that thickness.

(1" = 25,4mm)

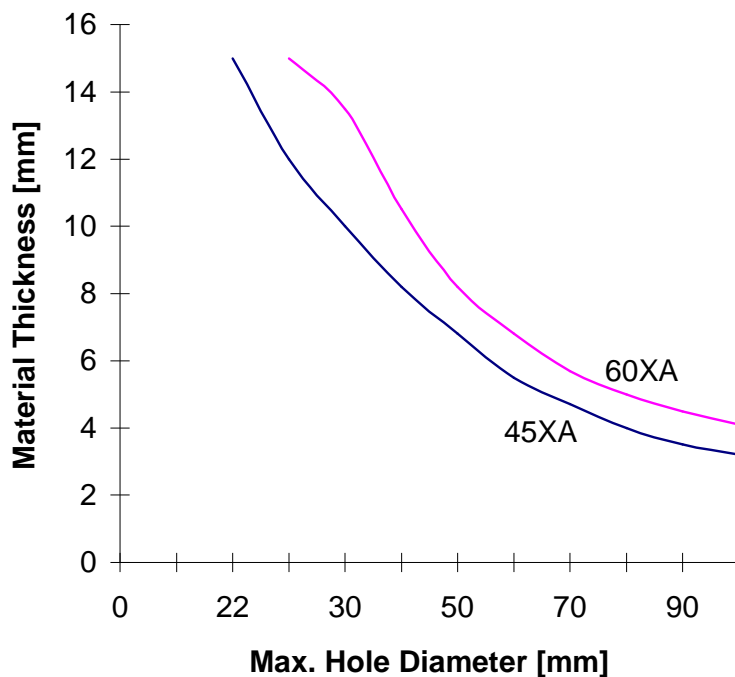

The machine constants are:

BULLDOG 50 330
BULLDOG 65 420

If you want to calculate the max. Material thickness / max. hole sizes use one of the following formulars:

Constants / Material Thickness = max. Diameter

or:

Constants / Diameter = Max. Material Thickness

Note:

BULLDOG 65 Hydraulic Steelworker

All capacities are based on materials to be punched having a tensile strength of 45 kg/mm² (65.000lbs). Always keep within the rated capacity of the machine and never attempt to punch a hole smaller in diameter than the thickness of material being punched.

BULLDOG 65 Hydraulic Steelworker

1. Example:

You are going to work with a material of 10mm ($\frac{3}{8}$ "') thickness on a BULLDOG 65 machine. The max. hole size is then calculated by:

$$420 / 10 = 42 \text{ [mm]} \quad \Rightarrow \text{The max. hole size is 42mm (1\frac{5}{8}"').}$$

2. Example:

Your punch / die diameter is 26mm (1"). The max. material thickness you can punch is calculated by:

$$420 / 26 = 15,4 \text{ [mm]} \quad \Rightarrow \text{The max. material thickness is 15mm (}\frac{3}{5}\text{").}$$

This system will probably prove to be convenient because when the machine capacity constant has been memorised, no tables or graphs are required to establish max. diameters through a known thickness of material.

Please Note: **DANGEROUS PRACTICE:**
DO NOT ATTEMPT TO PUNCH MATERIAL
THICKER THAN THE PUNCH DIAMETER!

4.6 BAR BENDING FACILITY AT PUNCHING STATION

Press Brake type tooling is available for fitting at the Punching Station giving press brake capacity of 4" x $\frac{1}{2}$ ".

IMPORTANT NOTICE - HEALTH & SAFETY AT WORK ACT, SECTION 6

Bending tools must not be fitted to this machine until adequate safety measures have been implemented. It is normally permitted to use the bending tools without additional fixed guarding provided the following steps have been taken:

1. The clearance between the top tool and the work piece is kept to a minimum and must not exceed 6mm at any time.
2. The bending tool is set by a skilled and competent person.
3. A lockable cover has been fitted to prevent unauthorised alteration of limit switch. The key should be retained by the setter.

Bending Tools are supplied with suitable cover and lock as standard.

BULLDOG 65 Hydraulic Steelworker

4.7 STANDARD PUNCH TOOLING

BULLDOG 65 Hydraulic Steelworker

In the following table you can find a list of the standard punch tooling of model BULLDOG 65. It includes which equipment is supplied with the machine. Other punches and dies are available on request. (see p 42)

piece	Art.No.	Description
1	0164405901	Punch holder, complete with quick change
1	0164405902	Punch holder
4	9099123540	Socket head screw
1	9079802100	Lock washer
1	0502105904	Quick change fixture
1	5053411638	Punch Ø 9/16''
1	3335	Stripper top plate
1	2407	Stripper pillar
2	3336	Stripper head
1	5066021642	Die Ø 19/32''
2	2556	Bolster clamp
1	3319	Bolster

With the Standard Quick-change device, you can punch from 1/8'' up to 1 1/4''

Extension of the punching range up to 1 9/16'' Ø is possible (see page 39)

BULLDOG 65 Hydraulic Steelworker

4.8 TYPICAL APPLICATIONS

(achieved with special tooling at punch station)

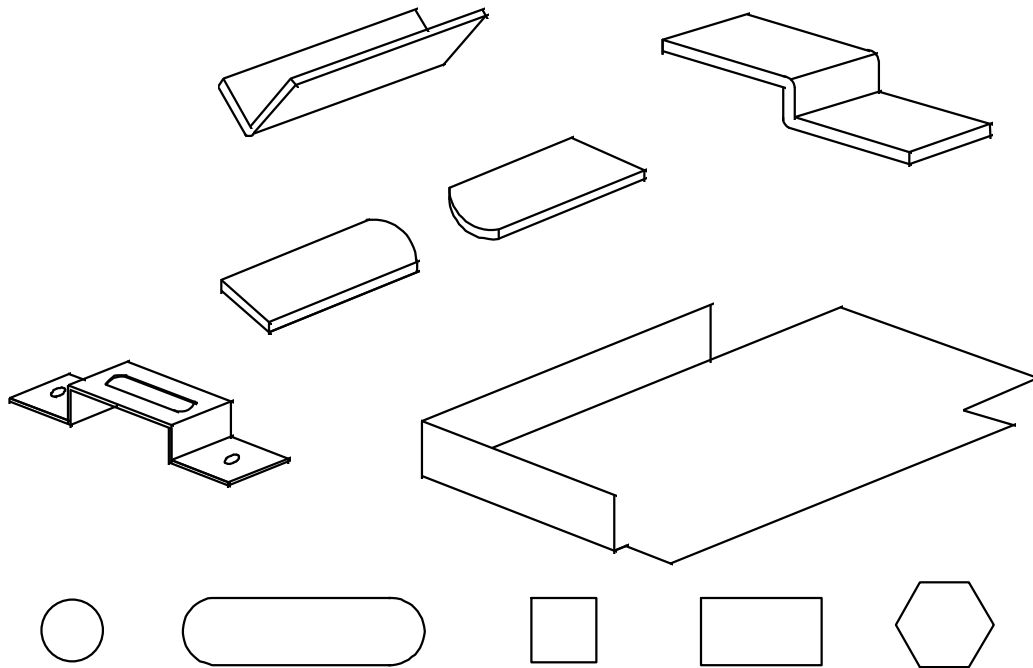

4.9 FLANGE PUNCHING

The standard bolster (3319) can accommodate flange punching in small sections. To achieve the correct back-mark it will be necessary to use an eccentric die so as to off-set the bolster.

The front portion of the punch table must be removed and the bolster re-positioned for flange punching.

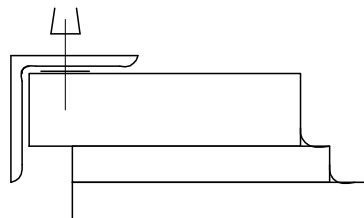

NORMAL FLANGE PUNCHING

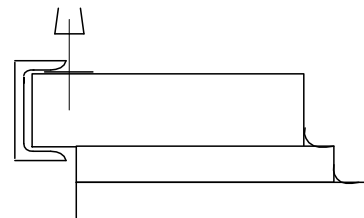

ECCENTRIC FLANGE PUNCHING

BULLDOG 65 Hydraulic Steelworker

5 SHEARING STATION

5.1 DESCRIPTION

The shearing unit is fitted with a simple robust hold-down which is adjustable to any thickness of material within the cutting capacity of the machine. A shear feed table with adjustable guides is fitted to allow the accurate feeding of materials. The guide can be adjusted to allow mitre cutting up to 45 degrees for flat bars or to trim the flanges of angle sections previously cut at the angle cutting station.

The standard shear blades as fitted permit the bottom blade to be turned four times giving new cutting edges, whilst the top blade must be ground to sharpen the cutting edge. These blades give minimum distortion from full capacity down to as light as 1/10" thickness.

Parallel top blades can be supplied (Pt. No.3309) to order for cutting narrow bar widths or where flatness of cut is not so important.

When the shear blades require sharpening, grind only on the cutting faces - max. regrinding 3/100", after grinding the blades must be adjusted to a clearance of 4/1000". Adjusting screws have been provided to reset the shear blades, the adjusting screws are positioned around blade fixing screws, accessible when shear table has been removed. Even clearance between top and bottom blades is important along the entire blade length and care should be taken to ensure that the bottom blade is in a vertical plane, parallel to top blade.

**WHEN ORDERING SPARE BLADES, ALWAYS QUOTE -
MODEL, TYPE AND SERIAL NUMBER OF MACHINE.**

5.2 SHEAR TOOLING - GENERAL GUIDES

1. The quality of the cut is an immediate indication of the condition of the blades.
2. Ensure hold-down is always set for relevant thickness of material being sheared.
DO NOT allow ends of bars to be fed beyond the hold down, because bar would tend to twist between blades and cause body distortion.
3. Always feed material between blades from the hold down side.
4. Keep the blade area clean. Do not allow 'build up' of mill scale.
5. Stay within the rated capacity of the machine.

BULLDOG 65 Hydraulic Steelworker

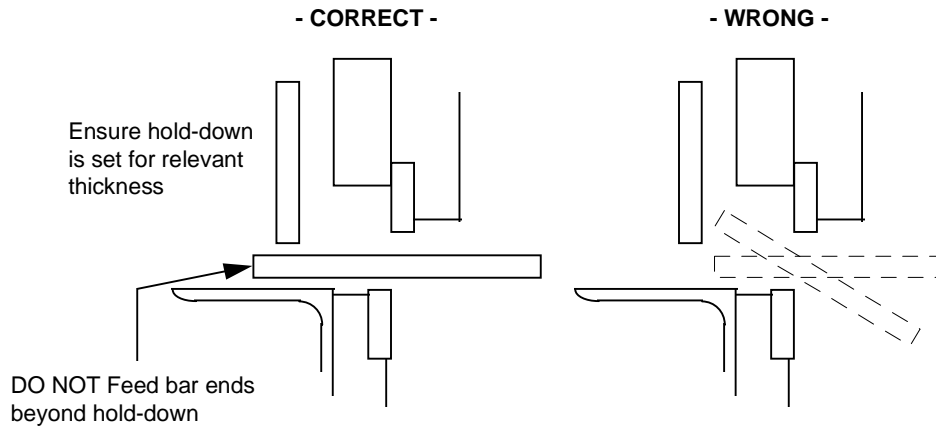

5.3 SHEAR BLADES

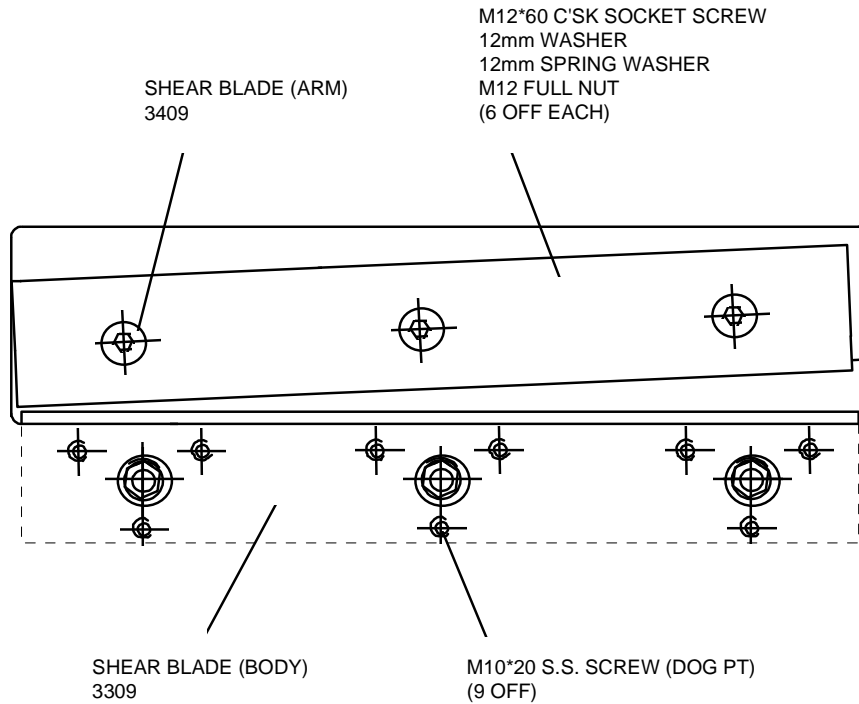

BULLDOG 65 Hydraulic Steelworker

6 ANGLE CUTTING

6.1 DESCRIPTION

This working station provides large capacity angle cutting at 90 degrees and lighter angle cutting at 45 degrees.

To cut angle section, place the material through the hold down into the cutting area, adjust the support screw to the material but leave sufficient clearance to enable the section to be fed on for progressive cutting.

To mitre cut at 45 degrees:

firstly cut the angles to length allowing approx. 1/2" oversize for end trimming.

1. Place the first end into the blade using the higher support position, trim approx. 6mm off the end of the section whilst maintaining 45 degrees to vertical position.
2. Place the other end into the blade using the left hand support position, trim section to length whilst maintaining 45 degrees to face of machine position.

To achieve other angles of cut between 45 degrees and 90 degrees, first cut the angle section to length and then trim the flange to required angle in the shear station.

The slot in the shear hold down allows angle sections to be positioned for left hand on right hand trimming, ensure hold down is set for relevant thickness.

Each cutting blade has four cutting edges and is retained by simple fixing screws.

DO NOT sharpen these blades, after turning four times replace with new blades.

**WHEN ORDERING REPLACEMENT BLADES, ALWAYS QUOTE -
MODEL, TYPE AND SERIAL NUMBER OF MACHINE.**

BULLDOG 65 Hydraulic Steelworker

6.2 ANGLE TOOLING - GENERAL GUIDES

1. The quality of cut is an immediate indication of the condition of the blades.
Keep sharp, keen cutting edges.
2. Ensure support screw is set for relevant thickness of material being cut.
3. Always feed material between blades from hold down side.
4. Keep cutting aperture clean, small slivers, short cuts and any other pieces should be removed from the blade area. DO NOT allow mill scale to 'build up' in the blade area.
5. Stay within the rated capacity of the machine.

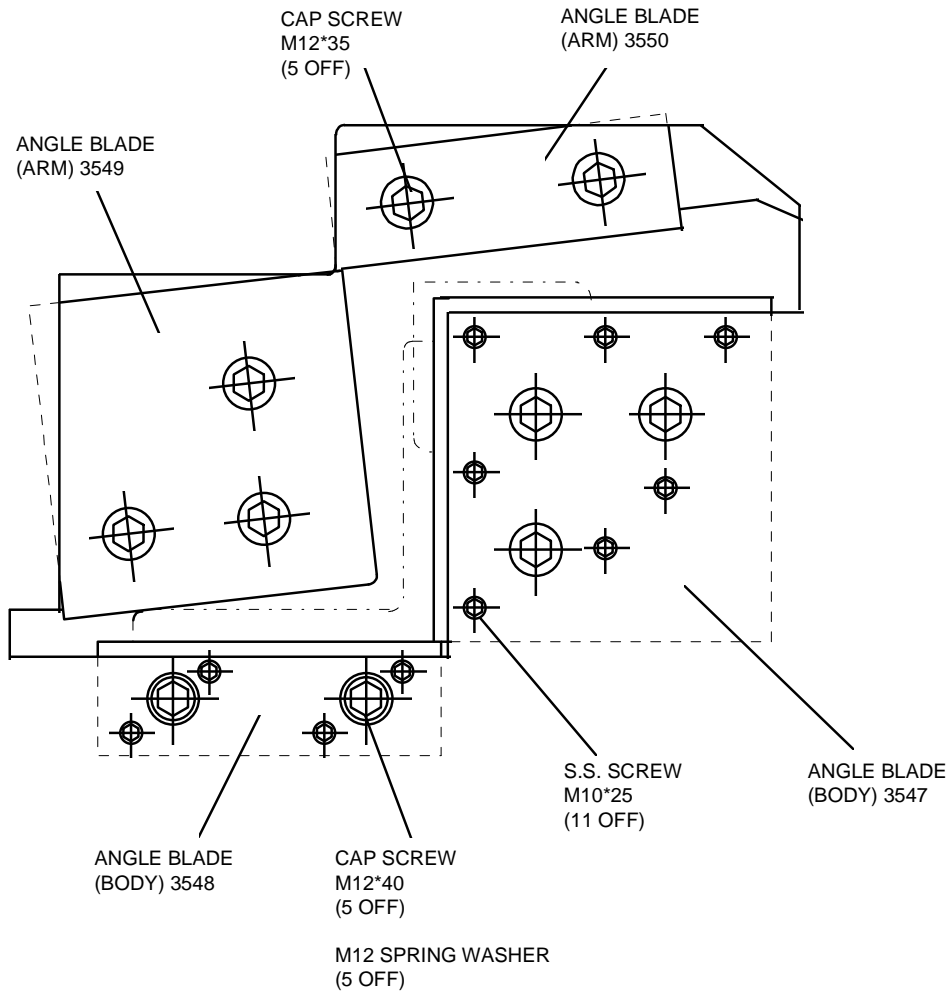

BULLDOG 65 Hydraulic Steelworker

6.3 GRINDING OF CHANNEL INSERT BLADES

Body Blade

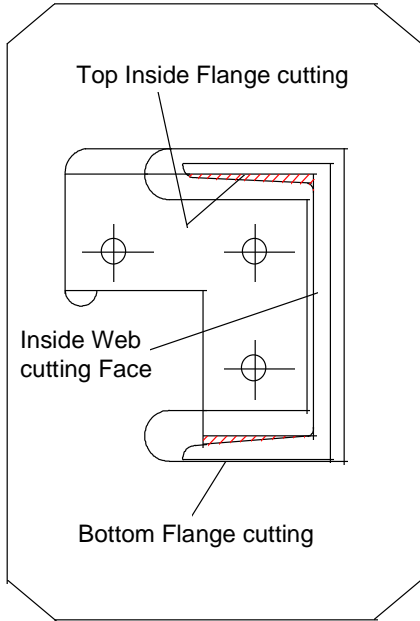

Fit blade to carrier, retain position with three screws, ensure blade is seating on both faces, see sketch. Mount a sample of channel, with a cleanly cut end, on to the blade with the bottom flange in line with bottom cutting face and the inside of the web square and in line with the inside web cutting face, as shown in sketch.

Having mounted channel correctly, scribe round inside of channel flanges.

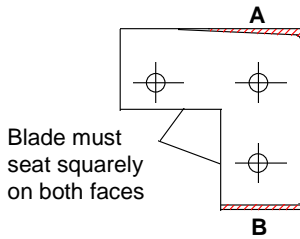

- Remove blade from carrier.
- With 'mark out' A continue inner flange line as shown.
- With 'mark out' B continue line from radius square to cutting face. Allow a small clearance when grinding to permit easy passage of channel.

Grinding

Grind insert blades to lines scribed, shown shaded in sketch.

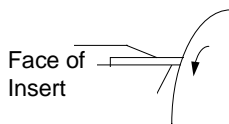

When hand grinding, if using face of grinding wheel, ensure angle between face of insert and cutting face does not exceed 90 degrees.

BULLDOG 65 Hydraulic Steelworker

6.4 GRINDING OF JOIST INSERT BLADE

Body Blade

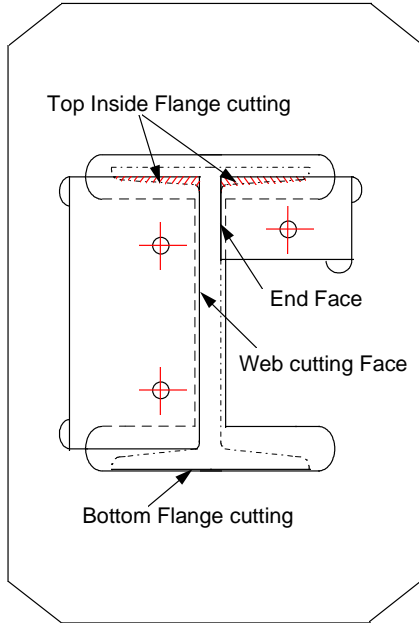

Fit blades to carrier, retain positions with fixing screws, ensure blades are seating correctly. Mount a sample of joiast, with a cleanly cut end, on to the blade with the bottom flange in line with **BOTTOM CUTTING FACE** and the web square and in line with **WEB CUTTING FACE**, as shown in sketch.

Having mounted joiast correctly, scribe round inside of joiast flanges.

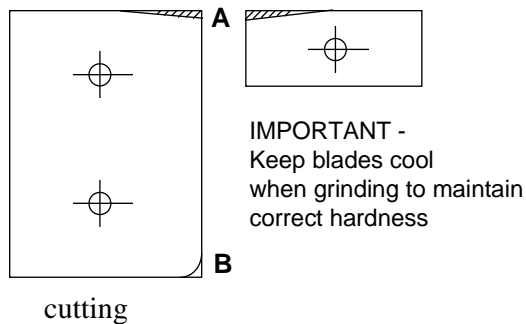

- Remove blades from carrier.
- With 'mark out' A continue inner flange line of required.
- With 'mark out' B radius to suit that of sample joiast.
- The **END FACE** may require clearance to permit easy passage of joiast for heavy or light sections, when blades are in position.

Grinding

Grind insert blades to lines scribed, shown shaded in sketch.

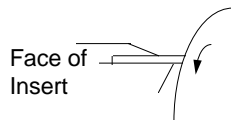

When hand grinding, if using face of grinding wheel, ensure angle between face of insert and cutting face does not exceed 90 degrees.

BULLDOG 65 Hydraulic Steelworker

7 SECTION CUTTING

7.1 DESCRIPTION

A variety of sections can be cropped at this aperture - round and square sections, unequal angle, channel, joist etc.

Blades for round and square section cropping are fitted as standard equipment and have apertures of varying sizes. The smallest aperture should be chosen, which will accept the material, thus ensuring a complete and well supported cut.

To change the blades, the material support must be removed. Release the four screws securing the blade clamps, remove blade clamps then withdraw the blades.

It will be noticed that the arm blade is smaller than the body blade.

This safeguards incorrect assembly when inserted carrier blades are used. Also notice the safety peg, there is a safety slot in the arm blade to prevent incorrect positioning.

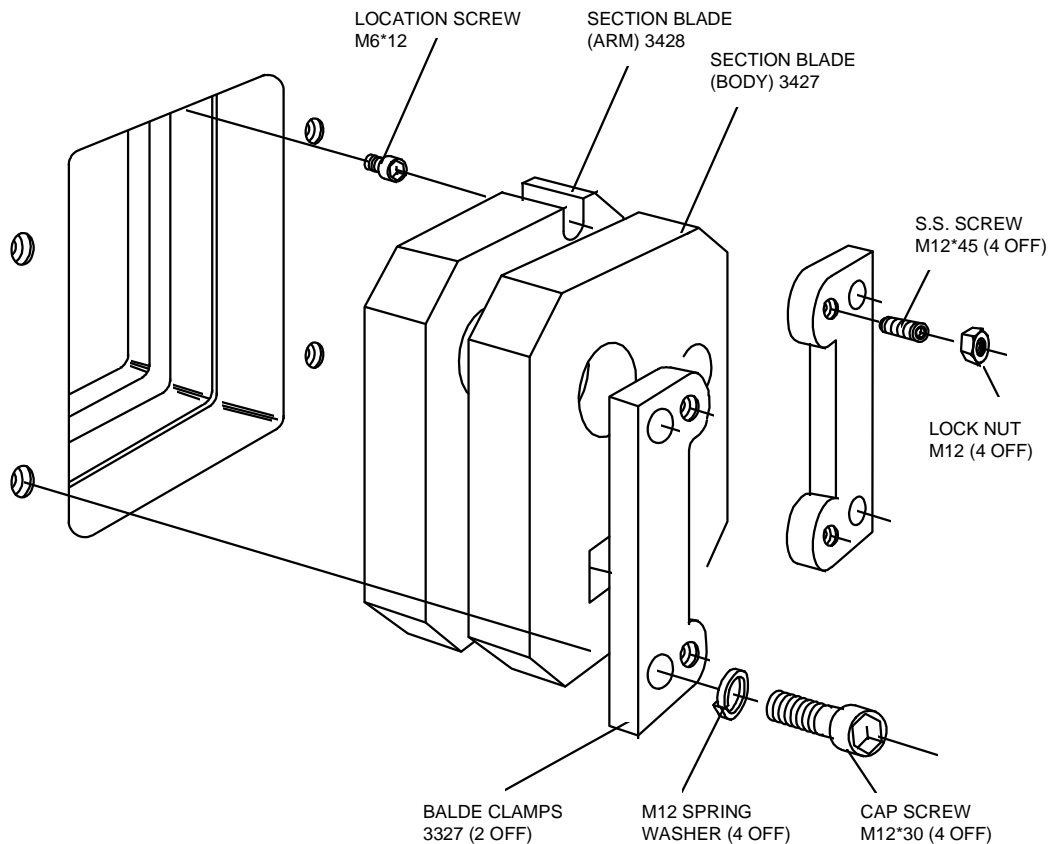

To set blade clearance:

Ensure arm blade is properly seated in shear arm.

Position body blade in frame firmly pushed against arm blade.

Secure blade clamp to frame.

Tighten the four SS screws, then release each one 0,2 of a turn.

Thigtten locknut whilst holding the SS screw with alan key.

BULLDOG 65 Hydraulic Steelworker

IMPORTANT:

- ⇒ Never remove screw fitted as safety peg in the arm blade milled recess.
- ⇒ In the case of worn solid blades, new blades must be fitted.
DO NOT attempt to regrind faces; this makes blades undersize for secure fitting.
- ⇒ In the case of worn insert blades, new inserts can be supplied for grinding to worn sample.
- ⇒ When fitting new blades reverse the removal procedure.
- ⇒ The blade clamps are marked (RH) right hand and (LH) left hand, ensure they are replaced correctly.
- ⇒ To cut sections place the material through the hold down into the cutting area, adjust the hold down screw (if fitted) to achieve square cut.

WHEN ORDERING SPARE BLADES, ALWAYS QUOTE-MODEL, TYPE AND SERIAL NUMBER OF MACHINE.

7.2 SECTION TOOLING - GENERAL GUIDES

1. The quality of the cut is an immediate indication of the condition of the blades.
Keep sharp, keen cutting edges.
2. Ensure bar sizes are used in smallest aperture that will accept them, ensuring well supported cut.
3. Always feed material between blades from hold down side.
4. Keep cutting aperture clean, small slivers, short ends and any other pieces should be removed from the blade area. DO NOT allow mill scale to 'build up' in the blade area.
5. Stay within the rated capacity of the machine.

8 NOTCHING STATION

8.1 DESCRIPTION

The notching station has a rectangular punch as standard fitting and is supplied with a notch table complete with adjustable side and back stops which allow repetitive material positioning.

Vee notch tooling can be fitted at this work station, or alternatively units can be supplied for narrow widths of rectangular or vee shapes; units also available for bar end shaping.

A particular feature of this work station, provides for some punch end units to be fitted.

When notch punch requires sharpening, grind side and front faces of punch only. The dies have four cutting edges and should be turned to present new cutting edge.

To adjust dies after punch grinding:

1. Slacken bolster fixing screws and position locking screws.
2. Move bolster into new side and front position on punch;
one side of bolster is adjustable on the die.
3. Clearances between punch and die faces should be maintained as follows:
.....at sides of punch $\frac{4}{1000}$ ''
.....at front of punch $\frac{12}{1000}$ ''
Adjust bolster on the two faces accordingly and retighten fixing screws -
check clearances.
4. Release adjustable die blade fixing screws and adjust blade to punch,
tighten fixing screws and check clearance.
5. Ensure fixing screws are tight and that the positioning locking screws have been reset.

**WHEN ORDERING SPARE PUNCHES AND DIES, ALWAYS QUOTE -
MODEL, TYPE AND SERIAL NUMBER OF MACHINE.**

8.2 NOTCHING TOOLING - GENERAL GUIDES

1. The quality of cut is an immediate indication of the condition of the tooling.
Keep sharp, keen cutting edges.
2. Check that the notched blank ejects after notching operation, thus avoiding
any 'build up' of slugs.
3. Stay within the rated capacity of the machine.

BULLDOG 65 Hydraulic Steelworker

8.3 RECTANGULAR NOTCH TOOLING ARRANGEMENT

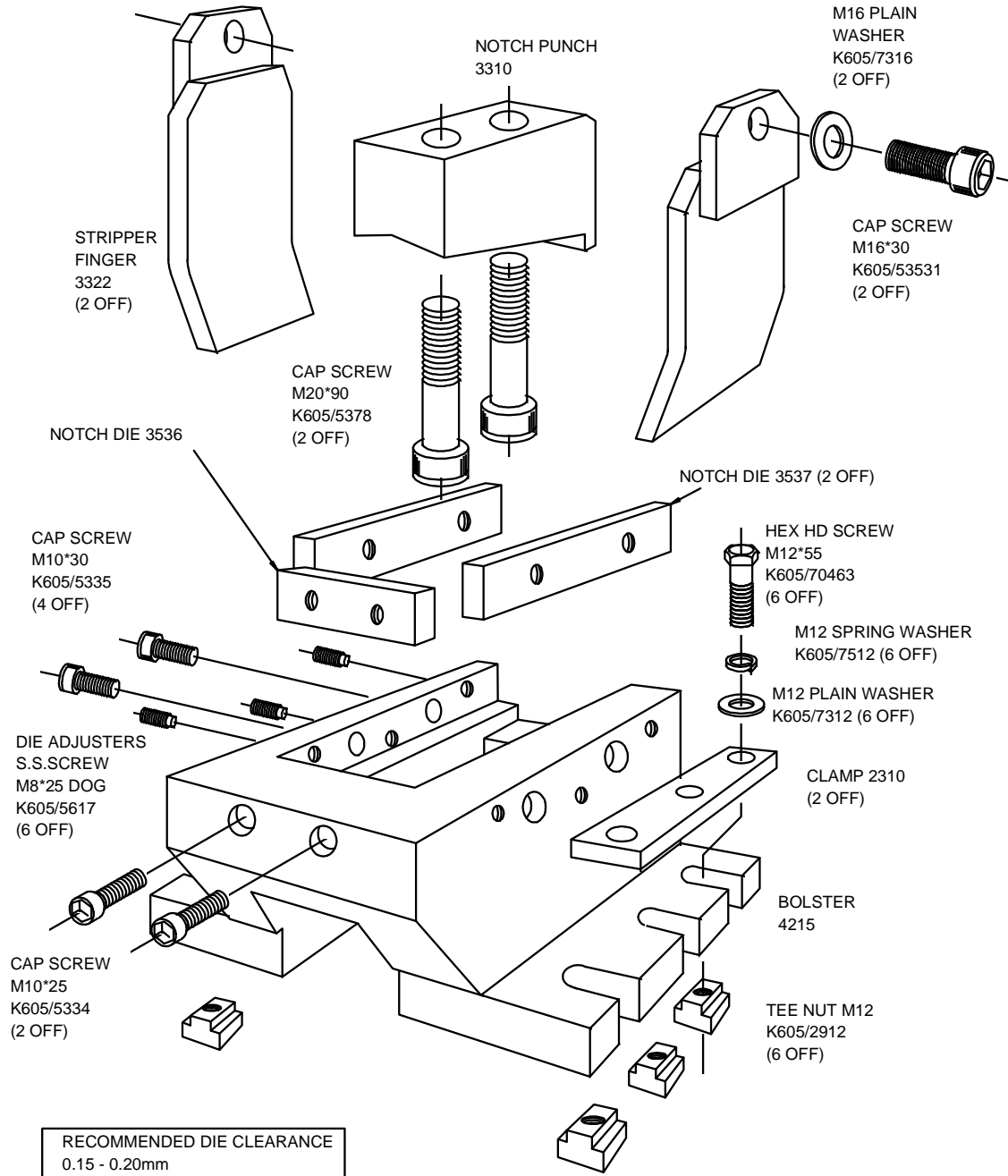

BULLDOG 65 Hydraulic Steelworker

9 FURTHER INFORMATION

9.1 CAPACITIES

9.1.1 Punching

Rated Capacity	65T
Max. Capacities	1 1/16" x 5/8"
Dia. x Thickness	1 1/2" x 7/16"
Max. Stroke Length	2 1/8"
Speed - 5/8" travel	26 full cycles/min
Throat Depth Standard	8 5/8"
Largest Hole	4"
Working Height	37"
Max. Section Flange Punch	4"

9.1.2 Shearing

Flat Bar	8 x 3/4"
Alternative	12 x 5/8"
Blade Length	12 1/2"
Angle Flange Trim	3 1/8" x 3/8"
Working Height	37"

9.1.3 Angle Cutting

At 90°	4 3/4" x 1/2"
At 90° (with modified blades)	5 1/8" x 1/2"
At 45° Mitre	3 1/8" x 5/16"
Working Height	44 3/4"

9.1.4 Section Cutting

Round/Square Bar	1 9/16" / 1 3/8"
Channel Beam	4" x 2"
Tee	3 x 3/8"

9.1.5 Notching

Material Thickness	3/8"
Width	1 5/8"
Depth: Vee-Rect.	2 3/8"-4"
Angle Flange	4 x 3/8"
Working Height	37"

BULLDOG 65 Hydraulic Steelworker

9.2 SPECIFICATION

Motor	5,5 HP
Nett Weight	2695 lb
Gross Weight	2948 lb
Machine Dims.	59 ¹ / ₂ '' x 23 ¹ / ₄ '' x 62''
Packed Dims.	65 ³ / ₈ '' x 30 ¹ / ₂ '' x 69 ⁵ / ₈ ''

9.3 ADDITIONAL TOOLING

Bending

Max. Bar Size	6 x 1/2''
---------------	-----------

Punching at Notch Station

Max. Capacity	3/4'' x 1/2''
Throat Depth	4 ³ / ₈ ''

Corner Notch

Max.	4''sq x 1/4''
------	---------------

Tube Notch

Max. Diam.	3 ¹ / ₄ ''
------------	----------------------------------

BULLDOG 65 Hydraulic Steelworker

9.4 STROKE ADJUSTMENT

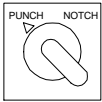
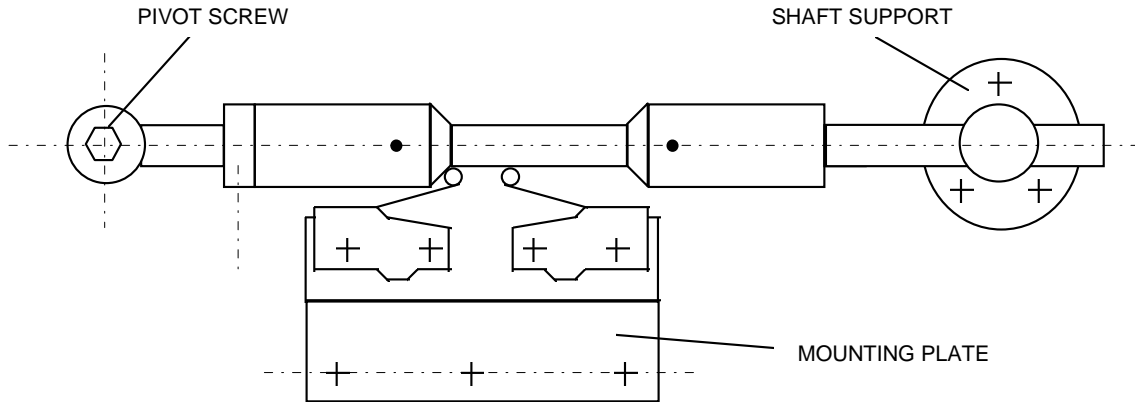

Selecting PUNCH on control switch returns punch to top of stroke position.

Re-adjustments

Before making any positional adjustments of switch CHECK:

1. Pivot screw is locked securely.
2. Shaft support screws are secure.

Having checked above, reposition mounting plate as required.

Switches should be operated by actuators before hydraulic system “pressure“, (i.e. before cylinder piston reaches end of cylinder, full cylinder stroke length).

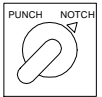

Selecting NOTCH on control switch returns notch / shear to open operating position.

Re-adjustments

Switch selector to PUNCH and make adjustments as above.

Note: Adjustments to stroke limiters can be arranged by switching to the INCH mode of operation; the punch position and/or shear-cutting position is then set by operating the foot pedal to achieve position required. Adjust appropriate stop position, tighten stop screw; then re-check setting under normal RUN condition.

BULLDOG 65 Hydraulic Steelworker

9.5 HYDRAULIC SYSTEM

A 4 KW (5,5HP) Motor drives a hydraulic pump, which through control valves feed the power cylinder of the machine. The cylinder is connected to a pivoted arm.

Hydraulic Oil - refer to the recommended oils label. The oil filler/breather is positioned on the tank accessible by removing the louvred cover at base of the machine.

Suction Strainer - inspect oil strainer every twelve months. The strainer is accessible, having released the screws in tank cover, if necessary wash in paraffin (Replacement L820/5020).

Sludge Tray - whilst lower cover is removed, check tray located under main frame once every twelve months.

9.6 CLEANING

Under normal operation, all visible working parts should be regularly cleaned of foreign matter, thus preventing excessive wear and possible failure.

9.7 REGULAR MAINTENANCE

- Daily** - Before starting machine -
Check fluid level in tank - top up as necessary.
Check oil level in oil pump - top up as necessary.
Check condition of all blades, punch and die.
Check surrounding work area is tidy, remove any off-cuts, slugs from floor area.
Clean off any mill scale which may have collected around the cutting apertures.
- Weekly** - But depending on work load
Examine power cable and foot pedal cable for damage or chafing.
Check movement of machine is smooth when running under no load condition.
- Monthly** - Check arm adjustment for any slackness.
- Yearly** - Change hydraulic fluid, inspect oil suction strainer.

BULLDOG 65 Hydraulic Steelworker

9.8 HYDRAULIC FLUID

Fill to top level of inspection glass. Use only mineral oil as recommended or equivalent.

Castrol	Hyspin AWS32-6018
B. P.	Energol HLP32
Shell	Pollus 37
Mobil	DTE 24
Esso	Nuto H32

9.9 OILING LUBRICANT

Check oil level in pump reservoir daily, operate pump 2/3 times daily.

Castrol	Magna DR 220
Shell	Tomma T220
B.P.	Energol GHI 220
Mobil	Vactra Oil No. 4
Esso	Febis K220

Lubricant Check

Before operating machine, the following important checks should be made.

- The Hydraulic fluid is at top level of inspection glass.
- The oil pump has been operated, and that there is oil pressure indicated, check oil level in pump.

BULLDOG 65 Hydraulic Steelworker

9.10 MACHINE ARM ADJUSTMENT

The Shear Arm is adjusted by four 24mm Socket Set Screws which apply pressure to the Internal Bronze Pressure Pads. These are located on the Feed (Hold Down) Side of the machine as shown in the figure below.

Adjusting Arm

Isolate machine before making any adjustments.

1. Slacken locking nuts at the four pad positions only (M24 lock nuts).
2. Turn adjusting screws clockwise until slight resistance is felt.
3. Tighten lock nuts and test movement of arm.

N. B. The arm should be adjusted prior to any adjustment of the shear blade.

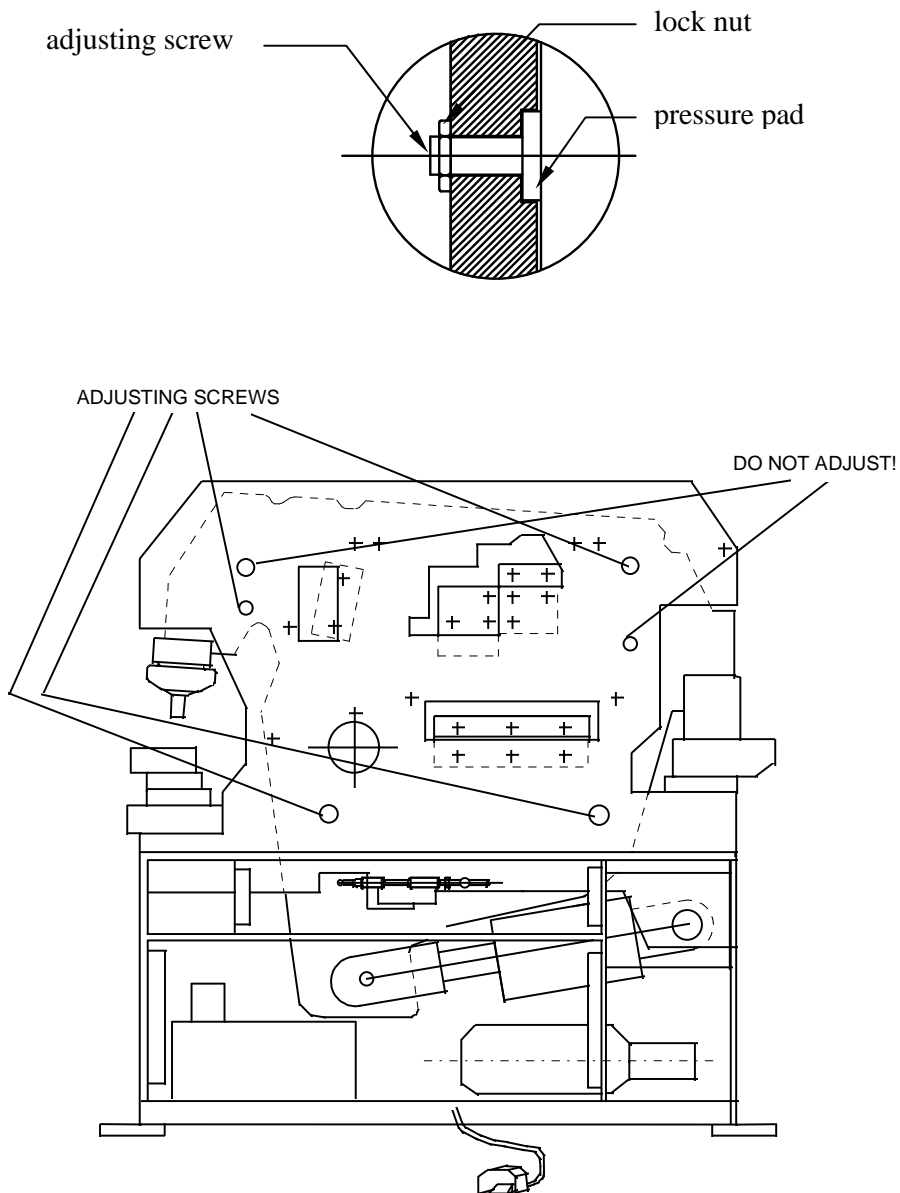

BULLDOG 65 Hydraulic Steelworker

9.11 PARTS LIST

When ordering spares always quote model, type and Serial Number of Machine.

Nr.	Part No.	Description	No. off
1	3283	Lower rem panel	1
2	3289	Clevis	1
3	3290	Main pivot	1
4	3291	Main pivot bush	1
5	3292	Cylinder pin	2
6	3293	Cylinder pin bush	1
7	3366	Lmt sw cover	1
8	3395	Top cover	1
9	3411	P.E. & N.E. Covers	2
10	3418	Louv front cover	1
11	3419	Louv rear cover	1
12	L815/5000	Hydraulic cylinder	1
13	2079	Hold down adjusting screw	1
14	2093	RAM pressure plate	1
15	2097	notch / shear guide	1
16	2307	LMT sw shaft support s/e	1
17	2340	Shaft swivel	1
18	2407	Stripper pillar	2
19	2433	Limit switch actuator	2
20	2434	s/e lmt boss adj collar	1
21	2435	Rod fixed stop	2
22	2556	Bolster clamps	2
23	2557	Punch retaining ring	1
24	2835	Angle wear bar	1
25	2887	Stripper pivot sleeve	1
26	L515/4124	Notch end cover	1
27	L515/4126	P/End rear guard	1
28	3309	shear blade (body)	1
29	3310	Rect notch punch	1
30	4215	Notch bolster	1
31	4221	Punch bolster	1
32	3321	shear table	1
33	3322	Notch strip finger	2
34	4220	Notch table	1
35	4223	Punch table	1

BULLDOG 65 Hydraulic Steelworker

No.	Part No.	Description	No. off
36	3327	Blade retainer plt	2
37	3976	Section aperture cover	1
38	3977	Shear/angle apert cover	2
39	3335	stripper top plt	1
40	3336	stripper head	1
41	3339	H/down plate weld	1
42	3353	H/D adj screw	1
43	3359	gear drive pin	1
44	3401	actuator shft assym	1
45	3402	switch mounting plate	1
46	3409	shear blade (arm)	1
47	3410	adj screw ret block	1
48	3420	shear chute	1
49	3421	Angle/sect H/D cover	1
50	K705/1910	VD 100 FP A 16	1
51	3427	section blade (body)	1
52	3428	section blade (arm)	1
53	4227	P/table ext	1
54	3466	Ext support plate	2
55	3536	Notch die	1
56	3537	Notch die	2
57	3547	Angle blade (body)	1
58	3548	Angle blade (body)	1
59	3549	Angle blade (arm)	1
60	3550	Angle blade (arm)	1
61	3552	Punch stripper mntg blk (LH)	1
62	3553	Punch stripper mntg blk (RH)	1
63	3554	cover spacer	1
64	3821	Sub plt	1
65	4242	Notch bolster clamp	2
66	4096	Angle h/d screw	1
67	4098	Angle h/d screw	1
68	4102	locking collar	2
69	4128	Punch stripper guard	1
70	L830/3872	Flex pipe (tank to pump)	1
71	L830/3873	Flex pipe (manifold „B“ to pump)	1
72	L830/3874	Flex pipe (manifold „C“ to cylinder)	1
73	L830/3875	Flex pipe (manifold „D“ to cylinder)	1

BULLDOG 65 Hydraulic Steelworker

No.	Part No.	Description	No. off
74	9004 - 22	Round punch 22mm	1
75	9023 - 22	Round die 22mm	1
76	9036	Punch adaptor	1
77	K410/7009	Foot switch	1
78	K411/338282	Micro switch	2
79	K705/2010	MRX 100 B M12	5
80	K705/3006	Stipper spring	1
81	K715/1005	IB 24 meter valve strt	2
82	K715/1203	IM 24 meter valve	3
83	K715/1538	114838 4 Way connector	1
84	K715/1539	114838 4 Way connector	3
85	K715/2015	Cone LE205	8
86	K715/2016	Bushing LE 305	8
87	K715/5040	Adaptor 50-1202-03	1
88	K715/6010	4mm Oil pipe	2
89	K715/6510	Pressure gauge	1
90	K715/7040	Oil pump	1
91	K715/7085	Elbow	1
92	K905/4020	Bevel gears	2
93	L605/2626	Notch / shear guide	5
94	L605/3320	Shear hold down	1
95	L605/4104	Section plate	1
96	L820/1012	Bellhousing	1
97	L820/2013	Coupling	1
98	L820/4510DC	Direction control valve	1
99	L820/45350	Sandwich plate	1
100	L820/5010	Oil sight glass	1
101	L820/5020	Strainer	1
102	L820/5030	Diffuser	1
103	L820/5041	Filler	1
104	L910/55000	Hydraulic pump	1

10 CIRCUITS

10.1 HYDRAULIC CIRCUIT

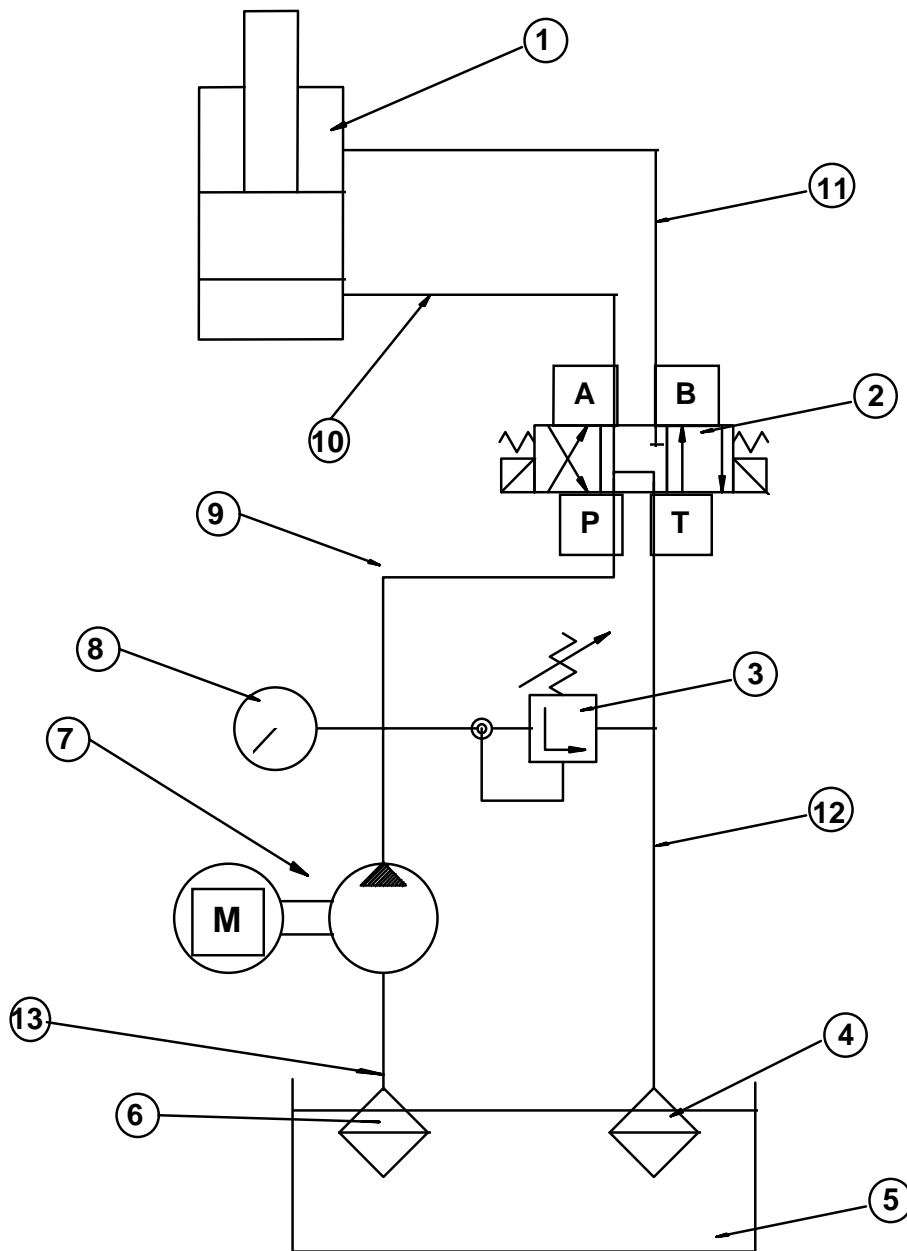

BULLDOG 65 Hydraulic Steelworker

Parts of the Hydraulic Circuit:

No.	Part No.	Description	No. off
1	L815/5000	hydraulic cylinder	1
2	L820/4513	Direction control valve	1
3	L820/45350	Relief valve	1
4	L820/5030	Diffuser	1
5	L920/6000	Tank (54 l)	1
6	L820/5020	Suction strainer	1
7	L910/55000	Hydraulic Pump	1
8		Manometer	1
9	3540	Flex Pipe (P.P.)	1
10	3539	Flex Pipe (A.A.)	1
11	3538	Flex Pipe (B.B.)	1
12	3542	Flex Pipe (T.T.)	1
13	3541	Flex Pipe (S.T.)	1

BULLDOG 65 Hydraulic Steelworker

10.2 ELECTRICAL CIRCUIT

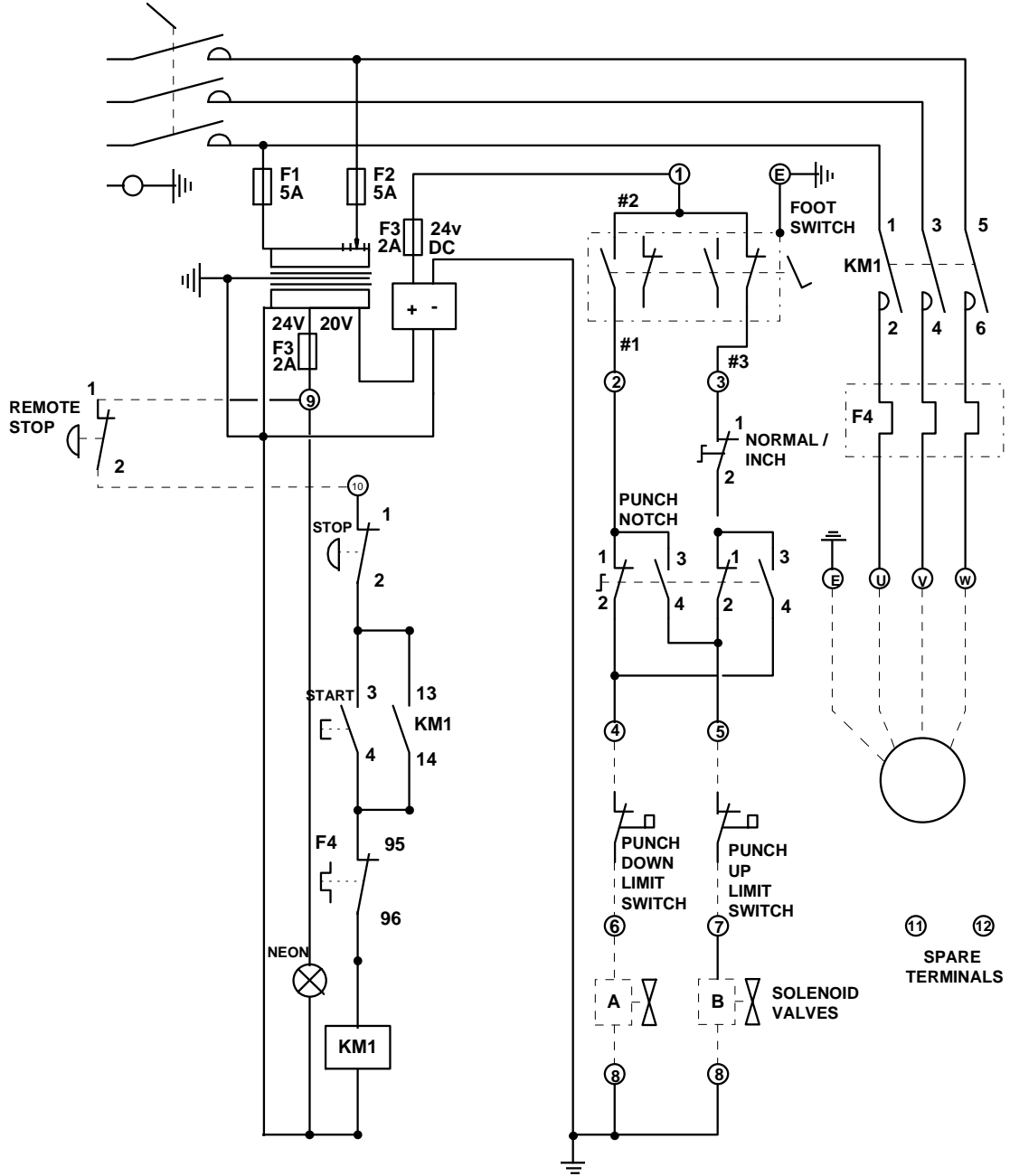

BULLDOG 65 Hydraulic Steelworker

11 SPECIAL TOOLING

11.1 90° VEE NOTCH TOOLING ARRANGEMENT

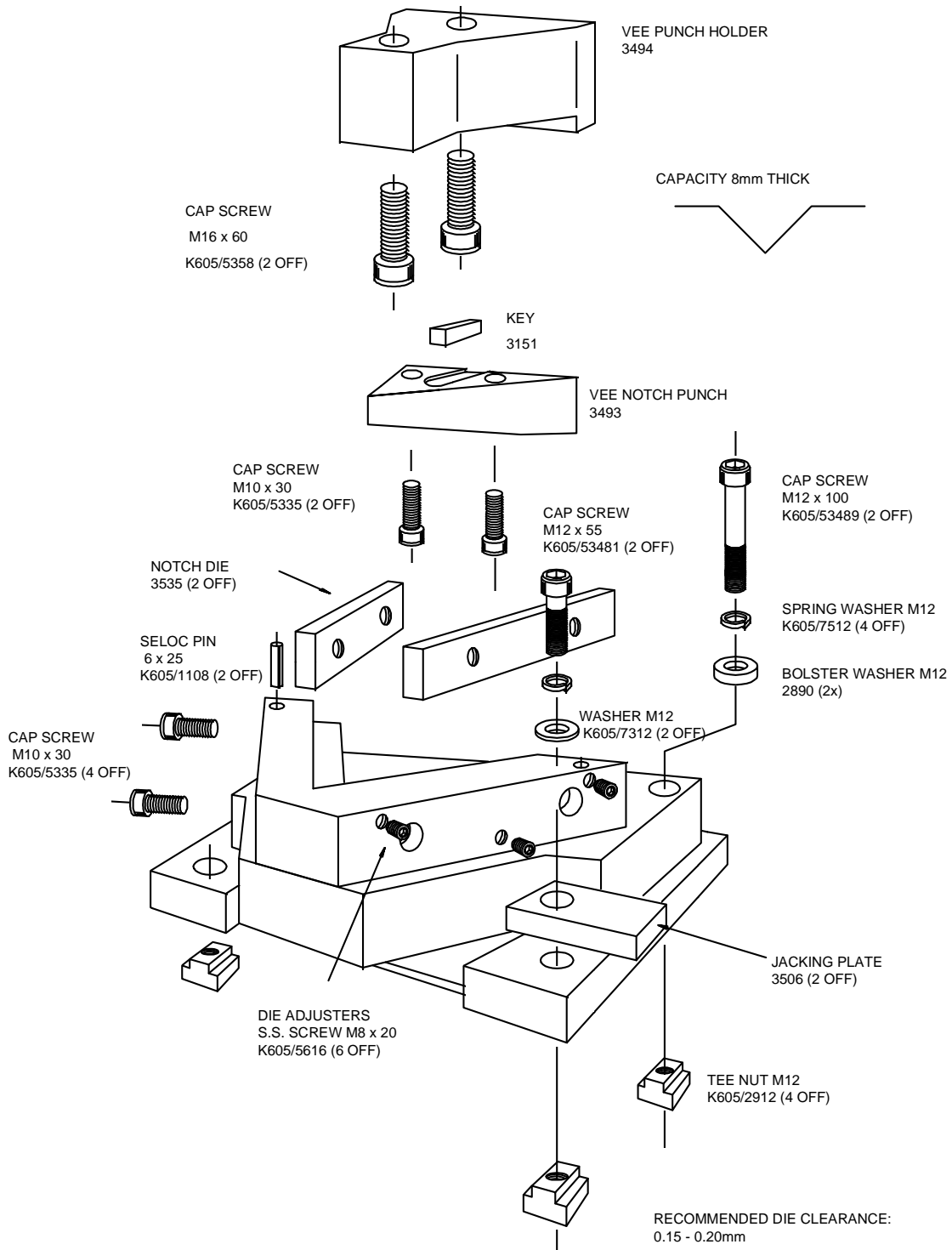

11.2 LARGE HOLE PUNCHING

BULLDOG 65 Hydraulic Steelworker

11.3 BAR BENDING UNIT

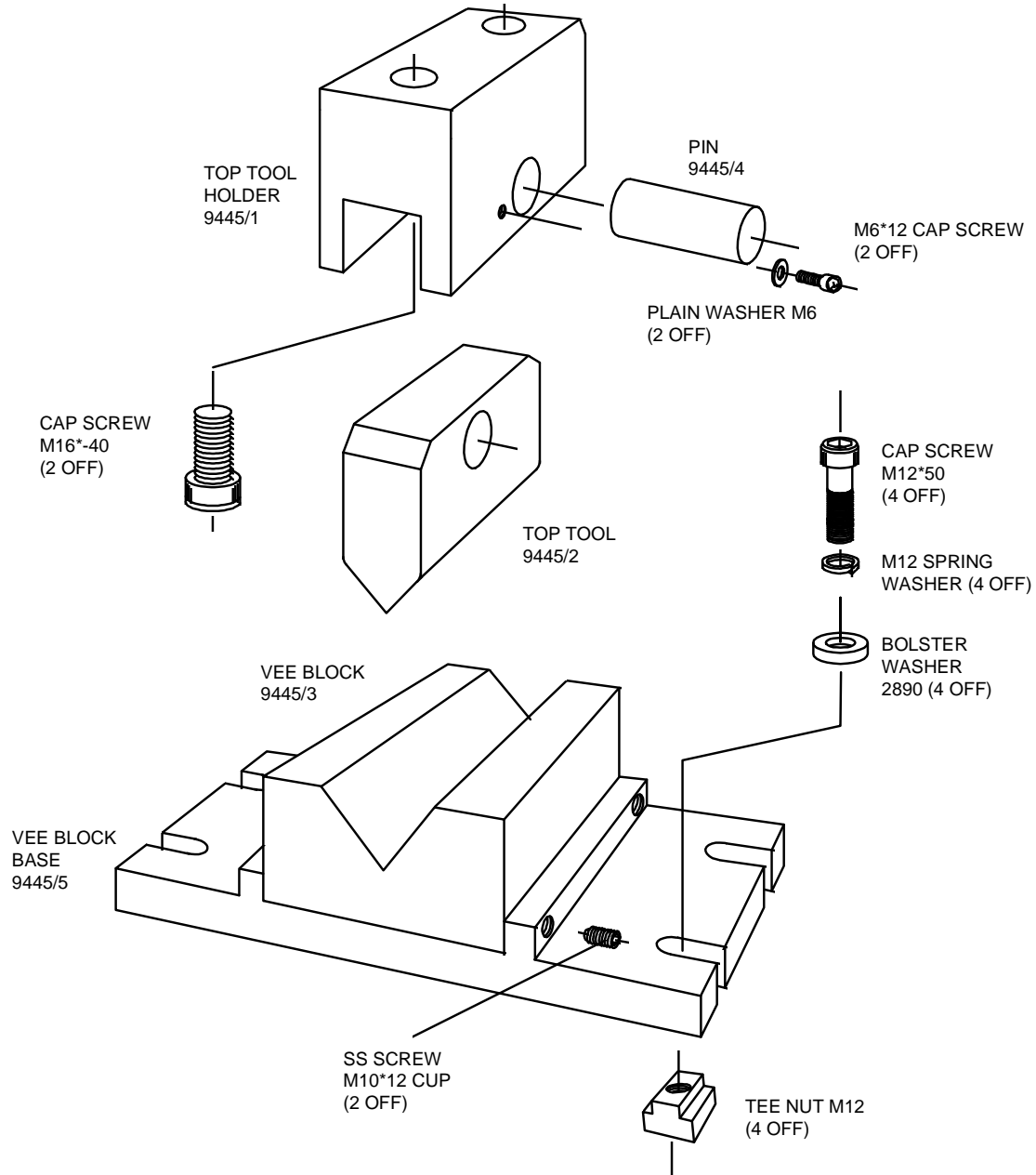

When bending always ensure work-piece is positioned central on VEE Block to avoid side loading ram. Air bending only. Adjust down stroke limit switch to avoid unnecessary pressuring of machine.

Capacity: 6'' x 1/2''

12 MANUAL APPENDIX

12.1 MITRING ANGLE 45 DEGREES ON BULLDOG MACHINES

Since the introduction of the requirements for health and safety, the accessibility and distance between hold-downs and blades have been amended.

To this effect the operation of mitring angle in the angle cutting station requires the following simple hold-down adjustment.

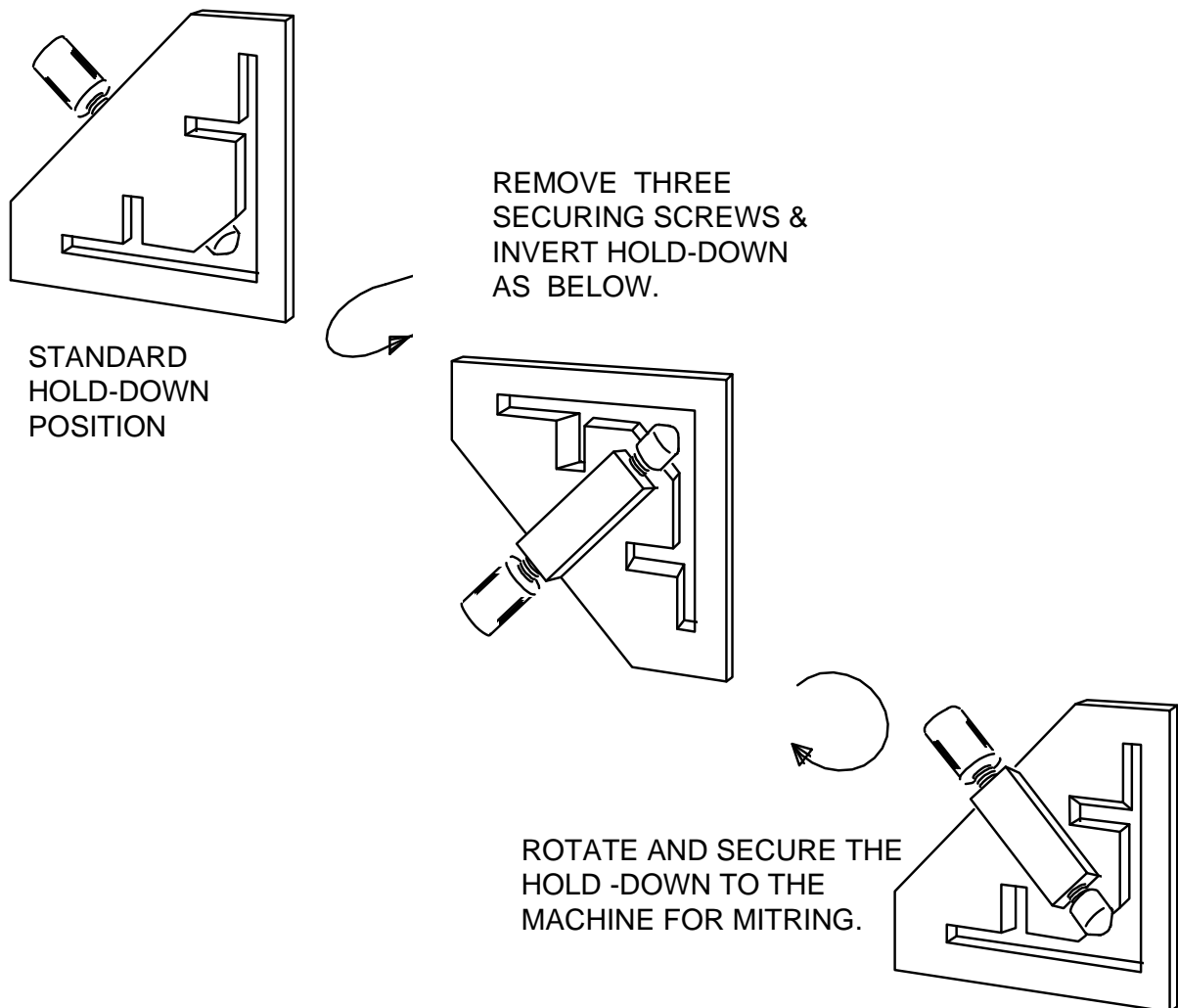

Once the hold-down is secured for mitring as position 3, it is also possible to use the hold-down for cutting angle at 90 degrees if required.

BULLDOG 65 Hydraulic Steelworker

Punches and dies to be ordered.

A) For standard punch tooling. (see p 13)

Rund punch

d Inch	Article-No.	d Inch	Article - No.
1 / 8	50534 11 604	15 / 32	50534 11 632
9 / 64	50534 11 605	31 / 64	50534 11 633
5 / 32	50534 11 606	1 / 2	50534 11 634
11 / 64	50534 11 607	33 / 64	50534 11 635
3 / 16	50534 11 608	17 / 32	50534 11 636
13 / 64	50534 11 611	35 / 64	50534 11 637
7 / 32	50534 11 612	9 / 16	50534 11 638
15 / 64	50534 11 613	37 / 64	50534 11 641
1 / 4	50534 11 614	19 / 32	50534 11 642
17 / 64	50534 11 615	39 / 64	50534 11 643
9 / 32	50534 11 616	5 / 8	50534 11 644
19 / 64	50534 11 617	41 / 64	50534 11 645
5 / 16	50534 11 618	21 / 32	50534 11 646
21 / 64	50534 11 621	43 / 64	50534 11 647
11 / 32	50534 11 622	11 / 16	50534 11 648
23 / 64	50534 11 623	45 / 64	50534 11 651
3 / 8	50534 11 624	23 / 32	50534 11 652
25 / 64	50534 11 625	47 / 64	50534 11 653
13 / 32	50534 11 626	3 / 4	50534 11 654
27 / 64	50534 11 627	49 / 64	50534 11 655
7 / 16	50534 11 628	25 / 32	50534 11 656
29 / 64	50534 11 631	51 / 64	50534 11 657

BULLDOG 65 Hydraulic Steelworker

d Inch	Article- No
13 / 16	50534 11 658
53 / 64	50534 11 661
27 / 32	50534 11 662
55 / 64	50534 11 663
7 / 8	50534 11 664
57 / 64	50534 11 665
29 / 32	50534 11 666
59 / 64	50534 11 667
15 / 16	50534 11 668
61 / 64	50534 11 671
31 / 32	50534 11 672
63 / 64	50534 11 673
1	50534 11 674
1 . 1 / 64	50534 11 675
1 . 1 / 32	50534 11 676
1 . 3 / 64	50534 11 677
1 . 1 / 16	50534 11 678
1 . 5 / 64	50534 11 681
1 . 3 / 32	50534 11 682
1 . 7 / 64	50534 11 683
1 . 1 / 8	50534 11 684
1 . 9 / 64	50534 11 685
1 . 5 / 32	50534 11 686
1 . 11 / 64	50534 11 687
1 . 3 / 16	50534 11 688
1 . 13 / 64	50534 11 691
1 . 7 / 32	50534 11 692
1 . 15 / 64	50534 11 693
1 . 1 / 4	50534 11 694

BULLDOG 65 Hydraulic Steelworker

Round die

d Inch	Article-No.	d Inch	Article-No.
9 / 64	50660 21 605	23 / 32	50660 21 652
5 / 32	50660 21 606	3 / 4	50660 21 654
11 / 64	50660 21 607	25 / 32	50660 21 656
3 / 16	50660 21 608	13 / 16	50660 21 658
7 / 32	50660 21 612	27 / 32	50660 21 662
1 / 4	50660 21 614	7 / 8	50660 21 664
9 / 32	50660 21 616	29 / 32	50660 21 666
5 / 16	50660 21 618	15 / 16	50660 21 668
11 / 32	50660 21 622	31 / 32	50660 21 672
3 / 8	50660 21 624	1	50660 21 674
13 / 32	50660 21 626	1 . 1 / 32	50660 21 676
7 / 16	50660 21 628	1 . 1 / 16	50660 21 678
15 / 32	50660 21 632	1 . 3 / 32	50660 21 682
1 / 2	50660 21 634	1 . 1 / 8	50660 21 684
17 / 32	50660 21 636	1 . 5 / 32	50660 21 686
9 / 16	50660 21 638	1 . 3 / 16	50660 21 688
19 / 32	50660 21 642	1 . 7 / 32	50660 21 692
5 / 8	50660 21 644	1 . 1 / 4	50660 21 694
21 / 32	50660 21 646	1 . 9 / 32	50660 21 696
11 / 16	50660 21 648	1 . 5 / 16	50660 21 697

B) For large hole punching. (see p. 39)

Round punch

d Inch	Article - No.
1 . 9 / 32	50534 31 696
1 . 5 / 16	50534 31 697
1 . 11 / 32	50534 31 698
1 . 3 / 8	50534 31 701
1 . 13 / 32	50534 31 702
1 . 7 / 16	50534 31 703
1 . 15 / 32	50534 31 704
1 . 1 / 2	50534 31 705
1 . 17 / 32	50534 31 706
1 . 9 / 16	50534 31 707

BULLDOG 65 Hydraulic Steelworker

Round die

d Inch	Article-No.	d Inch	Article-No.
7 / 32	50660 31 612	15 / 16	50660 31 668
1 / 4	50660 31 614	31 / 32	50660 31 672
9 / 32	50660 31 616	1	50660 31 674
5 / 16	50660 31 618	1 . 1 / 32	50660 31 676
11 / 32	50660 31 622	1 . 1 / 16	50660 31 678
3 / 8	50660 31 624	1 . 3 / 32	50660 31 682
13 / 32	50660 31 626	1 . 1 / 8	50660 31 684
7 / 16	50660 31 628	1 . 5 / 32	50660 31 686
15 / 32	50660 31 632	1 . 3 / 16	50660 31 688
1 / 2	50660 31 634	1 . 7 / 32	50660 31 692
17 / 32	50660 31 636	1 . 1 / 4	50660 31 694
9 / 16	50660 31 638	1 . 9 / 32	50660 31 696
19 / 32	50660 31 642	1 . 5 / 16	50660 31 697
5 / 8	50660 31 644	1 . 11 / 32	50660 31 698
21 / 32	50660 31 646	1 . 3 / 8	50660 31 701
11 / 16	50660 31 648	1 . 13 / 32	50660 31 702
23 / 32	50660 31 652	1 . 7 / 16	50660 31 703
3 / 4	50660 31 654	1 . 15 / 32	50660 31 704
25 / 32	50660 31 656	1 . 1 / 2	50660 31 705
13 / 16	50660 31 658	1 . 17 / 32	50660 31 706
27 / 32	50660 31 662	1 . 9 / 16	50660 31 707
7 / 8	50660 31 664	1 . 19 / 32	50660 31 708
29 / 32	50660 31 666	1 . 5 / 8	50660 31 711

To order these punches and dies please contact Pinney Machinery, also for information about other types of punches and dies (square, oblong).

BULLDOG 65 Hydraulic Steelworker

Operating Instruction Manual

MUBEA SYSTEME BULLDOG 65