

OPERATOR'S MANUAL AND PARTS LIST

MUBEA MODEL HIW

5 working stations for punching;
angle shearing; round and square bar shearing;
coping and flat bar shearing

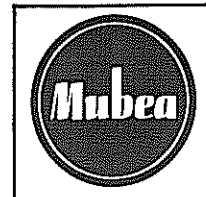

SIZE

SERIAL NUMBER

OPERATING INSTRUCTIONS

Page

3	General
4	Guards
5 – 6	Transport, Erection, Connection and Setting Going
7	Lubrication
8 – 10	Engagement
11 – 13	Flat Steel Shear
14 – 15	Coper-Notcher
16 – 17	Bar Shear
18 – 20	Angle Steel Shear
21 – 26	Punch
	Maintenance Prescriptions for Hydraulic plant
	Lubrication
	Foundation Drawing

PARTS LIST

Machine body
Section shear cylinder and slide
Manual engagement, Section shear
Foot engagement, Punch
Non deform blade
Bar shear blade
Rectangular coper and guard
Section shear knives
Punch tool assembly and Punch Cylinder
Hold down
Stripper, Punch
Support table, plate shear
Electric
Hydraulic power station
Pipework
Movable guard, plate shear
Movable guard, section shear
Movable guard, bar shear
Covering
Accessories
Length stop without scale



General

You have made a good choice, as you will soon see for yourself. The experience of decades and the latest knowhow in the field of punch and shears construction are incorporated in this MUBEA Machine. As numerous satisfied customers have confirmed time and time again, it is just the daily routine handling of this machine that makes its advantages particularly apparent.

In order to be able to fully utilize the machine, it is urgently recommended that you read and follow these operating instructions carefully.

Experience shows that the machine has an unusually long service life. Components which are subject to normal wear and tear can be replaced at any time. It is important that you then ask for Original MUBEA Spare Parts exclusively. Only then the service life of the machine and uniform quality of the result of its work can be attained. This is also true if you wish to extend the range of application of your machine by adding further tools.

Shop practice will very soon show you that MUBEA Machines can effectively be complimented and are thus universally useable, at the same time, economical in operation.

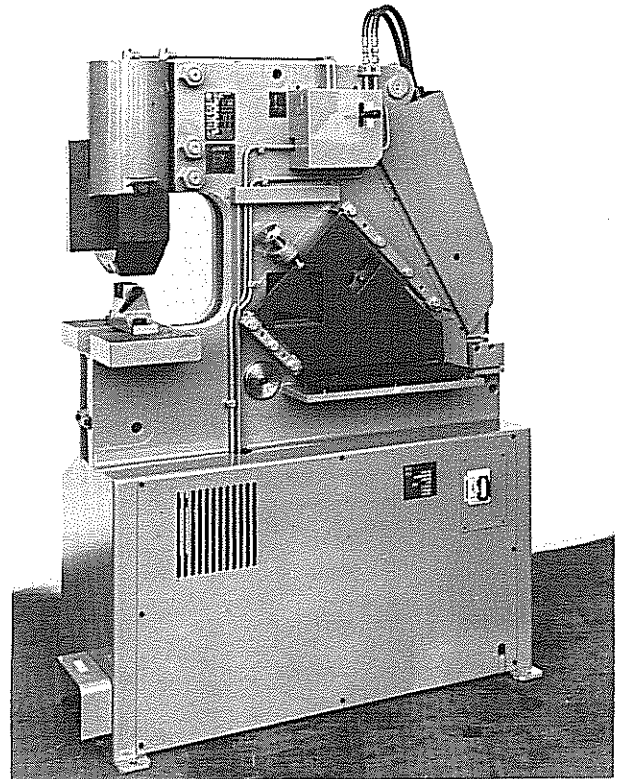

To give you a general picture of the components used in the construction machine and how these interact, you will find at the end of these operating instructions an exact outline of the parts with the corresponding article numbers.

If you should have any questions or problems of any kind, please get into touch with us or with our representation in your country, when present.

And another thing: Give the machine the care it deserves. You will find many hints on this throughout this manual.



Guards

Your MUBEA Machine corresponds to the regulations for the prevention of accidents and to the machine protection law.

For safety of operation, all working stations are provided with the necessary guards.

The figures of the various working stations and tools in these operating instructions do not show these guards as otherwise the functional representation would be affected.

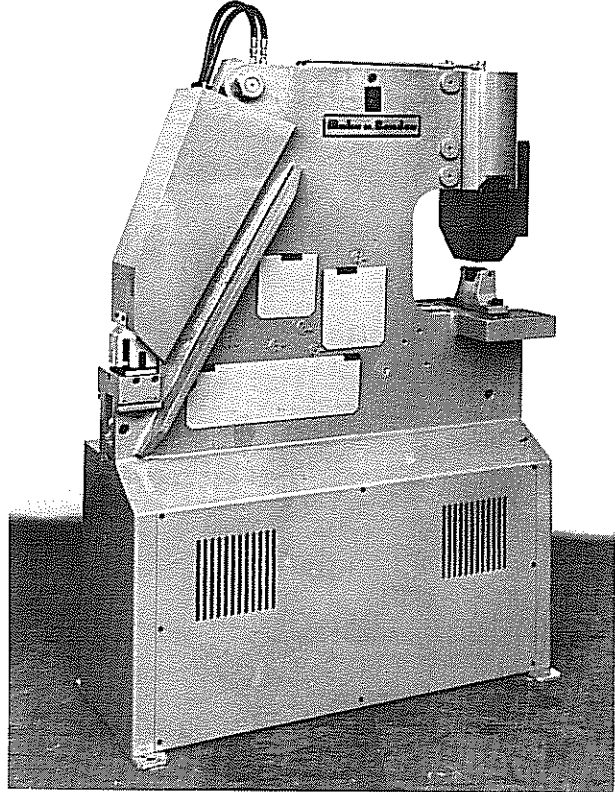

Guards at discharge side at the sectional shears, bar steel shears and flat steel shears

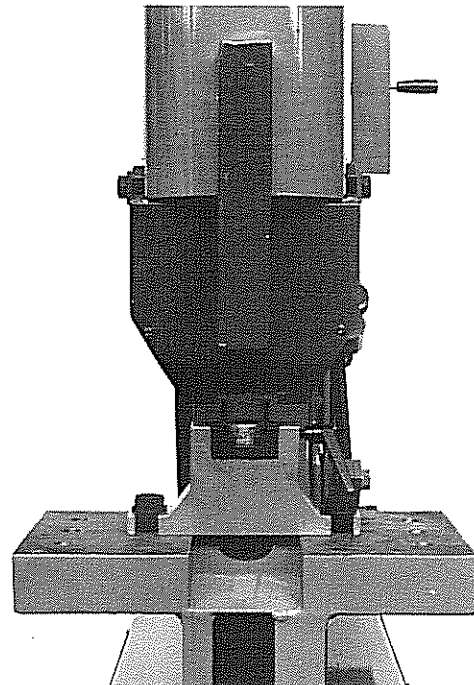
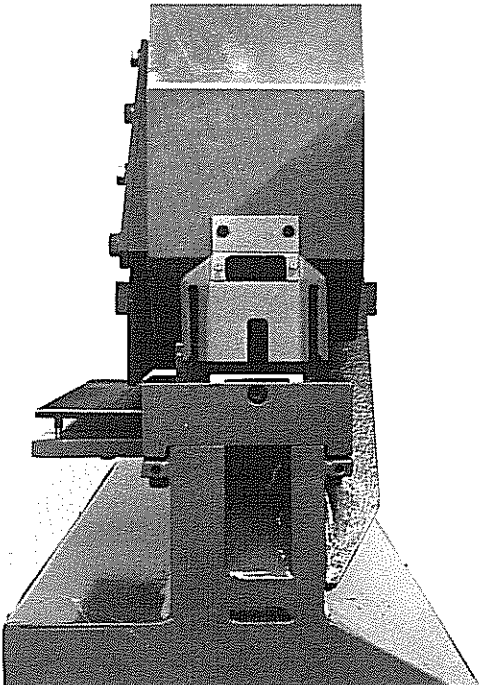

Guard for rectangular coping tool

Guard for punching tool

Transport

When transporting the machine by truck, stabilize by bolting to sturdy planks.

The weight of your machine is stated in the enclosed leaflet. When handling the machine by crane, insert the hook in the eyebolt provided for that purpose.

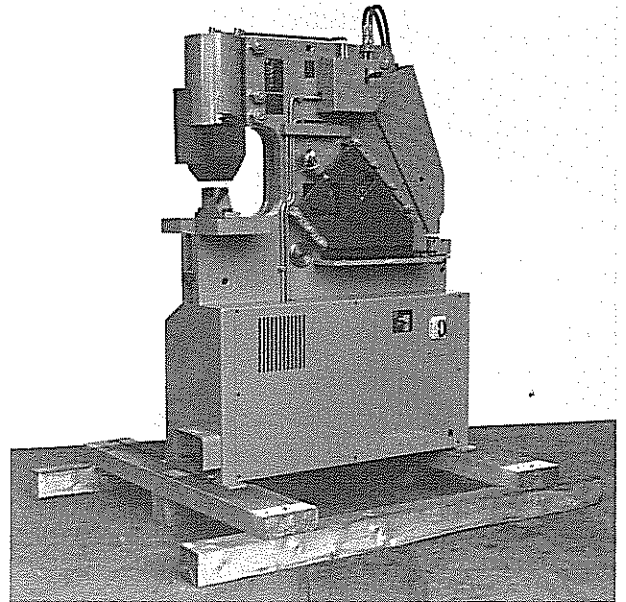

Fig. 1: Transporting the machine by truck

Erection

The working positions of the machine are at normal working levels.

Adjustment of level by platform or foundation basis is therefore unnecessary.

All the necessary data for providing a foundation level with the ground for stationary installation are given in the enclosed foundation plan. Tighten the foundation bolts securely after the grouting-in compound has set. Dowel plugs may be used instead of foundation bolts.

Check whether the machine is properly vertical.

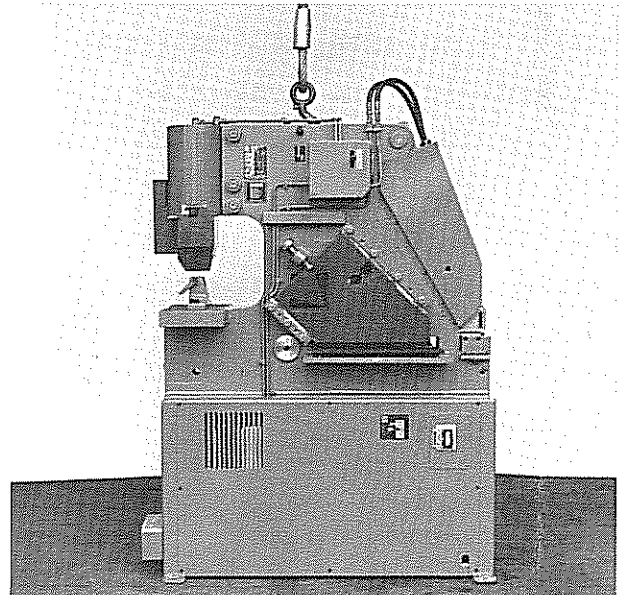

Fig. 2: Transporting the machine by crane

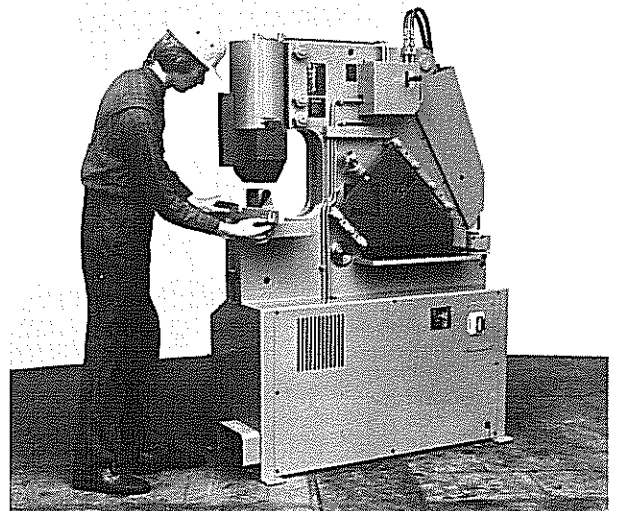

Fig. 3: Checking the upright position of the machine

Connection and Setting Going

In the base of the machine there is the drive with respective oil reservoir. Check whether the reservoir is filled up to approx. 3 cm under the reservoir cover. Checking is carried out by the filler cap.

When refilling, observe the maintenance prescriptions!

The machine is installed ready for work. In the base of the machine there is the main switch in the protective housing of the front panel to which the feeder line should be routed. Connection has to be carried out by an electrical expert as per the enclosed wiring diagram (check uniformity of tension).

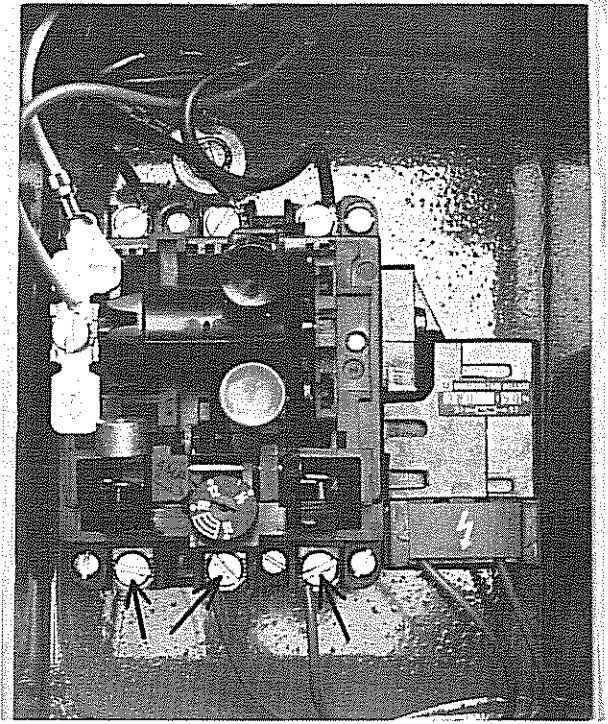

Fig. 4: Connection of the power supply

Switch on the motor briefly: If the motor does not rotate in the direction of the arrow, 2 phases have to be changed over. For checking, the motor should start up briefly in inching operation only.

Prior to setting going of the machine, check whether the slides move properly and the tools are properly seated and set. For this purpose actuate the engagements and tipped the slides gradually into the lower dead position.

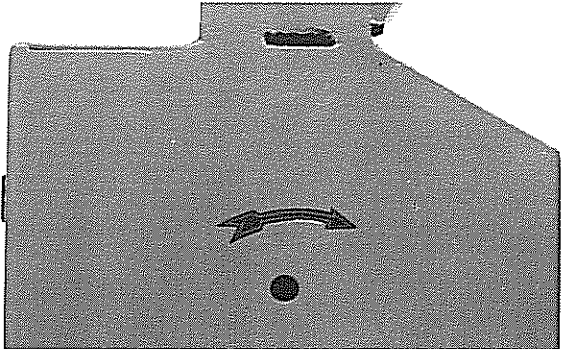

Fig. 5: Observe direction of rotation of the motor

Lubrication of the Machine

Lubricant

The machine should be exclusively lubricated with oil; the same oil may be employed for all lubrication points.

For following brands of oil may be used optionally:

ARAL-Deganit B 220

Viscosity 130 mm²/s at 50°C

SHELL-Tonna Oil T 220

Viscosity 128 mm²/s at 50°C

MOBIL OIL AG-VACTRA Oil No. 4

Viscosity 125 mm² at 50°C

ESSO AG-MILLCOT K 220

Viscosity 120 mm²/s at 50°C

BP-Energol HP-C 220

Viscosity 127 mm²/s at 50°C

FOR MACHINES SUPPLIED TO THE U.S.A.

Lubricate daily with oil

Lubricant:

CHEVRON VISTAC OIL 150X

Lubricating direction acc. to Lubrication chart.

Lubricate the machine thoroughly (see lubrication chart).

Lubricating is done by means of the oil gun which is included in the supplied tool set. Follow the enclosed lubrication chart and make sure that the prescribed quantities of oil are injected regularly.

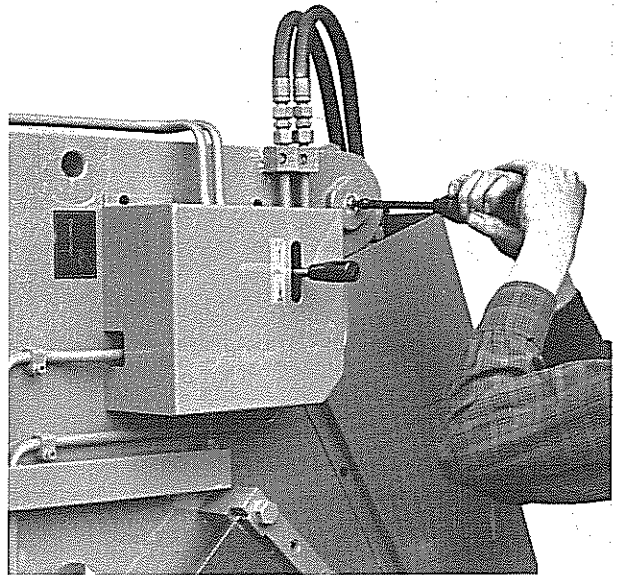

Fig. 6: Lubrication

Engagement (manual operation)

Each slide can be engaged separately. The slides can be controlled in any desired position for stopping and returning. Slide motion of the punch is released by foot operation. The shear slide is controlled by manual operation.

In central position the valves have free passage.

In the dead positions of the slides, the switch elements should no longer be actuated because of the incorporated overload safety device.

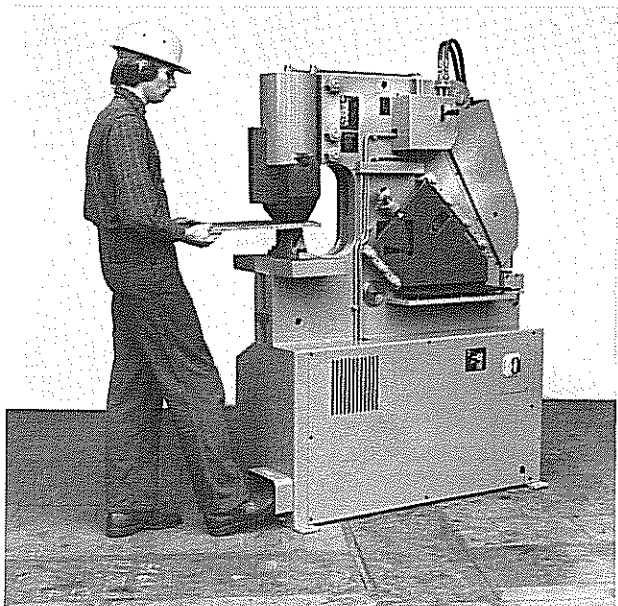

Fig. 7: Foot engagement to the punch

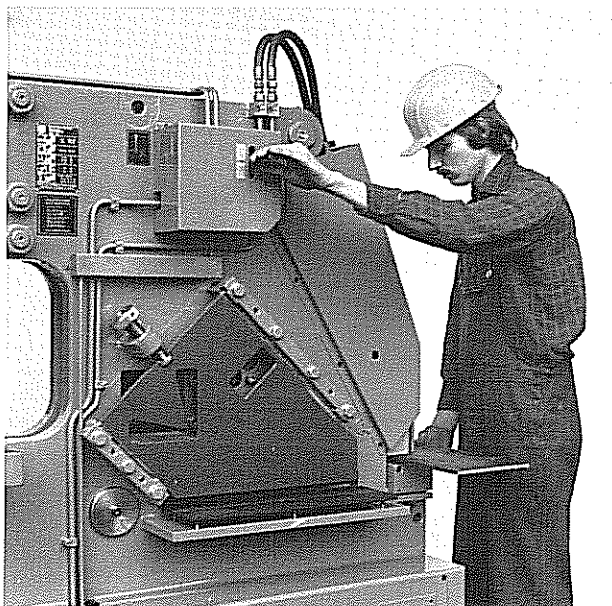

Fig. 9: Manual engagement to the shears

Electrical Engagement with Stroke Adjustment to the Punch (Special Equipment)

The punch has a relatively large working stroke. This large stroke is not always required for normal punching operations. To save time, the punch stroke can be exactly adjusted to the requirements. The exact stroke adjustment is particularly important if the punch is used for bending operations. With exactly adjusted working strokes there are produced exact bends.

The working strokes are released by a displaceable pedal switch which is placed, according to the corresponding requirements, at the place being most favourable for the operator.

If actuating the pedal switch, the slide moves downward. If the pedal switch is released, the automatic return motion begins up to the dead position. If the automatic return motion shall not occur, e.g. for setting the tools, the operation selector switch has to be set to "setting".

Adjustment of the stroke travel is carried out by the control rings attached to the control rod. The bottom control ring is provided for the upper stroke limitation and the top control ring for the lower stroke limitation. Due to this adjustment, the stroke length as well as its position can be determined.

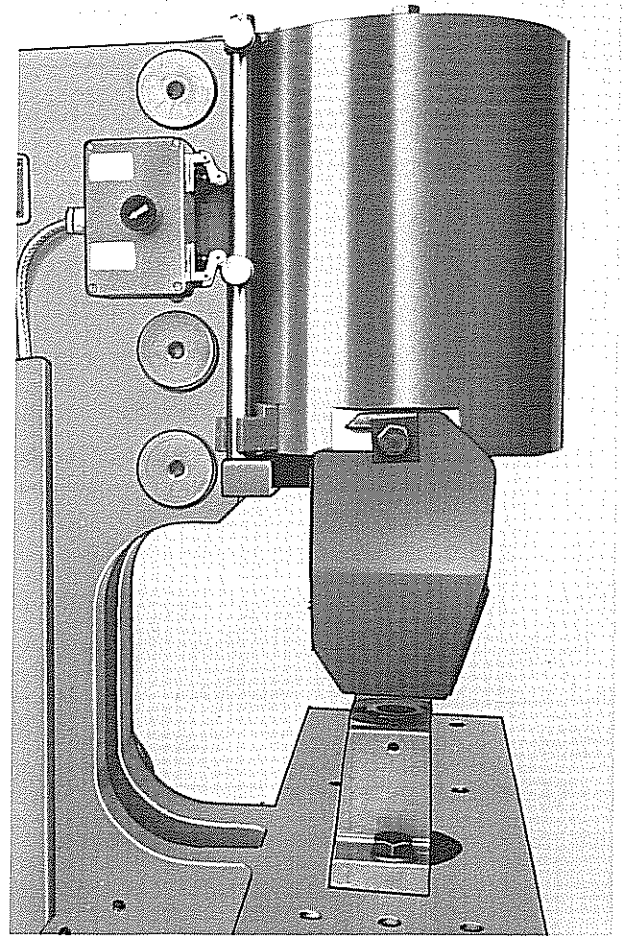

Fig. 10: Electrical engagement with stroke adjustment to the punch

Electrical engagement with stroke adjustment to the shears (special equipment)

Like the punch, the shears can also be equipped with electrical engagement. For reducing the length of stroke and in order to save time, in particular when coping, there is also provided a stroke adjustment. Also in this case the working strokes are released by a displaceable pedal switch. The preset working stroke occurs automatically after having briefly actuated the switch. If the automatic operation, e.g. for setting the tools, shall be switched off, then the operation switch has to be set to "setting". By tipping the pedal switch, the slide is controlled into the required position. Return occurs by changing over the operation switch. Adjustment of the stroke length and its position is carried out as at the stroke adjustment of the punch.

The shears side is in addition equipped with a plug junction for a length stop with contact switching. If the contact switch is actuated by the fed material, there occurs the automatic shears stroke. This is a help for the operator and increases considerably the output of the machine.

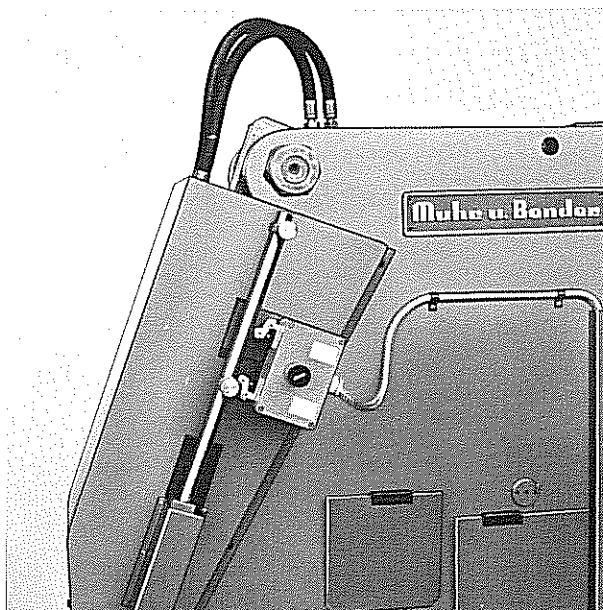

Fig. 11: Electrical engagement with stroke adjustment to the shears

THE FLAT STEEL SHEARS

1. The Blades

Top and bottom blades are exchangeable against one another and can be used on two sides.

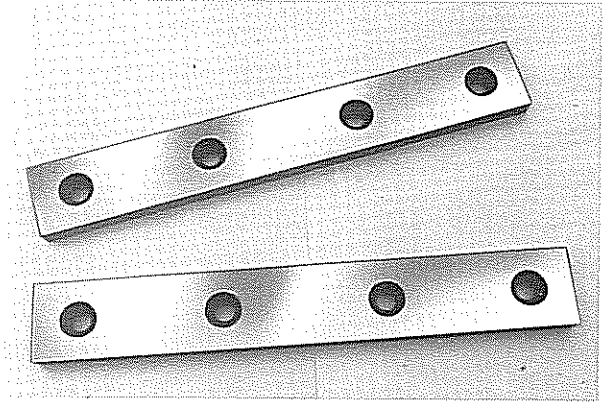

Fig. 12: Flat steel blades with 2 cutting edges

2. Sharpening

Sharpen the blades in time (at the longer front sides only). Sharpening must be exactly rectangular, and the front surface should be straight. It has then to be made sure that grinding down occurs uniformly so that the setting angle is not changed. Worn-out blades must be replaced by new MUBEA Blades.

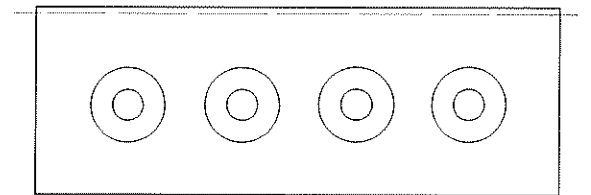

Fig. 13: Sharpening the flat steel blades

3. The Shearing Gap

Adjust the shearing gap between the blades to 0.2 mm - 0.4 mm. Measure the shearing gap with a feeler gauge while simultaneously turning the blade slide down slowly.

The blades are adjusted for cutting all heavy plate in the capacity range. For cutting extremely thin stock, reduce the shearing gap by a cardboard or metal shim.



Bild 14: Checking the shearing gap

4. Adjusting the Hold-down

The material to be cut must be securely held in the horizontal position. Faulty adjustment of the hold-down results in the blades being damaged or forcing apart of the shears.

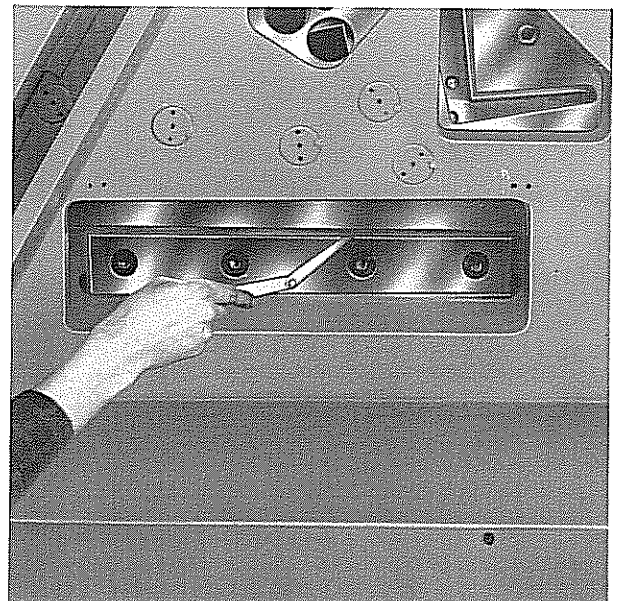
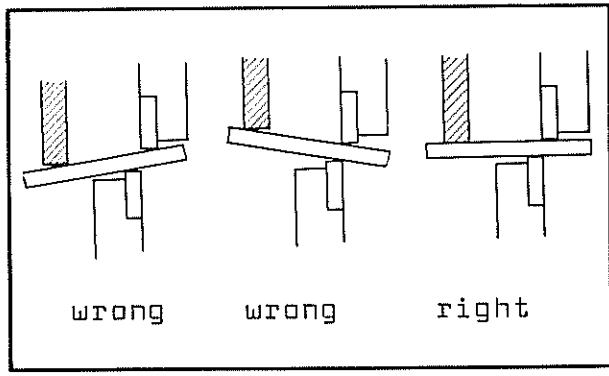

Fig. 15: Correct and wrong setting of the hold-down

For dismantling the hold-down, the same is displaced upwards with the adjusting wheel until the lateral openings in the plate correspond with the lugs of the covering strips. In this position, the hold-down can be removed to the front.

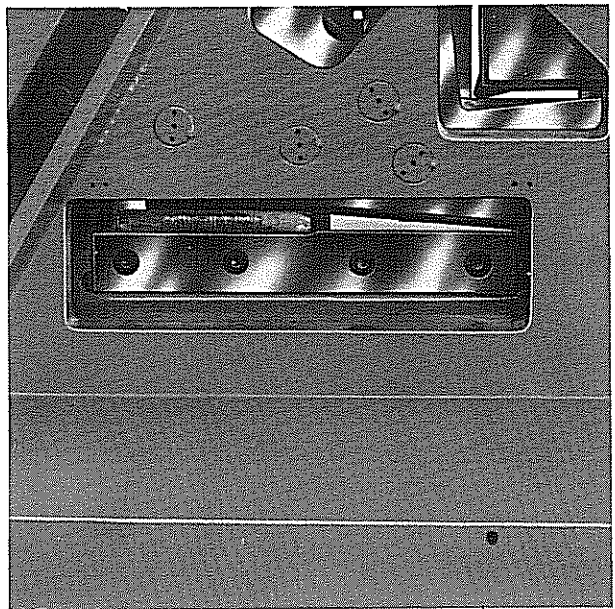

Fig. 16: Cutting flat steel

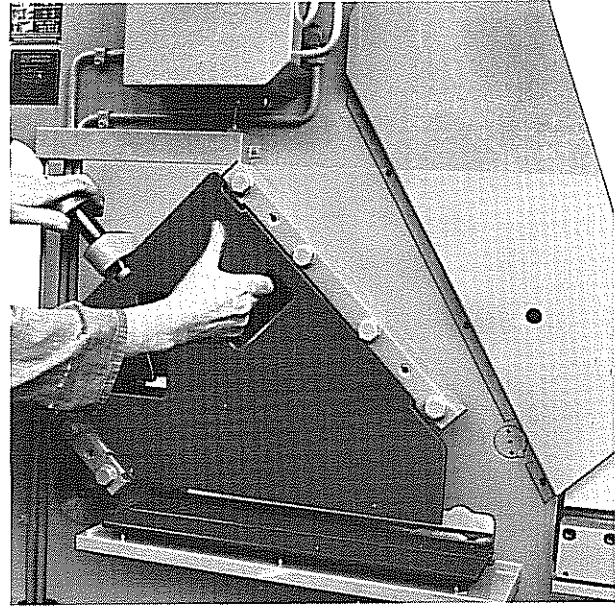

Fig. 17: Dismounting the hold-down

5. Changing the blades

a) Bottom blade

Loosen the fixing screws A and remove blade B from the machine.

b) Top Blade

Move the blade slide into lower dead position and then turn the fixing screws A out of the slide. Take top blade B out of the machine from the declining side. Fitting in reverse order.

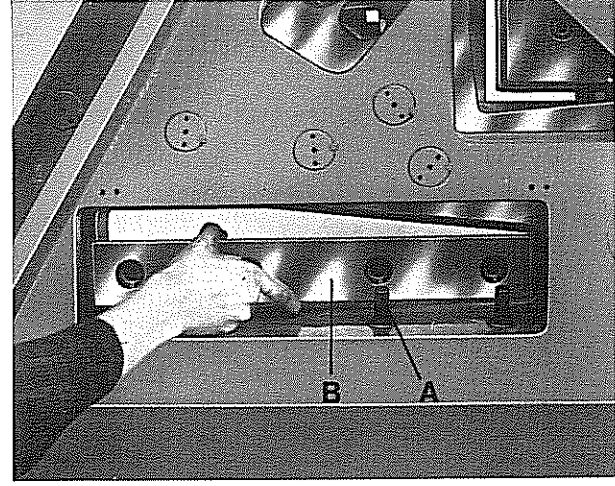

Fig. 18: Changing the bottom blade

6. Readjusting the Slide Guide

If after a longer use there is noted that the shearing gap has enlarged at the flat-steel blade, at the section blade and at the bar-steel blade, the slide guide must be reset.

At the infeed side of the machine, the locking screws A must be turned out of the machine, and guide screws B have to be raised by approx. 1 revolution (fig.20).

At the declining side, the locking screws A must be turned out of the machine, and the guide screws B have to be readjusted according to feeling (fig. 21).

There must be measured with the feeler gauge, at lowered blade slide, a uniform shearing gap at the 3 cutting points.

At this adjustment, the coping saddle must be dismantled.

Tighten firmly the guide screws B at the infeed side and then raise them 1/16 revolution.

Bore the guide screw B in this position with \varnothing 4.5 mm and screw in the locking screw A (fig. 20). Bore the guide screws A at the declining side with \varnothing 4.5 mm and screw in the locking screw B (fig. 21). Mount again the coping blade.

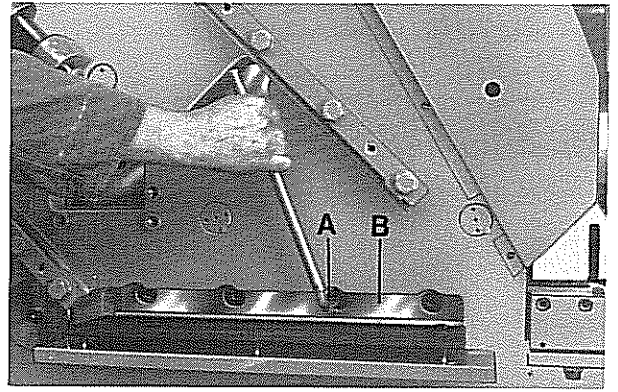

Fig. 19: Changing the top blade

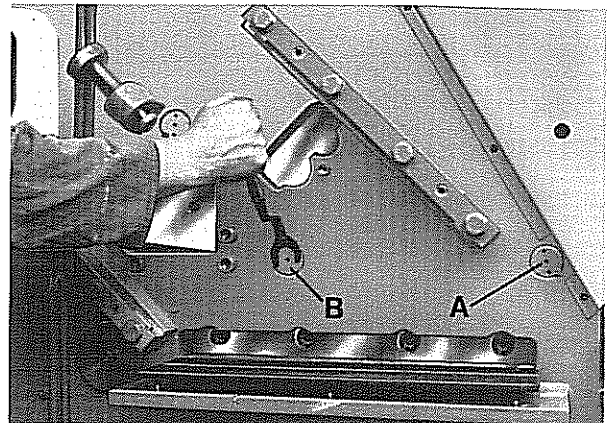

Fig. 20: Adjusting the slide guide, infeed side

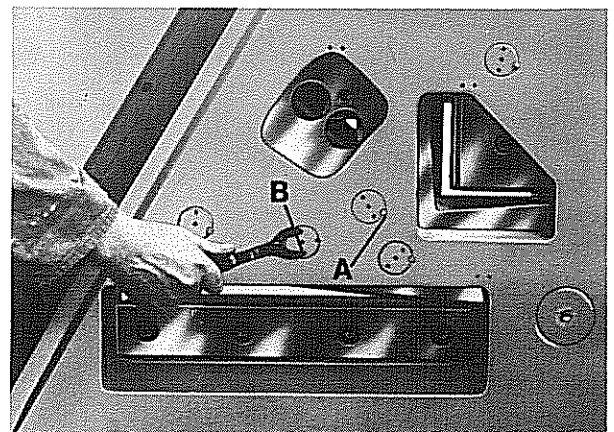

Fig. 21: Adjusting the slide guide, declining side



THE C O P E R - N O T C H E R

1. The Rectangular Notcher

Particularly suitable for notching and coping the flanges and webs of various sections.

Wider notchers are made by successive cuts. When triangular notches are to be made, the stock is placed at an angle of 45° . However, this procedure is not suitable for manufacturing frames, because of the sharp point produced.

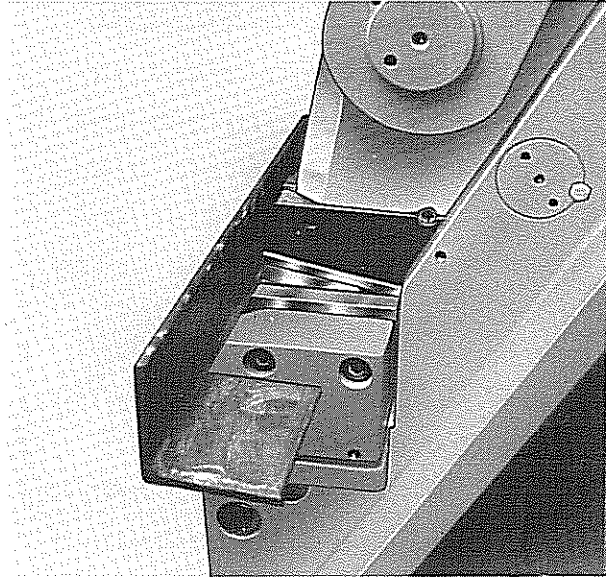

Fig. 22: Wide rectangular notching

2. Adjusting the Coping Tools

The coping saddle is adjustable in all directions, thus making it easy to set the lower blades relative to the upper blade. Make sure the shearing gap is uniform.

The shearing gap is set for the maximum capacity. If very thin stock is to be notched, then the shearing gap has to be reduced by backing with a cardboard or tinfoil shim. Lower the blade slide until the top coping blade dips into the lower part of the tool. Measure with feeler gauge.

For adjustment, loosen saddle screws A and move the saddle by means of adjusting screws B into correct position. Tighten firmly the saddle screws A and the thrust bolts C (see fig. 23).

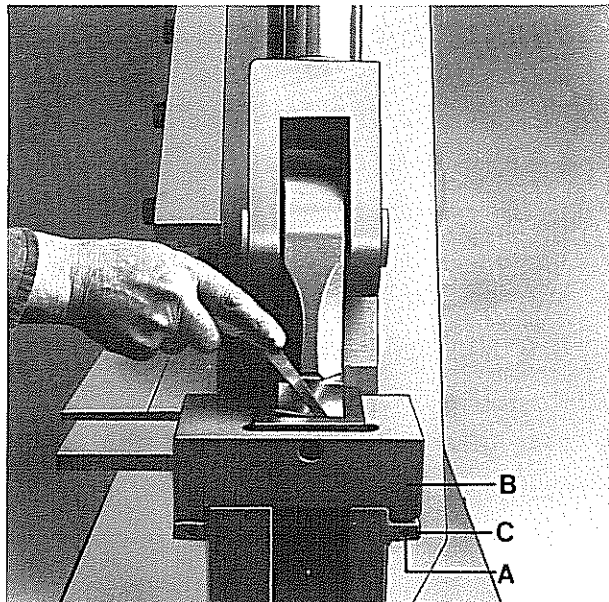
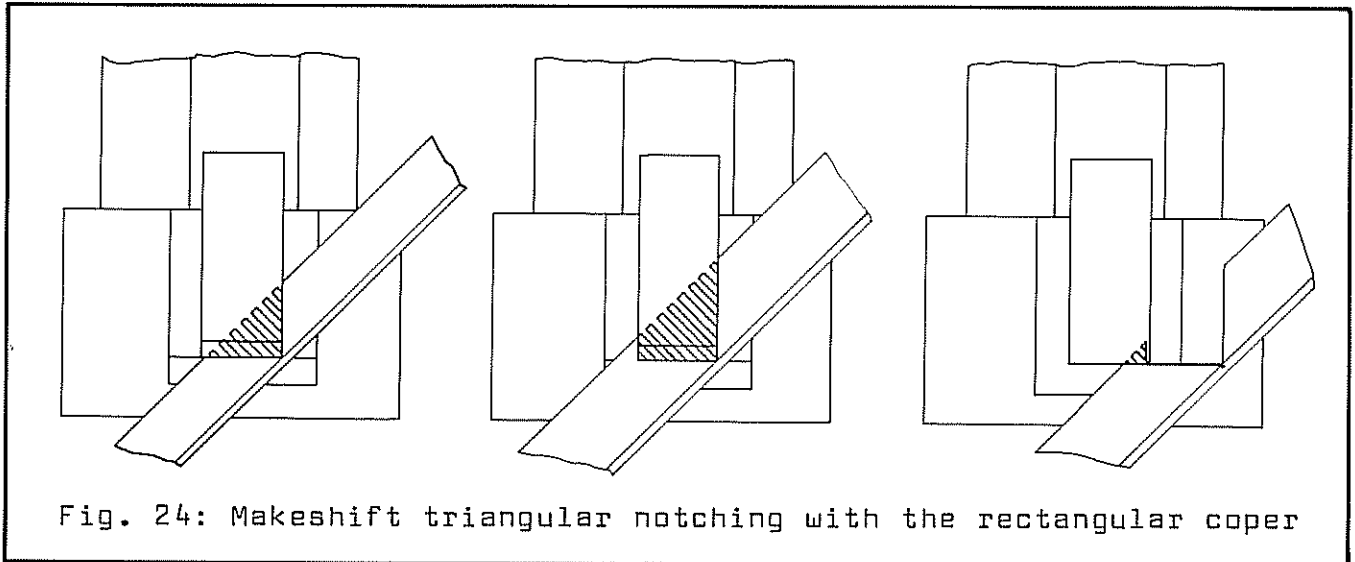

Fig. 23: Checking the shearing gap



3. Sharpening the Rectangular Notcher

Grind the upper blade at its lower faces and the lower blade at its upper faces only (make sure that the shearing gap is accurately reset when replacing the blades. Frequently wipe the cutting edges with oil).

4. Special Tools

Instead of the normal rectangular notching and coping tools there can be used also special notching and coping tools such as triangular notching and coping tools, notching and coping tools for rounding butt straps or coping of flat steel for their welding to round stock or tubes.

5. Special Accessories

If you wish to carry out notching and coping work without marking out, we supply you special work support tables.

Please let us have your enquiries. We will work out the most economic method for you.

Important note:

A guard is fitted to the copper-notcher. We strongly advise that this guard be kept in position at all times.

T H E B A R S H E A R S

1. Blades

The machine is normally equipped with blades for cutting round and square bars.

2. Sharpening

Sharpening is carried out in the shearing openings only. Since blunt blades require a higher cutting pressure and result in poor cuts, care should be taken to ensure that new MUBEA Blades are demanded in time.

3. The Shearing Gap

The shearing gap should be 0.2 - 0.4 mm. The blades are correctly set on delivery.

If the shearing gap shall be reduced, the blades have to be backed with a cardboard or tinfoil shim.

The shearing gap is checked with a feeler gauge at lowered blade slide.

4. Hold-down

The hold-down must always be adjusted in such a way that the stock is held in a horizontal position during cutting.

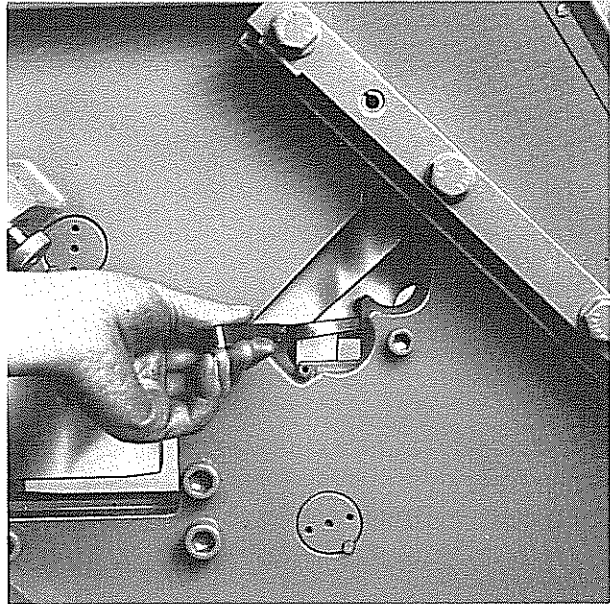

Fig. 27: Checking the shearing gap

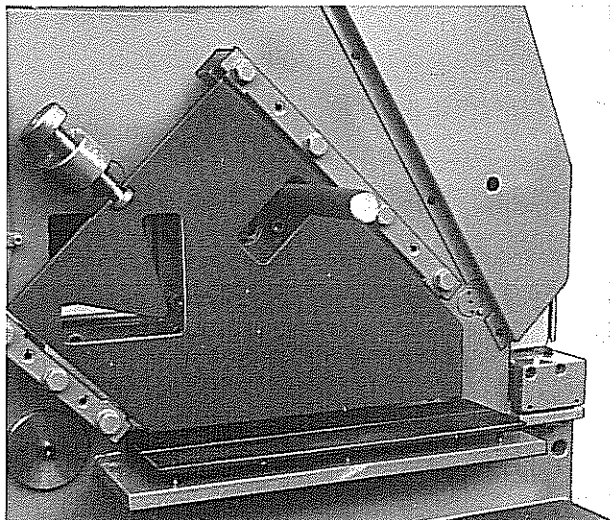

Fig. 28: Cutting round stock

5. Changing the Blades

a) Stationary blade

Loosen the blade screw.
Lift and remove the blade.

b) Movable blade

Loosen the blade screw from
the declining side of the
machine and remove the blade
through the opening in the
infeed side.

Fitting is carried out in the
reverse order.

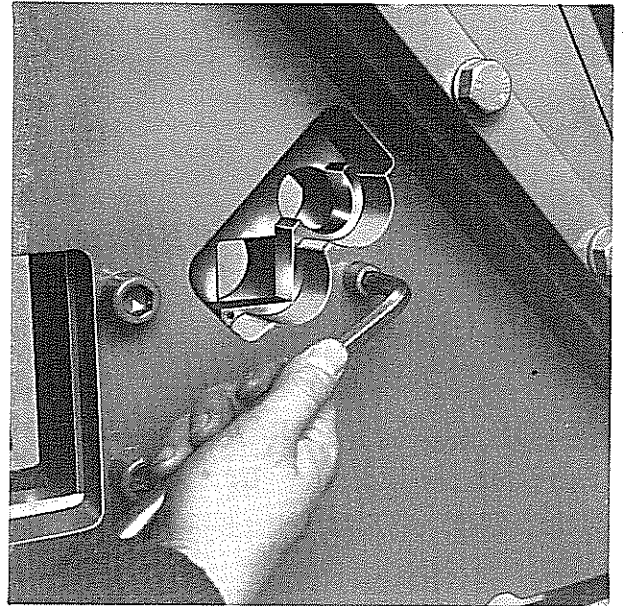

Fig. 29: Dismounting the
stationary blade

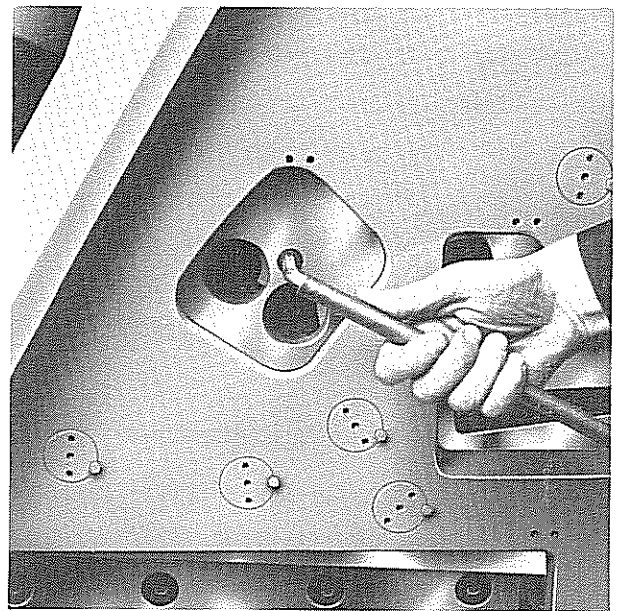

Fig. 30: Dismounting the
movable blade

6. Special Blades

If you wish to cut round stock
only, we supply you blades which
have round cutting openings only.
The diameters will be in accor-
dance with your requirements.



THE ANGLE STEEL SHEARS

1. General

The machine is designed for squaring off angle steel.

2. Sharpening of Blades

The blades must be sharpened at the cutting front faces only. Sharpening should occur uniformly so that the movable bit strikes exactly into the blade point of the fixed insert blades.

Of course, the blades should be sharpened only so far as this is allowed by the stroke of the blade slide. Blunt blades result in bad cutting results and higher load of the machine. Care should be taken to ensure that new MUBEA Blades are demanded in time.

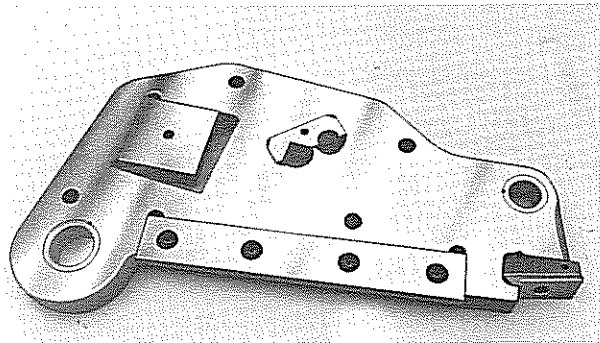

Fig. 31: Shear slide

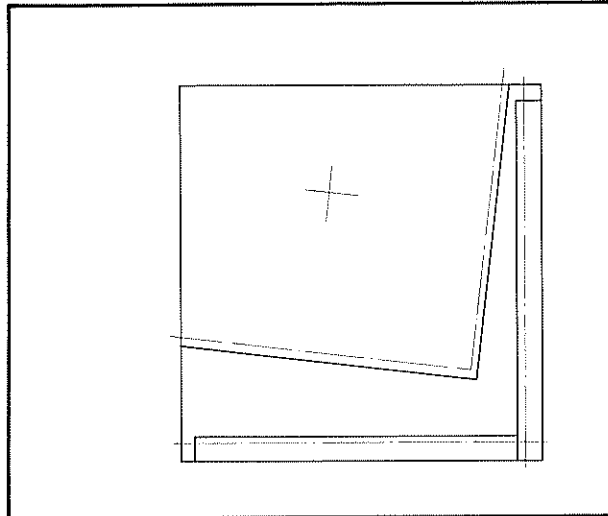

Fig. 32: Sharpen the blades uniformly

3. The Shearing Gap

The blades are set to the correct shearing gap of 0.2 to 0.4 mm on delivery. The shearing gap is reduced by backing of foils at the movable bit in the blade slide. The shearing gap is checked by means of a feeler gauge at lowered blade slide.

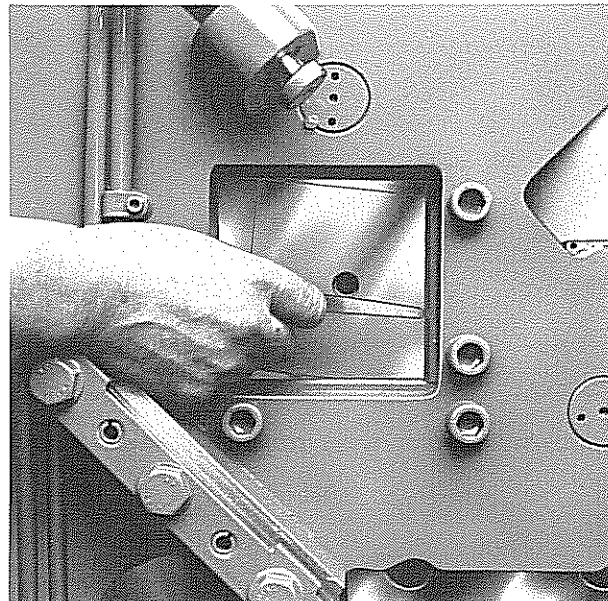

Fig. 33: Checking the shearing gap

4. The Hold-down

The hold-down must be set in such a way that the required angularity is achieved. There has to be ensured that the angular steel lies with the root at the point of the hold-down.

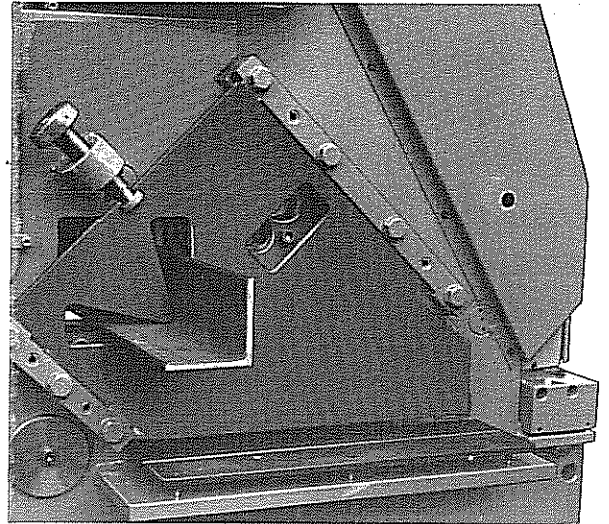

Fig. 34: Position of hold-down on shearing the angle steel

5. Dismounting of Blades

First of all the blade slide is lowered until there can be seen the contours of the movable blade bit in the section window of the machine body.

Loosen blade screw A from the declining side of the machine (see fig. 35a), and then dismount the bit through the section window in the machine body (see fig. 35b).

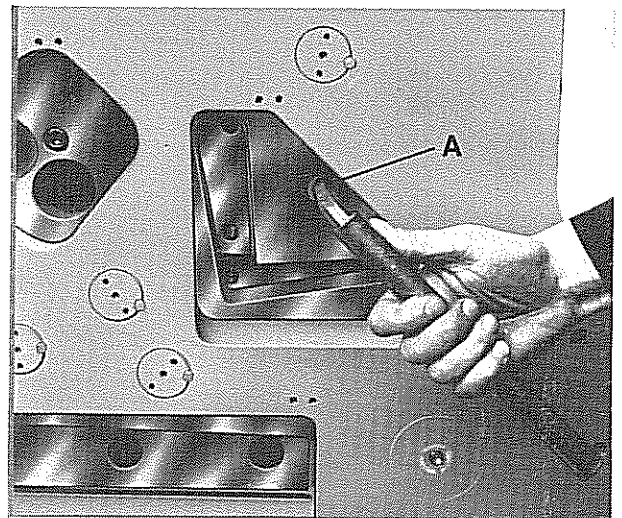

Fig. 35a: Dismounting the movable blade bit

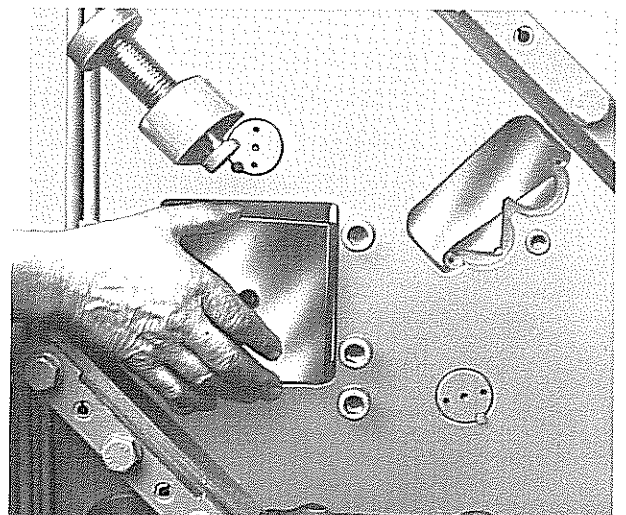

Fig. 35b) Dismounting the movable blade bit

Now the vertical blade in the machine body is dismantled after having loosened blade screws A. Afterwards blade screws B are loosened and the horizontal blade is taken out of the machine body. (see fig. 36 + 37)

Mounting of these blades is carried out in the reverse order.

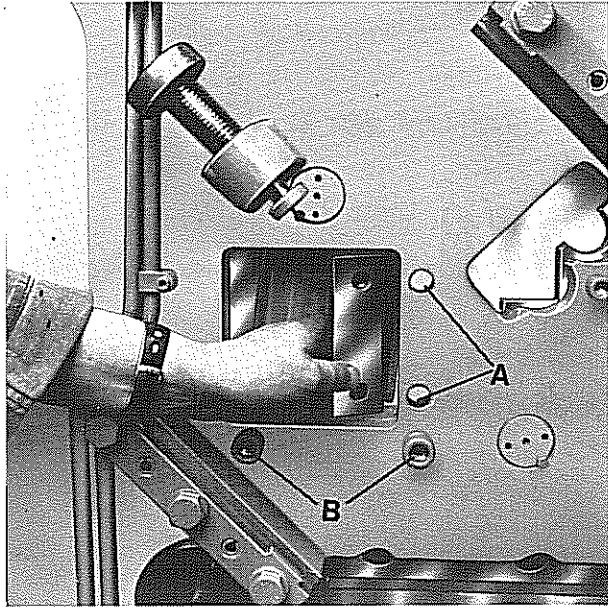

Fig. 36: Dismounting the vertical blade

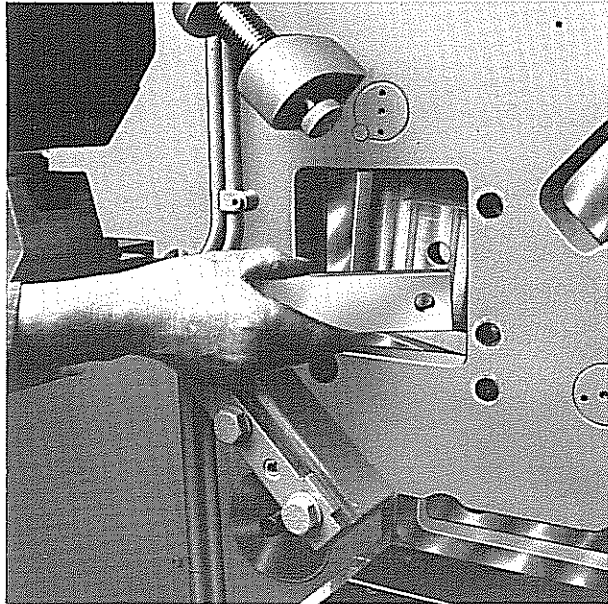

Fig. 37: Dismounting the horizontal blade

T H E P U N C H

THERE MUST BE USED ONLY PUNCHING DEVICES AND TOOLS WHICH ARE SUFFICIENTLY SECURED FROM FINGER INJURIES UP TO THE SHEARING POINT!

1. General

Since the punch works hydraulically and has a large stroke, its field of application is nearly unlimited. The large clamping table permits, besides small and big punching tools, also mounting of folding and bending tools.

In standard design the machine is equipped with a punching tool up to 30 mm hole diameter. Special tools up to 100 mm diameter form part of the MUBEA Standard Program.

As the piston rod of the drive cylinder is at the same time the working slide, there has to be taken care that there are always carried out centric applications of power only.

2. Fixing of Punch

At the front side of the piston rod there is a M 64 x 2 thread. Stamps in the diameter range up to 30 mm are clamped against the front face of the piston rod by means of a retaining nut and a taper sleeve.

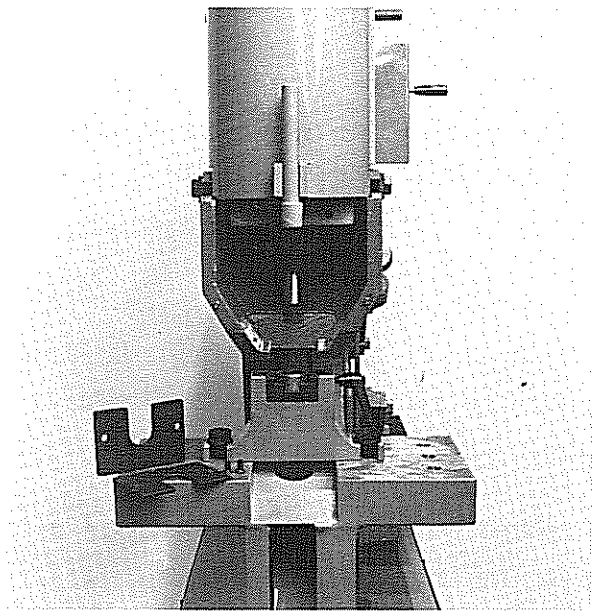

Fig. 38: Punch of normal mounting

3. Punch Saddle

The punch saddle with its large surface area ensures a secure tool position. There can be fitted dies up to 30 mm hole diameter.

The two fixing screws A (see fig. 39) only need to be loosened, and the saddle can already be removed from the machine.

The large saddle plate permits a nearly unlimited mounting of all special devices. Bending and folding tools are particularly well supported.

4. Setting the Tools and Control to the Hole Centre

On delivery the machine is equipped in such a way that punches and dies are exactly aligned. Aligning of the tools must be checked repeatedly during the punching operations. For this purpose the punch is tipped gradually into the die.

For setting of punches and dies, the saddle screws A must be loosened and saddle B pushed into the correct position (see fig. 39).

After adjusting, the saddle screws must be retightened firmly.

This process has to be repeated at each tool change.

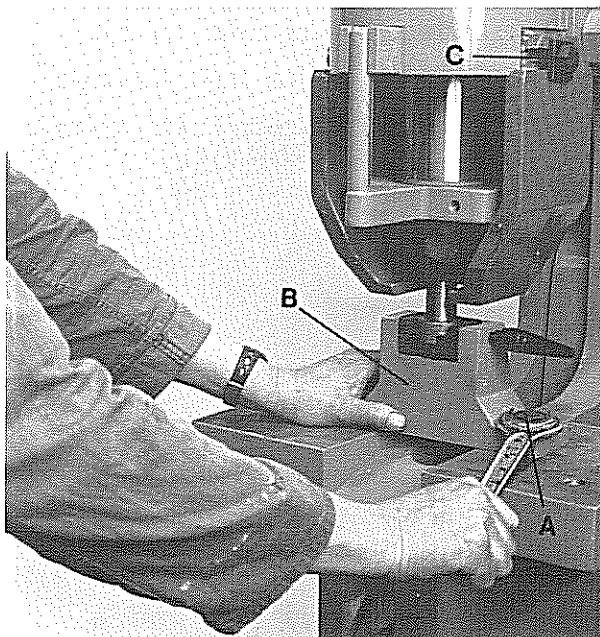

Fig. 39: Setting the punch tool

The shearing gap between punch and die should be about 5 % of the thickness of the material to be punched (When punching a thickness of 10 mm, the diameter of the die hole must be 1 mm larger than the punch diameter. The shearing gap ist then 0.5 mm.) Please therefore always specify the thickness of the material when ordering. Punch-marked material can be exactly brought up with slow speed or inching with the incorporated machine control. Faulty punching is therefore avoided.

5. The Stripper

The rugged stripper is directly fixed at the working cylinder by the two fixing screws C (see fig. 39). Differences of height between die and stripper are compensated by the delivered shims of different thicknesses which can be attached to the stripper.

6. MUBEA Standard Punches and Dies

MUBEA Punches and Dies are available in 4 standard sizes and fit all machines.

Size I	up to Ø 15
Size II	over Ø 15 up to Ø 30
Size III	over Ø 30 up to Ø 40
Size IV	over Ø 40 up to Ø 50

For punching holes in the flanges of channels or beams we supply flange dies with a surface inclination corresponding to the slope of the section flange.

For punching holes in small angles, tees, channels or beams near the web, flange or leg in accordance with the scratch gauge, eccentric dies are required having an off-center hole near the edge of the die. When fitting eccentric dies, slide the punch saddle backwards until the punch and the die hole are again co-axial.

Please ask for the detailed catalogue of MUBEA Standard Punches and Dies.

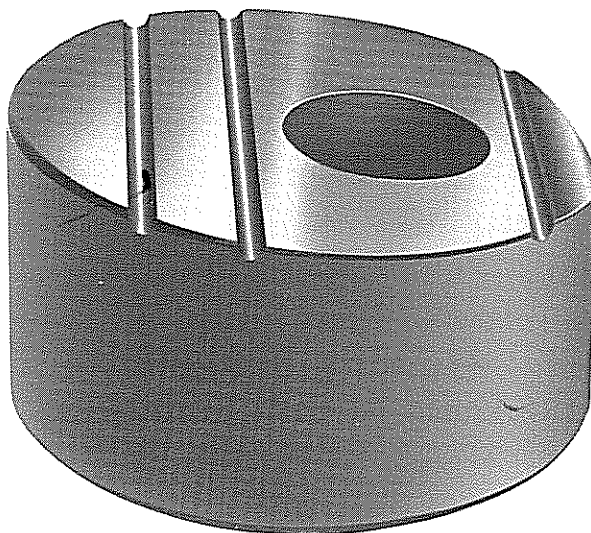

Fig. 40: Flange die for I beams

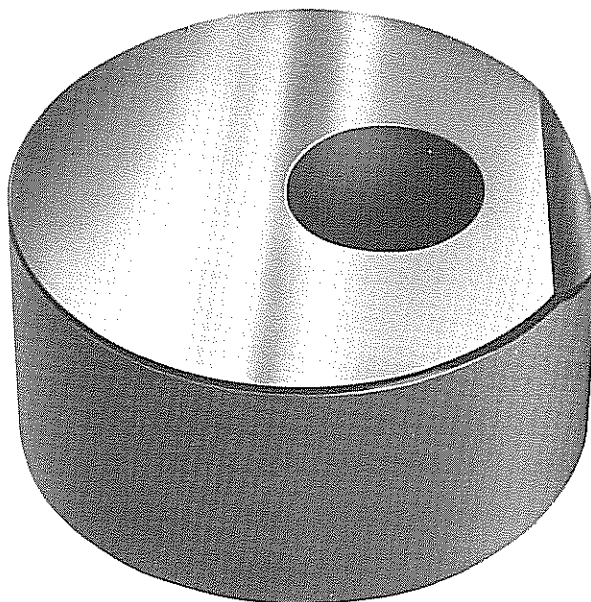

Fig. 41: Eccentric die for small angles

HIW	450		600		1000	
	mm	inch	mm	inch	mm	inch
a	255	10 ¹ / ₃₂	356	14 ¹ / ₆₄	356	14 ¹ / ₆₄
b	195	7 ¹¹ / ₁₆	281	11 ¹ / ₁₆	281	11 ¹ / ₁₆
c	83	3 ⁷ / ₁₆	119	4 ²⁷ / ₃₂	119	4 ²⁷ / ₃₂
d	205	8 ¹ / ₁₆	255	10 ¹ / ₃₂	255	10 ¹ / ₃₂
e	48	1 ⁵⁷ / ₆₄	47,5	1 ⁷ / ₈	68	2 ¹ / ₁₆
f	22,5	⁵⁷ / ₆₄	22,5	⁵⁷ / ₆₄	30	1 ³ / ₁₆
g	200	7 ⁷ / ₈	230	9 ¹ / ₁₆	230	9 ¹ / ₁₆
h	M 64 x 2		M 64 x 2		M 64 x 2	
k	255	10 ¹ / ₃₂	450	17 ²³ / ₃₂	1000	39 ³ / ₈

Fig. 42: Dimension of punch saddle model HIW

7. Regrinding the Punching Tools

Regrind punching tools at their faces only to prevent a change in the clearance between punch and die. To extend service life of the tools regularly wipe the cutting edges with oil.

In many cases it is more convenient to order new tools. This is more economical in the long run, and the ground finish is perfect.

8. Special Tools

The large MUBEA Program of standard tools makes available all the common special tools at short notice. The special feature of the MUBEA Punch design further offers a wide variety of possibilities for employing special tools, though these cannot be described briefly. The illustrated MUBEA Literature gives a better review of this area.

a) Special Punch Equipment for Accomodating Punches and Dies with a Cutting Diameter up to 50 mm

All punching tools, i.e. round, square, rectangular and elongated hole tools which are within the cutting range overstepping 30 mm up to 50 mm can be accomodated in this equipment.

The complete equipment consists of: Retaining nut M 64 with 50 mm through hole, insert with 40 mm

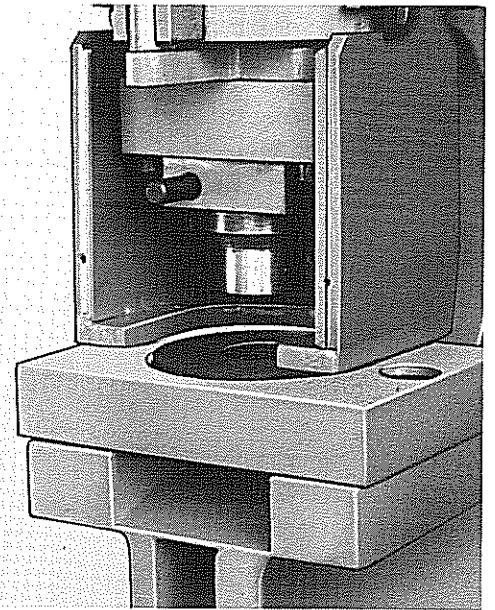

Fig. 44: Special punching equipment for accomodating punches and dies exceeding 50.5 to 100 mm cutting diameter

through hole, saddle with 80 mm seat and die holder 80/60.

When ordering the tools the thickness of the material to be punched and the tensile strength should be stated.

b) Special Punch Equipment for Accomodating Punches and Dies over 50.5 mm Cutting Diameter

This tool holding fixture, consisting of punch holder, stripper and saddle attachment, can accept all punching tools such as round, square, rectangular and elongated hole tools which are within the cutting range of 50.5 - 100 mm.

In the case of shaped punches (elongated hole and rectangle) the order should state whether the tools are to be employed longitudinally or transversally in the machine. In addition the thickness of the material to be punched and the tensile strength should be specified. The punches are fixed with a wedge.

c) Pipe Notching Tool

Pipe notching tools serve for notching pipes in such a way that they can be welded together squarely without additional finishing.

This equipment can notch pipes up to 60 mm outer diameter at a max. wall thickness of 6 mm. For different pipe diameters there are needed only the two cutting inserts for the movable and the stationary blade.

When submitting inquiries, please furnish the following information:

- a) Pipe dimension to be notched
- b) Outer diameter of the pipe
to which the notch is to be fitted
- c) Material of the pipe to be notched

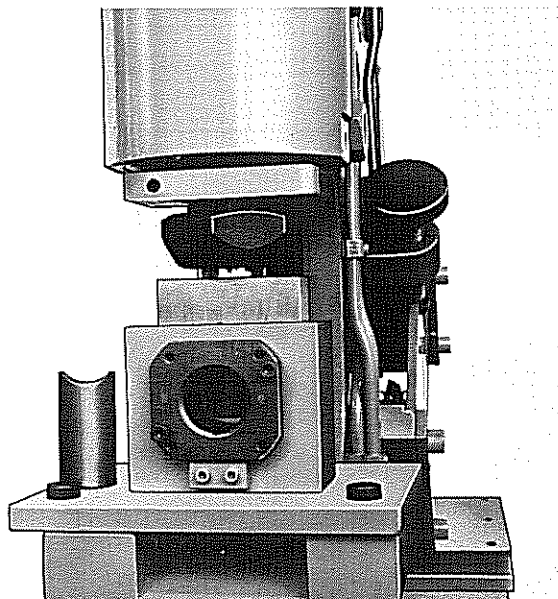

Fig. 45: Pipe notching tool

MAINTENANCE PRESCRIPTIONS
for HYDRAULIC PLANT

A. General

For functioning and service life of the hydraulic plant it is extremely important to observe the following maintenance prescriptions.

B. Filling Up the Oil Reservoir

Before starting, oil level of the oil reservoir should be checked. The oil level shall be about 3 cm below the reservoir cover. Checking is performed by means of the gauge stick at the filling filter. Filling should be carried out only via the filter element. After filling, the filler has to be perfectly closed.

For filling the plant there has to be used only high-grade branded hydraulic oil. At medium ambient temperatures (5°C to 35°C) there should be employed Hydraulic Oil HLP 46 (viscosity classification: ISO VG 46 DIN 51 519). At extreme low or high temperature, the manufacturer should be consulted.

All reputable oil manufacturers supply suitable oils. As mixing of the hydraulic oil of various manufacturers is not advisable, there should be always refilled the same type. The oil type of machines filled in the factory is stated on the oil reservoir.

C. Starting

At setting going of the plant there has by all means to be observed the correct direction of rotation of the motor. To avoid damages of the pump, the motor must start up in inching operation. The engagements should then not be actuated. When having ascertained the correct direction of rotation, the motor must be kept running for about 3 to 4 min. without actuating the engagements. To ensure escaping of the air



eventually existing in the system, each cylinder has afterwards to be moved out and in repeatedly without load over the whole stroke. After perfect venting, the plant can be started up under load.

The max. operating pressure adjusted in the factory is specified on the reference plate at the oil reservoir. Checking of the pressure can be carried out by means of a manometer at the measuring connection above the oil reservoir.

The stated max. operating pressure should not be exceeded.

D. Maintenance

Current checking of the oil level in the oil reservoir is necessary in order to avoid greater damages.

After approx. 10 operating hours the return filter fixed on the oil reservoir has to be cleaned for the first time. Cleaning should be done in rinsing oil or petroleum. Throw-away filter cartridges have to be replaced. After having fitted the clean and/or new filter element the plant is again ready for work. Further filter cleaning should be done at normal fouling about every 600 operating hours.

The first oil change should be carried out after approx. 600 operating hours. Afterwards the oil has to be renewed every 1 200 to 1 500 operating hours. After draining of the waste oil, the oil reservoir and the whole system have to be cleaned with rinsing oil. Water, leaches and petroleum are not suitable as purifying agents. After complete cleaning, the plant has to be closed and to be filled up with new, unused hydraulic oil. All filters have to be cleaned at every oil change. Of course, there has to be taken care of greatest cleanliness on refilling.

During operation there have to be permanently controlled the oil level, the leakage of the plant, fastening of the units and pipes as well as state of the hydraulic oil and the filters.

E. Eliminating troubles

Fault 1: Excessive noise in the plant

Cause	Reason	Elimination	
1.1 Cavitation in the pump	1.1.1 Hydraulic oil too cold (below + 5°C)	Heat the hydraulic oil to the temperature of + 5°C	
	1.1.2 Viscosity of the hydraulic oil is too high	Replace the hydraulic oil by a suitable one (see section "Filling Up the Oil Reservoir")	
	1.1.3 Steam generation	The max. oil temperature of + 70°C is exceeded. Refill hydraulic oil or replace it by prescribed one	
	1.1.4 Failure of the pump	Exchange the pump	
	1.1.5 Sealed reservoir	Clean vent-filter in the cover of the filler	
1.2 Foam formation or air pockets in the pressure fluid	1.2.1 Pressure fluid level in the reservoir is too low	Fill up on the correct level	
	1.2.2 Wrong hydraulic oil	Replace by suitable oil	
	1.2.3 Entering of air caused by the screwed joints in the suction pipe	Retighten or replace the screwed joints	
1.3 Mechanical vibrations	1.3.1 Vibrations of the pipings	retighten the attachments	
	1.3.1 Pump	1.3.1.1 Used up or damaged	Replace
	1.3.2 Drive motor	1.3.2.1 Used up or damaged	Repair or replace



Cause	Reason	Elimination
1.3.3 Safety or pressure limiting valve	1.3.3.1 Flatters	Adjust correctly or replace

Fault 2: No pressure or insufficient pressure

Cause	Reason	Elimination
2.1 Pump does not feed correctly	2.1.1 Air enters into the suction pipe	See 1.2.3
2.2 High pump temperature	2.2.1 Used up or damaged pump	Replace the pump
	2.2.2 Uninsufficient viscosity of the hydraulic oil	See 1.1.3
2.3 Leakage losses of the pressure side in the return motion	2.3.1 Mechanic control valve not connected through	Reset limitations of the engaging path
	2.3.2 Wrong adjustment of the pressure	Correct the adjustment
	2.3.3 Safety valve does not shut as there are dirt and defective parts	Clean, ascertain the damage, replace or renew
	2.3.4 Way valve open as there are dirt or defective parts electric fault	Clean the damaged unit, repair or replace
	2.3.5 Damaged cylinder bore, piston rod or piston seal	Renew the damaged parts
2.4 Failure of the pump	2.4.1 Damaged pump, defective drive, unsuitable viscosity of the liquid, etc.	See faults 1.3.1.1., 1.1.2

Cause	Reason	Elimination
4.4 Leak losses from the pressure side in the return motion	4.4.1 See faults 2.3.1 to 2.3.5	See faults 2.3.1 to 2.3.5
4.5 Pump rotates in the wrong direction	4.5.1 Wrong direction of rotation of the motor	Reverse polarity of the electric connections

Fault 5: Too high temperature of the pressure fluid

Cause	Reason	Elimination
5.1 Overflow losses	5.1.1 Pressure adjustment too high	Correct the adjustment
5.2 Leak losses from the pressure side in the return motion	5.2.1 Bad functioning of the valves and defective seals	See faults 2.3.1 to 2.3.5
	5.2.2 Wrong viscosity of the hydraulic oil (too low, too high)	Drain the hydraulic oil and use the prescribed oil
5.3 Overheated pump	5.3.1 Wear of the pump	Replace the pump
5.4 Too quick circulation of the pressure fluid	5.4.1 Pressure fluid level has become too low in the plant	Filling up of the plant on the prescribed level (see section "Filling up the Oil Reservoir")



Fault 3: Anomalous pressure or flow fluctuations and vibrations

Cause	Reason	Elimination
3.1 Cavitation in the pump	3.1.1 See faults 1.1.1 to 1.1.5	See faults 1.1.1 to 1.1.5
3.2 Foam formation or air pockets in the liquid	3.2.1 See faults 1.2.1 to 1.2.3	See faults 1.2.1 to 1.2.3
3.3 Mechanic vibrations	3.3.1 See faults 1.3.1	See faults 1.3.1
3.4 Flattering pressure limitating or safety valves	3.4.1 See faults 1.3.3.1	See faults 1.3.3.1
	3.4.2 Damaged valve seat	Repair or renew
3.5 Valves seize	3.5.1 Fouling	Drain the hydraulic oil, clean plant and parts, fill up with clean oil
	3.5.2 Defective or distorted	Replace the unit, eliminate distortion
3.6 Air pockets in the plant which cause irregular or yielding motion	3.6.1 Plant is not completely vented	Vent the plant (see section "Starting")
	3.6.2 Electric equipment defective	Trace and eliminate the error

Fault 4: Unsuufficient or no feed current

Cause	Reason	Elimination
4.1 Cavitation in the pump	4.1.1 See faults 1.1.1 to 1.1.5	See faults 1.1.1 to 1.1.5
4.2 Foam formation or air pockets in the pressure liquid	4.2.1 See faults 1.2.1 to 1.2.3	See faults 1.2.1 to 1.2.3
4.3 Used up pump	4.3.1 See faults 1.1.4	See faults 1.1.4