

Adjustable PT100 Bearing Temperature Sensor with grease nipple, type PT100V3C

Hot bearing WARNING device, for use in hazardous areas

Brochure

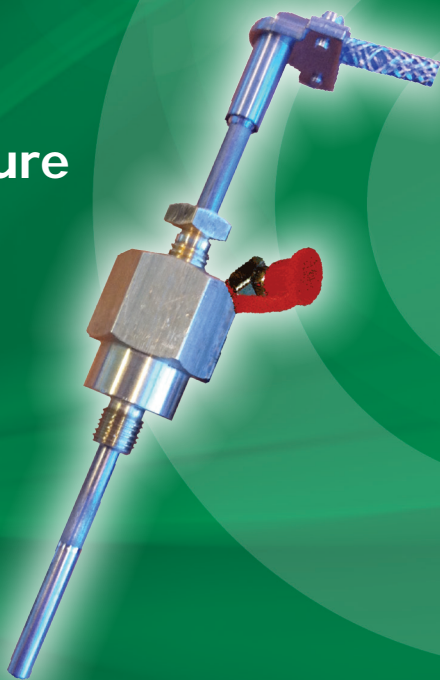

Accurate

Fail-safe

Adjustable Bearing Temperature Sensor, type PT100V3C With Grease nipple

The PT100V3C bearing temperature sensor with grease nipple is specially designed for accurate measuring of universal bearing housings.

The PT100V3C sensor is very easy to mount in the bearing housing without need for modifications. Use this installation method to avoid losing the guarantee on the bearing.

The advantage of measuring with a PT100 is that it sends a continuous output signal to the operating system.

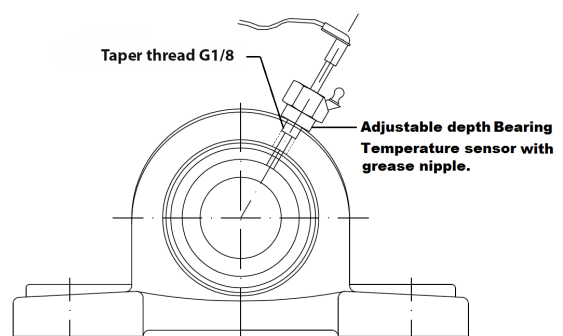

Contents

1.	Application	4
1.1	PT100V3C and ATEX regulations	4
2.	Functioning of the PT100V3C	4
2.1	Information PT100	4
3.	Mounting locations	5
3.1	Positioning PT100V3C	6
3.2	Installation diagram (digital (4 - 20mA) to PLC)	6
3.3	Positioning PT100V3C	6
3.4	Installation requirements	6
4.	Technical data	7
4.1	Technical data PT100V3C	7
5.	Various PT100V3C sensors	7
6.	Explosion protection worldwide	8
6.1	ATEX Groups	9
7.	Installation diagram	10
8.	PT100 connection data	11
8.1	PT100 sensor wiring diagram	11
8.2	Various indicators and transmitters available	11
9.	Safety notice to our customers	12
9.1	Customer safety and responsibilities	12

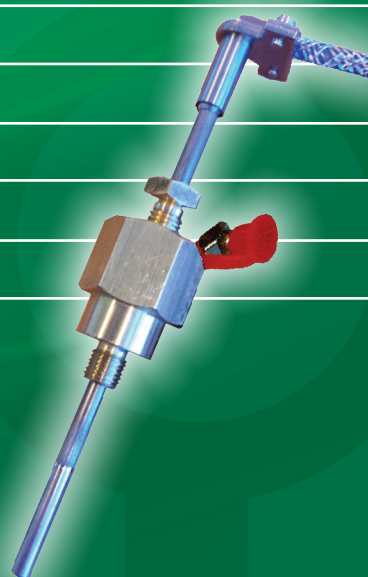

1. Application

The PT100V3C bearing temperature sensor with grease nipple is specially designed for accurate measuring of universal bearing housings.

The bearing temperature sensor emits a standard analogue output signal. The signal can be implemented very simply in an operating system. If the analogue signal is interrupted, the reason for this must be investigated (failsafe). Early detection of high temperature can prevent the bearing from becoming overheated, thereby reducing the risk of possible dust explosions.

The PT100V3C sensor is very easy to install in the bearing housing without need for modifications. Use this installation method to avoid losing the guarantee on the bearing.

The advantage of measuring with a PT100 is that it sends a continuous analogue output signal to the operating system. The measuring principle is: 1°C temperature difference results in a difference in resistance of 0.348 Ohms.

1.1 PT100V3C and ATEX regulations

The PT100V3C can be used in the following ATEX zones:

ATEX Classification Ex II 1D Ex iaD T85°C Ex II 1G Ex ia IIC T6 Tamb -40°C to 185°C

2. Functioning of the PT100V3C

2.1 Information PT100

The electrical conductivity of metal (i.e. platinum) is based on the mobility of free electrons. With increasing temperatures the atoms in the metal lattice will vibrate more vigorously and thus impede the free flow of electrons towards the positive pole of a voltage source. This impedance causes a resistance in linear proportion to the temperature. For generating the output signal, the PT100 is charged with a constant test current (approx. 1 mA). The resistance of the PT100 causes a voltage drop ($U = R \cdot I$), which can be analysed.

The resistance value is in conformance with the European standard: $R_{PT100} = 100 + 0.385055 \times T$. The positive temperature coefficient of a PT100 is 0.385055 Ohms per Kelvin.

PT100V3C adapter from female G1/8 to male 1/4BSP

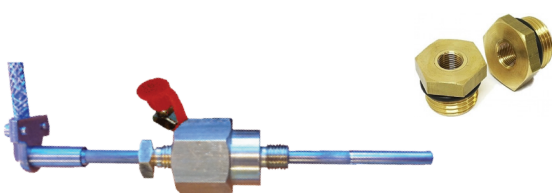

Do not damage the sealing surfaces or other seals!

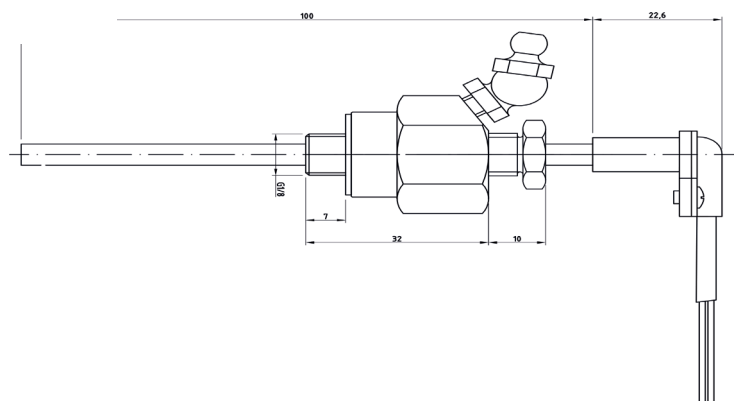

3. Mounting location

1. Rub-Block RB100DN or RB200DN belt misalignment monitoring location (both sides)
2. Bearing temperature sensor monitoring PT100 location (both sides)
3. Speed monitoring
4. Junction box small or large

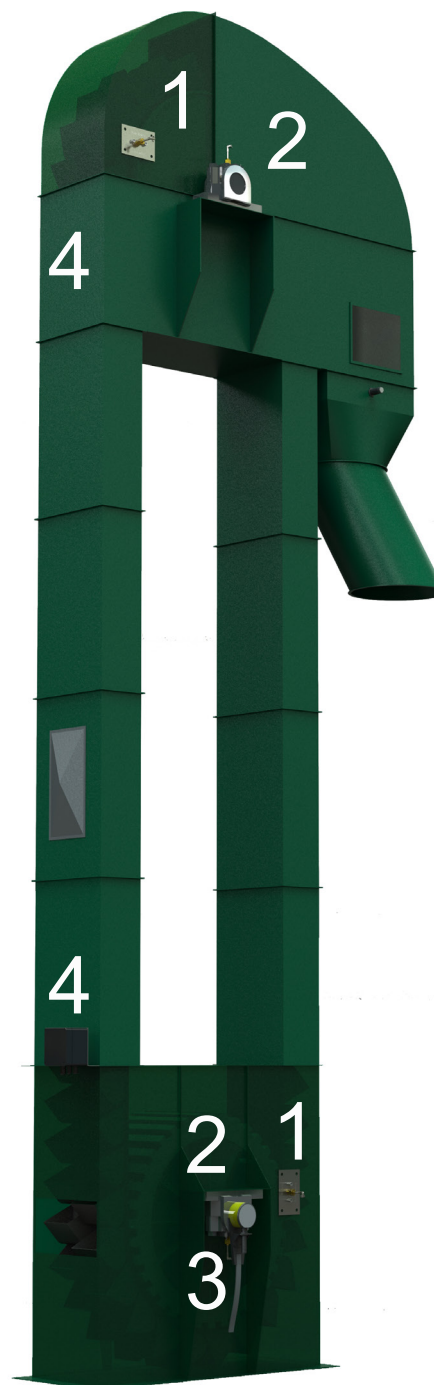
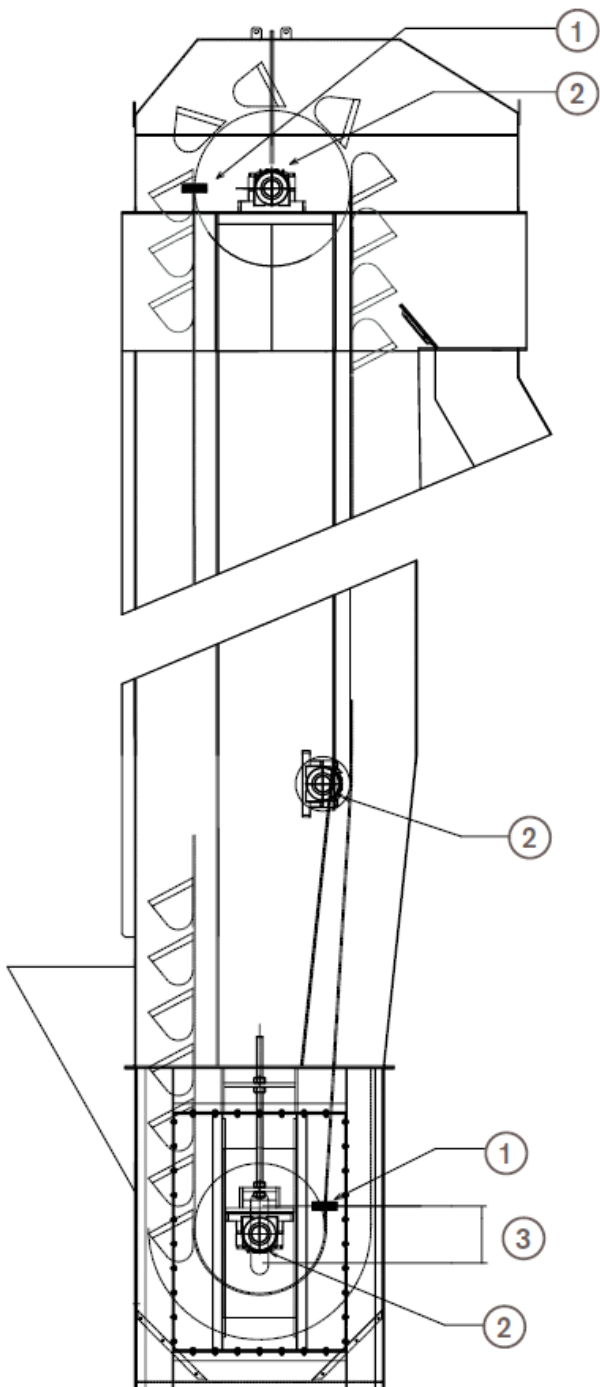

3.1 Positioning PT100V3C

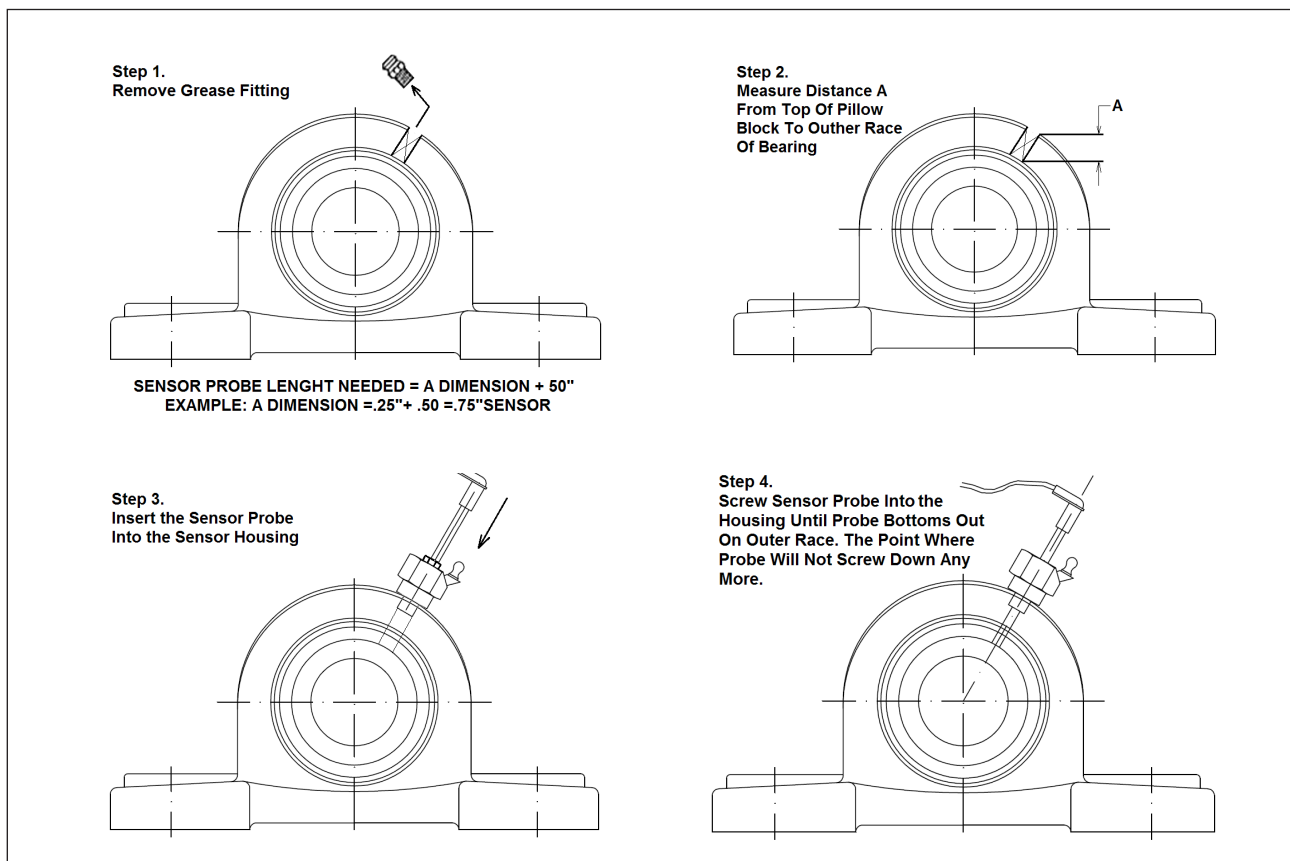

3.2 Installation requirements

For proper functioning of the PT100 sensor the following measures should be taken:

- ensure the installation and surroundings are quite dust-free and clean;
- earth the apparatus.

The PT100 sensor should be inserted up to the stop in the (1/8 NPT) hole designed for it, through the brass housing supplied. If not properly fitted, there will be no precise measuring and the risk of breaking the sensor will be very high.

The bearing temperature sensor produces a standard analogue output signal. It is very easy to implement this signal in a PLC system, for example a SIEMENS S7. If it is not possible implement an analogue signal, one can use an indicator or transmitter. The output signal is then converted from an analogue to a 4-20mA digital signal (see 7.2 further on in the documentation). Software for visualisation of the PT100 sensor can be programmed by a software engineer.

We recommend a 12 x 0.75 mm² shielded core cable for the field cabling between the PT100 and the control unit in order to avoid any electrical interference.

Warnings and symbols in this manual

- ⚠ This symbol indicates safety measures to avoid injury.
- ⚡ This symbol indicates ATEX Certified units with a zoning designation.

4. Technical data

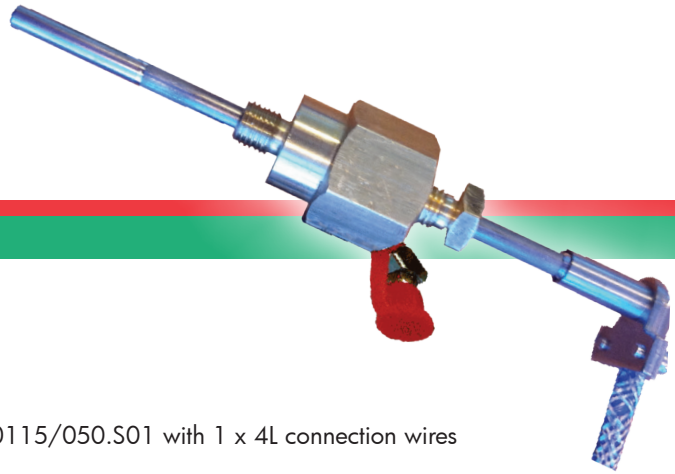

4.1 Technical Data PT100V3C

Sensor type	: R8-81227320-0115/050.S01 with 1 x 4L connection wires
Protection type	: IP 67
Tolerance class	: Class A DIN IEC751
Cable type	: PFA-PFA-V2A Cn 4 x 0,22 mm ²
Ambient temperature limit for cable	: - 40°C to + 185°C
Cable Length	: 3 meter, (several cable lengths available)
Measuring temperature limit	: - 40°C to + 280°C
Measuring current	: 1 mA
Output signal	: Analogue

Material

Material sensor	: Brass or stainless steel
Sensor housing plug	: Standard G1/8
Probe length	: 100 mm (various lengths available)
Probe diameter	: 5 mm
Grease nipple	: Standard

5. Various PT100V3C sensors

PARTNUMBER	DESCRIPTION
PT100V3C	PROBE LENGTH 100 mm - 4 CORE CABLE - CABLE LENGTH 3 MTR - ATEX IECE _x APPROVED
PT100V3C/5	PROBE LENGTH 100 mm - 4 CORE CABLE - CABLE LENGTH 5 MTR - ATEX IECE _x APPROVED
PT100V3C/D2	PROBE LENGTH 60 mm - 4 CORE CABLE - CABLE LENGTH 3 MTR - ATEX IECE _x APPROVED
PT100V3C/5/D2	PROBE LENGTH 60 mm - 4 CORE CABLE - CABLE LENGTH 5 MTR - ATEX IECE _x APPROVED
PT100V3C/D8	PROBE LENGTH 200 mm - 4 CORE CABLE - CABLE LENGTH 3 MTR - ATEX IECE _x APPROVED
PT100V3C/5/D8	PROBE LENGTH 200 mm - 4 CORE CABLE - CABLE LENGTH 5 MTR - ATEX IECE _x APPROVED
PT100V3C/5/D12	PROBE LENGTH 300 mm - 4 CORE CABLE - CABLE LENGTH 5 MTR - ATEX IECE _x APPROVED

6. Explosion protection worldwide

IEC
EC directive
NEC 500
NEC 505

Ex ia IIC T6
II 1G Ex ia IIC T6
Intrinsic safety Class I Division 1 Group ABCD T6
Class I Zone 0 AEx ia IIC T6



Groups

IEC/ATEX/NEC 505		NEC 500/CEC	
Gas groups			
Group I			
I	Methane	-*	
Group II			
IIA	Propane	Propane	Class I, Group D
IIB	Ethylene	Ethylene	Class I, Group C
IIB + H2	Ethylene + hydrogen	Acetylene	Class I, Group B
IIC	Acetylene Hydrogen	Hydrogen	Class I, Group A
Dust groups			
Group III*		Class II/Class III	
IIIA	Combustible flyings	Fibres, flyings	Class III
IIIB	Non-conducting dust	Non-carbon-containing dust	Class II, Group G
IIIC	Conducting dust	Carbon-containing dust	Class II, Group F
		Metal dust	Class II, Group E

* Are not within the scope of NEC or CEC | ** per IEC 2007 and CENELEC 2009

6.1 ATEX Groups

Conditions hazardous areas								
Material Groups	Temporary behaviour of the flammable material in the hazardous area	Classification of hazardous area						
		IEC	EPL*	EU Directive 94/9/EC (ATEX)			US NEC 500 Canada CEC	US NEC 505
				Zone	Group	Category		
Gases, vapours	Are present continuously, for long periods or frequently	Zone 0	Ga	Zone 0	II	1 G	Class I Division 1	Class 1 Zone 0
	Occur occasionally	Zone 1	Gb	Zone 1	II	2 G		Class 1 Zone 1
	Probably do not occur at all, but if they do, only rarely or for short periods	Zone 2	Gc	Zone 2	II	3 G	Class I Division 2	Class 1 Zone 2
Dust	Are present continuously, for long periods or frequently	Zone 20	Da	Zone 20	II	1 D	Class II Division 1	--
	Occur occasionally	Zone 21	Db	Zone 21	II	2 D		--
	Probably do not occur at all, due to suspended dust, but if they do, only rarely or for short periods	Zone 22	Dc	Zone 22	II	3 D	Class II Division 2	--
Methane, dust	Hazardous areas	--	Ma	--	I	M1	--	--
	Potentially hazardous areas	--	Mb	--	I	M2	--	--
Fibres/ flyings		--		--	--	--	Class III	--

*) Equipment Protection Level per IEC 2007 and CENELEC 2009

Ignition protection types (examples)					
Ignition protection type	Marking	Definition	IEC	ATEX approval	FM / UL
Flameproof enclosure	Ex d	Propagation of an explosion to the outside is prevented	IEC 60079-1	EN 60079-1	FM 3615 UL 1203
Intrinsic safety	Ex i	Limitation of the energy of sparks and temperatures	IEC 60079-11	EN 60079-11	FM 3610 UL 913
n	Ex n	Different protection principles only for Zone II/Div. 2	IEC 60079-15	EN 60079-15	FM 3611 ANSI/ISA 12.12.01

Temperature classes and max. surface temperatures									
Class	T1	T2	T2A, T2B T2C, T2D	T3	T3A, T3B T3C	T4	T4A	T5	T6
IEC/ATEX/NEC 505	450°C	300°C	--	200°C	--	135°C	--	100°C	85°C
NEC 500/CEC	450°C	300°C	280°C 260°C 230°C 215°C	200°C	180°C 165°C 160°C	135°C	120°C	100°C	85°C

7. Installation diagram

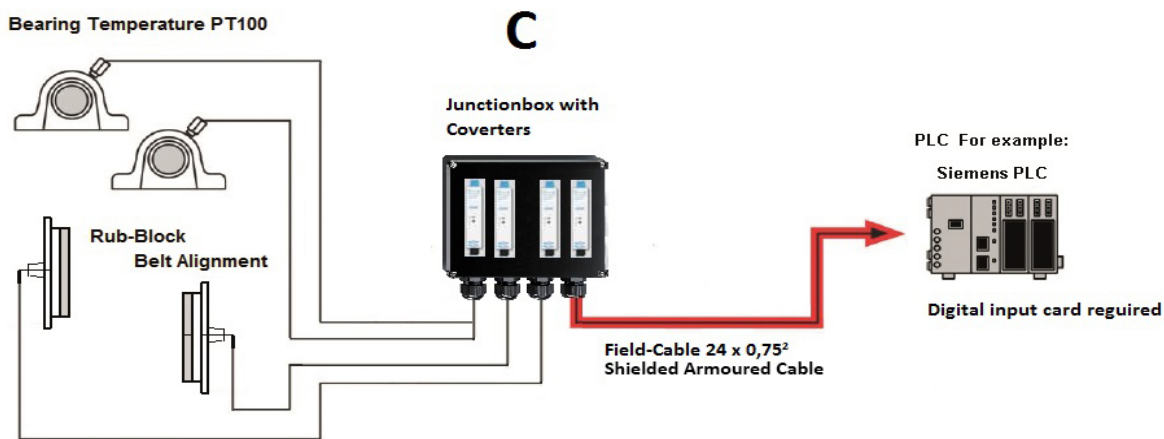
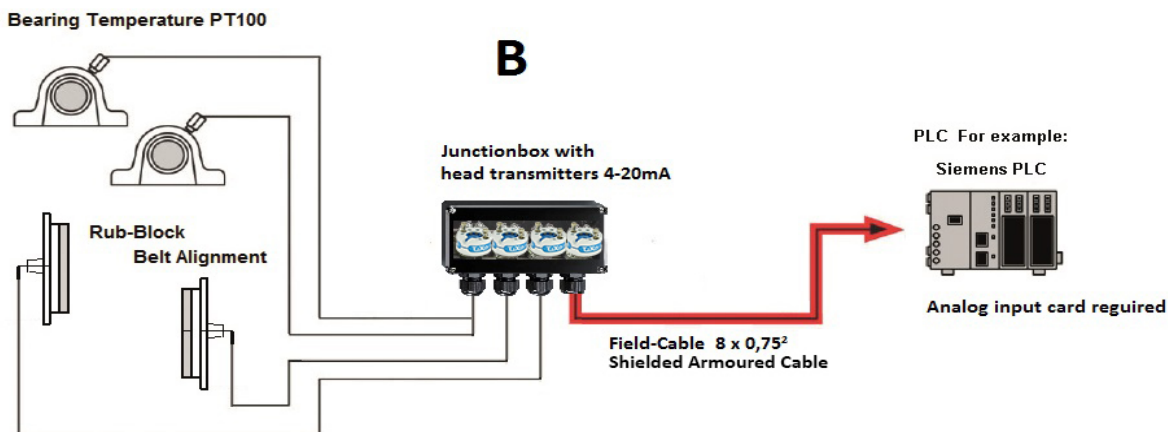
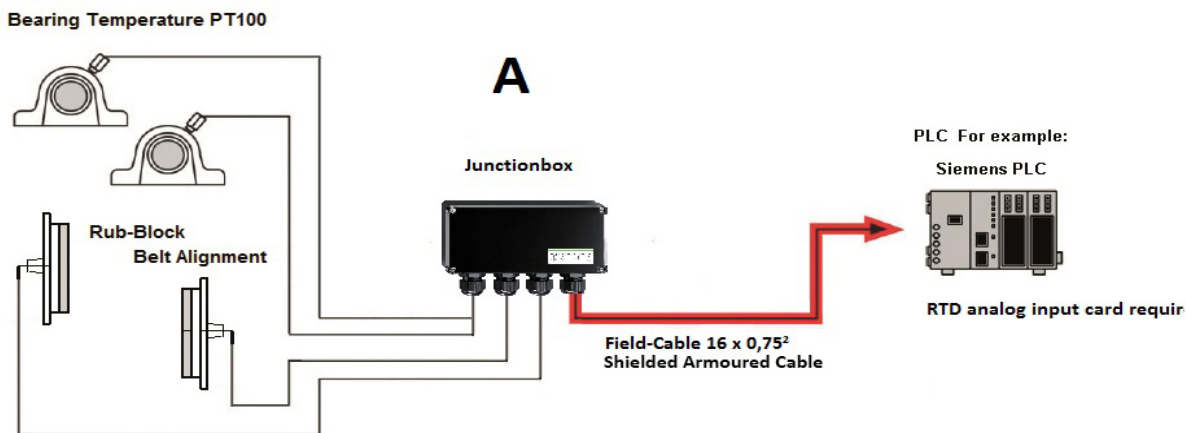

8. PT100 connection data

8.1 PT100 sensor wiring diagram

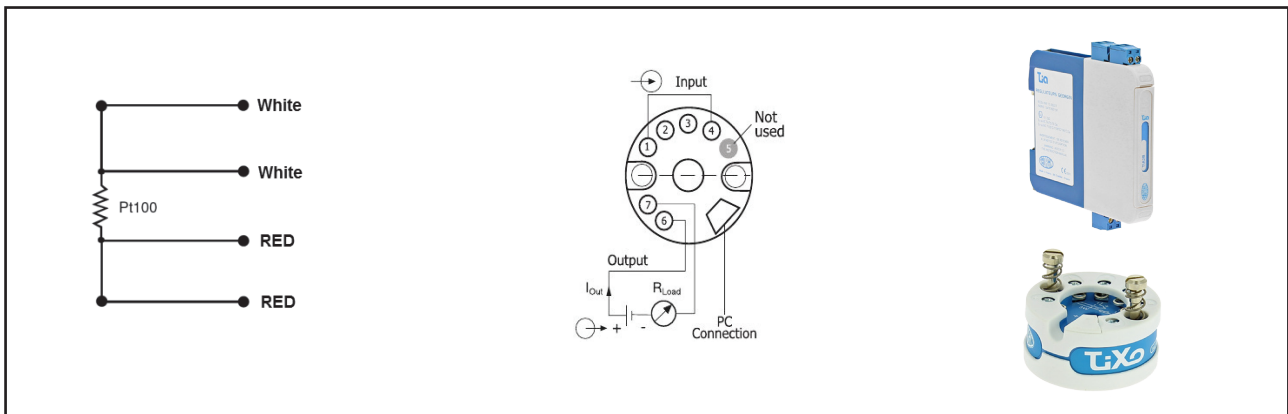

8.2 Various indicators and transmitters available

GSI 48 Series – Universal input – Panel mounting

SPECIFICATION

Description

Process indicator for analogue signals. Displaying a process, temperature, load cell or potentiometer signal in engineering units.

Input

thermocouples	: J, K, T, E, R, S, N
RTD	: Pt100
current	: 4÷20 mA
voltage	: 0÷50mV, 0÷10V

Accuracy

± 0.25% FS ±1°C	: for thermocouples J, K, T, E, N
± 0.25% FS ±3°C	: for thermocouples S, R
± 0.2% FS	: for Pt100
± 0.2% FS	: for input voltage, current

Alarm output

2x SPDT relay contact, 260Vca/1A/150VA
4x SPST relay contact, 260Vca/0,1A/50VA
Isolated 4...20mA

Operating Conditions: -10 ÷ +55°C/20 ÷ 85%RH

Power supply: 10-70Vdc and 21-53Vac or 85-260Vac and 100-300Vdc

Dimensions: 48 x 96 x 90 mm



8. Safety notice to our customers

- A. In order to maximise efficiency and safety it is vital to select the right equipment for each installation. The correct installation of this equipment as well as regular maintenance and inspection are equally important to proper operation and safety of the product. It is the end user's responsibility to ensure correct installation and maintenance of all our products.
- B. The installation of the wiring should be undertaken by an experienced and qualified professional electrician.
- C. Periodic inspection by a qualified person will help extend the lifespan of this product. Muller Beltex recommends that maintenance and inspection be carried out annually, at minimum, depending on the extent the product is used.

8.1 Customer safety responsibilities

1. Please read all operation manuals and safety instructions carefully to ensure that you understand the product operation and are able to safely and effectively use this product
2. Select a qualified and competent installer

Correct installation of the product is important for safety and proper performance. It is critical for the safety of your operation that those who are authorised be able to work with your equipment properly and that they be qualified to install these products. The product must be installed properly to function correctly and to perform to its designed functions. The installer or the personnel should be qualified, trained, and competent to undertake the installation in accordance with the person responsible.

WARNING The sealing surfaces and any flat seals present must not be damaged!
Installation and commissioning must be performed by qualified personnel. Read this operation manual carefully before starting up. We are not liable for personal injury or property damage incurred by incorrect use.

The user is required to check the latest product information on Muller Beltex' website before installing this product. Failure to do so could result in product failure or damage.

muller|beltex

Solid partners for powder and bulk handling components