

# MODEL 2200 FLEX ECONO-FOLD® PLANTER OPERATOR & PARTS MANUAL

**M0153**

**Rev. 4/97**

This manual is applicable to: Model: 2200 Flex Econo-Fold® Planters  
Serial Number: 605411 and on

Record the model number and serial number of your planter with date purchased:

Model Number \_\_\_\_\_ 2200 \_\_\_\_\_

Serial Number \_\_\_\_\_

Date Purchased \_\_\_\_\_

## SERIAL NUMBER

The serial number plate is located on the planter frame to be readily available. It is suggested that the serial number and purchase date also be recorded above.

The serial number provides important information about your planter and may be required to obtain the correct replacement part. Always provide the serial number and model number to your KINZE® Dealer when ordering parts or anytime correspondence is made with KINZE Manufacturing, Inc.

72359-134

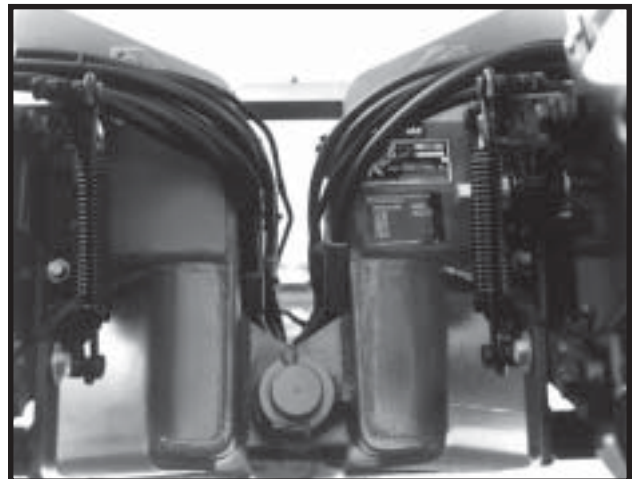



# PREDELIVERY/DELIVERY CHECK LIST

## TO THE DEALER

Predelivery service includes assembly, lubrication, adjustment and test. This service helps to ensure that the planter will be delivered to the customer ready for field use.

## PREDELIVERY CHECK LIST

After the planter has been completely assembled, use the following check list and inspect the planter. Check off each item as it is found satisfactory or after proper adjustment is made.

- Recheck to be sure row units and optional attachments are properly spaced and assembled.
- Be sure all grease fittings are in place and lubricated.
- Check planter and make sure all working parts are moving freely, bolts are tight and cotter pins are spread.
- Check all drive chains for proper tension and alignment.
- Check for oil leaks and proper hydraulic operation.
- Check to be sure hydraulic hoses are routed correctly to prevent damage to hoses.
- Inflate tires to specified PSI air pressure. Tighten wheel bolts to specified torque.
- Check to be sure all safety decals are correctly located and legible. Replace if damaged.
- Check to be sure the red reflectors and amber reflectors are correctly located and visible when the planter is in transport position.
- Check to be sure SMV sign is in place.
- Check to be sure safety/warning lights are installed correctly and working properly.
- Paint all parts scratched in shipment or assembly.
- Be sure all safety lockups are on the planter and correctly located.
- Be sure wing locking bolts and lift cylinder lockups work properly.

***This planter has been thoroughly checked and to the best of my knowledge is ready for delivery to the customer.***

\_\_\_\_\_  
(Signature Of Set-Up Person/Dealer Name/Date)

## OWNER REGISTER

Name \_\_\_\_\_ Date Sold \_\_\_\_\_

Street Address \_\_\_\_\_ Model \_\_\_\_\_

City, State/Province & ZIP \_\_\_\_\_ Serial Number \_\_\_\_\_

Dealer Name \_\_\_\_\_ Dealer Number \_\_\_\_\_

## DELIVERY CHECK LIST

At the time the planter is delivered, the following check list is a reminder of very important information which should be conveyed to the customer. Check off each item as it is fully explained to the customer.

- Advise the customer that the life expectancy of this or any other machine is dependent on regular lubrication as directed in the Operator & Parts Manual.
- Tell the customer about all applicable safety precautions.
- Along with the customer, check to be sure the red reflectors, amber reflectors and SMV sign are clearly visible with the planter in transport position and attached to the tractor. Check to be sure safety/warning lights are in working condition. Tell the customer to check federal, state/provincial and local regulations before towing or transporting on a road or highway.
- Give the Operator & Parts Manual to the customer and explain all operating adjustments.
- Read warranty to customer.
- Complete Warranty And Delivery Report form.

***To the best of my knowledge this machine has been delivered ready for field use and customer has been fully informed as to proper care and operation.***

---

(Signature Of Delivery Person/Dealer Name/Date)

## AFTER DELIVERY CHECK LIST

The following is a list of items we suggest to check during the first season of use of the equipment.

- Check with the customer as to the performance of the planter.
- Review with the customer the importance of proper maintenance and adherence with all safety precautions.
- Check for parts that may need to be adjusted or replaced.
- Check to be sure all safety decals, SMV sign and reflectors are correctly located and legible. Replace if damaged or missing.
- Check to be sure safety/warning lights are working properly.

---

(Signature Of Follow-Up Person/Dealer Name/Date)

**RETURN THIS COMPLETED FORM TO KINZE® IMMEDIATELY, along with Warranty And Delivery Report.  
Retain photocopy of this form at dealership for After Delivery Check.**

*Tear Along Perforation*

# TABLE OF CONTENTS

---

<b>TO THE OWNER</b> .....	1-1
<b>WARRANTY</b> .....	1-2
<b>INTRODUCTION</b> .....	2-1
<b>SPECIFICATIONS</b> .....	3-1
<b>SAFETY PRECAUTIONS</b> .....	4-1
<b>SAFETY WARNING SIGNS</b> .....	5-1
<b>MACHINE OPERATION</b>	
2 To 1 Drive Reduction .....	6-3
Checking Granular Chemical Application Rate .....	6-19
Checking Seed Population .....	6-18
Contact Drive Wheel Spring Adjustment .....	6-3
Electronic Seed Monitor System	
KM1000 Monitor .....	6-11
KM3000 Monitor .....	6-13
Field Test .....	6-17
Field To Transport Operation - Manual Wing Fold .....	6-5
Field To Transport Operation - Hydraulic Wing Fold .....	6-7
General Planting Rate Information .....	6-20
Hydraulic Marker Operation .....	6-4
Hydraulic Planter Lift Operation .....	6-4
Initial Preparation Of The Planter .....	6-1
Leveling The Planter .....	6-2
Marker Adjustment .....	6-9
Marker Speed Adjustment .....	6-9
Metric Conversion Table .....	6-17
Notched Single Disc Fertilizer Opener (Row Unit Mounted) .....	6-16
Optional Point Row Wrap Spring Clutch .....	6-10
Planting And Application Rate Charts .....	6-21
Ridge Planting .....	6-3
Shear Protection .....	6-4
Tire Pressure .....	6-2
Tire Scraper .....	6-3
Tractor Preparation And Hookup .....	6-1
Tractor Requirements .....	6-1
Tractor Planting Speed .....	6-17
Transmission Adjustment .....	6-3
Transporting The Planter .....	6-17
Transport To Field Operation - Manual Wing Fold .....	6-6
Transport To Field Operation - Hydraulic Wing Fold .....	6-8
<b>ROW UNIT OPERATION</b>	
Brush-Type Seed Meter .....	7-4
Coulter Mounted Residue Wheels .....	7-14
Covering Discs/Single Press Wheel Adjustment .....	7-2
Disc Furrowers (For Use With Frame Mounted Coulters) .....	7-11
Finger Pickup Seed Meter .....	7-3
Frame Mounted Coulter .....	7-9
Granular Chemical Banding Options .....	7-16
Granular Chemical Hopper .....	7-15
Granular Chemical Restrictor Plate .....	7-15
Planting Depth .....	7-1
Quick Adjustable Down Force Springs .....	7-8

# TABLE OF CONTENTS

---

## ROW UNIT OPERATION (Continued)

Row Unit Chain Routing .....	7-7
Row Unit Gauge Wheel Cover .....	7-7
Row Unit Mounted Bed Leveler .....	7-12
Row Unit Mounted Disc Furrower .....	7-11
Row Unit Mounted No Till Coulter .....	7-13
Row Unit Mounted Residue Wheel .....	7-12
Seed Firming Wheel .....	7-14
Seed Hopper .....	7-5
Seed Meter Drive Adjustment .....	7-6
Seed Meter Drive Release .....	7-3
Spring Tooth Incorporator .....	7-16
“V” Closing Wheel Adjustment .....	7-1

## LUBRICATION

Bushings .....	8-2
Drive Chains .....	8-1
Grease Fittings .....	8-3
Lubrication Symbols .....	8-1
Point Row Wrap Spring Clutch .....	8-1
Sealed Bearings .....	8-1
Wheel Bearings .....	8-3

## MAINTENANCE

15" Seed Opener Disc/Bearing Assembly .....	9-8
Brush-Type Seed Meter Maintenance .....	9-5
Brush-Type Seed Meter Troubleshooting .....	9-7
Chain Tension Adjustment .....	9-1
Closing Wheel Troubleshooting .....	9-7
Electrical Wiring Diagram For Light Package .....	9-24
Electrical Wiring Diagram For Point Row Wrap Spring Clutches .....	9-25
Electronic Seed Monitor Display Backlite Bulb Replacement (KM3000 Only) .....	9-16
Electronic Seed Monitor Row Indicator Bulb Replacement (KM1000 Only) .....	9-16
Electronic Seed Monitor System Troubleshooting .....	9-10
Finger Pickup Seed Meter Cleaning .....	9-3
Finger Pickup Seed Meter Inspection/Adjustment .....	9-2
Finger Pickup Seed Meter Troubleshooting .....	9-4
Gauge Wheel Adjustment .....	9-8
Hydraulic System Schematics .....	9-29
Lift Circuit Operation Troubleshooting .....	9-22
Marker Bearing Lubrication Or Replacement .....	9-23
Marker Sequencing/Flow Control Valve Inspection .....	9-20
Marker Operation Troubleshooting .....	9-21
Mounting Bolts And Hardware .....	9-1
Point Row Wrap Spring Clutch Inspection .....	9-17
Point Row Wrap Spring Clutch Troubleshooting .....	9-19
Preparation For Storage .....	9-24
Row Unit Mounted No Till Coulter .....	9-9
Seed Tube Guard/Inner Scraper .....	9-9
Torque Values Chart .....	9-1
Two-Speed Point Row Wrap Spring Clutch .....	9-20
Wheel Bearing Lubrication Or Replacement .....	9-23

<b>PARTS LIST INDEX</b> .....	P1
-------------------------------	----

<b>PARTS SECTION NUMERICAL INDEX</b> .....	a
--	---

# TO THE OWNER

---

KINZE Manufacturing, Inc. would like to thank you for your patronage. We appreciate your confidence in KINZE® farm machinery. Your KINZE® planter has been carefully designed and sturdily built to provide dependable operation in return for your investment.

**This manual has been prepared to aid you in the operation and maintenance of the planter. It should be considered a permanent part of the machine and remain with the machine when you sell it.**

It is the responsibility of the user to read and understand the Operator & Parts Manual in regards to safety, operation, lubrication and maintenance before operation of this equipment. It is the user's responsibility to inspect and service the machine routinely as directed in the Operator & Parts Manual. We have attempted to cover all areas of safety, operation, lubrication and maintenance; however, there may be times when special care must be taken to fit your conditions.

Throughout this manual the symbol  and the words **NOTE**, **CAUTION**, **WARNING** and **DANGER** are used to call your attention to important safety information. The definition of each of these terms used follows:

**NOTE:** Indicates a special point of information.

**CAUTION:** Indicates that a failure to observe can cause damage to the machine or equipment.



**WARNING:** Indicates that a failure to observe can cause damage to the machine or equipment and/or personal injury.



**DANGER:** Indicates that a failure to observe can cause most serious damage to the machine or equipment and/or most serious personal injury.



**WARNING:** Some photos in this manual may show safety covers, shields or lockups removed for visual clarity. **NEVER OPERATE** the machine without all safety covers, shields and lockups in place.

**NOTE:** Some photos in this manual may have been taken of prototype machines. Production machines may vary in appearance.

**NOTE:** Some photos and illustrations in this manual show optional attachments installed. Contact your KINZE® Dealer for purchase of optional attachments.

# WARRANTY

---

The KINZE® Limited Warranty for your new machine is stated on the back of the retail purchaser's copy of the Warranty And Delivery Report form.

Warranty, within the warranty period, is provided as part of KINZE's support program for registered KINZE® products which have been operated and maintained as described in this manual. Evidence of equipment abuse or modification beyond original factory specifications will void the warranty. Normal maintenance, service and repair is not covered by KINZE® warranty.

To register your KINZE® product for warranty, a Warranty And Delivery Report form must be completed by the KINZE® Dealer and signed by the retail purchaser, with copies to the Dealer, to the retail purchaser and to KINZE Manufacturing, Inc. Registration must be completed and sent to KINZE Manufacturing, Inc. within 30 days of delivery of the KINZE® product to the retail purchaser. KINZE Manufacturing, Inc. reserves the right to refuse warranty on serial numbered products which have not been properly registered.

Additional copies of the Limited Warranty can be obtained through your KINZE® Dealer.

If service or replacement of failed parts which are covered by the Limited Warranty are required, it is the user's responsibility to deliver the machine along with the retail purchaser's copy of the Warranty And Delivery Report to the KINZE® Dealer for service. KINZE® warranty does not include cost of travel time, mileage, hauling or labor. Any prior arrangement made between the Dealer and the retail purchaser in which the Dealer agrees to absorb all or part of this expense should be considered a courtesy to the retail purchaser.

*KINZE® warranty does not include cost of travel time, mileage, hauling or labor.*



# INTRODUCTION

---

The Model 2200 Flex Econo-Fold<sup>®</sup> planter is available in various row spacings and permits installation of various row unit attachments.

## GENERAL INFORMATION

The information used in this manual was current at the time of printing. However, due to KINZE's continual attempt to improve its product, production changes may cause your machine to appear slightly different in detail. KINZE Manufacturing, Inc. reserves the right to change specifications or design without notice and without incurring obligation to install the same on machines previously manufactured.

Right hand and left hand as used throughout this manual is determined by facing in the direction the machine will travel when in use unless otherwise stated.

73593-20



73593-23



# INTRODUCTION

---

# SPECIFICATIONS

**TYPE** - Pull Type - Two Section Center Flex/Manual Horizontal Front Fold (Hydraulic Wing Fold Optional)

**PLANTING UNIT TYPES** - Pull Row Units

**ROW SPACING**      8 Row Wide - 36" Or 38" Rows  
                          12 Row Narrow - 30" Rows

**DRIVE SYSTEM**    Two 4.10" x 6" Spring-Loaded Contact Drive Tires With No. 40 Chain  
                          Two Quick-Adjust End Mounted Seed Transmissions With Machined Sprockets  
                          7/8" Hex Drive/Drill Shafts With Spring-Loaded, Hardened Wing Couplers  
                          7.50" x 20" 6 Ply Transport/Ground Drive Tires

**TYPE LIFT**            Master/Slave Rephasing With Assist Cylinders (6 Cylinders)

**MARKERS**            Three-Fold Low Profile With Depth Band On Marker Blades

**HYDRAULICS**        Dual SCV For Independent Operation Of Lift And Markers  
                          Hydraulic Sequence Valve With Flow Controls For Markers

## Dimensions/Weights

PLANTER SIZE	8 Row 36"/38"	12 Row 30"
Transport Width	13' 9"	16' 4"
Planting Width	26' 3"	31' 6"
Transport Height	9' 1"	9' 1"
Weight*	6221 lbs.	7318 lbs.

\* Base machine weights include toolbar and hitch, row markers, hydraulic hoses, cylinders and fittings, tires, wheels and hubs, drive and drill shafts, seed transmissions, sprockets, chains and drive components, safety/warning lights, SMV sign, parking jack, KINZE plateless row units (closing wheel arms less closing wheels) with seed hopper and lid, and dual quick adjustable down force springs.

## MACHINE OPTIONS

- Electronic Seed Monitors - KM1000, KM3000 With Magnetic Distance Sensor Or KM3000 With Radar Distance Sensor
- 2 To 1 Drive Reduction Package
- Hydraulic Wing Fold Package
- Point Row Clutch Package

## ROW UNIT OPTIONS/ATTACHMENTS

- Finger Pickup Or Brush-Type Seed Meters
- Closing Wheels - Rubber "V", Cast Iron "V" Or Covering Discs/Single Press Wheel
- Gauge Wheel Covers
- Granular Chemical Application
- Spring Tooth Incorporator
- Row Unit Mounted No Till Coulter
- Row Unit Mounted Disc Furrowers
- Row Unit Mounted Bed Leveler
- Row Unit Mounted Notched Single Disc Fertilizer Openers
- Row Unit Mounted Residue Wheel
- Coulter Mounted Residue Wheels
- Frame Mounted No Till Coulter
- Disc Furrowers For Frame Mounted Coulter
- Seed Firming Wheel

# SPECIFICATIONS

---

# SAFETY PRECAUTIONS

Safe and careful operation of the tractor and planter at all times will contribute significantly to the prevention of accidents.

Since a large portion of farm accidents occur as a result of fatigue or carelessness, safety practices should be of utmost concern. Read and understand the instructions provided in this manual. Listed below are a few other safety suggestions that should become common practice.

 **Never allow the planter to be operated by anyone who is unfamiliar with the operation of all functions of the unit. All operators should read and thoroughly understand the instructions given in this manual prior to moving the unit.**

 **Never permit any persons other than the operator to ride on the tractor.**

 **Never ride on the planter or allow others to do so.**

 **Always make sure there are no persons near the planter when marker assemblies are in operation.**

 **Watch for obstructions such as wires, tree limbs, etc., when folding markers.**

83154-3

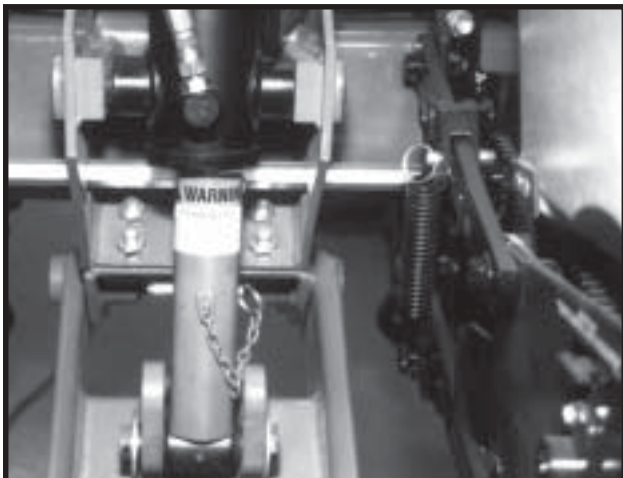

Lift Cylinder Lockups

 **Always install all lift cylinder lockups before transporting the planter or working under the unit.**

 **Limit towing speed to 15 MPH. Tow only with farm tractor of at least 50 HP size.**

 **Always make sure safety/warning lights, reflectors and SMV emblem are in place and visible prior to transporting the machine on public roads. In this regard, check federal, state/provincial and local regulations.**

 **Lower the planter when not in use and cycle the hydraulic control lever to relieve pressure in cylinders and hoses before disconnecting.**

60887-77

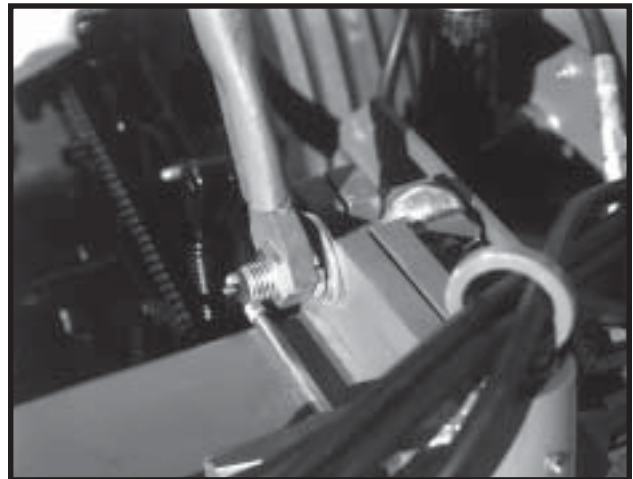

Wing Locking Bolt

 **Always secure wing locking bolts before operating the planter.**

 **Avoid standing between the wing and main frame when folding the planter. Wing may swing suddenly.**

# SAFETY PRECAUTIONS

---

72359-9

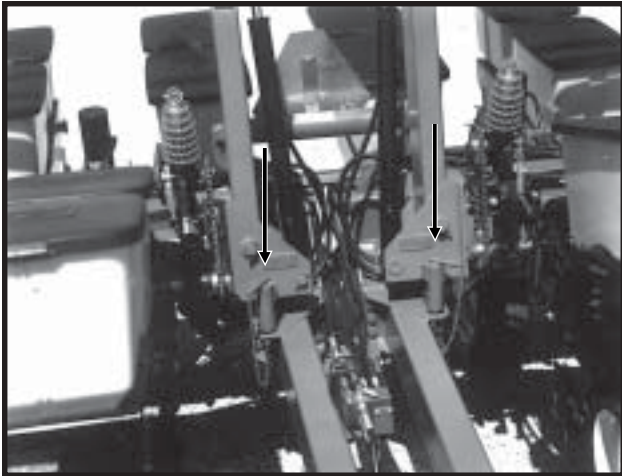

Wing Safety Pins



Always make sure wings are secured with safety pins before transporting the planter.



This planter is designed to be **DRIVEN BY GROUND TIRES ONLY**. The use of hydraulic, electric or PTO drives may create serious safety hazards to you and the people near by. If you install such drives you must follow all appropriate safety standards and practices to protect you and others near this planter from injury.



This machine has been designed and built with your safety in mind. Do not make any alterations or changes to this machine. Any alteration to the design or construction may create safety hazards.



Rim and tire servicing can be dangerous. Explosive separation of a tire and rim parts can cause serious injury or death.



Agricultural chemicals used with this unit can be dangerous. Improper selection or use can seriously injure persons, animals, plants, soil and other property. **BE SAFE:** Select the right chemical for the job. Handle it with care. Follow the instructions of the chemical manufacturer.

# SAFETY WARNING SIGNS

The “WARNING” signs illustrated on these pages are placed on the machine to warn of hazards. The warnings found on these signs are for your personal safety and those around you. OBSERVE THESE WARNINGS!

- Keep these signs clean so they can be readily observed. Wash with soap and water or cleaning solution as required.
- Replace “WARNING” signs should they become damaged, painted over or if they are missing.
- Check the SMV decal periodically. Replace if it shows loss of any of its reflective property.
- When replacing decals, clean the machine surface thoroughly using soap and water or cleaning solution to remove all dirt and grease.

72359-86

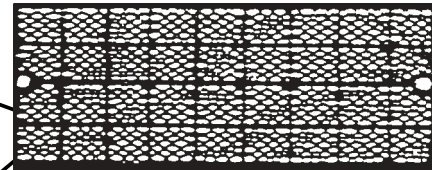
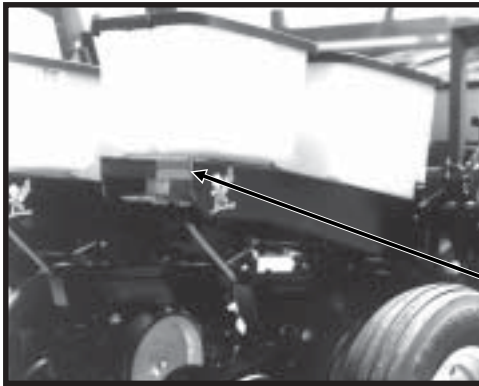

Part No. G7200-03 Red Reflector  
(Rear)

73593-5

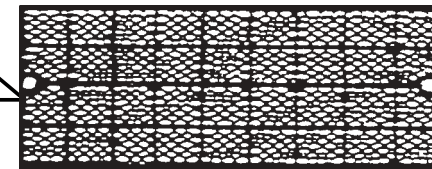
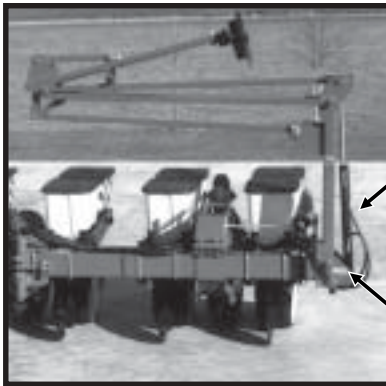

Part No. G7200-04 Amber Reflector  
(Front)

72359-83

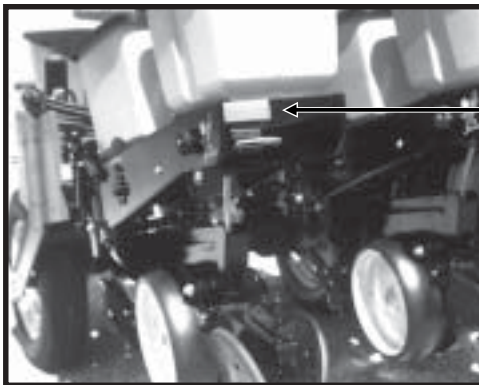

# SAFETY WARNING SIGNS

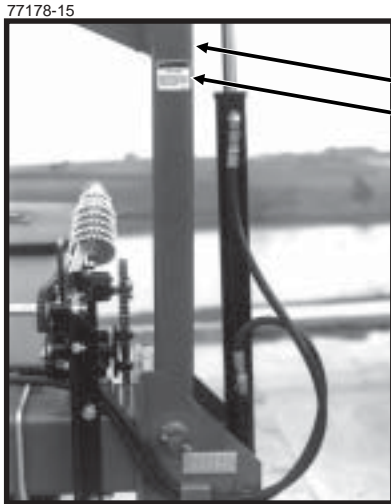

Part No. G7100-42

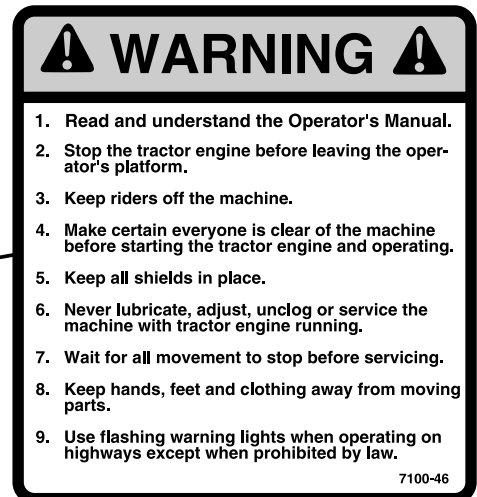
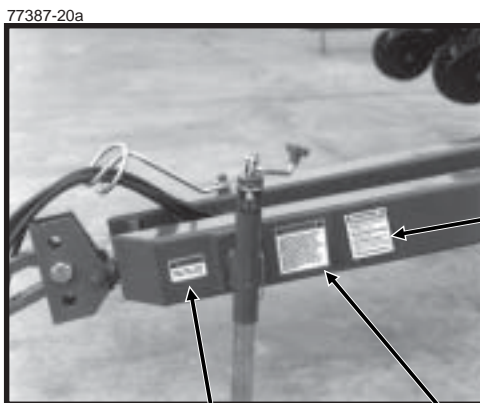

Part No. G7100-46



Part No. G7100-56





Part No. G7100-90

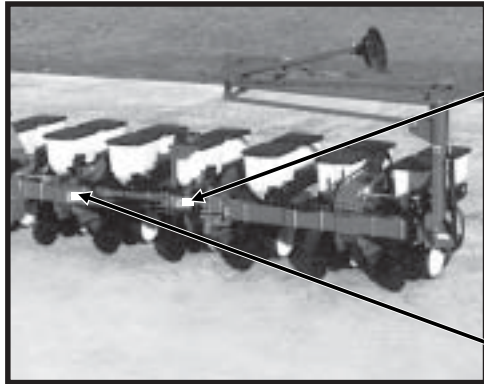

# SAFETY WARNING SIGNS

73593-20



 **WARNING** 

RAISE PLANTER COMPLETELY AND INSTALL CYLINDER LOCK-UPS BEFORE FOLDING. FOLD ON LEVEL GROUND. SECURE WINGS WITH SAFETY LATCHES BEFORE TOWING IN FOLDED POSITION.

7100-66

Part No. G7100-66 (Located on upper side of wheel module arm clamp.)

 **WARNING** 

ALWAYS LATCH WINGS AND INSTALL TRANSPORT PINS IN LATCHES BEFORE TRANSPORTING. WINGS MAY SWING OUT IF NOT PROPERLY LATCHED.

7100-71

Part No. G7100-71 (Located on upper side of wheel module arm clamp.)

77178-1

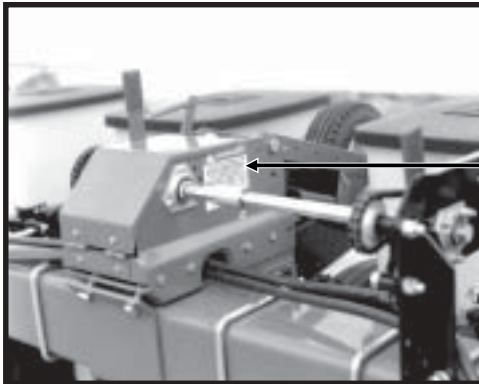

 **DANGER**

THIS PLANTER IS DESIGNED TO BE DRIVEN BY GROUND TIRES ONLY. THE USE OF HYDRAULIC, ELECTRIC OR PTO DRIVES MAY CREATE SERIOUS SAFETY HAZARDS TO YOU AND THE PEOPLE NEARBY. IF YOU INSTALL SUCH DRIVES YOU MUST FOLLOW ALL APPROPRIATE SAFETY STANDARDS AND PRACTICES TO PROTECT YOU AND OTHERS NEAR THIS PLANTER FROM INJURY.

7100-89

Part No. G7100-89

83154-3

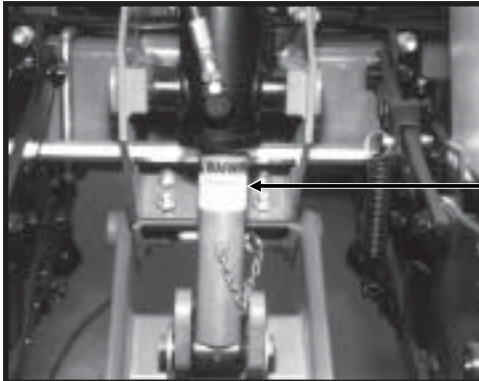

 **WARNING**

*TO AVOID INJURY ...*

ALWAYS USE THE HYDRAULIC CYLINDER SAFETY LOCKUP CHANNEL WHEN SERVICING MACHINE IN RAISED POSITION OR WHEN TRANSPORTING MACHINE ON THE ROAD. AFTER USE RETURN TO STORAGE LOCATION.

7100-47

Part No. G7100-47

# SAFETY WARNING SIGNS

65909-9

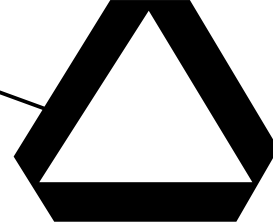
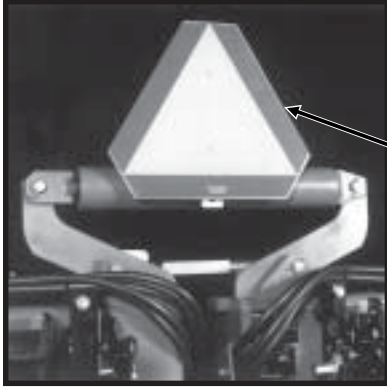

Part No. GD2199 SMV Emblem

77387-26

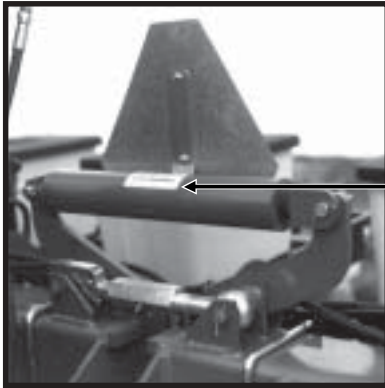

Part No. G7100-24

77178-17

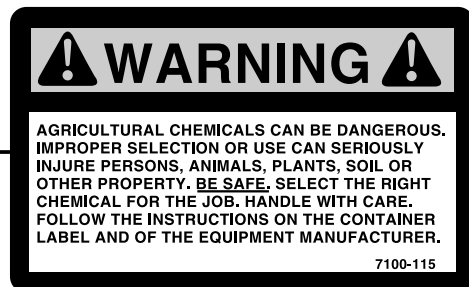

Part No. G7100-115  
Located on under side of granular  
chemical hopper lid.

# MACHINE OPERATION

The following information is general in nature and was written to aid the operator in preparation of the tractor and planter for use, and to provide general operating procedures. The operator's experience, familiarity with the machine and the following information should combine for efficient planter operation and good working habits.

**CAUTION:** Always raise the planter out of the ground when making sharp turns or backing up.

## INITIAL PREPARATION OF THE PLANTER

Lubricate the planter and row units per the lubrication information in this manual. Make sure all tires have been properly inflated. Check all drive chains for proper tension, alignment and lubrication.

## TRACTOR REQUIREMENTS

Consult your dealer for information on horsepower requirements and tractor compatibility. Requirements will vary with planter options, tillage and terrain. Two dual remote hydraulic outlets (SCV) are required on all sizes.

## TRACTOR PREPARATION AND HOOKUP

77387-20a



1. Adjust tractor drawbar to 13" to 17" above the ground. Adjust the drawbar so the hitch pin hole is directly below the center line of the PTO shaft. Make sure the drawbar is in a stationary position.

2. Back tractor to planter and connect with hitch pin. Make sure hitch pin is secured with locking pin or cotter pin.
3. Connect hydraulic hoses to tractor ports in a sequence which is both familiar and comfortable to the operator.

**CAUTION:** Always wipe hose ends to remove any dirt before connecting couplers to tractor ports.



**DANGER:** Before applying pressure to the hydraulic system, make sure all connections are tight and hoses and fittings have not been damaged. Hydraulic fluid escaping under pressure can have sufficient force to penetrate skin, causing injury or infection.

4. Connect ASAE Standards 7 terminal connector for warning lights on planter to ASAE Standards receptacle on tractor. If your tractor is not equipped with an ASAE Standards receptacle, check with your tractor manufacturer for availability. Check to be sure warning lights on planter are working in conjunction with warning lights on tractor.
5. Lower jack stand and remount horizontally on storage bracket.
6. Lower planter to the planting position and check to be sure planter is level fore and aft. If hitch height is too high or low, disconnect planter and adjust hitch clevis up or down as necessary.

**NOTE:** If using an auxiliary attaching system to retain the connection between the planter and tractor hitch, be sure the auxiliary attaching system is of sufficient strength and length and correctly attached. An auxiliary attaching system (safety chain) is available from KINZE® Repair Parts through your KINZE® Dealer. Install safety chain using safety chain mounting tab on planter hitch.

# MACHINE OPERATION

## LEVELING THE PLANTER

For proper operation of the planter and row units, it is important that the planter frame and row unit parallel arms be level. The toolbar should operate at a 20" ( $\pm 1$ ") height, measured to the bottom of the toolbar.

Unless the tractor drawbar is adjustable for height, the fore and aft level adjustment must be maintained by the position of the hitch clevis. Holes in the hitch bracket allow the clevis to be raised or lowered. When installing clevis mounting bolt, tighten hex nut to proper torque setting.

73593-9a

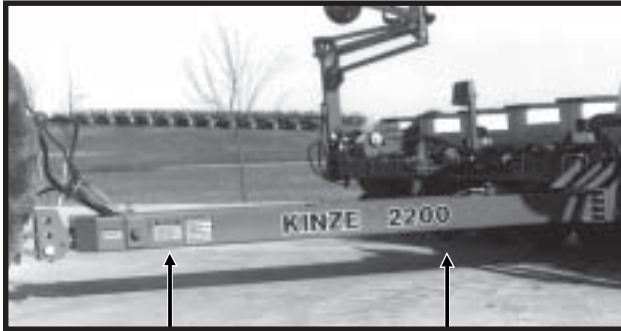

With the planter lowered to proper operating depth, check to be sure the frame is level fore and aft. Recheck once planter is in the field.

It is important for the planter to operate level laterally. Tire pressure must be maintained at pressures specified. See "Tire Pressure".

## TIRE PRESSURE

83154-11

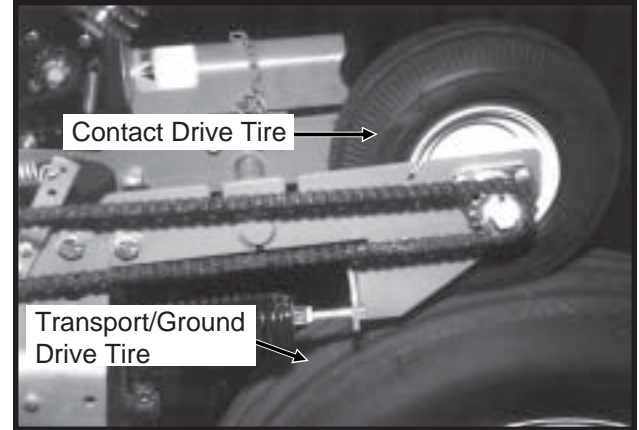

Tire pressure should be checked regularly and maintained as follows:

Transport/Ground Drive 7.50" x 20" ..... 40 PSI  
Contact Drive 4.10" x 6" ..... 60 PSI

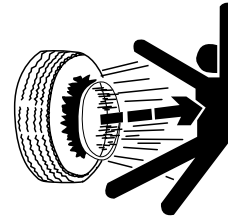

**DANGER:** Rim and tire servicing can be dangerous. Explosive separation of a tire and rim parts can cause serious injury or death.

Do not attempt to mount a tire unless you have the proper equipment and experience to perform the job. This should only be done by persons properly trained and equipped to do the job.

Always maintain the correct tire pressure. Do not inflate the tires above the recommended pressure.

When inflating tires, use a clip-on air chuck and extension hose long enough to allow you to stand to one side and NOT in front of or over the tire assembly. Use a safety cage to enclose the tire and rim assembly when inflating.

Inspect tires and wheels daily. Do not operate with low pressure, cuts, bubbles, damaged rims or missing lug bolts and nuts.

# MACHINE OPERATION

## TRANSMISSION ADJUSTMENT

Planting population rate changes are made at each end of the planter. The planter is designed to allow simple, rapid changes in sprockets to obtain the desired planting population. By removing the lynch pins on the hexagon shafts, sprockets can be interchanged with those from the sprocket storage rod bolted to the transmission on each side of the planter.

Chain tension is controlled by a spring-loaded dual-sprocket idler. The idler assembly is adjusted with a ratchet arm. This arm has a release position to remove spring tension for replacing sprockets. The amount of spring tension on the chain can be controlled by the ratchet arm.

The planting rate charts found at the back of this section will aid you in selecting the correct sprocket combinations.

60982-94

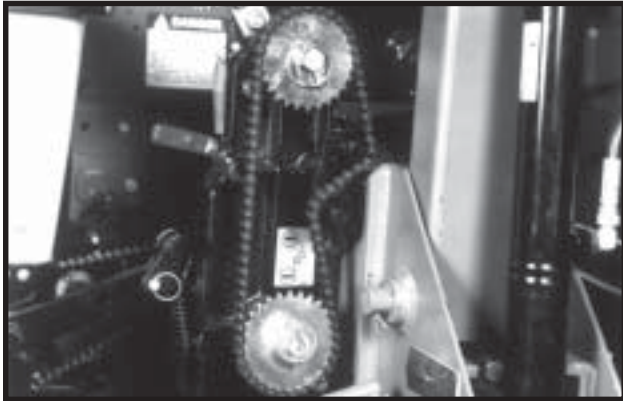

## 2 TO 1 DRIVE REDUCTION

60982-62

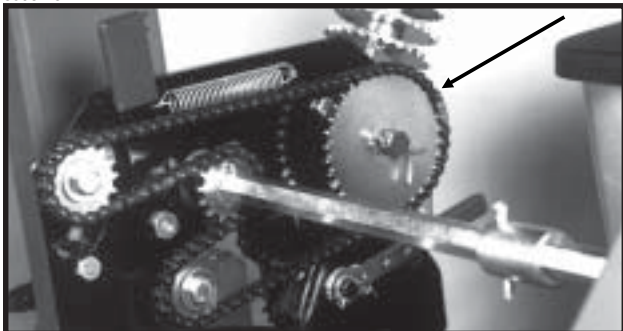

Replacing the 17 tooth drive sprocket located on the inner side of the top transmission shaft, with the 34 tooth 2 to 1 drive reduction sprocket will reduce the planter transmission speed and reduce planting rates by approximately  $\frac{1}{2}$ .

**IMPORTANT:** After each sprocket combination adjustment, make a field check to be sure you are planting at the desired rate.

## CONTACT DRIVE WHEEL SPRING ADJUSTMENT

There are two down pressure springs on each contact drive wheel. The down pressure is factory preset and should need no further adjustment.

The spring tension is set leaving  $2 \frac{1}{4}$ " between the spring plug and the bolt head.

83154-11

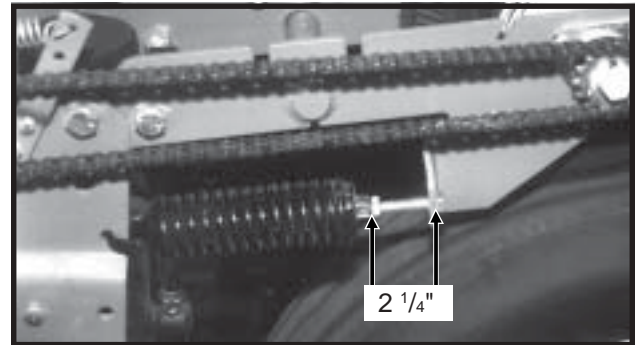

## TIRE SCRAPER

Due to the clearance between the wheel assembly and the transport tire when a planter is equipped with the 20" transport tire, a tire scraper should always be used. This will help prevent a buildup of dirt/mud between the wheel arm assembly and the tire. Adjust the scraper so it does not contact the tire.

83154-1

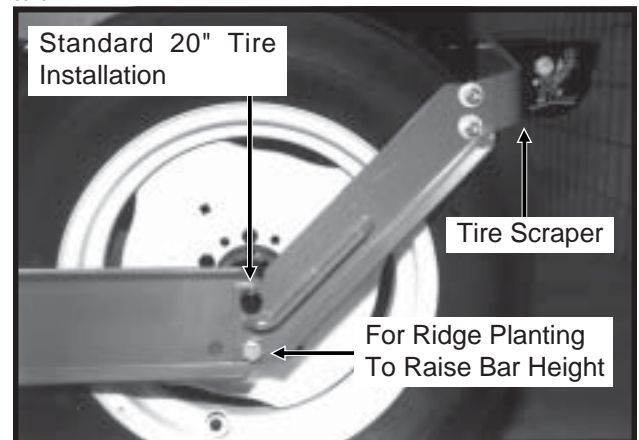

## RIDGE PLANTING

For ridge planting mount the 20" tires in the lower rear holes in the ground drive wheel arm to raise the bar height 3". Mount the contact drive wheel arm and springs in the lower set of mounting holes in the wheel module mount and raise the hitch height to maintain fore and aft levelness.

# MACHINE OPERATION

## SHEAR PROTECTION

The planter driveline and row unit components are protected from damage by shear pins.

61658-27

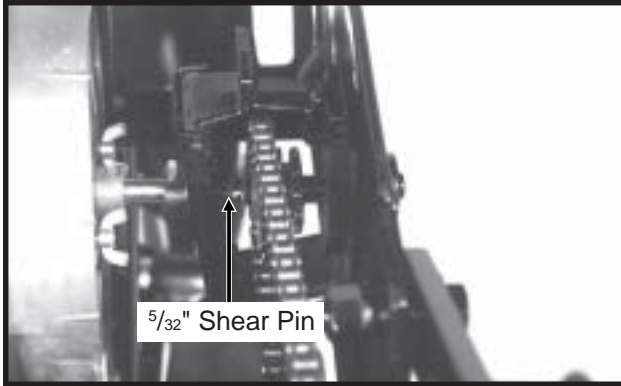

Row Unit Seed Meter Drive

60982-71

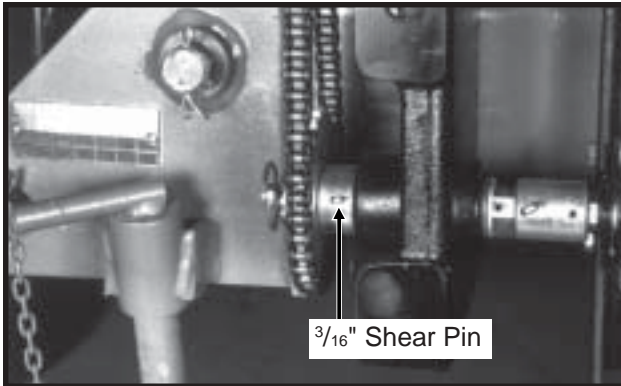

Transmission Shaft

If excessive load should cause a pin to shear, it is important to determine where binding has occurred before replacing the pin. Turn the shaft by hand, checking for misalignment and for the possibility of seized parts. When the shaft can be turned by hand (with the aid of a wrench) replace shear pins with same size and type. To prevent future binding or breakage of components, check driveline alignment and follow prescribed lubrication schedules.

60817-44

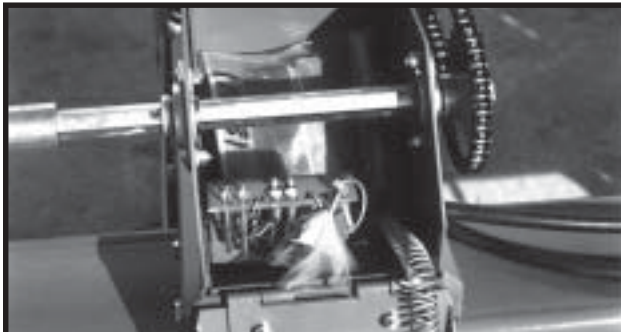

Additional shear pins can be found in the storage area located on the wheel module.

## HYDRAULIC MARKER OPERATION

All Model 2200 Planters are equipped with a dual valve hydraulic system. The dual valve system allows the markers to be operated independently of the planter lift cylinders. Each time a marker is raised, the sequencing valve will direct flow to lower the opposite marker.

Both markers can be used at the same time if desired. To do this, lower the planter and the marker that has been selected. Move the tractor control lever to the raise position and immediately return it to the lower position. This will shift the marker control valve and the remaining marker will be lowered. This is useful in planting contours and terraces.



**WARNING:** Always stand clear of the marker assemblies and blades when planter is in operation.

**NOTE:** On machines equipped with the hydraulic wing fold option, a hand operated selector valve on the hitch allows selection of the marker or wing fold functions. Remove pressure from the hydraulic system before moving the selector handle.

## HYDRAULIC PLANTER LIFT OPERATION

The planter lift system consists of one master, one slave and one lift assist cylinder on each side of the planter.

With this master/slave hydraulic lift system, oil is forced into the butt end of the master and lift assist cylinders when the hydraulic lever on the tractor is moved to the raise position. As the master cylinder is extended, oil from the rod end of the master cylinder is forced into the butt end of the slave cylinder. The displacement on the rod end of the master cylinder is equal to the displacement on the butt end of the slave cylinder. This causes the two cylinders to move at the same rate so the planter will raise and lower evenly.

**IMPORTANT:** The planter lift cylinders may get out of phase causing the planter to lift unevenly. On each master cylinder and each slave cylinder a valve located in the cylinder's piston allows the lift system to be rephased when the cylinders are cycled by lowering the planter to the ground and holding the hydraulic lever for 5 seconds. Cycle the system until the planter lifts and lowers evenly.



**WARNING:** Always position lockups in "safety" position over the cylinder rods when transporting or storing planter. See "Safety Precautions".

# MACHINE OPERATION

## FIELD TO TRANSPORT OPERATION - Manual Wing Fold



**WARNING:** Be sure the planter is on a level surface, fore and aft plus side to side. Avoid standing between the wing and main frame when folding the planter. Wing may swing suddenly.

### SUMMARIZED FIELD TO TRANSPORT SEQUENCE

- Fold markers and lower planter.
  - Position turnbuckle to lock frame rigid.
  - Loosen wing locking bolts.
  - Raise planter.
  - Install lockups on center lift cylinders.
  - Retract wing lift cylinders.
  - Swing wings forward and lock in place.
- NOTE: Read the following information for more detailed instructions.

1. Fold the markers into transport position and lower the planter to the ground.
2. Swing the center turnbuckle into position to lock the planter frame rigid and tighten slightly.

65909-46

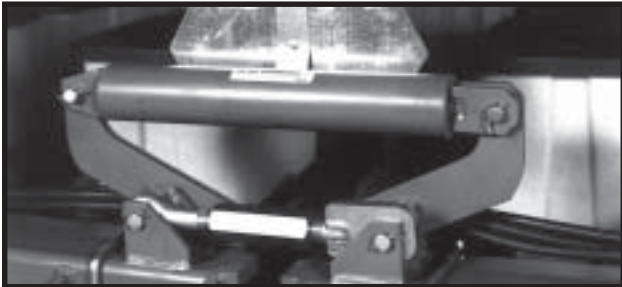

3. Using the special wrench which is stored on the hitch of the planter, loosen the 1 1/4" hex nuts which secure the wing locking bolts.

72359-160



4. Raise the planter.

5. Install cylinder lockups on the four center section lift cylinders.

83154-3

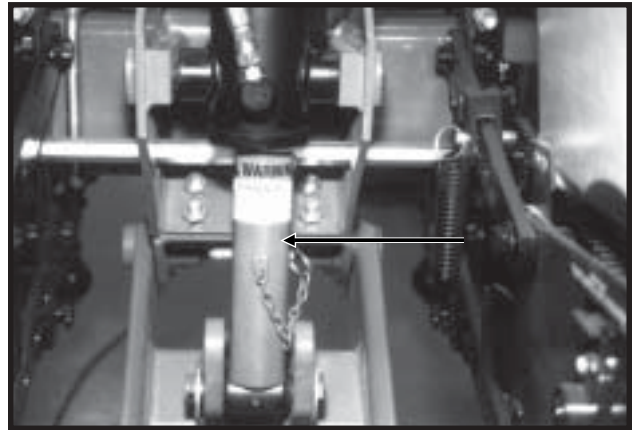

6. Place the tractor hydraulic lever in the lowering position and hold until the wing cylinders are fully retracted thus raising the wing tires.
7. Swing the wing locking bolt over to release the planter wing.
8. Swing the wing forward into transport position and lock wing in place at the marker support and hitch. Return wrench to storage position on tongue.

72359-9

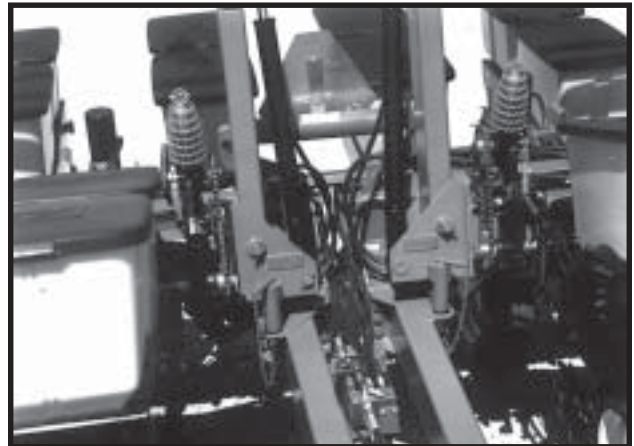

Photo Shows Both Wings Locked In Place

9. Repeat steps 7 and 8 on opposite planter wing.

# MACHINE OPERATION

## TRANSPORT TO FIELD OPERATION - Manual Wing Fold



**WARNING:** Be sure the planter is on a level surface, fore and aft plus side to side. Avoid standing between the wing and main frame when folding the planter. Wing may swing suddenly.

### SUMMARIZED TRANSPORT TO FIELD SEQUENCE

- With center lift cylinders retracted and lock ups in place, release wing lock pins and swing wings out.
- Swing wing locking bolts into place.
- Extend lift cylinders.
- Remove center section lift cylinder lockups.
- Lower planter.
- Tighten wing locking bolts.
- Release turnbuckle at center of planter.

NOTE: Read the following information for more detailed instructions.

1. If the wing lift tires are not raised, with the cylinder lockups in place on the four center section lift cylinders, move the tractor hydraulic lever to the lowering position until the cylinders are fully retracted thus raising the wing tires.
2. With the planter raised and the cylinder lockups in place, release the wing lock pins at the marker support and hitch. Swing the wings out to operating position.

72359-9

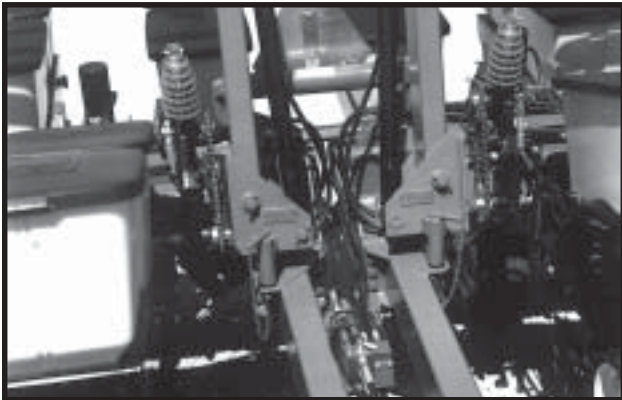

3. Swing the wing locking bolts into position to lock each wing.

74056-18



4. Operate the hydraulic lever to extend all the lift cylinders.
5. Remove the cylinder lockups from the four center section lift cylinders and place them in the storage position on the wheel module.
6. Lower the planter.
7. Using the special wrench which is stored on the hitch of the planter, tighten the 1 1/4" hex nuts to secure the wing locking bolts.

72359-160



8. Release the turnbuckle located in the center of the planter frame, using the special wrench, and fold it to one side. Return wrench to storage position on tongue.

65909-48



9. Raise the planter. If the planter does not raise even, lower the planter and hold the tractor remote in the lowering position for an additional few seconds.



# MACHINE OPERATION

## FIELD TO TRANSPORT OPERATION - Hydraulic Wing Fold



**WARNING:** Be sure the planter is on a level surface, fore and aft and side to side. Avoid standing between the wing and main frame when folding the planter. Wing may swing suddenly.

### SUMMARIZED FIELD TO TRANSPORT SEQUENCE

- Fold markers and lower planter.
  - Position turnbuckle to lock frame rigid.
  - Move selector valve to "fold" position.
  - Loosen wing locking bolts.
  - Raise planter.
  - Install lockups on center lift cylinders.
  - Retract wing lift cylinders.
  - Hydraulically fold wings forward. Lock wings in place.
- NOTE: Read the following information for more detailed instructions.

1. Fold the markers into transport position and lower planter to the ground.
2. Swing the center turnbuckle into position to lock the planter frame rigid and tighten slightly.

65909-46

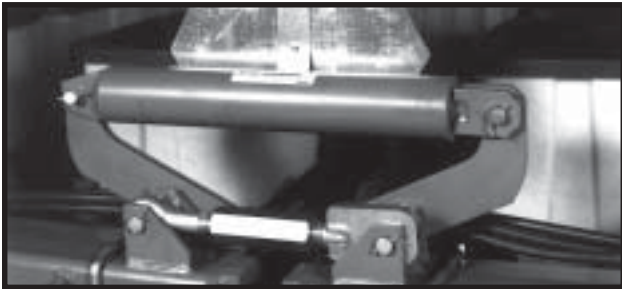

3. Move the lever on the hand operated selector valve to the "fold" position. (Remove pressure from the hydraulic system before moving the selector handle.)

72359-74

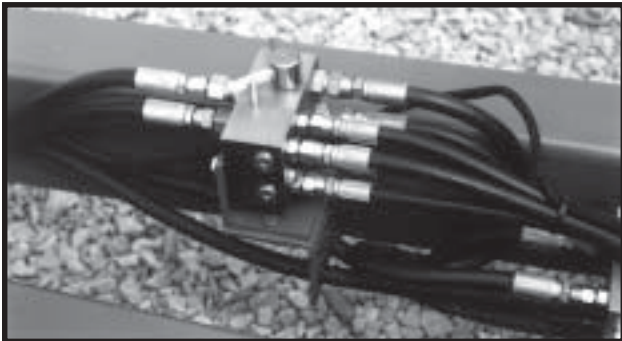

4. Using the special wrench which is stored on the hitch of the planter, loosen the 1 1/4" hex nuts which secure the wing locking bolts. Swing the wing locking bolt on each wing over to release the planter wings. Return wrench to storage position on tongue.

72359-160



5. Raise the planter.
6. Install cylinder lockups on the four center section lift cylinders.

83154-3

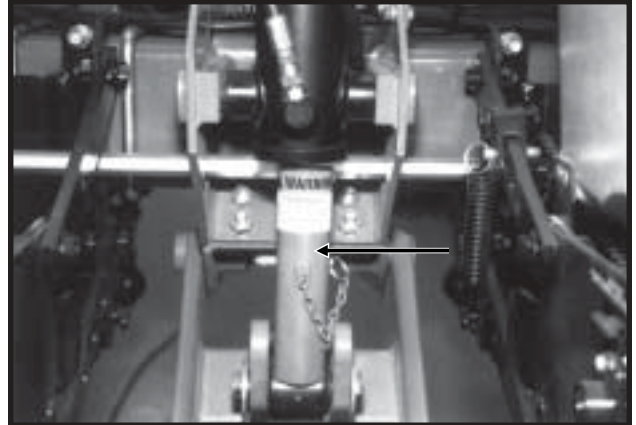

7. Place the tractor hydraulic lever in the lowering position and hold until the wing cylinders are fully retracted thus raising the wing tires.
8. Move the tractor hydraulic lever to fold the wings forward into transport position and lock wings in place at the marker support and hitch.

72359-9

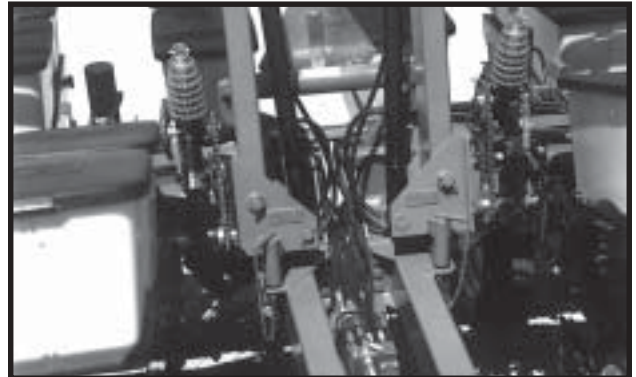

Photo shows both wings locked in place.

# MACHINE OPERATION

## TRANSPORT TO FIELD OPERATION - Hydraulic Wing Fold



**WARNING:** Be sure the planter is on a level surface, fore and aft and side to side. Avoid standing between the wing and main frame when folding the planter. Wing may swing suddenly.

### SUMMARIZED TRANSPORT TO FIELD SEQUENCE

- With center lift cylinders retracted and lock ups in place, release wing lock pins.
- Move selector valve to “fold” position.
- Hydraulically fold wings out.
- Swing wing locking bolts into place.
- Extend lift cylinders.
- Remove center section lift cylinder lockups.
- Lower planter.
- Tighten wing locking bolts.
- Release turnbuckle at center of planter.
- Move selector valve to “marker” position.

NOTE: Read the following information for more detailed instructions.

1. If the wing lift tires are not retracted, with the cylinder lockups in place on the four center section lift cylinders, move the tractor hydraulic lever to the lowering position until the cylinders are fully retracted thus raising the wing tires.
2. With the planter raised and the cylinder lockups in place, release the wing lock pins at the marker support and hitch.

72359-9

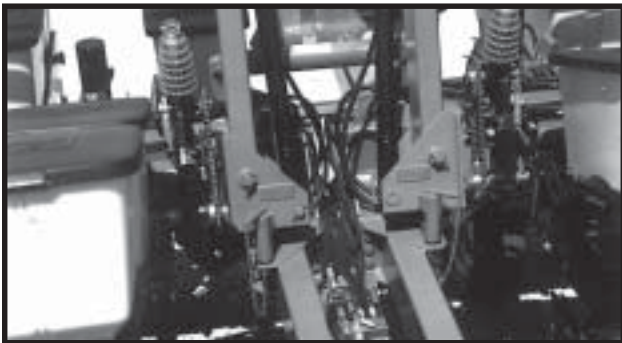

3. Position the selector handle on the manual selector valve in the “fold” position.

72359-74

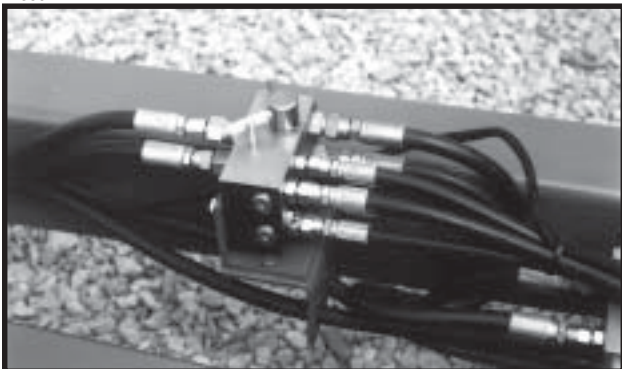

4. Move the tractor hydraulic lever and fold the wings out to operating position.
5. Swing the wing locking bolts into position to lock each wing.

74056-18



6. Operate the hydraulic lever to extend all the lift cylinders.
7. Remove the cylinder lockups from the four center section lift cylinders and place them in the storage position on the wheel module.
8. Lower the planter.
9. Using the special wrench which is stored on the hitch of the planter, tighten the 1 1/4" hex nuts to secure the wing locking bolts.

72359-160



10. Release the turnbuckle located in the center of the planter frame, using the special wrench, and fold it to one side. Return wrench to the storage position on the tongue.

65909-48



11. Move the selector handle on the manual selector valve to the “marker” position. (Remove pressure from the hydraulic system before moving the selector handle.)

# MACHINE OPERATION

## MARKER SPEED ADJUSTMENT

The marker hydraulic system is equipped with two flow control valves. One flow control valve controls the lowering speed of both markers and one controls the raising speed of both markers. To adjust marker speed, loosen the jam nut and turn the control clockwise or IN to slow the travel speed and counterclockwise or OUT to increase the travel speed. The flow control determines the amount of oil flow restriction through the valve, therefore determining travel speed of the markers.

60982-80

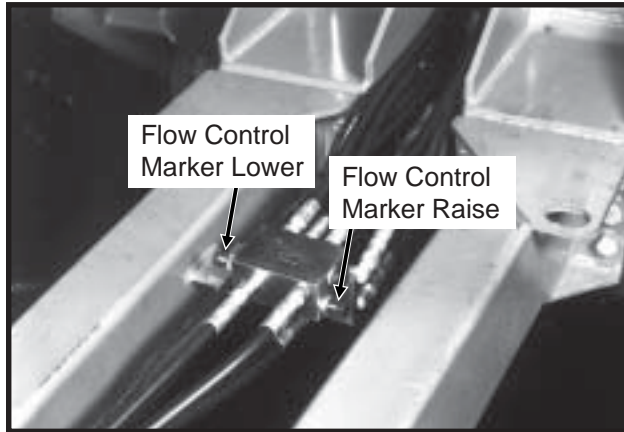

**DANGER:** The flow controls should be properly adjusted before the marker assembly is first put into use. Excessive travel speed of the markers can be dangerous and/or damage the marker assembly.

**NOTE:** When oil is cold, hydraulics operate slowly. Make sure all adjustments are made with warm oil.

**NOTE:** On a tractor where the oil flow can not be controlled, the rate of flow of oil from the tractor may be greater than the rate at which the marker cylinder can accept it. The tractor hydraulic control lever will have to be held until the cylinder reaches the end of its stroke. This occurs most often on tractors with an open center hydraulic system.

On tractors with a closed center hydraulic system, the tractor's hydraulic flow control can be set so the tractor's detent will function properly.

## MARKER ADJUSTMENT

To determine the correct length at which to set the marker assemblies, multiply the number of rows by the average row spacing in inches. This provides the total planting width. Adjust the marker extension so the distance from the marker blade to the center line of the planter is equal to the total planting width previously obtained. Both the planter and marker assembly should be lowered to the ground when measurements are being taken. The measurement should be taken from the point where the blade contacts the ground. Adjust right and left marker assemblies equally and securely tighten clamping bolts. An example of marker length adjustment follows:

Number	Row	Dimension Between
Of Rows	x Spacing	Planter Center Line
	(Inches)	And Marker Blade

8 Rows x 36" Spacing = 288" Marker Dimension
--

60569-53

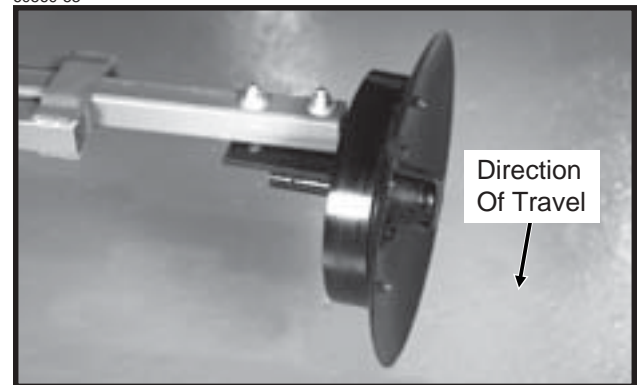

The marker blade is installed so the concave side of the blade is outward to throw dirt away from the grease seals. The spindle bracket is slotted so the hub and blade can be angled to throw more or less dirt. To adjust the hub and spindle, loosen the 1/2" mounting hardware and move the bracket as required. Tighten bolts to the specified torque.

**IMPORTANT:** A marker blade assembly that is set at a sharper angle than necessary will add unnecessary stress to the complete marker assembly and shorten the life of bearings and blades. Set the blade angle only as needed to leave a clear mark.

A field test is recommended to ensure the markers are properly adjusted. After the field test is made, make any minor adjustments as necessary.

A notched marker blade is available from KINZE® Repair Parts for use in severe no till conditions.

# MACHINE OPERATION

## OPTIONAL POINT ROW WRAP SPRING CLUTCH

73917-10

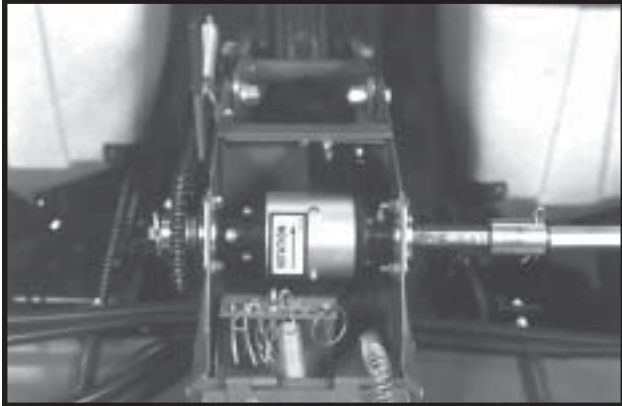

Style A - Point Row Wrap Spring Clutch

76695-10

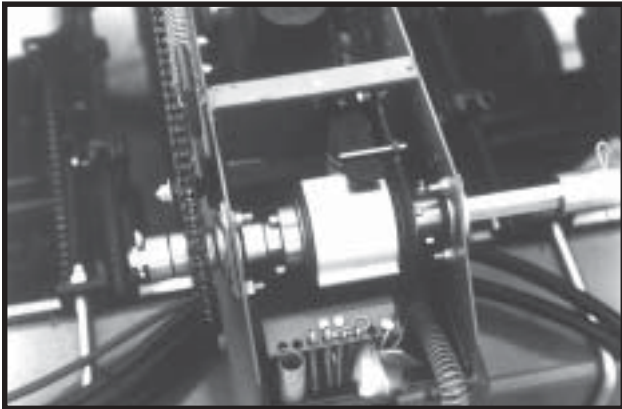

Style B - Point Row Wrap Spring Clutch

With the use of electric wrap spring clutches which disengage the drive, you have the capability to shut off either half of the planter for finishing up fields or for long point row situations.

60982-91

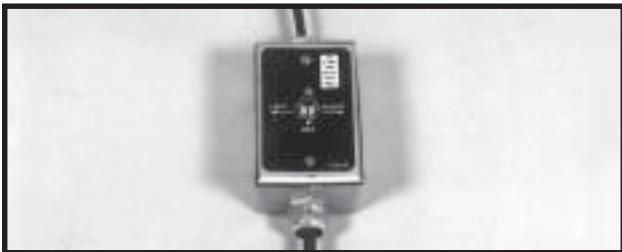

Style A - Point Row Wrap Spring Clutch Control Box

76740-48



Style B - Point Row Wrap Spring Clutch Control Box

The selector switch for the clutches is located on the tractor.

**NOTE: Switch should be left in OFF position when planter is not in use. If left in ON (Left or Right) position it will drain the tractor battery.**

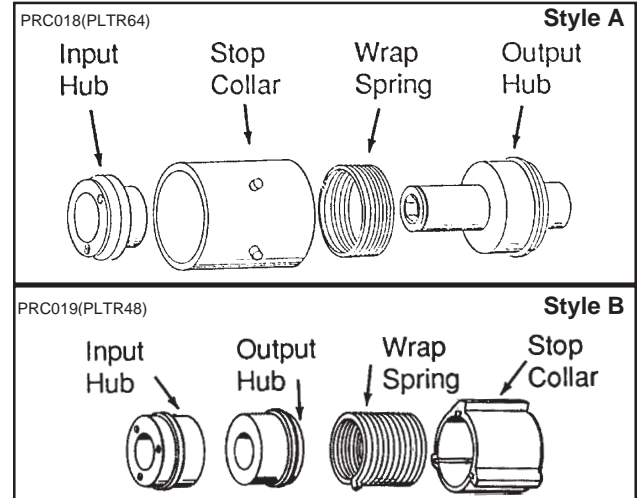

The wrap spring clutch consists of a wrap spring riding on an input hub and an output hub. During operation the wrap spring is wrapped tightly over the hubs connecting them in a positive engagement. The greater the force of rotation the tighter the grip of the spring on the hubs. Rotation in the opposite direction or stopping the spring from rotating prevents the transmission of torque from the input hub to the output hub stopping the planter drive.

The input end of the spring is bent outward and is referred to as the control tang. The control tang fits into a slot in the stop collar that is located between the input and output hubs and over the wrap spring. If the stop collar is allowed to rotate with the input hub, the clutch is engaged. If the stop collar is stopped from rotating the spring tang connected to it is forced back and the spring opens. This allows the input hub to continue rotating without transmitting torque to the output hub; therefore, stopping the planter drive.

The stop collar is controlled by the use of an electric solenoid and an actuator arm. When the selector switch on the tractor control panel is in the OFF position the solenoid coil is NOT ENERGIZED and the actuator arm will not contact the stop on the stop collar allowing it to rotate with the hubs and drive the planter.

When the operational switch is in the "DISENGAGE" (Right or Left) position the solenoid coil IS ENERGIZED and the plunger in the solenoid coil pulls the actuator arm against the stop on the stop collar, disengaging the wrap spring and stopping the planter drive.

# MACHINE OPERATION

## ELECTRONIC SEED MONITOR SYSTEM

The electronic seed monitor system consists of a console, which is mounted on the tractor; seed tubes with sensors, one of which is installed in each planter row unit; and a planter harness (harness, Y-connector and/or extension cable where applicable), which connects the individual seed tube sensors to the console.

The monitor system is powered by the tractor battery (requires 12 volts DC). The console receives information from each of the sensors and translates this information for the operator, to let him know whether or not all rows are planting.

Located on the bottom of the monitor console is the sound alarm which is equipped with an adjustable sound baffle.

### KM1000 MONITOR

(PLTR1)

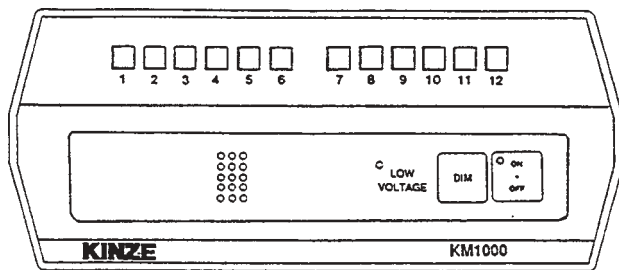

#### STEP 1 Turn the console ON by pressing the ON/OFF switch.

Each time the console is powered up it performs a sensor check and self-check. All row indicator lamps are turned on, the alarm sounds momentarily and then the console enters the operate mode. If a row indicator lamp does not come on when the console is powered up, it indicates that a problem exists with either the sensor, planter harness or a burned out row indicator lamp. See Troubleshooting in the Maintenance Section of this manual.

#### STEP 2 Begin planting and observe the row indicator lamps.

All indicator lamps should be flashing at approximately the same rate. If one of the row lamps is flashing at a slower rate than the others it would indicate that row is planting at a slower rate and it should be checked for proper seed population. The monitor continuously checks for seed flow while planting, as indicated by the flashing row indica-

tor lamps on the console. If any planter unit seed sensor is not detecting seeds, the alarm will sound continuously and the row indicator lamp corresponding to the planter row unit will stop flashing. When this happens, stop planting and check to see what is wrong with the row unit.

#### STEP 3 Lift the planter at the end of the row.

When the seed flow stops in all planter units, the alarm will sound and all row indicator lamps will stop flashing. After approximately 2-4 seconds the alarm will stop sounding.

**The intensity of the Row Indicator Lamps** can be controlled by pressing and holding the switch labeled DIM. To set the intensity, press and hold the DIM switch until the lamps are at the desired intensity and then release the switch. Holding the DIM switch will cause the intensity to decrease to its lowest level and then increase to its maximum level. This cycle will continue as long as the switch is depressed. When the console is turned OFF and then ON the row lamp intensity will return to maximum.

**If you are only using a portion of the number of rows on your planter**, the alarm can be silenced by disconnecting the seed sensors of the unused rows and turning the monitor OFF then back ON. The monitor will then ignore these unused rows and monitor the other rows normally.

When disabling planter rows, the monitor may look at the system as a different planter setup. Example, if you have an 8 row planter and you disable the right four rows (for planting point rows, etc.) by unplugging the seed sensors and turning the monitor OFF and back to ON, the monitor will look at it as a 4 row planter and shift the row indicator lamps to the center four positions. Therefore, planter row 1 will be indicated on the monitor as row 3, planter row 2 as row 4, etc. Row lamps 1, 2, 7 and 8 will be off.

If you disable the left four rows (planter rows 1, 2, 3 and 4) the monitor will operate normally as an 8 row system. Row indicators 1, 2, 3 and 4 will be off.

# MACHINE OPERATION

10/96

## KM1000 Bezel Decal Selection Chart

NO. ROWS	BEZEL DECAL	ROW LAMPS
4	12	
6	6	
8	16	
*8	16	
10	12	
12	12	
*12	12	
16	16	
*4 & 3 Solid Interplant®	16	
*6 & 3 Skip Row Interplant®	16	
*6 & 5 Solid Interplant®	16	
*8 & 5 Skip Row Interplant®	16	
*8 & 7 Solid Interplant®	16	

Row lamp indicates planter row in use.

Row lamp not used.

\* With Y-connector.

**NOTE:** Interplant® diagrams assume that first Interplant® row is connected to row 1 of harness and Interplant® harness is connected to R.H. half of Y-connector.

# MACHINE OPERATION

## KM3000 MONITOR

D-0841-0001(PLTR2)

### Upper Display

### Pressure Sensitive Switches

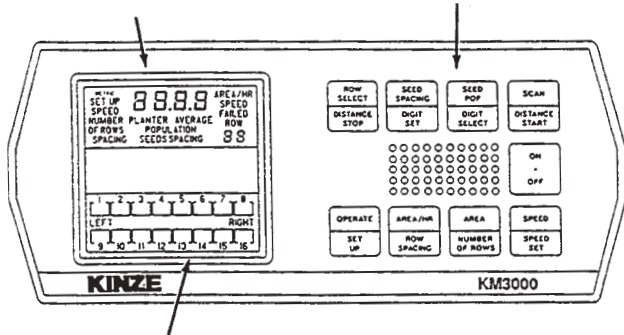

### Lower Display

The KM3000 console may be equipped with one of two optional distance sensor features, a radar sensor which is mounted on the tractor or a pulse wheel (magnetic distance sensor) which is installed on the planter drive.

The operator's controls on the front panel of the console consist of nine pressure sensitive switches. Eight of the nine switches are dual function switches, performing one function during the OPERATE MODE and another function during the SET UP MODE. All switch functions are color coded to define between the OPERATE and SET UP modes. The upper half of each dual function switch is olive brown in color and contains the Operate functions. The lower half of each dual function switch is tan in color and contains the Set Up functions.

**NOTE: The KM3000 is shipped from the factory setup for use with American measures. To convert the console to Metric measures, cut the wire loop (red wire) adjacent to the signal cable on the back of the console and tape the ends of the cut wire to prevent the two ends making contact with each other or the vehicle.**

**STEP 1 Turn console ON by pressing the ON-OFF switch.** Note that the upper display shows random segments for a short time then sequences through all entered SET UP constants (SPEED, NUMBER OF ROWS and ROW SPACING). If the constants are not valid the alarm will sound for approximately four seconds and the monitor will enter the SET UP mode. See "Entering Constants". If all constants are valid (as previously entered) the alarm will sound momentarily and the monitor will enter the OPERATE mode.

**NOTE: Monitor will not go from "SET UP" to "OPERATE" unless the planter harness is connected.**

**STEP 2 Select the desired OPERATE function to be displayed by pressing the labeled switch.**

In the **ROW SELECT** mode a specific row can be selected and continuously monitored.

**SEED SPACING** displays the seed spacing of each planter row in inches or centimeters.

**SEED POP** displays the seed population of each planter row in thousands of seeds per acre or hectare.

In the **SCAN** mode the display will sequence through all planter rows. The display message will be SEED POP or SEED SPACING as previously selected. With SEED POP selected after the population for the highest planter row number is displayed, the average population for the total planter is shown. With SEED SPACING selected after the seed spacing for the highest planter row number is displayed, the average seed spacing for the total planter is shown.

**AREA/HR** displays the predicted area in acres or hectares that will be covered in the next hour if the same planting rate is maintained. This prediction is based on the last 10 seconds of operation.

**AREA** displays the actual area covered in acres or hectares since the last reset. To reset area to .0, press and hold the AREA switch for approximately 5 seconds.

**SPEED** displays current vehicle ground speed in MPH or KmPH.

**A row failure** will be indicated by the FAILED ROW number being displayed in the lower right hand corner of the upper display, the corresponding segment in the lower display will be blank, and the alarm will sound continuously. Failures of more than one row will be indicated by the FAILED ROW number in the upper display sequencing through all failed rows, the corresponding segments of all failed rows in the lower display will be blank, and the alarm will sound continuously. When you lift your planter at the end of a row or stop in the field and seed flow stops in all planter units, the alarm will sound for approximately four seconds and all row indicator segments (lower display) will stop flashing. The upper display will show the FAILED ROW message and will sequence through all planter row numbers.

In the all row failure mode or immediately following power up, the operate functions (population, seed spacing and area) can be displayed by pressing the touch switch labeled with the desired function. This display condition will remain for one minute after the last time a switch is pressed or until seeds are detected by the seed sensors.

# MACHINE OPERATION

**A ground speed failure** will be indicated by the SPEED FAILED message being displayed in the upper display. To continue using the monitor system until a replacement ground speed sensor is obtained, disconnect the ground speed sensor cable, enter the SET UP mode and enter your normal planting speed in MPH or KmPH in place of the SPEED SET calibration number. **IMPORTANT:** The accuracy of the POPULATION, SEED SPACING and AREA readouts will depend on the vehicle ground speed. If you do not drive at the speed entered in SPEED SET memory these functions will not be accurate. AREA will not accumulate in this mode.

**IMPORTANT:** Under normal use the monitor will accumulate area whenever there is seed flow in at least one seed sensor. In the all rows failed condition, such as when turning around at the end of the field, the area accumulation will stop.

**The monitor can be used to count seeds in a selected row by performing the following:**

1. Place console in SET UP mode. (Before performing Step 2 make sure you have recorded the SPEED constant. See SPEED in "Entering Constants".)
2. Set the SPEED constant to 0000. This can be done by manually setting each digit to zero using the DIGIT SELECT and DIGIT SET switches or by pressing and holding the SPEED SET switch for approximately 5 seconds.
3. Enter the OPERATE mode by pressing the OPERATE switch.
4. Press and release the ROW SELECT switch until the desired planter row number is displayed in the lower right corner of the upper display. The monitor will now show seed count for the selected row.

To reset the display to zero and continue to monitor the same row unit, press the SCAN switch then the ROW SELECT.

To select another row unit, press the ROW SELECT switch until the desired planter row number is displayed. Each time the ROW SELECT switch is pressed the row number will be incremented one unit and the four digit display will be reset to zero.

**IMPORTANT:** To return to normal operation, enter the SET UP mode and re-enter the SPEED constant.

**The lower visual display** contains up to sixteen segments with each one corresponding to a planter row unit. When the monitor is turned on the console senses the number of seed sensors connected to the planter harness and activates a segment for each one. The segment flashes dark each time a seed is detected by the seed sensor. If up to 16 seed sensors are sensed the display will show segments for all sensors all the time. If more than 16 (17-32) seed sensors are sensed, then the display is split and up to 16 sensors are shown for the LEFT and RIGHT side of the planter.

**EXAMPLE:** If a 24 row planter is being used and the display message LEFT is on, the segments are showing seed flow for planter rows 1 through 12. When the display message RIGHT is on, the segments are showing seed flow for planter rows 13 through 24. When the RIGHT planter half is shown, the segment numbers 1 through 12 will represent planter rows 13 through 24 (segment 1 is planter row 13, segment 2 is row 14, up to segment 12 which is row 24).

## ENTERING CONSTANTS (KM3000 Only)

Upon initial power-up or whenever memory is lost the following three constants must be entered before the system will enter the "operate" mode. The following examples are for an 8 row planter with 36" row spacing.

### 1. **ROW SPACING** - *The distance between the rows on your planter.*

Press the "row spacing" switch. The upper display will show "set up", "row spacing" and "000.0".

Press the "digit select" switch (a short alarm burst will be heard each time the switch activates) until the "0" to the left of the decimal point is flashing. Press "digit set" switch until a "6" is shown in this location.

Press the "digit select" switch until the second "0" to the left of the decimal point is flashing.

Press the "digit set" switch until a "3" is shown in this location: 036.0.

**NOTE:** If you have a solid row planter of 15", 18", 19", 30", 36" or 38" row spacing, program that number in for row spacing. If you have a skip row planter, determine row spacing by taking the total distance between the two outside rows (in inches) and divide by the number of planter rows minus 1.



# MACHINE OPERATION

---

**EXAMPLE: 8 row 36" planter with 13 row 18" skip row Interplant®**

**Step 1. Total distance between center of outside row on left end of planter to center of outside row on right end of planter = 252"**

**Step 2. 13 rows (number of total rows) minus 1 = 12**

**Step 3. 252" / 12 = 21" average row spacing**

**Step 4. Program 21.0 (round to closest tenth)**

**2. NUMBER OF ROWS** - The number of active rows on your planter. (Example for 8 row planter)

Press the "number of rows" switch. The upper display will show "set up", "number of rows" and "00".

Press the "digit select" switch until the right hand "0" is flashing.

Press the "digit set" switch until an 8 is shown in this location: 08.

**3. SPEED** - A number that is the result of the speed calibration procedure. Used with either radar or magnetic distance sensors.

The speed set calibration number matches the console to the ground speed sensor when calibrated over a specified measured distance. When the calibration procedure is completed and the speed set constant established, the value should be written down and retained in the event battery voltage is removed from the console and the information in memory is lost. In this event, the constant may be re-entered manually using the "digit select" and "digit set" switches. The speed set calibration procedure must be repeated and new speed set number established if the radar or magnetic distance sensor mounting is changed for any reason.

**NOTE: When obtaining the following speed set number, actual in-field conditions should be simulated as close as possible.**

- A. Measure an accurate 400 foot (150 meter) in-field course, preferably on level ground. Mark the "start" and "finish" of the course so it will be plainly visible from the cab as you drive past.
- B. With the upper display showing messages "set up" and "speed" and the four digit display showing all zeros (to reset four digit display to zeros, press and hold the "speed set" switch for approximately 5 seconds), drive up to the marked course at normal planting speed.

- C. When even with the "start" marker, press the "distance start" switch. Four dashes will appear on the console display.

- D. Drive at a steady speed through the entire course. When even with the "finish" marker, press the "distance stop" switch.

- E. The speed set number will be displayed. Record this number for future reference.

SPEED SET NUMBER \_\_\_\_\_

**IMPORTANT: This procedure may have to be repeated after performing the Radar Vibration Test. See Radar Vibration Test.**

**NOTE: The accuracy of the area computations, population, seed spacing and vehicle ground speed readout are dependent upon the accuracy of the operator entered constants. Use care when determining the constants which describe your planter.**

## **RADAR VIBRATION TEST (KM3000 With Radar Sensor Only)**

To check for vibration, start vehicle engine and slowly increase engine RPM (while watching the ground speed readout) to approximately 1800 RPM. If the ground speed readings are above zero, the radar sensor must be mounted in an alternate, more stable location.

# MACHINE OPERATION

## NOTCHED SINGLE DISC FERTILIZER OPENER (Row Unit Mounted)

010997a

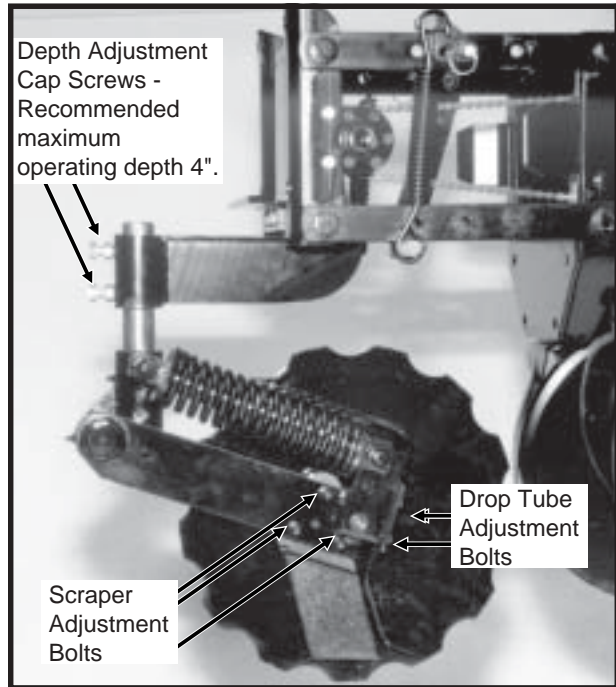

The notched single disc fertilizer opener is designed for use in minimum and no till soil conditions. Placement of fertilizer with the 16  $\frac{3}{4}$ " notched single disc fertilizer opener is recommended at 2  $\frac{1}{2}$ " - 3" from the row. **Never locate the opener to place fertilizer closer than 2\"**

Adjust blade-to-scraper contact so blade will turn by hand with slight resistance, but will not coast or freewheel. In dry loose soil, scraper adjustment is critical. If adjustment is not maintained, soil or residue may wedge causing the blade to push. If adjusted too tight, the blade will not turn causing the blade to push soil and residue. Adjustment is made using the three  $\frac{3}{8}$ " mounting carriage bolts and pivot pad on the scraper. Because of blade runout, rotate blade one full revolution after adjustment. Readjust scraper to blade tight spot as needed. **Never strike the scraper with a heavy object or damage may occur.**

Using the slotted mounting holes in the drop tube, adjust the drop tube so it is protected from soil contact and wear by the scraper. The liquid drop tube should be as far from the opener blade as possible while keeping it behind the scraper to prevent the liquid fertilizer from contacting the opener blade and causing liquid to be spattered on the planter.

Cap screws and jam nuts located on the opener pivot shaft allow 4" maximum blade depth adjustment. Be sure spring pin holes in pivot post remain parallel with opener mounting plate. Check fertilizer hose clearance after adjusting opener depth by swiveling opener left and right.

The opener spring is factory preset at 350 lbs. and requires no additional adjustment.



**WARNING: Spring under pressure. DO NOT disassemble.**

# MACHINE OPERATION

## TRANSPORTING THE PLANTER



**WARNING:** Always make sure safety/warning lights, reflectors and SMV emblem are in place and visible prior to transporting the machine on public roads. In this regard, check federal, state/provincial and local regulations.



**WARNING:** Always install safety lockups on lift cylinders and make sure wing lockup pins are in place to secure wings at hitch.

## TRACTOR PLANTING SPEED

Planters are designed to operate within a speed range of 2 to 8 MPH. See “Planting And Application Rate Charts”. Variations in ground speed will produce variations in rates. Finger pickup seed meter populations will tend to be disproportionately higher at high ground speeds.

NOTE: Due to a multitude of variables, seed spacing can be adversely affected at speeds above 5.5 mph.

## METRIC CONVERSION TABLE

Multiply	By	To Get
Inches (in.)	x 2.54	= centimeters (cm)
Inches (in.)	x 25.4	= millimeters (mm)
Feet (ft.)	x 30.48	= centimeters (cm)
Acres	x 0.405	= hectares (ha)
Miles per hour (mph)	x 1.609	= kilometers per hour (kmph)
Pounds (lbs.)	x 0.453	= kilograms (kg)
Bushels (bu.)	x 35.238	= liters (l)
Gallons (gal.)	x 3.785	= liters (l)
Pounds per square inch (psi)	x 6.894	= kilopascals (kPa) (100 kPa = 1 bar)
Inch pounds (in. lbs.)	x 0.113	= newtons-meters (N•m)
Foot pounds (ft. lbs.)	x 1.356	= newtons-meters (N•m)
Centimeters (cm)	x .394	= inches (in.)
Millimeters (mm)	x .0394	= inches (in.)
Centimeters (cm)	x .0328	= feet (ft.)
Hectares (ha)	x 2.469	= acres
Kilometers per hour (kmph)	x 0.621	= miles per hour (mph)
Kilograms (kg)	x 2.208	= pounds (lbs.)
Liters (l)	x 0.028	= bushels (bu.)
Liters (l)	x 0.264	= gallons (gal.)
Kilopascals (kPa) (100 kPa = 1 bar)	x 0.145	= pounds per square inch (psi)
Newtons-meters (N•m)	x 8.85	= inch pounds (in. lbs.)
Newtons-meters (N•m)	x 0.738	= foot pounds (ft. lbs.)

## FIELD TEST

With any change of field and/or planting conditions, seed size or planter adjustment, we recommend a field test be made to ensure proper seed placement and operation of row units. See “Rate Charts”, “Checking Seed Population”, and “Checking Granular Chemical Application Rate” at end of this section.

- Check the planter for fore and aft and lateral level operation. See “Leveling The Planter”.
- Check all row units to be certain they are running level. When planting, the row unit parallel arms should be parallel to the ground.
- Check row markers for proper operation and adjustment. See “Marker Adjustment” and “Marker Speed Adjustment”.
- Check for proper application rates and placement of granular chemicals on all rows. See “Checking Granular Chemical Application Rate”.
- Check for desired depth placement and seed population on all rows. See “Checking Seed Population”.

After the planter has been field tested, reinspect the machine.

- Hoses and fittings
- Bolts and nuts
- Cotter pins and spring pins
- Drive chain alignment

# MACHINE OPERATION

## CHECKING SEED POPULATION

1. Tie up one or more sets of closing wheels by running a light chain between the hopper support panel and closing wheels. It may be necessary to decrease closing wheel arm spring tension.

L0069(PLTR10)

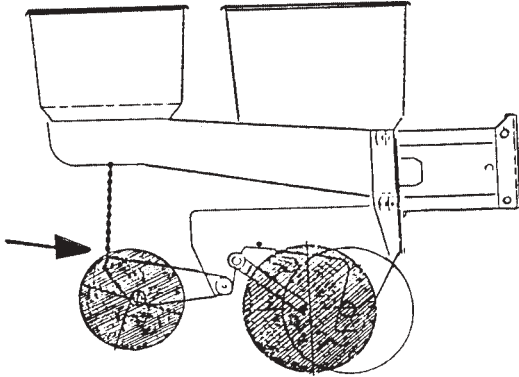

2. Plant a short distance and check to see if seed is visible in the seed trench. Adjust planting depth to a shallower setting if seed is not visible and recheck.

72359-108

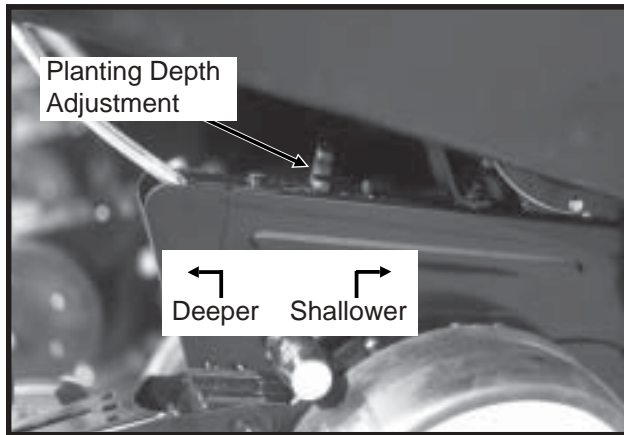

3. Measure  $\frac{1}{1000}$  of an acre. See chart for correct distance for row width spacing being planted. For example, if planting 30" rows  $\frac{1}{1000}$  of an acre would be 17' 5".

LENGTH OF ROW IN FEET AND INCHES			
Fraction Of Acre	Row Width		
	30"	36"	38"
$\frac{1}{1000}$	17' 5"	14' 6"	13' 10"

**NOTE:** When planting with closing wheels raised and planting depth set shallow, seeds may bounce or roll affecting seed spacing accuracy.

4. Count seeds in measured distance.
5. Multiply the number of seeds placed in the  $\frac{1}{1000}$  of an acre by 1000. This will give you total population.

EXAMPLE: With 30" row spacing 17' 5" equals  $\frac{1}{1000}$  acre.

26 Seeds			
Counted	x	1000	= 26,000 Seeds Per Acre

Seed count can be affected by drive ratio between drive wheel and seed meter, tire pressure and/or seed meter malfunction.

If seed check shows the average distance between seeds in inches is significantly different than the seed rate chart indicates, first check drive ratio between drive wheel and seed meter. Check drive wheel air pressure, check for incorrect sprocket(s) in drive line and check drive and driven sprockets in transmission for proper selection.

Second, check for seed meter malfunction. For example, if spacing between kernels of corn at the transmission setting being used is 8" and a gap of 16" is observed, a finger has lost its seed and not functioned properly. If two seeds are found within a short distance of each other, the finger has metered two seeds instead of one.

See "Finger Pickup Seed Meter Troubleshooting" and/or "Brush-Type Seed Meter Troubleshooting" in the Maintenance Section of this manual.

# MACHINE OPERATION

## Determining Pounds Per Acre (Brush-Type Seed Meter)

To determine pounds per acre:

Seeds Per Acre On Chart	÷	Seeds Per Pound From Seed Tag On Bag	=	Pounds Per Acre
-------------------------------	---	---	---	-----------------------

To determine bushels per acre:

Pounds Per Acre	÷	Unit Weight Of Seed	=	Bushels Per Acre
--------------------	---	------------------------	---	---------------------

The unit weight of:

- 1 Bushel Soybeans = 60 Pounds
- 1 Bushel Milo = 56 Pounds
- 1 Bushel Cotton = 32 Pounds

If seeds per pound information is not available the following is an average:

- 2,600 seeds per pound for medium size soybeans
- 15,000 seeds per pound for medium size milo
- 4,500 seeds per pound for medium size cotton

If seed check shows planting rate is significantly different than seed rate chart shows or if a particular meter is not planting accurately, see "Brush-Type Seed Meter Maintenance" and "Brush-Type Seed Meter Troubleshooting".

## CHECKING GRANULAR CHEMICAL APPLICATION RATE

Many things can affect the rate of delivery of granular chemicals such as temperature, humidity, speed, ground conditions, flowability of different material or any obstruction in the meter.

A field check is important to determine correct application rates.

72359-105



To check, fill insecticide and/or herbicide hoppers. Attach a calibrated vial to each granular chemical meter. Lower the planter and proceed as follows.

**NOTE: It is not necessary for seed meter clutch to be engaged during test. Disengage clutch to avoid dropping seed.**

Drive 1320 feet at planting speed. Weigh the chemical in ounces that was caught in one vial. Multiply that amount by the factor shown to determine pounds per acre.

LBS. PER ACRE FACTOR FOR GIVEN WIDTH	
Row Width	Factor
30"	0.83
36"	0.69
38"	0.65

**EXAMPLE:** You are planting 30" rows. You have planted for 1320 feet at the desired planting speed. You caught 12.0 ounces of chemical in one vial. 12.0 ounces times 0.83 equals 9.96 pounds per acre.

**NOTE: It is important to check calibration of all rows.**

### Metering Gate

Use the metering gate setting for distributing insecticide or herbicide as a starting point. The chart is based on a 5 miles per hour planting speed. For speeds faster than 5 miles per hour a higher gate setting should be used. For speeds slower than 5 miles per hour a lower gate setting should be used.



**WARNING: Agricultural chemicals can be dangerous if not selected and handled with care. Always read and follow directions supplied by the chemical manufacturer.**

# MACHINE OPERATION

## GENERAL PLANTING RATE INFORMATION

These planting rate charts are applicable to KINZE® Model 2200 Flex Econo-Fold® Planters. See "Tire Pressure" for recommended tire pressures.

Not all row spacings listed are applicable to all size planters.

**IMPORTANT: The sprocket combinations listed in these charts are best for average conditions. Changes in sprocket combinations may be required to obtain desired planting population. TO PREVENT PLANTING MISCALCULATIONS, MAKE FIELD CHECKS TO BE SURE YOU ARE PLANTING AT THE DESIRED RATE.**

The size and shape of seed may affect the planting rate.

### Finger Pickup Seed Meter (Corn, Oil Sunflower)

Larger grades will generally plant more accurately at the high end of the ground speed range than smaller grades. Higher than optimum speeds may result in population rate increase or higher incidence of doubles, particularly with small seed. Medium round corn seed is most desirable for planting accuracy at optimum speed. Only No. 3 and No. 4 oil sunflower seed are recommended for planting accuracy at optimum speed.

### Brush-Type Seed Meter (Soybean, Milo/Grain Sorghum, Acid-Delinted Cotton)

Rate charts are given in seeds per acre as well as seed spacing in inches rounded off to the nearest tenth of an inch. Because of the large range in seed size, pounds per acre is not a suggested method of selecting transmission settings. When using smaller size seeds it may appear the pounds per acre is below what was expected and vice versa on large seed. To determine pounds per acre, use the formula given in "Determining Pounds Per Acre (Brush-Type Seed Meter)" in the "Checking Seed Population" section of this manual.

**NOTE: Due to a multitude of variables, seed spacing can be adversely affected at speeds above 5.5 MPH.**

In some cases a 2 To 1 Drive Reduction Package may be required to obtain the desired population and seed spacing.

**NOTE: Use of the 2 To 1 Drive Reduction Package will reduce the planter transmission speed. The seeding rate will be approximately  $\frac{1}{2}$  of the chart reading when using the 2 To 1 Drive Reduction Package. Planting speed can affect actual seeding rate. Make a field check and adjust setting in the transmission as needed to obtain the desired seed drop.**

**EXAMPLE: 30" row spacing using 60 cell seed discs in brush-type seed meters.**  
 $80,928 \div 2 = 40,464$  Population (2.6" Seed Spacing x 2 = 5.2" Seed Spacing)

60982-62

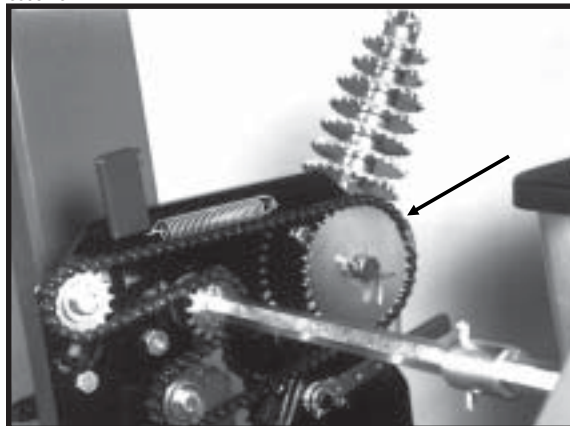

# MACHINE OPERATION

Z202

## PLANTING RATES FOR FINGER PICKUP SEED METERS APPROXIMATE SEEDS/ACRE FOR VARIOUS ROW WIDTHS

30" Rows	36" Rows	38" Rows	Transmission Sprockets		Recomm. Speed Range (MPH)	Average Seed Spacing In Inches
			Drive	Driven		
16,186	13,488	12,778	17	28	4 to 6	12.9
16,785	13,988	13,251	17	27	4 to 6	12.5
17,431	14,526	13,761	17	26	4 to 6	12.0
18,090	15,075	14,281	19	28	4 to 6	11.6
18,128	15,107	14,312	17	25	4 to 6	11.5
18,760	15,633	14,810	19	27	4 to 6	11.1
18,883	15,736	14,908	17	24	4 to 6	11.1
19,481	16,234	15,380	19	26	4 to 6	10.7
19,704	16,420	15,556	17	23	4 to 6	10.6
20,261	16,884	15,995	19	25	4 to 6	10.3
21,104	17,587	16,662	19	24	4 to 6	9.9
21,898	18,249	17,288	23	28	4 to 6	9.5
22,022	18,352	17,386	19	23	4 to 6	9.5
22,709	18,924	17,928	23	27	4 to 6	9.2
22,850	19,042	18,040	24	28	4 to 6	9.2
23,583	19,652	18,618	23	26	4 to 6	8.9
23,697	19,747	18,708	24	27	4 to 6	8.8
23,802	19,835	18,791	25	28	4 to 6	8.8
23,853	19,877	18,831	17	19	4 to 6	8.8
24,526	20,438	19,363	23	25	4 to 6	8.5
24,608	20,507	19,427	24	26	4 to 6	8.5
24,684	20,570	19,487	25	27	4 to 6	8.5
24,755	20,629	19,543	26	28	4 to 6	8.4
25,548	21,290	20,169	23	24	4 to 6	8.2
25,592	21,327	20,205	24	25	4 to 6	8.2
25,633	21,361	20,237	25	26	4 to 6	8.2
25,671	21,393	20,267	26	27	4 to 6	8.1
25,707	21,422	20,295	27	28	4 to 6	8.1
26,659	22,216	21,046	23	23	4 to 6	7.8
27,646	23,038	21,826	28	27	4 to 6	7.6
27,684	23,070	21,856	27	26	4 to 6	7.6
27,770	23,141	21,923	25	24	4 to 6	7.5
27,818	23,181	21,961	24	23	4 to 6	7.5
28,709	23,924	22,665	28	26	4 to 6	7.3
28,791	23,993	22,730	27	25	4 to 6	7.3
28,977	24,147	22,876	25	23	4 to 6	7.2
29,795	24,829	23,522	19	17	4 to 6	7.0
29,858	24,881	23,572	28	25	4 to 6	7.0
29,991	24,993	23,677	27	24	4 to 6	7.0
30,136	25,113	23,792	26	23	4 to 6	7.0
31,102	25,918	24,554	28	24	3 to 6	6.7
31,295	26,079	24,707	27	23	3 to 6	6.7
32,271	26,893	25,477	23	19	3 to 5.5	6.5
32,454	27,045	25,622	28	23	3 to 5.5	6.5
33,674	28,062	26,585	24	19	3 to 5.5	6.2
35,077	29,231	27,693	25	19	3 to 5	6.0
36,068	30,056	28,474	23	17	3 to 5	5.8
36,480	30,400	28,800	26	19	3 to 5	5.7
37,636	31,363	29,713	24	17	3 to 5	5.6
37,883	31,570	29,908	27	19	3 to 5	5.5
39,204	32,670	30,951	25	17	3 to 4.5	5.3
39,287	32,739	31,016	28	19	3 to 4.5	5.3
40,772	33,977	32,189	26	17	3 to 4.5	5.1
42,340	35,284	33,427	27	17	3 to 4.5	4.9
43,908	36,590	34,665	28	17	3 to 4.5	4.8

**IMPORTANT:** See "General Planting Rate Information" and "Checking Seed Population" pages for additional information. Always check seed population in the field to ensure planting rates are correct.

# MACHINE OPERATION

Z214/RH

## PLANTING RATES FOR BRUSH-TYPE SEED METERS

### APPROXIMATE SEEDS/ACRE FOR VARIOUS ROW WIDTHS

Transmission Sprockets		60 Cell Soybean Or High Rate Milo/ Grain Sorghum			Average Seed Spacing In Inches	48 Cell Specialty Soybean Or High Rate Acid-Delinted Cotton			Average Seed Spacing In Inches	Speed Range (MPH)
Drive	Driven	30" Rows	36" Rows	38" Rows		30" Rows	36" Rows	38" Rows		
17	28	80,928	67,440	63,891	2.6	64,742	53,952	51,113	3.2	2 to 8
17	27	83,926	69,938	66,257	2.5	67,141	55,950	53,006	3.1	2 to 8
17	26	87,154	72,628	68,805	2.4	69,723	58,102	55,044	3.0	2 to 8
19	28	90,449	75,374	71,407	2.3	72,359	60,299	57,126	2.9	2 to 8
19	27	93,799	78,166	74,052	2.2	75,039	62,533	59,242	2.8	2 to 8
17	24	94,416	78,680	74,539	2.2	75,533	62,944	59,631	2.8	2 to 8
17	23	98,521	82,101	77,780	2.1	78,817	65,681	62,224	2.7	2 to 8
19	25	101,303	84,419	79,976	2.1	81,042	67,535	63,981	2.6	2 to 8
19	24	105,524	87,937	83,309	2.0	84,419	70,350	66,647	2.5	2 to 8
23	28	109,491	91,243	86,440	1.9	87,593	72,994	69,152	2.4	2 to 8
19	23	110,112	91,760	86,931	1.9	88,090	73,408	69,545	2.4	2 to 8
24	28	114,252	95,210	90,199	1.8	91,402	76,168	72,159	2.3	2 to 8
24	27	118,483	98,736	93,539	1.8	94,786	78,989	74,831	2.2	2 to 8
17	19	119,263	99,386	94,155	1.8	95,410	79,509	75,324	2.2	2 to 8
24	26	123,040	102,534	97,137	1.7	98,432	82,027	77,710	2.1	2 to 8
26	28	123,773	103,144	97,715	1.7	99,018	82,515	78,172	2.1	2 to 8
24	25	127,962	106,635	101,023	1.6	102,370	85,308	80,818	2.0	2 to 8
26	27	128,357	106,964	101,334	1.6	102,686	85,571	81,067	2.0	2 to 8
23	23	133,294	111,078	105,232	1.6	106,635	88,862	84,186	2.0	2 to 8
27	26	138,420	115,350	109,279	1.5	110,736	92,280	87,423	1.9	2 to 8
24	23	139,089	115,907	109,807	1.5	111,271	92,726	87,846	1.9	2 to 8
25	23	144,884	120,737	114,382	1.4	115,907	96,590	91,506	1.8	2 to 8
19	17	148,975	124,146	117,612	1.4	119,180	99,317	94,090	1.8	2 to 8
27	24	149,955	124,963	118,386	1.4	119,964	99,970	94,709	1.7	2 to 8
28	24	155,509	129,591	122,770	1.3	124,407	103,673	98,216	1.7	2 to 8
23	19	161,355	134,463	127,386	1.3	129,084	107,570	101,909	1.6	2 to 8
28	23	162,270	135,225	128,108	1.3	129,816	108,180	102,486	1.6	2 to 8
24	19	168,371	140,309	132,924	1.2	134,696	112,247	106,339	1.6	2 to 8
25	19	175,386	146,155	138,463	1.2	140,309	116,924	110,770	1.5	2 to 8
23	17	180,338	150,282	142,372	1.2	144,270	120,226	113,898	1.5	2 to 8
26	19	182,402	152,001	144,001	1.1	145,922	121,601	115,201	1.4	2 to 7
27	19	189,417	157,848	148,540	1.1	151,534	126,278	118,832	1.4	2 to 7
28	19	196,433	163,694	155,078	1.1	157,146	130,955	124,062	1.3	2 to 7
26	17	203,861	169,884	160,943	1.0	163,089	135,907	128,754	1.3	2 to 7
27	17	211,702	176,418	167,133	0.9	169,362	141,134	133,706	1.2	2 to 7
28	17	219,542	182,952	173,323	0.9	175,634	146,362	138,658	1.2	2 to 7

**IMPORTANT:** See "General Planting Rate Information" and "Checking Seed Population" pages for additional information.

**NOTE:** When using the 2 To 1 Drive Reduction Package, rates will be approximately 1/2 of given numbers.

**IMPORTANT:** Always check seed population in the field to ensure planting rates are correct.



# MACHINE OPERATION

RH/Z215

## PLANTING RATES FOR BRUSH-TYPE SEED METERS (Continued)

### APPROXIMATE SEEDS/ACRE FOR VARIOUS ROW WIDTHS

Transmission Sprockets		36 Cell			Average Seed Spacing In Inches	30 Cell			Average Seed Spacing In Inches	Speed Range (MPH)
		Acid-Delinted Large Cotton				Milo/Grain Sorghum Or Acid-Delinted Cotton				
Drive	Driven	30" Rows	36" Rows	38" Rows		30" Rows	36" Rows	38" Rows		
17	28	48,557	40,464	38,335	4.3	40,464	33,720	31,945	5.2	2 to 8
17	27	50,356	41,963	39,754	4.2	41,963	34,969	33,129	5.0	2 to 8
17	26	52,292	43,577	41,283	4.0	43,577	36,314	34,403	4.8	2 to 8
19	28	54,269	45,224	42,844	3.9	45,225	37,687	35,704	4.6	2 to 8
19	27	56,279	46,900	44,431	3.7	46,900	39,083	37,026	4.5	2 to 8
17	24	56,650	47,208	44,723	3.7	47,208	39,340	37,270	4.4	2 to 8
17	23	59,113	49,261	46,668	3.5	49,261	41,051	38,890	4.2	2 to 8
19	25	60,782	50,651	47,986	3.4	50,652	42,210	39,988	4.1	2 to 8
19	24	63,314	52,762	49,985	3.3	52,762	43,968	41,654	4.0	2 to 8
23	28	65,695	54,746	51,864	3.2	54,746	45,621	43,220	3.8	2 to 8
19	23	66,067	55,056	52,159	3.2	55,056	45,880	43,465	3.8	2 to 8
24	28	68,551	57,126	54,119	3.0	57,126	47,605	45,099	3.7	2 to 8
24	27	71,090	59,242	56,123	2.9	59,242	49,368	46,770	3.5	2 to 8
17	19	71,558	59,632	56,493	2.9	59,631	49,693	47,077	3.5	2 to 8
24	26	73,824	61,520	58,282	2.8	61,520	51,267	48,569	3.4	2 to 8
26	28	74,264	61,886	58,629	2.8	61,886	51,572	48,858	3.4	2 to 8
24	25	76,772	63,981	60,614	2.7	63,981	53,317	50,511	3.3	2 to 8
26	27	77,014	64,178	60,800	2.7	64,178	53,482	50,667	3.3	2 to 8
23	23	79,976	66,647	63,139	2.6	66,647	55,539	52,616	3.1	2 to 8
27	26	83,052	69,210	65,567	2.5	69,210	57,675	54,640	3.0	2 to 8
24	23	83,453	69,544	65,884	2.5	69,544	57,954	54,904	3.0	2 to 8
25	23	86,930	72,442	68,629	2.4	72,442	60,368	57,191	2.9	2 to 8
19	17	89,385	74,488	70,567	2.3	74,488	62,073	58,806	2.8	2 to 8
27	24	89,973	74,978	71,032	2.3	74,978	62,481	59,193	2.8	2 to 8
28	24	93,305	77,755	73,662	2.2	77,755	64,796	61,385	2.7	2 to 8
23	19	96,813	80,678	76,432	2.2	80,678	67,231	63,693	2.6	2 to 8
28	23	97,362	81,135	76,864	2.1	81,135	67,613	64,054	2.6	2 to 8
24	19	101,023	84,185	79,754	2.1	84,185	70,155	66,462	2.5	2 to 8
25	19	105,232	87,693	83,078	2.0	87,693	73,078	69,231	2.4	2 to 8
23	17	108,233	90,169	85,423	1.9	90,169	75,141	71,186	2.3	2 to 8
26	19	109,441	91,201	86,401	1.9	91,201	76,001	72,001	2.3	2 to 7
27	19	113,650	94,709	89,124	1.8	94,709	78,924	74,770	2.2	2 to 7
28	19	117,860	98,216	93,047	1.8	98,216	81,847	77,539	2.1	2 to 7
26	17	122,317	101,930	96,566	1.7	101,930	84,942	80,471	2.1	2 to 7
27	17	127,021	105,851	100,280	1.6	105,851	88,209	83,566	2.0	2 to 7
28	17	131,725	109,771	103,994	1.6	109,771	91,476	86,661	1.9	2 to 7

**IMPORTANT:** See "General Planting Rate Information" and "Checking Seed Population" pages for additional information.

**NOTE:** When using the 2 To 1 Drive Reduction Package, rates will be approximately 1/2 of given numbers.

**IMPORTANT:** Always check seed population in the field to ensure planting rates are correct.

# MACHINE OPERATION

Z202

## PLANTING RATES FOR BRUSH-TYPE SEED METERS (Continued) APPROXIMATE HILLS/ACRE FOR VARIOUS ROW WIDTHS

Due to variations in cotton seed size, meters equipped with the 12 cell acid-delinted hill-drop cotton discs will plant from 3 to 6 seeds per cell. Select proper disc for seed size range to be planted.

*To determine planter transmission setting,* determine desired hill spacing and select the transmission ratio closest to the hill spacing in inches on the chart. To decrease population increase spacing. To increase population decrease spacing.

*To determine population per acre,* determine average seeds per hill and hills per acre by doing a field check. Measure  $1/1000$  of an acre ( $1/1000$  acre = Length of row 17' 5" for 30" row widths, 14' 6" for 36" row widths and 13' 10" for 38" row widths). Multiply average seeds per hill by hills per acre. EXAMPLE: 4 seeds per hill x (13 hills x 1000) = 52,000

Transmission Sprockets Drive Driven		NUMBER OF HILLS PER ACRE 12 Cell Hill-Drop Cotton, Acid-Delinted			Average Hill Spacing In Inches	Speed Range (MPH)
		30" Rows	36" Rows	38" Rows		
17	28	16,186	13,488	12,778	12.9	2 to 8
17	27	16,785	13,988	13,251	12.5	2 to 8
17	26	17,431	14,526	13,761	12.0	2 to 8
19	28	18,090	15,075	14,281	11.6	2 to 8
19	27	18,760	15,633	14,810	11.1	2 to 8
17	24	18,883	15,736	14,908	11.1	2 to 8
17	23	19,704	16,420	15,556	10.6	2 to 8
19	25	20,261	16,884	15,995	10.3	2 to 8
19	24	21,105	17,587	16,662	9.9	2 to 8
23	28	21,898	18,249	17,288	9.5	2 to 8
19	23	22,022	18,352	17,386	9.5	2 to 8
24	28	22,850	19,042	18,040	9.2	2 to 8
24	27	23,697	19,747	18,708	8.8	2 to 8
17	19	23,853	19,877	18,831	8.8	2 to 8
24	26	24,608	20,507	19,427	8.5	2 to 8
26	28	24,755	20,629	19,543	8.4	2 to 8
24	25	25,592	21,327	20,205	8.2	2 to 8
26	27	25,671	21,393	20,267	8.1	2 to 8
23	23	26,659	22,216	21,046	7.8	2 to 8
27	26	27,684	23,070	21,856	7.6	2 to 8
24	23	27,818	23,181	21,961	7.5	2 to 8
25	23	28,977	24,147	22,876	7.2	2 to 8
19	17	29,795	24,829	23,522	7.0	2 to 8
27	24	29,991	24,993	23,677	7.0	2 to 8
28	24	31,102	25,918	24,554	6.7	2 to 8
23	19	32,271	26,893	25,477	6.5	2 to 8
28	23	32,454	27,045	25,622	6.5	2 to 8
24	19	33,674	28,062	26,585	6.2	2 to 8
25	19	35,077	29,231	27,693	6.0	2 to 8
23	17	36,068	30,056	28,474	5.8	2 to 8
26	19	36,480	30,400	28,800	5.7	2 to 7
27	19	37,883	31,570	29,908	5.5	2 to 7
28	19	39,287	32,739	31,016	5.3	2 to 7
26	17	40,772	33,977	32,189	5.1	2 to 7
27	17	42,340	35,284	33,427	4.9	2 to 7
28	17	43,908	36,590	34,665	4.8	2 to 7

**IMPORTANT:** See "General Planting Rate Information" and "Checking Seed Population" pages for additional information.

**NOTE:** When using the 2 To 1 Drive Reduction Package, rates will be approximately  $1/2$  of given numbers.

**IMPORTANT:** Always check seed population in the field to ensure planting rates are correct.

# MACHINE OPERATION

## DRY INSECTICIDE APPLICATION RATES APPROXIMATE POUNDS/ACRE AT 5 MPH FOR VARIOUS ROW WIDTHS

Meter Setting	30" Rows	36" Rows	38" Rows
<b>CLAY GRANULES</b>			
10	4.9	4.1	3.9
11	5.4	4.5	4.3
12	6.1	5.1	4.8
13	6.9	5.7	5.4
14	7.7	6.4	6.0
15	8.5	7.1	6.7
16	9.6	8.0	7.6
17	10.7	8.9	8.4
18	11.4	9.5	9.0
19	13.1	10.9	10.3
20	14.2	11.8	11.2
21	15.5	12.9	12.3
22	16.4	13.7	12.9
23	17.2	14.3	13.6
24	18.8	15.7	14.9
25	20.9	17.4	16.5
26	23.0	19.2	18.1
27	24.1	20.0	19.0
28	25.4	21.2	20.1
29	27.8	23.2	22.0
30	29.6	24.7	23.4
<b>SAND GRANULES</b>			
5	2.9	2.4	2.3
6	4.9	4.0	3.8
7	5.3	4.4	4.2
8	6.3	5.3	5.0
9	7.8	6.5	6.1
10	8.9	7.4	7.0
11	10.2	8.5	8.0
12	11.2	9.3	8.8
13	12.6	10.5	10.0
14	14.1	11.7	11.1
15	15.5	12.9	12.3
16	17.5	14.6	13.8
17	19.4	16.2	15.3
18	21.8	18.2	17.2
19	24.3	20.2	19.1
20	25.7	21.4	20.3
21	27.6	23.0	21.8
22	29.6	24.7	23.4
23	32.0	26.7	25.3
24	34.4	28.7	27.2
25	36.9	30.7	29.1

**IMPORTANT:** The above chart represents average values and should be used only as a starting point. The granular chemical flows through the given meter opening at a nearly uniform rate regardless of roller speed. Your actual rate will vary depending upon the insecticide you are using, your planting speed and your plant population. Planting speed/ground speed has the greatest effect on application rate.

Your actual rate must be checked in the field with the actual insecticide that you are using and at the speed and population at which you will be planting.

# MACHINE OPERATION

---

## DRY HERBICIDE APPLICATION RATES

### APPROXIMATE POUNDS/ACRE AT 5 MPH FOR VARIOUS ROW WIDTHS

#### CLAY GRANULES

Meter Setting	30" Rows	36" Rows	38" Rows
10	4.7	3.9	3.7
11	5.2	4.4	4.1
12	5.8	4.9	4.6
13	6.5	5.4	5.1
14	7.3	6.1	5.7
15	8.2	6.9	6.5
16	9.0	7.5	7.1
17	9.9	8.2	7.8
18	10.7	8.9	8.4
19	11.6	9.7	9.2
20	12.6	10.5	10.0
21	13.6	11.3	10.7
22	14.6	12.1	11.5
23	15.7	13.1	12.4
24	17.0	14.1	13.4
25	18.1	15.1	14.3
26	19.4	16.2	15.3
27	20.9	17.4	16.5
28	22.6	18.8	17.8
29	24.3	20.2	19.1
30	26.7	22.2	21.1

**IMPORTANT:** The above chart represents average values and should be used only as a starting point. The granular chemical flows through the given meter opening at a nearly uniform rate regardless of roller speed. Your actual rate will vary depending upon the herbicide you are using, your planting speed and your plant population. Planting speed/ground speed has the greatest effect on application rate.

Your actual rate must be checked in the field with the actual herbicide that you are using and at the speed and population at which you will be planting.

# ROW UNIT OPERATION

## PLANTING DEPTH

Planting depth is maintained by the row unit gauge wheels. To increase or decrease the planting depth, first raise the planter to remove weight from the wheels. Then lift the depth adjustment handle and reposition it forward to decrease depth or rearward to increase planting depth. Adjust all units to the same setting initially. Then lower the planter and check operation and planting depth of all row units. It may be necessary to readjust some rows to obtain uniform operation.



**WARNING:** Never work under the planter while in raised position without using safety lockups.

72359-108

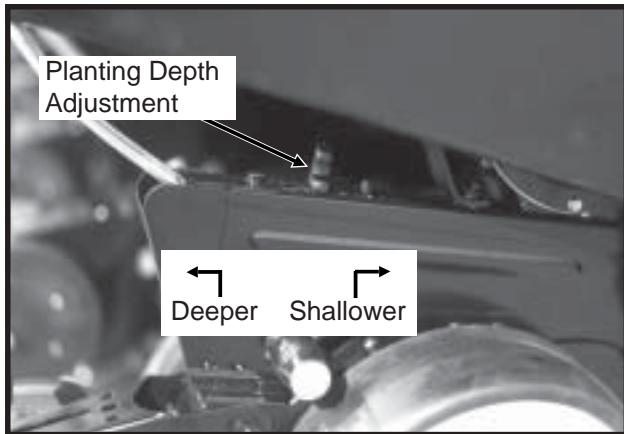

## “V” CLOSING WHEEL ADJUSTMENT (Rubber And Cast Iron)



**WARNING:** Raise planter and install safety lockups before making closing wheel adjustments.

After adjusting planting depth, check the operation of the “V” closing wheels. The “V” closing wheels should have enough down pressure to close the seed trench and ensure good soil to seed contact. To increase spring pressure on the closing wheels, move the 5-position quick adjustable down force lever located at the rear of the closing wheel arm to the rear. Moving the lever forward decreases spring tension.

Adjust all row units to a similar setting.

77121-10

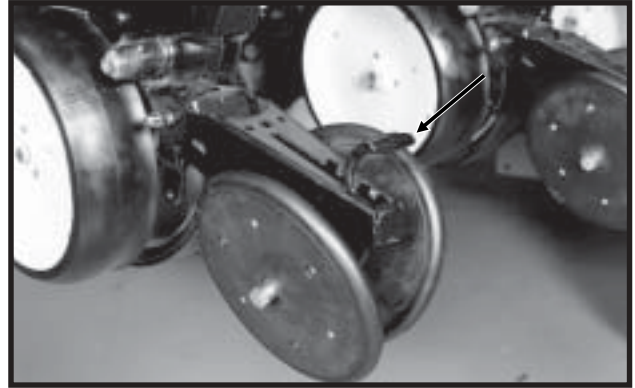

Light soil usually requires less down force at average depth (approximately 2") while heavy soil requires increased down force.

Eccentric bushings in the wheel arm stop allow for lateral adjustment of the “V” closing wheel assembly. Using a  $\frac{3}{4}$ " wrench, loosen the hardware which attaches the closing wheel arm to the wheel arm stop. Using another  $\frac{3}{4}$ " wrench turn the eccentric bushings until the **closing wheels are aligned with the seed trench**. Tighten hardware.

72359-129

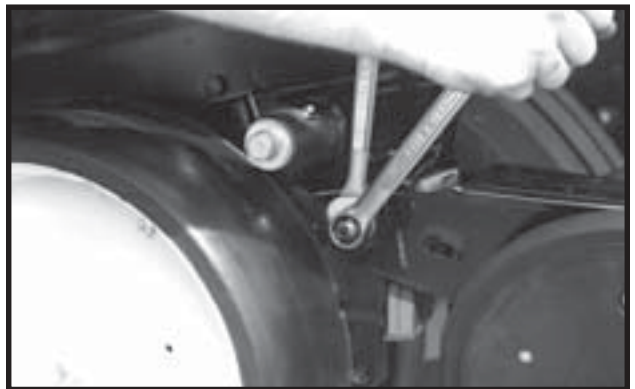

Spacers used for installation of the closing wheels can be moved from side to side for closing wheel spacing adjustment and the closing wheels can be installed in two locations either “offset” (to improve residue flow) or “directly” opposite. Under normal conditions the narrow position is preferred.

(PLTR95)

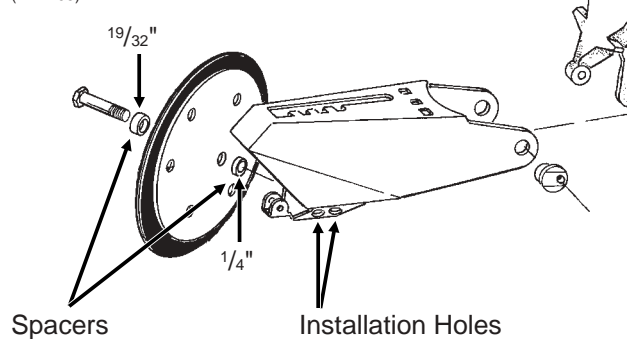

# ROW UNIT OPERATION

## COVERING DISCS/SINGLE PRESS WHEEL ADJUSTMENT



**WARNING:** Raise planter and install safety lockups before making covering discs/single press wheel adjustments.

72359-31



After adjusting planting depth, check the operation of the covering discs/single press wheels.

Initial press wheel down force setting should be with 2 1/2" between mounting arm tab and locking nut. To adjust down force spring, loosen 1/2" locking nut and turn adjusting bolt in to increase down force and out to decrease down force. Tighten locking nut against spring plug. Adjust all row units to a similar setting.

RH993(PLTR12)

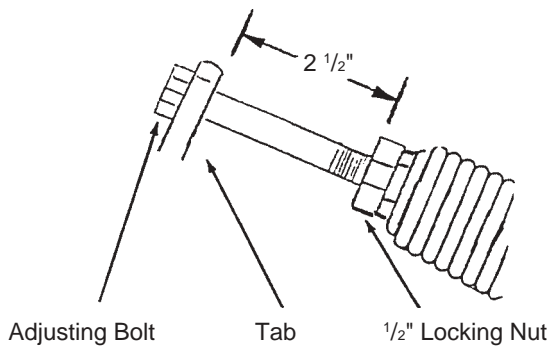

Eccentric bushings in the wheel arm stop allow for lateral adjustment of the covering discs/single press wheel assembly. Using a 3/4" wrench, loosen the hardware which attaches the assembly to the wheel arm stop. Using another 3/4" wrench, turn the eccentric bushings until the press wheel is aligned with the seed trench.

(PLTR96)

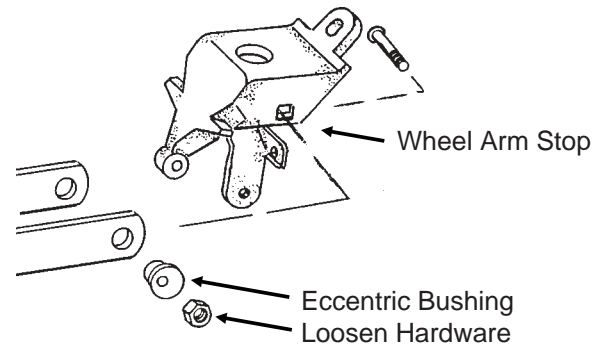

Two sets of holes in the mounting arm allow the covering discs to be located for staggered or side-by-side operation as desired.

72359-35

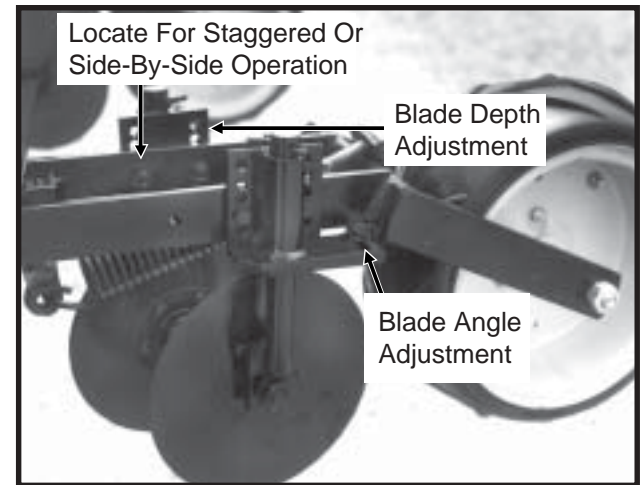

Five sets of holes in each disc bracket allow for 1/2" incremental blade depth adjustment.

Slotted holes in the disc mount and bracket allow for 0° - 15° blade angle adjustment.

Adjust covering discs on all row units to similar settings.

# ROW UNIT OPERATION

## SEED METER DRIVE RELEASE

The seed meter drive is equipped with a clutch release mechanism that allows the drive to be disconnected from the seed metering unit. Disconnecting the drive allows the operator to check granular chemical application rates without dropping seed. It also allows one or more of the rows to be disconnected when finishing fields.

72359-164

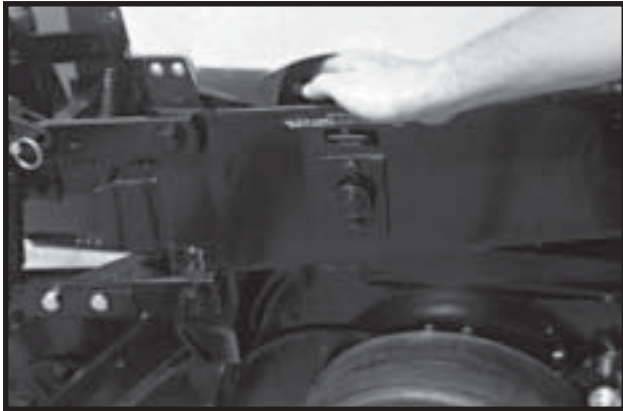

To disengage the drive, lift the release handle and pull outward until the handle locks in the slot in the side of the hopper side panel. To engage the row unit, lift and unlatch the handle. Spring tension will return the mechanism to the drive position.

Erratic seed spacing may result from misalignment between the drive coupler and seed meter input shaft. Misalignment may cause momentary stoppage of brush-type meter seed disc. Check alignment after initial installation. If adjustment is required, refer to "Meter Drive Adjustment" for correct procedure.

## FINGER PICKUP SEED METER

Refer to the planting rate chart for recommended seed drive transmission sprocket combinations.

60620-16

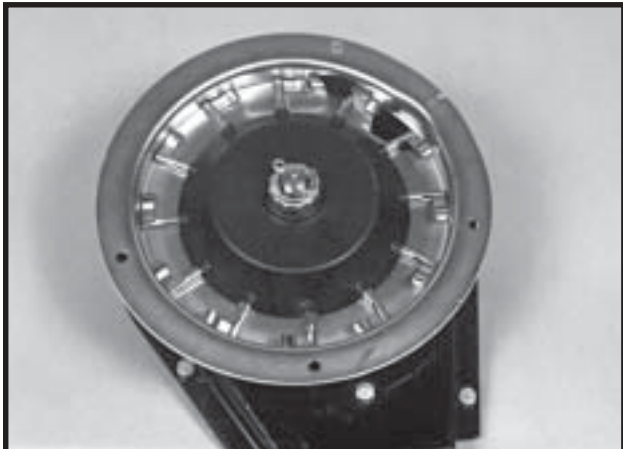

Shown With Corn Fingers Installed

The following seed fingers are available for use with the finger pickup seed meter:

(PLTR91/PLTR92)

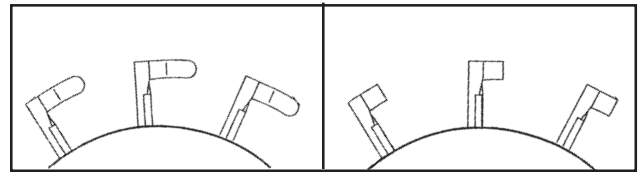

Corn Fingers

Oil Sunflower Fingers

No. 3 and/or No. 4 size oil sunflower seeds are recommended for use in the finger pickup seed meter equipped with oil sunflower fingers.

**IMPORTANT:** Always check seed population in the field to ensure planting rates are correct.

**IMPORTANT:** To provide efficient operation of the finger pickup seed meters and extend the life of components, sprinkle a teaspoon of powdered graphite over the top of the seed twice daily. The graphite will filter down into the seed pickup mechanism and provide lubrication.

82354-1



See "General Planting Rate Information", "Finger Pickup Seed Meter Troubleshooting" and "Finger Pickup Seed Meter Inspection/Adjustment" for additional information.

# ROW UNIT OPERATION

## BRUSH-TYPE SEED METER

60607-40(PLTR13)

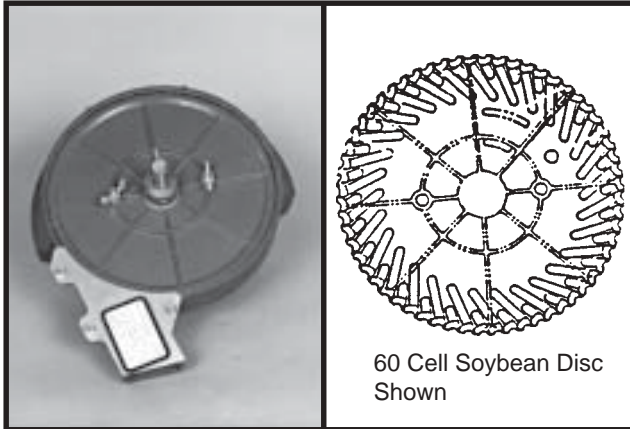

The following seed discs are available for use with the brush-type seed meter:

**Soybean:** 60 cells to meter seed sizes from 2200 to 4000 seeds per pound (Black color-coded). (PLTR14)

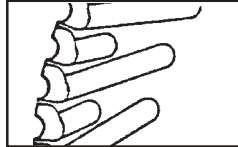

**Specialty soybean:** 48 cells to meter seed sizes from 1400 to 2200 seeds per pound (Dark blue color-coded). (PLTR15)

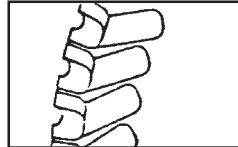

**Small milo/grain sorghum:** 30 cells to meter seed sizes from 14,000 to 20,000 seeds per pound (Red color-coded). (PLTR16)



**Large milo/grain sorghum:** 30 cells to meter seed sizes from 10,000 to 16,000 seeds per pound (Light blue color-coded). (PLTR17)

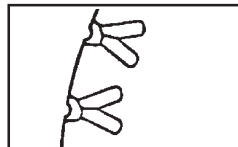

**High rate small milo/grain sorghum:** 60 cells to meter seed sizes from 12,000 to 18,000 seeds per pound (Red color-coded). (PLTR18)

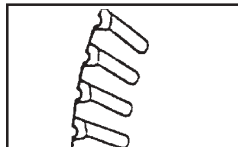

**High rate large milo/grain sorghum:** 60 cells to meter seed sizes from 10,000 to 14,000 seeds per pound (Yellow color-coded). (PLTR19)

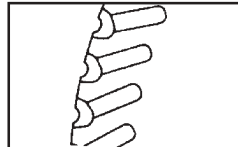

**Cotton, acid-delinted:** 30 cells to meter seed sizes from 4200 to 5200 seeds per pound (White color-coded). (PLTR20)

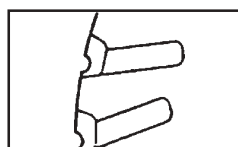

**Large cotton, acid-delinted:** 36 cells to meter seed sizes from 3800 to 4400 seeds per pound (Tan color-coded). (PLTR21)



**High rate cotton, acid-delinted:** 48 cells to meter seed sizes from 4200 to 5200 seeds per pound (Light green color-coded). (PLTR22)



**Hill-drop cotton, acid-delinted:** 12 cells, 3 to 6 seeds/cell, to meter seed sizes from 4000 to 5200 seeds per pound (Brown color-coded). (PLTR23)

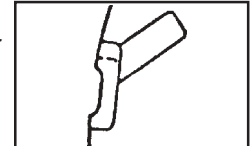

**Small hill-drop cotton, acid-delinted:** 12 cells, 3 to 6 seeds/cell, to meter seed sizes from 5000 to 6200 seeds per pound (Dark green color-coded). (PLTR23)

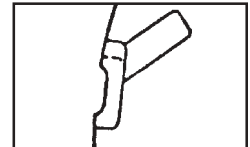

When installing the seed disc onto the meter hub, turn the disc counterclockwise while tightening the two wing nuts that retain the disc. The seed disc should have only slight resistance when rotated counterclockwise after wing nuts are tight.

The brush-type seed meter attaches to the seed hopper in the same manner as the finger pickup seed meter. Secure to bottom of seed hopper with two  $\frac{5}{16}$ " flanged hex nuts. DO NOT OVER TIGHTEN.

Erratic seed spacing may result from misalignment between the drive coupler and seed meter input shaft. Misalignment may cause momentary stoppage of seed disc. Check alignment after initial installation. If adjustment is required, refer to "Meter Drive Adjustment" for correct procedure.

Refer to the planting rate charts in this manual for recommended seed drive transmission sprocket combinations.

**IMPORTANT:** Use powdered graphite or talc with each hopper fill of seed. Additional graphite or talc may be required to retard buildup of seed treatments on meter components. Frequency of monitor seed tube cleaning may be affected due to use of additional graphite or talc.



# ROW UNIT OPERATION

82354-1



One tablespoon of **powdered graphite** per hopper fill of seed should be added to the seed each time the hopper is filled. This prolongs the life of the brush-type seed meter components, reduces buildup of seed treatment on components in the meter and improves seed spacing.

**Talc seed lubricant** may be used in lieu of graphite to reduce seed treatment buildup on seed disc and meter components and will improve meter performance. Coat seed disc and brushes with talc before installing meter. Fill hopper  $\frac{1}{2}$  full of seed, add  $\frac{1}{4}$  cup of talc and mix thoroughly. Finish filling hopper, add another  $\frac{1}{4}$  cup of talc and mix thoroughly. Adjust rate of talc use as needed so all seeds are coated, while avoiding a buildup of talc in the bottom of the hopper. Humid conditions and/or small sized seeds with extra seed treatment may require as much as one cup of talc per hopper to prevent seed treatment buildup on seed disc and/or brushes.

**CAUTION: Some liquid seed treatments or inoculants may create buildup on the seed disc or brushes. Check frequently for proper population and/or seed delivery when using any liquid seed treatment.** All seed treatment should be thoroughly mixed with the seed per the manufacturers' recommendations. Seed treatment dumped on top of the seed after the hopper is filled, and not mixed properly will cause bridging of the seed in the meter, reducing population or stopping the meter from planting. Additional graphite or talc may be required to retard buildup of seed treatments on meter components.

**IMPORTANT: Foreign material, such as hulls, stems, etc., may affect seed delivery. Clean seed is required to ensure accurate seed metering from the brush-type seed meter. Seed discs should be removed daily to check for buildup of foreign material, such as hulls, in the seed meter or the brushes.**

## SEED HOPPER

60620-69



The seed hopper has a capacity of 1.6 bushels.

When filling the seed hopper use clean seed and make certain there are no foreign objects in the hopper. **Replace hopper lids after hoppers are filled to prevent the accumulation of dust or dirt in the seed meter which will cause premature wear.** See "Finger Pickup Seed Meter Lubrication" and/or "Brush-Type Seed Meter Lubrication".

Periodically empty the hoppers completely to remove any foreign objects and ensure proper seed meter operation. To empty hopper, disengage drive release and hopper latch and lift hopper off the hopper support. See "Meter Drive Release".

# ROW UNIT OPERATION

## SEED METER DRIVE ADJUSTMENT

**IMPORTANT:** The seed meter drive coupler must be properly aligned with the meter input shaft.

Improper alignment between the drive coupler and input shaft of the meter can cause the meter housing to flex as the meter rotates. This continual flexing of the meter housing can cause damage to the housing. Any time the hopper support panel is removed or replaced vertical and horizontal alignment should be checked.

61658-27

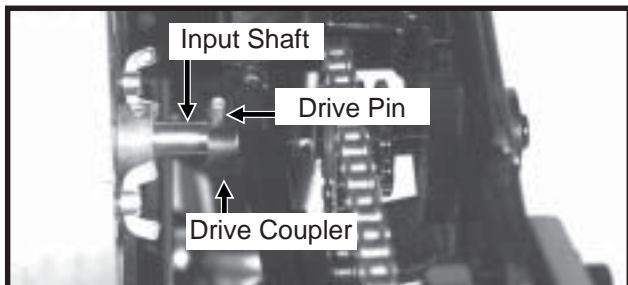

### To check alignment:

- Inspect meter input shaft to make sure drive pin is centered.
- Install hopper with meter onto support panel and latch hopper.
- Rotate meter input shaft so drive pin is vertical.
- Rotate drive clutch so slots in coupler are vertical.
- Engage clutch.
- Clutch coupler should engage meter shaft freely with equal amount of pin extending beyond each side of drive coupler.
- Disengage clutch.
- Rotate both meter shaft and drive clutch to the horizontal position.
- Re-engage clutch.
- Clutch coupler should engage meter shaft freely with equal amount of pin extending beyond each side of drive coupler.

### To adjust drive clutch:

- Slightly loosen both  $\frac{5}{16}$ " cap screws.
- Move clutch assembly to correct any misalignment.
- Tighten both  $\frac{5}{16}$ " cap screws.

72794-24

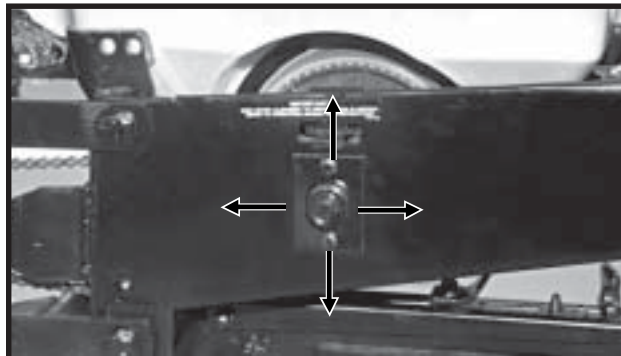

# ROW UNIT OPERATION

## ROW UNIT GAUGE WHEEL COVER

78896-6

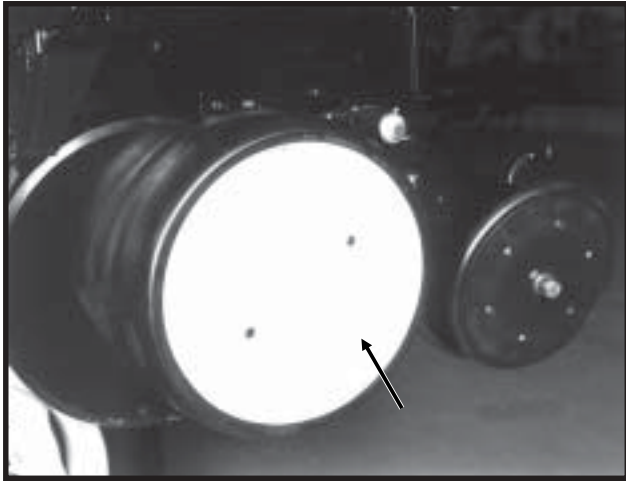

The row unit gauge wheel cover when installed on the gauge wheels next to the transport and/or drive wheels of the planter will aid in protecting the row units from rock damage.

## ROW UNIT CHAIN ROUTING

For proper operation and to minimize wear, the row unit drive chains must be properly tensioned and aligned.

Inspect and replace weak, worn or broken springs and/or idlers and idler bushings.

72359-124(PLTR25)

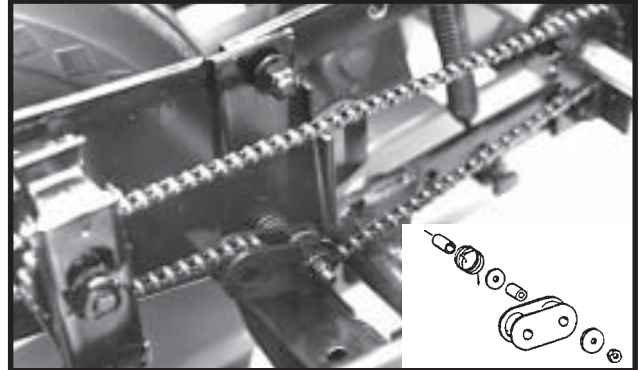

Row Unit Meter Drive

72359-97(PLTR26)

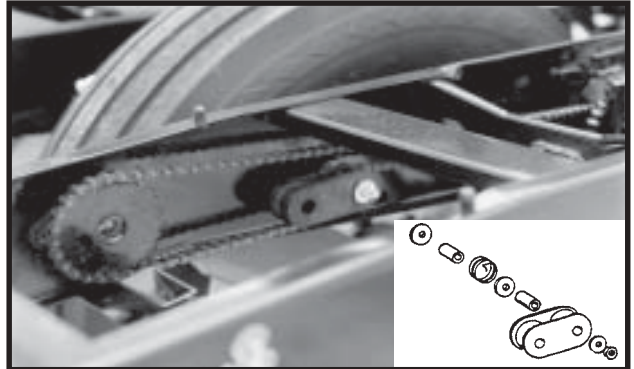

Row Unit Granular Chemical Drive

**NOTE: Make sure connector link is installed with closed end located as shown below.**

(PLTR24)



Direction Of Chain Travel →

# ROW UNIT OPERATION

## QUICK ADJUSTABLE DOWN FORCE SPRINGS

Quick adjustable down force springs are designed to increase penetration in hard soil and keep the row unit from bouncing in rough field conditions.

Two springs per row, one on the L.H. parallel arms and one on the R.H. parallel arms, are used unless equipped with row unit mounted no till coulters. Four springs per row are used with row unit mounted no till coulters. Two springs per row are used with disc furrowers, residue wheels and bed levelers; frame mounted coulters; and frame mounted coulters with disc furrowers.

61703-4

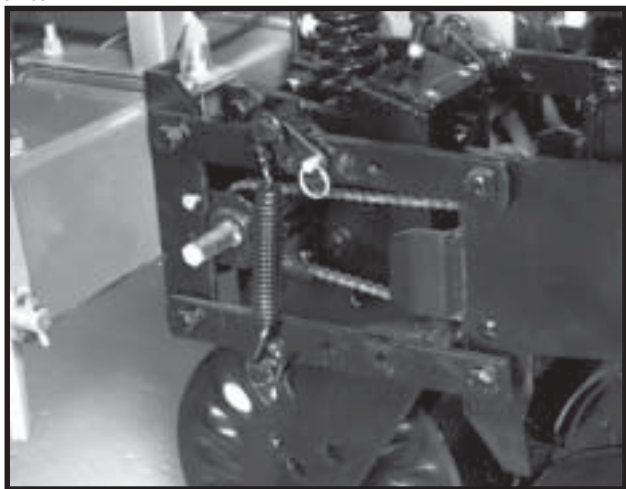

**Two Springs Per Row (Dual)**

72359-4

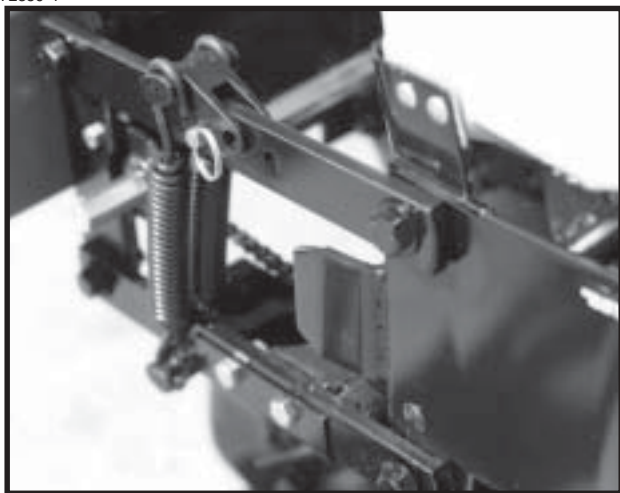

**Four Springs Per Row (Quad)  
(Used Only In Conjunction With Row Unit  
Mounted No Till Coulters)**

There are four positions for spring tension adjustment. Position 1 allows for minimum down pressure and position 4 for maximum down pressure.

L0096(PLTR27c)

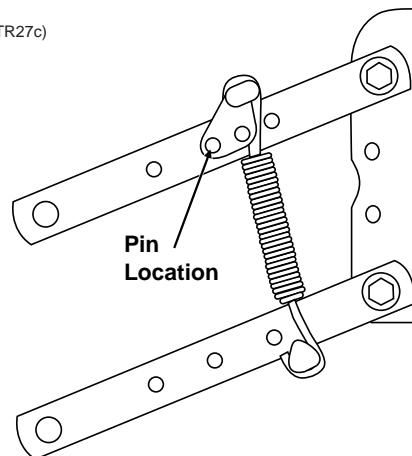

**Position 1 (Minimum)**

(PLTR28c)

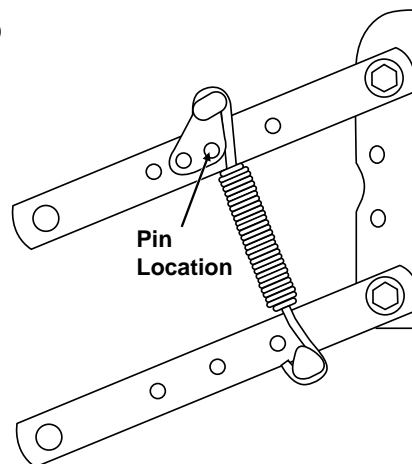

**Position 2**

(PLTR29c)

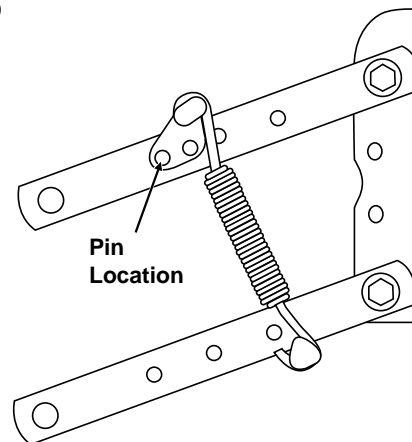

**Position 3**

# ROW UNIT OPERATION

(PLTR30c)

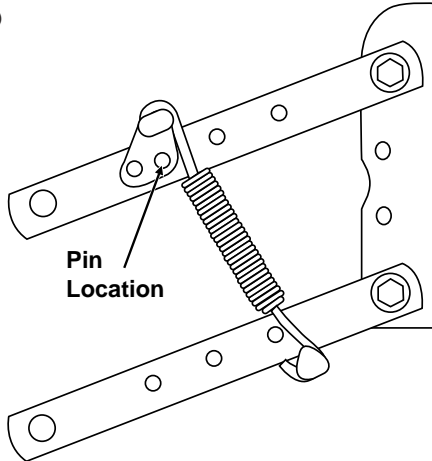

## Position 4 (Maximum)

To adjust spring tension, raise planter and remove spring mount pin at top of spring. Slide mount to desired position and install pin.

**NOTE:** It is necessary for the operator to adjust springs according to field conditions. If springs are adjusted for too much down pressure for field conditions, it is possible for the row units to lift the planter to the extent that the drive wheels do not make sufficient contact. Too much down pressure in soft field conditions can cause the row unit to run too deep.



**DANGER:** Always install safety lockups or lower machine to the ground before working under or around the machine.

**NOTE:** Springs must always be installed with open side of spring hooks toward seed hopper to prevent binding on spring mount adjustment pin.

## FRAME MOUNTED COULTER

Frame mounted coulters with 1" bubbled, 1" fluted (8 flutes) or  $\frac{3}{4}$ " fluted (13 flutes) blades may be used on pull row units only.

The frame mounted coulter is designed to allow required spring down pressure on the coulter for maximum penetration while exerting less shock load on the row unit.

The frame mounted coulter can be used with or without the depth control bar installed. In most applications, especially in rocky planting conditions, the depth control bar **should not be used**. Use of the depth control bar transfers down force from the coulter to the row unit making less down force available to the coulter blade.

56314-14

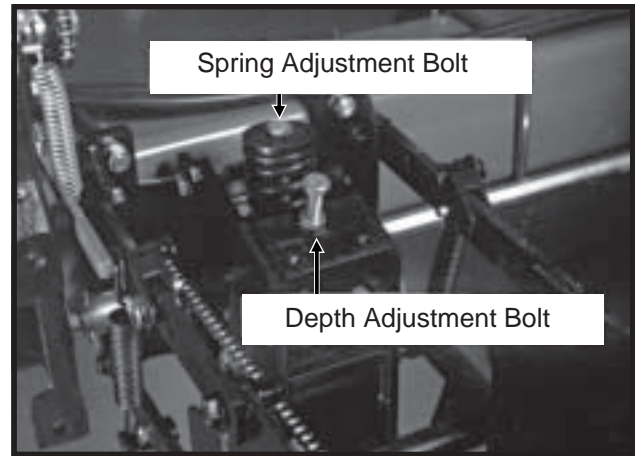

## DEPTH ADJUSTMENT (Without Depth Control Bar Installed)

When the depth control bar is not used, operating depth of the coulter blade is determined by adjusting the depth adjustment bolt and positioning of the blade assembly in the fork mount. The depth adjustment bolt will stop downward travel of the coulter arm assembly. One turn of the adjusting bolt will change depth setting approximately  $\frac{1}{4}$ ". Initial setting of the depth adjustment bolt should be with approximately  $1\frac{3}{8}$ " of thread showing. With this setting and the bar height at 20", the coulter depth will be approximately 2" with coulter mounting spindle in top hole. Turn the adjustment bolt clockwise to decrease operating depth. Turn the depth adjustment bolt counterclockwise to increase operating depth.

# ROW UNIT OPERATION

56314-16

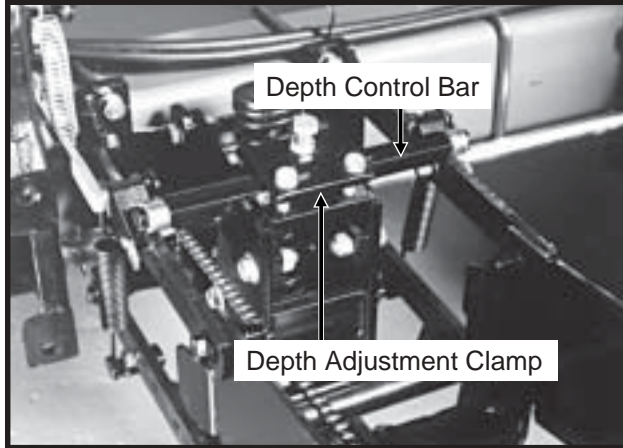

In certain applications it is desirable to use the depth control bar. In uneven terrain, use of the depth control bar allows greater depth control. The up and down movement of the row unit allows the coulter to move up and down at a rate of approximately  $\frac{1}{2}$  that of the row unit, maintaining a more uniform operating depth. When using the disc furrower attachment, the depth control bar should always be used, as operating depth of the coulter is critical for the disc furrowers to operate with minimal gouging.

## DEPTH ADJUSTMENT (With Depth Control Bar Installed)

When using the depth control bar, down force springs must be located in the forward position and the depth adjustment bolt used only to attach the depth adjustment clamp to the coulter assembly. Operating depth of the coulter blade is adjusted by positioning the blade assembly in the fork mount. Four blade mounting adjustment positions are available at  $\frac{1}{2}$ " increments. Initial position of the blade assembly should be in the top hole. This position will locate the coulter blade approximately  $\frac{1}{4}$ " deeper than the row unit opener blade. In heavy residue it may be desirable to position the blade assembly in the second position to insure that the residue is cut and not forced down into the seed zone. Additional holes are used to compensate for coulter blade wear.

56314-1

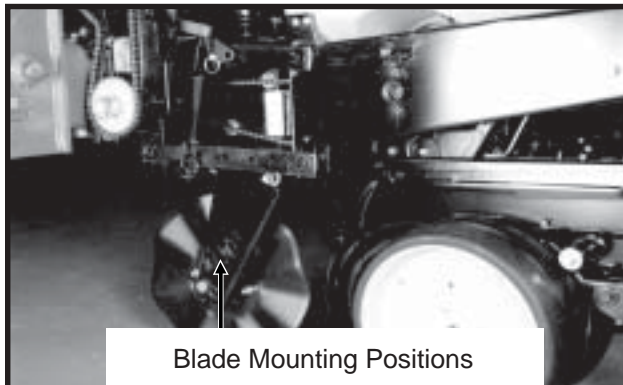

**Down force adjustment is made by** tightening or loosening the spring adjustment bolt. With the planter in the raised position, turn the bolt clockwise to increase down force or counterclockwise to decrease down force. Set all rows equally.

Compressed Spring Length (Including Washer)	Pounds Down Pressure With Blade $\frac{1}{2}$ " Above Maximum Down Position	Pounds Down Pressure With Blade 4" Above Maximum Down Position
13 $\frac{5}{16}$ "	90	230
12 $\frac{5}{16}$ "	190	330
Suggested initial setting.		
11 $\frac{5}{16}$ "	300	430

A5649rev.(PLTR44)

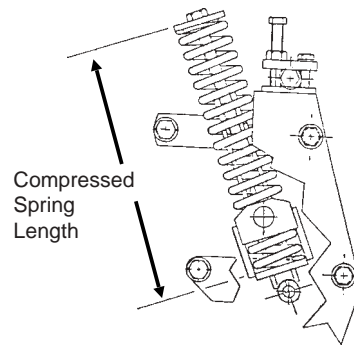

**NOTE: Excessive down force may cause increased wear on components.**

The coulter blade can be aligned with the row unit disc opener by moving the spacer washers from one side of the coulter blade hub to the other.

56314-12

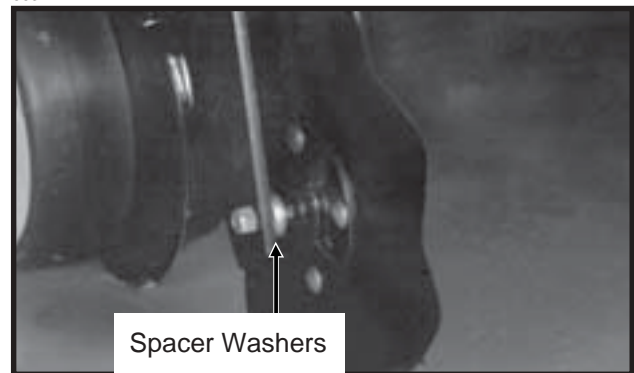

Field adjustment should be made as needed. Operating height of the planter frame will affect operating depth of the frame mounted coulter.

**NOTE: Torque  $\frac{5}{8}$ " spindle bolts to 120 ft. lbs.**

# ROW UNIT OPERATION

## DISC FURROWERS

(For Use With Frame Mounted Coulter)

Disc furrowers for use with the frame mounted coulter may be equipped with either 12" solid blades or 12" notched blades.

Disc furrowers are used to clear crop residue, dirt clods and dry soil from in front of the row units for a clean and smooth seed bed. Notched blades are used for heavier residue conditions. The notched blades cut crop residue and move it aside to prevent plugging or pushing.

56314-19

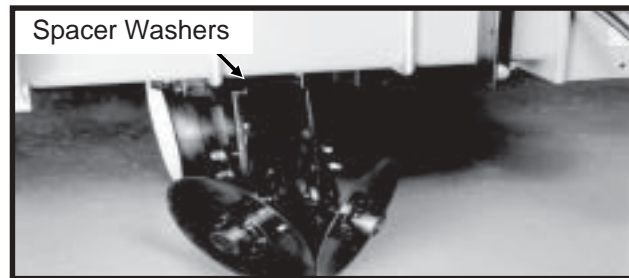

Blades can be adjusted so front edges meet by adding spacer washers between the disc furrower arm and frame mounted coulter fork mount.

Slotted holes in the frame mounted coulter fork mount and in the disc furrower arm allow for vertical and horizontal adjustment. Blades can be adjusted so the front edges meet or one blade can be moved to the rear and the other to the front of the slot so the cutting edge of one blade overlaps the edge of the other blade.

56314-17

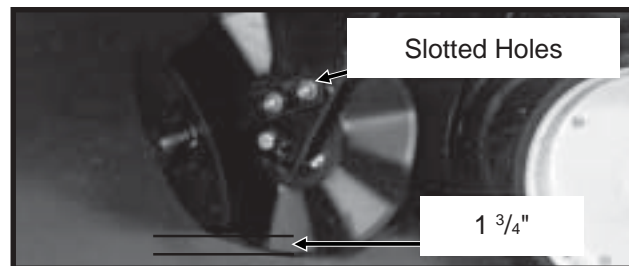

Initial setting for the disc furrowers is 1 3/4" shallower than the coulter blade. Further adjustment may be desired for various applications.

**NOTE: The depth control bar should always be used when the frame mounted coulter is equipped with disc furrowers.**

## ROW UNIT MOUNTED DISC FURROWER

The row unit mounted disc furrower for use on pull row units only may be equipped with either 12" solid blades or 12" notched blades.

Disc furrowers are used to clear crop residue, dirt clods and dry soil from in front of the row units for a clean and smooth seed bed. Notched blades are used for heavier residue conditions. The notched blades cut crop residue and move it aside to prevent plugging or pushing.

59386-23

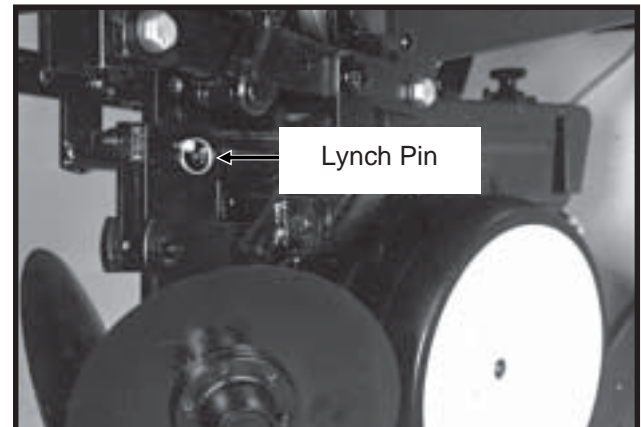

59386-20

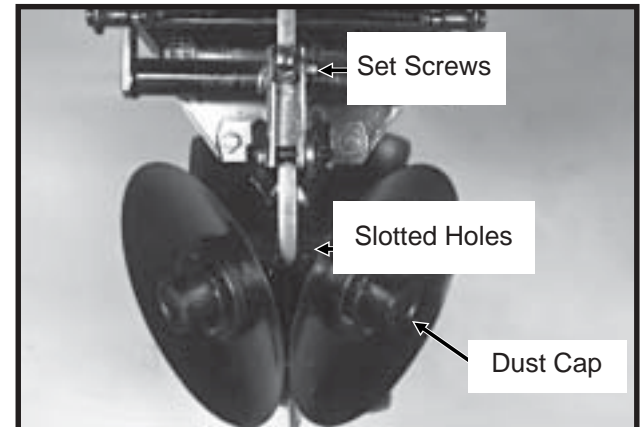

Vertical adjustment in 1/3" increments is possible by removing the lynch pin which secures the vertical support arm and moving the support arm up or down as required. Re-install lynch pin. Finer adjustment can be attained by removing the lynch pin and using the 5/8" x 2 1/4" set screw to clamp the support arm in the required position.

Slotted holes in the support arm where the blades are mounted allow fore and aft adjustment of the discs. Blades can be adjusted so the front edges meet or one blade can be moved to the rear and the other to the front of the slot so the cutting edge of one blade overlaps the edge of the other blade. The dust cap must be removed to make these adjustments.

# ROW UNIT OPERATION

## ROW UNIT MOUNTED BED LEVELER

59386-26

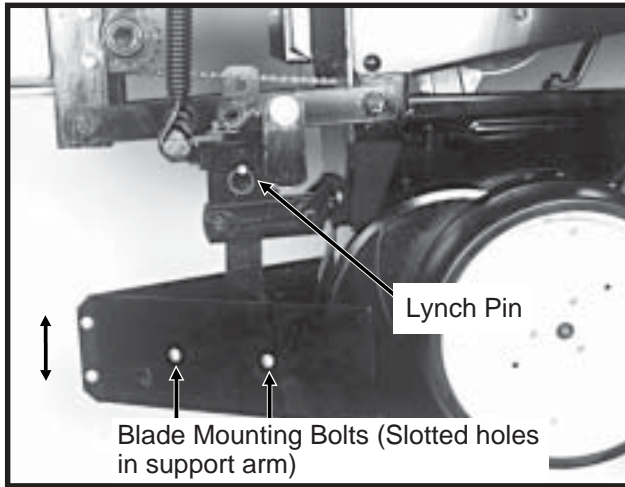

59386-30

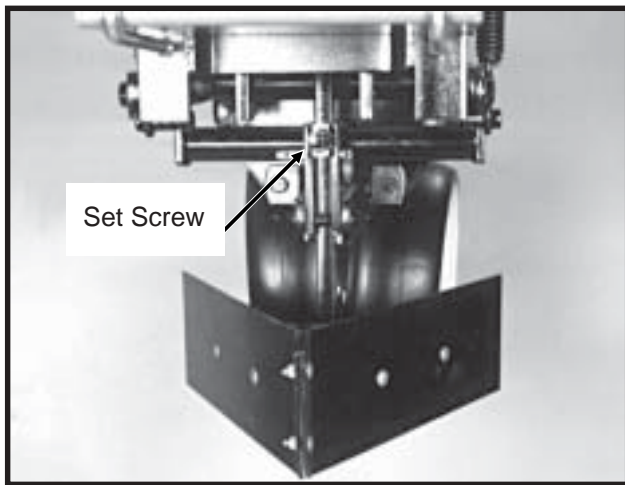

Row unit mounted bed levelers may be used on pull row units only.

Vertical adjustment in  $\frac{1}{3}$ " increments is possible by removing the lynch pin which secures the vertical support arm and moving the support arm up or down as required. Re-install lynch pin. Finer adjustment can be attained by removing the lynch pin and using the  $\frac{5}{8}$ " x  $2 \frac{1}{4}$ " set screw to clamp the support arm in the required position.

Slotted holes in the support arm where the blades are mounted allow tilting of the blades. The blades can be tilted up or down at the front for desired adjustment.

**NOTE: The row unit mounted bed leveler is not compatible with row spacings less than 36".**

## ROW UNIT MOUNTED RESIDUE WHEEL

The row unit mounted residue wheel is designed for use on pull row units.

Two adjustable springs on the parallel links on each residue wheel allow for down force adjustment. Position 1 as shown below provides minimum down pressure and position 3 maximum down pressure.

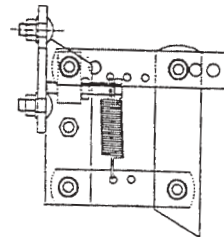

**Position 1 (Minimum)**(PLTR31)

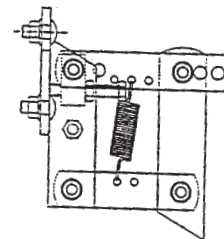

**Position 2**(PLTR32)

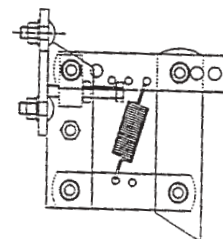

**Position 3 (Maximum)**(PLTR33)

For additional uplift or float, position springs as shown below.

(PLTR34)

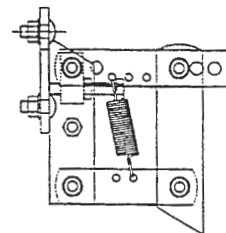

To adjust down force springs, raise the row unit out of the ground and reposition springs as shown for the desired down pressure.



# ROW UNIT OPERATION

76782-31

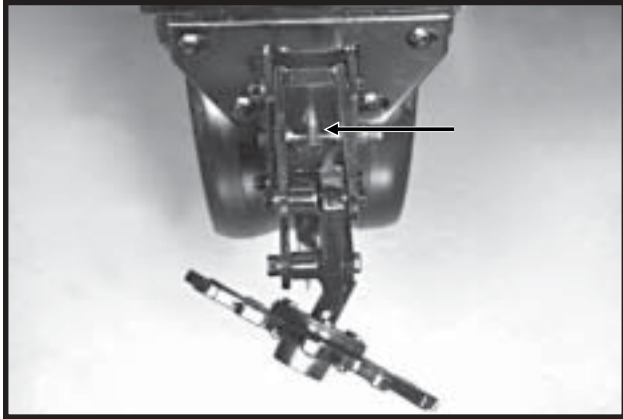

A full threaded bolt and jam nut located on the upper link allows maximum depth to be set for loose soil conditions. Initial setting should be 1 3/4" above the depth of the row unit double disc opener.

Three holes in the upper link allow for wheel angle adjustment. With the wheel mount in the most vertical position, using the rear hole in the upper link, the residue wheel is most aggressive. Moving the wheel mount to one of the forward holes reduces the aggressiveness of the wheel for use in mulch till applications where the soil is loose.

72794-29

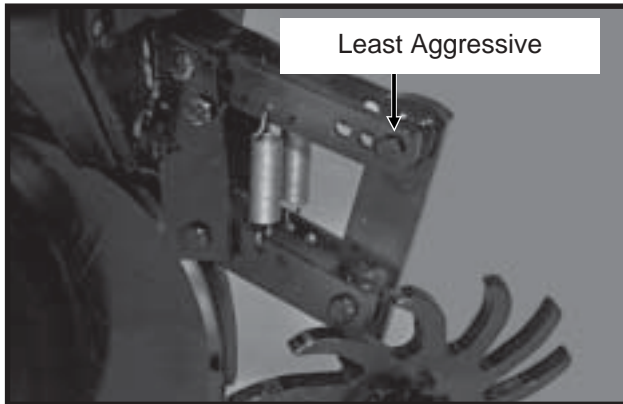

To lock the residue wheel up out of the ground, remove the 1/2" x 5" lockup bolt, raise the residue wheel and install bolt.

72794-31

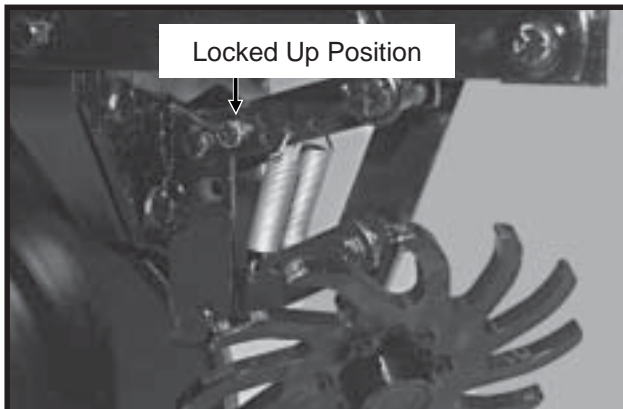

## ROW UNIT MOUNTED NO TILL COULTER

80367-10



Row unit mounted no till coulters with 1" bubbled, 1" fluted (8 flutes) or 3/4" fluted (13 flutes) blades may be used on pull row units. (3/4" fluted shown)

Four quick adjustable down force springs are required per row when using row unit mounted no till coulters. See "Quick Adjustable Down Force Springs".

For proper operation the coulters blade should be aligned in relation to the row unit double disc openers. The coulters assembly can be adjusted by loosening the four attaching bolts, moving coulters arm to align and tightening the four attaching bolts.

The coulters blade can be adjusted to one of four 1/2" incremental settings in the forked arm. Using the top adjustment hole places the 16" diameter coulters blade approximately 1/4" shallower than the row unit disc opener. Using the second adjustment hole from the top places the coulters blade approximately 1/4" below the row unit disc opener. Using the third adjustment hole places the coulters blade approximately 3/4" below the row unit disc opener and using the bottom adjustment hole places the coulters blade approximately 1 1/4" below the row unit disc opener. Initially the blade should be set in the highest position. As the coulters blade wears or the disc opener blades wear or for various planting conditions the blade may be adjusted to one of the three lower settings.

It is most desirable to run the coulters blade 1/4" shallower than the row unit disc opener so it won't disturb the seed bed below the seed trench opened by the double disc opener. (Continued On Following Page)

# ROW UNIT OPERATION

## ROW UNIT MOUNTED NO TILL COULTER (Continued)

In heavy residue it may be necessary to run the coultter blade deeper to insure cutting of residue and prevent pushing residue into the seed zone.

Operating depth can be checked by setting the planter down on a level concrete floor and checking the relationship between the coultter blade and row unit opener blade. Make sure the planter is level and coultter is square with the planter frame and aligned with the row unit disc opener.

**NOTE: Torque 5/8" spindle bolts to 120 ft. lbs.**

## COULTTER MOUNTED RESIDUE WHEELS

80376-15



Coultter mounted residue wheels are designed for use on pull row units. The coultter mounted residue wheels are attached to the row unit mounted no till coultter with one cap screw and sleeve allowing the unit to free-float. 2-position spindle bolt mounting allows the tined wheels to be mounted interlocked or staggered. Depth adjustment is made using a spring-loaded cam and pin with 11 positions in 1/4" increments. A high point on the cam allows the wheels to be locked up so they do not contact the ground.

## SEED FIRMING WHEEL

02209715

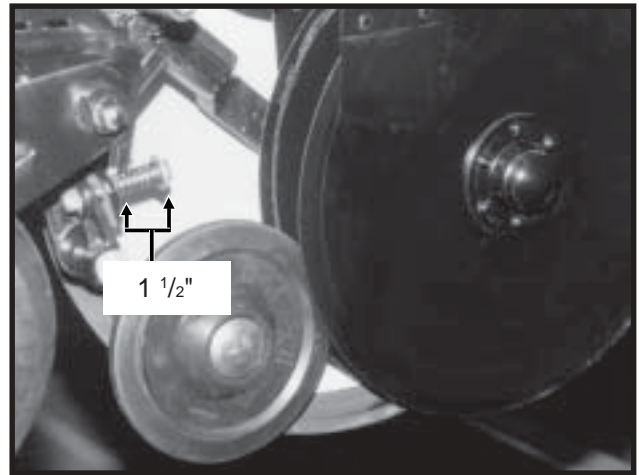

Shown with gauge wheel removed.

The seed firming wheel is designed for use on pull row units. Seed firming wheels are for use in dry loose soil conditions to gently and firmly press the seed into the seed bed before the closing wheels close the seed trench.

**NOTE: Certain soil types and moisture conditions may lead to erratic performance resulting in irregular seed placement.**

Initial spring tension is set leaving 1 1/2" between the washers.

# ROW UNIT OPERATION

## GRANULAR CHEMICAL HOPPER

61766-2

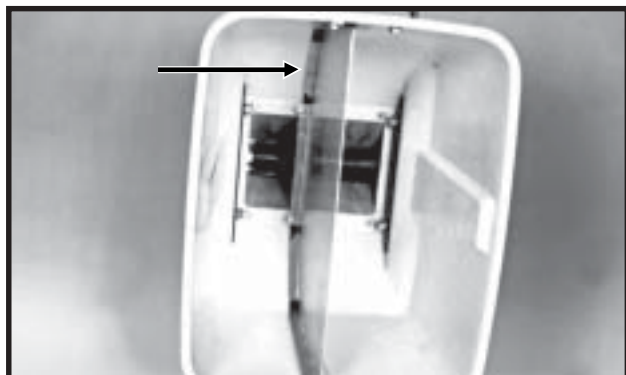

The granular chemical hopper has a 70 pound capacity. With the use of a hopper divider the hopper has two compartments with a 35 pound capacity in each.

Be sure no foreign objects get into the hopper when it is being filled. Replace the hopper lids after filling the hoppers to prevent the accumulation of dirt and moisture.

The metering gate located on the bottom of the hopper regulates the application rate. See "Dry Insecticide And Dry Herbicide Application Rate Charts" in this manual. Calibrate using the chemical manufacturers' instructions.



**DANGER:** Agricultural chemicals can be dangerous. Improper selection or use can seriously injure persons, animals, plants, soil or other property. **BE SAFE:** Select the right chemical for the job. Handle it with care. Follow the instructions on the container label.

The granular chemical clutch drive coupler and meter shaft can be disengaged and engaged by turning the throwout knob located at the rear of the hopper support panel. To engage the drive, turn the knob  $\frac{1}{4}$  turn clockwise. To disengage the drive, turn the knob  $\frac{1}{4}$  turn counterclockwise. Slotted holes in the hopper support panel and clutch housing allow for alignment adjustment between the clutch drive coupler and meter shaft.

72359-183

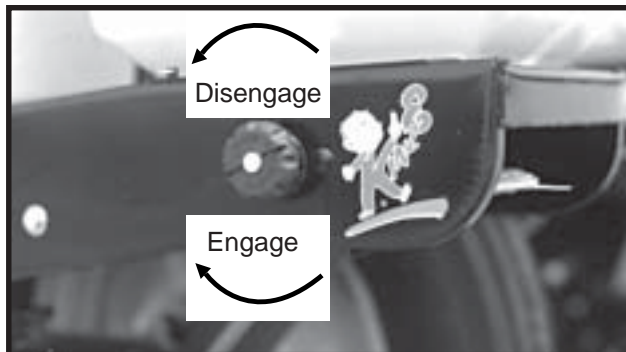

## GRANULAR CHEMICAL RESTRICTOR PLATE

65249-17

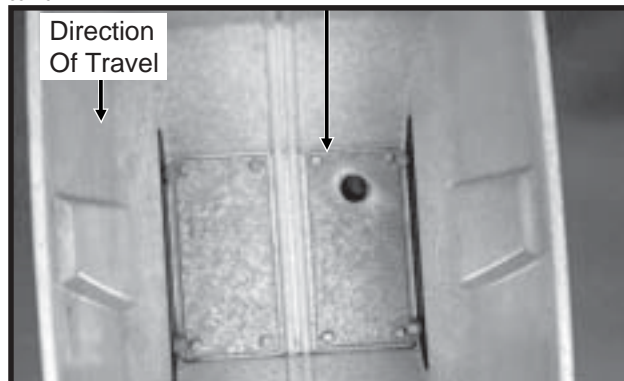

The granular chemical restrictor plate is designed for use in the granular chemical hopper when granular chemical application rates below 4 pounds per acre are desired. The plate restricts chemical flow to the meter outlet to prevent grinding of the material.

**IMPORTANT:** Check application rate of all rows in the field with the granular chemical you are using and at the speed and population at which you will be planting. See "Checking Granular Chemical Application Rate".



**DANGER:** Agricultural chemicals can be dangerous. Improper selection or use can seriously injure persons, animals, plants, soil or other property. **BE SAFE:** Select the right chemical for the job. Handle it with care. Follow the instructions on the container label.

# ROW UNIT OPERATION

## GRANULAR CHEMICAL BANDING OPTIONS

Granular chemical banding options allow front and/or rear banding.

With use of the granular chemical hopper divider and second meter, two banding applications may be utilized.

**NOTE: The granular chemical rear bander is not compatible with the covering discs/single press wheel option.**

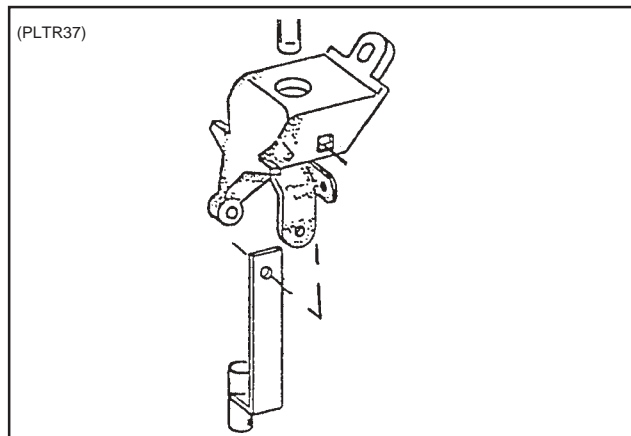

**Straight Drop In-Furrow Placement**

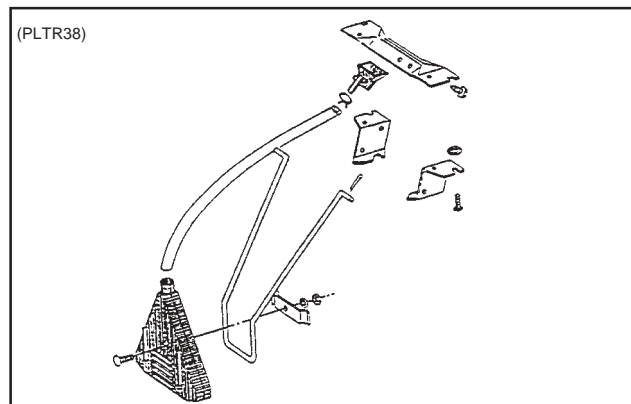

**14" Rear Banding**

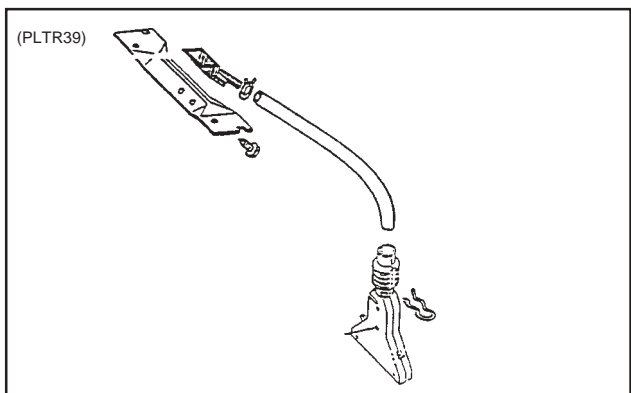

**4 1/2" Slope-Compensating Bander**

## SPRING TOOTH INCORPORATOR

The spring tooth incorporator smooths the soil behind the row unit and incorporates granular chemicals. The two mounting chains on each spring tooth incorporator should be adjusted so there is approximately 1/8" slack in the chain when the unit is lowered to planting position.

**NOTE: The spring tooth incorporator is not compatible with the covering discs/single press wheel option.**

73090-4

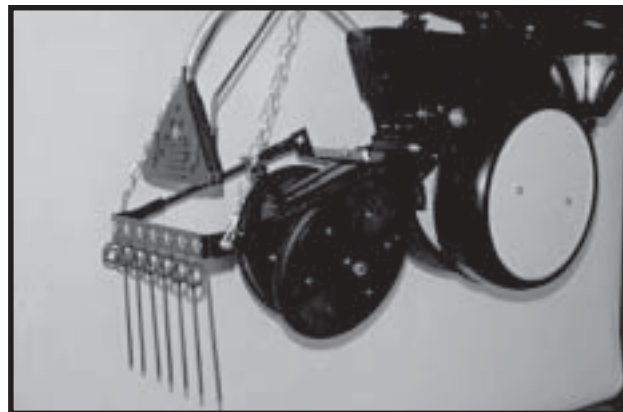

# LUBRICATION

The following pages show the locations of all lubrication points. Proper lubrication of all moving parts will help ensure efficient operation of your KINZE® planter and prolong the life of friction producing parts.



**DANGER:** Always install safety lockups or lower to the ground before working under the machine.

## LUBRICATION SYMBOLS

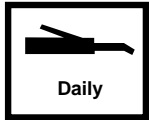

Lubricate at frequency indicated with an SAE multipurpose type grease.



Lubricate at frequency indicated with a high quality SAE 10 weight oil or a quality spray lubricant.

## SEALED BEARINGS

72794-21

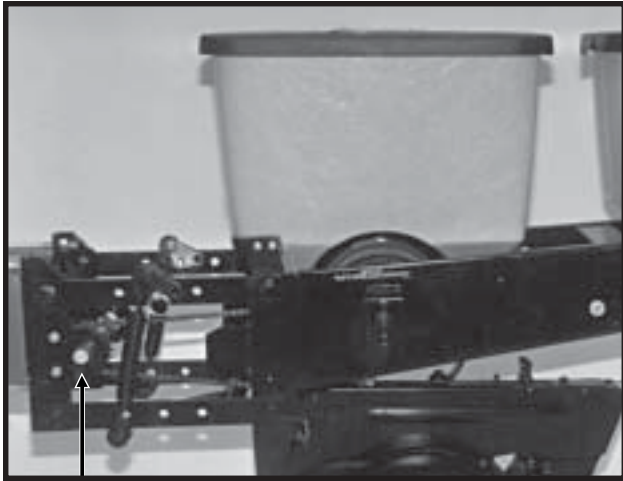

A number of sealed bearings are used on your KINZE® planter to provide trouble free operation. These are located in such areas as the drive shaft, row units and transmission bearings. Sealed bearings are lubricated for life, and due to the seals, relubrication is not practical.

## DRIVE CHAINS

60982-58

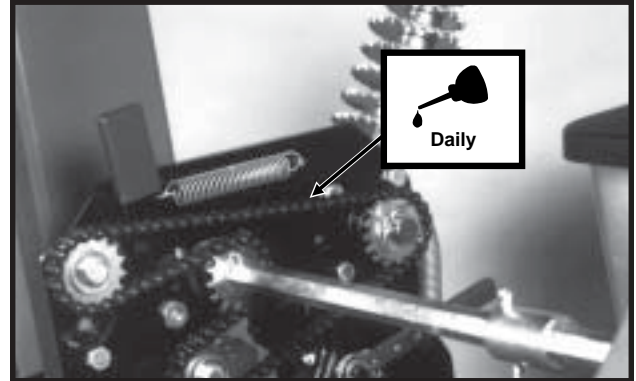

72359-123

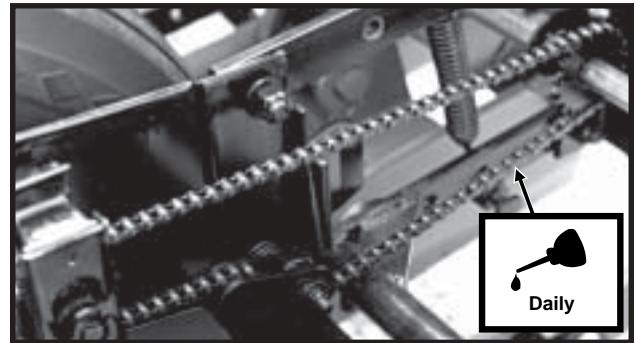

All transmission and drive chains should be lubricated daily with a high quality SAE 10 weight oil or a quality spray lubricant. Extreme operating conditions such as dirt, temperature or speed may require more frequent lubrication. If a chain becomes stiff, it should be removed, soaked and washed in solvent to loosen and remove dirt from the joints. Then soak the chain in oil so the lubricant can penetrate between the rollers and bushings.

## POINT ROW WRAP SPRING CLUTCH

73917-10

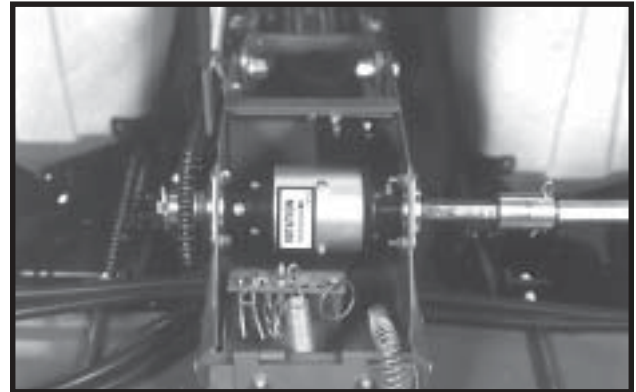

### Style A Shown

The point row wrap spring clutches are permanently lubricated and require no periodic maintenance. **DO NOT LUBRICATE. KEEP CLUTCHES CLEAN.**

# LUBRICATION

## BUSHINGS

Lubricate bushings at the frequency indicated.

Using a torque wrench, check each bolt for proper torque. If bolt is loose, it should be removed and the bushing inspected for cracks and wear. Replace bushing if necessary. **Only hardened flat washers should be used. Replace damaged flat washers with proper part. Torque bolts to 130 ft. lbs.**

59386-18

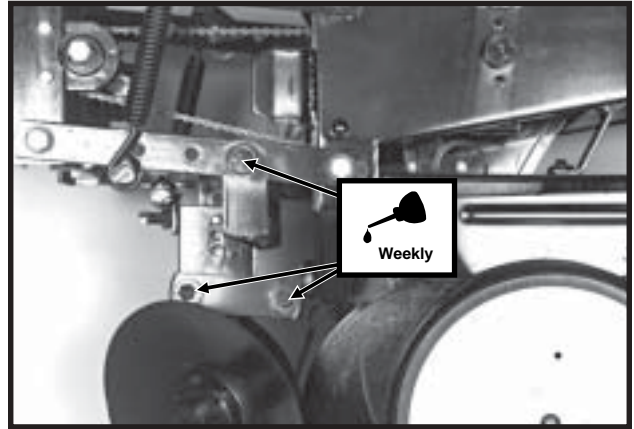

Row Unit Mounted Disc Furrower Parallel Linkage (6 per row)

59386-43

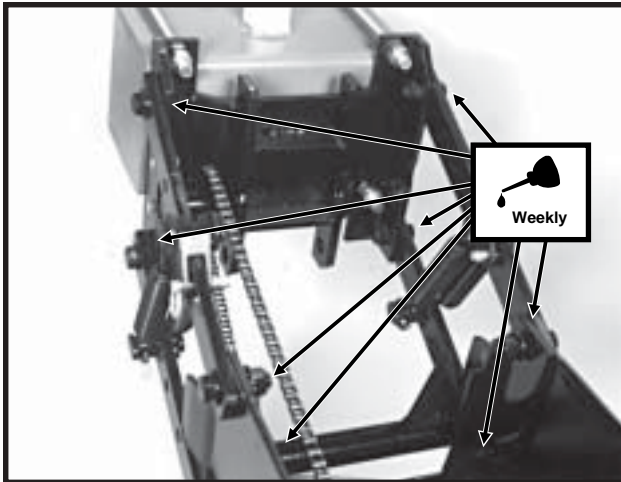

Pull Row Unit and/or Push Row Unit Parallel Linkage (8 per row)

59386-26

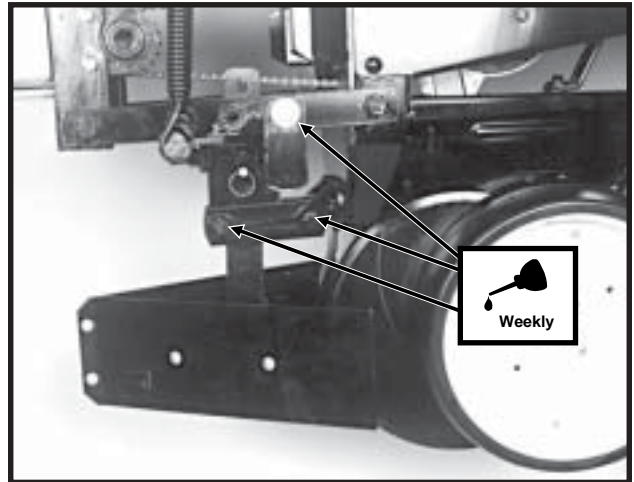

Row Unit Mounted Bed Leveler Parallel Linkage (6 per row)

56314-8

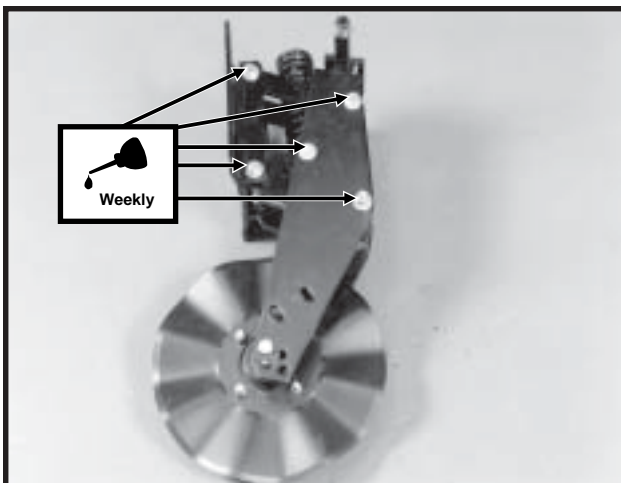

Frame Mounted Coulter Parallel Linkage (10 per row)

*Shown not installed on row unit for visual clarity.*

8/30/93-4

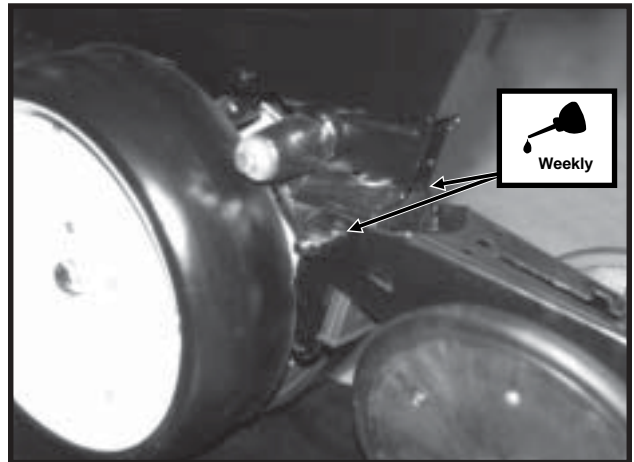

Row Unit "V" Closing Wheel and/or Covering Discs/Single Press Wheel Eccentric Bushings (2 per row)

# LUBRICATION

## WHEEL BEARINGS

Wheel bearings should be repacked with clean, heavy duty axle grease approximately once a year or at the beginning of each planting season. This applies to all drive wheels, transport wheels and marker hubs. Follow the procedure outlined for wheel bearing replacement with the exception that bearings and bearing cups are reused.

## GREASE FITTINGS

Those parts equipped with grease fittings should be lubricated at the frequency indicated with an SAE multipurpose type grease. Be sure to clean the fitting thoroughly before using grease gun. The frequency of lubrication recommended is based on normal operating conditions. Severe or unusual conditions may require more frequent attention.



**DANGER:** Always install safety lockups or lower to the ground before working under or around the machine.

**NOTE:** Numbers on below photo correspond to photos on following pages showing lubrication frequencies.

7359319a

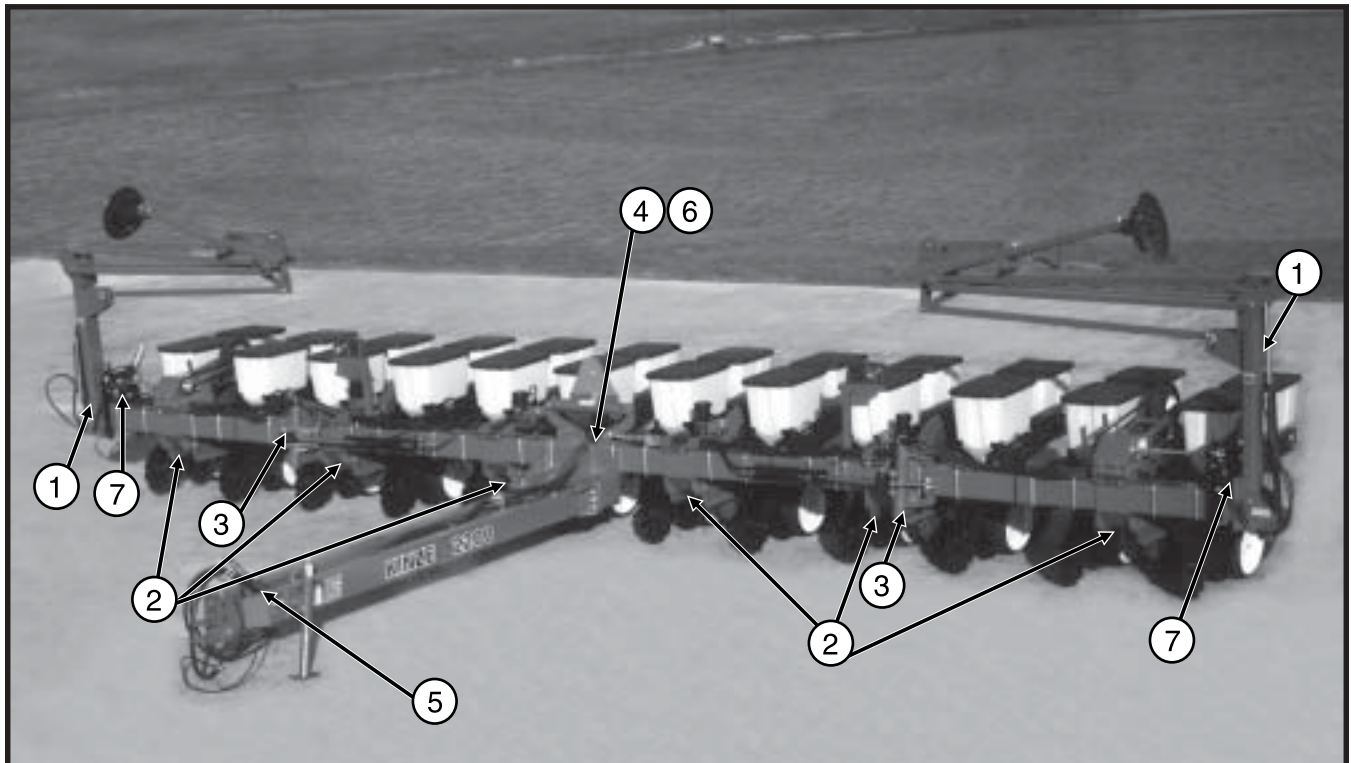

12 Row With Hydraulic Wing Fold Option Shown

# LUBRICATION

73593-18

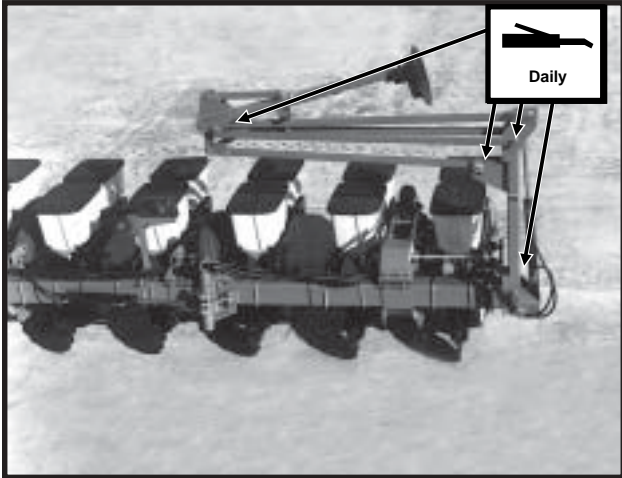

1. Marker Assemblies - 4 Zerks Per Assembly

60887-15

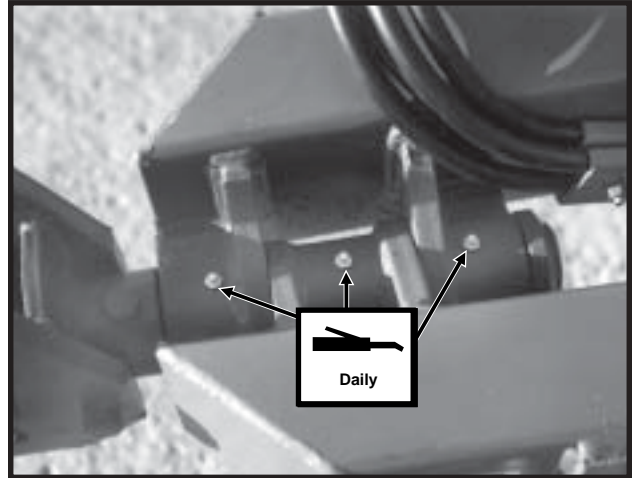

5. Hitch Flex Pin - 3 Zerks

60982-24

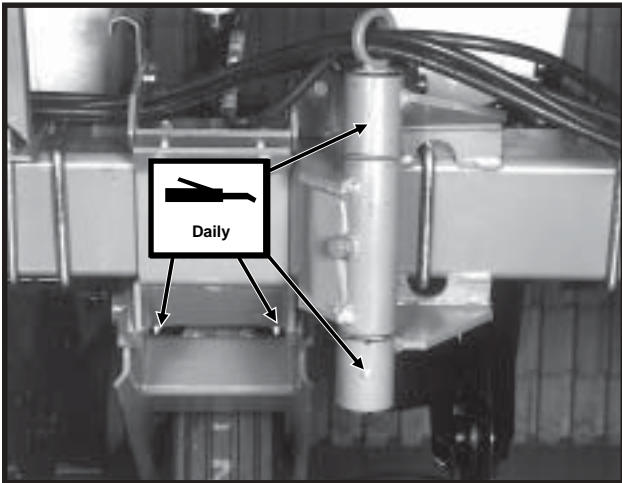

2. Wheel Pivots - 2 Zerks Per Wheel Module

3. Wing Hinges - 2 Zerks Per Wing

72359-134

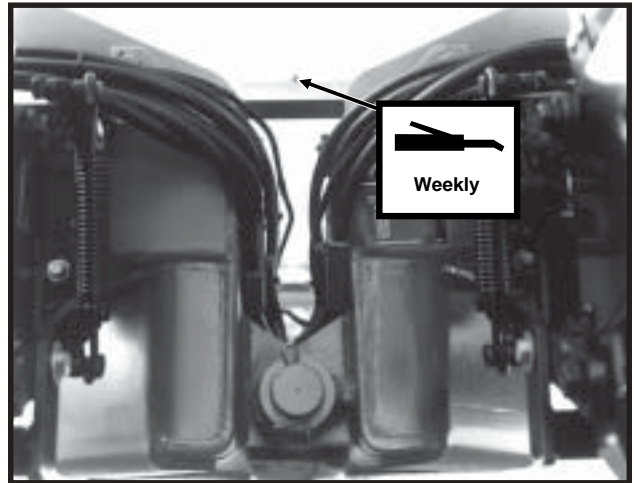

6. Turnbuckle - 1 Zerk

60982-10

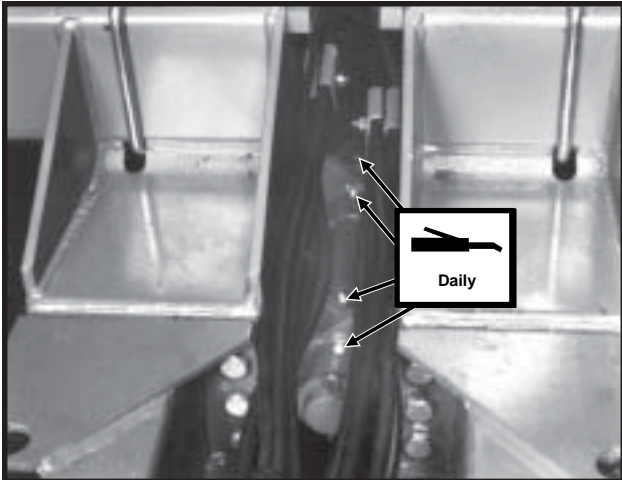

4. Center Frame Flex Pin - 4 Zerks

60982-56

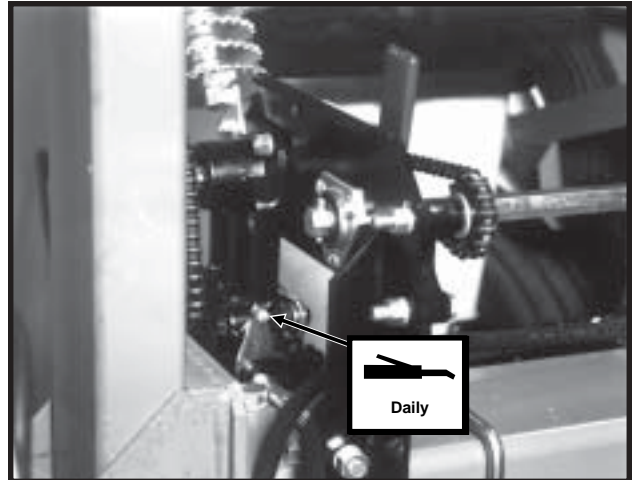

7. Transmission Assemblies - 1 Zerk (Idler)



# LUBRICATION

## Row Unit

72359-106

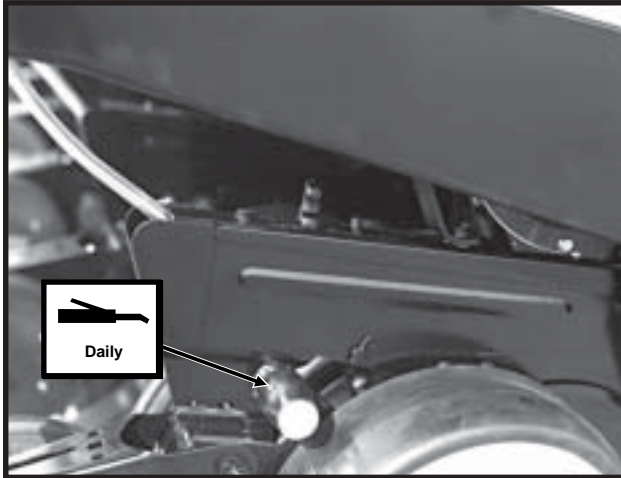

Gauge Wheel Arms - 1 Zerk Per Arm (Pump grease into hub until grease comes out around the seals.)

56673-6

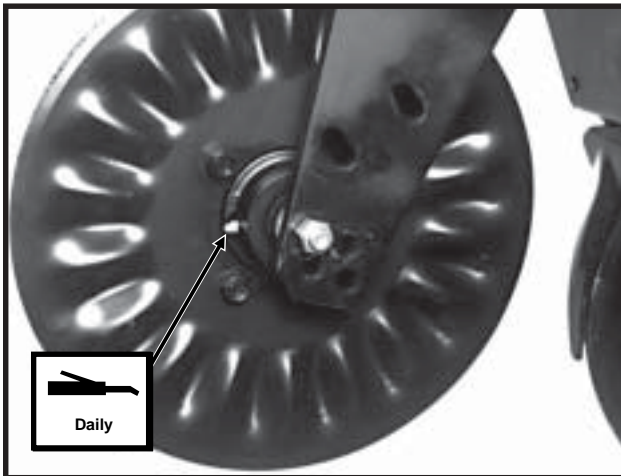

Frame Mounted Coultter Hubs - 1 Zerk Per Hub (Pump grease into hub until grease comes out around the seals.)

80367-10

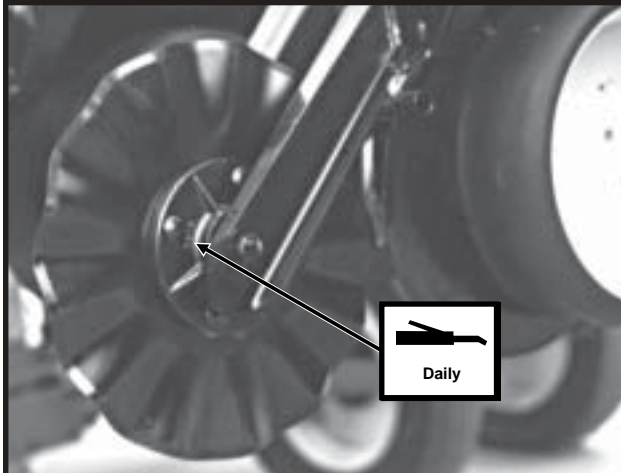

Row Unit Mounted No Till Coultter Hubs - 1 Zerk Per Hub (Pump grease into hub until grease comes out around the seals.)

## Notched Single Disc Fertilizer Opener

010997a

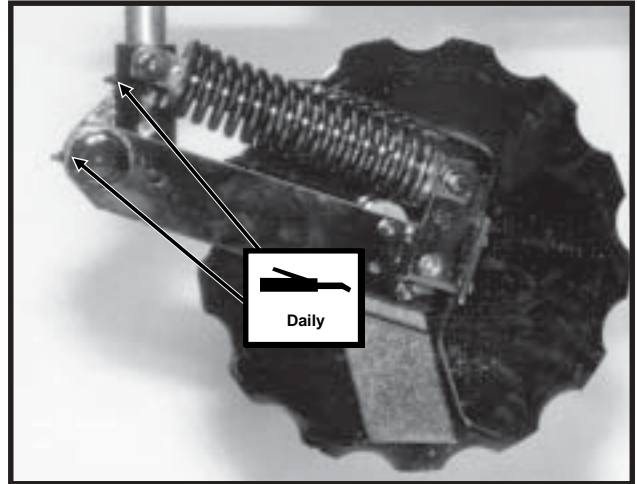

Notched Single Disc Fertilizer Opener - 2 Zerks

# LUBRICATION

---

# MAINTENANCE

## MOUNTING BOLTS AND HARDWARE

Before operating the planter for the first time, check to be sure all nuts and bolts are tight. Check all nuts and bolts again after approximately the first 50 hours of operation and at the beginning of each planting season thereafter.

All bolts used on the KINZE® planter are Grade 5 (high strength) unless otherwise noted. Refer to the torque values chart when tightening bolts.

**Row unit parallel linkage bushing bolts - 130 Ft. Lbs. (See "Bushings" in the Lubrication Section of this manual.)**

<sup>5</sup>/<sub>8</sub>" No Till Coulter Spindle Bolts – 120 Ft. Lbs.

**NOTE:** Over tightening bolts can cause as much damage as under tightening. Tightening a bolt beyond the recommended range can reduce its shock load capacity.



**WARNING:** Before operating the planter for the first time and periodically thereafter, check to be sure the lug nuts on the transport wheels are tight. This is especially important if the planter is to be transported for a long distance.

### TORQUE VALUES CHART - PLATED HARDWARE

Bolt Diameter	Grade 2		Grade 5		Grade 8	
	Coarse	Fine	Coarse	Fine	Coarse	Fine
1/4"	50 In. Lbs.	56 In. Lbs.	76 In. Lbs.	87 In. Lbs.	9 Ft. Lbs.	10 Ft. Lbs.
5/16"	8 Ft. Lbs.	9 Ft. Lbs.	13 Ft. Lbs.	14 Ft. Lbs.	18 Ft. Lbs.	20 Ft. Lbs.
3/8"	15 Ft. Lbs.	17 Ft. Lbs.	23 Ft. Lbs.	26 Ft. Lbs.	33 Ft. Lbs.	37 Ft. Lbs.
7/16"	25 Ft. Lbs.	27 Ft. Lbs.	37 Ft. Lbs.	41 Ft. Lbs.	52 Ft. Lbs.	58 Ft. Lbs.
1/2"	35 Ft. Lbs.	40 Ft. Lbs.	57 Ft. Lbs.	64 Ft. Lbs.	80 Ft. Lbs.	90 Ft. Lbs.
9/16"	50 Ft. Lbs.	60 Ft. Lbs.	80 Ft. Lbs.	90 Ft. Lbs.	115 Ft. Lbs.	130 Ft. Lbs.
5/8"	70 Ft. Lbs.	80 Ft. Lbs.	110 Ft. Lbs.	125 Ft. Lbs.	160 Ft. Lbs.	180 Ft. Lbs.
3/4"	130 Ft. Lbs.	145 Ft. Lbs.	200 Ft. Lbs.	220 Ft. Lbs.	280 Ft. Lbs.	315 Ft. Lbs.
7/8"	125 Ft. Lbs.	140 Ft. Lbs.	320 Ft. Lbs.	350 Ft. Lbs.	450 Ft. Lbs.	500 Ft. Lbs.
1"	190 Ft. Lbs.	205 Ft. Lbs.	480 Ft. Lbs.	530 Ft. Lbs.	675 Ft. Lbs.	750 Ft. Lbs.
1 1/8"	265 Ft. Lbs.	300 Ft. Lbs.	600 Ft. Lbs.	670 Ft. Lbs.	960 Ft. Lbs.	1075 Ft. Lbs.
1 1/4"	375 Ft. Lbs.	415 Ft. Lbs.	840 Ft. Lbs.	930 Ft. Lbs.	1360 Ft. Lbs.	1500 Ft. Lbs.
1 3/8"	490 Ft. Lbs.	560 Ft. Lbs.	1100 Ft. Lbs.	1250 Ft. Lbs.	1780 Ft. Lbs.	2030 Ft. Lbs.
1 1/2"	650 Ft. Lbs.	730 Ft. Lbs.	1450 Ft. Lbs.	1650 Ft. Lbs.	2307 Ft. Lbs.	2670 Ft. Lbs.

**NOTE:** Unplated hardware and bolts with lock nuts should be torqued approximately 1/3 higher than the above values. Bolts lubricated prior to installation should be torqued to 70% of value shown in chart.



**GRADE 2**  
No Marks



**GRADE 5**  
3 Marks



**GRADE 8**  
6 Marks

## CHAIN TENSION ADJUSTMENT

The drive chains are spring loaded and therefore self-adjusting. The only adjustment needed is to shorten the chain if wear stretches the chain and reduces spring tension. The pivot point of these idlers should be checked periodically to ensure they rotate freely.

Additional chain links can be found in the storage box located inside the wheel module.

60817-44

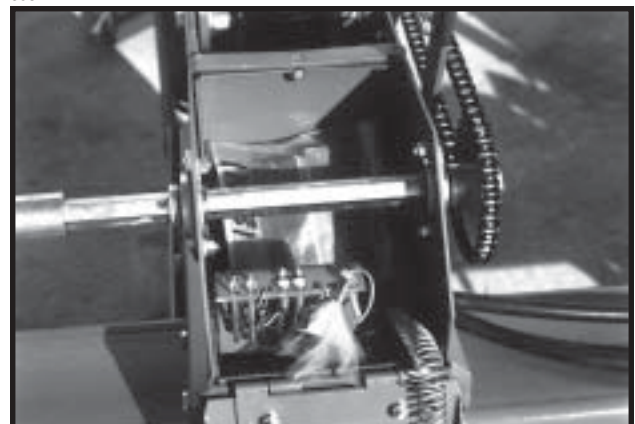

# MAINTENANCE

## FINGER PICKUP SEED METER INSPECTION/ADJUSTMENT

To inspect or service the finger pickup seed meter, remove the meter from the seed hopper by removing the two nuts which secure the mechanism to the hopper. Remove the baffle from the meter assembly by removing three cap screws. This will permit access to the finger pickup.

60620-8

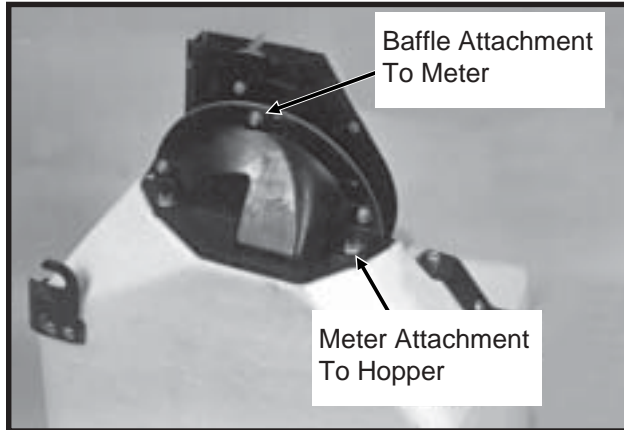

Rotate the seed meter drive by hand to ensure that the springs are holding the tabs of the fingers against the carrier plate where indicated in the photo and that the fingers are being raised in the correct area.

6062016a

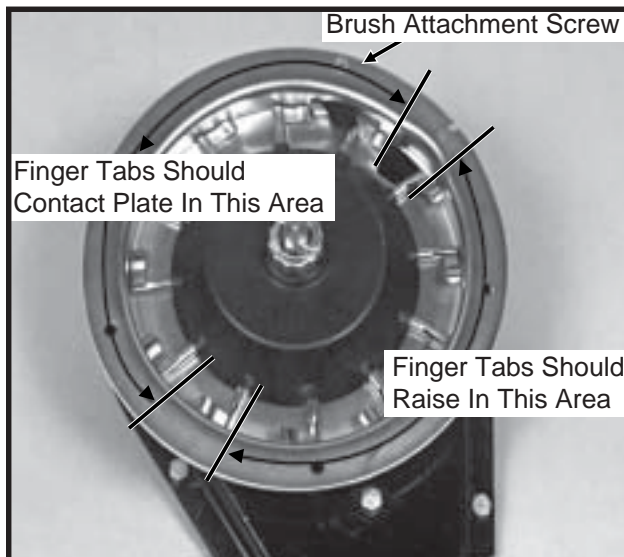

A build-up of debris or chaff may prevent proper finger operation and will require disassembly and cleaning of the corn meter as follows:

1. Remove cotter pin, cage nut and adjusting nut from drive shaft.
2. Carefully lift finger holder, along with fingers and cam, off of the shaft and clean.

60620-3

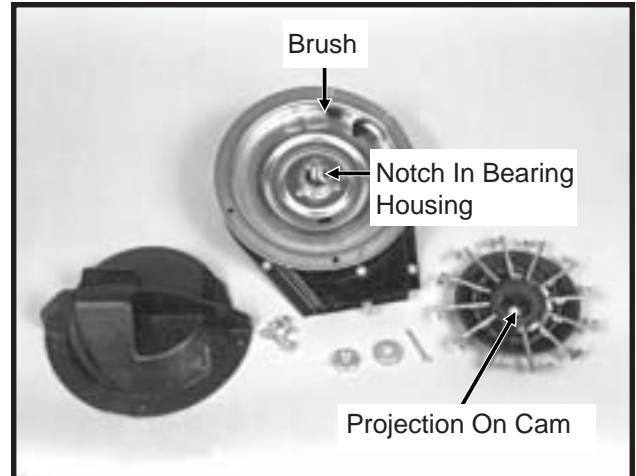

3. Check brush for wear and replace if necessary or following every 100 acres per row of operation.

EXAMPLE: Approximately 800 acres of corn on an 8 row machine or 1200 acres on a 12 row machine.

**NOTE: It is not necessary to remove finger holder to remove brush.**

4. To replace fingers or springs, remove springs from fingers and remove finger from holder by lifting it out of the friction fit slot. Under average conditions, life expectancy of these parts should be 600-900 acres per row of operation.

5. After cleaning and/or replacing defective parts, re-assemble the meter in the reverse order. When replacing fingers, make sure the open end of the spring loop is toward the inside of the finger holder.

60620-22

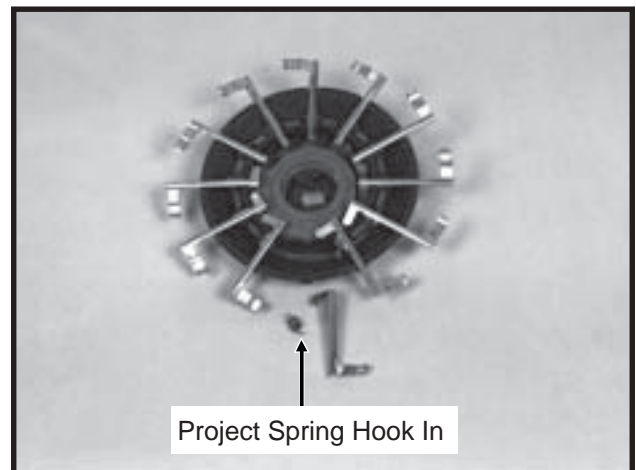

6. Make sure fingers are installed in holder so that holder will be positioned flush with the carrier plate when assembled. A projection on the cam is designed to align with a mating notch in the bearing housing to ensure proper operation when assembled.

# MAINTENANCE

50725-4

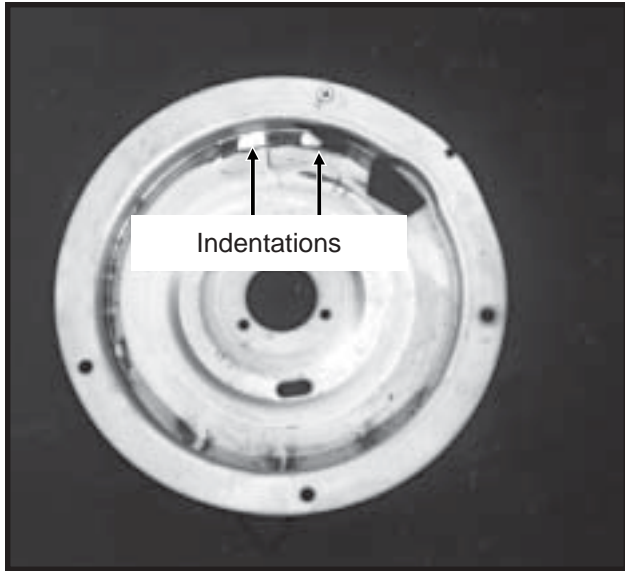

**Photo Shows Worn Plate**

7. Before installing the finger holder on the carrier plate, check the indentations on the carrier plate for wear. Excessive wear of the carrier plate at the indentations will cause over planting especially when using small sizes of seed corn.

Inspect the carrier plate annually. Under average conditions, the life expectancy of the carrier plate should be 250-300 acres per row of operation.

8. With finger holder flush against the carrier, install adjusting nut until it contacts the finger holder with a slight resistance. Continue to turn the nut an additional  $\frac{1}{3}$  turn or torque to 22 to 25 inch pounds of rolling torque on input shaft.
9. Turn finger holder by hand to make sure it is positioned firmly against the carrier, but is not over tightened and can be rotated with moderate force.
10. Install cage nut and cotter pin and reinstall housing.

**NOTE: Check tightness of adjusting nut on each unit after first day of use and periodically thereafter.**

To inspect or replace the seed belt, remove the four cap screws around the edge of the housing cover and the nut from the belt idler mounting bolt.

60620-13

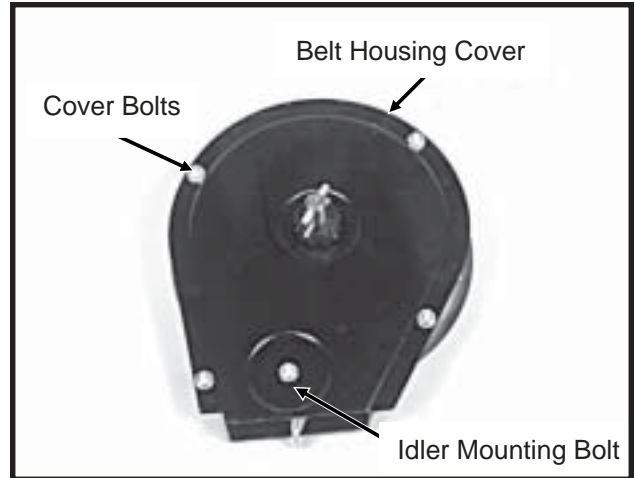

60887-97

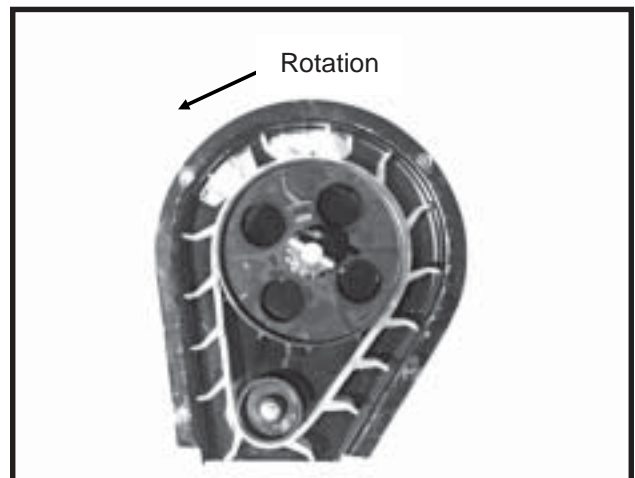

If the belt is being replaced, make sure it is installed to correctly orient the paddles as shown. A diagram molded into the drive sprocket also illustrates the correct orientation.

**CAUTION: Do not over tighten hardware.**

## FINGER PICKUP SEED METER CLEANING

1. Disassemble meter.
2. Blow out any foreign material present in the meter mechanism.
3. Wash in mild soap and water. **DO NOT USE GASOLINE, KEROSENE OR ANY OTHER PETROLEUM BASED PRODUCT.**
4. Dry thoroughly.
5. Coat lightly with a rust inhibitor.
6. Reassemble and store in a dry place.

# MAINTENANCE

## FINGER PICKUP SEED METER TROUBLESHOOTING

PROBLEM	POSSIBLE CAUSE	SOLUTION
One row not planting seed.	Drive release not engaged.	Engage drive release mechanism.
	Foreign material in hopper.	Clean hopper and finger carrier mechanism.
	Seed hopper empty.	Fill seed hopper.
	Pin sheared in drive release sprocket.	Replace pin. Inspect meter for obstructions or defective parts.
	Row unit drive chain off of sprocket or broken.	Check drive chain.
Drive release does not engage properly.	Drive release shaft is not aligned properly with meter drive shaft.	Align drive mechanism. See "Seed Meter Drive Adjustment".
Unit is skipping.	<b>Foreign material or obstruction in meter.</b>	<b>Clean out and inspect.</b>
	<b>Finger holder improperly adjusted.</b>	<b>Adjust to proper setting. (22 to 25 in. lbs. rolling torque)</b>
	<b>Broken fingers.</b>	<b>Replace fingers and/or springs as required.</b>
	Planting too slowly.	Increase planting speed to within recommended range.
Planting too many doubles.	Planting too fast.	Stay within recommended speed range.
	<b>Loose finger holder.</b>	<b>Adjust to specs. (22 to 25 in. lbs. rolling torque)</b>
	<b>Worn brush in carrier plate.</b>	<b>Inspect and replace if necessary.</b>
Over planting.	<b>Worn carrier plate.</b>	<b>Inspect and replace if necessary.</b>
Under planting.	<b>Belt installed backwards.</b>	<b>Remove and install correctly.</b>
	<b>Weak or broken springs.</b>	<b>Replace.</b>
	<b>Spring not properly installed.</b>	<b>Remove finger holder and correct.</b>
	<b>Seed belt catching or dragging.</b>	<b>Replace belt.</b>
	<b>Brush dislodging seed.</b>	<b>Replace brush.</b>
Irregular or incorrect seed spacing.	Driving too fast.	Check chart for correct speed.
	Wrong tire pressure.	Inflate tires to correct air pressure.
	Drive wheels slipping.	Reduce down pressure on row unit down force springs.
	Wrong sprockets.	Check seed rate charts for correct sprocket combinations.
Seed spacing not as indicated in charts.	Wrong tire pressure.	Inflate tires to correct air pressure.
	Inconsistent seed size.	Do field check and adjust sprockets accordingly.
	Wrong sprockets.	Check chart for correct sprocket combination.
	Charts are approximate.	Slight variations due to wear in meter components and tire slippage due to field conditions may produce seed spacing variations.
	Stiff or worn drive chains.	Replace chains.
Scattering of seeds.	Planting too fast.	Reduce planting speed.
	Seed tube improperly installed.	Check seed tube installation.
	Seed tube worn or damaged.	Replace seed tube.
Seed tubes and/or openers plugging.	Allowing planter to roll backward when lowering.	Lower planter only when tractor is moving forward.
Inconsistent seed depth.	Rough seed bed.	Adjust down pressure springs. Reduce planting speed.
	Partially plugged seed tube.	Inspect and clean.
	Seed tube improperly installed.	Install properly.

# MAINTENANCE

## BRUSH-TYPE SEED METER MAINTENANCE

60607-10

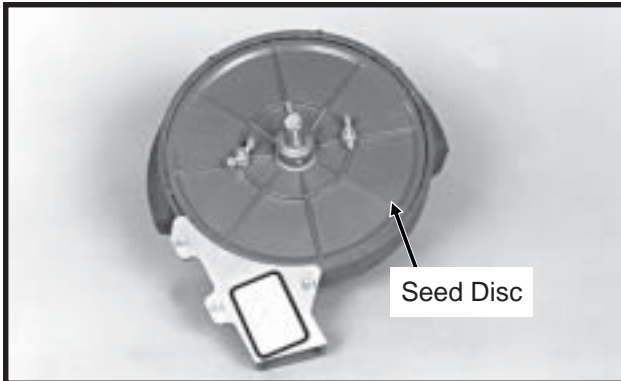

60607-3

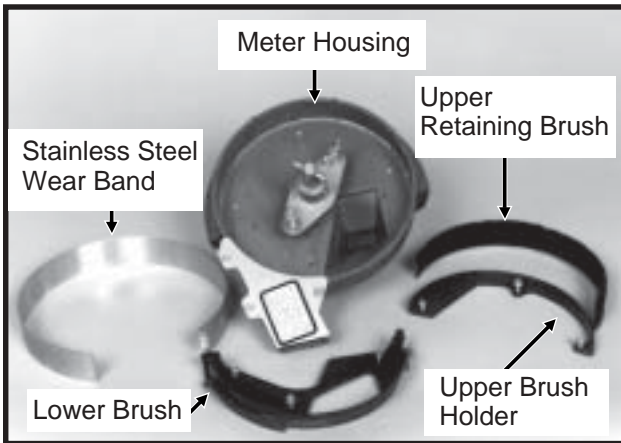

Only clean, high quality seed should be used for maximum meter accuracy. Damaged or cracked seed, hulls or foreign materials may become lodged in the upper seed retaining brush and greatly reduce meter accuracy. It is suggested that the seed disc be removed daily, inspected and cleaned. Check for buildup of foreign material on the seed disc, particularly in the seed loading slots. Clean the disc by washing it with soap and water. Check for cracked seed, hulls, etc. lodged between the brush holder and stainless steel wear band which can greatly reduce the accuracy of the meter because the retaining brush will not be able to retain the seed in the seed disc pocket. Use compressed air to clean the brush areas of the meter housing.

60607-8/60607-8L



**NOTE: Replace hopper lids after hoppers are filled to prevent accumulation of dust or dirt in the seed meter which will cause premature wear.**

Cleaning brush-type seed meter for storage:

1. Remove meter from seed hopper by removing the two nuts which secure the meter to the hopper.
2. Remove seed disc and wash with soap and water and dry thoroughly.
3. Remove upper retaining brush by removing the three hex head screws from the brush holder and removing brush holder and retaining brush.
4. Remove the three hex head screws from the lower brush and remove lower brush and stainless steel wear band.
5. Wash all parts and meter housing with soap and water and dry thoroughly.
6. Inspect all parts for wear and replace worn parts.
7. Reassemble meter except for seed disc. **Meter should be stored in a rodent-free space with seed disc removed.**

### Seed Disc Wear

HD112690(PLTR40)

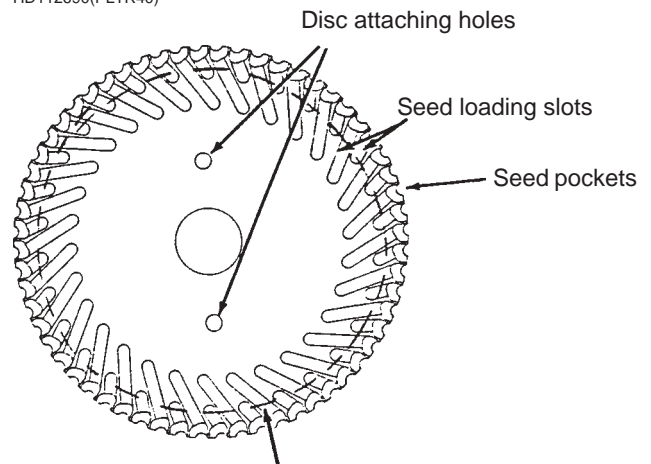

Area indicated is where most wear will be found

Most wear on the seed disc will be found in the area between the seed loading slots. If wear in this area is greater than .075" and accuracy starts to drop off at higher meter RPMs, the seed disc should be replaced. Wear will affect planting accuracy at high RPMs. To measure for wear, lay a straight edge across the surface of the disc and measure the gap between the disc and the straight edge.

Estimated life expectancy of the seed disc is 60-200 acres per row.

# MAINTENANCE

## Stainless Steel Wear Band

60607-38a

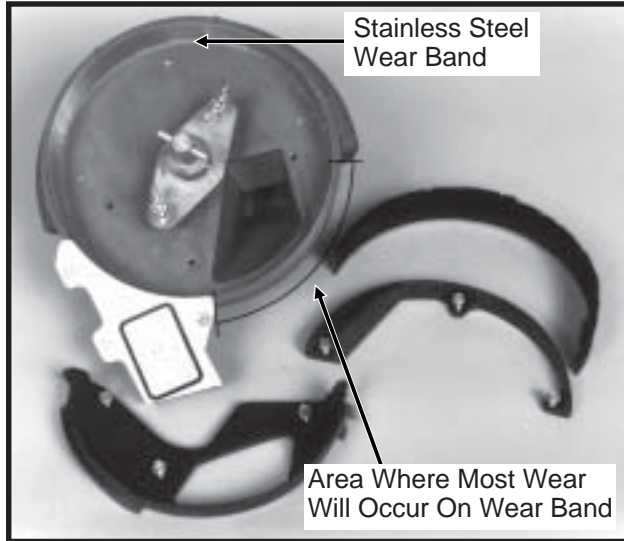

The purpose of the stainless steel wear band is to protect the meter housing from wear. The band is .030" thick and should be replaced when approximately .020" of wear is found in the primary area of wear. If the wear band is allowed to wear through or if the meter is used without the wear band in place, damage to the meter housing may occur.

Estimated life expectancy of the stainless steel wear band is 240-800 acres per row.

## Lower Brush

Estimated life expectancy of the lower brush is also 240-800 acres per row.

## Upper Retaining Brush

60607-21

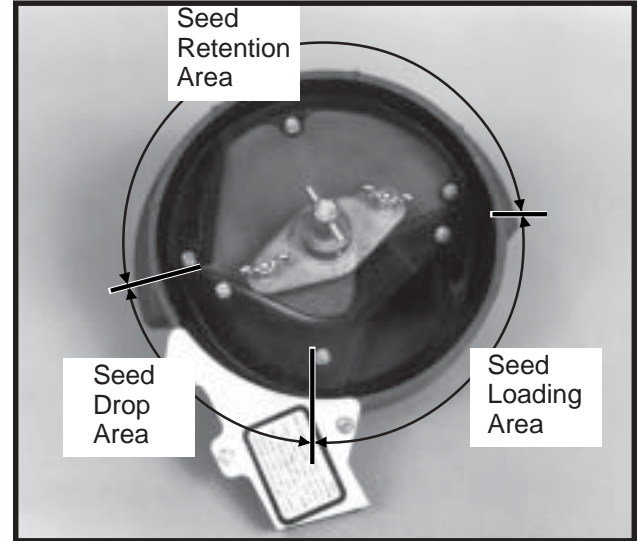

The upper retaining brush holds seed in the seed disc pocket in the seed retention area.

The retaining brush must apply enough pressure against the seed in the seed disc pocket as the disc rotates through the seed retention area to prevent the seed from dropping out of the disc pocket. A damaged spot, excessive wear on the brush or foreign material lodged in the brush may greatly reduce meter performance.

The upper retaining brush should be replaced at approximately 120-400 acres per row of use or sooner if damage or excessive wear is found.

## Installation Of Upper Retaining Brush

Position retaining brush into inner perimeter of seed retention area. Make sure the base of the brush is tight against the bottom of the meter housing. Install brush holder and three hex head screws. Tighten center screw first, left screw second and right screw last.

60607-6

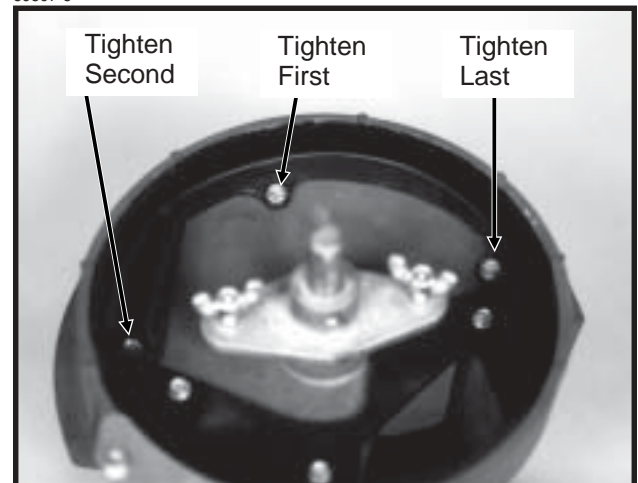



# MAINTENANCE

## BRUSH-TYPE SEED METER TROUBLESHOOTING

PROBLEM	POSSIBLE CAUSE	SOLUTION
Low count.	Meter RPMs too high.	Reduce planting speed.
	Misalignment between drive clutch and meter.	See "Seed Meter Drive Adjustment".
	Seed sensor not picking up all seeds dropped.	Clean seed tube. Switch meter to different row. If problem stays with same row, replace sensor.
	Lack of lubrication causing seeds not to release from disc properly.	Use graphite or talc as recommended.
	Seed size too large for seed disc being used.	Switch to smaller seed or appropriate seed disc. See "Brush-Type Seed Meter" for proper seed disc for size of seed being used.
	Seed treatment buildup in meter.	Reduce amount of treatment used and/or thoroughly mix treatment with seed.
Low count at low RPMs and higher count at higher RPMs.	Foreign material lodged in upper retaining brush.	Remove seed disc and remove foreign material from between brush holder and bristles. Clean with compressed air.
	Worn upper retaining brush.	Replace. See "Maintenance".
Low count at higher RPMs and normal count at low RPMs.	Seed disc worn in the agitation groove area.	Replace disc. See "Maintenance".
High count.	Seed size too small for seed disc.	Switch to larger seed or appropriate seed disc.
	Incorrect seed rate transmission setting.	Reset transmission. Refer to proper rate chart in "Machine Operation" section of manual.
	Upper brush too wide (fanned out) for small seed size.	Replace upper brush.
Upper retaining brush laid back.	Seed treatment buildup on brush.	Remove brush. Wash with soap and water. Dry thoroughly before reinstalling. See "Maintenance".
	Buildup of foreign material at base of brush.	Remove brush holder and brush. Clean with compressed air. Reinstall.

## CLOSING WHEEL TROUBLESHOOTING

PROBLEM	POSSIBLE CAUSE	SOLUTION
Closing wheel(s) leave severe imprint in soil.	Too much closing wheel down pressure.	Adjust closing wheel pressure.
Closing wheel(s) not firming soil around seed.	Insufficient closing wheel down pressure.	Adjust closing wheel pressure. Severe no till conditions may require use of cast iron closing wheels.
"V" closing wheel running on top of seed furrow.	Improper centering.	Align. See "V" Closing Wheel Adjustment.
Single closing wheel not directly over seed.	Improper centering.	Align. See "Covering Discs/Single Press Wheel Adjustment".

# MAINTENANCE

## GAUGE WHEEL ADJUSTMENT

To prevent an accumulation of dirt or trash, gauge wheels should just contact the opener blades. Gauge wheels and opener blades should turn with only slight resistance.

73090-24

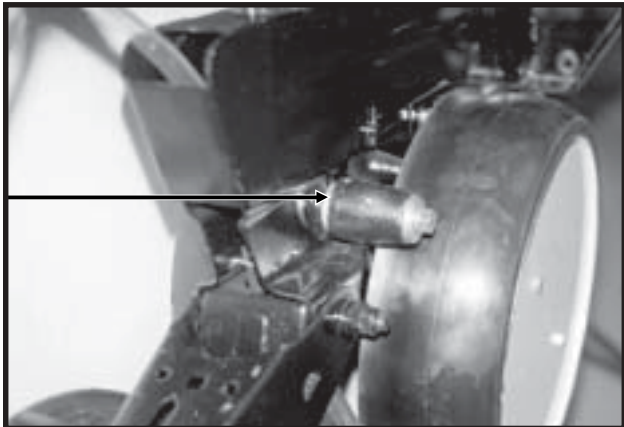

To adjust clearance between gauge wheels and opener blades, add or remove spacer washers between the shank and gauge wheel arm. Store remaining spacer washers between gauge wheel arm and flat washer on outer side of gauge wheel arm.

**NOTE:** It may be desirable to space gauge wheel further from blade when operating in sticky soils.

## 15" SEED OPENER DISC/BEARING ASSEMBLY

73090-13



If 1"-2" of blade contact cannot be maintained after removing spacer washers, the blade should be replaced.

### To replace disc/bearing assembly:

1. Remove gauge wheel.
2. Remove scraper.
3. Remove bearing dust cap.
4. Remove jam nut and washer from outside of disc/bearing assembly.

**NOTE:** Left hand side of opener uses a left hand threaded nut. DO NOT OVER TIGHTEN. Damage to mounting spindle will require replacement of row unit shank assembly.

5. Remove disc/bearing assembly. The spacer bushings between the shank and disc are used to maintain the 1"-2" blade-to-blade contact.
6. After installing new disc/bearing assembly, install washer and jam nut to secure disc/bearing assembly. Torque  $\frac{5}{8}$ "-11 Grade 2 nut to value shown in "Torque Values Chart".
7. Replace bearing dust cap.
8. Install scraper.
9. Install gauge wheel.

It may be necessary to replace only the bearing if the bearing sounds rough when the disc is rotated.

### To replace bearing:

1. Remove gauge wheel, scraper, bearing cap, jam nut, washer and disc/bearing assembly.
2. Remove  $\frac{1}{4}$ " rivets from bearing housing to expose bearing.
3. After installing new bearing, install three evenly spaced  $\frac{1}{4}$ " bolts into three of the six holes in the bearing housing to hold the bearing and bearing housing in place. Install rivets in the other three holes. Remove  $\frac{1}{4}$ " bolts and install rivets in those three holes.
4. Reinstall disc/bearing assembly, washer and jam nut. Torque  $\frac{5}{8}$ "-11 Grade 2 nut to value shown in "Torque Values Chart" at the beginning of this section.
5. Replace bearing dust cap.
6. Install scraper and gauge wheel.

# MAINTENANCE

## SEED TUBE GUARD/INNER SCRAPER

The seed tube guard protects the seed tube and acts as the inner scraper for the disc opener blades.

Remove the seed tube and check for wear. Excessive wear on the seed tube indicates a worn seed tube guard.

50881-9

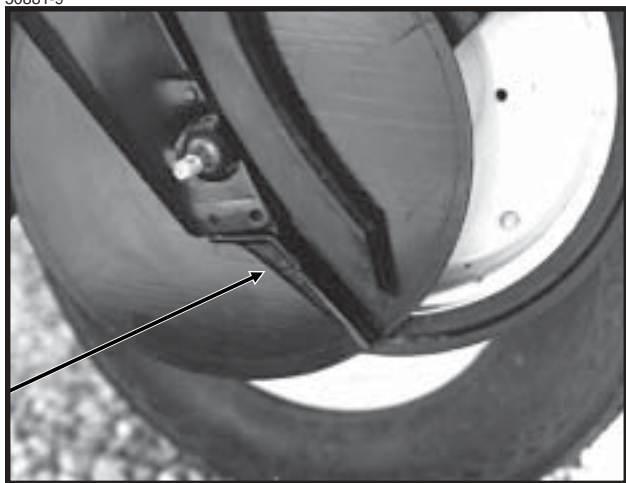

**No till planting or planting in hard ground conditions will increase seed tube guard wear and necessitate more frequent inspection.**

The gauge wheels and seed opener discs must be removed before the seed tube guard can be replaced.

## ROW UNIT MOUNTED NO TILL COULTER

80367-10



If properly maintained and lubricated the bearings in the row unit mounted no till coulters hub may never need to be replaced. Lubricate at frequency indicated in the Lubrication Section of this manual. Check periodically to be sure nuts and hardware are tightened to proper torque specification. Be sure the coulters are positioned square with the planter frame and aligned in front of row unit disc opener.

**NOTE: Torque  $\frac{5}{8}$ " spindle bolts to 120 ft. lbs.**

The coulters blade can be adjusted to one of four settings. Initially the blade is set in the highest position. As the blade wears it can be adjusted to one of the three lower settings. See "Row Unit Mounted No Till Coulters" in Operation Section of this manual.

When the 16" diameter coulters blade is worn to a 14  $\frac{1}{2}$ " diameter (maximum allowable wear), it should be replaced.

Timely lubrication at the frequency indicated in the Lubrication Section of this manual is necessary to purge moisture and dirt from bearing and seal. This will also lubricate the seal. Add grease until it comes out around the seal.

# MAINTENANCE

## ELECTRONIC SEED MONITOR SYSTEM TROUBLESHOOTING

LFD2-96/LFD1-96



The general procedure to use, if a problem occurs, is to isolate the cause to a sensor, sensor lead, planter harness, console cable or the console, in that order. Make necessary repairs after problem has been isolated.

### 1. Sensors

Check for excessive dirt inside sensor. Check for cut or damaged wires. Connect sensor to the planter harness in a row that is operating properly. If it then operates correctly, sensor is good.

In some cases static electricity may cause dust and seed treatment to accumulate on the sensing elements in the sensor. Enough may accumulate to cause the sensor to malfunction, which can cause monitor to indicate a fault condition. Low humidity and dry soil conditions tend to cause this condition. When this occurs, clean the inside of the sensors, using a dry bottle brush.

If, for any reason a sensor becomes inoperative and a replacement sensor is not immediately available, disconnect the sensor lead connector from the planter harness, turn monitor OFF and then back ON. This will keep the alarm from sounding for this row only. Replace the defective seed sensor (using high rate seed sensor only) as soon as possible. After sensor is replaced make certain the monitor is turned OFF and back ON to reactivate the sensor position.

If sensor leads are damaged, carefully cut away the cable covering at the damaged area. Repair damaged wire or wires by soldering wires together with rosin core solder, being sure to match wire colors, then tape each repaired wire. Finally, tape over cut portion of the cable cover. If necessary, relocate and secure cable so that the same type of damage will not occur again.

### 2. Planter Harness And Console Cable

Carefully examine planter harness and console cable for damage. If harness and/or cable is cut or pinched, carefully cut away the harness/cable covering. Repair cut or damaged wire by soldering wires together with rosin core solder, being sure to match wire colors. Tape each repaired wire, then tape over cut harness/cable covering. If necessary, relocate and secure harness/cable so that the same type of damage will not occur again.

### 3. Console

Check for a blown fuse, located on the console rear panel. Check battery connections and make certain they are clean and tight. Make certain battery is fully charged.

If console fuse is blown replace with a 5 amp, type AGC. If fuse blows again, console needs repair or replacement.

**CAUTION: DO NOT REPLACE FUSE WITH A FUSE HAVING A HIGHER AMPERAGE RATING.**

If the battery cable is not damaged, battery connections are clean and tight and the battery is fully charged, the console is defective and needs to be repaired or replaced.

# MAINTENANCE

## KM1000 TROUBLESHOOTING CHART

PROBLEM	POSSIBLE CAUSE	SOLUTION
1. Low Voltage Indicator is ON.	Connected to 6 volt battery.	Connect to 12 volt battery.
	System voltage insufficient.	Insure greater than 11.0 volts.
	Battery connection corroded.	Inspect battery connections. If console power cable terminals or battery terminals are dirty or corroded, clean terminals as required.
	Console defective.	Repair or replace console. Contact your KINZE® Dealer.
2. One row indicator lamp fails to flash when planting. Alarm does not sound.	Burned out row indicator lamp.	Replace row indicator lamp with a No. 1892 lamp only. (Part No. GR0595).
3. One row indicator lamp fails to flash when planting. Alarm sounds continuously. Seeds are being planted by the row unit.	Sensing elements inside seed sensor are dirty.	Clean sensing elements using a dry bottle brush. NOTE: Some seed treatment chemicals are detrimental to the operation of seed sensors and refuse to be removed by dry brushing. To remove such treatment from the inside of a sensor, proceed as follows: Wet a bottle brush with water, then apply a moderate amount of kitchen cleanser (such as Ajax® or Comet®) to the brush. Scrub inside of sensor until treatment is removed, then rinse sensor in clear cold water. Dry thoroughly.
	Defective sensor.	Plug suspect sensor cable into an adjacent row that is operating correctly. If sensor does not operate, sensor is defective.  If you wish to continue planting and a replacement sensor is not available, disconnect the defective sensor cable from the planter harness, turn the monitor OFF and then back ON. The monitor will ignore the disconnected row sensor and you can continue to monitor all other rows.

# MAINTENANCE

## KM1000 TROUBLESHOOTING CHART (Continued)

PROBLEM	POSSIBLE CAUSE	SOLUTION
<p>4. One row indicator lamp fails to come on when the console is powered up.</p>	<p>Burned out row indicator lamp.</p>	<p>Replace row indicator lamp with a number 1892 lamp only. (Part No. GR0595)</p>
	<p>Defective seed sensor or planter harness.</p>	<p>Disconnect the suspected sensor from the planter harness row lead. Disconnect the sensor from the planter harness of an adjacent row. Reverse the harness row leads to the sensors (connect the suspected sensor to the adjacent row planter harness lead and the adjacent sensor to the suspected row harness lead).</p> <p>Turn console power OFF then back ON. If the symptom moves to the adjacent row, the seed sensor is defective and needs replaced. If the symptom does not move, the planter harness or console is defective and needs repaired. Visually inspect the planter harness for cuts, pinching, etc., if damage is found, repair by cutting away the cable covering and splicing the wires (being sure to match wire colors). Solder the splices and tape each wire individually. Tape over repaired cable.</p>
	<p>Console defective.</p>	<p>Repair or replace console. Contact your KINZE® Dealer.</p>
<p>5. Monitor completely "dead".</p>	<p>Blown fuse.</p>	<p>Check fuse, located on rear panel of console. If fuse is blown, replace with a 5 amp, type AGC. If fuse blows again, check power connection to battery. If connections are reversed fuse will blow. If battery connections are correct, console needs repair or replacement. Contact your KINZE® Dealer.</p>
	<p>Poor battery connections.</p>	<p>Check battery connections. Connections must be clean and tight.</p>

# MAINTENANCE

## KM1000 TROUBLESHOOTING CHART (Continued)

PROBLEM	POSSIBLE CAUSE	SOLUTION
5. (Continued)	Cut or broken battery cable.	Visually inspect the battery cable for a cut or broken wire. If wires are cut or broken, splice the wires being sure to match wire colors. Solder the splices and tape each wire individually. USE ONLY ROSIN CORE SOLDER.
	Console defective.	Repair or replace console. Contact your KINZE® Dealer.
6. When monitor is turned ON, row indicator lamps are dark, green power indicator is ON and monitor will not enter operate mode.	Console not connected to planter harness.	Connect console cable to planter harness.
	Defective (shorted) seed sensor.	Leave monitor turned on. Unplug seed sensors one at a time starting with row 1. When you disconnect a sensor and the remaining row indicator lamps come on, the sensor or its cable is defective. Visually inspect the sensor cable. If damaged, repair. If no cable damage is found, the sensor is defective and needs to be replaced. If all but the last sensor is disconnected and the problem still exists, reconnect a sensor before disconnecting the last sensor. If the last sensor is disconnected and the problem still exists, the planter harness, console cable or console is at fault.
	Planter harness shorted.	Visually inspect the planter harness (including all row unit cables) for cuts, pinching and other types of damage. If damage is found, cut away cable covering and repair the individual wires. Tape over repaired wire and cable.
	Console defective.	If the console cable, planter harness, and seed sensors are normal, the console is at fault and needs to be repaired or replaced. Contact your KINZE® Dealer.

# MAINTENANCE

## KM3000 TROUBLESHOOTING CHART

PROBLEM	POSSIBLE CAUSE	SOLUTION
1. Display readout incomplete (fragmented) alarm sounds continuously.	Low battery voltage.	Recharge or replace battery.
	Battery connections corroded.	Inspect battery connection. If console power cable terminals or battery terminals are dirty or corroded, clean terminals as required.
	Console defective.	Repair or replace console. Contact your KINZE® Dealer.
2. One row indicator segment (lower display) fails to flash when planting. Population readout for the planter row is .0. Alarm sounds continuously. Seeds are being planted by the row unit.	Sensing elements inside seed sensor are dirty.	Clean sensing elements using a dry bottle brush. NOTE: Some seed treatment chemicals are detrimental to the operation of seed sensors and refuse to be removed by dry brushing. To remove such treatment from the inside of a sensor proceed as follows: Wet a bottle brush with water, then apply a moderate amount of kitchen cleanser (such as Ajax® or Comet®) to the brush. Scrub inside of sensor until treatment is removed, then rinse sensor in clear cold water. Dry thoroughly.
	Defective sensor.	Plug suspect sensor cable into an adjacent row that is operating correctly. If sensor does not operate, sensor is defective. If you wish to continue planting and a replacement sensor is not available, disconnect the defective sensor cable from the planter harness, turn the monitor OFF and then back ON. The monitor will ignore the disconnected row sensor and you can continue to monitor all other rows.
3. Display will not accumulate area planted.	Both radar ground and magnetic distance sensors are connected to the monitor at the same time.	Disconnect either the radar ground sensor or the magnetic distance sensor.



# MAINTENANCE

## KM3000 TROUBLESHOOTING CHART (Continued)

PROBLEM	POSSIBLE CAUSE	SOLUTION
4. Monitor completely "dead".	Blown console fuse.	Check fuse, located on rear panel of console. If fuse is blown, replace with a 5 amp, type AGC. If fuse blows again, check power connection to battery. If connections are reversed fuse will blow. If battery connections are correct, console needs to be repaired or replaced. Contact your KINZE® Dealer.
	Poor battery connections.	Check battery connections. Connections must be clean and tight.
	Cut or broken battery cable.	Visually inspect the battery cable for a cut or broken wire. If wires are cut or broken, splice the wires being sure to match wire colors. Solder the splices and tape each wire individually. USE ONLY ROSIN CORE SOLDER.
	Low battery voltage.	Check battery voltage. Must be at least 12 volts. If not, recharge or replace battery.
	Console defective.	Repair or replace console. Contact your KINZE® Dealer.
5. When monitor is turned ON, row display (lower display) remains blank. Upper display shows SPEED, NUMBER OF ROWS and ROW SPACING constants. Monitor will not enter OPERATE mode.	Console not connected to planter harness.	Connect console cable to planter harness.
	Defective (shorted) seed sensor.	Leave monitor turned ON. Unplug seed sensors one at a time starting with row 1. When you disconnect a sensor and the remaining row display segments come on and the monitor enters the operate mode, the sensor or its cable is defective. Visually inspect the sensor cable, if damaged repair. If no cable damage is found, the sensor is defective and needs replaced. If all sensors are disconnected and problem still exists, the planter harness, console cable or console is at fault.

# MAINTENANCE

## KM3000 TROUBLESHOOTING CHART (Continued)

PROBLEM	POSSIBLE CAUSE	SOLUTION
5. (Continued) When monitor is turned ON, row display (lower display) remains blank. Upper display shows SPEED, NUMBER OF ROWS and ROW SPACING constants. Monitor will not enter OPERATE mode.	Planter harness shorted.	Visually inspect the planter harness (including all row unit cables) for cuts, pinching and other types of damage. If damage is found, cut away cable covering and repair the individual wires. Tape over repaired wire and cable.
	Console cable shorted.	Visually inspect the console cable for cuts, pinching and other types of damage. If damage is found, cut away cable covering and repair the individual wires. Tape over repaired wire and cable.
	Console defective.	If the console cable, planter harness and seed sensors are normal, the console is at fault and needs to be repaired or replaced. Contact your KINZE® Dealer.

### SEED MONITOR ROW INDICATOR BULB REPLACEMENT (KM1000 Only)

D-0802-0002/D-0802-0003(PLTR41)

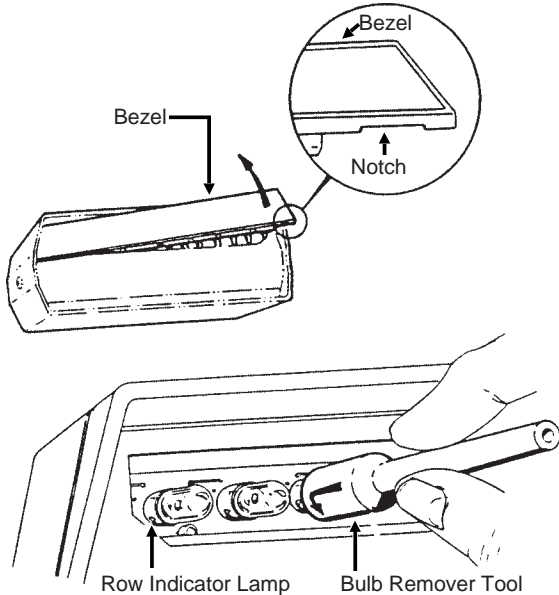

Carefully remove the row indicator bezel as shown. Use your fingernail to pry up along the lower outside edge of the bezel. Remove bezel. Remove burned out bulb using a bulb remover tool. Press in on bulb, turn  $\frac{1}{4}$  turn counterclockwise and remove bulb. Replace bulb with a No. 1892 (Part No. GR0595) only. Install bezel.

### SEED MONITOR DISPLAY BACKLITE BULB REPLACEMENT (KM3000 Only)

D-0841-0006(PLTR42)

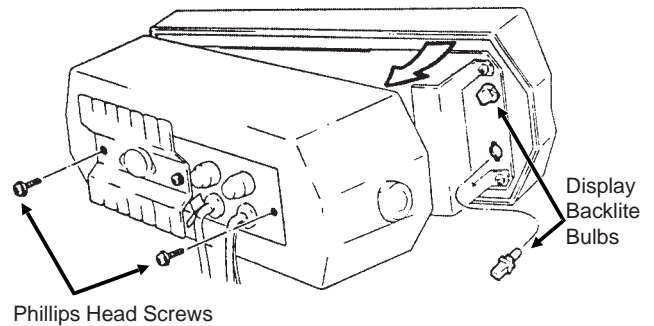

Remove the two outside Phillips head screws. **NOTE: DO NOT REMOVE THE CENTER PHILLIPS HEAD SCREW.** Carefully separate the console case from the front panel. Remove the defective bulb by turning the lamp assembly  $\frac{1}{4}$  turn counterclockwise and pulling straight out. Replace bulb with a GE No. 73 bulb (Part No. GR1084). Carefully assemble the console front panel, case and rear panel and install the two Phillips head screws. **CAUTION: Make sure that all wires are located where they will not be pinched or cut.**

# MAINTENANCE

## POINT ROW WRAP SPRING CLUTCH INSPECTION (STYLE A)

The point row wrap spring clutch is permanently lubricated and requires no periodic maintenance.

73917-10

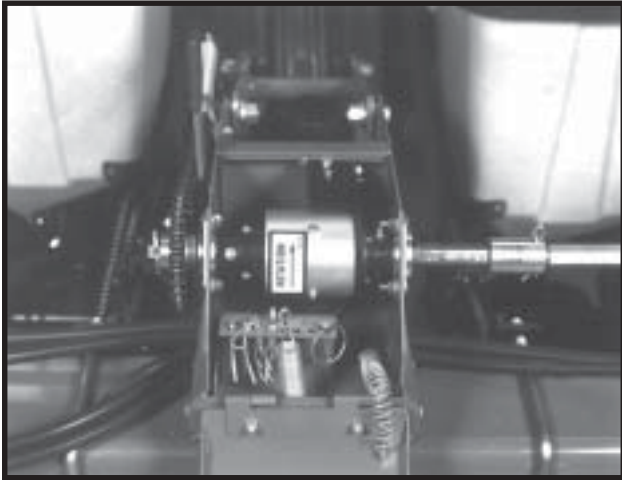

The right hand clutch operates clockwise and the left hand clutch operates counterclockwise. Therefore, some of the parts of the clutch such as the wrap spring differ from one side of the planter to the other. Be sure to use the correct repair part if a clutch must be repaired.

If the clutches fail to operate, check to see if the fuse in the wiring harness is blown. See "Point Row Clutch Troubleshooting".

**NOTE: Always replace fuse with MDL 10 amp slow blow fuse when replacing fuse.**

60982-91

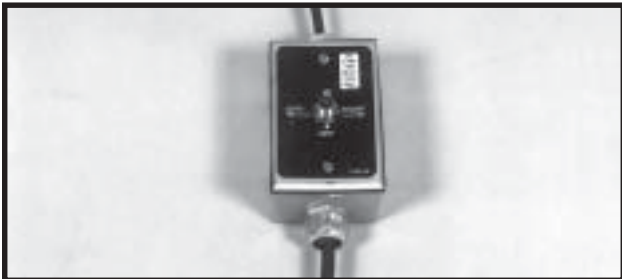

If the fuse in the wiring harness is not blown, determine if the problem is electrical or mechanical. Place the operational switch in the RIGHT or LEFT position. Check the clutch and wiring harness for power with a test light or volt meter. If the solenoid is operating properly, the plunger on the solenoid will retract causing a clicking sound. The plunger will also be magnetized which can be checked by touching the plunger with a metal object.

PRC018(PLTR65)

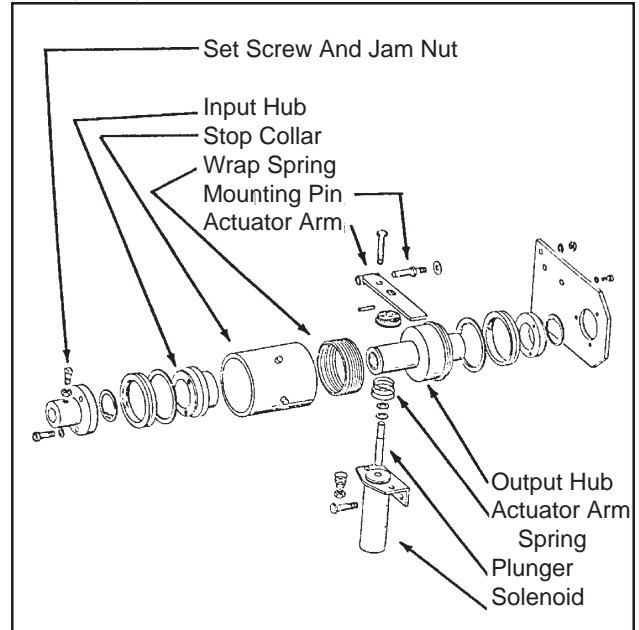

(PLTR66a)

### ACTUATOR ARM ADJUSTMENT

**NOTE: Gap between actuator arm and stop on stop collar should be not less than  $\frac{1}{16}$ " (.063") when the solenoid is NOT energized.**

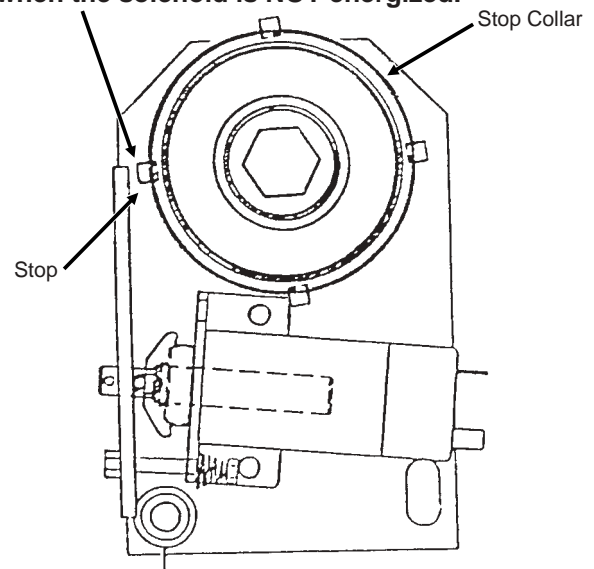

**NOTE: To adjust gap between actuator arm and stop, loosen nut on mounting pin and move pin in slot until there is at least  $\frac{1}{16}$ " gap between arm and stop on stop collar. Retighten nut.**

# MAINTENANCE

## POINT ROW WRAP SPRING CLUTCH INSPECTION (STYLE B)

The point row wrap spring clutch is permanently lubricated and requires no periodic maintenance.

76695-10



The right hand clutch operates clockwise and the left hand clutch operates counterclockwise. Therefore, some of the parts of the clutch such as the wrap spring differ from one side of the planter to the other. Be sure to use the correct repair parts if repair on the point row clutch is necessary.

**NOTE:** The point row clutch input shaft on the R.H. side of the machine will have an "R" stamped on it and the shaft on the L.H. side of the machine will have an "L" stamped on it.

The control box is equipped with a resettable circuit breaker. To reset the circuit breaker, press the red button on the circuit breaker until it snaps into place. If the circuit breaker continues to trip, check to see what is causing it to trip. See "Point Row Clutch Troubleshooting".

76740-48



If the circuit breaker on the control box is not tripped, determine if the problem is electrical or mechanical. Place the operational switch in the RIGHT or LEFT position. Check the clutch and wiring harness for power with a test light or volt meter. If the solenoid is operating properly, the plunger on the solenoid will retract causing a clicking sound. The plunger will also be magnetized which can be checked by touching the plunger with a metal object.

PRC019(PLTR53)

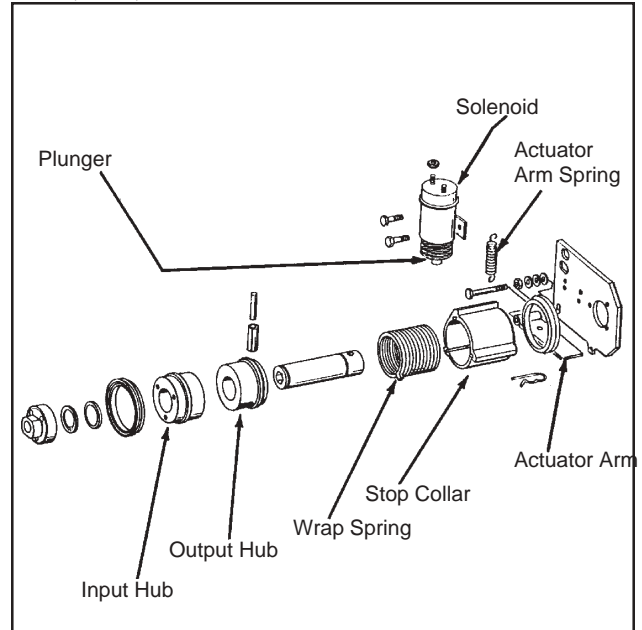

(PLTR54)

### ACTUATOR ARM ADJUSTMENT

**NOTE:** Gap between actuator arm and stop on stop collar should be  $\frac{1}{8}$ " ( $\pm \frac{1}{32}$ ") when the solenoid is NOT engaged.

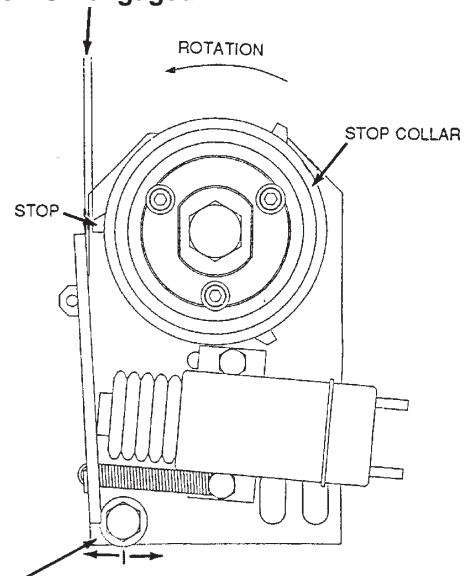

**NOTE:** To adjust gap between actuator arm and stop, loosen nut on mounting pin and move pin in slot until there is at least  $\frac{1}{8}$ " ( $\pm \frac{1}{32}$ ") gap between arm and stop on stop collar. Retighten nut.

# MAINTENANCE

## POINT ROW WRAP SPRING CLUTCH TROUBLESHOOTING

PROBLEM	POSSIBLE CAUSE	SOLUTION
Neither clutch will disengage.	*Fuse in wiring harness blown.	Replace with 10 amp slow blow fuse.
	**Circuit breaker tripped.	Press red button on control box.
	Poor terminal connection in wiring harness.	Repair or replace.
	Wiring damage in wiring harness.	Repair or replace.
	Low voltage at coil. (12 volts required)	Check battery connections.
One side of planter will not re-engage.	Shear pin in row unit transmission sheared.	Replace with one of equal size and grade.
One clutch will not engage.	Actuator arm and plunger stuck in disengaged position.	Remove, free up and reinstall.
	Actuator arm out of adjustment.	Adjust actuator arm mounting pin in slot so that actuator arm clears stop on stop collar as shown in "Point Row Wrap Spring Clutch Inspection".
	Wrap spring broken or stretched.	Disassemble clutch and replace spring.
	Foreign substance such as oil or grease on the input or output hubs.	Disassemble clutch. Clean hubs and spring and reassemble.
	Something touching the stop collar.	Check to ensure collar is free to turn with clutch.
	Clutch assembled incorrectly.	Check clutch and diagram for correct assembly.
Clutch slipping.	Wrap spring stretched.	"Lock" clutch output shaft from turning. Place torque wrench on input shaft and rotate in direction of drive. After input shaft has rotated a short distance the wrap spring should tighten onto the input hub. If slippage occurs at less than 100 ft. lbs. replace spring. If spring still slips after installing new spring, replace input hub.
Planter will not re-engage while planter is moving forward.	Spring in actuator arm not strong enough to push arm away from stop collar when operational switch is turned to the ON position.	Remove spring and stretch spring slightly or replace. Reinstall spring. If that fails, file the stop on the stop collar slightly so that the stop is not as aggressive.
Frequent solenoid burnout.	*Fuses too large.	Replace fuse in wiring harness with 10 amp slow blow fuse.
Frequent fuse burnout.	Low voltage (12 volts required).	Check power source voltage for partially discharged battery, etc.
	Damage to wiring harness.	Locate damage and repair or replace harness.
Clutch or clutches will not disengage.	Input and output shafts out of alignment.	Align input and output shafts to prevent drag.
	Input or output shaft is pushed in too far creating a coupler.	Reposition input and output shafts.

\* Applies to Style A point row wrap spring clutches only.

\*\* Applies to Style B point row wrap spring clutches only.

# MAINTENANCE

## TWO-SPEED POINT ROW WRAP SPRING CLUTCH

The two-speed point row wrap spring clutch is similar in design and operation to the standard point row wrap spring clutch except for the two-speed function. If a two-speed clutch or clutches fail to operate properly, refer to "Point Row Wrap Spring Clutch Inspection" and "Point Row Wrap Spring Clutch Troubelshooting" for additional information.

**NOTE: If the "Reduced Rate/Full Rate" functions fail to engage or disengage, see troubleshooting chart for possible cause.**

(EF29)

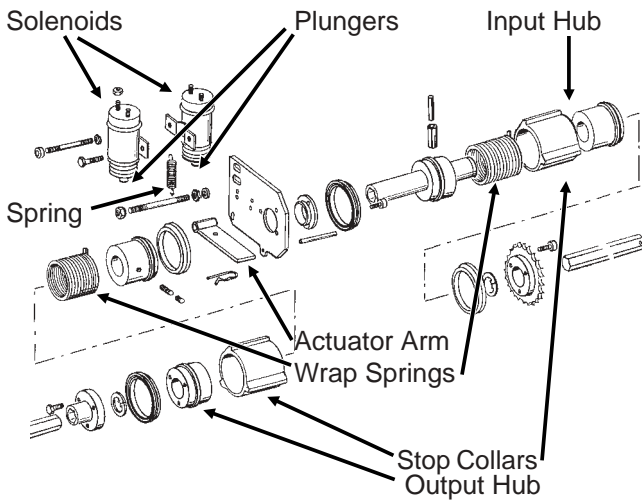

## MARKER SEQUENCING/FLOW CONTROL VALVE INSPECTION

The valve block assembly consists of the marker sequencing and flow control valves in one assembly.

The sequencing valve portion consists of a chambered body containing a spool and series of check valves to direct hydraulic oil flow. Should the valve malfunction, the components may be removed for inspection.

1. Remove valve block assembly from planter.
2. Remove detent assembly and port adapter assemblies from rear of valve block.

**IMPORTANT: Damage to the spool may occur if the detent assembly and port adapter assemblies are not removed prior to removal of the spool.**

3. Remove plug from both sides of valve block and remove spool.
4. Inspect all parts for pitting, contamination or foreign material. Also check seating surfaces inside the valve. Replace any parts found to be defective.
5. Lubricate spool with a light oil and re-install. Check to be sure spool moves freely in valve body.

**IMPORTANT: Make sure correct check ball(s) and spring are installed in each valve bore upon reassembly.**

A flow control valve is located on each side of the block assembly. The flow control valves should be adjusted for raise and lower speed as part of the assembly procedure or upon initial operation. If the valve fails to function properly or requires frequent adjustment, the needle valve should be removed for inspection. Check for foreign material and contamination. Be sure needle moves freely in adjustment screw. Replace any components found to be defective.

**NOTE: When oil is cold, hydraulics operate slowly. Make sure all adjustments are made with warm oil.**

(PLTR43)

**Port Adapter, Spring,  $\frac{7}{16}$ " Check Ball,  $\frac{1}{4}$ " Steel Ball**

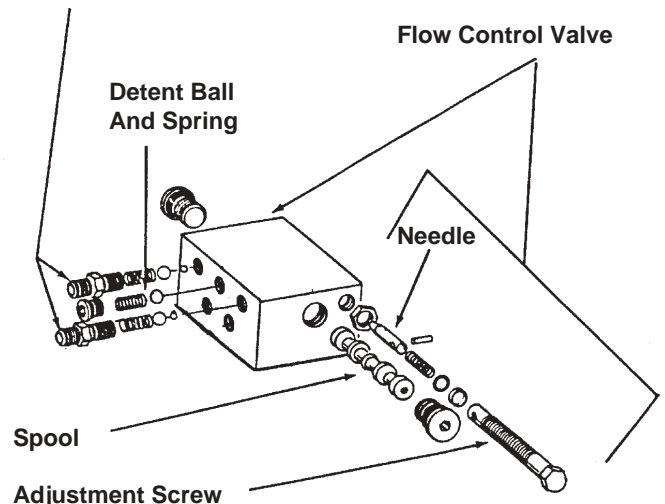

# MAINTENANCE

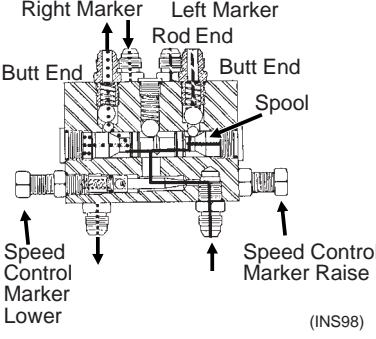
MARKER OPERATION TROUBLESHOOTING		
PROBLEM	POSSIBLE CAUSE	SOLUTION
<p>Same marker always operating.</p>  <p>(INS98)</p>	<p>Spool in sequencing valve not shifting.</p>	<p>Remove spool. Inspect for foreign material, making sure all ports in spool are open. Clean and reinstall.</p>
<p>Both markers lowering and only one raising at a time.</p>	<p>Hoses from cylinders to valve connected backwards.</p>	<p>Check hosing diagram in manual and correct.</p>
<p>Both markers lower and raise at same time</p>	<p>Foreign material under check ball in sequencing valve.</p>	<p>Remove hose fitting, spring and balls and clean. May be desirable to remove spool and clean as well.</p>
	<p>Check ball missing or installed incorrectly in sequencing valve.</p>	<p>Disassemble and correct. See above illustration.</p>
<p>Marker (in raised position) settling down.</p>	<p>Damaged o-ring in marker cylinder or cracked piston.</p>	<p>Disassemble cylinder and inspect for damage and repair.</p>
	<p>Spool in sequencing valve not shifting completely because detent ball or spring is missing.</p>	<p>Check valve assembly and install parts as needed.</p>
	<p>Spool in sequencing valve shifting back toward center position.</p>	<p>Restrict flow of hydraulic oil from tractor to sequencing valve.</p>
<p>Neither marker will move.</p>	<p>Flow control closed too far.</p>	<p>Loosen locking nut and turn flow control adjustment bolt out or counterclockwise until desired speed is set.</p>
<p>Markers moving too fast.</p>	<p>Flow control open too far.</p>	<p>Loosen locking nut and turn flow control adjustment bolt in or clockwise until desired speed is set.</p>
<p>Sporadic marker operation speed.</p>	<p>Needle sticking open in flow control valve.</p>	<p>Remove flow control, inspect and repair or replace.</p>

# MAINTENANCE

LIFT CIRCUIT OPERATION TROUBLESHOOTING			
PROBLEM	POSSIBLE CAUSE	TROUBLESHOOTING*	SOLUTION
Planter raising uneven.	Master cylinder is leaking.	Raise planter <b>slowly</b> until master cylinder reaches end of stroke. If master cylinder is leaking it will lag behind the slave cylinder and the tire will squat less. If planter settles when hydraulic lever is released, check assist cylinders.	Check for contamination in rephasing valve in piston. Prior to removing rephasing valve, measure the set screw setting by turning the set screw clockwise and counting the revolutions until it bottoms out. After cleaning rephasing valve, bottom the screw out and back it out the same number of revolutions as the original setting. Replace rephasing valve and adjust as stated above or replace piston. Install seal kit. Consult your KINZE® Dealer for leak testing and rephasing valve adjustment if necessary.
	Slave cylinder is leaking.	Raise and lower planter. As planter lowers the side with leaking slave cylinder will drop rapidly. Install wheel lockups on master and assist cylinders. Retract slave cylinder and observe which tire falls. If planter settles when hydraulic lever is released, check assist cylinders.	Check for contamination in rephasing valve in piston. Prior to removing rephasing valve, measure the set screw setting by turning the set screw clockwise and counting the revolutions until it bottoms out. After cleaning rephasing valve, bottom the screw out and back it out the same number of revolutions as the original setting. Replace rephasing valve and adjust as stated above or replace piston. Install seal kit. Consult your KINZE® Dealer for leak testing and rephasing valve adjustment if necessary.
Planter raising even; however, planter settles when hydraulic lever is released.	Assist cylinder is leaking.	Install lockups on the master cylinder. Retract assist cylinder and observe which tire falls.	Seal on piston is leaking. Install seal kit.

\* Operate hydraulics slowly to accentuate the problem. Rephase after each lowering cycle.



# MAINTENANCE

## MARKER BEARING LUBRICATION OR REPLACEMENT

1. Remove marker blade.
2. Remove dust cap from hub.
3. Remove cotter pin, nut and washer.
4. Slide hub from spindle.
5. Remove bearings and cups and discard if bearings are being replaced. Clean hub and dry. Remove bearings only and not cups if repacking.
6. Press in new bearing cups with thickest edge facing in. (Bearing replacement procedure only.)
7. Pack bearings with heavy duty wheel bearing grease thoroughly forcing grease between roller cone and bearing cage. Also fill the space between the bearing cups in the hub with grease.
8. Install rubber seal into grease seal. Place inner bearing in place and press in new rubber seal/grease seal.
9. Clean spindle and install hub.
10. Install outer bearing, washer or outer seal and slotted hex nut. Tighten slotted hex nut while rotating hub until there is some drag. This assures that all bearing surfaces are in contact. Back off slotted nut to nearest locking slot and install cotter pin.
11. Fill dust caps approximately  $\frac{3}{4}$  full of wheel bearing grease and install on hub.
12. Install blade and dust cap retainer on hub and tighten evenly and securely.

(PLTR45/PLTR99/PLTR98/PLTR102)

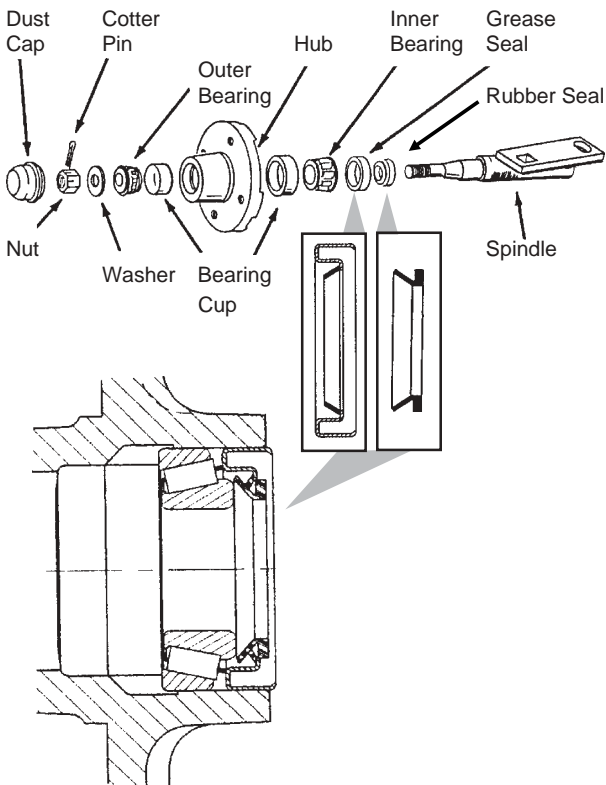

## WHEEL BEARING LUBRICATION OR REPLACEMENT

1. Raise tire clear of ground and remove wheel.
2. Remove double jam nuts and slide hub from spindle.
3. Remove bearings and cups and discard if bearings are being replaced. Clean hub and dry. Remove bearings only and not cups if repacking.
4. Press in new bearing cups with thickest edge facing in. (Bearing replacement procedure only.)
5. Pack bearings with heavy duty wheel bearing grease thoroughly forcing grease between roller cone and bearing cage. Also fill the space between the bearing cups in the hub with grease.
6. Place inner bearing in place.
7. Clean spindle and install hub.
8. Install outer bearing and jam nut. Tighten jam nut while rotating hub until there is some drag. This assures that all bearing surfaces are in contact. Back off jam nut  $\frac{1}{4}$  turn or until there is only slight drag when rotating the hub. Install second jam nut to lock against first.
9. Install wheel on hub and tighten evenly and securely.

PTD57(PLTR46)

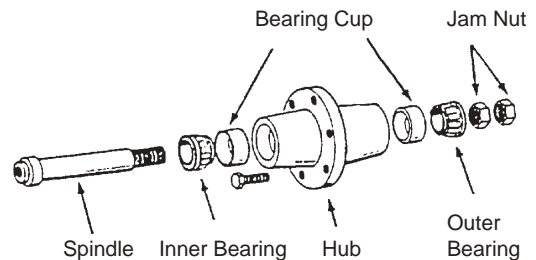

# MAINTENANCE

## PREPARATION FOR STORAGE

Store the planter in a dry sheltered area if possible.

Remove all trash that may be wrapped on sprockets or shafts and remove dirt that can draw and hold moisture.

Clean all drive chains and coat with a rust preventative spray, or remove chains and submerge in oil.

Lubricate planter and row units at all lubrication points.

If possible, remove weight from all tires particularly if the unit is stored outdoors, in which case it is best to remove wheels and tires for storage in a cool dry area.

Inspect the planter and row units for parts that are in need of replacement and order during the "off" season.

Make sure all seed, herbicide and insecticide hoppers are empty and clean.

Clean seed meters and store in a rodent-free dry area.

Remove seed discs from brush-type seed meter. Clean and store meters with discs removed.

Grease exposed areas of cylinder rods before storing planter.

Grease or paint disc openers and marker blades to prevent rust.

## ELECTRICAL WIRING DIAGRAM FOR LIGHT PACKAGE

(WGN66)

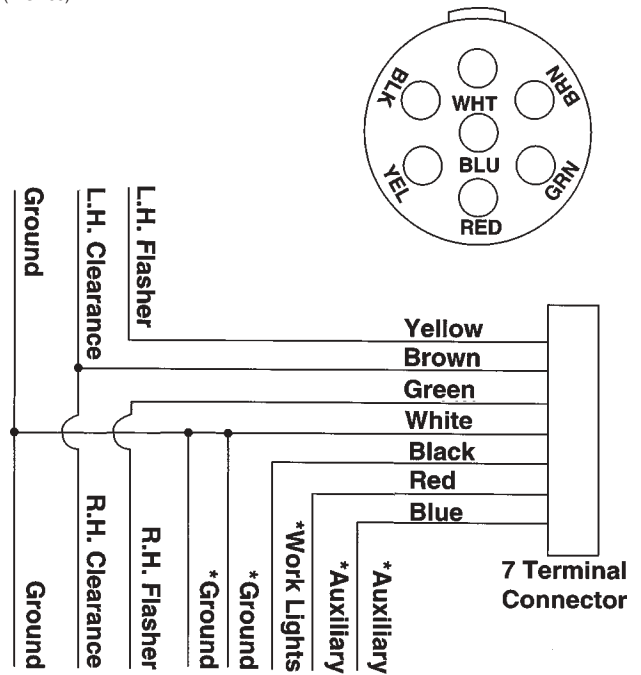

\*Optional lights and wires (to be supplied by customer) may be wired into existing plug terminals.

Light package supplied on the Model 2200 planter meets ASAE Standards. For the correct wiring harness to be wired into the lights on your tractor, check with the tractor manufacturer.

69922-35



# MAINTENANCE

## ELECTRICAL WIRING DIAGRAMS FOR POINT ROW WRAP SPRING CLUTCHES

### STYLE A

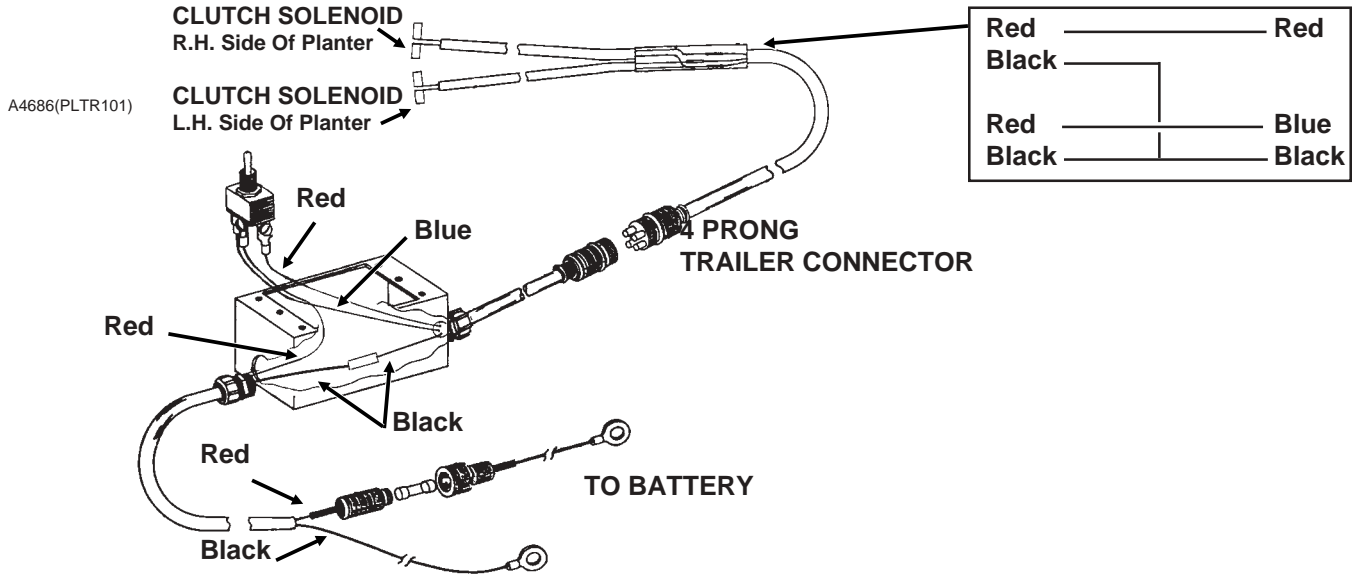

# MAINTENANCE

## ELECTRICAL WIRING DIAGRAMS FOR POINT ROW WRAP SPRING CLUTCHES

### STYLE B

(EF10/ONS241/SFP6)

CONTROL BOX ON TRACTOR

12 Amp Circuit Breaker

TRACTOR HARNESS

PLANTER HARNESS

TO BATTERY

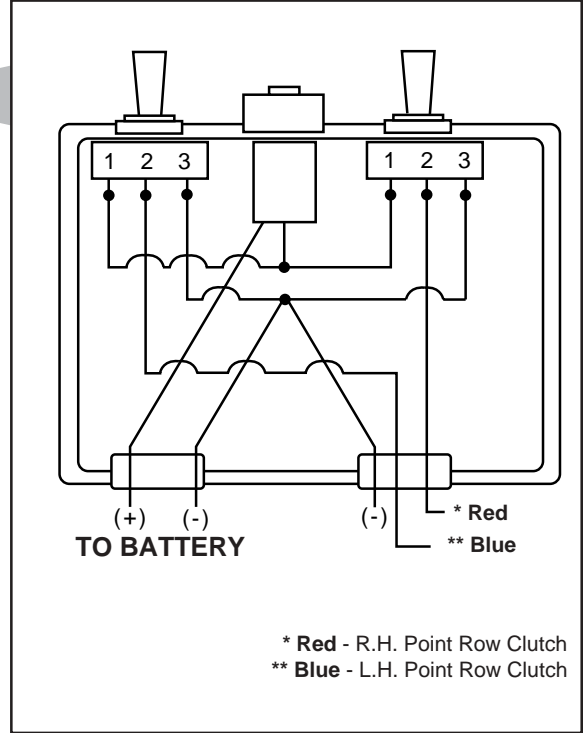

Black Blue Orange Red

Connects To Point Row Clutch Solenoid On L.H. Side Of Planter

Connects To Point Row Clutch Solenoid On R.H. Side Of Planter

POINT ROW CLUTCH FOR R.H. SIDE OF PLANTER

# MAINTENANCE

## ELECTRICAL WIRING DIAGRAMS FOR TWO-SPEED POINT ROW WRAP SPRING CLUTCHES

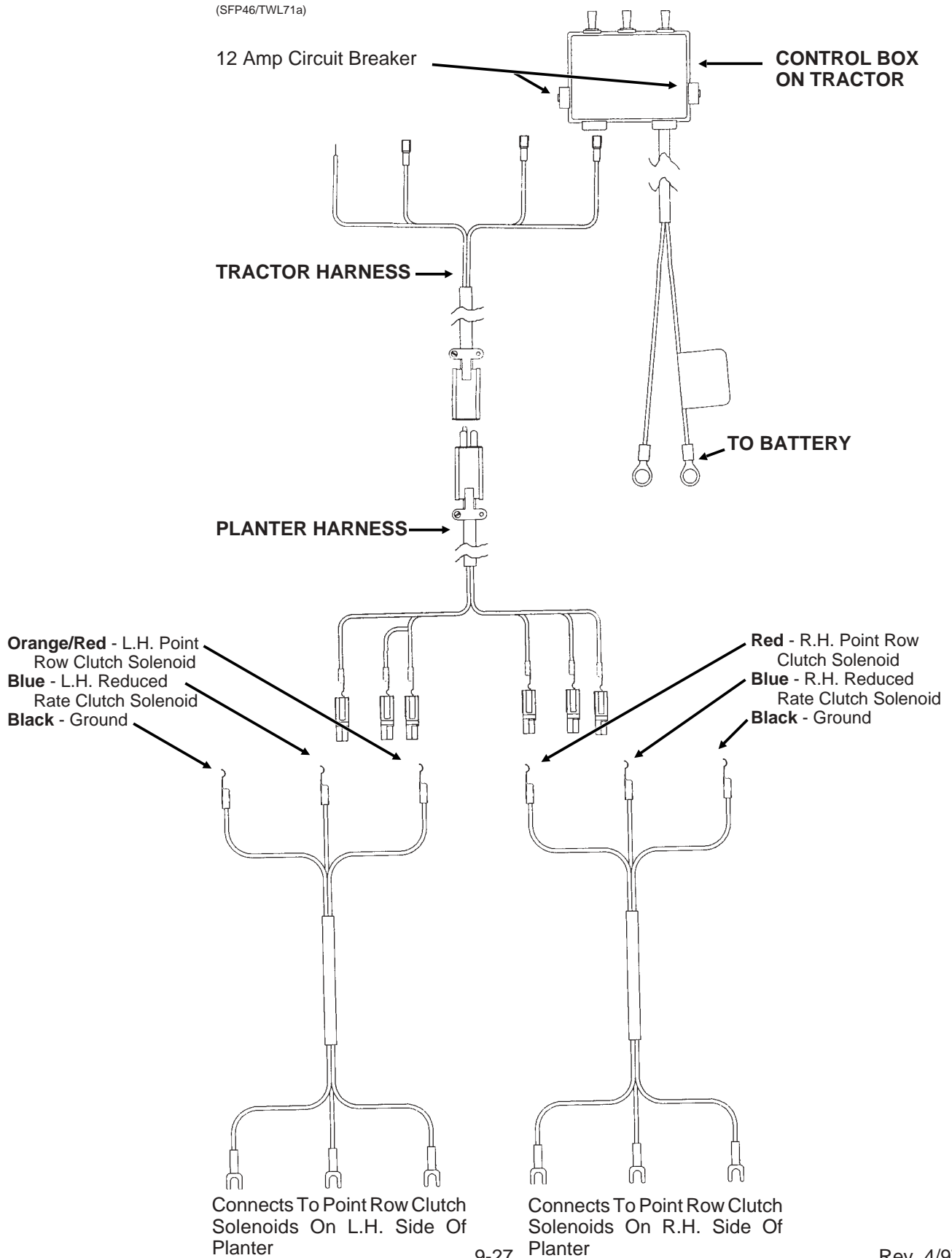

# MAINTENANCE

## ELECTRICAL WIRING DIAGRAMS FOR TWO-SPEED POINT ROW WRAP SPRING CLUTCHES

(INS242)

CONTROL BOX  
ON TRACTOR

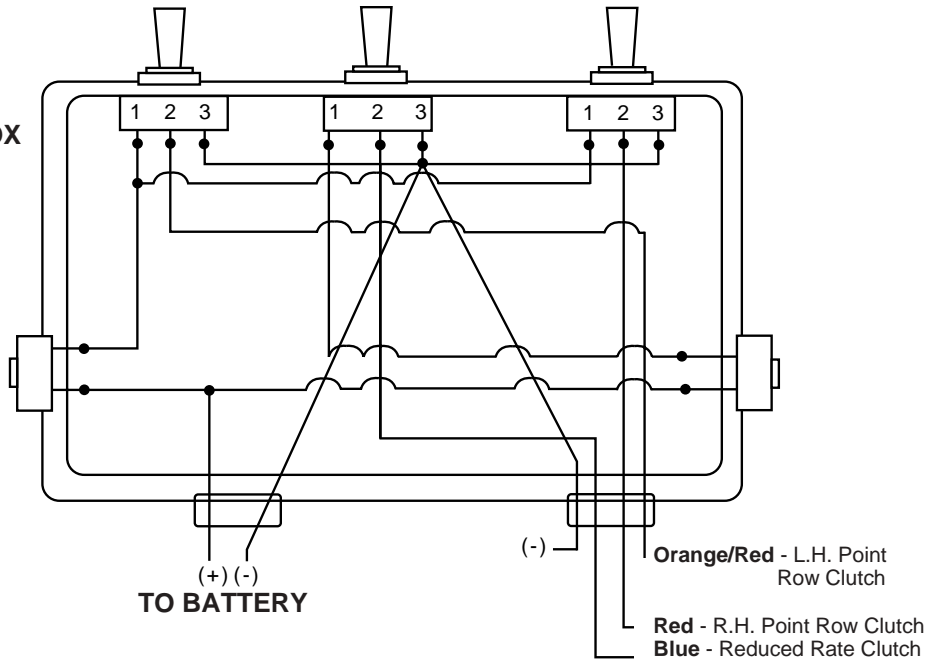

### TWO-SPEED POINT ROW CLUTCH FOR L.H. SIDE OF PLANTER SHOWN

(INS126)

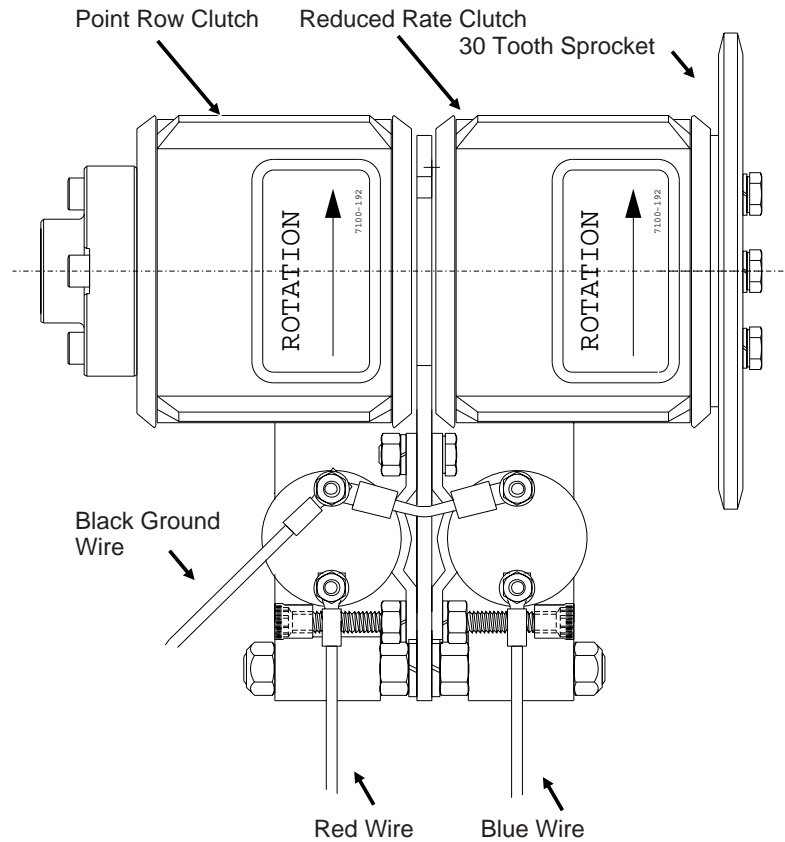

# MAINTENANCE

## HYDRAULIC SYSTEM SCHEMATIC

### Planter Raising

(INS103/INS104)

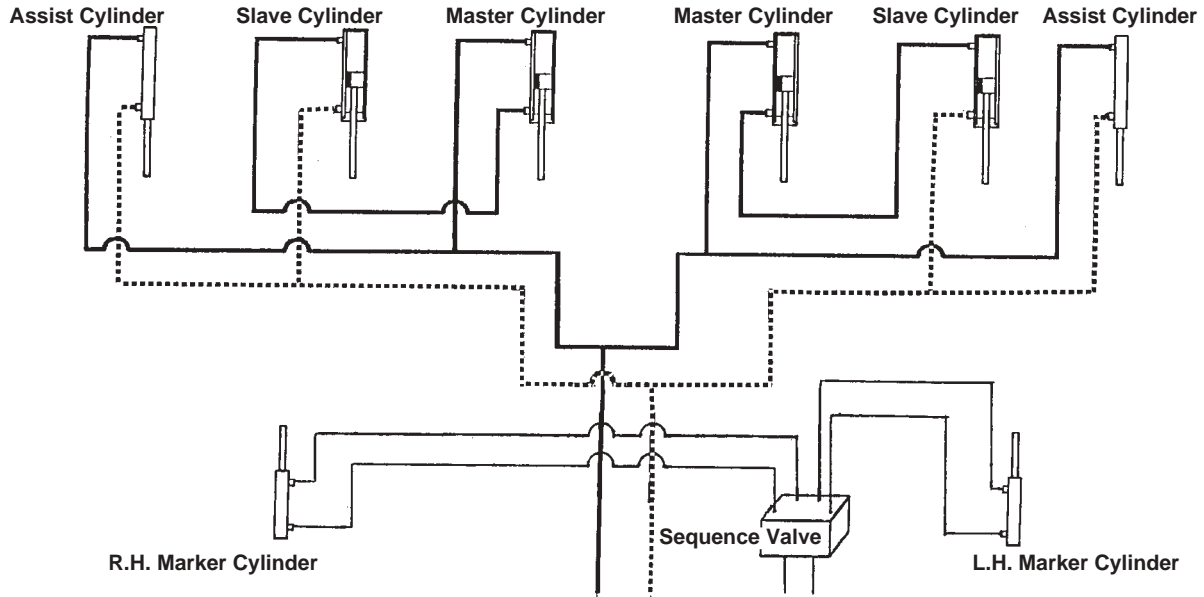

Return Oil .....  
Pressure Oil ———

## HYDRAULIC SYSTEM SCHEMATIC

### Planter Lowering

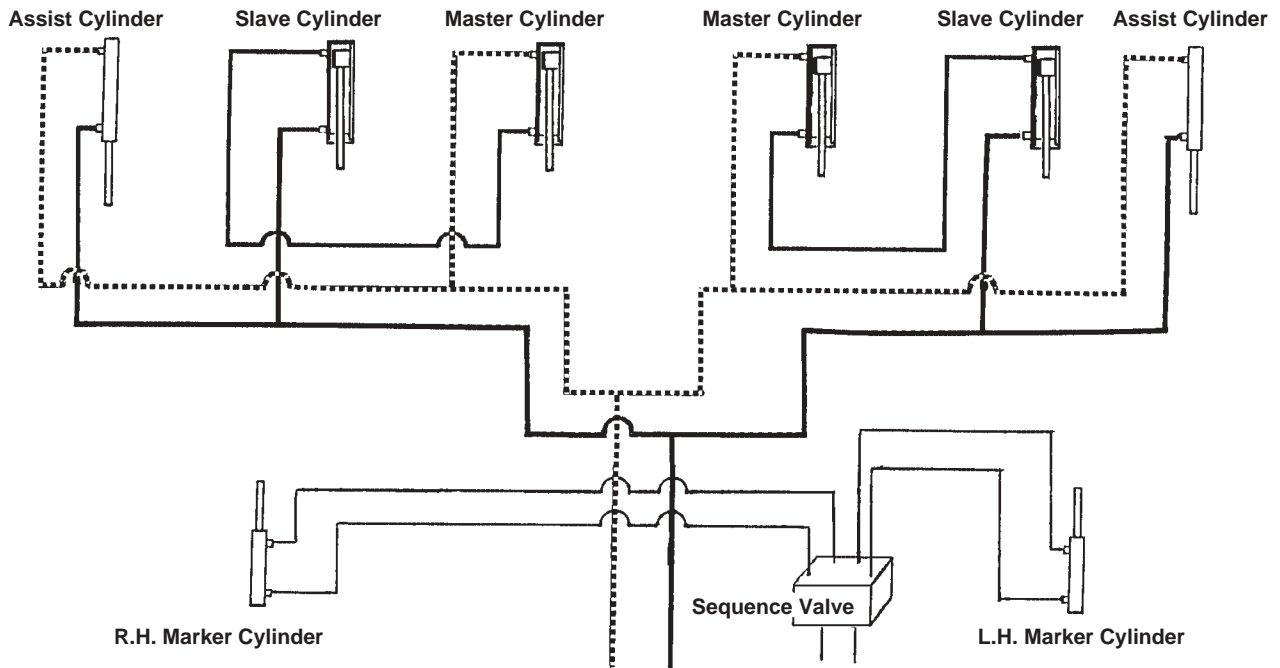

Return Oil .....  
Pressure Oil ———

# MAINTENANCE

---



# PARTS LIST INDEX

---

## ROW UNIT

Bed Leveler, Row Unit Mounted .....	P20
Brush-Type Seed Meter .....	P13
Covering Discs/Single Press Wheel .....	P6
Disc Furrower, Row Unit Mounted .....	P21
Finger Pickup Seed Meter .....	P12
Frame Mounted Coulter W/Disc Furrower .....	P24
Gauge Wheel .....	P5
Granular Chemical Banders .....	P14
Granular Chemical Hopper With Meter(s) And Throwout .....	P16
Granular Chemical Sub-Assemblies And Kits .....	P15
Hopper Support And Meter Drive .....	P10
No Till Coulter, Row Unit Mounted .....	P19
Parallel Arms, Mounting Support Plate And Quick Adjustable Down Force Springs .....	P4
Residue Wheel, Row Unit Mounted .....	P22
Residue Wheels, Coulter Mounter .....	P23
Seed Firming Wheel .....	P9
Seed Hopper .....	P11
Shank Assembly .....	P2
Spring Tooth Incorporator .....	P18
“V” Closing Wheels .....	P8

## BASE MACHINE

Contact Drive Wheel And Arm Assembly .....	P32
Cylinders .....	P49
Driveline .....	P34
Electrical Components .....	P62
Hitch And Frame Assembly .....	P26
Hydraulic System .....	P54
Hydraulic Wing Fold (Optional) .....	P28
Hydraulic Wing Fold Selector Valve .....	P53
Marker Assembly .....	P46
Marker Sequencing/Flow Control Valve .....	P52
Marker Spindle/Hub/Blade .....	P48
Point Row Wrap Spring Clutch (Optional) .....	P36
Safety Chain .....	P26
Transmission Assembly .....	P44
Transport And Ground Drive Wheel Assembly .....	P30
Two-Speed Point Row Wrap Spring Clutch .....	P40
Two-Speed Point Row Wrap Spring Clutch Drive .....	P42

## ELECTRONIC SEED MONITOR

Electronic Seed Monitor .....	P56
-------------------------------	-----

## FERTILIZER

Notched Single Disc Fertilizer Opener And Mount (Row Unit Mounted) .....	P58
SMV Sign, Decals, Reflectors And Tie Straps .....	P60
Numerical Index .....	a

# SHANK ASSEMBLY

RUB006/RUA044(RU1a)

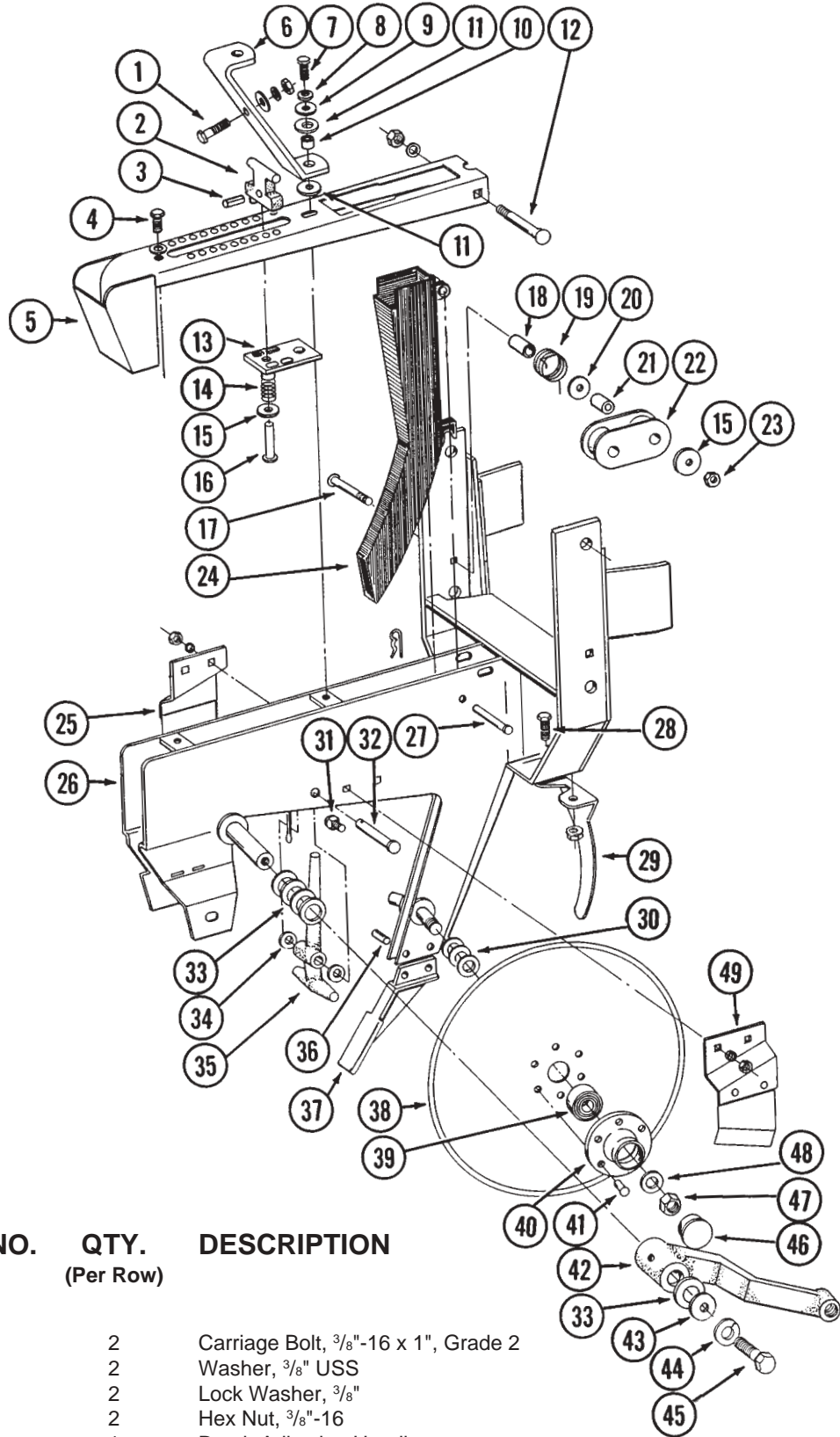

ITEM	PART NO.	QTY. (Per Row)	DESCRIPTION
1.	G10305	2	Carriage Bolt, 3/8"-16 x 1", Grade 2
	G10210	2	Washer, 3/8" USS
	G10229	2	Lock Washer, 3/8"
	G10101	2	Hex Nut, 3/8"-16
2.	GB0102	1	Depth Adjusting Handle
3.	G10605	1	Spring Pin, 5/32" x 3/4"
4.	G10001	1	Hex Head Cap Screw, 3/8"-16 x 1"
	G10229	1	Lock Washer, 3/8"
5.	GA0811	1	Shank Cover
6.	GD1027	1	Stabilizer Bracket

# SHANK ASSEMBLY

ITEM	PART NO.	QTY. (Per Row)	DESCRIPTION
7.	G10003	1	Hex Head Cap Screw, $\frac{3}{8}$ "-16 x 1 $\frac{1}{2}$ "
8.	G10229	1	Lock Washer, $\frac{3}{8}$ "
9.	G10208	1	Special Washer, $\frac{13}{32}$ "
10.	GD1110	1	Bushing, $\frac{1}{2}$ "
11.	GD1120	2	Rubber Washer
12.	G10304	1	Carriage Bolt, $\frac{3}{8}$ "-16 x 3", Grade 2
	G10108	1	Lock Nut, $\frac{3}{8}$ "-16
13.	GB0105	1	Depth Adjusting Slide
14.	GD1066	1	Compression Spring
15.	G10210	1	Washer, $\frac{3}{8}$ " USS
16.	G10552	1	Clevis Pin, $\frac{3}{8}$ " x 2"
17.	G10307	1	Carriage Bolt, $\frac{3}{8}$ "-16 x 3 $\frac{1}{2}$ ", Grade 2
18.	GD7318	1	Bushing, 1"
19.	GD1065	1	Idler Spring
20.	G10201	1	Special Washer
21.	GD1026	1	Spacer, 1 $\frac{3}{16}$ "
22.	GD9240	1	Idler
23.	G10108	1	Lock Nut, $\frac{3}{8}$ "-16
24.	GD1130	-	Seed Tube, Regular
	GA5880	-	Seed Tube W/High Rate Sensor
	GR1062	-	Seed Tube (With Holes For High Rate Sensor Installation)
	GR1087	-	Sensor Only (For GA5880)
25.	GA2012L	1	Disc Scraper, L.H.
26.	GA0860	1	Shank
27.	G10551	1	Clevis Pin, $\frac{1}{4}$ " x 2 $\frac{1}{2}$ "
	G10669	1	Hair Pin Clip, No. 22
28.	G10312	2	Carriage Bolt, $\frac{5}{16}$ "-18 x $\frac{3}{4}$ ", Grade 2
	G10620	2	Flange Nut, $\frac{5}{16}$ "-18
29.	GD1033	1	Shield
30.	G10213	-	Machine Bushing, .030" Gauge (As Required)
31.	G10328	4	Hex Head Cap Screw, $\frac{3}{8}$ "-16 x $\frac{5}{8}$ "
	G10622	4	Hex Flange Nut, $\frac{3}{8}$ "-16
32.	G10555	1	Clevis Pin, $\frac{1}{2}$ " x 2 $\frac{1}{2}$ "
	G10451	1	Cotter Pin, $\frac{1}{8}$ " x 1"
33.	G10526	-	Spacer Washer, .048" Gauge (As Required)
34.	G10206	2	Washer, $\frac{1}{2}$ " SAE
35.	GB0104	1	Depth Adjusting Stop
36.	G10814	2	Spring Pin, $\frac{1}{4}$ " x $\frac{7}{8}$ "
37.	GB0103	1	Seed Tube Guard/Inner Scraper
38.	GD1030	2	Disc, 15"
39.	GA2014	2	Bearing
40.	GD1031	2	Housing
41.	G10427	12	Rivet, $\frac{1}{4}$ " x $\frac{1}{2}$ "
42.		-	See "Gauge Wheel", Page P5
43.	G10216	2	Washer, $\frac{1}{2}$ " USS
44.	G10228	2	Lock Washer, $\frac{1}{2}$ "
45.	G10014	2	Hex Head Cap Screw, $\frac{1}{2}$ "-13 x 1"
46.	GD6533	2	Dust Cap
47.	G10503	1	Jam Nut, $\frac{5}{8}$ "-11, R.H.
	G10504	1	Jam Nut, $\frac{5}{8}$ "-11, L.H.
48.	G10204	2	Machine Bushing, $\frac{21}{32}$ "
49.	GA2012R	1	Disc Scraper, R.H.
A.	GA2013	-	Disc And Bearing Assembly, Less Bearing Cap (Items 38-41)
B.	G1K212	-	Meter Drive Idler Kit (Items 15 And 17-23)

# PARALLEL ARMS, MOUNTING SUPPORT PLATE AND QUICK ADJUSTABLE DOWN FORCE SPRINGS

RUB007/RUB015/RUB016/RUB013/RUB019/RUB020(RU2a/RU3/RU4)

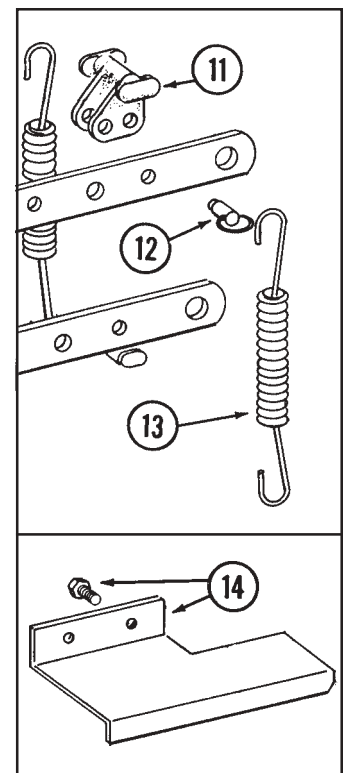
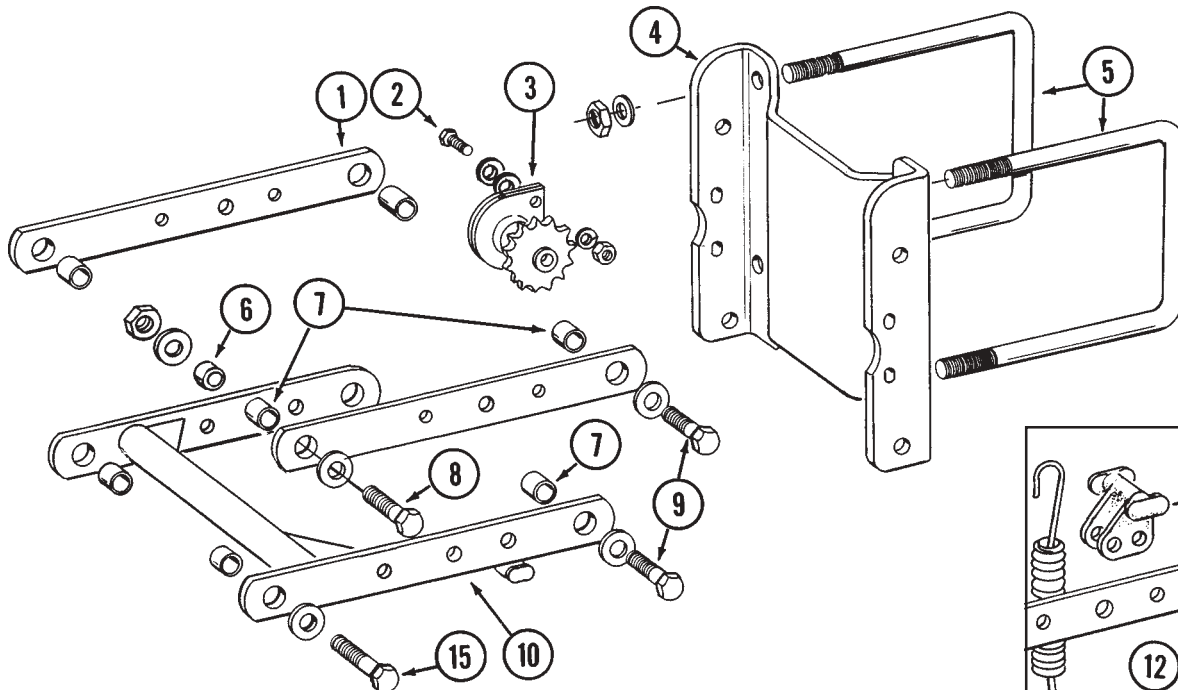

ITEM	PART NO.	QTY. (Per Row)	DESCRIPTION
1.	GD7619	2	Upper Parallel Arm
2.	G10004	2	Hex Head Cap Screw, 3/8"-16 x 1 1/4"
	G10210	-	Washer, 3/8" USS (As Required)
	G10229	2	Lock Washer, 3/8"
	G10101	2	Hex Nut, 3/8"-16
3.	GA1720	1	Bearing/Sprocket, 7/8" Bore
4.	GD10036	1	Mounting Support Plate
5.	GD1114	2	U-Bolt, 7" x 7" x 5/8"-11
	G10177	-	Hex Head Cap Screw, 5/8"-11 x 9 1/2"
	G10230	4	Lock Washer, 5/8"
	G10104	4	Hex Nut, 5/8"-11
6.	GD1109	2	Pivot Bushing, 1/4"
7.	GB0218	8	Bushing, 19/32"
8.	G10752	2	Hex Head Cap Screw, 5/8"-18 x 2 1/4"
	GD7805	4	Special Washer
	G10412	2	Lock Nut, 5/8"-18
9.	G10732	6	Hex Head Cap Screw, 5/8"-18 x 2"
	GD7805	6	Special Washer
	G10412	6	Lock Nut, 5/8"-18
10.	GA5651	1	Lower Parallel Arm
11.	GB0186	2	Spring Anchor
12.	G10545	2	Detent Pin, 1" Grip
13.	GD8249	-	Spring
14.	G7192X	-	Chain Shield Package With Hardware
	G10037	-	Hex Head Cap Screw, 1/2"-13 x 1 1/4"
	G10228	-	Lock Washer, 1/2"
	G10102	-	Hex Nut, 1/2"-13
15.	G10751	2	Hex Head Cap Screw, 5/8"-18 x 1 3/4"
	GD7805	2	Special Washer
	G10412	2	Lock Nut, 5/8"-18

# GAUGE WHEEL

RUB001/RUB018/RUA039/RUB018/RUA044(RU5a/RU6/RU7)

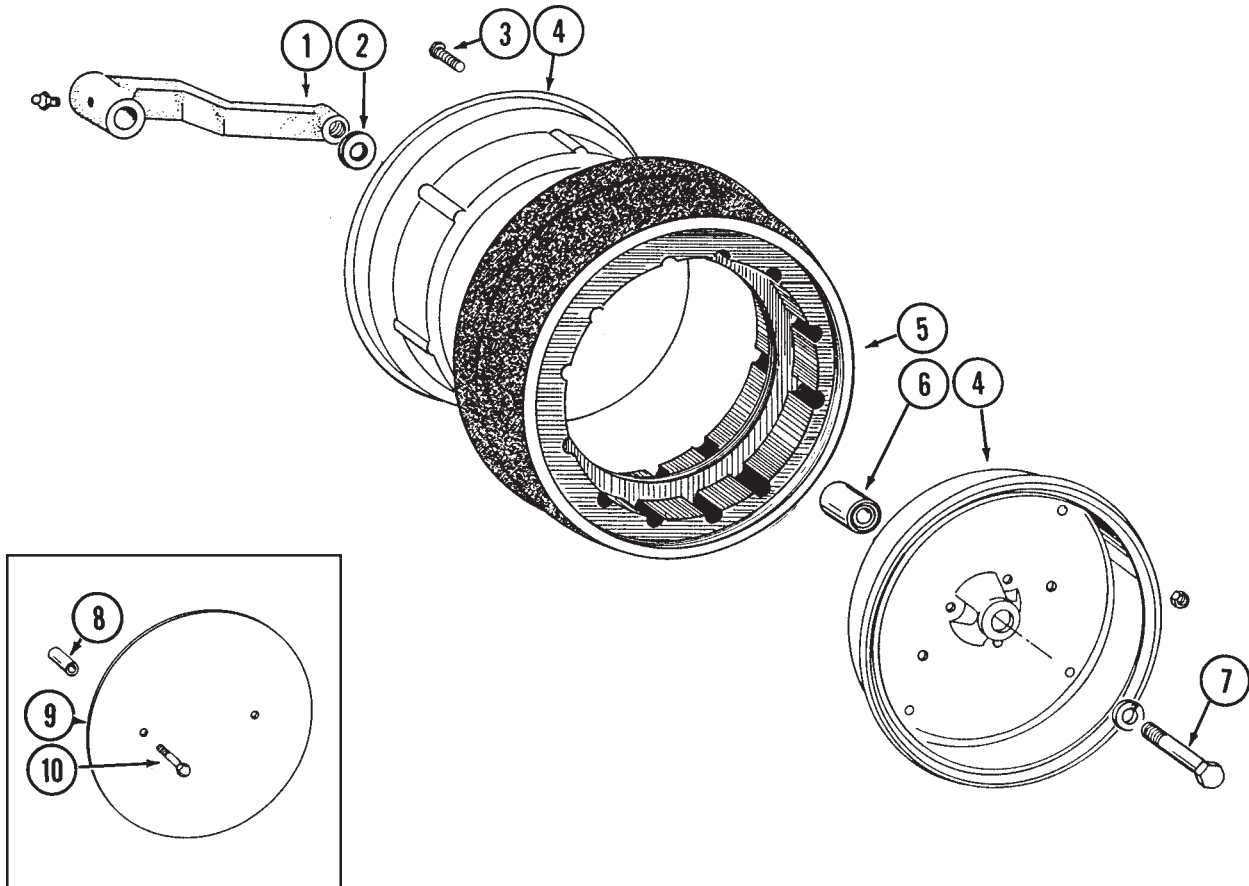

ITEM	PART NO.	QTY. (Per Row)	DESCRIPTION
1.	GA6614	2	Wheel Arm With Grease Fitting
	G10640	2	Grease Fitting, 1/4"-28
2.	G10204	1	Machine Bushing, 2 1/32"
3.	G10018	14	Hex Head Cap Screw, 5/16"-18 x 5/8"
	G10109	14	Lock Nut, 5/16"-18
4.	GD1048	4	Half Wheel
5.	GD1086	2	Tire
6.	GA6171	2	Bearing
7.	G10010	2	Hex Head Cap Screw, 5/8"-11 x 3"
	G10230	2	Lock Washer, 5/8"
8.	GD0973	4	Wheel Cover Sleeve, 1 1/2" (Optional)
9.	GD1353	2	Wheel Cover (Optional)
10.	G10069	4	Hex Head Cap Screw, 5/16"-18 x 2 1/4"
	G10232	4	Lock Washer, 5/16"
	G10106	4	Hex Nut, 5/16"-18
A.	GA6615	-	Gauge Wheel Complete (Items 3-6)

# COVERING DISCS/SINGLE PRESS WHEEL

RUA042/RUA044(RU8)

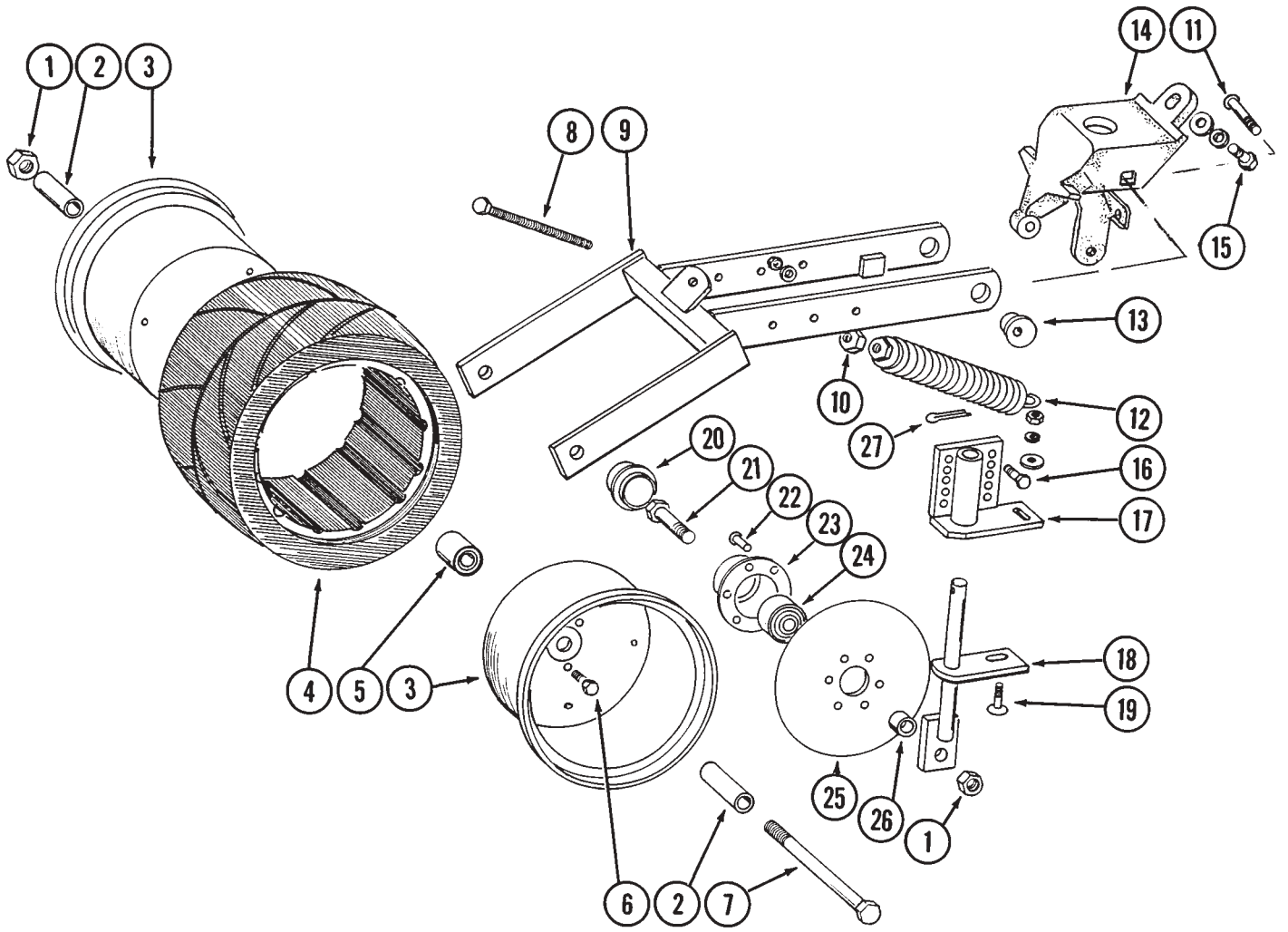

# COVERING DISCS/SINGLE PRESS WHEEL

---

ITEM	PART NO.	QTY. (Per Row)	DESCRIPTION
1.	G10107	3	Lock Nut, 5/8"-11
2.	GD3181-12	2	Spacer, 2 7/8"
3.	GD9562	2	Half Wheel
4.	GD9305	1	Tire
5.	GA6171	1	Bearing
6.	G10018	7	Hex Head Cap Screw, 5/16"-18 x 5/8"
	G10109	7	Lock Nut, 5/16"-18
7.	G10152	1	Hex Head Cap Screw, 5/8"-11 x 9"
8.	G10015	1	Adjusting Bolt, 1/2"-13 x 5"
9.	GA6619	1	Mounting Arm
10.	G10102	1	Hex Nut, 1/2"-13
11.	G10747	2	Carriage Bolt, 1/2"-13 x 2"
	G10111	2	Lock Nut, 1/2"-13
12.	GA2054	1	Spring
13.	GB0239	2	Eccentric Bushing
14.	GB0233	1	Wheel Arm Stop
15.	G10003	1	Hex Head Cap Screw, 3/8"-16 x 1 1/2"
	G10229	1	Lock Washer, 3/8"
	G10210	2	Washer, 3/8" USS
16.	G10171	4	Hex Head Cap Screw, 5/16"-18 x 1 1/4"
	G10232	4	Lock Washer, 5/16"
	G10106	4	Hex Nut, 5/16"-18
17.	GA6620	2	Bracket
18.	GA6618	2	Mount
19.	G10303	2	Carriage Bolt, 5/16"-18 x 1"
	G10219	2	Washer, 5/16" USS
	G10232	2	Lock Washer, 5/16"
	G10106	2	Hex Nut, 5/16"-18
20.	GD6533	2	Cap
21.	G10006	2	Hex Head Cap Screw, 5/8"-11 x 2 1/4"
22.	G10427	12	Rivet, 1/4" x 1/2"
23.	GD1031	2	Bearing Housing
24.	GA2014	2	Bearing
25.	GD9290	2	Blade, 8" Diameter
26.	GD1109	2	Spacer, 1/4"
A.	GA6733	-	Single Press Wheel Complete With Bearing (Items 3-6)
B.	GA6801	-	Covering Disc Complete With Bearing (Items 22-25)

# "V" CLOSING WHEELS

RUB004/RUA044/RUA046(RU9)

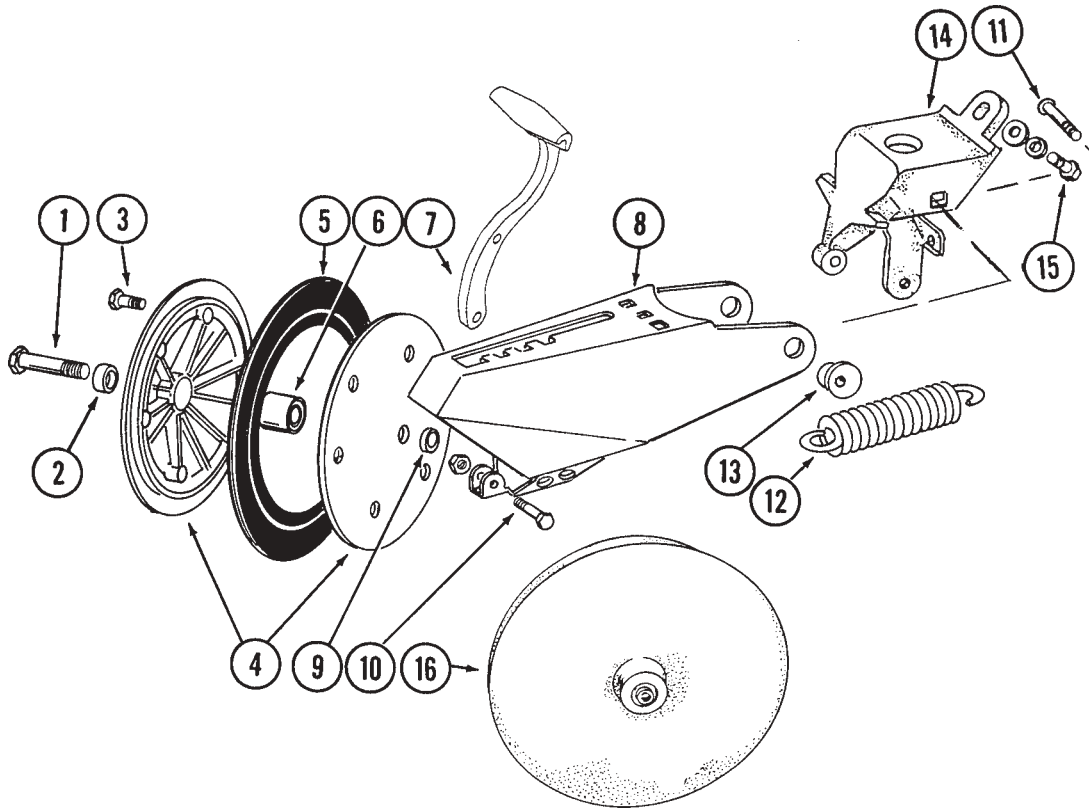

ITEM	PART NO.	QTY. (Per Row)	DESCRIPTION
1.	G10013	2	Hex Head Cap Screw, $\frac{5}{8}$ "-11 x 3 $\frac{1}{2}$ "
	G10107	2	Lock Nut, $\frac{5}{8}$ "-11
2.	GB0218	2	Bushing, $\frac{19}{32}$ "
3.	G10064	6	Hex Head Cap Screw, $\frac{1}{4}$ "-20 x 1"
	G10103	6	Hex Nut, $\frac{1}{4}$ "-20
4.	GD9120	4	Nylon Half Wheel
5.	GD1085	2	Rubber Tire, 1" x 12"
6.	GA6171	2	Bearing
7.	GB0254	1	Lever
8.	GA6613	1	Arm
9.	GD1109	2	Bushing, $\frac{1}{4}$ "
10.	G10133	1	Hex Head Cap Screw, $\frac{5}{16}$ "-18 x 1 $\frac{1}{2}$ "
	G10109	1	Lock Nut, $\frac{5}{16}$ "-18
11.	G10747	2	Carriage Bolt, $\frac{1}{2}$ "-13 x 2"
	G10111	2	Lock Nut, $\frac{1}{2}$ "-13
12.	GD8460	1	Spring
13.	GB0219	2	Eccentric Bushing
14.	GB0233	1	Wheel Arm Stop
15.	G10003	1	Hex Head Cap Screw, $\frac{3}{8}$ "-16 x 1 $\frac{1}{2}$ "
	G10229	1	Lock Washer, $\frac{3}{8}$ "
	G10210	2	Washer, $\frac{3}{8}$ " USS
16.	GA6597	-	Cast Iron Closing Wheel W/Bearing
	GA6171	-	Bearing
A.	GA6434	-	Rubber Closing Wheel Complete With Bearing (Items 3-6)



# SEED FIRING WHEEL

RUB006/RUA044(RU10a)

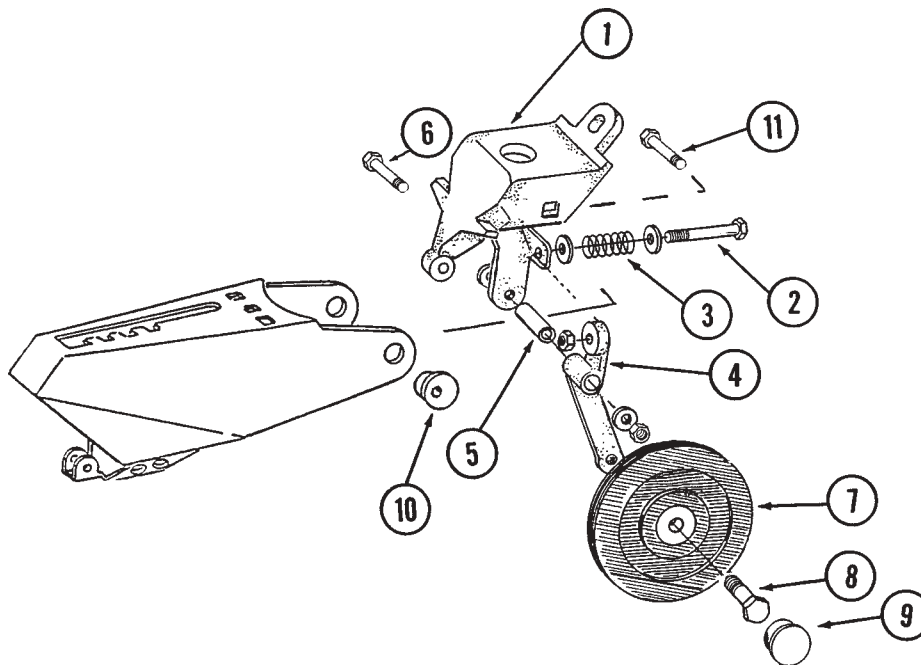

ITEM	PART NO.	QTY.	DESCRIPTION
		(Per Row)	
1.	GB0233	1	Wheel Arm Stop
2.	G10062	1	Hex Head Cap Screw, $\frac{3}{8}$ "-16 x 3"
	G10210	2	Washer, $\frac{3}{8}$ " USS
	G10108	1	Lock Nut, $\frac{3}{8}$ "-16
3.	GD9787	1	Spring
4.	GB0245	1	Arm
5.	GD9786	1	Bushing
6.	G10049	1	Hex Head Cap Screw, $\frac{3}{8}$ "-16 x 2 $\frac{1}{2}$ "
	G10210	2	Washer, $\frac{3}{8}$ " USS
	G10108	1	Lock Nut, $\frac{3}{8}$ "-16
7.	GA7580	1	Seed Firming Wheel W/Bearing And Snap Ring
	GA2014	-	Bearing
	G10770	-	Snap Ring
8.	G10055	1	Hex Head Cap Screw, $\frac{5}{8}$ "-11 x 1 $\frac{1}{4}$ "
9.	GD1079	1	Dust Cap
10.	GB0219	2	Eccentric Bushing
11.	G10747	2	Carriage Bolt, $\frac{1}{2}$ "-13 x 2"
	G10111	2	Lock Nut, $\frac{1}{2}$ "-13
A.	GA6937	-	Seed Firming Wheel Retrofit Package (Items 1-11)

# HOPPER SUPPORT AND METER DRIVE

RUB005(RU11c)

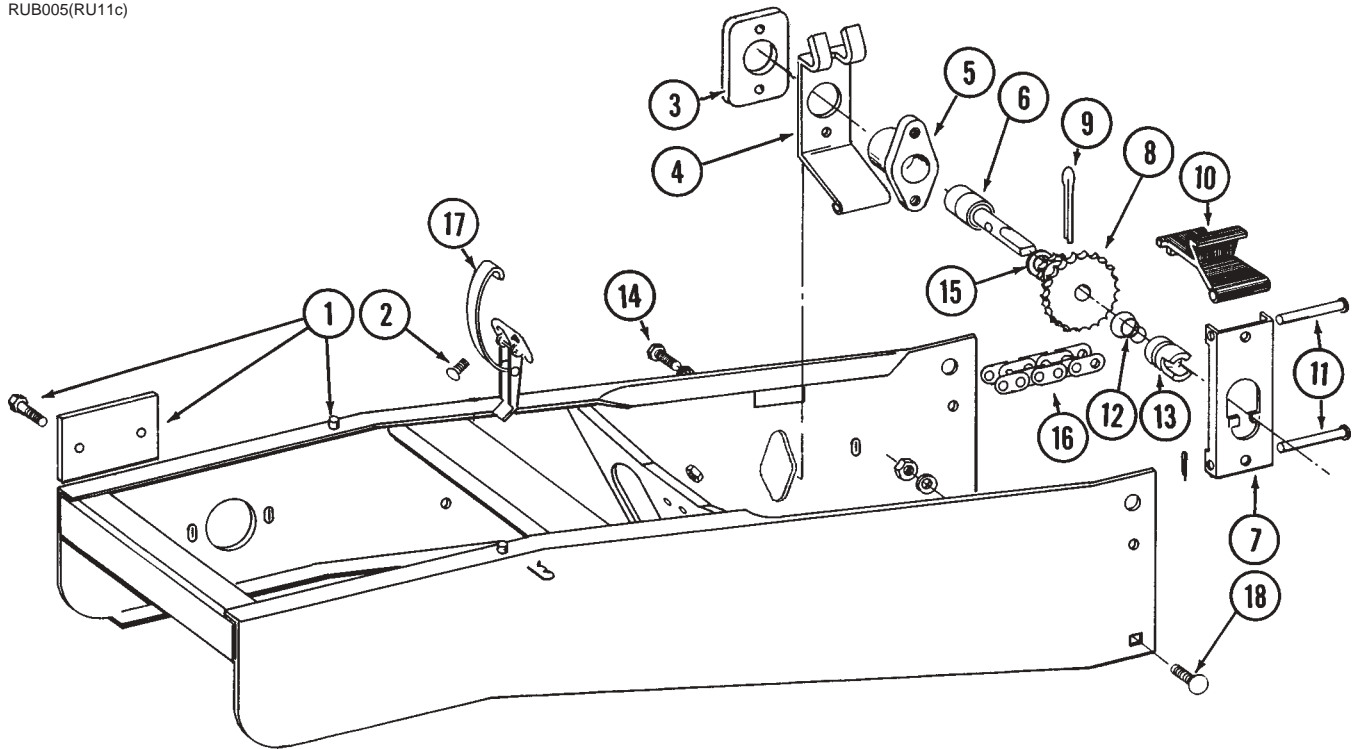

ITEM	PART NO.	QTY. (Per Row)	DESCRIPTION
1.	GR1066	1	Hopper Support W/Cover And Hardware
	GD7618	1	Cover
	G10312	2	Carriage Bolt, $\frac{5}{16}$ "-18 x $\frac{3}{4}$ "
2.	G10620	2	Flange Nut, $\frac{5}{16}$ "-18
	G10309	2	Carriage Bolt, $\frac{1}{4}$ "-20 x $\frac{5}{8}$ ", Grade 2
3.	G10621	2	Flange Nut, $\frac{1}{4}$ "-20
	GD2128	1	Plate
4.	GD1037	1	Bearing Support
5.	GB0108	1	Bearing Housing
6.	GA2016	1	Bearing
7.	GD1036	1	Drive Release Lever
8.	GB0107	1	Sprocket, 11/19 Tooth
9.	G10457	1	Cotter Pin, $\frac{5}{32}$ " x 1 $\frac{1}{2}$ "
10.	GD1035	1	Release Handle
11.	G10553	2	Clevis Pin, $\frac{1}{4}$ " x 2 $\frac{5}{8}$ "
	G10455	2	Cotter Pin, $\frac{1}{16}$ " x $\frac{1}{2}$ "
12.	GD10464	1	Compression Spring
13.	GB0243	1	Drive Coupler
14.	G10019	2	Hex Head Cap Screw, $\frac{5}{16}$ "-18 x 1"
	G10232	2	Lock Washer, $\frac{5}{16}$ "
15.	G10204	-	Machinery Bushing, $\frac{21}{32}$ " (As Required)
16.	G3303-98	1	Roller Chain, No. 41, 98 Links Including Connector Link
	G3303-16	-	Roller Chain, No. 41, 16 Links Including Connector Link (Used W/Row Unit Extension Brackets)
	GR0196	1	Connector Link, No. 41
17.	GA2007	1	Hopper Hold Down Latch
18.	G10305	1	Carriage Bolt, $\frac{3}{8}$ "-16 x 1", Grade 2
	G10229	1	Lock Washer, $\frac{3}{8}$ "
	G10101	1	Hex Nut, $\frac{3}{8}$ "-16
A.	GA4822	-	Meter Drive Assembly Complete (Items 3-14)

# SEED HOPPER

RUA015(RU12)

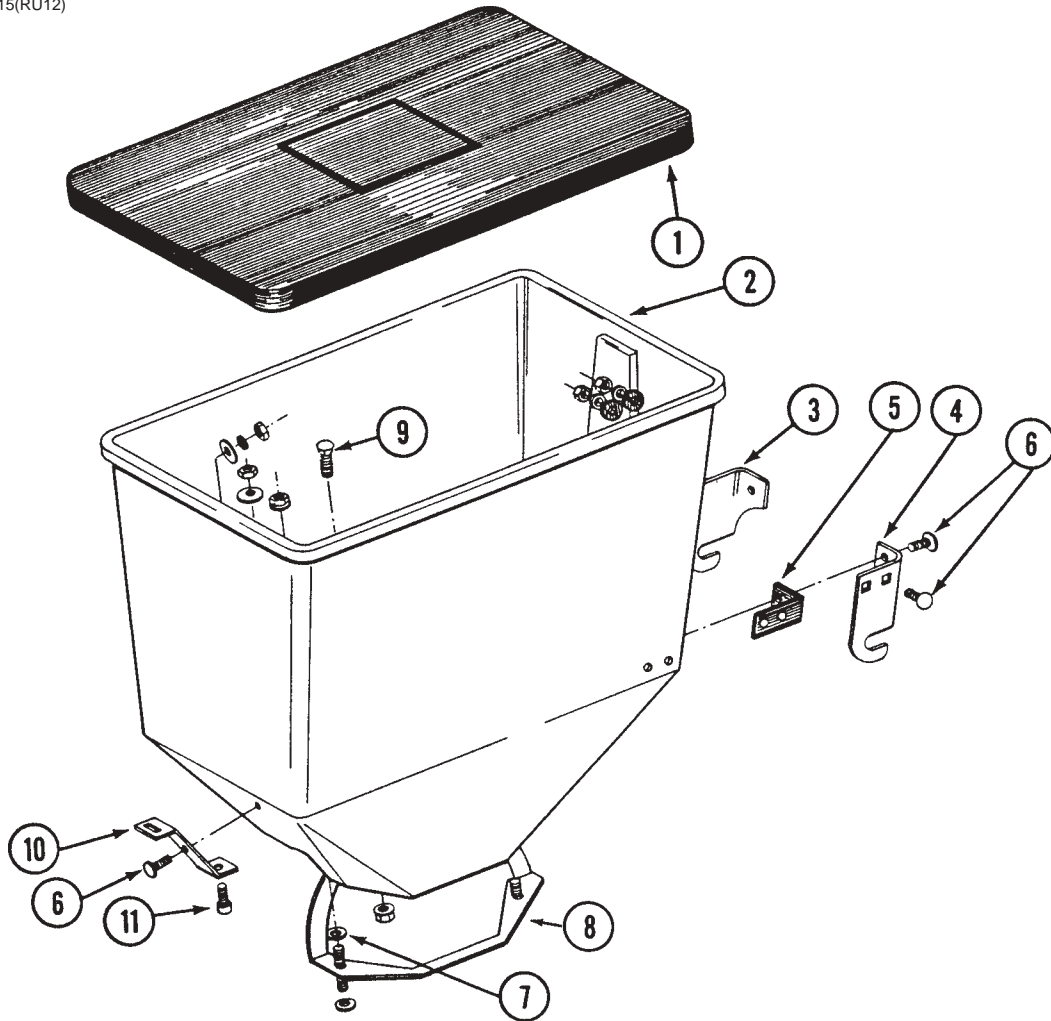

ITEM	PART NO.	QTY. (Per Row)	DESCRIPTION
1.	GA2327	1	Lid With Clip
2.	GD1053	1	Seed Hopper
3.	GD1051L	1	Bracket, Left Hand
4.	GD1051R	1	Bracket, Right Hand
5.	GD1054	2	Mounting Pad
6.	G10310	7	Carriage Bolt, 1/4"-20 x 3/4", Grade 2
	GD1121	7	Rubber Washer
	G10209	9	Washer, 1/4" USS
	G10110	7	Self Locking Nut, 1/4"-20
7.	GD1121	2	Rubber Washer
8.	GA2027	1	Retainer
9.	G10310	1	Carriage Bolt, 1/4"-20 x 3/4", Grade 2
	G10621	1	Whiz Lock Nut, 1/4"-20
10.	GD1055	1	Clip
11.	G10520	1	Hex Socket Head Cap Screw, 3/8"-16 x 3/4", Grade 8
	G10210	1	Washer, 3/8" USS
	G10229	1	Lock Washer, 3/8"
	G10101	1	Hex Nut, 3/8"-16
A.	GA2058	-	Seed Hopper With Hardware, Less Lid (Items 2-11)

# FINGER PICKUP SEED METER

RUA015(RU13/RU37)

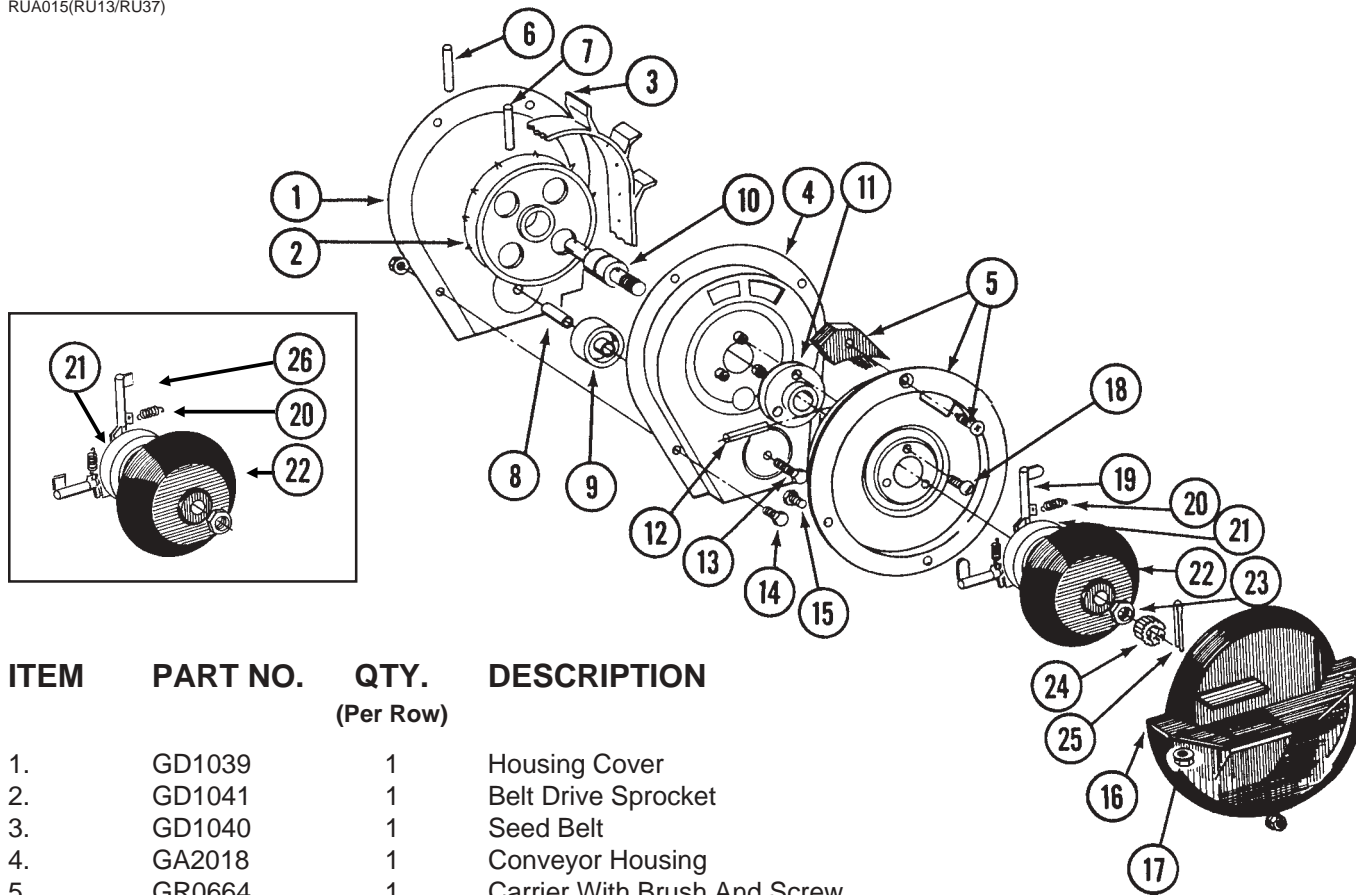

ITEM	PART NO.	QTY. (Per Row)	DESCRIPTION
1.	GD1039	1	Housing Cover
2.	GD1041	1	Belt Drive Sprocket
3.	GD1040	1	Seed Belt
4.	GA2018	1	Conveyor Housing
5.	GR0664	1	Carrier With Brush And Screw
	GA2020	-	Brush
	G10690	-	Rolling Thread Screw, No. 10 x 3/4"
6.	G10602	1	Spring Pin, 1/4" x 1 1/2"
7.	G10604	1	Spring Pin, 3/16" x 1 1/2"
8.	GB0120	1	Bushing
9.	GD1042	1	Idler
10.	GA2019	1	Bearing
11.	GB0110	1	Bearing Housing
12.	G10603	1	Spring Pin, 1/4" x 1 1/4"
13.	G10021	1	Hex Head Cap Screw, 1/4"-20 x 1 1/2"
	G10621	1	Flange Nut, 1/4"-20
14.	G10022	4	Hex Head Cap Screw, 1/4"-20 x 1/2"
	G10621	4	Flange Nut, 1/4"-20
15.	G10020	3	Hex Head Cap Screw, 1/4"-20 x 5/8"
	G10323	3	Hex Flange Nut, 1/4"-20
16.	GD1046	1	Seed Baffle
17.	G10620	2	Flange Nut, 5/16"-18
18.	G10401	3	Machine Screw, No. 10-32 x 5/8"
19.	GD1044	12	Finger, Corn
20.	GD6501	12	Spring
21.	GB0111	1	Cam
22.	GD1045	1	Finger Holder
23.	G10500	1	Jam Nut, 5/8"-18 UNF
24.	GD1083	1	Cage Nut, 5/8"-18
25.	G10470	1	Cotter Pin, 5/32" x 1"
26.	GD10226	12	Finger, Oil Sunflower
A.	GR0933	-	Finger Assembly, Corn (Items 19-22)
B.	GR1327	-	Finger Assembly, Oil Sunflower (Items 20-22 And 26)

# BRUSH-TYPE SEED METER

RUA037(RU14)

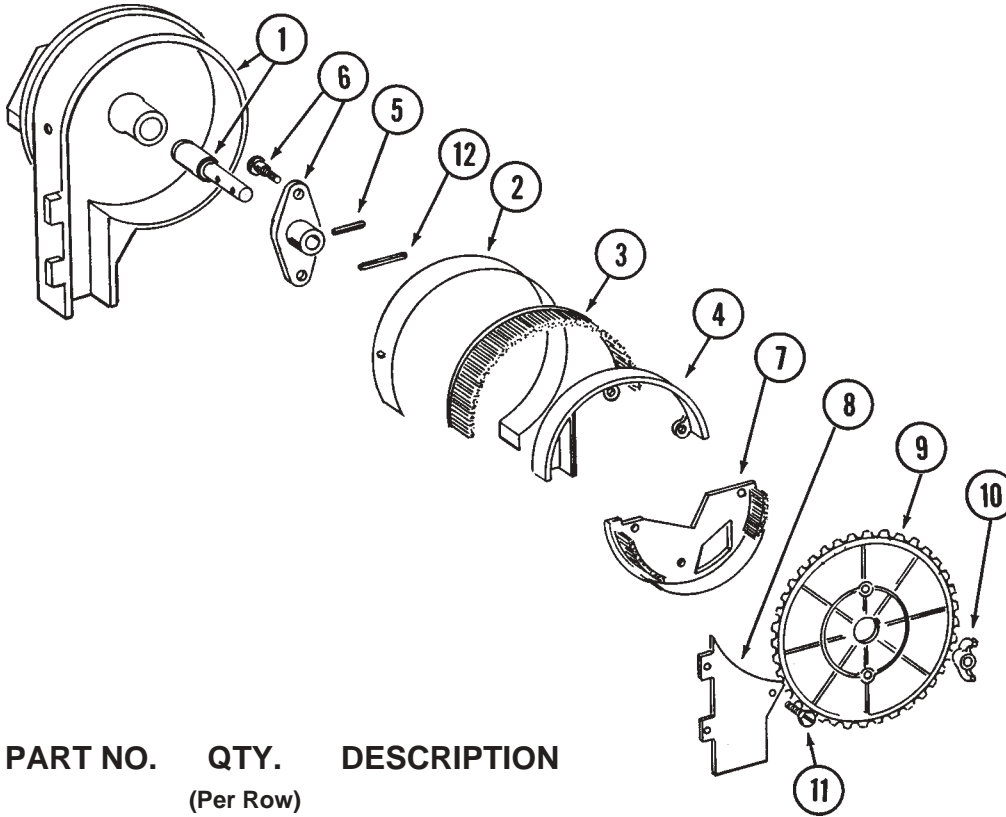

ITEM	PART NO.	QTY. (Per Row)	DESCRIPTION
1.	GA6027	1	Housing W/Bearing
	GA5698	-	Bearing
2.	GD8778	1	Wear Strip
3.	GA5699	1	Upper Retaining Brush
4.	GD8237	1	Retaining Brush Holder
5.	G10603	1	Spring Pin, 1/4" x 1 1/4"
6.	GA6038	1	Hub W/Shoulder Bolts
	GD1755	-	Shoulder Bolt, 1/4"-20 (2 Used)
7.	GA5834	1	Lower Brush
8.	GD7878	1	Cover
9.	GA5794	-	Seed Disc, Soybean, 60 Cell, Black Color-Coded
	GA6184	-	Seed Disc, Specialty Soybean, 48 Cell, Dark Blue Color-Coded
	GA5982	-	Seed Disc, Small Milo/Grain Sorghum, 30 Cell, Red Color-Coded
	GA6187	-	Seed Disc, Large Milo/Grain Sorghum, 30 Cell, Light Blue Color-Coded
	GA5795	-	Seed Disc, High Rate Small Milo/Grain Sorghum, 60 Cell, Red Color-Coded
	GA6633	-	Seed Disc, High Rate Large Milo/Grain Sorghum, 60 Cell, Yellow Color-Coded
	GA5796	-	Seed Disc, Cotton, Acid-Delinted, 30 Cell, White Color-Coded
	GA6168	-	Seed Disc, Large Cotton, Acid-Delinted, 36 Cell, Tan Color-Coded
	GA6478	-	Seed Disc, High Rate Cotton, Acid-Delinted, 48 Cell, Light Green Color-Coded
	GA6182	-	Seed Disc, Hill-Drop Cotton, Acid-Delinted, 12 Cell, Brown Color-Coded
	GA7255	-	Seed Disc, Small Hill-Drop Cotton, Acid-Delinted, 12 Cell, Dark Green Color-Coded
10.	G10531	2	Nylon Insert Wing Nut, 1/4"-20
11.	G10584	9	Slotted Tap Screw, No. 10-24 x 1/2"
12.	G10602	1	Spring Pin, 1/4" x 1 1/2"

# GRANULAR CHEMICAL BANDERS

RUA013/RUA016/RUA044(RU16a/RU15)

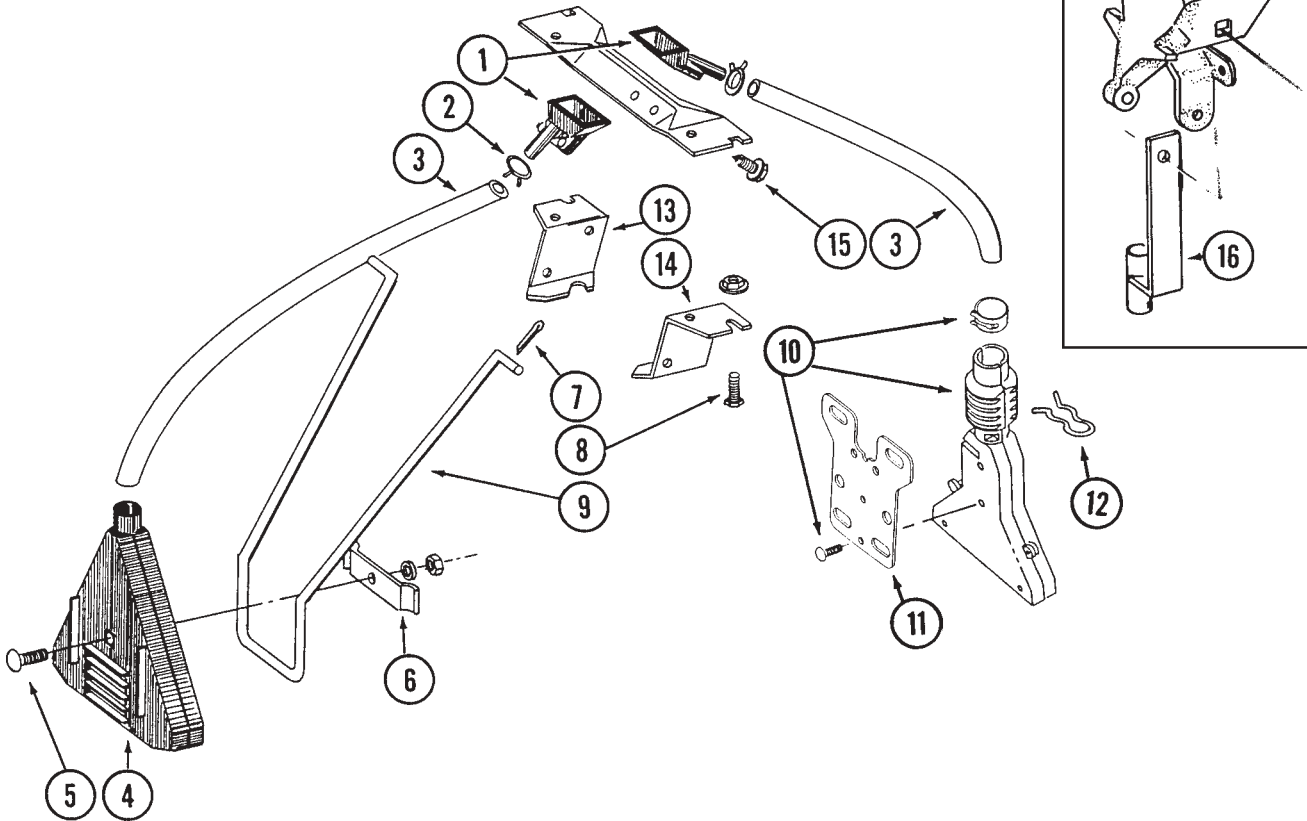

ITEM	PART NO.	QTY.	DESCRIPTION
1.	GD2423	-	Funnel
2.	G10680	-	Hose Clamp, 7/16"
3.	GD2947	-	Hose, 7/16" x 28"
4.	GA2075	-	Diffuser, 14" Band
5.	G10306	-	Carriage Bolt, 3/8"-16 x 2", Grade 2
	G10229	-	Lock Washer, 3/8"
	G10101	-	Hex Nut, 3/8"-16
6.	GD1118	-	Clamp
7.	G10452	-	Cotter Pin, 1/8" x 1/2"
8.	G10310	-	Carriage Bolt, 1/4"-20 x 3/4", Grade 2
	G10227	-	Lock Washer, 1/4"
	G10103	-	Hex Nut, 1/4"-20
9.	GD1116	-	Hanger
10.	GA6907	-	Slope-Compensating Bander W/Hardware (4 1/2" Band Width)
	G10864	-	Uni-Clamp
	G10757	2	Screw, No. 10-32 x 1 1/4"
	G10758	2	Hex Nut, No. 10-32
11.	GD9816	-	Bander Mounting Bracket (For Some Non-KINZE® Applications)
12.	GD1090	-	Spring Clip
13.	GD1115L	-	Hanger Bracket, L.H.
14.	GD1115R	-	Hanger Bracket, R.H.
15.	G10523	-	Self Tapping Screw, No. 10 x 1/2"
16.	GA6741	-	Bracket (Straight Drop In-Furrow)

# GRANULAR CHEMICAL SUB-ASSEMBLIES AND KITS

(RU65/RU66/RU67)

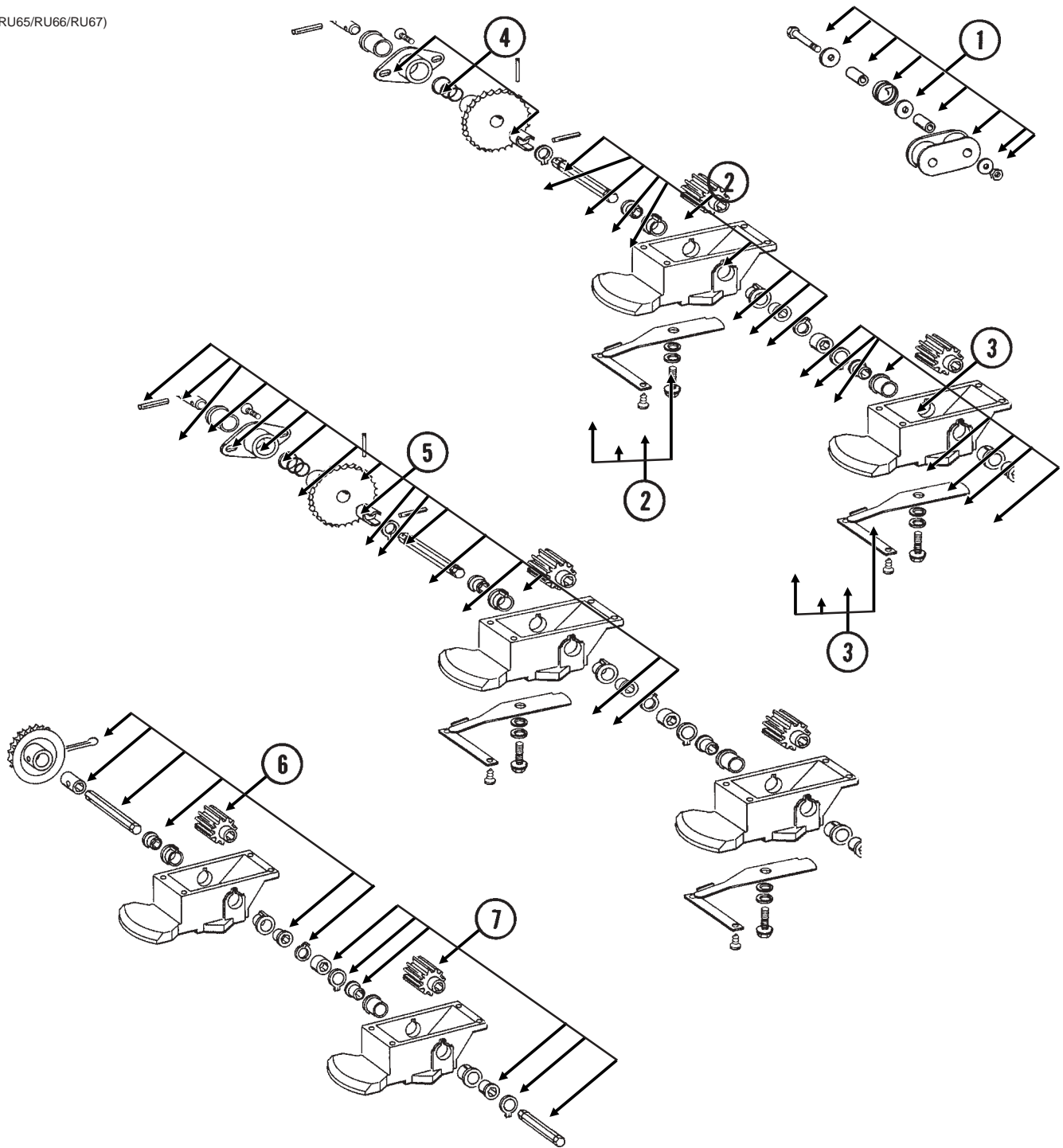

ITEM	PART NO.	QTY.	DESCRIPTION
1.	G1K213	1	Granular Chemical Idler Kit W/Instruction
2.	GA5553	1	Insecticide Housing Sub-Assembly
3.	GA5554	1	Herbicide Housing Sub-Assembly
4.	GA5746	1	Sprocket Sub-Assembly
5.	GA5623	1	Throwout Update Kit W/Instructions And Template
6.	GA5560	1	Primary Meter Roller Replacement Kit W/Instruction (Update For Non-Current Design)
7.	GA5561	1	Secondary Meter Roller Replacement Kit W/Instruction (Update For Non-Current Design)

# GRANULAR CHEMICAL HOPPER WITH METER(S) & THROWOUT

RUA006/RUA008/RUA033/RUA034/RUA044(RU18/RU19)

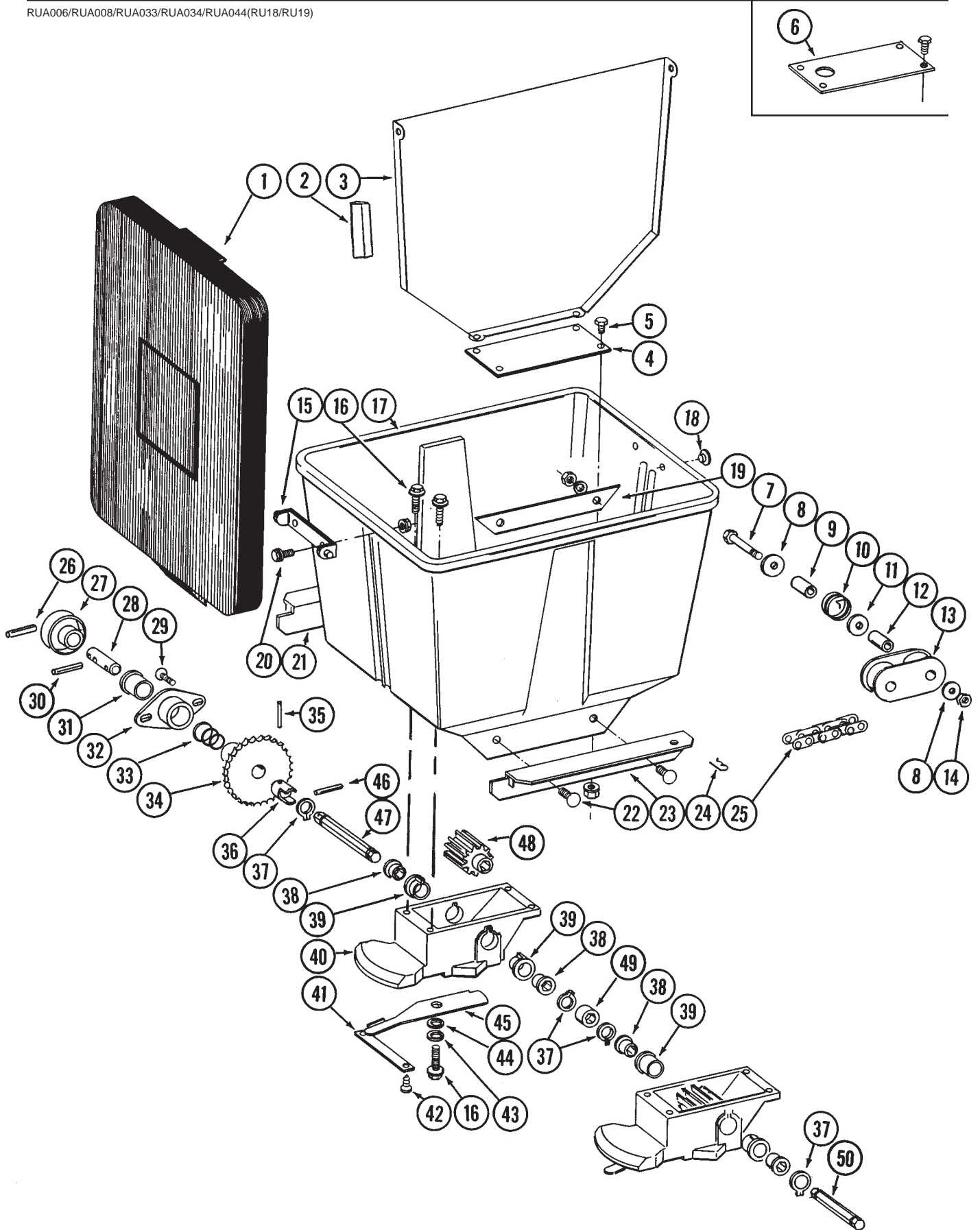



# GRANULAR CHEMICAL HOPPER WITH METER(S) & THROWOUT

---

ITEM	PART NO.	QTY. (Per Row)	DESCRIPTION
1.	GA4444	1	Lid
2.	G3314-40	-	Foam Strip, 40"
3.	GA2076	1	Divider (Used With Two Meters)
4.	GD1056	-	Cover Plate (1 Used With One Meter)
5.	G10022	4	Hex Head Cap Screw, 1/4"-20 x 1/2"
	G10621	4	Flange Nut, 1/4"-20
6.	GD8750	-	Restrictor Plate (Optional)
7.	G10049	1	Hex Head Cap Screw, 3/8"-16 x 2 1/2"
8.	G10210	2	Washer, 3/8" USS
9.	GD2971-10	1	Bushing, 9/16"
10.	GD9306	1	Spring
11.	G10201	1	Special Washer
12.	GD1026	1	Spacer, 1 3/16"
13.	GD9240	1	Idler
14.	G10108	1	Lock Nut, 3/8"-16
15.	GD1060	1	Hinge
16.	G10570	-	Self Tapping Screw, 1/4" x 3/4" (4 Used Per Meter)
17.	GD1058	1	Hopper
18.	GD1089	2	Plug
19.	GD1072	2	Strap
20.	G10023	2	Hex Head Cap Screw, 1/4"-20 x 3/4"
	G10621	2	Flange Nut, 1/4"-20
21.	GD1059L	1	Support, L.H.
22.	G10311	4	Carriage Bolt, 3/8"-16 x 3/4" Short Necked, Grade 2
	G10229	4	Lock Washer, 3/8"
	G10101	4	Hex Nut, 3/8"-16
23.	GD1059R	1	Support, R.H.
24.	G10670	2	Spring Locking Pin, No. 3
25.	G3303-114	1	Roller Chain, No. 41, 114 Pitch Including Connector Link
	GR0196	1	Connector Link, No. 41
26.	G10637	1	Spring Pin, 1/8" x 1 1/2"
27.	GD7587	1	Knob
28.	GD7589	1	Throwout Pin
29.	G10312	2	Carriage Bolt, 5/16"-18 x 3/4"
	G10620	2	Flange Nut, 5/16"-18
30.	G10602	1	Spring Pin, 1/4" x 1 1/2"
31.	GB0121	1	Bearing
32.	GB0183	1	Bearing Mount
33.	GD10464	1	Spring
34.	GA5533	1	Sprocket, 24 Tooth
35.	G10609	1	Spring Pin, 5/32" x 1"
36.	GB0184	1	Coupling
37.	G10567	1	Retaining Ring
38.	GD7258	-	Hex Bushing (2 Used Per Meter)
39.	GB0115	-	Bearing (2 Used Per Meter)
40.	GB0116	-	Granular Housing (1 Used Per Meter)
41.	GD1061	-	Support Strap (1 Used Per Meter)
42.	G10521	1	Self Tapping Screw, No. 10 x 3/8" (2 Used Per Meter)
43.	G10209	-	Washer, 1/4" USS (1 Used Per Meter)
44.	G10660	-	Wave Washer (1 Used Per Meter)
45.	GD1063	-	Metering Gate (1 Used Per Meter)
46.	G10546	1	Spring Pin, 3/16" x 1 1/4"
47.	GD7588	1	Shaft
48.	GD7148	-	Feed Roller, Hex Bore (1 Used Per Meter)
49.	GD7592	1	Coupler, Hex Bore (With 2nd Meter)
50.	GD7591	-	Shaft (1 Used In 2nd Meter)

# SPRING TOOTH INCORPORATOR

RUA011(RU20)

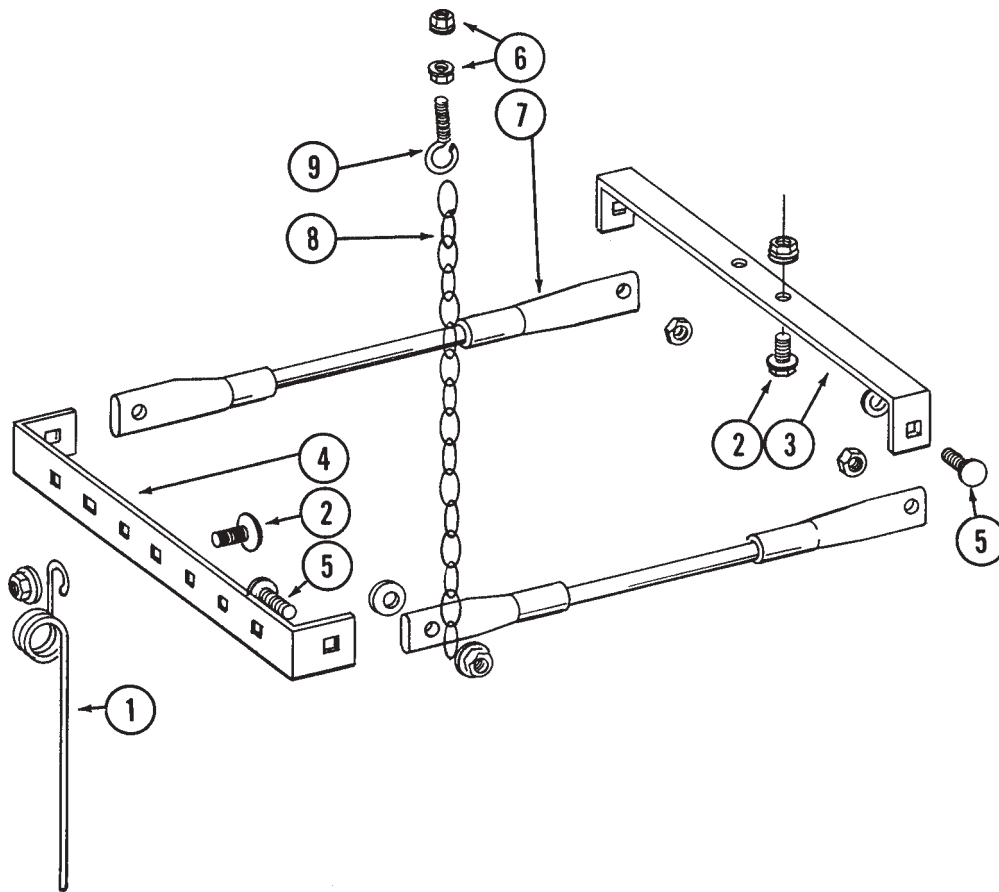

ITEM	PART NO.	QTY. (Per Row)	DESCRIPTION
1.	GD1145	7	Spring Tooth
2.	G10308	9	Carriage Bolt, $\frac{3}{8}$ "-16 x $\frac{3}{4}$ ", Grade 2
	G10622	9	Flange Lock Nut, $\frac{3}{8}$ "-16
3.	GD1143	1	Front Bracket
4.	GD1144	1	Rear Bracket
5.	G10305	4	Carriage Bolt, $\frac{3}{8}$ "-16 x 1", Grade 2
	G10529	4	External Tooth Lock Washer, $\frac{3}{8}$ "
	G10622	4	Flange Lock Nut, $\frac{3}{8}$ "-16
6.	G10621	4	Flange Lock Nut, $\frac{1}{4}$ "-20
7.	GA2094	2	Cable Assembly
8.	G3305-01	4	Chain
9.	GD2460	2	Eyebolt, $\frac{1}{4}$ "-20

# NO TILL COULTER, ROW UNIT MOUNTED

RUA036(RU21a)

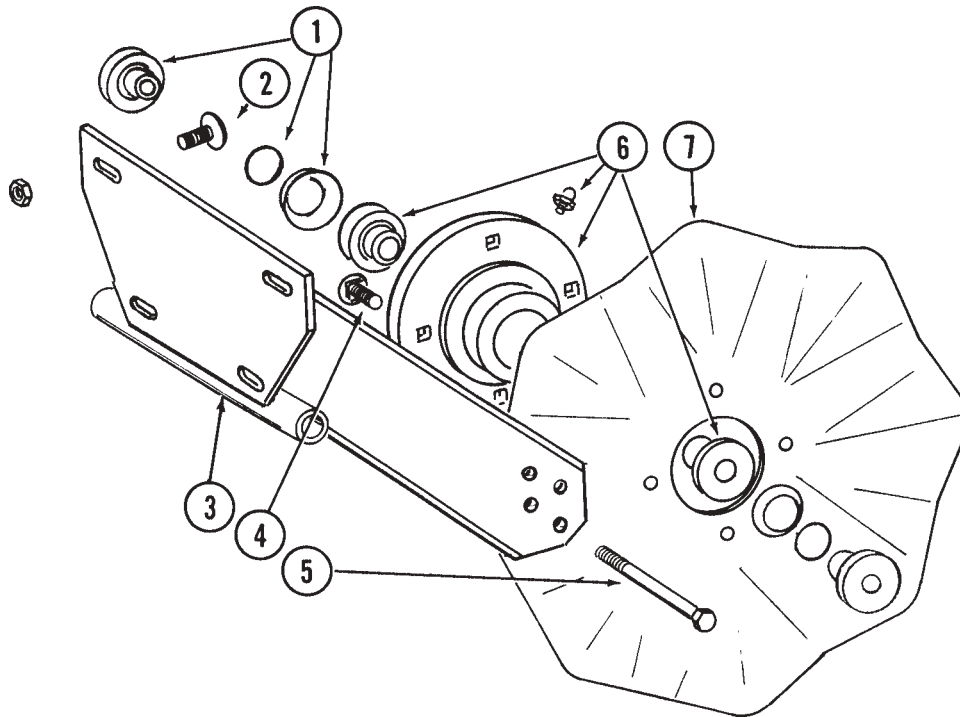

ITEM	PART NO.	QTY. (Per Row)	DESCRIPTION
1.	GB0227	2	Adapter W/O-Ring And Spring Washer
	GD8844	2	O-Ring
	GD8843	2	Spring Washer
2.	G10574	4	Carriage Bolt, 1/2"-13 x 1 1/4"
	G10111	4	Lock Nut, 1/2"-13
3.	GA5625	1	Arm
4.	G10574	4	Carriage Bolt, 1/2"-13 x 1 1/4"
	G10111	4	Lock Nut, 1/2"-13
5.	G10036	1	Hex Head Cap Screw, 5/8"-11 x 4"
	G10107	1	Lock Nut, 5/8"-11
6.	GA5640	1	Hub W/Bearings And Grease Fitting
	GA5622	-	Bearing (2 Used)
	G10640	-	Grease Fitting, 1/4"-28
7.	GD7803	-	Fluted Blade, 1", 8 Flutes (Shown)
	GD7804	-	Bubbled Blade, 1"
	GD9254	-	Fluted Blade, 3/4", 13 Flutes

# BED LEVELER, ROW UNIT MOUNTED

RUA038/RUA040(RU22a)

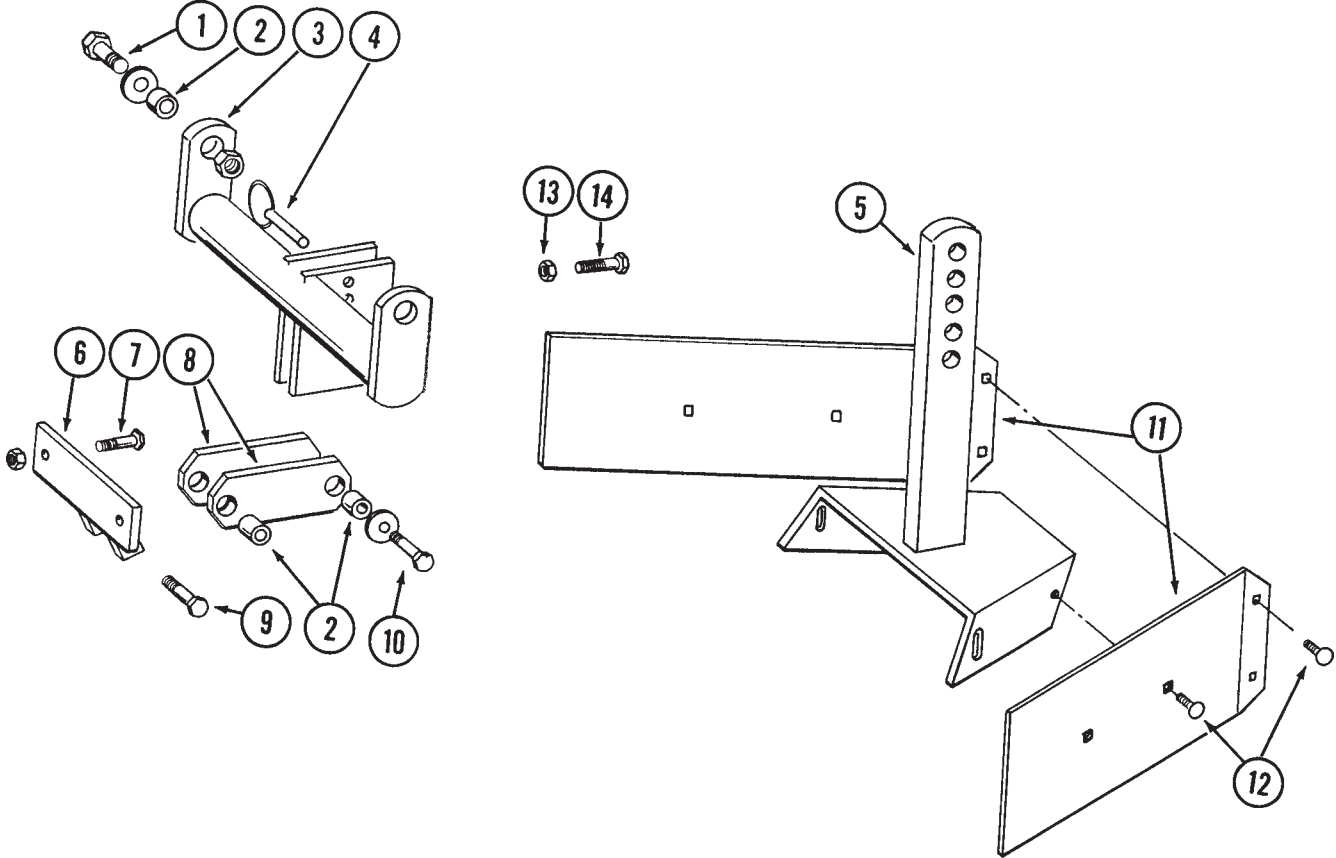

ITEM	PART NO.	QTY. (Per Row)	DESCRIPTION
1.	G10039	2	Hex Head Cap Screw, 1/2"-13 x 1 3/4"
	G10216	2	Washer, 1/2" USS
	G10111	2	Lock Nut, 1/2"-13
2.	GD7889	6	Bushing
3.	GA5719	1	Mounting Bracket
4.	G10536	1	Pin
5.	GA5892	1	Leveler
6.	GA5715	1	Anchor
7.	G10017	2	Hex Head Cap Screw, 1/2"-13 x 1 1/2"
	G10111	2	Lock Nut, 1/2"-13
8.	GD7890	2	Link
9.	G10017	2	Hex Head Cap Screw, 1/2"-13 x 1 1/2"
	G10216	2	Washer, 1/2" USS
	G10111	2	Lock Nut, 1/2"-13
10.	G10585	1	Hex Head Cap Screw, 1/2"-13 x 3 1/4"
	G10216	2	Washer, 1/2" USS
	G10111	1	Lock Nut, 1/2"-13
11.	GD8266	2	Blade
12.	G10303	6	Carriage Bolt, 5/16"-18 x 1"
	G10219	4	Washer, 5/16" USS
	G10109	6	Lock Nut, 5/16"-18
13.	G10503	1	Jam Nut, 5/8"-11
14.	G10597	1	Set Screw, 5/8"-11 x 2 1/4"

# DISC FURROWER, ROW UNIT MOUNTED

RUA038/RUA040(RU23a)

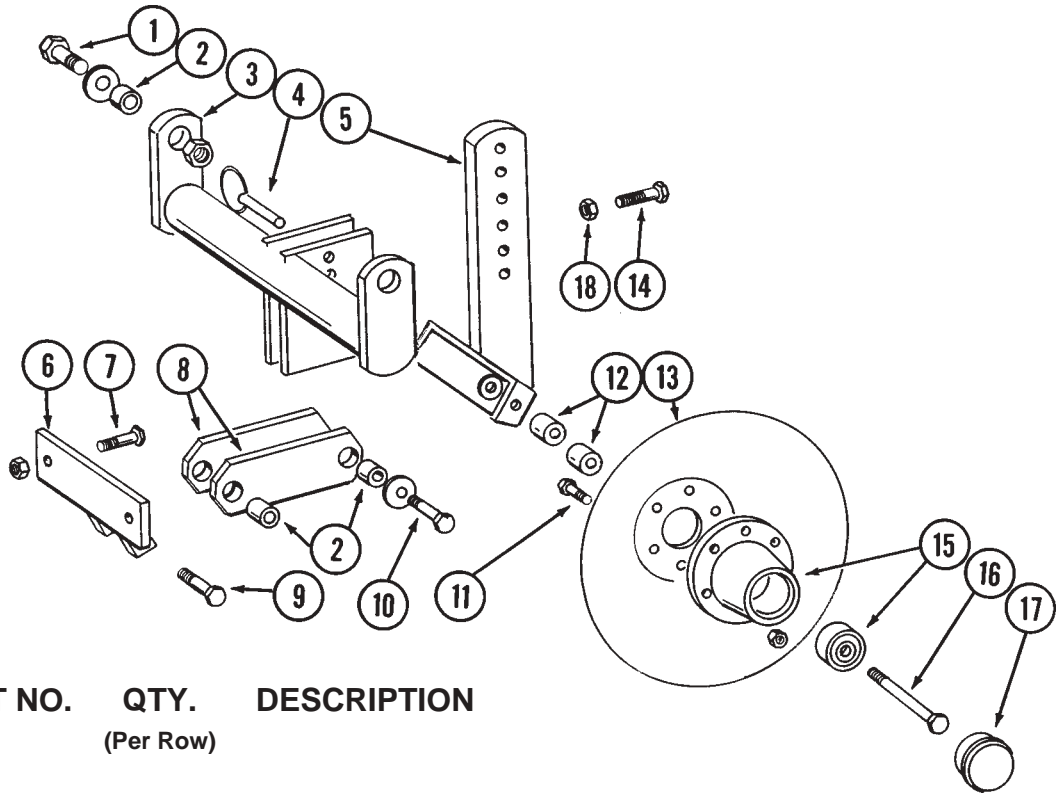

ITEM	PART NO.	QTY. (Per Row)	DESCRIPTION
1.	G10039	2	Hex Head Cap Screw, 1/2"-13 x 1 3/4"
	G10216	2	Washer, 1/2" USS
	G10111	2	Lock Nut, 1/2"-13
2.	GD7889	6	Bushing
3.	GA5719	1	Mounting Bracket
4.	G10536	1	Pin
5.	GA5718	1	Support Arm
6.	GA5715	1	Anchor
7.	G10017	2	Hex Head Cap Screw, 1/2"-13 x 1 1/2"
	G10111	2	Lock Nut, 1/2"-13
8.	GD7890	2	Link
9.	G10017	2	Hex Head Cap Screw, 1/2"-13 x 1 1/2"
	G10216	2	Washer, 1/2" USS
	G10111	2	Lock Nut, 1/2"-13
10.	G10585	1	Hex Head Cap Screw, 1/2"-13 x 3 1/4"
	G10216	2	Washer, 1/2" USS
	G10111	1	Lock Nut, 1/2"-13
11.	G10572	6	Truss Head Slotted Machine Screw, 5/16"-18 x 7/8"
	G10106	6	Hex Nut, 5/16"-18
12.	GD7817-01	2	Spacer, 3/4"
	GD7817-04	2	Spacer, 1/2"
13.	GD7823	-	Solid Blade, 12" (Shown)
	GD8307	-	Notched Blade, 12"
14.	G10597	1	Set Screw, 5/8"-11 x 2 1/4"
15.	GA5654	2	Hub W/Bearings
	GA2014	-	Bearing
16.	G10318	2	Hex Head Cap Screw, 5/8"-11 x 4 1/2"
	GD7805	2	Special Washer
	G10107	2	Lock Nut, 5/8"-11
17.	GD1132	2	Dust Cap
18.	G10503	1	Jam Nut, 5/8"-11

# RESIDUE WHEEL, ROW UNIT MOUNTED

RUA041/RUA045(RU24)

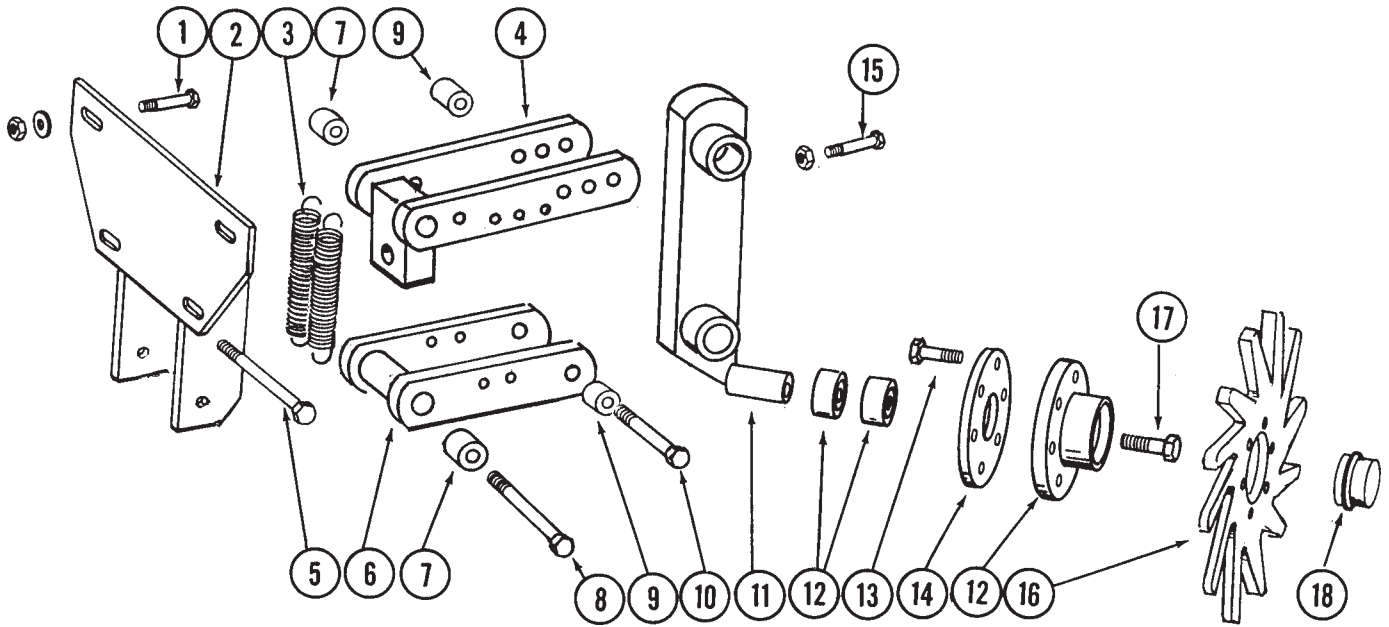

ITEM	PART NO.	QTY. (Per Row)	DESCRIPTION
1.	G10574	4	Carriage Bolt, 1/2"-13 x 1 1/4"
	G10216	4	Washer, 1/2" USS
	G10111	4	Lock Nut, 1/2"-13
2.	GA6832	1	Mount
3.	GD5857	2	Spring
4.	GA6833	1	Upper Link
5.	G10348	1	Hex Head Cap Screw, 1/2"-13 x 5" (Lockup Bolt)
	G10111	1	Lock Nut, 1/2"-13
6.	GA6834	1	Lower Link
7.	GD9715	2	Spacer, 2 15/16"
8.	G10045	2	Hex Head Cap Screw, 1/2"-13 x 4 1/2"
	G10228	2	Lock Washer, 1/2"
	G10102	2	Hex Nut, 1/2"-13
9.	GD9720	2	Spacer, 2 3/16"
10.	G10033	2	Hex Head Cap Screw, 1/2"-13 x 3 1/2"
	G10228	2	Lock Washer, 1/2"
	G10102	2	Hex Nut, 1/2"-13
11.	GA6838	1	Wheel Mount
12.	GA5654	2	Hub W/Bearings
	GA2014	-	Bearing
13.	G10133	6	Hex Head Cap Screw, 5/16"-18 x 1 1/2"
	G10109	6	Lock Nut, 5/16"-18
14.	GD9724	1	Backing Plate
15.	G10371	1	Hex Head Cap Screw, 1/2"-13 x 3", Full Thread
	G10501	1	Jam Nut, 1/2"-13
16.	GD10552	1	Wheel, 3/8" x 12"
17.	G10006	1	Hex Head Cap Screw, 5/8"-11 x 2 1/4"
18.	GD1132	1	Dust Cap
A.	GA7446	-	Wheel Assembly (Items 12-14 And 16)

# RESIDUE WHEELS, COULTER MOUNTED

RUA047(RU31a)

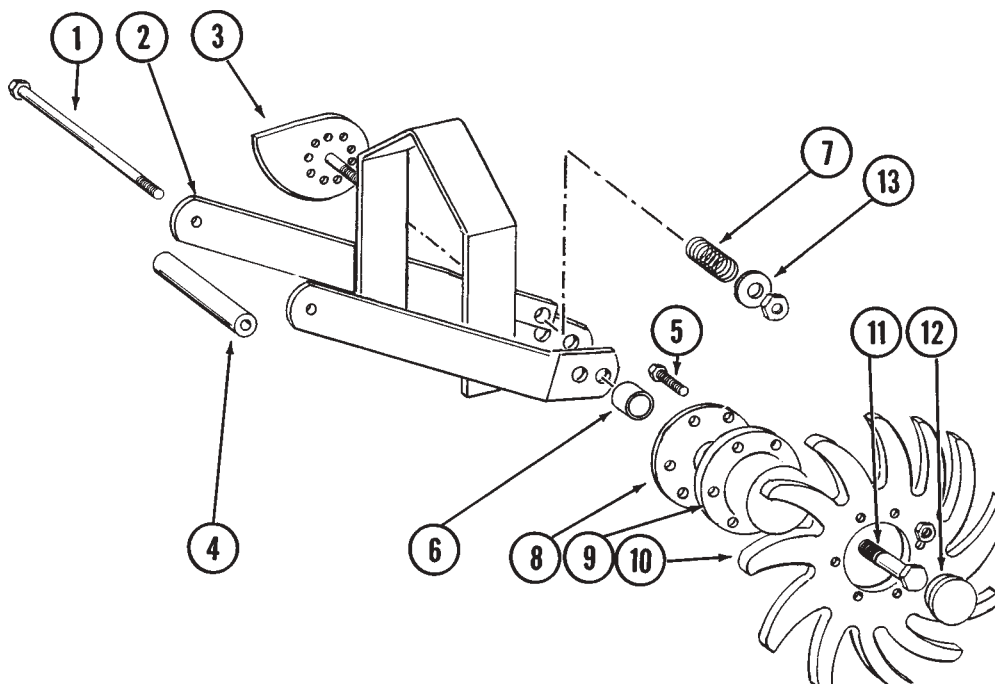

ITEM	PART NO.	QTY. (Per Row)	DESCRIPTION
1.	G10148	1	Hex Head Cap Screw, 1/2"-13 x 9 1/2"
	G10111	1	Lock Nut, 1/2"-13
2.	GA7271	1	Mount
3.	GA7412	1	Cam
4.	GD10526	1	Sleeve, 7 1/2"
5.	G10133	12	Hex Head Cap Screw, 5/16"-18 x 1 1/2"
	G10109	12	Lock Nut, 5/16"-18
6.	GD7817-04	2	Spacer, 1 1/4" O.D. x 1/2" Long
7.	GD10519	1	Spring
8.	GD9724	2	Backing Plate
9.	GA5654	2	Hub W/Bearings
	GA2014	-	Bearing
10.	GD10552	2	Wheel, 3/8" x 12"
11.	G10009	2	Hex Head Cap Screw, 5/8"-11 x 2 1/2"
12.	GD1132	2	Dust Cap
13.	G10206	1	Washer, 1/2" SAE
	G10111	1	Lock Nut, 1/2"-13
A.	GA7446	-	R.H. Wheel Assembly (Items 5 And 8-10) (Shown)
	GA7445	-	L.H. Wheel Assembly (Items 5 And 8-10)

# FRAME MOUNTED COULTER W/DISC FURROWER

RUA035/RUB016(RU25)

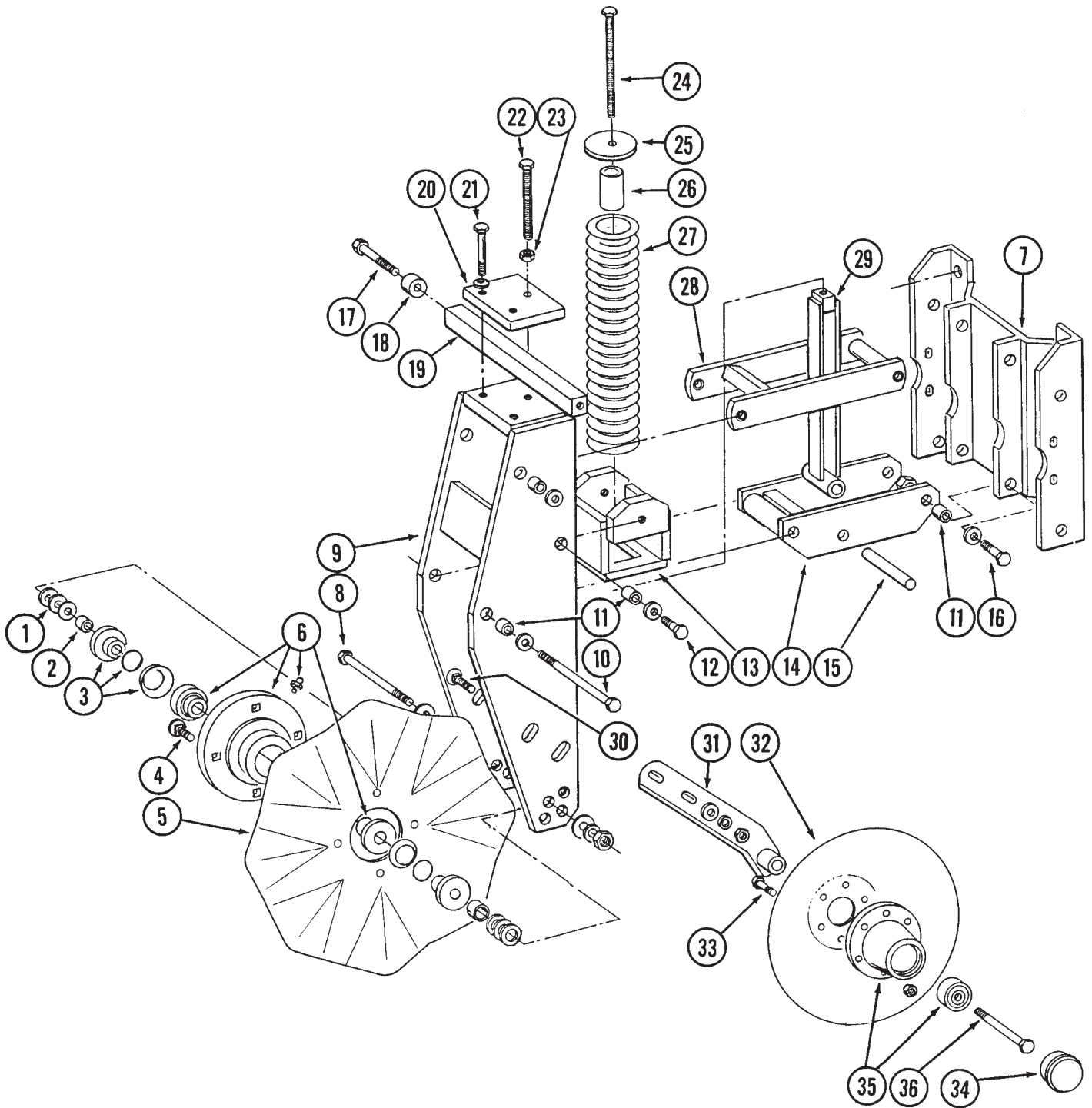



# FRAME MOUNTED COULTER W/DISC FURROWER

ITEM	PART NO.	QTY.	DESCRIPTION
(Per Row)			
1.	G10217	-	Washer, 5/8" USS (As Required)
2.	GD7817-04	2	Spacer, 1/2"
3.	GB0227	2	Adapter W/O-Ring And Spring Washer
	GD8844	-	O-Ring
	GD8843	-	Spring Washer
4.	G10574	4	Carriage Bolt, 1/2"-13 x 1 1/4"
	G10111	4	Lock Nut, 1/2"-13
5.	GD7803	-	Fluted Blade, 1", 8 Flutes (Shown)
	GD7804	-	Bubbled Blade, 1"
	GD9254	-	Fluted Blade, 3/4", 13 Flutes
6.	GA5640	1	Hub W/Bearings And Grease Fitting
	GA5622	-	Bearing (2 Used Per Hub)
	G10640	-	Grease Fitting, 1/4"-28
7.	GA5798	1	Support Plate
8.	G10068	1	Hex Head Cap Screw, 5/8"-11 x 6"
	G10107	1	Lock Nut, 5/8"-11
9.	GA5643	1	Fork Mount
10.	G10012	1	Hex Head Cap Screw, 5/8"-11 x 6 1/2"
	GD7805	2	Washer
	G10107	1	Lock Nut, 5/8"-11
11.	GB0218	10	Bushing, 19/32"
12.	G10055	2	Hex Head Cap Screw, 5/8"-11 x 1 1/4"
	GD7805	2	Washer
13.	GA5637	1	Spring Socket
14.	GA5631	1	Lower Parallel Link
15.	GD7815	1	Pin, 5/8" x 4 1/4"
16.	G10008	6	Hex Head Cap Screw, 5/8"-11 x 2"
	GD7805	6	Washer
	G10107	4	Lock Nut, 5/8"-11 (As Required)
17.	GD7818	2	Special Bolt
18.	GD7817-01	2	Roller, 3/4"
19.	GD7816	1	Depth Control Bar
20.	GD7811	1	Depth Adjustment Clamp
21.	G10581	2	Hex Head Cap Screw, 1/2"-13 x 2 1/4"
	G10228	2	Lock Washer, 1/2"
22.	G10582	1	Hex Head Cap Screw, 5/8"-11 x 4", Full Thread
23.	G10104	1	Hex Nut, 5/8"-11
24.	G10573	1	Hex Head Cap Screw, 5/8"-11 x 5 1/2", Full Thread
25.	GB0196	1	Washer
26.	GD7817-09	1	Stop, 1 3/4"
27.	GD7831	1	Compression Spring
28.	GA5630	1	Upper Parallel Link
29.	GA5635	1	Spring Guide
30.	G10747	4	Carriage Bolt, 1/2"-13 x 2"
	G10206	-	Washer, 1/2" SAE (As Required)
	G10228	4	Lock Washer, 1/2"
	G10102	4	Hex Nut, 1/2"-13
31.	GA5636	2	Arm
32.	GD7823	-	Solid Blade, 12" (Shown)
	GD8307	-	Notched Blade, 12"
33.	G10572	12	Truss Head Slotted Machine Screw, 5/16"-18 x 7/8"
	G10106	12	Hex Nut, 5/16"-18
34.	GD1132	2	Dust Cap
35.	GA5654	2	Hub W/Bearings
	GA2014	4	Bearing
36.	G10036	2	Hex Head Cap Screw, 5/8"-11 x 4"
	G10107	2	Lock Nut, 5/8"-11

# HITCH AND FRAME ASSEMBLY/SAFETY CHAIN

PHA024/PFA050/PFA063/PHA026/PHA027/PFA055(WGN47a/EF1b)

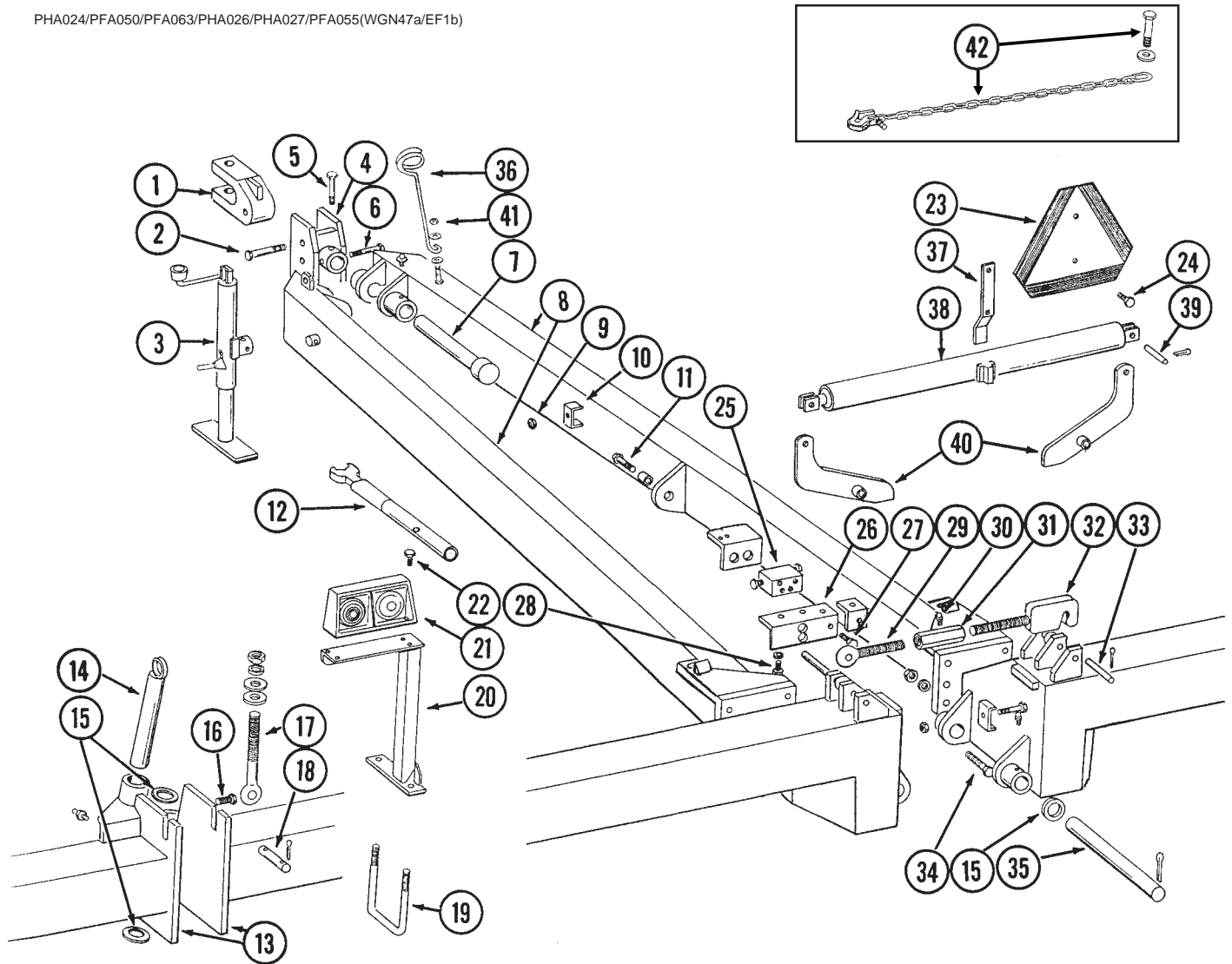

ITEM	PART NO.	QTY.	DESCRIPTION
1.	GB0156	1	Clevis
2.	G10169	1	Hex Head Cap Screw, 1 1/4"-7 x 6"
	G10157	1	Lock Nut, 1 1/4"-7
3.	G4100-02	1	Jack Assembly
	GR0255	-	Repair Kit (Chain And Pin)
4.	GA5745	1	Hitch Cap
5.	G10036	1	Hex Head Cap Screw, 5/8"-11 x 4"
	G10230	1	Lock Washer, 5/8"
	G10104	1	Hex Nut, 5/8"-11
6.	G10011	1	Hex Head Cap Screw, 5/8"-11 x 5 1/2"
	G10230	1	Lock Washer, 5/8"
	G10104	1	Hex Nut, 5/8"-11
7.	GA5755	1	Pin, 2 1/8" x 14"
8.	GA6804	1	Hitch W/Grease Fittings (Includes Items 4-7)
	G10641	-	Grease Fittings, 1/8" NPT
9.	G10108	-	Lock Nut, 3/8"-16
10.	GD5875	6	Clamp, 2" x 2 1/2"
	GD0740	2	Clamp, 3 1/2" x 4"

# HITCH AND FRAME ASSEMBLY/SAFETY CHAIN

ITEM	PART NO.	QTY.	DESCRIPTION
11.	G10028	1	Hex Head Cap Screw, 3/4"-10 x 3"
	GB0169	1	Bushing
	G10112	1	Lock Nut, 3/4"-10
12.	GA6798	1	Wrench
13.	A6803	1	Frame W/Grease Fittings, 294", 8 Row 36"/38" <b>(Non-Stock Item)</b>
	A6799	-	Frame W/Grease Fittings, 357 1/2", 12 Row 30" <b>(Non-Stock Item)</b>
	G10641	-	Grease Fitting, 1/8" NPT
14.	GA2493	2	Pin
15.	G10404	4	Machine Bushing
16.	G10007	2	Hex Head Cap Screw, 5/8"-11 x 1 1/2"
	G10230	2	Lock Washer, 5/8"
17.	GD3373	2	Eye Bolt
	G10139	4	Washer, 1 1/4" USS
	G10236	2	Lock Washer, 1 1/4"
	GD9688	2	Special Nut, 1 1/4"-7
18.	GD3311	2	Pin, 7/8" x 3 1/8"
	G10457	4	Cotter Pin, 5/32" x 1 1/2"
19.	GD7145	2	U-Bolt, 7" x 7" x 1/2"-13
	G10228	4	Lock Washer, 1/2"
	G10102	4	Hex Nut, 1/2"-13
20.	GA6823	1	Bracket, L.H. Side (Shown)
	GA6824	-	Bracket, R.H. Side
21.		-	See "Electrical Components", Page P62
22.	G10064	8	Hex Head Cap Screw, 1/4"-20 x 1"
	G10209	8	Washer, 1/4" USS
	G10110	8	Lock Nut, 1/4"-20
23.		-	See "SMV Sign, Decals, Reflectors And Tie Straps", Page P60
24.	G10023	2	Hex Head Cap Screw, 1/4"-20 x 3/4"
	G10110	2	Lock Nut, 1/4"-20
25.		-	See "Marker Sequencing/Flow Control Valve", Page P52
26.	GD7976	1	Bracket
27.	G10019	2	Hex Head Cap Screw, 5/16"-18 x 1"
	G10232	2	Lock Washer, 5/16"
	G10106	2	Hex Nut, 5/16"-18
28.	G10001	2	Hex Head Cap Screw, 3/8"-16 x 1"
	G10210	2	Washer, 3/8" USS
29.	GD3373	1	Eye Bolt
30.	G10641	1	Grease Fitting, 1/8" NPT
31.	GD7972	1	Turnbuckle
32.	GA7484	1	Hook
33.	GD8769	2	Pin, 7/8" x 6 1/4"
	G10459	4	Cotter Pin, 3/16" x 1 1/2"
34.	G10028	12	Hex Head Cap Screw, 3/4"-10 x 3"
	G10231	12	Lock Washer, 3/4"
	G10105	12	Hex Nut, 3/4"-10
35.	GD7948	1	Shaft, 2 1/8" x 20"
	G10461	2	Cotter Pin, 3/8" x 3"
36.	GD8260	1	Hose Holder
37.	GD2200	1	Spade
38.	GA7513	1	Spring Canister W/Mounting Hardware (Item 39)
39.	GD3311	2	Pin, 7/8" x 3 1/8"
	G10457	4	Cotter Pin, 5/32" x 1 1/2"
40.	GA6055	2	Arm
41.	G10217	2	Washer, 5/8"
	G10107	1	Lock Nut, 5/8"-11
42.	G1K235	-	Safety Chain Kit, 3/8" (Optional)
	G10826	-	Hex Head Cap Screw, 1"-8 x 2 1/2"
	G10200	-	Washer, 1" USS
	G10396	-	Lock Nut, 1"-8

# HYDRAULIC WING FOLD (OPTIONAL)

PFA063(EF2a)

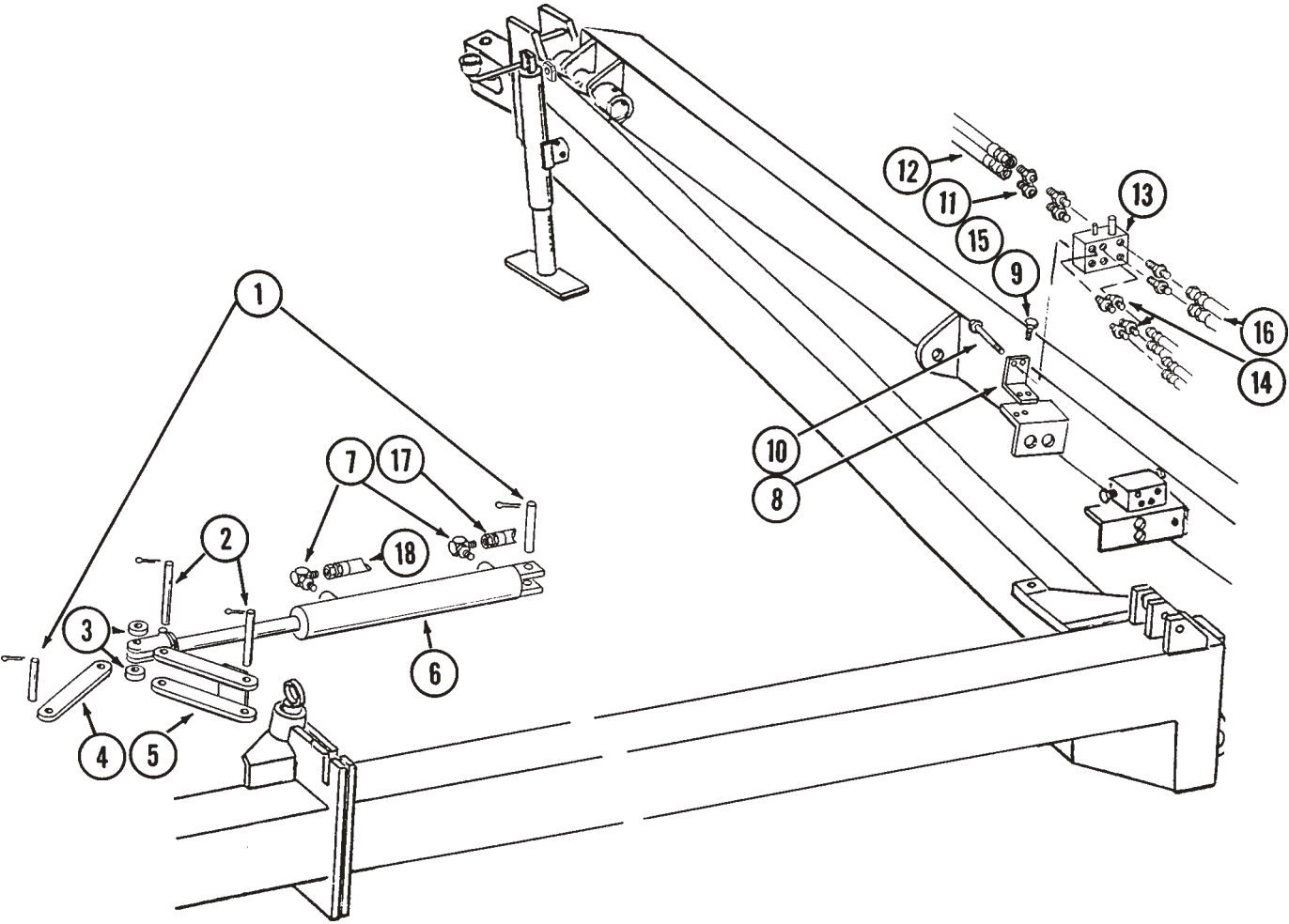

# HYDRAULIC WING FOLD (OPTIONAL)

---

ITEM	PART NO.	QTY.	DESCRIPTION
1.	GD9762	4	Pin, 1" x 3 1/2"
	G10463	8	Cotter Pin, 1/4" x 1 1/2"
2.	GD9591	4	Pin, 1" x 5 3/4"
	G10463	8	Cotter Pin, 1/4" x 1 1/2"
3.	GD5900-02	4	Sleeve
4.	GD9589	2	Link
5.	GA6800	2	Link
6.		-	See "Hydraulic Wing Fold Cylinder", Page P51
7.	G6801-06-08	4	Elbow, 9/16"-18 Male To 3/4"-16 O-Ring
8.	GD9699	1	Mounting Angle
9.	G10064	2	Hex Head Cap Screw, 1/4"-20 x 1"
	G10227	2	Lock Washer, 1/4"
	G10103	2	Hex Nut, 1/4"-20
10.	G10580	2	Hex Head Cap Screw, 1/4"-20 x 3"
	G10227	2	Lock Washer, 1/4"
	G10103	2	Hex Nut, 1/4"-20
11.	G2406-08-06	2	Reducer, 3/4"-16 Female JIC To 9/16"-18 Male JIC
12.		-	See "Hydraulic System", Page P54
13.		-	See "Hydraulic Wing Fold Selector Valve", Page P53
14.	G6400-06	4	Connector, 9/16"-18 Male JIC To O-Ring
15.	G6400-08-06	4	Connector, 3/4"-16 Male JIC To 9/16"-18 O-Ring
16.	GA3180	2	Hose Assembly, 3/8" x 25"
17.	GA1172	2	Hose Assembly, 1/4" x 105"
18.	GA1168	2	Hose Assembly, 1/4" x 120"

# TRANSPORT AND GROUND DRIVE WHEEL ASSEMBLY

PLA013/PLA034/PLA015/HTA014(PT54/PT55/PT2c/EF11)

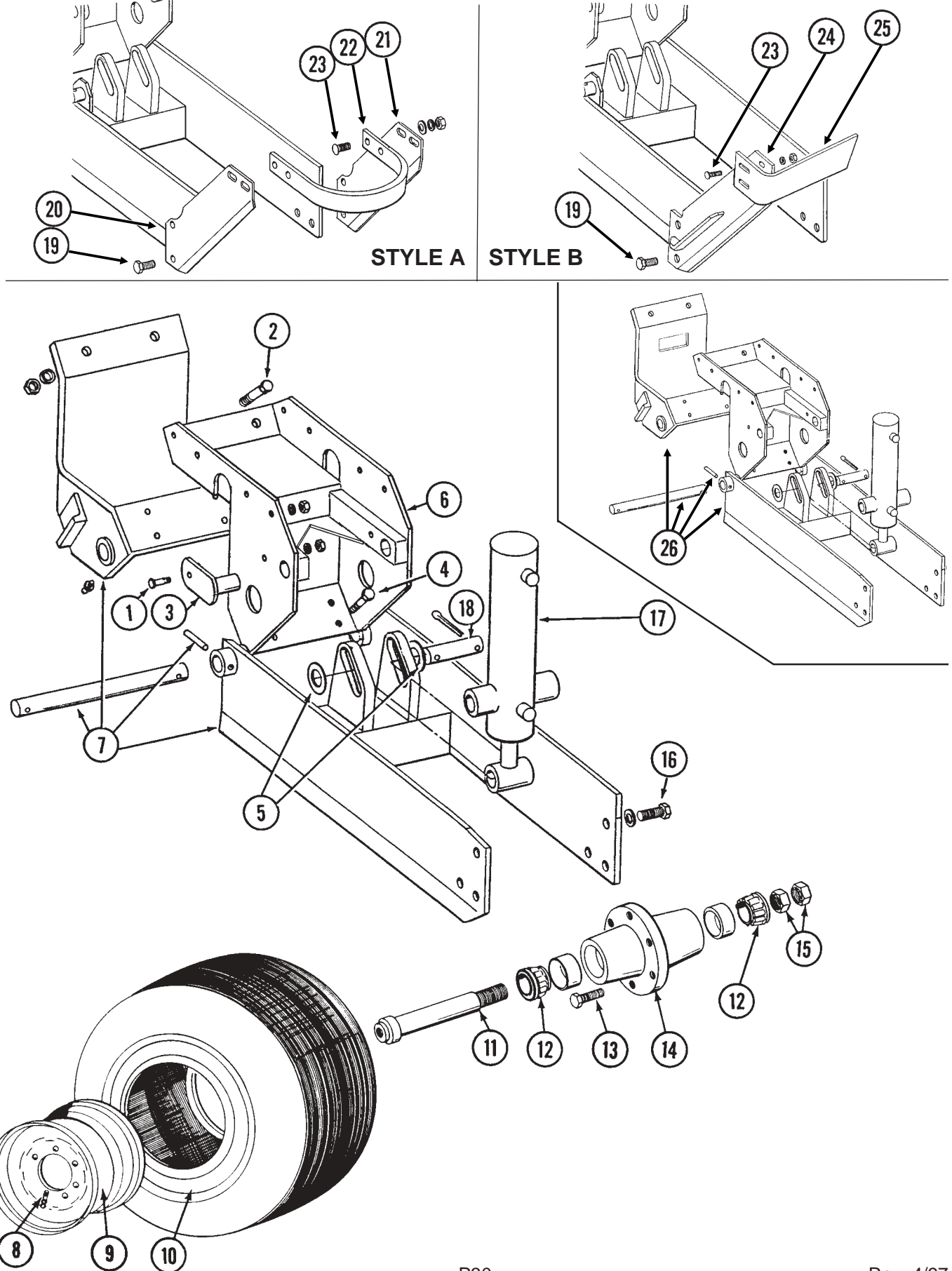

# TRANSPORT AND GROUND DRIVE WHEEL ASSEMBLY

ITEM	PART NO.	QTY. (Per Assy.)	DESCRIPTION
1.	G10581	2	Hex Head Cap Screw, 1/2"-13 x 2 1/4"
	G10111	2	Lock Nut, 1/2"-13
2.	G10009	2	Hex Head Cap Screw, 5/8"-11 x 2 1/2"
	G10230	2	Lock Washer, 5/8"
	G10104	2	Hex Nut, 5/8"-11
3.	GA5121	2	Pin
4.	G10008	4	Hex Head Cap Screw, 5/8"-11 x 2"
	G10230	4	Lock Washer, 5/8"
	G10104	4	Hex Nut, 5/8"-11
5.	G10139	2	Washer, 1 1/4" USS
6.	GA5122	1	Wheel Tower Clamp
7.	GA5124	1	Arm W/Pin, Clamp, Grease Fittings And Spring Pins
	GD5804	-	Pin, 1 1/4" x 12"
	GA5123	-	Clamp
	G10641	-	Grease Fitting, 1/8" NPT
	G10610	-	Spring Pin, 3/8" x 2"
8.	GA7434	1	Valve Stem
9.	GA2142	1	Rim, 5.50" x 20"
10.	GD9645	1	Tire, 7.50" x 20", 6 Ply Tubeless (Specify Brand)
	GD1166	1	Valve Stem (Not Shown)
11.	GA2558	1	Spindle
12.	GA0895	2	Cone
13.	GR0270	6	Lug Bolt, 9/16"-18
14.	GA2148	1	Hub W/Cups
	GR0434	-	Cup
15.	G10087	2	Jam Nut, 1 1/2"-10
16.	G10026	2	Hex Head Cap Screw, 3/4"-10 x 2"
	G10231	2	Lock Washer, 3/4"
17.		-	See "Master/Slave/List Assist Cylinders", Pages P49 And P50
18.	GD5841	1	Pin, 1 1/4" x 5 5/8"
	G10460	2	Cotter Pin, 1/4" x 2"
19.	G10025	2	Hex Head Cap Screw, 3/4"-10 x 1 1/2"
	G10231	2	Lock Washer, 3/4"
	G10105	2	Hex Nut, 3/4"-10
20.	GD5845	1	Scraper Mount, L.H.
21.	GD5846	1	Scraper Mount, R.H.
22.	GD5847	1	Scraper Bar
23.	G10636	4	Carriage Bolt, 1/2"-13 x 1 1/2"
	G10228	4	Lock Washer, 1/2"
	G10216	4	Washer, 1/2" USS
	G10102	4	Hex Nut, 1/2"-13
24.	GA7376	1	Scraper Mount
25.	GD10010	1	Scraper
26.	GA6855	-	Arm W/Pin, Clamp, Grease Fittings And Spring Pins
	GD5804	-	Pin, 1 1/4" x 12"
	GA6854	-	Clamp
	G10641	-	Grease Fitting, 1/8" NPT
	G10610	-	Spring Pin, 3/8" x 2"
A.	GA2147	-	Hub And Spindle Assembly (Items 11-16)
B.	GA7409	-	Scraper Assembly (Items 19 And 23-25)

# CONTACT DRIVE WHEEL AND ARM ASSEMBLY

PLA014(PT4b)

R.H. Side Shown

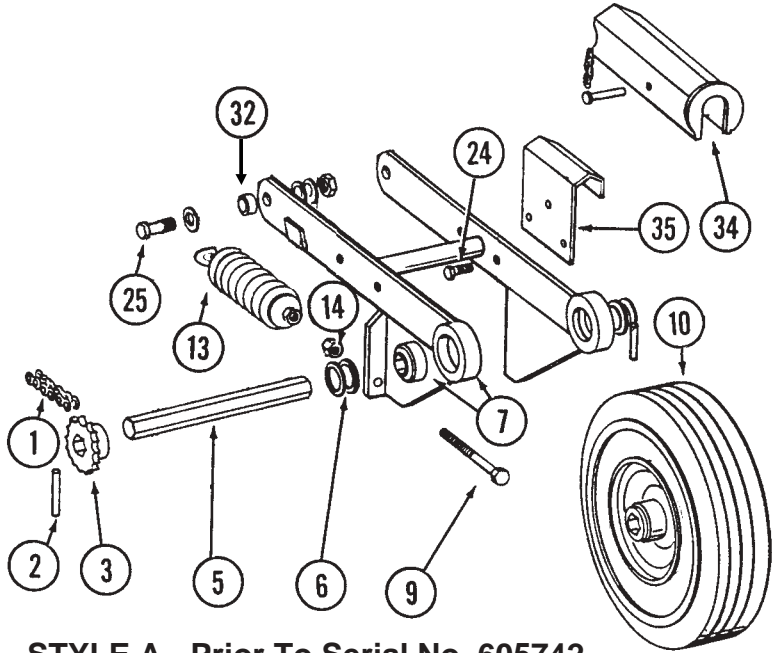
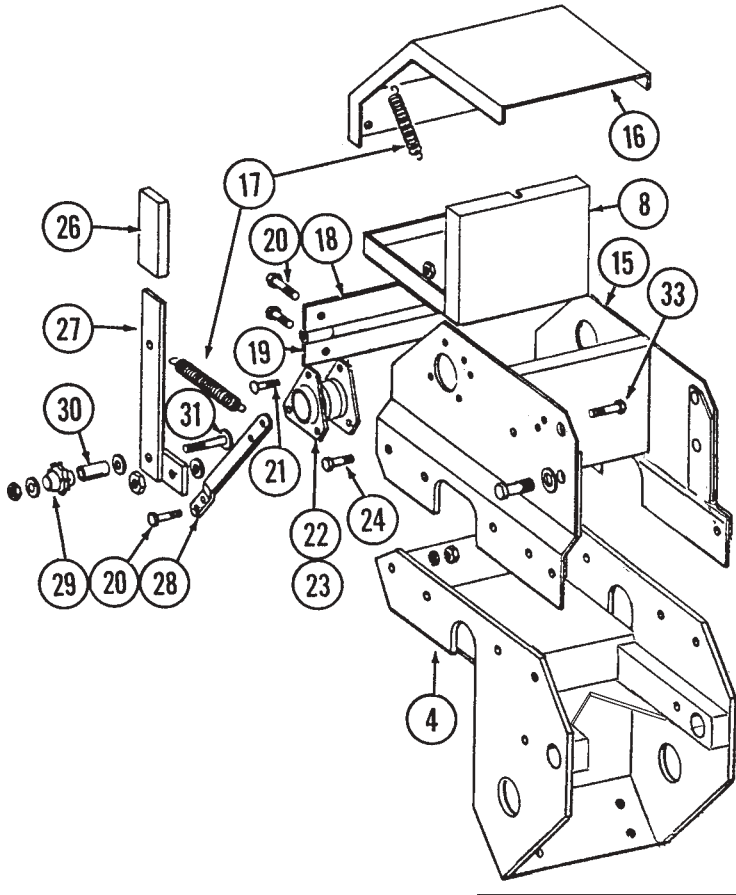

STYLE A - Prior To Serial No. 605742

STYLE B - Serial No. 605742 & On

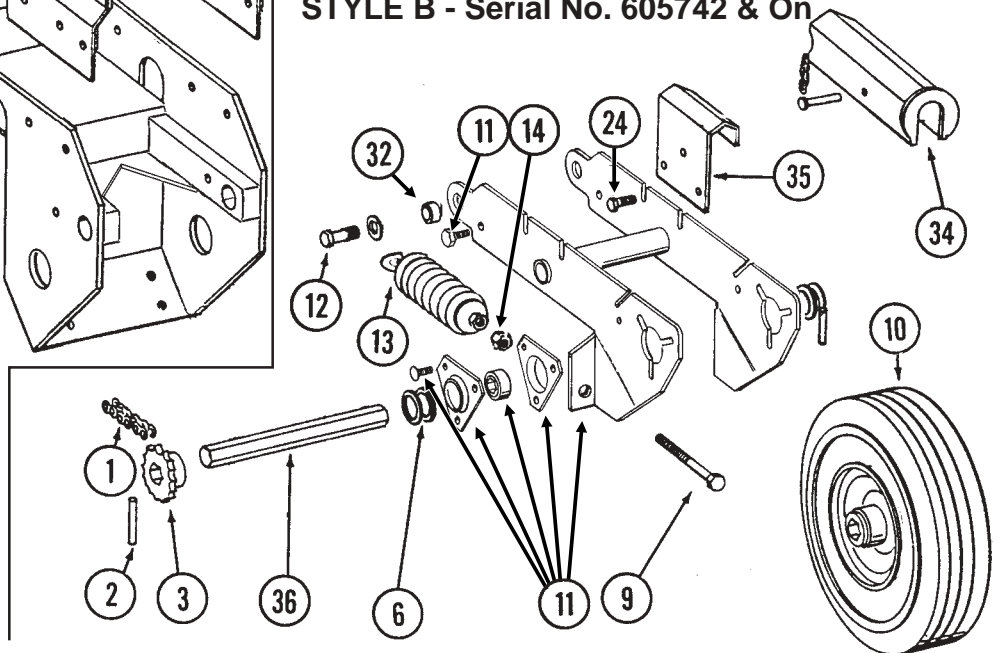

ITEM	PART NO.	QTY.	DESCRIPTION
		(Per Assy.)	
1.	G3310-132	1	Chain, No. 40, 132 Pitch Including Connector Link
	GR0912	-	Connector Link, No. 40
2.	G10602	2	Spring Pin, 1/4" x 1 1/2"
3.	GA5105	1	Sprocket, 15 Tooth
4.		-	See "Transport And Ground Drive Wheel Assembly", Page P30
5.	GD5797	1	Shaft, 7/8" x 10"
6.	G10233	6	Machine Bushing, 1"
7.	GA5120	1	Wheel Arm W/Bearings
	GA5116	-	Bearing, 7/8" Hex Bore Cylindrical
8.	GA7235	1	Tool Box Insert



# CONTACT DRIVE WHEEL AND ARM ASSEMBLY

ITEM	PART NO.	QTY.	DESCRIPTION
(Per Assy.)			
9.	G10890	2	Hex Head Adjusting Bolt, 1/2"-13 x 4", Grade 2
10.	GA5090	-	Tire And Rim Assembly
	GD5753	1	Tire, 4.10" x 6" (Specify Brand)
	GD5752	1	Tube
11.	GA7370	1	Arm W/Flangettes, Bearings And Hardware
	G3400-01	-	Flangette
	G2100-03	-	Bearing, 7/8" Hex Bore, Spherical
	G10055	2	Hex Head Cap Screw, 5/8"-11 x 1 1/4" (Stop Bolt)
	G10107	2	Lock Nut, 5/8"-11
12.	G10751	2	Hex Head Cap Screw, 5/8"-18 x 1 3/4"
	G10235	6	Machine Bushing
	GD7805	2	Special Washer
	G10412	2	Lock Nut, 5/8"-18
13.	GA2068	2	Spring
14.	G10501	2	Jam Nut, 1/2"
15.	GA5118	1	Mount
16.	GA5182	1	Cover
17.	GD5857	2	Spring
18.	GD5790	1	Hinge, Male
19.	GD5789	1	Hinge, Female
20.	G10023	4	Hex Head Cap Screw, 1/4"-20 x 3/4"
	G10227	4	Lock Washer, 1/4"
	G10103	4	Hex Nut, 1/4"-20
21.	G10303	-	Carriage Bolt, 5/16"-18 x 1"
	G10232	-	Lock Washer, 5/16"
	G10219	-	Washer, 5/16" USS (As Required)
	G10106	-	Hex Nut, 5/16"-18
22.	G3400-01	-	Flangette
23.	G2100-03	-	Bearing, 7/8" Hex Bore, Spherical
24.	G10001	4	Hex Head Cap Screw, 3/8"-16 x 1"
	G10229	4	Lock Washer, 3/8"
	G10101	4	Hex Nut, 3/8"-16
25.	G10005	2	Hex Head Cap Screw, 5/8"-11 x 1 3/4"
	G10235	4	Machine Bushing
	G10205	2	Washer, 5/8" SAE
	G10107	2	Lock Nut, 5/8"-11
26.	GD5827	1	Cover
27.	GA5157	1	Idler Arm, L.H.
	GA5158	-	Idler Arm, R.H.
28.	GD5860	1	Bar
29.	GD7426	1	Idler Sprocket, 12 Tooth
30.	GD1026	1	Sleeve, 1 3/16"
31.	G10306	1	Carriage Bolt, 3/8"-16 x 2"
	G10203	-	Washer, 3/8" SAE (As Required)
	G10210	-	Washer, 3/8" USS (As Required)
	G10108	1	Lock Nut, 3/8"-16
32.	GB0218	2	Bushing, 19/32"
33.	G10001	1	Hex Head Cap Screw, 3/8"-16 x 1"
	G10229	1	Lock Washer, 3/8"
	G10370	1	Machine Bushing
	GD5756	1	Special Nut
34.	GA5761	1	Lockup W/Pin
35.	GD7944	1	Mount
36.	GD6825-10.375	1	Shaft, 7/8" x 10 3/8"

# DRIVELINE

PTD036(EF5)

R.H. Side Shown

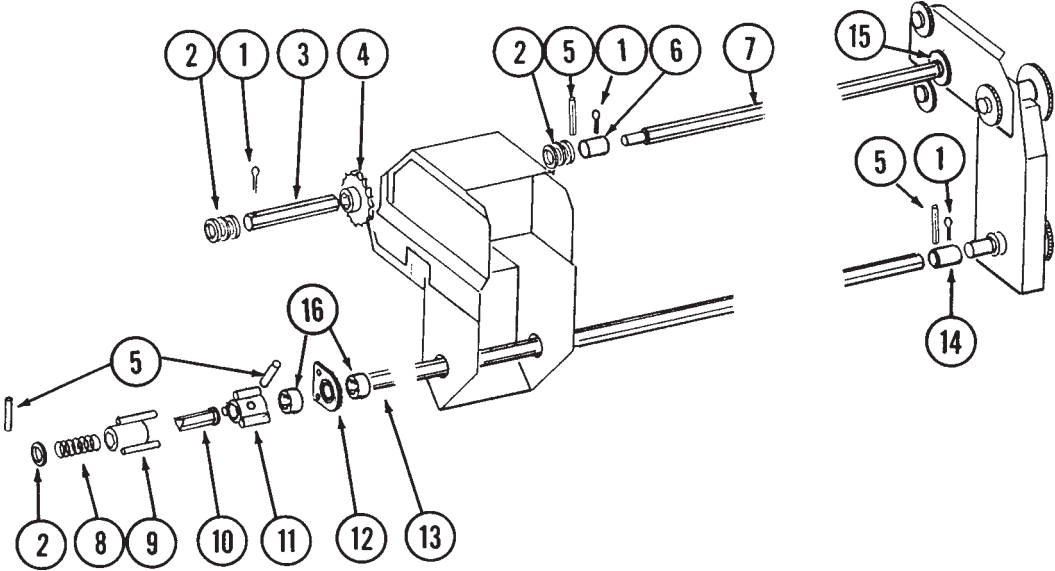

# DRIVELINE

---

ITEM	PART NO.	QTY.	DESCRIPTION
1.	G10460	6	Cotter Pin, 1/4" x 2"
2.	G10233	-	Machine Bushing (As Required)
3.	GD10656	2	Drive Shaft, 15 13/16", 8 Row 36"/38"
	GD6622	-	Drive Shaft, 14 7/8", 12 Row 30"
4.	GA5114	2	Sprocket, 30 Tooth
5.	G10602	8	Spring Pin, 1/4" x 1 1/2"
6.	GD5961	2	Coupler, 2 1/4"
7.	GD8052	2	Drive Shaft, 16 1/2", 12 Row 30"
	GD7989	-	Drive Shaft, 23 7/8", 8 Row 36"/38"
8.	GD2962	2	Spring
9.	GA2373	2	Coupler
10.	GA2447	1	Drill Shaft, Main Frame, 63", L.H., 8 Row 36"/38"
	GA2448	1	Drill Shaft, Main Frame, 73", R.H., 8 Row 36"/38"
	GA2449	-	Drill Shaft, Main Frame, 79", L.H., 12 Row 30"
	GA2450	-	Drill Shaft, Main Frame, 90", R.H., 12 Row 30"
11.	GA2374	2	Coupler
12.	GA2180	2	Hanger Bearing, 7/8" Hex
13.	GD6825-59	2	Drill Shaft, Wing, 8 Row 36"/38"
	GD6825-75.375	-	Drill Shaft, Wing, 12 Row 30"
14.	GD5886	2	Coupler
15.		-	See "Transmission Assembly", Page P44
16.	GD0917	4	Lock Collar, 7/8" Hex, Less Set Screws
	G10145	-	Set Screw, 5/16" - 18 x 1/2"

# POINT ROW WRAP SPRING CLUTCH (OPTIONAL)

PRC018/ECP013(EF6)

## STYLE A

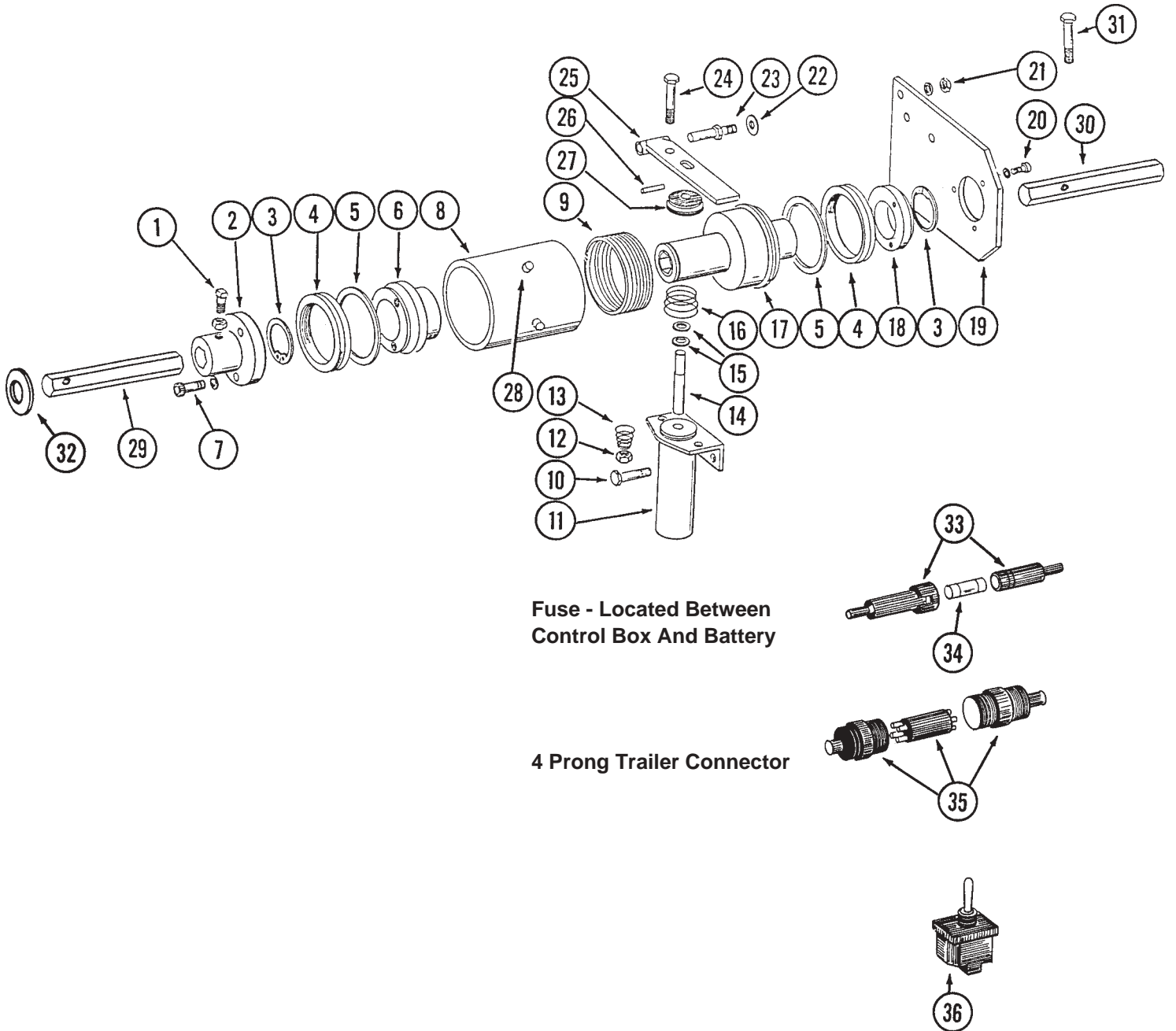

# POINT ROW WRAP SPRING CLUTCH (OPTIONAL)

---

ITEM	PART NO.	QTY. (Per Assy.)	DESCRIPTION
1.	G10131	2	Square Head Set Screw, $\frac{5}{16}$ "-18 x $\frac{3}{4}$ "
	G10498	2	Jam Nut, $\frac{5}{16}$ "-18
2.	GA6786	1	Coupler
3.	G10496	2	Inverted Snap Ring
4.	GD9664	2	V-Ring Seal
5.	GD9674	2	Teflon Ring
6.	GD9670	1	Input Hub
7.	G10374	3	Hex Socket Screw, $\frac{1}{4}$ "-20 x 1"
	G10227	3	Lock Washer, $\frac{1}{4}$ "
8.	GD9668	1	Stop Collar
9.	GD9671	1	Spring, L.H.
	GD9672	-	Spring, R.H.
10.	G10023	2	Hex Head Cap Screw, $\frac{1}{4}$ "-20 x $\frac{3}{4}$ "
	G10227	2	Lock Washer, $\frac{1}{4}$ "
	G10103	2	Hex Nut, $\frac{1}{4}$ "-20
11.	GA5557	1	Solenoid
12.	G10110	1	Lock Nut, $\frac{1}{4}$ "-20
13.	GD9216	1	Spring
14.	GD9689	1	Plunger
15.	G10203	1	Washer, $\frac{3}{8}$ " SAE
16.	GD8458PRC	1	Spring
17.	GA6785	1	Output Hub
18.	GD9667	1	Bushing
19.	GD9665	1	Mounting Plate
20.	G10253	3	Socket Screw, No. 10-32 x $\frac{1}{2}$ "
	G10257	3	Lock Washer, No. 10
21.	G10229	1	Lock Washer, $\frac{3}{8}$ "
	G10497	1	Jam Nut, $\frac{3}{8}$ "-16
22.	G10203	2	Washer, $\frac{3}{8}$ " SAE
23.	GD9679	1	Mounting Pin
24.	G10040	1	Hex Head Cap Screw, $\frac{1}{2}$ "-20 x 1 $\frac{3}{4}$ "
25.	GA6787	1	Actuator Arm
26.	G10187	1	Spring Pin, $\frac{5}{32}$ " x 2"
27.	GR0646	1	Boot
28.	GD9781	4	Hex Socket Cap Screw, $\frac{1}{4}$ "-20 x $\frac{3}{16}$ " (Stop On Stop Collar)
29.	GD9782	1	Input Shaft, 4 $\frac{1}{4}$ "
30.	GD7339	1	Output Shaft, 8"
31.	G10041	1	Hex Head Cap Screw, $\frac{5}{16}$ "-18 x 2"
	G10109	1	Lock Nut, $\frac{5}{16}$ "-18
32.	G10345	-	Machine Bushing, (As Required)
33.	GA1917	1	Fuse Holder
34.	GD10243	1	Fuse, MDL 10 Slow Blow
35.	GA1911	1	Trailer Connector, 4 Prong
36.	GA0533	1	Toggle Switch

# POINT ROW WRAP SPRING CLUTCH (OPTIONAL)

PRC018/ECP013(EF7/EF10/SFP6/TWL18)

## STYLE B

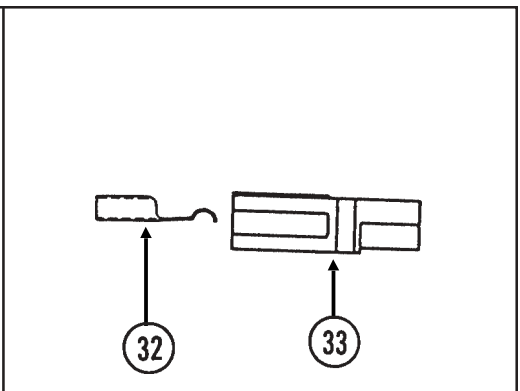
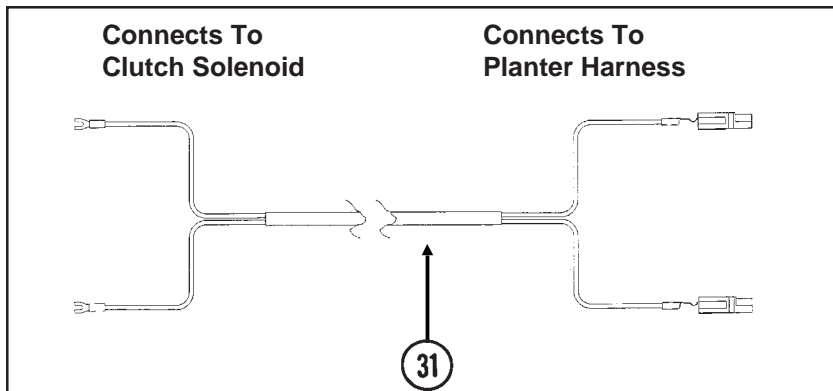
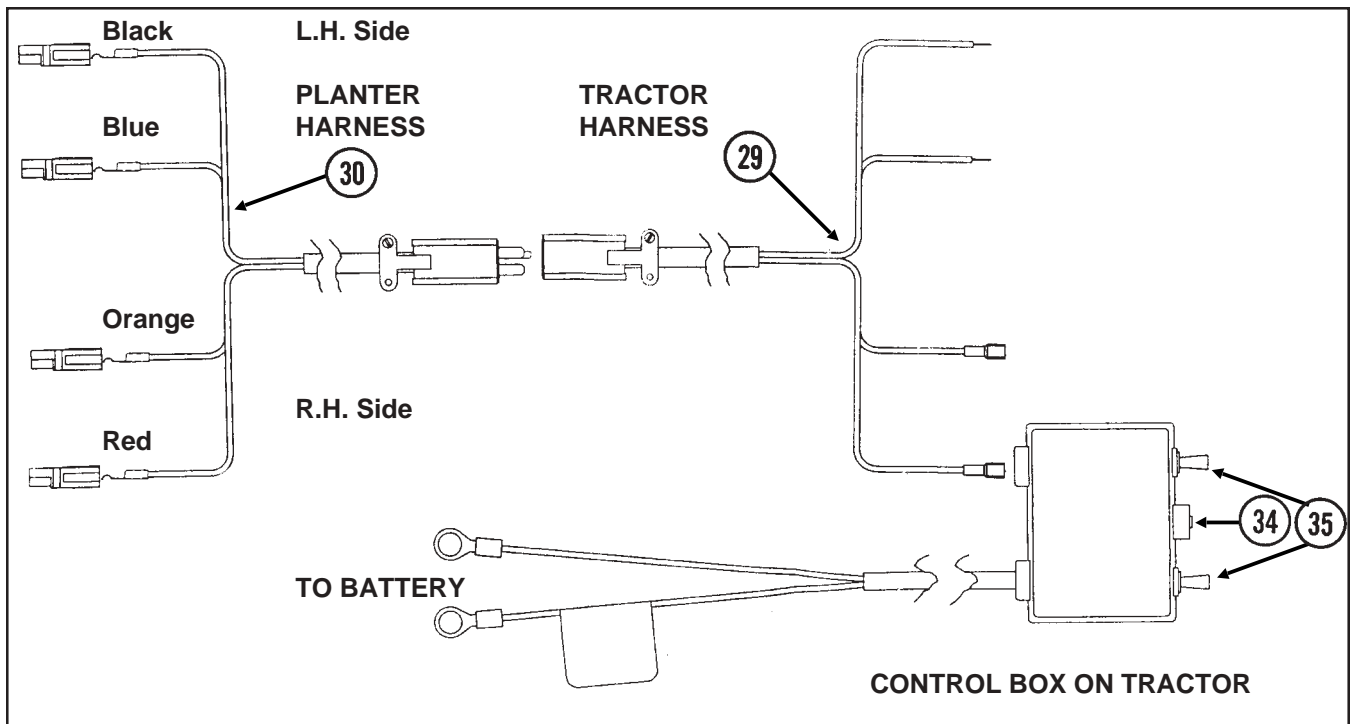
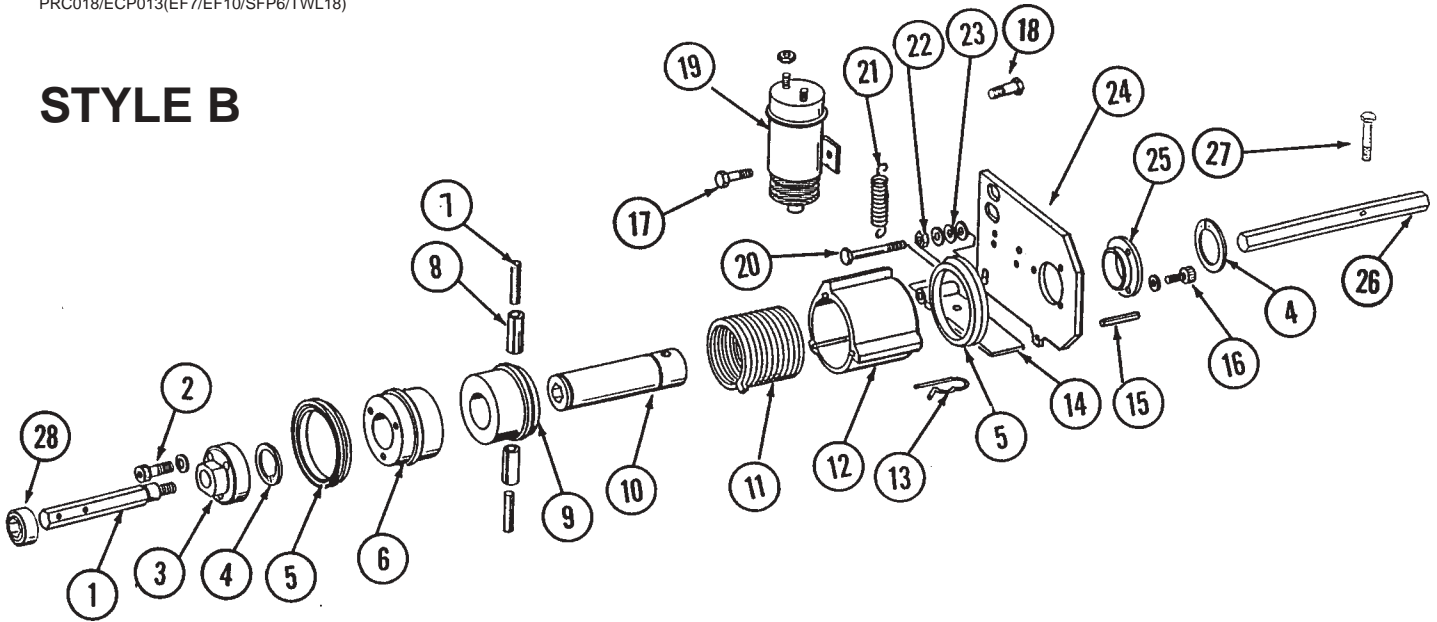

# POINT ROW WRAP SPRING CLUTCH (OPTIONAL)

ITEM	PART NO.	QTY. (Per Assy.)	DESCRIPTION
1.	GD10069	1	Input Shaft, L.H. Thread (L.H. Side Of Machine)
	GD10068	-	Input Shaft, R.H. Thread (R.H. Side Of Machine)
2.	G10374	3	Socket Head Screw, 1/4"-20 x 1"
	G10227	3	Lock Washer, 1/4"
3.	GD10071	1	Coupler W/L.H. Threads (L.H. Side Of Machine)
	GD10070	1	Coupler W/R.H. Threads (R.H. Side Of Machine)
4.	G10496	2	Snap Ring
5.	GD10120	2	Seal
6.	GD10104	1	Input Hub
7.	G10804	2	Spring Pin, 5/32" x 7/8"
8.	G10765	2	Spring Pin, 1/4" x 1"
9.	GD10105	1	Output Hub
10.	GD10106	1	Sleeve
11.	GD9672	1	Spring, R.H. (L.H. Side Of Machine)
	GD9671	-	Spring, L.H. (R.H. Side Of Machine)
12.	GD10102	1	Stop Collar
13.	G10816	1	Hair Pin Clip, No. 23
14.	GD10510	1	Actuator Arm
15.	G10859	1	Spring Pin, 3/16" x 2 1/4"
16.	G10253	3	Socket Head Screw, No. 10-32 x 1/2"
	G10257	3	Lock Washer, No. 10
17.	G10023	1	Hex Head Cap Screw, 1/4"-20 x 3/4"
	G10227	1	Lock Washer, 1/4"
	G10103	1	Hex Nut, 1/4"-20
18.	G10843	1	Hex Head Adjustment Bolt, 1/4"-20 x 2"
	G10209	1	Washer, 1/4" USS
	G10227	1	Lock Washer, 1/4"
	GD10282	1	Allen Nut, 1/4"-20
	G10103	1	Hex Nut, 1/4"-20
19.	GA7143	1	Solenoid Complete
	GR1306	1	Snap Ring
	GR1303	1	Spring
	GR1304	1	Boot
	GR1305	1	Plunger
	GR1307	1	Body
	G1K221	-	Plastic Ratchet Fastener (As Required)
20.	G10049	1	Hex Head Cap Screw, 3/8"-16 x 2 1/2"
	G10229	2	Lock Washer, 3/8"
	G10497	1	Hex Nut, 3/8"-16
21.	GD10123	1	Spring
22.	G10101	1	Hex Nut, 3/8"-16
23.	G10203	1	Washer, 3/8" SAE
24.	GD10103	1	Mounting Plate
25.	GD9667	1	Bushing
26.	GD7339	1	Output Shaft, 7/8" x 8"
27.	G10041	1	Hex Head Cap Screw, 5/16"-18 x 2"
	G10109	1	Lock Nut, 5/16"-18
28.	GD10200	2	Spacer, 3/4"
29.	GR1345	-	Harness W/Socket Connector, 152"
	GR1347	-	Socket Connector
30.	GR1344	-	Harness W/Plug Connector, 194"
	GR1346	-	Plug Connector
31.	GA7212	1	Wiring Harness, 192"
32.	GD9530	-	Contact
33.	GD9529	-	Housing
34.	GA7165	-	Circuit Breaker, 12 Amp
35.	GA7144	-	Two Position Switch
A.	GA7111	-	Point Row Wrap Spring Clutch, L.H. (R.H. Side Of Machine) (Items 1-25)
	GA7110	-	Point Row Wrap Spring Clutch, R.H. (L.H. Side Of Machine) (Items 1-25)

# TWO-SPEED POINT ROW WRAP SPRING CLUTCH

(EF29/SFP46/TWL71a/TWL76/TWL18)

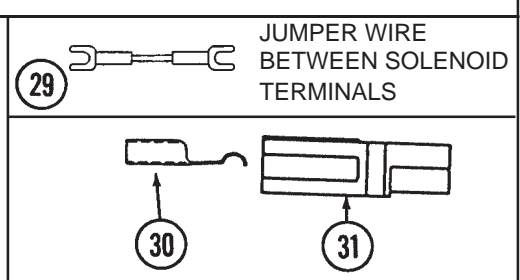
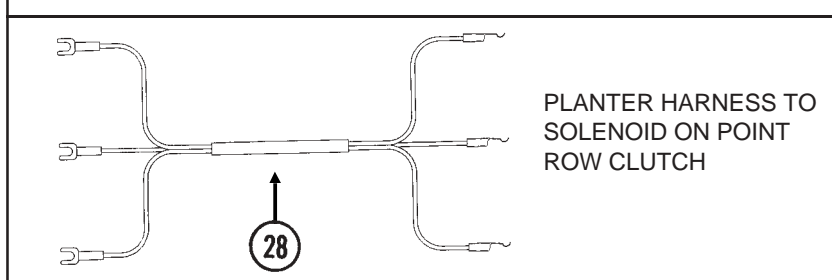
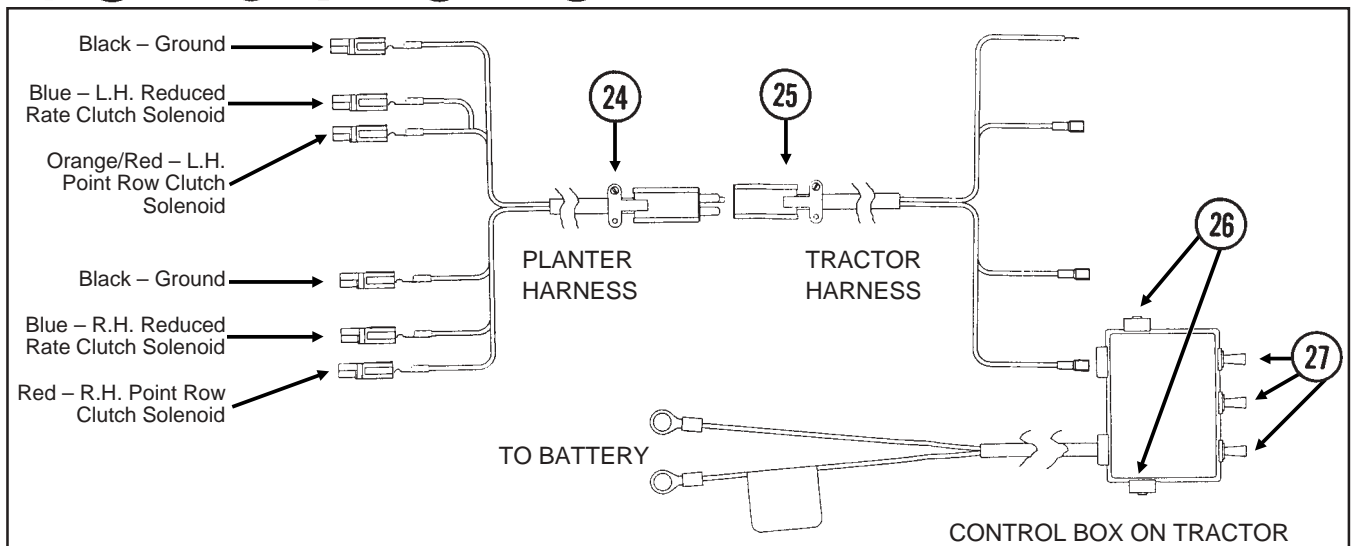
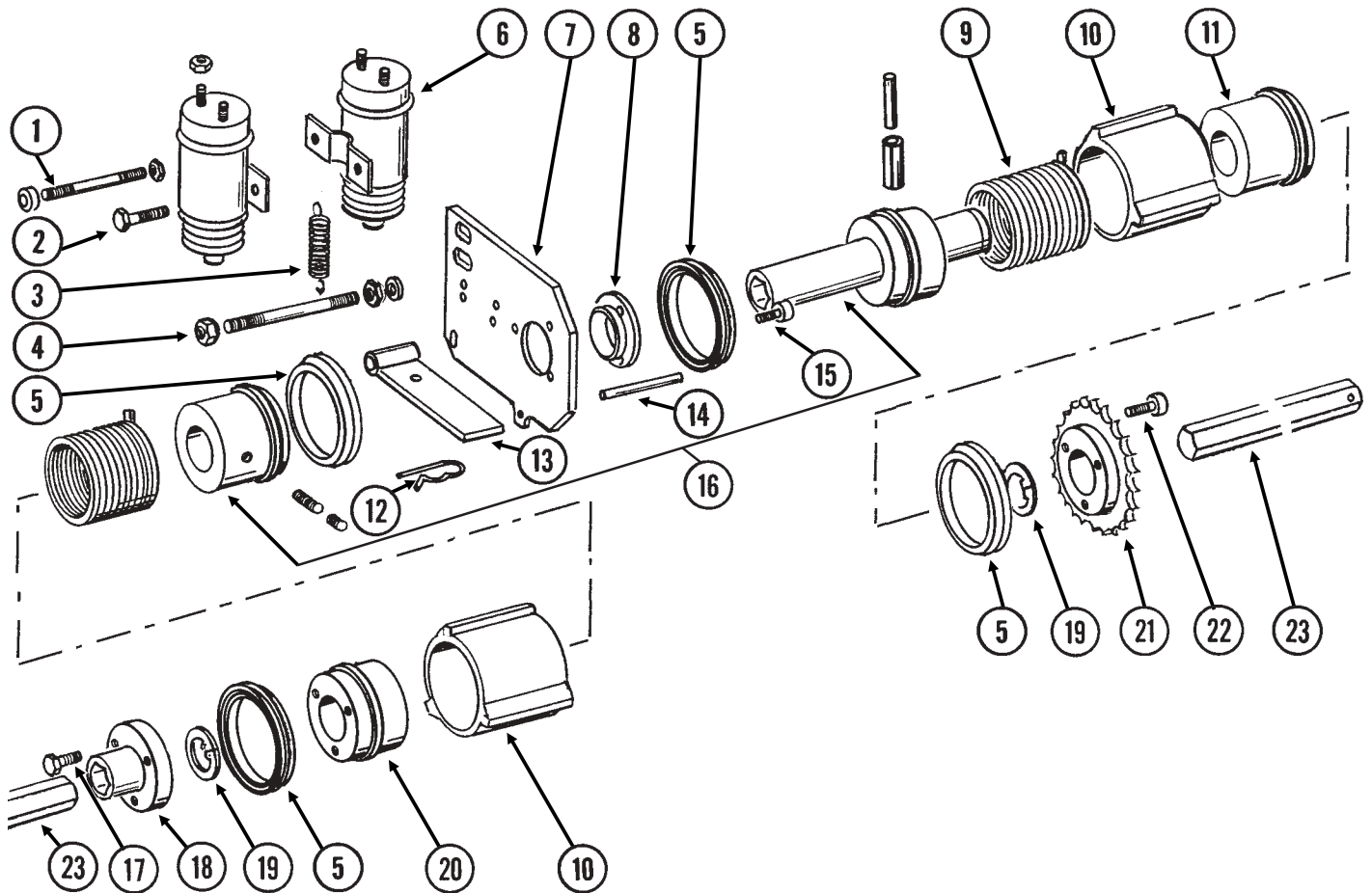



# TWO-SPEED POINT ROW WRAP SPRING CLUTCH

ITEM	PART NO.	QTY.	DESCRIPTION
		(Per Assy.)	
1.	GD10635	1	Threaded Bar, 1/4"-20 x 3 1/2"
	G10103	2	Hex Nut, 1/4"-20
	G10227	2	Lock Washer, 1/4"
	GD10282	2	Allen Nut, 1/4"-20
2.	G10023	1	Hex Head Cap Screw, 1/4"-20 x 3/4"
	G10227	1	Lock Washer, 1/4"
	G10103	1	Hex Nut, 1/4"-20
3.	GD10123	2	Spring
4.	GD10636	1	Threaded Bar, 3/8"-16 x 4 1/4"
	G10108	2	Lock Nut, 3/8"-16
	G10229	2	Lock Washer, 3/8"
	G10101	2	Hex Nut, 3/8"-16
5.	GD10120	4	Seal
6.	GA7143	2	Solenoid Complete
	GR1306	-	Snap Ring
	GR1303	-	Spring
	GR1304	-	Boot
	GR1305	-	Plunger
	GR1307	-	Body
7.	GD10103	1	Mounting Plate
8.	GD10586	1	Bushing
9.	GD9672	2	Spring, R.H. (L.H. Side of Machine)
	GD9671	-	Spring, L.H. (R.H. Side of Machine)
10.	GD10585	2	Stop Collar
11.	GD10580	1	Drive Hub
12.	G10816	2	Hair Pin Clip, No. 23
13.	GD10510	2	Actuator Arm
14.	G10859	1	Spring Pin, 3/16" x 2 1/4"
15.	G10876	3	Hex Socket Head Screw, No. 10-32 x 1/4"
16.	GA7463	1	Hub/Sleeve Assembly W/Pins And Screws
	G10873	-	Hex Socket Set Screw, 5/16"-18 x 3/4"
	G10872	-	Hex Socket Set Screw, 5/16"-18 x 1/4"
	G10804	-	Spring Pin, 5/32" x 7/8"
	G10765	-	Spring Pin, 1/4" x 1"
17.	G10374	3	Hex Socket Head Screw, 1/4"-20 x 1"
18.	GD10764	1	Hex Coupler
19.	G10496	2	Snap Ring
20.	GD10583	1	Driven Hub
21.	GD10672	1	Input Sprocket, 30 Tooth
22.	G10857	3	Hex Head Cap Screw, 1/4"-20 x 1 1/4"
	G10227	3	Lock Washer, 1/4"
23.		-	See "Two-Speed Point Row Wrap Spring Clutch Drive", Page P42
24.	GR1362	-	Harness W/Plug Connector, 60"
	GR1346	-	Plug Connector
25.	GR1361	-	Harness W/Socket Connector, 152"
	GR1347	-	Socket Connector
26.	GA7165	2	Circuit Breaker, 12 Amp
27.	GA7144	3	Two Position Switch
28.	GA7577	1	Wiring Harness, 24'
29.	GA7274	1	Jumper Wire, Between Solenoids
30.	GD9530	-	Contact
31.	GD9529	-	Housing

# TWO-SPEED POINT ROW WRAP SPRING CLUTCH DRIVE

(EF30)

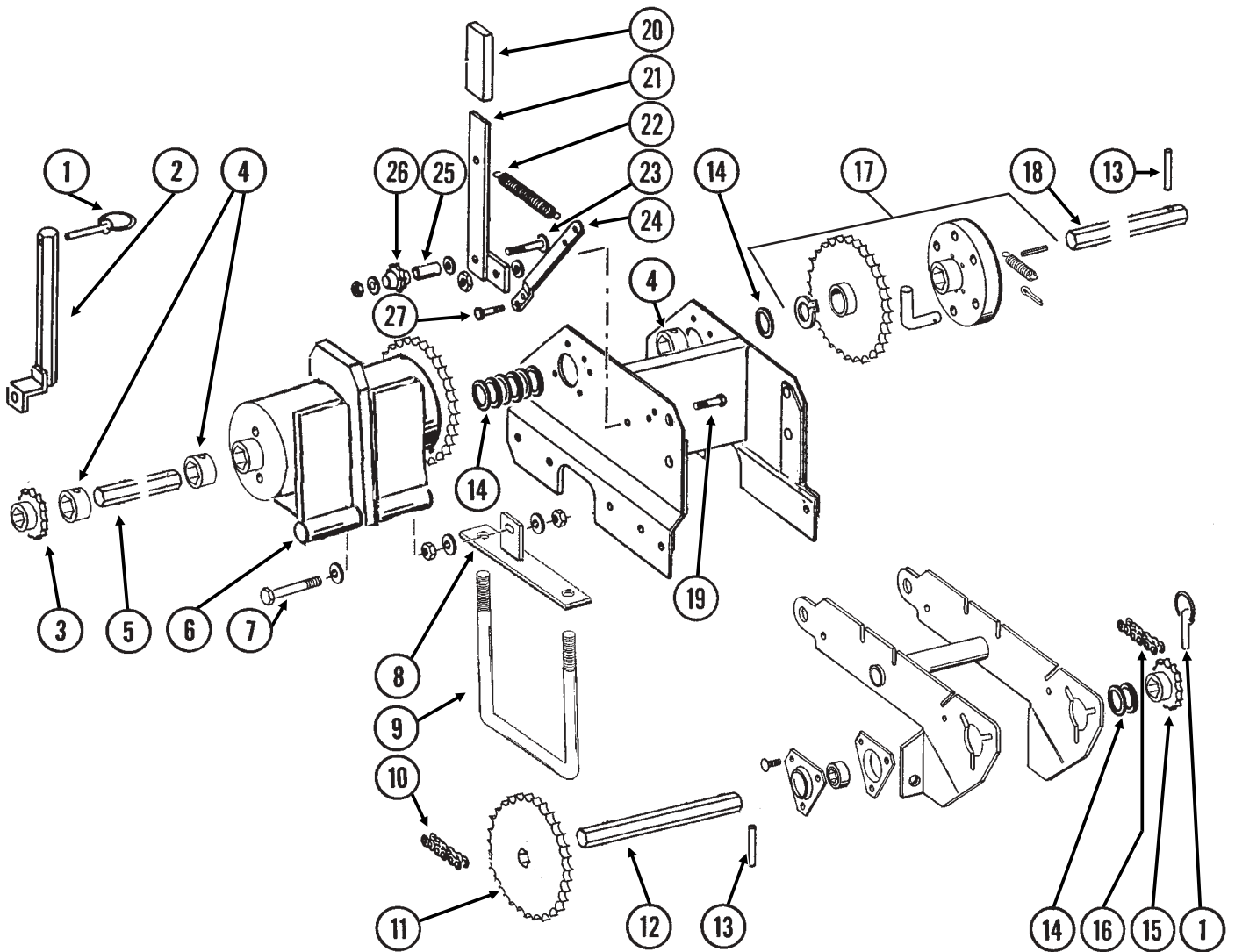

ITEM	PART NO.	QTY.	DESCRIPTION
		(Per Assy.)	
1.	GD2558	2	Lynch Pin, 1/4"
2.	GA7313	1	Sprocket Storage Rod
3.		-	See "Transmission Assembly", Page P44
4.	GD0917	3	Lock Collar (Less Set Screws)
	G10145	-	Set Screw, 5/16"-18 x 1/2"
5.	GD0914-24	1	Shaft, 7/8" x 24"
6.		-	See "Two-Speed Point Row Wrap Spring Clutch", Page P46
7.	G10062	1	Hex Head Cap Screw, 3/8"-16 x 3"
	G10203	3	Washer, 3/8" SAE
	G10101	2	Hex Nut, 3/8"-16

# TWO-SPEED POINT ROW WRAP SPRING CLUTCH DRIVE

ITEM	PART NO.	QTY. (Per Assy.)	DESCRIPTION
8.	GA7831	1	Bracket
9.	GD7145	1	U-Bolt, 7" x 7" x 1/2"-13
	G10228	2	Lock Washer, 1/2"
	G10102	2	Hex Nut, 1/2"-13
10.	G3310-140	1	Chain, No. 40, 140 Pitch Including Connector Link
	GR0912	-	Connector Link, No. 40
11.	GA5114	1	Sprocket, 30 Tooth
12.	GD10332	1	Shaft, 7/8" x 11"
13.	G10602	2	Spring Pin, 1/4" x 1 1/2"
14.	G10233	6	Machine Bushing, 1"
15.	GA5105	1	Sprocket, 15 Tooth
	GA5106	1	Sprocket, 17 Tooth
	GA5109	1	Sprocket, 24 Tooth
	GA5112	1	Sprocket, 27 Tooth
	GA5108	1	Sprocket, 23 Tooth (From Transmission)
	GA5110	1	Sprocket, 25 Tooth (From Transmission)
	GA5111	1	Sprocket, 26 Tooth (From Transmission)
16.	G3310-132	1	Chain, No. 40, 132 Pitch Including Connector Link
	G3310-08	-	Chain, No. 40, 8 Pitch Including Connector Link (Used With 2 To 1 Drive Reduction)
	GR0912	-	Connector Link, No. 40
17.	GA7320	1	Overrunning Sprocket Assembly, R.H.
	GA7321	-	Overrunning Sprocket Assembly, L.H.
	G10430	1	Ring
	GD1255	6	"L" Pin
	G10546	6	Spring, Pin, 3/16" x 1 1/4"
	G10470	6	Cotter Pin, 5/32" x 1"
	GD10366	6	Spring
	GA7317	1	Block
	GA7319	1	Sprocket W/Bushing, 30 Tooth
18.	GD2548-18	1	Shaft, 7/8" x 18"
19.	G10001	1	Hex Head Cap Screw, 3/8"-16 x 1"
	G10229	1	Lock Washer, 3/8"
	G10370	1	Machine Bushing
	GD5756	1	Special Nut
20.	GD5827	1	Cover
21.	GA5157	1	Idler Arm, L.H.
	GA5158	-	Idler Arm, R.H.
22.	GD5857	2	Spring
23.	G10306	1	Carriage Bolt, 3/8"-16 x 2"
	G10203	-	Washer, 3/8" SAE (As Required)
	G10210	-	Washer, 3/8" USS (As Required)
	G10108	1	Lock Nut, 3/8"-16
24.	GD5860	1	Bar
25.	GD1026	1	Sleeve, 1 3/16"
26.	GD7426	1	Idler Sprocket, 12 Tooth
27.	G10023	4	Hex Head Cap Screw, 1/4"-20 x 3/4"
	G10227	4	Lock Washer, 1/4"
	G10103	4	Hex Nut, 1/4"-20

# TRANSMISSION ASSEMBLY

PTD040/PTD066/PTD041(PT8a/PT8b)

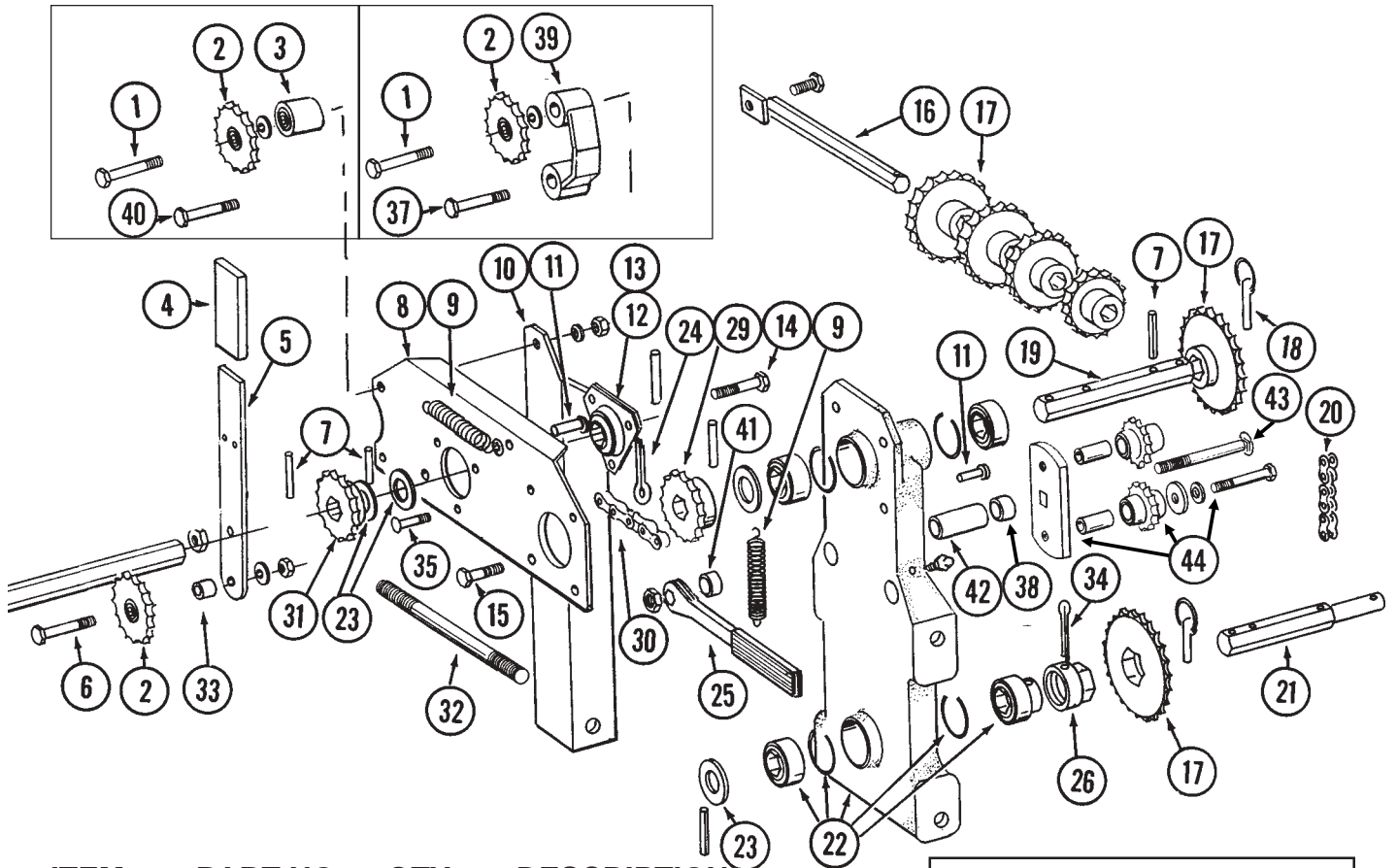

ITEM	PART NO.	QTY.	DESCRIPTION
1.	G10033	1	Hex Head Cap Screw, 1/2"-13 x 3 1/2"
	G10128	-	Machine Bushing (As Required)
	G10228	1	Lock Washer, 1/2"
	G10102	1	Hex Nut, 1/2"-13
2.	GA7154	1	Idler Sprocket W/Bearing, 18 Tooth
3.	GB0259	1	Spacer, 1"
4.	GD5827	1	Cover
5.	GD5829	1	Arm
6.	G10053	1	Hex Head Cap Screw, 1/2"-13 x 2 1/2"
	G10128	-	Machine Bushing (As Required)
	G10228	1	Lock Washer, 1/2"
	G10102	1	Hex Nut, 1/2"-13
7.	G10602	5	Spring Pin, 1/4" x 1 1/2"
8.	GD5824	1	Plate, R.H.
9.	GD5857	2	Spring
10.	GD5830	1	Angle Support, R.H.
11.	G10478	1	Clevis Pin, 5/16" x 1"
	G10409	1	Retaining Ring, 5/16"
12.	G2100-03	1	Bearing, 7/8" Hex Bore, Spherical
13.	G3400-01	2	Flangette
14.	G10001	1	Hex Head Cap Screw, 3/8"-16 x 1"
	G10229	1	Lock Washer, 3/8"
	G10203	-	Washer, 3/8" SAE (As Required)
	G10210	-	Washer, 3/8" USS (As Required)
	GD5756	1	Special Nut, 3/8"-16
15.	G10037	3	Hex Head Cap Screw, 1/2"-13 x 1 1/4"
	G10228	3	Lock Washer, 1/2"
	G10102	3	Hex Nut, 1/2"-13
16.	GA5146	1	Sprocket Storage Rod

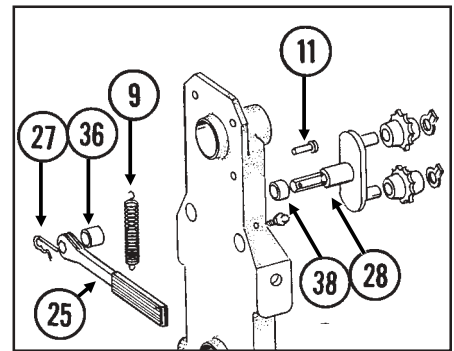

# TRANSMISSION ASSEMBLY

ITEM	PART NO.	QTY.	DESCRIPTION
17.	GA5106	1	Sprocket, 17 Tooth
	GA5107	1	Sprocket, 19 Tooth
	GA5108	2	Sprocket, 23 Tooth
	GA5109	1	Sprocket, 24 Tooth
	GA5110	1	Sprocket, 25 Tooth
	GA5111	1	Sprocket, 26 Tooth
	GA5112	1	Sprocket, 27 Tooth
	GA5113	1	Sprocket, 28 Tooth
18.	GD2558	3	Lynch Pin, 1/4"
19.	GD5835	1	Shaft, 7/8" x 7"
20.	G3310-80	1	Chain, No. 40, 80 Pitch Including Connector Link
	GR0912	-	Connector Link, No. 40
21.	GD7822	1	Shaft, 7/8" x 7"
22.	GA5629	1	Transmission Plate W/ Bearings, Grease Fittings And Retaining Rings
	GA5116	3	Bearing, 7/8" Hex Bore, Cylindrical
	GA5624	1	Special Bearing, 7/8" Hex Bore x 1.6"
	GD6551	4	Ring
	G10641	-	Grease Fitting, 1/8" NPT
23.	G10233	-	Machine Bushing
24.	G10460	1	Cotter Pin, 1/4" x 2"
25.	GA4235	1	Ratchet Wrench W/Protective Closure
	G10445	-	Protective Closure
26.	GD7127	1	Shear Coupler
27.	G10670	1	Hair Pin Clip, No. 3
28.	GA5628	1	Idler W/Sprockets And Rings
	GD7426	-	Sprocket
	G10435	-	Ring
29.	GA5106	1	Sprocket, 17 Tooth
	GA5202	-	Sprocket, 34 Tooth (2 To 1 Drive Reduction)
30.	G3310-89	1	Chain, No. 40, 89 Pitch Including Connector And Offset Link
	G3310-08	-	Chain, No. 40, 8 Pitch Including Connector Link (Used With 2 To 1 Drive Reduction)
	GR0911	-	Offset Link, No. 40
	GR0912	-	Connector Link, No. 40
31.	GA5105	1	Sprocket, 15 Tooth
32.	GD6793	2	Stud, 5/8"-11 x 9 1/2" (Threaded Both Ends)
	G10230	4	Lock Washer, 5/8"
	G10107	4	Hex Nut, 5/8"-11
33.	GD4887-01	1	Sleeve, 5/8"
34.	G10462	1	Cotter Pin, 3/16" x 2"
35.	G10303	3	Carriage Bolt, 5/16"-18 x 1"
	G10232	3	Lock Washer, 5/16"
	G10106	3	Hex Nut, 5/16"-18
36.	GD6819	1	Idler Sleeve, 7/16"
37.	G10053	1	Hex Head Cap Screw, 1/2"-13 x 2 1/2"
	G10228	1	Lock Washer, 1/2"
	G10102	1	Hex Nut, 1/2"-13
38.	GD2734-01	1	Sleeve, 1/2"
39.	GA7156	1	Idler Mount, R.H. (Sub GB0259 And G10017)
40.	G10017	1	Hex Head Cap Screw, 1/2"-13 x 1 1/2"
	G10228	1	Lock Washer, 1/2"
	G10102	1	Hex Nut, 1/2"-13
41.	GD10161	1	Spacer, 3/8"
42.	GD3180-16	1	Sleeve, 2 13/16"
43.	G10867	1	Carriage Bolt, 1/2"-13 x 5"
	G10111	1	Lock Nut, 1/2"-13
44.	GA7336	1	Idler W/Bolt-On Sprockets
	GD7426	-	Sprocket
	GD1026	-	Spacer, 1 3/16"
	G10210	-	Washer, 3/8" USS
	G10229	-	Lock Washer, 3/8"
	G10047	-	Hex Head Cap Screw, 3/8"-16 x 1 3/4"

# MARKER ASSEMBLY

MKR008/MKR012/MKR021 (MKR7)

R.H. Shown

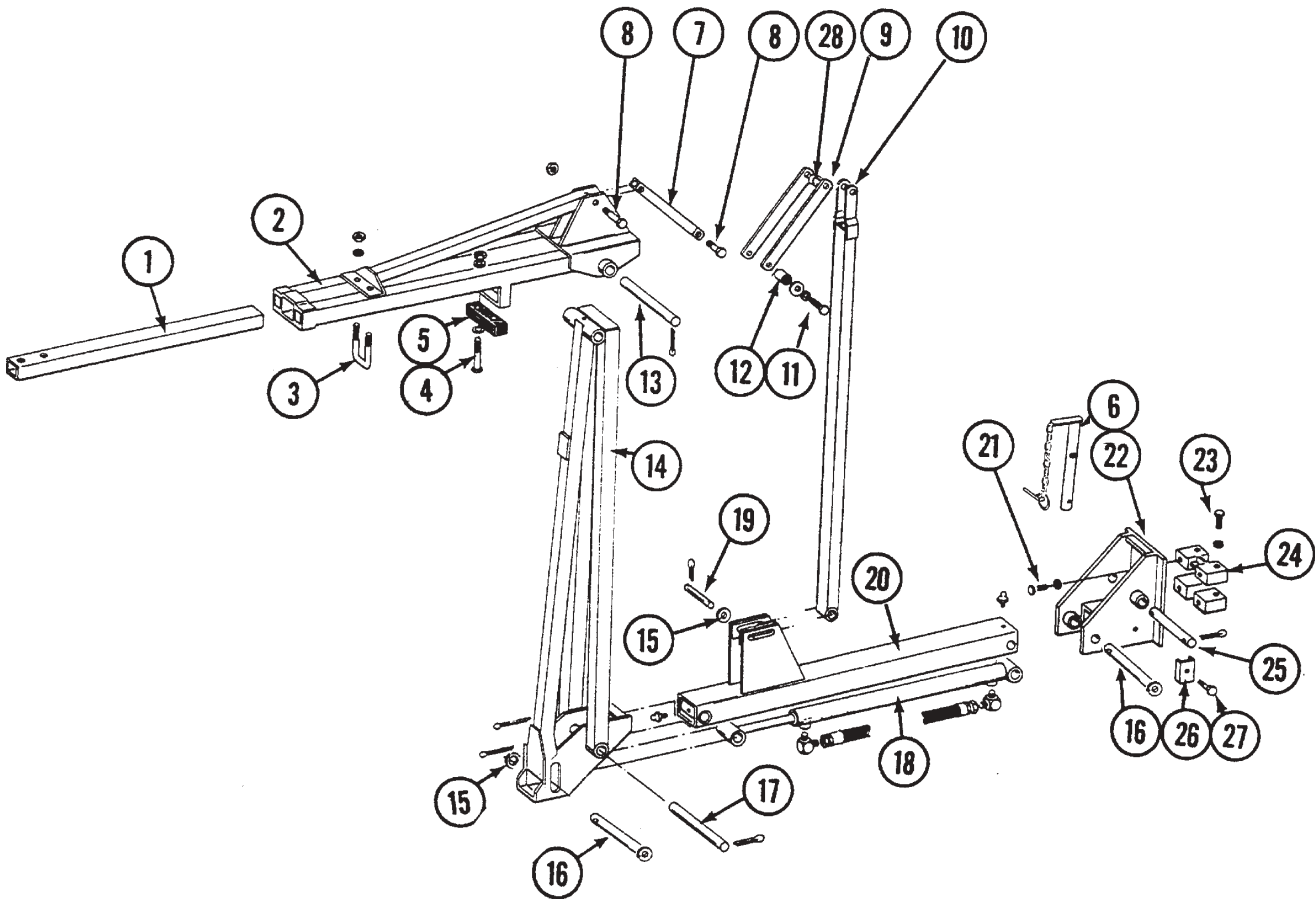

ITEM	PART NO.	QTY.	DESCRIPTION
		(Per Assy.)	
1.	GD0453-07	1	Extension Tube, 45", 8 Row 36"/38"
	GD0453-03	-	Extension Tube, 50", 12 Row 30"
2.	GA4905	1	Arm, Third Stage, 19 1/2", 8 Row 36"/38"
	GA4887	-	Arm, Third Stage, 35", 12 Row 30"
3.	GD2721	1	U-Bolt, 2" x 2" x 1/2"-13
	G10228	2	Lock Washer, 1/2"
	G10102	2	Hex Nut, 1/2"-13

# MARKER ASSEMBLY

ITEM	PART NO.	QTY. (Per Assy.)	DESCRIPTION
4.	G10048	2	Hex Head Cap Screw, $\frac{3}{8}$ "-16 x 2"
	G10210	2	Washer, $\frac{3}{8}$ " USS
	G10229	2	Lock Washer, $\frac{3}{8}$ "
	G10101	2	Hex Nut, $\frac{3}{8}$ "-16
5.	GD2698	1	Rubber Spacer
	GD7902	-	Spacer Bar (If Applicable) (Not Shown)
6.	GA5900	1	Pin W/Split Ring And $\frac{1}{4}$ " Lock Pin (Prior To Serial No. 605908)
	GA7817	-	Pin W/Split Ring And $\frac{3}{8}$ " Lock Pin (Serial No. 605908 & On)
	GD8280	-	Split Ring
	GD9695	-	Lock Pin, $\frac{1}{4}$ "
	GD10758	-	Lock Pin, $\frac{3}{8}$ "
7.	GA4894	1	Linkage, 15 $\frac{1}{4}$ "
8.	G10013	2	Hex Head Cap Screw, $\frac{5}{8}$ "-11 x 3 $\frac{1}{2}$ "
	G10107	2	Lock Nut, $\frac{5}{8}$ "-11
9.	GD8290	2	Bar
10.	GA4910	1	Linkage Tube W/Grease Fitting, 54 $\frac{3}{4}$ ", 8 Row 36"/38"
	GA4893	-	Linkage Tube W/Grease Fitting, 72 $\frac{3}{4}$ ", 12 Row 30"
	G10641	-	Grease Fitting, $\frac{1}{8}$ " NPT
11.	G10002	1	Hex Head Cap Screw, $\frac{3}{8}$ "-16 x $\frac{3}{4}$ "
	G10229	1	Lock Washer, $\frac{3}{8}$ "
	G10210	1	Washer, $\frac{3}{8}$ " USS
12.	GD7398	1	Threaded Sleeve
13.	GD2697	1	Pin, $\frac{7}{8}$ " x 11"
	G10463	2	Cotter Pin, $\frac{1}{2}$ " x 1 $\frac{1}{2}$ "
14.	GA4903	1	Arm W/Grease Fitting, Second Stage, 60", 8 Row 36"/38"
	GA4885	-	Arm W/Grease Fitting, Second Stage, 78", 12 Row 30"
	G10641	-	Grease Fitting, $\frac{1}{8}$ " NPT
15.	G10226	3	Washer, 1 $\frac{1}{4}$ " SAE
16.	GA6532	2	Pin, 1 $\frac{1}{4}$ " x 7 $\frac{5}{8}$ "
	G10460	2	Cotter Pin, $\frac{1}{4}$ " x 2"
17.	GD3214	1	Pin, 1 $\frac{1}{4}$ " x 12 $\frac{1}{4}$ "
	G10460	2	Cotter Pin, $\frac{1}{4}$ " x 2"
18.		-	See "Marker Cylinder", Page P50
19.	GD6136	1	Pin, 1 $\frac{1}{4}$ " x 5"
	G10460	2	Cotter Pin, $\frac{1}{4}$ " x 2"
20.	GA4884	1	Arm W/Grease Fittings, First Stage
	G10641	-	Grease Fitting, $\frac{1}{8}$ " NPT
21.	G10879	4	Flanged 12 Point Bolt, $\frac{5}{8}$ "-11 x 2"
22.	GA5764	1	Mount, R.H.
	GA5765	-	Mount, L.H.
23.	G10026	4	Hex Head Cap Screw, $\frac{3}{4}$ "-10 x 2"
	G10231	4	Lock Washer, $\frac{3}{4}$ "
24.	GB0177	2	Tap Block
25.	GD0652	1	Pin, 1 $\frac{1}{4}$ " x 9 $\frac{1}{2}$ "
	G10460	2	Cotter Pin, $\frac{1}{4}$ " x 2"
26.	GD5875	1	Hose Clamp
27.	G10133	1	Hex Head Cap Screw, $\frac{5}{16}$ "-18 x 1 $\frac{1}{2}$ "
	G10232	1	Lock Washer, $\frac{5}{16}$ "
	G10106	1	Hex Nut, $\frac{5}{16}$ "-18
28.	GD3180-08	1	Sleeve, $\frac{1}{2}$ "

# MARKER SPINDLE/HUB/BLADE

MKR020(MRK4)

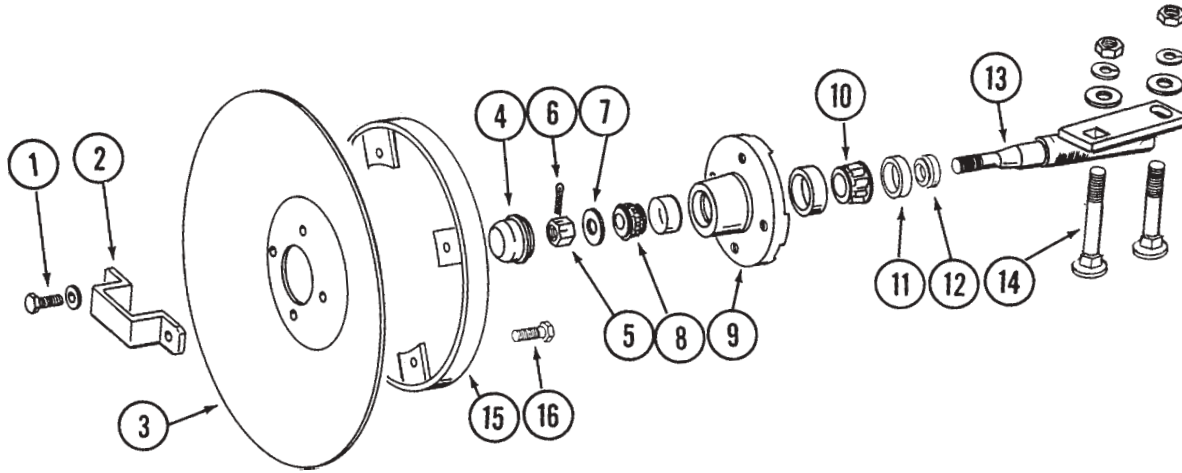

ITEM	PART NO.	QTY. (Per Assy.)	DESCRIPTION
1.	G10722	4	Hex Head Cap Screw, 1/2"-20 x 1"
	G10228	4	Lock Washer, 1/2"
2.	GD2597	1	Retainer
3.	GD0746	1	Solid Blade, 16" (Shown)
	GD10283	-	Notched Blade, 16" (Optional)
4.	GD0840	1	Dust Cap
5.	G10725	1	Hex Slotted Nut, 5/8"-18
6.	G10544	1	Cotter Pin, 5/32" x 1"
7.	G10724	1	Washer, 5/8"
8.	GA0257	1	Outer Bearing
9.	GA0167	1	Hub With Cups
	GR0151	-	Outer Cup
	GR0150	-	Inner Cup
10.	GA0245	1	Inner Bearing
11.	GA0243	1	Grease Seal
12.	GA0899	1	Rubber Seal
13.	GA1677	1	Spindle, L.H. (Shown)
	GA1676	-	Spindle, R.H.
14.	G10844	2	Carriage Bolt, 1/2"-13 x 3 1/2"
	G10168	2	Machine Bushing, 1/2", 7 Gauge
	G10228	2	Lock Washer, 1/2"
	G10102	2	Hex Nut, 1/2"-13
	G10109	2	Lock Washer, 1/2"
15.	GA5853	1	Depth Band
16.	G10019	4	Hex Head Cap Screw, 5/16"-18 x 1"
	G10109	4	Lock Nut, 5/16"-18
A.	GA1679	-	Hub And Spindle Assembly, L.H. (Items 1, 2 And 4-13)
	GA1678	-	Hub And Spindle Assembly, R.H. (Items 1, 2 And 4-13)



# MASTER LIFT CYLINDER

CYL038(CYL1)

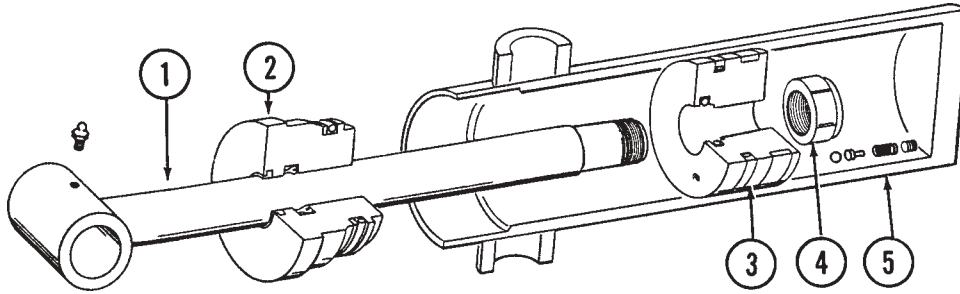

ITEM	PART NO.	QTY.	DESCRIPTION
1.	GA6137	1	Rod Assembly W/Grease Fitting
	G10449	-	Grease Fitting
2.	GD5947	1	Gland
3.	GA6135	1	Piston W/Rephasing Valve
	GR1169	-	Rephasing Valve Replacement Kit (Set Screw, Guide, Spring And Ball)
4.	GR0983	1	Lock Nut, 1"-14
5.	GA4295	1	Barrel
A.	GA6120	-	Cylinder Complete, 3 1/2" x 8" (Part No. Stamped On Barrel)
B.	GR0982	-	Seal Kit, Includes: (1)Wear Ring, (2)O-Rings, (1)BU Ring, (1)U-Cup, (1) Wiper, (1) Uniring

# SLAVE LIFT CYLINDER

CYL038(CYL1)

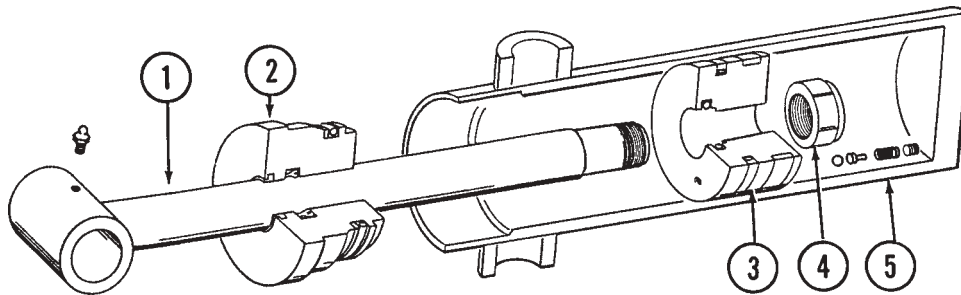

ITEM	PART NO.	QTY.	DESCRIPTION
1.	GA6137	1	Rod Assembly W/Grease Fitting
	G10449	-	Grease Fitting
2.	GD5946	1	Gland
3.	GA6134	1	Piston W/Rephasing Valve
	GR1169	-	Rephasing Valve Replacement Kit (Set Screw, Guide, Spring And Ball)
4.	GR0983	1	Lock Nut, 1"-14
5.	GA4297	1	Barrel
A.	GA6119	-	Cylinder Complete, 3 1/4" x 8" (Part No. Stamped On Barrel)
B.	GR0984	-	Seal Kit, Includes: (2)O-Ring, (1)BU Ring, (1)Wear Ring, (1)Rod Wiper, (1)Uniring, (1)U-Cup

# ASSIST LIFT CYLINDER

CYL026(CYL4)

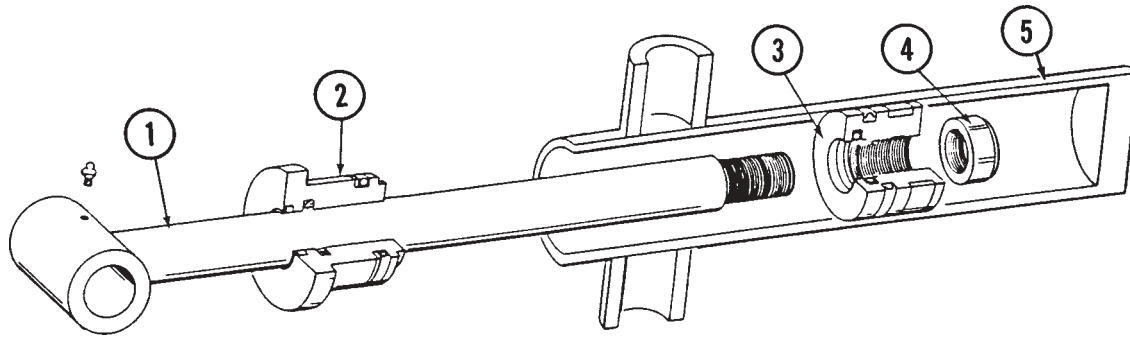

ITEM	PART NO.	QTY.	DESCRIPTION
1.	GA4322	1	Rod Assembly W/Grease Fitting
	G10449	-	Grease Fitting
2.	GD5954	1	Gland
3.	GD5956	1	Piston
4.	GR0923	1	Special Jam Nut, 1"-14
5.	GA5455	1	Barrel
A.	GA5093	-	Cylinder Complete, 2 1/2" x 8"
B.	GR0930	-	Seal Kit, Includes: (1)Wear Ring, (1)T-Seal, (2)O-Rings, (1)BU Ring, (1)U-Cup, (1)Wiper

# MARKER CYLINDER

CYL039(CYL13)

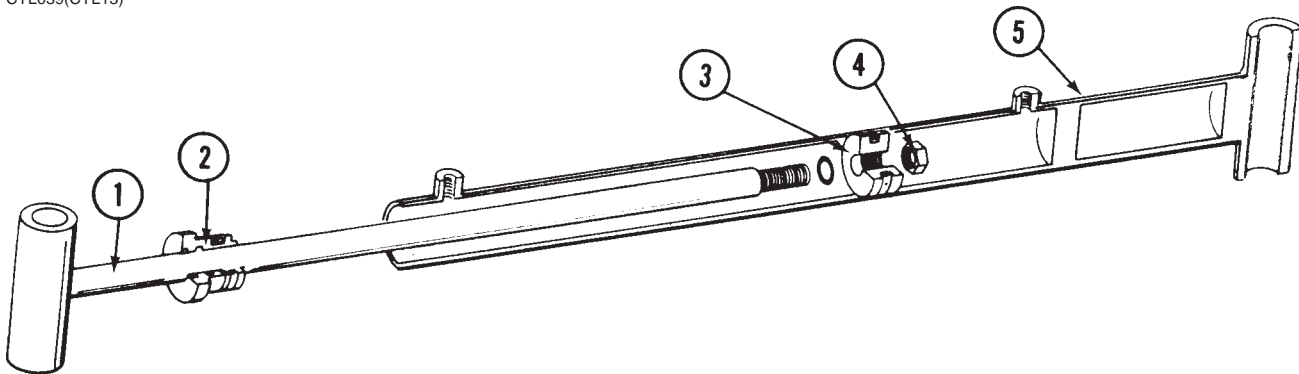

ITEM	PART NO.	QTY.	DESCRIPTION
1.	GA5459	1	Rod Assembly
2.	GD5949	1	Gland
3.	GD4632	1	Piston
4.	GR0959	1	Lock Nut, 3/4"-16
5.	GA5458	1	Barrel
A.	GA5096	-	Cylinder Complete, 2" x 20 1/16"
B.	GR0927	-	Seal Kit, Includes: (1)T Seal, (2)O-Rings, (1)BU Ring, (1)U-Cup,(1)Wiper

# HYDRAULIC WING FOLD CYLINDER

CYL032(CYL14)

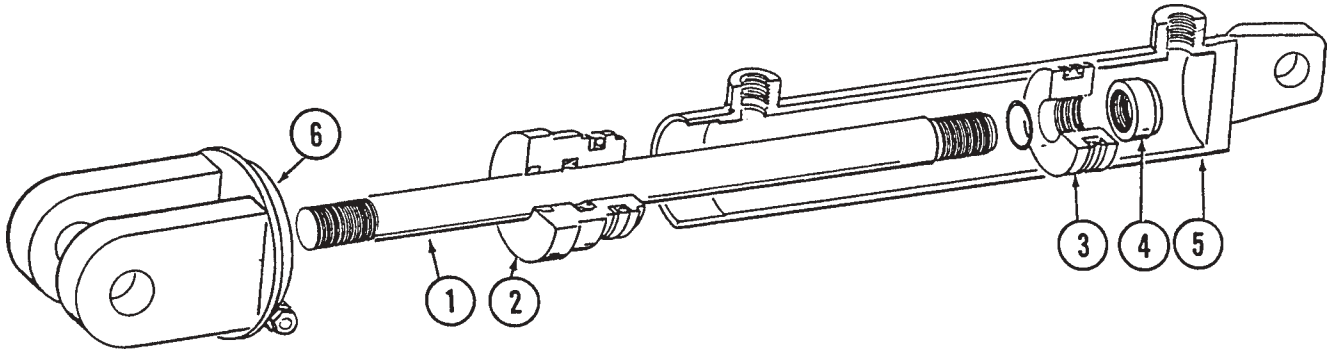

ITEM	PART NO.	QTY.	DESCRIPTION
1.	GD9241	1	Rod
2.	GD5951	1	Gland
3.	GD9239	1	Piston
4.	GR0983	1	Lock Nut, 1 1/4"-12
5.	GA6524	1	Barrel
6.	GA6525	1	Clevis W/ 3/8"-16 x 1 3/4" Socket Head Cap Screw And Lock Nut
A.	GA6349	-	Cylinder Complete, 3" x 16"
B.	GR1185	-	Seal Kit, Includes: (1)Wear Ring, (1)Uniring, (2)O-Rings, (1)BU Ring, (1)U-Cup, (1)Wiper

# MARKER SEQUENCING/FLOW CONTROL VALVE

VVB025(PT9a)

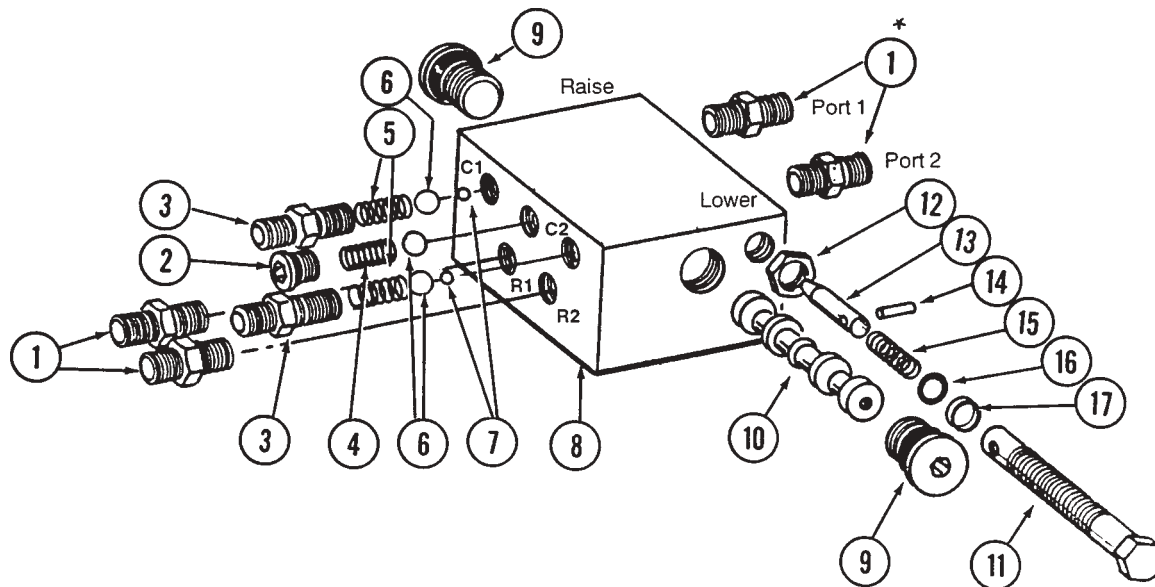

ITEM	PART NO.	QTY.	DESCRIPTION
1.	*G6400-06 GR1045	4 -	Connector W/O-Ring, $\frac{9}{16}$ "-18 Male 37° JIC To $\frac{9}{16}$ "-18 O-Ring
2.	GR1034 GR1035	1 -	Hex Socket O-Ring Plug W/O-Ring
3.	GR1032 GR1045	2 -	Port Adapter W/O-Ring
4.	GR1033	1	Detent Spring
5.	GR1036	2	Spring
6.	GR1044	3	$\frac{7}{16}$ " Check Ball
7.	GR1043	2	$\frac{1}{4}$ " Steel Ball
8.		-	Valve Body ( <b>Non-Stock Item</b> )
9.	GR1047 GR1037	2 -	Hex Socket Plug W/O-Ring
10.		-	Spool ( <b>Non-Stock Item</b> )
11.	GR1042	2	Adjustment Screw
12.	GR1048	2	Hex Jam Nut, $\frac{1}{2}$ "-20
13.	GR1038	2	Needle
14.	GR1039	2	Spring Pin
15.	GR1046	2	Compression Spring
16.	GR1040	2	O-Ring
17.	GR1041	2	Teflon BU Ring
A.	GA5552	-	Valve Assembly Complete (Items 1-17)
B.	GA5572	-	Flow Control Portion Only (Items 11-17)

\*Not used on machines with  $\frac{3}{8}$ " hoses.

# HYDRAULIC WING FOLD SELECTOR VALVE

---

VVB028(EF8)

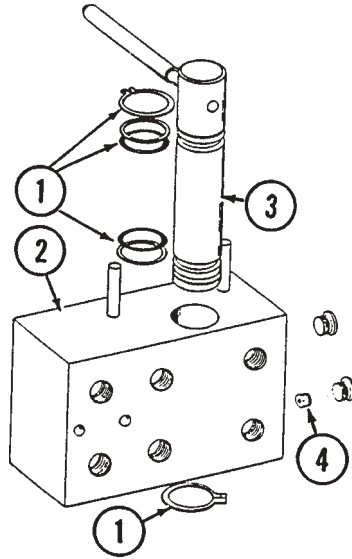

ITEM	PART NO.	QTY.	DESCRIPTION
1.	GR1096	-	Seal Kit
2.	R1176	-	Block <b>(Non-Stock Item)</b>
3.	GR1177	1	Spool W/Handle
4.	GR1178	1	Restrictor
A.	GA6438	-	Valve Assembly Complete

# HYDRAULIC SYSTEM

PHS036(F9)

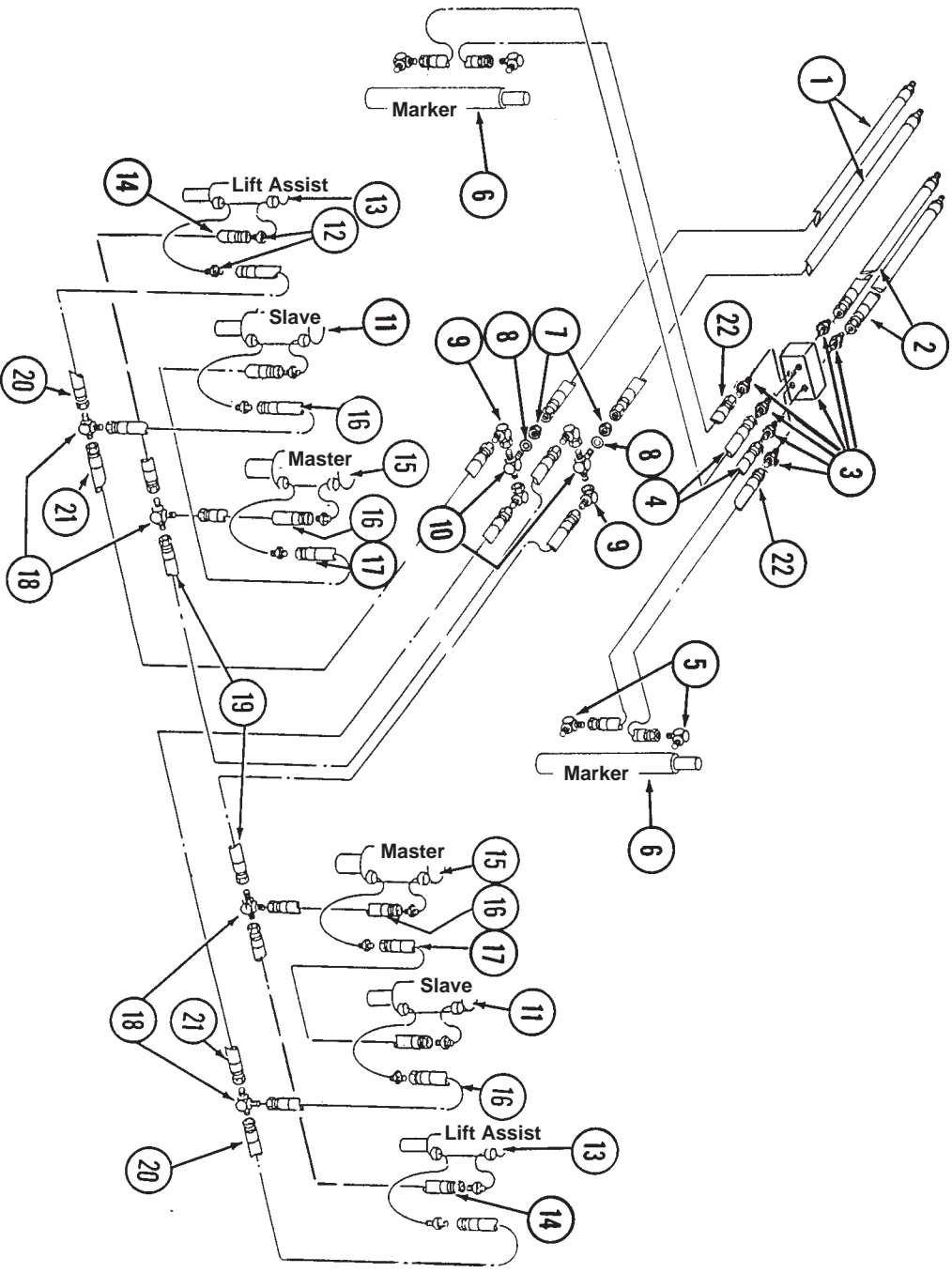

# HYDRAULIC SYSTEM

---

ITEM	PART NO.	QTY.	DESCRIPTION
1.	GA3162	2	Hose Assembly, $\frac{3}{8}$ " x 162", 8 Row 36"/38" And 12 Row 30"
2.	GA3189	2	Hose Assembly, $\frac{3}{8}$ " x 160", 8 Row 36"/38" And 12 Row 30"
3.		-	See "Marker Sequencing/Flow Control Valve", Page P52 And "Hitch And Frame Assembly", Page P26
4.	GA3168	2	Hose Assembly, $\frac{3}{8}$ " x 222", 8 Row 36"/38"
	GA3167	-	Hose Assembly, $\frac{3}{8}$ " x 255", 12 Row 30"
5.	G6801-08	4	Adjustable Elbow, $\frac{3}{4}$ "-16 Male JIC To $\frac{3}{4}$ "-16 O-Ring
6.		-	See "Marker Cylinder", Page P50
7.	G306-08	2	Lock Nut, $\frac{3}{4}$ "-16
8.	G10215	2	Machine Bushing
9.	G6500-08	4	Swivel Elbow, $\frac{3}{4}$ "-16 Male JIC To $\frac{3}{4}$ "-16 Female JIC
10.	G2703-08	2	Bulkhead Tee, $\frac{3}{4}$ "-16 Male JIC
11.		-	See "Slave Lift Cylinder", Page P49
12.	G6400-08	12	Connector, $\frac{3}{4}$ "-16 Male O-Ring To JIC
13.		-	See "Lift Assist Cylinder", Page P50
14.	GA1092	2	Hose Assembly, $\frac{3}{8}$ " x 104", 8 Row 36"/38"
	GA3115	-	Hose Assembly, $\frac{3}{8}$ " x 146", 12 Row 30"
15.		-	See "Master Lift Cylinder", Page P49
16.	GA1000	4	Hose Assembly, $\frac{3}{8}$ " x 15"
17.	GA1055	4	Hose Assembly, $\frac{3}{8}$ " x 66", 8 Row 36"/38"
	GA1006	-	Hose Assembly, $\frac{3}{8}$ " x 90", 12 Row 30"
18.	G2603-08	4	Tee, $\frac{3}{4}$ "-16 Male JIC
19.	GA1055	2	Hose Assembly, $\frac{3}{8}$ " x 66", 8 Row 36"/38"
	GA1022	-	Hose Assembly, $\frac{3}{8}$ " x 60", 12 Row 30"
20.	GA3127	4	Hose Assembly, $\frac{3}{8}$ " x 58", 8 Row 36"/38"
	GA1006	-	Hose Assembly, $\frac{3}{8}$ " x 90", 12 Row 30"
21.	GA1092	2	Hose Assembly, $\frac{3}{8}$ " x 104", 8 Row 36"/38"
	GA1010	-	Hose Assembly, $\frac{3}{8}$ " x 120", 12 Row 30"
22.	GA3174	2	Hose Assembly, $\frac{3}{8}$ " x 235", 8 Row 36"/38"
	GA3173	-	Hose Assembly, $\frac{3}{8}$ " x 267", 12 Row 30"

# ELECTRONIC SEED MONITOR

ECP017/D-0640-0001/D-0640-0003/D-0640-0004/D-1172-0001/D-1172-0002/ECP019/ECP020/ECP021/ECP022(MTR3a)

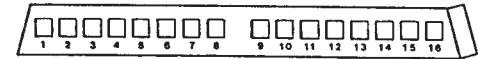
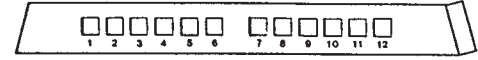
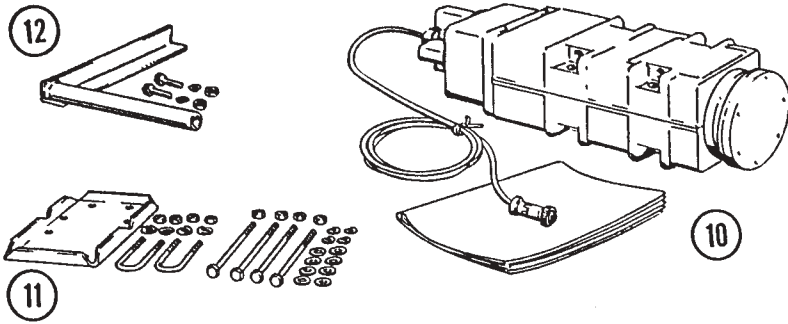

13

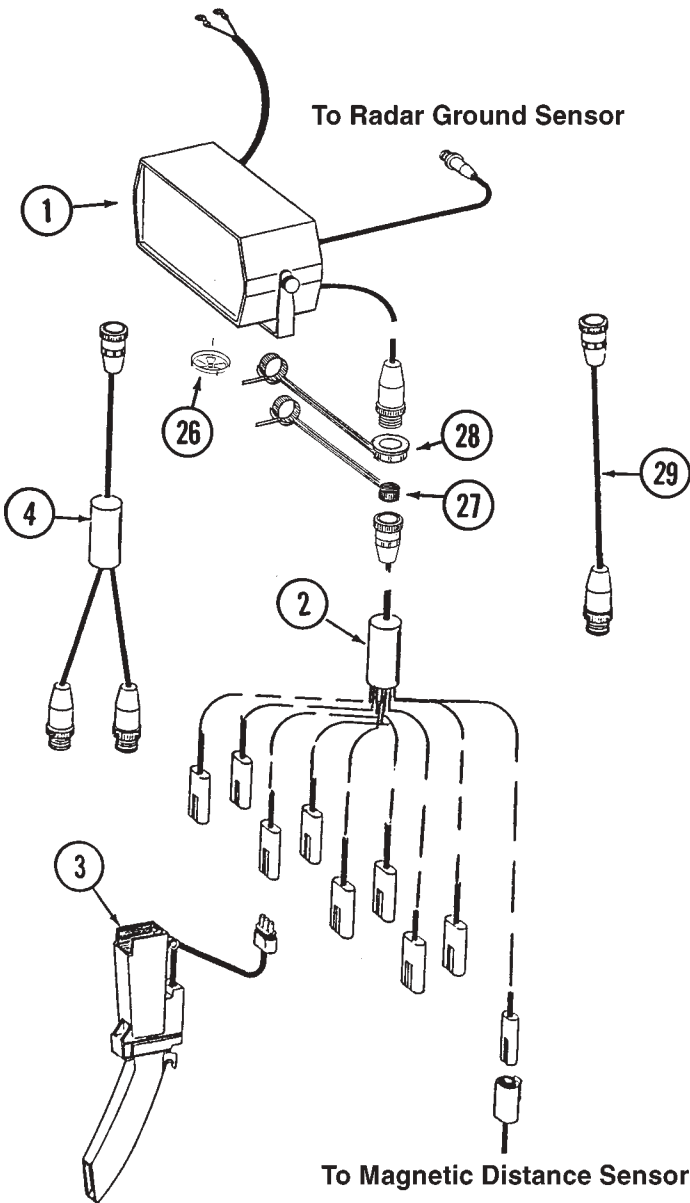

14

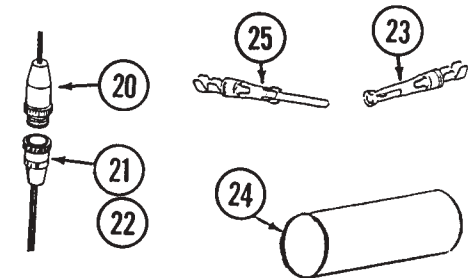
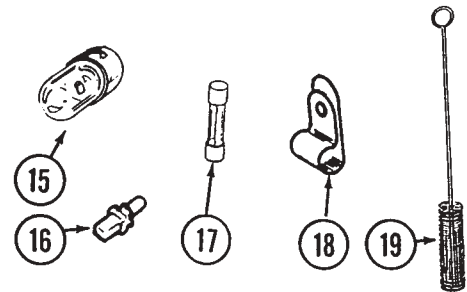
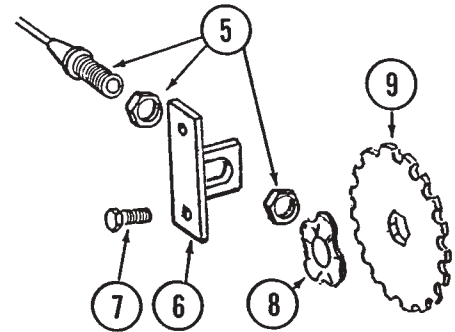



# ELECTRONIC SEED MONITOR

---

ITEM	PART NO.	QTY.	DESCRIPTION
1.	GA5873	1	Console W/Mounting Bracket, KM1000
	GA5874	-	Console W/Mounting Bracket, KM3000
	GR1077	-	Mounting Bracket, KM1000
	GR1078	-	Mounting Bracket, KM3000
	GR1079	-	Console Mounting Bracket Hardware Package (Includes 2 Wellnuts, 2 Knobs And 1/4" Hardware)
2.	GA5875	2	Planter Harness, 4 Row
	GA5876	-	Planter Harness, 6 Row
3.	GA5880	-	Seed Tube W/High Rate Sensor
	GR1062	-	Seed Tube (With Holes For High Rate Sensor Installation)
	GR1087	-	Sensor Only (For GA5880)
	GR0676	-	Sunshade
	GD2117	-	Tie Strap, 14 1/2"
4.	GA6045	1	Y-Connector, 8 Row
	GA5883	-	Y-Connector, 12 Row
5.	GA5600	1	Magnetic Distance Sensor (Use W/KM3000 Console Only)
6.	GD8770	1	Bracket
7.	G10004	2	Hex Head Cap Screw, 3/8"-16 x 1 1/4"
	G10229	2	Lock Washer, 3/8"
	G10101	2	Hex Nut, 3/8"-16
8.	GD8771	1	Spring Wave Washer
9.	GD8751	-	Magnetic Distance Sensor Pulse Wheel (Use W/KM3000 Console Only)
10.	GA4223	-	Radar Ground Speed Sensor (Use W/KM3000 Console Only)
11.	GA4229	-	Radar Sensor Mounting Bracket Package
12.	GA4230	-	Radar Sensor Pipe Mounting Package
13.	GR1082	1	KM1000 Bezel Decal, 12 Row (Used On 12 Row)
	GR1083	-	KM1000 Bezel Decal, 16 Row (Used On 8 and 16 Row)
14.	GR1080	1	KM1000 Bezel
15.	GR0595	1	Bulb, KM1000 Row Lamp
16.	GR1084	1	Bulb, KM3000 Backlite
17.	GR0866	1	Fuse, 5 Amp, Type AGC
	GR1085	1	Fuse, 2 Amp, Type AGC
18.	GD6291	-	Insulated Clamp
19.	GR0594	-	Brush
20.	GR0583	-	Console Connector Kit W/Pins And Shrink Tube
21.	GR0582	-	Harness Connector Kit W/Female Socket Contacts, Coupling Ring And Shrink Tube
22.	GR0807	-	Coupling Ring
23.	GR1171	-	Female Socket Contact
24.	GR1069	-	Shrink Tube, 2 1/2"
25.	GR1067	-	Pin
26.	GR1348	-	Sound Baffle W/Pin
27.	GD4564	-	Dust Cover
28.	GD4563	-	Dust Cap
29.	GA5881	1	Extension Cable, 15', 1-32 Rows
A.	GA6147	-	Sensor And Mounting Package (Items 5-9 And 18)

# NOTCHED SINGLE DISC FERTILIZER OPENER AND MOUNT (Row Unit Mounted)

(PT52d)

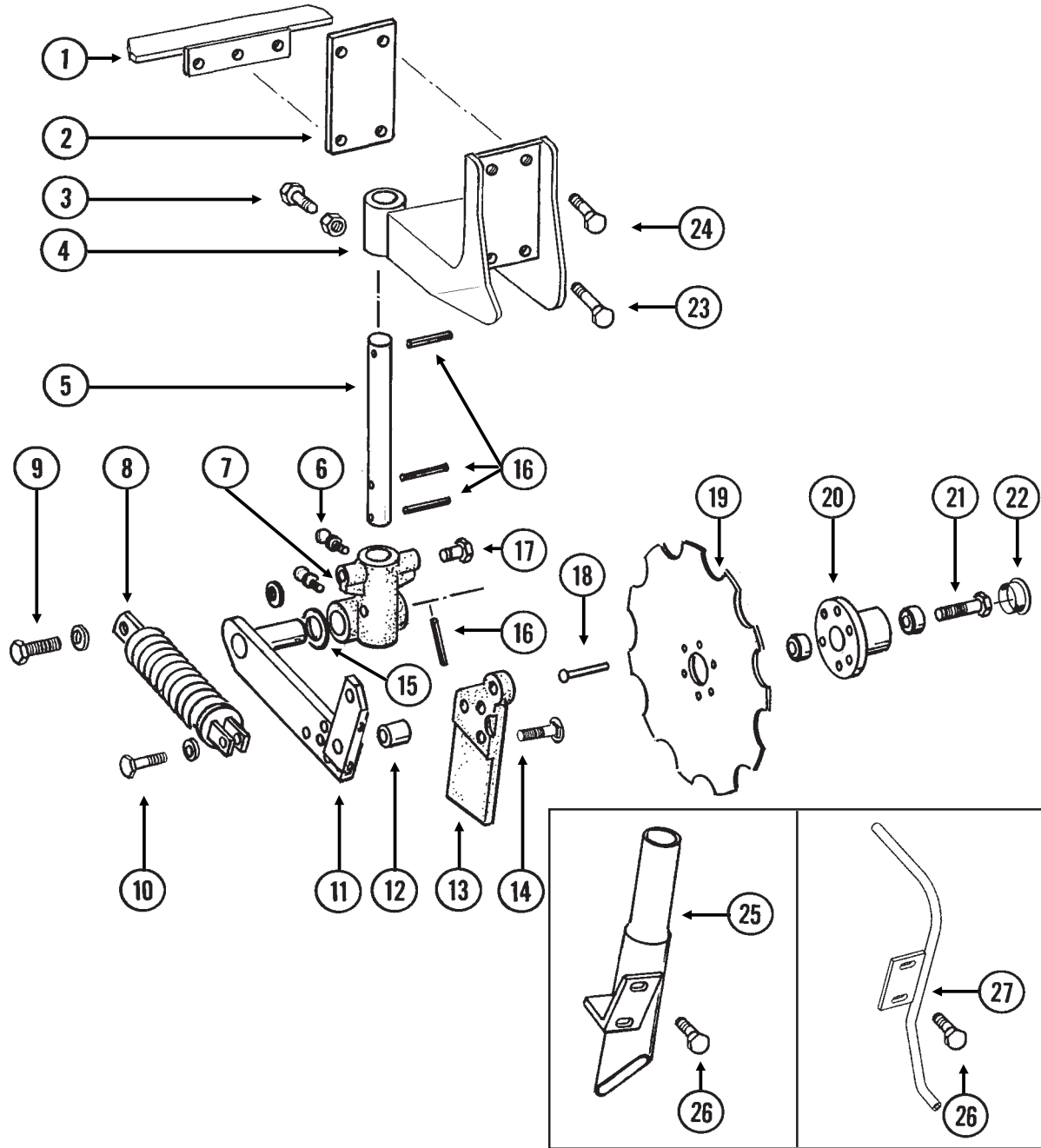

# NOTCHED SINGLE DISC FERTILIZER OPENER AND MOUNT (Row Unit Mounted)

ITEM	PART NO.	QTY.	DESCRIPTION
		(Per Assy.)	
1.	GA7844	1	Angle
2.	GD10307	1	Bar, 4" x 9"
3.	G10014	2	Hex Head Cap Screw, 1/2"-13 x 1"
	G10102	2	Hex Nut, 1/2"-13
4.	GA7263	1	Mount, L.H. (Shown)
	GA7262	-	Mount, R.H.
5.	GD10306	1	Shaft, 1 1/2" x 11 1/2"
6.	G10641	2	Grease Fitting, 1/8" NPT
7.	GB0250	1	Pivot
8.	GA6966	1	Compression Spring Assembly
9.	GD7818	1	Special Bolt
	GD7805	2	Special Washer
10.	G10047	1	Hex Head Cap Screw, 3/8"-16 x 1 3/4"
	G10210	2	Washer, 3/8"
	GD1026	1	Spacer, 1 3/16"
	G10108	1	Lock Nut, 3/8"-16
11.	GA6967	1	Pivot Arm, L.H. (Shown)
	GA6968	-	Pivot Arm, R.H.
12.	GD7817-05	1	Spacer, 1 1/4"
13.	GB0249	1	Scraper, L.H. (Shown)
	GB0248	-	Scraper, R.H.
14.	G10306	3	Carriage Bolt, 3/8"-16 x 2"
	G10108	3	Lock Nut, 3/8"-16
15.	G10450	2	Machine Bushing
16.	G10476	4	Spring Pin, 3/8" x 2 1/4"
17.	G10438	1	Hex Head Cap Screw, 1/2"-13 x 3/4"
18.	G10886	6	Truss Head Bolt, 5/16"-18 x 1"
	G10106	6	Hex Nut, 5/16"-18
19.	GD9934	1	Blade, 16 3/4"
20.	GA5654	1	Hub W/Bearings
	GA2014	-	Bearing
21.	G10013	1	Hex Head Cap Screw, 5/8"-11 x 3 1/2"
22.	GD1132	1	Dust Cap
23.	G10581	2	Hex Head Cap Screw, 1/2"-13 x 2 1/4"
	G10228	2	Lock Washer, 1/2"
	G10102	2	Hex Nut, 1/2"-13
24.	G10017	2	Hex Head Cap Screw, 1/2"-13 x 1 1/2"
	G10228	2	Lock Washer, 1/2"
25.	GA6973	1	Dry Drop Tube, L.H. (Shown)
	GA6972	-	Dry Drop Tube, R.H.
26.	G10043	2	Hex Head Cap Screw, 5/16"-18 x 3/4"
	G10232	2	Lock Washer, 5/16"
	G10219	2	Washer, 5/16" USS
27.	GA6985	1	Liquid Drop Tube, L.H. (Shown)
	GA6984	-	Liquid Drop Tube, R.H.

# SMV SIGN, DECALS, REFLECTORS AND TIE STRAPS

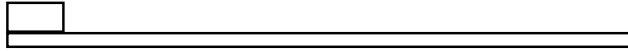

1

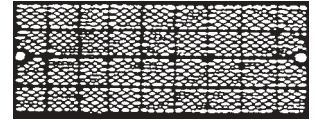

2

**! WARNING**

**TO AVOID INJURY --**  
 STAND CLEAR—KEEP OTHERS  
 AWAY WHEN RAISING OR LOWERING  
 MARKERS. BEFORE TRANSPORTING  
 PLANTER FULLY EXTEND HYDRAULIC  
 CYLINDERS AND INSTALL LOCKING  
 PINS WHERE PROVIDED.

7100-42

3

**! WARNING !**

1. Read and understand the Operator's Manual.
2. Stop the tractor engine before leaving the operator's platform.
3. Keep riders off the machine.
4. Make certain everyone is clear of the machine before starting the tractor engine and operating.
5. Keep all shields in place.
6. Never lubricate, adjust, unclog or service the machine with tractor engine running.
7. Wait for all movement to stop before servicing.
8. Keep hands, feet and clothing away from moving parts.
9. Use flashing warning lights when operating on highways except when prohibited by law.

7100-46

4

**! WARNING**

**TO AVOID INJURY ...**  
 ALWAYS USE THE HYDRAULIC CYLINDER  
 SAFETY LOCKUP CHANNEL WHEN  
 SERVICING MACHINE IN RAISED POSITION  
 OR WHEN TRANSPORTING MACHINE ON  
 THE ROAD. AFTER USE RETURN TO  
 STORAGE LOCATION.

7100-47

5

**KINZE**

6

**! WARNING**

**TOW ONLY WITH  
 FARM TRACTOR**

7100-56

7

**! WARNING !**

**RAISE PLANTER COMPLETELY AND  
 INSTALL CYLINDER LOCK-UPS BEFORE  
 FOLDING. FOLD ON LEVEL GROUND.  
 SECURE WINGS WITH SAFETY LATCHES  
 BEFORE TOWING IN FOLDED POSITION.**

7100-66

8

**! WARNING !**

**ALWAYS LATCH WINGS AND INSTALL  
 TRANSPORT PINS IN LATCHES  
 BEFORE TRANSPORTING. WINGS  
 MAY SWING OUT IF NOT  
 PROPERLY LATCHED.**

7100-71

9

**! DANGER**

**THIS PLANTER IS DESIGNED TO BE  
 DRIVEN BY GROUND TIRES ONLY.  
 THE USE OF HYDRAULIC, ELECTRIC  
 OR PTO DRIVES MAY CREATE  
 SERIOUS SAFETY HAZARDS TO YOU  
 AND THE PEOPLE NEARBY. IF YOU  
 INSTALL SUCH DRIVES YOU MUST  
 FOLLOW ALL APPROPRIATE SAFETY  
 STANDARDS AND PRACTICES  
 TO PROTECT YOU AND OTHERS NEAR  
 THIS PLANTER FROM INJURY.**

7100-89

10

**! WARNING !**

**THIS MACHINE HAS BEEN DESIGNED  
 AND BUILT WITH YOUR SAFETY IN  
 MIND. DO NOT MAKE ANY  
 ALTERATIONS OR CHANGES TO THIS  
 MACHINE. ANY ALTERATION TO THE  
 DESIGN OR CONSTRUCTION MAY  
 CREATE SAFETY HAZARDS.**

7100-90

11

**! WARNING !**

**AGRICULTURAL CHEMICALS CAN BE DANGEROUS.  
 IMPROPER SELECTION OR USE CAN SERIOUSLY  
 INJURE PERSONS, ANIMALS, PLANTS, SOIL OR  
 OTHER PROPERTY. BE SAFE, SELECT THE RIGHT  
 CHEMICAL FOR THE JOB. HANDLE WITH CARE.  
 FOLLOW THE INSTRUCTIONS ON THE CONTAINER  
 LABEL AND OF THE EQUIPMENT MANUFACTURER.**

7100-115

12

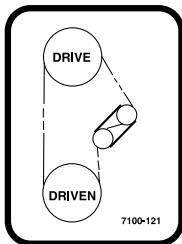

13

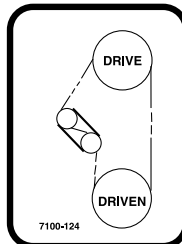

14



15

**USE 1 TABLESPOON POWDERED  
 GRAPHITE WITH EACH HOPPER  
 FILL OF SEED. SEED TREAT-  
 MENT, FOREIGN MATERIAL, DIRT,  
 OR SEED CHAFF MAY CAUSE  
 GRADUAL REDUCTION OF SEED  
 POPULATION. REFER TO  
 MANUAL FOR MAINTENANCE AND  
 CARE.**

7100-153

16

**USE  
 8 AMP  
 TIME  
 DELAY  
 FUSE  
 ONLY**

7100-155

17

**2200**

18

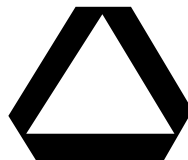

19

P60

**Econo • Fold**

7100-178

20

# SMV SIGN, DECALS, REFLECTORS AND TIE STRAPS

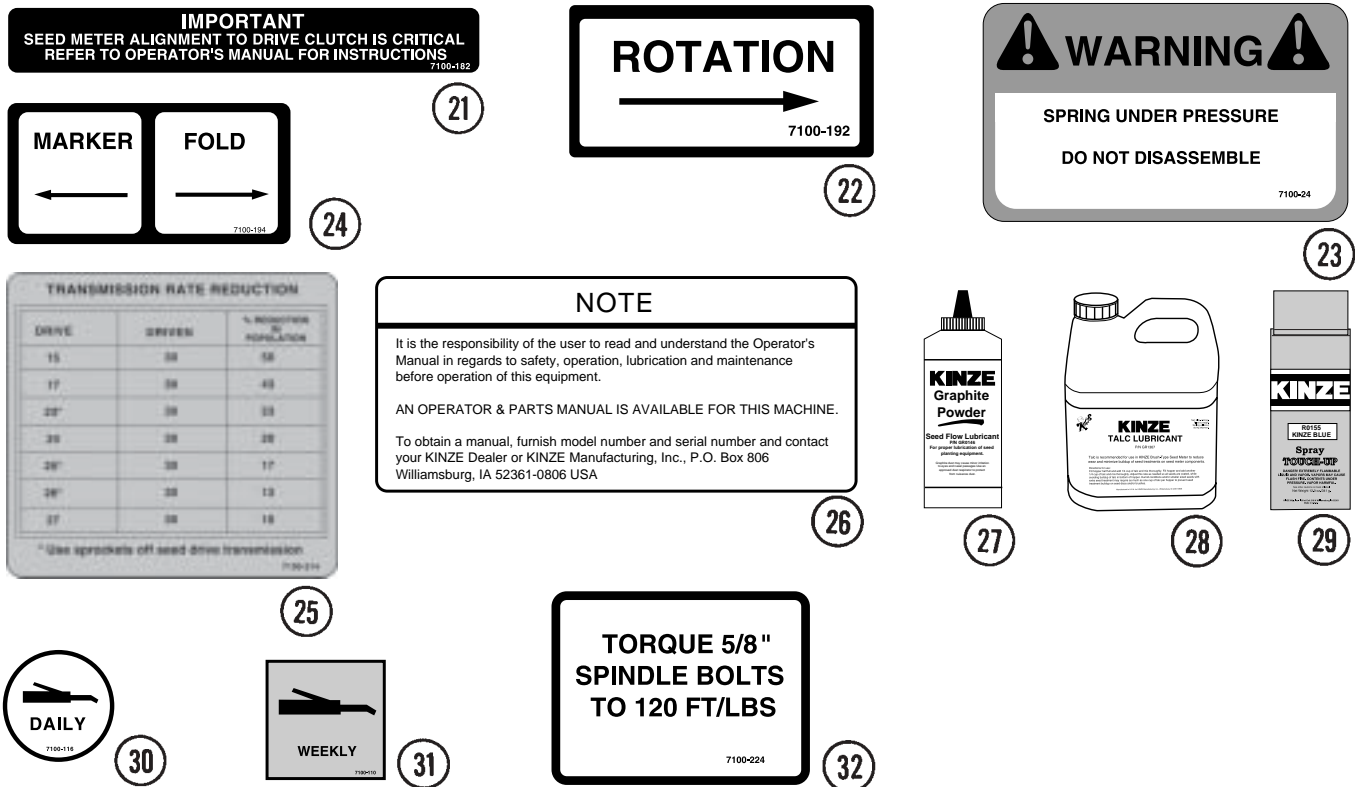

ITEM	PART NO.	QTY.	DESCRIPTION
1.	GD1162	-	Tie Strap, 28"
	GD1512	-	Tie Strap, 6"
	GD2117	-	Tie Strap, 14 1/2"
	GD2984	-	Tie Strap, 33"
2.	G7200-03	4	Reflector, Red
	G7200-04	4	Reflector, Amber
3.	G7100-42	4	Decal, Warning
4.	G7100-46	1	Decal, Warning
5.	G7100-47	4	Decal, Warning
6.	G7100-54	2	Decal, KINZE®, 4 3/16" x 17 3/16"
7.	G7100-56	1	Decal, Warning
8.	G7100-66	2	Decal, Warning
9.	G7100-71	2	Decal, Warning
10.	G7100-89	2	Decal, Danger
11.	G7100-90	1	Decal, Warning
12.	G7100-115	-	Decal, Caution (1 Per Granular Chemical Hopper)
13.	G7100-121	1	Decal, Transmission
14.	G7100-124	1	Decal, Transmission
15.	G7100-195	-	Decal, Logo (2 Per Row Unit)
16.	G7100-153	-	Decal, Information (1 Per Brush-Type Seed Meter)
17.	G7100-155	-	Decal, Instruction (Point Row Clutch)
18.	G7100-158	2	Decal, 2200
19.	GD2199	1	SMV Sign
20.	G7100-178	1	Decal, Econo-Fold®, 3/4" x 3"
21.	G7100-182	-	Decal, Meter Alignment (1 Per Row Unit)
22.	G7100-192	-	Decal, Point Row Clutch Rotation
23.	G7100-24	1	Decal, Warning
24.	G7100-194	-	Decal, Optional Hydraulic Fold Selector Valve
25.	G7100-214	1	Decal, Reduced Rate
26.	G7100-217	1	Decal, Note
27.	GR0146	-	Powdered Graphite, 1 Pound
28.	GR1367	-	Talc Seed Lubricant, 8 Pounds
29.	GR0155	-	Blue Paint, Aerosol
30.	G7100-116	1	Decal, Grease Daily
31.	G7100-110	1	Decal, Grease Weekly
32.	G7100-224	1	Decal, Bolt Torque

# ELECTRICAL COMPONENTS

(PT49b/PT50)

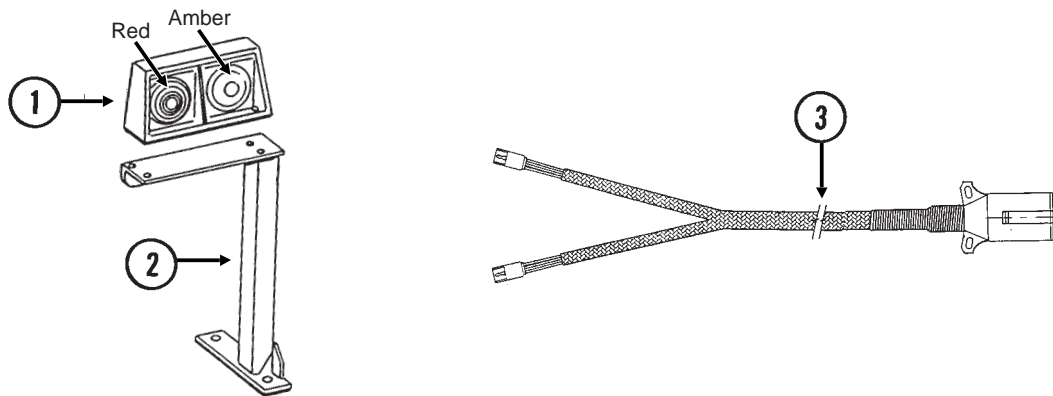

ITEM	PART NO.	QTY.	DESCRIPTION
1.	GA6699	1	Double Light Assembly (Shown)
	GA6700	1	Double Light Assembly
	GR1203	-	Red Lens
	GR1204	-	Amber Lens
	GR1205	-	Cover
	GR1206	-	Rubber Grommet (4)
	GR1207	-	Lamp Unit
	GR1208	-	Bulb
2.		-	See "Hitch And Frame Assembly", Page P26
3.	GA6814	-	Light Wiring Harness W/7 Terminal Female Connector, 329"
	GA5385	-	7 Terminal Female Connector

# NUMERICAL INDEX

Part No.	Page	Part No.	Page	Part No.	Page
G1K212	P3	G7200-03	P61	G10106	P21, P25
G1K213	P15, P17	G7200-04	P61	G10106	P5, P7, P27, P33, P45, P47, P59
G1K221	P39	G10001	P2, P27, P33, P43, P44	G10107	P7, P8, P19, P21, P25, P27, P33, P45, P47
G1K235	P27	G10002	P47	G10108	P3, P9, P17, P26, P33, P41, P43, P59
G306-08	P55	G10003	P3, P7, P8	G10109	P5, P7, P9, P20, P22, P23, P37, P39, P48
G2100-03	P33, P44	G10004	P4, P57	G10110	P11, P27, P37
G2406-08-06	P29	G10005	P33	G10111	P7, P8, P9, P19, P20, P21, P22, P23, P25, P31, P45
G2603-08	P55	G10006	P7, P22	G10112	P27
G2703-08	P55	G10007	P27	G10128	P44
G3303-16	P10	G10008	P25, P31	G10131	P37
G3303-98	P10	G10009	P23, P31	G10133	P8, P22, P23, P47
G3303-114	P17	G10010	P5	G10139	P27, P31
G3305-01	P18	G10011	P26	G10145	P35, P42
G3310-08	P43, P45	G10012	P25	G10148	P23
G3303-114	P17	G10013	P8, P47, P59	G10152	P7
G3310-80	P45	G10014	P3, P59	G10157	P26
G3310-89	P45	G10015	P7	G10168	P48
G3303-114	P17	G10017	P20, P21, P45, P59	G10169	P26
G3314-40	P17	G10018	P5, P7	G10171	P7
G3400-01	P33, P44	G10019	P10, P27, P48	G10177	P4
G4100-02	P26	G10020	P12	G10187	P37
G6400-06	P29, P52	G10021	P12	G10200	P27
G6400-08	P55	G10022	P12, P17	G10201	P3, P17
G6400-08-06	P29	G10023	P17, P27, P33, P37, P39, P41, P43	G10203	P33, P37, P39, P42, P43, P44
G6500-08	P55	G10025	P31	G10204	P3, P5, P10
G6799	P27	G10026	P31, P47	G10205	P33
G6801-06-08	P29	G10028	P27	G10206	P3, P23, P25
G6801-08	P55	G10033	P22, P44	G10208	P3
G6803	P27	G10036	P19, P25, P26	G10209	P11, P17, P27, P39
G7100-24	P61	G10037	P4, P44	G10210	P2, P3, P4, P7, P8, P9, P11, P17, P27, P33, P43, P44, P45, P47, P59
G7100-42	P61	G10039	P20, P21	G10213	P3
G7100-46	P61	G10040	P37	G10215	P55
G7100-47	P61	G10041	P37, P39	G10216	P3, P20, P21, P22, P31
G7100-54	P61	G10043	P59	G10217	P25, P27
G7100-56	P61	G10045	P22	G10219	P7, P20, P33, P59
G7100-66	P61	G10047	P45, P59	G10226	P47
G7100-71	P61	G10048	P47	G10227	P14, P29, P33, P37, P39, P41, P43
G7100-89	P61	G10049	P9, P17, P39	G10228	P3, P4, P22, P25, P27, P31, P43, P44, P45, P46, P48, P59
G7100-90	P61	G10053	P44, P45	G10229	P2, P3, P4, P7, P8, P10, P11, P14, P17, P33, P37, P39, P41, P43, P44, P45, P47, P57
G7100-110	P61	G10055	P9, P25, P33	G10230	P4, P5, P26, P27, P31, P45
G7100-115	P61	G10062	P9, P42		
G7100-116	P61	G10064	P8, P27, P29		
G7100-121	P61	G10068	P25		
G7100-124	P61	G10069	P5		
G7100-153	P61	G10087	P31		
G7100-155	P61	G10101	P2, P4, P10, P11, P14, P17, P33, P39, P41, P42, P47, P57		
G7100-158	P61	G10102	P4, P7, P22, P25, P27, P31, P43, P44, P45, P46, P48, P59		
G7100-178	P61	G10103	P8, P14, P29, P33, P37, P39, P41, P43		
G7100-182	P61	G10104	P4, P25, P26, P31		
G7100-192	P61	G10105	P27, P31		
G7100-194	P61				
G7100-195	P61				
G7100-214	P61				
G7100-217	P61				
G7100-224	P61				
G7192X	P4				

# NUMERICAL INDEX

Part No.	Page	Part No.	Page	Part No.	Page
G10231	P27, P31, P47	G10504	P3	G10765	P39, P41
G10232	P5, P7, P10, P27, P33, P45, P47, P59	G10520	P11	G10770	P9
G10233	P32, P35, P43, P45	G10521	P17	G10804	P39, P41
G10235	P33	G10523	P14	G10814	P3
G10236	P27	G10526	P3	G10816	P39, P41
G10253	P37, P39	G10529	P18	G10826	P27
G10257	P37, P39	G10531	P13	G10843	P39
G10303	P7, P20, P33, P45	G10536	P20, P21	G10844	P48
G10304	P3	G10544	P48	G10857	P41
G10305	P2, P10, P18	G10545	P4	G10859	P39, P41
G10306	P14, P33, P43, P59	G10546	P17, P43	G10864	P14
G10307	P3	G10551	P3	G10867	P45
G10308	P18	G10552	P3	G10872	P41
G10309	P10	G10553	P10	G10873	P41
G10310	P11, P14	G10555	P3	G10876	P41
G10311	P17	G10567	P17	G10879	P47
G10312	P3, P10, P17	G10570	P17	G10886	P59
G10318	P21	G10572	P21, P25	G10890	P33
G10323	P12	G10573	P25	GA0167	P48
G10328	P3	G10574	P19, P22, P25	GA0243	P48
G10345	P37	G10580	P29	GA0245	P48
G10348	P22	G10581	P25, P31, P59	GA0257	P48
G10370	P33, P43	G10582	P25	GA0533	P37
G10371	P22	G10584	P13	GA0811	P2
G10374	P37, P39, P41	G10585	P20, P21	GA0860	P3
G10396	P27	G10597	P20, P21	GA0895	P31
G10401	P12	G10602	P12, P13, P17, P32, P35, P43, P44	GA0899	P48
G10404	P27	G10603	P12, P13	GA1000	P55
G10409	P44	G10604	P12	GA1006	P55
G10412	P4, P33	G10605	P2	GA1010	P55
G10427	P3, P7	G10609	P17	GA1022	P55
G10430	P43	G10610	P31	GA1055	P55
G10435	P45	G10620	P3, P10, P12, P17	GA1092	P55
G10438	P59	G10621	P10, P11, P12, P17, P18	GA1168	P29
G10445	P45	G10622	P18	GA1172	P29
G10449	P49, P50	G10636	P31	GA1676	P48
G10450	P59	G10637	P17	GA1677	P48
G10451	P3	G10640	P5, P19, P25	GA1678	P48
G10452	P14	G10641	P26, P27, P31, P45, P47, P59	GA1679	P48
G10455	P10	G10644	P3	GA1720	P4
G10457	P10, P27	G10660	P17	GA1911	P37
G10459	P27	G10669	P3	GA1917	P37
G10460	P31, P35, P45, P47	G10670	P17, P45	GA2007	P10
G10461	P27	G10680	P14	GA2012L	P3
G10462	P45	G10690	P12	GA2012R	P3
G10463	P29, P47	G10722	P48	GA2013	P3
G10470	P12, P43	G10724	P48	GA2014	P3, P7, P9, P21, P23, P25, P59
G10476	P59	G10725	P48	GA2016	P10
G10478	P44	G10732	P4	GA2018	P12
G10496	P37, P39, P41	G10747	P7, P8, P9, P25	GA2019	P12
G10497	P37, P39	G10751	P4, P33	GA2020	P12
G10498	P37	G10752	P4	GA2027	P11
G10500	P12	G10757	P14	GA2054	P7
G10501	P22, P33	G10758	P14	GA2058	P11
G10503	P3, P20, P21			GA2068	P33



# NUMERICAL INDEX

Part No.	Page	Part No.	Page	Part No.	Page
GA2075	P14	GA5118	P33	GA5873	P57
GA2076	P17	GA5120	P32	GA5874	P57
GA2094	P18	GA5121	P31	GA5875	P57
GA2142	P31	GA5122	P31	GA5876	P57
GA2147	P31	GA5123	P31	GA5880	P3, P57
GA2148	P31	GA5124	P31	GA5881	P57
GA2180	P35	GA5146	P44	GA5883	P57
GA2327	P11	GA5157	P33, P43	GA5892	P20
GA2373	P35	GA5158	P33, P43	GA5900	P47
GA2374	P35	GA5182	P33	GA5982	P13
GA2447	P35	GA5202	P45	GA6027	P13
GA2448	P35	GA5385	P62	GA6038	P13
GA2449	P35	GA5455	P50	GA6045	P57
GA2450	P35	GA5458	P50	GA6055	P27
GA2493	P27	GA5459	P50	GA6119	P49
GA2558	P31	GA5533	P17	GA6120	P49
GA3115	P55	GA5552	P52	GA6134	P49
GA3127	P55	GA5553	P15	GA6135	P49
GA3162	P55	GA5554	P15	GA6137	P49
GA3167	P55	GA5557	P37	GA6147	P57
GA3168	P55	GA5560	P15	GA6168	P13
GA3173	P55	GA5561	P15	GA6171	P5, P7, P8
GA3174	P55	GA5572	P52	GA6182	P13
GA3180	P29	GA5600	P57	GA6184	P13
GA3189	P55	GA5622	P19, P25	GA6187	P13
GA4223	P57	GA5623	P15	GA6349	P51
GA4229	P57	GA5624	P45	GA6434	P8
GA4230	P57	GA5625	P19	GA6438	P53
GA4235	P45	GA5628	P45	GA6478	P13
GA4295	P49	GA5629	P45	GA6524	P51
GA4297	P49	GA5630	P25	GA6525	P51
GA4322	P50	GA5631	P25	GA6532	P47
GA4444	P17	GA5635	P25	GA6597	P8
GA4822	P10	GA5636	P25	GA6613	P8
GA4884	P47	GA5637	P25	GA6614	P5
GA4885	P47	GA5640	P19, P25	GA6615	P5
GA4887	P46	GA5643	P25	GA6618	P7
GA4893	P47	GA5651	P4	GA6619	P7
GA4894	P47	GA5654	P21, P22, P23, P25, P59	GA6620	P7
GA4903	P47	GA5698	P13	GA6633	P13
GA4905	P46	GA5699	P13	GA6699	P62
GA4910	P47	GA5715	P20, P21	GA6700	P62
GA5090	P33	GA5718	P21	GA6733	P7
GA5093	P50	GA5719	P20, P21	GA6741	P14
GA5096	P50	GA5745	P26	GA6785	P37
GA5105	P32, P43, P45	GA5746	P15	GA6786	P37
GA5106	P43, P45	GA5755	P26	GA6787	P37
GA5107	P45	GA5761	P33	GA6798	P27
GA5108	P43, P45	GA5764	P47	GA6800	P29
GA5109	P43, P45	GA5765	P47	GA6801	P7
GA5110	P43, P45	GA5794	P13	GA6804	P26
GA5111	P43, P45	GA5795	P13	GA6814	P62
GA5112	P43, P45	GA5796	P13	GA6823	P27
GA5113	P45	GA5798	P25	GA6824	P27
GA5114	P35, P43	GA5834	P13	GA6832	P22
GA5116	P32, P45	GA5853	P48	GA6833	P22

# NUMERICAL INDEX

Part No.	Page	Part No.	Page	Part No.	Page
GA6834	P22	GB0115	P17	GD1059L	P17
GA6838	P22	GB0116	P17	GD1059R	P17
GA6854	P31	GB0120	P12	GD1060	P17
GA6855	P31	GB0121	P17	GD1061	P17
GA6907	P14	GB0156	P26	GD1063	P17
GA6937	P9	GB0169	P27	GD1065	P3
GA6966	P59	GB0177	P47	GD1066	P3
GA6967	P59	GB0183	P17	GD1072	P17
GA6968	P59	GB0186	P4	GD1079	P9
GA6972	P59	GB0196	P25	GD1083	P12
GA6973	P59	GB0218	P4, P8, P25, P33	GD1085	P8
GA6984	P59	GB0219	P8, P9	GD1086	P5
GA6985	P59	GB0227	P19, P25	GD1089	P17
GA7110	P39	GB0233	P7, P8, P9	GD1090	P14
GA7111	P39	GB0239	P7	GD1109	P4, P7, P8
GA7143	P39, P41	GB0243	P10	GD1110	P3
GA7144	P39, P41	GB0245	P9	GD1114	P4
GA7154	P44	GB0248	P59	GD1115L	P14
GA7156	P45	GB0249	P59	GD1115R	P14
GA7165	P39, P41	GB0250	P59	GD1116	P14
GA7212	P39	GB0254	P8	GD1118	P14
GA7235	P32	GB0259	P44	GD1120	P3
GA7255	P13	GB1084	P17	GD1121	P11
GA7262	P59	GD0453-03	P16	GD1130	P3
GA7263	P59	GD0453-07	P46	GD1132	P21, P22, P23, P25, P59
GA7271	P23	GD0652	P47	GD1143	P18
GA7274	P41	GD0740	P26	GD1144	P18
GA7313	P42	GD0746	P48	GD1145	P18
GA7317	P43	GD0840	P48	GD1162	P61
GA7319	P43	GD0914-24	P42	GD1166	P31
GA7320	P43	GD0917	P35, P42	GD1255	P43
GA7321	P43	GD0973	P5	GD1353	P5
GA7336	P45	GD1026	P3, P17, P33, P43, P45, P59	GD1512	P61
GA7370	P33	GD1027	P2	GD1755	P13
GA7376	P31	GD1030	P3	GD2117	P57, P61
GA7409	P31	GD1031	P3, P7	GD2128	P10
GA7412	P23	GD1033	P3	GD2199	P61
GA7434	P31	GD1035	P10	GD2200	P27
GA7445	P23	GD1036	P10	GD2423	P14
GA7446	P22, P23	GD1037	P10	GD2460	P18
GA7463	P41	GD1039	P12	GD2548-18	P43
GA7484	P27	GD1040	P12	GD2558	P42, P45
GA7513	P27	GD1041	P12	GD2597	P48
GA7577	P41	GD1042	P12	GD2697	P47
GA7580	P9	GD1044	P12	GD2698	P47
GA7817	P47	GD1045	P12	GD2721	P46
GA7831	P43	GD1046	P12	GD2734-01	P45
GA7844	P59	GD1048	P5	GD2947	P14
GB0102	P2	GD1051L	P11	GD2962	P35
GB0103	P3	GD1051R	P11	GD2971-10	P17
GB0104	P3	GD1053	P11	GD2984	P61
GB0105	P3	GD1054	P11	GD3180-08	P47
GB0107	P10	GD1055	P11	GD3180-16	P45
GB0108	P10	GD1056	P17	GD3181-12	P7
GB0110	P12	GD1058	P17	GD3214	P47
GB0111	P12			GD3311	P27

# NUMERICAL INDEX

Part No.	Page	Part No.	Page	Part No.	Page
GD3373	P27	GD7592	P17	GD9589	P29
GD4563	P57	GD7618	P10	GD9591	P29
GD4564	P57	GD7619	P4	GD9645	P31
GD4632	P50	GD7803	P19, P25	GD9664	P37
GD4887-01	P45	GD7804	P19, P25	GD9665	P37
GD5752	P33	GD7805	P4, P21, P25, P33, P59	GD9667	P37, P39
GD5753	P33	GD7811	P25	GD9668	P37
GD5756	P33, P43, P44	GD7816	P25	GD9670	P37
GD5789	P33	GD7817-01	P21, P25	GD9671	P37, P39, P41
GD5790	P33	GD7817-04	P21, P23, P25	GD9672	P37, P39, P41
GD5797	P32	GD7817-05	P59	GD9674	P37
GD5804	P31	GD7817-09	P25	GD9679	P37
GD5824	P44	GD7818	P25, P59	GD9688	P27
GD5827	P33, P43, P44	GD7822	P45	GD9689	P37
GD5829	P44	GD7823	P21, P25	GD9695	P47
GD5830	P44	GD7831	P25	GD9699	P29
GD5835	P45	GD7851	P25	GD9715	P22
GD5841	P31	GD7878	P13	GD9720	P22
GD5845	P31	GD7889	P20, P21	GD9724	P22, P23
GD5846	P31	GD7890	P20, P21	GD9762	P29
GD5847	P31	GD7902	P47	GD9781	P37
GD5857	P22, P33, P43, P44	GD7944	P33	GD9782	P37
GD5860	P33, P43	GD7948	P27	GD9786	P9
GD5875	P26, P47	GD7972	P27	GD9787	P9
GD5886	P35	GD7976	P27	GD9816	P14
GD5900-02	P29	GD7989	P35	GD9934	P59
GD5946	P49	GD8052	P35	GD10010	P31
GD5947	P49	GD8237	P13	GD10036	P4
GD5949	P50	GD8249	P4	GD10068	P39
GD5951	P51	GD8260	P27	GD10069	P39
GD5954	P50	GD8266	P20	GD10070	P39
GD5956	P50	GD8280	P47	GD10071	P39
GD5961	P35	GD8290	P47	GD10102	P39
GD6136	P47	GD8307	P21, P25	GD10103	P39, P41
GD6291	P57	GD8458PRC	P37	GD10104	P39
GD6501	P12	GD8460	P8	GD10105	P39
GD6533	P3, P7	GD8750	P17	GD10106	P39
GD6551	P45	GD8751	P57	GD10120	P39, P41
GD6622	P35	GD8769	P27	GD10123	P39, P41
GD6793	P45	GD8770	P57	GD10161	P45
GD6819	P45	GD8771	P57	GD10200	P39
GD6825-10.375	P33	GD8778	P13	GD10226	P12
GD6825-59	P35	GD8843	P19, P25	GD10243	P37
GD6825-75.375	P35	GD8844	P19, P25	GD10282	P39, P41
GD7127	P45	GD9120	P8	GD10283	P48
GD7145	P27, P43	GD9216	P37	GD10306	P59
GD7148	P17	GD9239	P51	GD10307	P59
GD7258	P17	GD9240	P3, P17	GD10332	P43
GD7318	P3	GD9241	P51	GD10366	P43
GD7339	P37, P39	GD9254	P19, P25	GD10464	P10, P17
GD7398	P47	GD9290	P7	GD10510	P39, P41
GD7426	P33, P43, P45	GD9305	P7	GD10519	P23
GD7587	P17	GD9306	P17	GD10526	P23
GD7588	P17	GD9529	P39, P41	GD10552	P22, P23
GD7589	P17	GD9530	P39, P41	GD10580	P41
GD7591	P17	GD9562	P7	GD10583	P41

# NUMERICAL INDEX

Part No.	Page	Part No.	Page	Part No.	Page
GD10585	P41	GR1077	P57		
GD10586	P41	GR1078	P57		
GD10635	P41	GR1079	P57		
GD10636	P41	GR1080	P57		
GD10656	P35	GR1082	P57		
GD10672	P41	GR1083	P57		
GD10758	P47	GR1084	P57		
GD10764	P41	GR1085	P57		
GR0146	P61	GR1087	P3, P57		
GR0150	P48	GR1096	P53		
GR0151	P48	GR1169	P49		
GR0155	P61	GR1171	P57		
GR0196	P10, P17	GR1177	P53		
GR0225	P26	GR1178	P53		
GR0270	P31	GR1185	P51		
GR0434	P31	GR1203	P62		
GR0582	P57	GR1204	P62		
GR0583	P57	GR1205	P62		
GR0594	P57	GR1206	P62		
GR0595	P57	GR1207	P62		
GR0646	P37	GR1208	P62		
GR0664	P12	GR1303	P39, P41		
GR0676	P57	GR1304	P39, P41		
GR0807	P57	GR1305	P39, P41		
GR0866	P57	GR1306	P39, P41		
GR0911	P45	GR1307	P39, P41		
GR0912	P32, P43, P45	GR1327	P12		
GR0923	P50	GR1344	P39		
GR0927	P50	GR1345	P39		
GR0930	P50	GR1346	P39, P41		
GR0933	P12	GR1347	P39, P41		
GR0959	P50	GR1348	P57		
GR0982	P49	GR1361	P41		
GR0983	P49, P51	GR1362	P41		
GR0984	P49	GR1367	P61		
GR1032	P52	R1176	P53		
GR1033	P52				
GR1034	P52				
GR1035	P52				
GR1036	P52				
GR1037	P52				
GR1038	P52				
GR1039	P52				
GR1040	P52				
GR1041	P52				
GR1042	P52				
GR1043	P52				
GR1044	P52				
GR1045	P52				
GR1046	P52				
GR1047	P52				
GR1048	P52				
GR1062	P3, P57				
GR1066	P10				
GR1067	P57				
GR1069	P57				