

# M0156

## OPERATOR & PARTS MANUAL

### MODEL 2300 TWIN-LINE® PLANTER

This manual is applicable to:    Model: 2300 Twin-Line® Planters  
   Serial Number: 600500 and on

Record the model number and serial number of your planter with date purchased:

Model Number \_\_\_\_\_

Serial Number \_\_\_\_\_

Date Purchased \_\_\_\_\_

#### SERIAL NUMBER

The serial number plate is located on the planter frame to be readily available. It is suggested that the serial number and purchase date also be recorded above.

The serial number provides important information about your planter and may be required to obtain the correct replacement part. Always provide the serial number and model number to your KINZE Dealer when ordering parts or anytime correspondence is made with KINZE Manufacturing, Inc.

48618-29





# PREDELIVERY/DELIVERY CHECK LIST

## TO THE DEALER

Preelivery service includes assembly, lubrication, adjustment and test. This service helps to assure that the planter will be delivered to the customer ready for field use.

## PREDELIVERY CHECK LIST

After the planter has been completely assembled, use the following check list and inspect the planter. Check off each item as it is found satisfactory or after proper adjustment is made.

- Recheck to be sure row units and optional attachments are properly spaced and assembled.
- Be sure all grease fittings are in place and lubricated.
- Check planter and make sure all working parts are moving freely, bolts are tight and cotter pins are spread.
- Check all drive chains for proper tension and alignment.
- Check for oil leaks, proper hydraulic operation and proper chain alignment.
- Inflate tires to specified PSI air pressure. Tighten wheel bolts to specified torque.
- Check to be sure all safety decals are correctly located and legible. Replace if damaged.
- Check to be sure the red reflectors and amber reflectors are correctly located and visible when the planter is in transport position.
- Check to be sure SMV sign is in place.
- Check to be sure safety/warning lights are installed correctly and working properly.
- Paint all parts scratched in shipment or assembly.
- Be sure all safety lockups are on the planter and correctly located.

*This planter has been thoroughly checked and to the best of my knowledge is ready for delivery to the customer.*

---

(Signature of Set-up Person/Date)

## OWNER REGISTER

Name \_\_\_\_\_

Date Sold \_\_\_\_\_

Street Address \_\_\_\_\_

Model \_\_\_\_\_

City & State \_\_\_\_\_

Serial Number \_\_\_\_\_

## DELIVERY CHECK LIST

At the time the planter is delivered, the following check list is a reminder of very important information which should be conveyed to the customer. Check off each item as it is fully explained to the customer.

- Advise the customer that the life expectancy of this or any other machine is dependent on regular lubrication as directed in the operator's manual.
- Tell the customer about all applicable safety precautions.
- Along with the customer, check to be sure the red and amber reflectors and SMV sign are clearly visible with the planter in transport position and attached to the tractor. Check to be sure safety/warning lights are in working condition. Tell the customer to check federal, state/provincial and local regulations before towing or transporting on a road or highway.
- Give the operator's manual to the customer and explain all operating adjustments.
- Read warranty to customer.
- Complete Warranty And Delivery Report Form.

***To the best of my knowledge this machine has been delivered ready for field use and customer has been fully informed as to proper care and operation.***

---

(Signature of Delivery Person/Date)

## AFTER DELIVERY CHECK LIST

The following is a list of items we suggest to check during the first season of use of the equipment.

- Check with the customer as to the performance of the planter.
- Review with the customer the importance of proper maintenance and safety precautions.
- Check for parts that may need to be adjusted or replaced.
- Check to be sure all safety decals, SMV sign and reflectors are correctly located and legible. Replace if damaged or missing.
- Check to be sure safety/warning lights are working properly.

---

(Signature of Follow-up Person/Date)

**RETURN THIS COMPLETED FORM TO KINZE® IMMEDIATELY, along with Warranty And Delivery Report.  
Retain photocopy of this form at dealership for After Delivery Check.**

*Tear Along Perforation*

# TABLE OF CONTENTS

---

TO THE OWNER.....	1-1
WARRANTY.....	1-2
INTRODUCTION.....	2-1
SPECIFICATIONS.....	3-1/3-2
SAFETY PRECAUTIONS.....	4-1/4-2
SAFETY WARNING SIGNS.....	5-1/5-4
<b>MACHINE OPERATION</b>	
2 To 1 Drive Reduction.....	6-3
Checking Granular Chemical Application Rate.....	6-31
Checking Seed Population.....	6-30/6-31
Contact Drive Wheel Spring Adjustment.....	6-4
Control Console.....	6-5
Double Disc Fertilizer Opener.....	6-22
Dry Fertilizer Attachment.....	6-25/6-26
Dry Fertilizer Quick Fill Attachment.....	6-27
Electronic Seed Monitor System	
KM1000 Monitor.....	6-14/6-15
KM3000 Monitor.....	6-16/6-18
Field Test.....	6-21
General Planting Rate Information.....	6-32
Hydraulic Operation	
Marker Operation.....	6-12
Phasing The Hydraulic System.....	6-11
Plant To Transport Operation Procedure.....	6-9/6-11
Planter Lift System Operation.....	6-6/6-7
Tongue Lock Operation.....	6-6
Transport To Plant Operation Procedure.....	6-8/6-9
Valve Block Located On Front Side Of Main Frame.....	6-5/6-6
Valve Block Located On Hitch.....	6-6
Initial Preparation Of The Planter.....	6-1
Leveling The Planter.....	6-2
Leveling The Planter Wings.....	6-3
Liquid Fertilizer Attachment.....	6-28/6-29
Manual Safety Lockup.....	6-12
Marker Adjustment.....	6-20
Marker Lockup.....	6-12
Metric Conversion Table.....	6-21
Planting And Application Rate Charts.....	6-33/6-41
Point Row Wrap Spring Clutch.....	6-13
Ridge Planting.....	6-19
Rock Guards.....	6-19
Shear Protection.....	6-4
Single Disc Fertilizer Opener.....	6-23/6-24
Tire Pressure.....	6-2
Tongue Safety Pin.....	6-12
Tractor Preparation And Hookup.....	6-1
Tractor Requirements.....	6-1
Tractor Speed.....	6-20
Transmission Adjustment.....	6-3
Transporting The Planter.....	6-20
<b>ROW UNIT OPERATION</b>	
Brush-Type Seed Meter.....	7-4/7-5
Covering Discs/Single Press Wheel Adjustment.....	7-2
Disc Furrowers (For use with Frame Mounted Coulter).....	7-10
Dual Gauge Wheel.....	7-14
Finger Pickup Corn Meter.....	7-3
Frame Mounted Coulter.....	7-9/7-10

# TABLE OF CONTENTS

---

## ROW UNIT OPERATION (Continued)

Granular Chemical Hopper.....	7-6
Granular Chemical Restrictor Plate .....	7-14
Planting Depth.....	7-1
Push Unit Lockups .....	7-15
Quick Adjustable Down Force Springs .....	7-7/7-8
Row Unit Chain Routing.....	7-7
Row Unit Chain Shield.....	7-13
Row Unit Gauge Wheel Cover.....	7-14
Row Unit Mounted Bed Leveler.....	7-11
Row Unit Mounted Disc Furrower.....	7-11
Row Unit Mounted No Till Coulter.....	7-13
Row Unit Mounted Residue Wheel.....	7-12
Seed Hopper .....	7-5
Seed Meter Drive Adjustment.....	7-6
Seed Meter Drive Release.....	7-3
Spring Tooth Incorporator .....	7-14
"V" Closing Wheel Adjustment (Rubber And Cast Iron).....	7-1

## LUBRICATION

Bushings.....	8-2
Drive Chains.....	8-1
Grease Fittings.....	8-3/8-9
Liquid Fertilizer Piston Pump.....	8-3
Lubrication Symbols .....	8-1
Point Row Wrap Spring Clutches.....	8-1
Sealed Bearings.....	8-1
Wheel Bearings.....	8-3

## MAINTENANCE

15" Seed Opener Disc/Bearing Assembly.....	9-8
Brush-Type Seed Meter Maintenance .....	9-5/9-6
Brush-Type Seed Meter Troubleshooting.....	9-7
Chain Tension Adjustment.....	9-1
Closing Wheel Troubleshooting .....	9-7
Electrical Wiring Diagram For Control Box.....	9-24/9-25
Electrical Wiring Diagram For Light Package .....	9-23
Electronic Seed Monitor Display Backlite Bulb Replacement (KM3000 Only).....	9-16
Electronic Seed Monitor Row Indicator Bulb Replacement (KM1000 Only).....	9-16
Electronic Seed Monitor System Troubleshooting .....	9-10/9-16
Finger Pickup Corn Meter Cleaning.....	9-3
Finger Pickup Corn Meter Inspection/Adjustment.....	9-2/9-3
Finger Pickup Corn Meter Troubleshooting.....	9-4
Flow Control Valve Inspection.....	9-20
Gauge Wheel Adjustment.....	9-8
Marker Bearing Lubrication Or Replacement .....	9-20
Mounting Bolts And Hardware .....	9-1
Piston Pump Storage .....	9-22
Piston Pump Troubleshooting .....	9-22
Point Row Wrap Spring Clutch Inspection.....	9-17
Point Row Wrap Spring Clutch Troubleshooting.....	9-18
Preparation For Storage.....	9-21
Pressure Relief Valve Inspection.....	9-20
Row Unit Mounted No Till Coulter.....	9-9
Seed Tube Guard/Inner Scraper.....	9-9
Solenoid Valve Inspection.....	9-19
Solenoid Valve Troubleshooting .....	9-19
Torque Values Chart .....	9-1
Wheel Bearing Lubrication Or Replacement .....	9-21

PARTS LIST INDEX ..... P1

PARTS SECTION NUMERICAL INDEX ..... a

# TO THE OWNER

---

KINZE Manufacturing, Inc. would like to thank you for your patronage. We appreciate your confidence in KINZE® farm machinery. Your KINZE® planter has been carefully designed and sturdily built to provide dependable operation in return for your investment.

**This manual has been prepared to aid you in the operation and maintenance of the planter and should be considered a permanent part of the machine and should remain with the machine when you sell it.**

It is the responsibility of the user to read and understand the Operator's Manual in regards to safety, operation, lubrication and maintenance before operation of this equipment. It is the user's responsibility to inspect and service the machine routinely as directed in the Operator's Manual. We have attempted to cover all areas of safety, operation, lubrication and maintenance; however, there may be times when special care must be taken to fit your conditions.

Throughout this manual the symbol  and the words, **NOTE, CAUTION, WARNING and DANGER** are used to call your attention to important safety information. The definition of each of these terms used follows:

**NOTE:** Indicates a special point of information.

**CAUTION:** Indicates that a failure to observe can cause damage to the machine or equipment.

 **WARNING:** Indicates that a failure to observe can cause damage to the machine or equipment and/or personal injury.

 **DANGER:** Indicates that a failure to observe can cause most serious damage to the machine or equipment and/or most serious personal injury.

 **WARNING:** Some photos in this manual may show safety covers, shields or lockups removed for visual clarity. **NEVER OPERATE** the machine without all safety covers, shields and lockups in place.

**NOTE:** Some photos in this manual may have been taken of prototype machines. Production machines may vary in appearance.

**NOTE:** Some photos and illustrations in this manual show optional attachments installed. Contact your KINZE Dealer for purchase of optional attachments.

# WARRANTY

---

The KINZE Limited Warranty for your new machine is stated on the back of the retail purchaser's copy of the Warranty And Delivery Report form.

Warranty, within the warranty period, is provided as part of KINZE's support program for registered KINZE products which have been operated and maintained as described in this manual. Evidence of equipment abuse or modification beyond original factory specifications will void the warranty. Normal maintenance, service and repair is not covered by KINZE warranty.

To register your KINZE product for warranty, a Warranty And Delivery Report form must be completed by the KINZE Dealer and signed by the retail purchaser, with copies to the Dealer, to the retail purchaser and to KINZE. Registration must be completed and sent to KINZE within 30 days of delivery of the KINZE product to the retail purchaser. KINZE reserves the right to refuse warranty on serial numbered products which have not been properly registered.

Additional copies of the Limited Warranty can be obtained through your KINZE Dealer.

If service or replacement of failed parts which are covered by the Limited Warranty are required, it is the user's responsibility to deliver the machine along with the retail purchaser's copy of the Warranty And Delivery Report to the KINZE Dealer for service. KINZE warranty does not include cost of travel time, mileage, hauling or labor. Any prior arrangement made between the Dealer and the retail purchaser in which the Dealer agrees to absorb all or part of this expense should be considered a courtesy to the retail purchaser.

*KINZE warranty does not include cost of travel time, mileage, hauling or labor.*



# INTRODUCTION

---

The Model 2300 Twin-Line® planter is available in various configurations and row spacings. Optional inter-plant row spacing is obtainable with the addition of push type row units.

The Model 2300 Twin-Line® planter permits installation of liquid or dry fertilizer application equipment and various row unit attachments.

## GENERAL INFORMATION

The information used in this manual was current at the time of printing. However, due to KINZE's continual attempt to improve its product, production changes may cause your machine to appear slightly different in detail. KINZE Manufacturing, Inc. reserves the right to change specifications or design without notice and without incurring obligation to install the same on machines previously manufactured.

Right hand and left hand as used throughout this manual is determined by facing in the direction the machine will travel when in use unless otherwise stated.

60620-63



60620-42





# SPECIFICATIONS

---

**TYPE** - Pull Type (Hydraulically rotates endwise to transport)

**PLANTING UNIT TYPES** - Push and Pull Type Row Units

<b>ROW SPACING</b>	<u>Standard</u>	<u>Interplant</u>
	8 Row Wide - 36" or 38" Rows	15 - 18" or 19" Rows
	12 Row Narrow - 30" Rows	23 - 15" Rows
	12 Row Wide - 36" Rows	23 - 18" Rows
	12 Row Wide - 38" Rows	23 - 19" Rows
	16 Row Narrow - 30 " Rows	31 - 15" Rows

## DRIVE SYSTEM

Spring-loaded contact drive system.  
 7.50 x 20, 6 ply, rib implement wing tire - two on 8 and 12 row, four on 16 row.  
 4.8 x 8, 6 ply, contact drive tire - two on 8 and 12 row, four on 16 row.  
 No. 40 roller chain and spring-loaded idlers.  
 Point row clutches standard on 12 and 16 row models and optional on 8 row model.  
 7/8" hex drill and drive shafts and end mounted seed transmissions.

## TRANSPORT TIRES

8 and 12 row models are equipped with four 7.50 x 20, load rated D, bias ply tires.  
 16 row model is equipped with four 7.50 x 20, load rated E, bias ply tires.  
 Adjustable height wheels for ridge planting.

## TYPE LIFT

Master/slave hydraulics.  
 8 and 12 row - 2 master cylinders, 1 slave cylinder per wing wheel module (2 slave).  
 16 row - 2 slave cylinders, 1 master cylinder per wing wheel module (4 master).

**MARKERS** - Independently controlled. All models utilize depth band on marker disc.

## Dimensions/Operating

PLANTER SIZE	8 Row 36"/38"	12 Row 30"	12 Row 36"	12 Row 38"	16 Row 30"
WIDTH	26' 6"	31' 2"	37' 2"	39' 2"	41' 2"
LENGTH "Y" Hitch	20' 3"	22' 3"	24' 3"	24' 3"	25' 3"
LENGTH "T" Hitch	18' 3"	20' 3"	23' 3"	23' 3"	23' 3"

# SPECIFICATIONS

## Dimensions/Transport

PLANTER SIZE	8 Row 36"/38"	12 Row 30"	12 Row 36"	12 Row 38"	16 Row 30"
WIDTH Std., fertilizer or push units	13' 4"	11' 2"	13' 4"	13' 4"	11' 2"
WIDTH Push unit with no till coulters	13' 4"	12' 4"	13' 4"	13' 4"	12' 4"
LENGTH	31' 8"	37' 10"	43' 1"	44' 4"	47' 10"
HEIGHT	10' 4"	10' 4"	10' 8"	10' 8"	11' 0"

PLANTER SIZE	8 Row 36"/38"	12 Row 30"	12 Row 36"	12 Row 38"	16 Row 30"
*WEIGHT	11,015 lbs.	12,025 lbs.	12,663 lbs.	12,703 lbs.	14,702 lbs.

\* Base machine weights include planter frame with Y hitch, row markers, drive components, tires and wheels, hydraulic cylinders and KINZE plateless row units with rubber "V" closing wheels, seed hopper and lid, dual quick adjustable down force springs and KM1000 electronic seed monitor.

# SAFETY PRECAUTIONS

Safe and careful operation of the tractor and planter at all times will contribute significantly to the prevention of accidents.

Since a large portion of farm accidents occur as a result of fatigue or carelessness, safety practices should be of utmost concern. Read and understand the instructions provided in this manual. Listed below are a few other safety suggestions that should become common practice.

 **Never allow the planter to be operated by anyone who is unfamiliar with the operation of all functions of the unit. All operators should read and thoroughly understand the Instructions given in this manual prior to moving the unit.**

 **Never permit any persons other than the operator to ride on the tractor.**

 **Never ride on the planter or allow others to do so.**

 **Always make sure there are no persons near the planter when marker assemblies are in operation or when rotating the planter.**

60355-50



Tongue Safety Pin

48496-11



Manual Safety Lockup

 **Always install tongue safety pin and manual safety lockup before transporting planter.**

 **Never work under the planter while in raised position without using manual safety lockup.**

 **Before operating the planter for the first time and periodically thereafter, check to be sure the lug nuts on the transport wheels are tight. This is especially important if the planter is to be transported for a long distance.**

 **Watch for obstructions such as wires, tree limbs, etc., when folding markers.**

72359-65



 **Install lockup brackets on markers prior to transporting the planter or working around the unit.**

 **Limit towing speed to 15 MPH. Tow only with farm tractor of at least 90 HP size.**

 **Always make sure flashing safety lights, reflectors and SMV emblem are in place and visible prior to transporting the machine on public roads. In this regard, check federal, state/provincial and local regulations.**

 **Check to be sure all safety/warning lights are working before transporting the machine on public roads.**

 **On wide row models the two outer transport wheels are bolt-on to allow legal width truck shipment. Install outer transport wheel assemblies prior to unloading. DO NOT REMOVE THESE ASSEMBLIES AFTER PLANTER IS ASSEMBLED FOR USE. DO NOT fold planter or tow planter while the two outer transport wheels are removed. Tipping may occur because of narrow wheel base.**

# SAFETY PRECAUTIONS

---

 Avoid transporting planter with hoppers loaded whenever possible. When it is necessary to transport the planter with the hoppers loaded, the added weight should be distributed evenly on the planter frame before rotating the planter.

 This planter is designed to be **DRIVEN BY GROUND TIRES ONLY**. The use of hydraulic, electric or PTO drives may create serious safety hazards to you and the people near by. If you install such drives you must follow all appropriate safety standards and practices to protect you and others near this planter from injury.

 This machine has been designed and built with your safety in mind. Any alteration to the design or construction may create safety hazards. Do not make any alterations or changes to the equipment, but if any alterations or changes are made you must follow all appropriate safety standards and practices to protect you and others near this machine from injury.

 Rim and tire servicing can be dangerous. Explosive separation of a tire and rim parts can cause serious injury or death.

 Agricultural chemicals used with this unit can be dangerous. Improper selection or use can seriously injure persons, animals, plants, soil and other property. **BE SAFE:** Select the right chemical for the job. Handle it with care. Follow the instructions of the chemical manufacturer.

# SAFETY WARNING SIGNS

The "WARNING" signs illustrated on this page are placed on the machine to warn of hazards. The warnings found on these signs are for your personal safety and those around you. **OBSERVE THESE WARNINGS!**

- **Keep these signs clean so they can be readily observed. Wash with soap and water or cleaning solution as required.**
- **Replace "WARNING" signs should they become damaged, painted over or if they are missing.**
- **Check the SMV decal periodically. Replace if it shows loss of any of its reflective property.**
- **When replacing decals, clean the machine surface thoroughly using soap and water or cleaning solution to remove all dirt and grease.**

48496-11



48496-61



60355-24



Part No. G7100-02

# SAFETY WARNING SIGNS

60355-49

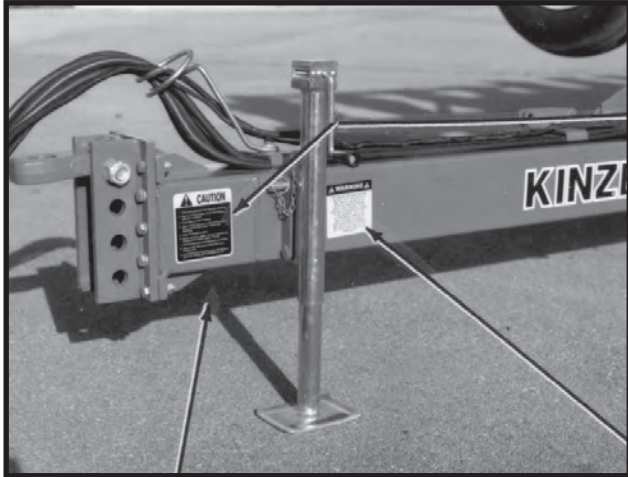

Part No. G7100-56



Part No. G7100-46



Part No. G7100-90

48618-27

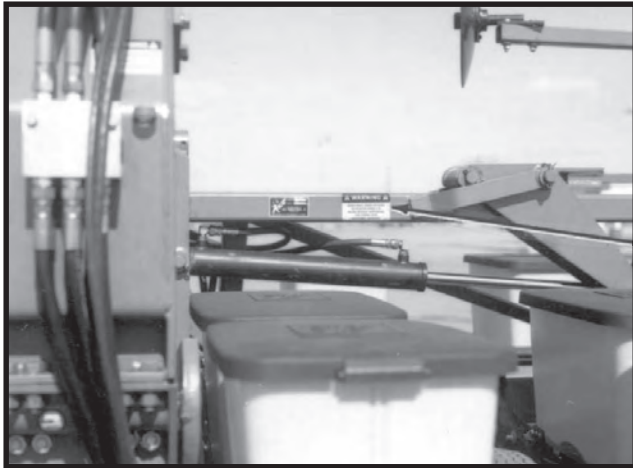

Part No. G7100-68

51376-37

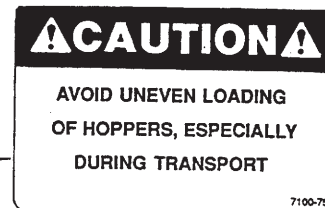

Part No. G7100-75



# SAFETY WARNING SIGNS

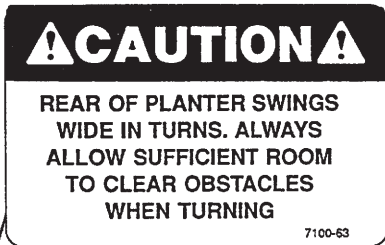

Part No. G7100-63



Part No. GD2199



Part No. G7100-89



Part No. G7100-117

73327-22

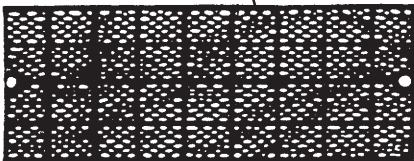

Part No. G7200-03  
 Red Reflector

60355-53

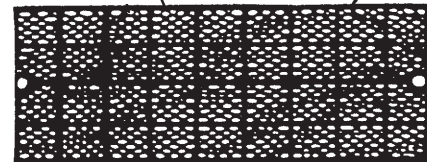
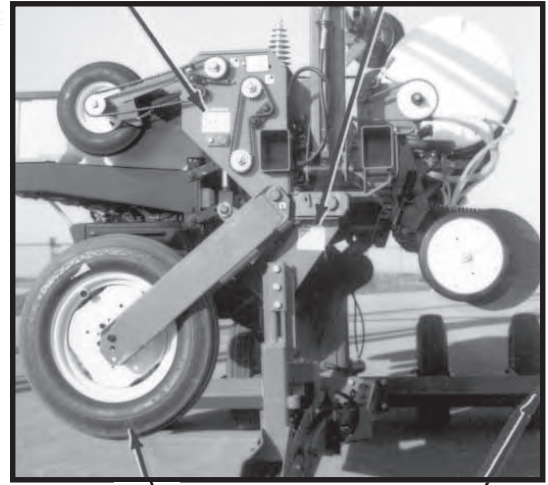

Part No. G7200-04  
 Amber Reflector

# SAFETY WARNING SIGNS

60355-60



Part No. G7100-42

Part No. G7100-83

51052-19



Part No. G7100-129

Located on axle on wide row models only.

53704-14

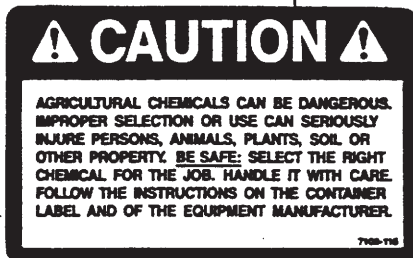

Part No. G7100-115

Located on under side of granular chemical

60569-14



Part No. G7100-103

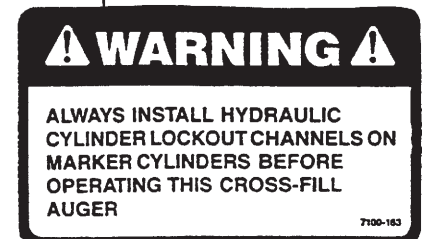

Part No. G7100-163

# MACHINE OPERATION

The following information is general in nature and was written to aid the operator in preparation of the tractor and planter for use, and to provide general operating procedures. The operator's experience, familiarity with the machine and the following information should combine for efficient planter operation and good working habits.

**CAUTION:** Always raise the planter out of the ground when making sharp turns or backing up.

## INITIAL PREPARATION OF THE PLANTER

Lubricate the planter and row units per the lubrication information in this manual. Make sure all tires have been properly inflated. Check all drive chains for proper tension, alignment and lubrication.

**!** **DANGER:** The outer transport wheels on wide row models are bolted on to allow legal width truck shipment. **DO NOT REMOVE THESE ASSEMBLIES AFTER PLANTER IS ASSEMBLED FOR USE. DO NOT fold planter or tow planter while the two outer transport wheels are removed. Tipping may occur because of narrow wheel base.**

## TRACTOR REQUIREMENTS

Consult your dealer for information on horsepower requirements and tractor compatibility. Requirements will vary with planter options, tillage and terrain. Three dual remote hydraulic outlets (SCV) are required on all models. 12 volt DC electrical system is required on all models.

## TRACTOR PREPARATION AND HOOKUP

60355-43



1. Adjust tractor drawbar to 13-17 inches above the ground. Adjust the drawbar so the hitch pin hole is directly below the center line of the PTO shaft. Make sure the drawbar is in a stationary position.

2. Install control console on tractor in a convenient location to the right of the operator and close to the hydraulic controls. Mount control console securely and route power cord to the power source.

The control console operates on 12 volt DC only. The console battery lead has two wires, a BLACK wire and a RED wire (tagged with "+"), each is terminated in a ring terminal. The RED wire must always be connected to the positive (+) battery terminal and the BLACK wire should always be connected to the negative (-) battery terminal.

The RED lead must be connected to the positive battery terminal regardless of whether the batteries use a positive ground (positive battery terminal connected to tractor chassis) or a negative ground (negative battery terminal connected to tractor chassis).

If two 12 volt batteries are connected in series, ALWAYS make power connection on battery which is grounded to tractor chassis.

If two 6 volt batteries are connected in series, make sure power connection at battery terminals ARE NOT connected to each other.

3. Back tractor to planter and connect with hitch pin. If the tractor is not equipped with a hitch pin locking device, make sure hitch pin is secured with a locking pin or cotter pin.

4. Connect hydraulic hoses to tractor ports in a sequence which is both familiar and comfortable to the operator.

**!** **DANGER:** Before applying pressure to the hydraulic system, make sure all connections are tight and hoses and fittings have not been damaged. Hydraulic fluid escaping under pressure can have sufficient force to penetrate skin, causing injury or infection.

**CAUTION:** Always wipe hose ends to remove any dirt before connecting couplers to tractor ports.

5. Connect cable on planter to control console cable on tractor. Connect ASAE Standards 7-pin connector for warnings lights on planter to ASAE Standards receptacle on tractor. If your tractor is not equipped with an ASAE Standards receptacle, check with your tractor manufacturer for availability. Check to be sure warning lights on planter are working in conjunction with warning lights on tractor.

6. Raise jack stand and remount horizontally on storage bracket.

7. Lower planter to the planting position and check to be sure the hitch is level. If hitch slopes up or down, disconnect planter and adjust hitch clevis up or down as necessary.

# MACHINE OPERATION

## LEVELING THE PLANTER

For proper operation of the planter and row units, it is important that the unit operate level.

60355-43

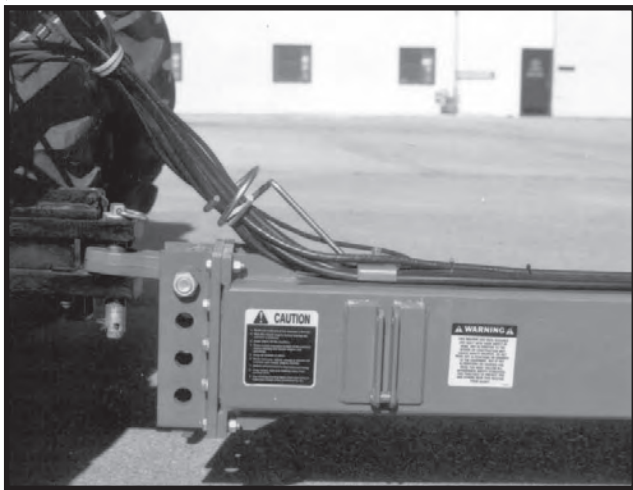

Four holes in the hitch bracket allow the clevis to be raised or lowered. In addition, the clevis may be turned over for a finer adjustment between mounting holes. When installing clevis mounting bolt, make sure lock nut is tightened to proper torque setting.

73327-6

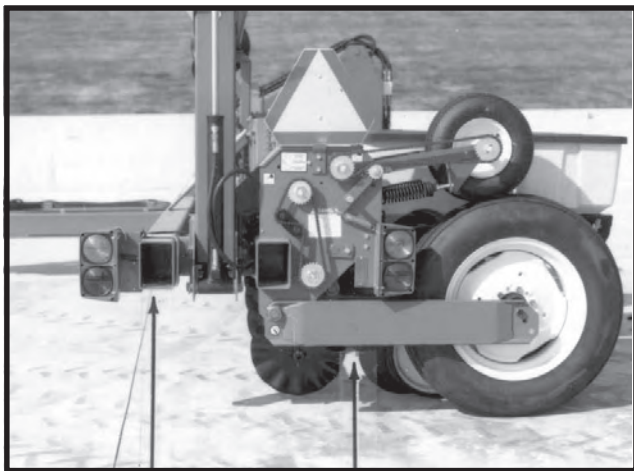

With the planter lowered to proper operating depth, check to be sure the frame is level fore and aft. Recheck once planter is in the field.

It is important for the planter to operate level laterally. Tire pressure must be maintained at pressures specified. See "Tire Pressure".

Once the planter has been fully loaded with seed, granular chemicals, fertilizer, etc.; a field check should be made to be sure the wings are level with the center frame. See "Leveling The Planter Wings".

## TIRE PRESSURE

72359-69

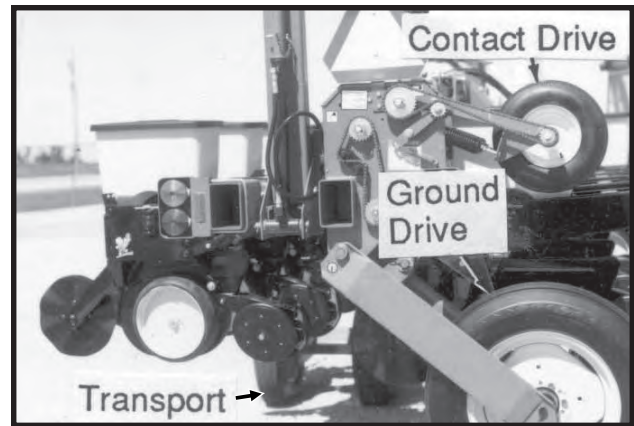

Tire pressure should be checked regularly and maintained as follows:

### 8 & 12 Row Models

7.50 x 20, Transport (Center Section) . . . . . 65 PSI  
7.50 x 20, Ground Drive (Wings) . . . . . 40 PSI  
4.8 x 8, Contact Drive . . . . . 50 PSI

### 16 Row Model

7.50 x 20, Transport (Center Section) . . . . . 90 PSI  
7.50 x 20, Ground Drive (Wings) . . . . . 40 PSI  
4.8 x 8, Contact Drive . . . . . 50 PSI

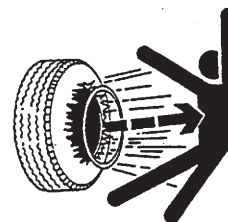

**DANGER:** Rim and tire servicing can be dangerous. Explosive separation of a tire and rim parts can cause serious injury or death.

The multipiece rim used on the transport wheels on the 16 Row 2300 Planter requires that specific procedures and safety instruction be followed in mounting and demounting of the tires.

Do not attempt to mount a tire unless you have the proper equipment and experience to perform the job. This should only be done by persons properly trained and equipped to do the job.

Always maintain the correct tire pressure. Do not inflate the tires above the recommended pressure.

When inflating tires, use a clip-on air chuck and extension hose long enough to allow you to stand to one side and NOT in front of or over the tire assembly. Use a safety cage to enclose the tire and rim assembly when inflating.

Inspect tires and wheels daily. Do not operate with low pressure, cuts, bubbles, damaged rims or missing lug bolts and nuts

# MACHINE OPERATION

## LEVELING THE PLANTER WINGS

If after the planter is loaded with seed, chemicals, fertilizer, etc.; the wings appear to be lower than the center frame, the following adjustment on each wing lift cylinder should be made.

There is one cylinder on each wing on 8 and 12 row models and two cylinders on each wing on the 16 row model.

1. Raise planter to raised transport position.
2. Install manual safety lockup pin.

51502-1

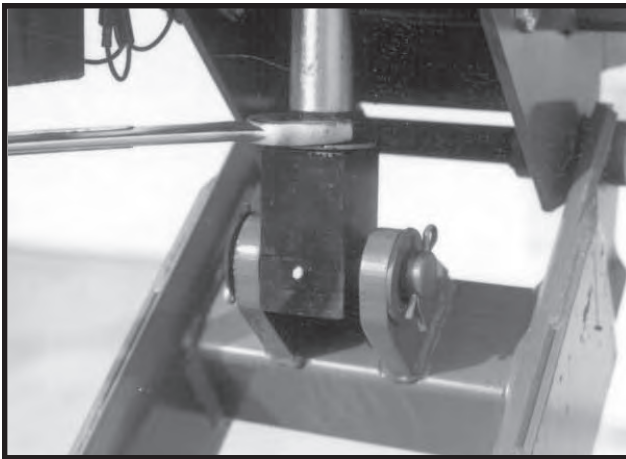

3. Loosen set screw (If Applicable) in cylinder clevis on wing lift cylinder. Using a 1 1/2" wrench on the cylinder rod, turn the rod to loosen the clevis enough to install the desired number of split washers. A supply of split washers can be found in the storage area on the wheel module.

4. Install the washer(s) and tighten the rod against the cylinder clevis.

5. Remove the manual safety lockup pin and lower the planter to planting position. Recheck levelness of planter frame.

## TRANSMISSION ADJUSTMENT

Planting population rate changes are made at each end of the planter. The planter is designed to allow simple, rapid changes in sprockets to obtain the desired planting population. By removing the lynch pins on the hexagon shafts, sprockets can be interchanged with those from the sprocket storage rod bolted to the wheel module on each side of the planter.

Chain tension is controlled by a spring-loaded dual-sprocket idler. The idler assembly is adjusted with a ratchet arm. This arm has a release position to remove spring tension for replacing sprockets. The amount of spring tension on the chain can be controlled by the ratchet arm.

A decal positioned on the transmission module provides proper chain routing. The planting rate charts found at the back of this section will aid you in selecting the correct sprocket combinations.

72359-41

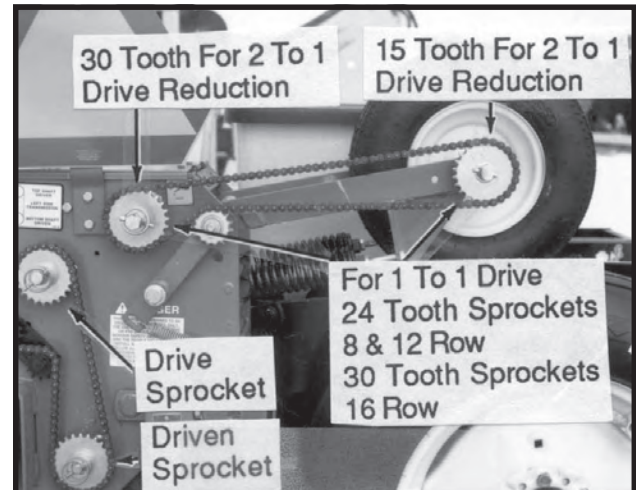

## 2 TO 1 DRIVE REDUCTION

A 2 to 1 drive reduction is recommended when inter-plant push units are used. On 8 and 12 Row Models replace the two 24 tooth sprockets(1:1) on each contact wheel drive with a 15 tooth sprocket on each contact wheel and a 30 tooth sprocket(2:1) on each driven shaft. On the 16 Row Models replace the 30 tooth sprocket(1:1) on each contact wheel with a 15 tooth sprocket(2:1). This will reduce the planter transmission speed and reduce planting rates by approximately 1/2.

**IMPORTANT:** After each sprocket combination adjustment, make a field check to be sure you are planting at the desired rate.

# MACHINE OPERATION

## CONTACT DRIVE WHEEL SPRING ADJUSTMENT

72359-44



There are two down pressure springs on each contact drive wheel. The down pressure is factory preset and should need no further adjustment.

The spring tension is set leaving 2 1/4" between the spring plug and the bolt head.

## SHEAR PROTECTION

The planter drive line, row unit and fertilizer components are protected from damage by shear pins.

If excessive load should cause a pin to shear, it is important to determine where binding has occurred before replacing the pin. Replace shear pins with same size and type.

Additional shear pins can be found in the storage area located on the wheel module.

To prevent future binding or breakage of components, check drive line alignment and follow prescribed lubrication schedules.

61658-27

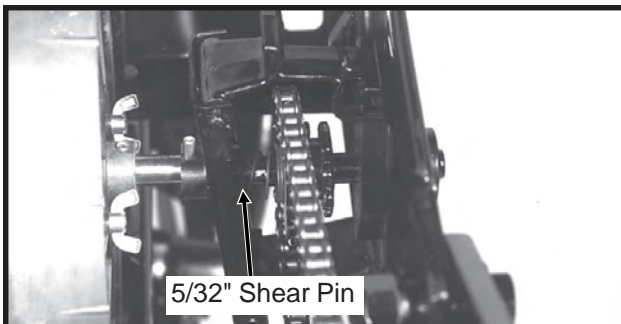

Row Unit Seed Meter Drive

50981-10

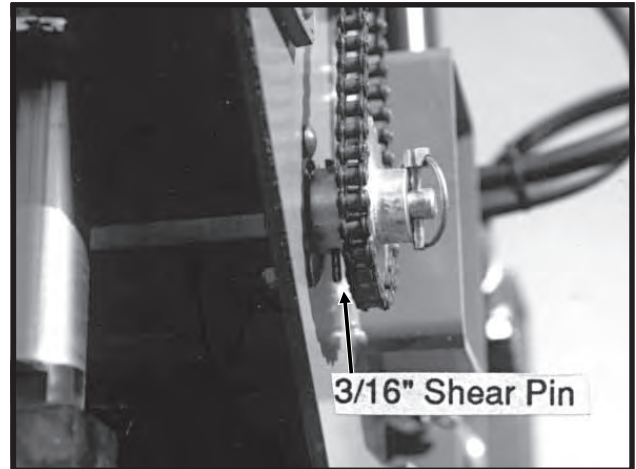

Transmission Shaft

60389-44

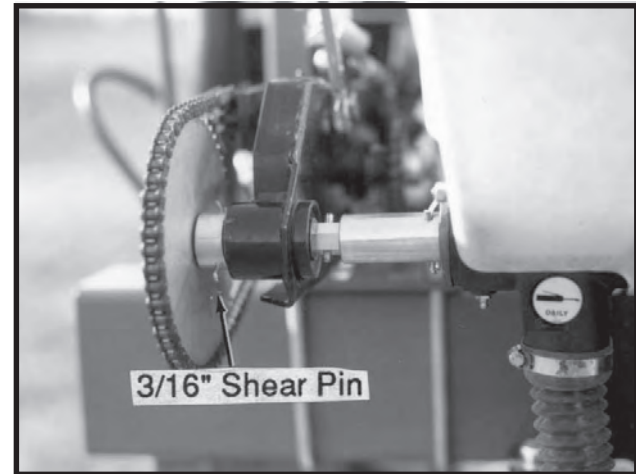

Dry Fertilizer Attachment Transmission

# MACHINE OPERATION

## CONTROL CONSOLE

60448-1

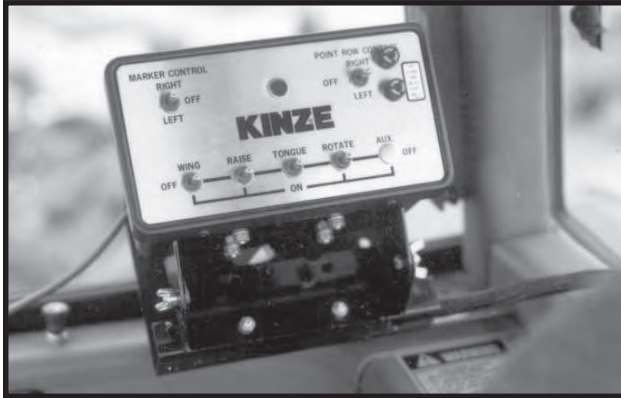

Switches on the control console located on the tractor in conjunction with the hydraulic levers are used to raise the planter to transport position, operate the rotate and tongue extension functions, lock and release the planter wings, and raise and lower the row markers.

If the planter is equipped with point row wrap spring clutches, the switch to operate the engage and disengage function of the point row clutches is located on the control console.

If the planter is equipped with the dry fertilizer quick fill option, a switch installed in the auxiliary position on the console in conjunction with the hydraulic marker control lever is used for operation of that option. The marker switch must be in the OFF position when the auxiliary switch is used.

The main fuse (15 amp) for the control console is located on the rear of the console. The two 8 amp slow blow fuses on the front panel of the control console are for the point row clutches.

**NOTE: The indicator light on the front panel of the control console will light if the marker switch or point row clutch switch is ON. Make sure this light is OFF before leaving the tractor. If left in the ON position it will drain the tractor battery.**

## HYDRAULIC OPERATION

All 2300 Planters are equipped for operation from three dual remote hydraulic outlets.

One set of outlets is used to raise and lower the planter, one set is used to operate the markers and wing locks, and one set is used to operate the rotate and tongue extension functions.

**WARNING:** Make sure all hydraulic hoses are properly connected before operating the planter. Never connect or disconnect hydraulic hoses without first stopping the tractor engine and moving the hydraulic operating levers in both directions to relieve any pressure in the system.

## VALVE BLOCK LOCATED ON FRONT SIDE OF MAIN FRAME

48837-9

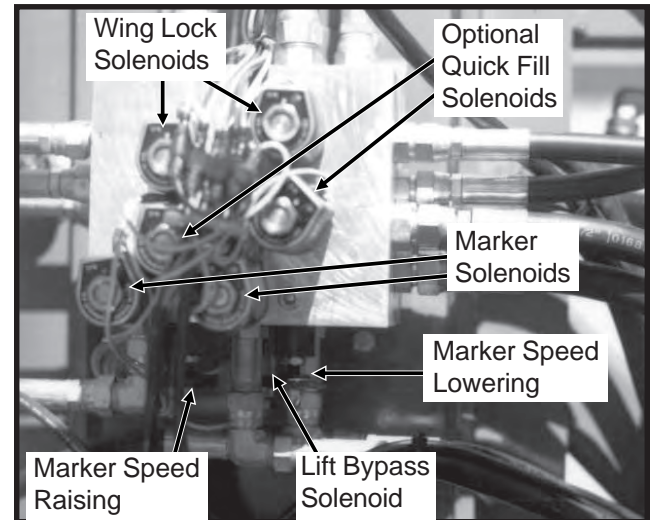

Shown with protective cover removed.

The valve block assembly located on the front side of the main frame of the planter is made up of the marker solenoids and flow controls, the lift bypass solenoid and check valves, and the wing lock solenoids.

Two solenoids, located to the front lower portion of the block, control which marker will operate when the tractor hydraulic lever is moved. See "Marker Operation".

The speed at which the markers will travel is controlled by the knurled adjustment knob or flow control on the bottom side of the valve block. The knob on the right side of the block will control the speed of the marker raising. The knob on the left side of the block will control the speed of the marker lowering.

**NOTE: Right and left is determined by facing in the direction the machine will travel when in use.**

# MACHINE OPERATION

Screw the knobs all the way in and turn back out about 1 1/2 turns and check marker speed. Travel time should be approximately 6 seconds. To increase speed of the marker, turn the knob out. To decrease speed of the marker, turn the knob in. Temperature of the hydraulic oil will affect the marker speed so additional adjustment may be necessary. Once marker adjustment has been made, tighten the lock nut against the valve block.

The solenoid valves located to the front upper portion of the block are used in conjunction with the planter lift system to lock the wings when the planter is being raised to transport position. See "Planter Lift System Operation".

**NOTE: These solenoids operate in pairs.**

The solenoid valve and pair of check valves located on the bottom side of the block are used in conjunction with the planter lift system when the planter is being raised to transport position. See "Planter Lift System Operation"

## VALVE BLOCK LOCATED ON HITCH

48630-7

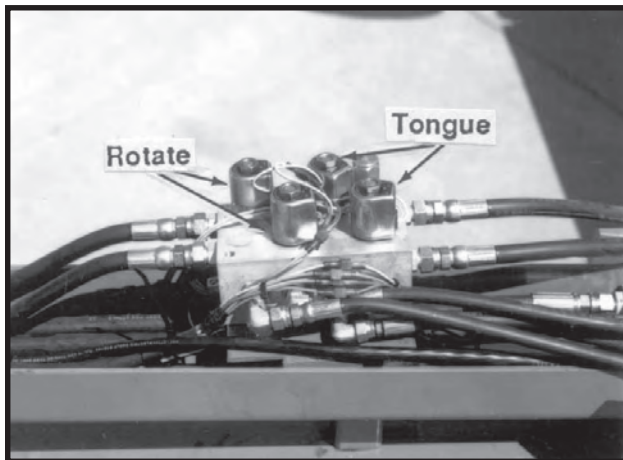

Shown with protective cover removed.

The valve block assembly located on the hitch of the planter is made up of two pairs of solenoid valves. Each pair is controlled by a momentary contact selector toggle switch on the control panel on the tractor. One pair rotates the planter to the transport or plant position and one pair extends or retracts the planter tongue. The switch must be held in contact when operated. See "Planter Operation Procedures".

**CAUTION: Valve block shown with cover removed for illustration purposes only. Cover should always be in place during operation.**

## TONGUE LOCK OPERATION

60355-22



A tongue lock is located on the rear section of the tongue. The purpose of the lock is to take pressure off the tongue cylinder and to lock the tongue into the planting position. The lock must release before the tongue will extend. This is accomplished when the 1 1/2" x 2 1/2" tongue lock cylinder raises the lock. A pressure relief valve located on top of the aluminum valve block on the tongue will not allow hydraulic oil to the tongue cylinder until oil pressure is developed at the latch cylinder. This ensures that the latch will release first.

## PLANTER LIFT SYSTEM OPERATION

The planter lift system consists of two lift cylinders located at the center of the machine and one lift cylinder on each outer wing on 8 and 12 row models and two lift cylinders on each outer wing on the 16 row model.

**NOTE: On all 8 and 12 row models, the lift cylinders located at the center of the machine are referred to as the master cylinders and the lift cylinders located on each outer wing as the slave cylinders. On the 16 row model, the lift cylinders located at the center of the machine are the slave cylinders and the lift cylinders located on each outer wing are the master cylinders.**

With the master/slave hydraulic lift system, oil is forced into the butt end of the master cylinders when the hydraulic lever on the tractor is moved to the raise position. As the master cylinders are extended, oil from the rod end of the master cylinder is forced into the butt end of the slave cylinders. All cylinders will extend at the same rate.



# MACHINE OPERATION

The slave cylinders and master cylinders include a rephasing valve in the piston which allows oil to bypass the cylinder piston in the lowered position if the system gets out of phase. Rephasing the system is necessary when the planter is taken from the transport position to the planting position. To rephase the system, hold the tractor hydraulic lever in the lowering position for an additional 15 to 20 seconds after all the cylinders are fully retracted.

An electric solenoid valve, located on the main frame valve block, allows oil to bypass the wing cylinders. This valve is controlled by the "raise" toggle switch located on the planter control console. This function is used only when taking the planter from the raised field position to the raised transport position.

## Raised Field Position

60620-39

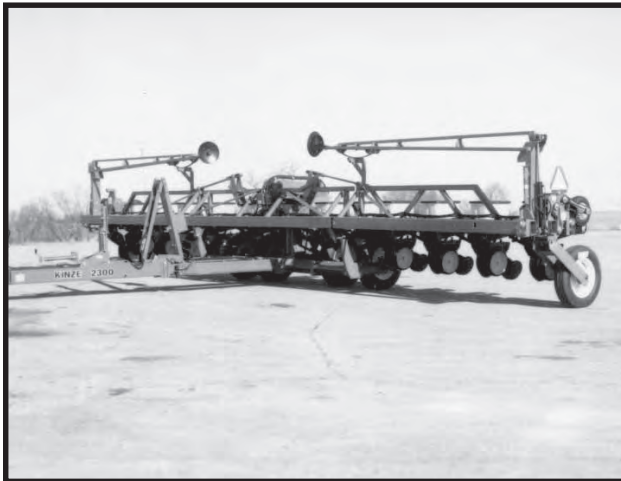

There are two raised positions on the planter. One is the raised field position which is when the planter wing cylinders are fully extended and the lift cylinders in the center are at half stroke, but because the bypass solenoid is not energized the wing cylinders cannot bypass oil preventing the planter from raising any higher. This position will raise the row units approximately 14 inches off the ground. This position is used in making turns or passing over waterways during field operation.

## Raised Transport Position

60620-49



The other raised position is the raised transport position. In this position the planter must be raised high enough so the row units will clear the transport wheels when the planter is rotated. To do this the planter is first raised to raised field position and the wings locked in the rigid position. See "Transport Operation Procedures". By holding down the "Raise" switch on the control console to energize the bypass solenoid and holding the tractor hydraulic lever in the raise position the planter will continue to raise until the center lift cylinders are fully extended. Near the extreme raise position, an automatic safety lock will swing into the lock position. Release the "Raise" switch and lower the planter onto the safety stand using the tractor's hydraulic lever. Install manual safety lockup pin to prevent accidental release of safety lock.

48496-11a

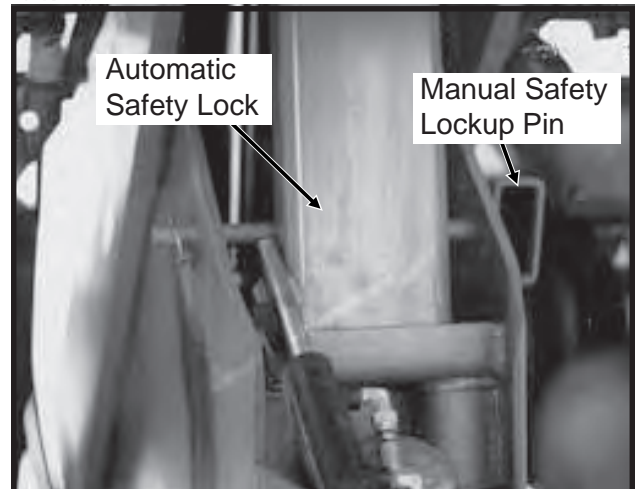

# MACHINE OPERATION

## TRANSPORT TO PLANT OPERATION PROCEDURE

1. Remove safety pins from tongue and center frame. Store safety pins in storage positions provided.

60355-50



48496-11

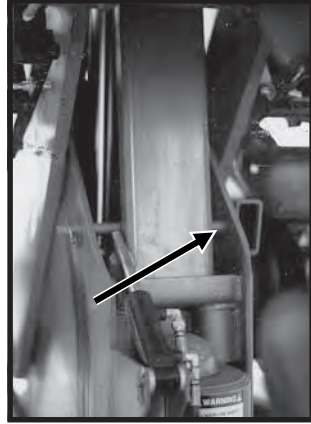

2. Release transport latch.

A. Press "Tongue" switch and hold.

60448-1a



B. Engage hydraulic tongue/rotation lever until tongue is retracted approximately 1" or only enough to release latch.

51502-5

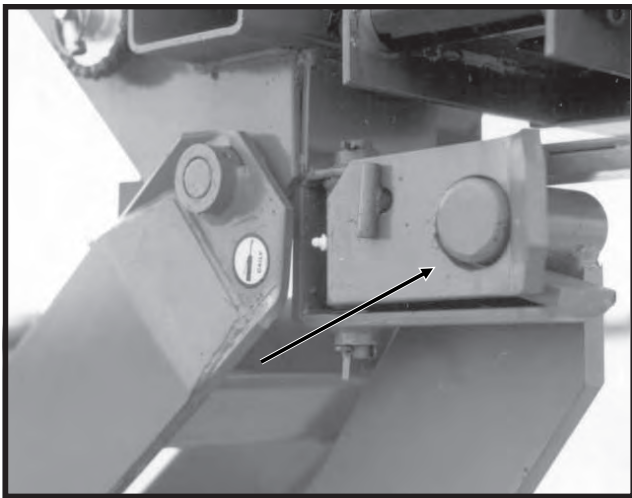

**CAUTION:** Retracting tongue too far at this point can cause the latch post on the tongue to strike attachments on the front tool bar.

3. Rotate planter to field position.

A. Press "Rotate" switch and hold.

60448-1b

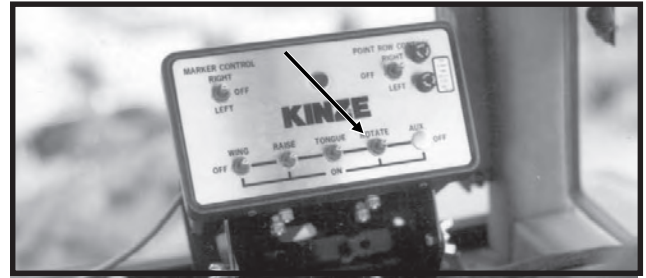

B. Engage and hold hydraulic tongue/rotation lever until rotation cylinder is fully retracted.

60620-30



48618-9

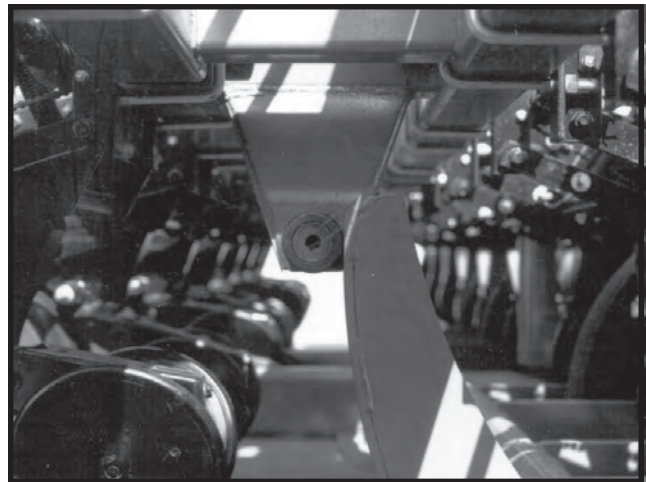

**CAUTION:** To prevent damage to the frame, units or tires, make sure the frame has been completely rotated to planting position so that the cams on the center section are tracking properly over the guides on the axle.

**NOTE:** During operation if the planter should get out of phase the center frame will raise too high in raised field position. This will allow the cams to raise above the cam guides. Without the support of the cams, damage to the planter may occur if operated in this condition. If this condition should occur, lower the planter and rephase the system.

# MACHINE OPERATION

4. Retract tongue.
  - A. Press "Tongue" switch and hold.

60448-1a

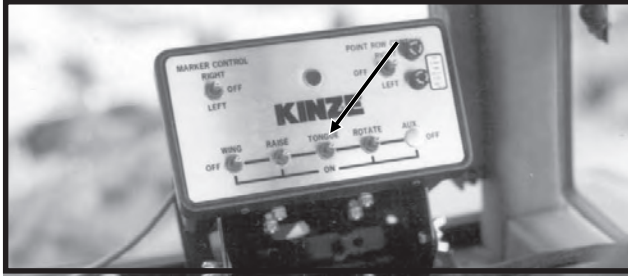

- B. Engage and hold hydraulic tongue/rotation lever until tongue is fully retracted and tongue lock hook drops into place.

60620-46



5. Release automatic safety lift lock.
  - A. Engage and hold hydraulic lift lever in down position momentarily to allow safety lock release cylinder to move into release position as shown.

48618-17

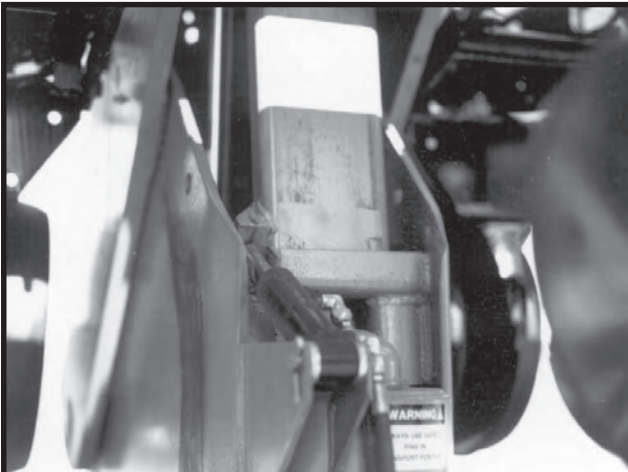

- B. Engage hydraulic lift lever to raise planter and allow release cylinder to release safety lock.
  - C. Lower planter to plant position.

**NOTE:** It may be necessary to hold "Raise" switch down to allow the planter to raise high enough to release the lock.

6. Release wing locks so wings may flex.
  - A. Press "Wing" switch and hold.

60448-1c



- B. Engage and hold hydraulic marker/wing lock lever until wing lock cylinders are fully retracted.

48618-23



**Unlocked For Planting**

7. Rephase hydraulic lift system.
  - A. Hold the hydraulic lift lever in the down position for several more seconds until the master/slave cylinders are completely re-phased. See "Phasing The Hydraulic System".

## PLANT TO TRANSPORT OPERATION PROCEDURE

1. Raise planter to raised field position.

60620-39



# MACHINE OPERATION

## 2. Lock wings in transport position.

- A. Press "Wing" switch down and hold.

60448-1c

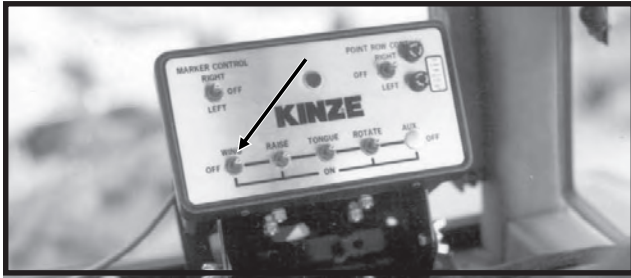

- B. Engage hydraulic marker/wing lock lever until wing lock cylinders are fully extended and wing locks are locked over center.

48618-26



### Locked For Transport

- C. Install marker lockups.

72359-65



## 3. Raise planter to transport position.

60620-49



- A. Press "Raise" switch down and hold.

60448-1d

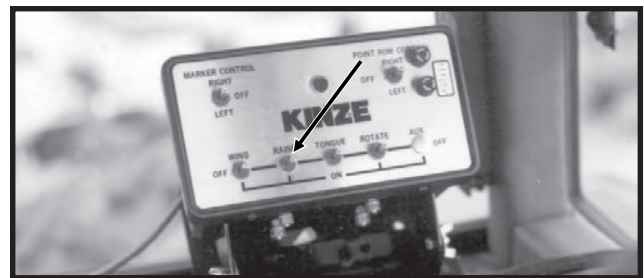

- B. Engage hydraulic lift lever until master cylinders are fully extended and the automatic safety lock is secured. Observe to be sure lock is secured.

48618-15



- C Release "Raise" switch and lower planter onto safety stand using hydraulic lift lever.

# MACHINE OPERATION

## 4. Extend tongue.

- A. Press "Tongue" switch down and hold.

60448-1a

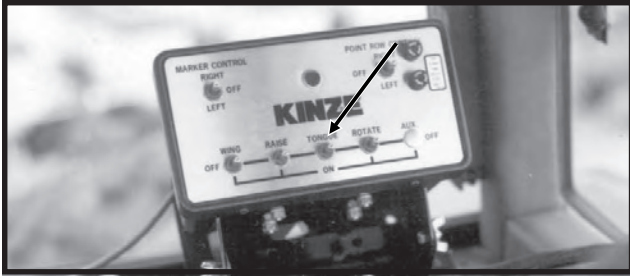

- B. Engage hydraulic tongue/rotation lever until tongue is fully extended. Tongue lock latch will automatically release.

60620-46



## 5. Rotate frame.

- A. Press "Rotate" switch and hold.

60448-1b

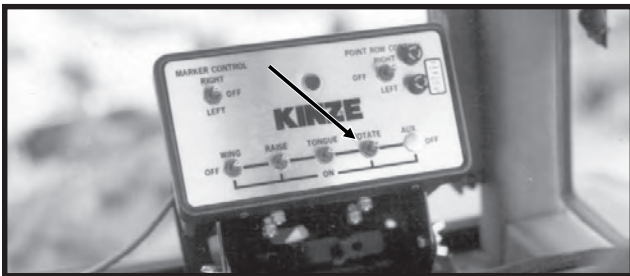

- B. Engage hydraulic tongue/rotation lever to rotate the planter until the transport latch is secured.

51502-5

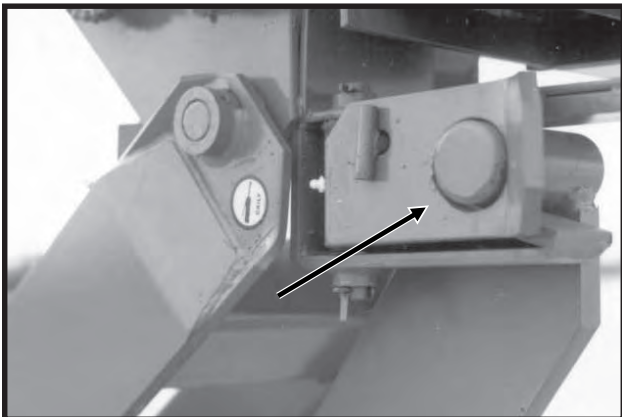

## 6. Install safety pins in tongue and center frame.

60355-50

48496-11



## PHASING THE HYDRAULIC SYSTEM

The master/slave hydraulic lift system must be kept in phase or "time" in order for the planter to raise and lower properly.

When the "Raise" switch on the control panel is used to raise the planter to the "raised transport position" the planter is taken out of phase. The system must then be rephased when it is lowered back to the planting position.

To rephase the system after raising to "transport position" or any time the planter hydraulic system should get out of phase, lower the planter to the ground and hold the tractor hydraulic control lever in the down position. This will allow the cylinders to bypass oil through the built-in rephasing valve in the pistons and allow all the cylinders to fully retract. Raise the planter and check to see if it is raising evenly. If not, lower the planter again and allow more time for the cylinders to bypass. 15 to 20 seconds is usually sufficient.

# MACHINE OPERATION

## MARKER OPERATION

60448-1e



Two solenoid valves along with a three position selector switch permits the operator to raise or lower the desired marker. See "Valve Block Located On Front Of Main Frame" for marker speed adjustment.

1. On the control panel, select which marker you want lowered.
2. Operate hydraulic control lever to lower marker.
3. If opposite marker is to be used next, change control switch to other side.
4. At end of field, using hydraulic control lever raise the down marker.
5. After making the turn; using the hydraulic lever, lower the pre-selected marker.
6. Continue to follow this procedure.

**NOTE: Both markers can be lowered at the same time by operating the switch in each position and operating the hydraulic lever twice. The markers will raise simultaneously with the switch in the OFF position.**

**NOTE: Switch should be left in OFF position when planter is not in use. If left in ON position it will drain the tractor battery.**

If the electrical system fails to operate properly:

- Check fuse.
- Check wiring connections.
- Check control switch.
- Check solenoid. SOLENOID HOUSING WILL BE MAGNETIZED WHEN ENERGIZED.

## MARKER LOCKUP

Install marker lockups over marker cylinder rods when transporting the planter or working around the planter. When lockups are not in use, store in the storage position provided on the first stage marker arm.

 **DANGER: To avoid serious injury, keep others away when raising or lowering markers.**

## MANUAL SAFETY LOCKUP

The manual safety lockup located on the front side of the center pivot assembly is an added safety device. Never allow anyone to work around or under the planter without first securing the manual safety lock in the locked position. When transporting the planter use the manual safety lockup for added safety.

48496-11

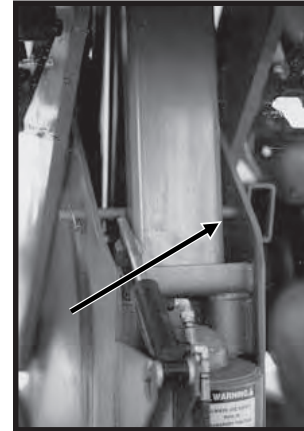

48496-57

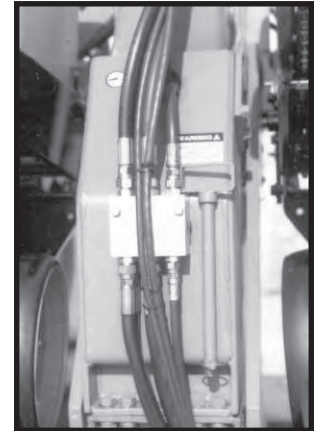

For normal operation remove the safety lockup pin and store it in the bracket provided on the rear side of the center pivot post.

## TONGUE SAFETY PIN

The tongue safety pin when installed will prevent the tongue cylinder from retracting far enough to release the transport latch should hydraulic pressure leak off or a sudden stop be made when transporting the planter. Never transport the planter without installing the tongue safety pin.

60355-50



60355-24



For normal operation remove the tongue safety pin and store in the bracket provided on the transport support post.

# MACHINE OPERATION

## POINT ROW WRAP SPRING CLUTCH (Standard on 12 and 16 Row/Optional on 8 Row)

73142-26

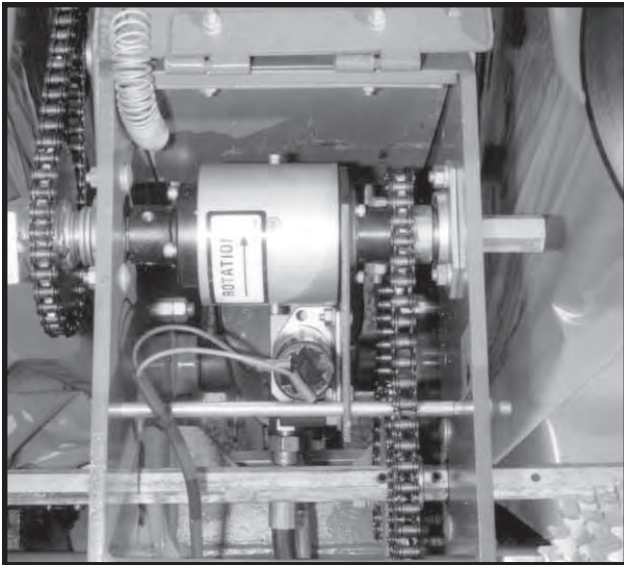

With the use of electric wrap spring clutches which disengage the drive, you have the capability to shut off either half of the planter for finishing up fields or for long point row situations.

60448-1f

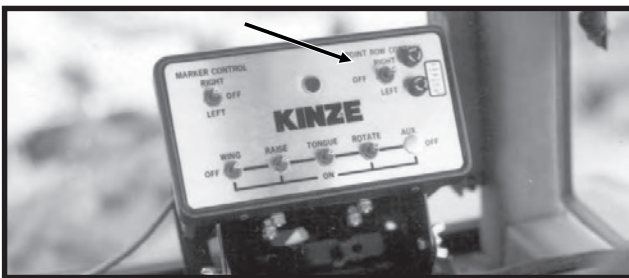

The selector switch for the clutches is located on the planter control panel.

**NOTE:** Switch should be left in OFF position when planter is not in use. If left in ON position it will drain the tractor battery.

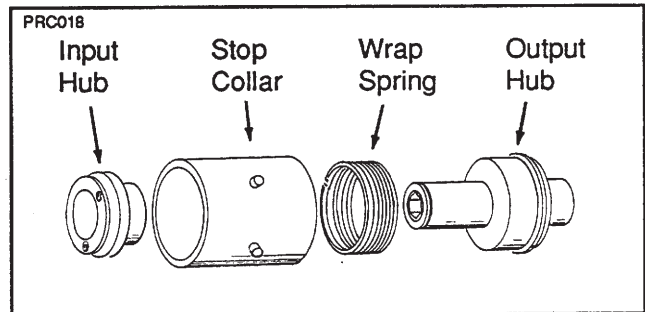

The wrap spring clutch consists of a wrap spring riding on an input hub and an output hub. During operation the wrap spring is wrapped tightly over the hubs connecting them in a positive engagement. The greater the force of rotation the tighter the grip of the spring on the hubs. Rotation in the opposite direction or stopping the spring from rotating prevents the transmission of torque from the input hub to the output hub stopping the planter drive.

The input end of the spring is bent outward and is referred to as the control tang. The control tang fits into a slot in the stop collar that is located between the input and output hubs and over the wrap spring. If the stop collar is allowed to rotate with the input hub, the clutch is engaged. If the stop collar is stopped from rotating the spring tang connected to it is forced back and the spring opens. This allows the input hub to continue rotating without transmitting torque to the output hub; therefore, stopping the planter drive.

The stop collar is controlled by the use of an electric solenoid and an actuator arm. When the selector switch on the tractor control panel is in the OFF position the solenoid coil is NOT ENERGIZED and the actuator arm will not contact the stop on the stop collar allowing it to rotate with the hubs and drive the planter.

When the operational switch is in the "DISENGAGE" (Right or Left) position the solenoid coil IS ENERGIZED and the plunger in the solenoid coil pulls the actuator arm against the stop on the stop collar, disengaging the wrap spring and stopping the planter drive.

**NOTE:** On the 16 row 30 model, the set screws and jam nuts in the input coupler are not used. An additional lock collar, located inside the outer wheel module, is used to secure the drive line and prevent the drive line from binding.

# MACHINE OPERATION

## ELECTRONIC SEED MONITOR SYSTEM

The electronic seed monitor system consists of a console, which is mounted on the tractor; seed tubes with sensors, one of which is installed in each planter row unit; and a planter harness (harness, Y-connector and/or extension cable where applicable), which connects the individual seed tube sensors to the console.

The monitor system is powered by the tractor battery (requires 12 volts DC). The console receives information from each of the sensors and translates this information for the operator, to let him know whether or not all rows are planting.

### KM1000 MONITOR

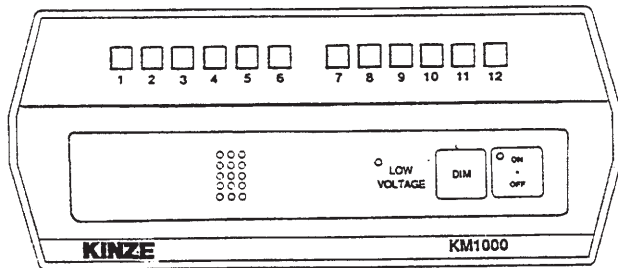

#### STEP 1 - Turn the console ON by pressing the ON/OFF switch.

Each time the console is powered up it performs a sensor check and self-check. All row indicator lamps are turned on, the alarm sounds momentarily and then the console enters the operate mode. If a row indicator lamp does not come on when the console is powered up, it indicates that a problem exists with either the sensor, planter harness or a burned out row indicator lamp. See Troubleshooting in the Maintenance Section of this manual.

#### STEP 2 - Begin planting and observe the row indicator lamps.

All indicator lamps should be flashing at approximately the same rate. If one of the row lamps is flashing at a slower rate than the others it would indicate that row is planting at a slower rate and it should be checked for proper seed population. The monitor continuously checks for seed flow while planting, as indicated by the flashing row indicator lamps on the console. If any planter unit seed sensor is not detecting seeds, the alarm will sound continuously and the row indicator lamp corresponding to the planter row unit will stop flashing. When this happens, stop planting and check to see what is wrong with the row unit.

**STEP 3 - Lift the planter at the end of the row.** When the seed flow stops in all planter units, the alarm will sound and all row indicator lamps will stop flashing. After approximately 2-4 seconds the alarm will stop sounding.

**The intensity of the Row Indicator Lamps** can be controlled by pressing and holding the switch labeled DIM. To set the intensity, press and hold the DIM switch until the lamps are at the desired intensity, release the switch. Holding the DIM switch will cause the intensity to decrease to its lowest level and then increase to its maximum level. This cycle will continue as long as the switch is depressed. When the console is turned OFF and then ON the row lamp intensity will return to maximum.

**If you are only using a portion of the number of rows on your planter,** the alarm can be silenced by disconnecting the seed sensors of the unused rows (Disconnect interplant rows at "Y" harness.) and turning the monitor OFF then back ON. The monitor will then ignore these unused rows and monitor the other rows normally.

When disabling planter rows, the monitor may look at the system as a different planter setup. Example, if you have an 8 row planter and you disable the right four rows (for planting point rows, etc.) by unplugging the seed sensors and turning the monitor OFF and back to ON, the monitor will look at it as a 4 row planter and shift the row indicator lamps to the center four positions. Therefore, planter row 1 will be indicated on the monitor as row 3, planter row 2 as row 4, etc. Row lamps 1, 2, 7 and 8 will be off.

If you disable the left four rows (planter rows 1, 2, 3 and 4) the monitor will operate normally as an 8 row system. Row indicators 1, 2, 3 and 4 will be off.



# MACHINE OPERATION

7/93

## KM1000 Bezel Decal Selection Chart

NO. ROWS	BEZEL DECAL	ROW LAMPS															
4	12																
6	6																
8	16																
*8	16																
10	12																
12	12																
*12	12																
16	16																
*4 & 3 Solid Interplant	16																
*6 & 3 Skip Row Interplant	16																
*6 & 5 Solid Interplant	16																
*8 & 5 Skip Row Interplant	16																
*8 & 7 Solid Interplant	16																

Row lamp indicates planter row in use.

Row lamp not used.

\* With "Y" connector.

**NOTE: Interplant diagrams assume that first interplant row is connected to row 1 of harness and harness is connected to R.H. half of "Y" connector.**

# MACHINE OPERATION

## KM3000 MONITOR

D-0841-0001

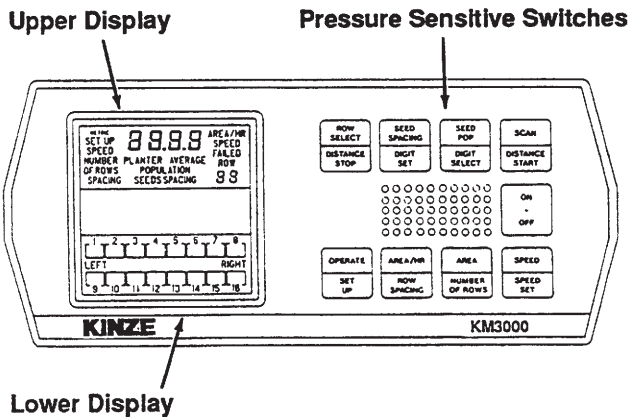

The KM3000 console may be equipped with one of two optional distance sensor features, a radar sensor which is mounted on the tractor or a pulse wheel (magnetic distance sensor) which is installed on the planter drive.

The operator's controls on the front panel of the console consist of nine pressure sensitive switches. Eight of the nine switches are dual function switches, performing one function during the OPERATE MODE and another function during the SET UP MODE. All switch functions are color coded to define between the OPERATE and SET UP modes. The upper half of each dual function switch is olive brown in color and contains the Operate functions. The lower half of each dual function switch is tan in color and contains the Set Up functions.

**NOTE: The KM3000 is shipped from the factory setup for use with American measures. To convert the console to Metric measures, cut the wire loop (red wire) adjacent to the signal cable on the back of the console and tape the ends of the cut wire to prevent the two ends making contact with each other or the vehicle.**

**STEP 1 - Turn console ON by pressing the ON-OFF switch.** Note that the upper display shows random segments for a short time then sequences through all entered SET UP constants (SPEED, NUMBER OF ROWS and ROW SPACING). If the constants are not valid the alarm will sound for approximately four seconds and the monitor will enter the SET UP mode. See "Entering Constants". If all constants are valid (as previously entered) the alarm will sound momentarily and the monitor will enter the OPERATE mode.

**NOTE: Monitor will not go from "SETUP" to "OPERATE" unless the planter harness is hooked up.**

**STEP 2 - Select the desired OPERATE function to be displayed by pressing the labeled switch.**

In the **ROW SELECT** mode a specific row can be selected and continuously monitored.

**SEED SPACING** displays the seed spacing of each planter row in inches or centimeters.

**SEED POP** displays the seed population of each planter row in thousands of seeds per acre or hectare.

In the **SCAN** mode the display will sequence through all planter rows. The display message will be SEED POP or SEED SPACING as previously selected. With SEED POP selected after the population for the highest planter row number is displayed, the average population for the total planter is shown. With SEED SPACING selected after the seed spacing for the highest planter row number is displayed, the average seed spacing for the total planter is shown.

**AREA/HR** displays the predicted area in acres or hectares that will be covered in the next hour if the same planting rate is maintained. This prediction is based on the last 10 seconds of operation.

**AREA** displays the actual area covered in acres or hectares since the last reset. To reset area to 0000, press and hold the AREA switch for approximately 5 seconds.

**SPEED** displays current vehicle ground speed in MPH or KmPH.

**A row failure** will be indicated by the FAILED ROW number being displayed in the lower right hand corner of the upper display, the corresponding segment in the lower display will be blank, and the alarm will sound continuously. Failures of more than one row will be indicated by the FAILED ROW number in the upper display sequencing through all failed rows, the corresponding segments of all failed rows in the lower display will be blank, and the alarm will sound continuously. When you lift your planter at the end of a row or stop in the field and seed flow stops in all planter units, the alarm will sound for approximately four seconds and all row indicator segments (lower display) will stop flashing. The upper display will show the FAILED ROW message and will sequence through all planter row numbers.

In the all row failure mode or immediately following power up, the operate functions (population, seed spacing and area) can be displayed by pressing the touch switch labeled with the desired function. This display condition will remain for one minute after the last time a switch is pressed or until seeds are detected by the seed sensors.

# MACHINE OPERATION

A **ground speed failure** will be indicated by the SPEED FAILED message being displayed in the upper display. To continue using the monitor system until a replacement ground speed sensor is obtained, disconnect the ground speed sensor cable, enter the SET UP mode and enter your normal planting speed in MPH or KmPH in place of the SPEED SET calibration number. **IMPORTANT:** The accuracy of the POPULATION, SEED SPACING and AREA readouts will depend on the vehicle ground speed. If you do not drive at the speed entered in SPEED SET memory these functions will not be accurate. AREA will not accumulate in this mode.

**IMPORTANT:** Under normal use the monitor will accumulate area whenever there is seed flow in at least one seed sensor. In the all rows failed condition, such as when turning around at the end of the field, the area accumulation will stop.

The monitor can be used to count seeds in a selected row by performing the following:

1. Place console in SET UP mode. (Before performing Step 2 make sure you have recorded the SPEED constant. See SPEED in "Entering Constants".)
2. Set the SPEED constant to 0000. This can be done by manually setting each digit to zero using the DIGIT SELECT and DIGIT SET switches or by pressing and holding the SPEED SET switch for approximately 5 seconds.
3. Enter the OPERATE mode by pressing the OPERATE switch.
4. Press and release the ROW SELECT switch until the desired planter row number is displayed in the lower right corner of the upper display. The monitor will now show seed counts for the selected row.

To reset the display to zero and continue to monitor the same row unit, press the SCAN switch then the ROW SELECT.

To select another row unit, press the ROW SELECT switch until the desired planter row number is displayed. Each time the ROW SELECT switch is pressed the row number will be incremented one unit and the four digit display will be reset to zero.

**IMPORTANT:** To return to normal operation, enter the SET UP mode and re-enter the SPEED constant.

The **lower visual display** contains up to sixteen segments and each one corresponds to a planter row unit. When the monitor is turned on the console senses the number of seed sensors connected to the planter harness and activates a segment for each one which flashes dark each time a seed is detected by the seed sensor. If up to 16 seed sensors are sensed the display will show segments for all sensors all the time. If more than 16 (17-32) seed sensors are sensed, then the display is split and up to 16 sensors are shown for the LEFT and RIGHT side of the planter.

**EXAMPLE:** If a 24 row planter is being used and the display message LEFT is on, the segments are showing seed flow for planter rows 1 through 12. When the display message RIGHT is on, the segments are showing seed flow for planter rows 13 through 24. When the RIGHT planter half is shown, the segment numbers 1 through 12 will represent planter rows 13 through 24 (segment 1 is planter row 13, segment 2 is row 14, up to segment 12 which is row 24).

## ENTERING CONSTANTS (KM3000 Only)

Upon initial power-up or whenever memory is lost the following three constants must be entered before the system will enter the "operate" mode. The following examples are for an 8 row planter with 30" row spacing.

**1. ROW SPACING** - The distance between the rows on your planter.

Press the "row spacing" switch. The upper display will show "set up", "row spacing" and "000.0".

Press the "digit select" switch (a short alarm burst will be heard each time the switch activates) until the second "0" to the left of the decimal point is flashing. Press the "digit set" switch until a "3" is shown in this location: 030.0.

NOTE: Holding the "digit set" switch will cause the digit to increment from 0 through 9.

**NOTE:** If you have a solid row planter of 15", 18", 19", 30", 36" or 38" row spacing, program that number in for row spacing. If you have a skip row planter, determine row spacing by taking the total distance between the two outside rows (in inches) and divide by the number of planter rows minus 1.

# MACHINE OPERATION

**EXAMPLE: 8 row 30" planter with 13 row 15" skip row interplant**

**Step 1. Total distance between center of outside row on left end of planter to center of outside row on right end of planter = 210"**

**Step 2. 13 rows (number of total rows) minus 1 = 12**

**Step 3. 210" ÷ 12 = 17.5" average row spacing**

**Step 4. Program 17.5 (round to closest tenth)**

**2. NUMBER OF ROWS** - The number of active rows on your planter. (Example for 8 row planter)

Press the "number of rows" switch. The upper display will show "set up", number of rows" and "00".

Press the "digit select" switch until the right hand "0" is flashing.

Press the "digit set" switch until a 8 is shown in this location: 08.

**3. SPEED** - A number that is the result of the speed calibration procedure. Used with both radar and magnetic distance sensors.

The speed set calibration number matches the console to the ground speed sensor when calibrated over a specified measured distance. When the calibration procedure is completed and the speed set constant established, the value should be written down and retained in the event battery voltage is removed from the console and the information in memory is lost. In this event, the constant may be re-entered manually using the "digit select" and "digit set" switches. The speed set calibration procedure must be repeated and new speed set number established if the radar or magnetic distance sensor mounting is changed for any reason.

**NOTE: When obtaining the following speed set number, actual in-field conditions should be simulated as close as possible.**

A. Measure an accurate 400 foot (150 meter) in-field course, preferably on level ground. Mark the "start" and "finish" of the course so it will be plainly visible from the cab as you drive past.

B. With the upper display showing messages "set up" and "speed" and the four digit display showing all zeros (to reset four digit display to zeros, press and hold the "speed set" switch for approximately 5 seconds), drive up to the marked course at normal planting speed.

C. When even with the "start" marker, press the "distance start" switch. Four dashes will appear on the console display.

D. Drive at a steady speed through the entire course. When even with the "finish" marker, press the "distance stop" switch.

E. The speed set number will be displayed. Record this number for future reference.

SPEED SET NUMBER \_\_\_\_\_

**IMPORTANT: This procedure may have to be repeated after performing the Radar Vibration Test. See Radar Vibration Test.**

**NOTE: The accuracy of the area computations, population, seed spacing and vehicle ground speed readout are dependent upon the accuracy of the operator entered constants. Use care when determining the constants which describe your planter.**

## RADAR VIBRATION TEST (KM3000 With Radar Sensor Only)

To check for vibration, start vehicle engine and slowly increase engine RPM (while watching the ground speed readout) to approximately 1800 RPM. If the ground speed readings are above zero, the radar sensor must be mounted in an alternate, more stable location.

## INTERPLANT ROWS

The half of the "Y" connector marked row 1 is used for the main rows on the planter and the other half for interplant rows. When interplant rows are not being used, switch the console to the OFF position and disconnect the interplant rows at the "Y" connector. Switch the console back ON. It will be necessary to reprogram "row spacing" and "number of rows" on the KM3000 console.

1. Press "SETUP" switch.
2. See ROW SPACING and NUMBER OF ROWS in "Entering Constants".
3. After entering constants press "OPERATION" switch to return to operation mode.

To activate the interplant rows, switch the console to the OFF position and reconnect the interplant rows at the "Y" connector. Switch the console ON. Reprogram "row spacing" and "number of rows" on the KM3000 console.

# MACHINE OPERATION

## ROCK GUARDS

56249-6

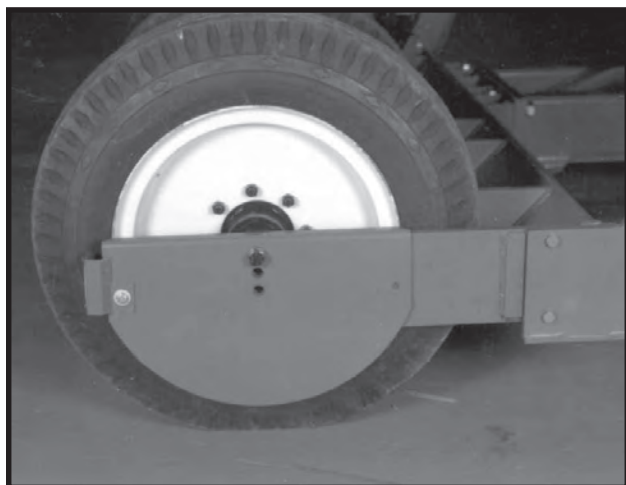

Transport wheel rock guards are designed for use on both sides of each of the four center transport wheels when the planter is used in rocky conditions. Rock guards will help prevent rocks from being picked up by the wheel causing damage to the row unit.

73090-2

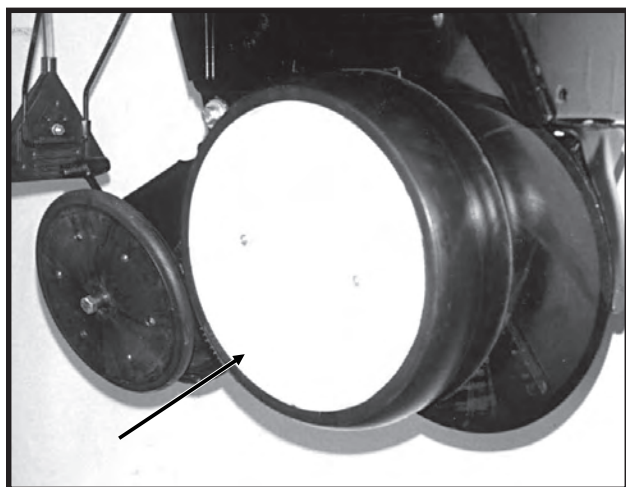

Row unit gauge wheel covers may be used in conjunction with transport wheel rock guards on row unit gauge wheels next to transport wheels.

## RIDGE PLANTING

When ridge planting, the drive wheels and transport wheels can be lowered 2" or 4" to the lower mounting holes in the wheel arms to increase the planter bar height. The contact drive tire must be lowered also. Hitch height should be raised accordingly to ensure level operation.

60607-35



**NOTE:** Photo shows wheels mounted in the standard position.

# MACHINE OPERATION

## MARKER ADJUSTMENT

To determine the correct length at which to set the marker assemblies, multiply the number of rows by the average row spacing in inches. This provides the total planting width. Adjust the marker extension so the distance from the marker blade to the center line of the planter is equal to the total planting width previously obtained. Both the planter and marker assembly should be lowered to the ground when measurements are being taken. The measurement should be taken from the point where the blade contacts the ground. Adjust right and left marker assemblies equally and securely tighten clamping bolts. An example of marker length adjustment follows:

Number of rows	X	Row spacing =	Dimension between planter center line and marker blade.
		(Inches)	

12 Rows X 30" Spacing = 360" Marker Dimension

60569-53

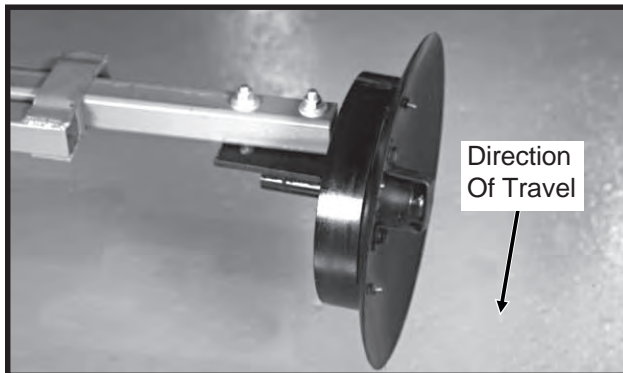

Marker blade shown with depth band.  
(Standard on 8 row wide - up.)

The marker blade is installed so the concave side of the blade is outward to throw dirt away from the grease seals. The spindle bracket is slotted so the hub and blade can be angled to throw more or less dirt. To adjust the hub and spindle, loosen the 1/2" x 3 1/2" cap screws and move the bracket as required. Tighten bolts to the specified torque.

**IMPORTANT: A marker blade assembly that is set at a sharper angle than necessary will add unnecessary stress to the complete marker assembly and shorten the life of bearings and blades. Set the blade angle only as needed to leave a clear mark.**

A field test is recommended to ensure the markers are properly adjusted. After the field test is made, make any minor adjustments necessary.

## TRANSPORTING THE PLANTER

**WARNING:** Always make sure safety/warning lights, reflectors and SMV emblem are in place and visible prior to transporting the machine on public roads. In this regard, check federal, state/provincial and local regulations.

**CAUTION:** Avoid transporting planter with hoppers loaded whenever possible. When it is necessary to transport the planter with the hoppers loaded, the added weight should be distributed evenly on the planter frame before rotating the planter.

**WARNING:** Install all safety lockups and safety lock pins.

## TRACTOR SPEED

Planters are designed to operate within a speed range of 2 to 8 MPH. Variations in ground speed will produce variations in rates. Finger pickup corn meter populations will tend to be disproportionately higher at high ground speeds.

# MACHINE OPERATION

## FIELD TEST

With any change of field and/or planting conditions or seed size, we recommend a field test be made to ensure proper seed placement and operation of row units. See "Rate Charts", "Checking Seed Population", and "Checking Granular Chemical Application Rate" at end of this section.

Check the planter for fore and aft and lateral level operation. See "Leveling The Planter" and "Leveling The Planter Wings".

Check all row units to be certain they are running level. When planting, the row unit parallel arms should be parallel to the ground.

Check row markers for proper operation and adjustment. See "Marker Adjustment" and marker speed adjustment in "Hydraulic Operation".

Check for proper application rates and placement of granular chemicals on all rows. See "Checking Chemical Application Rates".

Check for desired depth placement and seed population on all rows. See "Checking Seed Population".

Check for proper application rates of fertilizer on all rows. See proper "Fertilizer Application Rate Chart".

After the planter has been field tested, reinspect the machine.

Hoses and fittings

Bolts and nuts

Cotter pins and spring pins

Drive chain alignment

## METRIC CONVERSION TABLE

Multiply	By	To Get
Inches (in.)	x 2.54	= centimeters (cm)
Inches (in.)	x 25.4	= millimeters (mm)
Feet (ft.)	x 30.48	= centimeters (cm)
Acres	x 0.405	= hectares (ha)
Miles per hour (mph)	x 1.609	= kilometers per hour (kmph)
Pounds (lbs.)	x 0.453	= kilograms (kg)
Bushels (bu.)	x 35.238	= liters (l)
Gallons (gal.)	x 3.785	= liters (l)
Pounds per square inch (psi)	x 6.894	= kilopascals (kPa) (100 kPa = 1 bar)
Inch pounds (in. lbs.)	x 0.113	= newtons-meters (N•m)
Foot pounds (ft. lbs.)	x 1.356	= newtons-meters (N•m)
Centimeters (cm)	x .394	= inches (in.)
Millimeters (mm)	x .0394	= inches (in.)
Centimeters (cm)	x .0328	= feet (ft.)
Hectares (ha)	x 2.469	= acres
Kilometers per hour (kmph)	x 0.621	= miles per hour (mph)
Kilograms (kg)	x 2.208	= pounds (lbs.)
Liters (l)	x 0.028	= bushels (bu.)
Liters (l)	x 0.264	= gallons (gal.)
Kilopascals (kPa) (100 kPa = 1 bar)	x 0.145	= pounds per square inch (psi)
Newtons-meters (N•m)	x 8.85	= inch pounds (in. lbs.)
Newtons-meters (N•m)	x 0.738	= foot pounds (ft. lbs.)

# MACHINE OPERATION

## DOUBLE DISC FERTILIZER OPENER

The double disc fertilizer openers should be positioned during assembly to place the fertilizer no closer than 2" to either side of the row. If planter frame is level and at proper planting height, fertilizer depth will be approximately 4". Soil conditions can affect depth slightly.

The down pressure spring is factory preset at 250 pounds down pressure but may be adjusted for various soil conditions. To adjust spring tension, loosen the jam nut with 15/16" wrench and use a 1" wrench to turn the adjustment bolt clockwise to increase tension or counter-clockwise to decrease tension. Securely tighten the jam nut upon completion of tension adjustment. Do not attempt to set opener depth with spring pressure. The opener is designed to operate against a depth stop and spring up when encountering a foreign object or hard ground.

**CAUTION: Do not operate the double disc openers at full down pressure tension when planting in rocky ground. Chipping of the blades will occur.**

A gap of 1/32" to 1/16" should be maintained between the opener blades at the closest point. Blade adjustment can be made by moving inside spacer washers to the outer side of the blade. After making this adjustment, check to be sure bearing assembly rivets are not hitting the shank.

The outer scrapers on each blade may also be adjusted to make up for wear that may occur. Make sure the scraper is adjusted to allow only slight contact with the blade.

The opener assembly is designed to be locked in a raised position when the fertilizer attachment is not in use or during storage. To lock the opener, first raise the planter and place blocks under the openers. Then lower the planter until the hole in the pivot section aligns with the hole in the mounting bracket. Remove the lockup pin from the storage position in the mounting bracket and install it through the lockup hole and secure with cotter pins.

**! DANGER: Always install all cylinder lockup brackets before working under the unit.**

60389-23

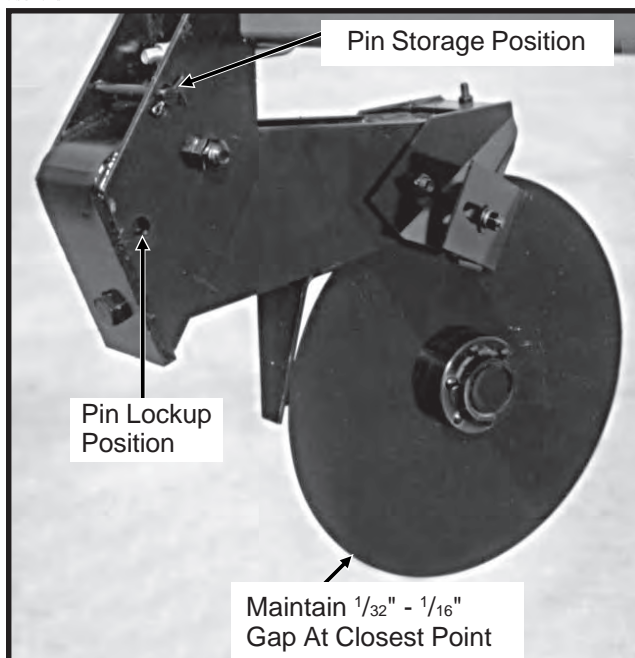



# MACHINE OPERATION

## SINGLE DISC FERTILIZER OPENER

60389-49

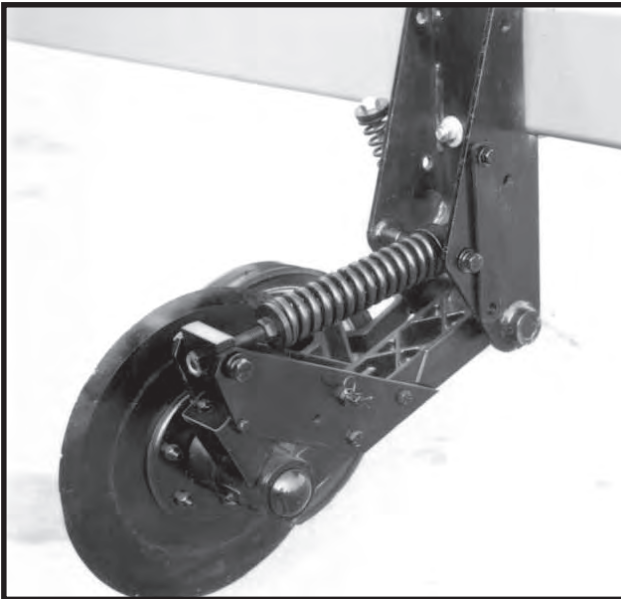

Placement of fertilizer with the single disc fertilizer opener is recommended at 3 1/2" - 4" from the row. **Never locate the opener to place fertilizer closer than 3".** With the single disc fertilizer opener mount located centered ahead of the row unit and the rear of the blade angled away from the row, the opener will place the fertilizer 3 1/2" beside the row.

If planter frame is level and at approximately 20" planting height, maximum blade depth for placement of fertilizer is approximately 5". Soil conditions can affect depth slightly.

**To adjust blade depth,** raise planter to remove weight from the fertilizer opener. Loosen inside adjustment nut (A) with 1 1/8" wrench. Turn outside nut (B) clockwise to decrease blade depth or counterclockwise to increase blade depth. One full turn of blade depth adjustment nuts changes blade depth 3/8". Tighten inside nut tight against block (C). Adjust all fertilizer openers to the same depth.

L0114

(Overhead View)

Direction Of Travel

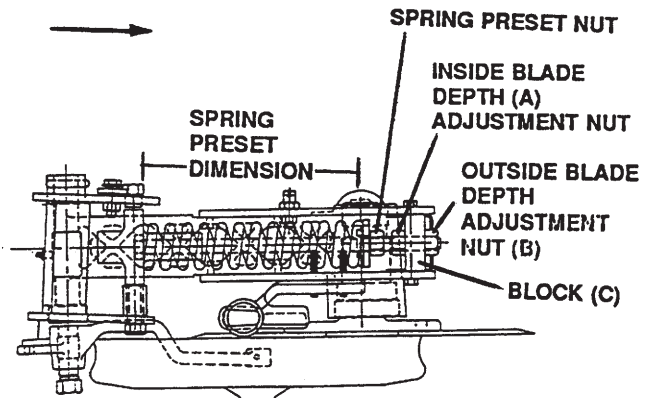

R.H. Configuration Shown

Fertilizer opener down pressure can be adjusted from 250 pounds to 640 pounds. **To make down pressure adjustments,** raise planter to remove weight from the fertilizer opener and turn spring preset nut clockwise to increase down pressure and counterclockwise to decrease down pressure. Adjust all rows to a similar setting. Minimal spring pressure for acceptable operation is recommended. See chart for setting spring length specifications.

SPRING PRESET DIMENSION	DOWN PRESSURE
11"	250 Pounds
10 3/4"	320 Pounds
*10 1/2"	370 Pounds
10 1/4"	450 Pounds
10"	520 Pounds
9 3/4"	580 Pounds
9 1/2"	640 Pounds

\* Suggested initial setting.

**CAUTION: DO NOT** adjust spring preset dimension to less than 9 1/2"

**IMPORTANT:** Excessive down pressure can cause up-lift on the planter frame and affect performance of the machine. When lowered to planting position, planter frame should be at a height of approximately 20". In loose ground conditions, excessive down pressure can cause openers to run too deep and push dirt ahead of opener and may stop soil press wheel and/or opener blade from turning.



**DANGER:** Always install all lockup brackets before working under the machine.

# MACHINE OPERATION

**CAUTION:** Do not operate the single disc openers at full down pressure tension when planting in rocky ground. Chipping or breakage of the blade will occur.

The spring loaded scraper should be adjusted periodically to maintain 1/8" gap between drop tube and opener blade. If this dimension is not maintained the fertilizer may not drop into the proper location.

FOC016

Loosen scraper adjustment bolt. Slotted hole in scraper allows up or down adjustment.

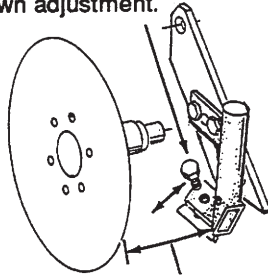

Adjust scraper to maintain 1/8" gap between drop tube and opener blade. Distance is exaggerated in above illustration.

Additional press wheel down pressure may be desirable in heavy moist soils. To increase press wheel spring pressure turn press wheel spring adjustment bolt clockwise.

60389-63

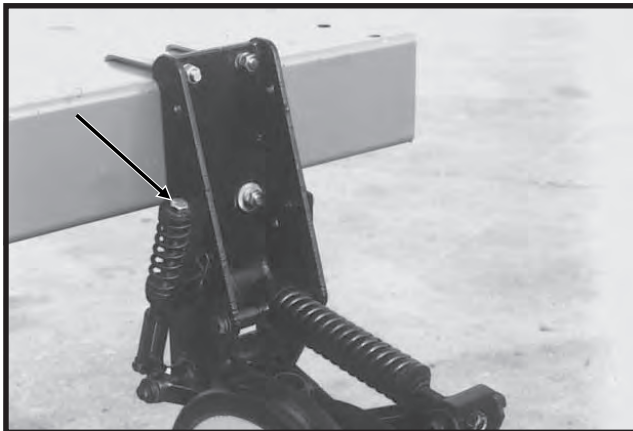

**NOTE:** The soil press wheel is not intended to be used for gauging fertilizer opener operating depth.

The single disc fertilizer opener is designed to be locked in a raised position when the fertilizer attachment is not in use or during storage.

To lock the single disc fertilizer opener in the raised position, proceed as follows:

**Step 1.** With the planter in the planting position, remove outside blade depth adjustment nut. ("B" in illustration on previous page.)

**Step 2.** Raise planter until adjustment bolt clears adjustment block.

**Step 3.** Raise spring to clear blade assembly and at the same time raise blade assembly until storage strap can be positioned onto lockup pin and install hair pin clip.

**Step 4.** Re-install depth adjustment nut and tighten.

60356-4

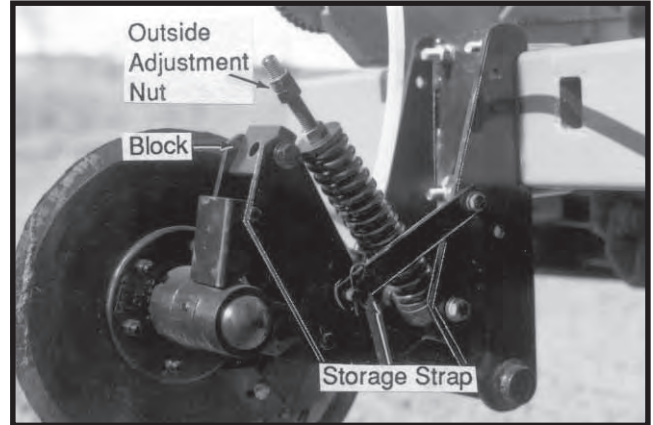

**Step 5.** (Where Applicable - If the single disc fertilizer opener is equipped with a lockup bar the soil press wheel is raised and locked automatically when the blade assembly is raised and this step is not necessary.) Raise soil press wheel until lockup hole in soil press wheel spring adjustment bolt is visible. Remove hair pin clip from storage position and install in lockup hole.

60389-63

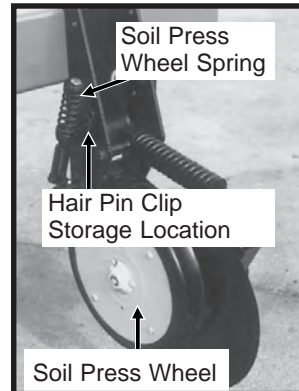

60355-32



## Manual soil press wheel lockup

FOC016

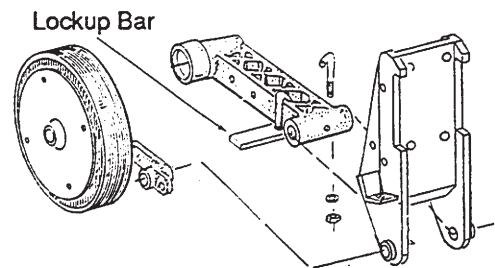

## Automatic soil press wheel lockup

# MACHINE OPERATION

## DRY FERTILIZER ATTACHMENT

60389-34



Shown with Quick Fill Attachment Installed

The rate of fertilizer application is determined by the drive/driven sprocket combination on the fertilizer drive and by the auger position in the hopper.

60389-39

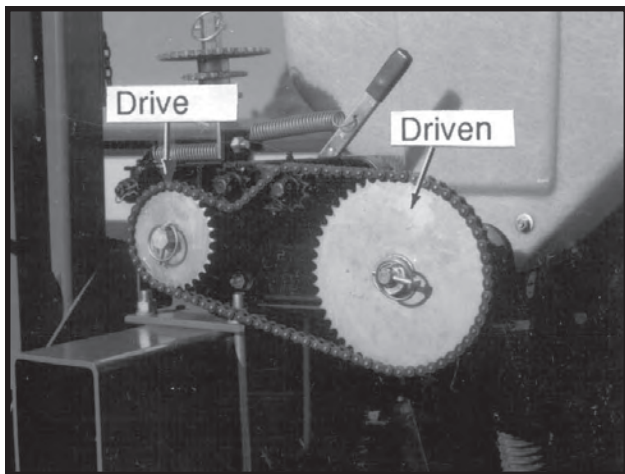

Shown with augers positioned for low rate delivery



Shown with augers positioned for high rate delivery

Remove 1/4" stainless steel cap screws holding augers in place on shaft and reposition augers to change delivery rate.

See Dry Fertilizer Application Rate Chart at the end of this section. Uneven delivery of fertilizer will occur if the high rate position is used at too low a rate setting.

A fertilizer transmission is located on each side of the planter directly ahead of the row unit transmission on all models. This transmission is designed to allow simple, rapid changes in sprockets to obtain the desired fertilizer application rates. By removing the pins on the hexagon shafts, sprockets can be interchanged with those on the sprocket storage rod bolted to the transmission plate. Chain tension is controlled by a spring loaded idler. This idler is adjusted with a ratchet arm located to the inside of the transmission. This arm has a release position to remove spring tension for replacing sprockets. The amount of spring tension on the chain can be controlled by the ratchet arm. The fertilizer application charts found at the end of this section will aid you in selecting the correct sprocket combinations.

**IMPORTANT:** After each sprocket combination adjustment, make a field check to be sure you are applying fertilizer at the desired rate.

The dry fertilizer attachment meters granules by volume rather than weight. For this reason, and given the variances in brands and fertilizer analysis, the weight metered during actual application may vary considerably. Use the chart for reference only. It is suggested that a container be used to catch and measure application (as explained following the application chart) to obtain a closer estimate.

Since most fertilizers easily absorb moisture, it is important that fertilizer be kept dry during use and storage. In addition to waste, deposits of fertilizer left in the hopper can cause metal corrosion. Hoppers should be emptied at the end of each day's use.

**IMPORTANT:** Certain analysis of fertilizer, if placed too close to the seed, may cause germination or seedling damage especially if used in amounts in excess of fertilizer manufacturer's recommendations. Check with your fertilizer dealer or manufacturer for the correct amount and placement.

**WARNING:** Agricultural chemicals can be dangerous if not selected and handled with care. Always read and follow directions supplied by the chemical manufacturer.

# MACHINE OPERATION

## CLEANING

The dry fertilizer hoppers are designed to tip forward for dumping and ease of cleaning. To dump hoppers, first disconnect the drive shaft from the transmission or adjacent hopper. **LOOSEN HOSE CLAMP AND REMOVE HOSES FROM EACH HOPPER.** Remove the two rear 1/2" x 1 1/4" cap screws from between hopper support and hopper mount. Loosen the two front 1/2" x 1 1/4" cap screws. Rotate hopper lids to the back side of the hopper and carefully tip hopper forward. After dumping contents, flush all loose fertilizer from the hopper and hoses.

48837-29

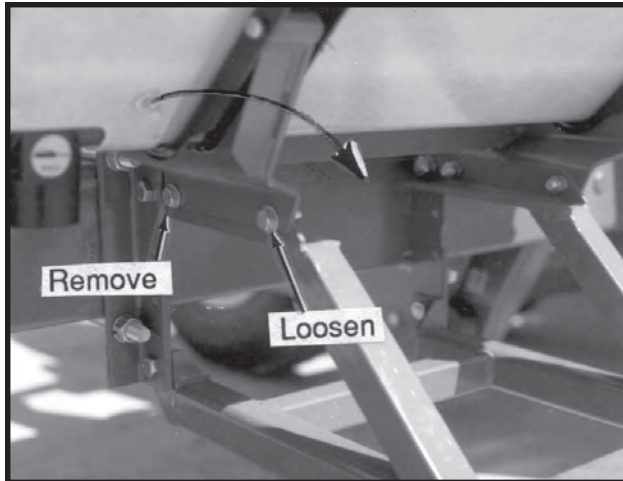

60389-30

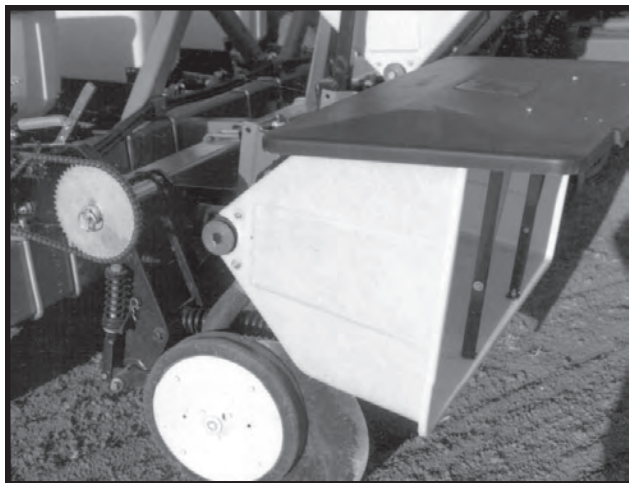

At the end of the planting season, or when fertilizer attachment is not going to be used for a period of time, the hoppers should be disassembled, cleaned and coated with a rust preventative.

To disassemble auger assemblies, remove 1/4" cotter pin and bearing from one end of the shaft. Pull auger assembly from opposite end of hopper. Remove stainless steel cap screws from auger shaft and remove all auger components for cleaning. Coat all parts with rust preventative before reassembly. Reinstall auger halves in proper low rate or high rate position.

To reassemble, slide auger assembly through the outlet housing back into the hopper. Secure in place by reinstalling the bearing and cotter pin.

59542-38



Check auger installation by rotating shaft in the direction of planter travel to see that the spirals on the auger move toward the ends of the hopper. If not, remove auger assembly, turn 180° and reinstall.

Be certain augers turn freely. If not, loosen the 5/16" carriage bolts in the outlet housings, rotate the auger several times and retighten the 5/16" carriage bolts. This should allow the housings to realign themselves with the auger.

Install auger baffles over the augers and secure in place with two hair pin clips in each hopper. Do not operate fertilizer attachment without auger baffles in place.

**IMPORTANT:** Frequent lubrication of auger bearings is critical to ensure that the augers will turn freely. Check lubrication section for frequency.

**NOTE:** Be sure the auger assembly is installed so the flighting on the augers move material to the outer openings in the hopper when the augers are rotated in the direction they will turn when the planter is in operation.

# MACHINE OPERATION

## DRY FERTILIZER QUICK FILL ATTACHMENT

The quick fill attachment allows one point filling of all dry fertilizer hoppers. Located near the fill hopper is the hydraulic motor which drives the attachment and the flow control valve which controls the speed of the auger and also works as a safety valve for shutting off the auger. A pair of specially installed solenoid valves, controlled by the auxiliary switch on the control panel, operates the auger.

60389-36



**WARNING:** Always install hydraulic cylinder lockout channels on marker cylinders before operating quick fill attachment.

**NOTE:** The quick fill attachment can be equipped for use with a closed center hydraulic system or open center hydraulic system. See Illustrations 1 and 2.

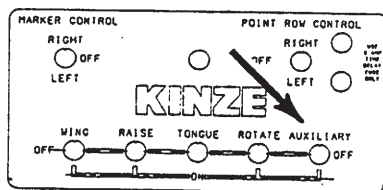

1. Be sure marker switch on control console is in OFF position.
2. Move auxiliary switch on control console to ON position.
3. Operate hydraulic (marker) control lever to engage quick fill auger.

At the end of each season or if the quick fill attachment is not being used for a period of time, pull the augers from the quick fill tubes and thoroughly clean the augers and tubes and treat with a rust preventative.

**DANGER:** Keep clothing, yourself and others well clear when augers are in operation.

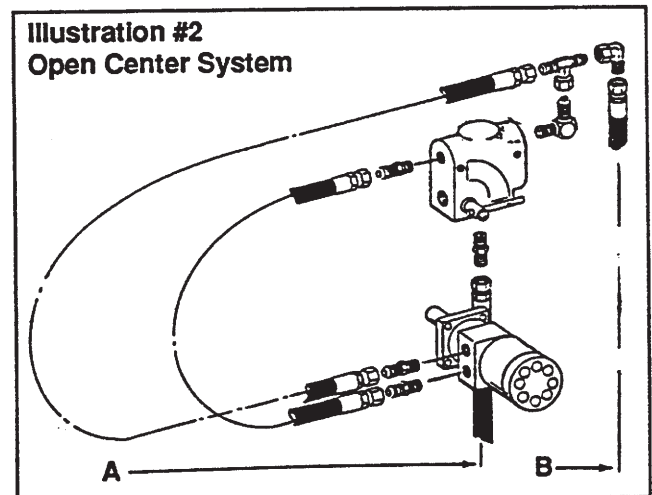
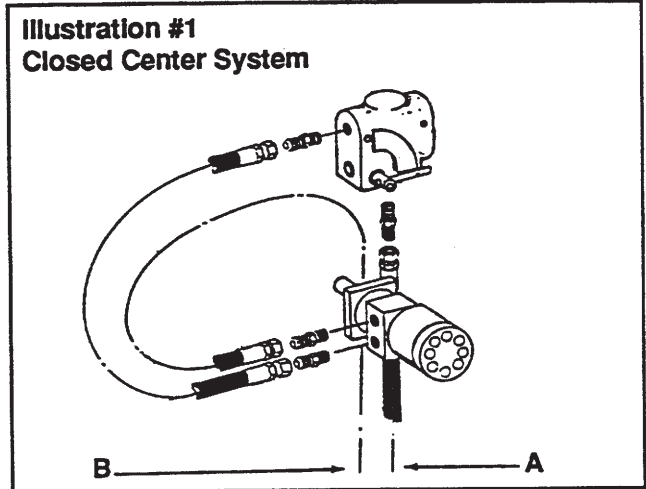

48630-6

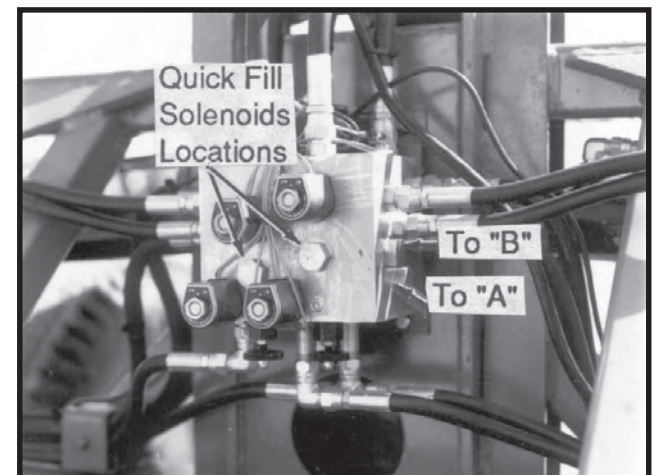

Shown with protective cover removed.

# MACHINE OPERATION

## LIQUID FERTILIZER ATTACHMENT

### OPTIONAL SQUEEZE PUMP

60355-18



60355-63

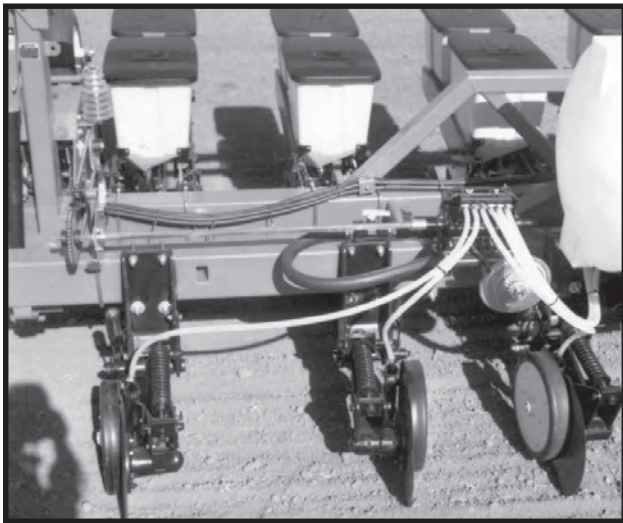

Shown with single disc fertilizer openers installed.

On machines equipped with the squeeze pump option, the rate of liquid fertilizer application is determined by the combination of sprockets on the squeeze pump driven and drive shafts. When changing sprocket combinations, make sure sprockets are in alignment, sprocket retaining collars are tight and chain tension is sufficiently restored.

The delivery rate chart found at the end of this section provides an approximate application rate only. Actual delivery will vary with temperature and the particular fertilizer being used.

**IMPORTANT:** Certain analysis of fertilizer, if placed too close to the seed, may cause germination or seedling damage especially if used in amounts in excess of fertilizer manufacturers recommendations. Check with your fertilizer dealer or manufacturer for the correct amount and placement.



**WARNING:** Agricultural chemicals can be dangerous if not selected and handled with care. Always read and follow directions supplied by the chemical manufacturer.

Shut-off valves provided at various locations should be closed to shut off flow when the planter sets overnight or for extended periods of time. It is also important to close the tank valves whenever service on the pump or hoses is being performed. To prolong the life of the hoses in the squeeze pump, the discharge manifold must be repositioned to the rearward position when not in use to prevent hose distortion.

00137-6

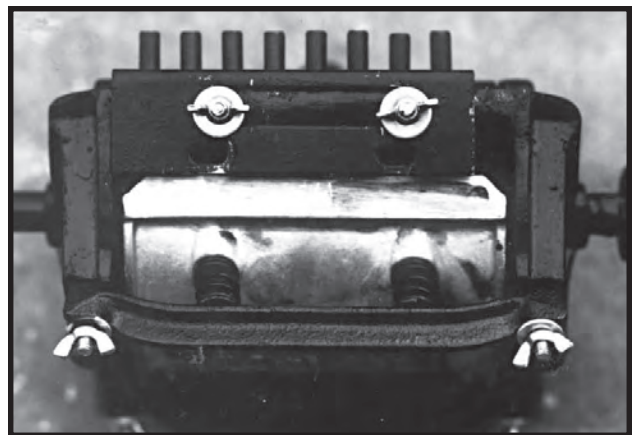

**Discharge Manifold Rearward**

00137-7

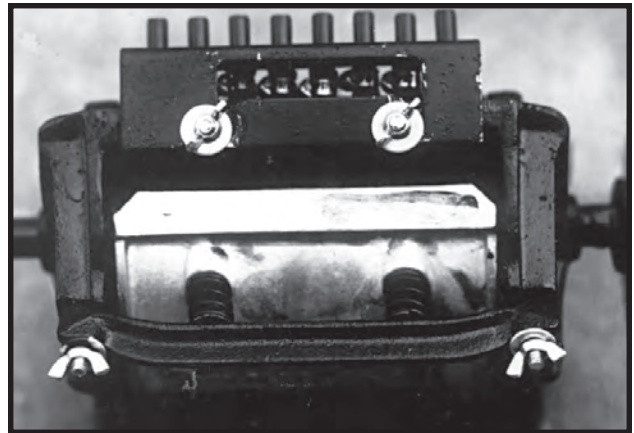

**Discharge Manifold Forward**

The discharge manifold must be in the forward position when the pump is in operation. To reposition the manifold, loosen the wing nuts and slide the manifold forward and sideways or rearward as required and retighten nuts.

# MACHINE OPERATION

**CAUTION:** Avoid excessive pressure when using the quick fill attachment. The rubber plugs installed in the manifold may be forced out under pressure.

If either of the end pump hoses should run off the back plate, loosen the hose clamp on the intake manifold and rotate the hose as follows.

48931-2

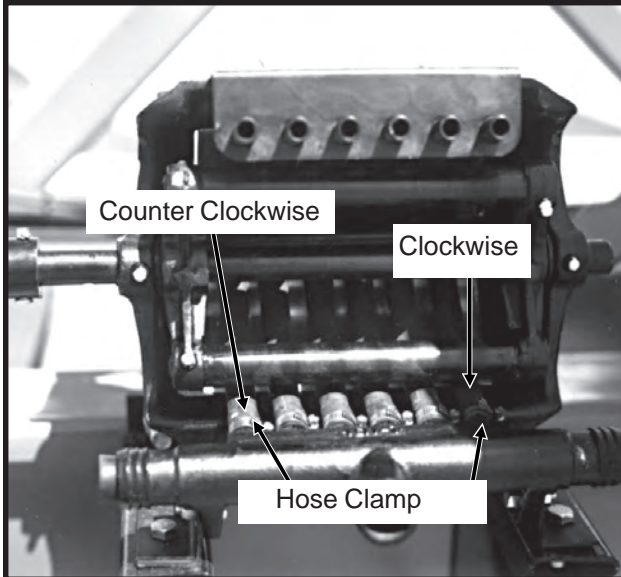

For the right hand hose (facing the pump from front of planter) twist the hose 1/4 turn in the clockwise direction.

For the left hand hose (facing front of pump) twist the hose 1/4 turn in the counter-clockwise direction.

Retighten hose clamp.

## OPTIONAL PISTON PUMP

69045-6

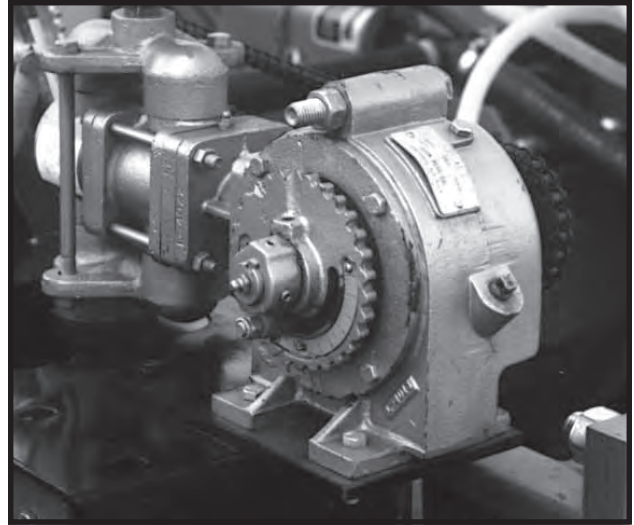

If the machine is equipped with the piston pump option, the rate of liquid fertilizer application is determined by the piston pump settings.

The delivery rate chart found at the end of this section provides an approximate application rate only. Actual delivery will vary with temperature and the particular fertilizer being used.

To adjust delivery rate, loosen the 3/8" lock nut on the arm with pointer and rotate the scale flange until the pointer is over the desired scale setting. The adjustment wrench will facilitate rotation of the scale flange. Tighten 3/8" lock nut being careful not to over tighten.

The operator and instruction manual shipped with the pump and flow divider should be kept and stored with this manual for future reference.

**NOTE:** Periodically check flow to all rows. If one or more lines are plugged, set rate will be delivered to remaining rows.

## CLEANING

The tanks and all hoses are made of sturdy plastic and rubber to resist corrosion. However, the tanks, hoses and metering pump should be thoroughly cleaned with water at the end of the planting season or prior to an extended period of non-use. Do not allow fertilizer to crystalize due to cold temperature or evaporation.

See "Piston Pump Storage" (If Applicable) in the Maintenance Section of this manual.

# MACHINE OPERATION

## CHECKING SEED POPULATION

1. Tie up one or more sets of closing wheels by running a light chain between the hopper support panel and closing wheels. It may be necessary to decrease closing wheel arm spring tension.

L0069

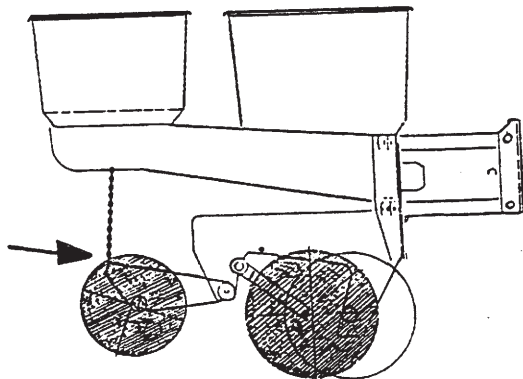

2. Plant a short distance and check to see if seed is visible in the seed trench. Adjust planting depth to a shallower setting if seed is not visible and recheck.

72359-108

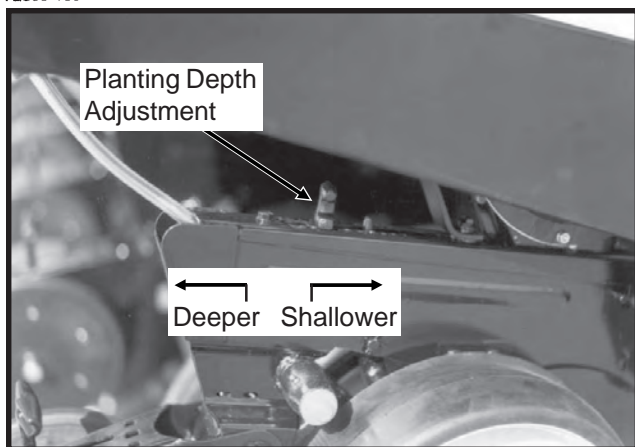

3. Measure 1/1000 of an acre. See chart for correct distance for row width spacing being planted. For example, if planting 30" rows 1/1000 of an acre would be 17'5".

LENGTH OF ROW IN FEET AND INCHES			
Fraction Of Acre	Row Width		
	30"	36"	38"
1/1000	17'5"	14'6"	13'10"

**NOTE:** When planting with closing wheels raised and planting depth set shallow, seeds may bounce or roll affecting seed spacing accuracy.

4. Count seeds in measured distance.

5. Multiply the number of seeds placed in the 1/1000 of an acre by 1000. This will give you total population.

EXAMPLE: With 30" row spacing 17'5" equals 1/1000 acre.

26 Seeds			
Counted	x	1000	= 26,000 Seeds Per Acre

Seed count can be affected by drive ratio between drive wheel and seed meter, tire pressure and/or seed meter malfunction.

If seed check shows the average distance between seeds in inches is significantly different than the seed rate chart indicates, first check drive ratio between drive wheel and seed meter. Check drive wheel air pressure, check for incorrect sprocket(s) in drive line and check drive and driven sprockets in transmission for proper selection.

Second, check for seed meter malfunction. For example, if spacing between kernels of corn at the transmission setting being used is 8" and a gap of 16" is observed, a finger has lost its seed and not functioned properly. If two seeds are found within a short distance of each other, the finger has metered two seeds instead of one.

See "Finger Pickup Corn Meter Troubleshooting" and/or "Brush-Type Seed Meter Troubleshooting" in the Maintenance Section of this manual.



# MACHINE OPERATION

## Determining Pounds Per Acre (Brush-Type Seed Meter)

To determine pounds per acre:

Seeds Per Acre On Chart	÷	Seeds Per Pound From Seed Tag On Bag	=	Pounds Per Acre
-------------------------------	---	---	---	-----------------------

To determine bushels per acre:

Pounds Per Acre	÷	Unit Weight Of Seed	=	Bushels Per Acre
--------------------	---	------------------------	---	---------------------

The unit weight of:

- 1 Bushel Soybeans = 60 Pounds
- 1 Bushel Cottonseed = 32 Pounds
- 1 Bushel Milo = 56 Pounds

If seeds per pound information is not available the following is an average:

- 2,600 seeds per pound for medium size soybeans
- 15,000 seeds per pound for medium size milo
- 4,500 seeds per pound for medium size cotton

If seed check shows planting rate is significantly different than seed rate chart shows or if a particular meter is not planting accurately, see "Brush-Type Seed Meter Maintenance and Troubleshooting".

## CHECKING GRANULAR CHEMICAL APPLICATION RATE

Many things can affect the rate of delivery of granular chemicals. Temperature, humidity, speed, ground conditions, flowability of different material or any obstruction in the meter.

A field check is important to determine correct application rates.

72359-105



To check, fill insecticide and/or herbicide hoppers. Attach a calibrated vial to each granular chemical meter. Lower the planter and proceed as follows.

**NOTE: It is not necessary for seed meter clutch to be engaged during test. Disengage clutch to avoid dropping seed.**

Drive 1320 feet at planting speed. Weigh the chemical in ounces that was caught in one vial. Multiply that amount by the factor shown to determine pounds per acre.

LBS. PER ACRE FACTOR FOR GIVEN WIDTH	
Row Width	Factor
30 Inch	0.83
36 Inch	0.69
38 Inch	0.65

**EXAMPLE:** You are planting 30" rows. You have planted for 1320 feet at the desired planting speed. You caught 12.0 ounces of chemical in one vial. 12.0 ounces times 0.83 equals 9.96 pounds per acre.

**NOTE: It is important to check calibration of all rows.**

### Metering Gate

Use the metering gate setting for distributing insecticide or herbicide as a starting point. The chart is based on a 5 miles per hour planting speed. For speeds faster than 5 miles per hour a higher gate setting should be used. For speeds slower than 5 miles per hour a lower gate setting should be used.

**⚠ WARNING: Agricultural chemicals can be dangerous if not selected and handled with care. Always read and follow directions supplied by the chemical manufacturer.**

# MACHINE OPERATION

## GENERAL PLANTING RATE INFORMATION

These planting rate charts are applicable to KINZE Model 2300 Twin-Line® Planters. See "Tire Pressure" for recommended tire pressures.

Not all row spacings listed are applicable to all model planters.

**IMPORTANT: The sprocket combinations listed in these charts are best for average conditions. Changes in sprocket combinations may be required to obtain desired planting population. TO PREVENT PLANTING MISCALCULATIONS, MAKE FIELD CHECKS TO BE SURE YOU ARE PLANTING AT THE DESIRED RATE.**

The size and shape of seed may affect the planting rate.

### Finger Pickup Corn Meter

Larger grades will generally plant more accurately at the high end of the ground speed range than small grades. Higher than optimum speeds may result in population rate increase or higher incidence of doubles, particularly with small seed.

### Brush-Type Seed Meter (Soybean, Milo/Sorghum, Acid-delinted Cotton)

Rate charts are given in seeds per acre as well as seed spacing in inches rounded off to the nearest tenth of an inch. Because of the large range in seed size, pounds per acre is not a suggested method of selecting transmission settings. When using smaller size seeds it may appear the pounds per acre is below what was expected and vice versa on large seed. To determine pounds per acre, use the formula given in "Determining Pounds Per Acre (Brush-Type Seed Meter)" in the "Checking Seed Population" section of this manual.

Seed population per acre with 15" rows will be double the rate for 30" rows, as well as 18" rows versus 36" rows and 19" rows versus 38" rows, at the listed sprocket combination.

In some cases when planting 15" row soybeans or milo/ grain sorghum, a 2 to 1 drive reduction package may be required to obtain the desired population and seed spacing.

**NOTE: Use of the 2 to 1 drive reduction package will reduce the planter transmission speed. The seeding rate will be approximately 1/2 of the chart reading when using the 2 to 1 drive reduction package. Planting speed can affect actual seeding rate. Make a field check and adjust setting in the transmissions as needed to obtain the desired seed drop.**

72359-41

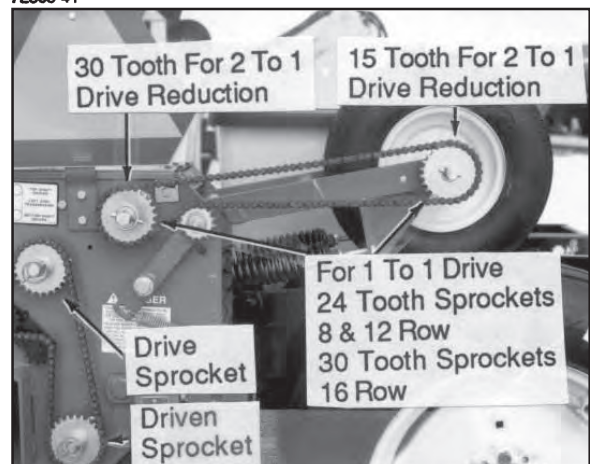

# MACHINE OPERATION

## PLANTING RATES FOR FINGER PICKUP CORN METERS APPROXIMATE SEED POPULATIONS/ACRE FOR VARIOUS ROW WIDTHS

30 Inch	36 Inch	38 Inch	Transmission Sprockets		Recomm. Speed Range (MPH)	Average Seed Spacing In Inches
			Drive	Driven		
16,186	13,488	12,778	17	28	4 to 8	12.9
16,785	13,988	13,251	17	27	4 to 8	12.5
17,431	14,526	13,761	17	26	4 to 8	12.0
18,090	15,075	14,281	19	28	4 to 8	11.6
18,128	15,107	14,312	17	25	4 to 8	11.5
18,760	15,633	14,810	19	27	4 to 8	11.1
18,883	15,736	14,908	17	24	4 to 8	11.1
19,481	16,234	15,380	19	26	4 to 8	10.7
19,704	16,420	15,556	17	23	4 to 8	10.6
20,261	16,884	15,995	19	25	4 to 8	10.3
21,104	17,587	16,662	19	24	4 to 8	9.9
21,898	18,249	17,288	23	28	4 to 8	9.5
22,022	18,352	17,386	19	23	4 to 8	9.5
22,709	18,924	17,928	23	27	4 to 8	9.2
22,850	19,042	18,040	24	28	4 to 8	9.2
23,583	19,652	18,618	23	26	4 to 8	8.9
23,697	19,747	18,708	24	27	4 to 8	8.8
23,802	19,835	18,791	25	28	4 to 8	8.8
23,853	19,877	18,831	17	19	4 to 7.5	8.8
24,526	20,438	19,363	23	25	4 to 7.5	8.5
24,608	20,507	19,427	24	26	4 to 7.5	8.5
24,684	20,570	19,487	25	27	4 to 7.5	8.5
24,755	20,629	19,543	26	28	4 to 7.5	8.4
25,548	21,290	20,169	23	24	4 to 7.5	8.2
25,592	21,327	20,205	24	25	4 to 7.5	8.2
25,633	21,361	20,237	25	26	4 to 7.5	8.2
25,671	21,393	20,267	26	27	4 to 7.5	8.1
25,707	21,422	20,295	27	28	4 to 7.5	8.1
26,659	22,216	21,046	23	23	4 to 7	7.8
27,646	23,038	21,826	28	27	4 to 7	7.6
27,684	23,070	21,856	27	26	4 to 7	7.6
27,770	23,141	21,923	25	24	4 to 7	7.5
27,818	23,181	21,961	24	23	4 to 7	7.5
28,709	23,924	22,665	28	26	4 to 6.5	7.3
28,791	23,993	22,730	27	25	4 to 6.5	7.3
28,977	24,147	22,876	25	23	4 to 6.5	7.2
29,795	24,829	23,522	19	17	4 to 6.5	7.0
29,858	24,881	23,572	28	25	4 to 6.5	7.0
29,991	24,993	23,677	27	24	4 to 6.5	7.0
30,136	25,113	23,792	26	23	4 to 6.5	7.0
31,102	25,918	24,554	28	24	3 to 6	6.7
31,295	26,079	24,707	27	23	3 to 6	6.7
32,271	26,893	25,477	23	19	3 to 5.5	6.5
32,454	27,045	25,622	28	23	3 to 5.5	6.5
33,674	28,062	26,585	24	19	3 to 5.5	6.2
35,077	29,231	27,693	25	19	3 to 5	6.0
36,068	30,056	28,474	23	17	3 to 5	5.8
36,480	30,400	28,800	26	19	3 to 5	5.7
37,636	31,363	29,713	24	17	3 to 5	5.6
37,883	31,570	29,908	27	19	3 to 5	5.5
39,204	32,670	30,951	25	17	3 to 4.5	5.3
39,287	32,739	31,016	28	19	3 to 4.5	5.3
40,772	33,977	32,189	26	17	3 to 4.5	5.1
42,340	35,284	33,427	27	17	3 to 4.5	4.9
43,908	36,590	34,665	28	17	3 to 4.5	4.8

**IMPORTANT:** See "General Planting Rate Information" and "Checking Seed Population" pages for additional information. Always check seed population in the field to ensure planting rates are correct.

# MACHINE OPERATION

Z214/RH

## PLANTING RATES FOR BRUSH-TYPE SEED METERS

### APPROXIMATE SEEDS/ACRE FOR VARIOUS ROW WIDTHS

Transmission Sprockets		60 Cell Soybean Or High Rate Milo/ Grain Sorghum			Average Seed Spacing In Inches	48 Cell Specialty Soybean Or High Rate Acid-delinted Cotton			Average Seed Spacing In Inches	Speed Range (MPH)
Drive	Driven	30 Inch	36 Inch	38 Inch		30 Inch	36 Inch	38 Inch		
17	28	80,928	67,440	63,891	2.6	64,742	53,952	51,113	3.2	2 to 8
17	27	83,926	69,938	66,257	2.5	67,141	55,950	53,006	3.1	2 to 8
17	26	87,154	72,628	68,805	2.4	69,723	58,102	55,044	3.0	2 to 8
19	28	90,449	75,374	71,407	2.3	72,359	60,299	57,126	2.9	2 to 8
19	27	93,799	78,166	74,052	2.2	75,039	62,533	59,242	2.8	2 to 8
17	24	94,416	78,680	74,539	2.2	75,533	62,944	59,631	2.8	2 to 8
17	23	98,521	82,101	77,780	2.1	78,817	65,681	62,224	2.7	2 to 8
19	25	101,303	84,419	79,976	2.1	81,042	67,535	63,981	2.6	2 to 8
19	24	105,524	87,937	83,309	2.0	84,419	70,350	66,647	2.5	2 to 8
23	28	109,491	91,243	86,440	1.9	87,593	72,994	69,152	2.4	2 to 8
19	23	110,112	91,760	86,931	1.9	88,090	73,408	69,545	2.4	2 to 8
24	28	114,252	95,210	90,199	1.8	91,402	76,168	72,159	2.3	2 to 8
24	27	118,483	98,736	93,539	1.8	94,786	78,989	74,831	2.2	2 to 8
17	19	119,263	99,386	94,155	1.8	95,410	79,509	75,324	2.2	2 to 8
24	26	123,040	102,534	97,137	1.7	98,432	82,027	77,710	2.1	2 to 8
26	28	123,773	103,144	97,715	1.7	99,018	82,515	78,172	2.1	2 to 8
24	25	127,962	106,635	101,023	1.6	102,370	85,308	80,818	2.0	2 to 8
26	27	128,357	106,964	101,334	1.6	102,686	85,571	81,067	2.0	2 to 8
23	23	133,294	111,078	105,232	1.6	106,635	88,862	84,186	2.0	2 to 8
27	26	138,420	115,350	109,279	1.5	110,736	92,280	87,423	1.9	2 to 8
24	23	139,089	115,907	109,807	1.5	111,271	92,726	87,846	1.9	2 to 8
25	23	144,884	120,737	114,382	1.4	115,907	96,590	91,506	1.8	2 to 8
19	17	148,975	124,146	117,612	1.4	119,180	99,317	94,090	1.8	2 to 8
27	24	149,955	124,963	118,386	1.4	119,964	99,970	94,709	1.7	2 to 8
28	24	155,509	129,591	122,770	1.3	124,407	103,673	98,216	1.7	2 to 8
23	19	161,355	134,463	127,386	1.3	129,084	107,570	101,909	1.6	2 to 8
28	23	162,270	135,225	128,108	1.3	129,816	108,180	102,486	1.6	2 to 8
24	19	168,371	140,309	132,924	1.2	134,696	112,247	106,339	1.6	2 to 8
25	19	175,386	146,155	138,463	1.2	140,309	116,924	110,770	1.5	2 to 8
23	17	180,338	150,282	142,372	1.2	144,270	120,226	113,898	1.5	2 to 8
26	19	182,402	152,001	144,001	1.1	145,922	121,601	115,201	1.4	2 to 7
27	19	189,417	157,848	148,540	1.1	151,534	126,278	118,832	1.4	2 to 7
28	19	196,433	163,694	155,078	1.1	157,146	130,955	124,062	1.3	2 to 7
26	17	203,861	169,884	160,943	1.0	163,089	135,907	128,754	1.3	2 to 7
27	17	211,702	176,418	167,133	0.9	169,362	141,134	133,706	1.2	2 to 7
28	17	219,542	182,952	173,323	0.9	175,634	146,362	138,658	1.2	2 to 7

**IMPORTANT:** See "General Planting Rate Information" and "Checking Seed Population" pages for additional information.

**NOTE:** When using the 2 to 1 Drive Reduction Package, rates will be approximately 1/2 of given numbers.

**IMPORTANT:** Always check seed population in the field to ensure planting rates are correct.

# MACHINE OPERATION

RH/Z215

## PLANTING RATES FOR BRUSH-TYPE SEED METERS (Continued)

### APPROXIMATE SEEDS/ACRE FOR VARIOUS ROW WIDTHS

Transmission Sprockets		36 Cell Acid-delinted Large Cotton			Average Seed Spacing In Inches	30 Cell Milo/Grain Sorghum Or Acid-delinted Cotton			Average Seed Spacing In Inches	Speed Range (MPH)
Drive	Driven	30 Inch	36 Inch	38 Inch		30 Inch	36 Inch	38 Inch		
17	28	48,557	40,464	38,335	4.3	40,464	33,720	31,945	5.2	2 to 8
17	27	50,356	41,963	39,754	4.2	41,963	34,969	33,129	5.0	2 to 8
17	26	52,292	43,577	41,283	4.0	43,577	36,314	34,403	4.8	2 to 8
19	28	54,269	45,224	42,844	3.9	45,225	37,687	35,704	4.6	2 to 8
19	27	56,279	46,900	44,431	3.7	46,900	39,083	37,026	4.5	2 to 8
17	24	56,650	47,208	44,723	3.7	47,208	39,340	37,270	4.4	2 to 8
17	23	59,113	49,261	46,668	3.5	49,261	41,051	38,890	4.2	2 to 8
19	25	60,782	50,651	47,986	3.4	50,652	42,210	39,988	4.1	2 to 8
19	24	63,314	52,762	49,985	3.3	52,762	43,968	41,654	4.0	2 to 8
23	28	65,695	54,746	51,864	3.2	54,746	45,621	43,220	3.8	2 to 8
19	23	66,067	55,056	52,159	3.2	55,056	45,880	43,465	3.8	2 to 8
24	28	68,551	57,126	54,119	3.0	57,126	47,605	45,099	3.7	2 to 8
24	27	71,090	59,242	56,123	2.9	59,242	49,368	46,770	3.5	2 to 8
17	19	71,558	59,632	56,493	2.9	59,631	49,693	47,077	3.5	2 to 8
24	26	73,824	61,520	58,282	2.8	61,520	51,267	48,569	3.4	2 to 8
26	28	74,264	61,886	58,629	2.8	61,886	51,572	48,858	3.4	2 to 8
24	25	76,772	63,981	60,614	2.7	63,981	53,317	50,511	3.3	2 to 8
26	27	77,014	64,178	60,800	2.7	64,178	53,482	50,667	3.3	2 to 8
23	23	79,976	66,647	63,139	2.6	66,647	55,539	52,616	3.1	2 to 8
27	26	83,052	69,210	65,567	2.5	69,210	57,675	54,640	3.0	2 to 8
24	23	83,453	69,544	65,884	2.5	69,544	57,954	54,904	3.0	2 to 8
25	23	86,930	72,442	68,629	2.4	72,442	60,368	57,191	2.9	2 to 8
19	17	89,385	74,488	70,567	2.3	74,488	62,073	58,806	2.8	2 to 8
27	24	89,973	74,978	71,032	2.3	74,978	62,481	59,193	2.8	2 to 8
28	24	93,305	77,755	73,662	2.2	77,755	64,796	61,385	2.7	2 to 8
23	19	96,813	80,678	76,432	2.2	80,678	67,231	63,693	2.6	2 to 8
28	23	97,362	81,135	76,864	2.1	81,135	67,613	64,054	2.6	2 to 8
24	19	101,023	84,185	79,754	2.1	84,185	70,155	66,462	2.5	2 to 8
25	19	105,232	87,693	83,078	2.0	87,693	73,078	69,231	2.4	2 to 8
23	17	108,233	90,169	85,423	1.9	90,169	75,141	71,186	2.3	2 to 8
26	19	109,441	91,201	86,401	1.9	91,201	76,001	72,001	2.3	2 to 7
27	19	113,650	94,709	89,124	1.8	94,709	78,924	74,770	2.2	2 to 7
28	19	117,860	98,216	93,047	1.8	98,216	81,847	77,539	2.1	2 to 7
26	17	122,317	101,930	96,566	1.7	101,930	84,942	80,471	2.1	2 to 7
27	17	127,021	105,851	100,280	1.6	105,851	88,209	83,566	2.0	2 to 7
28	17	131,725	109,771	103,994	1.6	109,771	91,476	86,661	1.9	2 to 7

**IMPORTANT:** See "General Planting Rate Information" and "Checking Seed Population" pages for additional information.

**NOTE:** When using the 2 to 1 Drive Reduction Package, rates will be approximately 1/2 of given numbers.

**IMPORTANT:** Always check seed population in the field to ensure planting rates are correct.

# MACHINE OPERATION

## PLANTING RATES FOR BRUSH-TYPE SEED METERS (Continued) APPROXIMATE HILLS/ACRE FOR VARIOUS ROW WIDTHS

Due to variations in cotton seed size, meters equipped with the 12 cell acid-delinted hill-drop cotton disc will plant from 3 to 6 seeds per cell.

To determine planter transmission setting, determine desired hill spacing and select the transmission ratio closest to the hill spacing in inches on the chart. To decrease population increase spacing. To increase population decrease spacing.

To determine population per acre, determine average seeds per hill and hills per acre by doing a field check. Measure 1/1000 of an acre (1/1000 acre = Length of row 17' 5" for 30" row widths, 14' 6" for 36" row widths, 13' 10" for 38" row widths and 13' 1" for 40" row widths). Multiply average seeds per hill by hills per acre. EXAMPLE: 4 seeds per hill x (13 hills x 1000) = 52,000

Transmission Sprockets Drive Driven		NUMBER OF HILLS PER ACRE 12 Cell Hill-drop Cotton, Acid-delinted			Average Hill Spacing In Inches	Speed Range (MPH)
		30 Inch	36 Inch	38 Inch		
17	28	16,186	13,488	12,778	12.9	2 to 8
17	27	16,785	13,988	13,251	12.5	2 to 8
17	26	17,431	14,526	13,761	12.0	2 to 8
19	28	18,090	15,075	14,281	11.6	2 to 8
19	27	18,760	15,633	14,810	11.1	2 to 8
17	24	18,883	15,736	14,908	11.1	2 to 8
17	23	19,704	16,420	15,556	10.6	2 to 8
19	25	20,261	16,884	15,995	10.3	2 to 8
19	24	21,105	17,587	16,662	9.9	2 to 8
23	28	21,898	18,249	17,288	9.5	2 to 8
19	23	22,022	18,352	17,386	9.5	2 to 8
24	28	22,850	19,042	18,040	9.2	2 to 8
24	27	23,697	19,747	18,708	8.8	2 to 8
17	19	23,853	19,877	18,831	8.8	2 to 8
24	26	24,608	20,507	19,427	8.5	2 to 8
26	28	24,755	20,629	19,543	8.4	2 to 8
24	25	25,592	21,327	20,205	8.2	2 to 8
26	27	25,671	21,393	20,267	8.1	2 to 8
23	23	26,659	22,216	21,046	7.8	2 to 8
27	26	27,684	23,070	21,856	7.6	2 to 8
24	23	27,818	23,181	21,961	7.5	2 to 8
25	23	28,977	24,147	22,876	7.2	2 to 8
19	17	29,795	24,829	23,522	7.0	2 to 8
27	24	29,991	24,993	23,677	7.0	2 to 8
28	24	31,102	25,918	24,554	6.7	2 to 8
23	19	32,271	26,893	25,477	6.5	2 to 8
28	23	32,454	27,045	25,622	6.5	2 to 8
24	19	33,674	28,062	26,585	6.2	2 to 8
25	19	35,077	29,231	27,693	6.0	2 to 8
23	17	36,068	30,056	28,474	5.8	2 to 8
26	19	36,480	30,400	28,800	5.7	2 to 7
27	19	37,883	31,570	29,908	5.5	2 to 7
28	19	39,287	32,739	31,016	5.3	2 to 7
26	17	40,772	33,977	32,189	5.1	2 to 7
27	17	42,340	35,284	33,427	4.9	2 to 7
28	17	43,908	36,590	34,665	4.8	2 to 7

**IMPORTANT:** See "General Planting Rate Information" and "Checking Seed Population" pages for additional information.

**NOTE:** When using the 2 to 1 Drive Reduction Package, rates will be approximately 1/2 of given numbers.

**IMPORTANT:** Always check seed population in the field to ensure planting rates are correct.

# MACHINE OPERATION

## DRY INSECTICIDE APPLICATION RATES APPROXIMATE POUNDS/ACRE AT 5 MPH FOR VARIOUS ROW WIDTHS

Meter Setting	30 Inch	36 Inch	38 Inch
<b>CLAY GRANULES</b>			
10	4.9	4.1	3.9
11	5.4	4.5	4.3
12	6.1	5.1	4.8
13	6.9	5.7	5.4
14	7.7	6.4	6.0
15	8.5	7.1	6.7
16	9.6	8.0	7.6
17	10.7	8.9	8.4
18	11.4	9.5	9.0
19	13.1	10.9	10.3
20	14.2	11.8	11.2
21	15.5	12.9	12.3
22	16.4	13.7	12.9
23	17.2	14.3	13.6
24	18.8	15.7	14.9
25	20.9	17.4	16.5
26	23.0	19.2	18.1
27	24.1	20.0	19.0
28	25.4	21.2	20.1
29	27.8	23.2	22.0
30	29.6	24.7	23.4
<b>SAND GRANULES</b>			
5	2.9	2.4	2.3
6	4.9	4.0	3.8
7	5.3	4.4	4.2
8	6.3	5.3	5.0
9	7.8	6.5	6.1
10	8.9	7.4	7.0
11	10.2	8.5	8.0
12	11.2	9.3	8.8
13	12.6	10.5	10.0
14	14.1	11.7	11.1
15	15.5	12.9	12.3
16	17.5	14.6	13.8
17	19.4	16.2	15.3
18	21.8	18.2	17.2
19	24.3	20.2	19.1
20	25.7	21.4	20.3
21	27.6	23.0	21.8
22	29.6	24.7	23.4
23	32.0	26.7	25.3
24	34.4	28.7	27.2
25	36.9	30.7	29.1

**IMPORTANT:** The above chart represents average values and should be used only as a starting point. The granular chemical flows through the given meter opening at a nearly uniform rate regardless of roller speed. Your actual rate will vary depending upon the insecticide you are using, your planting speed and your plant population. Planting speed/ground speed has the greatest affect on application rate.

Your actual rate must be checked in the field with the actual insecticide that you are using and at the speed and population at which you will be planting.

# MACHINE OPERATION

## DRY HERBICIDE APPLICATION RATES

APPROXIMATE POUNDS/ACRE AT 5 MPH FOR VARIOUS ROW WIDTHS

### CLAY GRANULES

Meter Setting	30 Inch	36 Inch	38 Inch
10	4.7	3.9	3.7
11	5.2	4.4	4.1
12	5.8	4.9	4.6
13	6.5	5.4	5.1
14	7.3	6.1	5.7
15	8.2	6.9	6.5
16	9.0	7.5	7.1
17	9.9	8.2	7.8
18	10.7	8.9	8.4
19	11.6	9.7	9.2
20	12.6	10.5	10.0
21	13.6	11.3	10.7
22	14.6	12.1	11.5
23	15.7	13.1	12.4
24	17.0	14.1	13.4
25	18.1	15.1	14.3
26	19.4	16.2	15.3
27	20.9	17.4	16.5
28	22.6	18.8	17.8
29	24.3	20.2	19.1
30	26.7	22.2	21.1

**IMPORTANT:** The above chart represents average values and should be used only as a starting point. The granular chemical flows through the given meter opening at a nearly uniform rate regardless of roller speed. Your actual rate will vary depending upon the herbicide you are using, your planting speed and your plant population. Planting speed/ground speed has the greatest affect on application rate.

Your actual rate must be checked in the field with the actual herbicide that you are using and at the speed and population at which you will be planting.



# MACHINE OPERATION

## DRY FERTILIZER APPLICATION RATES

### APPROXIMATE RATE IN POUNDS PER ACRE

Drive Sprocket	Driven Sprocket	Low Rate Setting			High Rate Setting		
		30" Rows	36" Rows	38" Rows	30" Rows	36" Rows	38" Rows
15	35	29	24	23	86	71	68
15	33	33	27	26	98	82	78
15	30	36	30	28	109	90	86
19	33	41	34	33	124	104	98
19	30	45	38	36	138	114	108
15	19	52	43	41	158	132	125
30	35	56	47	44	172	143	136
30	33	60	50	47	182	152	144
33	35	63	53	50	189	158	149
35	33	70	58	56	212	177	168
33	30	73	60	57	220	184	174
19	15	84	70	66	272	227	215
30	19	104	87	82	316	263	250
33	19	115	96	91	347	290	275
35	19	122	102	97	368	307	291
30	15	132	110	104	400	334	316
33	15	145	121	115	440	367	348
35	15	154	129	122	467	389	369

NOTE: Uneven delivery may result in attempting to use lower rates than indicated by the chart.

Direction  
Of Rotation



High Rate Position



Low Rate Position

Above chart for planters equipped with contact drive. See "Tire Pressure" for recommended tire pressures.

This chart was calculated with a bulk density of 65 pounds per cubic foot.

**IMPORTANT:** Fertilizer application rates can vary from the weights calculated in the above chart. To prevent application miscalculations, make field checks to be sure you are applying fertilizer at the desired rate.

To check the exact number of pounds your fertilizer attachment will actually deliver on a 30 inch row spacing, proceed as follows:

Remove one spout from one of the fertilizer hoppers and attach a container under the opening. Engage the fertilizer attachment and drive forward for 174 feet. Weigh the amount of fertilizer caught in the container and multiply that amount by 100. The result will be the pounds of fertilizer delivered per acre when planting in 30 inch rows. To convert this delivery rate for wider rows, multiply by the following conversion factors:

36" multiply by 0.83

38" multiply by 0.79

# MACHINE OPERATION

## LIQUID FERTILIZER SQUEEZE PUMP APPLICATION RATES

### GALLONS PER ACRE

Drive	Driven	30 Inch Rows	36 Inch Rows	38 Inch Rows	Drive	Driven	30 Inch Rows	36 Inch Rows	38 Inch Rows
16	62	6.2	5.0	4.9	46	44	25.3	20.2	20.0
16	*60	6.4	5.1	5.1	20	18	26.8	21.4	21.2
18	62	7.0	5.6	5.5	18	16	27.2	21.7	21.5
18	*60	7.2	5.8	5.7	52	46	27.3	21.8	21.6
16	52	7.4	5.9	5.9	*60	52	27.9	22.4	22.0
20	62	7.8	6.2	6.2	52	44	28.5	22.8	22.5
18	52	8.4	6.7	6.6	62	52	28.8	23.1	22.7
16	46	8.4	6.7	6.6	20	16	30.2	24.1	23.8
16	44	9.2	7.0	7.0	*60	46	31.5	25.2	24.9
20	52	9.3	7.5	7.3	62	46	32.6	26.0	25.7
18	46	9.4	7.6	7.5	*60	44	32.9	26.3	26.0
18	44	9.9	7.9	7.8	62	44	34.1	27.3	26.8
20	46	10.5	8.4	8.3	44	30	35.5	28.3	28.0
20	44	11.0	8.8	8.7	30	20	36.3	29.0	28.6
30	62	11.7	9.3	9.2	46	30	37.0	29.7	29.2
30	*60	12.1	9.7	9.5	30	18	40.3	32.2	31.8
16	30	12.8	10.3	10.2	52	30	41.9	33.5	33.1
30	52	13.9	11.1	11.0	30	16	45.3	36.3	35.7
18	30	14.5	11.6	11.4	*60	30	48.3	38.6	38.2
30	46	15.8	12.6	12.4	62	30	49.9	40.0	39.4
20	30	16.1	12.8	12.8	44	20	53.2	42.5	42.0
30	44	16.5	13.2	13.0	46	20	55.5	44.4	43.9
44	62	17.2	13.7	13.6	44	18	59.0	47.3	46.6
44	*60	17.7	14.2	14.0	46	18	61.8	49.5	48.8
46	62	18.0	14.3	14.2	52	20	62.8	50.2	49.6
46	*60	18.5	14.8	14.6	44	16	66.4	52.8	52.4
18	20	19.4	15.5	15.2	46	16	69.4	55.5	54.8
52	62	20.2	16.2	16.0	52	18	69.8	55.8	55.1
44	52	20.4	16.4	16.1	*60	20	72.5	58.0	57.2
52	*60	20.9	16.7	16.5	62	20	74.9	60.0	59.1
46	52	21.4	17.1	16.9	52	18	78.5	62.8	62.0
16	18	21.5	17.2	17.0	*60	18	80.5	64.4	63.6
18	20	21.7	17.4	17.2	62	18	83.2	66.6	65.7
44	46	23.1	18.5	18.2	*60	16	90.6	72.5	71.5
*60	62	23.4	18.7	18.5	62	16	93.6	74.9	73.9
62	*60	25.0	20.0	19.7					

\*Optional sprocket.

Above chart for planters equipped with contact drive. See "Tire Pressure" for recommended tire pressures.

This chart was calculated based on a solution weighing ten pounds per gallon.

**IMPORTANT:** Fertilizer application rates can vary from the above chart. To prevent application miscalculations, make field checks to be sure you are applying fertilizer at the desired rate.

# MACHINE OPERATION

## LIQUID FERTILIZER PISTON PUMP APPLICATION RATES

### GALLONS PER ACRE

Pump Setting	1	2	3	4	5	6	7	8	9	10
8 Row 36	7.7	15.3	22.9	30.6	38.2	45.9	53.5	61.2	68.8	76.5
8 Row 38	7.2	14.5	21.7	29.0	36.2	43.5	50.7	58.0	65.2	72.4
12 Row 30	6.1	12.2	18.4	24.5	30.6	36.7	42.8	48.9	55.1	61.2
12 Row 36	5.1	10.2	15.3	20.4	25.5	30.6	35.7	40.8	45.9	51.0
12 Row 38	4.8	9.7	14.5	19.3	24.2	29.0	33.8	38.6	43.5	48.3
16 Row 30	4.6	9.2	13.8	18.4	22.9	27.5	32.1	36.7	41.3	45.9

Above chart for planters equipped with contact drive and 50 tooth drive sprocket and 23 tooth driven sprocket. See "Tire Pressure" for recommended tire pressures. Chart is based on average wheel slippage and liquid viscosities.

Measure and weigh one gallon of actual fertilizer solution to determine exact application rate. This chart was calculated based on a solution weighing ten pounds per gallon.

**IMPORTANT:** Fertilizer application rates can vary from the above chart. To prevent application miscalculations, make field checks to be sure you are applying fertilizer to all rows at the desired rate.

**NOTE:** Flow to all rows should be checked periodically. If one or more lines are plugged, the desired rate will be delivered to the remaining rows keeping total application rate at desired rate.



# ROW UNIT OPERATION

## PLANTING DEPTH

Planting depth is maintained by the row unit gauge wheels. To increase or decrease the planting depth, first raise the planter to remove weight from the wheels. Then lift the depth adjustment handle and reposition it forward to decrease depth or rearward to increase planting depth. Adjust all units to the same depth initially. Then lower the planter and check operation and planting depth of all row units. It may be necessary to readjust some rows to obtain uniform operation.

**! WARNING:** Never work under the planter while in raised position without using safety lock-ups.

72359-108

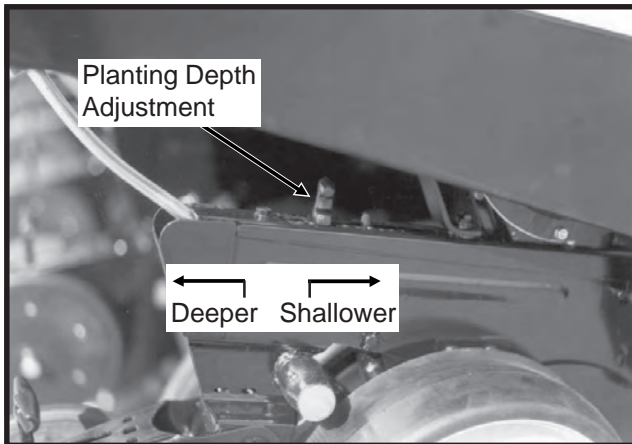

## "V" CLOSING WHEEL ADJUSTMENT (Rubber And Cast Iron)

**! WARNING:** Raise planter and install safety lockups before making closing wheel adjustments.

After adjusting planting depth, check the operation of the "V" closing wheels. The "V" closing wheels should have enough down pressure to close the seed trench and ensure good soil to seed contact. To increase spring pressure on the closing wheels, move the 5-position quick adjustable down force lever located at the rear of the closing wheel arm to the rear. Moving the lever forward decreases spring tension.

Adjust all row units to a similar setting.

72359-131

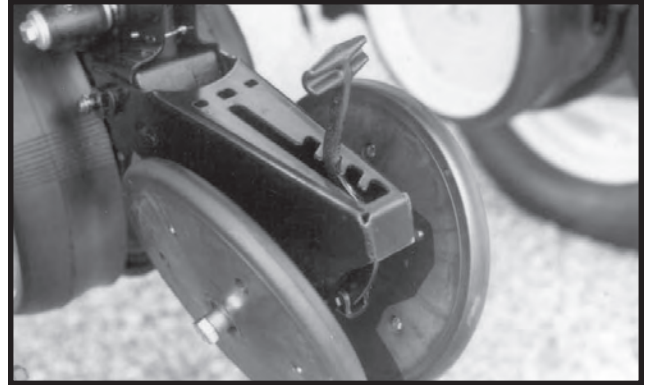

Light soil usually requires less down force at average depth (approximately 2") while heavy soil requires increased down force.

Eccentric bushings in the wheel arm stop allow for lateral adjustment of the "V" closing wheel assembly. Loosen the 3/4" hardware which attaches the closing wheel arm to the wheel arm stop. Using another 3/4" wrench turn the eccentric bushings until the closing wheels are aligned with the row unit. Tighten 3/4" hardware.

72359-129

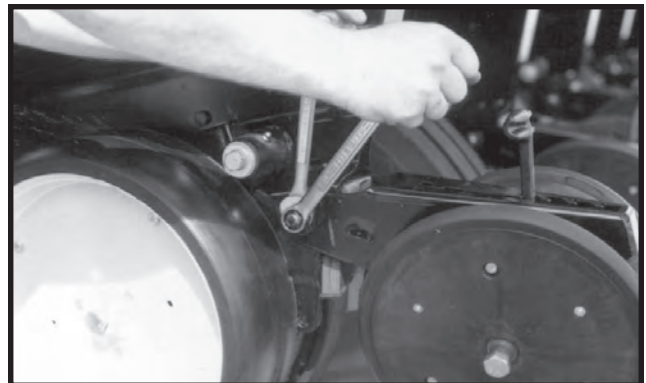

Spacers used for installation of the closing wheels can be moved from side to side for closing wheel spacing adjustment and the closing wheels can be installed in two locations either "offset" (to improve residue flow) or "directly" opposite.

72369-15



# ROW UNIT OPERATION

## COVERING DISCS/SINGLE PRESS WHEEL ADJUSTMENT

**⚠ WARNING:** Raise planter and install safety lockups before making covering discs/single press wheel adjustments.

72359-31

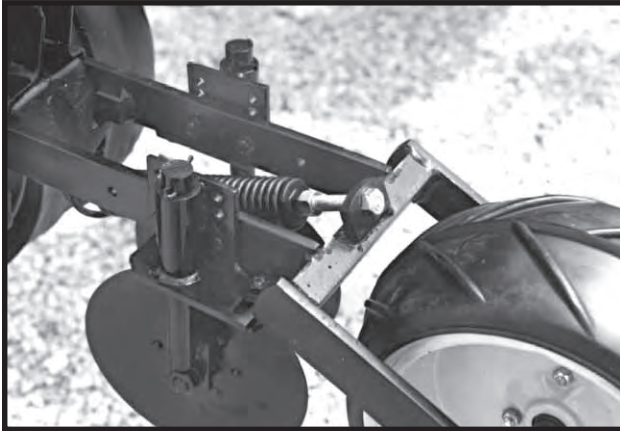

After adjusting planting depth, check the operation of the covering discs/single press wheels.

Initial press wheel down force setting should be with 2 1/2" between mounting arm tab and locking nut. To adjust down force spring, loosen 1/2" locking nut and turn adjusting bolt in to increase down force and out to decrease down force. Tighten locking nut against spring plug. Adjust all row units to a similar setting.

RH993

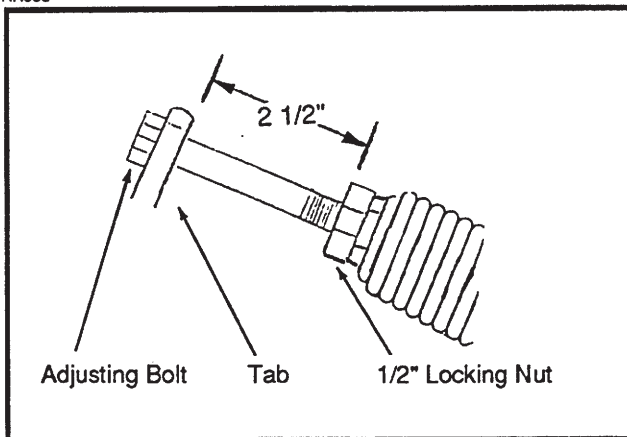

Eccentric bushings in the wheel arm stop allow for lateral adjustment of the covering discs/single press wheel assembly. Loosen the 3/4" hardware which attaches the assembly to the wheel arm stop. Using another 3/4" wrench, turn the eccentric bushings until the press wheel is aligned with the row unit.

72369-9

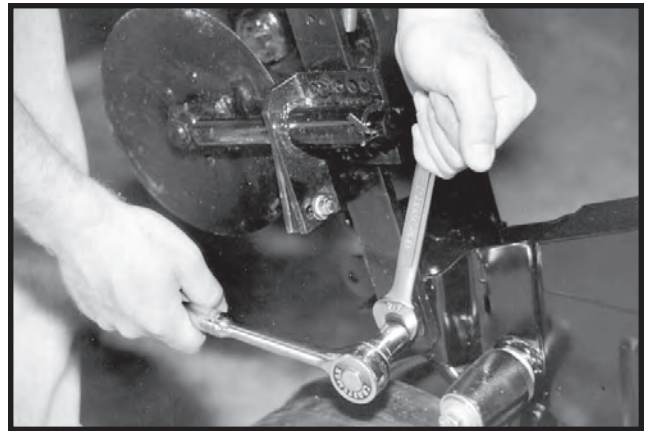

Two sets of holes in the mounting arm allow the covering discs to be located for staggered or side by side operation as desired.

72359-35

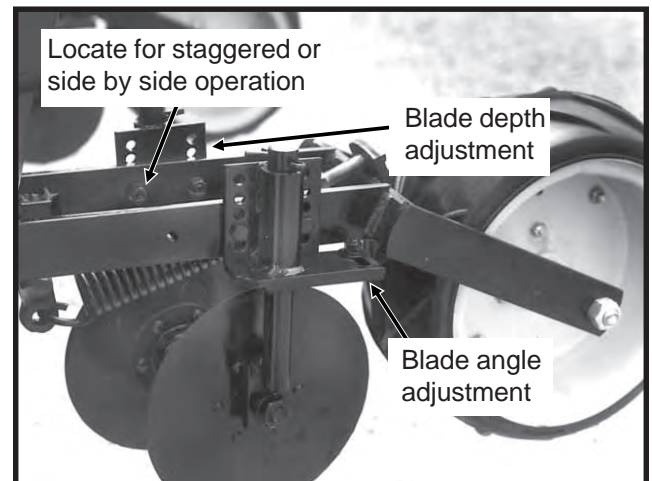

Five sets of holes in each disc bracket allow for 1/2" incremental blade depth adjustment.

Slotted holes in the disc mount and bracket allow for 0° - 15° blade angle adjustment.

Adjust covering discs on all row units to similar settings.

# ROW UNIT OPERATION

## SEED METER DRIVE RELEASE

The seed meter drive is equipped with a clutch release mechanism that allows the drive to be disconnected from the seed metering unit. Disconnecting the drive allows the operator to check granular chemical application rates without dropping seed. It also allows one or more of the rows to be disconnected when finishing fields.

72359-164

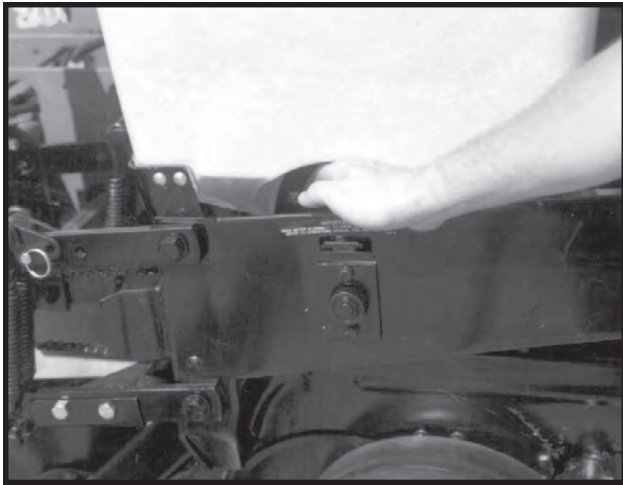

To disengage the drive, lift the release handle and pull outward until the handle locks in the slot in the side of the hopper side panel. To engage the row unit, lift and unlatch the handle. Spring tension will return the mechanism to the drive position.

Erratic seed spacing may result from misalignment between the drive coupler and seed meter input shaft. Misalignment may cause momentary stoppage of brush-type meter seed disc. Check alignment after initial installation. If adjustment is required, refer to "Meter Drive Adjustment" for correct procedure.

## FINGER PICKUP CORN METER

Refer to the planting rate charts for recommended seed drive transmission sprocket combinations.

60620-14

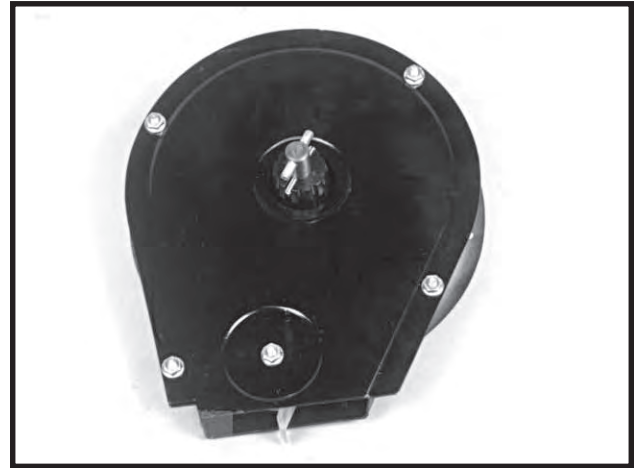

**IMPORTANT:** To provide efficient operation of the finger pickup corn meters and extend the life of components, sprinkle a teaspoon of powdered graphite over the top of the seed twice daily. The graphite will filter down into the seed pickup mechanism and provide lubrication.

53761-1



See "Finger Pickup Corn Meter Troubleshooting" and "Finger Pickup Corn Meter Inspection/Adjustment" for additional information.

# ROW UNIT OPERATION

## BRUSH-TYPE SEED METER

60607-40

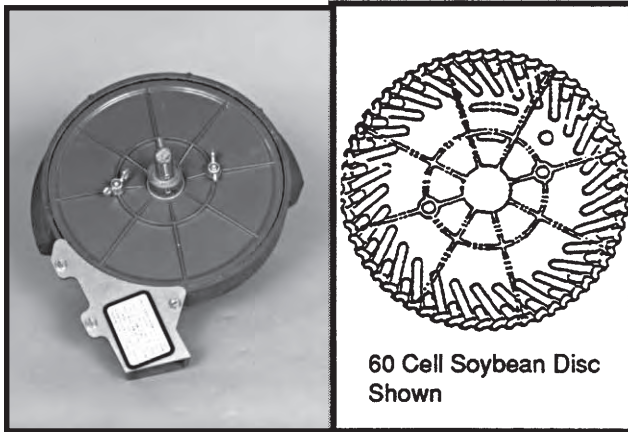

60 Cell Soybean Disc Shown

The following seed discs are available for use with the brush-type seed meter:

**Soybean:** 60 cells to meter seed sizes from 2200 to 4000 seeds per pound (Black color-coded).

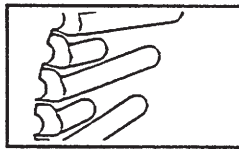

**Specialty soybean:** 48 cells to meter seed sizes from 1400 to 2200 seeds per pound (Dark blue color-coded).

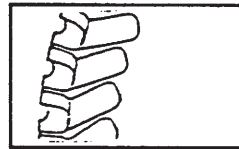

**Small milo/grain sorghum:** 30 cells to meter seed sizes from 14,000 to 20,000 seeds per pound (Red color-coded).

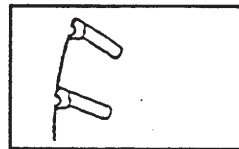

**Large milo/grain sorghum:** 30 cells to meter seed sizes from 10,000 to 16,000 seeds per pound (Light blue color-coded).

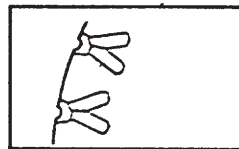

**High rate small milo/grain sorghum:** 60 cells to meter seed sizes from 12,000 to 18,000 seeds per pound (Red color-coded).

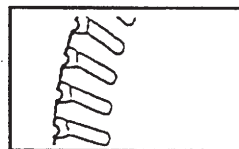

**High rate large milo/grain sorghum:** 60 cells to meter seed sizes from 10,000 to 14,000 seeds per pound (Yellow color-coded).

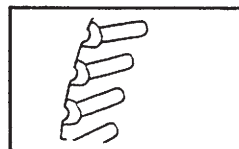

**Cotton, acid-delinted:** 30 cells to meter seed sizes from 4200 to 5200 seeds per pound (White color-coded).

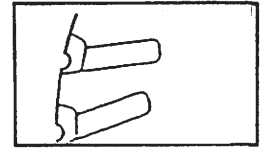

**Large cotton, acid-delinted:** 36 cells to meter seed sizes 3800 to 4400 seeds per pound (Tan color-coded).

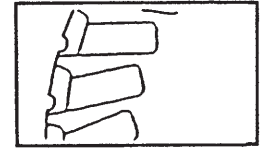

**High rate cotton, acid-delinted:** 48 cells to meter seed sizes 4200 to 5200 seeds per pound (Light green color-coded).

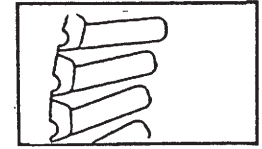

**Hill-drop cotton, acid-delinted:** 12 cells, 3 to 6 seeds/cell, to meter seed sizes from 4000 to 5200 seeds per pound (Brown color-coded).

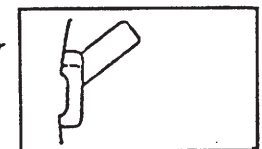

When installing the seed disc onto the meter hub, turn the disc counterclockwise while tightening the two wing nuts that retain the disc. The seed disc should have only slight resistance when rotated counterclockwise after wing nuts are tight.

The brush-type seed meter attaches to the seed hopper in the same manner as the finger pickup corn meter. Secure to bottom of seed hopper with two 5/16" flanged hex nuts. DO NOT OVER TIGHTEN.

Erratic seed spacing may result from misalignment between the drive coupler and seed meter input shaft. Misalignment may cause momentary stoppage of seed disc. Check alignment after initial installation. If adjustment is required, refer to "Meter Drive Adjustment" for correct procedure.

Refer to the planting rate charts in this manual for recommended seed drive transmission sprocket combinations.

**IMPORTANT:** Use powdered graphite or talc with each hopper fill of seed. Additional graphite or talc may be required to retard buildup of seed treatments on meter components. Frequency of monitor seed tube cleaning may be affected due to use of additional graphite or talc.



# ROW UNIT OPERATION

53761-1



One tablespoon of **powdered graphite** per hopper fill of seed should be added to the seed each time the hopper is filled. This prolongs the life of the seed meter components, reduces buildup of seed treatment on components in the meter and improves seed spacing.

**Talc seed lubricant** may be used in lieu of graphite to reduce seed treatment buildup on seed disc and meter components and will improve meter performance. Coat seed disc and brushes with talc before installing meter. Fill hopper 1/2 full of seed, add 1/4 cup of talc and mix thoroughly. Finish filling hopper, add another 1/4 cup of talc and mix thoroughly. Adjust rate of talc use as needed so all seeds are coated, while avoiding a buildup of talc in the bottom of the hopper. Humid conditions and/or small sized seeds with extra seed treatment may require as much as one cup of talc per hopper to prevent seed treatment buildup on seed disc and/or brushes.

**CAUTION:** Some liquid seed treatments or inoculants may create buildup on the seed disc or brushes. Check frequently for proper population and/or seed delivery when using any liquid seed treatment. All seed treatment should be thoroughly mixed with the seed per the manufacturers' recommendations. Seed treatment dumped on top of the seed after the hopper is filled, and not mixed properly will cause bridging of the seed in the meter, reducing population or stopping the meter from planting. Additional graphite or talc may be required to retard buildup of seed treatments on meter components.

**IMPORTANT:** Foreign material, such as hulls, stems, etc., may affect seed delivery. Clean seed is required to ensure accurate seed metering from the brush-type seed meter. Seed discs should be removed daily to check for buildup of foreign material, such as hulls, in the seed meter or the brushes.

## SEED HOPPER

60620-69



The seed hopper has a capacity of 1.6 bushels.

When filling the seed hopper use clean seed and make certain there are no foreign objects in the hopper. **Replace hopper lids after hoppers are filled to prevent the accumulation of dust or dirt in the seed meter which will cause premature wear.** See "Finger Pickup Corn Meter Lubrication" and/or "Brush-Type Seed Meter Lubrication".

Periodically empty the hoppers completely to remove any foreign objects and ensure proper seed meter operation. To empty hopper, disengage drive release and hopper latch and lift hopper off the hopper support. See "Meter Drive Release".

# ROW UNIT OPERATION

## GRANULAR CHEMICAL HOPPER

61766-2

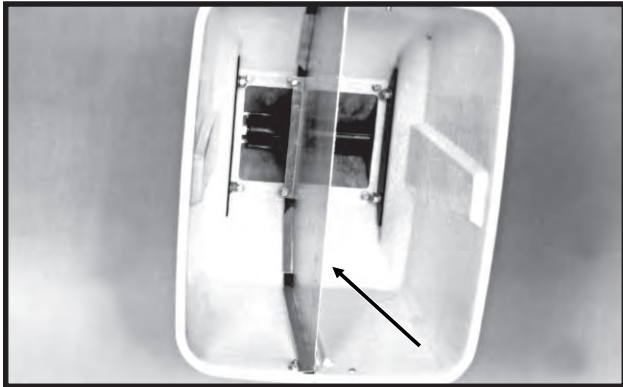

The granular chemical hopper has a 70 pound capacity. With the use of a hopper divider the hopper has two compartments with a 35 pound capacity in each.

Be sure no foreign objects get into the hopper when it is being filled. Replace the hopper lids after filling the hoppers to prevent the accumulation of dirt and moisture.

The metering gate located on the bottom of the hopper regulates the application rate. See "Dry Insecticide and Dry Herbicide Application Rate Charts" in this manual. Calibrate using the chemical manufacturers' instructions.

**! DANGER: Agricultural chemicals can be dangerous. Improper selection or use can seriously injure persons, animals, plants, soil or other property. BE SAFE: Select the right chemical for the job. Handle it with care. Follow the instructions on the container label.**

The granular chemical clutch drive coupler and meter shaft can be disengaged and engaged by turning the throwout knob located at the rear of the hopper support panel. To engage the drive, turn the knob 1/4 turn clockwise. To disengage the drive, turn the knob 1/4 turn counterclockwise. Slotted holes in the hopper support panel and clutch housing allow for alignment adjustment between the clutch drive coupler and meter shaft.

72359-182

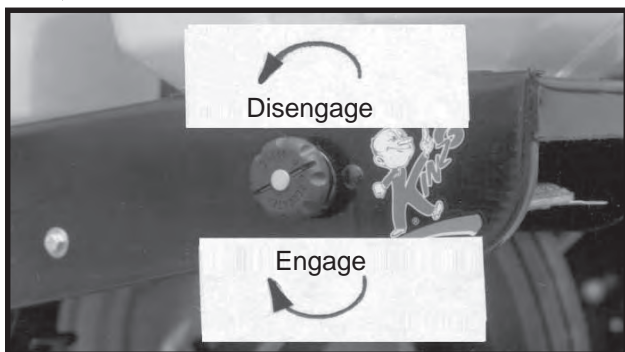

## SEED METER DRIVE ADJUSTMENT

**IMPORTANT: The seed meter drive coupler must be properly aligned with the meter input shaft.**

Improper alignment between the drive coupler and input shaft of the meter can cause the meter housing to flex as the meter rotates. This continual flexing of the meter housing can cause damage to the housing. Any time the hopper support panel is removed or replaced vertical and horizontal alignment should be checked.

61658-27

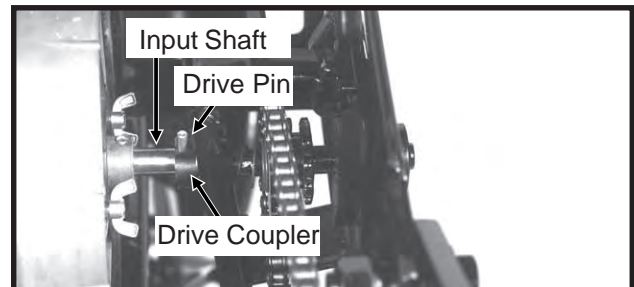

**To check alignment:**

- Inspect meter input shaft to make sure drive pin is centered.
- Install hopper with meter onto support panel. Latch hopper.
- Rotate meter input shaft so drive pin is vertical.
- Rotate drive clutch so slots in coupler are vertical.
- Engage clutch.
- Clutch coupler should engage meter shaft freely with equal amount of pin extending beyond each side of drive coupler.
- Disengage clutch.
- Rotate both meter shaft and drive clutch to the horizontal position.
- Re-engage clutch.
- Clutch coupler should engage meter shaft freely with equal amount of pin extending beyond each side of drive coupler.

**To adjust drive clutch:**

- Slightly loosen both 5/16" cap screws.
- Move clutch assembly to correct any misalignment.
- Tighten both 5/16" cap screws.

72794-24

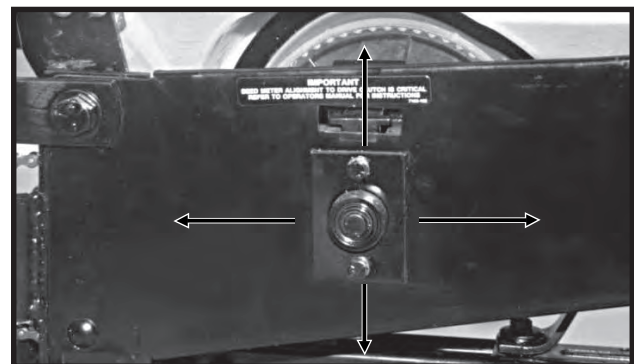

# ROW UNIT OPERATION

## ROW UNIT CHAIN ROUTING

For proper operation and to minimize wear, the row unit drive chains must be properly tensioned and aligned.

Inspect and replace weak, worn or broken springs and/or idlers and idler bushings.

72359-124

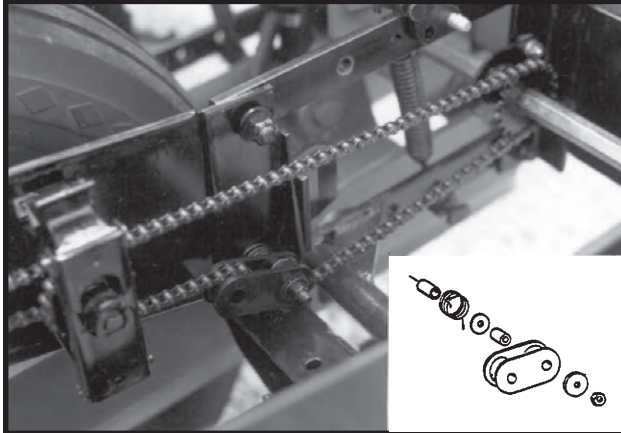

**Row Unit Meter Drive**

72359-97

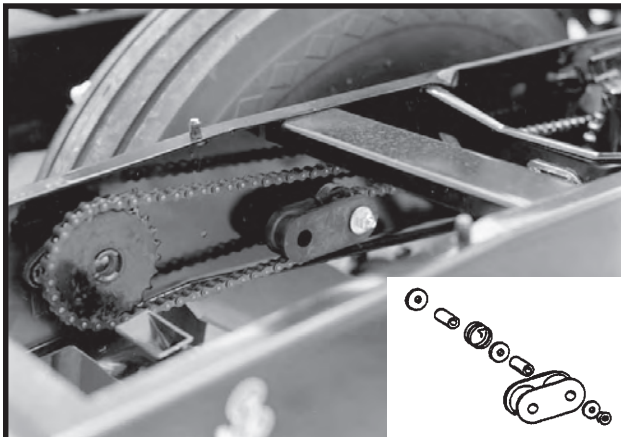

**Row Unit Granular Chemical Drive**

8/30/93-9

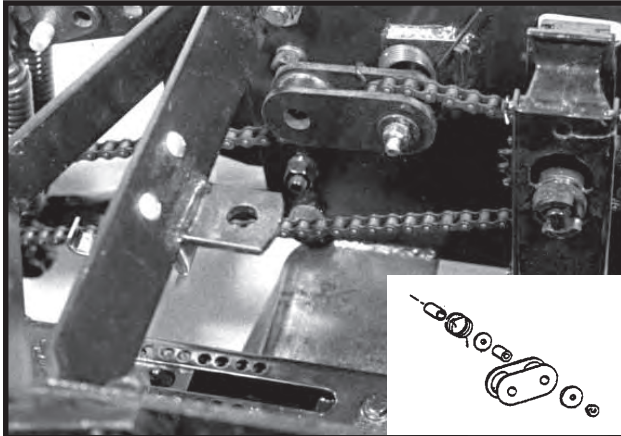

**Interplant Push Row Unit Meter Drive**

## QUICK ADJUSTABLE DOWN FORCE SPRINGS

Quick adjustable down force springs are designed to increase penetration in hard soil and keep the row unit from bouncing in rough field conditions.

Two springs per row, one on the L.H. parallel arms and one on the R.H. parallel arms, are used unless equipped with row unit mounted no till coulters. Four springs per row are used with row unit mounted no till coulters. Two springs per row are used with frame mounted coulters, row unit mounted and frame mounted disc furrowers and row unit mounted bed levelers.

61703-4

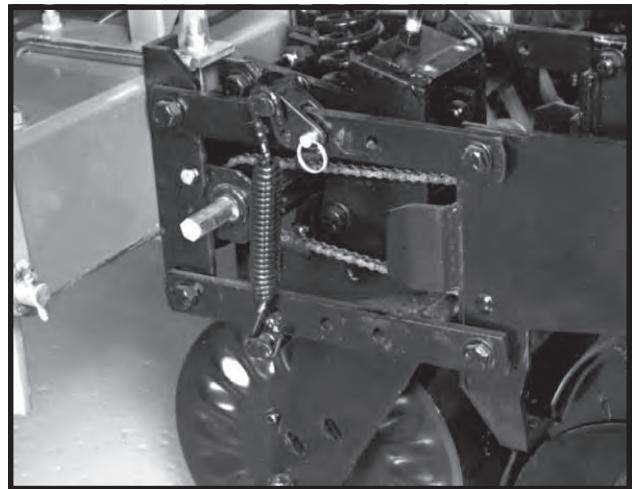

**Two Springs Per Row (Dual)**

72359-4

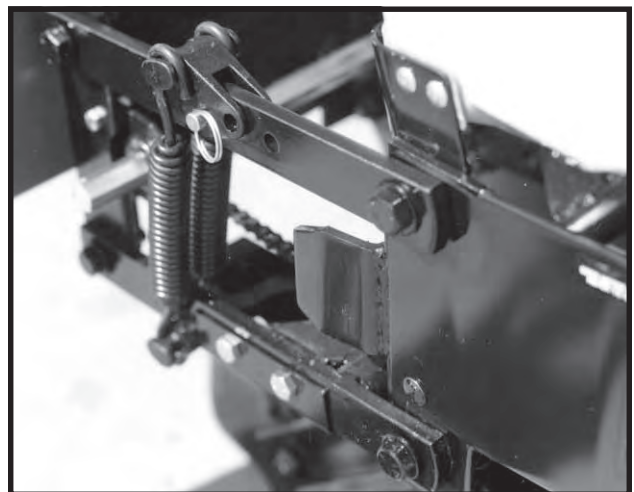

**Four Springs Per Row (Quad)  
(Used only in conjunction with row unit mounted no till coulters)**

# ROW UNIT OPERATION

There are four positions for spring tension adjustment. Position one allows for minimum down pressure and position four for maximum down pressure.

L0096

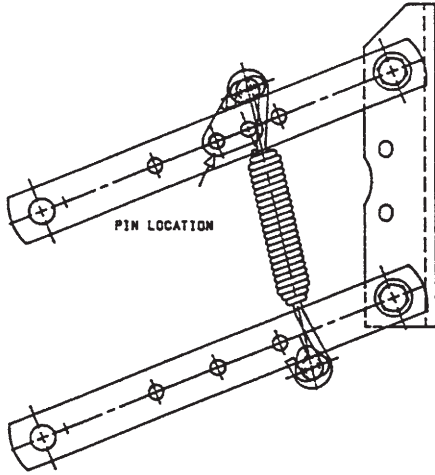

Position 1 (Minimum)

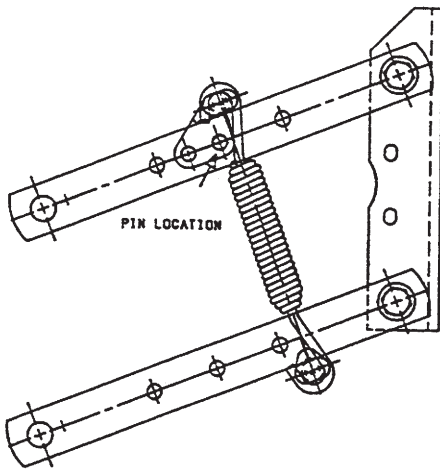

Position 2

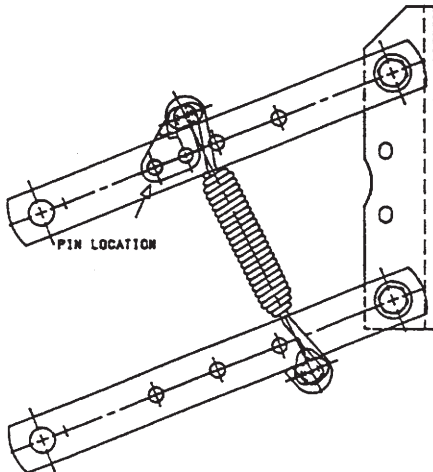

Position 3

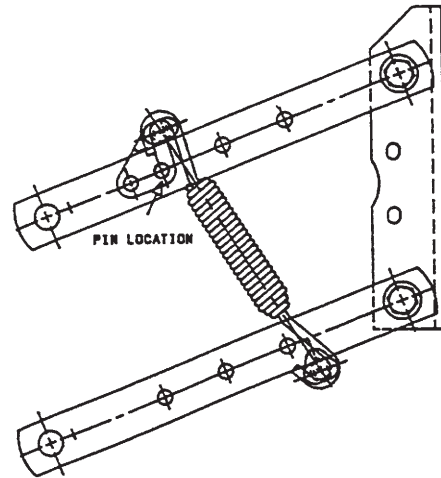

Position 4 (Maximum)

To adjust spring tension, raise planter and remove spring mount pin at top of spring. Slide mount to desired position and install pin.

**NOTE:** It is necessary for the operator to adjust springs according to field conditions. If springs are adjusted for too much down pressure for field conditions, it is possible for the row units to lift the planter to the extent that the drive wheels do not make sufficient contact. Too much down pressure in soft field conditions can cause the row unit to run too deep.

**⚠ DANGER:** Always install safety lockups or lower machine to the ground before working under or around the machine.

**NOTE:** Springs must always be installed with open side of spring hooks toward seed hopper to prevent binding on spring mount adjustment pin.

# ROW UNIT OPERATION

## FRAME MOUNTED COULTER

Frame mounted coulters with 1" bubbled, 1" fluted (8 flutes) or 3/4" fluted (13 flutes) blades may be used on KINZE plateless row units only. (Not compatible with interplant push row units.)

The frame mounted coulters is designed to allow required spring down pressure on the coulters for maximum penetration while exerting less shock load on the row unit.

The frame mounted coulters can be used with or without the depth control bar installed. In most applications, especially in rocky planting conditions, the depth control bar **should not be used**. Use of the depth control bar transfers down force from the coulters to the row unit making less down force available to the coulters blade.

56314-14

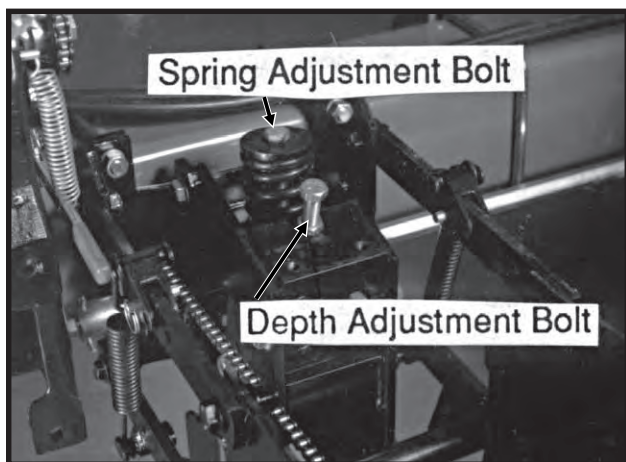

### DEPTH ADJUSTMENT (Without Depth Control Bar Installed)

When the depth control bar is not used, operating depth of the coulters blade is determined by adjusting the depth adjustment bolt and positioning of the blade assembly in the fork mount. The depth adjustment bolt will stop downward travel of the coulters arm assembly. One turn of the adjusting bolt will change depth setting approximately 1/4". Initial setting of the depth adjustment bolt should be with approximately 1 3/8" of thread showing. With this setting and the bar height at 21", the coulters depth will be approximately 2" with coulters mounting spindle in top hole. Turn the adjustment bolt clockwise to decrease operating depth. Turn the depth adjustment bolt counterclockwise to increase operating depth.

56314-16

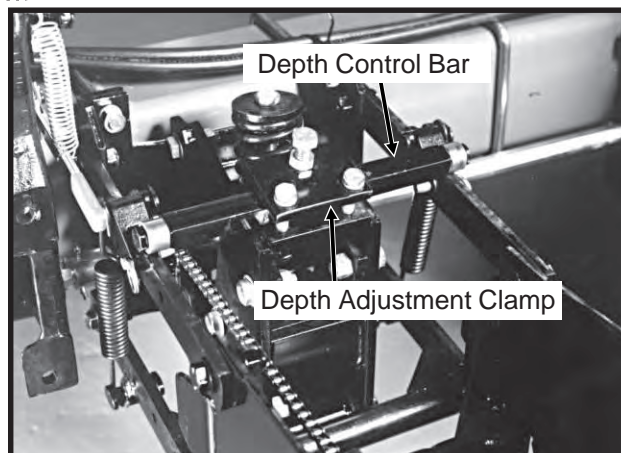

In certain applications it is desirable to use the depth control bar. In uneven terrain, use of the depth control bar allows greater depth control. The up and down movement of the row unit allows the coulters to move up and down at a rate of approximately 1/2 that of the row unit, maintaining a more uniform operating depth. When using the disc furrower attachment, the depth control bar should always be used as operating depth of the coulters is critical for the disc furrowers to operate with minimal gouging.

### DEPTH ADJUSTMENT (With Depth Control Bar Installed)

When using the depth control bar, down force springs must be located in the forward position and the depth adjustment bolt used only to attach the depth adjustment clamp to the coulters assembly. Operating depth of the coulters blade is adjusted by positioning the blade assembly in the fork mount. Four blade mounting adjustment positions are available at 1/2" increments. Initial position of the blade assembly should be the top hole. This position will locate the coulters blade approximately 1/4" shallower than the row unit opener blade. In heavy residue it may be desirable to position the blade assembly in the second position to insure that the residue is cut and not forced down into the seed zone. Additional holes are used to compensate for coulters blade wear.

56314-1

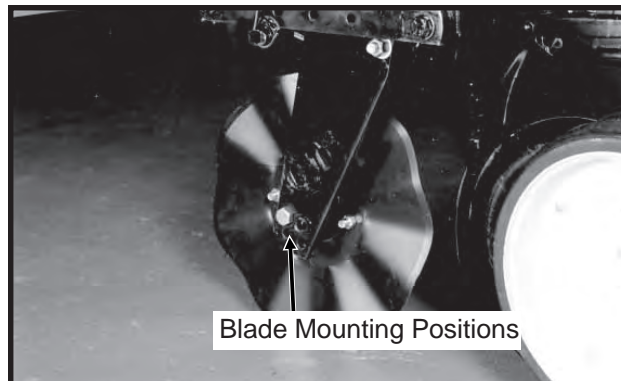

# ROW UNIT OPERATION

Down force adjustment is made by tightening or loosening the spring adjustment bolt. With the planter in the raised position, turn the bolt clockwise to increase down force or counterclockwise to decrease down force. Set all rows equally.

Compressed Spring Length (Including Washer)	Pounds Down Pressure With Blade 1/2" Above Maximum Down Position	Pounds Down Pressure With Blade 4" Above Maximum Down Position
13 5/16"	90	230
12 5/16"	190	330
Suggested initial setting		
11 5/16"	300	430

A5649rev.

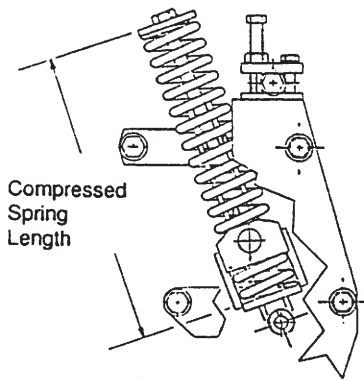

**NOTE: Excessive down force may cause increased wear on components.**

The coultter blade can be aligned with the row unit disc opener by moving the spacer washers from one side of the coultter blade hub to the other.

56314-12

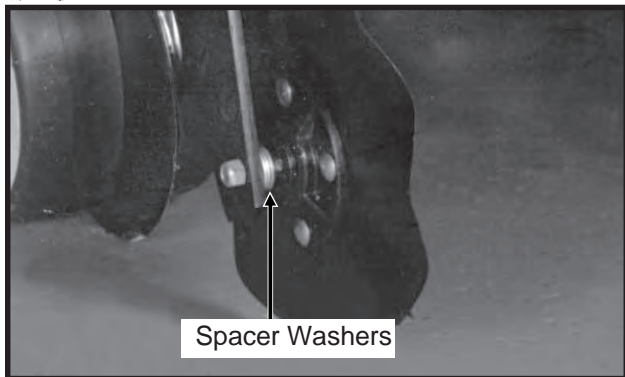

Field adjustment should be made as needed. Operating height of the planter frame will affect operating depth of the frame mounted coultter.

## DISC FURROWERS

(For use with Frame Mounted Coultter)

Disc furrowers for use with the frame mounted coultter may be equipped with either 12" solid blades or 12" notched blades.

Disc furrowers are used to clear crop residue, dirt clods and dry soil from in front of the row units for a clean and smooth seed bed. Notched blades are used for heavier trash conditions. The notched blades cut crop residue and move it aside to prevent plugging or pushing the soil.

56314-19



Discs can be adjusted so front edges meet by adding spacer washers between the disc furrower arm and frame mounted coultter fork mount.

Slotted holes in the frame mounted coultter fork mount and in the disc furrower arm allow for vertical and horizontal adjustment. Discs can be adjusted so the front edges meet or one disc can be moved to the rear and the other to the front of the slot so cutting edge of one disc overlaps the edge of the other disc.

56314-17

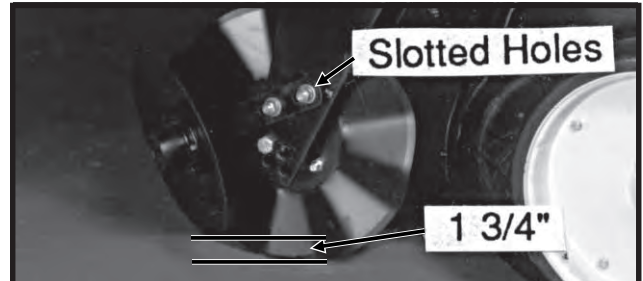

Initial setting for the disc furrowers is 1 3/4" shallower than the coultter blade. Further adjustment may be desired for various applications.

**NOTE: The depth control bar should always be used when the frame mounted coultter is equipped with disc furrowers.**

64730-10



**NOTE: A cylinder stop (See Parts Section) MUST BE used on each wing lock cylinder on all 30" row machines equipped with frame mounted coultters with disc furrowers to limit downward flex of the wing approximately 4% during field operation. (Does not affect upward flex.)**

# ROW UNIT OPERATION

## ROW UNIT MOUNTED DISC FURROWER

The row unit mounted disc furrower for use on KINZE plateless row units only (Not compatible with interplant push row units.) may be equipped with either 12" solid blades or 12" notched blades.

Disc furrowers are used to clear crop residue, dirt clods and dry soil from in front of the row units for a clean and smooth seed bed. Notched blades are used for heavier trash conditions. The notched blades cut crop residue and move it aside to prevent plugging or pushing the soil.

59386-23

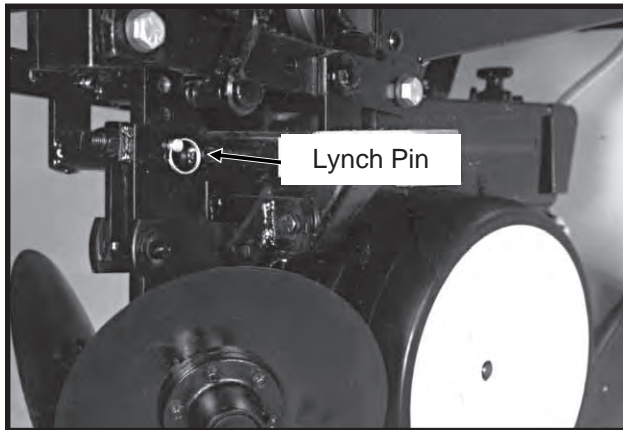

59386-20

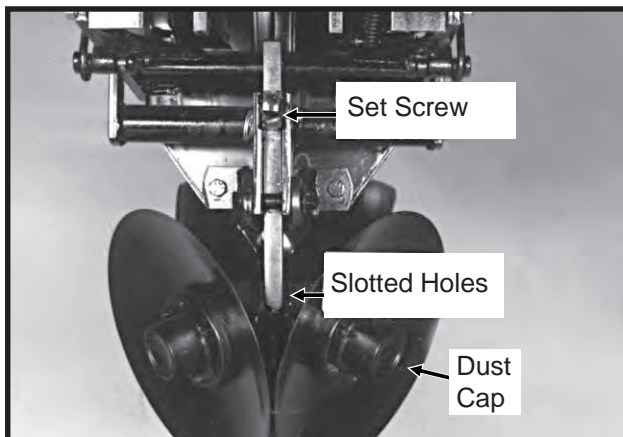

Vertical adjustment in 1/3" increments is possible by removing the lynch pin which secures the vertical support arm and moving the support arm up or down as required. Re-install lynch pin. Finer adjustment can be attained by removing the lynch pin and using the 5/8" x 2 1/4" set screw to clamp the support arm in the required position.

Slotted holes in the support arm where the discs are mounted allow fore and aft adjustment of the discs. Discs can be adjusted so the front edges meet or one disc can be moved to the rear and the other to the front of the slot so cutting edge of one disc overlaps the edge of the other disc. The dust cap must be removed to make these adjustments.

## ROW UNIT MOUNTED BED LEVELER

59386-26

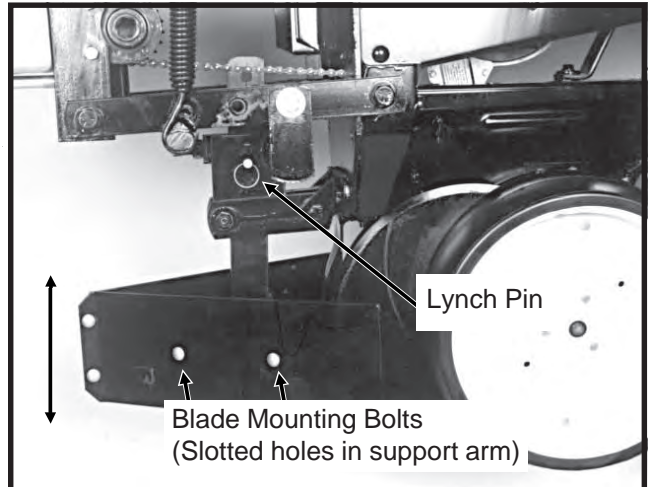

59386-30

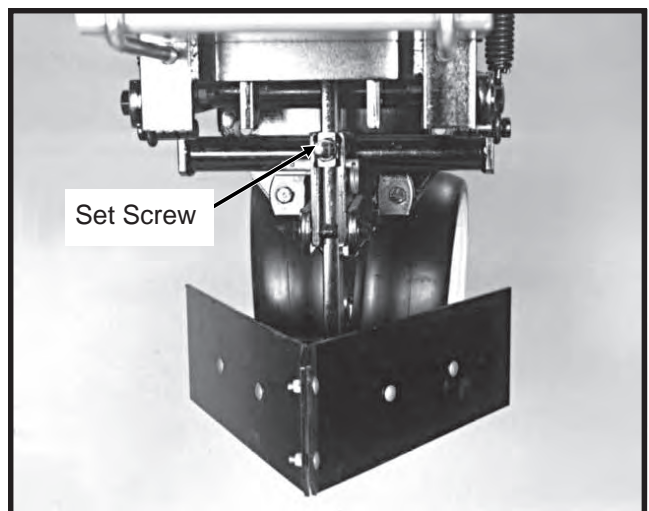

Row unit mounted bed levelers may be used on KINZE plateless row units only. They are not compatible with interplant push row units.

Vertical adjustment in 1/3" increments is possible by removing the lynch pin which secures the vertical support arm and moving the support arm up or down as required. Re-install lynch pin. Finer adjustment can be attained by removing the lynch pin and using the 5/8" x 2 1/4" set screw to clamp the support arm in the required position.

Slotted holes in the support arm where the blades are mounted allow tilting of the blades. The blades can be tilted up or down at the front for desired adjustment.

**NOTE: The row unit mounted bed leveler is not compatible with row spacings less than 36".**

# ROW UNIT OPERATION

## ROW UNIT MOUNTED RESIDUE WHEEL

The row unit mounted residue wheel may be used on KINZE plateless row units and interplant push row units.

Two adjustable springs on the parallel links on each residue wheel allow for down force adjustment. Position one as shown below provides minimum down pressure and position three maximum down pressure.

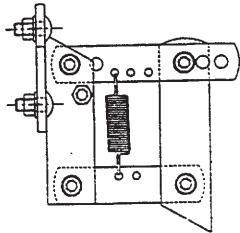

Position 1 (Minimum)

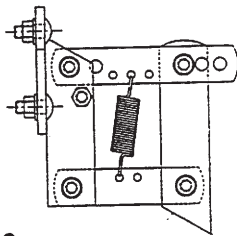

Position 2

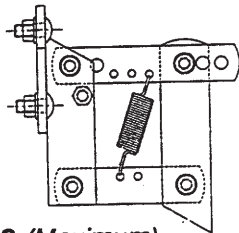

Position 3 (Maximum)

For additional uplift or float, position springs as shown below.

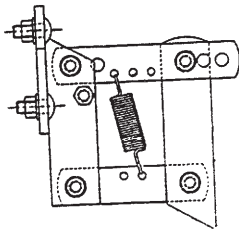

To adjust down force springs, raise the row unit out of the ground and reposition springs as shown for the desired down pressure.

Three holes in the upper link allow for wheel angle adjustment. With the wheel mount in the most vertical position, using the rear hole in the upper link, the residue wheel is most aggressive. Moving the wheel mount to one of the forward holes reduces the aggressiveness of the wheel for use in minimum till applications where the soil is loose.

72794-29

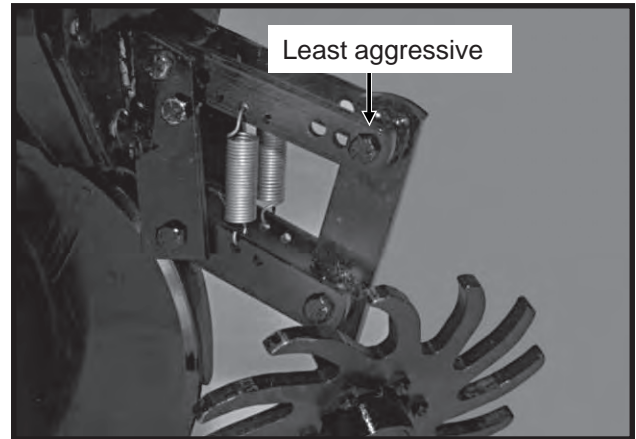

To lock the residue wheel up out of the ground, remove the 1/2" x 5" lockup bolt, raise the residue wheel and install bolt.

72794-31

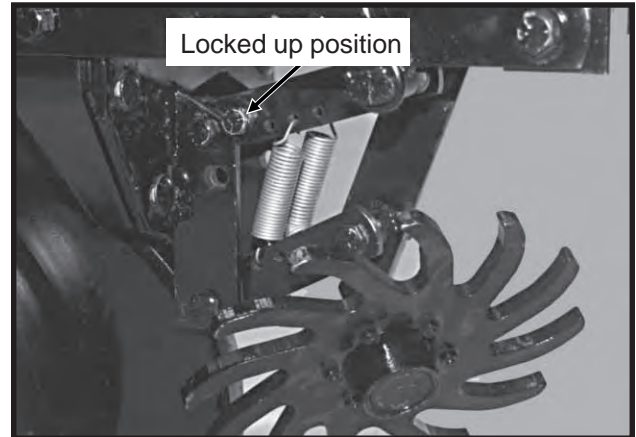



# ROW UNIT OPERATION

## ROW UNIT MOUNTED NO TILL COULTER

60569-42



Row unit mounted no till coulters with 1" bubbled, 1" fluted (8 flutes) or 3/4" fluted (13 flutes) blades may be used on plateless row units and interplant push row units. (1" fluted shown)

Four quick adjustable down force springs are required per row when using row unit mounted no till coulters. See "Quick Adjustable Down Force Springs".

For proper operation the coulters blade should be aligned in relation to the row unit double disc openers. The coulters assembly can be adjusted by loosening the four attaching bolts, moving coulters arm to align and tightening the four attaching bolts.

The coulters blade can be adjusted to one of four 1/2" incremental settings in the forked arm. Using the top adjustment hole places the 16" diameter coulters blade approximately 1/4" shallower than the row unit disc opener. Using the second adjustment hole from the top places the coulters blade approximately 1/4" below the row unit disc opener. Using the third adjustment hole places the coulters blade approximately 3/4" below the row unit disc opener and using the bottom adjustment hole places the coulters blade approximately 1 1/4" below the row unit disc opener. Initially the blade should be set in the highest position. As the coulters blade wears or the disc opener blades wear or for various planting conditions the blade may be adjusted to one of the three lower settings.

It is most desirable to run the coulters blade 1/4" shallower than the row unit disc opener so it won't disturb the seed bed below the seed trench opened by the double disc opener.

In heavy residue it may be necessary to run the coulters blade deeper to insure cutting of residue and prevent pushing residue into the seed zone.

Operating depth can be checked by setting the planter down on a level concrete floor and checking the relationship between the coulters blade and row unit opener blade. Make sure the planter is level and coulters is square with the planter frame and aligned with the row unit disc opener.

## ROW UNIT CHAIN SHIELD

RUB015/RUB016

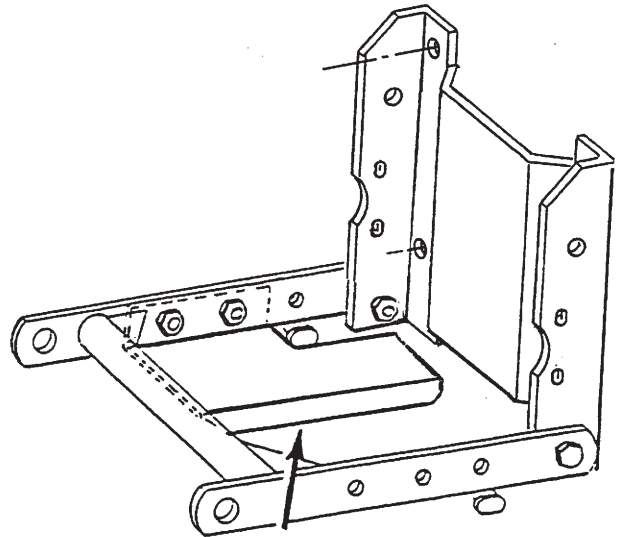

This row unit chain shield is designed for use on conventional row units when row unit mounted no till coulters are used. The shield **CANNOT BE USED** on interplant push units or row units equipped with frame mounted coulters, row unit mounted disc furrowers, row unit mounted residue wheels or row unit mounted bed levelers.

The shield protects the row unit drive chain from damage caused by residue in no till conditions.

# ROW UNIT OPERATION

## DUAL GAUGE WHEEL

72359-53

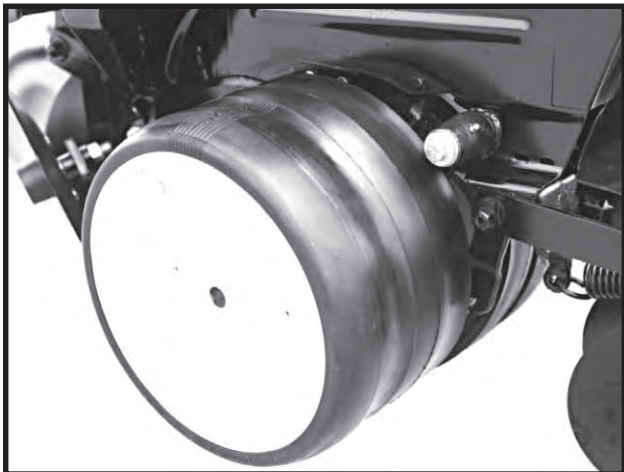

The dual gauge wheel is used to provide added width for additional row unit flotation in light sandy soil.

In some applications such as narrow row widths (less than 36") or where clearance is a problem, the added width of the dual gauge wheel may prevent its use.

## ROW UNIT GAUGE WHEEL COVER

73090-2

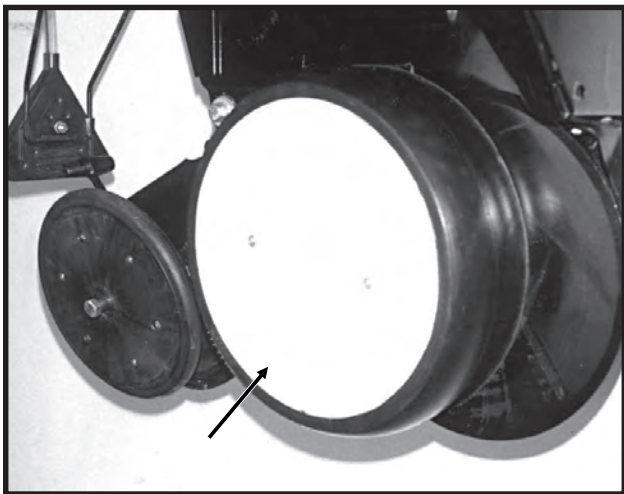

The row unit gauge wheel cover when installed on the gauge wheel next to the transport and/or drive wheel of the planter will aid in protecting the row unit from rock damage.

## GRANULAR CHEMICAL RESTRICTOR PLATE

65249-18



The granular chemical restrictor plate is designed for use in the granular chemical hopper when granular chemical application rates below 4 pounds are desired.

**IMPORTANT:** Check application rate of all rows in the field with the granular chemical you are using and at the speed and population at which you will be planting. See "Checking Granular Chemical Application Rate".

**!** **DANGER:** Agricultural chemicals can be dangerous. Improper selection or use can seriously injure persons, animals, plants, soil or other property. **BE SAFE:** Select the right chemical for the job. Handle it with care. Follow the instructions on the container label.

## SPRING TOOTH INCORPORATOR

The spring tooth incorporator smooths the soil behind the row unit and incorporates granular chemicals. The two mounting chains on each spring tooth incorporator should be adjusted so there is approximately 1/8" slack in the chain when the unit is lowered to planting position.

73090-4

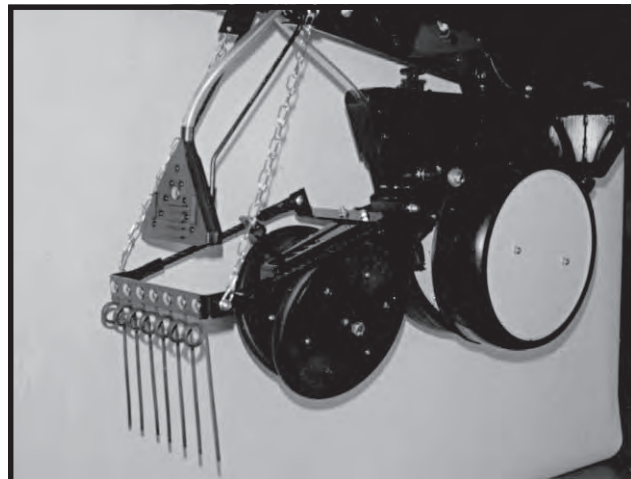

# ROW UNIT OPERATION

---

## PUSH UNIT LOCKUPS

Push unit lockups are designed to allow the push units to be locked in the raised position.

60569-6

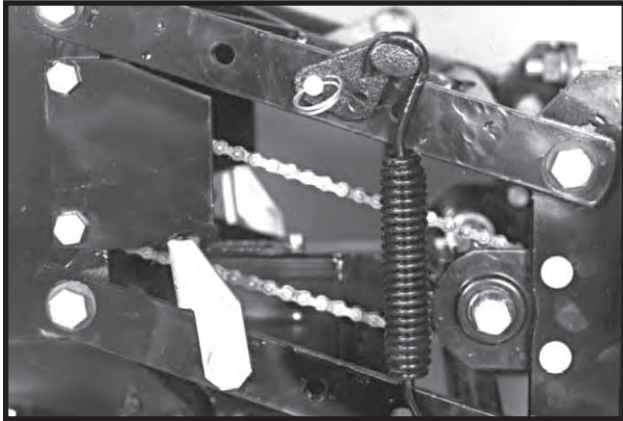

**Raised Position**

### To lock in raised position:

1. With the planter in the raised position, place a wooden (approximately 8") block under the disc opener assembly of each push unit. (Or use other means of raising each push unit.)
2. Lower the planter until the push unit is in the extreme raised position.
3. Rotate both right hand and left hand lockups into place under the push unit stops as shown in the "Raised Position" photo.
4. Raise planter.
5. Remove wooden blocks.

60569-9

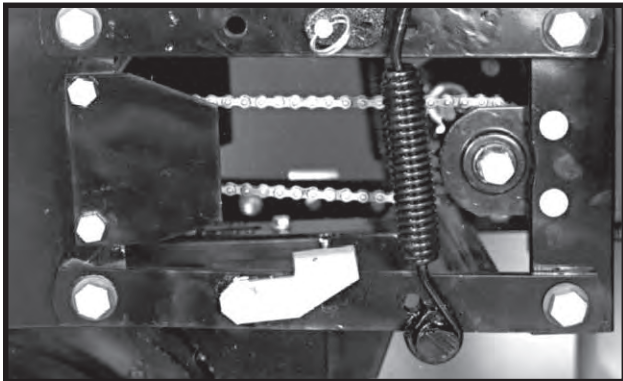

**Planting Position**

### To release lockups:

Reverse of above procedure. At Step 3, rotate lockups out from under the push unit stops as shown in "Planting Position" photo.

**!** **DANGER:** Always install all safety lockups or lower planter to the ground before working under or around the machine.

# ROW UNIT OPERATION

---

# LUBRICATION

The following pages show the locations of all lubrication points. Proper lubrication of all moving parts will help ensure efficient operation of your KINZE planter and prolong the life of friction producing parts.

**⚠ DANGER:** Always install safety lockups or lower to the ground before working under the machine.

## LUBRICATION SYMBOLS



Lubricate at frequency indicated with an SAE multipurpose type grease.



Lubricate at frequency indicated with a high quality SAE 10 weight oil or a quality spray lubricant.

## SEALED BEARINGS

72794-21

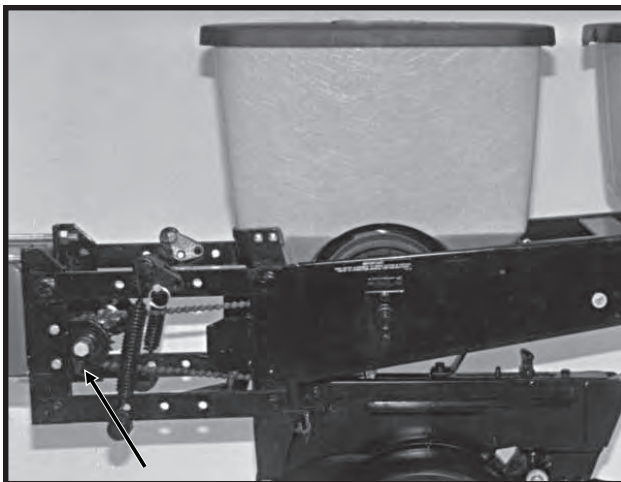

A number of sealed bearings are used on your KINZE planter to provide trouble free operation. These are located in such areas as the drive shaft, row units and transmission bearings. Sealed bearings are lubricated for life, and due to the seals, relubrication is not practical.

## DRIVE CHAINS

48618-1

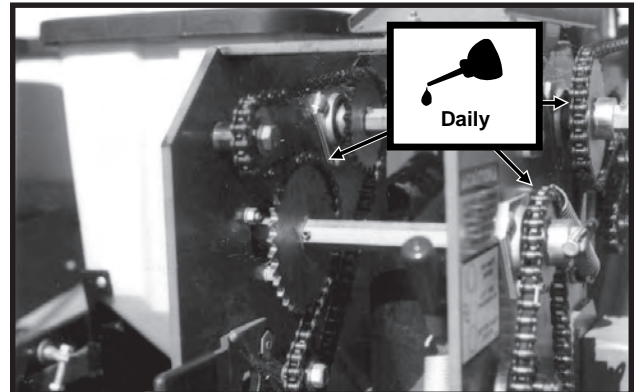

72359-123

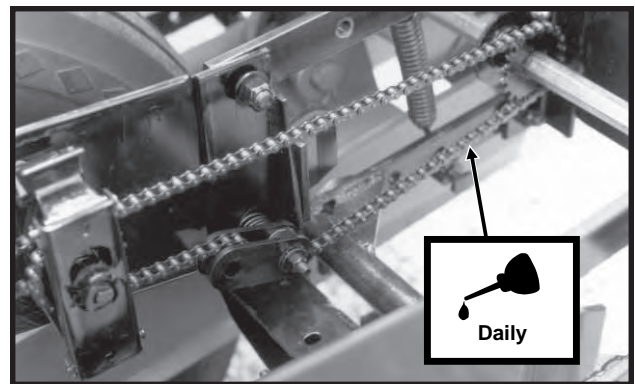

All transmission and drive chains should be lubricated daily with a high quality SAE 10 weight oil or a quality spray lubricant. Extreme operating conditions such as dirt, temperature or speed may require more frequent lubrication. If a chain becomes stiff, it should be removed, soaked and washed in solvent to loosen and remove dirt from the joints. Then soak the chain in oil so the lubricant can penetrate between the rollers and bushings.

## POINT ROW WRAP SPRING CLUTCHES

73142-26

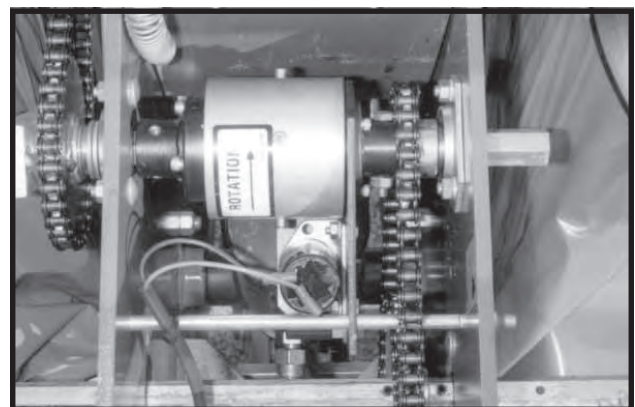

The point row wrap spring clutches are permanently lubricated and require no periodic maintenance. DO NOT LUBRICATE. KEEP CLUTCHES CLEAN.

# LUBRICATION

## BUSHINGS

Lubricate bushings at the frequency indicated.

Using a wrench, check each bolt for proper torque. If bolt is loose, it should be removed and the bushing inspected for cracks and wear. Replace bushing if necessary. **Only hardened flat washers should be used. Replace damaged flat washers with proper part. Torque bolts to 130 ft. lbs.**

59386-43

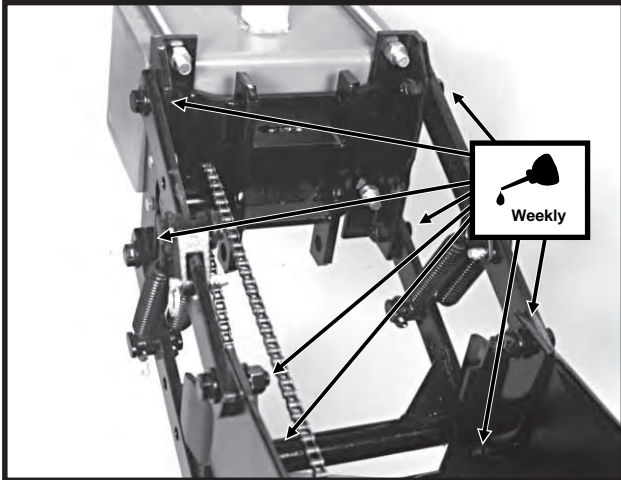

**Row Unit and/or Push Unit Parallel Linkage  
(8 per row)**

56314-8

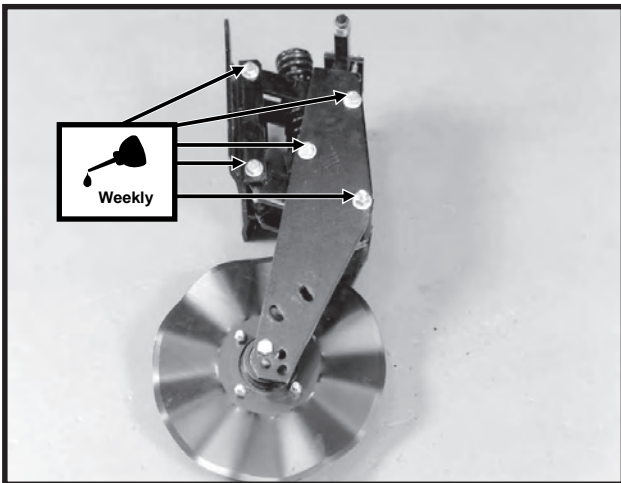

**Frame Mounted Coulters Parallel Linkage  
(10 per row)**

*Shown not installed on row unit for visual clarity.*

59386-18

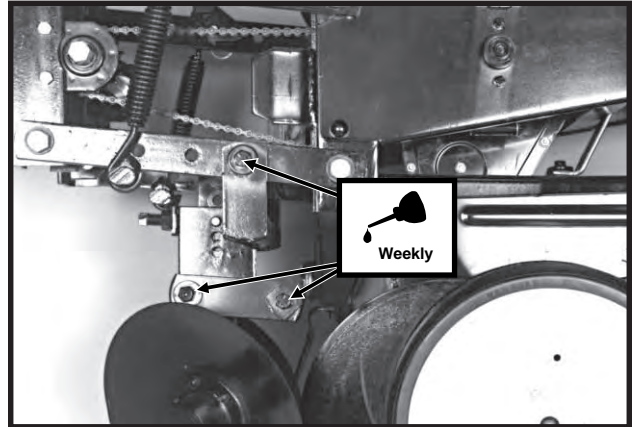

**Row Unit Mounted Disc Furrower Parallel Linkage  
(6 per row)**

59386-26

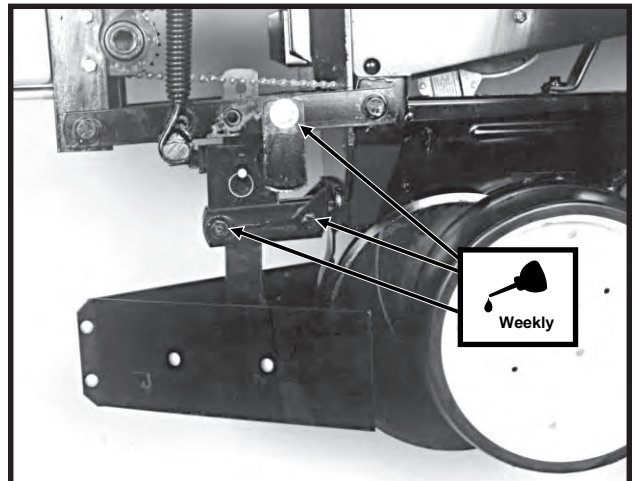

**Row Unit Mounted Bed Leveler Parallel Linkage  
(6 per row)**

8/30/93-4

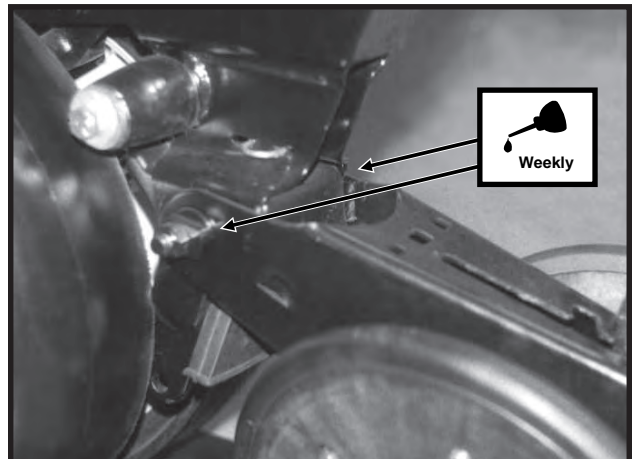

**Row Unit Closing Wheel Eccentric Bushings  
(2 per row)**

# LUBRICATION

## WHEEL BEARINGS

Wheel bearings should be checked annually. Inspect for lubrication. The transport wheel hubs are equipped with grease fittings. Pump grease into the hub until grease comes out around the seals. See "Grease Fittings" for lubrication frequency.

Jack wheel off the ground. Check for endplay in the bearings by moving the tire in and out. Rotate the tire to check for roughness in the bearings. If bearings sound rough, the hub should be removed and the bearings inspected and replaced if necessary. See "Wheel Bearing Packing Or Replacement".

## LIQUID FERTILIZER PISTON PUMP

69045-6

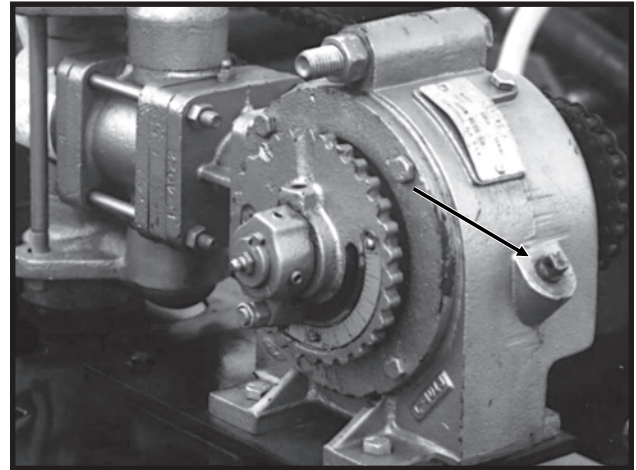

Check crankcase oil daily and maintain at plug level. Fill as needed with EP 90 weight gear oil.

Refer to operator and instruction manual shipped with the pump and flow divider for additional information.

## GREASE FITTINGS

Those parts equipped with grease fittings should be lubricated at the frequency indicated with an SAE multipurpose type grease. Be sure to clean the fitting thoroughly before using grease gun. The frequency of lubrication recommended is based on normal operating conditions. Severe or unusual conditions may require more frequent attention.

**!** **DANGER:** Always install safety lockups or lower to the ground before working under or around the machine.

### 12 Row Shown

48496-21

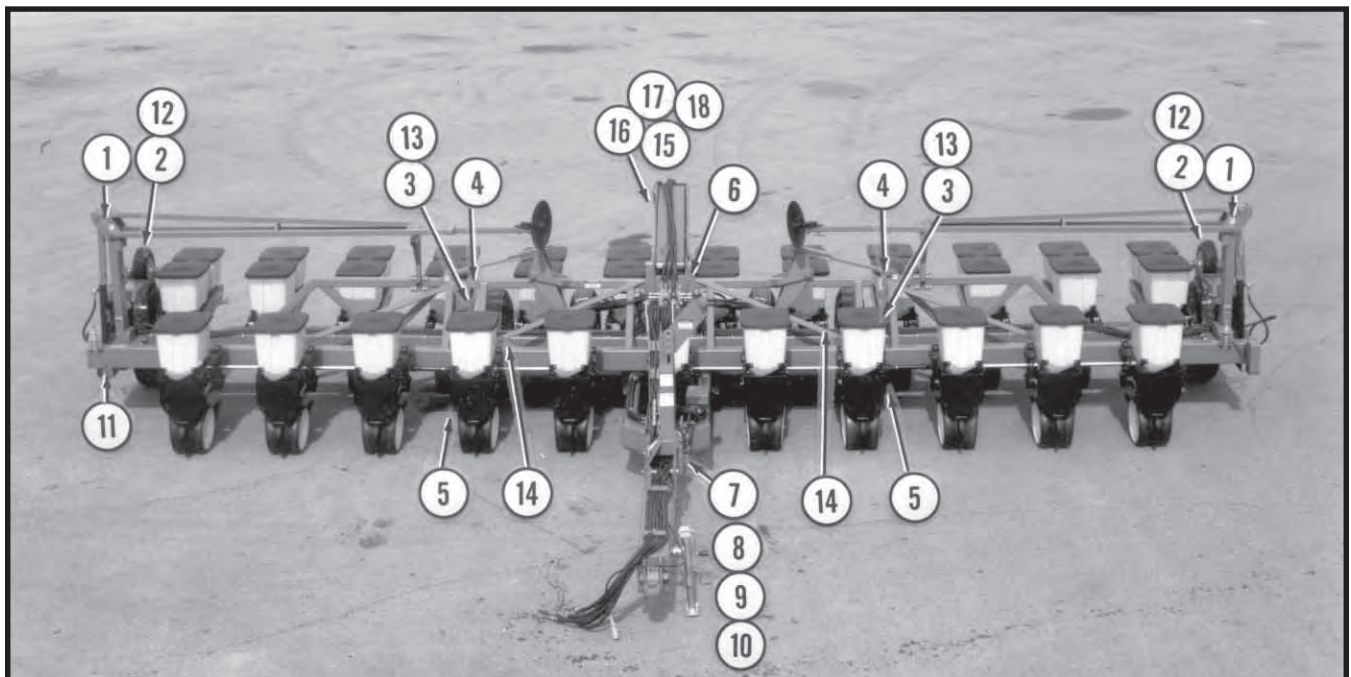

# LUBRICATION

72359-66

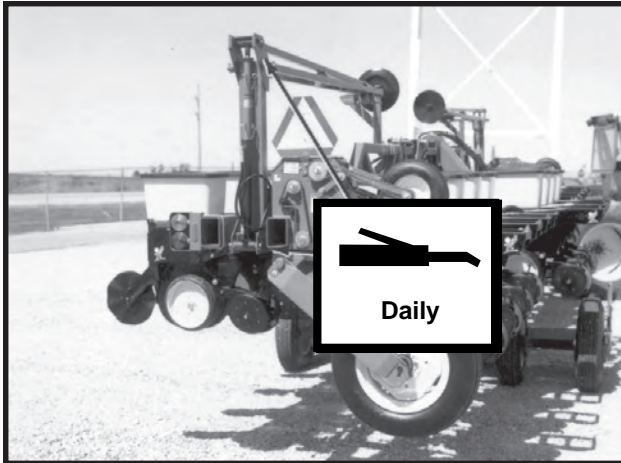

1. Marker Assemblies - 4 Zerks Per Assembly On 8 Row 30, 8 Row Wide & 12 Row 30. 2 Zerks Per Assembly On 12 Row Wide & 16 Row 30.

60356-1

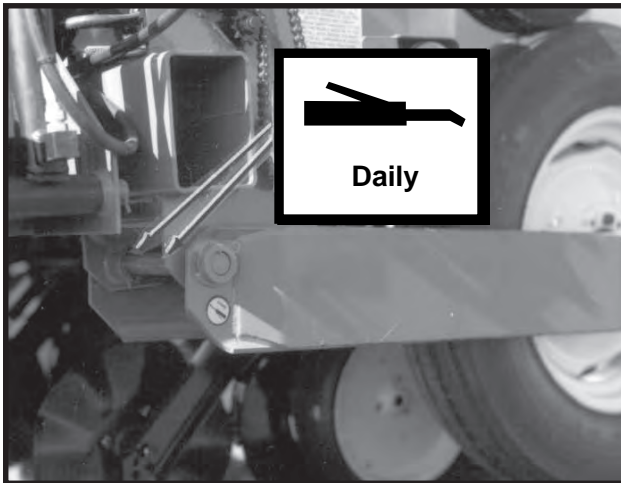

2. Drive Wheel Pivot - 2 Zerks Per Wheel Module

51502-8

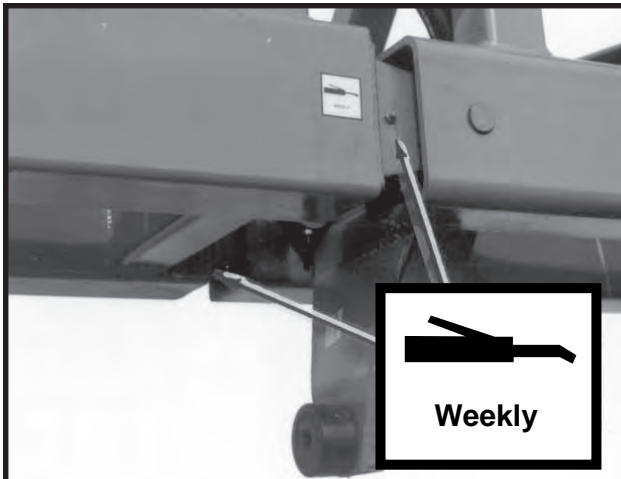

3. Wing Hinges - 2 Zerks Per Wing

48618-26

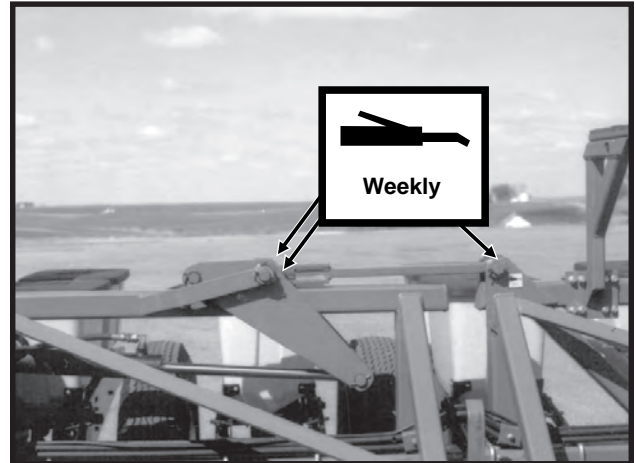

4. Wing Locks - 3 Zerks Per Wing

48837-12

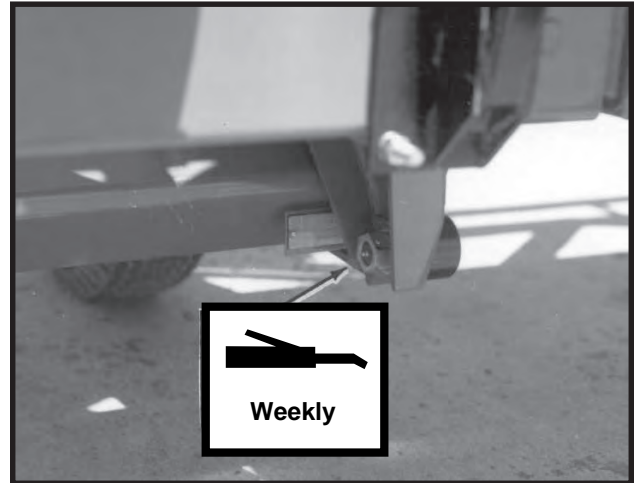

5. Cam Follower - 1 Zerk Per Follower

51052-20

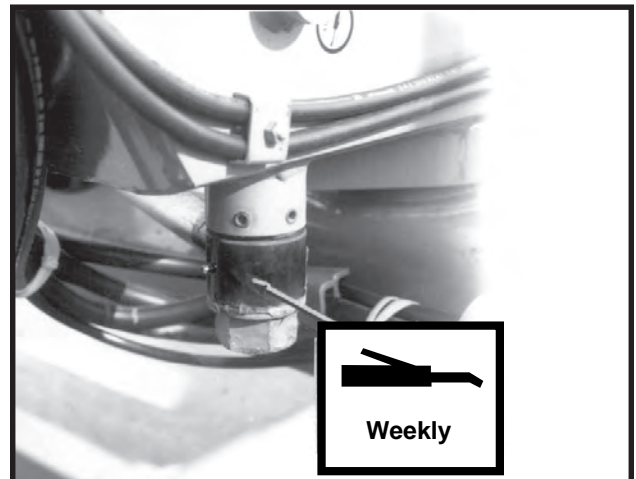

6. Rotation Cylinder - 1 Zerk



# LUBRICATION

60355-24

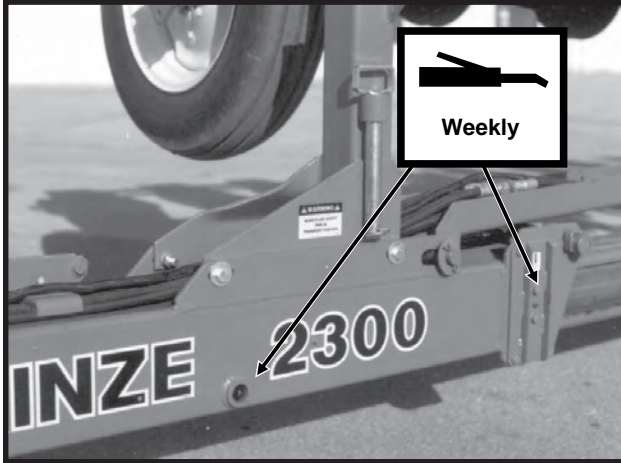

7. Hitch Slide - 4 Zerks

60887-99

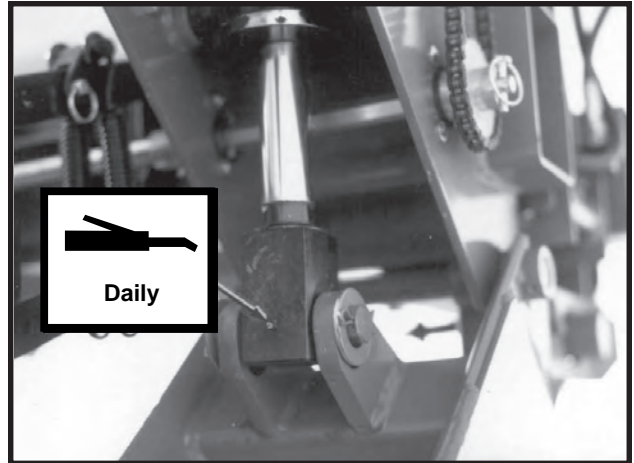

12. Slave Cylinders (On Wings) - 1 Zerk Per Cylinder

60355-7

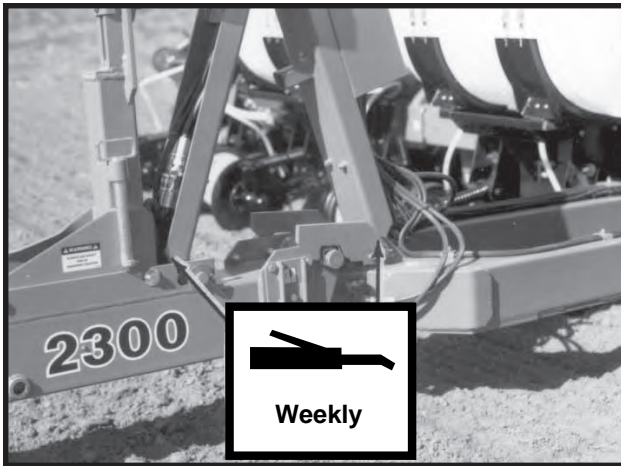

- 8. Hose Takeup (Front) - 1 Zerk
- 9. Hose Takeup (Rear) - 1 Zerk
- 10. Tongue Hook - 2 Zerks

51293-20

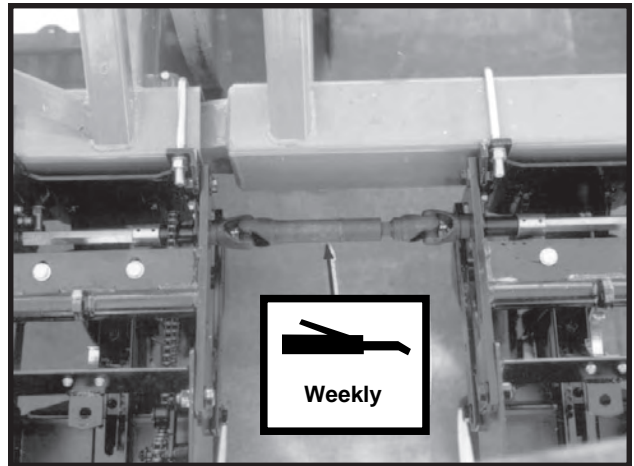

13. U-Joints - 1 Zerk Per Hinge Area

51502-5

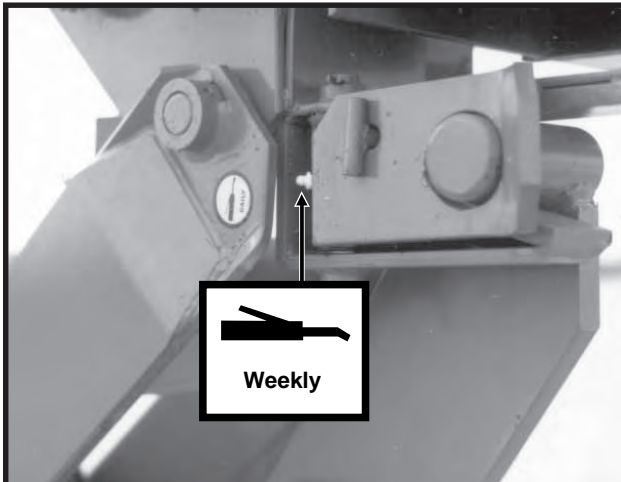

11. Transport Latch - 1 Zerk

51502-7



14. Transport Wheel Bearings - 1 Zerk Per Hub

# LUBRICATION

51502-7

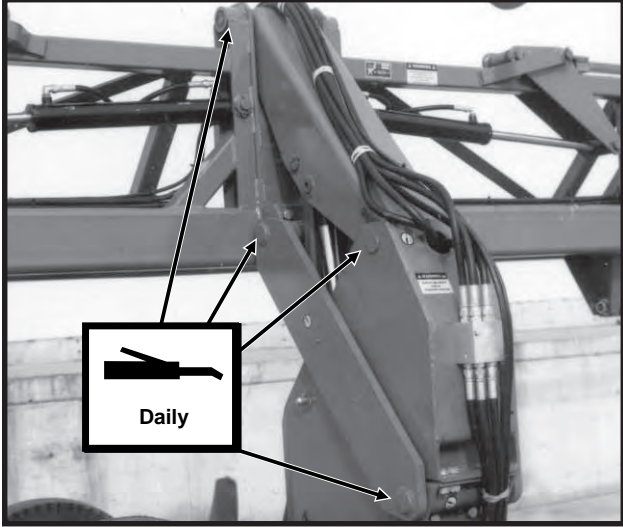

- 15. Upper Lift Arm - 2 Zerks
- 16. Lower Lift Arm - 5 Zerks

51502-3

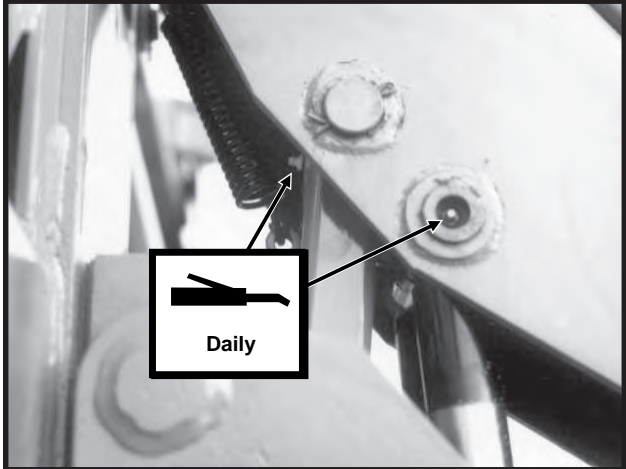

- 17. Safety Lock - 1 Zerk
- 18. Pivot Pin - 2 Zerks

# LUBRICATION

## Row Unit

72359-106

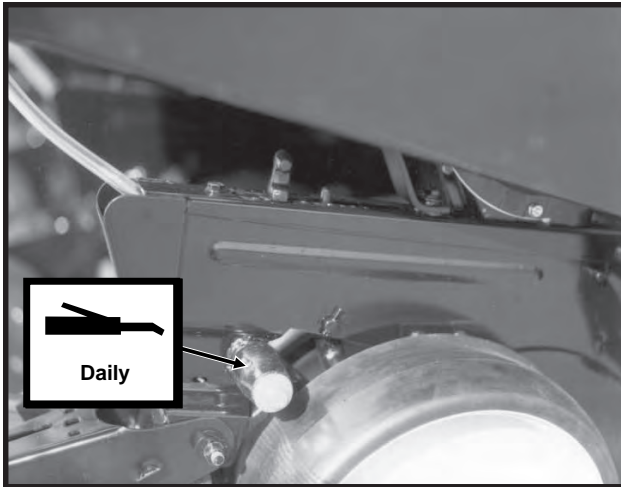

Gauge Wheel Arm - 1 Zerk Per Arm

72359-115

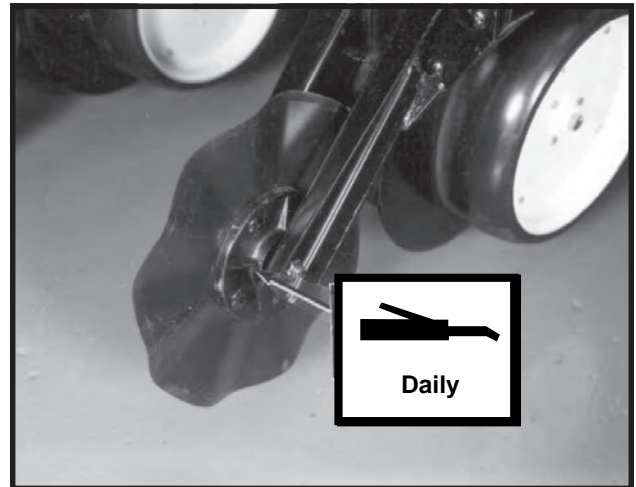

Row Unit Mounted No Till Coulter Hub - 1 Zerk Per Hub

56673-6

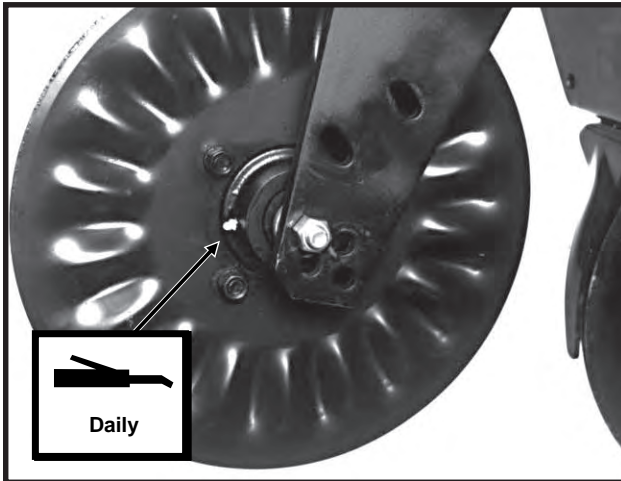

Frame Mounted Coulter Hub - 1 Zerk Per Hub

# LUBRICATION

## Dry Fertilizer Attachment

60389-15rev

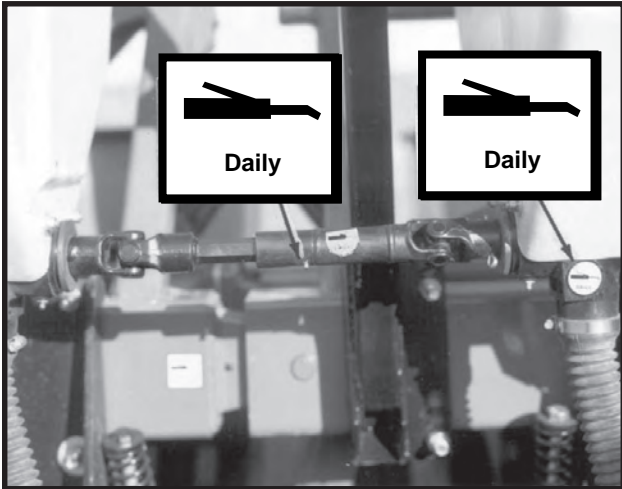

Fertilizer Hopper - 2 Zerks Per Hopper  
U-Joint - 1 Zerk Per Hinge Area

60389-6

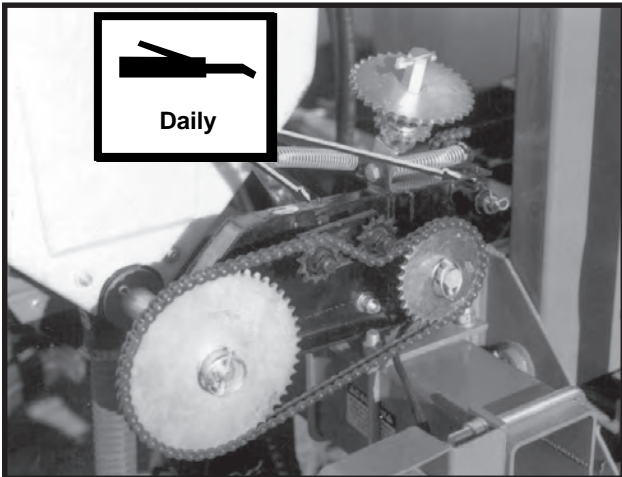

Fertilizer Transmission - 2 Zerks Per Transmission

## Liquid Fertilizer Attachment

48931-2

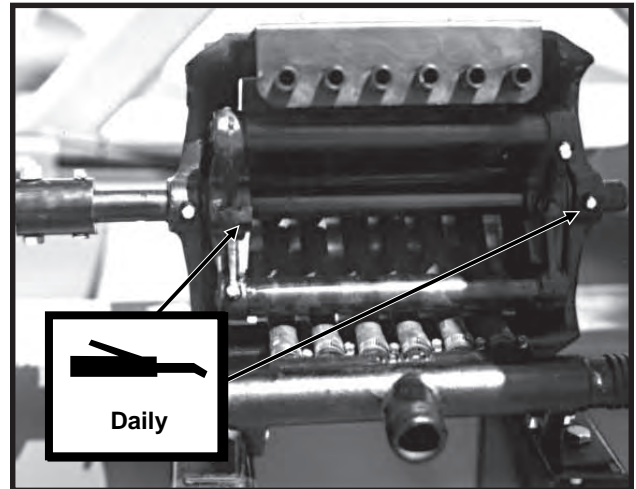

Squeeze Pump - 8 Zerks Per Pump

60356-10

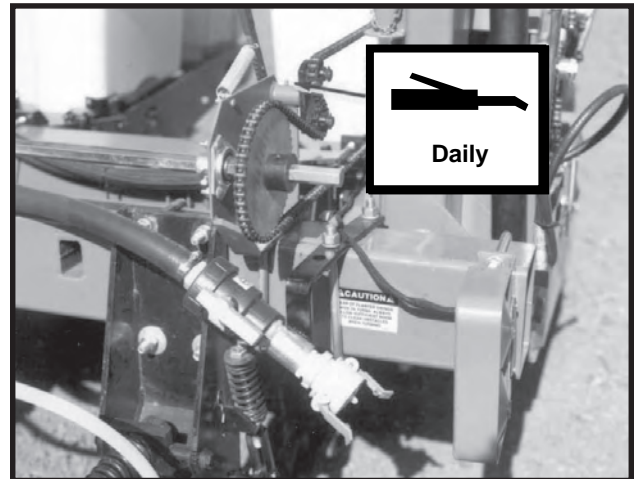

Squeeze Pump/Piston Pump Drive Chain Idler - 1 Zerk  
Per Plate (Squeeze pump drive shown)

69045-6

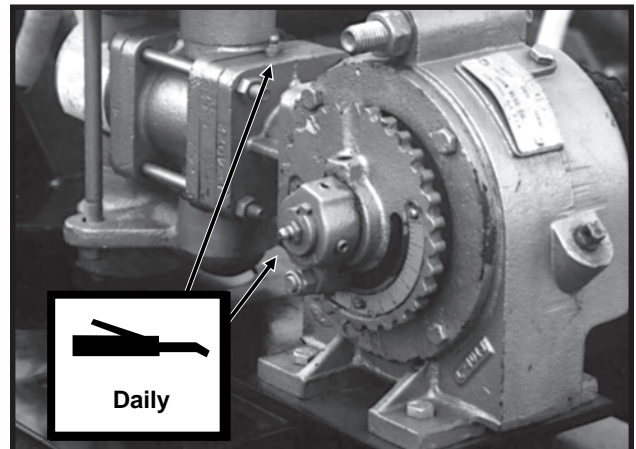

Piston Pump - 2 Zerks (Fill zerk on outboard stuffing  
box until lubricant seeps out of drain hole in bottom.)

# LUBRICATION

---

## Single Disc Fertilizer Opener

60389-58

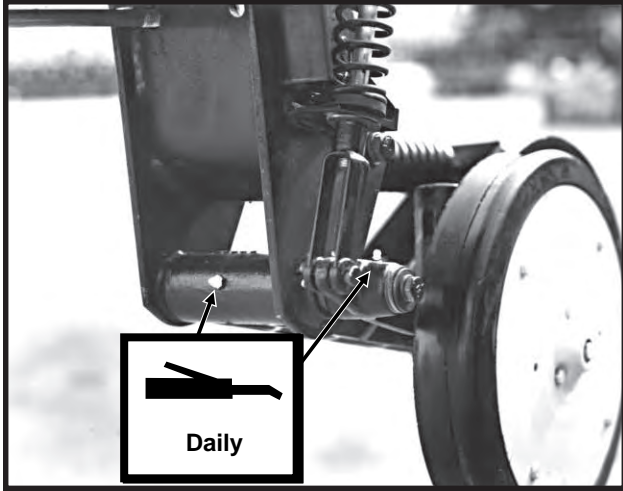

60389-60

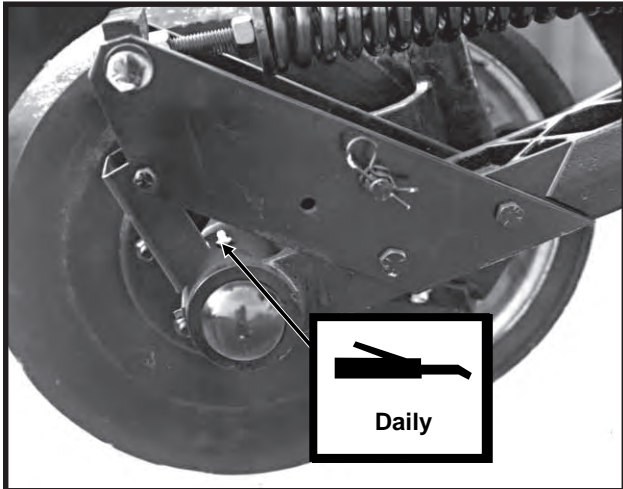

3 Zerks Per Single Disc Fertilizer Opener

# LUBRICATION

---

# MAINTENANCE

## MOUNTING BOLTS AND HARDWARE

Before operating the planter for the first time, check to be sure all nuts and bolts are tight. Check all nuts and bolts again after approximately the first 50 hours of operation and at the beginning of each planting season thereafter.

All bolts used on the KINZE planter are Grade 5 (high strength) unless otherwise noted. Refer to the torque values chart when tightening bolts.

Pivot linkage bushing bolts - 130 Ft. Lbs. (See "Bushings" in the Lubrication Section of this manual.)

**NOTE:** Over tightening bolts can cause as much damage as under tightening. Tightening a bolt beyond the recommended range can reduce its shock load capacity.

**WARNING:** Before operating the planter for the first time and periodically thereafter, check to be sure the lug nuts on the transport wheels are tight. This is especially important if the planter is to be transported for a long distance.

Center Section Transport Tires Lug Nuts - 125 Ft. Lbs.  
Wing Ground Drive Tires Lug Nuts - 90 Ft. Lbs.

**TORQUE VALUES CHART - PLATED HARDWARE**

Bolt Diameter	Grade 2		Grade 5		Grade 8	
	Coarse	Fine	Coarse	Fine	Coarse	Fine
1/4"	50 In. Lbs.	56 In. Lbs.	76 In. Lbs.	87 In. Lbs.	9 Ft. Lbs.	10 Ft. Lbs.
5/16"	8 Ft. Lbs.	9 Ft. Lbs.	13 Ft. Lbs.	14 Ft. Lbs.	18 Ft. Lbs.	20 Ft. Lbs.
3/8"	15 Ft. Lbs.	17 Ft. Lbs.	23 Ft. Lbs.	26 Ft. Lbs.	33 Ft. Lbs.	37 Ft. Lbs.
7/16"	25 Ft. Lbs.	27 Ft. Lbs.	37 Ft. Lbs.	41 Ft. Lbs.	52 Ft. Lbs.	58 Ft. Lbs.
1/2"	35 Ft. Lbs.	40 Ft. Lbs.	57 Ft. Lbs.	64 Ft. Lbs.	80 Ft. Lbs.	90 Ft. Lbs.
9/16"	50 Ft. Lbs.	60 Ft. Lbs.	80 Ft. Lbs.	90 Ft. Lbs.	115 Ft. Lbs.	130 Ft. Lbs.
5/8"	70 Ft. Lbs.	80 Ft. Lbs.	110 Ft. Lbs.	125 Ft. Lbs.	160 Ft. Lbs.	180 Ft. Lbs.
3/4"	130 Ft. Lbs.	145 Ft. Lbs.	200 Ft. Lbs.	220 Ft. Lbs.	280 Ft. Lbs.	315 Ft. Lbs.
7/8"	125 Ft. Lbs.	140 Ft. Lbs.	320 Ft. Lbs.	350 Ft. Lbs.	450 Ft. Lbs.	500 Ft. Lbs.
1"	190 Ft. Lbs.	205 Ft. Lbs.	480 Ft. Lbs.	530 Ft. Lbs.	675 Ft. Lbs.	750 Ft. Lbs.
1 1/8"	265 Ft. Lbs.	300 Ft. Lbs.	600 Ft. Lbs.	670 Ft. Lbs.	960 Ft. Lbs.	1075 Ft. Lbs.
1 1/4"	375 Ft. Lbs.	415 Ft. Lbs.	840 Ft. Lbs.	930 Ft. Lbs.	1360 Ft. Lbs.	1500 Ft. Lbs.
1 3/8"	490 Ft. Lbs.	560 Ft. Lbs.	1100 Ft. Lbs.	1250 Ft. Lbs.	1780 Ft. Lbs.	2030 Ft. Lbs.
1 1/2"	650 Ft. Lbs.	730 Ft. Lbs.	1450 Ft. Lbs.	1650 Ft. Lbs.	2307 Ft. Lbs.	2670 Ft. Lbs.

**NOTE:** Unplated bolts should be torqued approximately 1/3 higher than the above values. Bolts having lock nuts should be tightened to approximately 50% of amounts shown in chart. Bolts lubricated prior to installation should be torqued to 70% of value shown on chart.



**GRADE 2**  
No Marks



**GRADE 5**  
3 Marks



**GRADE 8**  
6 Marks

## CHAIN TENSION ADJUSTMENT

The drive chains are spring loaded and therefore self-adjusting. The only adjustment needed is to shorten the chain if wear stretches the chain and reduces spring tension. The pivot point of these idlers should be checked periodically to ensure they will rotate freely.

Additional chain links can be found in the storage box located inside the wheel module.

73321-7

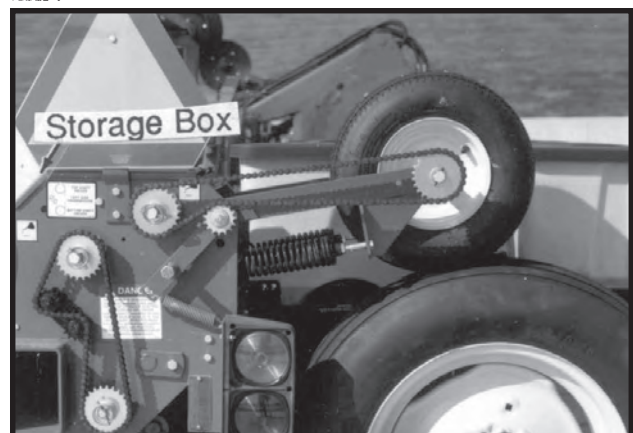

# MAINTENANCE

## FINGER PICKUP CORN METER INSPECTION/ADJUSTMENT

To inspect or service the finger pickup corn meter, remove the meter from the seed hopper by removing the two nuts which secure the mechanism to the hopper. Remove the baffle from the meter assembly by removing three cap screws. This will permit access to the finger pickup.

60620-8

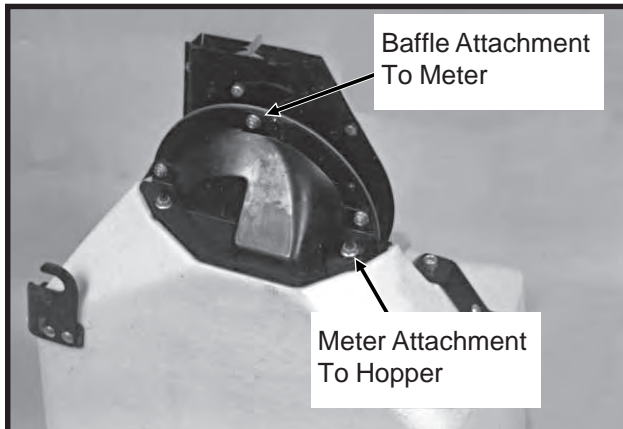

Rotate the seed meter drive by hand to ensure that the springs are holding the tabs of the fingers against the carrier plate where indicated in the photo and that the fingers are being raised in the correct area.

60620-17

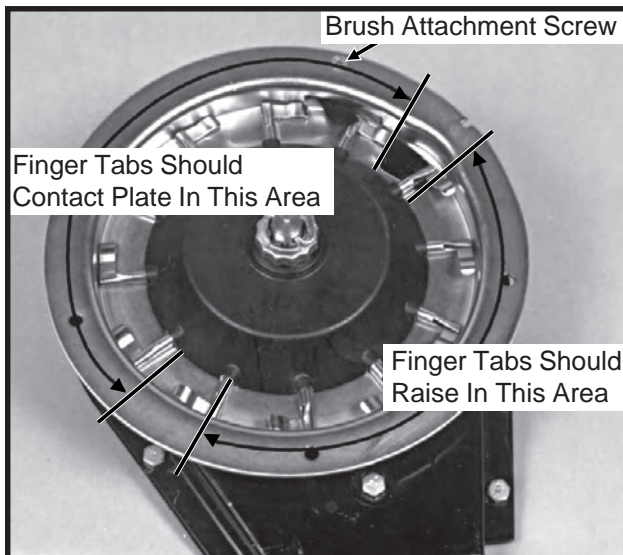

A build-up of debris or chaff may prevent proper finger operation and will require disassembly and cleaning of the corn meter as follows:

1. Remove cotter pin, cage nut and adjusting nut from drive shaft.
2. Carefully lift finger holder, along with fingers and cam, off of the shaft and clean.

60620-3

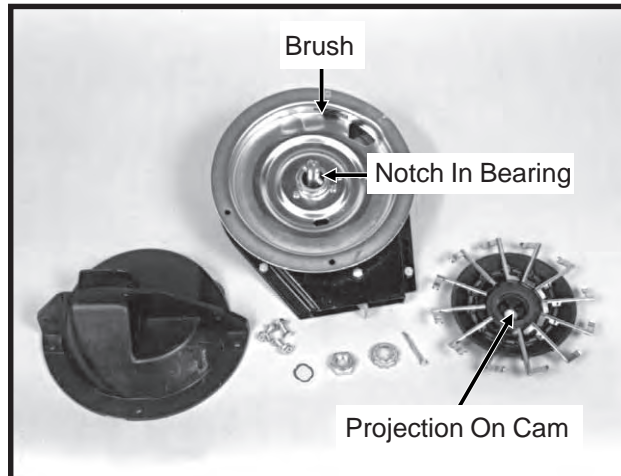

3. Check brush for wear and replace if necessary or following every 100 acres per row of operation.

**EXAMPLE:** Approximately 600 acres of corn on a 6 row machine or 800 acres on an 8 row machine.

**NOTE:** It is not necessary to remove finger holder to remove brush.

4. To replace fingers or springs, remove springs from fingers and remove finger from holder by lifting it out of the friction fit slot. Under average conditions, life expectancy of these parts should be 600-900 acres per row of operation.

5. After cleaning and/or replacing defective parts, reassemble the meter in the reverse order. When replacing fingers, make sure the open end of the spring loop is toward the inside of the finger holder.

60620-22

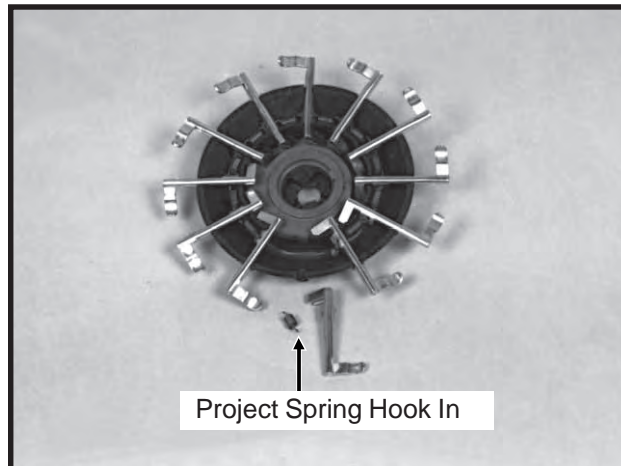

6. Make sure fingers are installed in holder so that holder will be positioned flush with the carrier plate when assembled. A projection on the cam is designed to align with a mating notch in the bearing housing to ensure proper operation when assembled.



# MAINTENANCE

50725-4

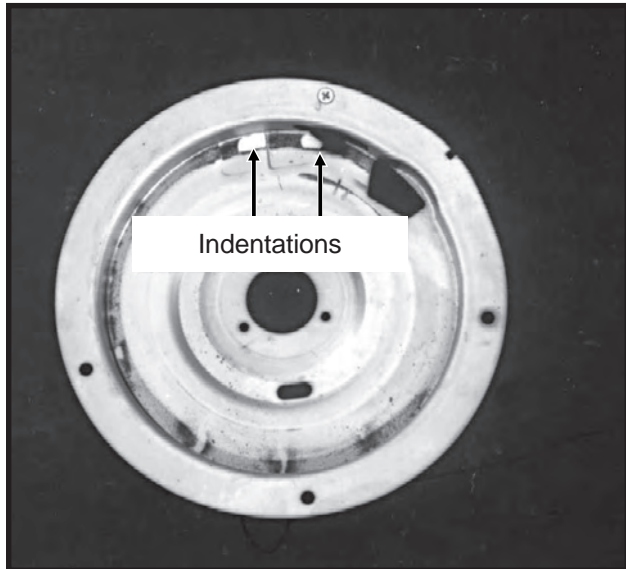

Photo shows worn plate

7. Before installing the finger holder on the carrier plate, check the indentations on the carrier plate for wear. Excessive wear of the carrier plate at the indentations will cause over planting especially when using small sizes of seed corn.

Inspect the carrier plate annually. Under average conditions, the life expectancy of the carrier plate should be 250-300 acres per row of operation.

8. With finger holder flush against the carrier, install adjusting nut until it contacts the finger holder with a slight resistance. Continue to turn the nut an additional 1/3 turn or torque to 22 to 25 inch pounds of rolling torque on input shaft.

9. Turn finger holder by hand to make sure it is positioned firmly against the carrier, but is not over tightened and can be rotated with moderate force.

10. Install cage nut and cotter pin and reinstall housing.

**NOTE:** Check tightness of adjusting nut on each unit after first day of use and periodically thereafter.

To inspect or replace the seed belt, remove the four cap screws around the edge of the housing cover and the nut from the belt idler mounting bolt.

60620-13

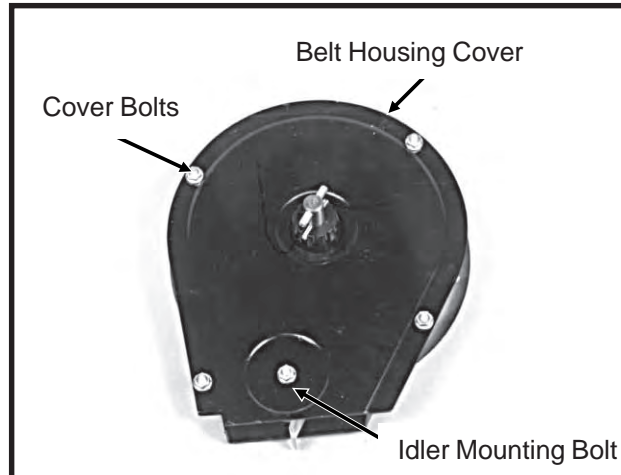

60887-97

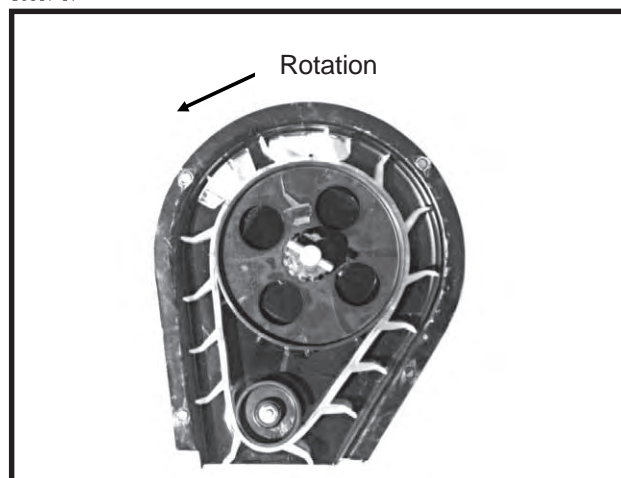

If the belt is being replaced, make sure it is reinstalled to correctly orient the paddles as shown. A diagram molded into the drive sprocket also illustrates the correct orientation.

**CAUTION:** Do not over tighten hardware.

## FINGER PICKUP CORN METER CLEANING

1. Disassemble meter.
2. Blow out any foreign material present in the meter mechanism.
3. Wash in mild soap and water. **DO NOT USE GASOLINE, KEROSENE OR ANY OTHER PETROLEUM BASED PRODUCT.**
4. Dry thoroughly.
5. Coat lightly with a rust inhibitor.
6. Store in a dry place.

# MAINTENANCE

## FINGER PICKUP CORN METER TROUBLESHOOTING

Problem	Possible Cause	Solution
One row not planting seed.	Drive release not engaged.	Engage drive release mechanism.
	Foreign material in hopper.	Clean hopper and finger carrier mechanism.
	Seed hopper empty.	Fill seed hopper.
	Pin sheared in drive release sprocket.	Replace pin. Inspect meter for obstructions or defective parts.
Drive release does not engage properly.	Row unit drive chain off of sprocket or broken.	Check drive chain.
	Drive release shaft is not aligned properly with meter drive shaft.	Align drive mechanism. See "Meter Drive Adjustment".
Unit is skipping.	<b>Foreign material or obstruction in meter.</b>	<b>Clean out and inspect.</b>
	<b>Finger holder improperly adjusted.</b>	<b>Adjust to proper setting. (22 to 25 in. lbs. rolling torque)</b>
	<b>Broken fingers.</b>	<b>Replace fingers and/or springs as required.</b>
	Planting too slowly.	Increase planting speed to within recommended range.
Planting too many doubles.	Planting too fast.	Stay within recommended speed range.
	<b>Loose finger holder.</b>	<b>Adjust to specs. (22 to 25 in. lbs. rolling torque)</b>
	<b>Worn brush in carrier plate.</b>	<b>Inspect and replace if necessary.</b>
Over planting.	<b>Worn carrier plate.</b>	<b>Inspect and replace if necessary.</b>
Under planting.	<b>Belt installed backwards.</b>	<b>Remove and install correctly.</b>
	<b>Weak springs.</b>	<b>Replace.</b>
	<b>Spring not properly installed.</b>	<b>Remove finger holder and correct.</b>
	<b>Seed belt catching or dragging.</b>	<b>Replace belt.</b>
	<b>Brush dislodging seed.</b>	<b>Replace brush.</b>
Irregular or incorrect seed spacing.	Driving too fast.	Check chart for correct speed.
	Wrong tire pressure.	Inflate tires to correct air pressure.
	Drive wheels slipping.	Reduce down pressure on row unit down force springs.
Seed spacing not as indicated in charts.	Wrong sprockets.	Check seed rate charts for correct sprocket combinations.
	Wrong tire pressure.	Inflate tires to correct air pressure.
	Inconsistent seed size.	Do field check and adjust sprockets accordingly.
	Wrong sprockets.	Check chart for correct sprocket combination.
Scattering of seeds.	Charts are approximate.	Slight variations due to wear in meter components and tire slippage due to field conditions may produce seed spacing variations.
	Stiff or worn drive chains.	Replace chains.
Seed tubes and/or openers plugging.	Planting too fast.	Reduce planting speed.
	Seed tube improperly installed.	Check seed tube installation.
	Seed tube worn or damaged.	Replace seed tube.
Inconsistent seed depth.	Allowing planter to roll backward when lowering.	Lower planter only when tractor is moving forward.
	Rough seed bed.	Adjust down pressure springs.
	Partially plugged seed tube.	Reduce planting speed.
	Seed tube improperly installed.	Inspect and clean. Install properly.

# MAINTENANCE

## BRUSH-TYPE SEED METER MAINTENANCE

60607-10

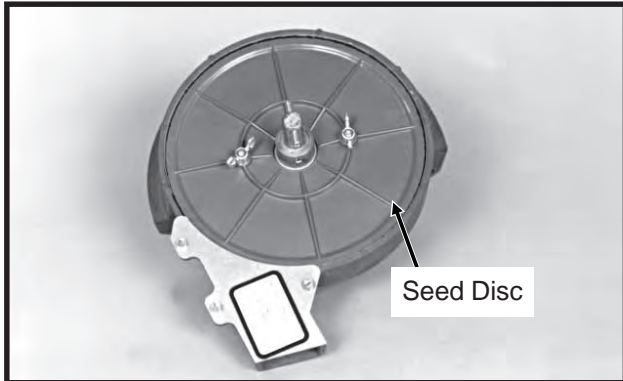

60607-3

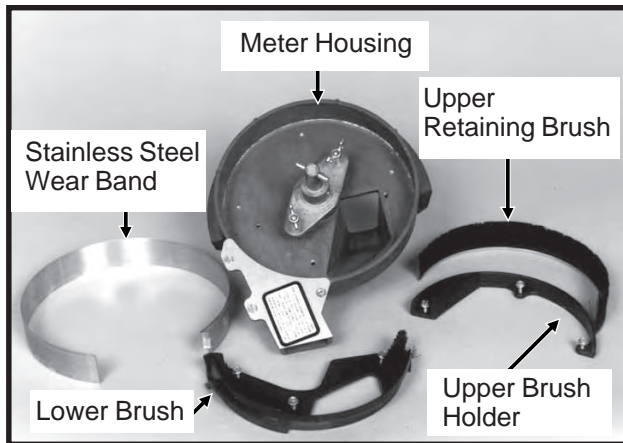

Only clean, high quality seed should be used for maximum meter accuracy. Damaged or cracked seed, hulls or foreign materials may become lodged in the upper seed retaining brush and greatly reduce meter accuracy. It is suggested that the seed disc be removed daily, inspected and cleaned. Check for buildup of foreign material on the seed disc, particularly in the seed loading slots. Clean the disc by washing it with soap and water. Check for cracked seed, hulls, etc. lodged between the brush holder and stainless steel wear band which can greatly reduce the accuracy of the meter because the retaining brush will not be able to retain the seed in the seed disc pocket. Use compressed air to clean the brush areas of the meter housing.

60607-8



**NOTE: Replace hopper lids after hoppers are filled to prevent accumulation of dust or dirt in the seed meter which will cause premature wear.**

Cleaning brush-type seed meter for storage:

1. Remove meter from seed hopper by removing the two nuts which secure the meter to the hopper.
2. Remove seed disc and wash with soap and water and dry thoroughly.
3. Remove upper retaining brush by removing the three hex head screws from the brush holder and removing brush holder and retaining brush.
4. Remove the three hex head screws from the lower brush and and remove lower brush and stainless steel wear band.
5. Wash all parts and meter housing with soap and water and dry thoroughly.
6. Inspect all parts for wear and replace worn parts.
7. Reassemble meter except for seed disc. **Meter should be stored without seed disc installed.**

### Seed Disc Wear

HD112690

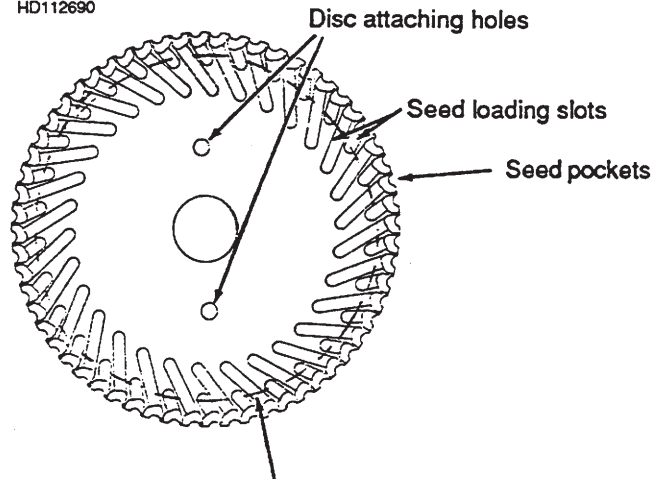

Area indicated is where most wear will be found

Most wear on the seed disc will be found in the area between the seed loading slots. If wear in this area is greater than .075" and accuracy starts to drop off at higher meter RPMs, the seed disc should be replaced. Wear will affect planting accuracy at high RPMs. To measure for wear lay a straight edge across the surface of the disc and measure the gap between the disc and the straight edge.

Estimated life expectancy of the seed disc is 60-200 acres per row.

# MAINTENANCE

## Stainless Steel Wear Band

60607-38

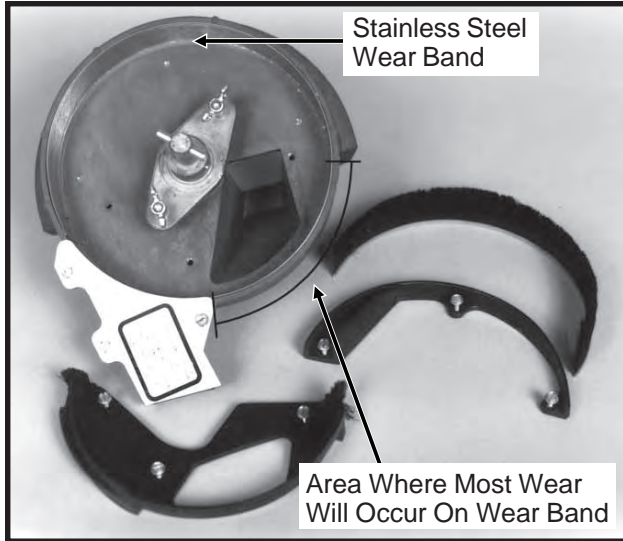

The purpose of the stainless steel wear band is to protect the meter housing from wear. The band is .030" thick and should be replaced when approximately .020" of wear is found in the primary area of wear. If the wear band is allowed to wear through or if the meter is used without the wear band in place, damage to the meter housing may occur.

Estimated life expectancy of the stainless steel wear band is 240-800 acres per row.

## Lower Brush

Estimated life expectancy of the lower brush is also 240 - 800 acres per row.

## Upper Retaining Brush

60607-21

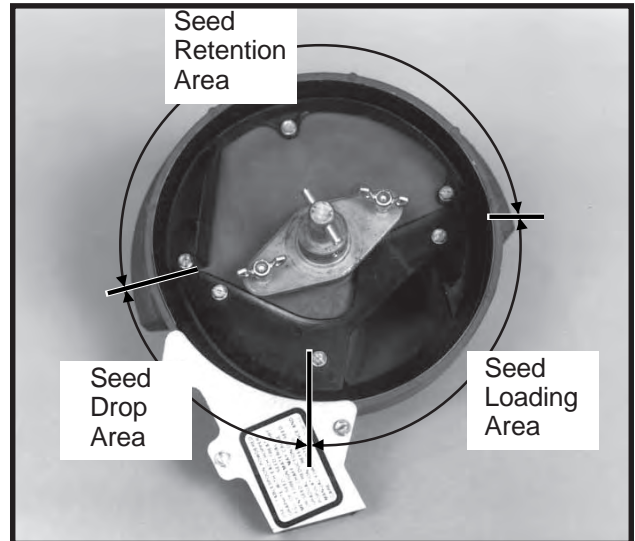

The upper retaining brush holds seed in the seed disc pocket in the seed retention area.

The retaining brush must apply enough pressure against the seed in the seed disc pocket as the disc rotates through the seed retention area to prevent the seed from dropping out of the disc pocket. A damaged spot, excessive wear on the brush or foreign material lodged in the brush may greatly reduce meter performance.

The upper retaining brush should be replaced at approximately 120 - 400 acres per row of use or sooner if damage or excessive wear is found.

## Installation Of Upper Retaining Brush

Position retaining brush into inner perimeter of seed retention area. Make sure the base of the brush is tight against the bottom of the meter housing. Install brush holder and three hex head screws. Tighten center screw first, left screw second and right screw last.

60607-6

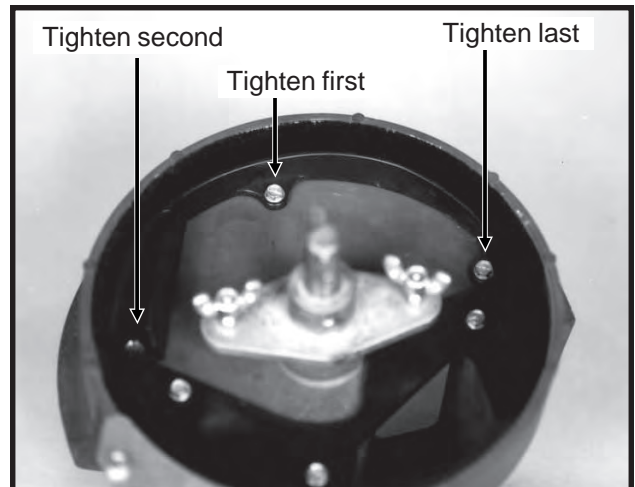

# MAINTENANCE

## BRUSH-TYPE SEED METER TROUBLESHOOTING

Problem	Possible Cause	Solution
Low count.	Meter RPM's too high.	Reduce planting speed.
	Misalignment between drive clutch and meter.	See "Meter Drive Adjustment".
	Seed sensor not picking up all seeds dropped.	Clean seed tube. Switch meter to different row. If problem stays with same row, replace sensor.
	Lack of lubrication causing seeds not to release from disc properly.	Use graphite or talc as recommended.
Low count at low RPMs and higher count at higher RPMs.	Seed size too large for seed disc being used.	Switch to smaller seed or appropriate seed disc. See "Brush-Type Seed Meter" for proper seed disc for size of seed being used.
	Seed treatment buildup in meter.	Reduce amount of treatment used and/or thoroughly mix treatment with seed.
	Foreign material lodged in upper retaining brush.	Remove seed disc and remove foreign material from between brush holder and bristles. Clean with compressed air.
Low count at higher RPMs and normal count at low RPMs.	Worn upper retaining brush.	Replace. See "Maintenance".
	Seed disc worn in the agitation groove area.	Replace disc. See "Maintenance".
High count.	Seed size too small for seed disc.	Switch to larger seed or appropriate seed disc.
	Incorrect seed rate transmission setting.	Reset transmission.
Upper retaining brush layed back.	Seed treatment buildup on brush.	Remove brush. Wash with soap and water. Dry thoroughly before reinstalling. See "Maintenance".
	Buildup of foreign material at base of brush.	Remove brush holder and brush. Clean with compressed air. Reinstall.

## CLOSING WHEEL TROUBLESHOOTING

Problem	Possible Cause	Solution
Closing wheel(s) leave severe imprint in soil.	Too much closing wheel down pressure.	Adjust closing wheel pressure.
Closing wheel(s) not firming soil around seed.	Insufficient closing wheel down pressure.	Adjust closing wheel pressure.
"V" closing wheel running on top of seed furrow.	Improper centering.	Align. See "'V Closing Wheel Adjustment".
Single closing wheel not directly over seed.	Improper centering.	Align. See "Covering Discs/Single Press Wheel Adjustment".

# MAINTENANCE

## GAUGE WHEEL ADJUSTMENT

To prevent an accumulation of dirt or trash, gauge wheels should just contact the opener blades. Gauge wheels and opener blades should turn with only slight resistance.

73090-24

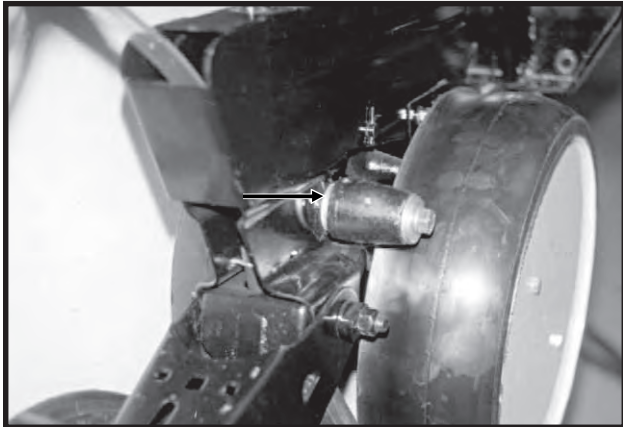

To adjust clearance between gauge wheels and opener blades, add or remove spacer washers between the shank and gauge wheel arm. Store remaining spacer washers between gauge wheel arm and flat washer on outer side of gauge wheel arm.

**NOTE:** It may be desirable to space gauge wheel further from blade when operating in sticky soils.

## 15" SEED OPENER DISC/BEARING ASSEMBLY

73090-13



If 2" of blade contact cannot be maintained after removing spacer washers, the blade should be replaced.

### To replace disc/bearing assembly:

1. Remove gauge wheel.
2. Remove bearing dust cap.
3. Remove jam nut and washer from outside of disc/bearing assembly.

**NOTE:** Left hand side of opener uses a left hand threaded nut. **DO NOT OVER TIGHTEN.** Damage to mounting spindle will require replacement of row unit shank assembly.

4. Remove disc/bearing assembly. The spacer bushings between the shank and disc are used to maintain the blade to blade contact at 2".
5. After installing new disc/bearing assembly, install washer and jam nut to secure disc/bearing assembly. Torque 5/8"-11 Grade 2 nut to value shown in Torque Values Chart.
6. Replace bearing dust cap.

It may be necessary to replace only the bearing if the bearing sounds rough when the disc is rotated.

### To replace bearing:

1. Remove gauge wheel, bearing cap, jam nut, washer and disc/bearing assembly.
2. Remove 1/4" rivets from bearing housing to expose bearing.
3. After installing new bearing, install three evenly spaced 1/4" bolts into three of the six holes in the bearing housing to hold the bearing and bearing housing in place. Install rivets in the other three holes. Remove 1/4" bolts and install rivets in those three holes.
4. Reinstall disc/bearing assembly, washer and jam nut. Torque 5/8"-11 Grade 2 nut to value shown in Torque Values Chart at end of this section.
5. Replace bearing dust cap.

# MAINTENANCE

## SEED TUBE GUARD/INNER SCRAPER

The seed tube guard protects the seed tube and acts as the inner scraper for the disc opener blades.

Remove the seed tube and check for wear. Excessive wear on the seed tube indicates a worn seed tube guard.

72369-62

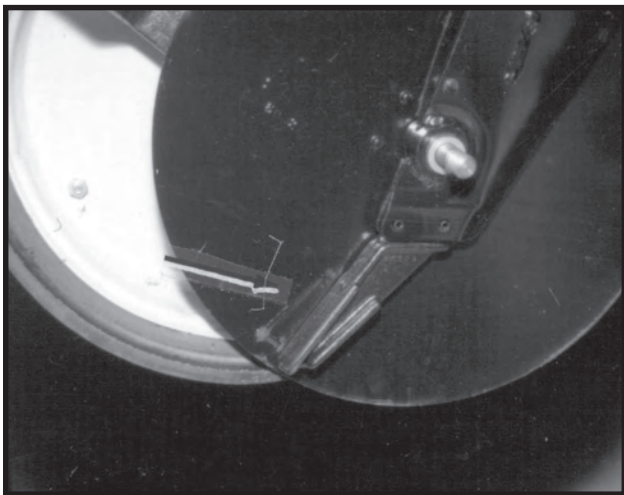

No till planting or planting in hard ground conditions will increase seed tube guard wear and necessitate more frequent inspection.

The gauge wheel and seed opener discs must be removed before the seed tube guard can be replaced.

## ROW UNIT MOUNTED NO TILL COULTER

59386-40

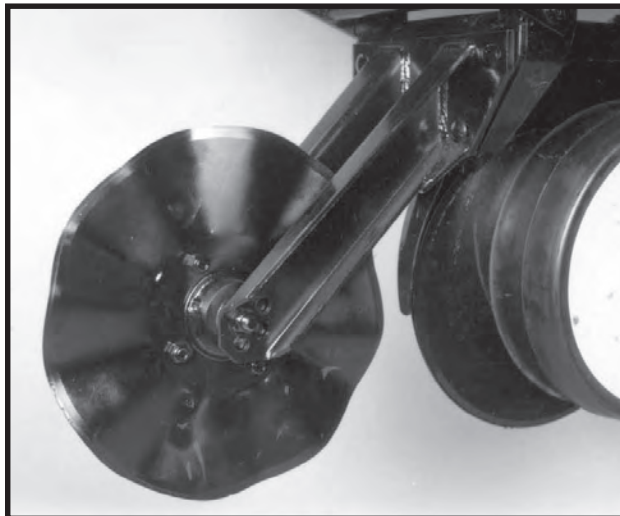

If properly maintained and lubricated the bearings in the row unit mounted no till coulters hub may never need to be replaced. Lubricate at frequency indicated in the Lubrication Section of this manual. Check periodically to be sure nuts and hardware are tightened to proper torque specification. Be sure the coulters are positioned square with the planter frame and aligned in front of row unit disc opener.

The coulters blade can be adjusted to one of four settings. Initially the blade is set in the highest position. As the blade wears it can be adjusted to one of the three lower settings. See "Row Unit Mounted No Till Coulters" in Operation Section of this manual.

When the 16" diameter coulters blade is worn to a 14 1/2" diameter (maximum allowable wear), it should be replaced.

Timely lubrication at the frequency indicated in the lubrication section of this manual is necessary to purge moisture and dirt from bearing and seal. This will also lubricate the seal. Add grease until it comes out around the seal.

# MAINTENANCE

## ELECTRONIC SEED MONITOR SYSTEM TROUBLESHOOTING

60656-5



The general procedure to use, if a problem occurs, is to isolate the cause to a sensor, sensor lead, planter harness, console cable or the console, in that order. Make necessary repairs after problem has been isolated.

### 1. Sensors

Check for excessive dirt inside sensor. Check for cut or damaged wires. Connect sensor to the planter harness in a row that is operating properly. If it then operates correctly, sensor is good.

In some cases static electricity may cause dust and seed treatment to accumulate on the sensing elements in the sensor. Enough may accumulate to cause the sensor to malfunction, which can cause monitor to indicate a fault condition. Low humidity and dry soil conditions tend to cause this condition. When this occurs, clean the inside of the sensors, using a dry bottle brush.

If, for any reason a sensor becomes inoperative and a replacement sensor is not immediately available, disconnect the sensor lead connector from the planter harness, turn monitor OFF and then back ON. This will keep the alarm from sounding for this row only. Replace the defective seed sensor (using high rate seed sensor only) as soon as possible. After sensor is replaced make certain the monitor is turned OFF and back ON to reactivate the sensor position.

If sensor leads are damaged, carefully cut away the cable covering at the damaged area. Repair damaged wire or wires by soldering wires together with rosin core solder, being sure to match wire colors, then tape each repaired wire. Finally, tape over cut portion of the cable cover. If necessary, relocate and secure cable so that the same type of damage will not occur again.

### 2. Planter Harness And Console Cable

Carefully examine planter harness and console cable for damage. If harness and/or cable is cut or pinched, carefully cut away the harness/cable covering. Repair cut or damaged wire by soldering wires together with rosin core solder, being sure to match wire colors. Tape each repaired wire, then tape over cut harness/cable covering. If necessary, relocate and secure harness/cable so that the same type damage will not occur again.

### 3. Console

Check for a blown fuse, located on the console rear panel. Check battery connections and make certain they are clean and tight. Make certain battery is fully charged.

If console fuse is blown replace with a 5-amp type AGC. If fuse blows again, console needs repair or replacement.

**CAUTION: DO NOT REPLACE FUSE WITH A FUSE HAVING A HIGHER AMPERAGE RATING.**

If the battery cable is not damaged, battery connections are clean and tight and the battery is fully charged, the console is defective and needs to be repaired or replaced.



# MAINTENANCE

## KM1000 TROUBLESHOOTING CHART

SYMPTOM	PROBABLE CAUSE	ACTION REQUIRED
<p>1. Low Voltage Indicator is ON.</p>	<p>Connected to 6 volt battery.</p>	<p>Connect to 12 volt battery.</p>
	<p>System voltage insufficient.</p>	<p>Insure greater than 11.0 volts.</p>
	<p>Battery connection corroded.</p>	<p>Inspect battery connections. If console power cable terminals or battery terminals are dirty or corroded, clean terminals as required.</p>
	<p>Console defective.</p>	<p>Repair or replace console. Contact your KINZE Dealer.</p>
<p>2. One row indicator lamp fails to flash when planting. Alarm does not sound.</p>	<p>Burned out row indicator lamp.</p>	<p>Replace row indicator lamp with a 1892 lamp only. (Part No. GR0595).</p>
<p>3. One row indicator lamp fails to flash when planting. Alarm sounds continuously. Seeds are being planted by the row unit.</p>	<p>Sensing elements inside seed sensor.</p>	<p>Clean sensing elements using a dry bottle brush. NOTE: Some seed treatment chemicals are detrimental to the operation of seed sensors and refuse to be removed by dry brushing. To remove such treatment from the inside of a sensor, proceed as follows: Wet a bottle brush with water, then apply a moderate amount of kitchen cleanser (such as Ajax® or Comet®) to the brush. Scrub inside of sensor until treatment is removed, then rinse sensor in clear cold water. Dry thoroughly.</p>
	<p>Defective sensor.</p>	<p>Plug suspect sensor cable into an adjacent row that is operating correctly. If sensor does not operate, sensor is defective.</p> <p>If you wish to continue planting and a replacement sensor is not available, disconnect the defective sensor cable from the planter harness, turn the monitor OFF and then back ON. The monitor will ignore the disconnected row sensor and you can continue to monitor all other rows.</p>

# MAINTENANCE

## KM1000 TROUBLESHOOTING CHART (Continued)

SYMPTOM	PROBABLE CAUSE	ACTION REQUIRED
<p>4. One row indicator lamp fails to come on when the console is powered up.</p>	<p>Burned out row indicator lamp.</p>	<p>Replace row indicator lamp with a number 1892 lamp only. (Part No. GR0595)</p>
	<p>Defective seed sensor or planter harness.</p>	<p>Disconnect the suspected sensor from the planter harness row lead. Disconnect the sensor from the planter harness of an adjacent row. Reverse the harness row leads to the sensors (connect the suspected sensor to the adjacent row planter harness lead and the adjacent sensor to the suspected row harness lead).</p> <p>Turn console power OFF then back ON. If the symptom moves to the adjacent row, the seed sensor is defective and needs replaced. If the symptom does not move, the planter harness or console is defective and needs repaired. Visually inspect the planter harness for cuts, pinching, etc., if damage is found, repair by cutting away the cable covering and splicing the wires (being sure to match wire colors). Solder the splices and tape each wire individually. Tape over repaired cable.</p>
	<p>Console defective.</p>	<p>Repair or replace console. Contact your KINZE Dealer.</p>
<p>5. Monitor completely "dead".</p>	<p>Blown fuse.</p>	<p>Check fuse, located on rear panel of console. If fuse is blown, replace with a 5-amp, type AGC. If fuse blows again, check power connection to battery. If connections are reversed fuse will blow. If battery connections are correct, console needs repair or replacement. Contact your KINZE Dealer.</p>
	<p>Poor battery connections.</p>	<p>Check battery connections. Connections must be clean and tight.</p>

# MAINTENANCE

## KM1000 TROUBLESHOOTING CHART (Continued)

SYMPTOM	PROBABLE CAUSE	ACTION REQUIRED
5. (Cont'd.)	Cut or broken battery cable.	Visually inspect the battery cable for a cut or broken wire. If wires are cut or broken, splice the wires being sure to match wire colors. Solder the splices and tape each wire individually. USE ONLY ROSIN CORE SOLDER.
	Console defective.	Repair or replace console. Contact your KINZE Dealer.
6. When monitor is turned ON, row indicator lamps are dark, green power indicator is ON and monitor will not enter operate mode.	Defective (shorted) seed sensor.	Leave monitor turned on. Unplug seed sensors one at a time starting with row 1. When you disconnect a sensor and the remaining row indicator lamps come on, the sensor or its cable is defective. Visually inspect the sensor cable. If damaged, repair. If no cable damage is found, the sensor is defective and needs to be replaced. If all but the last sensor is disconnected and the problem still exists, reconnect a sensor before disconnecting the last sensor. If the last sensor is disconnected and the problem still exists, the planter harness, console cable or console is at fault.
	Planter harness shorted.	Visually inspect the planter harness (including all row unit cables) for cuts, pinching and other types of damage. If damage is found, cut away cable covering and repair the individual wires. Tape over repaired wire and cable.
	Console defective.	If the console cable, planter harness, and seed sensors are normal, the console is at fault and needs to be repaired or replaced. Contact your KINZE Dealer.

# MAINTENANCE

## KM3000 TROUBLESHOOTING CHART

SYMPTOM	PROBABLE CAUSE	ACTION REQUIRED
<p>1. Display readout incomplete (fragmented) alarm sounds continuously.</p>	<p>Low battery voltage.</p>	<p>Recharge or replace battery.</p>
	<p>Battery connections corroded.</p>	<p>Inspect battery connection. If console power cable terminals or battery terminals are dirty or corroded, clean terminals as required.</p>
	<p>Console defective.</p>	<p>Repair or replace console. Contact your KINZE Dealer.</p>
<p>2. One row indicator segment (lower display) fails to flash when planting. Population readout for the planter row is .0. Alarm sounds continuously. Seeds are being planted by the row unit.</p>	<p>Sensing elements inside of seed sensor are dirty.</p>	<p>Clean sensing elements using a dry bottle brush.            NOTE: Some seed treatment chemicals are detrimental to the operation of seed sensors and refuse to be removed by dry brushing. To remove such treatment from the inside of a sensor proceed as follows:            Wet a bottle brush with water, then apply a moderate amount of kitchen cleanser (such as Ajax® or Comet®) to the brush. Scrub inside of sensor until treatment is removed, then rinse sensor in clear cold water. Dry thoroughly.</p>
	<p>Defective sensor.</p>	<p>Plug suspect sensor cable into an adjacent row that is operating correctly. If sensor does not operate, sensor is defective.            If you wish to continue planting and a replacement sensor is not available, disconnect the defective sensor cable from the planter harness, turn the monitor OFF and then back ON. The monitor will ignore the disconnected row sensor and you can continue to monitor all other rows.</p>

# MAINTENANCE

## KM3000 TROUBLESHOOTING CHART (Continued)

SYMPTOM	PROBABLE CAUSE	ACTION REQUIRED
<p>3. Monitor completely "dead".</p>	<p>Blown console fuse.</p>	<p>Check fuse, located on rear panel of console. If fuse is blown, replace with a 5-amp, type AGC. If fuse blows again, check power connection to battery. If connections are reversed fuse will blow. If battery connections are correct, console needs to be repaired or replaced. Contact your KINZE Dealer.</p>
	<p>Poor battery connections.</p>	<p>Check battery connections. Connections must be clean and tight.</p>
	<p>Cut or broken battery cable.</p>	<p>Visually inspect the battery cable for a cut or broken wire. If wires are cut or broken, splice the wires being sure to match wire colors. Solder the splices and tape each wire individually. USE ONLY ROSIN CORE SOLDER.</p>
	<p>Low battery voltage.</p>	<p>Check battery voltage. Must be at least 12 volts. If not, recharge or replace battery.</p>
	<p>Console defective.</p>	<p>Repair or replace console. Contact your KINZE Dealer.</p>
<p>4. When monitor is turned ON, row display (lower display) remains blank. Upper display shows SPEED, NUMBER OF ROWS, and ROW SPACING constants. Monitor will not enter OPERATE mode.</p>	<p>Defective (shorted) seed sensor.</p>	<p>Leave monitor turned ON. Unplug seed sensors one at a time starting with row 1. When you disconnect a sensor and the remaining row display segments come on and the monitor enters the operate mode, the sensor or its cable is defective. Visually inspect the sensor cable, if damaged repair. If no cable damage is found, the sensor is defective and needs replaced. If all sensors are disconnected and problem still exists, the planter harness, console cable or console is at fault.</p>

# MAINTENANCE

## KM3000 TROUBLESHOOTING CHART (Continued)

SYMPTOM	PROBABLE CAUSE	ACTION REQUIRED
4. (Cont'd.)	Planter harness shorted.	Visually inspect the planter harness (including all row unit cables) for cuts, pinching and other types of damage. If damage is found, cut away cable covering and repair the individual wires. Tape over repaired wire and cable.
	Console cable shorted.	Visually inspect the console cable for cuts, pinching and other types of damage. If damage is found, cut away cable covering and repair the individual wires. Tape over repaired wire and cable.
	Console defective.	If the console cable, planter harness and seed sensors are normal, the console is at fault and needs to be repaired or replaced. Contact your KINZE Dealer.

### SEED MONITOR ROW INDICATOR BULB REPLACEMENT (KM1000 Only)

D-0802-0002/D-0802-0003

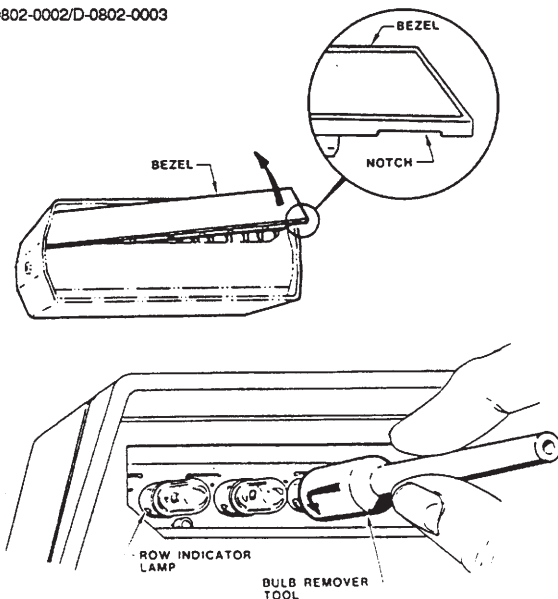

Carefully remove the row indicator bezel as shown. Use your fingernail to pry up along the lower outside edge of the bezel. Remove bezel. Remove burned out bulb using a bulb remover tool. Press in on bulb, turn 1/4 turn counterclockwise and remove bulb. Replace bulb with a No. 1892 (Part No. GR0595) only. Replace bezel.

### SEED MONITOR DISPLAY BACKLITE BULB REPLACEMENT (KM3000 Only)

D-0841-0006

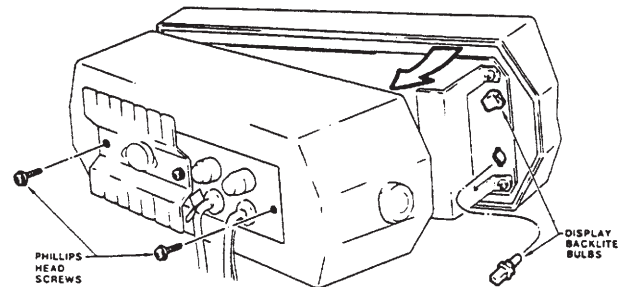

Remove the two outside Phillips head screws. **NOTE: DO NOT REMOVE THE CENTER PHILLIPS HEAD SCREW.** Carefully separate the console case from the front panel. Remove the defective bulb by turning the lamp assembly 1/4 turn counterclockwise and pulling straight out. Replace bulb with a GE #73 bulb (Part No. GR1084). Carefully assemble the console front panel, case and rear panel and install the two Phillips head screws. **CAUTION: Make sure that all wires are located where they will not be pinched or cut.**

# MAINTENANCE

## POINT ROW WRAP SPRING CLUTCH INSPECTION

Standard On 12 And 16 Row/Optional On 8 Row

The point row wrap spring clutch is permanently lubricated and requires no periodic maintenance.

73145-26

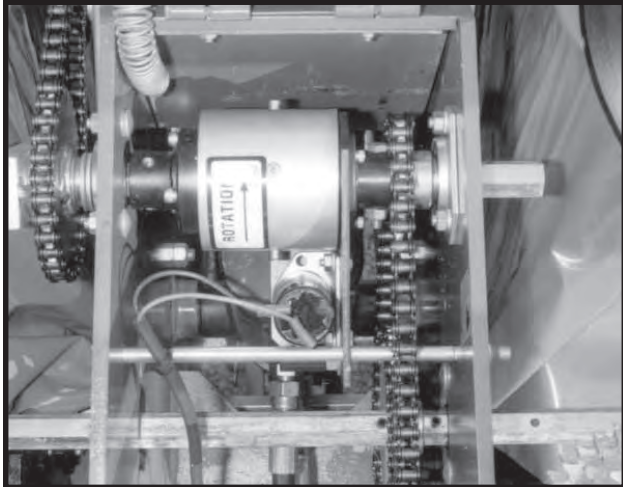

The right hand clutch operates clockwise and the left hand clutch operates counterclockwise. Therefore, some of the parts of the clutch such as the wrap spring differ from one side of the planter to the other. Be sure to use the correct repair part if a clutch must be repaired.

If the clutch or clutches fail to operate first determine if the problem is electrical or mechanical. Place the operational switch in the RIGHT or LEFT position. When the switch is in the RIGHT or LEFT position and the fuse on the rear of the control console is in working condition, the red indicator light on the control console should be lighted. If light does not come on, check the fuses on the front of the control console. See "Point Row Wrap Spring Clutch Troubleshooting" chart. If fuses are not blown, check the clutch and wiring harness for power with a test light or volt meter. If the solenoid is operating properly, the plunger on the solenoid will retract causing a clicking sound. The plunger will also be magnetized which can be checked by touching the plunger with a metal object.

**NOTE:** Always replace fuse with proper size and type when replacing fuse. Use AGC-15 fuse on rear of control console and MDL-8 amp slow blow fuse on front of control console.

PRC018

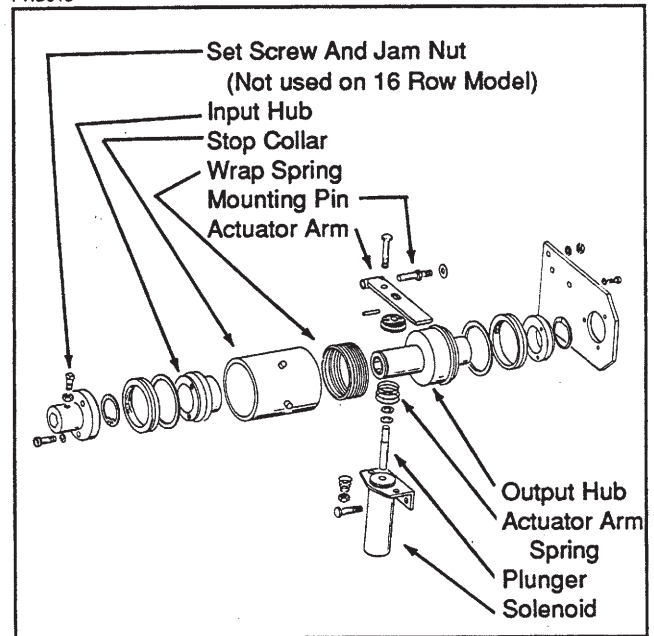

### ACTUATOR ARM ADJUSTMENT

**NOTE:** Gap between actuator arm and stop on stop collar should be not less than 1/16" (.063) when the solenoid is NOT energized.

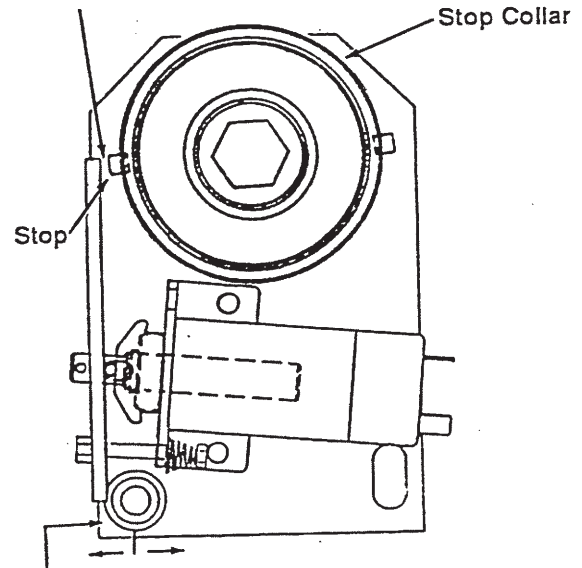

**NOTE:** To adjust gap between actuator arm and stop, loosen nut on mounting pin and move pin in slot until there is at least 1/16" gap between arm and stop on stop collar. Retighten nut.

# MAINTENANCE

## POINT ROW WRAP SPRING CLUTCH TROUBLESHOOTING

PROBLEM	POSSIBLE CAUSE	POSSIBLE SOLUTION
Neither clutch will disengage.	Main fuse blown in control box.	Replace fuse in rear of control box.
	Poor terminal connection in wiring harness.	Repair or replace.
	Wiring damage in wiring harness.	Repair or replace.
	Low voltage at coil. (12 volts required)	Check battery connections.
One side of planter will not re-engage.	Shear pin in row unit transmission sheared.	Replace with one of equal size and grade.
One clutch will not engage.	Fuse blown.	Replace fuse on front panel.
	Actuator arm and plunger stuck in disengaged position.	Remove, free up and reinstall.
	Actuator arm out of adjustment.	Adjust actuator arm mounting pin in slot so that actuator arm clears stop on stop collar by approximately 1/16" when clutch is rotated.
	Wrap spring broken or stretched.	Disassemble clutch and replace spring.
	Foreign substance such as oil or grease on the input or output hubs.	Disassemble clutch. Clean hubs and spring and reassemble.
	Something touching the stop collar.	Check to ensure collar is free to turn with clutch.
	Clutch assembled incorrectly.	Check clutch and diagram for correct assembly.
Clutch slipping.	Wrap spring stretched.	"Lock" clutch output shaft from turning. Place torque wrench on input shaft and rotate in direction of drive. After input shaft has rotated a short distance the wrap spring should tighten onto the input hub. If slippage occurs at less than 100 ft. lbs. replace spring. If spring still slips after installing new spring, replace input hub.
Planter will not re-engage while planter is moving forward.	Spring in actuator arm not strong enough to push arm away from stop collar when operational switch is turned to the ON position.	Remove spring and stretch spring slightly or replace. Reinstall spring. If that fails, file the stop on the stop collar slightly so that the stop is not as aggressive.
Frequent solenoid burnout.	Fuses too large.	Replace fuses on front panel with 8 amp slow blow fuses.
Frequent fuse burnout.	Low voltage (12 volts required).	Check power source voltage for partially discharged battery, etc.
	Damage to wiring harness.	Locate damage and repair or replace harness.
Clutch or clutches will not disengage.	Input and output shafts out of alignment.	Align input and output shafts to prevent drag.
	Input or output shaft is pushed in too far creating a coupler.	Reposition input and output shafts.



# MAINTENANCE

## SOLENOID VALVE INSPECTION

VVB019

The solenoid valve consists of a chambered body containing a cartridge valve which is activated by an electrical coil.

If the solenoid or solenoids fail to operate, first determine if the problem is electrical or hydraulic. If the valve is working properly, a click will be heard when the solenoid coil is energized. This will be the valve stem opening up. If no sound is heard, check the solenoid coil by touching the top of the coil housing with a metallic object such as a pliers or screwdriver. If the coil is working properly, the coil housing will be strongly magnetized when energized. If the voltage to the coil is low, the coil will be weakly magnetized when energized and no click will be heard.

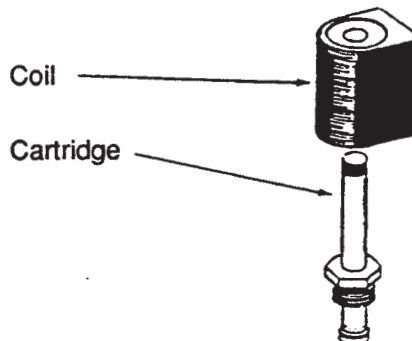

SOLENOID VALVE TROUBLESHOOTING		
PROBLEM	POSSIBLE CAUSE	POSSIBLE SOLUTION
None of the solenoids will operate.	Low Voltage.	Must be connected to 12 volt DC only. Negative ground.
	Blown fuse.	Replace fuse in back of control panel on tractor with 15 amp only.
	Battery connection.	Clean and tighten.
	Wiring harness damaged.	Repair or replace.
One solenoid valve will not operate.	Bad switch.	Replace on control panel.
	Cut wire in harness.	Locate and repair.
	Bad coil.	Replace.
	Poor connection at coil.	Check.
Valve operating when not energized.	Valve stem stuck open.	Replace cartridge.
	O-ring leaking.	Install new o-ring kit.
	Foreign material under poppet.	Remove cartridge and clean.

# MAINTENANCE

## FLOW CONTROL VALVE INSPECTION

VVB020

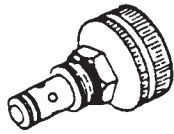

The flow control valves should be adjusted for raise and lower speed as part of the assembly procedure or upon initial operation. If the valve fails to function properly or requires frequent adjustment, it should be removed for inspection. Check for foreign material and contamination on both the valve and the seating area of the valve body. Replace any components found to be defective.

## PRESSURE RELIEF VALVE INSPECTION

VVB020

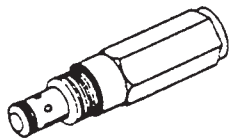

If the pressure relief valve fails to release the tongue lock or function properly, remove the valve from the valve block and check for foreign material or check to see if the o-ring is leaking internally. Replace if found to be defective.

## MARKER BEARING LUBRICATION OR REPLACEMENT

1. Remove marker blade.
2. Remove hub cap from hub.
3. Remove cotter pin, nut and washer.
4. Slide hub from spindle.
5. Remove bearings and cups and discard if bearings are being replaced. Clean hub and dry. Remove bearings only if repacking.
6. Press in new bearing cups with thickest edge facing in. (Bearing replacement procedure only.)
7. Pack bearings with heavy duty wheel bearing grease thoroughly forcing grease between roller cone and bearing cage. Also, fill the space between the bearing cups in the hub with grease.
8. Place inner bearing in place and press in new rubber seal and grease seal.
9. Clean spindle and install hub.
10. Install outer bearing, washer and slotted hex nut. Tighten slotted hex nut while rotating hub until there is some drag. This assures that all bearing surfaces are in contact. Back off slotted nut to nearest locking slot and install cotter pin.
11. Fill hub caps approximately 3/4 full of wheel bearing grease and install on hub.
12. Install blade and hub cap retainer on hub and tighten evenly and securely.

MKR020

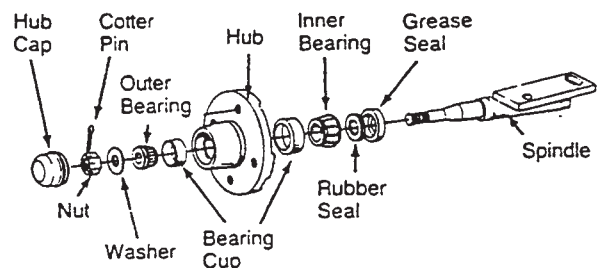

# MAINTENANCE

## WHEEL BEARING LUBRICATION OR REPLACEMENT

**NOTE: Each transport wheel hub is equipped with a grease fitting for lubrication. The below procedure is used only for bearing replacement.**

1. Raise tire clear of ground and remove wheel.
2. Remove double jam nuts and slide hub from spindle.
3. Remove bearings, seals (Where Applicable) and cups and discard if bearings are being replaced. Clean hub and dry. Remove bearings only if repacking.
4. Press in new bearing cups with thickest edge facing in. (Bearing replacement procedure only.)
5. Pack bearings with heavy duty wheel bearing grease thoroughly forcing grease between roller cone and bearing cage. Also fill the space between the bearing cups in the hub with grease.
6. Place inner bearing and seal (Where Applicable) in place.
7. Clean spindle and install hub.
8. Install outer bearing, seal (Where Applicable) and stepped nut. Tighten jam nut while rotating hub until there is some drag. This assures that all bearing surfaces are in contact. Back off jam nut 1/4 turn or until there is only slight drag when rotating the hub. Install second jam nut to lock against first.
9. Install wheel on hub and tighten evenly and securely.

PTD057

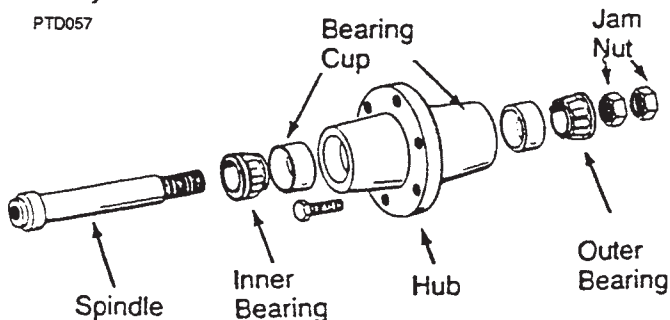

HTA029

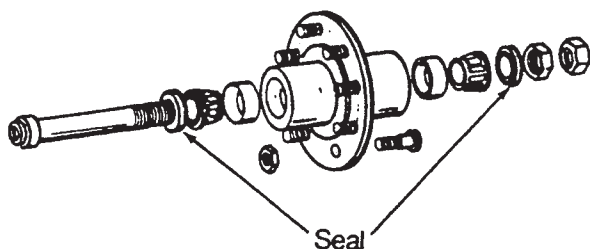

## PREPARATION FOR STORAGE

Store the planter in a dry sheltered area if possible.

Remove all trash that may be wrapped on sprockets or shafts and remove dirt that can draw and hold moisture.

Clean all drive chains and coat with a rust preventative spray, or remove chains and submerge in oil.

Lubricate planter and row units at all lubrication points.

If possible, remove weight from all tires particularly if the unit is stored outdoors, in which case it is best to remove wheels and tires for storage in a cool dry area.

Inspect the planter for parts that are in need of replacement and order during the "off" season.

Make sure all seed, herbicide and insecticide hoppers are empty and clean.

Clean seed meters and store in a dry area.

Remove seed discs from brush-type seed meter, clean and store meters with discs removed.

Grease exposed areas of cylinder rods before storing planter.

Grease or paint disc openers and marker blades to prevent rust.

Flush liquid fertilizer tanks, hoses and metering pump with clean water. See "Piston Pump Storage" if applicable.

Empty dry fertilizer hoppers, clean hoppers, disassemble and clean metering augers, reassemble coating all metal parts with rust preventative.

Pull augers from dry fertilizer quick fill tubes and thoroughly clean augers and tubes and treat with a rust preventative.

# MAINTENANCE

## PISTON PUMP STORAGE

KEEP AIR OUT OF PUMP! This is the only way to prevent corrosion. Even for short periods of storage, the entrance of air into the pump, will cause RAPID AND SEVERE CORROSION.

### Overnight Storage

SUSPENSION FERTILIZER must be flushed from the pump for ANY storage period.

### Winter Storage

1. Flush pump thoroughly with 5 to 10 gallons of fresh water and circulate until all corrosive salts are dissolved in the pump.
2. With the pump set on 10, draw in a mixture of half diesel fuel and half 10 weight oil until the discharge is clean. Then plug inlet and outlet.

69045-6

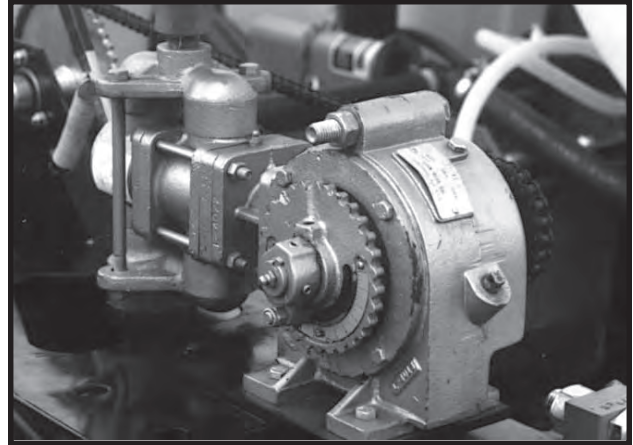

### PISTON PUMP TROUBLESHOOTING

PROBLEM	POSSIBLE CAUSE	POSSIBLE SOLUTION
Pump hard or impossible to prime.	Valves fouled or in wrong place.	Inspect and clean valves.
	Air leak in suction line.	Repair leak.
	Pump set too low.	Adjust pump setting.
	Packing washers worn out.	Replace.
Low metering.	Valves fouled or in wrong place.	Inspect and clean valves.
	Air leak in suction line.	Repair leak.
	Pump set too low.	Adjust pump setting.
	Broken valve spring.	Replace spring.
Over meters.	Broken discharge valve spring.	Replace spring.
	Trash under valves.	Inspect and clean valves.
	Improper rate setting.	Adjust pump setting.
Leaks through when stopped.	Broken discharge valve spring.	Replace spring.
	Trash under valves.	Inspect and clean valves.
Fertilizer solution leaking under stuffing box.	Packing washers worn out.	Replace.
Pump using excessive oil.	Oil seals or o-ring worn and leaking.	Replace.
Pump operates noisily.	Crankcase components worn excessively.	Inspect and replace if necessary.

# MAINTENANCE

## ELECTRICAL WIRING DIAGRAM FOR LIGHT PACKAGE

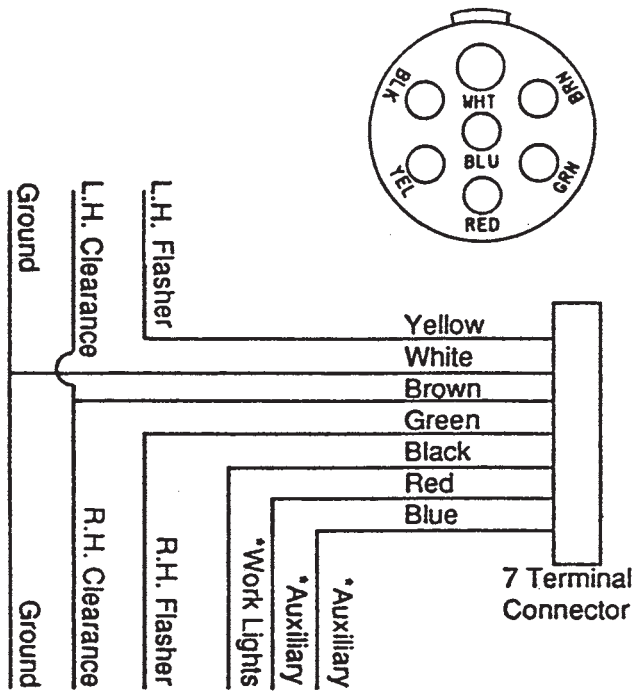

\*Optional lights and wires (to be supplied by customer) may be wired into existing plug terminals.

Light package supplied on the Model 2300 Twin-Line® planter meets ASAE standards. For the correct wiring harness to be wired into the lights on your tractor, check with the tractor manufacturer.

69922-35



# MAINTENANCE

## ELECTRICAL WIRING DIAGRAM FOR CONTROL BOX

73383-19

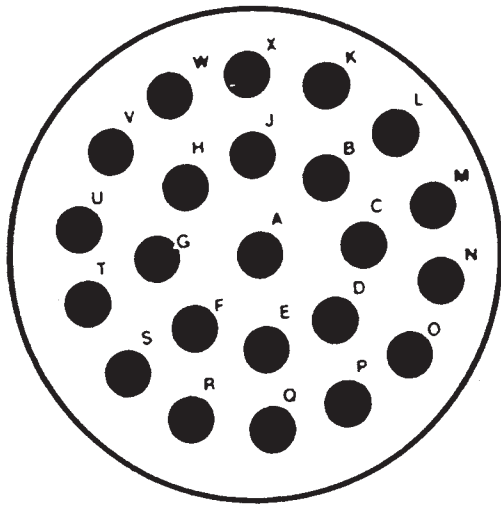

23 PIN CONNECTOR

**NOTE:** Before doing any electrical work, disconnect the tractor battery. Keep wiring harnesses away from high temperature areas or sharp edges. DO NOT route the wiring harnesses along battery cables. Use tie straps to keep wire harness away from moving parts on tractor and planter. Be sure ground connections to the tractor frame are clean to provide good electrical contact.

### Copper Conductor Straps

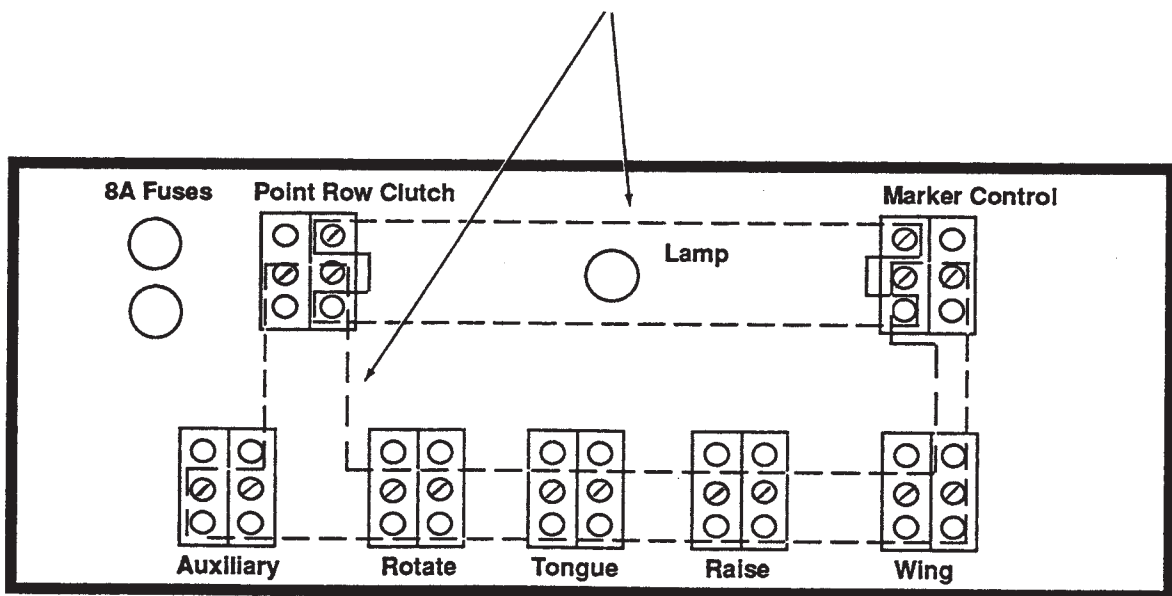

**CONTROL BOX IN CAB**  
(Viewed from rear side of front cover)

# MAINTENANCE

RH100893

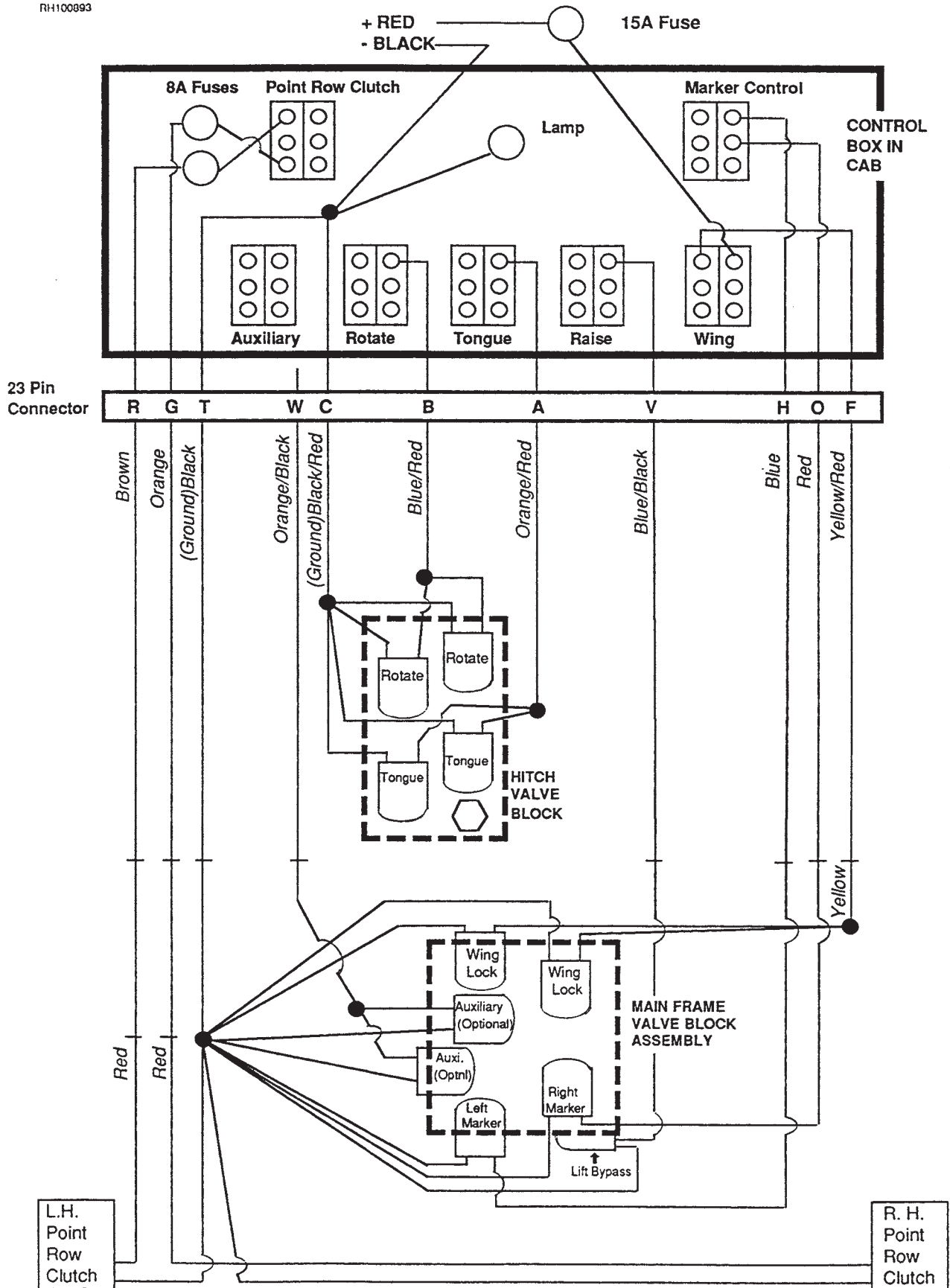

# MAINTENANCE

---



# PARTS LIST INDEX

---

## ROW UNIT

Bed Leveler, Row Unit Mounted .....	P18
Brush-Type Seed Meter .....	P12
Covering Discs/Single Press Wheel .....	P6/P7
Disc Furrower, Row Unit Mounted .....	P19
Finger Pickup Corn Meter .....	P11
Frame Mounted Coulter W/Disc Furrower .....	P22/P23
Gauge Wheel .....	P5
Granular Chemical Banders .....	P13
Granular Chemical Hopper With Meter(s) & Throwout .....	P14/P15
Hopper Support And Meter Drive .....	P9
No Till Coulter, Row Unit Mounted .....	P17
Parallel Arms, Mounting Support Plate And Quick Adjustable Down Force Springs .....	P4
Residue Wheel, Row Unit Mounted .....	P20/P21
Seed Hopper .....	P10
Shank Assembly .....	P2/P3
Spring Tooth Incorporator .....	P16
"V" Closing Wheels .....	P8

## BASE MACHINE

Axle And Transport Wheels .....	P38/P39
Center Lift Arms .....	P37
Center Pivot.....	P36
Contact Drive Wheel .....	P40/P41
Cylinders .....	P63/P68
Electrical Components .....	P48/P49
Frames .....	P32/P35
Hitches .....	P26/P31
Hydraulic System .....	P60/P62
Inner Module Drive .....	P44
Marker Assemblies .....	P50/P53
Marker Spindle/Hub/Blade .....	P54
Point Row Wrap Spring Clutch .....	P46/P47
Ratchet/Sprocket Assembly, 16 Row 30 .....	P45
Row Unit Extensions .....	P69
Transmission And Row Unit Drill Shaft .....	P42/P43
Valve/Junction Blocks .....	P56/P59
Valves (Solenoid, Flow Control, Pressure Relief, Check) .....	P55

## ELECTRONIC SEED MONITOR

Electronic Seed Monitor .....	P72/P73
-------------------------------	---------

## INTERPLANT

Interplant Push Row Unit .....	P24/P25
Interplant Push Unit Drive .....	P70/P71

## FERTILIZER

Double Disc Fertilizer Opener .....	P74/P75
Dry Fertilizer .....	P81/P85
Dry Fertilizer Quick Fill .....	P86/P89
Dry/Liquid Fertilizer Mounts (Double Disc Openers) .....	P80
Dry/Liquid Fertilizer Mounts (Single Disc Openers) .....	P80
Liquid Fertilizer .....	P90/P104
Single Disc Fertilizer Opener .....	P76/P79

SMV, Decals, Reflectors And Tie Straps .....	P105/P107
--	-----------

Numerical Index .....	a
-----------------------	---

# SHANK ASSEMBLY

RUB006/RUA044

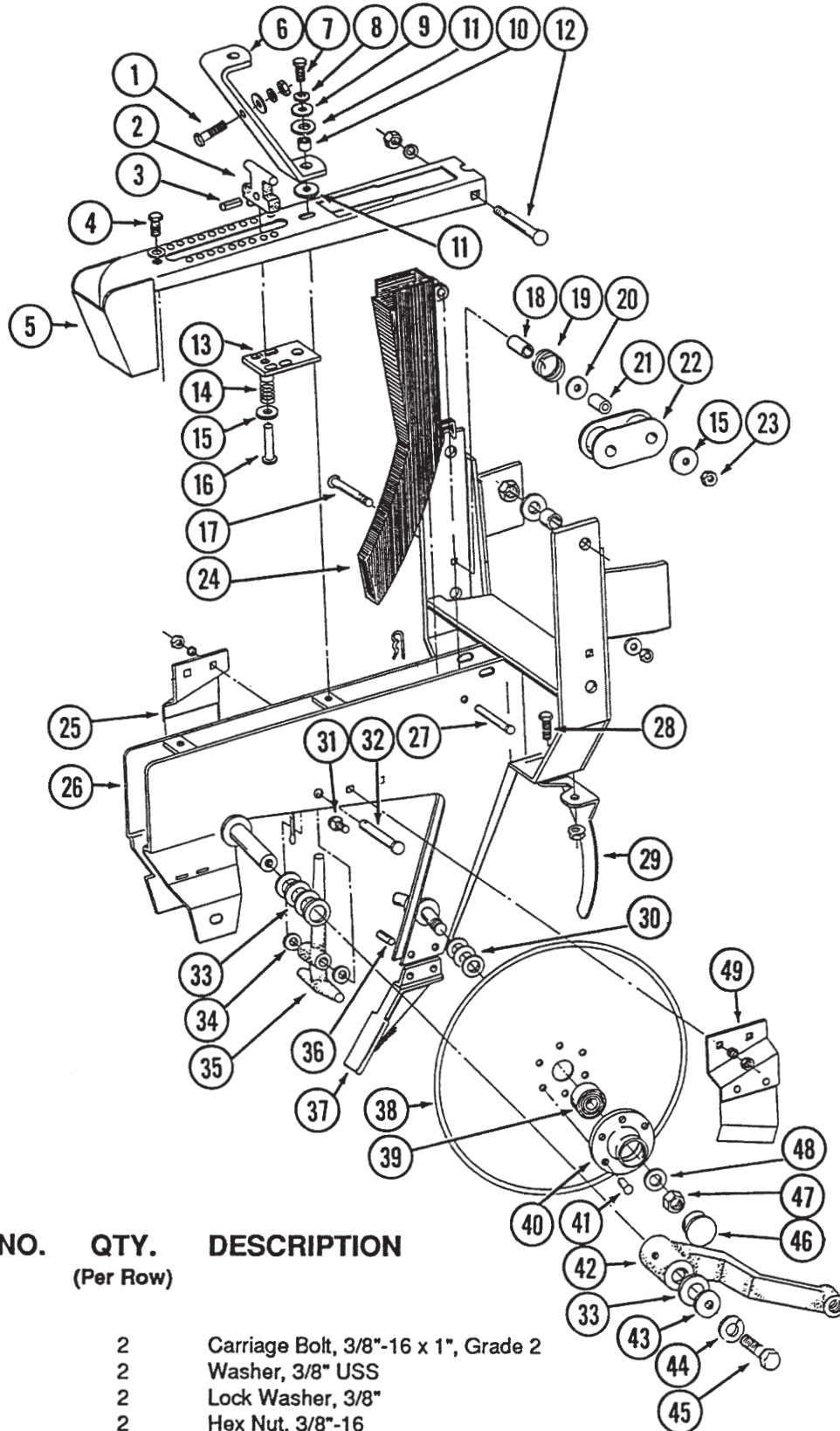

ITEM	PART NO.	QTY. (Per Row)	DESCRIPTION
1.	G10305	2	Carriage Bolt, 3/8"-16 x 1", Grade 2
	G10210	2	Washer, 3/8" USS
	G10229	2	Lock Washer, 3/8"
	G10101	2	Hex Nut, 3/8"-16
2.	GB0102	1	Depth Adjusting Handle
3.	G10605	1	Spring Pin, 5/32" x 3/4"
4.	G10001	1	Hex Head Cap Screw, 3/8"-16 x 1"
	G10229	1	Lock Washer, 3/8"
5.	GA0811	1	Shank Cover
6.	GD1027	1	Stabilizer Bracket

# SHANK ASSEMBLY

ITEM	PART NO.	QTY. (Per Row)	DESCRIPTION
7.	G10003	1	Hex Head Cap Screw, 3/8"-16 x 1 1/2"
8.	G10229	1	Lock Washer, 3/8"
9.	G10208	1	Special Washer, 13/32"
10.	GD1110	1	Bushing
11.	GD1120	2	Rubber Washer
12.	G10304	1	Carriage Bolt, 3/8"-16 x 3", Grade 2
	G10108	1	Lock Nut, 3/8"-16
13.	GB0105	1	Depth Adjusting Slide
14.	GD1066	1	Compression Spring
15.	G10210	1	Washer, 3/8" USS
16.	G10552	1	Clevis Pin, 3/8" x 2"
17.	G10307	1	Carriage Bolt, 3/8"-16 x 3 1/2", Grade 2
18.	GD7318	1	Bushing, 1"
19.	GD1065	1	Idler Spring
20.	G10201	1	Special Washer
21.	GD1026	1	Spacer, 1 3/16"
22.	GD9240	1	Idler
23.	G10108	1	Lock Nut, 3/8"-16
24.	GD1130	-	Seed Tube, Regular
	GA5880	-	Seed Tube W/High Rate Sensor
	GR1062	-	Seed Tube (With holes for high rate sensor installation)
	GR1087	-	Sensor Only (For GA5880)
25.	GA2012L	1	Disc Scraper, Left Hand
26.	GA0860	1	Shank
27.	G10551	1	Clevis Pin, 1/4" x 2 1/2"
	G10669	1	Hair Pin Clip, No. 22
28.	G10312	2	Carriage Bolt, 5/16"-18 x 3/4", Grade 2
	G10620	2	Flange Nut, 5/16"-18
29.	GD1033	1	Shield
30.	G10213	-	Machine Bushing, .030 Gauge (As Required)
31.	G10328	4	Hex Head Cap Screw, 3/8"-16 x 5/8"
	G10229	4	Lock Washer, 3/8"
	G10101	4	Hex Nut, 3/8"-16
32.	G10555	1	Clevis Pin, 1/2" x 2 1/2"
	G10451	1	Cotter Pin, 1/8" x 1"
33.	G10526	-	Spacer Washer, .048 Gauge (As Required)
34.	G10206	2	Washer, 1/2"
35.	GB0104	1	Depth Adjusting Stop
36.	G10601	2	Spring Pin, 1/4" x 3/4"
37.	GB0241	1	Seed Tube Guard/Inner Scraper
38.	GD1030	2	Disc, 15"
39.	GA2014	2	Bearing
40.	GD1031	2	Housing
41.	G10427	12	Rivet, 1/4" x 1/2"
42.		-	See "Gauge Wheel"
43.	G10216	2	Washer, 1/2" USS
44.	G10228	2	Lock Washer, 1/2"
45.	G10014	2	Hex Head Cap Screw, 1/2"-13 x 1"
46.	GD6533	2	Bearing Cap
47.	G10503	1	Jam Nut, 5/8"-11, Right Hand
	G10504	1	Jam Nut, 5/8"-11, Left Hand
48.	G10204	2	Washer, 21/32"
49.	GA2012R	1	Disc Scraper, Right Hand
A.	GA2013	-	Disc And Bearing Assembly, Less Bearing Cap (Items 38-41)
B.	G1K212	-	Meter Drive Idler Kit (Items 15 and 17-23)

# PARALLEL ARMS, MOUNTING SUPPORT PLATE AND QUICK ADJUSTABLE DOWN FORCE SPRINGS

RUB007/RUB015/RUB016/RUB013

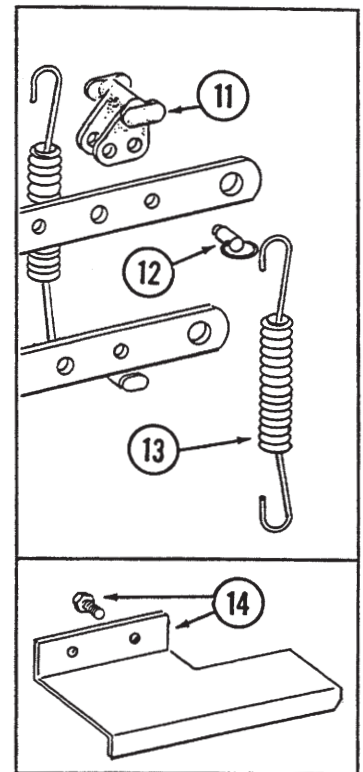
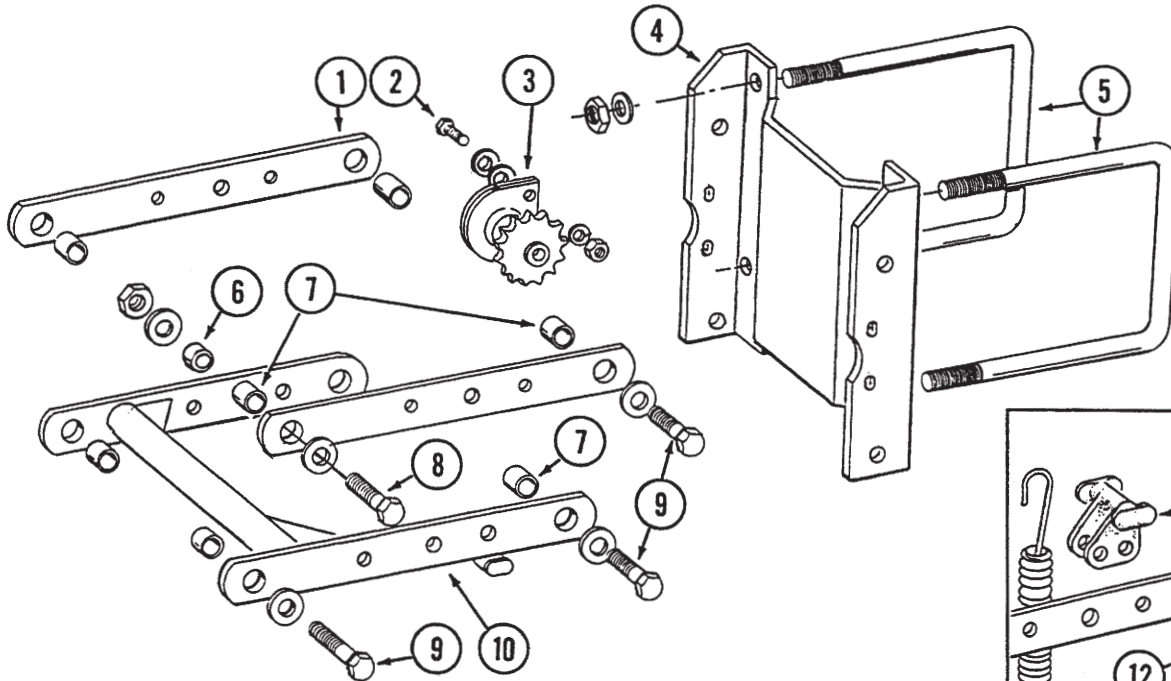

ITEM	PART NO.	QTY. (Per Row)	DESCRIPTION
1.	GD7619	2	Upper Parallel Arm
2.	G10004	2	Hex Head Cap Screw, 3/8"-16 x 1 1/4"
	G10210	-	Washer, 3/8" USS (As Required)
	G10229	2	Lock Washer, 3/8"
	G10101	2	Hex Nut, 3/8"-16
3.	GA1720	1	Bearing/Sprocket, 7/8" Bore
4.	GA6822	1	Mounting Support Plate
5.	GD1113	2	U-Bolt, 5" x 7" x 5/8"-11
	G10230	4	Lock Washer, 5/8"
	G10104	4	Hex Nut, 5/8"-11
6.	GD1109	2	Pivot Bushing, 1/4"
7.	GB0218	8	Bushing, 1/2"
8.	G10752	2	Hex Head Cap Screw, 5/8"-18 x 2 1/4"
	GD7805	4	Special Washer
	G10412	2	Lock Nut, 5/8"-18
9.	G10732	6	Hex Head Cap Screw, 5/8"-18 x 2"
	GD7805	6	Special Washer
	G10412	6	Lock Nut, 5/8"-18
10.	GA5651	1	Lower Parallel Arm
11.	GB0186	2	Spring Anchor
12.	G10545	2	Detent Pin, 1" Grip
13.	GD8249	-	Spring
14.	G7192X	-	Chain Shield Package With Hardware (Used with Row Unit Mounted No Till Coulters)
	G10037	-	Hex Head Cap Screw, 1/2"-13 x 1 1/4"
	G10228	-	Lock Washer, 1/2"
	G10102	-	Hex Nut, 1/2"-13

# GAUGE WHEEL

RUB001/RUB018/RUA039/RUB018/RUA044

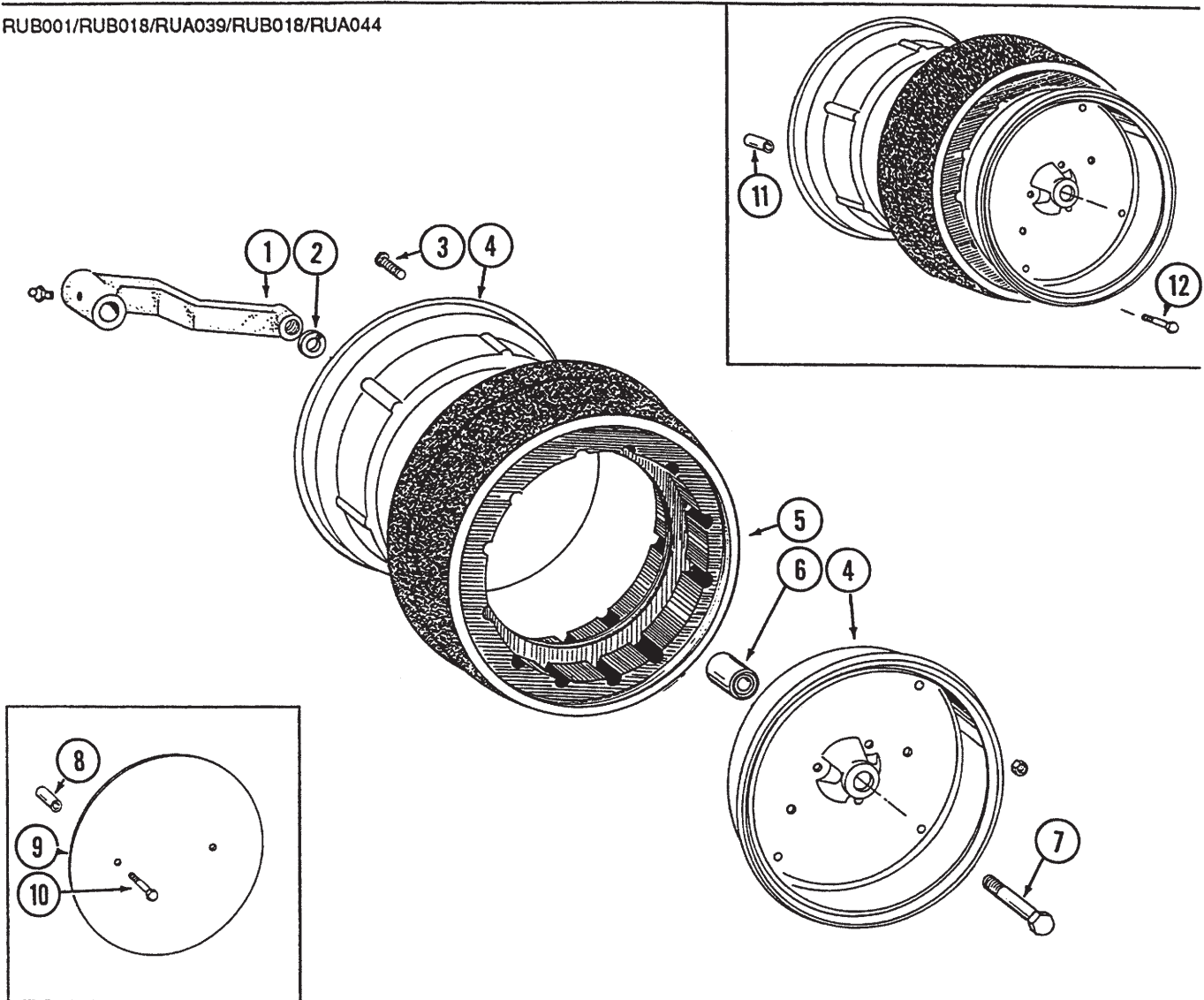

ITEM	PART NO.	QTY. (Per Row)	DESCRIPTION
1.	GA6614	2	Wheel Arm With Grease Fitting
	G10640	2	Grease Fitting, 1/4"-20
2.	G10230	2	Lock Washer, 5/8"
3.	G10018	14	Hex Head Cap Screw, 5/16"-18 x 5/8"
	G10109	14	Lock Nut, 5/16"-18
4.	GD1048	4	Half Wheel
5.	GD1086	2	Tire
6.	GA6171	2	Bearing
7.	G10010	2	Hex Head Cap Screw, 5/8"-11 x 3"
8.	GD0973	4	Wheel Cover Sleeve, 1 1/2"
9.	GD1353	2	Wheel Cover (Optional)
10.	G10069	4	Hex Head Cap Screw, 5/16"-18 x 2 1/4"
	G10232	4	Lock Washer, 5/16"
	G10106	4	Hex Nut, 5/16"-18
11.	GD8811	8	Dual Gauge Wheel Sleeve, 4 1/8" (Optional)
12.	G10764	8	Hex Head Cap Screw, 5/16"-18 x 5"
	G10109	8	Lock Nut, 5/16"-18
A.	GA6615	-	Gauge Wheel Complete (Items 3-6)

# COVERING DISCS/SINGLE PRESS WHEEL

RUA042/RUA044

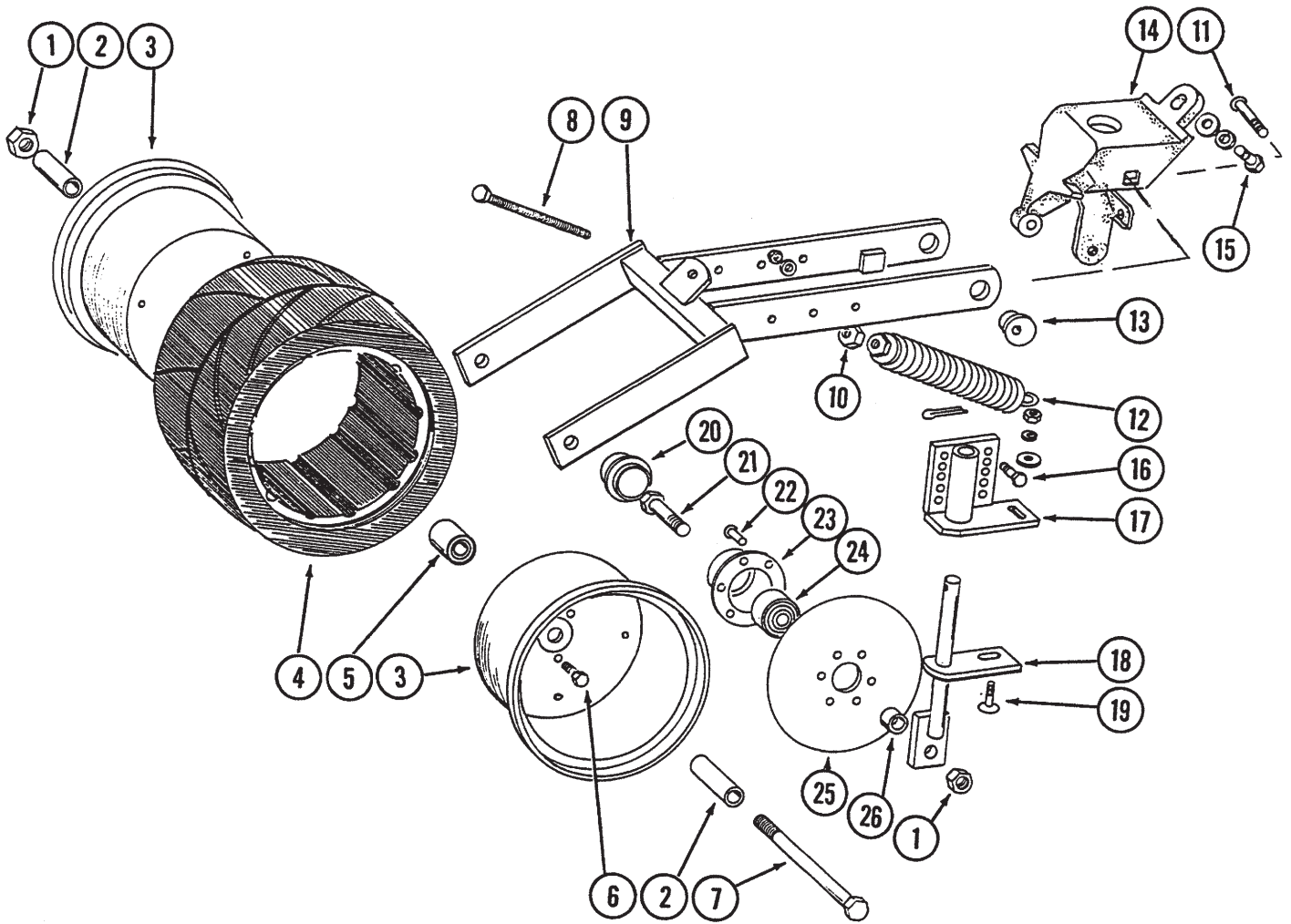

# COVERING DISCS/SINGLE PRESS WHEEL

---

ITEM	PART NO.	QTY. (Per Row)	DESCRIPTION
1.	G10107	3	Lock Nut, 5/8"-11
2.	GD3181-12	2	Spacer, 2 7/8"
3.	GD9562	2	Half Wheel
4.	GD9305	1	Tire
5.	GA6171	1	Bearing
6.	G10018	7	Hex Head Cap Screw, 5/16"-18 x 5/8"
	G10109	7	Lock Nut, 5/16"-18
7.	G10152	1	Hex Head Cap Screw, 5/8"-11 x 9"
8.	G10015	1	Adjusting Bolt, 1/2"-13 x 5"
9.	GA6619	1	Mounting Arm
10.	G10102	1	Hex Nut, 1/2"-13
11.	G10747	2	Carriage Bolt, 1/2"-13 x 2"
	G10111	2	Lock Nut, 1/2"-13
12.	GA2054	1	Spring
13.	GB0239	2	Eccentric Bushing
14.	GB0233	1	Wheel Arm Stop
15.	G10003	1	Hex Head Cap Screw, 3/8"-16 x 1 1/2"
	G10229	1	Lock Washer, 3/8"
	G10210	2	Washer, 3/8" USS
16.	G10171	4	Hex Head Cap Screw, 5/16"-18 x 1 1/4"
	G10232	4	Lock Washer, 5/16"
	G10106	4	Hex Nut, 5/16"-18
17.	GA6620	2	Bracket
18.	GA6618	2	Mount
19.	G10303	2	Carriage Bolt, 5/16"-18 x 1"
	G10219	2	Washer, 5/16" USS
	G10232	2	Lock Washer, 5/16"
	G10106	2	Hex Nut, 5/16"-18
20.	GD6533	2	Cap
21.	G10006	2	Hex Head Cap Screw, 5/8"-11 x 2 1/4"
22.	G10427	12	Rivet, 1/4" x 1/2"
23.	GD1031	2	Bearing Housing
24.	GA2014	2	Bearing
25.	GD9290	2	Blade, 8" Diameter
26.	GD1109	2	Spacer, 1/4"
A.	GA6733	-	Single Press Wheel Complete With Bearing (Items 3-6)
B.	GA6801	-	Covering Disc Complete With Bearing (Items 22-25)

# "V" CLOSING WHEELS

RUB004/RUA044

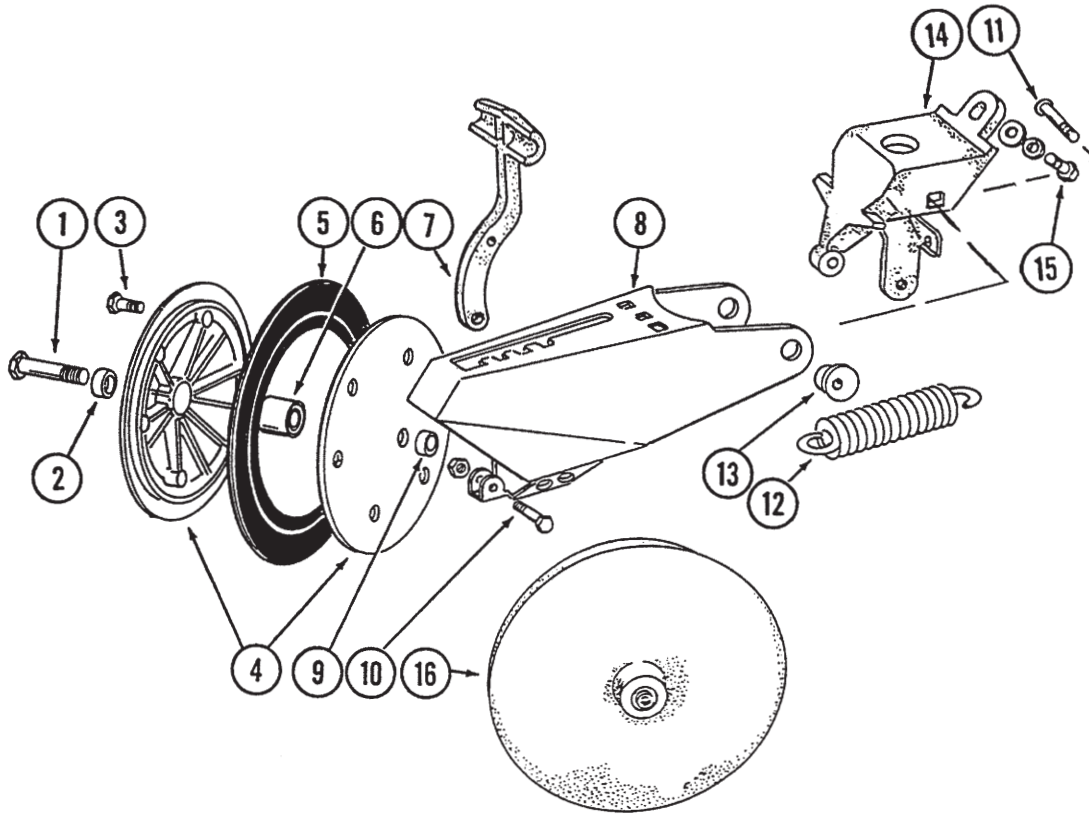

ITEM	PART NO.	QTY. (Per Row)	DESCRIPTION
1.	G10013	2	Hex Head Cap Screw, 5/8"-11 x 3 1/2"
	G10107	2	Lock Nut, 5/8"-11
2.	GB0218	2	Spacer, 1/2"
3.	G10064	6	Hex Head Cap Screw, 1/4"-20 x 1"
	G10103	6	Hex Nut, 1/4"-20
4.	GD9120	4	Nylon Half Wheel
5.	GD1085	2	Rubber Tire, 1" x 15"
6.	GA6171	2	Bearing
7.	GB0215	1	Lever
8.	GA6613	1	Arm
9.	GD1109	2	Bushing, 1/4"
10.	G10133	1	Hex Head Cap Screw, 5/16"-18 x 1 1/2"
	G10109	1	Lock Nut, 5/16"-18
11.	G10747	2	Carriage Bolt, 1/2"-13 x 2"
	G10111	2	Lock Nut, 1/2"-13
12.	GD8460	1	Spring
13.	GB0219	2	Eccentric Bushing
14.	GB0233	1	Wheel Arm Stop
15.	G10003	1	Hex Head Cap Screw, 3/8"-16 x 1 1/2"
	G10229	1	Lock Washer, 3/8"
	G10210	2	Washer, 3/8" USS
16.	GA6597	-	Cast Iron Closing Wheel W/Bearing
	GA6171	-	Bearing
A.	GA6434	-	Rubber Closing Wheel Complete With Bearing (Items 3-6)



# HOPPER SUPPORT AND METER DRIVE

RUB005

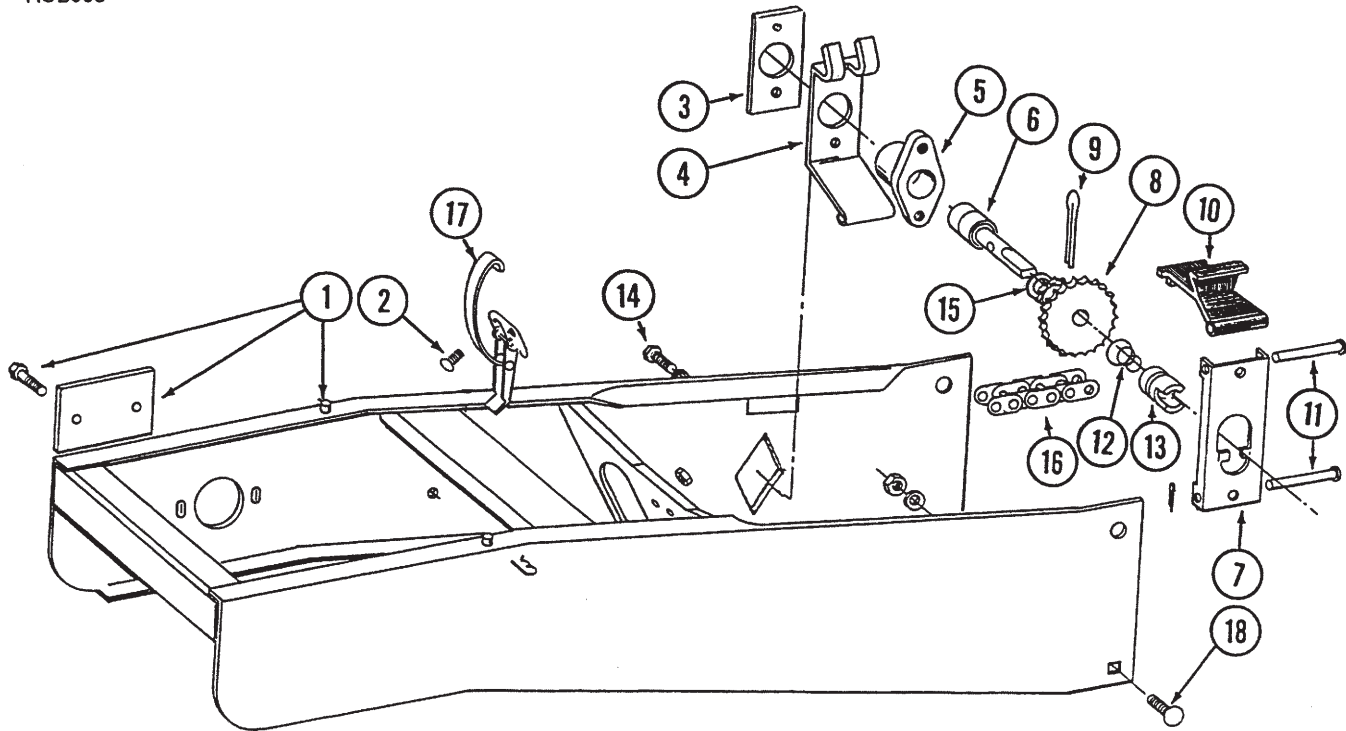

ITEM	PART NO.	QTY. (Per Row)	DESCRIPTION
1.	GR1066	1	Hopper Support W/Cover And Hardware
	GD7618	1	Cover
	G10312	2	Carriage Bolt, 5/16"-18 x 3/4"
	G10620	2	Flange Nut, 5/16"-18
2.	G10309	2	Carriage Bolt, 1/4"-20 x 5/8", Grade 2
	G10621	2	Flange Nut, 1/4"-20
3.	GD2128	1	Plate
4.	GD1037	1	Bearing Support
5.	GB0108	1	Bearing Housing
6.	GA2016	1	Bearing
7.	GD1036	1	Drive Release Lever
8.	GB0107	1	Sprocket, 11/19 Tooth
9.	G10457	1	Cotter Pin, 5/32" x 1 1/2"
10.	GD1035	1	Release Handle
11.	G10553	2	Clevis Pin, 1/4" x 2 5/8"
	G10455	2	Cotter Pin, 1/16" x 1/2"
12.	GD8458	1	Compression Spring
13.	GB0243	1	Drive Coupler
14.	G10019	2	Hex Head Cap Screw, 5/16"-18 x 1"
	G10232	2	Lock Washer, 5/16"
15.	G10204	-	Machinery Bushing, 21/32" (As Required)
16.	G3303-98	1	Roller Chain, No. 41, 98 Links Including Connector Link
	GR0196	1	Connector Link, No. 41
17.	GA2007	1	Hopper Hold Down Latch
18.	G10305	1	Carriage Bolt, 3/8"-16 x 1", Grade 2
	G10229	1	Lock Washer, 3/8"
	G10101	1	Hex Nut, 3/8"-16
A.	GA4822	-	Meter Drive Assembly Complete (Items 3-14)

# SEED HOPPER

RUA015

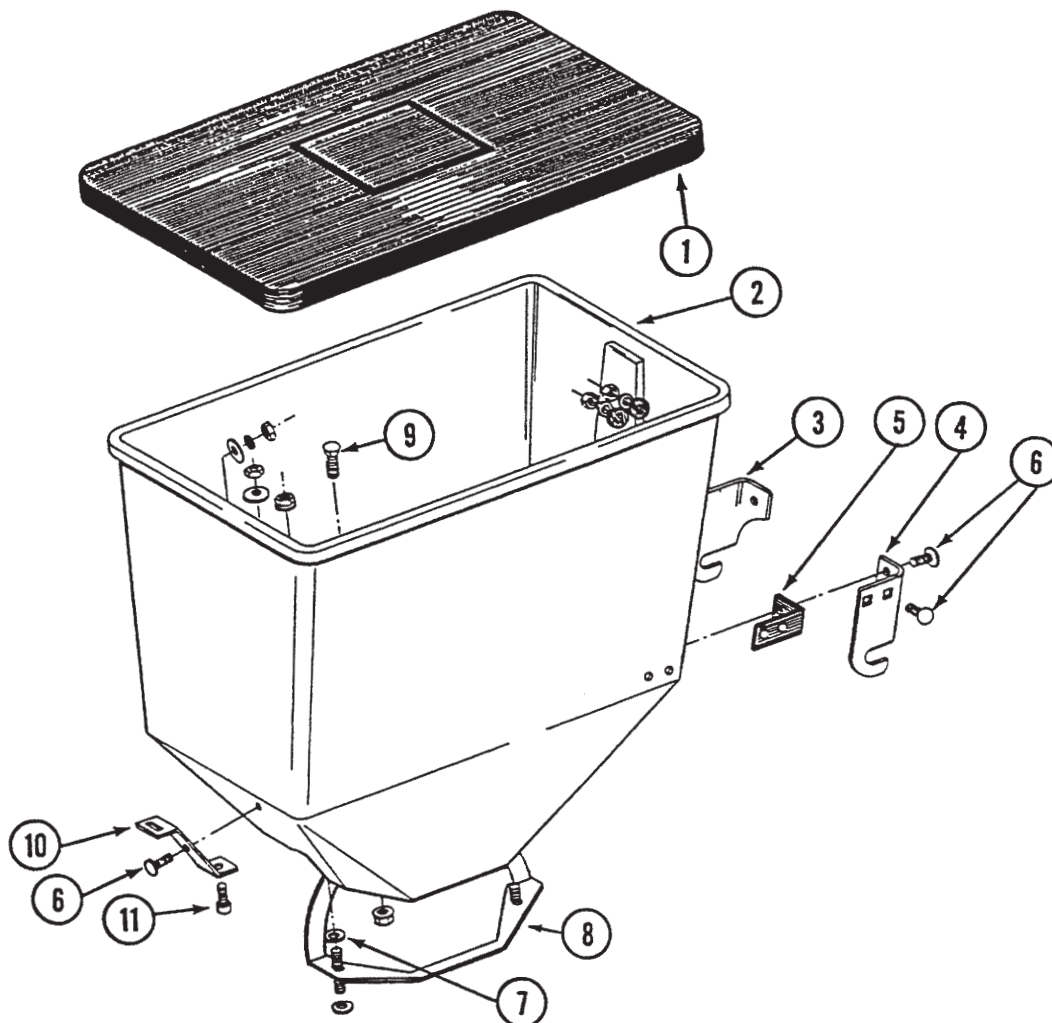

ITEM	PART NO.	QTY. (Per Row)	DESCRIPTION
1.	GA2327	1	Lid With Clip
2.	GD1053	1	Seed Hopper
3.	GD1051L	1	Bracket, Left Hand
4.	GD1051R	1	Bracket, Right Hand
5.	GD1054	2	Mounting Pad
6.	G10310	7	Carriage Bolt, 1/4"-20 x 3/4", Grade 2
	GD1121	7	Rubber Washer
	G10209	7	Washer, 1/4" USS
	G10110	7	Self Locking Nut, 1/4"-20
7.	GD1121	2	Rubber Washer
8.	GA2027	1	Retainer
9.	G10310	1	Carriage Bolt, 1/4"-20 x 3/4", Grade 2
	G10621	1	Whiz Lock Nut, 1/4"
10.	GD1055	1	Clip
11.	G10520	1	Hex Head Cap Screw, 3/8"-16 x 3/4", Grade 8
	G10210	1	Washer, 3/8" USS
	G10229	1	Lock Washer, 3/8"
	G10101	1	Hex Nut, 3/8"-16
A.	GA2058	-	Seed Hopper With Hardware, Less Lid (Items 2-11)

# FINGER PICKUP CORN METER

RUA015

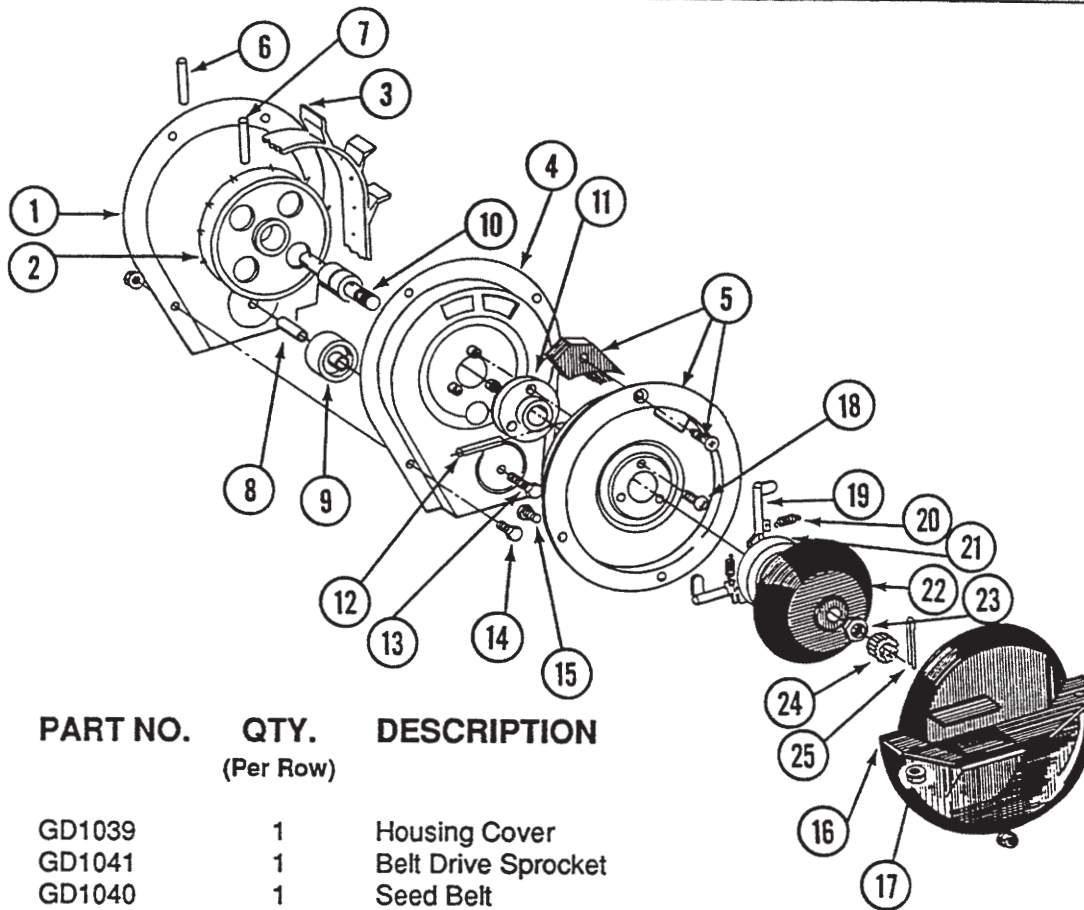

ITEM	PART NO.	QTY. (Per Row)	DESCRIPTION
1.	GD1039	1	Housing Cover
2.	GD1041	1	Belt Drive Sprocket
3.	GD1040	1	Seed Belt
4.	GA2018	1	Conveyor Housing
5.	GR0664	1	Carrier With Brush And Screw
	GA2020	-	Brush
	G10690	-	Rolling Thread Screw, No. 10 x 3/4"
6.	G10602	1	Spring Pin, 1/4" x 1 1/2"
7.	G10604	1	Spring Pin, 3/16" x 1 1/2"
8.	GB0120	1	Bushing
9.	GD1042	1	Idler
10.	GA2019	1	Bearing
11.	GB0110	1	Bearing Housing
12.	G10603	1	Spring Pin, 1/4" x 1 1/4"
13.	G10021	1	Hex Head Cap Screw, 1/4"-20 x 1 1/2"
	G10621	1	Flange Nut, 1/4"
14.	G10022	4	Hex Head Cap Screw, 1/4"-20 x 1/2"
	G10621	4	Flange Nut, 1/4"
15.	G10020	3	Hex Head Cap Screw, 1/4"-20 x 5/8"
	G10323	3	Hex Flange Nut, 1/4"-20
16.	GD1046	3	Seed Baffle
17.	G10620	2	Flange Nut, 5/16"-18
18.	G10401	3	Machine Screw, No. 10-32 x 5/8"
19.	GD1044	-	Finger (12 Per Meter)
20.	GD6501	12	Spring
21.	GB0111	1	Cam
22.	GD1045	1	Finger Holder
23.	G10500	1	Jam Nut, 5/8"-18 UNF
24.	GD1083	1	Cage Nut, 5/8"
25.	G10470	1	Cotter Pin, 5/32" x 1"
A.	GR0933	-	Finger Assembly (Items 19-22)

# BRUSH-TYPE SEED METER

RUA037

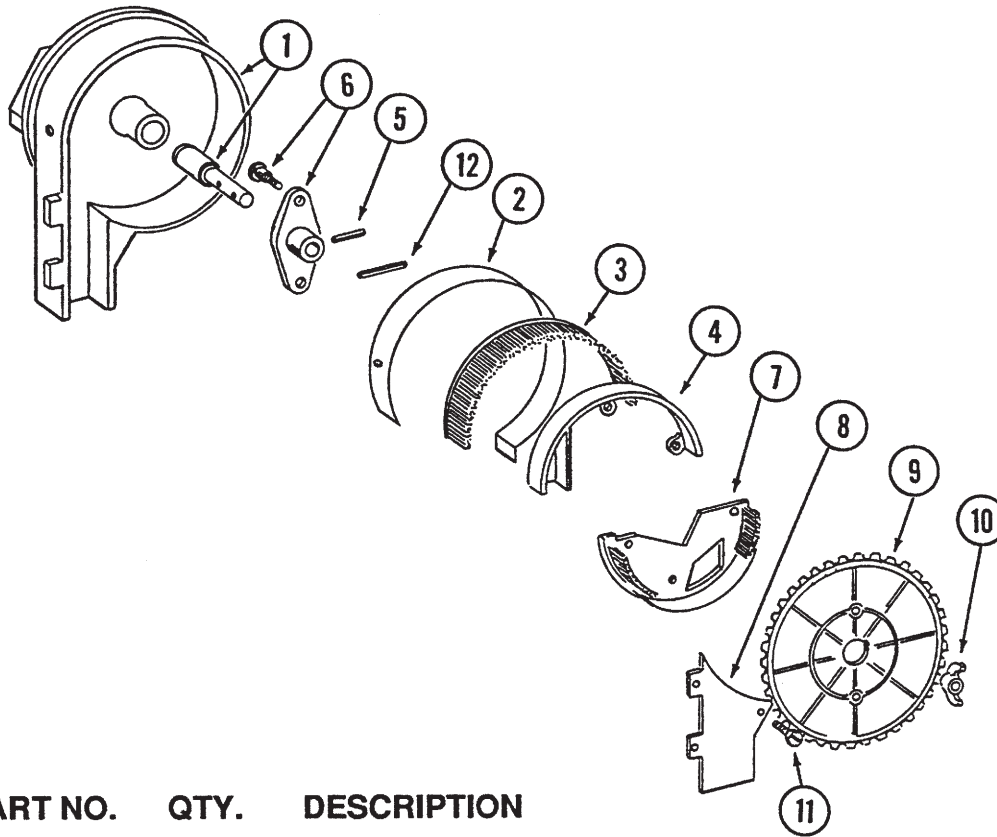

ITEM	PART NO.	QTY. (Per Row)	DESCRIPTION
1.	GA6027	1	Housing W/Bearing
	GA5698	-	Bearing
2.	GD8778	1	Wear Strip
3.	GA5699	1	Upper Retaining Brush
4.	GD8237	1	Retaining Brush Holder
5.	G10603	1	Spring Pin, 1/4" x 1 1/4"
6.	GA6038	1	Hub W/Shoulder Bolts
	GD1755	-	Shoulder Bolt, 1/4" (2 Used)
7.	GA5834	1	Lower Brush
8.	GD7878	1	Cover
9.	GA5794	-	Seed Disc, Soybean, 60 Cell, Black Color-coded
	GA6184	-	Seed Disc, Specialty Soybean, 48 Cell, Dark Blue Color-coded
	GA5982	-	Seed Disc, Small Milo/Grain Sorghum, 30 Cell, Red Color-coded
	GA6187	-	Seed Disc, Large Milo/Grain Sorghum, 30 Cell, Light Blue Color-coded
	GA5795	-	Seed Disc, High Rate Small Milo/Grain Sorghum, 60 Cell, Red Color-coded
	GA6633	-	Seed Disc, High Rate Large Milo/Grain Sorghum, 60 Cell, Yellow Color-coded
	GA5796	-	Seed Disc, Cotton, Acid-delinted, 30 Cell, White Color-coded
	GA6168	-	Seed Disc, Large Cotton, Acid-delinted, 36 Cell, Tan Color-coded
	GA6478	-	Seed Disc, High Rate Cotton, Acid-delinted, 48 Cell, Light Green Color-coded
	GA6182	-	Seed Disc, Hill-drop Cotton, Acid-delinted, 12 Cell, Brown Color-coded
10.	G10531	2	Nylon Insert Wing Nut, 1/4"-20
11.	G10584	9	Slotted Tap Screw, No. 10-24 x 1/2"
12.	G10602	1	Spring Pin, 1/4" x 1 1/4"

# GRANULAR CHEMICAL BANDERS

RUA013/RUA016/RUA044

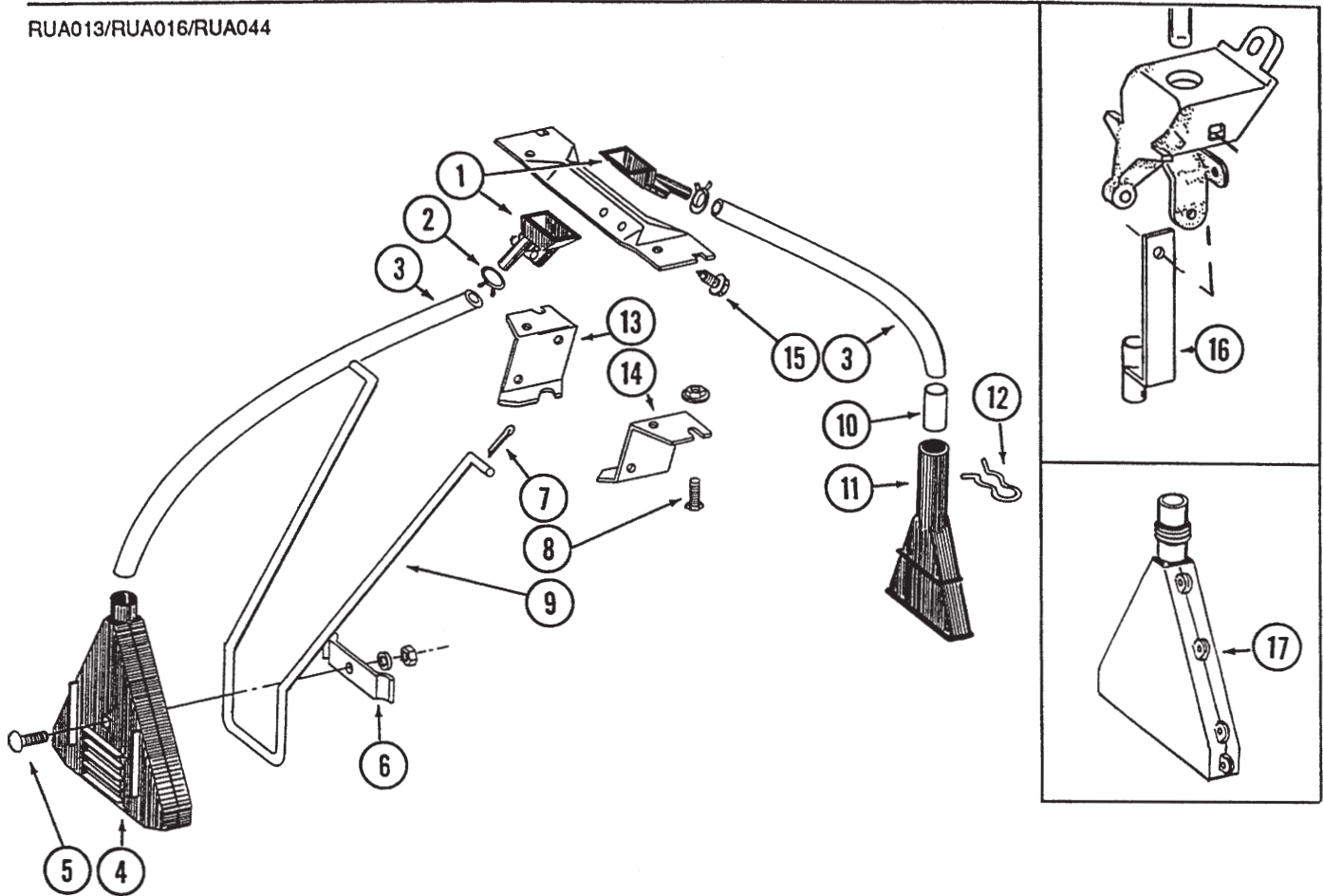

ITEM	PART NO.	QTY.	DESCRIPTION
1.	GD2423	-	Funnel
2.	G10680	-	Hose Clamp, 7/16"
3.	GD2947	-	Hose, 7/16" x 28"
4.	GA2075	-	Diffuser, 14" Band
5.	G10306	-	Carriage Bolt, 3/8"-16 x 2", Grade 2
	G10229	-	Lock Washer, 3/8"
	G10101	-	Hex Nut, 3/8"-16
6.	GD1118	-	Clamp
7.	G10452	-	Cotter Pin, 1/8" x 1/2"
8.	G10310	-	Carriage Bolt, 1/4"-20 x 3/4", Grade 2
	G10227	-	Lock Washer, 1/4"
	G10103	-	Hex Nut, 1/4"-20
9.	GD1116	-	Hanger
10.	GD1082	-	Tube
11.	GD1081	-	Spreader (7" Band)
12.	GD1090	-	Spring Clip
13.	GD1115L	-	Hanger Bracket, L.H.
14.	GD1115R	-	Hanger Bracket, R.H.
15.	G10523	-	Self Tapping Screw, No. 10 x 1/2"
16.	GA6741	-	Bracket (Direct Drop))
17.	GA6476	-	Slope-compensating Bander (3 1/2" or 7" Band)

# GRANULAR CHEMICAL HOPPER WITH METER(S) & THROWOUT

RUA006/RUA008/RUA033/RUA034/RUA044

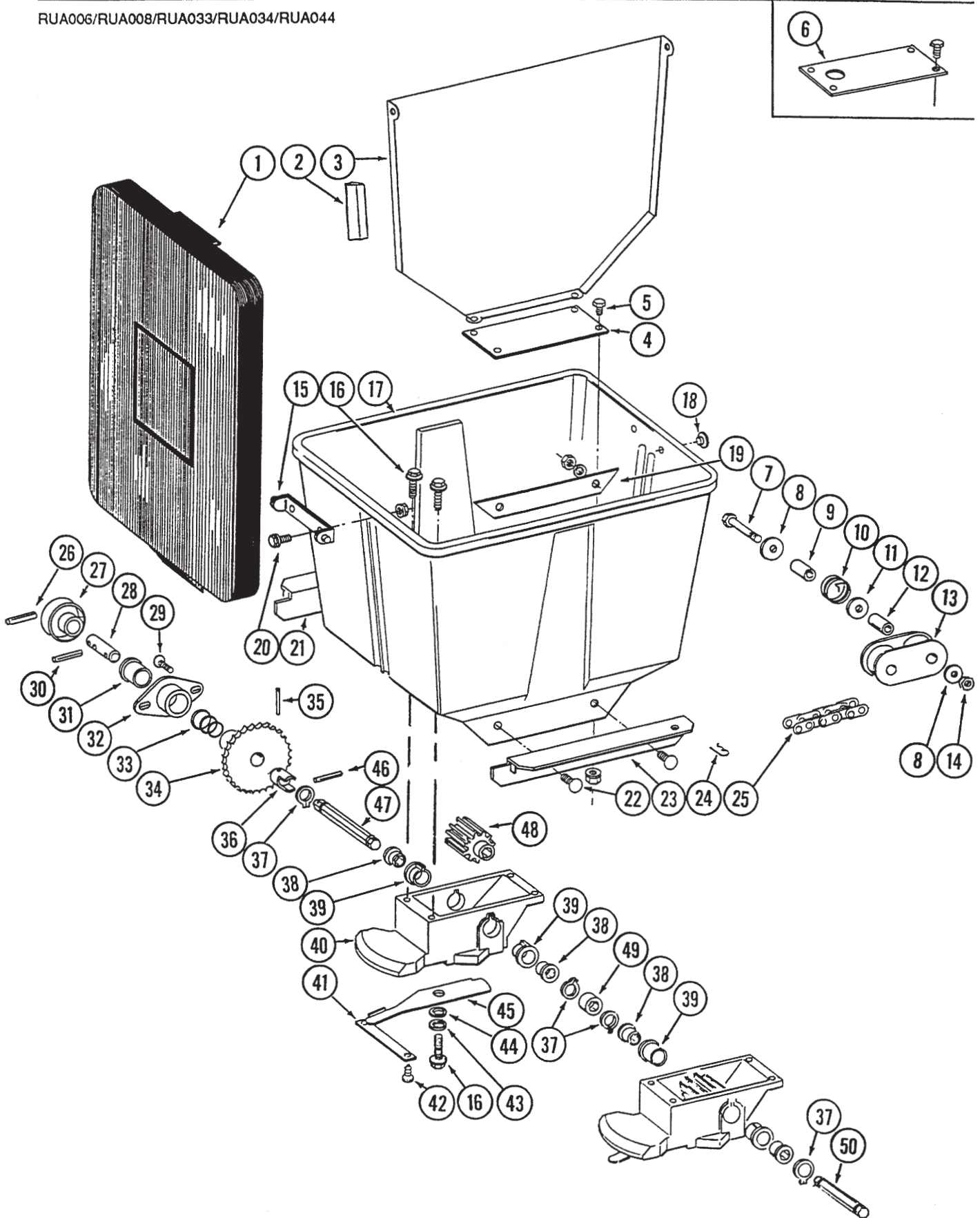

# GRANULAR CHEMICAL HOPPER WITH METER(S) & THROWOUT

ITEM	PART NO.	QTY. (Per Row)	DESCRIPTION
1.	GA4444	1	Lid
2.	G3314-40	-	Foam Strip, 40"
3.	GA2076	1	Divider (Used With Two Meters)
4.	GD1056	-	Cover Plate (1 Used With One Meter)
5.	G10022	4	Hex Head Cap Screw, 1/4"-20 x 1/2"
	G10621	4	Flange Nut, 1/4"-20
6.	GD8750	-	Restrictor Plate (Optional)
7.	G10049	1	Hex Head Cap Screw, 3/8"-16 x 2 1/2"
8.	G10210	2	Washer, 3/8" USS
9.	GD2971-03	1	Bushing, 7/16"
10.	GD9306	1	Spring
11.	G10201	1	Special Washer
12.	GD1026	1	Spacer, 1 3/16"
13.	GD9240	1	Idler
14.	G10108	1	Lock Nut, 3/8"-16
15.	GD1060	1	Hinge
16.	G10570	-	Self Tapping Screw, 1/4" x 3/4" (1 Used Per Meter)
17.	GD1058	1	Hopper
18.	GD1089	2	Plug
19.	GD1072	2	Strap
20.	G10023	2	Hex Head Cap Screw, 1/4"-20 x 3/4"
	G10621	2	Flange Nut, 1/4"-20
21.	GD1059L	1	Support, Left Hand
22.	G10311	4	Carriage Bolt, 3/8"-16 x 3/4" Short Necked, Grade 2
	G10229	4	Lock Washer, 3/8"
	G10101	4	Hex Nut, 3/8"-16
23.	GD1059R	1	Support, Right Hand
24.	G10670	2	Spring Locking Pin, No. 3
25.	G3303-114	1	Roller Chain, No. 41, 114 Pitch Including Connector Link
	GR0196	1	Connector Link, No. 41
26.	G10637	1	Spring Pin, 1/8" x 1 1/2"
27.	GD7587	1	Knob
28.	GD7589	1	Throwout Pin
29.	G10312	2	Carriage Bolt, 5/16"-18 x 3/4"
	G10620	2	Flange Nut, 5/16"-18
30.	G10602	1	Spring Pin, 1/4" x 1 1/2"
31.	GB0121	1	Bearing
32.	GB0183	1	Bearing Mount
33.	GD8458	1	Spring
34.	GA5533	1	Sprocket, 24 Tooth
35.	G10609	1	Spring Pin, 5/32" x 1"
36.	GB0184	1	Coupling
37.	G10567	1	Retaining Ring
38.	GD7258	-	Hex Bushing (2 Per Meter)
39.	GB0115	-	Bearing (2 Used Per Meter)
40.	GB0116	-	Granular Housing (1 Used Per Meter)
41.	GD1061	-	Support Strap (1 Used Per Meter)
42.	G10521	1	Self Tapping Screw, No. 10 x 3/8" (2 Per Meter)
43.	G10209	-	Washer, 1/4" USS (1 Used Per Meter)
44.	G10660	-	Wave Washer (1 Used Per Meter)
45.	GD1063	-	Metering Gate (1 Used Per Meter)
46.	G10546	1	Spring Pin, 3/16" x 1 1/4"
47.	GD7588	1	Shaft
48.	GD7148	-	Feed Roller, Hex Bore (1 Used Per Meter)
49.	GD7592	1	Coupler, Hex Bore (With 2nd Meter)
50.	GD7591	-	Shaft (1 Used On 2nd Meter)
A.	G1K213	-	Granular Chemical Idler Kit (Items 7-14)

# SPRING TOOTH INCORPORATOR

RUA011

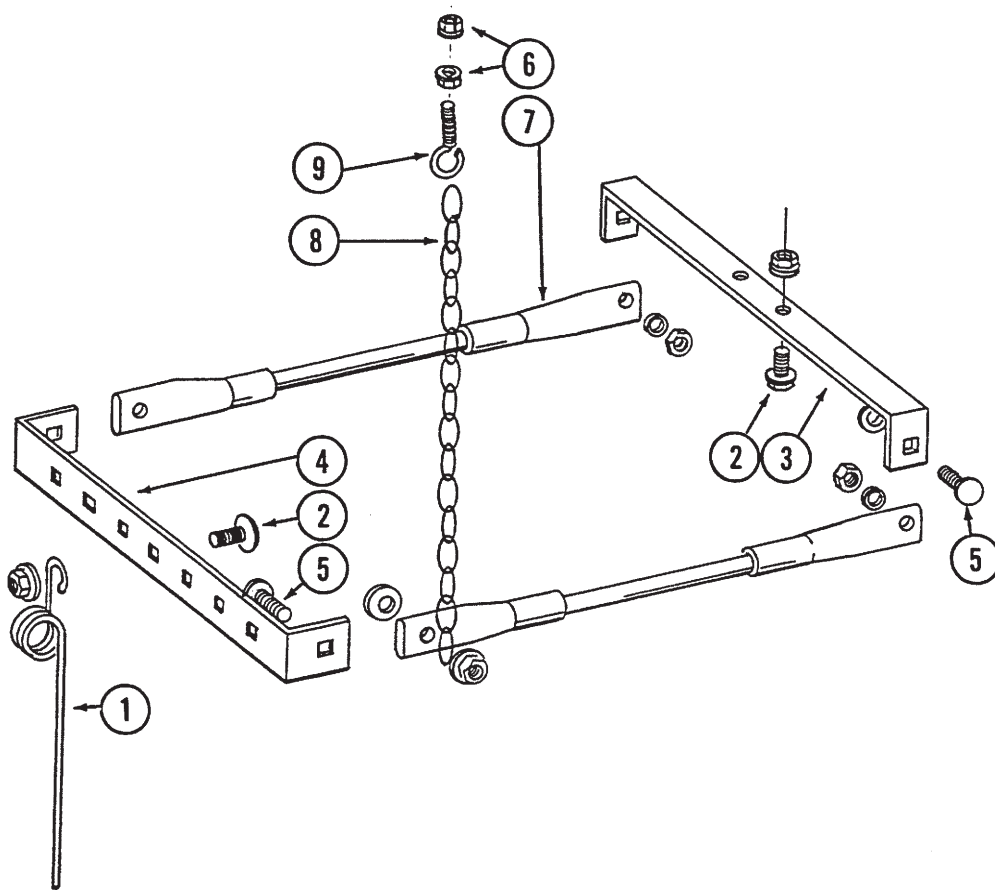

ITEM	PART NO.	QTY. (Per Row)	DESCRIPTION
1.	GD1145	7	Spring Tooth
2.	G10308	9	Carriage Bolt, 3/8"-16 x 3/4", Grade 2
	G10622	9	Flange Lock Nut, 3/8"-16
3.	GD1143	1	Front Bracket
4.	GD1144	1	Rear Bracket
5.	G10305	4	Carriage Bolt, 3/8"-16 x 1", Grade 2
	G10529	4	External Tooth Lock Washer, 3/8"
	G10622	4	Flange Lock Nut, 3/8"-16
6.	G10621	4	Flange Lock Nut, 1/4"-20
7.	GA2094	2	Cable Assembly
8.	G3305-01	4	Chain
9.	GD2460	2	Eyebolt, 1/4"-20



# NO TILL COULTER, ROW UNIT MOUNTED

(Plateless Row Unit & Interplant Push Row Unit)

RUA036

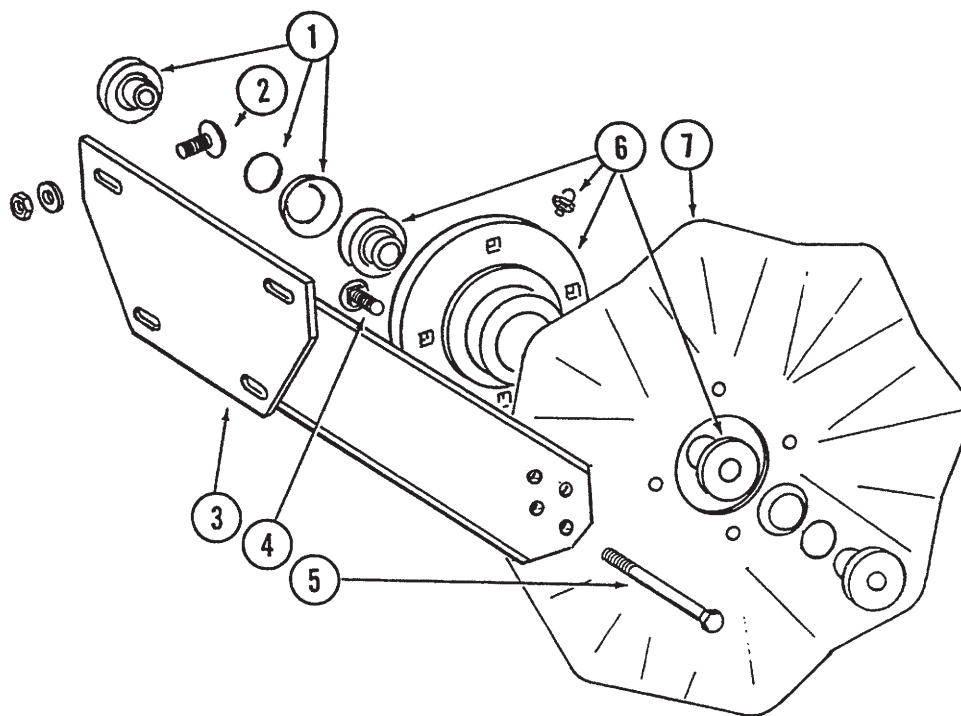

ITEM	PART NO.	QTY.	DESCRIPTION
		(Per Row)	
1.	GB0227	2	Adapter W/O-Ring And Spring Washer
	GD8844	2	O-Ring
	GD8843	2	Spring Washer
2.	G10574	4	Carriage Bolt, 1/2"-13 x 1 1/4"
	G10206	4	Washer, 1/2" SAE
	G10111	4	Lock Nut, 1/2"-13
3.	GA5625	1	Arm
4.	G10574	4	Carriage Bolt, 1/2"-13 x 1 1/4"
	G10111	4	Lock Nut, 1/2"-13
5.	G10036	1	Hex Head Cap Screw, 5/8"-11 x 4"
	G10107	1	Lock Nut, 5/8"-11
6.	GA5640	1	Hub W/Bearings And Grease Fitting
	GA5622	-	Bearing (2 used)
	G10640	-	Grease Fitting, 1/4"-20
7.	GD7803	-	Fluted Blade, 1", 8 Flutes (Shown)
	GD7804	-	Bubbled Blade, 1"
	GD9254	-	Fluted Blade, 3/4", 13 Flutes

# BED LEVELER, ROW UNIT MOUNTED

RUA038/RUA040

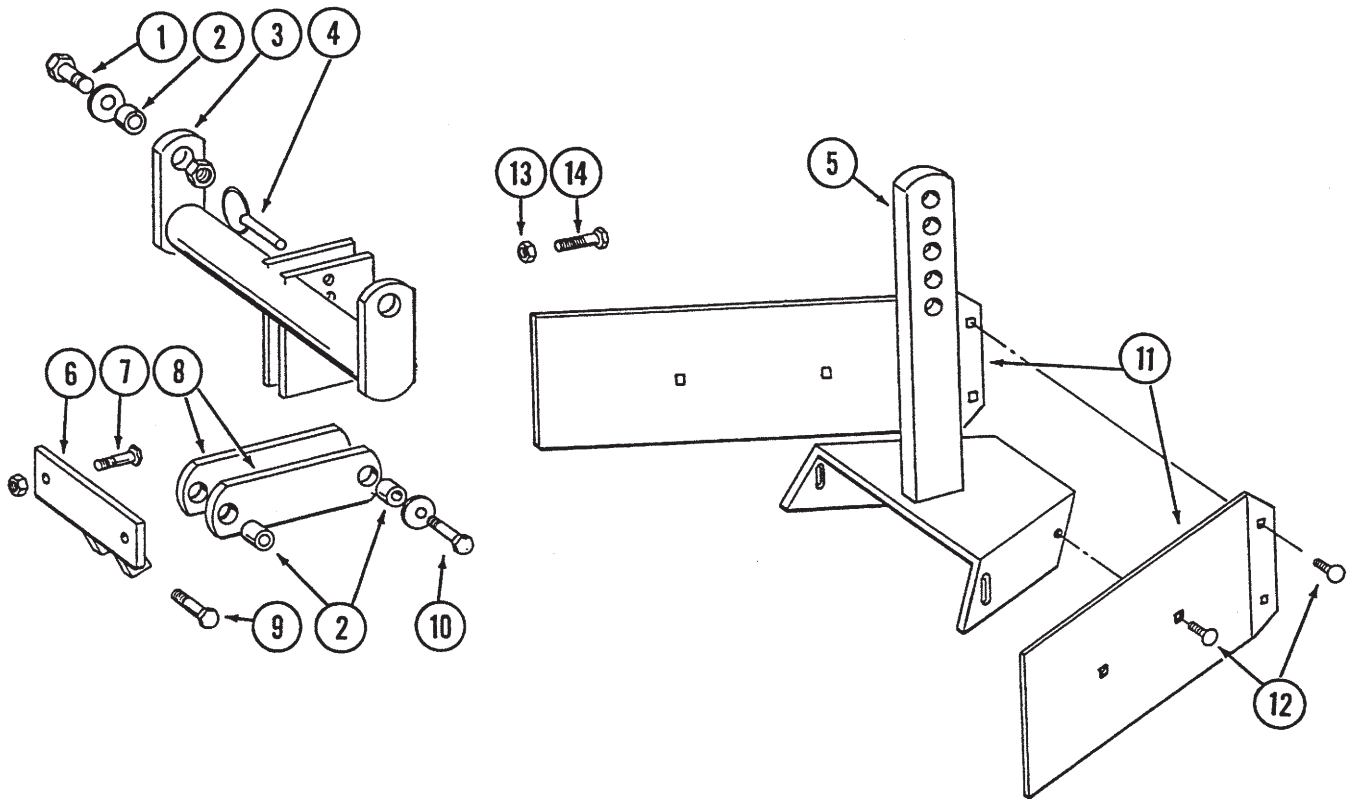

ITEM	PART NO.	QTY.	DESCRIPTION
		(Per Row)	
1.	G10039	2	Hex Head Cap Screw, 1/2"-13 x 1 3/4"
	G10216	2	Washer, 1/2" USS
	G10111	2	Lock Nut, 1/2"-13
2.	GD7889	6	Bushing
3.	GA5719	1	Mounting Bracket
4.	G10536	1	Pin
5.	GA5892	1	Leveler
6.	GA5715	1	Anchor
7.	G10017	2	Hex Head Cap Screw, 1/2"-13 x 1 1/2"
	G10111	2	Lock Nut, 1/2"-13
8.	GD7890	2	Link
9.	G10017	2	Hex Head Cap Screw, 1/2"-13 x 1 1/2"
	G10216	2	Washer, 1/2" USS
	G10111	2	Lock Nut, 1/2"-13
10.	G10585	1	Hex Head Cap Screw, 1/2"-13 x 3 1/4"
	G10216	2	Washer, 1/2" USS
	G10111	1	Lock Nut, 1/2"-13
11.	GD8266	2	Blade
12.	G10303	6	Carriage Bolt, 5/16"-18 x 1"
	G10219	4	Washer, 5/16" USS
	G10109	6	Lock Nut, 5/16"
13.	G10503	1	Jam Nut, 5/8"-11
14.	G10597	1	Set Screw, 5/8"-11 x 2 1/4"

# DISC FURROWER, ROW UNIT MOUNTED

RUA038/RUA040

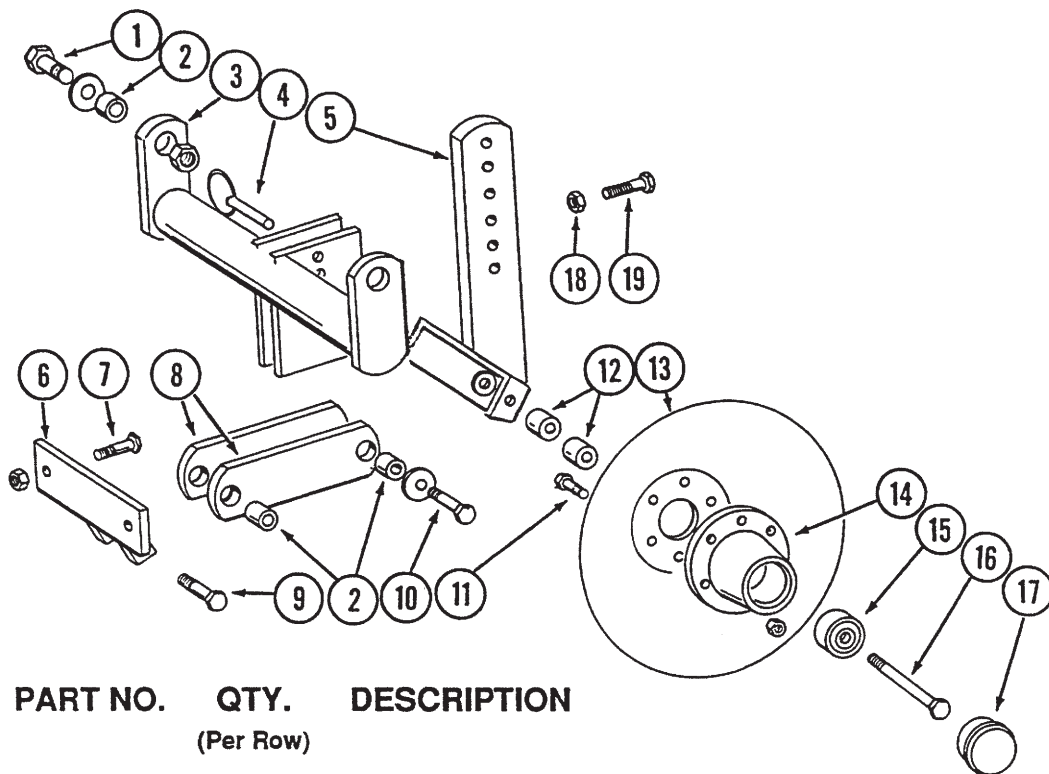

ITEM	PART NO.	QTY.	DESCRIPTION
		(Per Row)	
1.	G10039	2	Hex Head Cap Screw, 1/2"-13 x 1 3/4"
	G10216	2	Washer, 1/2" USS
	G10111	2	Lock Nut, 1/2"-13
2.	GD7889	6	Bushing
3.	GA5719	1	Mounting Bracket
4.	G10536	1	Pin
5.	GA5718	1	Support Arm
6.	GA5715	1	Anchor
7.	G10017	2	Hex Head Cap Screw, 1/2"-13 x 1 1/2"
	G10111	2	Lock Nut, 1/2"-13
8.	GD7890	2	Link
9.	G10017	2	Hex Head Cap Screw, 1/2"-13 x 1 1/2"
	G10216	2	Washer, 1/2" USS
	G10111	2	Lock Nut, 1/2"-13
10.	G10585	1	Hex Head Cap Screw, 1/2"-13 x 3 1/4"
	G10216	2	Washer, 1/2" USS
	G10111	1	Lock Nut, 1/2"-13
11.	G10572	6	Truss Head Slotted Machine Screw, 5/16"-18 x 7/8"
	G10106	6	Hex Nut, 5/16"-18
12.	GD7817-01	2	Spacer, 3/4"
	GD7817-04	2	Spacer, 1/2"
13.	GD7823	-	Solid Disc, 12" (Shown)
	GD8307	-	Notched Disc, 12"
14.	GB0195	2	Hub
15.	GA2014	4	Bearing
16.	G10318	2	Hex Head Cap Screw, 5/8"-11 x 4 1/2"
	GD7805	2	Special Washer
	G10107	2	Lock Nut, 5/8"-11
17.	GD1132	2	Dust Cap
18.	G10503	1	Jam Nut, 5/8"-11
19.	G10597	1	Set Screw, 5/8"-11 x 2 1/4"

# RESIDUE WHEEL, ROW UNIT MOUNTED

RUA041/RUA045

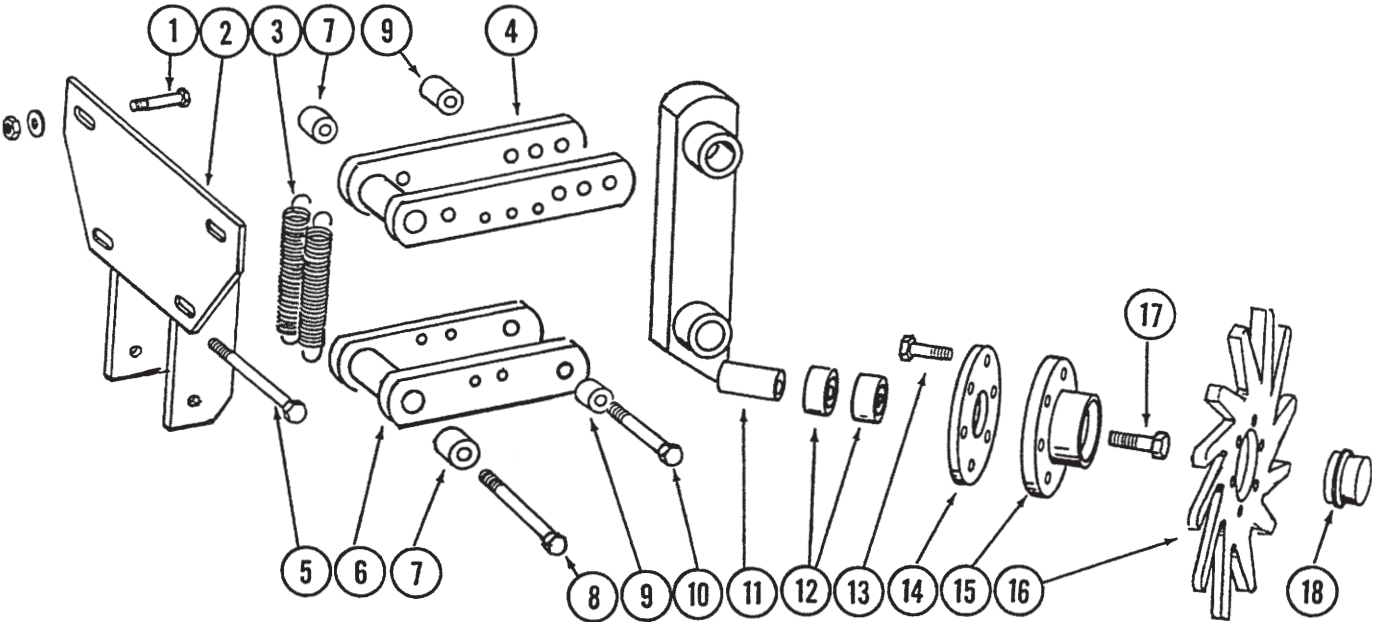

# RESIDUE WHEEL, ROW UNIT MOUNTED

ITEM	PART NO.	QTY. (Per Row)	DESCRIPTION
1.	G10574	4	Carriage Bolt, 1/2"-13 x 1 1/4"
	G10216	4	Washer, 1/2" USS
	G10111	4	Lock Nut, 1/2"-13
2.	GA6832	1	Mount
3.	GD5857	2	Spring
4.	GA6833	1	Upper Link
5.	G10348	1	Hex Head Cap Screw, 1/2-13 x 5"
	G10111	1	Lock Nut, 1/2"-13
6.	GA6834	1	Lower Link
7.	GD9715	2	Spacer, 2 15/16"
8.	G10045	2	Hex Head Cap Screw, 1/2"-13 x 4 1/2"
	G10228	2	Lock Washer, 1/2"
	G10102	2	Hex Nut, 1/2"-13
9.	GD9720	2	Spacer, 2 3/16"
10.	G10033	2	Hex Head Cap Screw, 1/2"-13 x 3 1/2"
	G10228	2	Lock Washer, 1/2"
	G10102	2	Hex Nut, 1/2"-13
11.	GA6838	1	Wheel Mount
12.	GA2014	2	Bearing
13.	G10133	6	Hex Head Cap Screw, 5/16"-18 x 1 1/2"
	G10109	6	Lock Nut, 5/16"-18
14.	GD9724	1	Backing Plate
15.	GB0195	1	Hub
16.	GD9723	1	Wheel
17.	G10006	1	Hex Head Cap Screw, 5/8"-11 x 2 1/4"
18.	GD1132	1	Dust Cap

# FRAME MOUNTED COULTER W/DISC FURROWER

RUA035/RUB016

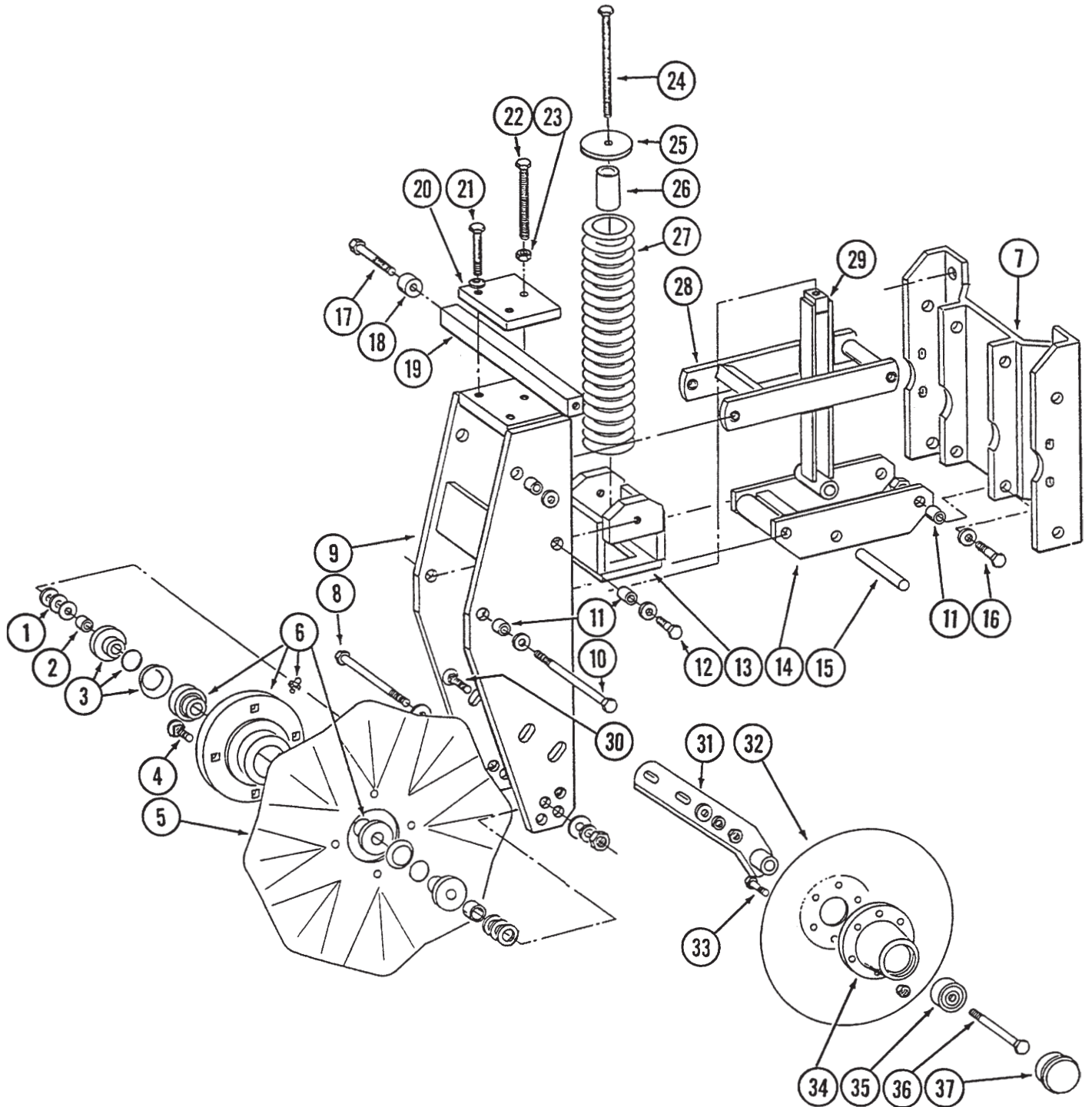

# FRAME MOUNTED COULTER W/DISC FURROWER

ITEM	PART NO.	QTY. (Per Row)	DESCRIPTION
1.	G10217	-	Washer, 5/8" USS (As Required)
2.	GD7817-04	2	Spacer, 1/2"
3.	GB0227	2	Adapter W/O-Ring And Spring Washer
	GD8844	-	O-Ring
	GD8843	-	Spring Washer
4.	G10574	4	Carriage Bolt, 1/2"-13 x 1 1/4"
	G10111	4	Lock Nut, 1/2"-13
5.	GD7803	-	Fluted Blade, 1", 8 Flutes (Shown)
	GD7804	-	Bubbled Blade, 1"
	GD9254	-	Fluted Blade, 3/4", 13 Flutes
6.	GA5640	1	Hub W/Bearings And Grease Fitting
	GA5622	-	Bearing (2 used per hub)
	G10640	-	Grease Fitting, 1/4"-20
7.	GA5798	1	Support Plate
8.	G10068	1	Hex Head Cap Screw, 5/8"-11 x 6"
	G10107	1	Lock Nut, 5/8"-11
9.	GA5643	1	Fork Mount
10.	G10012	1	Hex Head Cap Screw, 5/8"-11 x 6 1/2"
	GD7805	2	Washer
	G10107	1	Lock Nut, 5/8"-11
11.	GB0218	10	Bushing, 1/2"
12.	G10055	2	Hex Head Cap Screw, 5/8"-11 x 1 1/4"
	GD7805	2	Washer
13.	GA5637	1	Spring Socket
14.	GA5631	1	Lower Parallel Link
15.	GD7815	1	Pin, 5/8" x 4 1/4"
16.	G10008	6	Hex Head Cap Screw, 5/8"-11 x 2"
	GD7805	6	Washer
	G10107	4	Lock Nut, 5/8"-11 (As Required)
17.	GD7818	2	Special Bolt
18.	GD7817-01	2	Roller, 3/4"
19.	GD7816	1	Depth Control Bar
20.	GD7811	1	Depth Adjustment Clamp
21.	G10581	2	Hex Head Cap Screw, 1/2"-13 x 2 1/4"
	G10228	2	Lock Washer, 1/2"
22.	G10582	1	Hex Head Cap Screw, 5/8"-11 x 4", Full Thread
23.	G10104	1	Hex Nut, 5/8"-11
24.	G10573	1	Hex Head Cap Screw, 5/8"-11 x 5 1/2", Full Thread
25.	GB0196	1	Washer
26.	GD7817-09	1	Stop, 1 3/4"
27.	GD7831	1	Compression Spring
28.	GA5630	1	Upper Parallel Link
29.	GA5635	1	Spring Guide
30.	G10197	4	Carriage Bolt, 1/2"-13 x 2"
	G10206	-	Washer, 1/2" SAE (As required)
	G10228	4	Lock Washer, 1/2"
	G10102	4	Hex Nut, 1/2"-13
31.	GA5636	2	Arm
32.	GD7823	-	Solid Disc, 12" (Shown)
	GD8307	-	Notched Disc, 12"
33.	G10572	12	Truss Head Slotted Machine Screw, 5/16"-18 x 7/8"
	G10106	12	Hex Nut, 5/16"-18
34.	GB0195	2	Hub
35.	GA2014	4	Bearing
36.	G10036	2	Hex Head Cap Screw, 5/8"-11 x 4"
	G10107	2	Lock Nut, 5/8"-11
37.	GD1132	2	Dust Cap

# INTERPLANT PUSH ROW UNIT

RPU001/RPU009/RUA044

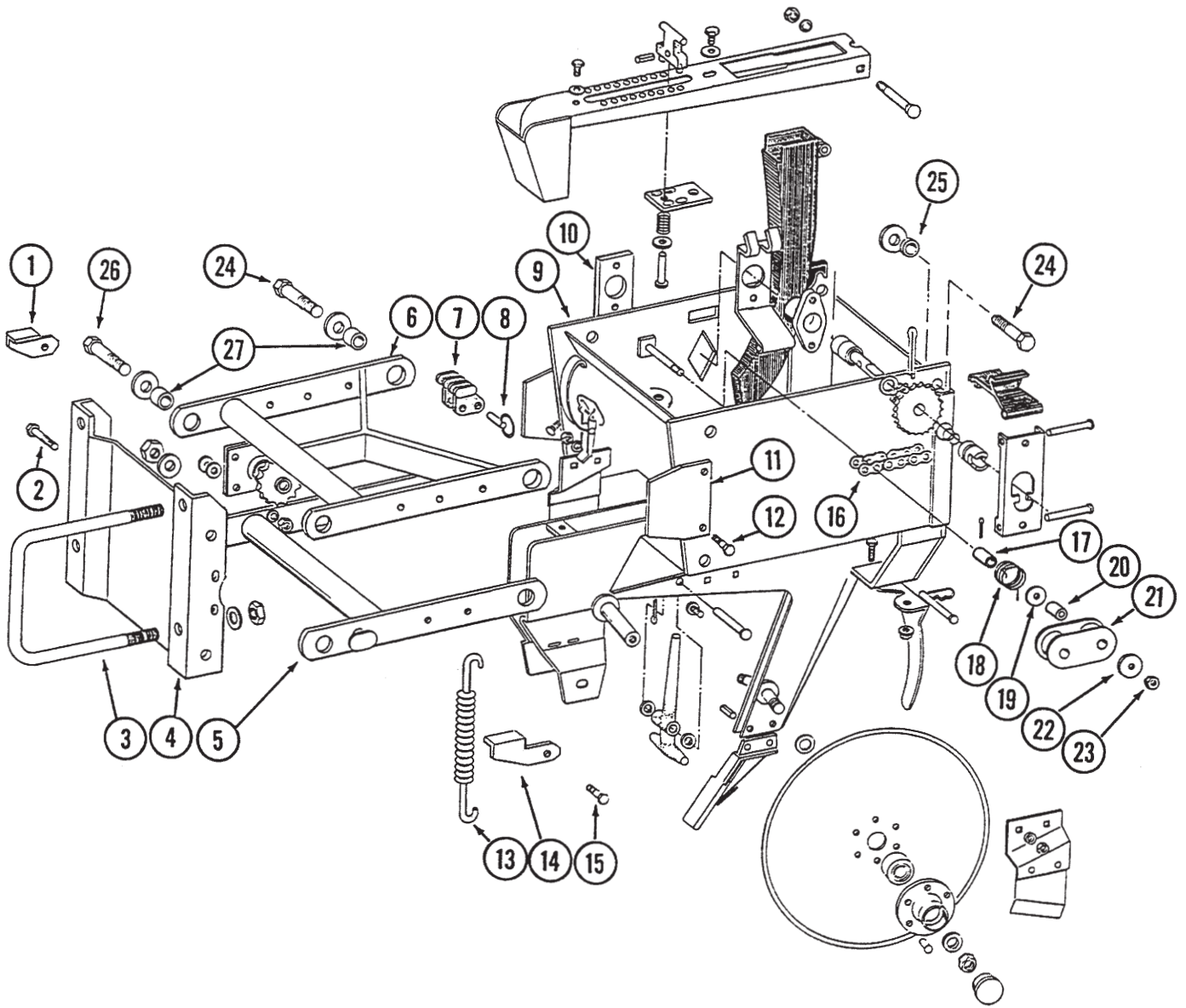



# INTERPLANT PUSH ROW UNIT

ITEM	PART NO.	QTY. (Per Row)	DESCRIPTION
1.	GD7627	1	Lockup, L.H.
2.	G10004	2	Hex Head Cap Screw, 3/8"-16 x 1 1/4"
	G10210	-	Washer, 3/8" USS (As Required)
	G10229	2	Lock Washer, 3/8"
	G10101	2	Hex Nut, 3/8"-16
3.	GD1113	2	U-Bolt, 5" x 7" x 5/8"-11
	G10230	4	Lock Washer, 5/8"
	G10104	4	Hex Nut, 5/8"-11
4.	GA5786	1	Mounting Plate
5.	GA5787	1	Lower Arm
6.	GA5788	1	Upper Arm
7.	GB0186	2	Spring Anchor
8.	G10545	2	Detent Pin, 1" Grip
9.	GA5846	1	Shank Assembly
10.	GD2128	1	Plate
11.	GD6161	2	Stop Bar
12.	G10037	4	Hex Head Cap Screw, 1/2"-13 x 1 1/4"
	G10228	4	Lock Washer, 1/2"
	G10102	4	Hex Nut, 1/2"-13
13.	GD8249	-	Spring
14.	GD7626	1	Lockup, R.H.
15.	G10017	2	Hex Head Cap Screw, 1/2"-13 x 1 1/2"
	G10228	2	Lock Washer, 1/2"
	G10111	2	Lock Nut, 1/2"-13
16.	G3303-96	1	Roller Chain, No. 41, 96 Links Including Connector Link
	GR0196	1	Connector Link, No. 41
17.	GD7318	1	Bushing, 1"
18.	GD2134	1	Spring
19.	G10201	1	Special Washer
20.	GD1026	1	Spacer, 1 3/16"
21.	GD9240	1	Idler
22.	G10210	1	Washer, 3/8" USS
23.	G10108	1	Lock Nut, 3/8"-16
24.	G10751	6	Hex Head Cap Screw, 5/8"-18 x 1 3/4"
	GD7805	6	Special Washer
	G10412	6	Lock Nut, 5/8"-18
25.	GD1109	2	Pivot Bushing, 1/4"
26.	G10732	4	Hex Head Cap Screw, 5/8"-18 x 2"
	GD7505	4	Special Washer
	G10412	4	Lock Nut, 5/8"-18
27.	GB0218	8	Bushing, 1/2"
A.	GA5564	-	Lockup Package, Includes: (1) GD7627, (1) GD7626, (2) G10228, (2) G10017, (2) G10111

# OUTER HITCH

PHA021/PHA0255

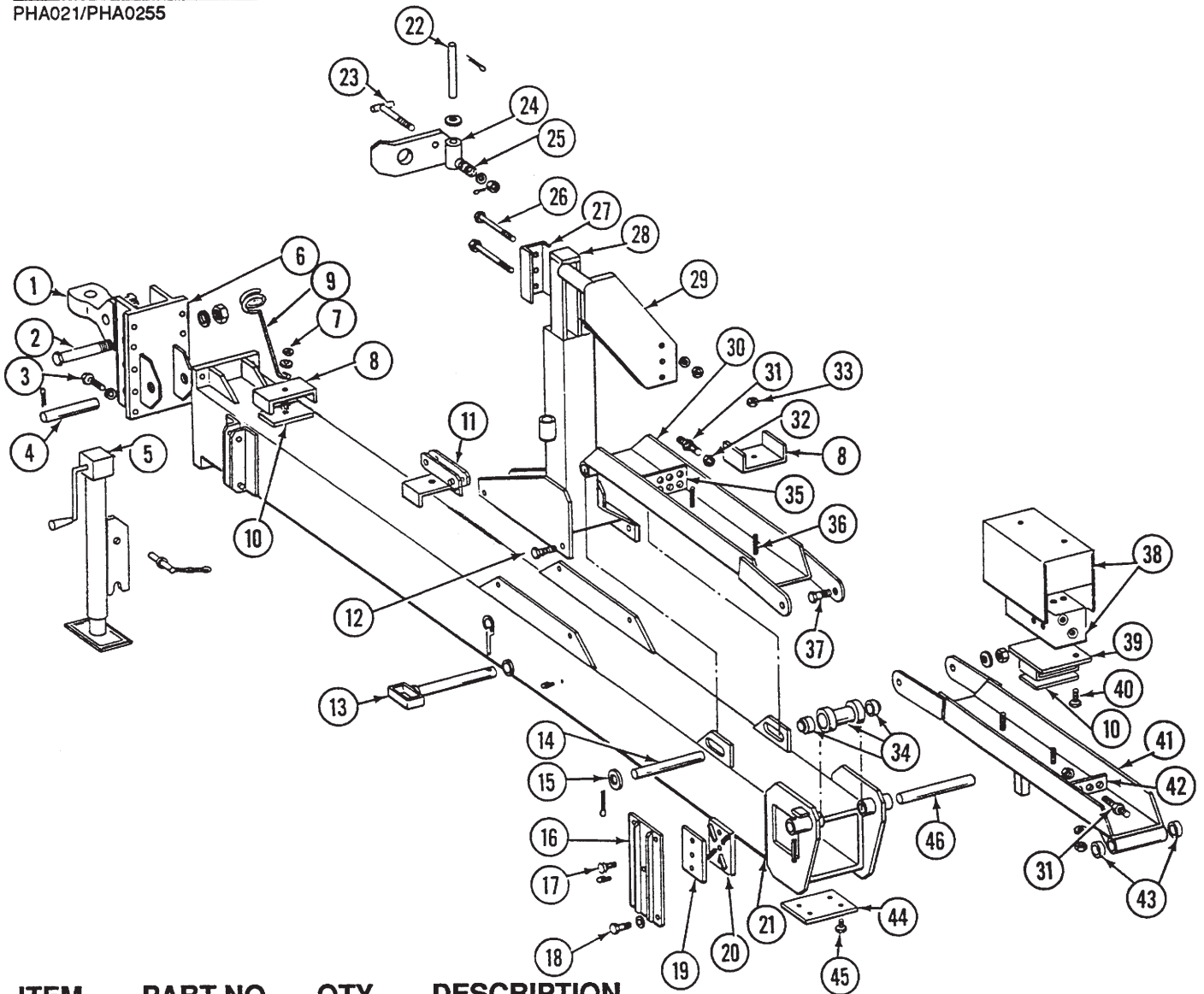

ITEM	PART NO.	QTY.	DESCRIPTION
1.	GB0237	1	Clevis, Single, 12(Shown)/16 Row
	GB0156	-	Clevis, Double, 8 Row
2.	G10169	1	Hex Head Cap Screw, 1 1/4"-7 x 6"
	G10157	1	Lock Nut, 1 1/4"-7
3.	G10005	6	Hex Head Cap Screw, 5/8"-11 x 1 3/4"
	G10009	4	Hex Head Cap Screw, 5/8"-11 x 2 1/2"
	G10230	10	Lock Washer, 5/8"
	G10104	4	Hex Nut, 5/8"-11
4.	GD5173	1	Pin, 1 1/4" x 5 1/8"
	G10462	2	Cotter Pin, 3/16" x 2"
5.	GA4994	1	Jack Assembly Complete
	GA4995	-	Detent Pin Assembly
	GR0517	-	Pin
	GR0516	-	Crank Assembly
	GR0515	-	Bevel Gear
6.	GA4420	1	Mount, 8 Row 36/38 And 12 Row 30, 12 Row 36/38 With "Y" Hitch
	GA4839	-	Mount, 12 Row 36/38 With "T" Hitch And 16 Row
7.	G10111	1	Lock Nut, 1/2"-12
8.	GD8188	-	Clamp, 3" x 5 3/8"

# OUTER HITCH

ITEM	PART NO.	QTY.	DESCRIPTION
9.	GD8260	1	Hose Holder
10.	GD8189	-	Rubber Strap
11.	GA5842	1	Bracket, Jack Mount
12.	G10009	4	Hex Head Cap Screw, 5/8"-11 x 2 1/2"
	G10217	4	Washer, 5/8" USS
	G10230	4	Lock Washer, 5/8"
	G10104	4	Hex Nut, 5/8"-11
13.	GA4402	1	Pin, 12 3/4", 8 Row 36/38 and 12 Row 30
	GA4845	-	Pin, 14 3/4", 12 Row 36/38 and 16 Row 30
	GD2558	-	Lynch Pin, 1/4"
	GD2557	-	Lynch Pin, 7/16"
14.	GD2168	1	Pin, 1 1/4" x 9 3/4"
	G10460	2	Cotter Pin, 1/4" x 2"
15.	G10139	-	Washer, 1 1/4" USS (Where Applicable)
	G10226	-	Washer, 1 1/4" SAE (Where Applicable)
16.	GA3858	2	Wear Mount W/Grease Fitting, 8 Row 36/38 And 12 Row 30, 12 Row 36/38 With "Y" Hitch
	GA2653	-	Wear Mount W/Grease Fitting, L.H., 12 Row 36/38 With "T" Hitch And 16 Row 30
	GA4882	-	Wear Mount W/Grease Fitting, R.H., 12 Row 36/38 With "T" Hitch And 16 Row 30
	G10641	-	Grease Fitting, 1/8" NPT
17.	G10014	4	Hex Head Cap Screw, 1/2"-13 x 1"
	G10228	4	Lock Washer, 1/2"
18.	G10017	8	Hex Head Cap Screw, 1/2"-13 x 1 1/2", 8/12 Row
	G10016	-	Hex Head Cap Screw, 1/2"-13 x 2", 16 Row
	G10228	8	Lock Washer, 1/2"
	G10102	8	Hex Nut, 1/2"-13
19.	GD5154	-	Shim (As Required), 8 Row 36/38 And 12 Row 30, 12 Row 36/38 With "Y" Hitch
	GD3501	-	Shim (As Required), 12 Row 36/38 With "T" Hitch And 16 Row 30
20.	GD5153	-	Wear Pad, Bronze, All 8 Row 36/38 And 12 Row 30, 12 Row 36/38 With "Y" Hitch
	GD3478	-	Wear Pad, Bronze, 12 Row 36/38 With "T" Hitch And 16 Row 30
21.		-	Outer Hitch, "Y", 73", 8 Row 36/38 (Non-stock Item)
		-	Outer Hitch, "T", 97", 8 Row 36/38 (Non-stock Item)
		-	Outer Hitch, "Y", 97", 12 Row 30 (Non-stock Item)
		-	Outer Hitch, "T", 121", 12 Row 30(Shown) (Non-stock Item)
		-	Outer Hitch, "Y", 121", 12 Row 36/38 (Non-stock Item)
		-	Outer Hitch, "T", 151 1/2", 12 Row 36/38 (Non-stock Item)
		-	Outer Hitch, "Y", 127 1/2", 16 Row 30 (Non-stock Item)
		-	Outer Hitch, "T", 151 1/2", 16 Row 30 (Non-stock Item)
22.	GD4732	1	Pin, 7/8" x 6 1/2"
	G10463	2	Cotter Pin, 1/4" x 1 1/2"
23.	GA3574	1	"T" Pin
	G10216	1	Washer, 1/2" USS
	G10335	1	Hex Jam Nut, 1/2"-13
	G10470	1	Cotter Pin, 5/32" x 1"
24.	GA4397	1	Lock Plate W/Grease Fitting
	G10641	-	Grease Fitting, 1/8" NPT
25.	GD4721	1	Spring
26.	G10050	2	Hex Head Cap Screw, 3/4"-10 x 5"
	G10231	2	Lock Washer, 3/4"
	G10105	2	Hex Nut, 3/4"-10

# OUTER HITCH

ITEM	PART NO.	QTY.	DESCRIPTION
27.	GD6730	1	Bar
28.	GA4401	1	Transport Post
29.	GA4399	1	Latch Post
30.	GA4598	1	Takeup W/Grease Fitting, 21 1/2", 8 Row 36/38 With "Y" Hitch
	GA4412	-	Takeup W/Grease Fitting, 41", 8 Row 36/38 With "T" Hitch And 12 Row 30 (Shown) With "Y" Hitch
	GA4415	-	Takeup W/Grease Fitting, 53", 12 Row 30 With "T" Hitch And 12 Row 36/38 And 16 Row 30 With "Y" Hitch
	GA5587	-	Takeup W/Grease Fitting, 65", 12 Row 36/38 And 16 Row 30 With "T" Hitch
	G10641	-	Grease Fitting, 1/8" NPT
31.	G2700-10	-	Tube Union, 7/8"-14 JIC
	G2403-10	-	Union, 7/8"-14 JIC
	G2700-08	-	Bulkhead, 3/4"-16 JIC
32.	G306-10	-	Lock Nut, 7/8"-14
	G306-08	-	Lock Nut, 3/4"-16
33.	G10108	-	Lock Nut, 3/8"-16
34.	GA4418	1	Roller W/Bronze Bushings, 8/12 Row
	GA4842	-	Roller W/Bronze Bushings, 16 Row
	GD6556	-	Bronze Bushing
35.	GA2627	-	Bulkhead
36.	G10164	-	Hex Head Cap Screw, 3/8"-16 x 2 1/4"
	G10210	-	Washer, 3/8"
	G10229	-	Lock Washer, 3/8"
	G10101	-	Hex Nut, 3/8"-16
37.	G10689	2	Carriage Bolt, 5/8"-11 x 2"
	GB0218	2	Bushing
	G10230	2	Lock Washer, 5/8"
	G10217	2	Washer, 5/8" USS
	G10104	2	Hex Nut, 5/8"-11
38.		-	See "Valve Block - Located On Hitch"
39.	GA5841	1	Mount
40.	G10004	-	Hex Head Cap Screw, 3/8"-16 x 1 1/4"
41.	GA4599	1	Takeup W/Grease Fitting, 21 1/2", 8 Row 36/38 With "Y" Hitch
	GA4414	-	Takeup W/Grease Fitting, 41", 8 Row 36/38 With "T" Hitch And 12 Row 30 With "Y" Hitch (Shown)
	GA4417	-	Takeup W/Grease Fitting, 53", 12 Row 30 With "T" Hitch And 12 Row 36/38 With "Y" Hitch
	GA5498	-	Takeup W/Grease Fitting, 53", 16 Row 30 With "Y" Hitch
	GA5586	-	Takeup W/Grease Fitting, 65", 12 Row 36/38 And 16 Row 30 With "T" Hitch
	G10641	-	Grease Fitting, 1/8" NPT
42.	GA4607	-	Bulkhead
43.	GD0752-15	-	Sleeve, 1", 12 Row 36/38 With "T" Hitch And 16 Row 30
	G10226	-	Washer, 1 1/4" SAE (8 And 12 Row As Required)
44.	GD3488	-	Shim, 1/2" x 5" x 6 1/2", 16 Row 30 Only
	GD7518	-	Shim, 3/8" x 5" x 6 1/2", 12 Row 36/38 With "T" Hitch And 16 Row 30
	GD7519	-	Shim, 16 Ga. x 5" x 6 1/2", 12 Row 36/38 With "T" Hitch And 16 Row 30
45.	G10014	4	Hex Head Cap Screw, 1/2"-13 x 1"
	G10228	4	Lock Washer, 1/2"
	G10216	4	Washer, 1/2" USS
46.	GD5804	1	Shaft, 1 1/4" x 12", 8/12 Row
	GD7251	-	Shaft, 1 1/4" x 14", 16 Row
	G10610	2	Spring Pin, 3/8" x 2"

# INNER HITCH, "T"

PHA022

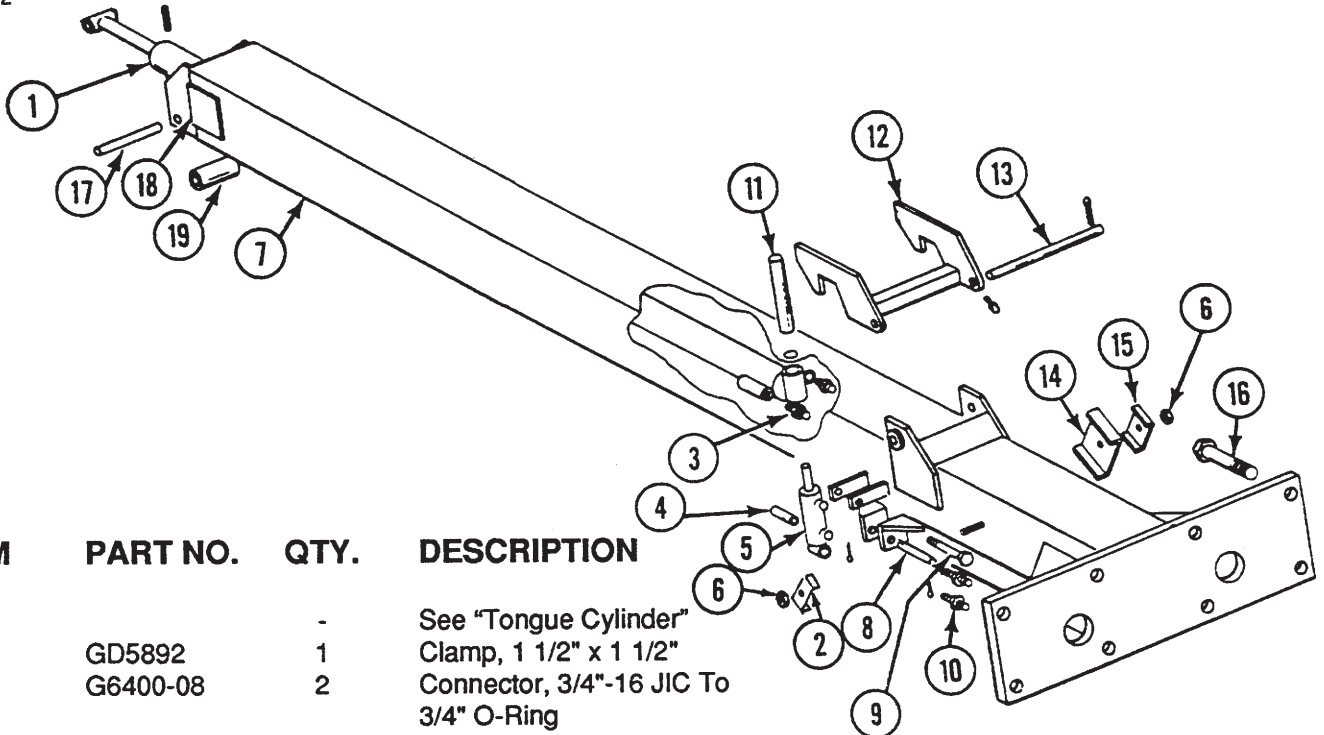

ITEM	PART NO.	QTY.	DESCRIPTION
1.		-	See "Tongue Cylinder"
2.	GD5892	1	Clamp, 1 1/2" x 1 1/2"
3.	G6400-08	2	Connector, 3/4"-16 JIC To 3/4" O-Ring
4.	GD2971-09	-	Sleeve, 5/8" O.D. x 2"
	GD3180-03	-	Sleeve, 7/8" O.D. x 1 15/16" (As Required)
5.		-	See "Tongue Lock Cylinder"
6.	G10108	-	Lock Nut, 3/8"-16
7.		-	Inner Hitch, 129 1/2", 8 Row 36/38 (Non-stock Item)
		-	Inner Hitch, 153 1/2", 12 Row 30 (Non-stock Item)
		-	Inner Hitch, 188 1/4", 12 Row 36/38 (Non-stock Item)
		-	Inner Hitch, 188 1/4", 16 Row 30 (Non-stock Item)
8.	GD7137	1	Pin, 3/4" x 3 1/4"
	G10457	2	Cotter Pin, 5/32" x 1 1/2"
9.	G10062	1	Hex Head Cap Screw, 3/8"-16 x 3"
	G10101	1	Hex Nut, 3/8"-16
10.	G6400-06-08	-	Connector, 3/4"-16 O-Ring To 9/16"-18 JIC
	G6502-06	-	Swivel Elbow, 9/16"-18 JIC Male To Female, 45°
11.	GD3537-07	1	Shaft, 1 1/4" x 6 5/8", 8 Row 36/38 And 12 Row 30
	GD3537-08	-	Shaft, 1 1/4" x 7 5/8", 12 Row 36/38 And 16 Row 30
12.	GA4407	1	Tongue Hook W/Grease Fittings, 8 Row 36/38 And 12 Row 30
	GA4841	-	Tongue Hook W/Grease Fittings, 12 Row 36/38 And 16 Row 30
	G10641	-	Grease Fitting, 1/8" NPT
13.	GD5804	1	Shaft, 1 1/4" x 12", 8 Row 36/38 And 12 Row 30
	GD7883	-	Shaft, 1 1/4" x 14 1/2", 12 Row 36/38 And 16 Row 30
	G10468	2	Cotter Pin, 3/8" x 2"
14.	GD0740	-	Clamp, 4" x 3 1/2"
15.	GD5875	-	Clamp, 2 1/2" x 2"
16.	G10119	8	Hex Head Cap Screw, 1"-14 x 3", Grade 5
	G10118	8	Lock Washer, 1"
	G10117	8	Hex Nut, 1"-14, Grade 5
17.	GD6807	1	Shaft, 1 1/4" x 7"
	G10610	2	Spring Pin, 3/8" x 2"
18.	GD5153	-	Bronze Wear Pad
	GD5154	-	Shim
19.	GA4411	1	Roller W/Bronze Bushings
	GD6556	-	Bronze Bushing

# INNER HITCH, "Y"

PHA023

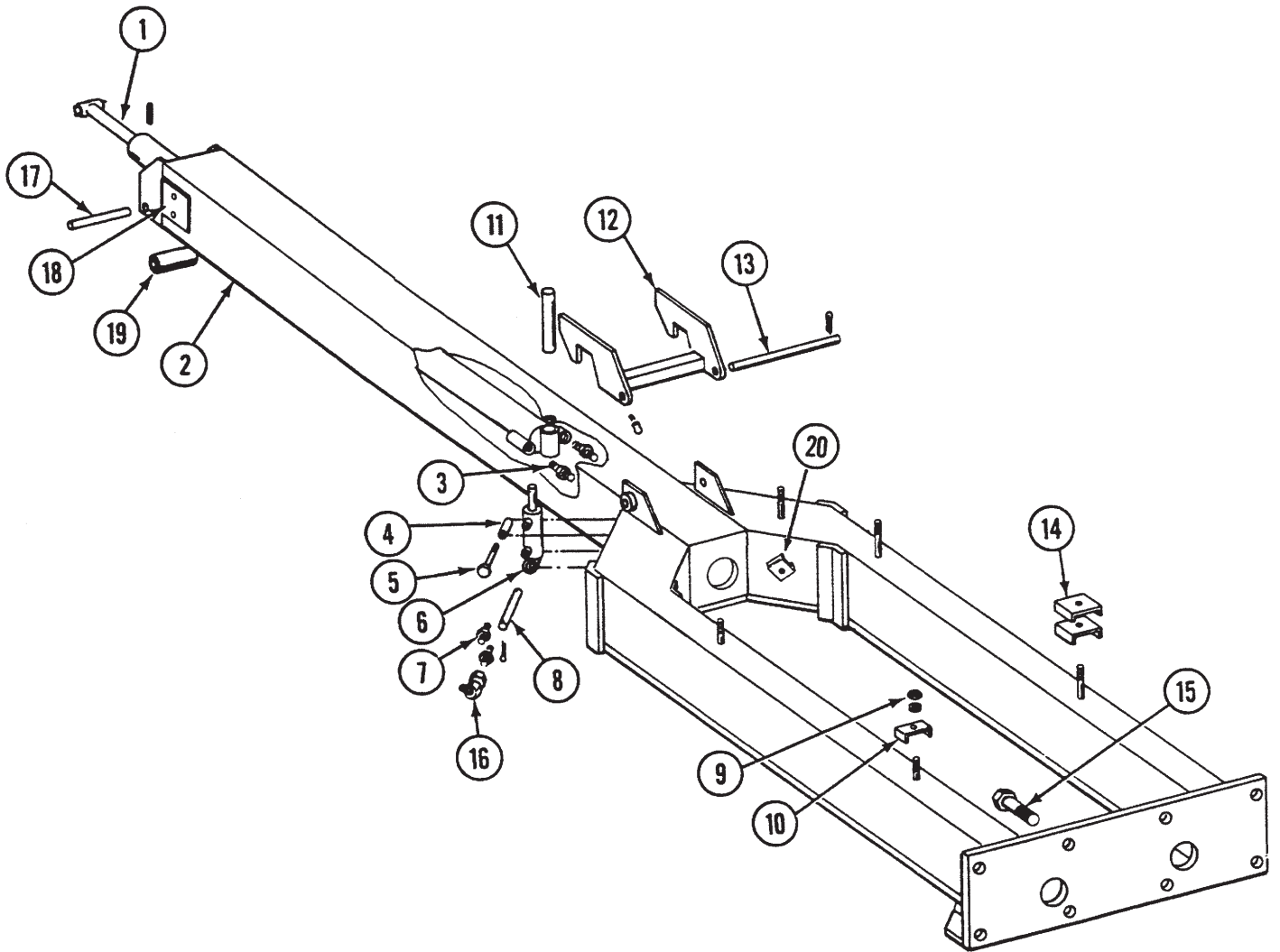

# INNER HITCH, "Y"

ITEM	PART NO.	QTY.	DESCRIPTION
1.		-	See "Tongue Cylinder"
2.		-	Inner Hitch, 152 1/4", 8 Row 36/38 (Non-stock Item)
		-	Inner Hitch, 176 1/2", 12 Row 30(Shown) (Non-stock Item)
		-	Inner Hitch, 198 1/2", 12 Row 36/38 (Non-stock Item)
		-	Inner Hitch, 212 1/4", 16 Row 30 (Non-stock Item)
3.	G6400-08	2	Connector, 3/4"-16 JIC To 3/4" O-Ring
4.	GD2971-09	-	Sleeve, 5/8" O.D. x 2"
	GD3180-03	-	Sleeve, 7/8" O.D. x 15/16" (As Required)
5.	G10062	1	Hex Head Cap Screw, 3/8"-16 x 3"
	G10101	1	Hex Nut, 3/8"-16
6.		-	See "Tongue Lock Cylinder"
7.	G6400-06-08	-	Connector, 3/4"-16 O-Ring To 9/16"-18 JIC
8.	GD7137	1	Pin, 3/4" x 3 1/4"
	G10457	2	Cotter Pin, 5/32" x 1 1/2"
9.	G10108	-	Lock Nut, 3/8"-16
10.	GD5892	-	Clamp, 1 1/2" x 1 1/2"
11.	GD3537-07	1	Shaft, 1 1/4" x 6 5/8", 8/12 Row
	GD3537-08	-	Shaft, 1 1/4" x 7 5/8", 16 Row
12.	GA4407	1	Tongue Hook W/Grease Fittings, 8 Row 36/38 And 12 Row 30
	GA4841	-	Tongue Hook W/Grease Fittings, 12 Row 36/38 And 16 Row 30
	G10641	-	Grease Fitting, 1/8" NPT
13.	GD5804	1	Shaft, 1 1/4" x 12", 8 Row 36/38 And 12 Row 30
	GD7883	-	Shaft, 1 1/4" x 14 1/2", 12 Row 36/38 And 16 Row 30
	G10468	2	Cotter Pin, 3/8" x 2"
14.	GD6027	-	Clamp, 2 1/2" x 2 1/2"
15.	G10119	8	Hex Head Cap Screw, 1"-14 x 3", 8/12 Row
	G10118	8	Lock Washer, 1"
	G10017	8	Hex Nut, 1"-14, Grade 5
	G10494	-	Hex Head Cap Screw, 1 1/4"-7 x 3 1/2", 16 Row
	G10236	-	Lock Washer, 1 1/4"
	G10239	-	Hex Nut, 1 1/4"-7
16.	G6502-06	1	Swivel Elbow, 9/16"-18 JIC Male To Female, 45°
17.	GD6807	1	Shaft, 1 1/4" x 7", 8/12 Row
	GD7247	-	Shaft, 1 1/4" x 8", 16 Row
	G10610	2	Spring Pin, 3/8" x 2"
18.	GD5153	-	Bronze Wear Pad
	GD5154	-	Shim
19.	GA4411	1	Roller W/Bronze Bushings, 8/12 Row
	GA4418	-	Roller W/Bronze Bushings, 16 Row
	GD6556	-	Bronze Bushing
20.	GD8188	-	Clamp, 3" x 5 3/8"

# CENTER FRAME

PFA038/PLA014

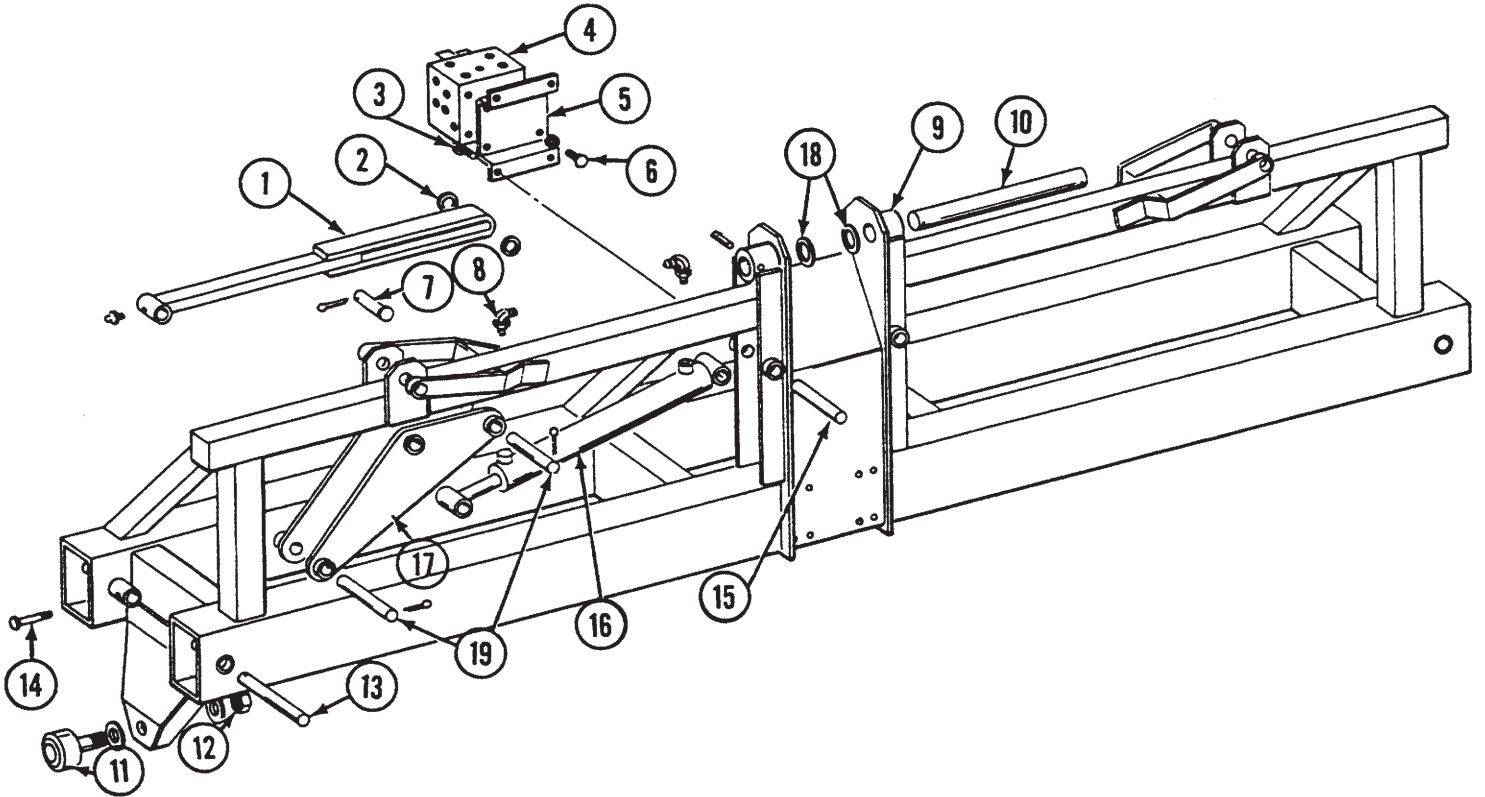
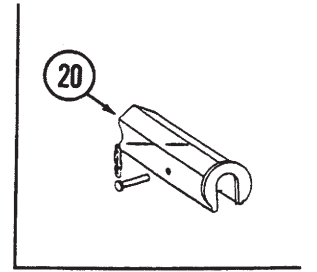



# CENTER FRAME

ITEM	PART NO.	QTY.	DESCRIPTION
1.	GA3400	2	Link W/Grease Fitting, 12 Row 30 And 16 Row 30
	GA2845	-	Link W/Grease Fitting, 8 Row 36/38 And 12 Row 36/38
	G10641	-	Grease Fitting, 1/8" NPT
2.	GD4171	4	Washer, 1 1/4", Hardened
3.	G10004	4	Hex Head Cap Screw, 3/8"-16 x 1 1/4"
	G10229	4	Lock Washer, 3/8"
	G10101	4	Hex Nut, 3/8"-16
4.		-	See "Junction Block - Located On Front Side Of Center Frame"
5.	GD6731	1	Mounting Plate
6.	G10583	4	Hex Head Cap Screw, 5/16"-18 x 2 3/4"
	G10232	4	Lock Washer, 5/16"
7.	GA2621	2	Pin, 1 1/4" x 3 1/8"
	G10460	4	Cotter Pin, 1/4" x 2"
8.	G6801-08	4	Elbow, 3/4"-16 JIC To 3/4"-16 O-Ring
9.		-	Frame, 165", 8 Row 36/38 (Non-stock Item)
		-	Frame, 133", 12 Row 30 And 16 Row 30 (Non-stock Item)
		-	Frame, 165", 12 Row 36/38 (Non-stock Item)
10.	GD6659	1	Pin, 2 1/8" x 16"
	G10695	2	Spring Pin, 1/2" x 1 1/2"
11.	GA2566	2	Cam Follower W/Grease Fitting
	G10640	-	Grease Fitting, 1/4"-28
12.	G10139	2	Washer, 1 1/4" USS
	G10281	2	Hex Nut, 1 1/4"-12 NF
13.	GD6683	4	Pin, 1 1/4" x 7 1/2"
14.	G10486	4	Hex Head Cap Screw, 3/8"-16 x 2 3/4", Grade 8
	G10108	4	Lock Nut, 3/8"-16
15.	GD1701	2	Pin, 1 1/4" x 6 1/2"
	G10460	4	Cotter Pin, 1/4" x 2"
16.		-	See "Wing Lock Cylinder"
17.	GA3429	2	Toggle W/Grease Fittings
	G10641	-	Grease Fitting, 1/8" NPT
	G10640	-	Grease Fitting, 1/4"-28
18.	G10234	-	Machine Bushing, 10 Gauge
19.	GD4108	4	Pin, 1 1/4" x 7 1/2"
	G10460	8	Cotter Pin, 1/4" x 2"
20.	G1K190	1	Cylinder Stop Kit, Includes 2 Cylinder Lockups (Where Applicable)

# WING FRAME

PFA039/PFA046/PFA055

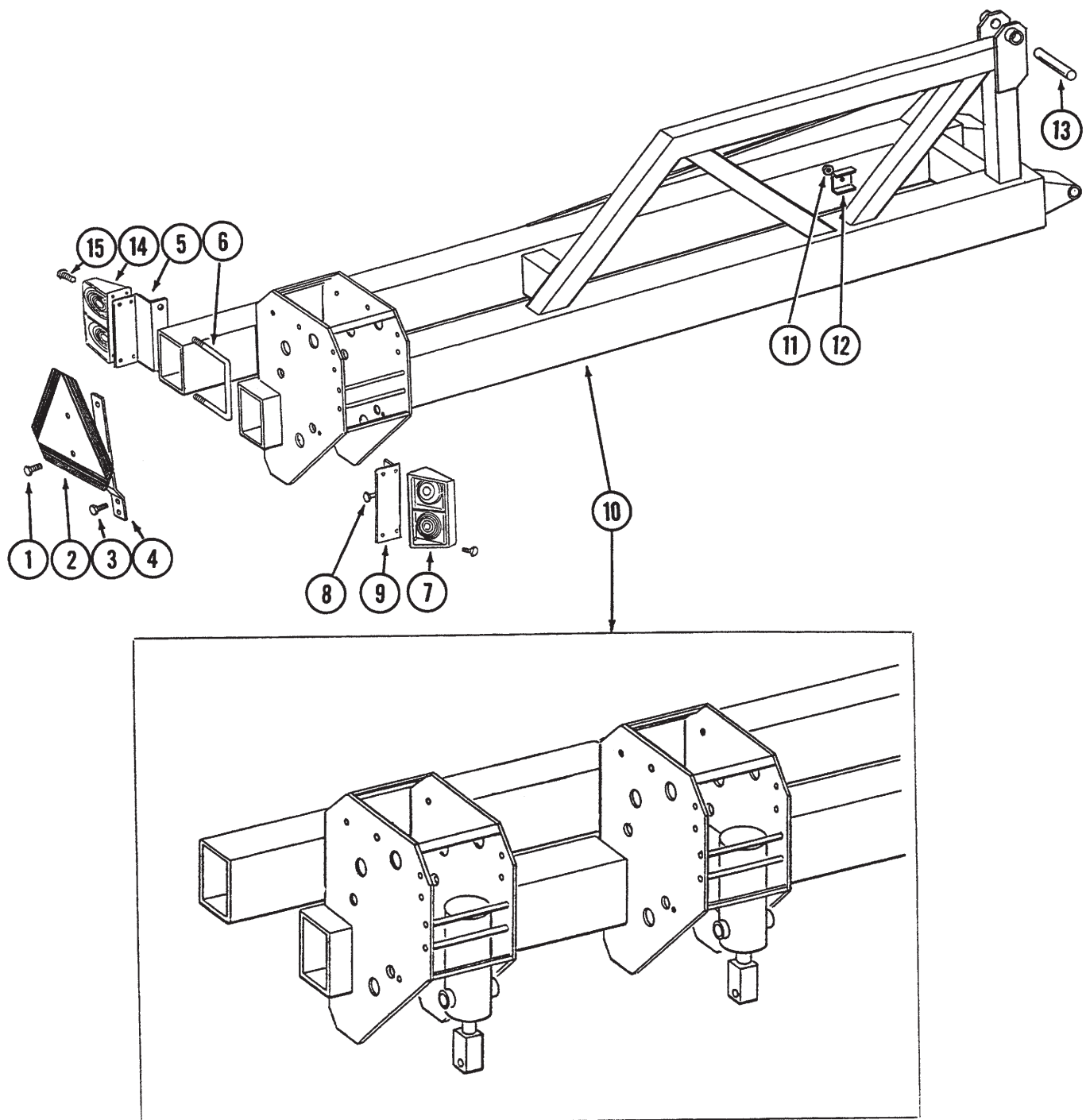

# WING FRAME

ITEM	PART NO.	QTY.	DESCRIPTION
1.	G10022	2	Hex Head Cap Screw, 1/4"-20 x 1/2"
	G10227	2	Lock Washer, 1/4"
	G10103	2	Hex Nut, 1/4"-20
2.		-	See "SMV, Decals, Reflectors And Tie Straps"
3.	G10031	2	Hex Head Cap Screw, 5/16"-18 x 1 3/4"
	G10232	2	Lock Washer, 5/16"
	G10106	2	Hex Nut, 5/16"-18
4.	GD6783	1	Bracket
5.	GA6792	1	Light Bracket
6.	GD1113	1	U-Bolt, 5" x 7" x 5/8"-11
	G10230	2	Lock Washer, 5/8"
	G10104	2	Hex Nut, 5/8"-11
7.	GA6700	1	Double Light Assembly, R.H.
	GR1203	-	Red Lens
	GR1204	-	Amber Lens
	GR1205	-	Cover
	GR1206	-	Rubber Grommet (4)
	GR1207	-	Lamp Unit
	GR1208	-	Bulb
			NOTE: See "Electrical Components" for wiring harness.
8.	G10019	2	Hex Head Cap Screw, 3/8"-18 x 1"
	G10232	2	Lock Washer, 3/8"
	G10106	2	Hex Nut, 3/8"-18
9.	GD9681	1	Light Bracket
10.		-	Wing, L.H. And R.H., 71 1/4", 8 Row 36 (Non-stock Item)
		-	Wing, L.H. And R.H., 79 1/4", 8 Row 38 (Non-stock Item)
		-	Wing, L.H. And R.H., 123 1/4", 12 Row 30 (Non-stock Item)
		-	Wing, L.H. And R.H., 139 1/2", 12 Row 36 (Non-stock Item)
		-	Wing, L.H. And R.H., 150 1/2", 12 Row 38 (Non-stock Item)
		-	Wing, L.H. And R.H., 183 1/4", 16 Row 30 (Two Wheel Towers Per Wing) (Non-stock Item)
11.	G10108	-	Lock Nut, 3/8"-16
12.	GD5875	-	Clamp, 2 1/2" x 2"
13.	GD1701	2	Pin, 1 1/4" x 6 1/2"
	G10460	4	Cotter Pin, 1/4" x 2"
14.	GA6699	1	Double Light Assembly, L.H.
	GR1203	-	Red Lens
	GR1204	-	Amber Lens
	GR1205	-	Cover
	GR1206	-	Rubber Grommet (4)
	GR1207	-	Lamp Unit
	GR1208	-	Bulb
			NOTE: See "Electrical Components" for wiring harness.
15.	G10064	8	Hex Head Cap Screw, 1/4"-20 x 1"
	G10209	8	Washer, 1/4" USS
	G10110	8	Lock Nut, 1/4"-20

# CENTER PIVOT

PFA040

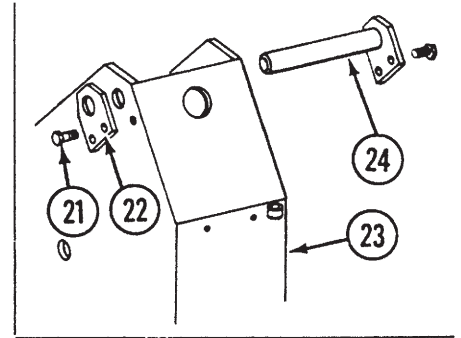
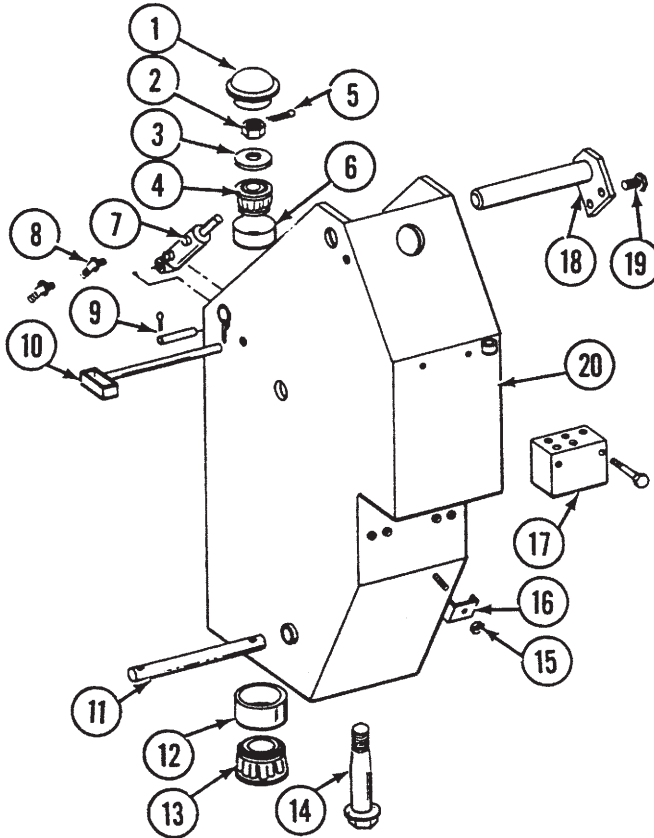

ITEM	PART NO.	QTY.	DESCRIPTION
1.	GD4927	1	Cap
2.	G10070	1	Hex Jam Nut, 1 1/4"-12, Grade 2
3.	GD4171	1	Hardened Washer, 1 1/4"
4.	GA0705	1	Cone
5.	G10460	1	Cotter Pin, 1/4" x 2"
6.	GR0322	1	Cup
7.	-	-	See "Lift Lock Cylinder"
8.	G6801-06-08	2	Elbow, 3/4"-16 O-Ring To 9/16"-18 JIC
9.	GD7137	2	Pin, 3/4" x 3 1/4"
	G10457	4	Cotter Pin, 5/32" x 1 1/2"
10.	GA4436	1	Pin
	GD2558	1	Lynch Pin, 1/4"
11.	GD6660	1	Pin, 1 1/2" x 13 5/8"
	G10489	2	Spring Pin, 3/8" x 1 1/2"
12.	GD6554	1	Cup
13.	GA4288	1	Cone
14.	GA4746	1	Pivot Bolt, Tapered
15.	G10101	-	Hex Nut, 3/8"-16
16.	GD5892	-	Clamp, 1 1/2" x 1 1/2"
17.	-	-	See "Junction Block - Located On Rear Side Of Center Frame"
18.	GA4362	1	Pin, 11 1/4", 8/12 Row
19.	G10005	2	Hex Head Cap Screw, 5/8"-11 x 1 3/4"
20.	-	-	Rotating Housing, 8/12 Row (Non-stock Item)
21.	G10026	2	Hex Head Cap Screw, 3/4"-10 x 2", 16 Row
22.	GD7210	-	Plate, 16 Row Only
23.	-	-	Rotating Housing, 16 Row (Non-stock Item)
24.	GA4875	-	Pin, 12", 16 Row

# CENTER LIFT ARMS

PFA041

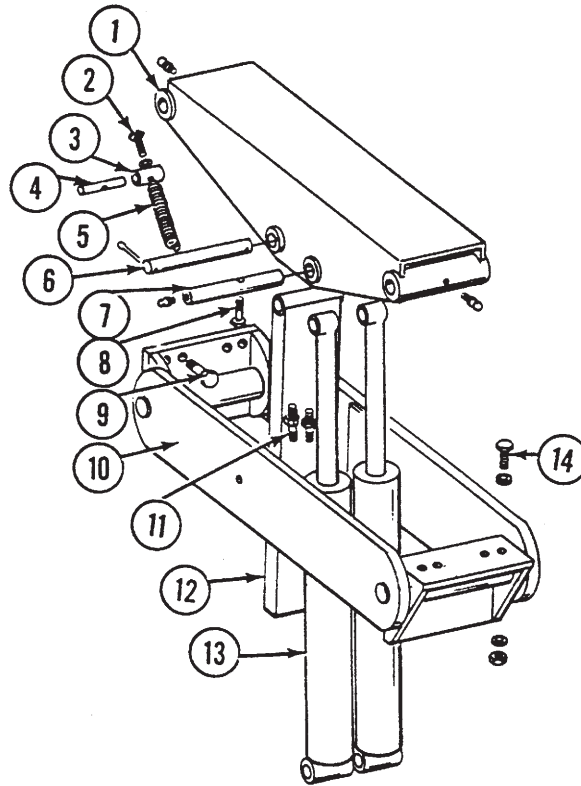

ITEM	PART NO.	QTY.	DESCRIPTION
1.	GA4360	1	Upper Lift Arm W/Grease Fittings
	G10641	-	Grease Fitting, 1/8" NPT
2.	G10077	1	Hex Head Cap Screw, 7/16"-14 x 4 1/2"
	G10081	1	Washer, 7/16" USS
3.	GD6701	1	Sleeve, 1 1/2"
4.	GD6700	1	Pin, 3/4" x 2 1/2"
5.	GA2052	1	Spring W/Plug
6.	GD6657	1	Pin, 1 1/2" x 9 3/4"
	G10462	2	Cotter Pin, 3/16" x 2"
7.	GA4361	1	Pin W/Grease Fittings
	G10641	-	Grease Fitting, 1/8" NPT
8.	G10486	1	Hex Head Cap Screw, 3/8"-16 x 2 3/4", Grade 8
	G10108	1	Lock Nut, 3/8"-16
9.	G10097	8	Hex Head Cap Screw, 3/4"-16 x 2 1/2"
10.	GA4356	1	Lower Lift Arm W/Grease Fittings
	G10641	-	Grease Fitting, 1/8" NPT
11.	G6400-L-10	4	Connector, 7/8"-14 O-Ring To 7/8"-14 JIC
12.	GA4347	1	Safety Lock W/Grease Fitting
	G10641	-	Grease Fitting, 1/8" NPT
13.		-	See "Master Lift Cylinder"
14.	G10480	4	Hex Head Cap Screw, 3/4"-16 x 2"
	GD2169	4	Special Washer
	G10098	4	Hex Nut, 3/4"-16

# AXLE AND TRANSPORT WHEELS

HTA029/HTA031/HTA032/PFA051

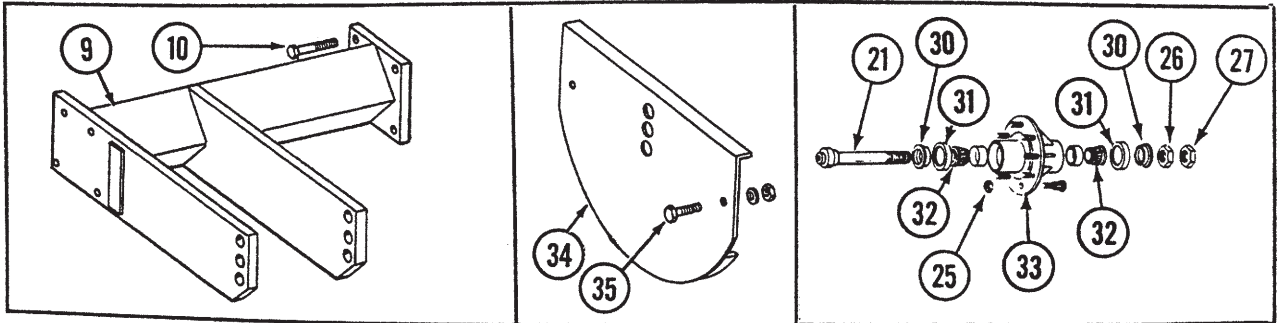
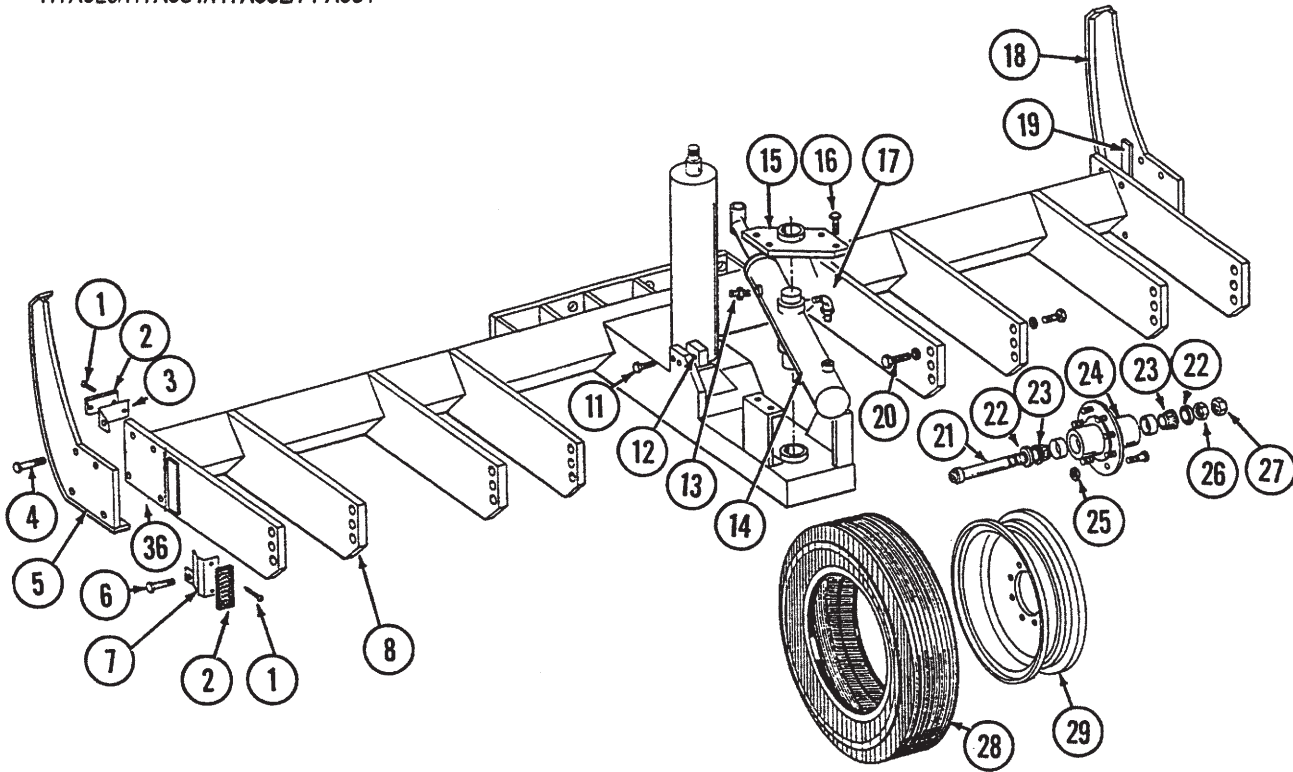

ITEM	PART NO.	QTY.	DESCRIPTION
1.	G10482	4	Slotted Screw, #8 x 3/4"
2.		-	See "SMV, Decals, Reflectors And Tie Straps"
3.	GD6955	1	Mount, L.H. (Shown)
	GD6956	1	Mount, R.H.
4.	G10010	8	Hex Head Cap Screw, 5/8"-11 x 3"
	G10230	8	Lock Washer, 5/8"
	G10104	8	Hex Nut, 5/8"-11
5.	GA4367	1	Anti-Rotation Track, L.H.
6.	G10039	2	Hex Head Cap Screw, 1/2"-13 x 1 3/4"
	G10228	2	Lock Washer, 1/2"
	G10102	2	Hex Nut, 1/2"-13
7.	GD6957	1	Mount, L.H. (Shown)
	GD6958	1	Mount, R.H.
8.		-	Axle, 132", 12 Row 30 (Shown) (Non-stock Item)
		-	Axle, 85", 8 Row 36/38 And 12 Row 36/38 (Non-stock Item)
		-	Axle, 132", 16 Row 30 (Non-stock Item)

# AXLE AND TRANSPORT WHEELS

ITEM	PART NO.	QTY.	DESCRIPTION
9.	GA4627	1	Axle Stub, L.H., Wide Row Models Only (Shown)
	GA4628	1	Axle Stub, R.H., Wide Row Models Only
10.	G10479	8	Hex Head Cap Screw, 1"-14 x 3", Grade 8
	G10118	8	Lock Washer, 1"
	G10155	8	Hex Nut, 1"-14, Grade 8
11.	G10016	2	Hex Head Cap Screw, 1/2"-13 x 2"
	G10228	2	Lock Washer, 1/2"
12.	GD3389	1	Tap Block
	GD3398	-	Shim, 16 Gauge
	GD7888	-	Shim, 22 Gauge
13.	G6400-06-08	1	Connector, 3/4"-16 O-Ring To 9/16"-18 JIC
14.		-	See "Rotation Cylinder"
15.	GA4366	1	Cap Plate
16.	G10008	4	Hex Head Cap Screw, 5/8"-11 x 2"
	G10005	4	Hex Head Cap Screw, 5/8"-11 x 1 3/4"
	GD2169	4	Special Washer
	G10230	4	Lock Washer, 5/8"
	G10104	4	Hex Nut, 5/8"-11
17.	G6801-06-08	1	Elbow, 3/4"-16 O-Ring To 9/16"-18 JIC
18.	GA4368	1	Anti-Rotation Track, R.H.
19.	GD3607-08	2	Bar
20.	G10448	8	Hex Head Cap Screw, 7/8"-9 x 2 1/2", Grade 8
	G10330	8	Lock Washer, 7/8"
21.	GA4727	-	Spindle, 1 3/4"
22.	GA4722	-	Seal
23.	GA4723	-	Cone
24.	GA4729	-	Hub W/Cups, Bolts And Grease Fitting, 8 Bolt, 1 3/4" Bore, 8/12 Row
	G10641	-	Grease Fitting, 1/8" NPT
	GD7079	-	Cup
	GR0528	-	Bolt
25.	GR0531	-	Nut, 5/8"-18 UNF
26.	GD7089	-	Special Nut, 1 3/4"-12 UNF
27.	GD7864	-	Special Hex Nut, 1 3/4"-12 UNF
28.	GD7257	-	Tire, 7.50-20, Load Rated D, Bias Ply, 8/12 Row
	GD7256	-	Tube, 8/12 Row
	GD7262	-	Tire, 7.50-20, Load Rated E, Bias Ply, 16 Row
	GD7256	-	Tube, 16 Row
	GD7263	-	Flap, 16 Row
29.	GA4291	-	Rim, W7B x 20H, 8/12 Row
	GA4869	-	Rim, 16 Row
30.	GD7163	-	Spacer
31.	GA4799	-	Seal
32.	GA4800	-	Cone
33.	GA4801	-	Hub W/Cups, Bolts And Grease Fitting, 8 Bolt, 1 3/4" Bore, 16 Row
	GD7167	-	Cup
	GR0528	-	Bolt, Grade 5
	G10641	-	Grease Fitting, 1/8" NPT
34.	GA5716	-	Rock Guard (Optional)
35.	G10037	-	Hex Head Cap Screw, 1/2"-13 x 1 1/4"
	G10228	-	Lock Washer, 1/2"
	G10102	-	Hex Nut, 1/2"-13
36.	GD8364	-	Shim, 12 Gauge (As Required)
	GD8365	-	Shim, 14 Gauge (As Required)

# CONTACT DRIVE WHEEL

PTD057/PFA046/PTD075rev.

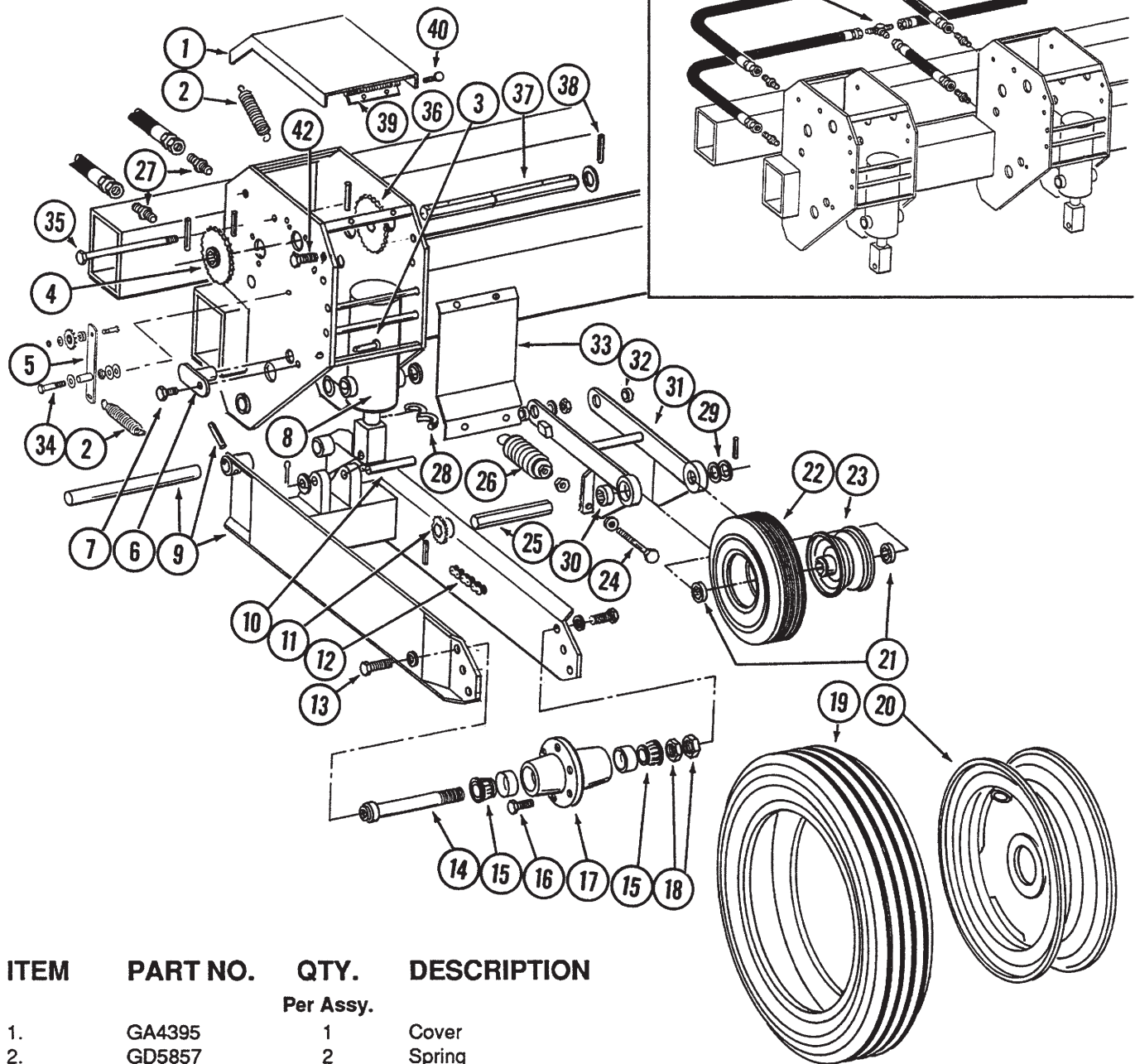

ITEM	PART NO.	QTY.	DESCRIPTION
		Per Assy.	
1.	GA4395	1	Cover
2.	GD5857	2	Spring
3.	G10478	1	Clevis Pin, 5/16" x 1"
	G10409	1	Ring
4.	GA5109	1	Sprocket, 24 Tooth, 8/12 Row
	GA5114	-	Sprocket, 30 Tooth-2 To 1 Reduction, 8/12 Row(Shown)
		-	See "Ratchet/Sprocket Assembly", 16 Row
5.	GA6534	1	Idler W/Sprocket And Hardware
	GA5103	-	Sprocket
	G10017	-	Hex Head Cap Screw, 1/2"-13 x 1 1/2"
	G10206	-	Washer, 1/2" SAE
	G10501	-	Lock Nut, 1/2"-13
6.	GA5121	2	Pin
7.	G10017	2	Hex Head Cap Screw, 1/2"-13 x 1 1/2"
	G10228	2	Lock Washer, 1/2"
	G10102	2	Hex Nut, 1/2"-13
8.		-	See "Slave Lift Cylinder"



# CONTACT DRIVE WHEEL

ITEM	PART NO.	QTY.	DESCRIPTION
		Per Assy.	
9.	GA4389	1	Wheel Module W/Pin
	GD6712	-	Pin, 1 1/4" x 12 1/2"
	G10610	-	Roll Pin, 3/8" x 2"
10.	GD5841	1	Pin, 1 1/4" x 5 5/8"
	G10460	2	Cotter Pin, 1/4" x 2"
11.	GA5109	1	Sprocket, 24 Tooth, 8/12 Row
	GA5105	-	Sprocket, 15 Tooth-2 To 1 Reduction, 8/12/16 Row (Shown)
	GA5114	-	Sprocket, 30 Tooth, 16 Row
12.	G3310-112	1	Chain, No. 40, 112 Pitch Including Connector Link, 8/12 Row
	G3310-118	-	Chain, No. 40, 118 Pitch Including Connector Link, 16 Row
	GR0912	-	Connector Link, No. 40
13.	G10026	2	Hex Head Cap Screw, 3/4"-10 x 2"
	G10231	2	Lock Washer, 3/4"
14.	GA4376	1	Spindle
15.	GA0895	2	Cone
16.	GR0270	6	Bolt, 9/16" x 1 1/8", Grade 5
17.	GA2148	1	Hub W/Cups, 6 Bolt
	GR0434	-	Cup
18.	G10087	2	Hex Jam Nut, 1 1/2"-12
19.	GD9645	1	Tire, 7.50 x 20, 6 Ply Tubeless
	GD1166	-	Valve Stem
20.	GA2908	1	Rim, 5.5 x 20
21.	GD1199-03	-	Spacer, 5/8" (As Required)
22.	GD4700	1	Tire, 4.8 x 8, 6 Ply, Rib Implement
	GD4701	-	Valve Stem
23.	GA3553	1	Rim
24.	G10038	2	Hex Head Cap Screw, 1/2"-13 x 3"
	G10501	2	Hex Jam Nut, 1/2"-13
25.	GD6775	1	Shaft, 7/8" x 12"
26.	GA2068	2	Spring
27.	G6400-08	2	Connector, 3/4"-16 JIC To O-Ring
28.	GD6959	-	Split Washer, 1 1/2" (As Required), 8/12 Row
	GD7171	-	Split Washer, 1 1/4" (As Required), 16 Row
29.	G10233	-	Machine Bushing
30.	GA5116	2	Bearing, 7/8" Hex Bore
31.	GA4387	1	Wheel Arm
32.	GB0218	2	Bushing
33.	GD6895	1	Shield
34.	G10743	1	Hex Head Cap Screw, 5/8"-11 x 3 3/4"
	G10235	-	Machine Bushing (As Required)
	G10205	-	Washer, 5/8"-11 SAE (As Required)
	G10104	1	Hex Nut, 5/8"-11
	G10107	1	Lock Nut, 5/8"-11
35.	G10595	-	Hex Head Cap Screw, 3/8"-16 x 10" (Used To Secure Point Row Clutch)
	G10108	-	Lock Nut, 3/8"
36.		-	See "Inner Module Drive"
37.	GD7763	-	Shaft, 7/8" x 14", Used On 8 Row Models (See "Point Row Clutch For Models Equipped With Point Row Clutches.)
38.	G10602	2	Spring Pin, 1/4" x 1 1/2"
39.	GD5789	1	Hinge, Female
	GD5790	1	Hinge, Male
40.	G10064	2	Hex Head Cap Screw, 1/4"-20 x 1"
	G10227	2	Lock Washer, 1/4"
	G10103	2	Hex Nut, 1/4"-20
41.	G2603-08	2	Tee, 3/4"-16 JIC
42.	G10005	2	Hex Head Cap Screw, 5/8"-11 x 1 3/4"
	G10235	4	Machine Bushing
	G10205	2	Washer, 5/8" SAE
	G10107	2	Lock Nut, 5/8"-11

# TRANSMISSION AND ROW UNIT DRILL SHAFT

PTD056/PTD065/RUB007

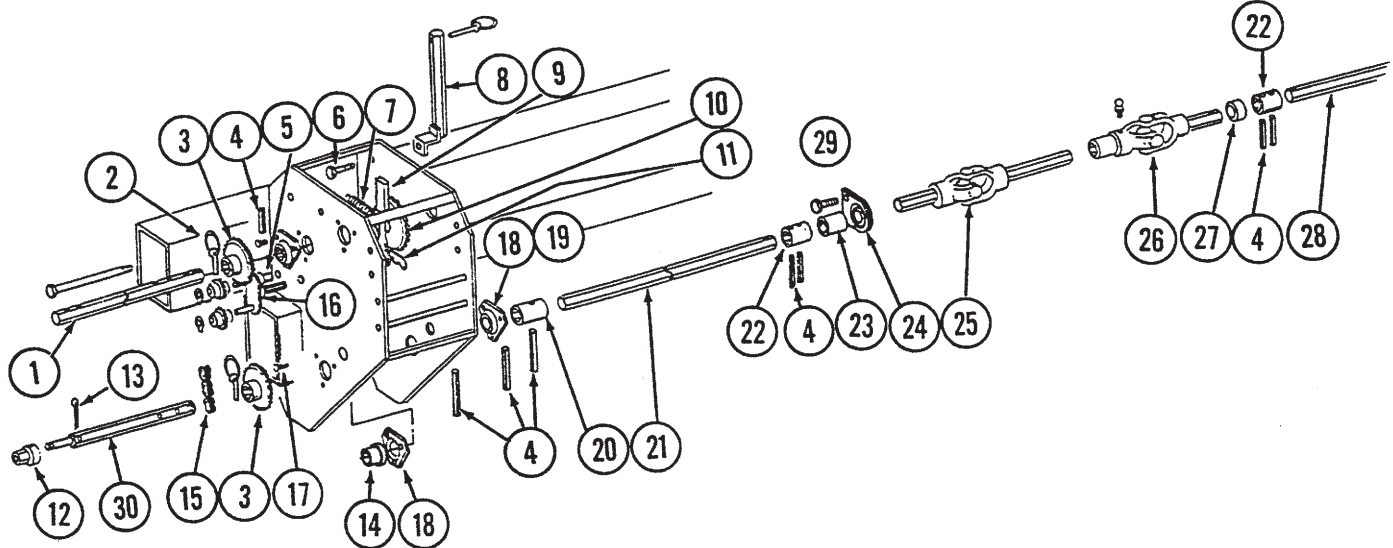
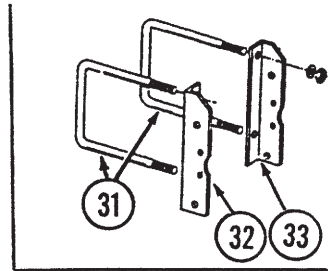

ITEM	PART NO.	QTY. Per Side	DESCRIPTION
1.	GD6780	1	Shaft, 7/8" x 15", 8/12 Row
	GD8640	-	Shaft, 7/8" x 46 1/2", 16 Row
2.	GD2558	3	Lynch Pin, 1/4"
3.	GA5106	1	Sprocket, 17 Tooth
	GA5107	1	Sprocket, 19 Tooth
	GA5108	2	Sprocket, 23 Tooth
	GA5109	1	Sprocket, 24 Tooth
	GA5110	1	Sprocket, 25 Tooth
	GA5111	1	Sprocket, 26 Tooth
	GA5112	1	Sprocket, 27 Tooth
	GA5113	1	Sprocket, 28 Tooth
4.	G10602	-	Spring Pin, 1/4" x 1 1/2"
5.	G10478	1	Clevis Pin, 5/16" x 1"
	G10409	1	Ring
6.	G10037	1	Hex Head Cap Screw, 1/2"-13 x 1 1/4"
	G10228	1	Lock Washer, 1/2"
	G10102	1	Hex Nut, 1/2"-13
7.	GD5857	1	Spring

# TRANSMISSION AND ROW UNIT DRILL SHAFT

ITEM	PART NO.	QTY.	DESCRIPTION
8.	GA4630	1	Sprocket Storage Rod
9.	GA4235	1	Ratchet Wrench W/Protective Closure
	G10445	-	Protective Closure, Red
10.		-	See "Inner Module Drive"
11.	G10670	1	Hair Pin Clip, No. 3
12.	GD7127	1	Shear Coupler
13.	G10462	-	Cotter Pin, 3/16" x 2"
14.	GA5548	1	Special Bearing
15.	G3310-80	1	Chain, No. 40, 80 Pitch Including Connector Link
	GR0912	-	Connector Link, No. 40
16.	GA4424	1	Idler W/Sprockets And Rings
	GD7426	-	Sprocket
	G10435	-	Ring
17.	G10303	-	Carriage Bolt, 5/16"-18 x 1"
	G10232	-	Lock Washer, 5/16"
	G10106	-	Hex Nut, 5/16"-18
18.	G3400-01	-	Flangette
19.	G2100-03	-	Bearing, 7/8" Hex
20.	GD5212	1	Coupler
21.	GD5887-54.25	1	Drill Shaft, Wing, 8 Row 36/38
	GD5887-101	-	Drill Shaft, Wing, 12 Row 30
	GD5887-121.75	-	Drill Shaft, Wing, 12 Row 36
	GD5887-128.75	-	Drill Shaft, Wing, 12 Row 38
	GD5887-161	-	Drill Shaft, Wing, 16 Row 30
22.	GD5886	2	Coupler
23.	GD1199-04	1	Spacer, 2"
24.	GA2180	1	Bearing Hanger, 7/8" Hex
25.	GA4394	1	U-Joint, 14 3/4", 12 Row 30 And 16 Row 30
	GA5647	-	U-Joint, 19 3/4", 8 Row 36/38
	GA4637	-	U-Joint, 21 3/4", 12 Row 36
	GA4638	-	U-Joint, 23 3/4", 12 Row 38
26.	GA4393	1	U-Joint W/Grease Fitting, 15"
	G10640	-	Grease Fitting, 1/4"-28
27.	GD1199-03	1	Spacer, 5/8"
28.	GD5887-36	1	Drill Shaft, Main Frame, 12 Row 30 And 16 Row 30
	GD5887-44	-	Drill Shaft, Main Frame, 8 Row 36/38 And 12 Row 36/38
29.	G10001	2	Hex Head Cap Screw, 3/8"-16 x 1"
	G10229	2	Lock Washer, 3/8"
	G10101	2	Hex Nut, 3/8"-16
30.	GD7612	1	Shaft, 7/8" x 13 1/2"
31.	GD1113	-	U-Bolt, 5" x 7" x 5/8"-11
	G10230	-	Lock Washer, 5/8"
	G10104	-	Hex Nut, 5/8"-11
32.	GD1022L	-	Support Angle (8 Row 38)
33.	GD2298	-	Support Angle (8 Row 38)

# INNER MODULE DRIVE

PTD058/PFA046

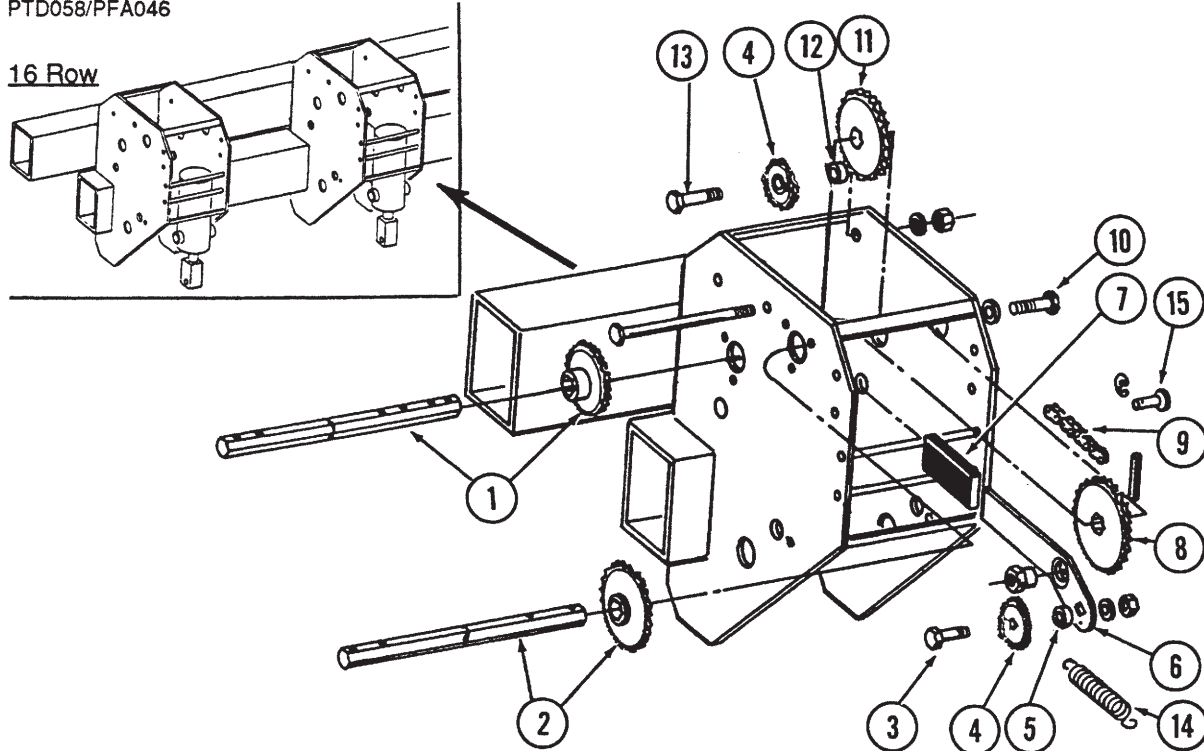

ITEM	PART NO.	QTY.	DESCRIPTION
		Per Module	
1.		-	See "Transmission And Row Unit Drill Shaft"
2.		-	See "Contact Drive Wheel"
3.	G10016	1	Hex Head Cap Screw, 1/2"-13 x 2"
	G10228	1	Lock Washer, 1/2"
	G10102	1	Hex Nut, 1/2"-13
4.	GA5103	1	Idler Sprocket W/Bearing, 15 Tooth
5.	GD4887-01	1	Sleeve, 5/8"
6.	GA4425	1	Idler Arm, L.H. (Shown)
	GA4426	-	Idler Arm, R.H.
7.	GD5827	1	Cover
8.	GA5107	1	Sprocket, 19 Tooth
9.	G3310-85	1	Chain, No. 40, 85 Pitch Including Connector Link
	GR0912	-	Connector Link, No. 40
	GR0911	-	Offset Link, No. 40
10.	G10004	1	Hex Head Cap Screw, 3/8"-16 x 1 1/4"
	G10229	1	Lock Washer, 3/8"
	GD5756	1	Special Nut, 3/8"-16
11.	GA5115	1	Sprocket, 33 Tooth
12.	GD6897	1	Spacer
13.	G10038	1	Hex Head Cap Screw, 1/2"-13 x 3"
	G10228	1	Lock Washer, 1/2"
	G10102	1	Hex Nut, 1/2"-13
14.	GD5857	1	Spring
15.	G10478	1	Clevis Pin, 5/16" x 1"
	G10409	1	Ring

PTD016

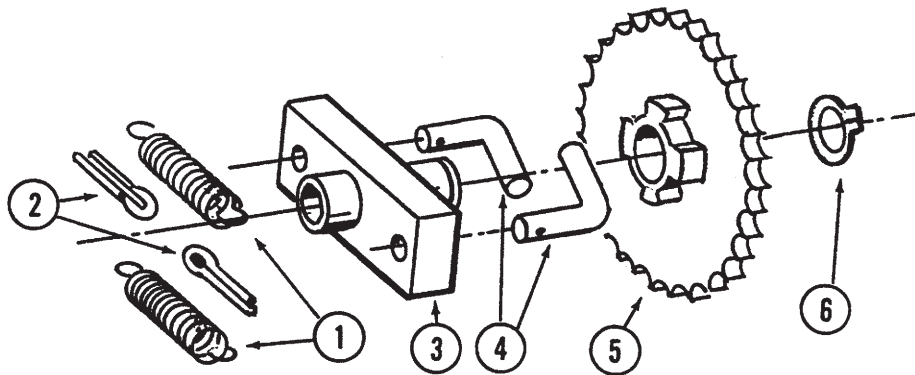

ITEM	PART NO.	QTY.	DESCRIPTION
1.	GD1256	2	Spring
2.	G10464	2	Cotter Pin, 3/16" x 1"
3.	GA0378	1	Block
4.	GD1255	2	"L" Pin
5.	GA5165	1	Sprocket, 30 Tooth
6.	G10430	1	Ring
A.	GA5164	-	Ratchet/Sprocket Assembly Complete

# POINT ROW WRAP SPRING CLUTCH

PRC018

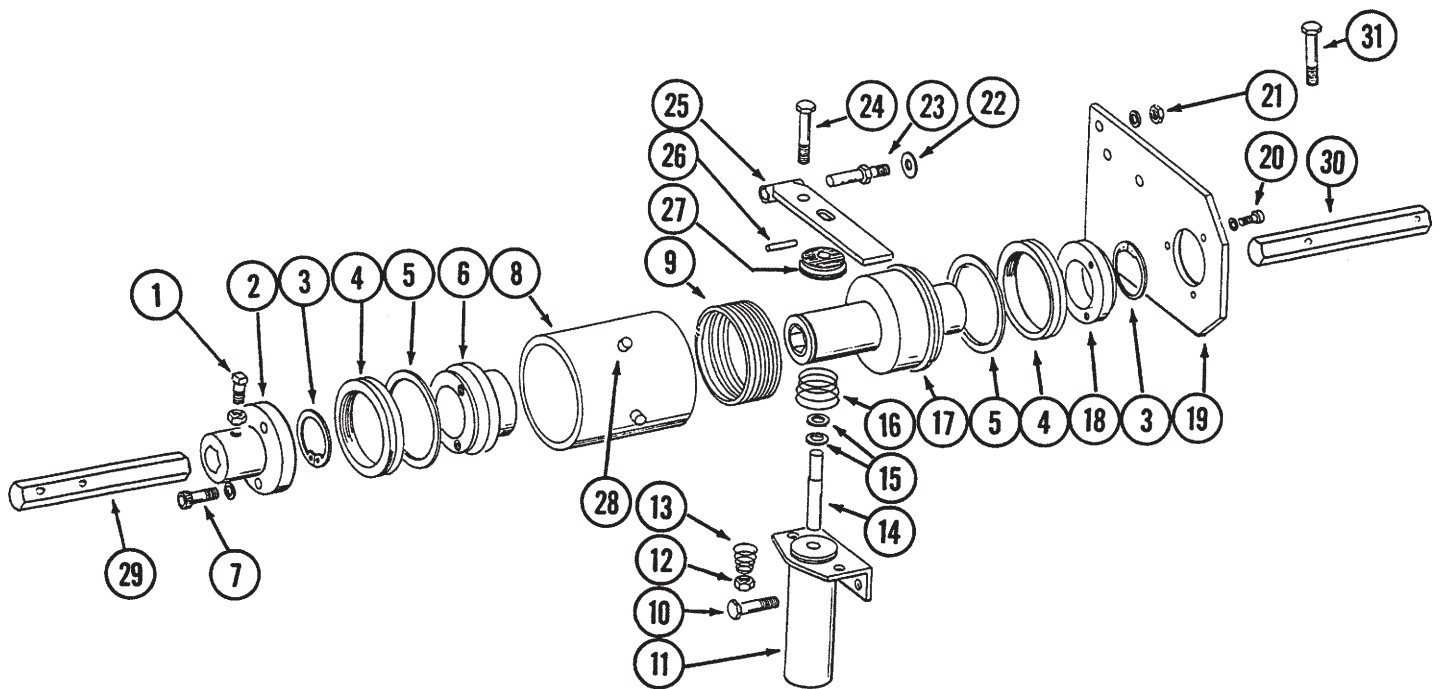

# POINT ROW WRAP SPRING CLUTCH

ITEM	PART NO.	QTY. Per Assy.	DESCRIPTION
1.	G10131	2	Square Head Set Screw, 5/16"-18 X 3/4" (8 And 12 Row Only)
	G10498	2	Jam Nut, 5/16"-18 (8 And 12 Row Only)
2.	GA6786	1	Coupler
3.	G10496	2	Inverted Snap Ring
4.	GD9664	2	V-Ring Seal
5.	GD9674	2	Teflon Ring
6.	GD9670	1	Input Hub
7.	G10374	3	Hex Socket Screw, 1/4"-20 x 1"
	G10227	3	Lock Washer, 1/4"
8.	GD9668	1	Stop Collar
9.	GD9671	1	Spring, L.H.
10.	G10023	2	Hex Head Cap Screw, 1/4"-20 x 3/4"
	G10227	2	Lock Washer, 1/4"
	G10103	2	Hex Nut, 1/4"-20
11.	GA5557	1	Solenoid
12.	G10110	1	Lock Nut, 1/4"-20
13.	GD9216	1	Spring
14.	GD9689	1	Plunger
15.	G10203	1	Washer, 3/8" SAE
16.	GD8458	1	Spring
17.	GA6785	1	Output Hub
18.	GD8667	1	Bushing
19.	GD9665	1	Mounting Plate
20.	G10253	3	Socket Screw, #10-32 x 1/2"
	G10257	3	Lock Washer, #10
21.	G10229	1	Lock Washer, 3/8"
	G10497	1	Jam Nut, 3/8"-16
22.	G10203	2	Washer, 3/8" SAE
23.	GD9679	1	Mounting Pin
24.	G10040	1	Hex Head Cap Screw, 1/2"-20 x 1 3/4"
25.	GA6787	1	Actuator Arm
26.	G10187	1	Spring Pin, 5/32" x 2"
27.	GR0646	1	Boot
28.	GD9781	4	Hex Socket Cap Screw, 1/4"-20 x 3/16" (Stop On Stop Collar)
29.	GD9060	1	Input Shaft, 5", 8 And 12 Row (Shown)
	GD9222	-	Input Shaft, 36", 16 Row
30.	GD7762	-	Output Shaft, 6 3/8", 8, 12 And 16 Row (Shown)
	GD7157	-	Output Shaft, 5 3/8", 12 And 16 Row
31.	G10041	1	Hex Head Cap Screw, 5/16"-18 x 2"
	G10109	1	Lock Nut, 5/16"-18
32.	GA4855	2	Wiring Harness, 180", 8 Row Models (3/16" Spades) (Not Shown)
	GA4854	-	Wiring Harness, 210", 12 Row 30 (3/16" Spades) (Not Shown)
	GA4996	-	Wiring Harness, 264", 12 Row 36/38 (3/16" Spades) (Not Shown)
	GA4817	-	Wiring Harness, 240", 16 Row Model (3/16" Spades) (Not Shown)

# ELECTRICAL COMPONENTS

ECP011/ECP018

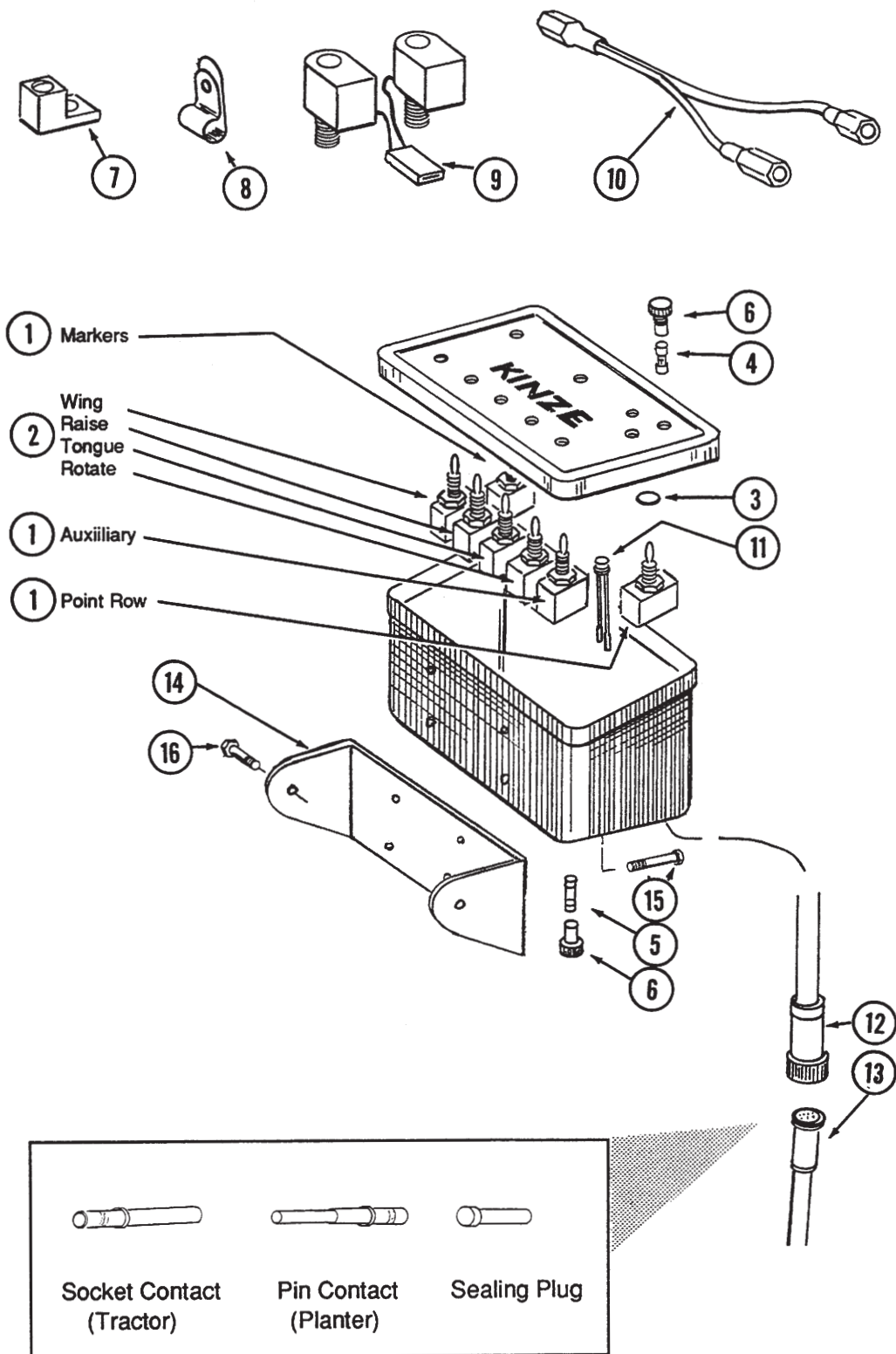



# ELECTRICAL COMPONENTS

ITEM	PART NO.	QTY.	DESCRIPTION
1.	GA2528	-	Switch, 3 Position Toggle
2.	GA2526	-	Switch, 2 Way Momentary Contact
3.	GD3860	-	O-Ring
4.	GD8253	2	Fuse, MDL-8 Amp Slow Blow
5.	GD2829	1	Fuse, AGC-15 Amp
6.	GA2612	3	Fuse Holder With Spade
7.	GA3584	-	Ground Clamp
8.	GD6291	-	Insulated Clamp
9.	G10269	-	Male Tab Terminal
	G10266	-	Female Terminal
10.	GA3589	-	Harness, 2"
11.	GA5845	1	Indicator Light
12.	GA6108	1	Connector With Cable Clamp (23 Pin)
	GD8740	-	Socket Contact (13 Used)
	GD8739	-	Sealing Plug (10 Used)
13.	GA6109	1	Connector With Cable Clamp (23 Pin)
	GD8741	-	Pin Contact (13 Used)
	GD8739	-	Sealing Pin (10 Used)
14.	GD3805	2	Mounting Bracket
15.	G10020	4	Hex Head Cap Screw, 1/4"-20 x 5/8"
	G10227	4	Lock Washer, 1/4"
	G10103	4	Hex Nut, 1/4"-20
16.	G10020	2	Hex Head Cap Screw, 1/4"-20 x 5/8"
	G10531	2	Wing Nut, 1/4"-20
A.	GA6124	-	Control Box Assembly With Mounting Brackets And Short Harness (23 Pin)
B.	GA6319	-	Wiring Harness, 150", 8 Row 36/38 "Y" Hitch
	GA6320	-	Wiring Harness, 180", 8 Row 36/38 "T" Hitch
	GA6112	-	Wiring Harness, 198", 12 Row 30 "Y" Hitch
	GA6111	-	Wiring Harness, 252", 12 Row 30 "T" Hitch, 12 Row 36/38 And 16 Row 30 "Y" Hitch
	GA6113	-	Wiring Harness, 300", 12 Row 36/38 And 16 Row 30 "T" Hitch (Not Shown) TRACTOR TO VALVE BLOCK ON HITCH
C.	GA4437	-	Wiring Harness, 277", 8 Row 36/38 And 12 Row 30 "Y" Hitch
	GA4439	-	Wiring Harness, 216", 8 Row 36/38, 12 Row 30 And 16 Row 30 "T" Hitch
	GA4813	-	Wiring Harness, 290", 12 Row 36/38 And 16 Row 30 "Y" Hitch
	GA4051	-	Wiring Harness, 258", 12 Row 36/38 "T" Hitch (Not Shown) VALVE BLOCK ON HITCH TO VALVE BLOCK ON FRAME
D.	GA6794	-	Wiring Harness, 612", All 8 Row 36/38
	GA6795	-	Wiring Harness, 684", All 12 Row 30
	GA6797	-	Wiring Harness, 768", 12 Row 36/38 "Y" Hitch
	GA6796	-	Wiring Harness, 780", 12 Row 36/38 "T" Hitch And All 16 Row 30 (Not Shown) WARNING LIGHTS
E.	GA6348	-	Harness Extension, 15', (Not Shown)

# MARKER ASSEMBLY

# 8 ROW 36/38 & 12 ROW 30

MKR019/MKR022

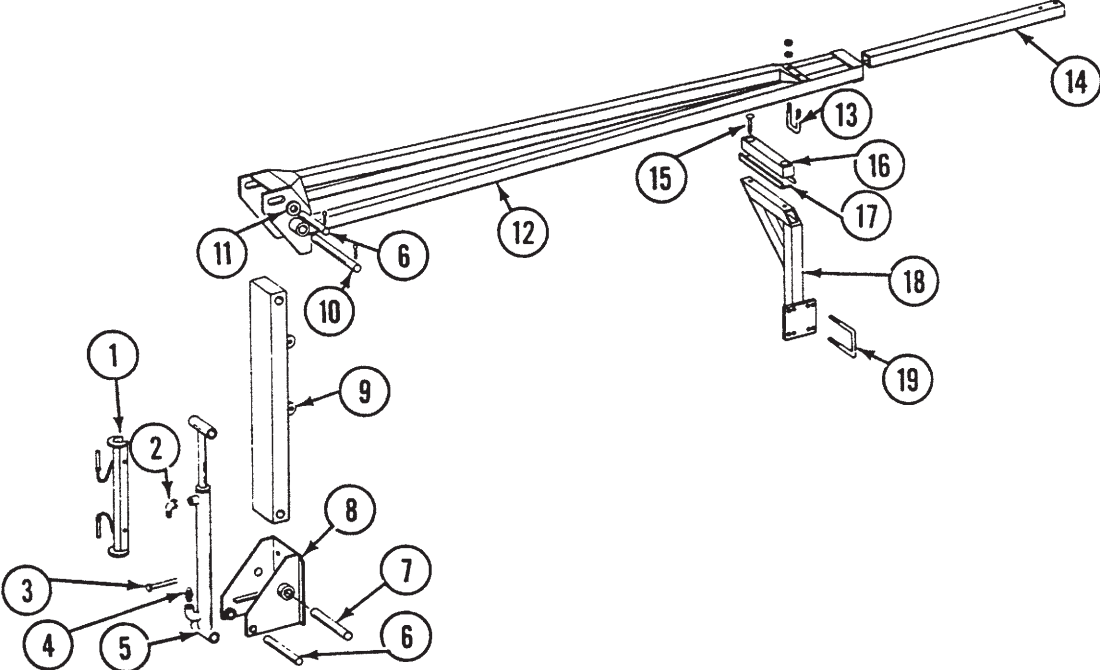

# MARKER ASSEMBLY

# 8 ROW 36/38 & 12 ROW 30

ITEM	PART NO.	QTY.	DESCRIPTION
		Per Assy.	
1.	GA5526	1	Lockup
2.	G6801-08	1	Elbow, 3/4"-16 JIC To 3/4"-16 O-Ring
3.	G10318	4	Hex Head Cap Screw, 5/8"-11 x 4 1/2"
	G10205	4	Washer, 5/8" SAE
	G10230	4	Lock Washer, 5/8"
	G10104	4	Hex Nut, 5/8"-11
4.	G6400-08	1	Connector, 3/4"-16 JIC To 3/4"-16 O-Ring
5.		-	See "Marker Cylinder"
6.	GD2161	2	Pin, 1 1/4" x 8 1/2"
	G10460	4	Cotter Pin, 1/4" x 2"
7.	GD0652	1	Pin, 1 1/4" x 9 1/2"
	G10460	2	Cotter Pin, 1/4" x 2"
8.	GA5130	1	Mount
9.	GA4611	1	First Stage W/Grease Fittings
	G10641	-	Grease Fitting, 1/8" NPT
10.	GD3214	1	Pin, 1 1/4" x 12 1/4"
	G10460	2	Cotter Pin, 1/4" x 2"
11.	G10226	-	Washer, 1 1/4" SAE (As Required)
	G10159	-	Machine Bushing, 10 Gauge (As Required)
	G10322	-	Machine Bushing, 18 Gauge (As Required)
12.	GA4353	1	Arm W/Grease Fittings, 12 Row 30
	G10641	-	Grease Fitting, 1/8" NPT
	GA5192	-	Arm, 8 Row 36/38
13.	GD2721	1	U-Bolt, 2" x 2" x 1/2"-13
	G10228	2	Lock Washer, 1/2"
	G10102	2	Hex Nut, 1/2"-13
14.	GD0453-07	1	Extension Tube, 45", 12 Row 30
	GD0453-08	-	Extension Tube, 65", 8 Row 36/38
15.	G10039	2	Hex Head Cap Screw, 1/2"-13 x 1 3/4"
	G10228	2	Lock Washer, 1/2"
	G10102	2	Hex Nut, 1/2"-13
16.	GD4512	1	Rubber Stop
17.	GD6772	1	Retainer
18.	GA4421	-	Stand, 12 Row 30 Only
19.	GD4743	-	U-Bolt, 3" x 3" x 1/2"-13
	G10228	-	Lock Washer, 1/2"
	G10102	-	Hex Nut, 1/2"-13

# MARKER ASSEMBLY

# 12 ROW 36/38 AND 16 ROW 30

MKR019/MKR022/MKR023

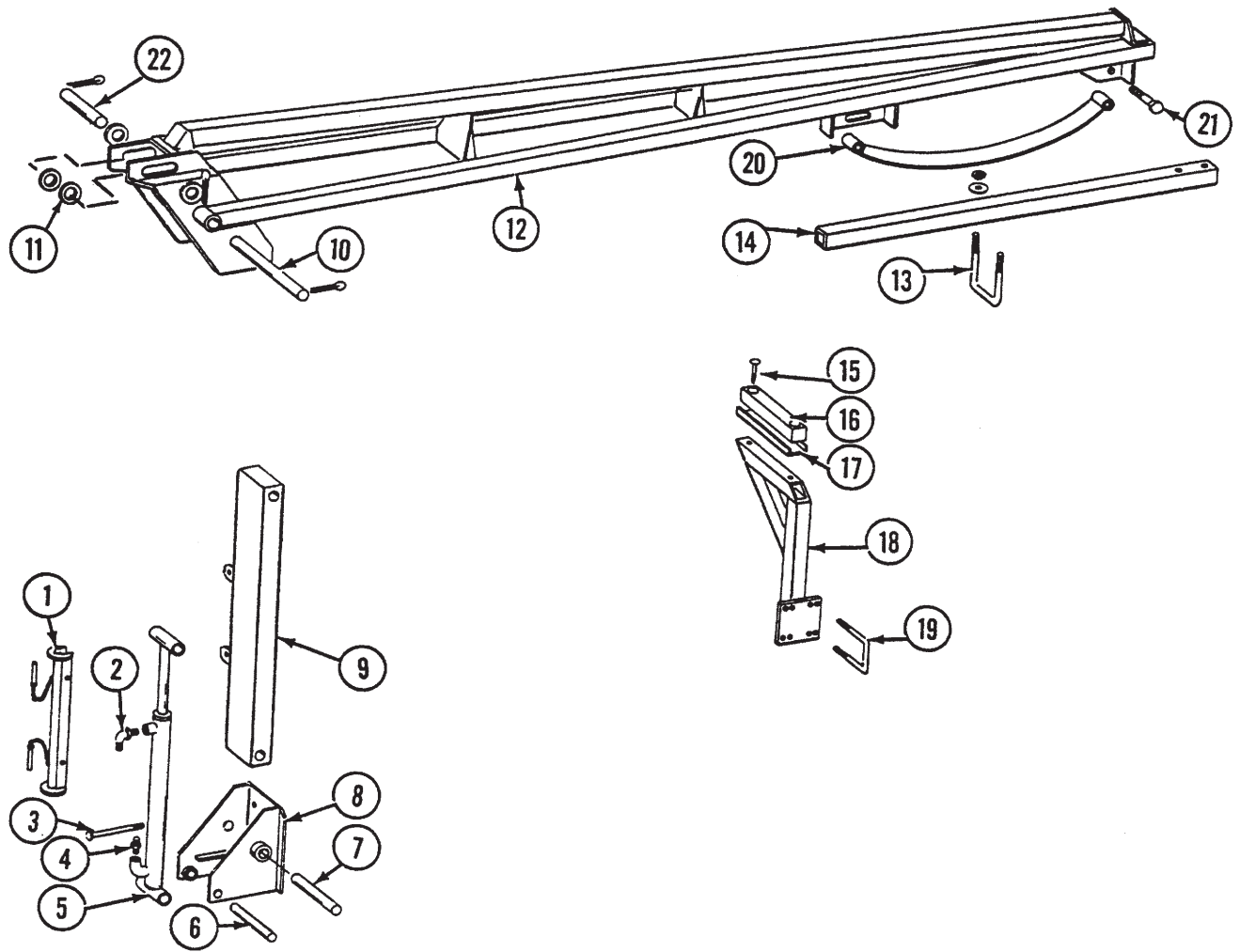

12 Row Shown

<b>ITEM</b>	<b>PART NO.</b>	<b>QTY.</b> Per Assy.	<b>DESCRIPTION</b>
1.	GA5527	1	Lockup
2.	G6801-08	1	Elbow, 3/4"-16 JIC To 3/4"-16 O-Ring
3.	G10068	4	Hex Head Cap Screw, 5/8"-11 x 6"
	G10008	2	Hex Head Cap Screw, 5/8"-11 x 2"
	G10205	6	Washer, 5/8" SAE
	G10230	6	Lock Washer, 5/8"
	G10104	6	Hex Nut, 5/8"-11
4.	G6400-08	1	Connector, 3/4"-16 JIC To 3/4"-16 O-Ring
	G6801-08	-	Elbow, 3/4"-16 JIC To 3/4"-16 O-Ring
5.		-	See "Marker Cylinder"
6.	GD0652	1	Pin, 1 1/4" x 9 1/2"
	G10460	2	Cotter Pin, 1/4" x 2"
7.	GD7209	1	Pin, 1 1/4" x 11 1/2"
	G10049	2	Hex Head Cap Screw, 3/8"-16 x 2 1/2"
	G10108	2	Lock Nut, 3/8"-16
8.	GA4877	1	Mount
9.	GA4878	1	First Stage W/Grease Fittings, R.H.
	GA4983	-	First Stage W/Grease Fittings, L.H.
	G10641	-	Grease Fitting, 1/8" NPT
10.	GD0737	1	Pin, 1 1/4" x 13 1/4"
	G10460	2	Cotter Pin, 1/4" x 2"
11.	G10226	-	Washer, 1 1/4" SAE
	G10159	-	Machine Bushing, 10 Gauge
	G10322	-	Machine Bushing, 18 Gauge
12.	GA4978	1	Arm, 138 1/4", 12 Row 36
	GA4979	-	Arm, 150 1/4", 12 Row 38
	GA4853	-	Arm, 172 1/4", 16 Row 30
13.	GD2721	1	U-Bolt, 2" x 2" x 1/2"-13
	G10228	2	Lock Washer, 1/2"
	G10102	2	Hex Nut, 1/2"-13
14.	GD0453-04	1	Extension Tube, 60", 12 Row 36/38
	GD0453-03	-	Extension Tube, 50", 16 Row 30
15.	G10039	2	Hex Head Cap Screw, 1/2"-13 x 1 3/4"
	G10228	2	Lock Washer, 1/2"
	G10102	2	Hex Nut, 1/2"-13
16.	GD4512	1	Rubber Stop
17.	GD6772	1	Retainer
18.	GA4421	1	Stand
19.	GD4743	2	U-Bolt, 3" x 3" x 1/2"-13
	G10228	4	Lock Washer, 1/2"
	G10102	4	Hex Nut, 1/2"-13
20.	GA4991	1	Leaf Spring
21.	G10515	2	Hex Head Cap Screw, 9/16"-12 x 3 1/2"
	G10517	-	Washer, 9/16" USS
	G10516	2	Lock Nut, 9/16"-12
22.	GD1701	1	Pin, 1 1/4" x 6 1/2"
	G10460	2	Cotter Pin, 1/4" x 2"

# MARKER SPINDLE/HUB/BLADE

MKR020

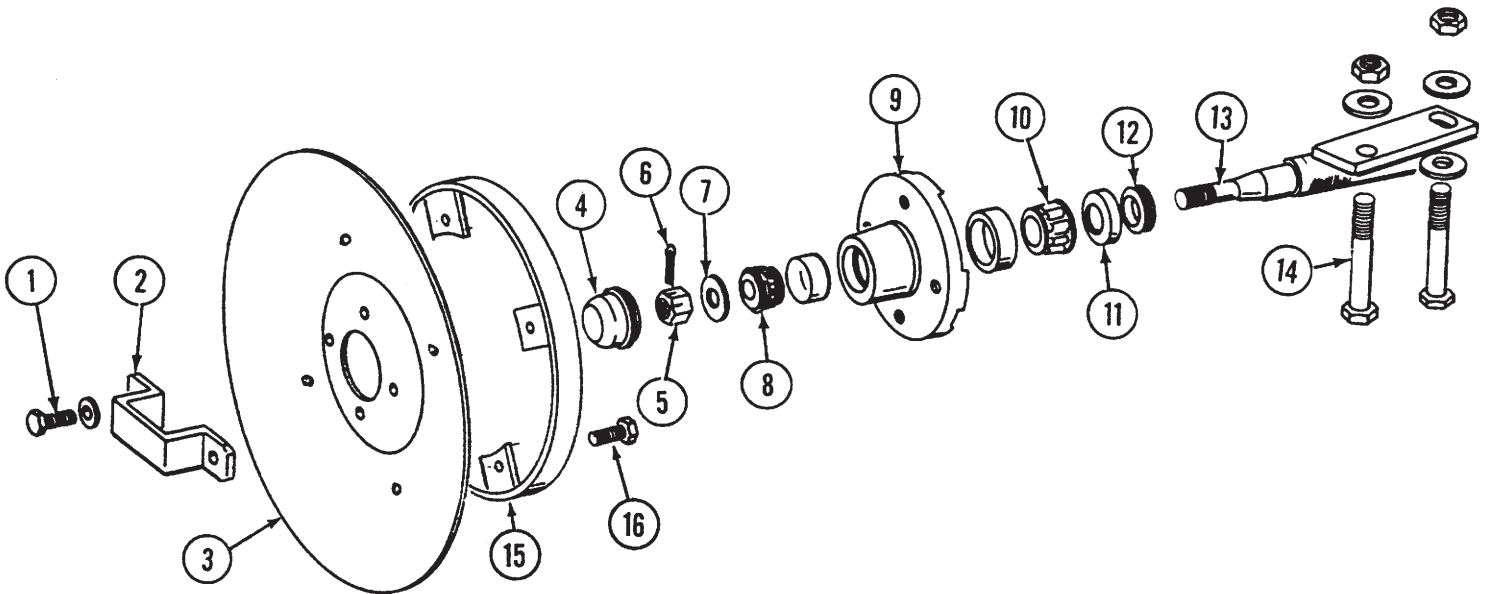

ITEM	PART NO.	QTY.	DESCRIPTION
		Per Assy.	
1.	G10722	4	Hex Head Cap Screw, 1/2"-20 x 1"
	G10228	4	Lock Washer, 1/2"
2.	GD2597	1	Retainer
3.	GD0746	1	Blade, 16"
4.	GD0840	1	Cap
5.	G10725	1	Hex Slotted Nut, 5/8"-18
6.	G10544	1	Cotter Pin, 5/32" x 1"
7.	G10724	1	Washer, 5/8"
8.	GA0257	1	Outer Bearing
9.	GA0167	1	Hub With Cups
	GR0151	-	Outer Cup
	GR0150	-	Inner Cup
10.	GA0245	1	Inner Bearing
11.	GA0243	1	Grease Seal
12.	GA0899	1	Rubber Seal
13.	GA1676	1	Spindle, R.H. (Shown)
	GA1677	-	Spindle, L.H.
14.	G10033	2	Hex Head Cap Screw, 1/2"-13 x 3 1/2"
	G10168	3	Machine Bushing, 1/2", 7 Gauge
	G10102	2	Hex Nut, 1/2"-13
15.	GA5853	1	Depth Band
16.	G10019	4	Hex Head Cap Screw, 5/16"-18 x 1"
	G10109	4	Lock Nut, 5/16"-18
A.	GA1679	-	Hub And Spindle Assembly, L.H. (Items 1 And 4-13)
	GA1678	-	Hub And Spindle Assembly, R.H. (Items 1 And 4-13)

# SOLENOID VALVE

VVB019

ITEM	PART NO.	QTY.	DESCRIPTION
1.	GR0760	1	Plate
2.	GR0761	1	Hex Nut
3.	GR0762	1	Coil
4.	GR0763	1	Cartridge
A.	GA2484	-	Solenoid Valve Complete
B.	GR0764	-	Seal Kit, Includes: (2)O-Rings, (1)BU Ring

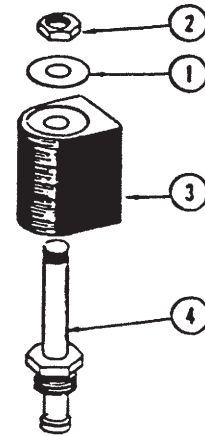

# FLOW CONTROL VALVE

VVB020

ITEM	PART NO.	QTY.	DESCRIPTION
A.	GA3413	-	Flow Control Valve
B.	GR0764	-	Seal Kit, Includes: (2)O-Rings, (1)BU Ring



# PRESSURE RELIEF VALVE

VVB020

ITEM	PART NO.	QTY.	DESCRIPTION
A.	GA3407	-	Pressure Relief Valve, 1000 PSI
B.	GR0764	-	Seal Kit, Includes: (2)O-Rings, (1)BU Ring

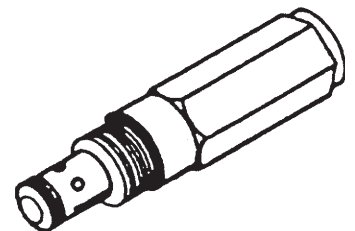

# CHECK VALVE

VVB020

ITEM	PART NO.	QTY.	DESCRIPTION
A.	GA4293	-	Check Valve
B.	GR0764	-	Seal Kit, Includes: (2)O-Rings, (1)BU Ring

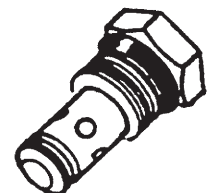

# VALVE BLOCK - LOCATED ON HITCH

VVB021

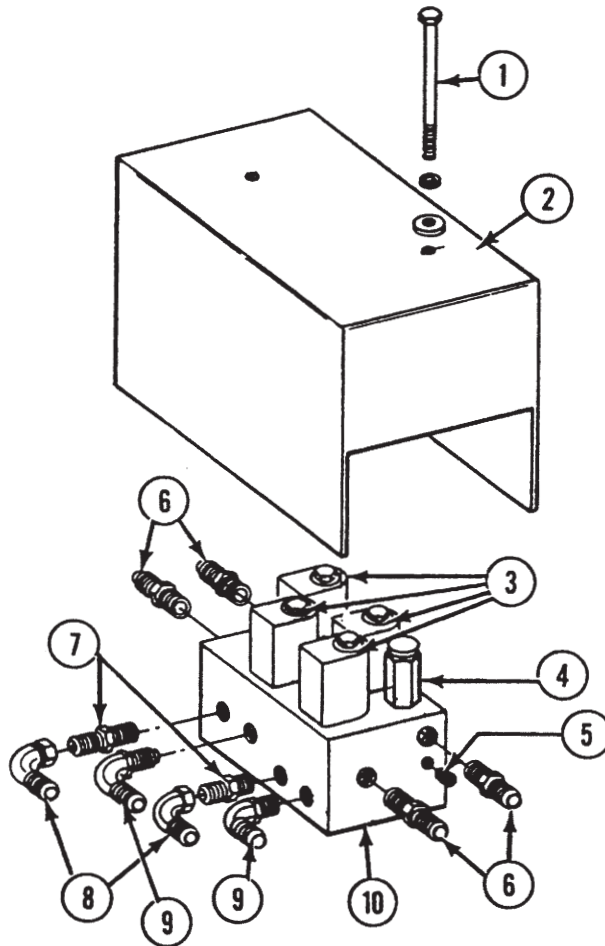

ITEM	PART NO.	QTY.	DESCRIPTION
1.	G10172	2	Hex Head Cap Screw, 3/8"-16 x 5"
	G10061	-	Hex Head Cap Screw, 3/8"-16 x 3 1/2"
	G10210	2	Washer, 3/8" USS
	G10229	2	Lock Washer, 3/8"
2.	GA4392	1	Cover, 12 3/16" x 7 1/2", 8 Row 36/38 "T" Hitch And All 12 And 16 Row Models
	GA4663	-	Cover, 10 1/8" x 5 1/4", 8 Row 36/38 "Y" Hitch
3.	-	-	See "Solenoid Valve"
4.	-	-	See "Pressure Relief Valve"
5.	G6408-H06-O	1	Hex Socket Head Plug, 9/16"-18 O-Ring
6.	G6400-08	4	Connector, 3/4"-16 JIC To 3/4"-16 O-Ring
7.	G6400-06-08	2	Connector, 9/16"-18 JIC To 3/4"-16 O-Ring
8.	G6500-06	2	Elbow, 9/16"-18 JIC Male To Female
9.	G6801-06-08	2	Elbow, 9/16"-18 JIC To 3/4"-16 O-Ring
10.	GD5039	1	Block



# JUNCTION BLOCK - LOCATED ON REAR SIDE OF CENTER FRAME

VVB024

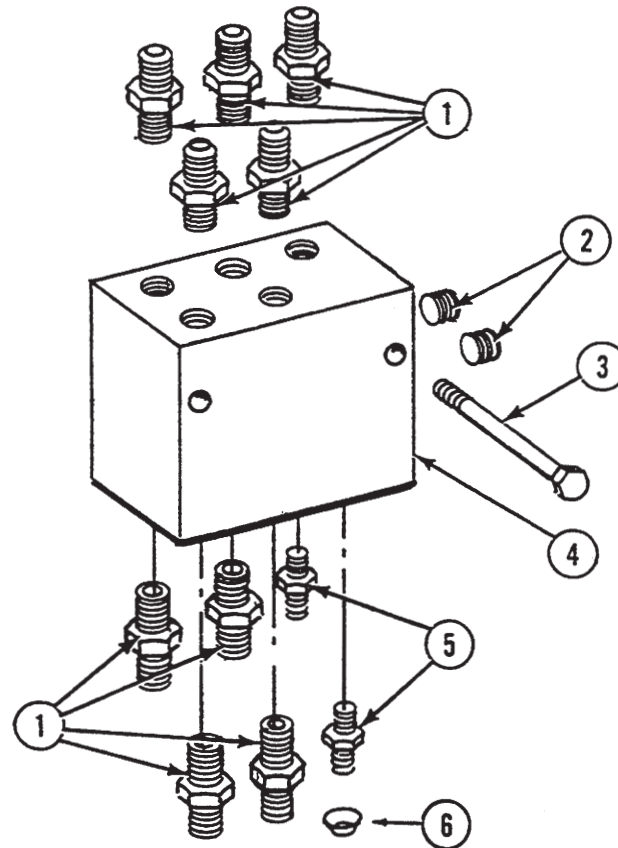

ITEM	PART NO.	QTY.	DESCRIPTION
1.	G6400-10	9	Connector, 7/8"-14 JIC To O-Ring
2.	G6408-H06-O	2	Hex Socket Head Plug, 9/16"-18 O-Ring
3.	G10172	2	Hex Head Cap Screw, 3/8"-16 x 5"
4.	GD6713	1	Block
5.	G6400-06-08	2	Connector, 9/16"-18 JIC To 3/4"-16 O-Ring
6.	GA6621	-	Restrictor W/Pin, 16 Row Only
	G10744	-	Pin, 1/32" x 1/2"

# VALVE BLOCKS - LOCATED ON FRONT SIDE OF CENTER FRAME

VVB022/VVB023

8 And 12 Row

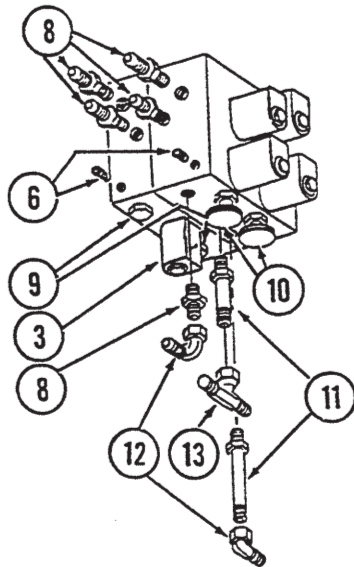

Right Hand View

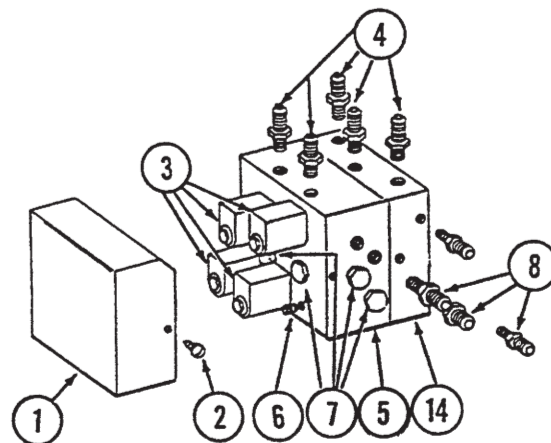

Left Hand View

ITEM	PART NO.	QTY.	DESCRIPTION
1.	GA4639	1	Cover
2.	G10518	2	Screw, No. 12 x 3/8"
3.		-	See "Solenoid Valve"
4.	G6400-10	5	Connector, 7/8"-14 JIC To O-Ring
5.	GD7654	1	Block
6.	G6408-H06-O	3	Hex Socket Head Plug, 9/16"-18 O-Ring
7.	G6408-10	4	Plug, 7/8"-14 O-Ring
8.	G6400-08	9	Connector, 3/4"-16 JIC To O-Ring
9.		-	See "Check Valve"
10.		-	See "Flow Control Valve"
11.	G6400-L-08	2	Long Connector, 3/4"-16 JIC To O-Ring
12.	G6500-08	2	Elbow, 3/4"-16 JIC Male To Female
13.	G6600-08	1	Tee, 3/4"-16 JIC
14.	GD7906	1	Block

# VALVE BLOCKS - LOCATED ON FRONT SIDE OF CENTER FRAME

VVB022/VVB023

16 Row

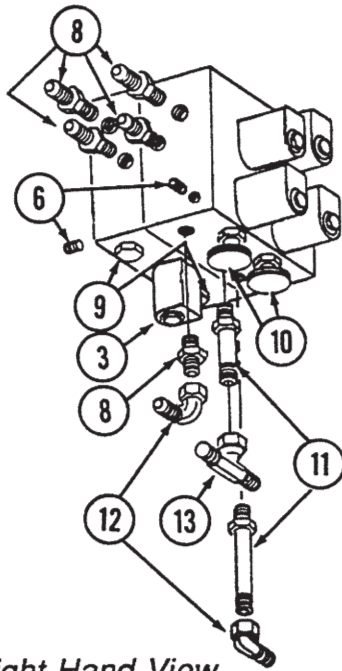

Right Hand View

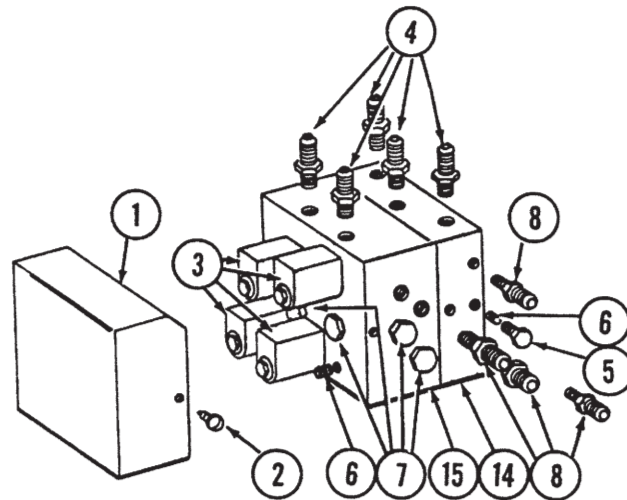

Left Hand View

ITEM	PART NO.	QTY.	DESCRIPTION
1.	GA4639	1	Cover
2.	G10518	2	Screw, No. 12 x 3/8"
3.	-	-	See "Solenoid Valve"
4.	G6400-10	5	Connector, 7/8"-14 JIC To O-Ring
5.	G6408-08	1	Plug, 3/4"-16 O-Ring
6.	G10350	1	Hex Socket Head Plug, 1/4" NPT
	G6408-H06-O	3	Hex Socket Head Plug, 9/16"-18 O-Ring
7.	G6408-10	4	Plug, 7/8"-14 O-Ring
8.	G6400-08	9	Connector, 3/4"-16 JIC To O-Ring
9.	-	-	See "Check Valve"
10.	-	-	See "Flow Control Valve"
11.	G6400-L-08	2	Long Connector, 3/4"-16 JIC To O-Ring
12.	G6500-08	2	Elbow, 3/4"-16 JIC Male To Female
13.	G6600-08	1	Tee, 3/4"-16 JIC
14.	GD7655	1	Block
15.	GD7654	1	Block

# HYDRAULIC SYSTEM

PHS032

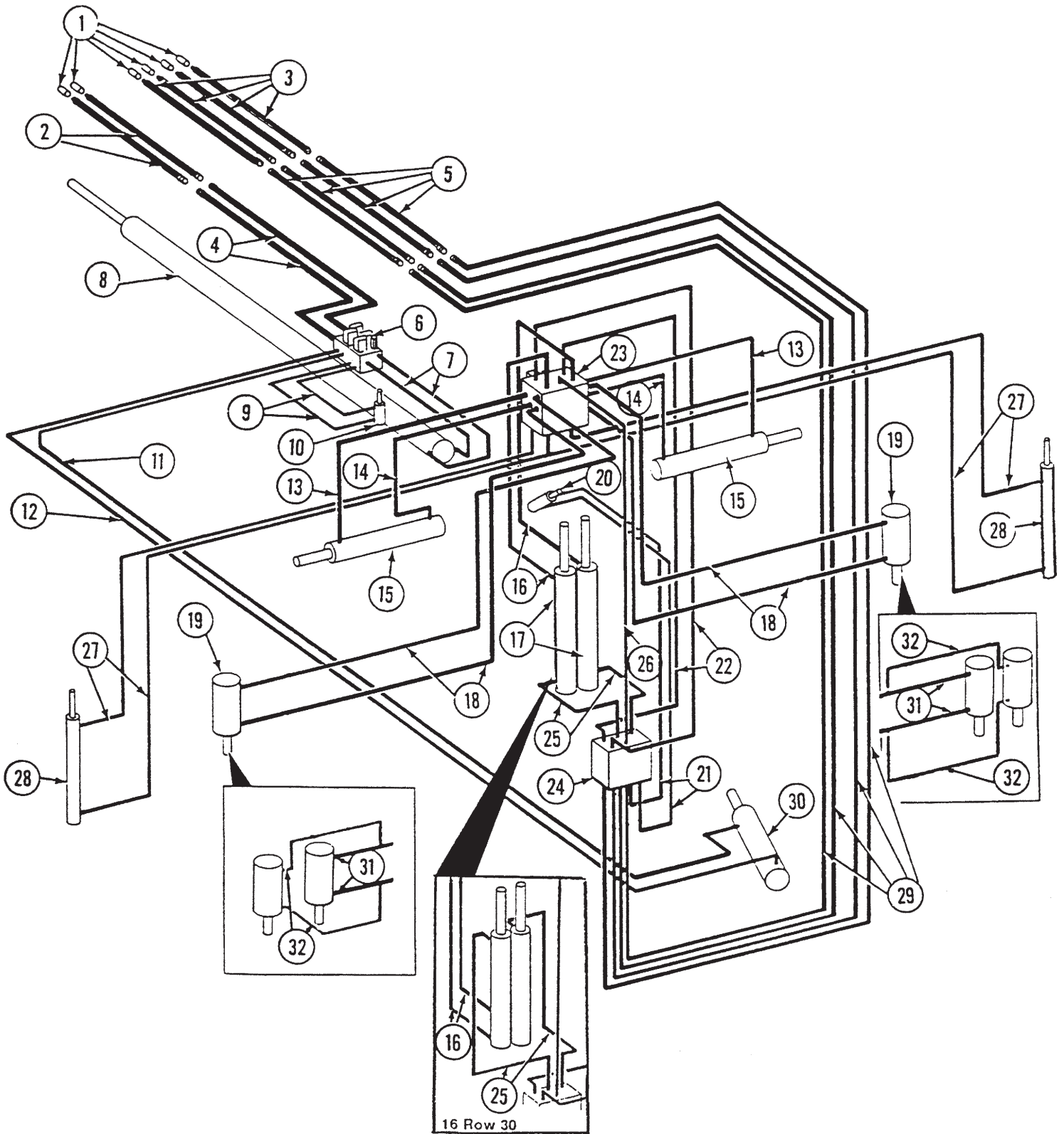

\* Not used on 8 Row 36/38 with "Y" hitch.

# HYRAULIC SYSTEM

---

ITEM	PART NO.	QTY.	DESCRIPTION
1.	GD4086	6	Tip, Pioneer
2.	GA1012	2	Hose Assembly, 3/8" x 140", *8 Row 36/38 "T" Hitch
	GA1081	-	Hose Assembly, 3/8" x 168", 12 Row 30/36/38 "Y" Hitch And 12 Row 30 "T" Hitch
	GA3130	-	Hose Assembly, 3/8" x 173", 16 Row 30 "Y" Hitch
	GA3134	-	Hose Assembly, 3/8" x 198", 12 Row 36/38, 16 Row 30 "T" Hitch
3.	GA1423	4	Hose Assembly, 1/2" x 140", *8 Row 36/38 "T" Hitch
	GA1470	-	Hose Assembly, 1/2" x 168", 12 Row 30/36/38 "Y" Hitch And 12 Row 30 "T" Hitch
	GA1476	-	Hose Assembly, 1/2" x 173", 16 Row 30 "Y" Hitch
	GA1477	-	Hose Assembly, 1/2" x 198", 12 Row 36/38, 16 Row 30 "T" Hitch
4.	GA3162	2	Hose Assembly, 3/8" x 162", 8 Row 36/38 "Y" Hitch
	GA3158	-	Hose Assembly, 3/8" x 46", 8 Row 36/38 "T" Hitch And 12 Row 30 "Y" Hitch
	GA3157	-	Hose Assembly, 3/8" x 70", 12 Row 30 "T" Hitch And 12 Row 36/38, 16 Row 30 "T"/"Y" Hitch
5.	GA1470	4	Hose Assembly, 1/2" x 168", 8 Row 36/38 "Y" Hitch
	GA1425	-	Hose Assembly, 1/2" x 60", 8 Row 36/38 "T" Hitch And 12 Row 30 "Y" Hitch
	GA1465	-	Hose Assembly, 1/2" x 84", 12 Row 30 "T" Hitch And 12 Row 36/38, 16 Row 30 "T"/"Y" Hitch
6.		-	See "Valve Block - Located On Hitch"
7.	GA3159	2	Hose Assembly, 3/8" x 97", 8 Row 36/38, 12 Row 30 "T" Hitch
	GA3128	-	Hose Assembly, 3/8" x 52", 8 Row 36/38 "Y" Hitch
	GA3156	-	Hose Assembly, 3/8" x 68", 12 Row 30/36/38 "Y" Hitch
	GA3140	-	Hose Assembly, 3/8" x 94", 12 Row 36/38 "T" Hitch And 16 Row 30 "T"/"Y" Hitch
8.		-	See "Tongue Cylinders"
9.	GA1139	2	Hose Assembly, 1/4" x 40", 8 Row 36/38, 12 Row 30 "T" Hitch And 12 Row 30/36/38 "Y" Hitch
	GA1181	-	Hose Assembly, 1/4" x 32", 8 Row 36/38 "Y" Hitch
	GA1132	-	Hose Assembly, 1/4" x 44", 12 Row 36/38 "T" Hitch And 16 Row 30 "T"/"Y" Hitch
10.		-	See "Tongue Lock Cylinder"
11.	GA1102	1	Hose Assembly, 1/4" x 95", 8 Row 36/38, 12 Row 30 "T" Hitch
	GA1116	-	Hose Assembly, 1/4" x 136", 8 Row 36/38 "Y" Hitch
	GA1109	-	Hose Assembly, 1/4" x 145", 12 Row 30/36/38 "Y" Hitch
	GA1183	-	Hose Assembly, 1/4" x 157", 16 Row 30 "Y" Hitch
	GA1150	-	Hose Assembly, 1/4" x 103", 12 Row 36/38, 16 Row 30 "T" Hitch
12.	GA1134	1	Hose Assembly, 1/4" x 116", 8 Row 36/38, 12 Row 30 "T" Hitch
	GA1110	-	Hose Assembly, 1/4" x 150", 8 Row 36/38 "Y" Hitch
	GA1129	-	Hose Assembly, 1/4" x 168", 12 Row 30/36/38 "Y" Hitch
	GA1105	-	Hose Assembly, 1/4" x 125", 12 Row 36/38 "T" Hitch
	GA1121	-	Hose Assembly, 1/4" x 180", 16 Row 30 "Y" Hitch
	GA1168	-	Hose Assembly, 1/4" x 120", 16 Row 30 "T" Hitch
13.	GA3155	2	Hose Assembly, 3/8" x 28 1/2"
14.	GA1003	2	Hose Assembly, 3/8" x 27"
15.		-	See "Wing Lock Cylinder"
16.	GA1465	2	Hose Assembly, 1/2" x 84"
17.		-	See "Center Lift Cylinder"

# HYDRAULIC SYSTEM

---

ITEM	PART NO.	QTY.	DESCRIPTION
18.	GA3101	4	Hose Assembly, 3/8" x 168", 8 Row 36/38
	GA3154	-	Hose Assembly, 3/8" x 196", 12 Row 30
	GA1093	-	Hose Assembly, 3/8" x 230", 12 Row 36
	GA1033	-	Hose Assembly, 3/8" x 250", 12 Row 38
	GA1057	-	Hose Assembly, 3/8" x 216", 16 Row 30
19.		-	See "Wing Lift Cylinders"
20.		-	See "Lift Lock Cylinder"
21.	GA1170	2	Hose Assembly, 1/4" x 90"
22.	GA1464	2	Hose Assembly, 1/2" x 72"
23.		-	See "Valve Blocks - Located On Front Side Of Center Frame"
24.		-	See "Junction Block - Located On Rear Side Of Center Frame"
25.	GA1458	2	Hose Assembly, 1/2" x 34"
26.	GA1463	1	Hose Assembly, 1/2" x 68"
27.	GA1029	4	Hose Assembly, 3/8" x 190", 8 Row 36/38
	GA1057	-	Hose Assembly, 3/8" x 216", 12 Row 30
	GA3141	-	Hose Assembly, 3/8" x 260", 12 Row 36
	GA1034	-	Hose Assembly, 3/8" x 272", 12 Row 38
	GA1036	-	Hose Assembly, 3/8" x 280", 16 Row 30
28.		-	See "Marker Cylinders"
29.	GA1467	4	Hose Assembly, 1/2" x 120", 8 Row 36/38, 12 Row 30 "T" Hitch
	GA1461	-	Hose Assembly, 1/2" x 169", 8 Row 36/38, 12 Row 30/36/38 "Y" Hitch
	GA1469	-	Hose Assembly, 1/2" x 185", 16 Row 30 "Y" Hitch
	GA1478	-	Hose Assembly, 1/2" x 128", 12 Row 36/38, 16 Row 30 "T" Hitch
30.		-	See "Rotation Cylinder"
31.	GA3122	4	Hose Assembly, 3/8" x 10 1/2", 16 Row 30 Only
32.	GA1018	4	Hose Assembly, 3/8" x 40", 16 Row 30 Only

# WING LOCK CYLINDER, ALL MODELS MARKER CYLINDER, 12 ROW WISE AND 16 ROW 30

CYL032

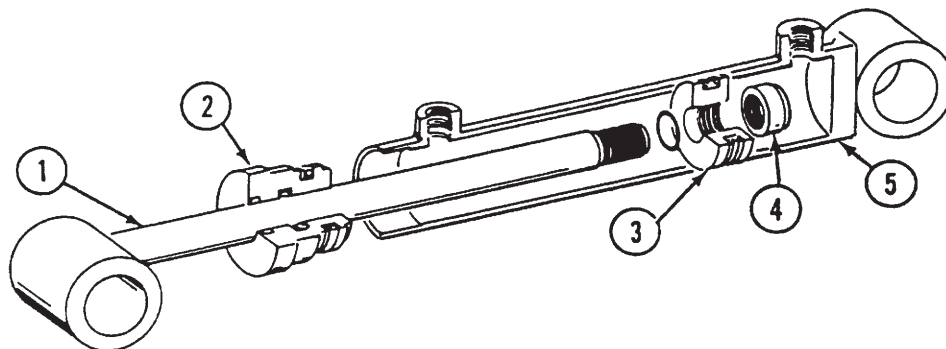

ITEM	PART NO.	QTY.	DESCRIPTION
1.	GA4193	1	Rod Assembly
2.	GD5954	1	Gland
3.	GD4525	1	Piston
4.	GR0964	1	Special Jam Nut
5.	GA4192	1	Barrel
A.	GA4115	-	Cylinder Complete, 2 1/2" x 20 1/16"
B.	GR0963	-	Seal Kit, Includes: (1)T Seal, (2)O-Rings, (1)BU Ring, (1)U-Cup, (1)Wiper

# MARKER CYLINDER, 8 ROW WIDE AND 12 ROW 30

CYL039

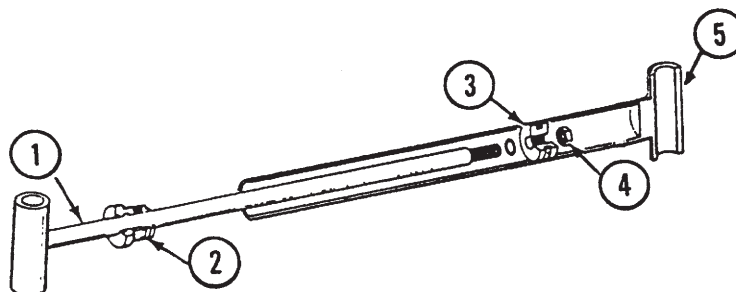

ITEM	PART NO.	QTY.	DESCRIPTION
1.	GA5459	1	Rod Assembly
2.	GD5949	1	Gland
3.	GD4632	1	Piston
4.	GR0959	1	Lock Nut, 3/4"-16
5.	GA5460	1	Barrel
A.	GA5097	-	Cylinder Complete, 2" x 20 1/16"
B.	GR0927	-	Seal Kit, Includes: (1)T Seal, (2)O-Rings, (1)BU Ring, (1)U-Cup, (1)Wiper

# CENTER LIFT CYLINDER, ALL MODELS

CYL033

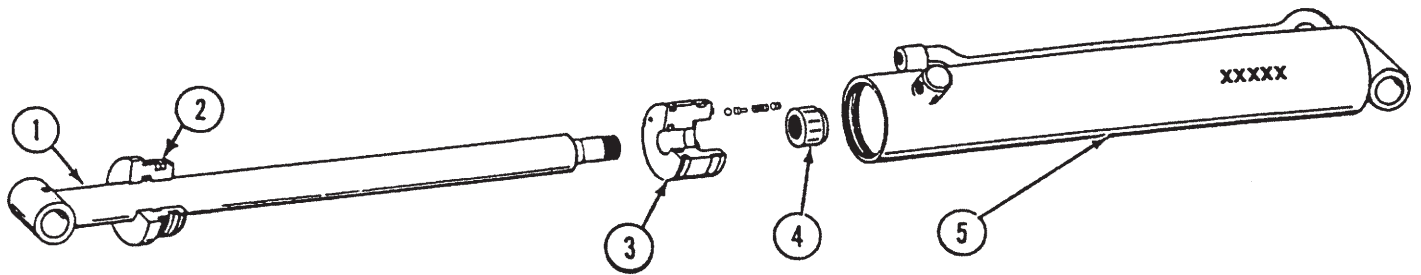

ITEM	PART NO.	QTY.	DESCRIPTION
1.	GA6139	1	Rod Assembly
2.	GD7132	1	Gland
3.	GA6133	1	Piston W/Rephasing Valve
	GR1169	-	Rephasing Valve Replacement Kit (Set Screw, Guide, Spring And Ball)
4.	GR0993	1	Lock Nut, 1 1/8"-12
5.	GA5809	1	Barrel
A.	GA6123	-	Cylinder Complete, 4" x 20" (Part No. Stamped On Barrel)
B.	GR0992	-	Seal Kit, Includes: (1)Wear Ring, (2)O-Rings, (1)BU Ring, (1)U-Cup, (1)Wiper, (1) Uniring

# WING LIFT CYLINDER, 8 AND 12 ROW

CYL031

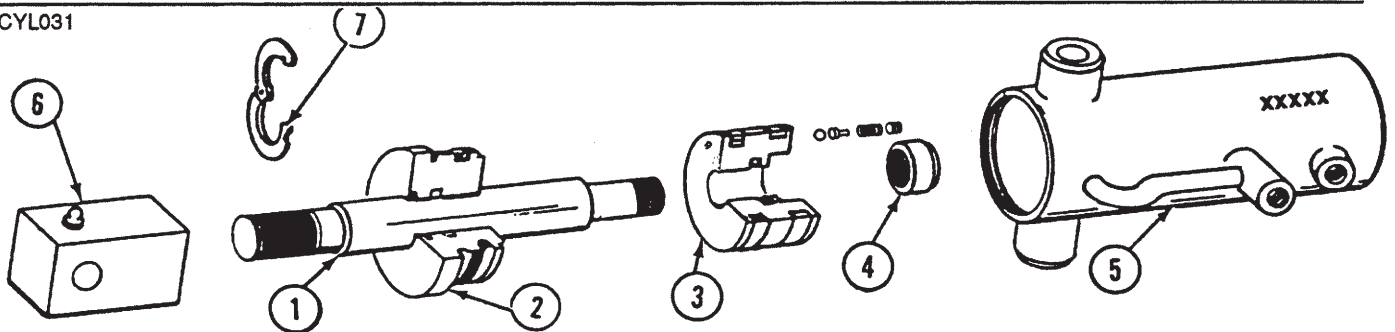

ITEM	PART NO.	QTY.	DESCRIPTION
1.	GD8757	1	Rod
2.	GD7164	1	Gland
3.	GA6133	1	Piston W/Rephasing Valve
	GR1169	-	Rephasing Valve Replacement Kit (Set Screw, Guide, Spring And Ball)
4.	GR0993	1	Lock Nut, 1 1/8"-12
5.	GA4802	1	Barrel
6.	GA4797	1	Clevis
7.	GD6959	1	Split Washer
A.	GA6118	-	Cylinder Complete With Split Washer, 4" x 5 1/2" (Part No. Stamped On Barrel)
B.	GR1007	-	Seal Kit, Includes: (2)O-Rings, (1)BU Ring, (1)Wear Ring, (1)Rod Wiper, (1)U-Cup, (1)Uniring



# WING LIFT CYLINDER, 16 ROW

CYL031

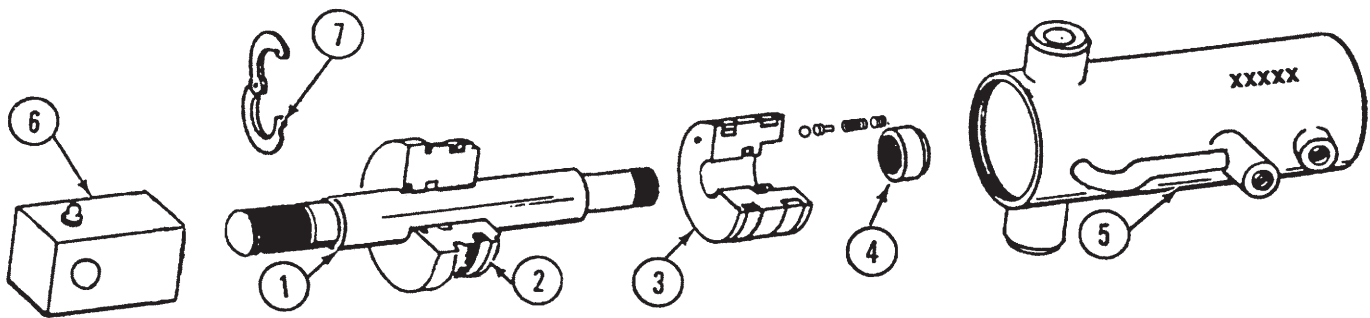

ITEM	PART NO.	QTY.	DESCRIPTION
1.	GD8758	1	Rod
2.	GD7800	1	Gland
3.	GA6136	1	Piston W/Rephasing Valve
	GR1169	-	Rephasing Valve Replacement Kit (Set Screw, Guide, Spring And Ball)
4.	GR1049	1	Lock Nut, 7/8"-14
5.	GA5617	1	Barrel
6.	GA4797	1	Clevis
7.	GD6959	1	Split Washer
A.	GA6122	-	Cylinder Complete With Split Washer, 3 3/4" x 5 1/2" (Part No. Stamped On Barrel)
B.	GR1050	-	Seal Kit, Includes: (2)O-Rings, (1)BU Ring, (1)Wear Ring, (1)Rod Wiper, (1)U-Cup, (1)Uniring

# LIFT LOCK CYLINDER, ALL MODELS

CYL035/CYL050

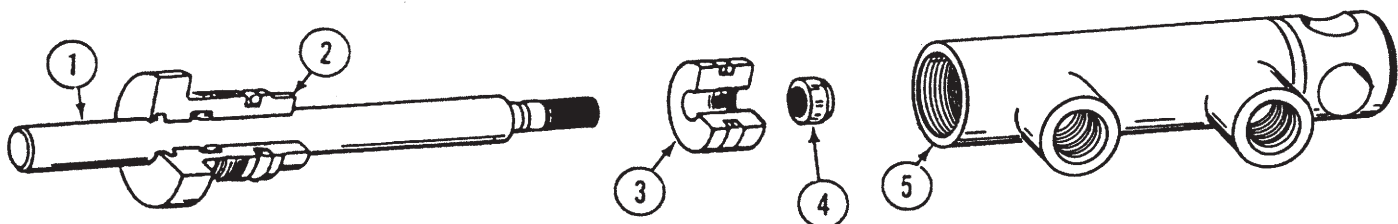

ITEM	PART NO.	QTY.	DESCRIPTION
1.	GD7124	1	Rod
2.	GD7122	1	Gland
3.	GD7120	1	Piston
4.	GR0999	1	Lock Nut, 1/2"-20
5.	GA6020	1	Barrel
A.	GA4309	-	Cylinder Complete, 1 1/2" x 2 1/2"
B.	GR1001	-	Seal Kit, Includes: (2)O-Rings, (1)U-Cup, (1)Rod Wiper, (1)Seal

# TONGUE LOCK CYLINDER, ALL MODELS

CYL035

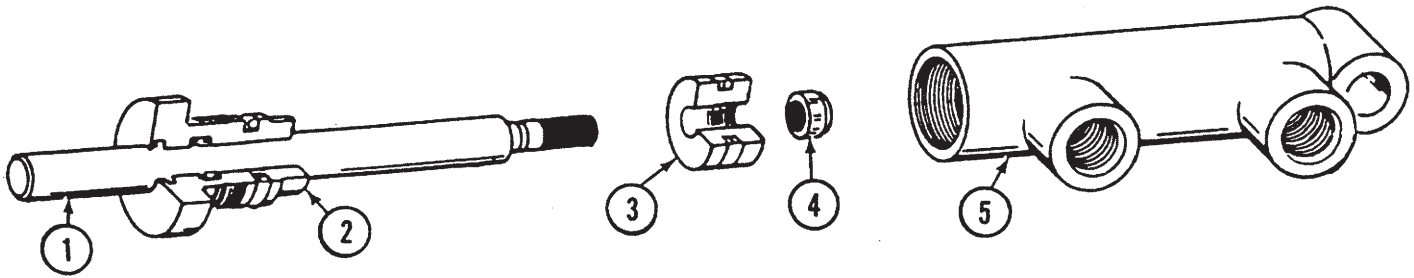

ITEM	PART NO.	QTY.	DESCRIPTION
1.	GD7123	1	Rod
2.	GD7122	1	Gland
3.	GD7120	1	Piston
4.	GR0999	1	Lock Nut, 1/2"-20
5.	GA4754	1	Barrel
A.	GA4310	-	Cylinder Complete, 1 1/2" x 2 1/2"
B.	GR1001	-	Seal Kit, Includes: (2)O-Rings, (1)U-Cup, (1)Rod Wiper, (1)Seal

# ROTATION CYLINDER, ALL MODELS

CYL034

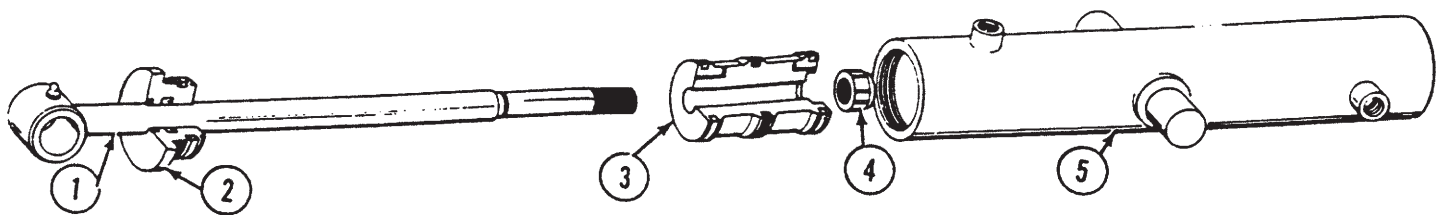

ITEM	PART NO.	QTY.	DESCRIPTION
1.	GA4768	1	Rod Assembly
2.	GD6571	1	Gland
3.	GD7136	1	Piston
4.	GR0987	1	Lock Nut, 1 1/4" Thin
5.	GA4769	1	Barrel
A.	GA4284	-	Cylinder Complete, 4" x 16"
B.	GR1003	-	Seal Kit, Includes: (1)Uniring, (2)O-Rings, (1)BU Ring, (1)U-Cup, (1)Wiper, (1)Cast Iron Ring

# TONGUE CYLINDER 8 ROW 36/38 WITH "Y" HITCH

CYL034

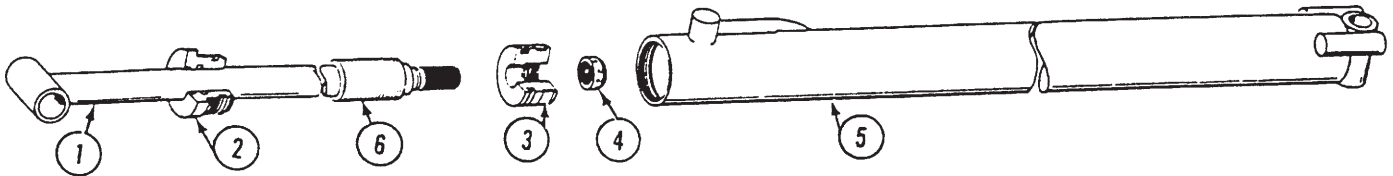

ITEM	PART NO.	QTY.	DESCRIPTION
1.	GA4791	1	Rod Assembly
2.	GD7146	1	Gland
3.	GD4527	1	Piston
4.	GR0987	1	Lock Nut, 1 1/4"-12 Thin
5.	GA4792	1	Barrel
6.	GD7147	1	Spacer
A.	GA4484	-	Cylinder Complete, 3" x 36"
B.	GR1004	-	Seal Kit, Includes: (2)O-Rings, (1)BU Ring, (1)Wear Ring, (1)Wiper, (1)U-Cup, (1)T Seal W/BU Rings

# TONGUE CYLINDER 8 ROW 36/38 WITH "T" HITCH 12 ROW 30 WITH "Y" HITCH

CYL034

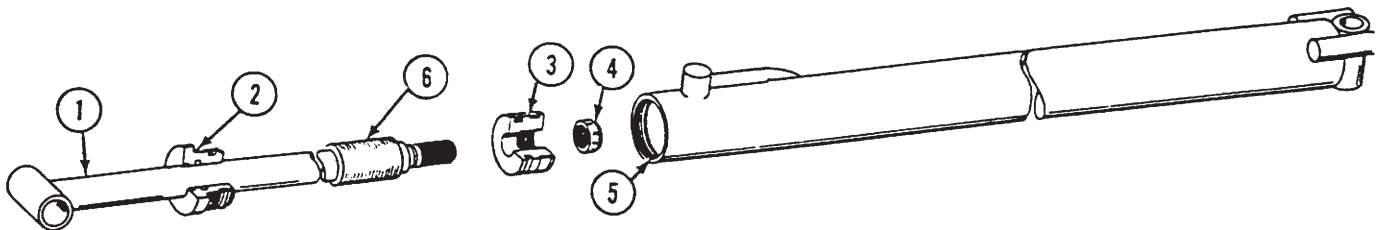

ITEM	PART NO.	QTY.	DESCRIPTION
1.	GA4780	1	Rod Assembly
2.	GD7146	1	Gland
3.	GD4527	1	Piston
4.	GR0987	1	Lock Nut, 1 1/4"-12 Thin
5.	GA4779	1	Barrel
6.	GD7147	1	Spacer
A.	GA4285	-	Cylinder Complete, 3" x 60"
B.	GR1004	-	Seal Kit, Includes: (2)O-Rings, (1)BU Ring, (1)Wear Ring, (1)Wiper, (1)U-Cup, (1)T Seal W/BU Ring

P67

# TONGUE CYLINDER

## 12 ROW 30 WITH "T" HITCH

## 12 ROW 36/38, 16 ROW 30 WITH "Y" HITCH

CYL036

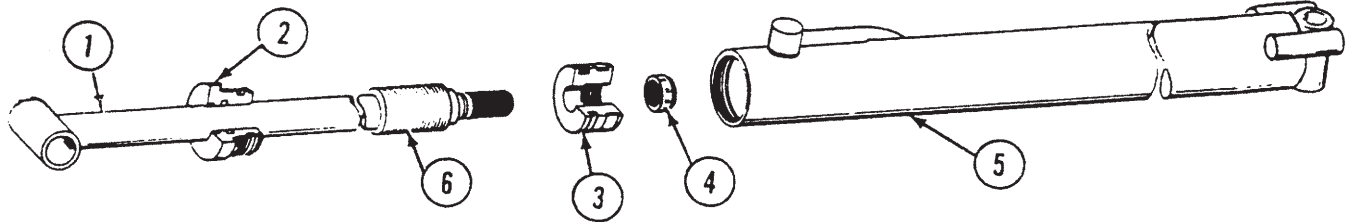

ITEM	PART NO.	QTY.	DESCRIPTION
1.	GA4782	1	Rod Assembly
2.	GD7146	1	Gland
3.	GD4527	1	Piston
4.	GR0987	1	Lock Nut, 1 1/4"-12 Thin
5.	GA4781	1	Barrel
6.	GD7147	1	Spacer
A.	GA4332	-	Cylinder Complete, 3" x 84"
B.	GR1004	-	Seal Kit, Includes: (1)Wear Ring, (2)O-Rings, (1)BU Ring, (1)U-Cup, (1)Wiper, (1)T Seal W/BU Rings

# TONGUE CYLINDER

## 12 ROW 36/38, 16 ROW 30 WITH "T" HITCH

CYL036

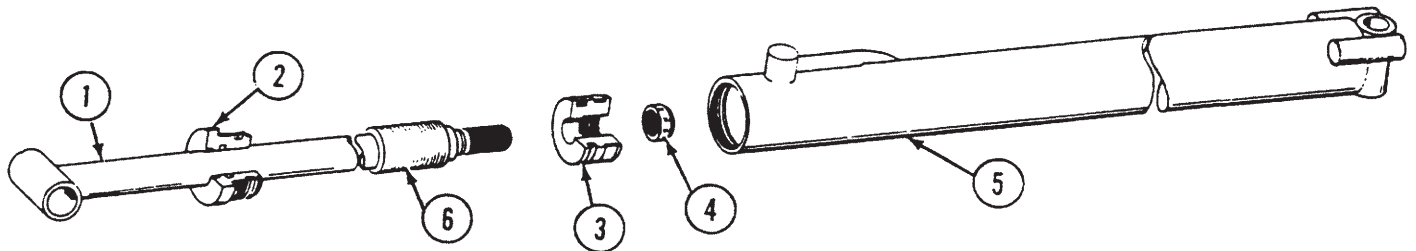

ITEM	PART NO.	QTY.	DESCRIPTION
1.	GA5620	1	Rod Assembly
2.	GD7146	1	Gland
3.	GD4527	1	Piston
4.	GR0987	1	Lock Nut, 1 1/4"-12 Thin
5.	GA5619	1	Barrel
6.	GD7147	1	Spacer
A.	GA5584	-	Cylinder Complete, 3" x 108"
B.	GR1004	-	Seal Kit, Includes: (1)Wear Ring, (2)O-Rings, (1)BU Ring, (1)U-Cup, (1)Wiper, (1)T Seal W/BU Rings

# ROW UNIT EXTENSIONS

PTD067

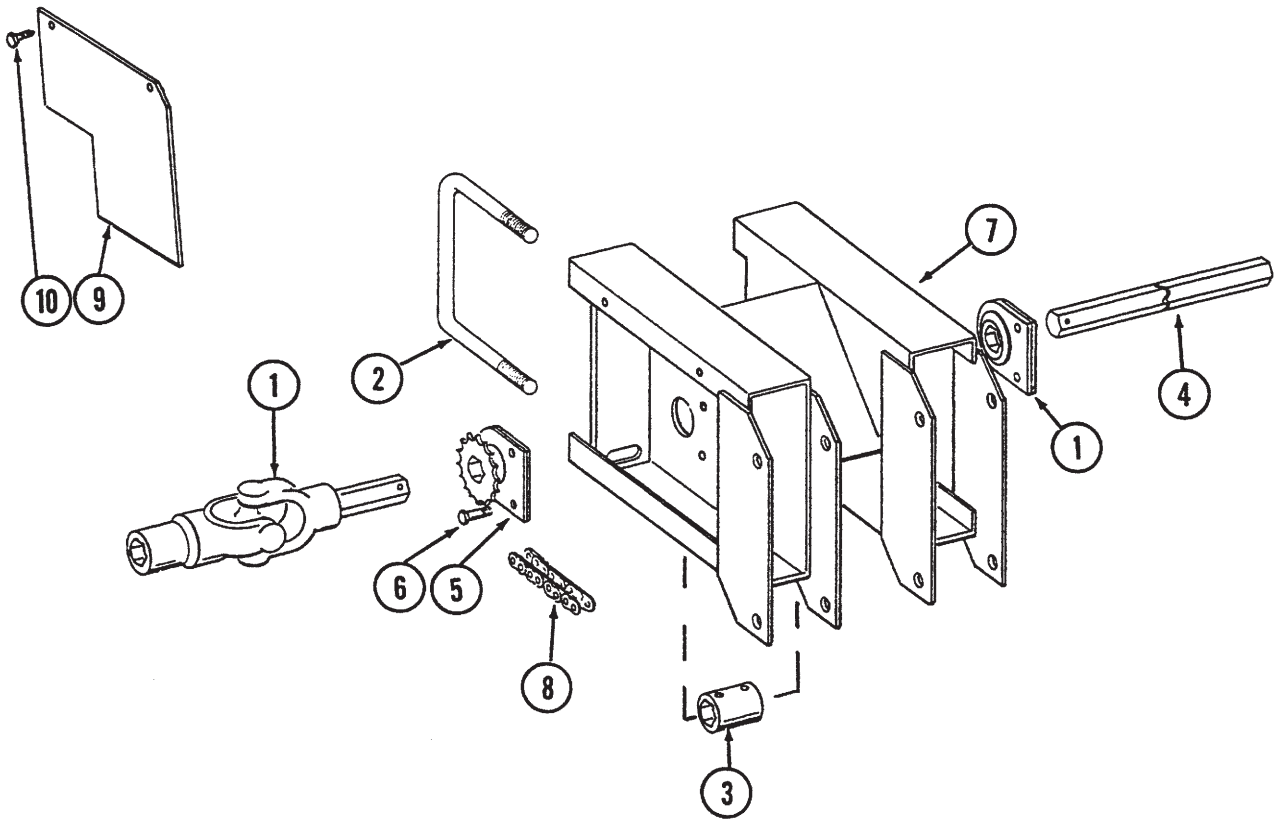

ITEM	PART NO.	QTY.	DESCRIPTION
1.		-	See "Transmission And Row Unit Drill Shaft"
2.		-	See "Parallel Arms, Mounting Bracket And Quick Adjustable Down Force Springs"
3.		-	See "Transmission And Row Unit Drill Shaft"
4.		-	Main Frame Drill Shaft - See "Transmission And Row Unit Drill Shaft"
5.		-	See "Parallel Arms, Mounting Bracket And Quick Adjustable Down Force Springs"
6.		-	See "Parallel Arms, Mounting Bracket And Quick Adjustable Down Force Springs"
7.	GA5639	4	Extension Bracket, 15"
8.	G3303-53	4	Chain, No. 41, 53 Pitch Including Connector And Offset Link (Add to row unit drive chain)
	GR0196	-	Connector Link, No. 41
	GR0201	-	Offset Link, No. 41
9.	GD8733	3	Mud Guard
10.	G10570	6	Self Tapping Screw, 1/4" x 3/4"

# INTERPLANT PUSH UNIT DRIVE

PTD059

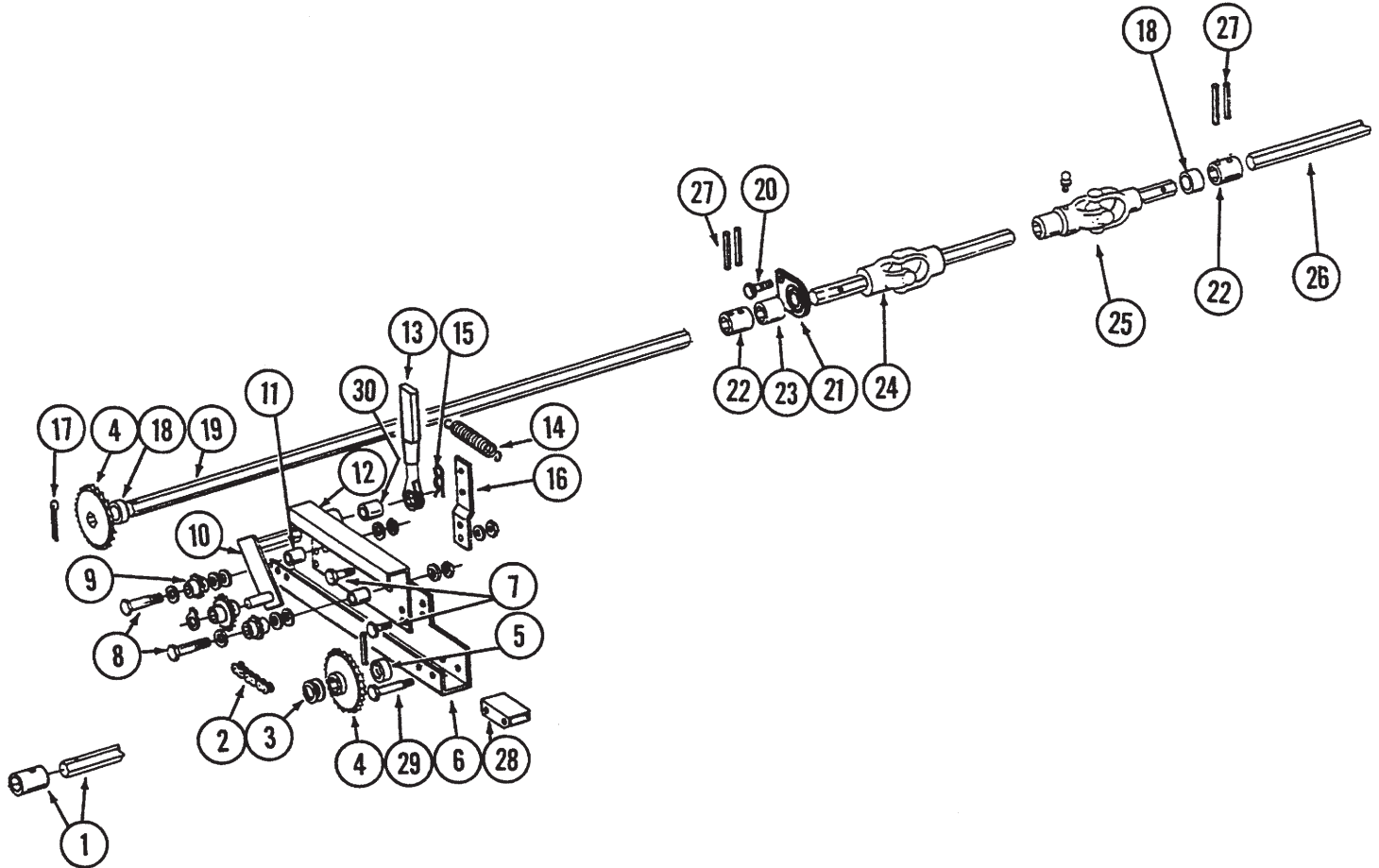

ITEM	PART NO.	QTY. Per Side	DESCRIPTION
1.		-	See "Transmission And Row Unit Drill Shaft"
2.	G3310-138	1	Chain, No. 40, 138 Pitch Including Connector Link
	GR0912	-	Connector Link, No. 40
3.	G10233	-	Machine Bushing (As Required)
4.	GA5107	2	Sprocket, 19 Tooth

# INTERPLANT PUSH UNIT DRIVE

ITEM	PART NO.	QTY. Per Side	DESCRIPTION
5.	GD0917	1	Lock Collar, Less Set Screws
	G10145	2	Set Screw, 5/16"-18 x 1/2"
6.	GD6828	1	Chain Cover
7.	G10064	4	Hex Head Cap Screw, 1/4"-20 x 1"
	G10227	4	Lock Washer, 1/4"
	G10103	4	Hex Nut, 1/4"-20
8.	G10049	2	Hex Head Cap Screw, 3/8"-16 x 2 1/2"
	G10210	-	Washer, 3/8" USS
	G10229	2	Lock Washer, 3/8"
	G10101	2	Hex Nut, 3/8"-16
9.	GD7426	2	Idler Sprocket
10.	GA4523	1	Idler With Sprocket And Ring
	GD7426	-	Sprocket
	G10435	-	Ring
11.	GD1026	2	Sleeve
12.	GA4525	1	Cover, L.H. (Shown)
	GA4524	-	Cover, R.H.
13.	GA4235	1	Ratchet Wrench Kit With Protective Cover
	G10445	-	Protective Cover
14.	GD5857	1	Spring
15.	G10670	1	Hair Pin Clip, No. 3
16.	GD5860	1	Bar
17.	G10460	1	Cotter Pin, 1/4" x 2"
18.	GD1199-03	1	Spacer, 5/8"
19.	GD6825-11.25	1	Drill Shaft, Wing, 8 Row 36/38
	GD6825-71.25	-	Drill Shaft, Wing, 12 Row 30
	GD6825-83.25	-	Drill Shaft, Wing, 12 Row 36
	GD6825-87.25	-	Drill Shaft, Wing, 12 Row 38
	GD6825-131.25	-	Drill Shaft, Wing, 16 Row 30
20.	G10001	2	Hex Head Cap Screw, 3/8"-16 x 1"
	G10229	2	Lock Washer, 3/8"
	G10101	2	Hex Nut, 3/8"-16
21.	GA2180	1	Bearing Hanger, 7/8" Hex Bore
22.	GD5886	2	Coupler
23.	GD1199-04	1	Spacer, 2"
24.	GA4638	1	U-Joint, 23 3/4", 8 Row 38 And 12 Row 36/38
	GA4637	-	U-Joint, 21 3/4", 8 Row 36
	GA4394	-	U-Joint, 14 3/4", 12 Row 30 And 16 Row 30
25.	GA4393	1	U-Joint With Grease Fitting, 15"
	G10640	-	Grease Fitting, 1/4"-28
26.	GD5887-58.5	1	Drill Shaft, Main Frame, L.H., 12 Row 30 And 16 Row 30
	GD5887-39	-	Drill Shaft, Main Frame, R.H., 12 Row 30 And 16 Row 30
	GD5887-74	-	Drill Shaft, Main Frame, L.H., 8 Row 36/38 And 12 Row 36/38
	GD5887-48	-	Drill Shaft, Main Frame, R.H., 8 Row 36/38 And 12 Row 36/38
27.	G10602	4	Spring Pin, 1/4" x 1 1/2"
28.	GD7905	1	Wear Block
29.	G10403	4	Hex Head Cap Screw, 1/4"-20 x 2 1/2"
	G10227	4	Lock Washer, 1/4"
	G10103	4	Hex Nut, 1/4"-20
30.	GD6819	1	Sleeve

# ELECTRONIC SEED MONITOR

ECP017/D-0640-0001/D-0640-0003/D-0640-0004/D-1172-0001/D-1172-0002/ECP019/ECP020/ECP021/ECP022

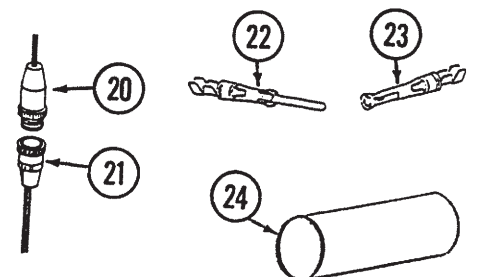
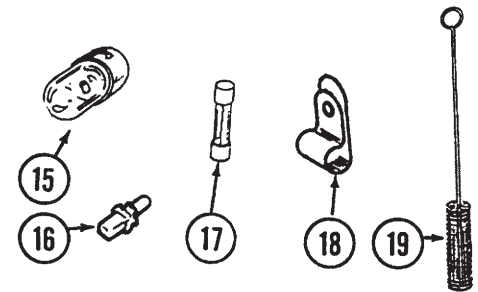
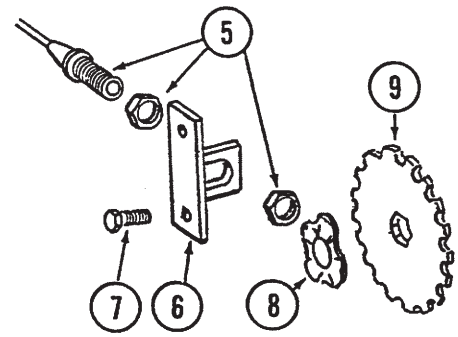
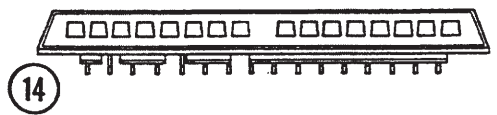
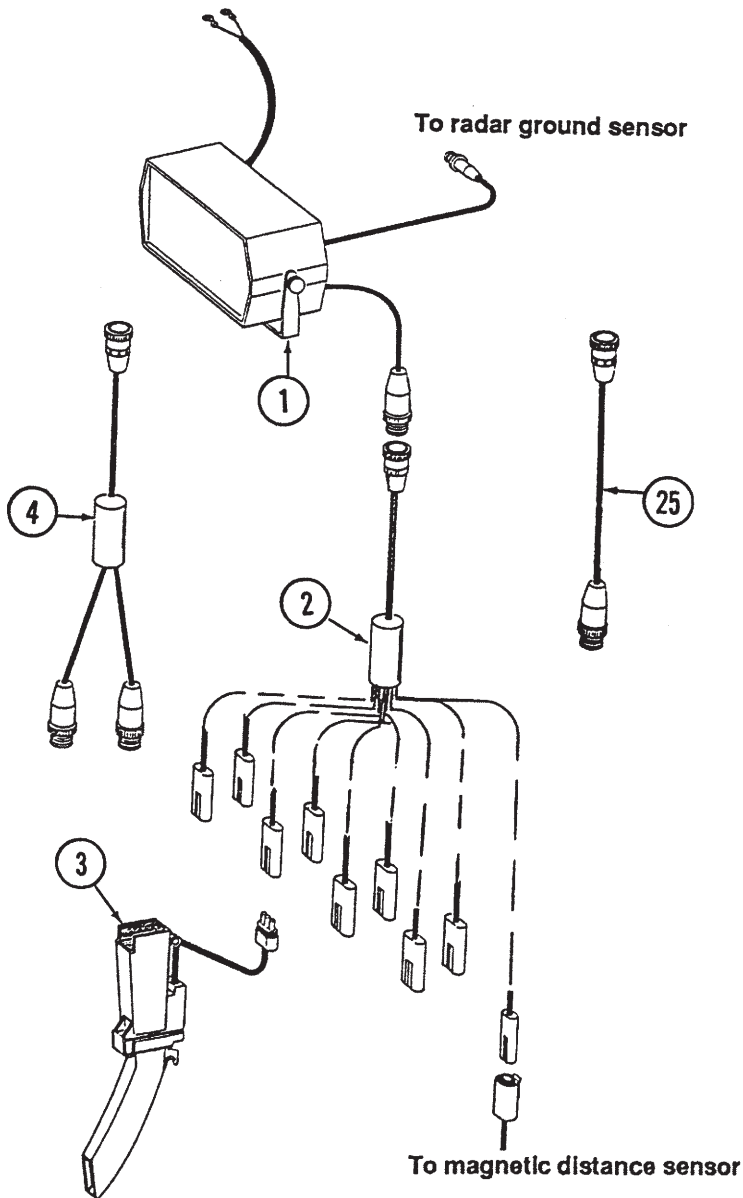
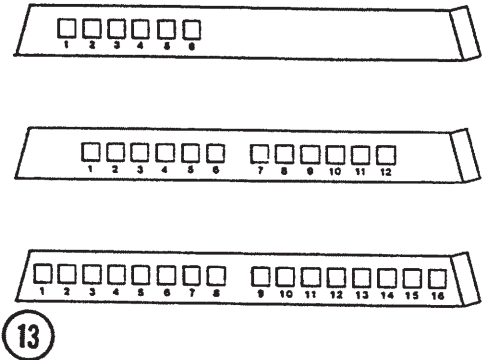
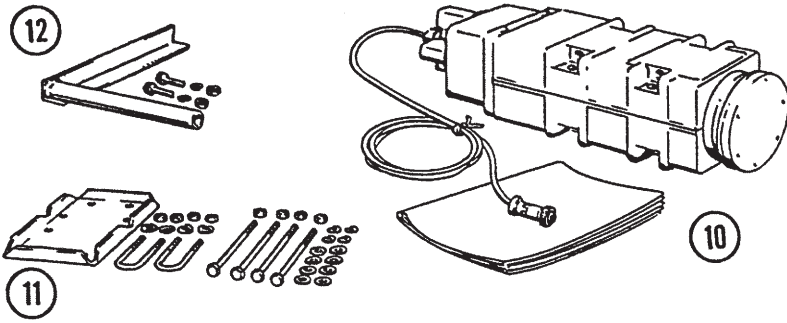



# ELECTRONIC SEED MONITOR

---

ITEM	PART NO.	QTY.	DESCRIPTION
1.	GA5873	1	Console W/Mounting Bracket, KM1000
	GA5874	-	Console W/Mounting Bracket, KM3000
	GR1077	-	Mounting Bracket, KM1000
	GR1078	-	Mounting Bracket, KM3000
	GR1079	-	Console Mounting Bracket Hardware Package (Includes 2 wellnuts, 2 knobs and 1/4" hardware)
2.	GA5877	1	Planter Harness, 8 Row
	GA5878	-	Planter Harness, 12 Row
	GA5879	-	Planter Harness, 16 Row
3.	GA5880	-	Seed Tube W/High Rate Sensor
	GR1062	-	Seed Tube (With holes for high rate sensor installation)
	GR1087	-	Sensor Only (For GA5880)
	GR0676	-	Sunshade
4.	GD2117	-	Tie Strap, 14 1/2"
	GA5884	1	Y-Connector, 16 Row
	GA5885	-	Y-Connector, 24 Row
	GA5886	-	Y-Connector, 32 Row
5.	GA5600	1	Magnetic Distance Sensor (Use W/KM3000 Console Only)
6.	GD8770	1	Bracket
7.	G10004	2	Hex Head Cap Screw, 3/8"-16 x 1 1/4"
	G10229	2	Lock Washer, 3/8"
	G10101	2	Hex Nut, 3/8"-16
8.	GD8771	1	Spring Wave Washer
9.	GD8751	-	Magnetic Distance Sensor Pulse Wheel (Use W/KM3000 Console Only)
10.	GA4223	-	Radar Ground Sensor (Use W/KM3000 Console Only)
11.	GA4229	-	Radar Sensor Mounting Bracket Package
12.	GA4230	-	Radar Sensor Pipe Mounting Package
13.	GR1082	1	KM1000 Bezel Decal, 12 Row (Used On 12 Row)
	GR1083	-	KM1000 Bezel Decal, 16 Row (Used On 8 and 16 Row)
14.	GR1080	1	KM1000 Bezel
15.	GR0595	1	Bulb, KM1000 Row Lamp
16.	GR1084	1	Bulb, KM3000 Backlite
17.	GR0866	1	Fuse, 5-amp, Type AGC
	GR1085	1	Fuse, 2-amp, Type AGC
18.	GD6291	-	Insulated Clamp
19.	GR0594	-	Brush
20.	GR0583	-	Hitch Console Connector Kit W/Pins And Shrink Tube
21.	GR0582	-	Hitch Harness Connector Kit W/Female Socket Contacts And Shrink Tube
			Pin
22.	GR1067	-	Pin
23.	GR1171	-	Female Socket Contact
24.	GR1069	-	Shrink Tube, 2 1/2"
25.	GA5881	-	Extension Cable, 15", 1-32 Rows
	GA5882	-	Extension Cable, 30", 1-32 Rows
A.	GA6147	-	Sensor And Mounting Package (Items 5-9 And 18)

# DOUBLE DISC FERTILIZER OPENER

FOC007

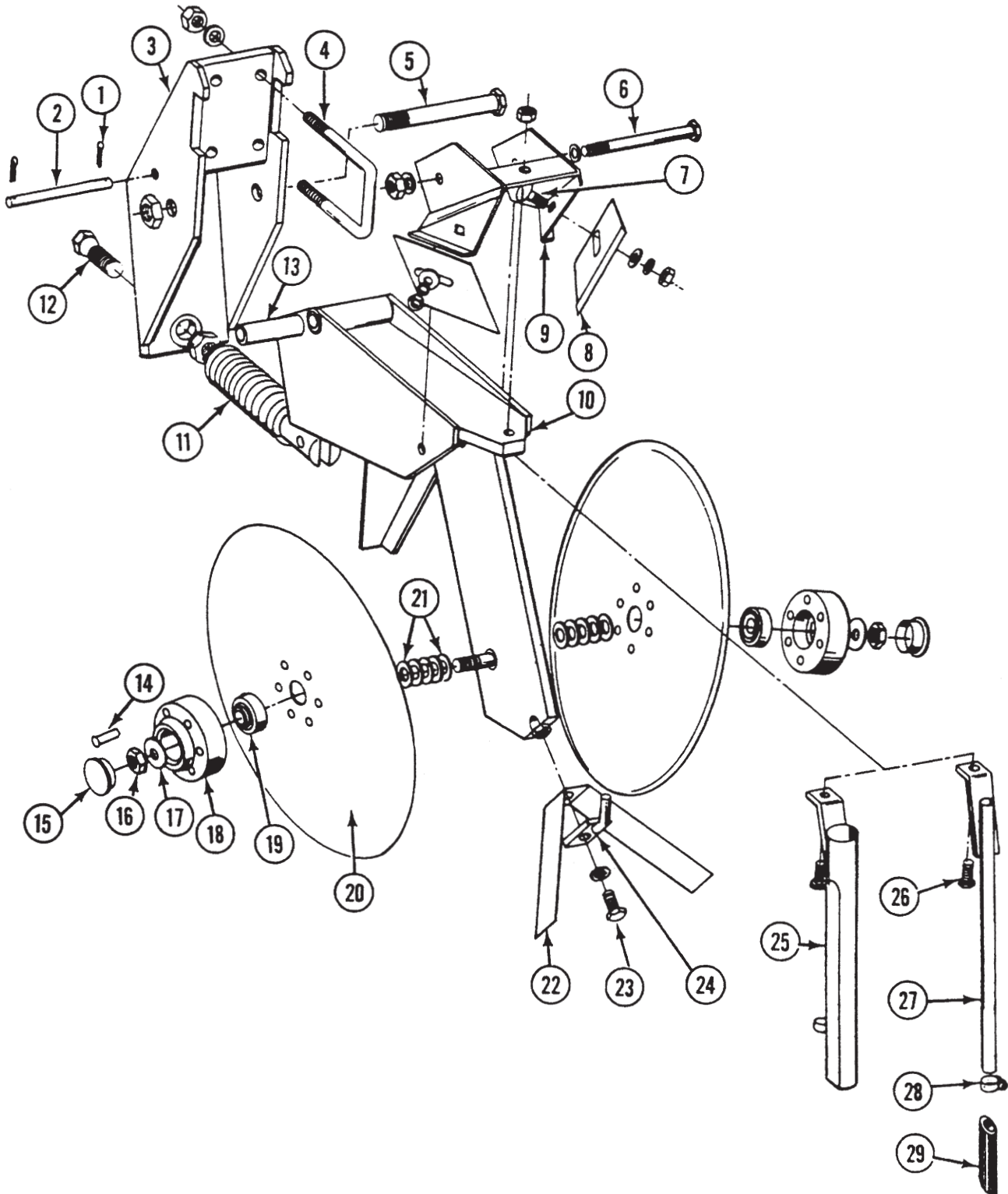

# DOUBLE DISC FERTILIZER OPENER

ITEM	PART NO.	QTY.	DESCRIPTION
		Per Assy.	
1.	G10451	2	Cotter Pin, 1/8" x 1"
2.	GD1657	1	Lockup Pin
3.	GA0785	1	Bracket
4.	GD1339	2	U-Bolt, 2 1/2" x 2 1/2" x 1/2"-13
	G10228	4	Lock Washer, 1/2"
	G10102	4	Hex Nut, 1/2"-13
5.	G10046	1	Hex Head Cap Screw, 5/8"-11 x 5"
	G10107	1	Lock Nut, 5/8"-11
6.	G10045	1	Hex Head Cap Screw, 1/2"-13 x 4 1/2"
	G10111	1	Lock Nut, 1/2"-13
7.	G10305	2	Carriage Bolt, 3/8"-16 x 1"
	G10210	2	Washer, 3/8" USS
	G10229	2	Lock Washer, 3/8"
	G10101	2	Hex Nut, 3/8"-16
8.	GD1673	2	Scraper
9.	GA0810	1	Scraper Mount
10.	GA0308	1	Shank
11.	GA0328	1	Spring
12.	GD0962	1	Hex Head Adjusting Bolt, 5/8"-18
	G10499	1	Jam Nut, 5/8"-18
13.	GD0487	1	Bushing
14.	G10542	12	Rivet, 1/4" x 1 5/16"
15.	GD1132	2	Cap
16.	G10503	1	Jam Nut, R.H., 5/8"-11
	G10504	1	Jam Nut, L.H., 5/8"-11
17.	G10204	2	Machine Bushing, 21/32"
18.	GB0134	2	Hub
19.	GA2014	2	Bearing
20.	GD1030	2	Blade
21.	G10213	-	Machine Bushing, 11/16"
22.	GD2589	1	Inner Scraper
23.	G10019	1	Hex Head Cap Screw, 5/16"-18 x 1"
	G10232	1	Lock Washer, 5/16"
24.	GA0312	1	Mount
25.	GA1369	-	Drop Tube, Dry Fertilizer
26.	G10133	1	Hex Head Cap Screw, 5/16"-18 x 1 1/2"
	G10109	1	Lock Nut, 5/16"-18
27.	GA0318	-	Drop Tube, Liquid Fertilizer
28.	G10681	-	Clamp, No. 6
29.	GD1797	-	Extension
A.	GA0320	-	Disc And Bearing Assembly (Items 18-20)

# SINGLE DISC FERTILIZER OPENER (Soil Press Wheel)

FOC016/FOC007

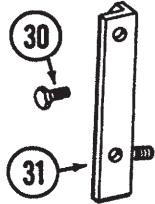
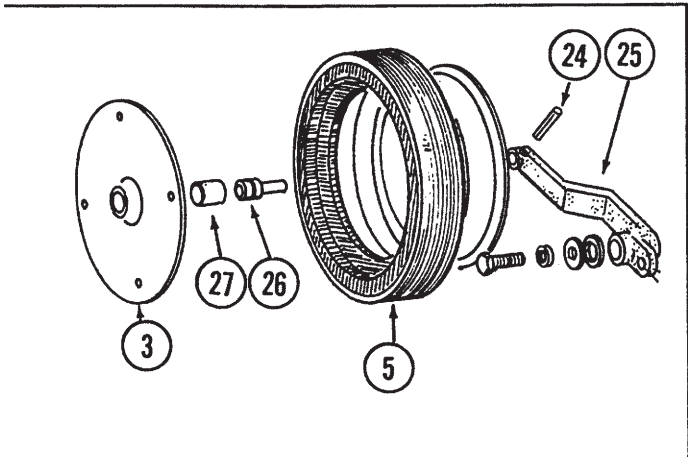
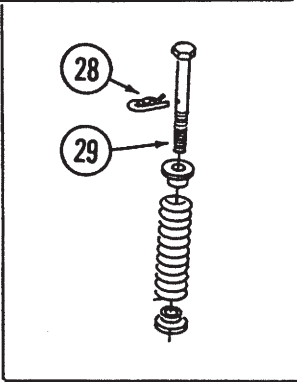
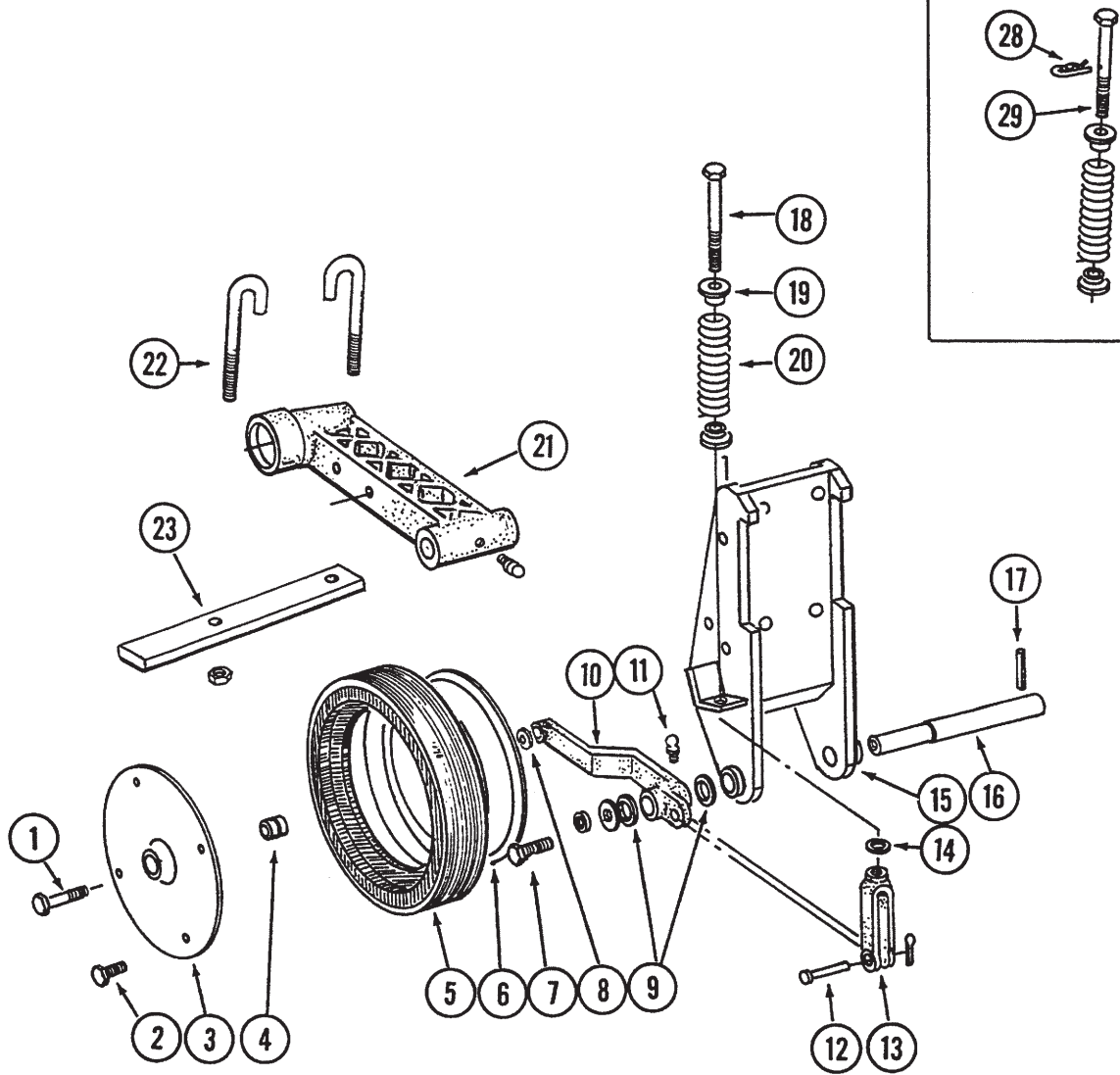

# SINGLE DISC FERTILIZER OPENER (Soil Press Wheel)

ITEM	PART NO.	QTY. Per Assy.	DESCRIPTION
1.	G10010	1	Hex Head Cap Screw, 5/8"-11 x 3"
2.	G10018	4	Hex Head Cap Screw, 5/16"-18 x 5/8"
	G10109	4	Lock Nut, 5/16"-18
3.	GD4888	1	Half Wheel
4.	GA6171	1	Bearing
5.	GD4850	1	Offset Tire
6.	GD1048	1	Half Wheel
7.	G10438	1	Hex Head Cap Screw, 1/2"-13 x 3/4"
	G10228	1	Lock Washer, 1/2"
	G10216	1	Washer, 1/2" USS
8.	G10230	1	Lock Washer, 5/8"
9.	G10526	10	Bushing
10.	GD9628	-	Wheel Arm, R.H.
	GD9629	1	Wheel Arm, L.H. (Shown)
11.	G10640	1	Grease Fitting, 1/4"-28
12.	G10560	1	Clevis Pin, 1/2" x 1 3/4"
	G10456	1	Cotter Pin, 1/8" x 3/4"
13.	GD8218	1	Yoke
14.	G10205	1	Washer, 5/8" SAE
15.	GA5728	-	Opener Mount, R.H.
	GA5727	1	Opener Mount, L.H. (Shown)
16.	GD7911	1	Pivot Pin
17.	G10610	1	Spring Pin, 3/8" x 2"
18.	GD9709	1	Special Bolt
19.	GB0212	2	Washer
20.	GD8308	1	Spring
21.		-	See "Single Disc Fertilizer Opener (Disc And Drop Tube)"
22.	GD9705	2	J-Bolt
	G10228	2	Lock Washer, 1/2"
	G10120	2	Hex Nut, 1/2"-13
23.	GD9705	1	Lockup Bar
24.	G10603	1	Spring Pin, 1/4" x 1 1/4"
25.	GD8030	-	Wheel Arm, R.H.
	GD8031	1	Wheel Arm, L.H. (Shown)
26.	GA2022	1	Bearing
27.	GB0118	1	Sleeve
28.	G10592	1	Hair Pin Clip, No. 11
29.	GD8214	1	Special Bolt
30.	G10005	-	Hex Head Cap Screw, 5/8"-11 x 1 3/4"
	G10230	-	Lock Washer, 5/8"
	G10104	-	Hex Nut, 5/8"-11
31.	GA6345	-	Mounting Angle, L.H. (As Required) (Shown)
	GA6344	-	Mounting Angle, R.H. (As Required)

# SINGLE DISC FERTILIZER OPENER (Disc And Drop Tube)

FOC016/FOC007

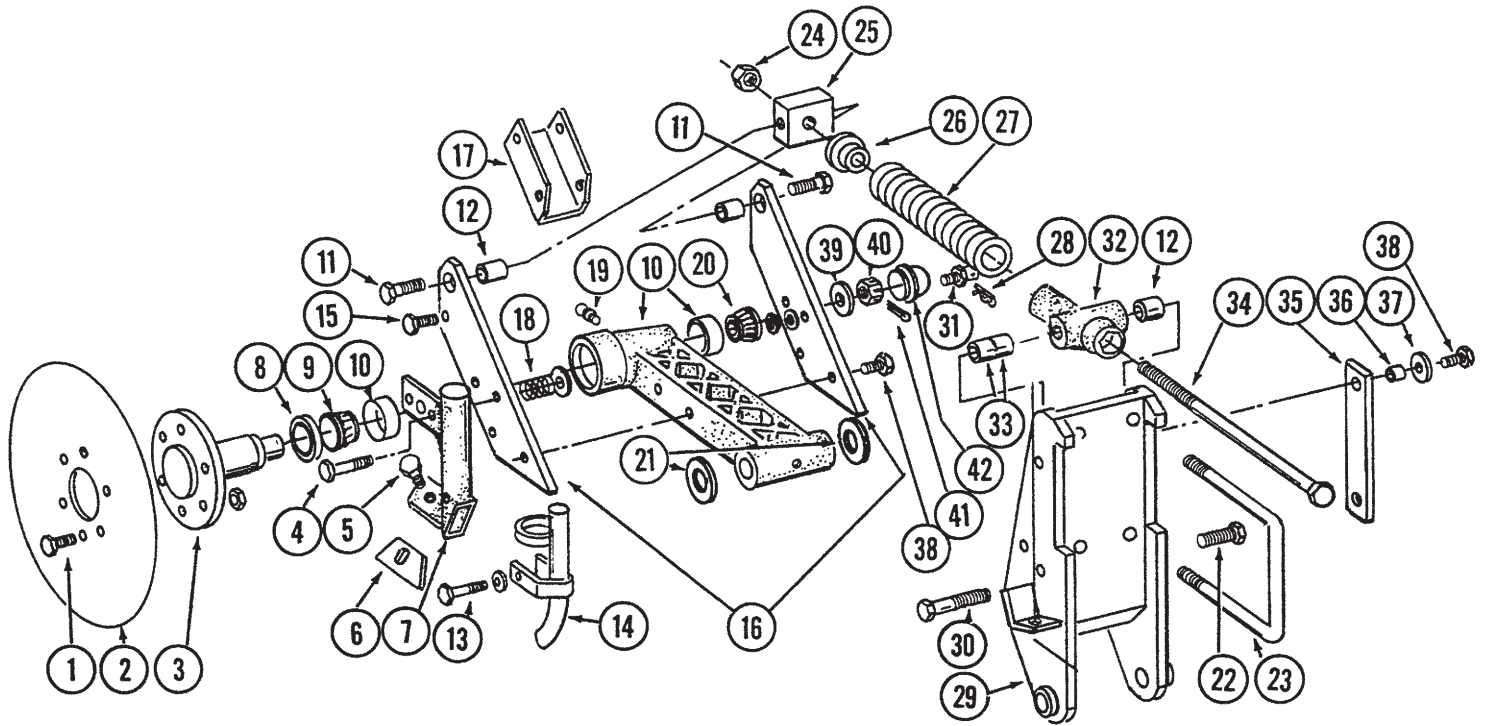

ITEM	PART NO.	QTY.	DESCRIPTION
		Per Assy.	
1.	G10594	6	Bolt, 1/2"-13 x 1 1/2"
	G10111	6	Lock Nut, 1/2"-13
2.	GD7900	1	Blade, 18"
3.	GB0205	1	Spindle
4.	G10049	2	Hex Head Cap Screw, 3/8"-16 x 2 1/2"
	G10210	2	Lock Washer, 3/8"
	G10108	2	Lock Nut, 3/8"-16
5.	G10599	1	Carriage Bolt, 3/8"-16 x 1 1/4"
	G10210	1	Washer, 3/8"
	G10229	1	Lock Washer, 3/8"
	G10101	1	Hex Nut, 3/8"-16
6.	GD7912	1	Scraper
7.	GB0210	-	Drop Tube, R.H.
	GB0209	1	Drop Tube, L.H. (Shown)

# SINGLE DISC FERTILIZER OPENER (Disc And Drop Tube)

ITEM	PART NO.	QTY.	DESCRIPTION
		Per Assy.	
8.	GA4286	1	Seal
9.	GA4287	1	Outer Bearing
10.	GA5887	1	Arm W/Cups
	GD6553	-	Outer Cup
	GR0188	-	Inner Cup
11.	G10055	2	Hex Head Cap Screw, 5/8"-11 x 1 1/4"
	G10230	2	Lock Washer, 5/8"
	G10205	2	Washer, 5/8" SAE
12.	GB0218	3	Bushing
13.	G10403	1	Hex Head Cap Screw, 1/4"-20 x 2 1/2"
	G10209	2	Washer, 1/4" USS
	G10110	1	Lock Nut, 1/4"-20
14.	GA6408	1	Liquid Drop Tube
15.	G10001	2	Hex Head Cap Screw, 3/8"-16 x 1"
	G10108	2	Lock Nut, 3/8"-16
16.	GD8224	2	Bar
17.	GD8238	1	Channel
18.	GD7962	2	Spring
19.	G10641	2	Grease Fitting, 1/8" NPT
20.	GA0237	1	Inner Bearing
21.	G10322	-	Bushing (As Required)
22.	G10007	1	Hex Head Cap Screw, 5/8"-11 x 1 1/2"
	G10205	1	Washer, 5/8" SAE
	G10230	1	Lock Washer, 5/8"
23.	GD1113	2	U-Bolt, 5" x 7" x 5/8"-11
	G10230	4	Lock Washer, 5/8"
	G10104	4	Hex Nut, 5/8"-11
24.	G10230	1	Lock Washer, 3/4"
	G10105	1	Hex Nut, 3/4"-10
25.	GD7908	1	Block
26.	GB0213	1	Spring Guide
27.	GD2115	1	Compression Spring
28.	G10592	1	Hair Pin Clip, No. 11
29.	GA5728	-	Opener Mount, R.H.
	GA5727	1	Opener Mount, L.H. (Shown)
30.	G10010	1	Hex Head Cap Screw, 5/8"-11 x 3"
	G10205	2	Washer, 5/8" SAE
	G10230	1	Lock Washer, 5/8"
31.	GD8276	1	Pin
	G10237	1	Lock Washer, 7/16"
	G10100	1	Hex Nut, 7/16"-14
32.	GB0206	1	Guide Rod
33.	GD8815	2	Bronze Bushing, 1 1/8"
34.	GD7907	1	Special Bolt
35.	GD8239	1	Storage Strap
36.	GD7904-02	1	Tube
37.	G10216	3	Washer, 1/2" USS
38.	G10039	5	Hex Head Cap Screw, 1/2"-13 x 1 3/4"
	G10111	5	Lock Nut, 1/2"-13
39.	G10220	1	Machine Bushing
40.	G10507	1	Slotted Nut, 1"-14
41.	G10459	1	Cotter Pin, 3/16" x 1 1/2"
42.	GD1104	1	Cap

# DRY/LIQUID FERTILIZER MOUNTS (Double Disc Openers)

DFC015

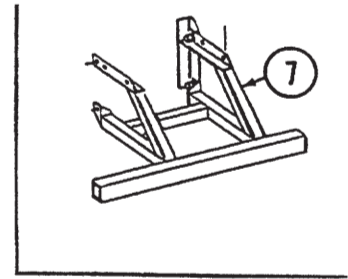
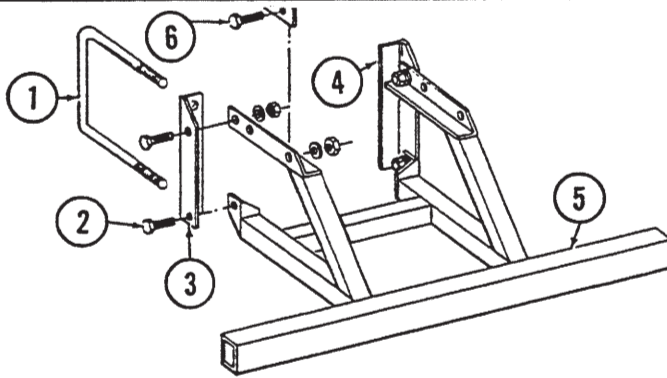

ITEM	PART NO.	QTY.	DESCRIPTION
		Per Assy.	
1.	GD1747	2	U-Bolt, 5" x 7" x 3/4"-10
	G10231	4	Lock Washer, 3/4"
	G10105	4	Hex Nut, 3/4"-10
2.	G10007	4	Hex Head Cap Screw, 5/8"-11 x 1 1/2"
	G10230	4	Lock Washer, 5/8"
	G10104	4	Hex Nut, 5/8"-11
3.	GD4782	1	Angle, R.H.
4.	GD4781	1	Angle, L.H.
5.	GA3624	1	Opener Mount
6.	G10017	4	Hex Head Cap Screw, 1/2"-13 x 1 1/2"
	G10228	4	Lock Washer, 1/2"
	G10102	4	Hex Nut, 1/2"-13
7.	GA4827	-	Opener Mount, Special, L.H.
	GA4828	-	Opener Mount, Special, R.H. (Shown)

# DRY/LIQUID FERTILIZER MOUNTS (Single Disc Openers)

DFC015/DFC019

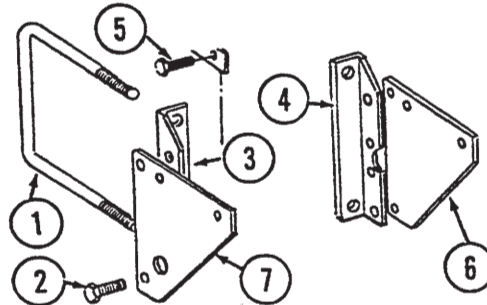

ITEM	PART NO.	QTY.	DESCRIPTION
		Per Assy.	
1.	GD1747	2	U-Bolt, 5" x 7" x 3/4"-10
	G10231	4	Lock Washer, 3/4"
	G10105	4	Hex Nut, 3/4"-10
2.	G10007	4	Hex Head Cap Screw, 5/8"-11 x 1 1/2"
	G10230	4	Lock Washer, 5/8"
	G10104	4	Hex Nut, 5/8"-11
3.	GD4782	1	Angle, R.H.
4.	GD4781	1	Angle, L.H.
5.	G10017	4	Hex Head Cap Screw, 1/2"-13 x 1 1/2"
	G10228	4	Lock Washer, 1/2"
	G10102	4	Hex Nut, 1/2"-13
6.	GD8023	2	Plate, Liquid Fertilizer
7.	GD8314	-	Plate, Dry Fertilizer
8.	GD8722	-	Holder (As Required)



# DRY FERTILIZER HOPPER MOUNT AND COUPLERS

DFC015

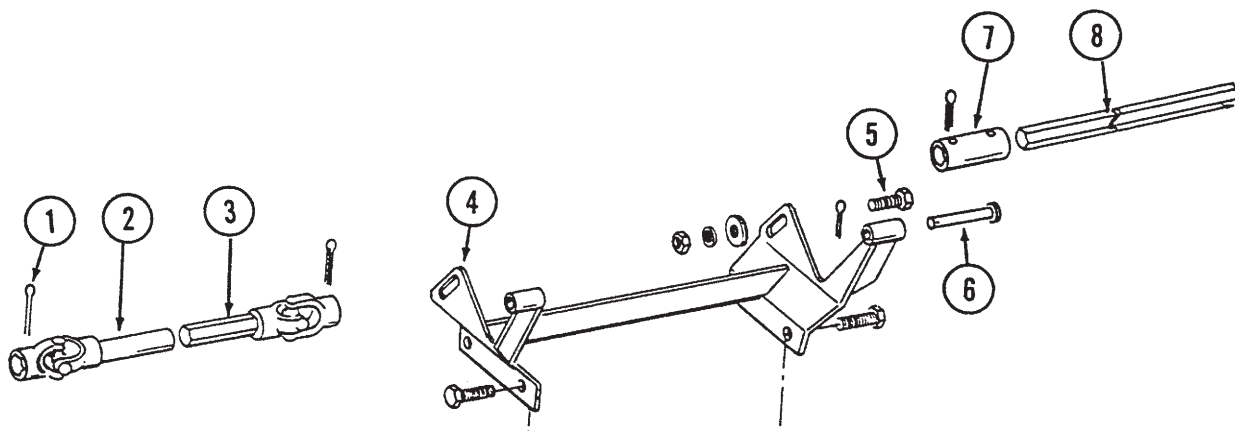

ITEM	PART NO.	QTY.	DESCRIPTION
		Per Assy.	
1.	G10460	-	Cotter Pin, 1/4" x 2"
2.	GA5674	-	U-Joint, 10"
	G10640	-	Grease Fitting, 1/4"-28
3.	GA5673	-	U-Joint, 11", 12 Row 30 And 16 Row 30
	GA5675	-	U-Joint, 26", 8 Row 36/38 And 12 Row 36/38
4.	GA3627	1	Hopper Mount
5.	G10037	2	Hex Head Cap Screw, 1/2"-13 x 1 1/4"
	G10206	2	Washer, 1/2" SAE
	G10228	2	Lock Washer, 1/2"
	G10102	2	Hex Nut, 1/2"-13
6.	G10561	2	Clevis Pin, 1/2" x 3"
	G10451	2	Cotter Pin, 1/8" x 1"
7.	GD7867	-	Coupler, 3", 12 Row 30 And 16 Row 30 (1 hole)
	GD7868	-	Coupler, 7", 8 Row 36/38 And 12 Row 36/38 (1 hole)
	GD5886	-	Coupler, 1 3/4", 8 Row 36/38, 12 Row 30/36/38 And 16 Row 30 (2 holes) (Shown)
8.	GD6825-06	-	Shaft, 6", 8 Row 36 (2 holes)
	GD2548-15.5	-	Shaft, 15 1/2", 12 Row 30 And 16 Row 30 (1 hole)
	GD2548-27.5	-	Shaft, 27 1/2", 12 Row 36/38 (1 hole)
	GD7869	-	Shaft, 3 1/4", 12 Row 36/38 (3 holes)

# DRY FERTILIZER HOPPER AND MOUNTS

DFC009/DFC018

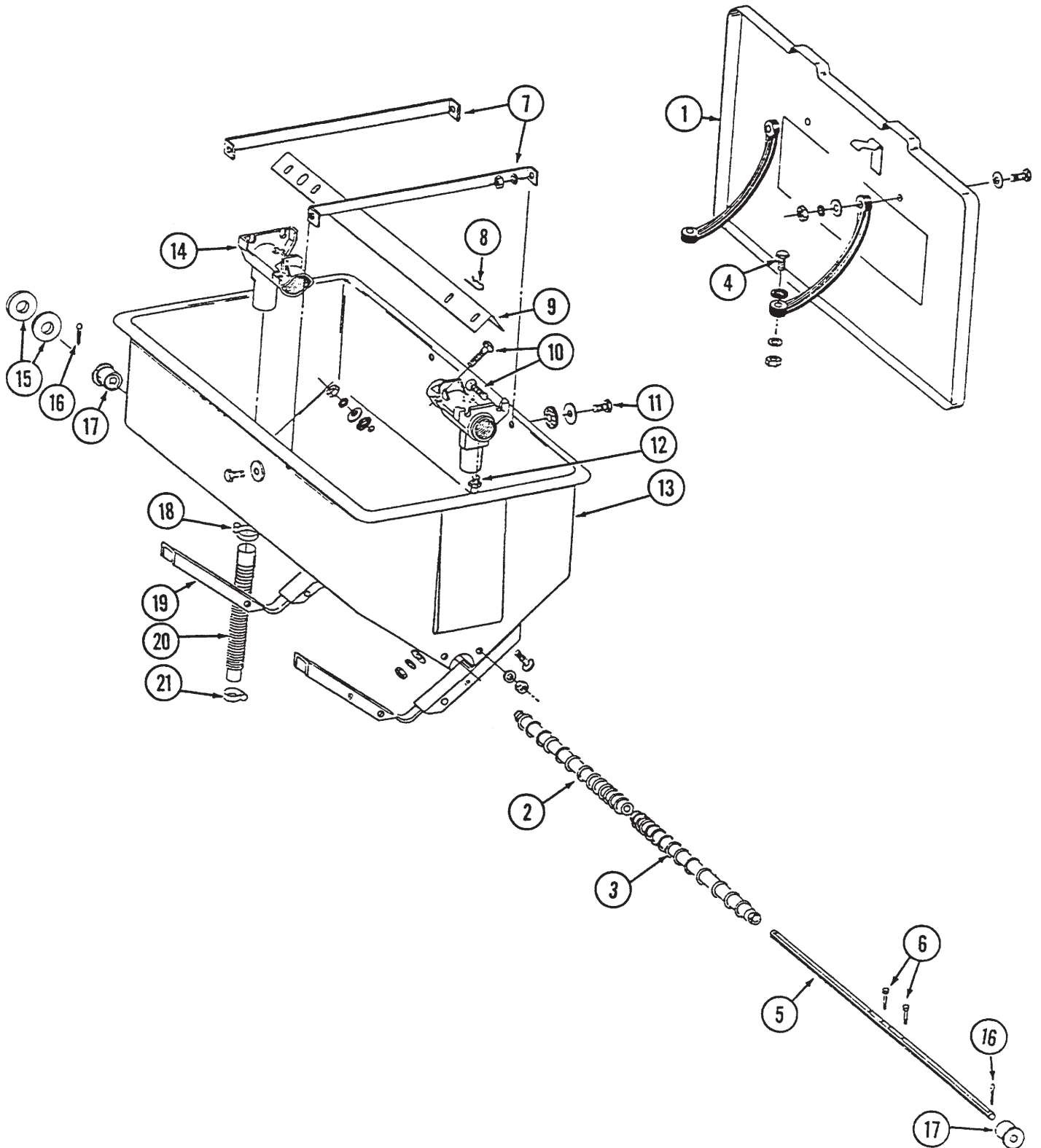

# DRY FERTILIZER HOPPER AND MOUNTS

ITEM	PART NO.	QTY.	DESCRIPTION
		Per Hopper	
1.	GA0898	1	Lid With Retainers, Clips, Rivets, Rubber Straps And Hardware
	GD1380	-	Front Clip
	GD2412	-	Rear Retainer
	G10655	-	Rivet, 3/16" x 13/32"
	GD1210	-	Rubber Strap
	G10171	-	Hex Head Cap Screw, 5/16"-18 x 1 1/4"
	G10219	-	Washer, 5/16" USS
	G10232	-	Lock Washer, 5/16"
	G10106	-	Hex Nut, 5/16"-18
2.	GB0198	1	Auger, R.H.
3.	GB0199	1	Auger, L.H.
4.	G10133	2	Hex Head Cap Screw, 5/16"-18 x 1 1/2"
	G10219	2	Washer, 5/16" USS
	G10232	2	Lock Washer, 5/16"
	G10106	2	Hex Nut, 5/16"-18
5.	GD7848	1	Shaft
6.	G10587	2	Hex Head Cap Screw, 1/4"-20 x 2", Stainless Steel
	G10588	2	Hex Nut, 1/4"-20, Stainless Steel
7.	GD1209	2	Strap
8.	G10670	2	Hair Pin Clip, No. 3
9.	GD1207	1	Baffle
10.	G10303	4	Carriage Bolt, 5/16"-18 x 1", Grade 2
	G10219	4	Washer, 5/16" USS
	G10232	4	Lock Washer, 5/16"
	G10106	4	Hex Nut, 5/16"-18
11.	G10171	4	Hex Head Cap Screw, 5/16"-18 x 1 1/4"
	G10201	4	Special Washer
	GD1213	4	Rubber Washer
	G10232	4	Lock Washer, 5/16"
	G10106	4	Hex Nut, 5/16"-18
12.	G10641	2	Grease Fitting, 1/8" NPT
13.	GD1379	1	Hopper
14.	GD1200	2	Outlet Housing
15.	G10233	4	Machine Bushing (Use on inner side of two middle hoppers only)
16.	G10460	2	Cotter Pin, 1/4" x 2"
17.	GB0200	2	Bearing
18.	G10676	2	Clamp, No. 36
19.	GA5652	2	Saddle
20.	GD3790	2	Rubber Tube
21.	G10672	2	Clamp, No. 28

# DRY FERTILIZER DRIVE

DFC016

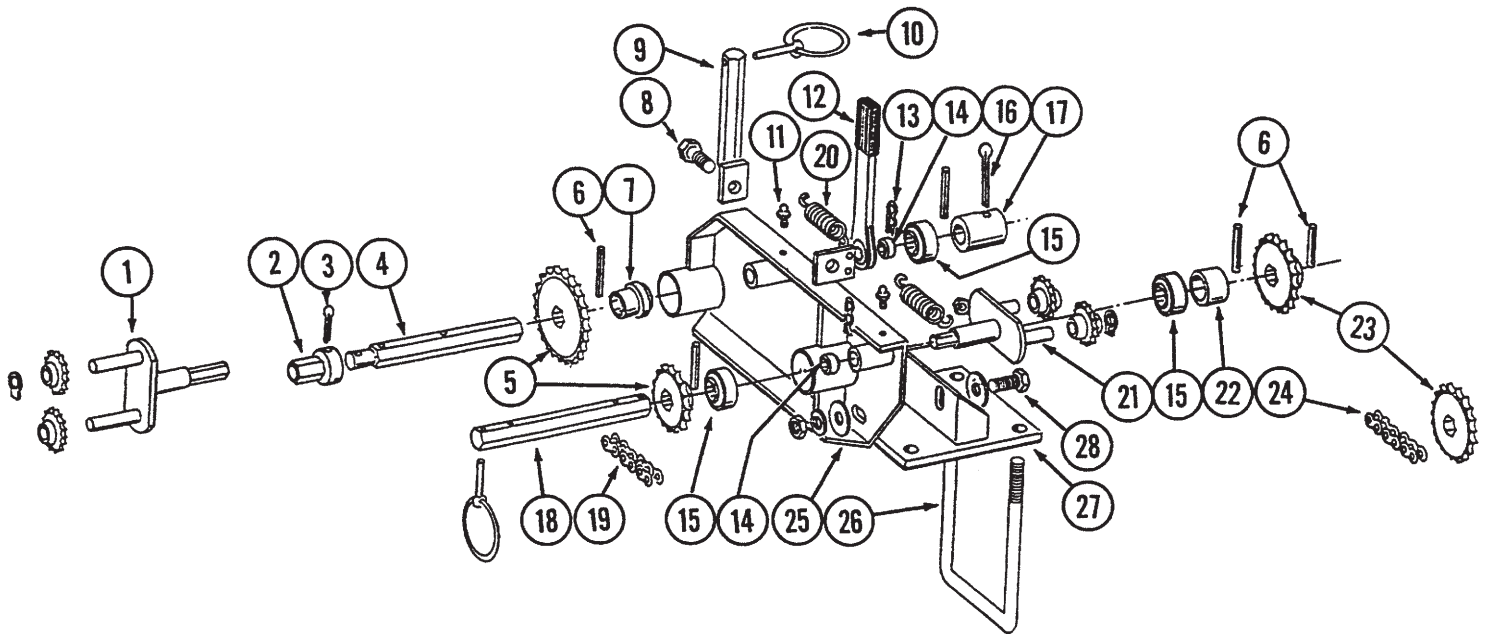

# DRY FERTILIZER DRIVE

ITEM	PART NO.	QTY. Per Side	DESCRIPTION
1.	GA5136	1	Idler With Sprockets And Rings
	GD7426	-	Sprocket
	G10435	-	Ring
2.	GD7127	1	Shear Coupler
3.	G10462	1	Cotter Pin, 3/16" x 2"
4.	GD7866	1	Shaft, 7/8" x 7 1/2"
5.	GA5105	1	Sprocket, 15 Tooth
	GA5107	1	Sprocket, 19 Tooth
	GA5114	1	Sprocket, 30 Tooth
	GA5115	1	Sprocket, 33 Tooth
	GA6337	1	Sprocket, 35 Tooth
6.	G10602	6	Spring Pin, 1/4" x 1 1/2"
7.	GA5624	1	Extended Bearing
8.	G10037	1	Hex Head Cap Screw, 1/2"-13 x 1 1/4"
	G10111	1	Lock Nut, 1/2"-13
9.	GA5229	1	Rod
10.	GD2558	3	Lynch Pin, 1/4"
11.	G10640	2	Grease Fitting, 1/4"-28
12.	GA4235	1	Ratchet Wrench Kit With Protective Closure
	G10445	-	Protective Closure
13.	G10670	2	Hair Pin Clip, No. 3
14.	GD6819	1	Sleeve
15.	GA5116	3	Bearing, 7/8" Hex
16.	G10460	1	Cotter Pin, 1/4" x 2"
17.	GD7867	1	Coupler, 3", 12 Row 30 And 16 Row 30
	GD7868	-	Coupler, 7", 8 Row 36/38 And 12 Row 36/38
18.	GD6902	1	Shaft, 7/8" x 7 3/4"
19.	G3310-88	1	Chain, No. 40, 88 Pitch Including Connector Link
	GR0912	-	Connector Link, No. 40
20.	GD5857	2	Spring
21.	GA4626	1	Idler With Sprockets And Rings
	GD7426	-	Sprocket
	G10435	-	Ring
22.	GD1199-03	1	Spacer, 5/8"
23.	GA5109	2	Sprocket, 24 Tooth
24.	G3310-118	1	Chain, No. 40, 118 Pitch Including Connector Link
	GR0912	-	Connector Link, No. 40
25.	GA5671	1	Transmission Plate, L.H.
	GA5672	-	Transmission Plate, R.H.
26.	GD1134	2	U-Bolt, 7" x 5" x 5/8"-11
	G10230	4	Lock Washer, 5/8"
	G10104	4	Hex Nut, 5/8"-11
27.	GA4624	1	Mount
28.	G10017	2	Hex Head Cap Screw, 1/2"-13 x 1 1/2"
	G10206	4	Washer, 1/2" SAE
	G10228	2	Lock Washer, 1/2"
	G10102	2	Hex Nut, 1/2"-13

# DRY FERTILIZER QUICK FILL

DFQ002/DFQ003/DFQ004/DFQ005

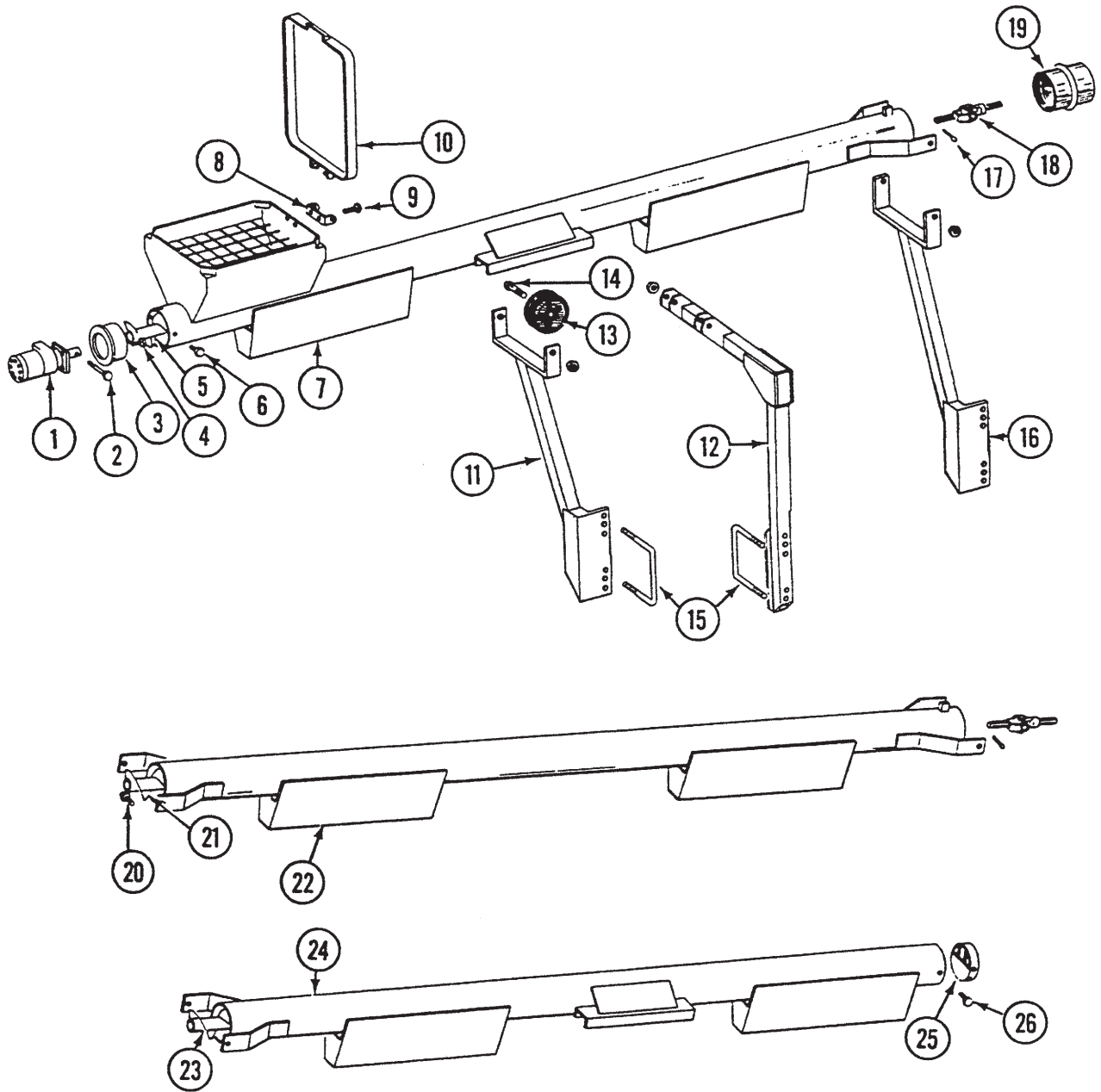

ITEM	PART NO.	QTY.	DESCRIPTION
1.		-	See "Dry Fertilizer Quick Fill Hydraulic System"
2.	G10041	1	Hex Head Cap Screw, 5/16"-18 x 2"
	G10109	1	Lock Nut, 5/16"-18
3.	GB0174	1	Motor Mount
4.	G10004	4	Hex Head Cap Screw, 3/8"-16 x 1 1/4"
	G10229	4	Lock Washer, 3/8"
5.	GA4659	1	Auger, L.H. Side, 69 1/2", 8 Row 36/38
	GA5420	-	Auger, L.H. Side, 110 3/4", 12 Row 30
	GA5421	-	Auger, L.H. Side, 121 1/2", 12 Row 36
	GA5422	-	Auger, L.H. Side, 131 1/2", 12 Row 38
	GA5423	-	Auger, L.H. Side, 170 3/4", 16 Row 30

# DRY FERTILIZER QUICK FILL

ITEM	PART NO.	QTY.	DESCRIPTION
6.	G10023	2	Hex Head Cap Screw, 1/4"-20 x 3/4"
	G10227	2	Lock Washer, 1/4"
7.	GA4655	1	Auger Tube, L.H. Side, 72", 8 Row 36/38
	GA5409	-	Auger Tube, L.H. Side, 113 1/4", 12 Row 30
	GA5413	-	Auger Tube, L.H. Side, 124", 12 Row 36
	GA5415	-	Auger Tube, L.H. Side, 134", 12 Row 38
	GA5411	-	Auger Tube, L.H. Side, 173 1/4", 16 Row 30
8.	GD1060	1	Hinge
9.	G10064	2	Hex Head Cap Screw, 1/4"-20 x 1"
	G10227	2	Lock Washer, 1/4"
	G10103	2	Hex Nut, 1/4"-20
10.	GA4444	1	Lid
11.	GA4640	-	Wheel Mount, R.H., 12 Row 30/36/38 And 16 Row 30
	GA4641	-	Wheel Mount, L.H., 12 Row 30/36/38 (Shown) And 16 Row 30
12.	GA4652	1	Wheel Mount, R.H., 8 Row 36/38
	GA4651	1	Wheel Mount, L.H., 8 Row 36/38 (Shown)
13.	GA4005	4	Wheel With Bearing
14.	G10033	4	Hex Head Cap Screw, 1/2"-13 x 3 1/2"
	G10216	8	Washer, 1/2" USS
	G10111	4	Lock Nut, 1/2"-13
15.	GD1113	4	U-Bolt, 5" x 7" x 5/8"-11
	G10230	8	Lock Washer, 5/8"
	G10104	8	Hex Nut, 5/8"-11
16.	GA4644	1	Hinge Mount, R.H.
	GA4645	1	Hinge Mount, L.H. (Shown)
17.	G10460	4	Cotter Pin, 1/4" x 2"
18.	GA5442	2	U-Joint
19.	GD6115	2	Boot
20.	G10009	4	Hex Head Cap Screw, 5/8"-11 x 2 1/2"
	G10217	8	Washer, 5/8" USS
	G10107	4	Lock Nut, 5/8"-11
21.	GA4658	1	Auger, Center, 139 3/4", 8 Row 36/38
	GA5424	-	Auger, Center, 115 3/4", 12 Row 30 And 16 Row 30
	GA5425	-	Auger, Center, 154 1/4", 12 Row 36/38
22.	GA4656	1	Auger Tube, Center, 142 1/2", 8 Row 36/38
	GA5412	-	Auger Tube, Center, 118 1/2", 12 Row 30 And 16 Row 30
	GA5417	-	Auger Tube, Center, 157", 12 Row 36/38
23.	GA4657	1	Auger, R.H. Side, 45 1/4", 8 Row 36/38
	GA5426	-	Auger, R.H. Side, 96 1/4", 12 Row 30
	GA5427	-	Auger, R.H. Side, 106 3/4", 12 Row 36
	GA5440	-	Auger, R.H. Side, 115 1/4", 12 Row 38
	GA5441	-	Auger, R.H. Side, 156 1/4", 16 Row 30
24.	GA4654	1	Auger Tube, R.H. Side, 72", 8 Row 36/38
	GA5408	-	Auger Tube, R.H. Side, 104 1/4", 12 Row 30
	GA5414	-	Auger Tube, R.H. Side, 115", 12 Row 36
	GA5416	-	Auger Tube, R.H. Side, 125", 12 Row 38
	GA5410	-	Auger Tube, R.H. Side, 164 1/4", 16 Row 30
25.	GA5373	1	End Shield
26.	G10023	8	Hex Head Cap Screw, 1/4"-20 x 3/4"
	G10227	8	Lock Washer, 1/4"
	G10103	8	Hex Nut, 1/4"-20

# DRY FERTILIZER QUICK FILL HYDRAULIC SYSTEM

PHS030/PHS031

## Closed Center System

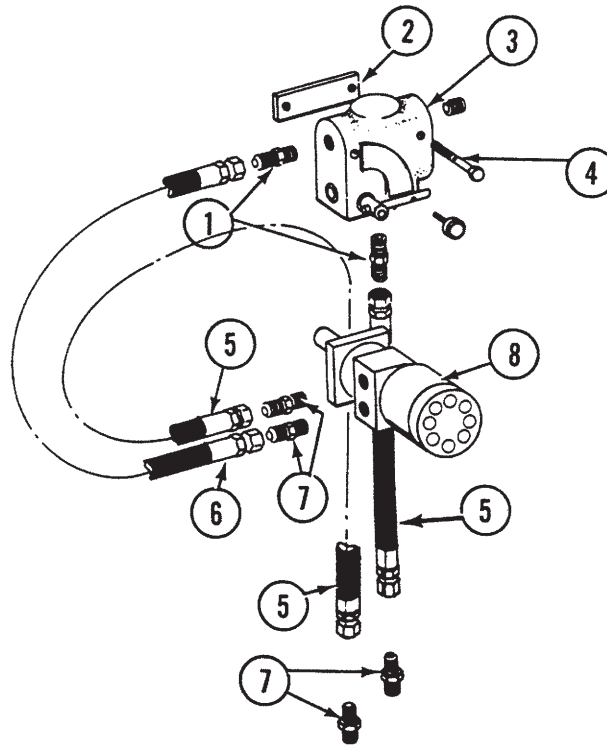

## Open Center System

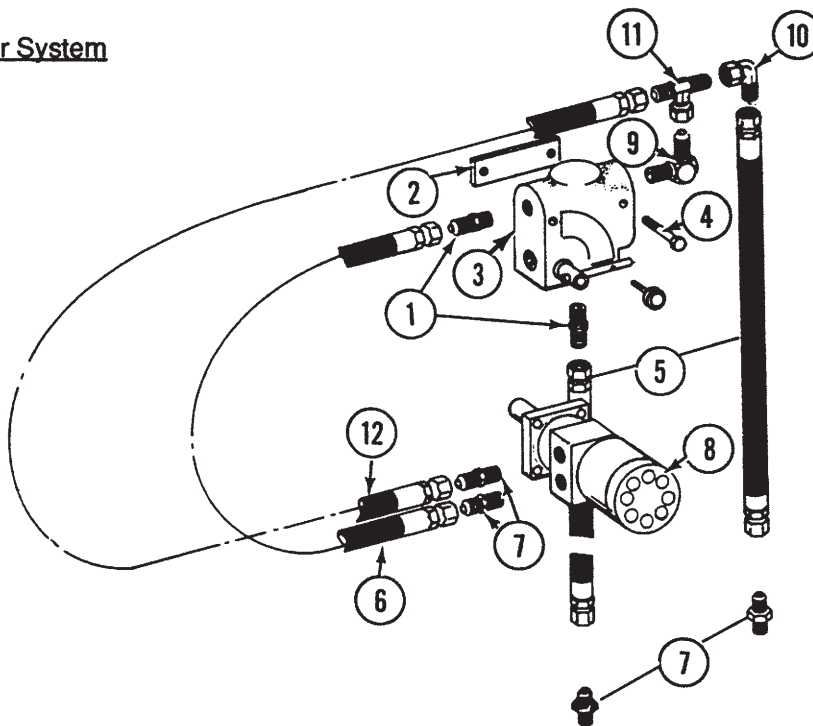



# DRY FERTILIZER QUICK FILL HYDRAULIC SYSTEM

---

ITEM	PART NO.	QTY.	DESCRIPTION
1.	G2404-10-08	2	Adapter, 7/8"-14 JIC To 1/2" NPT
2.	GD6244	1	Spacer
3.	GA5374	1	Flow Control Valve
	GR0979	-	O-Ring
	GR0980	-	Handle
	GR0981	-	Side Lever Spool
4.	G10403	2	Hex Head Cap Screw, 1/4"-20 x 2 1/2"
	G10110	2	Lock Nut, 1/4"-20
5.	GA1469	2-3	Hose Assembly, 1/2" x 185", 8 Row 36/38
	GA1468	-	Hose Assembly, 1/2" x 220", 12 Row 30
	GA1471	-	Hose Assembly, 1/2" x 264", 12 Row 36/38
	GA1426	-	Hose Assembly, 1/2" x 278", 16 Row 30
6.	GA1450	1	Hose Assembly, 1/2" x 22"
7.	G6400-10	4	Connector, 7/8"-14 JIC To 7/8"-14 O-Ring
8.	GA5163	1	Motor
9.	G2501-10-08	-	Elbow, 7/8"-14 JIC To 1/2" NPT
10.	G6501-10	-	Swivel Elbow, 7/8"-14 JIC
11.	G6600-10	-	Swivel Outlet Tee, 7/8"-14 JIC
12.	GA1424	-	Hose Assembly, 1/2" x 30"

# LIQUID FERTILIZER TANKS, SADDLES, SADDLE MOUNTS AND HOSES

LFC021/LFC023

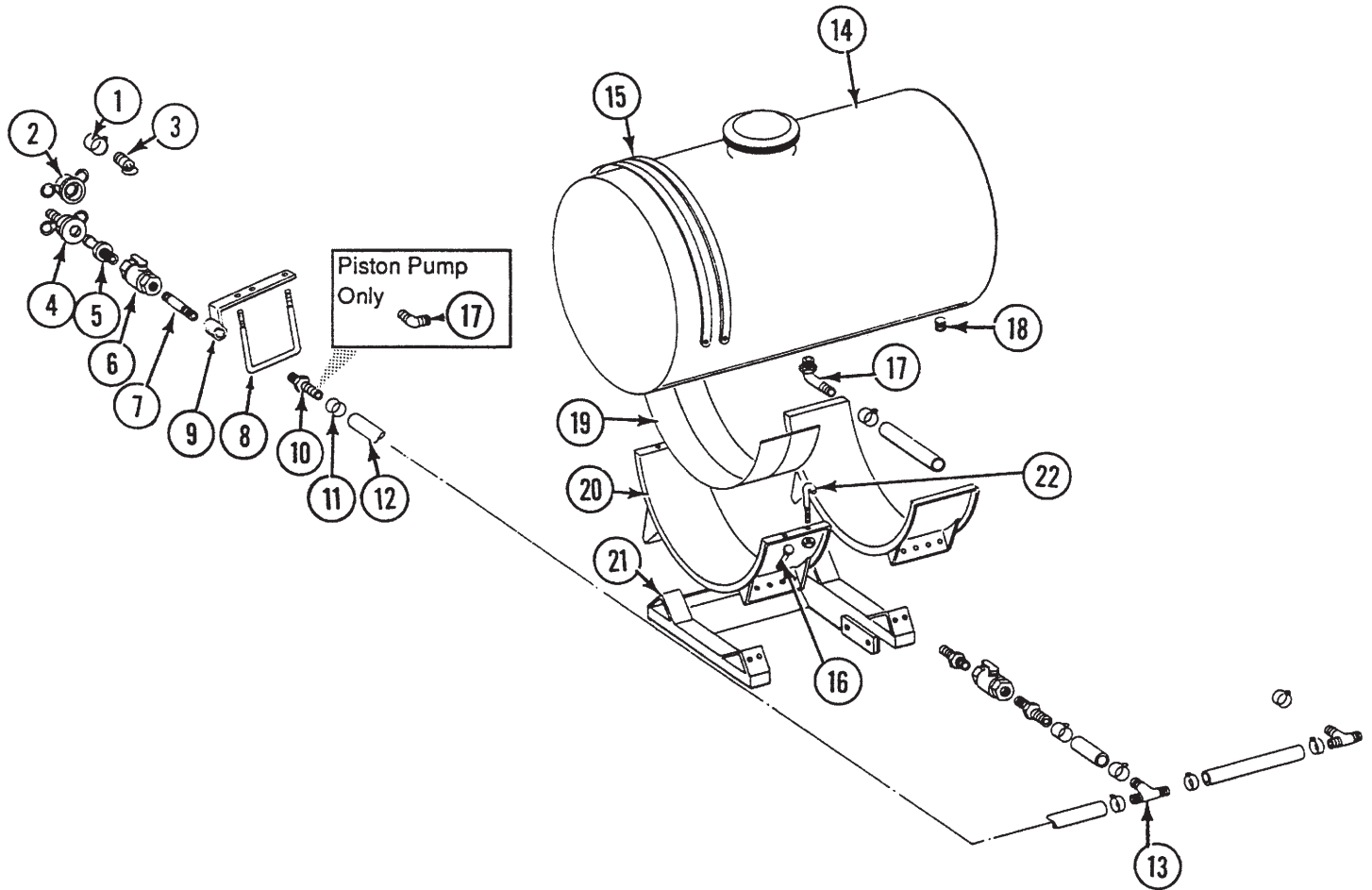

# LIQUID FERTILIZER TANKS, SADDLES, SADDLE MOUNTS AND HOSES

---

ITEM	PART NO.	QTY.	DESCRIPTION
1.	G10672	1	Clamp, No. 28
2.	GD1515	1	Dust Cap, 1 1/4"
3.	GD1517	1	Dust Plug
4.	GD1516	1	Adapter
5.	GD1514	1	Adapter
6.	GA4976	-	Ball Valve, Full Port
	GR1015	-	Body O-Ring
	GR1016	-	Stem O-Ring
	GR1017	-	Teflon Seat
	GR1018	-	Ball
	GR1019	-	Handle
7.	G10619	-	Pipe Nipple, 1 1/4" x 3"
8.	GD8306	1	U-Bolt, 7" x 5" x 1/2"-13
	G10228	2	Lock Washer, 1/2"
	G10102	2	Hex Nut, 1/2"-13
9.	GA5917	1	Quick Fill Mount
10.	G10626	-	Adapter, 1 1/4" NPT To 1 1/4" Barb
11.	G10674	-	Clamp, No. 24
12.	G4200-01	1	Hose, 1 1/4" x 22', 8 Row 36/38
	G4200-06	-	Hose, 1 1/4" x 40', 12 Row 30
	G4200-05	-	Hose, 1 1/4" x 50', 12 Row 36/38 And 16 Row 30
13.	G10633	-	Tee, 1 1/4"
14.	GD1812	-	Tank With Lid And Fittings, 30" x 150 Gallon, 8 Row Models (Qty. 2)
	GA5258	-	Tank With Lid And Fittings, 30" x 110 Gallon, 12/16 Row Models (Qty. 4)
	GR0508	-	Nylon Fitting, 1 1/4"
	GR0509	-	Fill Well (Use With GR0510)
	GR1005	-	Fill Well, Threaded (Use With GR1006)
	GR0510	-	Lid, 10" (Use With GR0509)
	GR1006	-	Lid, 10", Threaded (Use With GR1005)
	GR0513	-	Nylon Fitting, 3/8"
15.	GD1520	-	Band, 30" (4 Per Tank)
16.	G10003	-	Hex Head Cap Screw, 3/8"-16 x 1 1/2"
	G10210	-	Washer, 3/8" USS
	G10229	-	Lock Washer, 3/8"
	G10101	-	Hex Nut, 3/8"-16
17.	G10629	-	Elbow
18.	G10096	-	Nylon Plug, 3/4"
19.	GD1862	-	Pad, 8" x 14'
20.	GA5264	-	Saddle (2 Per Tank)
21.	GA4621	-	Tank Mount (2 Per Tank)
22.	GD1337	-	J-Bolt, 5/16" (8 Per Tank)
	G10109	-	Lock Nut, 5/16"-18 (8 Per Tank)

# LIQUID FERTILIZER PISTON PUMP DRIVE

LFC022/LFC024/LFC026/CCU007

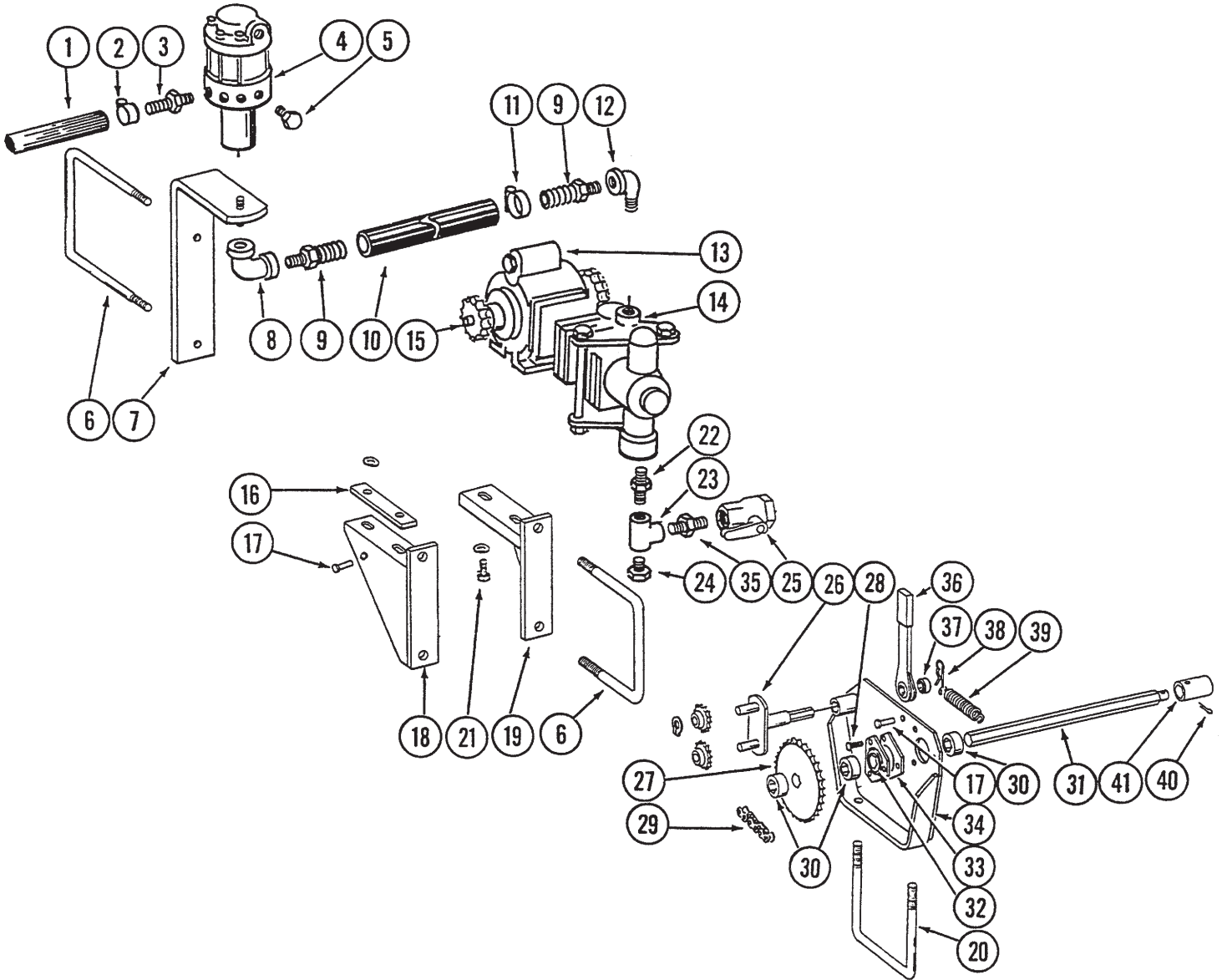

ITEM	PART NO.	QTY. Per Side	DESCRIPTION
1.	G4300-10 G4300-12 G4300-05	- - -	Hose, 1/2" x 60', 8 Row Models Hose, 1/2" x 90', 12 Row 30 Hose, 1/2" x 100', 12 Row 36/38 And 16 Row
2.	G10673	-	Clamp, No. 8
3.	GD8816	-	Hose Barb
4.		-	See "Liquid Fertilizer Flow Divider"
5.	G10292	-	Plug, 1/4" NPT
6.	GD1113 G10230 G10104	3 6 6	U-Bolt, 5" x 7" x 5/8"-11 Lock Washer, 5/8" Hex Nut, 5/8"-11

# LIQUID FERTILIZER PISTON PUMP DRIVE

---

ITEM	PART NO.	QTY.	DESCRIPTION
		Per Side	
7.	GA6527	1	Support
8.	G10733	1	Elbow, 3/4"
9.	G10734	-	Hose Barb, 3/4"
10.	G4205-06	-	Hose, 3/4" x 110"
11.	G10675	-	Clamp, No. 20
12.	G10735	1	Elbow, 90°, 3/4"
13.		-	See "Liquid Fertilizer Piston Pump (Crankcase Assembly)"
14.		-	See "Liquid Fertilizer Piston Pump (Cylinder Assembly)"
15.	GA6509	1	Sprocket W/Set Screw, 23 Tooth
16.	GD9242	2	Spacer
17.	G10478	1	Clevis Pin, 5/16" x 1"
	G10409	1	Retaining Ring
	G10669	1	Hair Pin Clip, No. 22
18.	GA4619	1	Pump Mount, L.H.
19.	GA4620	1	Pump Mount, R.H.
20.	GD1134	1	U-Bolt, 7" x 5" x 5/8"-11
	G10230	2	Lock Washer, 5/8"
	G10104	2	Hex Nut, 5/8"-11
21.	G10047	4	Hex Head Cap Screw, 3/8"-16 x 1 3/4"
	G10210	4	Washer, 3/8" USS
	GR1122	4	Mounting Pad
	G10229	4	Lock Washer, 3/8"
	G10101	4	Hex Nut, 3/8"-16
22.	G10728	1	Reducing Nipple, 1 1/2" To 1 1/4"
23.	G10719	1	Tee, 1 1/4"
24.	G10739	1	Pipe Plug, 1 1/4"
25.		-	See "Liquid Fertilizer Tanks, Saddles, Mounts And Hoses"
26.	GA5136	1	Idler W/Sprockets And Rings
	GD7426	-	Sprocket
	G10435	-	Ring
27.	GA5194	1	Sprocket, 50 Tooth
28.	G10303	3	Carriage Bolt, 5/16"-18 x 1"
	G10232	3	Lock Washer, 5/16"
	G10106	3	Hex Nut, 5/16"-18
29.	G3310-152	1	Chain, No. 40, 152 Pitch Including Connector
	GR0912	-	Connector Link, No. 40
30.	GD0917	3	Lock Collar, 7/8" Hex, Less Set Screws
	G10145	-	Set Screw, 5/16"-18 x 1/2"
31.	GD9277	1	Shaft, 25"
32.	G2100-03	1	Bearing, 7/8" Hex Bore, Spherical
33.	G3400-01	2	Flangette
34.	GA6530	1	Drive Plate W/Grease Fitting, R.H. (Shown)
	GA6531	-	Drive Plate W/Grease Fitting, L.H.
	G10640	-	Grease Fitting, 1/4"-28
35.	G10619	1	Close Nipple, 1 1/4"
36.	GA4235	1	Ratchet Arm W/Protective Closure
	G10445	-	Protective Closure
37.	GD6819	1	Sleeve
38.	G10670	1	Hair Pin Clip, No. 3
39.	GD5857	1	Spring
40.	G10460	1	Cotter Pin, 1/4" x 2"
41.	GD9048	1	Coupler, 2 1/2"

# LIQUID FERTILIZER PISTON PUMP (Crankcase Assembly)

JB-L4400-991/CCU007

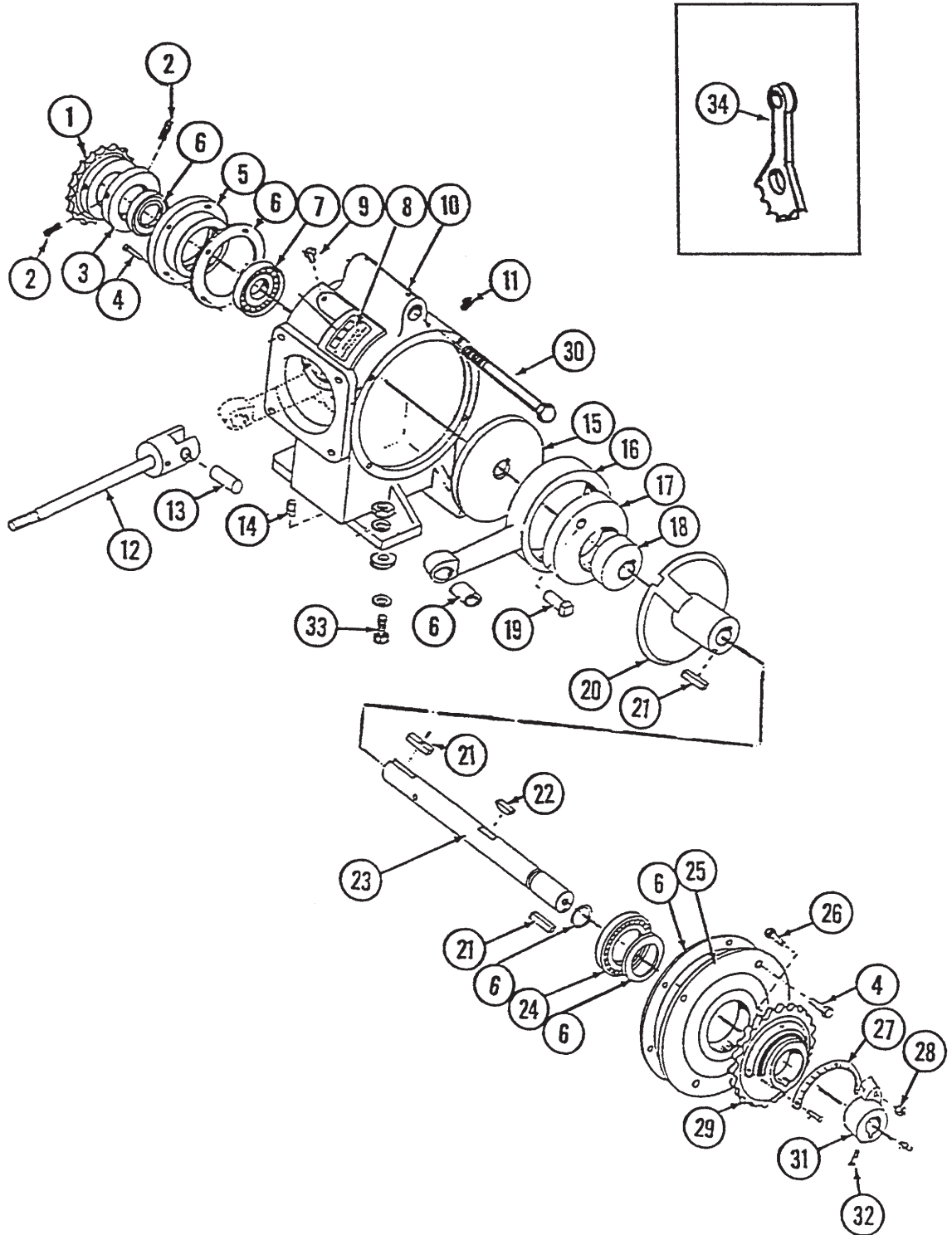

# LIQUID FERTILIZER PISTON PUMP (Crankcase Assembly)

---

ITEM	PART NO.	QTY.	DESCRIPTION
1.		-	See "Liquid Fertilizer Piston Pump Drive"
2.	G10688	2	Hex Socket Head Set Screw, 3/8"-16 x 5/8"
3.	GR1147	1	Spacer
4.	G10019	4	Hex Bolt, 5/16"-18 x 1"
5.	GR1102	1	Housing
6.	GR1173	-	Repair Kit, Also Includes Item 5 On "Liquid Fertilizer Piston Pump (Cylinder Assembly)" Pages
7.	GR1104	1	Bearing
8.	GR1105	1	Name Plate
9.	G10054	2	Hex Bolt, 5/16"-18 x 1/2"
10.	GR1106	1	Crankcase
11.	GR1107	1	Vent Plug
12.		-	See "Liquid Fertilizer Piston Pump (Cylinder Assembly)"
13.		-	See "Liquid Fertilizer Piston Pump (Cylinder Assembly)"
14.	GR1123	3	Plug
15.	GR1108	1	Disc
16.	GR1109	1	Connecting Rod
17.	GR1110	1	Large Eccentric
18.	GR1111	1	Small Eccentric
19.	GR1120	1	Eccentric Pin
20.	GR1119	1	Sleeve
21.	GR1118	3	Setting Arm Key
22.	GR1112	1	Woodruff Key
23.	GR1148	1	Crankshaft
24.	GR1116	1	Bearing
25.	GR1166	1	Cover Plate
26.	GR1167	1	Square Head Bolt, 3/8"-16 x 1 3/4"
27.	GR1168	1	Scale
28.	G10108	1	Lock Nut, 3/8"-16
29.	GR1114	1	Flange
30.	G10318	1	Hex Head Cap Screw, 5/8"-11 x 4 1/2"
	G10104	1	Hex Nut, 5/8"-11
31.	GR1165	1	Arm
32.	G10693	4	Hex Socket Head Set Screw, 5/16"-18 x 3/8"
33.		-	See "Liquid Fertilizer Piston Pump Drive"
34.	GR1100	1	Adjustment Wrench
A.	GA6154	-	Piston Pump Complete, Includes Crankcase (Items 2-34) and Cylinder (Items 1-22) Assemblies

# LIQUID FERTILIZER PISTON PUMP (Cylinder Assembly)

JB-L4400-991/SKH007

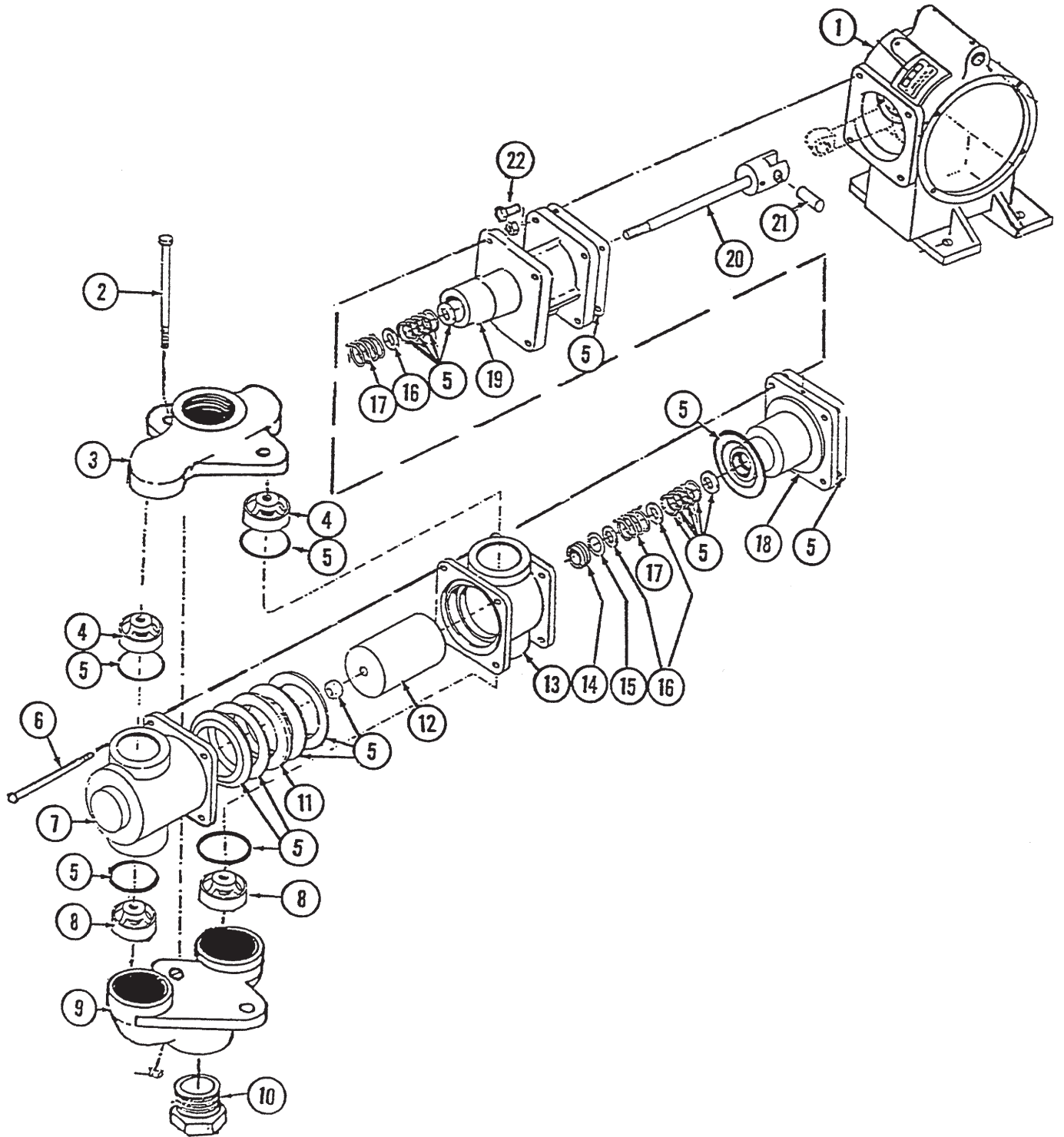



# LIQUID FERTILIZER PISTON PUMP (Cylinder Assembly)

---

ITEM	PART NO.	QTY.	DESCRIPTION
1.		-	See "Liquid Fertilizer Piston Pump (Crankcase Assembly)"
2.	G10686	2	Hex Head Cap Screw, 3/8"-16 x 8"
	G10101	2	Hex Nut, 3/8"-16
3.	GR1145	1	Discharge Manifold
4.	GR1144	2	Discharge Valve
5.	GR1173	-	Repair Kit, Also Includes Item 6 On "Liquid Fertilizer Piston Pump (Crankcase Assembly)" Pages
6.	G10687	4	Hex Head Cap Screw, 3/8"-16 x 5 1/2"
	G10101	4	Hex Nut, 3/8"-16
7.	GR1143	1	Outboard Cylinder
8.	GR1142	2	Suction Valve
9.	GR1140	1	Suction Manifold
10.		-	See "Liquid Fertilizer Piston Pump Drive"
11.	GR1137	1	Flange Packing Washer
12.	GR1136	1	Plunger
13.	GR1135	1	Inboard Cylinder
14.	GR1134	1	Stuffing Box Insert
15.	GR1133	1	Retaining Ring
16.	GR1129	3	Washer
17.	GR1130	2	Packing Spring
18.	GR1132	1	Outboard Stuffing Box
19.	GR1127	1	Crosshead Guide
20.	GR1125	1	Piston Rod
21.	GR1124	1	Pin
22.	G10019	4	Hex Head Cap Screw, 5/16"-18 x 1"

# LIQUID FERTILIZER PISTON PUMP FLOW DIVIDER

IB-L2190-991

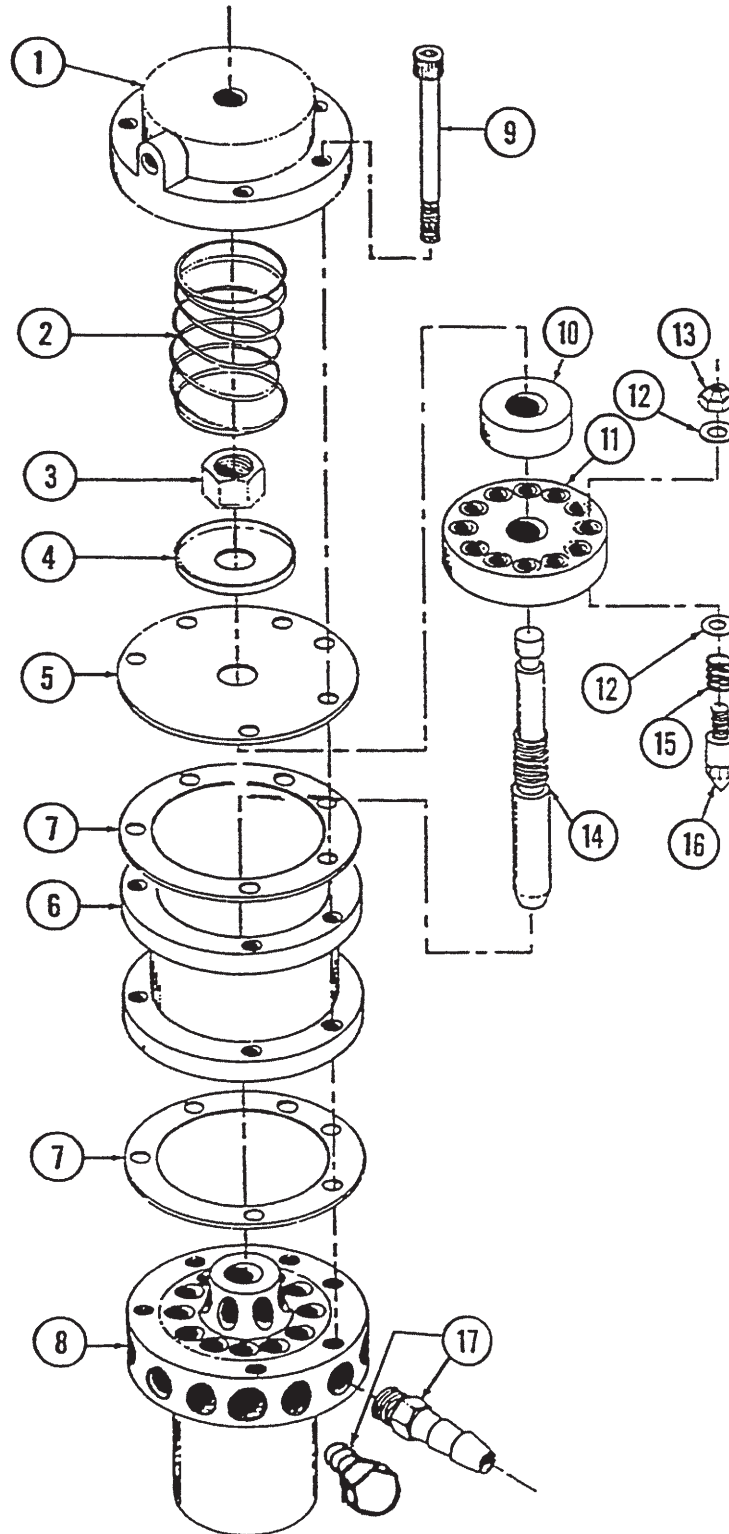

# LIQUID FERTILIZER PISTON PUMP FLOW DIVIDER

---

ITEM	PART NO.	QTY.	DESCRIPTION
1.	GR1150	1	Cap
2.	GR1151	1	Spring
3.	G10358	1	Hex Nut, 9/16"-18
4.	GR1152	1	Plate
5.	GR1153	1	Diaphragm
6.	GR1154	1	Housing
7.	GR1155	2	Gasket
8.	*	1	Manifold
9.	GR1157	6	Socket Screw, 1/4"
10.	GR1158	1	Lock
11.	*	1	Disk
12.	*	24	Stainless Steel Washer
13.	*	12	Valve Nut
14.	GR1162	1	Plunger
15.	*	12	Spring
16.	*	12	Valve
17.		-	See "Liquid Fertilizer Piston Pump Drive"
A.	GA6158	1	Liquid Fertilizer Piston Pump Flow Divider Complete

\* Factory calibration required. Replacement not recommended. Always be sure timing marks on disk and manifold line up.

# LIQUID FERTILIZER SQUEEZE PUMP DRIVE

LFC022

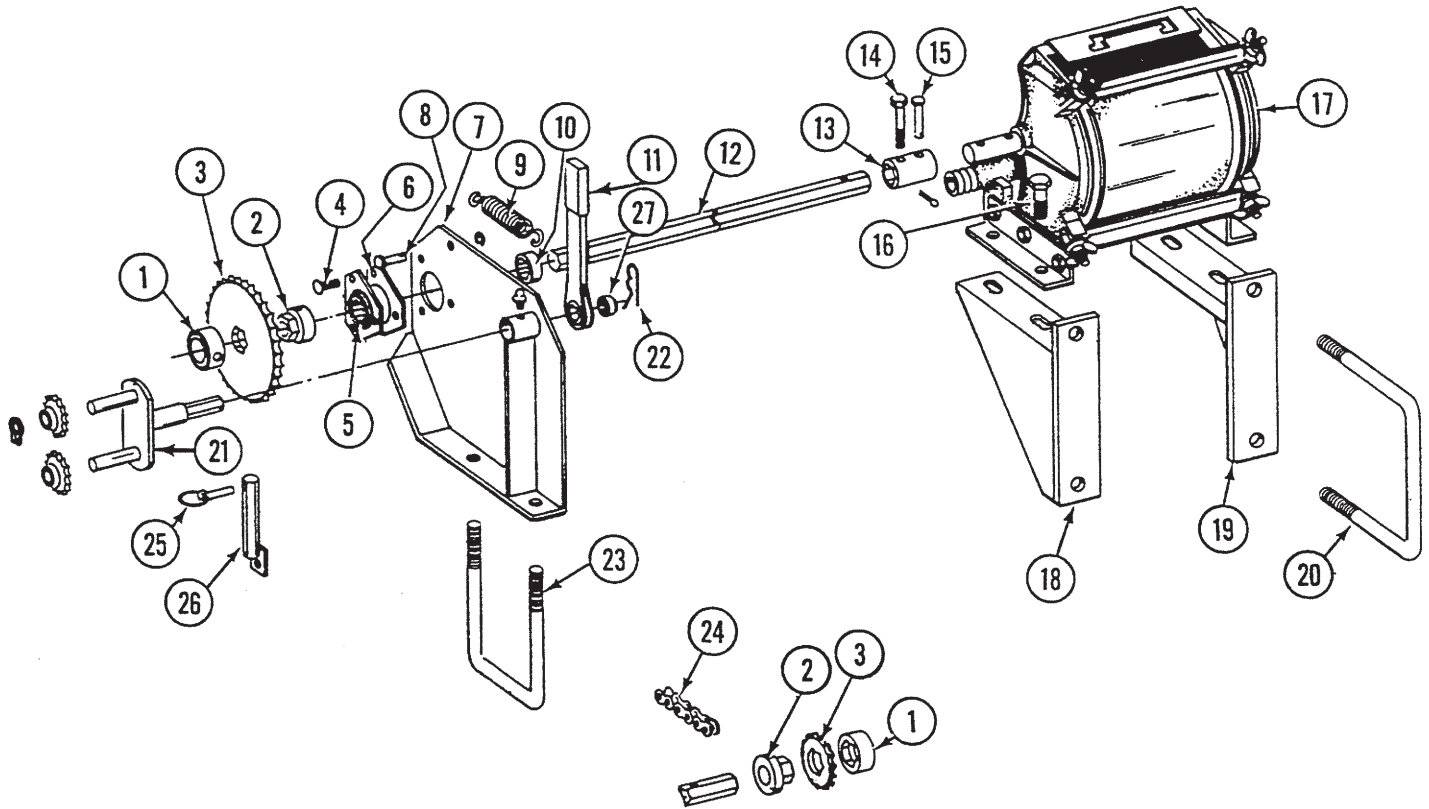

ITEM	PART NO.	QTY. Per Side	DESCRIPTION
1.	GA2355	1	Lock Collar With Set Screws
	G10120	-	Set Screw, 3/8"-16 x 1/2"
2.	GA2354	1	Adapter With Set Screws
	G10120	-	Set Screw, 3/8"-16 x 1/2"
3.	G2500-70	1	Sprocket, 16 Tooth
	G2500-71	1	Sprocket, 18 Tooth
	G2500-72	1	Sprocket, 20 Tooth
	G2500-73	1	Sprocket, 30 Tooth
	G2500-74	1	Sprocket, 44 Tooth
	G2500-75	1	Sprocket, 46 Tooth
	G2500-76	1	Sprocket, 52 Tooth
	G2500-78	1	Sprocket, 62 Tooth
	G2500-77	-	Sprocket, 60 Tooth (Optional)

# LIQUID FERTILIZER SQUEEZE PUMP DRIVE

ITEM	PART NO.	QTY. Per Side	DESCRIPTION
4.	G10303	3	Carriage Bolt, 5/16"-18 x 1"
	G10232	3	Lock Washer, 5/16"
	G10106	3	Hex Nut, 5/16"-18
5.	G2100-03	1	Bearing, 7/8" Hex
6.	G3400-01	2	Flangette
7.	GA4617	1	Drive Plate With Grease Fitting, L.H.
	GA4618	-	Drive Plate With Grease Fitting, R.H.
	G10641	-	Grease Fitting, 1/8" NPT
8.	G10478	1	Clevis Pin, 5/16" x 1"
	G10409	1	Retaining Ring, 5/16"
9.	GD5857	1	Spring
10.	GD0917	1	Lock Collar, Less Set Screws
	G10145	-	Set Screw, 5/16"-18 x 1/2"
11.	GA4235	1	Ratchet Wrench With Protective Closure
	G10445	-	Protective Closure
12.	GD2548-48	1	Shaft, 7/8" x 48", 8 Row 36/38 (Trim Excess) And 12 Row 30
	GD2548-72	-	Shaft, 7/8" x 72", 12 Row 36/38
	GD2548-70	-	Shaft, 7/8" x 70", 16 Row 30
13.	GD6924	1	Coupler
14.	G10339	1	Hex Head Cap Screw, 5/16"-18 x 2"
	G10232	1	Lock Washer, 5/16"
	G10106	1	Hex Nut, 5/16"-18
15.	G10558	1	Clevis Pin, 5/16" x 1 3/4"
	G10467	1	Cotter Pin, 5/32" x 3/4"
16.	G10004	4	Hex Head Cap Screw, 3/8"-14 x 1 1/4"
	G10210	4	Washer, 3/8" USS
	G10229	4	Lock Washer, 3/8"
	G10101	4	Hex Nut, 3/4"-14
17.		-	See "Liquid Fertilizer Squeeze Pump"
18.	GA4619	1	Pump Mount, L.H.
19.	GA4620	1	Pump Mount, R.H.
20.	GD1113	2	U-Bolt, 5" x 7" x 5/8"-11
	G10230	4	Lock Washer, 5/8"
	G10104	4	Hex Nut, 5/8"-11
21.	GA5136	1	Idler With Sprockets And Rings
	GD7426	-	Sprocket
	G10435	-	Ring
22.	G10670	1	Hair Pin Clip, No. 3
23.	GD1134	1	U-Bolt, 7" x 5" x 5/8"-11
	G10230	2	Lock Washer, 5/8"
	G10104	2	Hex Nut, 5/8"-11
24.	G3310-176	1	Chain, No. 40, 176 Pitch Including Connector Link
	GR0912	-	Connector Link, No. 40
25.	GD2558	1	Lynch Pin, 1/4"
26.	GA5251	1	Storage Rod
27.	GD6819	1	Sleeve

# LIQUID FERTILIZER SQUEEZE PUMP

# 8 ROW MODELS

LFC011

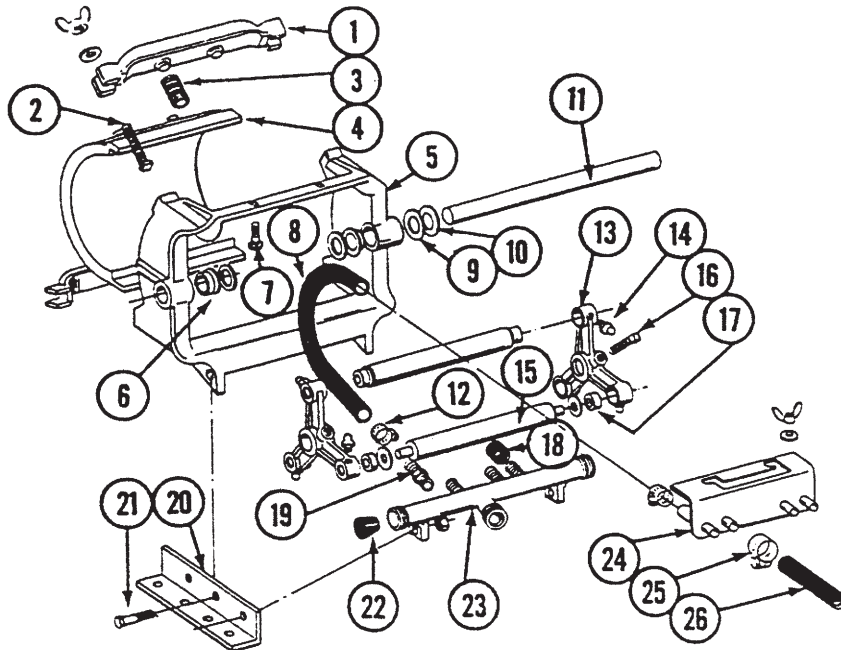

TEM	PART NO.	QTY.	DESCRIPTION
1.	GR0216	2	Spring Anchor Bar
2.	G10130	4	Square Head Machine Bolt, 5/16"-18 x 1 3/4"
	G10219	4	Washer, 5/16" USS
	G10144	4	Wing Nut, 5/16"-18
3.	GR0214	4	Spring
4.	GR0212	1	Plate
5.	GR0208	1	Frame
6.	GR0207	2	Nylon Bushing
7.	G10303	2	Carriage Bolt, 5/16"-18 x 1"
	G10219	2	Washer, 5/16" USS
	G10144	2	Wing Nut, 5/16"-18
8.	GR0215	4	Metering Hose, 1/2" x 13"
9.	GR0225	2	Shim, 1/32"
10.	GR0226	2	Shim, 3/64"
11.	GR0210	1	Shaft
12.	G10681	8	Clamp, No. 6
13.	GR0223	3	Roller Arm
14.	G10640	2	Grease Fitting, 1/4"-28
15.	GR0209	3	Roller
16.	G10131	2	Set Screw, 5/16"-18 x 3/4"
17.	GR0227	6	Nylon Bushing
18.	GR0211	2	Rubber Cap
19.	GR0232	4	Adapter
20.	GR0213	2	Angle
21.	G10004	4	Hex Head Cap Screw, 3/8"-16 x 1 1/4"
	G10101	4	Hex Nut, 3/8"-16
22.	GR0217	2	Manifold Plug
23.	GR0228	1	Intake Manifold
24.	GR0224	1	Discharge Manifold
25.	G10673	-	Clamp, No. 8
26.	G4300-10	1	Hose, 1/2" x 60'
A.	GA0321	-	Squeeze Pump Complete, 4 Rows (Items 1-24)

# LIQUID FERTILIZER SQUEEZE PUMP

# 12 ROW MODELS

LCF011

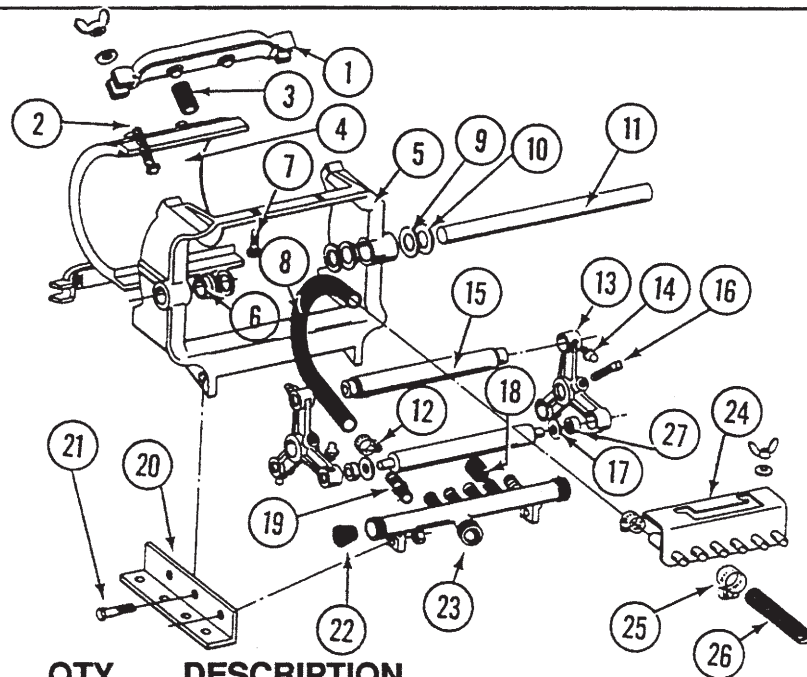

ITEM	PART NO.	QTY.	DESCRIPTION
1.	GR0216	2	Spring Anchor Bar
2.	G10130	4	Square Head Machine Bolt, 5/16"-18 x 1 3/4"
	G10219	4	Washer, 5/16" USS
	G10144	4	Wing Nut, 5/16"-18
3.	GR0214	4	Spring
4.	GR0212	1	Plate
5.	GR0208	1	Frame
6.	GR0207	2	Nylon Bushing
7.	G10303	2	Carriage Bolt, 5/16"-18 x 1"
	G10219	2	Washer, 5/16" USS
	G10144	2	Wing Nut, 5/16"-18
8.	GR0215	6	Metering Hose, 1/2" x 13"
9.	GR0225	2	Shim, 1/32"
10.	GR0226	2	Shim, 3/64"
11.	GR0210	1	Shaft
12.	G10681	12	Clamp, No. 6
13.	GR0231	2	Roller Arm
14.	G10640	8	Grease Fitting, 1/4"-28
15.	GR0233	3	Roller
16.	G10131	2	Set Screw, 5/16"-18 x 3/4"
17.	GR0229	6	Nylon Bushing
18.	GR0211	-	Rubber Cap
19.	GR0232	6	Adapter
20.	GR0213	2	Angle
21.	G10004	4	Hex Head Cap Screw, 3/8"-16 x 1 1/4"
	G10101	4	Hex Nut, 3/8"-16
22.	GR0217	2	Manifold Plug
23.	GR0228	1	Intake Manifold
24.	GR0224	1	Discharge Manifold
25.	G10673	-	Clamp, No. 8
26.	G4300-12	1	Hose, 1/2" x 95', 12 Row 30
	G4300-05	-	Hose, 1/2" x 100', 12 Row 36/38
27.	GR0230	6	Roller Bearing
A.	GA0322	-	Squeeze Pump Complete, 6 Rows (Items 1-24 And 27)

# LIQUID FERTILIZER SQUEEZE PUMP

# 16 ROW MODEL

LFC010

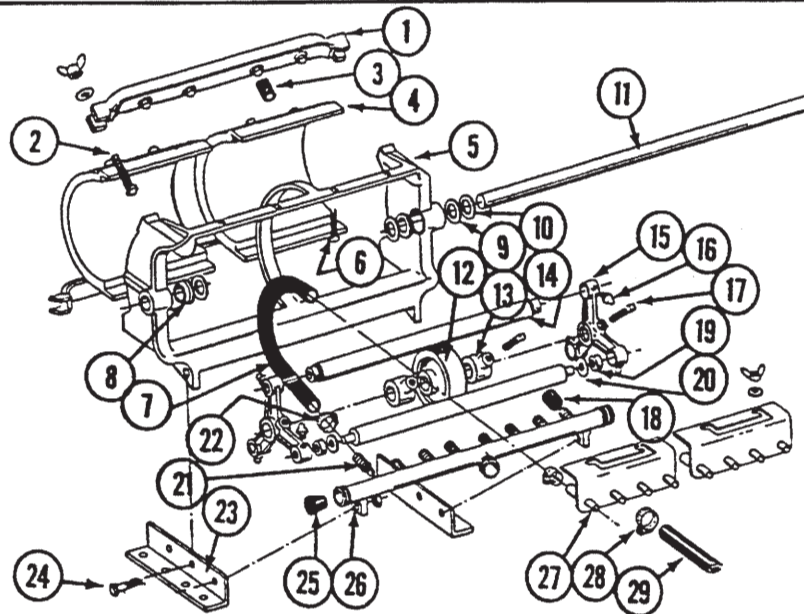

ITEM	PART NO.	QTY.	DESCRIPTION
1.	GR0221	2	Spring Anchor Bar
2.	G10130	4	Square Head Machine Bolt, 5/16"-18 x 1 3/4"
	G10219	4	Washer, 5/16" USS
	G10144	4	Wing Nut, 5/16"-18
3.	GR0214	8	Spring
4.	GR0212	2	Plate
5.	GR0222	1	Frame
6.	G10303	4	Round Head Machine Bolt, 5/16"-18 x 1"
	G10219	4	Washer, 5/16" USS
	G10144	4	Wing Nut, 5/16"-18
7.	GR0215	8	Metering Hose, 1/2" x 13"
8.	GR0207	2	Nylon Bushing
9.	GR0225	4	Shim, 1/32"
10.	GR0226	4	Shim, 3/64"
11.	GR0220	1	Shaft
12.	GR0281	1	Back Up Roller
13.	GR0282	2	Set Collar
14.	GR0283	3	Roller
15.	GR0231	2	Roller Arm
16.	G10640	8	Grease Fitting, 1/4"-28
17.	G10131	2	Set Screw, 5/16"-18 x 3/4"
18.	GR0211	-	Rubber Cap
19.	GR0230	6	Bearing
20.	GR0229	6	Nylon Washer
21.	GR0232	8	Adapter
22.	G10681	16	Clamp, No. 6
23.	GR0279	1	Angle, Left
	GR0280	1	Angle, Right
24.	G10004	4	Hex Head Cap Screw, 3/8"-16 x 1 1/4"
	G10101	4	Hex Nut, 3/8"-16
25.	GR0217	2	Manifold Plug
26.	GR0284	1	Intake Manifold
27.	GR0236	2	Discharge Manifold
28.	G10673	-	Clamp, No. 8
29.	G4300-05	2	Hose, 1/2" x 100'
A.	GA0323	-	Squeeze Pump Complete, 8 Rows (Items 1 - 27)



# SMV, DECALS, REFLECTORS AND TIE STRAPS

**⚠ WARNING ⚠**

ALWAYS USE SAFETY PINS IN TRANSPORT POSITION

1

**⚠ CAUTION**

1. Read and understand the Operator's Manual.
2. Stop the tractor engine before leaving the operator's platform.
3. Keep riders off the machine.
4. Make certain everyone is clear of the machine before starting the tractor engine and operating.
5. Keep all shields in place.
6. Never lubricate, adjust, unplug or service the machine with tractor engine running.
7. Wait for all movement to stop before servicing.
8. Keep hands, feet and clothing away from moving parts.
9. Use flashing warning lights when operating on highways except when prohibited by law.

3

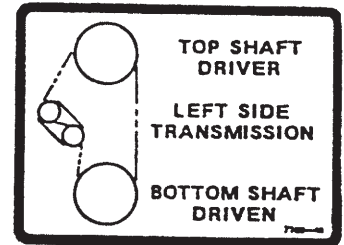

4

**⚠ WARNING**

**TO AVOID INJURY - Stand clear -** - Keep others away when raising or lowering markers. Before transporting planter fully extend hydraulic cylinders and install locking pins where provided.

700-42 017188

2

**KINZE**

5

**⚠ WARNING**

TOW ONLY WITH FARM TRACTOR.

7100-56

6

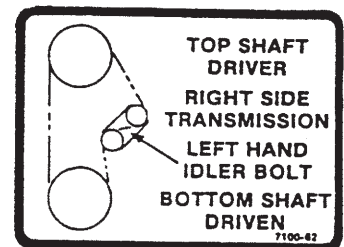

7

**⚠ CAUTION ⚠**

REAR OF PLANTER SWINGS WIDE IN TURNS. ALWAYS ALLOW SUFFICIENT ROOM TO CLEAR OBSTACLES WHEN TURNING

7100-15

8

**IMPORTANT**

Always rephase the hydraulic system after transporting.

1. Lower the planter to the ground.
2. Hold the hydraulic lever for 15 seconds to rephase the hydraulic system.
3. Resume normal operation.

7100-64

9

**⚠ WARNING ⚠**

NEVER WALK UNDER OR WORK ON PLANTER WHEN IT IS RAISED WITHOUT SUPPORTING THE FRAMES WITH ADDITIONAL SUPPORTS.

7100-48

10

**INSTRUCTION**

TRANSPORT TO PLANTING

1. RELEASE TRANSPORT LOCK.
2. ROTATE PLANTER.
3. RELEASE LIFT LOCK.
4. LOWER PLANTER AND REPHASE SYSTEM.
5. RELEASE WING LOCKS.
6. RAISE TO RAISED FIELD POSITION.
7. RETRACT TONGUE.

7100-73

11

**INSTRUCTION**

PLANTING TO TRANSPORT

1. SECURE WING LOCKS.
2. RAISE TO RAISED FIELD POSITION.
3. FULLY EXTEND TONGUE.
4. RAISE TO LOCKED TRANSPORT POSITION.
5. ROTATE PLANTER.

7100-74

12

**⚠ CAUTION ⚠**

AVOID UNEVEN LOADING OF HOPPERS, ESPECIALLY DURING TRANSPORT

7100-75

13

**⚠ WARNING ⚠**

— TO AVOID INJURY — ALWAYS USE HYDRAULIC CYLINDER SAFETY LOCKOUT CHANNELS WHEN TRANSPORTING PLANTER ON THE ROAD. AFTER USE RETURN TO STORAGE LOCATION.

7100-63

14

**⚠ DANGER**

THIS PLANTER IS DESIGNED TO BE DRIVEN BY GROUND TIRES ONLY. THE USE OF HYDRAULIC, ELECTRIC OR PTO DRIVES MAY CREATE SERIOUS SAFETY HAZARDS TO YOU AND THE PEOPLE NEAR BY. IF YOU INSTALL SUCH DRIVES YOU MUST FOLLOW ALL APPROPRIATE SAFETY STANDARDS AND PRACTICES TO PROTECT YOU AND OTHERS NEAR THIS PLANTER FROM INJURY.

7100-61

15

# SMV, DECALS, REFLECTORS AND TIE STRAPS

## ⚠ WARNING ⚠

THIS MACHINE HAS BEEN DESIGNED AND BUILT WITH YOUR SAFETY IN MIND. ANY ALTERATION TO THE DESIGN OR CONSTRUCTION MAY CREATE SAFETY HAZARDS. DO NOT MAKE ANY ALTERATIONS OR CHANGES TO THE EQUIPMENT, BUT IF ANY ALTERATIONS OR CHANGES ARE MADE YOU MUST FOLLOW ALL APPROPRIATE SAFETY STANDARDS AND PRACTICE TO PROTECT YOU AND OTHERS NEAR THIS MACHINE FROM INJURY.

7100-90

16

## ⚠ DANGER

**- ROTATING AUGER -**  
KEEP CLOTHING, YOURSELF AND OTHERS WELL CLEAR WHEN OPERATING

7100-103

17



18



19

## ⚠ CAUTION ⚠

AGRICULTURAL CHEMICALS CAN BE DANGEROUS. IMPROPER SELECTION OR USE CAN SERIOUSLY INJURE PERSONS, ANIMALS, PLANTS, SOIL, OR OTHER PROPERTY. **BE SAFE:** SELECT THE RIGHT CHEMICAL FOR THE JOB. HANDLE IT WITH CARE. FOLLOW THE INSTRUCTIONS ON THE CONTAINER LABEL AND OF THE EQUIPMENT MANUFACTURER.

7100-115

20



7100-116

21

## ⚠ DANGER

SERIOUS INJURY OR DEATH CAN RESULT FROM CONTACT WITH ELECTRIC LINES. USE CARE TO AVOID CONTACT WITH ELECTRIC LINES WHEN MOVING OR OPERATING THIS MACHINE.

7100-117

22

## ATTENTION

Connect directly to **BATTERY** wherever possible

Connect black lead to negative terminal

Connect to **12 Volts Only**

7100-123

23

# DANGER

DANGER: The two outer transport wheels are bolt-on to allow legal width truck shipment. Install outer transport wheel assemblies prior to unloading. DO NOT REMOVE THESE ASSEMBLIES AFTER PLANTER IS ASSEMBLED FOR USE. DO NOT fold planter or tow planter while the two outer transport wheels are removed. Tipping may occur because of narrow wheel base.

7100-129

24



25

USE 1 TABLESPOON POWDERED GRAPHITE WITH EACH HOPPER FILL OF SEED. SEED TREATMENT, FOREIGN MATERIAL, DIRT, OR SEED CHAFF MAY CAUSE GRADUAL REDUCTION OF SEED POPULATION. REFER TO MANUAL FOR MAINTENANCE AND CARE.

7100-153

26

USE **8 AMP** TIME DELAY FUSE ONLY

7100-155

27

# 2300

28

## MARKER SPEED CONTROL

RAISE SEE MANUAL FOR PROPER ADJUSTMENT LOWER

7100-166

29

## ⚠ WARNING ⚠

ALWAYS INSTALL HYDRAULIC CYLINDER LOCKOUT CHANNELS ON MARKER CYLINDERS BEFORE OPERATING THIS CROSS-FILL AUGER

7100-163

30

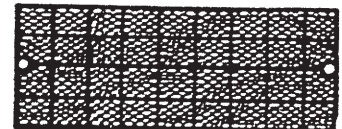

31

# SMV, DECALS, REFLECTORS AND TIE STRAPS



**IMPORTANT**  
SEED METER ALIGNMENT TO DRIVE CLUTCH IS CRITICAL  
REFER TO OPERATORS MANUAL FOR INSTRUCTIONS  
7100-182

35



36



ITEM	PART NO.	QTY.	DESCRIPTION
1.	G7100-02	3	Decal, Warning
2.	G7100-42	4	Decal, Warning
3.	G7100-46	1	Decal, Caution
4.	G7100-49	1	Decal, Left Side Transmission
5.	G7100-54	2	Decal, KINZE, 4 3/16" x 17 3/16"
	G7100-104	2	Decal, KINZE, 3" x 12" (Dry Fertilizer Quick Fill Attachment)
6.	G7100-56	1	Decal, Caution
7.	G7100-62	1	Decal, Right Side Transmission
8.	G7100-63	1	Decal, Caution
9.	G7100-64	1	Decal, Important
10.	G7100-68	2	Decal, Warning
11.	G7100-73	1	Decal, Transport To Planting
12.	G7100-74	1	Decal, Planting To Transport
13.	G7100-75	2	Decal, Caution
14.	G7100-83	2	Decal, Warning
15.	G7100-89	2	Decal, Danger
16.	G7100-90	1	Decal, Warning
17.	G7100-103	1	Decal, Danger (Dry Fertilizer Quick Fill Attachment)
18.	G7100-110	-	Decal, Grease Weekly
19.	G7100-111	-	Decal, Oil Daily
20.	G7100-115	-	Decal, Caution (1 Per Granular Chemical Hopper)
21.	G7100-116	-	Decal, Grease Daily
22.	G7100-117	1	Decal, Danger
23.	G7100-123	1	Decal, Attention (Wide Row Models Only)
24.	G7100-129	1	Decal, Danger
25.	G7100-195	-	Decal, Logo (2 Per Row Unit)
26.	G7100-153	-	Decal, Information (1 Per Brush-Type Seed Meter)
27.	G7100-155	1	Decal, Instruction
28.	G7100-159	2	Decal, 2300
29.	G7100-160	1	Decal, Information
30.	G7100-163	1	Decal, Warning (Dry Fertilizer Attachment)
31.	G7200-03	4	Reflector, Red
	G7200-04	2	Reflector, Amber
32.	GD2199	1	SMV Sign
33.	GD1512	-	Tie Strap, 7"
	GD2117	-	Tie Strap, 14 1/2"
	GD1162	-	Tie Strap, 28"
	GD2984	-	Tie Strap, 33"
34.	GD7638-01	1	LineLoc, Red
	GD7638-02	1	LineLoc, Blue
	GD7638-03	1	LineLoc, Green
35.	G7100-182	-	Decal, Meter Alignment (1 Per Row Unit)
36.	G7100-192	-	Decal, Point Row Clutch Rotation
37.	GR0146	-	Powdered Graphite, 1 Pound (Not Shown)
	GR1179	-	Talc Seed Lubricant, 2 Pounds (Not Shown)
38.	GR0155	-	Blue Paint, Aerosol (Not Shown)
	GR0439	-	Blue Paint, Quart (Not Shown)
	GR0440	-	Blue Paint, Gallon (Not Shown)



# NUMERICAL INDEX

Part No.	Page	Part No.	Page	Part No.	Page
G1K190	P33	G6502-06	P29, P31	G10015	P7
G1K212	P3	G6600-08	P58, P59	G10016	P27, P39, P44
G1K213	P15	G6600-10	P89	G10017	P18, P19, P25, P27
G306-08	P28	G6801-06-08	P36, P39, P56		P31, P40, P80, P85
G306-10	P28	G6801-08	P33, P51, P53	G10018	P5, P7, P77
G2100-03	P43, P93, P101	G7100-02	P107	G10019	P9, P35, P54, P75
G2403-10	P28	G7100-42	P107		P95, P97
G2404-10-08	P89	G7100-46	P107	G10020	P11, P49, P49
G2500-70	P100	G7100-49	P107	G10021	P11
G2500-71	P100	G7100-54	P107	G10022	P11, P15, P35
G2500-72	P100	G7100-56	P107	G10023	P15, P47, P87
G2500-73	P100	G7100-62	P107	G10026	P36, P41
G2500-74	P100	G7100-63	P107	G10031	P35
G2500-75	P100	G7100-64	P107	G10033	P21, P54, P87
G2500-76	P100	G7100-68	P107	G10036	P17, P23
G2500-77	P100	G7100-73	P107	G10037	P4, P25, P39, P42
G2500-78	P100	G7100-74	P107	G10037	P81, P85
G2501-10-08	P89	G7100-75	P107	G10038	P41, P44
G2603-08	P41	G7100-83	P107	G10039	P18, P19, P38, P51
G2700-08	P28	G7100-89	P107	G10039	P53, P79
G2700-10	P28	G7100-90	P107	G10040	P47
G3303-53	P69	G7100-103	P107	G10041	P47, P86
G3303-96	P25	G7100-104	P107	G10045	P21, P75
G3303-98	P9	G7100-110	P107	G10046	P75
G3303-114	P15	G7100-111	P107	G10047	P93
G3305-01	P16	G7100-115	P107	G10049	P15, P53, P71, P78
G3310-80	P43	G7100-116	P107	G10050	P27
G3310-85	P44	G7100-117	P107	G10054	P95
G3310-88	P85	G7100-123	P107	G10055	P23, P79
G3310-112	P41	G7100-129	P107	G10061	P56
G3310-118	P41, P85	G7100-153	P107	G10062	P29, P31
G3310-138	P70	G7100-155	P107	G10064	P8, P35, P41, P71, P87
G3310-152	P93	G7100-159	P107	G10068	P23, P53
G3310-176	P101	G7100-160	P107	G10069	P5
G3314-40	P15	G7100-163	P107	G10070	P36
G3400-01	P43, P93, P101	G7100-182	P107	G10077	P37
G4200-01	P91	G7100-192	P107	G10081	P37
G4200-05	P91	G7100-195	P107	G10087	P41
G4200-06	P91, P93	G7192X	P4	G10096	P91
G4300-05	P92, P103, P104	G7200-03	P107	G10097	P37
G4300-10	P92, P102	G7200-04	P107	G10098	P37
G4300-12	P92, P103	G10001	P2, P43, P71, P79	G10100	P79
G6400-06-08	P29, P31, P39	G10003	P3, P7, P8, P91	G10101	P2, P3, P4, P9, P10
	P56, P57	G10004	P4, P25, P28, P33		P13, P15, P25, P28
G6400-08	P29, P31, P41, P51		P44, P73, P86, P101		P29, P31, P33, P36
	P53, P56, P58, P59		P102, P103, P104		P43, P71, P73, P75
G6400-10	P57, P58, P59, P89	G10005	P26, P36, P39, P41		P78, P91, P93, P97
G6400-L-08	P58, P59		P77		P101, P102, P103, P104
G6400-L-10	P37	G10006	P7, P21	G10102	P4, P7, P21, P23, P25
G6408-08	P59	G10007	P79, P80		P27, P38, P39, P40
G6408-10	P58, P59	G10008	P23, P39, P53		P42, P44, P51, P53
G6408-H06-O	P56, P57, P58	G10009	P26, P27, P87		P54, P75, P80, P81
	P59	G10010	P5, P38, P77, P79		P85, P91
G6500-06	P56	G10012	P23	G10103	P8, P13, P35, P41
G6500-08	P58, P59	G10013	P8		P47, P49, P71, P87
G6501-10	P89	G10014	P3, P27, P28		

# NUMERICAL INDEX

Part No.	Page	Part No.	Page	Part No.	Page
G10104	P4, P23, P25, P26		P10, P15, P25, P28	G10310	P10, P13
	P27, P28, P35, P38		P56, P71, P75, P78	G10311	P15
	P39, P41, P43, P51		P91, P93, P101	G10312	P3, P9, P15
	P53, P77, P79, P80	G10213	P3, P75	G10318	P19, P51, P95
	P85, P87, P92, P93	G10216	P3, P18, P19, P21	G10322	P51, P53, P79
	P95, P101		P27, P28, P77, P79	G10323	P11
G10105	P27, P79, P80		P87	G10328	P3
G10106	P5, P7, P19, P23	G10217	P23, P27, P28, P87	G10330	P39
	P35, P43, P83, P93	G10219	P7, P18, P83, P83	G10335	P27
	P101		P102, P103, P104	G10339	P101
G10107	P7, P8, P17, P19, P23	G10220	P79	G10348	P21
	P41, P75, P87	G10226	P27, P28, P51, P53	G10350	P59
G10108	P3, P15, P25, P28	G10227	P13, P35, P41, P47	G10358	P99
	P29, P31, P33, P35		P49, P71, P87	G10374	P47
	P37, P41, P53, P78	G10228	P3, P4, P21, P23	G10401	P11
	P79, P95		P25, P27, P28, P38	G10403	P71, P79, P89
G10109	P5, P7, P8, P18, P21		P39, P40, P42, P44	G10409	P40, P42, P44, P93
	P47, P54, P75, P77		P51, P53, P54, P75		P101
	P86, P91		P77, P80, P81, P85	G10412	P4, P25
G10110	P10, P35, P47, P79		P91	G10427	P3, P7
	P89	G10229	P2, P3, P4, P7, P8, P9	G10430	P45
G10111	P7, P8, P17, P18, P19		P10, P13, P15, P25	G10435	P43, P71, P85, P93
	P21, P23, P25, P26		P28, P33, P43, P44		P101
	P75, P78, P79, P85		P47, P56, P71, P73	G10438	P77
	P87		P75, P78, P86, P91	G10445	P43, P71, P85, P93
G10117	P29		P93, P101		P101
G10118	P29, P31, P39	G10230	P4, P5, P25, P26, P27	G10448	P39
G10119	P29, P31		P28, P35, P38, P39	G10451	P3, P75, P81
G10120	P77, P100		P43, P51, P53, P77	G10452	P13
G10130	P102, P103, P104		P79, P80, P85, P87	G10455	P9
G10131	P47, P102, P103, P104		P92, P93, P101	G10456	P77
G10133	P8, P21, P75, P83	G10231	P27, P41, P80	G10457	P9, P29, P31, P36
G10139	P27, P33	G10232	P5, P7, P9, P33, P35	G10459	P79
G10144	P102, P103, P104		P43, P75, P83, P83	G10460	P27, P33, P33, P33
G10145	P71, P93, P101		P93, P101		P35, P36, P41, 51
G10152	P7	G10233	P41, P70, P83		P53, P71, P81, P83
G10155	P39	G10234	P33		P85, P87, P93
G10157	P26	G10235	P41	G10462	P26, P37, P43, P85
G10159	P51, P53	G10236	P31	G10463	P27
G10164	P28	G10237	P79	G10464	P45
G10168	P54	G10239	P31	G10467	P101
G10169	P26	G10253	P47	G10468	P29, P31
G10171	P7, P83	G10257	P47	G10470	P11, P27
G10172	P56, P57	G10266	P49	G10478	P40, P42, P44, P93
G10187	P47	G10269	P49		P101
G10197	P23	G10281	P33	G10479	P39
G10201	P3, P15, P25, P83	G10292	P92	G10480	P37
G10203	P47	G10303	P7, P18, P43, P83	G10482	P38
G10204	P3, P9, P75		P93, P101, P102	G10486	P33, P37
G10205	P41, P51, P53, P77		P103, P104	G10489	P36
	P79	G10304	P3	G10494	P31
G10206	P3, P17, P23, P40	G10305	P2, P9, P16, P75	G10496	P47
	P81, P85	G10306	P13	G10497	P47
G10208	P3	G10307	P3	G10498	P47
G10209	P10, P15, P35, P79	G10308	P16	G10499	P75
G10210	P2, P3, P4, P7, P8	G10309	P9	G10500	P11

# NUMERICAL INDEX

Part No.	Page	Part No.	Page	Part No.	Page
G10501	P40, P41	G10633	P91	GA0328	P75
G10503	P3, P18, P19, P75	G10637	P15	GA0378	P45
G10504	P3, P75	G10640	P5, P17, P23, P33	GA0705	P36
G10507	P79		P43, P71, P77, P81	GA0810	P75
G10515	P53		P85, P93, P102, P103	GA0811	P2
G10516	P53		P104	GA0860	P3
G10517	P53	G10641	P27, P28, P29, P31	GA0875	P75
G10518	P58, P59		P33, P37, P39, P51	GA0895	P41
G10520	P10		P53, P79, P83, P101	GA0898	P83
G10521	P15	G10655	P83	GA0899	P54
G10523	P13	G10660	P15	GA1003	P61
G10526	P3, P77	G10669	P3, P93	GA1012	P61
G10529	P16	G10670	P15, P43, P71, P83	GA1018	P62
G10531	P12, P49		P85, P93, P101	GA1029	P62
G10536	P18, P19	G10672	P83, P91	GA1033	P62
G10542	P75	G10673	P92, P102, P103, P104	GA1034	P62
G10544	P54	G10674	P91	GA1036	P62
G10545	P4, P25	G10675	P93	GA1057	P62, P62
G10546	P15	G10676	P83	GA1081	P61
G10551	P3	G10680	P13	GA1093	P62
G10552	P3	G10681	P75, P102, P103, P104	GA1102	P61
G10553	P9	G10686	P97	GA1105	P61
G10555	P3	G10687	P97	GA1109	P61
G10558	P101	G10688	P95	GA1110	P61
G10560	P77	G10689	P28	GA1116	P61
G10561	P81	G10690	P11	GA1121	P61
G10567	P15, P69	G10693	P95	GA1129	P61
G10572	P19, P23	G10695	P33	GA1132	P61
G10573	P23	G10719	P93	GA1134	P61
G10574	P17, P21, P23	G10722	P54	GA1139	P61
G10581	P23	G10724	P54	GA1150	P61
G10582	P23	G10725	P54	GA1168	P61
G10583	P33	G10728	P93	GA1170	P62
G10584	P12	G10732	P4, P25	GA1181	P61
G10585	P18, P19, P41	G10733	P93	GA1183	P61
G10587	P83	G10734	P93	GA1369	P75
G10588	P83	G10735	P93	GA1423	P61
G10592	P77, P79	G10739	P93	GA1424	P89
G10594	P78	G10743	P41	GA1425	P61
G10597	P18, P19	G10744	P57	GA1426	P89
G10599	P78	G10747	P7, P8	GA1450	P89
G10601	P3	G10751	P25	GA1458	P62
G10602	P9, P11, P12, P15	G10752	P4	GA1461	P62
	P41, P42, P71, P85	G10764	P5	GA1463	P62
G10603	P11, P12, P77	GA0167	P54	GA1464	P62
G10604	P11	GA0237	P79	GA1465	P61
G10605	P2	GA0243	P54	GA1467	P62
G10609	P15	GA0245	P54	GA1468	P89
G10610	P28, P29, P31, P41	GA0257	P54	GA1469	P62, P89
	P77	GA0308	P75	GA1470	P61
G10619	P91, P93	GA0312	P75	GA1471	P89
G10620	P3, P11, P15	GA0318	P75	GA1476	P61
G10621	P9, P10, P11, P15, P16	GA0320	P75	GA1477	P61
G10622	P16, P16	GA0321	P102	GA1478	P62
G10626	P91	GA0322	P103	GA1676	P54
G10629	P91	GA0323	P104	GA1677	P54

# NUMERICAL INDEX

Part No.	Page	Part No.	Page	Part No.	Page
GA1678	P54	GA3574	P27	GA4425	P44
GA1679	P54	GA3584	P49	GA4426	P44
GA1720	P4	GA3589	P49	GA4436	P36
GA2007	P9	GA3624	P80	GA4437	P49
GA2012L	P3	GA3627	P81	GA4439	P49
GA2012R	P3	GA3858	P27	GA4444	P15, P87
GA2013	P3	GA4005	P87	GA4484	P67
GA2014	P3, P7, P19, P21 P23, P75	GA4051	P49	GA4523	P71
GA2016	P9	GA4115	P63	GA4524	P71
GA2018	P11	GA4192	P63	GA4525	P71
GA2019	P11	GA4193	P63	GA4598	P28
GA2020	P11	GA4223	P73	GA4599	P28
GA2022	P77	GA4229	P73	GA4607	P28
GA2027	P10	GA4230	P73	GA4611	P51
GA2052	P37	GA4235	P43, P71, P85, P93 P101	GA4617	P101
GA2054	P7	GA4284	P66	GA4618	P101
GA2058	P10	GA4285	P67	GA4619	P93, P101
GA2068	P41	GA4286	P79	GA4620	P93, P101
GA2075	P13	GA4287	P79	GA4621	P91
GA2076	P15	GA4288	P36	GA4624	P85
GA2094	P16	GA4291	P39	GA4626	P85
GA2148	P41	GA4293	P55	GA4627	P39
GA2180	P43, P71	GA4293	P55	GA4628	P39
GA2327	P10	GA4309	P65	GA4630	P43
GA2354	P100	GA4310	P66	GA4637	P43, P71
GA2355	P100	GA4332	P68	GA4638	P43, P71
GA2484	P55	GA4347	P37	GA4639	P58, P59
GA2526	P49	GA4353	P51	GA4640	P87
GA2528	P49	GA4356	P37	GA4641	P87
GA2566	P33	GA4360	P37	GA4644	P87
GA2612	P49	GA4361	P37	GA4645	P87
GA2621	P33	GA4362	P36	GA4651	P87
GA2627	P28	GA4366	P39	GA4652	P87
GA2653	P27	GA4367	P38	GA4654	P87
GA2845	P33	GA4368	P39	GA4655	P87
GA2908	P41	GA4376	P41	GA4656	P87
GA3101	P62	GA4387	P41	GA4657	P87
GA3122	P62	GA4389	P41	GA4658	P87
GA3128	P61	GA4392	P56	GA4659	P86
GA3130	P61	GA4393	P43, P71	GA4663	P56
GA3134	P61	GA4394	P43, P71	GA4722	P39
GA3140	P61	GA4395	P40	GA4723	P39
GA3141	P62	GA4397	P27	GA4727	P39
GA3154	P62	GA4399	P28	GA4729	P39
GA3155	P61	GA4401	P28	GA4746	P36
GA3156	P61	GA4402	P27	GA4754	P66
GA3157	P61	GA4407	P29, P31	GA4768	P66
GA3158	P61	GA4411	P29, P31	GA4769	P66
GA3159	P61	GA4412	P28	GA4779	P67
GA3162	P61	GA4414	P28	GA4780	P67
GA3400	P33	GA4415	P28	GA4781	P68
GA3407	P55	GA4417	P28	GA4782	P68
GA3413	P55	GA4418	P28, P31	GA4791	P67
GA3429	P33	GA4420	P26	GA4792	P67
GA3553	P41	GA4421	P51, P53	GA4797	P64, P65
		GA4424	P43	GA4799	P39



# NUMERICAL INDEX

Part No.	Page	Part No.	Page	Part No.	Page
GA4800	P39	GA5408	P87	GA5698	P12
GA4801	P39	GA5409	P87	GA5699	P12
GA4802	P64	GA5410	P87	GA5715	P18, P19
GA4813	P49	GA5411	P87	GA5716	P39
GA4817	P47	GA5412	P87	GA5718	P19
GA4822	P9	GA5413	P87	GA5719	P18, P19
GA4827	P80	GA5414	P87	GA5727	P77, P79
GA4828	P80	GA5415	P87	GA5728	P77, P79
GA4839	P26	GA5416	P87	GA5786	P25
GA4841	P29, P31	GA5417	P87	GA5787	P25
GA4842	P28	GA5420	P86	GA5788	P25
GA4845	P27	GA5421	P86	GA5794	P12
GA4853	P53	GA5422	P86	GA5795	P12
GA4854	P47	GA5423	P86	GA5796	P12
GA4855	P47	GA5424	P87	GA5798	P23
GA4869	P39	GA5425	P87	GA5809	P64
GA4875	P36	GA5426	P87	GA5834	P12
GA4877	P53	GA5427	P87	GA5841	P28
GA4878	P53	GA5440	P87	GA5842	P27
GA4882	P27	GA5441	P87	GA5845	P49
GA4976	P91	GA5442	P87	GA5846	P25
GA4978	P53	GA5459	P63	GA5853	P54
GA4979	P53	GA5460	P63	GA5873	P73
GA4983	P53	GA5498	P28	GA5874	P73
GA4991	P53	GA5526	P51	GA5877	P73
GA4994	P26	GA5527	P53	GA5878	P73
GA4995	P26	GA5533	P15	GA5879	P73
GA4996	P47	GA5548	P43	GA5880	P3, P73
GA5097	P63	GA5557	P47	GA5881	P73
GA5103	P40, P44	GA5564	P25	GA5882	P73
GA5105	P41, P85	GA5584	P68	GA5884	P73
GA5106	P42	GA5586	P28	GA5885	P73
GA5107	P42, P44, P70, P85	GA5587	P28	GA5886	P73
GA5108	P42	GA5600	P73	GA5887	P79
GA5109	P40, P41, P42, P85	GA5617	P65	GA5892	P18
GA5110	P42	GA5619	P68	GA5917	P91
GA5111	P42	GA5620	P68	GA5954	P63
GA5112	P42	GA5622	P17, P23	GA5982	P12
GA5113	P42	GA5624	P85	GA6020	P65
GA5114	P40, P41, P85	GA5625	P17	GA6027	P12
GA5115	P44, P85	GA5630	P23	GA6038	P12
GA5116	P41, P85	GA5631	P23	GA6108	P49
GA5121	P40	GA5635	P23	GA6109	P49
GA5130	P51	GA5636	P23	GA6111	P49
GA5136	P85, P93, P101	GA5637	P23	GA6112	P49
GA5163	P89	GA5639	P69	GA6113	P49
GA5164	P45	GA5640	P17, P23	GA6118	P64
GA5165	P45	GA5643	P23	GA6122	P65
GA5192	P51	GA5647	P43	GA6123	P64
GA5194	P93	GA5651	P4	GA6124	P49
GA5229	P85	GA5652	P83	GA6133	P64
GA5251	P101	GA5671	P85	GA6136	P65
GA5258	P91	GA5672	P85	GA6139	P64
GA5264	P91	GA5673	P81	GA6147	P73
GA5373	P87	GA5674	P81	GA6154	P95
GA5374	P89	GA5675	P81	GA6158	P99

# NUMERICAL INDEX

Part No.	Page	Part No.	Page	Part No.	Page
GA6168	P12	GB0118	P77	GD1042	P11
GA6171	P5, P7, P8, P77	GB0120	P11	GD1044	P11
GA6182	P12	GB0121	P15	GD1045	P11
GA6184	P12	GB0134	P75	GD1046	P11
GA6187	P12	GB0156	P26	GD1048	P5, P77
GA6319	P49	GB0174	P86	GD1051L	P10
GA6320	P49	GB0183	P15	GD1051R	P10
GA6337	P85	GB0184	P15	GD1053	P10
GA6344	P77	GB0186	P4, P25	GD1054	P10
GA6345	P77	GB0195	P19, P21, P23	GD1055	P10
GA6348	P49	GB0196	P23	GD1056	P15
GA6408	P79	GB0198	P83	GD1058	P15
GA6434	P8	GB0199	P83	GD1059L	P15
GA6476	P13	GB0200	P83	GD1059R	P15
GA6478	P12	GB0205	P78	GD1060	P15, P87
GA6509	P93	GB0206	P79	GD1061	P15
GA6527	P93	GB0209	P78	GD1063	P15
GA6530	P93	GB0210	P78	GD1065	P3
GA6531	P93	GB0212	P77	GD1066	P3
GA6534	P40	GB0213	P79	GD1072	P15
GA6597	P8	GB0215	P8	GD1081	P13
GA6613	P8	GB0218	P4, P8, P23, P25, P28	GD1082	P13
GA6614	P5		P41, P79	GD1083	P11
GA6615	P5	GB0219	P8	GD1085	P8
GA6618	P7	GB0227	P17, P23	GD1086	P5
GA6619	P7	GB0233	P7, P8	GD1089	P15
GA6620	P7	GB0237	P26	GD1090	P13
GA6621	P57	GB0239	P7	GD1104	P79
GA6633	P12	GB0241	P3	GD1109	P4, P7, P8, P25
GA6699	P35	GB0243	P9	GD1110	P3
GA6700	P35	GD0453-03	P53	GD1113	P4, P25, P35, P43
GA6733	P7	GD0453-04	P53		P79, P87, P92, P101
GA6741	P13	GD0453-07	P51	GD1115L	P13
GA6785	P47	GD0453-08	P51	GD1115R	P13
GA6786	P47	GD0487	P75	GD1116	P13
GA6787	P47	GD0652	P51, P53	GD1118	P13
GA6792	P35	GD0737	P53	GD1120	P3
GA6794	P49	GD0740	P29	GD1121	P10
GA6795	P49	GD0746	P54	GD1130	P3
GA6796	P49	GD0752-15	P28	GD1132	P19, P21, P23, P75
GA6797	P49	GD0840	P54	GD1134	P85, P93, P101
GA6801	P7	GD0917	P71, P93, P101	GD1143	P16
GA6822	P4	GD0962	P75	GD1144	P16
GA6832	P21	GD0973	P5	GD1145	P16
GA6833	P21	GD1022L	P43	GD1162	P107
GA6834	P21	GD1026	P3, P15, P25, P71	GD1166	P41
GA6838	P21	GD1027	P2	GD1199-03	P41, P43, P71, P85
GB0102	P2	GD1030	P3, P75	GD1199-04	P43, P71
GB0104	P3	GD1031	P3, P7	GD1200	P83
GB0105	P3	GD1033	P3	GD1207	P83
GB0107	P9	GD1035	P9	GD1209	P83
GB0108	P9	GD1036	P9	GD1210	P83
GB0110	P11	GD1037	P9	GD1213	P83
GB0111	P11	GD1039	P11	GD1255	P45
GB0115	P15	GD1040	P11	GD1256	P45
GB0116	P15	GD1041	P11	GD1337	P91

# NUMERICAL INDEX

Part No.	Page	Part No.	Page	Part No.	Page
GD1339	P75	GD3607-08	P39	GD6501	P11
GD1353	P5	GD3790	P83	GD6533	P3, P7
GD1379	P83	GD3805	P49	GD6553	P79
GD1380	P83	GD3860	P49	GD6554	P36
GD1512	P107	GD4086	P61	GD6556	P28, P29, P31
GD1514	P91	GD4108	P33	GD6571	P66
GD1515	P91	GD4171	P33, P36	GD6657	P37
GD1516	P91	GD4512	P51, P53	GD6659	P33
GD1517	P91	GD4525	P63	GD6660	P36
GD1520	P91	GD4527	P67, P67, P68	GD6683	P33
GD1657	P75	GD4632	P63	GD6700	P37
GD1673	P75	GD4700	P41	GD6701	P37
GD1701	P33, P35, P53	GD4701	P41	GD6712	P41
GD1747	P80	GD4721	P27	GD6713	P57
GD1755	P12	GD4732	P27	GD6730	P28
GD1797	P75	GD4743	P51, P53	GD6731	P33
GD1812	P91	GD4781	P80	GD6772	P51, P53
GD1862	P91	GD4782	P80	GD6775	P41
GD2115	P79	GD4850	P77	GD6780	P42
GD2117	P73, P107	GD4860	P71	GD6783	P35
GD2128	P9, P25	GD4887-01	P44	GD6807	P29, P31
GD2134	P25	GD4888	P77	GD6819	P71, P85, P93, P101
GD2161	P51	GD4927	P36	GD6825-06	P81
GD2168	P27	GD5039	P56	GD6825-11.25	P71
GD2169	P37, P39	GD5153	P27, P29, P31	GD6825-71.25	P71
GD2199	P107	GD5154	P27, P29, P31	GD6825-83.25	P71
GD2298	P43	GD5173	P26	GD6825-87.25	P71
GD2412	P83	GD5212	P43	GD6825-131.25	P71
GD2423	P13	GD5756	P44	GD6828	P71
GD2460	P16	GD5789	P41	GD6895	P41
GD2548-15.5	P81	GD5790	P41	GD6897	P44
GD2548-27.5	P81	GD5804	P28, P29, P31	GD6902	P85
GD2548-48	P101	GD5827	P44	GD6924	P101
GD2548-70	P101	GD5841	P41	GD6955	P38
GD2548-72	P101	GD5857	P21, P40, P42, P44 P71, P85, P93, P101	GD6956	P38
GD2557	P27	GD5875	P29, P35	GD6957	P38
GD2558	P27, P36, P42, P85 P101	GD5886	P43, P71, P81	GD6958	P38
GD2589	P75	GD5887-36	P43	GD6959	P41, P64, P65
GD2597	P54	GD5887-39	P71	GD7079	P39
GD2721	P51, P53	GD5887-44	P43	GD7089	P39
GD2829	P49	GD5887-48	P71	GD7120	P65, P66
GD2947	P13	GD5887-54.25	P43	GD7122	P65, P66
GD2971-03	P15	GD5887-58.5	P71	GD7123	P66
GD2971-09	P29, P31	GD5887-74	P71	GD7124	P65
GD2984	P107	GD5887-101	P43	GD7127	P43, P85
GD3180-03	P29, P31	GD5887-121.75	P43	GD7132	P64
GD3181-12	P7	GD5887-128.75	P43	GD7136	P66
GD3214	P51	GD5887-161	P43	GD7137	P29, P31, P36
GD3389	P39	GD5892	P29, P31, P36	GD7146	P67, P68
GD3398	P39	GD5949	P63	GD7147	P67, P68
GD3478	P27	GD6027	P31	GD7148	P15
GD3488	P28	GD6115	P87	GD7157	P47
GD3501	P27	GD6161	P25	GD7163	P39
GD3537-07	P29, P31	GD6244	P89	GD7164	P64
GD3537-08	P29, P31	GD6291	P49, P73	GD7167	P39
				GD7171	P41

# NUMERICAL INDEX

Part No.	Page	Part No.	Page	Part No.	Page
GD7209	P53	GD7900	P78	GD9222	P47
GD7210	P36	GD7904-02	P79	GD9240	P3, P15, P25
GD7247	P31	GD7905	P71	GD9242	P93
GD7251	P28	GD7906	P58	GD9254	P17, P23
GD7256	P39, P39	GD7907	P79	GD9277	P93
GD7257	P39	GD7908	P79	GD9290	P7
GD7258	P15	GD7911	P77	GD9305	P7
GD7262	P39	GD7912	P78	GD9306	P15
GD7263	P39	GD7962	P79	GD9562	P7
GD7318	P3, P25	GD8023	P80	GD9628	P77
GD7426	P43, P71, P85, P93	GD8030	P77	GD9629	P77
	P101	GD8031	P77	GD9645	P41
GD7505	P25	GD8188	P26, P31	GD9664	P47
GD7518	P28	GD8189	P27	GD9665	P47
GD7519	P28	GD8214	P77	GD9668	P47
GD7587	P15	GD8218	P77	GD9670	P47
GD7588	P15	GD8224	P79	GD9671	P47
GD7589	P15	GD8237	P12	GD9674	P47
GD7591	P15	GD8238	P79	GD9679	P47
GD7592	P15	GD8239	P79	GD9681	P35
GD7612	P43	GD8249	P4, P25	GD9689	P47
GD7618	P9	GD8253	P49	GD9705	P77
GD7619	P4	GD8260	P27	GD9709	P77
GD7626	P25	GD8266	P18	GD9715	P21
GD7627	P25	GD8276	P79	GD9720	P21
GD7638-01	P107	GD8306	P91	GD9723	P21
GD7638-02	P107	GD8307	P19, P23	GD9724	P21
GD7638-03	P107	GD8308	P77	GD9781	P47
GD7654	P58, P59	GD8314	P80	GR0146	P107
GD7655	P59	GD8364	P39	GR0150	P54
GD7762	P47	GD8365	P39	GR0151	P54
GD7763	P41	GD8458	P9, P15, P47	GR0155	P107
GD7800	P65	GD8460	P8	GR0188	P79
GD7803	P17, P23	GD8640	P42	GR0196	P9, P15, P25, P69
GD7804	P17, P23	GD8667	P47	GR0201	P69
GD7805	P4, P19, P23, P25	GD8722	P80	GR0207	P102, P103, P104
GD7811	P23	GD8733	P69	GR0208	P102, P103
GD7815	P23	GD8739	P49	GR0209	P102
GD7816	P23	GD8740	P49	GR0210	P102, P103
GD7817-01	P19, P23	GD8741	P49	GR0211	P102, P103, P104
GD7817-04	P19, P23	GD8750	P15	GR0212	P102, P103, P104
GD7817-09	P23	GD8751	P73	GR0213	P102, P103
GD7818	P23	GD8757	P64	GR0214	P102, P103, P104
GD7823	P19, P23	GD8758	P65	GR0215	P102, P103, P104
GD7831	P23	GD8770	P73	GR0216	P102, P103
GD7848	P83	GD8771	P73	GR0217	P102, P103, P104
GD7864	P39	GD8778	P12	GR0220	P104
GD7866	P85	GD8811	P5	GR0221	P104
GD7867	P81, P85	GD8815	P79	GR0222	P104
GD7868	P81, P85	GD8816	P92	GR0223	P102
GD7869	P81	GD8843	P17, P23	GR0224	P102, P103
GD7878	P12	GD8844	P17, P23	GR0225	P102, P103, P104
GD7883	P29, P31	GD9048	P93	GR0226	P102, P103, P104
GD7888	P39	GD9060	P47	GR0227	P102
GD7889	P18, P19	GD9120	P8	GR0228	P102, P103
GD7890	P18, P19	GD9216	P47	GR0229	P103, P104

# NUMERICAL INDEX

Part No.	Page	Part No.	Page	Part No.	Page
GR0230	P103, P104	GR1005	P91	GR1145	P97
GR0231	P103, P104	GR1006	P91	GR1147	P95
GR0232	P102, P103, P104	GR1007	P64	GR1148	P95
GR0233	P103	GR1015	P91	GR1150	P99
GR0236	P104	GR1016	P91	GR1151	P99
GR0270	P41	GR1017	P91	GR1152	P99
GR0279	P104	GR1018	P91	GR1153	P99
GR0280	P104	GR1019	P91	GR1154	P99
GR0281	P104	GR1049	P65	GR1155	P99
GR0282	P104	GR1050	P65	GR1157	P99
GR0283	P104	GR1062	P3, P73	GR1158	P99
GR0284	P104	GR1066	P9	GR1162	P99
GR0322	P36	GR1067	P73	GR1165	P95
GR0434	P41	GR1069	P73	GR1166	P95
GR0439	P107	GR1077	P73	GR1167	P95
GR0440	P107	GR1078	P73	GR1168	P95
GR0508	P91	GR1079	P73	GR1169	P64, P65
GR0509	P91	GR1080	P73	GR1171	P73
GR0510	P91	GR1082	P73	GR1173	P95, P97
GR0513	P91	GR1083	P73	GR1179	P107
GR0515	P26	GR1084	P73	GR1203	P35
GR0516	P26	GR1085	P73	GR1204	P35
GR0517	P26	GR1087	P3, P73	GR1205	P35
GR0528	P39	GR1100	P95	GR1206	P35
GR0531	P39	GR1102	P95	GR1207	P35
GR0582	P73	GR1104	P95	GR1208	P35
GR0583	P73	GR1105	P95		
GR0594	P73	GR1106	P95		
GR0595	P73	GR1107	P95		
GR0646	P47	GR1108	P95		
GR0664	P11	GR1109	P95		
GR0676	P73	GR1110	P95		
GR0760	P55	GR1111	P95		
GR0761	P55	GR1112	P95		
GR0762	P55	GR1114	P95		
GR0763	P55	GR1116	P95		
GR0764	P55	GR1118	P95		
GR0866	P73	GR1119	P95		
GR0911	P44	GR1120	P95		
GR0912	P41, P43, P44, P70 P85, P93, P101	GR1122	P93		
GR0927	P63	GR1123	P95		
GR0933	P11	GR1124	P97		
GR0959	P63	GR1125	P97		
GR0963	P63	GR1127	P97		
GR0964	P63	GR1129	P97		
GR0979	P89	GR1130	P97		
GR0980	P89	GR1132	P97		
GR0981	P89	GR1133	P97		
GR0987	P66, P67, P68	GR1134	P97		
GR0992	P64	GR1135	P97		
GR0993	P64	GR1136	P97		
GR0999	P65, P66	GR1137	P97		
GR1001	P65, P66	GR1140	P97		
GR1003	P66	GR1142	P97		
GR1004	P67, P68	GR1143	P97		
		GR1144	P97		