

MODEL 2400 TWIN-LINE® PLANTER OPERATOR & PARTS MANUAL

M0163

1/99

This manual is applicable to: Model: 2400 Twin-Line® Planters
Serial Number: 625000 and on

Record the model number and serial number of your planter with date purchased:

Model Number _____ 2400 _____

Serial Number _____

Date Purchased _____

SERIAL NUMBER

The serial number plate is located on the planter frame to be readily available. It is suggested that the serial number and purchase date also be recorded above.

The serial number provides important information about your planter and may be required to obtain the correct replacement part. Always provide the serial number and model number to your KINZE® Dealer when ordering parts or anytime correspondence is made with KINZE Manufacturing, Inc.

01209909a

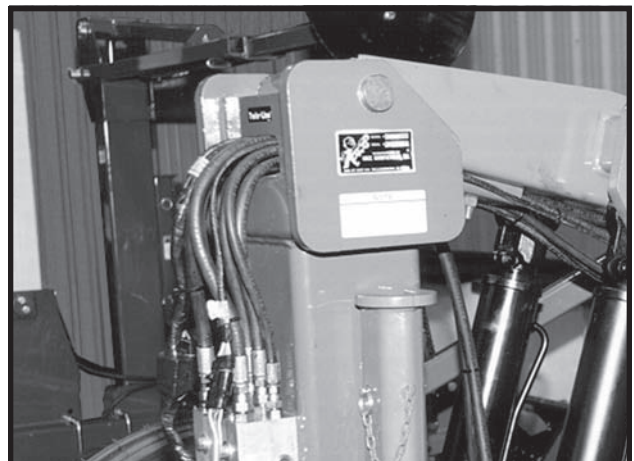

*KINZE®, Interplant® and Twin-Line® are registered trademarks of KINZE Manufacturing, Inc.
The following marks are owned by their respective companies: John Blue®/John Blue Company and CDS®/CDS Ag Industries, Inc.*

PREDELIVERY/DELIVERY CHECK LIST

TO THE DEALER

Preelivery service includes assembly, lubrication, adjustment and test. This service helps to ensure that the planter will be delivered to the customer ready for field use.

PREDELIVERY CHECK LIST

After the planter has been completely assembled, use the following check list and inspect the planter. Check off each item as it is found satisfactory or after proper adjustment is made.

- Recheck to be sure row units and optional attachments are properly spaced and assembled.
- Be sure all grease fittings are in place and lubricated.
- Check planter and make sure all working parts are moving freely, bolts are tight and cotter pins are spread.
- Check all drive chains for proper tension and alignment.
- Check for oil leaks and proper hydraulic operation.
- Check to be sure hydraulic hoses are routed correctly to prevent damage to hoses.
- Inflate tires to specified PSI air pressure. Tighten wheel bolts to specified torque.
- Check to be sure all safety decals are correctly located and legible. Replace if damaged.
- Check to be sure the red reflectors and amber reflectors are correctly located and visible when the planter is in transport position.
- Check to be sure SMV sign is in place.
- Check to be sure safety/warning lights are installed correctly and working properly.
- Paint all parts scratched in shipment or assembly.
- Be sure all safety lockups are on the planter and correctly located.
- Check electrical wiring connections and operation.

This planter has been thoroughly checked and to the best of my knowledge is ready for delivery to the customer.

(Signature Of Set-Up Person/Dealer Name/Date)

OWNER REGISTER

Name _____

Date Sold _____

Street Address _____

Model _____

City, State/Province & ZIP _____

Serial Number _____

Dealer Name _____

Dealer Number _____

DELIVERY CHECK LIST

At the time the planter is delivered, the following check list is a reminder of very important information which should be conveyed to the customer. Check off each item as it is fully explained to the customer.

- Advise the customer that the life expectancy of this or any other machine is dependent on regular lubrication as directed in the Operator & Parts Manual.
- Tell the customer about all applicable safety precautions.
- Along with the customer, check to be sure the red reflectors, amber reflectors and SMV sign are clearly visible with the planter in transport position and attached to the tractor. Check to be sure safety/warning lights are in working condition. Tell the customer to check federal, state/provincial and local regulations before towing or transporting on a road or highway.
- Give the Operator & Parts Manual to the customer and explain all operating adjustments.
- Read warranty to customer.
- Complete Warranty And Delivery Report Form.

To the best of my knowledge this machine has been delivered ready for field use and customer has been fully informed as to proper care and operation.

(Signature Of Delivery Person/Dealer Name/Date)

AFTER DELIVERY CHECK LIST

The following is a list of items we suggest to check during the first season of use of the equipment.

- Check with the customer as to the performance of the planter.
- Review with the customer the importance of proper maintenance and adherence with all safety precautions.
- Check for parts that may need to be adjusted or replaced.
- Check to be sure all safety decals, SMV sign and reflectors are correctly located and legible. Replace if damaged or missing.
- Check to be sure safety/warning lights are working properly.

(Signature Of Follow-Up Person/Dealer Name/Date)

**RETURN THIS COMPLETED FORM TO KINZE® IMMEDIATELY, along with Warranty And Delivery Report.
Retain photocopy of this form at dealership for After Delivery Check.**

Tear Along Perforation

TABLE OF CONTENTS

TO THE OWNER	1-1
WARRANTY	1-2
INTRODUCTION	2-1
SPECIFICATIONS	3-1
SAFETY PRECAUTIONS	4-1
SAFETY WARNING SIGNS	5-1
MACHINE OPERATION	
Checking Granular Chemical Application Rate	6-46
Checking Seed Population	6-45
Contact Drive Wheel Spring Adjustment	6-2
Double Disc Fertilizer Opener	6-42
Electronic Seed Monitor System	
KPM I Monitor	6-12
KPM II Monitor	6-18
Field Operation	6-8
Field Test	6-40
Field To Transport Sequence	6-8
General Planting Rate Information	6-47
Half Rate (2 To 1) Drive	6-4
Hydraulic/Electric Operation	6-5
Initial Preparation Of The Planter	6-1
Interplant® Clutch Sprocket	6-41
Leveling The Planter	6-2
Liquid Fertilizer Attachment	6-44
Manual Safety Lockup	6-39
Marker Adjustment	6-11
Marker Operation	6-10
Marker Safety Lockup	6-40
Marker Speed Adjustment	6-11
Metric Conversion Table	6-41
Notched Single Disc Fertilizer Opener	6-43
Notched Single Disc Fertilizer Opener Mounted Residue Wheel	6-43
Planting And Application Rate Charts	6-48
Planting Speed	6-40
Shear Protection	6-4
Standard Rate Drive	6-4
Tire Pressure	6-3
Tractor Preparation And Hookup	6-1
Tractor Requirements	6-1
Transmission Adjustment	6-3
Transport Latch Locking Pin	6-39
Transport To Field Sequence	6-6
Transporting The Planter	6-40
ROW UNIT OPERATION	
Brush-Type Seed Meter	7-4
Coulter Mounted Residue Wheels	7-13
Covering Discs/Single Press Wheel Adjustment	7-2
Disc Furrowers (For Use With Frame Mounted Coulter)	7-11
Finger Pickup Seed Meter	7-3
Frame Mounted Coulter	7-9
Granular Chemical Banding Options	7-16
Granular Chemical Hopper	7-15
Granular Chemical Restrictor Plate	7-15
Planting Depth	7-1
Push Row Unit Lockups	7-16
Quick Adjustable Down Force Springs	7-8

TABLE OF CONTENTS

ROW UNIT OPERATION (Continued)	
Row Unit Chain Routing	7-7
Row Unit Mounted Disc Furrower	7-11
Row Unit Mounted No Till Coulter	7-13
Row Unit Mounted Residue Wheel	7-12
Seed Firming Wheel	7-14
Seed Hopper	7-5
Seed Meter Drive Adjustment	7-6
Seed Meter Drive Release	7-6
Spring Tooth Incorporator	7-14
“V” Closing Wheel Adjustment (Rubber And Cast Iron)	7-1
LUBRICATION	
Bushings	8-3
Drive Chains	8-1
Grease Fittings	8-5
Liquid Fertilizer Piston Pump	8-4
Lubrication Symbols	8-1
Sealed Bearings	8-1
Wheel Bearings	8-4
MAINTENANCE	
15" Seed Opener Disc/Bearing Assembly	9-8
Brush-Type Seed Meter Maintenance	9-5
Brush-Type Seed Meter Troubleshooting	9-7
Chain Tension Adjustment	9-1
Check Valve	9-11
Closing Wheel Troubleshooting	9-7
Electrical Control Console Schematic	9-18
Electrical Wiring Diagram For Light Package	9-17
Electrical Wiring Harness Schematic (On Tractor)	9-19
Electrical Wiring Harness Schematic (On Planter)	9-20
Finger Pickup Seed Meter Cleaning	9-3
Finger Pickup Seed Meter Inspection/Adjustment	9-2
Finger Pickup Seed Meter Troubleshooting	9-4
Flow Control Valve Inspection	9-11
Gauge Wheel Adjustment	9-8
Hydraulic System Schematic	9-22
KPM I/KPM II Electronic Seed Monitor Troubleshooting	9-10
Lift Circuit Troubleshooting	9-12
Marker Bearing Lubrication Or Replacement	9-14
Marker Circuit Troubleshooting	9-13
Mounting Bolts And Hardware	9-1
Piston Pump Storage	9-16
Piston Pump Troubleshooting	9-16
Preparation For Storage	9-17
Push Pad Replacement/Adjustment	9-15
Rotation Cylinder Circuit Troubleshooting	9-12
Row Unit Mounted No Till Coulter	9-9
Seed Tube Guard/Inner Scraper	9-9
Solenoid Valve Inspection	9-11
Solenoid Valve Troubleshooting	9-11
Torque Values Chart	9-1
Transport Latch Post Wear Pad Replacement/Adjustment	9-15
Transport Wheel Bearing Replacement	9-14
PARTS LIST INDEX	P1
PARTS SECTION NUMERICAL INDEX	a

TO THE OWNER

KINZE Manufacturing, Inc. would like to thank you for your patronage. We appreciate your confidence in KINZE® farm machinery. Your KINZE® planter has been carefully designed and sturdily built to provide dependable operation in return for your investment.

This manual has been prepared to aid you in the operation and maintenance of the planter. It should be considered a permanent part of the machine and remain with the machine when you sell it.

It is the responsibility of the user to read and understand the Operator & Parts Manual in regards to safety, operation, lubrication and maintenance before operation of this equipment. It is the user's responsibility to inspect and service the machine routinely as directed in the Operator & Parts Manual. We have attempted to cover all areas of safety, operation, lubrication and maintenance; however, there may be times when special care must be taken to fit your conditions.

Throughout this manual the symbol  and the words **NOTE**, **CAUTION**, **WARNING** and **DANGER** are used to call your attention to important safety information. The definition of each of these terms used follows:

NOTE: Indicates a special point of information.

CAUTION: Indicates that a failure to observe can cause damage to the machine or equipment.



WARNING: Indicates that a failure to observe can cause damage to the machine or equipment and/or personal injury.



DANGER: Indicates that a failure to observe can cause most serious damage to the machine or equipment and/or most serious personal injury.



WARNING: Some photos in this manual may show safety covers, shields or lockups removed for visual clarity. **NEVER OPERATE** the machine without all safety covers, shields and lockups in place.

NOTE: Some photos in this manual may have been taken of prototype machines. Production machines may vary in appearance.

NOTE: Some photos and illustrations in this manual show optional attachments installed. Contact your KINZE® Dealer for purchase of optional attachments.

WARRANTY

The KINZE® Limited Warranty for your new machine is stated on the back of the retail purchaser's copy of the Warranty And Delivery Report form.

Warranty, within the warranty period, is provided as part of KINZE's support program for registered KINZE® products which have been operated and maintained as described in this manual. Evidence of equipment abuse or modification beyond original factory specifications will void the warranty. Normal maintenance, service and repair is not covered by KINZE® warranty.

To register your KINZE® product for warranty, a Warranty And Delivery Report form must be completed by the KINZE® Dealer and signed by the retail purchaser, with copies to the Dealer, to the retail purchaser and to KINZE Manufacturing, Inc. Registration must be completed and sent to KINZE Manufacturing, Inc. within 30 days of delivery of the KINZE® product to the retail purchaser. KINZE Manufacturing, Inc. reserves the right to refuse warranty on serial numbered products which have not been properly registered.

Additional copies of the Limited Warranty can be obtained through your KINZE® Dealer.

If service or replacement of failed parts which are covered by the Limited Warranty are required, it is the user's responsibility to deliver the machine along with the retail purchaser's copy of the Warranty And Delivery Report to the KINZE® Dealer for service. KINZE® warranty does not include cost of travel time, mileage, hauling or labor. Any prior arrangement made between the Dealer and the retail purchaser in which the Dealer agrees to absorb all or part of this expense should be considered a courtesy to the retail purchaser.

KINZE® warranty does not include cost of travel time, mileage, hauling or labor.

INTRODUCTION

The Model 2400 Twin-Line[®] Planter is available in various configurations and row spacings. Optional Interplant[®] row spacings are obtainable with the addition of push type row units.

The Model 2400 Twin-Line[®] Planter permits installation of liquid fertilizer application equipment and various row unit attachments.

GENERAL INFORMATION

The information used in this manual was current at the time of printing. However, due to KINZE's continual attempt to improve its product, production changes may cause your machine to appear slightly different in detail. KINZE Manufacturing, Inc. reserves the right to change specifications or design without notice and without incurring obligation to install the same on machines previously manufactured.

Right hand and left hand as used throughout this manual is determined by facing in the direction the machine will travel when in use unless otherwise stated.

01209903a

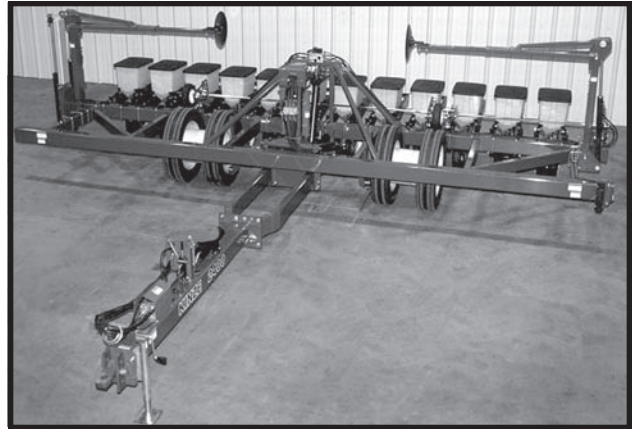

Shown With Planter In Operating Position

02019905b



**Shown With Planter In Transport Position
(Interplant[®] Package Installed)**

INTRODUCTION

SPECIFICATIONS

TYPE - Pull Type - Rigid Frame - Hydraulically rotates endwise to transport

PLANTING UNIT TYPES - Push and Pull Row Units

ROW SPACING - Pull	Interplant® Push
12 Row 20" Rows	11 - 10" Rows
12 Row 22" Rows	11 - 11" Rows

DRIVE SYSTEM - Spring-loaded contact drive system
- Two 4.10" x 6" contact drive tires
- No. 40 roller chain and spring-loaded idlers
- 7/8" hex drill and drive shafts and end mounted seed transmission

TRANSPORT TIRES - Four 255 - 70R x 22.5" radial load range H tubeless rib implement tires with custom center groove

TYPE LIFT - One master cylinder - Two slave cylinders with counter balance valves

MARKERS - Independently controlled - Two-fold low profile

MACHINE OPTIONS

- Finger Pickup Or Brush-Type Seed Meters
- Electronic Seed Monitors - KPM I or KPM II with magnetic distance sensor or radar distance sensor
- Interplant® Options
- Liquid Fertilizer Options
- Half Rate (2 To 1) Drive Reduction Package

ROW UNIT OPTIONS/ATTACHMENTS

- Finger Pickup Or Brush-Type Seed Meters
- Closing Wheels - Rubber "V", Cast Iron "V" Or Covering Discs/Single Press Wheel (Pull Units Only)
- Granular Chemical Application
- Spring Tooth Incorporator
- Gauge Wheel Covers
- Row Unit Mounted No Till Coulter
- Row Unit Mounted Disc Furrowers
- Row Unit Mounted Residue Wheel
- Coulter Mounted Residue Wheels
- Frame Mounted No Till Coulter
- Disc Furrowers For Frame Mounted Coulter
- Seed Firming Wheel

SPECIFICATIONS

Dimensions/Operating

PLANTER SIZE	12 Row 20"	12 Row 22"
WIDTH	22' 6"	22' 6"
LENGTH	22' 7"	22' 7"

Dimensions/Transport

PLANTER SIZE	12 Row 20"	12 Row 22"
WIDTH Base Machine	11' 3"	11' 7"
WIDTH Push unit with no till coulters	12' 9"	12' 9"
LENGTH	26' 0"	26' 0"
HEIGHT	10' 6"	10' 6"

Weight

PLANTER SIZE	12 Row 20"	12 Row 22"
*Base Machine Weight	8086 lbs.	8086 lbs.

* Base Machine weights include planter frame, row markers, drive components, tires and wheels, hydraulic cylinders and KINZE® pull row units (closing wheel arms less closing wheels).

SAFETY PRECAUTIONS

Safe and careful operation of the tractor and planter at all times will contribute significantly to the prevention of accidents.

Since a large portion of farm accidents occur as a result of fatigue or carelessness, safety practices should be of utmost concern. Read and understand the instructions provided in this manual and on the warning signs. Review these instructions frequently! Listed below are other safety suggestions that should become common practice.

 **Never allow the planter to be operated by anyone who is unfamiliar with the operation of all functions of the unit. All operators should read and thoroughly understand the instructions given in this manual prior to moving the unit.**

 **Never permit any persons other than the operator to ride on the tractor.**

 **Never ride on the planter or allow others to do so.**

 **Always make sure there are no persons near the planter when marker assemblies are in operation or when rotating the planter.**

 **Always keep hands, feet and clothing away from moving parts. Do not wear loose-fitting clothing which may catch in moving parts.**

 **Always wear protective clothing, substantial shoes and suitable hearing and eye sight protectors applicable for the situation.**

 **Do not allow anyone to stand between the tongue or hitch and the towing vehicle when backing up to the planter.**

 **Use a tractor equipped with a roll-over-protective-system and fasten your seat belt prior to starting the engine.**

 **Be aware of bystanders, particularly children! Always look around to make sure it is safe to start the engine of the towing vehicle or move the planter. This is particularly important with higher noise levels and quiet cabs, as you may not hear people shouting.**

 **Install safety lockup brackets on markers prior to transporting the planter or working around the unit.**

02019903a

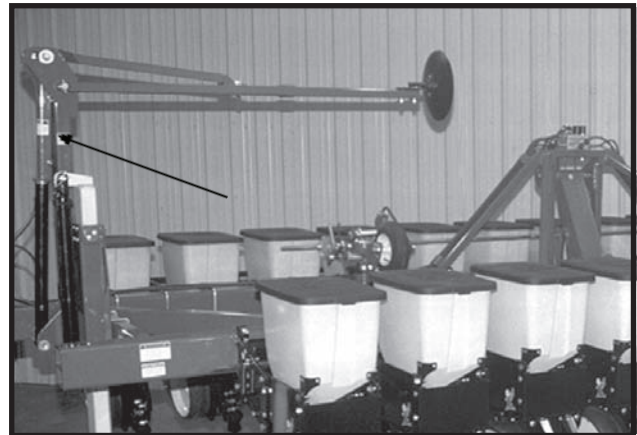

 **Watch for obstructions such as wires, tree limbs, etc., when folding markers.**

 **Care must be taken when operating row markers around overhead power lines.**

 **Never work under the planter while in raised position without using safety lockups.**

 **This planter is designed to be DRIVEN BY GROUND TIRES ONLY. The use of hydraulic, electric or PTO drives may create serious safety hazards to you and the people near by. If you install such drives you must follow all appropriate safety standards and practices to protect you and others near this planter from injury.**

SAFETY PRECAUTIONS

-  Always install safety lockups on center lift cylinders and transport latch locking pin before transporting planter.

01199915

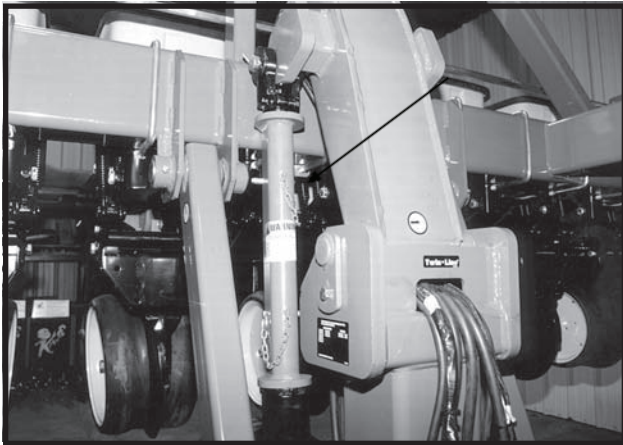

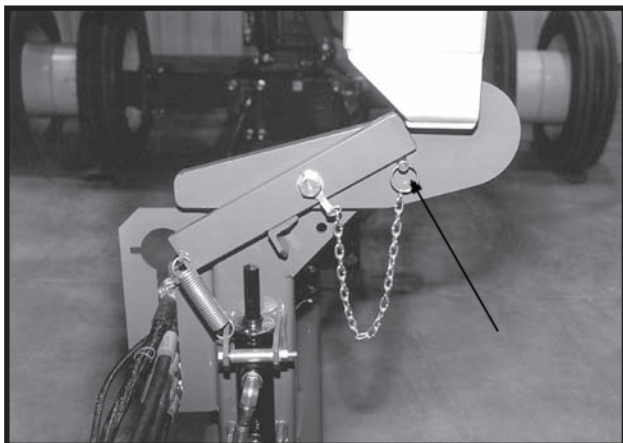

Safety Lockup On Center Lift Cylinders

01199904a



Transport Latch Locking Pin

-  Before operating the planter for the first time and periodically thereafter, check to be sure the lug nuts on the transport wheels are tight. This is especially important if the planter is to be transported for a long distance.
-  If the planter is going to be transported on a public highway, a safety chain should be obtained and installed. Always follow federal, state/provincial and local regulations regarding a safety chain when towing farm equipment on a public highway. Only a safety chain (not an elastic or nylon/plastic tow strap) should be used to retain the connection between the towing and towed machines in the event of separation of the primary attaching system.

-  This machine has been designed and built with your safety in mind. Do not make any alterations or changes to this machine. Any alteration to the design or construction may create safety hazards.

-  Check to be sure all safety/warning lights are working before transporting the machine on public roads.

-  Avoid transporting planter with hoppers loaded whenever possible. When it is necessary to transport the planter with the hoppers loaded, the added weight should be distributed evenly on the planter frame before rotating the planter.

-  Limit towing speed to 15 MPH. Tow only with farm tractor of a minimum 90 HP.

-  Always make sure safety/warning lights, reflectors and SMV sign are in place and visible prior to transporting the machine on public roads. In this regard, check federal, state/provincial and local regulations.

-  Allow for unit length when making turns.

-  Always drive at a safe speed relative to local conditions and ensure your speed is low enough for an emergency stop to be safe and secure. Keep speed to a minimum.

-  Reduce speed prior to turns to avoid the risk of overturning.

-  Always keep the tractor in gear to provide engine braking when going downhill. Do not coast.

-  Avoid sudden uphill turns on steep slopes.

-  Be a safe and courteous driver. Always yield to oncoming traffic in all situations, including narrow bridges, intersections, etc.

SAFETY PRECAUTIONS



Rim and tire servicing can be dangerous. Explosive separation of a tire and rim parts can cause serious injury or death.



Agricultural chemicals used with this unit can be dangerous. Improper selection or use can seriously injure persons, animals, plants, soil and other property. **BE SAFE:** Select the right chemical for the job. Handle it with care. Follow the instructions of the chemical manufacturer.



Store the planter in an area away from human activity. **DO NOT** permit children to play in or around the stored unit.



Make sure the parked machine is on a hard, level surface. Wheel chocks may be needed to prevent unit from rolling.



Good maintenance is your responsibility. Poor maintenance is an invitation to trouble.

SAFETY PRECAUTIONS

SAFETY WARNING SIGNS

The “WARNING” signs illustrated on these pages are placed on the machine to warn of hazards. The warnings found on these signs are for your personal safety and those around you. **OBSERVE THESE WARNINGS!**

- **Keep these signs clean so they can be readily observed. Wash with soap and water or cleaning solution as required.**
- **Replace “WARNING” signs should they become damaged, painted over or if they are missing.**
- **Check the SMV decal periodically. Replace if it shows loss of any of its reflective property.**
- **When replacing decals, clean the machine surface thoroughly using soap and water or cleaning solution to remove all dirt and grease.**

01209906a

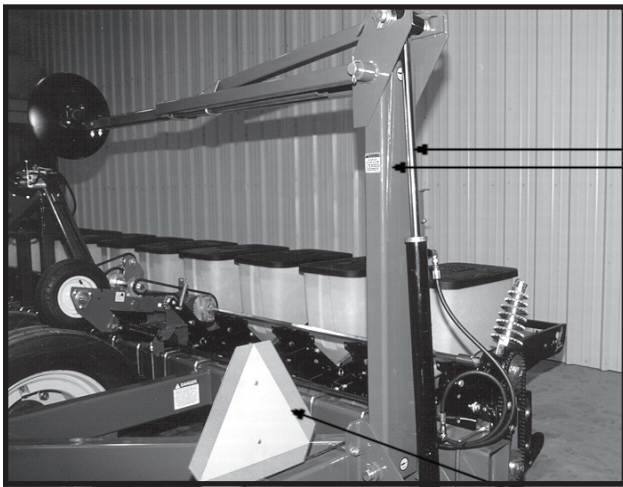

Part No. G7100-42 (Qty. 2 Per Marker)

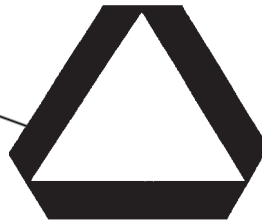

Part No. GD2199 (Qty. 1)

02019903a

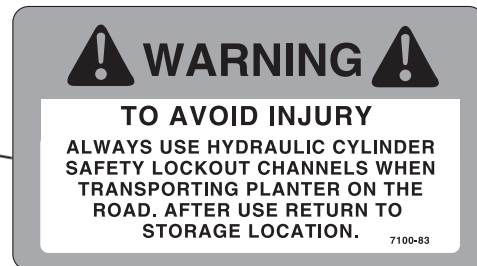
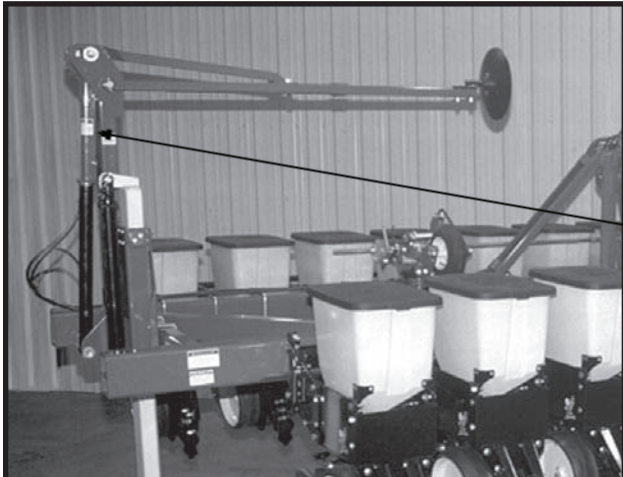

Part No. G7100-83 (Qty. 1 Per Marker Lockup)

SAFETY WARNING SIGNS

01199908

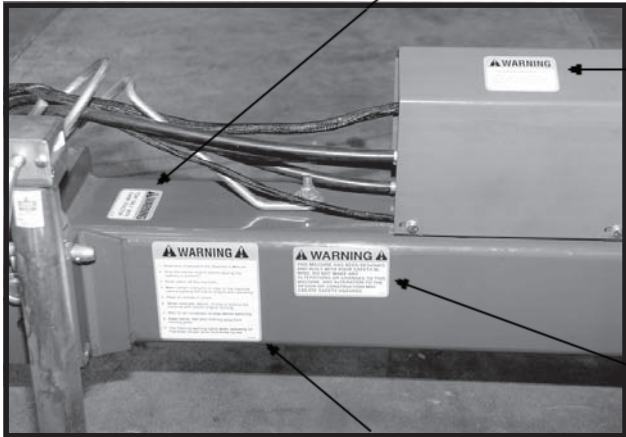

! WARNING

TOW ONLY WITH FARM TRACTOR

7100-56

Part No. G7100-56 (Qty. 1)

! WARNING

TO AVOID INJURY - -

ALWAYS LOWER PLANTER UNITS TO THE GROUND BEFORE UNHITCHING PLANTER. TONGUE CAN RAISE SUDDENLY.

7100-43

Part No. G7100-43 (Qty. 1)

! WARNING !

THIS MACHINE HAS BEEN DESIGNED AND BUILT WITH YOUR SAFETY IN MIND. DO NOT MAKE ANY ALTERATIONS OR CHANGES TO THIS MACHINE. ANY ALTERATION TO THE DESIGN OR CONSTRUCTION MAY CREATE SAFETY HAZARDS.

7100-90

Part No. G7100-46 (Qty. 1)

! WARNING !

1. Read and understand the Operator's Manual.
2. Stop the tractor engine before leaving the operator's platform.
3. Keep riders off the machine.
4. Make certain everyone is clear of the machine before starting the tractor engine and operating.
5. Keep all shields in place.
6. Never lubricate, adjust, unclog or service the machine with tractor engine running.
7. Wait for all movement to stop before servicing.
8. Keep hands, feet and clothing away from moving parts.
9. Use flashing warning lights when operating on highways except when prohibited by law.

7100-46

Part No. G7100-90 (Qty. 1)

SAFETY WARNING SIGNS

01209903a

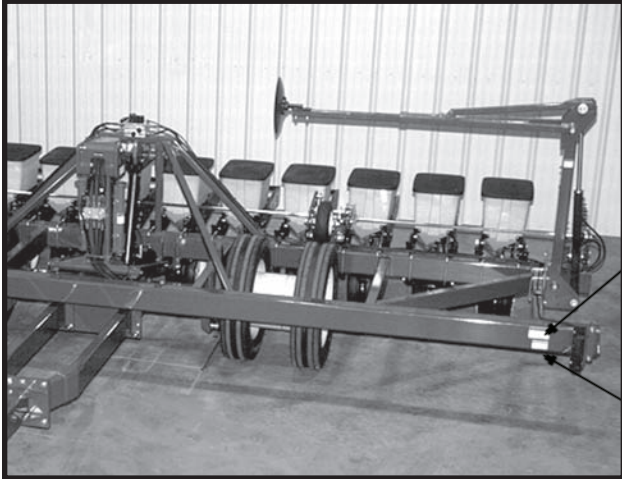

Part No. G7100-68 (Qty. 2 - One On Each Side Of Planter)



Part No. G7100-75 (Qty. 2 - One On Each Side Of Planter)

01209918

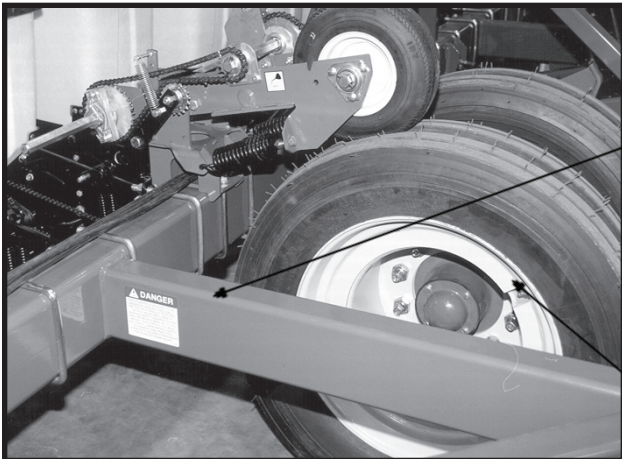

Part No. G7100-89 (Qty. 2 - One On Each Side Of Planter)



Part No. G7100-219 (Qty. 4 - One On Each Transport Wheel Hub)

SAFETY WARNING SIGNS



Part No. G7100-68 (Qty. 2 - One On Each Side Of Planter)



Part No. G7100-63 (Qty. 2 - One On Each Side Of Planter)

01199905

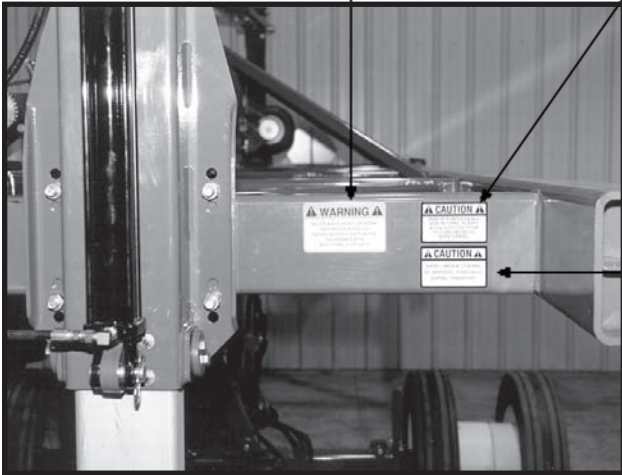

Part No. G7100-75 (Qty. 2 - One On Each Side Of Planter)

01209905a

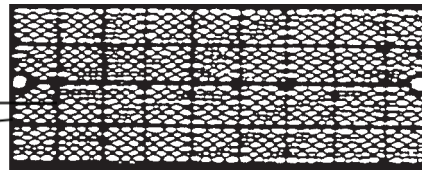
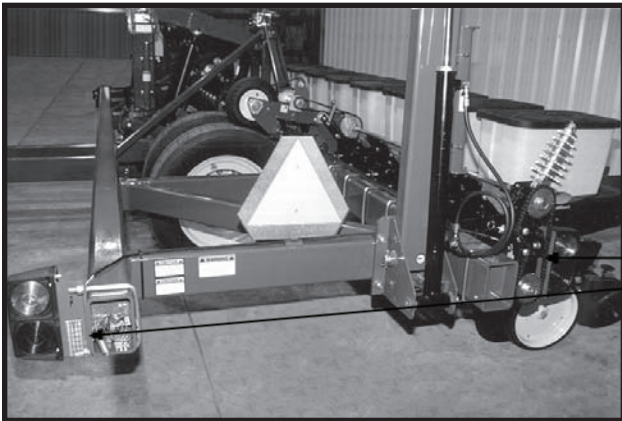

Part No. G7200-03 Red Reflector (Qty. 2 - Rear Of Planter In Transport)

02019905b

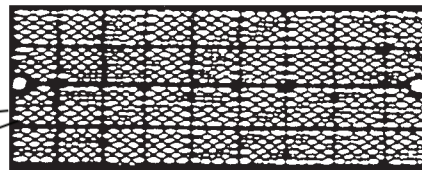
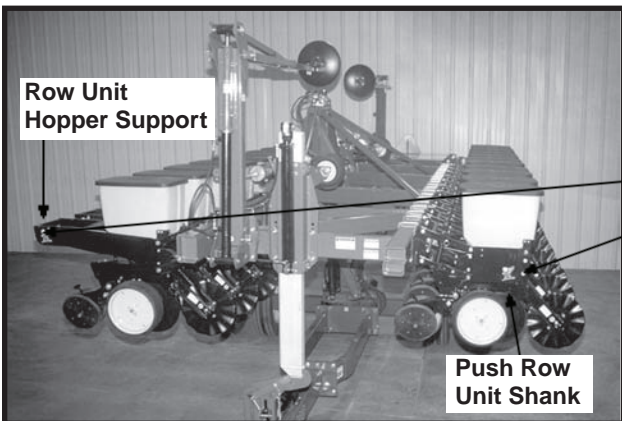

Part No. G7200-04 Amber Reflector (Qty. 1 - Front Of Planter In Transport On Outer Most Edge Of Row Unit Hopper Support/Qty. 1 - Front Of Planter In Transport On Outer Most Edge Of Push Row Unit Shank When Equipped With Interplant®)

SAFETY WARNING SIGNS



01199915

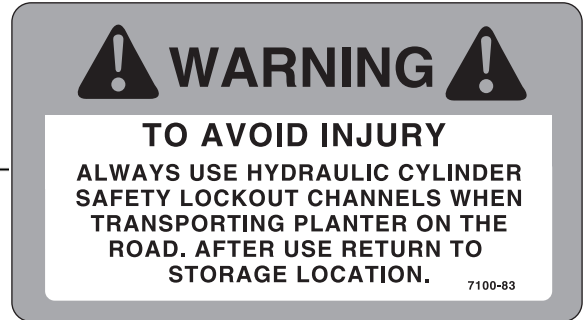
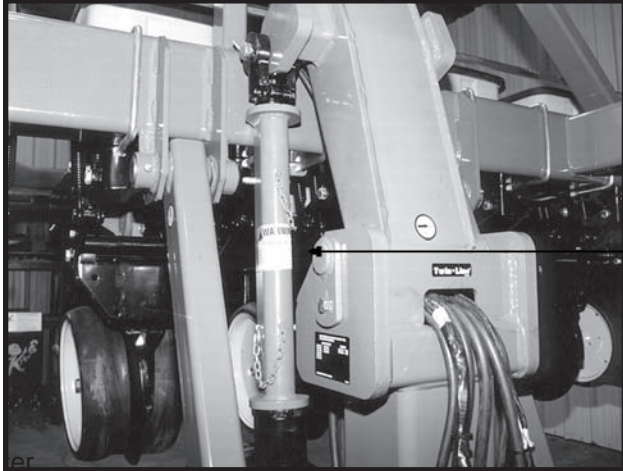

Part No. G7100-83 (Qty. 2 - One On Each Cen-
Lift [Slave] Cylinder Safety Lockup)

77178-17a



Part No. G7100-115 (1 Per Row Unit - Located
Under Side Of Granular Chemical Hopper)

SAFETY WARNING SIGNS



MACHINE OPERATION

The following information is general in nature and was written to aid the operator in preparation of the tractor and planter for use, and to provide general operating procedures. The operator's experience, familiarity with the machine and the following information should combine for efficient planter operation and good working habits.

CAUTION: Always raise the planter out of the ground when making sharp turns or backing up.

INITIAL PREPARATION OF THE PLANTER

Lubricate the planter and row units per the lubrication information in this manual. Make sure all tires have been properly inflated. Check all drive chains for proper tension, alignment and lubrication.

TRACTOR REQUIREMENTS

Consult your dealer for information on horsepower requirements and tractor compatibility. Requirements will vary with planter options, tillage and terrain. Two dual remote hydraulic outlets (SCV) are required on all sizes. A 12 volt DC electrical system is required on all sizes.

TRACTOR PREPARATION AND HOOKUP

02019923c

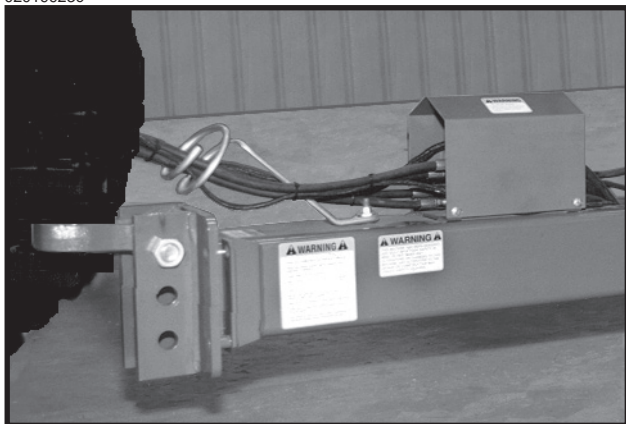

1. Adjust tractor drawbar to 13-17 inches above the ground. Adjust the drawbar so the hitch pin hole is directly below the center line of the PTO shaft. Make sure the drawbar is in a stationary position.
2. Install control console on tractor in a convenient location to the right of the operator and close to the hydraulic controls. Mount control console securely and route power cord to the power source. The control console operates on 12 volt DC only. The console battery lead has two wires, a BLACK wire and a RED wire (tagged with "+"). Each lead is terminated in a ring terminal. The BLACK wire should always be connected to the chassis ground battery terminal.

If two 12 volt batteries are connected in series, ALWAYS make power connection on battery which is grounded to tractor chassis.

If two 6 volt batteries are connected in series, make sure power connection provides 12 volt DC across the positive terminal on one battery and negative terminal of the second battery.

3. Back tractor to planter and connect with 1 1/4" - 1 1/2" diameter hitch pin. If the tractor is not equipped with a hitch pin locking device, make sure hitch pin is secured with a locking pin or cotter pin.
4. Connect hydraulic hoses to tractor ports in a sequence which is both familiar and comfortable to the operator.

The hydraulic hoses are color coded as follows:

Red AA - Lift Functions (Return)

Red BB - Lift Functions (Pressure)

Blue AA - Marker And Fold/Unfold Functions (Return)

Blue BB - Marker And Fold/Unfold Functions (Pressure)



DANGER: Before applying pressure to the hydraulic system, make sure all connections are tight and hoses and fittings have not been damaged. Hydraulic fluid escaping under pressure can have sufficient force to penetrate skin, causing injury or infection.

CAUTION: Always wipe hose ends to remove any dirt before connecting couplers to tractor ports.

5. Connect cable on planter to control console cable on tractor. Connect ASAE Standards 7 terminal connector for warning lights on planter to ASAE Standards receptacle on tractor. If your tractor is not equipped with an ASAE Standards receptacle, check with your tractor manufacturer for availability. Check to be sure warning lights on planter are working in conjunction with warning lights on tractor.
6. Remove jack and remount horizontally on storage bracket.

D102999101a



MACHINE OPERATION

7. Lower planter to the planting position and check to be sure the hitch is level. If hitch slopes up or down, disconnect planter and adjust hitch clevis up or down as necessary.

NOTE: If using an auxiliary attaching system to retain the connection between the planter and tractor hitch, be sure the auxiliary attaching system is of sufficient strength and length and correctly attached. An auxiliary attaching system (safety chain) is available from KINZE® Repair Parts through your KINZE® Dealer. Attach safety chain using clevis mounting hole on planter hitch.

01209905a

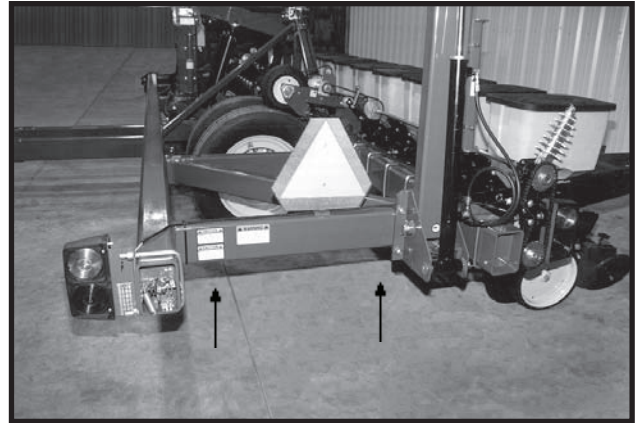

It is important for the planter to operate level laterally. Tire pressure must be maintained at pressures specified. See "Tire Pressure".

LEVELING THE PLANTER

For proper operation of the planter and row units, it is important that the planter frame and row unit parallel arms be approximately level. The toolbar should operate at a 20"-22" height, measured to the bottom of the toolbar.

Unless the tractor drawbar is adjustable for height, the fore and aft level adjustment must be maintained by the position of the hitch clevis. Three holes in the hitch bracket allow the clevis to be raised or lowered. In addition, the clevis may be turned over for a finer adjustment between mounting holes. When installing clevis mounting bolt, make sure lock nut is tightened to proper torque setting.

02019923a

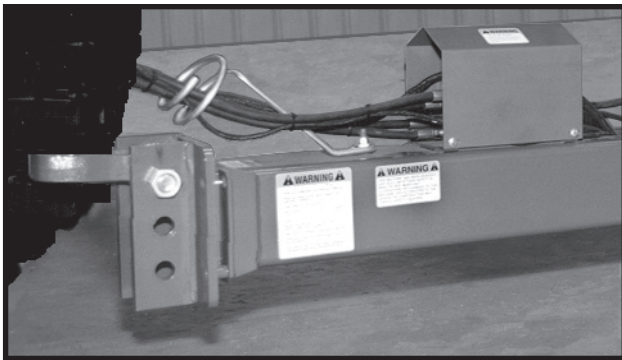

With the planter lowered to proper operating depth, check to be sure the frame is level fore and aft. Recheck once planter is in the field.

CONTACT DRIVE WHEEL SPRING ADJUSTMENT

There are two down pressure springs on each contact drive wheel. The down pressure is factory preset and should need no further adjustment.

The spring tension is set leaving 2" between the spring plug and the bolt head.

1209903

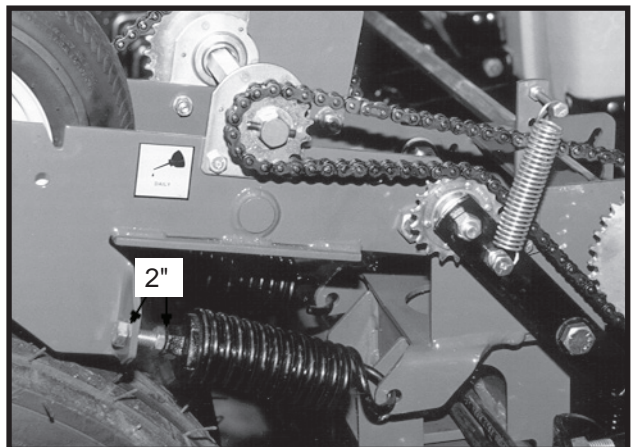

MACHINE OPERATION

TIRE PRESSURE

1209918

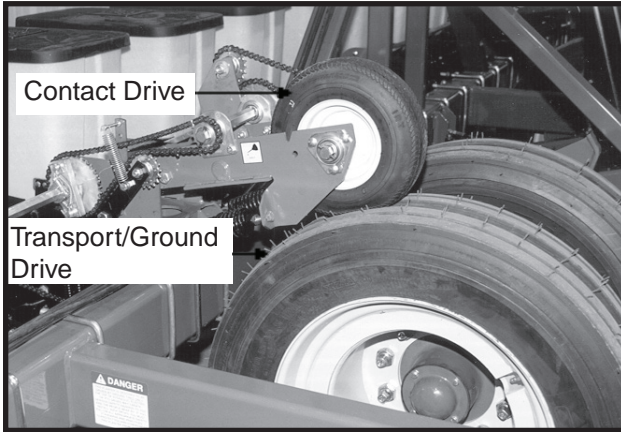

Tire pressure should be checked regularly and maintained as follows:

Transport/Ground Drive 255-70R x 22.5" 75 PSI
Contact Drive 4.10" x 6" 50 PSI

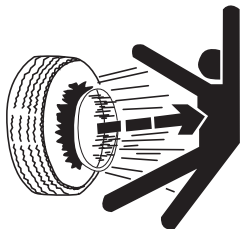

DANGER: Rim and tire servicing can be dangerous. Explosive separation of a tire and rim parts can cause serious injury or death.

Do not attempt to mount a tire unless you have the proper equipment and experience to perform the job. This should only be done by persons properly trained and equipped to do the job.

Always maintain the correct tire pressure. Do not inflate the tires above the recommended pressure.

When inflating tires, use a clip-on air chuck and extension hose long enough to allow you to stand to one side and NOT in front of or over the tire assembly. Use a safety cage to enclose the tire and rim assembly when inflating.

Inspect tires and wheels daily. Do not operate with low pressure, cuts, bubbles, damaged rims or missing lug bolts and nuts.

TRANSMISSION ADJUSTMENT

Planting population rate changes are made at the end mounted transmission. The planter is designed to allow simple, rapid changes in sprockets to obtain the desired planting population. By removing the lynch pins on the hexagon shafts, sprockets can be interchanged with those from the sprocket storage rod bolted to the transmission.

Chain tension is controlled by a spring-loaded dual-sprocket idler. The idler assembly is adjusted with a ratchet arm. This arm has a release position to remove spring tension for replacing sprockets. The amount of spring tension on the chain is controlled by the ratchet arm.

The planting rate charts found at the back of this section will aid you in selecting the correct sprocket combinations.

01209904

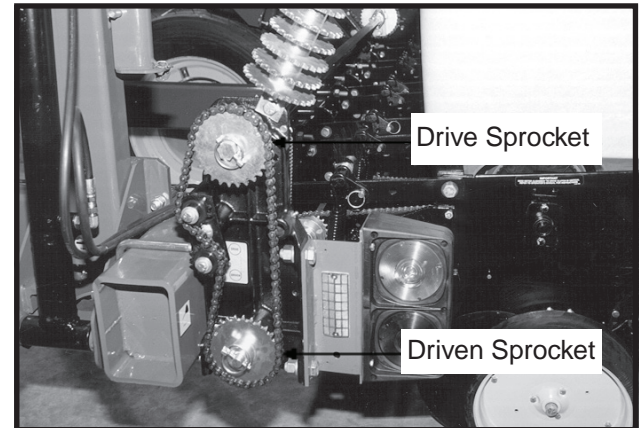

MACHINE OPERATION

STANDARD RATE DRIVE

01209913

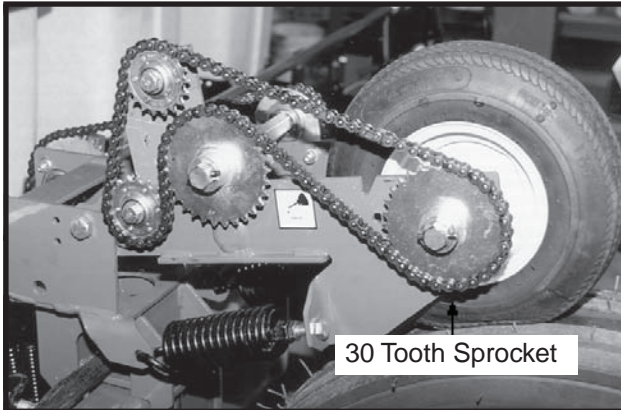

Seed planting rate charts are based on the standard rate drive unless specified otherwise. The standard rate drive uses a 30 tooth sprocket as shown above. Using the 15 tooth half rate (2 to 1) drive reduction sprocket in place of the 30 tooth sprocket will reduce the planting and application rates by approximately 50%. See "Half Rate (2 To 1) Drive".

HALF RATE (2 TO 1) DRIVE

01239901

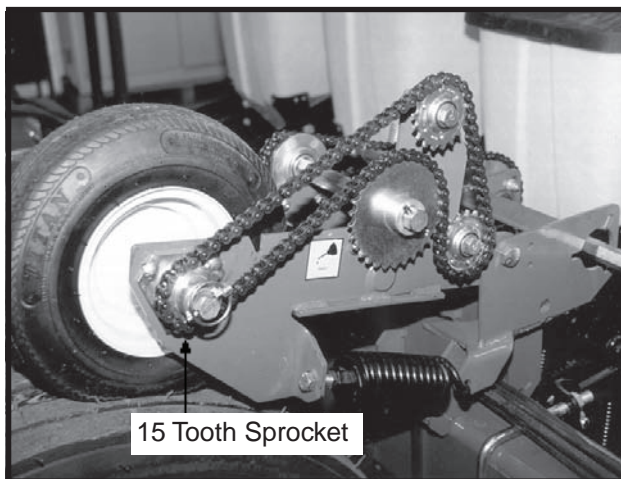

Half rate (2 to 1) drive is recommended only when desired population falls below that shown on planting rate charts. Replacing the 30 tooth drive sprocket located on the contact drive wheel, with the 15 tooth half rate (2 to 1) drive reduction sprocket will reduce the planter transmission speed and planting and application rates by approximately 50%.

A 93 pitch chain is supplied with the Half Rate (2 To 1) Drive Reduction Package to allow use of the smaller 15 tooth sprocket.

IMPORTANT: After each sprocket combination adjustment, make a field check to be sure you are planting at the desired rate.

SHEAR PROTECTION

The planter drive line, row unit and fertilizer components are protected from damage by shear pins.

If excessive load should cause a pin to shear, it is important to determine where binding has occurred before replacing the pin. Replace shear pins with same size and type.

Additional shear pins can be found in the storage area located inside the forward planter toolbar.

To prevent future binding or breakage of components, check drive line alignment and follow prescribed lubrication schedules.

NOTE: Drill shaft/transmission coupler alignment is critical.

61658-27

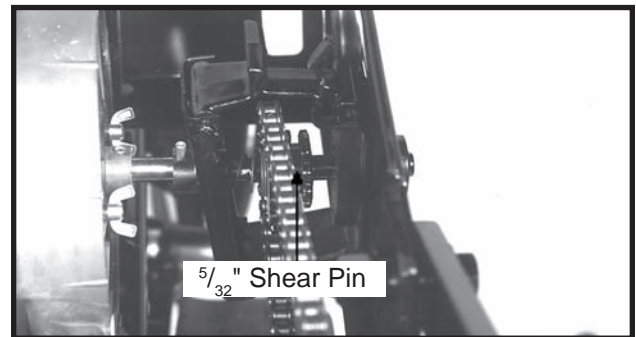

Row Unit Seed Meter Drive

01209923

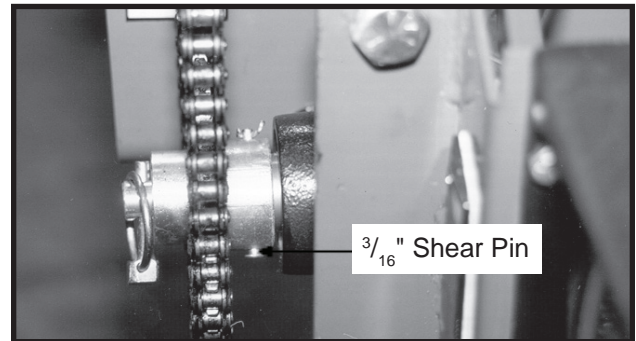

Transmission Shaft

MACHINE OPERATION

HYDRAULIC/ELECTRIC OPERATION

76746-24

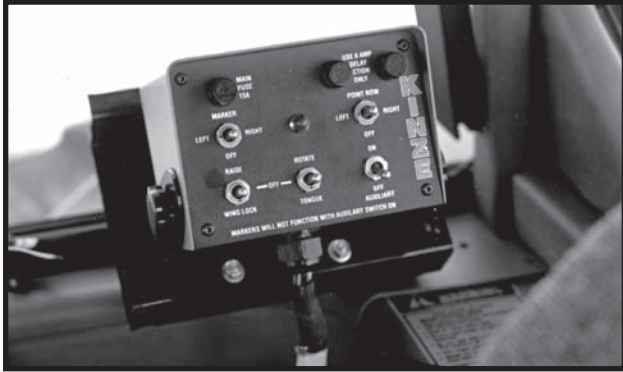

Switches on the control console located on the tractor are used to raise the planter to transport position, operate the rotate function and raise and lower the row markers.

All 2400 planters are equipped to operate from two dual remote (SCV) hydraulic outlets. One set of hydraulic outlets, in conjunction with the switch on the control console, is used to operate the raise to transport function. The second set, in conjunction with the switches on the control console, is used to operate the markers and fold/unfold functions.

! DANGER: Care must be taken when operating row markers around overhead power lines.

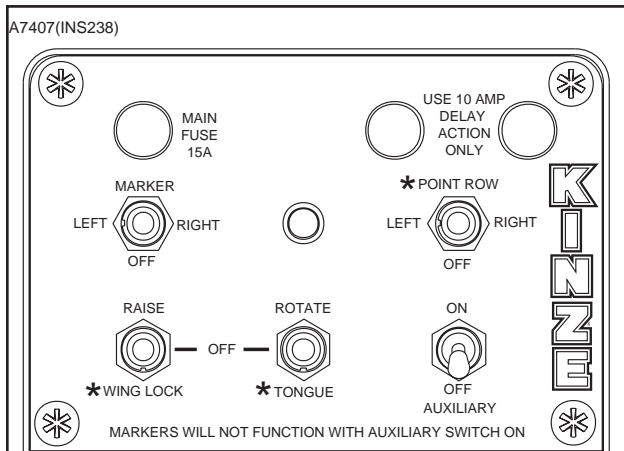

*Not used on the 2400 planter.

NOTE:

1. Operating marker or point row switch in either direction lights panel light.
2. Point row clutch switch operates independently of the rest of the control box.
3. Power to the marker switch is fed through the auxiliary switch and the two transport function switches. Operating any of the switches in the lower row disables the marker function and turns off the panel light. (If the point row clutch switch is in the "off" position.)

The marker and point row selector switches are an "on-off-on" type. Point row clutches are not available on the 2400 planter and, therefore, that switch is not used.

NOTE: For safety the marker selector switch should be placed in its "off" (center) position. An indicator light on the control box panel is "on" whenever the marker circuit or point row circuit is energized.

The raise/wing lock and rotate/tongue (fold function) switches are "on-off-on" momentary "on" type and must be held in position while operating the tractor hydraulic lever. Activating a fold function switch disables the marker circuit. The wing lock and tongue functions are not used on the 2400 planter.

The auxiliary switch is an "on-off" type switch. All 2400 planters are shipped with the auxiliary switch installed in the control console. The auxiliary switch must be in the "off" position to enable other functions to operate.

NOTE: Activating the auxiliary switch disables all other control console switches except the point row clutch switch.

NOTE: When operating make sure the planter is lowered all the way to ensure push pads are contacting the axle. Operating with frame partially raised will increase wear on cam rollers and other components.

! DANGER: Never work under the planter while in raised position without installing safety lockups.

! WARNING: Make sure all hydraulic hoses are properly connected before operating the planter. Never connect or disconnect hydraulic hoses without first stopping the tractor engine and moving the hydraulic operating levers in both directions to relieve any pressure in the system.

NOTE: The planter will not lower when the tractor valve is in float position or in the lower position with the engine off. The planter lift cylinders are equipped with counter balance valves that require pressure from the tractor to allow them to retract.

MACHINE OPERATION

TRANSPORT TO FIELD SEQUENCE

SUMMARIZED TRANSPORT TO FIELD SEQUENCE

- Remove transport latch locking pin.
- Remove manual safety lockups.
- Rotate planter to planting position.
- Lower planter to the ground.
- Rephase planter lift cylinders.
- Remove marker lockups.

NOTE: Read the following information for more detailed instructions.

02019905

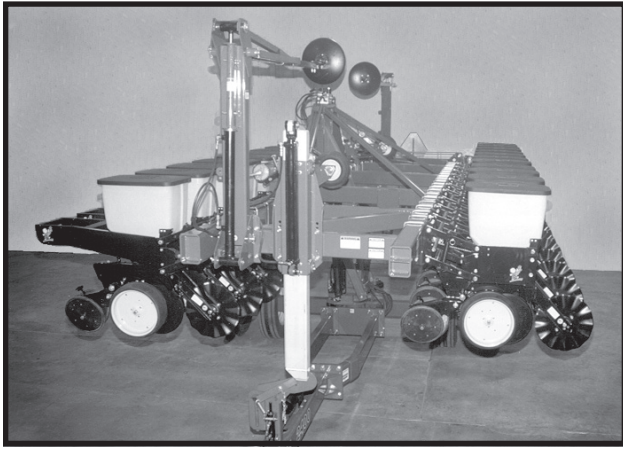

1. Remove the transport latch locking pin from the locked position and place it in the storage location.

01199904a

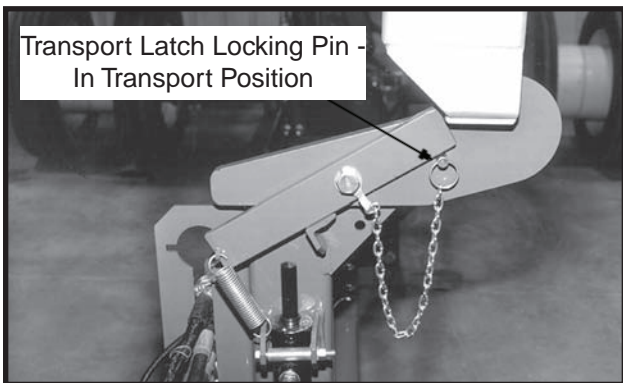

01199904b

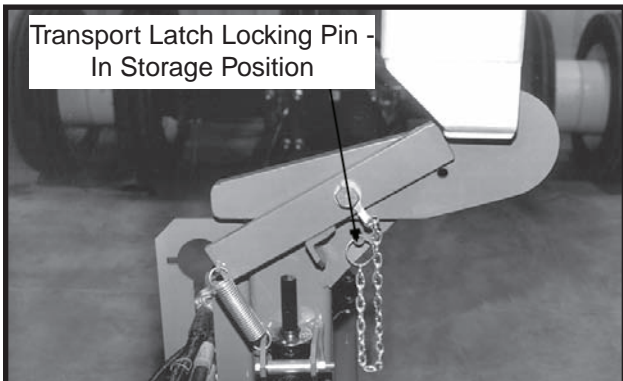

2. Remove the manual safety lockup from each center lift cylinder.

01199915

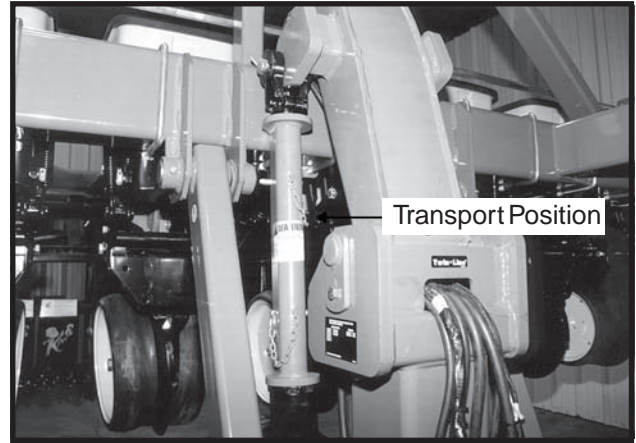

Place them in the storage location on each side of the center pivot assembly

01209909



MACHINE OPERATION

3. Hold the control console switch labeled “ROTATE/TONGUE” in “**rotate**” and operate the hydraulic lever to unfold the planter.

76746-24

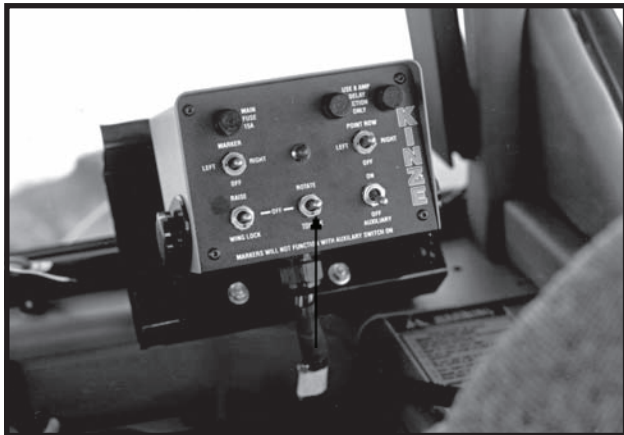

The transport latch will automatically release and the planter will rotate into planting position.

02019903a



4. Lower the planter to the ground. The planter will lower at a slower speed until transport latch post is fully raised. Hold the hydraulic lever until the planter stalls.

02019906a

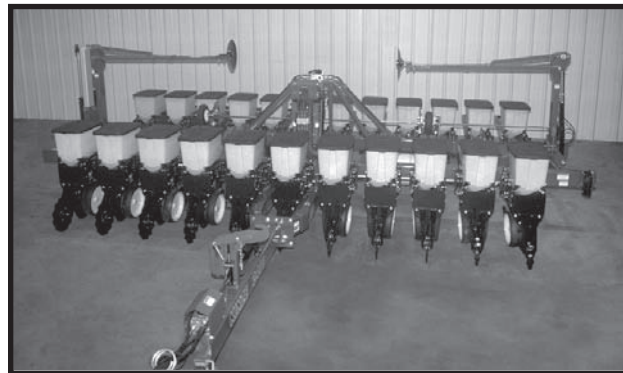

NOTE: If the planter does not stop at the proper “raised field position” during field operation, the planter lift system could be out of phase. To re-phase the system, hold the control console switch labeled “RAISE” and operate the hydraulic lever to completely raise the planter. Release the “RAISE” switch and hold the hydraulic lever to lower the planter until it stalls.

5. Remove and store marker lockups.

02019919a

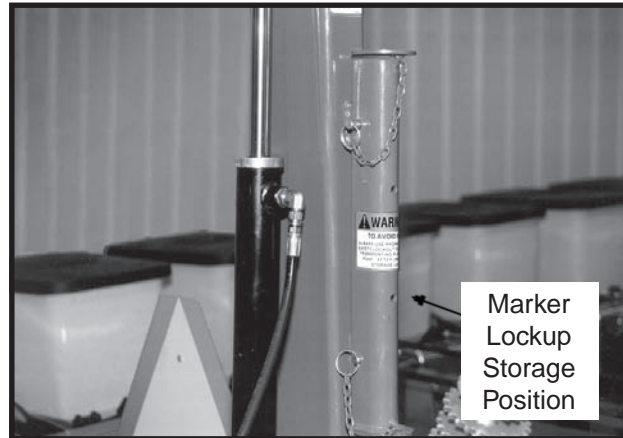

MACHINE OPERATION

FIELD OPERATION

There are two raised positions on the planter.

One is the “raised field position” which is when the planter is raised using only the hydraulic lever. The solenoid, located on the hitch, is not energized. The master cylinder on the hitch strokes out and the slave cylinders, located at the center of the planter, only begin to raise. In the “raised field position” the row units are approximately 14” off the ground. This position is used in making turns or passing over waterways during field operation.

The second raised position is when the planter is raised to transport height. See “Field To Transport Sequence”.

02019901a



Raised Field Position

FIELD TO TRANSPORT SEQUENCE

SUMMARIZED FIELD TO TRANSPORT SEQUENCE

- Install marker lockups.
- Raise planter to fully raised position.
- Rotate planter to transport position.
- Install transport latch locking pin.
- Install manual safety lockups.

NOTE: Read the following information for more detailed instructions.

1. Install marker lockups.

02019903a

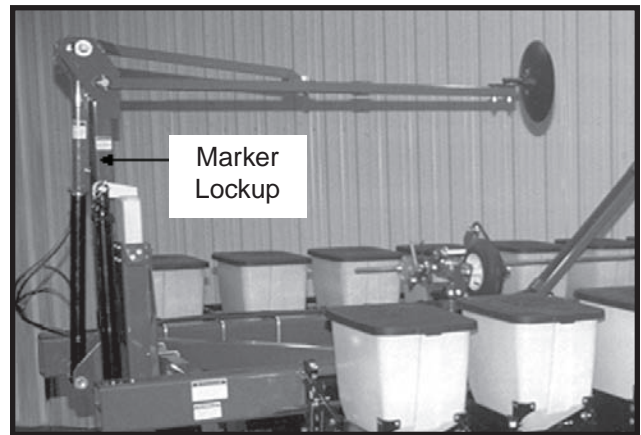

2. Hold the control console switch labeled “RAISE” and operate the hydraulic lever to fully raise the planter as shown below.

76746-24

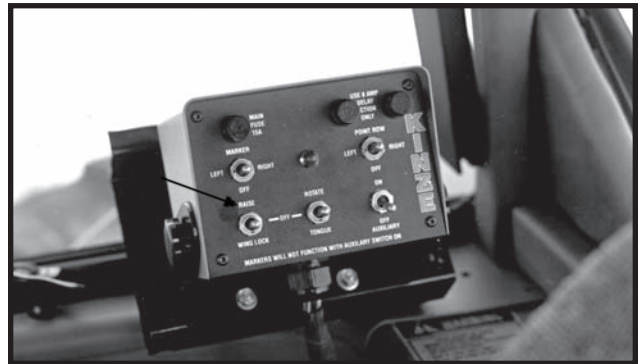

02019901a



MACHINE OPERATION

3. Hold the control console switch labeled "ROTATE/TONGUE" in "rotate" and operate the hydraulic lever to rotate the planter until the transport latch is secured.

76746-24



01199904b

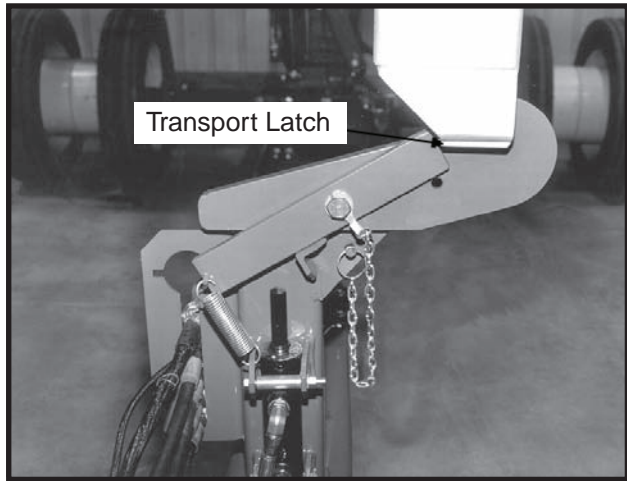

4. Install transport latch locking pin.

01199904a

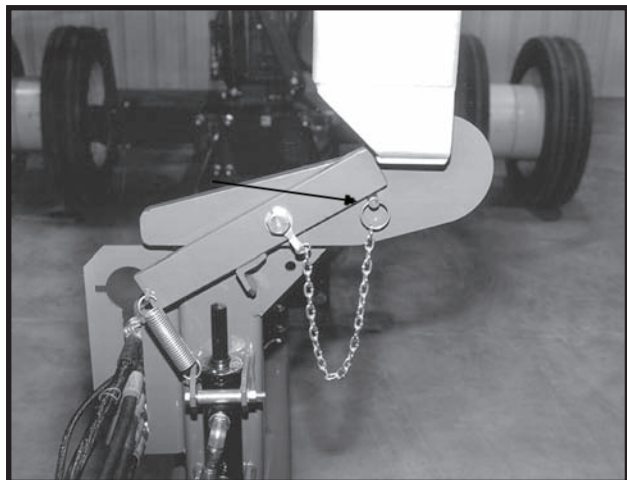

5. Remove the manual safety lockups from their storage position on the side of the center pivot assembly.

01209917

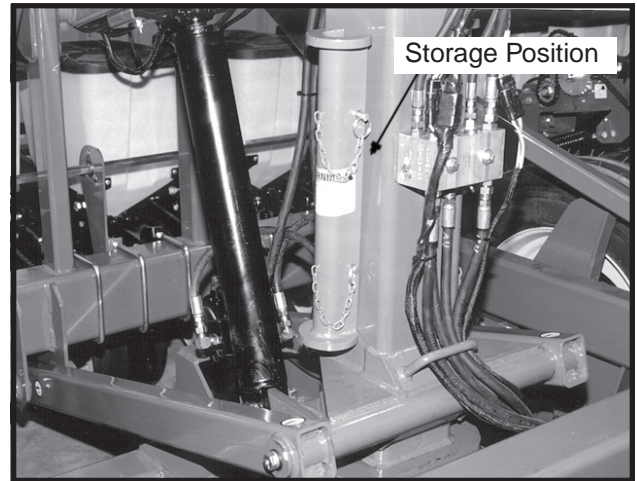

Install a lockup on each center lift cylinder.

01199915

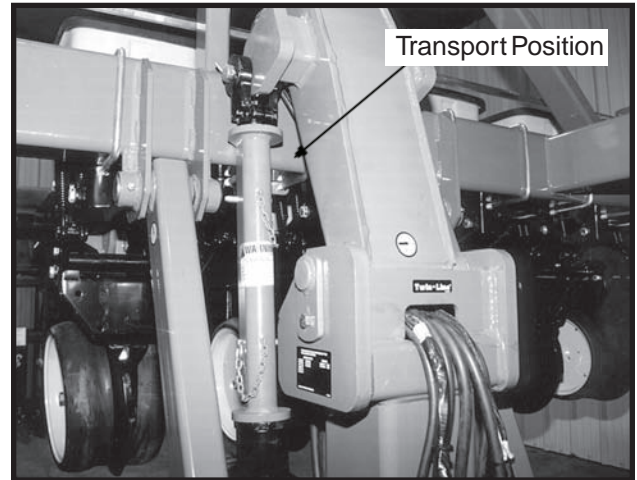

NOTE: For safety purposes it is recommended that the manual safety lockups always be installed prior to working under the planter when the planter is in the raised position or while transporting the planter.

MACHINE OPERATION

MARKER OPERATION

02019920

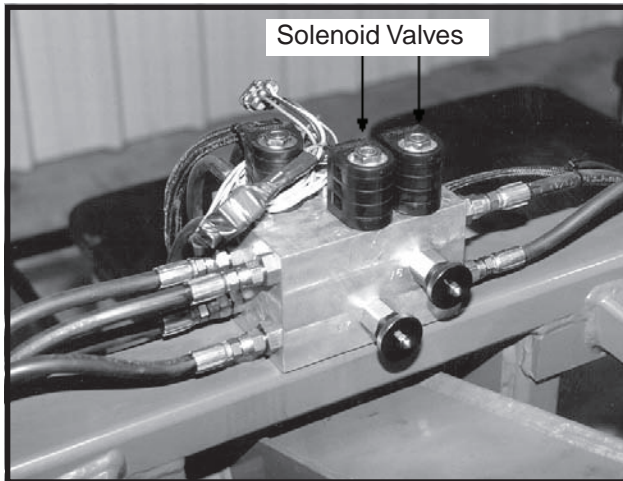

NOTE: Both markers can be lowered by operating the switch in each position and operating the hydraulic lever twice. The markers will raise simultaneously with the hydraulic lever in the raise position.

NOTE: Switch should be left in OFF position when planter is not in use. If left in ON position, it will drain the tractor battery.

If the electrical system fails to operate properly:

- Check fuse.
- Check wiring connections.
- Check control switch.
- Check solenoid. SOLENOID HOUSING WILL BE MAGNETIZED WHEN ENERGIZED.

76746-24

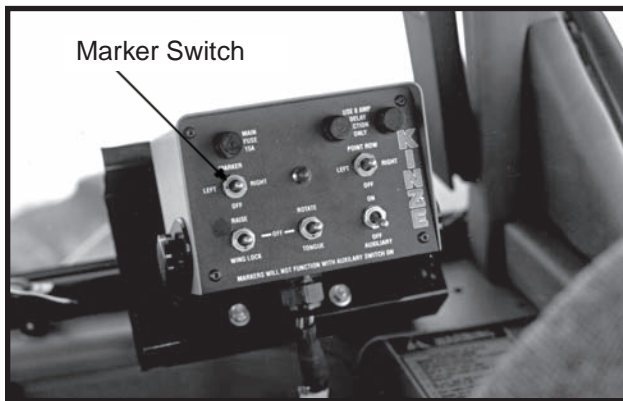

Three Position Selector Switch On Control Console

Two solenoid valves, located on the valve block on the center of the planter frame, along with a three position selector switch on the control console permits the operator to raise or lower the desired marker.

See “Marker Speed Adjustment.”

1. On the control console, select which marker you want lowered.
2. Operate hydraulic control lever to lower marker.
3. If opposite marker is to be used next, change control switch to other side.
4. At end of field, using hydraulic control lever, raise the down marker.
5. After making the turn; using the hydraulic lever, lower the pre-selected marker.
6. Continue to follow this procedure.

MACHINE OPERATION

MARKER SPEED ADJUSTMENT

The marker hydraulic system is equipped with two flow control valves. One flow control valve controls the lowering speed of both markers and one controls the raising speed of both markers. To adjust marker speed, loosen the jam nut and turn the control clockwise, or IN, to slow the travel speed and counterclockwise, or OUT, to increase the travel speed. The flow control determines the amount of oil flow restriction through the valve, therefore determining travel speed.

01209909a

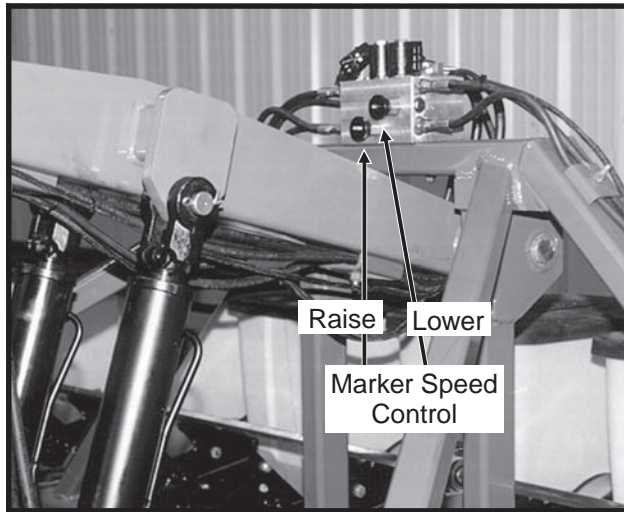

DANGER: The flow controls should be properly adjusted before the marker assembly is first put to use. Excessive travel speed of the markers can be dangerous and/or damage the marker assembly.



DANGER: Care must be taken when operating row markers around overhead power lines.

NOTE: When oil is cold, hydraulics operate slowly. Make sure all adjustments are made with warm oil.

NOTE: On a tractor where the oil flow can not be controlled, the rate of flow of oil from the tractor may be greater than the rate at which the marker cylinder can accept the oil. The tractor hydraulic control lever will have to be held until the cylinder reaches the end of its stroke. This occurs most often on tractors with an open center hydraulic system.

On tractors equipped with flow control valves, marker speed adjustment should be made with the tractor flow controls in maximum position. After marker speed is set, the tractor flow controls can be adjusted to allow the SCV valve to stay in detent during the marker raise or lower cycle.

MARKER ADJUSTMENT

To determine the correct length at which to set the marker assemblies, multiply the number of rows by the average row spacing in inches. This provides the total planting width. Adjust the marker extension so the distance from the marker blade to the center line of the planter is equal to the total planting width previously obtained. Both the planter and marker assembly should be lowered to the ground when measurements are being taken. The measurement should be taken from the point where the blade contacts the ground. Adjust right and left marker assemblies equally and securely tighten clamping bolts. An example of marker length adjustment follows:

Number of rows	x	Row spacing (Inches)	=	Dimension between planter center line and marker blade.
----------------	---	----------------------	---	---------------------------------------------------------

12 Rows x 20" Spacing = 240" Marker Dimension

72359-61



The marker blade is installed so the concave side of the blade is outward to throw dirt away from the grease seals. The spindle bracket is slotted so the hub and blade can be angled to throw more or less dirt. To adjust the hub and spindle, loosen the 1/2" hardware and move the bracket as required. Tighten bolts to the specified torque.

IMPORTANT: A marker blade assembly that is set at a sharper angle than necessary will add unnecessary stress to the complete marker assembly and shorten the life of bearings and blades. Set the blade angle only as needed to leave a clear mark.

A field test is recommended to ensure the markers are properly adjusted. After the field test is made, make any minor adjustments as necessary.

A notched marker blade is available from KINZE® Repair Parts for use in severe no till conditions.

KPM I MONITOR

(MTR28)

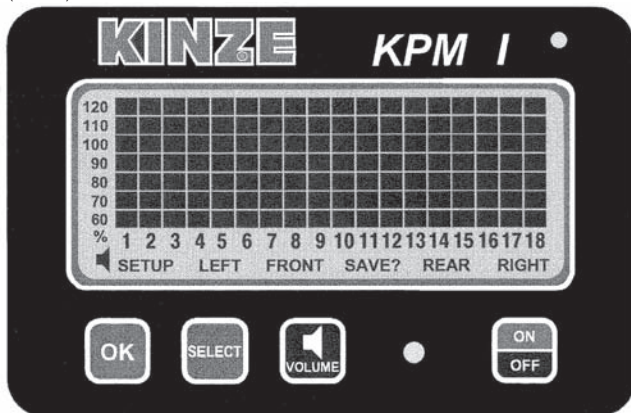

The electronic seed monitor system consists of a console, which is mounted on the tractor; seed tubes with computerized sensors, one of which is installed in each planter row unit; a primary harness, which connects the console to the planter harness; and a planter harness (junction harness and/or harness extension where applicable), to which the individual seed tube sensors connect.

Seed flow for up to 36 rows, in two 18 row sections (left/right or rear/front), may be monitored with one monitor. For less complicated applications, all rows may be programmed in one section and the other section left disabled.

The monitor system is powered by the tractor battery (requires 12 volts DC). The console receives information from each of the sensors and translates this information.

The single backlit Liquid Crystal Display (LCD) shows the active section, the number of monitored rows per section, the relative seed rate for each row (using a bar graph display) and scrolls various alarm and warning messages when an alarm condition exists. A continuous audio alarm will sound upon system malfunction or underflow conditions for any monitored row. Alarms must be acknowledged by the user. Various warnings may sound the buzzer or flash some icons.

The monitor will power down if no activity is sensed for more than one hour. No activity means there has been no new seed flow and no operator push key input.

Monitor Key Functions.....	6-12
LCD Functions.....	6-12
Changing The Audio Volume.....	6-13
Warnings And Alarms.....	6-13
Replacing A Faulty Sensor.....	6-14
Field Operation.....	6-15
Connecting Seed Tubes.....	6-15

MONITOR KEY FUNCTIONS

Each key press is acknowledged by the monitor with a short beep.

OK

- Ends and saves the new setup during installation.
- Acknowledges and silences alarms in the operation mode.

SELECT

- Selects the application mode (rear/front or left/right) at the beginning of installation setup.
- Selects the active section(s) (rear, rear/front, left, right or left/right) in the normal mode.
- Has no affect on a system configured to monitor only one section.

VOLUME

- Pressing the key will turn the beeper on.
- Holding the key for periods of 2 seconds increases the volume until it reaches the maximum, at which time it rolls over to the minimum level.

ON/OFF

- Powers the unit on and off.

LCD FUNCTIONS

The monitor collects data on the planting rates from all active rows and calculates an average. This average will determine the 100% mark. Seed rate for each row is then compared to the average value and the result is displayed on the bar graph.

The information regarding each section is displayed alternately every 5 seconds. While operating a system with two sections programmed, one or both sections may be selected any time. When only one section is selected, the monitor calculates the average based on the remaining active rows from that section.

STEP 1 Press SELECT key once to show one section. The flashing icon shows the section that is not selected. The selected section is continuously displayed on the LCD.

EXAMPLE: The system is setup to display rear/front sections. Press SELECT key. The FRONT icon will be flashing and the REAR section will be displayed on the bargraph. After 1 minute the front row icon will stop flashing. The monitor will stay in this REAR only display through power down and power up. Each time the monitor is turned on while in REAR only mode, the FRONT icon will flash for 1 minute. Also if seed flow is sensed in the FRONT section while planting, the FRONT icon will resume flashing.

STEP 2 Press SELECT key again to activate both sections.

EXAMPLE: Press SELECT key a second time. The information regarding each section will display alternately every 5 seconds.

For simple applications, where only one section is programmed, the display will automatically lock on that section. Pressing SELECT key will have no affect.

NOTE: When alternating between two sections, the display will lock on the section containing the first recognized alarm until the alarm is acknowledged by pressing the OK key or the alarm condition is removed.

CHANGING THE AUDIO VOLUME

STEP 1 Press and hold down the VOLUME key.

STEP 2 The SETUP and VOLUME icons will turn on and the beeper will sound continuously. The intensity of the sound will change every 2 seconds. After the maximum volume is reached, the next change will set the volume to minimum and will continue to get louder every 2 seconds. When the desired volume is reached, release the key.

WARNINGS AND ALARMS

1. System Alarms - A system alarm is entered when the monitor detects a faulty sensor or one of several other communication faults.

The corresponding row number starts flashing and the beeper sounds. All segments on the corresponding bar graph are turned off. Pushing the OK key to acknowledge the alarm will turn the beeper off. The row number will continue to flash until the alarm condition is removed. If the monitor detects a faulty sensor and there is no planting activity present, the monitor will scroll "CHECK CONNECTION".

Another type of system alarm occurs when the monitor detects a data communication bus error. The three possible data communication bus errors are:

LCD Display	Error Condition
SYS HI	The data communication lead (green) has been shorted to the power lead (white).
SYS LO	The data communication lead (green) has been shorted to the ground lead (black).
SYS EC	An internal error has been detected.

2. Under Flow Alarms - If the seed rate for one or more rows is less than 55% of the calculated average, the corresponding 60% segment will stay on, the corresponding row number starts flashing and the alarm sounds. Pushing the OK to acknowledge the alarm will turn the alarm off. The 60% segment of the bar graph remains on and the row number continues to flash until the alarm condition is corrected.

NOTE: All alarms present within a short time before planting stops, are frozen on the screen and the text LOW or FAIL will display on the LCD. If the underflow is between 0% and 10%, this warrants a "FAIL" condition. If the under flow is between 10% and 55%, a "LOW" condition is generated. If multiple rows have an underflow condition, "FAIL" will display if any one or more rows is between 0% and 10%. This allows the user to identify and fix the problem rows.

NOTE: This warning will not trigger unless a minimum time of continuous planting has passed.

NOTE: If all the rows show a seed rate of zero, the condition will not generate an alarm. It will be assumed the planter has stopped. The row numbers and the bottom 60% segment will remain on for all selected rows.

3. **Multiple Alarms** - If more than one alarm condition occurs at the same time, pushing the OK key will acknowledge all alarms that are currently displayed. For example, if one row on the front and one row on the rear are alarming, pushing OK key will only acknowledge one of them. However, if there are two alarms on the front, both alarms would be acknowledged with one push of the OK key.
4. **Section Not Selected Warning** - If the monitor was programmed for two sections and only one is currently selected for display (by pressing the SELECT key), the icon of the disabled section will flash for a period of 1 minute, then turn off at each power up. If seed flow is sensed in the disabled section, the icon for that section (front, left or right) will begin to flash.
5. **Seed Planting Stopped Warning** - When the monitor detects no seed flow on all rows, the monitor will emit 3 short beeps to alert the user. This warning will occur each time the planter is stopped, each time the planter is raised at the end of a row or if the mechanical drive fails while planting.

NOTE: This warning will not trigger unless a minimum time of continuous planting has passed.

6. **Seed Counting Sensor In Calibration Warning** - All seed counting sensors run a self-calibration sequence on power up. While in calibration the bottom segment of each corresponding bar graph will flash if the monitor detects movement or planting activity. If the monitor does not detect this, the message "WAIT CALIBRATION" will be scrolled.

7. **Seed Counting Sensor Too Dirty Warning** - After the seed counting sensors end their internal self-calibration, the monitor may detect one or more sensors are either too dirty or blocked. If the monitor detects planting or movement, the corresponding bar graph remains flashing. The monitor will display "CLEAN SENSORS" on the LCD if no movement or planting is detected, prompting the user to clean the tubes. If the tubes are dirty, they will still show seed flow with less accuracy. If the tubes are blocked the user will get an alarm as soon as planting starts. The corresponding bar graph will remain flashing until the problem is corrected and the monitor is powered down and then powered back up.

8. **Low Battery Warning** - The monitor is constantly monitoring its input voltage to quickly detect low power conditions. If the monitor detects that the input voltage has dropped below 10.5V, it will display "LOW POWER" on the LCD, provided that the monitor does not detect planting.

NOTE: After the alarms have been acknowledged and if the alarm condition is still present, the LCD will continue to display the alarm condition.

REPLACING A FAULTY SENSOR

To replace a faulty sensor; (a) turn the monitor off, (b) disconnect the faulty sensor, (c) turn the monitor back on and (d) plug in the replacement sensor. The monitor will chirp twice to acknowledge the new sensor was learned and saved.

To replace more than one faulty sensor, proceed as stated above beginning with the lowest numbered row in the rear or left section and continue to replace sensors in increasing order. Then move on to the front or right section and continue in increasing row number order.

NOTE: If the monitor is not turned off and then on, the replacement sensor(s) will be ignored until the next power on, at which point they will be randomly learned by the monitor.

FIELD OPERATION

(MTR28e/MTR28c/MTR28d/MTR28b)

Press the ON/OFF key to turn the monitor on and off.



Information regarding each section is displayed alternately every 5 seconds.

REAR/FRONT CONFIGURATION

- Press the SELECT key once to show REAR section only.
- Press the SELECT key a second time to return to each section being displayed alternately every 5 seconds.
- Press the SELECT key a third time to show REAR section only again.



LEFT/RIGHT CONFIGURATION

- Press the SELECT key once to show LEFT section only.
- Press the SELECT key a second time to show RIGHT section only.
- Press the SELECT key a third time to return to each section being displayed alternately every 5 seconds.



NOTE: SELECT key has no function when only a single section is being used.

Press the VOLUME key to increase or decrease volume. See "Changing The Audio Volume".



Press the OK key to silence alarms. See "Warnings And Alarms".



CONNECTING SEED TUBES

STEP 1 All the seed tubes w/sensors must be disconnected from the harness and the monitor must be off.

STEP 2 Press the ON key. The monitor automatically enters the setup procedure. If the monitor was accidentally powered on with no sensors attached, the user can turn the monitor off at this point and the previous configuration is not lost.

STEP 3 Press the SELECT key. Each time you press the SELECT key the mode will toggle between rear/front and left/right. The selected display will be solid and the configuration not currently selected will be flashing. By default the monitor starts in rear/front mode.

01229910

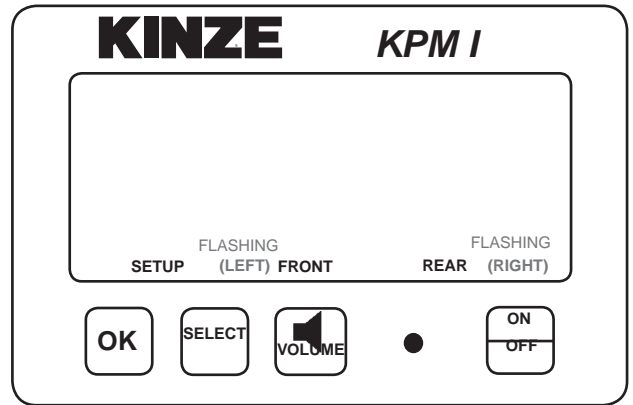

01229911

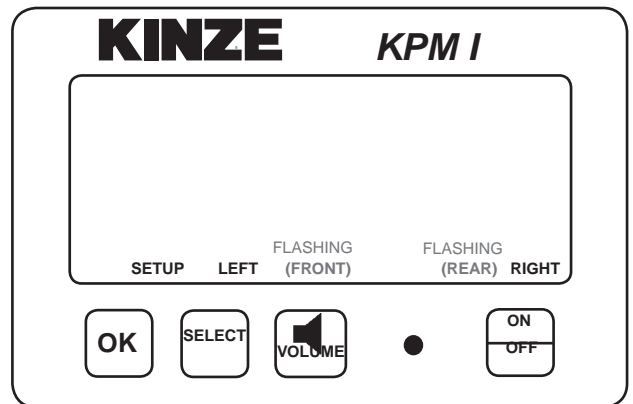

NOTE: The Model 2400 20" and 22" planters will use the rear configuration only. When Interplant® rows are in use, select the rear/front configuration. When all rows can be viewed on a single display (rear), pressing the select key has no function.

STEP 4 Press and hold the OK key to confirm the selection and continue holding until the row numbers appear on the display. During confirmation, the display will alternate between “NEW” and “SYS” to alert the user that the previous configuration will be lost. With the rear/front mode selected, the monitor automatically starts with the rear section. The REAR icon shows solid and the FRONT icon starts to flash. With the left/right mode selected, the monitor automatically starts with the left section. The LEFT icon shows solid and the RIGHT icon starts to flash.

STEP 5 Plug each seed tube w/sensor into the harness in a predetermined order. Row 1 first, row 2 second and so on up to 18 rows. When a sensor is plugged in, the corresponding row number on the LCD display will stay solid, the monitor will chirp twice and the LED (Light Emitting Diode) on the seed tube sensor will turn on for approximately 30 seconds to show connection is made. NOTE: Unless there is a faulty sensor, the installer should just have to connect the sensors in the proper order without checking the monitor is acknowledging each sensor.

01229912

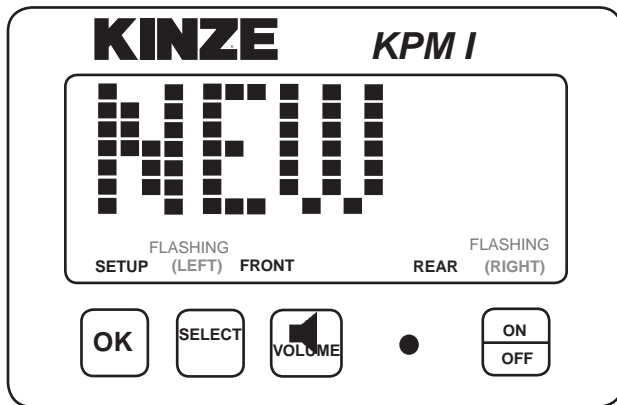

01229915

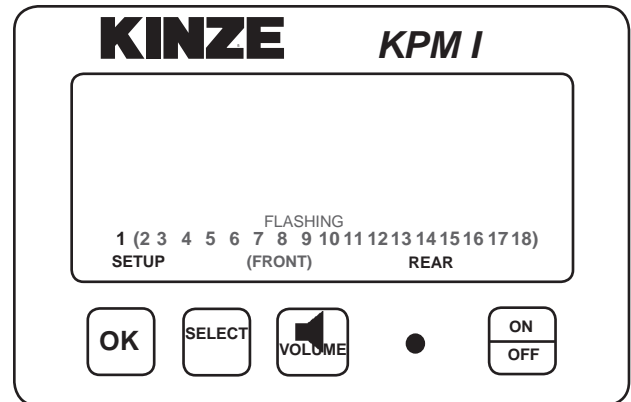

01229912a

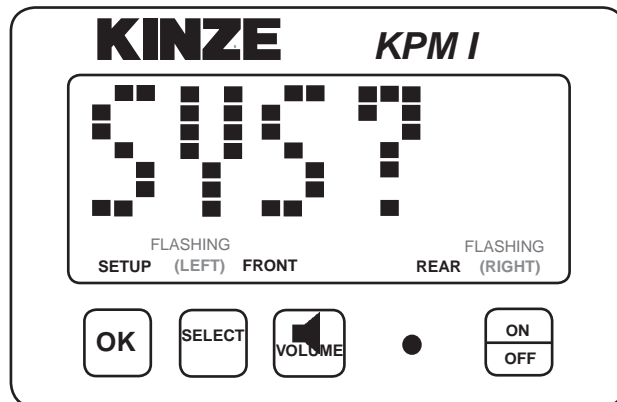

STEP 6 When all the seed tubes w/sensors for the current section are installed, check to be sure the monitor displays solid numbers for the number of sensors connected.

01229916

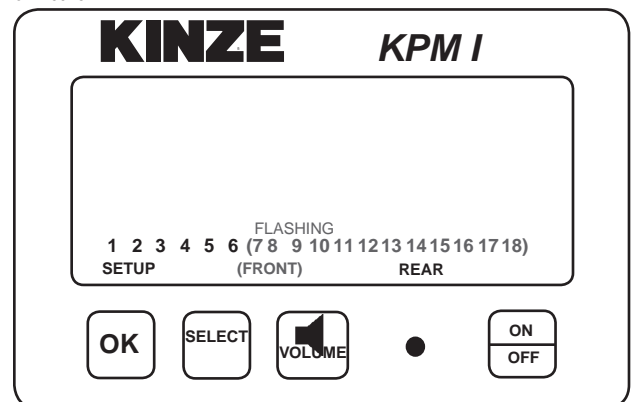

STEP 7 If this condition is satisfied, press and hold the OK key to save the setup for the current section. The SAVE? icon will show followed by continuous short beeps indicating the monitor is preparing to save. The installer has 5 seconds to decide if he wants to save the current configuration. During this time the short beeps will sound. To complete the save, hold the OK key pressed until the word "DONE" shows on the screen followed by a long beep and the SAVE? icon turns off. When the OK key is released the monitor will continue with the second section installation.

STEP 8 Follow Steps 5 through 7 to install the second section. If no seed tubes are installed on the second section, press and hold the OK key until the word "DONE" shows on the screen followed by a long beep and the SAVE? icon turns off.

01229917

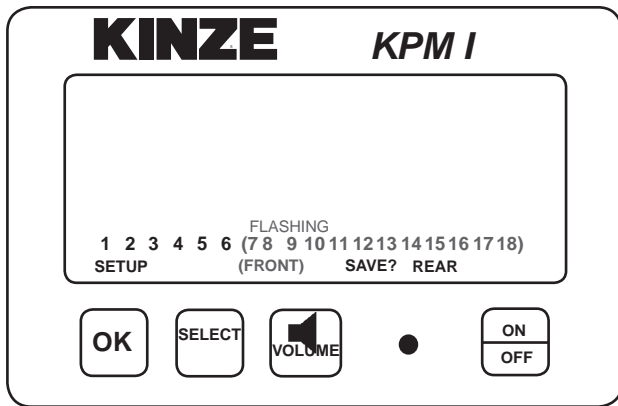

01229919

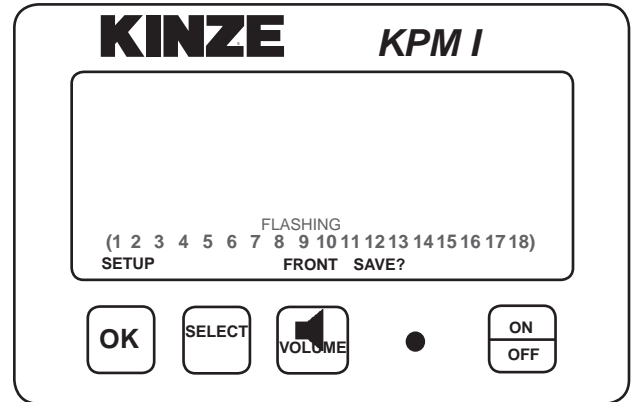

01229920

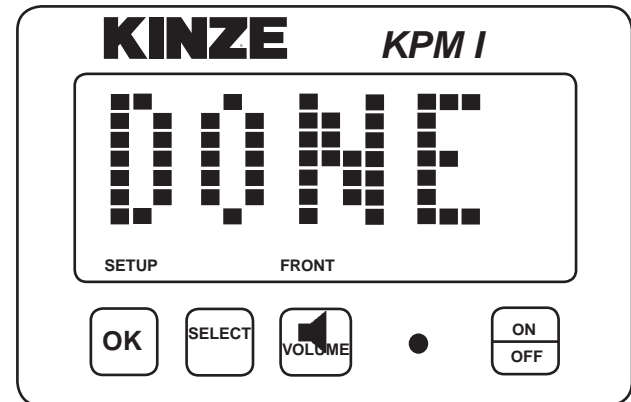

01229918

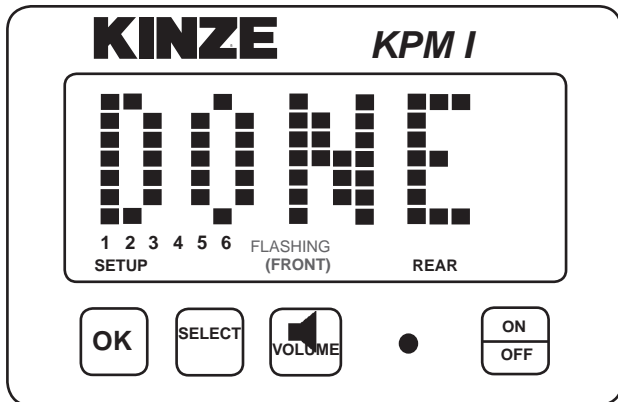

NOTE: Individual seed tubes may be unplugged for special situations. An alarm will sound which can be silenced by touching the OK key. The monitor will recognize the seed tube(s) when reconnected.

KPM II MONITOR

(MTR29)

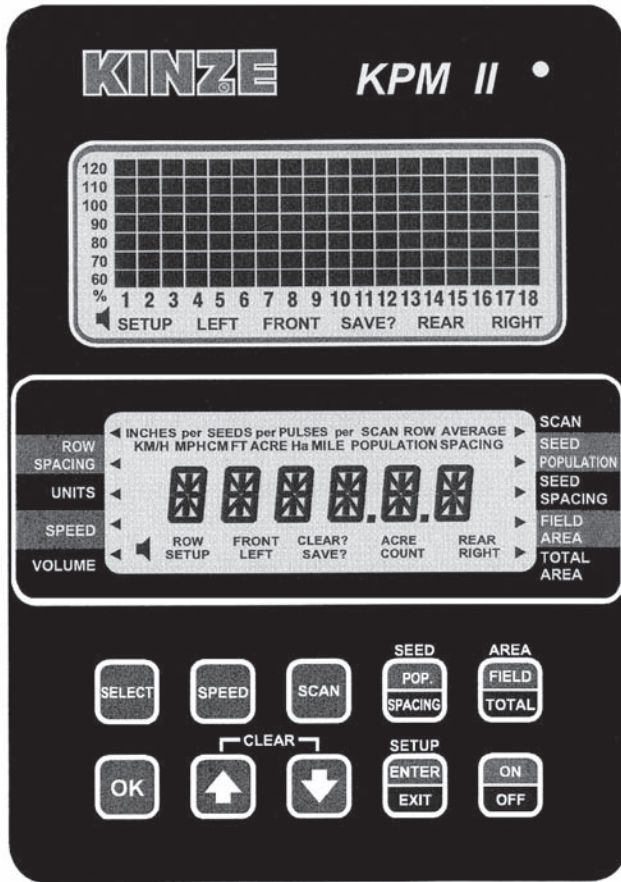

The electronic seed monitor system consists of a console, which is mounted on the tractor; seed tubes with computerized sensors, one of which is installed in each planter row unit; a primary harness, which connects the console to the planter harness; and a planter harness (junction harness and/or harness extensions where applicable) to which the individual seed tube sensors and rotation sensors connect. The monitor works with a magnetic (pickup) distance sensor or radar distance sensor.

Seed flow for up to 36 rows, in two 18 row sections (left/right or rear/front), may be monitored with one monitor. For less complicated applications, all rows may be programmed in one section and the other left disabled.

The monitor system is powered by the tractor battery (requires 12 volts DC). The console receives information from each of the sensors and translates this information.

The monitor has two backlit Liquid Crystal Displays (LCD). The upper display shows the active section, the number of monitored rows per section, the relative seed rate for each row (using a bar graph display) and scrolls various alarm and warning messages when an alarm condition exists. A continuous audio alarm will sound upon system malfunction or underflow conditions for any monitored row. Alarms must be acknowledged by the user. Various warnings may sound the buzzer or flash one or more icons. The lower display is used to display alphanumeric data such as row spacing, units (Metric or English), speed, volume, seed population, seed spacing, field area, total area and distance sensor pulses per mile/kilometer.

The monitor will power down if no activity is sensed for more than one hour. No activity means there has been no new seed flow and no operator push key input.

Monitor Key Function.....	6-19
Upper LCD Functions.....	6-20
Lower LCD Functions.....	6-21
Programming	
Changing The Audio Volume.....	6-23
Units (Metric Or English).....	6-24
Row Spacing	6-24
Speed	6-26
Clearing Total Area.....	5-27
Acre Counter/Speedometer Mode.....	6-28
Warnings And Alarms	6-28
Replacing A Faulty Sensor	6-29
Field Operation	6-29
Clearing Field Area.....	6-30
Connecting Seed Tubes, Radar/Magnetic Distance Sensors And/Or Shaft Rotation Sensors.....	
	6-31

MONITOR KEY FUNCTIONS

Push keys allow the user to select or change the operating mode, the active displays or the current configuration. Depending on the operating mode or the current display selected, some keys are valid while some are not. Each key press if valid is acknowledged by a short beep and an action is taken. If the key press has no action associated, the key press is considered invalid and the user will not get any feedback.

SELECT

- Selects the application mode (rear/front or left/right) at the beginning of installation in the setup mode.
- Selects the active section(s) (rear, rear/front, left, right or left/right) in the normal mode.
- Has no affect on a system configured to monitor only one section.
- While programming the monitor, the key will select the digit to change.

SPEED

- Immediately displays the current ground speed.

SCAN

- If the current average population or average spacing is displayed, this key sequentially displays the seed population/spacing on each row.
- If the display shows functions other than average seed population or spacing, pressing SCAN will sequentially display speed, average seed population and average seed spacing.
- Pressing a second time freezes the display on the current row.
- Pressing a third time restarts the sequential display.

SEED POPULATION/SEED SPACING

- Immediately displays the average seed POPULATION and the average seed SPACING of all active rows.
- Each press alternates between seed spacing and seed population.

AREA FIELD/AREA TOTAL

- Immediately displays the field and total area planted since the field/total area was last cleared.
- Each press alternates between field area and total area.

OK

- Ends and saves the new setup during installation.
- Acknowledges and silences alarms in the operation mode.

UP ARROW AND DOWN ARROW

- Scrolls sequentially through the display options on the lower LCD display.
- Freezes on the current row in the scan mode.
- Scrolls sequentially through the rows when the population scan is frozen.
- Used to enter programmable values in the programming mode.
- The Up and Down Arrow keys can be pressed at the same time to start the CLEAR function.

SETUP ENTER/SETUP EXIT

- Enters and exits the programming mode.

ON/OFF

- Powers the unit on and off.

UPPER LCD FUNCTIONS

(MTR29H)

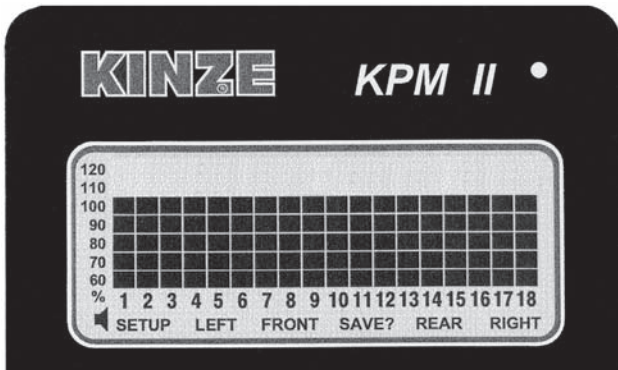

The monitor collects data on the planting rates from all active rows and calculates an average. This average will determine the 100% mark. Seed rate for each row is then compared to the average value and the result is displayed on the bar graph.

The information regarding each section is displayed alternately every 5 seconds. While operating a system with two sections programmed, one or both sections may be selected any time. When only one section is selected, the monitor calculates the average based on the remaining active rows from that section.

STEP 1 Press SELECT key once to show one section. The flashing icon shows the section that is not selected. The selected section icon is continuously displayed on the LCD.

EXAMPLE: The system is setup to display rear/front sections. Press SELECT key. The FRONT icon will be flashing and the REAR section will be displayed on the bar graph. After 1 minute the front row icon will stop flashing. The monitor will stay in this REAR only display through power down and power up. Each time the monitor is turned on while in REAR only mode, the FRONT icon will flash for 1 minute. Also if seed flow is sensed in the FRONT section while planting, the FRONT icon will resume flashing.

When the front section is disabled, the row spacing will automatically double to maintain the proper implement width in the monitor. A 23 row 15" configuration changes to a 12 row 30" configuration with a touch of the SELECT key.

STEP 2 Press SELECT key again to activate both sections.

EXAMPLE: Press SELECT key a second time. The information regarding each section will display alternately every 5 seconds.

For simple applications, where only one section is programmed, the display will automatically lock on that section. Pressing the SELECT key will have no affect.

NOTE: When alternating between two sections, the display will lock on the section containing the first recognized alarm until the alarm is acknowledged by pressing the OK key or the alarm condition is removed.

LOWER LCD FUNCTIONS

(MTR29g)

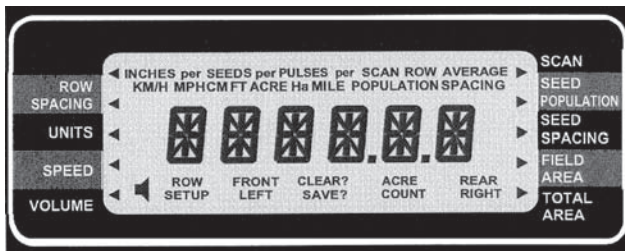

- The UP and DOWN arrow keys will sequentially change what is being displayed on the lower LCD. Pressing the UP or DOWN arrow keys will move the arrow head icon (on the left and right hand side of the display) to another item. For example, if the arrow icon is pointing to SPEED, ground speed will be displayed on the LCD. Pressing the UP arrow key will move the icon to UNITS. The display will change to display all the icons used to represent the current (English or Metric) measurement system.
- The shortcut keys SPEED, SEED POPULATION/SPACING and AREA FIELD/TOTAL allow direct access to their respective displays. For example, no matter what is currently being displayed on the lower LCD, pressing the SPEED key will change the display to the current speed. Pressing the SEED POPULATION/SPACING or AREA FIELD/TOTAL keys will alternate between the two functions assigned to that key.
- Pressing the SCAN key while displaying seed spacing or population will cause a sequential display of each individual row. Pressing the SCAN key a second time will freeze the display on the currently displayed row. The UP or DOWN arrow keys can be used to change the currently displayed row. Pressing the SCAN key will restart the automatic advancing of the scan function.
- Pressing the SCAN key while displaying speed will cause a sequential display of speed, average planter population and average seed spacing. Pressing the SCAN key a second time will freeze the display on the currently displayed reading.

current spacing between rows in inches or centimeters. The ROW SPACING icons turn on, displaying a 3 digit, one decimal place format. In the acre counter mode, this function displays the implement width in feet or meters, using a 3 digit, no decimal places format.

UNITS

Press the arrow keys to UNITS to display all the icons from the currently selected English or Metric measurement system. For the English system, the icons are: INCH, MPH, FT, ACRE and MILE. For the Metric system, the icons are: M, KM/H and Ha.

SPEED

Press the SPEED key to display the current speed in MPH or KM/H, using a 3 digit, one decimal place format.

VOLUME

Press the arrow keys to VOLUME to display the presently selected audio volume. The SPEAKER icon turns on.

SCAN

Press the SCAN key to display the seed spacing or seed population (See below) of each individual row. (1)Pressing the SCAN key while displaying any other function will cause the monitor to sequentially display speed, average seed population and average seed spacing. (2)Pressing the SCAN key a second time will freeze the display. (3)Pressing the SCAN key a third time restarts the sequential display. The UP and DOWN arrow keys can be used to change the current display.

ROW SPACING

Press the arrow keys to ROW SPACING to display the

SEED POPULATION/SEED SPACING

Each SEED POP/SPACING key press alternates between seed population and seed spacing.

Seed population displays the average number of seeds or the row average number of seeds per acre or seeds per hectare for all the active rows. The average is displayed using a 6 digits, no decimal places format. The AVERAGE POPULATION icon will turn on. When in the scan mode, the scan arrow and SCAN ROW POPULATION will appear. The ROW number icon and the current row will be displayed on the left and the population will be displayed on the right in 1000's using 3 digits, one decimal place (e.g. 32.9 means 32,900). When in scan freeze mode, the scan arrow and ROW POPULATION will turn on (scan arrow may be flashing). The UP and DOWN keys may be used to lock on the desired row.

Seed spacing displays the average distance or the row average distance between seeds for all active rows in inches per seed or centimeters per seed, using a 3 digit, one decimal place format. When the average is displayed the AVERAGE SPACING icons are turned on. When in the scan mode, the scan arrow and SCAN ROW SPACING icons will appear. The ROW number icon and the current row will be displayed on the left and the spacing will be displayed on the right. The display will sequence to the next row every 5 seconds. When in scan freeze mode, the scan arrow and SPACING will turn on (scan arrow may be flashing). The UP and DOWN keys may be used to lock on the desired row.

FIELD AREA/TOTAL AREA

Each AREA FIELD/TOTAL key press alternates between field area and total area.

Field area displays the total number of acres or hectares, using a 6 digit, one decimal place format.

NOTE: When FIELD AREA is selected, the UP or DOWN key must be held in slightly longer than normal so the monitor will not mistake this action with a CLEAR, which consists of the UP and DOWN arrow keys pressed simultaneously. A beep will sound when the function activates.

Total area displays the total number of acres or hectares, using a 6 digit, one decimal place format. The total area counter updates every time the field area counter increments. Clearing the total area counter will also clear the field area counter.

When the monitor is programmed as a rear only or rear/front configuration and shaft rotation sensors are installed, pressing the up arrow to move beyond row spacing lights an arrow on an unlabeled area above ROW SPACING. This is the automatically set division line between the L.H. shaft sensor and the R.H. shaft sensor. The display shows the first row on the rear section and the front section assigned to the R.H. shaft rotation sensor.

EXAMPLE: On a 12 row 30" planter with Interplant®, the display would appear as follows:

092597-21



THIS DISPLAY IS NOT ACCESSIBLE ON LEFT/RIGHT CONFIGURATIONS OR SYSTEMS WITHOUT SHAFT ROTATION SENSORS.

PROGRAMMING - Changing The Audio Volume

STEP 1 To enter the programming mode, press and hold the SETUP key. The monitor will emit several short beeps, followed by a long beep. On the lower LCD, the SETUP icon turns on and the arrow head icon will flash, indicating that the user can select an item to program.

NOTE: The monitor must be in a programmable function (row spacing, units, seed, volume or area) to enter setup. The monitor will not enter setup in seed population or seed spacing.

STEP 2 Press the UP or DOWN arrow keys to move the flashing arrow to VOLUME. As the arrow icon moves, the lower LCD will display the current setting of the item selected.

STEP 3 Press the OK key and the flashing arrow becomes solid and the beeper will sound.

NOTE: The lower LCD will display the current volume and the SPEAKER icon is turned on. Settings are from 0 to 7.

- Use the UP or DOWN arrow keys to change the setting. With every UP arrow key push, the beeper will increment by one step between the minimum and the maximum. If the maximum level (7) is reached the volume rolls over to the minimum level (0).

- Pressing the DOWN arrow key lowers the volume until the minimum level (0), at which point the volume rolls over to the maximum level (7).

STEP 4 To exit without saving, press and release the OK key. The monitor will restore the lower LCD to show the setting of the item, and the arrow icon will flash, allowing the user to select another item to program.

To exit and save, press and hold the OK key. The monitor will emit several short beeps and SAVE? icon is turned on. After a short time a long beep is heard, and the lower LCD will display the word "DONE". Release the OK key. If the OK key is released BEFORE the word "DONE" is displayed, the changes WILL NOT BE SAVED. The word "DONE" MUST be displayed in order for the save to have occurred.

NOTE: The programming mode may be exited at any time, by pressing the SETUP key. Pressing this key will return the monitor to its normal operation. All items changed and saved will come into affect immediately. Any items changed, but not saved will revert to the original programmed value.

PROGRAMMING - Units (Metric Or English)

STEP 1 To enter the programming mode, press and hold the SETUP key. The monitor will emit several short beeps, followed by a long beep. On the lower LCD, the SETUP icon turns on and the arrow head icon will flash, indicating that the user can select an item to program.

NOTE: The monitor must be in a programmable function (row spacing, units, seed, volume, area) to enter setup. The monitor will not enter setup in seed population or seed spacing.

STEP 2 Press the UP or DOWN arrow keys to move the flashing arrow to UNITS. As the arrow icon moves, the lower LCD will display the current setting of the item selected.

STEP 3 Press the OK key and the flashing arrow becomes solid and the beeper will sound.

NOTE: The lower LCD will alternately display all Metric icons or all English icons, indicating the Metric or English mode respectively.

•Use the UP or DOWN arrow keys to change the setting.

STEP 4 To exit without saving, press and release the OK key. The monitor will restore the lower LCD to show the setting of the item, and the arrow icon will flash, allowing the user to select another item to program.

To exit and save, press and hold the OK key. The monitor will emit several short beeps and SAVE? icon is turned on. After a short time a long beep is heard, and the lower LCD will display the word "DONE". Release the OK key. If the OK key is released BEFORE the word "DONE" is displayed, the changes WILL NOT BE SAVED. The word "DONE" MUST be displayed in order for the save to have occurred.

NOTE: The programming mode may be exited at any time, by pressing the SETUP key. Pressing this key will return the monitor to its normal operation. All items changed and saved will come into affect immediately. Any items changed, but not saved will revert to the original programmed value.

PROGRAMMING - Row Spacing

STEP 1 Prior to entering the programming mode, the application mode (rear/ront or left/right) must be active. If the monitor is programmed in a rear/front configuration, both sections will be active (alternating every 5 seconds). You can then set the row spacing to the Interplant® row spacing.

EXAMPLE: On a 12 row 30" with Interplant® set the row spacing to 15.0 with front active.

When the monitor is in normal field operation mode, disabling the front section will automatically change the row spacing to 30".

STEP 2 To enter the programming mode, press and hold the SETUP key. The monitor will emit several short beeps, followed by a long beep. On the lower LCD, the SETUP icon turns on and the arrow head icon will flash, indicating that the user can select an item to program.

NOTE: The monitor must be in a programmable function (row spacing, units, seed, volume, area) to enter setup. The monitor will not enter setup in seed population or seed spacing.

STEP 3 Press the UP or DOWN arrow keys to move the flashing arrow to ROW SPACING. As the arrow icon moves, the lower LCD will display the current setting of the item selected.

STEP 4 Press the OK key and the flashing arrow becomes solid and the beeper will sound.

NOTE: The lower LCD will display the current row spacing (in inches or centimeters) and ROW SPACING icon is turned on.

•The least significant digit of the displayed value will be blinking.
•This value can be changed by pressing either the UP or DOWN arrow keys.
•Once this digit is correct, press the MODE SELECT key and the blinking digit will move to the next significant digit, where the process can be repeated.

NOTE: The monitor limits the entry of row spacing to a minimum of 10.0 inches (25.4 cm) and to a maximum of 99.9 inches (253.7 cm). If the monitor is configured to a rear/front configuration, the limits change to a minimum of 5.0 inches (12.7 cm) and a maximum of 49.9 inches (126.8 cm).

STEP 5 To exit without saving, press and release the OK key. The monitor will restore the lower LCD to show the setting of the item and the arrow icon will flash, allowing the user to select another item to program.

To exit and save, press and hold the OK key. The monitor will emit several short beeps and SAVE? icon is turned on. After a short time a long beep is heard, and the lower LCD will display the word "DONE". Release the OK key. If the OK key is released BEFORE the word "DONE" is displayed, the changes WILL NOT BE SAVED. The word "DONE" MUST be displayed in order for the save to have occurred.

To exit setup mode, press the SETUP key.

NOTE: The programming mode may be exited at any time, by pressing the SETUP key. Pressing this key will return the monitor to its normal operation. All items changed and saved will come into affect immediately. Any items changed, but not saved will revert to the original programmed value.

PROGRAMMING - Speed

STEP 1 To enter the programming mode, press and hold the SETUP key. The monitor will emit several short beeps, followed by a long beep. On the lower LCD, the SETUP icon turns on and the arrow head icon will flash, indicating that the user can select an item to program.

NOTE: The monitor must be in a programmable function (row spacing, units, seed, volume, area) to enter setup. The monitor will not enter setup in seed population or seed spacing.

STEP 2 Press the UP or DOWN arrow keys to move the flashing arrow to SPEED. As the arrow icon moves, the lower LCD will display the current setting of the item selected.

STEP 3 Press the OK key and the flashing arrow becomes solid and the beeper will sound.

The speed constant is used to record how many pulses are generated per mile (or kilometer) from the ground speed sensor. The lower LCD will display the current pulses per mile (or kilometer), using a 6 digit, no decimal place format. The PULSES per MILE (or PULSES per KM) icons are turned on.

NOTE: It is highly recommended that a field calibration be done to establish the PPM (Pulses Per Mile) number on a new machine installation. Several factors can affect this value such as wheel slip on the magnetic distance sensor, mount angle and height on radar distance sensor, etc. IT IS NOT UNCOMMON FOR THE MPH ON THE MONITOR TO VARY SLIGHTLY FROM THE TRACTOR SPEEDOMETER. Adjusting the PPM in the monitor to make the MPH agree can cause serious errors in acre/ hectare counts and population readings. Do field checks to verify populations and seed spacings.

NOTE: On new system installations, the monitor will default to 500 PPM. This will have to be changed to obtain accurate readings from the monitor.

- In field conditions, measure 330 ft. ($\frac{1}{16}$ mile) or 100m, depending on the unit of measurement selected.

- Pull the tractor up to the starting line.

- Press the UP and DOWN arrow keys at the same time and hold them down until the CLEAR? icon is displayed and the monitor beeps several times. When the data is actually cleared, the monitor will emit a long beep and the number of pulses is cleared.

- Drive the tractor for 330 feet ($\frac{1}{16}$ mile) or 100 meters and stop.

- The monitor will count the number of pulses and display them.

STEP 4 To exit without saving, press and release the OK key. The monitor will restore the lower LCD to show the setting of the item, and the arrow icon will flash, allowing the user to select another item to program.

To exit and save, press and hold the OK key. The monitor will emit several short beeps and SAVE? icon is turned on. After a short time a long beep is heard, and the lower LCD will display the word "DONE". Release the OK key. If the OK key is released BEFORE the word "DONE" is displayed, the changes WILL NOT BE SAVED. The word "DONE" MUST be displayed in order for the save to have occurred.

NOTE: The programming mode may be exited at any time, by pressing the SETUP key. Pressing this key will return the monitor to its normal operation. All items changed and saved will come into affect immediately. Any items changed, but not saved will revert to the original programmed value.

NOTE: If a discrepancy occurs and digits must be changed, follow Steps 1 and 2 to enter the programming mode and proceed as follows:

- Press the OK key and the flashing arrow becomes solid. The least significant digit of the displayed value will be blinking.
- This value can be changed by pressing either the UP or DOWN arrow keys.
- Once this digit is correct, press the MODE SELECT key and the blinking digit will move to the next significant digit, where the process can be repeated.

The monitor limits the entry of pulses per mile or kilometer to a minimum of 500 PPM (310 ppkm), and to a maximum of 500,000 PPM (310,686 ppkm).

KEY Action	Flashing Digit	Display Value
Press The UP Key	Right Most Digit	2031, 2032, 2033
Press The MODE SELECT Key	Second Digit From Right	2033
Press The DOWN Key	Second Digit From Right	2023, 2013, 2003, 2093, 2083
Press The MODE SELECT Key Twice	Left Most Digit	2083
Press The DOWN Key	Left Most Digit	1083, 0500 (Min. Value), 9500, 8500

PROGRAMMING - Clearing Total Area

STEP 1 To enter the programming mode, press and hold the SETUP key. The monitor will emit several short beeps, followed by a long beep. On the lower LCD, the SETUP icon turns on and the arrow head icon will flash, indicating that the user can select an item to program.

NOTE: The monitor must be in a programmable function (row spacing, units, seed, volume, area) to enter setup. The monitor will not enter setup in seed population or seed spacing.

STEP 2 Press the UP or DOWN arrow keys to move the flashing arrow to TOTAL AREA. As the arrow icon moves, the lower LCD will display the current setting of the item selected.

STEP 3 Press the OK key and the flashing arrow becomes solid and the beeper will sound.

- The lower LCD will display the total area and the ACRE (or Ha) icon turns on.
- With the flashing arrow on TOTAL AREA, press the OK key.

• To reset the counter, press the UP and DOWN arrow keys at the same time and hold them down for a short period of time to clear the data. The CLEAR? icon will be displayed and the monitor will beep several times. When the data is actually cleared, the monitor will emit a long beep, and the field area is reset to zeros. After the long beep, the previous recorded total area is not retrievable. Once cleared, the user **may not** choose to exit programming mode without saving as described in Step 4.

NOTE: Clearing the total area counter will also clear the field area counter.

STEP 4 To exit and save, press and hold the OK key. The monitor will emit several short beeps and SAVE? icon is turned on. After a short time a long beep is heard, and the lower LCD will display the word "DONE". Release the OK key. If the OK key is released BEFORE the word "DONE" is displayed, the changes WILL NOT BE SAVED. The word "DONE" MUST be displayed in order for the save to have occurred.

NOTE: The programming mode may be exited at any time, by pressing the SETUP key. Pressing this key will return the monitor to its normal operation. All items changed and saved will come into affect immediately. Any items changed, but not saved will revert to the original programmed value.

ACRE COUNTER/SPEEDOMETER MODE

If the monitor is installed with only a radar distance sensor (no seed tubes attached), the monitor becomes a speedometer. If (a) the monitor is connected to a radar distance sensor, (b) the signal cable from the back of the console is connected to a sensing switch (Part No. G1K249 Acre Counter Switch Kit) instead of the seed tubes and (c) the implement width in feet (or meters) is programmed into the monitor, the monitor will function as an acre counter.

The seed spacing and seed population functions are not available in this mode. If the monitor is powered down, the seed tubes connected and the monitor powered up, the monitor will again show seed population and seed spacing in inches or centimeters. Row spacing reverts back to its programmed setting.

WARNINGS AND ALARMS

- System Alarms** - A system alarm is entered when the monitor detects a faulty sensor or one of several other communication faults.

The corresponding row number starts flashing and the beeper sounds. All segments on the corresponding bar graph are turned off. Pushing the OK key to acknowledge the alarm will turn the beeper off. The row number will continue to flash until the alarm condition is removed. If the monitor detects a faulty sensor and there is no planting activity present, the monitor will scroll "CHECK CONNECTION".

If the distance sensor is detected as faulty, the monitor will display either "PICKUP" or "RADAR", depending on the type of sensor installed, and the audible alarm will sound. The user can push the OK key to acknowledge the alarm. When the distance sensor is faulty, the monitor will change to a bar graph only mode where the rows are still displayed relative to each other. No area related information (speed, field acres, total acres, seed spacing or seed population) will be accumulated or displayed.

If a rotation shaft sensor is faulty, LSHAFT, RSHAFT or SHAFTS will display.

Another type of system alarm occurs when the monitor detects a data communication bus error.

The three possible data communication bus errors are:

LCD Display	Error Condition
SYS HI	The data communication lead (green) has been shorted to the power lead (white).
SYS LO	The data communication lead (green) has been shorted to the ground lead (black).
SYS EC	An internal error has been detected.

- Under Flow Alarms** - If the seed rate for one or more rows is less than 55% of the calculated average, the corresponding 60% segment will stay on, the corresponding row number starts flashing and the alarm sounds. Pushing the OK key to acknowledge the alarm will turn the alarm off. The 60% segment of the bar graph remains on and the row number continues to flash until the alarm condition is corrected.

NOTE: All alarms present within a short time before planting stops are frozen on the screen and the text LOW or FAIL will display on the LCD. If the underflow is between 0% and 10%, this warrants a "FAIL" condition. If the under flow is between 10% and 55%, a "LOW" condition is generated. If multiple rows have an underflow condition, "FAIL" will display if any one or more rows is between 0% and 10%. This allows the user to identify and fix the problem rows.

NOTE: This warning will not trigger unless a minimum time of continuous planting has passed.

NOTE: If all the rows show a seed rate of zero, the condition will not generate an alarm. It will be assumed the planter has stopped. The row numbers and the bottom 60% segment will remain on for all selected rows.

- Multiple Alarms** - If more than one alarm condition occurs at the same time, pushing the OK key will acknowledge all alarms that are currently displayed. For example, if one row on the front and one row on the rear are alarming, pushing the OK key will only acknowledge one of them. However, if there are two alarms on the front, both alarms would be acknowledged with one push of the OK key.

4. **Section Not Selected Warning** - If the monitor was programmed for two sections and only one is currently selected for display (by pressing the SELECT key), the icon of the disabled section will flash for a period of 1 minute, then turn off at each power up. If seed flow is sensed in the disabled section, the icon for that section (front, left or right) will begin to flash.
5. **Seed Planting Stopped Warning** - When the monitor detects no seed flow on all rows, the monitor will emit 3 short beeps to alert the user. This warning will occur each time the planter is stopped, each time the planter is raised at the end of a row or if the mechanical drive fails while planting.
NOTE: This warning will not trigger unless a minimum time of continuous planting has passed.
6. **Seed Counting Sensor In Calibration Warning** - All seed counting sensors run a self-calibration sequence on power up. While in calibration the bottom segment of each corresponding bar graph will flash if the monitor detects movement or planting activity. If the monitor does not detect this, the message "WAIT CALIBRATION" will be scrolled.
7. **Seed Counting Sensor Too Dirty Warning** - After the seed counting sensors end their internal self-calibration, the monitor may detect one or more sensors are either too dirty or blocked. If the monitor detects planting or movement, the corresponding bar graph remains flashing. The monitor will display "CLEAN SENSORS" on the top LCD if no movement or planting is detected, prompting the user to clean the tubes. If the tubes are dirty, they will still show seed flow with less accuracy. If the tubes are blocked the user will get an alarm as soon as planting starts. The corresponding bar graph will remain flashing until the problem is corrected and the monitor is powered down and then powered back up.
8. **Low Battery Warning** - The monitor is constantly monitoring its input voltage to quickly detect low power conditions. If the monitor detects that the input voltage has dropped below 10.5V, it will display "LOW POWER" on the top LCD, provided that the monitor does not detect speed or planting.

NOTE: After the alarms have been acknowledged and if the alarm condition is still present, the LCD will continue to display the alarm condition.

REPLACING A FAULTY SENSOR

To replace a faulty sensor; (a) turn the monitor off, (b) disconnect the faulty sensor, (c) turn the monitor back on and (d) plug in the replacement sensor. The monitor will chirp twice to acknowledge the new sensor was learned and saved.

To replace more than one faulty sensor, proceed as stated above beginning with the lowest numbered row in the rear/left section and continue to replace sensors in ascending order. Then move on to the front/right section and continue in ascending order.

If the monitor detects a faulty distance sensor, the lower LCD will immediately move to the speed display, show the word "PICKUP" or "RADAR" depending on the distance sensor installed, and the alarm will sound.

NOTE: If the monitor is not turned off and then on, the replacement sensor(s) will be ignored until the next power on, at which point the sensors will be randomly learned by the monitor.

FIELD OPERATION

Press the ON/OFF key to turn the monitor on and off.



(MTR28e)

Information regarding each section is displayed alternately every 5 seconds.

REAR/FRONT CONFIGURATION

- Press the SELECT key once to show REAR section only. (Monitor sets correct row spacing)
- Press the SELECT key a second time to return to each section being displayed alternately every 5 seconds. (Monitor sets correct row spacing)
- Press the SELECT key a third time to show REAR section only again.



(MTR28c)

LEFT/RIGHT CONFIGURATION

- Press the SELECT key once to show LEFT section only.
- Press the SELECT key a second time to show RIGHT section only.
- Press the SELECT key a third time to return to each section being displayed alternately every 5 seconds.



(MTR28c)

NOTE: SELECT key has no function when only a single section is being used.

At power up, the lower LCD will show speed (MPH or KmPH).

(MTR29g/MTR29b/MTR29a/MTR29c/MTR29f/MTR29c/MTR29f)

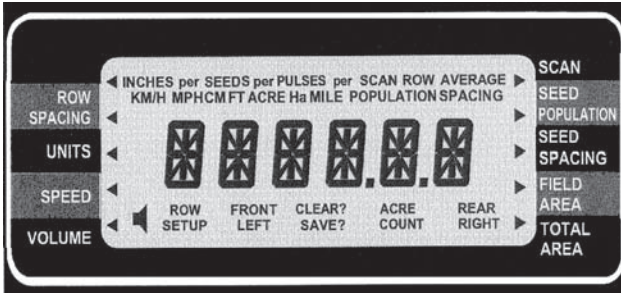

Press the UP or DOWN arrow keys to move the flashing arrow on the lower LCD to change what is displayed on the lower LCD.



Press the shortcut keys SPEED, SEED POPULATION/ SEED SPACING or AREA FIELD/TOTAL for direct access to these displays.



(MTR29c/MTR29d/MTR29b/MTR29c)

Press the SEED POPULATION/SEED SPACING or AREA FIELD/TOTAL keys to alternate between the two functions assigned to that key.



Press the SEED POPULATION/SEED SPACING key to choose average row seed spacing/population per acre.



Press the SCAN key to display individual rows starting at row 1.



Press the SCAN key again to lock on current row.

Press the SCAN key again to resume scrolling.

Use the UP or DOWN arrow keys to move to a particular row.



Press the SEED POPULATION/SEED SPACING key to go back to planter average.



CLEARING FIELD AREA

(MTR29n/MTR28b)

To reset the counter, press the UP or DOWN arrow keys to move the arrow in the lower display to FIELD AREA.

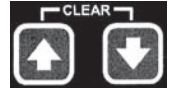

Press the UP and DOWN arrow keys at the same time and hold them down for a short period of time to clear the data. The CLEAR? icon will be displayed and the monitor will beep several times. When the data is actually cleared, the monitor will emit a long beep, and the field area is reset to zeros. After the long beep, the previous field area recorded is not retrievable.



NOTE: Clearing the field area counter will not clear the total area counter. See "Programming-Clearing Total Area" for clearing total area.

Press the OK key to silence alarms. See "Warnings And Alarms".



CONNECTING SEED TUBES, RADAR/MAGNETIC DISTANCE SENSORS AND/OR SHAFT ROTATION SENSORS

STEP 1 All the seed tubes w/sensors (including the radar, magnetic distance and shaft rotation sensors) must be unplugged from the harness and/or console and the monitor must be off.

NOTE: If the monitor detects a radar sensor but no seed tubes at power up, it will automatically go into ACRE COUNT mode. See "Acre Counter/Speedometer Mode".

NOTE: Disconnect magnetic distance sensor between MDS adapter and planter harness. **DO NOT** disconnect between MDS and MDS Adapter.

01189909

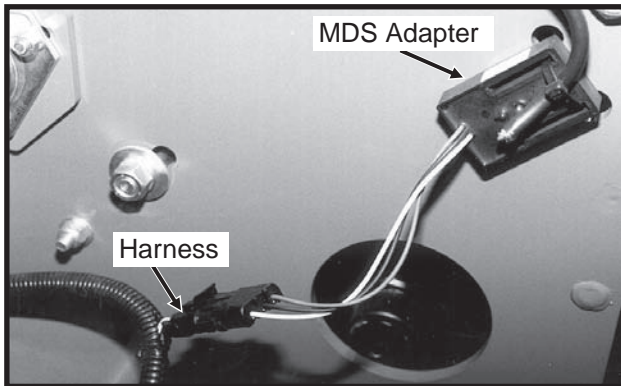

01189910

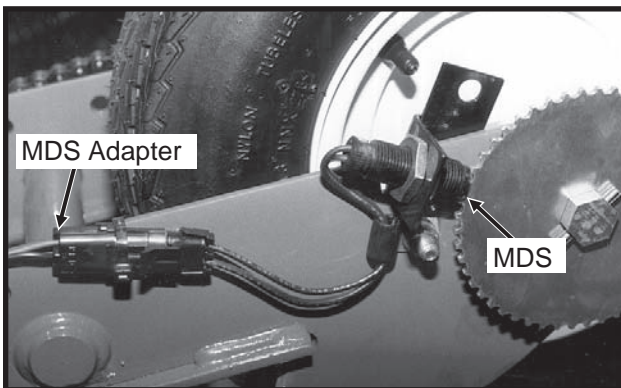

STEP 2 Press the ON key. The monitor automatically enters the setup procedure.

STEP 3 Press the SELECT key. Each time you press the SELECT key the mode will toggle between rear/front and left/right. The selected display will be solid and the configuration not currently selected will be flashing. By default the monitor starts in rear/front mode.

01139923

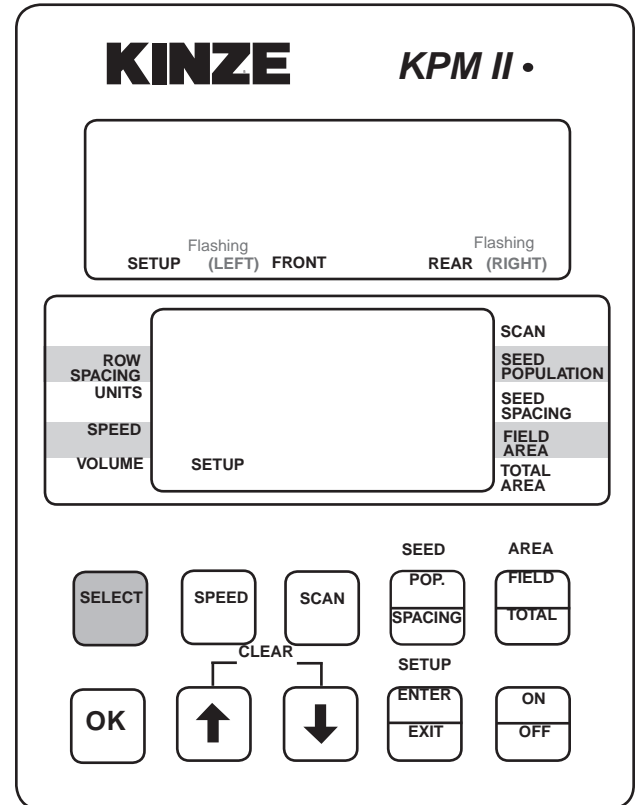

01139924

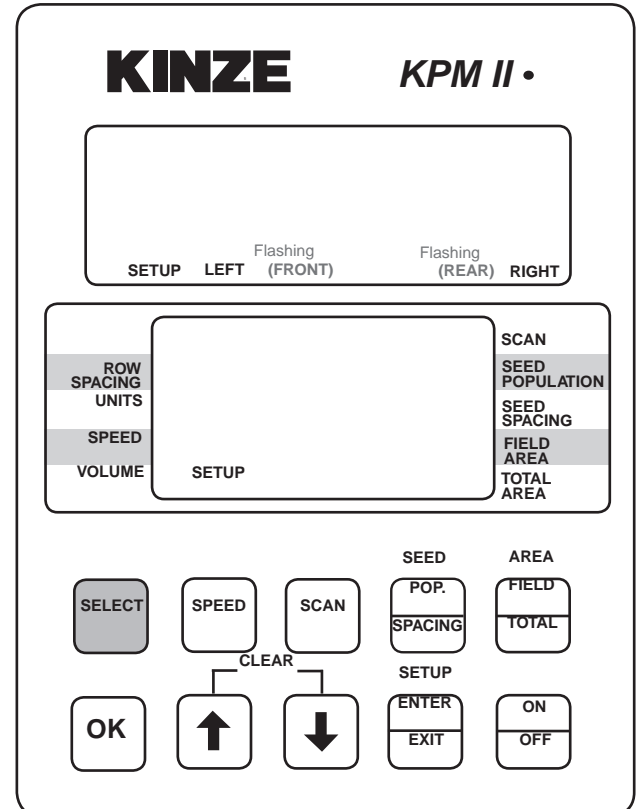

NOTE: For Model 2400 20" and 22" planters select the rear configuration only. When Interplant® rows are in use, select the rear/front configurations.

STEP 4 Press and hold the OK key to confirm selection. The upper display will alternate between NEW and SYS?

The alarm will sound four short beeps followed by one long beep. At this point your selection has been saved and row numbers will appear flashing on the upper display.

01139922

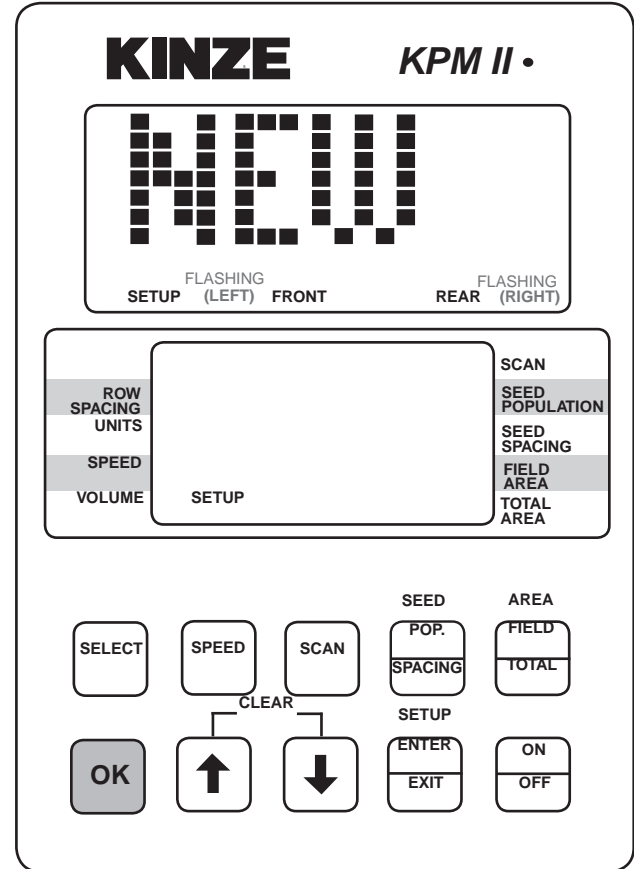

01139922

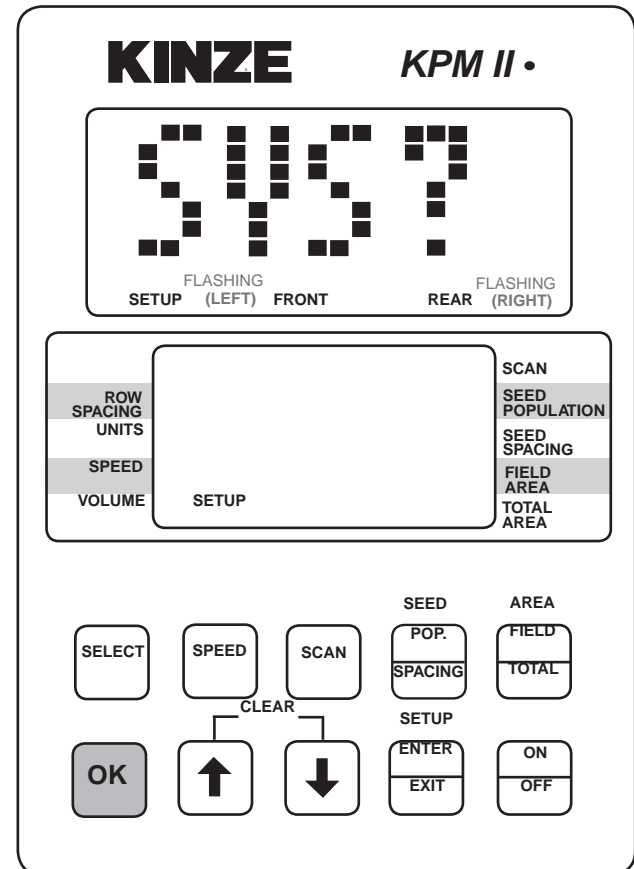

STEP 5 Determine which row you want as number one and plug seed tube w/sensor into the harness.

Continue plugging in sensor along with shaft rotation sensor if so equipped. Row 1 first, row 2 second and so on up to 18 rows. When a sensor is plugged in, the corresponding row number on the upper LCD display will stay solid, the monitor will chirp twice and a red LED (Light Emitting Diode) on the seed tube sensor will turn on for approximately 30 seconds to show connection is made.

D04219901

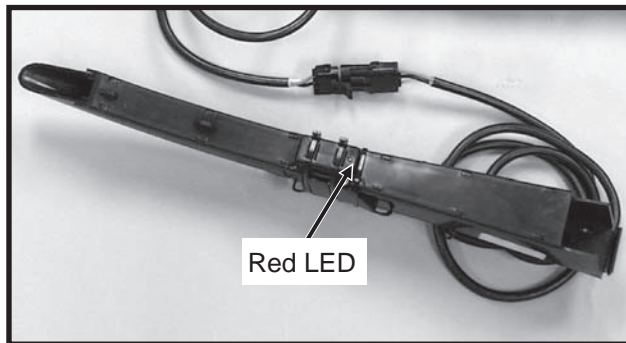

01139921

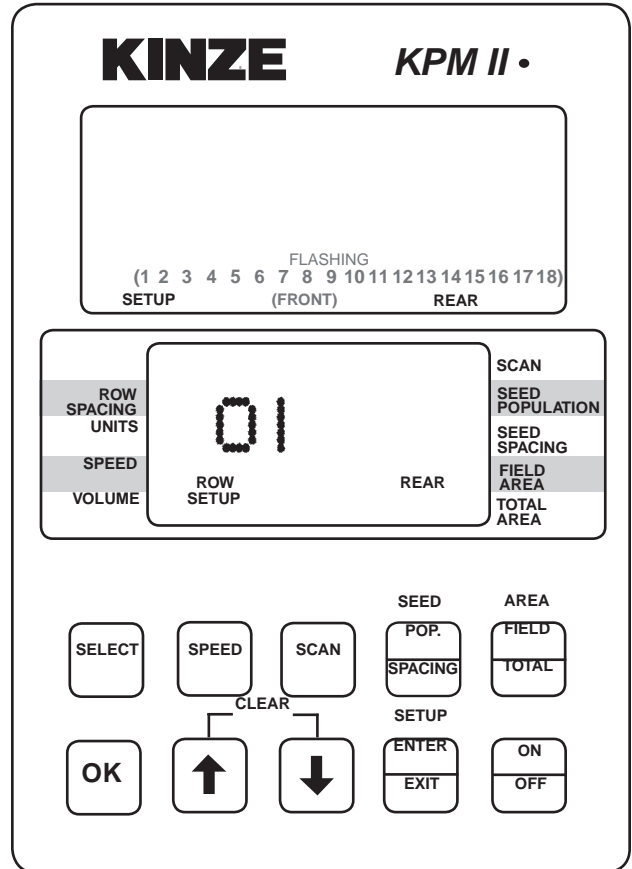

01139911

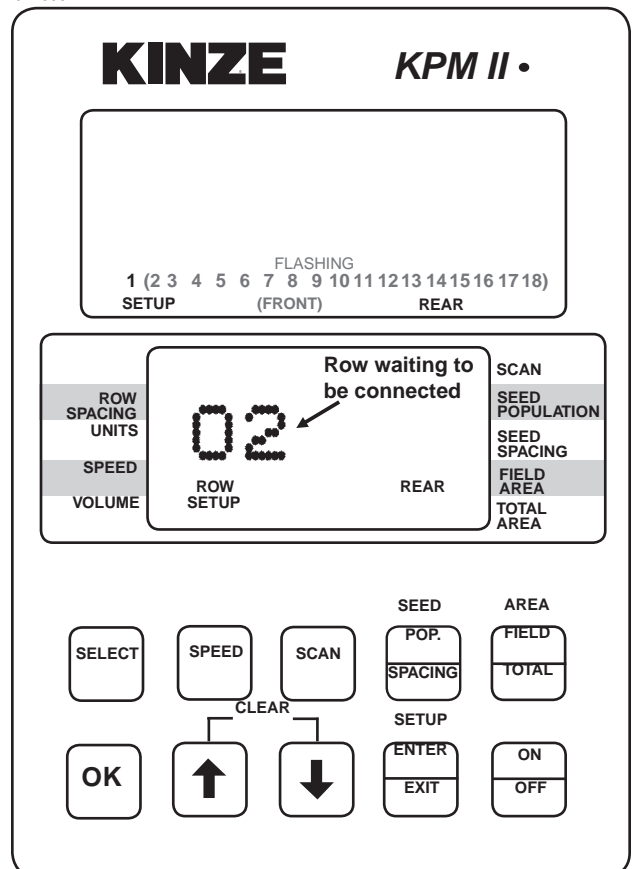

STEP 6 If the monitor system includes shaft rotation sensors, these can be installed at any time as the seed tubes are connected. The first shaft rotation sensor installed will be assigned to the rows on the L.H. half of the planter and the second shaft rotation sensor connected will be assigned to the rows on the R.H. half of the planter.

01189906

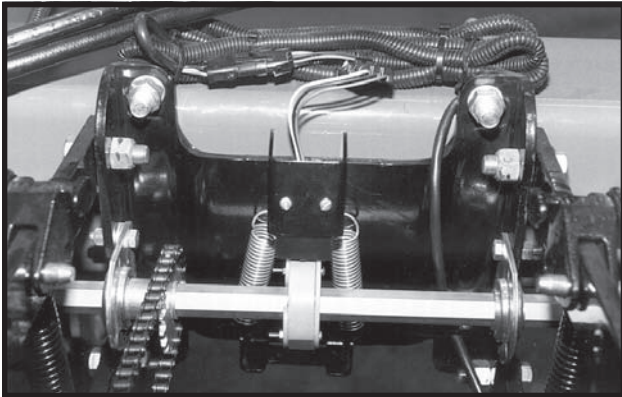

LSHAFT will display on the upper LCD when the first shaft rotation sensor is installed. RSHAFT will display when the second shaft rotation sensor is installed.

01139919

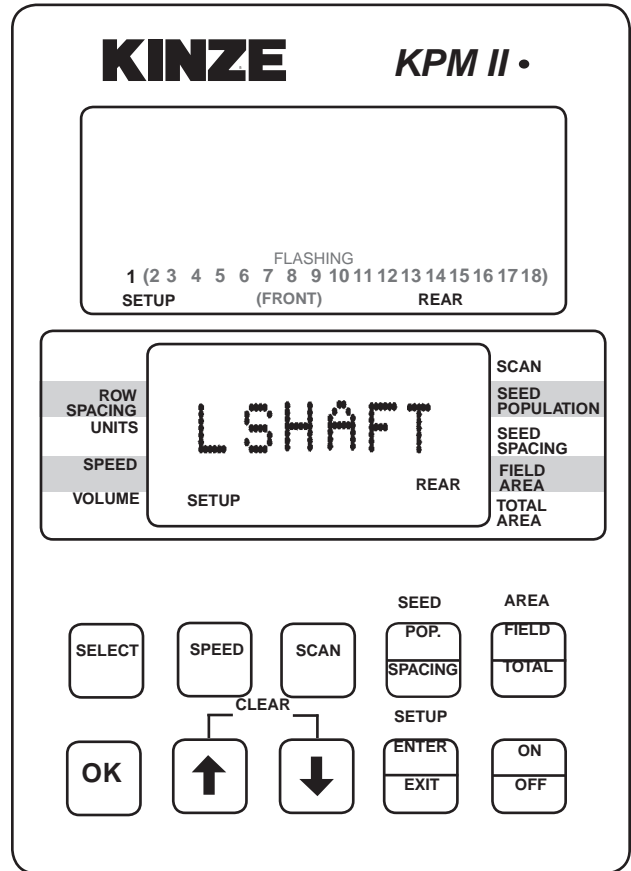

01139916

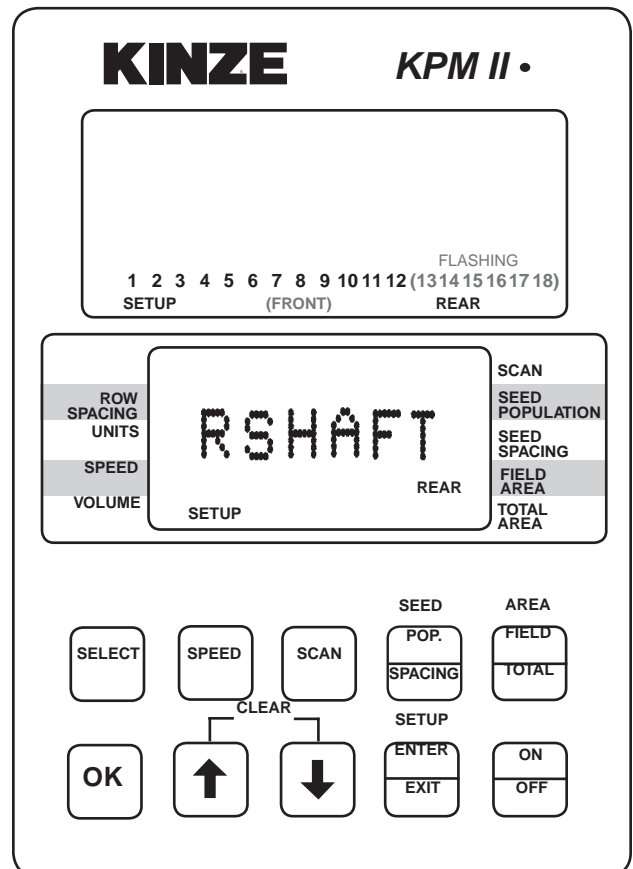

STEP 7 When all the seed tubes for the current section (Front/Rear or Left/Right) are installed, check to be sure the monitor displays solid numbers for the number of seed tubes connected. Press and hold the OK key to save the setup for the current section. The SAVE? icon will display followed by continuous short beeps indicating the monitor is preparing to save. The installer has 5 seconds to decide to save the current configuration. During this time, the four short beeps will sound followed by a long beep and the SAVE? icon will turn off and the word “DONE” shows on the screen. The monitor will continue to the second section installation (If Applicable).

01139914

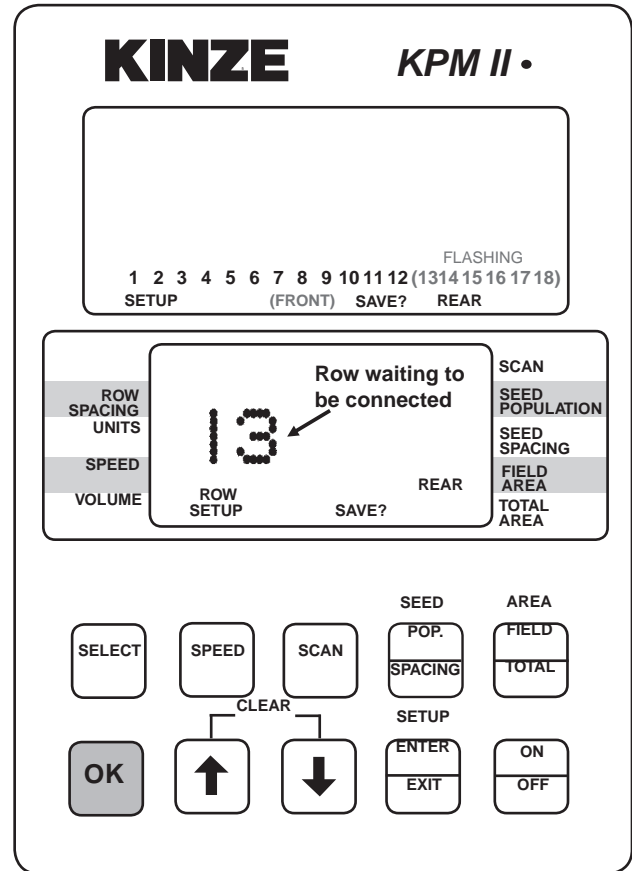

01139913

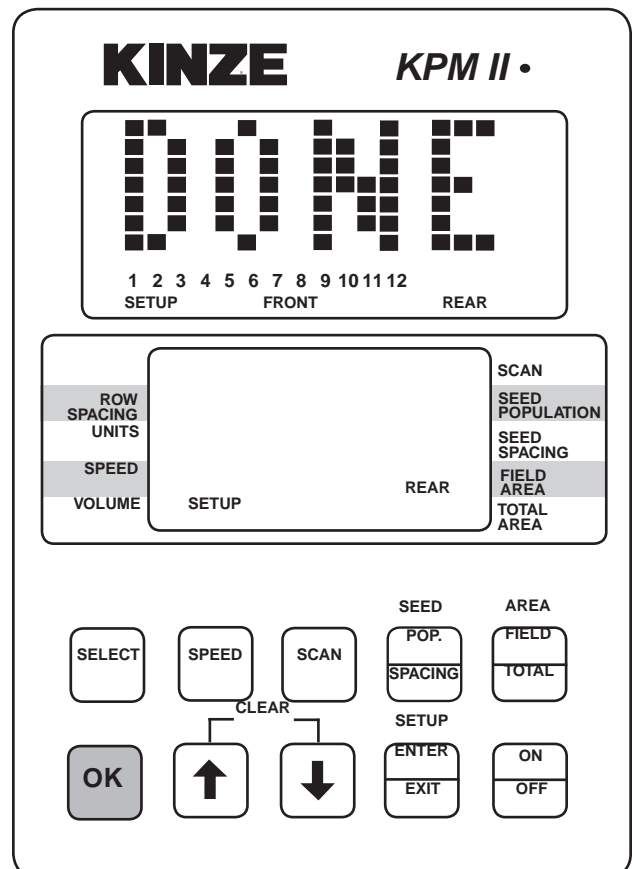

STEP 8 Follow Steps 5 through 7 to install the second section. If no seed tubes are installed on the second section, press and hold the OK key. The word "DONE" will appear on upper display. The alarm will sound four short beeps followed by one long beep and the SAVE? icon turns off. When you release the OK key the upper display will scroll (WAITING CALIBRATION). The lower display will show GNDSPD and the alarm will sound continually until the MDS is plugged in. If the system will be using a radar sensor, turn the console off. Radar sensor can be installed later.

01139912

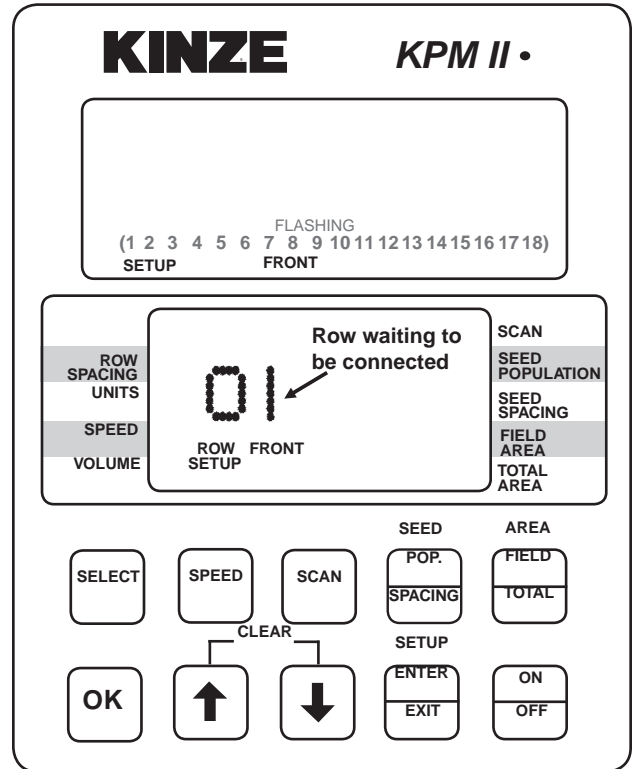

01139920

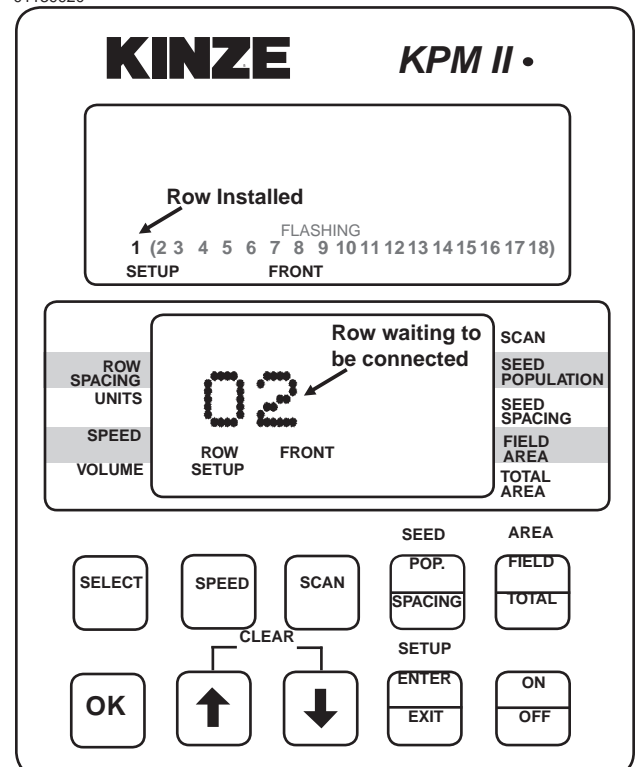

01139910

KINZE
KPM II •

Rows Installed

1 2 3 4 5 6 7 8 9 10 11 (12 13 14 15 16 17 18) FLASHING

SETUP FRONT SAVE?

ROW SPACING UNITS
SPEED
VOLUME

Row waiting to be connected

ROW SETUP FRONT SAVE?

SCAN
SEED POPULATION
SEED SPACING
FIELD AREA
TOTAL AREA

SELECT

SPEED

SCAN

SEED POP. SPACING

AREA FIELD TOTAL

CLEAR

OK

↑

↓

SEED SETUP ENTER EXIT

AREA ON OFF

01139910a

KINZE
KPM II •

DONE

1 2 3 4 5 6 7 8 9 10 11 (12 13 14 15 16 17 18) FLASHING

SETUP FRONT

ROW SPACING UNITS
SPEED
VOLUME

FRONT

SETUP

SCAN
SEED POPULATION
SEED SPACING
FIELD AREA
TOTAL AREA

SELECT

SPEED

SCAN

SEED POP. SPACING

AREA FIELD TOTAL

CLEAR

OK

↑

↓

SEED SETUP ENTER EXIT

AREA ON OFF

STEP 9 When both sections are finished and saved, the monitor will exit the setup mode.

NOTE: To reprogram the system to monitor more or less rows (up to the maximum of 18 per section, 36 total), all sensors must be unplugged, followed by the complete setup procedure.

NOTE: Individual seed tubes may be unplugged for special situations. An alarm will sound which can be silenced by touching the OK key. The monitor will recognize the seed tube(s) when reconnected.

NOTE: If the distance sensor has not been plugged in at this time the console will give continuous beeps, "WAIT CALIBRATION" will scroll across the upper LCD and "GNDSPD" will be shown in the lower LCD. Plug in the distance sensor and the monitor will display either "PICKUP" if a magnetic (pickup) distance sensor is connected, or "RADAR" if a radar distance sensor is installed. Only one distance sensor can be installed at a time.

01139909

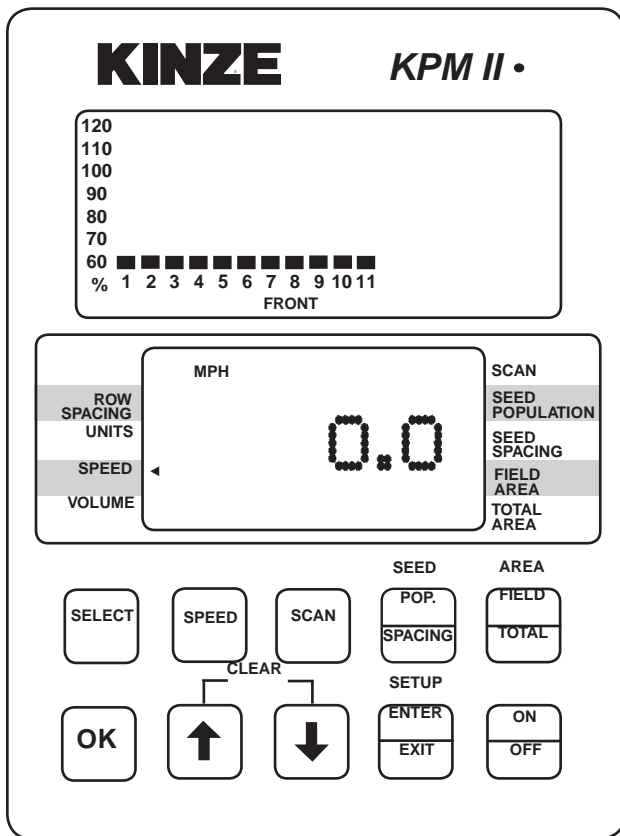

01139915

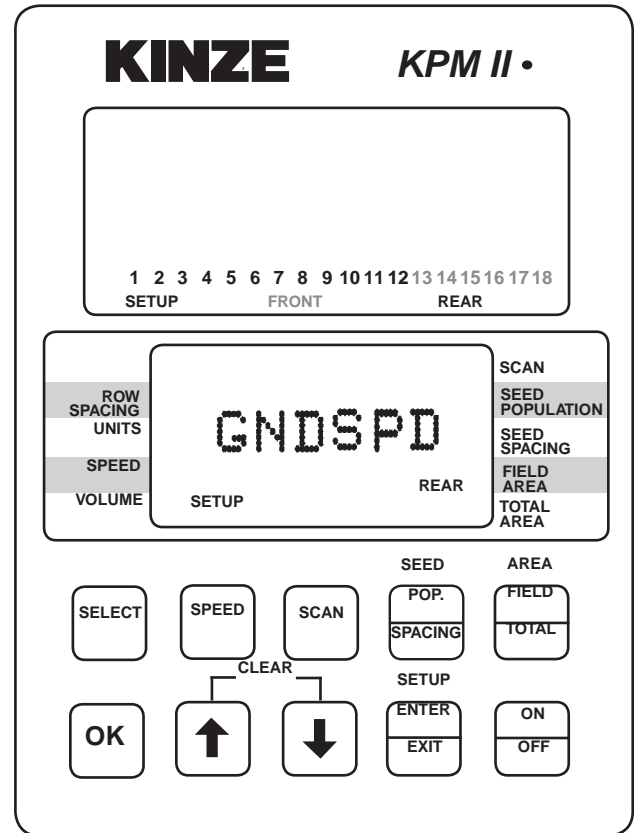

NOTE: See "Programming - Row Spacing" for programming applicable row spacing.

See "KPM I/KPM II Electronic Seed Monitor Troubleshooting" in the Maintenance Section.

MACHINE OPERATION

MANUAL SAFETY LOCKUPS

Never allow anyone to work around or under the planter without first installing the manual safety lockups. When transporting the planter use the manual safety lockups for added safety.

01199915

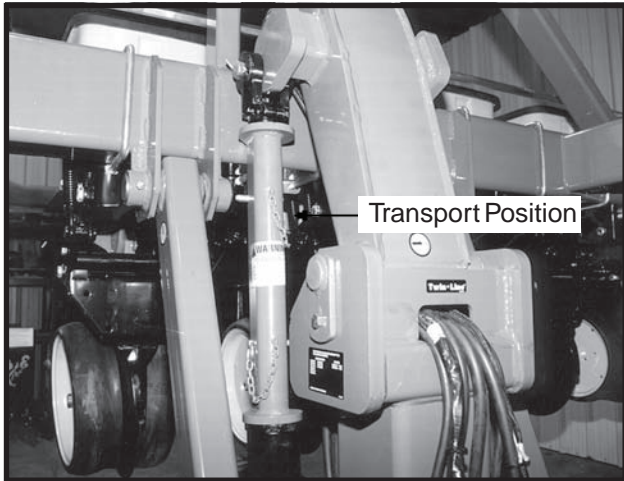

Manual Safety Lockups In Locked Position

01209909a

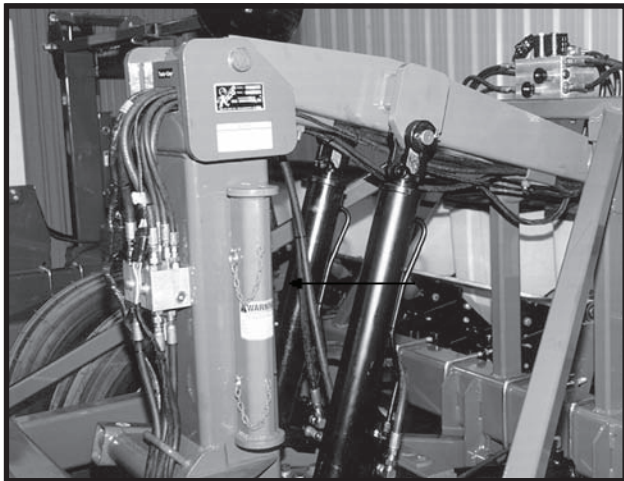

Manual Safety Lockups In Storage Location

For field operation remove the manual safety lockups and store on the side of the center pivot assembly.

TRANSPORT LATCH LOCKING PIN

The transport latch locking pin when installed will prevent the latch bar from disengaging and allowing the planter frame to swing out of the transport position. Never transport the planter without installing the transport latch locking pin.

01199904a

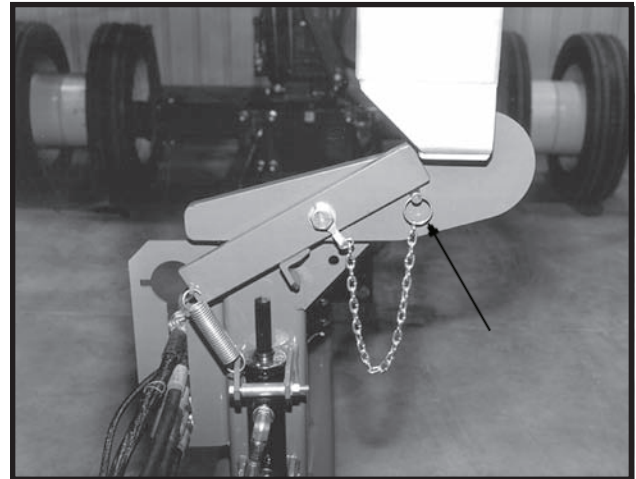

Transport Latch Locking Pin Installed For Transport

01209921a

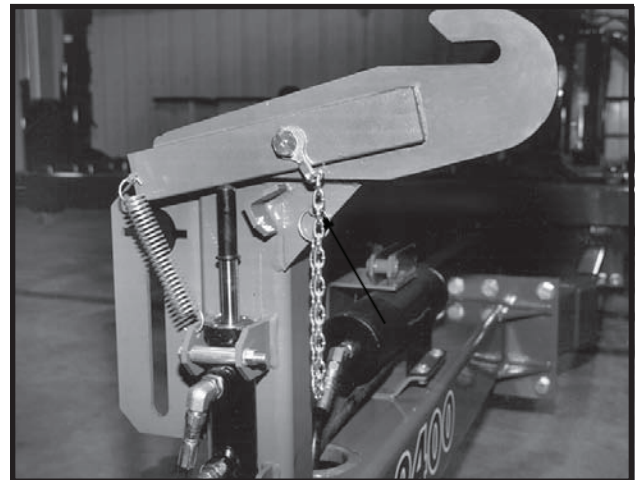

Transport Latch Locking Pin Stored For Field Operation

For field operation remove the transport latch locking pin and store in the location provided on the latch post.

MACHINE OPERATION

MARKER SAFETY LOCKUP

02019903a

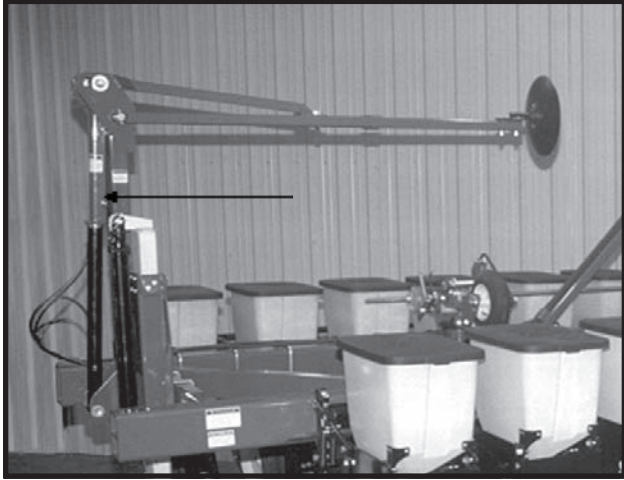

Install safety lockups over marker cylinder rods when transporting the planter or working around the planter. When lockups are not in use, store in the storage position provided on the first stage marker arm.



DANGER: To avoid serious injury, keep others away when raising or lowering markers.

TRANSPORTING THE PLANTER



WARNING: Always make sure safety/warning lights, reflectors and SMV sign are in place and visible prior to transporting the machine on public roads. In this regard, check federal, state/provincial and local regulations.

CAUTION: Avoid transporting planter with hoppers loaded whenever possible. When it is necessary to transport the planter with the hoppers loaded, the added weight should be distributed evenly on the planter frame before rotating the planter.



Install all safety lockups prior to transporting the planter

PLANTING SPEED

Planters are designed to operate within a speed range of 2 to 8 MPH. See “Planting And Application Rate Charts”. Variations in ground speed will produce variations in rates. Finger pickup seed meter populations will tend to be disproportionately higher at high ground speeds.

NOTE: Due to a multitude of variables, seed spacing can be adversely affected at speeds above 5.5 MPH.

FIELD TEST

With any change of field and/or planting conditions, seed size or planter adjustment, we recommend a field test be made to ensure proper seed placement and operation of row units. See “Rate Charts”, “Checking Seed Population”, and “Checking Granular Chemical Application Rate” at end of this section.

- Check the planter for fore to aft and lateral level operation. See “Leveling The Planter”.
- Check all row units to be certain they are running level. When planting, the row unit parallel arms should be approximately parallel to the ground.
- Check row markers for proper operation and adjustment. See “Marker Adjustment” and marker speed adjustment in “Hydraulic Operation”.
- Check for proper application rates and placement of granular chemicals on all rows. See “Checking Granular Chemical Application Rate”.
- Check for desired depth placement and seed population on all rows. See “Checking Seed Population”.
- Check for proper application rates of fertilizer on all rows. See proper “Fertilizer Application Rate Chart”.

After the planter has been field tested, reinspect the machine.

- Hoses and fittings
- Bolts and nuts
- Cotter pins and spring pins
- Drive chain alignment

MACHINE OPERATION

METRIC CONVERSION TABLE

Multiply	By	To Get
Inches (in.)	x 2.54	= centimeters (cm)
Inches (in.)	x 25.4	= millimeters (mm)
Feet (ft.)	x 30.48	= centimeters (cm)
Acres	x 0.405	= hectares (ha)
Miles per hour (mph)	x 1.609	= kilometers per hour (Km/h)
Pounds (lbs.)	x 0.453	= kilograms (kg)
Bushels (bu.)	x 35.238	= liters (l)
Gallons (gal.)	x 3.785	= liters (l)
Pounds per square inch (psi)	x 6.894	= kilopascals (kPa) (100 kPa = 1 bar)
Inch pounds (in. lbs.)	x 0.113	= newtons-meters (N•m)
Foot pounds (ft. lbs.)	x 1.356	= newtons-meters (N•m)
Centimeters (cm)	x .394	= inches (in.)
Millimeters (mm)	x .0394	= inches (in.)
Centimeters (cm)	x .0328	= feet (ft.)
Hectares (ha)	x 2.469	= acres
Kilometers per hour (Km/h)	x 0.621	= miles per hour (mph)
Kilograms (kg)	x 2.208	= pounds (lbs.)
Liters (l)	x 0.028	= bushels (bu.)
Liters (l)	x 0.264	= gallons (gal.)
Kilopascals (kPa) (100 kPa = 1 bar)	x 0.145	= pounds per square inch (psi)
Newtons-meters (N•m)	x 8.85	= inch pounds (in. lbs.)
Newtons-meters (N•m)	x 0.738	= foot pounds (ft. lbs.)

INTERPLANT® CLUTCH SPROCKET

01239905

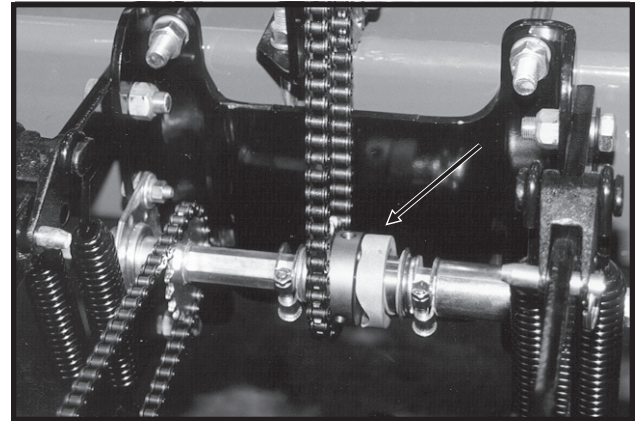

The Interplant® clutch sprocket is designed to allow the push row unit drill shaft to be disengaged when only the pull row units are being used.

To engage or disengage the push row unit drill shaft using the clutch sprocket, rotate the knurled collar on the clutch sprocket ¼ turn. Then using a 7/8" wrench on the drill shaft, rock the drill shaft slightly to take pressure off of the spring loaded pins in the clutch to allow the clutch to engage or disengage.



DANGER: Always install all safety lockups or lower planter to the ground before working under or around the machine.

MACHINE OPERATION

DOUBLE DISC FERTILIZER OPENER

The double disc fertilizer openers should be positioned during assembly **to place fertilizer no closer than 2" to either side of the row.** If planter frame is level and at proper 20" planting height, fertilizer depth will be approximately 4". Soil conditions can affect depth slightly.

The down pressure spring is factory preset at 250 lbs. down pressure but may be adjusted for various soil conditions. To adjust spring tension, loosen the jam nut with a $1\frac{5}{16}$ " wrench and use a 1" wrench to turn the adjustment bolt clockwise to increase tension or counterclockwise to decrease tension. Securely tighten the jam nut upon completion of tension adjustment. Do not attempt to set opener depth with spring pressure. The opener is designed to operate against a depth stop and spring up when encountering a foreign object or hard ground.

CAUTION: Do not operate the double disc openers at full down pressure tension when planting in rocky ground. Chipping of the blades will occur.

A gap of $\frac{1}{32}$ " to $\frac{1}{16}$ " should be maintained between the opener blades at the closest point. Blade adjustment can be made by moving inside spacer washers to the outer side of the blade. After making this adjustment, check to be sure bearing assembly rivets are not contacting the shank.

D06259919

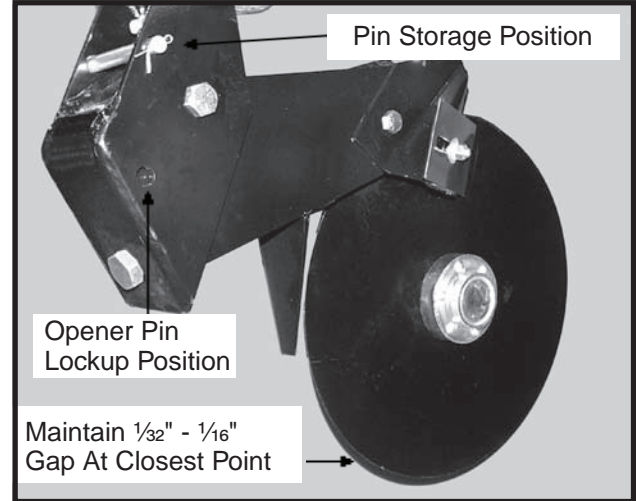

The outer scrapers on each blade may also be adjusted to make up for wear that may occur. Make sure the scrapers are adjusted to allow only slight contact with the blades.

The opener assembly is designed to be locked in a raised position when the fertilizer attachment is not in use or during storage. To lock the opener up, first raise the planter and place blocks under the openers. Then lower the planter until the hole in the pivot section aligns with the hole in the mounting bracket. Remove the lockup pin from the storage position in the mounting bracket and install it through the lockup hole and secure with cotter pins.



DANGER: Always install all cylinder lockup brackets before working under the unit.

MACHINE OPERATION

NOTCHED SINGLE DISC FERTILIZER OPENER

The notched single disc fertilizer opener is designed for use in minimum and no till soil conditions. Placement of fertilizer with the 16 3/4" notched single disc fertilizer opener is recommended at 2 1/2" - 3" from the row. **Never locate the opener to place fertilizer closer than 2".**

Adjust blade depth on each row using the cap screws and jam nuts located on the opener pivot shaft. The blade can be adjusted to allow a maximum 4" blade depth. Be sure the spring pin holes in the pivot post remain parallel with the opener mounting plate. Check fertilizer hose clearance after adjusting opener depth by swiveling the opener left and right. Torque cap screws and jam nuts to 57 ft. lbs.

The opener spring is factory preset at 350 lbs. and is not adjustable.

WARNING: Spring under pressure. DO NOT disassemble.



(FRTZ155)

← DIRECTION OF TRAVEL

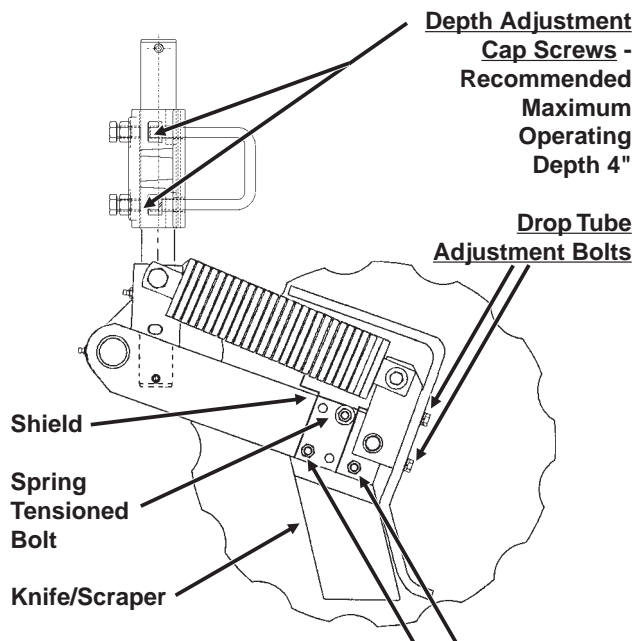

Knife/Scraper Leading Edge Adjustment Bolts (If not equipped with a shield and spring tensioned bolt, the third knife/scraper attachment bolt is also an adjustment bolt.)

Adjust knife/scraper leading edge contact on each row so blade will turn by hand with slight resistance, but will not coast or freewheel. In dry loose soil, knife/scraper adjustment is critical. If adjustment is not maintained, soil or residue may wedge causing the blade to push. If the knife/scraper is adjusted too tight, the blade will not turn causing the blade to push soil and residue. Knife/scraper leading edge adjustment is made using the two lower 3/8" mounting carriage bolts and pivot pad on the knife/scraper. Because of blade runout, rotate blade one full revolution after adjustment. Readjust knife/scraper-to-blade contact at tight spot as required. **Never strike the knife/scraper with a heavy object or damage may occur.**

Adjust drop tube on each row using the slotted mounting holes in the drop tube. Adjust drop tube so it is protected by the knife/scraper from soil contact and wear. The liquid drop tube should be adjusted as far from the opener blade as possible while keeping it behind the knife/scraper. This adjustment prevents the liquid fertilizer from contacting the opener blade.

NOTCHED SINGLE DISC FERTILIZER OPENER MOUNTED RESIDUE WHEEL

D05219901

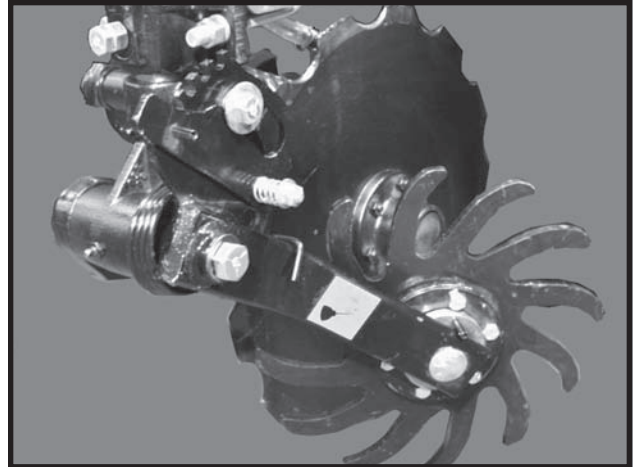

The notched single disc fertilizer opener mounted residue wheel is designed for applications where row unit mounted residue wheel attachments cannot be installed. The residue wheel is attached to the notched single disc fertilizer opener using 5/8" x 3 1/2" and 1/2" x 1 3/4" hardware.

Depth adjustment is made by lifting the residue wheel and moving the adjustment lever down to increase depth or up to decrease depth in 1" increments. Adjust all rows the same.

MACHINE OPERATION

LIQUID FERTILIZER ATTACHMENT

PISTON PUMP

69045-6

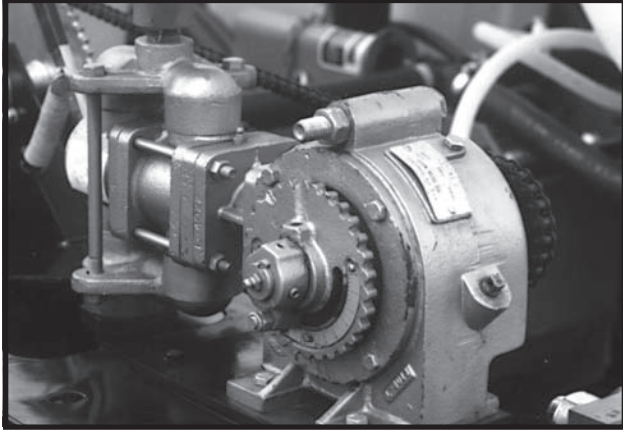

If the machine is equipped with the piston pump option, the rate of liquid fertilizer application is determined by the piston pump settings.

The delivery rate chart found at the end of this section provides an approximate application rate only. Actual delivery will vary with temperature and the particular fertilizer being used.

To adjust delivery rate, loosen the $\frac{3}{8}$ " lock nut that secures the arm with the pointer and rotate the scale flange until the pointer is over the desired scale setting. The adjustment wrench will facilitate rotation of the scale flange. Tighten the $\frac{3}{8}$ " lock nut being careful not to over tighten.

(PLTR9)

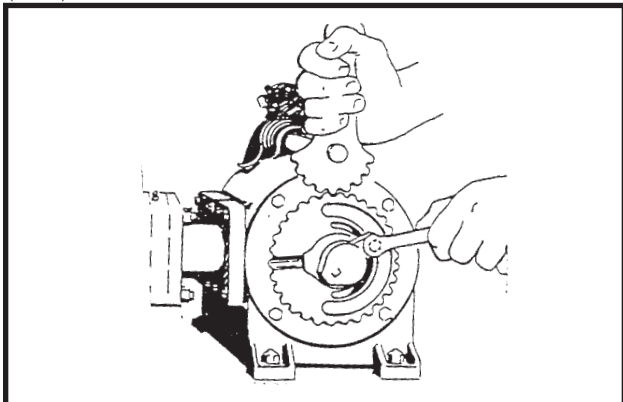

The operator and instruction manual shipped with the pump and flow divider should be kept and stored with this manual for future reference.

NOTE: Periodically check flow to all rows. If one or more lines are plugged, set rate will be delivered to remaining rows.

CLEANING

The tanks and all hoses are made of sturdy plastic and rubber to resist corrosion. However, the tanks, hoses and metering pump should be thoroughly cleaned with water at the end of the planting season or prior to an extended period of non-use. Do not allow fertilizer to crystalize due to cold temperature or evaporation.

The strainer, located between the piston pump and ball valve (On machines equipped with the piston pump.), should be taken apart and cleaned daily. Remove the end cap to clean the screen.

(INS220)

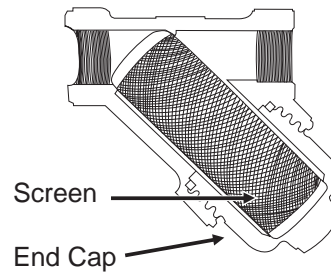

See "Piston Pump Storage" (If Applicable) in the Maintenance Section of this manual.

MACHINE OPERATION

CHECKING SEED POPULATION

1. Tie up one or more sets of closing wheels by running a light chain or rubber tarp strap between the hopper support panel and closing wheels. It may be necessary to decrease closing wheel arm spring tension.

L0069(PLTR10)

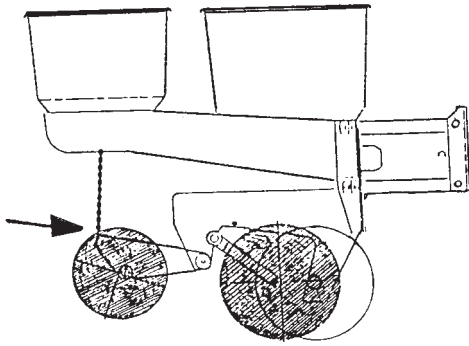

2. Plant a short distance and check to see if seed is visible in the seed trench. Adjust planting depth to a shallower setting if seed is not visible and recheck.

72359-108

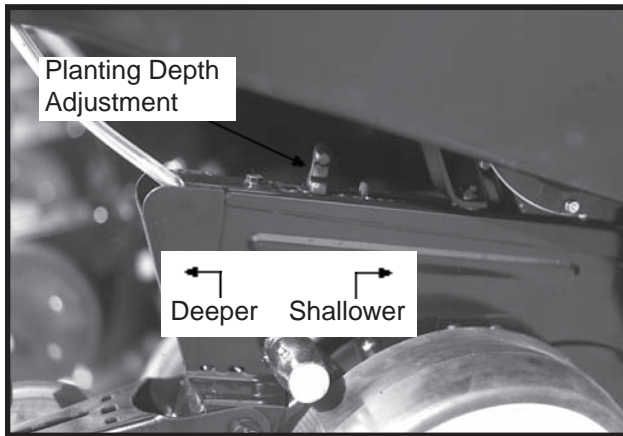

3. Measure $\frac{1}{1000}$ of an acre. See chart for correct distance for row width being planted. For example, if planting 20" rows $\frac{1}{1000}$ of an acre would be 26' 2".

LENGTH OF ROW IN FEET AND INCHES				
Fraction Of Acre	Row Width			
	10"	11"	20"	22"
$\frac{1}{1000}$	52' 3"	47' 6"	26' 2"	23' 9"

NOTE: When planting with closing wheels raised and planting depth set shallow, seeds may bounce or roll affecting seed spacing accuracy.

4. Count seeds in measured distance.
5. Multiply the number of seeds placed in the $\frac{1}{1000}$ of an acre by 1000. This will give you total population.

EXAMPLE: With 20" row spacing 26' 2" equals $\frac{1}{1000}$ acre.

26 Seeds				
Counted	x	1000	=	26,000 Seeds Per Acre

Seed count can be affected by drive ratio between drive wheel and seed meter, tire pressure and/or seed meter malfunction.

If seed check shows the average distance between seeds in inches is significantly different than the seed rate chart indicates, first check drive ratio between drive wheel and seed meter. Check drive wheel air pressure, check for incorrect sprocket(s) in driveline and check drive and driven sprockets on transmission for proper selection.

Second, check for seed meter malfunction. For example, if spacing between kernels of corn at the transmission setting being used is 8" and a gap of 16" is observed, a finger has lost its seed and not functioned properly. If two seeds are found within a short distance of each other, the finger has metered two seeds instead of one.

See "Finger Pickup Seed Meter Troubleshooting" and/or "Brush-Type Seed Meter Troubleshooting" in the Maintenance Section of this manual.

MACHINE OPERATION

Determining Pounds Per Acre (Brush-Type Seed Meter)

To determine pounds per acre:

Seeds Per Acre On Chart	÷	Seeds Per Pound From Seed Tag On Bag	=	Pounds Per Acre
-------------------------------	---	-----------------------------------------------	---	-----------------------

To determine bushels per acre:

Pounds Per Acre	÷	Unit Weight Of Seed	=	Bushels Per Acre
--------------------	---	------------------------	---	---------------------

The unit weight of:

- 1 Bushel Soybeans = 60 Pounds
- 1 Bushel Milo = 56 Pounds
- 1 Bushel Cotton = 32 Pounds

If seeds per pound information is not available the following is an average:

- 2,600 seeds per pound for medium size soybeans
- 15,000 seeds per pound for medium size milo
- 4,500 seeds per pound for medium size cotton

If seed check shows planting rate is significantly different than seed rate chart shows or if a particular meter is not planting accurately, see "Brush-Type Seed Meter Maintenance" and "Brush-Type Seed Meter Troubleshooting".

CHECKING GRANULAR CHEMICAL APPLICATION RATE

Many things can affect the rate of delivery of granular chemicals such as temperature, humidity, speed, ground conditions, flowability of different material or any obstruction in the meter.

A field check is important to determine correct application rates.

72359-105

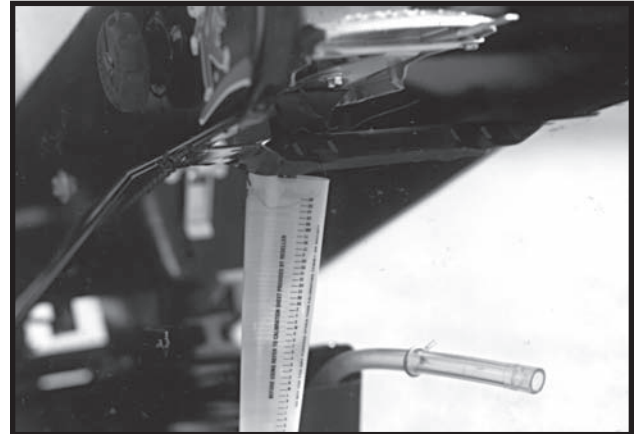

To check, fill insecticide and/or herbicide hoppers. Attach a calibrated vial to each granular chemical meter. Lower the planter and proceed as follows:

NOTE: It is not necessary for seed meter clutch to be engaged during test. Disengage clutch to avoid dropping seed.

Drive 1,320 feet at planting speed. Weigh the chemical in ounces that was caught in one vial. Multiply that amount by the factor shown to determine pounds per acre.

LBS. PER ACRE FACTOR FOR GIVEN ROW WIDTH	
Row Width	Factor
20"	1.25
22"	1.13

EXAMPLE: You are planting 20" rows. You have planted for 1320 feet at the desired planting speed. You caught 12.0 ounces of chemical in one vial. 12.0 ounces times 1.25 equals 15.0 pounds per acre.

NOTE: It is important to check calibration of all rows.

Metering Gate

Use the metering gate setting for distributing insecticide or herbicide as a starting point. The charts are based on a 5 miles per hour planting speed. For speeds faster than 5 miles per hour a higher gate setting should be used. For speeds slower than 5 miles per hour a lower gate setting should be used.



WARNING: Agricultural chemicals can be dangerous if not selected and handled with care. Always read and follow directions supplied by the chemical manufacturer.

MACHINE OPERATION

GENERAL PLANTING RATE INFORMATION

These planting rate charts are applicable to KINZE® Model 2400 Twin-Line® planters. See “Tire Pressure” for recommended tire pressures.

Not all row spacings listed are applicable to all size planters.

IMPORTANT: The sprocket combinations listed in these charts are best for average conditions. Changes in sprocket combinations may be required to obtain desired planting population. TO PREVENT PLANTING MISCALCULATIONS, MAKE FIELD CHECKS TO BE SURE YOU ARE PLANTING AT THE DESIRED RATE.

The size and shape of seed may affect the planting rate.

Finger Pickup Seed Meter (Corn, Oil Sunflower)

Larger grades will generally plant more accurately at the high end of the ground speed range than smaller grades. Higher than optimum speeds may result in population rate increase or higher incidence of doubles, particularly with small seed. Medium round corn seed is most desirable for planting accuracy at optimum speed. Only No. 3 and No. 4 oil sunflower seed are recommended for planting accuracy at optimum speed.

NOTE: Seed additives, added to the seed in the hopper, may adversely affect performance of the finger pickup seed meter and accelerate wear. See “Finger Pickup Seed Meter” in the Row Unit Operation section.

Brush-Type Seed Meter (Soybean, Milo/Grain Sorghum, Acid-Delinted Cotton)

Rate charts are given in seeds per acre as well as seed spacing in inches rounded to the nearest tenth of an inch. Because of the large range in seed size, pounds per acre is not a suggested method of selecting transmission settings. When using smaller size seeds it may appear the pounds per acre is below what was expected and vice versa on large seed. To determine pounds per acre, use the formula given in “Determining Pounds Per Acre (Brush-Type Seed Meter)” in the “Checking Seed Population” section of this manual.

NOTE: Due to a multitude of variables, seed spacing can be adversely affected at speeds above 5.5 MPH.

Seed population per acre with **10" rows will be double the rate for 20" rows**, as well as 11" rows versus 22", at the listed sprocket combination. See pages 6-49 and 6-50.

In some cases when planting 10"-11" row soybeans, milo/grain sorghum or cotton, a **Half Rate (2 To 1) Drive Reduction Package** may be required to obtain the desired population and seed spacing.

NOTE: Use of the Half Rate (2 To 1) Drive Reduction Package will reduce the planter transmission speed. The seeding rate will be approximately 50% of the chart reading when using the Half Rate (2 To 1) Drive Reduction Package. Planting speed can affect actual seeding rate. Make a field check and adjust setting on the transmission as needed to obtain the desired seed drop.

01239901

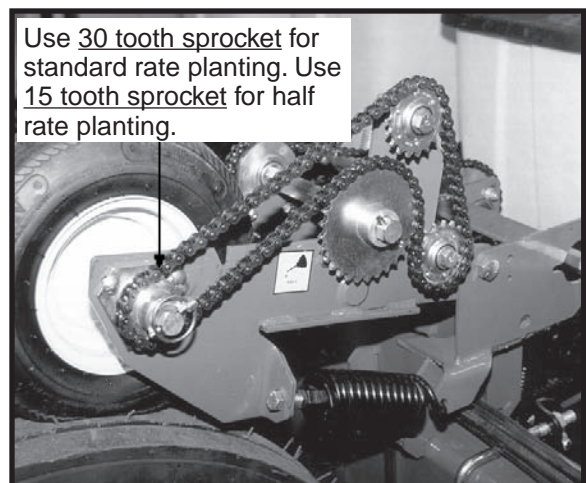

MACHINE OPERATION

PLANTING RATES FOR FINGER PICKUP SEED METERS (STANDARD DRIVE) APPROXIMATE SEEDS/ACRE FOR VARIOUS ROW WIDTHS

20" Rows	22" Rows	Transmission Sprockets		Recomm. Speed Range (MPH)	Average Seed Spacing In Inches
		Drive	Driven		
24,279	22,013	17	28	4 to 6	12.9
25,178	22,828	17	27	4 to 6	12.5
26,147	23,706	17	26	4 to 6	12.0
27,135	24,602	19	28	4 to 6	11.6
27,192	24,654	17	25	4 to 6	11.5
28,140	25,514	19	27	4 to 6	11.1
28,325	25,681	17	24	4 to 6	11.1
29,222	26,494	19	26	4 to 6	10.7
29,556	26,797	17	23	4 to 6	10.6
30,392	27,555	19	25	4 to 6	10.3
31,656	28,701	19	24	4 to 6	9.9
32,847	29,781	23	28	4 to 6	9.5
33,033	29,950	19	23	4 to 6	9.5
34,064	30,884	23	27	4 to 6	9.2
34,275	31,076	24	28	4 to 6	9.2
35,375	32,073	23	26	4 to 6	8.9
35,546	32,228	24	27	4 to 6	8.8
35,703	32,371	25	28	4 to 6	8.8
35,780	32,440	17	19	4 to 6	8.8
36,789	33,355	23	25	4 to 6	8.5
36,912	33,467	24	26	4 to 6	8.5
37,026	33,570	25	27	4 to 6	8.5
37,133	33,667	26	28	4 to 6	8.4
38,322	34,745	23	24	4 to 6	8.2
38,388	34,805	24	25	4 to 6	8.2
38,450	34,861	25	26	4 to 6	8.2
38,507	34,913	26	27	4 to 6	8.1
38,561	34,962	27	28	4 to 6	8.1
39,989	36,256	23	23	4 to 6	7.8
41,469	37,599	28	27	4 to 6	7.6
41,526	37,650	27	26	4 to 6	7.6
41,655	37,767	25	24	4 to 6	7.5
41,727	37,832	24	23	4 to 6	7.5
43,064	39,044	28	26	4 to 6	7.3
43,187	39,156	27	25	4 to 6	7.3
43,466	39,409	25	23	4 to 6	7.2
44,693	40,521	19	17	4 to 6	7.0
44,787	40,607	28	25	4 to 6	7.0
44,987	40,788	27	24	4 to 6	7.0
45,204	40,985	26	23	4 to 6	7.0
46,653	42,299	28	24	3 to 6	6.7
46,943	42,561	27	23	3 to 6	6.7
48,407	43,889	23	19	3 to 5.5	6.5
48,681	44,137	28	23	3 to 5.5	6.5
50,511	45,797	24	19	3 to 5.5	6.2
52,616	47,705	25	19	3 to 5	6.0
54,102	49,052	23	17	2 to 5	5.8
54,720	49,613	26	19	3 to 5	5.7
56,454	51,185	24	17	3 to 5	5.6
56,825	51,521	27	19	3 to 5	5.5
58,806	53,317	25	17	3 to 4.5	5.3
59,931	53,430	28	19	3 to 4.5	5.3
61,158	55,450	26	17	3 to 4.5	5.1
63,510	57,582	27	17	3 to 4.5	4.9
65,862	59,715	28	17	3 to 4.5	4.8

IMPORTANT: See "General Planting Rate Information" and "Checking Seed Population" pages for additional information. Always check seed population in the field to ensure planting rates are correct.

MACHINE OPERATION

Z214/RH

PLANTING RATES FOR BRUSH-TYPE SEED METERS (STANDARD DRIVE)

APPROXIMATE SEEDS/ACRE FOR 20"/22" ROW WIDTHS

Transmission Sprockets		60 Cell Soybean Or High Rate Milo/ Grain Sorghum		Average Seed Spacing In Inches	48 Cell Specialty Soybean Or High Rate Acid-Delinted Cotton		Average Seed Spacing In Inches	Speed Range (MPH)
		20" Rows	22" Rows		20" Rows	22" Rows		
17	28	121,392	110,062	2.6	97,113	88,049	3.2	2 to 8
17	27	125,889	114,139	2.5	100,712	91,312	3.1	2 to 8
17	26	130,731	118,529	2.5	104,712	94,823	3.0	2 to 8
19	28	135,674	123,011	2.3	108,593	98,408	2.9	2 to 8
19	27	140,699	127,567	2.2	112,559	102,053	2.8	2 to 8
17	24	141,624	128,406	2.2	113,300	102,725	2.8	2 to 8
17	23	147,782	133,989	2.1	118,226	107,191	2.7	2 to 8
19	25	151,955	137,772	2.1	121,563	110,217	2.6	2 to 8
19	24	158,286	143,513	2.0	126,629	114,810	2.5	2 to 8
23	28	164,237	148,908	1.9	131,390	119,126	2.4	2 to 8
19	23	165,168	149,752	1.9	132,135	119,802	2.4	2 to 8
24	28	171,379	155,383	1.8	137,103	124,307	2.3	2 to 8
24	27	177,725	161,137	1.8	142,179	128,909	2.2	2 to 8
17	19	178,895	162,198	1.8	143,115	129,758	2.2	2 to 8
24	26	184,560	167,334	1.7	147,648	133,868	2.1	2 to 8
26	28	185,660	168,331	1.7	148,527	134,664	2.1	2 to 8
24	25	191,943	174,028	1.6	153,555	139,223	2.0	2 to 8
26	27	192,536	174,566	1.6	154,029	139,653	2.0	2 to 8
23	23	199,941	181,280	1.6	159,953	145,024	2.0	2 to 8
27	26	207,630	188,251	1.5	166,104	150,601	1.9	2 to 8
24	23	208,634	189,161	1.5	166,907	151,329	1.9	2 to 8
25	23	217,326	197,042	1.4	173,861	157,634	1.8	2 to 8
19	17	223,463	202,606	1.4	178,770	162,085	1.8	2 to 8
27	24	224,933	203,939	1.4	179,946	163,151	1.7	2 to 8
28	24	233,264	211,492	1.3	186,661	169,194	1.7	2 to 8
23	19	242,033	219,443	1.3	193,626	175,554	1.6	2 to 8
28	23	243,405	220,687	1.3	194,724	176,550	1.6	2 to 8
24	19	252,557	228,985	1.2	202,044	183,187	1.6	2 to 8
25	19	263,079	238,525	1.2	210,464	190,820	1.5	2 to 8
23	17	270,507	245,260	1.2	216,405	196,207	1.5	2 to 8
26	19	273,603	248,067	1.1	218,883	198,454	1.4	2 to 7
27	19	284,126	257,607	1.1	227,301	206,086	1.4	2 to 7
28	19	294,650	267,149	1.1	235,719	213,719	1.3	2 to 7
26	17	305,792	277,251	1.0	244,634	221,801	1.3	2 to 7
27	17	317,553	289,915	0.9	245,043	230,332	1.2	2 to 7
28	17	329,313	298,577	0.9	263,451	238,862	1.2	2 to 7

IMPORTANT: See “General Planting Rate Information” and “Checking Seed Population” pages for additional information.

NOTE: When using the Half Rate (2 To 1) Drive Reduction Package, rates will be approximately 50% of given numbers.

IMPORTANT: Always check seed population in the field to ensure planting rates are correct.

MACHINE OPERATION

Z214/RH

PLANTING RATES FOR BRUSH-TYPE SEED METERS (STANDARD DRIVE)

APPROXIMATE SEEDS/ACRE FOR 10"/11" ROW WIDTHS

Transmission Sprockets		60 Cell Soybean Or High Rate Milo/ Grain Sorghum		Average Seed Spacing In Inches	48 Cell Specialty Soybean Or High Rate Acid-Delinted Cotton		Average Seed Spacing In Inches	Speed Range (MPH)
Drive	Driven	10" Rows	11" Rows		10" Rows	11" Rows		
17	28	242,784	220,124	2.6	194,226	176,098	3.2	2 to 8
17	27	251,778	228,278	2.5	201,424	182,624	3.1	2 to 8
17	26	261,462	237,058	2.4	209,424	189,646	3.0	2 to 8
19	28	271,348	246,022	2.3	217,078	196,816	2.9	2 to 8
19	27	281,398	255,134	2.2	225,118	204,106	2.8	2 to 8
17	24	283,248	256,812	2.2	226,600	205,450	2.8	2 to 8
17	23	295,564	267,978	2.1	236,452	214,382	2.7	2 to 8
19	25	303,910	275,544	2.1	243,126	220,434	2.6	2 to 8
19	24	316,572	287,026	2.0	253,258	229,620	2.5	2 to 8
23	28	328,474	297,816	1.9	262,780	238,252	2.4	2 to 8
19	23	330,336	299,504	1.9	264,270	239,604	2.4	2 to 8
24	28	342,758	310,766	1.8	274,206	248,614	2.3	2 to 8
24	27	355,450	322,274	1.8	284,358	257,818	2.2	2 to 8
17	19	357,790	324,396	1.8	286,230	259,516	2.2	2 to 8
24	26	369,120	334,668	1.7	295,296	267,736	2.1	2 to 8
26	28	371,320	336,662	1.7	297,054	269,328	2.1	2 to 8
24	25	383,886	348,056	1.6	307,110	278,446	2.0	2 to 8
26	27	385,072	349,132	1.6	308,058	279,306	2.0	2 to 8
23	23	399,882	362,560	1.6	319,906	290,048	2.0	2 to 8
27	26	415,260	376,502	1.5	332,208	301,202	1.9	2 to 8
24	23	417,268	378,322	1.5	333,814	302,658	1.9	2 to 8
25	23	434,652	394,084	1.4	347,722	315,268	1.8	2 to 8
19	17	446,926	405,212	1.4	357,540	324,170	1.8	2 to 8
27	24	449,866	407,878	1.4	359,862	326,302	1.7	2 to 8
28	24	466,528	422,984	1.3	373,322	338,388	1.7	2 to 8
23	19	484,066	438,886	1.3	387,252	351,108	1.6	2 to 8
28	23	486,810	441,374	1.3	389,448	353,100	1.6	2 to 8
24	19	505,114	457,970	1.2	404,088	366,374	1.6	2 to 8
25	19	526,158	477,050	1.2	420,928	381,640	1.5	2 to 8
23	17	541,014	490,520	1.2	432,810	392,414	1.5	2 to 8
26	19	547,206	496,134	1.1	437,766	396,908	1.4	2 to 7
27	19	568,252	515,214	1.1	454,602	412,172	1.4	2 to 7
28	19	589,300	534,298	1.1	471,438	427,438	1.3	2 to 7
26	17	611,584	554,502	1.0	489,268	443,602	1.3	2 to 7
27	17	635,106	579,830	0.9	490,086	460,664	1.2	2 to 7
28	17	658,626	597,154	0.9	526,902	477,724	1.2	2 to 7

IMPORTANT: See "General Planting Rate Information" and "Checking Seed Population" pages for additional information.

NOTE: When using the Half Rate (2 To 1) Drive Reduction Package, rates will be approximately 50% of given numbers.

IMPORTANT: Always check seed population in the field to ensure planting rates are correct.

MACHINE OPERATION

RH/Z215

PLANTING RATES FOR BRUSH-TYPE SEED METERS (STANDARD DRIVE)

APPROXIMATE SEEDS/ACRE FOR VARIOUS ROW WIDTHS

Transmission Sprockets		36 Cell Acid-Delinted Large Cotton		Average Seed Spacing In Inches	30 Cell Milo/Grain Sorghum Or Acid-Delinted Cotton		Average Seed Spacing In Inches	Speed Range (MPH)
Drive	Driven	20" Rows	22" Rows		20" Rows	22" Rows		
17	28	72,836	66,038	4.3	60,696	55,031	5.2	2 to 8
17	27	75,534	68,484	4.2	62,945	57,070	5.0	2 to 8
17	26	78,438	71,117	4.0	65,366	59,265	4.8	2 to 8
19	28	81,404	73,806	3.9	67,838	61,506	4.6	2 to 8
19	27	84,419	76,539	3.7	70,350	63,784	4.5	2 to 8
17	24	84,975	77,044	3.7	70,812	64,203	4.4	2 to 8
17	23	88,670	80,394	3.5	73,892	66,995	4.2	2 to 8
19	25	91,173	82,664	3.5	75,978	68,887	4.1	2 to 8
19	24	94,971	86,107	3.3	79,143	71,756	4.0	2 to 8
23	28	98,543	89,345	3.2	82,119	74,455	3.8	2 to 8
19	23	99,101	89,851	3.2	82,584	74,876	3.8	2 to 8
24	28	102,827	93,229	3.0	85,689	77,691	3.7	2 to 8
24	27	106,635	96,682	2.9	88,863	80,569	3.5	2 to 8
17	19	107,337	97,319	2.9	89,447	81,098	3.5	2 to 8
24	26	110,736	100,401	2.8	99,280	83,667	3.4	2 to 8
26	28	111,396	100,999	2.8	92,829	84,165	3.4	2 to 8
24	25	115,158	104,410	2.7	95,972	87,014	3.3	2 to 8
26	27	115,521	104,739	2.7	96,267	87,282	3.3	2 to 8
23	23	119,964	108,767	2.6	99,971	90,640	3.1	2 to 8
27	26	124,578	112,951	2.5	103,815	94,126	3.0	2 to 8
24	23	125,180	113,496	2.5	104,316	94,580	3.0	2 to 8
25	23	130,395	118,225	2.4	108,663	98,521	2.9	2 to 8
19	17	134,078	121,564	2.3	111,732	101,304	2.8	2 to 8
27	24	134,960	122,363	2.3	112,467	101,970	2.8	2 to 8
28	24	139,958	126,895	2.2	116,633	105,747	2.7	2 to 8
23	19	145,220	131,666	2.2	121,017	109,722	2.6	2 to 8
28	23	146,043	132,412	2.1	121,703	110,344	2.6	2 to 8
24	19	151,535	137,391	2.1	126,278	114,492	2.5	2 to 8
25	19	157,848	143,116	2.0	131,540	119,262	2.4	2 to 8
23	17	162,350	147,197	1.9	135,254	122,630	2.3	2 to 8
26	19	164,162	148,840	1.9	136,802	124,033	2.3	2 to 7
27	19	170,475	154,564	1.8	142,064	128,804	2.2	2 to 7
28	19	176,790	160,290	1.8	147,324	133,574	2.1	2 to 7
26	17	183,476	166,351	1.7	152,895	138,625	2.1	2 to 7
27	17	190,532	172,749	1.6	158,777	143,957	2.0	2 to 7
28	17	197,588	179,146	1.6	164,657	149,289	1.9	2 to 7

IMPORTANT: See “General Planting Rate Information” and “Checking Seed Population” pages for additional information.

NOTE: When using the Half Rate (2 To 1) Drive Reduction Package, rates will be approximately 50% of given numbers.

IMPORTANT: Always check seed population in the field to ensure planting rates are correct.

MACHINE OPERATION

PLANTING RATES FOR BRUSH-TYPE SEED METERS (STANDARD DRIVE) APPROXIMATE HILLS/ACRE FOR VARIOUS ROW WIDTHS

Due to variations in cotton seed size, meters equipped with 12 cell acid-delinted hill-drop cotton discs will plant from 3 to 6 seeds per cell. Select proper disc for seed size range to be planted.

To determine planter transmission setting, determine desired hill spacing and select the transmission ratio closest to the hill spacing in inches on the chart. To decrease population increase spacing. To increase population decrease spacing.

To determine population per acre, determine average seeds per hill and hills per acre by doing a field check. Measure $\frac{1}{1,000}$ of an acre (1/1000 acre = Length of row 26' 2" for 20" row widths, and 23' 9" for 22" row widths). Multiply average seeds per hill by hills per acre. EXAMPLE: 4 seeds per hill x (13 hills x 1000) = 52,000

Transmission Sprockets Drive Driven		NUMBER OF HILLS PER ACRE		Average Hill Spacing In Inches	Speed Range (MPH)
		12 Cell Hill-Drop Cotton, Acid-Delinted			
		20" Rows	22" Rows		
17	28	24,279	22,013	12.9	2 to 8
17	27	25,178	22,828	12.5	2 to 8
17	26	26,147	23,706	12.0	2 to 8
19	28	27,135	24,602	11.6	2 to 8
19	27	28,140	25,514	11.1	2 to 8
17	24	28,325	25,681	11.1	2 to 8
17	23	29,556	26,797	10.6	2 to 8
19	25	30,392	27,555	10.3	2 to 8
19	24	31,658	28,703	9.9	2 to 8
23	28	32,847	29,781	9.5	2 to 8
19	23	33,033	29,950	9.5	2 to 8
24	28	34,275	31,076	9.2	2 to 8
24	27	35,546	32,228	8.8	2 to 8
17	19	35,780	32,440	8.8	2 to 8
24	26	36,912	33,467	8.5	2 to 8
26	28	37,133	33,667	8.4	2 to 8
24	25	38,388	34,805	8.2	2 to 8
26	27	38,507	34,913	8.1	2 to 8
23	23	39,989	36,256	7.8	2 to 8
27	26	41,526	37,650	7.6	2 to 8
24	23	41,727	37,832	7.5	2 to 8
25	23	43,466	39,409	7.2	2 to 8
19	17	44,693	40,521	7.0	2 to 8
27	24	44,987	40,788	7.0	2 to 8
28	24	46,653	42,299	6.7	2 to 8
23	19	48,407	43,889	6.5	2 to 8
28	23	48,681	44,137	6.5	2 to 8
24	19	50,511	45,797	6.2	2 to 8
25	19	52,616	47,705	6.0	2 to 8
23	17	54,102	49,052	5.8	2 to 8
26	19	54,720	49,613	5.7	2 to 7
27	19	56,825	51,521	5.5	2 to 7
28	19	58,931	53,430	5.3	2 to 7
26	17	61,158	55,450	5.1	2 to 7
27	17	63,510	57,582	4.9	2 to 7
28	17	65,862	59,715	4.8	2 to 7

IMPORTANT: See "General Planting Rate Information" and "Checking Seed Population" pages for additional information.

NOTE: When using the Half Rate (2 To 1) Drive Reduction Package, rates will be approximately 50% of given numbers.

IMPORTANT: Always check seed population in the field to ensure planting rates are correct.

MACHINE OPERATION

DRY INSECTICIDE APPLICATION RATES APPROXIMATE POUNDS/ACRE AT 5 MPH FOR VARIOUS ROW WIDTHS

Meter Setting	20" Rows	22" Rows
CLAY GRANULES		
10	7.4	6.7
11	8.1	7.3
12	9.2	8.3
13	10.4	9.4
14	11.6	10.5
15	12.8	11.6
16	14.4	13.1
17	16.1	14.6
18	17.1	15.5
19	19.7	17.8
20	21.3	19.3
21	23.3	21.1
22	24.6	22.3
23	25.8	23.4
24	28.2	25.6
25	31.4	28.4
26	34.5	31.3
27	36.2	32.8
28	38.1	34.5
29	41.7	37.8
30	44.4	40.3
SAND GRANULES		
5	4.4	3.9
6	7.4	6.7
7	8.0	7.2
8	9.5	8.6
9	11.7	10.6
10	13.4	12.1
11	15.3	13.9
12	16.8	15.2
13	18.9	17.1
14	21.2	19.2
15	23.3	21.1
16	26.6	23.8
17	29.1	26.4
18	32.7	29.7
19	36.5	33.1
20	38.6	35.0
21	41.4	37.5
22	44.4	40.3
23	48.0	43.5
24	51.6	46.8
25	55.4	50.2

IMPORTANT: The above chart represents average values and should be used only as a starting point. The granular chemical flows through the given meter opening at a nearly uniform rate regardless of roller speed. Your actual rate will vary depending upon the insecticide you are using, your planting speed and your plant population. Planting speed/ground speed has the greatest effect on application rate.

Your actual rate must be checked in the field with the actual insecticide that you are using and at the speed and population at which you will be planting.

MACHINE OPERATION

DRY HERBICIDE APPLICATION RATES

APPROXIMATE POUNDS/ACRE AT 5 MPH FOR VARIOUS ROW WIDTHS

CLAY GRANULES

Meter Setting	20" Rows	22" Rows
10	7.1	6.4
11	7.8	7.1
12	8.7	7.9
13	9.8	8.8
14	11.0	9.9
15	12.3	11.2
16	13.5	12.2
17	14.9	13.5
18	16.1	14.6
19	17.4	15.8
20	18.9	17.1
21	20.4	18.5
22	21.9	19.9
23	23.6	21.4
24	25.5	23.1
25	27.2	24.6
26	29.1	26.4
27	31.4	28.4
28	33.9	30.7
29	36.5	33.1
30	40.1	36.3

IMPORTANT: The above chart represents average values and should be used only as a starting point. The granular chemical flows through the given meter opening at a nearly uniform rate regardless of roller speed. Your actual rate will vary depending upon the herbicide you are using, your planting speed and your plant population. Planting speed/ground speed has the greatest effect on application rate.

Your actual rate must be checked in the field with the actual herbicide that you are using and at the speed and population at which you will be planting.

MACHINE OPERATION

LIQUID FERTILIZER PISTON PUMP APPLICATION RATES

GALLONS PER ACRE

Pump Setting	1	2	3	4	5	6	7	8	9	10
12 Row 20"	7.7	15.6	23.3	30.9	38.7	46.5	54.3	62.0	69.8	77.6
12 Row 22"	7.1	14.6	21.7	28.8	36.1	43.4	50.7	57.8	65.1	72.4

Above chart is for planters equipped with contact drive and the Model LM-2455-R (GA8069) piston pump. See "Tire Pressure" for recommended tire pressures. Chart is based on average wheel slippage and liquid viscosities.

Measure and weigh one gallon of actual fertilizer solution to determine exact application rate. This chart was calculated based on a solution weighing ten pounds per gallon.

IMPORTANT: Fertilizer application rates can vary from the above chart. To prevent application miscalculations, make field checks to be sure you are applying fertilizer to all rows at the desired rate.

NOTE: Flow to all rows should be checked periodically. If one or more lines are plugged, the desired rate will be delivered to the remaining rows keeping total application rate at desired rate.

To check the exact number of gallons your fertilizer attachment will actually deliver on a 20" row spacing, proceed as follows:

Remove the hose from one of the fertilizer openers and insert it into a collection container which has been secured to the planter frame. Engage the fertilizer attachment and drive forward for 262'. Measure the fluid ounces caught in the container and multiply that amount by 100. Divide that amount by 128. The result will be the gallons of fertilizer delivered per acre when planting in 20" rows. Rinse the collection container and repeat test on other rows if necessary. To convert this delivery rate for wider rows, multiply by the following conversion factor:

22" multiply by 0.91

MACHINE OPERATION

ROW UNIT OPERATION

PLANTING DEPTH

Planting depth is maintained by the row unit gauge wheels. To increase or decrease the planting depth, first raise the planter to remove weight from the wheels. Then lift the depth adjustment handle and reposition it forward to decrease depth or rearward to increase planting depth. Adjust all units to the same setting initially. Then lower the planter and check operation and planting depth of all row units. It may be necessary to readjust some rows to obtain uniform operation.



WARNING: Never work under the planter while in raised position without using safety lockups.

72359-108

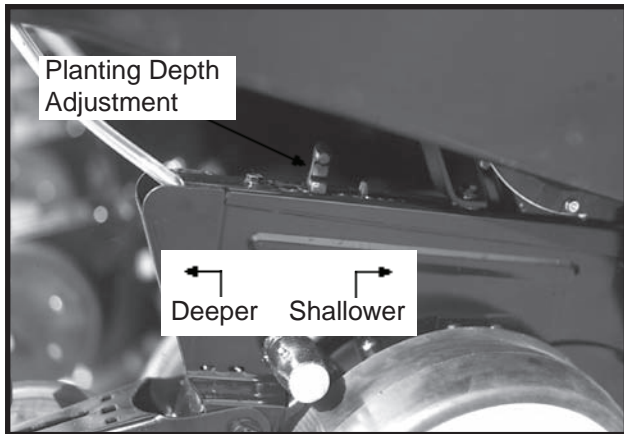

“V” CLOSING WHEEL ADJUSTMENT (Rubber And Cast Iron)



WARNING: Raise planter and install safety lockups before making closing wheel adjustments.

After adjusting planting depth, check the operation of the “V” closing wheels. The “V” closing wheels should have enough down pressure to close the seed trench and ensure good soil to seed contact. To increase spring pressure on the closing wheels, move the 5-position quick adjustable down force lever located on the top of the closing wheel arm to the rear. Moving the lever forward decreases spring tension.

Adjust all row units to a similar setting.

77121-10

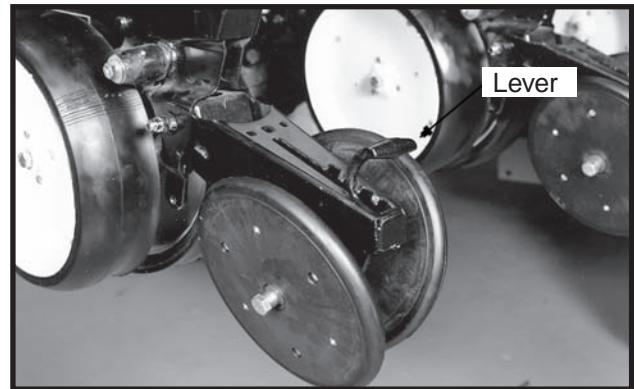

Light soil usually requires less down force at average depth (approximately 2”) while heavy soil requires increased down force.

Eccentric bushings in the wheel arm stop allow for lateral adjustment of the “V” closing wheel assembly. Using a 3/4” wrench, loosen the hardware which attaches the closing wheel arm to the wheel arm stop. Using another 3/4” wrench turn the eccentric bushings until the **closing wheels are aligned with the seed trench**. Tighten hardware.

72359-129

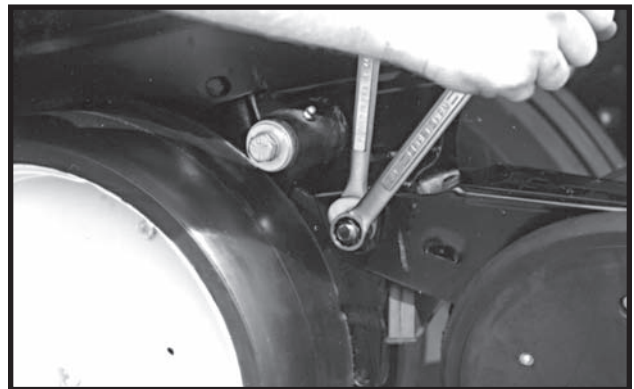

Bushings used for installation of the closing wheels can be moved from side to side for closing wheel spacing adjustment and the closing wheels can be installed in two locations either “offset” (to improve residue flow) or “directly” opposite. Under normal conditions the narrow position is preferred.

(PLTR95)

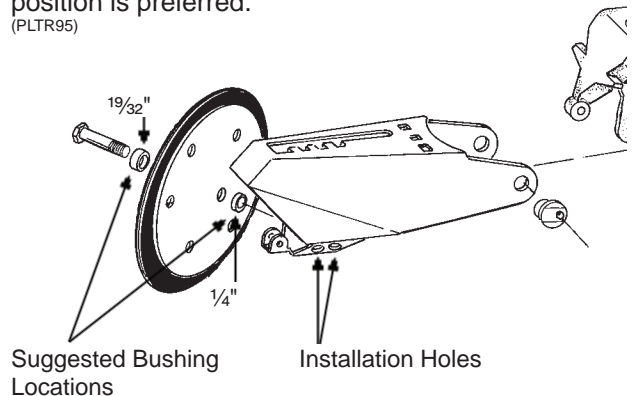

ROW UNIT OPERATION

COVERING DISCS/SINGLE PRESS WHEEL ADJUSTMENT



WARNING: Raise planter and install safety lockups before making covering discs/single press wheel adjustments.

72359-31



After adjusting planting depth, check the operation of the covering discs/single press wheels.

Initial press wheel down force setting should be with 2 1/2" between mounting arm tab and locking nut. To adjust down force spring, loosen 1/2" locking nut and turn adjusting bolt in to increase down force and out to decrease down force. Tighten locking nut against spring plug. Adjust all row units to a similar setting.

RH993(PLTR12)

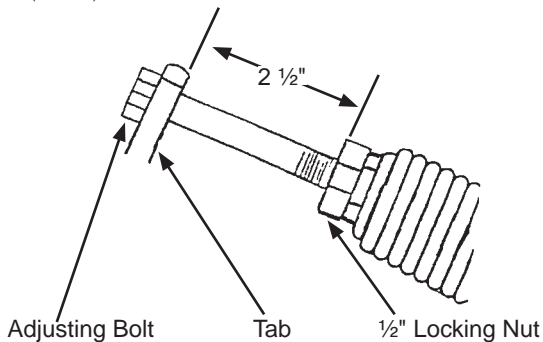

Eccentric bushings in the wheel arm stop allow for lateral adjustment of the covering discs/single press wheel assembly. Using a 3/4" wrench, loosen the hardware which attaches the assembly to the wheel arm stop. Using another 3/4" wrench, turn the eccentric bushings until the press wheel is aligned with the seed trench.

(PLTR96)

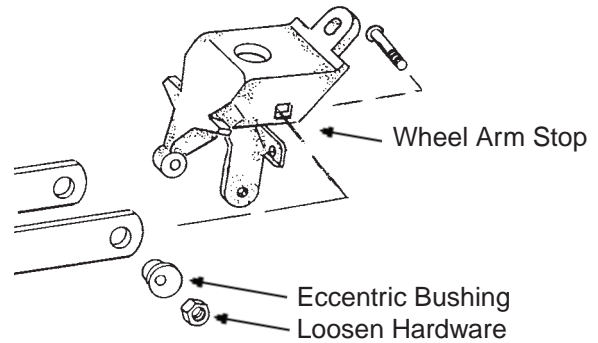

Two sets of holes in the mounting arm allow the covering discs to be located for staggered or side-by-side operation as desired.

72359-35

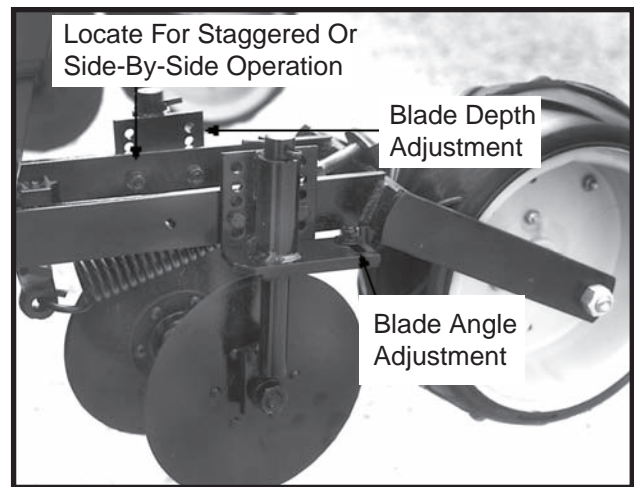

Five sets of holes in each disc bracket allow for 1/2" incremental blade depth adjustment.

Slotted holes in the disc mount and bracket allow for 0° - 15° blade angle adjustment.

Adjust covering discs on all row units to similar settings.

ROW UNIT OPERATION

FINGER PICKUP SEED METER

Refer to the planting rate chart for recommended seed drive transmission sprocket combinations.

60620-16

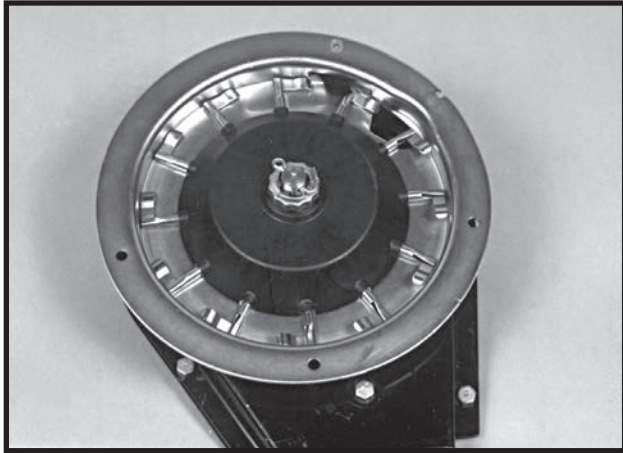

Shown With Corn Fingers Installed

The following seed fingers are available for use with the finger pickup seed meter:

(PLTR91/PLTR92)

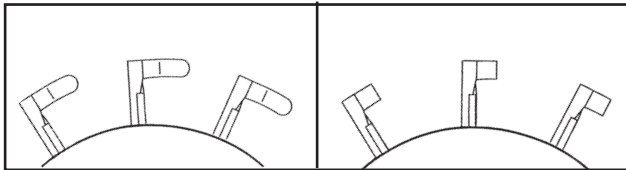

Corn Fingers

Oil Sunflower Fingers

No. 3 and/or No. 4 size oil sunflower seeds are recommended for use in the finger pickup seed meter equipped with oil sunflower fingers.

IMPORTANT: Always check seed population in the field to ensure planting rates are correct.

IMPORTANT: To ensure efficient operation of the finger pickup seed meter and extend the life of its components, mix one teaspoon of powdered graphite with the seed twice daily. Even distribution of the graphite with the seed is critical with newer seed coatings to provide lubrication for the seed pickup mechanism. Graphite application frequency may need to be increased if using additional seed additives.

82354-1



See "General Planting Rate Information", "Finger Pickup Seed Meter Troubleshooting" and "Finger Pickup Seed Meter Inspection/Adjustment" for additional information.

ROW UNIT OPERATION

BRUSH-TYPE SEED METER

60607-40(PLTR13)

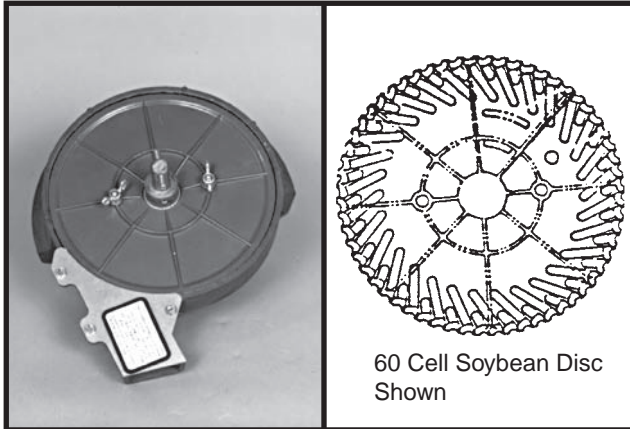

60 Cell Soybean Disc Shown

The following seed discs are available for use with the brush-type seed meter:

Soybean: 60 cells to meter seed sizes from 2200 to 4000 seeds per pound (Black color-coded).

(PLTR14)

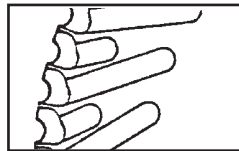

Specialty soybean: 48 cells to meter seed sizes from 1400 to 2200 seeds per pound (Dark blue color-coded).

(PLTR15)



Small milo/grain sorghum: 30 cells to meter seed sizes from 14,000 to 20,000 seeds per pound (Red color-coded).

(PLTR16)

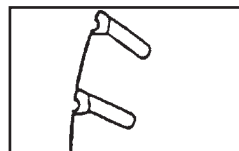

Large milo/grain sorghum: 30 cells to meter seed sizes from 10,000 to 16,000 seeds per pound (Light blue color-coded).

(PLTR17)

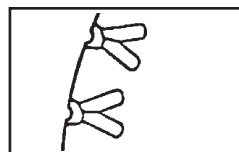

High rate small milo/grain sorghum:

60 cells to meter seed sizes from 12,000 to 18,000 seeds per pound (Red color-coded). (PLTR18)

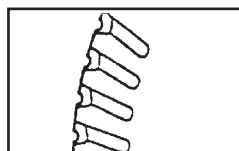

High rate large milo/grain sorghum:

60 cells to meter seed sizes from 10,000 to 14,000 seeds per pound (Yellow color-coded). (PLTR19)

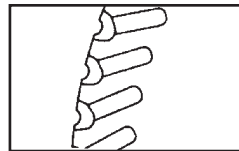

Cotton, acid-delinted: 30 cells to meter seed sizes from 4200 to 5200 seeds per pound (White color-coded).

(PLTR20)

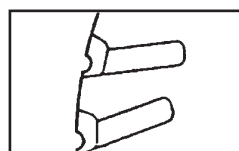

Large cotton, acid-delinted: 36 cells to meter seed sizes from 3800 to 4400 seeds per pound (Tan color-coded).

(PLTR21)



High rate cotton, acid-delinted: 48 cells to meter seed sizes from 4200 to 5200 seeds per pound (Light green color-coded).

(PLTR22)



Hill-drop cotton, acid-delinted: 12 cells, 3 to 6 seeds/cell, to meter seed sizes from 4000 to 5200 seeds per pound (Brown color-coded). (PLTR23)

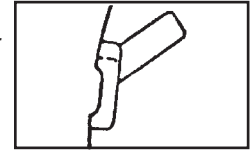

Small hill-drop cotton, acid-delinted: 12 cells, 3 to 6 seeds/cell, to meter seed sizes from 5000 to 6200 seeds per pound (Dark green color-coded).

(PLTR23)

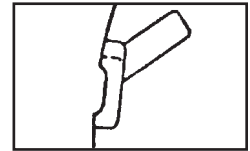

When installing the seed disc onto the meter hub, turn the disc counterclockwise while tightening the two wing nuts that retain the disc. The seed disc should have only slight resistance when rotated counterclockwise after wing nuts are tight.

The brush-type seed meter attaches to the seed hopper in the same manner as the finger pickup seed meter. Secure to bottom of seed hopper with two $\frac{5}{16}$ " flanged hex nuts. DO NOT OVER TIGHTEN.

Erratic seed spacing may result from misalignment between the drive coupler and seed meter input shaft. Misalignment may cause momentary stoppage of seed disc. Check alignment after initial installation. If adjustment is required, refer to "Meter Drive Adjustment" for correct procedure.

Refer to the planting rate charts in this manual for recommended seed drive transmission sprocket combinations.

IMPORTANT: Use powdered graphite or talc with each hopper fill of seed. Additional graphite or talc may be required to retard buildup of seed treatments on meter components. Frequency of monitor seed tube cleaning may be affected due to use of additional graphite or talc.

ROW UNIT OPERATION

82354-1



One tablespoon of **powdered graphite** per hopper fill of seed should be mixed in with the seed each time the hopper is filled. This prolongs the life of the brush-type seed meter components, reduces buildup of seed treatment on components in the meter and improves seed spacing.

Talc seed lubricant may be used in lieu of or in addition to graphite to reduce seed treatment buildup on seed disc and meter components and will improve meter performance. Coat seed disc and brushes with talc before installing meter. Fill hopper $\frac{1}{2}$ full of seed, add $\frac{1}{4}$ cup of talc and mix thoroughly. Finish filling hopper, add another $\frac{1}{4}$ cup of talc and mix thoroughly. Adjust rate of talc use as needed so all seeds are coated, while avoiding a buildup of talc in the bottom of the hopper. Humid conditions and/or small sized seeds with extra seed treatment may require as much as one cup of talc per hopper to prevent seed treatment buildup on the seed disc and/or brushes.

CAUTION: Some liquid seed treatments or inoculants may create buildup on the seed disc or brushes. Check frequently for proper population and/or seed delivery when using any liquid seed treatment. All seed treatment should be thoroughly mixed with the seed per the manufacturers' recommendations. Seed treatment dumped on top of the seed after the hopper is filled, and not mixed properly will cause bridging of the seed in the meter, reducing population or stopping the meter from planting. Additional graphite or talc may be required to retard buildup of seed treatments on meter components.

IMPORTANT: Foreign material, such as hulls, stems, etc., may affect seed delivery. Clean seed is required to ensure accurate seed metering from the brush-type seed meter. Seed discs should be removed daily to check for buildup of foreign material, such as hulls, in the seed meter or the brushes.

SEED HOPPER

60620-69



The seed hopper has a capacity of 1.6 bushels.

When filling the seed hopper use clean seed and make certain there are no foreign objects in the hopper. **Replace hopper lids after hoppers are filled to prevent the accumulation of dust or dirt in the seed meter which will cause premature wear.** See "Finger Pickup Seed Meter Lubrication" and/or "Brush-Type Seed Meter Lubrication".

Periodically empty the hoppers completely to remove any foreign objects and to ensure proper seed meter operation. To empty hopper, disengage drive release and hopper latch and lift hopper off the hopper support. See "Meter Drive Release".

ROW UNIT OPERATION

SEED METER DRIVE ADJUSTMENT

IMPORTANT: The seed meter drive coupler must be properly aligned with the meter input shaft.

Improper alignment between the drive coupler and input shaft of the meter can cause the meter housing to flex as the meter rotates. This continual flexing of the meter housing can cause damage to the housing. Any time the hopper support panel is removed or replaced, vertical and horizontal alignment should be checked.

61658-27

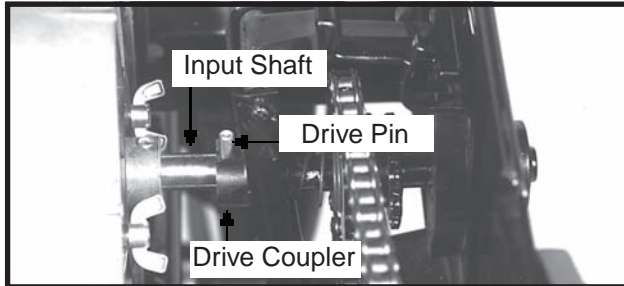

To check alignment:

- Inspect meter input shaft to make sure drive pin is centered.
- Install hopper with meter onto support panel and latch hopper.
- Rotate meter input shaft so drive pin is vertical.
- Rotate drive clutch so slots in coupler are vertical.
- Engage clutch.
- Clutch coupler should engage meter shaft freely with equal amount of pin extending beyond each side of drive coupler.
- Disengage clutch.
- Rotate both meter shaft and drive clutch to the horizontal position.
- Re-engage clutch.
- Clutch coupler should engage meter shaft freely with equal amount of pin extending beyond each side of drive coupler.

To adjust drive clutch:

- Slightly loosen both $\frac{5}{16}$ " cap screws.
- Move clutch assembly to correct any misalignment.
- Tighten both $\frac{5}{16}$ " cap screws.

72794-24

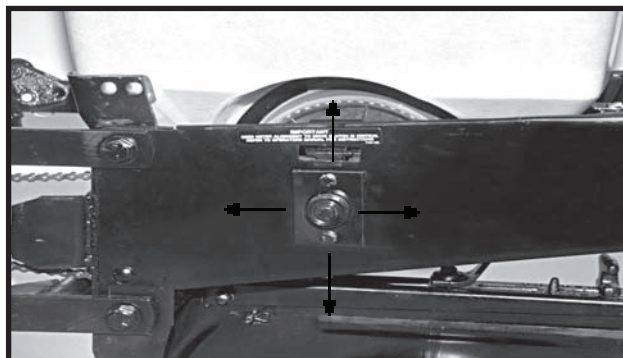

SEED METER DRIVE RELEASE

The seed meter drive is equipped with a clutch release mechanism that allows the drive to be disconnected from the seed metering unit for removal of seed hopper. Disconnecting the drive allows the operator to check granular chemical application rates without dropping seed. It also allows one or more of the rows to be disconnected when finishing fields.

72359-164

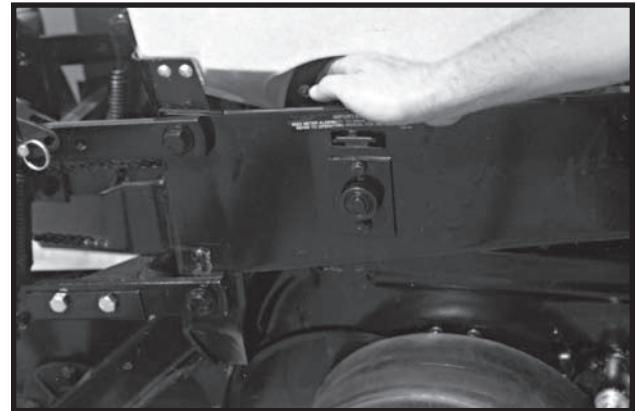

To disengage the drive, lift the release handle and pull outward until the handle locks in the slot in the side of the hopper side panel. To engage the row unit, lift and unlatch the handle. Spring tension will return the mechanism to the drive position.

Erratic seed spacing may result from misalignment between the drive coupler and seed meter input shaft. Misalignment may cause momentary stoppage of brush-type meter seed disc. Check alignment after initial installation. If adjustment is required, refer to "Meter Drive Adjustment" for correct procedure.

ROW UNIT OPERATION

ROW UNIT CHAIN ROUTING

For proper operation and to minimize wear, the row unit drive chains must be properly tensioned and aligned.

Inspect and replace weak, worn or broken springs and/or idlers and idler bushings.

NOTE: When idler shows signs of wear, it can be reversed for prolonged use.

72359-124(PLTR25)

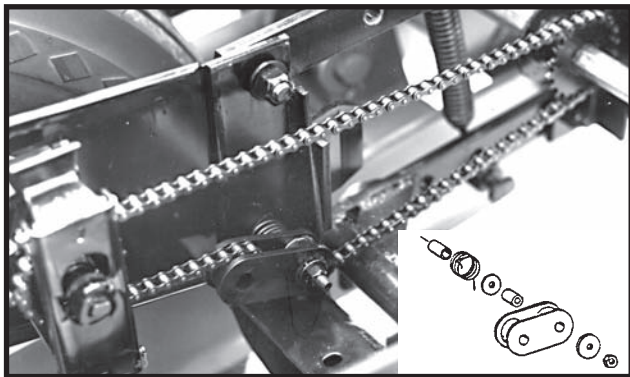

Pull Row Unit Meter Drive

72359-97(PLTR26)

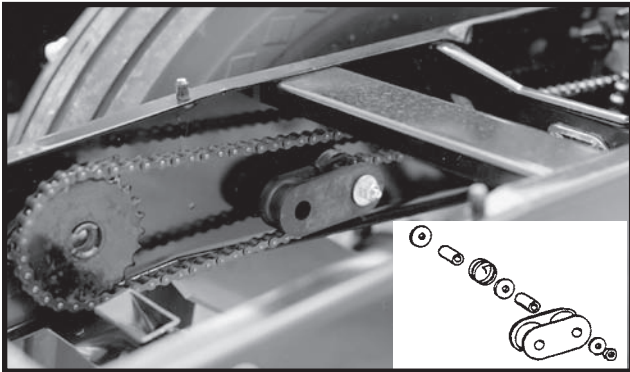

Row Unit Granular Chemical Drive

03279806(PLTR26)

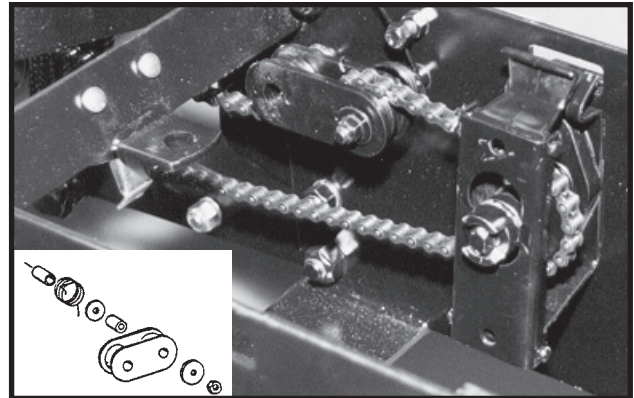

Push Row Unit Meter Drive

NOTE: Make sure connector link is installed with closed end located as shown below.

(PLTR24)



ROW UNIT OPERATION

QUICK ADJUSTABLE DOWN FORCE SPRINGS

Quick adjustable down force springs are designed to increase penetration in hard soil and keep the row unit from bouncing in rough field conditions.

Two springs per row, one on the L.H. parallel arms and one on the R.H. parallel arms, are used unless equipped with row unit mounted no till coulters. Four springs per row are used with row unit mounted no till coulters.

61703-4

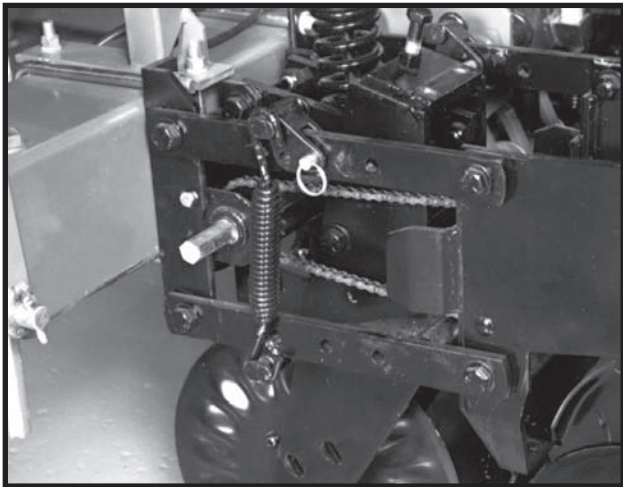

Two Springs Per Row (Dual)

72359-4

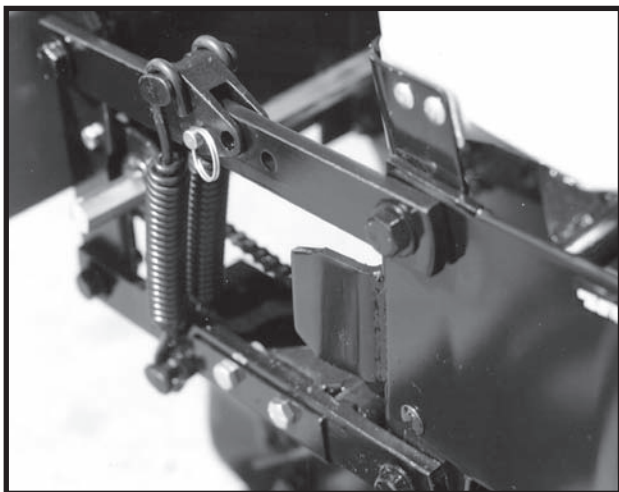

**Four Springs Per Row (Quad)
(Used Only In Conjunction With Row Unit Mounted No Till Coulters)**

There are four positions for spring tension adjustment. Position 1 allows for minimum down pressure and position 4 for maximum down pressure.

L0096(PLTR27d)

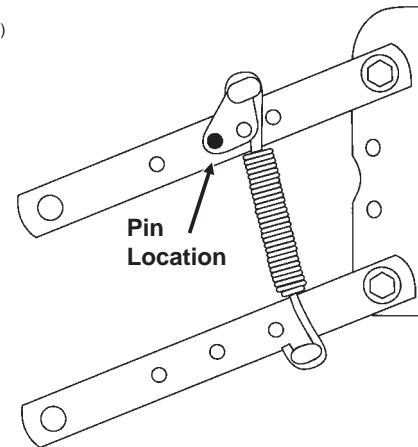

Position 1 (Minimum)

(PLTR28d)

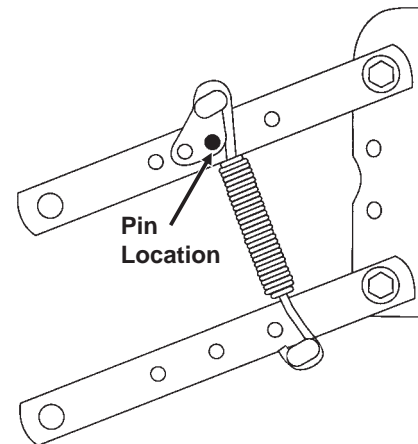

Position 2

(PLTR29d)

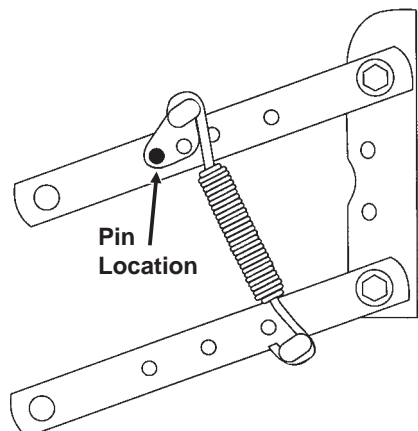

Position 3

ROW UNIT OPERATION

(PLTR30d)

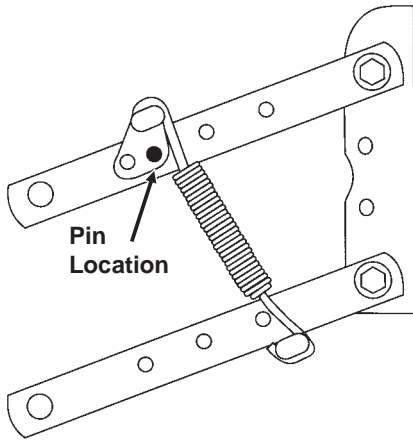

Position 4 (Maximum)

To adjust spring tension, raise planter and remove spring mount pin at top of spring. Slide mount to desired position and install pin.

NOTE: It is necessary for the operator to adjust springs according to field conditions. If springs are adjusted for too much down pressure for field conditions, it is possible for the row units to lift the planter to the extent that the drive wheels do not make sufficient contact. Too much down pressure in soft field conditions can cause the row unit to run too deep.



DANGER: Always install safety lockups or lower machine to the ground before working under or around the machine.

NOTE: Springs must always be installed with open side of spring hooks toward seed hopper to prevent binding on spring mount adjustment pin.

FRAME MOUNTED COULTER

Frame mounted coulters with 1" bubbled, 1" fluted (8 flutes) or 3/4" fluted (13 flutes) blades may be used on pull row units only. (Not compatible with push row units.)

The frame mounted coulter is designed to allow required spring down pressure on the coulter for maximum penetration while exerting less shock load on the row unit.

The frame mounted coulter can be used with or without the depth control bar installed. In most applications, especially in rocky planting conditions, the depth control bar **should not be used**. Use of the depth control bar transfers down force from the coulter to the row unit making less down force available to the coulter blade.

56314-14

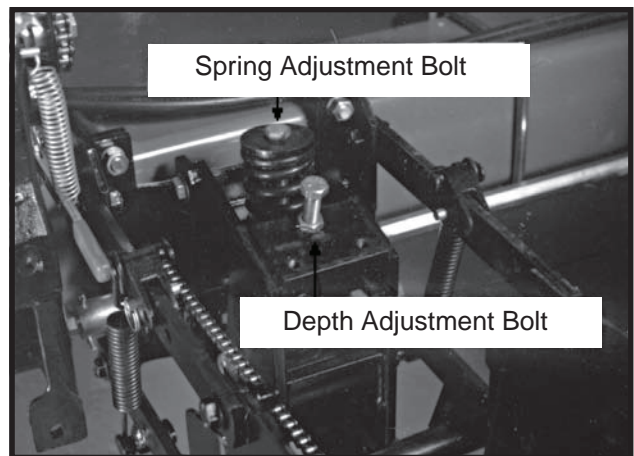

DEPTH ADJUSTMENT (Without Depth Control Bar Installed)

When the depth control bar is not used, operating depth of the coulter blade is determined by adjusting the depth adjustment bolt and positioning of the blade assembly in the fork mount. The depth adjustment bolt will stop downward travel of the coulter arm assembly. One turn of the adjusting bolt will change depth setting approximately 1/4". Initial setting of the depth adjustment bolt should be with approximately 1 3/8" of thread showing. With this setting and the bar height at 20", the coulter depth will be approximately 2" with coulter mounting spindle in top hole. Turn the adjustment bolt clockwise to decrease operating depth. Turn the depth adjustment bolt counterclockwise to increase operating depth.

ROW UNIT OPERATION

56314-16

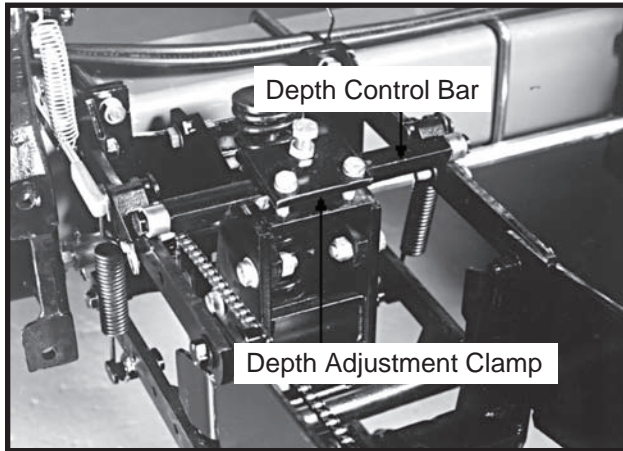

Depth Control Bar

Depth Adjustment Clamp

In certain applications it is desirable to use the depth control bar. In uneven terrain, use of the depth control bar allows greater depth control. The up and down movement of the row unit allows the coulters to move up and down at a rate of approximately 1/2 that of the row unit, maintaining a more uniform operating depth. When using the disc furrower attachment, the depth control bar should always be used, as operating depth of the coulters is critical for the disc furrowers to operate with minimal gouging.

DEPTH ADJUSTMENT (With Depth Control Bar Installed)

When using the depth control bar, down force springs must be located in the forward position and the depth adjustment bolt used only to attach the depth adjustment clamp to the coulters assembly. Operating depth of the coulters blade is adjusted by positioning the blade assembly in the fork mount. Four blade mounting adjustment positions are available at 1/2" increments. Initial position of the blade assembly should be in the top hole. This position will locate the coulters blade approximately 1/4" deeper than the row unit opener blade. In heavy residue it may be desirable to position the blade assembly in the second position to insure that the residue is cut and not forced down into the seed zone. Additional holes are used to compensate for coulters blade wear.

56314-1

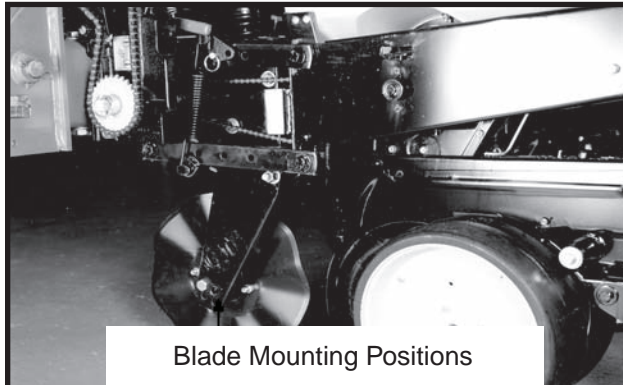

Blade Mounting Positions

Down force adjustment is made by tightening or loosening the spring adjustment bolt. With the planter in the raised position, turn the bolt clockwise to increase down force or counterclockwise to decrease down force. Set all rows equally.

Compressed Spring Length (Including Washer)	Pounds Down Pressure With Blade 1/2" Above Maximum Down Position	Pounds Down Pressure With Blade 4" Above Maximum Down Position
13 5/16"	90	230
12 5/16"	190	330
Suggested initial setting.		
11 5/16"	300	430

A5649rev.(PLTR44)

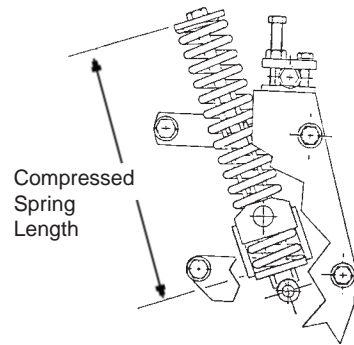

NOTE: Excessive down force may cause increased wear on components.

The coulters blade can be aligned with the row unit disc opener by moving the spacer washers from one side of the coulters blade hub to the other.

56314-12

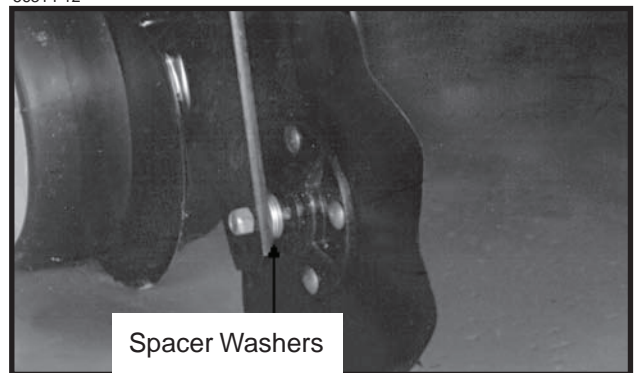

Spacer Washers

Field adjustment should be made as needed. Operating height of the planter frame will affect operating depth of the frame mounted coulters.

NOTE: Torque 5/8" spindle bolts to 120 ft. lbs.

ROW UNIT OPERATION

DISC FURROWERS (For Use With Frame Mounted Coulter)

Disc furrowers for use with the frame mounted coulter may be equipped with either 12" solid blades or 12" notched blades.

Disc furrowers are used to clear crop residue, dirt clods and dry soil from in front of the row units for a clean and smooth seed bed. Notched blades are used for heavier residue conditions. The notched blades cut crop residue and move it aside to prevent plugging or pushing.

56314-19

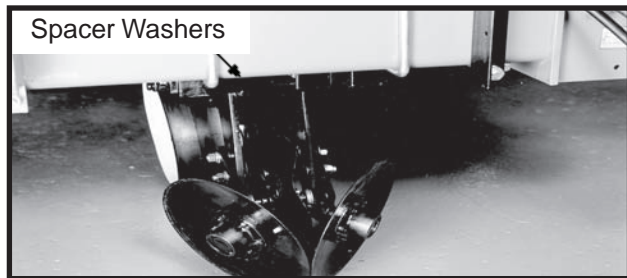

Blades can be adjusted so front edges meet by adding spacer washers between the disc furrower arm and frame mounted coulter fork mount.

Slotted holes in the frame mounted coulter fork mount and in the disc furrower arm allow for vertical and horizontal adjustment. Blades can be adjusted so the front edges meet or one blade can be moved to the rear and the other to the front of the slot so the cutting edge of one blade overlaps the edge of the other blade.

56314-17

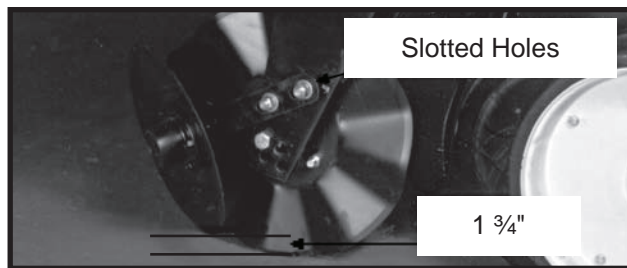

Initial setting for the disc furrowers is 1 3/4" shallower than the coulter blade. Further adjustment may be desired for various applications.

NOTE: The depth control bar should always be used when the frame mounted coulter is equipped with disc furrowers.

ROW UNIT MOUNTED DISC FURROWER

The row unit mounted disc furrower for use on pull row units only (Not compatible with Interplant® push row units.) may be equipped with either 12" solid blades or 12" notched blades.

Disc furrowers are used to clear crop residue, dirt clods and dry soil from in front of the row units for a clean and smooth seed bed. Notched blades are used for heavier residue conditions. The notched blades cut crop residue and move it aside to prevent plugging or pushing.

59386-23

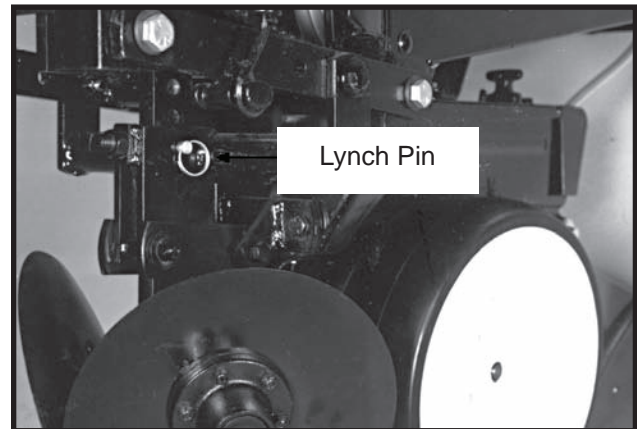

59386-20

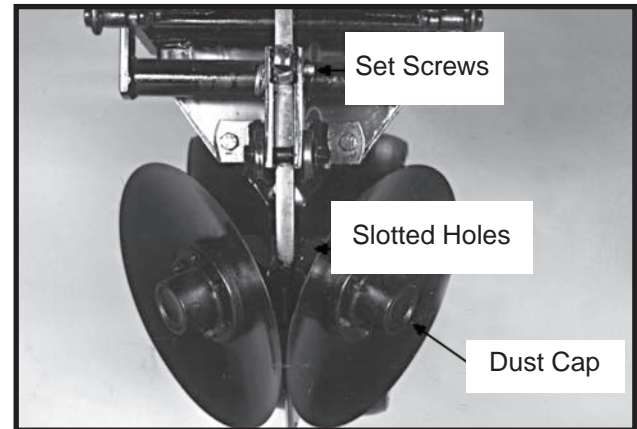

Vertical adjustment in 1/8" increments is possible by removing the lynch pin which secures the vertical support arm and moving the support arm up or down as required. Re-install lynch pin. Finer adjustment can be attained by removing the lynch pin and using the 5/8" x 2 1/4" set screw to clamp the support arm in the required position.

Slotted holes in the support arm where the blades are mounted allow fore and aft adjustment of the discs. Blades can be adjusted so the front edges meet or one blade can be moved to the rear and the other to the front of the slot so the cutting edge of one blade overlaps the edge of the other blade. The dust cap must be removed to make these adjustments.

ROW UNIT OPERATION

ROW UNIT MOUNTED RESIDUE WHEEL

The row unit mounted residue wheel may be used on pull row units and push row units.

Two adjustable springs on the parallel links on each residue wheel allow for down force adjustment. Position 1 as shown below provides minimum down pressure and position 3 maximum down pressure.

Position 1 (Minimum) (PLTR31a)

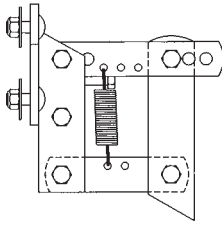

Position 2 (PLTR32a)

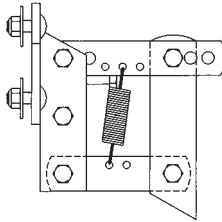

Position 3 (Maximum) (PLTR33a)

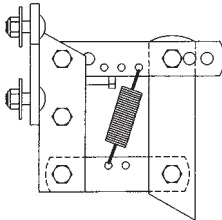

For additional uplift or float, position springs as shown below.

(PLTR34a)

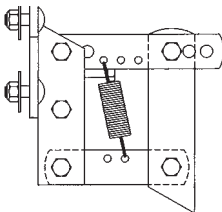

To adjust down force springs, raise the row unit out of the ground and reposition springs as shown for the desired down pressure.

76782-31

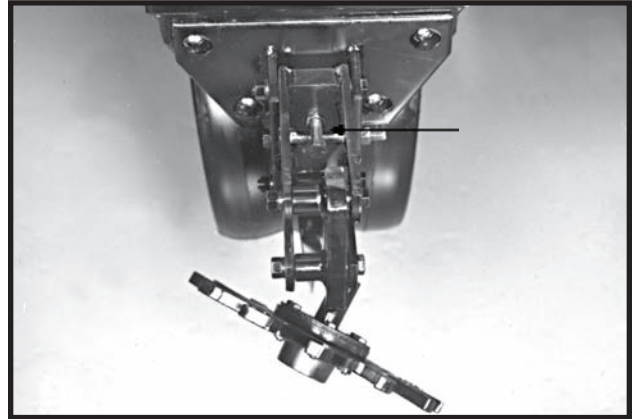

A full threaded bolt and jam nut located on the upper link allows maximum depth to be set for loose soil conditions. Initial setting should be 1 3/4" above the depth of the row unit double disc opener.

Three holes in the upper link allow for wheel angle adjustment. With the wheel mount in the most vertical position, using the rear hole in the upper link, the residue wheel is most aggressive. Moving the wheel mount to one of the forward holes reduces the aggressiveness of the wheel for use in mulch till applications where the soil is loose.

72794-29

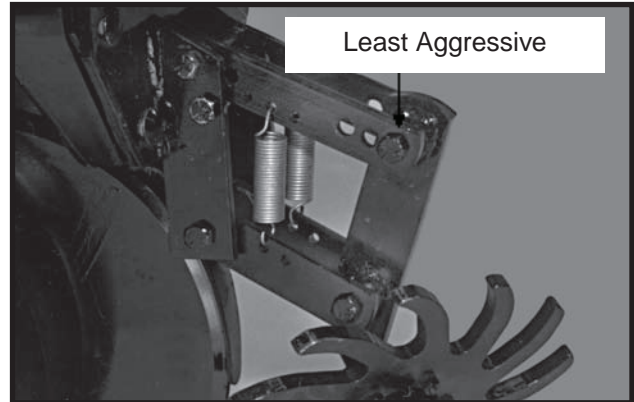

To lock the residue wheel up out of the ground, remove the 1/2" x 5" lockup bolt, raise the residue wheel and install bolt.

72794-31

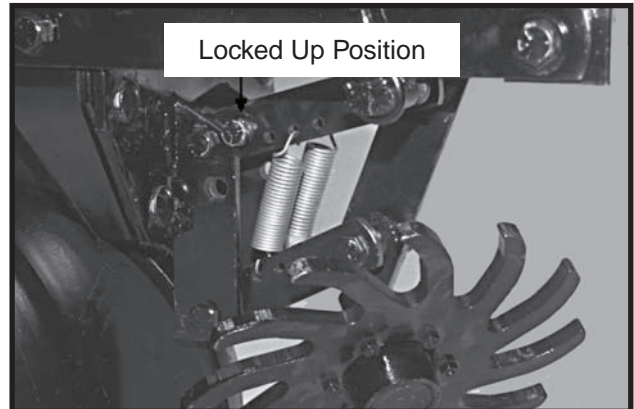

ROW UNIT OPERATION

ROW UNIT MOUNTED NO TILL COULTER

80367-10



Row unit mounted no till coulters with 1" bubbled, 1" fluted (8 flutes) or $\frac{3}{4}$ " fluted (13 flutes) blades may be used on pull row units and push row units. ($\frac{3}{4}$ " fluted shown)

Four quick adjustable down force springs are required per row when using row unit mounted no till coulters. See "Quick Adjustable Down Force Springs".

For proper operation the coulters blade should be aligned in relation to the row unit double disc openers. The coulters assembly can be adjusted by loosening the four attaching bolts, moving coulters arm to align and tightening the four attaching bolts.

The coulters blade can be adjusted to one for four $\frac{1}{2}$ " incremental settings in the forked arm. Initial location of the coulters is in the top hole. As the coulters blade wears, the blade should be adjusted downward to one of the three lower settings to maintain the coulters blade at or slightly below the opener discs. In very hard soil conditions such as compacted wheel tracks, opener penetration and cutting of surface residue may be improved by adjusting the coulters to operate below the depth of the double disc opener blades.

Operating depth can be checked by setting the planter down on a level concrete floor and checking the relationship between the coulters blade and row unit opener blade. Make sure the planter is level and coulters is square with the planter frame and aligned with the row unit disc opener.

NOTE: Torque $\frac{5}{8}$ " spindle bolts to 120 ft. lbs.

COULTER MOUNTED RESIDUE WHEELS

80376-15

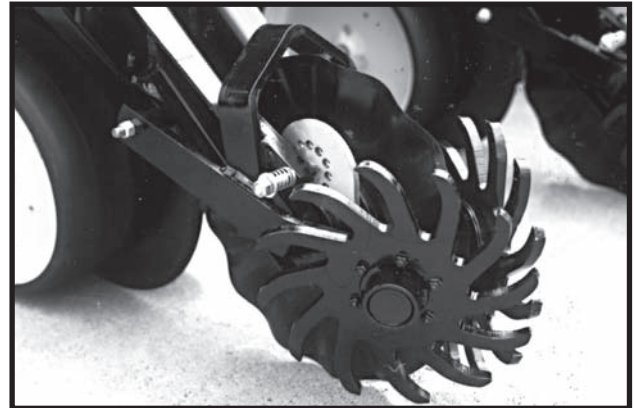

Coulters mounted residue wheels are designed for use on pull row unit and push row units.

The coulters mounted residue wheels are attached to the row unit mounted no till coulters with one cap screw and sleeve allowing the unit to free-float. A 2-position spindle bolt mounting allows the tined wheels to be mounted interlocked or staggered. Depth adjustment is made using a spring-loaded cam and pin with 11 positions in $\frac{1}{4}$ " increments. A high point on the cam allows the wheels to be locked up so they do not contact the ground.

ROW UNIT OPERATION

SEED FIRMING WHEEL

76782-5

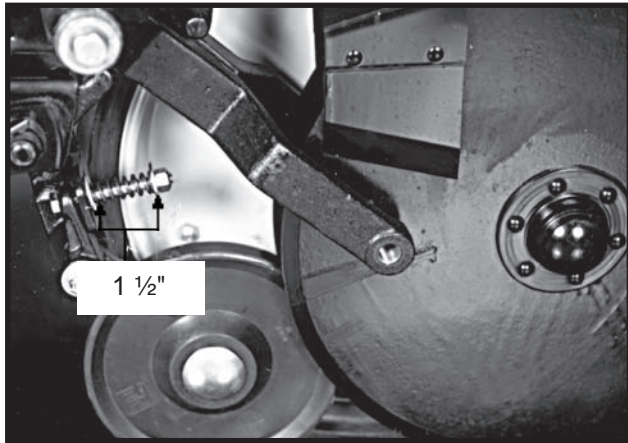

Shown with gauge wheel removed.

The seed firming wheel is designed for use on pull row units and push row units. Seed firming wheels are for use in dry loose soil conditions to gently and firmly press the seed into the seed bed before the closing wheels close the seed trench.

NOTE: Certain soil types and moisture conditions may lead to erratic performance resulting in irregular seed placement.

Initial spring tension is set leaving 1 1/2" between the washers.

SPRING TOOTH INCORPORATOR

The spring tooth incorporator smooths the soil behind the row unit and incorporates granular chemicals. The two mounting chains on each spring tooth incorporator should be adjusted so there is approximately 1/8" slack in the chain when the unit is lowered to planting position.

NOTE: The spring tooth incorporator is not compatible with the covering discs/single press wheel option.

73090-4a

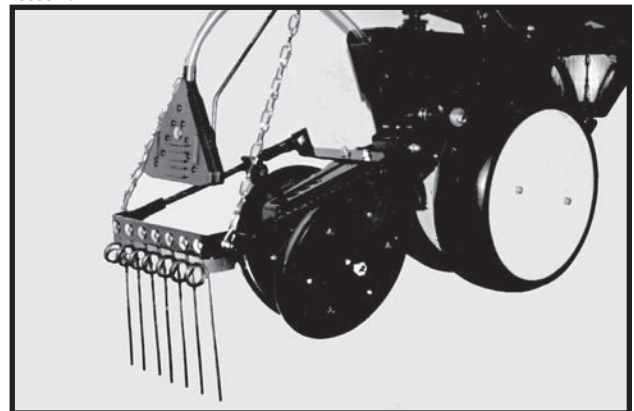

ROW UNIT OPERATION

GRANULAR CHEMICAL HOPPER

61766-2

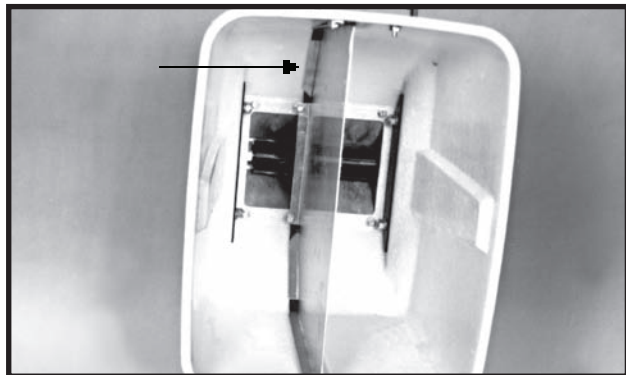

The granular chemical hopper has a 70 pound capacity. With the use of a hopper divider the hopper has two compartments with a 35 pound capacity in each.

Be sure no foreign objects get into the hopper when it is being filled. Replace the hopper lids after filling the hoppers to prevent the accumulation of dirt and moisture.

The metering gate located on the bottom of the hopper regulates the application rate. See “Dry Insecticide And Dry Herbicide Application Rate Charts” in this manual. Calibrate using the chemical manufacturers’ instructions.



DANGER: Agricultural chemicals can be dangerous. Improper selection or use can seriously injure persons, animals, plants, soil or other property. **BE SAFE:** Select the right chemical for the job. Handle it with care. Follow the instructions on the container label.

The granular chemical clutch drive coupler and meter shaft can be disengaged and engaged by turning the throwout knob located at the rear of the hopper support panel. To engage the drive, turn the knob ¼ turn clockwise. To disengage the drive, turn the knob ¼ turn counterclockwise. Slotted holes in the hopper support panel and clutch housing allow for alignment adjustment between the clutch drive coupler and meter shaft.

72359-183

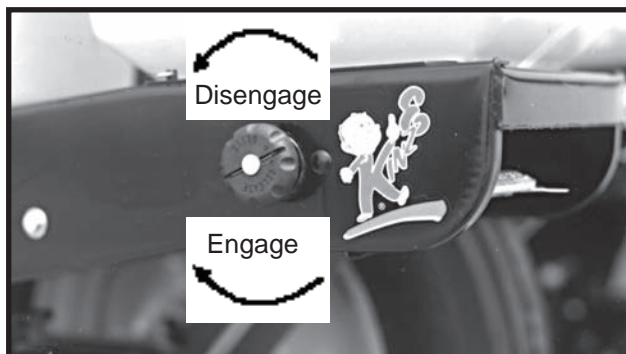

GRANULAR CHEMICAL RESTRICTOR PLATE

65249-17

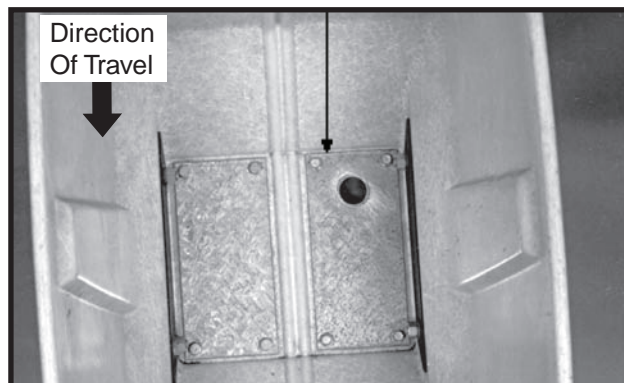

The granular chemical restrictor plate is designed for use in the granular chemical hopper when granular chemical application rates below 4 pounds per acre are desired. The plate restricts chemical flow to the meter outlet to prevent grinding of the material.

IMPORTANT: Check application rate of all rows in the field with the granular chemical you are using and at the speed and population at which you will be planting. See “Checking Granular Chemical Application Rate”.



DANGER: Agricultural chemicals can be dangerous. Improper selection or use can seriously injure persons, animals, plants, soil or other property. **BE SAFE:** Select the right chemical for the job. Handle it with care. Follow the instructions on the container label.

ROW UNIT OPERATION

GRANULAR CHEMICAL BANDING OPTIONS

Granular chemical banding options allow front and/or rear banding.

With use of the granular chemical hopper divider and second meter, two banding applications may be utilized.

NOTE: The granular chemical rear bander is not compatible with the covering discs/single press wheel option.

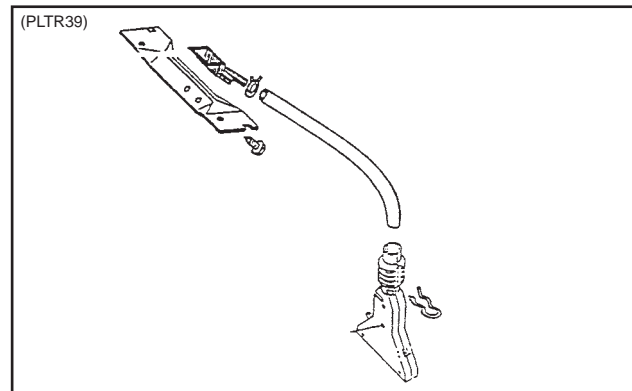

4 1/2" Slope-Compensating Bander

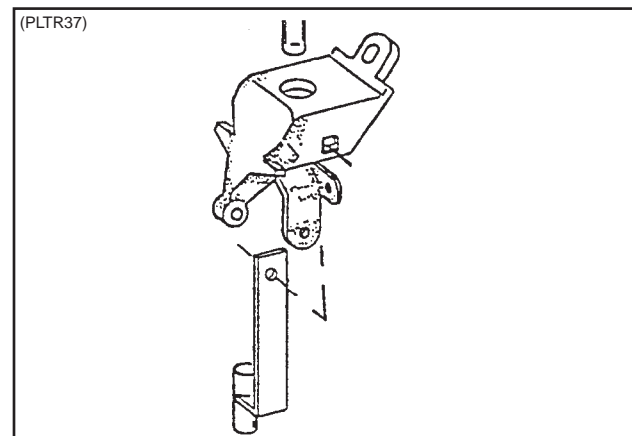

Straight Drop In-Furrow Placement

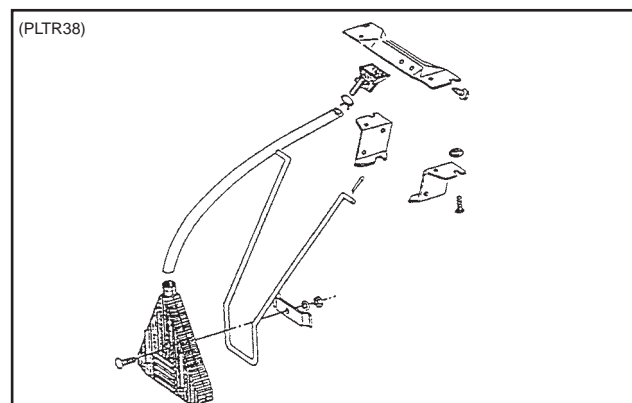

14" Rear Banding

PUSH ROW UNIT LOCKUPS

Push row unit lockups are designed to allow the push units to be locked in the raised position.

60569-6



Raised Position

To lock in raised position:

1. With the planter in the raised position, place a wooden (approximately 8") block under the disc opener assembly of each push unit. (Or use other means of raising each push unit.)
2. Lower the planter until the push unit is in the extreme raised position.
3. Rotate both right hand and left hand lockups into place under the push unit stops as shown in the "Raised Position" photo.
4. Raise planter.
5. Remove wooden blocks.

60569-9

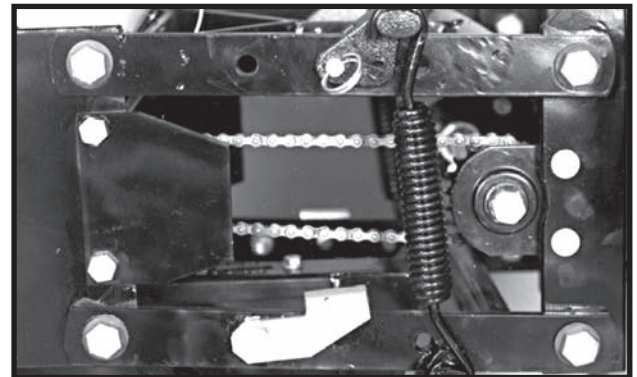

Planting Position

To release lockups:

Reverse of above procedure. At Step 3, rotate lockups out from under the push unit stops as shown in "Planting Position" photo.



DANGER: Always install all safety lockups or lower planter to the ground before working under or around the machine.

LUBRICATION

The following pages show the locations of all lubrication points. Proper lubrication of all moving parts will help ensure efficient operation of your KINZE® planter and prolong the life of friction producing parts.



DANGER: Always install safety lockups or lower to the ground before working under the machine.

LUBRICATION SYMBOLS



Lubricate at frequency indicated with an SAE multi-purpose type grease.



Lubricate at frequency indicated with a high quality SAE 10 weight oil or a quality spray lubricant.

SEALED BEARINGS

72794-21a

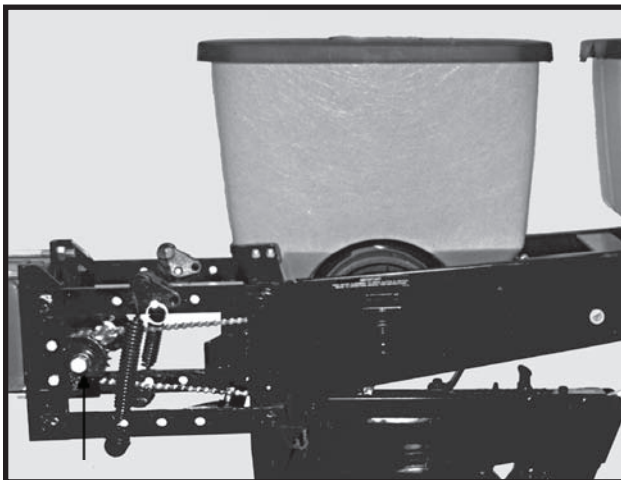

A number of sealed bearings are used on your KINZE® planter to provide trouble free operation. These are located in such areas as the drive shaft, row units and transmission bearings. Sealed bearings are lubricated for life. Due to the seals, relubrication is not practical.

DRIVE CHAINS

All transmission and drive chains should be lubricated daily with a high quality SAE 10 weight oil or a quality spray lubricant. Extreme operating conditions such as dirt, temperature or speed may require more frequent lubrication. If a chain becomes stiff, it should be removed, soaked and washed in solvent to loosen and remove dirt from the joints. Then soak the chain in oil so the lubricant can penetrate between the rollers and bushings.

72359-123

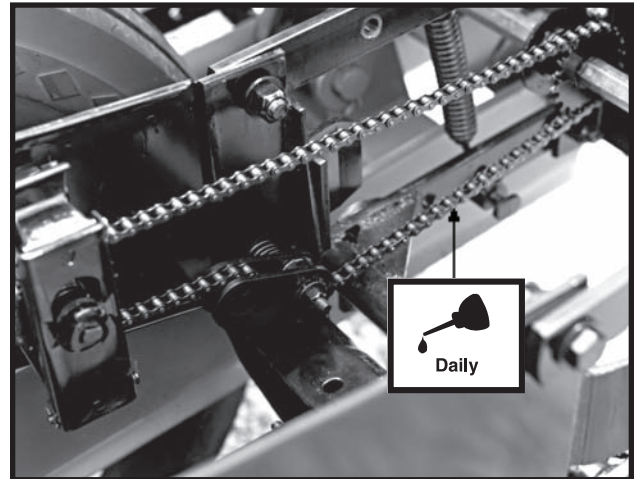

Pull Row Unit Seed Meter Drive Chain(s)

72359-126

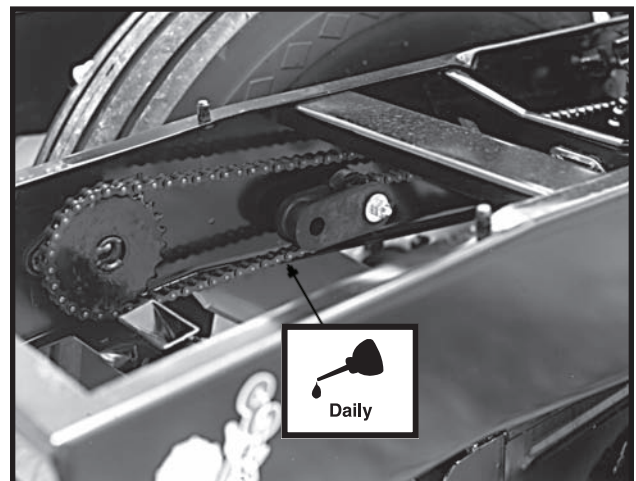

Row Unit Granular Chemical Meter Drive Chain(s)

LUBRICATION

08229714

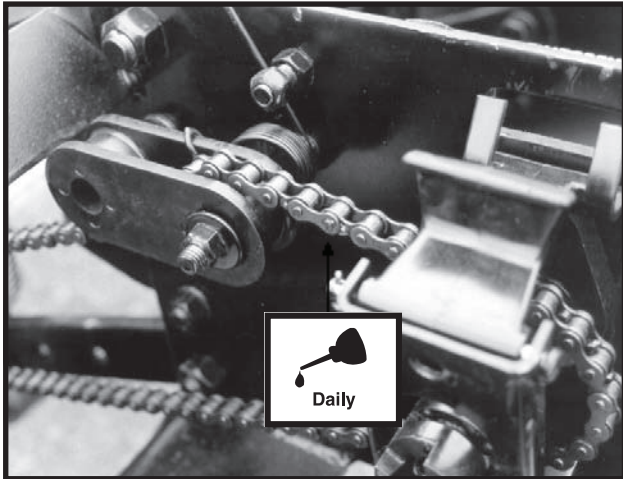

Push Unit Seed Meter Drive Chain(s)

01209908

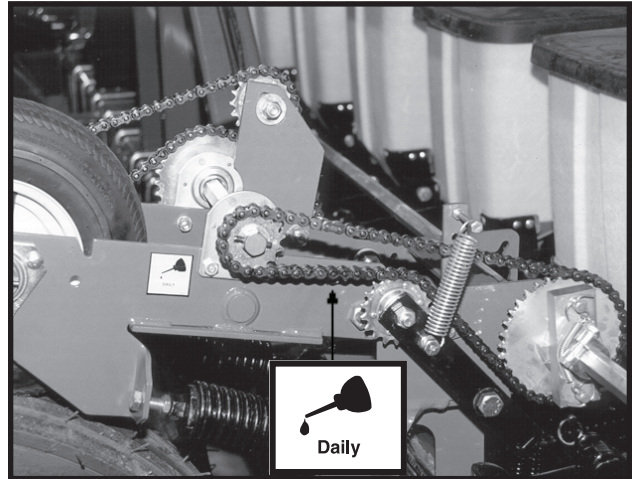

Contact Wheel Driven Chain(s)

01209904

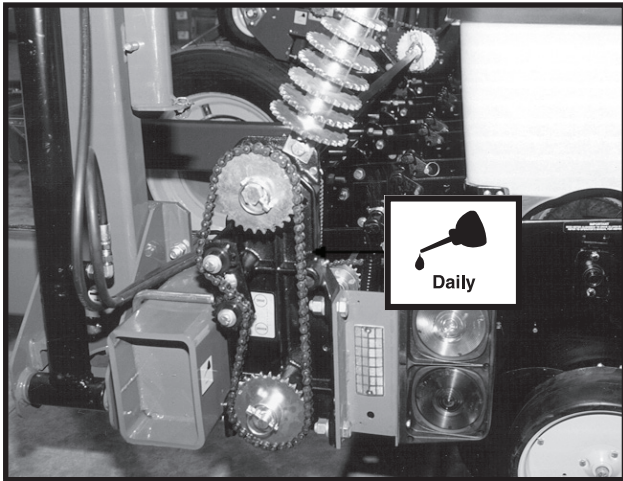

Planter Transmission Drive Chain

01239906

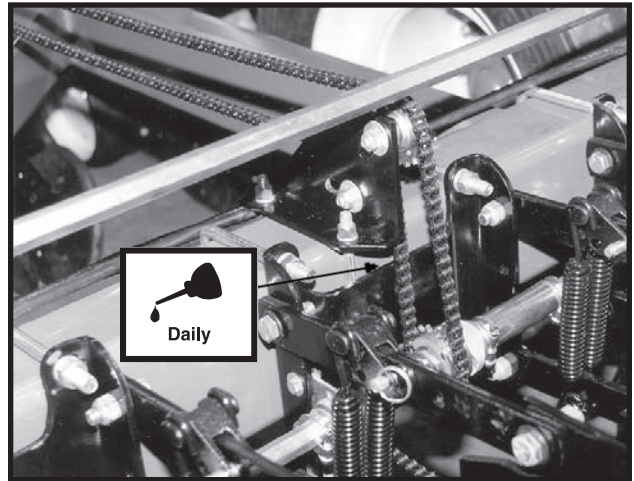

Push Unit Drive Chain

01239901

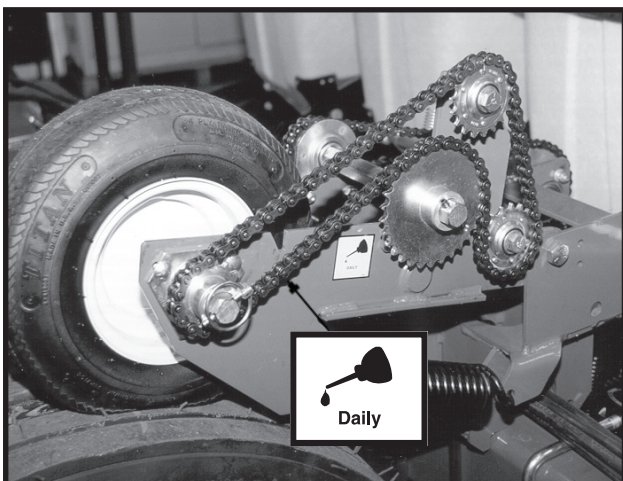

Contact Wheel Drive Chain(s)

(FRTZ198)

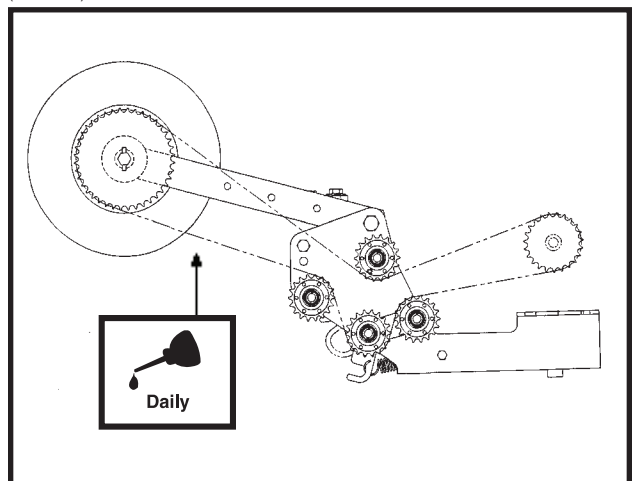

Liquid Fertilizer Drive Chain (Piston Pump)

LUBRICATION

BUSHINGS

Lubricate bushings at the frequency indicated.

Using a torque wrench, check each bolt for proper torque. If bolt is loose, it should be removed and the bushing inspected for cracks and wear. Replace bushing if necessary **Only hardened flat washers should be used. Replace damaged flat washers with proper part. Torque bolts to 130 ft. lbs.**

59386-18

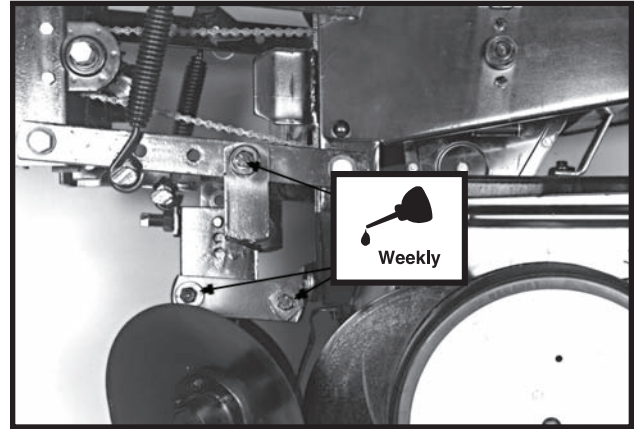

Row Unit Mounted Disc Furrower Parallel Linkage (6 Per Row)

59386-43

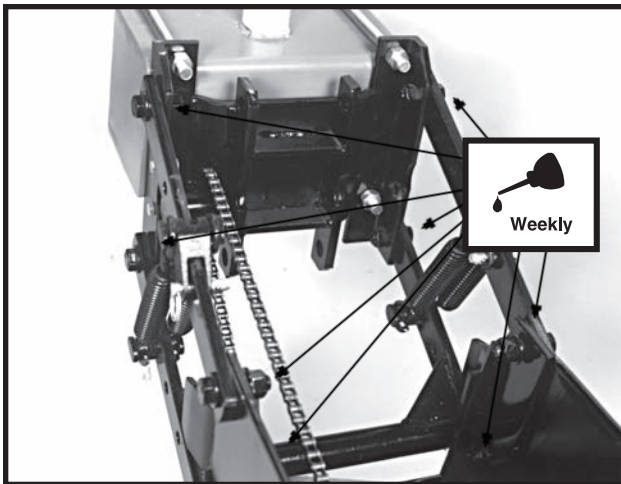

Pull Row Unit and/or Push Row Unit Parallel Linkage (8 Per Row)

78896-18

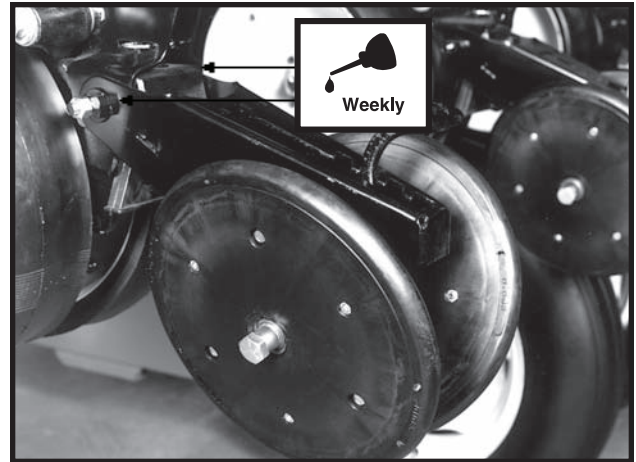

Row Unit Closing Wheel and/or Covering Discs/ Single Press Wheel Eccentric Bushings (2 Per Row)

56314-8

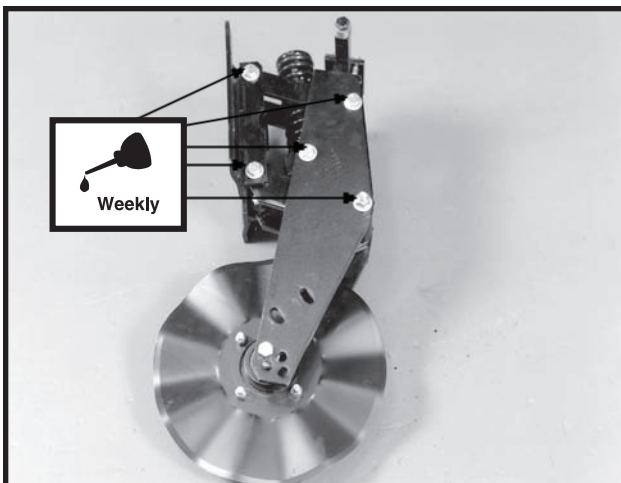

Frame Mounted Coulter Parallel Linkage (10 Per Row)

Shown not installed on row unit for visual clarity.

01199904

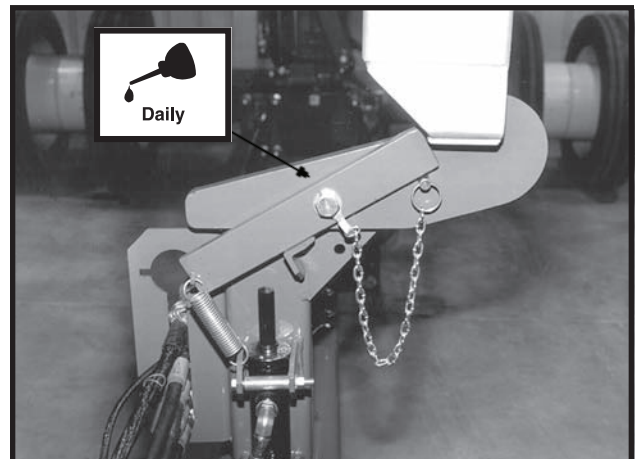

Transport Latch (1 Location)

LUBRICATION

01209913

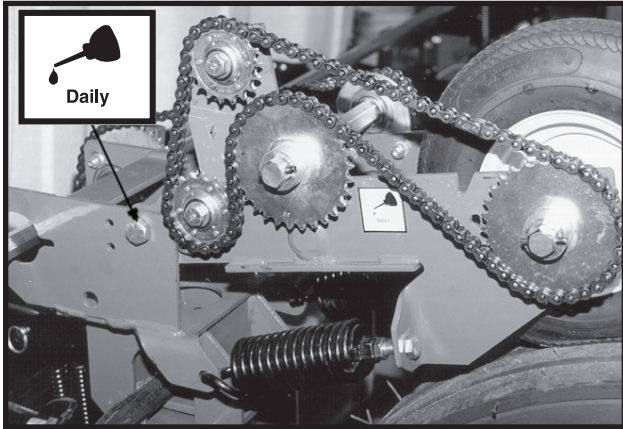

Contact Drive Wheel Arm (2 Per Wheel Assembly)

(FRTZ198)

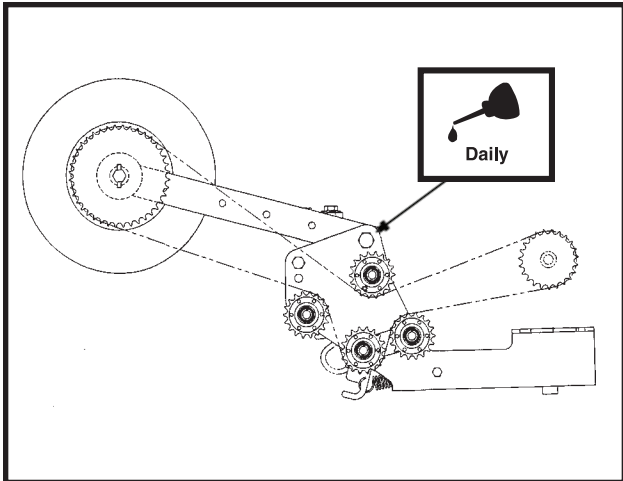

Optional Piston Pump Drive Wheel Arm Assembly (2 Per Wheel Assembly)

D05219901

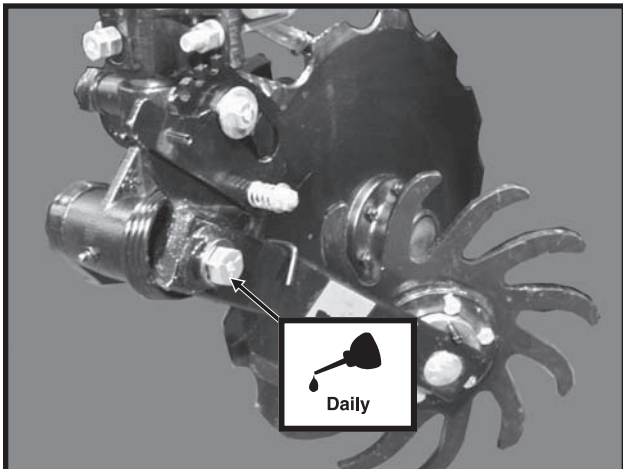

Optional Notched Single Disc Fertilizer Opener Residue Wheel (1 Per Row)

WHEEL BEARINGS

Wheel bearings should be checked annually. Inspect for lubrication. The transport wheel hubs are equipped with grease fittings. Pump grease into the hub until grease comes out around the seals. See "Grease Fittings" for lubrication frequency.

Jack wheel off the ground. Check for endplay in the bearings by moving the tire in and out. Rotate the tire to check for roughness in the bearings. If bearings sound rough, the hub should be removed and the bearings inspected and replaced if necessary. See "Wheel Bearing Packing Or Replacement."

LIQUID FERTILIZER PISTON PUMP

12229799

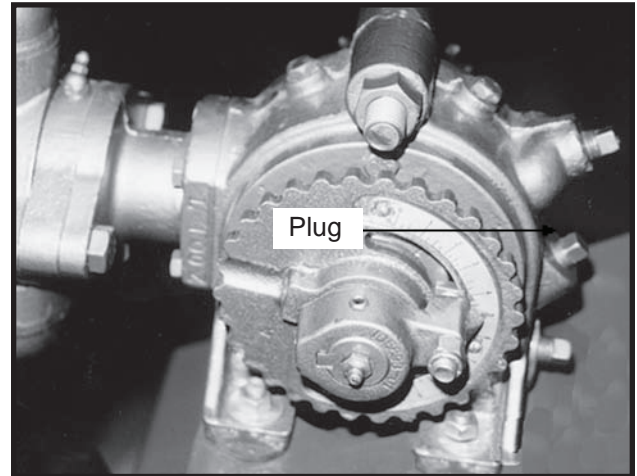

Check crankcase oil daily and maintain at plug level. Fill as needed with EP 90 weight gear oil.

Refer to operator and instruction manual supplied with the pump and flow divider for additional information.

LUBRICATION

GREASE FITTINGS

Those parts equipped with grease fittings should be lubricated at the frequency indicated with an SAE multipurpose type grease. Be sure to clean the fitting thoroughly before using grease gun. The frequency of lubrication recommended is based on normal operating conditions. Severe or unusual conditions may require more frequent attention.



DANGER: Always install safety lockups or lower to the ground before working under or around the machine.

NOTE: Numbers on below photo correspond to photos on following pages showing lubrication frequencies.

2400W

12 Row 20" With Interplant® Shown

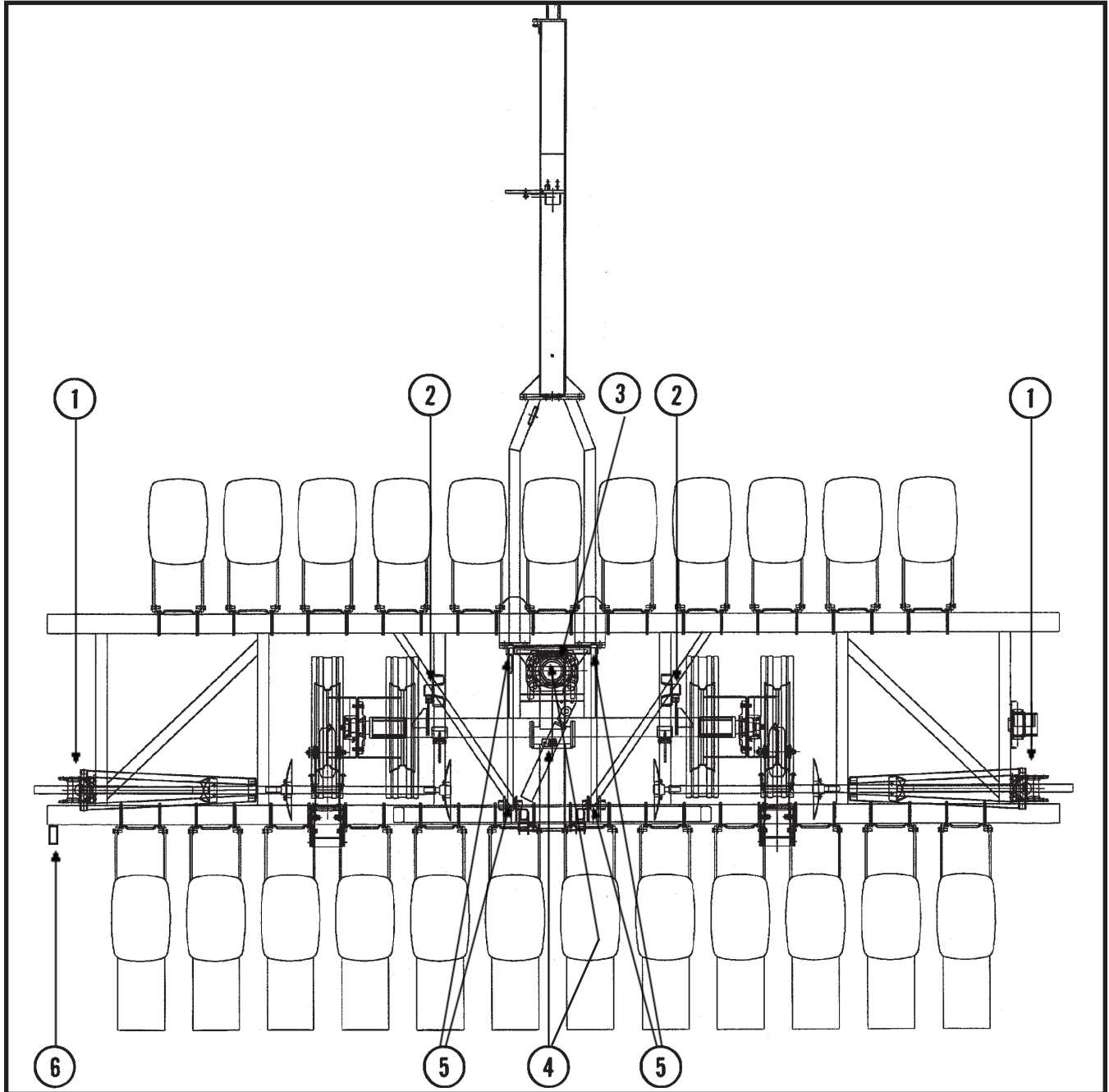

LUBRICATION

01209902a

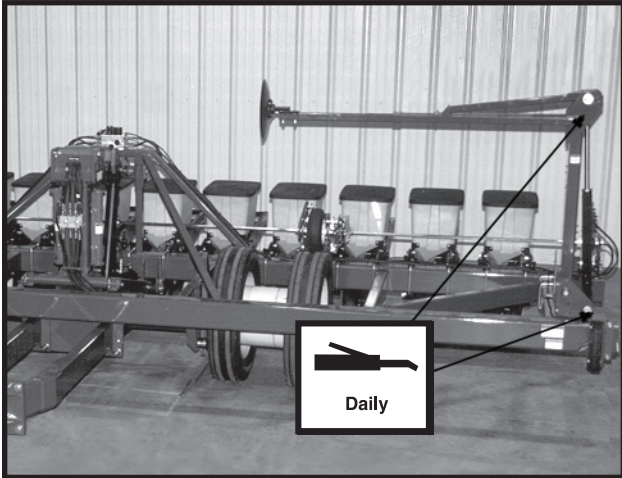

1. Marker Assemblies - 2 Zerks Per Assembly

01209912

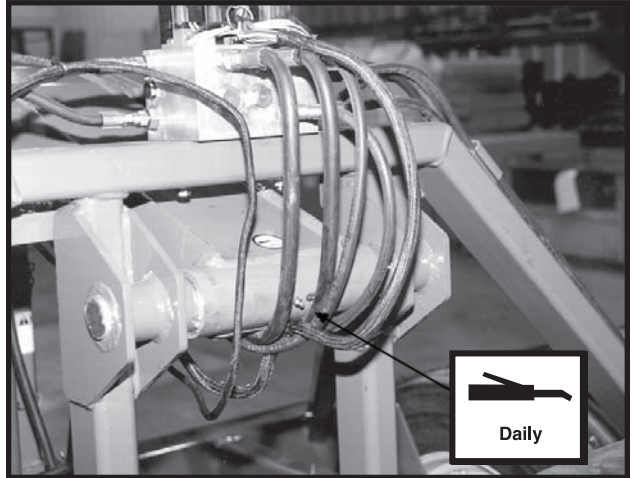

4. Upper Lift Arm - 2 Zerks

01199919a

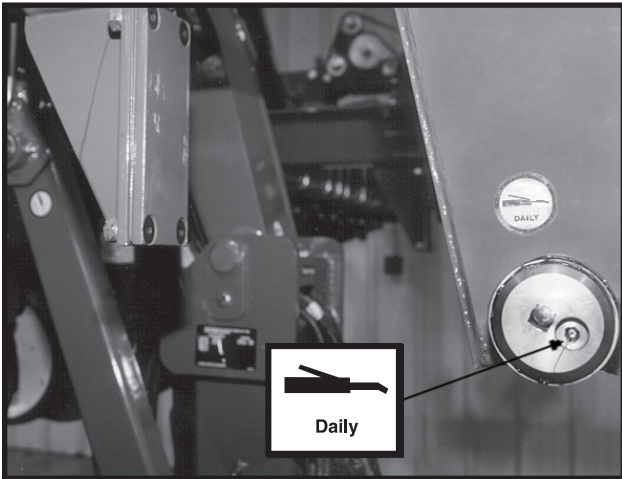

2. Cam Follower - 1 Zerk Per Follower

01209917

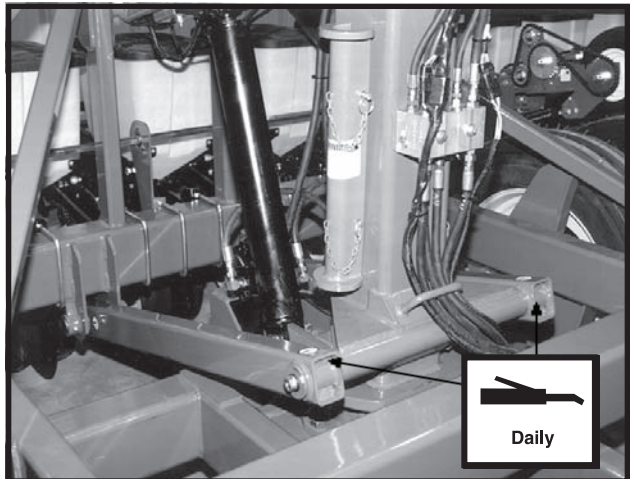

5. Lower Lift Arms - 2 Zerks Per Arm

01199914

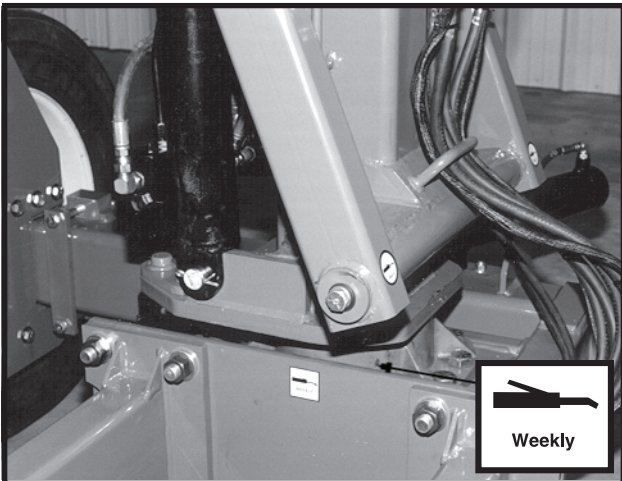

3. Center Pivot Hub - 1 Zerk

01209904

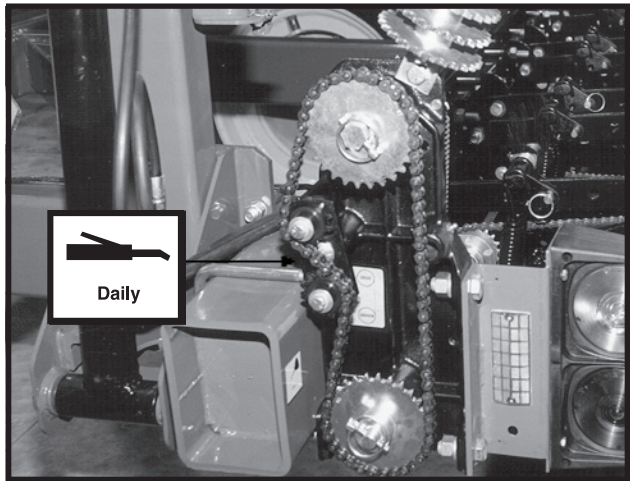

6. Transmission Assembly - 1 Zerk

LUBRICATION

Row Unit

72359-106

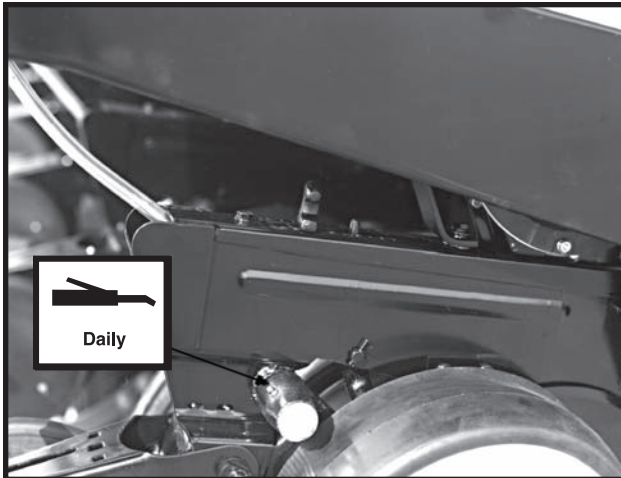

Gauge Wheel Arms - 1 Zerk Per Arm

56673-6

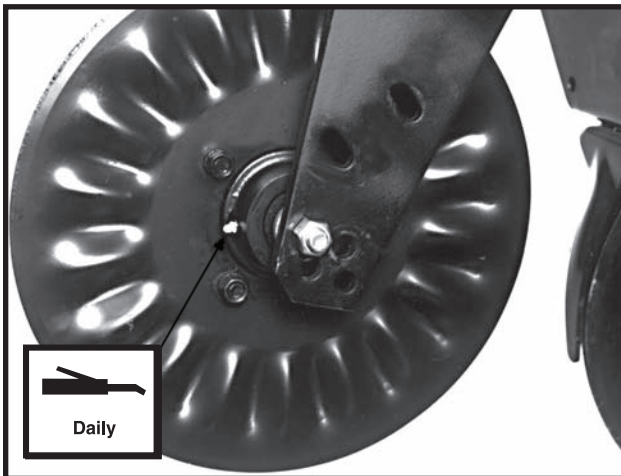

Frame Mounted Coulter Hubs - 1 Zerk Per Hub
(Pump grease into hub until grease comes out around the seals. Spin hub while filling with grease.)

80367-10

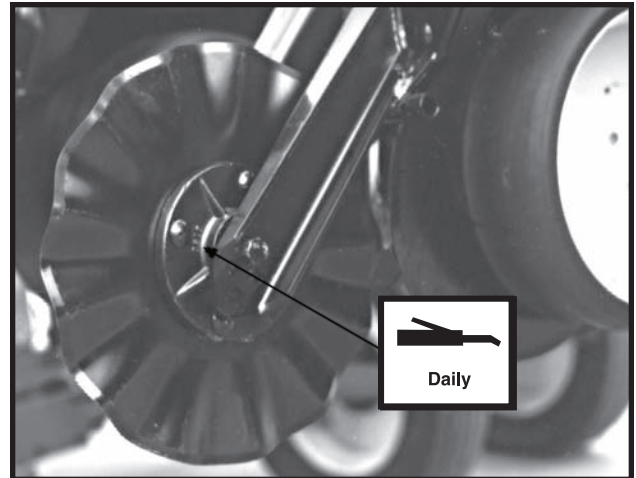

Row Unit Mounted No Till Coulter Hubs - 1 Zerk Per Hub
(Pump grease into hub until grease comes out around the seals. Spin hub while filling with grease.)

LUBRICATION

Liquid Fertilizer Attachment

12229799

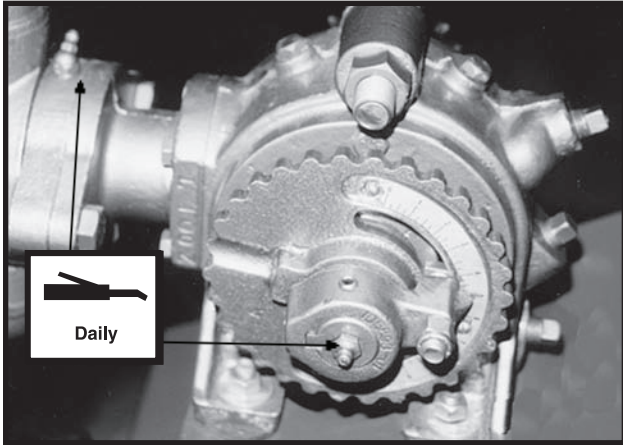

Piston Pump - 2 Zerks (Fill zerk on outboard stuffing box until lubricant seeps out of drain hole in bottom.)

Notched Single Disc Fertilizer Opener

80376-37

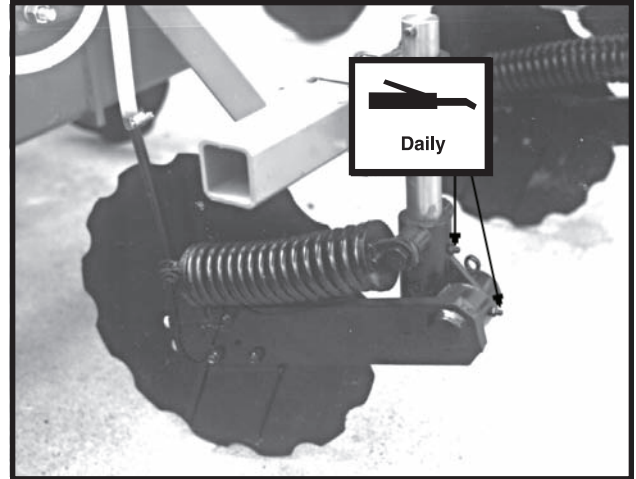

2 Zerks Per Notched Single Disc Fertilizer Opener

MAINTENANCE

MOUNTING BOLTS AND HARDWARE

Before operating the planter for the first time, check to be sure all nuts and bolts are tight. Check all nuts and bolts again after approximately the first 50 hours of operation and at the beginning of each planting season thereafter.

All bolts used on the KINZE® planter are Grade 5 (high strength) unless otherwise noted. Refer to the torque values chart when tightening bolts.

Row unit parallel linkage bushing bolts - 130 Ft. Lbs. (See "Bushings" in the Lubrication Section of this manual.)

NOTE: Over tightening bolts can cause as much damage as under tightening. Tightening a bolt beyond the recommended range can reduce its shock load capacity.





WARNING: Before operating the planter for the first time and periodically thereafter, check to be sure the lug nuts on the transport wheels are tight. This is especially important if the planter is to be transported for a long distance.

**Transport Tire Lug Nuts - 425 Ft. Lbs.
5/8" No Till Coulter Spindle Bolts - 120 Ft. Lbs.**

TORQUE VALUES CHART - PLATED HARDWARE						
Bolt Diameter	Grade 2		Grade 5		Grade 8	
	Coarse	Fine	Coarse	Fine	Coarse	Fine
1/4"	50 In. Lbs.	56 In. Lbs.	76 In. Lbs.	87 In. Lbs.	9 Ft. Lbs.	10 Ft. Lbs.
5/16"	8 Ft. Lbs.	9 Ft. Lbs.	13 Ft. Lbs.	14 Ft. Lbs.	18 Ft. Lbs.	20 Ft. Lbs.
3/8"	15 Ft. Lbs.	17 Ft. Lbs.	23 Ft. Lbs.	26 Ft. Lbs.	33 Ft. Lbs.	37 Ft. Lbs.
7/16"	25 Ft. Lbs.	27 Ft. Lbs.	37 Ft. Lbs.	41 Ft. Lbs.	52 Ft. Lbs.	58 Ft. Lbs.
1/2"	35 Ft. Lbs.	40 Ft. Lbs.	57 Ft. Lbs.	64 Ft. Lbs.	80 Ft. Lbs.	90 Ft. Lbs.
9/16"	50 Ft. Lbs.	60 Ft. Lbs.	80 Ft. Lbs.	90 Ft. Lbs.	115 Ft. Lbs.	130 Ft. Lbs.
5/8"	70 Ft. Lbs.	80 Ft. Lbs.	110 Ft. Lbs.	125 Ft. Lbs.	160 Ft. Lbs.	180 Ft. Lbs.
3/4"	130 Ft. Lbs.	145 Ft. Lbs.	200 Ft. Lbs.	220 Ft. Lbs.	280 Ft. Lbs.	315 Ft. Lbs.
7/8"	125 Ft. Lbs.	140 Ft. Lbs.	320 Ft. Lbs.	350 Ft. Lbs.	450 Ft. Lbs.	500 Ft. Lbs.
1"	190 Ft. Lbs.	205 Ft. Lbs.	480 Ft. Lbs.	530 Ft. Lbs.	675 Ft. Lbs.	750 Ft. Lbs.
1 1/8"	265 Ft. Lbs.	300 Ft. Lbs.	600 Ft. Lbs.	670 Ft. Lbs.	960 Ft. Lbs.	1075 Ft. Lbs.
1 1/4"	375 Ft. Lbs.	415 Ft. Lbs.	840 Ft. Lbs.	930 Ft. Lbs.	1360 Ft. Lbs.	1500 Ft. Lbs.
1 3/8"	490 Ft. Lbs.	560 Ft. Lbs.	1100 Ft. Lbs.	1250 Ft. Lbs.	1780 Ft. Lbs.	2030 Ft. Lbs.
1 1/2"	650 Ft. Lbs.	730 Ft. Lbs.	1450 Ft. Lbs.	1650 Ft. Lbs.	2307 Ft. Lbs.	2670 Ft. Lbs.

NOTE: Unplated hardware and bolts with lock nuts should be torqued approximately 1/3 higher than the above values. Bolts lubricated prior to installation should be torqued to 70% of value shown in chart.

	GRADE 2 No Marks		GRADE 5 3 Marks		GRADE 8 6 Marks
-------------------------------------------------------------------------------------	----------------------------	-------------------------------------------------------------------------------------	---------------------------	---------------------------------------------------------------------------------------	---------------------------

CHAIN TENSION ADJUSTMENT

The drive chains have a spring loaded idler and therefore are self-adjusting. The only adjustment needed is to shorten the chain if wear stretches the chain and reduces spring tension. The pivot point of these idlers should be checked periodically to ensure they rotate freely.

(MT18a)

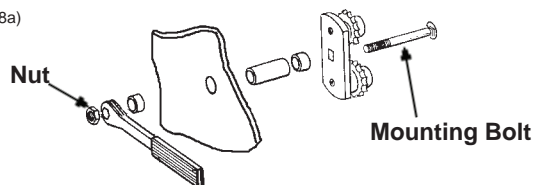

NOTE: The nut on the mounting bolt (on applicable idler assemblies) must be kept tight or chain tension will not be maintained and adjustment wrench will not function properly.

Additional chain links can be found in the storage area located inside the forward planter toolbar.

1239909

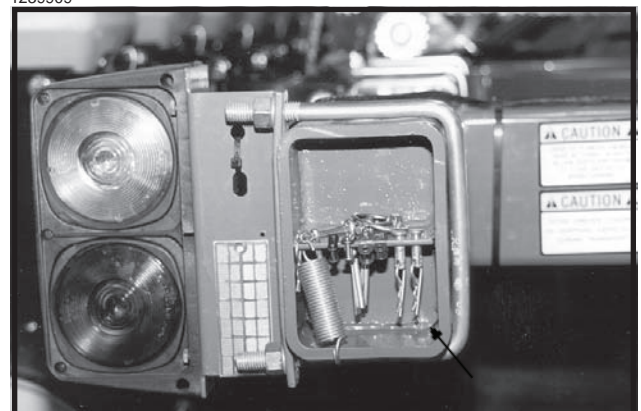

MAINTENANCE

FINGER PICKUP SEED METER INSPECTION/ADJUSTMENT

To inspect or service the finger pickup seed meter, remove the meter from the seed hopper by removing the two nuts which secure the mechanism to the hopper. Remove the baffle from the meter assembly by removing three cap screws. This will permit access to the finger pickup.

60620-8

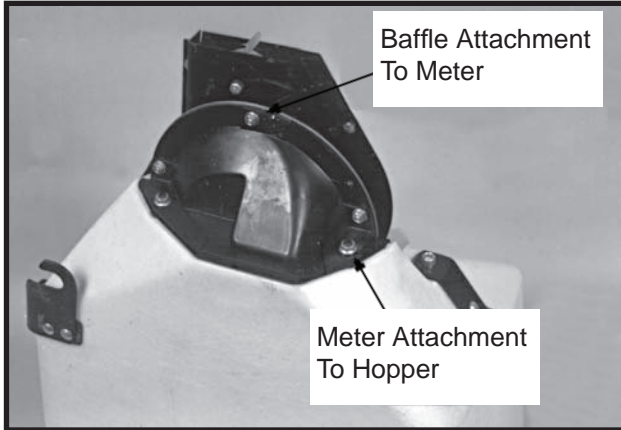

Rotate the seed meter drive by hand to ensure that the springs are holding the tabs of the fingers against the carrier plate where indicated in the photo and that the fingers are being raised in the correct area.

60620-16a

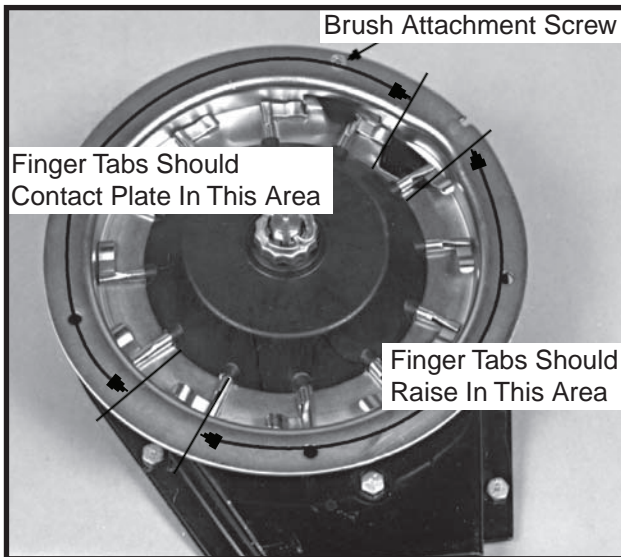

A build-up of debris or chaff may prevent proper finger operation and will require disassembly and cleaning of the corn meter as follows:

1. Remove cotter pin, cover nut, adjusting nut and wave washer (If Applicable) from drive shaft.
2. Carefully lift finger holder, along with fingers and cam, off of the shaft and clean.

60620-3a

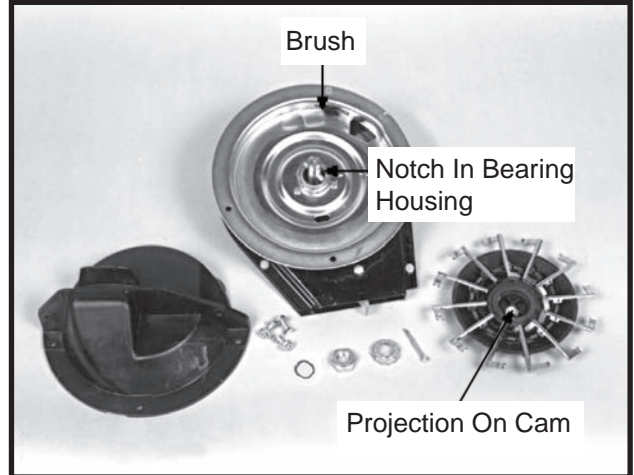

3. Check brush for wear and replace if necessary or following every 100 acres per row of operation.

EXAMPLE: Approximately 1200 acres on a 12 row machine.

NOTE: It is not necessary to remove finger holder to remove brush.

4. To replace fingers or springs, remove springs from fingers and remove finger from holder by lifting it out of the friction fit slot. Under average conditions, life expectancy of these parts should be 600-900 acres per row of operation.
5. After cleaning and/or replacing defective parts, reassemble the meter in the reverse order. When replacing fingers, make sure the open end of the spring loop is toward the inside of the finger holder.

60620-22

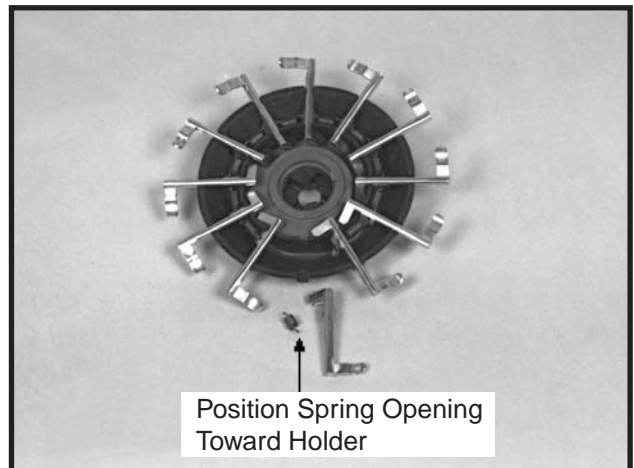

6. Make sure fingers are installed in holder so that holder will be positioned flush with the carrier plate when assembled. A projection on the cam is designed to align with a mating notch in the bearing housing to ensure proper operation when assembled.

MAINTENANCE

50725-4

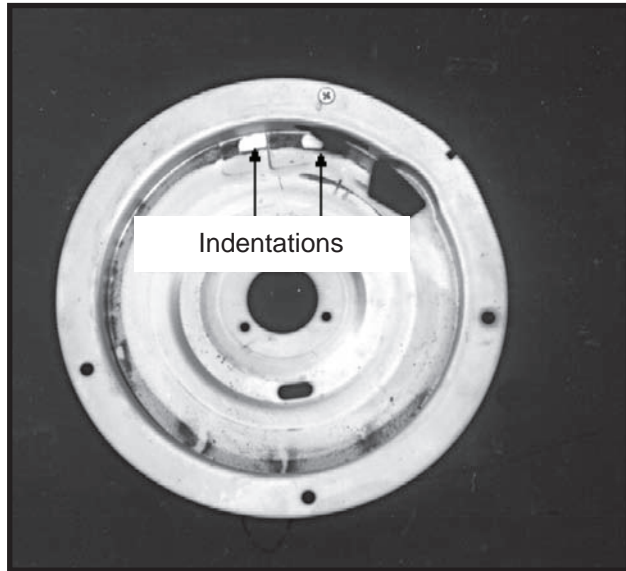

Photo shows worn plate

7. Before installing the finger holder on the carrier plate, check the indentations on the carrier plate for wear. Excessive wear of the carrier plate at the indentations will cause over planting especially when using small sizes of seed corn.

Inspect the carrier plate annually. Under average conditions, the life expectancy of the carrier plate should be 250-300 acres per row of operation.

8. With finger holder flush against the carrier, install wave washer and adjusting nut. Tighten adjusting nut to fully compress wave washer. Then back off $\frac{1}{2}$ to 2 flats ($\frac{1}{2}$ to $\frac{1}{3}$ turn) to obtain rolling torque of 14 to 22 inch pounds.
9. Turn finger holder by hand to make sure it is positioned firmly against the carrier, but is not over tightened and can be rotated with moderate force.
10. Install cover nut and cotter pin and reinstall housing.

NOTE: Check tightness of adjusting nut on each unit after first day of use and periodically thereafter.

To inspect or replace the seed belt, remove the four cap screws around the edge of the housing cover and the nut from the belt idler mounting bolt.

60620-13

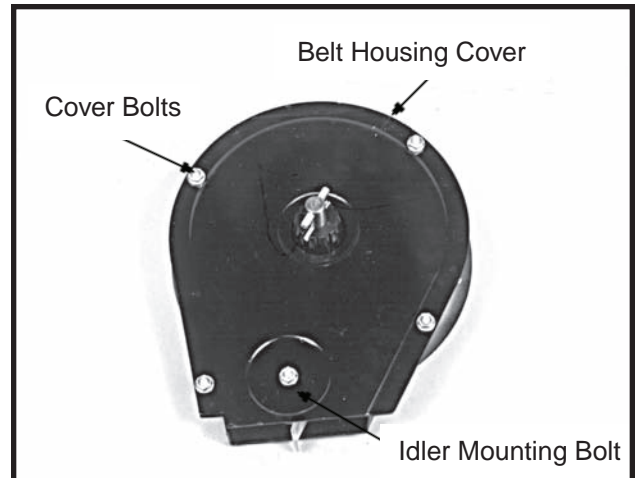

60887-97

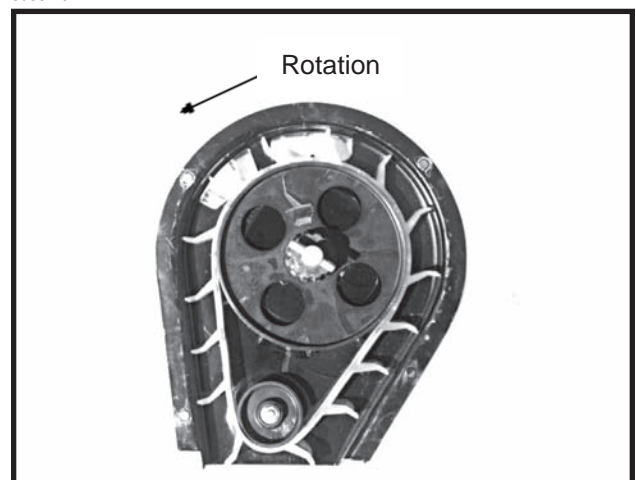

If the belt is being replaced, make sure it is installed to correctly orient the paddles as shown. A diagram molded into the drive sprocket also illustrates the correct orientation.

CAUTION: Do not over tighten hardware.

FINGER PICKUP SEED METER CLEANING

1. Disassemble meter.
2. Blow out any foreign material present in the meter mechanism.
3. Wash in mild soap and water. **DO NOT USE GASOLINE, KEROSENE OR ANY OTHER PETROLEUM BASED PRODUCT.**
4. Dry thoroughly.
5. Coat lightly with a rust inhibitor.
6. Reassemble and store in a dry place.

MAINTENANCE

FINGER PICKUP SEED METER TROUBLESHOOTING

PROBLEM	POSSIBLE CAUSE	SOLUTION
One row not planting seed.	Drive release not engaged.	Engage drive release mechanism.
	Foreign material in hopper.	Clean hopper and finger carrier mechanism.
	Seed hopper empty.	Fill seed hopper.
	Pin sheared in drive release sprocket.	Replace pin. Inspect meter for obstructions or defective parts.
	Row unit drive chain off of sprocket or broken.	Check drive chain.
Drive release does not engage properly.	Drive release shaft is not aligned properly with meter drive shaft.	Align drive mechanism. See "Seed Meter Drive Adjustment".
Unit is skipping.	Foreign material or obstruction in meter.	Clean out and inspect.
	Finger holder improperly adjusted.	Adjust to proper setting. (14 to 22 in. lbs. rolling torque)
	Broken fingers.	Replace fingers and/or springs as required.
	Planting too slowly.	Increase planting speed to within recommended range.
Planting too many doubles.	Planting too fast.	Stay within recommended speed range.
	Loose finger holder.	Adjust to specs. (14 to 22 in. lbs. rolling torque)
	Worn brush in carrier plate.	Inspect and replace if necessary.
Over planting.	Worn carrier plate.	Inspect and replace if necessary.
	Seed hopper additive being used.	Reduce or eliminate additive or increase graphite.
Under planting.	Belt installed backwards.	Remove and install correctly.
	Weak or broken springs.	Replace.
	Spring not properly installed.	Remove finger holder and correct.
	Seed belt catching or dragging.	Replace belt.
	Brush dislodging seed.	Replace brush.
Irregular or incorrect seed spacing.	Driving too fast.	Check chart for correct speed.
	Wrong tire pressure.	Inflate tires to correct air pressure.
	Drive wheels slipping.	Reduce down pressure on row unit down force springs.
	Wrong sprockets.	Check seed rate charts for correct sprocket combinations.
Seed spacing not as indicated in charts.	Wrong tire pressure.	Inflate tires to correct air pressure.
	Inconsistent seed size.	Do field check and adjust sprockets accordingly.
	Wrong sprockets.	Check chart for correct sprocket combination.
	Charts are approximate.	Slight variations due to wear in meter components and tire slippage due to field conditions may produce seed spacing variations.
	Stiff or worn drive chains.	Replace chains.
Scattering of seeds.	Planting too fast.	Reduce planting speed.
	Seed tube improperly installed.	Check seed tube installation.
	Seed tube worn or damaged.	Replace seed tube.
Seed tubes and/or openers plugging.	Allowing planter to roll backward when lowering.	Lower planter only when tractor is moving forward.
Inconsistent seed depth.	Rough seed bed.	Adjust down pressure springs. Reduce planting speed.
	Partially plugged seed tube.	Inspect and clean.
	Seed tube improperly installed.	Install properly.

MAINTENANCE

BRUSH-TYPE SEED METER MAINTENANCE

60607-10

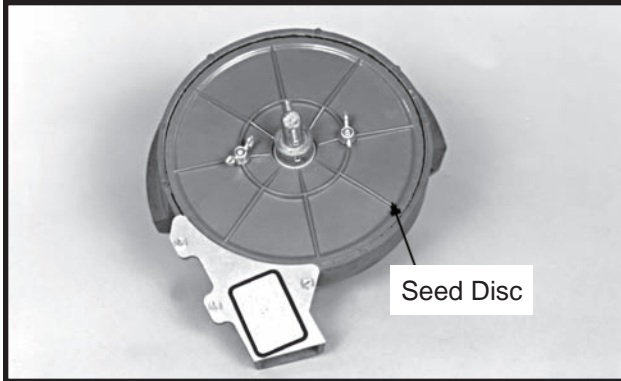

60607-3

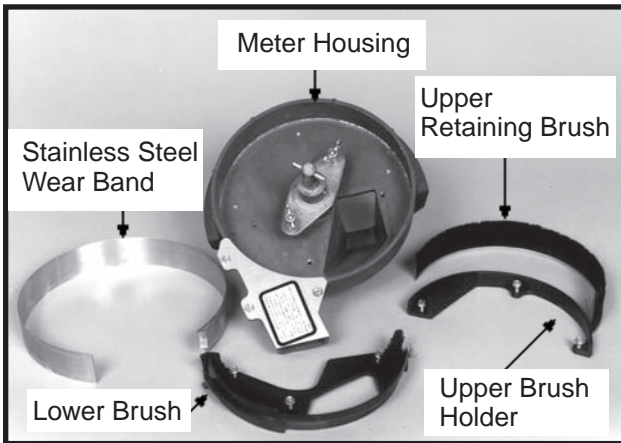

Only clean, high quality seed should be used for maximum meter accuracy. Damaged or cracked seed, hulls or foreign materials may become lodged in the upper seed retaining brush and greatly reduce meter accuracy. It is suggested that the seed disc be removed daily, inspected and cleaned. Check for buildup of foreign material on the seed disc, particularly in the seed loading slots. Clean the disc by washing it with soap and water. Check for cracked seed, hulls, etc. lodged between the brush holder and stainless steel wear band which can greatly reduce the accuracy of the meter because the retaining brush will not be able to retain the seed in the seed disc pocket. Clean the brush areas of the meter housing thoroughly.

60607-8/60607-8L



NOTE: Replace hopper lids after hoppers are filled to prevent accumulation of dust or dirt in the seed meter which will cause premature wear.

Cleaning brush-type seed meter for storage:

1. Remove meter from seed hopper by removing the two nuts which secure the meter to the hopper.
2. Remove seed disc and wash with soap and water and dry thoroughly.
3. Remove upper retaining brush by removing the three hex head screws from the brush holder and removing brush holder and retaining brush.
4. Remove the three hex head screws from the lower brush and remove lower brush and stainless steel wear band.
5. Wash all parts and meter housing with soap and water and dry thoroughly.
6. Inspect all parts for wear and replace worn parts.
7. Reassemble meter except for seed disc. **Meter should be stored in a rodent-free space with seed disc removed.**

Seed Disc Wear

(PLTR40b)

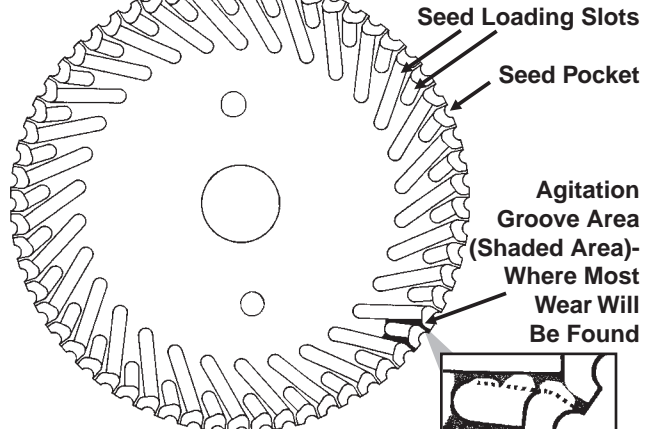

Most wear on the seed disc will be found in the agitation groove area (area between the seed loading slots). Wear will affect planting accuracy at high RPM. To measure for wear, lay a straight edge across the surface of the disc and measure the gap between the disc (at the agitation groove area) and the straight edge. If the agitation groove areas are worn in excess of .030" and accuracy starts to drop off at higher meter RPM, the seed disc should be replaced.

Estimated life expectancy of the seed disc under normal operating conditions should be approximately 200 acres per row. Severe operating conditions such as dust, lack of lubrication or abrasive seed coating could greatly reduce life expectancy of the seed disc.

MAINTENANCE

Upper Retaining Brush

60607-21

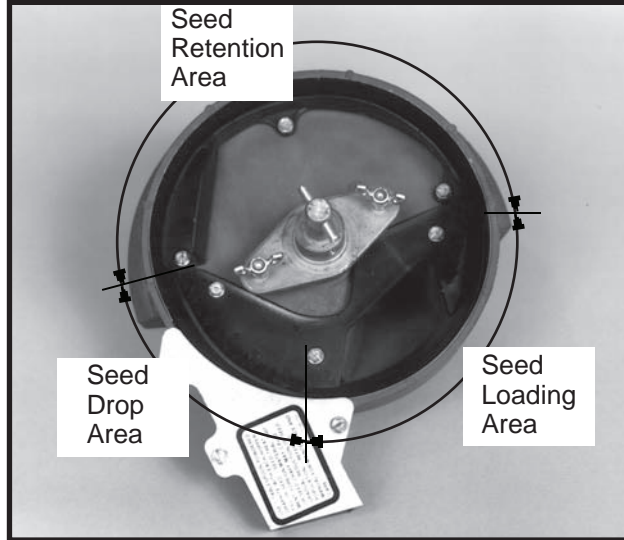

The upper retaining brush holds seed in the seed disc pocket in the seed retention area.

The retaining brush must apply enough pressure against the seed in the seed disc pocket as the disc rotates through the seed retention area to prevent the seed from dropping out of the disc pocket. A damaged spot, excessive wear on the brush or foreign material lodged in the brush may greatly reduce meter performance.

The upper retaining brush should be replaced at approximately 120-400 acres per row of use or sooner if damage or excessive wear is found.

Installation Of Upper Retaining Brush

Position retaining brush into inner perimeter of seed retention area. Make sure the base of the brush is tight against the bottom of the meter housing. Install brush holder and three hex head screws. Tighten center screw first, left screw second and right screw last.

60607-21

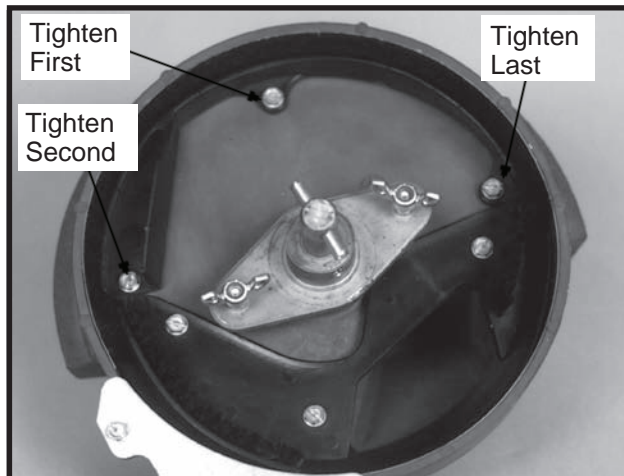

Stainless Steel Wear Band

60607-38a

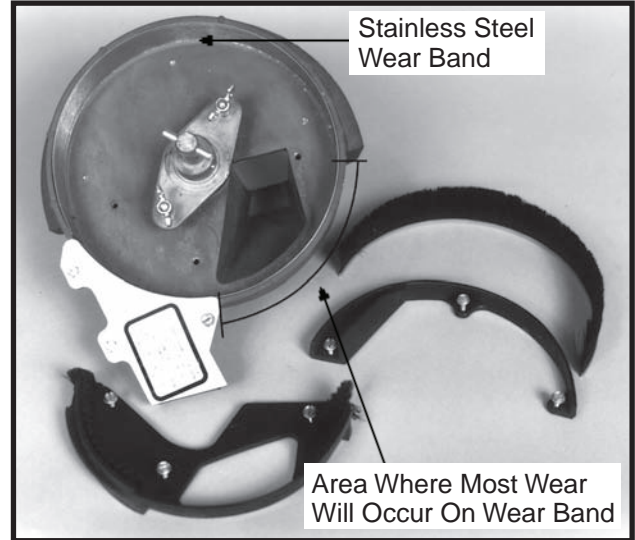

The purpose of the stainless steel wear band is to protect the meter housing from wear. The band is .030" thick and should be replaced when approximately .020" of wear is found in the primary area of wear. If the wear band is allowed to wear through or if the meter is used without the wear band in place, damage to the meter housing may occur.

Estimated life expectancy of the stainless steel wear band is 240-800 acres per row.

Lower Brush

60607-3

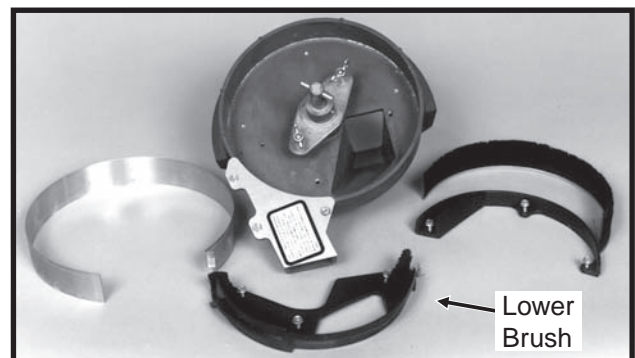

The lower brush has several functions. One function is to move seed down the seed loading slots to the seed pockets. The second function is to isolate seed in the reservoir from entering the seed tube and a third is to clean the seed loading slots.

Estimated life expectancy of the lower brush is 240-800 acres per row. The lower brush should be replaced if the bristles are deformed or missing or if there are cracks in the brush holder.

MAINTENANCE

BRUSH-TYPE SEED METER TROUBLESHOOTING

PROBLEM	POSSIBLE CAUSE	SOLUTION
Low count.	Meter RPM too high.	Reduce planting speed.
	Misalignment between drive clutch and meter.	See "Seed Meter Drive Adjustment".
	Seed sensor not picking up all seeds dropped.	Clean seed tube. Switch meter to different row. If problem stays with same row, replace sensor.
	Lack of lubrication causing seeds not to release from disc properly.	Use graphite or talc as recommended.
	Seed size too large for seed disc being used.	Switch to smaller seed or appropriate seed disc. See "Brush-Type Seed Meter" for proper seed disc for size of seed being used.
	Seed treatment buildup in meter.	Reduce amount of treatment used and/or thoroughly mix treatment with seed. Add talc.
Low count at low RPM and higher count at higher RPM.	Foreign material lodged in upper retaining brush.	Remove seed disc and remove foreign material from between brush holder and bristles. Clean thoroughly.
	Worn upper retaining brush.	Replace. See "Maintenance".
Low count at higher RPM and normal count at low RPM.	Seed disc worn in the agitation groove area.	Replace disc. See "Maintenance".
High count.	Seed size too small for seed disc.	Switch to larger seed or appropriate seed disc.
	Incorrect seed rate transmission setting.	Reset transmission. Refer to proper rate chart in "Machine Operation" section of manual.
	Upper brush too wide (fanned out) for small seed size.	Replace upper brush.
Upper retaining brush laid back.	Seed treatment buildup on brush.	Remove brush. Wash with soap and water. Dry thoroughly before reinstalling. See "Maintenance".
	Buildup of foreign material at base of brush.	Remove brush holder and brush. Clean thoroughly. Reinstall.

CLOSING WHEEL TROUBLESHOOTING

PROBLEM	POSSIBLE CAUSE	SOLUTION
Closing wheel(s) leave severe imprint in soil.	Too much closing wheel down pressure.	Adjust closing wheel pressure.
Closing wheel(s) not firming soil around seed.	Insufficient closing wheel down pressure.	Adjust closing wheel pressure. Severe no till conditions may require use of cast iron closing wheels.
"V" closing wheel running on top of seed furrow.	Improper centering.	Align. See "V Closing Wheel Adjustment".
Single closing wheel not directly over seed.	Improper centering.	Align. See "Covering Discs/Single Press Wheel Adjustment".

MAINTENANCE

GAUGE WHEEL ADJUSTMENT

To prevent an accumulation of dirt or trash, gauge wheels should lightly contact the opener blades. Gauge wheels and opener blades should turn with only slight resistance.

73090-24

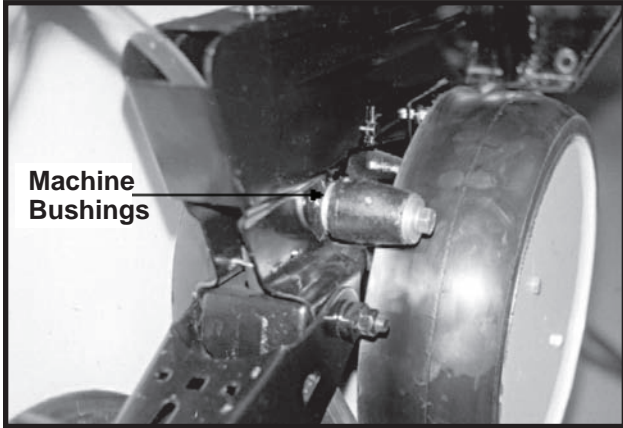

(RU61a)

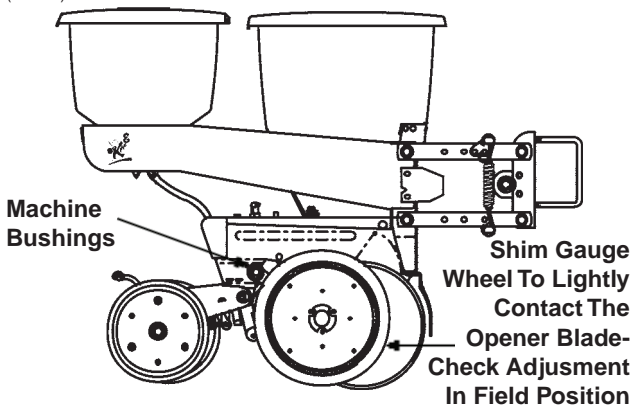

To adjust clearance between gauge wheels and opener blades, add or remove machine bushings between the shank and gauge wheel arm. Store remaining machine bushings between gauge wheel arm and flat washer on outer side of gauge wheel arm.

NOTE: It may be desirable to space gauge wheel further from blade when operating in sticky soils.

15" SEED OPENER DISC/BEARING ASSEMBLY

1"-2" of blade-to-blade contact should be maintained to properly open and form the seed trench. As the blade diameter decreases due to wear, it will be necessary to remove machine bushings to maintain 1"-2" of contact.

If 1"-2" of blade-to-blade contact cannot be maintained after removing machine bushings or if blade diameter wears below 14 1/2", the blade should be replaced.

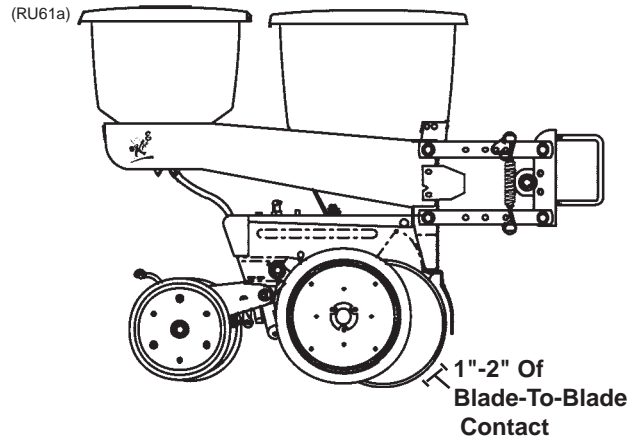

To replace disc/bearing assembly:

1. Remove gauge wheel.
2. Remove scraper.
3. Remove bearing dust cap.
4. Remove jam nut and washer from outside of disc/bearing assembly.

NOTE: Left hand side of opener uses a left hand threaded nut. **DO NOT OVER TIGHTEN.** Damage to mounting spindle will require replacement of row unit shank assembly.

5. Remove disc/bearing assembly. The machine bushings between the shank and disc are used to maintain the 1"-2" blade-to-blade contact.
6. After installing new disc/bearing assembly, install washer and jam nut to secure disc/bearing assembly. Torque 5/8"-11 Grade 2 nut to value shown in "Torque Values Chart".
7. Replace bearing dust cap.
8. Install scraper.
9. Install gauge wheel.

It may be necessary to replace only the bearing if there is excessive endplay or if the bearing sounds rough when the disc is rotated.

To replace bearing:

1. Remove gauge wheel, scraper, bearing cap, jam nut, washer and disc/bearing assembly.
2. Remove 1/4" rivets from bearing housing to expose bearing.
3. After installing new bearing, install three evenly spaced 1/4" bolts into three of the six holes in the bearing housing to hold the bearing and bearing housing in place. Install rivets in the other three holes. Remove 1/4" bolts and install rivets in those three holes.
4. Reinstall disc/bearing assembly, washer and jam nut. Torque 5/8"-11 Grade 2 nut to value shown in "Torque Values Chart" at the beginning of this section.
5. Replace bearing dust cap.
6. Install scraper and gauge wheel.

MAINTENANCE

SEED TUBE GUARD/INNER SCRAPER

The seed tube guard protects the seed tube and acts as the inner scraper for the disc opener blades.

Remove the seed tube and check for wear. Excessive wear on the seed tube indicates a worn seed tube guard.

50881-9

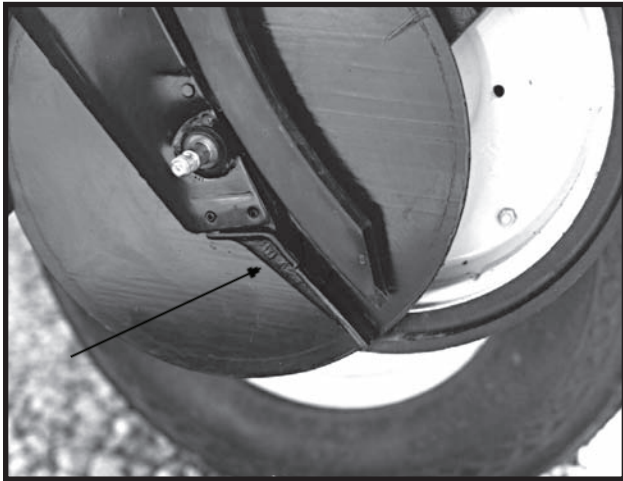

No till planting or planting in hard ground conditions will increase seed tube guard wear and necessitate more frequent inspection.

The gauge wheels and seed opener discs must be removed before the seed tube guard can be replaced.

ROW UNIT MOUNTED NO TILL COULTER

80367-10



Lubricate at frequency indicated in the Lubrication Section of this manual. Check periodically to be sure nuts and hardware are tightened to proper torque specification.

NOTE: Torque $\frac{5}{8}$ " spindle bolts to 120 ft. lbs.

Be sure the coulters are positioned square with the row unit and aligned in front of row unit disc opener.

The coulters can be adjusted to one of four settings. Initially the blade is set in the highest position. As the blade wears it can be adjusted to one of the three lower settings. See "Row Unit Mounted No Till Coulters" in Operation Section of this manual.

When the 16" diameter coulters blade is worn to a 14 $\frac{1}{2}$ " diameter (maximum allowable wear), it should be replaced.

Timely lubrication at the frequency indicated in the lubrication section of this manual is necessary to purge moisture and dirt from bearing and seal. This will also lubricate the seal.

NOTE: Add grease until it comes out around the seal. Spin hub while filling with grease.

MAINTENANCE

KPM I/KPM II ELECTRONIC SEED MONITOR TROUBLESHOOTING

PROBLEM	POSSIBLE CAUSE	SOLUTION
Single sensor communication alarm comes on (alarm on with no bargraph and a flashing row number on a single row).	Bad seed tube sensor.	Replace sensor.
	Break in the harness just before the seed tube sensor.	Inspect for break in harness and repair. If break can't be found, replace harness section.
	Dirty or corroded connector.	Clean connector.
Sensor communication alarms come on for all sensors (alarm on with no bargraphs and flashing row numbers on all rows).	Faulty monitor.	Replace monitor.
	Break in the harness just after the monitor.	Inspect for break in harness and repair. If break can't be found, replace harness section.
	Dirty or corroded connector.	Clean connector.
Sensor communication alarms come on for some sensors (alarm on with no bargraphs and flashing row numbers on all rows).	Break in the harness.	Inspect for break in harness and repair. If break can't be found, replace harness section corresponding with the alarming sensors.
	Dirty or corroded connector.	Clean connector.
Bad monitor values (such as speed, area, etc.) being displayed. (KPM II Only)	Incorrect monitor settings.	Change settings to properly correspond to the system.
	Bad radar/magnetic distance sensor.	Replace sensor.
	Improperly mounted radar sensor.	Properly mount sensor.
Underplanting or no planting alarm on a single sensor when planting (alarm on with a single bargraph segment on and a flashing row number on a single row).	Seed tube sensor is blocked.	Clean sensor.
	Faulty seed tube sensor.	Replace sensor.
Seed tube sensor dirty or blocked warning comes on (after calibration, bargraph keeps flashing for a single row).	Seed tube sensor is dirty.	Clean sensor.
	Faulty seed tube sensor.	Replace sensor.
LED light on the seed tube sensor will not come on.	Faulty seed tube sensor.	Replace sensor.
	Dirty or corroded connector.	Clean connector.
	Break in the harness just before the sensor.	Repair harness.
Erroneous MPH readings at idle. (Radar Distance Sensor Only)	Radar sensor not located in a stable location.	Relocate to a more stable location.

MAINTENANCE

SOLENOID VALVE INSPECTION

The solenoid valve consists of a chambered body containing a cartridge valve which is activated by an electrical coil.

If the solenoid or solenoids fail to operate, first determine if the problem is electrical or hydraulic. If the valve is working properly, a click will be heard when the solenoid coil is energized. This will be the valve stem opening up. If no sound is heard, check the solenoid coil by touching the top of the coil housing with a metallic object such as a pliers or screwdriver. If the coil is working properly, the coil housing will be strongly magnetized when energized. If the voltage to the coil is low, the coil will be weakly magnetized when energized and no click will be heard.

VVB019(PLTR55)

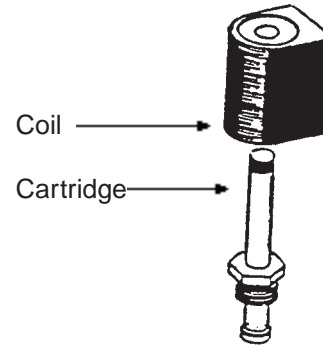

SOLENOID VALVE TROUBLESHOOTING		
PROBLEM	POSSIBLE CAUSE	SOLUTION
None of the solenoids will operate.	Low Voltage.	Must be connected to 12 volt DC only. Negative ground.
	Blown fuse.	Replace fuse in control console on tractor with AGC-15 amp only.
	Battery connection.	Clean and tighten.
	Wiring harness damaged.	Repair or replace.
One solenoid valve will not operate.	Bad switch.	Replace on control panel.
	Cut wire in harness.	Locate and repair.
	Bad coil.	Replace.
	Poor connection at coil.	Check.
Valve operating when not energized.	Valve stem stuck open.	Replace cartridge.
	O-ring leaking.	Install new o-ring kit.
	Foreign material under poppet.	Remove cartridge and clean.

FLOW CONTROL VALVE INSPECTION

VVB020(TWL28)

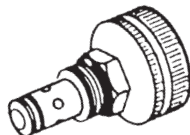

The flow control valves should be adjusted for raise and lower speed as part of the assembly procedure or upon initial operation. If the valve fails to function properly or requires frequent adjustment, it should be removed for inspection. Check for foreign material and contamination on both the valve and the seating area of the valve body. Replace any components found to be defective.

CHECK VALVE

VVB020(TWL30a)

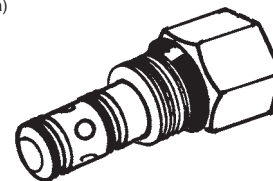

The check valve, located in the valve block on the planter hitch, traps oil flow in the planters lift system to hold the toolbar tight against the axle during field operation. Hydraulic pressure from the tractor is required to lift the toolbar. Consult your KINZE® Dealer for service.

MAINTENANCE

LIFT CIRCUIT TROUBLESHOOTING

PROBLEM	POSSIBLE CAUSE	SOLUTION
Planter will raise to raised field position, but will not raise to transport position.	Solenoid valve coil in port V3 is not energized.	Be sure control console switch is in "raise" position to energize solenoid coil in port V3. Check control console fuse by moving auxiliary switch to ON position. If red light comes on the fuse is OK. Return auxiliary to OFF position. Check for poor wire connection or damaged wire and repair. Solenoid valve coil is defective. All solenoid valves used on the planter are the same. Switch the solenoid coil with one you know is working. If this cures the problem, replace defective coil.
	Solenoid valve cartridge in port V3 is stuck closed.	All solenoid valves used on the planter are the same. Switch the solenoid cartridge with one you know is working. If this cures the problem, replace defective cartridge.
Planter will not raise.	Tractor may have hydraulic problem.	Repair tractor hydraulics.
	Planter may be overloaded with hopper extensions and/or extra fertilizer tanks, coulters or non-KINZE® approved attachments.	Remove weight.

ROTATION CYLINDER CIRCUIT TROUBLESHOOTING

PROBLEM	POSSIBLE CAUSE	SOLUTION
Cylinder does not extend or retract.	Solenoid valve coil in port V1 defective.	Check switch on control console. Replace if defective. Check coil ground wire. Check for poor connection or damaged wire.
	Solenoid valve cartridge in port V1 is stuck closed.	Replace cartridge. Test cartridge by switching with one you know is working properly. Try cartridge from port V1 which is the raise-to-transport cartridge.

NOTE: One set of hydraulic outlets, in conjunction with the switches on the control console, are used to operate the markers and rotation function. The rotation function is controlled by one solenoid valve located in the valve block on the planter hitch. Energize the solenoid valve to operate the rotation function.

MAINTENANCE

MARKER CIRCUIT TROUBLESHOOTING

PROBLEM	POSSIBLE CAUSE	SOLUTION
Right marker lowering slower than left marker.	Solenoid valve cartridge in port V2 not opening completely.	Switch cartridge with one in port V1. If problem follows cartridge, replace cartridge.
	Hose pinched or collapsed.	Inspect hose routing. Replace or repair hoses as required.
Left marker lowering slower than right marker.	Solenoid valve cartridge in port V1 not opening completely.	Switch cartridge with one in port V2. If problem follows cartridge, replace cartridge.
	Hose pinched or collapsed.	Inspect hose routing. Replace or repair hoses as required.
Both markers lowering.	Solenoid valve cartridge stuck open. If marker switch is in the left marker position, the right cartridge (V2) is defective. If the marker switch is in the right marker position, the left cartridge (V1) is defective.	Replace solenoid valve cartridge.
Neither marker will lower.	Blown fuse.	Check red light on control console. It should be on if switch is on. If light is not on, switch to opposite marker position. If light comes on, switch may be defective. Replace switch. Otherwise replace fuse.
	Coils at V2 and V1 not energized.	Poor ground on wire, bad wire connection or damaged wire. Repair as required.
	Marker flow control valve closed too far.	See Operation Section for adjustment.
Neither marker will raise.	Marker flow control valve closed too far.	See Operation Section for adjustment.
Right marker will not lower.	Solenoid coil in port V2 not energized.	Check switch on control console. Replace if defective. Check coil ground wire. Check for poor connection or damaged wire.
	Solenoid cartridge in port V2 stuck closed.	Switch cartridge with one on the planter you know is operating properly. If right marker lowers, replace defective cartridge.
Left marker will not lower.	Solenoid coil in port V1 not energized.	Check switch on control console. Replace if defective. Check coil ground wire. Check for poor connection or damaged wire.
	Solenoid cartridge in port V1 stuck closed.	Switch cartridge with one on the planter you know is operating properly. If right marker lowers, replace defective cartridge.
Markers traveling too fast and damaging pivot at rod end of marker cylinders.	Marker flow control valve out of adjustment.	See Operation Section for adjustment.

MAINTENANCE

MARKER BEARING LUBRICATION OR REPLACEMENT

1. Remove marker blade.
2. Remove dust cap from hub.
3. Remove cotter pin, nut and washer.
4. Slide hub from spindle.
5. Remove bearings and cups and discard if bearings are being replaced. Clean hub and dry. Remove bearings only and not cups if repacking.
6. Press in new bearing cups with thickest edge facing in. (Bearing replacement procedure only.)
7. Pack bearings with heavy duty wheel bearing grease thoroughly forcing grease between roller cone and bearing cage. Also fill the space between the bearing cups in the hub with grease.
8. Install rubber seal into grease seal. Place inner bearing in place and press in new rubber seal/grease seal.
9. Clean spindle and install hub.
10. Install outer bearing, washer and slotted hex nut. Tighten slotted hex nut while rotating hub until there is some drag. This assures that all bearing surfaces are in contact. Back off slotted nut to nearest locking slot and install cotter pin.
11. Fill dust caps approximately $\frac{3}{4}$ full of wheel bearing grease and install on hub.
12. Install blade and dust cap retainer on hub and tighten evenly and securely.

(PLTR45/PLTR99/PLTR98/PLTR102)

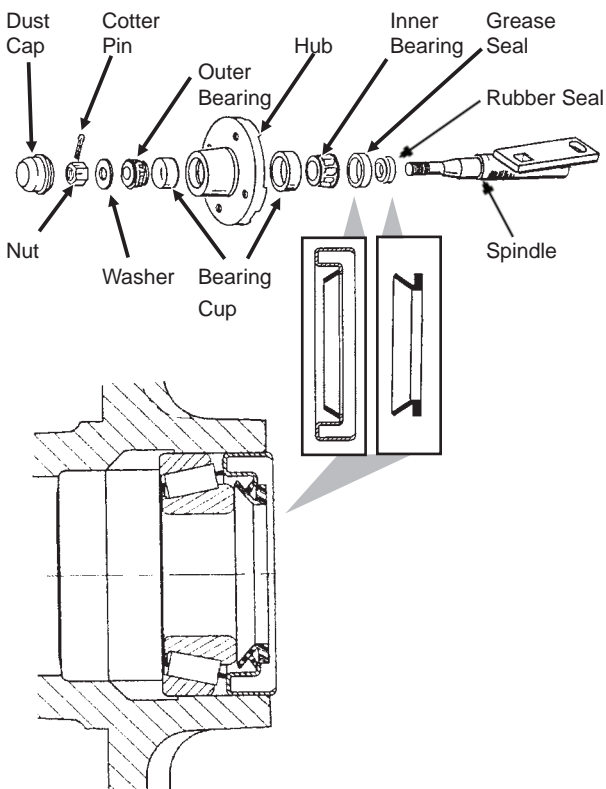

TRANSPORT WHEEL BEARING REPLACEMENT

1. Raise tire clear of ground and remove wheel.
2. Remove dust cap attachment hardware and remove cap from wheel hub.
3. Remove cotter pin, axle nut and 2" washer.
4. Slide hub from axle spindle, using a hub puller if necessary.
5. Remove bearings and cups from hub and discard. Thoroughly clean and dry wheel hub.
6. Press in new bearing cups with thickest edges facing in.
7. Pack bearing with heavy-duty wheel bearing grease, thoroughly forcing grease between roller cone and bearing cage. Also fill the space between the bearing cups in the hub with grease.
8. Place inner bearing in hub and press in new grease seal with lip pointing towards bearing.
9. Clean axle spindle and install hub.
10. Install outer bearing, 2" washer and slotted hex nut. Tighten slotted hex nut while rotating the hub until there is some drag. This assures that all bearing surfaces are in contact. Back off slotted nut to nearest locking slot and install cotter pin. Check for endplay in bearings.
11. Fill dust cap half full of wheel bearing grease and install on hub with attachment bolts.
12. Install wheel and remove jack. Torque inner and outer budd nuts to 450-500 ft. lbs.

HTA002(PLTR149)

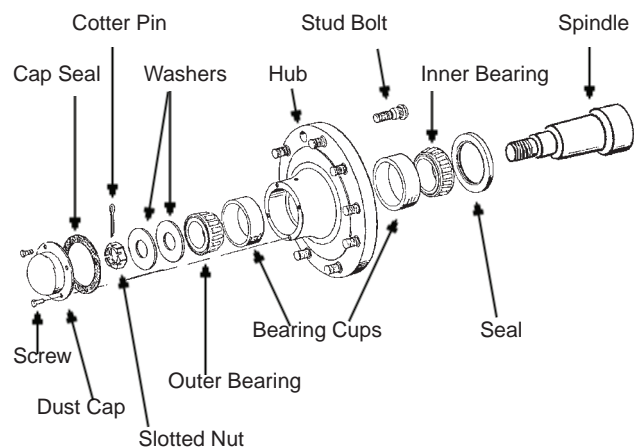

MAINTENANCE

TRANSPORT LATCH POST WEAR PAD REPLACEMENT/ADJUSTMENT

01209915

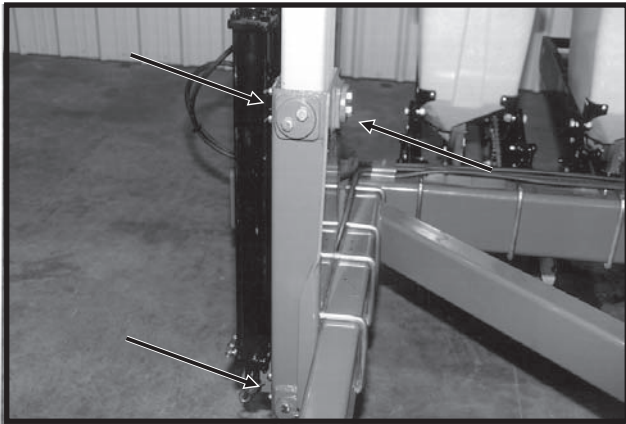

The transport latch post assembly consists of a plated tubular post equipped with two stationary and six adjustable wear pad assemblies. Each adjustable wear pad assembly consists of a poly wear pad, a threaded adjustment plug and a cap. The assembly is held in place by the threaded adjustment plug and locked in position by the cap and two 1/2" hex head cap screws.

Check wear and pad adjustment annually.

To check wear pad adjustment, visually inspect all six adjustable assemblies. Each wear pad should lightly contact the plated post. If adjustment is necessary, loosen two 1/2" cap screws on cap. Hand tighten wear pad assembly until poly pad lightly contacts post. Re-tighten 1/2" cap screws to 25-30 ft. lbs.

(TWL69a)

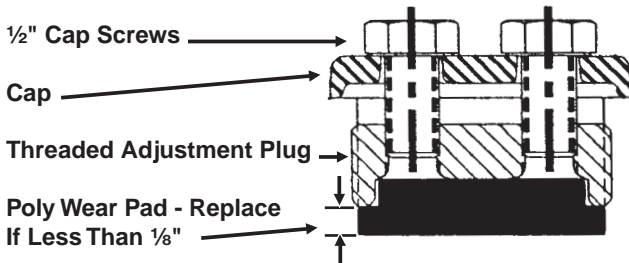

CAUTION: DO NOT OVER TIGHTEN WEAR PADS. OVER TIGHTENING WILL CAUSE PREMATURE WEAR.

PUSH PAD SHIM REPLACEMENT/ADJUSTMENT

01199909a

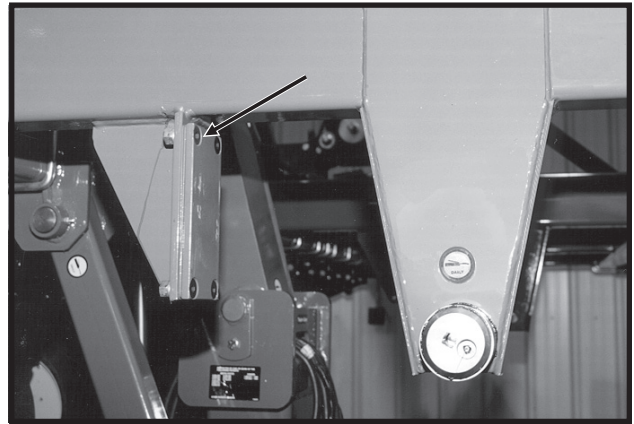

Shims on the push pads on the planter frame can be added or removed to adjust planter frame height.

Frame height is correct when distance between frame and top of axle measured just in front of push pads is 2-2 3/4".

D12209901

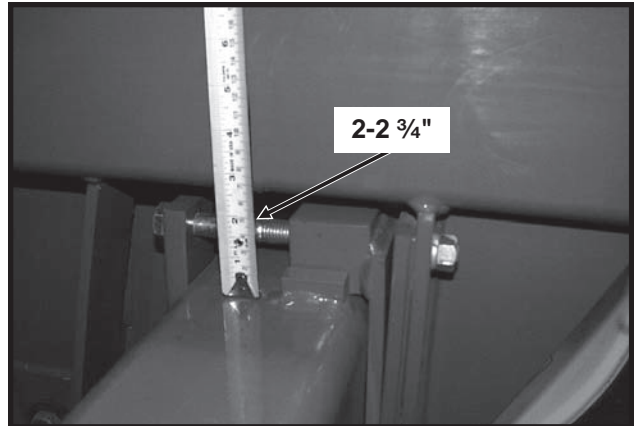

MAINTENANCE

PISTON PUMP STORAGE

KEEP AIR OUT OF PUMP! This is the only way to prevent corrosion. Even for short periods of storage, the entrance of air into the pump, will cause **RAPID AND SEVERE CORROSION**.

Overnight Storage

SUSPENSION FERTILIZER must be flushed from the pump for **ANY** storage period.

Winter Storage

1. Flush pump thoroughly with 5 to 10 gallons of fresh water and circulate until all corrosive salts are dissolved in the pump.
2. With the pump set on 10, draw in a mixture of half diesel fuel and half 10 weight oil until the discharge is clean. Then plug inlet and outlet.

12229799

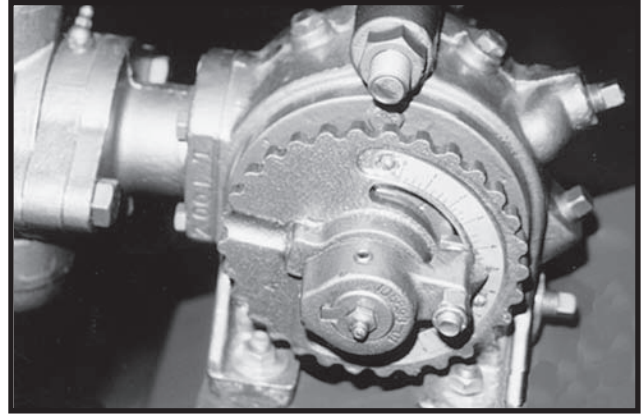

PISTON PUMP TROUBLESHOOTING

PROBLEM	POSSIBLE CAUSE	SOLUTION
Pump hard or impossible to prime.	Valves fouled or in wrong place.	Inspect and clean valves.
	Air leak in suction line.	Repair leak.
	Pump set too low.	Adjust pump setting.
	Packing washers worn out.	Replace.
Low metering.	Valves fouled or in wrong place.	Inspect and clean valves.
	Air leak in suction line.	Repair leak.
	Pump set too low.	Adjust pump setting.
	Broken valve spring.	Replace spring.
Over meters.	Broken discharge valve spring.	Replace spring.
	Trash under valves.	Inspect and clean valves.
	Improper rate setting.	Adjust pump setting.
Leaks through when stopped.	Broken discharge valve spring.	Replace spring.
	Trash under valves.	Inspect and clean valves.
Fertilizer solution leaking under stuffing box.	Packing washers worn out.	Replace.
Pump using excessive oil.	Oil seals or o-ring worn and leaking.	Replace.
Pump operates noisily.	Crankcase components worn excessively.	Inspect and replace if necessary.

MAINTENANCE

PREPARATION FOR STORAGE

Store the planter in a dry sheltered area if possible.

Remove all trash that may be wrapped on sprockets or shafts and remove dirt that can draw and hold moisture.

Clean all drive chains and coat with a rust preventative spray, or remove chains and submerge in oil.

Lubricate planter and row units at all lubrication points.

If possible, remove weight from all tires particularly if the unit is stored outdoors, in which case it is best to remove wheels and tires for storage in a cool dry area.

Inspect the planter for parts that are in need of replacement and order during the "off" season.

Make sure all seed, herbicide and insecticide hoppers are empty and clean.

Clean seed meters and store in a rodent-free dry area.

Remove seed discs from brush-type seed meter, clean and store meters with discs removed.

Grease exposed areas of cylinder rods before storing planter.

Grease or paint disc openers and marker blades to prevent rust.

Flush liquid fertilizer tanks, hoses and metering pump with clean water. See "Piston Pump Storage" if applicable.

ELECTRICAL WIRING DIAGRAM FOR LIGHT PACKAGE

(WGN66a)

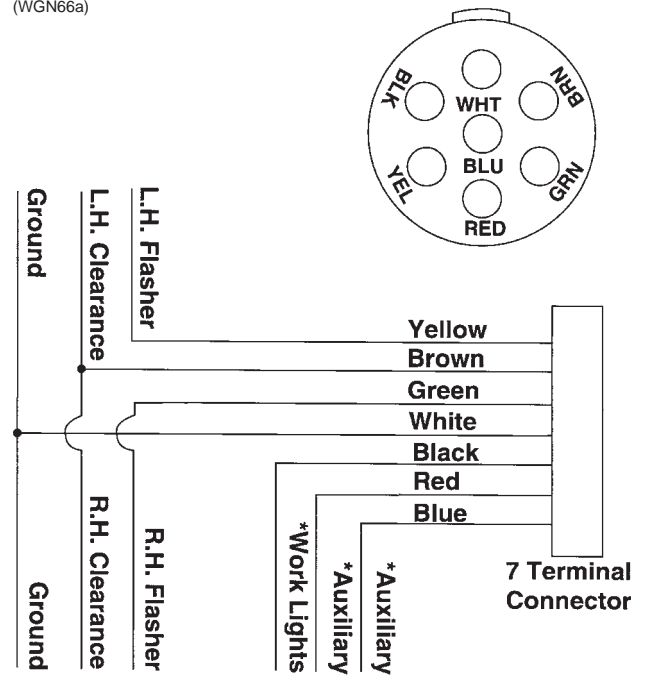

* Optional auxiliary lights and wires (to be supplied by customer) may be wired into existing plug terminals.

Light package supplied on the Model 2400 Twin-Line® Planter meets ASAE Standards. For the correct wiring harness to be wired into the lights on your tractor, check with the tractor manufacturer.

69922-35



MAINTENANCE

ELECTRICAL CONTROL CONSOLE SCHEMATIC

NOTE: Before doing any electrical work, disconnect the control console from the tractor battery. Keep wiring harnesses away from high temperature areas or sharp edges. DO NOT route the wiring harnesses along battery cables. Use tie straps to keep wire harness away from moving parts on tractor and planter. Be sure ground connections to the tractor frame are clean to provide good electrical contact.

A7407(PLTR82a)

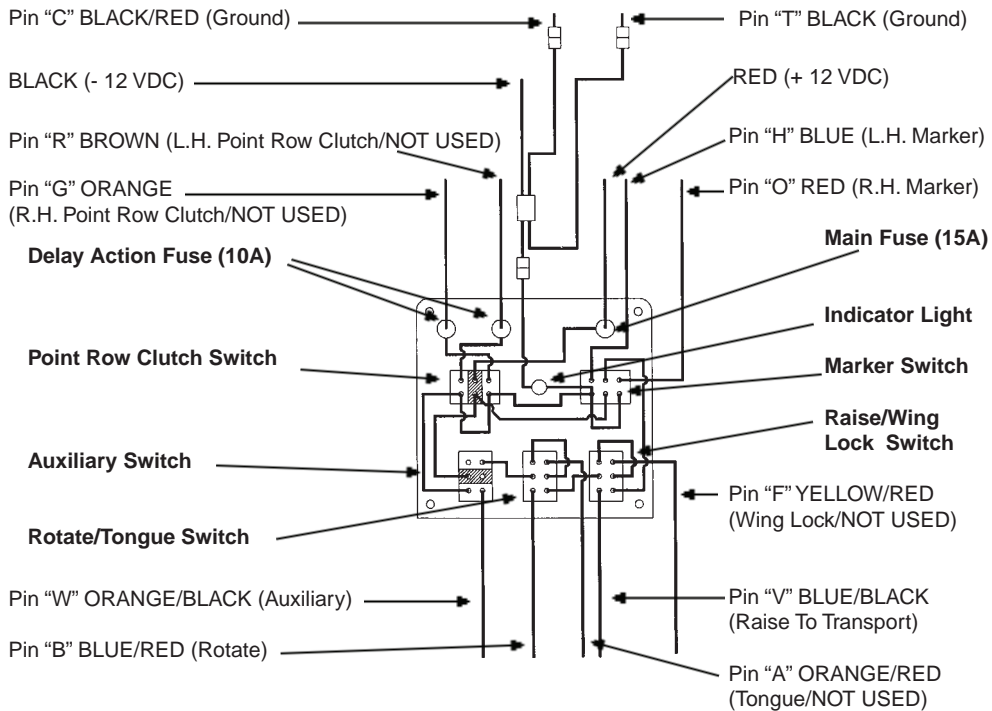

A7407(INS238)

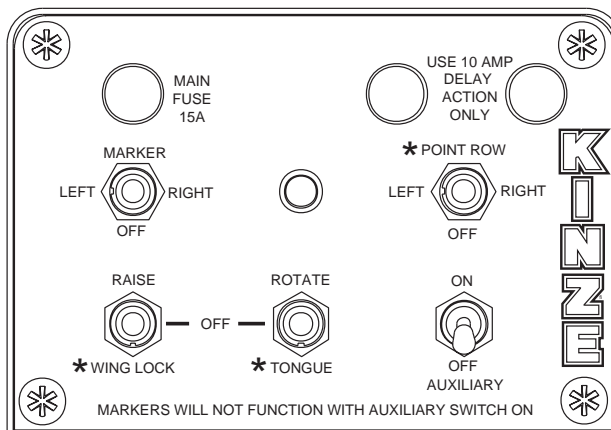

NOTE:

1. Operating marker or point row switch in either direction lights panel light.
2. Point row clutch switch operates independently of the rest of the control box.
3. Power to the marker switch is fed through the auxiliary switch and the two transport function switches. Operating any of the switches in the lower row disables the marker function and turns off the panel light. (If the point row clutch switch is in the "off" position.)

*Not used on Model 2400 planter.

MAINTENANCE

ELECTRICAL WIRING HARNESS SCHEMATIC (On Tractor)

A7368(ELC10/ELC13)

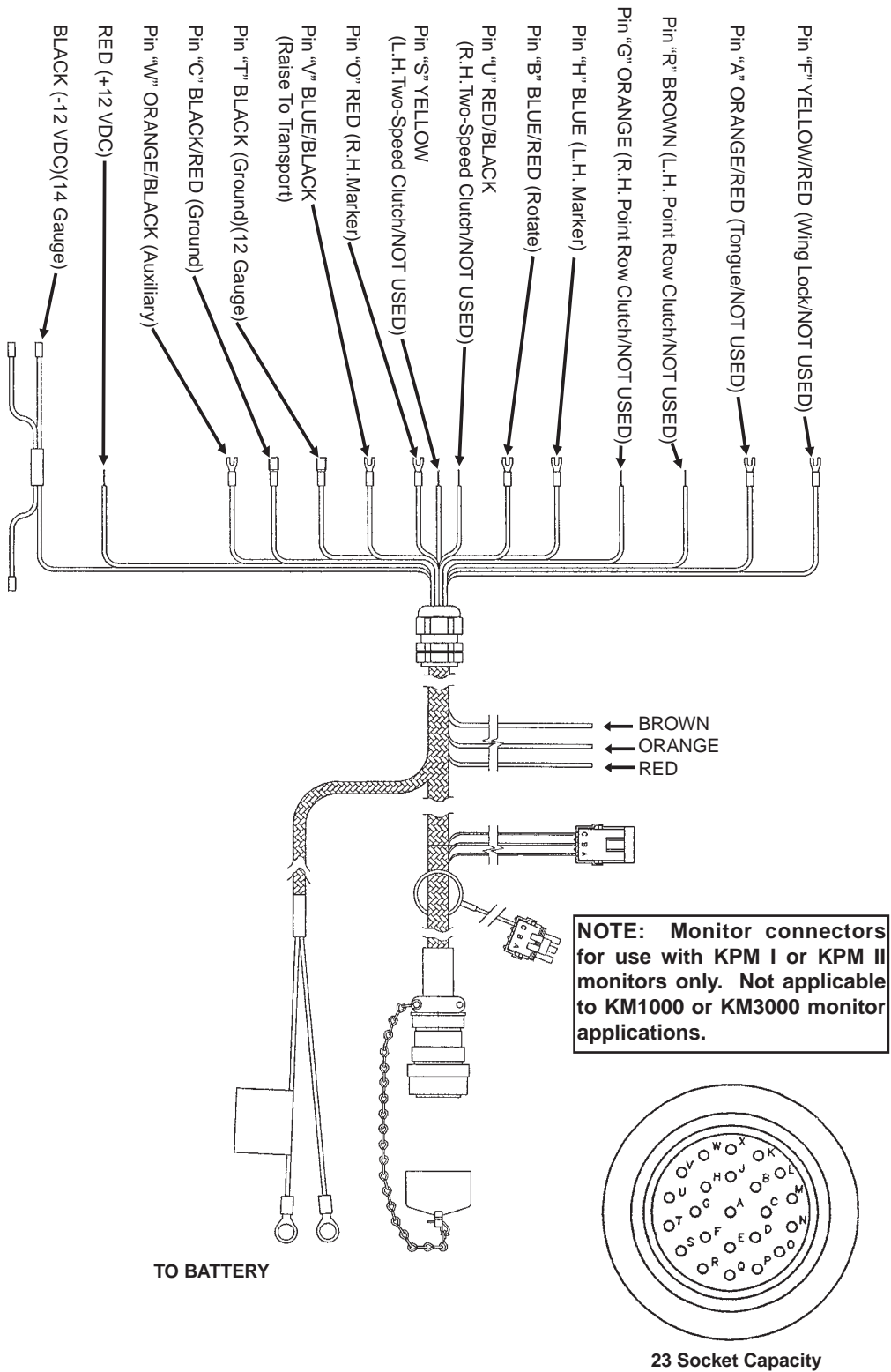

MAINTENANCE

ELECTRICAL WIRING HARNESS SCHEMATIC (On Planter)

(ELC13/A8432a)

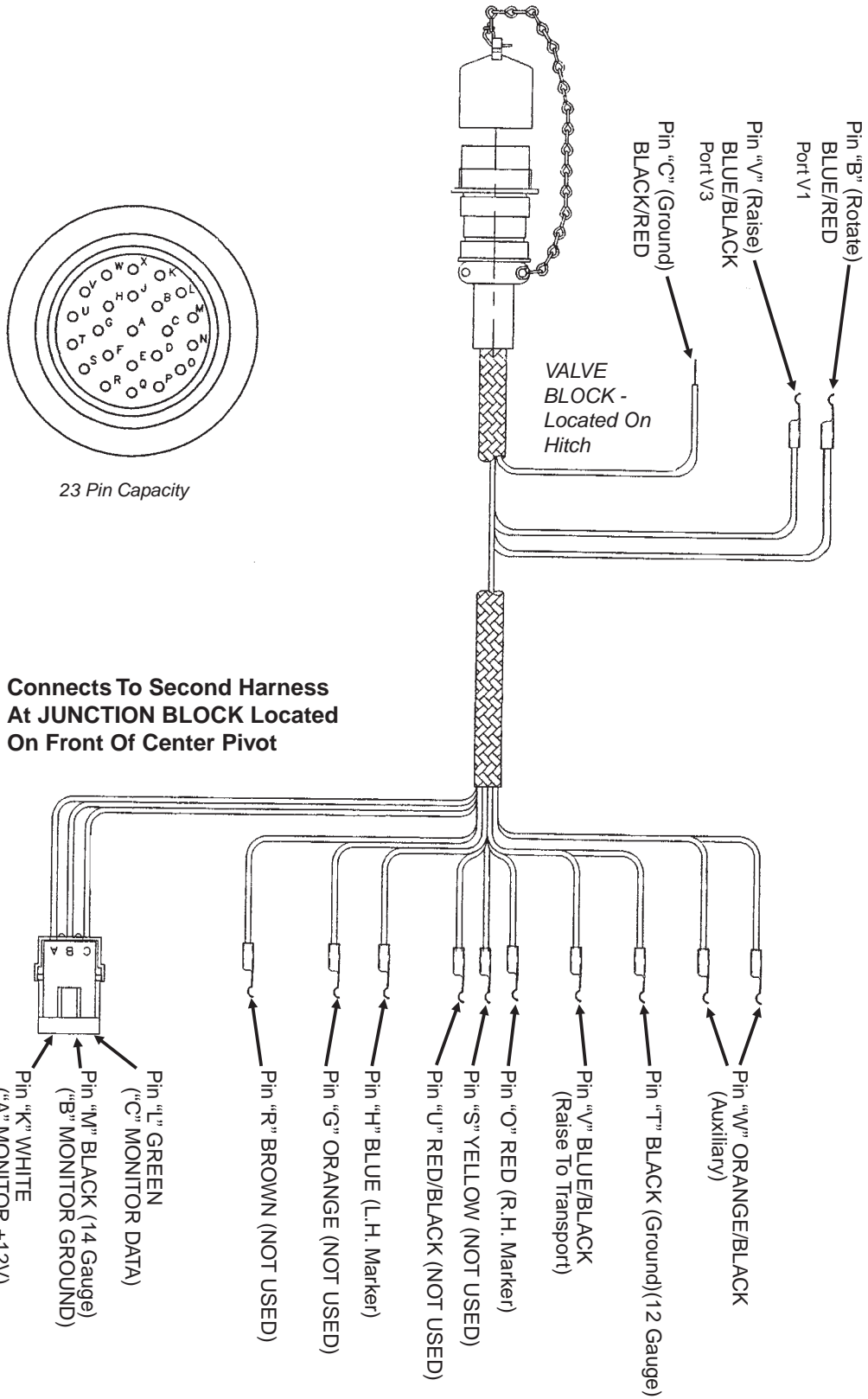

MAINTENANCE

ELECTRICAL WIRING HARNESS SCHEMATIC (On Planter)

(A8433)

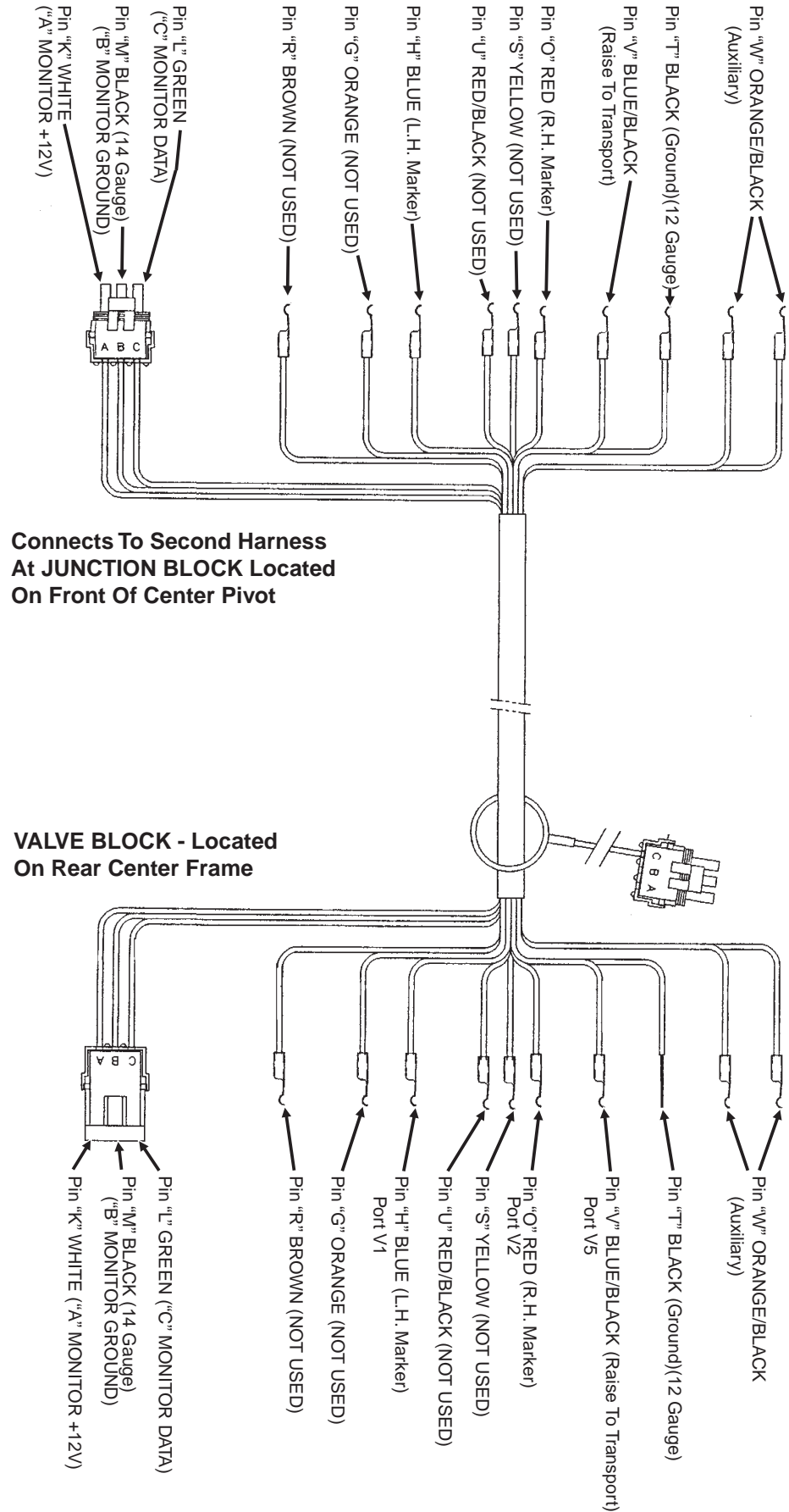

MAINTENANCE

HYDRAULIC SYSTEM SCHEMATIC

(TWL164a/TWL160/TWL161/TWL163/TWL162/TWL158c/TWL158b)

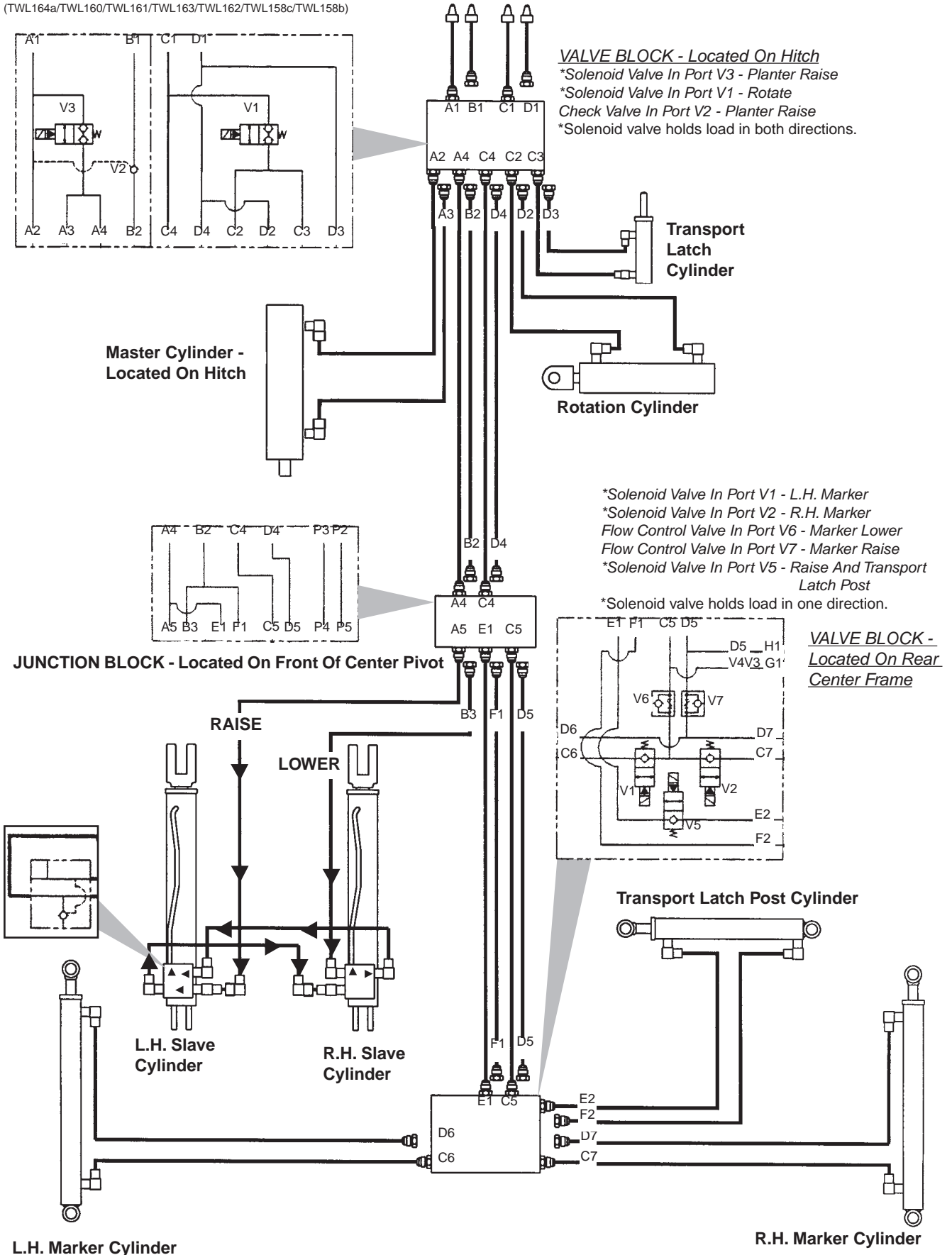

PARTS LIST INDEX

ROW UNIT

Brush-Type Seed Meter	P13
Covering Discs/Single Press Wheel	P6
Disc Furrower, Row Unit Mounted	P20
Finger Pickup Seed Meter	P12
Frame Mounted Coulter W/Disc Furrower	P24
Gauge Wheel	P5
Granular Chemical Banders	P14
Granular Chemical Hopper With Meter(s) & Throwout	P16
Granular Chemical Sub-Assemblies And Kits.....	P15
Hopper Support And Meter Drive	P10
No Till Coulter, Row Unit Mounted.....	P19
Parallel Arms, Mounting Support Plate And Quick Adjustable Down Force Springs	P4
Residue Wheel, Row Unit Mounted	P22
Residue Wheels, Coulter Mounter	P23
Seed Firming Wheel	P9
Seed Hopper.....	P11
Shank Assembly	P2
Spring Tooth Incorporator	P18
“V” Closing Wheels	P8

BASE MACHINE

Axle And Transport/Ground Drive Wheel Assembly.....	P40
Center Pivot	P38
Check Valve	P57
Contact Drive Wheel Assembly	P42
Cylinders.....	P60
Driveline.....	P46
Electrical Components.....	P48
Flow Control Valve	P57
Frame Lift Linkage	P36
Hitch And Safety Chain.....	P28
Hitch Extensions	P32
Hydraulic System.....	P58
Junction Block - Located On Front Of Center Pivot	P54
Marker Assembly	P50
Marker Spindle/Hub/Blade.....	P52
Planter Frame	P34
Safety Chain	P28
Solenoid Valves	P56
Transmission.....	P44
Transport Latch Post.....	P30
Valve Block - Located On Hitch	P53
Valve Block - Located On Rear Center Frame.....	P55

ELECTRONIC SEED MONITOR

Electronic Seed Monitor (KPM I/KPM II).....	P64
---------------------------------------------	-----

INTERPLANT®

Interplant® Push Row Unit	P26
Interplant® Driveline	P66

FERTILIZER

Fertilizer Openers And Mounts	P68
Liquid Fertilizer	P74
Residue Wheel, Notched Single Disc Fertilizer Opener Mounted	P72

SMV, Decals, Reflectors And Tie Straps.....	P86
---------------------------------------------	-----

Numerical Index.....	a
----------------------	---

SHANK ASSEMBLY

RUB006/RUA044(RU1g)

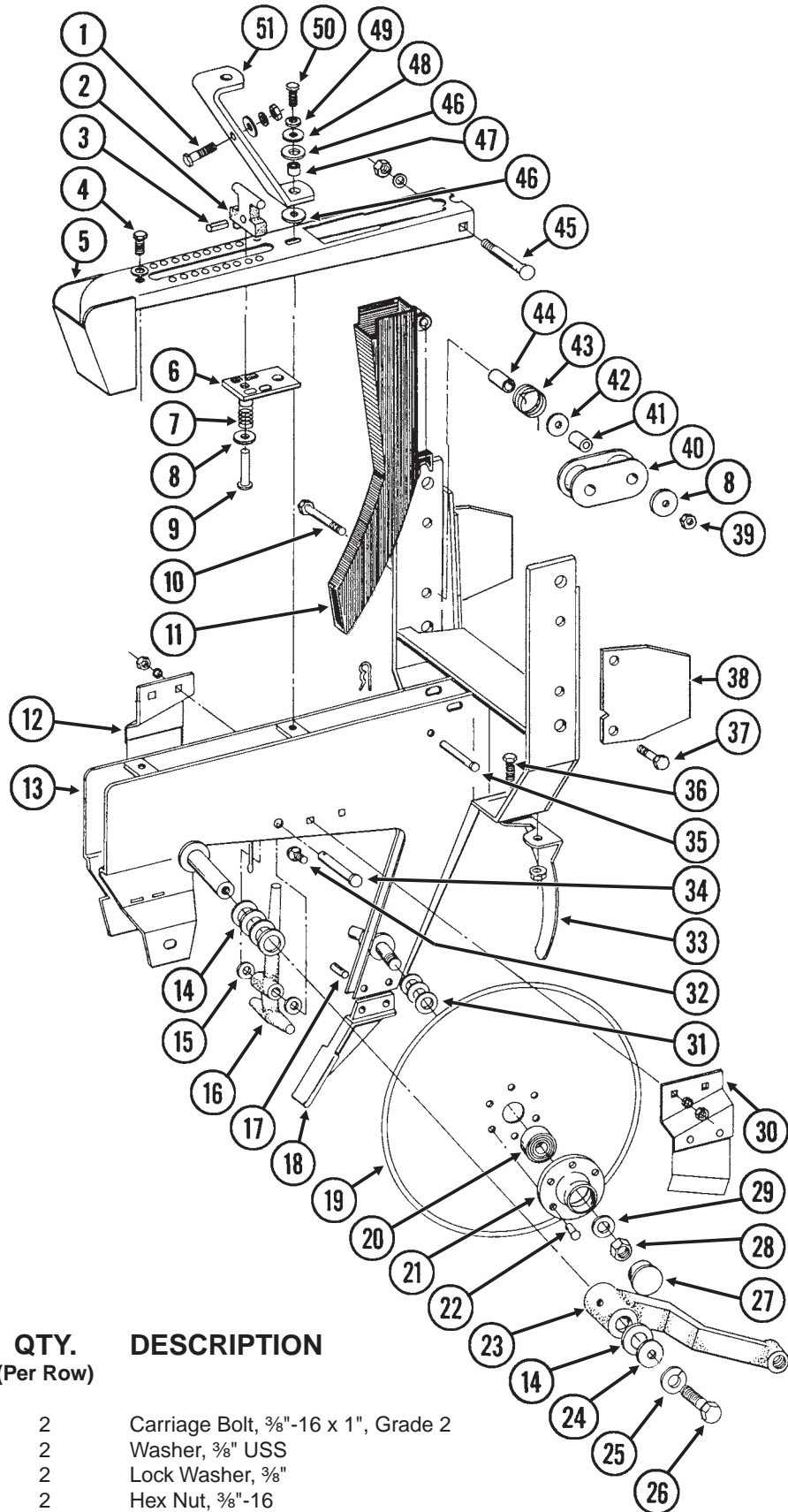

ITEM	PART NO.	QTY. (Per Row)	DESCRIPTION
1.	G10305	2	Carriage Bolt, 3/8"-16 x 1", Grade 2
	G10210	2	Washer, 3/8" USS
	G10229	2	Lock Washer, 3/8"
	G10101	2	Hex Nut, 3/8"-16
2.	GB0102	1	Depth Adjusting Handle
3.	G10605	1	Spring Pin, 5/32" x 3/4"
4.	G10001	1	Hex Head Cap Screw, 3/8"-16 x 1"
	G10229	1	Lock Washer, 3/8"

SHANK ASSEMBLY

ITEM	PART NO.	QTY. (Per Row)	DESCRIPTION
5.	GA0811	1	Shank Cover
6.	GB0105	1	Depth Adjusting Slide
7.	GD1066	1	Compression Spring
8.	G10210	1	Washer, 3/8" USS
9.	G10552	1	Clevis Pin, 3/8" x 2"
10.	G10326	1	Hex Head Cap Screw, 3/8"-16 x 3 3/4"
11.	GD1130	-	Seed Tube, Regular, See "Electronic Seed Monitor" For Seed Tube With Sensor, Pages P64 And P65
12.	GA2012L	1	Disc Scraper, L.H.
13.	GA1306	1	Shank
14.	G10526	-	Machine Bushing, 1", .048" (As Required)
15.	G10206	2	Washer, 1/2" SAE
16.	GB0104	1	Depth Adjusting Stop
17.	G10814	2	Spring Pin, 1/4" x 7/8"
18.	GB0103	1	Seed Tube Guard/Inner Scraper
19.	GD1030	2	Disc, 15"
20.	GA2014	2	Bearing
21.	GD10473	2	Housing
22.	G10427	12	Rivet, 1/4" x 1/2"
23.		-	See "Gauge Wheel", Page P5
24.	G10216	2	Washer, 1/2" USS
25.	G10228	2	Lock Washer, 1/2"
26.	G10014	2	Hex Head Cap Screw, 1/2"-13 x 1"
27.	GD6533	2	Dust Cap
28.	G10503	1	Jam Nut, 5/8"-11, R.H.
	G10504	1	Jam Nut, 5/8"-11, L.H.
29.	G10204	2	Special Machine Bushing, 5/8" x 1" O.D.
30.	GA2012R	1	Disc Scraper, R.H.
31.	G10213	-	Machine Bushing, 5/8", (.030" Thick) (As Required)
32.	G10328	4	Hex Head Cap Screw, 3/8"-16 x 5/8"
	G10622	4	Flange Nut, 3/8"-16
33.	GD1033	1	Shield
34.	G10555	1	Clevis Pin, 1/2" x 2 1/2"
	G10451	1	Cotter Pin, 1/8" x 1"
35.	G10551	1	Clevis Pin, 1/4" x 2 1/2"
	G10669	1	Hair Pin Clip, No. 22
36.	G10312	2	Carriage Bolt, 5/16"-18 x 3/4", Grade 2
	G10620	2	Flange Nut, 5/16"-18
37.	G10004	3	Hex Head Cap Screw, 3/8"-16 x 1 1/4"
	G10229	3	Lock Washer, 3/8"
	G10101	3	Hex Nut, 3/8"-16
38.	GD10867	2	Stop
39.	G10108	1	Lock Nut, 3/8"-16
40.	GD9240	1	Idler
41.	GD1026	1	Spacer, 1 3/16"
42.	G10201	1	Special Washer
43.	GD1065	1	Idler Spring
44.	GD7318	1	Bushing, 1"
45.	G10304	1	Carriage Bolt, 3/8"-16 x 3", Grade 2
	G10108	1	Lock Nut, 3/8"-16
46.	GD1120	2	Rubber Washer
47.	GD1110	1	Bushing, 1/2"
48.	G10208	1	Special Washer, 1 3/32"
49.	G10229	1	Lock Washer, 3/8"
50.	G10003	1	Hex Head Cap Screw, 3/8"-16 x 1 1/2"
51.	GD1027	1	Stabilizer Bracket
A.	GA2013	-	Disc And Bearing Assembly, Less Bearing Cap (Items 19-22)

PARALLEL ARMS, MOUNTING SUPPORT PLATE AND QUICK ADJUSTABLE DOWN FORCE SPRINGS

RUB007/RUB015/RUB016/RUB013/RUB019/RUB020(RU2d/RU3a)

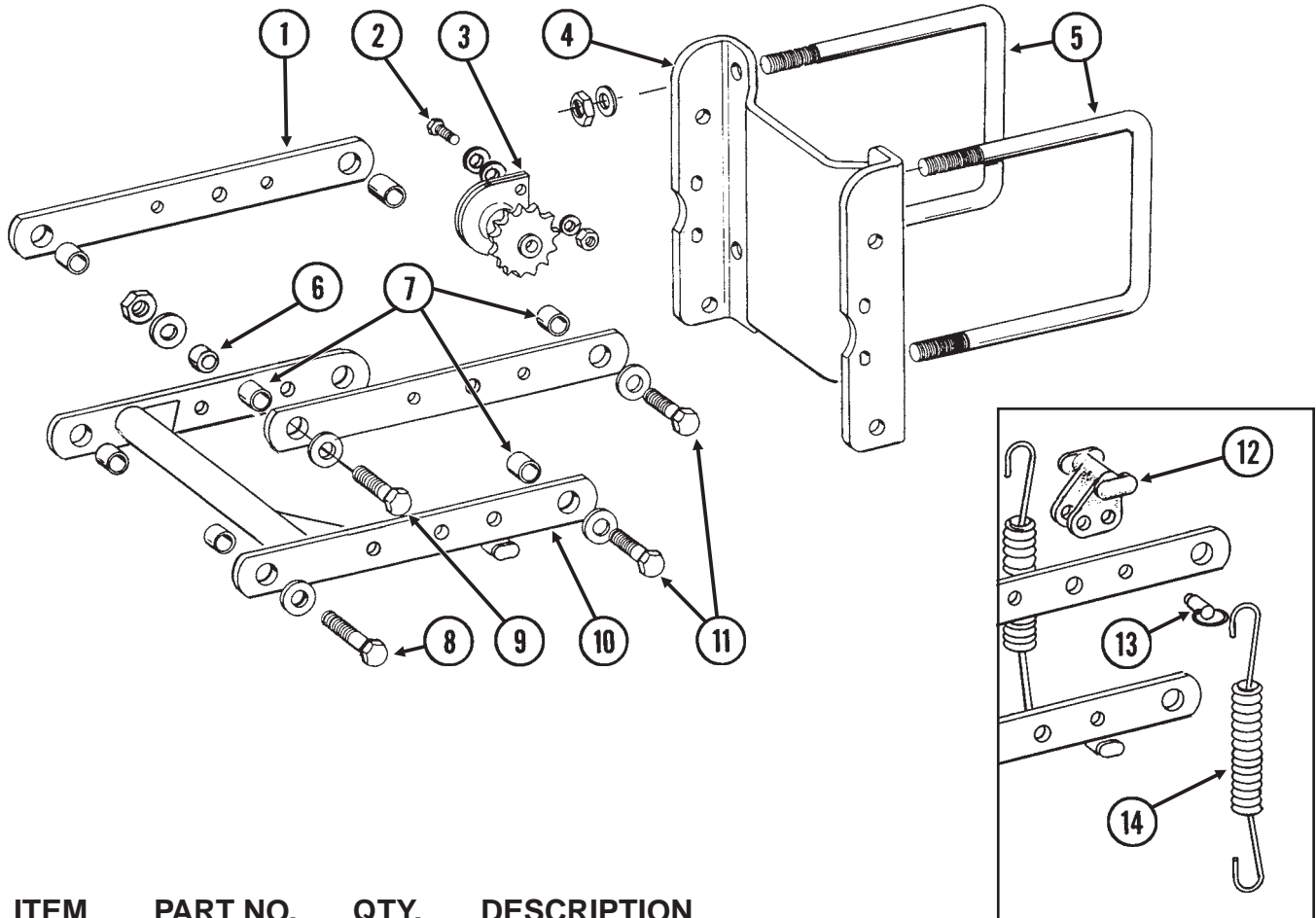

ITEM	PART NO.	QTY. (Per Row)	DESCRIPTION
1.	GD7619	2	Upper Parallel Arm
2.	G10004	2	Hex Head Cap Screw, 3/8"-16 x 1 1/4"
	G10210	-	Washer, 3/8" USS (As Required)
	G10229	2	Lock Washer, 3/8"
	G10101	2	Hex Nut, 3/8"-16
3.	GA1720	1	Bearing/Sprocket, 7/8" Bore
4.	GD10036	1	Mounting Support Plate
5.	GD1113	2	U-Bolt, 5" x 7" x 5/8"-11
	G10230	4	Lock Washer, 5/8"
	G10104	4	Hex Nut, 5/8"-11
6.	GD1109	2	Pivot Bushing, 1/4"
7.	GB0218	8	Bushing, 1 9/32"
8.	G10751	2	Hex Head Cap Screw, 5/8"-18 x 1 3/4"
	GD7805	2	Special Washer
	G10412	2	Lock Nut, 5/8"-18
9.	G10752	2	Hex Head Cap Screw, 5/8"-18 x 2 1/4"
	GD7805	4	Special Washer
	G10412	2	Lock Nut, 5/8"-18
10.	GA5651	1	Lower Parallel Arm
11.	G10732	4	Hex Head Cap Screw, 5/8"-18 x 2"
	GD7805	4	Special Washer
	G10412	4	Lock Nut, 5/8"-18
12.	GB0186	2	Spring Anchor
13.	G10545	2	Detent Pin, 1" Grip
14.	GD8249	-	Spring

GAUGE WHEEL

RUB001/RUB018/RUA039/RUB018/RUA044(RU5a/RU6)

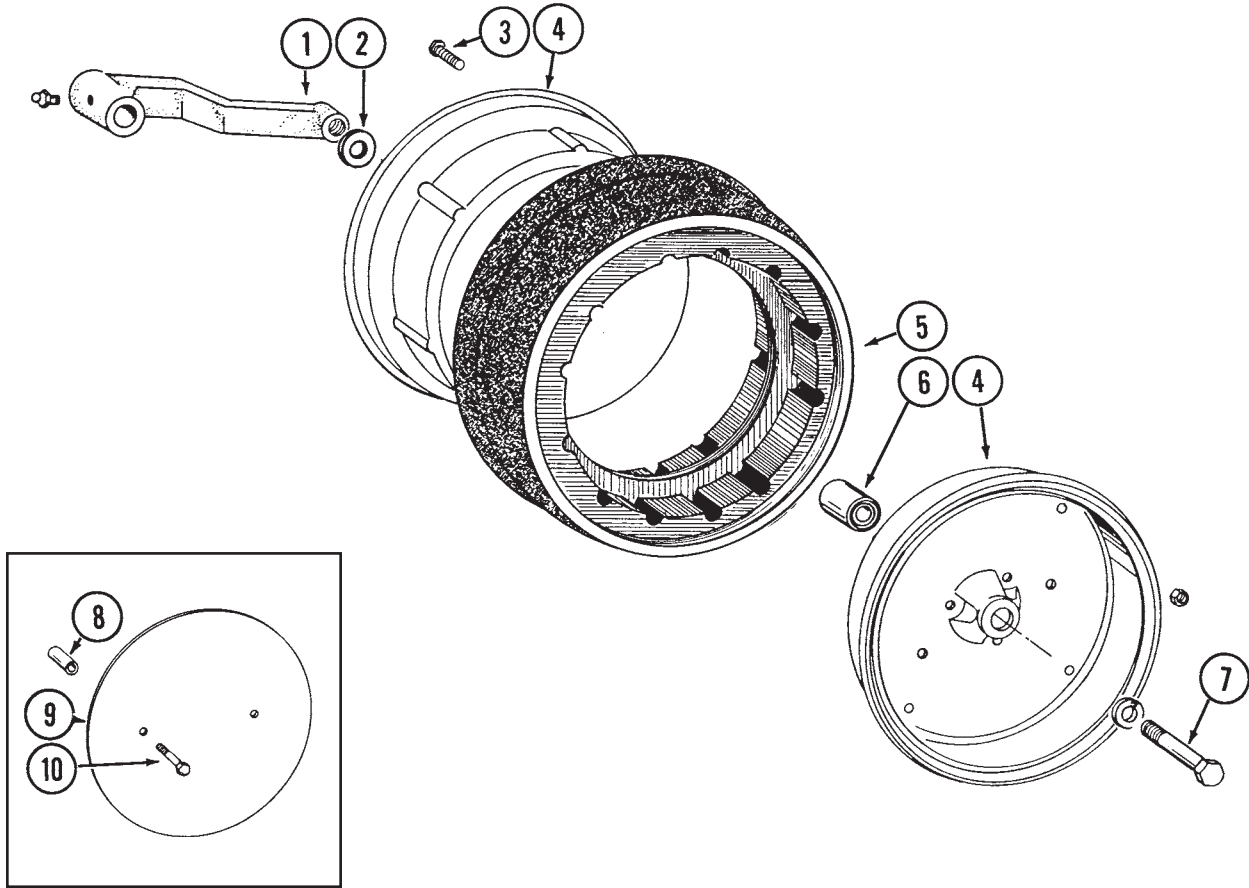

ITEM	PART NO.	QTY. (Per Row)	DESCRIPTION
1.	GA6614	2	Wheel Arm With Grease Fitting
	G10640	2	Grease Fitting, 1/4"-28
2.	G10204	1	Special Machine Bushing, 5/8" x 1" O.D.
3.	G10018	14	Hex Head Cap Screw, 5/16"-18 x 5/8"
	G10109	14	Lock Nut, 5/16"-18
4.	GD1048	4	Half Wheel
5.	GD1086	2	Tire
6.	GA6171	2	Bearing
7.	G10010	2	Hex Head Cap Screw, 5/8"-11 x 3"
	G10230	2	Lock Washer, 5/8"
8.	GD0973	4	Wheel Cover Sleeve, 1 1/2" (Optional)
9.	GD1353	2	Wheel Cover (Optional)
10.	G10069	4	Hex Head Cap Screw, 5/16"-18 x 2 1/4"
	G10232	4	Lock Washer, 5/16"
	G10106	4	Hex Nut, 5/16"-18
A.	GA6615	-	Gauge Wheel Complete (Items 3-6)

COVERING DISCS/SINGLE PRESS WHEEL

RUA042/RUA044(RU8)

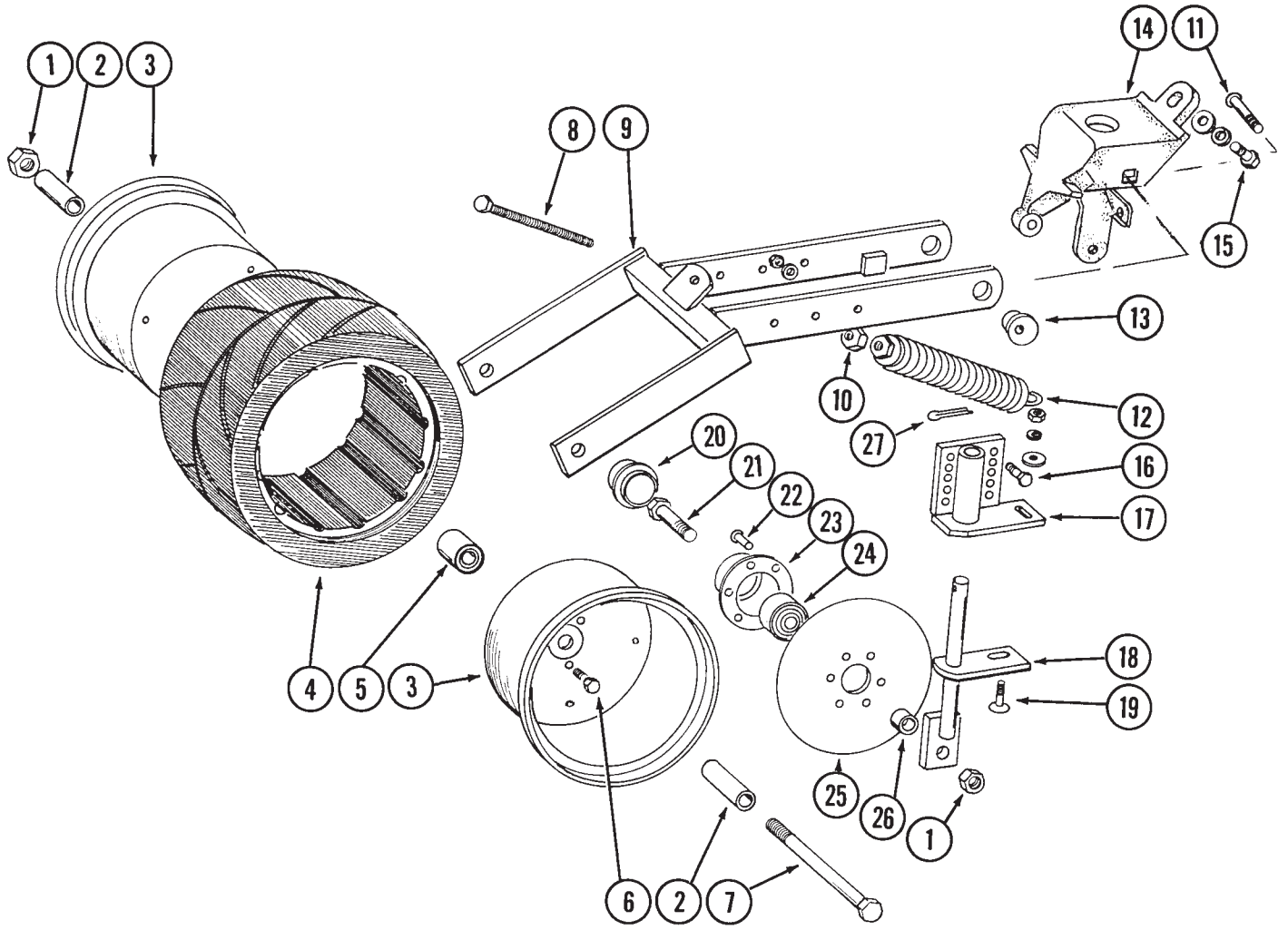

COVERING DISCS/SINGLE PRESS WHEEL

ITEM	PART NO.	QTY. (Per Row)	DESCRIPTION
1.	G10107	3	Lock Nut, 5/8"-11
2.	GD3181-12	2	Spacer, 2 7/8"
3.	GD9562	2	Half Wheel
4.	GD9305	1	Tire
5.	GA6171	1	Bearing
6.	G10018	7	Hex Head Cap Screw, 5/16"-18 x 5/8"
	G10109	7	Lock Nut, 5/16"-18
7.	G10152	1	Hex Head Cap Screw, 5/8"-11 x 9"
8.	G10015	1	Adjusting Bolt, 1/2"-13 x 5"
9.	GA6619	1	Mounting Arm
10.	G10102	1	Hex Nut, 1/2"-13
11.	G10801	2	Carriage Bolt, 1/2"-13 x 2 1/4"
	G10315	-	Carriage Bolt, 1/2"-13 x 2 1/2"
	G10216	2	Washer, 1/2" USS
	G10102	2	Hex Nut, 1/2"-13
12.	GA2054	1	Spring
13.	GB0239	2	Eccentric Bushing
14.	GB0233	1	Wheel Arm Stop
15.	G10003	1	Hex Head Cap Screw, 3/8"-16 x 1 1/2"
	G10229	1	Lock Washer, 3/8"
	G10210	2	Washer, 3/8" USS
16.	G10171	4	Hex Head Cap Screw, 5/16"-18 x 1 1/4"
	G10232	4	Lock Washer, 5/16"
	G10106	4	Hex Nut, 5/16"-18
17.	GA6620	2	Bracket
18.	GA6618	2	Mount
19.	G10303	2	Carriage Bolt, 5/16"-18 x 1"
	G10219	2	Washer, 5/16" USS
	G10232	2	Lock Washer, 5/16"
	G10106	2	Hex Nut, 5/16"-18
20.	GD6533	2	Cap
21.	G10006	2	Hex Head Cap Screw, 5/8"-11 x 2 1/4"
22.	G10427	12	Rivet, 1/4" x 1/2"
23.	GD10473	2	Bearing Housing
24.	GA2014	2	Bearing
25.	GD9290	2	Blade, 8" Diameter
26.	GD1109	2	Spacer, 1/4"
27.	G10463	2	Cotter Pin, 1/4" x 1 1/2"
A.	GA6733	-	Single Press Wheel Complete With Bearing (Items 3-6)
B.	GA6801	-	Covering Disc Complete With Bearing (Items 22-25)

"V" CLOSING WHEELS

RUB004/RUA044/RUA046(RU9)

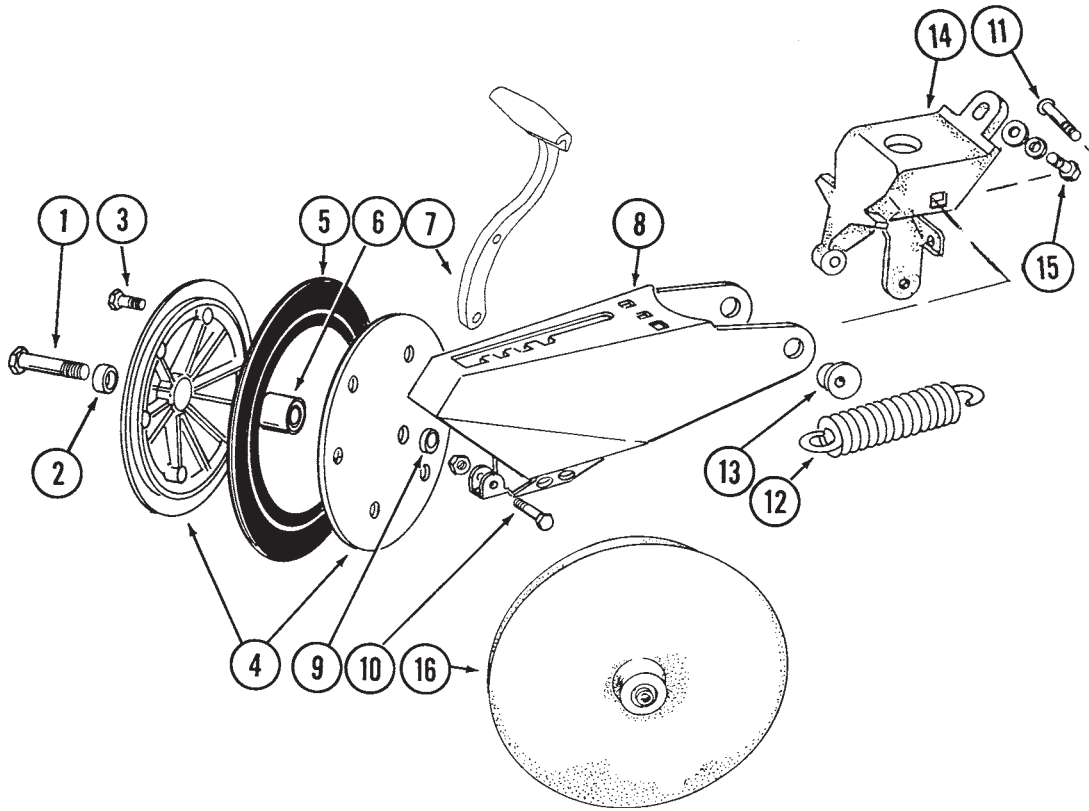

ITEM	PART NO.	QTY. (Per Row)	DESCRIPTION
1.	G10013	2	Hex Head Cap Screw, 5/8"-11 x 3 1/2"
	G10107	2	Lock Nut, 5/8"-11
2.	GB0218	2	Bushing, 19/32"
3.	G10064	6	Hex Head Cap Screw, 1/4"-20 x 1"
	G10103	6	Hex Nut, 1/4"-20
4.	GD9120	4	Nylon Half Wheel
5.	GD1085	2	Rubber Tire, 1" x 12"
6.	GA6171	2	Bearing
7.	GB0254	1	Lever
8.	GA6613	1	Arm
9.	GD1109	2	Bushing, 1/4"
10.	G10133	1	Hex Head Cap Screw, 5/16"-18 x 1 1/2"
	G10109	1	Lock Nut, 5/16"-18
11.	G10747	2	Carriage Bolt, 1/2"-13 x 2"
	G10111	2	Lock Nut, 1/2"-13
12.	GD8460	1	Spring
13.	GB0219	2	Eccentric Bushing
14.	GB0233	1	Wheel Arm Stop
15.	G10003	1	Hex Head Cap Screw, 3/8"-16 x 1 1/2"
	G10229	1	Lock Washer, 3/8"
	G10210	2	Washer, 3/8" USS
16.	GA6597	-	Cast Iron Closing Wheel W/Bearing
	GA6171	-	Bearing
A.	GA6434	-	Rubber Closing Wheel Complete With Bearing (Items 3-6)

SEED FIRING WHEEL

RUB006/RUA044(RU10b)

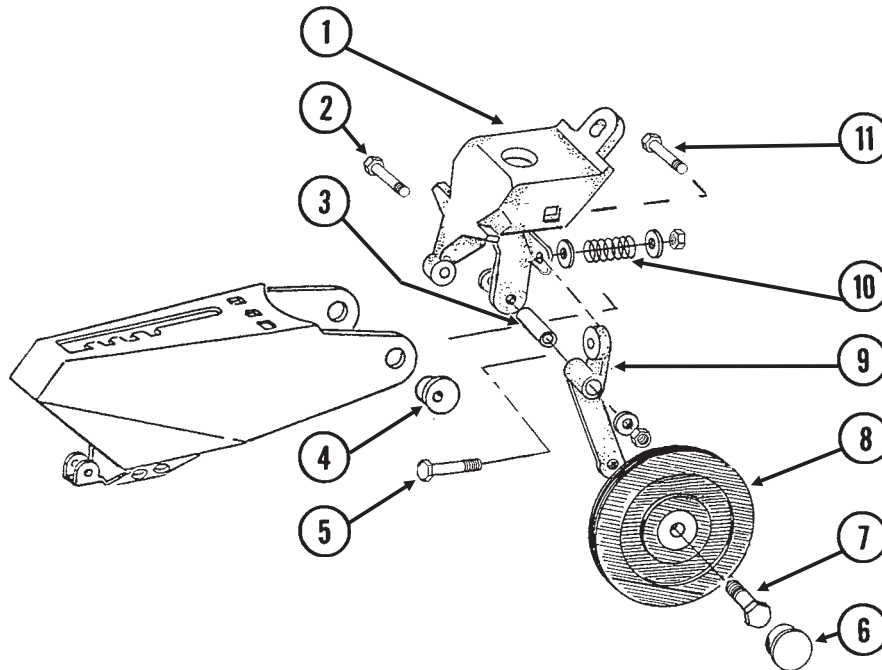

ITEM	PART NO.	QTY.	DESCRIPTION
		(Per Row)	
1.	GB0233	1	Wheel Arm Stop
2.	G10049	1	Hex Head Cap Screw, 3/8"-16 x 2 1/2"
	G10210	2	Washer, 3/8" USS
	G10108	1	Lock Nut, 3/8"-16
3.	GD9786	1	Bushing
4.	GB0219	2	Eccentric Bushing
5.	G10062	1	Hex Head Cap Screw, 3/8"-16 x 3"
	G10210	2	Washer, 3/8" USS
	G10108	1	Lock Nut, 3/8"-16
6.	GD1079	1	Dust Cap
7.	G10055	1	Hex Head Cap Screw, 5/8"-11 x 1 1/4"
8.	GA7580	1	Seed Firming Wheel W/Bearing And Snap Ring
	GA2014	-	Bearing
	G10770	-	Snap Ring, 1 11/16"
9.	GB0245	1	Arm
10.	GD9787	1	Spring
11.	G10747	2	Carriage Bolt, 1/2"-13 x 2"
	G10111	2	Lock Nut, 1/2"-13
A.	GA6937	-	Seed Firming Wheel Retrofit Package (Items 1-11)

HOPPER SUPPORT AND METER DRIVE

RUB005(RU11c)

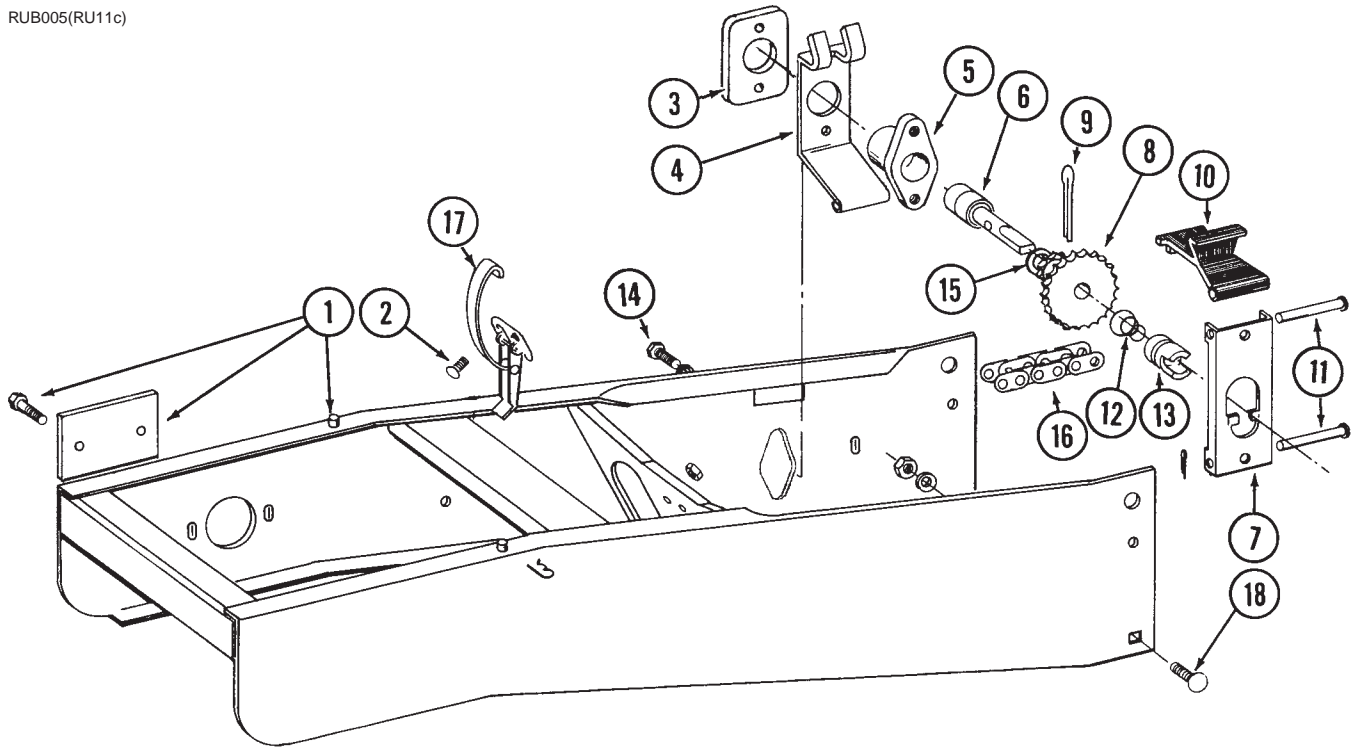

ITEM	PART NO.	QTY. (Per Row)	DESCRIPTION
1.	GR1066	1	Hopper Support W/Cover And Hardware
	GD7618	1	Cover
	G10312	2	Carriage Bolt, 5/16"-18 x 3/4"
	G10620	2	Flange Nut, 5/16"-18
2.	G10309	2	Carriage Bolt, 1/4"-20 x 5/8", Grade 2
	G10621	2	Flange Nut, 1/4"-20
3.	GD2128	1	Plate
4.	GD1037	1	Bearing Support
5.	GB0108	1	Bearing Housing
6.	GA2016	1	Bearing
7.	GD1036	1	Drive Release Lever
8.	GB0107	1	Sprocket, 11/19 Tooth
9.	G10457	1	Cotter Pin, 5/32" x 1 1/2"
10.	GD1035	1	Release Handle
11.	G10553	2	Clevis Pin, 1/4" x 2 5/8"
	G10455	2	Cotter Pin, 1/16" x 1/2"
12.	GD10464	1	Compression Spring
13.	GB0243	1	Drive Coupler
14.	G10019	2	Hex Head Cap Screw, 5/16"-18 x 1"
	G10232	2	Lock Washer, 5/16"
15.	G10204	-	Special Machine Bushing, 5/8" x 1" O.D. (As Required)
16.	G3303-98	1	Roller Chain, No. 41, 98 Links Including Connector Link
	GR0196	1	Connector Link, No. 41
17.	GA2007	1	Hopper Hold Down Latch
18.	G10305	1	Carriage Bolt, 3/8"-16 x 1", Grade 2
	G10004	-	Hex Head Cap Screw, 3/8"-16 x 1 1/4"
	G10229	1	Lock Washer, 3/8"
	G10101	1	Hex Nut, 3/8"-16
A.	GA4822	-	Meter Drive Assembly Complete (Items 3-14)

SEED HOPPER

RUA015(RU12b)

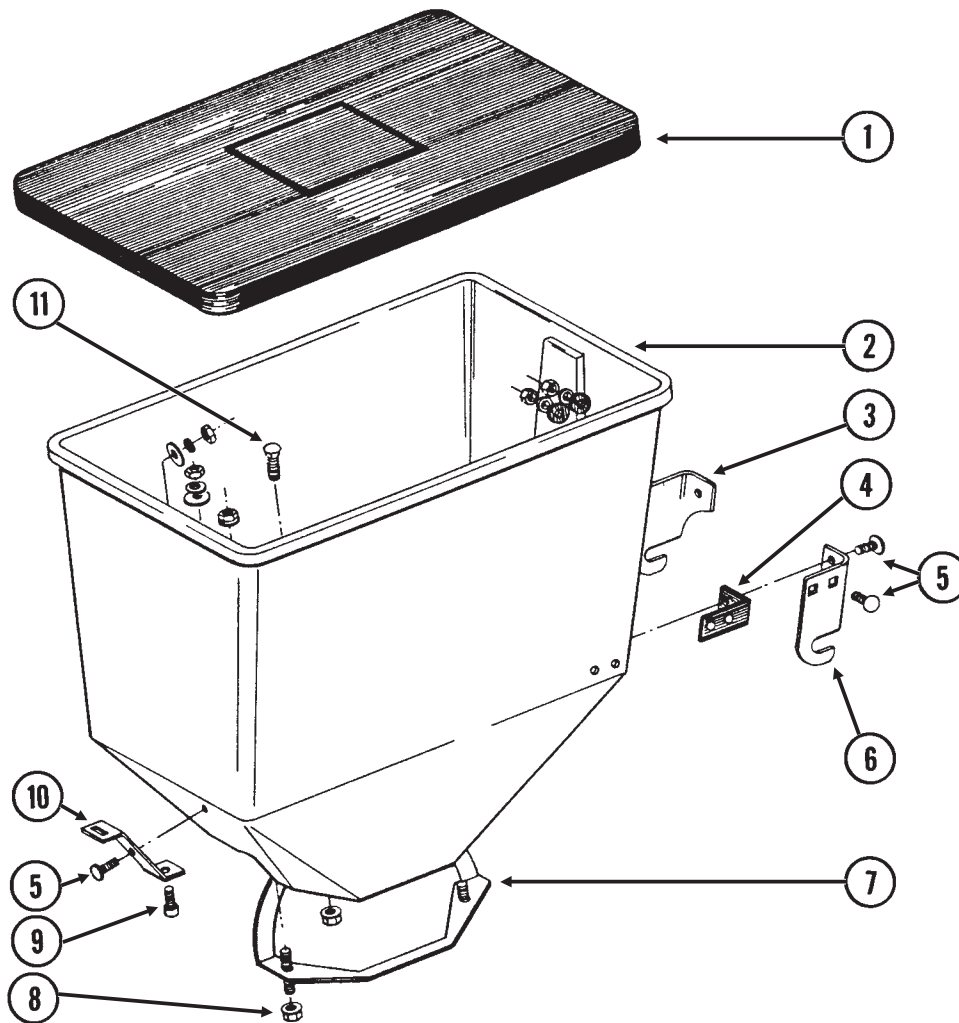

ITEM	PART NO.	QTY. (Per Row)	DESCRIPTION
1.	GA2327	1	Lid With Clip
2.	GD1053	1	Seed Hopper
3.	GD1051L	1	Bracket, Left Hand
4.	GD1054	2	Mounting Pad
5.	G10310	7	Carriage Bolt, 1/4"-20 x 3/4", Grade 2
	GD1121	7	Rubber Washer
	G10209	7	Washer, 1/4" USS
	G10110	7	Self Locking Nut, 1/4"-20
6.	GD1051R	1	Bracket, Right Hand
7.	GA2027	1	Retainer
8.	G10620	4	Flange Nut, 5/16"-18
9.	G10520	1	Hex Socket Head Cap Screw, 3/8"-16 x 3/4", Grade 8
	G10210	1	Washer, 3/8" USS
	G10229	1	Lock Washer, 3/8"
	G10101	1	Hex Nut, 3/8"-16
10.	GD1055	1	Clip
11.	G10310	1	Carriage Bolt, 1/4"-20 x 3/4", Grade 2
	G10621	1	Flange Nut, 1/4"-20
A.	GA2058	-	Seed Hopper With Hardware, Less Lid (Items 2-11)

FINGER PICKUP SEED METER

RUA015(RU13a/RU37b)

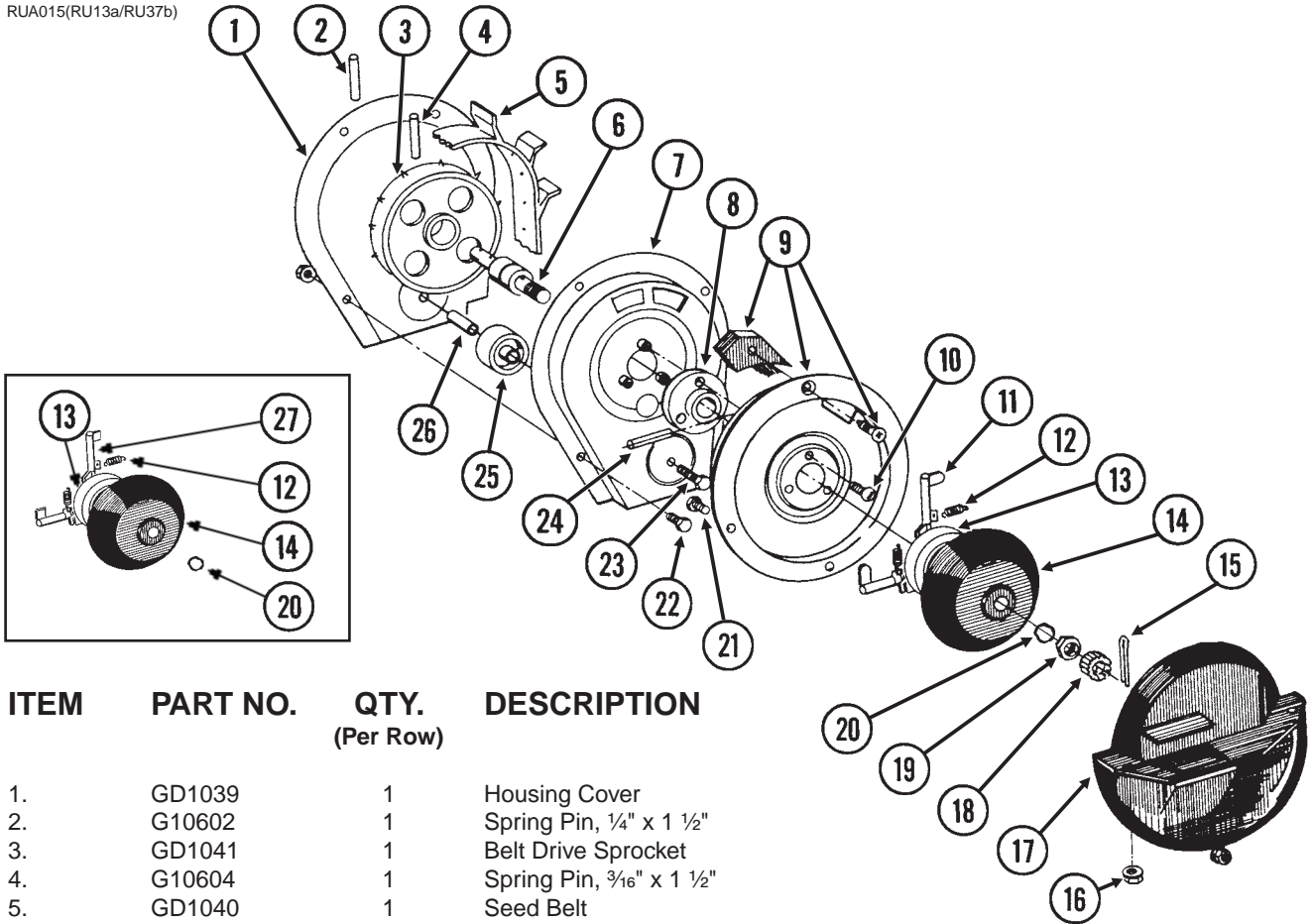

ITEM	PART NO.	QTY. (Per Row)	DESCRIPTION
1.	GD1039	1	Housing Cover
2.	G10602	1	Spring Pin, 1/4" x 1 1/2"
3.	GD1041	1	Belt Drive Sprocket
4.	G10604	1	Spring Pin, 3/16" x 1 1/2"
5.	GD1040	1	Seed Belt
6.	GA2019	1	Bearing
7.	GA2018	1	Conveyor Housing
8.	GB0110	1	Bearing Housing
9.	GR0664	1	Carrier With Brush And Screw
	GA2020	-	Brush
	G10690	-	Rolling Thread Screw, No. 10 x 3/4"
10.	G10401	3	Slotted Hex Washer Head Screw, No. 10-32 x 5/8"
11.	GD10733	12	Finger, Corn
12.	GD6501	12	Spring
13.	GB0111	1	Cam
14.	GD1045	1	Finger Holder
15.	G10470	1	Cotter Pin, 5/32" x 1"
16.	G10620	2	Flange Nut, 5/16"-18
17.	GD1046	1	Seed Baffle
18.	GD1083	1	Cover Nut, 5/8"-18
19.	G10500	1	Jam Nut, 5/8"-18 UNF
20.	GA8343	1	Wave Washer, 5/8" (Triple Wave)
21.	G10020	3	Hex Head Cap Screw, 1/4"-20 x 5/8"
	G10323	3	Hex Flange Nut, 1/4"-20
22.	G10022	4	Hex Head Cap Screw, 1/4"-20 x 1/2"
	G10621	4	Flange Nut, 1/4"-20
23.	G10021	1	Hex Head Cap Screw, 1/4"-20 x 1 1/2"
	G10621	1	Flange Nut, 1/4"-20
24.	G10603	1	Spring Pin, 1/4" x 1 1/4"
25.	GD1042	1	Idler
26.	GB0120	1	Bushing
27.	GD10226	12	Finger, Oil Sunflower
A.	GR0933	-	Finger Assembly, Corn (Items 11-14 And 20)
B.	GR1327	-	Finger Assembly, Oil Sunflower (Items 12-14, 20 And 27)

BRUSH-TYPE SEED METER

RUA037(RU14)

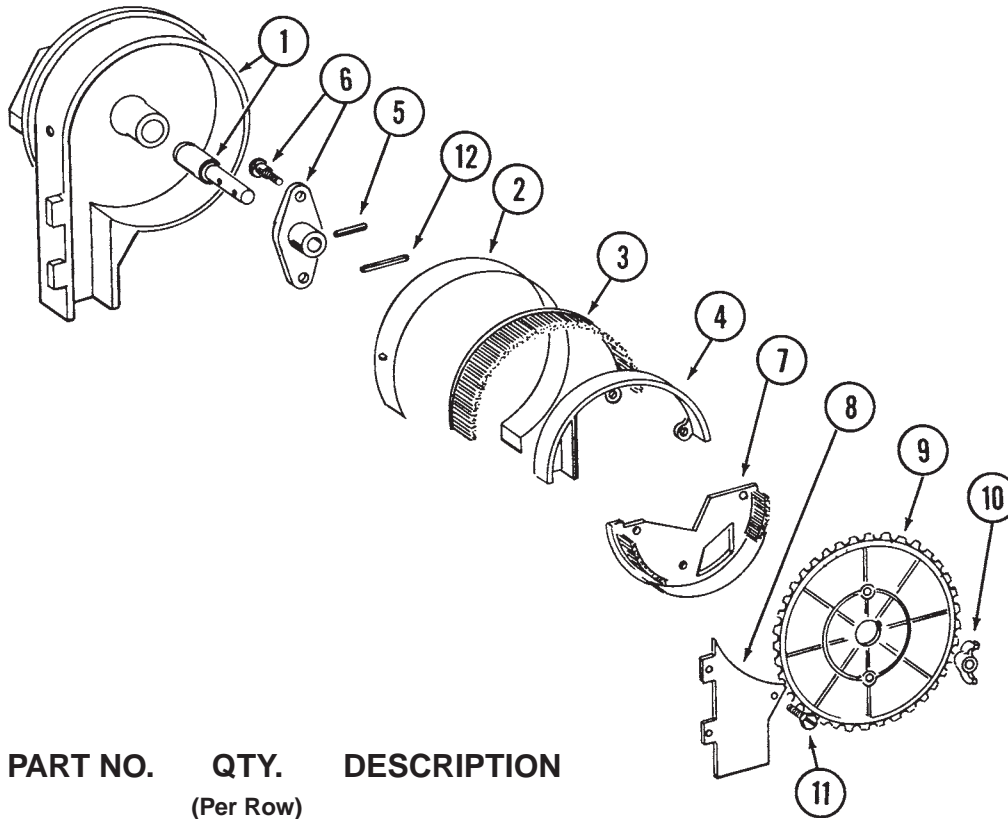

ITEM	PART NO.	QTY. (Per Row)	DESCRIPTION
1.	GA6027	1	Housing W/Bearing
	GA5698	-	Bearing
2.	GD8778	1	Wear Strip
3.	GA5699	1	Upper Retaining Brush
4.	GD8237	1	Retaining Brush Holder
5.	G10603	1	Spring Pin, 1/4" x 1 1/4"
6.	GA6038	1	Hub W/Shoulder Bolts
	GD1755	-	Shoulder Bolt, 1/4"-20 (2 Used)
7.	GA5834	1	Lower Brush
8.	GD7878	1	Cover
9.	GA5794	-	Seed Disc, Soybean, 60 Cell, Black Color-Coded
	GA6184	-	Seed Disc, Specialty Soybean, 48 Cell, Dark Blue Color-Coded
	GA5982	-	Seed Disc, Small Milo/Grain Sorghum, 30 Cell, Red Color-Coded
	GA6187	-	Seed Disc, Large Milo/Grain Sorghum, 30 Cell, Light Blue Color-Coded
	GA5795	-	Seed Disc, High Rate Small Milo/Grain Sorghum, 60 Cell, Red Color-Coded
	GA6633	-	Seed Disc, High Rate Large Milo/Grain Sorghum, 60 Cell, Yellow Color-Coded
	GA5796	-	Seed Disc, Cotton, Acid-Delinted, 30 Cell, White Color-Coded
	GA6168	-	Seed Disc, Large Cotton, Acid-Delinted, 36 Cell, Tan Color-Coded
	GA6478	-	Seed Disc, High Rate Cotton, Acid-Delinted, 48 Cell, Light Green Color-Coded
	GA6182	-	Seed Disc, Hill-Drop Cotton, Acid-Delinted, 12 Cell, Brown Color-Coded
	GA7255	-	Seed Disc, Small Hill-Drop Cotton, Acid-Delinted, 12 Cell, Dark Green Color-Coded
10.	G10531	2	Nylon Insert Wing Nut, 1/4"-20
11.	G10584	9	Slotted Tap Screw, No. 10-24 x 1/2"
12.	G10602	1	Spring Pin, 1/4" x 1 1/2"

GRANULAR CHEMICAL BANDERS

RUA013/RUA016/RUA044(RU16a/RU15)

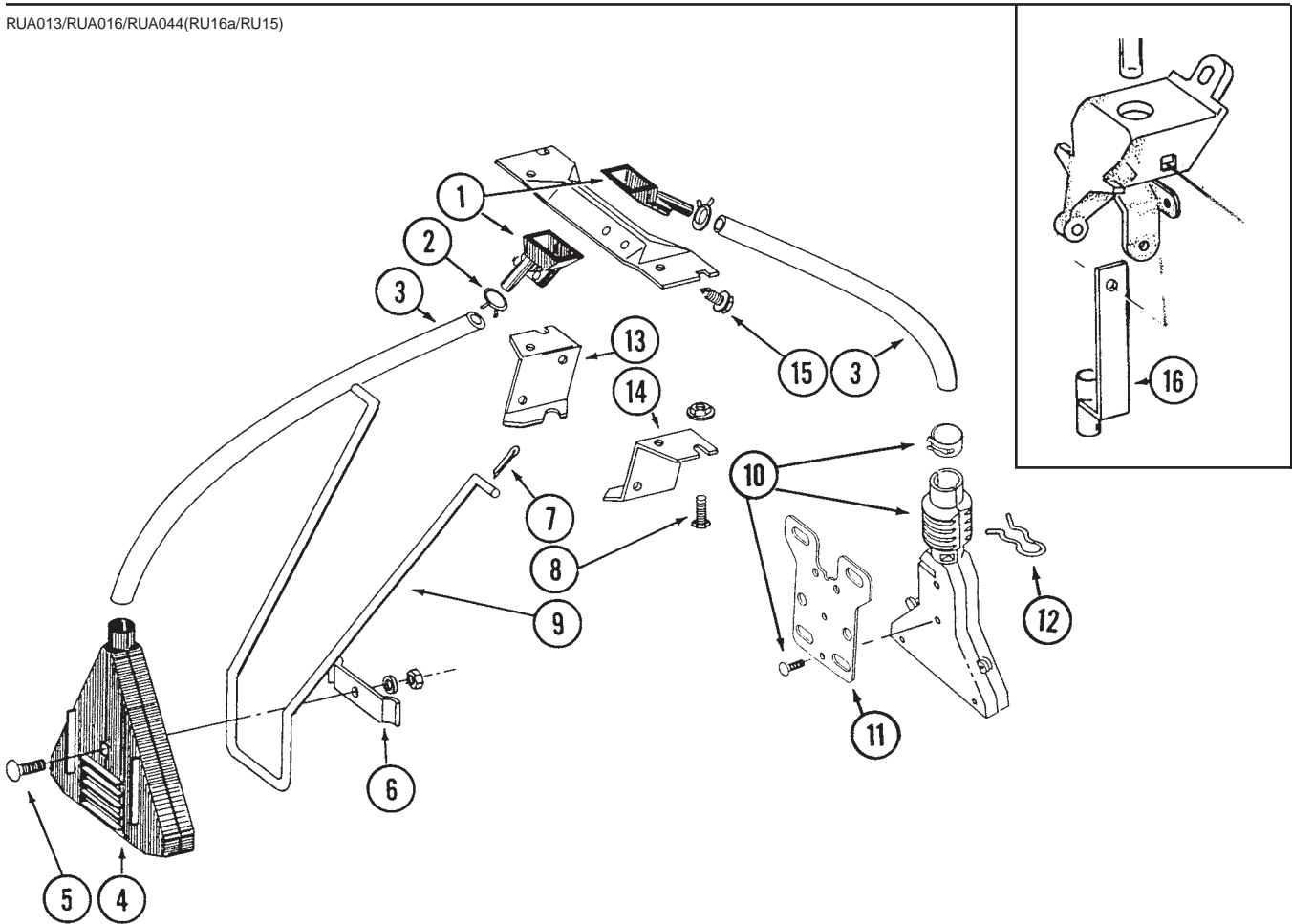

ITEM	PART NO.	QTY.	DESCRIPTION
1.	GD2423	-	Funnel
2.	G10680	-	Hose Clamp, 7/16"
3.	GD2947	-	Hose, 7/16" x 28"
4.	GA2075	-	Diffuser, 14" Band
5.	G10306	-	Carriage Bolt, 3/8"-16 x 2", Grade 2
	G10229	-	Lock Washer, 3/8"
	G10101	-	Hex Nut, 3/8"-16
6.	GD1118	-	Clamp
7.	G10452	-	Cotter Pin, 1/8" x 1/2"
8.	G10310	-	Carriage Bolt, 1/4"-20 x 3/4", Grade 2
	G10227	-	Lock Washer, 1/4"
	G10103	-	Hex Nut, 1/4"-20
9.	GD1116	-	Hanger
10.	GA6907	-	Slope-Compensating Bander W/Hardware (4 1/2" Band Width)
	G10864	-	Uni-Clamp
	G10757	2	Screw, No. 10-32 x 1 1/4"
	G10758	2	Hex Nut, No. 10-32
11.	GD9816	-	Bander Mounting Bracket (For Some Non-KINZE® Applications)
12.	GD1090	-	Spring Clip
13.	GD1115L	-	Hanger Bracket, L.H.
14.	GD1115R	-	Hanger Bracket, R.H.
15.	G10523	-	Self Tapping Screw, No. 10 x 1/2"
16.	GA6741	-	Bracket (Straight Drop In-Furrow)

GRANULAR CHEMICAL SUB-ASSEMBLIES AND KITS

(RU65/RU66/RU67)

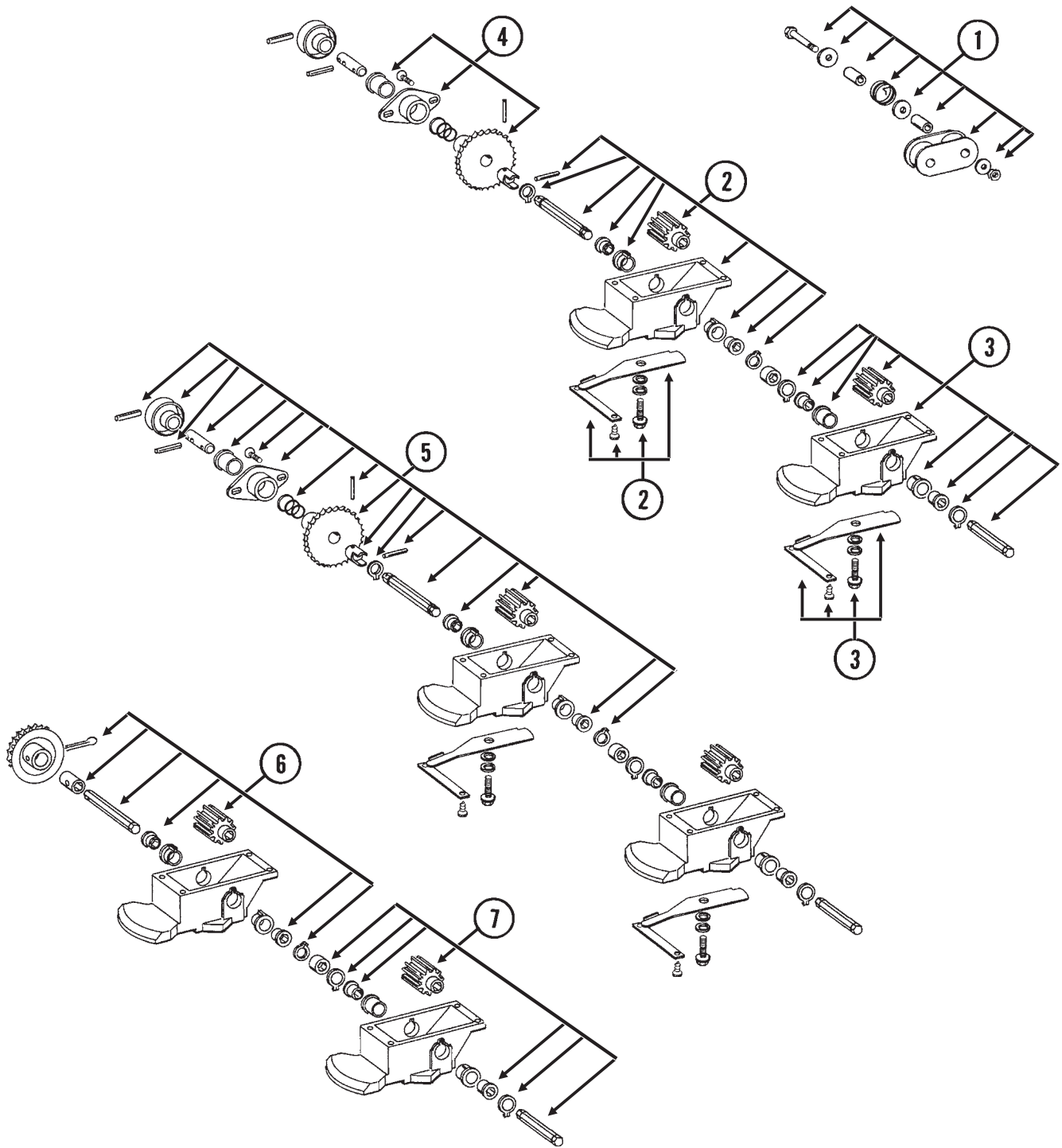

ITEM	PART NO.	QTY.	DESCRIPTION
1.	G1K213	1	Granular Chemical Idler Kit W/Instruction
2.	GA5553	1	Insecticide Housing Sub-Assembly
3.	GA5554	1	Herbicide Housing Sub-Assembly
4.	GA5746	1	Sprocket Sub-Assembly
5.	GA5623	1	Throwout Update Kit W/Instructions And Template
6.	GA5560	1	Primary Meter Roller Replacement Kit W/Instruction (Update For Non-Current Design)
7.	GA5561	1	Secondary Meter Roller Replacement Kit W/Instruction (Update For Non-Current Design)

GRANULAR CHEMICAL HOPPER WITH METER(S) & THRO-UOUT

RUA006/RUA008/RUA033/RUA034/RUA044(RU18/RU19)

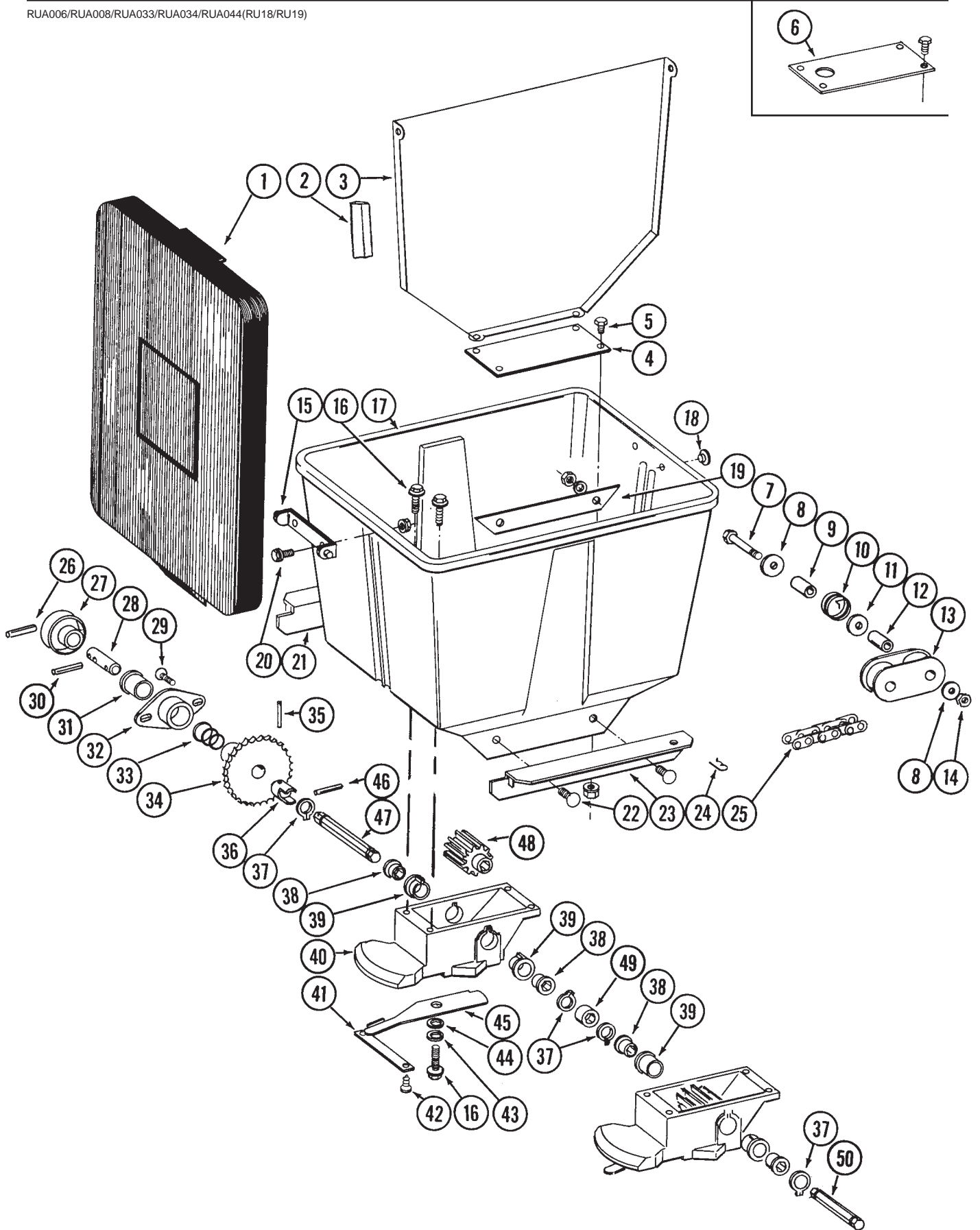

GRANULAR CHEMICAL HOPPER WITH METER(S) & THROWOUT

ITEM	PART NO.	QTY. (Per Row)	DESCRIPTION
1.	GA4444	1	Lid
2.	G3314-40	-	Foam Strip, 40"
3.	GA2076	1	Divider (Used With Two Meters)
4.	GD1056	-	Cover Plate (1 Used With One Meter)
5.	G10022	4	Hex Head Cap Screw, 1/4"-20 x 1/2"
	G10621	4	Flange Nut, 1/4"-20
6.	GD8750	-	Restrictor Plate (Optional)
7.	G10049	1	Hex Head Cap Screw, 3/8"-16 x 2 1/2"
8.	G10210	2	Washer, 3/8" USS
9.	GD2971-10	1	Bushing, 9/16"
10.	GD11219	1	Spring
11.	G10201	1	Special Washer
12.	GD1026	1	Spacer, 1 3/16"
13.	GD9240	1	Idler
14.	G10108	1	Lock Nut, 3/8"-16
15.	GD1060	1	Hinge
16.	G10570	-	Self Tapping Screw, 1/4" x 3/4" (5 Used Per Meter)
17.	GD1058	1	Hopper
18.	GD1089	2	Plug
19.	GD1072	2	Strap
20.	G10023	2	Hex Head Cap Screw, 1/4"-20 x 3/4"
	G10621	2	Flange Nut, 1/4"-20
21.	GD1059L	1	Support, L.H.
22.	G10311	4	Carriage Bolt, 3/8"-16 x 3/4" Short Necked, Grade 2
	G10229	4	Lock Washer, 3/8"
	G10101	4	Hex Nut, 3/8"-16
23.	GD1059R	1	Support, R.H.
24.	G10670	2	Spring Locking Pin, No. 3
25.	G3303-114	1	Roller Chain, No. 41, 114 Pitch Including Connector Link
	GR0196	1	Connector Link, No. 41
26.	G10637	1	Spring Pin, 1/8" x 1 1/2"
27.	GD11239	1	Knob
28.	GD7589	1	Throwout Pin
29.	G10312	2	Carriage Bolt, 5/16"-18 x 3/4"
	G10620	2	Flange Nut, 5/16"-18
30.	G10602	1	Spring Pin, 1/4" x 1 1/2"
31.	GB0121	1	Bearing
32.	GB0183	1	Bearing Mount
33.	GD10464	1	Spring
34.	GA5533	1	Sprocket, 24 Tooth
35.	G10609	1	Spring Pin, 5/32" x 1"
36.	GB0184	1	Coupling
37.	G10567	1	Retaining Ring
38.	GD7258	-	Hex Bushing (2 Used Per Meter)
39.	GB0115	-	Bearing (2 Used Per Meter)
40.	GB0116	-	Granular Housing (1 Used Per Meter)
41.	GD1061	-	Support Strap (1 Used Per Meter)
42.	G10521	1	Self Tapping Screw, No. 10 x 3/8" (2 Used Per Meter)
43.	G10209	-	Washer, 1/4" USS (1 Used Per Meter)
44.	G10660	-	Wave Washer (1 Used Per Meter)
45.	GD1063	-	Metering Gate (1 Used Per Meter)
46.	G10546	1	Spring Pin, 3/16" x 1 1/4"
47.	GD7588	1	Shaft
48.	GD7148	-	Feed Roller, Hex Bore (1 Used Per Meter)
49.	GD7592	1	Coupler, Hex Bore (With 2nd Meter)
50.	GD7591	-	Shaft (1 Used In 2nd Meter)

SPRING TOOTH INCORPORATOR

RUA011(RU20)

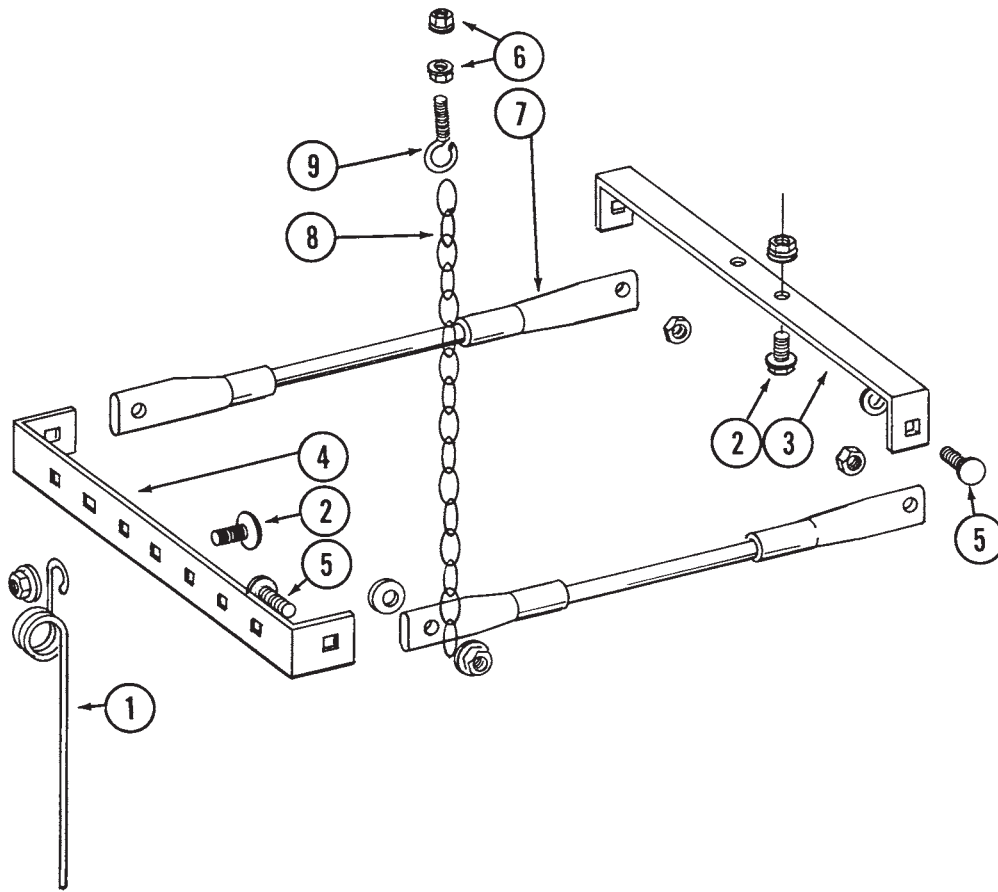

ITEM	PART NO.	QTY. (Per Row)	DESCRIPTION
1.	GD1145	7	Spring Tooth
2.	G10308	9	Carriage Bolt, 3/8"-16 x 3/4", Grade 2
	G10622	9	Flange Nut, 3/8"-16
3.	GD1143	1	Front Bracket
4.	GD1144	1	Rear Bracket
5.	G10305	4	Carriage Bolt, 3/8"-16 x 1", Grade 2
	G10529	4	External Tooth Lock Washer, 3/8"
	G10622	4	Flange Nut, 3/8"-16
6.	G10621	4	Flange Nut, 1/4"-20
7.	GA2094	2	Cable Assembly
8.	G3305-01	4	Chain
9.	GD2460	2	Eyebolt, 1/4"-20

NO TILL COULTER, ROW UNIT MOUNTED

RUA036(RU21a)

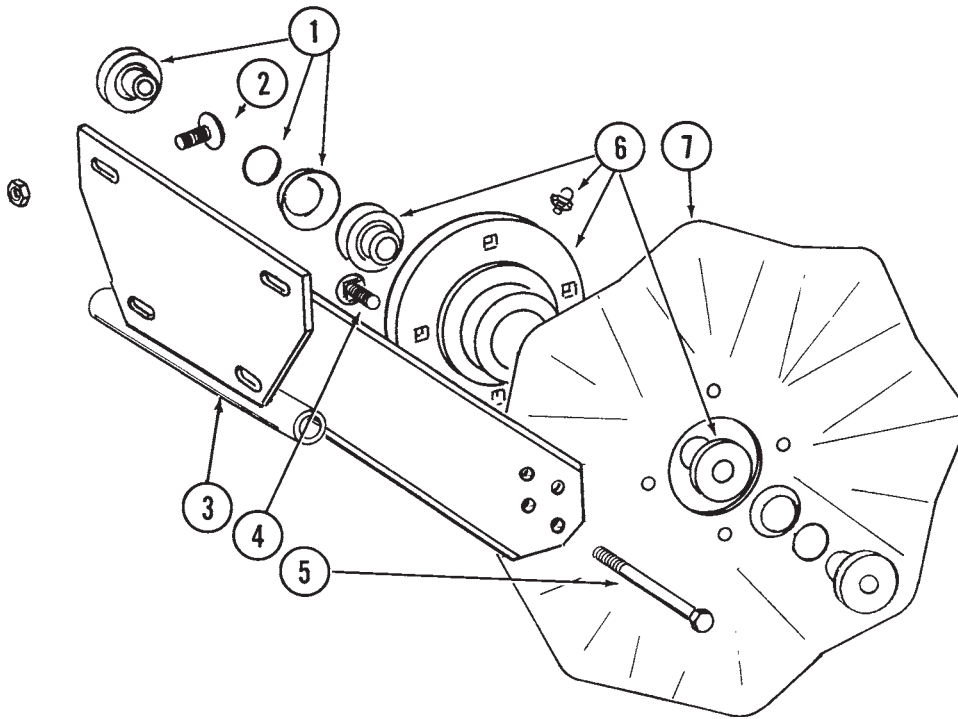

ITEM	PART NO.	QTY. (Per Row)	DESCRIPTION
1.	GB0227	2	Adapter W/O-Ring And Spring Washer
	GD8844	2	O-Ring
	GD8843	2	Spring Washer
2.	G10574	4	Carriage Bolt, 1/2"-13 x 1 1/4"
	G10111	4	Lock Nut, 1/2"-13
3.	GA5625	1	Arm
4.	G10574	4	Carriage Bolt, 1/2"-13 x 1 1/4"
	G10111	4	Lock Nut, 1/2"-13
5.	G10036	1	Hex Head Cap Screw, 5/8"-11 x 4"
	G10107	1	Lock Nut, 5/8"-11
6.	GA5640	1	Hub W/Bearings And Grease Fitting
	GA5622	-	Bearing (2 Used)
	G10640	-	Grease Fitting, 1/4"-28
7.	GD7803	-	Fluted Blade, 1", 8 Flutes (Shown)
	GD7804	-	Bubbled Blade, 1"
	GD9254	-	Fluted Blade, 3/4", 13 Flutes

DISC FURROWER, ROW UNIT MOUNTED

RUA038/RUA040(RU23a)

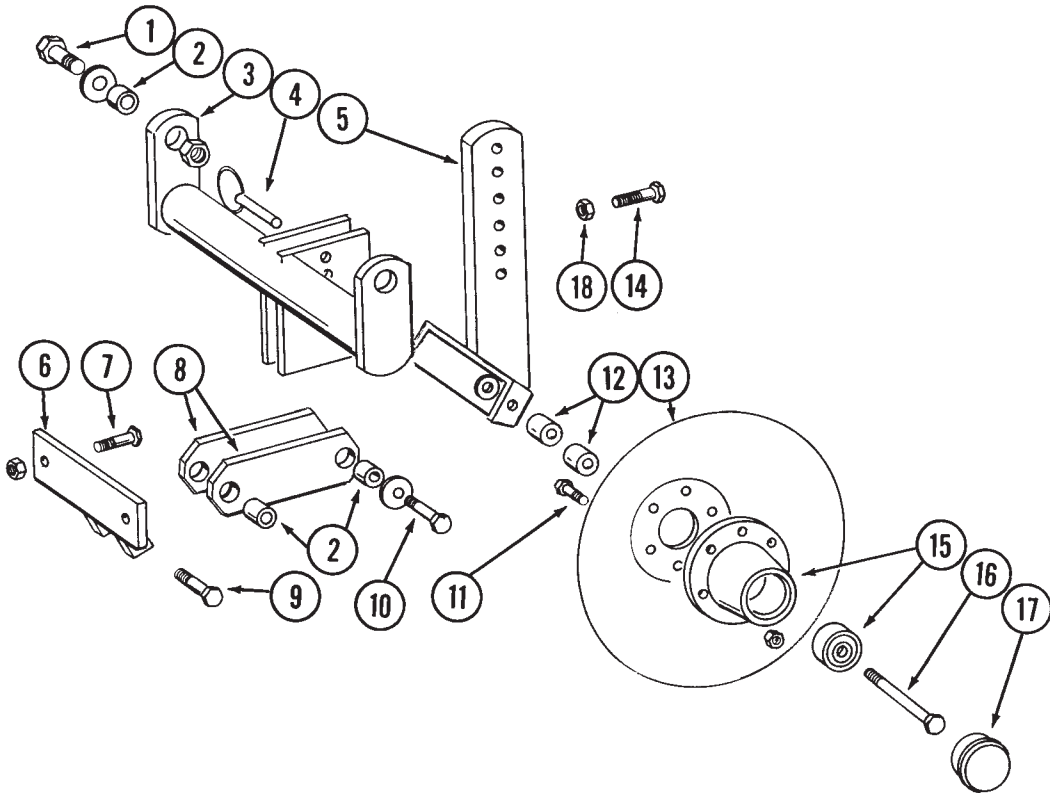

DISC FURROWER, ROW UNIT MOUNTED

ITEM	PART NO.	QTY. (Per Row)	DESCRIPTION
1.	G10039	2	Hex Head Cap Screw, 1/2"-13 x 1 3/4"
	G10216	2	Washer, 1/2" USS
	G10111	2	Lock Nut, 1/2"-13
2.	GD7889	6	Bushing
3.	GA5719	1	Mounting Bracket
4.	G10536	1	Pin
5.	GA5718	1	Support Arm
6.	GA5715	1	Anchor
7.	G10017	2	Hex Head Cap Screw, 1/2"-13 x 1 1/2"
	G10111	2	Lock Nut, 1/2"-13
8.	GD7890	2	Link
9.	G10017	2	Hex Head Cap Screw, 1/2"-13 x 1 1/2"
	G10216	2	Washer, 1/2" USS
	G10111	2	Lock Nut, 1/2"-13
10.	G10585	1	Hex Head Cap Screw, 1/2"-13 x 3 1/4"
	G10216	2	Washer, 1/2" USS
	G10111	1	Lock Nut, 1/2"-13
11.	G10572	6	Truss Head Slotted Machine Screw, 5/16"-18 x 7/8"
	G10106	6	Hex Nut, 5/16"-18
12.	GD7817-01	2	Spacer, 3/4"
	GD7817-04	2	Spacer, 1/2"
13.	GD7823	-	Solid Blade, 12" (Shown)
	GD8307	-	Notched Blade, 12"
14.	G10597	1	Set Screw, 5/8"-11 x 2 1/4"
15.	GA5654	2	Hub W/Bearings
	GA2014	-	Bearing
16.	G10318	2	Hex Head Cap Screw, 5/8"-11 x 4 1/2"
	GD7805	2	Special Washer
	G10107	2	Lock Nut, 5/8"-11
17.	GD1132	2	Dust Cap
18.	G10503	1	Jam Nut, 5/8"-11

RESIDUE WHEEL, ROW UNIT MOUNTED

RUA041/RUA045(RU24a)

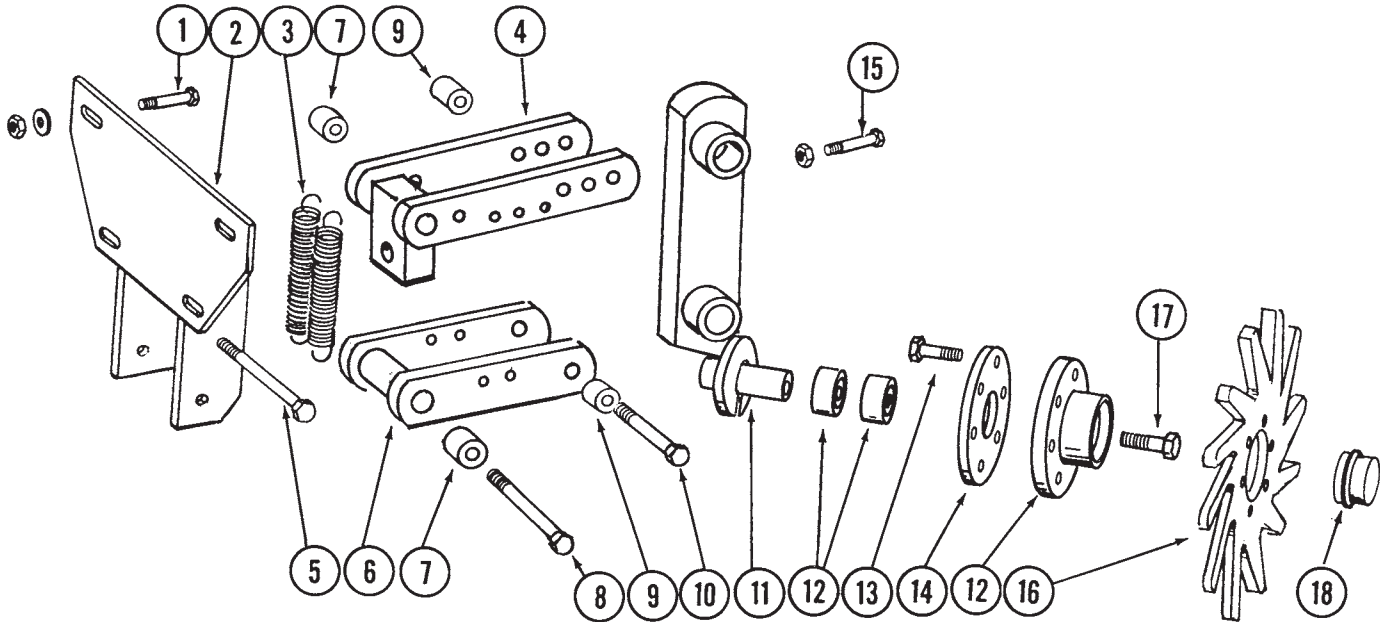

ITEM	PART NO.	QTY. (Per Row)	DESCRIPTION
1.	G10574	4	Carriage Bolt, 1/2"-13 x 1 1/4"
	G10216	4	Washer, 1/2" USS
	G10111	4	Lock Nut, 1/2"-13
	GA6832	1	Mount
3.	GD5857	2	Spring
4.	GA6833	1	Upper Link
5.	G10348	1	Hex Head Cap Screw, 1/2"-13 x 5" (Lockup Bolt)
	G10111	1	Lock Nut, 1/2"-13
6.	GA6834	1	Lower Link
7.	GD9715	2	Spacer, 3"
8.	G10045	2	Hex Head Cap Screw, 1/2"-13 x 4 1/2"
	G10228	2	Lock Washer, 1/2"
	G10102	2	Hex Nut, 1/2"-13
9.	GD9720	2	Spacer, 3"
10.	G10033	2	Hex Head Cap Screw, 1/2"-13 x 3 1/2"
	G10228	2	Lock Washer, 1/2"
	G10102	2	Hex Nut, 1/2"-13
11.	GA6838	1	Wheel Mount
12.	GA5654	2	Hub W/Bearings
	GA2014	-	Bearing
13.	G10133	6	Hex Head Cap Screw, 5/16"-18 x 1 1/2"
	G10109	6	Lock Nut, 5/16"-18
14.	GD9724	1	Backing Plate
15.	G10371	1	Hex Head Cap Screw, 1/2"-13 x 3", Full Thread
	G10501	1	Jam Nut, 1/2"-13
16.	GD10552	1	Wheel, 3/8" x 12"
17.	G10006	1	Hex Head Cap Screw, 5/8"-11 x 2 1/4"
18.	GD1132	1	Dust Cap
A.	GA7446	-	Wheel Assembly (Items 12-14 And 16)

RESIDUE WHEELS, COULTER MOUNTED

RUA047(RU31a)

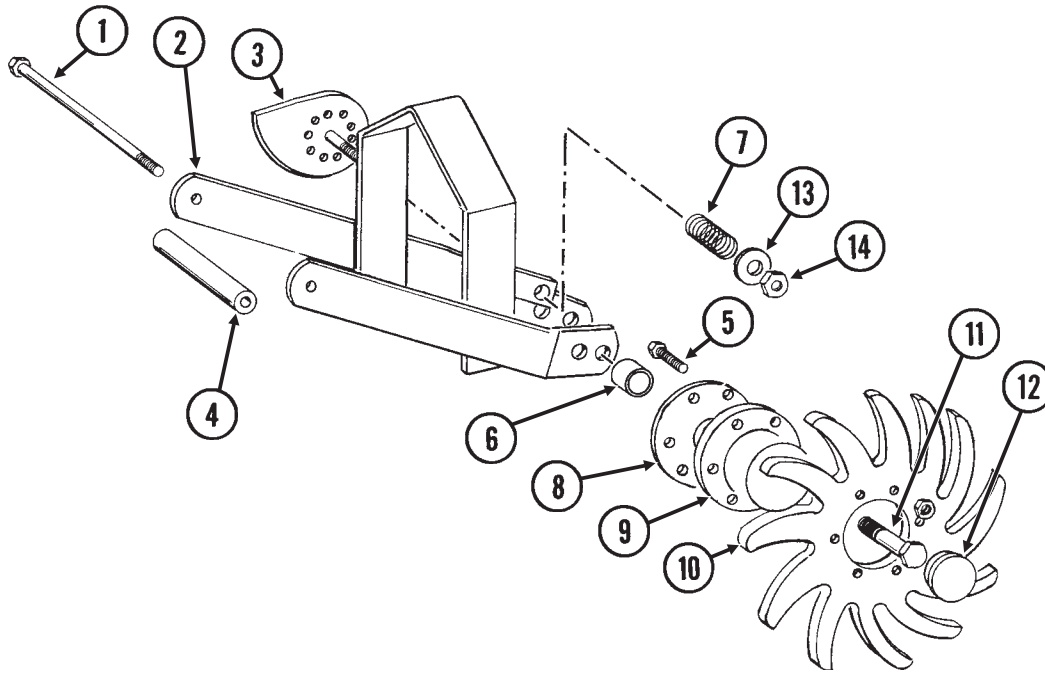

ITEM	PART NO.	QTY. (Per Row)	DESCRIPTION
1.	G10148	1	Hex Head Cap Screw, 1/2"-13 x 9 1/2"
	G10974	1	Lock Nut W/Nylon Insert, 1/2"-13
2.	GA7271	1	Mount
3.	GA7412	1	Cam
4.	GD10526	1	Sleeve, 7 1/2"
5.	G10133	12	Hex Head Cap Screw, 5/16"-18 x 1 1/2"
	G10109	12	Lock Nut, 5/16"-18
6.	GD7817-04	2	Spacer, 1 1/4" O.D. x 1/2" Long
7.	GD10519	1	Spring
8.	GD9724	2	Backing Plate
9.	GA5654	2	Hub W/Bearings
	GA2014	-	Bearing
10.	GD10552	2	Wheel, 3/8" x 12"
11.	G10009	2	Hex Head Cap Screw, 5/8"-11 x 2 1/2"
12.	GD1132	2	Dust Cap
13.	G10206	1	Washer, 1/2" SAE
	G10111	1	Lock Nut, 1/2"-13
14.	G10974	1	Lock Nut W/Nylon Insert, 1/2"-13
A.	GA7446	-	R.H. Wheel Assembly (Items 5 And 8-10)(Shown)
	GA7445	-	L.H. Wheel Assembly (Items 5 And 8-10)

FRAME MOUNTED COULTER W/DISC FURROWER

RUA035/RUB016(RU25b)

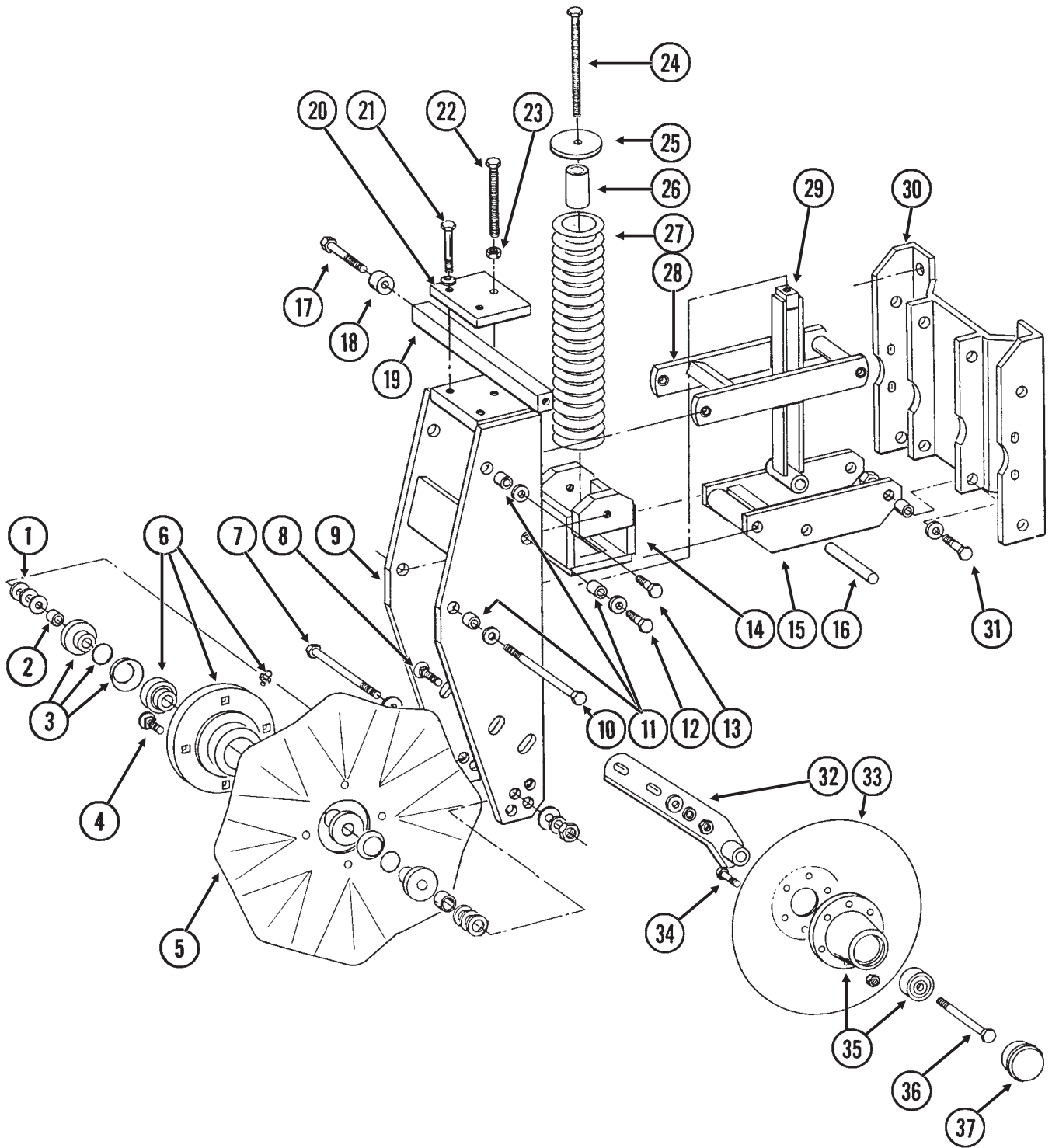

FRAME MOUNTED COULTER W/DISC FURROWER

ITEM	PART NO.	QTY. (Per Row)	DESCRIPTION
1.	G10217	-	Washer, 5/8" USS (As Required)
2.	GD7817-04	2	Spacer, 1/2"
3.	GB0227	2	Adapter W/O-Ring And Spring Washer
	GD8844	-	O-Ring
	GD8843	-	Spring Washer
4.	G10574	4	Carriage Bolt, 1/2"-13 x 1 1/4"
	G10111	4	Lock Nut, 1/2"-13
5.	GD7803	-	Fluted Blade, 1", 8 Flutes (Shown)
	GD7804	-	Bubbled Blade, 1"
	GD9254	-	Fluted Blade, 3/4", 13 Flutes
6.	GA5640	1	Hub W/Bearings And Grease Fitting
	GA5622	-	Bearing (2 Used Per Hub)
	G10640	-	Grease Fitting, 1/4"-28
7.	G10068	1	Hex Head Cap Screw, 5/8"-11 x 6"
	G10107	1	Lock Nut, 5/8"-11
8.	G10747	4	Carriage Bolt, 1/2"-13 x 2"
	G10206	-	Washer, 1/2" SAE (As Required)
	G10228	4	Lock Washer, 1/2"
	G10102	4	Hex Nut, 1/2"-13
9.	GA5643	1	Fork Mount
10.	G10012	1	Hex Head Cap Screw, 5/8"-11 x 6 1/2"
	GD7805	2	Special Washer
	GD1109	-	Bushing, 41/64" I.D. x 7/8" O.D. x 1/4" Long (As Required)
	G10107	2	Lock Nut, 5/8"-11
11.	GB0218	10	Bushing, 21/32" I.D. x 7/8" O.D. x 1 9/32" Long
12.	G10055	2	Hex Head Cap Screw, 5/8"-11 x 1 1/4"
	GD7805	2	Special Washer
13.	G10008	2	Hex Head Cap Screw, 5/8"-11 x 2"
	GD7805	2	Special Washer
	GD1109	-	Bushing, 41/64" I.D. x 7/8" O.D. x 1/4" Long (As Required)
	G10107	2	Lock Nut, 5/8"-11
14.	GA5637	1	Spring Socket
15.	GA5631	1	Lower Parallel Link
16.	GD7815	1	Pin, 5/8" x 4 1/4"
17.	GD7818	2	Special Bolt
18.	GD7817-01	2	Roller, 3/4"
19.	GD7816	1	Depth Control Bar
20.	GD7811	1	Depth Adjustment Clamp
21.	G10581	2	Hex Head Cap Screw, 1/2"-13 x 2 1/4"
	G10228	2	Lock Washer, 1/2"
22.	G10582	1	Hex Head Cap Screw, 5/8"-11 x 4", Full Thread
23.	G10104	1	Hex Nut, 5/8"-11
24.	G10573	1	Hex Head Cap Screw, 5/8"-11 x 5 1/2", Full Thread
25.	GB0196	1	Washer
26.	GD7817-09	1	Stop, 1 3/4"
27.	GD7831	1	Compression Spring
28.	GA5630	1	Upper Parallel Link
29.	GA5635	1	Spring Guide
30.	GA5798	1	Support Plate
31.	G10008	4	Hex Head Cap Screw, 5/8"-11 x 2"
	GD7805	4	Special Washer
	G10107	2	Lock Nut, 5/8"-11 (As Required)
32.	GA5636	2	Arm
33.	GD7823	-	Solid Blade, 12" (Shown)
	GD8307	-	Notched Blade, 12"
34.	G10572	12	Truss Head Slotted Machine Screw, 5/16"-18 x 7/8"
	G10106	12	Hex Nut, 5/16"-18
35.	GA5654	2	Hub W/Bearings
	GA2014	4	Bearing
36.	G10036	2	Hex Head Cap Screw, 5/8"-11 x 4"
	G10107	2	Lock Nut, 5/8"-11
37.	GD1132	2	Dust Cap P25

INTERPLANT® PUSH ROW UNIT

RPU001/RPU009/RUA044/RPU010(RU26g)

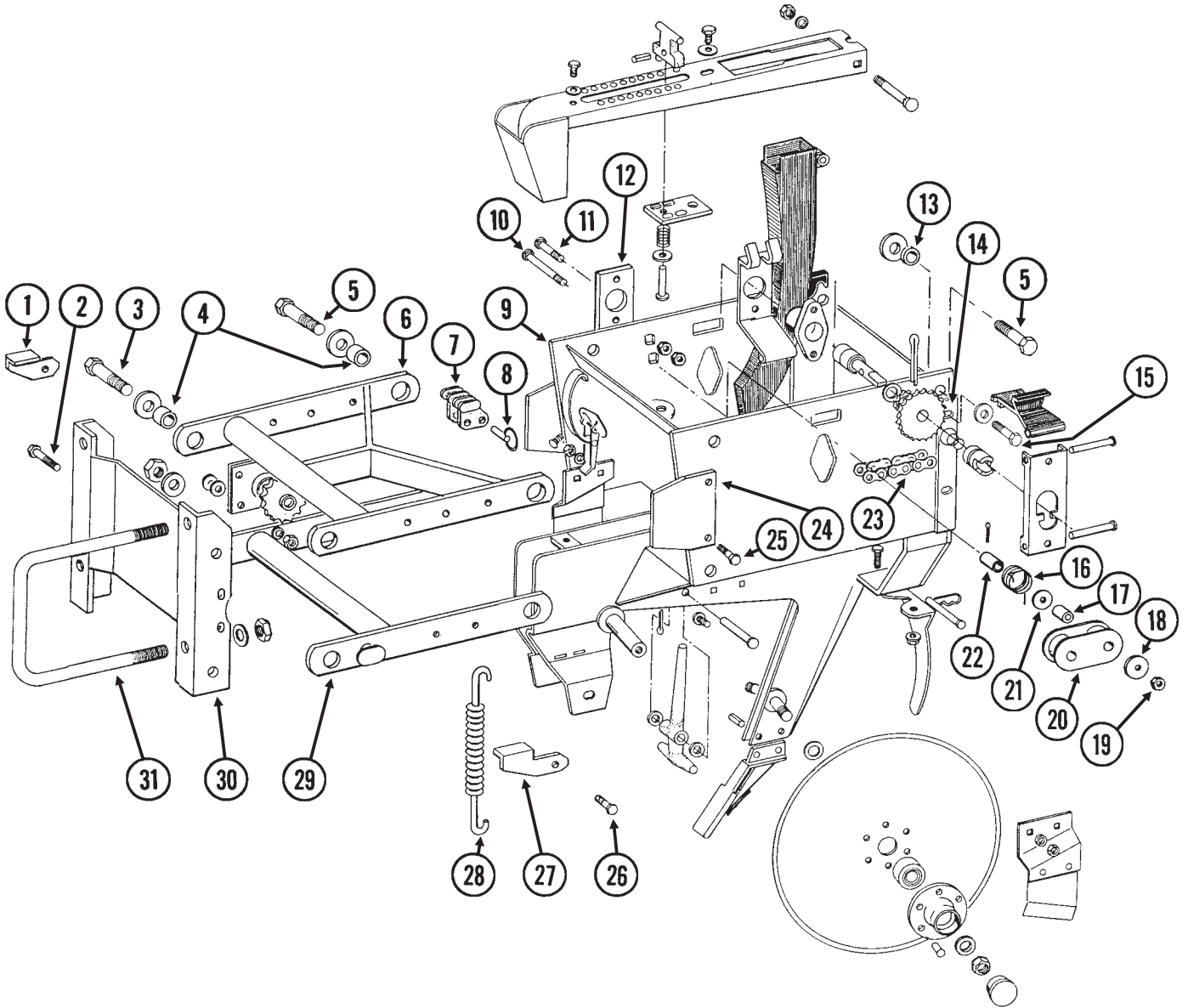

INTERPLANT® PUSH ROW UNIT

ITEM	PART NO.	QTY. (Per Row)	DESCRIPTION
1.	D7627	1	Lockup, L.H. (Non-Stock Item Sub GA5564)
2.	G10004	2	Hex Head Cap Screw, 3/8"-16 x 1 1/4"
	G10210	-	Washer, 3/8" USS (As Required)
	G10229	2	Lock Washer, 3/8"
	G10101	2	Hex Nut, 3/8"-16
3.	G10732	4	Hex Head Cap Screw, 5/8"-18 x 2"
	GD7805	4	Special Washer
	G10412	4	Lock Nut, 5/8"-18
4.	GB0218	8	Bushing, 1 9/32"
5.	G10751	6	Hex Head Cap Screw, 5/8"-18 x 1 3/4"
	GD7805	6	Special Washer
	G10412	6	Lock Nut, 5/8"-18
6.	GA5788	1	Upper Arm
7.	GB0186	2	Spring Anchor
8.	G10545	2	Detent Pin, 1" Grip
9.	GA8167	-	Push Unit Shank
10.	G10307	1	Carriage Bolt, 3/8"-16 x 3 1/2"
11.	G10599	1	Carriage Bolt, 3/8"-16 x 1 1/4"
	G10101	1	Hex Nut, 3/8"-16
	G10108	1	Lock Nut, 3/8"-16
12.	GD2128	1	Plate
13.	GD1109	2	Pivot Bushing, 1/4"
14.	GD11233	-	Cover
15.	G10003	4	Hex Head Cap Screw, 3/8"-16 x 1 1/2"
	G10210	4	Washer, 3/8" USS
	G10622	4	Flange Nut, 3/8"-16
16.	GD11218	1	Spring
17.	GD1026	1	Spacer, 1 3/16"
18.	G10210	1	Washer, 3/8" USS
19.	G10108	1	Lock Nut, 3/8"-16
20.	GD9240	1	Idler
21.	G10201	1	Special Washer
22.	GD8893-01	1	Bushing, 1 3/8"
23.	G3303-96	1	Roller Chain, No. 41, 96 Links Including Connector Link
	GR0196	1	Connector Link, No. 41
24.	GD10710	2	Stop Bar
25.	G10037	4	Hex Head Cap Screw, 1/2"-13 x 1 1/4"
	G10228	4	Lock Washer, 1/2"
	G10102	4	Hex Nut, 1/2"-13
26.	G10017	2	Hex Head Cap Screw, 1/2"-13 x 1 1/2"
	G10228	2	Lock Washer, 1/2"
	G10111	2	Lock Nut, 1/2"-13
27.	D7626	1	Lockup, R.H. (Non-Stock Item Sub GA5564)
28.	GD8249	-	Spring
29.	GA5787	1	Lower Arm
30.	GA5786	1	Mounting Plate
31.	GD1113	2	U-Bolt, 5" x 7" x 5/8"-11
	G10230	4	Lock Washer, 5/8"
	G10104	4	Hex Nut, 5/8"-11
A.	GA5564	-	Lockup Package, Includes: (1) GD7627, (1) GD7626, (2) G10228, (2) G10017, (2) G10111

HITCH AND SAFETY CHAIN

WAC011/PHA048/PHS049(WGN47b/TWL169)

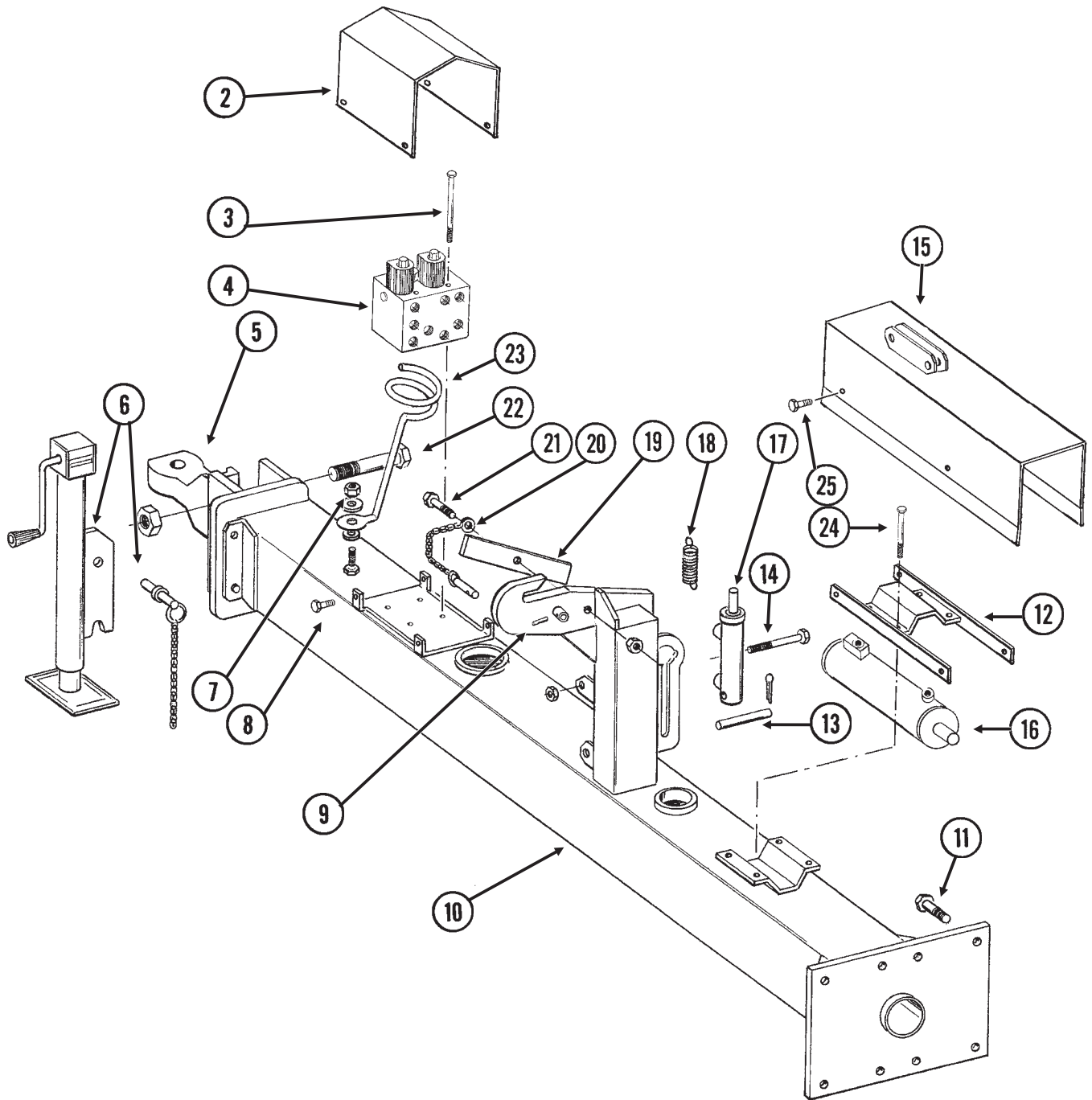
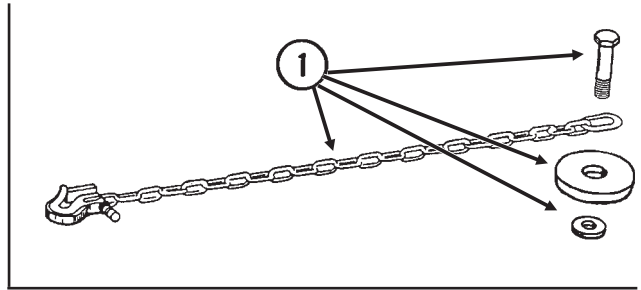

HITCH AND SAFETY CHAIN

ITEM	PART NO.	QTY.	DESCRIPTION
1.	G1K299	1	Safety Chain Kit, 1/2" (Optional)
	G10119	1	Hex Head Cap Screw, 1"-8 x 3"
	GD10646	1	Special Washer
	G10200	1	Washer, 1" USS
	G10396	1	Lock Nut, 1"-8
2.	GD11510	-	Cover
3.	G10935	4	Hex Head Cap Screw, 1/4"-20 x 5"
	G10209	4	Flat Washer, 1/4" USS
	G10227	4	Lock Washer, 1/4"
4.		-	See "Valve Block - Located On Hitch", Page P59
5.	GB0237	1	Clevis, Single
6.	GA4994	1	Jack Assembly Complete
	GA4995	-	Detent Pin Assembly
	GR0517	-	Pin
	GR0516	-	Crank Assembly
	GR0515	-	Bevel Gear
7.	G10217	1	Washer, 5/8" USS
	G10107	1	Lock Nut, 5/8"-11
8.	G10043	4	Hex Head Cap Screw, 5/16"-18 x 3/4"
	G10232	4	Lock Washer, 5/16"
	G10106	4	Hex Nut, 5/16"-18
9.	G10765	-	Spring Pin, 1/4" x 1"
10.	A8349	-	Front Hitch (Non-Stock Item)
11.	G10441	8	Hex Head Cap Screw, 7/8"-9 x 3"
	GD10063	16	Hardened Washer
	G10442	8	Hex Nut, 7/8"-9
12.	GA8765	1	Cover Mount
13.	GD7137	1	Pin, 3/4" x 3 3/8"
	G10457	2	Cotter Pin, 5/32" x 1 1/2"
14.	G10061	1	Hex Head Cap Screw, 3/8"-16 x 3 1/2"
	GD2971-09	1	Sleeve, 2"
	G10229	1	Lock Washer, 3/8"
	G10101	1	Hex Nut, 3/8"-16
15.	GA8764	1	Cover/Bracket, Jack Storage
16.		-	See "Master Cylinder", Page P56
17.			See "Transport Latch Cylinder", Page P57
18.	GD5857	1	Spring
19.	GA7016	1	Catch Bar
20.	GA7022	1	Detent Pin W/Chain (Transport Latch Locking Pin)
21.	G10006	1	Hex Head Cap Screw, 5/8"-11 x 2 1/4"
	GB0218	1	Bushing, 19/32"
	GD5154	1	Shim
	G10107	1	Lock Nut, 5/8"-11
22.	G10169	1	Hex Head Cap Screw, 1 1/4"-7 x 6"
	G10157	1	Lock Nut, 1 1/4"-7
23.	GD8260	1	Hose Holder
24.	G10063	4	Hex Head Cap Screw, 3/8"-16 x 4"
	G10029	4	Lock Washer, 3/8"
	G10101	4	Hex Nut, 3/8"-16
25.	G10001	4	Hex Head Cap Screw, 3/8"-16 x 1"
	G10229	4	Lock Washer, 3/8"

TRANSPORT LATCH POST

PHA049(2400m)

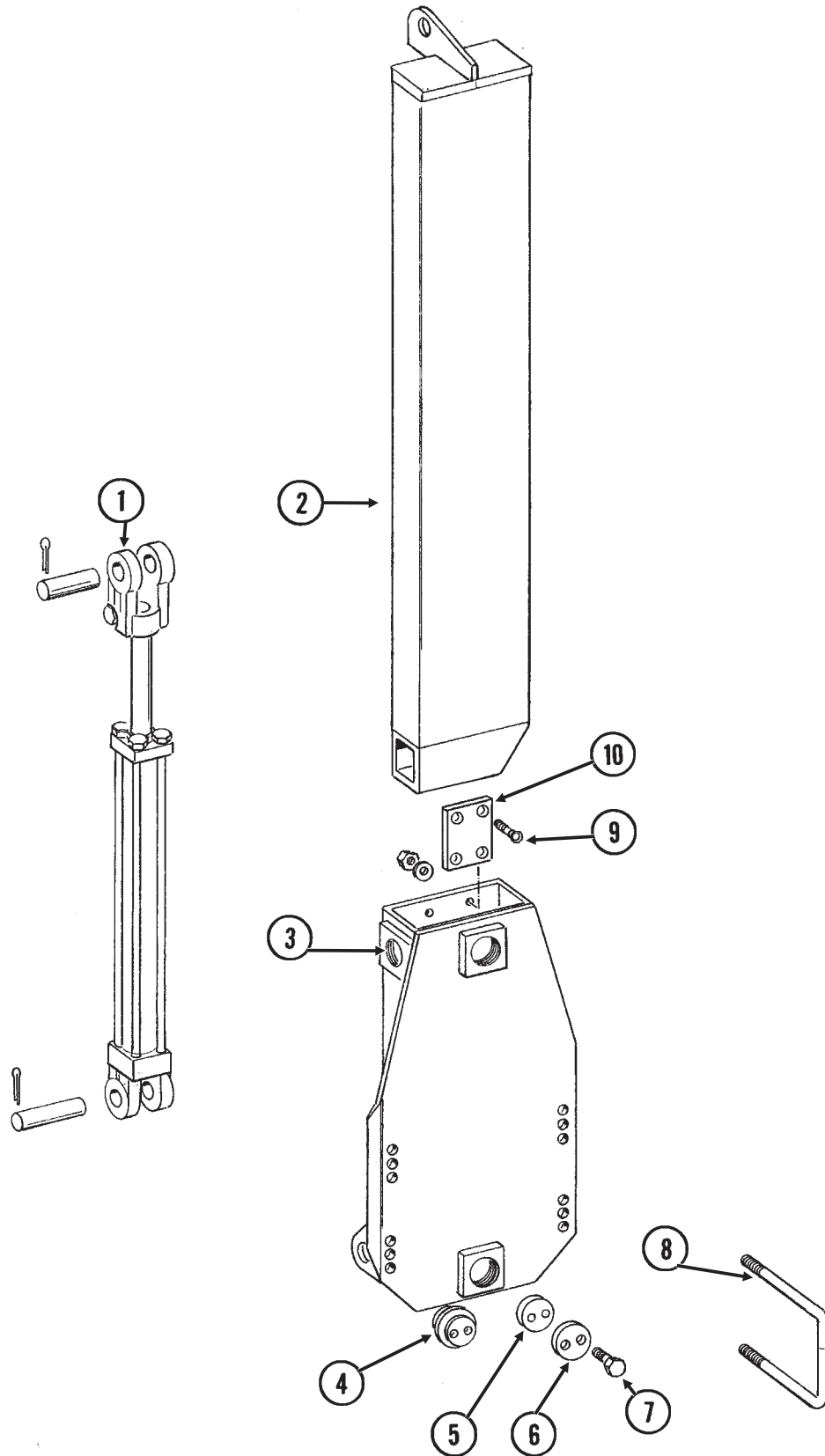

TRANSPORT LATCH POST

ITEM	PART NO.	QTY.	DESCRIPTION
1.		-	See "Transport Latch Post Cylinder", Page P62
2.	GA8356	1	Catch Post
3.	GA8357	1	Catch Mount
4.	GD9093	6	Poly Wear Pad
5.	GB0230	6	Cap
6.	GB0234	6	Adjustment Plug
7.	G10438	8	Hex Head Cap Screw, 1/2"-13 x 3/4"
	G10014	4	Hex Head Cap Screw, 1/2"-13 x 1"
8.	GD11489	2	U-Bolt, 3" x 6" x 5/8"-11
	G10230	4	Lock Washer, 5/8"
	G10104	4	Hex Nut, 5/8"-11
9.	G10934	8	Flat Head Hex Socket Cap Screw, 5/16"-18 x 1"
	G10221	8	Washer, 5/16" SAE
	G10232	8	Lock Washer, 5/16"
	G10106	8	Hex Nut, 5/16"-18
10.	GD11473	2	Pad

HITCH EXTENSIONS

PHA050/PHA051(2400L)

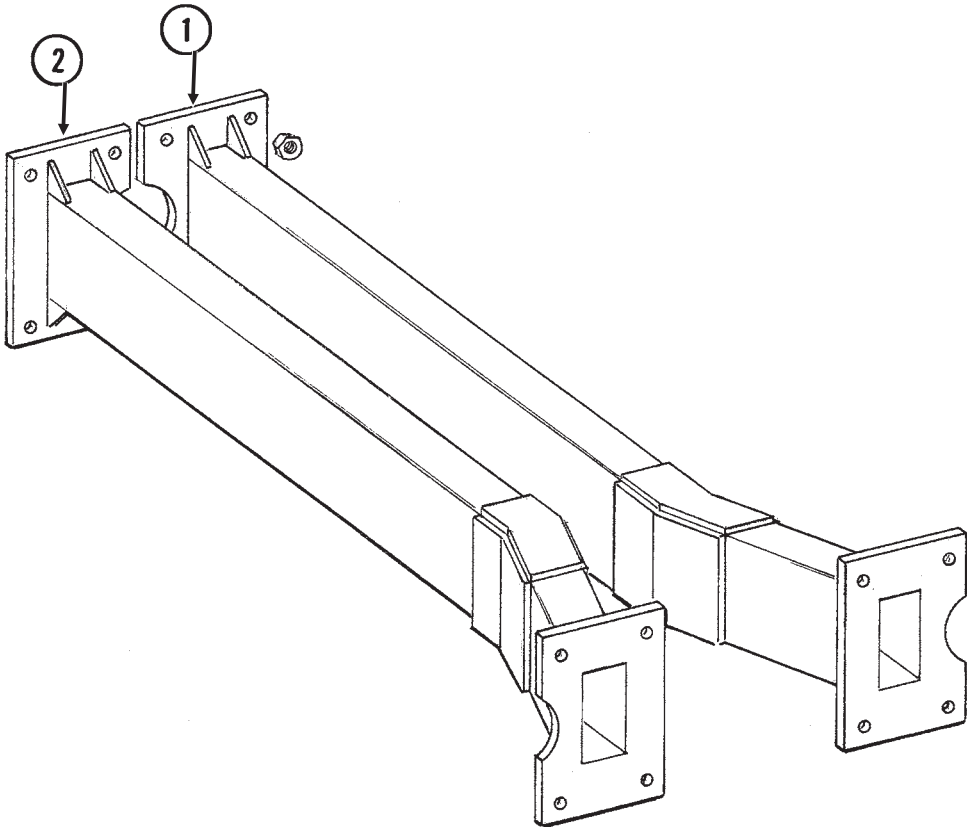
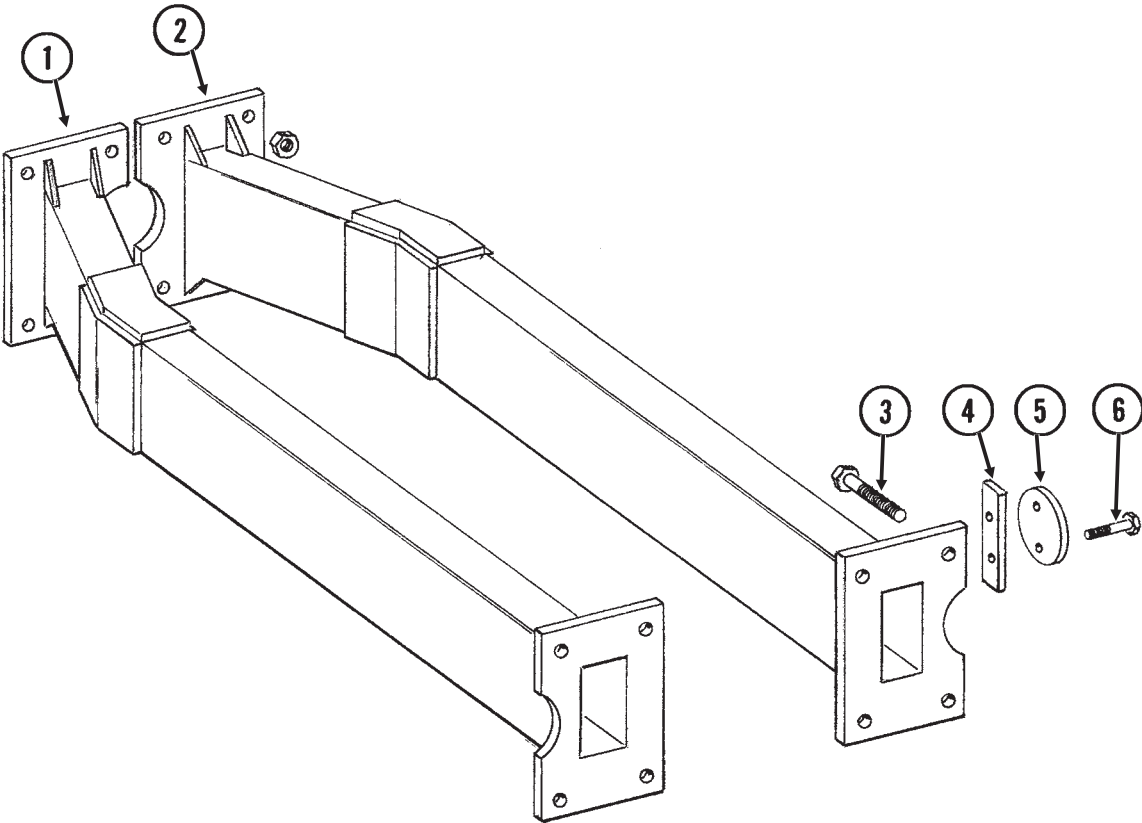

HITCH EXTENSIONS

ITEM	PART NO.	QTY.	DESCRIPTION
1.	GA8350	1	Hitch Extension W/Push Unit Hole, R.H.
2.	GA8362	1	Hitch Extension W/Fertilizer Hole, L.H.
3.	G10441	8	Hex Head Cap Screw, 7/8"-9 x 3"
	GD10063	16	Hardened Washer
	G10442	8	Hex Nut, 7/8"-9
4.	GD11512	1	Dust Cap Bar
5.	GD11507	1	Dust Cap
6.	G10048	2	Hex Head Cap Screw, 3/8"-16 x 2"
	G10229	2	Lock Washer, 3/8"

PLANTER FRAME

PFA080/PFA081a/PFA081b/PFA081c/PFA084(2400i/2400j)

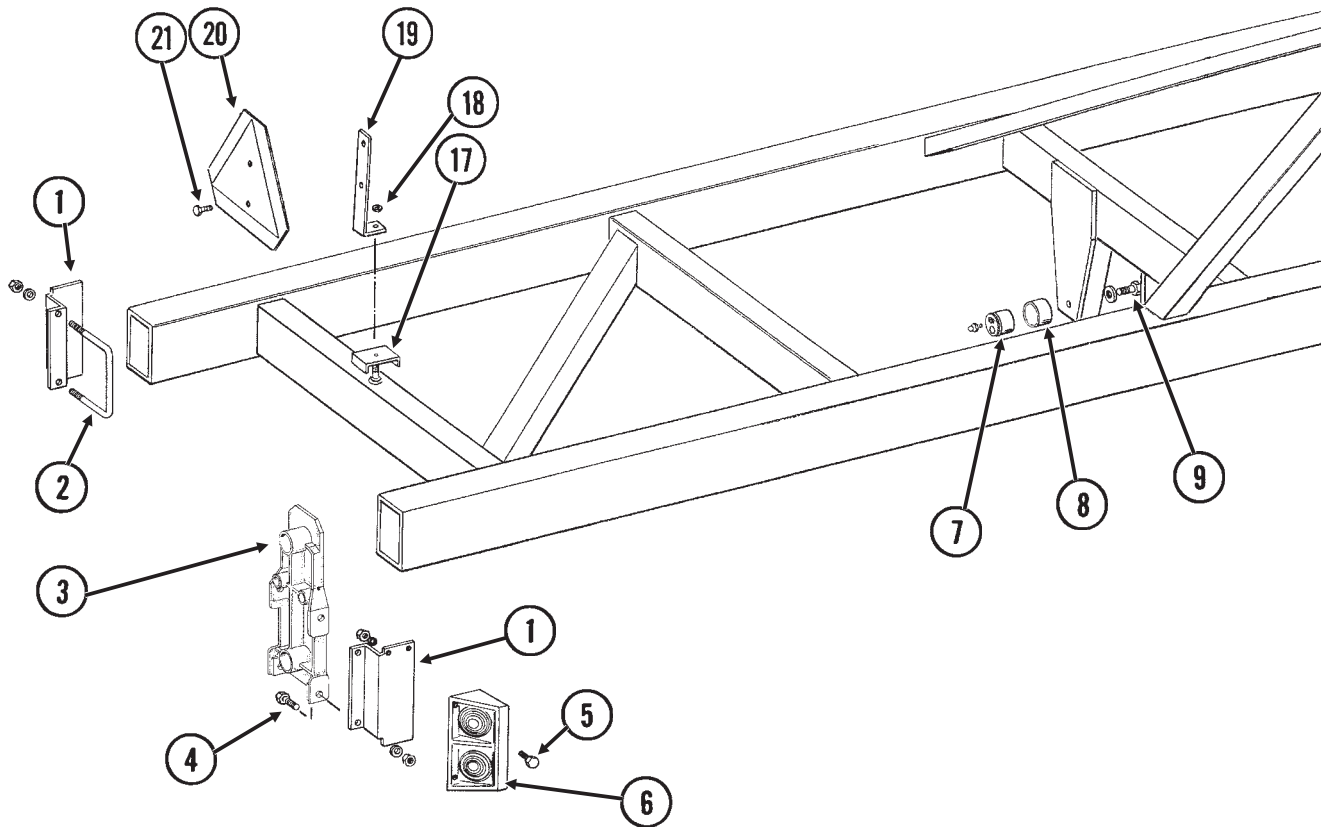

ITEM	PART NO.	QTY.	DESCRIPTION
1.	GA6792	2	Light Bracket
2.	GD1113	1	U-Bolt, 5" x 7" x 5/8"-11
	G10230	2	Lock Washer, 5/8"
	G10104	2	Hex Nut, 5/8"-11
3.		-	See "Transmission", Pages P44 And P45
4.	G10005	2	Hex Head Cap Screw, 5/8"-11 x 1 3/4"
	G10230	2	Lock Washer, 5/8"
	G10104	2	Hex Nut, 5/8"-11
5.	G10064	8	Hex Head Cap Screw, 1/4"-20 x 1"
	G10227	8	Lock Washer, 1/4"
	G10103	8	Hex Nut, 1/4"-20
6.		-	See "Electrical Components", Pages P48 And P49
7.	GA6497	2	Cam Follower W/Grease Fitting
	G10640	-	Grease Fitting, 1/4"-28
8.	GD10532	2	Sleeve
9.	G10025	2	Hex Head Cap Screw, 3/4"-10 x 1 1/2"
	G10231	2	Lock Washer, 3/4"
	GD9052	2	Washer

PLANTER FRAME

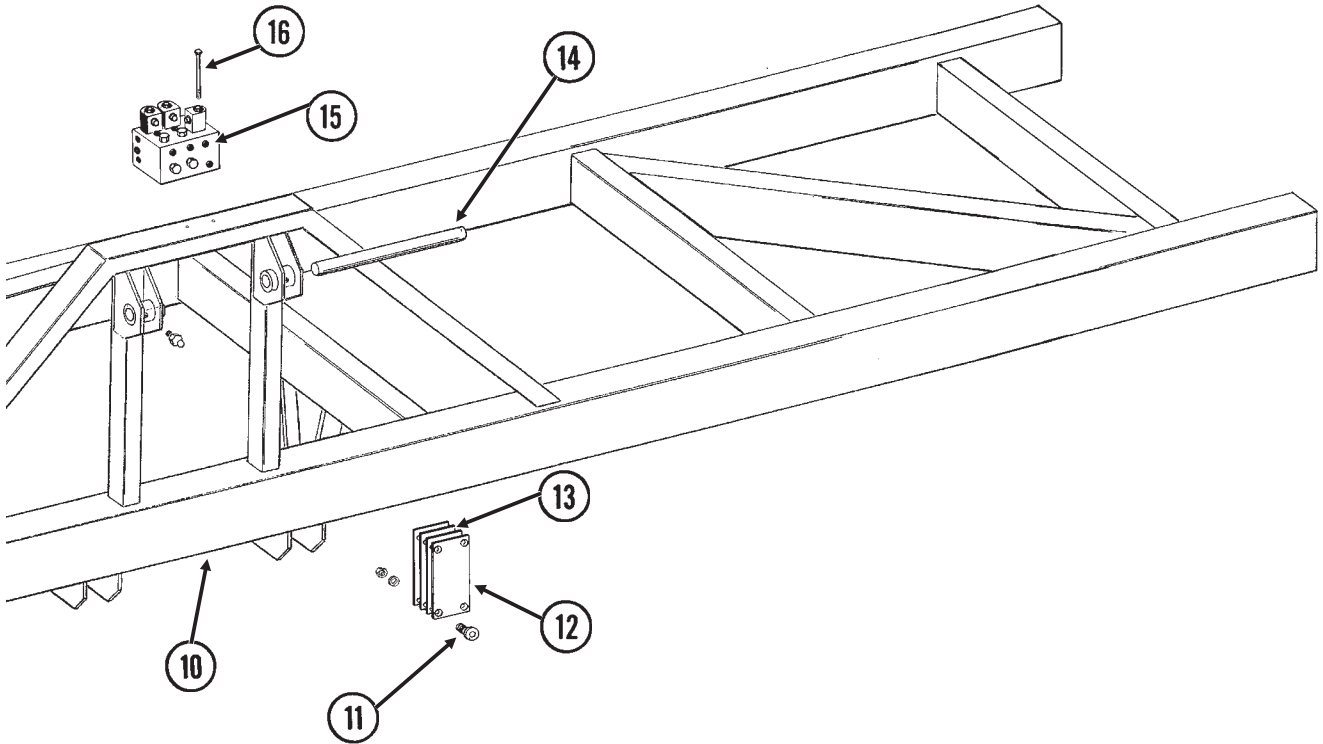

ITEM	PART NO.	QTY.	DESCRIPTION
10.	A8352	1	Frame, 270" (Non-Stock Item)
11.	G10361	8	Flat Head Hex Socket Countersunk Cap Screw, 1/2"-13 x 1 1/2"
	G10228	8	Lock Washer, 1/2"
	G10102	8	Hex Nut, 1/2"-13
12.	GD11362	2	Push Pad
13.	GD11359	6	Shim
14.		-	See "Frame Lift Linkage", Pages P36 And P37
15.		-	See "Valve Block - Located On Rear Center Frame", Page P55
16.	G10937	1	Hex Head Cap Screw, 3/8"-16 x 6 1/2"
	G10954	1	Hex Head Cap Screw, 3/8"-16 x 7"
	G10210	2	Washer, 3/8" USS
	G10229	2	Lock Washer, 3/8"
	G10101	2	Hex Nut, 3/8"-16
17.	GD0740	-	Hose Clamp
	GD5875	-	Hose Clamp
18.	G10101	-	Hex Nut, 3/8"-16
19.	GD11555	-	SMV Bracket
20.			See "SMV, Decals, Reflectors And Tie Straps", Pages P86 And P87
21.	G10022	2	Hex Head Cap Screw, 1/4"-20 x 1/2"
	G10227	2	Lock Washer, 1/4"
	G10103	2	Hex Nut, 1/4"-20

FRAME LIFT LINKAGE

PFA082(MKR14c/2400n)

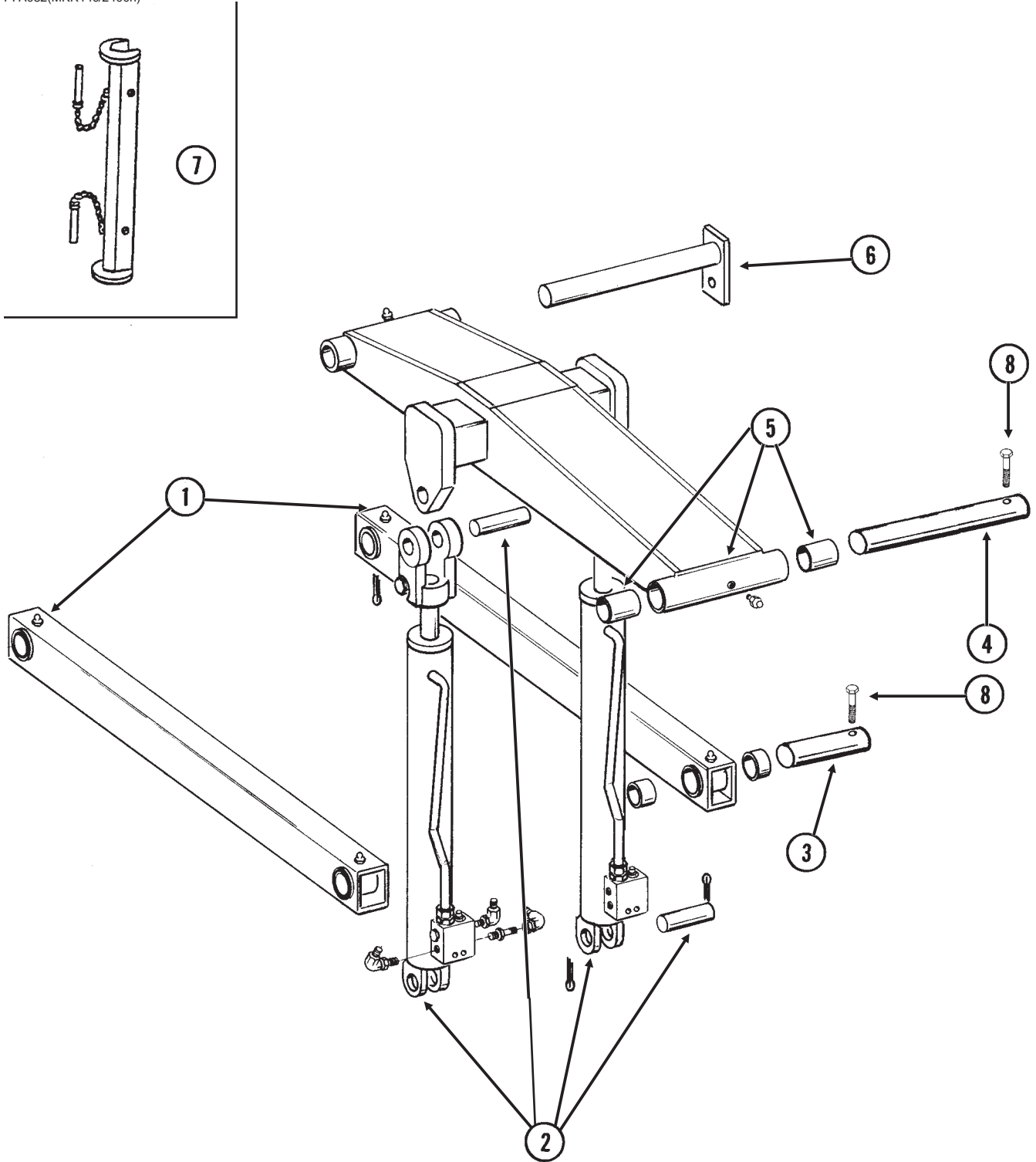

FRAME LIFT LINKAGE

ITEM	PART NO.	QTY.	DESCRIPTION
1.	GA8373	2	Lower Arm W/Grease Fittings And Bronze Bushings
	G10640	-	Grease Fitting, 1/4"-28
	GD11428	-	Bronze Bushing (4 Per Arm)
2.		-	See "Slave Cylinder", Page P60
3.	GD11444	2	Pin, 1 3/4" x 7 3/8"
4.	GD11445	1	Pin, 1 3/4" x 18 1/4" -
5.	GA8372	1	Upper Lift Arm W/Grease Fittings And Bronze Bushings
	G10641	-	Grease Fitting, 1/8" NPT
	G10373	-	Grease Fitting, 45°, 1/8"-27
	GD11427	-	Bronze Bushing (4 Per Arm)
6.		-	See "Center Pivot", Pages P38 And P39
7.	GA8172	2	Safety Lockup W/Detent Pins, 20"
	G10536	-	Detent Pin, 1/2" x 2 1/2"
8.	G10755	3	Hex Head Cap Screw, 5/16"-18 x 3"
	G10109	3	Hex Nut, 5/16 "-18

CENTER PIVOT

PFA083(2400e)

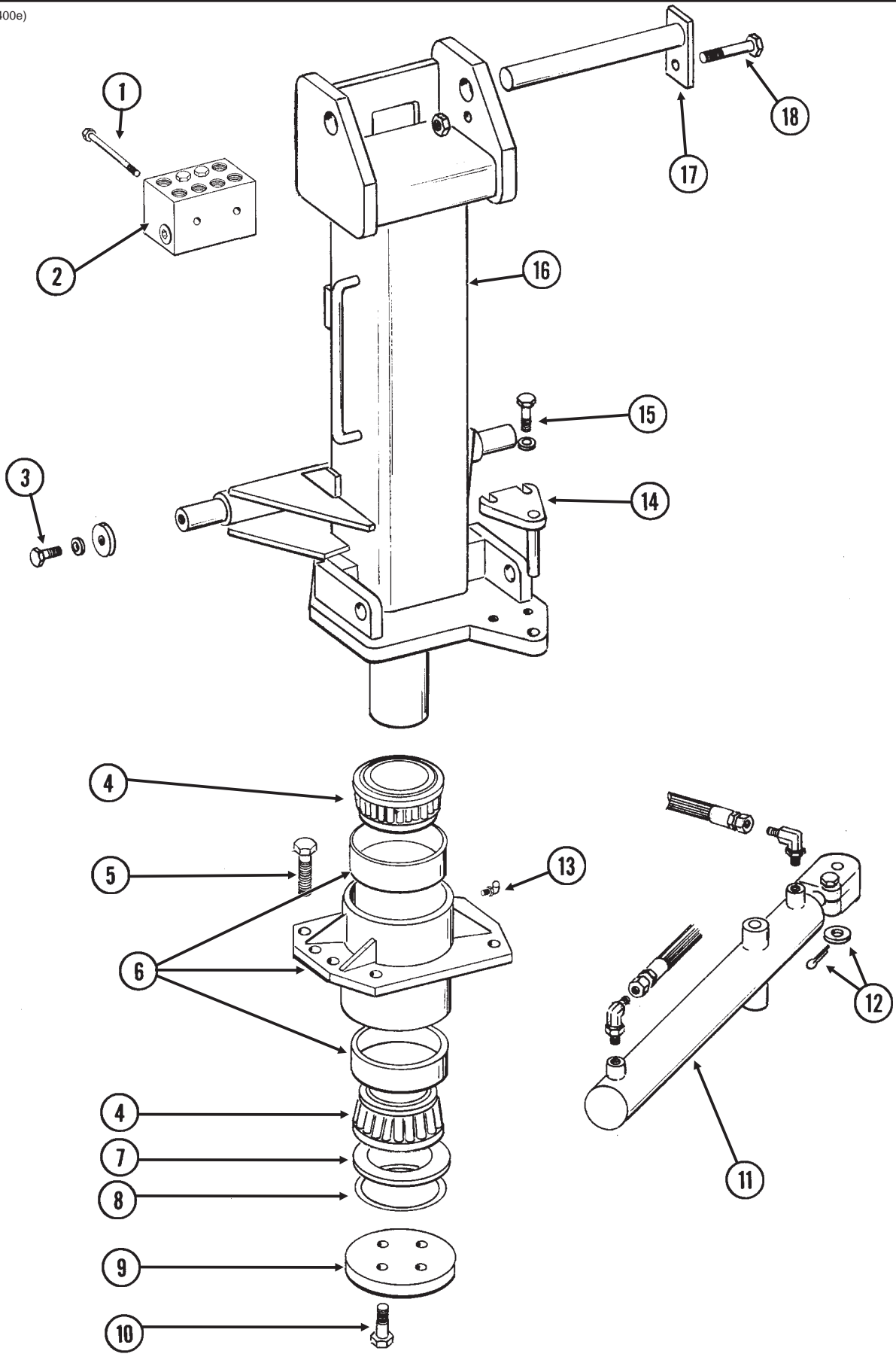

CENTER PIVOT

ITEM	PART NO.	QTY.	DESCRIPTION
1.	G10936	2	Hex Head Cap Screw, 5/16"-18 x 3 1/2"
	G10210	2	Flat Washer, 3/8" USS
	G10229	2	Lock Washer, 3/8"
2.		-	See "Junction Block - Located On Front Of Center Pivot", Page P54
3.	G10007	2	Hex Head Cap Screw, 5/8"-11 x 1 1/2"
	GD11456	2	Washer, 1 1/16" I.D. x 2 1/2" O.D. x 1/4" Thick
	GD7805	2	Special Washer
	G10230	2	Lock Washer, 5/8"
4.	GA7096	2	Cone
5.	G10441	8	Hex Head Cap Screw, 7/8"-9 x 3", Grade 8
	GD10063	8	Hardened Washer
	G10442	8	Hex Nut, 7/8"-9
6.	GA7067	1	Bearing Housing W/Cups
	GD10011	-	Cup
7.	GD10012	10	Shim, .005" Thick (As Required)
	GD10014	10	Shim, .007" Thick (As Required)
	GD10013	10	Shim, .020" Thick (As Required)
8.	GD9130	1	O-Ring
9.	GD9636	1	Bearing Cap
10.	G10027	4	Hex Head Cap Screw, 3/4"-10 x 2 1/2"
	GD2169	4	Hardened Washer
11.		-	See "Rotation Cylinder", Page P63
12.	G10139	1	Washer, 1 1/4" USS
	G10460	1	Cotter Pin, 1/4" x 2"
13.	G10779	-	Grease Fitting, 90°, 1/4"-28
14.	GA8351	1	Hammer Strap
15.	G10394	2	Hex Head Cap Screw, 3/4"-10 x 2"
	GD2169	2	Hardened Washer
	G10231	2	Lock Washer, 3/4"
16.	GA8355	1	Center Post
17.	GA8374	1	Hammer Strap
18.	G10016	1	Hex Head Cap Screw, 1/2"-13 x 2"
	G10228	1	Lock Washer, 1/2"
	G10102	1	Hex Nut, 1/2"-13

AXLE AND TRANSPORT/GROUND DRIVE WHEEL ASSEMBLY

HTA047/HTA048(2400q/2400p/A7434)

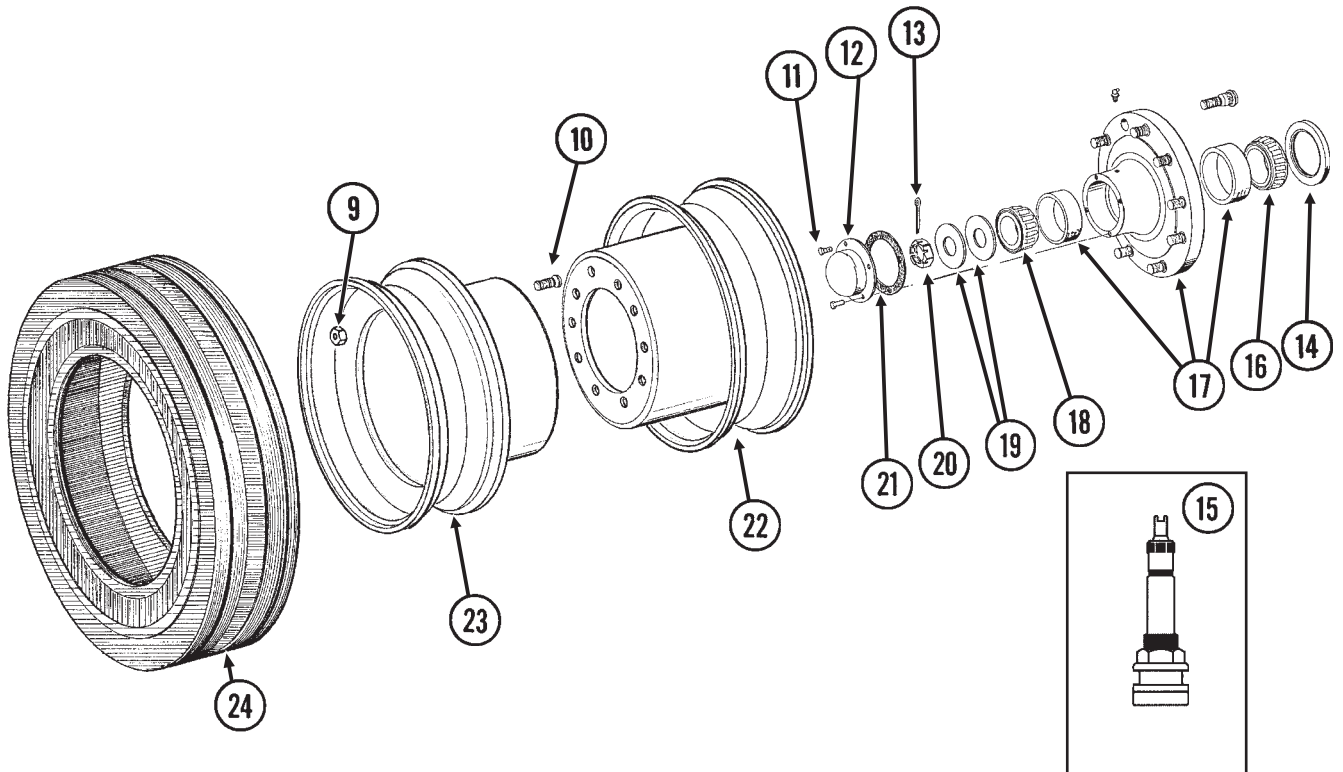
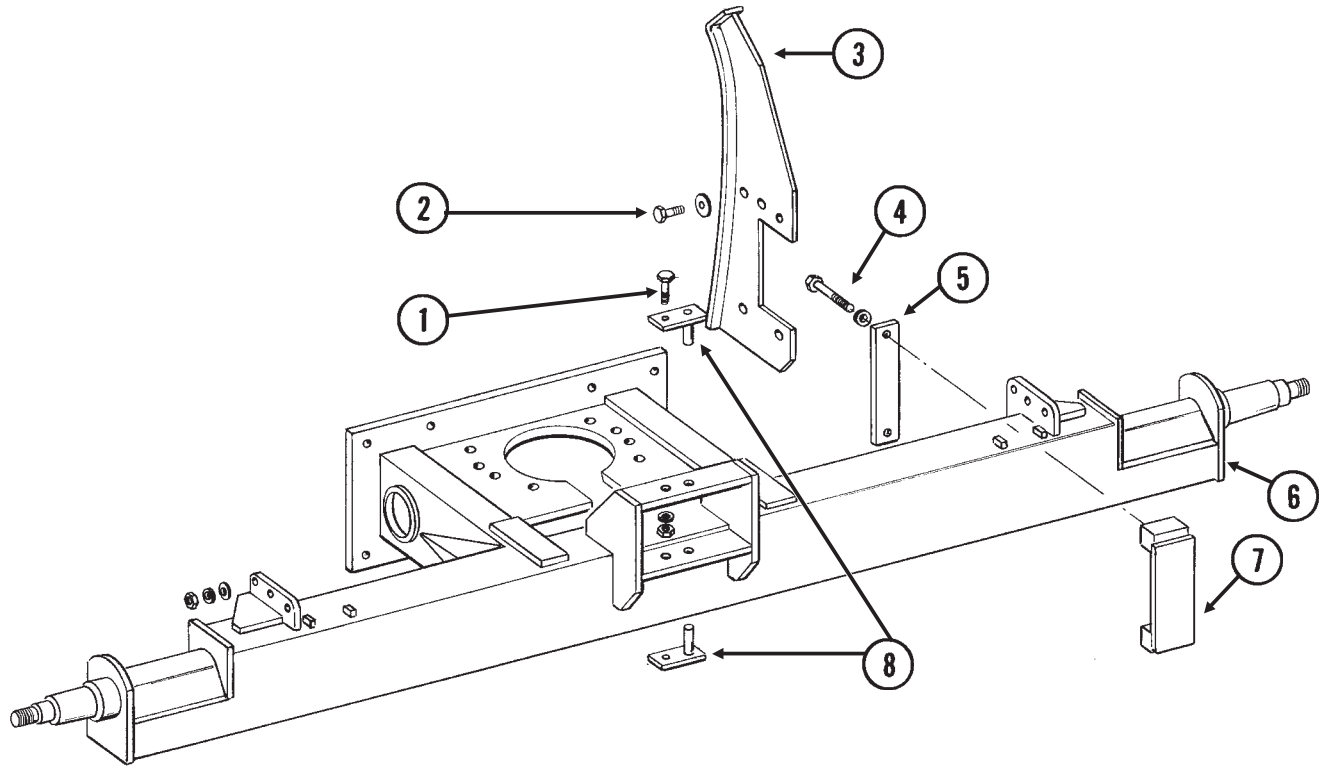

AXLE AND TRANSPORT/GROUND DRIVE WHEEL ASSEMBLY

ITEM	PART NO.	QTY. (Per Assy.)	DESCRIPTION
1.	G10017	2	Hex Head Cap Screw, 1/2"-13 x 1 1/2"
	G10228	2	Lock Washer, 1/2"
	G10102	2	Hex Nut, 1/2"-13
2.	G10008	10	Hex Head Cap Screw, 5/8"-11 x 2"
	GD7805	20	Special Washer
	G10107	10	Lock Nut, 5/8"-11
3.	GA8402	1	Cam Guide
4.	G10318	2	Hex Head Cap Screw, 5/8"-11 x 4 1/2"
	G10230	2	Lock Washer, 5/8"
5.	GD11454	1	Bar
6.	GA8348	1	Axle
7.	GA8383	1	Push Pad
8.	GA8405	2	Hammer Strap
9.	GD9509	10	Outer Budd Nut
10.	GD9508	10	Inner Budd Nut
11.	G10376	4	Hex Head Cap Screw, 5/16"-18 x 3/4"
12.	GD1529	1	Dust Cap
13.	G10460	1	Cotter Pin, 1/4" x 2"
14.	GA5988	1	Seal
15.	GA7434	1	Valve Stem
16.	GA5987	1	Inner Bearing
17.	GA5965	1	Hub W/Cups, Grease Fitting And Stud Bolts (10 Bolt)
	GR0322	-	Outer Cup
	GD8532	-	Inner Cup
	G10373	-	Grease Fitting, 45°, 1/8"-27
	GR0257	-	Stud Bolt, 3/4"-16 x 2 1/2"
	GA0705	1	Outer Bearing
18.	GA0705	1	Outer Bearing
19.	G10139	2	Washer, 1 1/4"
20.	G10070	1	Slotted Hex Nut, 1 1/4"-12
21.	GD1536	1	Seal
22.	GA8354	1	Long Rim, 15 1/4" Deep
23.	GA8353	1	Short Rim, 11 1/4" Deep
24.	GD10785	1	Tire, 255-70R x 22.5"

* Specific brand requests will be supplied only as available from current KINZE® stock. If a specific brand requested is not in stock, the brand available will be supplied.

CONTACT DRIVE WHEEL ASSEMBLY

PLA037(2400a)

L.H. Side Shown

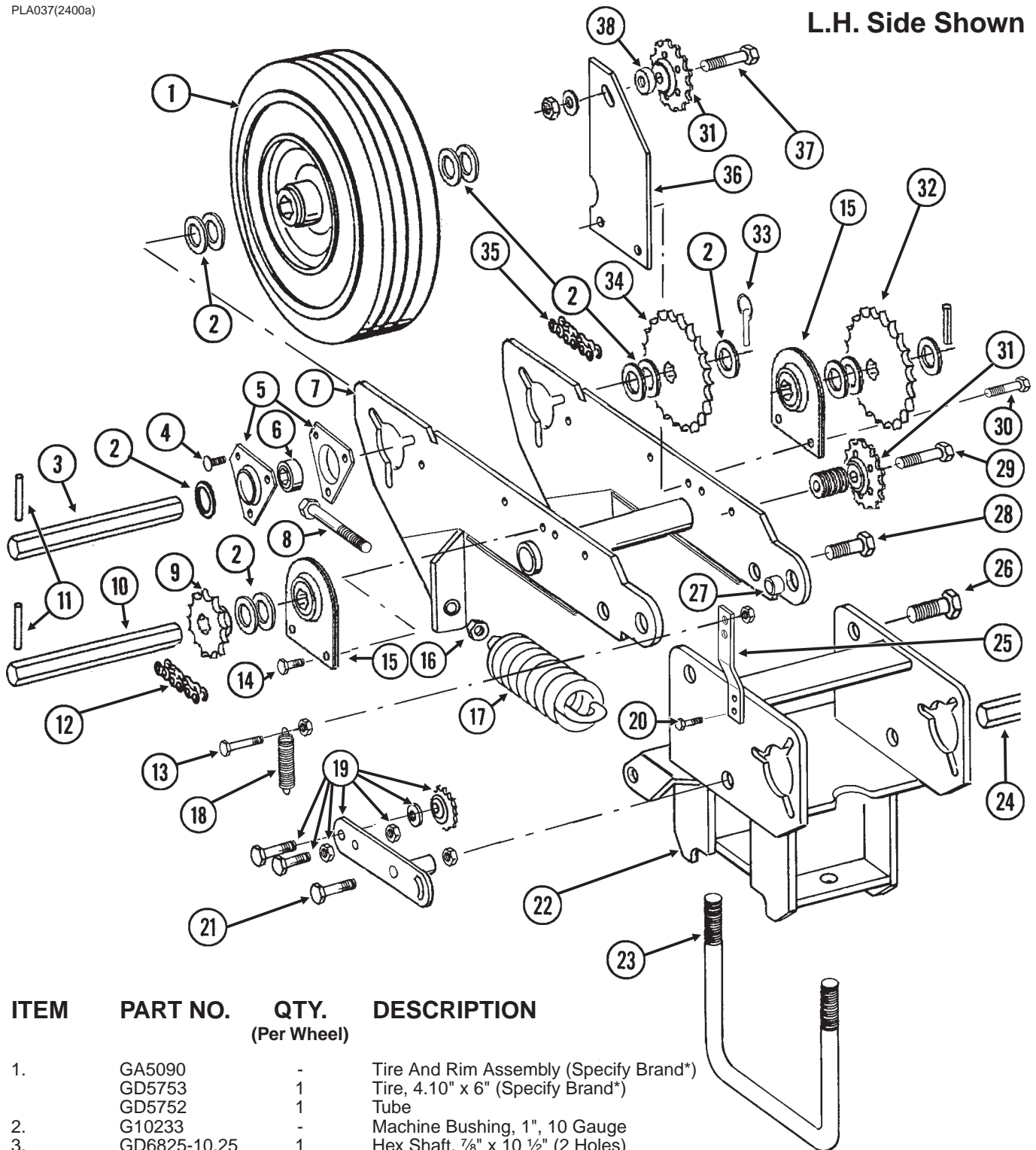

ITEM	PART NO.	QTY. (Per Wheel)	DESCRIPTION
1.	GA5090 GD5753 GD5752	- 1 1	Tire And Rim Assembly (Specify Brand*) Tire, 4.10" x 6" (Specify Brand*) Tube
2.	G10233	-	Machine Bushing, 1", 10 Gauge
3.	GD6825-10.25	1	Hex Shaft, 7/8" x 10 1/2" (2 Holes)
4.	G10303 G10219 G10232 G10106	6 6 6 6	Carriage Bolt, 5/16"-18 x 1" Washer, 5/16" USS Lock Washer, 5/16" Hex Nut, 5/16"-18
5.	G3400-01	4	Flangette
6.	G2100-03	2	Bearing, 7/8" Hex Bore, Spherical
7.	GA7369	1	Wheel Arm
8.	G10890	2	Hex Head Adjusting Bolt, 1/2"-13 x 4", Grade 2
9.	GA5105	1	Sprocket, 15 Tooth
10.	GD6825-11.375	1	Hex Shaft, 7/8" x 11 3/8" (2 Holes)
11.	G10602	4	Spring Pin, 1/4" x 1 1/2"

CONTACT DRIVE WHEEL ASSEMBLY

ITEM	PART NO.	QTY. (Per Wheel)	DESCRIPTION
12.	G3310-83	1	Chain, No. 40, 83 Pitch Including Connector Link And Offset Link
	GR0912	-	Connector Link, No. 40
	GR0911	-	Offset Link, No. 40
13.	G10746	1	Hex Head Cap Screw, 1/4"-20 x 2 3/4"
	G10103	1	Hex Nut, 1/4"-20
	G10110	1	Lock Nut, 1/4"-20
14.	G10001	3	Hex Head Cap Screw, 3/8"-16 x 1"
	G10229	3	Lock Washer, 3/8"
	G10101	3	Hex Nut, 3/8"-16
15.	GA2180	2	Bearing Hanger, 7/8" Hex
16.	G10501	2	Jam Nut, 1/2"-13
17.	GA2068	2	Spring
18.	GD5857	1	Spring
19.	GA8477	1	Idler W/Sprocket And Hardware
	G10100	2	Hex Nut, 7/16"-14
	G10421	1	Hex Head Cap Screw, 7/16"-14 x 1 1/4"
	G10128	3	Bushing, 1/2"
	G10111	1	Lock Nut, 1/2"-13
	G10016	1	Hex Head Cap Screw, 1/2"-13 x 2"
	GA7154	1	Idler Sprocket W/Bearing, 18 Tooth
20.	G10019	2	Hex Head Cap Screw, 5/16"-18 x 1"
	G10232	2	Lock Washer, 5/16"
	G10106	2	Hex Nut, 5/16"-18
21.	G10862	1	Hex Head Cap Screw, 5/8"-11 x 3 1/4"
	G10503	1	Jam Nut, 5/8"-11
	G10107	1	Lock Nut, 5/8"-11
22.	GA8426	1	Wheel Mount
23.	GD1134	1	U-Bolt, 7" x 5" x 5/8"-11
	G10230	2	Lock Washer, 5/8"
	G10104	2	Hex Nut, 5/8"-11
24.		-	See "Driveline", Pages P46 And P47
25.	GD5860	1	Bar
26.	G10751	2	Hex Head Cap Screw, 5/8"-18 x 1 3/4"
	G10235	6	Machine Bushing
	GD7805	2	Special Washer
	G10412	2	Lock Nut, 5/8"-18
27.	GB0218	2	Bushing, 2 1/32" I.D. x 7/8" O.D. x 1 9/32" Long
28.	G10055	2	Hex Head Cap Screw, 5/8"-11 x 1 1/4" (Stop Bolt)
	G10107	2	Lock Nut, 5/8"-11
29.	G10053	1	Hex Head Cap Screw, 1/2"-13 x 2 1/2"
	G10128	5	Machine Bushing, 1/2", 14 Gauge
	G10111	1	Lock Nut, 1/2"-13
30.	G10004	1	Hex Head Cap Screw, 3/8"-16 x 1 1/4"
	G10229	1	Lock Washer, 3/8"
	G10101	1	Hex Nut, 3/8"-16
31.	GA7154	2	Idler Sprocket, 18 Tooth
32.	GA5114	1	Sprocket, 30 Tooth
33.	GD2558	1	Lynch Pin, 1/4"
34.	GA5114	1	Sprocket, 30 Tooth
	GA5105	1	Sprocket, 15 Tooth, Used With Half Rate (2 To 1) Drive
35.	G3310-101	1	Chain, No. 40, 101 Pitch Including Connector Link And Offset Link
	G3310-93	1	Chain, No. 40, 93 Pitch Including Connector Link And Offset Link, Used With Half Rate (2 To 1) Drive
	GR0912	-	Connector Link, No. 40
	GR0911	-	Offset Link, No. 40
36.	GD11125	1	Bar
37.	G10053	1	Hex Head Cap Screw, 1/2"-13 x 2 1/2"
	G10216	1	Washer, 1/2" USS
	G10111	1	Lock Nut, 1/2"-13
38.	GD11158	1	Spacer, 3/4" O.D. x 9/16" Long

* Specific brand requests will be supplied only as available from current KINZE® stock. If a specific brand requested is not in stock, the brand available will be supplied. Different brand tires may have different diameters. Change in tire brand could result in rate changes. To maintain consistent planting rates throughout all rows, it is recommended that all contact tires be of the same brand and be equally inflated.

TRANSMISSION

PTD004(2400h)

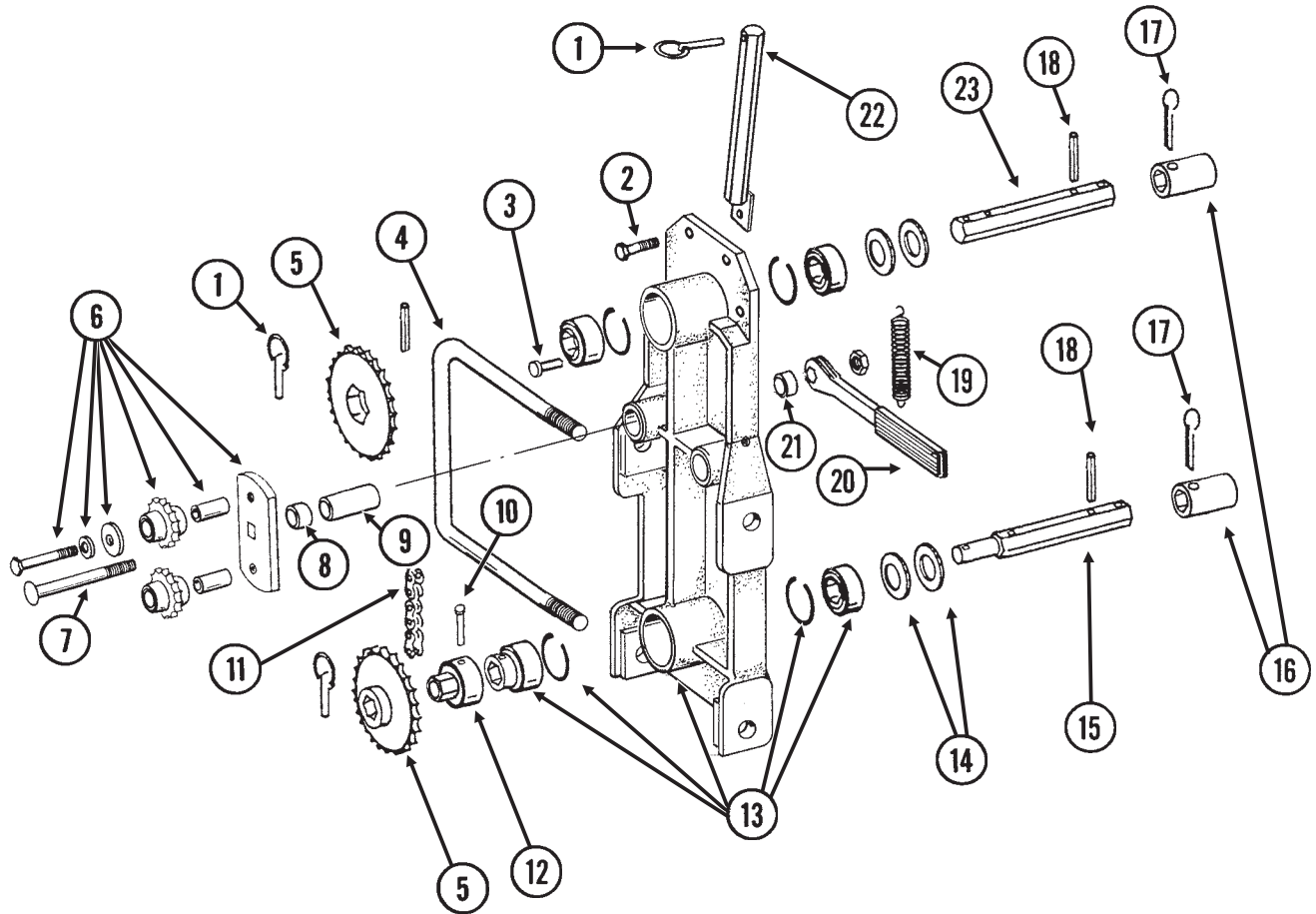

TRANSMISSION

ITEM	PART NO.	QTY.	DESCRIPTION
1.	GD2558	3	Lynch Pin, 1/4"
2.	G10017	1	Hex Head Cap Screw, 1/2"-13 x 1 1/2"
	G10228	1	Lock Washer, 1/2"
	G10102	1	Hex Nut, 1/2"-13
3.	G10478	1	Clevis Pin, 5/16" x 1"
	G10409	1	Retaining Ring, 5/16"
4.	GD1113	1	U-Bolt, 7" x 5" x 5/8"-11
	G10230	2	Lock Washer, 5/8"
	G10104	2	Hex Nut, 5/8"-11
5.	GA5106	1	Sprocket, 17 Tooth
	GA5107	1	Sprocket, 19 Tooth
	GA5108	2	Sprocket, 23 Tooth
	GA5109	1	Sprocket, 24 Tooth
	GA5110	1	Sprocket, 25 Tooth
	GA5111	1	Sprocket, 26 Tooth
	GA5112	1	Sprocket, 27 Tooth
	GA5113	1	Sprocket, 28 Tooth
6.	GA7336	1	Idler W/Bolt-On Sprockets
	GD7426	-	Sprocket
	GD1026	-	Spacer, 1 3/16"
	G10210	-	Washer, 3/8" USS
	G10229	-	Lock Washer, 3/8"
	G10047	-	Hex Head Cap Screw, 3/8"-16 x 1 3/4"
7.	G10867	1	Carriage Bolt, 1/2"-13 x 5"
	G10111	1	Lock Nut, 1/2"-13
8.	GD2734-01	1	Sleeve, 1/2"
9.	GD3180-16	1	Sleeve, 2 13/16"
10.	G10821	1	Clevis Pin, 3/16" x 2"
	G10099	1	Cotter Pin, 3/32" x 1/2"
11.	G3310-80	1	Chain, No. 40, 80 Pitch Including Connector Link
	GR0912	-	Connector Link, No. 40
12.	GD7127	1	Shear Coupler
	GR0912	-	Connector Link, No. 40
13.	GA5629	1	Transmission Plate W/Bearings, Grease Fittings And Retaining Rings
	GA5116	3	Bearing, 7/8" Hex Bore, Cylindrical
	GA5624	1	Special Bearing, 7/8" Hex Bore x 1.6"
	GD6551	4	Ring
	G10640	-	Grease Fitting, 1/4"-28
14.	G10233	4	Machine Bushing, 1", 10 Gauge
15.	GD7822	1	Shaft, 7/8" x 7"
16.	GD7867	2	Coupler, 3"
17.	G10460	2	Cotter Pin, 1/4" x 2"
18.	G10602	3	Spring Pin, 1/4" x 1 1/2"
19.	GD5857	1	Spring
20.	GA4235	1	Ratchet Wrench W/Protective Closure
	G10445	-	Protective Closure
21.	GD10161	1	Spacer, 3/8"
22.	GA5146	1	Sprocket Storage Rod
23.	GD5835	1	Shaft, 7/8" x 7"

DRIVELINE

PTD091(2400s)

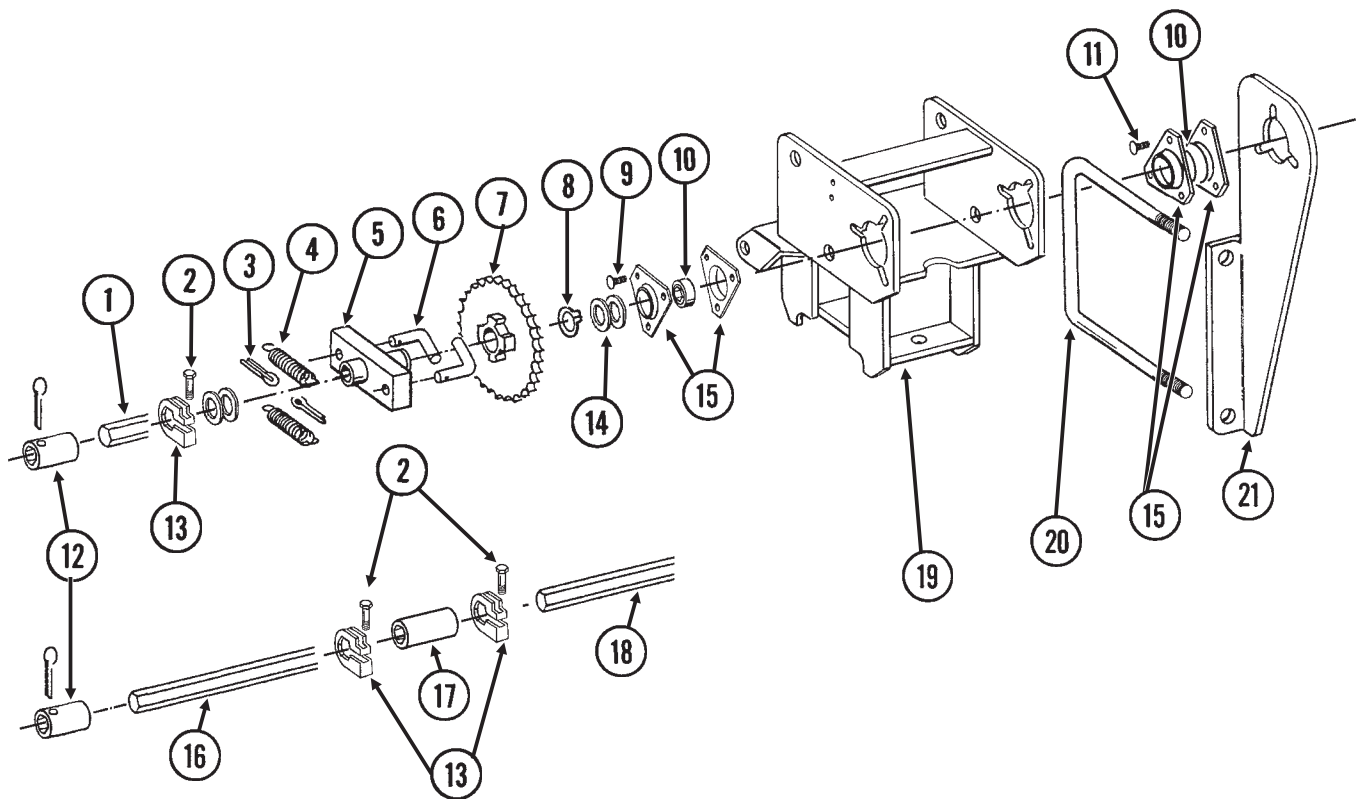

DRIVELINE

ITEM	PART NO.	QTY.	DESCRIPTION
1.	GD0914-204	1	Hex Shaft, 7/8" x 204" (No Holes)
2.	G10031	-	Hex Head Cap Screw, 5/16"-18 x 1 3/4"
	G10620	-	Flange Nut, 5/16"-18
3.	G10464	2	Cotter Pin, 3/16" x 1"
4.	GD1256	2	Spring
5.	GA0378	1	Block And Hub Assembly
6.	GD1255	2	"L" Pin
7.	GA7574	1	Hub/Sprocket Assembly, 34 Tooth
8.	G10430	1	External Retaining Ring, 1 1/4"
9.	G10303	6	Carriage Bolt, 5/16"-18 x 1"
	G10232	6	Lock Washer, 5/16"
	G10106	6	Hex Nut, 5/16"-18
10.	G2100-03	3	Bearing, 7/8" Hex Bore, Spherical
11.	G10303	3	Carriage Bolt, 5/16"-18 x 1"
	G10219	3	Washer, 5/16" USS
	G10232	3	Lock Washer, 5/16"
	G10106	3	Hex Nut, 5/16"-18
12.		-	See "Transmission", Pages P44 And P45
13.	GD11045	-	Lock Clamp
14.	G10233	-	Machine Bushing, 1", 10 Gauge
15.	G3400-01	6	Flangette
16.	GD0914-43	1	Hex Shaft, 7/8" x 43" (No Holes)
17.	GD1719	1	Coupler, 4"
18.	GD0914-206	1	Hex Shaft, 7/8" x 206" (No Holes)
19.		-	See "Contact Drive Wheel Assembly", Pages P42 And P43
20.	GD1113	1	U-Bolt, 7" x 5" x 5/8"-11
	G10230	2	Lock Washer, 5/8"
	G10104	2	Hex Nut, 5/8"-11
21.	GD11549	1	Center Support
A.	GA8451	-	Ratchet/Sprocket Assembly, L.H. (Items 3-8)(Shown)
	GA8450	-	Ratchet/Sprocket Assembly, R.H. (Items 3-8)
B.	G1K269	-	Lock Clamp Kit (Items 2 And 13)

ELECTRICAL COMPONENTS

ECP010/ECP011/ECP018/ECP023(TWL19a/TWL18/TWL23/A8430/A8431/ELC14/ELC3a/ELC5c/MTR27a/ELC8/A8433/A8432a/TWL20a/ELC10/ELC4)

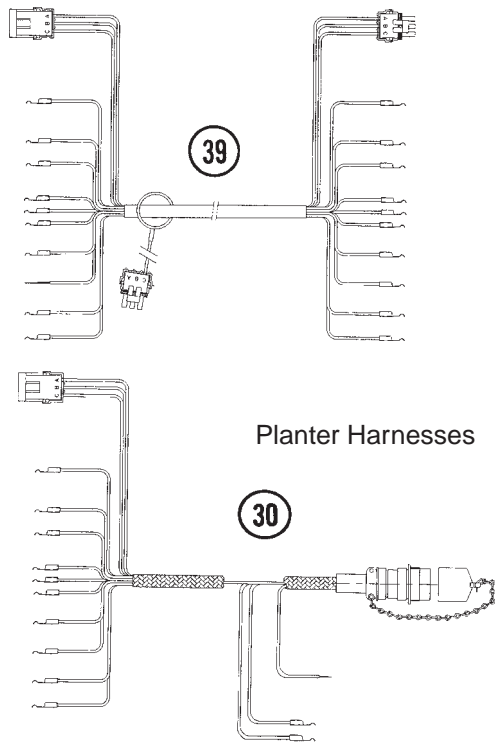
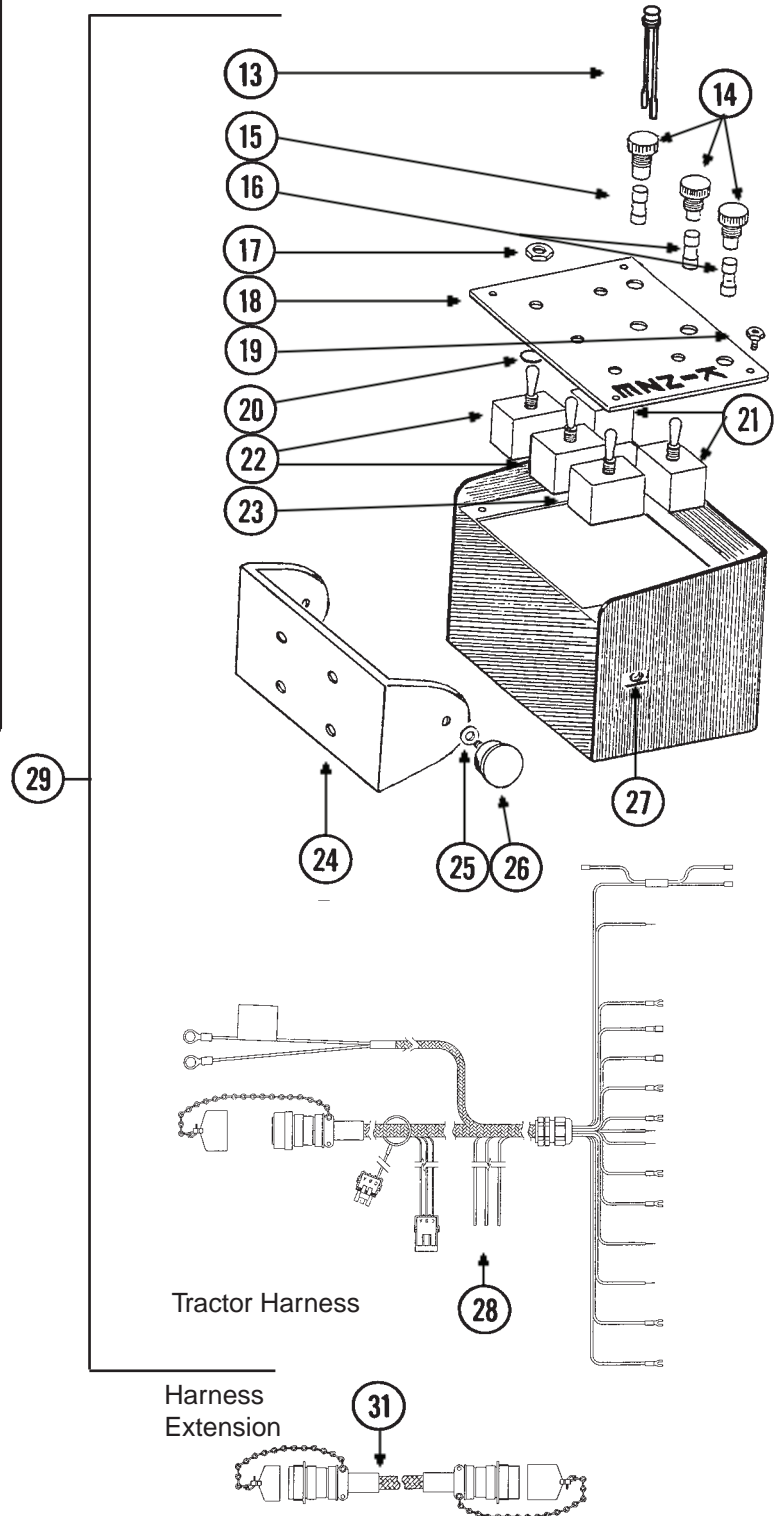
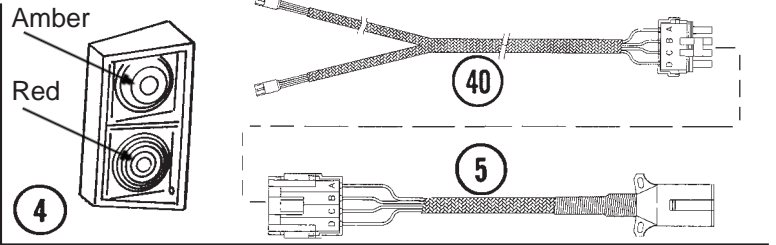
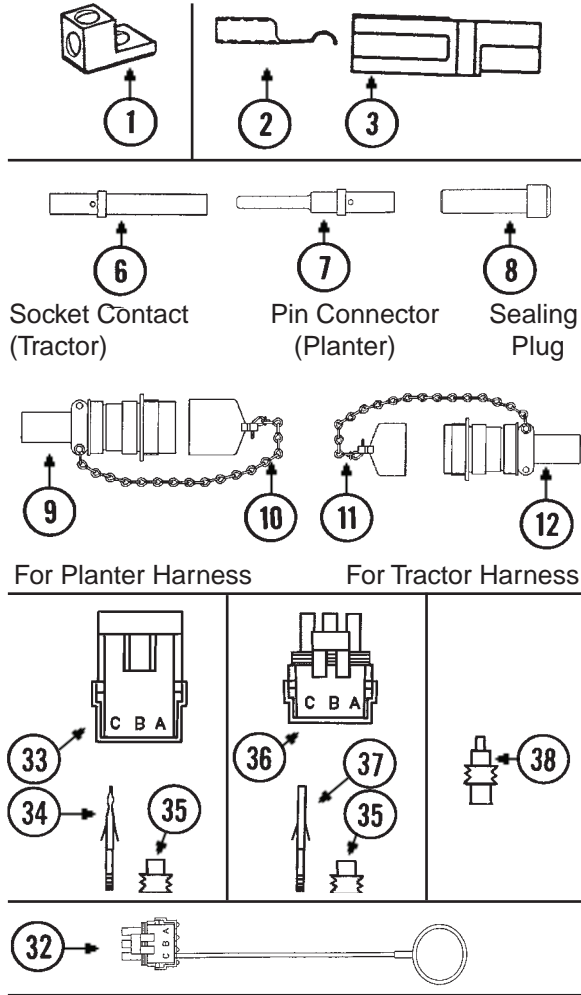

ELECTRICAL COMPONENTS

ITEM	PART NO.	QTY.	DESCRIPTION
1.	GA3584	-	Ground Clamp
2.	GD9530	-	Contact
3.	GD9529	-	Housing
4.	GA6699	1	Double Light Assembly (Shown)
	GA6700	1	Double Light Assembly
	GR1203	-	Red Lens
	GR1204	-	Amber Lens
	GR1205	-	Cover
	GR1206	-	Rubber Grommet (4)
	GR1207	-	Lamp Unit
	GR1208	-	Bulb
5.	GA8430	1	Light Wiring Harness W/7 Terminal Female Connector, 23' 6"
	GA5385	-	7 Terminal Female Connector
6.	GD8740	-	Socket Contact, No. 14
7.	GD8741	-	Pin Connector, No. 14
8.	GD8739	-	Sealing Plug, No. 12
9.	GA6109	1	Connector With Cable Clamp, 23 Pin Capacity
10.	GA7862	-	Dust Cap W/Chain
11.	GA7863	-	Dust Cap W/Chain
12.	GA6108	1	Connector With Cable Clamp, 23 Socket Capacity
13.	GA7077	1-4	Indicator Light
14.	GA2612	3-5	Fuse Holder W/Spade
15.	GD2829	1-2	Fuse, 15 Amp, Type AGC
16.	GD10243	2-6	Fuse, MOL 10 Amp Delay Action
17.	GR1363	5	Hex Face Nut, 1 ⁵ / ₃₂ "-32
	GR1364	5	Internal Tooth Lock Washer, 1 ⁵ / ₃₂ "
18.	GD9897	1	Cover Plate (Shown)
	GD10318	-	Cover Plate, Planters Equipped With Two-Speed Point Row Clutch
19.	GR1292	4	Pan Head Screw, No. 8-32 x 1/2"
20.	GD3860	-	O-Ring (If Applicable)
21.	GA2528	2	Switch, 3 Position Toggle, On/Off/On
22.	GA6978	2	Switch, 3 Position Momentary, On/Off/ Momentary On
23.	GA6977	1-2	Switch, 2 Position Toggle, On/Off
24.	GD9896	1	Mounting Bracket
25.	G10211	4	Washer, 1/4" SAE
26.	GA6975	2	Knob
27.	GR1290	2	Cage Nut, 1/4"-20
28.	GA7368	1	Harness W/Dust Cap And Power Cable
29.	G7408X	-	Control Console Assembly With Mounting Brackets, Short Harness W/Dust Cap And Power Cable
30.	GA8432	1	Hydraulic Wiring Harness W/Dust Cap, 16'
31.	GA7399	-	Harness Extension W/Dust Caps, 15'
32.	GA8047	-	Dust Plug
33.	GD11079	-	Housing
34.	GD11080	-	Pin Contact, No. 18
35.	GD11081	-	Seal
36.	GD11090	-	Housing
37.	GD11091	-	Socket Contact, No. 18
38.	GD11089	-	Sealing Plug
39.	GA8433	1	Hydraulic Wiring Harness, 6' 6"
40.	GA8431	1	Light Wiring Harness, 22'
A.	G1K248	-	Harness Ends Repair Kit (3 Housings, 9 Seals, 9 Pin Contacts) (Items 33-35)
B.	G1K252	-	Harness Ends Repair Kit (3 Housings, 9 Seals, 9 Socket Contacts) (Items 35-37)

NOTE: See "Electronic Seed Monitor" for those components.

MARKER ASSEMBLY

MKR019/MKR027(MKR23)

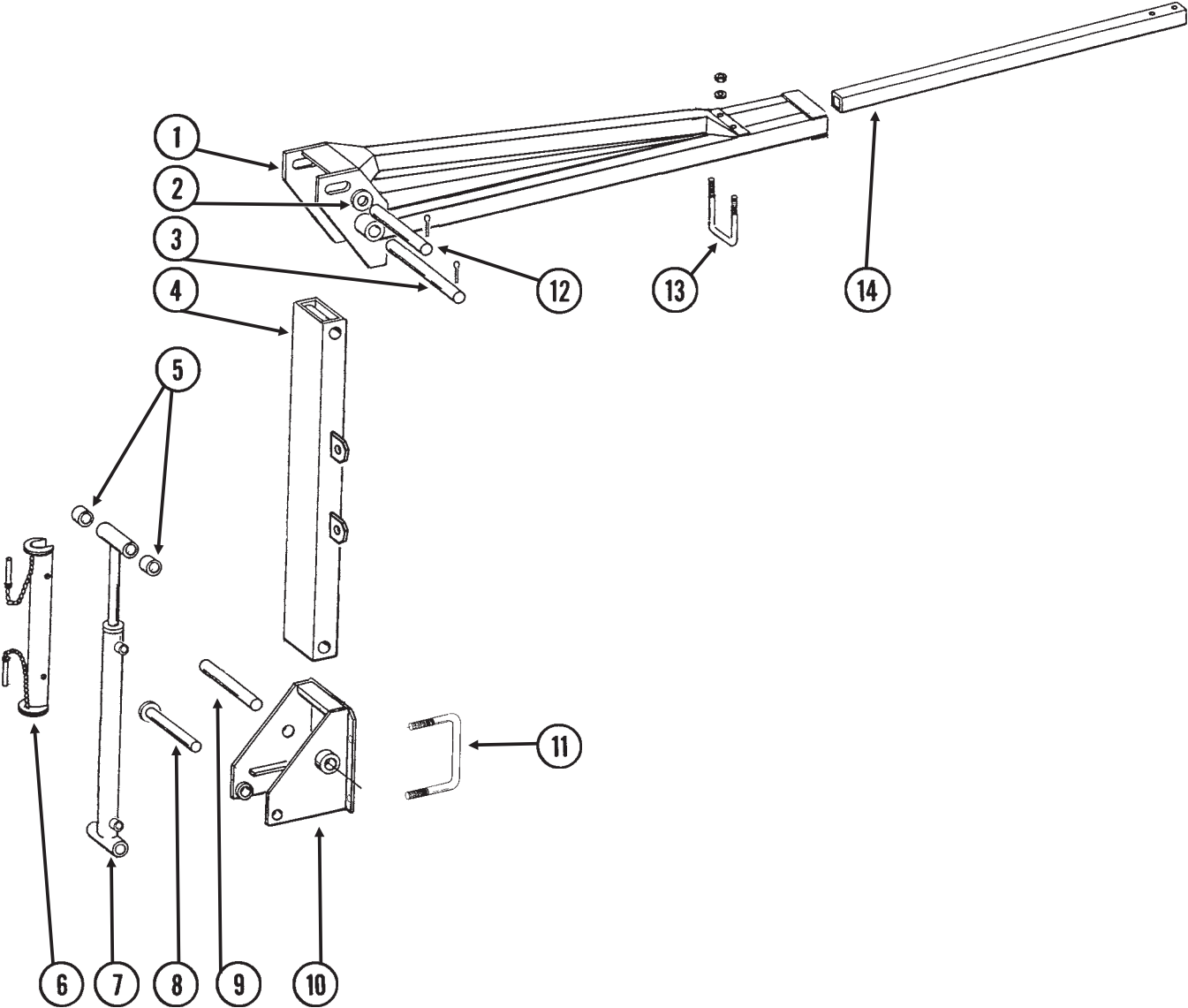

MARKER ASSEMBLY

ITEM	PART NO.	QTY.	DESCRIPTION
		(Per Assy.)	
1.	GA8472	1	Arm, Second Stage, 51 7/8"
2.	G10226	-	Washer, 1 1/4" SAE (As Required)
	G10159	-	Machine Bushing, 10 Gauge (As Required)
	G10322	-	Machine Bushing, 18 Gauge (As Required)
3.	GD3214	1	Pin, 1 1/4" x 12 1/4"
	G10460	2	Cotter Pin, 1/4" x 2"
4.	GA8407	1	First Stage W/Grease Fittings
	G10641	2	Grease Fitting, 1/8" NPT
5.	GD0752-41	4	Sleeve, 1"
6.	GA8170	1	Safety Lockup W/Detent Pins
	G10536	-	Detent Pin, 1/2" x 2 1/2"
7.		-	See "Marker Cylinder", Page P63
8.	GA6532	1	Pin, 1 1/4" x 7 5/8"
	G10460	1	Cotter Pin, 1/4" x 2"
9.	GD0652	1	Pin, 1 1/4" x 9 1/2"
	G10460	2	Cotter Pin, 1/4" x 2"
10.	GA8382	1	Mount
11.	GD11489	2	U-Bolt, 3" x 6" x 5/8"-11
	G10230	4	Lock Washer, 5/8"
	G10104	4	Hex Nut, 5/8"-11
12.	GD2161	1	Pin, 1 1/4" x 8 1/2"
	G10460	2	Cotter Pin, 1/4" x 2"
13.	GD2721	-	U-Bolt, 2" x 2" x 1/2"-13
	G10228	-	Lock Washer, 1/2"
	G10102	-	Hex Nut, 1/2"-13
14.	GD0453-08	-	Extension Tube, 65"

MARKER SPINDLE/HUB/BLADE

MKR020(MKR3a)

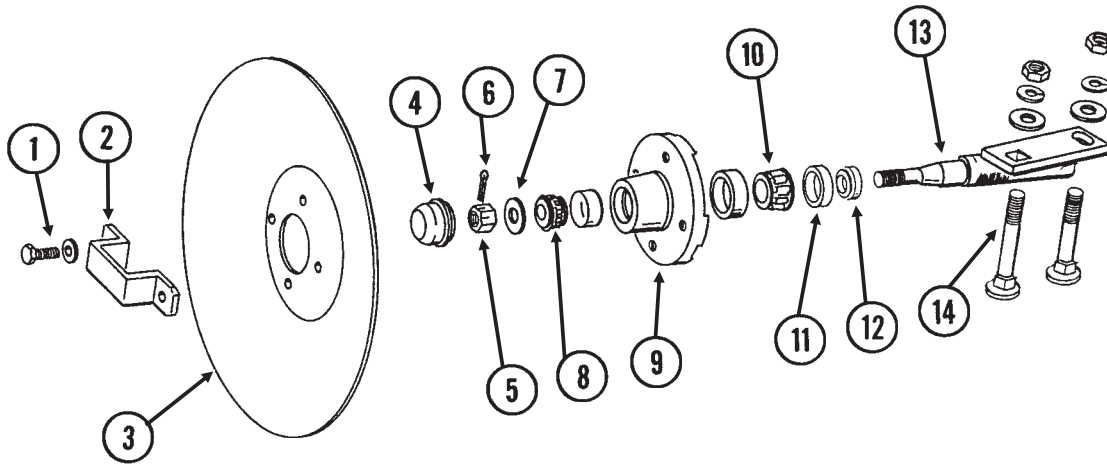

ITEM	PART NO.	QTY.	DESCRIPTION
		(Per Assy.)	
1.	G10722	4	Hex Head Cap Screw, 1/2"-20 x 1"
	G10228	4	Lock Washer, 1/2"
2.	GD2597	1	Retainer
3.	GD0746	1	Solid Blade, 16" (Shown)
	GD10283	-	Notched Blade, 16" (Optional)
4.	GD0840	1	Dust Cap
5.	G10725	1	Hex Slotted Nut, 5/8"-18
6.	G10544	1	Cotter Pin, 5/32" x 1"
7.	G10724	1	Washer, 5/8"
8.	GA0257	1	Outer Bearing
9.	GA0167	1	Hub With Cups
	GR0151	-	Outer Cup
	GR0150	-	Inner Cup
10.	GA0245	1	Inner Bearing
11.	GA0243	1	Grease Seal
12.	GA0899	1	Rubber Seal
13.	GA1676	1	Spindle, R.H.
	GA1677	-	Spindle, L.H. (Shown)
14.	G10844	2	Carriage Bolt, 1/2"-13 x 3 1/2"
	G10168	2	Machine Bushing, 1/2", 7 Gauge
	G10228	2	Lock Washer, 1/2"
	G10102	2	Hex Nut, 1/2"-13
A.	GA1679	-	Hub And Spindle Assembly, L.H. (Items 1, 2 And 4-13)
	GA1678	-	Hub And Spindle Assembly, R.H. (Items 1, 2 And 4-13)

VALVE BLOCK - LOCATED ON HITCH

PHS049(2400b)

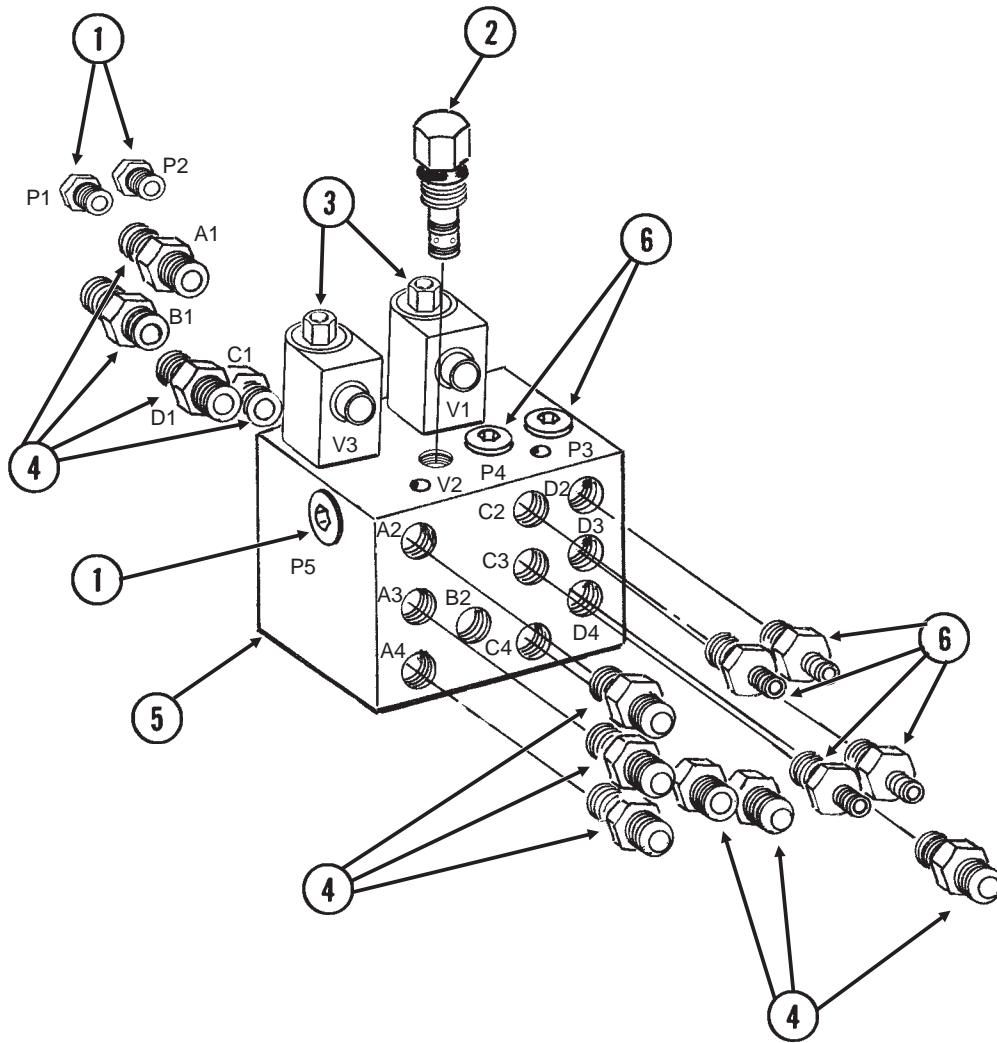

ITEM	PART NO.	QTY.	DESCRIPTION
1.	G6408-H06-O GR1045	5 -	Plug W/O-Ring, 1/16"-18 O-Ring, Hex Socket Head O-Ring
2.		-	See "Check Valve", Page P57
3.		-	See "G1K276 Solenoid Valve", Page P56
4.	G6400-08 GR1037	10 -	Connector W/O-Ring, 3/4"-16 Male JIC To O-Ring O-Ring
5.	GD11460	1	Block
6.	G6400-06 GR1045	4 -	Connector W/O-Ring, 1/16"-18 Male JIC To O-Ring O-Ring

JUNCTION BLOCK - LOCATED ON FRONT OF CENTER PIVOT

(2400d)

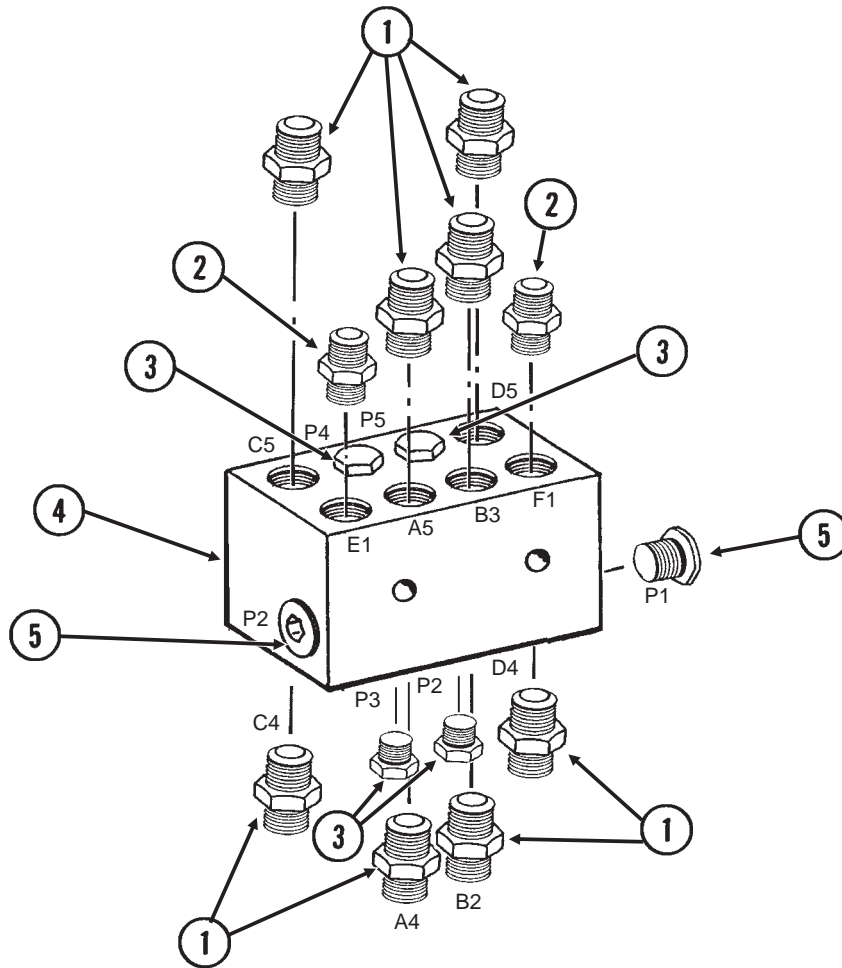

ITEM	PART NO.	QTY.	DESCRIPTION
1.	G6400-08 GR1037	8 -	Connector W/O-Ring, 3/4"-16 Male JIC To O-Ring O-Ring
2.	G6400-06 GR1045	2 -	Connector W/O-Ring, 1/8"-18 Male JIC To O-Ring O-Ring
3.	G6408-08 GR1037	4 -	Plug W/O-Ring, 3/4"-16 O-Ring O-Ring
4.	GD11459	1	Block
5.	G6408-H06-O GR1045	2 -	Plug W/O-Ring, 1/8"-18 O-Ring, Hex Socket Head O-Ring

VALVE BLOCK - LOCATED ON REAR CENTER FRAME

PHS050(2400f)A8455

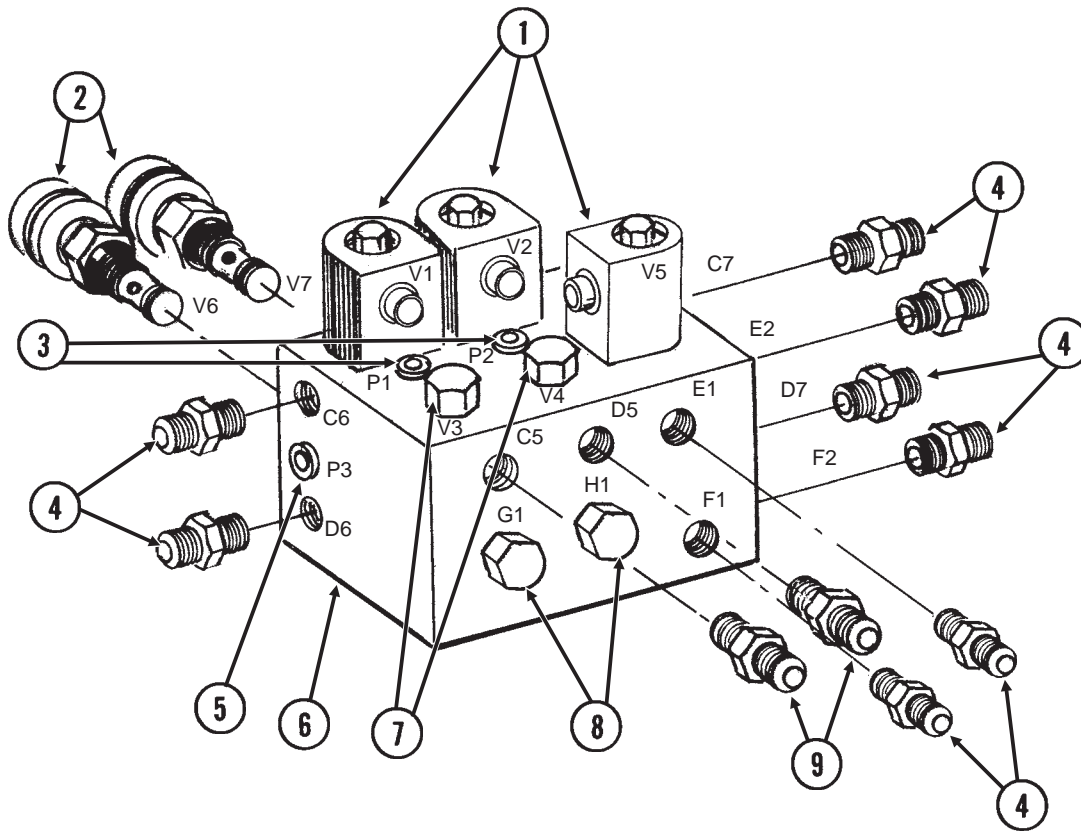

ITEM	PART NO.	QTY.	DESCRIPTION
1.		-	See "G1K275 Solenoid Valve", Page P56
2.		-	See "Flow Control Valve", Page P56
3.	G6408-H06-O	2	Plug W/O-Ring, 1/16"-18 O-Ring, Hex Socket Head
	GR1045	-	O-Ring
4.	G6400-06	8	Connector W/O-Ring, 1/16"-18 Male JIC To O-Ring
	GR1045	-	O-Ring
5.	G6408-06	1	Plug W/O-Ring, 1/16"-18 O-Ring
	GR1045	-	O-Ring
6.	GD11461	1	Block
7.	G6408-10	2	Plug W/O-Ring, 7/8"-14 O-Ring
	GR1466	-	O-Ring
8.	G6408-08	2	Plug W/O-Ring, 3/4"-16 O-Ring, Hex Socket Head
	GR1037	-	O-Ring
9.	G6400-08	2	Connector W/O-Ring, 3/4"-16 JIC To O-Ring
	GR1037	-	O-Ring

SOLENOID VALVE (G1K275)

VVB019(TWL27c/TWL18/PLTR75c)

ITEM	PART NO.	QTY.	DESCRIPTION
1.	GR0761	1	Hex Nut
2.	G1K274	1	Coil Kit W/Housings And Contacts
3.	GR9529	2	Housing
	GR9530	2	Contact
	GR0763	1	Cartridge
A.	G1K275	-	Solenoid Valve Kit W/Housings And Contacts
	GD9529	2	Housing
	GD9530	2	Contact
B.	GR0764	-	Seal Kit, Includes: (2)O-Rings, (1)BU Ring

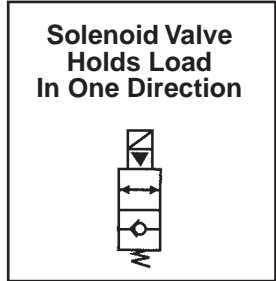
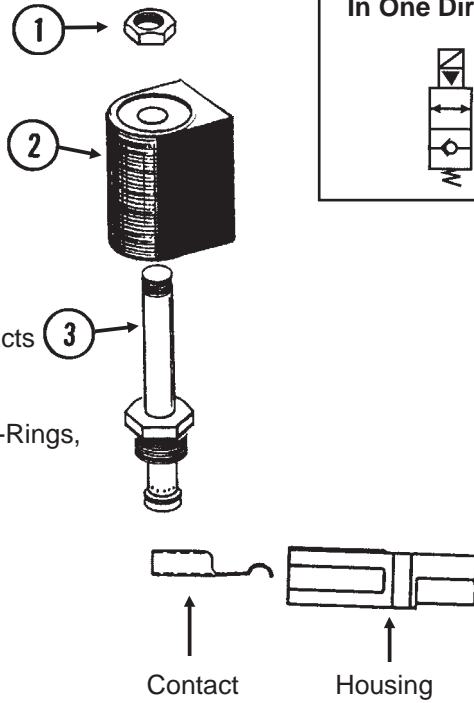

SOLENOID VALVE (G1K276)

VVB019(FF25/TWL18/PLTR75c)

ITEM	PART NO.	QTY.	DESCRIPTION
1.	GR1322	1	Hex Nut
2.	G1K274	1	Coil Kit W/Housings And Contacts
3.	GR9529	2	Housing
	GR9530	2	Contact
	GR1321	1	Cartridge
A.	G1K276	-	Solenoid Valve Kit W/Housings And Contacts
	GD9529	2	Housing
	GD9530	2	Contact
B.	GR0764	-	Seal Kit, Includes: (2)O-Rings, (1)BU Ring

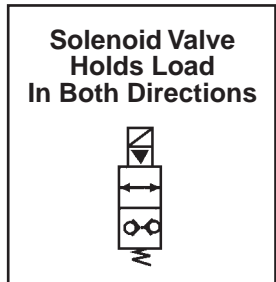
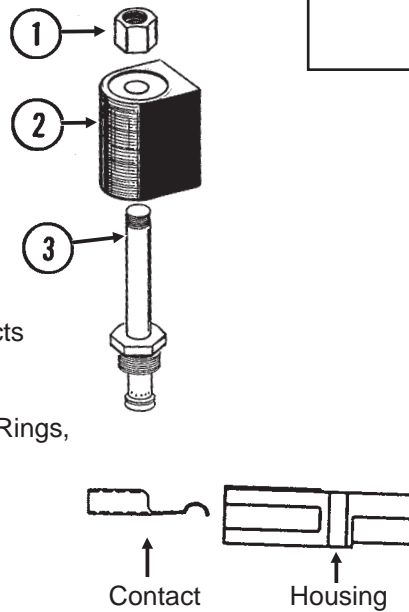

CHECK VALVE

VVB020(TWL30a)

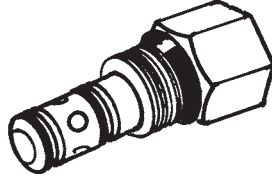

ITEM	PART NO.	QTY.	DESCRIPTION
A.	GA8406	-	Check Valve
B.	GR1468	-	Seal Kit, Includes: (4)O-Rings, (5)BU Rings

FLOW CONTROL VALVE

VVB020(TWL28)

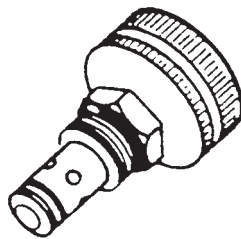

ITEM	PART NO.	QTY.	DESCRIPTION
A.	GA3413	-	Flow Control Valve
B.	GR0764	-	Seal Kit, Includes: (2)O-Rings, (1)BU Ring

HYDRAULIC SYSTEM

(TWL158b/TWL158c)

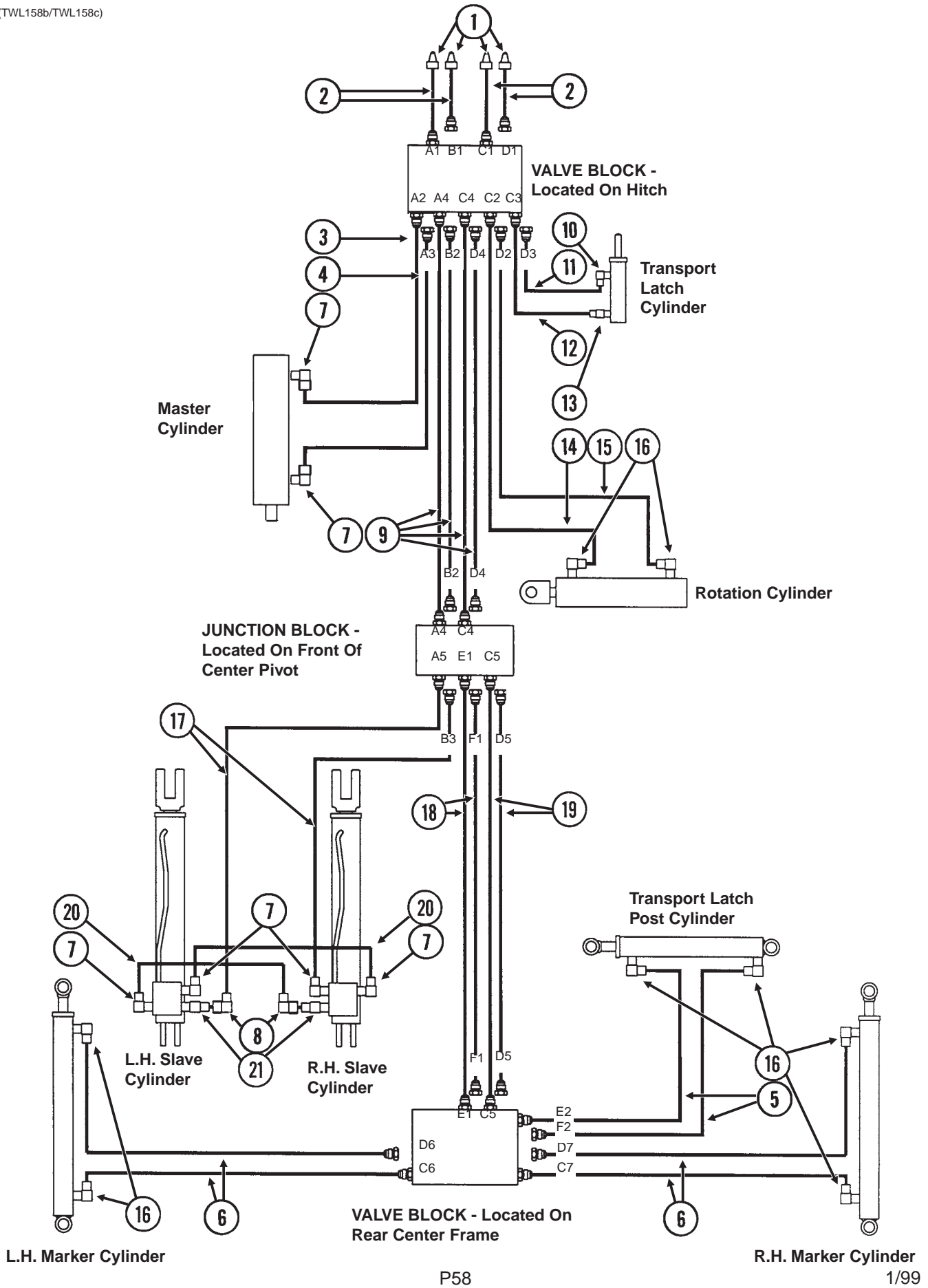

HYDRAULIC SYSTEM

ITEM	PART NO.	QTY.	DESCRIPTION
1.	GD4086	4	Tip, Pioneer
2.	*A3123	4	Hose Assembly, 3/8" x 72"
3.	*A1021	1	Hose Assembly, 3/8" x 56"
4.	*A3158	1	Hose Assembly, 3/8" x 46"
5.	*A7609	2	Hose Assembly, 1/4" x 164"
6.	*A7610	4	Hose Assembly, 1/4" x 175"
7.	G6801-08	6	Elbow W/O-Ring, 90°, 3/4"-16 Male JIC To O-Ring
	GR1037	-	O-Ring
8.	G6500-08	2	Swivel Elbow, 90°, 3/4"-16 Male JIC To Female
9.	*A3206	4	Hose Assembly, 3/8" x 184"
10.	G6801-06	1	Elbow W/O-Ring, 90°, 9/16"-18 Male JIC To O-Ring
	GR1045	-	O-Ring
11.	*A1169	1	Hose Assembly, 1/4" x 24"
12.	*A1192	1	Hose Assembly, 1/4" x 20"
13.	G6400-06	1	Connector W/O-Ring, 9/16"-18 Male JIC To O-Ring
	GR1045	-	O-Ring
14.	*A7606	1	Hose Assembly, 1/4" x 177"
15.	*A7607	1	Hose Assembly, 1/4" x 187"
16.	G6801-06-08	8	Elbow W/O-Ring, 90°, 9/16"-18 Male JIC To 3/4"-16 O-Ring
	GR1037	-	O-Ring
17.	*A1096	2	Hose Assembly, 3/8" x 50 1/2"
18.	*A1113	2	Hose Assembly, 1/4" x 80"
19.	*A3129	2	Hose Assembly, 3/8" x 79"
20.	*A1079	2	Hose Assembly, 3/8" x 24"
21.	G6400-L-08	2	Long Connector W/O-Ring, 3/4"-16 Male JIC To O-Ring
	GR1037	-	O-Ring

* Hydraulic hose is not stocked by KINZE® Repair Parts, but can be made available on a special order basis. Call for quote.

SLAVE CYLINDER

CYL062(CYL54)

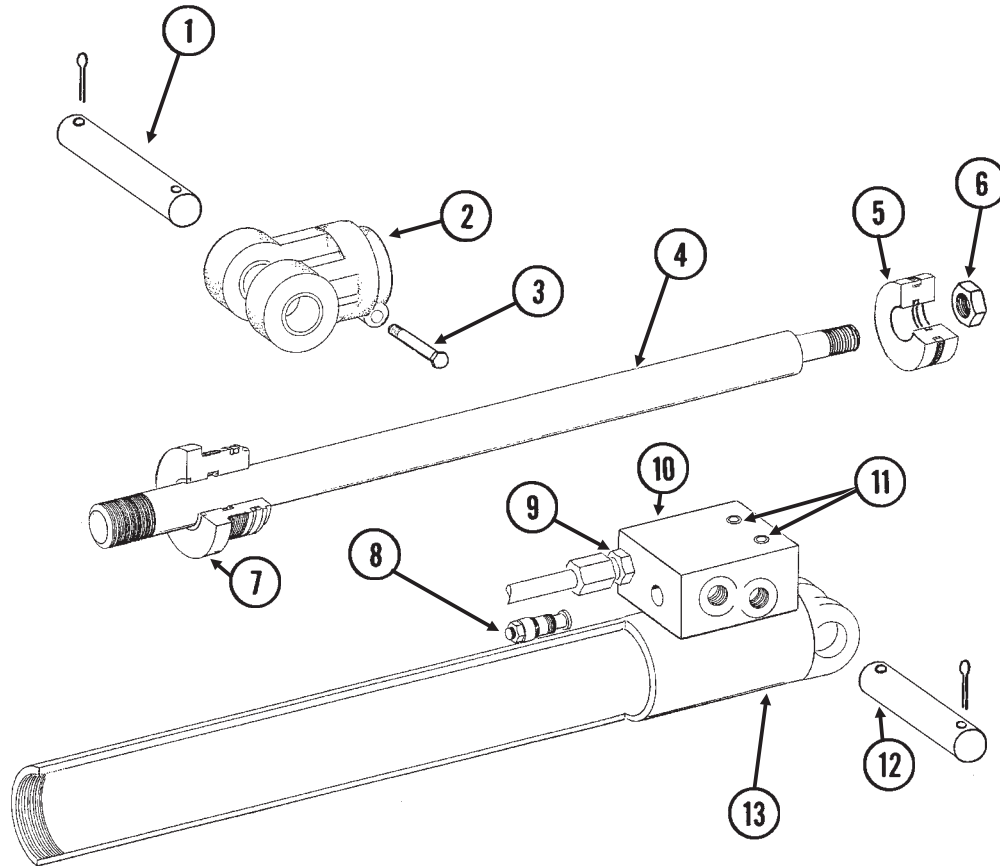

ITEM	PART NO.	QTY.	DESCRIPTION
1.	GR1287	1	Pin W/Cotter Pins
	G10460	-	Cotter Pin, 1/4" x 2"
2.	GA8130	1	Clevis W/Bushings
	GR1401	-	Bushing
3.	G10048	1	Hex Head Cap Screw, 3/8"-16 x 2"
	G10101	1	Hex Nut, 3/8"-16
4.	GD11521	1	Rod
5.	GD11520	1	Piston
6.	GR0983	1	Lock Nut, 1"-14
7.	GD11522	1	Gland
8.	GR1183	1	Counter Balance Valve
9.	G6400-08	1	Connector W/O-Ring, 3/4"-16 Male JIC To O-Ring
	GR1037	-	O-Ring
10.	GD11579	1	Block
11.	G10932	2	Hex Socket Head Cap Screw, 5/16"-18 x 2", Grade 8
12.	GR1454	1	Pin W/Cotter Pins, 1 1/4" x 3 1/2"
	G10460	-	Cotter Pin, 1/4" x 2"
13.	A8467	1	Barrel (Non-Stock Item)
A.	GA8181	-	Cylinder Complete, 3" x 20" <i>(Part Number Stamped On Barrel)</i>
B.	GR1453	-	Seal Kit, Includes: (1)Seal, (3)O-Rings, (1)RU Ring, (1)U-Cup, (1)Wiper

MASTER CYLINDER

(CYL14b))

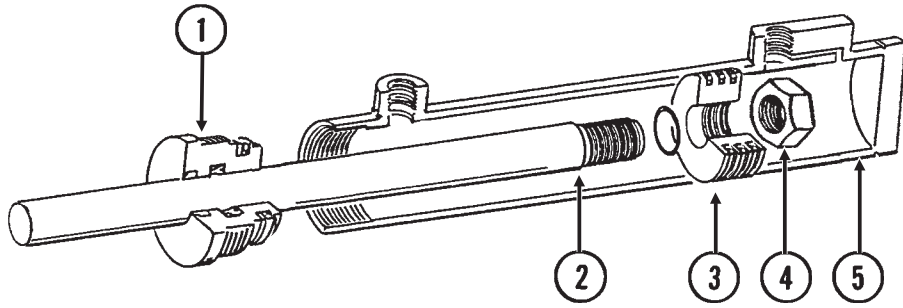

ITEM	PART NO.	QTY.	DESCRIPTION
1.	GD11513	1	Gland
2.	GD11763	1	Rod
3.	GD11294	1	Piston
4.	G10958	1	Lock Nut, 1"-14
5.	A8744	1	Barrel (Non-Stock Item)
A.	GA8745	-	Cylinder Complete, 4 1/2" x 9 3/4" <i>(Part Number Stamped On Barrel)</i>
B.	GR1496	-	Seal Kit, Includes: (2)O-Rings, (1)Piston Ring, (1)Seal Expander, (1)BU Ring, (2) C1 Rings, (1)Wiper, (1)U-Packing

TRANSPORT LATCH CYLINDER

CYL035/CYL050(CYL9b)

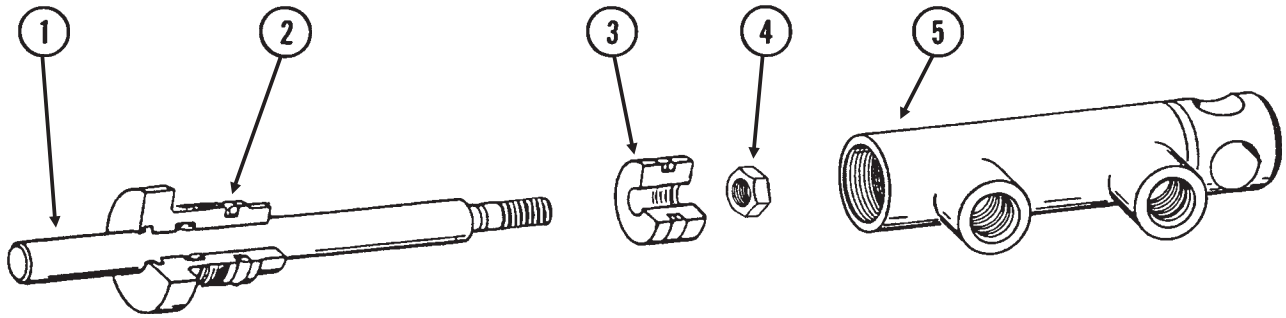

ITEM	PART NO.	QTY.	DESCRIPTION
1.	GD7124	1	Rod
2.	GD7122	1	Gland
3.	GD7120	1	Piston
4.	GR0999	1	Lock Nut, 1/2"-20
5.	A6020	1	Barrel (Non-Stock Item)
A.	GA4309	-	Cylinder Complete, 1 1/2" x 2 1/2"
B.	GR1001	-	Seal Kit, Includes: (2)O-Rings, (1)U-Cup, (1)Rod Wiper, (1)Seal

TRANSPORT LATCH POST CYLINDER

(CYL22b)

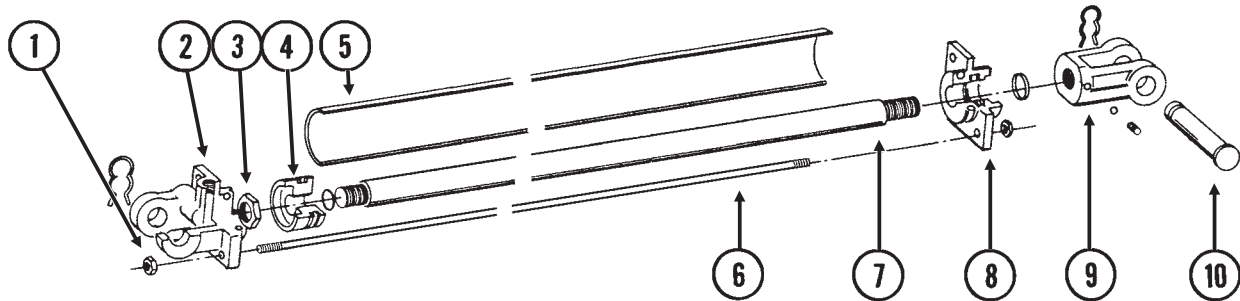

ITEM	PART NO.	QTY.	DESCRIPTION
1.	GR1476	8	Tie Rod Nut
2.	GR1469	1	End Clevis
3.	GR1478	1	Piston Nut
4.	GR1472	1	Piston
5.	R1474	1	Barrel (Non-Stock Item)
6.	GR1475	4	Tie Rod
7.	GR1473	1	Rod
8.	GR1470	1	Gland
9.	GR1471	1	Rod Clevis
10.	GR1479	2	Clevis Pin W/Clip
A.	GA8456A	-	Cylinder Complete, 2" x 24"
B.	GR1477	-	Seal Kit, Includes: (1)Seal, (5)O-Rings, (5)BU Seals

ROTATION CYLINDER

CYL061(CYL53)

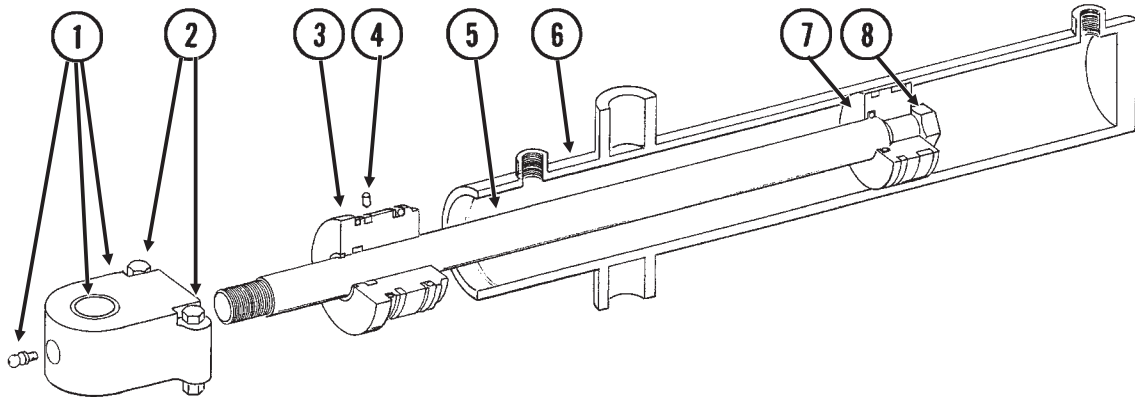

ITEM	PART NO.	QTY.	DESCRIPTION
1.	GA8497	1	Clevis W/Spring Bushing And Grease Fitting
	GR1462	-	Spring Bushing
	G10591	-	Grease Fitting, 1/4"-28 Taper
2.	G10939	2	Hex Head Cap Screw, 3/8"-16 x 2 1/4"
	G10108	2	Lock Nut, 3/8"-16
3.	GD11572	1	Gland
4.	GR1463	1	Locking Insert
5.	GD11570	1	Rod Assembly
6.	A8496	1	Barrel (Non-Stock Item)
7.	GD11571	1	Piston
8.	GR0986	1	Lock Nut, 1"-14
A.	GA8180	-	Cylinder Complete, 3" x 16" <i>(Part Number Stamped On Barrel)</i>
B.	GR1464	-	Seal Kit, Includes: (1)Rod Wiper, (2)Seals, (1)BU Ring, (3)O-Rings, (1)Wear Ring

MARKER CYLINDER

CYL039(CYL13a)

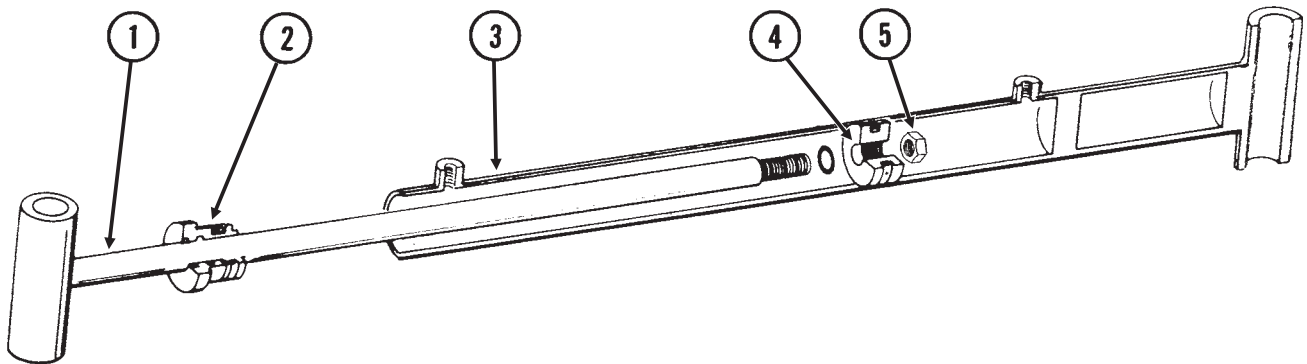

ITEM	PART NO.	QTY.	DESCRIPTION
1.	GA5459	1	Rod Assembly
2.	GD5949	1	Gland
3.	A5458	1	Barrel (Non-Stock Item)
4.	GD4632	1	Piston
5.	GR0959	1	Lock Nut, 3/4"-16
A.	GA5096	-	Cylinder Complete, 2" x 20 1/16"
B.	GR0927	-	Seal Kit, Includes: (1)T Seal, (2)O-Rings, (1)BU Ring, (1)U-Cup,(1)Wiper

ELECTRONIC SEED MONITOR

(MTR27g)

Radar Distance Sensor

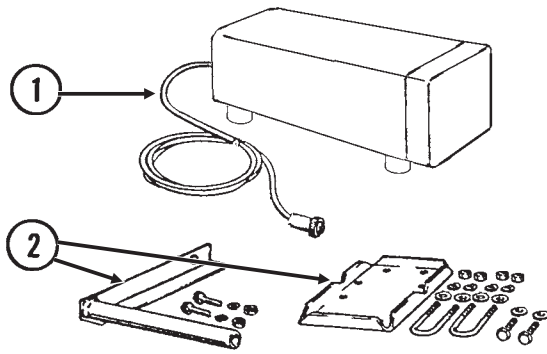

Magnetic Distance Sensor (MDS)

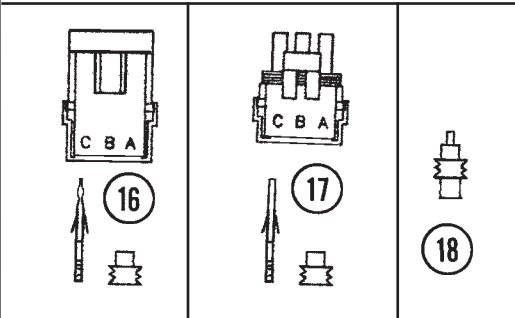
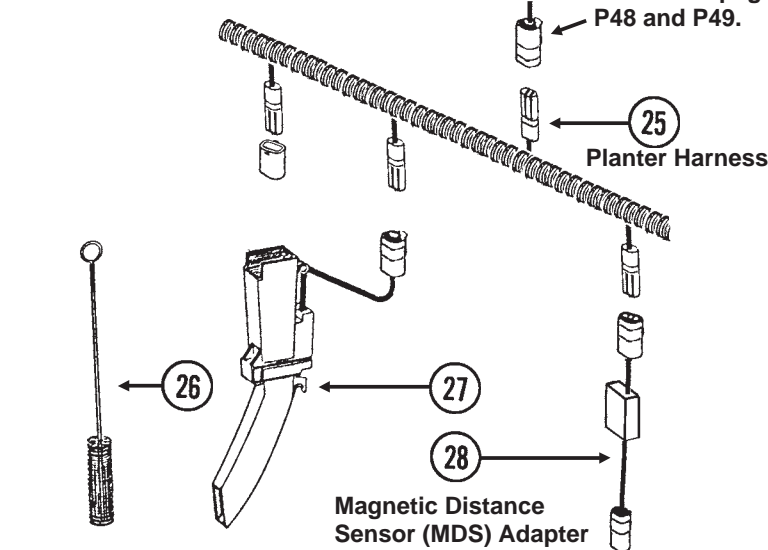
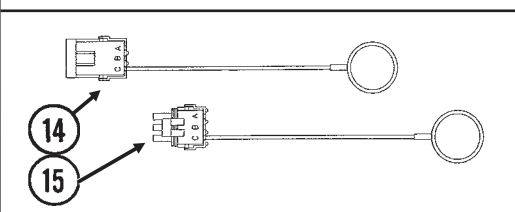
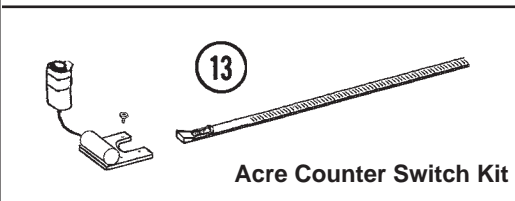
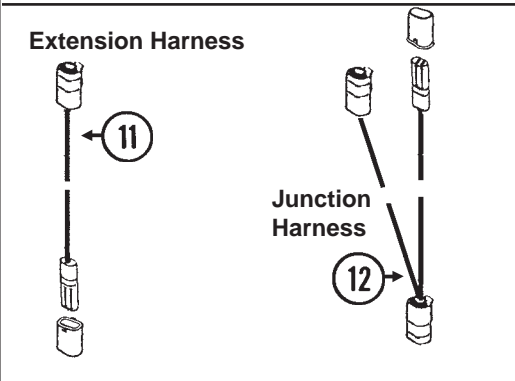
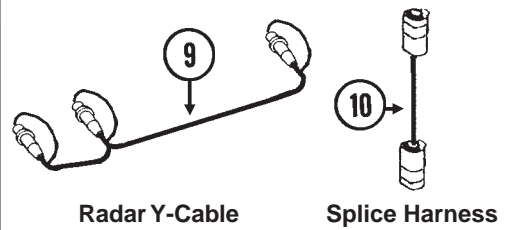
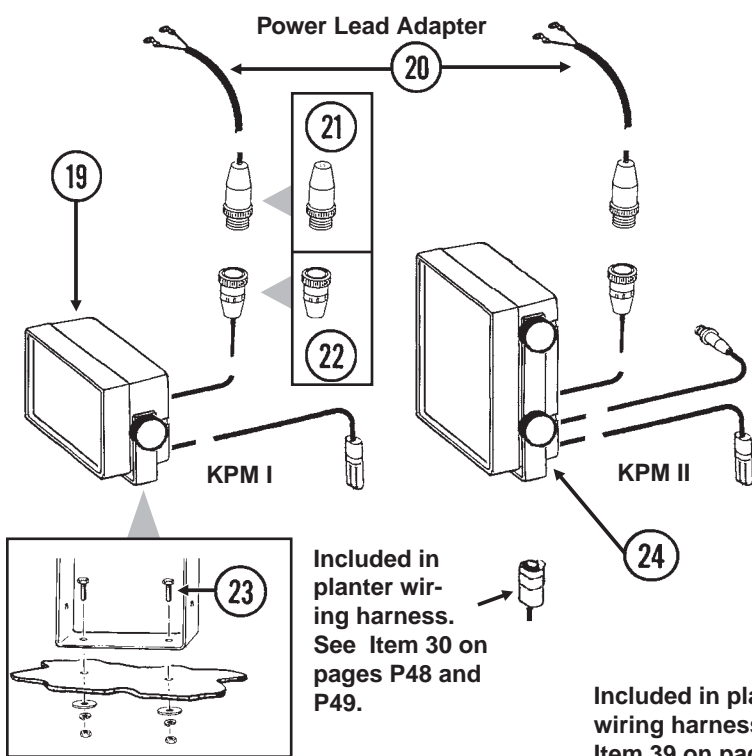
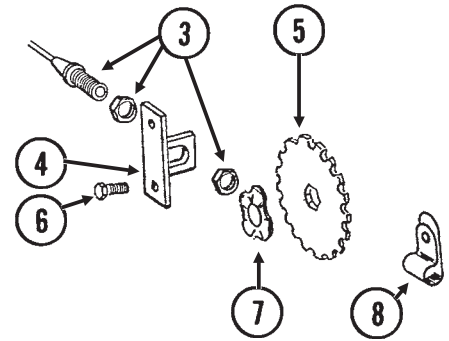

ELECTRONIC SEED MONITOR

ITEM	PART NO.	QTY.	DESCRIPTION
1.	GA7858	-	Radar Ground Speed Sensor W/20' Cable (Use W/KPM II Console Only)
2.	GA8026	-	Radar Sensor Pipe/Mounting Bracket Package
3.	GA5600	1	Magnetic Distance Sensor (Used W/KPM II Console Only)
4.	GD8770	1	Bracket
5.	GD8751	-	Magnetic Distance Sensor Pulse Wheel (Use W/KPM II Console Only)
6.	G10004	2	Hex Head Cap Screw, 3/8"-16 x 1 1/4"
	G10229	2	Lock Washer, 3/8"
	G10101	2	Hex Nut, 3/8"-16
7.	GD8771	1	Spring Wave Washer
8.	GD6291	-	Insulated Clamp
9.	GR0586	1	Radar Y-Cable (Used To Connect Radar Distance Sensor For Multiple Functions)
10.	GA7857	-	Splice Harness, 1'
11.	GA7854	-	Extension Harness, 15'
	GA7855	-	Extension Harness, 30'
12.	GA7853	-	Junction Harness
13.	G1K249	-	Acre Counter Switch Kit (Used W/KPM II Console Only)
14.	GA8046	-	Dust Plug
15.	GA8047	-	Dust Plug
16.	G1K248	-	Harness Ends Repair Kit, Includes: (3) Female Connectors, (9) Male Terminal Pins, (9) Seals
17.	G1K252	-	Harness Ends Repair Kit, Includes: (3) Male Connectors, (9) Female Terminal Pins, (9) Seals
18.	GD11089	-	Sealing Plug
19.	GA7847	1	KPM I Console W/Mounting Bracket, Power Lead Adapter (Item 20), Brush (Item 26) And Dust Plug (Item 14)
	GR1390	-	Mounting Bracket, KPM I
	GR1392	-	Console Mounting Bracket Hardware Package (Includes 2 Knobs And 1/4" Hardware)
20.	GA7856	1	Power Lead Adapter
21.	G1K267	-	Power Lead Adapter Connector Kit, 3 Pin, Includes Cable Clamp, 3-Pin Connector And 3 Male Terminal Pins
22.	G1K268	-	Console Connector Kit, 3 Pin, Includes Cable Clamp, 3-Pin Connector, Lock Ring And 3 Female Terminal Pin
23.	G10022	2	Hex Head Cap Screw, 1/4"-20 x 1/2"
	G10211	2	Washer, 1/4" SAE
	G10227	2	Lock Washer, 1/4"
	G10103	2	Hex Nut, 1/4"-20
24.	GA7846	-	KPM II Console W/Mounting Bracket, Power Lead Adapter (Item 20), Brush (Item 26) And Dust Plug (Item 14)
	GR1391	-	Mounting Bracket, KPM II
	GR1393	-	Console Mounting Bracket Hardware Package (Includes 4 Knobs And 1/4" Hardware)
25.	GA7851	-	Planter Harness, 12 Rows (16 Connectors)
26.	GR0594	-	Brush
27.	GA7848	-	Seed Tube W/Computerized Sensor (Sub G1K284)
	GR1395	-	Sensor Only
	GR1394	-	Seed Tube (With Holes For Computerized Sensor Installation)
	GD2117	-	Tie Strap, 14 1/2"
28.	GA7859	1	Magnetic Distance Sensor Adapter (Digital To Analog)
A.	GA6147	-	Sensor And Mounting Package (Items 3-8)

INTERPLANT® DRIVELINE

PTD073(2400Ta)

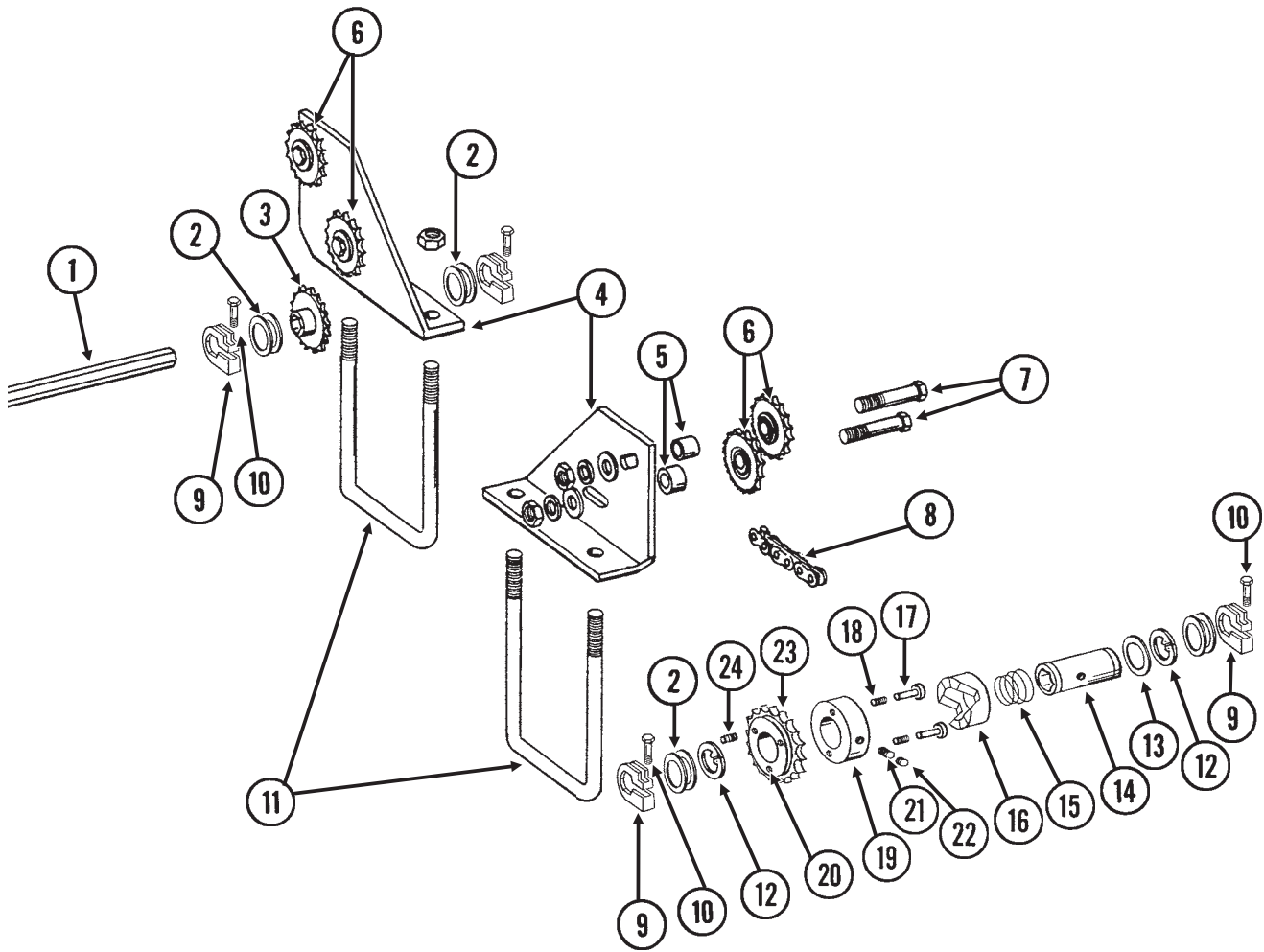

INTERPLANT® DRIVELINE

ITEM	PART NO.	QTY.	DESCRIPTION
1.	GD0914-208	-	Hex Shaft, 7/8" x 208" (No Holes)
2.	G10233	-	Machine Bushing (As Required)
3.	GA5107	2	Sprocket, 19 Tooth
4.	GD11569	2	Mount
5.	GD9229	4	Spacer
6.	GA7154	-	Idler Sprocket W/Bearing, 18 Tooth
7.	G10581	4	Hex Head Cap Screw, 1/2"-13 x 2 1/4"
	G10216	4	Washer, 1/2" USS
	G10228	4	Lock Washer, 1/2"
	G10102	4	Hex Nut, 1/2"-13
8.	G3310-328	1	Chain, No. 40, 328 Pitch Including Connector Link
	GR0912	-	Connector Link, No. 40
9.	GD11045	6	Lock Clamp
10.	G10031	6	Hex Head Cap Screw, 5/16"-18 x 1 3/4"
	G10620	6	Flange Nut, 5/16"-18
11.	GD8306	2	U-Bolt, 7" x 5" x 1/2"-13
	G10228	4	Lock Washer, 1/2"
	G10102	-	Hex Nut, 1/2"-13
12.	G10496	2	External Inverted Snap Ring, 1 1/2"
13.	GR1411	1	Shim
14.	GR1407	1	Drive Shaft
15.	GR1408	1	Compression Spring
16.	GR1409	1	Knurled Collar
17.	GR1410	1	Pin
18.	GR1413	1	Spring
19.	GR1405	1	Lock Collar
20.	GR1406	1	Bushing
21.	G10120	1	Hex Socket Set Screw, 3/8"-16 x 1/2"
22.	G10906	1	Hex Socket Set Screw, 3/8"-16 x 1/4"
23.	GR1412	1	Sprocket, 19 Tooth
24.	G10905	3	Hex Socket Head Cap Screw, No. 10-24 x 3/8"
A.	GA8092	-	Clutch Sprocket Assembly, 19 Tooth (Items 12-24)
B.	G1K269	-	Lock Clamp Kit (Items 9 And 10)

DOUBLE DISC FERTILIZER OPENER AND MOUNT

(FRTZ175/FRTZ168a)

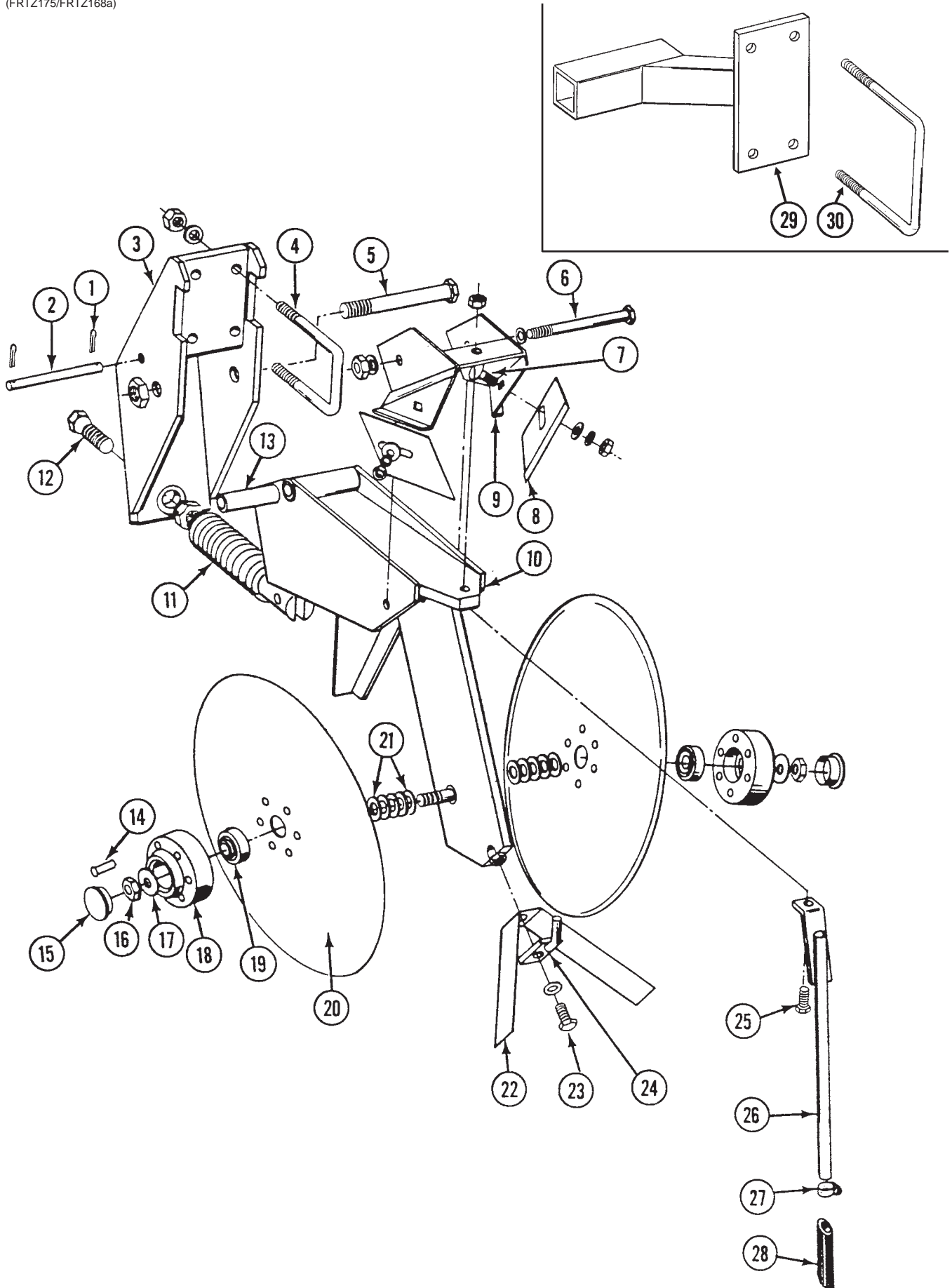

DOUBLE DISC FERTILIZER OPENER AND MOUNT

ITEM	PART NO.	QTY.	DESCRIPTION
		(Per Assy.)	
1.	G10451	2	Cotter Pin, 1/8" x 1"
2.	GD1657	1	Lockup Pin
3.	GA0785	1	Bracket
4.	GD1138	2	U-Bolt, 2 1/2" x 2 1/2" x 1/2"-13
	G10228	4	Lock Washer, 1/2"
	G10102	4	Hex Nut, 1/2"-13
5.	G10046	1	Hex Head Cap Screw, 5/8"-11 x 5"
	G10107	1	Lock Nut, 5/8"-11
6.	G10045	1	Hex Head Cap Screw, 1/2"-13 x 4 1/2"
	G10111	1	Lock Nut, 1/2"-13
7.	G10305	2	Carriage Bolt, 3/8"-16 x 1"
	G10210	2	Washer, 3/8" USS
	G10229	2	Lock Washer, 3/8"
	G10101	2	Hex Nut, 3/8"-16
8.	GD1673	2	Scraper
9.	GA0810	1	Scraper Mount
10.	GA0308	1	Shank
11.	GA0328	1	Spring
12.	GD0962	1	Hex Head Adjusting Bolt, 5/8"-18 x 3 1/4"
	G10499	1	Jam Nut, 5/8"-18
13.	GD0487	1	Bushing
14.	G10542	12	Rivet, 1/4" x 1 5/16"
15.	GD1132	2	Dust Cap
16.	G10503	1	Jam Nut, R.H., 5/8"-11
	G10504	1	Jam Nut, L.H., 5/8"-11
17.	G10204	2	Special Machine Bushing, 5/8" x 1" O.D.
18.	GB0134	2	Hub
19.	GA2014	2	Bearing
20.	GD1030	2	Blade
21.	G10213	-	Machine Bushing, 5/8" (.030" Thick)
22.	GD2589	1	Inner Scraper
23.	G10019	1	Hex Head Cap Screw, 5/16"-18 x 1"
	G10232	1	Lock Washer, 5/16"
24.	GA0312	1	Mount
25.	G10133	1	Hex Head Cap Screw, 5/16"-18 x 1 1/2"
	G10109	1	Lock Nut, 5/16"-18
26.	GA0318	-	Drop Tube, Liquid Fertilizer
27.	G10681	-	Clamp, No. 6
28.	GD1797	-	Extension
29.	GA8081	-	Opener Mount, L.H. (Shown)
	GA8080	-	Opener Mount, R.H.
30.	GD1113	2	U-Bolt, 5" x 7" x 5/8"-11
	G10230	4	Lock Washer, 5/8"
	G10104	4	Hex Nut, 5/8"-11
A.	GA0320	-	Disc And Bearing Assembly (Items 18-20)

NOTCHED SINGLE DISC FERTILIZER OPENER AND MOUNT

(PT67/FRTZ168a)

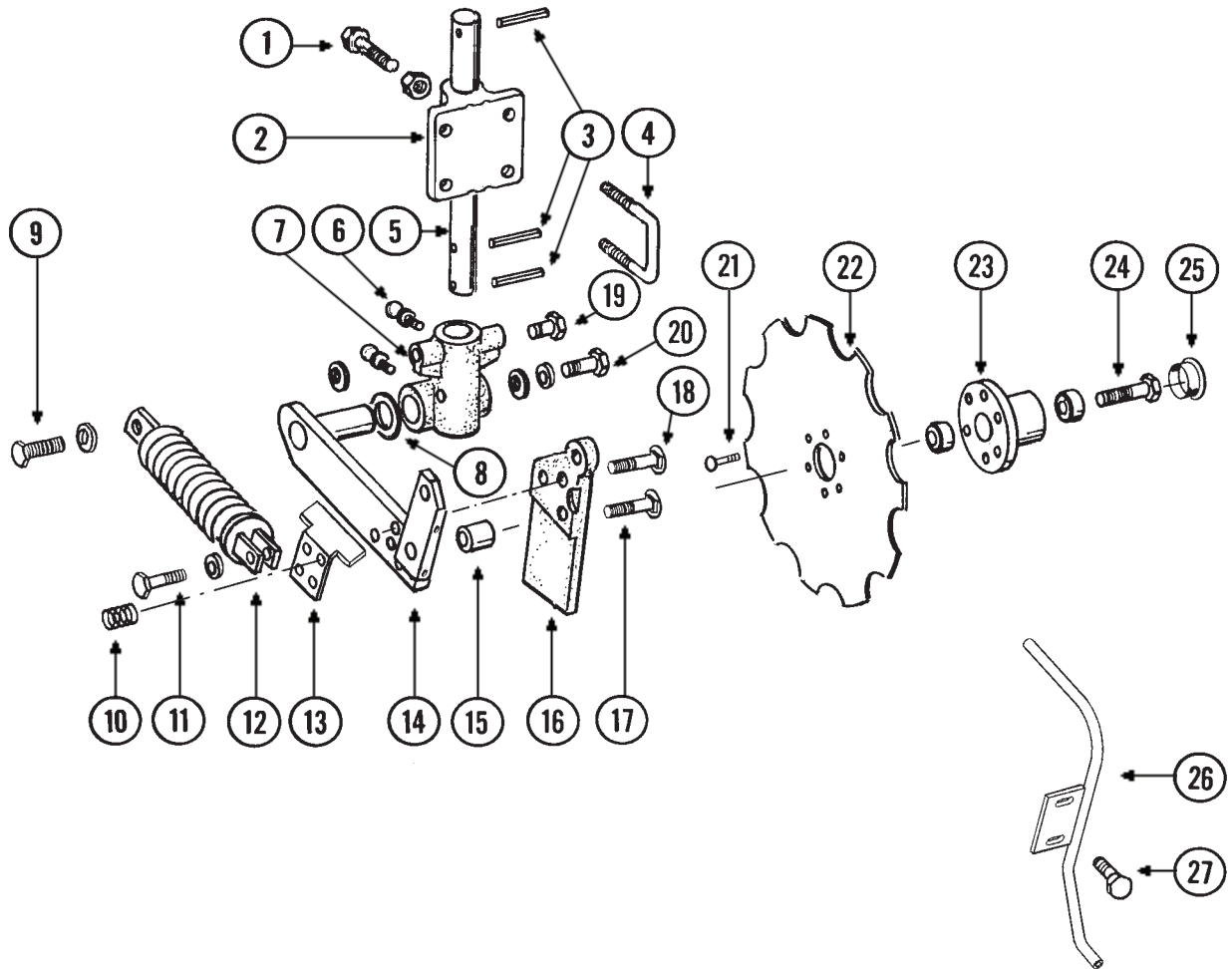
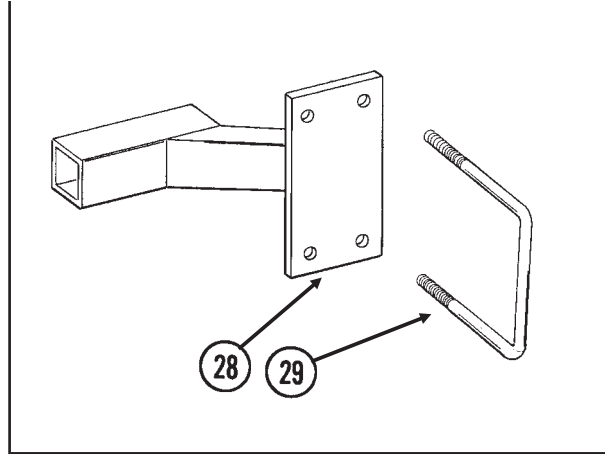

NOTCHED SINGLE DISC FERTILIZER OPENER AND MOUNT

ITEM	PART NO.	QTY.	DESCRIPTION
		(Per Assy.)	
1.	G10014	2	Hex Head Cap Screw, 1/2"-13 x 1"
	G10102	2	Hex Nut, 1/2"-13
2.	GB0270	1	Mount
3.	G10476	3	Spring Pin, 3/8" x 2 1/4"
4.	GD1138	2	U-Bolt, 2 1/2" x 2 1/2" x 1/2"-13
	G10228	4	Lock Washer, 1/2"
	G10102	4	Hex Nut, 1/2"-13
5.	GD9908	1	Shaft, 1 1/2" x 14"
6.	G10641	2	Grease Fitting, 1/8" NPT
7.	GB0250	1	Pivot
8.	G10450	2	Machine Bushing
9.	GD7818	1	Special Bolt
	GD7805	2	Special Washer
10.	GD11106	1	Spring
11.	G10047	1	Hex Head Cap Screw, 3/8"-16 x 1 3/4"
	G10210	1	Washer, 3/8"
	GD1026	1	Spacer, 1 3/16"
	G10108	1	Lock Nut, 3/8"-16
12.	GA6966	1	Compression Spring Assembly
13.	GD11097	1	Shield
14.	GA8007	1	Pivot Arm, L.H. (Shown)
	GA8008	-	Pivot Arm, R.H.
15.	GD7817-05	1	Spacer, 1 1/4"
16.	GB0249	1	Knife/Scraper, L.H. (Shown)
	GB0248	-	Knife/Scraper, R.H.
17.	G10306	2	Carriage Bolt, 3/8"-16 x 2"
	G10108	2	Lock Nut, 3/8"-16
18.	G10898	1	Carriage Bolt, 3/8"-16 x 2 3/4"
	G10210	1	Washer, 3/8" USS
	G10108	1	Lock Nut, 3/8"-16
19.	G10438	1	Hex Head Cap Screw, 1/2"-13 x 3/4"
20.	G10007	1	Hex Head Cap Screw, 5/8"-11 x 1 1/2"
	G10230	1	Lock Washer, 5/8"
	G10217	1	Washer, 5/8" USS
21.	G10886	6	Truss Head Bolt, 5/16"-18 x 1"
	G10106	6	Hex Nut, 5/16"-18
22.	GD9934	1	Blade, 16 3/4"
23.	GA5654	1	Hub W/Bearings
	GA2014	-	Bearing
24.	G10013	1	Hex Head Cap Screw, 5/8"-11 x 3 1/2"
25.	GD1132	1	Dust Cap
26.	GA6984	1	Liquid Drop Tube, R.H.
	GA6985	-	Liquid Drop Tube, L.H.
27.	G10043	2	Hex Head Cap Screw, 5/16"-18 x 3/4"
	G10232	2	Lock Washer, 5/16"
	G10219	2	Washer, 5/16" USS
28.	GA8081	-	Opener Mount, L.H. (Shown)
	GA8080	-	Opener Mount, R.H.
29.	GD1113	2	U-Bolt, 5" x 7" x 5/8"-11
	G10230	4	Lock Washer, 5/8"
	G10104	4	Hex Nut, 5/8"-11

RESIDUE WHEEL, NOTCHED SINGLE DISC FERTILIZER OPENER MOUNTED

DFC024(FRTZ165i)

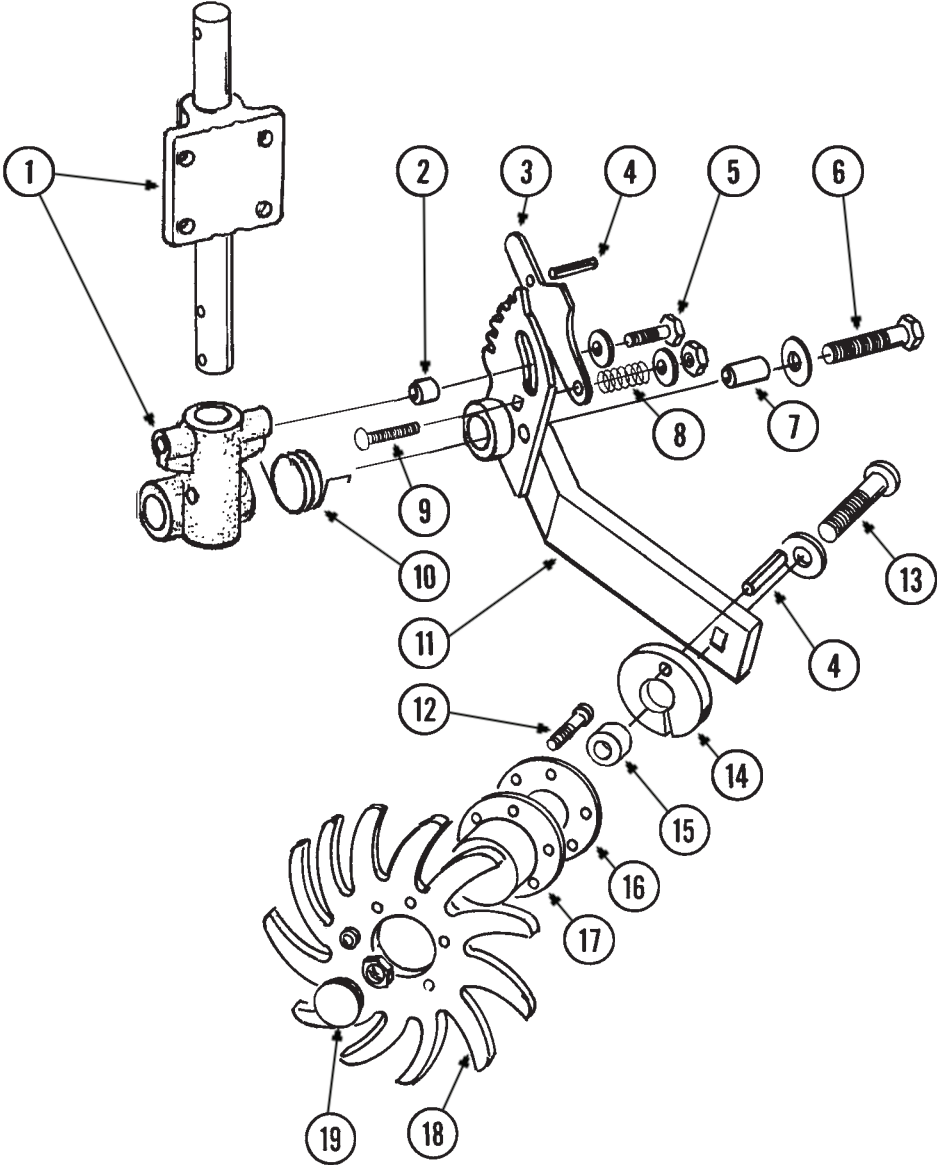

RESIDUE WHEEL, NOTCHED SINGLE DISC FERTILIZER OPENER MOUNTED

ITEM	PART NO.	QTY.	DESCRIPTION
		(Per Assy.)	
1.		-	See "Notched Single Disc Fertilizer Opener", Pages P70 And P71
2.	GD11053	1	Bushing, 7/8" Long
3.	GD11178	1	Adjustment Lever
4.	G10603	2	Spring Pin, 1/4" x 1 1/4"
5.	G10919	1	Self-Locking Hex Head Cap Screw, 1/2"-13 x 1 3/4"
	G10216	1	Washer, 1/2" USS
6.	G10920	1	Self-Locking Hex Head Cap Screw, 5/8"-11 x 3 1/2"
	GD7805	1	Special Washer
7.	GD11358	1	Hardened Bushing, 2 1/8" Long
8.	GD7962	1	Spring
9.	G10306	1	Carriage Bolt, 3/8"-16 x 2"
	G10203	1	Washer, 3/8" USS
	G10108	1	Lock Nut, 3/8"-16
10.	GD11265	1	Spring, L.H. (Shown)
	GD11266	-	Spring, R.H.
11.	GA7999	1	Mount, L.H. (Shown)
	GA7998	-	Mount, R.H.
12.	G10133	6	Hex Head Cap Screw, 5/16"-18 x 1 1/2"
	G10109	6	Lock Nut, 5/16"-18
13.	G10908	1	Carriage Bolt, 5/8"-11 x 3"
	G10503	1	Hex Jam Nut, 5/8"-11
14.	GD11188	1	Spacer
15.	GD7817-04	1	Spacer, 1 1/4" O.D. x 1/2" Long
16.	GD9724	1	Backing Plate
17.	GA5654	1	Hub W/Bearings
	GA2014	-	Bearing
18.	GD10552	2	Wheel, 3/8" x 12"
19.	GD1132	2	Dust Cap
A.	GA7445	-	L.H. Wheel Assembly (Items 12 And 16-18)(Shown)
	GA7446	-	R.H. Wheel Assembly (Items 12 And 16-18)

LIQUID FERTILIZER TANKS, SADDLES, SADDLE MOUNTS AND HOSES

LFC037/LFC038(FRTZ196)

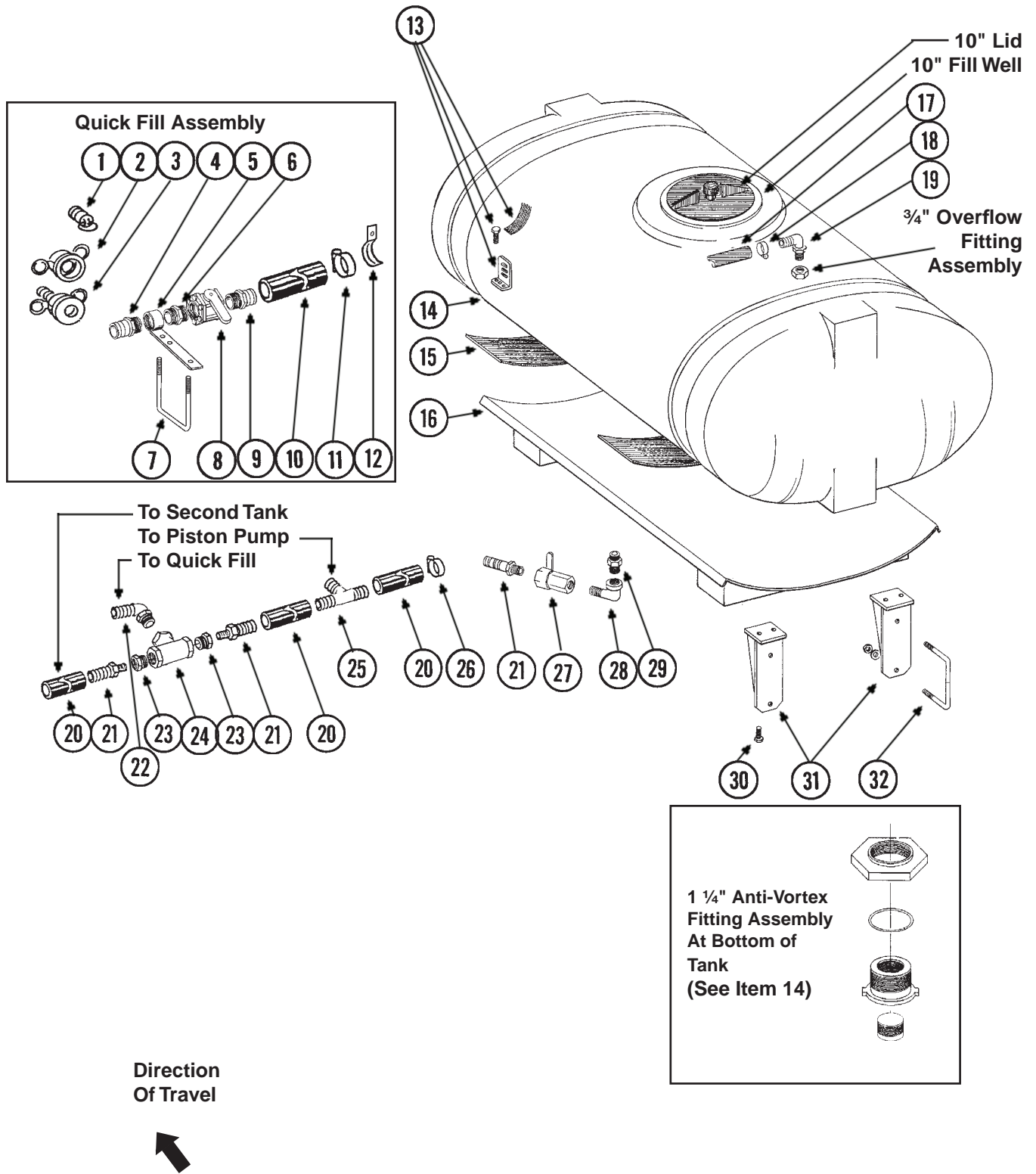

LIQUID FERTILIZER TANKS, SADDLES, SADDLE MOUNTS AND HOSES

ITEM	PART NO.	QTY.	DESCRIPTION
1.	GD10777	1	Dust Plug, 2" Male Cam Lock
2.	GD3622	1	Adapter, 2" Female NPT To Cam Lock
3.	GD3951	1	Dust Cap, 2" Cam Lock
4.	GD3623	1	Adapter, 2" Male NPT To Cam Lock
5.	GA8082	1	Quick Fill Mount, 2"
6.	G10623	1	Pipe Nipple, 2" NPT
7.	GD1134	1	U-Bolt, 7" x 5" x 5/8"-11
	G10230	2	Lock Washer, 5/8"
	G10104	2	Hex Nut, 5/8"-11
8.	GA2660	1	Shutoff Valve, 2" NPT
9.	G10628	1	Adapter, 2" NPT To Barb
10.	G4201-04	1	Hose, 2" x 15'
11.	G10676	2	Clamp, No. 36
12.	GD11235	1	Hose Clamp, 2"
13.	GA8114	2	Tank Mounting Hardware Package, Includes: (2)Straps, (4)Anchors, (8)G10485, (8)10901
	G10485	-	Hex Head Tap Bolt, 3/8"-16 x 5"
	G10901	-	Lock Nut, 3/8"-16
14.	GA8085	2	Tank With Lid And Fittings, 200 Gallon
	GR1005	-	Fill Well, 10", Threaded (Top Of Tank)
	GR1006	-	Lid, 10", Threaded (Top Of Tank)
	GR0513	-	3/4" Polypropylene Overflow Fitting Assembly (Nut, Bushing And O-Ring) (Top Of Tank)
	GR1435	-	1 1/4" Anti-Vortex Fitting Assembly (Nut, Bushing And O-Ring) (Bottom Of Tank)
15.	GD1862	-	Pad, 8" x 14'
16.	GA8088	2	Tank Saddle
17.	G4205-09	-	Hose, 3/4" x 180" (3/4" x 48" Per Tank)
18.	G10278	4	Hose Clamp, No. 16
19.	G10917	2	Elbow, 90°, 3/4" NPT To Barb
20.	G4200-01	1	Hose, 1 1/4" x 25'
21.	G10626	4	Adapter, 1 1/4" NPT To Barb
22.	G10630	1	Elbow, 90°, 2" NPT To Barb
23.	G10616	2	Reducing Bushing, 2" NPT To 1 1/4" NPT
24.	G10888	1	Tee, 2" NPT
25.	G10633	1	Tee, 1 1/4" Barb
26.	G10674	10	Clamp, No. 24
27.	GA4976	2	Shutoff Valve, 1 1/4" NPT
	GR1015	-	Body O-Ring
	GR1016	-	Stem O-Ring
	GR1017	-	Teflon Seal
	GR1018	-	Ball
	GR1019	-	Handle
28.	G10887	2	Elbow, 90°, 1 1/4" NPT
29.	G10619	2	Pipe Nipple, 1 1/4" NPT
30.	G10017	16	Hex Head Cap Screw, 1/2"-13 x 1 1/2"
	G10216	32	Washer, 1/2" USS
	G10228	16	Lock Washer, 1/2"
	G10102	16	Hex Nut, 1/2"-13
31.	GA8438	8	Saddle Mount
32.	GD1113	8	U-Bolt, 5" x 7" x 5/8"-11
	G10230	16	Lock Washer, 5/8"
	G10104	16	Hex Nut, 5/8"-11

LIQUID FERTILIZER PISTON PUMP DRIVE

LFC028(TWL43f)

40 Tooth Drive Sprocket And 18 Tooth Driven Sprocket

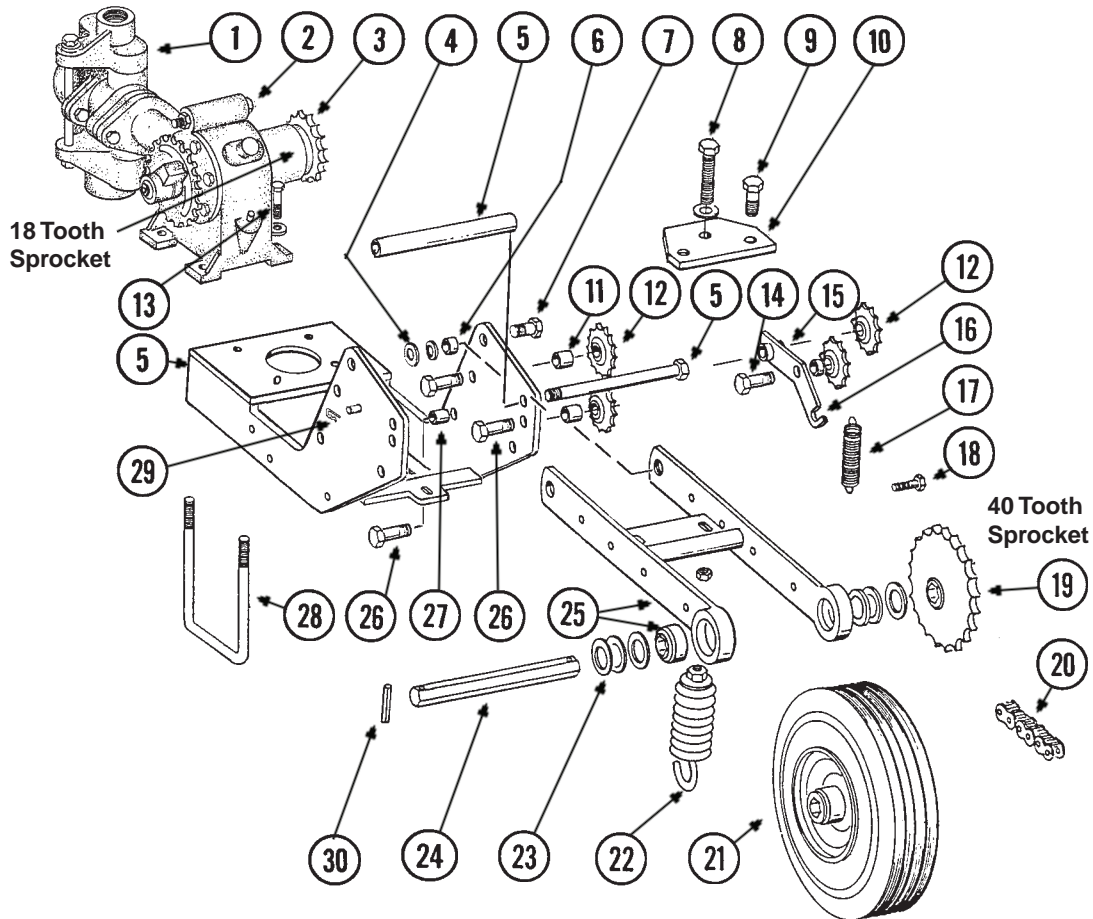

ITEM	PART NO.	QTY.	DESCRIPTION
1.		-	See "Liquid Fertilizer Piston Pump (Cylinder Assembly)", Pages P82 And P83
2.		-	See "Liquid Fertilizer Piston Pump (Crankcase Assembly)", Pages P80 And P81
3.		-	Sprocket, 18 Tooth, See "Liquid Fertilizer Piston Pump (Crankcase Assembly)", Pages P80 And P81
4.	GD7805	2	Hardened Washer
5.	GA8486	1	Pump Mount W/Sleeve And Sleeve Mounting Hardware
	GD10165	1	Sleeve, 6 3/4"
	G10819	1	Hex Head Cap Screw, 1/2"-13 x 8 1/2"
	G10228	1	Lock Washer, 1/2"
	G10102	1	Hex Nut, 1/2"-13
6.	GB0218	2	Bushing, 1 9/32"

LIQUID FERTILIZER PISTON PUMP DRIVE

ITEM	PART NO.	QTY.	DESCRIPTION
7.	G10005	2	Hex Head Cap Screw, 5/8"-11 x 1 3/4"
	G10235	2	Machine Bushing
	G10107	2	Lock Nut, 5/8"-11
8.	G10371	1	Hex Head Cap Screw, 1/2"-13 x 3"
	G10206	1	Washer, 1/2"
	G10102	1	Hex Nut, 1/2"-13
9.	G10039	2	Hex Head Cap Screw, 1/2"-13 x 1 3/4"
	G10206	2	Washer, 1/2"
	G10228	2	Lock Washer, 1/2"
	G10102	2	Hex Nut, 1/2"-13
10.	GD10156	1	Spring Mount
11.	GD10007	2	Spacer, 1 1/8"
12.	GA7154	4	Idler Sprocket, 18 Tooth
13.	G10003	4	Hex Head Cap Screw, 3/8"-16 x 1 1/2"
	GR1122	4	Mounting Pad
	G10210	4	Washer, 3/8" USS
	G10229	4	Lock Washer, 3/8"
	G10101	4	Hex Nut, 3/8"-16
14.	G10016	1	Hex Head Cap Screw, 1/2"-13 x 2"
	G10228	1	Lock Washer, 1/2"
	G10102	1	Hex Nut, 1/2"-13
15.	GD10161	1	Spacer, 3/8"
16.	GA7179	1	Idler Arm
17.	GD5857	1	Spring
18.	G10003	1	Hex Head Cap Screw, 3/8"-16 x 1/2"
	G10229	1	Lock Washer, 3/8"
	G10101	2	Hex Nut, 3/8"-16
19.	GA7180	1	Sprocket, 40 Tooth
20.	G3310-160	1	Chain, No. 40, 160 Pitch Including Connector Link
	GR0912	-	Connector Link, No. 40
21.	GA5090	1	Tire And Rim Assembly (Specify Brand*)
	GD5753	-	Tire, 4.10" x 6" (Specify Brand*)
	GD5752	-	Tube
22.	GA2068	1	Spring
23.	G10233	5	Machine Bushing
24.	GD5797	1	Shaft, 10"
25.	GA6415	1	Wheel Arm W/Bearings
	GA5116	-	Bearing
26.	G10038	3	Hex Head Cap Screw, 1/2"-13 x 3"
	G10228	3	Lock Washer, 1/2"
	G10102	3	Hex Nut, 1/2"-13
27.	GD7904-04	-	Sleeve, 1 1/8"
28.	GD1134	2	U-Bolt, 7" x 5" x 5/8"-11
	G10230	4	Lock Washer, 5/8"
	G10104	4	Hex Nut, 5/8"-11
29.	G10670	1	Hair Pin Clip, No. 3
30.	G10602	2	Spring Pin, 1/4" x 1 1/2"

* Specific brand requests will be supplied only as available from current KINZE® stock. If a specific brand requested is not in stock, the brand available will be supplied. Different brand tires may have different diameters. Change in tire brand could result in rate changes.

LIQUID FERTILIZER FLOW DIVIDER MOUNT AND HOSES

(FRTZ176c)

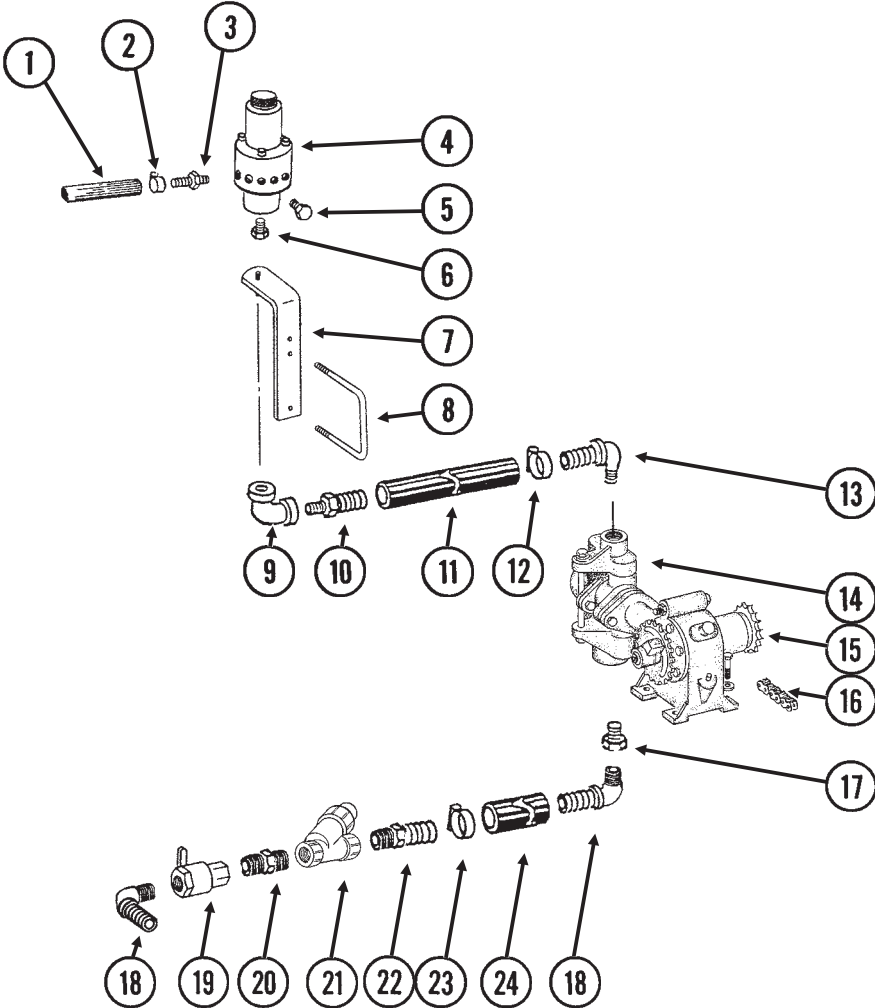

LIQUID FERTILIZER FLOW DIVIDER MOUNT AND HOSES

ITEM	PART NO.	QTY.	DESCRIPTION
1.	G4300-06	1	Hose, 7/16" x 160'
2.	G10673	24	Clamp, No. 8
3.	GD8816	12	Adapter, 1/4" NPT To 1/2" Barb
4.		-	See "Liquid Fertilizer Flow Divider", Pages P84 And P85
5.	G10292	-	Plug, 1/4" NPT
6.	G10613	1	Reducing Bushing, 1" NPT To 3/4" NPT
7.	GA6527	1	Support
8.	GD1113	1	U-Bolt, 5" x 7" x 5/8"-11
	G10230	2	Lock Washer, 5/8"
	G10104	2	Hex Nut, 5/8"-11
9.	G10733	1	Elbow, 3/4"
10.	G10734	1	Adapter, 3/4" NPT To Barb
11.		-	Hose, 3/4", See "Liquid Fertilizer Tanks, Saddles, Saddle Mounts And Hoses", Pages P74 And P75
12.	G10278	2	Clamp, No. 16
13.	G10896	1	Elbow, 90°, 3/4" Barb To 1" NPT
14.		-	See "Liquid Fertilizer Piston Pump (Cylinder Assembly)", Pages P82 And P83
15.		-	See "Liquid Fertilizer Piston Pump (Crankcase Assembly)", Pages P80 And P81
16.		-	See "Liquid Fertilizer Piston Pump Drive", Pages P76 And P77
17.	G10615	1	Reducing Bushing, 1 1/2" NPT To 1 1/4" NPT
18.	G10629	2	Elbow, 90°, 1 1/4" NPT To Barb
19.	GA4976	2	Shutoff Valve, 1 1/4" NPT
	GR1015	-	Body O-Ring
	GR1016	-	Stem O-Ring
	GR1017	-	Teflon Seal
	GR1018	-	Ball
	GR1019	-	Handle
20.	G10619	1	Pipe Nipple, 1 1/4" NPT
21.	GA3893	1	Strainer Complete
	GR0880	-	Screen, No. 40 Mesh
	GR0881	-	Gasket
	GR0882	-	"Y" Body
	GR0883	-	End Cap
22.	G10626	2	Adapter, 1 1/4" NPT To Barb
23.	G10674	2	Hose Clamp, No. 24
24.		-	Hose, 1 1/4", See "Liquid Fertilizer Tanks, Saddles, Saddle Mounts And Hoses", Pages P74 And P75

LIQUID FERTILIZER PISTON PUMP (Crankcase Assembly) Uses 18 Tooth Sprocket

JB-L4400-991/CCU077(FRTZ172a)

John Blue® Model LM-2455-R

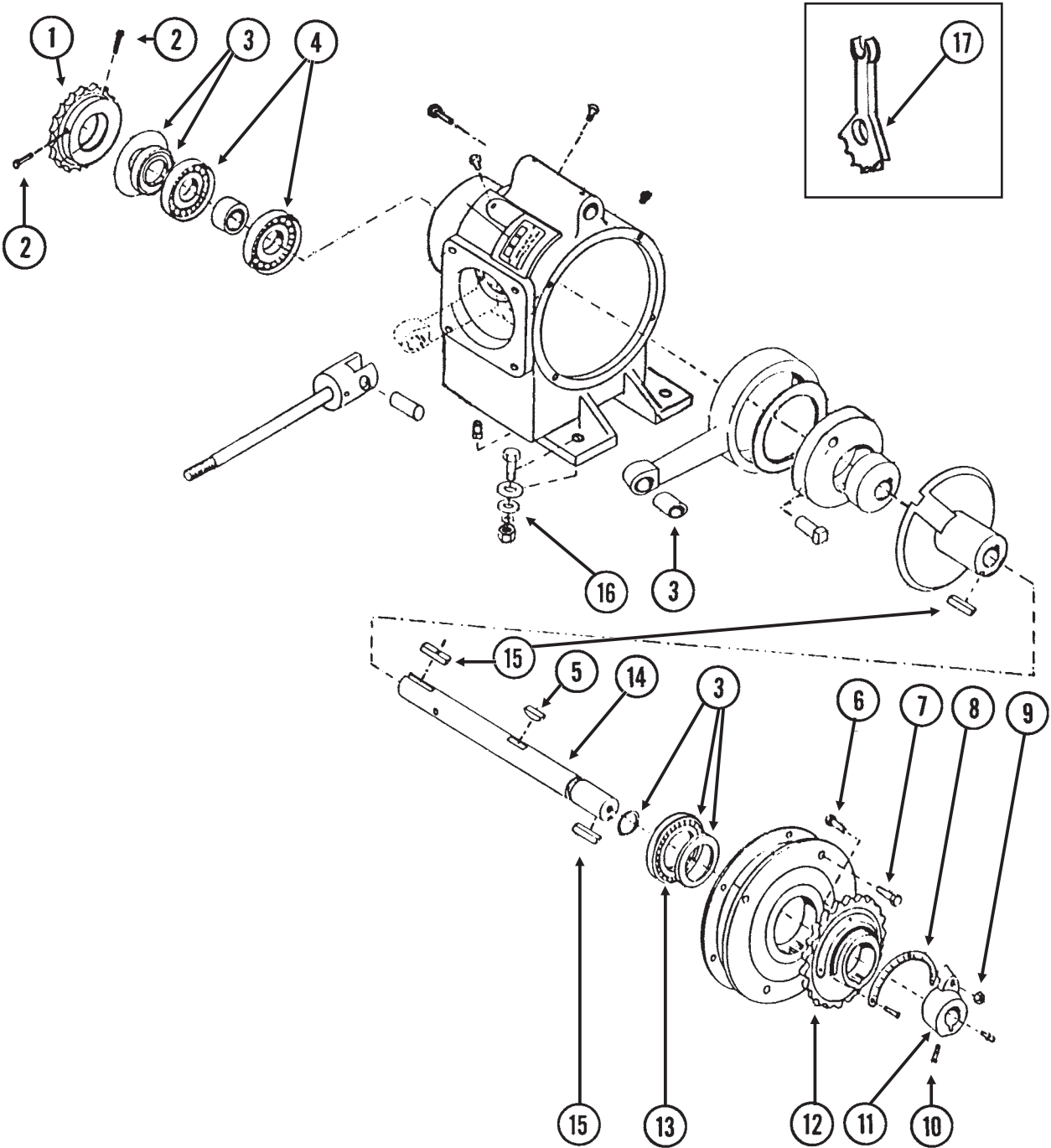

LIQUID FERTILIZER PISTON PUMP (Crankcase Assembly) Uses 18 Tooth Sprocket

ITEM	PART NO.	QTY.	DESCRIPTION
1.	GR1389	1	Sprocket, 18 Tooth
2.	G10688	2	Hex Socket Head Set Screw, 3/8"-16 x 5/8"
3.	GR1425	1	Repair Kit, Also Includes Item 1 On Pages P82 And P83
4.	GR1427	2	Bearing
5.	GR1420	1	Woodruff Key, 3/8"-16 x 1 3/4"
6.	GR1167	1	Square Head Bolt
7.	G10043	4	Hex Bolt, 5/16"-18 x 3/4"
8.	GR1426	1	Scale
9.	G10108	1	Lock Nut, 3/8"-16
10.	G10693	3	Hex Socket Head Set Screw, 5/16"-18 x 3/8"
11.	GR1165	1	Arm
12.	GR1114	1	Flange
13.	GR1116	1	Bearing
14.	GR1421	1	Crankshaft
15.	GR1118	2	Setting Arm Key
16.		-	See "Liquid Fertilizer Piston Pump Drive", Pages P76 And P77
17.	GR1424	1	Adjustment Wrench
A.	GA8069	-	Piston Pump Complete With 18 Tooth Sprocket (LM-2455-R), Includes Crankcase Assembly On This Page And Cylinder Assembly On Pages P82 And P83

LIQUID FERTILIZER PISTON PUMP (Cylinder Assembly) Uses 18 Tooth Sprocket

JB-L2190-991(FRTZ171)

John Blue® Model LM-2455-R

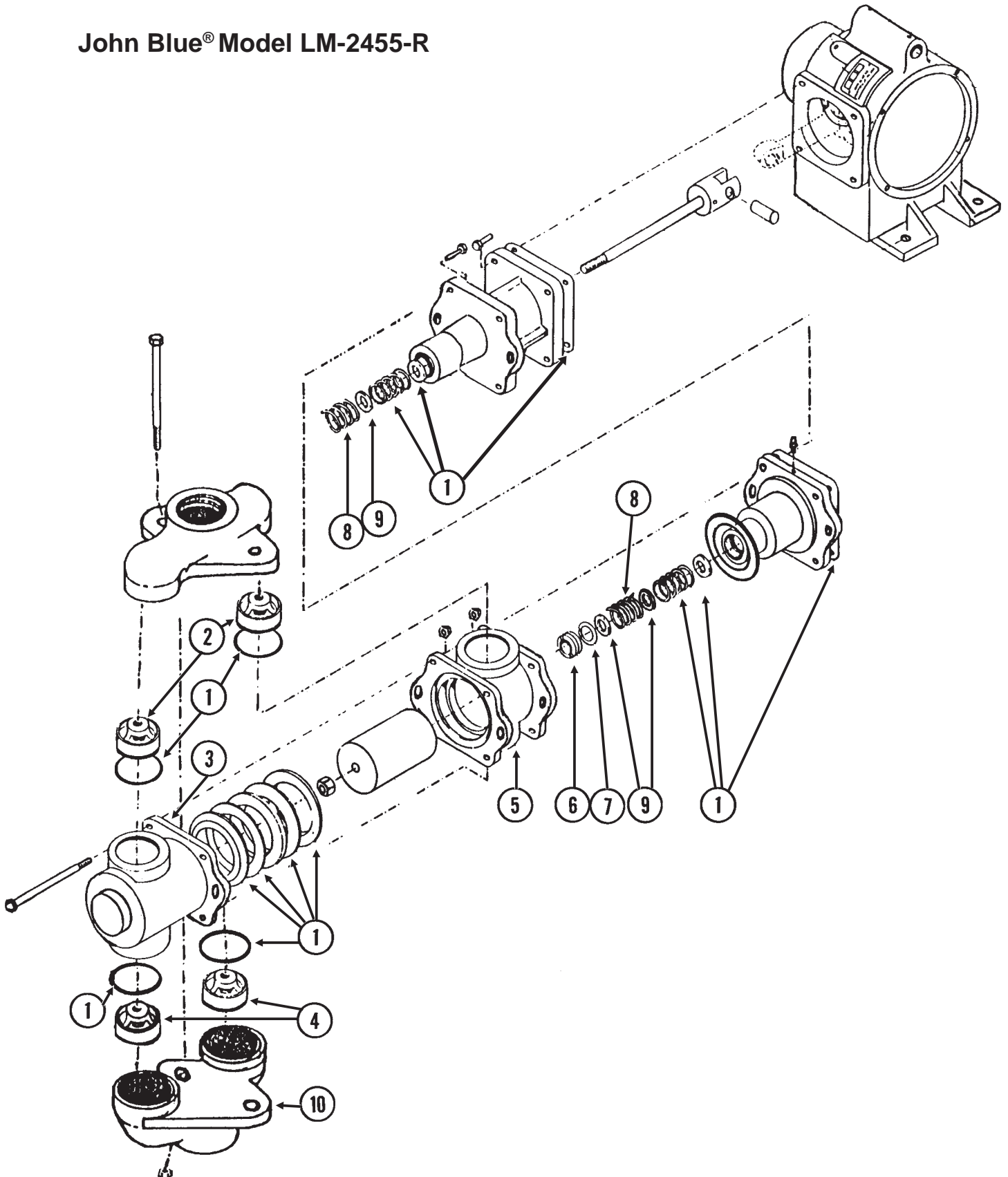

LIQUID FERTILIZER PISTON PUMP (Cylinder Assembly) Uses 18 Tooth Sprocket

ITEM	PART NO.	QTY.	DESCRIPTION
1.	GR1425	1	Repair Kit, Also Includes Item 3 On Pages P80 And P81
2.	GR1144	2	Discharge Valve
3.	GR1423	1	Outboard Cylinder
4.	GR1142	2	Suction Valve
5.	GR1422	1	Inboard Cylinder
6.	GR1134	1	Stuffing Box Insert
7.	GR1133	1	Retaining Ring
8.	GR1130	2	Packing Spring
9.	GR1129	3	Washer
10.	GR1451	1	Suction Manifold

LIQUID FERTILIZER PISTON PUMP FLOW DIVIDER

(FRTZ159)

CDS® Flow Divider

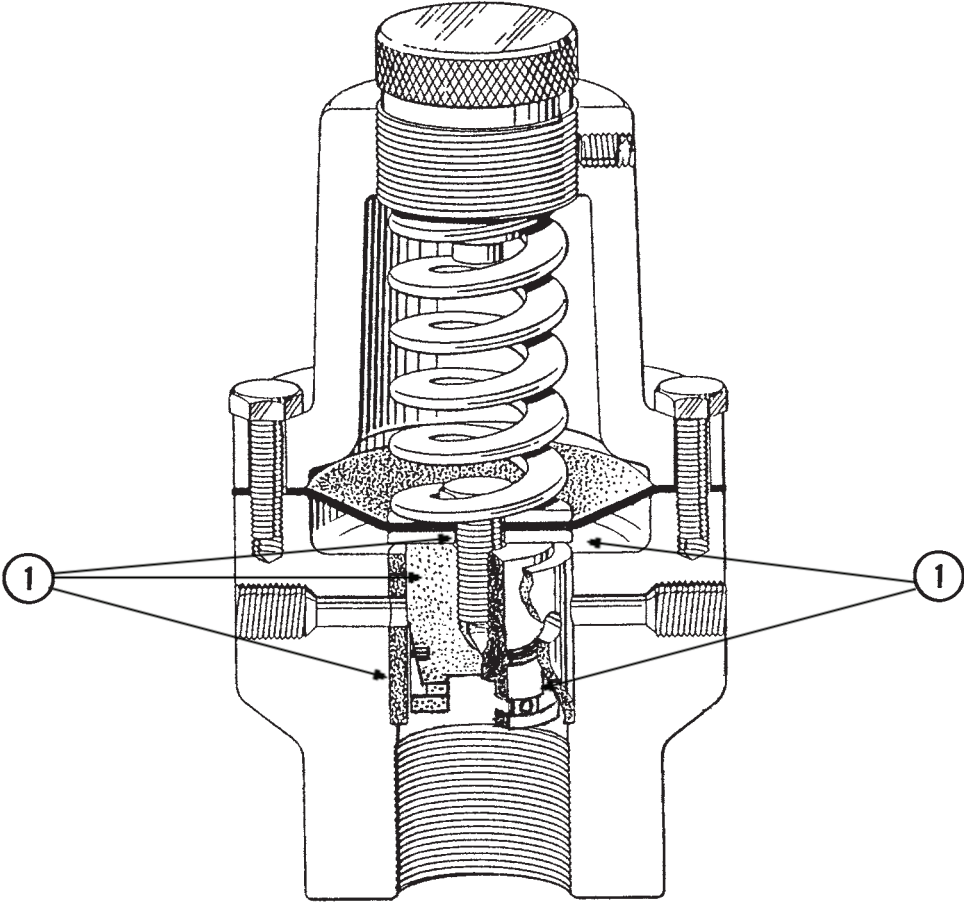

LIQUID FERTILIZER PISTON PUMP FLOW DIVIDER

ITEM	PART NO.	QTY.	DESCRIPTION
1.	GR1388	1	Repair Kit, Includes: (2)Washers, (1)Piston, (1)O-Ring, (1)Piston Bolt, (1)Piston Ring
A.	GA8068	1	Liquid Fertilizer Piston Pump Flow Divider Complete, 12 Outlet

SMV, DECALS, REFLECTORS AND TIE STRAPS



1



2

WARNING

AGRICULTURAL CHEMICALS CAN BE DANGEROUS. IMPROPER SELECTION OR USE CAN SERIOUSLY INJURE PERSONS, ANIMALS, PLANTS, SOIL OR OTHER PROPERTY. **BE SAFE.** SELECT THE RIGHT CHEMICAL FOR THE JOB. HANDLE WITH CARE. FOLLOW THE INSTRUCTIONS ON THE CONTAINER LABEL AND OF THE EQUIPMENT MANUFACTURER.

7100-115

3



4

DANGER

SERIOUS INJURY OR DEATH CAN RESULT FROM CONTACT WITH ELECTRICAL LINES. USE CARE TO AVOID CONTACT WITH ELECTRIC LINES WHEN MOVING OR OPERATING THIS MACHINE.

7100-117

5

ATTENTION

Connect directly to **BATTERY** whenever possible

Connect black lead to negative terminal

Connect to 12 Volts Only

7100-124

6

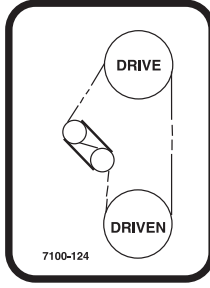

7

USE 1 TABLESPOON POWDERED GRAPHITE WITH EACH HOPPER FILL OF SEED. SEED TREATMENT, FOREIGN MATERIAL, DIRT, OR SEED CHAFF MAY CAUSE GRADUAL REDUCTION OF SEED POPULATION. REFER TO MANUAL FOR MAINTENANCE AND CARE.

7100-153

8

Twin-Line

7100-177

9

IMPORTANT

SEED METER ALIGNMENT TO DRIVE CLUTCH IS CRITICAL. REFER TO OPERATOR'S MANUAL FOR INSTRUCTIONS.

7100-182

10



11

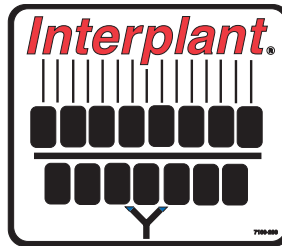

12

NOTE

It is the responsibility of the user to read and understand the Operator's Manual in regards to safety, operation, lubrication and maintenance before operation of this equipment.

AN OPERATOR & PARTS MANUAL IS AVAILABLE FOR THIS MACHINE.

To obtain a manual, furnish model number and serial number and contact your KINZE Dealer or KINZE Manufacturing, Inc., P.O. Box 806 Williamsburg, IA 52361-0806 USA

13

WARNING

MAXIMUM INFLATION PRESSURE 75 PSI

7100-139

14

KINZE 2400

15

TORQUE 5/8" SPINDLE BOLTS TO 120 FT/LBS. CHECK PERIODICALLY AND RE-TORQUE AS NEEDED.

7100-231

16

WARNING

TO AVOID INJURY - STAND CLEAR - KEEP OBJECTS AWAY WHEN RAISING OR LOWERING MARKERS. BEFORE TRANSPORTING PLANTER FULLY EXTEND HYDRAULIC CYLINDERS AND INSTALL LOCKING PIN WHERE PROVIDED.

7100-20

17

WARNING

TO AVOID INJURY - ALWAYS LOWER PLANTER UNITS TO THE GROUND BEFORE UNHITCHING PLANTER. TONGUE CAN RAISE SUDDENLY.

7100-43

18

WARNING

1. Read and understand the Operator's Manual.
2. Stop the tractor engine before leaving the operator's platform.
3. Keep riders off the machine.
4. Make certain everyone is clear of the machine before starting the tractor engine and operating.
5. Keep all shields in place.
6. Never lubricate, adjust, unplug or service the machine with tractor engine running.
7. Wait for all movement to stop before servicing.
8. Keep hands, feet and clothing away from moving parts.
9. Use flashing warning lights when operating on highways except when prohibited by law.

7100-46

19

KINZE

20

WARNING

TOW ONLY WITH FARM TRACTOR

7100-55

21

CAUTION

REAR OF PLANTER SWINGS WIDE IN TURNS. ALWAYS ALLOW SUFFICIENT ROOM TO CLEAR OBSTACLES WHEN TURNING.

7100-87

22

WARNING

NEVER WALK UNDER OR WORK ON PLANTER WHEN IT IS RAISED WITHOUT SUPPORTING THE FRAMES WITH ADDITIONAL SUPPORTS.

7100-44

23

CAUTION

AVOID UNEVEN LOADING OF HOPPERS, ESPECIALLY DURING TRANSPORT

7100-5

24

WARNING

TO AVOID INJURY ALWAYS USE HYDRAULIC CYLINDER SAFETY LOCKOUT CHANNELS WHEN TRANSPORTING PLANTER ON THE ROAD. AFTER USE RETURN TO STORAGE LOCATION.

7100-43

25

DANGER

THIS PLANTER IS DESIGNED TO BE DRIVEN BY GROUND TIRES ONLY. THE USE OF HYDRAULIC, ELECTRIC OR PTO DRIVES MAY CREATE SERIOUS SAFETY HAZARDS TO YOU AND THE PEOPLE NEARBY. IF YOU INSTALL SUCH DRIVES YOU MUST FOLLOW ALL APPROPRIATE SAFETY STANDARDS AND PRACTICES TO PROTECT YOU AND OTHERS NEAR THIS PLANTER FROM INJURY.

7100-89

26

WARNING

THIS MACHINE HAS BEEN DESIGNED AND BUILT WITH YOUR SAFETY IN MIND. ANY ALTERATION TO THE DESIGN OR CONSTRUCTION MAY CREATE SAFETY HAZARDS. DO NOT MAKE ANY ALTERATIONS OR CHANGES TO THE EQUIPMENT, BUT IF ANY ALTERATIONS OR CHANGES ARE MADE YOU MUST FOLLOW ALL APPROPRIATE SAFETY STANDARDS AND PRACTICES TO PROTECT YOU AND OTHERS NEAR THIS MACHINE FROM INJURY.

7100-80

27

SMV, DECALS, REFLECTORS AND TIE STRAPS



ITEM	PART NO.	QTY.	DESCRIPTION
1.	G7100-110	-	Decal, Grease Weekly
2.	G7100-111	-	Decal, Oil Daily
3.	G7100-115	-	Decal, Warning (1 Per Granular Chemical Hopper)
4.	G7100-116	-	Decal, Grease Daily
5.	G7100-117	1	Decal, Danger
6.	G7100-123	1	Decal, Attention
7.	G7100-124	1	Decal, Transmission
8.	G7100-153	-	Decal, Information (1 Per Brush-Type Seed Meter)
9.	G7100-177	1	Decal, Twin-Line®
10.	G7100-182	-	Decal, Meter Alignment (1 Per Row Unit)
11.	G7100-195	-	Decal, Logo (2 Per Row Unit)
12.	G7100-208	-	Decal, Interplant®
13.	G7100-217	1	Decal, Note
14.	G7100-219	4	Decal, Warning
15.	G7100-233	2	Decal, 2400
16.	G7100-234	-	Decal, Bolt Torque (Frame Mounted Coultter)
17.	G7100-42	4	Decal, Warning
18.	G7100-43	1	Decal, Warning
19.	G7100-46	1	Decal, Warning
20.	G7100-54	2	Decal, KINZE®, 4 3/16" x 17 3/16"
21.	G7100-56	1	Decal, Warning
22.	G7100-63	2	Decal, Caution
23.	G7100-68	4	Decal, Warning
24.	G7100-75	4	Decal, Caution
25.	G7100-83	4	Decal, Warning
26.	G7100-89	2	Decal, Danger
27.	G7100-90	1	Decal, Warning
28.	G7200-03	2	Reflector, Red
	G7200-04	2	Reflector, Amber
29.	GD1512	-	Tie Strap, 7"
	GD2117	-	Tie Strap, 14 1/2"
	GD1162	-	Tie Strap, 28"
	GD2984	-	Tie Strap, 33"
30.	GR0155	-	Blue Paint, Aerosol
31.	GR0146	-	Graphite Powder, 1 Pound
32.	GD2199	1	SMV Sign
33.	GD10057-01	-	Hose Identification Sleeve, Red AA
	GD10057-02	-	Hose Identification Sleeve, Red BB
	GD10057-03	-	Hose Identification Sleeve, Blue AA
	GD10057-04	-	Hose Identification Sleeve, Blue BB
34.	GR1367	-	Talc Seed Lubricant, 8 Pounds

NOTES

NUMERICAL INDEX

Part No.	Page	Part No.	Page	Part No.	Page
A1021	P59	G10047	P45, P71	G10201	P3, P17, P27
A1079	P59	G10048	P33, P60	G10203	P73
A1096	P59	G10049	P9, P17	G10204	P3, P5, P10, P69
A1113	P59	G10053	P43	G10206	P3, P23, P25, P77
A1169	P59	G10055	P9, P25, P43	G10208	P3
A1192	P59	G10061	P29	G10209	P11, P17, P29
A3123	P59	G10062	P9	G10210	P2, P3, P4, P7, P8, P9, P11, P17, P27, P35, P39, P45, P69, P71, P77
A3129	P59	G10063	P29	G10211	P49, P65
A3206	P59	G10064	P8, P34	G10213	P3, P69
A5458	P63	G10068	P25	G10216	P3, P7, P21, P22, P43, P67, P73, P75
A6020	P62	G10069	P5	G10217	P25, P29, P71
A7606	P59	G10070	P41	G10219	P7, P42, P47, P71
A7607	P59	G10099	P45	G10221	P31
A7609	P59	G10100	P43	G10226	P51
A7610	P59	G10101	P2, P3, P4, P10, P11, P14, P17, P27, P29, P35, P43, P60, P65, P69, P77	G10227	P14, P29, P34, P35, P65
A8349	P29	G10102	P7, P22, P25, P27, P35, P39, P41, P45, P51, P52, P67, P69, P71, P75, P76, P77	G10228	P3, P22, P25, P27, P35, P39, P41, P45, P51, P52, P67, P69, P71, P75, P76, P77
A8352	P35	G10103	P8, P14, P34, P35, P43, P65	G10229	P2, P3, P4, P7, P8, P10, P11, P14, P17, P27, P29, P33, P35, P39, P43, P45, P65, P69, P77
A8467	P60	G10104	P4, P25, P27, P31, P34, P43, P45, P47, P51, P69, P71, P75, P77, P79	G10230	P4, P5, P27, P31, P34, P39, P41, P43, P45, P47, P51, P69, P71, P75, P77, P79
A8496	P63	G10106	P5, P7, P21, P25, P29, P31, P42, P43, P47, P71	G10231	P34, P39
A8744	P61	G10107	P7, P8, P19, P21, P25, P29, P41, P43, P69, P77	G10232	P5, P7, P10, P29, P31, P42, P43, P47, P69, P71
D7626	P27	G10108	P3, P9, P17, P27, P63, P71, P73, P81	G10233	P42, P45, P47, P67, P77
D7627	P27	G10109	P5, P7, P8, P22, P23, P37, P69, P73	G10235	P43, P77
G10001	P2, P29, P43	G10110	P11, P43	G10278	P75, P79
G10003	P3, P7, P8, P27, P77	G10111	P8, P9, P19, P21, P22, P23, P25, P27, P43, P45, P69	G10292	P79
G10004	P3, P4, P10, P27, P43, P65	G10119	P29	G10303	P7, P42, P47
G10005	P34, P77	G10120	P67	G10304	P3
G10006	P7, P22, P29	G10128	P43	G10305	P2, P10, P18, P69
G10007	P39, P71	G10133	P8, P22, P23, P69, P73	G10306	P14, P71, P73
G10008	P25, P41	G10139	P39, P41	G10307	P27
G10009	P23	G10148	P23	G10308	P18
G10010	P5	G10152	P7	G10309	P10
G10012	P25	G10157	P29	G10310	P11, P14
G10013	P8, P71	G10159	P51	G10311	P17
G10014	P3, P31, P71	G10168	P52	G10312	P3, P10, P17
G10015	P7	G10169	P29	G10315	P7
G10016	P39, P43, P77	G10171	P7	G10318	P21, P41
G10017	P21, P27, P41, P45, P75	G10200	P29		
G10018	P5, P7				
G10019	P10, P43, P69				
G10020	P12				
G10021	P12				
G10022	P12, P17, P35, P65				
G10023	P17				
G10025	P34				
G10027	P39				
G10029	P29				
G10031	P47, P67				
G10033	P22				
G10036	P19, P25				
G10037	P27				
G10038	P77				
G10039	P21, P77				
G10043	P29, P71, P81				
G10045	P22, P69				
G10046	P69				

NUMERICAL INDEX

Part No.	Page	Part No.	Page	Part No.	Page
G10322.....	P51	G10567.....	P17	G10747.....	P8, P9, P25
G10323.....	P12	G10570.....	P17	G10751.....	P4, P27, P43
G10326.....	P3	G10572.....	P21, P25	G10752.....	P4
G10328.....	P3	G10573.....	P25	G10755.....	P37
G10348.....	P22	G10574.....	P19, P22,	G10757.....	P14
G10361.....	P35	P25	G10758.....	P14
G10371.....	P22, P77	G10581.....	P25, P67	G10765.....	P29
G10373.....	P37, P41	G10582.....	P25	G10770.....	P9
G10376.....	P41	G10584.....	P13	G10779.....	P39
G10394.....	P39	G10585.....	P21	G10801.....	P7
G10396.....	P29	G10591.....	P63	G10814.....	P3
G10401.....	P12	G10597.....	P21	G10819.....	P76
G10409.....	P45	G10599.....	P27	G10821.....	P45
G10412.....	P4, P27, P43	G10602.....	P12, P13, P17,	G10844.....	P52
G10421.....	P43	P42, P45, P77	G10862.....	P43
G10427.....	P3, P7	G10603.....	P12, P13, P73	G10864.....	P14
G10430.....	P47	G10604.....	P12	G10867.....	P45
G10438.....	P31, P71	G10605.....	P2	G10886.....	P71
G10441.....	P29, P33, P39	G10609.....	P17	G10887.....	P75
G10442.....	P29, P33, P39	G10613.....	P79	G10888.....	P75
G10445.....	P45	G10615.....	P79	G10890.....	P42
G10450.....	P71	G10616.....	P75	G10896.....	P79
G10451.....	P3, P69	G10619.....	P75, P79	G10898.....	P71
G10452.....	P14	G10620.....	P3, P10, P11, P12,	G10901.....	P75
G10455.....	P10	P17, P47, P67	G10905.....	P67
G10457.....	P10, P29	G10621.....	P10, P11, P12,	G10906.....	P67
G10460.....	P39, P41, P45,	P17, P18	G10908.....	P73
.....	P51, P60	G10622.....	P18, P27, P3	G10917.....	P75
G10463.....	P7	G10623.....	P75	G10919.....	P73
G10464.....	P47	G10626.....	P75, P79	G10920.....	P73
G10470.....	P12	G10628.....	P75	G10932.....	P60
G10476.....	P71	G10629.....	P79	G10934.....	P31
G10478.....	P45	G10630.....	P75	G10935.....	P29
G10485.....	P75	G10633.....	P75	G10936.....	P39
G10496.....	P67	G10637.....	P17	G10937.....	P35
G10499.....	P69	G10640.....	P5, P19, P25,	G10939.....	P63
G10500.....	P12	P34, P37, P45	G10954.....	P35
G10501.....	P22, P43	G10641.....	P37, P51, P71	G10958.....	P61
G10503.....	P3, P21, P43,	G10660.....	P17	G10974.....	P23
.....	P69, P73	G10669.....	P3	G1K213.....	P15
G10504.....	P3, P69	G10670.....	P17, P77	G1K248.....	P49, P65
G10520.....	P11	G10673.....	P79	G1K249.....	P65
G10521.....	P17	G10674.....	P75, P79	G1K252.....	P49, P65
G10523.....	P14	G10676.....	P75	G1K267.....	P65
G10526.....	P3	G10680.....	P14	G1K268.....	P65
G10529.....	P18	G10681.....	P69	G1K269.....	P47, P67
G10531.....	P13	G10688.....	P81	G1K274.....	P56
G10536.....	P21, P37, P51	G10690.....	P12	G1K275.....	P56
G10542.....	P69	G10693.....	P81	G1K276.....	P56
G10544.....	P52	G10722.....	P52	G1K299.....	P29
G10545.....	P4, P27	G10724.....	P52	G2100-03.....	P42, P47
G10546.....	P17	G10725.....	P52	G3303-114.....	P17
G10551.....	P3	G10732.....	P4, P27	G3303-96.....	P27
G10552.....	P3	G10733.....	P79	G3303-98.....	P10
G10553.....	P10	G10734.....	P79	G3305-01.....	P18
G10555.....	P3	G10746.....	P43	G3310-101.....	P43

NUMERICAL INDEX

Part No.	Page	Part No.	Page	Part No.	Page
G3310-160.....	P77	GA0257	P52	GA5108	P45
G3310-328.....	P67	GA0308	P69	GA5109	P45
G3310-80.....	P45	GA0312	P69	GA5110	P45
G3310-83.....	P43	GA0318	P69	GA5111	P45
G3310-93.....	P43	GA0320	P69	GA5112	P45
G3314-40.....	P17	GA0328	P69	GA5113	P45
G3400-01.....	P42, P47	GA0378	P47	GA5114	P43
G4200-01.....	P75	GA0705	P41	GA5116	P45, P77
G4201-04.....	P75	GA0785	P69	GA5146	P45
G4205-09.....	P75	GA0810	P69	GA5385	P49
G4300-06.....	P79	GA0811	P3	GA5459	P63
G6400-06.....	P53, P54, P55, P59	GA0899	P52	GA5533	P17
G6400-08.....	P53, P54, P55, P60	GA1306	P3	GA5553	P15
G6400-L-08	P59	GA1676	P52	GA5554	P15
G6408-06.....	P55	GA1677	P52	GA5560	P15
G6408-08.....	P54, P55	GA1678	P52	GA5561	P15
G6408-10.....	P55	GA1679	P52	GA5564	P27
G6408-H06-O	P53, P54, P55	GA1720	P4	GA5600	P65
G6500-08.....	P59	GA2007	P10	GA5622	P19, P25
G6801-06.....	P59	GA2012L	P3	GA5623	P15
G6801-06-08	P59	GA2012R	P3	GA5624	P45
G6801-08.....	P59	GA2013	P3	GA5625	P19
G7100-110.....	P87	GA2014	P3, P7, P9, P21, P22, P23, P25,	GA5629	P45
G7100-111.....	P87		P69, P71, P73	GA5630	P25
G7100-115.....	P87	GA2016	P10	GA5631	P25
G7100-116.....	P87	GA2018	P12	GA5635	P25
G7100-117.....	P87	GA2019	P12	GA5636	P25
G7100-123.....	P87	GA2020	P12	GA5637	P25
G7100-124.....	P87	GA2027	P11	GA5640	P19, P25
G7100-153.....	P87	GA2054	P7	GA5643	P25
G7100-177.....	P87	GA2058	P11	GA5651	P4
G7100-182.....	P87	GA2068	P43, P77	GA5654	P21, P22, P23, P25, P71, P73
G7100-195.....	P87	GA2075	P14	GA5698	P13
G7100-208.....	P87	GA2076	P17	GA5699	P13
G7100-217.....	P87	GA2094	P18	GA5715	P21
G7100-219.....	P87	GA2180	P43	GA5718	P21
G7100-233.....	P87	GA2327	P11	GA5719	P21
G7100-234.....	P87	GA2528	P49	GA5746	P15
G7100-42.....	P87	GA2612	P49	GA5786	P27
G7100-43.....	P87	GA2660	P75	GA5787	P27
G7100-46.....	P87	GA3413	P57	GA5788	P27
G7100-54.....	P87	GA3584	P49	GA5794	P13
G7100-56.....	P87	GA3893	P79	GA5795	P13
G7100-63.....	P87	GA4235	P45	GA5796	P13
G7100-68.....	P87	GA4309	P62	GA5798	P25
G7100-75.....	P87	GA4444	P17	GA5834	P13
G7100-83.....	P87	GA4822	P10	GA5965	P41
G7100-89.....	P87	GA4976	P75, P79	GA5982	P13
G7100-90.....	P87	GA4994	P29	GA5987	P41
G7200-03.....	P87	GA4995	P29	GA5988	P41
G7200-04.....	P87	GA5090	P77	GA6027	P13
G7408X	P49	GA5096	P63	GA6038	P13
GA0167	P52	GA5105	P42, P43	GA6108	P49
GA0243	P52	GA5106	P45	GA6109	P49
GA0245	P52	GA5107	P45, P67	GA6147	P65

NUMERICAL INDEX

Part No.	Page	Part No.	Page	Part No.	Page
GA6168	P13	GA7580	P9	GA8430	P49
GA6171	P5, P7, P8	GA7846	P65	GA8431	P49
GA6182	P13	GA7847	P65	GA8432	P49
GA6184	P13	GA7848	P65	GA8433	P49
GA6187	P13	GA7851	P65	GA8438	P75
GA6415	P77	GA7853	P65	GA8450	P47
GA6434	P8	GA7854	P65	GA8451	P47
GA6478	P13	GA7855	P65	GA8456	P62
GA6497	P34	GA7856	P65	GA8472	P51
GA6527	P79	GA7857	P65	GA8477	P43
GA6532	P51	GA7858	P65	GA8486	P76
GA6597	P8	GA7859	P65	GA8497	P63
GA6613	P8	GA7862	P49	GA8745	P61
GA6614	P5	GA7863	P49	GA8764	P29
GA6615	P5	GA7998	P73	GA8765	P29
GA6618	P7	GA7999	P73	GB0102	P2
GA6619	P7	GA8007	P71	GB0103	P3
GA6620	P7	GA8008	P71	GB0104	P3
GA6633	P13	GA8026	P65	GB0105	P3
GA6699	P49	GA8046	P65	GB0107	P10
GA6700	P49	GA8047	P49, P65	GB0108	P10
GA6733	P7	GA8068	P85	GB0110	P12
GA6741	P14	GA8069	P81	GB0111	P12
GA6792	P34	GA8080	P69, P71	GB0115	P17
GA6801	P7	GA8081	P69, P71	GB0116	P17
GA6832	P22	GA8082	P75	GB0120	P12
GA6833	P22	GA8085	P75	GB0121	P17
GA6834	P22	GA8088	P75	GB0134	P69
GA6838	P22	GA8092	P67	GB0183	P17
GA6907	P14	GA8114	P75	GB0184	P17
GA6937	P9	GA8130	P60	GB0186	P27, P4
GA6966	P71	GA8167	P27	GB0196	P25
GA6975	P49	GA8170	P51	GB0218	P4, P8, P25, P27, P29, P43, P76
GA6977	P49	GA8172	P37	GB0219	P8, P9
GA6978	P49	GA8180	P63	GB0227	P19, P25
GA6984	P71	GA8181	P60	GB0230	P31
GA6985	P71	GA8343	P12	GB0233	P7, P8, P9
GA7016	P29	GA8348	P41	GB0234	P31
GA7022	P29	GA8350	P33	GB0237	P29
GA7067	P39	GA8351	P39	GB0239	P7
GA7077	P49	GA8353	P41	GB0243	P10
GA7096	P39	GA8354	P41	GB0245	P9
GA7154	P43, P67, P77	GA8355	P39	GB0248	P71
GA7179	P77	GA8356	P31	GB0249	P71
GA7180	P77	GA8357	P31	GB0250	P71
GA7255	P13	GA8362	P33	GB0254	P8
GA7271	P23	GA8372	P37	GB0270	P71
GA7336	P45	GA8373	P37	GD0453-08	P51
GA7368	P49	GA8374	P39	GD0487	P69
GA7369	P42	GA8382	P51	GD0652	P51
GA7399	P49	GA8383	P41	GD0740	P35
GA7412	P23	GA8402	P41	GD0746	P52
GA7434	P41	GA8405	P41	GD0752-41	P51
GA7445	P23, P73	GA8406	P57	GD0840	P52
GA7446	P22, P23, P73	GA8407	P51	GD0914-204	P47
GA7574	P47	GA8426	P43		

NUMERICAL INDEX

Part No.	Page	Part No.	Page	Part No.	Page
GD0914-206	P47	GD1063	P17	GD11428	P37
GD0914-208	P67	GD1065	P3	GD1143	P18
GD0914-43	P47	GD1066	P3	GD1144	P18
GD0962	P69	GD10710	P27	GD11444	P37
GD0973	P5	GD1072	P17	GD11445	P37
GD10007	P77	GD10733	P12	GD1145	P18
GD10011	P39	GD10777	P75	GD11454	P41
GD10012	P39	GD10785	P41	GD11456	P39
GD10013	P39	GD1079	P9	GD11459	P54
GD10014	P39	GD1083	P12	GD11460	P53
GD10036	P4	GD1085	P8	GD11461	P55
GD10057-01	P87	GD1086	P5	GD11473	P31
GD10057-02	P87	GD10867	P3	GD11489	P31, P51
GD10057-03	P87	GD1089	P17	GD11507	P33
GD10057-04	P87	GD1090	P14	GD11510	P29
GD10063	P29, P33, P39	GD11045	P47, P67	GD11512	P33
GD10156	P77	GD11053	P73	GD11513	P61
GD10161	P45, P77	GD11079	P49	GD11520	P60
GD10165	P76	GD11080	P49	GD11521	P60
GD10226	P12	GD11081	P49	GD11522	P60
GD10243	P49	GD11089	P49, P65	GD11549	P47
GD1026	P3, P17, P27, P45, P71	GD1109	P4, P7, P8, P25, P27	GD11555	P35
GD1027	P3	GD11090	P49	GD11569	P67
GD10283	P52	GD11091	P49	GD11570	P63
GD1030	P3, P69	GD11097	P71	GD11571	P63
GD10318	P49	GD1110	P3	GD11572	P63
GD1033	P3	GD11106	P71	GD11579	P60
GD1035	P10	GD11125	P43	GD1162	P87
GD1036	P10	GD1113	P4, P27, P34, P45, P47, P69, P71, P75, P79	GD11763	P61
GD1037	P10	GD11158	P43	GD1255	P47
GD1039	P12	GD1115L	P14	GD1256	P47
GD1040	P12	GD1115R	P14	GD1353	P5
GD1041	P12	GD1116	P14	GD1512	P87
GD1042	P12	GD11178	P73	GD1529	P41
GD1045	P12	GD1118	P14	GD1536	P41
GD1046	P12	GD11188	P73	GD1657	P69
GD10464	P10, P17	GD1120	P3	GD1673	P69
GD10473	P3, P7	GD1121	P11	GD1719	P47
GD1048	P5	GD11218	P27	GD1755	P13
GD10519	P23	GD11219	P17	GD1797	P69
GD1051L	P11	GD11233	P27	GD1862	P75
GD1051R	P11	GD11235	P75	GD2117	P65, P87
GD10526	P23	GD11239	P17	GD2128	P10, P27
GD1053	P11	GD11265	P73	GD2161	P51
GD10532	P34	GD11266	P73	GD2169	P39
GD1054	P11	GD11294	P61	GD2199	P87
GD1055	P11	GD1130	P3	GD2423	P14
GD10552	P22, P23, P73	GD1132	P21, P22, P23, P25, P69, P71, P73	GD2460	P18
GD1056	P17	GD1134	P43, P75, P77	GD2558	P43, P45
GD1058	P17	GD11358	P73	GD2589	P69
GD1059L	P17	GD11359	P35	GD2597	P52
GD1059R	P17	GD11362	P35	GD2721	P51
GD10646	P29	GD1138	P69, P71	GD2734-01	P45
GD1060	P17	GD11427	P37	GD2829	P49
GD1061	P17			GD2947	P14
				GD2971-09	P29

NUMERICAL INDEX

Part No.	Page	Part No.	Page	Part No.	Page
GD2971-10	P17	GD7822	P45	GR0155	P87
GD2984	P87	GD7823	P21, P25	GR0196	P10, P17, P27
GD3180-16	P45	GD7831	P25	GR0257	P41
GD3181-12	P7	GD7867	P45	GR0322	P41
GD3214	P51	GD7878	P13	GR0513	P75
GD3622	P75	GD7889	P21	GR0515	P29
GD3623	P75	GD7890	P21	GR0516	P29
GD3860	P49	GD7904-04	P77	GR0517	P29
GD3951	P75	GD7962	P73	GR0586	P65
GD4086	P59	GD8237	P13	GR0594	P65
GD4632	P63	GD8249	P4, P27	GR0664	P12
GD5154	P29	GD8260	P29	GR0761	P56
GD5752	P42, P77	GD8306	P67	GR0763	P56
GD5753	P42, P77	GD8307	P21, P25	GR0764	P56, P57
GD5797	P77	GD8460	P8	GR0880	P79
GD5835	P45	GD8532	P41	GR0881	P79
GD5857	P22, P29, P43, P45, P77	GD8739	P49	GR0882	P79
GD5860	P43	GD8740	P49	GR0883	P79
GD5875	P35	GD8741	P49	GR0911	P43
GD5949	P63	GD8750	P17	GR0912	P43, P45, P67, P77
GD6291	P65	GD8751	P65	GR0927	P63
GD6501	P12	GD8770	P65	GR0933	P12
GD6533	P3, P7	GD8771	P65	GR0959	P63
GD6551	P45	GD8778	P13	GR0983	P60
GD6825-10.25	P42	GD8816	P79	GR0986	P63
GD6825-11.375	P42	GD8843	P19, P25	GR0999	P62
GD7120	P62	GD8844	P19, P25	GR1001	P62
GD7122	P62	GD8893-01	P27	GR1005	P75
GD7124	P62	GD9052	P34	GR1006	P75
GD7127	P45	GD9093	P31	GR1015	P75, P79
GD7137	P29	GD9120	P8	GR1016	P75, P79
GD7148	P17	GD9130	P39	GR1017	P75, P79
GD7258	P17	GD9229	P67	GR1018	P75, P79
GD7318	P3	GD9240	P3, P17, P27	GR1019	P75, P79
GD7426	P45	GD9254	P19, P25	GR1037	P53, P54, P55, P59, P60
GD7588	P17	GD9290	P7	GR1045	P53, P54, P55, P59
GD7589	P17	GD9305	P7	GR1066	P10
GD7591	P17	GD9508	P41	GR1114	P81
GD7592	P17	GD9509	P41	GR1116	P81
GD7618	P10	GD9529	P49, P56	GR1118	P81
GD7619	P4	GD9530	P49, P56	GR1122	P77
GD7803	P19, P25	GD9562	P7	GR1129	P83
GD7804	P19, P25	GD9636	P39	GR1130	P83
GD7805	P4, P21, P25, P27, P39, P41, P43, P71, P73, P76	GD9715	P22	GR1133	P83
GD7811	P25	GD9720	P22	GR1134	P83
GD7815	P25	GD9724	P22, P23, P73	GR1142	P83
GD7816	P25	GD9786	P9	GR1144	P83
GD7817-01	P21, P25	GD9787	P9	GR1165	P81
GD7817-04	P21, P23, P25, P73	GD9816	P14	GR1167	P81
GD7817-05	P71	GD9896	P49	GR1183	P60
GD7817-09	P25	GD9897	P49	GR1203	P49
GD7818	P25, P71	GD9908	P71	GR1204	P49
		GD9934	P71	GR1205	P49
		GR0146	P87	GR1206	P49
		GR0150	P52	GR1207	P49
		GR0151	P52	GR1208	P49

NUMERICAL INDEX

Part No.	Page	Part No.	Page	Part No.	Page
GR1287	P60	GR9530	P56		
GR1290	P49	R1474	P62		
GR1292	P49				
GR1321	P56				
GR1322	P56				
GR1327	P12				
GR1363	P49				
GR1364	P49				
GR1367	P87				
GR1388	P85				
GR1389	P81				
GR1390	P65				
GR1391	P65				
GR1392	P65				
GR1393	P65				
GR1394	P65				
GR1395	P65				
GR1401	P60				
GR1405	P67				
GR1406	P67				
GR1407	P67				
GR1408	P67				
GR1409	P67				
GR1410	P67				
GR1411	P67				
GR1412	P67				
GR1413	P67				
GR1420	P81				
GR1421	P81				
GR1422	P83				
GR1423	P83				
GR1424	P81				
GR1425	P81, P83				
GR1426	P81				
GR1427	P81				
GR1435	P75				
GR1451	P83				
GR1453	P60				
GR1454	P60				
GR1462	P63				
GR1463	P63				
GR1464	P63				
GR1466	P55				
GR1468	P57				
GR1469	P62				
GR1470	P62				
GR1471	P62				
GR1472	P62				
GR1473	P62				
GR1475	P62				
GR1476	P62				
GR1477	P62				
GR1478	P62				
GR1479	P62				
GR1496	P61				
GR9529	P56				

NUMERICAL INDEX

Part No.	Page	Part No.	Page	Part No.	Page