

# 3 POINT MOUNTED PLANTER COMPONENTS PACKAGE

M0141

We at Kinze Manufacturing wish to thank you for your patronage and appreciate your confidence in Kinze products. Your Kinze components have been carefully designed and sturdily built to provide years of dependable operation in return for your investment.

This manual has been prepared to aid you in the operation and maintenance of the components. Do not use or operate equipment equipped with Kinze components until this manual has been read and understood.

Throughout this manual the symbol  and the words, NOTE, CAUTION, WARNING and DANGER are used to call your attention to important safety information. The definition of each of these terms used follows:

**NOTE:** Indicates a special point of information.

**CAUTION:** Indicated that a failure to observe can cause damage to the machine or equipment.

 **WARNING:** Indicates that a failure to observe can cause damage to the machine or equipment and/or personal injury.

 **DANGER:** Indicates that a failure to observe can cause most serious damage to the machine or equipment and/or most serious personal injury.

This manual is applicable to the 3 Point Mounted Planter Components Package and attachments.

Use of KINZE trademark(s) without permission from KINZE Manufacturing, Inc. is prohibited. Only complete machines wholly manufactured and/or offered for sale by KINZE are to be labeled with the KINZE trademark. Planters assembled using components with toolbars supplied from any other source may not be represented as complete KINZE planters. Misrepresentation of KINZE trademark(s) will not be tolerated by KINZE MANUFACTURING, INC.



# TABLE OF CONTENTS

---

## OPERATORS SECTION

INTRODUCTION .....	3-1
General Information .....	3-1
SAFETY PRECAUTIONS .....	4-1
SAFETY WARNING SIGNS .....	5-1/5-2
OPERATION	
Leveling The Row Units .....	6-1
Parking Stand Adjustment .....	6-1
Transmission Adjustment .....	6-2
Wheel Module Height Adjustment .....	6-2
Shear Protection .....	6-3
Tire Pressure .....	6-3
Marker Speed Adjustment .....	6-3
Marker Adjustment .....	6-4
Hydraulic Operation .....	6-4
Marker Lockup .....	6-5
Planting Depth .....	6-5
Closing Wheel Pressure .....	6-5
Closing Wheel Lateral Adjustment .....	6-5
Plateless Drive Release .....	6-6
Plateless Corn Meter .....	6-6
Plateless Feed Cup Meter .....	6-7
Plateless Seed Hopper .....	6-8
Granular Chemical Hopper .....	6-8
Plateless Drive Adjustment .....	6-9
Row Unit Chain Routing .....	6-9
Down Pressure Spring Adjustment .....	6-10
Heavy Duty Coulters .....	6-11
Spring Tooth Incorporator .....	6-11
Field Test .....	6-12
Metric Conversion Table .....	6-12
Checking Seed Population .....	6-13/6-14
Corn Meter .....	6-13
Soybean Feed Cup Meter .....	6-13/6-14
Milo Feed Cup Meter .....	6-14
Checking Granular Chemical Application Rate .....	6-14
General Planting Rate Information .....	6-15
Planting Rate Charts .....	6-16/6-22
Granular Chemical Application Rate Charts .....	6-23/6-24
Trouble Shooting .....	6-25/6-28
Closing Wheel .....	6-25
Plateless Corn Meter .....	6-25/6-26
Feed Cup Meter .....	6-27/6-28

# TABLE OF CONTENTS

---

## OPERATORS SECTION (Continued)

### LUBRICATION

Lubrication Symbols .....	7-1
Sealed Bearings .....	7-1
Drive Chains .....	7-1
Wheel Bearings .....	7-1
Grease Fittings .....	7-1
Lubrication Locations .....	7-2/7-3
Parallel Arm Bushings .....	7-4
Corn Meter Lubrication .....	7-4

### MAINTENANCE

Mounting Bolts And Hardware .....	8-1
Chain Tension Adjustment .....	8-2
Flow Control Valve Inspection .....	8-2
Sequencing Valve Inspection .....	8-2
Plateless Corn Meter Inspection/Adjustment .....	8-3/8-4
Plateless Corn/Feed Cup Meter Cleaning .....	8-4
Gauge Wheel Adjustment .....	8-5
15" Seed Opener Disc/Bearing Assembly .....	8-5
Seed Tube Guard .....	8-6
Heavy Duty Coultter .....	8-6
Marker Bearing Lubrication Or Replacement .....	8-7
Wheel Bearing Lubrication Or Replacement .....	8-7
Preparation For Storage .....	8-8
Wiring Diagram .....	8-8

<b>PARTS SECTION .....</b>	<b>P1</b>
----------------------------	-----------

# INTRODUCTION

---

The 3 Point Mounted Planter Row Unit And Drive (Planter Components) Package is available with a choice of 2 Row up to 40" (102 cm) spacing, 4 Row up to 40" (102 cm) spacing, 6 row up to 40" (102 cm) spacing or 8 Row up to 40" (102 cm) spacing. Each Planter Row Unit And Drive Package includes plateless row units (as required) with seed hopper and lid and standard down force springs, three point hitch, two adjustable height drive/gauge wheels with 7.60" x 15" tires, drive hubs and drive components, transmission for end mounting with sprockets and chains, 7/8" (2.2 cm) hex drill and drive shafts and two parking stands.

Conventional row unit marker sets are available with a choice of 4 Row 30" (76 cm), 4 Row 36" (91 cm) to 40" (102 cm) and 6 Row 30" (76 cm). Low profile row marker sets are available with a choice of 6 Row 36" (91 cm) to 40" (102 cm), 8 Row 30" (76 cm) and 8 Row 36" (91 cm) to 40" (102 cm).

Packages are available for Front Drive Wheel Conversion, 2 to 1 Drive Reduction, Dual Lift Assist Wheels and Single Valve Alternating Marker Conversion.

Corn, soybean and milo meters; granular chemical application equipment; spring tooth incorporators; heavy duty down force springs and heavy duty coulters are available for use with the row unit.

## GENERAL INFORMATION

The information used in this manual was current at the time of printing. However, due to Kinze's continual attempt to improve its product, production changes may cause your Kinze components to appear slightly different in detail. Kinze Manufacturing reserves the right to change specifications or design without notice and without incurring obligation to install the same on Kinze components previously manufactured.

Right hand and left hand as used throughout this manual is determined by facing in the direction the machine will travel when in use unless otherwise stated.



# SAFETY PRECAUTIONS

---

Safe and careful operation of the tractor and planter at all times will contribute significantly to the prevention of accidents.

Since a large portion of farm accidents occur as a result of fatigue or carelessness, safety practices should be of utmost concern. Read and understand the instructions provided in this manual. Listed below are a few other safety suggestions that should become common practice.

 **Never permit any persons other than the operator to ride on the tractor.**

 **Never ride on the planter frame or allow others to do so.**

 **Limit transport speed to 15 MPH (24 km/h). Transport only with farm tractor of sufficient size and horse power.**

 **Never allow the planter to be operated by anyone who is unfamiliar with the operation of all functions of the unit. All operators should read and thoroughly understand the instructions given in this manual prior to moving the unit.**

 **Always make sure flashing safety lights, SMV sign and reflectors are in place and visible prior to transporting the machine on public roads. In this regard, check federal, state and local regulations.**

 **Never work under the planter while in raised position.**

 **Always make sure there are no persons near the planter when marker assemblies are in operation.**

 **Watch for obstructions such as wires, tree limbs, etc., when folding markers.**

 **If a cylinder has been removed for any reason, do not attach the rod end of the cylinder until the cylinder is cycled several times to remove any air that may be trapped in the system.**

 **Agricultural chemicals used with the row unit can be dangerous. Improper selection or use can seriously injure persons, animals, plants, soil and other property. BE SAFE: Select the right chemical for the job. Handle it with care. Follow the instructions of the chemical manufacturer.**

 **Install safety lockups on markers, as provided, prior to transporting the planter or working around the unit.**

 **Lower the planter when not in use and cycle the hydraulic control lever to relieve pressure in hoses.**

 **Before applying pressure to the hydraulic system, make sure all connections are tight and that hoses and fittings have not been damaged. Hydraulic fluid escaping under pressure can have sufficient force to penetrate skin causing injury or infection.**

 **This planter is designed to be DRIVEN BY GROUND TIRES ONLY. The use of hydraulic, electric or PTO drives may create serious safety hazards to you and the people near by. If you install such drives you must follow all appropriate safety standards and practices to protect you and others near this planter from injury.**

 **This machine has been designed and built with your safety in mind. Any alteration to the design or construction may create safety hazards. Do not make any alterations or changes to the equipment, but if any alterations or changes are made you must follow all appropriate safety standards and practices to protect you and others near this machine from injury.**





# SAFETY WARNING SIGNS

The "WARNING" signs illustrated on these pages are placed on the machine to warn of hazards. The warnings found on these signs are for your personal safety and those around you. **OBSERVE THESE WARNINGS!**

- Keep these signs clean so they can be readily observed. Wash with soap and water or cleaning solution as required.
- Replace "WARNING" signs should they become damaged, painted over or if they are missing.
- Check SMV sign periodically. Replace if it shows loss of any of its reflective property.
- When replacing decals, clean the machine surface thoroughly using soap and water or cleaning solution to remove all dirt and grease.

52567-6

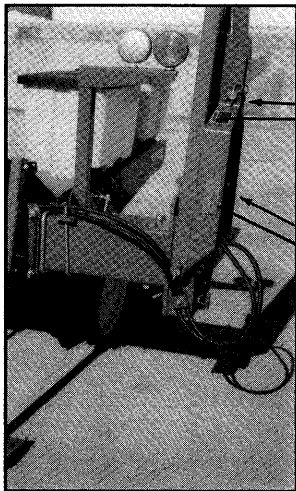

Conventional Marker



Part No. 7100-42 (Qty. 4)

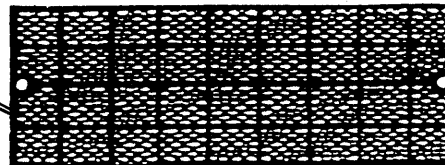

Part No. 7200-03 (Qty. 2)

Red Reflector

Part No. 7200-04 (Qty. 2)

Amber Reflector

53704-20

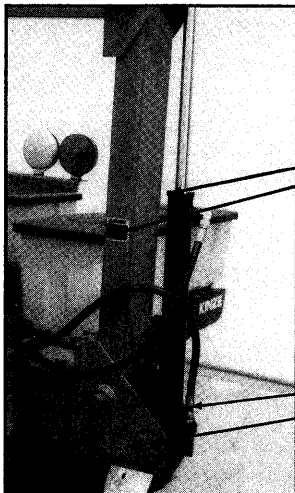

Low Profile Marker



Part No. 7100-42 (Qty. 4)

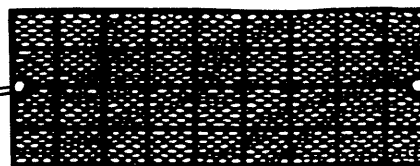

Part No. 7200-03 (Qty. 2)

Red Reflector

Part No. 7200-04 (Qty. 2)

Amber Reflector

# SAFETY WARNING SIGNS

52567-9

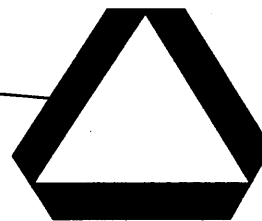
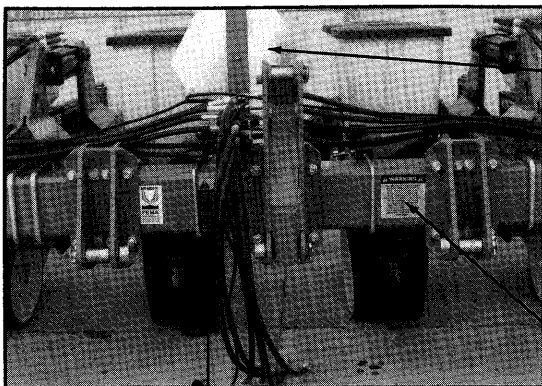

Part No. D2199 (Qty. 1)  
SMV Sign

 **CAUTION**

1. Read and understand the Operator's Manual.
2. Stop the tractor engine before leaving the operator's platform.
3. Keep riders off the machine.
4. Make certain everyone is clear of the machine before starting the tractor engine and operating.
5. Keep all shields in place.
6. Never lubricate, adjust, unclog or service the machine with tractor engine running.
7. Wait for all movement to stop before servicing.
8. Keep hands, feet and clothing away from moving parts.
9. Use flashing warning lights when operating on highways except when prohibited by law.

Part No. 7100-46 (Qty. 1)

 **WARNING** 

THIS MACHINE HAS BEEN DESIGNED AND BUILT WITH YOUR SAFETY IN MIND. ANY ALTERATION TO THE DESIGN OR CONSTRUCTION MAY CREATE SAFETY HAZARDS. DO NOT MAKE ANY ALTERATIONS OR CHANGES TO THE EQUIPMENT, BUT IF ANY ALTERATIONS OR CHANGES ARE MADE YOU MUST FOLLOW ALL APPROPRIATE SAFETY STANDARDS AND PRACTICE TO PROTECT YOU AND OTHERS NEAR THIS MACHINE FROM INJURY.

7100-90

Part No. 7100-90 (Qty. 1)

53051-17

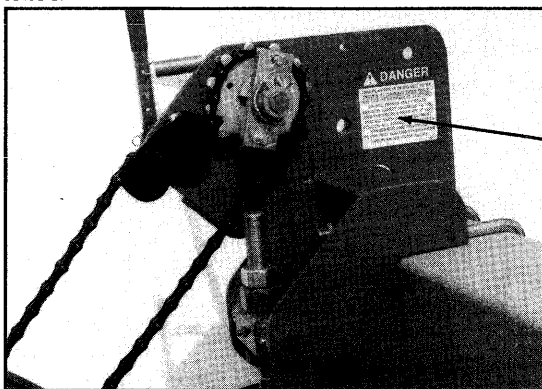

 **DANGER**

THIS PLANTER IS DESIGNED TO BE DRIVEN BY GROUND TIRES ONLY. THE USE OF HYDRAULIC, ELECTRIC OR PTO DRIVES MAY CREATE SERIOUS SAFETY HAZARDS TO YOU AND THE PEOPLE NEAR BY. IF YOU INSTALL SUCH DRIVES YOU MUST FOLLOW ALL APPROPRIATE SAFETY STANDARDS AND PRACTICES TO PROTECT YOU AND OTHERS NEAR THIS PLANTER FROM INJURY.

7100-89

Part No. 7100-89 (Qty. 2)

# SAFETY WARNING SIGNS

53704-15

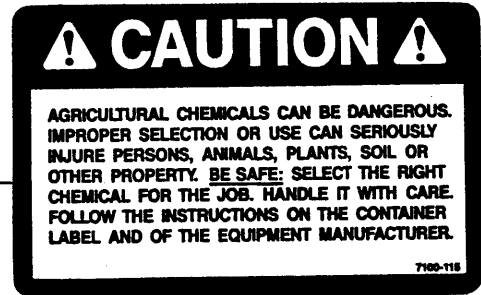

Part No. 7100-115 (Qty. 1 Per Granular Chemical Hopper Lid)

52567-9

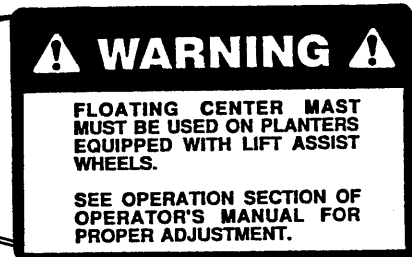
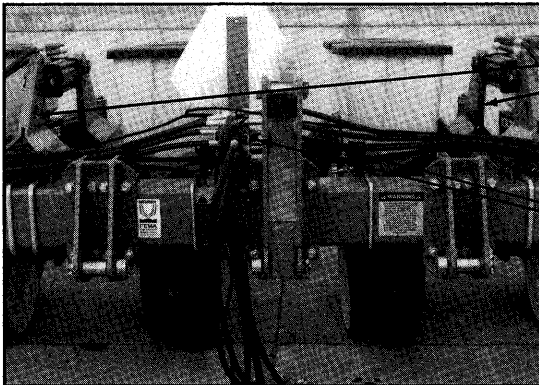

Part No. 7100-133 (Qty. 4)



# OPERATION

The following information is general in nature and was written to provide general operating information.

## LEVELING THE ROW UNITS

For proper operation of the row units, they must operate level.

After the planter has been lowered to the correct operating depth, stop the tractor and stand beside the planter to check fore and aft levelness. If the row units angle up or downward, adjust accordingly.

In order to maintain lateral levelness, it is important that tire pressure be maintained at pressures specified and that drive wheel height is adjusted equally. See "Wheel Module Height Adjustment".

On planters equipped with lift assist wheels, adjustment holes on the lift assist cylinder mounts allow for adjustment for lift height and adjustment for leveling the planter frame. Also depth stops on the lift assist cylinders can be added or removed for additional adjustment.

53761-6



51138-5

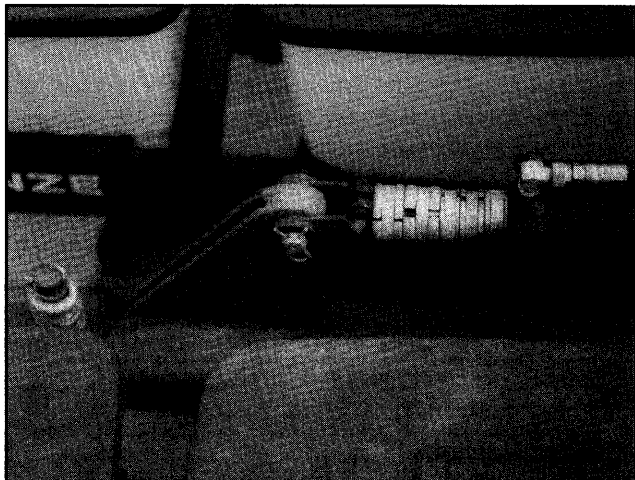

## PARKING STAND ADJUSTMENT

52567-47R

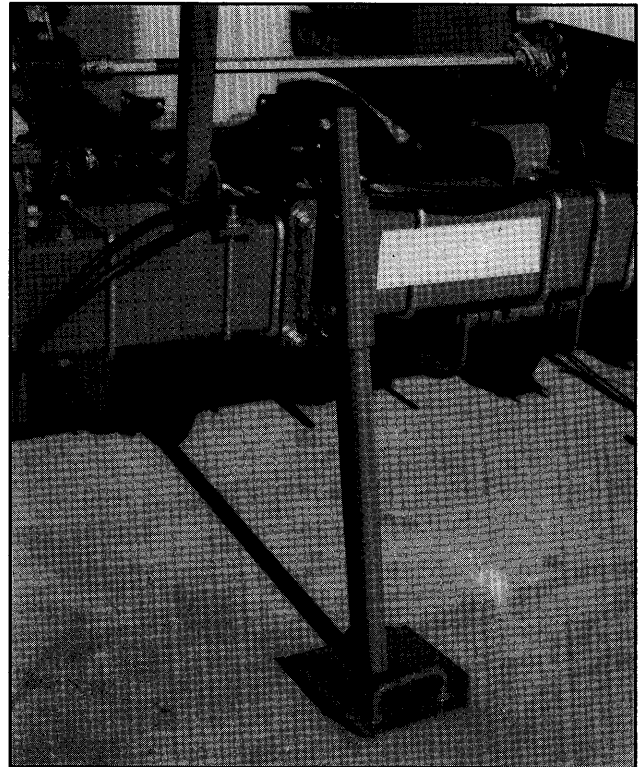

Two parking stands are supplied and must be positioned so they are not directly behind the tractor tire or they will hit when the planter is raised.

Raise to top position and pin when planting. Lower and pin for parking and storage.

On planters equipped with front mounted drive wheels, parking stands are not required.

Each parking stand has six positioning holes which allow for height adjustment from 19" to 25".

# OPERATION

## TRANSMISSION ADJUSTMENT

00139-4

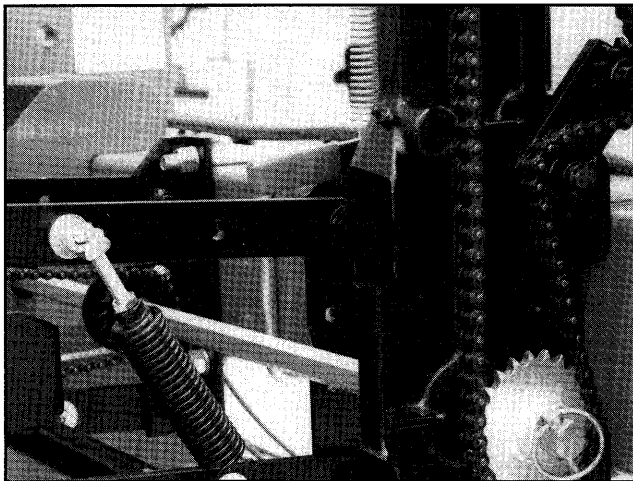

Planting population rate changes are made at the seed transmission. The transmission is designed to allow simple, rapid changes in sprockets to obtain the desired planting population. By removing the lynch pins on the hexagon shafts, sprockets can be interchanged with those from the sprocket storage rod bolted to the transmission.

Chain tension is controlled by a spring-loaded dual-sprocket idler. The idler assembly is adjusted with a ratchet arm. This arm has a release position to remove spring tension for replacing sprockets. The amount of spring tension on the chain is controlled by the ratchet arm.

A decal positioned on the transmission plate provides proper chain routing. The planting rate charts found in the Operation Section of this manual will aid you in selecting the correct sprocket combinations.

**NOTE: Use of the 2 to 1 drive reduction package will reduce drive line speed and application rates to approximately 50% of standard.**

## WHEEL MODULE HEIGHT ADJUSTMENT

51803-20

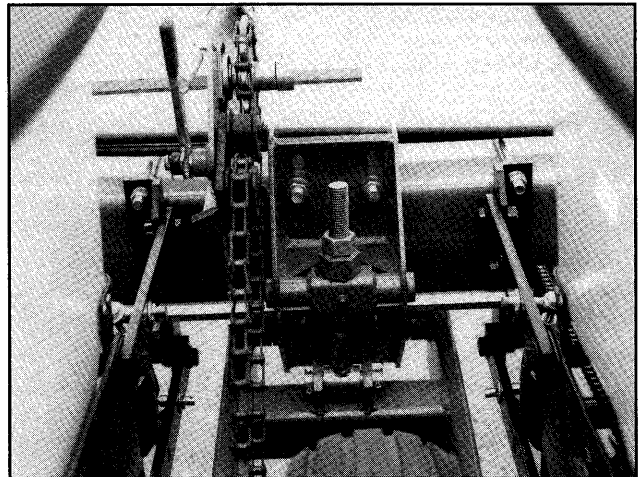

Standard Rear Mounted Wheel Module

52607-8

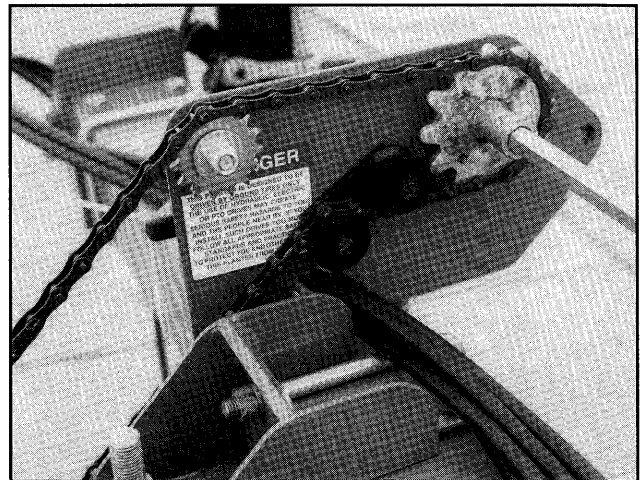

Optional Front Mounted Wheel Module

The wheel module assembly is designed so the drive wheel height can be adjusted to maintain a frame height of 20 1/2" in all planting situations. This is particularly useful when the planter is used for ridge planting or planting on beds. The wheel module assembly has an adjustment range of 7". Offset No. 2050 chain links which are included with the package will need to be added when the upper end of the range is used. To adjust the wheel assembly, first release chain tension, loosen the jam nut using a 1 1/2" wrench or a 15" adjustable wrench and turn the adjusting nut using a 1 7/8" wrench or 15" adjustable wrench (clockwise to decrease frame height/counter clockwise to increase frame height). Tighten the jam nut and adjust chain tension.

# OPERATION

## SHEAR PIN PROTECTION

The transmission and row unit components are protected from damage by a shear pin which connects the drill shaft to the transmission. Another shear pin is located in the plateless drive clutch on the row unit.

00138-25

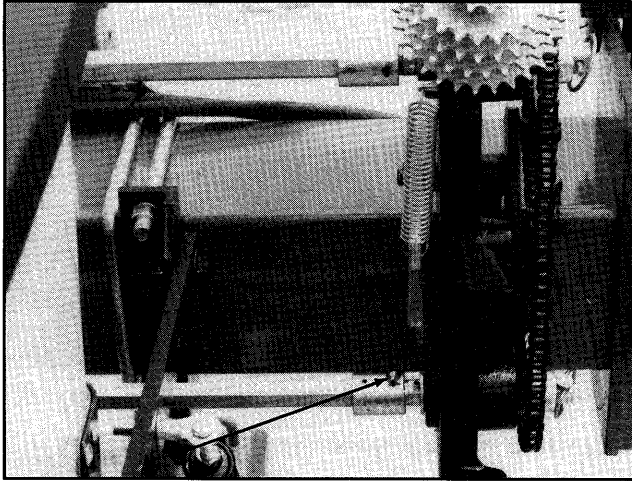

50691-21

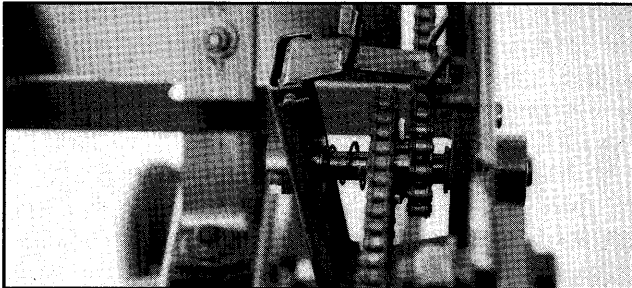

If excessive load on the drill shaft or in the plateless drive should cause a pin to shear, it is important to determine where binding has occurred before replacing the pin. Turn the drill shaft by hand checking for misalignment of the shaft. If necessary, loosen the mounting hardware on each bearing drive sprocket assembly, then align sprockets and retighten mounting hardware. Check for the possibility of seized parts and for improper chain tension or alignment.

Make certain to replace the shear pin with one of identical size and grade.

To prevent future binding or breakage of components, follow prescribed lubrication schedules.

## TIRE PRESSURE

Tire pressure should be checked regularly and maintained as follows:

7.60 x 15" 4 Ply - 40 PSI

**IMPORTANT:** Tire pressure must be correctly maintained in all drive wheel tires to insure levelness and proper operation of planter. All rate charts are based on rolling radius of 7.60 x 15" tires inflated to 40 PSI.

## MARKER SPEED ADJUSTMENT

Both the left and right marker assemblies, whether single or dual valve systems, have flow control valves built into the hydraulic system. This permits the operator to manually adjust the proper speed of "raise" and "lower" for the markers as there is a valve for each direction of travel.

52567-50

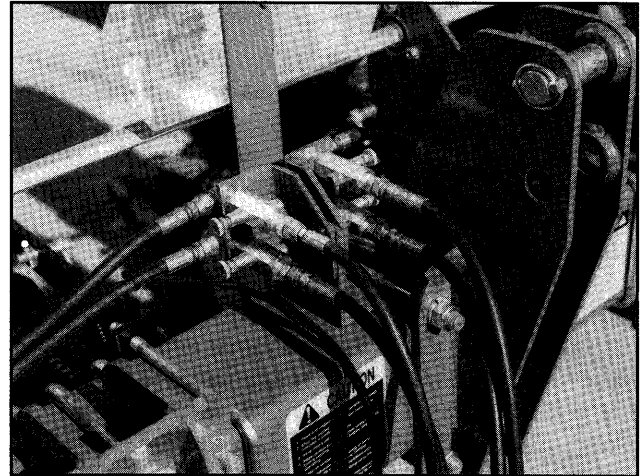

**CAUTION:** The flow controls should be properly adjusted before the marker assembly is first put into use to prevent equipment damage.

To properly match the marker cylinder speed to your tractor's hydraulic system, loosen the lock nut which secures the knurled adjustment knob in place. The raise or lower time is increased by closing the valve (clockwise). This restricts oil flow and slows the speed of the marker cylinder. To increase the cylinder speed turn the valve counterclockwise, opening the valve.

**NOTE:** After the flow controls have been adjusted, the marker speed will decrease with cold oil supply. Make sure that all adjustments are made with warm oil. Do not over tighten lock nut.

# OPERATION

## MARKER ADJUSTMENT

To determine the correct length at which to set the marker assemblies, multiply the number of rows by the row spacing in inches. This provides the total planting width. Adjust the marker extension so that the distance from the marker blade to the center line of the planter is equal to the total planting width previously obtained. Both the planter and marker assembly should be lowered to the ground when the measurements are being taken. Measurement should be taken from the point where the blade contacts the ground. Adjust right and left marker assemblies equally and securely tighten clamping bolts. An example of marker length adjustment follows:

$$\begin{array}{rcl} \text{Number of rows} & \times & \text{Row spacing (Inches)} \\ & = & \text{Dimension between planter center line and marker blade.} \end{array}$$

$4 \text{ Rows} \times 30" \text{ Row Spacing} = 120" \text{ Marker Dimension}$
---

The marker blade is installed so the concave side of the blade is outward to throw dirt away from the grease seals. The spindle bracket is slotted so the hub and blade can be angled to throw more or less dirt. To adjust the hub and spindle, loosen the 1/2" x 3 1/2" cap screws and move the bracket as required. Then tighten bolts to the specified torque.

**IMPORTANT: A marker blade assembly that is set at a sharper angle than necessary will add unnecessary stress to the complete marker assembly and shorten the life of bearings and blades. Set the blade angle only as needed to leave a clear mark.**

A field test is recommended to ensure the markers are properly adjusted. After the field test is made, make any minor adjustments necessary.

00137-5

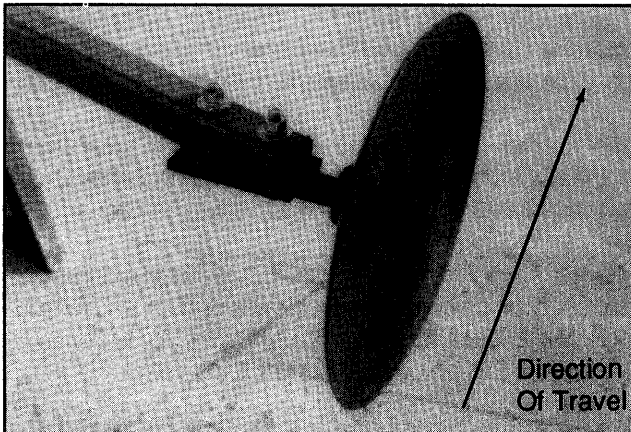

## HYDRAULIC OPERATION

One, two or three control valves systems may be required depending on how the planter is equipped.

52567-50

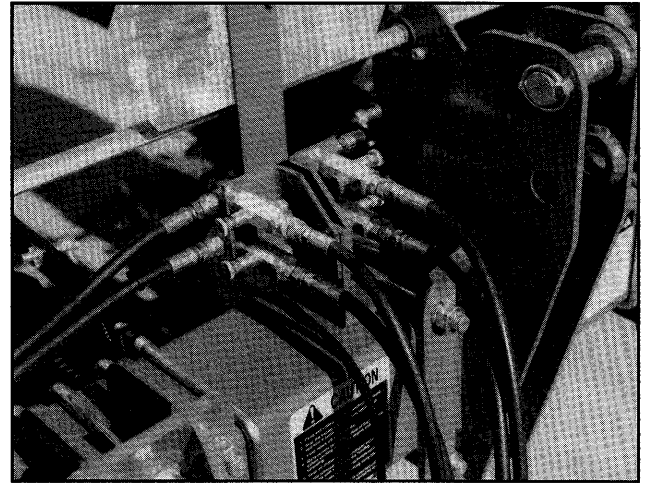

Standard Dual Control Valve Marker System

The dual valve marker system allows each marker to be operated independently. The single valve marker system uses a sequencing valve which directs hydraulic flow to operate the markers alternately.

With the dual valve marker system both markers can be used at the same time by using both hydraulic control levers simultaneously. With the single valve marker system both markers can be used at the same time by first lowering the marker and moving the hydraulic control lever to the raise position and immediately returning it to the lower position. This will shift the marker control valve and the remaining marker will be lowered. This is useful in planting contours and terraces.

**! WARNING: Always stand clear of marker assemblies and blades when planter is operating.**

**! WARNING: Always position lockups in "Safety" position when transporting or storing planter. See Safety Precautions.**

**! DANGER: If a marker cylinder has been removed for any reason, do not attach the rod end of the cylinder until the cylinder is cycled several times to remove any air that may be trapped in the system.**



# OPERATION

## MARKER LOCKUPS (If Applicable)

00139-1

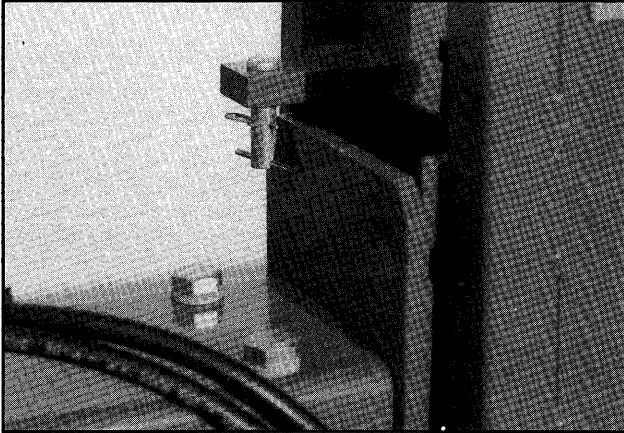

Install marker lockups when transporting the planter or working around the planter. When not in use, store lockup pin in raised position with hair pin clip on upper side of tab.

## PLANTING DEPTH

Planting depth is maintained by the row unit gauge wheels. To increase or decrease the planting depth, first raise the planter to remove weight from the wheels. Then lift the depth adjustment handle and reposition it forward to decrease depth or rearward to increase planting depth. Adjust all units to the same depth initially. Then lower the planter and check operation and planting depth of all row units. It may be necessary to readjust some rows to obtain uniform operation.

**! WARNING: Never work under the planter while in raised position without using safety lockups.**

00138-2



## CLOSING WHEEL PRESSURE

After adjusting for planting depth, check the operation of the closing wheels. The closing wheels should gently close the row without sinking in or compacting the soil. To increase spring pressure on the closing wheels, turn the adjustment bolt located at the rear of the closing wheel arm in a clockwise direction. Turning the bolt counterclockwise decreases spring tension.

Adjust all row units to a similar setting. Tension setting can be determined by checking the position of the tension spring through the viewing slot on top of the closing wheel arm. When planting in light soil at average depth (approximately 2") start by setting the dimension between the bolt head and the rear edge of the spring plug at 2 inches. For medium soil at average depth, increase spring tension to obtain 1 1/2" between the bolt head and spring plug. For heavy soil and average planting depths of 2 to 3 inches, set the bolt dimension at approximately 1".

**IMPORTANT: In field conditions that require a light soil setting of more than 2", it is recommended that a jam nut be placed on the bolt and tightened against the spring plug. This will prevent bolt loss when operating with minimum spring tension.**

## CLOSING WHEEL LATERAL ADJUSTMENT

Slotted holes in the wheel arm stop allow for lateral adjustment of the closing wheel assembly.

Loosen hardware which attaches the closing wheel arm to the wheel arm stop. Shift the closing wheel assembly within the limits of the adjustment slots until the closing wheels are aligned with the row unit. Tighten hardware.

**! WARNING: Raise planter and install safety lockups before making closing wheel adjustments.**

# OPERATION

## PLATELESS DRIVE RELEASE

The plateless drive is equipped with a clutch release mechanism that allows the drive to be disconnected from the seed metering unit. Disconnecting the drive allows the operator to check granular chemical application rates without dropping seed. It also allows one or more of the rows to be disconnected when finishing fields.

00138-3



To disengage the drive, lift the release handle and pull outward until the handle locks in the slot in the side of the hopper side panel. To engage the row unit, lift and unlatch the handle. Spring tension will return the mechanism to the drive position.

## PLATELESS CORN METER (Finger Pickup Meter)

Refer to the planting rate charts at the end of the Operation Section for recommended seed drive transmission sprocket combinations.

50981-1

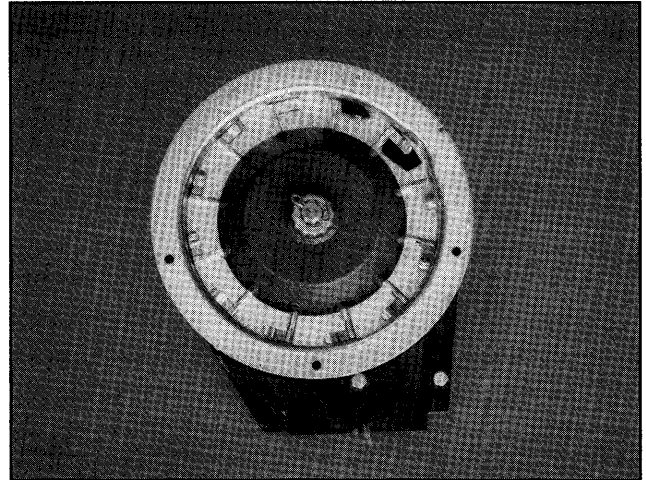

Meter shown with seed baffle removed.

# OPERATION

## PLATELESS FEED CUP METER

00138-5

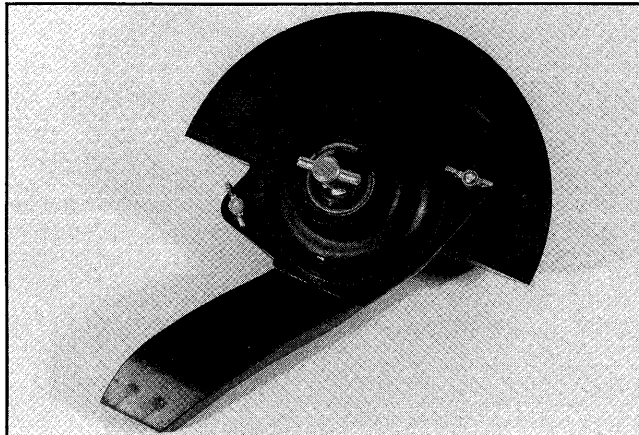

00138-6

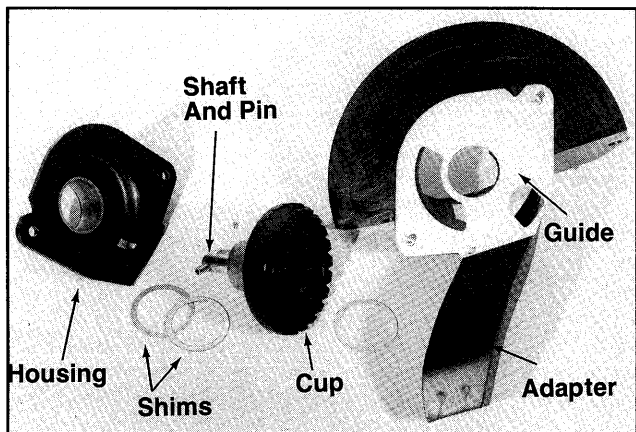

The feed cup meter is used for planting soybeans and milo. The meter consists of a shaft and pin assembly, feed cup housing, (medium rate milo, low rate milo or soybean) feed cup, (medium rate milo, low rate milo or soybean) seed guide and a feed cup adapter. Spacer shims are also used with milo cups and guides. The seed guide and feed cup housing are both notched to ensure correct installation by aligning with a projection on the feed cup adapter. Make sure all parts are seated when assembling the meter.

53714-8

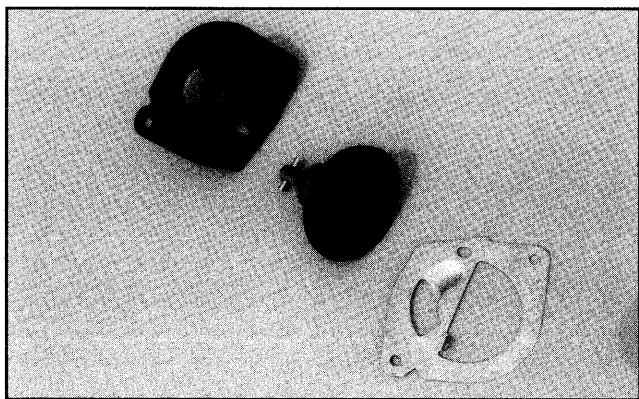

Soybean cup and guide

53714-3

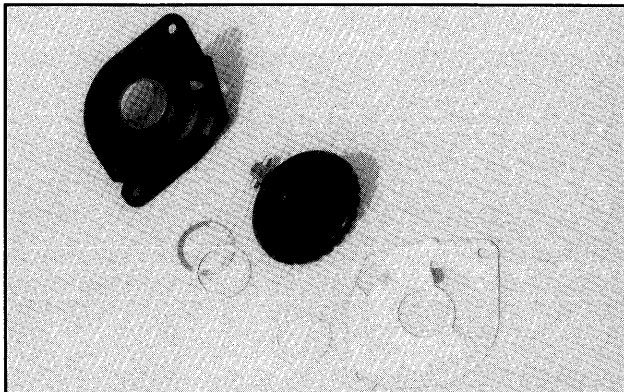

Low rate milo cup, guide and shims

53714-2

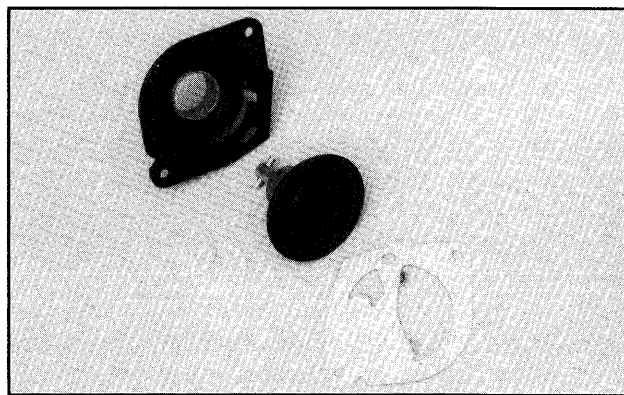

Medium rate milo cup, guide and shims

When planting **low rate milo**, it may be necessary to adjust the seed clearance to obtain the desired planting rates. Three shims have been supplied with each seed meter, and must be used on either side of the feed cup. For precision planting of small seeds ( $9/64$ " in diameter, or smaller) place all three shims between the feed cup and the housing. When seeds are approximately  $10/64$ " in diameter, place one washer between the feed cup and housing and two washers between the feed cup and seed guide. Progressively larger seeds ( $11/64$ " or larger) will require one washer shim between the feed cup and housing and two between the feed cup and seed guide.

When using the **medium rate milo** cup and guide, 2 to 3 shims are used as required between the cup and cup housing to remove end play in the meter.

Assemble the feed housing, shims, feed cup and seed guide ensuring that notches in parts are aligned. Make sure feed cup housing and seed guide are seated and secure feed meters together with wing nuts.

Refer to planting rate charts at the end of the Operation Section for recommended seed drive transmission sprocket combinations.

# OPERATION

## PLATELESS SEED HOPPER

00138-7

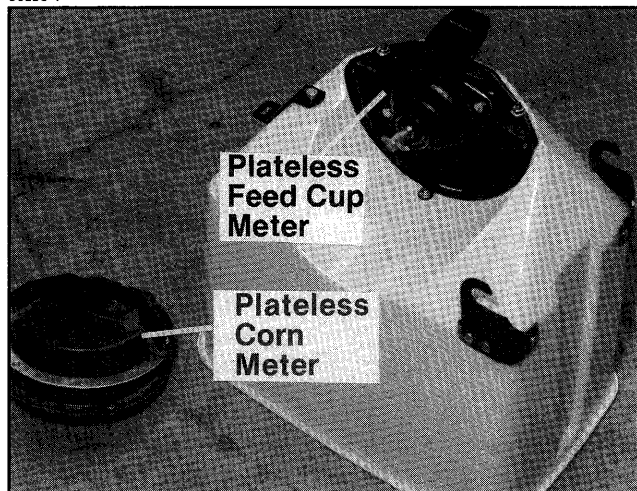

The seed hopper has a capacity of 1.6 bushels.

When filling the seed hopper use clean seeds and make certain there are no foreign objects in the hopper. Replace hopper lids after hoppers are filled to prevent the accumulation of dust or dirt in the seed meter. See "Corn Meter Lubrication".

Periodically empty the hoppers completely to remove any foreign objects and ensure proper seed meter operation. To empty hopper disengage drive release and hopper latch and lift hopper off the hopper support. See "Plateless Drive Release".

## GRANULAR CHEMICAL HOPPER

50981-8

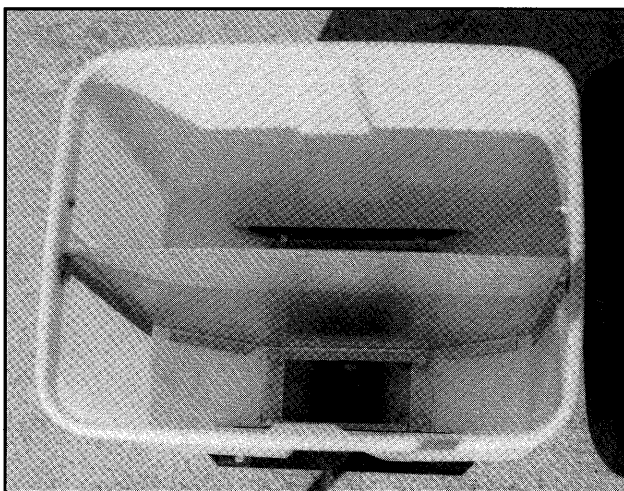

The granular chemical hopper has a 70 pound capacity. With the use of a hopper divider the hopper has two compartments with a 35 pound capacity in each.

Be sure no foreign objects get into the hopper when it is being filled. Replace the hopper lids after filling the hoppers to prevent the accumulation of dirt and moisture buildup.

The metering gate located to the rear of the hopper regulates the application rate. See "Dry Insecticide and Dry Herbicide Application Rate Charts" at the end of the Operation Section.

**!** **DANGER:** Agricultural chemical can be dangerous. Improper selection or use can seriously injure persons, animals, plants, soil or other property. **BE SAFE:** Select the right chemical for the job. Handle it with care. Follow the instructions on the container label.

# OPERATION

## PLATELESS DRIVE ADJUSTMENT

**IMPORTANT:** The plateless drive coupler must be properly aligned with the meter input shaft.

Alignment is preset at the factory, but should be checked any time the hopper support panel is removed or replaced.

To check alignment, rotate meter input shaft so drive pin in input shaft is vertical. Check to be sure drive pin is centered in the input shaft and an equal amount of pin extends beyond each side of the drive coupler.

50981-4

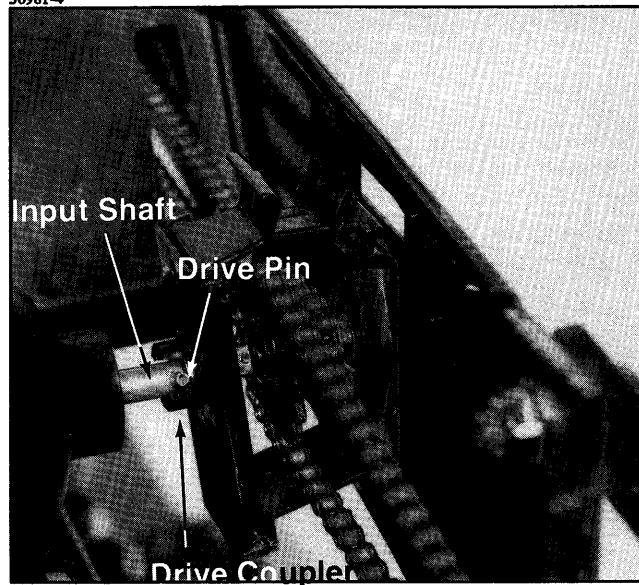

If realignment is necessary, loosen the (A) four bolts which attach the support panel to the shank and the (B) two bolts which attach the hopper support panel to the stabilizer bracket. Move the support panel up or down until proper alignment is obtained. Tighten bolts.

50981-2

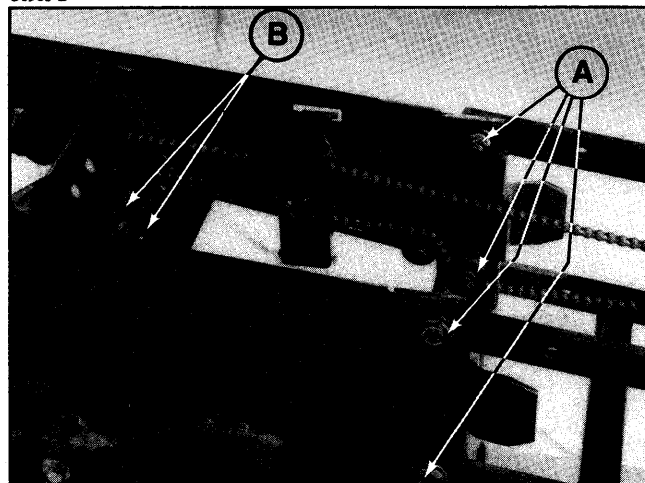

## ROW UNIT CHAIN ROUTING

For proper operation and to minimize wear, the row unit drive chains must be properly tensioned and aligned.

Inspect and replace weak, worn or broken springs and/or idlers.

00138-13

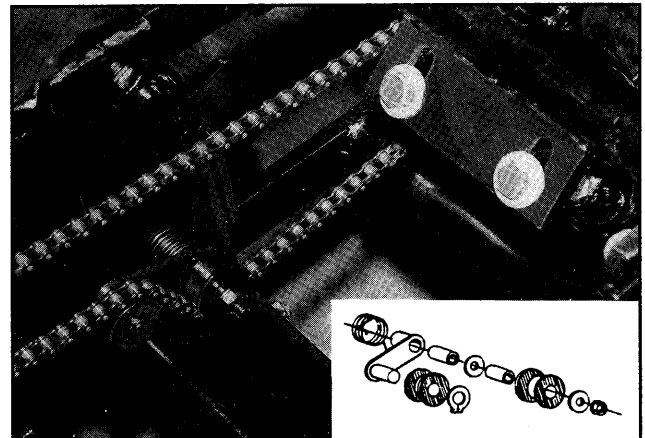

Plateless Seed Drive

50677-20

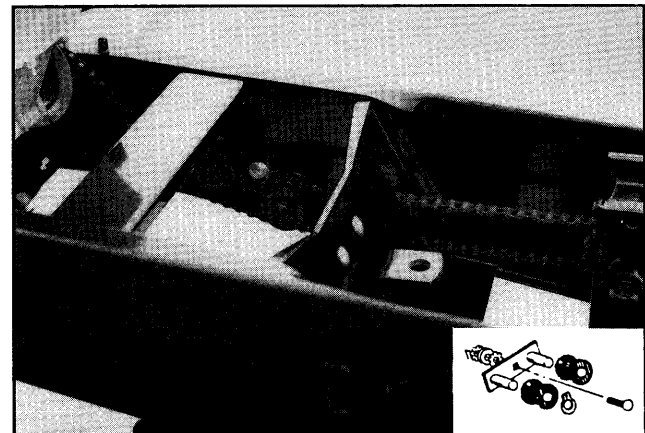

Granular Chemical Drive

# OPERATION

## DOWN PRESSURE SPRING ADJUSTMENT

The standard down pressure springs and heavy duty down pressure springs, used when heavy duty coulters are used, are designed to increase penetration in hard soil and keep the row unit from bouncing in rough field conditions.

To increase down pressure with either type of system, loosen the jam nuts and turn the adjusting bolts clockwise. Tighten lock nuts to maintain setting when desired down pressure is obtained.

00138-15

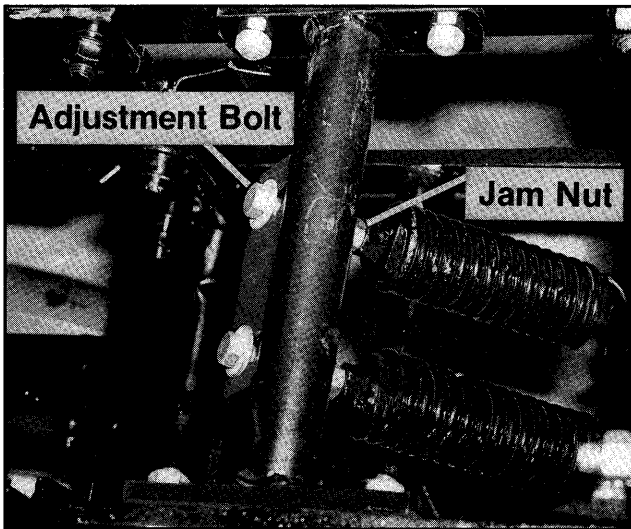

**Heavy Duty Down Pressure Springs**

**IMPORTANT:** Over tightening heavy duty down pressure springs can cause up-lift on the planter frame. If this occurs, back off down pressure spring adjustment bolt or add ballast to the planter frame (not to exceed planter frame weight load recommendations). When lowered to planting position, planter frame should be at a height of approximately 20 1/2" in planting position.

00138-26

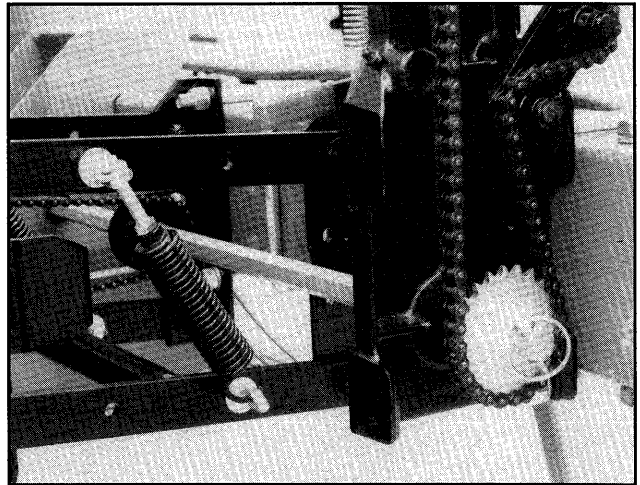

**Standard Down Pressure Springs**

If interference with other attachments does not allow outside attachment of standard down pressure springs as shown, the springs can be mounted to the inboard side of the parallel arms.

# OPERATION

## HEAVY DUTY COULTER

Heavy duty down pressure springs are required when using heavy duty coulters. See "Down Pressure Springs Adjustment".

The coulters arm can be adjusted to one of three settings. Using the top adjustment hole places the coulters blade approximately 1/4" shallower than the row unit disc opener. Using the middle adjustment hole places the coulters blade approximately 1/4" below the row unit disc opener. Using the bottom adjustment hole places the coulters blade approximately 11/16" below the row unit disc opener. Initially the arm is set to position the coulters blade in the highest position. As the blade wears or for various planting conditions the arm can be adjusted to one of the two lower settings.

00138-1

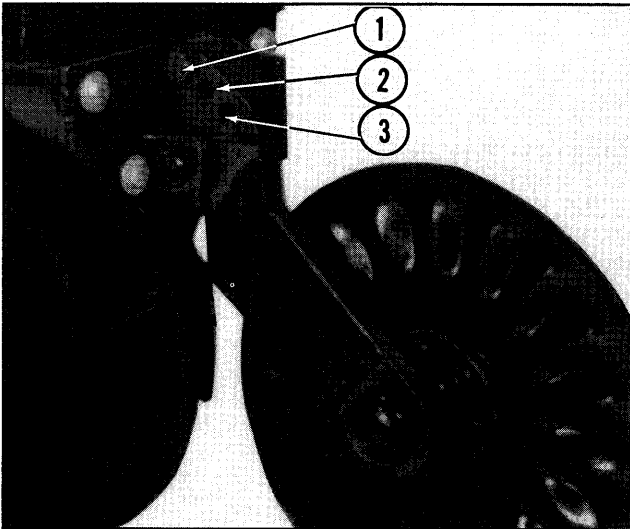

1. Top adjustment hole is used under most conditions and when unit is new and there is no wear on coulters blade or row unit disc opener.

2. Middle adjustment hole is used in heavy residue to prevent residue from being pushed down into the seed zone.

3. Bottom adjustment hole is used to maintain desired depth after the coulters blade is worn down.

It is most desirable to run the coulters blade 1/4" shallower than the row unit disc opener so it won't disturb the seed bed.

Operating depth can be checked by setting the planter down on a level concrete floor and checking the relationship between the coulters blade and row unit opener blade. Make sure the planter is level and coulters is positioned square with the planter frame and aligned with the row unit disc opener.

## SPRING TOOTH INCORPORATOR

The spring tooth incorporator smooths the soil behind the row unit and incorporates the granular chemical. The two mounting chains on each spring tooth incorporator should be adjusted so there is approximately 1/8" slack in the chain when the unit is lowered to planting position.

00138-17

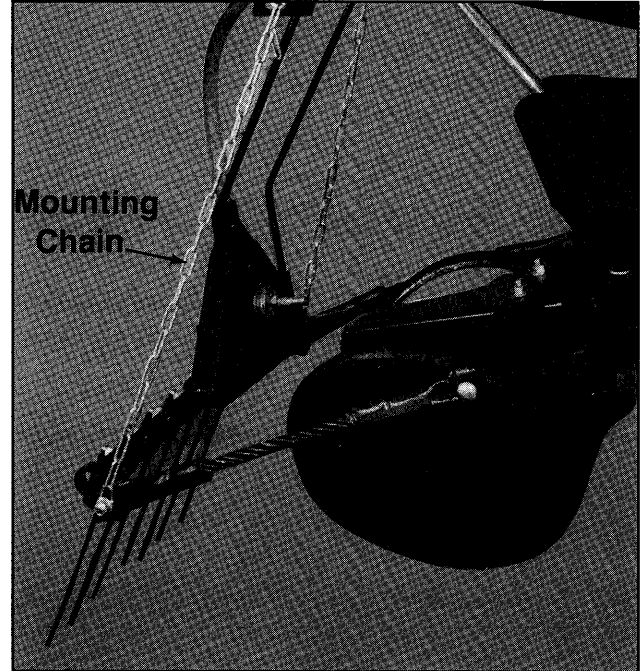

# OPERATION

## FIELD TEST

A field test of the planter should be made prior to initial operation and periodically thereafter to ensure proper planter operation.

- Check the planter for fore and aft and lateral level operation.
- Check **all** row units to be certain they are running level. When planting, the row unit parallel arms should be parallel to the ground.
- Check row markers for proper operation and adjustment. See "Marker Adjustment", "Marker Speed Adjustment" and "Hydraulic Operation".
- Check for proper application rates and placement of granular chemicals on **all** rows. See "Checking Chemical Application Rates".
- Check for desired depth placement and seed population on **all** rows. Consult "Checking Seed Population".

After the planter has been field tested, reinspect the machine.

- Hoses And Fittings
- Bolts And Nuts
- Cotter Pins And Roll Pins
- Drive Chain Alignment And Tension

## METRIC CONVERSION TABLE

Multiply	By	To Get
Inches (in.)	x 2.54	= centimeters (cm)
Feet (ft.)	x 30.48	= centimeters (cm)
Acres	x 0.405	= hectares (ha)
Miles per hour (MPH)	x 1.609	= kilometers per hour (km/h)
Pounds (lbs.)	x 0.453	= kilograms (kg)
Bushels (bu.)	x 35.238	= liters (l)
Pounds per square inch (PSI)	x 6.894	= kilopascals (kPa)
Inch pounds (in. lbs.)	x 0.113	= newtons-metres (N•m)
Foot pounds (ft. lbs.)	x 1.356	= newtons-metres (N•m)
Centimeters (cm)	x .394	= inches (in.)
Centimeters (cm)	x .0328	= feet (ft.)
Hectares (ha)	x 2.469	= acres
Kilometres per hour (km/h)	x 0.621	= miles per hour (MPH)
Kilograms (kg)	x 2.208	= pounds (lbs.)
Liters (l)	x 0.028	= bushels (bu.)
Kilopascals (kPa)	x 0.145	= pounds per square inch (PSI)
Newtons-metres (N•m)	x 8.85	= inch pounds (in. lbs.)
Newtons-metres (N•m)	x 0.738	= foot pounds (ft. lbs.)



# OPERATION

## CHECKING SEED POPULATION

1. Tie up one or more sets of closing wheels by running a light chain between the hopper support panel and closing wheels. It may be necessary to decrease closing wheel arm spring tension.

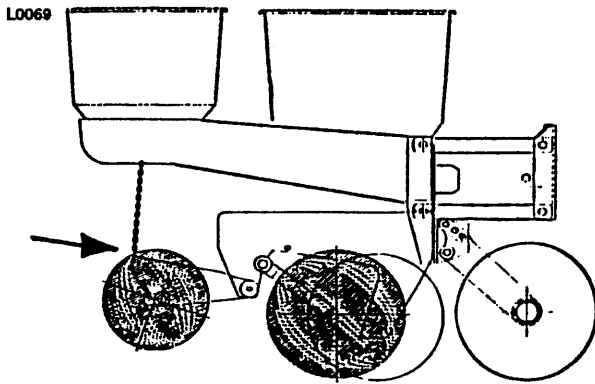

2. Plant a short distance and check to see if seed is visible in the seed trench. Adjust planting depth to a shallower setting if seed is not visible and recheck.

50677-12

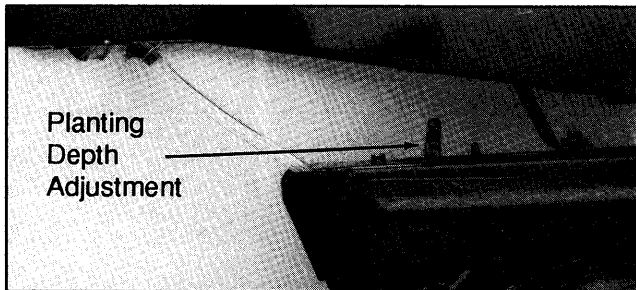

3. Measure 1/1000 of an acre. See chart for correct distance for row width spacing being planted. For example: If planting 30" rows, 1/1000 of an acre would be 17'5".

LENGTH OF ROW IN FEET AND INCHES				
Fraction Of Acre	Row Width			
	30"	36"	38"	40"
1/1000	17'5"	14'6"	13'10"	13' 1"

**NOTE: When planting with closing wheels raised and planting depth set shallow, seeds may bounce or roll affecting seed spacing accuracy.**

4. Count seeds in measured distance.

5. Multiply the number of seeds placed in the 1/1000 of an acre by 1000. This will give you total population.

EXAMPLE: With 30" row spacing 17'5" equals 1/1000 acre.

26 Seeds			
Counted	x	1000	= 26,000 Seeds Per Acre

## Corn Meter

Seed count can be affected by two things; drive ratio between drive wheel and corn meter, and/or corn meter malfunction.

If seed check shows the average distance between seeds in inches is significantly different than the seed rate chart indicates, first check drive ratio between drive wheel and corn meter. Check drive wheel pressure, check for incorrect sprocket(s) in drive line and check drive and driven sprockets in transmission for proper selection.

Second check for corn meter malfunction. FOR EXAMPLE: If spacing between kernels at the transmission setting being used is 8" and a gap of 16" is observed, a finger has lost its seed and not functioned properly. Seed population will be less than the desired amount. If two seeds are found within a few inches of each other, the finger has metered two seeds instead of one.

See "Plateless Corn Meter Trouble Shooting".

## Soybean Feed Cup Meter

1. Check seeds per pound on seed bag.

2. Use seed rate chart closest to seed count per pound listed on bag. Use small seeds chart for 2700 or more seeds per pound, medium seeds chart for 2200 to 2700 seeds per pound and large seeds chart for 2200 and less seeds per pound.

3. To determine seeds per foot:

Seeds	Desired Lbs.		Seeds
Per Lb.	X	Per Acre	= Per Acre

Seeds	Ft. Of Row		Seeds
Per Acre	÷	Per Acre	= Per Ft.

34,800 Ft. = 1 Acre/15" Rows	17,400 Ft. = 1 Acre/30" Rows
29,000 Ft. = 1 Acre/18" Rows	14,500 Ft. = 1 Acre/36" Rows
27,600 Ft. = 1 Acre/19" Rows	13,800 Ft. = 1 Acre/38" Rows
	13,100 Ft. = 1 Acre/40" Rows

# OPERATION

4. To determine seeds per acre, count seeds in 1/1000 of an acre and multiply by 1000.

If seed check shows planting rate is significantly different than seed rate chart shows, see "Feed Cup Meter Trouble Shooting".

## Milo Feed Cup Meter

1. Check seeds per pound on seed bag.
2. Use seed rate chart for the medium or low rate milo meter being used and the desired pounds per acre. Use medium rate chart and medium rate milo meter for 4.3 lbs. per acre through 45.6 lbs. per acre. Use low rate chart and low rate milo meter for 1.3 lbs. per acre through 13.9 lbs. per acre.
3. To determine seeds per foot:

Seeds	Desired Lbs.		Seeds
Per Lb.	X	Per Acre	= Per Acre

Seeds	Ft. Of Row		Seeds
Per Acre	÷	Per Acre	= Per Ft.

34,800 Ft. = 1 Acre/15" Rows	17,400 Ft. = 1 Acre/30" Rows
29,000 Ft. = 1 Acre/18" Rows	14,500 Ft. = 1 Acre/36" Rows
27,600 Ft. = 1 Acre/19" Rows	13,800 Ft. = 1 Acre/38" Rows
	13,100 Ft. = 1 Acre/40" Rows

4. To determine seeds per acre, count seeds in 1/1000 of an acre and multiply by 1000.
5. To determine pounds per acre, multiply seeds per acre planted by seeds per pound as stated on seed bag.

If seed check shows planting rate is significantly different than seed chart shows, see "Feed Cup Meter Trouble Shooting".

**NOTE: The milo and soybean meter are volume type meters and the rate charts are a starting point only. Actual rate may vary because of seed size, planting speed, meter wear, etc.**

## CHECKING GRANULAR CHEMICAL APPLICATION RATE

Many things can affect the rate of delivery. Temperature, humidity, speed, ground conditions, flow-ability of different material or any obstruction in the metering.

A field check is important for correct application rates.

53761-3



To check, fill insecticide and/or herbicide hoppers. Attach a calibrated vial to each granular diffuser. Lower the planter and proceed as follows.

Drive 1320 feet at planting speed. Weigh the chemical in ounces that was caught in one bag. Multiply that amount by the factor shown to determine pounds per acre.

LBS. PER ACRE FACTOR FOR GIVEN WIDTH	
Row Width	Factor
30 Inch	0.83
36 Inch	0.69
38 Inch	0.65
40 Inch	0.62

**EXAMPLE:** You are planting 30" rows. You have planted for 1320 feet at the desired planting speed. You caught 12.0 ounces of chemical in one bag. 12.0 ounces times 0.83 equals 9.96 pounds per acre.

## Metering Gate

Use the metering gate setting for distributing insecticide or herbicide as a starting point. The chart is based on a 5 miles per hour planting speed. For speeds faster than 5 miles per hour a higher gate setting should be used. For speeds slower than 5 miles per hour a lower gate setting should be used.



**WARNING:** Agricultural chemicals can be dangerous if not selected and handled with care. Always read and follow directions supplied by the chemical manufacturer.

## GENERAL PLANTING RATE INFORMATION

These planting rate charts are for 3 Point Mounted planters. See "Tire Pressure" for recommended tire pressures.

Not all row spacings listed are applicable to all model planters.

**IMPORTANT: The sprocket combinations listed in these charts are best for average conditions. Changes in sprocket combinations may be required to obtain desired planting population. TO PREVENT PLANTING MISCALULATIONS, MAKE FIELD CHECKS TO BE SURE YOU ARE PLANTING AT THE DESIRED RATE.**

The size and shape of seed will affect the planting rate.

### Corn

Larger grades will generally plant more accurately at the high end of the ground speed range than small grades. Higher than optimum speeds may result in population rate increase or higher incidence of doubles, particularly with small seed.

### Soybeans

Soybeans vary in size from about 1800 seeds/lb. to approximately 3500 seeds/lb. The size marked on each bag is an average. Seeds within each bag may vary in size by as much as 50% greater or 50% smaller than the average. These charts are based on uniformly sized soybeans. Your actual planting rate will vary somewhat from the chart. Generally, larger beans will result in lower rates and smaller beans will result in higher rates.

Use small seed chart for 2700 or more seeds per pound, medium seed chart for 2200 to 2700 seeds per pound and large seed chart for 2200 and less seeds per pound.

### Milo

Milo seeds vary in size from about 12,000 seeds/lb. to about 25,000 seeds/lb. The size marked on each bag is an average. Seeds within each bag may vary in size by as much as 50% greater or 50% smaller than average.

Use medium rate chart and medium rate milo meter for 4.3 pounds per acre through 15.6 pounds per acre. Use low rate chart and low rate milo meter for 1.4 pounds per acre through 4.8 pounds per acre.

**NOTE: Use of the 2 to 1 drive reduction package will reduce the planter transmission speed. The seeding rate will be approximately 1/2 of the chart reading when using the 2 to 1 drive reduction package. Planting speed can affect actual seeding rate, so make a field check and adjust setting in the transmissions as needed to obtain the desired seed drop.**

## PLANTING RATES FOR PLATELESS CORN METERS SEED POPULATIONS/ACRE FOR DIFFERENT ROW WIDTHS

30 Inch	36 Inch	38 Inch	40 Inch	Transmission Sprockets		Recomm. Speed Range (MPH)	Average Seed Spacing In Inches
				Drive	Driven		
15,900	13,300	12,600	11,900	17	28	4 to 8	13.2
16,500	13,800	13,000	12,400	17	27	4 to 8	12.7
17,200	14,300	13,500	12,900	17	26	4 to 8	12.2
17,700	14,800	14,000	13,300	19	28	4 to 8	11.8
17,800	14,900	14,100	13,400	17	25	4 to 8	11.8
18,500	15,400	14,600	13,800	19	27	4 to 8	11.4
18,600	15,500	14,700	13,900	17	24	4 to 8	11.3
19,200	16,000	15,100	14,400	19	26	4 to 8	10.9
19,400	16,200	15,300	14,500	17	23	4 to 8	10.8
19,900	16,700	15,700	15,000	19	25	4 to 8	10.5
20,800	17,300	16,400	15,600	19	24	4 to 8	10.1
21,500	18,000	17,000	16,200	23	28	4 to 8	9.7
21,700	18,100	17,100	16,300	19	23	4 to 8	9.7
22,300	18,700	17,600	16,800	23	27	4 to 8	9.4
22,500	18,800	17,800	16,900	24	28	4 to 8	9.3
23,200	19,400	18,300	17,300	23	26	4 to 8	9.0
23,300	19,500	18,400	17,400	24	27	4 to 8	9.0
23,400	19,600	18,500	17,500	25	28	4 to 8	9.0
23,500	19,700	18,600	17,600	17	19	4 to 7.5	8.9
24,100	20,100	19,000	18,000	23	25	4 to 7.5	8.7
24,200	20,200	19,100	18,100	24	26	4 to 7.5	8.7
24,300	20,300	19,200	18,200	25	27	4 to 7.5	8.6
24,400	20,400	19,300	18,300	26	28	4 to 7.5	8.6
25,000	21,000	19,700	18,700	23	24	4 to 7.5	8.3
25,100	21,100	19,800	18,800	24	25	4 to 7.5	8.3
25,200	21,200	19,900	18,900	25	26	4 to 7.5	8.3
25,300	21,300	20,000	19,000	26	27	4 to 7.5	8.3
25,400	21,400	20,100	19,100	27	28	4 to 7.5	8.3
26,200	21,900	20,700	19,700	23	23	4 to 7	8.0
27,100	22,600	21,400	20,300	28	27	4 to 7	7.7
27,200	22,700	21,500	20,400	27	26	4 to 7	7.7
27,300	22,800	21,600	20,500	25	24	4 to 7	7.7
27,400	22,900	21,700	20,600	24	23	4 to 7	7.7
28,300	23,600	22,300	21,200	28	26	4 to 6.5	7.4
28,400	23,700	22,400	21,300	27	25	4 to 6.5	7.4
28,500	23,800	22,500	21,400	25	23	4 to 6.5	7.4
29,300	24,500	23,100	21,900	19	17	4 to 6.5	7.2
29,400	24,600	23,200	22,000	28	25	4 to 6.5	7.1
29,500	24,700	23,300	22,100	27	24	4 to 6.5	7.1
29,700	24,800	23,400	22,200	26	23	4 to 6.5	7.1
30,600	25,600	24,200	23,000	28	24	3 to 6	6.9
30,800	25,700	24,300	23,100	27	23	3 to 6	6.8
31,800	26,500	25,100	23,800	23	19	3 to 5.5	6.6
31,900	26,700	25,200	24,000	28	23	3 to 5.5	6.6
33,100	27,700	26,200	24,900	24	19	3 to 5.5	6.3
34,500	28,800	27,300	25,900	25	19	3 to 5	6.1
35,500	29,600	28,000	26,600	23	17	3 to 5	5.9
35,900	30,000	28,300	26,900	26	19	3 to 5	5.8
37,000	30,900	29,200	27,800	24	17	3 to 5	5.7
37,300	31,100	29,400	28,000	27	19	3 to 5	5.6
38,600	32,200	30,500	28,900	25	17	3 to 4.5	5.4
38,700	32,300	30,600	29,000	28	19	3 to 4.5	5.4
40,100	33,500	31,700	30,100	26	17	3 to 4.5	5.2
41,700	34,800	32,900	31,300	27	17	3 to 4.5	5.0
43,200	36,100	34,100	32,100	28	17	3 to 4.5	4.9

**IMPORTANT:** See "General Planting Rate Information" page at front of this section.

## PLANTING RATES FOR PLATELESS SOYBEAN METERS APPROXIMATE POUNDS/ACRE FOR DIFFERENT ROW WIDTHS - MEDIUM SEEDS

30 Inch	36 Inch	38 Inch	40 Inch	Transmission Sprockets		Recomm. Speed Range (MPH)
				Drive	Driven	
38	32	30	28	17	28	4 to 8
39	33	31	29	17	27	4 to 8
40	34	32	30	17	26	4 to 8
42	35	33	31	19	28	4 to 8
43	36	34	32	19	27	4 to 8
44	37	35	33	17	24	4 to 8
46	38	36	34	17	23	4 to 8
47	39	37	35	19	25	4 to 8
49	41	39	37	19	24	4 to 8
50	42	40	38	23	28	4 to 8
51	43	40	39	19	23	4 to 8
54	45	43	40	24	28	4 to 8
55	46	43	41	24	27	4 to 8
56	47	44	42	17	19	4 to 8
57	48	45	43	24	26	4 to 8
58	48	46	44	26	28	4 to 8
59	49	47	44	24	25	4 to 8
60	50	48	45	26	27	4 to 7.5
62	52	49	47	23	23	4 to 7
64	53	51	48	27	26	4 to 6.5
65	54	52	49	24	23	3 to 6
68	57	54	51	25	23	3 to 5.5
70	58	55	53	19	17	3 to 5.5
71	59	56	54	27	24	3 to 5
73	61	58	55	28	24	3 to 5
75	62	59	56	23	19	3 to 5
76	63	60	57	28	23	3 to 5
78	65	62	59	24	19	3 to 5
81	68	64	61	25	19	3 to 5
84	70	66	63	23	17	3 to 5
85	71	67	64	26	19	3 to 5
88	73	70	66	27	19	3 to 5
91	76	72	68	28	19	3 to 5
95	70	75	72	26	17	3 to 5
98	82	77	74	27	17	3 to 5
102	85	81	77	28	17	3 to 5

**IMPORTANT:** See "General Planting Rate Information" page at front of this section.

**NOTE:** When using the 2 to 1 Drive Reduction Package, rates will be approximately 1/2 of given numbers.

# OPERATION

# 3 POINT MOUNTED

## PLANTING RATES FOR PLATELESS SOYBEAN METERS APPROXIMATE BEANS/ACRE FOR DIFFERENT ROW WIDTHS - SMALL SEEDS

30 Inch	36 Inch	38 Inch	40 Inch	Transmission Sprockets		Recomm Speed Range (MPH)	Seeds/ Foot	Spaing (Inches)
				Drive	Driven			
142,300	118,600	112,300	106,700	17	28	4 to 8	8	1.5
147,600	123,000	116,500	110,700	17	27	4 to 8	8	1.4
153,300	127,700	121,000	114,900	17	26	4 to 8	9	1.4
159,100	132,500	125,500	119,300	19	28	4 to 8	9	1.3
164,900	137,500	130,200	123,700	19	27	4 to 8	9	1.3
166,000	138,400	131,000	124,500	17	24	4 to 8	10	1.3
173,300	144,400	136,700	129,900	17	23	4 to 8	10	1.2
178,100	148,500	140,600	133,600	19	25	4 to 8	10	1.2
185,600	154,600	146,500	139,200	19	24	4 to 8	11	1.1
192,500	160,500	152,000	144,400	23	28	4 to 8	11	1.1
193,600	161,400	152,800	145,200	19	23	4 to 8	11	1.1
200,900	167,400	158,600	150,700	24	28	4 to 8	12	1.0
208,400	173,600	164,400	156,300	24	27	4 to 8	12	1.0
209,700	174,800	165,500	157,300	17	19	4 to 7.5	12	1.0
216,400	180,300	170,800	162,300	24	26	4 to 7.5	12	1.0
217,700	181,400	171,800	163,200	26	28	4 to 7.5	13	0.9
225,000	187,500	177,600	168,800	24	25	4 to 7.5	13	0.9
225,700	188,100	178,200	169,300	26	27	4 to 7.5	13	0.9
234,400	195,300	185,000	175,800	23	23	4 to 7	14	0.9
243,400	202,800	192,100	182,600	27	26	4 to 7	14	0.9
244,600	203,800	193,000	183,400	24	23	4 to 7	14	0.9
254,800	212,300	210,100	191,100	25	23	4 to 6.5	15	0.8
262,000	218,300	206,800	196,500	19	17	4 to 6.5	15	0.8
263,700	219,800	208,100	197,800	27	24	4 to 6.5	15	0.8
273,500	227,900	215,800	205,100	28	24	3 to 6	16	0.8
283,700	236,500	224,000	212,800	23	19	3 to 5.5	16	0.7
285,400	237,800	225,200	214,000	28	23	3 to 5.5	16	0.7
296,100	246,700	233,700	222,100	24	19	3 to 5.5	17	0.7
308,400	257,000	243,400	231,300	25	19	3 to 5	18	0.7
317,100	264,300	250,300	237,900	23	17	3 to 5	18	0.7
320,800	267,300	253,200	240,600	26	19	3 to 5	18	0.7
333,100	277,600	262,900	249,800	27	19	3 to 5	19	0.6
345,400	287,900	272,600	259,100	28	19	3 to 4.5	20	0.6
358,500	298,700	282,900	268,900	26	17	3 to 4.5	21	0.6
372,300	310,200	293,800	279,200	27	17	3 to 4.5	21	0.6
386,100	321,700	304,700	289,600	28	17	3 to 4.5	22	0.5

**IMPORTANT:** See "General Planting Rate Information" page at front of this section.

**NOTE:** When using the 2 to 1 Drive Reduction Package, rates will be approximately 1/2 of given numbers.

## PLANTING RATES FOR PLATELESS SOYBEAN METERS APPROXIMATE BEANS/ACRE FOR DIFFERENT ROW WIDTHS - MEDIUM SEEDS

30 Inch	36 Inch	38 Inch	40 Inch	Transmission Sprockets		Recomm. Speed Range (MPH)	Seeds/ Foot	Seed Spacing (Inches)
				Drive	Driven			
94,100	78,500	74,300	70,600	17	28	4 to 8	5	2.2
97,600	81,400	77,100	73,200	17	27	4 to 8	6	2.1
101,400	84,500	80,100	76,100	17	26	4 to 8	6	2.1
105,200	87,700	83,100	78,900	19	28	4 to 8	6	2.0
109,100	90,900	86,200	81,900	19	27	4 to 8	6	1.9
109,800	91,500	86,700	82,400	17	24	4 to 8	6	1.9
114,600	95,500	90,500	86,000	17	23	4 to 8	7	1.8
117,800	98,200	93,100	88,400	19	25	4 to 8	7	1.8
122,700	102,300	96,900	92,100	19	24	4 to 8	7	1.7
127,300	106,100	100,600	95,500	23	28	4 to 8	7	1.6
128,100	106,700	101,200	96,100	19	23	4 to 8	7	1.6
132,900	110,800	105,000	99,700	24	28	4 to 8	8	1.6
137,800	114,900	108,800	103,400	24	27	4 to 8	8	1.5
138,700	115,600	109,600	104,100	17	19	4 to 8	8	1.5
143,100	119,300	113,000	107,400	24	26	4 to 8	8	1.5
144,000	120,000	113,700	108,000	26	28	4 to 8	8	1.5
148,800	124,100	117,600	111,700	24	25	4 to 8	9	1.4
149,300	124,400	117,900	112,000	26	27	4 to 8	9	1.4
155,000	129,200	122,500	116,300	23	23	4 to 8	9	1.4
161,000	134,200	127,200	120,800	27	26	4 to 8	9	1.3
161,800	134,800	127,800	121,400	24	23	4 to 8	9	1.3
168,500	140,500	133,100	126,400	25	23	4 to 8	10	1.2
173,300	144,400	136,900	130,000	19	17	4 to 8	10	1.2
174,400	145,400	137,800	130,900	27	24	4 to 8	10	1.2
180,900	150,800	142,900	135,700	28	24	4 to 8	10	1.2
187,700	156,400	148,200	140,800	23	19	4 to 8	11	1.1
188,700	157,300	149,100	141,600	28	23	4 to 8	11	1.1
195,800	163,200	154,700	146,900	24	19	4 to 8	11	1.1
204,000	170,000	161,100	153,100	25	19	4 to 8	12	1.0
209,700	174,800	165,700	157,400	23	17	4 to 8	12	1.0
212,100	176,800	167,600	159,200	26	19	4 to 8	12	1.0
220,300	183,600	174,000	165,300	27	19	4 to 8	13	0.9
228,500	190,400	180,500	171,400	28	19	4 to 8	13	0.9
237,100	197,600	187,300	177,900	26	17	4 to 8	14	0.9
246,200	205,200	194,500	184,700	27	17	4 to 8	14	0.9
255,300	212,800	201,700	191,600	28	17	4 to 8	15	0.8

**IMPORTANT:** See "General Planting Rate Information" page at front of this section.

**NOTE:** When using the 2 to 1 Drive Reduction Package, rates will be approximately 1/2 of given numbers.

**PLANTING RATES FOR PLATELESS SOYBEAN METERS  
APPROXIMATE BEANS/ACRE FOR DIFFERENT ROW WIDTHS - LARGE SEEDS**

30 Inch	36 Inch	38 Inch	40 Inch	Transmission Sprockets		Recomm. Speed Range (MPH)	Seeds/ Foot	Seed Spacing (Inches)
				Drive	Driven			
63,000	52,500	49,700	47,300	17	28	4 to 8	4	3.3
65,300	54,400	51,500	48,900	17	27	4 to 8	4	3.2
67,800	56,500	53,500	50,800	17	26	4 to 8	4	3.1
70,500	58,800	55,700	52,900	19	28	4 to 8	4	3.0
73,000	60,800	57,600	54,800	19	27	4 to 8	4	2.9
73,500	61,300	58,000	55,100	17	24	4 to 8	4	2.8
76,800	64,000	60,600	57,600	17	23	4 to 8	4	2.7
79,000	65,800	62,400	59,300	19	25	4 to 8	5	2.6
82,300	68,500	64,900	61,700	19	24	4 to 8	5	2.5
85,300	71,000	67,300	63,900	23	28	4 to 8	5	2.5
85,800	71,500	67,700	64,300	19	23	4 to 8	5	2.4
89,000	74,200	70,300	66,800	24	28	4 to 8	5	2.3
92,300	76,900	72,800	69,200	24	27	4 to 8	5	2.3
93,000	77,500	73,400	69,800	17	19	4 to 8	5	2.2
95,800	79,800	75,600	71,800	24	26	4 to 8	6	2.2
96,500	80,400	76,200	72,400	26	28	4 to 8	6	2.2
99,500	82,900	78,600	74,600	24	25	4 to 8	6	2.1
100,000	83,300	78,900	75,000	26	27	4 to 7.5	6	2.1
103,800	86,500	81,900	77,800	23	23	4 to 7	6	2.0
107,800	89,800	85,100	80,800	27	26	4 to 6.5	6	2.0
108,300	90,200	85,500	81,200	24	23	3 to 6	6	2.0
112,800	94,000	89,000	84,600	25	23	3 to 5.5	7	2.0
116,000	96,700	91,600	87,000	19	17	3 to 5.5	7	1.8
116,800	97,300	92,200	87,600	27	24	3 to 5	7	1.8
121,000	100,800	95,500	90,800	28	24	3 to 5	7	1.7
125,800	104,800	99,300	94,300	23	19	3 to 5	7	1.7
126,300	105,200	99,700	94,700	28	23	3 to 5	7	1.7
131,000	109,200	103,400	98,300	24	19	3 to 5	8	1.6
136,500	113,800	107,800	102,400	25	19	3 to 5	8	1.5
140,500	117,100	110,900	105,400	23	17	3 to 5	8	1.5
142,000	118,300	112,100	106,500	26	19	3 to 5	8	1.5
147,500	122,900	116,400	110,600	27	19	3 to 5	9	1.4
153,000	127,500	120,800	114,800	28	19	3 to 5	9	1.4
158,800	132,300	125,300	119,100	26	17	3 to 5	9	1.3
164,800	137,300	130,100	123,600	27	17	3 to 5	10	1.3
171,000	142,500	135,000	128,300	28	17	3 to 5	10	1.2

**IMPORTANT:** See "General Planting Rate Information" page at front of this section.

**NOTE:** When using the 2 to 1 Drive Reduction Package, rates will be approximately 1/2 of given numbers.



**PLANTING RATES FOR PLATELESS MEDIUM RATE MILO METERS  
APPROXIMATE POUNDS/ACRE FOR DIFFERENT ROW WIDTHS - MEDIUM SEEDS**

30 Inch	36 Inch	38 Inch	40 Inch	Transmission Sprockets		Recomm. Speed Range (MPH)
				Drive	Driven	
5.8	4.8	4.6	4.3	17	28	4 to 8
6.0	5.0	4.7	4.5	17	27	4 to 8
6.2	5.2	4.9	4.6	17	26	4 to 8
6.4	5.4	5.1	4.8	19	28	4 to 8
6.7	5.6	5.3	5.0	19	27	4 to 8
6.9	5.8	5.5	5.2	17	24	4 to 8
7.2	6.0	5.7	5.4	17	23	4 to 8
7.3	6.1	5.7	5.4	19	25	4 to 8
7.5	6.2	5.9	5.6	19	24	4 to 8
7.8	6.5	6.2	5.8	23	28	4 to 8
8.1	6.7	6.4	6.0	19	23	4 to 8
8.4	7.0	6.6	6.3	24	28	4 to 8
8.7	7.2	6.9	6.5	24	27	4 to 8
8.8	7.3	6.9	6.6	17	19	4 to 7.5
9.1	7.5	7.1	6.8	24	26	4 to 7.5
9.1	7.6	7.2	6.8	26	28	4 to 7.5
9.4	7.8	7.4	7.0	24	25	4 to 7.5
9.5	7.9	7.5	7.1	26	27	4 to 7.5
9.5	7.9	7.5	7.1	23	23	4 to 7
10.2	8.5	8.1	7.6	27	26	4 to 7
10.2	8.5	8.1	7.7	24	23	4 to 7
10.6	8.8	8.4	7.9	25	23	4 to 6.5
10.7	8.9	8.4	8.0	19	17	4 to 6.5
11.0	9.2	8.7	8.2	27	24	4 to 6.5
11.1	9.3	8.8	8.3	28	24	3 to 6
11.6	9.6	9.1	8.6	23	19	3 to 5.5
11.9	9.9	9.4	8.9	28	23	3 to 5.5
12.0	10.0	9.5	9.0	24	19	3 to 5.5
12.4	10.3	9.8	9.3	25	19	3 to 5
12.9	10.8	10.2	9.7	23	17	3 to 5
13.3	11.1	10.5	10.0	26	19	3 to 5
13.9	11.6	11.0	10.4	27	19	3 to 5
14.5	12.0	11.4	10.8	28	19	3 to 4.5
14.5	12.1	11.4	10.8	26	17	3 to 4.5
15.1	12.5	11.9	11.2	27	17	3 to 4.5
15.6	13.0	12.3	11.7	28	17	3 to 4.5

**IMPORTANT:** See "General Planting Rate Information" page at front of this section.

**NOTE:** When using the 2 to 1 Drive Reduction Package, rates will be approximately 1/2 of given numbers.

## PLANTING RATES FOR PLATELESS LOW RATE MILO METERS APPROXIMATE POUNDS/ACRE FOR DIFFERENT ROW WIDTHS - MEDIUM SEEDS

30 Inch	36 Inch	38 Inch	40 Inch	Transmission Sprockets		Recomm. Speed Range (MPH)
				Drive	Driven	
1.8	1.5	1.5	1.4	17	28	4 to 8
1.8	1.5	1.5	1.4	17	27	4 to 8
1.9	1.6	1.5	1.4	17	26	4 to 8
2.0	1.6	1.6	1.5	19	28	4 to 8
2.0	1.7	1.6	1.6	19	27	4 to 8
2.1	1.8	1.7	1.6	17	24	4 to 8
2.2	1.8	1.7	1.7	17	23	4 to 8
2.2	1.8	1.8	1.7	19	25	4 to 8
2.3	1.9	1.8	1.7	19	24	4 to 8
2.4	2.0	1.9	1.8	23	28	4 to 8
2.5	2.0	2.0	1.9	19	23	4 to 8
2.6	2.1	2.0	1.9	24	28	4 to 8
2.7	2.2	2.1	2.0	24	27	4 to 8
2.7	2.2	2.1	2.0	17	19	4 to 7.5
2.8	2.3	2.2	2.1	24	26	4 to 7.5
2.8	2.3	2.2	2.1	26	28	4 to 7.5
2.9	2.4	2.3	2.2	24	25	4 to 7.5
2.9	2.4	2.3	2.2	26	27	4 to 7.5
2.9	2.4	2.3	2.2	23	23	4 to 7
3.1	2.6	2.5	2.4	27	26	4 to 7
3.1	2.6	2.5	2.4	24	23	4 to 7
3.2	2.7	2.6	2.5	25	23	4 to 6.5
3.3	2.7	2.6	2.5	19	17	4 to 6.5
3.4	2.8	2.7	2.6	27	24	4 to 6.5
3.4	2.8	2.7	2.6	28	24	3 to 6
3.5	2.9	2.8	2.7	23	19	3 to 5.5
3.6	3.0	2.9	2.8	28	23	3 to 5.5
3.7	3.0	2.9	2.8	24	19	3 to 5.5
3.8	3.1	3.0	2.9	25	19	3 to 5
4.0	3.3	3.1	3.0	23	17	3 to 5
4.1	3.4	3.2	3.1	26	19	3 to 5
4.2	3.5	3.4	3.2	27	19	3 to 5
4.4	3.7	3.5	3.4	28	19	3 to 4.5
4.4	3.7	3.5	3.4	26	17	3 to 4.5
4.6	3.8	3.6	3.5	27	17	3 to 4.5
4.8	4.0	3.8	3.6	28	17	3 to 4.5

**IMPORTANT:** See "General Planting Rate Information" page at front of this section.

**NOTE:** When using the 2 to 1 Drive Reduction Package, rates will be approximately 1/2 of given numbers.

## DRY INSECTICIDE APPLICATION RATES APPROXIMATE POUNDS/ACRE AT 5 MPH FOR DIFFERENT ROW WIDTHS

Meter Setting	30 Inch	36 Inch	38 Inch	40 Inch
<b>CLAY GRANULES</b>				
10	5.1	4.3	4.0	3.8
11	5.6	4.7	4.4	4.2
12	6.3	5.3	5.0	4.7
13	7.1	5.9	5.6	5.3
14	7.9	6.6	6.2	5.9
15	8.8	7.3	6.9	6.6
16	9.9	8.3	7.8	7.4
17	11.0	9.2	8.7	8.3
18	11.8	9.8	9.3	8.9
19	13.5	11.3	10.7	10.1
20	14.6	12.2	11.5	11.0
21	16.0	13.3	12.6	12.0
22	16.9	14.1	13.3	12.7
23	17.7	14.8	14.0	13.3
24	19.4	16.2	15.3	14.6
25	21.5	17.9	17.0	16.1
26	23.7	19.8	18.7	17.8
27	24.8	20.7	19.6	18.6
28	26.2	21.8	20.7	19.7
29	28.7	23.9	22.7	21.5
30	30.5	25.4	24.1	22.9
<b>SAND GRANULES</b>				
5	3.0	2.5	2.4	2.3
6	5.0	4.2	3.9	3.8
7	5.5	4.6	4.3	4.1
8	6.5	5.4	5.1	4.9
9	8.0	6.7	6.3	6.0
10	9.2	7.7	7.3	6.9
11	10.5	8.8	8.3	7.9
12	11.5	9.6	9.1	8.6
13	13.0	10.8	10.3	9.8
14	14.5	12.1	11.4	10.9
15	16.0	13.3	12.6	12.0
16	18.0	15.0	14.2	13.5
17	20.0	16.7	15.8	15.0
18	22.5	18.8	17.8	16.9
19	25.0	20.8	19.7	18.8
20	26.5	22.1	20.9	19.9
21	28.5	23.8	22.5	21.4
22	30.5	25.4	24.1	22.9
23	33.0	27.5	26.1	24.8
24	35.5	29.6	28.0	26.6
25	38.0	31.7	30.0	28.5

**IMPORTANT:** The above chart represents average values and should be used only as a starting point. The granular chemical flows through the given meter opening at a nearly uniform rate regardless of roller speed. Your actual rate will vary depending upon the insecticide you are using, your planting speed and your plant population. Planting speed/ground speed has the greatest affect on application rate.

Your actual rate must be checked in the field with the actual insecticide that you are using and at the speed and population at which you will be planting.

**DRY HERBICIDE APPLICATION RATES  
APPROXIMATE POUNDS/ACRE AT 5 MPH FOR DIFFERENT ROW WIDTHS**

**CLAY GRANULES**

Meter Setting	30 Inch	36 Inch	38 Inch	40 Inch
10	4.8	4.0	3.8	3.6
11	5.4	4.5	4.3	4.1
12	6.0	5.0	4.7	4.5
13	6.7	5.6	5.3	5.0
14	7.5	6.3	5.9	5.6
15	8.5	7.1	6.7	6.4
16	9.3	7.8	7.3	7.0
17	10.2	8.5	8.1	7.7
18	11.0	9.2	8.7	8.3
19	12.0	10.0	9.5	9.0
20	13.0	10.8	10.3	9.8
21	14.0	11.7	11.1	10.5
22	15.0	12.5	11.8	11.3
23	16.2	13.5	12.8	12.2
24	17.5	14.6	13.8	13.1
25	18.7	15.6	14.8	14.0
26	20.0	16.7	15.8	15.0
27	21.5	17.9	17.0	16.1
28	23.3	19.4	18.4	17.5
29	25.0	20.8	19.7	18.8
30	27.5	22.9	21.7	20.6

**IMPORTANT:** The above chart represents average values and should be used only as a starting point. The granular chemical flows through the given meter opening at a nearly uniform rate regardless of roller speed. Your actual rate will vary depending upon the herbicide you are using, your planting speed and your plant population. Planting speed/ground speed has the greatest affect on application rate.

Your actual rate must be checked in the field with the actual herbicide that you are using and at the speed and population at which you will be planting.

# OPERATION

## TROUBLE SHOOTING

### Closing Wheel

Problem	Possible Cause	Solution
Closing wheels leave severe imprint in soil.	Too much closing wheel down pressure.	Adjust closing wheel pressure.
Closing wheels not firming soil around seed.	Insufficient closing wheel down pressure.	Adjust closing wheel pressure.
Closing wheel running on top of seed furrow.	Improper centering.	Align.

### Plateless Corn Meter

Problem	Possible Cause	Solution
One row not planting seed.	Drive release not engaged.	Engage drive release mechanism.
	Foreign material in hopper.	Clean hopper and finger carrier mechanism.
	Seed hopper empty.	Fill seed hopper.
	Pin sheared in drive release sprocket.	Replace pin. Inspect meter for obstructions or defective parts.
	Row unit drive chain off of sprocket or broken.	Check drive chain.
Drive release does not engage properly.	Drive release shaft is not aligned properly with finger carrier drive shaft.	Align drive mechanism by shifting hopper support.
Unit is skipping.	Foreign material or obstruction in meter.	Clean out and inspect.
	Finger holder improperly adjusted.	Adjust to proper setting.
	Broken fingers.	Replace fingers and/or springs as required.
	Planting too slowly.	Increase planting speed to within recommended range.
Planting too many doubles.	Planting too fast.	Stay within recommended speed range.
	Loose finger holder.	Adjust to specs.
	Worn brush in carrier plate.	Replace brush.

# OPERATION

## TROUBLE SHOOTING (Continued)

### Plateless Corn Meter (Continued)

Problem	Possible Cause	Solution
Over planting.	Worn carrier plate.	Inspect and replace if necessary.
Irregular or incorrect seed spacing.	Driving too fast.	Check chart for correct speed.
	Wrong tire pressure.	Inflate tires to correct air pressure.
	Drive wheels slipping.	Reduce down pressure on row unit down pressure springs.
	Wrong sprockets.	Check seed rate charts for correct sprocket combinations.
Seed spacing not as indicated in charts.	Wrong tire pressure.	Inflate tires to correct air pressure.
	Inconsistent seed size.	Do field check and adjust sprockets accordingly.
	Wrong sprockets.	Check chart for correct sprocket combination.
	Charts are approximate.	Slight variations due to wear may produce seed spacing variations.
Scattering of seeds.	Planting too fast.	Reduce planting speed.
	Seed tube improperly installed.	Check seed tube installation.
	Seed tube worn or damaged.	Replace seed tube.
Seed tubes and/or openers plugging.	Allowing planter to roll backward when lowering.	Lower planter only when tractor is moving forward.
Inconsistent seed depth.	Rough seed bed.	Adjust down pressure springs. Reduce planting speed.
	Partially plugged seed tube.	Inspect and clean.
	Seed tube improperly installed.	Install properly.

# OPERATION

## TROUBLE SHOOTING (Continued)

### Feed Cup Meter

Problem	Possible Cause	Solution
One row not planting seed.	Drive release not engaged.	Engage drive release mechanism.
	Pin sheared in drive release sprocket.	Replace pin. Inspect for obstructions in meter.
	Foreign material in hopper.	Inspect hopper and meter for foreign material (such as paper).
Drive release parts breaking.	Drive coupler not aligned properly with feed cup shaft.	Align drive mechanism by shifting hopper support.
	Feed cup not turning freely.	Inspect feed cup and bushings.
Planting lower rate than desired.	Worn feed cup.	Replace feed cup.
	Obstruction in feed cup or hopper.	Clean and inspect.
	Wrong feed cup.	Replace with proper feed cup for seed being planted.
	Seed treatment building up in feed cup.	Clean thoroughly.
	Wrong seed guide plate used with seed cup.	Replace with proper guide/cup combination.
	Improper number of shims used with low rate milo feed cup.	Adjust number of shims as required.
Planting higher rate than desired.	Wrong feed cup.	Replace with proper feed cup.
	Feed cup housing not installed correctly.	Inspect feed cup installation. Check for proper seating of feed cup housing.
	Improper number of shims used with low rate milo feed cup.	Adjust number of shims as required.

# OPERATION

## TROUBLE SHOOTING (Continued)

### Feed Cup Meter (Continued)

Problem	Possible Cause	Solution
Bunching of seed.	Drive coupler not aligned properly. Feed cup housing not seated properly. Weak idler spring. Obstruction in hopper.	Align drive mechanism by shifting hopper support. Check installation of feed cup housing. Replace as required. Clean hopper and meter of all foreign material.
Feed cup meters hard driving.	Build up of seed treatment in feed cups. Drive not properly aligned with meter input shaft. Planter drive rusty and dirty.	Clean feed cups and housings. Align drive mechanism by shifting hopper support. Clean and lubricate or replace drive chain.



# LUBRICATION

The following pages show the locations of all lubrication points. Proper lubrication of all moving parts will help ensure efficient operation of your planter and prolong the life of friction producing parts.

**⚠ DANGER:** Always install safety lockups or lower to the ground before working under the machine.

## LUBRICATION SYMBOLS



Lubricate at frequency indicated with an SAE multipurpose type grease.



Lubricate at frequency indicated with a high quality SAE 10 weight oil or a quality spray lubricant.

## SEALED BEARINGS

51803-20

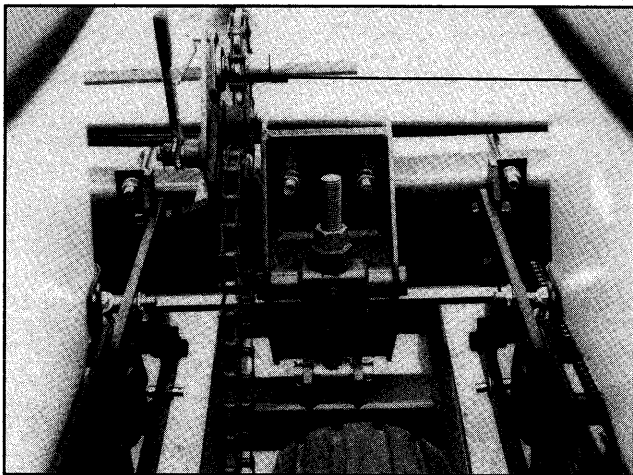

A number of sealed bearings are used to provide trouble free operation. These are located in such areas as the drive shaft, row units and transmission bearings. Sealed bearings are lubricated for life, and due to the seals, relubrication is not practical.

## DRIVE CHAINS

52567-69

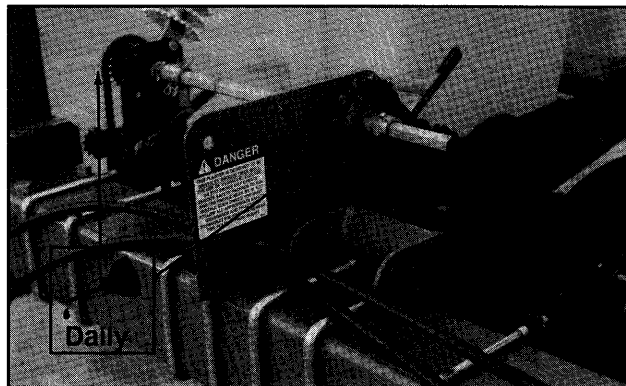

All transmission and drive chains should be lubricated daily with a high quality SAE 10 weight oil or a quality spray lubricant. Extreme operating conditions such as dirt, temperature or speed may require more frequent lubrication. If a chain becomes stiff, it should be removed, soaked and washed in solvent to loosen and remove dirt from the joints. Then soak the chain in oil so the lubricant can penetrate between the rollers and bushings.

## WHEEL BEARINGS

Wheel bearings should be checked annually. Inspect for lubrication. Pump grease into the hub until grease comes out around the seals.

Lift wheel off the ground. Check for endplay in the bearings by moving the tire in and out. Rotate the tire to check for roughness in the bearings. If bearings sound rough, the hub should be removed and the bearings inspected and replaced if necessary. See "Wheel Bearing Packing Or Replacement".

## GREASE FITTINGS

Those parts equipped with grease fittings should be lubricated at the frequency indicated with an SAE multipurpose type grease. Be sure to clean the fitting thoroughly before using grease gun. The frequency of lubrication recommended is based on normal operating conditions. Severe or unusual conditions may require more frequent attention.

# LUBRICATION

**⚠ DANGER:** Always install safety lockups or lower to the ground before working under or around the machine.

00139-4

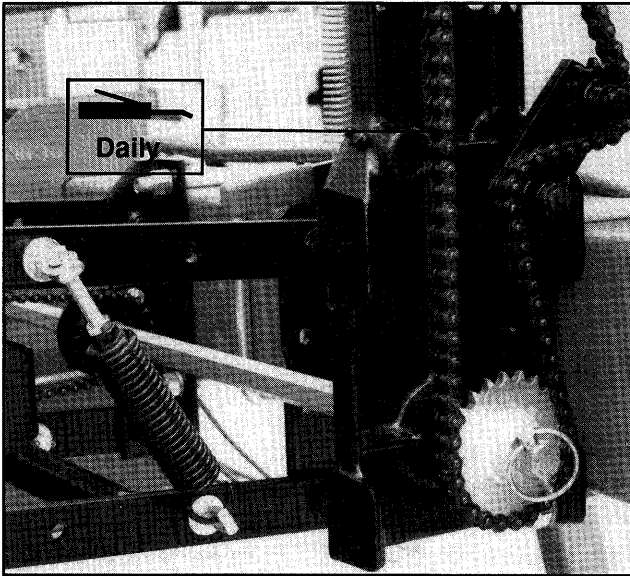

1. Transmission Assembly - 1 Zerk Per Assembly (Idler)

51803-20

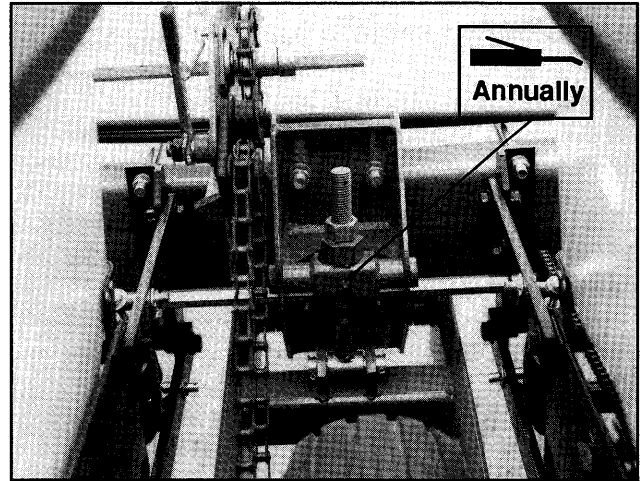

2. Wheel Module Jack Screw - 1 Zerk Per Module

52567-7

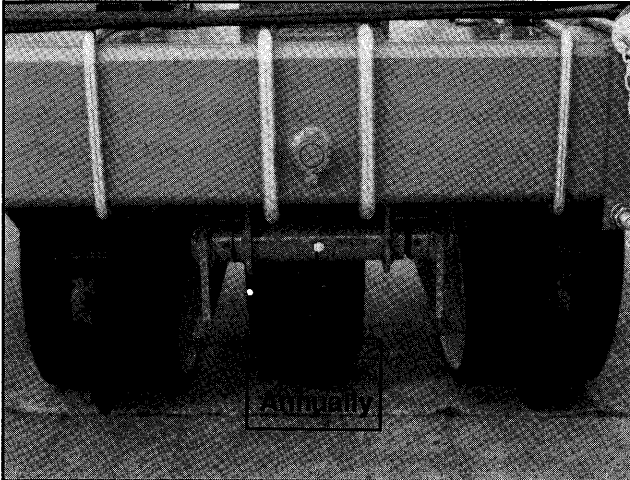

3. Wheel Module Shaft - 1 Zerk Per Module

00138-2

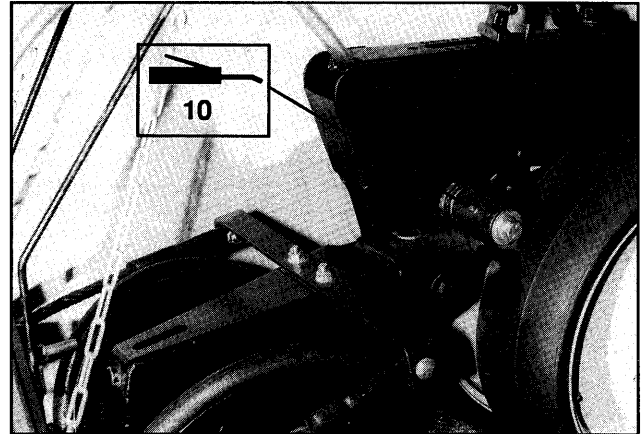

4. Gauge Wheel Arm - 2 Zerks Per Row Unit

# LUBRICATION

51138-4



5. Lift Assist Wheel Arm - 2 Zerks Per Arm Assembly

00138-19



6. Heavy Duty Coulter Arm - 1 Zerk Per Coulter Arm

Pump grease into grease fitting until there is slight pressure. Over greasing will force the dust cap off.

52567-6

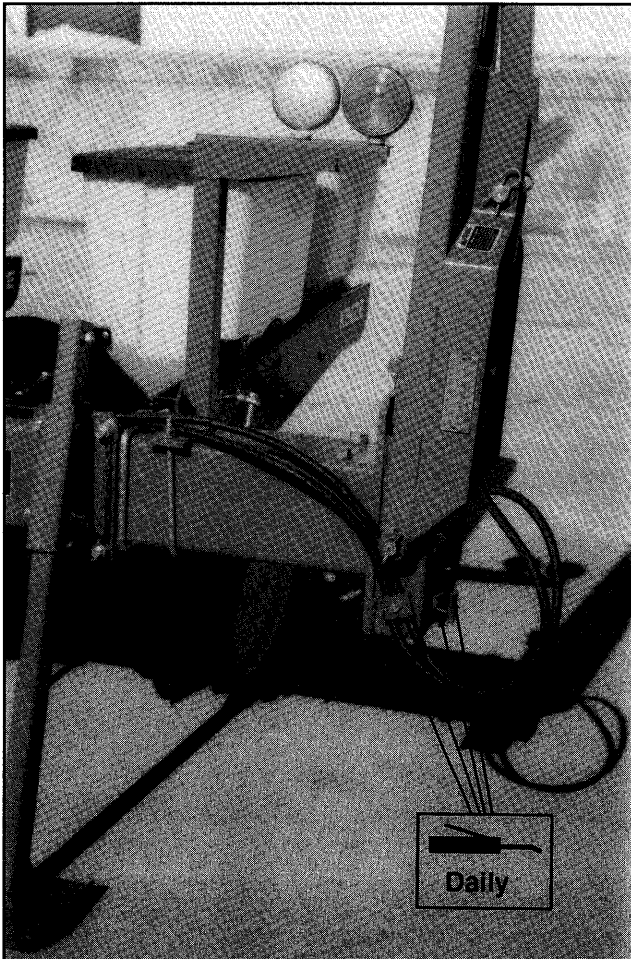

7. Conventional Markers - 4 Zerks Per Assembly

53704-9

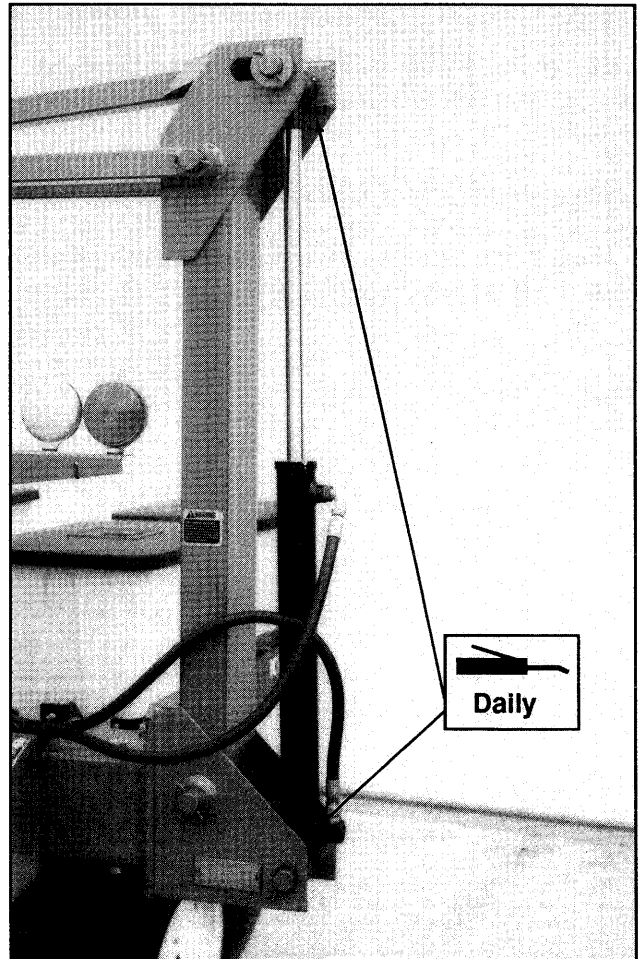

8. Low Profile Markers - 2 Zerks Per Assembly

# LUBRICATION

## PARALLEL ARM BUSHINGS

50691-5

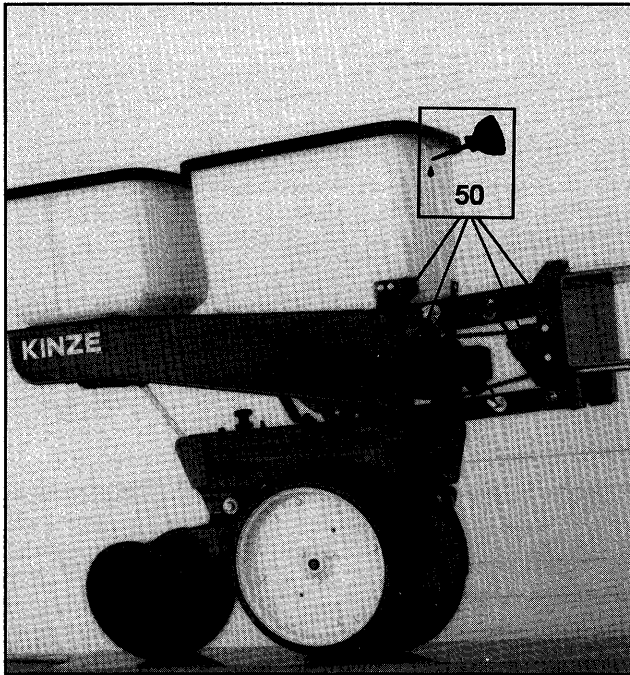

Lubricate bushing located on each of the eight parallel arm mounting bolts on each row unit at the frequency indicated.

Using a wrench, check each bolt for looseness. If bolt is loose, it should be removed and the bushing inspected for cracks and wear. Replace bushing if necessary. Torque bolt to 112 ft. lbs.

## CORN METER LUBRICATION

To provide efficient operation of the finger type plateless corn meter and extend the life of components, sprinkle a teaspoon of powdered graphite over the top of the seed once daily. The graphite will filter down into the seed pickup mechanism and provide lubrication.

53761-1



# MAINTENANCE

## MOUNTING BOLTS AND HARDWARE

Before operating the planter for the first time, check to be sure all nuts and bolts are tight. Check all nuts and bolts again after approximately the first 50 hours of operation and at the beginning of each planting season thereafter.

All bolts used on the components are Grade 5 (high strength) unless otherwise noted. Refer to the torque values chart when tightening bolts.

**NOTE: Over tightening bolts can cause as much damage as under tightening. Tightening a bolt beyond the recommended range can reduce its shock load capacity.**

TORQUE VALUES CHART - PLATED HARDWARE						
Bolt Diameter	Grade 2		Grade 5		Grade 8	
	Course	Fine	Course	Fine	Course	Fine
1/4	50 In. Lbs.	56 In. Lbs.	76 In. Lbs.	87 In. Lbs.	9 Ft. Lbs.	10 Ft. Lbs.
5/16	8 Ft. Lbs.	9 Ft. Lbs.	13 Ft. Lbs.	14 Ft. Lbs.	18 Ft. Lbs.	20 Ft. Lbs.
3/8	15 Ft. Lbs.	17 Ft. Lbs.	23 Ft. Lbs.	26 Ft. Lbs.	33 Ft. Lbs.	37 Ft. Lbs.
7/16	25 Ft. Lbs.	27 Ft. Lbs.	37 Ft. Lbs.	41 Ft. Lbs.	52 Ft. Lbs.	58 Ft. Lbs.
1/2	35 Ft. Lbs.	40 Ft. Lbs.	57 Ft. Lbs.	64 Ft. Lbs.	80 Ft. Lbs.	90 Ft. Lbs.
9/16	50 Ft. Lbs.	60 Ft. Lbs.	80 Ft. Lbs.	90 Ft. Lbs.	115 Ft. Lbs.	130 Ft. Lbs.
5/8	70 Ft. Lbs.	80 Ft. Lbs.	110 Ft. Lbs.	125 Ft. Lbs.	160 Ft. Lbs.	180 Ft. Lbs.
3/4	130 Ft. Lbs.	145 Ft. Lbs.	200 Ft. Lbs.	220 Ft. Lbs.	280 Ft. Lbs.	315 Ft. Lbs.
7/8	125 Ft. Lbs.	140 Ft. Lbs.	320 Ft. Lbs.	350 Ft. Lbs.	450 Ft. Lbs.	500 Ft. Lbs.
1	190 Ft. Lbs.	205 Ft. Lbs.	480 Ft. Lbs.	530 Ft. Lbs.	675 Ft. Lbs.	750 Ft. Lbs.
1 1/8	265 Ft. Lbs.	300 Ft. Lbs.	600 Ft. Lbs.	670 Ft. Lbs.	960 Ft. Lbs.	1075 Ft. Lbs.
1 1/4	375 Ft. Lbs.	415 Ft. Lbs.	840 Ft. Lbs.	930 Ft. Lbs.	1360 Ft. Lbs.	1500 Ft. Lbs.
1 3/8	490 Ft. Lbs.	560 Ft. Lbs.	1100 Ft. Lbs.	1250 Ft. Lbs.	1780 Ft. Lbs.	2030 Ft. Lbs.
1 1/2	650 Ft. Lbs.	730 Ft. Lbs.	1450 Ft. Lbs.	1650 Ft. Lbs.	2307 Ft. Lbs.	2670 Ft. Lbs.

**NOTE: Unplated bolts should be torqued approximately 1/3 higher than the above values. Bolts having lock nuts should be tightened to approximately 50% of amounts shown in chart. Bolts lubricated prior to installation should be torqued to 70% of value shown on chart.**



**GRADE 2**  
No Marks



**GRADE 5**  
3 Marks



**GRADE 8**  
6 Marks

# MAINTENANCE

## CHAIN TENSION ADJUSTMENT

The drive chains are spring loaded and chain tension is adjustable with the use of the ratchet idler arm. The pivot point of these idlers should be checked periodically to ensure they will rotate freely.

00139-6

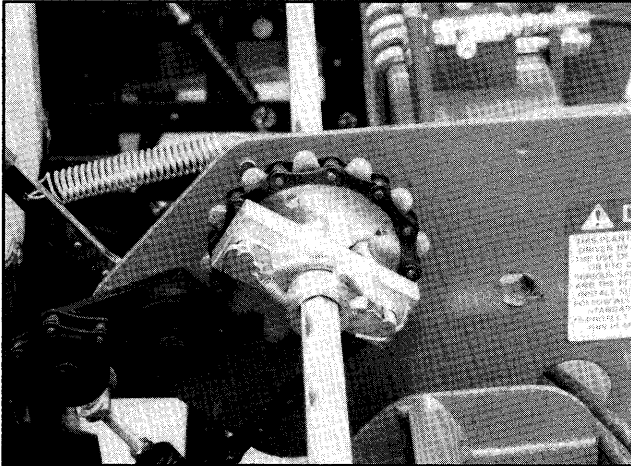

## FLOW CONTROL VALVE INSPECTION

The flow control valves should be adjusted for raise and lower speed as part of the assembly procedure or upon initial operation. If the valve fails to function properly or requires frequent adjustment, the needle valve should be removed for inspection. Check for foreign material and contamination on both the valve and the seating area of the valve body. Replace any components found to be defective.

**NOTE:** The flow control valve must be installed with the arrow pointed toward the tractor.

VVB001

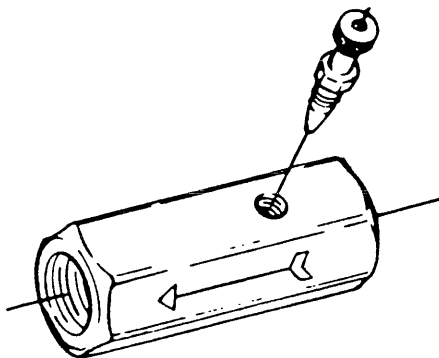

## SEQUENCING VALVE INSPECTION

The sequencing valve consists of a chambered body containing a spool and a series of check valves to direct hydraulic flow. Should the valve malfunction, the components may be removed for inspection. The spool is accessible by removing either side plug and one check valve is accessible from the top of the valve body. It is necessary to disconnect the outlet hoses from the back of the valve to gain access to the remaining retainers and check valves. Inspect all parts for pitting, contamination or foreign material. Also check seating surfaces inside the valve. Replace any parts found to be defective.

**IMPORTANT:** Make sure correct check ball and spring are installed in each check valve bore upon reassembly.

VVB002

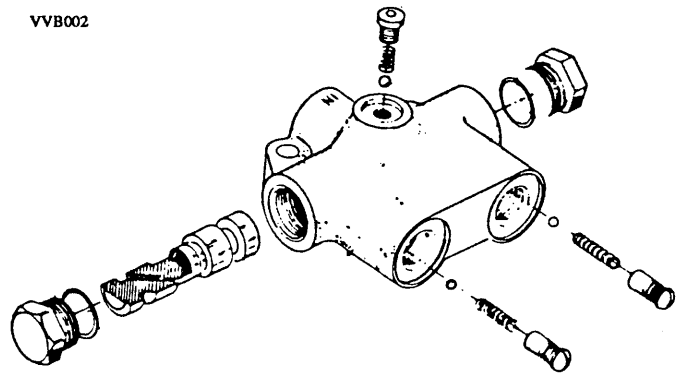

# MAINTENANCE

## PLATELESS CORN METER INSPECTION/ADJUSTMENT

To inspect or service the finger pickup corn meter, remove the meter from the seed hopper by removing the two nuts which secure the mechanism to the hopper. Remove the housing from the meter assembly by removing three cap screws. This will permit access to the finger pickup.

00138-20

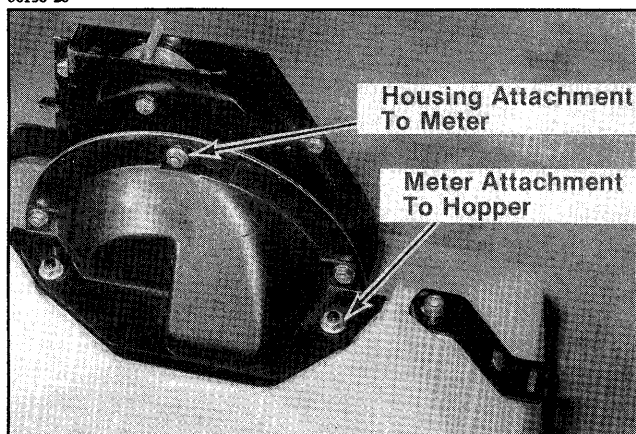

Rotate the seed meter drive by hand to ensure that the springs are holding the tabs of the fingers against the carrier plate where indicated in the photo and that the fingers are being raised in the correct area.

00138-4

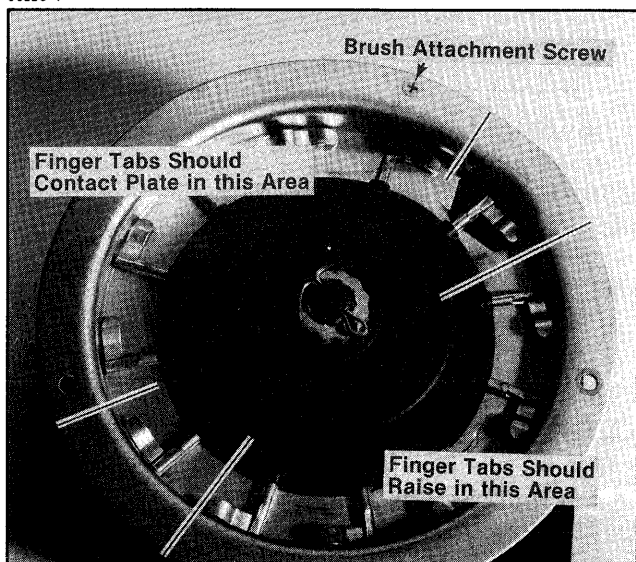

A build-up of debris or chaff may prevent proper finger operation and will require disassembly and cleaning of the corn meter as follows:

1. Remove cotter pin, lock nut and adjusting nut from drive shaft.
2. Carefully lift finger holder, along with fingers and cam off of the shaft and clean.

00138-21

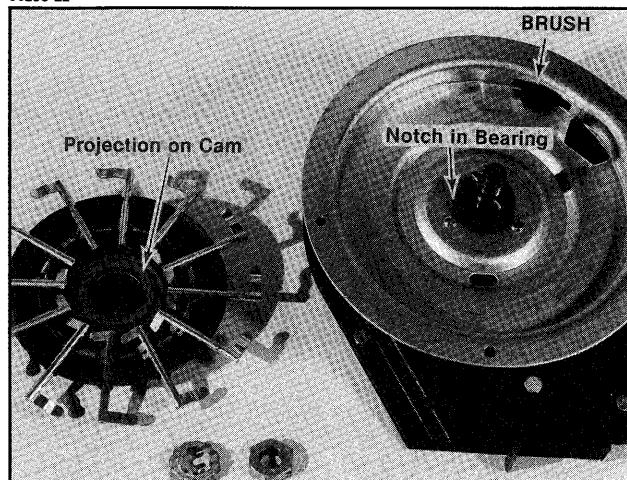

3. Check brush for wear and replace if necessary or following every 100 acres per row of operation.

EXAMPLE: Approximately 600 acres of corn on a 6 row planter or 800 acres on an 8 row planter.

**NOTE: It is not necessary to remove finger holder to remove brush.**

4. To replace fingers or springs, remove springs from fingers and remove finger from holder by lifting it out of the friction fit slot. Under average conditions, life expectancy of these parts should be 600-900 acres per row of operation.

5. After cleaning and/or replacing defective parts, reassemble the meter in the reverse order. When replacing fingers, make sure the open end of the spring loop is toward the inside of the finger holder.

00138-22

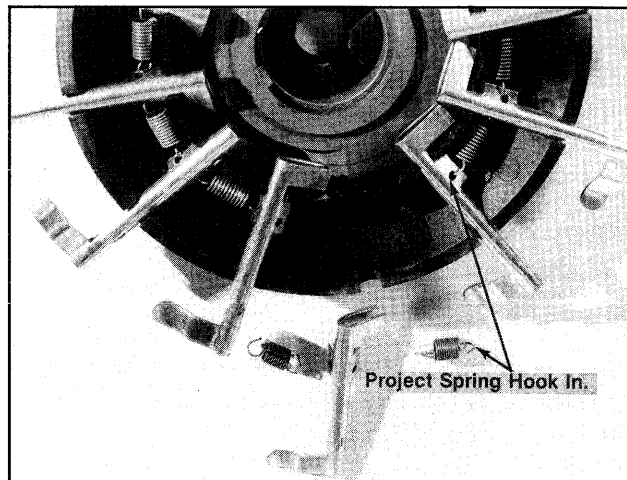

6. Make sure fingers are installed in holder so that holder will be positioned flush with the carrier plate when assembled. A projection on the cam is designed to align with a notch in the bearing to ensure proper operation when assembled.

# MAINTENANCE

50725-4

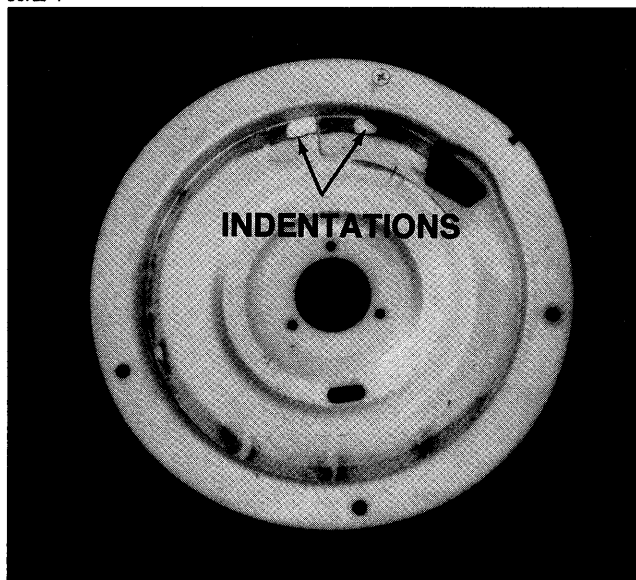

Photo shows worn plate

7. Before installing the finger holder on the carrier plate, check the indentations on the carrier plate for wear. Excessive wear of the carrier plate at the indentations will cause over planting especially when using small sizes of seed corn.

Inspect the carrier plate yearly. Under average conditions, the life expectancy of the carrier plate should be 250-300 acres per row of operation.

8. With finger holder flush against the carrier, install adjusting nut until it contacts the finger holder with a slight resistance. Continue to turn the nut an additional 1/3 turn or torque to 22 to 25 inch pounds of rolling torque on input shaft.

9. Turn finger holder by hand to make sure it is positioned firmly against the carrier, but is not over tightened and can be rotated with moderate force.

10. Install cage nut and cotter pin and reinstall housing.

**NOTE: Check tightness of adjusting nut on each unit after first day of use and periodically thereafter.**

To inspect or replace the seed belt, remove the four cap screws around the edge of the housing cover and the nut from the belt idler mounting bolt.

00138-24

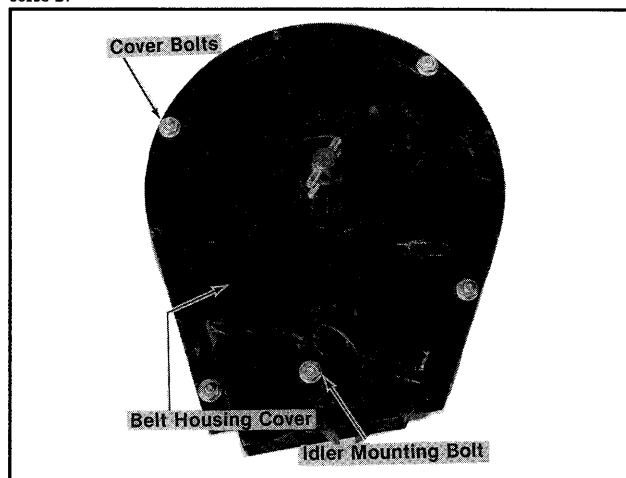

00138-23

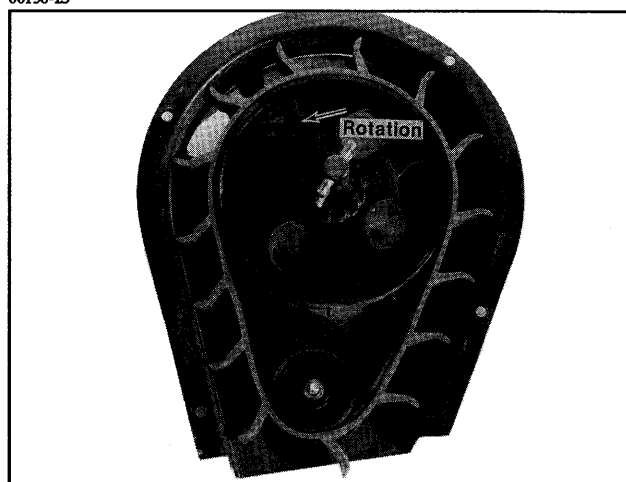

If the belt is being replaced, make sure it is reinstalled to correctly orient the paddles as shown. A diagram molded into the drive sprocket also illustrates the correct orientation.

**CAUTION: Do not over tighten hardware.**

## PLATELESS CORN/FEED CUP METER CLEANING

1. Disassemble meter.
2. Blow out loose dirt.
3. Wash in mild soap and water. Do not use gasoline or kerosene.
4. Dry thoroughly.
5. Coat lightly with a rust inhibitor.
6. Store in a dry place.



# MAINTENANCE

## GAUGE WHEEL ADJUSTMENT

To prevent an accumulation of dirt or trash, gauge wheels should just touch the opener blades. Gauge wheels and opener blades should turn with only slight resistance.

00138-2

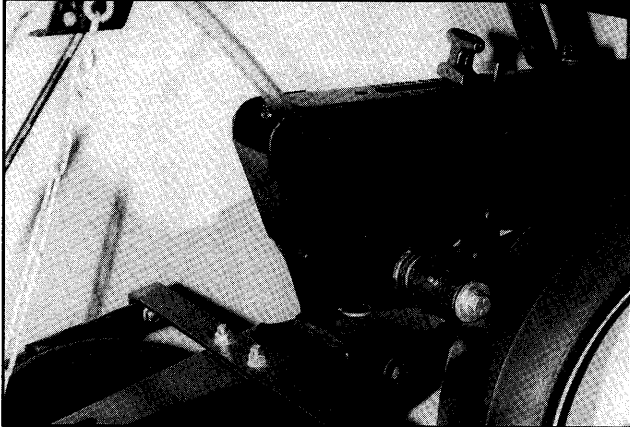

To adjust gauge wheel and opener blade clearance, add or remove 1 1/64" spacer washers between the shank and gauge wheel arm. Store remaining spacer washers between gauge wheel arm and lock washer on outer side of gauge wheel arm.

**NOTE:** It may be desirable to space gauge wheel further from blade when operating in sticky soils.

## 15" SEED OPENER DISC/BEARING ASSEMBLY

When the 15" seed opener disc is worn to 14 1/2" or less, the disc and bearing should be replaced.

00138-1

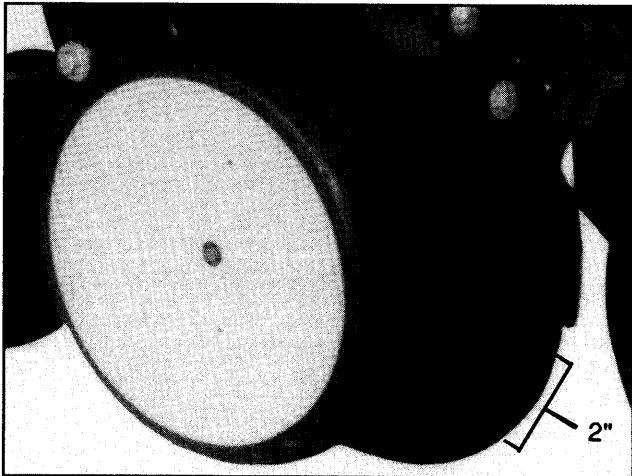

2" of blade to blade contact.  
Replace when worn to 14 1/2" or less.

To replace disc/bearing assembly:

1. Remove gauge wheel.
2. Remove bearing dust cap.
3. Remove jam nut and washer from outside of disc/bearing assembly.

**NOTE:** Left hand side of opener uses a left hand threaded nut.

4. Remove disc/bearing assembly. The spacer bushings between the shank and disc are used to maintain the blade to blade contact at 2".

5. After installing new disc/bearing assembly, install washer and jam nut to secure disc/bearing assembly. Torque 5/8"-11 Grade 2 nut to value shown in Torque Values Chart at the end of this section.

6. Replace bearing dust cap.

It may be necessary to replace only the bearing if the bearing sounds rough when the disc is rotated.

To replace bearing:

1. Remove gauge wheel, bearing cap, jam nut, washer and disc/bearing assembly.

2. Remove 1/4" rivets from bearing housing to expose bearing.

3. After installing new bearing, evenly spaced install three 1/4" bolts into three of the six in the bearing housing to hold the bearing and bearing housing in place. Install rivets in the other three holes. Remove 1/4" bolts and install rivets in those three holes..

4. Reinstall disc/bearing assembly, washer and jam nut. Torque 5/8"-11 Grade 2 nut to value shown in Torque Values Chart at end of this section.

5. Replace bearing dust cap.

# MAINTENANCE

## SEED TUBE GUARD

Remove the seed tube and check for wear. Excessive wear on the seed tube indicates a worn seed tube guard.

50881-9

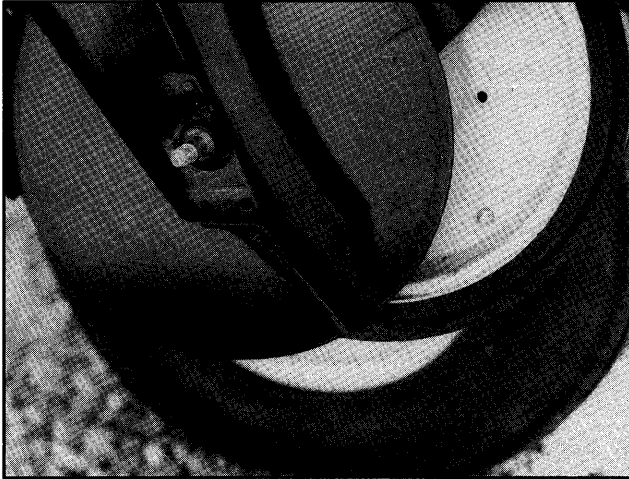

No-till planting or planting in hard ground conditions will increase seed tube guard wear and necessitate more frequent inspection.

The gauge wheel and seed opener discs must be removed before the seed tube guard can be replaced.

## HEAVY DUTY COULTER

If properly maintained and lubricated the bearings in the heavy duty coulters arm may never need to be replaced. Lubricate at frequency indicated in the Lubrication Section of this manual. Check periodically to be sure nuts and hardware are tight. Be sure the coulters is positioned square with the planter frame.

The coulters arm can be adjusted to one of three settings. Initially the arm is set to position the coulters blade in the highest position. As the blade wears the arm can be adjusted to one of the two lower settings. See "Heavy Duty Coulters" in Operation Section of this manual.

00138-1

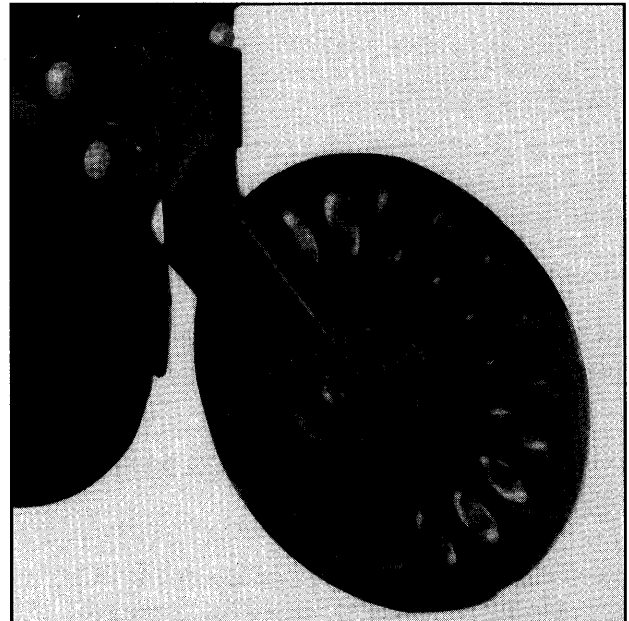

When the 16" coulters blade is worn to 14 1/2" (maximum allowable wear), it should be replaced.

# MAINTENANCE

## MARKER BEARING LUBRICATION OR REPLACEMENT

1. Remove marker blade and hub cap retainer.
2. Remove hub cap from hub.
3. Remove cotter pin, nut and washer.
4. Slide hub from spindle.
5. Remove bearings and cups and discard if bearings are being replaced. Clean hub and dry. Remove bearings only and not cups if repacking.
6. Press in new bearing cups with thickest edge facing in. (Bearing replacement procedure only.)
7. Pack bearings with heavy duty wheel bearing grease thoroughly forcing grease between roller cone and bearing cage. Also fill the space between the bearing cups in the hub with grease.
8. Place inner bearing in place and press in new rubber seal and grease seal.
9. Clean spindle and install hub.
10. Install outer bearing, washer or outer seal and slotted hex nut. Tighten slotted hex nut while rotating hub until there is some drag. This assures that all bearing surfaces are in contact. Back off slotted nut to nearest locking slot and install cotter pin.
11. Fill hub caps approximately 3/4 full of wheel bearing grease and install on hub.
12. Install blade and hub cap retainer on hub and tighten evenly and securely.

MKR020

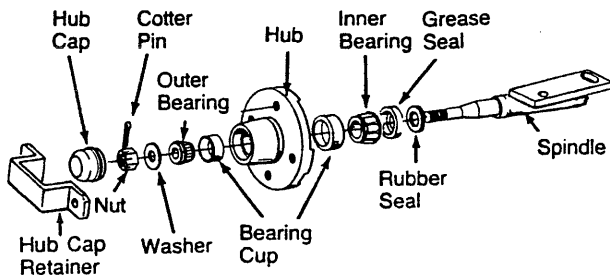

## WHEEL BEARING LUBRICATION OR REPLACEMENT

1. Raise tire clear of ground and remove wheel.
2. Remove double jam nuts and slide hub from spindle.
3. Remove bearings and cups and discard if bearings are being replaced. Clean hub and dry. Remove bearings only and not cups if repacking.
4. Press in new bearing cups with thickest edge facing in. (Bearing replacement procedure only.)
5. Pack bearings with heavy duty wheel bearing grease thoroughly forcing grease between roller cone and bearing cage. Also fill the space between the bearing cups in the hub with grease.
6. Place inner bearing in place.
7. Clean spindle and install hub.
8. Install outer bearing and jam nut. Tighten jam nut while rotating hub until there is some drag. This assures that all bearing surfaces are in contact. Back off jam nut 1/4 turn or until there is only slight drag when rotating the hub. Install second jam nut to lock against first.
9. Install wheel on hub and tighten evenly and securely.

HTA014

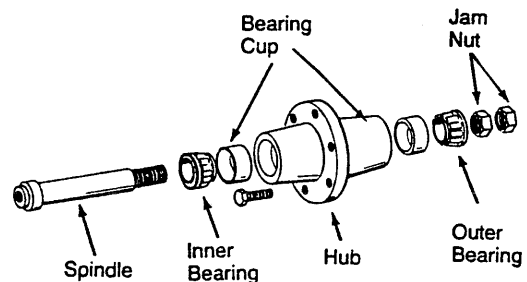

# MAINTENANCE

## PREPARATION FOR STORAGE

Store the planter in a dry sheltered area if possible.

Remove all trash that may be wrapped on sprockets or shafts and remove dirt that can draw and hold moisture.

Clean all drive chains and coat with a rust preventative spray, or remove chains and submerge in oil.

Lubricate components and row units at all lubrication points.

If possible, remove weight from all tires particularly if the unit is stored outdoor, in which case it is best to remove wheels and tires for storage in a cool dry area.

Inspect the components and row units for parts that are in need of replacement and order during the "off" season.

Make sure all seed, herbicide and insecticide hoppers are empty and clean.

Clean seed meters and store in a dry area. (Refer to row unit manual for proper procedures)

Grease exposed areas of cylinder rods before storing planter.

Grease or paint disc openers to prevent rust.

## WIRING DIAGRAM

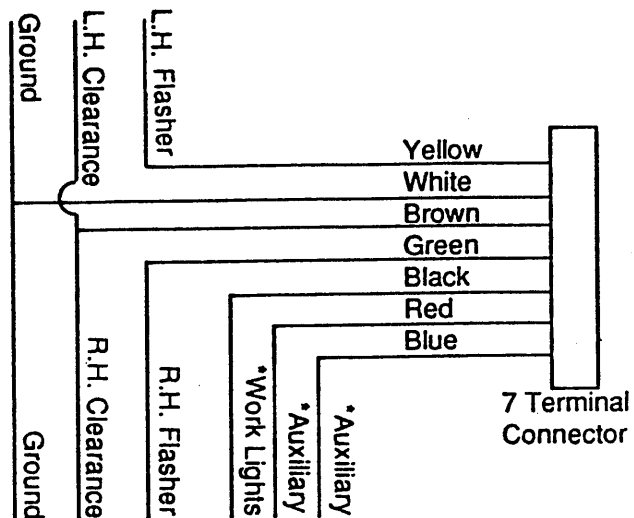

\*Optional lights and wires (to be supplied by customer) may be wired into existing plug terminals.

Light package supplied on the 3 Point Mounted planter meets ASAE standards. For the correct wiring harness to be wired into the lights on your tractor, check with the tractor manufacturer.

# PARTS LIST INDEX

---

Toolbar Components .....	P2/P3
Drive Wheel Assembly .....	P4
Front Mounted Drive Wheel (Optional) .....	P5
Dual Lift Assist W/Floating Center Mast (Optional) .....	P6/P7
Drive Line .....	P8/P9
Transmission Assembly .....	P10/P11
Conventional Marker .....	P12/P13
Low Profile Marker .....	P14/P15
Marker Spindle/Hub/Blade .....	P16
Hydraulic System, Dual Valve .....	P17
Hydraulic System, Optional Single Valve .....	P18
Conventional Marker Cylinder .....	P19
Low Profile Marker Cylinder .....	P19
Dual Lift Assist Cylinder .....	P20
Sequencing Valve .....	P21
Flow Control Valve .....	P21
Shank Assembly .....	P22/P23
Gauge Wheel .....	P24
Closing Wheel .....	P25
Hopper Support And Plateless Hopper Drive .....	P26
Parallel Arms And Mounting Brackets .....	P27
Plateless Seed Hopper .....	P28
Finger Pickup Meter .....	P29
Feed Cup Meter .....	P30
Granular Chemical Banders .....	P31
Granular Chemical Hopper With Meter(s) .....	P32/P33
Standard Down Pressure Springs .....	P34
Heavy Duty Down Pressure Springs .....	P34
Heavy Duty Coulter .....	P35
Spring Tooth Incorporator .....	P36/P37
Decals, Reflectors And Tie Straps .....	P38/P39
Numerical Index .....	a

# TOOLBAR COMPONENTS

PFA043

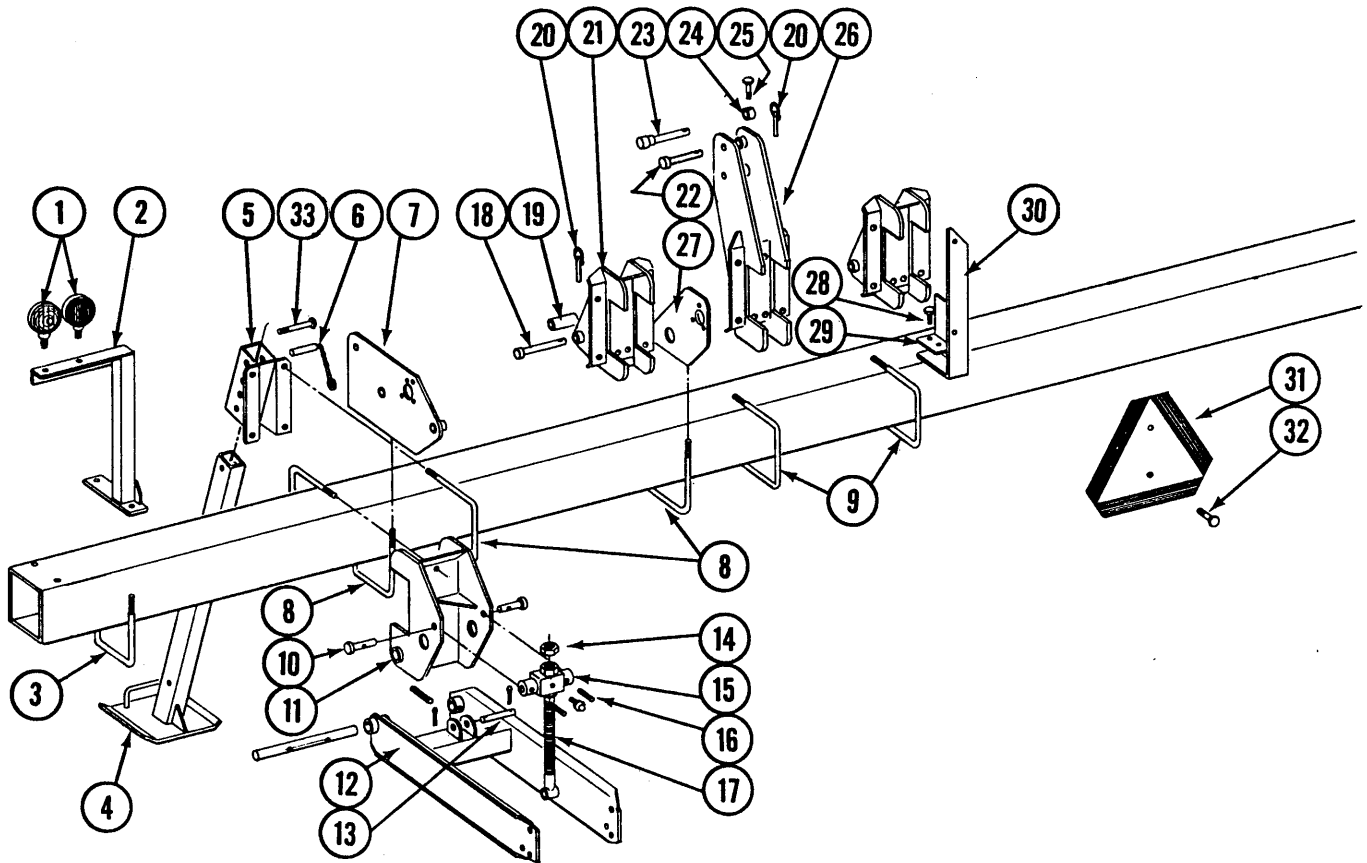

ITEM	PART NO.	DESCRIPTION	
1.	A4122	Single Red Light Complete W/Female Terminal Less Wiring Harness	
	A4123	Double Amber Light Complete W/Male Terminal Less Wiring Harness	
	R0968	Bulb, No. 1156	
	R0970	Red Lens	
	R0969	Amber Lens	
	10289	Hex Nut, 1/2"-20	
	10525	Star Washer, 1/2"	
	10266	Female Terminal	
	10269	Male Terminal	
	A4783	Wiring Harness, 180", 2 And 4 Row	
	A4784	Wiring Harness, 246", 6 And 8 Row	
	2.	A4775	Bracket, L.H. (Shown)
		A4776	Bracket, R.H.
	3.	D7145	U-Bolt, 7" x 7" x 1/2"-13
10228		Lock Washer, 1/2"	
10102		Hex Nut, 1/2"-13	

# TOOLBAR COMPONENTS

---

ITEM	PART NO.	DESCRIPTION
4.	A4732	Parking Stand
5.	A4707	Mount
6.	A4733	Detent Pin W/Chain
7.	A4699	Drive Plate, L.H. (Shown)
	A4700	Drive Plate, R.H.
8.	D1114	U-Bolt, 7" x 7" x 5/8"-11
	10230	Lock Washer, 5/8"
	10104	Hex Nut, 5/8"-11
9.	D1748	U-Bolt, 7" x 7" x 3/4"-10
	10231	Lock Washer, 3/4"
	10105	Hex Nut, 3/4"-10
10.	A4704	Pin
11.	*	Module W/Grease Fitting
	10641	Grease Fitting, 1/8" NPT
12.	*	Arm W/Shaft And Spring Pin
	D7042	Shaft, 1 1/4" x 12 1/8"
	10610	Spring Pin, 3/8" x 2"
13.	D7041	Pin, 1" x 4"
	10459	Cotter Pin, 3/16" x 1 1/2"
14.	10117	Hex Nut, 1"-8, Grade 2
15.	A4711	Jack Screw Mount W/Grease Fitting
	10641	Grease Fitting, 1/8" NPT
16.	10489	Spring Pin, 3/8" x 1 1/2"
17.	A4705	Adjuster Screw
18.	A4665	Lower Link Pin
19.	D7090	Adapter Bushing, Category 3
20.	D2557	Lynch Pin, 7/16"
21.	*	Lower Link
22.	A4666	Link Pin, Category 3, 1 1/4"
23.	A4938	Link Pin, Optional Category 2, 1"
24.	D7338	Sleeve, Optional Category 2
25.	10048	Hex Head Cap Screw, 3/8"-16 x 2"
	10229	Lock Washer, 3/8"
	10101	Hex Nut, 3/8"-16
26.	*	Center Mast
27.	A4709	Carrier Bearing Mount, L.H. (Shown), 4 Row Wide through 8 Row Wide
	A5466	Carrier Bearing Mount, R.H., 8 Row 40" Only
28.	10001	Hex Head Cap Screw, 3/8"-16 x 1"
	10229	Lock Washer, 3/8"
29.	D5807	Valve Mounting Bracket
30.	D7152	SMV Mounting Bracket
31.	D2199	SMV Emblem
32.	10023	Hex Head Cap Screw, 1/4"-20 x 3/4"
	10110	Lock Nut, 1/4"-20
33.	10016	Hex Head Cap Screw, 1/2"-13 x 2"
	10111	Lock Nut, 1/2"-13

# DRIVE WHEEL ASSEMBLY

PLA025

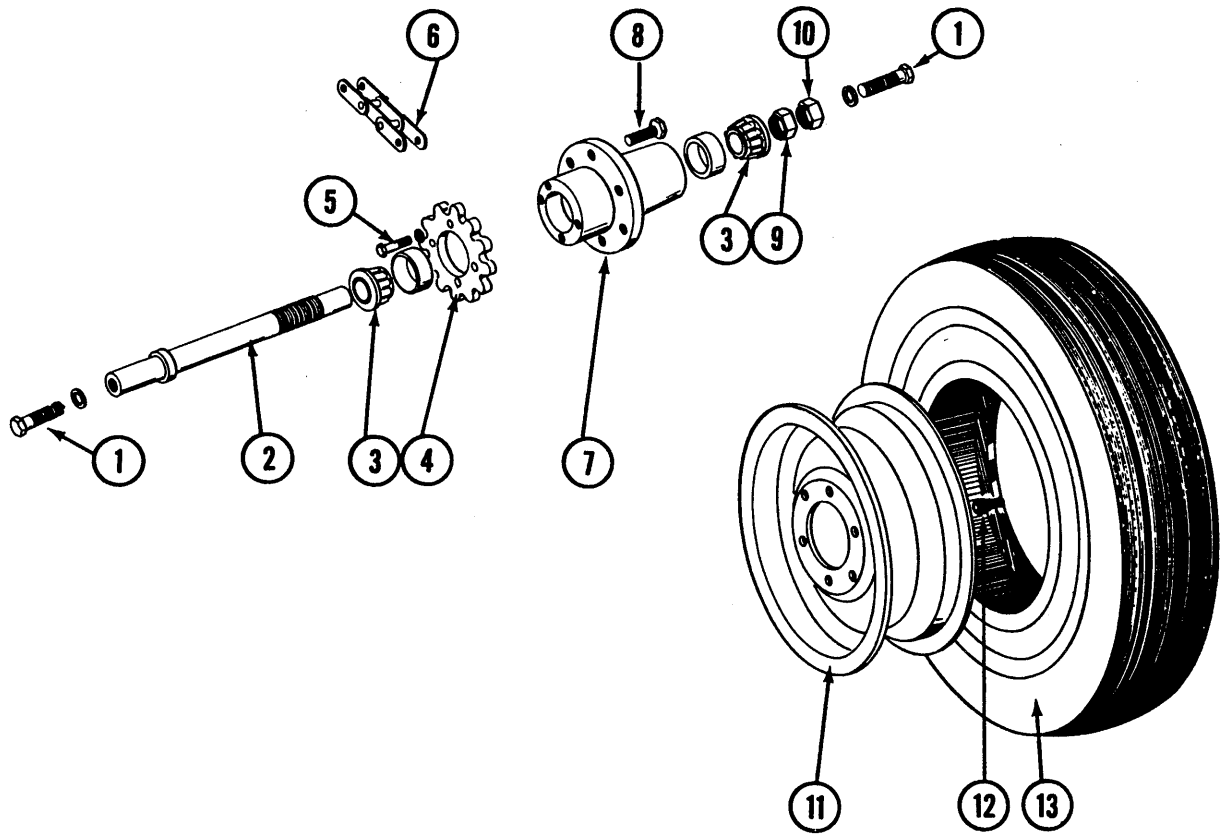

ITEM	PART NO.	DESCRIPTION
1.	10026	Hex Head Cap Screw, 3/4"-10 x 2"
	10231	Lock Washer, 3/4"
2.	A4693	Spindle
3.	A0895	Bearing
4.	2500-17	Sprocket, 12 Tooth
5.	10019	Hex Head Cap Screw, 5/16"-18 x 1"
	10232	Lock Washer, 5/16"
6.	3200-62	Chain, No. 2050, 62 Pitch Including Connector Link
	3200-06	Chain, No. 2050 (Add to chain when using 2 to 1 reduction sprockets.)
	R0195	Connector Link, No. 2050
	R0200	Offset Link, No. 2050
7.	A0926	Hub W/Cups, 6 Bolt
	R0434	Cup
8.	R0270	Bolt, 9/16"-18
9.	10092	Hex Nut, 1 1/2"-12, Grade 2
10.	10087	Jam Nut, 1 1/2"-12, Grade 2
11.	A4696	Wheel, 15" x 5"
12.	D1166	Valve Stem
13.	D0844	Tire, 7.60 x 15, 4 Ply



# FRONT MOUNTED DRIVE WHEEL (OPTIONAL)

PTD064

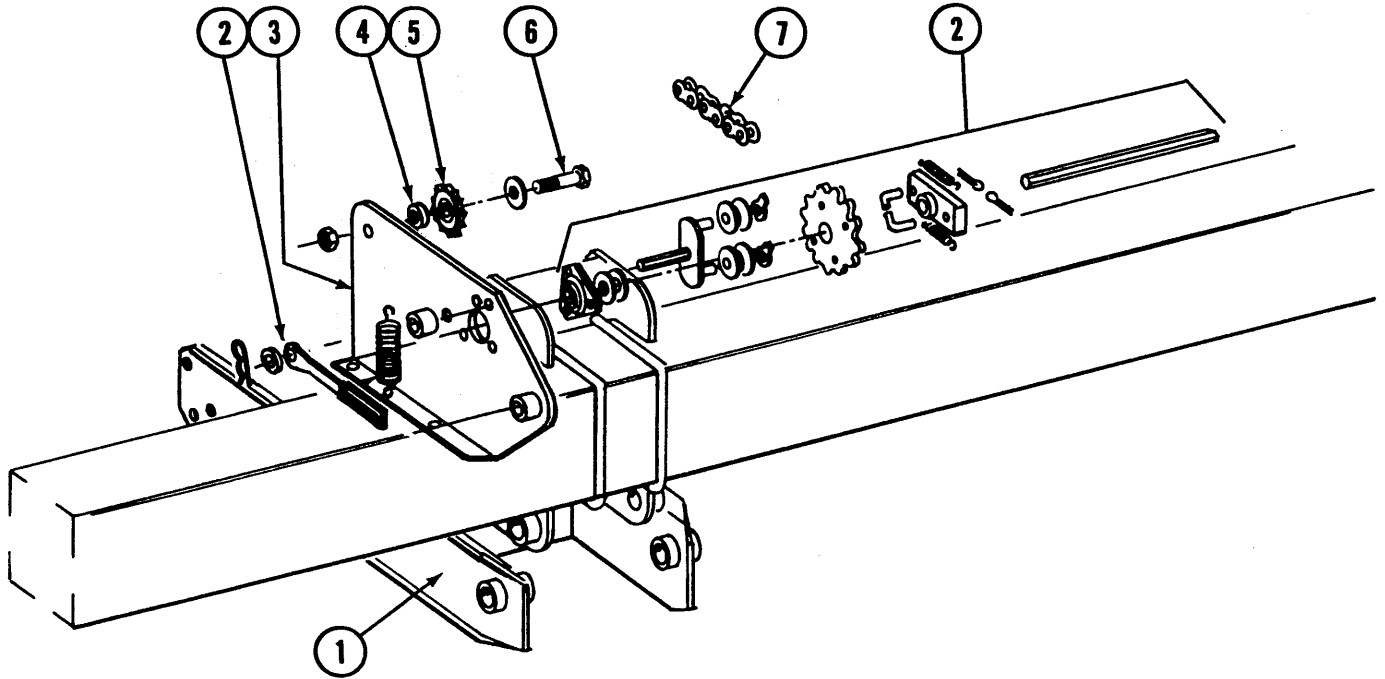

ITEM	PART NO.	DESCRIPTION
1.		See "Toolbar Components"
2.		See "Drive Line"
3.		See "Toolbar Components"
4.	D7101	Sleeve
5.	A0262	Idler Sprocket W/Bearing, 15 Tooth
6.	10009	Hex Head Cap Screw, 5/8"-11 x 2 1/2"
	10217	Washer, 5/8" USS (As Required)
	10107	Lock Nut, 5/8"-11
7.	3200-18	Chain, No. 2050, 18 Pitch Including Connector Link (Add to chain when using front mounted drive. See "Drive Wheel Assembly".)
	R0195	Connector Link, No. 2050

# DUAL LIFT ASSIST W/FLOATING CENTER MAST (OPTIONAL)

PFA045/PLA015/HTA014

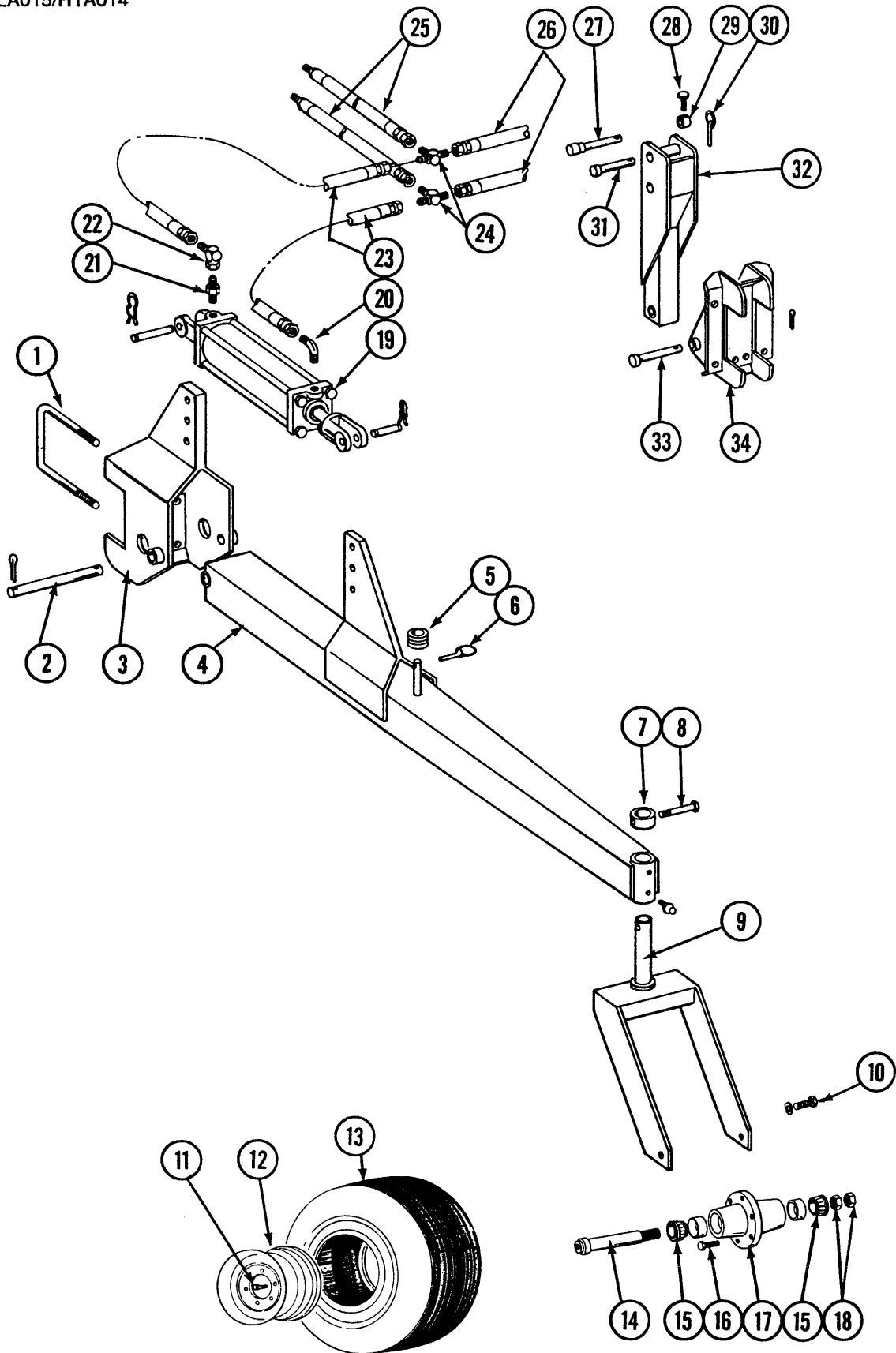

# DUAL LIFT ASSIST W/FLOATING CENTER MAST (OPTIONAL)

ITEM	PART NO.	DESCRIPTION
1.	D1748	U-Bolt, 7" x 7" x 3/4"-10
	10231	Lock Washer, 3/4"
	10105	Hex Nut, 3/4"-10
2.	D1702	Pin, 1 1/4" x 10 1/4"
	10460	Cotter Pin, 1/4" x 2"
3.	*	Wheel Tower
4.	*	Tube W/Grease Fittings
	10641	Grease Fitting, 1/8" NPT
5.	A4743	Stroke Control Collar Kit, Includes: (1) 3/4", (1) 1", (1) 1 1/4", (1) 1 1/2"
6.	D2558	Lynch Pin, 1/4"
7.	D7068	Cap
8.	10032	Hex Head Cap Screw, 1/2"-13 x 3 3/4"
	10228	Lock Washer, 1/2"
	10102	Hex Nut, 1/2"-13
9.	A4715	Caster Wheel
10.	10026	Hex Head Cap Screw, 3/4"-10 x 2"
	10231	Lock Washer, 3/4"
11.	D1166	Valve Stem
12.	A5196	Wheel W/Valve Protector, 15" x 5"
13.	D0844	Tire, 7.60 x 15, 4 Ply
14.	A2558	Spindle
15.	A0895	Bearing
16.	R0270	Bolt, 9/16"-12
17.	A2148	Hub W/Cups, 6 Bolt
	R0434	Cup
18.	10087	Jam Nut, 1 1/2"-10, Grade 2
19.		See "Dual Lift Assist Cylinder"
20.	2501-08-08	Elbow, 3/4"-16 JIC To 1/2" NPT
21.	2404-08-08	Adapter, 3/4"-16 JIC To 1/2" NPT
22.	6500-08	Elbow, 3/4"-16 JIC Male To Female
23.	A1039	Hose Assembly, 3/8" x 76"
24.	2603-08	Tee, 3/4"-16 JIC
25.	A1005	Hose Assembly, 3/8" x 48"
26.	A1055	Hose Assembly, 3/8" x 66"
27.	A4938	Link Pin, Optional Category 2, 1 1/4"
28.	10048	Hex Head Cap Screw, 3/8"-16 x 2"
	10229	Lock Washer, 3/8"
	10101	Hex Nut, 3/8"-16
29.	D7338	Sleeve, Category 2, 1"
30.	D2557	Lynch Pin, 7/16"
31.	A4666	Link Pin, Category 3, 1 1/4"
32.	*	Floating Top Mast
33.	A4665	Lower Link Pin
	10468	Cotter Pin, 3/8" x 2"
34.	*	Lower Link

# DRIVE LINE

PTD062

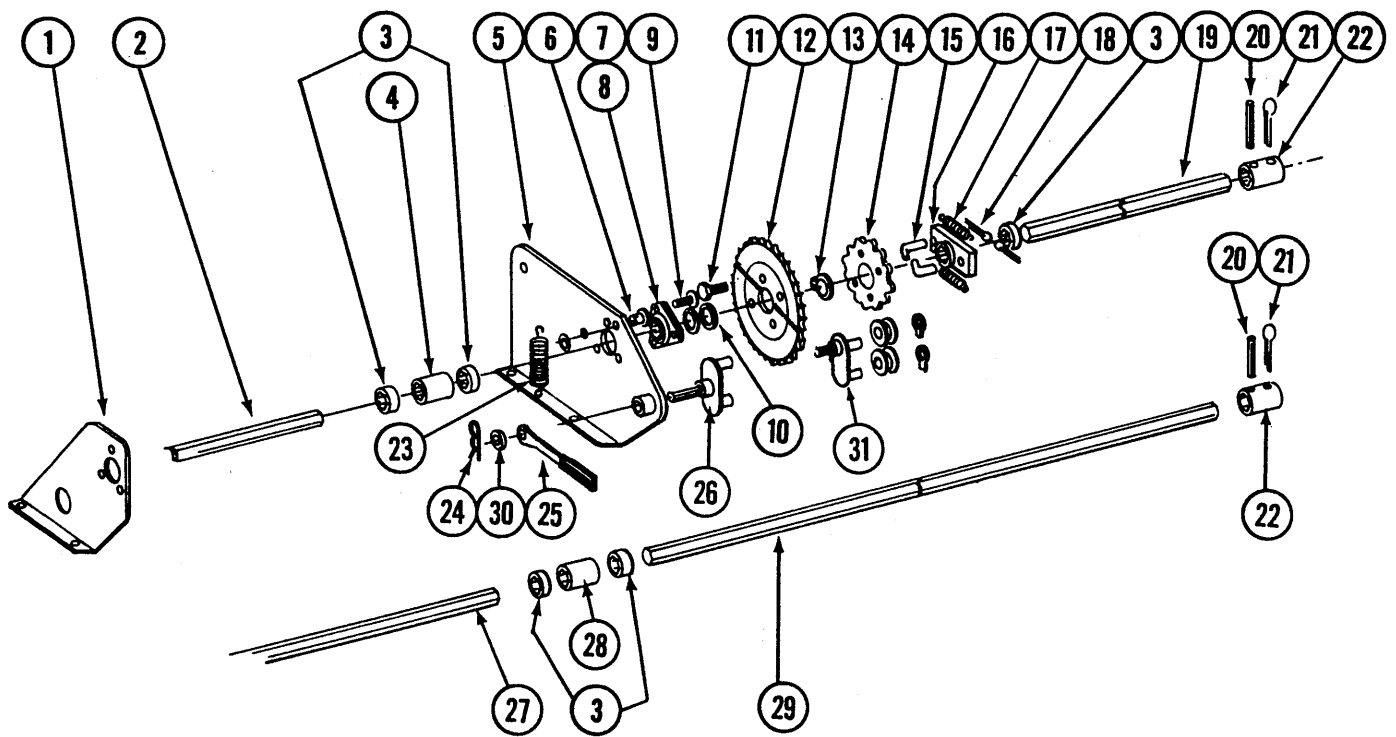

# DRIVE LINE

ITEM	PART NO.	DESCRIPTION
1.		See "Toolbar Components"
2.	D0914-120	Drive Shaft, 8 Row 40" Only
3.	D0917	Lock Collar, 7/8 Hex, Less Set Screws
	10145	Set Screw, 5/16"-18 x 1/2"
4.	D1719	Coupler, 4", 8 Row 40" Only
5.		See "Toolbar Components"
6.	10478	Clevis Pin, 5/16" x 1"
	10409	Retaining Ring
7.	2100-03	Bearing, 7/8 Hex Bore, Spherical
8.	3400-01	Flangette
9.	10312	Carriage Bolt, 5/16"-18 x 3/4"
	10232	Lock Washer, 5/16"
	10106	Hex Nut, 5/16"-18
10.	10233	Machine Bushing
11.	10002	Hex Head Cap Screw, 3/8"-16 x 3/4"
	10229	Lock Washer, 3/8"
12.	A2359	Sprocket, 48 Tooth, 2 To 1 Reduction
13.	10430	Ring
14.	A0376	Sprocket, 12 Tooth Ratchet
15.	D1255	"L" Pin
16.	A0378	Block
17.	D1256	Spring
18.	10464	Cotter Pin, 3/16" x 1"
19.	D5887-90	Drive Shaft, 2 Row Up To 40" Spacing
	D5887-106	Drive Shaft, 4 Row Up To 40" Spacing
	D5887-186	Drive Shaft, 6 Row Up To 40" Spacing
	D5887-144	Drive Shaft, 8 Row Up To 40" Spacing
20.	10602	Spring Pin, 1/4" x 1 1/2"
21.	10460	Cotter Pin, 1/4" x 2"
22.	D5886	Coupler
23.	D5857	Spring
24.	10670	Hair Pin Clip, No.3
25.	A4235	Ratchet Wrench W/Protective Closure
	10445	Protective Closure
26.	A0901	Idler W/Spools And Rings
	D0916	Spool
	10435	Ring
27.	D5887-144	Drill Shaft, 8 Row 40" Only
28.	D7153	Coupler, 12", 8 Row 40" Only
29.	D5887-75	Drill Shaft, 2 Row Up To 40" Spacing
	D5887-135	Drill Shaft, 4 Row Up To 40" Spacing
	D5887-215	Drill Shaft, 6 Row Up To 40" Spacing
	D5887-144	Drill Shaft, 8 Row Up To 40" Spacing
30.	D6819	Sleeve
31.	A5545	Idler W/Spools And Rings (For use with 2 to 1 reduction sprocket.)
	D0916	Spool
	10435	Ring
A.	A0261R	Ratchet Sprocket Assembly, R.H. (Items 13-18)
	A0261L	Ratchet Sprocket Assembly, L.H. (Items 13-18)
B.	7090X	2 To 1 Reduction Package, Includes: (8) 10002, (8) 10229, (2) 3200-06, (2) A2359, (2) A5545

# TRANSMISSION ASSEMBLY

PTD041

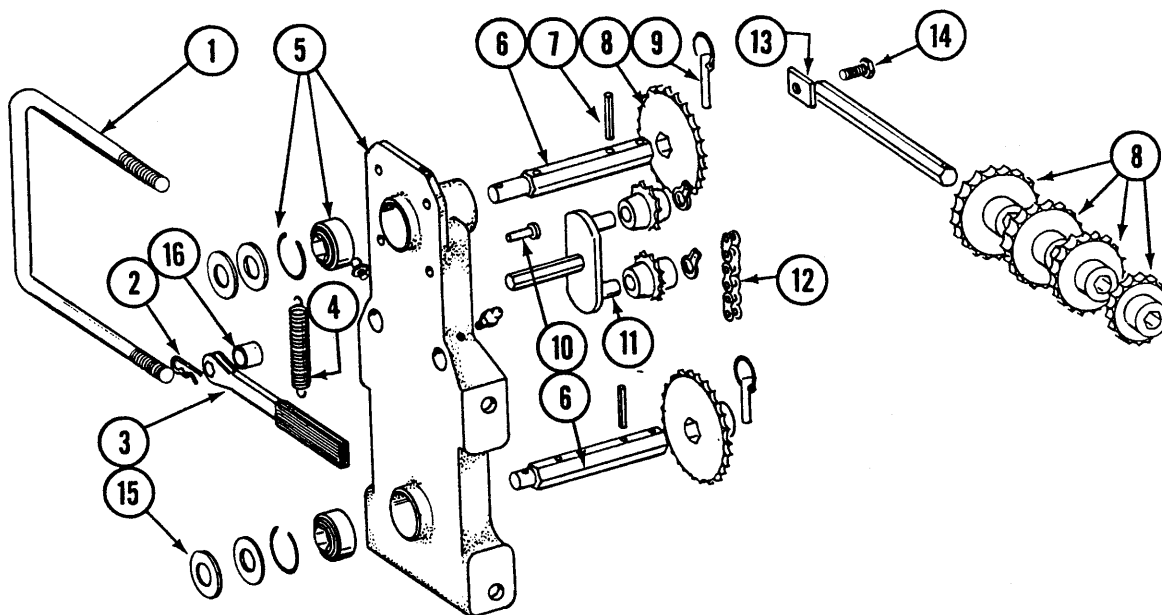

# TRANSMISSION ASSEMBLY

---

ITEM	PART NO.	DESCRIPTION
1.	D1114	U-Bolt, 7" x 7" x 5/8"-11
	10230	Lock Washer, 5/8"
	10107	Hex Nut, 5/8"-11
2.	10670	Hair Pin Clip, No. 3
3.	A4235	Ratchet Wrench W/Protective Closure
	10445	Protective Closure
4.	D5857	Spring
5.	A5144	Transmission Plate W/Bearing, Grease Fittings And Retaining Rings
	A5116	Bearing, 7/8 Hex Bore, Cylindrical
	D6551	Ring
	10641	Grease Fitting, 1/8" NPT
6.	D5215	Shaft, 7/8" x 6 3/8"
7.	10602	Spring Pin, 1/4" x 1 1/2"
8.	A5106	Sprocket, 17 Tooth
	A5107	Sprocket, 19 Tooth
	A5108	Sprocket, 23 Tooth (Qty. 2)
	A5109	Sprocket, 24 Tooth
	A5110	Sprocket, 25 Tooth
	A5111	Sprocket, 26 Tooth
	A5112	Sprocket, 27 Tooth
	A5113	Sprocket, 28 Tooth
9.	D2558	Lynch Pin, 1/4"
10.	10478	Clevis Pin, 5/16" x 1"
	10409	Retaining Ring, 5/16"
11.	A5136	Idler W/Sprockets And Rings
	D5815	Sprocket
	10435	Ring
12.	3310-80	Chain, No. 40, 80 Pitch Including Connector Link
	R0912	Connector Link, No. 40
13.	A5146	Sprocket Storage Rod
14.	10037	Hex Head Cap Screw, 1/2"-13 x 1 1/4"
	10228	Lock Washer, 1/2"
	10102	Hex Nut, 1/2"-13
15.	10233	Machine Bushing
16.	D6819	Sleeve

# CONVENTIONAL MARKER 4 ROW 30"/WIDE AND 6 ROW 30"

MKR010

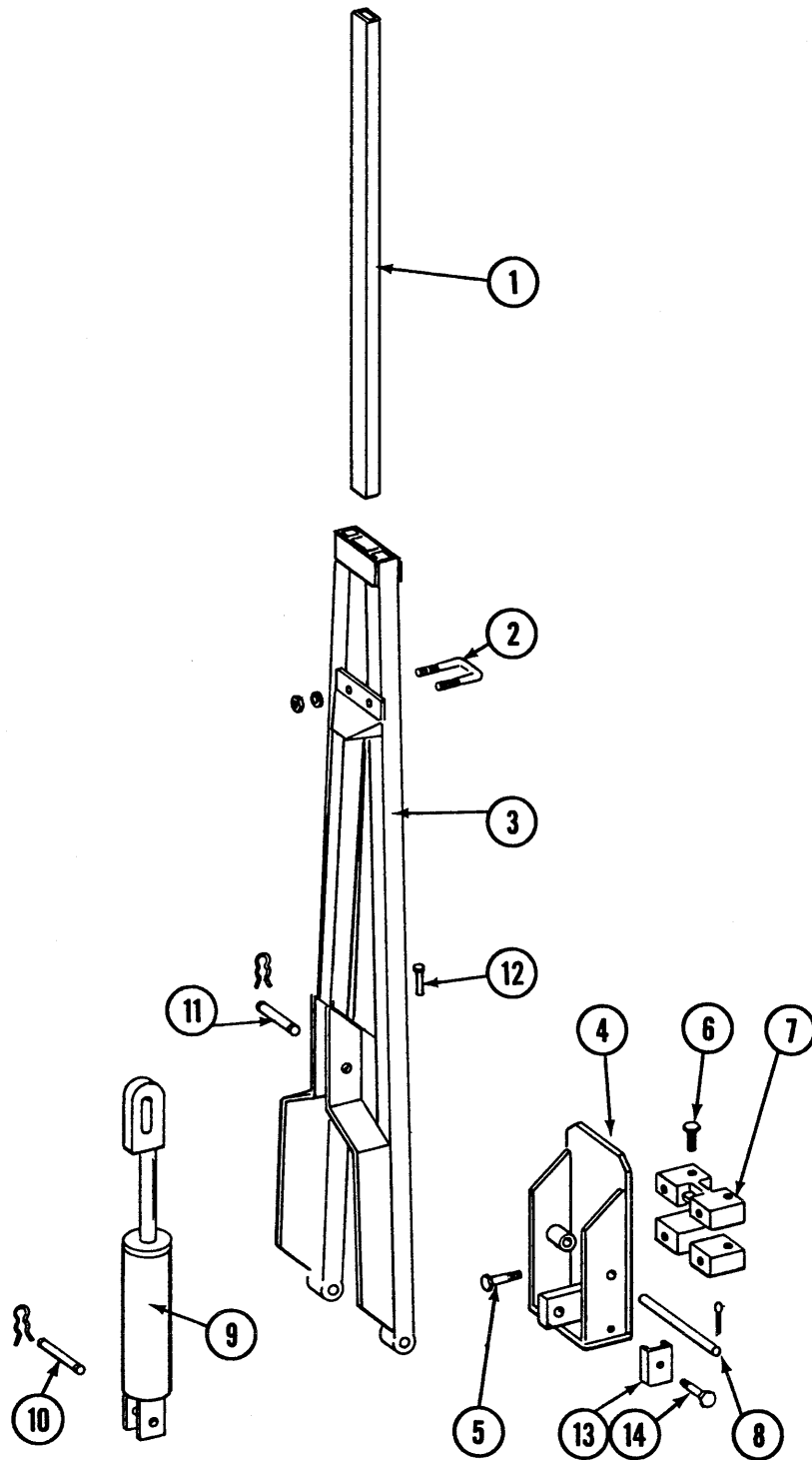



# CONVENTIONAL MARKER

## 4 ROW 30"/WIDE AND 6 ROW 30"

---

ITEM	PART NO.	DESCRIPTION
1.	D0453-02	Extension Tube, 40", 4 Row 30" And 6 Row 30"
	D0453-03	Extension Tube, 50", 4 Row 36"/38"/40"
2.	D2721	U-Bolt, 2" x 2" x 1/2"-13
	10228	Lock Washer, 1/2"
	10102	Hex Nut, 1/2"-13
3.	A5175	Arm, 31 1/2", 4 Row 30"
	A5184	Arm W/Grease Fittings, 44 1/2", 4 Row 36"/38"/40"
	A5183	Arm W/Grease Fittings, 58 1/2", 6 Row 30"
	10640	Grease Fitting, 1/4"-28
4.	A5177	Mount W/Grease Fittings, 4 Row 30"
	A5178	Mount, 4 Row 36"/38"/40" And 6 Row 30"
	10640	Grease Fitting, 1/4"-28
5.	10008	Hex Head Cap Screw, 5/8"-11 x 2", Grade 2
	10230	Lock Washer, 5/8"
6.	10026	Hex Head Cap Screw, 3/4"-10 x 2"
	10231	Lock Washer, 3/4"
7.	B0177	Tap Block
8.	D0438	Pin, 13 1/2"
	10460	Cotter Pin, 1/4" x 2"
9.		See "Conventional Marker Cylinder"
10.	R0367	Pin, 2 7/8"
	R0193	Clip
11.	R0375	Pin, 3 1/2"
	R0193	Clip
12.	D0462	Lockup Pin
	10670	Hair Pin Clip, No. 3
	10187	Spring Pin, 5/32" x 2"
13.	D5892	Hose Clamp
14.	10133	Hex Head Cap Screw, 5/16"-18 x 1 1/2"
	10232	Lock Washer, 5/16"
	10106	Hex Nut, 5/16"-18

# LOW PROFILE MARKER 6 ROW WIDE AND 8 ROW 30"/WIDE

MKR019/MKR008

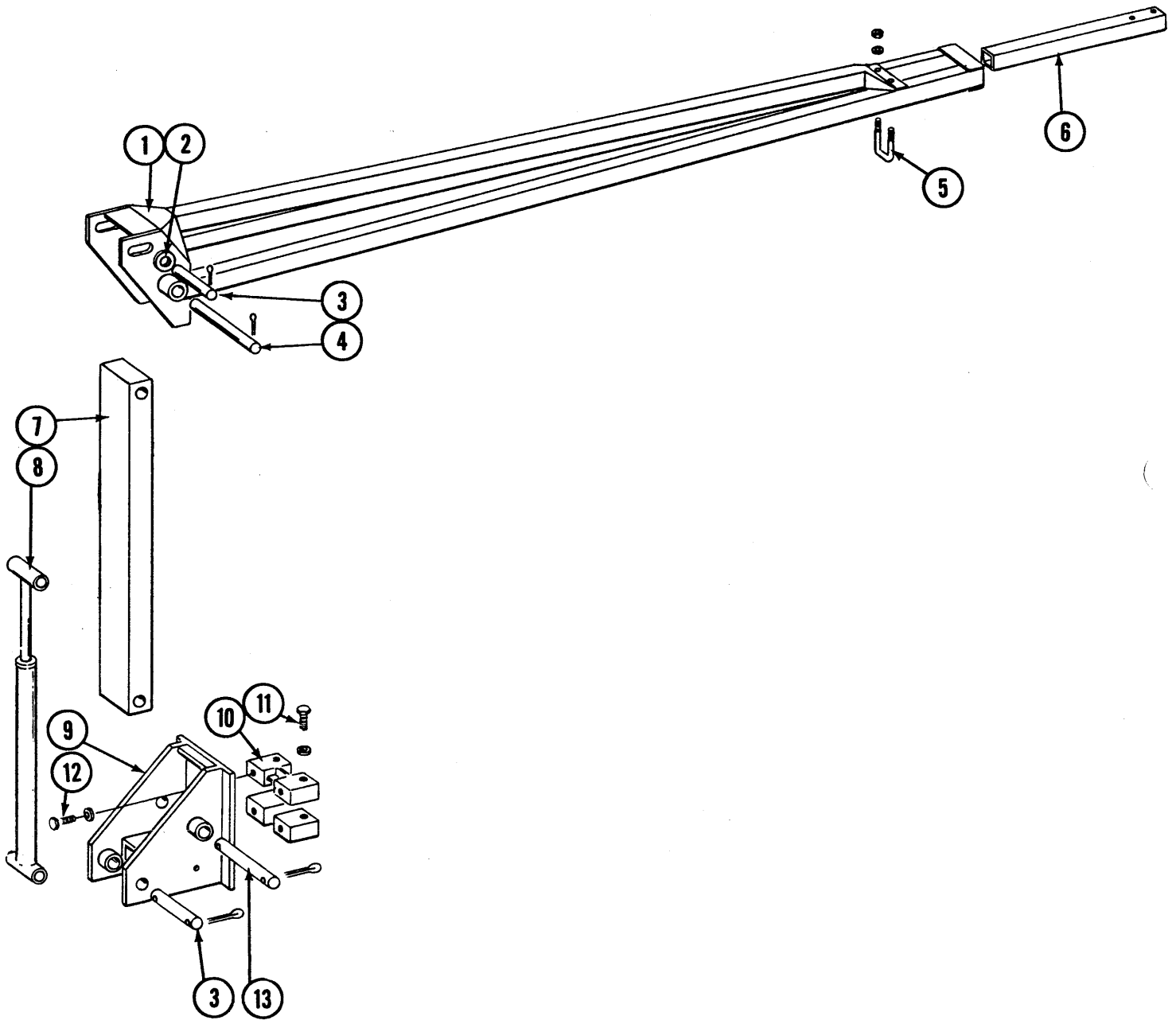

# LOW PROFILE MARKER

## 6 ROW WIDE AND 8 ROW 30"/WIDE

---

ITEM	PART NO.	DESCRIPTION
1.	A5190	Arm, Second Stage, 41 1/2", 6 Row 36"/38"/40"
	A5188	Arm, Second Stage, 52 1/2", 8 Row 30"
	A5192	Arm, Second Stage, 73 1/8", 8 Row 36"/38"/40"
2.	10226	Washer, 1 1/4" SAE
3.	D2161	Pin, 1 1/4" x 8 1/2"
	10460	Cotter Pin, 1/4" x 2"
4.	D3214	Pin, 1 1/4" x 12 1/4"
	10460	Cotter Pin, 1/4" x 2"
5.	D2721	U-Bolt, 2" x 2" x 1/2"-13
	10228	Lock Washer, 1/2"
	10102	Hex Nut, 1/2"-13
6.	D0453-04	Extension Tube, 60", 6 Row 36"/38"/40"
	D0453-03	Extension Tube, 50", 8 Row 30"
	D0453-08	Extension Tube, 65", 8 Row 36"/38"/40"
7.	A5173	Arm W/Grease Fittings, First Stage
	10641	Grease Fitting, 1/8" NPT
8.		See "Low Profile Marker Cylinder"
9.	A5130	Mount
10.	B0177	Tap Block
11.	10026	Hex Head Cap Screw, 3/4"-10 x 2"
	10231	Lock Washer, 3/4"
12.	10008	Hex Head Cap Screw, 5/8"-11 x 2", Grade 2
	10230	Lock Washer, 5/8"
13.	D0652	Pin, 1 1/4" x 9 1/2"
	10460	Cotter Pin, 1/4" x 2"

# MARKER SPINDLE/HUB/BLADE

MKR020

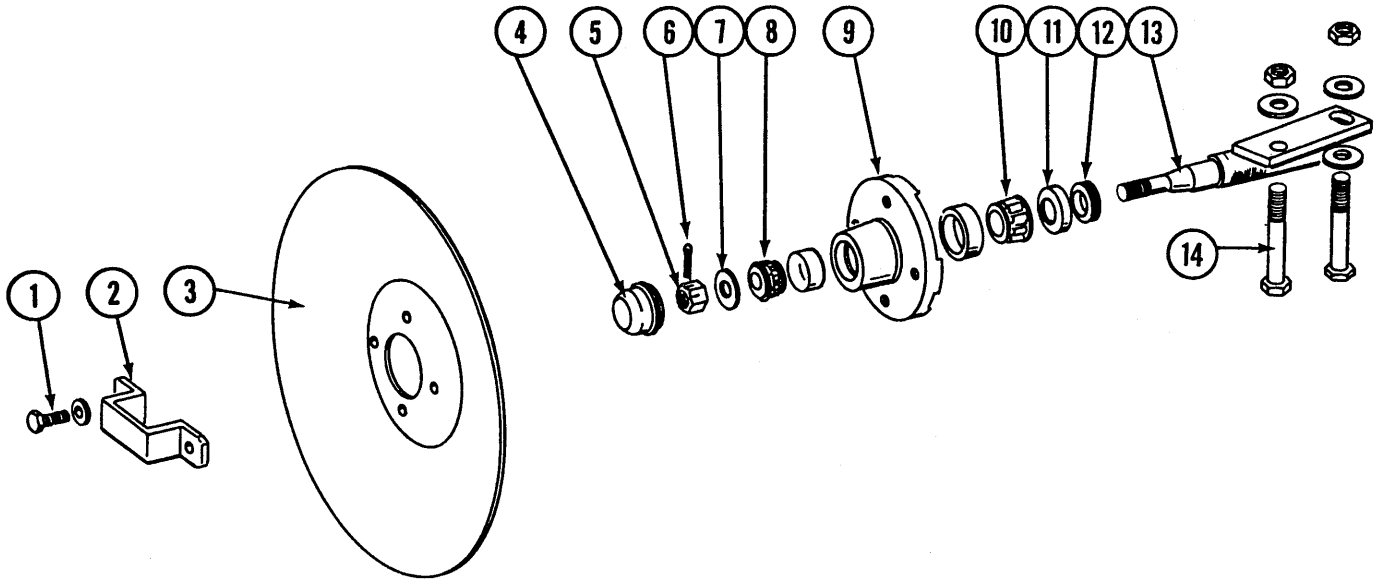

ITEM	PART NO.	DESCRIPTION
1.	10722	Hex Head Cap Screw, 1/2"-20 x 1"
	10228	Lock Washer, 1/2"
2.	D2597	Retainer
3.	D0746	Blade, 16"
4.	D0840	Cap
5.	10725	Hex Slotted Nut, 5/8"-18
6.	10544	Cotter Pin, 5/32" x 1"
7.	10724	Washer, 5/8"
8.	A0257	Outer Bearing
9.	A0167	Hub With Cups
	R0151	Outer Cup
	R0150	Inner Cup
10.	A0245	Inner Bearing
11.	A0243	Grease Seal
12.	A0899	Rubber Seal
13.	A1677	Spindle, L.H.
	A1676	Spindle, R.H.
14.	10033	Hex Head Cap Screw, 1/2"-13 x 3 1/2"
	10168	Machine Bushing, 1/2", 7 Gauge
	10102	Hex Nut, 1/2"-13
A.	A1679	Hub And Spindle Assembly, L.H. (Items 1 And 4-13)
	A1678	Hub And Spindle Assembly, R.H. (Items 1 And 4-13)

# HYDRAULIC SYSTEM, DUAL VALVE

PHS033

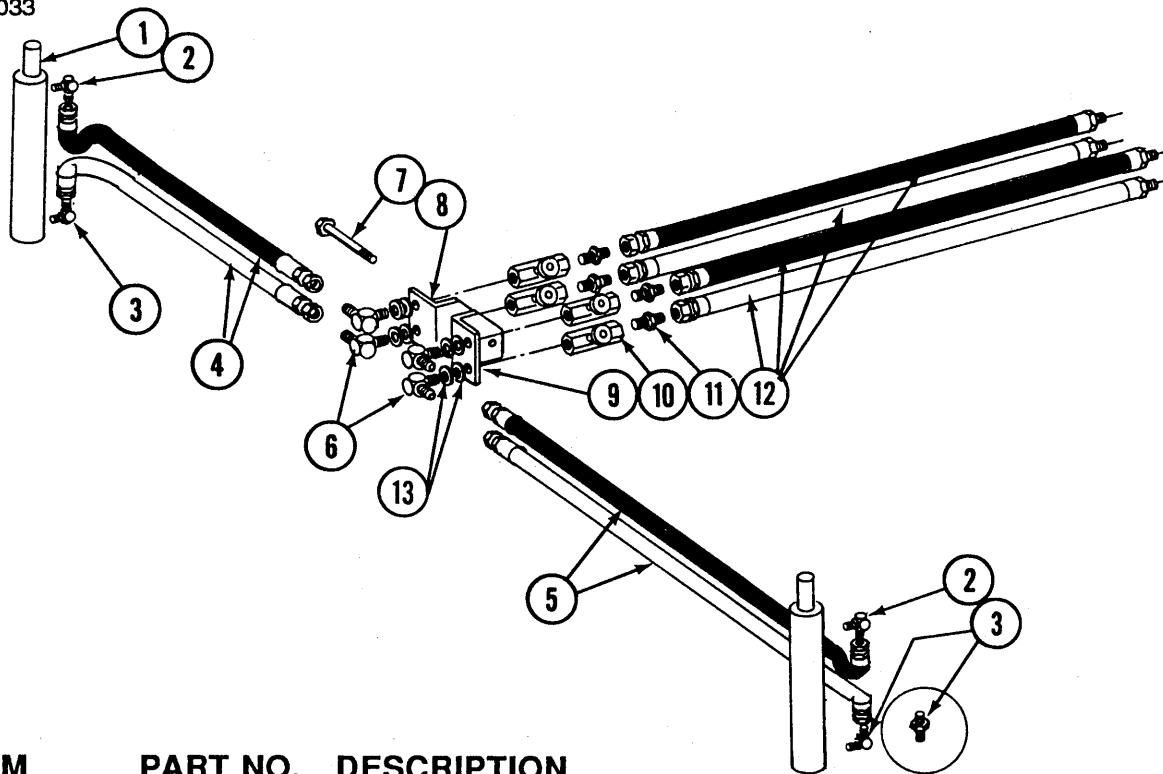

ITEM	PART NO.	DESCRIPTION
1.		See "Conventional Marker Cylinder" or "Low Profile Marker Cylinder"
2.	6801-06-08	Elbow, 9/16"-18 Male JIC To 3/4"-16 O-Ring, 4 Row 30"/Wide And 6 Row 30"
	6801-08	Elbow, 3/4"-16 Male JIC To 3/4"-16 O-Ring, 6 Row Wide And 8 Row 30"/Wide
3.	6801-06-08	Elbow, 9/16"-18 Male JIC To 3/4"-16 O-Ring, 4 Row 30"/Wide And 6 Row 30"
4.	6400-08	Connector, 3/4"-16 Male O-Ring To JIC, 6 Row Wide And 8 Row 30"/Wide
	A1150	Hose Assembly, 1/4" x 103", 4 Row 30"
	A1134	Hose Assembly, 1/4" x 116", 4 Row Wide
	A1106	Hose Assembly, 1/4" x 130", 6 Row 30"
	A3114	Hose Assembly, 1/4" x 156", 6 Row Wide
	A1049	Hose Assembly, 1/4" x 160", 8 Row 30"
5.	A3154	Hose Assembly, 1/4" x 196", 8 Row Wide
	A1170	Hose Assembly, 1/4" x 90", 4 Row 30"
	A1172	Hose Assembly, 1/4" x 105", 4 Row Wide
	A1168	Hose Assembly, 1/4" x 120", 6 Row 30"
	A3115	Hose Assembly, 1/4" x 146", 6 Row Wide
	A1013	Hose Assembly, 1/4" x 150", 8 Row 30"
	A1028	Hose Assembly, 1/4" x 186", 8 Row Wide
6.	2501-06-06	Elbow, 90°, 9/16"-18 Male JIC To 3/8" NPT, 4 Row 30"/Wide And 6 Row 30"
	2501-08-06	Elbow, 90°, 3/4"-16 Male JIC To 3/8" NPT, 6 Row Wide And 8 Row 30"/Wide
7.	10004	Hex Head Cap Screw, 3/8"-16 x 1 1/4"
	10229	Lock Washer, 3/8"
	10101	Hex Nut, 3/8"-16
8.	*	Mounting Bracket, L.H.
9.	*	Mounting Bracket, R.H.
10.		See "Flow Control Valve"
11.	2404-06-06	Adapter, 9/16"-18 Male JIC To 3/8" NPT, 4 Row 30"/Wide And 6 Row 30"
	2404-08-06	Adapter, 3/4"-16 Male JIC To 3/8" NPT, 6 Row Wide And 8 Row 30"/Wide
12.	A1101	Hose Assembly, 1/4" x 48", 4 Row 30"/Wide And 6 Row 30"
	A1005	Hose Assembly, 3/8" x 48", 6 Row Wide And 8 Row 30"/Wide
13.	10204	Machine Bushing
	10213	Special Bushing

# HYDRAULIC SYSTEM, OPTIONAL SINGLE VALVE

PHS034

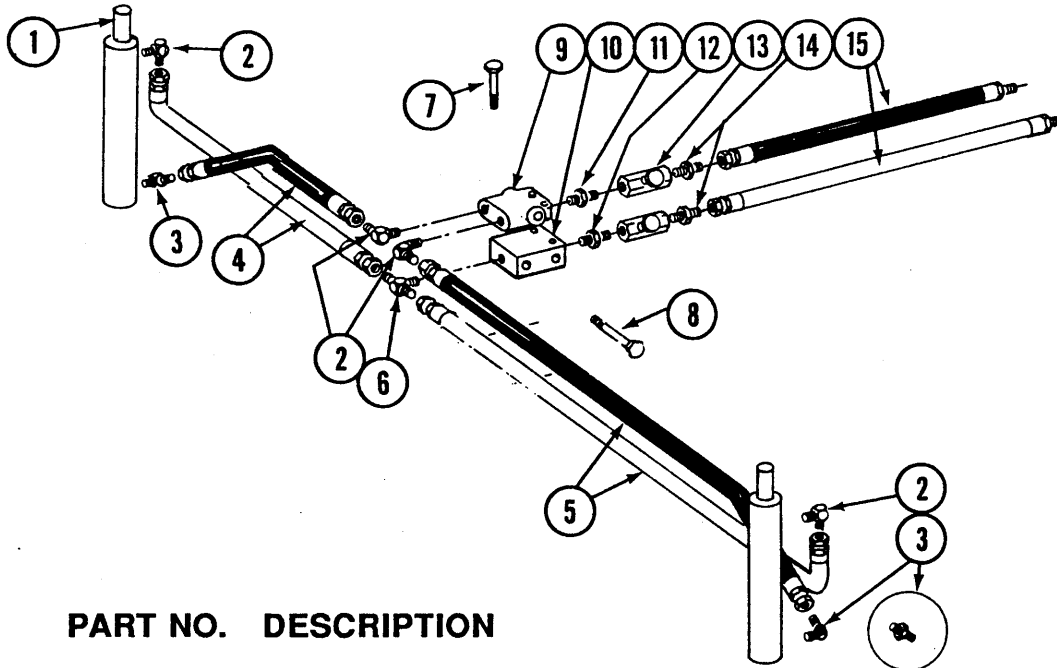

ITEM	PART NO.	DESCRIPTION
1.		See "Conventional Marker Cylinder" or "Low Profile Marker Cylinder"
2.	6801-06-08	Elbow, 9/16"-18 Male JIC To 3/4"-16 O-Ring, 4 Row 30"/Wide And 6 Row 30"
	6801-08	Elbow, 3/4"-16 Male JIC To 3/4"-16 O-Ring, 6 Row Wide And 8 Row 30"/Wide
3.	6801-06-08	Elbow, 9/16"-18 Male JIC To 3/4"-16 O-Ring, 4 Row 30"/Wide And 6 Row 30"
4.	6400-08	Connector, 3/4"-16 Male O-Ring To JIC, 6 Row Wide And 8 Row 30"/Wide
	A1150	Hose Assembly, 1/4" x 103", 4 Row 30"
	A1134	Hose Assembly, 1/4" x 116", 4 Row Wide
	A1106	Hose Assembly, 1/4" x 130", 6 Row 30"
	A3114	Hose Assembly, 1/4" x 156", 6 Row Wide
	A1049	Hose Assembly, 1/4" x 160", 8 Row 30"
	A3154	Hose Assembly, 1/4" x 196", 8 Row Wide
5.	A1170	Hose Assembly, 1/4" x 90", 4 Row 30"
	A1172	Hose Assembly, 1/4" x 105", 4 Row Wide
	A1168	Hose Assembly, 1/4" x 120", 6 Row 30"
	A3115	Hose Assembly, 1/4" x 146", 6 Row Wide
	A1013	Hose Assembly, 1/4" x 150", 8 Row 30"
	A1028	Hose Assembly, 1/4" x 186", 8 Row Wide
6.	2601-06-06	Tee, 9/16"-18 Male JIC To 3/8" NPT, 4 Row 30"/Wide And 6 Row 30"
	2601-08-06	Tee, 3/4"-16 Male JIC To 3/8" NPT, 6 Row Wide And 8 Row 30"/Wide
7.	10325	Hex Head Cap Screw, 3/8"-16 x 2 3/4"
	10229	Lock Washer, 3/8"
	10101	Hex Nut, 3/8"-16
8.	10004	Hex Head Cap Screw, 3/8"-16 x 1 1/4"
	10229	Lock Washer, 3/8"
9.		See "Sequencing Valve"
10.	D5861	Block
11.	6401-08-06	Adapter, 3/4"-16 Male O-Ring To 3/8" NPT
12.	5404-06-06	Coupling, 3/8" Male NPT
13.		See "Flow Control Valve"
14.	2404-06-06	Adapter, 9/16"-18 Male JIC To 3/8" NPT, 4 Row 30"/Wide And 6 Row 30"
	2404-08-06	Adapter, 3/4"-16 Male JIC To 3/8" NPT, 6 Row Wide And 8 Row 30"/Wide
15.	A1101	Hose Assembly, 1/4" x 48", 4 Row 30"/Wide And 6 Row 30"
	A1005	Hose Assembly, 3/8" x 48", 6 Row Wide And 8 Row 30"/Wide

# CONVENTIONAL MARKER CYLINDER 4 ROW 30"/WIDE AND 6 ROW 30"

CYL030

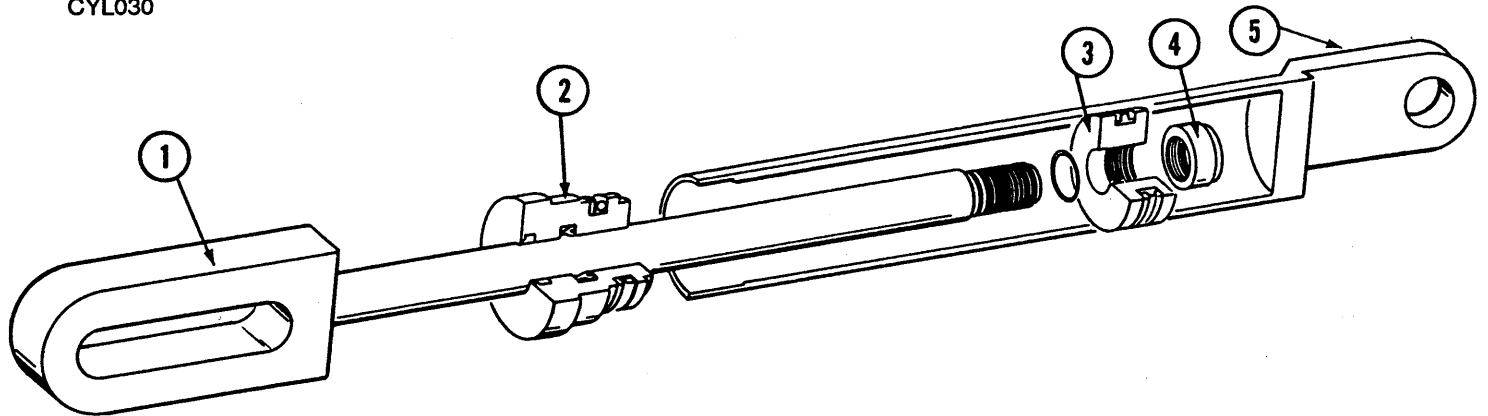

ITEM	PART NO.	DESCRIPTION
------	----------	-------------

- |    |       |                   |
|----|-------|-------------------|
| 1. | A5453 | Rod Assembly      |
| 2. | D5949 | Gland             |
| 3. | D4632 | Piston            |
| 4. | R0959 | Lock Nut, 3/4"-16 |
| 5. | A5454 | Barrel            |

- |    |       |  |
|----|-------|--|
| A. | A5095 | Cylinder Complete, 2" x 8"   |
| B. | R0927 | Seal Kit, Includes: (1) T Seal, (2) O-Rings, (1) BU Ring, (1) U-Cup, (1) Wiper |

# LOW PROFILE MARKER CYLINDER 6 ROW WIDE AND 8 ROW 30"/WIDE

CYL039

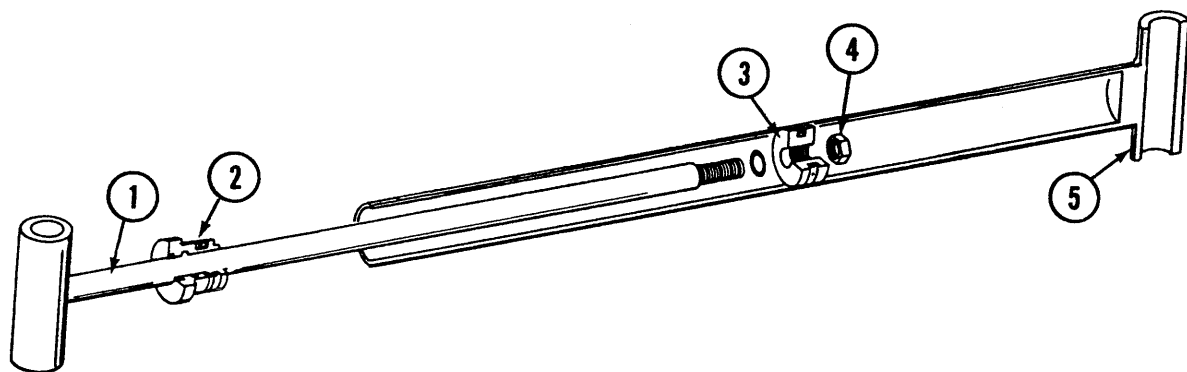

ITEM	PART NO.	DESCRIPTION
------	----------	-------------

- |    |       |                   |
|----|-------|-------------------|
| 1. | A5459 | Rod Assembly      |
| 2. | D5949 | Gland             |
| 3. | D4632 | Piston            |
| 4. | R0959 | Lock Nut, 3/4"-16 |
| 5. | A5460 | Barrel            |

- |    |       |  |
|----|-------|--|
| A. | A5097 | Cylinder Complete, 2" x 20"  |
| B. | R0927 | Seal Kit, Includes: (1) T Seal, (2) O-Rings, (1) BU Ring, (1) U-Cup, (1) Wiper |

# DUAL LIFT ASSIST CYLINDER

CYL022

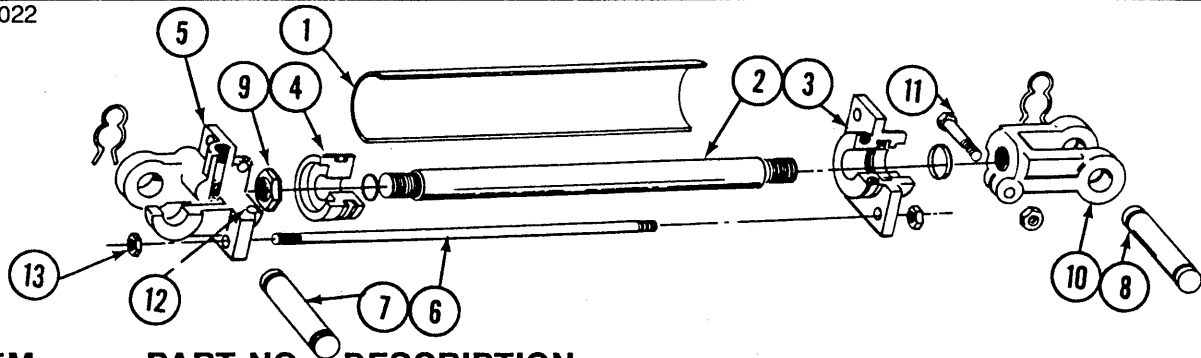

ITEM	PART NO.	DESCRIPTION
1.	*	Barrel
2.	R0174	Shaft
3.	R0175	Gland
4.	R0176	Piston
5.	R0177	Clevis
6.	R0178	Tie Rod
7.	R0179	Pin W/Clips, 3 5/8"
	R0193	Clip
8.	R0180	Pin W/Clips, 3 1/2"
	R0193	Clip
9.	R0203	Lock Nut, 1"-14
10.	R0456	Clevis
11.	10047	Hex Head Cap Screw, 3/8"-16 x 1 3/4"
	10101	Hex Nut, 3/8"-16
12.	10170	Pipe Plug, 1/2"
13.	R0181	Hex Nut, 1/2"-13
A.	A1803	Cylinder Complete W/Pins And Clips, 3 1/2" x 8"
B.	R0153	Seal Kit, Includes: (1) Wiper, (3) BU Washers, (5) O-Rings

# DUAL LIFT ASSIST CYLINDER

CYL048

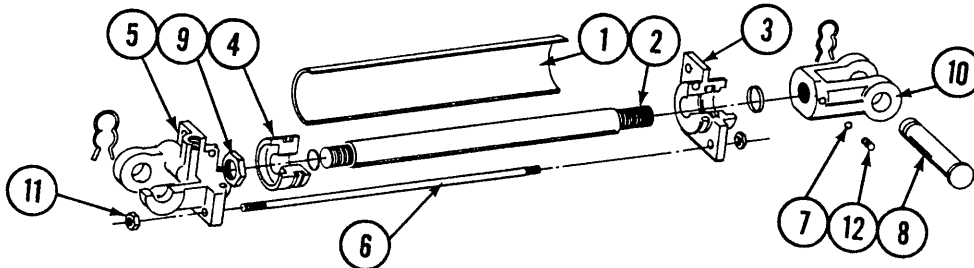

ITEM	PART NO.	DESCRIPTION
1.	*	Barrel
2.	R0709	Shaft
3.	R1025	Gland
4.	R1026	Piston
5.	R1027	Clevis
6.	R1024	Tie Rod
7.	R0716	Nylon Ball
8.	R0717	Pin W/Clip
9.	R0663	Nut
10.	R0714	Clevis
11.	R0181	Hex Nut, 1/2"-13
12.	10210	Set Screw, 3/8"-16 x 3/8"
A.	A5482	Cylinder Complete W/Pins And Clips, 3 1/2" x 8"
B.	R1028	Seal Kit, Includes: (1) Wiper, (4) BU Rings, (5) O-Rings, (1) U-Cup



# SEQUENCING VALVE

VVB002/VVB003

STYLE A

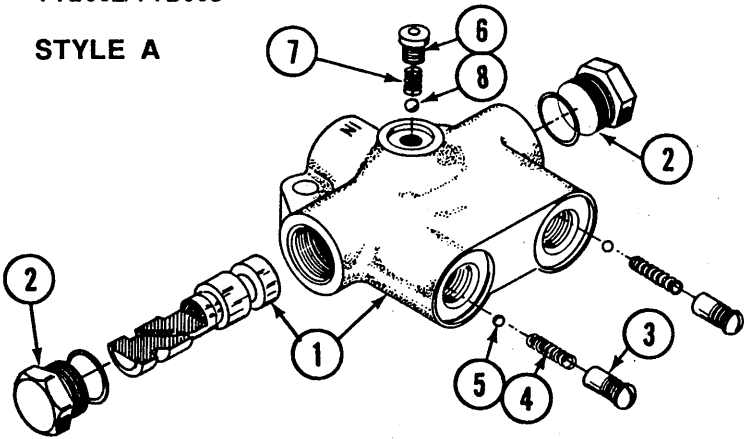

STYLE B

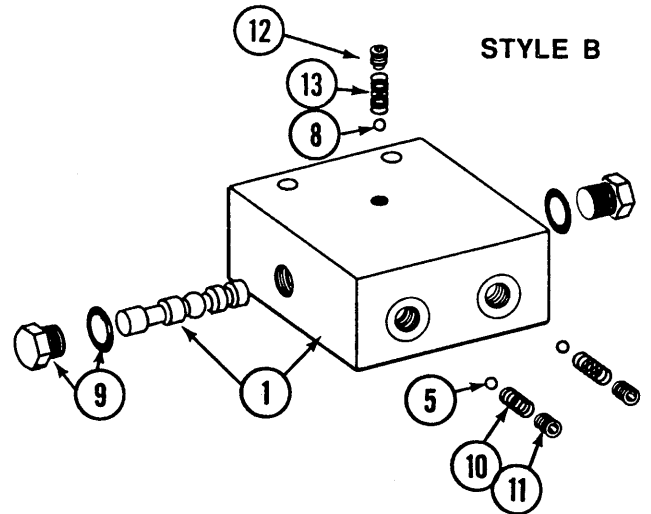

ITEM	PART NO.	DESCRIPTION
1.		Valve Body And Spool
2.	R0271	Plug Assembly, O-Ring Boss
3.	R0273	Retainer
4.	R0277	Spring
5.	R0275	Ball, 3/16"
6.	R0274	Plug
7.	R0278	Spring
8.	R0276	Ball, 1/4"
9.	R0811	Plug
10.	R0812	Spring
11.	R0813	Set Screw
12.	10334	Hex Socket Pipe Plug, 1/16"
13.	R0814	Spring
A.	A0282A	Sequencing Valve Complete, Style A
B.	A0282B	Sequencing Valve Complete, Style B

# FLOW CONTROL VALVE

VVB001

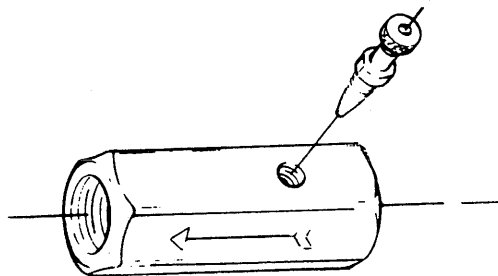

ITEM	PART NO.	DESCRIPTION
A.	A0270A	Flow Control Valve (To identify-Rego KLF375 stamped on body)
	R0103	Needle Valve Only
B.	A0270B	Flow Control Valve (To identify-Deltrol stamped on valve body)
	R0642	Needle Valve Only
C.	A0270C	Flow Control Valve (To identify-Parrol stamped on valve body)
	R0767	Needle Valve Only

# SHANK ASSEMBLY

RUB006/RUA004

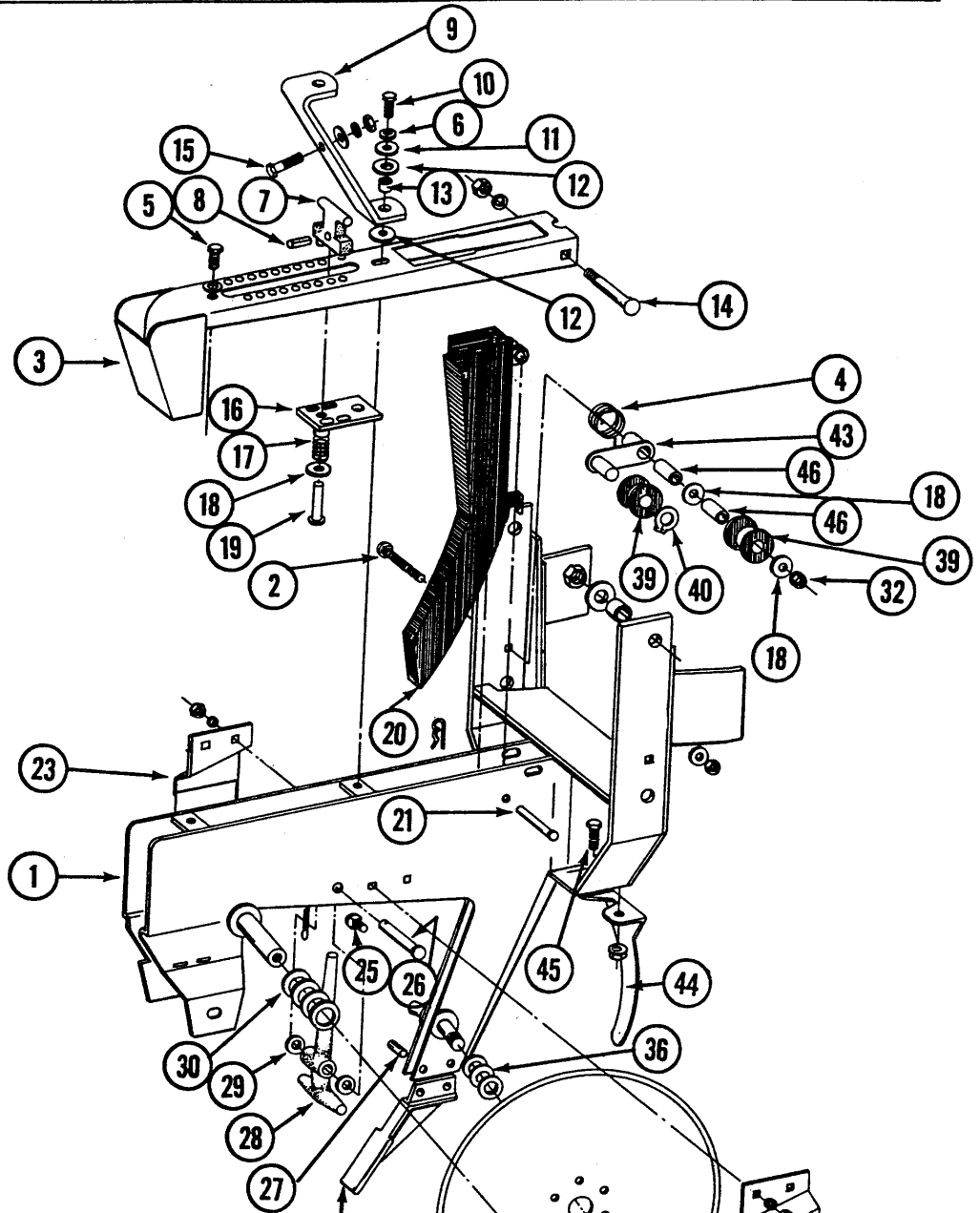

ITEM	PART NO.	DESCRIPTION
------	----------	-------------

- |     |       |  |
|-----|-------|--|
| 1.  | A0860 | Shank                                    |
| 2.  | 10307 | Carriage Bolt, 3/8"-16 x 3 1/2", Grade 2 |
| 3.  | A0811 | Shank Cover                              |
| 4.  | D1065 | Idler Spring                             |
| 5.  | 10001 | Hex Head Cap Screw, 3/8"-16 x 1"         |
|     | 10229 | Lock Washer, 3/8"                        |
| 6.  | 10229 | Lock Washer, 3/8"                        |
| 7.  | B0102 | Depth Adjusting Handle                   |
| 8.  | 10605 | Spring Pin, 5/32" x 3/4"                 |
| 9.  | D1027 | Stabilizer Bracket                       |
| 10. | 10003 | Hex Head Cap Screw, 3/8"-16 x 1 1/2"     |
| 11. | 10208 | Special Washer, 13/32"                   |
| 12. | D1120 | Rubber Washer                            |
| 13. | D1110 | Bushing                                  |

# SHANK ASSEMBLY

ITEM	PART NO.	DESCRIPTION
14.	10304	Carriage Bolt, 3/8"-16 x 3", Grade 2
	10229	Lock Washer, 3/8"
	10101	Hex Nut, 3/8"-16
15.	10305	Carriage Bolt, 3/8"-16 x 1", Grade 2
	10210	Washer, 3/8" USS
	10229	Lock Washer, 3/8"
	10101	Hex Nut, 3/8"-16
16.	B0105	Depth Adjusting Slide
17.	D1066	Compression Spring
18.	10210	Washer, 3/8" USS
19.	10552	Clevis Pin, 3/8" x 2"
20.	D1130	Seed Tube, Regular
	R0667	Seed Tube With Holes For Sensor Installation
21.	10551	Clevis Pin, 1/4" x 2 1/2"
	10669	Spring Locking Pin, No. 22
22.	B0103	Seed Tube Guard
23.	A2012L	Disc Scraper, Left Hand
24.	A2012R	Disc Scraper, Right Hand
25.	10328	Hex Head Cap Screw, 3/8"-16 x 5/8"
	10229	Lock Washer, 3/8"
	10101	Hex Nut, 3/8"-16
26.	10555	Clevis Pin, 1/2" x 2 1/2"
	10451	Cotter Pin, 1/8" x 1"
27.	10601	Spring Pin, 1/4" x 3/4"
28.	B0104	Depth Adjusting Stop
29.	10206	Washer, 1/2"
30.	10526	Spacer Washer, 1 1/64"
31.		Wheel Arm, See "Gauge Wheel"
32.	10108	Lock Nut, 3/8"-16
33.	10216	Washer, 1/2" USS
34.	10228	Lock Washer, 1/2"
35.	10014	Hex Head Cap Screw, 1/2"-13 x 1"
36.	10213	Machine Bushing, 1 3/64"
37.	D1030	Disc, 15"
38.	A2014	Bearing
39.	D1068	Idler Spool
40.	10435	Retaining Ring
41.	10204	Washer, 21/34"
42.	10503	Jam Nut, 5/8"-11, Right Hand
	10504	Jam Nut, 5/8"-11, Left Hand
43.	A2056	Idler Arm
44.	D1033	Shield
45.	10303	Carriage Bolt, 5/16"-18 x 1", Grade 2
	10620	Flange Nut, 5/16"-18
46.	D1026	Spacer
47.	D1031	Housing
48.	D6533	Bearing Cap
49.	10427	Rivet, 1/4" x 1/2"
50.	A4063	Seed Tube (IHC)
51.	10049	Hex Head Cap Screw, 3/8"-16 x 2 1/2"
	10229	Lock Washer, 3/8"
	10101	Hex Nut, 3/8"-16
A.	A2013	Disc And Bearing Assembly, Less Bearing Cap(Items 37-38, 47 And 49)
B.	1K138	Bearing Repair Kit(Items 38 And 47-49)

# GAUGE WHEEL

RUB001

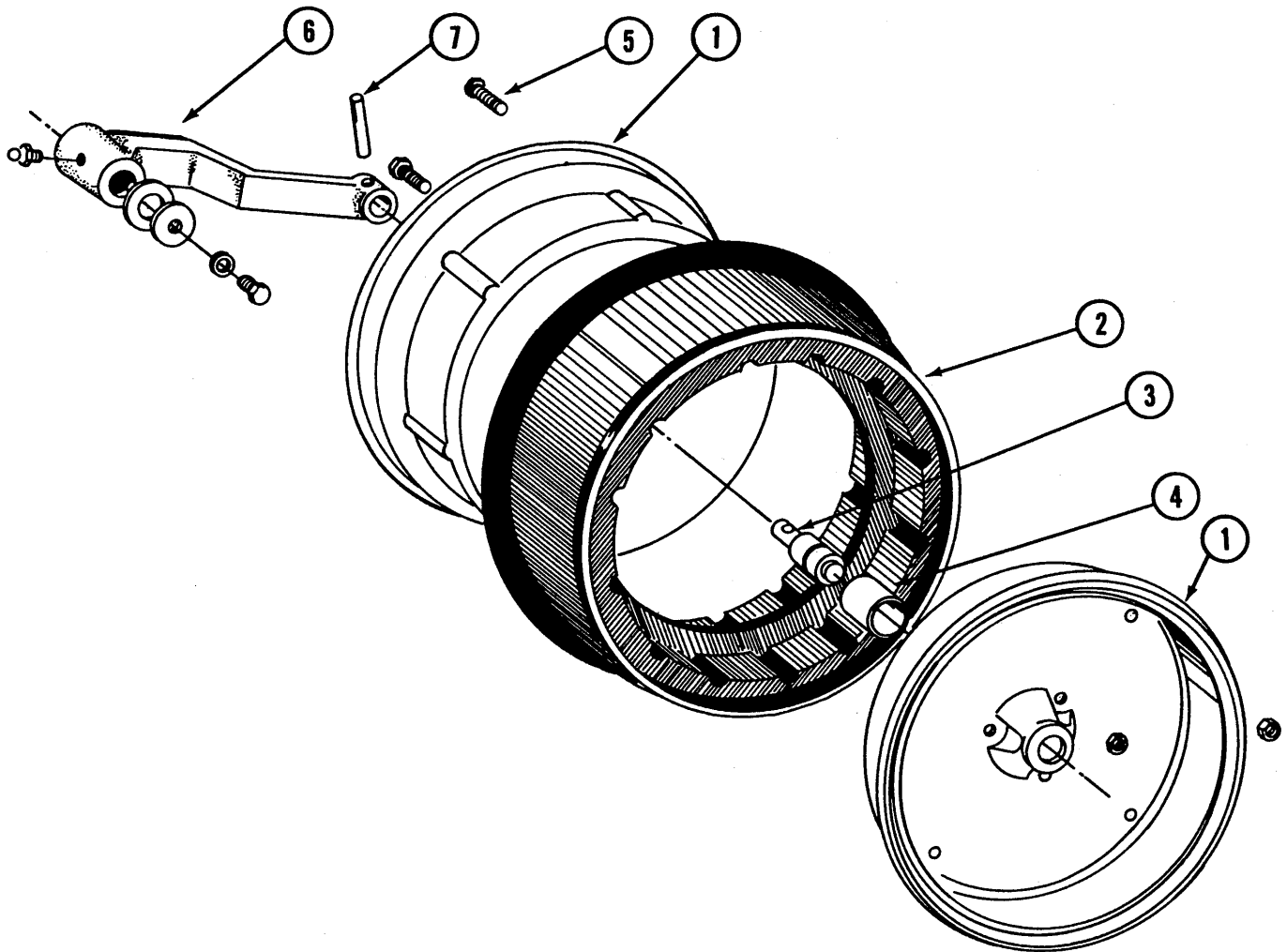

ITEM	PART NO.	DESCRIPTION
1.	D1048	Half Wheel
2.	D1086	Tire
3.	A2022	Bearing
4.	B0118	Bearing Sleeve
5.	10018	Hex Head Cap Screw, 5/16"-18 x 5/8"
	10109	Lock Nut, 5/16"-18
6.	A2116	Wheel Arm With Grease Fitting
	10640	Grease Fitting, 1/4"-20
7.	10608	Spiral Pin, 1/4" x 1 1/4"
A.	A2021	Gauge Wheel Complete(Items 1-5)

# CLOSING WHEEL

RUB004/RUB003

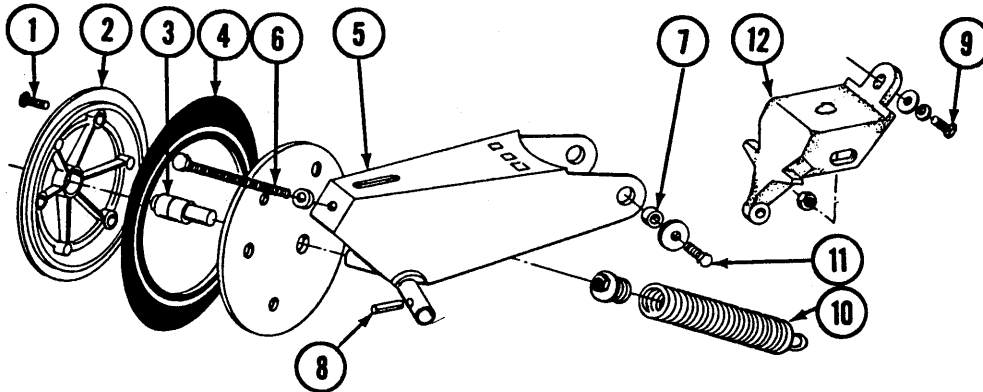

ITEM	PART NO.	DESCRIPTION
1.	10064	Hex Head Cap Screw, 1/4"-20 x 1"
	10103	Hex Nut, 1/4"-20
2.	D4455	Half Wheel, Nylon
3.	A2022	Bearing
4.	D1085	Tire, 1" x 15"
5.	A2024	Arm With Spindles
6.	10015	Hex Head Cap Screw, 1/2"-13 x 5", Grade 2 Full Thread
	10525	Internal Tooth Lock Washer, 1/2"
7.	D1111	Bushing
8.	10607	Spiral Spring Pin, 1/4" x 1"
9.	10003	Hex Head Cap Screw, 3/8"-16 x 1 1/2"
	10229	Lock Washer, 3/8"
	10210	Washer, 3/8" USS
10.	A2054	Spring With Plug
11.	10016	Hex Head Cap Screw, 1/2"-13 x 2"
	10216	Washer, 1/2" USS
	10111	Lock Nut, 1/2"-13
12.	B0113	Wheel Arm Stop
A.	A3086	Standard Closing Wheel Complete With Bearing, Nylon(Items 1-4)

# HOPPER SUPPORT AND PLATELESS HOPPER DRIVE

RUB005

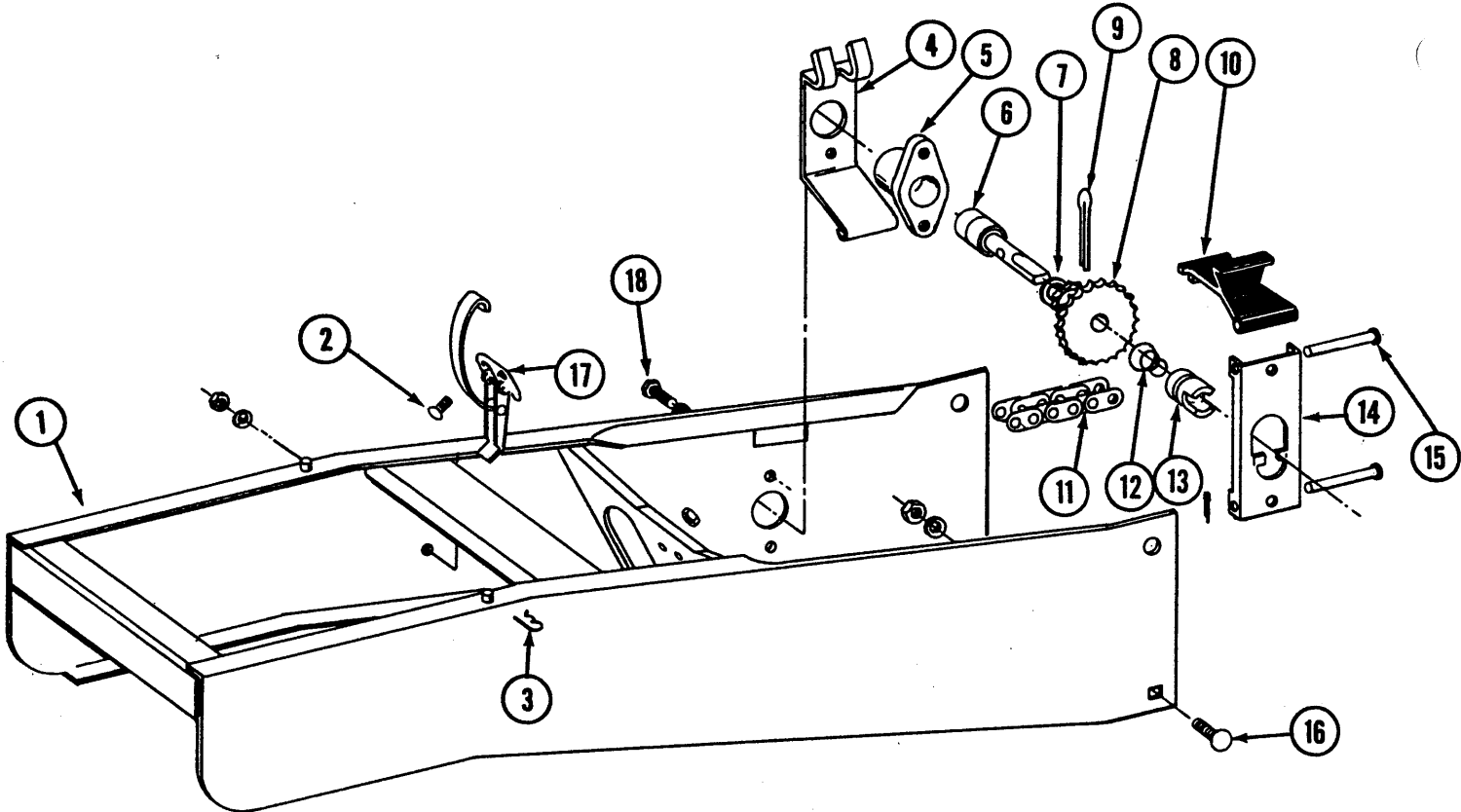

ITEM	PART NO.	DESCRIPTION
1.	A0861	Hopper Support
2.	10309	Carriage Bolt, 1/4"-20 x 5/8", Grade 2
	10621	Flange Nut, 1/4"-20
3.	10670	Spring Locking Pin, No. 3
4.	D1037	Bearing Support
5.	B0108	Bearing Housing
6.	A2016	Bearing
7.	10204	Machinery Bushing, 21/32"
8.	B0107	Sprocket, 11/19 Tooth
9.	10454	Cotter Pin, 5/32" x 2"
10.	D1035	Release Handle
11.	3303-98	Roller Chain, No. 41, 98 Links Including Connector Link
	R0196	Connector Link, No. 41
12.	D1075	Compression Spring
13.	B0109	Drive Coupler
14.	D1036	Drive Release Lever
15.	10553	Clevis Pin, 1/4" x 2 5/8"
	10455	Cotter Pin, 1/16" x 1/2"
16.	10305	Carriage Bolt, 3/8"-16 x 1", Grade 2
	10229	Lock Washer, 3/8"
	10101	Hex Nut, 3/8"-16
17.	A2007	Hopper Hold Down Latch
18.	10018	Hex Head Cap Screw, 5/16"-18 x 5/8"
	10232	Lock Washer, 5/16"
A.	A2015	Plateless Hopper Drive Assembly Complete (Items 4-10, 12-15 And 18)

# PARALLEL ARMS AND MOUNTING BRACKETS

RUB007

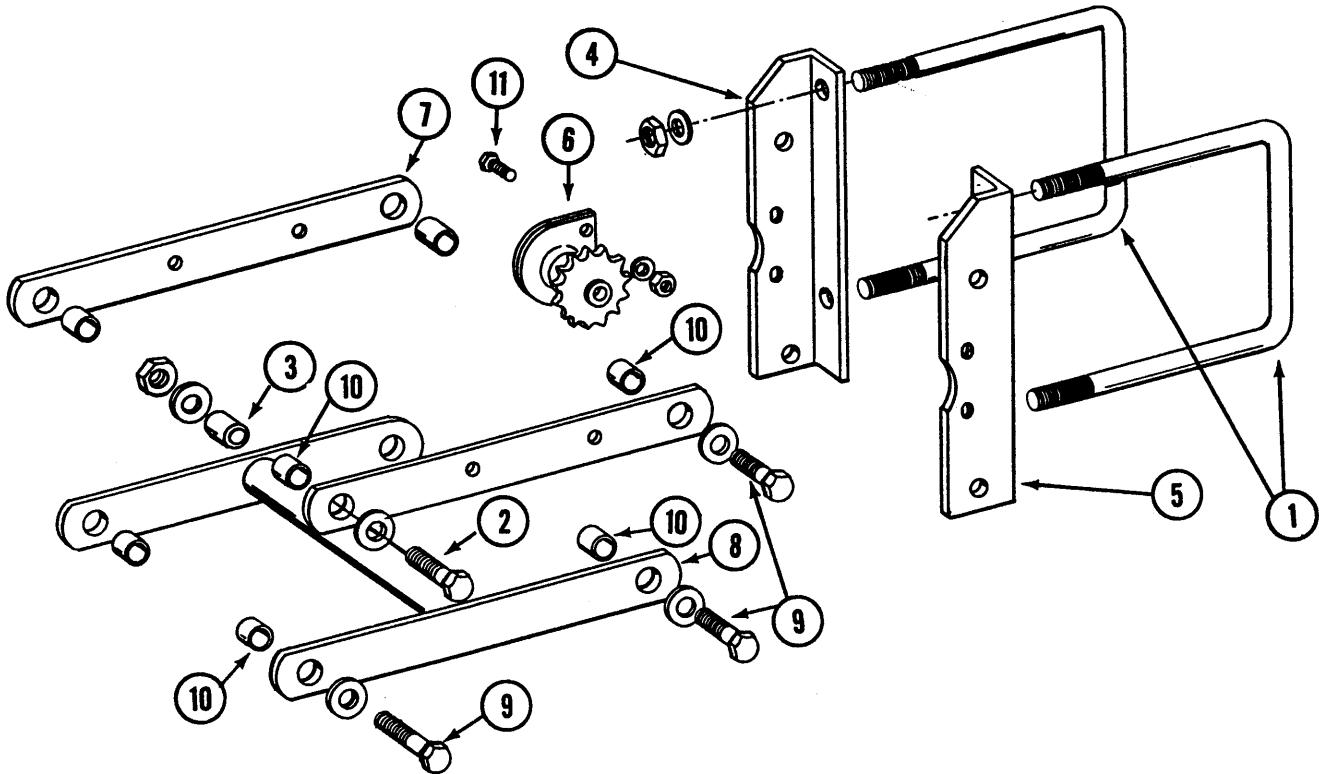

ITEM	PART NO.	DESCRIPTION
1.	D1114	U-Bolt, 7" x 7" x 5/8"-11
	10230	Lock Washer, 5/8"
	10104	Hex Nut, 5/8"-11
	10152	Hex Head Cap Screw, 5/8"-11 x 9" (Where Applicable)
	10205	Washer, 5/8" SAE (Where Applicable)
2.	10006	Hex Head Cap Screw, 5/8"-11 x 2 1/4"
	10483	Washer, 5/8" Special
	10205	Washer, 5/8" SAE
	10107	Lock Nut, 5/8"-11
	3.	D1109
4.	D1022L	Support, Left Hand
5.	D2298	Support, Right Hand
6.	A1720	Bearing And Sprocket, 7/8" Bore
7.	D1020	Upper Arm
8.	A2004	Lower Arm
9.	10005	Hex Head Cap Screw, 5/8"-11 x 1 3/4"
	10483	Washer, 5/8" Special
	10107	Lock Nut, 5/8"-11
10.	B0123	Bushing
11.	10001	Hex Head Cap Screw, 3/8"-16 x 1"
	10229	Lock Washer, 3/8"
	10101	Hex Nut, 3/8"-16

# PLATELESS SEED HOPPER

RUA015

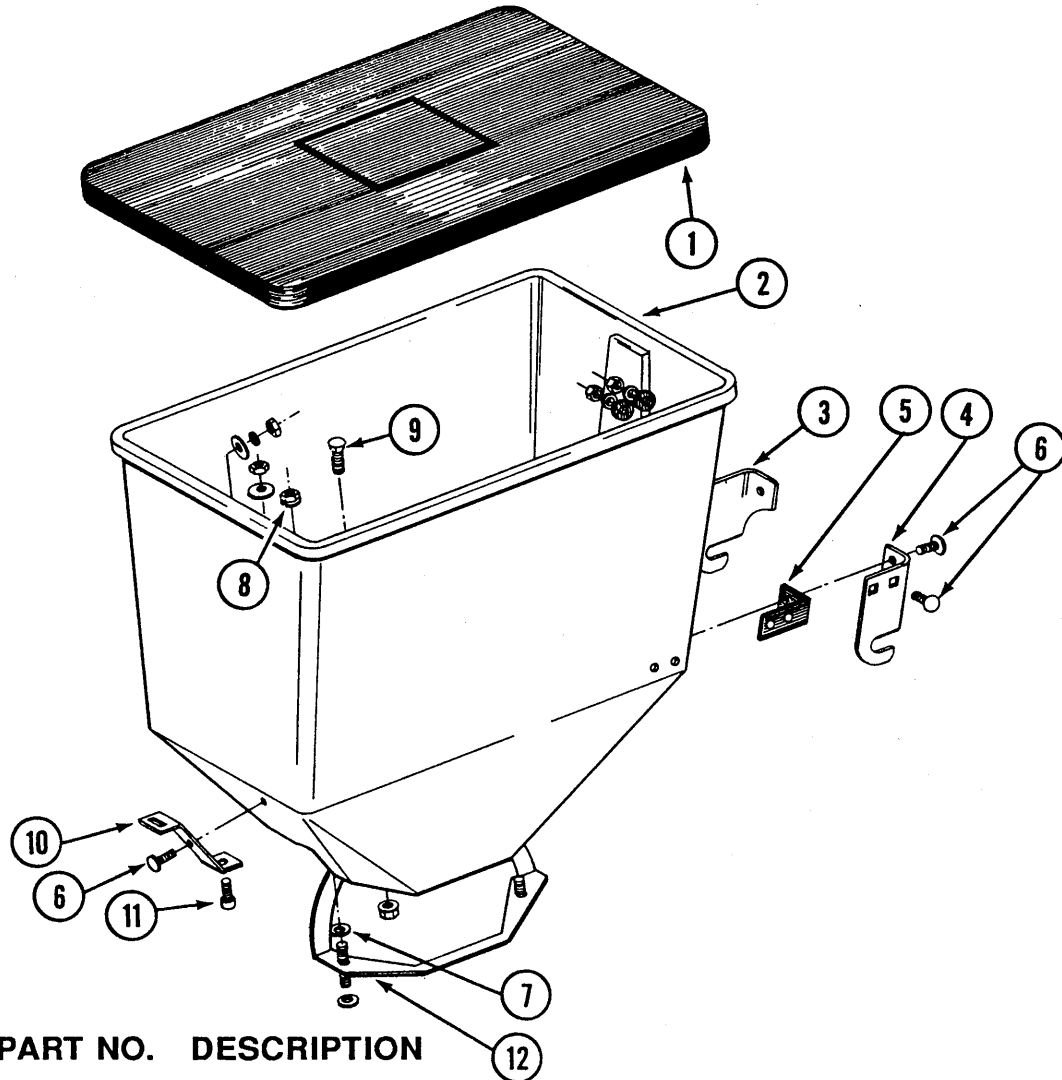

ITEM	PART NO.	DESCRIPTION
1.	A2327	Lid With Clip
2.	D1053	Seed Hopper
3.	D1051L	Bracket, Left Hand
4.	D1051R	Bracket, Right Hand
5.	D1054	Mounting Pad
6.	10310	Carriage Bolt, 1/4"-20 x 3/4", Grade 2
	D1121	Rubber Washer
	10209	Washer, 1/4" USS
	10110	Self Locking Nut, 1/4"-20
7.	D1121	Rubber Washer
8.	10620	Flange Nut, 5/16"-18
9.	10310	Carriage Bolt, 1/4"-20 x 3/4", Grade 2
	10621	Whiz Lock Nut, 1/4"
10.	D1055	Clip
11.	10520	Hex Head Cap Screw, 3/8"-16 x 3/4", Grade 8
	10210	Washer, 3/8" USS
	10229	Lock Washer, 3/8"
	10101	Hex Nut, 3/8"-16
12.	A2027	Retainer
A.	A2058	Seed Hopper With Hardware, Less Lid(Items 2-12)



# FINGER PICKUP METER

RUA015

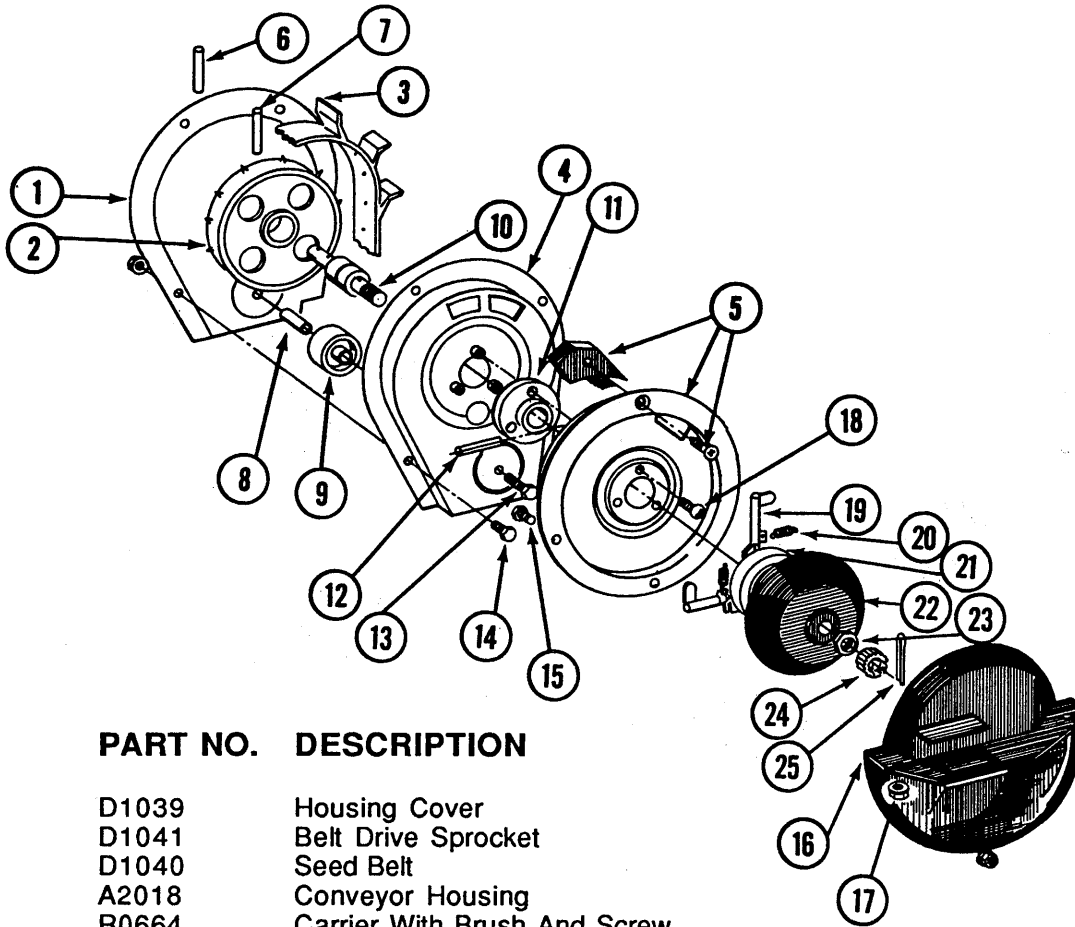

ITEM	PART NO.	DESCRIPTION
1.	D1039	Housing Cover
2.	D1041	Belt Drive Sprocket
3.	D1040	Seed Belt
4.	A2018	Conveyor Housing
5.	R0664	Carrier With Brush And Screw
	A2020	Brush
	10690	Rolling Thread Screw, No. 10 x 3/4"
6.	10602	Spring Pin, 1/4" x 1 1/2"
7.	10604	Spring Pin, 3/16" x 1 1/2"
8.	B0120	Bushing
9.	D1042	Idler
10.	A2019	Bearing
11.	B0110	Bearing Housing
12.	10603	Spring Pin, 1/4" x 1 1/4"
13.	10021	Hex Head Cap Screw, 1/4"-20 x 1 1/2"
	10621	Flange Nut, 1/4"
14.	10022	Hex Head Cap Screw, 1/4"-20 x 1/2"
	10621	Flange Nut, 1/4"
15.	10020	Hex Head Cap Screw, 1/4"-20 x 5/8"
	10323	Hex Flange Nut, 1/4"-20
16.	D1046	Seed Baffle
17.	10620	Flange Nut, 5/16"-18
18.	10401	Machine Screw, No. 10-32 x 5/8"
19.	D1044	Finger (12 Per Meter)
20.	D6501	Spring
21.	B0111	Cam
22.	D1045	Finger Holder
23.	10500	Jam Nut, 5/8"-18 UNF
24.	D1083	Cage Nut, 5/8"
25.	10457	Cotter Pin, 5/32" x 1 1/2"
A.	R0933	Finger Assembly(Items 19-22)

# FEED CUP METER

RUA015/RUA007/RUA014

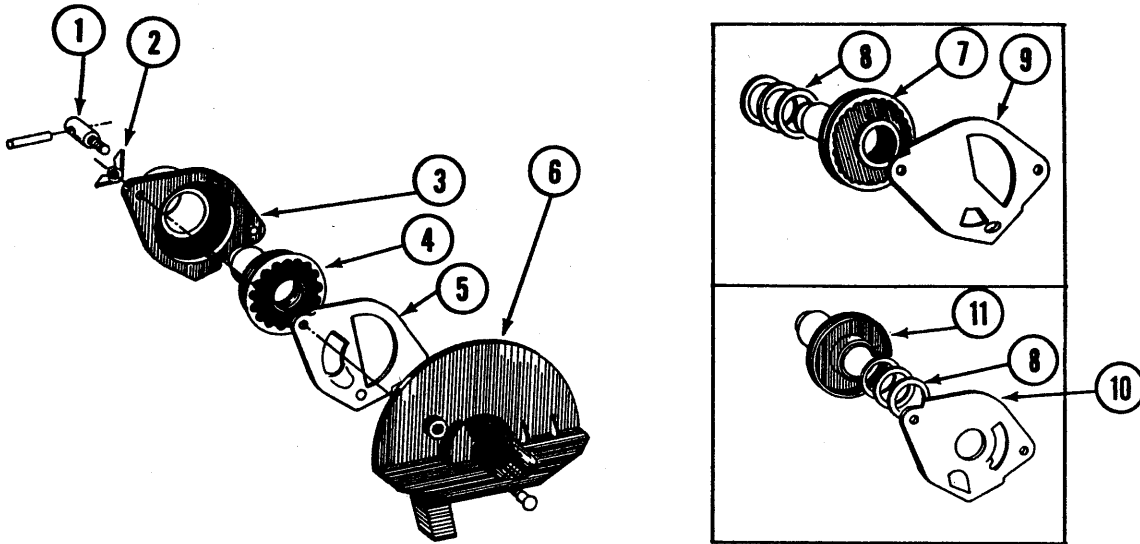

ITEM	PART NO.	DESCRIPTION
1.	A2033	Feed Cut Shaft And Pin Assembly
2.	10531	Wing Nut, 1/4"-20
3.	A2032	Feed Cup Housing
4.	A2031	Feed Cup, Soybean
5.	D1073	Seed Guide, Soybean
6.	A2109	Feed Cup Adapter
7.	A2569	Feed Cup, Medium Rate Milo
8.	10225	Spacer Washer
9.	D1124	Seed Guide, Medium Rate Milo
10.	D1125	Seed Guide, Low Rate Milo
11.	A2084	Feed Cup, Low Rate Milo

# GRANULAR CHEMICAL BANDERS

RUA013/RUA012

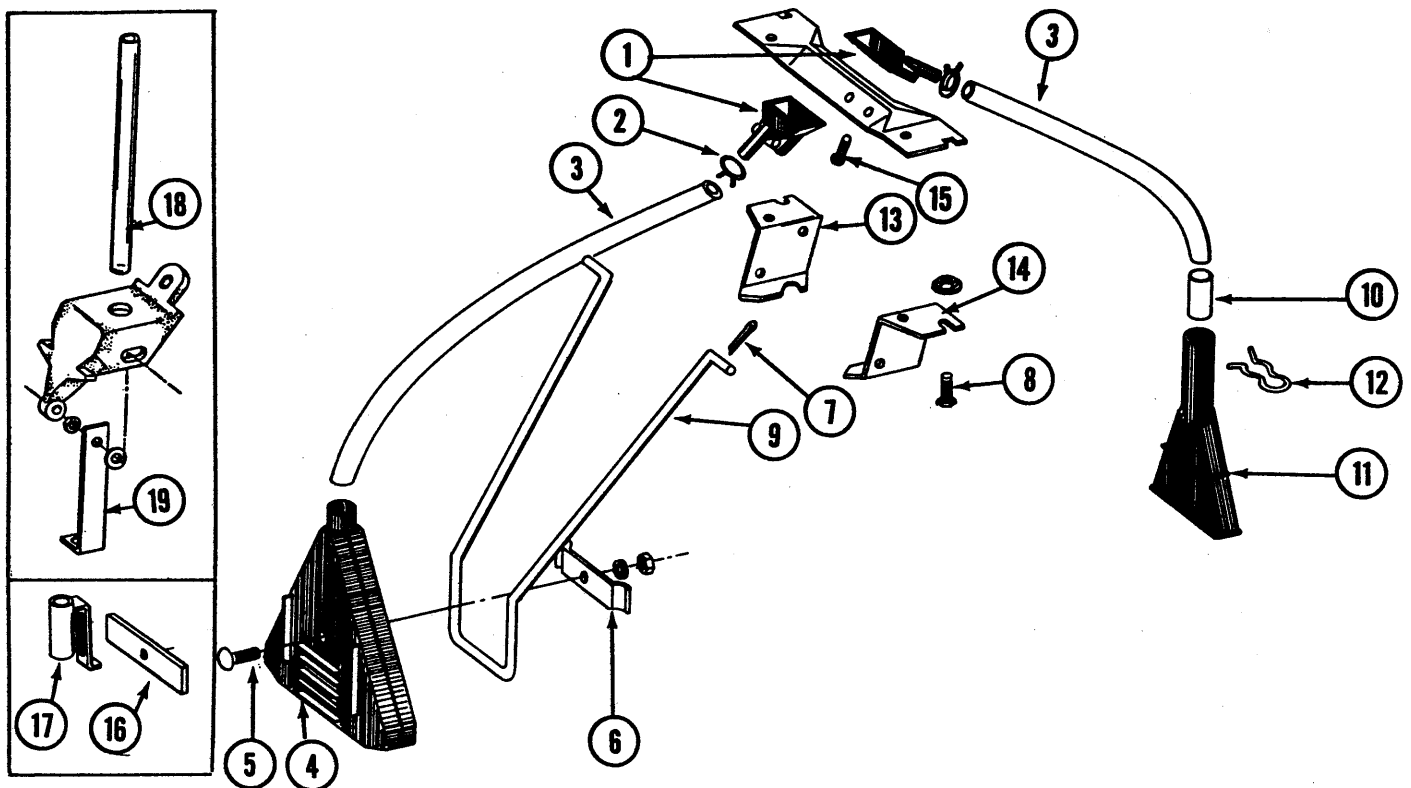

ITEM	PART NO.	DESCRIPTION
1.	D2423	Funnel
2.	10680	Hose Clamp, 7/16"
3.	D1128	Hose, 7/16" x 18"
4.	A2075	Diffuser, 14" Band
5.	10306	Carriage Bolt, 3/8"-16 x 2", Grade 2
	10229	Lock Washer, 3/8"
	10101	Hex Nut, 3/8"-16
6.	D1118	Clamp
7.	10452	Cotter Pin, 1/8" x 1/2"
8.	10310	Carriage Bolt, 1/4"-20 x 3/4", Grade 2
	10227	Lock Washer, 1/4"
	10103	Hex Nut, 1/4"-20
9.	D1116	Hanger
10.	D1082	Tube
11.	D1081	Spreader, 7" Band
12.	D1090	Spring Clip
13.	D1115L	Hanger Bracket, L.H.
14.	D1115R	Hanger Bracket, R.H.
15.	10523	Self Tapping Screw, No. 10 x 1/2"
16.	D1323	Strap (Rear Mount)
17.	A0485	Tube With Bracket (Rear Mount)
18.	D2947	Hose, 7/16" x 28" (Direct Drop)
19.	D2864	Bracket (Direct Drop)

# GRANULAR CHEMICAL HOPPER WITH METER(S)

RUA006/RUA008/RUB005

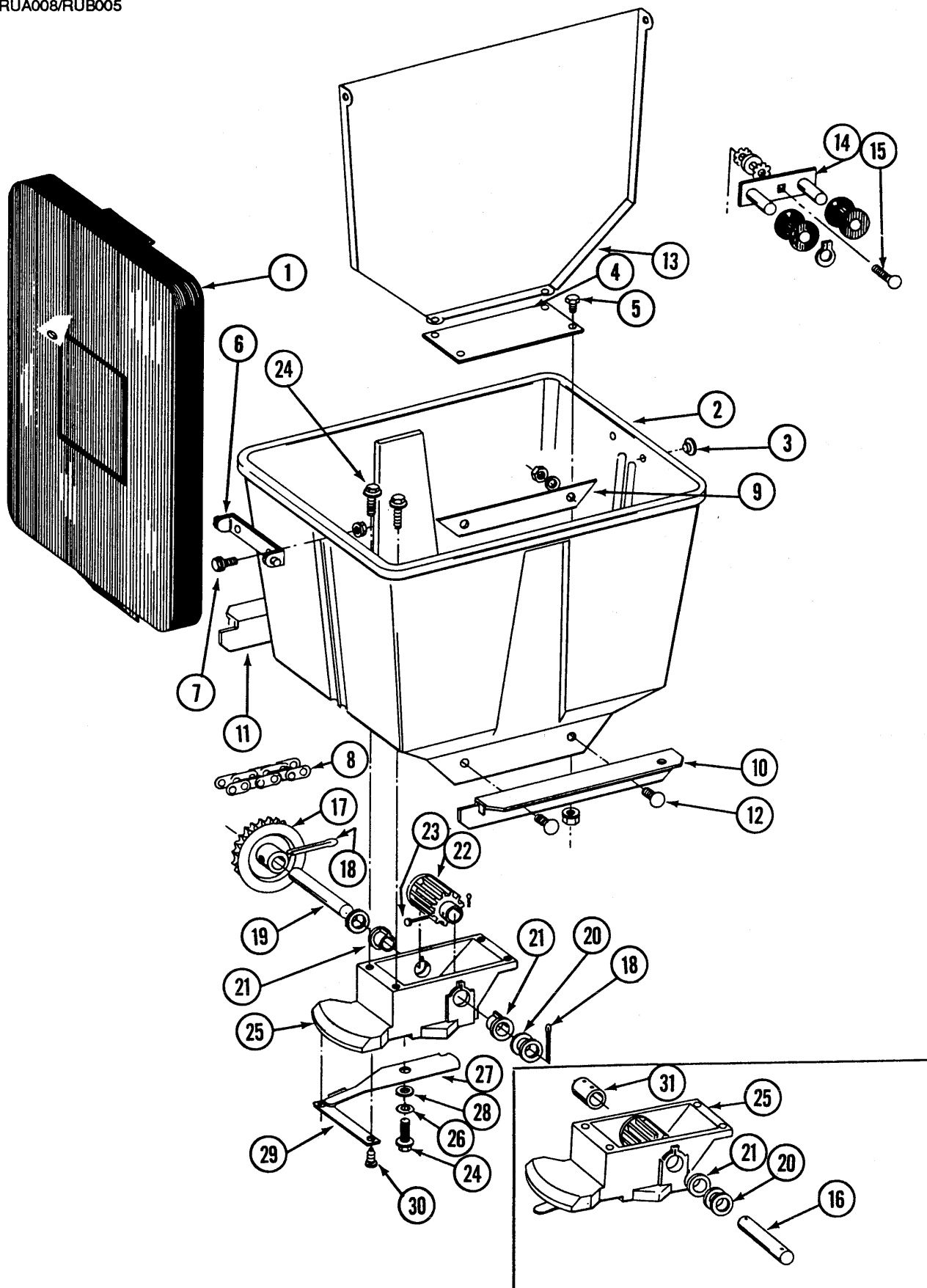

# GRANULAR CHEMICAL HOPPER WITH METER(S)

ITEM	PART NO.	DESCRIPTION
1.	A4444	Lid
2.	D1058	Hopper
3.	D1089	Plug
4.	D1056	Cover Plate
5.	10022	Hex Head Cap Screw, 1/4"-20 x 1/2"
	10621	Flange Nut, 1/4"-20
6.	D1060	Hinge
7.	10023	Hex Head Cap Screw, 1/4"-20 x 3/4"
	10621	Flange Nut, 1/4"-20
8.	3303-114	Roller Chain, No. 41, 114 Pitch Including Connector Link
	R0196	Connector Link, No. 41
9.	D1072	Strap
10.	D1059R	Support, Right Hand
11.	D1059L	Support, Left Hand
12.	10311	Carriage Bolt, 3/8"-16 x 3/4" Short Necked, Grade 2
	10229	Lock Washer, 3/8"
	10101	Hex Nut, 3/8"-16
13.	A2076	Divider
14.	A2008	Idler Arm With Spools And Rings
	D1067	Spool
	10435	Ring
15.	10305	Carriage Bolt, 3/8"-16 x 1", Grade 2
	10524	Internal-External Lock Washer, 3/8"
	10207	Washer, 3/8"
	10229	Lock Washer, 3/8"
	10101	Hex Nut, 3/8"-16
16.	D1122	Shaft
17.	B0117	Sprocket, 24 Tooth
18.	10457	Cotter Pin, 5/32" x 1 1/2"
19.	D1064	Shaft
20.	10215	Machine Bushing, 14 Gauge x 3/4"
21.	B0115	Bearing
22.	A2029	Feed Roller
23.	10554	Clevis Pin, 3/16" x 1"
	10455	Cotter Pin, 1/16" x 1/2"
24.	10522	Self Tapping Screw, 1/4" x 3/4"
25.	B0116	Granular Housing
26.	10660	Wave Washer
27.	D1063	Metering Gate
28.	10209	Washer, 1/4" USS
29.	D1061	Support Strap
30.	10521	Self Tapping Screw, No. 10 x 3/8"
31.	D1119	Coupler
A.	A2048	Granular Chemical Meter With Drive Sprocket (Items 17-30)
B.	A2077	Granular Chemical Meter With Coupler (Items 16, 18 And 20-31)

# STANDARD DOWN PRESSURE SPRINGS

RUA009

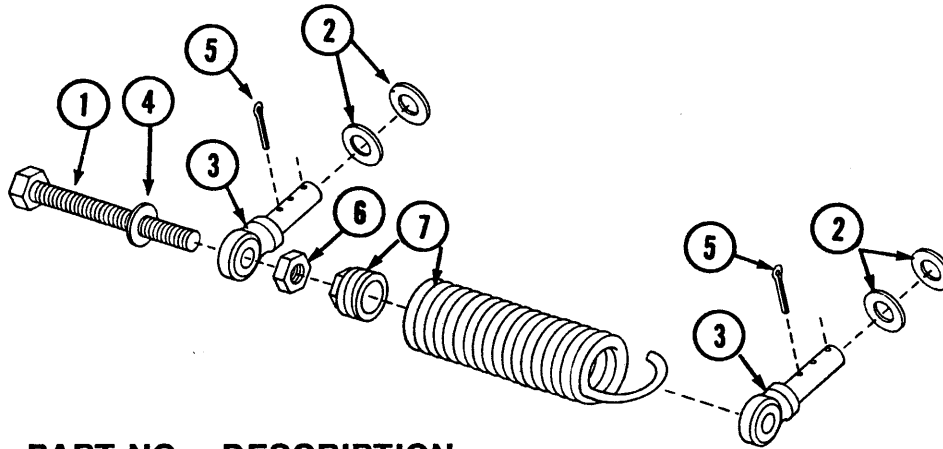

ITEM	PART NO.	DESCRIPTION
1.	10024	Hex Head Cap Screw, 7/16"-14 x 4" Full Thread , Grade 2
2.	10081	Washer, 7/16" USS
3.	A2036	Eyebolt
4.	10206	Machine Bushing, 1/2" SAE
5.	10456	Cotter Pin, 1/8" x 3/4"
6.	10502	Jam Nut, 7/16"-14
7.	A2052	Tension Spring With Plug

# HEAVY DUTY DOWN PRESSURE SPRINGS

RUB007

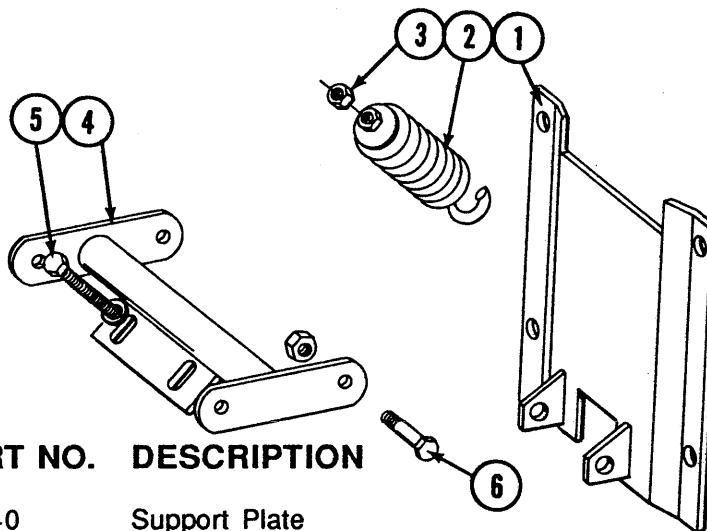

ITEM	PART NO.	DESCRIPTION
1.	A5140	Support Plate
2.	A2068	Tension Spring With Plug
3.	10501	Jam Nut, 1/2"-13
4.	A2066	Spring Tube
5.	10051	Hex Head Cap Screw, 1/2"-13 x 3" Full Thread, Grade 2
	10216	Washer, 1/2" USS
6.	10017	Hex Head Cap Screw, 1/2"-13 x 1 1/2"
	10111	Lock Nut, 1/2"-13
A.	A2065	Heavy Duty Down Pressure Springs Complete, 1 Row (Items 1-6)

# HEAVY DUTY COULTER

RUA001

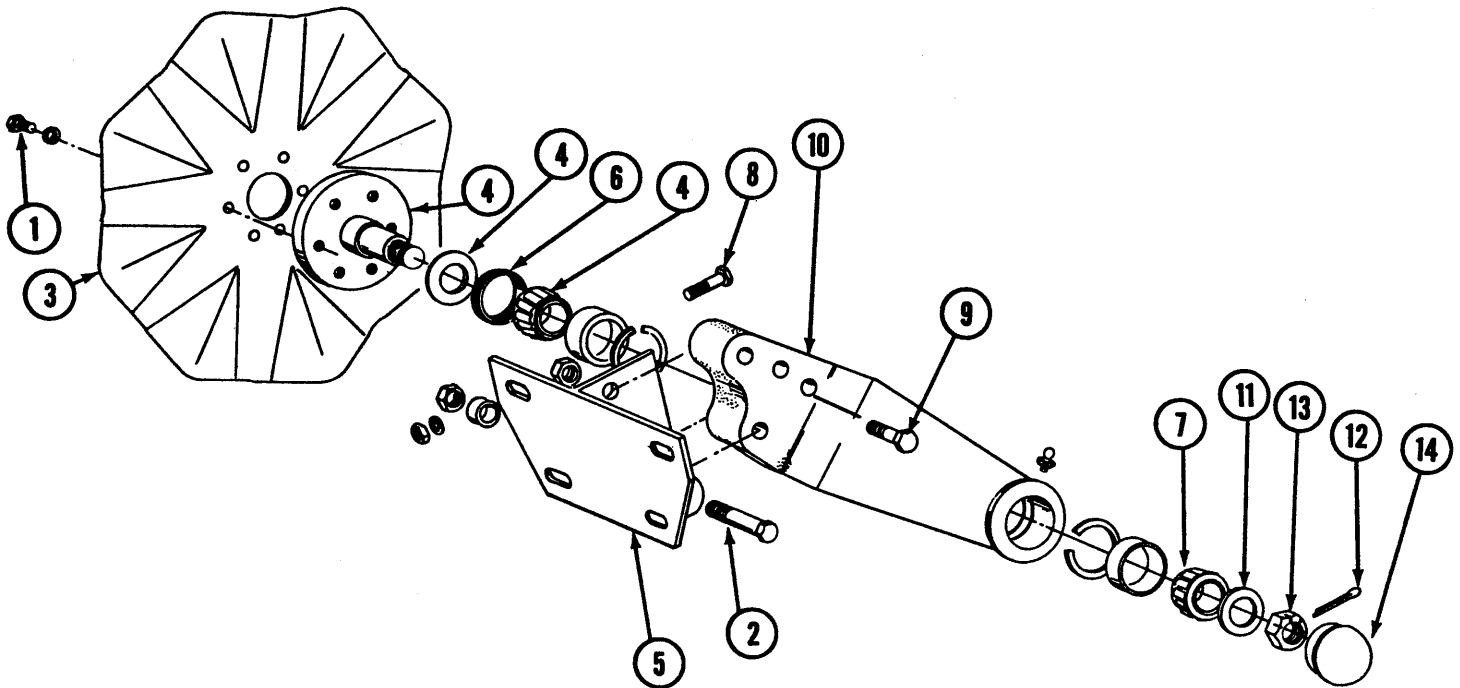

ITEM	PART NO.	DESCRIPTION
1.	10002	Hex Head Cap Screw, 3/8"-16 x 3/4"
	10229	Lock Washer, 3/8"
2.	10044	Hex Head Cap Screw, 3/4"-10 x 4"
	D1142	Bushing
	10112	Lock Nut, 3/4"-10
3.	D1105	16" Fluted Blade, 2" Theoretical Width Of Cut (Shown)
	D1106	16" Ripple Blade, 1" Theoretical Width Of Cut
4.	R0978	Spindle With Bearing And Bushing
	A2287	Bearing
	10322	Machine Bushing
5.	A1624	Mounting Bracket
6.	D4433	Seal Ring
7.	A0237	Bearing
8.	10037	Hex Head Cap Screw, 1/2"-13 x 1 1/4"
	10216	Washer, 1/2" USS
	10111	Lock Nut, 1/2"-13
9.	10013	Hex Head Cap Screw, 5/8"-11 x 3 1/2"
	10107	Lock Nut, 5/8"-11
10.	A2286	Arm With Bearing Cups, Snap Rings And Grease Fitting
	R0188	Bearing Cup
	D1102	Snap Ring
	10640	Grease Fitting, 1/4"-20
11.	10220	Machine Bushing
12.	10459	Cotter Pin, 3/16" x 1 1/2"
13.	10507	Slotted Jam Nut, 1"-14 UNF
14.	D1104	Hub Cap

# SPRING TOOTH INCORPORATOR

RUA011

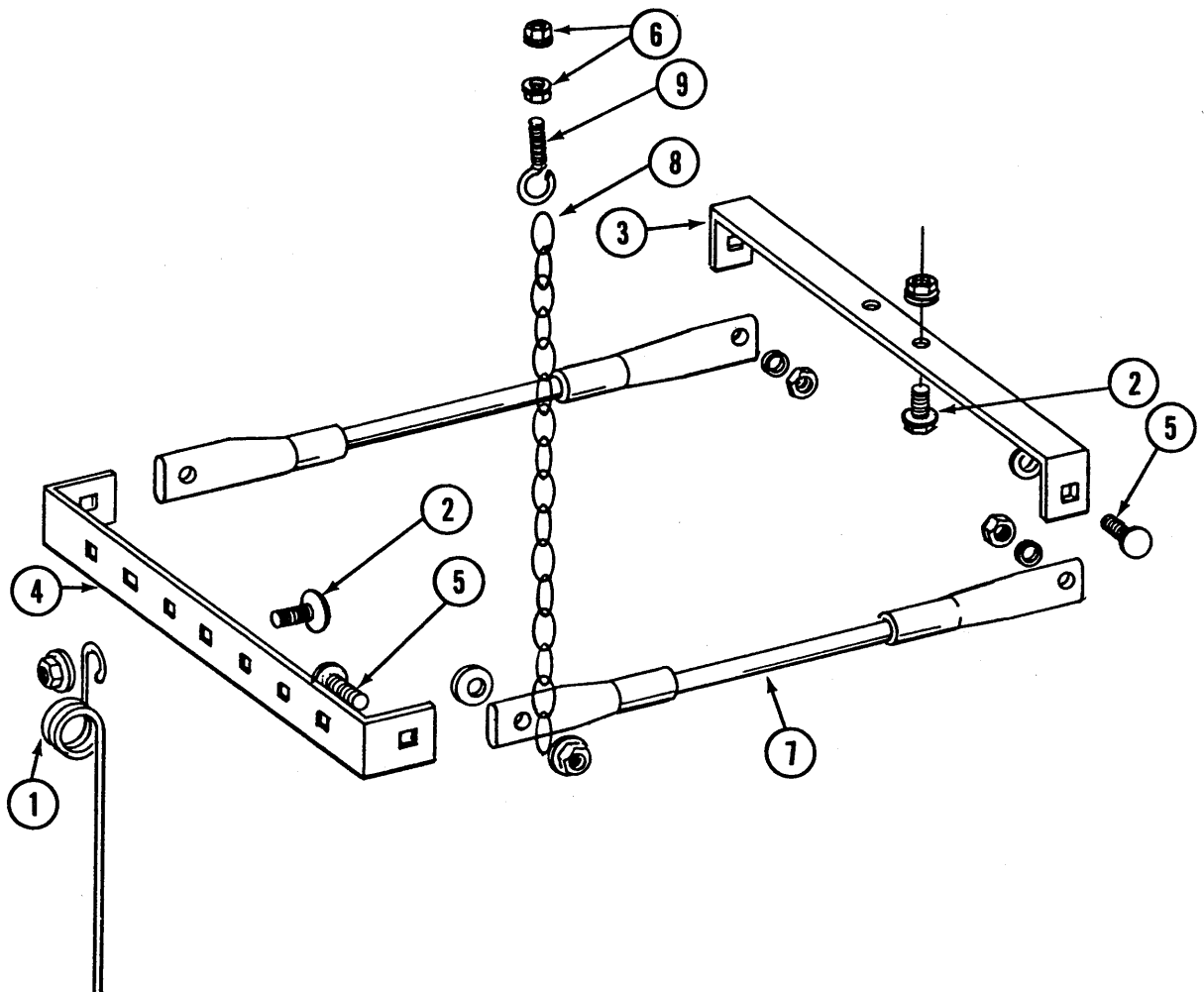



# SPRING TOOTH INCORPORATOR

---

ITEM	PART NO.	DESCRIPTION
1.	D1145	Spring Tooth
2.	10308	Carriage Bolt, 3/8"-16 x 3/4", Grade 2
	10622	Flange Lock Nut, 3/8"-16
3.	D1143	Front Bracket
4.	D1144	Rear Bracket
5.	10305	Carriage Bolt, 3/8"-16 x 1", Grade 2
	10529	External Tooth Lock Washer, 3/8"
	10622	Flange Lock Nut, 3/8"-16
6.	10621	Flange Lock Nut, 1/4"-20
7.	A2094	Cable Assembly
8.	3305-01	Chain
9.	D2460	Eyebolt, 1/4"-20

# DECALS, REFLECTORS AND TIE STRAPS



1



2

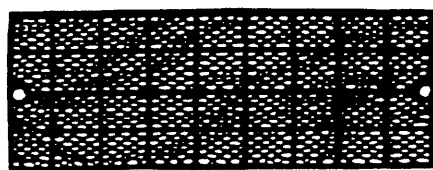

3



4



5



6

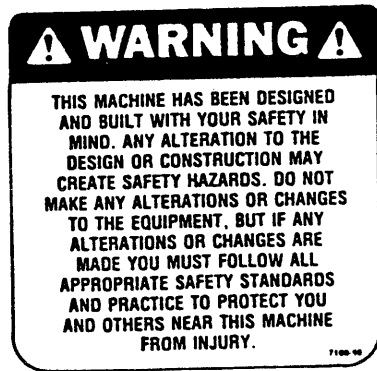

7

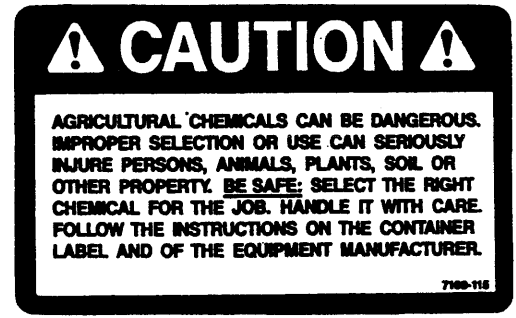

8

# DECALS, REFLECTORS AND TIE STRAPS

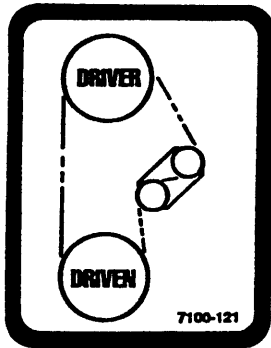

9

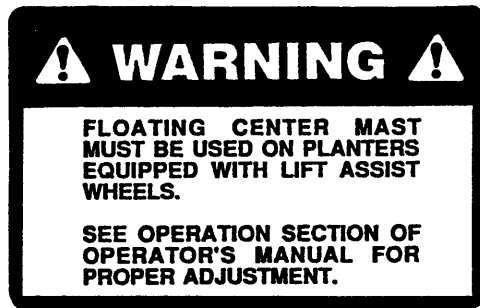

10

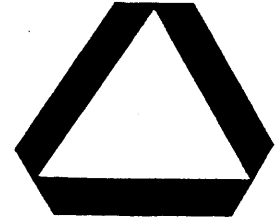

11

ITEM	PART NO.	DESCRIPTION
1.	D1512	Tie Strap, 6"
	D2117	Tie Strap, 14 1/2"
2.	7100-23	Row Unit Decal, KINZE
3.	7200-03	Reflector, Red
	7200-04	Reflector, Amber
4.	7100-42	Decal, Warning
5.	7100-46	Decal, Caution
6.	7100-89	Decal, Danger
7.	7100-90	Decal, Warning
8.	7100-115	Decal, Caution
9.	7100-121	Decal, Transmission
10.	7100-133	Decal, Warning
11.	D2199	\$MV Sign
12.	R0146	Seed Flow Lube/Graphite, 1 Pound Can (Not Shown)



# NUMERICAL INDEX

PART NO.	PAGE	PART NO.	PAGE	PART NO.	PAGE
A0167	P16	A2020	P29	A4733	P3
A0237	P35	A2021	P24	A4743	P7
A0243	P16	A2022	P24, P25	A4775	P2
A0245	P16	A2024	P25	A4776	P2
A0257	P16	A2027	P28	A4783	P2
A0261L	P9	A2029	P33	A4784	P2
A0261R	P9	A2031	P30	A4938	P3, P7
A0262	P5	A2032	P30	A5095	P19
A0270A	P21	A2033	P30	A5097	P19
A0270B	P21	A2036	P34	A5106	P11
A0270C	P21	A2048	P33	A5107	P11
A0282A	P21	A2052	P34	A5108	P11
A0282B	P21	A2054	P25	A5109	P11
A0376	P9	A2056	P23	A5110	P11
A0378	P9	A2058	P28	A5111	P11
A0485	P31	A2065	P34	A5112	P11
A0811	P22	A2066	P34	A5113	P11
A0860	P22	A2068	P34	A5116	P11
A0861	P26	A2075	P31	A5130	P15
A0895	P4, P7	A2076	P33	A5136	P11
A0899	P16	A2077	P33	A5140	P34
A0901	P9	A2084	P30	A5144	P11
A0926	P4	A2094	P37	A5146	P11
A1005	P7, P17, P18	A2109	P30	A5173	P15
A1013	P17, P18	A2116	P24	A5175	P13
A1028	P17, P18	A2148	P7	A5177	P13
A1039	P7	A2286	P35	A5178	P13
A1049	P17, P18	A2287	P3	A5183	P13
A1055	P7	A2327	P28	A5184	P13
A1101	P17, P18	A2359	P9	A5188	P15
A1106	P17, P18	A2558	P7	A5190	P15
A1134	P17, P18	A2569	P30	A5192	P15
A1150	P17, P18	A3086	P25	A5196	P7
A1168	P17, P18	A3114	P17, P18	A5453	P19
A1170	P17, P18	A3115	P17, P18	A5454	P19
A1172	P17, P18	A3154	P17, P18	A5459	P19
A1624	P35	A4063	P23	A5460	P19
A1676	P16	A4122	P2	A5466	P3
A1677	P16	A4123	P2	A5482	P20
A1678	P16	A4235	P9, P11	A5545	P9
A1679	P16	A4444	P33	B0102	P22
A1720	P27	A4665	P3, P7	B0103	P23
A1803	P20	A4666	P3, P7	B0104	P23
A2004	P27	A4693	P4	B0105	P23
A2007	P26	A4696	P4	B0107	P26
A2008	P33	A4699	P3	B0108	P26
A2012L	P23	A4700	P3	B0109	P26
A2012R	P23	A4704	P3	B0110	P29
A2013	P23	A4705	P3	B0111	P29
A2014	P23	A4707	P3	B0113	P25
A2015	P26	A4709	P3	B0115	P33
A2016	P26	A4711	P3	B0116	P33
A2018	P29	A4715	P7	B0117	P33
A2019	P29	A4732	P3	B0118	P24

# NUMERICAL INDEX

PART NO.	PAGE	PART NO.	PAGE	PART NO.	PAGE
B0120	P29	D1081	P31	D4632	P19
B0123	P27	D1082	P31	D5215	P11
B0177	P13, P15	D1083	P29	D5807	P3
D0438	P13	D1085	P25	D5815	P11
D0453-02	P13	D1086	P24	D5857	P9, P11
D0453-03	P13, P15	D1089	P33	D5861	P18
D0453-04	P15	D1090	P31	D5886	P9
D0453-08	P15	D1102	P35	D5887-106	P9
D0462	P13	D1104	P35	D5887-135	P9
D0652	P15	D1105	P35	D5887-144	P9
D0746	P16	D1106	P35	D5887-186	P9
D0840	P16	D1109	P27	D5887-215	P9
D0844	P4, P7	D1110	P22	D5887-75	P9
D0914-120	P9	D1111	P25	D5887-90	P9
D0916	P9	D1114	P3, P11, P27	D5892	P13
D0917	P9	D1115L	P31	D5949	P19
D1020	P27	D1115R	P31	D6501	P29
D1022L	P27	D1116	P31	D6533	P23
D1026	P23	D1118	P31	D6551	P11
D1027	P22	D1119	P33	D6819	P9, P11
D1030	P23	D1120	P22	D7041	P3
D1031	P23	D1121	P28	D7042	P3
D1033	P23	D1122	P33	D7068	P7
D1035	P26	D1124	P30	D7090	P3
D1036	P26	D1125	P30	D7101	P5
D1037	P26	D1128	P31	D7145	P2
D1039	P29	D1130	P23	D7152	P3
D1040	P29	D1142	P35	D7153	P9
D1041	P29	D1143	P37	D7338	P3, P7
D1042	P29	D1144	P37	R0103	P21
D1044	P29	D1145	P37	R0146	P39
D1045	P29	D1166	P4, P7	R0150	P16
D1046	P29	D1255	P9	R0151	P16
D1048	P24	D1256	P9	R0153	P20
D1051L	P28	D1323	P31	R0174	P20
D1051R	P28	D1512	P39	R0175	P20
D1053	P28	D1702	P7	R0176	P20
D1054	P28	D1719	P9	R0177	P20
D1055	P28	D1748	P3, P7	R0178	P20
D1056	P33	D2117	P39	R0179	P20
D1058	P33	D2161	P15	R0180	P20
D1059L	P33	D2199	P3, P39	R0181	P20
D1059R	P33	D2298	P27	R0188	P35
D1060	P33	D2423	P31	R0193	P13, P20
D1061	P33	D2460	P37	R0195	P4, P5
D1063	P33	D2557	P3, P7	R0196	P26, P33
D1064	P33	D2558	P7, P11	R0200	P4
D1065	P22	D2597	P16	R0203	P20
D1066	P23	D2721	P13, P15	R0270	P4, P7
D1067	P33	D2864	P31	R0271	P21
D1068	P23	D2947	P31	R0273	P21
D1072	P33	D3214	P15	R0274	P21
D1073	P30	D4433	P35	R0275	P21
D1075	P26	D4455	P25	R0276	P21

# NUMERICAL INDEX

PART NO.	PAGE	PART NO.	PAGE	PART NO.	PAGE
R0277	P21	10032	P7	10229	P3, P7, P9, P17, P18, P22, P23, P25, P26, P27, P28, P31, P33, P35
R0278	P21	10033	P16	10230	P3, P11, P13, P15, P27
R0367	P13	10037	P11, P35	10231	P3, P4, P7, P13, P15
R0375	P13	10044	P35	10232	P4, P9, P13, P26
R0434	P4, P7	10047	P20	10233	P9, P11
R0456	P20	10048	P3, P7	10265	P2
R0642	P21	10049	P23	10269	P2
R0663	P20	10051	P34	10289	P2
R0664	P29	10064	P25	10303	P23
R0667	P23	10081	P34	10304	P23
R0709	P20	10087	P4, P7	10305	P23, P26, P33, P37
R0714	P20	10092	P4	10306	P31
R0716	P20	10101	P3, P7, P17, P18, P20, P23, P26, P27, P28, P31, P33	10307	P22
R0717	P20	10102	P2, P7, P11, P13, P15, P16	10308	P37
R0767	P21	10103	P25, P31	10309	P26
R0811	P21	10104	P3, P27	10310	P28, P31
R0812	P21	10105	P3, P7	10311	P33
R0813	P21	10106	P9, P13	10312	P9
R0814	P21	10107	P5, P11, P27, P35	10322	P35
R0912	P11	10108	P23	10323	P29
R0927	P19	10109	P24	10325	P18
R0933	P29	10110	P3, P28	10328	P23
R0959	P19	10111	P3, P25, P34, P35	10334	P21
R0968	P2	10112	P35	10401	P29
R0969	P2	10117	P3	10409	P9, P11
R0970	P2	10133	P13	10427	P23
R0978	P35	10145	P9	10430	P9
R1024	P20	10152	P27	10435	P9, P11, P23, P33
R1025	P20	10168	P16	10445	P9, P11
R1026	P20	10170	P20	10451	P23
R1027	P20	10187	P13	10452	P31
R1028	P20	10204	P17, P23, P26	10454	P26
1K138	P23	10205	P27	10455	P26, P33
10001	P3, P22, P27	10206	P23, P34	10456	P34
10002	P9, P35	10207	P33	10457	P29, P33
10003	P22, P25	10208	P22	10459	P3, P35
10004	P17, P18	10209	P28, P33	10460	P7, P9, P13, P15
10005	P27	10210	P20, P23, P25, P28	10464	P9
10006	P27	10213	P17, P23	10468	P
10008	P13, P15	10215	P33	10478	P9, P11
10009	P5	10216	P23, P25, P34, P35	10483	P27
10013	P35	10217	P5	10489	P3
10014	P23	10220	P35	10500	P29
10015	P25	10225	P30	10501	P34
10016	P3, P25	10226	P15	10502	P34
10017	P34	10227	P31	10503	P23
10018	P24, P26	10228	P2, P7, P11, P13, P15, P16, P23	10504	P23
10019	P4				
10020	P29				
10021	P29				
10022	P29, P33				
10023	P3, P33				
10024	P34				
10026	P4, P7, P13, P15				

# NUMERICAL INDEX

PART NO.	PAGE	PART NO.	PAGE
10504	P23	3303-98	P26
10507	P35	3305-01	P37
10520	P28	3310-80	P11
10521	P33	3400-01	P9
10522	P33	5405-06-06	P18
10523	P31	6400-08	P17, P18
10524	P33	6401-08-06	P18
10525	P2, P25	6500-08	P7
10526	P23	6801-06-08	P17, P18
10529	P37	6801-08	P17, P18
10531	P30	7090X	P9
10544	P16	7100-115	P39
10551	P23	7100-121	P39
10552	P23	7100-133	P39
10553	P26	7100-23	P39
10554	P33	7100-42	P39
10555	P23	7100-46	P39
10601	P23	7100-89	P39
10602	P9, P11, P29	7100-90	P39
10603	P29	7200-03	P39
10604	P29	7200-04	P39
10605	P22		
10607	P25		
10608	P24		
10610	P3		
10620	P23, P28, P29		
10621	P26, P28, P29, P33, P37		
10622	P37		
10640	P13, P24, P35		
10641	P3, P7, P11, P15		
10660	P33		
10669	P23		
10670	P9, P11, P13, P26		
10680	P31		
10690	P29		
10722	P16		
10724	P16		
10725	P16		
2100-03	P9		
2404-06-06	P17, P18		
2404-08-06	P17, P18		
2404-08-08	P7		
2500-17	P4		
2501-06-06	P17		
2501-08-06	P17		
2501-08-08	P7		
2601-06-06	P18		
2601-08-06	P18		
2603-08	P7		
3200-06	P4		
3200-18	P5		
3200-62	P4		
3303-114	P3		

\* None stock items.