

**MODEL 3110**  
**3 POINT MOUNTED PLANTER**  
(EdgeVac® Seed Metering)

**OPERATOR & PARTS**  
**MANUAL**

**M0183**

**Rev. 3/08**

This manual is applicable to: Model: 3110 3 Point Mounted Planters  
Serial Number: 603507 And On

Record the model number and serial number of your planter along with date purchased:

Model Number 3110

Serial Number \_\_\_\_\_

Date Purchased \_\_\_\_\_

Monitor Serial Number _____
Measured Pulses Per Mile/Km (Radar Distance Sensor) _____
Measured Pulses Per Mile/Km (Magnetic Distance Sensor) _____

**SERIAL NUMBER**

The serial number plate is located on the planter frame to be readily available. It is suggested that your serial number and purchase date also be recorded above.

The serial number provides important information about your planter and may be required to obtain the correct replacement part. Always provide the model number and serial number to your KINZE® Dealer when ordering parts or anytime correspondence is made with KINZE Manufacturing, Inc.

D11080509





# PREDELIVERY/DELIVERY CHECKLIST

## TO THE DEALER

Predelivery service includes assembly, lubrication, adjustment and test. This service helps to ensure that the planter will be delivered to the customer ready for field use.

## PREDELIVERY CHECKLIST

After the planter has been completely assembled, use the following checklist and inspect the planter. Check off each item as it is found satisfactory or after proper adjustment is made.

- Recheck to be sure row units are properly spaced and optional attachments are correctly assembled.
- Be sure shipping stand has been removed.
- Be sure all grease fittings are in place and lubricated.
- Check planter and make sure all working parts are moving freely, bolts are tight and cotter pins are spread.
- Check all drive chains for proper tension and alignment.
- Check for oil leaks and proper hydraulic operation.
- Check to be sure hydraulic hoses are routed correctly to prevent damage.
- Inflate tires to specified PSI air pressure. Tighten wheel lug nuts/bolts to specified torques.
- Check to be sure all safety decals are correctly located and legible. Replace if damaged.
- Check to be sure the reflective decals and SMV sign are correctly located and visible when the planter is in transport position.
- Check to be sure safety/warning lights are installed correctly and working properly.
- Paint all parts scratched in shipment or assembly.
- Be sure all safety lockup devices are on the planter and correctly located.
- Auxiliary safety chain is properly installed and hardware is torqued to specification.

***This planter has been thoroughly checked and to the best of my knowledge is ready for delivery to the customer.***

\_\_\_\_\_  
(Signature Of Set-Up Person/Dealer Name/Date)

## OWNER REGISTER

Name \_\_\_\_\_ Delivery Date \_\_\_\_\_  
Street Address \_\_\_\_\_ Model No. 3110 Serial No. \_\_\_\_\_  
City, State/Province \_\_\_\_\_ Dealer Name \_\_\_\_\_  
ZIP/Postal Code \_\_\_\_\_ Dealer No. \_\_\_\_\_

## DELIVERY CHECKLIST

At the time the planter is delivered, the following checklist is to be used as a reminder of very important information which should be conveyed to the customer. Check off each item as it is fully explained to the customer.

- Check for proper operation of vacuum fan with tractor to be used with planter.
- Advise the customer that the life expectancy of this or any other machine is dependent on regular lubrication as directed in the Operator & Parts Manual.
- Tell the customer about all applicable safety precautions.
- Along with the customer, check to be sure the reflective decals and SMV sign are clearly visible with the planter in transport position and attached to the tractor. Check to be sure safety/warning lights are in working condition. Tell the customer to check federal, state/provincial and local regulations before towing or transporting on a road or highway.
- Give the Operator & Parts Manual to the customer and explain all operating adjustments.
- Read warranty to customer.
- Complete Warranty And Delivery Report form.

***To the best of my knowledge this machine has been delivered ready for field use and customer has been fully informed as to proper care and operation.***

---

(Signature Of Delivery Person/Dealer Name/Date)

## AFTER DELIVERY CHECKLIST

The following is a list of items we suggest to check during the first season of use of the equipment.

- Check with the customer as to the performance of the planter.
- Check with the customer as to the performance of the EdgeVac® Seed Metering System.
- Review with the customer the importance of proper maintenance and adherence with all safety precautions.
- Check for parts that may need to be adjusted or replaced.
- Check to be sure all safety warning signs (decals), reflective decals and SMV sign are correctly located and that decals are legible. Replace if damaged or missing.
- Check to be sure safety/warning lights are working properly.

---

(Signature Of Follow-Up Person/Dealer Name/Date)

**RETURN THIS COMPLETED FORM TO KINZE® IMMEDIATELY along with Warranty And Delivery Report.  
Retain photocopy of this form at dealership for After Delivery Check.**

# TABLE OF CONTENTS

---

<b>TO THE OWNER</b> .....	1-1
<b>WARRANTY</b> .....	1-2
<b>INTRODUCTION</b> .....	2-1
<b>SPECIFICATIONS</b> .....	3-1
<b>SAFETY PRECAUTIONS</b> .....	4-1
<b>SAFETY WARNING SIGNS</b> .....	5-1
<b>MACHINE OPERATION</b>	
Analog Vacuum Gauge .....	6-8
Checking Granular Chemical Application Rate .....	6-79
Checking Seed Population .....	6-78
Contact Wheel Spring Adjustment .....	6-6
Contact Wheel Drive Sprockets .....	6-6
Digital Vacuum Gauge Operation .....	6-8
Electronic Seed Monitor System	
KPM I .....	6-11
KPM II Stack-Mode .....	6-17
KPM III .....	6-45
<b>Field Adjustments</b>	
Seed Rate Transmission Adjustment .....	6-6
Field Test .....	6-78
Front Mounted Drive Wheel Option .....	6-76
Initial Preparation Of The Planter .....	6-1
Leveling The Planter .....	6-4
Metric Conversion Table .....	6-77
Parking Stand Adjustment .....	6-5
Planting Speed .....	6-77
Point Row Clutches .....	6-75
Row Marker Operation .....	6-9
Row Marker Length Adjustment .....	6-10
Row Marker Lockups (Conventional Row Markers Only) .....	6-1
Row Marker Speed Adjustment .....	6-9
Shear Protection .....	6-7
Tire Pressure .....	6-5
Toolbar Height Adjustment .....	6-5
Tractor Preparation And Hookup .....	6-2
Tractor Requirements .....	6-1
Transporting The Planter .....	6-76
Vacuum Fan Motor Valve Block Assembly .....	6-8
Wrap Spring Wrench Operation .....	6-7

# TABLE OF CONTENTS

---

## SEED METER OPERATION/MAINTENANCE

### Field Adjustments

General Planting Rate Information .....	7-1
Planting And Application Rate Charts .....	7-5
Seed Meter Singulator Brush And Vacuum Level Adjustment .....	7-23
Seed Meter .....	7-2
Seed Meter Cleanout .....	7-4
Seed Meter Drive Release .....	7-25
Seed Meter Maintenance.....	7-26
Seed Metering System Troubleshooting .....	7-27
Vacuum Manifold Maintenance.....	7-26

## ROW UNIT OPERATION

Closing Wheel Shield.....	8-2
Coulter Mounted Residue Wheels .....	8-13
Covering Discs/Single Press Wheel Adjustment .....	8-2
Drag Closing Attachment.....	8-3
Dual Gauge Wheels.....	8-7
Frame Mounted Coulter .....	8-8
Granular Chemical Bander Shield .....	8-15
Granular Chemical Banding Options .....	8-15
Granular Chemical Hopper And Drive .....	8-14
Planting Depth .....	8-1
Quick Adjustable Down Force Springs .....	8-6
Residue Wheels (For Use With Frame Mounted Coulter).....	8-9
Row Unit Chain Routing .....	8-5
Row Unit Mounted Bed Leveler .....	8-10
Row Unit Mounted Disc Furrower.....	8-9
Row Unit Mounted No Till Coulter.....	8-12
Row Unit Mounted Residue Wheel.....	8-10
Seed Hopper .....	8-4
Spring Tooth Incorporator .....	8-15
“V” Closing Wheel Adjustment (Rubber And Cast Iron).....	8-1

## LUBRICATION

Bushings.....	9-3
Drive Chains .....	9-1
Grease Fittings .....	9-4
Lubrication Symbols .....	9-1
Sealed Bearings .....	9-1
Wheel Bearings .....	9-3
Wrap Spring Wrench Assembly .....	9-4

# TABLE OF CONTENTS

---

## MAINTENANCE

15" Seed Opener Disc Blade/Bearing Assembly .....	10-5
Chain Tension Adjustment .....	10-2
Coulter Mounted Residue Wheels .....	10-9
Drag Closing Attachment.....	10-3
Electrical Wiring Diagram For Light Package.....	10-18
Electrical Wiring Diagrams For Point Row Clutches .....	10-19
Frame Mounted Coulter And Attachment .....	10-6
Gauge Wheel Adjustment.....	10-3
Gauge Wheel Arm Bushing And/Or Seal Replacement .....	10-4
Gauge Wheel Arm Pivot Spindle Replacement .....	10-4
Granular Chemical Attachment.....	10-10
Hydraulic Diagram - Vacuum Fan Motor System .....	10-20
Mounting Bolts And Hardware .....	10-1
Point Row Clutch Inspection .....	10-13
Preparation For Storage .....	10-18
Row Marker Bearing Lubrication Or Replacement .....	10-17
Row Marker Sequencing/Flow Control Valve Inspection .....	10-15
Row Unit Mounted Bed Leveler .....	10-8
Row Unit Mounted Disc Furrower.....	10-7
Row Unit Mounted No Till Coulter.....	10-9
Row Unit Mounted Residue Wheel.....	10-8
Seed Meter Maintenance..... <i>See "Seed Meter Operation/Maintenance" Section</i>	
Seed Tube Guard/Inner Scraper .....	10-6
Spring Tooth Incorporator .....	10-10
Tire Pressure .....	10-2
Torque Values Chart .....	10-1
<b>Troubleshooting</b>	
Closing Wheel Troubleshooting .....	10-3
KPM I/KPM II Stack-Mode Electronic Seed Monitors Troubleshooting .....	10-11
KPM III Electronic Seed Monitor Troubleshooting .....	10-12
Point Row Clutch Troubleshooting .....	10-14
Row Marker Operation Troubleshooting .....	10-16
Seed Metering System Troubleshooting..... <i>See "Seed Meter Operation/     Maintenance" Section</i>	
Wheel Bearing Lubrication Or Replacement .....	10-17

<b>PARTS LIST INDEX .....</b>	<b>P1</b>
-------------------------------	-----------

<b>PARTS SECTION NUMERICAL INDEX .....</b>	<b>P77</b>
--	------------

# TABLE OF CONTENTS

---



# TO THE OWNER

---

KINZE Manufacturing, Inc. would like to thank you for your patronage. We appreciate your confidence in KINZE® farm machinery. Your KINZE® planter has been carefully designed to provide dependable operation in return for your investment.

**This manual has been prepared to aid you in the operation and maintenance of the planter. It should be considered a permanent part of the machine and remain with the machine when you sell it.**

It is the responsibility of the user to read and understand the Operator & Parts Manual in regards to safety, operation, lubrication and maintenance before operation of this equipment. It is the user's responsibility to inspect and service the machine routinely as directed in the Operator & Parts Manual. We have attempted to cover all areas of safety, operation, lubrication and maintenance; however, there may be times when special care must be taken to fit your conditions.

Throughout this manual the symbol  and/or the words **NOTE, IMPORTANT, CAUTION, WARNING** or **DANGER** are used to call your attention to important information. The definition of each of these terms follows:

**NOTE:** Indicates a special point of information or addresses a machine adjustment.

**IMPORTANT:** Indicates an operation or maintenance condition which, if not corrected, could result in damage to machine, property, crops or the environment.



**CAUTION:** Indicates a potentially hazardous situation which, if not avoided, may result in minor or moderate personal injury.



**WARNING:** Indicates a potentially hazardous situation which, if not avoided, could result in death or serious personal injury.



**DANGER:** Indicates an imminently hazardous situation, which if not avoided, will result in death or serious personal injury.



**WARNING:** Some photos in this manual may show safety covers, shields or lockup devices removed for visual clarity. **NEVER OPERATE** the machine without all safety covers, shields and lockup devices in place.

**NOTE:** Some photos in this manual may show prototype machines or similar models and vary slightly in appearance.

**NOTE:** Some photos and illustrations in this manual show optional attachments installed. Contact your KINZE® Dealer for purchase of optional attachments.

# WARRANTY

---

The KINZE® Limited Warranty for your new machine is stated on the back of the retail purchaser's copy of the Warranty And Delivery Report form. Additional copies of the Limited Warranty can be obtained through your KINZE® Dealer.

Warranty, within the warranty period, is provided as part of KINZE's support program for registered KINZE® products which have been operated and maintained as described in this manual. Evidence of equipment abuse or modification beyond original factory specifications will void the warranty. Normal maintenance, service and repair is not covered by KINZE® warranty.

To register your KINZE® product for warranty, a Warranty And Delivery Report form must be completed by the KINZE® Dealer and signed by the retail purchaser, with copies to the Dealer, to the retail purchaser and to KINZE Manufacturing, Inc.. Registration must be completed and sent to KINZE Manufacturing, Inc. within 30 days of delivery of the KINZE® product to the retail purchaser. KINZE Manufacturing, Inc. reserves the right to refuse warranty on serial numbered products which have not been properly registered.

If service or replacement of failed parts which are covered by the Limited Warranty are required, it is the user's responsibility to deliver the machine along with the retail purchaser's copy of the Warranty And Delivery Report to the KINZE® Dealer for service. KINZE® warranty does not include cost of travel time, mileage, hauling or labor. Any prior arrangement made between the Dealer and the retail purchaser in which the Dealer agrees to absorb all or part of this expense should be considered a courtesy to the retail purchaser.

*KINZE® warranty does not include cost of travel time, mileage, hauling or labor.*

# INTRODUCTION

---

The Model 3110 3 Point Mounted Planter is available in various sizes and row spacings and permits installation of optional row unit attachments.

## GENERAL INFORMATION

The information used in this manual was current at the time of printing. However, due to KINZE's continual attempts to improve its product, production changes may cause your machine to appear slightly different in detail. KINZE Manufacturing, Inc. reserves the right to change specifications or design without notice and without incurring obligation to install the same on machines previously manufactured.

Right hand (R.H.) and left hand (L.H.), as used throughout this manual, are determined by facing in the direction the machine will travel when in use, unless otherwise stated.

D11080518a

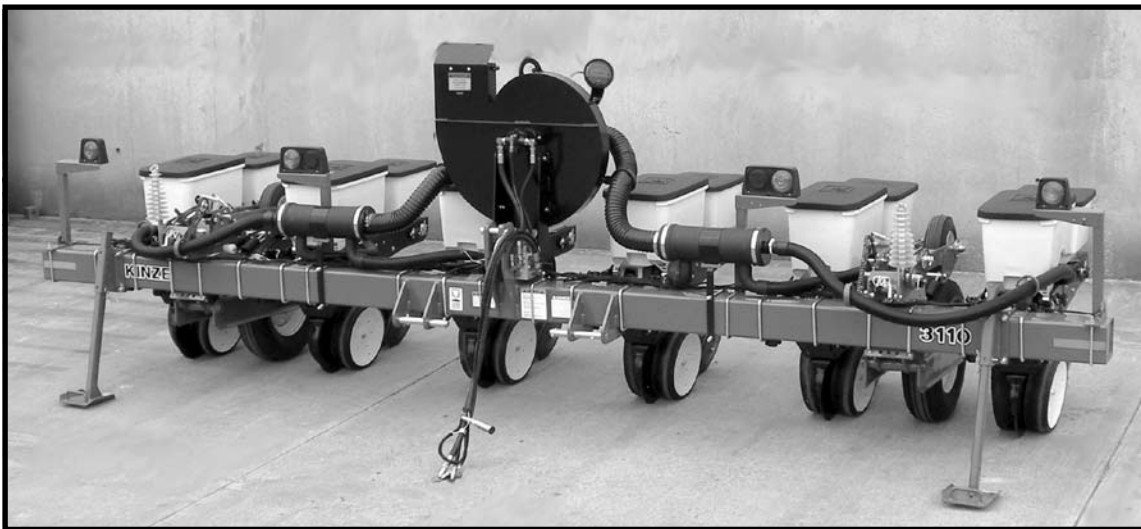

**Model 3110 6 Row 30" Without The Optional Row Marker Package Installed**

# INTRODUCTION

---

# SPECIFICATIONS

---

**BASE MACHINE TYPE** - 3 Point Mounted Rigid

**SEED METER TYPE** - EdgeVac® Seed Metering System

**EDGEVAC® SEED METERING SYSTEM INCLUDES -**

EdgeVac® Seed Meters (Less Seed Discs), Meter Drive Clutches, No. 41 Chains, 1.75 Bu. Seed Hoppers With Lids, 20" Diameter Vacuum Fan With Mounting Components, Hydraulic Motor, Hoses And Fittings, 4" Diameter Vacuum Feed Hoses, Distribution Manifolds And 2" Diameter Vacuum Distribution Hoses

**PLANTING UNIT TYPE** - Pull Row Units

**ROW SPACING** - 6 Row Narrow - 30" Rows  
- 6 Row Wide - 36", 38" And 40" Rows  
- 8 Row Narrow - 30" Rows  
- 8 Row Wide - 36", 38" And 40" Rows

**DRIVE SYSTEM** - Spring-Loaded Contact Drive System  
- Two 4.10" x 6" Contact Drive Tires  
- Two 7.60" x 15" Ground Tires  
- Two Wheel Module-Mounted Seed Transmissions With No. 40 Chains And Spring-Loaded Idlers  
- Optional Point Row Clutches  
- Two 7/8" Hex Drill Shafts

**SEED METER/VACUUM SYSTEM HYDRAULIC REQUIREMENTS -**

- 13 GPM @ 2000 PSI  
- Zero PSI Case Drain Plus One Set Of Remote Outlets For Vacuum Fan Hydraulic Motor

**ROW MARKERS (OPTIONAL)**

- 6 Row 30" - Heavy Duty Conventional Design  
- 6 Row Wide And 8 Row 30"/Wide - Low Profile Two-Fold Design  
(8 row wide utilizes depth bands on marker disc blades.)

**ROW MARKER HYDRAULICS** - One Set Of Remote Outlets Plus Sequencing Valve

**HITCH** - Category 2, 3, 3N

# SPECIFICATIONS

---

## DIMENSIONS & WEIGHTS

PLANTER SIZE	TRANSPORT WIDTH *	OPERATING & TRANSPORT LENGTH	WEIGHT **
6 Row 30"	17' 8"	5' 3"	2763 lbs.
6 Row 36"/38"/40"	21' 0"	5' 3"	2854 lbs.
8 Row 30"	21' 10"	5' 3"	3407 lbs.
8 Row 36"/38"/40"	27' 8"	5' 3"	3830 lbs.

\* Transport width includes optional row markers.

\*\* Base machine weight includes toolbar with 3 point hitch, wheel modules with tires and wheels, seed transmissions with drive components, parking stands, optional row markers with hydraulic cylinders and hoses, and KINZE pull row units (closing wheel arms less closing wheels) with seed hoppers and lids, quick adjustable dual down force springs, EdgeVac® seed meters (less seed discs) and vacuum seed metering manifolds, fans and hoses.

## MACHINE OPTIONS

- Row Marker Package
- Electronic Seed Monitors - KPM I  
KPM II Stack-Mode With Magnetic Distance Sensor Or  
Radar Distance Sensor  
KPM III With Magnetic Distance Sensor Or Radar Distance Sensor
- Front Mounted Drive Wheel Conversion Package
- Point Row Clutch Package

## ROW UNIT OPTIONS/ATTACHMENTS

- Seed Meter Discs
- Closing Options
  - Rubber "V" Closing Wheels
  - Cast Iron "V" Closing Wheels
  - Covering Discs/Single Press Wheel
  - Drag Closing Attachment
- Dual Gauge Wheels
- Granular Chemical Application
- Hopper Panel Extension Package
- Spring Tooth Incorporator
- Row Unit Mounted No Till Coulter
- Row Unit Mounted Disc Furrowers
- Row Unit Mounted Bed Leveler
- Row Unit Mounted Residue Wheel
- Coulter Mounted Residue Wheels
- Frame Mounted Coulter
- Residue Wheels Attachments For Frame Mounted Coulter

# SAFETY PRECAUTIONS

Safe and careful operation of the tractor and planter at all times will contribute significantly to the prevention of accidents.

Since a large portion of farm accidents occur as a result of fatigue or carelessness, safety practices should be of utmost concern. Read and understand the instructions provided in this manual and on the warning signs. Review these instructions frequently! Listed below are other safety suggestions that should become common practice.

 **Never permit any persons other than the operator to ride on the tractor.**

 **Never ride on the planter or allow others to do so.**

 **Always keep hands, feet and clothing away from moving parts. Do not wear loose fitting clothing which may catch in moving parts.**

 **Do not allow anyone to stand between the hitch and towing vehicle when backing up to the planter.**

 **Be aware of bystanders, particularly children! Always look around to make sure it is safe to start the engine of the towing vehicle or move the planter. This is particularly important with higher noise levels and quiet cabs, as you may not hear people shouting.**

 **Always wear protective clothing, substantial shoes and suitable hearing and eye sight protectors applicable for the situation.**

 **Limit transport speed to 15 MPH. Transport only with farm tractor of sufficient size and horsepower. (See Machine Operation Section)**

 **Always follow federal, state/provincial and local regulations when towing farm equipment on a public highway. Only a safety chain (not an elastic or nylon/plastic tow strap) should be used to retain the connection between the towing and towed machines in the event of separation of the primary attaching system.**

 **Always drive at a safe speed relative to local conditions and ensure your speed is low enough for an emergency stop to be safe and secure. Keep speed to a minimum.**

 **Never allow the planter to be operated by anyone who is unfamiliar with the operation of all functions of the unit. All operators should read and thoroughly understand the instructions given in this manual prior to moving the unit.**

 **Always make sure safety/warning lights, SMV sign and reflective decals are in place and visible prior to transporting the machine on public roads. In this regard, check federal, state/provincial and local regulations.**

 **Never work under the planter while in raised position.**

 **Always make sure there are no persons near the planter when row marker assemblies are in operation.**

 **Watch for obstructions such as wires, tree limbs, etc. when folding row markers.**

46331-89b



 **Install safety lockup devices on row markers, as provided, prior to transporting the planter or working around the unit.**

# SAFETY PRECAUTIONS



Lower the planter when not in use and cycle the hydraulic control lever to relieve pressure in hoses.



Pressurized hydraulic fluid can penetrate body tissue and result in serious infection, injury, or death. Before applying pressure to the hydraulic system, make sure all connections are tight and that hoses and fittings have not been damaged. Leaks can be invisible. Keep away from suspected leaks. Relieve pressure in the hydraulic system before searching for leaks, disconnecting hoses, or performing any other work on the system. Fluid injected under the skin must be IMMEDIATELY removed by a surgeon familiar with this type of injury.



Use a tractor equipped with a roll-over-protective-system and fasten your seat belt prior to starting the engine.



Allow for unit length when making turns.



Avoid sudden uphill turns on steep slopes.



Always keep the tractor in gear to provide engine braking when going downhill. Do not coast.



This planter is designed to be DRIVEN BY GROUND TIRES ONLY. The use of aftermarket hydraulic, electric or PTO drives may create serious safety hazards to you and the people nearby. If you install such drives you must follow all appropriate safety standards and practices to protect you and others near this planter from injury.



This machine has been designed and built with your safety in mind. Do not make any alterations or changes to this machine. Any alteration to the design or construction may create safety hazards.



If a row marker cylinder has been disconnected or removed for any reason, do not attach the rod end of the cylinder until the cylinder is cycled several times to remove any air that may be trapped in the system.



To avoid serious injury or death, care must be taken when operating row markers around overhead power lines.



Check to be sure all safety/warning lights are working before transporting the machine on public roads.



Be a safe and courteous driver. Always yield to oncoming traffic in all situations, including narrow bridges, intersections, etc.



Rim and tire servicing can be dangerous. Explosive separation of a tire and rim parts can cause serious injury or death.



Agricultural chemicals used with this unit can be dangerous. Improper selection or use can seriously injure persons, animals, plants, soil and other property. BE SAFE: Select the right chemical for the job. Handle it with care. Follow the instructions on the container label and of the equipment manufacturer.



Serious injury or death can result from contact with electric lines. Use care to avoid contact with electric lines when moving or operating this machine.



Store the planter in an area away from human activity. DO NOT permit children to play on or around the stored unit.



Make sure the parked machine is on a hard, level surface. Wheel chocks may be needed to prevent unit from rolling.



Good maintenance is your responsibility. Poor maintenance is an invitation to trouble.



Never operate vacuum fan with cover removed.



Always wear ear protection when working around operating vacuum fan.



Reduce speed prior to turns to avoid the risk of overturning.



# SAFETY WARNING SIGNS

The “WARNING” signs illustrated on these pages are placed on the machine to warn of hazards. The warnings found on these signs are for your personal safety and the safety of those around you. OBSERVE THESE WARNINGS!

- Keep these signs clean so they can be readily observed. Wash with soap and water or cleaning solution as required.
- Replace “WARNING” signs should they become damaged, painted over or if they are missing.
- Check reflective decals and SMV sign periodically. Replace if they show loss of any of their reflective properties.
- When replacing decals, clean the machine surface thoroughly using soap and water or cleaning solution to remove all dirt and grease.

**NOTE:** Style and locations of SMV sign, reflective decals and safety/warning lights conform to ANSI/SAE S279.13 DEC2005 and ANSI/SAE S276.6 JAN2005.

D07270546



Part No. G7100-90

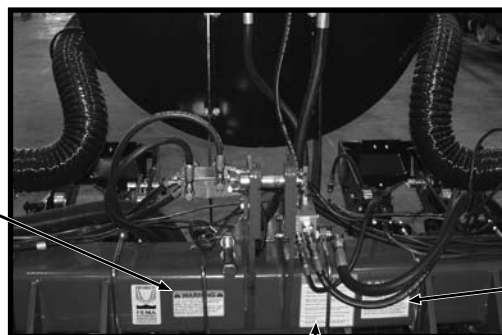

Part No. G7100-89



Part No. G7100-46

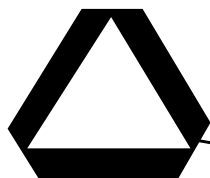

Part No. G7100-36

D11080522



Part No. G7100-301  
(Qty. 2 - One On Each Side Of Fan)

# SAFETY WARNING SIGNS

LF082203101



Part No. G7100-259 Amber Reflective Decal  
(Qty. 2 - One Forward-Facing On Each End  
Of Toolbar)

D06039901

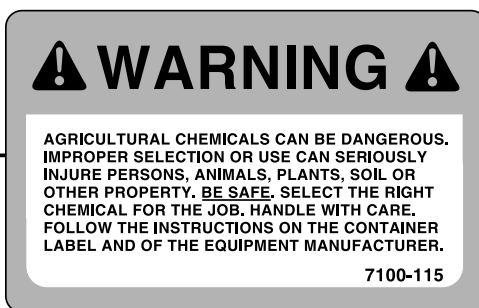

Part No. G7100-115 (1 Per Row Unit -  
Located On Underside Of Granular  
Chemical Hopper Lids)

# SAFETY WARNING SIGNS

D101900103

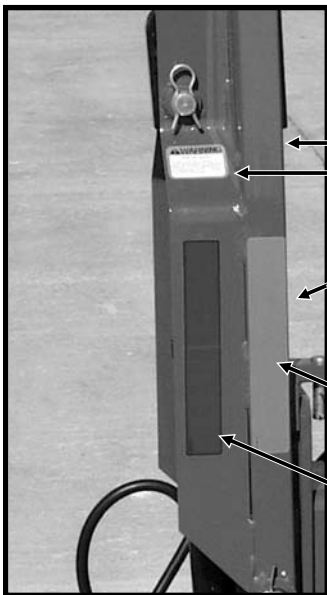

Conventional Row Marker



Part No. G7100-42 (Qty. 4 - Two Per Row Marker)



Part No. G7100-259 Amber Reflective Decal Front (Qty. 2 - One Per Row Marker) (If Applicable)

Part No. G7100-260 Orange Reflective Decal Inside Rear (Qty. 2 - One Per Row Marker) (If Applicable)

Part No. G7100-258 Red Reflective Decal Outside Rear (Qty. 2 - One Per Row Marker) (If Applicable)

D102400118a

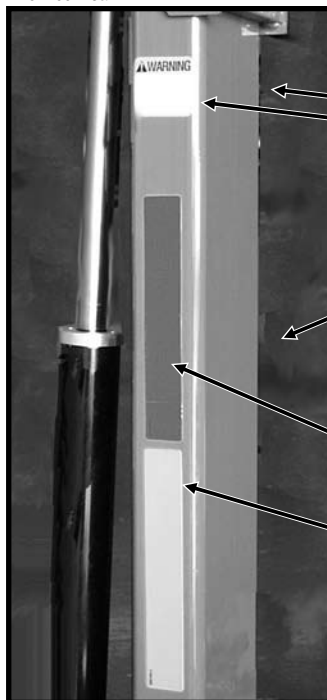

Low Profile Row Marker



Part No. G7100-42 (Qty. 4 - Two Per Row Marker)



Part No. G7100-259 Amber Reflective Decal Front (Qty. 2 - One Per Row Marker) (If Applicable)

Part No. G7100-258 Red Reflective Decal Top Rear (Qty. 2 - One Per Row Marker) (If Applicable)

Part No. G7100-260 Orange Reflective Decal Bottom Rear (Qty. 2 - One Per Row Marker) (If Applicable)

**NOTE:** If the machine is not equipped with row markers, one red and one orange reflective decal are located on the rear side of each safety/warning light mounting bracket and an amber reflective decal is located on the front side of each safety/warning light mounting bracket.

# SAFETY WARNING SIGNS

(MT34)

## 6 Row Sizes

### Standard

D060800114

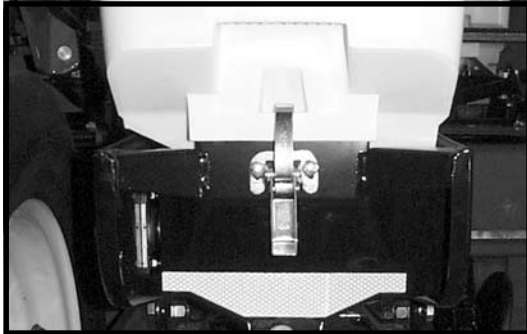

Part No. G7100-261 Red Reflective Decal  
(Qty. 2 - One Per Row Unit - Located On The  
Hopper Support) (If Applicable)

### With Optional Granular Chemical

D062300102

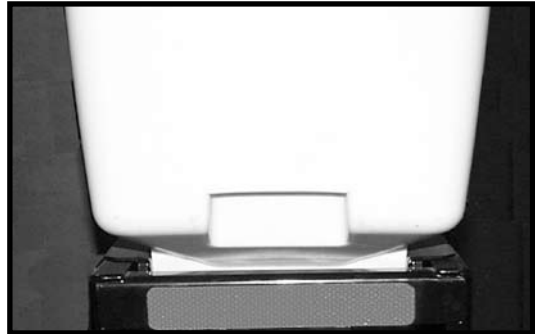

Part No. G7100-258 Red Reflective Decal  
(Qty. 2 - One Per Row Unit - Located On The  
Granular Chemical Hopper Panel Extension)  
(If Applicable)

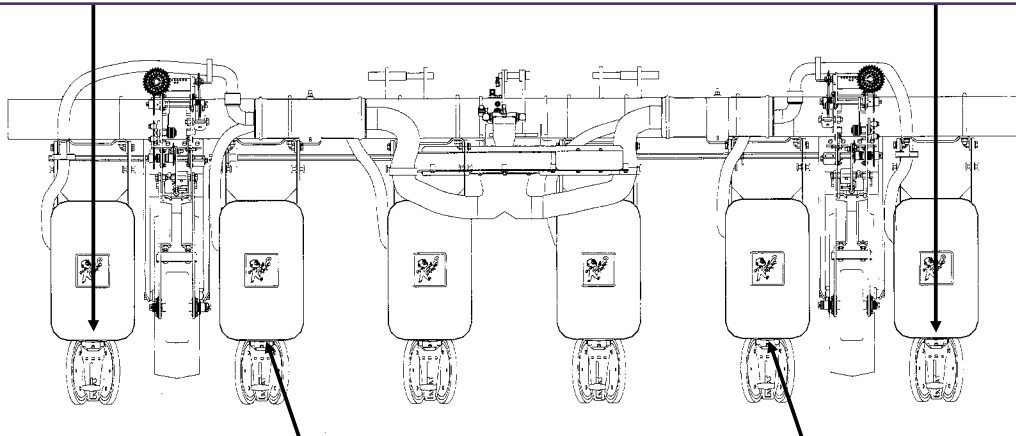

D060800114

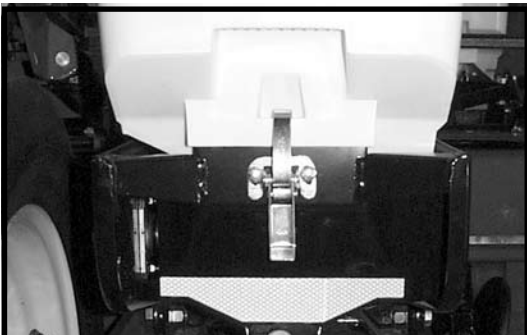

Part No. G7100-263 Orange Reflective Decal  
(Qty. 2 - One Per Row Unit - Located On The  
Hopper Support) (If Applicable)

D062300102

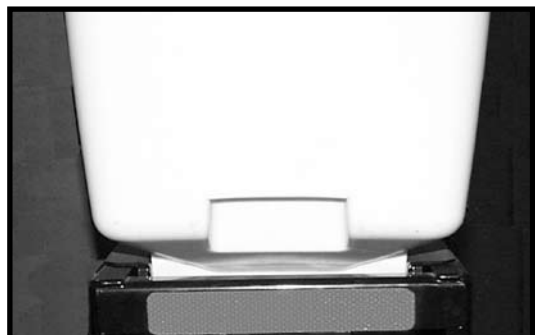

Part No. G7100-260 Orange Reflective Decal  
(Qty. 2 - One Per Row Unit - Located On The  
Granular Chemical Hopper Panel Extension)  
(If Applicable)

# SAFETY WARNING SIGNS

(MT36)

## 8 Row Sizes

### Standard

### With Optional Granular Chemical

D060800114

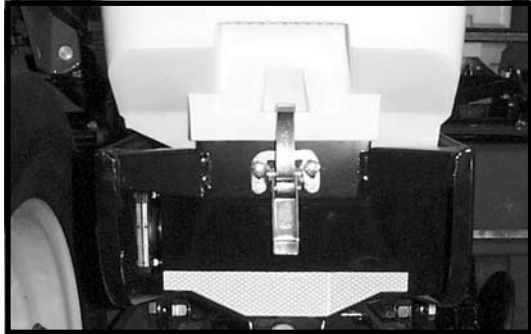

Part No. G7100-261 Red Reflective Decal  
(Qty. 4 - One Per Row Unit - Located On The  
Hopper Support) (If Applicable)

D062300102

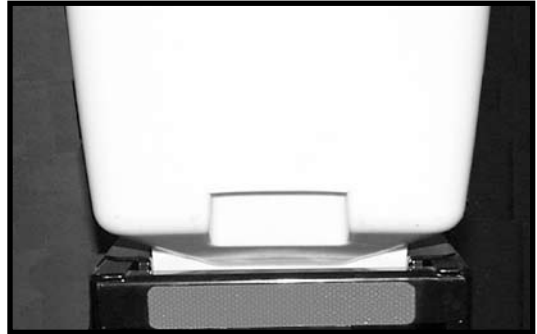

Part No. G7100-258 Red Reflective Decal  
(Qty. 4 - One Per Row Unit - Located On The  
Granular Chemical Hopper Panel Extension)  
(If Applicable)

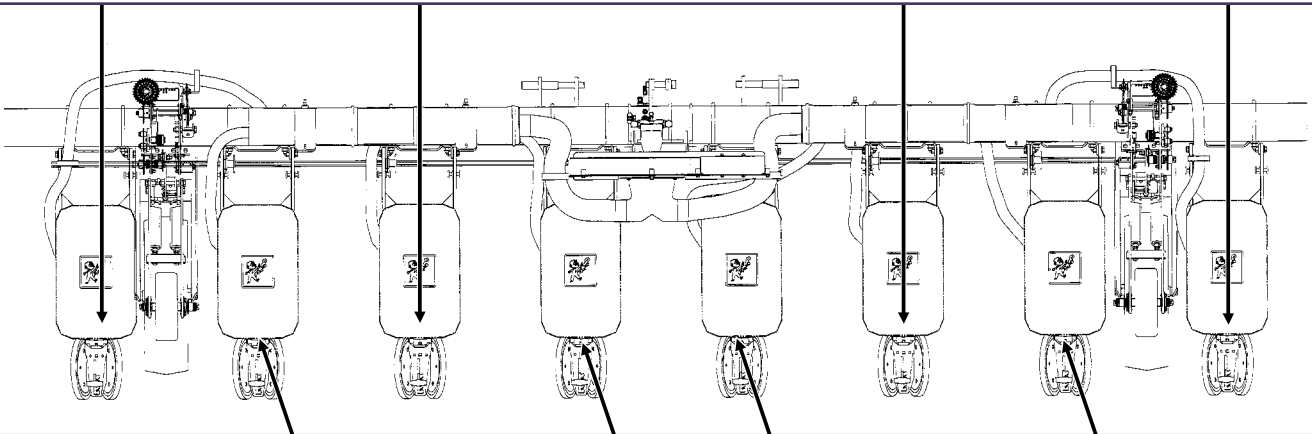

D060800114

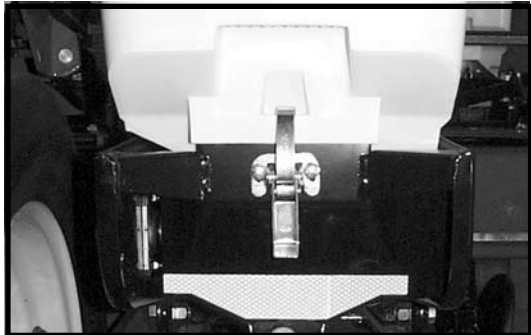

Part No. G7100-263 Orange Reflective Decal  
(Qty. 4 - One Per Row Unit - Located On The  
Hopper Support) (If Applicable)

D062300102

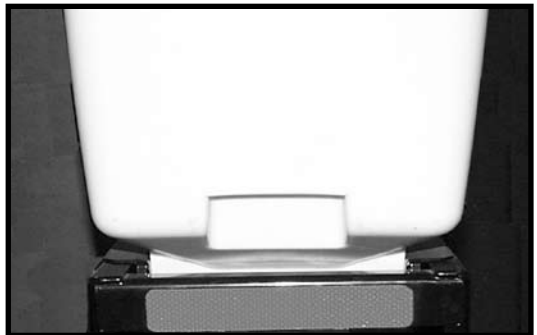

Part No. G7100-260 Orange Reflective Decal  
(Qty. 4 - One Per Row Unit - Located On The  
Granular Chemical Hopper Panel Extension)  
(If Applicable)

# SAFETY WARNING SIGNS

(D08220676)

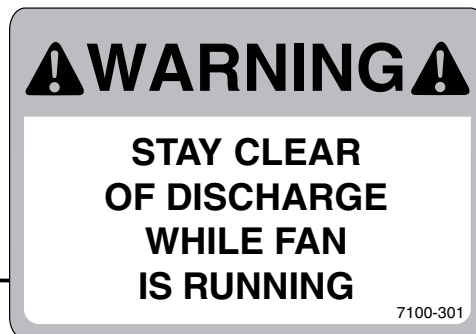

Part No. G7100-301 (Qty. 2 - One On Each Side Of Fan)

# MACHINE OPERATION

The following information is general in nature and was written to aid the operator in preparation of the tractor and planter for use, and to provide general operating procedures. The operator's experience, familiarity with the machine and the following information should combine for efficient planter operation and good working habits.

**IMPORTANT: Always raise the planter out of the ground when making sharp turns or backing up.**

The KINZE® EdgeVac® Seed Metering System includes seed meters, seed discs and an air system consisting of a hydraulic driven vacuum fan which draws air through manifolds, hoses and the seed meters on each row unit.



**WARNING: Never operate vacuum fan with cover removed.**

## ROW MARKER LOCKUPS (Conventional Row Markers Only)

APO041(MKR17)

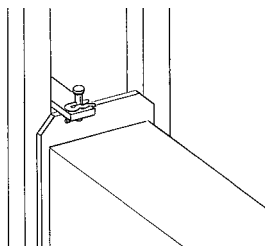

**Pin Stored In Raised Position For Marker Operation**

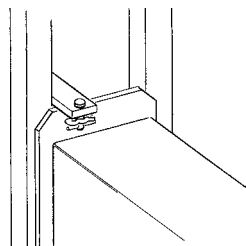

**Row Marker Locked Up For Transport Or Working Around The Machine**

When lockups are not in use, store lockup pin in raised position with hair pin clip on upper side of tab. Install marker lockups when transporting the planter or working around the planter.



**DANGER: To avoid serious injury or death, keep others away when raising or lowering row markers.**

## INITIAL PREPARATION OF THE PLANTER

Lubricate the planter and row units per the lubrication information in this manual. Make sure all tires have been properly inflated. See "Tire Pressure". Check all drive chains for proper tension, alignment and lubrication.

## TRACTOR REQUIREMENTS

Approximate required minimum tractor horsepower (HP) required for field work is listed below:

6 Row Sizes - 55-85 HP

8 Row Sizes - 75-110 HP

**NOTE: The tractor must have adequate 3 point hitch lift capacity to lift the weight of the machine, attachments, seed and dry chemicals. Shipping weights do not include seed, dry chemicals or additional optional attachments.**

Tractor front end stability is necessary for safe efficient operation. Therefore, it may be necessary to add front ballast to your tractor for satisfactory field operation, as well as adequate transport stability. Refer to your tractor operator's manual for front ballast recommendations.

A quick-attaching coupler (quick hitch) is recommended for safe and easy attaching and detaching.

**A 12 volt DC electrical system is required on all sizes to operate planter safety/warning lights.**

# MACHINE OPERATION

One SCV remote hydraulic outlet is required to operate optional row markers and one SCV plus a zero pressure case drain is required to operate the seed metering system vacuum fan.

Maximum hydraulic flow rate of 13 GPM @ 2000 PSI is required to operate the vacuum fan motor.

**IMPORTANT: Connect hydraulic motor case drain to a case drain return line with zero PSI on the tractor. Failure to connect to a return with zero PSI will cause damage to the hydraulic motor shaft seal. Warranty will not apply on damaged motors resulting from improper hydraulic line connection. DO NOT connect hydraulic motor case drain to a SCV outlet or motor return circuit connection. Contact tractor manufacturer for specific details on “zero pressure return”.**

**NOTE: A Flow Control Needle Valve Kit, to provide a flow control option for tractors that are not equipped with a method for fine adjustment of hydraulic flow, is available from KINZE® Repair Parts through your KINZE® Dealer.**

D04050604

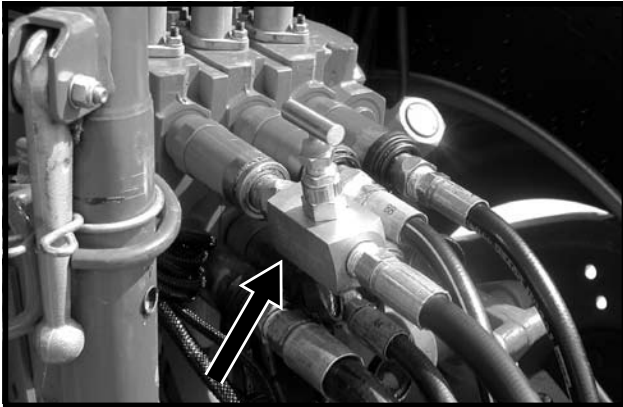

G1K426 Needle Valve Kit

## TRACTOR PREPARATION AND HOOKUP

1. Set tractor rear wheel spacing at double the planter row spacing. For example: On a planter set for 36" rows, set the tractor wheel spacing at 72" center-to-center. On wide front end tractors set front wheel spacing equal to rear wheel spacing. Check tractor operator's manual for correct front and rear tire pressure.
2. Adjust lift links on tractor so planter will lift level from side to side and raise high enough for planter transport clearance. Set the sway blocks on the tractor in position to prevent side sway. Be sure the individual lift link arms are in the float position.
3. Back tractor up to planter. Position lower hitch pins and bushings as shown in the following diagrams for your type of tractor hitch. Line up holes and insert hitch pins and lock in place with pins provided. It may be necessary to change the length of the tractor upper link with the adjusting handle.

D09109910

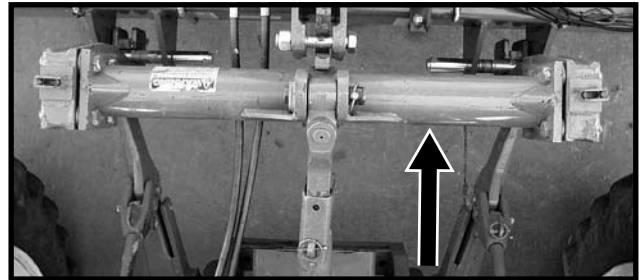

When using a quick-attaching coupler (customer supplied), match pin location to pin spacing in quick-attaching coupler.

### Lower Hitch Pins

D082203114



Category 2 Requires Pin Only  
Category 3 And 3N Requires Pin And Bushing



# MACHINE OPERATION

## Lower Hitch Pins

PFA065(PLTR76)

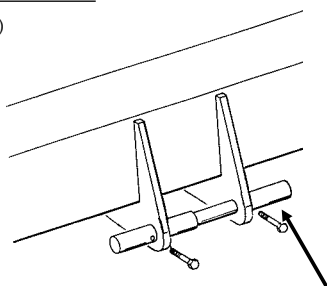

Category 2 Bushing Position

PFA066(PLTR77)

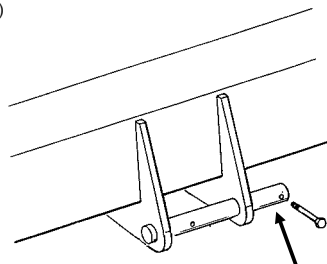

Category 3 And 3N Bushing Position

## Upper Hitch Pin

The upper hitch point has two sets of holes. The hitch pin must be positioned in the lower set of holes for use with tractors equipped with Category 2 quick-attaching coupler. The hitch pin must be positioned in the upper set of holes for use with tractors equipped with Category 3N and 3 quick-attaching coupler.

D08269907a

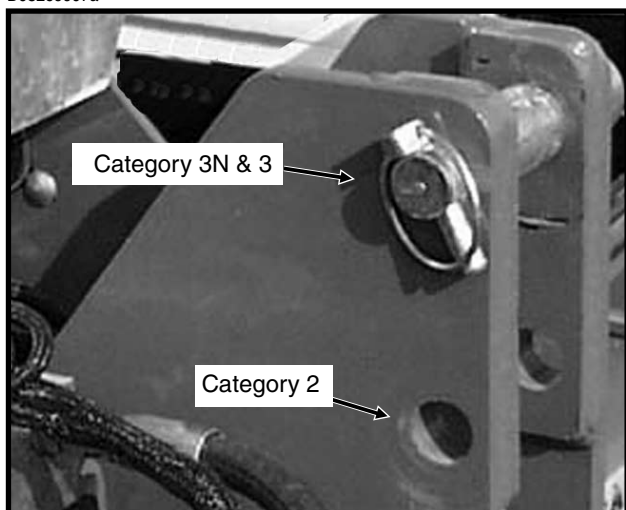

4. Connect ASAE Standards 7 terminal connector for safety/warning lights on planter to ASAE Standards receptacle on tractor. If your tractor is not equipped with an ASAE Standards receptacle, check with your tractor manufacturer for availability. Check to be sure safety/warning lights on planter are working in conjunction with safety/warning lights on tractor.

Connect harness on planter to digital vacuum gauge console on tractor. Connect power lead to power source. A power lead adapter may be required.

5. Connect hydraulic hoses to tractor ports in a sequence that is both familiar and comfortable to the operator. See "Tractor Requirements".

Before attaching hoses, move tractor control levers back and forth to relieve any pressure in the tractor hydraulic system.

The vacuum fan motor operation hydraulic hoses are as follows:

- 3/8" Hose From Motor - Case Drain
- 3/4" Hose From Motor - Return
- 1/2" Hose From Motor - Pressure

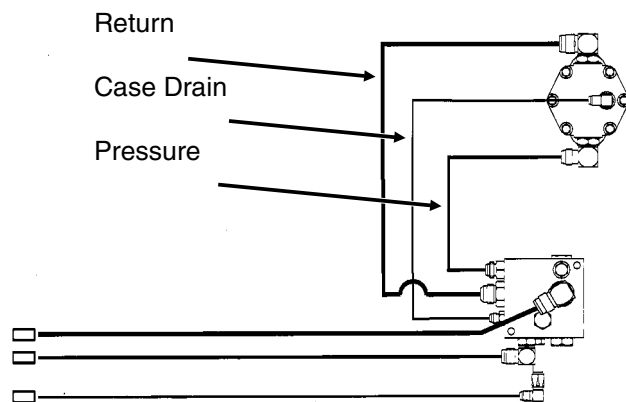

(Continued On Following Page)

**NOTE: Always use top hole when not using quick-attaching coupler.**

# MACHINE OPERATION

**IMPORTANT:** Always wipe hose ends to remove any dirt before connecting couplers to tractor ports.

**CAUTION:** Before the row markers are operated, make sure all row marker lockups are in working position.

**DANGER:** Before applying pressure to the hydraulic system, make sure all connections are tight and that hoses and fittings have not been damaged. Hydraulic fluid escaping under pressure can have sufficient force to penetrate skin causing injury or infection.

**WARNING:** Never operate fan with cover removed.

6. Raise planter slowly and watch for any interference. Remove pin from each parking stand and raise each to the transport position. Secure stands in raised position with pin in lowest hole.

7. For proper operation of the planter and row units, it is important that the planter frame and row unit parallel arms be level side-to-side and front-to-rear. The toolbar should operate at a 20"-22" height from planting surface. Tire pressure must be maintained at pressures specified and toolbar height must be adjusted equally. Check to be sure planter toolbar is level and at correct operating height. See "Leveling The Planter".

**WARNING:** As a general safety practice and to avoid damage to the tractor hydraulic system, always lower the planter when not in use.

## LEVELING THE PLANTER

1. Drive the tractor and planter on level ground.
2. Lower the planter to the ground.
3. Check to be sure toolbar height is 20"-22". See "Toolbar Height Adjustment".

(MT20a)

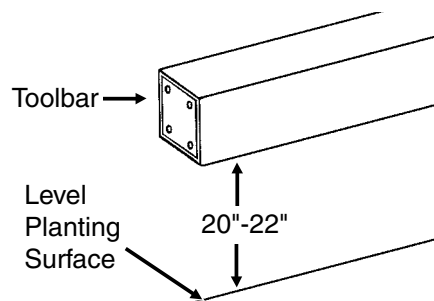

4. Check to be sure planter is level front-to-rear and row unit parallel arms are level. Adjust upper link on tractor accordingly.

D11080541

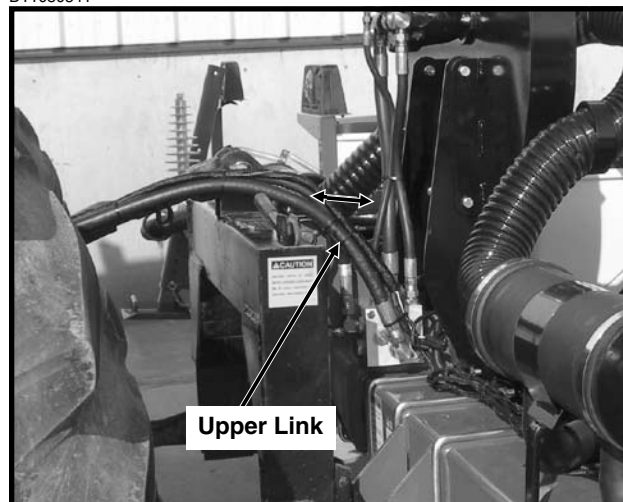

Shown With Customer-Supplied Quick Hitch

# MACHINE OPERATION

## TOOLBAR HEIGHT ADJUSTMENT

D082103118

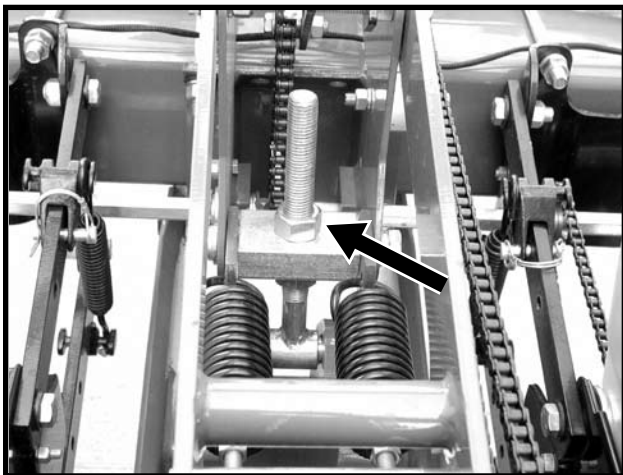

**Standard Rear Mounted Drive Wheel**

D06160303

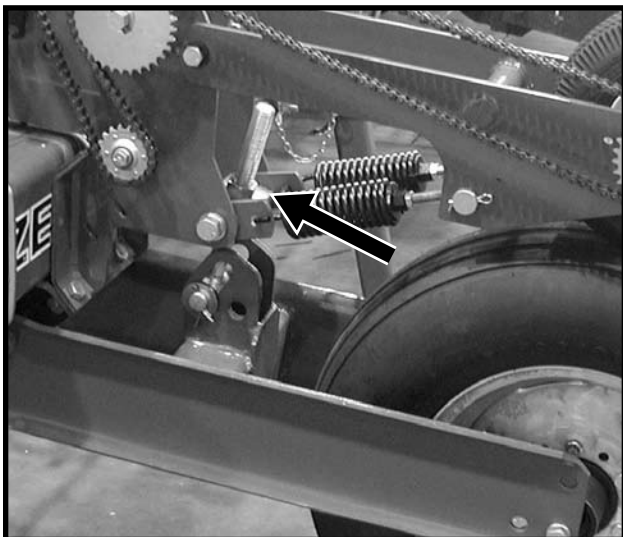

**Optional Front Mounted Drive Wheel**

The drive wheel assembly is designed so the wheel can be adjusted to maintain a toolbar height of 20"-22" from the planting surface in all planting situations. This is particularly useful when the planter is used for ridge planting or planting on beds. The drive wheel assembly has an adjustment range of 7".

To adjust toolbar height:

1. Loosen the jam nut using a 1 1/2" wrench or a 15" adjustable wrench.
2. Turn the adjusting nut using a 1 7/8" wrench or 15" adjustable wrench (clockwise to decrease frame height or counter clockwise to increase frame height).
3. Tighten the jam nut.

## PARKING STAND ADJUSTMENT

D11080520



Two parking stands, located on the front side of the main frame, are standard on all Model 3110 planters. The stands must be positioned so they are not directly behind the tractor tire or they will hit when the planter is raised.

Raise to top position and pin when planting. Lower and pin for parking and storage.

On planters equipped with front mounted drive wheels, parking stands are not required.

Each parking stand has six positioning holes. By using these positioning holes, you can set the toolbar height from 19" to 25".

## TIRE PRESSURE

Tire pressure should be checked regularly and maintained as follows:

7.60" x 15" 8 Ply Ground Drive/Gauge .....	40 PSI
4.10" x 6" Contact Drive .....	50 PSI

**NOTE: Tire pressure must be correctly maintained in all drive wheel tires to ensure level and proper operation of planter. All rate charts are based on above tire pressures.**

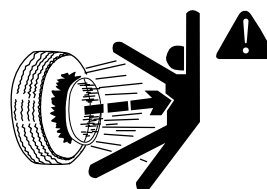

**DANGER: Rim and tire servicing can be dangerous. Explosive separation of tire and rim parts can cause serious injury or death.**

**Do not attempt to mount a tire unless you have the proper equipment and experience to perform the job. This should only be done by persons properly trained and equipped to do the job.**

**(Continued On Following Page)**

# MACHINE OPERATION

(Continued)

Always maintain the correct tire pressures. Do not inflate the tires above the recommended pressures.

When inflating tires, use a clip-on air chuck and extension hose long enough to allow you to stand to one side and NOT in front of or over the tire assembly. Use a safety cage to enclose the tire and rim assembly when inflating.

Inspect tires and wheels daily. Do not operate with low pressure, cuts, bubbles, damaged rims or missing lug bolts and nuts.

## SEED RATE TRANSMISSION ADJUSTMENT

D11080536

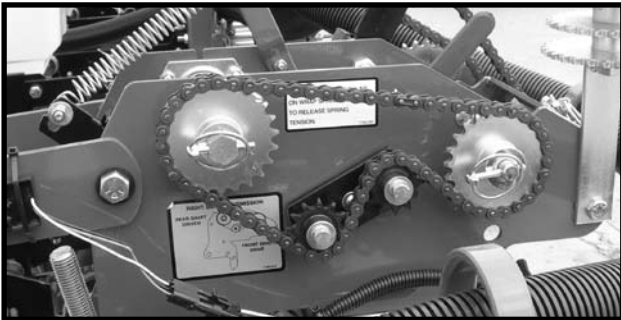

Planting population rate changes are made at the seed rate transmissions. The seed rate transmissions are designed to allow simple, rapid changes of sprockets to obtain the desired planting population. By removing the lynch pins on the hexagon shafts, sprockets can be interchanged with those from the sprocket storage rod bolted to each transmission.

Chain tension is controlled by a spring-loaded, dual-sprocket idler. The idler assembly is adjusted with an easy-release idler arm. This arm has a release position to remove spring tension for replacing sprockets. The amount of spring tension on the chain is controlled by the idler arm. See "Wrap Spring Wrench Operation".

A decal positioned near each transmission illustrates proper chain routing. The planting rate charts found in the Seed Meter Operation/Maintenance section will aid you in selecting the correct sprocket combinations.

## CONTACT WHEEL DRIVE SPROCKETS

A7293a

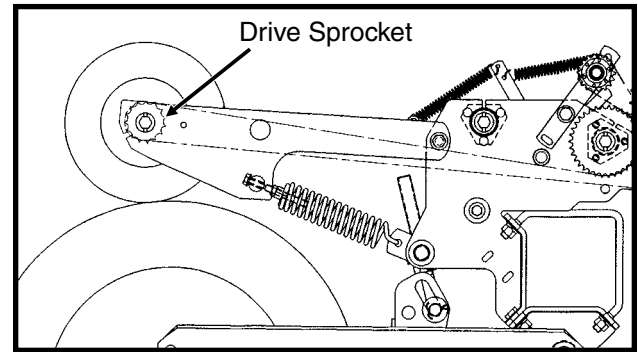

**NOTE:** 15 tooth, 19 tooth or 30 tooth drive sprockets at each contact drive wheel can be interchanged from the sprocket storage rod bolted to each transmission. The 15 and 19 tooth sprockets require use of a 218 pitch No. 40 chain. The 30 tooth sprocket requires use of a 224 pitch No. 40 chain.

Chain tension is controlled by a spring-loaded sprocket idler. The amount of spring tension on the chain is controlled by the idler arm.

The planting rate charts found in Seed Meter Operation/Maintenance section will aid you in selecting the correct sprocket.

**NOTE:** 15, 19 and 30 tooth drive sprockets are NOT applicable to all rate charts. Check chart titles to ensure the proper rate chart is selected.

**NOTE:** After each sprocket combination adjustment, make a field test to be sure you are planting at the desired rate.

## CONTACT WHEEL SPRING ADJUSTMENT

There are two down pressure springs on each contact drive wheel. The spring tension is factory preset and should need no further adjustment.

The tension is set leaving 1" between the spring plug and the mounting shaft as shown below.

(SPF61)

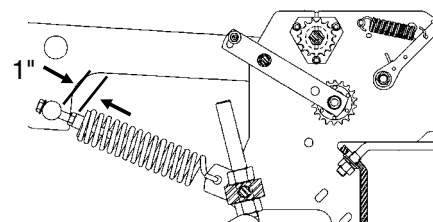

# MACHINE OPERATION

## SHEAR PROTECTION

The planter driveline and seed and granular chemical drivelines are protected from damage by shear pins.

D11080536

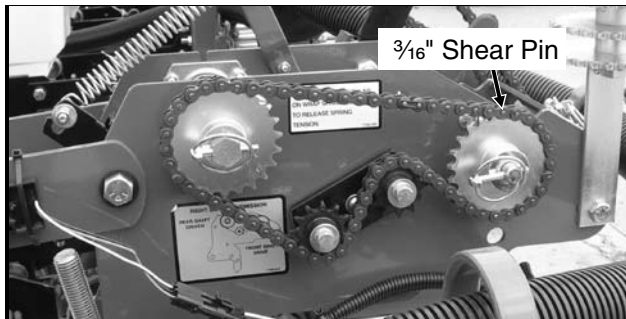

### Transmission Shaft

If excessive load should cause a pin to shear, it is important to determine where binding has occurred before replacing the pin. Replace shear pins with same size and type.

To prevent future binding or breakage of components, check driveline alignment and follow prescribed lubrication schedules.

## WRAP SPRING WRENCH OPERATION

The chain idlers are equipped with wrap spring wrenches. Chain tension is released and/or added as shown below.

To release chain tension, rotate the knurled collar on the wrap spring wrench while rotating the chain idler away from the chain.

D10290305

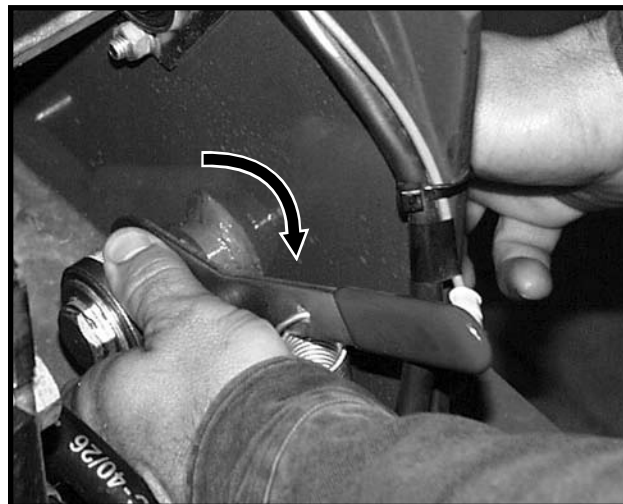

To add chain tension, rotate the chain idler into the chain while rotating the handle to tension idler spring.

D10290304



The wrap spring wrenches are made in L.H. and R.H. configurations, which can be identified by the silver or gold release collars, respectively.

# MACHINE OPERATION

## DIGITAL VACUUM GAUGE OPERATION

The digital vacuum gauge console is equipped with an ON-OFF-ON type selector switch. The “FAN 1” setting should be used when the planter is equipped with one vacuum fan.

**NOTE: The toggle switch should be left in OFF position when the planter is not in use. If left in either fan position, the tractor battery will be drained.**

D10240583



The digital vacuum gauge is calibrated at the factory, however, vacuum will vary throughout the manifold system and it may be necessary to adjust the digital readout so it agrees with the actual vacuum at the meter. With the seed discs loaded with seed, compare the digital vacuum gauge readout to the reading taken from the analog gauge or a hand held gauge at several meters along the length of the planter. The elbows located on the covers of the seed meters allow testing of meter vacuum levels without removing the vacuum hoses. If there is more difference than 1" or 2" (H<sub>2</sub>O), the digital gauge can be adjusted by inserting a small flat blade screwdriver into the opening on the back of the digital gauge housing and turning the potentiometer until the digital gauge displays the vacuum that is present at the meter. Compare readings at 10" and 20" of vacuum.

## ANALOG VACUUM GAUGE

The analog vacuum gauge connects directly to the manifold. The digital vacuum gauge should then be calibrated to match that reading. See “Digital Vacuum Gauge Operation”.

D06260653



The only adjustment to the gauge is to “zero” the needle with no vacuum present. If there is a significant difference between this gauge and a reading taken at the meters, a different manifold location should be found to connect hose to the gauge.

## VACUUM FAN MOTOR VALVE BLOCK ASSEMBLY

A pressure relief valve in the hydraulic circuit prevents build up of oil pressure over 35 PSI in the case drain line when the vacuum fan motor is in operation. This valve will vent oil to the outside of the valve block through a drain hole in the aluminum valve block. This can occur whenever the case drain is connected improperly or pressure in the motor circuit builds.

See “Hydraulic Diagram - Vacuum Fan Motor System” in Maintenance section.

The valve block also contains a check valve that serves two purposes. This valve (a) prevents the vacuum fan from operating in the wrong direction if pressure is applied to the return side of the motor and (b) allows the fan to coast to a stop when the tractor hydraulic control is returned to the neutral position.

**NOTE: If reverse pressure is applied the fan will turn at a reduced speed.**

# MACHINE OPERATION

## ROW MARKER OPERATION

The machine is equipped with a single control valve system for the optional row markers.

**! DANGER:** To avoid serious injury or death, care must be taken when operating row markers around overhead power lines.

(A11058)

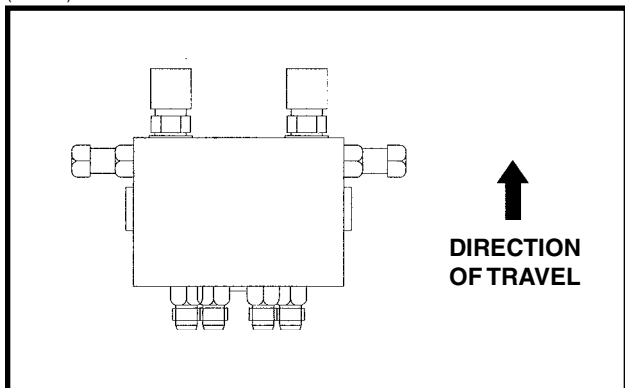

Sequencing/Flow Control Valve Used With Single Valve Row Marker Hydraulic System

The single valve marker system uses a sequencing valve which directs hydraulic flow to operate the markers alternately.

With the single valve marker system, both markers can be used at the same time by first lowering one marker and moving the hydraulic control to the raise position and immediately returning it to the lower position. This will shift the marker control valve spool and the opposite marker will be lowered.

**! WARNING:** Always stand clear of row marker assemblies and blades when planter is operating.

**! WARNING:** Install safety lockup devices on markers, as provided, prior to transporting the planter or working around the machine.

**! WARNING:** If a marker cylinder has been disconnected or removed for any reason, do not attach the rod end of the cylinder until the cylinder is cycled several times to remove any air that may be trapped in the system.

**! DANGER:** Serious injury or death can result from contact with electric lines. Use care to avoid contact with electric lines when moving or operating this machine.

## ROW MARKER SPEED ADJUSTMENT

The marker hydraulic system includes two flow control valves. One flow control valve sets the lowering speed of both markers and one sets the raising speed of both markers. To adjust marker speed, loosen the jam nut and turn the control(s) clockwise or IN to slow the travel speed and counterclockwise or OUT to increase the travel speed. The flow control(s) determines the amount of oil flow restriction through the valve(s), therefore varying travel speed of the markers. Tighten jam nut after adjustments are complete.

(A11058)

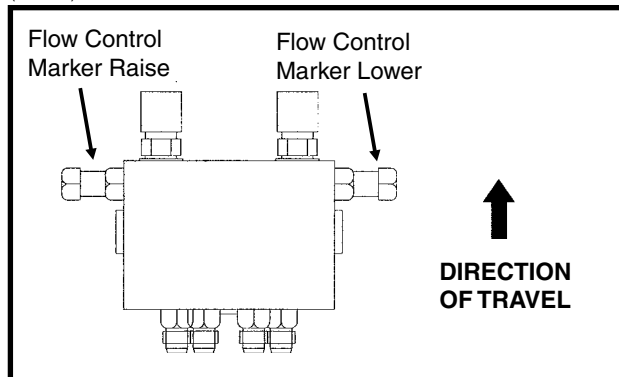

Sequencing/Flow Control Valve Used With Single Valve Row Marker Hydraulic System

**IMPORTANT:** The flow controls should be properly adjusted before the marker assembly is first put into use. Excessive travel speed of the markers can damage the marker assembly.

**! DANGER:** To avoid serious injury or death, care must be taken when operating row markers around overhead power lines.

**NOTE:** When oil is cold, hydraulics operate slowly. Make sure all adjustments are made with warm oil.

**NOTE:** On a tractor where the oil flow can not be controlled, the rate of flow of oil from the tractor may be greater than the rate at which the marker cylinder can accept the oil. The tractor hydraulic control will have to be held until the cylinder reaches the end of its stroke. This occurs most often on tractors with open center hydraulic systems.

On tractors with closed center hydraulic systems, the tractor's hydraulic flow control should be adjusted to the full flow position. If oil is restricted, the sequencing valve may not shift properly.

(PLTR78)

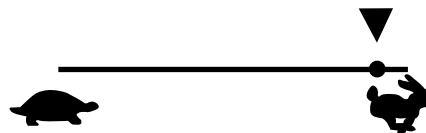

# MACHINE OPERATION

## ROW MARKER LENGTH ADJUSTMENT

To determine the correct length at which to set the row marker assemblies, multiply the number of rows by the average row spacing in inches. This provides the total planting width. Adjust the row marker extension so the distance from the marker disc blade to the center line of the planter is equal to the total planting width previously obtained. Both the planter and row marker assembly should be lowered to the ground when the measurements are being taken. Measurement should be taken from the point where the blade contacts the ground. Adjust right and left row marker assemblies equally and securely tighten clamping bolts. An example of marker length adjustment follows:

Number Of Rows	x	Row Spacing (Inches)	=	Dimension Between Planter Center Line And Marker Blade.
-------------------	---	----------------------------	---	---

6 Rows	x	30" Row Spacing	=	240" Marker Dimension
--------	---	--------------------	---	--------------------------

The marker blade is installed so the concave side of the blade is outward to throw dirt away from the grease seals. The spindle assembly is slotted so the hub and blade can be angled to throw more or less dirt. To adjust the hub and spindle, loosen the 1/2" hardware and move the assembly as required. Tighten bolts to the specified torque.

**IMPORTANT: A marker blade assembly that is set at a sharper angle than necessary will add unnecessary stress to the complete marker assembly and shorten the life of bearings and blades. Set the blade angle only as needed to leave a clear mark.**

A field test is recommended to ensure the markers are properly adjusted. After the field test is made, make any minor adjustments as necessary.

60569-53

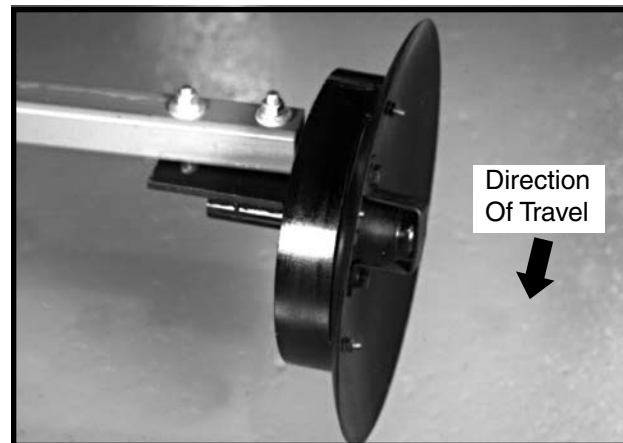

**Row Marker Disc Blade Shown With Depth Band (Standard On 8 Row Wide)**

A notched marker disc blade, for use in more severe no till conditions, is available from KINZE® through your KINZE® Dealer.



## KPM I ELECTRONIC SEED MONITOR

(MTR28)

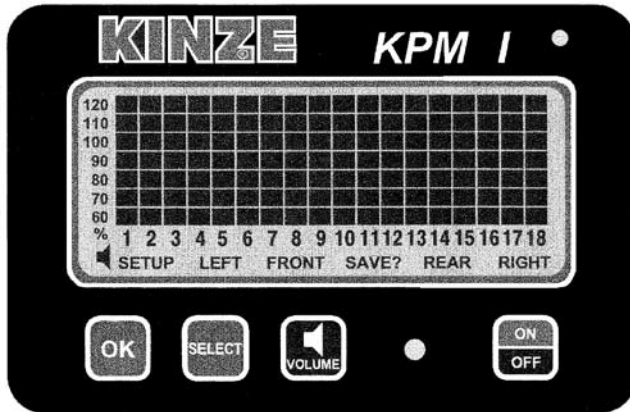

The KPM I electronic seed monitor system consists of a console, which is mounted on the tractor; seed tubes with computerized sensors, one of which is installed in each planter row unit; a primary harness\*, which connects the console to the planter harness; and a planter harness (junction Y-harness and/or harness extension where applicable), to which the individual seed tube sensors connect.

Seed flow for up to 36 rows, in two 18 row sections (left/right or rear/front), may be monitored with one monitor. For less complicated applications (18 rows or less), all rows may be programmed in one section and the other section left disabled.

The monitor system is powered by the tractor battery (requires 12 volts DC). The console receives information from each of the sensors and translates this information.

The single backlit Liquid Crystal Display (LCD) shows the active section, the number of monitored rows per section, the relative seed rate for each row (using a bar graph display) and scrolls various alarm and warning messages when an alarm condition exists. A continuous audible alarm will sound upon system malfunction or underflow conditions for any monitored row. Alarms must be acknowledged by the user. Various warnings may sound the alarm or flash one or more icons.

The monitor will power down if no activity is detected within one hour. No activity means there has been no new seed flow and no operator push key input. (If Applicable)

**\* NOTE: The primary harness, on all 3000 Series Planters, is hard-wired into the safety/warning light harness or control console harness included as standard equipment with the planter.**

Monitor Key Functions.....	6-11
LCD Functions .....	6-11
Changing The Audible Alarm Volume .....	6-12
Warnings And Alarms .....	6-12
Replacing A Faulty Sensor .....	6-13
Field Operation .....	6-14
Programming/Connecting Seed Tubes .....	6-14

### MONITOR KEY FUNCTIONS

Each key press is acknowledged by the monitor with a short beep.

#### OK

- Ends and saves the new setup during installation.
- Acknowledges and silences alarms in the operation mode.

#### SELECT

- Selects the application mode (rear/front or left/right) at the beginning of installation setup.
- Selects the active section(s) (rear, rear/front, left, right or left/right) in the operation mode.
- Has no effect on a system configured to monitor only one section.

#### VOLUME

- Pressing the key will turn the audible alarm on.
- Holding the key for periods of 2 seconds increases the volume until it reaches the maximum, at which time it rolls over to the minimum level.

#### ON/OFF

- Powers the unit on and off.

### LCD FUNCTIONS

The monitor collects data on the planting rates from all active rows and calculates an average. This average will determine the 100% mark. Seed rate for each row is then compared to the average value and the result is displayed on the bar graph.

The information regarding each section is displayed alternately every 5 seconds. While operating a system with two sections programmed, one or both sections may be selected any time. When only one section is selected, the monitor calculates the average based on the remaining active rows from that section.

**STEP 1** Press SELECT key once to show one section. The flashing icon shows the section that is not selected. The selected section is continuously displayed on the LCD.

**EXAMPLE:** The system is setup to display rear/front sections. Press SELECT key. The FRONT icon will be flashing and the REAR section will be displayed on the bar graph. After 1 minute the FRONT icon will stop flashing. The monitor will stay in this REAR only display through power down and power up. Each time the monitor is turned on while in REAR only mode, the FRONT icon will flash for 1 minute. Also if seed flow is sensed in the FRONT section while planting, the FRONT icon will resume flashing.

**STEP 2** Press SELECT key again to activate both sections.

**EXAMPLE:** Press SELECT key a second time. The information regarding each section will display alternately every 5 seconds.

For simple applications, where only one section is programmed, the display will automatically lock on that section. Pressing SELECT key will have no affect.

**NOTE:** When alternating between two sections, the display will lock on the section containing the first recognized alarm until the alarm is acknowledged by pressing the OK key or the alarm condition is removed.

## CHANGING THE AUDIBLE ALARM VOLUME

**STEP 1** Press and hold down the VOLUME key.

**STEP 2** The SETUP and VOLUME icons will turn on and the alarm will sound continuously. The intensity of the sound will change every 2 seconds. After the maximum volume is reached, the next change will set the volume to minimum and will continue to get louder every 2 seconds. When the desired volume is reached, release the key.

## WARNINGS AND ALARMS

- 1. System Alarms** - A system alarm is activated when the monitor detects a faulty sensor or one of several other communication faults.

The corresponding row number starts flashing and the alarm sounds. All segments on the corresponding bar graph are turned off. Pushing the OK key to acknowledge the warning will turn the audible alarm off. The row number will continue to flash until the alarm condition is removed. If the monitor detects a faulty sensor and there is no planting activity present, the monitor will scroll "CHECK CONNECTION".

Another type of system alarm occurs when the monitor detects a data communication bus error. The three possible data communication bus errors are:

LCD Display	Error Condition
SYS HI	The data communication lead (green) has been shorted to the power lead (white).
SYS LO	The data communication lead (green) has been shorted to the ground lead (black).
SYS EC	An internal error has been detected.

- 2. Under Flow Alarms** - If the seed rate for one or more rows is less than 55% of the calculated average, the corresponding 60% segment will stay on, the corresponding row number starts flashing and the alarm sounds. Pushing the OK key to acknowledge the alarm will turn the alarm off. The 60% segment of the bar graph remains on and the row number continues to flash until the alarm condition is corrected.

**NOTE:** All alarms present within a short time before planting stops, are frozen on the screen and the text LOW or FAIL will display on the LCD. If the under flow is between 0% and 10%, this warrants a "FAIL" condition. If the under flow is between 10% and 55%, a "LOW" condition is generated. If multiple rows have an under flow condition, "FAIL" will display if any one or more rows is between 0% and 10%. This allows the user to identify and fix the problem rows.

**NOTE: This warning will not trigger unless a minimum time of continuous planting has passed.**

**NOTE: If all the rows show a seed rate of zero, the condition will not generate an alarm. It will be assumed the planter has stopped. The row numbers and the bottom 60% segment will remain on for all selected rows.**

3. **Multiple Alarms** - If more than one alarm condition occurs at the same time, pushing the OK key will acknowledge all alarms that are currently displayed. For example, if one row on the front and one row on the rear are alarming, pushing the OK key will only acknowledge one of them. However, if there are two alarms on the front, both alarms would be acknowledged with one push of the OK key.
4. **Section Not Selected Warning** - If the monitor was programmed for two sections and only one is currently selected for display (by pressing the SELECT key), the icon of the disabled section will flash for a period of 1 minute, then turn off at each power up. If seed flow is sensed in the disabled section, the icon for that section (front, left or right) will begin to flash.
5. **Seed Planting Stopped Warning** - When the monitor detects no seed flow on all rows, the monitor will emit 3 short beeps to alert the user. This warning will occur each time the planter is stopped, each time the planter is raised at the end of a row or if the mechanical drive fails while planting.

**NOTE: This warning will not trigger unless a minimum time of continuous planting has passed.**

6. **Seed Counting Sensor In Calibration Warning** - All seed counting sensors run a self-calibration sequence on power up. While in calibration the bottom segment of each corresponding bar graph will flash if the monitor detects movement or planting activity. If the monitor does not detect this, the message "WAIT CALIBRATION" will be scrolled.

7. **Seed Counting Sensor Too Dirty Warning** - After the seed counting sensors end their internal self-calibration, the monitor may detect one or more sensors are either too dirty or blocked. If the monitor detects planting or movement, the corresponding bar graph remains flashing. The monitor will display "CLEAN SENSORS" on the LCD if no movement or planting is detected, prompting the user to clean the tubes. If the tubes are dirty, they will still show seed flow with less accuracy. If the tubes are blocked the user will get an alarm as soon as planting starts. The corresponding bar graph will remain flashing until the problem is corrected and the monitor is powered down and then powered back up.
8. **Low Battery Warning** - The monitor is constantly monitoring its input voltage to quickly detect low power conditions. If the monitor detects that the input voltage has dropped below 11.0V, it will display "LOW POWER" on the LCD, provided that the monitor does not detect planting.

**NOTE: After the alarms have been acknowledged and if the alarm condition is still present, the LCD will continue to display the alarm condition.**

## REPLACING A FAULTY SENSOR

To replace a faulty sensor; (a) disconnect the faulty sensor and check the monitor to be sure the correct sensor was disconnected, (b) turn the monitor off, (c) after a few seconds, turn the monitor back on and (d) plug in the replacement sensor. The monitor will chirp twice to acknowledge the new sensor was learned and saved.

To replace more than one faulty sensor, proceed as stated above beginning with the lowest numbered row in the rear or left section and continue to replace sensors in increasing order. Then move on to the front or right section and continue in ascending row number order.

**NOTE: If the monitor is not turned off and then on, the replacement sensor(s) will be ignored until the next power on, at which point they will be randomly learned by the monitor.**

## FIELD OPERATION

(MTR28e/MTR28c/MTR28d/MTR28b)

Press the ON/OFF key to turn the monitor on and off.



Information regarding each section is displayed alternately every 5 seconds.

### REAR/FRONT CONFIGURATION

- Press the SELECT key once to show REAR section only.
- Press the SELECT key a second time to return to each section being displayed alternately every 5 seconds.
- Press the SELECT key a third time to show REAR section only again.



### LEFT/RIGHT CONFIGURATION

- Press the SELECT key once to show LEFT section only.
- Press the SELECT key a second time to show RIGHT section only.
- Press the SELECT key a third time to return to each section being displayed alternately every 5 seconds.



**NOTE: SELECT key has no function when only a single section is being used.**

Press the VOLUME key to increase or decrease volume. See “Changing The Audible Alarm Volume”.



Press the OK key to silence alarms. See “Warnings And Alarms”.



## PROGRAMMING/CONNECTING SEED TUBES

**STEP 1** All the seed tubes w/sensors must be disconnected from the harness and the monitor must be off.

**STEP 2** Press the ON key. The monitor automatically enters the setup procedure. If the monitor was accidentally powered on with no sensors attached, the user can turn the monitor off at this point and the previous configuration is not lost.

**STEP 3** Press the SELECT key. Each time you press the SELECT key the mode will toggle between rear/front and left/right. The selected display will be solid and the configuration not currently selected will be flashing. By default the monitor starts in rear/front mode.

01229910

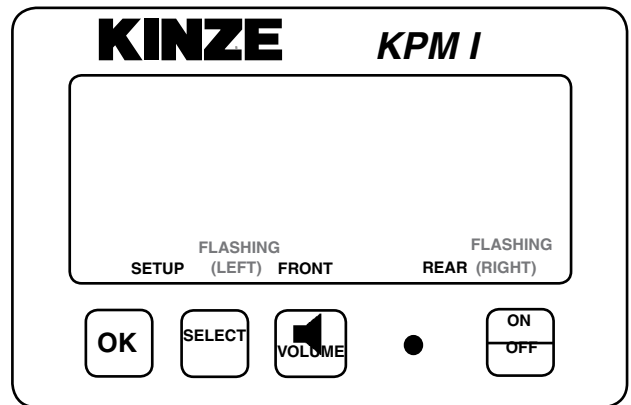

01229911

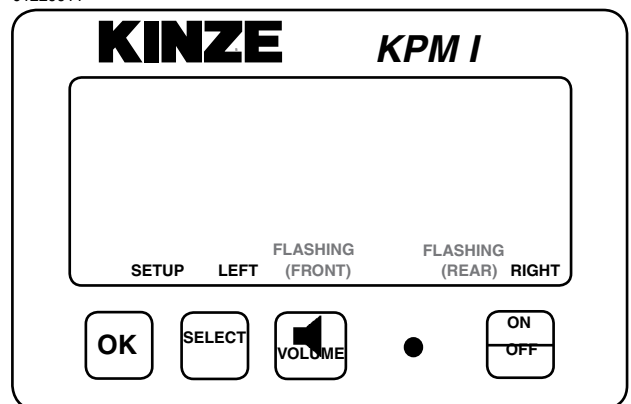

**NOTE: Model 3110 planters will use the rear configuration only.**

**STEP 4** Press and hold the OK key to confirm the selection and continue holding until the row numbers appear on the display. During confirmation, the display will alternate between “NEW” and “SYS” to alert the user that the previous configuration will be lost. With the rear/front mode selected, the monitor automatically starts with the rear section. The REAR icon shows solid and the FRONT icon starts to flash. With the left/right mode selected, the monitor automatically starts with the left section. The LEFT icon shows solid and the RIGHT icon starts to flash.

**STEP 5** Plug each seed tube w/sensor into the harness in a predetermined order. Row 1 first, row 2 second and so on up to 18 rows. When a sensor is plugged in, the corresponding row number on the LCD display will stay solid, the monitor will chirp twice and the LED (Light Emitting Diode) on the seed tube sensor will turn on for approximately 30 seconds to show connection is made. NOTE: Unless there is a faulty sensor, the installer should just have to connect the sensors in the proper order without checking the monitor is acknowledging each sensor.

01229912

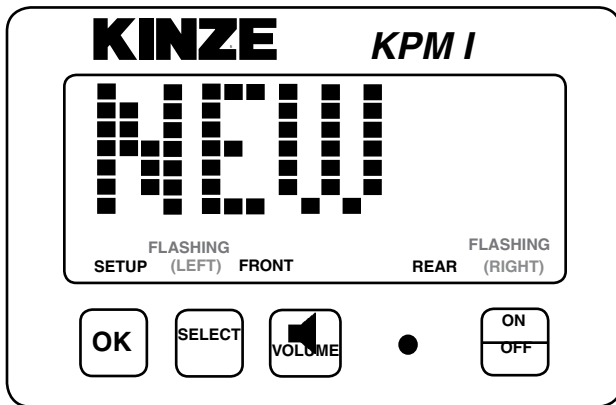

01229915

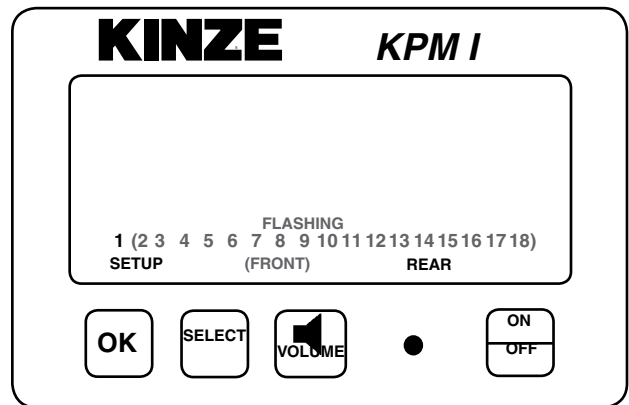

01229912a

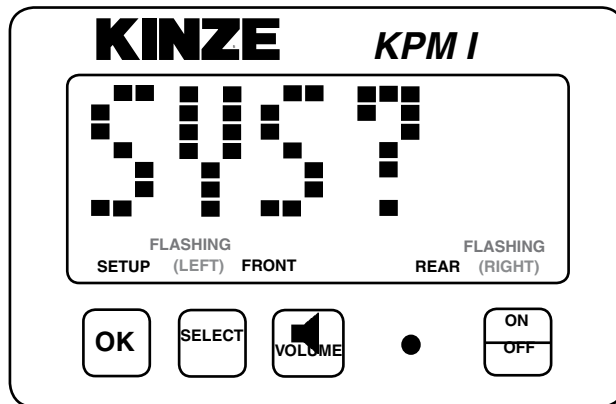

**STEP 6** When all the seed tubes w/sensors for the current section are installed, check to be sure the monitor displays solid numbers for the number of sensors connected.

01229916

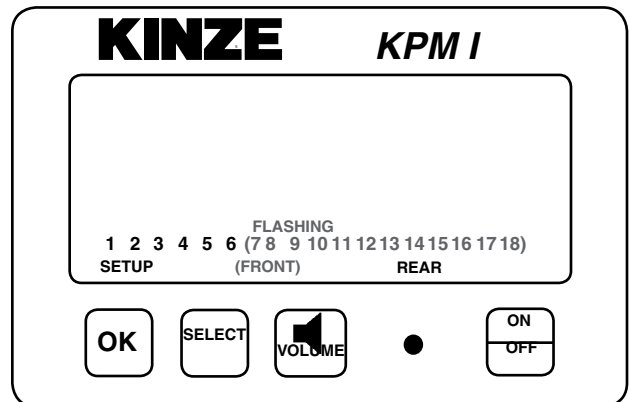

**STEP 7** If this condition is satisfied, press and hold the OK key to save the setup for the current section. The SAVE? icon will show followed by continuous short beeps indicating the monitor is preparing to save. The installer has 5 seconds to decide if he wants to save the current configuration. During this time the short beeps will sound. To complete the save, hold the OK key pressed until the word “DONE” shows on the screen followed by a long beep and the SAVE? icon turns off. When the OK key is released the monitor will continue with the second section installation.

01229917

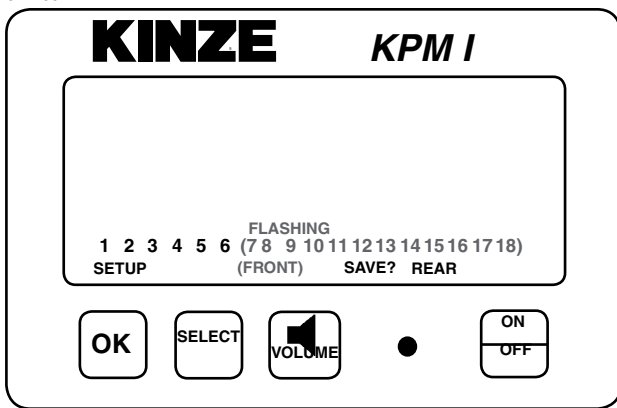

01229918

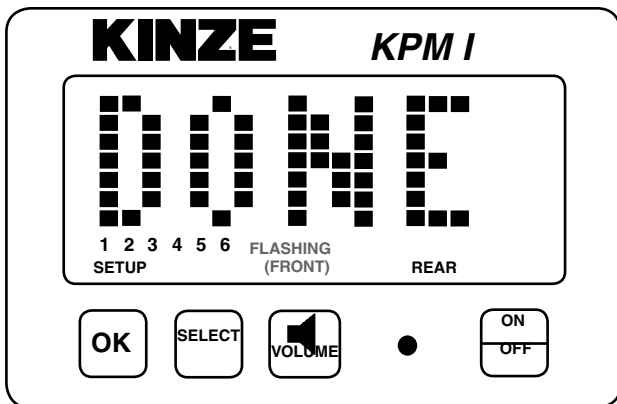

**STEP 8** Follow STEPS 5 through 7 to install the second section. If no seed tubes are installed on the second section, press and hold the OK key until the word “DONE” shows on the screen followed by a long beep and the SAVE? icon turns off.

01229919

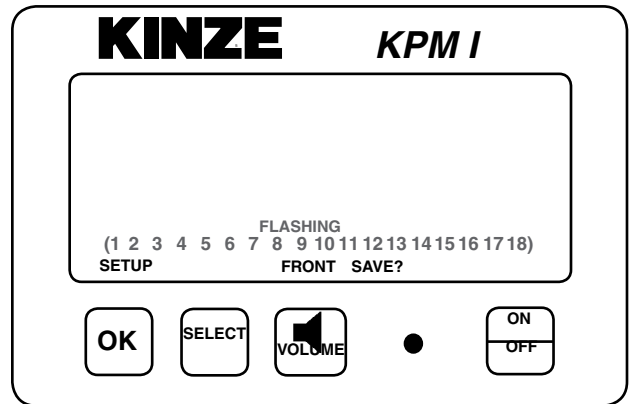

01229920

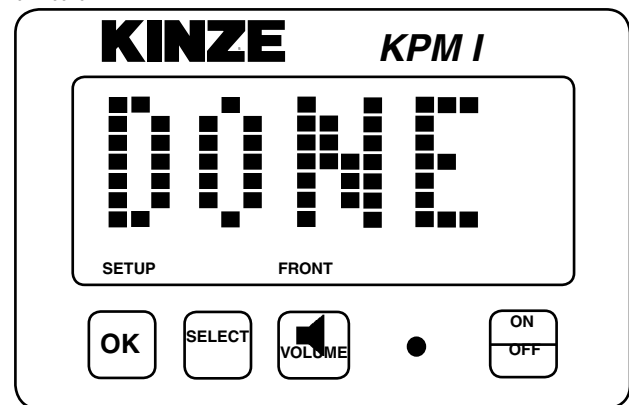

**NOTE:** Individual seed tubes may be unplugged for special situations. An alarm will sound which can be silenced by touching the OK key. The monitor will recognize each seed tube when reconnected.

**See “KPM I/KPM II Stack-Mode Electronic Seed Monitors Troubleshooting” in the Maintenance Section.**

## KPM II STACK-MODE ELECTRONIC SEED MONITOR

(MTR41d)

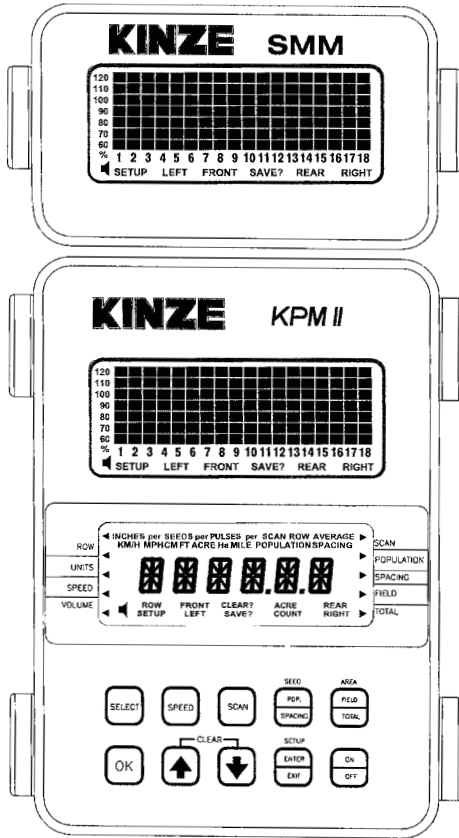

**NOTE: SMM console may not be applicable to all models.**

The KPM II Stack-Mode electronic seed monitor system consists of (a) a KPM II Stack-Mode console, which is mounted on the tractor; (b) seed tubes with sensors, one of which is installed in each planter row unit; (c) a magnetic distance sensor, which is installed on the planter, or a radar distance sensor, which is installed on the tractor; (d) shaft rotation sensors, which are installed on the planter drill shafts; and (e) a planter harness (junction Y-harness and/or extension harness where applicable), to which the individual seed tube sensors connect. The primary harness, which connects the monitor console to the planter harness, is hard-wired into the safety/warning light harness or control console harness included as standard equipment with the planter.

The software design of the KPM II Stack-Mode console allows the use of an add-on SMM console for simultaneous viewing of the seed flow bar graphs for standard (up to 36 rows) and/or Interplant® System rows (up to 36 rows). A total of 72 rows may be displayed in multiple sections (rear/front, left/right or four sections). The SMM console must be used to allow utilization of the four section feature.

The monitor system is powered by the tractor battery (requires 12 volts DC). The console receives information from each of the sensors and translates this information.

The KPM II Stack-Mode console has two backlit Liquid Crystal Displays (LCD). The upper display shows the active section, the number of monitored rows per section, the relative seed rate for each row (using a bar graph display) and scrolls various alarm and warning messages when an alarm condition exists. A continuous audible alarm will sound upon system malfunction or underflow conditions for any monitored row. Alarms must be acknowledged by the user. Various warnings may sound the alarm or flash one or more icons. The lower display is used to display alphanumeric data such as row spacing, units (Metric or English), speed, volume, seed population, seed spacing, field area, total area and distance sensor pulses per mile/kilometer.

The SMM console has one backlit Liquid Crystal Display (LCD) which functions the same as the upper display on the KPM II Stack-Mode console except it does not scroll alarm and warning messages. The SMM console must be programmed into the system before printed text will display on the LCD.

The monitor system will power down if no activity is detected within one hour. No activity means there has been no new seed flow and no operator push key input.

Monitor Key Functions.....	6-18
Upper LCD Functions.....	6-19
Lower LCD Functions.....	6-20
<b>Programming</b>	
Changing The Audible Alarm Volume.....	6-22
Units (Metric Or English).....	6-23
Row Spacing .....	6-23
Speed .....	6-25
Clearing Total Area.....	6-26
Area Counter/Speedometer Mode.....	6-27
Warnings And Alarms .....	6-27
Replacing A Faulty Sensor .....	6-28
Field Operation .....	6-29
Clearing Field Area .....	6-30
<b>Programming/SMM Console, Shaft Rotation Sensors, Seed Tubes And/Or Radar/Magnetic Distance Sensors .....</b>	<b>6-31</b>
Row-By-Row Alarm Level Setting .....	6-43

## MONITOR KEY FUNCTIONS

Push keys allow the user to select or change the operating mode, the active displays or the current configuration. Depending on the operating mode or the current display selected, some keys are valid while some are not. Each key press, if valid, is acknowledged by a short beep and an action is taken. If the key press has no action associated, the key press is considered invalid, and the user will not get any feedback.

### SELECT

- Selects the application mode (rear/front, left/right or four sections up to a maximum of 72 rows) at the beginning of installation in the setup mode.
- Selects the active section(s) (rear, rear/front, left, right or left/right) in the operation mode.
- Has no affect on a system configured to monitor only one section.
- While programming the monitor, the key will select the digit to change.

### SPEED

- Immediately displays the current ground speed.

### SCAN

- If the current average population or average spacing is displayed, this key sequentially displays the seed population/spacing on each row.
- If the display shows functions other than average seed population or spacing, pressing SCAN will sequentially display speed, average seed population and average seed spacing.
- Pressing a second time freezes the display on the current row.
- Pressing a third time restarts the sequential display.

### SEED POPULATION/SEED SPACING

- Immediately displays the average seed POPULATION and the average seed SPACING of all active rows.
- Each press alternates between seed spacing and seed population.

### AREA FIELD/AREA TOTAL

- Immediately displays the field or total area planted since the field/total area was last cleared.
- Each press alternates between field area and total area.

### OK

- Ends and saves the new setup during installation.
- Acknowledges and silences alarms in the operation mode.

### UP ARROW AND DOWN ARROW

- Scrolls sequentially through the display options on the lower LCD display.
- Freezes on the current row in the scan mode.
- Scrolls sequentially through the rows when the population scan is frozen.
- Used to enter programmable values in the programming mode.
- The UP and DOWN Arrow keys can be pressed at the same time to start the CLEAR function.

### SETUP ENTER/SETUP EXIT

- Enters and exits the programming mode.

### ON/OFF

- Powers the unit on and off.



## UPPER LCD FUNCTIONS

(MTR29h)

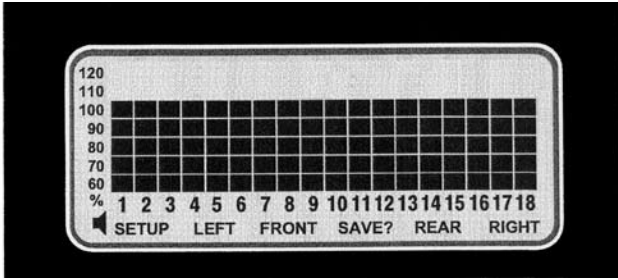

The monitor collects data on the planting rates from all active rows and calculates an average. This average will determine the 100% mark. Seed rate for each row is then compared to the average value and the result is displayed on the bar graph.

With only the KPM II Stack-Mode console programmed into the system, the information regarding each section is displayed alternately every 5 seconds. While operating a system with two sections programmed, one or both sections may be selected any time. When only one section is selected, the monitor calculates the average based on the remaining active rows from that section.

With the SMM console programmed into the system, two sections are viewed at the same time. If the system configuration is for four sections, the display will alternate every 5 seconds between a pair of sections. The select key will lock the display on rear sections. The SMM console shows RIGHT in the left/right configuration, FRONT in the rear/front configuration and FRONT RIGHT/REAR RIGHT in four sections configuration. The KPM II Stack-Mode console shows LEFT in the left/right configuration, REAR in the rear/front configuration and FRONT LEFT/REAR LEFT in four sections configuration.

**STEP 1** Press SELECT key once to show one section. The flashing icon shows the section that is not selected. The selected section icon is continuously displayed on the LCD.

**EXAMPLE:** The system is setup to display rear section on KPM II Stack-Mode console and front section on SMM console. Press SELECT key. The FRONT icon will be flashing and the REAR section will be displayed on the bar graph. The SMM console is only backlit. After 1 minute the front row icon will stop flashing. The monitor will stay in this REAR only display through power down and power up. Each time the monitor is turned on while in REAR only mode, the FRONT icon will flash for 1 minute.

If seed flow is sensed in the FRONT section while planting, the FRONT icon will resume flashing.

When the front section is disabled, the row spacing will automatically double to maintain the proper implement width in the monitor. A 23 or 24 row 15" configuration changes to a 12 row 30" configuration with a touch of the SELECT key.

**STEP 2** Press SELECT key again to activate both sections.

For simple applications, where only one section is programmed, the display will automatically lock on that section. Pressing the SELECT key will have no affect.

**NOTE:** When alternating between two sections, the display will lock on the section containing the first recognized alarm until the alarm is acknowledged by pressing the OK key or the alarm condition is removed.

## LOWER LCD FUNCTIONS

(MTR29g)

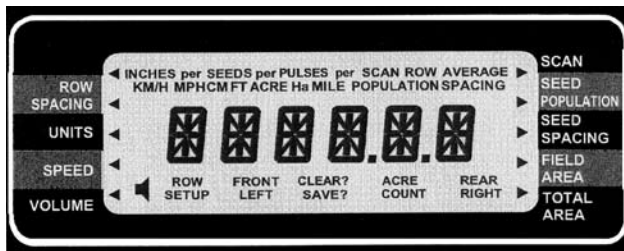

- The UP and DOWN arrow keys will sequentially change what is being displayed on the lower LCD. Pressing the UP or DOWN arrow keys will move the arrow head icon (on the left and right hand side of the display) to another item. For example, if the arrow icon is pointing to SPEED, ground speed will be displayed on the LCD. Pressing the UP arrow key will move the icon to UNITS. The display will change to display all the icons used to represent the current (English or Metric) measurement system.
- The shortcut keys SPEED, SEED POPULATION/SPACING and AREA FIELD/TOTAL allow direct access to their respective displays. For example, no matter what is currently being displayed on the lower LCD, pressing the SPEED key will change the display to the current speed. Pressing the SEED POPULATION/SPACING or AREA FIELD/TOTAL keys will alternate between the two functions assigned to those keys.
- Pressing the SCAN key while displaying seed spacing or population will cause a sequential display of each individual row. Pressing the SCAN key a second time will freeze the display on the currently displayed row. The UP or DOWN arrow keys can be used to change the currently displayed row. Pressing the SCAN key will restart the automatic advancing of the scan function.
- Pressing the SCAN key while displaying speed will cause a sequential display of speed, average planter population and average seed spacing. Pressing the SCAN key a second time will freeze the display on the currently displayed reading.

Press the arrow keys to ROW SPACING to display the current spacing between rows in inches or centimeters. The ROW SPACING icons turn on, displaying a 3 digit, one decimal place format. In the area count mode, this function displays the implement width in feet or meters, using a 3 digit, no decimal places format.

### UNITS

Press the arrow keys to UNITS to display all the icons from the currently selected English or Metric measurement system. For the English system, the icons are: INCH, MPH, FT, ACRE and MILE. For the Metric system, the icons are: M, KM/H and Ha.

### SPEED

Press the SPEED key to display the current speed in MPH or KM/H, using a 3 digit, one decimal place format.

### VOLUME

Press the arrow keys to VOLUME to display the presently selected audible alarm volume. The SPEAKER icon turns on.

### SCAN

Press the SCAN key to display the seed spacing or seed population (see Steps 1-3 following) of each individual row. (1)Pressing the SCAN key while displaying any other function will cause the monitor to sequentially display speed, average seed population and average seed spacing. (2)Pressing the SCAN key a second time will freeze the display. (3)Pressing the SCAN key a third time restarts the sequential display. The UP and DOWN arrow keys can be used to change the current display.

# MACHINE OPERATION

# KPM II STACK-MODE

## SEED POPULATION/SEED SPACING

Each SEED POP/SPACING key press alternates between seed population and seed spacing.

Seed population displays the average number of seeds or the row average number of seeds per acre or seeds per hectare for all the active rows. The average is displayed using a 6 digits, no decimal places format. The AVERAGE POPULATION icon will turn on. When in the scan mode, the scan arrow and SCAN ROW POPULATION will appear. The ROW number icon and the current row will be displayed on the left and the population will be displayed on the right in 1000's using 3 digits, one decimal place (e.g. 32.9 means 32,900). When in scan freeze mode, the scan arrow and ROW POPULATION will turn on (scan arrow may be flashing). The UP and DOWN keys may be used to lock on the desired row.

Seed spacing displays the average distance or the row average distance between seeds for all active rows in inches per seed or centimeters per seed using a 3 digit, one decimal place format. When the average is displayed the AVERAGE SPACING icons are turned on. When in the scan mode, the scan arrow and SCAN ROW SPACING icons will appear. The ROW number icon and the current row will be displayed on the left and the spacing will be displayed on the right. The display will sequence to the next row every 5 seconds. When in scan freeze mode, the scan arrow and SPACING will turn on (scan arrow may be flashing). The UP and DOWN keys may be used to lock on the desired row.

## FIELD AREA/TOTAL AREA

Each AREA FIELD/TOTAL key press alternates between field area and total area.

Field area displays the total number of acres or hectares using a 6 digit, one decimal place format.

**NOTE: When FIELD AREA is selected, the UP or DOWN key must be held in slightly longer than normal so the monitor will not mistake this action with a CLEAR, which consists of the UP and DOWN arrow keys pressed simultaneously. A beep will sound when the function activates.**

Total area displays the total number of acres or hectares using a 6 digit, one decimal place format. The total area counter updates every time the field area counter increments. Clearing the total area counter will also clear the field area counter.

When the monitor is programmed as a rear only or rear/front configuration and shaft rotation sensors are installed, pressing the UP arrow to move beyond row spacing lights an arrow on an unlabeled area above ROW SPACING. This is the automatically set division line between the L.H. shaft sensor and the R.H. shaft sensor. The display shows the first row on the rear section and the front section assigned to the R.H. shaft rotation sensor.

**EXAMPLE: On a 12 Row 30" planter with Interplant® Package, the display would appear as follows:**

092597-21

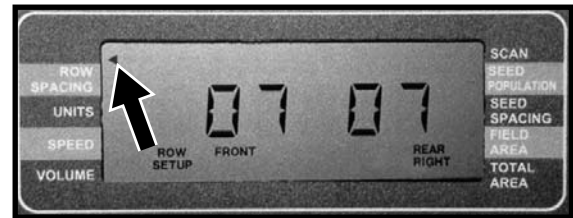

THIS DISPLAY IS NOT ACCESSIBLE ON LEFT/RIGHT CONFIGURATIONS OR SYSTEMS WITHOUT SHAFT ROTATION SENSORS.

## PROGRAMMING - Changing The Audible Alarm Volume

**STEP 1** To enter the programming mode, press and hold the SETUP key. The monitor will emit several short beeps, followed by a long beep. On the lower LCD, the SETUP icon turns on and the arrow head icon will flash, indicating that the user can select an item to program.

**NOTE: The monitor must be in a programmable function (row spacing, units, speed, volume or area) to enter setup. The monitor will not enter setup in seed population or seed spacing.**

**STEP 2** Press the UP or DOWN arrow keys to move the flashing arrow to VOLUME. As the arrow icon moves, the lower LCD will display the current setting of the item selected.

**STEP 3** Press the OK key and the flashing arrow becomes solid and the audible alarm will sound.

**NOTE: The lower LCD will display the current volume and the SPEAKER icon is turned on. Settings are from 0 to 9.**

- Use the UP or DOWN arrow keys to change the setting. With every UP arrow key push, the alarm will increment by one step between the minimum and the maximum. If the maximum level (9) is reached the volume rolls over to the minimum level (0).
- Pressing the DOWN arrow key lowers the volume until the minimum level (0) is reached, at which point the volume rolls over to the maximum level (9).

**STEP 4** To exit without saving, press and release the OK key. The monitor will restore the lower LCD to show the setting of the item, and the arrow icon will flash, allowing the user to select another item to program.

To exit and save, press and hold the OK key. The monitor will emit several short beeps and SAVE? icon is turned on. After a short time a long beep is heard, and the lower LCD will display the word "DONE". Release the OK key. If the OK key is released BEFORE the word "DONE" is displayed, the changes WILL NOT BE SAVED. The word "DONE" MUST be displayed in order for the save to have occurred.

**NOTE: The programming mode may be exited at any time, by pressing the SETUP key. Pressing this key will return the monitor to its normal operation. All items changed and saved will come into effect immediately. Any items changed, but not saved will revert to the original programmed value.**

# MACHINE OPERATION

# KPM II STACK-MODE

## PROGRAMMING - Units (Metric Or English)

**STEP 1** To enter the programming mode, press and hold the SETUP key. The monitor will emit several short beeps, followed by a long beep. On the lower LCD, the SETUP icon turns on and the arrow head icon will flash, indicating that the user can select an item to program.

**NOTE: The monitor must be in a programmable function (row spacing, units, speed, volume or area) to enter setup. The monitor will not enter setup in seed population or seed spacing.**

**STEP 2** Press the UP or DOWN arrow keys to move the flashing arrow to UNITS. As the arrow icon moves, the lower LCD will display the current setting of the item selected.

**STEP 3** Press the OK key and the flashing arrow becomes solid and the audible alarm will sound.

**NOTE: The lower LCD will alternately display all Metric icons or all English icons, indicating the Metric or English mode respectively.**

- Use the UP or DOWN arrow keys to change the setting.

**STEP 4** To exit without saving, press and release the OK key. The monitor will restore the lower LCD to show the setting of the item, and the arrow icon will flash, allowing the user to select another item to program.

To exit and save, press and hold the OK key. The monitor will emit several short beeps and SAVE? icon is turned on. After a short time a long beep is heard, and the lower LCD will display the word "DONE". Release the OK key. If the OK key is released BEFORE the word "DONE" is displayed, the changes WILL NOT BE SAVED. The word "DONE" MUST be displayed in order for the save to have occurred.

**NOTE: The programming mode may be exited at any time, by pressing the SETUP key. Pressing this key will return the monitor to its normal operation. All items changed and saved will come into effect immediately. Any items changed, but not saved will revert to the original programmed value.**

## PROGRAMMING - Row Spacing

**STEP 1** Prior to entering the programming mode, the application mode (rear/front, left/right or four sections) must be active. If the monitor is programmed in a rear/front configuration, both sections will be active (alternating every 5 seconds if the SMM console is not used). You can then set the row spacing to the Interplant® System row spacing.

EXAMPLE: On a 12 Row 30" with Interplant® Package set the row spacing to 15.0 with front active.

When the monitor is in normal field operation mode, disabling the front section will automatically change the row spacing to 30".

**STEP 2** To enter the programming mode, press and hold the SETUP key. The monitor will emit several short beeps, followed by a long beep. On the lower LCD, the SETUP icon turns on and the arrow head icon will flash, indicating that the user can select an item to program.

**NOTE: The monitor must be in a programmable function (row spacing, units, speed, volume or area) to enter setup. The monitor will not enter setup in seed population or seed spacing.**

**STEP 3** Press the UP or DOWN arrow keys to move the flashing arrow to ROW SPACING. As the arrow icon moves, the lower LCD will display the current setting of the item selected.

**STEP 4** Press the OK key and the flashing arrow becomes solid and the audible alarm will sound.

**NOTE: The lower LCD will display the current row spacing (in inches or centimeters) and ROW SPACING icon is turned on.**

- The least significant digit of the displayed value will be blinking.
- This value can be changed by pressing either the UP or DOWN arrow keys.
- Once this digit is correct, press the MODE SELECT key and the blinking digit will move to the next significant digit, where the process can be repeated.

**NOTE:** The monitor limits the entry of row spacing to a minimum of 10.0 inches (25.4 cm) and to a maximum of 99.9 inches (253.7 cm). If the monitor is configured to a rear/front configuration, the limits change to a minimum of 5.0 inches (12.7 cm) and a maximum of 49.9 inches (126.8 cm).

**STEP 5** To exit without saving, press and release the OK key. The monitor will restore the lower LCD to show the setting of the item and the arrow icon will flash, allowing the user to select another item to program.

To exit and save, press and hold the OK key. The monitor will emit several short beeps and SAVE? icon is turned on. After a short time a long beep is heard, and the lower LCD will display the word "DONE". Release the OK key. If the OK key is released BEFORE the word "DONE" is displayed, the changes WILL NOT BE SAVED. The word "DONE" MUST be displayed in order for the save to have occurred.

To exit setup mode, press the SETUP key.

**NOTE:** The programming mode may be exited at any time, by pressing the SETUP key. Pressing this key will return the monitor to its normal operation. All items changed and saved will come into effect immediately. Any items changed, but not saved will revert to the original programmed value.

# MACHINE OPERATION

# KPM II STACK-MODE

## PROGRAMMING - Speed

**STEP 1** To enter the programming mode, press and hold the SETUP key. The monitor will emit several short beeps, followed by a long beep. On the lower LCD, the SETUP icon turns on and the arrow head icon will flash, indicating that the user can select an item to program.

**NOTE: The monitor must be in a programmable function (row spacing, units, speed, volume or area) to enter setup. The monitor will not enter setup in seed population or seed spacing.**

**STEP 2** Press the UP or DOWN arrow keys to move the flashing arrow to SPEED. As the arrow icon moves, the lower LCD will display the current setting of the item selected.

**STEP 3** Press the OK key and the flashing arrow becomes solid and the audible alarm will sound. The R.H. digit on the display will be blinking.

The speed constant is used to record how many pulses are generated per mile (or kilometer) from the ground speed sensor. The lower LCD will display the current pulses per mile (or kilometer) using a 6 digit, no decimal place format. The PULSES per MILE (or PULSES per KM) icons are turned on.

**NOTE: It is highly recommended that a field calibration be done to establish the PPM/PPKM (Pulses Per Mile/Kilometer) number on a new machine installation. Several factors can affect this value such as wheel slip on the magnetic distance sensor, mounting angle and height on the radar distance sensor, etc. IT IS NOT UNCOMMON FOR THE SPEED ON THE MONITOR TO VARY SLIGHTLY FROM THE TRACTOR SPEEDOMETER. *Adjusting the PPM/PPKM in the monitor to make the speed agree can cause serious errors in acre/hectare and population counts. Do field checks to verify populations and seed spacings.***

**NOTE: On new system installations, the monitor will default to 500 PPM (310 PPKM). This will have to be changed to obtain accurate readings from the monitor.**

- In field conditions, measure 330 feet ( $\frac{1}{16}$  mile) or 100 meters, depending on the unit of measurement selected.

- Pull the tractor up to the starting line.

- Press the UP and DOWN arrow keys at the same time and hold them down until the CLEAR? icon is displayed and the monitor beeps several times. When the data is actually cleared, the monitor will emit a long beep and the number of pulses is cleared.

**NOTE: If the PPM/PPKM number starts to count pulses with the tractor not moving, check the radar for vibration or other kinds of interference.**

- Drive the tractor for 330 feet ( $\frac{1}{16}$  mile) or 100 meters and stop.

- The monitor will count the number of pulses and display them.

**STEP 4** To exit without saving, press and release the OK key. The monitor will restore the lower LCD to show the previous setting of the item, and the arrow icon will flash, allowing the user to select another item to program.

To exit and save, press and hold the OK key. The monitor will emit several short beeps and SAVE? icon is turned on. After a short time a long beep is heard, and the lower LCD will display the word "DONE". Release the OK key. If the OK key is released BEFORE the word "DONE" is displayed, the changes WILL NOT BE SAVED. The word "DONE" MUST be displayed in order for the save to have occurred.

**NOTE: The programming mode may be exited at any time, by pressing the SETUP key. Pressing this key will return the monitor to its normal operation. All items changed and saved will come into effect immediately. Any items changed, but not saved will revert to the original programmed value.**

NOTE: If a discrepancy occurs and digits must be changed, follow STEPS 1 and 2 to enter the programming mode and proceed as follows:

- Press the OK key and the flashing arrow becomes solid. The least significant digit of the displayed value will be blinking.
- This value can be changed by pressing either the UP or DOWN arrow keys.
- Once this digit is correct, press the SELECT key and the blinking digit will move to the next significant digit, where the process can be repeated.

The monitor limits the entry of pulses per mile or kilometer to a minimum of 500 PPM (310 PPKM), and to a maximum of 500,000 PPM (310,686 PPKM).

KEY Action	Flashing Digit	Display Value
Press The UP Key	Right Most Digit	2031, 2032, 2033
Press The SELECT Key	Second Digit From Right	2033
Press The DOWN Key	Second Digit From Right	2023, 2013, 2003, 2093, 2083
Press The SELECT Key Twice	Left Most Digit	2083
Press The DOWN Key	Left Most Digit	1083, 0500 (Min. Value), 9500, 8500

## PROGRAMMING - Clearing Total Area

**NOTE: Clearing the total area counter will also clear the field area counter.**

**STEP 1** To enter the programming mode, press and hold the SETUP key. The monitor will emit several short beeps followed by a long beep. On the lower LCD, the SETUP icon turns on and the arrow head icon will flash, indicating that the user can select an item to program.

**NOTE: The monitor must be in a programmable function (row spacing, units, speed, volume or area) to enter setup. The monitor will not enter setup in seed population or seed spacing.**

**STEP 2** Press the UP or DOWN arrow keys to move the flashing arrow to TOTAL AREA. As the arrow icon moves, the lower LCD will display the current setting of the item selected.

**STEP 3** Press the OK key and the flashing arrow becomes solid and the audible alarm will sound.

- The lower LCD will display the total area and the ACRE (or Ha) icon turns on.
- With the flashing arrow on TOTAL AREA, press the OK key.

• To reset the counter, press the UP and DOWN arrow keys at the same time and hold them down for a short period of time to clear the data. The CLEAR? icon will be displayed and the monitor will beep several times. When the data is actually cleared, the monitor will emit a long beep, and the total area is reset to zeros. After the long beep, the previous recorded total area is not retrievable. Once cleared, the user **may not** choose to exit programming mode without saving as described in STEP 4.

**STEP 4** To exit and save, press and hold the OK key. The monitor will emit several short beeps and SAVE? icon is turned on. After a short time a long beep is heard, and the lower LCD will display the word "DONE". Release the OK key. If the OK key is released BEFORE the word "DONE" is displayed, the changes WILL NOT BE SAVED. The word "DONE" MUST be displayed in order for the save to have occurred.

**NOTE: The programming mode may be exited at any time, by pressing the SETUP key. Pressing this key will return the monitor to its normal operation. All items changed and saved will come into effect immediately. Any items changed, but not saved will revert to the original programmed value.**



# MACHINE OPERATION

# KPM II STACK-MODE

## AREA COUNTER/SPEEDOMETER MODE

If the monitor is installed with only a radar distance sensor (no seed tubes attached), the monitor becomes a speedometer. If (a) the monitor is connected to a radar distance sensor, (b) the signal cable from the back of the console is connected to a sensing switch (Part No. G1K249 Acre Counter Switch Kit) instead of the seed tubes and (c) the implement width in feet (or meters) is programmed into the monitor, the monitor will function as an area counter.

The seed spacing and seed population functions are not available in this mode. If the monitor is powered down, the seed tubes connected and the monitor powered up, the monitor will again show seed population and seed spacing in inches or centimeters. Row spacing reverts back to its programmed setting.

## WARNINGS AND ALARMS

- 1. System Alarms** - A system alarm is activated when the monitor detects a faulty sensor or one of several other communication faults.

The corresponding row number starts flashing and the audible alarm sounds. All segments on the corresponding bar graph are turned off. Pushing the OK key to acknowledge the warning will turn the alarm off. The row number will continue to flash until the alarm condition is removed. If the monitor detects a faulty sensor and there is no planting activity present, the monitor will scroll "CHECK CONNECTION".

If the distance sensor is detected as faulty, the monitor will display either "PICKUP" or "RADAR", depending on the type of sensor installed, and the audible alarm will sound. The user can push the OK key to acknowledge the alarm. When the distance sensor is faulty, the monitor will change to a bar graph only mode where the rows are still displayed relative to each other. No area related information (speed, field area, total area, seed spacing or seed population) will be accumulated or displayed.

If a rotation shaft sensor is faulty, "LSHAFT", "RSHAFT" or "SHAFTS" will display.

Another type of system alarm occurs when the monitor detects a data communication bus error.

The four possible data communication bus errors are:

LCD Display	Error Condition
SYS HI	The data communication lead (green) has been shorted to the power lead (white).
SYS LO	The data communication lead (green) has been shorted to the ground lead (black).
SYS EC	An internal error has been detected.
COP	Cycled power ON/OFF to quickly.

- 2. Under Flow Alarms** - If the seed rate for one or more rows is less than 55% of the calculated average, the corresponding 60% segment will stay on, the corresponding row number starts flashing and the alarm sounds. Pushing the OK key to acknowledge the warning will turn the alarm off. The 60% segment of the bar graph remains on and the row number continues to flash until the alarm condition is corrected.

**NOTE: All alarms present within a short time before planting stops are frozen on the screen and the text LOW or FAIL will display on the LCD. If the under flow is between 0% and 10%, this warrants a "FAIL" condition. If the under flow is between 10% and 55%, a "LOW" condition is generated. If multiple rows have an under flow condition, "FAIL" will display if any one or more rows is between 0% and 10%. This allows the user to identify and fix the problem rows.**

**NOTE: This warning will not trigger unless a minimum time of continuous planting has passed.**

**NOTE: If all the rows show a seed rate of zero, the condition will not generate an alarm. It will be assumed the planter has stopped. The row numbers and the bottom 60% segment will remain on for all selected rows.**

- 3. Multiple Alarms** - If more than one alarm condition occurs at the same time, pushing the OK key will acknowledge all alarms that are currently displayed. For example, if one row on the front and one row on the rear are alarming, pushing the OK key will only acknowledge one of them. However, if there are two alarms on the front, both alarms would be acknowledged with one push of the OK key.

4. **Section Not Selected Warning** - If the monitor was programmed for two sections and only one is currently selected for display (by pressing the SELECT key), the icon of the disabled section will flash for a period of 1 minute, then turn off at each power up. If seed flow is sensed in the disabled section, the icon for that section (front, left or right) will begin to flash.
5. **Seed Planting Stopped Warning** - When the monitor detects no seed flow on all rows, the monitor will emit 3 short beeps to alert the user. This warning will occur each time the planter is stopped, each time the planter is raised at the end of a row or if the mechanical drive fails while planting.

**NOTE: This warning will not trigger unless a minimum time of continuous planting has passed.**

6. **Seed Counting Sensor In Calibration Warning** - All seed counting sensors run a self-calibration sequence on power up. While in calibration the bottom segment of each corresponding bar graph will flash if the monitor detects movement or planting activity. If the monitor does not detect this, the message "WAIT CALIBRATION" will be scrolled.
7. **Seed Counting Sensor Too Dirty Warning** - After the seed counting sensors end their internal self-calibration, the monitor may detect one or more sensors are either too dirty or blocked. If the monitor detects planting or movement, the corresponding bar graph remains flashing. The monitor will display "CLEAN SENSORS" on the top LCD if no movement or planting is detected, prompting the user to clean the tubes. If the tubes are dirty, they will still show seed flow with less accuracy. If the tubes are blocked the user will get an alarm as soon as planting starts. The corresponding bar graph will remain flashing until the problem is corrected and the monitor is powered down and then powered back up.
8. **Low Battery Warning** - The monitor is constantly monitoring its input voltage to quickly detect low power conditions. If the monitor detects that the input voltage has dropped below 11.0V, it will display "LO SYS" on the lower LCD on the KPM II Stack-Mode console, provided that the monitor does not detect speed or planting.

**NOTE: After the alarms have been acknowledged and if the alarm condition is still present, the LCD will continue to display the alarm condition.**

## REPLACING A FAULTY SENSOR

**NOTE: Stack-Mode Seed Sensors are identified by a blue 3-pin connector. Replace Stack-Mode Seed Sensors with like components only.**

To replace a faulty sensor; (a) disconnect the faulty sensor and check the monitor to be sure the correct sensor was disconnected, (b) turn the monitor off, (c) after a few seconds, turn the monitor back on and (d) plug in the replacement sensor. The monitor will chirp twice to acknowledge the new sensor was learned and saved.

To replace more than one faulty sensor, proceed as stated above for rear/front or left/right configurations beginning with the lowest numbered row in the rear or left section and continue to replace sensors in ascending order. Then move on to the front or right section and continue in ascending order. For four section configurations, begin with rear/left and continue to rear/right, then front/left and ending with front/right.

If the monitor detects a faulty distance sensor, the lower LCD will immediately move to the speed display, show the word "PICKUP" or "RADAR" depending on the distance sensor installed, and the alarm will sound.

**NOTE: If the monitor is not turned off and then on, the replacement sensor(s) will be ignored until the next power on, at which point the sensors will be randomly learned by the monitor.**

# MACHINE OPERATION

# KPM II STACK-MODE

## FIELD OPERATION

Press the ON/OFF key to turn the monitor on.



(MTR28e)

Information regarding each section is displayed alternately every 5 seconds.

### REAR/FRONT CONFIGURATION (Without SMM Console Installed)

- Press the SELECT key once to show REAR section only. (Monitor sets correct row spacing.)
- Press the SELECT key a second time to return to each section being displayed alternately every 5 seconds on KPM II Stack-Mode console. (Monitor sets correct row spacing.)
- Press the SELECT key a third time to show REAR section only again.



(MTR28c)

### REAR/FRONT CONFIGURATION (With SMM Console Installed)

- Press the SELECT key once to show REAR section only on KPM II Stack-Mode console. (Monitor sets correct row spacing.)
- Press the SELECT key a second time to show FRONT section on SMM console and REAR section on KPM II Stack-Mode console. (Monitor sets correct row spacing.)
- Press the SELECT key a third time to show REAR section only again.



(MTR28c)

### FOUR SECTION CONFIGURATION (With SMM Console Installed)

- Press the SELECT key once to show REAR and LEFT sections on KPM II Stack-Mode console and REAR and RIGHT sections on SMM console. (Monitor sets correct row spacing.)
- Press the SELECT key a second time to return to all four sections, alternating right front and right rear on SMM console and alternating left front and left rear on KPM II Stack-Mode console. (Monitor sets correct row spacing.)
- Press the SELECT key a third time to show REAR and LEFT sections on KPM II Stack-Mode console and REAR and RIGHT sections on SMM console again.



(MTR28c)

**NOTE: SELECT key has no function when only a single section is being used.**

At power up, the lower LCD will show speed (MPH or KM/H).

(MTR29g/MTR29b/MTR29a/MTR29c/MTR29f/MTR29c/MTR29f)

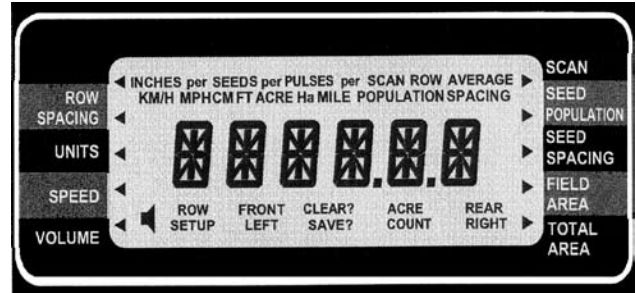

Press the UP or DOWN arrow keys to move the flashing arrow on the lower LCD to change what is displayed on the lower LCD.

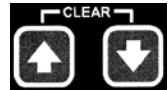

Press the shortcut keys SPEED, SEED POPULATION/SEED SPACING or AREA FIELD/TOTAL for direct access to these displays.



(MTR29c/MTR29d/MTR29b/MTR29c)

Press the SEED POPULATION/SEED SPACING or AREA FIELD/TOTAL keys to alternate between the two functions assigned to that key.



Press the SEED POPULATION/SEED SPACING key to choose average seed spacing/population per acre.



Press the SCAN key to display individual rows starting at row 1.

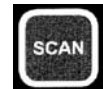

Press the SCAN key again to lock on current row.

Press the SCAN key again to resume scrolling.

Use the UP or DOWN arrow keys to move to a particular row.



Press the SEED POPULATION/SEED SPACING key to go back to planter average.



## CLEARING FIELD AREA

(MTR29n/MTR28b)

To reset the counter, press the UP or DOWN arrow keys to move the arrow in the lower display to FIELD AREA.

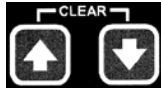

Press the UP and DOWN arrow keys at the same time and hold them down for a short period of time to clear the data. The CLEAR? icon will be displayed and the monitor will beep several times. When the data is actually cleared, the monitor will emit a long beep, and the field area is reset to zero. After the long beep, the previous field area recorded is not retrievable.



**NOTE: Clearing the field area counter will not clear the total area counter. See “Programming-Clearing Total Area” for clearing total area.**

Press the OK key to silence alarms. See “Warnings And Alarms”.



# MACHINE OPERATION

# KPM II STACK-MODE

**PROGRAMMING/CONNECTING SMM CONSOLE, SHAFT ROTATION SENSORS, SEED TUBES AND/OR RADAR/MAGNETIC DISTANCE SENSORS**

**STEP 1** All sensors (including the seed tubes w/ sensors, radar, magnetic distance, SMM console and shaft rotation sensors) must be unplugged from the harness and/or console and the monitor must be off.

**NOTE:** If the monitor detects a radar sensor but no seed tubes at power up, it will automatically go into AREA COUNT mode. See "Area Counter/Speedometer Mode".

**NOTE:** Disconnect magnetic distance sensor between MDS adapter and planter harness. DO NOT disconnect between MDS and MDS adapter.

01189909

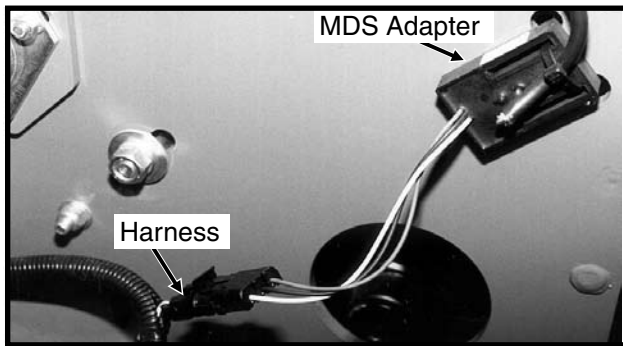

01189910

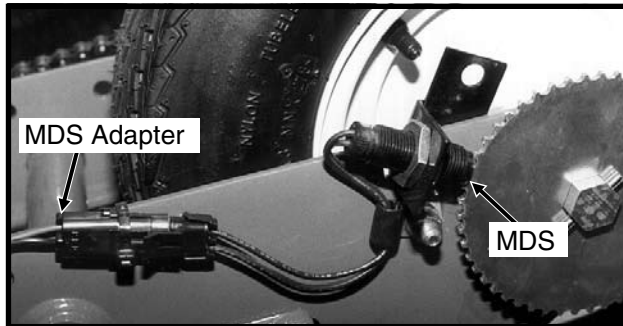

**STEP 2** Press the ON key. The monitor automatically enters the setup procedure. Monitor will scroll "NO SENSOR" on top LCD of KPM II Stack-Mode console.

**STEP 3** The monitor automatically defaults to rear/front. Press the SELECT key once for left/right and twice for four sections (front right/front left/rear right/rear left). The selected display will be solid and the configuration not currently selected will be flashing.

12060211

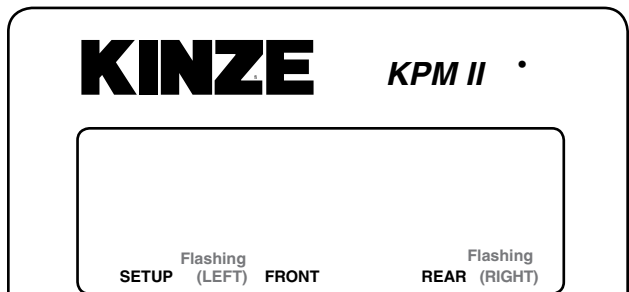

ROW	SETUP	SCAN
UNITS		SEED
SPEED		SEED
VOLUME		FIELD
		TOTAL

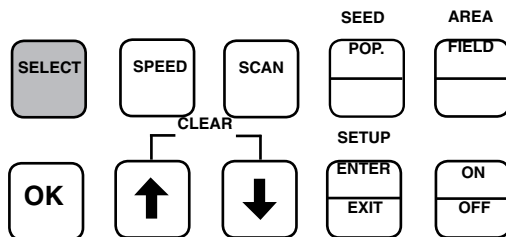

**NOTE:** SMM console may not be applicable to all models.

# MACHINE OPERATION

# KPM II STACK-MODE

12060211

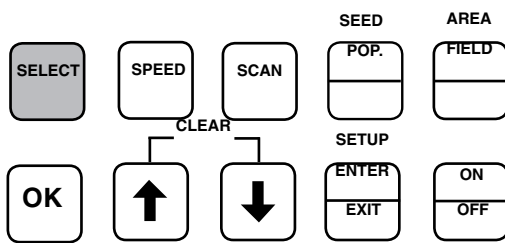
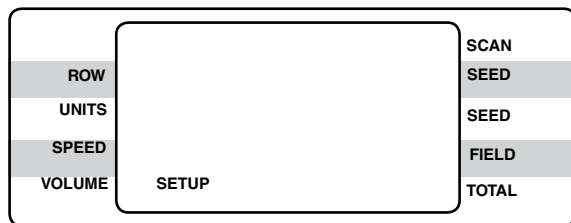
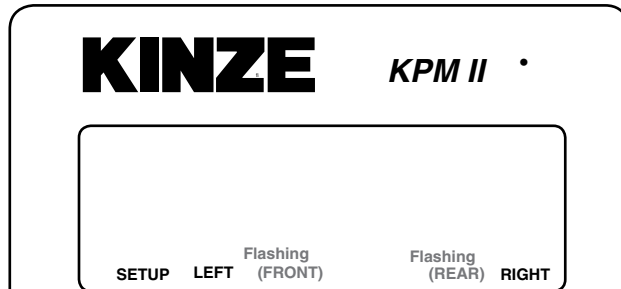

**NOTE: SMM console may not be applicable to all models.**

**NOTE: Model 3110 planters select the rear configuration only.**

**STEP 4** Press and hold the OK key to confirm selection. The upper display will alternate between "NEW" and "SYS?".

The alarm will sound four short beeps followed by one long beep. At this point your selection has been saved and row numbers will appear flashing on the upper display.

12060211

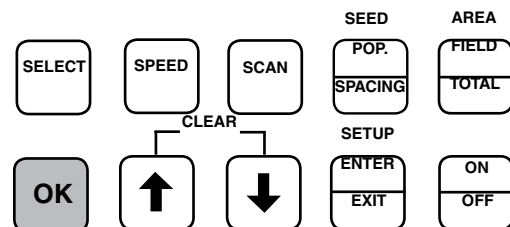
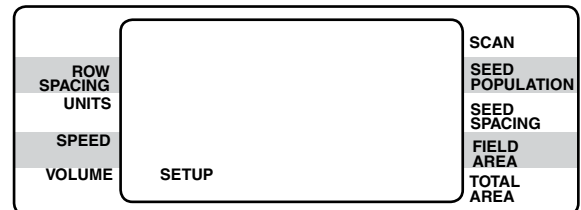
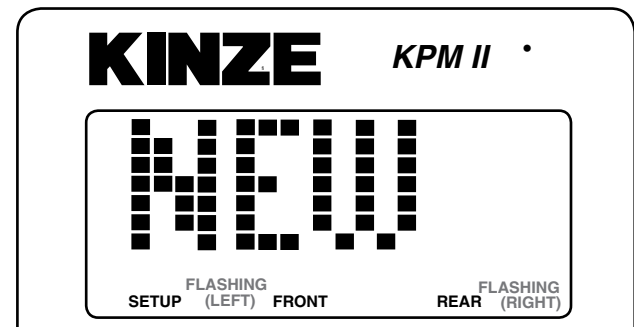

**NOTE: SMM console may not be applicable to all models.**

# MACHINE OPERATION

# KPM II STACK-MODE

**NOTE: Illustrated using rear/front configuration.** The KPM II Stack-Mode console shows LEFT in the left/right configuration, REAR in the rear/front configuration and FRONT LEFT/REAR LEFT in the four sections configuration.

**STEP 5** (If Applicable) Connect SMM console into junction Y-harness which was installed between the KPM II Stack-Mode console and the primary harness. The SMM console will show a lighted screen and KPM will show on the lower LCD.

12060211



12060211

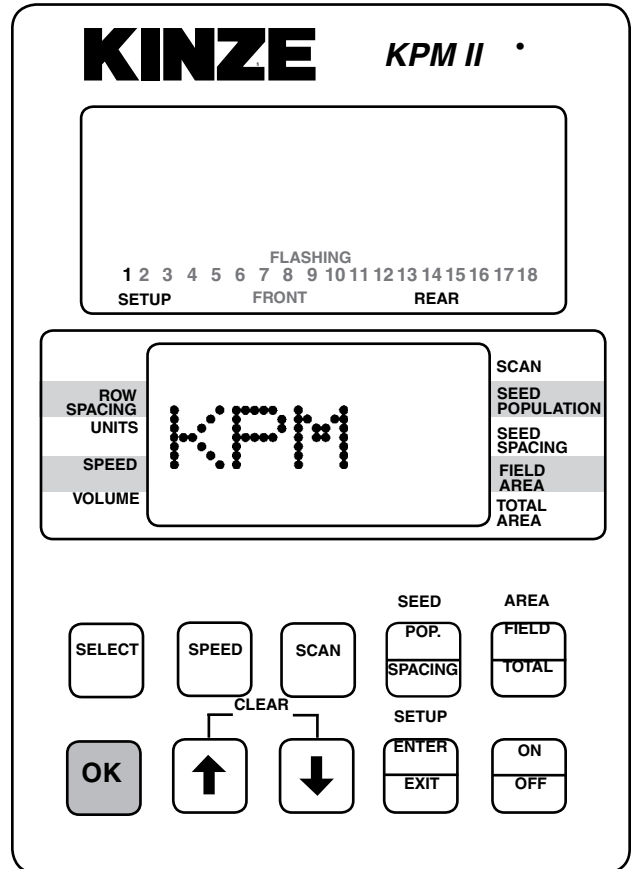
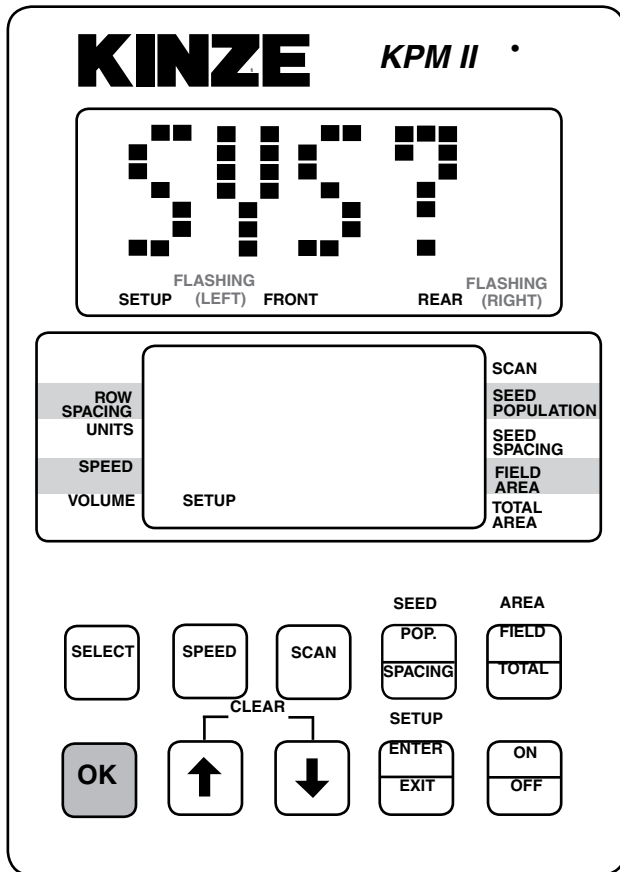

**NOTE: SMM console may not be applicable to all models.**

**NOTE: SMM console may not be applicable to all models.**

# MACHINE OPERATION

# KPM II STACK-MODE

**STEP 6** If the monitor system includes shaft rotation sensors, these should be installed at this time. Plug in the L.H. shaft first, then the R.H. shaft. L.H. and R.H. is determined by facing in the direction the machine will travel when in use.

01189906

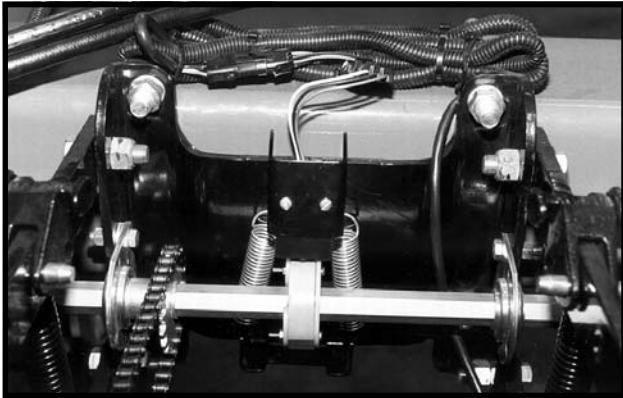

D12140713

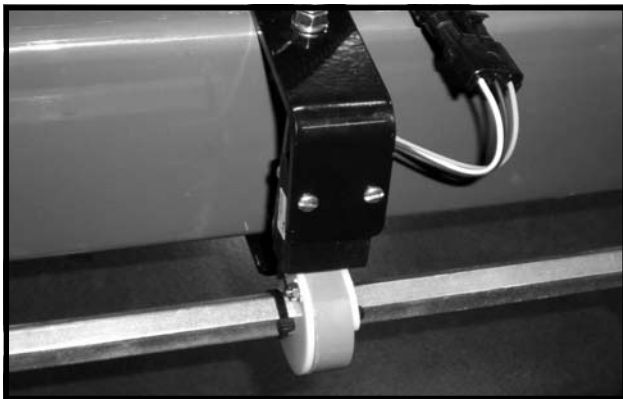

“LSHAFT” or “SHAFT 1” will display on the lower LCD when the first shaft rotation sensor is installed. “RSAFT” or “SHAFT 2” will display when the second shaft rotation sensor is installed.

**NOTE:** Illustrated using rear/front configuration. The KPM II Stack-Mode console shows LEFT in the left/right configuration, REAR in the rear/front configuration and FRONT LEFT/REAR LEFT in the four sections configuration.

12060211

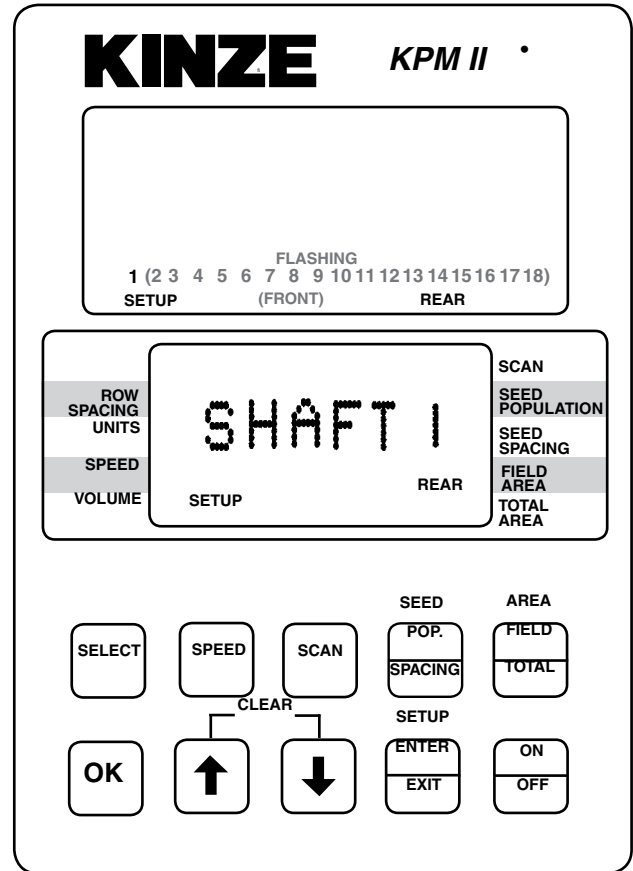

**NOTE:** SMM console may not be applicable to all models.



# MACHINE OPERATION

# KPM II STACK-MODE

## STEP 6 (Continued)

12060211

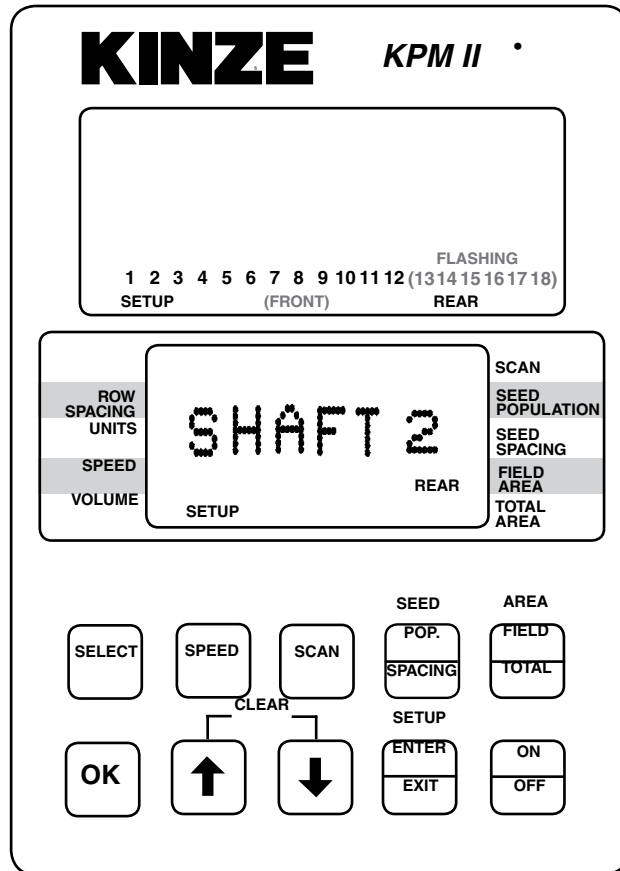

**NOTE: SMM console may not be applicable to all models.**

## STEP 7 Determine which row you want as number one and plug the seed tube w/sensor into the harness.

Continue plugging in sensors along with shaft rotation sensors if so equipped. Row 1 first, row 2 second and so on up to 18 rows. When a sensor is plugged in, the corresponding row number on the upper LCD display will stay solid, the monitor will chirp twice and a red LED (Light Emitting Diode) on the seed tube sensor will turn on for approximately 30 seconds to show connection is made.

(A11948)

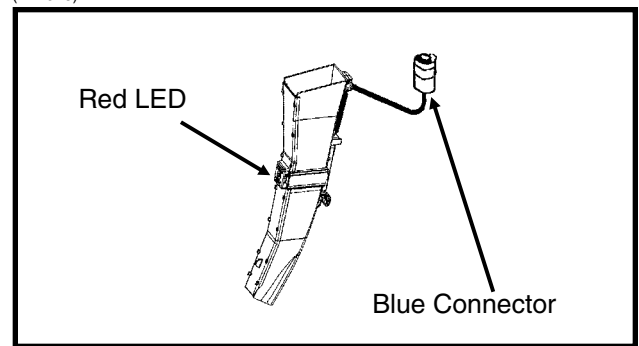

## STEP 7 (Continued)

**NOTE: Illustrated using rear/front configuration.**  
 The KPM II Stack-Mode console shows LEFT in the left/right configuration, REAR in the rear/front configuration and REAR LEFT/FRONT LEFT in the four sections configuration.

12060211

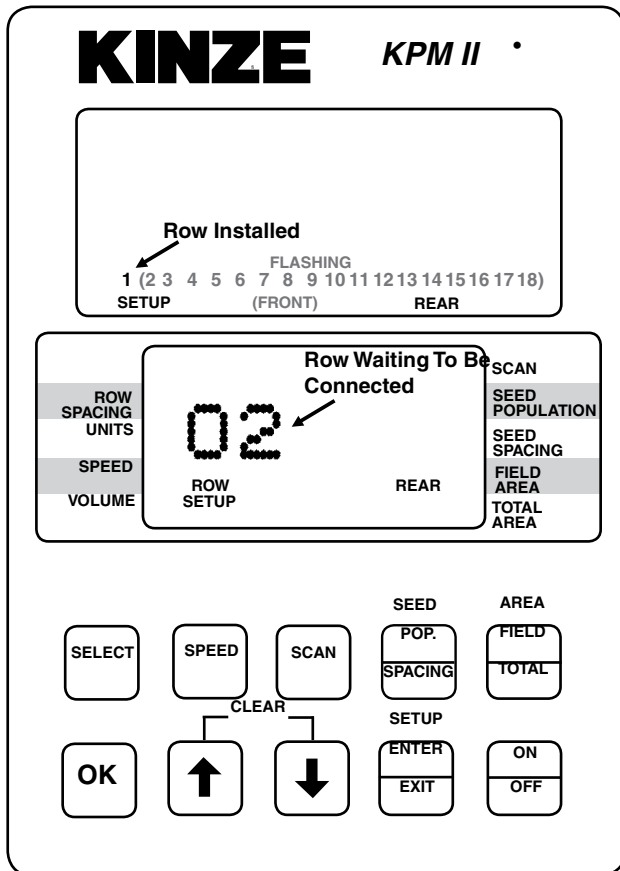

**NOTE: SMM console may not be applicable to all models.**

# MACHINE OPERATION

# KPM II STACK-MODE

**STEP 8** When all the seed tubes for the current section (rear/front, left/right or four section) are installed, check to be sure the upper LCD on the KPM II Stack-Mode console displays solid numbers for the number of seed tubes connected. Press and hold the OK key to save the setup for the current section. The SAVE? icon will display followed by continuous short beeps indicating the monitor is preparing to save. The installer has 5 seconds to decide to save the current configuration. During this time, four short beeps will sound followed by a long beep and the SAVE? icon will turn off and the word "DONE" shows on the screen. The monitor will continue to the second section installation (If Applicable).

**NOTE: Illustrated using rear/front configuration.** The KPM II Stack-Mode console shows LEFT in the left/right configuration, REAR in the rear/front configuration and REAR LEFT/FRONT LEFT in the four sections configuration.

12060211

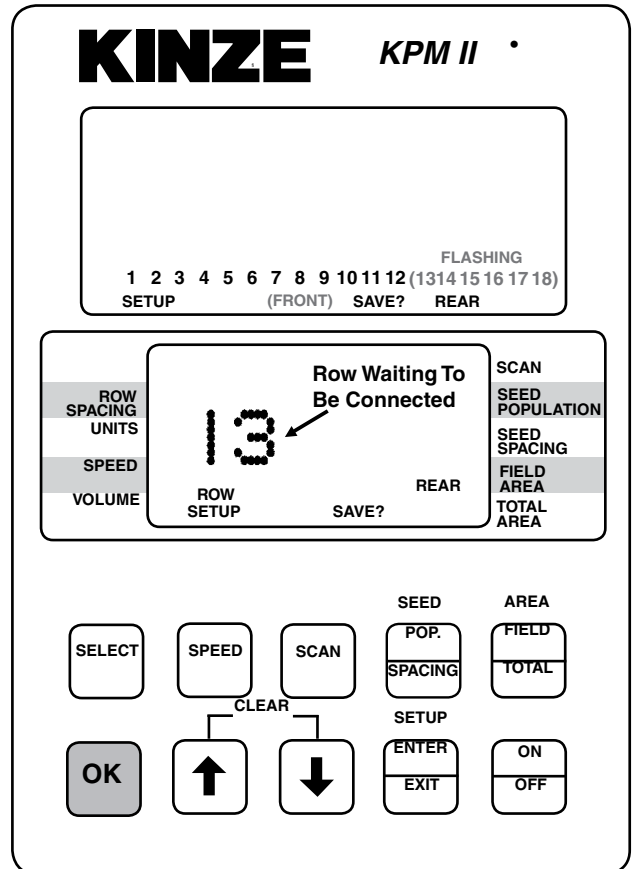

**NOTE: SMM console may not be applicable to all models.**

## STEP 8 (Continued)

12060211

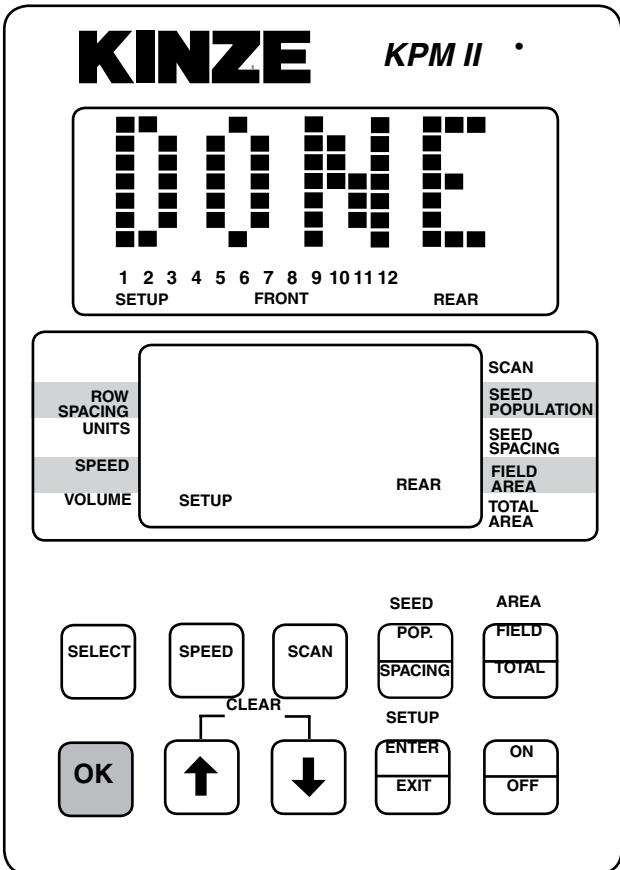

**NOTE: SMM console may not be applicable to all models.**

# MACHINE OPERATION

# KPM II STACK-MODE

**STEP 9** Follow STEPS 6, 7 and 8 to install the second, third and fourth sections (If Applicable). If no seed tubes are installed on the additional sections, press and hold the OK key. The word "DONE" will appear on upper display. The alarm will sound four short beeps followed by one long beep and the SAVE? icon turns off. The monitor has exited the setup mode. When you release the OK key the upper display will scroll "WAITING CALIBRATION". The lower display will show "GNDSPD" and the alarm will sound continually until the distance sensor is connected. See STEP 10.

**NOTE:** The SMM console LCD remains blank (except the backlighted screen) until the entire system is saved.

**NOTE:** Illustrated using rear/front configuration. The KPM II Stack-Mode console shows LEFT in the left/right configuration, REAR in the rear/front configuration and FRONT LEFT/REAR LEFT in the four sections configuration. The SMM console shows RIGHT in the left/right configuration, FRONT in the front/rear configuration and FRONT RIGHT/REAR RIGHT in four sections configuration.

12060212

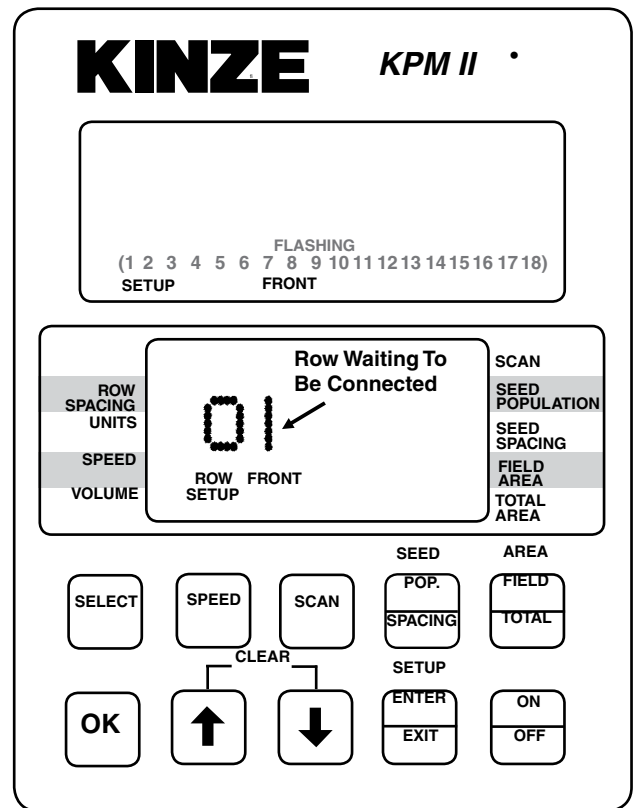

**NOTE:** SMM console may not be applicable to all models.

# MACHINE OPERATION

# KPM II STACK-MODE

## STEP 9 (Continued)

12060213



12060214

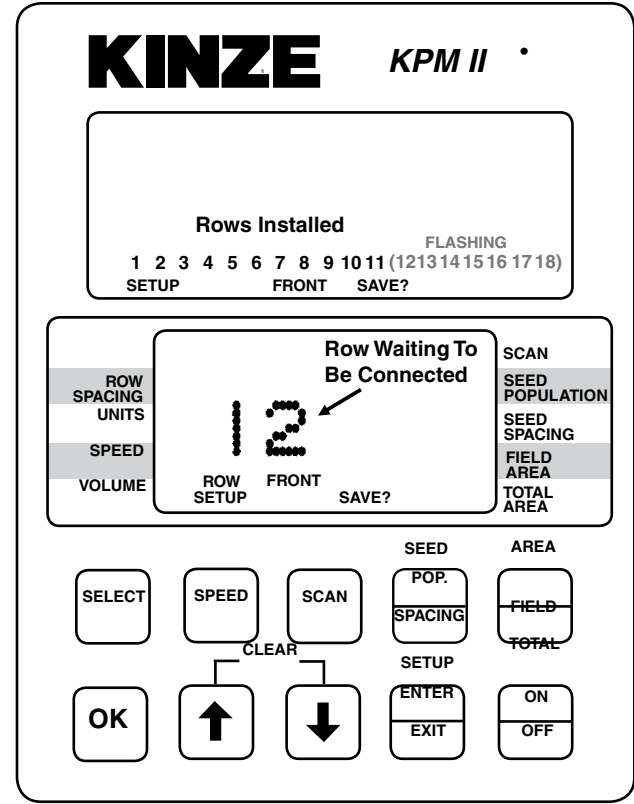
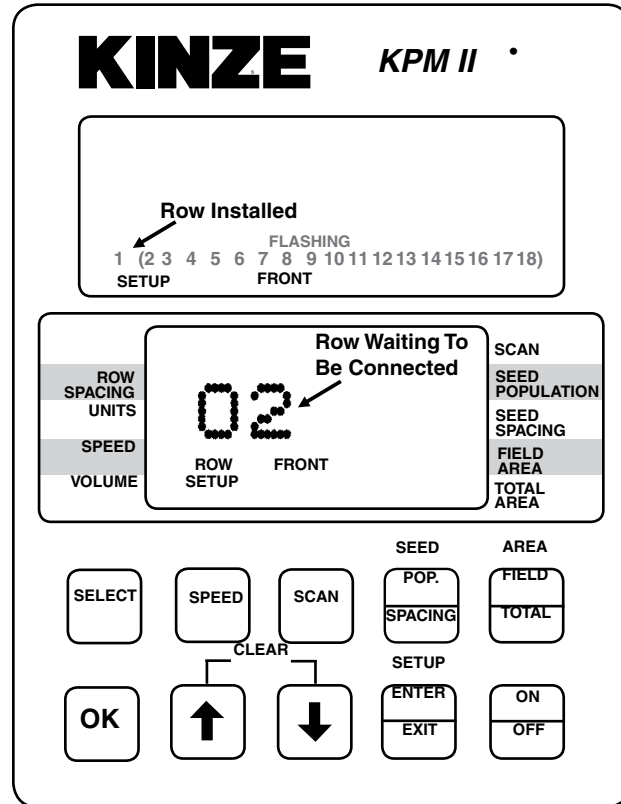

**NOTE: SMM console may not be applicable to all models.**

**NOTE: SMM console may not be applicable to all models.**

**STEP 9** (Continued)

12060215

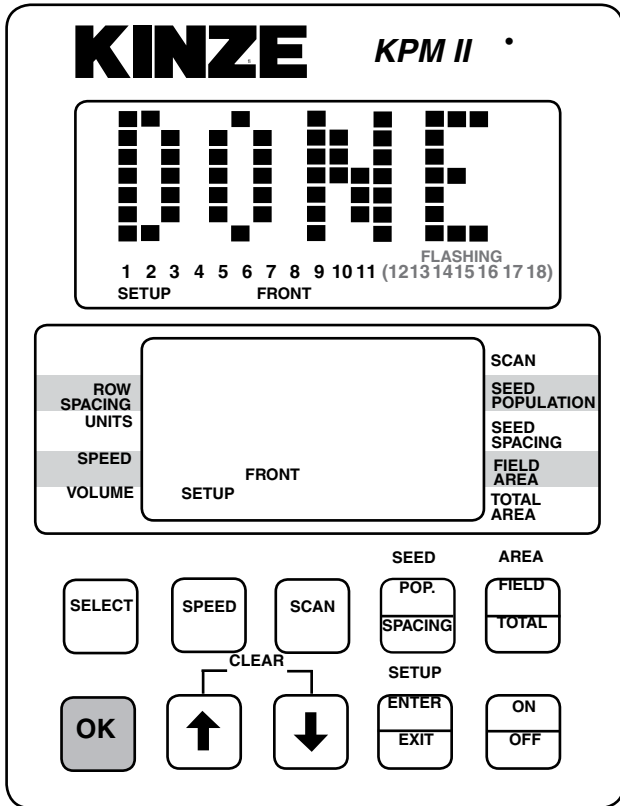
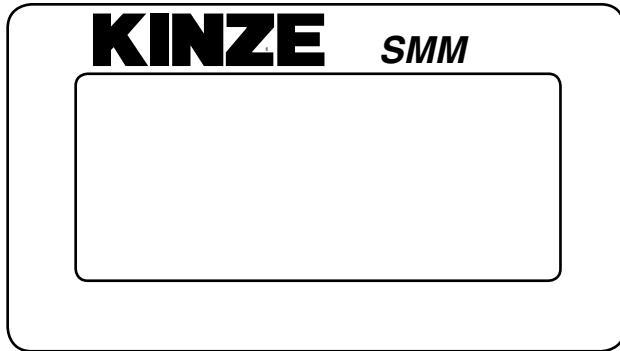

**NOTE:** SMM console may not be applicable to all models.

**STEP 10** With the lower display showing “GNDSPD”, connect the distance sensor. The monitor will display “PICKUP” if a magnetic distance sensor is connected or “RADAR” if a radar distance sensor is installed. Only one distance sensor can be connected at a time.

**NOTE:** Illustrated using rear/front configuration. The KPM II Stack-Mode console shows LEFT in the left/right configuration, REAR in the rear/front configuration and FRONT LEFT/REAR LEFT in the four sections configuration. The SMM console shows RIGHT in the left/right configuration, FRONT in the rear/front configuration and FRONT RIGHT/REAR RIGHT in four sections configuration.

**NOTE:** To connect the radar distance sensor, install the 10" monitor/radar adapter between the console and radar distance sensor to adapt the monitor system to various tractor radar systems. **DO NOT CONNECT 10" MONITOR/RADAR ADAPTER PRIOR TO THIS STEP.**

# MACHINE OPERATION

# KPM II STACK-MODE

## STEP 10 (Continued)

12060216

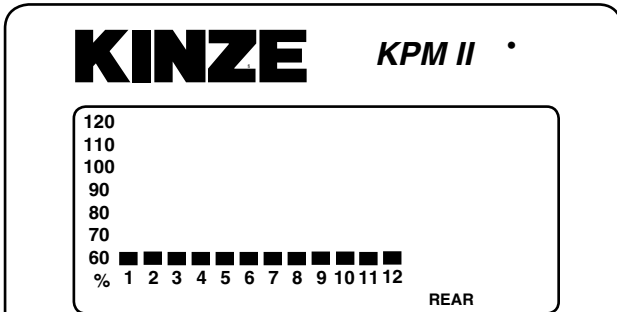
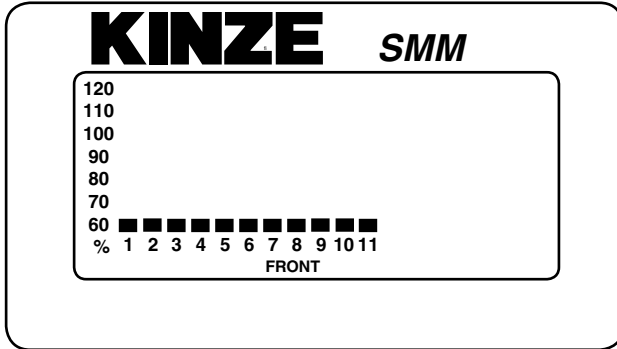

**KINZE KPM II**

ROW SPACING UNITS: GNDSPD

SPEED: REAR

VOLUME

SCAN: SEED POPULATION, SEED SPACING, FIELD AREA, TOTAL AREA

SELECT, SPEED, SCAN, POP. SPACING, FIELD TOTAL

OK, CLEAR (UP/DOWN), SETUP (ENTER/EXIT), ON/OFF

**NOTE: SMM console may not be applicable to all models.**

**NOTE: To reprogram the system to monitor more or less rows (up to the maximum of 18 per section, 72 total in four section configuration), all sensors must be unplugged, followed by the complete setup procedure.**

**NOTE: Individual seed tubes may be unplugged for special situations. An alarm will sound which can be silenced by touching the OK key. The monitor will recognize the seed tube(s) when reconnected.**

12060217

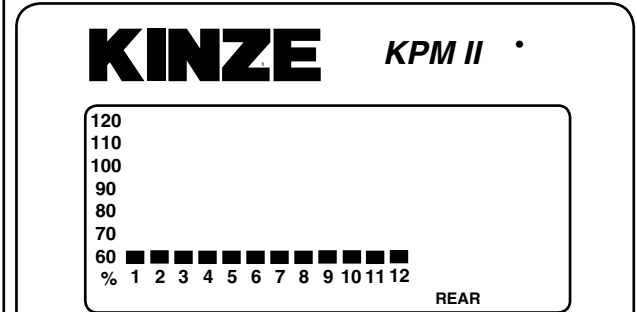
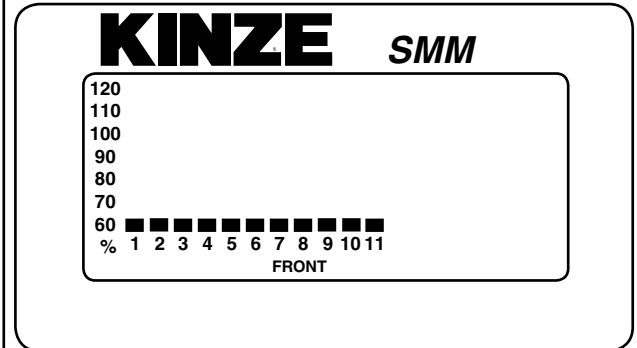

**KINZE KPM II**

ROW SPACING UNITS: MPH

SPEED: 0.0

VOLUME

SCAN: SEED POPULATION, SEED SPACING, FIELD AREA, TOTAL AREA

SELECT, SPEED, SCAN, POP. SPACING, FIELD TOTAL

OK, CLEAR (UP/DOWN), SETUP (ENTER/EXIT), ON/OFF

**NOTE: SMM console may not be applicable to all models.**



**ROW-BY-ROW ALARM LEVEL SETTING**  
*(Requires Version V2.05 Or Higher Software -  
 KPM II Stack-Mode Monitors Only)*

This feature allows the audio alarm to be disabled on selected rows in applications such as planting seed corn.

**NOTE: The system should be programmed to monitor all planter rows prior to performing these steps.**

**NOTE: Illustrated using rear/front configuration.** The KPM II Stack-Mode console shows LEFT in the left/right configuration, REAR in the rear/front configuration and FRONT LEFT/REAR LEFT in the four sections configuration. The SMM console shows RIGHT in the left/right configuration, FRONT in the rear/front configuration and FRONT RIGHT/REAR RIGHT in four sections configuration.

**STEP 1** Enter the programming mode by pressing and holding the SETUP key. The monitor will emit several short beeps, followed by a long beep. On the lower LCD, the SETUP icon will turn on and the arrow head icon will flash, indicating the user can select an item to program.

**NOTE: The monitor must be in a programmable function (row spacing, unit, speed, volume or area) to enter setup. The monitor will not enter setup in seed population or seed spacing.**

**STEP 2** Press the UP or DOWN arrow keys to move the flashing arrow to SEED POPULATION. As the arrow icon moves, the lower LCD will display the current setting of each item selected.

12060218

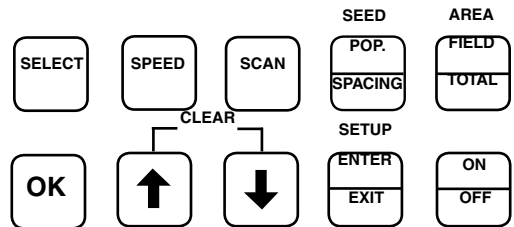
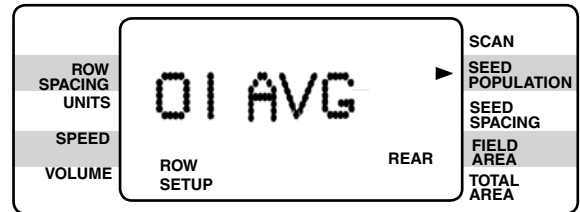
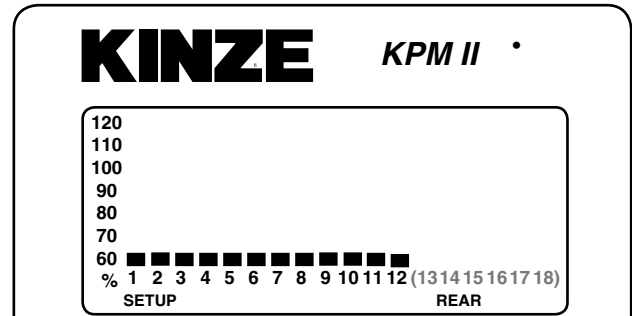
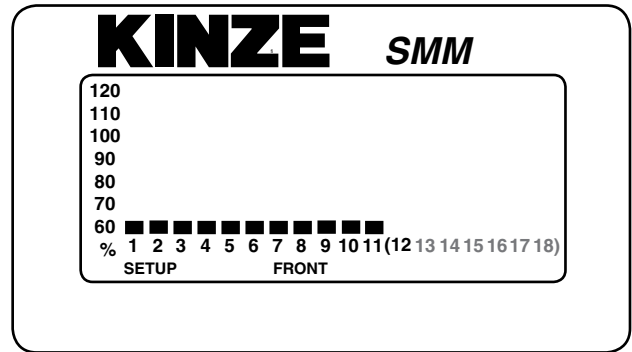

**NOTE: SMM console may not be applicable to all models.**

**STEP 3** Press the OK key. Row number starts flashing.

**STEP 4** Arrow UP or DOWN to desired row.

**STEP 5** Press SELECT key. "AVG" starts flashing.

**STEP 6** Arrow UP or DOWN to choose one of the following options.

HIGH - For Early Alarm (70%)  
AVG - For Standard Alarm Setting (55%)  
LOW - For Failed Alarm Only (25%)  
OFF - To Disable Row Alarm

**STEP 7** Press and hold the OK key to save alarm setting. There will be four short beeps, one long beep and the word "DONE" will appear when the save is completed.

**STEP 8** Repeat STEPS 3 through 7 for each row on which you wish to adjust the alarm setting.

**STEP 9** When finished, press the SETUP key to exit setup mode.

**NOTE: The programming mode may be exited at any time by pressing the SETUP key. Pressing this key will return the monitor to its normal operation. All items changed and saved will come into effect immediately. Any items changed, but not saved will revert to the original programmed value.**

**NOTE: Repeat STEPS 3 through 7 to change seed monitor back to the original settings when special row-by-row alarm level settings are no longer required.**

**NOTE:**  
**See "Programming - Row Spacing" for programming applicable row spacing.**

**See "KPM I/KPM II Stack-Mode Electronic Seed Monitor Troubleshooting" in the Maintenance Section.**

## KPM III ELECTRONIC SEED MONITOR

D10190501



The KPM III electronic seed monitor system consists of (a) a KPM III console, which is mounted on the tractor; (b) seed tubes with sensors, one of which is installed in each planter row unit; (c) a magnetic distance sensor, which is installed on the planter, or a radar distance sensor, which is installed on the tractor; (d) shaft rotation sensors (if applicable), which are installed on the planter drill shafts; and (e) planter harnesses (junction Y-harness and/or extension harness where applicable), to which the individual seed tube sensors connect. The primary harness, which connects the monitor console to the planter harness, is hard-wired into the safety/warning light harness or control console harness included as standard equipment with the planter.

The software design of the KPM III console allows simultaneous viewing of seed flow bargraphs for standard and/or Interplant® System rows (up to 36 rows).

The monitor system is powered by the tractor battery (requires 12 volts DC). The console receives information from each of the sensors and translates this information.

The KPM III console uses a single backlit Liquid Crystal Display (LCD) to show, the number of monitored rows, the relative seed rate for each row (using bargraph displays) and displays various alarm and warning messages when an alarm condition exists. A continuous audible alarm will sound upon system malfunction or underflow conditions for any monitored row. Alarms must be acknowledged by the user. Various warnings may sound the alarm or flash one or more messages. The LCD also shows alphanumeric data such as row spacing, units (Metric or English), speed (MPH or KM/H), volume, seed population, seed spacing, field area and total area.

The monitor system will power down if no activity is detected within one hour. No activity means there has been no new seed flow and no operator push key input.

<b>Monitor Key Functions.....</b>	<b>6-46</b>
<b>Configuring Planter Monitor .....</b>	<b>6-47</b>
<b>Programming/Connecting Seed Tubes, Shaft Rotation Sensors And/Or Radar/Magnetic Distance Sensors.....</b>	<b>6-49</b>
<b>Changing Volume, Contrast And Backlighting .....</b>	<b>6-51</b>
<b>Programming Interplant® Condition, Row Spacing And Units (Metric Or English) .....</b>	<b>6-52</b>
<b>Programming Row Unit Alarms Levels .....</b>	<b>6-53</b>
<b>Speed Sensor Calibration/Programming .....</b>	<b>6-54</b>
<b>Reprogramming Speed Sensor.....</b>	<b>6-55</b>
<b>Adding Interplant® Rows (If Rear Rows Have Previously Been Programmed).....</b>	<b>6-59</b>
<b>Adding Even-Row Package (If Front Rows Have Previously Been Programmed).....</b>	<b>6-61</b>
<b>Enabling/Disabling Interplant® Rows.....</b>	<b>6-63</b>
<b>Warnings And Alarms .....</b>	<b>6-66</b>
<b>Field Operation .....</b>	<b>6-68</b>
<b>Area Management.....</b>	<b>6-69</b>
<b>Area Counters.....</b>	<b>6-71</b>
<b>Clearing Field Area.....</b>	<b>6-72</b>
<b>Acre Count Mode.....</b>	<b>6-72</b>
<b>Replacing Faulty Sensor(s) .....</b>	<b>6-74</b>

## MONITOR KEY FUNCTIONS

Push keys allow the user to select or change the operating mode, the active displays or the current configuration. Depending on the operating mode or the current display selected, some keys may not be active. Each key press, if valid, is acknowledged by a short beep and an action is taken. If the key press has no action associated, the key press is considered invalid, and the user will not receive feedback.

D10190501

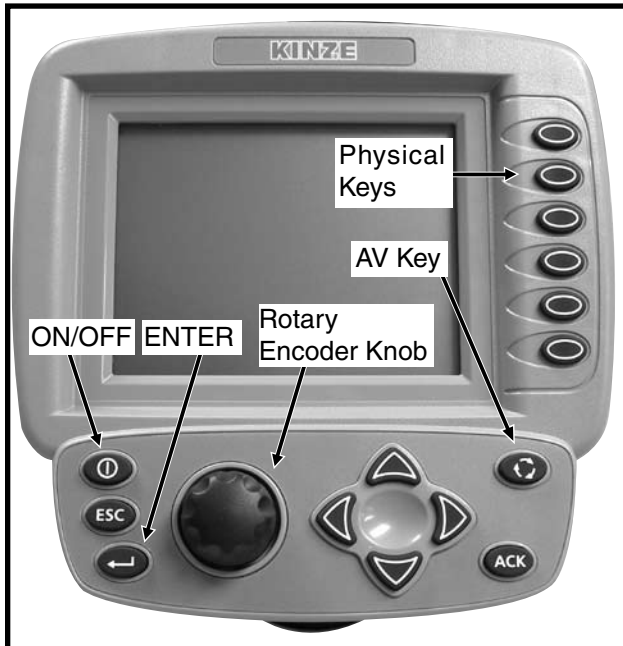

### PHYSICAL KEYS

- Located on R.H. side of console and referred to as F1, F2, F3, F4, F5 and F6
- Keys are referenced in descending order with F1 at the top and F6 at the bottom.



### ON/OFF KEY

- Powers the unit on and off.



### ESC KEY

- Used as the CANCEL (escape) key.



### ENTER KEY

- Confirms or accepts the highlighted selection.



### ROTARY ENCODER KNOB

- Turn knob clockwise to increase or counterclockwise to decrease value of item.
- Turn knob clockwise to scroll up or counterclockwise to scroll down.
- Press knob to enter selection.

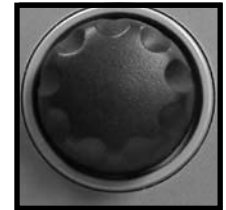

### AV (AUDIO/VIDEO) KEY

- Set alarm volume.
- Adjust the contrast.
- Adjust backlighting of the LCD display.



### ACK (ACKNOWLEDGE) KEY

- Used to silence (acknowledge) the warning alarm when various error conditions occur.

**NOTE: Alarms can be viewed by pressing the STATUS key.**



### ARROW KEYS

- UP arrow key is used to increase the value of an item by one or to scroll up.
- DOWN arrow key is used to decrease the value of an item by one or to scroll down.
- LEFT arrow key multiplies the numeric value of the item by 10.
- RIGHT arrow key divides the numeric value of the item by 10.



**NOTE: Within the LCD, the black box around the smaller box as shown below indicates which field is selected/highlighted. Turning the rotary encoder knob or pressing the UP or DOWN arrow keys moves the black box. When the black box is positioned on a programmable item, such as Shaft Sensors, Speed Sensor, Front Row Units or Rear Row Units, pressing the knob or ENTER key will highlight the programmable item. A programmable item may only be changed when it is highlighted.**

D02140616

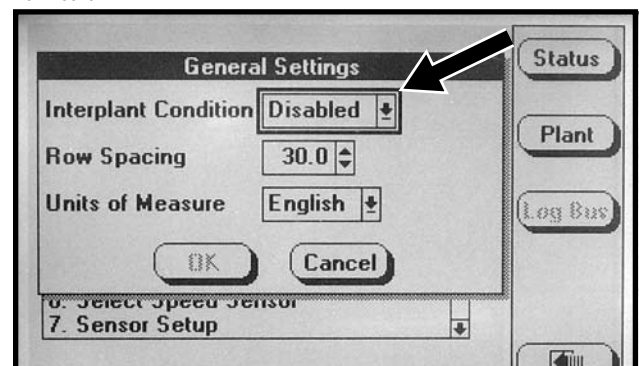

## CONFIGURING PLANTER MONITOR

When the KPM III is powered on for the first time it will go directly into the “Planter Configuration” screen (STEP 4).

**STEP 1** Press the F6 key until “Mode Selection” screen appears.

D02140614

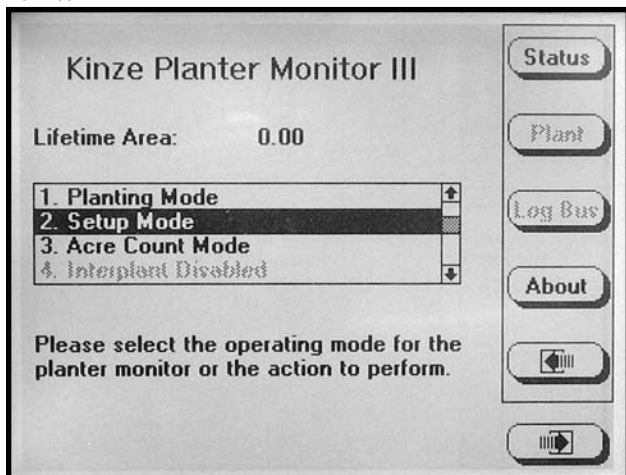

**STEP 2** Select “Setup Mode” by turning the rotary encoder knob or using the UP or DOWN arrow keys. Press the knob or ENTER key to display highlighted item.

**STEP 3** Select “Configure Planter Monitor” by turning the knob or using the UP and DOWN arrow keys. Press the knob or the ENTER key to display the highlighted item.

D02140624

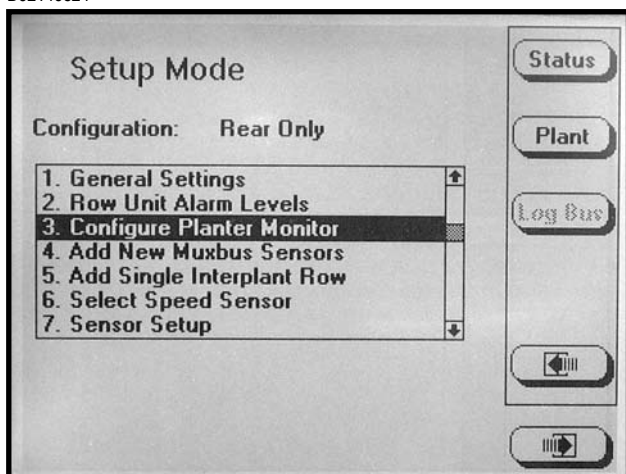

**NOTE:** The planter monitor cannot be reconfigured while planting.

**NOTE:** If the monitor has already been configured the message shown below will appear.

D02140634

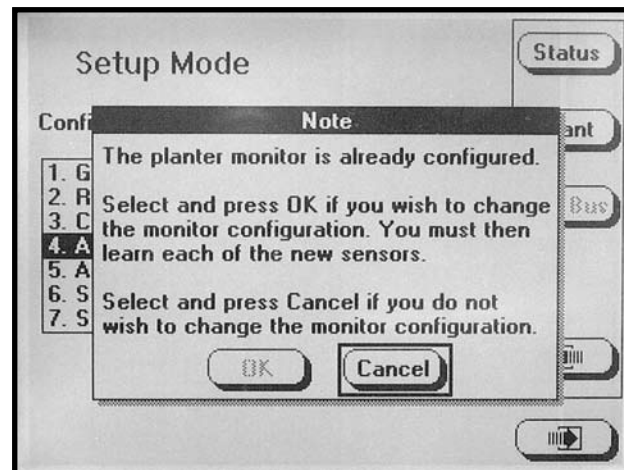

**STEP 4** Press the knob or ENTER key, to highlight the “Shaft Sensors” field. Enter the number of “Shaft Sensors” by turning the knob or using the UP or DOWN arrow keys. When the correct value is displayed press the knob or ENTER key. The black box will advance to “Speed Sensor” field.

D05310601

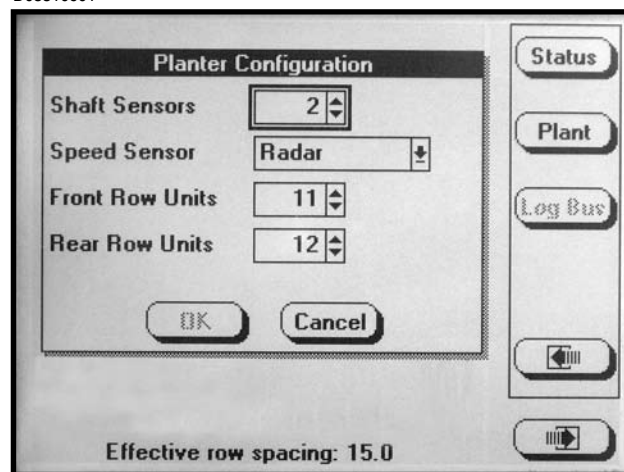

**NOTE:** The numeric value may be changed only if the item is highlighted. Turning the rotary encoder knob increases or decreases the value of the item. The UP arrow key may be used to increase the value of the item by one and the DOWN arrow key may be used to decrease the value of the field by one.

**STEP 5** Press the knob or ENTER key and a drop down menu will appear; select either “Radar” or “Coil Pick-Up” (MDS) by turning the knob or using the UP or DOWN arrow keys. When the desired selection is highlighted press the knob or ENTER key. The black box will advance to “Front Row Units” field.

D05310604

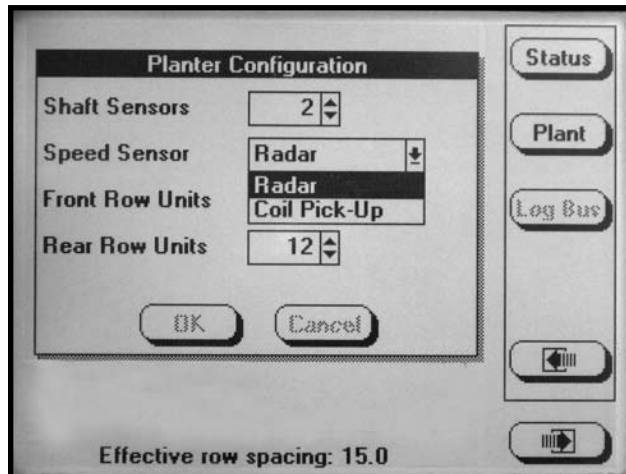

**STEP 7** Press the knob or ENTER key to highlight the “Rear Row Units” field. Turn the knob or use the UP or DOWN arrow keys to obtain correct number of pull row units. Press the knob or ENTER key when desired quantity is displayed. The black box will advance to the OK key.

D05310606

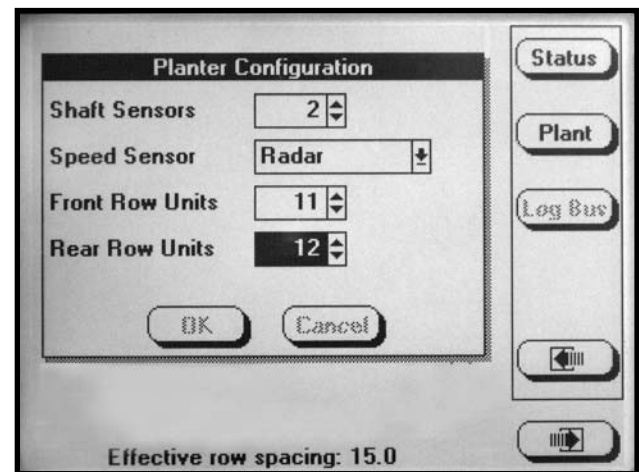

**STEP 6** If there are front rows on the planter, press the knob or ENTER key to highlight the “Front Row Units” field. Turn the knob or use the UP or DOWN arrow keys to obtain correct number of push row units. Press the knob or ENTER key when desired quantity is displayed. The black box will advance to “Rear Row Units” field. If no front rows need to be entered simply turn the knob or press the DOWN arrow key to advance to “Rear Row Units”.

**STEP 8** Press the knob or the ENTER key to save the information.

D05310607

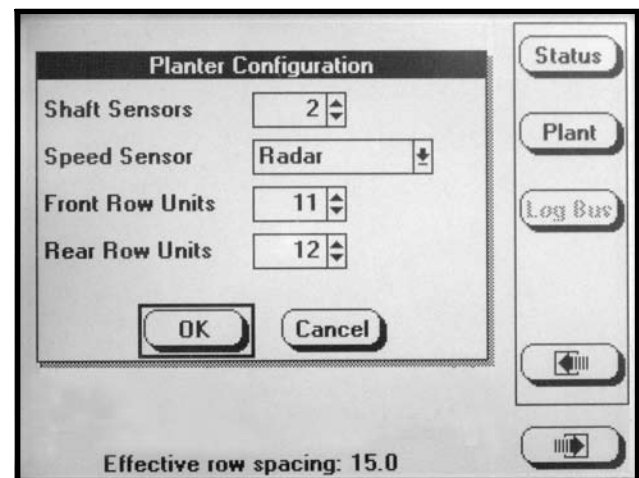

D05310605

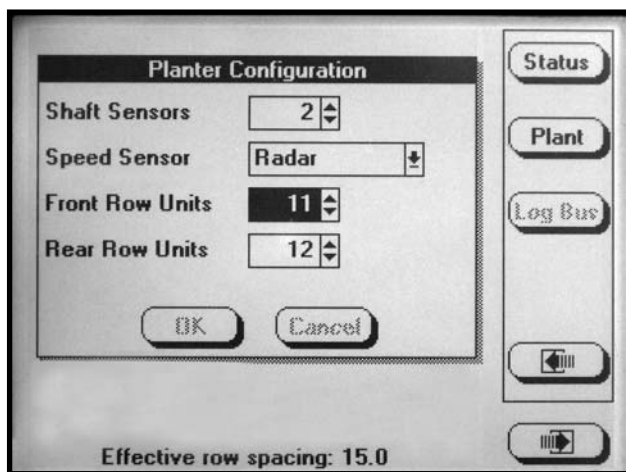

**NOTE:** To prevent the configuration from being saved press ESC or select the CANCEL button, then press the rotary encoder knob or ENTER key.

**STEP 9** The monitor screen shown below will appear.

If the new planter configuration is to be saved turn the knob or press the UP or DOWN arrow keys to select the OK button then press the knob or ENTER key to save the planter configuration into the KPM III. If the monitor configuration is not to be changed select the CANCEL key, press the knob or ENTER key to CANCEL or press the ESC key.

If OK is selected the monitor will advance to "Sensor Setup"(STEP 4 in PROGRAMMING/CONNECTING SEED TUBES, SHAFT ROTATION SENSORS AND/OR RADAR/MAGNETIC DISTANCE SENSORS section).

**NOTE: STEP 9 does not apply if configuring the monitor for the first time.**

D02140634

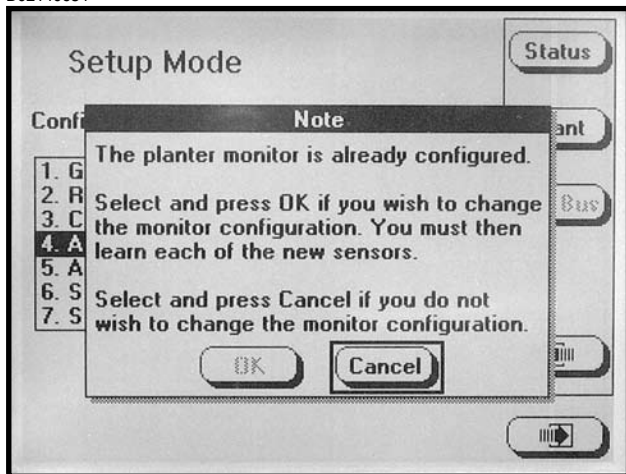

## PROGRAMMING/CONNECTING SEED TUBES, SHAFT ROTATION SENSORS AND/OR RADAR/MAGNETIC DISTANCE SENSORS

**STEP 1** To enter "Mode Selection", press F6 key until the "Mode Selection" screen appears.

**STEP 2** Select "Setup Mode" by turning the rotary encoder knob or press the UP or DOWN arrow keys. Press the knob or ENTER key to display the highlighted item.

**STEP 3** Select "Sensor Setup" by turning the knob or using the UP or DOWN arrow keys. Press the knob or ENTER key to display the highlighted item.

D02140641

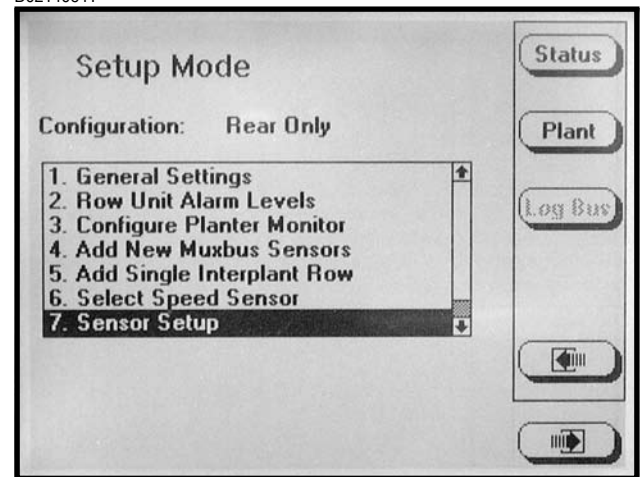

**STEP 4** Attach the planter harness to the KPM III. Do NOT connect any of the sensors to the planter harness. With [Auto Detect] selected press the INSTALL key.

D02210601a

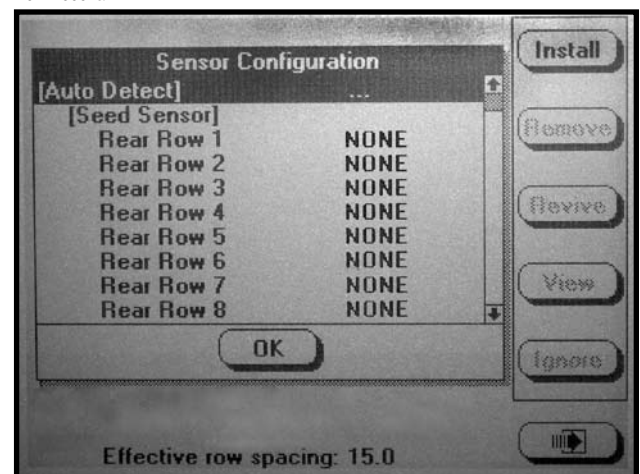

**STEP 5** Plug in the first seed sensor (row 1), working from left to right (rear row units and front next if applicable). When a sensor is connected to the planter harness wait for the monitor to acknowledge with two beeps.

Continue connecting seed sensors along with shaft rotation sensors or speed sensors. Progress will reflect on the LCD screen. The example below indicates that the last seed sensor found was Front Row 7 and the monitor is looking for the next sensor.

When all sensors are installed press the F1 key to end the installation.

D02170617

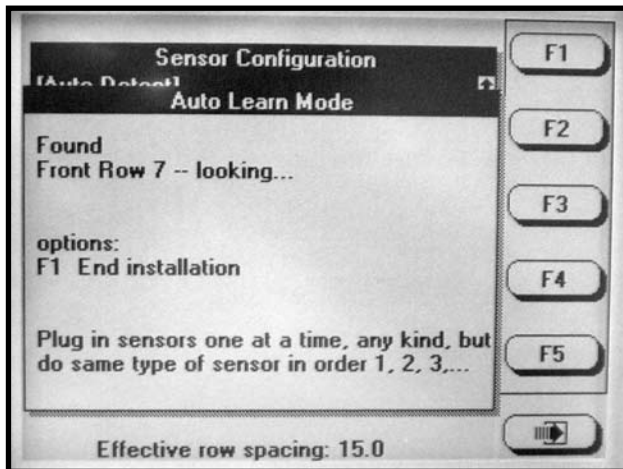

**NOTE:** After each sensor has been installed “OK” will appear after the sensor name.

D02210601b

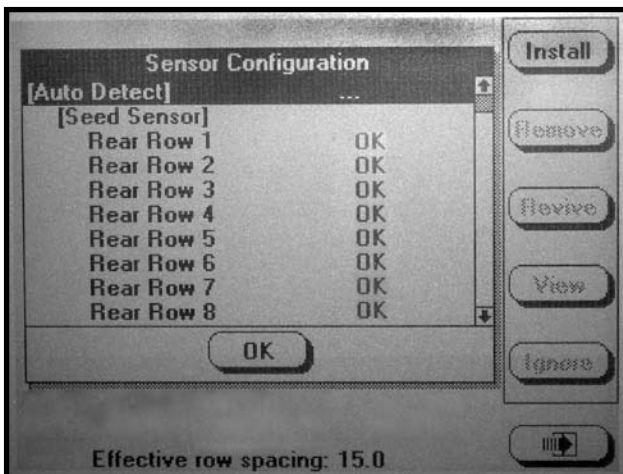

**STEP 6** If “OK” appears behind ALL sensors, press the knob or the ENTER key to save the configuration. The “Setup Mode” menu will then appear.

**NOTE:** If “NONE” appears after a sensor, the sensor was not recognized. All sensors must be disconnected from the planter harness and reconnected as described in STEP 5.

**NOTE:** If “OK slow” appears after a sensor, the sensor is able to communicate but at a slower speed. For the system to run at top speed of 9600 baud the slow sensor must be replaced.

D05310609

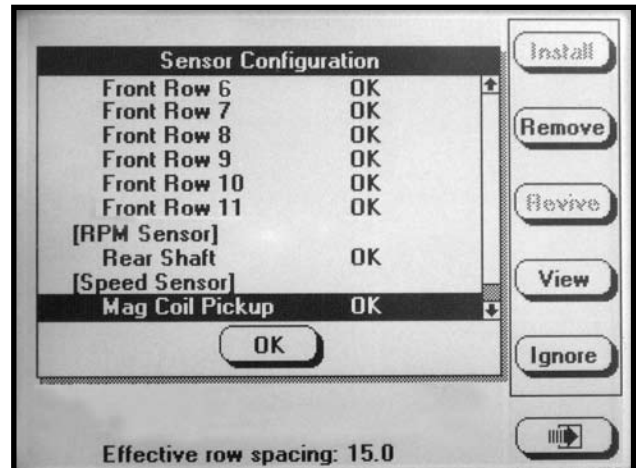

**STEP 7** To return to “Planting Mode” select the PLANT key or press the F6 key until “Planting Mode” screen appears.



## CHANGING VOLUME, CONTRAST AND BACKLIGHTING

The alarm volume and LCD screen contrast and backlighting may be adjusted at anytime, regardless of what is displayed on the screen.

**STEP 1** Press the AV key. The speaker adjustment dialog box will appear in the lower L.H. corner of the display.

D05310610

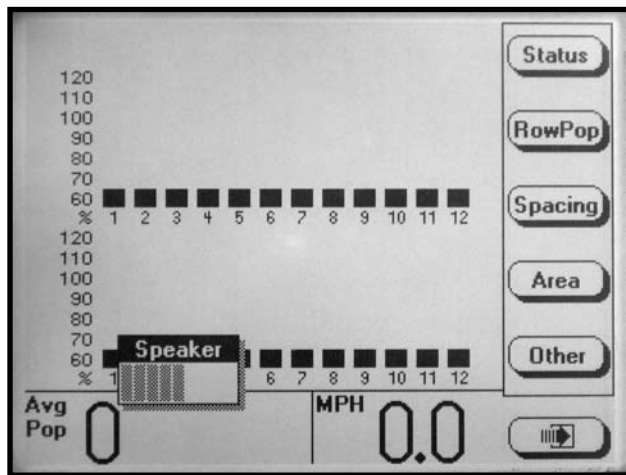

**STEP 2** Use the LEFT and RIGHT arrows or turn the rotary encoder knob to adjust the volume. The volume of the sound emitted from the speaker changes as the adjustment is being made.

**STEP 3** To adjust contrast or backlight, go to STEP 4. If finished press ENTER to save and exit.

**STEP 4** Press the AV button a second time. The contrast adjustment dialog box will appear in the lower portion of the display.

D05310611

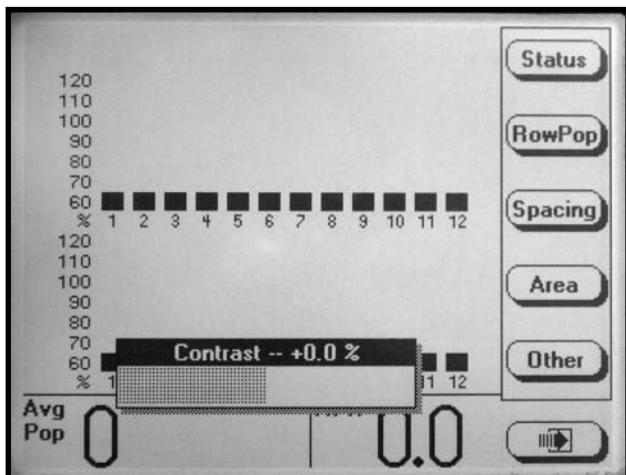

**STEP 5** Use the LEFT and RIGHT arrows or turn the knob to adjust contrast. The effect of the adjustment will be visible on the display.

**STEP 6** To adjust backlighting go to STEP 7. If finished press ENTER to save and exit.

**STEP 7** Press the AV button a third time. The backlight adjustment dialog box will appear in the lower L.H. corner of the display.

D05310612

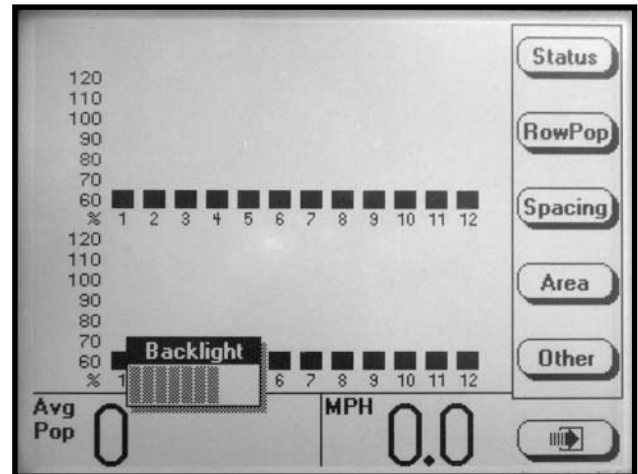

**STEP 8** Use the LEFT and RIGHT arrows or turn the knob to adjust backlighting. The effect of the adjustment will be visible on the display.

**STEP 9** Press the knob, ENTER or press the AV button a fourth time to save the volume, contrast and backlight settings. The backlight adjustment dialog box will disappear.

PROGRAMMING INTERPLANT® CONDITION,  
ROW SPACING AND UNITS (Metric Or English)

**STEP 1** To enter “Mode Selection” screen press the F6 key until “Mode Selection” screen appears.

D02140614

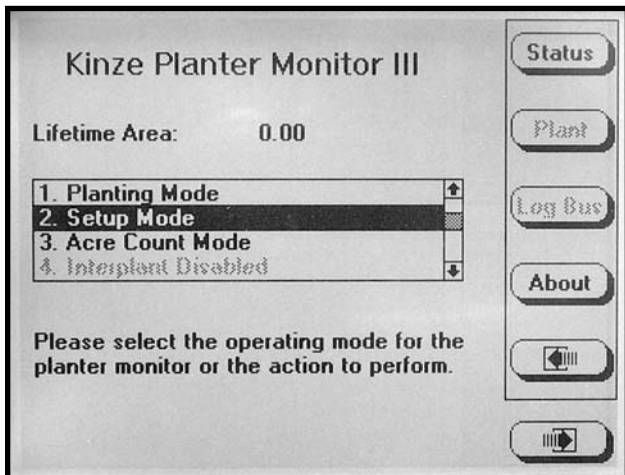

**STEP 2** Select “Setup Mode” by turning the rotary encoder knob or using the UP or DOWN arrow keys. Press the knob or ENTER key to display the highlighted item.

**STEP 3** Select “General Settings” by turning the knob or using the UP or DOWN arrow keys. Press the knob or the ENTER key to display the highlighted item.

D02140615

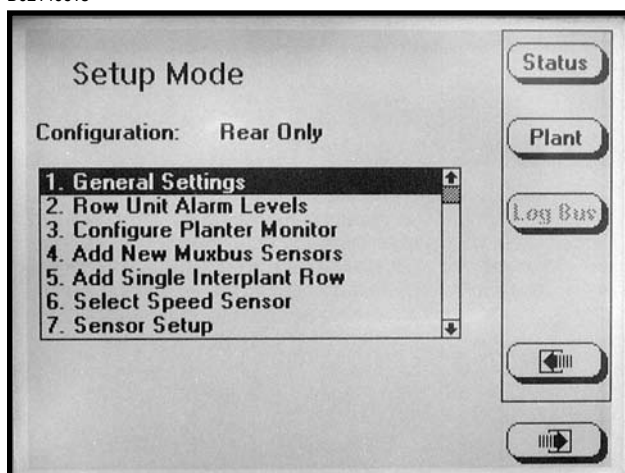

**STEP 4** Press the knob or ENTER key and a drop down menu will appear. Select either “Enabled” (push row units are being used for planting) or “Disabled” (push row units are not being used for planting and no seed rate alarms will be generated for the front rows; no bargraphs are to be displayed for the front rows and the front rows do not contribute to the average population and spacing or acre counts). Use the knob or UP or DOWN arrow keys to make selection. Press the knob or ENTER key to select highlighted item. The black box will advance to “Row Spacing” field.

D02140616

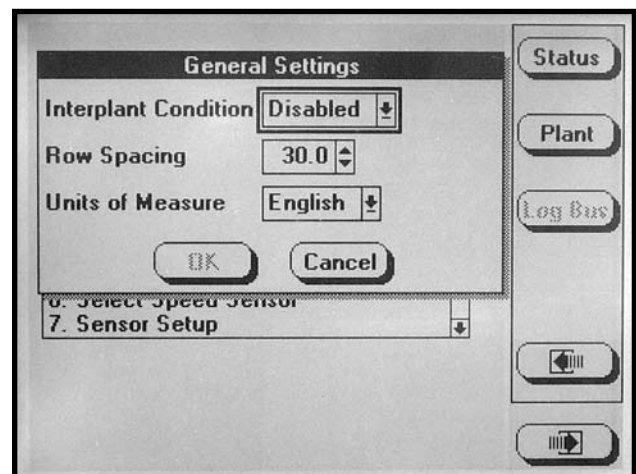

**NOTE:** When English is selected inches are displayed, if Metric is selected centimeters are displayed.

**STEP 5** Press the knob or ENTER key to enter the correct value for “Row Spacing”. Turn the knob to increase or decrease the number. The UP arrow key is used to increase the value of the item by one and the DOWN arrow key is used to decrease the value of the field by one. The LEFT arrow key multiplies the value of the item by 10 and the RIGHT arrow key divides the value of the item by 10. When the correct number has been entered press the knob or ENTER key. The black box will advance to “Units of Measure” field.

**NOTE:** The narrowest row spacing the planter is equipped to plant should be entered for “Row Spacing”. Example: 12 Row 30" with Interplant, row spacing would be set to 15".

**STEP 6** Select “Units Of Measure” field by pressing the knob or ENTER key and a drop down menu will appear. Select either “English” or “Metric” by turning the knob or using the UP or DOWN arrow keys. Press the knob or the ENTER key. The black box will advance to OK.

**STEP 7** Press the knob or ENTER key, when correct values are entered.

**STEP 8** To return to “Planting Mode” press the PLANT key.

## PROGRAMMING ROW UNIT ALARM LEVELS

The Row Unit Alarm Levels allow the thresholds for the seed rate alarms to be set. The default is 50% or Average. If the average population drops below 50% for a given row a seed rate alarm will be generated for that row unit. The alarm threshold can be set to 70%, 50%, 10% or disabled for any row.

**NOTE:** When the alarm threshold is disabled for any row no seed rate alarm will be generated.

D02140623

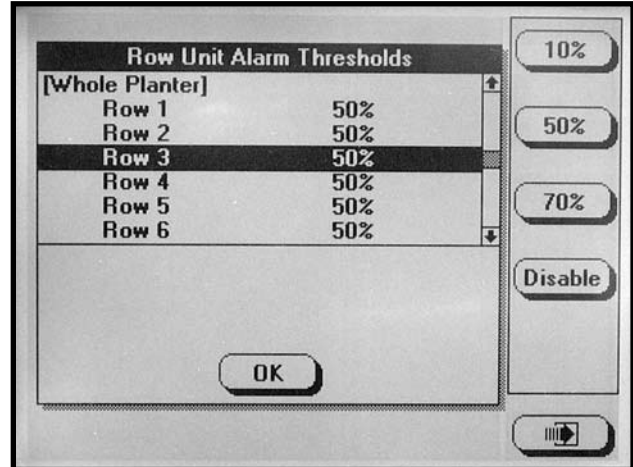

The alarm thresholds can be set for the whole planter, any planter section or individual rows.

**NOTE:** A section is determined by a set of rows driven by one or more shafts, designated to a single shaft sensor.

**STEP 1** To enter “Mode Selection”, press F6 key until the “Mode Selection” screen appears.

**STEP 2** Select “Setup Mode” by turning the rotary encoder knob or using the UP or DOWN arrow keys. Press the knob or ENTER key to display the highlighted item.

**STEP 3** Select “Row Unit Alarm Levels” by turning the knob or using the UP or DOWN arrow keys. Press the knob or ENTER key to display the highlighted item.

**STEP 4** To set alarm thresholds for whole planter, select “Whole Planter”. Press the key next to the desired threshold. When the desired threshold has been specified for all row units, press the knob or ENTER key.

To set alarm thresholds for all the rows in one section, select rear section or front section. Press the key next to the desired threshold. When the desired threshold has been specified for all row units, press the knob or ENTER key.

To set alarm thresholds for individual rows, select the desired row. Press the key next to the desired threshold. When the desired threshold has been specified for all row units, press the knob or ENTER key.

**STEP 5** To return to “Planting Mode” press the PLANT key.

## SPEED SENSOR CALIBRATION/PROGRAMMING

**STEP 1** To enter the “Speed Sensor Calibration” mode, press F6 until the “Mode Selection” screen appears. (If Applicable) Select “Setup Mode” and press the rotary encoder knob or ENTER key. Press F6 to advance to the “Speed Sensor Calibration” screen.

The Distance Pulse Count is used to record how many pulses are generated per mile/kilometer from the ground speed sensor. The monitor will display the current pulses per mile/kilometer using a 6 digit, no decimal place format.

D02140643

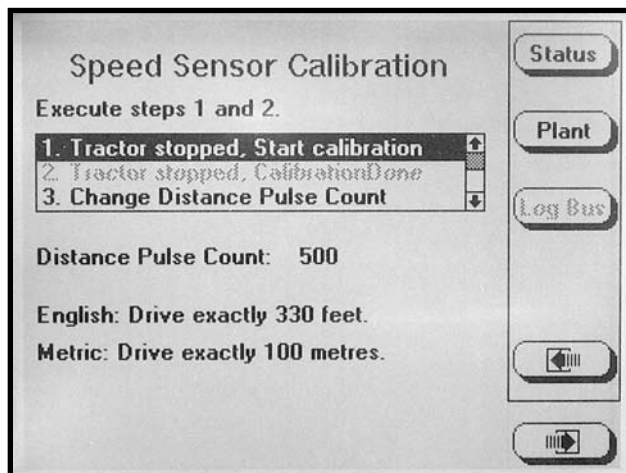

**NOTE:** A field calibration must be performed to establish the Distance Pulse Count number. Several factors can affect this value, such as wheel slip on the magnetic distance sensor. IT IS NOT UNCOMMON FOR THE SPEED ON THE MONITOR TO VARY SLIGHTLY FROM THE TRACTOR SPEEDOMETER. *Adjusting the Distance Pulse Count in the monitor to make the speed agree with the tractor can cause serious errors in acre/hectare and population/spacing readings. Do field checks to verify populations and seed spacing.*

- In field conditions, measure 330 feet or 100 meters, depending on the unit of measurement selected. Place a marker at the start point and end point.
- Pull the tractor up to the starting point.
- Select “Tractor stopped. Start calibration”.
- Press the rotary encoder knob or ENTER key to change the Distance Pulse Count on the display to 0.

**NOTE:** If the Distance Pulse Count number starts to count pulses with the tractor not moving, check radar distance sensor for vibration or other interference.

- Drive the tractor for 330 feet or 100 meters.
- The monitor will count the number of pulses and display them.
- Stop the tractor at the end point.
- Select “Tractor stopped. Calibration Done”.
- Press the knob or ENTER key.

**NOTE:** Repeat the above steps multiple times. Record and average the values. Use this average for the Distance Pulse Count number constant.

**STEP 2** Select “Change Distance Pulse Count” by turning the knob or using the DOWN arrow key. Press the knob or ENTER key.

D02200605

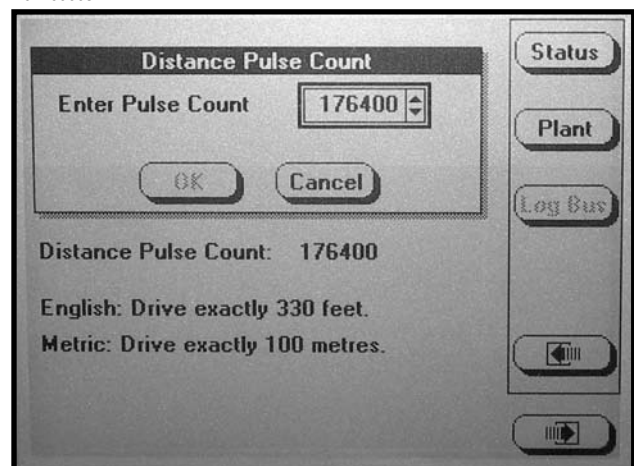

**NOTE:** The Distance Pulse Count will vary from the above example.

**STEP 3** To return to “Planting Mode” press the PLANT key.

WHEN THE CORRECT DISTANCE PULSE COUNT IS KNOWN, CALIBRATION IS NOT NEEDED AND THE FOLLOWING STEPS MAY BE USED.

**STEP 1** To enter the “Speed Sensor Calibration” screen, press F6 key until the “Mode Selection” screen appears. (If Applicable) Select “Setup Mode” and press the rotary encoder knob or ENTER key. Press F6 key to advance to the “Speed Sensor Calibration” screen.

**STEP 2** Select “Change Distance Pulse” field by turning the knob or using the UP or DOWN arrow keys. Press the knob or ENTER key.

D02200605

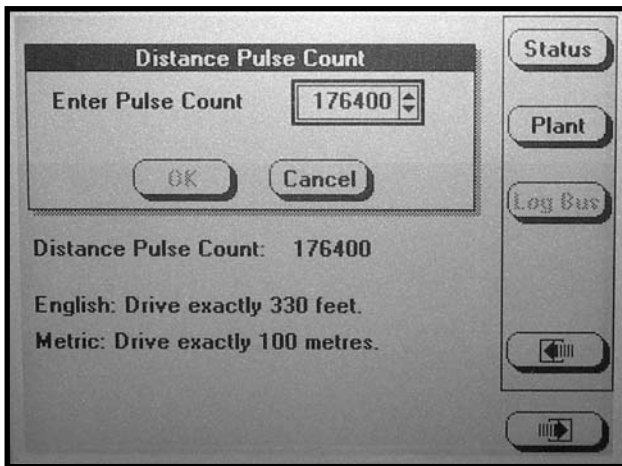

**NOTE: The Distance Pulse Count will vary from the above example.**

**STEP 3** With the “Enter Pulse Count” field selected press the knob or ENTER key.

**STEP 4** Change the Pulse Count to the desired value using the UP or DOWN arrow keys or turn the knob until the desired value is obtained. Press the knob or ENTER key.

**NOTE: The LEFT arrow key multiplies the value of the item by 10 and the RIGHT arrow key divides the value of the item by 10.**

**STEP 5** Select OK by pressing the knob or ENTER key to save the new count. Select CANCEL to retain the old value of the Distance Pulse Count.

**STEP 6** Press PLANT key to return to main planting screen.

## REPROGRAMMING SPEED SENSOR

This setting must be specified when the monitor is first configured. It will be necessary to reprogram to use an alternate speed sensor.

**NOTE: Speed sensors may not be changed while planting.**

## RADAR TO MAGNETIC DISTANCE SENSOR

**STEP 1** Press the F6 key until the “Mode Selection” screen appears. Select “Setup Mode” by turning the rotary encoder knob or using the UP or DOWN arrow keys. Press the knob or ENTER key to display the highlighted item.

D02140614

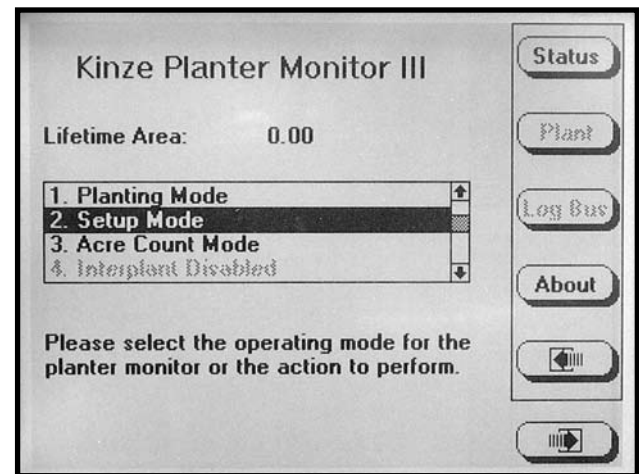

**STEP 2** Turn the knob or use the UP or DOWN arrow keys to choose “Sensor Setup”. Press the knob or ENTER key to display the highlighted item.

D02140641

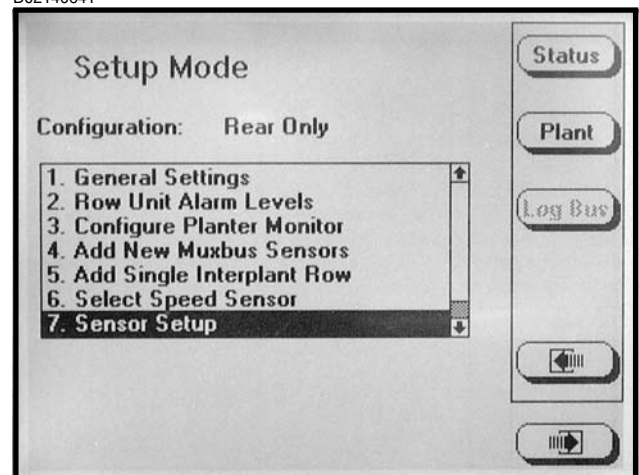

**STEP 3** Turn the knob or use the UP or DOWN arrow keys to highlight “Mag Coil Pickup”. Plug in Magnetic Distance Sensor and press the INSTALL key. Press the knob or ENTER key to save information.

D05310609a

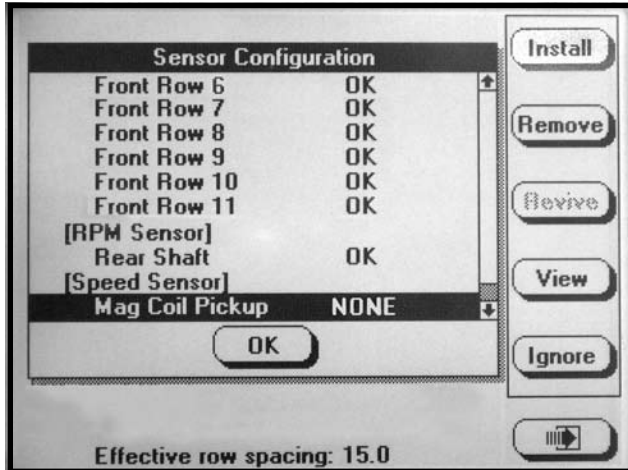

**STEP 4** Turn the knob or use the UP or DOWN arrow keys to select “Select Speed Sensor” and press the knob or ENTER key. Press the knob or ENTER key to select the “Speed Sensor” field and a drop down menu will appear. Turn the knob or use the UP or DOWN arrow keys to select “Coil Pick-Up” and press the knob or ENTER key to make selection. The black box will advance to OK press the knob or ENTER key to save the information.

D02140639

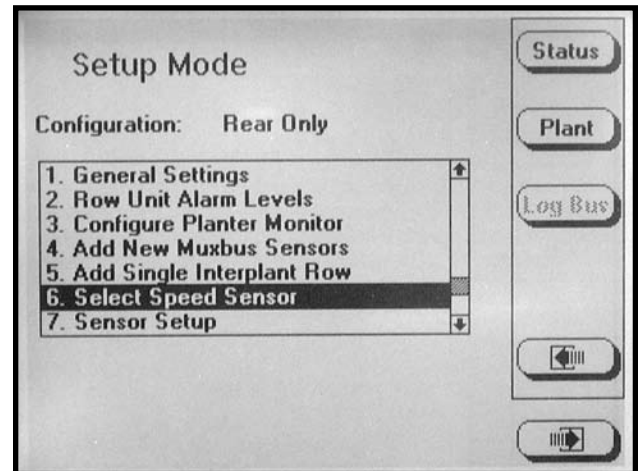

D05310609

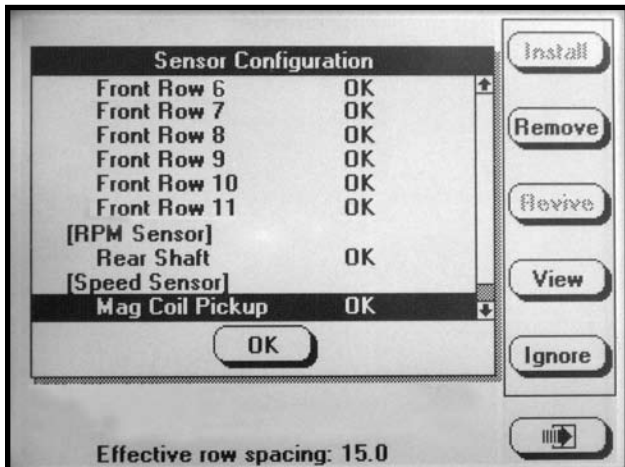

D02140639

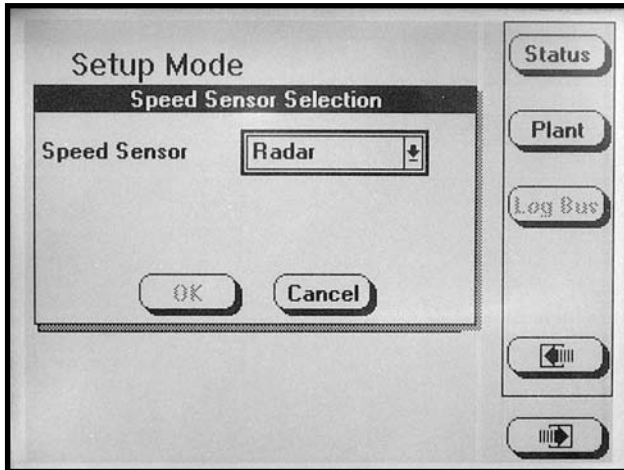

**NOTE:** To prevent the configuration from being changed select CANCEL, then press the rotary encoder knob, ENTER key or ESC key.

D06210601

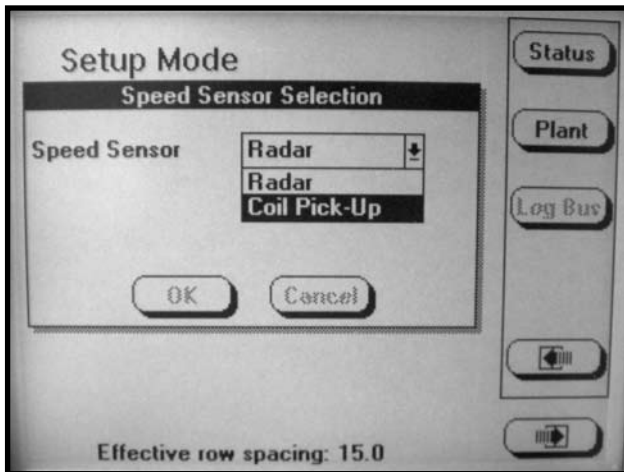

**STEP 5** Unplug the radar from the tractor.

**STEP 6** Press the PLANT key to return to main planting screen.

**NOTE:** When switching between speed sensors, verify the distance pulse count is correct for the chosen sensor. There will be significant distance pulse count variation between radar and coil pick-up sensors.

## MAGNETIC DISTANCE SENSOR TO RADAR

**STEP 1** Press the F6 key until the “Mode Selection” screen appears. Select “Setup Mode” by turning the rotary encoder knob or using the UP or DOWN arrow keys. Press the knob or ENTER key to display the highlighted item.

D02140614

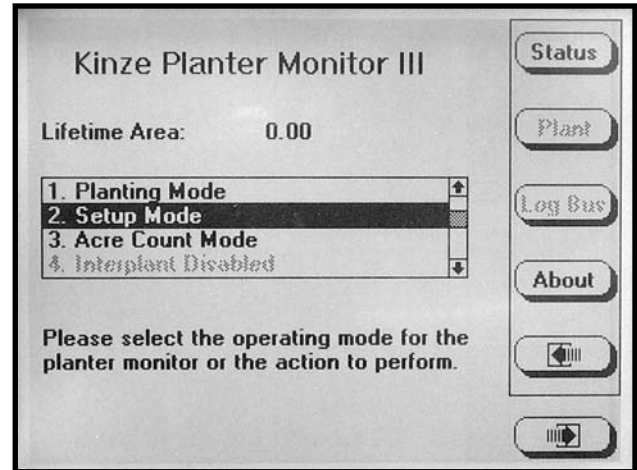

**STEP 2** Turn the knob or use the UP or DOWN arrow keys to choose “Sensor Setup”. Turn the knob or use the UP or DOWN arrow keys to highlight “Mag Coil Pickup”. Press the REMOVE key, a note will appear for confirmation select as appropriate. Unplug Magnetic Distance Sensor and press the knob or ENTER key to save the information.

D02140641

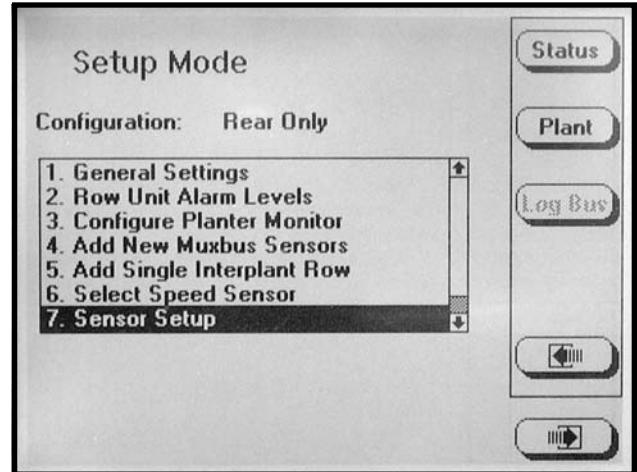

D05310609

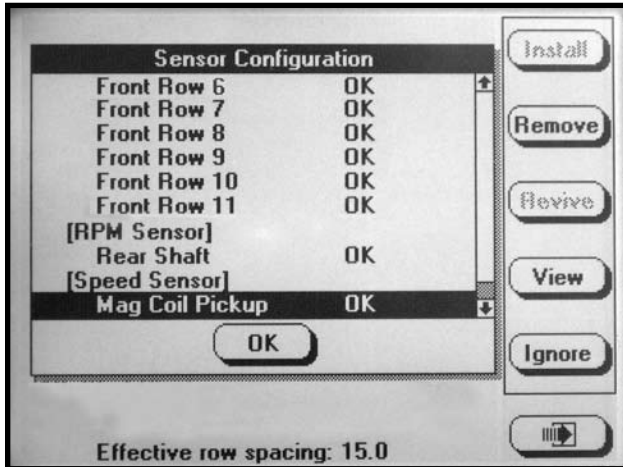

**STEP 3** Turn the knob or use the UP or DOWN arrow keys to select “Select Speed Sensor” and press the knob or ENTER key. Press the knob or ENTER key to select the “Speed Sensor” field and a drop down menu will appear. Turn the knob or use the UP or DOWN arrow keys to select “Radar” and press the knob or ENTER key to make selection.

**NOTE:** To prevent the configuration from being changed select CANCEL, then press the knob, ENTER key or ESC key.

D02140640

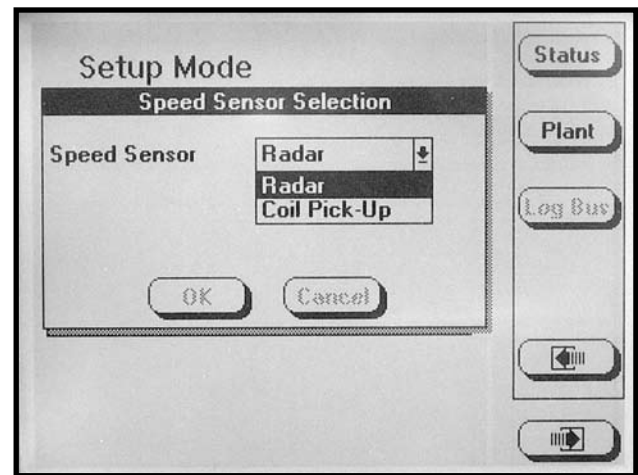

**STEP 4** Plug in the Radar and the black box will advance to OK. Press the knob or ENTER key to save the information.

**STEP 5** Press the PLANT key to return to main planting screen.

**NOTE:** When switching between speed sensors, verify the distance pulse count is correct for the chosen sensor. There will be significant distance pulse count variation between radar and magnetic distance sensors.

D02140639

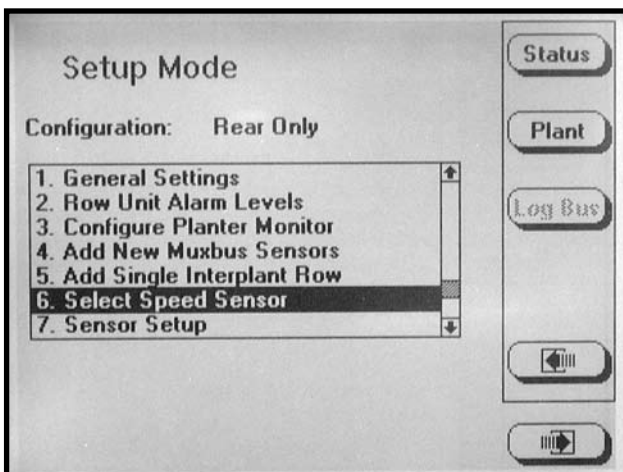

D02140639

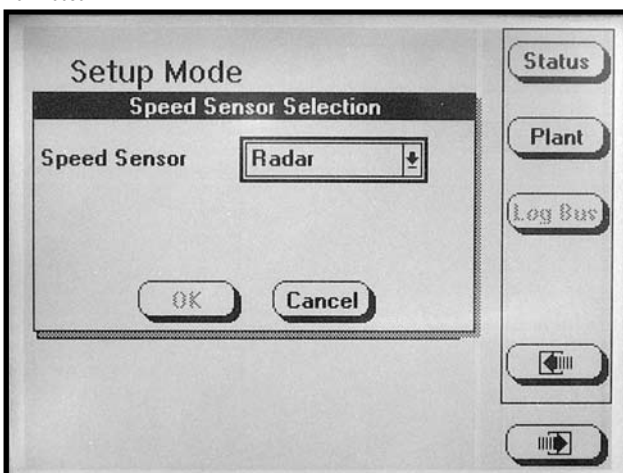



**ADDING INTERPLANT® ROWS (If Rear Rows Have Previously Been Programmed)**

**STEP 1** Press the F6 key until “Mode Selection” screen appears.

**STEP 2** Select “Setup Mode” by turning the rotary encoder knob or using the UP or DOWN arrow keys. Press the knob or ENTER key to display the highlighted item.

D02140614

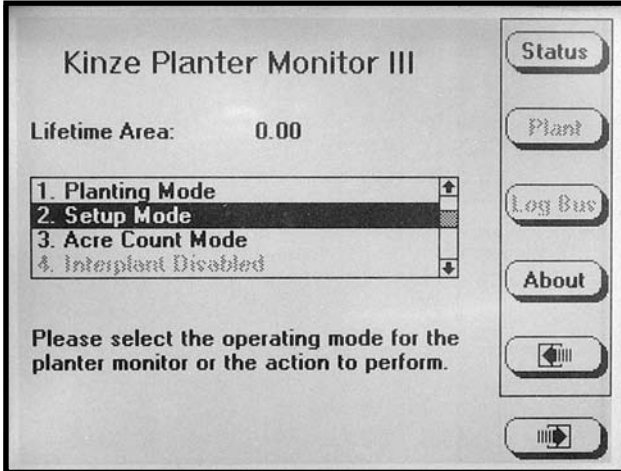

**STEP 3** Select “Add New Muxbus Sensors” by turning the knob or using the UP and DOWN arrow keys. Press the knob or ENTER key to display the highlighted item.

D02140633

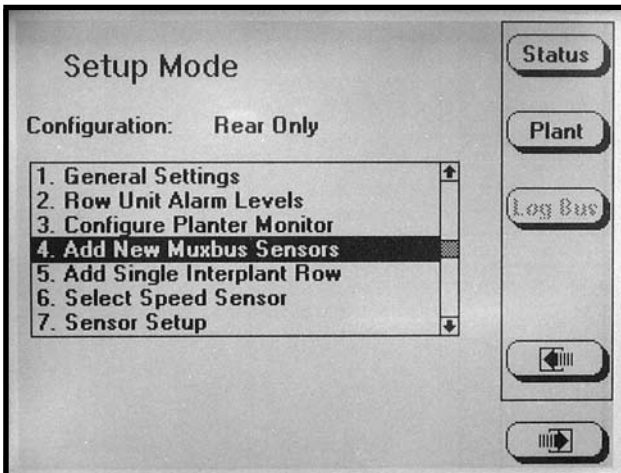

**STEP 4** The note shown below will appear. Select OK by turning the knob or using the UP or DOWN arrow keys. Press the knob or ENTER key to make the selection.

D03010601

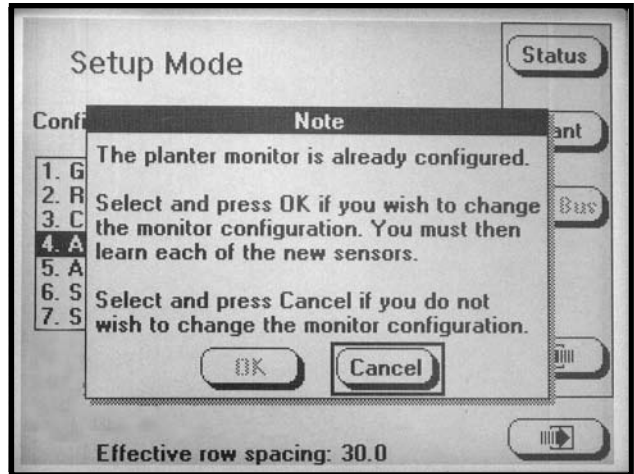

**STEP 5** Turn the knob or use the UP or DOWN arrow keys to select the “Front Row Units” field and press the knob or ENTER key to highlight the field. Turn the knob or use the UP or DOWN arrow keys to obtain the desired number of rows. When the correct value has been entered press the knob or ENTER key. The black box will advance to the OK key. Press the knob or ENTER key to save the information.

**NOTE:** To prevent the configuration from being changed select CANCEL, then press the knob, ENTER key or ESC key.

D02220674

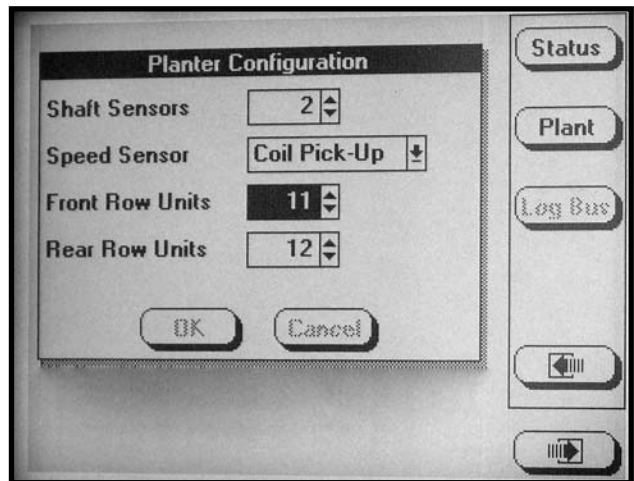

**NOTE:** Attempting to add rear rows while adding new muxbus sensors will cause the following note to appear.

D02220675

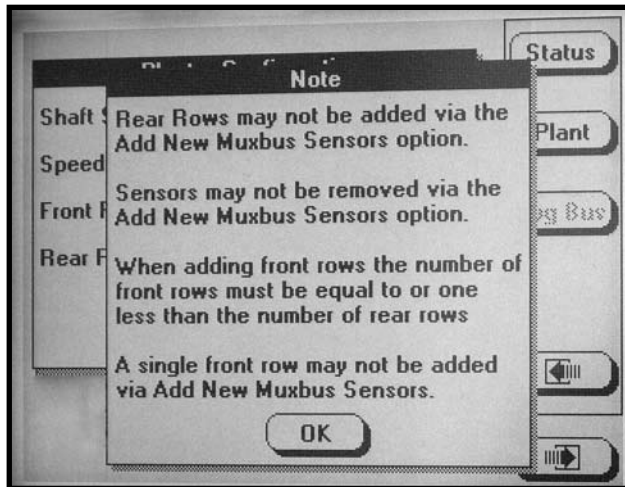

**STEP 6** The note shown below will appear. Select OK by turning the knob or using the UP or DOWN arrow keys. Press the knob or ENTER key to make the selection.

D03010603

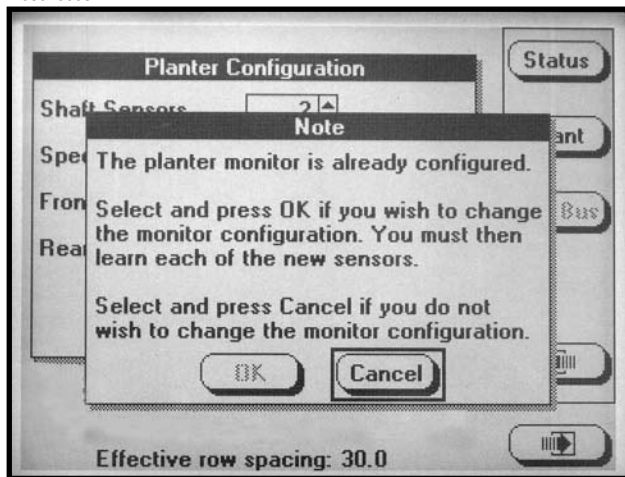

**NOTE:** To prevent the configuration from being changed select CANCEL, then press the knob, ENTER key or ESC key.

**STEP 7** The sensor configuration screen will appear. With [Auto Detect] highlighted select INSTALL. Begin to install sensors from left to right.

D02230604a

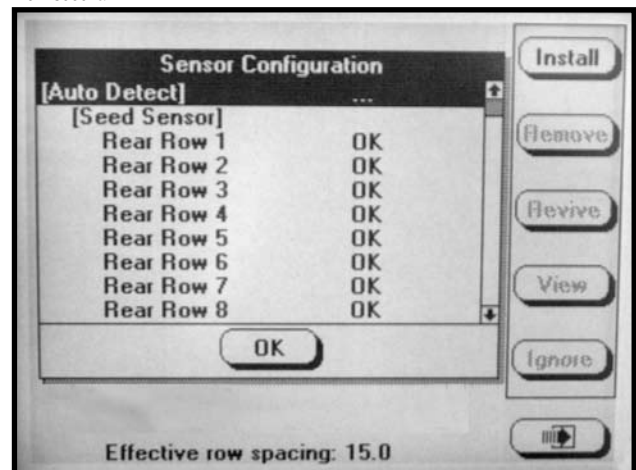

D02220672

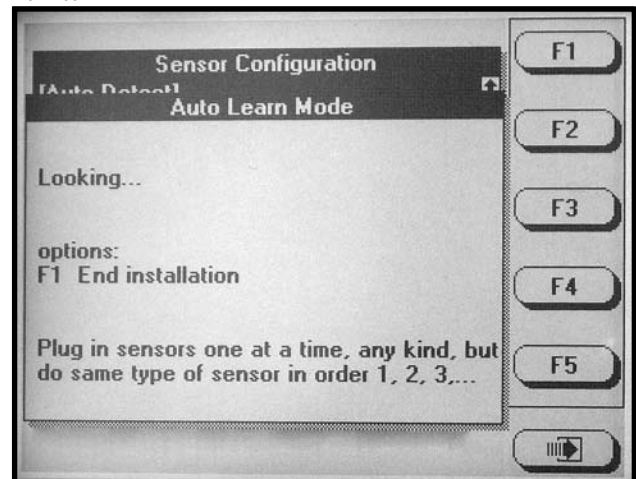

**STEP 8** When all sensors are learned select F1 to end installation. Scroll down to verify the front rows are learned. Select OK by pressing the knob or ENTER key.

**NOTE:** "OK" will appear next to each sensor if no errors are detected.

**STEP 9** Select “General Settings”, by turning the knob or using the UP or DOWN arrow keys. Press the knob or ENTER key to make the selection.

D02140615

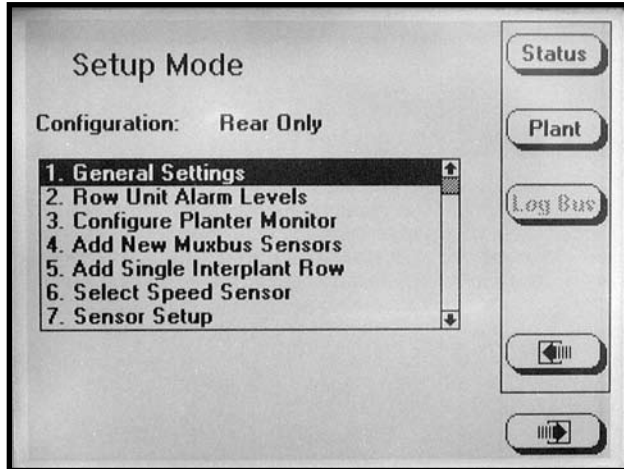

**STEP 10** Select the “Row Spacing” field by turning the knob or using the UP or DOWN arrow keys. Press the knob or ENTER key to highlight field. Adjust the row spacing to Interplant spacing by turning the knob or using the UP or DOWN arrow keys. Press the knob or ENTER key to enter the value. Then turn the knob or use the UP or DOWN arrow keys to advance to OK. Press the knob or enter key to save row spacing.

**NOTE:** To prevent the configuration from being changed select CANCEL, then press the knob, ENTER key or ESC key.

**STEP 11** To return to “Planting Mode” press the PLANT key.

## ADDING EVEN-ROW PACKAGE (If Front Rows Have Previously Been Programmed)

**STEP 1** Press the F6 key until “Mode Selection” screen appears.

**STEP 2** Select “Setup Mode” by turning the rotary encoder knob or using the UP or DOWN arrow keys. Press the knob or ENTER key to display the highlighted item.

D02140614

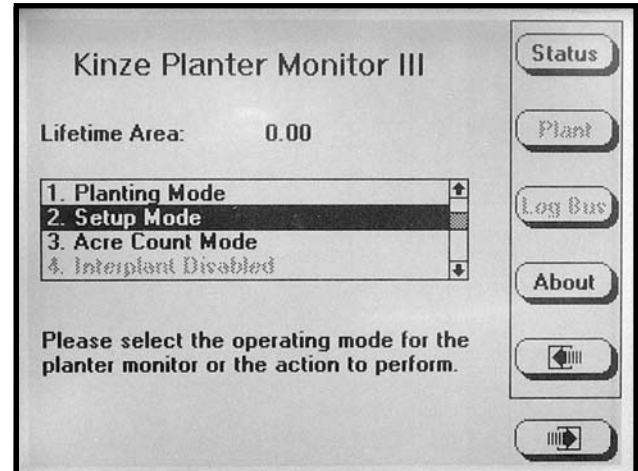

**STEP 3** Select “Add Single Interplant Row” by turning the knob or using the UP and DOWN arrow keys. Press the knob or the ENTER key to display the highlighted item.

D022206200

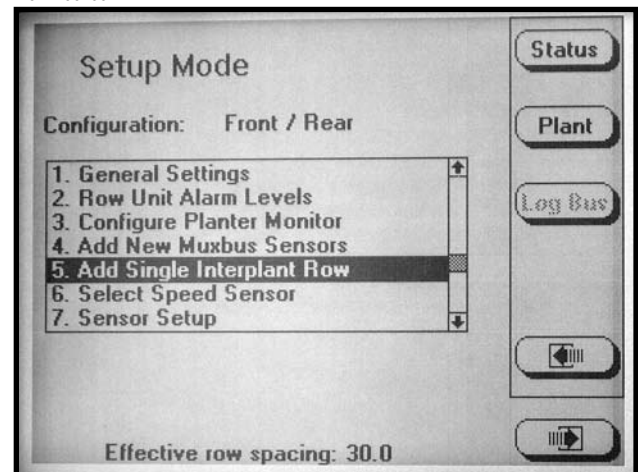

**STEP 4** To confirm the following note turn the knob or use the UP or DOWN arrow keys to select OK and then press the knob or ENTER key to confirm. If the single Interplant row is not to be added select the CANCEL key and press the knob or ENTER key to cancel or press the ESC key.

D022206201

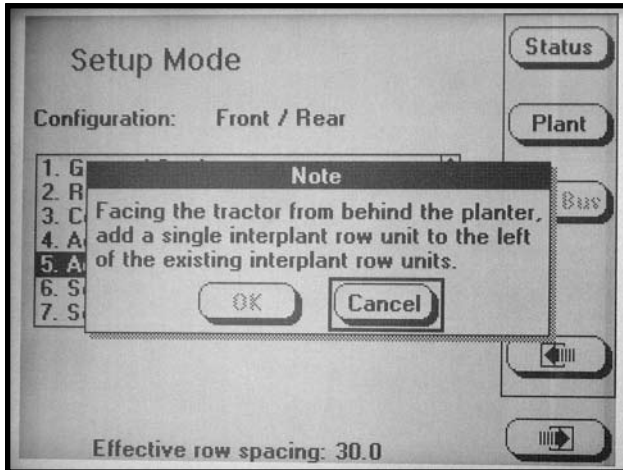

**STEP 5** To “Add Single Interplant Row” the following screen will appear.

If the single Interplant row is to be added turn the knob or use the UP or DOWN arrow keys to select OK and then press the knob or ENTER key to add the Interplant row. If the single Interplant row is not to be added select the CANCEL key and press the knob or ENTER key to cancel or press the ESC key.

D022206202

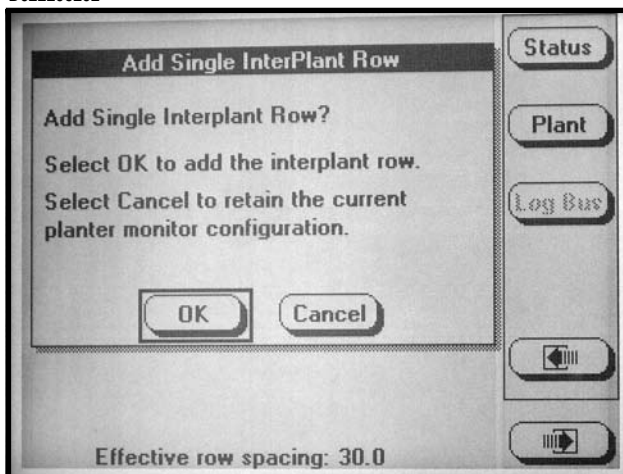

**STEP 6** The “Sensor Configuration” screen will appear. Plug in the new sensor then scroll down to highlight “Front Row 1” by turning the knob or using the UP or DOWN arrow keys. Select INSTALL to learn the new sensor. Press the knob or ENTER key to return to setup mode.

D02220670

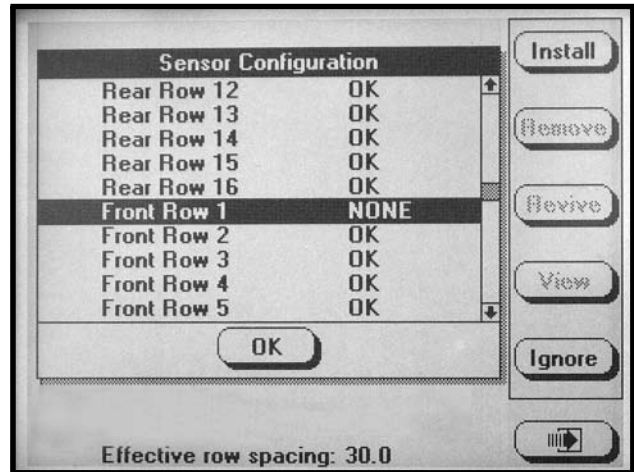

**STEP 7** To return to “Planting Mode” press the PLANT key.

## ENABLING/DISABLING INTERPLANT® ROWS

To Enable or Disable Interplant (a) press the F6 key until the “Mode Selection” screen appears, (b) turn the rotary encoder knob or use the UP or DOWN arrow keys to highlight “Disable/Enable Interplant”, (c) press the knob or ENTER key to “Disable” or “Enable” Interplant. To verify selection, the row spacing is displayed on the bottom of the screen.

D03010605a

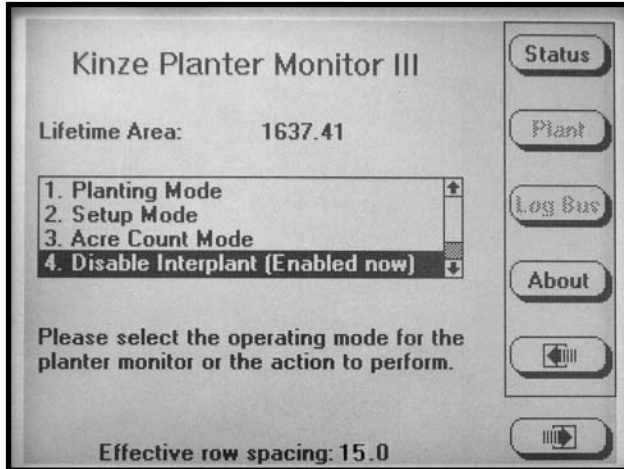

Either select the “Planting Mode” by turning the knob or using the UP arrow key and press the knob or ENTER key or press F6 to return to the “Planting Mode”.

D02240602

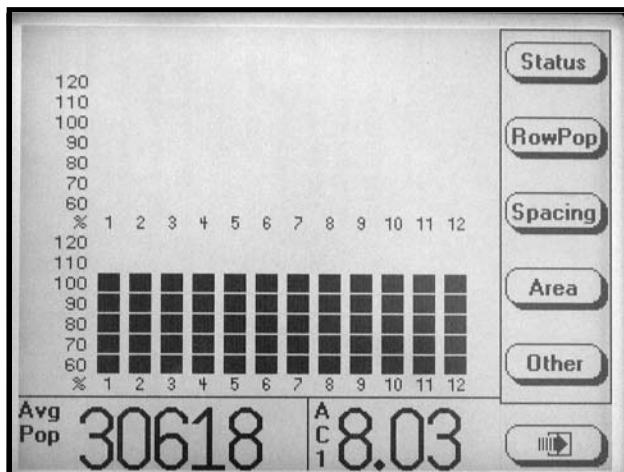

## ROW POPULATION

- Press the ROW POP key to display row population. Average planter population will be shown in the lower L.H. corner of the display.

D05310614

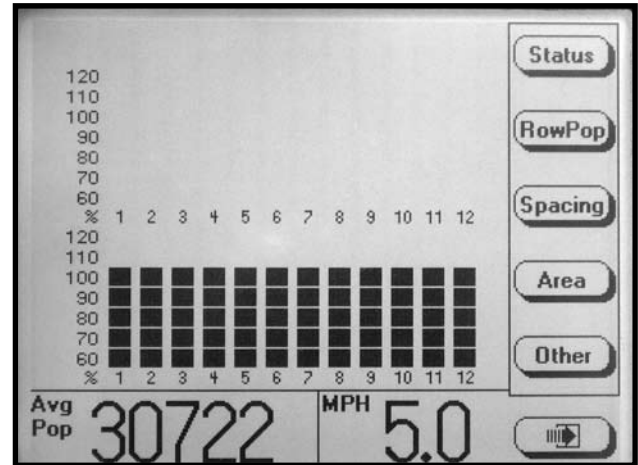

- Press the SCAN key and the monitor will scan through each row in ascending order displaying the average seed population for each row. After all rows have been scanned the average population is displayed and scan function will continue with the first rear row.

D02240604

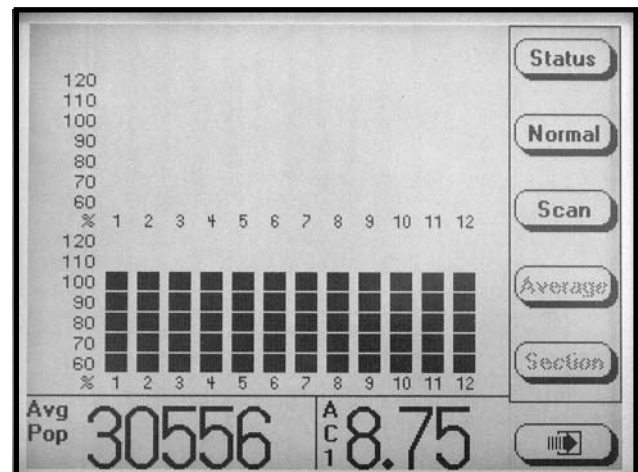

- Press the FREEZE key to stop scanning, the left display item will be frozen on a particular row. “Frzn” appears in the lower L.H. corner to indicate the display is frozen. To resume scan press the SCAN key.

**EXAMPLE: When average row population is shown, R3 indicates rear row 3, F2 indicates front row 2, etc.**

D05310615

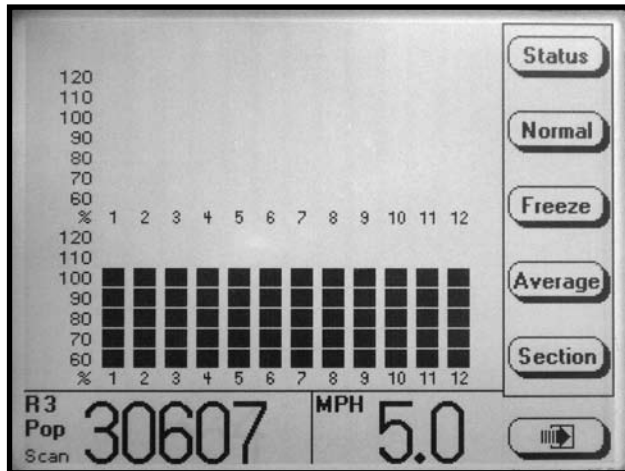

- When either Scan or Frzn is displayed in the L.H. corner the SECTION and arrow keys function as follows: (a) SECTION or RIGHT arrow key advances to the first row of the next section; (b) SECTION or LEFT arrow key selects the first row of the previous section, wrapping around to the first row of the last section when moving past the first section; (c) UP arrow key moves forward to the next row of the planter, wrapping around to the first row when moving past the last row; (d) DOWN arrow key moves backward to the previous row of the planter, wrapping around to the last row of the planter when moving past the first row.
- Press the AVERAGE key to display the average population in the bottom L.H. corner.
- Press the NORMAL key to display the normal screen for planting mode.

**NOTE: If the rows are being scanned and the AVERAGE key is selected the scan function will stop.**

## ROW SPACING

- Press the SPACING key to display seed spacing keys. Seed spacing will appear in the bottom L.H. corner of the display.

D02240602

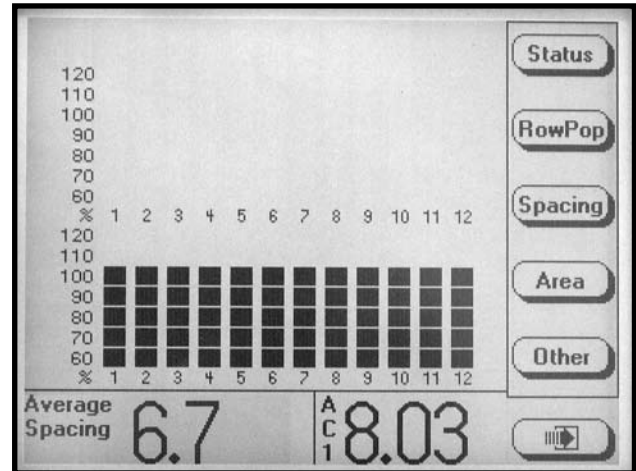

D02240605

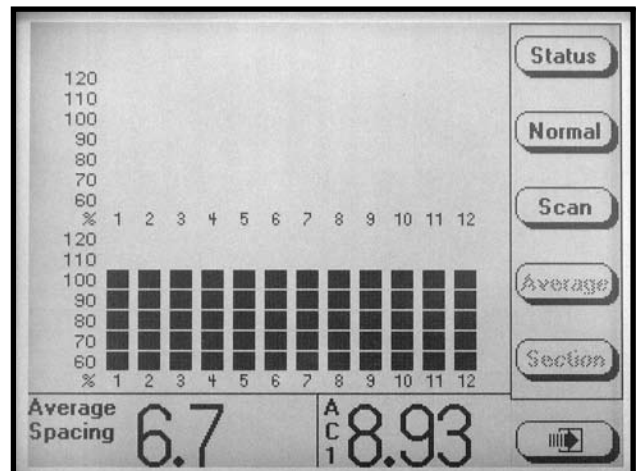

- Press the SCAN key and the monitor will scan through each row in ascending order displaying the average seed spacing for each row. Scan appears in the L.H. corner to indicate the display is scanning. After all rows have been scanned the average population is displayed and scanning will continue with the first rear row.
- Press the FREEZE key to stop scanning and the left display item will be frozen on a particular row. “Frzn” appears to indicate the display is frozen. To resume scan press the SCAN key.

- When either "Scan" or "Frzn" is displayed in the left display item the SECTION and arrow keys function as follows: (a) SECTION and RIGHT arrow key advances to the first row of the next section; (b) LEFT arrow key selects the first row of the previous section, wrapping around to the first row of the last section when moving past the first section; (c) UP arrow key moves forward to the next row of the planter, wrapping around to the first row when moving past the last row; (d) DOWN arrow key moves backward to the previous row of the planter, wrapping around to the last row of the planter when moving past the first row.

- Press the AVERAGE key to display the average seed spacing in the bottom L.H. corner.
- Press the NORMAL key to display the main planting mode.

**NOTE: If the rows are being scanned and the AVERAGE key is selected the scan function will stop.**

### SPEED/SHAFT ROTATION

- Press the OTHER key to display items available to display in the bottom R.H. corner.

- Press the SHAFT key to view the average meter shaft RPM. The value will appear in the bottom R.H. corner of the display.

**NOTE: Applicable to planters with shaft rotation sensors installed.**

D02240607

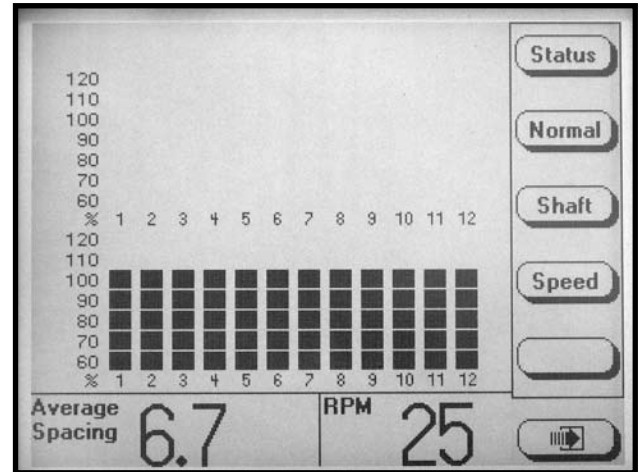

- Press the SPEED key to view the ground speed. The value will appear in the bottom R.H. corner of the display.

D02240602

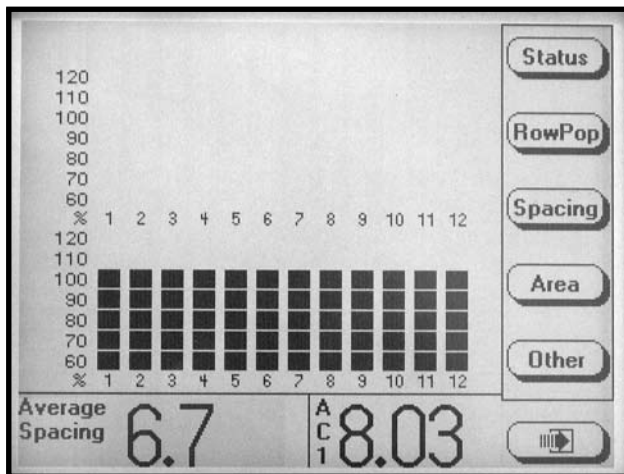

D02240608

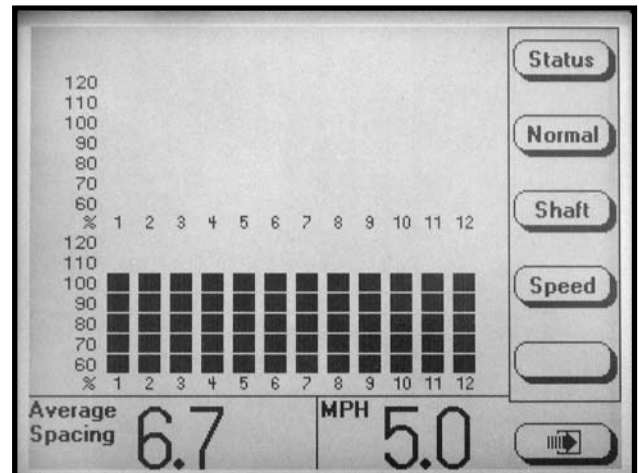

**NOTE: The appropriate units of measure will be displayed (English or Metric).**

- Press NORMAL to bring back the standard key labels.

D02240606

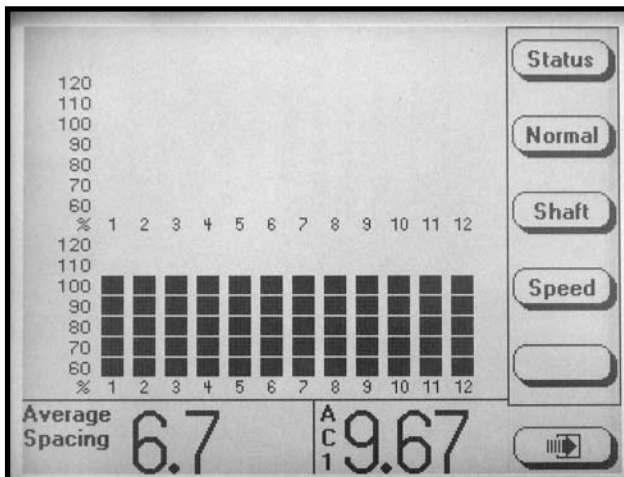

## WARNINGS AND ALARMS

1. **Seed Rate Alarm** - A seed rate alarm is activated whenever the row average seed population drops below the threshold set for that row.

The corresponding row on the bargraph starts flashing and the monitor emits a series of beeps that persist until the alarm is clear or the ACK button is pressed. "Seed Rate Alarm" appears in the upper left corner of the screen. The bargraph for the row drops down based on the threshold set for the alarm.

**EXAMPLE: If the threshold is 70% the lower two bargraph segments are shown. If the threshold is 50% or 10% the lowest bargraph segment is shown.**

The status message associated with an alarm contains more information about the alarm. To view the "Status Message" for a seed rate alarm, press the STATUS key.

If the sensor is detecting no seed flow it will display which row is not functioning. The alarm may be indicating a mechanical problem that is reducing the seed flow or an electrical problem causing the seed counts to be incorrect.

**NOTE: The only way to remove an alarm is to find and correct the problem. Alarms are not reported for rows that seed rate alarm thresholds have been disabled.**

**NOTE: The percentage shown in the alarm message is the percentage at the time the alarm occurred.**

2. **Section Not Planting** - When the monitor detects an entire section not planting, the monitor will emit three beeps to alert the user. The bargraph for the affected section flashes and is reduced to the lowest segment. An alarm message is added to the list of "Status Messages". Press the STATUS key to view the alarm message.

3. **Seed Counting Sensors Not Communicating With Monitor** - When the monitor detects a communication error between the sensor and the monitor, the monitor will emit two beeps to alert the user. Try to reestablish communication with sensor(s) by pressing F2. If the monitor is unable to establish communication there may be (a) a faulty sensor, (b) a poor electrical connection or (c) a cut or pinched wire harness.

D02220687

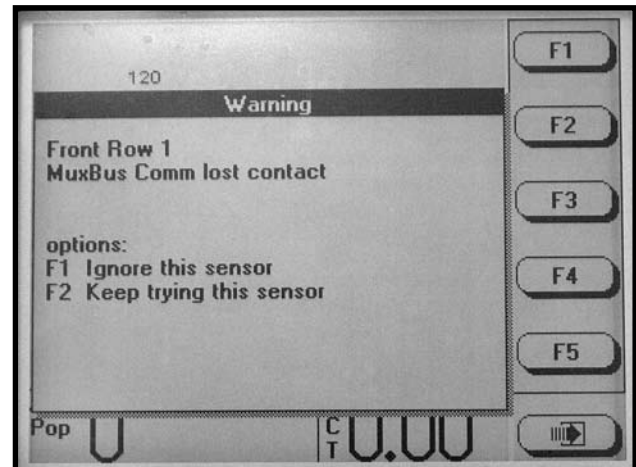

If multiple sensors have lost contact, the message will indicate which sensors have lost contact.

D02220659a

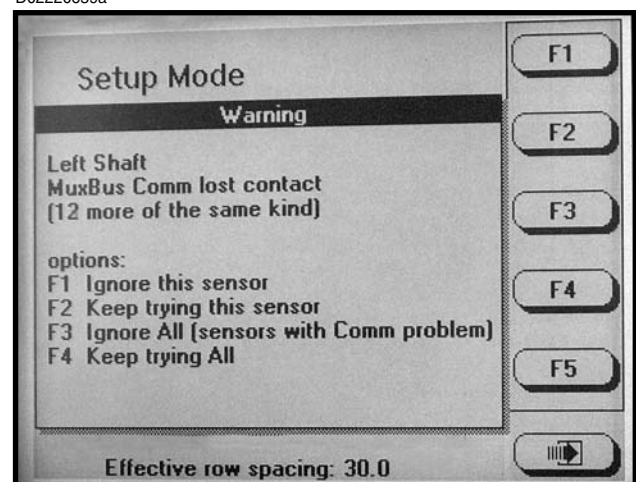

**NOTE: When it is known that a sensor or a group of sensors are faulty, F1 or F3 should be pressed. The monitor will no longer try to communicate with the sensor(s). In the planting mode the corresponding bargraphs will be grayed out in the main screen.**



D02220691



**NOTE:** If the sensors are not faulty, F2 or F4 should be pressed and the message shown below will appear when the STATUS key is pressed.

D02220685

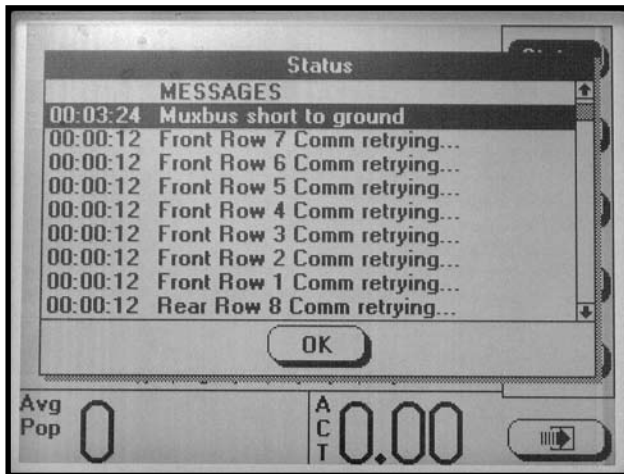

**NOTE:** If a sensor has been ignored, the sensor configuration screen will display as shown below.

D02220692

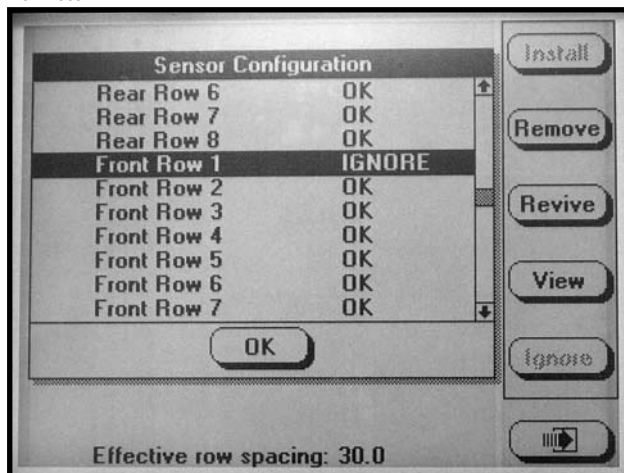

- Seed Counting Sensors Too Dirty Warning** - When powering on the KPM III, each of the seed sensors will do a self check. If a seed tube is too dirty, the message "Clean Or Replace Sensor As Necessary" will be displayed and the bargraph for that row will flash. The LED on the seed tube sensor will not flash. The sensor will not function until the problem is corrected.

**NOTE:** After the alarms have been acknowledged and if the alarm condition is still present, the LCD screen will continue to display the alarm condition.

- Wire Shorts** - When a wire is shorted any one of the messages shown below will appear, stating which wires are shorted. The short must be located and fixed to continue planting. Cycle the power on the monitor to clear the alarm.

D02220683

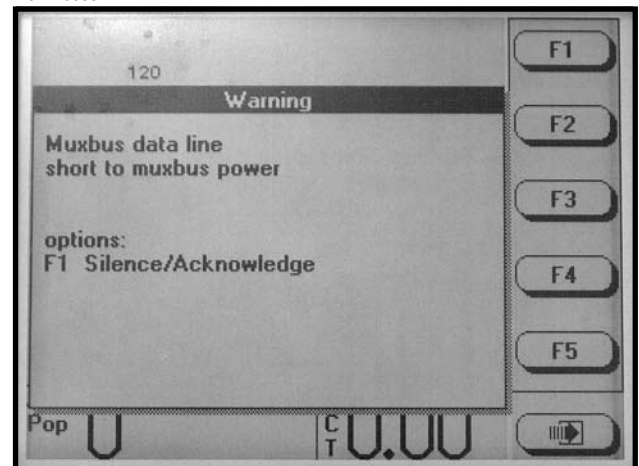

D02220684

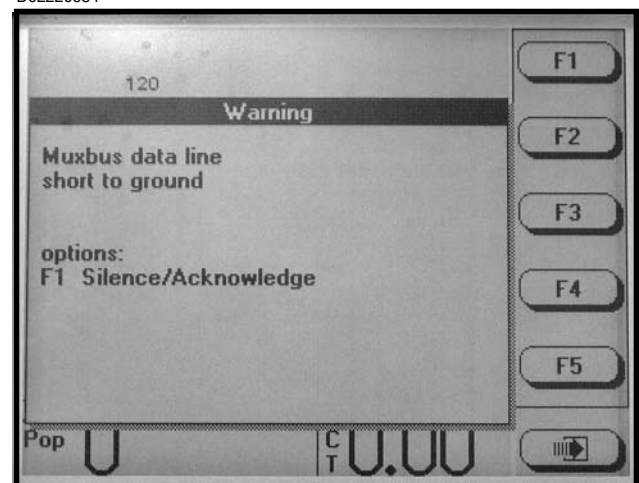

## FIELD OPERATION

Press the ON/OFF key to turn the monitor ON.

If the monitor has been configured, it will enter the normal planting mode and attempt to communicate with the seed sensors.

D02200606

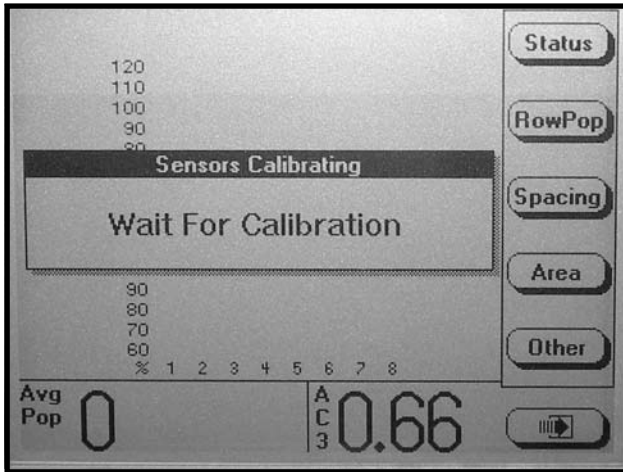

**NOTE:** Do not attempt planting before the “Wait For Calibration” message disappears. If planter is moving while sensors are calibrating alarms will be generated.

**NOTE:** If the monitor can communicate with the sensors the normal planting mode screen will be displayed.

D0220689a

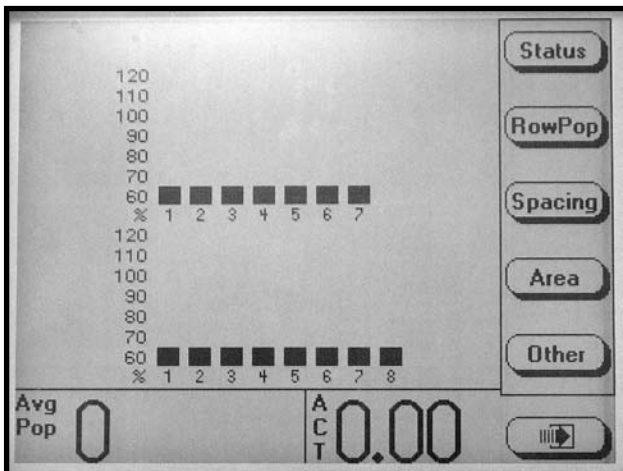

If the monitor does not detect any sensors the message shown below will appear.

D02200627

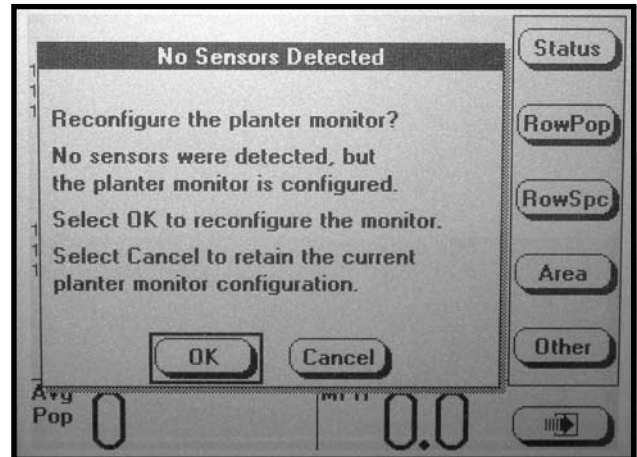

**NOTE:** Selecting OK will reconfigure the monitor requiring all sensors to be re-learned. Selecting CANCEL will maintain the current configuration and the monitor will continue trying to communicate with the sensors.

## AREA MANAGEMENT

There are 10 area counters: Total Area, Field Area and area counters 1 through 8. The Total Area is always active but may be cleared. If it is cleared, the Field Area is also cleared. Field Area and Area Counters 1 through 8 may be cleared independent of each other. They may also be started or stopped at anytime. In addition, there is a Lifetime Area Counter (located on the Mode Selection Screen) which can not be disabled or cleared by the user.

To enter the "Area Management" screen, press the F6 key until the "Area Management" screen appears.

D02210626a

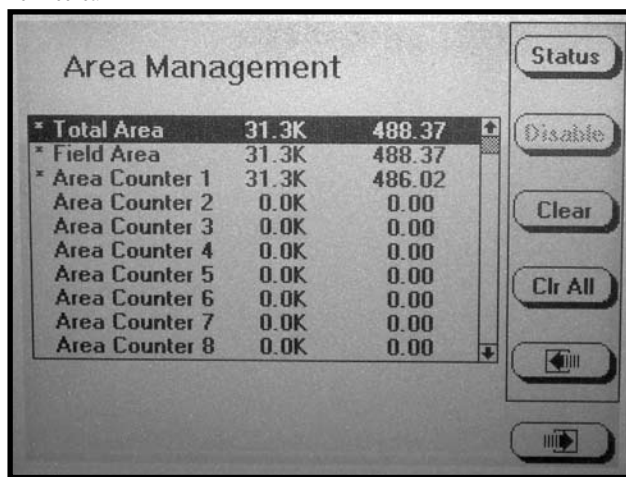

**NOTE: Total area counter can never be disabled, but can be reset to zero (cleared).**

- The asterisk next to the name of the area counter indicates the area counter is enabled and accumulating area.

**EXAMPLE:** In the photo shown above, 31.3K indicates the average seed population for the accumulated area is 31,300 seeds per unit area (acre/hectare). This number has been rounded off. The actual seed population ranges anywhere from 30,500 to 31,499 per unit area. The last column of numbers is the area accumulated (acres/hectares).

- Turn the knob or use the UP or DOWN arrow keys to highlight the desired "Area Counter".
- Press the ENABLE or DISABLE key.

**NOTE: Up to four area counters can be enabled at one time (two area counters in addition to Total Area and Field Area). If four area counters are already enabled, disable one active area counter in order to enable a new area counter. To disable or enable area counters see next column.**

**NOTE: When a key is dimmed it does not perform any operation on the highlighted area counter.**

### ENABLE AREA COUNTER

Each of the "Disabled Area Counters" may be enabled up to a total of four "Area Counters". To Enable a Disabled "Area Counter": (a) highlight the desired "Area Counter" by turning the rotary encoder knob or using the UP or DOWN arrow keys; (b) press the ENABLE key or press the knob or ENTER key and an asterisk will appear next to the "Area Counter". The Enabled "Area Counter" starts accumulating area.

### DISABLE AREA COUNTER

Each of the Enabled Area Counters may be disabled, with the exception of the Total Area Counter. To disable an enabled area counter: (a) highlight that "Area Counter"; (b) press the DISABLE key or press the rotary encoder knob or ENTER key and the asterisk next to the "Area Counter" will disappear. The "Disabled Area Counter" will no longer accumulate area.

**NOTE: Attempts to disable an Area Counter that is currently being displayed while planting will cause the following alarm.**

D02210627a

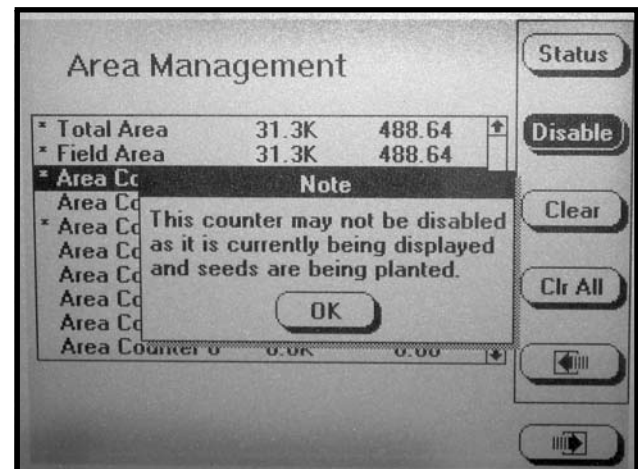

D02210626a

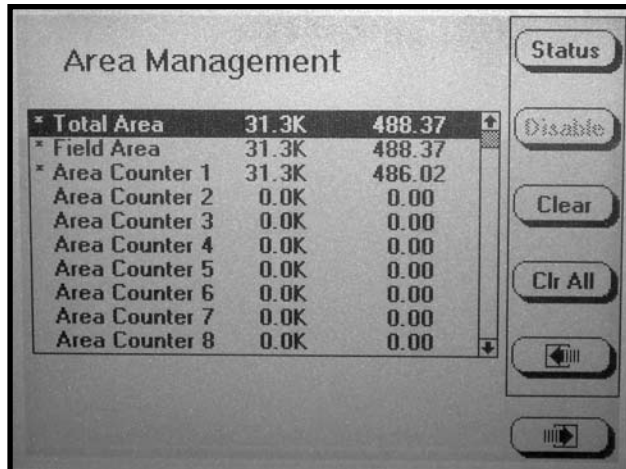

**NOTE:** If the total area is highlighted and the CLEAR key is pressed the following request for confirmation will appear.

D02200612

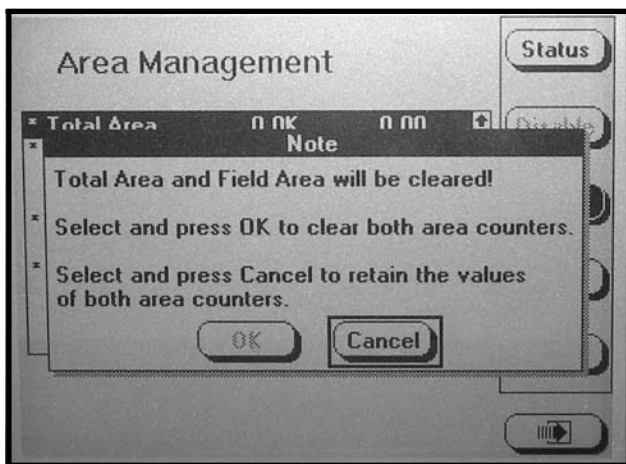

## CLEAR AREA COUNTER

Total Area, Field Area and Area Counters 1 through 8 can be cleared, whether it is Enabled or Disabled. Clearing the “Total Area” counter forces the “Field Area” counter to also be cleared. Clearing any other “Area Counter” including the “Field Area” counter clears only that counter.

**NOTE:** Lifetime Area Counter can never be cleared or disabled.

To clear an Area Counter: (a) highlight the desired area counter, by turning the rotary encoder knob or using the UP or DOWN arrow keys, (b) press the CLEAR key, (c) the request for confirmation shown below will appear, (d) turn the knob or use the UP or DOWN arrow keys to select OK or CANCEL, (e) press the knob or ENTER key to make selection.

To Clear All Area Counters except the “Total Area Counter”: (a) select the CLR ALL key; (b) a request for confirmation will appear; (c) turn the knob or use the UP or DOWN arrow keys to select either OK or CANCEL; (d) press the knob or ENTER key to confirm selection.

D02210628

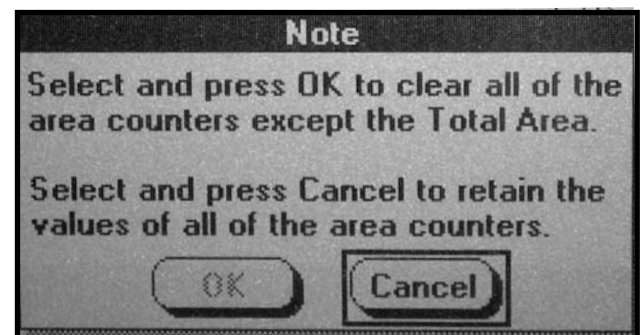

## AREA COUNTERS

**STEP 1** On the main planting screen press the AREA key.

D02240602

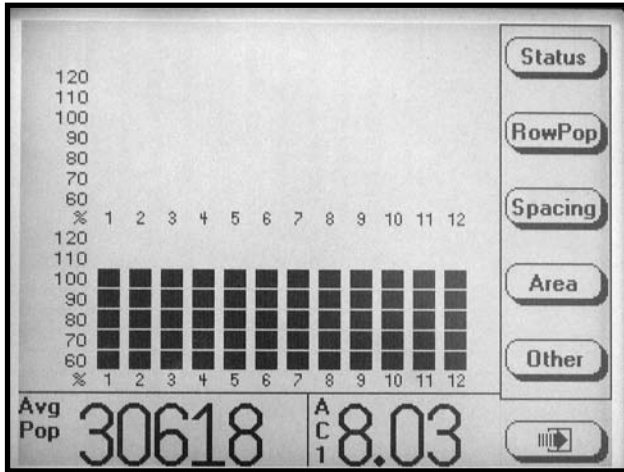

**STEP 2** Press the SELECT key to display the list of the Enabled Area Counters.

D02240603

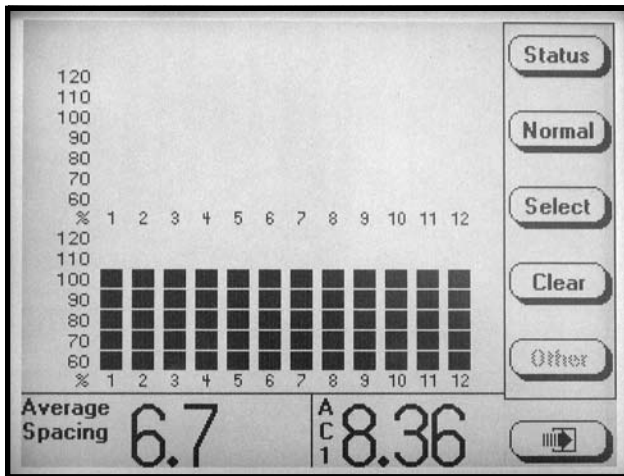

**STEP 3** To select the desired active "Area Counter" turn the knob or use the UP or DOWN arrows to highlight the desired "Area Counter".

D02240609

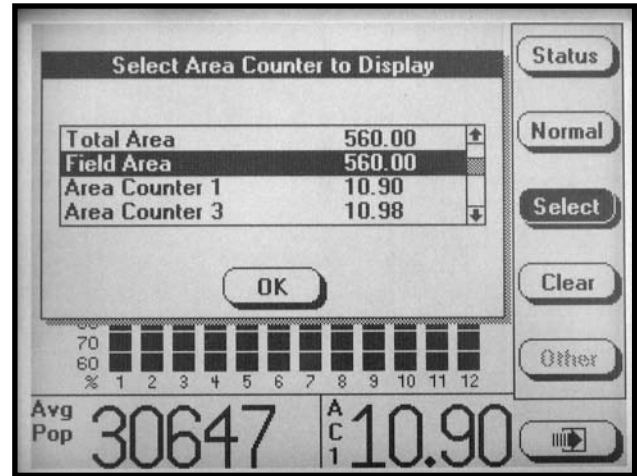

**STEP 4** Press the knob or ENTER key to select OK. The planting screen will then be displayed. Press NORMAL to display main planting screen.

D02240610

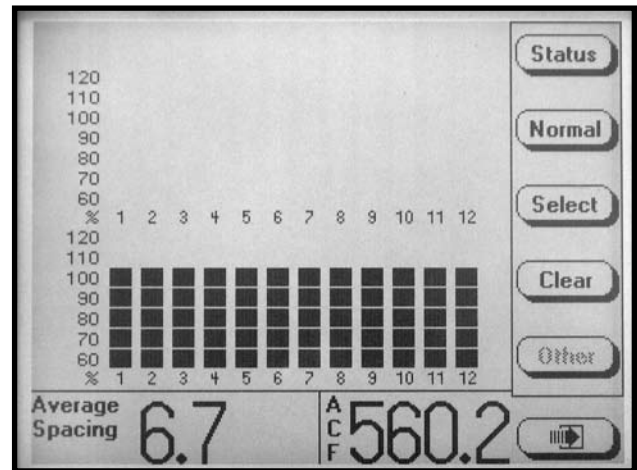

**NOTE:** The abbreviation for the selected area counter numerical value will appear in the bottom R.H. corner of the screen. In the above photo "ACF" represents "Area Counter Field".

## CLEARING FIELD AREA

To reset the counter, display the main planting screen by pressing the F6 key until it appears. Press the AREA key then select the CLEAR key, a dialog box will appear requesting confirmation to clear. Select OK or CANCEL key by turning the rotary encoder knob or using the UP or DOWN arrow keys. Press the knob or ENTER key to verify the selection.

D02210625

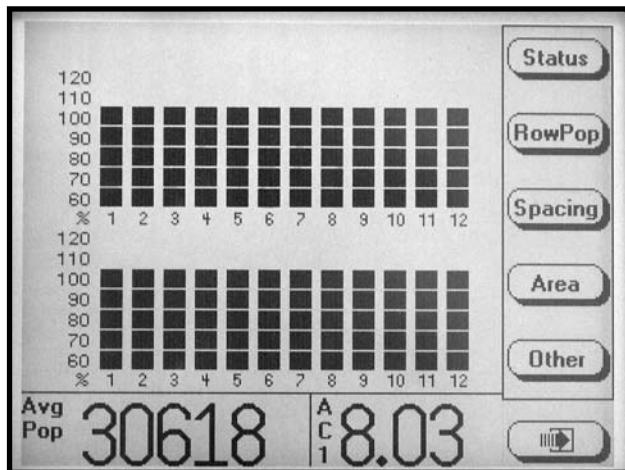

D02210625

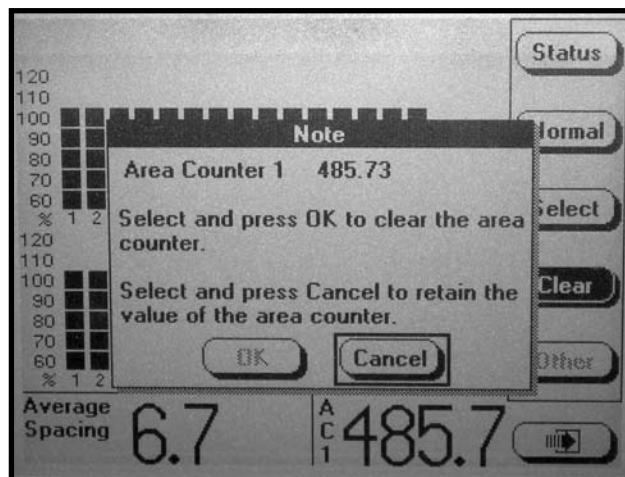

**NOTE:** Only the displayed Area Counter can be disabled.

## ACRE COUNT MODE

When a tractor is equipped with a radar distance sensor, accumulating area without a planter attached is possible. Two routes are provided to enter acre count mode: (a) Installation of an Acre Count Switch Kit or (b) entry into Acre Count Mode.

### Acre Count Switch Kit

**STEP 1** With the monitor OFF, attach an Acre Count Switch Kit to the Muxbus connector and then turn monitor ON and advance to STEP 2.

### Acre Count Mode

**STEP 1** Press the F6 key until the "Mode Selection" screen appears. Turn the rotary encoder knob or use the UP or DOWN arrow keys to select "Acre Count Mode". Press the knob or ENTER key.

D02200618

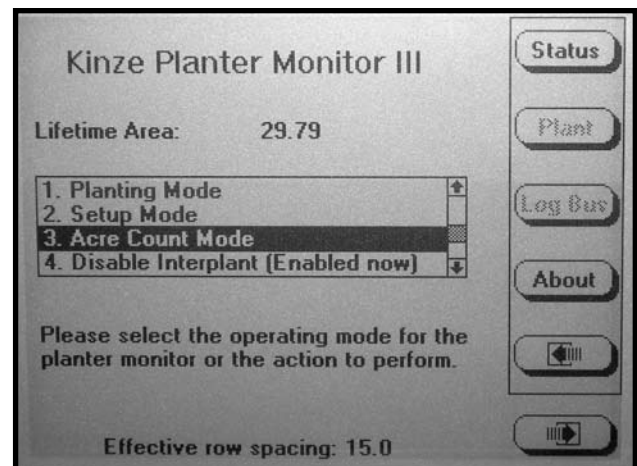

**NOTE:** If no radar unit is detected a warning will appear.

**NOTE:** If using acre count mode, area (acres or hectares) is accumulated in "Lifetime Area Counter."

**NOTE: DO NOT BEGIN ACCUMULATING AREA IF THE RADAR UNIT HAS NOT BEEN CALIBRATED. Always check the distance pulse count value immediately after entering acre count mode and before pressing start.**

**STEP 2** In the menu, “Units & Width” will be highlighted. Press the knob or ENTER key.

D02200619

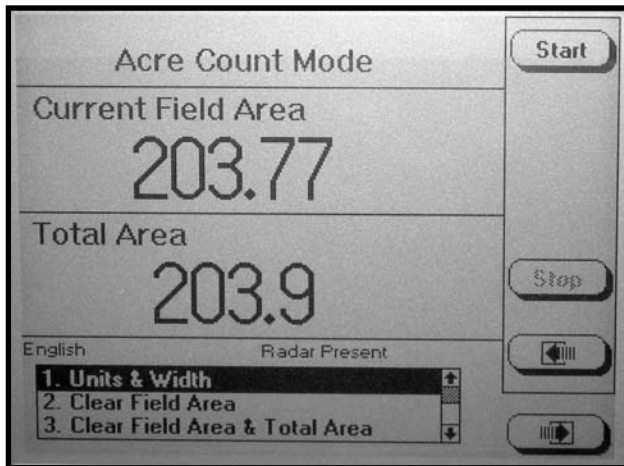

**STEP 3** A drop down menu will appear. Select the correct units of measure “English” or “Metric” by turning the knob or using the UP or DOWN arrow keys. Press the knob or ENTER key to make the selection. The black box will advance to “Implement Width” field showing implement width in feet.

D02200621

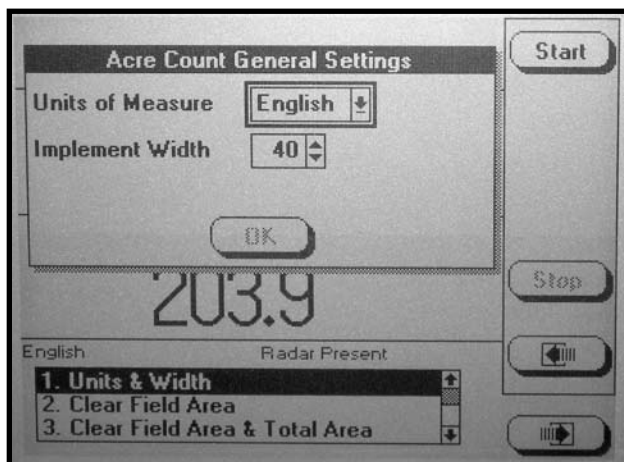

**STEP 4** Press the knob or ENTER key to highlight the field. Turn the knob or use the UP or DOWN arrow keys to select desired number in feet. When desired number is obtained press the knob or ENTER key. The black box will advance to OK key.

**NOTE: The implement width entered in acre count mode has no effect on planting mode settings.**

**STEP 5** Press the knob or ENTER key when done.

**NOTE: Tractor should be at a complete stop before starting.**

**STEP 6** To begin accumulating area press the START key.

**STEP 7** To stop accumulating area or to move to a different location, press the STOP key.

There are two counters in the Acre Count Mode (Field Area Counter and Total Area Counter). The “Field Area” counter can be cleared independent of the “Total Area” counter. Clearing the “Total Area” counter causes the “Field Area” counter to also be cleared.

- To Clear Field Area. Highlight “Clear Field Area” and press the knob or ENTER key. A note will appear verifying the decision to reset the field area to zero. Select OK and press the knob or ENTER key to clear the field to zero. Select Cancel and press the knob or the ENTER key to retain the current field value.

- To Clear Both Field Area And Total Area. Highlight the “Clear Field Area & Total Area” and press the knob or ENTER key. A note will appear to verify the decision to reset the field area and the total area to zero. Select OK and press the knob or ENTER key to clear the field to zero. Select CANCEL and press the knob or ENTER key to retain the current field value.

With planter reconnected to monitor return to normal plant screen by pressing the F6 key until the “Mode Selection” screen appears. Select “Planting Mode” by turning the knob or using the UP or DOWN arrow keys, press the knob or ENTER key.

## REPLACING FAULTY SENSOR(S)

To replace a single faulty sensor: (a) turn OFF the monitor, (b) replace the sensor, (c) turn monitor ON. It will then recognize that a single sensor has been replaced.

**NOTE: Monitor will beep twice when the new sensor(s) is learned.**

To replace more than one faulty sensor:

- STEP 1** Press F6 key until the “Mode Selection” screen appears.
- STEP 2** Select “Setup Mode” by turning the knob or press the UP or DOWN arrow keys. Press the knob or ENTER key to display the highlighted item.
- STEP 3** Select “Sensor Setup” by turning the knob or using the UP or DOWN arrow keys. Press the knob or ENTER key to display the highlighted item.

D02140641

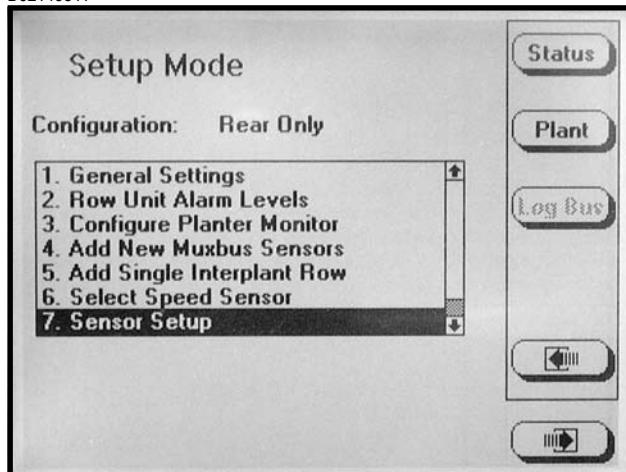

- STEP 4** Highlight faulty sensor. Press REMOVE key and unplug sensor. Plug in new sensor and press INSTALL key.

Repeat above procedure for each faulty sensor being replaced.

D02210601a

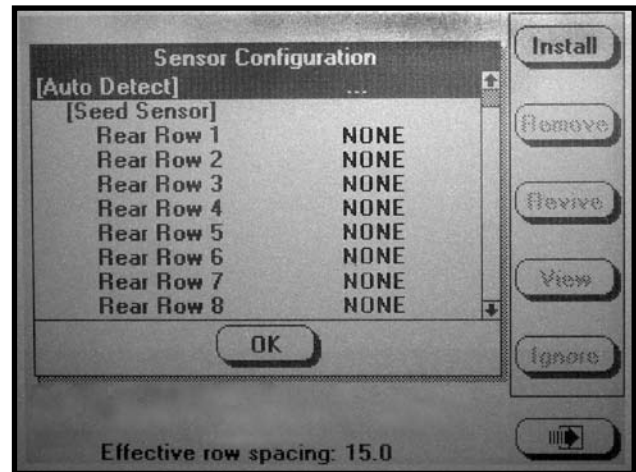

**NOTE: Highlighting a sensor and pressing VIEW gives additional information when troubleshooting a problem. If a faulty sensor has been ignored it may be highlighted in the list of sensors, press REVIVE. The monitor will try to communicate with the sensor. If successful, “OK” will appear next to the sensor.**

- STEP 5** Press the knob or ENTER key to return to “Setup Mode” screen.
- STEP 6** To return to “Planting Mode” press the PLANT key.

**See “KPM III Electronic Seed Monitor Troubleshooting” in the Maintenance Section.**



# MACHINE OPERATION

## POINT ROW CLUTCHES

81014-12b

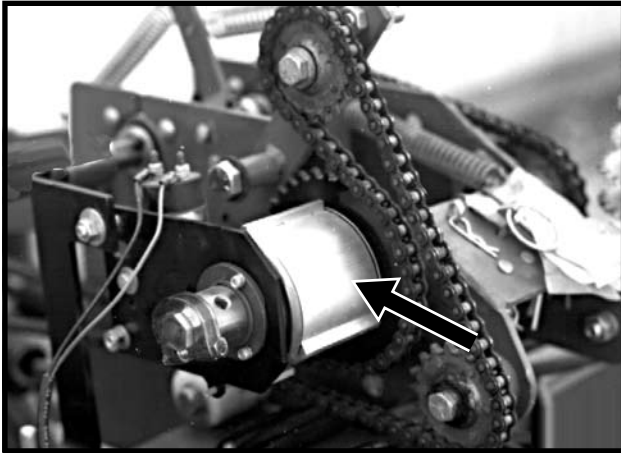

L.H. Side Of Planter Shown

With the use of electric-activated clutches, which disengage the drive, either half of the planter may be shut off for finishing up fields or for long point row situations.

76740-48



Point Row Clutch Control Box

The selector switch for the clutches is located on the tractor.

**NOTE: Switch should be left in OFF position when planter is not in use. If left in ON (left or right) position, the tractor battery will be discharged.**

(EF40c)

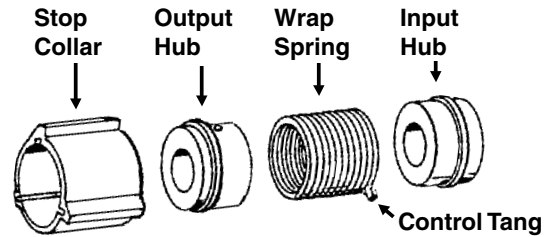

The point row clutch consists of a wrap spring riding on an input hub and an output hub. During operation the wrap spring is wrapped tightly over the hubs connecting them in a positive engagement. The greater the force of rotation the tighter the grip of the spring on the hubs. Rotation in the opposite direction or stopping the spring from rotating prevents the transmission of torque from the input hub to the output hub stopping the planter drive.

The input end of the spring is bent outward and is referred to as the control tang. The control tang fits into a slot in the stop collar that is located between the input and output hubs and over the wrap spring. If the stop collar is allowed to rotate with the input hub, the clutch is engaged. If the stop collar is stopped from rotating the control tang connected to it is forced back and the spring opens. This allows the input hub to continue rotating without transmitting torque to the output hub; therefore, stopping the planter drive.

The stop collar is controlled by the use of an electric solenoid and an actuator arm. When the selector switch on the tractor control box is in the OFF position the solenoid coil is NOT ENERGIZED and the actuator arm will not contact the stop on the stop collar allowing it to rotate with the hubs and drive the planter.

When the operational switch is in the "DISENGAGE" (right or left) position the solenoid coil IS ENERGIZED and the plunger in the solenoid coil pulls the actuator arm against the stop on the stop collar, disengaging the wrap spring and stopping the planter drive.

# MACHINE OPERATION

## FRONT MOUNTED DRIVE WHEEL OPTION

An optional Front Mounted Drive Wheel Conversion Package is available if front-mounted drive wheels are desired.

D06120303

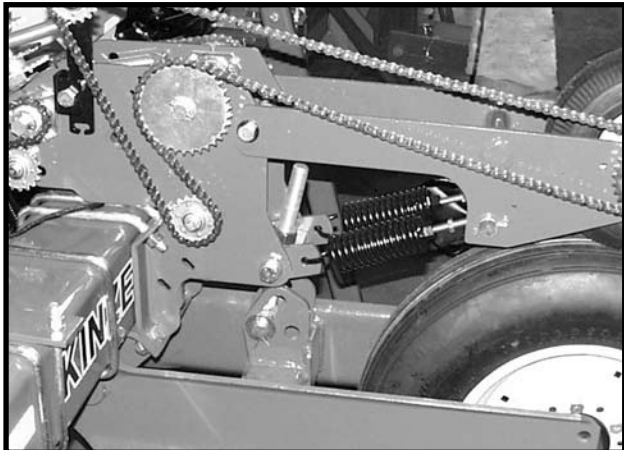

R.H. Side Of Planter Shown

D06120307

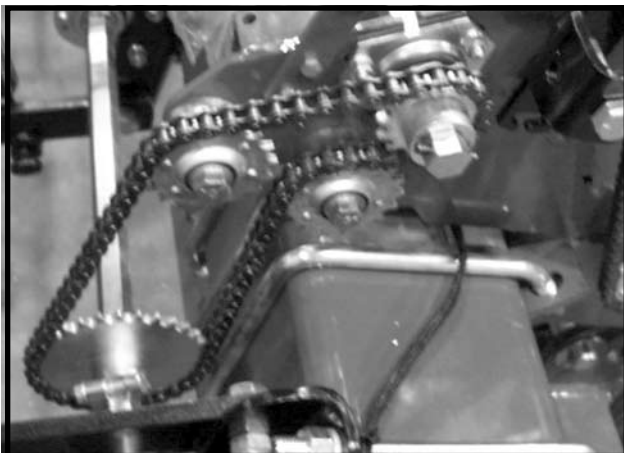

R.H. Side Of Planter Shown

## TRANSPORTING THE PLANTER



**WARNING:** Always make sure safety/warning lights, reflective decals and SMV sign are in place and visible prior to transporting the machine on public roads. In this regard, check and comply with all federal, state/provincial and local regulations.



**WARNING:** Always install all safety lockup devices before transporting the planter.

# MACHINE OPERATION

## METRIC CONVERSION TABLE

MULTIPLY	BY	TO GET
Inches (in.)	x 2.54	= centimeters (cm)
Inches (in.)	x 25.4	= millimeters (mm)
Feet (ft.)	x 30.48	= centimeters (cm)
Acres	x 0.405	= hectares (ha)
Miles per hour (mph)	x 1.609	= kilometers per hour (Km/h)
Pounds (lbs.)	x 0.453	= kilograms (kg)
Bushels (bu.)	x 35.238	= liters (l)
Gallons (gal.)	x 3.785	= liters (l)
Pounds per square inch (psi)	x 6.894	= kilopascals (kPa) (100 kPa = 1 bar)
Inch pounds (in. lbs.)	x 0.113	= newtons-meters (N•m)
Foot pounds (ft. lbs.)	x 1.356	= newtons-meters (N•m)
Centimeters (cm)	x .394	= inches (in.)
Millimeters (mm)	x .0394	= inches (in.)
Centimeters (cm)	x .0328	= feet (ft.)
Hectares (ha)	x 2.469	= acres
Kilometers per hour (Km/h)	x 0.621	= miles per hour (mph)
Kilograms (kg)	x 2.208	= pounds (lbs.)
Liters (l)	x 0.028	= bushels (bu.)
Liters (l)	x 0.264	= gallons (gal.)
Kilopascals (kPa) (100 kPa = 1 bar)	x 0.145	= pounds per square inch (psi)
Newtons-meters (N•m)	x 8.85	= inch pounds (in. lbs.)
Newtons-meters (N•m)	x 0.738	= foot pounds (ft. lbs.)

## PLANTING SPEED

Planters are designed to operate within a speed range of 2 to 8 MPH. Generally, higher ground speeds will cause more variation in seed spacing. Speeds above 5.5 MPH are typically not recommended. See “Planting And Application Rate Charts” in Seed Meter Operation/ Maintenance section for specific recommendations.

# MACHINE OPERATION

## FIELD TEST

With any change in seed, planting conditions or planter adjustments, we recommend a field test be made to ensure proper seed placement and operation of row units. See “Planting And Application Rate Charts” in the Seed Meter Operation/Maintenance section and “Checking Seed Population” and “Checking Granular Chemical Application Rate” at the end of this section. Be sure to check seed placement and population on **all** rows.

- ❑ Check the planter for fore to aft and lateral level operation. See “Leveling The Planter”.
- ❑ Check **all** row units to be certain they are running level. When planting, the row unit parallel arms should be approximately parallel to the ground.
- ❑ Check row markers for proper operation and adjustment. See “Row Marker Length Adjustment”, “Row Marker Speed Adjustment” and “Row Marker Operation”.
- ❑ Check for proper application rates and placement of granular chemicals on **all** rows. See “Checking Granular Chemical Application Rate”.
- ❑ Check for desired depth placement and seed population on **all** rows. See “Checking Seed Population”.

After the planter has been field tested, reinspect the machine.

- Hoses And Fittings
- Bolts And Nuts
- Cotter Pins And Roll Pins
- Drive Chain Alignment And Tension

## CHECKING SEED POPULATION

1. Tie up one or more sets of closing wheels by running a chain or rubber tarp strap between the hopper support panel and closing wheels. It may be necessary to decrease closing wheel arm spring tension.

(RU113g)

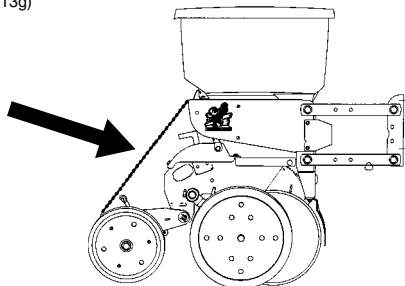

2. Plant a short distance and check to see if seed is visible in the seed trench. Adjust planting depth to a shallower setting if seed is not visible and recheck.

D020705102

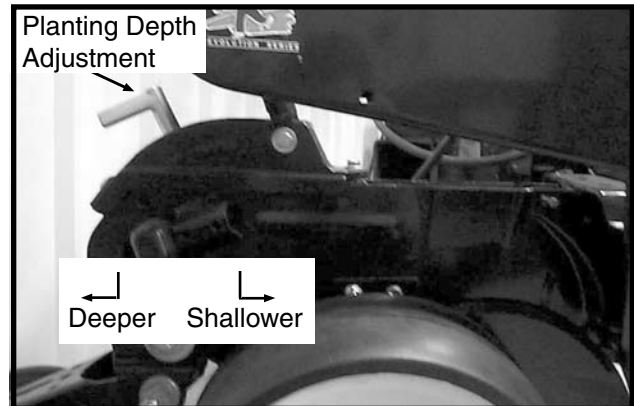

3. Measure  $\frac{1}{1000}$  of an acre. See chart for correct distance for row width being planted. For example, if planting 30" rows  $\frac{1}{1000}$  of an acre would be 17' 5".

LENGTH OF ROW IN FEET AND INCHES				
Fraction Of Acre	Row Width			
	30"	36"	38"	40"
$\frac{1}{1000}$	17' 5"	14' 6"	13' 10"	13' 1"

**NOTE: When planting with closing wheels raised and planting depth set shallow, seeds may bounce or roll affecting seed spacing accuracy.**

4. Count seeds in measured distance.
5. Multiply the number of seeds placed in  $\frac{1}{1000}$  of an acre by 1000. This will give you total population.

EXAMPLE: With 30" row spacing 17' 5" equals  $\frac{1}{1000}$  acre.

26 Seeds Counted	x	1000	=	26,000 Seeds Per Acre
---------------------	---	------	---	-----------------------

Seed count can be affected by drive ratio between drive wheel and seed meter, tire pressure and/or seed meter malfunction.

If seed check shows the average distance between seeds in inches is significantly different than the seed rate chart indicates, first check drive ratio between drive wheel and seed meter. Check drive wheel air pressure, check for incorrect sprocket(s) in driveline and check drive and driven sprockets on transmission for proper selection.

Second, check for seed meter malfunction. For example, if spacing between kernels of corn at the transmission setting being used is 8" and a gap of 16" is observed, a seed cell has lost its seed. If two seeds are found within a short distance of each other, the seed cell has metered two seeds instead of one.

See “Seed Metering System Troubleshooting” in the Seed Meter Operation/Maintenance section of this manual.

# MACHINE OPERATION

## Determining Pounds Per Acre

To determine pounds per acre:

Seeds Per Acre On Chart	÷	Seeds Per Pound From Seed Tag On Bag	=	Pounds Per Acre
-------------------------------	---	---	---	-----------------------

To determine bushels per acre:

Pounds Per Acre	÷	Unit Weight Of Seed	=	Bushels Per Acre
--------------------	---	------------------------	---	---------------------

The unit weight of:

- 1 Bushel Soybeans = 60 Pounds
- 1 Bushel Milo/Grain Sorghum = 56 Pounds
- 1 Bushel Cotton = 32 Pounds

If seeds per pound information is not available the following is an average:

- 2,600 seeds per pound for medium size soybeans
- 15,000 seeds per pound for medium size milo/grain sorghum
- 4,500 seeds per pound for medium size cotton

If seed population check shows planting rate is significantly different than seed rate chart shows or if a particular meter is not planting accurately, see "Seed Metering System Troubleshooting" in the Seed Meter Operation/Maintenance section of this manual.

## CHECKING GRANULAR CHEMICAL APPLICATION RATE

Many things can affect the rate of delivery of granular chemicals such as temperature, humidity, speed, ground conditions, flowability of different material or any obstruction in the meter.



**WARNING: Agricultural chemicals can be dangerous if not selected and handled with care. Always read and follow directions supplied by the chemical manufacturer.**

A field check is important to determine correct application rates.

D05149901



To check, fill insecticide and/or herbicide hoppers. Attach a calibrated vial to each granular chemical meter. Lower the planter and proceed as follows.

**NOTE: It is not necessary for seed meter clutch to be engaged during test. Disengage clutch to avoid dropping seed.**

Drive 1320 feet at planting speed. Weigh the chemical in ounces that was caught in one vial. Multiply that amount by the factor shown to determine pounds per acre.

POUNDS PER ACRE FACTOR FOR GIVEN ROW WIDTH	
Row Width	Factor
30"	0.83
36"	0.69
38"	0.65
40"	0.62

EXAMPLE: You are planting 30" rows. You have planted for 1320 feet at the desired planting speed. You caught 12.0 ounces of chemical in one vial. 12.0 ounces times 0.83 equals 9.96 pounds per acre.

**NOTE: It is important to check calibration of all rows.**

### Metering Gate

Use the metering gate setting for distributing insecticide or herbicide as a starting point. The charts are based on a 5 miles per hour planting speed. For speeds faster than 5 miles per hour a higher gate setting should be used. For speeds slower than 5 miles per hour a lower gate setting should be used.

# MACHINE OPERATION

---

# SEED METER OPERATION/MAINTENANCE

## GENERAL PLANTING RATE INFORMATION

These planting rate charts are applicable to KINZE® Model 3110 EdgeVac® 3 Point Mounted Planters. See "Tire Pressure" for recommended tire pressures.

**IMPORTANT: The sprocket combinations listed in these charts are best for average conditions. Changes in sprocket combinations may be required to obtain desired planting population. TO PREVENT PLANTING MISCALCULATIONS, MAKE FIELD CHECKS TO BE SURE YOU ARE PLANTING AT THE DESIRED RATE.**

The size and shape of seed may affect the planting rate.

The following seed discs are available for use with the KINZE® EdgeVac® Seed Metering System:

**Corn/Popcorn:** 39 cell. Light blue color-coded. For all seed corn grades from 35 to 70 pounds per 80,000 kernel count unit or popcorn seed size range from 2210 to 4200 seeds per pound. *When planting popcorn this seed disc requires use of seed baffle. See "Seed Meter" on pages 7-2 and 7-3 for additional information.*

**Low-Rate Corn/Popcorn:** 24 cell. Light green color-coded. For all seed corn grades from 35 to 70 pounds per 80,000 kernel count unit or popcorn seed size range from 2210 to 4200 seeds per pound. *When planting popcorn this seed disc requires use of seed baffle. See "Seed Meter" on pages 7-2 and 7-3 for additional information.*

**Soybean:** 60 cell. Black color-coded. Seed size range from 2200 to 4000 seeds per pound. *This seed disc requires use of seed baffle. See "Seed Meter" on pages 7-2 and 7-3 for additional information.*

**Soybean, High-Rate:** 120 cell. Dark blue color-coded. Seed size range from 2200 to 4000 seeds per pound. *This seed disc requires use of seed baffle. See "Seed Meter" on pages 7-2 and 7-3 for additional information.*

**Milo/Grain Sorghum:** 60 cell. Yellow color-coded. Seed size range from 10,000 to 20,000 seeds per pound. *This seed disc requires use of seed baffle and cleanout brush. See "Seed Meter" on pages 7-2 and 7-3 for additional information.*

**Hill-Drop Cotton, Acid-Delinted (3 Seeds Per Cell):** 20 cell. Brown color-coded. Cotton seed size range from 3800 to 5200 seeds per pound. *This seed disc requires use of cleanout brush w/ball-type ejector. See "Seed Meter" on pages 7-2 and 7-3 for additional information.*

**Cotton, Acid-Delinted/Small Dry Edible Bean:** 54 cell. Dark green color-coded. Cotton seed size range from 3800 to 5200 seeds per pound or dry edible bean seed size range from 1200 to 2500 seeds per pound. *This seed disc requires use of cleanout brush w/ball-type ejector. See "Seed Meter" on pages 7-2 and 7-3 for additional information.*

**Large Dry Edible Bean:** 54 cell. Tan color-coded. Seed size range from 800 to 1200 seeds per pound.

**NOTE: Due to a multitude of variables, seed spacing can be adversely affected at speeds above 5.5 MPH.**

**NOTE: See "Seed Meter Singulator Brush And Vacuum Level Adjustments" on page 7-23.**

**NOTE: 15, 19 and 30 tooth drive sprockets are NOT applicable to all rate charts. Check chart titles to ensure the proper rate chart is selected. 15 and 19 tooth sprockets require use of 218 pitch No. 40 chains and 30 tooth sprockets require use of 224 pitch No. 40 chains.**

**NOTE: Planting rates over 250,000 seeds/acre are not recommended. See subject seed disc and/or drive ratio on pages 7-11 and 7-13.**

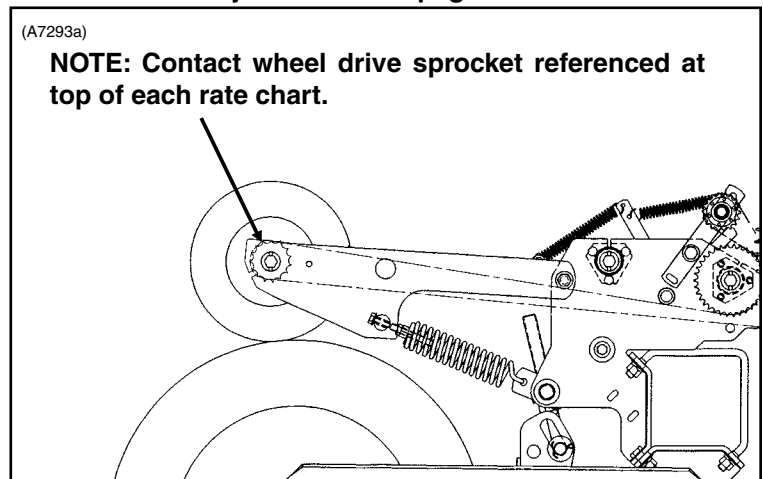

# SEED METER OPERATION/MAINTENANCE

## SEED METER

(METR71/METR71a)

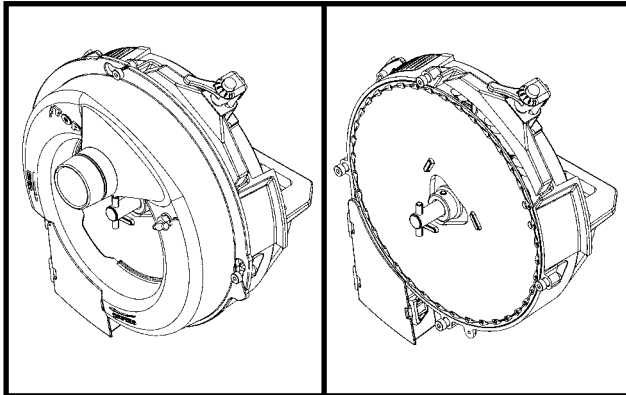

(METR70/D14467a)

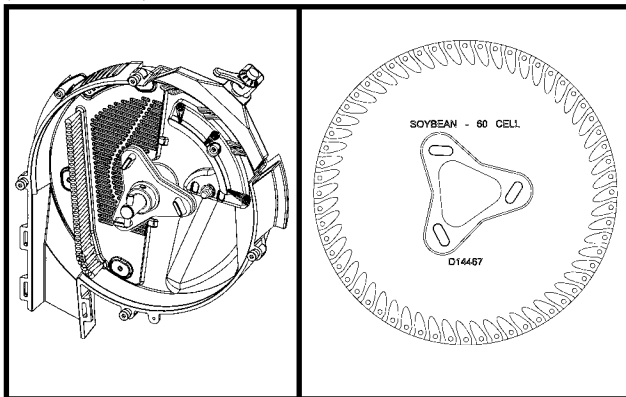

The seed discs below and at right are available for use with the KINZE® EdgeVac® Seed Metering System:

**Corn/Popcorn:** 39 cell. For all seed corn grades from 35 to 70 pounds per 80,000 kernel count unit. Popcorn seed size range from 2210 to 4200 seeds per pound (*Light blue color-coded.*)

(D14465)

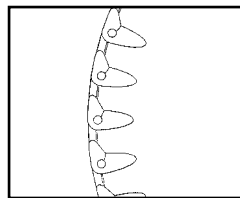

**Low-Rate Corn/Popcorn:** 24 cell. For all seed corn grades from 35 to 70 pounds per 80,000 kernel count unit. Popcorn seed size range from 2210 to 4200 seeds per pound. (*Light green color-coded.*)

(D16734a)

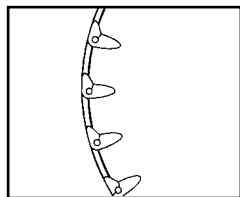

**Soybean:** 60 cell. Seed size range from 2200 to 4000 seeds per pound. (*Black color-coded.*)

(D14467a)

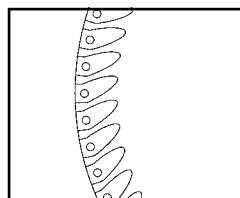

**Soybean, High-Rate:** 120 cell. Seed size range from 2200 to 4000 seeds per pound. (*Dark blue color-coded.*)

(D14468a)

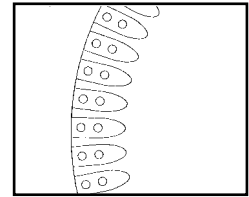

**Milo/Grain Sorghum:** 60 cell. Seed size range from 10,000 to 20,000 seeds per pound. (*Yellow color-coded.*)

(D17050)

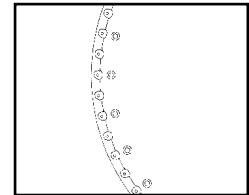

**Hill-Drop Cotton, Acid-Delinted (3 Seeds Per Cell):** 20 cell. Cotton seed size range from 3800 to 5200 seeds per pound. (*Brown color-coded.*)

(D17187)

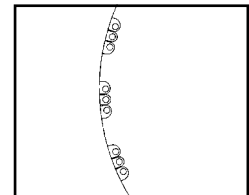

**Cotton, Acid-Delinted/Small Dry Edible Bean:** 54 cell. Cotton seed size range from 3800 to 5200 seeds per pound. Dry edible bean seed size range from 1200 to 2500 seeds per pound. (*Dark green color-coded.*)

(D17186)

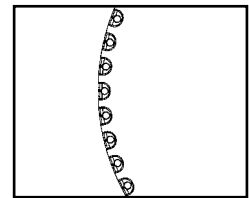

**Large Dry Edible Bean:** 54 cell. Seed size range from 800 to 1200 seeds per pound. (*Tan color-coded.*)

(D14477)

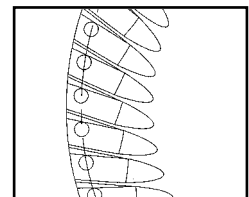

Install the selected seed disc. Position the vacuum cover on the meter by aligning the keyhole slots over the bolt heads. Push the cover on the meter and turn counter clockwise to lock in place. **See following page for additional components required with specific seed discs.**

**NOTE:** Use of damaged seed or seed containing foreign material will cause plugging of seed disc orifices and require more frequent seed meter cleanout to prevent underplanting.



# SEED METER OPERATION/MAINTENANCE

## **SEED BAFFLE**

- Milo/Grain Sorghum
- Soybeans
- Popcorn

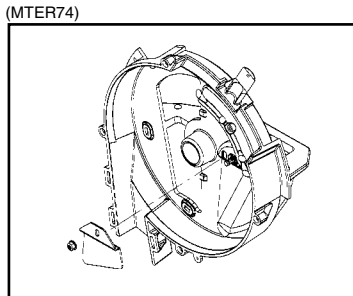

The **seed baffle** is designed to prevent excessive seed in the meter from restricting air flow through the seed. **Used with 60 Cell Milo/Grain Sorghum Disc, 60 Cell Soybean Disc, 120 Cell High-Rate Soybean Disc and 39 Cell and 24 Cell Popcorn Discs.**

## **CLEANOUT BRUSH**

- Milo/Grain Sorghum

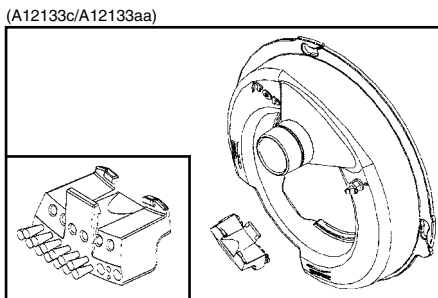

The **cleanout brush** is designed to remove foreign material and seed remnants to help prevent plugging of seed disc orifices.

**Used with 60 Cell Milo/Grain Sorghum Disc.**

## **CLEANOUT BRUSH W/BALL-TYPE EJECTOR**

- Cotton
- Small Edible Beans

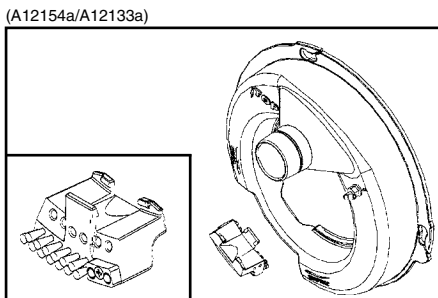

The **cleanout brush w/ball-type ejector** is designed to eject seed remnants from the seed disc orifices. **Used with 20 Cell Hill-Drop Cotton, Acid-Delinted (3 Seeds Per Cell) Disc and 54 Cell Acid-Delinted Cotton/Small Dry Edible Bean Disc.**

**NOTE:** Foreign material in seed disc orifices, such as seed chips, hulls, stems, etc., may affect seed delivery. Clean seed is required to ensure accurate seed metering from the vacuum seed meter. Seed discs should be removed daily to check for buildup of foreign material in the seed disc orifices.

(METR70)

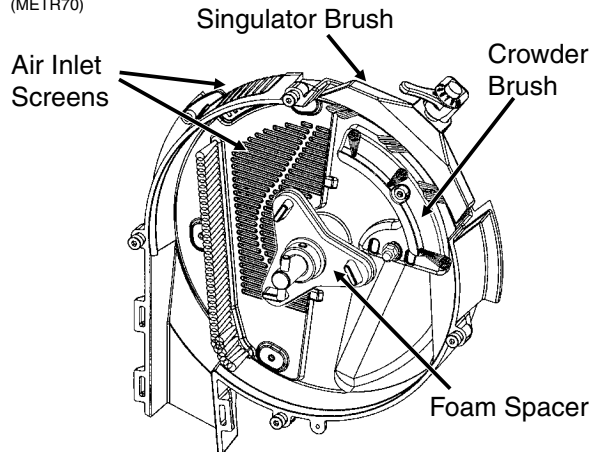

The crowder brush aids in the singulation of small flat seeds by (a) crowding seeds to the outer perimeter of the seed disc and (b) orienting seeds to allow the singulator brush to be more effective.

The air inlet screens allow air to enter the system and aids in keeping field residue or other foreign material out of the meter.

The foam spacer gently preloads the seed disc against the vacuum cover when no vacuum is present.

(METR71)

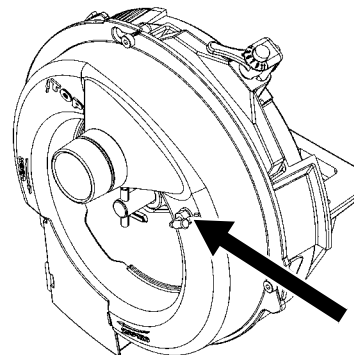

The  $\frac{3}{16}$ " hose barb elbow on the seed meter vacuum cover allows measurement of vacuum level at each meter. A customer-supplied vacuum gauge is required.

See "Seed Meter Singulator Brush And Vacuum Level Adjustments", "Seed Meter Maintenance" and "Preparation For Storage" for additional EdgeVac® Seed Metering System information.

# SEED METER OPERATION/MAINTENANCE

---

One tablespoon of **powdered graphite** should be mixed with the seed each time the hoppers are filled. Regular graphite use will prolong the life of the vacuum seed meter components, improve seed spacing, and may reduce buildup of seed treatments. Apply graphite around the outer perimeter of the hopper as shown below.

D05300104b



**NOTE: DO NOT apply graphite only in the center of the hopper. It will filter too quickly through the seed and not distribute as evenly as desired.**

**NOTE: Additional graphite or talc may be required to retard buildup of seed treatments on meter components. More frequent cleaning of monitor seed tubes may be necessary due to use of additional graphite or talc.**

**Talc seed lubricant** may be used in lieu of or in addition to graphite to improve seed release from the meter. Fill hopper  $\frac{1}{2}$  full of seed, add  $\frac{1}{4}$  cup of talc and **mix thoroughly**. Finish filling hopper, add another  $\frac{1}{4}$  cup of talc and **mix thoroughly**. Adjust rate of talc use as needed so all seeds are coated, while avoiding a buildup of talc in the bottom of the hopper. Humid conditions and/or small sized seeds with extra seed treatment may require as much as one cup of talc per hopper to maintain meter performance.

**NOTE: Some liquid seed treatments or inoculants may create buildup on the seed disc or brushes. Check frequently for proper population and/or seed delivery when using any liquid seed treatment.** All seed treatment should be thoroughly mixed with the seed per the manufacturers' recommendations. Seed treatment dumped on top of the seed after the hopper is filled, and not mixed properly may cause bridging of the seed in the meter, reducing population or stopping the meter from planting.

## SEED METER CLEANOUT

To maintain genetic purity, thorough seed meter cleanout is important.

To clean the seed meter, disengage the seed drive and remove the seed hopper and meter. Lay the hopper on its right side.

Disassemble seed meter by rotating vacuum cover clockwise to align keyhole slots with bolt heads. Lift off cover. Remove seed disc. Empty the meter and hopper by allowing the seed to run out of the meter. Inspect brushes in meter to ensure all seed is removed. Replace seed disc and install vacuum cover.

**NOTE: Use of damaged seed or seed containing foreign material will cause plugging of seed cell orifices and require more frequent seed meter cleanout to prevent underplanting.**

# SEED METER OPERATION/MAINTENANCE

**PLANTING RATES FOR CORN/POPCORN 39 CELL DISC  
15 TOOTH CONTACT WHEEL DRIVE SPROCKET (See Page 7-1)  
APPROXIMATE SEEDS/ACRE FOR VARIOUS ROW WIDTHS**

30" Rows	36" Rows	38" Rows	40" Rows	Transmission Sprockets		Recomm. Speed (MPH)	Average Spacing In Inches
				Drive	Driven		
23,207	19,339	18,321	17,405	15	28	4 to 6	9.0
24,066	20,055	19,000	18,050	15	27	4 to 6	8.7
24,992	20,827	19,730	18,744	15	26	4 to 6	8.4
25,992	21,660	20,520	19,494	15	25	4 to 6	8.0
26,301	21,918	20,764	19,726	17	28	4 to 6	7.9
27,075	22,562	21,375	20,306	15	24	4 to 6	7.7
27,275	22,729	21,533	20,456	17	27	4 to 6	7.7
28,252	23,543	22,304	21,189	15	23	4 to 6	7.4
28,324	23,603	22,361	21,243	17	26	4 to 6	7.4
29,395	24,496	23,207	22,046	19	28	4 to 6	7.1
29,457	24,548	23,256	22,093	17	25	4 to 6	7.1
30,484	25,403	24,066	22,863	19	27	4 to 6	6.9
30,685	25,570	24,225	23,013	17	24	4 to 6	6.8
31,656	26,380	24,992	23,742	19	26	4 to 6	6.6
32,019	26,682	25,278	24,014	17	23	4 to 6	6.5
32,923	27,436	25,992	24,692	19	25	4 to 6	6.4
34,199	28,500	27,000	25,650	15	19	4 to 6	6.1
34,294	28,579	27,075	25,721	19	24	4 to 6	6.1
35,584	29,653	28,092	26,688	23	28	4 to 6	5.9
35,786	29,821	28,252	26,839	19	23	4 to 6	5.8
36,902	30,751	29,133	27,676	23	27	4 to 6	5.7
37,131	30,942	29,314	27,848	24	28	4 to 6	5.6
38,223	31,852	30,176	28,667	15	17	4 to 6	5.5
38,506	32,088	30,400	28,880	24	27	4 to 6	5.4
38,759	32,300	30,600	29,070	17	19	4 to 6	5.4
39,854	33,211	31,464	29,890	23	25	4 to 6	5.2
40,225	33,521	31,757	30,169	26	28	4 to 6	5.2
41,514	34,595	32,775	31,136	23	24	4 to 6	5.0
41,587	34,655	32,832	31,190	24	25	4 to 6	5.0
41,772	34,810	32,978	31,329	27	28	4 to 6	5.0
43,319	36,099	34,199	32,490	23	23	4 to 6	4.8
44,924	37,436	35,466	33,693	28	27	4 to 6	4.7
44,985	37,488	35,515	33,739	27	26	4 to 6	4.6
45,203	37,669	35,686	33,902	24	23	4 to 6	4.6
46,652	38,876	36,830	34,989	28	26	4 to 6	4.5
46,785	38,987	36,935	35,089	27	25	4 to 6	4.5
47,086	39,239	37,173	35,315	25	23	4 to 6	4.4
48,416	40,346	38,223	36,312	19	17	4 to 6	4.3
48,734	40,612	38,474	36,551	27	24	4 to 6	4.3
48,970	40,808	38,660	36,727	26	23	4 to 6	4.3
50,539	42,116	39,899	37,904	28	24	4 to 6	4.1
50,853	42,378	40,147	38,140	27	23	4 to 6	4.1
52,439	43,699	41,399	39,329	23	19	4 to 6	4.0
52,737	43,947	41,634	39,552	28	23	4 to 6	4.0
54,719	45,599	43,199	41,039	24	19	4 to 6	3.8
56,999	47,499	44,999	42,749	25	19	4 to 6	3.7
58,609	48,840	46,270	43,956	23	17	4 to 6	3.6
59,279	49,399	46,799	44,459	26	19	4 to 6	3.5
61,157	50,964	48,282	45,868	24	17	4 to 6	3.4
61,559	51,299	48,599	46,169	27	19	4 to 6	3.4
63,705	53,087	50,293	47,779	25	17	4 to 6	3.3
63,839	53,199	50,399	47,879	28	19	4 to 6	3.3
66,253	55,211	52,305	49,690	26	17	4 to 6	3.2
66,423	55,352	52,439	49,817	23	15	4 to 6	3.1
68,801	57,334	54,317	51,601	27	17	4 to 6	3.0

**IMPORTANT: See "General Planting Rate Information" and "Checking Seed Population" pages for additional information. Always check seed population in the field to ensure planting rates are correct.**

# SEED METER OPERATION/MAINTENANCE

**PLANTING RATES FOR CORN/POPCORN 39 CELL DISC  
19 TOOTH CONTACT WHEEL DRIVE SPROCKET (See Page 7-1)  
APPROXIMATE SEEDS/ACRE FOR VARIOUS ROW WIDTHS**

30" Rows	36" Rows	38" Rows	40" Rows	Transmission Sprockets		Recomm. Speed (MPH)	Average Spacing In Inches
				Drive	Driven		
29,395	24,496	23,207	22,046	15	28	4 to 6	7.1
30,484	25,403	24,066	22,863	15	27	4 to 6	6.9
31,656	26,380	24,992	23,742	15	26	4 to 6	6.6
32,923	27,436	25,992	24,692	15	25	4 to 6	6.4
33,315	27,762	26,301	24,986	17	28	4 to 6	6.3
34,294	28,579	27,075	25,721	15	24	4 to 6	6.1
34,549	28,790	27,275	25,911	17	27	4 to 6	6.1
35,786	29,821	28,252	26,839	15	23	4 to 6	5.8
35,877	29,898	28,324	26,908	17	26	4 to 6	5.8
37,234	31,028	29,395	27,926	19	28	4 to 6	5.6
37,312	31,094	29,457	27,984	17	25	4 to 6	5.6
38,613	32,178	30,484	28,960	19	27	4 to 6	5.4
38,867	32,389	30,685	29,150	17	24	4 to 6	5.4
40,098	33,415	31,656	30,074	19	26	4 to 6	5.2
40,557	33,797	32,019	30,418	17	23	4 to 6	5.2
41,702	34,752	32,923	31,277	19	25	4 to 6	5.0
43,319	36,099	34,199	32,490	15	19	4 to 6	4.8
43,440	36,200	34,294	32,580	19	24	4 to 6	4.8
45,073	37,561	35,584	33,805	23	28	4 to 6	4.6
45,328	37,774	35,786	33,996	19	23	4 to 6	4.6
46,742	38,952	36,902	35,057	23	27	4 to 6	4.5
47,032	39,194	37,131	35,274	24	28	4 to 6	4.4
48,416	40,346	38,223	36,312	15	17	4 to 6	4.3
48,774	40,645	38,506	36,581	24	27	4 to 6	4.3
49,095	40,913	38,759	36,821	17	19	4 to 6	4.3
50,481	42,068	39,854	37,861	23	25	4 to 6	4.1
50,952	42,460	40,225	38,214	26	28	4 to 6	4.1
52,585	43,821	41,514	39,439	23	24	4 to 6	4.0
52,676	43,897	41,587	39,507	24	25	4 to 6	4.0
52,911	44,093	41,772	39,684	27	28	4 to 6	4.0
54,871	45,726	43,319	41,153	23	23	4 to 6	3.8
56,903	47,420	44,924	42,678	28	27	4 to 6	3.7
56,982	47,485	44,985	42,736	27	26	4 to 6	3.7
57,257	47,714	45,203	42,943	24	23	4 to 6	3.7
59,092	49,243	46,652	44,319	28	26	4 to 6	3.5
59,261	49,384	46,785	44,446	27	25	4 to 6	3.5
59,643	49,702	47,086	44,732	25	23	4 to 6	3.5
61,327	51,105	48,416	45,995	19	17	4 to 6	3.4
61,730	51,442	48,734	46,298	27	24	4 to 6	3.4
62,028	51,690	48,970	46,521	26	23	4 to 6	3.4
64,016	53,347	50,539	48,012	28	24	4 to 6	3.3
64,414	53,678	50,853	48,310	27	23	4 to 6	3.2
66,423	55,352	52,439	49,817	23	19	4 to 6	3.1
66,800	55,666	52,737	50,100	28	23	4 to 6	3.1
69,311	57,759	54,719	51,983	24	19	4 to 6	3.0
72,199	60,166	56,999	54,149	25	19	4 to 6	2.9
74,237	61,865	58,609	55,678	23	17	4 to 6	2.8
75,087	62,572	59,279	56,315	26	19	4 to 6	2.8
77,465	64,554	61,157	58,099	24	17	4 to 6	2.7
77,975	64,979	61,559	58,481	27	19	4 to 6	2.7
80,693	67,244	63,705	60,520	25	17	4 to 6	2.6
80,863	67,386	63,839	60,647	28	19	4 to 6	2.6
83,921	69,934	66,253	62,940	26	17	4 to 6	2.5
84,136	70,113	66,423	63,102	23	15	4 to 6	2.5
87,148	72,624	68,801	65,361	27	17	4 to 6	2.4

**IMPORTANT: See "General Planting Rate Information" and "Checking Seed Population" pages for additional information. Always check seed population in the field to ensure planting rates are correct.**

# SEED METER OPERATION/MAINTENANCE

## PLANTING RATES FOR LOW-RATE CORN/POPCORN 24 CELL DISC

15 TOOTH CONTACT WHEEL DRIVE SPROCKET (See Page 7-1)

### APPROXIMATE SEEDS/ACRE FOR VARIOUS ROW WIDTHS

30" Rows	36" Rows	38" Rows	40" Rows	Transmission Sprockets		Recomm. Speed (MPH)	Average Spacing In Inches
				Drive	Driven		
14,281	11,901	11,275	10,711	15	28	4 to 6	14.6
14,810	12,342	11,692	11,108	15	27	4 to 6	14.1
15,380	12,816	12,142	11,535	15	26	4 to 6	13.6
15,995	13,329	12,628	11,996	15	25	4 to 6	13.1
16,185	13,488	12,778	12,139	17	28	4 to 6	12.9
16,661	13,884	13,154	12,496	15	24	4 to 6	12.5
16,785	13,987	13,251	12,589	17	27	4 to 6	12.5
17,386	14,488	13,726	13,039	15	23	4 to 6	12.0
17,430	14,525	13,761	13,073	17	26	4 to 6	12.0
18,089	15,074	14,281	13,567	19	28	4 to 6	11.6
18,127	15,106	14,311	13,596	17	25	4 to 6	11.5
18,759	15,633	14,810	14,070	19	27	4 to 6	11.1
18,883	15,736	14,907	14,162	17	24	4 to 6	11.1
19,481	16,234	15,380	14,611	19	26	4 to 6	10.7
19,704	16,420	15,556	14,778	17	23	4 to 6	10.6
20,260	16,883	15,995	15,195	19	25	4 to 6	10.3
21,046	17,538	16,615	15,784	15	19	4 to 6	9.9
21,104	17,587	16,661	15,828	19	24	4 to 6	9.9
21,898	18,248	17,288	16,423	23	28	4 to 6	9.5
22,022	18,352	17,386	16,516	19	23	4 to 6	9.5
22,709	18,924	17,928	17,032	23	27	4 to 6	9.2
22,850	19,041	18,039	17,137	24	28	4 to 6	9.2
23,522	19,602	18,570	17,641	15	17	4 to 6	8.9
23,696	19,747	18,707	17,772	24	27	4 to 6	8.8
23,852	19,877	18,830	17,889	17	19	4 to 6	8.8
24,525	20,438	19,362	18,394	23	25	4 to 6	8.5
24,754	20,628	19,543	18,565	26	28	4 to 6	8.4
25,547	21,289	20,169	19,160	23	24	4 to 6	8.2
25,592	21,326	20,204	19,194	24	25	4 to 6	8.2
25,706	21,422	20,294	19,279	27	28	4 to 6	8.1
26,658	22,215	21,046	19,994	23	23	4 to 6	7.8
27,645	23,038	21,825	20,734	28	27	4 to 6	7.6
27,683	23,069	21,855	20,763	27	26	4 to 6	7.6
27,817	23,181	21,961	20,863	24	23	4 to 6	7.5
28,709	23,924	22,665	21,532	28	26	4 to 6	7.3
28,791	23,992	22,730	21,593	27	25	4 to 6	7.3
28,976	24,147	22,876	21,732	25	23	4 to 6	7.2
29,794	24,829	23,522	22,346	19	17	4 to 6	7.0
29,990	24,992	23,677	22,493	27	24	4 to 6	7.0
30,135	25,113	23,791	22,601	26	23	4 to 6	6.9
31,101	25,918	24,553	23,326	28	24	4 to 6	6.7
31,294	26,079	24,706	23,471	27	23	4 to 6	6.7
32,270	26,892	25,477	24,203	23	19	4 to 6	6.5
32,453	27,044	25,621	24,340	28	23	4 to 6	6.4
33,673	28,061	26,584	25,255	24	19	4 to 6	6.2
35,076	29,230	27,692	26,307	25	19	4 to 6	6.0
36,067	30,056	28,474	27,050	23	17	4 to 6	5.8
36,479	30,400	28,800	27,360	26	19	4 to 6	5.7
37,635	31,362	29,712	28,226	24	17	4 to 6	5.6
37,883	31,569	29,907	28,412	27	19	4 to 6	5.5
39,203	32,669	30,950	29,402	25	17	4 to 6	5.3
39,286	32,738	31,015	29,464	28	19	4 to 6	5.3
40,771	33,976	32,188	30,578	26	17	4 to 6	5.1
40,876	34,063	32,270	30,657	23	15	4 to 6	5.1
42,339	35,283	33,426	31,754	27	17	4 to 6	4.9

**IMPORTANT: See "General Planting Rate Information" and "Checking Seed Population" pages for additional information. Always check seed population in the field to ensure planting rates are correct.**

# SEED METER OPERATION/MAINTENANCE

## PLANTING RATES FOR LOW-RATE CORN/POPCORN 24 CELL DISC 19 TOOTH CONTACT WHEEL DRIVE SPROCKET (See Page 7-1) APPROXIMATE HILLS/ACRE FOR VARIOUS ROW WIDTHS

30" Rows	36" Rows	38" Rows	40" Rows	Transmission Sprockets		Recomm. Speed (MPH)	Average Spacing In Inches
				Drive	Driven		
18,089	15,074	14,281	13,567	15	28	4 to 6	11.6
18,759	15,633	14,810	14,070	15	27	4 to 6	11.1
19,481	16,234	15,380	14,611	15	26	4 to 6	10.7
20,260	16,883	15,995	15,195	15	25	4 to 6	10.3
20,501	17,084	16,185	15,376	17	28	4 to 6	10.2
21,104	17,587	16,661	15,828	15	24	4 to 6	9.9
21,261	17,717	16,785	15,945	17	27	4 to 6	9.8
22,022	18,352	17,386	16,516	15	23	4 to 6	9.5
22,078	18,399	17,430	16,559	17	26	4 to 6	9.5
22,913	19,094	18,089	17,185	19	28	4 to 6	9.1
22,961	19,135	18,127	17,221	17	25	4 to 6	9.1
23,762	19,802	18,759	17,821	19	27	4 to 6	8.8
23,918	19,932	18,883	17,939	17	24	4 to 6	8.7
24,676	20,563	19,481	18,507	19	26	4 to 6	8.5
24,958	20,798	19,704	18,719	17	23	4 to 6	8.4
25,663	21,386	20,260	19,247	19	25	4 to 6	8.1
26,658	22,215	21,046	19,994	15	19	4 to 6	7.8
26,732	22,277	21,104	20,049	19	24	4 to 6	7.8
27,737	23,114	21,898	20,803	23	28	4 to 6	7.5
27,894	23,245	22,022	20,921	19	23	4 to 6	7.5
28,764	23,970	22,709	21,573	23	27	4 to 6	7.3
28,943	24,119	22,850	21,707	24	28	4 to 6	7.2
29,794	24,829	23,522	22,346	15	17	4 to 6	7.0
30,015	25,012	23,696	22,511	24	27	4 to 6	7.0
30,212	25,177	23,852	22,659	17	19	4 to 6	6.9
31,066	25,888	24,525	23,299	23	25	4 to 6	6.7
31,355	26,129	24,754	23,516	26	28	4 to 6	6.7
32,360	26,967	25,547	24,270	23	24	4 to 6	6.5
32,416	27,013	25,592	24,312	24	25	4 to 6	6.5
32,561	27,134	25,706	24,421	27	28	4 to 6	6.4
33,767	28,139	26,658	25,325	23	23	4 to 6	6.2
35,017	29,181	27,645	26,263	28	27	4 to 6	6.0
35,066	29,221	27,683	26,299	27	26	4 to 6	6.0
35,235	29,362	27,817	26,426	24	23	4 to 6	5.9
36,364	30,304	28,709	27,273	28	26	4 to 6	5.7
36,468	30,390	28,791	27,351	27	25	4 to 6	5.7
36,703	30,586	28,976	27,527	25	23	4 to 6	5.7
37,739	31,450	29,794	28,305	19	17	4 to 6	5.5
37,988	31,656	29,990	28,491	27	24	4 to 6	5.5
38,171	31,809	30,135	28,628	26	23	4 to 6	5.5
39,395	32,829	31,101	29,546	28	24	4 to 6	5.3
39,639	33,033	31,294	29,730	27	23	4 to 6	5.3
40,876	34,063	32,270	30,657	23	19	4 to 6	5.1
41,107	34,256	32,453	30,831	28	23	4 to 6	5.1
42,653	35,544	33,673	31,990	24	19	4 to 6	4.9
44,430	37,025	35,076	33,323	25	19	4 to 6	4.7
45,685	38,070	36,067	34,263	23	17	4 to 6	4.6
46,207	38,506	36,479	34,655	26	19	4 to 6	4.5
47,671	39,726	37,635	35,753	24	17	4 to 6	4.4
47,985	39,987	37,883	35,988	27	19	4 to 6	4.4
49,657	41,381	39,203	37,243	25	17	4 to 6	4.2
49,762	41,468	39,286	37,321	28	19	4 to 6	4.2
51,643	43,036	40,771	38,733	26	17	4 to 6	4.0
51,776	43,147	40,876	38,832	23	15	4 to 6	4.0
53,630	44,691	42,339	40,222	27	17	4 to 6	3.9

**IMPORTANT: See "General Planting Rate Information" and "Checking Seed Population" pages for additional information. Always check seed population in the field to ensure planting rates are correct.**

# SEED METER OPERATION/MAINTENANCE

## PLANTING RATES FOR SOYBEAN AND MILO/GRAIN SORGHUM 60 CELL DISCS

15 TOOTH CONTACT WHEEL DRIVE SPROCKET (See Page 7-1)

### APPROXIMATE SEEDS/ACRE FOR VARIOUS ROW WIDTHS

30" Rows	36" Rows	38" Rows	40" Rows	Transmission Sprockets		Recomm. Speed (MPH)	Average Spacing In Inches
				Drive	Driven		
35,703	29,752	28,186	26,777	15	28	4 to 6	5.9
37,025	30,854	29,230	27,769	15	27	4 to 6	5.6
38,449	32,041	30,355	28,837	15	26	4 to 6	5.4
39,987	33,323	31,569	29,990	15	25	4 to 6	5.2
40,463	33,719	31,945	30,347	17	28	4 to 6	5.2
41,653	34,711	32,884	31,240	15	24	4 to 6	5.0
41,962	34,968	33,128	31,471	17	27	4 to 6	5.0
43,464	36,220	34,314	32,598	15	23	4 to 6	4.8
43,576	36,313	34,402	32,682	17	26	4 to 6	4.8
45,223	37,686	35,703	33,918	19	28	4 to 6	4.6
45,319	37,766	35,778	33,989	17	25	4 to 6	4.6
46,898	39,082	37,025	35,174	19	27	4 to 6	4.5
47,207	39,339	37,269	35,405	17	24	4 to 6	4.4
48,702	40,585	38,449	36,527	19	26	4 to 6	4.3
49,259	41,050	38,889	36,945	17	23	4 to 6	4.2
50,650	42,209	39,987	37,988	19	25	4 to 6	4.1
52,615	43,845	41,538	39,461	15	19	4 to 6	4.0
52,761	43,967	41,653	39,571	19	24	4 to 6	4.0
54,744	45,620	43,219	41,058	23	28	4 to 6	3.8
55,055	45,879	43,464	41,291	19	23	4 to 6	3.8
56,772	47,310	44,820	42,579	23	27	4 to 6	3.7
57,124	47,604	45,098	42,843	24	28	4 to 6	3.7
58,805	49,004	46,425	44,103	15	17	4 to 6	3.6
59,240	49,367	46,769	44,430	24	27	4 to 6	3.5
59,630	49,692	47,076	44,722	17	19	4 to 6	3.5
61,314	51,095	48,405	45,985	23	25	4 to 6	3.4
61,885	51,571	48,856	46,414	26	28	4 to 6	3.4
63,868	53,224	50,422	47,901	23	24	4 to 6	3.3
63,979	53,316	50,510	47,985	24	25	4 to 6	3.3
64,265	53,554	50,735	48,199	27	28	4 to 6	3.3
66,645	55,538	52,615	49,984	23	23	4 to 6	3.1
69,113	57,595	54,563	51,835	28	27	4 to 6	3.0
69,208	57,674	54,638	51,906	27	26	4 to 6	3.0
69,543	57,952	54,902	52,157	24	23	4 to 6	3.0
71,772	59,810	56,662	53,829	28	26	4 to 6	2.9
71,977	59,981	56,824	53,983	27	25	4 to 6	2.9
72,440	60,367	57,190	54,330	25	23	4 to 6	2.9
74,486	62,071	58,805	55,864	19	17	4 to 6	2.8
74,976	62,480	59,191	56,232	27	24	4 to 6	2.8
75,338	62,782	59,477	56,503	26	23	4 to 6	2.8
77,753	64,794	61,384	58,314	28	24	4 to 6	2.7
78,236	65,196	61,765	58,677	27	23	4 to 6	2.7
80,676	67,230	63,691	60,507	23	19	4 to 6	2.6
81,133	67,611	64,053	60,850	28	23	4 to 6	2.6
84,183	70,153	66,461	63,138	24	19	4 to 6	2.5
87,691	73,076	69,230	65,768	25	19	4 to 6	2.4
90,167	75,139	71,184	67,625	23	17	4 to 6	2.3
91,199	75,999	71,999	68,399	26	19	4 to 6	2.3
94,087	78,406	74,279	70,565	24	17	4 to 6	2.2
94,706	78,922	74,768	71,030	27	19	4 to 6	2.2
98,008	81,673	77,374	73,506	25	17	4 to 6	2.1
98,214	81,845	77,537	73,660	28	19	4 to 6	2.1
101,928	84,940	80,469	76,446	26	17	4 to 6	2.1
102,189	85,158	80,676	76,642	23	15	4 to 6	2.0
105,848	88,207	83,564	79,386	27	17	4 to 6	2.0

**IMPORTANT: See "General Planting Rate Information" and "Checking Seed Population" pages for additional information. Always check seed population in the field to ensure planting rates are correct.**

# SEED METER OPERATION/MAINTENANCE

## PLANTING RATES FOR SOYBEAN AND MILO/GRAIN SORGHUM 60 CELL DISCS

### 19 TOOTH CONTACT WHEEL DRIVE SPROCKET (See Page 7-1)

#### APPROXIMATE SEEDS/ACRE FOR VARIOUS ROW WIDTHS

30" Rows	36" Rows	38" Rows	40" Rows	Transmission Sprockets		Recomm. Speed (MPH)	Average Spacing In Inches
				Drive	Driven		
45,223	37,686	35,703	33,918	15	28	4 to 6	4.6
46,898	39,082	37,025	35,174	15	27	4 to 6	4.5
48,702	40,585	38,449	36,527	15	26	4 to 6	4.3
50,650	42,209	39,987	37,988	15	25	4 to 6	4.1
51,253	42,711	40,463	38,440	17	28	4 to 6	4.1
52,761	43,967	41,653	39,571	15	24	4 to 6	4.0
53,152	44,293	41,962	39,864	17	27	4 to 6	3.9
55,055	45,879	43,464	41,291	15	23	4 to 6	3.8
55,196	45,997	43,576	41,397	17	26	4 to 6	3.8
57,283	47,736	45,223	42,962	19	28	4 to 6	3.7
57,404	47,836	45,319	43,053	17	25	4 to 6	3.6
59,405	49,504	46,898	44,554	19	27	4 to 6	3.5
59,796	49,830	47,207	44,847	17	24	4 to 6	3.5
61,689	51,408	48,702	46,267	19	26	4 to 6	3.4
62,395	51,996	49,259	46,796	17	23	4 to 6	3.4
64,157	53,464	50,650	48,118	19	25	4 to 6	3.3
66,645	55,538	52,615	49,984	15	19	4 to 6	3.1
66,830	55,692	52,761	50,123	19	24	4 to 6	3.1
69,343	57,786	54,744	52,007	23	28	4 to 6	3.0
69,736	58,113	55,055	52,302	19	23	4 to 6	3.0
71,911	59,926	56,772	53,933	23	27	4 to 6	2.9
72,358	60,298	57,124	54,268	24	28	4 to 6	2.9
74,486	62,071	58,805	55,864	15	17	4 to 6	2.8
75,037	62,531	59,240	56,278	24	27	4 to 6	2.8
75,531	62,943	59,630	56,648	17	19	4 to 6	2.8
77,664	64,720	61,314	58,248	23	25	4 to 6	2.7
78,387	65,323	61,885	58,791	26	28	4 to 6	2.7
80,900	67,416	63,868	60,675	23	24	4 to 6	2.6
81,040	67,534	63,979	60,780	24	25	4 to 6	2.6
81,402	67,835	64,265	61,052	27	28	4 to 6	2.6
84,417	70,348	66,645	63,313	23	23	4 to 6	2.5
87,544	72,953	69,113	65,658	28	27	4 to 6	2.4
87,664	73,053	69,208	65,748	27	26	4 to 6	2.4
88,087	73,406	69,543	66,066	24	23	4 to 6	2.4
90,911	75,759	71,772	68,183	28	26	4 to 6	2.3
91,171	75,975	71,977	68,378	27	25	4 to 6	2.3
91,758	76,465	72,440	68,818	25	23	4 to 6	2.3
94,349	78,624	74,486	70,761	19	17	4 to 6	2.2
94,969	79,141	74,976	71,227	27	24	4 to 6	2.2
95,428	79,523	75,338	71,571	26	23	4 to 6	2.2
98,487	82,072	77,753	73,865	28	24	4 to 6	2.1
99,098	82,582	78,236	74,324	27	23	4 to 6	2.1
102,189	85,158	80,676	76,642	23	19	4 to 6	2.0
102,769	85,641	81,133	77,077	28	23	4 to 6	2.0
106,632	88,860	84,183	79,974	24	19	4 to 6	2.0
111,075	92,563	87,691	83,306	25	19	4 to 6	1.9
114,211	95,176	90,167	85,659	23	17	4 to 6	1.8
115,518	96,265	91,199	86,639	26	19	4 to 6	1.8
119,177	99,314	94,087	89,383	24	17	4 to 6	1.8
119,961	99,968	94,706	89,971	27	19	4 to 6	1.7
124,143	103,452	98,008	93,107	25	17	4 to 6	1.7
124,404	103,670	98,214	93,303	28	19	4 to 6	1.7
129,109	107,591	101,928	96,831	26	17	4 to 6	1.6
129,440	107,866	102,189	97,080	23	15	4 to 6	1.6
134,074	111,729	105,848	100,556	27	17	4 to 6	1.6

**IMPORTANT: See "General Planting Rate Information" and "Checking Seed Population" pages for additional information. Always check seed population in the field to ensure planting rates are correct.**



# SEED METER OPERATION/MAINTENANCE

**PLANTING RATES FOR SOYBEAN 60 CELL DISC  
30 TOOTH CONTACT WHEEL DRIVE SPROCKET (See Page 7-1)  
APPROXIMATE SEEDS/ACRE FOR VARIOUS ROW WIDTHS**

30" Rows	36" Rows	38" Rows	40" Rows	Transmission Sprockets		Recomm. Speed (MPH)	Average Spacing In Inches
				Drive	Driven		
96,608	80,507	76,270	72,456	15	28	4 to 6	2.2
100,186	83,489	79,095	75,140	15	27	4 to 6	2.1
104,040	86,700	82,137	78,030	15	26	4 to 6	2.0
108,201	90,168	85,422	81,151	15	25	4 to 6	1.9
109,489	91,241	86,439	82,117	17	28	4 to 6	1.9
112,710	93,925	88,981	84,533	15	24	4 to 6	1.9
113,545	94,620	89,640	85,159	17	27	4 to 6	1.8
117,610	98,008	92,850	88,208	15	23	4 to 6	1.8
117,912	98,260	93,088	88,434	17	26	4 to 6	1.8
122,371	101,975	96,608	91,778	19	28	4 to 6	1.7
122,628	102,190	96,812	91,969	17	25	4 to 6	1.7
126,903	105,752	100,186	95,177	19	27	4 to 6	1.6
127,738	106,448	100,846	95,804	17	24	4 to 6	1.6
131,784	109,820	104,040	98,838	19	26	4 to 6	1.6
133,291	111,076	105,230	99,968	17	23	4 to 6	1.6
137,055	114,213	108,201	102,791	19	25	4 to 6	1.5
142,370	118,642	112,397	106,778	15	19	4 to 6	1.5
142,766	118,971	112,710	107,075	19	24	4 to 6	1.5
148,133	123,444	116,947	111,100	23	28	4 to 6	1.4
148,973	124,144	117,610	111,730	19	23	4 to 6	1.4
153,619	128,016	121,278	115,214	23	27	4 to 6	1.4
154,573	128,811	122,032	115,930	24	28	4 to 6	1.4
159,120	132,600	125,621	119,340	15	17	4 to 6	1.3
160,298	133,582	126,551	120,224	24	27	4 to 6	1.3
161,353	134,461	127,384	121,015	17	19	4 to 6	1.3
165,909	138,257	130,981	124,432	23	25	4 to 6	1.3
167,454	139,545	132,201	125,559	26	28	4 to 6	1.2
172,822	144,018	136,438	129,617	23	24	4 to 6	1.2
173,122	144,268	136,675	129,092	24	25	4 to 6	1.2
173,895	144,912	137,286	130,421	27	28	4 to 6	1.2
180,336	150,280	142,370	135,252	23	23	4 to 6	1.2
187,015	155,846	147,643	140,261	28	27	4 to 6	1.1
187,272	156,060	147,846	140,454	27	26	4 to 6	1.1
188,176	156,814	148,560	141,132	24	23	4 to 6	1.1
194,207	161,840	153,322	145,655	28	26	4 to 6	1.1
194,762	162,302	153,760	146,072	27	25	4 to 6	1.1
196,017	163,347	154,750	147,013	25	23	4 to 6	1.1
201,551	167,960	159,120	151,163	19	17	4 to 6	1.0
202,877	169,065	160,166	152,158	27	24	4 to 6	1.0
203,858	169,881	160,940	152,894	26	23	4 to 6	1.0
210,391	175,326	166,099	157,793	28	24	4 to 6	1.0
211,698	176,415	167,130	158,774	27	23	4 to 6	1.0
218,301	181,917	172,343	163,726	23	19	4 to 6	1.0
219,539	182,949	173,320	164,654	28	23	4 to 6	1.0
227,792	189,827	179,836	170,844	24	19	4 to 6	0.9
237,284	197,736	187,329	177,963	25	19	4 to 6	0.9
243,983	203,319	192,618	182,987	23	17	4 to 6	0.9
246,775	205,646	194,822	185,081	26	19	4 to 6	0.8
	212,159	200,993	190,943	24	17	4 to 6	0.8
	213,555	202,315	192,200	27	19	4 to 6	0.8
	220,999	209,368	198,899	25	17	4 to 6	0.8
	221,465	209,809	199,319	28	19	4 to 6	0.8
	229,839	217,743	206,855	26	17	4 to 6	0.8
	230,429	218,301	207,489	23	15	4 to 6	0.8
	238,679	226,117	214,811	27	17	4 to 6	0.7

**IMPORTANT: See "General Planting Rate Information" and "Checking Seed Population" pages for additional information. Always check seed population in the field to ensure planting rates are correct.**

# SEED METER OPERATION/MAINTENANCE

**PLANTING RATES FOR HIGH-RATE SOYBEAN 120 CELL DISC  
15 TOOTH CONTACT WHEEL DRIVE SPROCKET (See Page 7-1)  
APPROXIMATE SEEDS/ACRE FOR VARIOUS ROW WIDTHS**

30" Rows	36" Rows	38" Rows	40" Rows	Transmission Sprockets		Recomm. Speed (MPH)	Average Spacing In Inches
				Drive	Driven		
71,406	59,505	56,373	53,554	15	28	4 to 6	2.9
74,050	61,708	58,461	55,538	15	27	4 to 6	2.8
76,898	64,082	60,709	57,674	15	26	4 to 6	2.7
79,974	66,645	63,138	59,981	15	25	4 to 6	2.6
80,926	67,439	63,889	60,695	17	28	4 to 6	2.6
83,306	69,422	65,768	62,480	15	24	4 to 6	2.5
83,924	69,936	66,255	62,943	17	27	4 to 6	2.5
86,928	72,440	68,628	65,196	15	23	4 to 6	2.4
87,151	72,626	68,804	65,364	17	26	4 to 6	2.4
90,447	75,372	71,406	67,835	19	28	4 to 6	2.3
90,637	75,531	71,556	67,978	17	25	4 to 6	2.3
93,797	78,164	74,050	70,348	19	27	4 to 6	2.2
94,414	78,678	74,537	70,810	17	24	4 to 6	2.2
97,404	81,170	76,898	73,053	19	26	4 to 6	2.1
98,519	82,099	77,778	73,889	17	23	4 to 6	2.1
101,301	84,417	79,974	75,975	19	25	4 to 6	2.1
105,229	87,691	83,076	78,922	15	19	4 to 6	2.0
105,521	87,935	83,306	79,141	19	24	4 to 6	2.0
109,488	91,240	86,438	82,116	23	28	4 to 6	1.9
110,109	91,758	86,928	82,582	19	23	4 to 6	1.9
113,544	94,620	89,640	85,158	23	27	4 to 6	1.8
114,249	95,207	90,196	85,687	24	28	4 to 6	1.8
117,609	98,008	92,849	88,207	15	17	4 to 6	1.8
118,480	98,734	93,537	88,860	24	27	4 to 6	1.8
119,260	99,383	94,152	89,445	17	19	4 to 6	1.8
122,627	102,189	96,811	91,970	23	25	4 to 6	1.7
123,770	103,141	97,713	92,827	26	28	4 to 6	1.7
127,737	106,447	100,845	95,802	23	24	4 to 6	1.6
127,959	106,632	101,020	95,969	24	25	4 to 6	1.6
128,530	107,108	101,471	96,397	27	28	4 to 6	1.6
133,290	111,075	105,229	99,968	23	23	4 to 6	1.6
138,227	115,189	109,127	103,670	28	27	4 to 6	1.5
138,417	115,347	109,276	103,813	27	26	4 to 6	1.5
139,086	115,905	109,804	104,314	24	23	4 to 6	1.5
143,543	119,619	113,324	107,658	28	26	4 to 6	1.5
143,954	119,961	113,648	107,965	27	25	4 to 6	1.5
144,881	120,734	114,380	108,661	25	23	4 to 6	1.4
148,971	124,143	117,609	111,729	19	17	4 to 6	1.4
149,952	124,960	118,383	112,464	27	24	4 to 6	1.4
150,676	125,563	118,955	113,007	26	23	4 to 6	1.4
155,505	129,588	122,767	116,629	28	24	4 to 6	1.3
156,471	130,393	123,530	117,353	27	23	4 to 6	1.3
161,351	134,459	127,383	121,014	23	19	4 to 6	1.3
162,266	135,222	128,105	121,700	28	23	4 to 6	1.3
168,367	140,306	132,921	126,275	24	19	4 to 6	1.2
175,382	146,152	138,459	131,536	25	19	4 to 6	1.2
180,334	150,278	142,369	135,250	23	17	4 to 6	1.2
182,397	151,998	143,998	136,798	26	19	4 to 6	1.1
188,175	156,812	148,559	141,131	24	17	4 to 6	1.1
189,413	157,844	149,536	142,059	27	19	4 to 6	1.1
196,015	163,346	154,749	147,011	25	17	4 to 6	1.1
196,428	163,690	155,075	147,321	28	19	4 to 6	1.1
203,856	169,880	160,939	152,892	26	17	4 to 6	1.0
204,378	170,315	161,351	153,284	23	15	4 to 6	1.0
211,696	176,414	167,129	158,772	27	17	4 to 6	1.0

**IMPORTANT: See "General Planting Rate Information" and "Checking Seed Population" pages for additional information. Always check seed population in the field to ensure planting rates are correct.**

# SEED METER OPERATION/MAINTENANCE

**PLANTING RATES FOR HIGH-RATE SOYBEAN 120 CELL DISC  
19 TOOTH CONTACT WHEEL DRIVE SPROCKET (See Page 7-1)  
APPROXIMATE SEEDS/ACRE FOR VARIOUS ROW WIDTHS**

30" Rows	36" Rows	38" Rows	40" Rows	Transmission Sprockets		Recomm. Speed (MPH)	Average Spacing In Inches
				Drive	Driven		
90,447	75,372	71,406	67,835	15	28	4 to 6	2.3
93,797	78,164	74,050	70,348	15	27	4 to 6	2.2
97,404	81,170	76,898	73,053	15	26	4 to 6	2.1
101,301	84,417	79,974	75,975	15	25	4 to 6	2.1
102,507	85,422	80,926	76,880	17	28	4 to 6	2.0
105,521	87,935	83,306	79,141	15	24	4 to 6	2.0
106,303	88,586	83,924	79,727	17	27	4 to 6	2.0
110,109	91,758	86,928	82,582	15	23	4 to 6	1.9
110,392	91,993	87,151	82,794	17	26	4 to 6	1.9
114,566	95,472	90,447	85,925	19	28	4 to 6	1.8
114,807	95,673	90,637	86,106	17	25	4 to 6	1.8
118,809	99,008	93,797	89,107	19	27	4 to 6	1.8
119,591	99,659	94,414	89,693	17	24	4 to 6	1.7
123,379	102,816	97,404	92,534	19	26	4 to 6	1.7
124,791	103,992	98,519	93,593	17	23	4 to 6	1.7
128,314	106,928	101,301	96,236	19	25	4 to 6	1.6
133,290	111,075	105,229	99,968	15	19	4 to 6	1.6
133,661	111,384	105,521	100,245	19	24	4 to 6	1.6
138,685	115,571	109,488	104,014	23	28	4 to 6	1.5
139,472	116,227	110,109	104,604	19	23	4 to 6	1.5
143,822	119,852	113,544	107,866	23	27	4 to 6	1.5
144,715	120,596	114,249	108,536	24	28	4 to 6	1.4
148,971	124,143	117,609	111,729	15	17	4 to 6	1.4
150,075	125,062	118,480	112,556	24	27	4 to 6	1.4
151,062	125,885	119,260	113,297	17	19	4 to 6	1.4
155,328	129,440	122,627	116,496	23	25	4 to 6	1.3
156,775	130,646	123,770	117,581	26	28	4 to 6	1.3
161,800	134,833	127,737	121,350	23	24	4 to 6	1.3
162,081	135,067	127,959	121,561	24	25	4 to 6	1.3
162,805	135,670	128,530	122,103	27	28	4 to 6	1.3
168,834	140,695	133,290	126,626	23	23	4 to 6	1.2
175,087	145,906	138,227	131,316	28	27	4 to 6	1.2
175,328	146,107	138,417	131,496	27	26	4 to 6	1.2
176,175	146,812	139,086	132,131	24	23	4 to 6	1.2
181,822	151,518	143,543	136,366	28	26	4 to 6	1.1
182,341	151,951	143,954	136,756	27	25	4 to 6	1.1
183,516	152,930	144,881	137,637	25	23	4 to 6	1.1
188,697	157,248	148,971	141,523	19	17	4 to 6	1.1
189,939	158,282	149,952	142,454	27	24	4 to 6	1.1
190,856	159,047	150,676	143,142	26	23	4 to 6	1.1
196,973	164,145	155,505	147,730	28	24	4 to 6	1.1
198,197	165,164	156,471	148,648	27	23	4 to 6	1.1
204,378	170,315	161,351	153,284	23	19	4 to 6	1.0
205,537	171,281	162,266	154,153	28	23	4 to 6	1.0
213,264	177,720	168,367	159,948	24	19	4 to 6	1.0
222,150	185,125	175,382	166,613	25	19	4 to 6	0.9
228,423	190,352	180,334	171,317	23	17	4 to 6	0.9
231,036	192,530	182,397	173,277	26	19	4 to 6	0.9
238,354	198,629	188,175	178,766	24	17	4 to 6	0.9
239,923	199,935	189,413	179,942	27	19	4 to 6	0.9
248,286	206,905	196,015	186,214	25	17	4 to 6	0.8
248,809	207,340	196,428	186,606	28	19	4 to 6	0.8
	215,181	203,856	193,663	26	17	4 to 6	0.8
	215,733	204,378	194,160	23	15	4 to 6	0.8
	223,457	211,696	201,112	27	17	4 to 6	0.8

**IMPORTANT: See "General Planting Rate Information" and "Checking Seed Population" pages for additional information. Always check seed population in the field to ensure planting rates are correct.**

# SEED METER OPERATION/MAINTENANCE

PLANTING RATES FOR ACID-DELINTED HILL-DROP COTTON (3 SEEDS PER CELL), 20 CELL DISC

15 TOOTH CONTACT WHEEL DRIVE SPROCKET (See Page 7-1)

APPROXIMATE HILLS/ACRE FOR VARIOUS ROW WIDTHS

30" Rows	36" Rows	38" Rows	40" Rows	Transmission Sprockets		Recomm. Speed (MPH)	Average Spacing In Inches
				Drive	Driven		
11,901	9,917	9,395	8,926	15	28	4 to 6	17.6
12,342	10,285	9,743	9,256	15	27	4 to 6	16.9
12,816	10,680	10,118	9,612	15	26	4 to 6	16.3
13,329	11,108	10,523	9,997	15	25	4 to 6	15.7
13,488	11,240	10,648	10,116	17	28	4 to 6	15.5
13,884	11,570	10,961	10,413	15	24	4 to 6	15.1
13,987	11,656	11,043	10,490	17	27	4 to 6	14.9
14,488	12,073	11,438	10,866	15	23	4 to 6	14.4
14,525	12,104	11,467	10,894	17	26	4 to 6	14.4
15,074	12,562	11,901	11,306	19	28	4 to 6	13.9
15,106	12,589	11,926	11,330	17	25	4 to 6	13.8
15,633	13,027	12,342	11,725	19	27	4 to 6	13.4
15,736	13,113	12,423	11,802	17	24	4 to 6	13.3
16,234	13,528	12,816	12,176	19	26	4 to 6	12.9
16,420	13,683	12,963	12,315	17	23	4 to 6	12.7
16,883	14,070	13,329	12,663	19	25	4 to 6	12.4
17,538	14,615	13,846	13,154	15	19	4 to 6	11.9
17,587	14,656	13,884	13,190	19	24	4 to 6	11.9
18,248	15,207	14,406	13,686	23	28	4 to 6	11.5
18,352	15,293	14,488	13,764	19	23	4 to 6	11.4
18,924	15,770	14,940	14,193	23	27	4 to 6	11.0
19,041	15,868	15,033	14,281	24	28	4 to 6	11.0
19,602	16,335	15,475	14,701	15	17	4 to 6	10.7
19,652	16,376	15,515	14,739	23	26	4 to 6	10.6
19,747	16,456	15,590	14,810	24	27	4 to 6	10.6
19,835	16,529	15,659	14,876	25	28	4 to 6	10.5
19,877	16,564	15,692	14,907	17	19	4 to 6	10.5
20,438	17,032	16,135	15,328	23	25	4 to 6	10.2
20,506	17,088	16,189	15,380	24	26	4 to 6	10.2
20,569	17,141	16,239	15,427	25	27	4 to 6	10.2
20,628	17,190	16,285	15,471	26	28	4 to 6	10.1
21,289	17,741	16,807	15,967	23	24	4 to 6	9.8
21,326	17,772	16,837	15,995	24	25	4 to 6	9.8
21,361	17,801	16,864	16,020	25	26	4 to 6	9.8
21,392	17,827	16,889	16,044	26	27	4 to 6	9.8
21,422	17,851	16,912	16,066	27	28	4 to 6	9.8
22,215	18,513	17,538	16,661	23	23	4 to 6	9.4
23,038	19,198	18,188	17,278	28	27	4 to 6	9.1
23,069	19,225	18,213	17,302	27	26	4 to 6	9.1
23,141	19,284	18,269	17,356	25	24	4 to 6	9.0
23,181	19,317	18,301	17,386	24	23	4 to 6	9.0
23,924	19,937	18,887	17,943	28	26	4 to 6	8.7
23,992	19,994	18,941	17,994	27	25	4 to 6	8.7
24,147	20,122	19,063	18,110	25	23	4 to 6	8.7
24,829	20,690	19,602	18,621	19	17	4 to 6	8.4
24,881	20,734	19,643	18,661	28	25	4 to 6	8.4
24,992	20,827	19,730	18,744	27	24	4 to 6	8.4
25,113	20,927	19,826	18,834	26	23	4 to 6	8.3
25,918	21,598	20,461	19,438	28	24	4 to 6	8.1
26,079	21,732	20,588	19,559	27	23	4 to 6	8.0
26,892	22,410	21,230	20,169	23	19	4 to 6	7.8
27,044	22,537	21,351	20,283	28	23	4 to 6	7.7
28,061	23,384	22,154	21,046	24	19	4 to 6	7.5
29,230	24,359	23,077	21,923	25	19	4 to 6	7.2
30,056	25,046	23,728	22,542	23	17	4 to 6	7.0

**IMPORTANT: See "General Planting Rate Information" and "Checking Seed Population" pages for additional information. Always check seed population in the field to ensure planting rates are correct.**

# SEED METER OPERATION/MAINTENANCE

PLANTING RATES FOR ACID-DELINTED HILL-DROP COTTON (3 SEEDS PER CELL), 20 CELL DISC  
 19 TOOTH CONTACT WHEEL DRIVE SPROCKET (See Page 7-1)  
 APPROXIMATE HILLS/ACRE FOR VARIOUS ROW WIDTHS

30" Rows	36" Rows	38" Rows	40" Rows	Transmission Sprockets		Recomm. Speed (MPH)	Average Spacing In Inches
				Drive	Driven		
15,074	12,562	11,901	11,306	15	28	4 to 6	13.9
15,633	13,027	12,342	11,725	15	27	4 to 6	13.4
16,234	13,528	12,816	12,176	15	26	4 to 6	12.9
16,883	14,070	13,329	12,663	15	25	4 to 6	12.4
17,084	14,237	13,488	12,813	17	28	4 to 6	12.2
17,587	14,656	13,884	13,190	15	24	4 to 6	11.9
17,717	14,764	13,987	13,288	17	27	4 to 6	11.8
18,352	15,293	14,488	13,764	15	23	4 to 6	11.4
18,399	15,332	14,525	13,799	17	26	4 to 6	11.4
19,094	15,912	15,074	14,321	19	28	4 to 6	11.0
19,135	15,945	15,106	14,351	17	25	4 to 6	10.9
19,802	16,501	15,633	14,851	19	27	4 to 6	10.6
19,932	16,610	15,736	14,949	17	24	4 to 6	10.5
20,563	17,136	16,234	15,422	19	26	4 to 6	10.2
20,798	17,332	16,420	15,599	17	23	4 to 6	10.1
21,386	17,821	16,883	16,039	19	25	4 to 6	9.8
22,215	18,513	17,538	16,661	15	19	4 to 6	9.4
22,277	18,564	17,587	16,708	19	24	4 to 6	9.4
23,114	19,262	18,248	17,336	23	28	4 to 6	9.0
23,245	19,371	18,352	17,434	19	23	4 to 6	9.0
23,970	19,975	18,924	17,978	23	27	4 to 6	8.7
24,119	20,099	19,041	18,089	24	28	4 to 6	8.7
24,829	20,690	19,602	18,621	15	17	4 to 6	8.4
24,892	20,744	19,652	18,669	23	26	4 to 6	8.4
25,012	20,844	19,747	18,759	24	27	4 to 6	8.4
25,124	20,937	19,835	18,843	25	28	4 to 6	8.3
25,177	20,981	19,877	18,883	17	19	4 to 6	8.3
25,888	21,573	20,438	19,416	23	25	4 to 6	8.1
25,975	21,645	20,506	19,481	24	26	4 to 6	8.0
26,055	21,712	20,569	19,541	25	27	4 to 6	8.0
26,129	21,774	20,628	19,597	26	28	4 to 6	8.0
26,967	22,472	21,289	20,225	23	24	4 to 6	7.8
27,013	22,511	21,326	20,260	24	25	4 to 6	7.7
27,057	22,547	21,361	20,293	25	26	4 to 6	7.7
27,097	22,581	21,392	20,323	26	27	4 to 6	7.7
27,134	22,612	21,422	20,351	27	28	4 to 6	7.7
28,139	23,449	22,215	21,104	23	23	4 to 6	7.4
29,181	24,318	23,038	21,886	28	27	4 to 6	7.2
29,221	24,351	23,069	21,916	27	26	4 to 6	7.2
29,312	24,426	23,141	21,984	25	24	4 to 6	7.1
29,362	24,469	23,181	22,022	24	23	4 to 6	7.1
30,304	25,253	23,924	22,728	28	26	4 to 6	6.9
30,390	25,325	23,992	22,793	27	25	4 to 6	6.9
30,586	25,488	24,147	22,939	25	23	4 to 6	6.8
31,450	26,208	24,829	23,587	19	17	4 to 6	6.6
31,516	26,263	24,881	23,637	28	25	4 to 6	6.6
31,656	26,380	24,992	23,742	27	24	4 to 6	6.6
31,809	26,508	25,113	23,857	26	23	4 to 6	6.6
32,829	27,357	25,918	24,622	28	24	4 to 6	6.4
33,033	27,527	26,079	24,775	27	23	4 to 6	6.3
34,063	28,386	26,892	25,547	23	19	4 to 6	6.1
34,256	28,547	27,044	25,692	28	23	4 to 6	6.1
35,544	29,620	28,061	26,658	24	19	4 to 6	5.9
37,025	30,854	29,230	27,769	25	19	4 to 6	5.6
38,070	31,725	30,056	28,553	23	17	4 to 6	5.5

**IMPORTANT: See "General Planting Rate Information" and "Checking Seed Population" pages for additional information. Always check seed population in the field to ensure planting rates are correct.**

# SEED METER OPERATION/MAINTENANCE

PLANTING RATES FOR ACID-DELINTED COTTON/SMALL DRY EDIBLE BEAN 54 CELL DISC  
 15 TOOTH CONTACT WHEEL DRIVE SPROCKET (See Page 7-1)  
 APPROXIMATE SEEDS/ACRE FOR VARIOUS ROW WIDTHS

30" Rows	36" Rows	38" Rows	40" Rows	Transmission Sprockets		Recomm. Speed (MPH)	Average Spacing In Inches
				Drive	Driven		
32,132	26,777	25,368	24,099	15	28	4 to 6	6.5
33,323	27,769	26,307	24,992	15	27	4 to 6	6.3
34,604	28,837	27,319	25,953	15	26	4 to 6	6.0
35,988	29,990	28,412	26,991	15	25	4 to 6	5.8
36,417	30,347	28,750	27,313	17	28	4 to 6	5.7
37,488	31,240	29,596	28,116	15	24	4 to 6	5.6
37,766	31,471	29,815	28,324	17	27	4 to 6	5.5
39,118	32,598	30,882	29,338	15	23	4 to 6	5.3
39,218	32,682	30,962	29,414	17	26	4 to 6	5.3
40,701	33,918	32,132	30,526	19	28	4 to 6	5.1
40,787	33,989	32,200	30,590	17	25	4 to 6	5.1
42,209	35,174	33,323	31,656	19	27	4 to 6	5.0
42,486	35,405	33,542	31,865	17	24	4 to 6	4.9
43,832	36,527	34,604	32,874	19	26	4 to 6	4.8
44,334	36,945	35,000	33,250	17	23	4 to 6	4.7
45,585	37,988	35,988	34,189	19	25	4 to 6	4.6
47,353	39,461	37,384	35,515	15	19	4 to 6	4.4
47,485	39,571	37,488	35,613	19	24	4 to 6	4.4
49,270	41,058	38,897	36,952	23	28	4 to 6	4.2
49,549	41,291	39,118	37,162	19	23	4 to 6	4.2
51,095	42,579	40,338	38,321	23	27	4 to 6	4.1
51,412	42,843	40,588	38,559	24	28	4 to 6	4.1
52,924	44,103	41,782	39,693	15	17	4 to 6	4.0
53,316	44,430	42,092	39,987	24	27	4 to 6	3.9
53,667	44,722	42,369	40,250	17	19	4 to 6	3.9
55,182	45,985	43,565	41,387	23	25	4 to 6	3.8
55,696	46,414	43,971	41,772	26	28	4 to 6	3.8
57,481	47,901	45,380	43,111	23	24	4 to 6	3.6
57,581	47,985	45,459	43,186	24	25	4 to 6	3.6
57,838	48,199	45,662	43,379	27	28	4 to 6	3.6
59,981	49,984	47,353	44,985	23	23	4 to 6	3.5
62,202	51,835	49,107	46,652	28	27	4 to 6	3.4
62,288	51,906	49,174	46,716	27	26	4 to 6	3.4
62,588	52,157	49,412	46,941	24	23	4 to 6	3.3
64,595	53,829	50,996	48,446	28	26	4 to 6	3.2
64,779	53,983	51,141	48,584	27	25	4 to 6	3.2
65,196	54,330	51,471	48,897	25	23	4 to 6	3.2
67,037	55,864	52,924	50,278	19	17	4 to 6	3.1
67,478	56,232	53,272	50,609	27	24	4 to 6	3.1
67,804	56,503	53,530	50,853	26	23	4 to 6	3.1
69,977	58,314	55,245	52,483	28	24	4 to 6	3.0
70,412	58,677	55,588	52,809	27	23	4 to 6	3.0
72,608	60,507	57,322	54,456	23	19	4 to 6	2.9
73,020	60,850	57,647	54,765	28	23	4 to 6	2.9
75,765	63,138	59,814	56,824	24	19	4 to 6	2.8
78,922	65,768	62,307	59,191	25	19	4 to 6	2.6
81,150	67,625	64,066	60,863	23	17	4 to 6	2.6
82,079	68,399	64,799	61,559	26	19	4 to 6	2.5
84,679	70,565	66,851	63,509	24	17	4 to 6	2.5
85,236	71,030	67,291	63,927	27	19	4 to 6	2.5
88,207	73,506	69,637	66,155	25	17	4 to 6	2.4
88,393	73,660	69,784	66,294	28	19	4 to 6	2.4
91,735	76,446	72,422	68,801	26	17	4 to 6	2.3
91,970	76,642	72,608	68,978	23	15	4 to 6	2.3
95,263	79,386	75,208	71,448	27	17	4 to 6	2.2

**IMPORTANT: See "General Planting Rate Information" and "Checking Seed Population" pages for additional information. Always check seed population in the field to ensure planting rates are correct.**

# SEED METER OPERATION/MAINTENANCE

**PLANTING RATES FOR ACID-DELINTED COTTON/SMALL DRY EDIBLE BEAN 54 CELL DISC  
19 TOOTH CONTACT WHEEL DRIVE SPROCKET (See Page 7-1)  
APPROXIMATE SEEDS/ACRE FOR VARIOUS ROW WIDTHS**

30" Rows	36" Rows	38" Rows	40" Rows	Transmission Sprockets		Recomm. Speed (MPH)	Average Spacing In Inches
				Drive	Driven		
40,701	33,918	32,132	30,526	15	28	4 to 6	5.1
42,209	35,174	33,323	31,656	15	27	4 to 6	5.0
43,832	36,527	34,604	32,874	15	26	4 to 6	4.8
45,585	37,988	35,988	34,189	15	25	4 to 6	4.6
46,128	38,440	36,417	34,596	17	28	4 to 6	4.5
47,485	39,571	37,488	35,613	15	24	4 to 6	4.4
47,836	39,864	37,766	35,877	17	27	4 to 6	4.4
49,549	41,291	39,118	37,162	15	23	4 to 6	4.2
49,676	41,397	39,218	37,257	17	26	4 to 6	4.2
51,555	42,962	40,701	38,666	19	28	4 to 6	4.1
51,663	43,053	40,787	38,747	17	25	4 to 6	4.0
53,464	44,554	42,209	40,098	19	27	4 to 6	3.9
53,816	44,847	42,486	40,362	17	24	4 to 6	3.9
55,521	46,267	43,832	41,640	19	26	4 to 6	3.8
56,156	46,796	44,334	42,117	17	23	4 to 6	3.7
57,741	48,118	45,585	43,306	19	25	4 to 6	3.6
59,981	49,984	47,353	44,985	15	19	4 to 6	3.5
60,147	50,123	47,485	45,110	19	24	4 to 6	3.5
62,408	52,007	49,270	46,806	23	28	4 to 6	3.4
62,762	52,302	49,549	47,072	19	23	4 to 6	3.3
64,720	53,933	51,095	48,540	23	27	4 to 6	3.2
65,122	54,268	51,412	48,841	24	28	4 to 6	3.2
67,037	55,864	52,924	50,278	15	17	4 to 6	3.1
67,534	56,278	53,316	50,650	24	27	4 to 6	3.1
67,978	56,648	53,667	50,984	17	19	4 to 6	3.1
69,897	58,248	55,182	52,423	23	25	4 to 6	3.0
70,549	58,791	55,696	52,911	26	28	4 to 6	3.0
72,810	60,675	57,481	54,607	23	24	4 to 6	2.9
72,936	60,780	57,581	54,702	24	25	4 to 6	2.9
73,262	61,052	57,838	54,947	27	28	4 to 6	2.9
75,975	63,313	59,981	56,982	23	23	4 to 6	2.8
78,789	65,658	62,202	59,092	28	27	4 to 6	2.7
78,898	65,748	62,288	59,173	27	26	4 to 6	2.7
79,279	66,066	62,588	59,459	24	23	4 to 6	2.6
81,820	68,183	64,595	61,365	28	26	4 to 6	2.6
82,053	68,378	64,779	61,540	27	25	4 to 6	2.5
82,582	68,818	65,196	61,937	25	23	4 to 6	2.5
84,914	70,761	67,037	63,685	19	17	4 to 6	2.5
85,472	71,227	67,478	64,104	27	24	4 to 6	2.4
85,885	71,571	67,804	64,414	26	23	4 to 6	2.4
88,638	73,865	69,977	66,479	28	24	4 to 6	2.4
89,189	74,324	70,412	66,891	27	23	4 to 6	2.3
91,970	76,642	72,608	68,978	23	19	4 to 6	2.3
92,492	77,077	73,020	69,369	28	23	4 to 6	2.3
95,969	79,974	75,765	71,977	24	19	4 to 6	2.2
99,968	83,306	78,922	74,976	25	19	4 to 6	2.1
102,790	85,659	81,150	77,093	23	17	4 to 6	2.0
103,966	86,639	82,079	77,975	26	19	4 to 6	2.0
107,259	89,383	84,679	80,445	24	17	4 to 6	1.9
107,965	89,971	85,236	80,974	27	19	4 to 6	1.9
111,729	93,107	88,207	83,796	25	17	4 to 6	1.9
111,964	93,303	88,393	83,973	28	19	4 to 6	1.9
116,198	96,831	91,735	87,148	26	17	4 to 6	1.8
116,496	97,080	91,970	87,372	23	15	4 to 6	1.8
120,667	100,556	95,263	90,500	27	17	4 to 6	1.7

**IMPORTANT: See "General Planting Rate Information" and "Checking Seed Population" pages for additional information. Always check seed population in the field to ensure planting rates are correct.**

# SEED METER OPERATION/MAINTENANCE

## PLANTING RATES FOR LARGE DRY EDIBLE BEAN 54 CELL DISC 15 TOOTH CONTACT WHEEL DRIVE SPROCKET (See Page 7-1) APPROXIMATE SEEDS/ACRE FOR VARIOUS ROW WIDTHS

30" Rows	36" Rows	38" Rows	40" Rows	Transmission Sprockets		Recomm. Speed (MPH)	Average Spacing In Inches
				Drive	Driven		
32,132	26,777	25,368	24,099	15	28	4 to 6	6.5
33,323	27,769	26,307	24,992	15	27	4 to 6	6.3
34,604	28,837	27,319	25,953	15	26	4 to 6	6.0
35,988	29,990	28,412	26,991	15	25	4 to 6	5.8
36,417	30,347	28,750	27,313	17	28	4 to 6	5.7
37,488	31,240	29,596	28,116	15	24	4 to 6	5.6
37,766	31,471	29,815	28,324	17	27	4 to 6	5.5
39,118	32,598	30,882	29,338	15	23	4 to 6	5.3
39,218	32,682	30,962	29,414	17	26	4 to 6	5.3
40,701	33,918	32,132	30,526	19	28	4 to 6	5.1
40,787	33,989	32,200	30,590	17	25	4 to 6	5.1
42,209	35,174	33,323	31,656	19	27	4 to 6	5.0
42,486	35,405	33,542	31,865	17	24	4 to 6	4.9
43,832	36,527	34,604	32,874	19	26	4 to 6	4.8
44,334	36,945	35,000	33,250	17	23	4 to 6	4.7
45,585	37,988	35,988	34,189	19	25	4 to 6	4.6
47,353	39,461	37,384	35,515	15	19	4 to 6	4.4
47,485	39,571	37,488	35,613	19	24	4 to 6	4.4
49,270	41,058	38,897	36,952	23	28	4 to 6	4.2
49,549	41,291	39,118	37,162	19	23	4 to 6	4.2
51,095	42,579	40,338	38,321	23	27	4 to 6	4.1
51,412	42,843	40,588	38,559	24	28	4 to 6	4.1
52,924	44,103	41,782	39,693	15	17	4 to 6	4.0
53,316	44,430	42,092	39,987	24	27	4 to 6	3.9
53,667	44,722	42,369	40,250	17	19	4 to 6	3.9
55,182	45,985	43,565	41,387	23	25	4 to 6	3.8
55,696	46,414	43,971	41,772	26	28	4 to 6	3.8
57,481	47,901	45,380	43,111	23	24	4 to 6	3.6
57,581	47,985	45,459	43,186	24	25	4 to 6	3.6
57,838	48,199	45,662	43,379	27	28	4 to 6	3.6
59,981	49,984	47,353	44,985	23	23	4 to 6	3.5
62,202	51,835	49,107	46,652	28	27	4 to 6	3.4
62,288	51,906	49,174	46,716	27	26	4 to 6	3.4
62,588	52,157	49,412	46,941	24	23	4 to 6	3.3
64,595	53,829	50,996	48,446	28	26	4 to 6	3.2
64,779	53,983	51,141	48,584	27	25	4 to 6	3.2
65,196	54,330	51,471	48,897	25	23	4 to 6	3.2
67,037	55,864	52,924	50,278	19	17	4 to 6	3.1
67,478	56,232	53,272	50,609	27	24	4 to 6	3.1
67,804	56,503	53,530	50,853	26	23	4 to 6	3.1
69,977	58,314	55,245	52,483	28	24	4 to 6	3.0
70,412	58,677	55,588	52,809	27	23	4 to 6	3.0
72,608	60,507	57,322	54,456	23	19	4 to 6	2.9
73,020	60,850	57,647	54,765	28	23	4 to 6	2.9
75,765	63,138	59,814	56,824	24	19	4 to 6	2.8
78,922	65,768	62,307	59,191	25	19	4 to 6	2.6
81,150	67,625	64,066	60,863	23	17	4 to 6	2.6
82,079	68,399	64,799	61,559	26	19	4 to 6	2.5
84,679	70,565	66,851	63,509	24	17	4 to 6	2.5
85,236	71,030	67,291	63,927	27	19	4 to 6	2.5
88,207	73,506	69,637	66,155	25	17	4 to 6	2.4
88,393	73,660	69,784	66,294	28	19	4 to 6	2.4
91,735	76,446	72,422	68,801	26	17	4 to 6	2.3
91,970	76,642	72,608	68,978	23	15	4 to 6	2.3
95,263	79,386	75,208	71,448	27	17	4 to 6	2.2

**IMPORTANT: See "General Planting Rate Information" and "Checking Seed Population" pages for additional information. Always check seed population in the field to ensure planting rates are correct.**



# SEED METER OPERATION/MAINTENANCE

**PLANTING RATES FOR LARGE DRY EDIBLE BEAN 54 CELL DISC  
19 TOOTH CONTACT WHEEL DRIVE SPROCKET (See Page 7-1)  
APPROXIMATE SEEDS/ACRE FOR VARIOUS ROW WIDTHS**

30" Rows	36" Rows	38" Rows	40" Rows	Transmission Sprockets		Recomm. Speed (MPH)	Average Spacing In Inches
				Drive	Driven		
40,701	33,918	32,132	30,526	15	28	4 to 6	5.1
42,209	35,174	33,323	31,656	15	27	4 to 6	5.0
43,832	36,527	34,604	32,874	15	26	4 to 6	4.8
45,585	37,988	35,988	34,189	15	25	4 to 6	4.6
46,128	38,440	36,417	34,596	17	28	4 to 6	4.5
47,485	39,571	37,488	35,613	15	24	4 to 6	4.4
47,836	39,864	37,766	35,877	17	27	4 to 6	4.4
49,549	41,291	39,118	37,162	15	23	4 to 6	4.2
49,676	41,397	39,218	37,257	17	26	4 to 6	4.2
51,555	42,962	40,701	38,666	19	28	4 to 6	4.1
51,663	43,053	40,787	38,747	17	25	4 to 6	4.0
53,464	44,554	42,209	40,098	19	27	4 to 6	3.9
53,816	44,847	42,486	40,362	17	24	4 to 6	3.9
55,521	46,267	43,832	41,640	19	26	4 to 6	3.8
56,156	46,796	44,334	42,117	17	23	4 to 6	3.7
57,741	48,118	45,585	43,306	19	25	4 to 6	3.6
59,981	49,984	47,353	44,985	15	19	4 to 6	3.5
60,147	50,123	47,485	45,110	19	24	4 to 6	3.5
62,408	52,007	49,270	46,806	23	28	4 to 6	3.4
62,762	52,302	49,549	47,072	19	23	4 to 6	3.3
64,720	53,933	51,095	48,540	23	27	4 to 6	3.2
65,122	54,268	51,412	48,841	24	28	4 to 6	3.2
67,037	55,864	52,924	50,278	15	17	4 to 6	3.1
67,534	56,278	53,316	50,650	24	27	4 to 6	3.1
67,978	56,648	53,667	50,984	17	19	4 to 6	3.1
69,897	58,248	55,182	52,423	23	25	4 to 6	3.0
70,549	58,791	55,696	52,911	26	28	4 to 6	3.0
72,810	60,675	57,481	54,607	23	24	4 to 6	2.9
72,936	60,780	57,581	54,702	24	25	4 to 6	2.9
73,262	61,052	57,838	54,947	27	28	4 to 6	2.9
75,975	63,313	59,981	56,982	23	23	4 to 6	2.8
78,789	65,658	62,202	59,092	28	27	4 to 6	2.7
78,898	65,748	62,288	59,173	27	26	4 to 6	2.7
79,279	66,066	62,588	59,459	24	23	4 to 6	2.6
81,820	68,183	64,595	61,365	28	26	4 to 6	2.6
82,053	68,378	64,779	61,540	27	25	4 to 6	2.5
82,582	68,818	65,196	61,937	25	23	4 to 6	2.5
84,914	70,761	67,037	63,685	19	17	4 to 6	2.5
85,472	71,227	67,478	64,104	27	24	4 to 6	2.4
85,885	71,571	67,804	64,414	26	23	4 to 6	2.4
88,638	73,865	69,977	66,479	28	24	4 to 6	2.4
89,189	74,324	70,412	66,891	27	23	4 to 6	2.3
91,970	76,642	72,608	68,978	23	19	4 to 6	2.3
92,492	77,077	73,020	69,369	28	23	4 to 6	2.3
95,969	79,974	75,765	71,977	24	19	4 to 6	2.2
99,968	83,306	78,922	74,976	25	19	4 to 6	2.1
102,790	85,659	81,150	77,093	23	17	4 to 6	2.0
103,966	86,639	82,079	77,975	26	19	4 to 6	2.0
107,259	89,383	84,679	80,445	24	17	4 to 6	1.9
107,965	89,971	85,236	80,974	27	19	4 to 6	1.9
111,729	93,107	88,207	83,796	25	17	4 to 6	1.9
111,964	93,303	88,393	83,973	28	19	4 to 6	1.9
116,198	96,831	91,735	87,148	26	17	4 to 6	1.8
116,496	97,080	91,970	87,372	23	15	4 to 6	1.8
120,667	100,556	95,263	90,500	27	17	4 to 6	1.7

**IMPORTANT: See "General Planting Rate Information" and "Checking Seed Population" pages for additional information. Always check seed population in the field to ensure planting rates are correct.**

# SEED METER OPERATION/MAINTENANCE

## DRY INSECTICIDE APPLICATION RATES APPROXIMATE POUNDS/ACRE AT 5 MPH FOR VARIOUS ROW WIDTHS

Meter Setting	30" Rows	36" Rows	38" Rows	40" Rows
<b>CLAY GRANULES</b>				
10	4.9	4.1	3.9	3.7
11	5.4	4.5	4.3	4.1
12	6.1	5.1	4.8	4.6
13	6.9	5.7	5.4	5.2
14	7.7	6.4	6.0	5.8
15	8.5	7.1	6.7	6.4
16	9.6	8.0	7.6	7.2
17	10.7	8.9	8.4	8.0
18	11.4	9.5	9.0	8.6
19	13.1	10.9	10.3	9.8
20	14.2	11.8	11.2	10.7
21	15.5	12.9	12.3	11.6
22	16.4	13.7	12.9	12.3
23	17.2	14.3	13.6	12.9
24	18.8	15.7	14.9	14.1
25	20.9	17.4	16.5	15.7
26	23.0	19.2	18.1	17.3
27	24.1	20.0	19.0	18.1
28	25.4	21.2	20.1	19.1
29	27.8	23.2	22.0	20.9
30	29.6	24.7	23.4	22.2
<b>SAND GRANULES</b>				
5	2.9	2.4	2.3	2.2
6	4.9	4.0	3.8	3.7
7	5.3	4.4	4.2	3.9
8	6.3	5.3	5.0	4.8
9	7.8	6.5	6.1	5.9
10	8.9	7.4	7.0	6.7
11	10.2	8.5	8.0	7.7
12	11.2	9.3	8.8	8.4
13	12.6	10.5	10.0	9.5
14	14.1	11.7	11.1	10.6
15	15.5	12.9	12.3	11.6
16	17.5	14.6	13.8	13.1
17	19.4	16.2	15.3	14.6
18	21.8	18.2	17.2	16.4
19	24.3	20.2	19.1	18.2
20	25.7	21.4	20.3	19.3
21	27.6	23.0	21.8	20.7
22	29.6	24.7	23.4	22.2
23	32.0	26.7	25.3	24.0
24	34.4	28.7	27.2	25.8
25	36.9	30.7	29.1	26.7

**NOTE:** The above chart represents average values and should be used only as a starting point. The granular chemical flows through the given meter opening at a nearly uniform rate regardless of roller speed. Your actual rate will vary depending upon the insecticide you are using, your planting speed and your plant population. Planting speed/ground speed has the greatest effect on application rate.

Your actual rate must be checked in the field with the actual insecticide that you are using and at the speed and population at which you will be planting. See "Checking Granular Chemical Application Rate" page for additional information.



**WARNING:** Agricultural chemicals can be dangerous if not selected and handled with care. Always read and follow directions supplied by the chemical manufacturer.

# SEED METER OPERATION/MAINTENANCE

## DRY HERBICIDE APPLICATION RATES

### APPROXIMATE POUNDS/ACRE AT 5 MPH FOR VARIOUS ROW WIDTHS

#### CLAY GRANULES

Meter Setting	30" Rows	36" Rows	38" Rows	40" Rows
10	4.7	3.9	3.7	3.5
11	5.2	4.4	4.1	3.9
12	5.8	4.9	4.6	4.4
13	6.5	5.4	5.1	4.9
14	7.3	6.1	5.7	5.5
15	8.2	6.9	6.5	6.2
16	9.0	7.5	7.1	6.8
17	9.9	8.2	7.8	7.4
18	10.7	8.9	8.4	8.0
19	11.6	9.7	9.2	8.7
20	12.6	10.5	10.0	9.5
21	13.6	11.3	10.7	10.2
22	14.6	12.1	11.5	11.0
23	15.7	13.1	12.4	11.8
24	17.0	14.1	13.4	12.8
25	18.1	15.1	14.3	13.6
26	19.4	16.2	15.3	14.6
27	20.9	17.4	16.5	15.7
28	22.6	18.8	17.8	17.0
29	24.3	20.2	19.1	18.2
30	26.7	22.2	21.1	20.0

**NOTE:** The above chart represents average values and should be used only as a starting point. The granular chemical flows through the given meter opening at a nearly uniform rate regardless of roller speed. Your actual rate will vary depending upon the herbicide you are using, your planting speed and your plant population. Planting speed/ground speed has the greatest effect on application rate.

Your actual rate must be checked in the field with the actual herbicide that you are using and at the speed and population at which you will be planting. See "Checking Granular Chemical Application Rate" page for additional information.



**WARNING:** Agricultural chemicals can be dangerous if not selected and handled with care. Always read and follow directions supplied by the chemical manufacturer.

# SEED METER OPERATION/MAINTENANCE

---

**Page intentionally left blank.**

# SEED METER OPERATION/MAINTENANCE

## SEED METER SINGULATOR BRUSH AND VACUUM LEVEL ADJUSTMENTS

### SEED DISC SELECTION

CROP	CELLS	SEED SIZE RANGE	COLOR-CODE
Corn	39	35 To 70 Lbs./80,000 Kernel Count Unit	Light Blue
Low-Rate Corn	24	35 To 70 Lbs./80,000 Kernel Count Unit	Light Green
Popcorn	39	2210 To 4200 Seeds/Lb.	Light Blue
Low-Rate Popcorn	24	2210 To 4200 Seeds/Lb.	Light Green
Soybean	60	2200 To 4000 Seeds/Lb.	Black
High-Rate Soybean	120	2200 To 4000 Seeds/Lb.	Dark Blue
Milo/Grain Sorghum	60	10,000 To 20,000 Seeds/Lb.	Yellow
Hill-Drop Cotton, Acid-Delinted (3 Seeds Per Cell)	20	3800 To 5200 Seeds/Lb.	Brown
Cotton, Acid-Delinted	54	3800 To 5200 Seeds/Lb.	Dark Green
Dry Edible Bean (Small)	54	1200 To 2500 Seeds/Lb.	Dark Green
Dry Edible Bean (Large)	54	800 To 1200 Seeds/Lb.	Tan

### EDGEVAC® INITIAL SETTINGS

CROP	SIZE	SINGULATOR SEED DISC	VACUUM BRUSH SETTING	SETTING (H <sub>2</sub> O)	SEE NOTES
Corn	35-45 Lbs./80K	Corn/Popcorn	7	20	4, 5
	45-60 Lbs./80K	Corn/Popcorn	6	20	4, 5
	60-70 Lbs./80K	Corn/Popcorn	5	20	4, 5
Popcorn	2210-4200 Seeds/Lb.	Corn/Popcorn	9	18	1, 4, 5
Soybeans	2200-4000 Seeds/Lb.	Soybean	5	10	1
Milo/Grain Sorghum	10,000-20,000 Seeds/Lb.	Milo/Grain Sorghum	7	18	1, 2
Hill-Drop Cotton	3800-5200 Seeds/Lb.	Hill-Drop Cotton	8	23	3
Cotton	3800-5200 Seeds/Lb.	Cotton	8	20	3
Edible Beans	800-1200 Seeds/Lb.	Large Edible Bean	5	18	5
	1200-2500 Seeds/Lb.	Small Edible Bean	6	18	3, 5

#### NOTES:

1. Requires use of seed meter baffle. Refer to page 7-3 for additional information.
2. Requires use of cleanout brush. Refer to page 7-3 for additional information.
3. Requires use of cleanout brush w/ball-type ejector. Refer to page 7-3 for additional information.
4. For flat seeds, higher vacuum level may be required.
5. Larger seeds may require a lower numbered singulator brush setting from the initial setting. Smaller seeds may require a higher numbered setting.

Refer to the planting rate charts in this manual for seed drive transmission sprocket combinations.

**IMPORTANT:** See “General Planting Rate Information” and “Checking Seed Population” pages for additional information. Always check seed population in the field to ensure planting rates are correct.

**NOTE:** Singulator brush settings are marked from 1 thru 11. The lower the singulator brush setting, the less aggressive. The higher singulator brush settings are the most aggressive. Refer to illustrations on page 7-24.

**NOTE:** Optimum meter performance will be attained with consistent seed size and shape. A mixture of seed sizes and shapes will affect meter performance.

**NOTE:** Use 1 tablespoon powdered graphite with each hopper fill of seed. Seed treatment, foreign material, dirt or seed chaff may cause gradual reduction of seed disc fill (population). See “Seed Meter”.

**NOTE:** Excessive seed treatment, humidity and light-weight seed can affect meter performance. Use ½ cup of talc with each hopper fill of seed and mix thoroughly so that all seeds are coated, adjust rates as needed. Use of talc will aid the seed flow into the meter, singulation and seed drop from the disc.

# SEED METER OPERATION/MAINTENANCE

**STEP 1** Select seed disc (and seed meter baffle, cleanout brush and/or cleanout brush w/ball-type ejector if applicable) to match crop and population.

**STEP 2** Adjust the singulator brush to initial setting. Note that seed size, seed shape, seed treatments, travel speed and planting rate will all affect meter performance.

D06260660

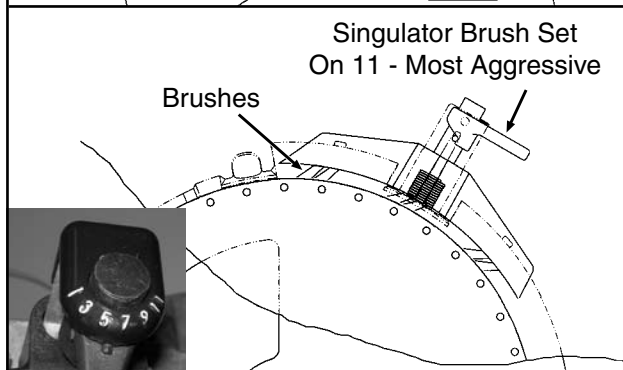
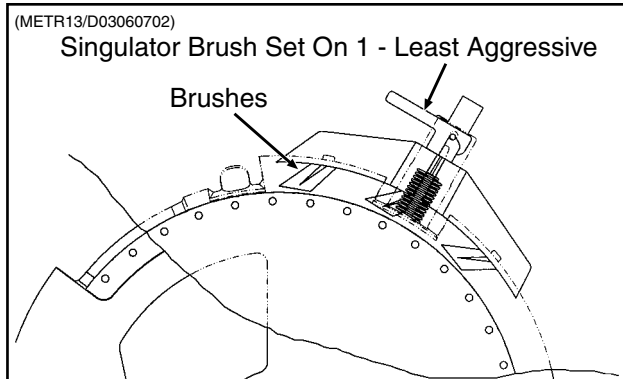
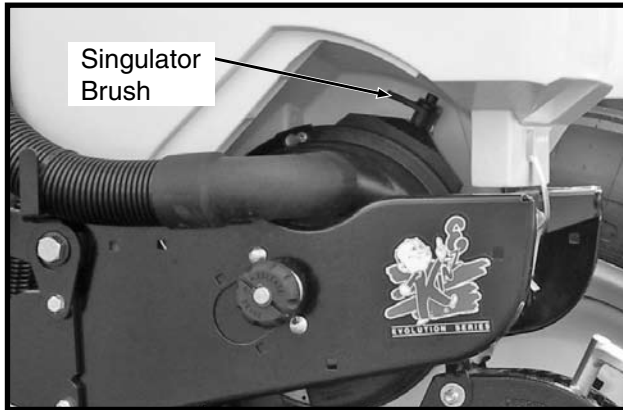

**STEP 3** With vacuum fan running, lower planter to planting position and drive forward a short distance to load seed into the seed disc cells.

Adjust vacuum level to the initial setting according to the tables on preceding page. Note that seed size, seed shape, seed treatments, travel speed and planting rate will all affect meter performance.

**NOTE:** Vacuum reading will be much lower when seed disc cells are empty. Prior to setting vacuum level, load all seed cells.

D10240583



See "Digital Vacuum Gauge Operation" in Machine Operation section

**NOTE:** Operate vacuum fan 3-5 minutes to bring oil up to normal operating temperature prior to making the final vacuum level adjustment.

**STEP 4** Perform optional seed disc fill check.

D101906132



D101906130



With vacuum hose connected and vacuum fan operating, remove vacuum cover and seed disc as an assembly. Inspect seed discs for proper seed fill.

See "Seed Metering System Troubleshooting" at the end of this section.

# SEED METER OPERATION/MAINTENANCE

---

## SEED METER DRIVE RELEASE

The seed meter drive is equipped with a clutch release mechanism that allows the drive to be disengaged from the seed metering unit for removal of the seed meter and mount or hopper. Disconnecting the drive allows the operator to check granular chemical application rates without dropping seed. It also allows the drive to one or more of the rows to be disconnected when finishing fields.

D011006101

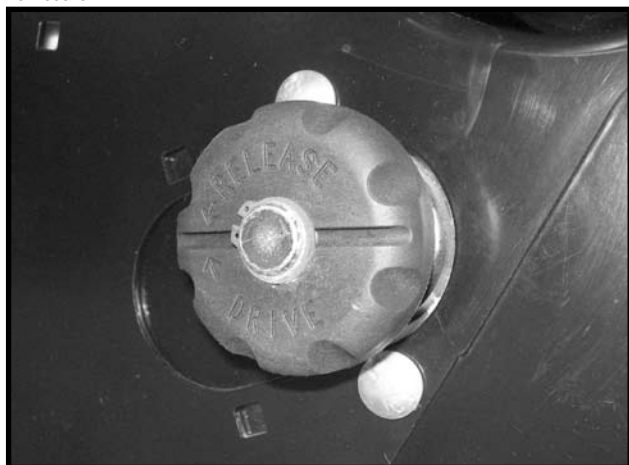

To disengage the drive, turn the knob  $\frac{1}{4}$  turn counter-clockwise. To engage the drive, turn the knob  $\frac{1}{4}$  turn clockwise.

# SEED METER OPERATION/MAINTENANCE

## SEED METER MAINTENANCE

(METR71)

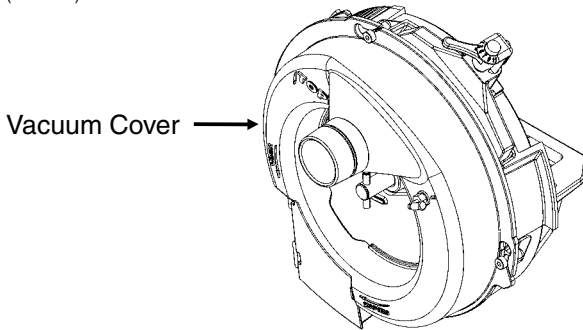

Clean, high quality seed should be used for maximum meter accuracy. Damaged or cracked seed, hulls or foreign material may become lodged in the seed disc orifices and greatly reduce meter accuracy.

It is suggested that the seed disc be inspected and cleaned daily, checking for any buildup of foreign material or any blocked orifices. Clean the seed disc by washing it with soap and water as needed. Dry thoroughly.

Inspect singulator brush for wear and replace if necessary following every 200 acres per row of operation.

The seed disc and/or vacuum cover should be replaced if abnormally high vacuum is required for consistent operation or if consistent operation can not be achieved. If adjustment of the singulator brush does not affect performance of the meter or if the brushes appear frayed, the singulator brush may need to be replaced. If the seed disc orifices are plugged frequently with seed remnants, the cleanout brush or cleanout brush with ball-type ejector (if applicable) may need to be replaced. High quality seed should be used to attain best performance.

(METR70)

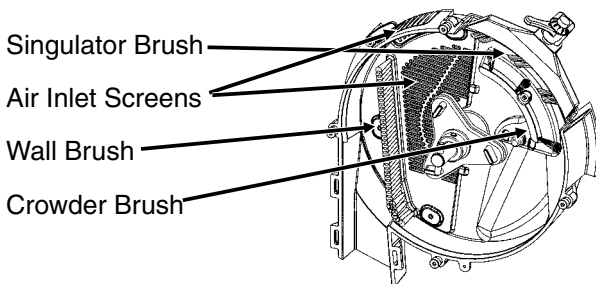

Prior to each planting season, inspect seed discs, singulator brush, crowder brush, wall brush and air inlet screens and clean or replace as needed.

See "Preparation For Storage" for additional EdgeVac® Seed Metering System maintenance.

**IMPORTANT:** Replace hopper lids after hoppers are filled to prevent accumulation of dust or dirt in the seed meter which will cause premature wear.

**NOTE:** Remove seed discs from meters for annual storage and store the seed discs vertically on a dowel or pipe.

## VACUUM MANIFOLD MAINTENANCE

In the course of normal operation, dust will accumulate in manifolds and hoses. Manifolds should be cleaned annually. More frequent cleaning may be necessitated by abnormally dusty planting conditions.

Remove vacuum hose from each seed meter. Operate the vacuum fan at full hydraulic flow from the tractor for two minutes to clear manifolds, hoses and fittings of dust and debris.



# SEED METER OPERATION/MAINTENANCE

## SEED METERING SYSTEM TROUBLESHOOTING

PROBLEM	POSSIBLE CAUSE	SOLUTION
Low seed count.	Meter RPM too high.	Reduce planting rate or planting speed.
	Singulator brush setting too aggressive.	Adjust singulator brush.
	Vacuum level too low.	Increase fan speed.
	Seed sensor not picking up all seeds dropped.	Clean seed tube. Move meter to different row.
	Seeds sticking to seed disc.	Use graphite or talc to aid release.
	Seed treatment buildup in seed disc recesses.	Reduce amount of treatment used and or mix thoroughly. Add talc.
	Seed size too large for disc used.	Use appropriate disc for seed size.
	Wrong transmission setting.	Change transmission to desired rate.
	Wrong seed disc.	Use appropriate disc for seed type and size.
	Drive wheel slippage.	Compensate by adjusting transmission sprockets.
	Low tire pressure.	Adjust tire pressure to correct level.
	Failed/worn drive components.	Inspect and replace parts as required.
	Plugged orifices in seed disc.	Inspect and clean disc. Check cleanout brush. (If Applicable)
	Loss of vacuum at meter.	Check for foreign material between vacuum cover and disc. Inspect parts for wear/damage. Clean or replace as required.
	Seed bridging in hopper.	Add graphite to improve seed flow.
	Faulty vacuum gauge reading.	Repair/replace gauge.
	Dirt in vacuum manifold.	Check vacuum manifold for dirt and clean.
	Seed baffle (If Applicable) not allowing seed flow due to bridging of seed.	Thoroughly mix talc to coat all seeds. Remove seed baffle. See "Seed Meter" in Seed Meter Operation/Maintenance section.
	60 cell soybean disc not filling properly due to excessive RPM.	Replace with 120 cell soybean disc.
	Seed disc worn.	Replace.
Vacuum cover worn.	Replace.	
Not planting seed.	Seed hoppers empty.	Fill seed hopper.
	Seed tube plugged/damaged.	Clean or replace tube.
	Meter drive damaged.	Repair/replace drive components.
	Low/no vacuum.	Inspect vacuum system and repair as necessary.
	Singulator brush setting too aggressive.	Adjust singulator brush.
	Faulty vacuum gauge.	Repair/replace vacuum gauge.
	Seed bridging in hopper.	Add graphite to improve seed flow.
	Loss of vacuum at meter.	Check for foreign material between vacuum cover and disc. Inspect parts for wear/damage. Clean and/or replace as required.
	Wrong seed disc.	Use appropriate disc for seed type and size.
	Meter drive clutch not engaged.	Engage drive clutch.
	Fan not running.	Start fan.
Dirt in vacuum manifold.	Check vacuum manifold for dirt and clean.	

(Continued On Following Page)

# SEED METER OPERATION/MAINTENANCE

## SEED METERING SYSTEM TROUBLESHOOTING (Continued)

PROBLEM	POSSIBLE CAUSE	SOLUTION
Not planting seed. (Continued)	Seed baffle (If Applicable) not allowing seed flow due to bridging of seed.	Thoroughly mix talc to coat all seeds. Remove seed baffle. See "Seed Meter" in Seed Meter Operation/Maintenance section.
	60 cell soybean disc not filling properly due to excessive RPM.	Replace with 120 cell soybean disc.
High seed count.	Wrong transmission setting.	Change transmission to desired rate.
	High vacuum.	Adjust vacuum level to appropriate level.
	Wrong seed disc.	Replace seed disc.
	Singulator brush setting not aggressive enough.	Adjust singulator brush.
	Worn singulator brush.	Inspect brush and replace as required.
	Seed leaking past wall brush.	Inspect wall brush condition and installation. Replace as necessary.
	Faulty vacuum gauge.	Check gauge line for dirt/obstruction. Repair/replace vacuum gauge.
Poor seed spacing.	Obstruction in seed tube.	Clean seed tube.
	Dirty/damaged seed disc.	Inspect seed disc for damage, foreign material in orifices or seed treatment buildup in recesses. Clean or replace as required.
	Wrong vacuum setting.	Adjust vacuum to appropriate level.
	Excess foreign material in seed.	Inspect and clean meter and seed discs. Use clean, undamaged seed.
	Incorrect singulator brush setting.	Adjust singulator brush to appropriate setting.
	Inconsistent driveline.	Inspect drive components for rust, misalignment, worn or damaged parts. Replace/repair as required.
	Toolbar not level or wrong height.	Adjust hitch to level toolbar and row units.
	Planting too fast for conditions.	Reduce speed.
	Rough field conditions.	Reduce speed.
Irregular seed population.	Driving too fast.	Reduce speed.
	Drive wheels slipping.	Reduce speed. Decrease row unit down pressure spring settings.
Unable to achieve desired vacuum level.	Tractor hydraulic flow set too low.	Increase flow to fan motor.
	Incorrect hydraulic connections.	Check all hydraulic connections and hose routings.
	Damaged fan components.	Inspect motor and impeller for wear/damage and repair/replace as necessary.
	Vacuum hose pinched/kinked/ blocked.	Inspect air lines for any damage or obstruction. Clean air lines and manifold by removing end cap from manifold and running fan at high speed.
	Vacuum hose loose/disconnected.	Inspect and reattach all air hoses.
	Tractor not producing required hydraulic flow/pressure.	Have tractor serviced by qualified technician.
	Dirt in vacuum gauge line.	Check gauge line for dirt/obstruction and clean.

# ROW UNIT OPERATION

## PLANTING DEPTH

Planting depth is maintained by the row unit gauge wheels. To increase or decrease the planting depth, first raise the planter to remove weight from the wheels. Then push down on the depth adjustment handle and reposition it forward to decrease depth or rearward to increase planting depth. Adjust all units to the same setting initially. Then lower the planter and check operation and planting depth of all row units. It may be necessary to readjust some rows to obtain uniform operation. Available depth adjustment range is approximately 1/2" to 3 1/2".



**WARNING: Never work under the planter while in raised position without using safety lockup devices.**

D020705102

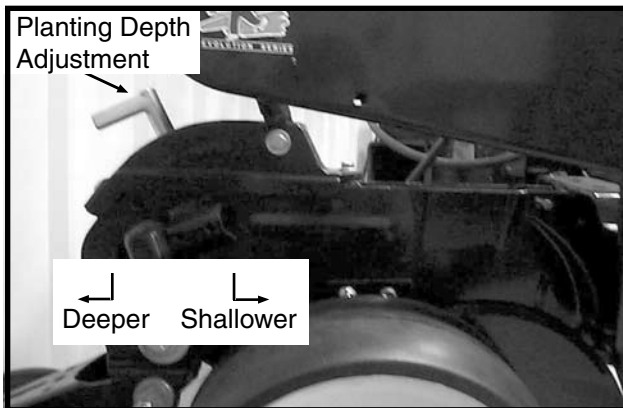

## "V" CLOSING WHEEL ADJUSTMENT (Rubber And Cast Iron)



**WARNING: Raise planter and install safety lockup devices before making closing wheel adjustments.**

After adjusting planting depth, check the operation of the "V" closing wheels. The "V" closing wheels should have enough down pressure to close the seed trench and ensure good soil to seed contact. To increase spring pressure on the closing wheels, move the 5-position quick adjustable down force lever located on the top of the closing wheel arm to the rear. Moving the lever forward decreases spring tension.

Adjust all row units to a similar setting.

LF212299-15

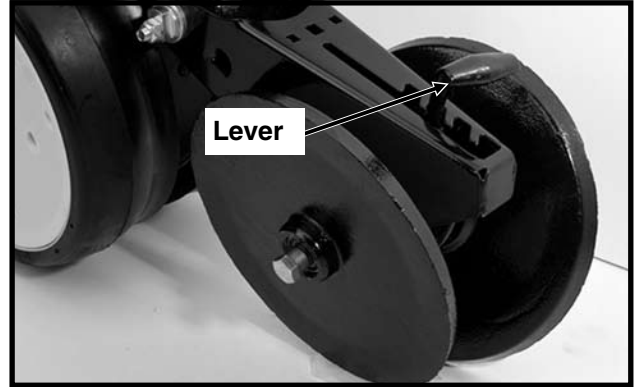

Light soil usually requires less down force at average depth (approximately 2") while heavy soil requires increased down force.

Eccentric bushings in the wheel arm stop allow for lateral adjustment of the "V" closing wheel assembly. Using a 3/4" wrench, loosen the hardware which attaches the closing wheel arm to the wheel arm stop. Using another 3/4" wrench turn the eccentric bushings until the **closing wheels are aligned with the seed trench**. Tighten hardware.

LF2122299-15

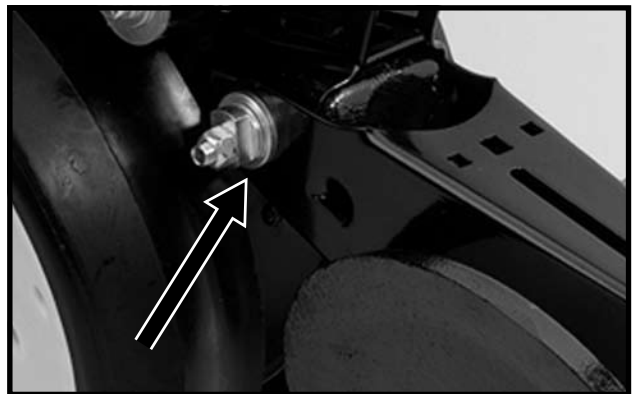

The closing wheels can be installed in two locations either "offset" (to improve residue flow) or "directly" opposite. If set "directly" opposite, the forward installation holes should be used.

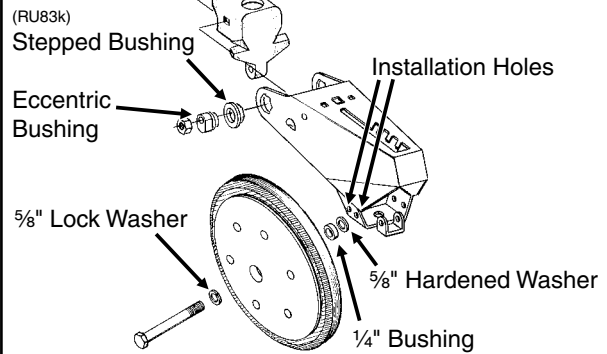

# ROW UNIT OPERATION

## CLOSING WHEEL SHIELD

(Rubber And Cast Iron "V" Closing Wheels)

D11090208a

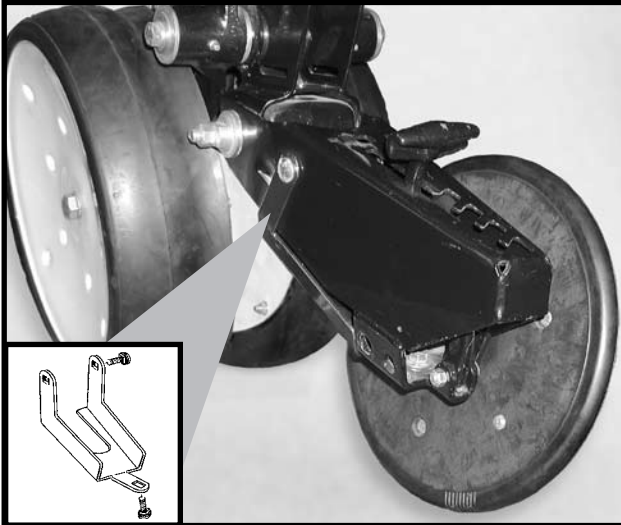

**Shown With Closing Wheel Removed For Visual Clarity**

The optional closing wheel shield is designed to be installed onto the underside of the closing wheel arm to help prevent root balls and stalks from plugging the closing wheels.

## COVERING DISCS/SINGLE PRESS WHEEL ADJUSTMENT



**WARNING:** Raise planter and install safety lockup devices before making covering discs/single press wheel adjustments.

72359-31



After adjusting planting depth, check the operation of the covering discs/single press wheels.

Initial press wheel down force setting should be with 2 1/2" between mounting arm tab and locking nut. To adjust down force spring, loosen 1/2" locking nut and turn adjusting bolt in to increase down force or out to decrease down force. Tighten locking nut against spring plug. Adjust all row units to a similar setting.

RH993(PLTR12)

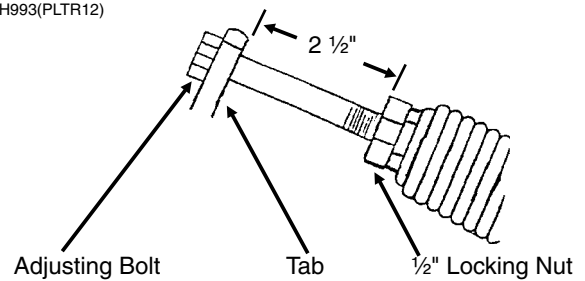

# ROW UNIT OPERATION

Eccentric bushings in the wheel arm stop allow for lateral adjustment of the covering discs/single press wheel assembly. Using a 3/4" wrench, loosen the hardware which attaches the assembly to the wheel arm stop. Using another 3/4" wrench, turn the eccentric bushings until the press wheel is aligned with the seed trench.

(RU94b)

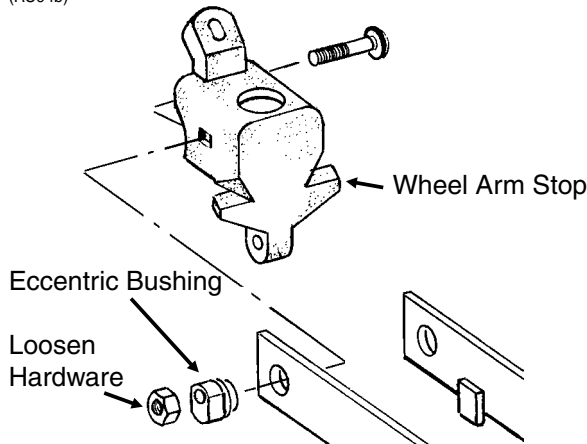

Two sets of holes in the mounting arm allow the covering discs to be located for staggered or side-by-side operation as desired.

72359-35

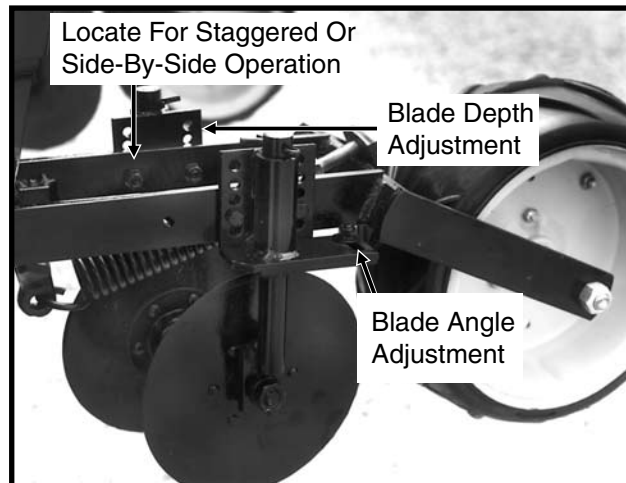

Five sets of holes in each disc bracket allow for 1/2" incremental blade depth adjustment.

Slotted holes in the disc mount and bracket allow for 0° - 15° blade angle adjustment.

Adjust covering discs on all row units to similar settings.

## DRAG CLOSING ATTACHMENT

LF212299-18

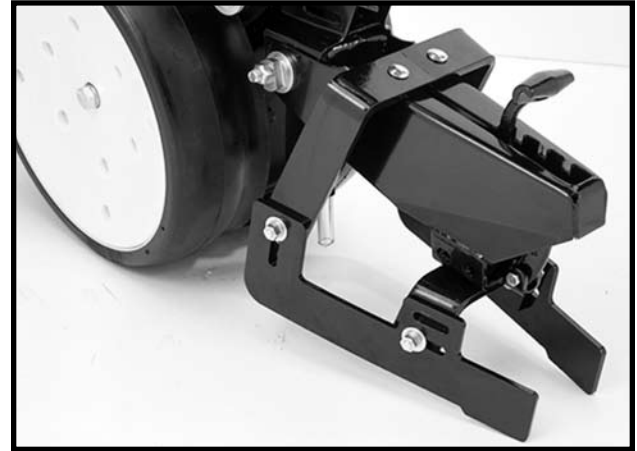

The drag closing attachment is designed to pull loose soil over the seed trench.

Front and rear adjustment is made using the slotted holes in the blades. Adjust all rows the same.

**NOTE: Use of a seed firming wheel or other seed firming device is recommended with the drag closing attachment.**

**WARNING: Raise planter and install safety lockup devices before making drag closing attachment adjustments.**

(RU90d)

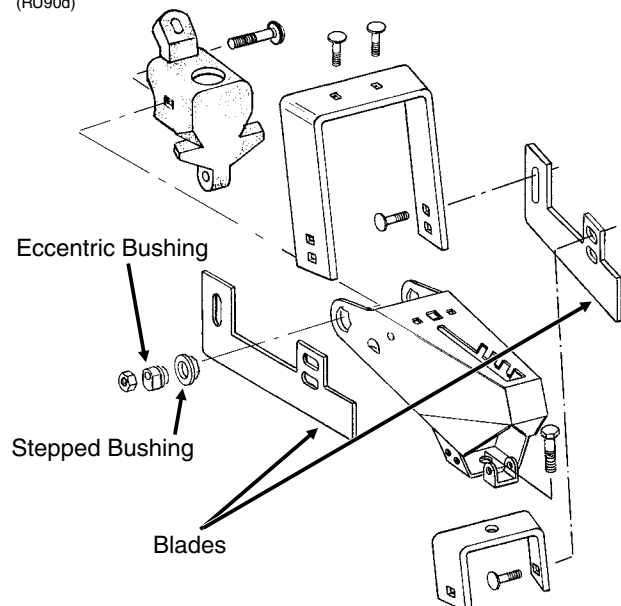

Eccentric bushings allow for lateral adjustment of the drag closing attachment. Using a 3/4" wrench, loosen the hardware which attaches the assembly to the wheel arm stop. Using another 3/4" wrench, turn the eccentric bushings until the drag closing attachment is aligned with the seed trench.

# ROW UNIT OPERATION

---

## SEED HOPPER

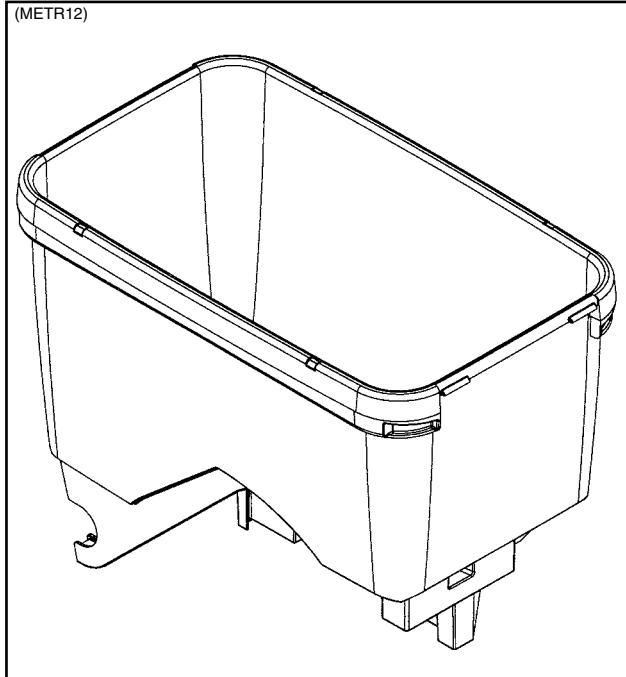

Seed hopper capacity is 1.75 bushels.

When filling the seed hopper use clean seed and make certain there are no foreign objects in the hopper. **Replace hopper lids after hoppers are filled to prevent the accumulation of dust or dirt in the seed meter which will cause premature wear.** See "Seed Meter" in Seed Meter Operation/Maintenance section.

Periodically empty the hoppers completely to remove any foreign material and to ensure proper seed meter operation. To empty hopper, disengage meter drive and hopper latch and lift hopper off the hopper support. See "Seed Meter Drive Release" in Seed Meter Operation/Maintenance section.

# ROW UNIT OPERATION

## ROW UNIT CHAIN ROUTING

For proper operation and to minimize wear, the row unit drive chains must be properly tensioned and aligned.

Inspect and replace weak, worn or broken springs and/or idlers and idler bushings.

**NOTE: When idler shows signs of wear, it can be reversed for prolonged use.**

D051705103

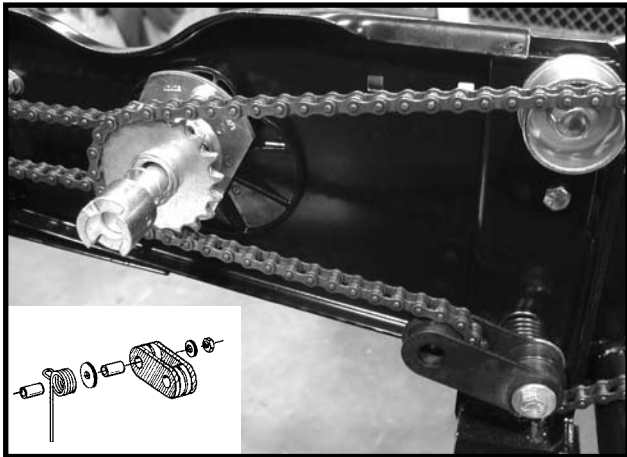

**Pull Row Unit Meter Drive**

D051705102

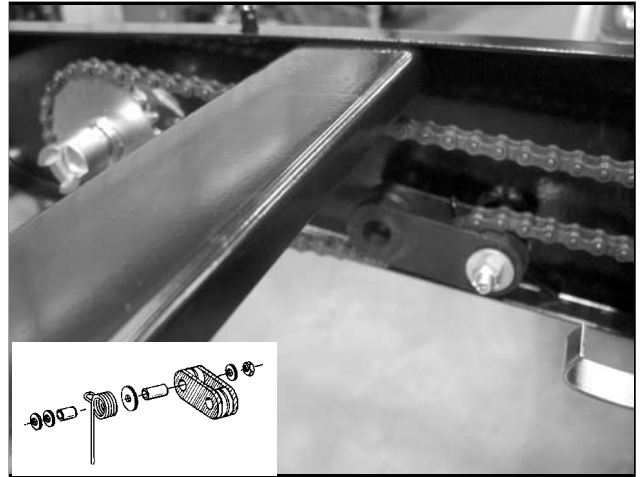

**Row Unit Granular Chemical Drive**

**NOTE: Make sure connector link is installed with closed end oriented properly as shown below.**

(PLTR24)

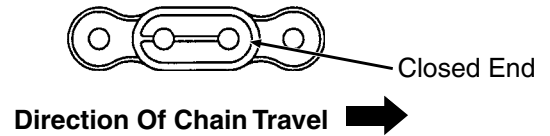

# ROW UNIT OPERATION

## QUICK ADJUSTABLE DOWN FORCE SPRINGS

Quick adjustable down force springs are designed to increase penetration in hard soil and keep the row unit from bouncing in rough field conditions.

Two springs per row, one on the L.H. parallel arms and one on the R.H. parallel arms, are used unless equipped with row unit mounted no till coulters. Four springs per row are used with row unit mounted no till coulters.

D06300305



**Two Springs Per Row (Dual)**

D07010301

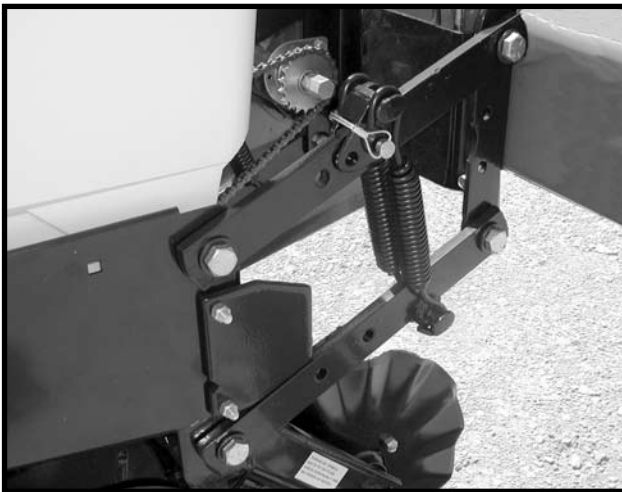

**Four Springs Per Row (Quad)  
(Used Only In Conjunction With Row Unit  
Mounted No Till Coulters)**

**NOTE: Four springs per row are to be used with row unit mounted no till coulters only.**

There are four positions for spring tension adjustment. Position 1 allows for minimum down pressure and position 4 for maximum down pressure.

L0096(PLTR27e)

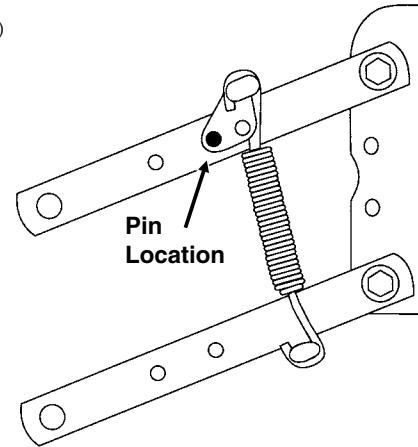

**Position 1 (Minimum)**

(PLTR28e)

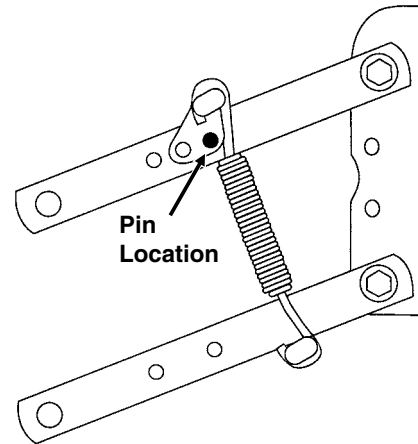

**Position 2**

(PLTR29e)

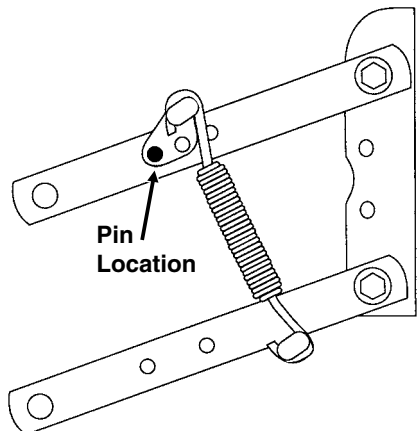

**Position 3**



# ROW UNIT OPERATION

(PLTR30e)

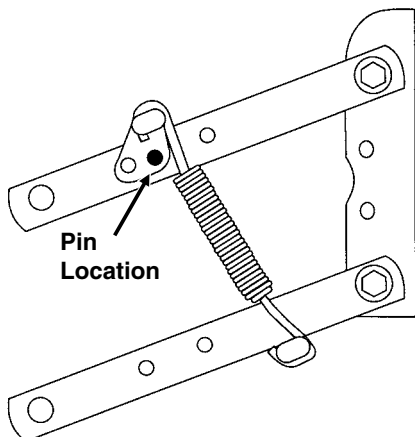

## Position 4 (Maximum)

To adjust spring tension, raise planter and remove spring mount pin at top of spring. Slide mount to desired position and install pin.

**NOTE:** It is necessary for the operator to adjust springs according to field conditions. If springs are adjusted for too much down pressure for field conditions, it is possible for the row units to lift the planter to the extent that the drive wheels do not make sufficient contact. Too much down pressure in soft field conditions can cause the row unit to run too deep.



**WARNING:** Always install safety lockup devices or lower machine to the ground before working under or around the machine.

**IMPORTANT:** Springs must always be installed with open side of spring hooks toward seed hoppers to prevent binding on spring mount adjustment pins.

## DUAL GAUGE WHEELS

Dual gauge wheels are used to provide added width for additional row unit flotation in light sandy soil.

In some applications such as narrow row widths (less than 36") or where clearance is a problem, the added width of the dual gauge wheel may prevent its use.

LF212199-1

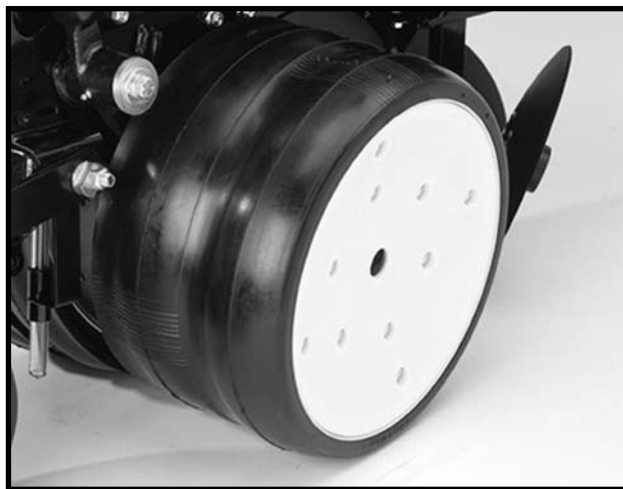

# ROW UNIT OPERATION

## FRAME MOUNTED COULTER

LF083002101

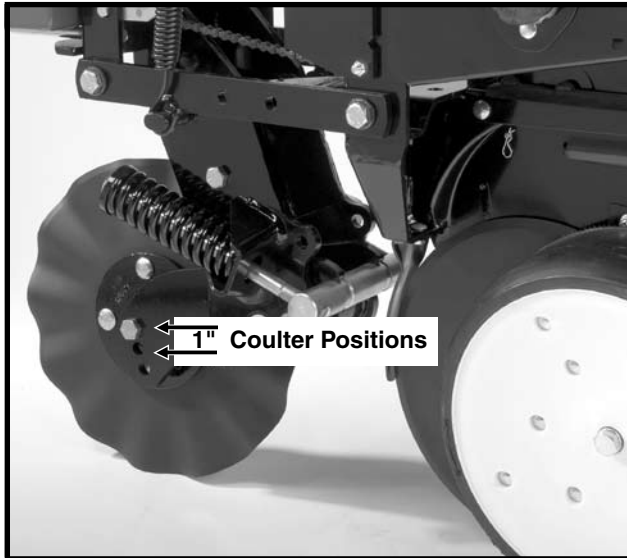

Frame mounted coulters with 1" bubbled, 1" fluted (8 flutes) or 3/4" fluted (13 flutes) blades may be used on pull row units only. (Not compatible with push row units.)

The frame mounted coulters is designed to apply necessary spring down pressure on the coulters for maximum penetration while exerting less shock load on the row unit.

The initial location of the coulters blade is in the top hole. The blade can be relocated to one of the lower two holes (1" increments) as wear occurs or if deeper operation of the blade is desired.

LF083002101

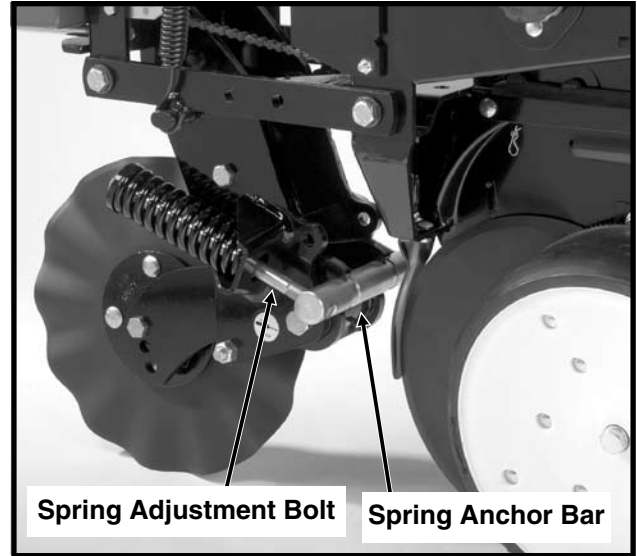

### DOWN PRESSURE ADJUSTMENT

Down force adjustment is made by tightening or loosening the two spring adjustment bolts. With the planter in raised position, turn the bolts clockwise to increase down pressure or counterclockwise to decrease down force. Set both springs the same.

Down force on the blade is shown below in lbs.

End Of Spring Adjustment Bolt Flush With Spring Anchor Bar (Shown Above)	End Of Spring Adjustment Bolt Extended 1/2" Through Spring Anchor Bar	All Threads Used (Maximum)
275 lbs.	400 lbs.	500 lbs.

**NOTE: Avoid setting down pressure higher than is required for consistent soil penetration. Excessive pressure will increase the chances of damage to coulters components when the coulters strikes an obstacle.**

# ROW UNIT OPERATION

## RESIDUE WHEELS (For Use With Frame Mounted Coulter)

The residue wheels for use with the frame mounted coulter may be used on pull row units only.

LF083002102



**STYLE A Shown**

The residue wheels are attached to the frame mounted coulter with two cap screws and sleeves allowing the unit to free-float. A 2-position spindle bolt mounting allows the tired wheels to be mounted interlocked or staggered. Depth adjustment is made using a spring-loaded cam and pin with 11 positions in 1/4" increments. A high point on the cam allows the wheels to be locked up so they do not contact the ground. A weed guard, located on the inboard side of each wheel, aids in the prevention of weed wrap which can cause premature bearing failure.

(RU135i)

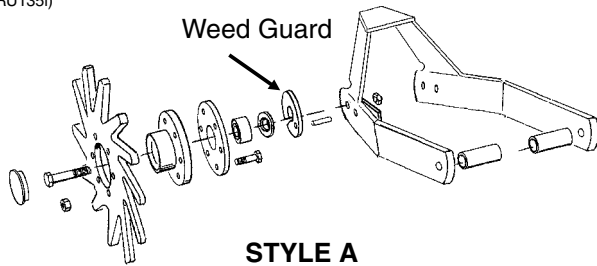

**STYLE A**

(RU135m)

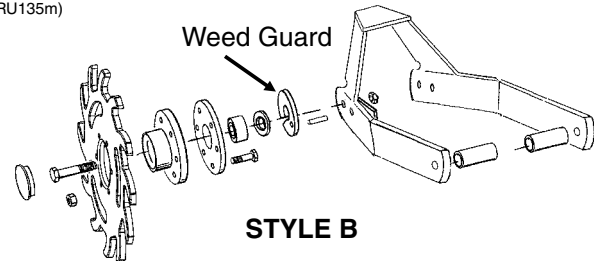

**STYLE B**

**NOTE: Opening in weed guard must point down.**

## ROW UNIT MOUNTED DISC FURROWER

The row unit mounted disc furrower is for use on pull row units only and may be equipped with either 12" solid blades or 12" notched blades.

Disc furrowers are used to clear crop residue, dirt clods and dry soil from in front of the row units for a clean and smooth seed bed. Notched blades are used for heavier residue conditions. The notched blades cut crop residue and move it aside to prevent plugging or pushing.

LF212299-22

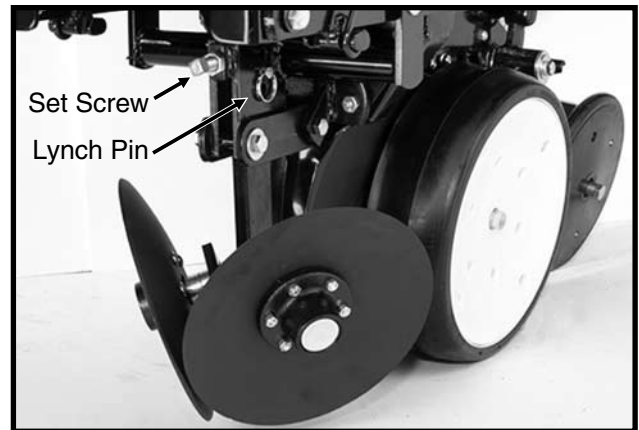

Vertical adjustment in 1/3" increments is possible by removing the lynch pin which secures the vertical support arm and moving the support arm up or down as required. Reinstall lynch pin. Finer adjustment can be attained by removing the lynch pin and using the 5/8" x 2 1/4" set screw to clamp the support arm in the required position.

(RU98e)

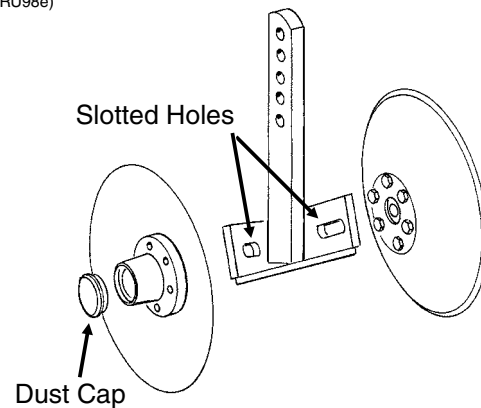

Slotted holes in the support arm where the blades are mounted allow fore and aft adjustment of the disc blades. Blades can be adjusted so the front edges meet or one blade can be moved to the rear and the other to the front of the slot so the cutting edge of one blade overlaps the edge of the other blade. The dust cap must be removed to make these adjustments.

# ROW UNIT OPERATION

## ROW UNIT MOUNTED BED LEVELER

LF212299-25a

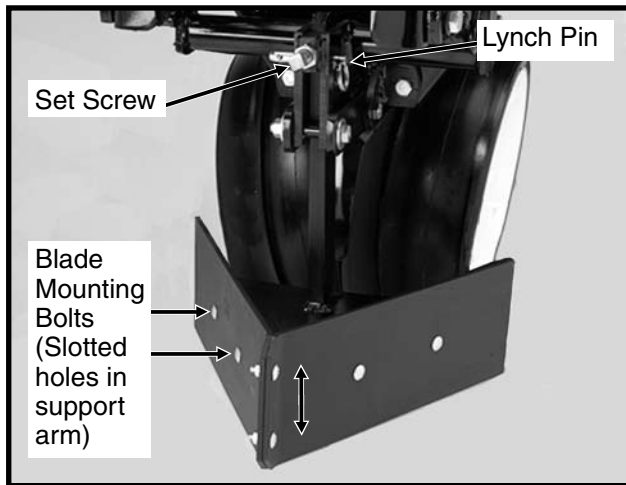

Row unit mounted bed levelers may be used on pull row units only. They are not compatible with push row units.

Vertical adjustment in  $\frac{1}{3}$ " increments is possible by removing the lynch pin which secures the vertical support arm and moving the support arm up or down as required. Re-install lynch pin. Finer adjustment can be attained by removing the lynch pin and using the  $\frac{5}{8}$ " x  $2 \frac{1}{4}$ " set screw to clamp the support arm in the required position.

Slotted holes in the support arm where the blades are mounted allow tilting of the blades. The blades can be tilted up or down at the front for desired adjustment.

**NOTE: The row unit mounted bed leveler is not compatible with row spacings less than 36".**

## ROW UNIT MOUNTED RESIDUE WHEEL

The row unit mounted residue wheel may be used on pull row units and push row units.

D101701113

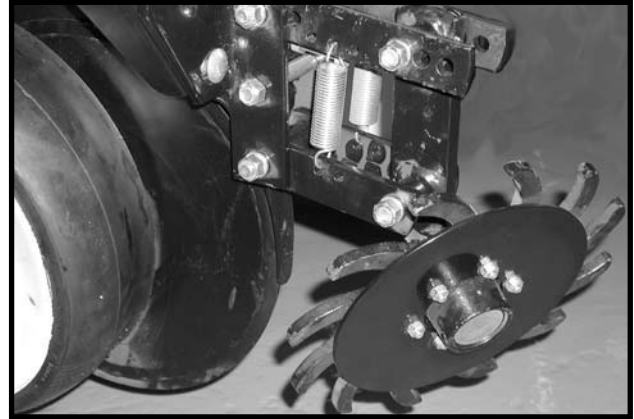

STYLE A

(A12685)

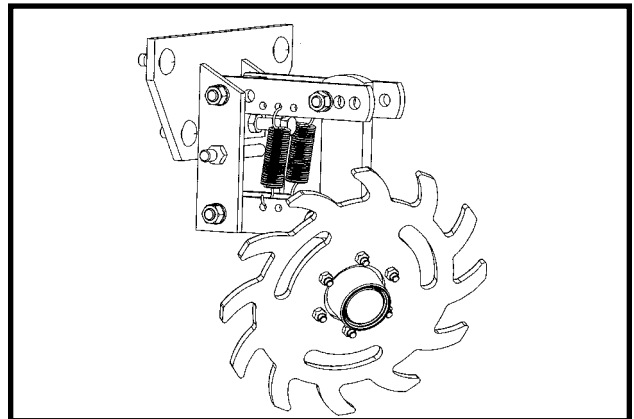

STYLE B

# ROW UNIT OPERATION

Two adjustable springs on the parallel links on each residue wheel allow for down force adjustment. Position 1 as shown below provides minimum down pressure and position 3 maximum down pressure.

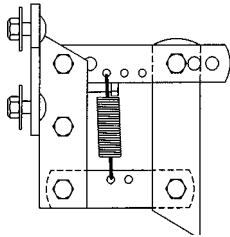

**Position 1 (Minimum)** (PLTR31a)

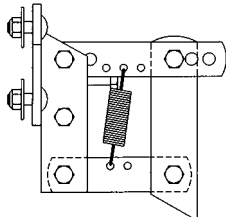

**Position 2** (PLTR32a)

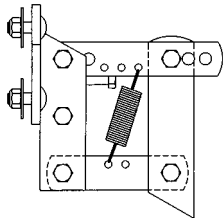

**Position 3 (Maximum)** (PLTR33a)

For additional uplift or float, position springs as shown below.

(PLTR34a)

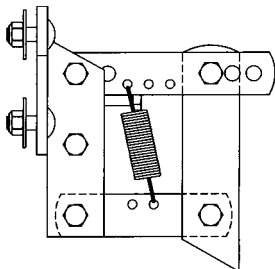

To adjust down force springs, raise the row unit out of the ground and reposition springs as shown for the desired down pressure.

D10170112

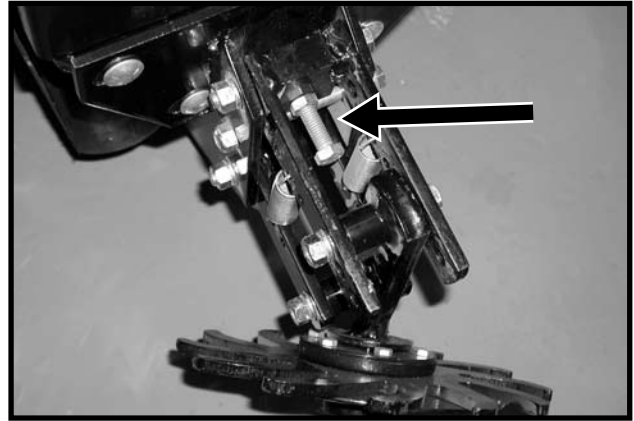

A full threaded bolt and jam nut located on the upper link allows maximum depth to be set for loose soil conditions. Initial setting should be 1 3/4" above the depth of the row unit double disc opener.

Three holes in the upper link allow for wheel angle adjustment. With the wheel mount in the most vertical position, using the rear hole in the upper link, the residue wheel is most aggressive. Moving the wheel mount to one of the forward holes reduces the aggressiveness of the wheel for use in mulch till applications where the soil is loose.

D101701202

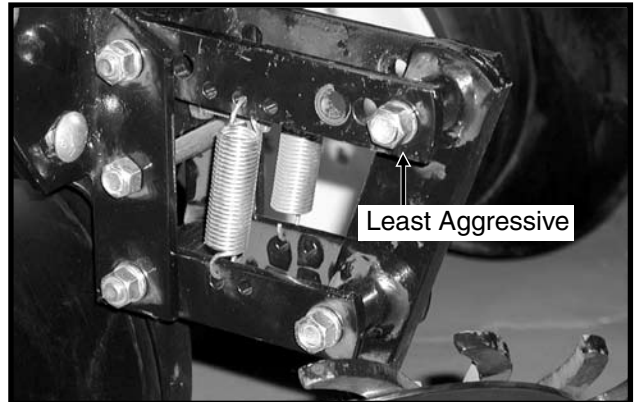

To lock the residue wheel up out of the ground, remove the 1/2" x 5" lockup bolt, raise the residue wheel and install bolt.

D011701203

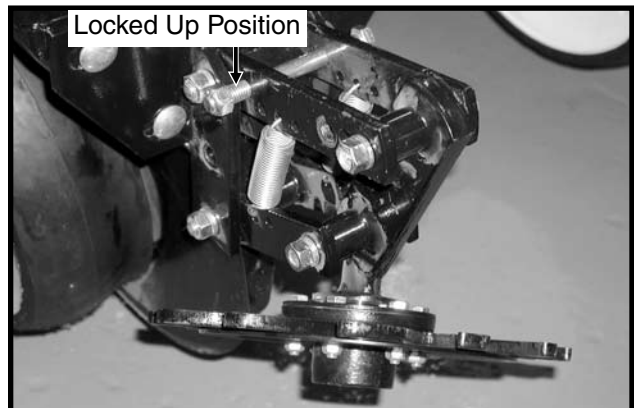

# ROW UNIT OPERATION

---

## ROW UNIT MOUNTED NO TILL COULTER

LF212299-19a

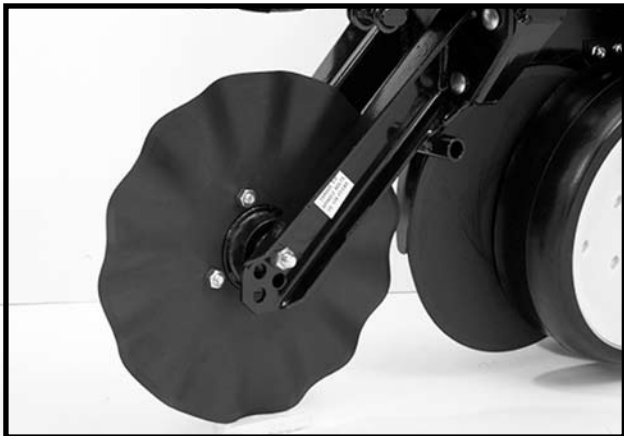

**STYLE A (Two Sleeves For Installing Coulters Mounted Residue Wheels)**

D05170706a



**STYLE B (One Sleeve For Installing Coulters Mounted Residue Wheels)**

Row unit mounted no till coulters with 1" bubbled, 1" fluted (8 flutes) or  $\frac{3}{4}$ " fluted (13 flutes) blades may be used on pull row units and push row units. ( $\frac{3}{4}$ " fluted shown)

Four quick adjustable down force springs are required per row when using row unit mounted no till coulters. See "Quick Adjustable Down Force Springs".

For proper operation, the coulters should be aligned in relation to the row unit double disc openers. The coulters assembly can be adjusted by loosening the four attaching bolts, moving coulters arm to align and tightening the four attaching bolts.

The coulters blade can be adjusted to one of four  $\frac{1}{2}$ " incremental settings in the forked arm. Initial location of the coulters is in the top hole. As the coulters blade wears, the blade should be adjusted downward to one of the three lower settings to maintain the coulters blade at or slightly below the opener discs. In very hard soil conditions such as compacted wheel tracks, opener penetration and cutting of surface residue may be improved by adjusting the coulters to operate below the depth of the double disc opener blades.

Operating depth can be checked by setting the planter down on a level concrete floor and checking the relationship between the coulters blade and row unit opener blade. Make sure the planter is level and coulters is square with the planter frame and aligned with the row unit disc opener.

**NOTE: Torque  $\frac{3}{8}$ " spindle hardware to 120 ft. lbs.**

# ROW UNIT OPERATION

## COULTER MOUNTED RESIDUE WHEELS

LF212299-23



**STYLE A - Used With Style A Row Unit Mounted No Till Coulters**

D05170708a



**STYLE B - Used With Style B Row Unit Mounted No Till Coulters**

Coulters mounted residue wheels are designed for use on pull row units and push row units. Row unit extension brackets are required on the four center pull row units if the planter is equipped with coulters mounted residue wheels.

The coulters mounted residue wheels are attached to the row unit mounted no till coulters with one cap screw and sleeve allowing the unit to free-float. A 2-position spindle bolt mounting allows the tined wheels to be mounted interlocked or staggered. A lock nut on the inside of the mount locks the spindle cap screw. Depth adjustment is made using a spring-loaded cam and pin with 11 positions in 1/4" increments. A high point on the cam allows the wheels to be locked up so they do not contact the ground. A weed guard, located on the inboard side of each wheel, aids in the prevention of weed wrap which can cause premature bearing failure.

(RU104tt)

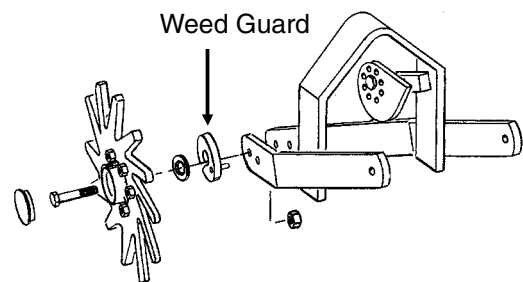

**STYLE A**

(RU153a)

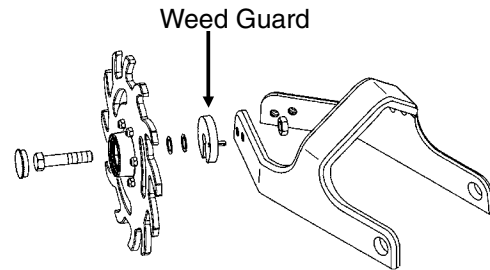

**STYLE B**

**NOTE: Opening in weed guard must point down.**

# ROW UNIT OPERATION

---

## GRANULAR CHEMICAL HOPPER AND DRIVE

LF212299-6



The granular chemical hopper has a 1.4 cubic feet capacity.

Be sure no foreign objects get into the hopper when it is being filled. Replace the hopper lids after filling the hoppers to prevent the accumulation of dirt and moisture.

The metering gate located on the bottom of the hopper regulates the application rate. See “Dry Insecticide And Dry Herbicide Application Rate Charts” in this manual. Calibrate using the chemical manufacturers’ instructions.



**WARNING: Agricultural chemicals can be dangerous. Improper selection or use can seriously injure persons, animals, plants, soil or other property. BE SAFE: Select the right chemical for the job. Handle it with care. Follow the instructions on the container label and of the equipment manufacturer.**

The granular chemical clutch drive coupler and meter shaft can be disengaged and engaged by turning the throwout knob located at the rear of the hopper support panel. To engage the drive, turn the knob  $\frac{1}{4}$  turn clockwise. To disengage the drive, turn the knob  $\frac{1}{4}$  turn counterclockwise. Slotted holes in the hopper support panel and clutch housing allow for alignment adjustment between the clutch drive coupler and meter shaft.

LF212299-4

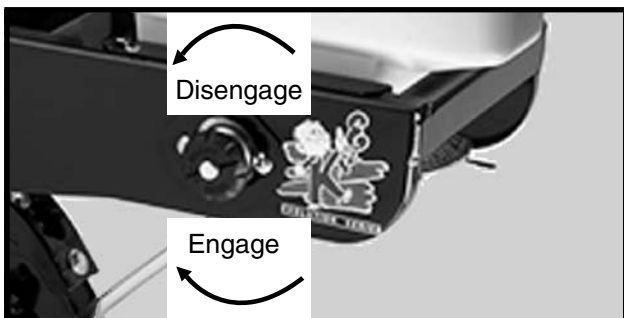



# ROW UNIT OPERATION

## GRANULAR CHEMICAL BANDING OPTIONS

Granular chemical banding options allow 4 1/2" slope-compensating banding, straight drop in-furrow placement or 14" rear banding.

**NOTE: The granular chemical rear bander is not compatible with the covering discs/single press wheel option.**

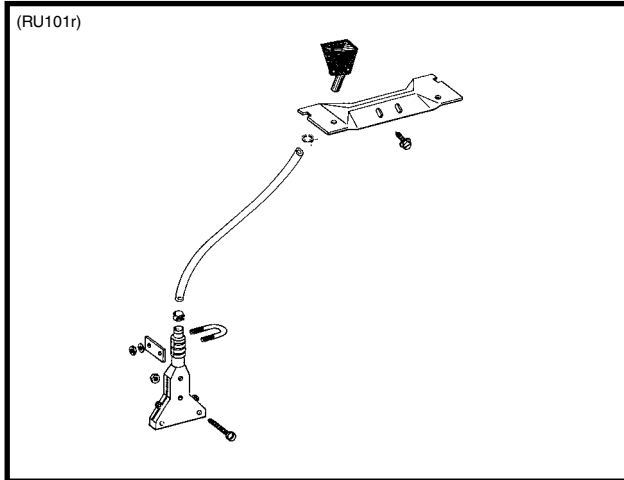

4 1/2" Slope-Compensating Bander

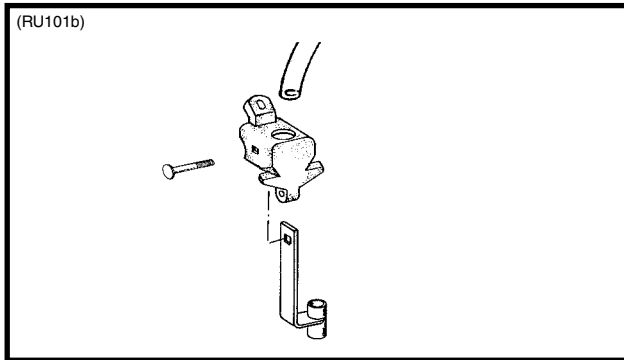

Straight Drop In-Furrow Placement

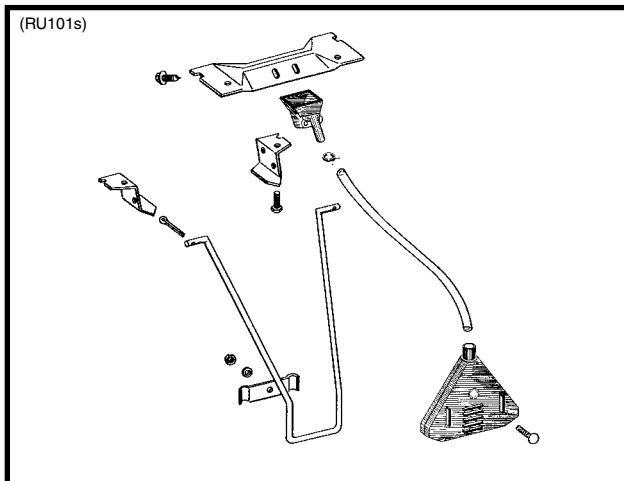

## GRANULAR CHEMICAL BANDER SHIELD

The optional granular chemical bander shield is designed to be installed onto the underside of the wheel arm stop to shield crop residue from lodging in the granular chemical bander.

(RU83m)

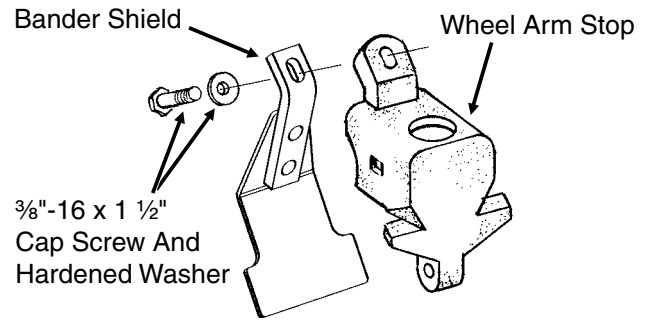

## SPRING TOOTH INCORPORATOR

The spring tooth incorporator smoothes the soil behind the row unit and incorporates granular chemicals. The two mounting chains on each spring tooth incorporator should be adjusted so there is approximately 1/8" slack in the chain when the unit is lowered to planting position.

**NOTE: The spring tooth incorporator is not compatible with the covering discs/single press wheel option.**

LF212299-26



# ROW UNIT OPERATION

---

# LUBRICATION

The following pages show the locations of all lubrication points. Proper lubrication of all moving parts will help ensure efficient operation of your KINZE® planter and prolong the life of friction producing parts.

**! WARNING:** Always install safety lockup devices or lower the planter to the ground before working under the machine.

## LUBRICATION SYMBOLS

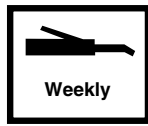
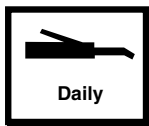

Lubricate at frequency indicated with an SAE multipurpose grease.



Lubricate at frequency indicated with a high quality SAE 10 weight oil or a quality spray lubricant.

## SEALED BEARINGS

LF212199-3

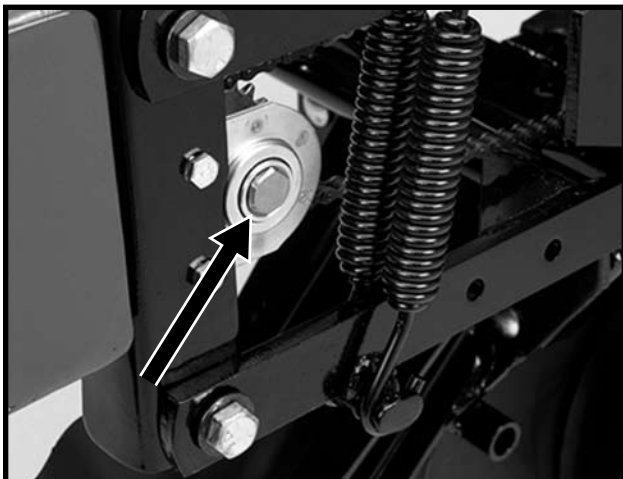

A number of sealed bearings are used on your KINZE® planter to provide trouble free operation. These are located in such areas as the drive shaft, row units and transmission bearings. Sealed bearings are lubricated for life. Due to the seals, relubrication is not practical.

## DRIVE CHAINS

All transmission and drive chains should be lubricated daily with a high quality chain lubricant. Extreme operating conditions such as dirt, temperature or speed may require more frequent lubrication. If a chain becomes stiff, it should be removed, soaked and washed in solvent to loosen and remove dirt from the joints. Then soak the chain in oil so the lubricant can penetrate between the rollers and bushings.

D051705103

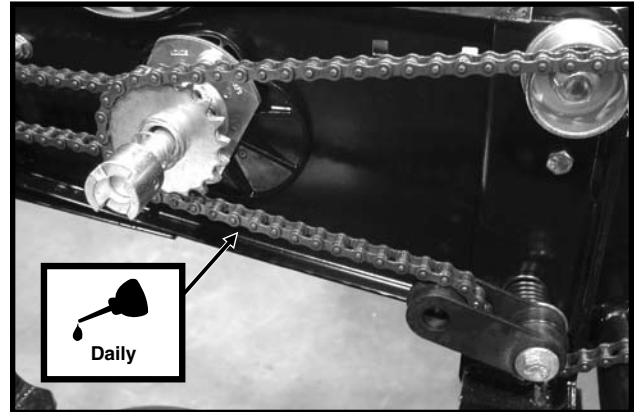

Row Unit Drive Chains

D051705102

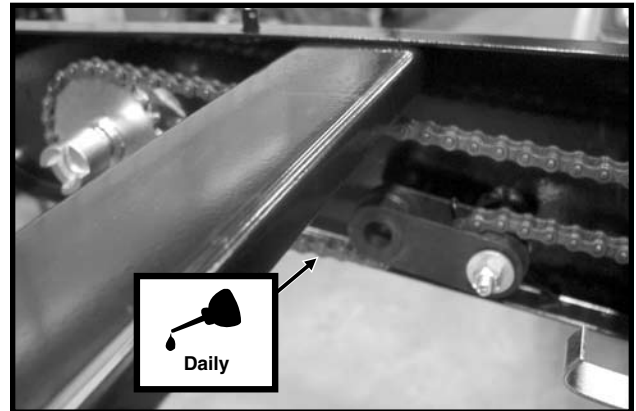

Row Unit Granular Chemical Drive Chains

D11080512

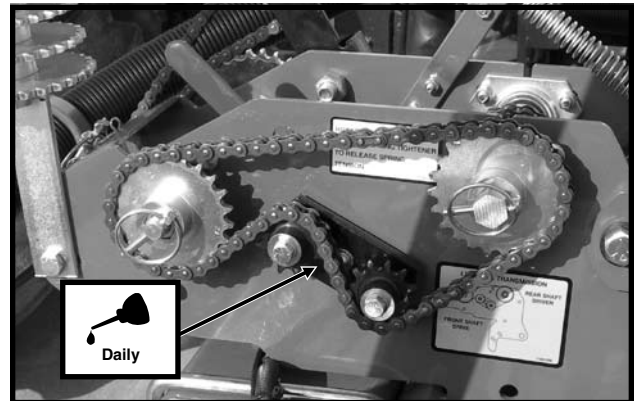

Seed Rate Transmission Drive Chains

# LUBRICATION

D06160305

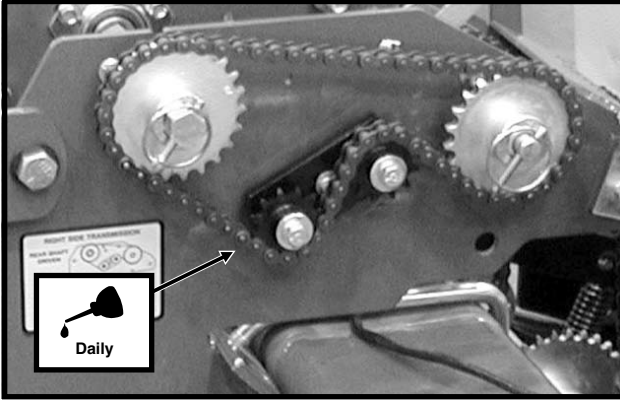

**Seed Rate Transmission Drive Chains  
(With Front Mounted Drive Wheel Option)**

81014-12b

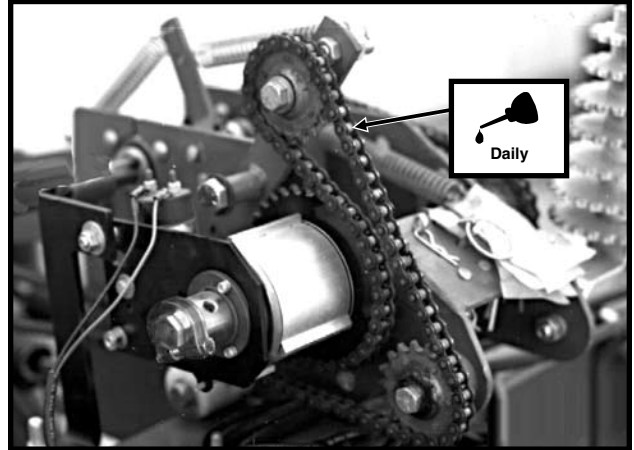

**Contact Wheel Drive Chains  
(With Optional Point Row Clutches)**

D11080533

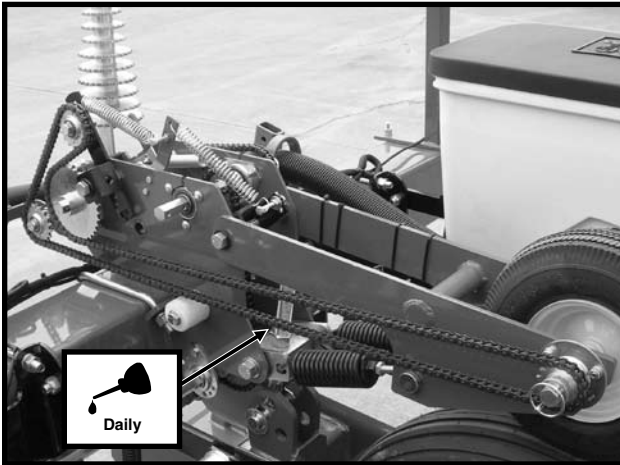

**Contact Wheel Drive Chains**

D082203208

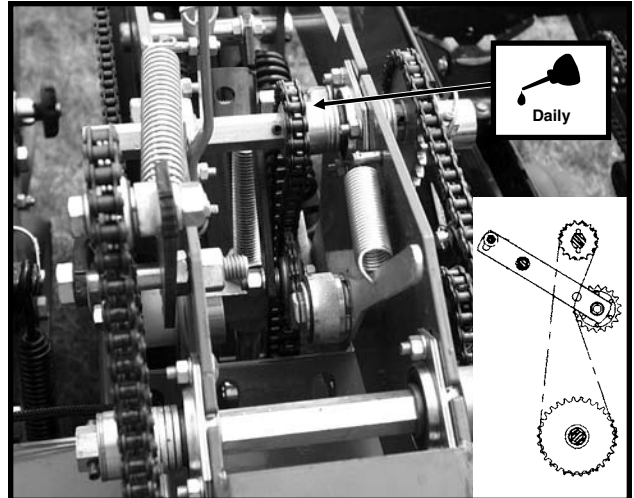

**Wheel Module Drive Chains**

D06120303

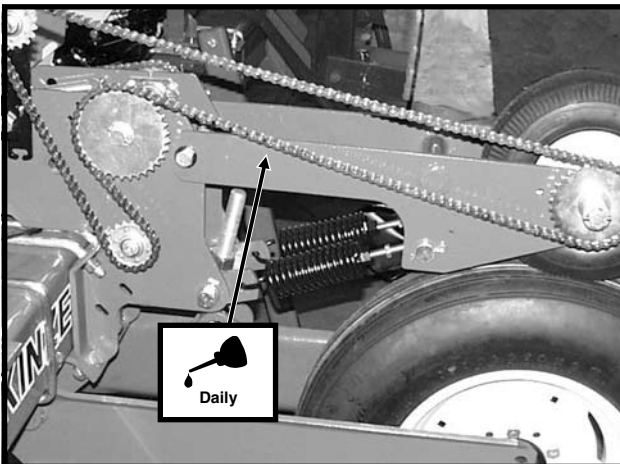

**Contact Wheel Drive Chains  
(With Front Mounted Drive Wheel Option)**

D06200307

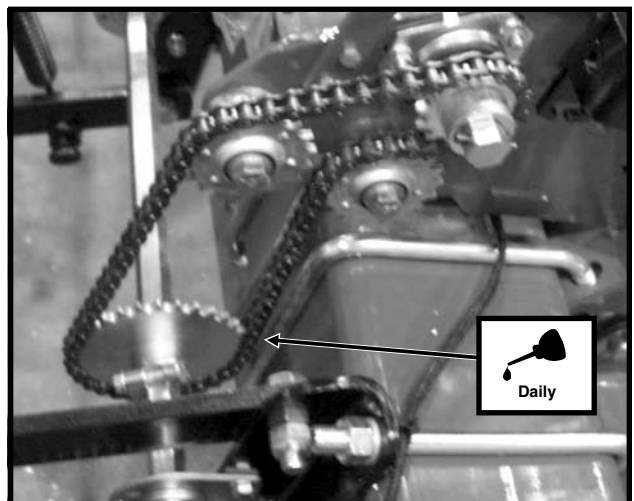

**Wheel Module Drive Chains  
(With Front Mounted Drive Wheel Option)**

# LUBRICATION

## WHEEL BEARINGS

All wheel bearings should be repacked annually and checked for wear. This applies to all drive wheels and marker hubs.

To check for wear, raise the wheel off the ground. Check for endplay in the bearings by moving the tire in and out. Rotate the tire to check for roughness in the bearings. If bearings sound rough, the hub should be removed and the bearings inspected and replaced if necessary. See "Wheel Bearing Lubrication Or Replacement".

To repack wheel hubs, follow the procedure outlined for wheel bearing replacement with the exception that bearings and bearing cups are reused.

## BUSHINGS

Lubricate bushings at the frequency indicated.

Using a torque wrench, check each bolt for proper torque. If bolt is loose, it should be removed and the bushing inspected for cracks and wear. Replace bushing if necessary. **Only hardened flat washers should be used. Replace damaged flat washers with proper part. Torque hardware to 130 ft. lbs.**

D06300305

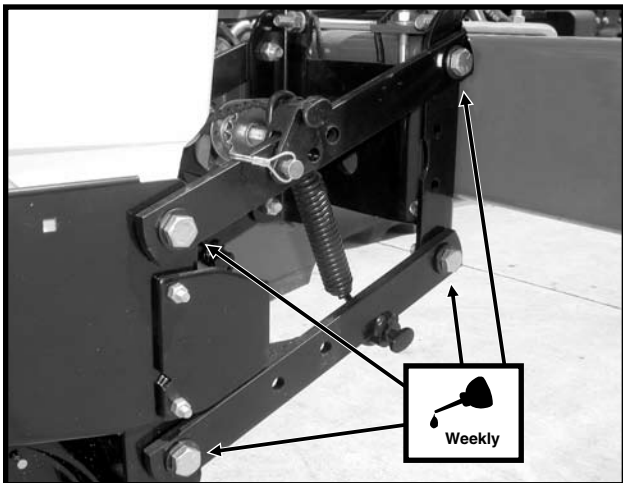

**Pull Row Unit And/Or Push Row Unit Parallel Linkages (8 Per Row)**

LF212299-22



**Row Unit Mounted Disc Furrower Parallel Linkages (6 Per Row)**

59386-26

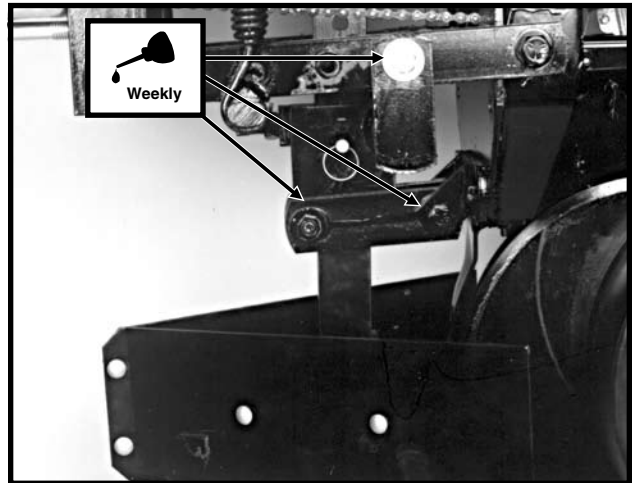

**Row Unit Mounted Bed Leveler Parallel Linkages (6 Per Row)**

LF212199-2

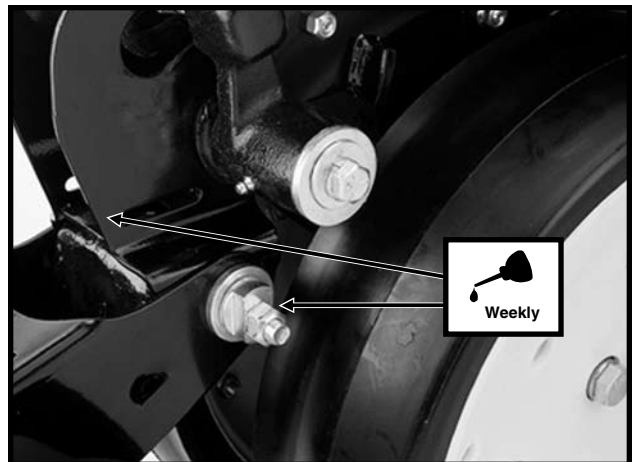

**Row Unit "V" Closing Wheel, Covering Discs/ Single Press Wheel And/Or Drag Closing Wheel Eccentric Bushings (2 Per Row)**

# LUBRICATION

## WRAP SPRING WRENCH ASSEMBLY

The chain idler is equipped with a wrap spring wrench. The wrench components may require occasional lubrication to operate correctly. Disassembly is required to lubricate. (a) Remove the 1/4"-20 x 1/2" cap screw that secures the idler with sprockets to the wrench tightener shaft. (b) Remove the wrap spring wrench from the planter. (c) Tip the wrap spring wrench on its side and lubricate using a high quality spray lubricant. Lubricant must be absorbed into the wrap spring area. (d) Reinstall wrench on planter.

D101303102



## GREASE FITTINGS

Those parts equipped with grease fittings should be lubricated at the frequency indicated with an SAE multipurpose grease. Be sure to clean the fitting thoroughly before using grease gun. The frequency of lubrication recommended is based on normal operating conditions. Severe or unusual conditions may require more frequent attention.

**NOTE:** Numbers on illustration below correspond to photos on following pages showing lubrication frequencies.

(MT34)

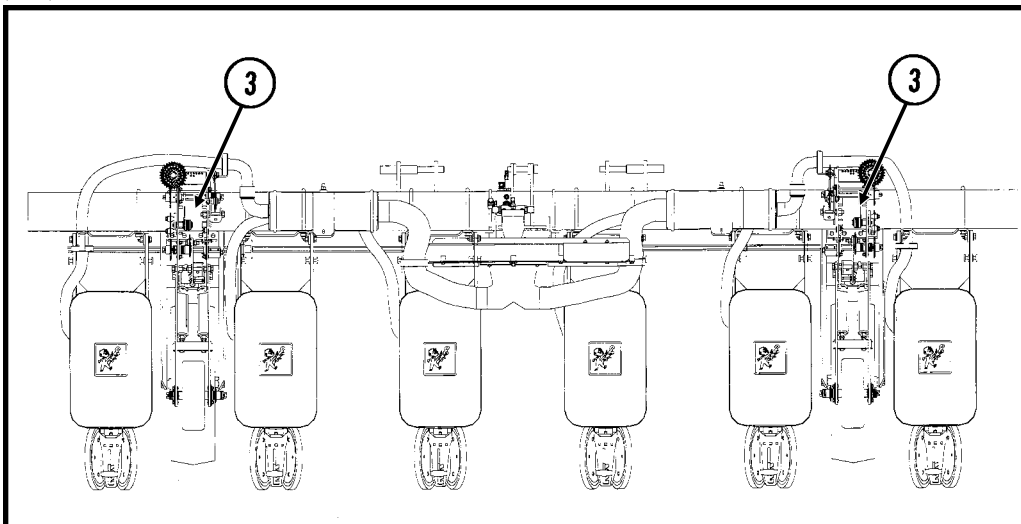

MKR29

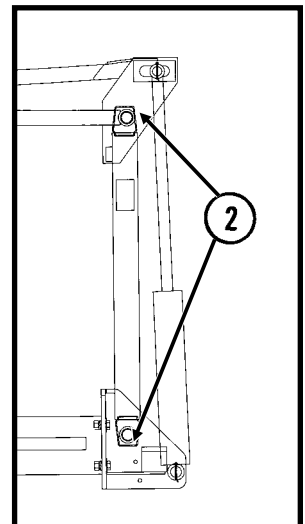

Model 3110 6 Row 30" Shown



**WARNING:** Always install safety lockup devices or lower the planter to the ground before working under or around the machine.

# LUBRICATION

D09109903

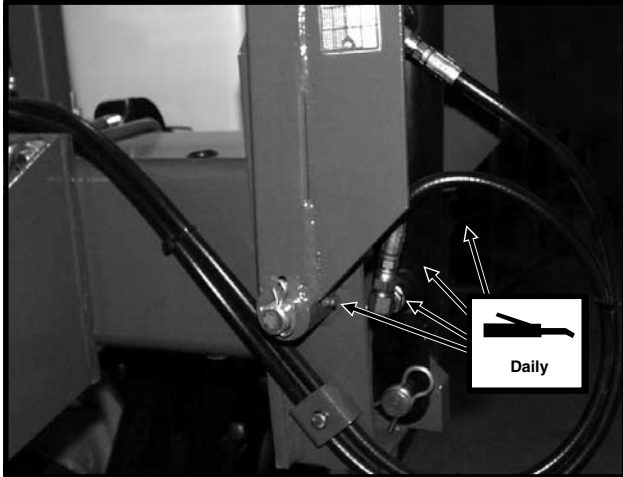

1. Conventional Row Markers - 4 Zerks Per Assembly

MKR29

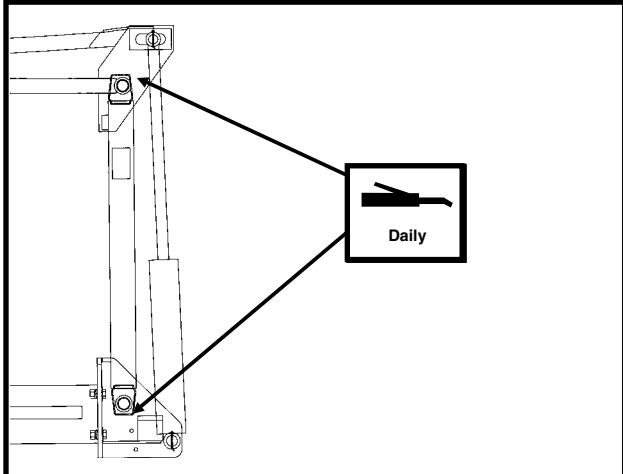

2. Low Profile Row Markers - 2 Zerks Per Assembly

D082203212

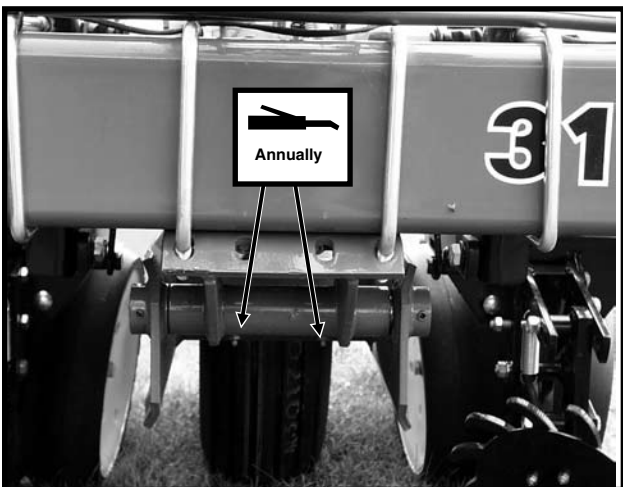

3. Wheel Module Shaft - 2 Zerks Per Module

## Row Unit

LF212199-2

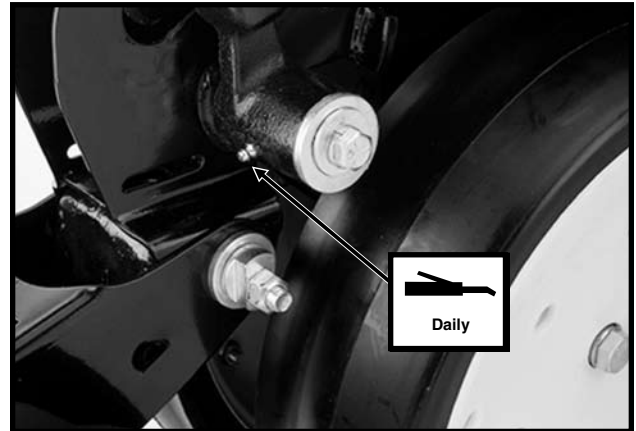

Gauge Wheel Arms - 1 Zerk Per Arm  
(Seals in gauge wheel arm are installed with lip facing out to allow grease to purge dirt away from seal. Pump grease into arm until fresh grease appears between washers and arm.)

LF083002101

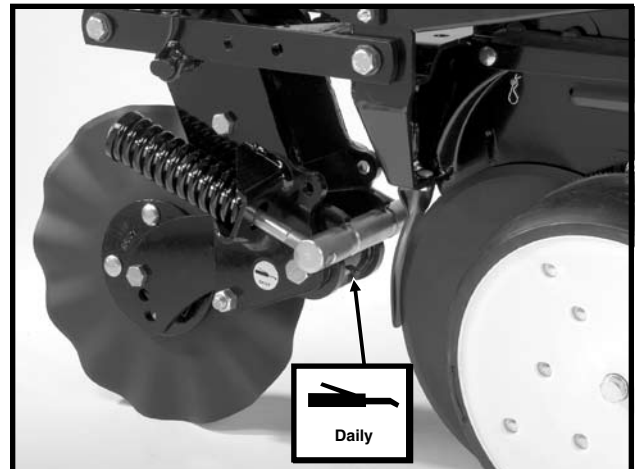

Frame Mounted Coulter - 1 Zerk Per Arm

# LUBRICATION

---



# MAINTENANCE

## MOUNTING BOLTS AND HARDWARE

Before operating the planter for the first time, check to be sure all hardware is tight. Check all hardware again after approximately the first 50 hours of operation and at the beginning of each planting season thereafter.

All hardware used on the KINZE® planter is Grade 5 (high strength) unless otherwise noted. Grade 5 cap screws are marked with three radial lines on the head. If hardware must be replaced, be sure to replace it with hardware of equal size, strength and thread type. Refer to the torque values chart when tightening hardware.

**Row Unit Parallel Linkage Bushing Hardware - 130 Ft. Lbs.** (See “Bushings” in the Lubrication Section of this manual.)

**5/8" No Till Coulter Spindle Hardware - 120 Ft. Lbs.**

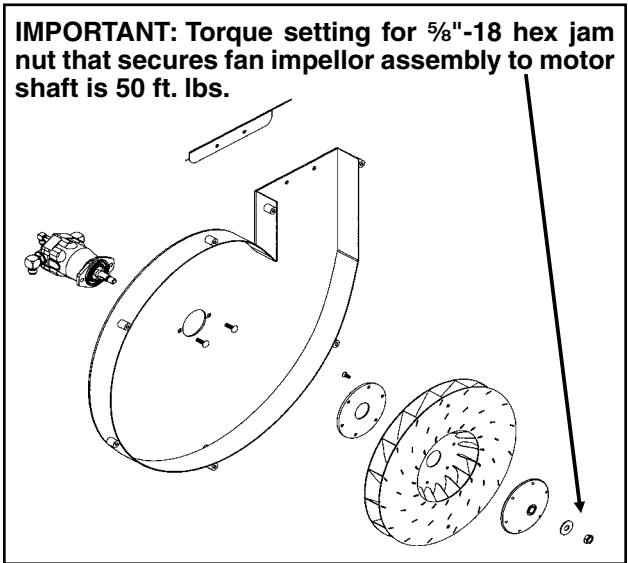

**IMPORTANT: Over tightening hardware can cause as much damage as under tightening. Tightening hardware beyond the recommended range can reduce its shock load capacity.**

**TORQUE VALUES CHART - PLATED HARDWARE**

Bolt Diameter	Grade 2		Grade 5		Grade 8	
	Coarse	Fine	Coarse	Fine	Coarse	Fine
1/4"	50 In. Lbs.	56 In. Lbs.	76 In. Lbs.	87 In. Lbs.	9 Ft. Lbs.	10 Ft. Lbs.
5/16"	8 Ft. Lbs.	9 Ft. Lbs.	13 Ft. Lbs.	14 Ft. Lbs.	18 Ft. Lbs.	20 Ft. Lbs.
3/8"	15 Ft. Lbs.	17 Ft. Lbs.	23 Ft. Lbs.	26 Ft. Lbs.	33 Ft. Lbs.	37 Ft. Lbs.
7/16"	25 Ft. Lbs.	27 Ft. Lbs.	37 Ft. Lbs.	41 Ft. Lbs.	52 Ft. Lbs.	58 Ft. Lbs.
1/2"	35 Ft. Lbs.	40 Ft. Lbs.	57 Ft. Lbs.	64 Ft. Lbs.	80 Ft. Lbs.	90 Ft. Lbs.
9/16"	50 Ft. Lbs.	60 Ft. Lbs.	80 Ft. Lbs.	90 Ft. Lbs.	115 Ft. Lbs.	130 Ft. Lbs.
5/8"	70 Ft. Lbs.	80 Ft. Lbs.	110 Ft. Lbs.	125 Ft. Lbs.	160 Ft. Lbs.	180 Ft. Lbs.
3/4"	130 Ft. Lbs.	145 Ft. Lbs.	200 Ft. Lbs.	220 Ft. Lbs.	280 Ft. Lbs.	315 Ft. Lbs.
7/8"	125 Ft. Lbs.	140 Ft. Lbs.	320 Ft. Lbs.	350 Ft. Lbs.	450 Ft. Lbs.	500 Ft. Lbs.
1"	190 Ft. Lbs.	205 Ft. Lbs.	480 Ft. Lbs.	530 Ft. Lbs.	675 Ft. Lbs.	750 Ft. Lbs.
1 1/8"	265 Ft. Lbs.	300 Ft. Lbs.	600 Ft. Lbs.	670 Ft. Lbs.	960 Ft. Lbs.	1075 Ft. Lbs.
1 1/4"	375 Ft. Lbs.	415 Ft. Lbs.	840 Ft. Lbs.	930 Ft. Lbs.	1360 Ft. Lbs.	1500 Ft. Lbs.
1 3/8"	490 Ft. Lbs.	560 Ft. Lbs.	1100 Ft. Lbs.	1250 Ft. Lbs.	1780 Ft. Lbs.	2030 Ft. Lbs.
1 1/2"	650 Ft. Lbs.	730 Ft. Lbs.	1450 Ft. Lbs.	1650 Ft. Lbs.	2307 Ft. Lbs.	2670 Ft. Lbs.

**NOTE: Unplated hardware and bolts with lock nuts should be torqued approximately 1/3 higher than the above values. Bolts lubricated prior to installation should be torqued to 70% of value shown in chart.**



**GRADE 2**  
No Marks



**GRADE 5**  
3 Marks



**GRADE 8**  
6 Marks

# MAINTENANCE

## TIRE PRESSURE

Tire pressure should be checked regularly and maintained as follows:

- 7.60" x 15" 8 Ply Ground Drive/Gauge ..... 40 PSI
- 4.10" x 6" Contact Drive ..... 50 PSI

**NOTE: Tire pressure must be correctly maintained in all drive wheel tires to ensure level and proper operation of planter. All rate charts are based on above tire pressures.**

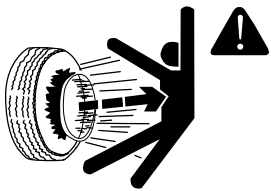

**DANGER: Rim and tire servicing can be dangerous. Explosive separation of tire and rim parts can cause serious injury or death.**

**Do not attempt to mount a tire unless you have the proper equipment and experience to perform the job. This should only be done by persons properly trained and equipped to do the job.**

**Always maintain the correct tire pressures. Do not inflate the tires above the recommended pressures.**

**When inflating tires, use a clip-on air chuck and extension hose long enough to allow you to stand to one side and NOT in front of or over the tire assembly. Use a safety cage to enclose the tire and rim assembly when inflating.**

**Inspect tires and wheels daily. Do not operate with low pressure, cuts, bubbles, damaged rims or missing lug bolts and nuts.**

## CHAIN TENSION ADJUSTMENT

The drive chains have spring loaded idlers and therefore are self-adjusting. The only adjustment needed is to shorten the chain if wear stretches the chain and reduces spring tension. The pivot point of these idlers should be checked periodically to ensure they rotate freely. See "Wrap Spring Wrench Assembly" in Lubrication Section for additional information.

Additional chain links can be found in the storage area located in the wheel module.

81014-12b

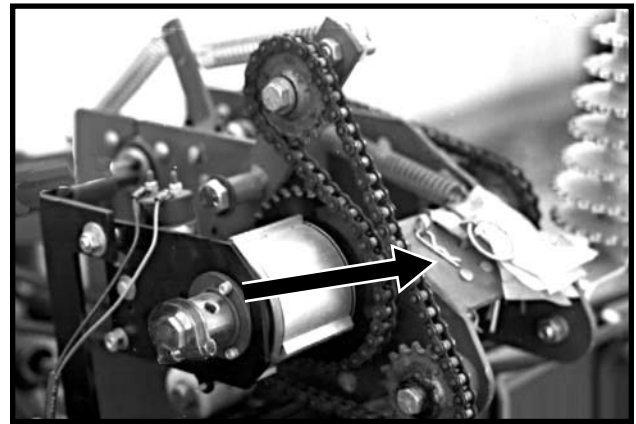

# MAINTENANCE

## CLOSING WHEEL TROUBLESHOOTING

PROBLEM	POSSIBLE CAUSE	SOLUTION
Closing wheel(s) leave severe imprint in soil.	Too much closing wheel down pressure.	Adjust closing wheel pressure.
Closing wheel(s) not firming soil around seed.	Insufficient closing wheel down pressure.	Adjust closing wheel pressure. Severe no till conditions may require use of cast iron closing wheels.
“V” closing wheel running on top of seed furrow.	Improper centering.	Align. See “V Closing Wheel Adjustment”.
Single closing wheel not directly over seed.	Improper centering.	Align. See “Covering Discs/Single Press Wheel Adjustment”.

## DRAG CLOSING ATTACHMENT

LF212299-18



Prior to storage of the planter, inspect each drag closing attachment and replace any worn or broken parts. Check for loose hardware and tighten as needed.

LF212199-2

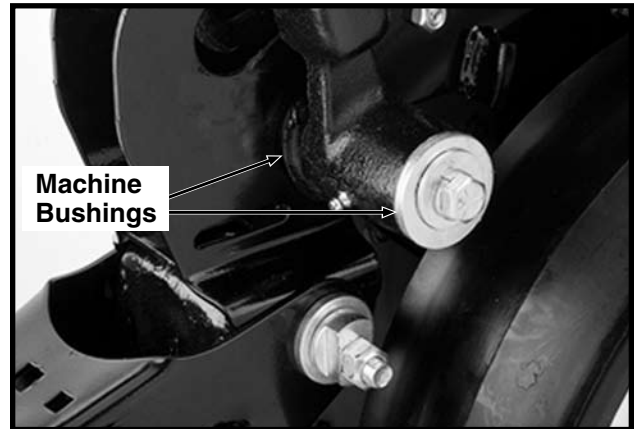

(RU113g)

## GAUGE WHEEL ADJUSTMENT

To prevent an accumulation of dirt or trash, gauge wheels should lightly contact the opener blades. Gauge wheels and opener blades should turn with only slight resistance.

To adjust clearance between gauge wheels and opener blades, add or remove machine bushings between the shank and gauge wheel arm. Store remaining machine bushings between gauge wheel arm and flat washer on outer side of gauge wheel arm.

**NOTE:** It may be desirable to space gauge wheel further from blade when operating in sticky soils.

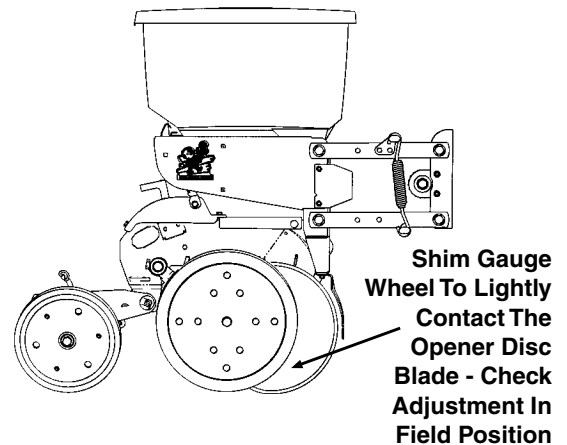

# MAINTENANCE

## GAUGE WHEEL ARM BUSHING AND/OR SEAL REPLACEMENT

(RU113g)

Gauge Wheel Arm Bushings/Seals

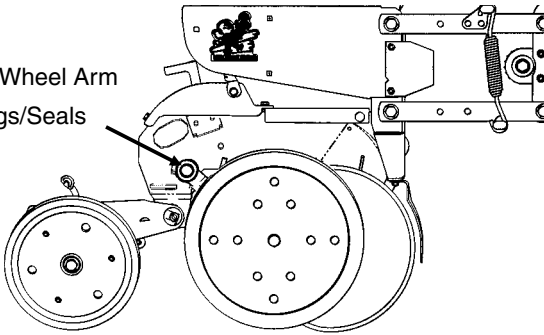

**NOTE: A Gauge Wheel Arm Bushing And Seal Driver Kit (G1K296), for use in bushing and seal replacement, is available through your KINZE® Dealer.**

### To replace gauge wheel arm assembly bushing(s) and/or seal(s):

1. Remove gauge wheel from arm.
2. Remove the gauge wheel arm assembly from the shank assembly.
3. Remove seal and bushing and discard. Clean and dry inner bore.

(A7975/RU122)

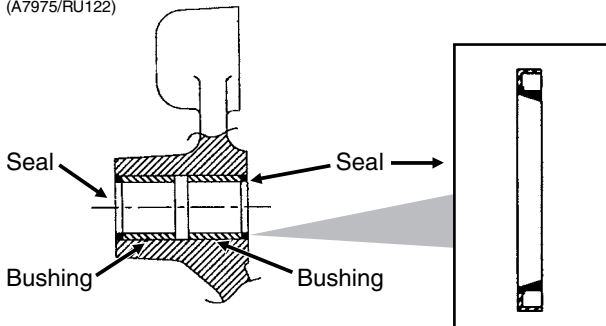

4. Drive/press replacement bushing inside bore of arm to a depth of .125" below flush.
5. Coat wiping edge of seal with grease.
6. Drive/press seal into place with lip to the outside as shown above.

**NOTE: Use extra care to protect the sealing lip during installation. Apply uniform pressure to assemble the seal into the bore of the arm. Never apply a direct hammer blow to the seal surface.**

7. Inspect gauge wheel pivot spindle.
8. Reinstall gauge wheel arm assembly and gauge wheel.

**NOTE: Special machine bushing between gauge wheel arm and gauge wheel.**

9. Shim for proper gauge wheel tire/disc blade clearance.
10. Lubricate with an SAE multipurpose grease.

## GAUGE WHEEL ARM PIVOT SPINDLE REPLACEMENT

(RU113g)

Gauge Wheel Pivot Spindle

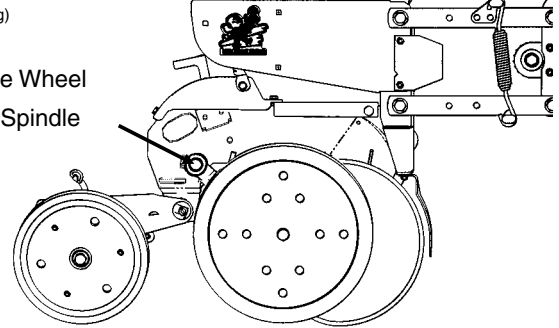

### To replace gauge wheel pivot spindle:

1. Remove the gauge wheel and arm assemblies from the shank assembly.
2. Remove 1/2" x 3/4" cap screw that locks the pivot spindle in place and remove the spindle.

D06189902

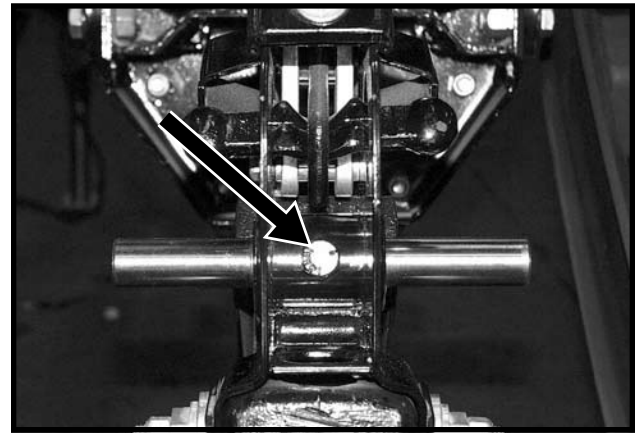

3. Install the replacement spindle and position as shown below. Exact centering is critical.

(A7966)

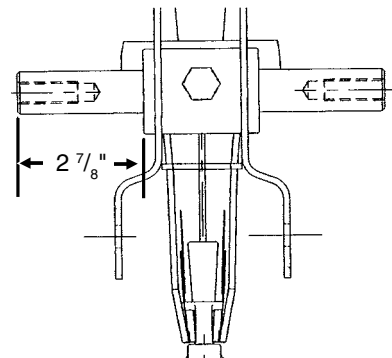

4. Install 1/2" x 3/4" cap screw and torque to lock pivot spindle in place.
5. Install gauge wheel and arm assemblies. Shim for proper gauge wheel tire/disc blade clearance.

# MAINTENANCE

## 15" SEED OPENER DISC BLADE/ BEARING ASSEMBLY

Approximately 1" - 1 1/2" of blade-to-blade contact should be maintained to properly open and form the seed trench. As the blade diameter decreases, due to wear, it will be necessary to relocate machine bushings from inside to outside to maintain approximately 1" - 1 1/2" of contact.

**NOTE: If proper blade-to-blade contact cannot be maintained after relocating machine bushings or if blade diameter wears below 14 1/2", the blades should be replaced.**

**IMPORTANT: Excessive blade contact may result in premature disc opener bearing/hub failures and excessive wear on seed tube guard/inner scraper. When properly adjusted, if one blade is held in fixed position, the opposite blade should be able to be rotated with minimal force (Less than 5 pounds force at outer edge of blade).**

(RU113g)

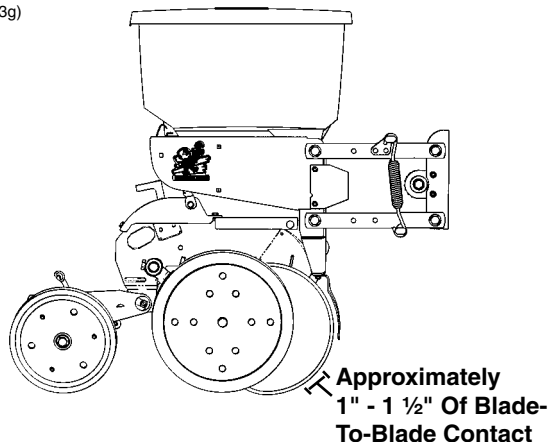

### To replace disc blade/bearing assembly:

1. Remove gauge wheel.
2. Remove scraper.
3. Remove bearing dust cap.
4. Remove cap screw, washer and disc blade/bearing assembly. The machine bushings between the shank and disc blade are used to maintain the approximate 1" - 1 1/2" of blade-to-blade contact.

**IMPORTANT: Left hand side of opener uses a left hand threaded cap screw. DO NOT OVERTIGHTEN. Damage to shank threads will require replacement of row unit shank assembly.**

5. Install machine bushing(s), new disc blade/bearing assembly, washer and cap screw. Torque 5/8"-11 Grade 5 cap screw to value shown in "Torque Values Chart".

**NOTE: Replace disc blades only with disc blades of equal thickness.**

6. Replace bearing dust cap.
7. Install scraper.
8. Install gauge wheel.

It may be necessary to replace only the bearing if there is excessive endplay or if the bearing sounds or feels rough when the disc blade is rotated.

### To replace bearing:

1. Remove gauge wheel, scraper, bearing cap, cap screw, washer and disc blade/bearing assembly.
2. Remove 1/4" rivets from bearing housing to expose bearing.
3. After installing new bearing, install three evenly spaced 1/4" cap screws into three of the six holes in the bearing housing to hold the bearing and bearing housing in place. Install rivets in the other three holes. Remove 1/4" cap screws and install rivets in those three holes.
4. Reinstall disc blade/bearing assembly, washer and cap screw. Torque 5/8"-11 cap screw to value shown in "Torque Values Chart" at the beginning of this section.
5. Replace bearing dust cap.
6. Install scraper and gauge wheel.

# MAINTENANCE

## SEED TUBE GUARD/INNER SCRAPER

The seed tube guard protects the seed tube and acts as the inner scraper for the seed opener disc blades.

Remove the seed tube and check for wear. Excessive wear on the seed tube indicates a worn seed tube guard. Replace the seed tube guard if it measures  $\frac{5}{8}$ " or less at the lower end. A new seed tube guard measures approximately  $\frac{7}{8}$ ".

LF212199-12

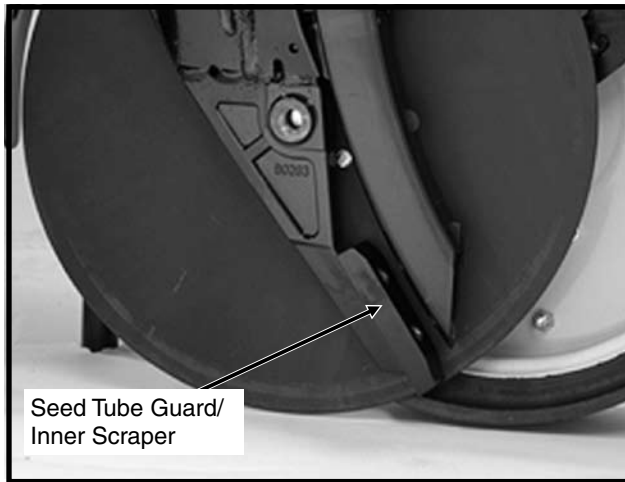

Shown With Gauge Wheel And Seed Opener Disc Blade Removed For Visual Clarity

**IMPORTANT: No till planting or planting in hard ground conditions, especially when the planter is not equipped with no till coulters, and/or excessive blade-to-blade contact will increase seed tube guard wear and necessitate more frequent inspection and/or replacement.**

To replace the seed tube guard, remove the seed tube and the two hex socket head cap screws which attach the seed tube guard. Hold the replacement seed tube guard centered between the seed opener disc blades. Install, but DO NOT tighten, the hex socket head cap screws. Using a clamp or vise-grip, squeeze the opener blades together in front of the seed tube guard. Tighten the seed tube guard retaining screws. Remove the clamps. The distance between the seed tube guard and opener blades should be equal on both sides. Reinstall seed tube.

**IMPORTANT: Over tightening the hex socket head cap screws may damage the threads in the shank and require replacement of the shank. A seed tube guard that is worn excessively may allow the blades to wear into the row unit shank, also requiring replacement of the shank.**

## FRAME MOUNTED COULTER

LF083002101

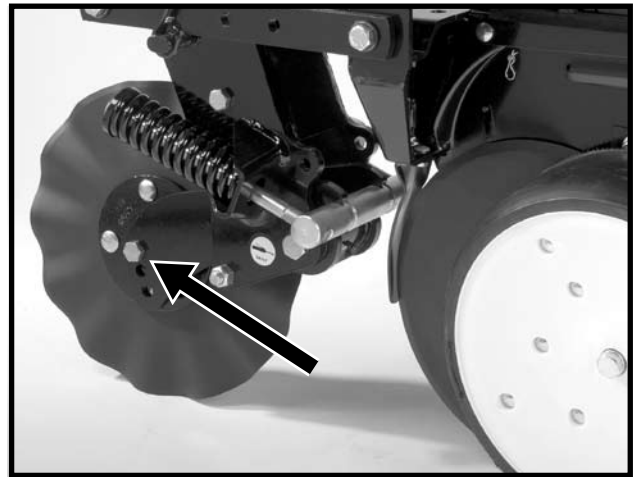

**NOTE: Torque  $\frac{5}{8}$ " spindle hardware to 120 ft. lbs.**

See "Frame Mounted Coulters" in Row Unit Operation section of this manual for depth and spring adjustment.

When the 16" diameter coulters blade (1" fluted, 1" bubbled or  $\frac{3}{4}$ " fluted) is worn to 14  $\frac{1}{2}$ " (maximum allowable wear), it should be replaced.

# MAINTENANCE

## RESIDUE WHEELS (For Use With Frame Mounted Coulter)

LF083002102



**STYLE A**

(RU154)

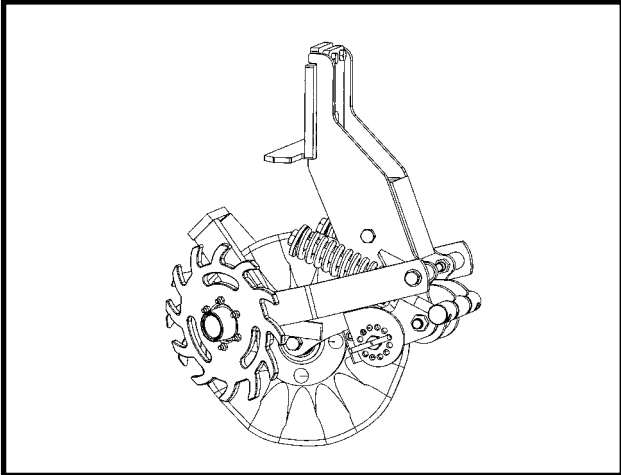

**STYLE B**

The wheel hub is equipped with sealed bearings. If a bearing sounds or feels rough when the wheel is rotated, replace the bearings.

## ROW UNIT MOUNTED DISC FURROWER

LF212299-22

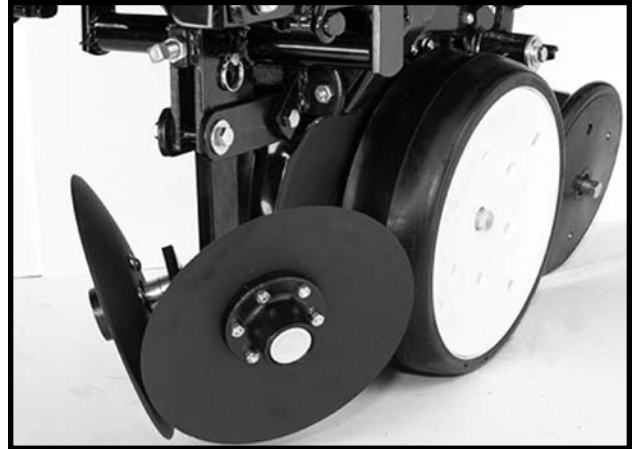

Lubricate the bushings in the support arm and mounting bracket at the frequency indicated in the Lubrication Section of this manual. Using a torque wrench, check each bolt for proper torque. If the bolt is loose, it should be removed and the bushing inspected for cracks and wear. Replace bushings as necessary. **Only hardened flat washers should be used. Replace damaged flat washers with proper part. Torque cap screws to 130 ft. lbs.**

The blade hubs are equipped with sealed bearings. If bearings sound or feel rough when the blade is rotated, replace the bearings.

When the 12" diameter blades (solid or notched) are worn to 11", they should be replaced.

# MAINTENANCE

## ROW UNIT MOUNTED BED LEVELER

LF212299-25a

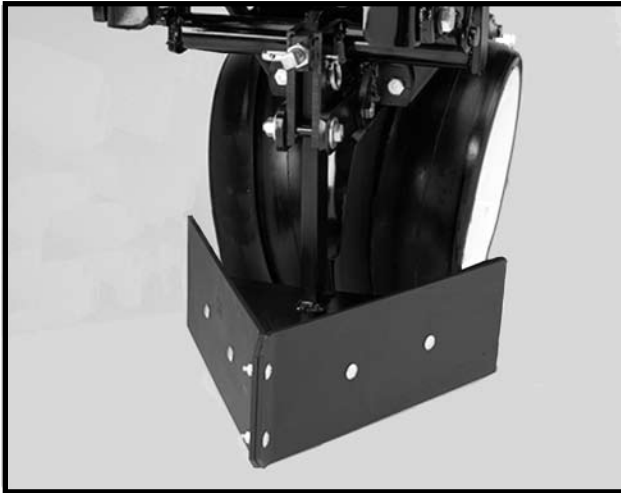

59386-26

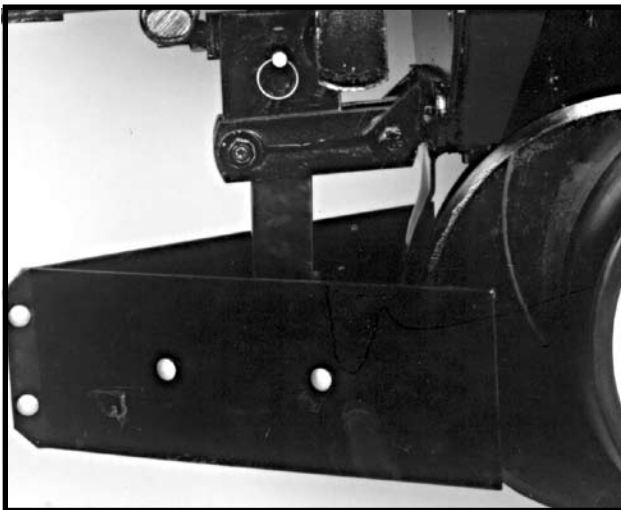

Lubricate the bushings in the mounting bracket and links at the frequency indicated in the Lubrication Section of this manual. Using a torque wrench, check each bolt for proper torque. If the bolt is loose, it should be removed and the bushing inspected for cracks and wear. Replace bushing if necessary. **Only hardened flat washers should be used. Replace damaged flat washers with proper part. Torque hardware to 130 ft. lbs.**

## ROW UNIT MOUNTED RESIDUE WHEEL

D101701113



STYLE A

(A12685)

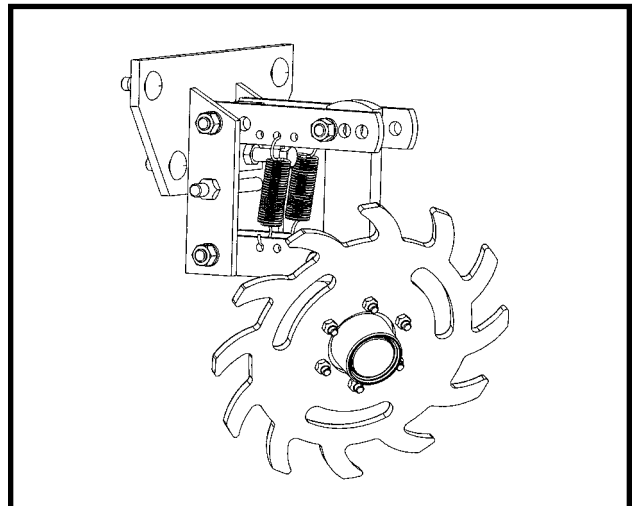

STYLE B

The wheel hub is equipped with sealed bearings. If a bearing sounds or feels rough when the wheel is rotated, replace the bearings.



# MAINTENANCE

## ROW UNIT MOUNTED NO TILL COULTER

LF212299-19a

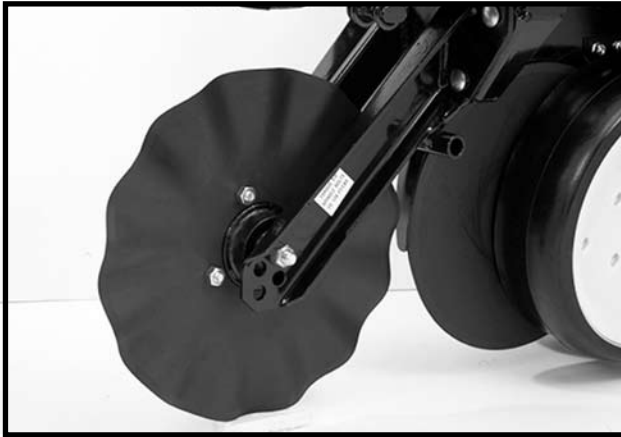

**STYLE A (Two Sleeves For Installing Coulters Mounted Residue Wheels)**

D05170706a



**STYLE B (One Sleeve For Installing Coulters Mounted Residue Wheels)**

Check periodically to be sure nuts and hardware are tightened to proper torque specification.

**NOTE: Torque  $\frac{5}{8}$ " spindle hardware to 120 ft. lbs.**

Be sure the coulters are positioned square with the row unit and aligned in front of row unit disc opener.

The coulters blade can be adjusted to one of four settings. Initially the blade is set in the highest position. As the blade wears it can be adjusted to one of the three lower settings. See "Row Unit Mounted No Till Coulters" in Row Unit Operation section of this manual.

When the 16" diameter coulters blade is worn to 14  $\frac{1}{2}$ " (maximum allowable wear), it should be replaced.

## COULTER MOUNTED RESIDUE WHEELS

LF212299-23



**STYLE A - Used With Style A Row Unit Mounted No Till Coulters**

D05170708a



**STYLE B - Used With Style B Row Unit Mounted No Till Coulters**

The wheel hubs are equipped with sealed bearings. If bearings sound or feel rough when the wheel is rotated, replace the bearings.

# MAINTENANCE

## GRANULAR CHEMICAL ATTACHMENT

Prior to storage of the planter, disengage the granular chemical drive by rotating the throwout knob ¼ turn counterclockwise. Remove the drive chain and empty and clean all granular chemical hoppers. Clean the drive chains and coat them with a rust preventive spray or submerge chains in oil. Inspect and replace any worn or broken parts.

Install hoppers and chains. Check chain alignment.

LF212299-4

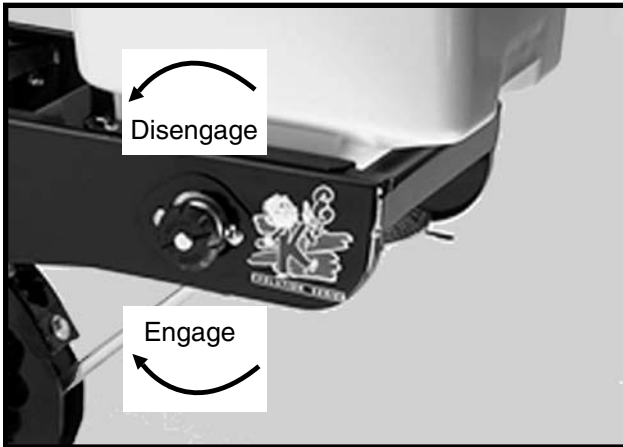

## SPRING TOOTH INCORPORATOR

Prior to storage of the planter, inspect each spring tooth incorporator and replace any worn or broken parts. Check for loose hardware and tighten as needed.

LF212299-26

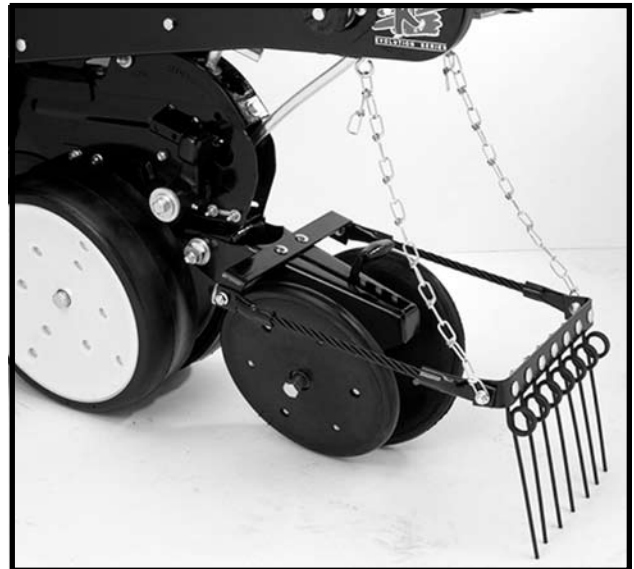

# MAINTENANCE

## KPM I/KPM II STACK-MODE ELECTRONIC SEED MONITORS TROUBLESHOOTING

PROBLEM	POSSIBLE CAUSE	SOLUTION
Single sensor communication alarm comes on (alarm on with no bargraph and a flashing row number on a single row).	Faulty seed tube sensor.	Replace sensor.
	Break in the harness just before the seed tube sensor.	Inspect for break in harness and repair. If break can't be found, replace harness section.
	Dirty or corroded connector.	Clean connector.
Sensor communication alarms come on for all sensors (alarm on with no bargraphs and flashing row numbers on all rows).	Faulty monitor.	Repair/Replace monitor.
	Break in the harness just after the monitor.	Inspect for break in harness and repair. If break can't be found, replace harness section.
	Dirty or corroded connector.	Clean connector.
Sensor communication alarms come on for some sensors (alarm on with no bargraphs and flashing row numbers on all rows).	Break in the harness.	Inspect for break in harness and repair. If break can't be found, replace harness section corresponding with the alarming sensors.
	Dirty or corroded connector.	Clean connector.
Faulty monitor values (such as speed, area, etc.) being displayed. (KPM II Stack-Mode Only)	Incorrect monitor settings.	Change settings to properly correspond to the system.
	Faulty radar/magnetic distance sensor.	Replace sensor.
	Improperly mounted radar sensor.	Properly mount sensor.
Underplanting or no planting alarm on a single sensor when planting (alarm on with a single bargraph segment on and a flashing row number on a single row).	Seed tube sensor is blocked.	Clean sensor.
	Faulty seed tube sensor.	Replace sensor.
	Meter not planting or underplanting.	Repair/replace meter.
	Chain broken or off sprocket.	Repair as necessary.
Seed tube sensor dirty or blocked warning comes on (after calibration, bargraph keeps flashing for a single row).	Seed tube sensor is dirty.	Clean sensor.
	Faulty seed tube sensor.	Replace sensor.
LED on the seed tube sensor will not come on.	Faulty seed tube sensor.	Replace sensor.
	Dirty or corroded connector.	Clean connector.
	Break in the harness just before the sensor.	Repair harness.
Erroneous MPH readings at idle. (Radar Distance Sensor Only)	Radar sensor not located in a stable location.	Relocate to a more stable location.

# MAINTENANCE

## KPM III ELECTRONIC SEED MONITOR TROUBLESHOOTING

PROBLEM	POSSIBLE CAUSE	SOLUTION
Single sensor communication alarm comes on.	Faulty seed tube sensor.	Replace sensor.
	Break in the harness just before the seed tube sensor.	Inspect for break in harness and repair. If break can't be found, replace harness section.
	Dirty or corroded connector.	Clean connector.
Sensor communication alarms come on for all sensors.	Faulty monitor.	Repair/Replace monitor.
	Break in the harness just after the monitor.	Inspect for break in harness and repair. If break can't be found, replace harness section.
	Dirty or corroded connector.	Clean connector.
Sensor communication alarms come on for some sensors.	Break in the harness.	Inspect for break in harness and repair. If break can't be found, replace harness section corresponding with the alarming sensors.
	Dirty or corroded connector.	Clean connector.
Faulty monitor values (such as speed, area, etc.) being displayed.	Incorrect monitor settings.	Change settings to properly correspond to the system.
	Faulty radar/magnetic distance sensor.	Replace sensor.
	Improperly mounted radar sensor.	Properly mount sensor.
Underplanting or no planting alarm on a single sensor when planting (alarm on with a single bargraph segment on and a flashing row number on a single row.	Seed tube sensor is blocked.	Clean sensor.
	Faulty seed tube sensor.	Replace sensor.
	Meter not planting or underplanting.	Repair/replace meter.
	Chain broken or off sprocket.	Repair as necessary.
Seed tube sensor dirty or blocked warning comes on.	Seed tube sensor is dirty.	Clean sensor.
	Faulty seed tube sensor.	Replace sensor.
LED on the seed tube sensor will not come on.	Faulty seed tube sensor.	Replace sensor.
	Dirty or corroded connector.	Clean connector.
	Break in the harness just before the sensor.	Repair harness.
Erroneous MPH readings at idle. (Radar Distance Sensor Only)	Radar sensor not located in a stable location.	Relocate to a more stable location.

# MAINTENANCE

## POINT ROW CLUTCH INSPECTION

The point row clutch is permanently lubricated and sealed and requires no periodic maintenance.

81014-12b

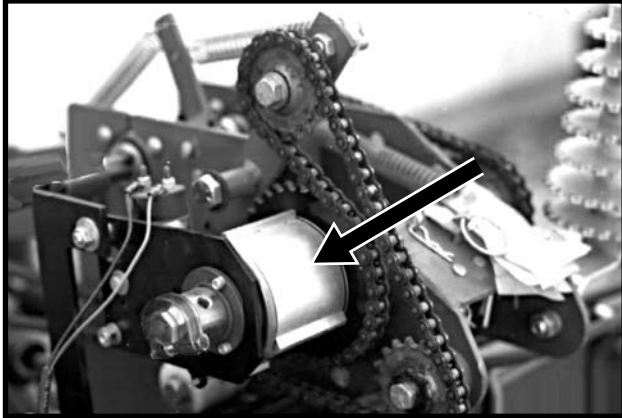

L.H. Side Of Planter Shown

The right hand clutch operates clockwise and the left hand clutch operates counterclockwise. Therefore, some of the parts of the clutch such as the wrap spring differ from one side of the planter to the other. Be sure to use the correct repair part if a clutch must be repaired.

The control box is equipped with a resettable circuit breaker. To reset the circuit breaker, press the red button on the circuit breaker until it snaps into place. If the circuit breaker continues to trip, check to see what is causing it to trip. See "Point Row Clutch Troubleshooting".

76740-48



If the circuit breaker on the control box is not tripped, determine if the problem is electrical or mechanical. Place the operational switch in the RIGHT or LEFT position. Check the clutch and wiring harness for power with a test light or volt meter. If the solenoid is operating properly, the plunger on the solenoid will retract causing a clicking sound. The plunger will also be magnetized which can be checked by touching the plunger with a metal object.

(TWL70c)

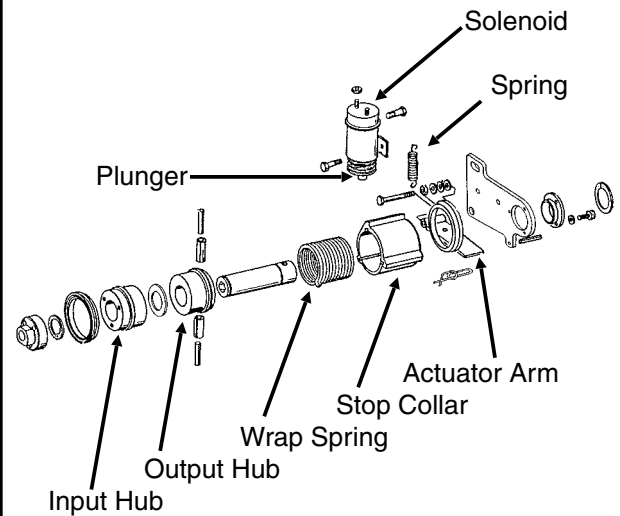

(A7110)

## ACTUATOR ARM ADJUSTMENT

**NOTE:** Gap between actuator arm and stop on stop collar should be  $\frac{1}{8}$ " ( $\pm \frac{1}{32}$ ") when the solenoid is NOT engaged.

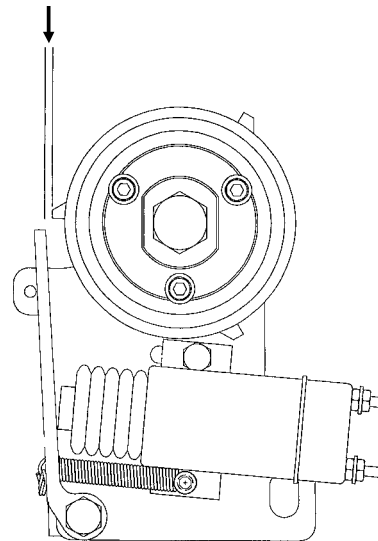

**NOTE:** To adjust gap between actuator arm and stop, loosen nut on mounting pin and move pin in slot until there is  $\frac{1}{8}$ " ( $\pm \frac{1}{32}$ ") gap between arm and stop on stop collar. Retighten nut.

# MAINTENANCE

## POINT ROW CLUTCH TROUBLESHOOTING

PROBLEM	POSSIBLE CAUSE	SOLUTION
None of the clutches will disengage.	Main fuse blown in control console.	Replace defective fuse.
	Poor terminal connection in wiring harness.	Repair or replace.
	Wiring damage in wiring harness.	Repair or replace.
	Low voltage at coil. (12 volts required)	Check battery connections.
One section of planter will not re-engage.	Shear pin at seed drive transmission(s) sheared.	Replace pin with one of equal size and grade.
One clutch will not engage.	Fuses blown.	Replace defective fuses.
	Actuator arm and plunger stuck in disengaged position.	Remove, free up and reinstall.
	Actuator arm out of adjustment.	Adjust actuator arm mounting pin in slot so that actuator arm clears stop on stop collar by approximately $\frac{1}{8}$ " when clutch is rotated.
	Wrap spring broken or stretched.	Disassemble clutch and replace spring.
	Something touching the stop collar.	Check to ensure collar is free to turn with clutch.
	Clutch assembled incorrectly.	Check clutch and diagram for correct assembly.
Clutch slipping.	Wrap spring stretched.	"Lock" clutch output shaft from turning. Place torque wrench on input shaft and rotate in direction of drive. After input shaft has rotated a short distance the wrap spring should tighten onto the input hub. If slippage occurs at less than 100 ft. lbs. replace spring. If spring still slips after installing new spring, replace input hub.
Planter section will not re-engage while planter is moving forward.	Spring in actuator arm not strong enough to push arm away from stop collar when operational switch is turned to the ON position.	Remove spring from inside solenoid and stretch spring slightly or replace. Reinstall spring. If that fails, file the stop on the stop collar slightly so that the stop is not as aggressive.
Frequent solenoid burnout.	Fuses too large.	Replace fuses on front panel with 10 amp slow blow fuses.
Frequent fuse burnout.	Low voltage (12 volts required).	Check power source voltage for partially discharged battery, etc.
	Damage to wiring harness.	Locate damage and repair or replace harness.
Clutch or clutches will not disengage.	Input and output shafts out of alignment.	Align input and output shafts to prevent drag.
	Input or output shaft is pushed in too far creating a coupler.	Reposition input and output shafts.

# MAINTENANCE

## ROW MARKER SEQUENCING/FLOW CONTROL VALVE INSPECTION

The valve block assembly consists of the row marker sequencing and flow control valves in one assembly.

The sequencing valve portion consists of a chambered body containing a spool and series of check valves to direct hydraulic oil flow. Should the valve malfunction, the components may be removed for inspection.

1. Remove valve block assembly from planter.
2. Remove detent assembly and port adapter assemblies from rear of valve block.

**IMPORTANT: Damage to the spool may occur if the detent assembly and port adapter assemblies are not removed prior to removal of the spool.**

3. Remove plug from both sides of valve block and remove spool.
4. Inspect all parts for pitting, contamination or foreign material. Also check seating surfaces inside the valve. Replace any parts found to be defective.
5. Lubricate spool with a light oil and re-install. Check to be sure spool moves freely in valve body.

**IMPORTANT: Make sure correct check ball(s) and spring(s) are installed in each valve bore upon reassembly.**

A flow control valve is located on each side of the block assembly. The flow control valves should be adjusted for raise and lower speed as part of the assembly procedure or upon initial operation. If the valve fails to function properly or requires frequent adjustment, the needle valve should be removed for inspection. Check for foreign material and contamination. Be sure needle moves freely in adjustment screw. Replace any components found to be defective.

**NOTE: When oil is cold, hydraulics operate slowly. Make sure all adjustments are made with warm oil.**

(PLTR43)

Port Adapter, Spring,  $\frac{7}{16}$ " Check Ball,  $\frac{1}{4}$ " Steel Ball

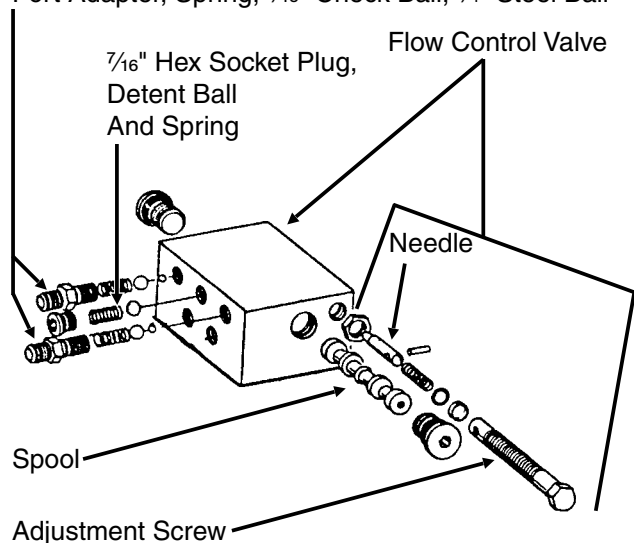

## CHECK VALVE INSPECTION

(Located In Valve Block Below Vacuum Fan Motor Assembly)

(TWL24b)

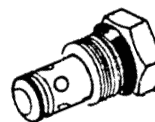

The check valve operates as a check in the return line to prevent reverse operation of the vacuum fan motor. If the valve fails to function properly, it should be removed for inspection. Check for foreign material or check to see if the o-ring is leaking internally. Replace if found to be defective.

## RELIEF VALVE CARTRIDGE INSPECTION (Located In Valve Block Below Vacuum Fan Motor Assembly)

(A11340)



The pressure relief valve helps prevent damage to the vacuum fan motor by limiting pressure in the motor case drain line. It is set to open at 35 PSI. If the valve fails to function properly, it should be removed for inspection. Check for foreign material and contamination on both the valve and the seating area of the valve body. Replace if found to be defective.

**NOTE: Case drain pressure will build if the case drain hose to the tractor is connected where pressure is present.**

# MAINTENANCE

## ROW MARKER OPERATION TROUBLESHOOTING

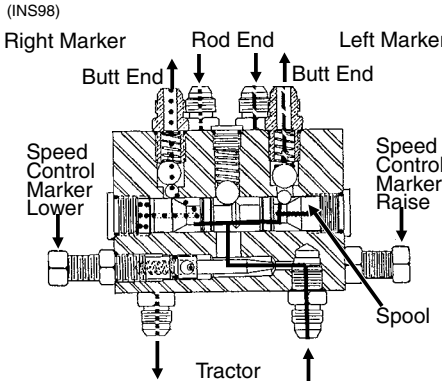
PROBLEM	POSSIBLE CAUSE	SOLUTION
Both markers lowering and only one raising at a time.	Hoses from cylinders to valve connected backwards.	Check to ensure proper hose routing. (See illustration below.)
Same marker always operating.	Spool in sequencing valve not shifting.  	Remove spool, inspect for foreign material, making sure all ports in spool are open. Clean and re-install.
Both markers lower and raise at same time.	Foreign material under check ball in sequencing valve.	Remove hose fitting, spring and balls and clean. May be desirable to remove spool and clean as well.
	Check ball missing or installed incorrectly in sequencing valve.	Disassemble and correct. See illustration in Parts Section.
Marker (in raised position) settling down.	Damaged o-ring in marker cylinder or cracked piston.	Disassemble cylinder and inspect for damage and repair.
	Spool in sequencing valve not shifting completely because detent ball or spring is missing.	Check valve assembly and install parts as needed.
	Spool in sequencing valve shifting back toward center position.	Restrict flow of hydraulic oil from tractor to sequencing valve.
Neither marker will move.	Flow control closed too far.	Loosen locking nut and turn flow control adjustment bolt out or counterclockwise until desired speed is set.
Markers moving too fast.	Flow control open too far.	Loosen locking nut and turn flow control adjustment bolt in or clockwise until desired speed is set.
Sporadic marker operation speed.	Needle sticking open in flow control valve.	Remove flow control, inspect and repair or replace.



# MAINTENANCE

## ROW MARKER BEARING LUBRICATION OR REPLACEMENT

1. Remove row marker blade.
2. Remove dust cap from hub.
3. Remove cotter pin, nut and washer.
4. Slide hub from spindle.
5. Remove bearings and cups and discard if bearings are being replaced. Clean hub and dry. Remove bearings only and not cups if repacking.
6. Press in new bearing cups with thickest edge facing in. (Bearing replacement procedure only.)
7. Pack bearings with heavy duty wheel bearing grease thoroughly forcing grease between roller cone and bearing cage. Also fill the space between the bearing cups in the hub with grease.
8. Install rubber seal into grease seal. Place inner bearing in place and press in new rubber seal/grease seal.
9. Clean spindle and install hub.
10. Install outer bearing, washer and slotted hex nut. Tighten slotted hex nut while rotating hub until there is some drag. This assures that all bearing surfaces are in contact. Back off slotted nut to nearest locking slot and install cotter pin.
11. Fill dust caps approximately  $\frac{3}{4}$  full of wheel bearing grease and install on hub.
12. Install blade and dust cap retainer on hub and tighten evenly and securely.

(PLTR45/PLTR99/PLTR98/PLTR102)

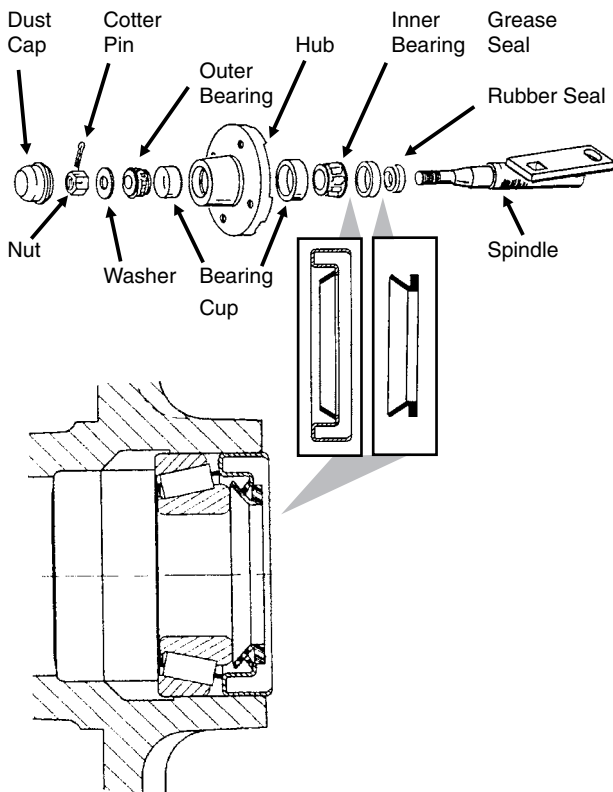

## WHEEL BEARING LUBRICATION OR REPLACEMENT

1. Raise tire clear of ground and remove wheel.
2. Remove double jam nuts and slide hub from spindle.
3. Remove bearings and cups and discard if bearings are being replaced. Clean hub and dry. Remove bearings only and not cups if repacking.
4. Press in new bearing cups with thickest edge facing in. (Bearing replacement procedure only.)
5. Pack bearings with heavy duty wheel bearing grease thoroughly forcing grease between roller cone and bearing cage. Also fill the space between the bearing cups in the hub with grease.
6. Place spacer (If Applicable) and inner bearing in place.
7. Clean spindle and install hub.
8. Install outer bearing and jam nut. Tighten jam nut while rotating hub until there is some drag. This assures that all bearing surfaces are in contact. Back off jam nut  $\frac{1}{4}$  turn or until there is only slight drag when rotating the hub. Install second jam nut to lock against first.

9. Install wheel on hub and tighten evenly and securely.

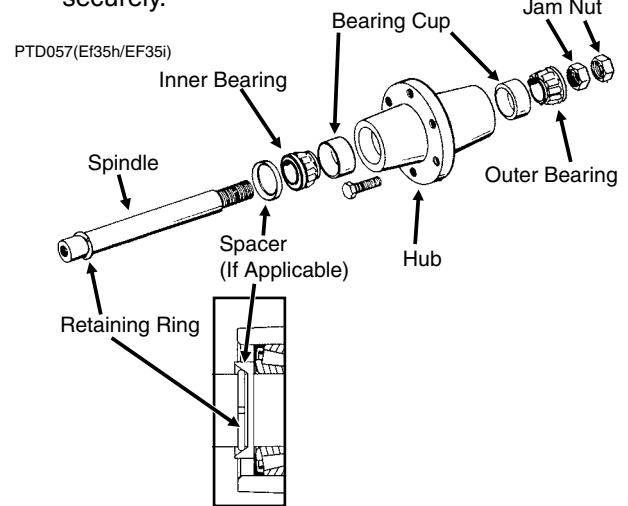

# MAINTENANCE

## PREPARATION FOR STORAGE

Store the planter in a dry sheltered area if possible.

Remove all trash that may be wrapped on sprockets or shafts and remove dirt that can draw and hold moisture.

Clean all drive chains and coat with a rust preventative spray, or remove chains and submerge in oil.

Lubricate planter and row units at all lubrication points.

Inspect the planter for parts that are in need of replacement and order during the "off" season.

Make sure all seed and granular chemical hoppers are empty and clean.

Remove seed discs from seed meters, clean and store meters in a rodent-free, dry area with discs removed. Store seed discs vertically on a dowel or pipe.

Remove vacuum hose from the each seed meter. Operate the vacuum fan at full hydraulic flow from the tractor for two minutes to clear manifolds, hoses and fittings of dust and debris.

Clean breather on analog vacuum gauge.

Grease or paint disc openers/blades and row marker disc blades to prevent rust.

## ELECTRICAL WIRING DIAGRAM FOR LIGHT PACKAGE

(WGN66b)

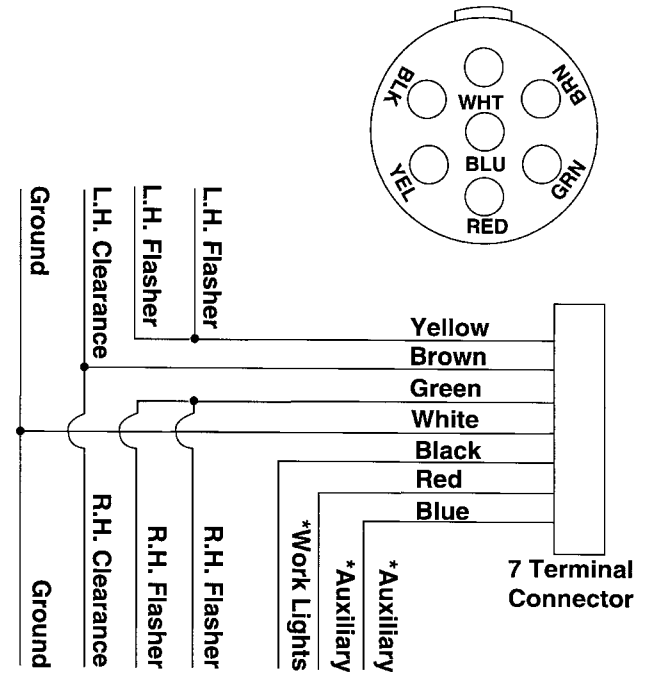

\* Optional customer-supplied auxiliary lights and wires may be wired into existing plug terminals.

(A9507a)

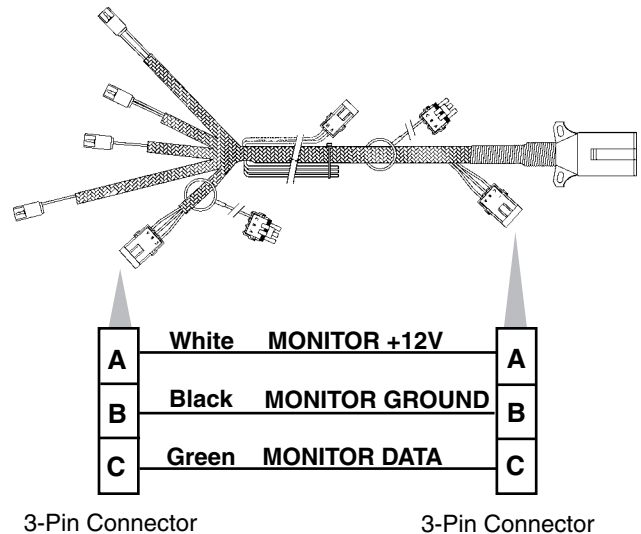

The light package supplied on the Model 3110 planter meets ASAE Standards. For the correct wiring harness to be wired into the lights on your tractor, check with the tractor manufacturer.

# MAINTENANCE

## ELECTRICAL WIRING DIAGRAMS FOR POINT ROW CLUTCHES

(EF10b/INS241/SFP6)

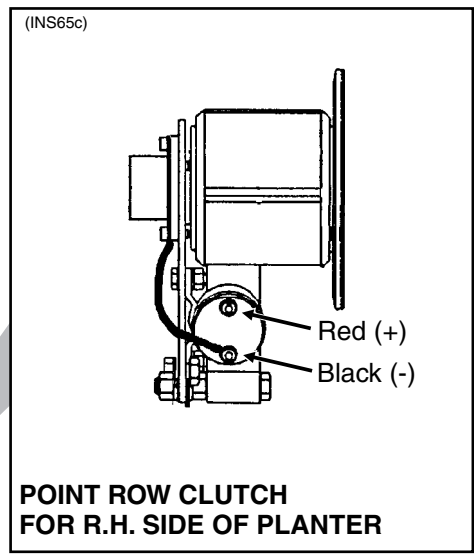
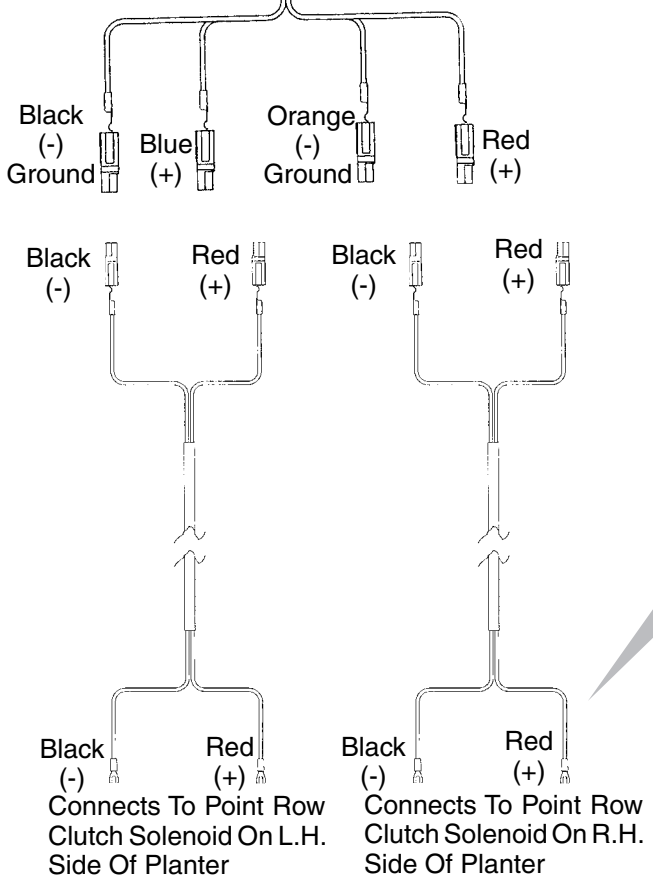
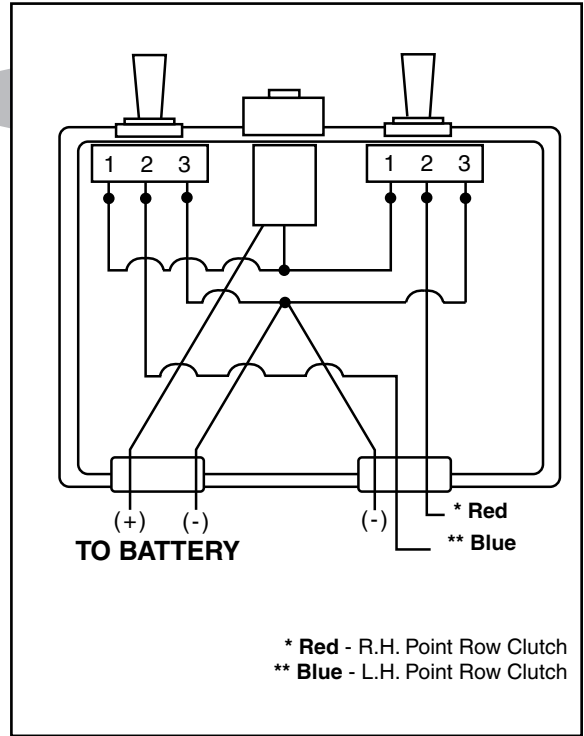
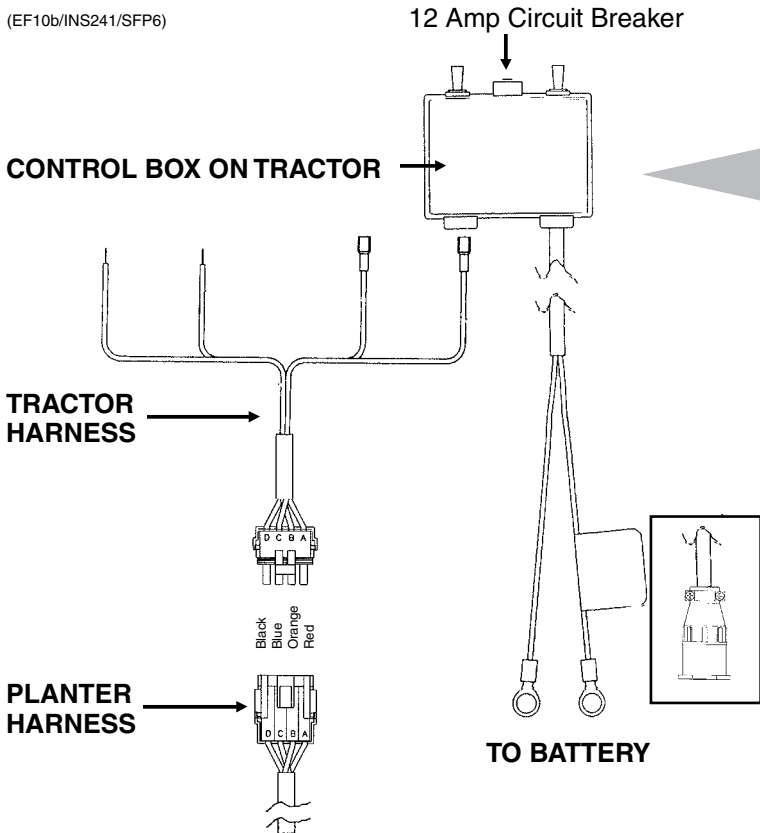

# MAINTENANCE

## HYDRAULIC DIAGRAM - VACUUM FAN MOTOR SYSTEM

(MT35a)

Case Drain (3/8" Hose)  
Pressure (1/2" Hose)  
Return (3/4" Hose)

**IMPORTANT:** Connect hydraulic motor case drain to a case drain return line with zero pressure on the tractor. Failure to connect to a return with zero pressure will cause damage to the hydraulic motor. **DO NOT** connect hydraulic motor case drain to SCV outlet. Contact tractor manufacturer for specific details on "zero pressure return".

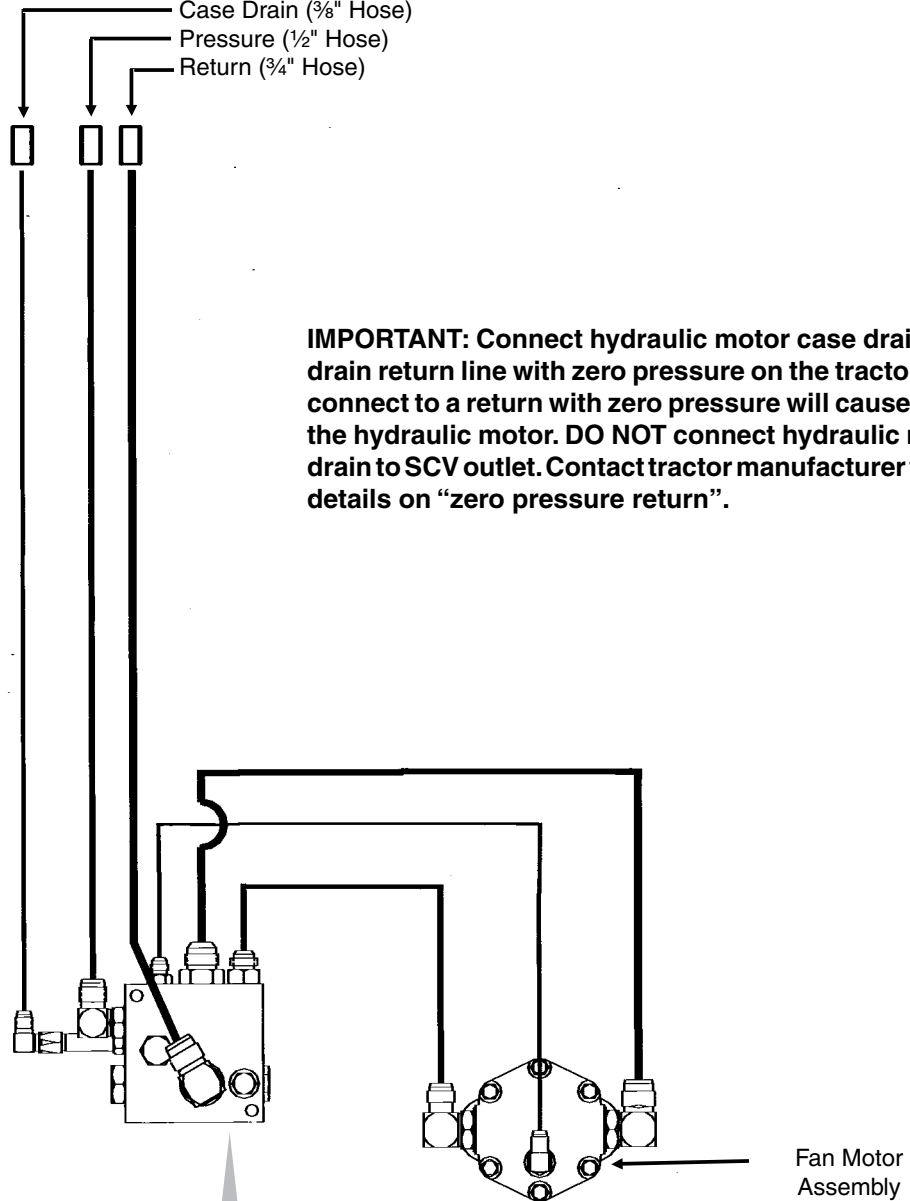

A11068bb

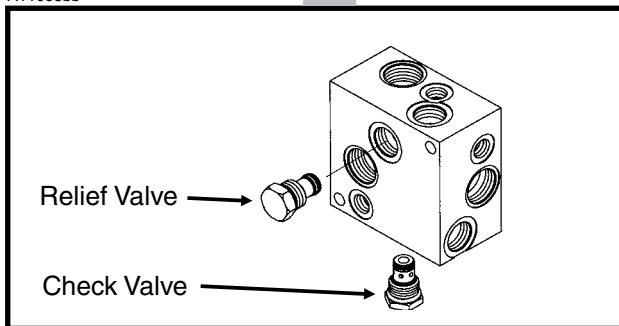

Relief Valve

Check Valve

Vacuum Fan Motor Valve  
Block Assembly  
(See Machine Operation  
Section)

# PARTS LIST INDEX

---

## ROW UNIT

15" Seed Opener Disc Blade/Bearing Assembly And Scrapers .....	P5
Coulter Mounted Residue Wheels .....	P28
Covering Discs/Single Press Wheel .....	P8
Drag Closing Attachment.....	P11
Frame Mounted Coulter W/Residue Wheels.....	P30
Gauge Wheels .....	P6
Granular Chemical Banding Options .....	P19
Granular Chemical Hopper And Hopper Panel Extension.....	P16
Granular Chemical Meter And Meter Drive.....	P18
Hopper Support And Meter Drive .....	P12
Parallel Arms, Mounting Support Plate And Quick Adjustable Down Force Springs .....	P4
Row Unit Mounted Bed Leveler .....	P22
Row Unit Mounted Disc Furrower .....	P24
Row Unit Mounted No Till Coulter .....	P21
Row Unit Mounted Residue Wheel .....	P26
Seed Hopper And Lid .....	P13
Seed Meter .....	P14
Shank Assembly, Seed Tube And Depth Adjustment .....	P2
Spring Tooth Incorporator .....	P20
"V" Closing Wheels .....	P10

## EDGEVAC® SYSTEM

Digital Vacuum Gauge, Analog Vacuum Gauge And Vacuum Fan Assembly....	P32
Manifolds And Distribution Hoses.....	P38
Optional Flow Control Needle Valve Components.....	P36
Vacuum Fan Hydraulic Components .....	P34
Vacuum Fan Hydraulic Motor Assembly .....	P36
Vacuum Fan Motor Valve Block Assembly (Located Below Vacuum Fan Assembly) .....	P37

## BASE MACHINE

Contact Wheel Assembly.....	P44
Cylinders.....	P62
Electrical Components.....	P68
Front Mounted Drive Wheel .....	P50
Ground Drive Wheel Assembly.....	P42
Module Drive .....	P48
Point Row Clutch .....	P52
Point Row Clutch Electrical Components .....	P54
Row Marker Assemblies.....	P56
Row Marker Hydraulic System .....	P66
Row Marker Sequencing/Flow Control Valve.....	P64
Row Marker Spindle/Hub/Blade.....	P60
Seed Rate Transmission And Module Drive Assembly.....	P46
Toolbar Assembly .....	P40

## ELECTRONIC SEED MONITOR

KPM I Electronic Seed Monitor.....	P70
KPM II Stack-Mode Electronic Seed Monitor.....	P72
KPM III Electronic Seed Monitor.....	P72

Decals, Paint And Miscellaneous .....	P74
---------------------------------------	-----

Numerical Index.....	P77
----------------------	-----

# SHANK ASSEMBLY, SEED TUBE AND DEPTH ADJUSTMENT

(D17014/METR29cc/A10142a/D16245)

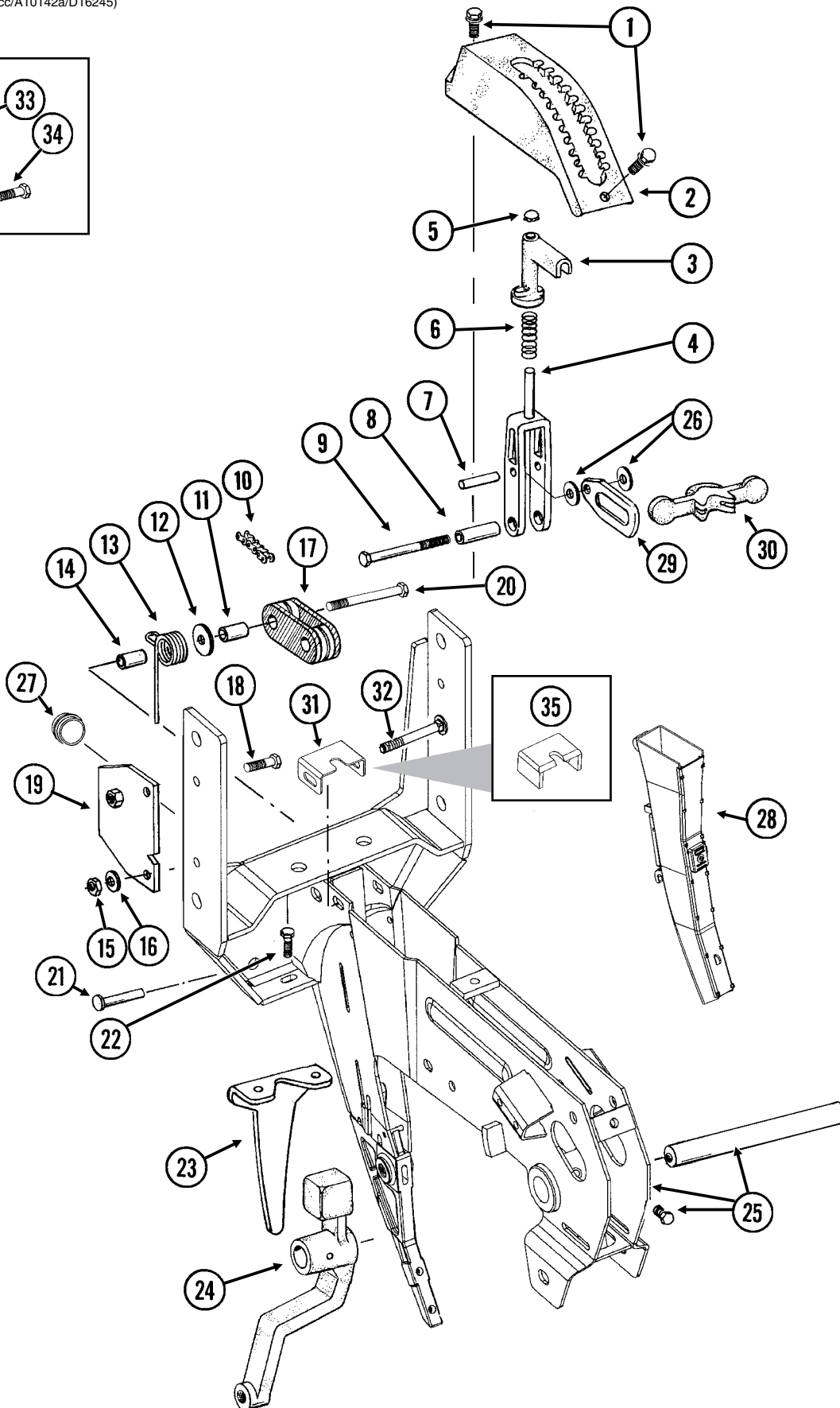
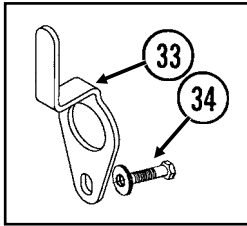

# SHANK ASSEMBLY, SEED TUBE AND DEPTH ADJUSTMENT

---

ITEM	PART NO.	QTY. (Per Row)	DESCRIPTION
1.	G11015	2	Hex Washer Head Cap Screw, 3/8"-16 x 1 1/4"
2.	GB0274	1	Cover, Depth Adjustment
3.	GB0266	1	Handle, Depth Adjustment
4.	GB0267	1	Lever, Depth Adjustment
5.	GD3612	1	Cap Plug
6.	GD10993	1	Spring
7.	GD13361	1	Pin, 3/8" x 1 2/3"
8.	GD11259	1	Sleeve, 3/8" I.D. x 5/8" O.D. x 1 25/32" Long
9.	G11008	1	Hex Head Cap Screw, 3/8"-24 x 2 1/2", Grade 8
	G11007	1	Lock Nut, 3/8"-24, Grade C
10.	G3303-104	1	Chain, No. 41, 104 Pitch Including Connector Link
	GR0196	1	Connector Link, No. 41
11.	GD1026	1	Sleeve, 1 3/16" Long
12.	G10201	1	Special Washer, 3/8" x 1 1/2" O.D.
13.	GD1065	1	Idler Spring
14.	GD7318	1	Sleeve, 1" Long
15.	G10108	1	Lock Nut, 3/8"-16
16.	G10210	1	Washer, 3/8" USS
17.	GD11962	1	Idler
18.	G10003	3	Hex Head Cap Screw, 3/8"-16 x 1 1/2"
	G10108	3	Lock Nut, 3/8"-16
19.	GD10867	2	Stop
20.	G10326	1	Hex Head Cap Screw, 3/8"-16 x 3 3/4"
21.	G10551	1	Clevis Pin, 1/4" x 2 1/2"
	G10669	1	Hair Pin Clip, No. 22
22.	G10312	2	Carriage Bolt, 5/16"-18 x 3/4"
	G10620	2	Serrated Flange Nut, 5/16"-18
23.	GD1033	1	Shield
24.		-	Wheel Arm, See "Gauge Wheels", Pages P6 And P7
25.	GA10157	1	Shank W/Gauge Wheel Pivot Spindle And Set Screw
	GD11001	-	Spindle
	G10438	-	Hex Head Cap Screw, 1/2"-13 x 3/4"
26.	G10207	2	Washer, 7/8" O.D. x 1 3/32" I.D. x .134" (If Applicable)
27.	GD11845	1	Dust Cap
28.			See "KPM I Electronic Seed Monitor" "KPM II Stack-Mode Electronic Seed Monitor And KPM III Electronic Seed Monitor", Pages P70-P73
29.	GB0285	1	Collar, Depth Adjustment
30.	GB0265	1	Pivot Link, Depth Adjustment
31.	GD15970	1	Sun Shade
32.	G10304	1	Carriage Bolt, 3/8"-16 x 3"
	G10108	1	Lock Nut, 3/8"-16
33.	GD17014	1	Hose Guide
34.	G10047	1	Hex Head Cap Screw, 3/8"-16 x 1 3/4"
	G10203	2-3	Washer, 3/8" SAE
	G10108	1	Lock Nut, 3/8"-16
35.	GD16245	-	Sun Shade (Rubber)

# PARALLEL ARMS, MOUNTING SUPPORT PLATE AND QUICK ADJUSTABLE DOWN FORCE SPRINGS

RUB021/RUB022(RU78f/RU79a)

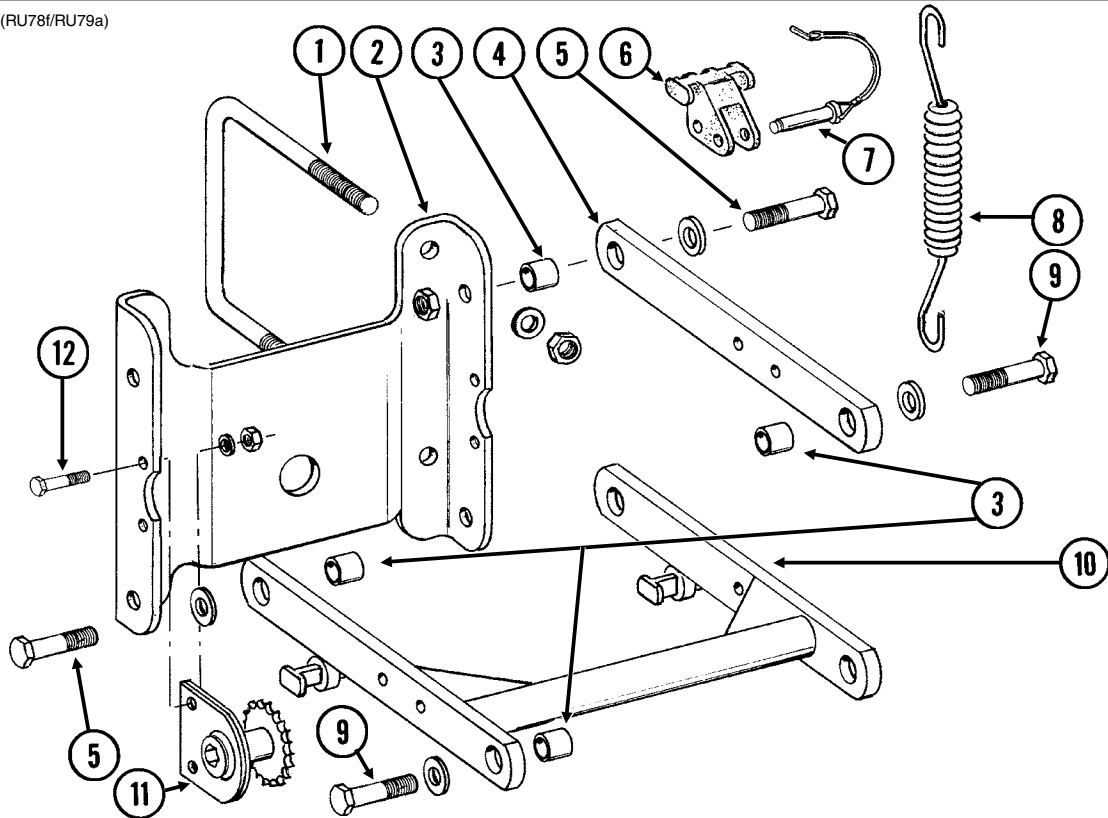

ITEM	PART NO.	QTY. (Per Row)	DESCRIPTION
1.	GD1114 G10230 G10104	2 4 4	U-Bolt, 7" x 7" x 5/8"-11 Lock Washer, 5/8" Hex Nut, 5/8"-11
2.	GD10036	1	Mounting Support Plate
3.	GB0218	4	Bushing, 2 1/32" I.D. x 7/8" O.D. x 1 9/32" Long
4.	GD11422	2	Upper Parallel Arm
5.	G10732 GD7805 G10412	4 4 4	Hex Head Cap Screw, 5/8"-18 x 2" Special Washer, 5/8", Hardened Lock Nut, 5/8"-18
6.	GB0186	2	Spring Anchor
7.	GD14217	2	Tab Lock Pin, 7/16" x 1 1/2"
8.	GD8249	2-4	Spring
9.		-	See "Hopper Support And Meter Drive", Page P12
10.	GA5651	1	Lower Parallel Arm
11.	GA1720	1	Bearing/Sprocket, 7/8" Hex Bore
12.	G10001 G10229 G10101	2 2 2	Hex Head Cap Screw, 3/8"-16 x 1" Lock Washer, 3/8" Hex Nut, 3/8"-16
A.	G6326X	-	U-Bolt Package For 7" x 7" Toolbar, Includes: (2) GD1114, (4) G10230, (4) G10104



# 15" SEED OPENER DISC BLADE/BEARING ASSEMBLY AND SCRAPERS

(RU139)

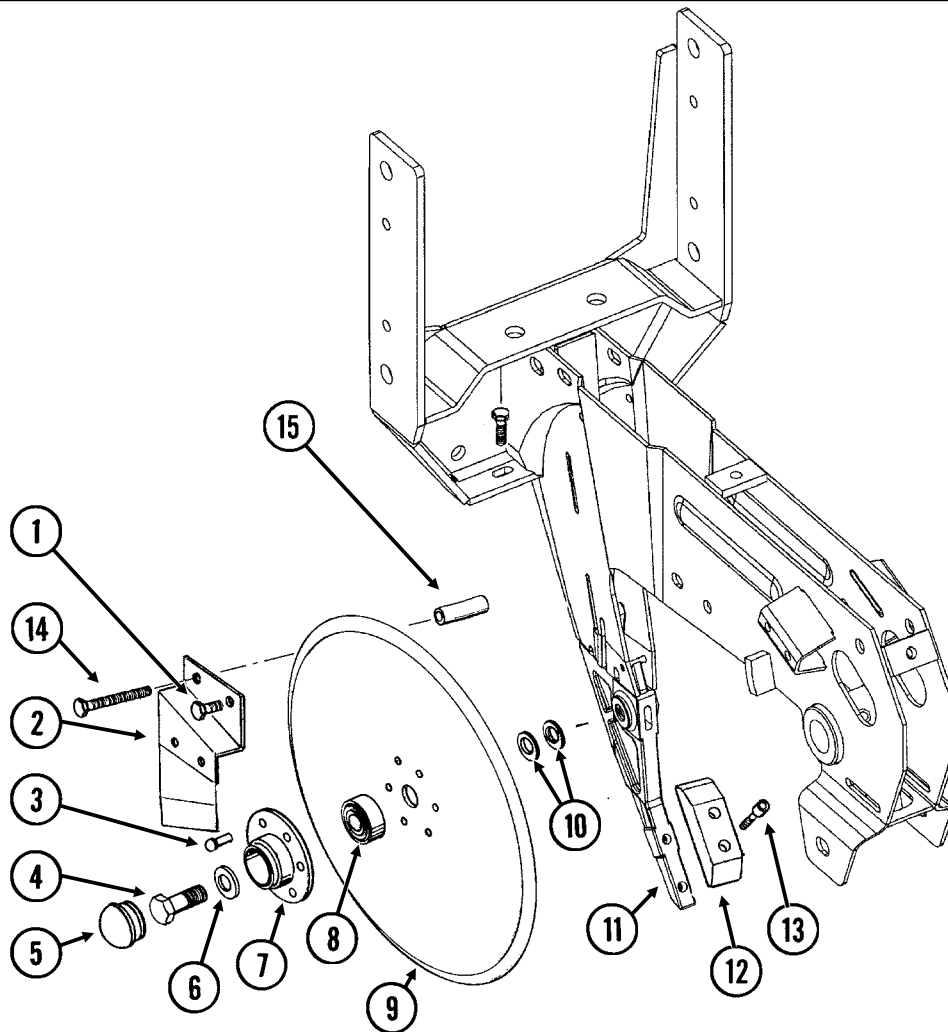

ITEM	PART NO.	QTY. (Per Row)	DESCRIPTION
1.	G10328	2	Hex Head Cap Screw, 3/8"-16 x 5/8"
	G10622	2	Serrated Flange Nut, 3/8"-16
2.	GA2012R	1	Disc Scraper, R.H.
	GA2012L	-	Disc Scraper, L.H. (Shown)
3.	G10427	12	Rivet, 1/4" x 1/2"
4.	GD11017	1	Special Hex Head Cap Screw, 5/8"-11 x 1 1/2", L.H. Threads
	G10007	1	Hex Head Cap Screw, 5/8"-11 x 1 1/2"
5.	GD11845	2	Dust Cap
6.	G10204	2	Special Machine Bushing, 5/8" x 1" O.D.
7.	GD10473	2	Bearing Housing
8.	GA2014	2	Bearing
9.	GD11306	2	Disc Blade, 3.5 mm x 15"
10.	G10213	-	Machine Bushing, 5/8" (.030" Thick)(As Required)
11.		-	See "Shank Assembly", Pages P2 And P3
12.	GB0301	1	Seed Tube Guard/Inner Scraper
13.	G10912	2	Hex Socket Head Cap Screw, 5/16"-18 x 1", Grade 8
14.	G10325	1	Hex Head Cap Screw, 3/8"-16 x 2 3/4"
	G10622	1	Serrated Flange Nut, 3/8"-16
15.	GD11259	1	Sleeve, 3/8" I.D. x 5/8" O.D. x 1 25/32" Long
A.	GA8324	-	Disc Blade/Bearing Assembly, Less Dust Cap (Items 3 And 7-9)

# GAUGE WHEELS

(RU140/RU84b)

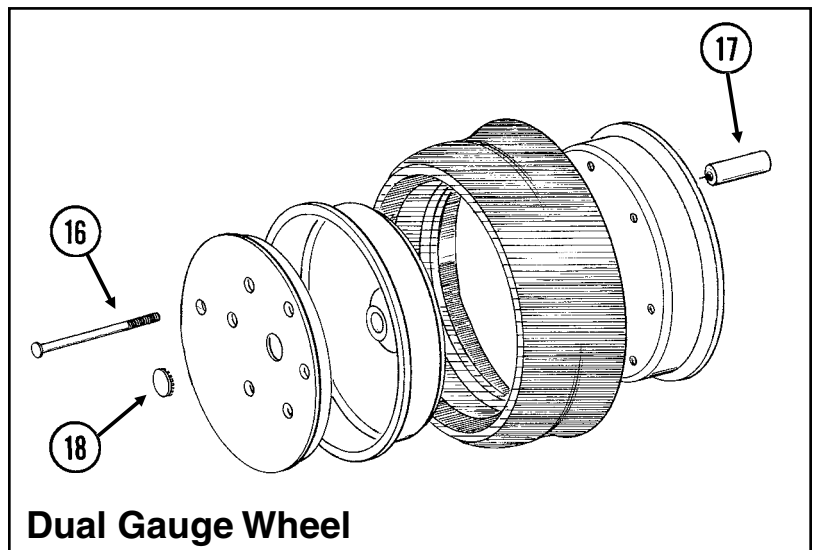
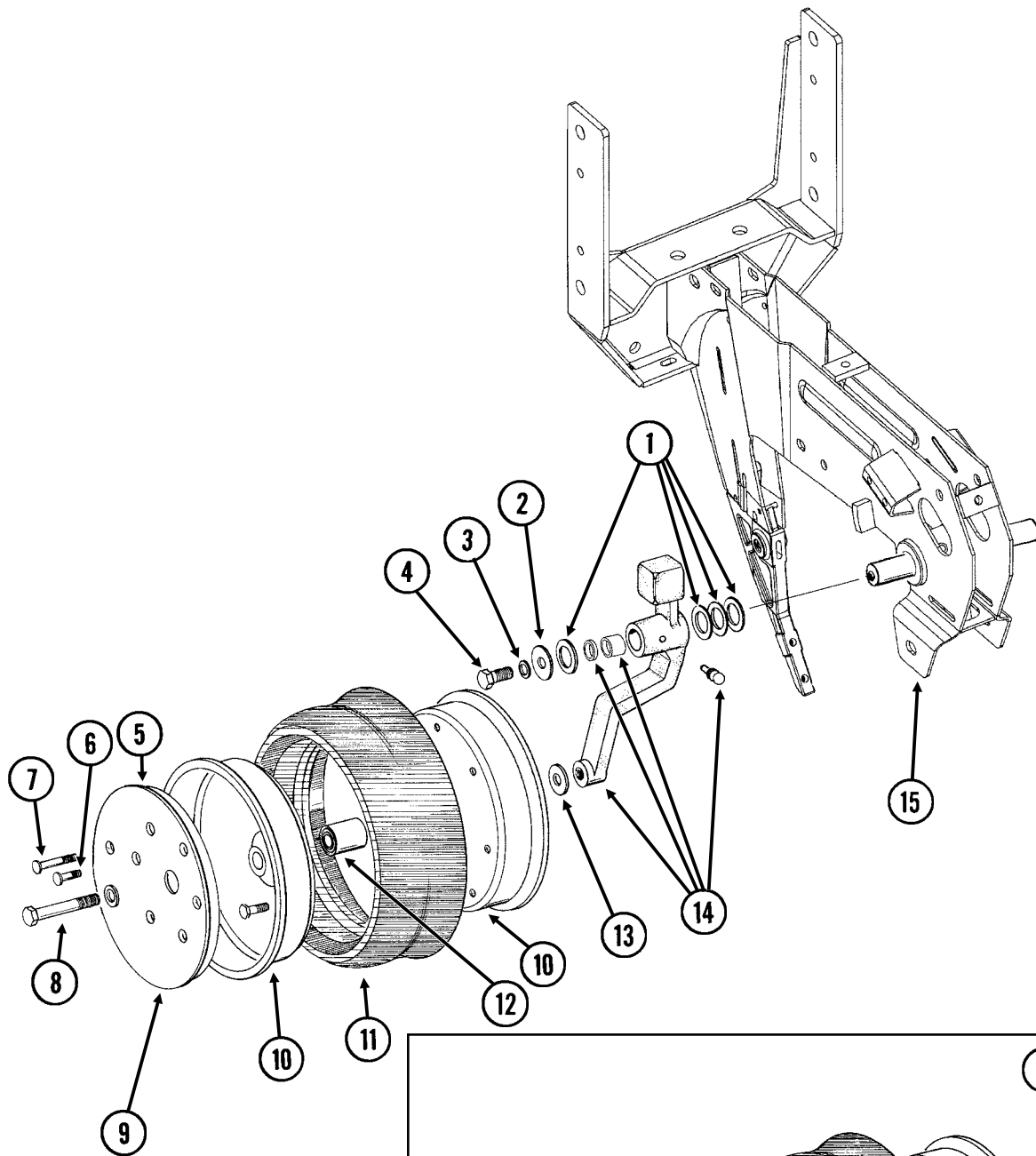

**Dual Gauge Wheel**

# GAUGE WHEELS

ITEM	PART NO.	QTY. (Per Row)	DESCRIPTION
1.	G10940	-	Machine Bushing, 1" (.048" Thick)
2.	G10216	2	Washer, 1/2" USS
3.	G10228	2	Lock Washer, 1/2"
4.	G10014	1	Hex Head Cap Screw, 1/2"-13 x 1"
5.	GD11453	2	Cover
6.	G10338	12	Carriage Bolt, 5/16"-18 x 1 1/4"
	G10620	12	Serrated Flange Nut, 5/16"-18
7.	G10924	8	Carriage Bolt, 5/16"-18 x 1 3/4"
	G10620	8	Serrated Flange Nut, 5/16"-18
8.	G10010	2	Hex Head Cap Screw, 5/8"-11 x 3"
	G10230	2	Lock Washer, 5/8"
9.	G10018	14	Hex Head Cap Screw, 5/16"-18 x 5/8"
	G10109	14	Lock Nut, 5/16"-18, Grade 8
10.	GD11423	4	Half Wheel
11.	GD1086	2	Tire
12.	GA6171	2	Bearing
13.	G10204	2	Special Machine Bushing, 5/8" x 1" O.D.
14.	GA7975	1	Wheel Arm W/Grease Fitting, Bushings And Seals, L.H. (Shown)
	GA7976	1	Wheel Arm W/Grease Fitting, Bushings And Seals, R.H.
	G10640	1	Grease Fitting, 1/4"-28 (Per Arm)
	GB0276	2	Bushing, 1" I.D. x 1 1/4" O.D. x 1" Long (Per Arm)
	GD10991	2	Seal (Per Arm)
15.		-	See "Shank Assembly", Pages P2 And P3
16.	G10944	8	Carriage Bolt, 5/16"-18 x 6" (Replaces Item 7)
	G10620	8	Serrated Flange Nut, 5/16"-18
17.	GD8811	8	Dual Gauge Wheel Sleeve, 4 1/8"
18.	GD11936	1	Plug, 1 1/8"
A.	GA7949	-	Gauge Wheel Complete (Items 5-7 And 9-12)
B.	G1K296	-	Gauge Wheel Arm Bushing And Seal Driver Kit, Includes: (1) Seal Driver, (1) Bushing Driver, (1) Instruction

# COVERING DISCS/SINGLE PRESS WHEEL

RUA054/RUB026(RU94d)

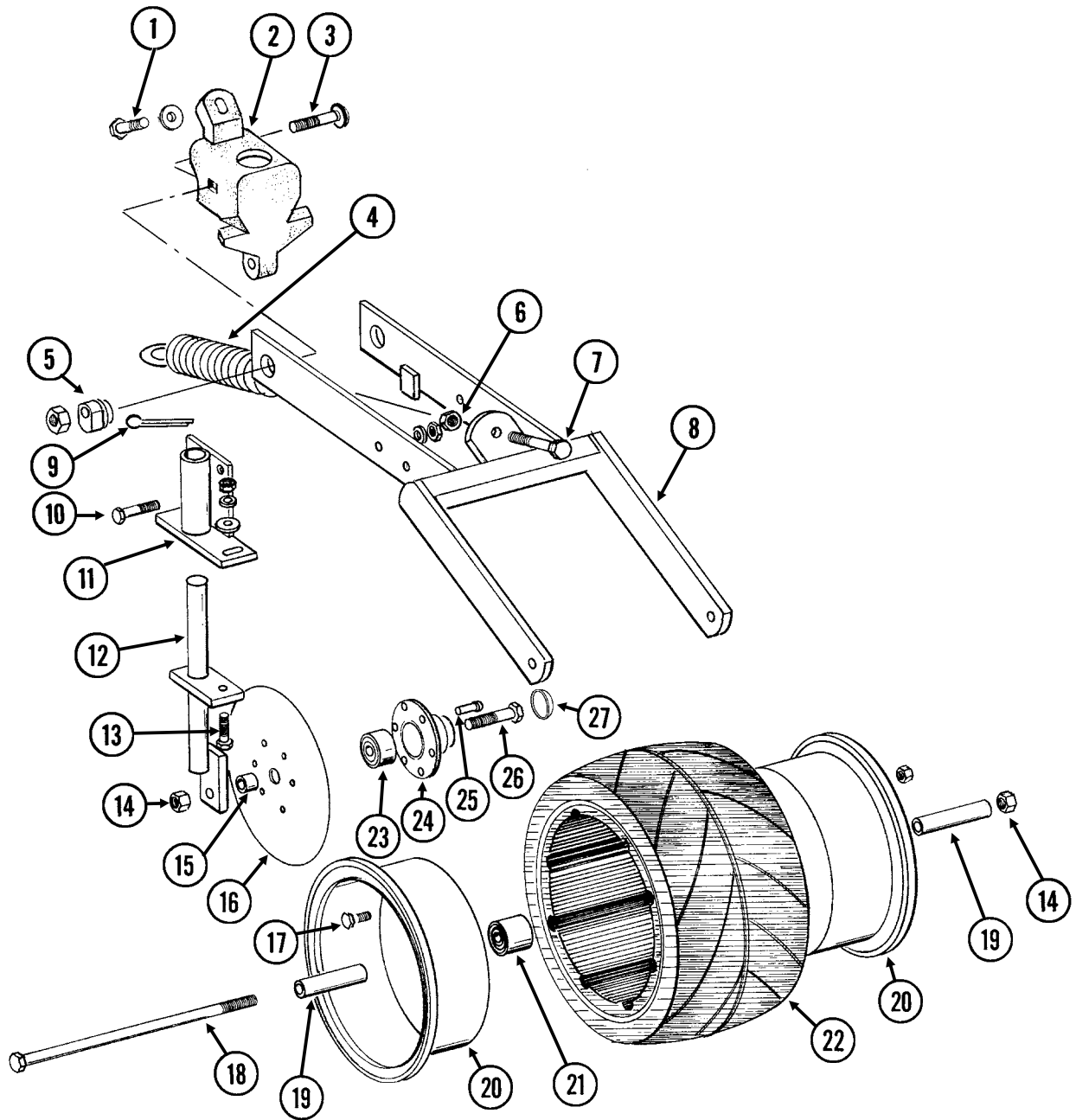

# COVERING DISCS/SINGLE PRESS WHEEL

ITEM	PART NO.	QTY. (Per Row)	DESCRIPTION
1.	G10001	1	Hex Head Cap Screw, 3/8"-16 x 1"
	G10210	1	Washer, 3/8" USS
2.	GB0268	1	Wheel Arm Stop
3.	G10801	2	Carriage Bolt, 1/2"-13 x 2 1/4"
	G10315	-	Carriage Bolt, 1/2"-13 x 2 1/2" (Used W/Straight Drop In-Furrow Granular Chemical Bracket)
	G10102	2	Hex Nut, 1/2"-13
4.	GA2054	1	Spring
5.	GB0239	2	Eccentric Bushing
6.	G10102	1	Hex Nut, 1/2"-13
7.	G10015	1	Adjusting Bolt, 1/2"-13 x 5"
8.	GA6619	1	Mounting Arm
9.	G10463	2	Cotter Pin, 1/4" x 1 1/2"
10.	G10171	4	Hex Head Cap Screw, 5/16"-18 x 1 1/4"
	G10232	4	Lock Washer, 5/16"
	G10106	4	Hex Nut, 5/16"-18
11.	GA6620	2	Bracket
12.	GA6618	2	Mount
13.	G10303	2	Carriage Bolt, 5/16"-18 x 1"
	G10219	2	Washer, 5/16" USS
	G10232	2	Lock Washer, 5/16"
	G10106	2	Hex Nut, 5/16"-18
14.	G10107	3	Lock Nut, 5/8"-11
15.	GD1109	2	Bushing, 4 1/64" I.D. x 7/8" O.D. x 1/4" Long
16.	GD9290	2	Disc Blade, 8"
17.	G10018	7	Hex Head Cap Screw, 5/16"-18 x 5/8"
	G10109	7	Lock Nut, 5/16"-18, Grade 8
18.	G10152	1	Hex Head Cap Screw, 5/8"-11 x 9"
19.	GD3180-12	2	Sleeve, 5/8" I.D. x 7/8" O.D. x 2 7/8" Long
20.	GD9562	2	Half Wheel
21.	GA6171	1	Bearing
22.	GD9305	1	Tire
23.	GA2014	2	Bearing
24.	GD10473	2	Bearing Housing
25.	G10427	12	Rivet, 1/4" x 1/2"
26.	G10006	2	Hex Head Cap Screw, 5/8"-11 x 2 1/4"
27.	GD11845	2	Dust Cap
A.	GA6733	-	Single Press Wheel Complete W/Bearing (Items 17 And 20-22)
B.	GA6801	-	Covering Disc Blade Complete W/Bearing (Items 16 And 23-25)

# “V” CLOSING WHEELS

(RU83i/RU83n)

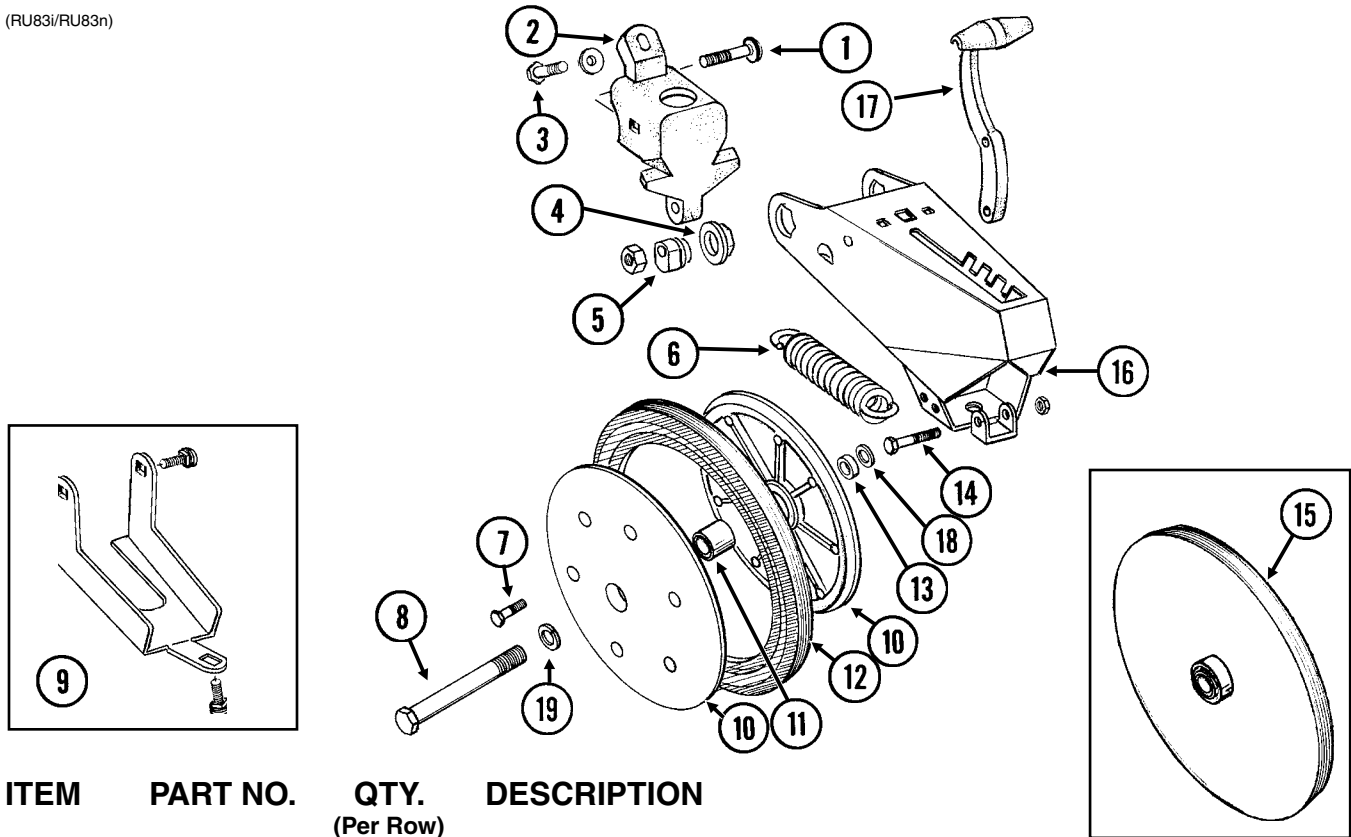

ITEM	PART NO.	QTY. (Per Row)	DESCRIPTION
1.	G10801	2	Carriage Bolt, 1/2"-13 x 2 1/4"
	G10315	-	Carriage Bolt, 1/2"-13 x 2 1/2" (Used W/Straight Drop In-Furrow Granular Chemical Bracket)
2.	G10111	2	Lock Nut, 1/2"-13
	GB0268	1	Wheel Arm Stop
3.	G10001	1	Hex Head Cap Screw, 3/8"-16 x 1"
	G10210	1	Washer, 3/8" USS
4.	GB0282	2	Stepped Bushing
5.	GB0239	2	Eccentric Bushing
6.	GD8460	1	Spring
7.	G10064	6	Hex Head Cap Screw, 1/4"-20 x 1"
8.	G10013	2	Hex Head Cap Screw, 5/8"-11 x 3 1/2"
	G10107	2	Lock Nut, 5/8"-11
9.	G1K345	-	Closing Wheel Shield Kit W/Hardware And Instruction
	G10308	2	Carriage Bolt, 3/8"-16 x 3/4"
	G10599	1	Carriage Bolt, 3/8"-16 x 1 1/4"
	G10210	1	Washer, 3/8" USS
	G10229	3	Lock Washer, 3/8"
	G10101	3	Hex Nut, 3/8"-16
	G10101	3	Hex Nut, 3/8"-16
10.	GD9120	4	Nylon Half Wheel
11.	GA6171	2	Bearing
12.	GD1085	2	Rubber Tire, 1" x 12"
13.	GD1109	2	Bushing, 4 1/64" I.D. x 7/8" O.D. x 1/4" Long
14.	G10133	1	Hex Head Cap Screw, 5/16"-18 x 1 1/2"
	G10109	1	Lock Nut, 5/16"-18, Grade 8
15.	GA6597	-	Cast Iron Closing Wheel W/Bearing
	GA6171	-	Bearing
16.	GA8322	1	Arm
17.	GB0254	1	Lever
18.	GD7805	2	Special Washer, 5/8", Hardened
19.	G10230	2	Lock Washer, 5/8"
A.	GA6434	-	Rubber Closing Wheel Complete W/Bearing (Items 7 And 10-12)

# DRAG CLOSING ATTACHMENT

RUB050(RU90c)

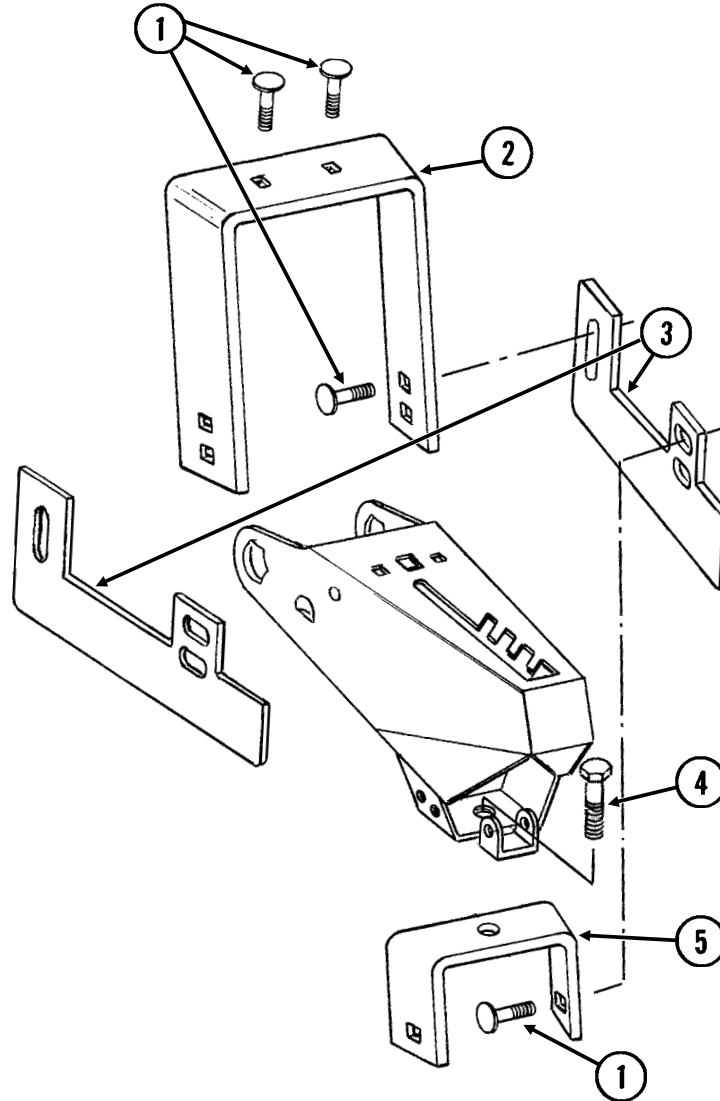

ITEM	PART NO.	QTY.	DESCRIPTION
		(Per Row)	
1.	G10599	6	Carriage Bolt, 3/8"-16 x 1 1/4"
	G10210	6	Washer, 3/8" USS
	G10229	6	Lock Washer, 3/8"
	G10101	6	Hex Nut, 3/8"-16
2.	GD11508	1	Front Bracket
3.	GD11313	2	Blade
4.	G10007	1	Hex Head Cap Screw, 5/8"-11 x 1 1/2"
	G10230	1	Lock Washer, 5/8"
	G10104	1	Hex Nut, 5/8"-11
5.	GD11509	1	Rear Bracket
A.	G7566X	-	Drag Closing Attachment Complete (Items 1-5)

# HOPPER SUPPORT AND METER DRIVE

(METR22)

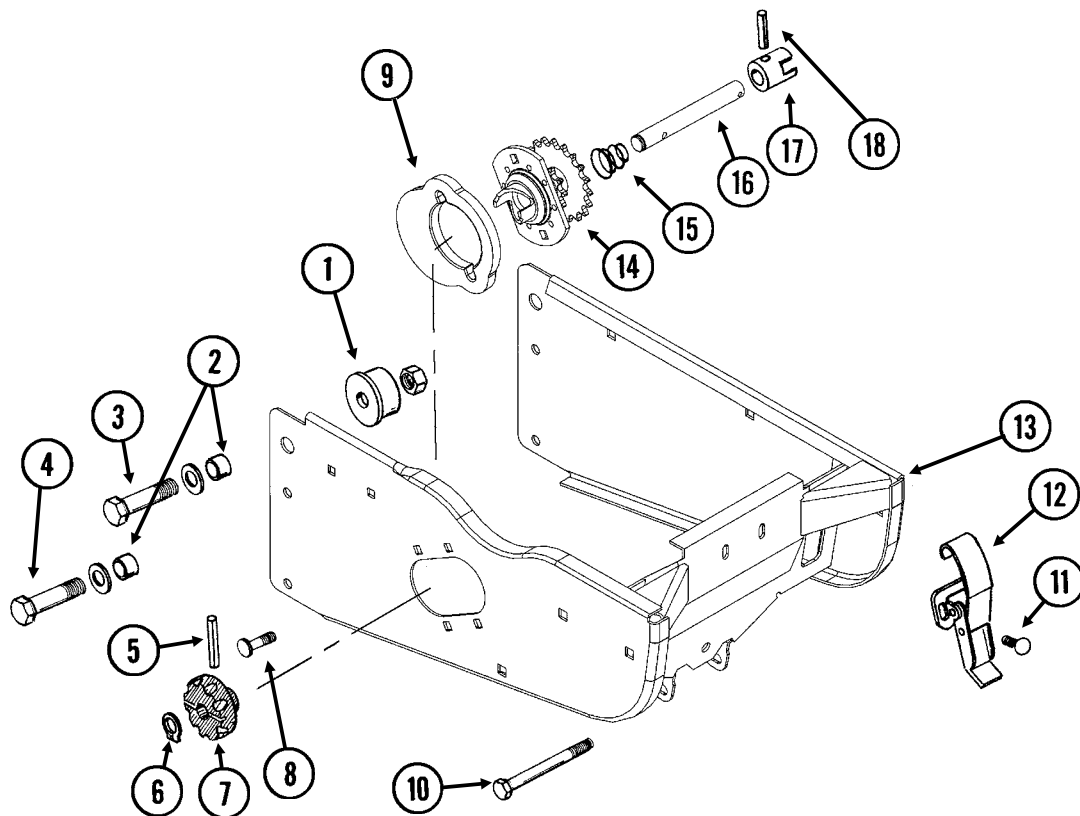

ITEM	PART NO.	QTY. (Per Row)	DESCRIPTION
1.	GB0314	2	Hopper Mount
2.	GB0218	4	Bushing, 2 <sup>1</sup> / <sub>32</sub> " I.D. x 7 <sup>8</sup> / <sub>8</sub> " O.D. x 1 <sup>19</sup> / <sub>32</sub> " Long
3.	G10752	2	Hex Head Cap Screw, 5 <sup>8</sup> / <sub>8</sub> "-18 x 2 1 <sup>4</sup> / <sub>4</sub> "
	GD7805	2	Special Washer, 5 <sup>8</sup> / <sub>8</sub> ", Hardened
	G10412	2	Lock Nut, 5 <sup>8</sup> / <sub>8</sub> "-18
4.	G10751	2	Hex Head Cap Screw, 5 <sup>8</sup> / <sub>8</sub> "-18 x 1 3 <sup>4</sup> / <sub>4</sub> "
	GD7805	2	Special Washer, 5 <sup>8</sup> / <sub>8</sub> ", Hardened
	G10412	2	Lock Nut, 5 <sup>8</sup> / <sub>8</sub> "-18
5.	G10602	1	Spring Pin, 1 <sup>4</sup> / <sub>4</sub> " x 1 1 <sup>2</sup> / <sub>2</sub> "
6.	G10567	1	External Retaining Ring, 5 <sup>8</sup> / <sub>8</sub> "
7.	GD11239	1	Knob
8.	G10338	2	Carriage Bolt, 5 <sup>16</sup> / <sub>16</sub> "-18 x 1 1 <sup>4</sup> / <sub>4</sub> "
	G10620	2	Serrated Flange Nut, 5 <sup>16</sup> / <sub>16</sub> "-18
9.	GB0331	1	Clutch Adapter Plate
10.	G10061	1	Hex Head Cap Screw, 3 <sup>8</sup> / <sub>8</sub> "-16 x 3 1 <sup>2</sup> / <sub>2</sub> "
	G10210	2	Washer, 3 <sup>8</sup> / <sub>8</sub> " USS
	G10108	1	Lock Nut, 3 <sup>8</sup> / <sub>8</sub> "-16
11.	G10309	2	Carriage Bolt, 1 <sup>4</sup> / <sub>4</sub> "-20 x 5 <sup>8</sup> / <sub>8</sub> ", Grade 2
	G10621	2	Serrated Flange Nut, 1 <sup>4</sup> / <sub>4</sub> "-20
12.	GA2007	1	Hopper Hold Down Latch
13.	GA10155	1	Hopper Support
14.	GA10137	1	Double Sprocket And Bearing, Drive Clutch, 11/19 Tooth
15.	GD11413	1	Spring
16.	GD15747	1	Shaft
17.	GB0278	1	Coupler
18.	G10546	1	Spring Pin, 3 <sup>16</sup> / <sub>16</sub> " x 1 1 <sup>4</sup> / <sub>4</sub> "
A.	GA10151	-	Meter Drive Assembly, 11/19 Sprocket (Items 5-7 And 14-18)



# SEED HOPPER AND LID

---

(METR12)

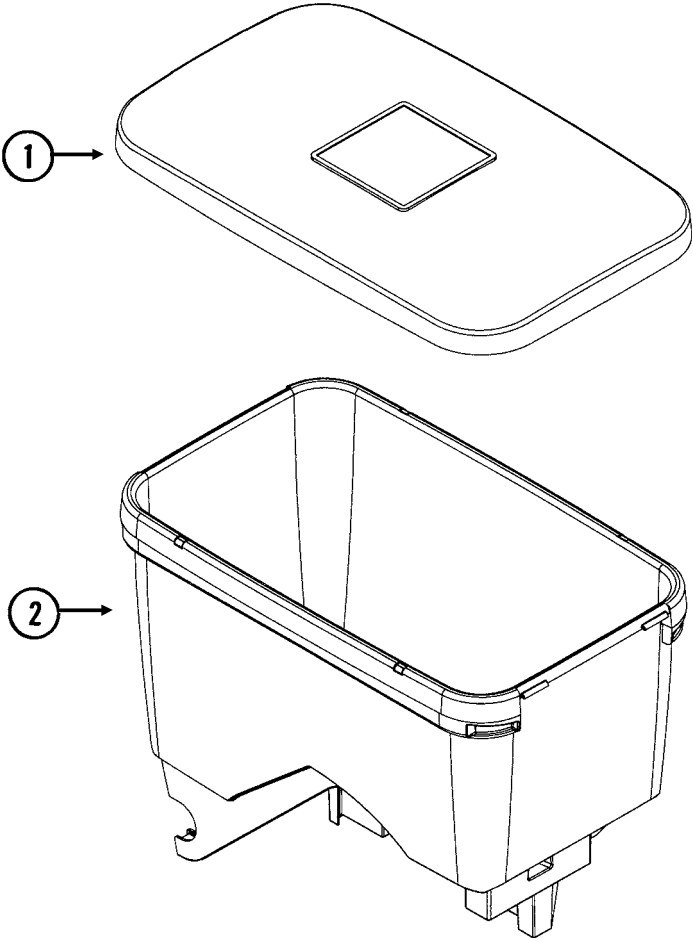



ITEM	PART NO.	QTY.	DESCRIPTION
1.	GD11279	1	Lid
2.	GA10634	1	Seed Hopper

# SEED METER

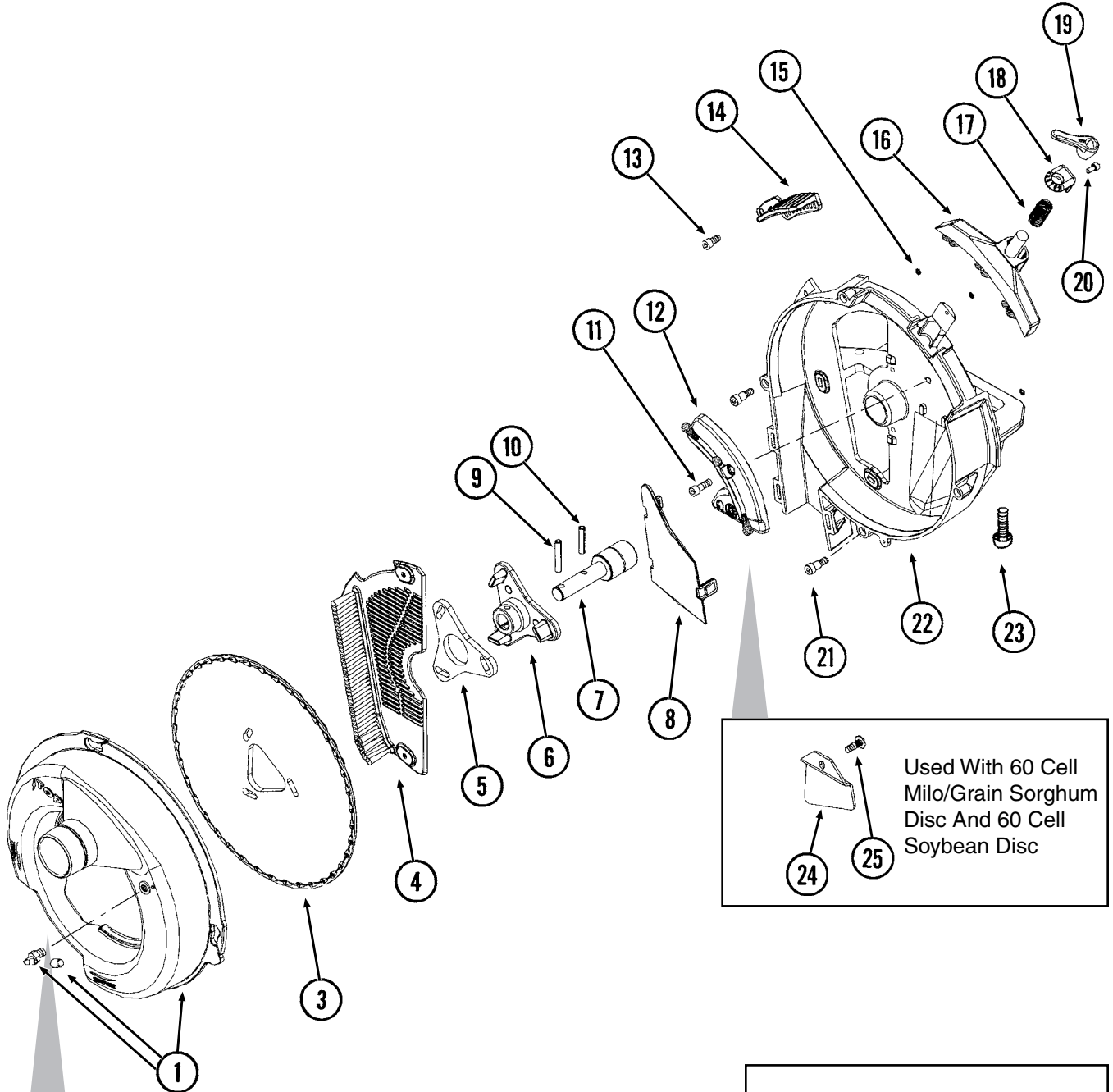
(METR69/METR65/A12133)



Used With 60 Cell  
Milo/Grain Sorghum  
Disc And 60 Cell  
Soybean Disc

	<p><b>2</b> Used With 60 Cell Milo/Grain Sorghum Disc</p>
	<p><b>27</b> Used With 20 Cell Hill-Drop Acid-Delinted Cotton Disc And 54 Cell Acid-Delinted Cotton/ Small Dry Edible Bean Disc</p>

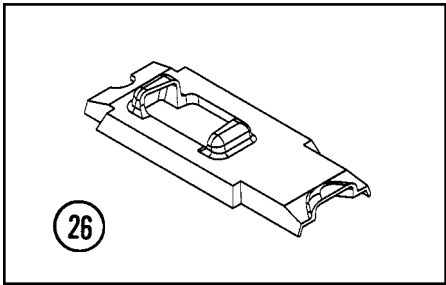

# SEED METER

ITEM	PART NO.	QTY.	DESCRIPTION
1.	GA11911	1	Vacuum Cover W/Elbow And Cap
	GD17099	-	3/16" Hose Barb Elbow
	GD17152	-	Cap
2.	GA12133	1	Cleanout Brush <b>(Used With 60 Cell Milo/Grain Sorghum Disc)</b>
3.	GD17049	-	Seed Disc, Corn/Popcorn, 39 Cell, <b>Light Blue Color-Coded</b>
	GD17048	-	Seed Disc, Low-Rate Corn/Popcorn, 24 Cell, <b>Light Green Color-Coded</b>
	GD14467	-	Seed Disc, Soybean, 60 Cell, <b>Black Color-Coded</b>
	GD14468	-	Seed Disc, High-Rate Soybean, 120 Cell, <b>Dark Blue Color-Coded</b>
	GD17050	-	Seed Disc, Milo/Grain Sorghum, 60 Cell, <b>Yellow Color-Coded</b>
	GD17187	-	Seed Disc, Hill-Drop Cotton, Acid-Delinted, 3 Seeds Per Cell, 20 Cell, <b>Brown Color-Coded</b>
	GD17186	-	Seed Disc, Cotton, Acid-Delinted/Small Dry Edible Bean, 54 Cell, <b>Dark Green Color-Coded</b>
	GD14477	-	Seed Disc, Large Dry Edible Bean, 54 Cell, <b>Tan Color-Coded</b>
4.	GD17028	1	Wall Brush/Vent
5.	GD17021	1	Foam Spacer
6.	GB0328	1	Mount
7.	GA5698	1	Bearing
8.	GD14541	1	Discharge Cover
9.	G10602	1	Spring Pin, 1/4" x 1 1/2"
10.	G10603	1	Spring Pin, 1/4" x 1 1/4"
11.	G11213	1	Hex Socket Head Cap Screw, 1/4"-20 x 3/4"
12.	GA11935	1	Crowder Brush
13.	G10260	1	Hex Socket Head Cap Screw, 1/4"-20 x 1/2"
14.	GD17047	1	Air Inlet Screen
15.	GD17162	3	Push Nut, 1/8" I.D.
16.	GA10755	1	Singulator Brush
17.	GD14592	1	Spring
18.	GB0358	1	Cap
19.	GD15663	1	Brush Adjustment Lever
20.	G11173	1	Hex Socket Head Cap Screw, No. 10-24 x 3/8", Stainless Steel
21.	G11172	4	Hex Socket Head Shoulder Screw, 1/4"-20 x 3/8", Stainless Steel
22.	GB0319	1	Housing
23.	G11009	2	Locking Thumbscrew, 5/16"-18 x 3/4"
24.	GD17104	1	Seed Baffle <b>(Used With 60 Cell Milo/Grain Sorghum Disc And 60 Cell Soybean Disc)</b>
25.	G11210	1	Rib Neck Bolt, 1/4"-20 x 3/4"
	G10323	1	Hex Flange Nut, 1/4"-20
26.	GD15700	1	Shank Cover, EdgeVac® Meter
27.	GA12154	-	Cleanout Brush W/Ball-Type Ejector <b>(Used With 20 Cell Hill-Drop Acid-Delinted Cotton Disc And 54 Cell Acid-Delinted Cotton/Small Dry Edible Bean Disc)</b>

# GRANULAR CHEMICAL HOPPER AND HOPPER PANEL EXTENSION

(METR14d)

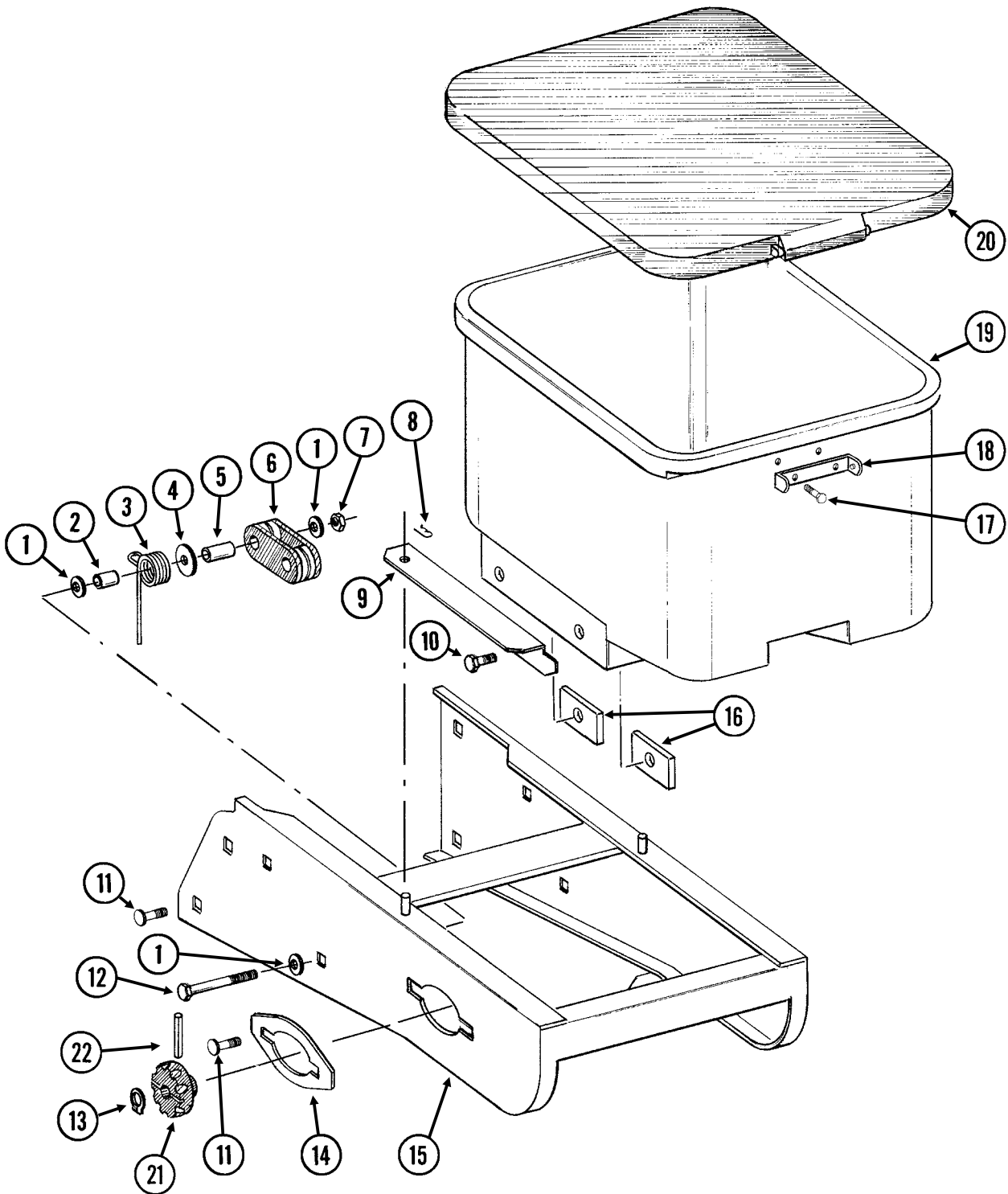

# GRANULAR CHEMICAL HOPPER AND HOPPER PANEL EXTENSION

---

ITEM	PART NO.	QTY. (Per Row)	DESCRIPTION
1.	G10210	3	Washer, 3/8" USS
2.	GD2971-10	1	Sleeve, 9/16" Long
3.	GD11219	1	Spring
4.	G10201	1	Special Washer, 3/8" x 1 1/2" O.D.
5.	GD1026	1	Sleeve, 1 3/16" Long
6.	GD11962	1	Idler
7.	G10108	1	Lock Nut, 3/8"-16
8.	G10670	2	Hair Pin Clip, No. 3
9.	GD1059L	1	Support, L.H. (Shown)
	GD1059R	1	Support, R.H.
10.	G10002	4	Hex Head Cap Screw, 3/8"-16 x 3/4"
	G10229	4	Lock Washer, 3/8"
11.	G10312	8	Carriage Bolt, 5/16"-18 x 3/4"
	G10620	8	Serrated Flange Nut, 5/16"-18
12.	G10325	1	Hex Head Cap Screw, 3/8"-16 x 2 3/4"
13.	G10567	3	External Retaining Ring, 5/8"
14.	GD11305	1	Plate
15.	A10759	1	Hopper Panel Extension <b>(Non-Stock Item)</b> <b>(Sub Wholegoods Order Code 700-01099)</b>
16.	GD11424	4	Block
17.	G10023	2	Hex Head Cap Screw, 1/4"-20 x 3/4"
	G10621	2	Serrated Flange Nut, 1/4"-20
18.	GD1060	1	Hinge
19.	GA8371	1	Hopper
20.	GA4444	1	Lid
21.	GD11239	1	Knob
22.	G10602	1	Spring Pin, 1/4" x 1 1/2"

# GRANULAR CHEMICAL METER AND METER DRIVE

RUA051/RUB028(RU91a)

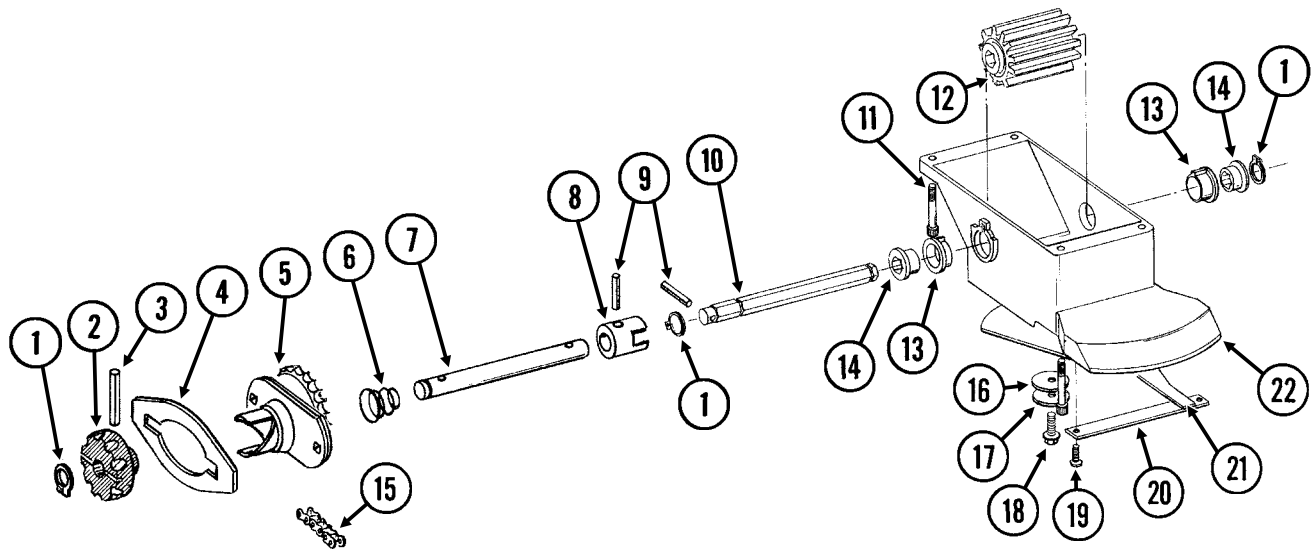

ITEM	PART NO.	QTY. (Per Row)	DESCRIPTION
1.	G10567	3	External Retaining Ring, 5/8"
2.	GD11239	1	Knob
3.	G10602	1	Spring Pin, 1/4" x 1 1/2"
4.		-	See "Granular Chemical Hopper And Hopper Panel Extension", Pages P16 And P17
5.	GA8364	1	Sprocket And Bearing, Drive Clutch, 24 Tooth
6.	GD11413	1	Spring
7.	GD11240	1	Shaft
8.	GB0278	1	Coupler
9.	G10546	2	Spring Pin, 3/16" x 1 1/4"
10.	GD11297	1	Shaft
11.	G10921	4	Hex Socket Head Cap Screw, No. 10-24 x 7/8"
	G10257	4	Lock Washer, No. 10
12.	GD7148	1	Feed Roller, Hex Bore
13.	GB0115	2	Bearing
14.	GD7258	2	Hex Bushing
15.	G3303-108	1	Chain, No. 41, 108 Pitch Including Connector Link
	GR0196	1	Connector Link, No. 41
16.	G10660	1	Wave Washer, 1/2"
17.	G10209	1	Washer, 1/4" USS
18.	G10570	1	Slotted Hex Self-Tapping Screw, 1/4"-20 x 3/4"
19.	G11073	2	Slotted Hex Self-Tapping Screw, No. 10 x 3/8"
20.	GD1061	1	Support Strap
21.	GD1063	1	Metering Gate
22.	GB0116	1	Granular Housing
A.	GA8326	-	Granular Chemical Meter Complete (Items 1, 9, 10, 12-14 And 16-22)

# GRANULAR CHEMICAL BANDING OPTIONS

RUA061/RUA073(RU101mm/RU83m)

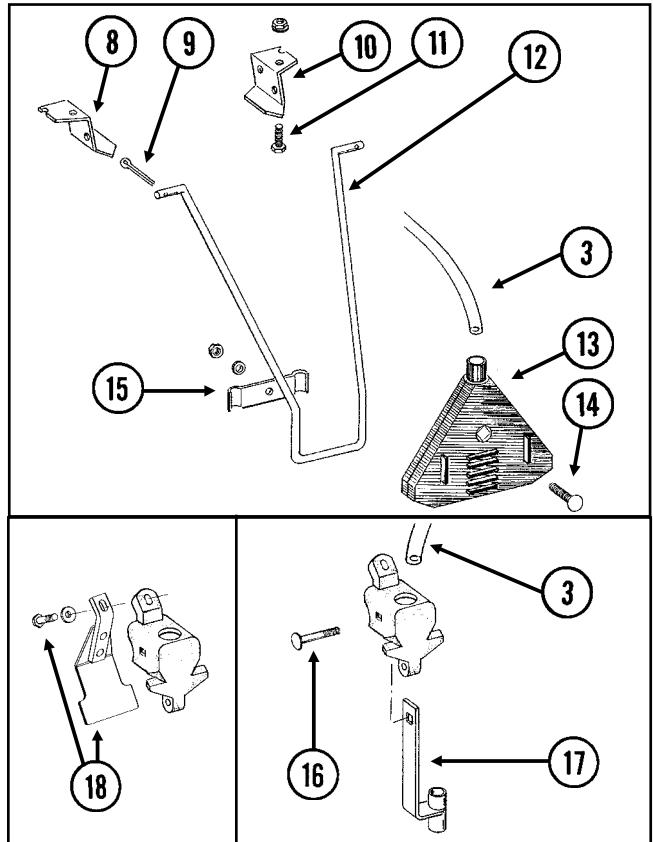
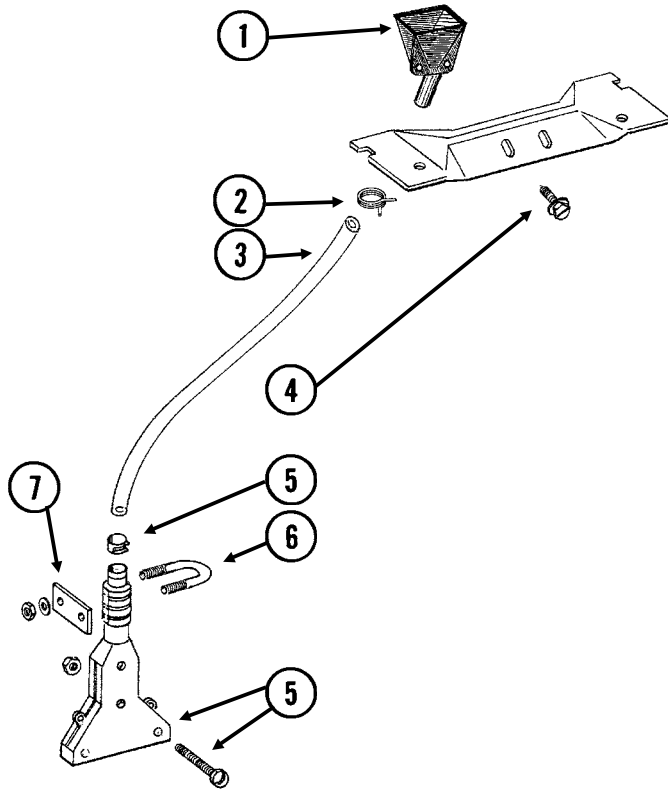

ITEM	PART NO.	QTY.	DESCRIPTION
1.	GD2423	1	Funnel
2.	G11209	1	Wire Hose Clamp, 3/4"
3.	GD2947	1	Hose, 7/16" x 28"
4.	G10523	2	Slotted Pan Head Self-Tapping Screw, No. 10 x 1/2"
5.	GA6907	1	Slope-Compensating Bander W/Hardware (4 1/2" Band Width)
	G10864	1	Uni-Clamp
	G10757	2	Pan Head Screw, No. 10-32 x 1 1/4"
	G10758	2	Hex Nut, No. 10-32
6.	GD10963	1	U-Bolt, 1 1/2" x 1 5/16" x 1/4"-20
	G10209	2	Washer, 1/4" USS
	G10110	2	Lock Nut, 1/4"-20, Grade B
7.	GD10984	1	Spacer
8.	GD1115L	-	Hanger Bracket, L.H.
9.	G10452	-	Cotter Pin, 1/8" x 1/2"
10.	GD1115R	-	Hanger Bracket, R.H.
11.	G10310	-	Carriage Bolt, 1/4"-20 x 3/4", Grade 2
	G10227	-	Lock Washer, 1/4"
	G10103	-	Hex Nut, 1/4"-20
12.	GD1116	-	Hanger
13.	GA2075	-	Diffuser, 14" Band
14.	G10306	-	Carriage Bolt, 3/8"-16 x 2"
	G10229	-	Lock Washer, 3/8"
	G10101	-	Hex Nut, 3/8"-16
15.	GD1118	-	Clamp
16.	G10315	1	Carriage Bolt, 1/2"-13 x 2 1/2" (Replaces Existing 1/2" x 2 1/4" Hardware)
17.	GA6741	1	Bracket (Straight Drop In-Furrow)
18.	G1K385	-	Bander Shield Kit W/Hardware And Instruction
	G10003	1	Hex Head Cap Screw, 3/8"-16 x 1 1/2"
	GD14659	1	Special Washer, 3/8", Hardened

# SPRING TOOTH INCORPORATOR

RUA055(RU95)

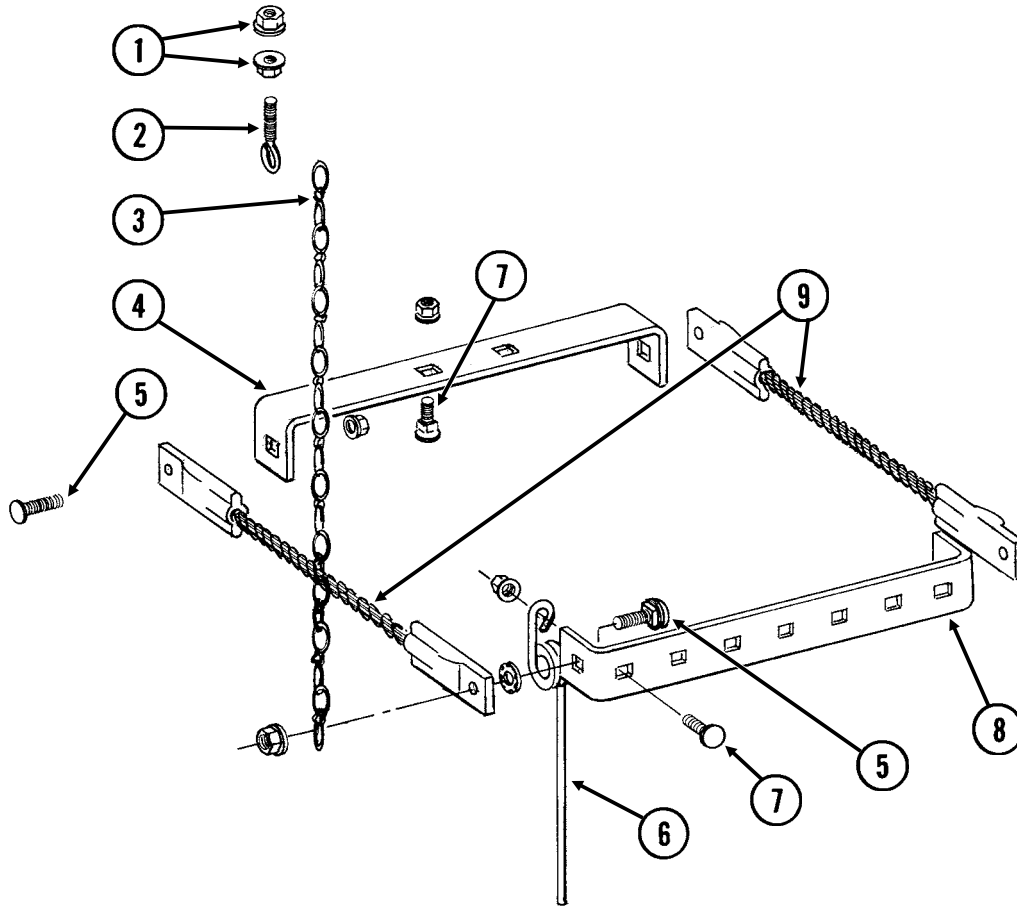

ITEM	PART NO.	QTY. (Per Row)	DESCRIPTION
1.	G10621	4	Serrated Flange Nut, 1/4"-20
2.	GD2460	2	Eyebolt, 1/4"-20
3.	G3305-01	4	Twin Loop Chain, 9 Links
4.	GD1143	1	Front Bracket
5.	G10305	4	Carriage Bolt, 3/8"-16 x 1"
	G10529	4	External Tooth Lock Washer, 3/8"
	G10622	4	Serrated Flange Nut, 3/8"-16
6.	GD1145	7	Spring Tooth
7.	G10308	9	Carriage Bolt, 3/8"-16 x 3/4"
	G10622	9	Serrated Flange Nut, 3/8"-16
8.	GD1144	1	Rear Bracket
9.	GA2094	2	Cable Assembly



# ROW UNIT MOUNTED NO TILL COULTER

(D14398/RU102c/RU152)

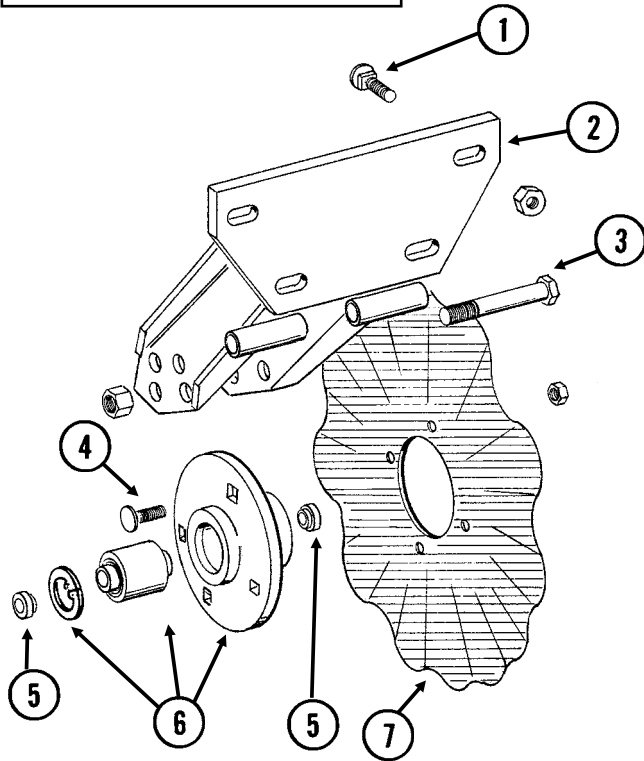
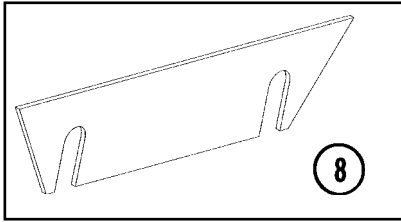

**STYLE A**

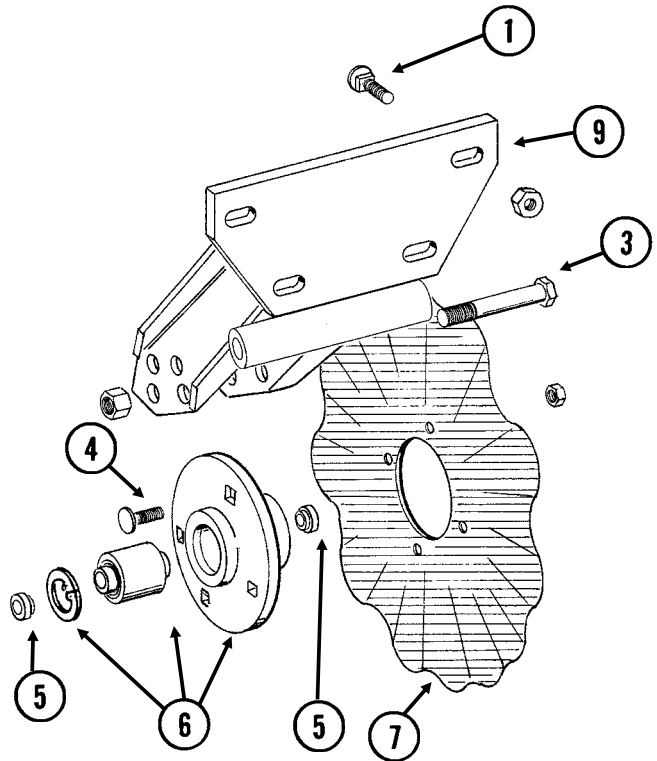

**STYLE B**

ITEM	PART NO.	QTY.	DESCRIPTION
		(Per Row)	
1.	G10574	4	Carriage Bolt, 1/2"-13 x 1 1/4"
	G10111	4	Lock Nut, 1/2"-13
2.	GA5625	1	Arm
3.	G10036	1	Hex Head Cap Screw, 5/8"-11 x 4"
	G10107	1	Lock Nut, 5/8"-11
4.	G10574	4	Carriage Bolt, 1/2"-13 x 1 1/4"
	G10111	4	Lock Nut, 1/2"-13
5.	GD11677	2	Adapter
6.	GA8641	1	Hub W/Bearing And Retaining Ring
	GA8603	-	Bearing, Double Row
	GD11652	-	Retaining Ring, 2 7/16"
7.	GD7803	-	Disc Blade, Fluted, 1", 8 Flutes (Shown)
	GD7804	-	Disc Blade, Bubbled, 1"
	GD9254	-	Disc Blade, Fluted, 3/4", 13 Flutes
8.	GD14398	-	Spacer
9.	GA11520	1	Arm (Style B)

# ROW UNIT MOUNTED BED LEVELER

RUA059/RUA060(RU99/RU100)

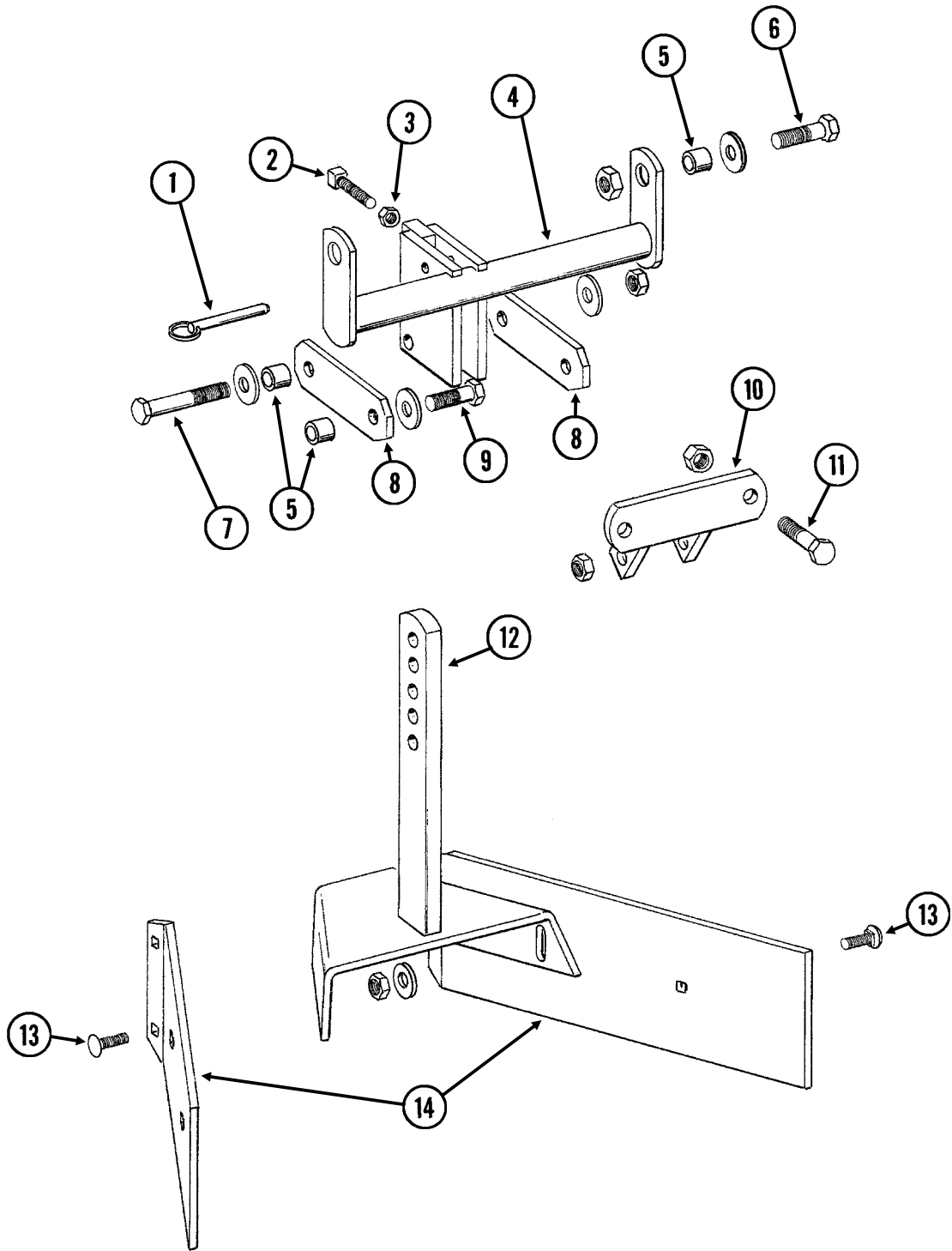

# ROW UNIT MOUNTED BED LEVELER

---

ITEM	PART NO.	QTY. (Per Row)	DESCRIPTION
1.	G10536	1	Detent Pin, 1/2" x 2 1/2" Grip
2.	G10597	1	Square Head Set Screw, 5/8"-11 x 2 1/4"
3.	G10503	1	Hex Jam Nut, 5/8"-11, Grade 2
4.	GA5719	1	Mounting Bracket
5.	GD7889	6	Bushing, 1" O.D. x 9/16" I.D. x 7/16" Long
6.	G10039	2	Hex Head Cap Screw, 1/2"-13 x 1 3/4"
	GD14674	2	Special Washer, 1/2", Hardened
	G10111	2	Lock Nut, 1/2"-13
7.	G10585	1	Hex Head Cap Screw, 1/2"-13 x 3 1/4"
	G10216	2	Washer, 1/2" USS
	G10111	1	Lock Nut, 1/2"-13
8.	GD7890	2	Link
9.	G10017	2	Hex Head Cap Screw, 1/2"-13 x 1 1/2"
	G10216	2	Washer, 1/2" USS
	G10111	2	Lock Nut, 1/2"-13
10.	GA5715	1	Anchor
11.	G10017	2	Hex Head Cap Screw, 1/2"-13 x 1 1/2"
	G10111	2	Lock Nut, 1/2"-13
12.	GA5892	1	Leveler
13.	G10303	6	Carriage Bolt, 5/16"-18 x 1"
	G10219	4	Washer, 5/16" USS
	G10109	6	Lock Nut, 5/16"-18, Grade 8
14.	GD8266	2	Blade

# ROW UNIT MOUNTED DISC FURROWER

RUA059/RUA058(RU99/RU98g)

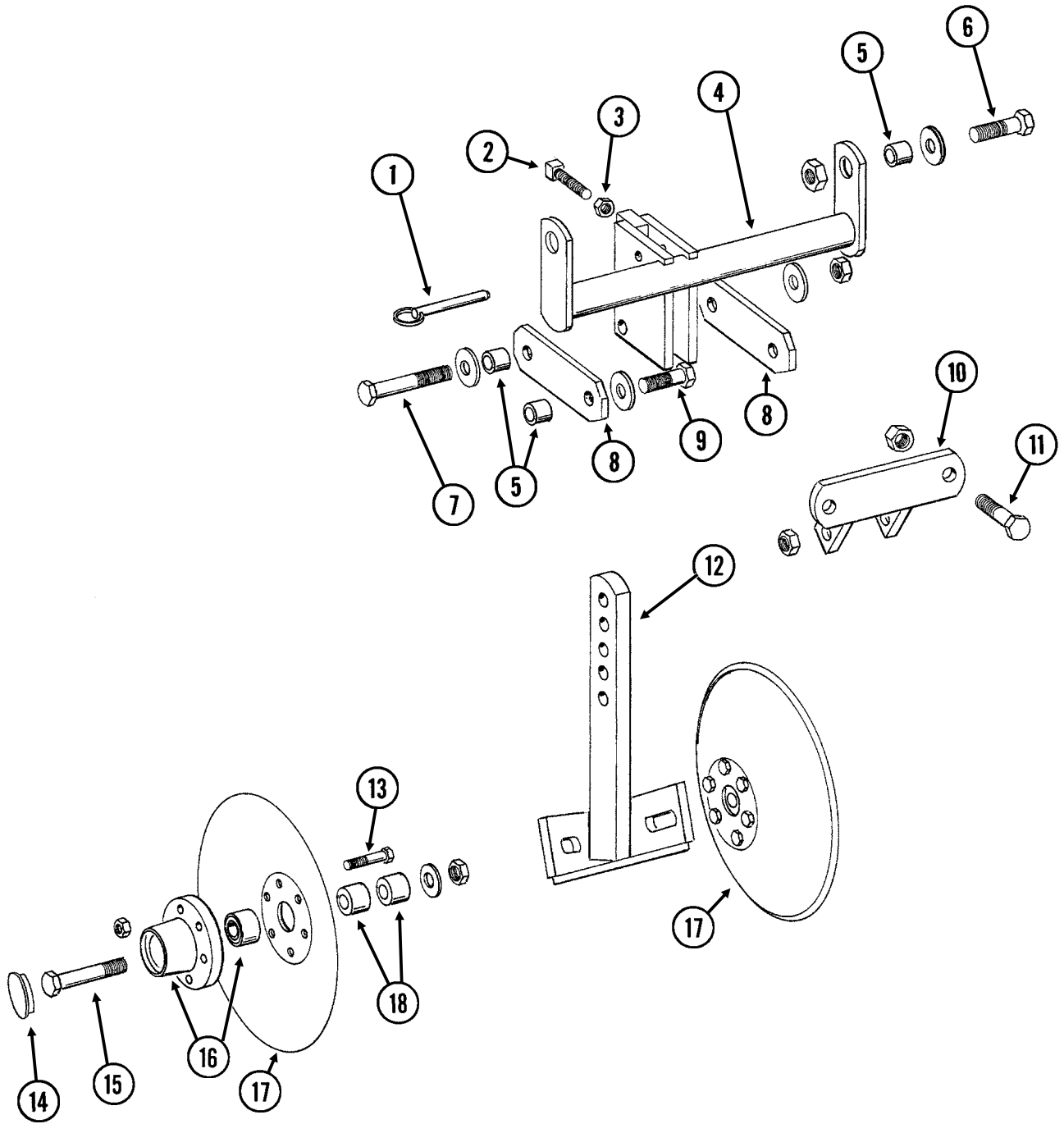

# ROW UNIT MOUNTED DISC FURROWER

---

ITEM	PART NO.	QTY. (Per Row)	DESCRIPTION
1.	G10536	1	Detent Pin, 1/2" x 2 1/2" Grip
2.	G10597	1	Square Head Set Screw, 5/8"-11 x 2 1/4"
3.	G10503	1	Hex Jam Nut, 5/8"-11, Grade 2
4.	GA5719	1	Mounting Bracket
5.	GD7889	6	Bushing, 1" O.D. x 9/16" I.D. x 7/16" Long
6.	G10039	2	Hex Head Cap Screw, 1/2"-13 x 1 3/4"
	GD14674	2	Special Washer, 1/2", Hardened
	G10111	2	Lock Nut, 1/2"-13
7.	G10585	1	Hex Head Cap Screw, 1/2"-13 x 3 1/4"
	G10216	2	Washer, 1/2" USS
	G10111	1	Lock Nut, 1/2"-13
8.	GD7890	2	Link
9.	G10017	2	Hex Head Cap Screw, 1/2"-13 x 1 1/2"
	G10216	2	Washer, 1/2" USS
	G10111	2	Lock Nut, 1/2"-13
10.	GA5715	1	Anchor
11.	G10017	2	Hex Head Cap Screw, 1/2"-13 x 1 1/2"
	G10111	2	Lock Nut, 1/2"-13
12.	GA5718	1	Support Arm
13.	G10572	6	Truss Head Slotted Machine Screw, 5/16"-18 x 7/8"
	G10106	6	Hex Nut, 5/16"-18
14.	GD1132	2	Dust Cap
15.	G10318	2	Hex Head Cap Screw, 5/8"-11 x 4 1/2"
	GD7805	2	Special Washer, 5/8", Hardened
	G10107	2	Lock Nut, 5/8"-11
16.	GA5654	2	Hub W/Bearings
	GA2014	-	Bearing
17.	GD7823	-	Disc Blade, Solid, 12" (Shown)
	GD8307	-	Disc Blade, Notched, 12"
18.	GD7817-01	2	Spacer, 1 1/16" I.D. x 3/4" Long
	GD7817-04	2	Spacer, 1 1/16" I.D. x 1/2" Long

# ROW UNIT MOUNTED RESIDUE WHEEL

(RU103dd/RU103d)

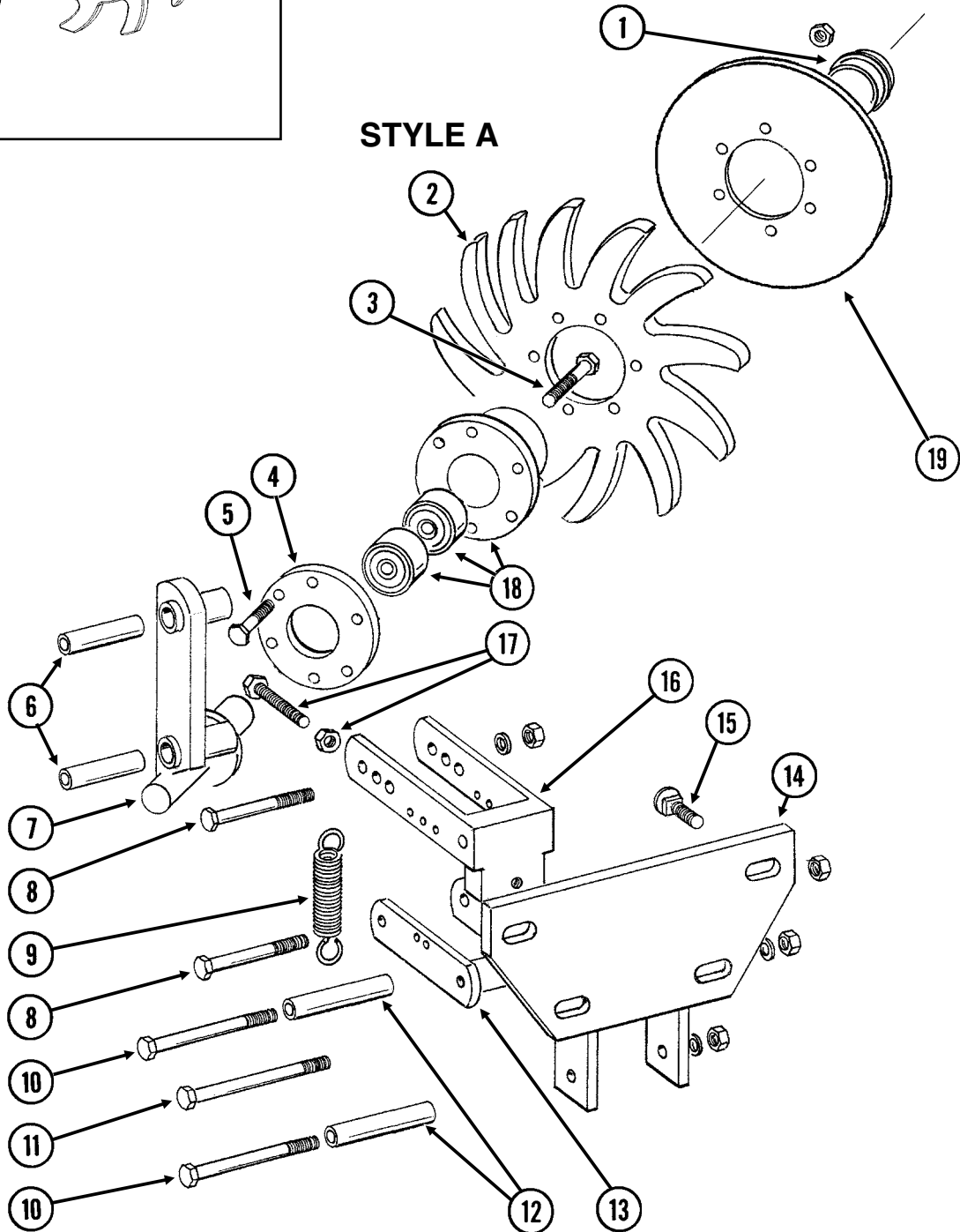
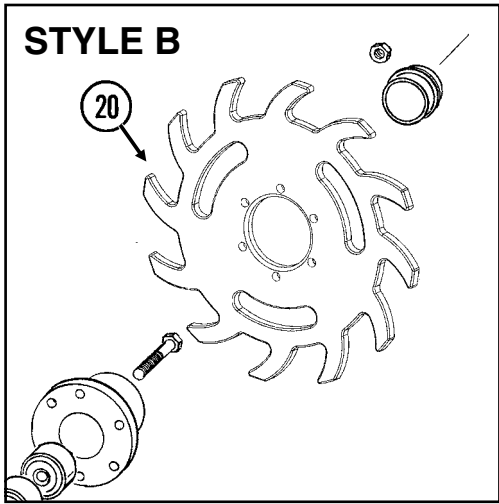

# ROW UNIT MOUNTED RESIDUE WHEEL

ITEM	PART NO.	QTY. (Per Row)	DESCRIPTION
1.	GD1132	1	Dust Cap
2.	GD10552	1	Wheel, 12 Tine, 3/8" x 12"
3.	G10006	1	Hex Head Cap Screw, 5/8"-11 x 2 1/4"
4.	GD9724	1	Backing Plate
5.	G10133	6	Hex Head Cap Screw, 5/16"-18 x 1 1/2"
	G10109	6	Lock Nut, 5/16"-18, Grade 8
6.	GD9720	2	Spacer, 1/2" x 2 3/16" Long
7.	GA6838	1	Wheel Mount
8.	G10033	2	Hex Head Cap Screw, 1/2"-13 x 3 1/2"
	G10228	2	Lock Washer, 1/2"
	G10102	2	Hex Nut, 1/2"-13
9.	GD5857	2	Spring
10.	G10045	2	Hex Head Cap Screw, 1/2"-13 x 4 1/2"
	G10228	2	Lock Washer, 1/2"
	G10102	2	Hex Nut, 1/2"-13
11.	G10348	1	Hex Head Cap Screw, 1/2"-13 x 5" (Lockup Bolt)
	G10111	1	Lock Nut, 1/2"-13
12.	GD9715	2	Spacer, 1/2" x 3" Long
13.	GA6834	1	Lower Link
14.	GA6832	1	Mount
15.	G10574	4	Carriage Bolt, 1/2"-13 x 1 1/4"
	G10111	4	Lock Nut, 1/2"-13
16.	GA6833	1	Upper Link
17.	G10371	1	Hex Head Cap Screw, 1/2"-13 x 3", Full Thread
	G10501	1	Hex Jam Nut, 1/2"-13, Grade 2
18.	GA5654	1	Hub W/Bearings
	GA2014	-	Bearing
19.	GD12534	-	Cover
20.	GB0387	1	Wheel, 12 Tine, 3/8" x 12"
A.	GA7446	-	Wheel Assembly, 12 Tine, R.H. (Items 2, 4, 5 And 18)
B.	GA12236	-	Wheel Assembly, 12 Tine, R.H. (Items 4, 5, 18 And 20)

# COULTER MOUNTED RESIDUE WHEELS

(RU104uuu/RU153)

## STYLE A - Used With Style A Row Unit Mounted No Till Coulter

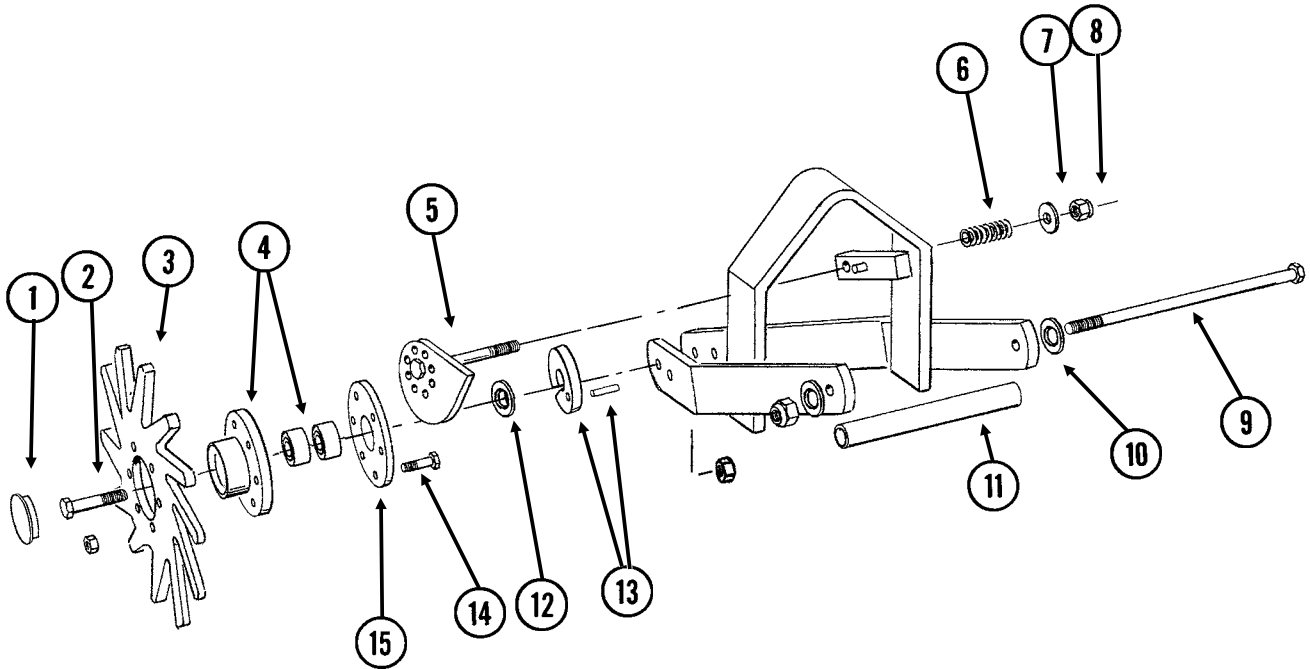

## STYLE B - Used With Style B Row Unit Mounted No Till Coulter

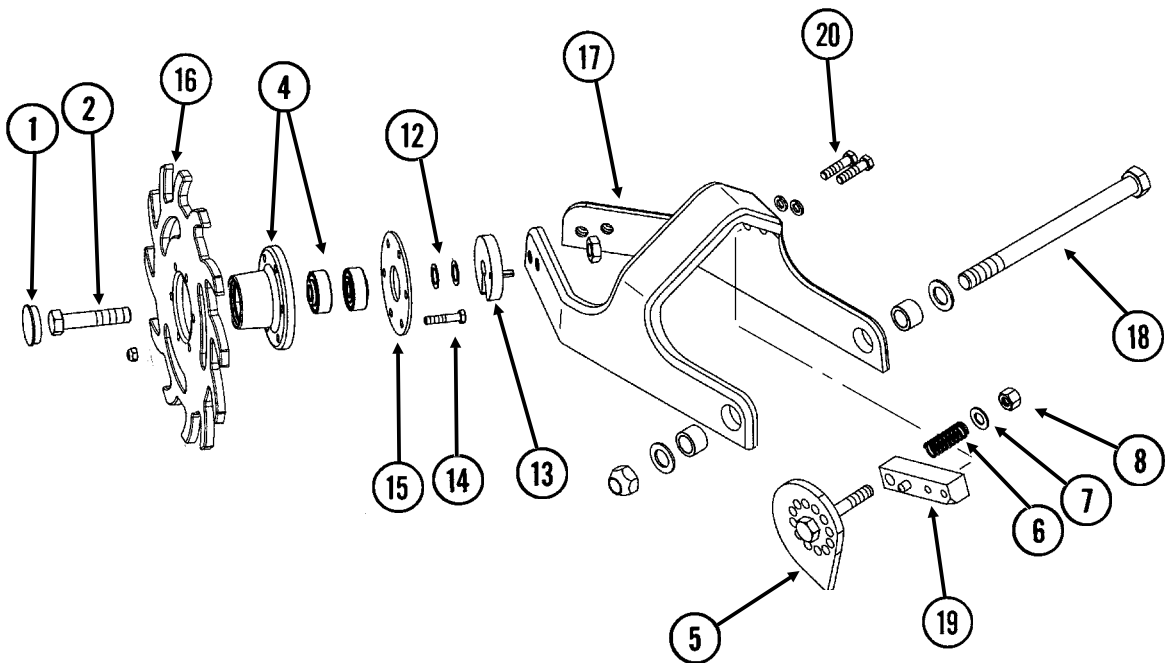



# COULTER MOUNTED RESIDUE WHEELS

ITEM	PART NO.	QTY. (Per Row)	DESCRIPTION
1.	GD1132	2	Dust Cap
2.	G10010	2	Hex Head Cap Screw, 5/8"-11 x 3"
	G10503	2	Hex Jam Nut, 5/8"-11, Grade 2
3.	GD10552	2	Wheel, 12 Tine, 3/8" x 12"
4.	GA5654	2	Hub W/Bearings
	GA2014	-	Bearing
5.	GA7412	1	Cam
6.	GD10519	1	Spring
7.	G10206	1	Washer, 1/2" SAE
8.	G10974	1	Lock Nut W/Nylon Insert, 1/2"-13
9.	G11098	1	Hex Head Cap Screw, 1/2"-13 x 9 1/2", Grade 8
	GD14674	2	Special Washer, 1/2", Hardened
	G10974	1	Lock Nut W/Nylon Insert, 1/2"-13
10.	GA7271	1	Mount
11.	GD10526	1	Sleeve, 7 1/2"
12.	G10213	2	Machine Bushing, 5/8" (.030" Thick)
13.	GA8760	2	Weed Guard W/Spring Pin
	G10765	-	Spring Pin, 1/4" x 1"
14.	G10133	12	Hex Head Cap Screw, 5/16"-18 x 1 1/2"
	G10109	12	Lock Nut, 5/16"-18, Grade 8
15.	GD9724	2	Backing Plate
16.	GB0387	2	Wheel, 12 Tine, 3/8" x 12"
17.	GB0401	1	Mount
18.	G11236	1	Hex Head Cap Screw, 3/4"-10 x 10 1/2"
	GB0383	2	Bushing, 1 1/8" O.D. x 25/32" I.D. x 3/4" Long
	G10194	2	Washer, 3/4" SAE
	G11228	1	Lock Nut, 3/4"-10
19.	GA12256	1	Locking Pin
20.	G10003	2	Hex Head Cap Screw, 3/8"-16 x 1 1/2"
	G10229	2	Lock Washer, 3/8"
A.	GA7446	-	Wheel Assembly, 12 Tine, R.H. (Items 3, 4, 14 And 15) (Shown)
	GA7445	-	Wheel Assembly, 12 Tine, L.H. (Items 3, 4, 14 And 15)
B.	GA12236	-	Wheel Assembly, 12 Tine, R.H. (Items 4, 14, 15 And 16) (Shown)
	GA12235	-	Wheel Assembly, 12 Tine, L.H. (Items 4, 14, 15 And 16)
C.	G1K467	-	Residue Wheel Mount Kit (Items 17-20)

# FRAME MOUNTED COULTER W/RESIDUE WHEELS

(RU135c/RU135g/RU135hh)

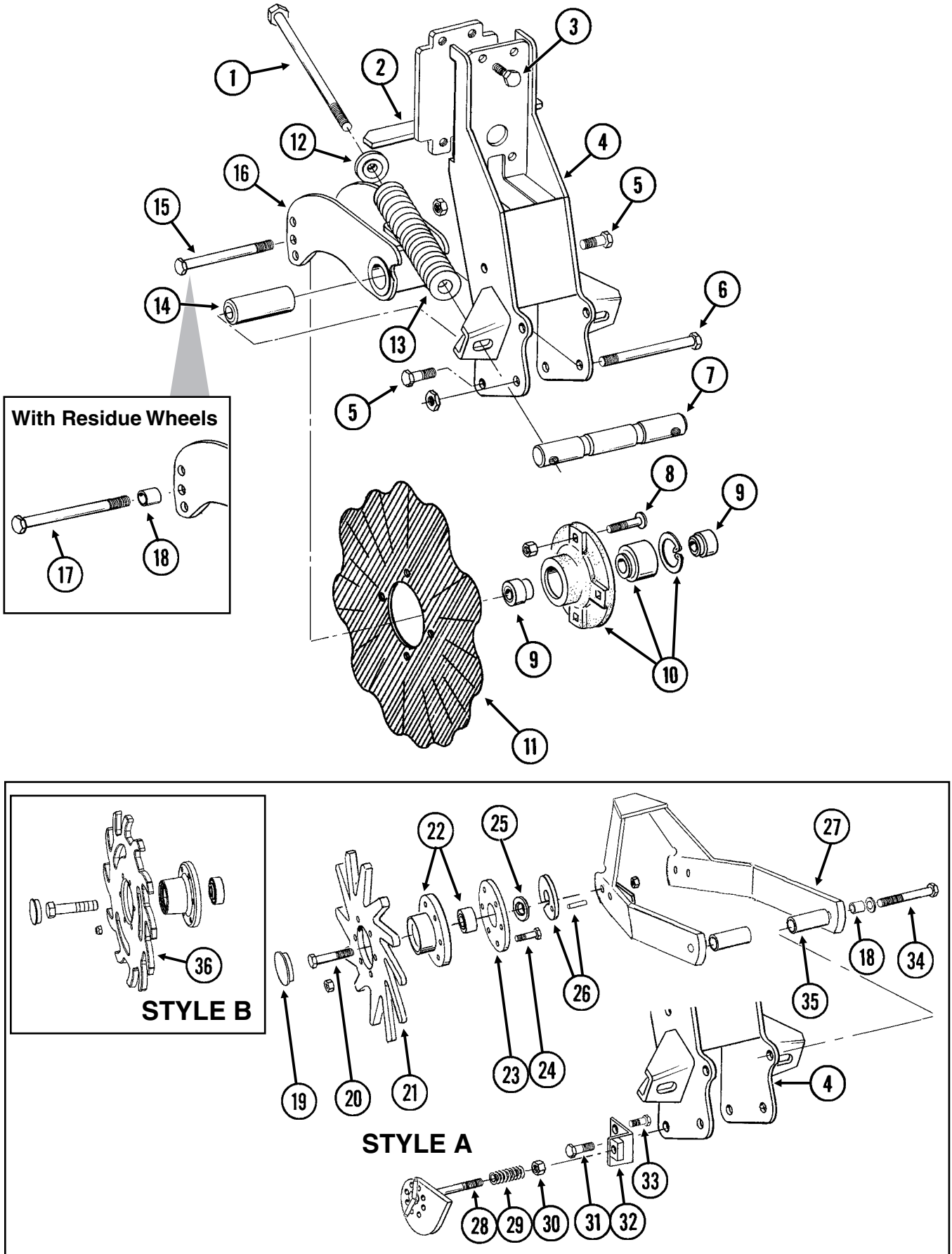

# FRAME MOUNTED COULTER W/RESIDUE WHEELS

ITEM	PART NO.	QTY. (Per Row)	DESCRIPTION
1.	G11010	2	Hex Head Cap Screw, 3/4"-10 x 12"
2.	GA9844	1	Plate W/Angle
3.	G10039	4	Hex Head Cap Screw, 1/2"-13 x 1 3/4"
4.	GA9131	1	Coulter Frame
5.	G10007	4	Hex Head Cap Screw, 5/8"-11 x 1 1/2"
	G10107	4	Lock Nut, 5/8"-11
6.	G10400	1	Hex Head Cap Screw, 3/4"-10 x 6 1/2"
	G10112	1	Lock Nut, 3/4"-10
7.	GD12826	1	Spring Anchor Bar
8.	G10574	4	Carriage Bolt, 1/2"-13 x 1 1/4"
	G10111	4	Lock Nut, 1/2"-13
9.	GD12827	2	Adapter
10.	GA8641	1	Hub W/Bearing And Retaining Ring
	GA8603	1	Bearing, Double Row
	GD11652	1	Retaining Ring, 2 7/16"
11.	GD7803	1	Disc Blade, Fluted, 1", 8 Flutes (Shown)
	GD7804	-	Disc Blade, Bubbled, 1"
	GD9254	-	Disc Blade, Fluted, 3/4", 13 Flutes
12.	GB0213	2	Spring Seat
13.	GD12817	2	Compression Spring
14.	GD12829	1	Sleeve
15.	G10046	1	Hex Head Cap Screw, 5/8"-11 x 5"
	G10107	1	Lock Nut, 5/8"-11
16.	GA9845	1	Coulter Arm W/Grease Fitting
	G10643	-	Grease Fitting, 45°, 1/4"-28
17.	G10011	1	Hex Head Cap Screw, 5/8"-11 x 5 1/2"
	G10107	1	Lock Nut, 5/8"-11
18.	GB0218	3	Bushing, 2 1/32" I.D. x 7/8" O.D. x 1 9/32" Long
19.	GD1132	2	Dust Cap
20.	G10010	2	Hex Head Cap Screw, 5/8"-11 x 3"
	G10503	2	Hex Jam Nut, 5/8"-11, Grade 2
21.	GD10552	2	Wheel, 12 Tine, 3/8" x 12"
22.	GA5654	2	Hub W/Bearings
	GA2014	-	Bearing
23.	GD9724	2	Backing Plate
24.	G10133	12	Hex Head Cap Screw, 5/16"-18 x 1 1/2"
	G10109	12	Lock Nut, 5/16"-18, Grade 8
25.	G10213	2	Machine Bushing, 5/8" (.030" Thick)
26.	GA9862	2	Weed Guard W/Spring Pin
	G10765	-	Spring Pin, 1/4" x 1"
27.	GA9865	1	Mount
28.	GA9861	1	Cam
29.	GD10519	1	Spring
30.	G10974	1	Lock Nut W/Nylon Insert, 1/2"-13
31.	G10005	1	Hex Head Cap Screw, 5/8"-11 x 1 3/4"
	G10107	4	Lock Nut, 5/8"-11
32.	GA9864	1	Support
33.	G10014	1	Hex Head Cap Screw, 1/2"-13 x 1"
	G10102	1	Hex Nut, 1/2"-13
34.	G10011	2	Hex Head Cap Screw, 5/8"-11 x 5 1/2"
	G10205	2	Washer, 5/8" SAE
	G10730	2	Lock Nut W/Nylon Insert, 5/8"-11
35.	GD14170	2	Sleeve, 3"
A.	GA7446	-	Wheel Assembly, 12 Tine, R.H. (Items 21-24) (Shown)
	GA7445	-	Wheel Assembly, 12 Tine, L.H. (Items 21-24)
B.	GA12236	-	Wheel Assembly, 12 Tine, R.H. (Items 22, 23, 24 And 36) (Shown)
	GA12235	-	Wheel Assembly, 12 Tine, L.H. (Items 22, 23, 24 And 36)

# DIGITAL VACUUM GAUGE, ANALOG VACUUM GAUGE AND VACUUM FAN ASSEMBLY

(A11154/A11156/GR1736/A10765/A11158/A11699/A7856/A11155/A8329/METR23bb)

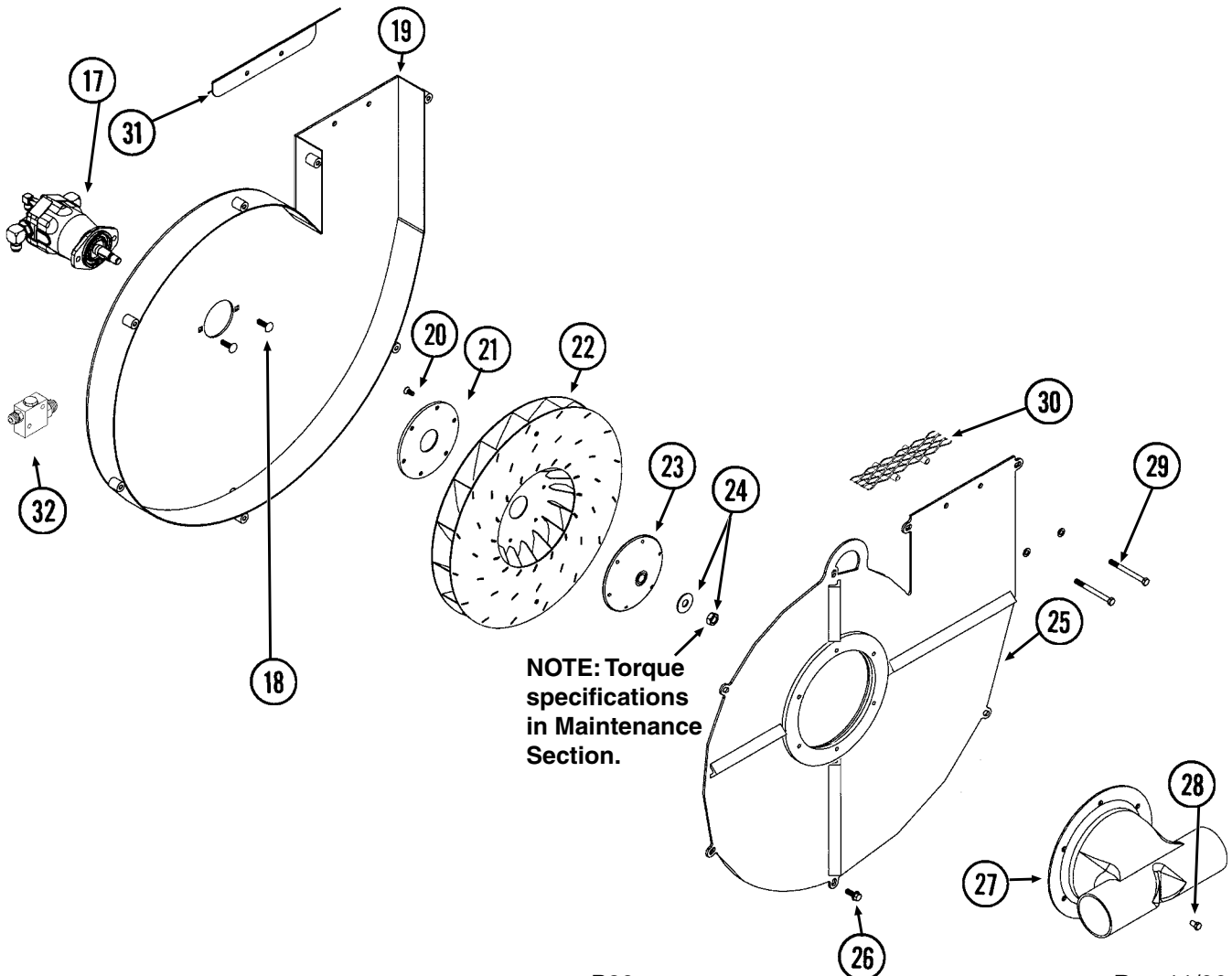
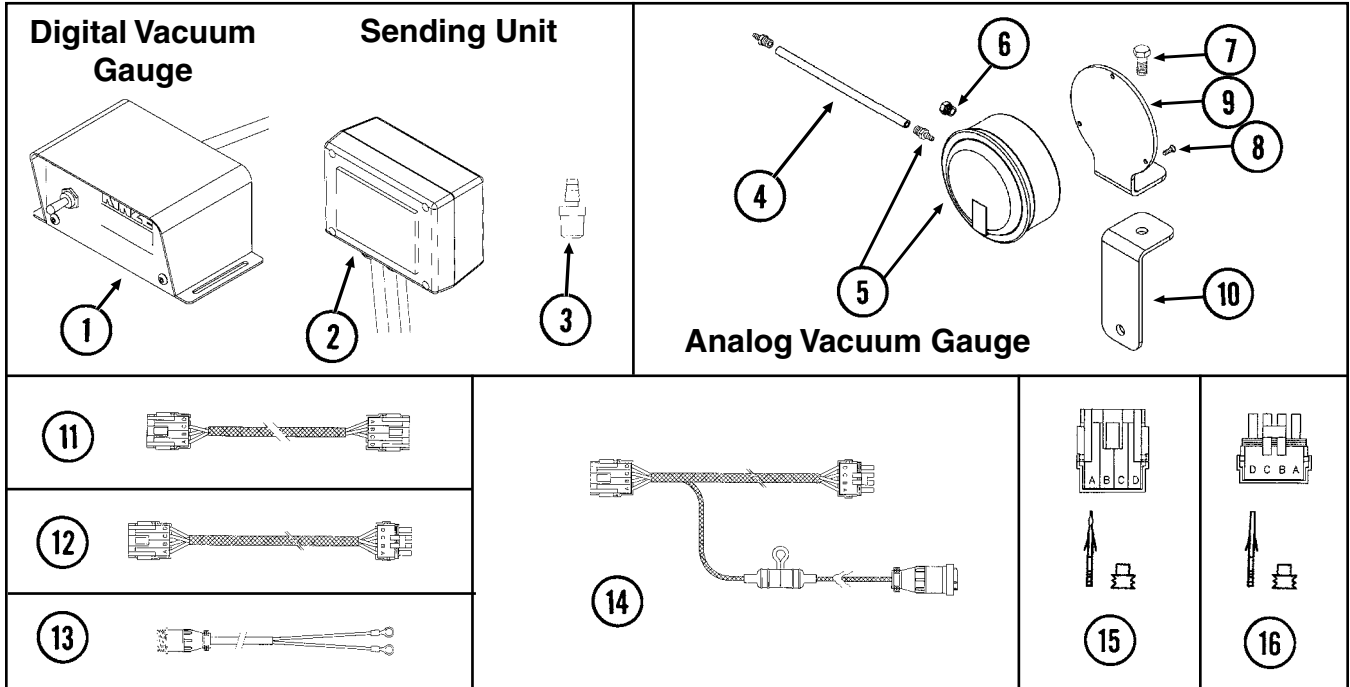

# DIGITAL VACUUM GAUGE, ANALOG VACUUM GAUGE AND VACUUM FAN ASSEMBLY

ITEM	PART NO.	QTY. (Per Assy.)	DESCRIPTION
1.	GA11154	1	Digital Vacuum Gauge W/4-Pin Connector
2.	GA11156	1	Sending Unit W/ 1/4" Tubing And Harness W/4-Pin Male Connector
	GD16224-01	-	Tubing, 1/4" x 45"
	GA11175	-	Strain Relief
3.	GR1736	1	Hose Barb, 3/16" To 1/8" NPT
4.	GD15849-02	1	Clear Plastic Tubing, 5/16" O.D. x 120"
5.	GA10765	1	Analog Vacuum Gauge W/Hose Barb
	GR1777	-	Hose Barb, 1/8" NPT To 3/16" Barb
6.	GA10799	1	Breather, 1/8" Male NPT
7.	G10001	1	Hex Head Cap Screw, 3/8"-16 x 1"
	G10108	1	Lock Nut, 3/8"-16
8.	G11215	3	Hex Socket Head Cap Screw, No. 6-32 x 3/8", Grade 8
9.	GD15804	1	Mount
10.	GD15803	1	Support
11.	GA11157	1	Harness, 120"
12.	GA11699	-	Extension Harness, 180"
13.	GA7856	-	Power Lead Adapter
14.	GA11155	1	Harness W/Fuse Holder And Fuse, 132"
	GD14258	-	Fuse Holder
	GD14660	-	Fuse, 2 Amp Delay Action
	G1K268	-	Console Cable Connector Kit, Includes: (1) 3-Pin Connector, (1) Cable Clamp, (1) Lock Ring, (3) Female Terminal Pins
15.	GA8328	-	4-Pin Connector W/Female Housing, 4 Seals And 4 Pin Contacts
16.	GA8329	-	4-Pin Connector W/Male Housing, 4 Seals And 4 Sockets
17.		-	See "Vacuum Fan Hydraulic Motor Assembly", Page P36
18.	G10599	2	Carriage Bolt, 3/8"-16 x 1 1/4"
	G10229	2	Lock Washer, 3/8"
	G10101	2	Hex Nut, 3/8"-16
19.	GA10148	1	Shroud
20.	G11133	6	Hex Socket Head Cap Screw, 5/16"-18 x 3/4", Grade 8
21.	GD15789	1	Backing Plate
22.	GA10635	1	Impeller
23.	GD15790	1	Hub
24.	G10205	1	Washer, 5/8" SAE
	G10499	1	Hex Jam Nut, 5/8"-18, Grade 2
25.	GA10752	1	Cover
26.	G11124	7	Whiz Lock Bolt, 3/8"-18 x 1"
27.	GD14536	1	Manifold
28.	G11123	6	Whiz Lock Bolt, 3/8"-16 x 3/4"
29.	G10063	2	Hex Head Cap Screw, 3/8"-16 x 4"
	G10753	2	Hex Head Cap Screw, 3/8"-16 x 4 1/2"
	G10203	2	Washer, 3/8" SAE
	G10108	2	Lock Nut, 3/8"-16
30.	GA11987	1	Screen
31.	GD15863	1	Discharge Deflector
32.		-	See "Vacuum Fan Motor Valve Block (Located Below Vacuum Fan Assembly)", Page P37
A.	GA10143	-	Vacuum Fan Assembly (Items 17-26 And 29-31)

# VACUUM FAN HYDRAULIC COMPONENTS

(A11154/A11156/GR1736/A10765/A11158/A11699/A7856/A11155/A8329/METR23bb)

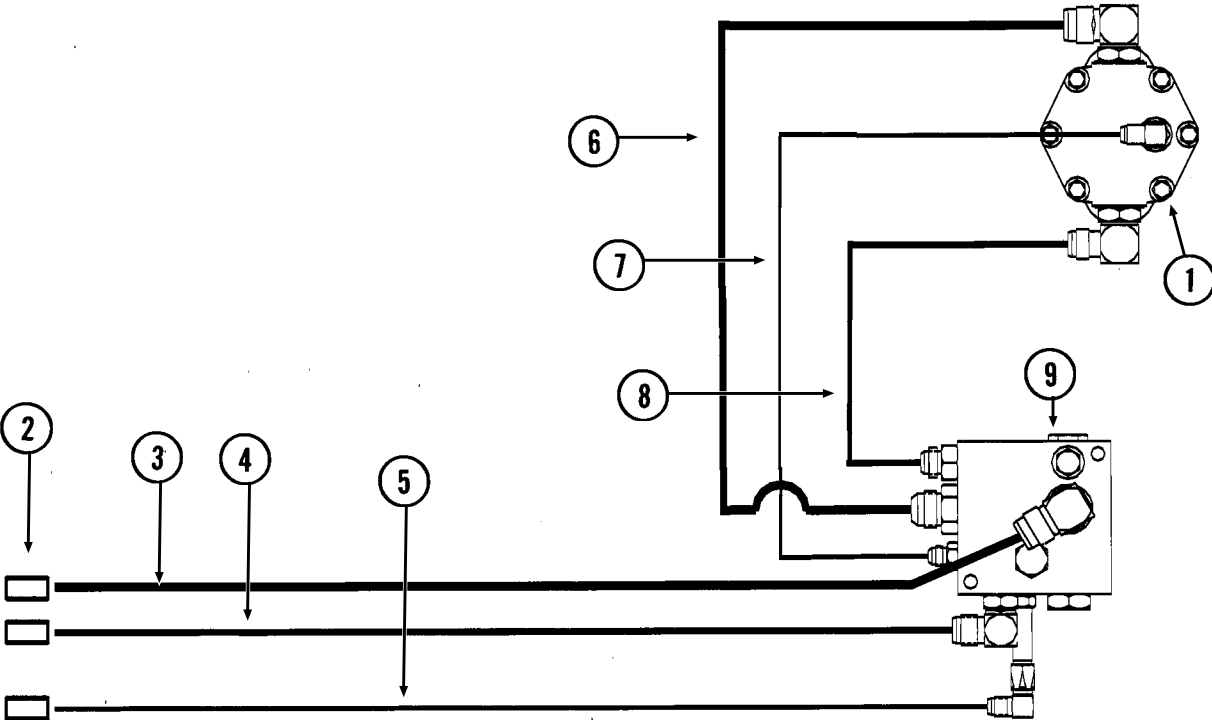

# VACUUM FAN HYDRAULIC COMPONENTS

---

ITEM	PART NO.	QTY. (Per Assy.)	DESCRIPTION
1.		-	See "Vacuum Fan Hydraulic Motor Assembly", Page P36
2.	GD4086	3	ISO Coupler
3.	*A3337	1	Hose Assembly, 3/4" x 60"
4.	*A8247	1	Hose Assembly, 1/2" x 60"
5.	*A3266	1	Hose Assembly, 3/8" x 60"
6.	*A3367	1	Hose Assembly, 3/4" x 21"
7.	*A3292	1	Hose Assembly, 3/8" x 23"
8.	*A8273	1	Hose Assembly, 1/2" x 21"
9.		-	See "Vacuum Fan Motor Valve Block Assembly (Located Below Vacuum Fan Assembly)", Page P37

\* Hydraulic hose is not stocked by KINZE® Repair Parts, but can be made available on a special order basis. Call for quote.

# VACUUM FAN HYDRAULIC MOTOR ASSEMBLY

(METR21a)

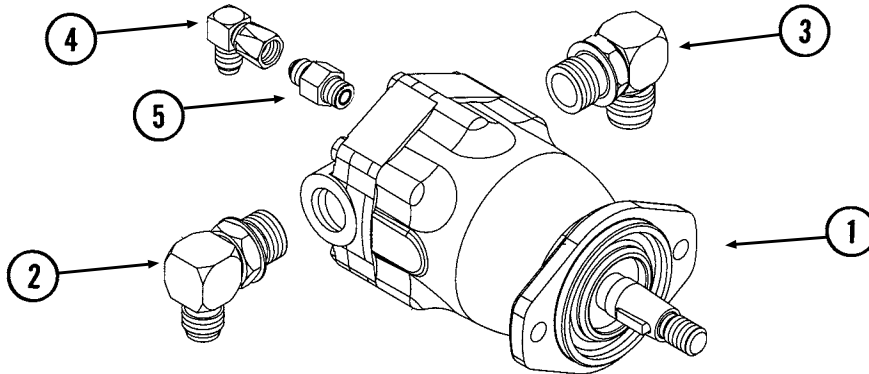

ITEM	PART NO.	QTY.	DESCRIPTION
1.	GA10149 GR1734	1 -	Hydraulic Motor Seal Kit
2.	G6801-10-12 GR1467	1 -	Elbow W/O-Ring, 90°, 7/8"-14 Male JIC To 1 1/16"-12 O-Ring O-Ring
3.	G6801-12 GR1467	1 -	Elbow W/O-Ring, 90°, 1 1/8"-12 Male JIC To O-Ring O-Ring
4.	G6500-06	1	Swivel Elbow, 90°, 9/16"-18 Male JIC To Female
5.	G6400-06 GR1045	1 -	Connector W/O-Ring, 9/16"-18 Male JIC To O-Ring O-Ring

## OPTIONAL FLOW CONTROL NEEDLE VALVE KIT

(A11650)

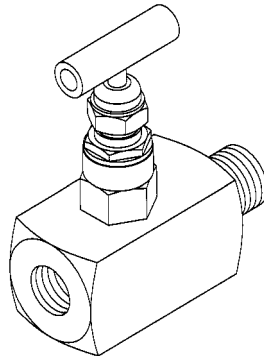

ITEM	PART NO.	QTY.	DESCRIPTION
1.	G1K426	-	Needle Valve Kit W/Instructions



# VACUUM FAN MOTOR VALVE BLOCK ASSEMBLY (Located Below Vacuum Fan Assembly)

(A11060a)

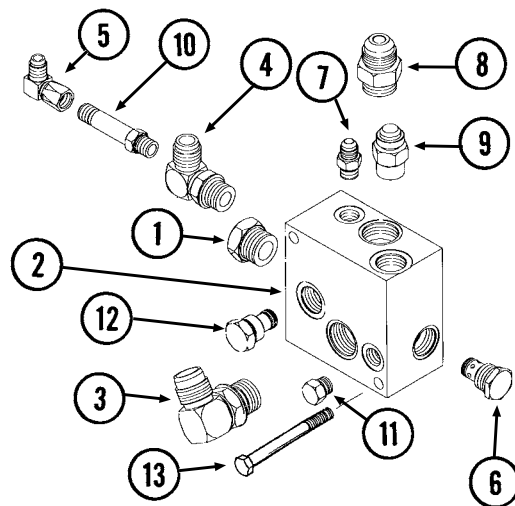

ITEM	PART NO.	QTY.	DESCRIPTION
1.	G6408-12 GR1467	1 -	Plug W/O-Ring, 1 1/16"-12 O-Ring
2.	GD16188	1	Valve Block
3.	G6801-12 GR1467	1 -	Elbow W/O-Ring, 90°, 1 1/16"-12 Male JIC To O-Ring
4.	G6801-10 GR1466	1 -	Elbow W/O-Ring, 90°, 7/8"-14 Male JIC To O-Ring
5.	G6500-06	1	Swivel Elbow, 90°, 9/16"-18 Male JIC To Female
6.	GA4293	1	Check Valve
7.	G6400-06 GR1045	1 -	Connector W/O-Ring, 9/16"-18 Male JIC To O-Ring
8.	G6400-12 GR1467	1 -	Connector W/O-Ring, 1 1/16"-12 Male JIC To O-Ring
9.	G6400-10 GR1466	1 -	Connector W/O-Ring, 7/8"-14 Male JIC To O-Ring
10.	G6400-L-06 GR1045	1 -	Long Connector W/O-Ring, 9/16"-18 Male JIC To O-Ring
11.	G6408-06 GR1045	1 -	Plug W/O-Ring, 9/16"-18 O-Ring
12.	GA11934	1	Relief Valve Cartridge
13.	G10038 G10216 G10228 G10102	2 2 2 2	Hex Head Cap Screw, 1/2"-13 x 3" Washer, 1/2" USS Lock Washer, 1/2" Hex Nut, 1/2"-13

# MANIFOLDS AND DISTRIBUTION HOSES

(MT37a/METR36a)

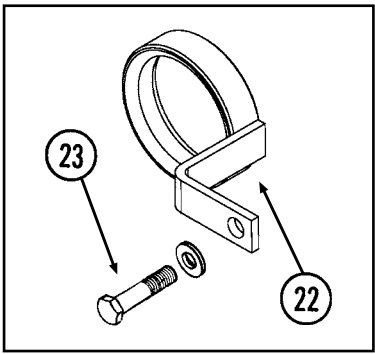
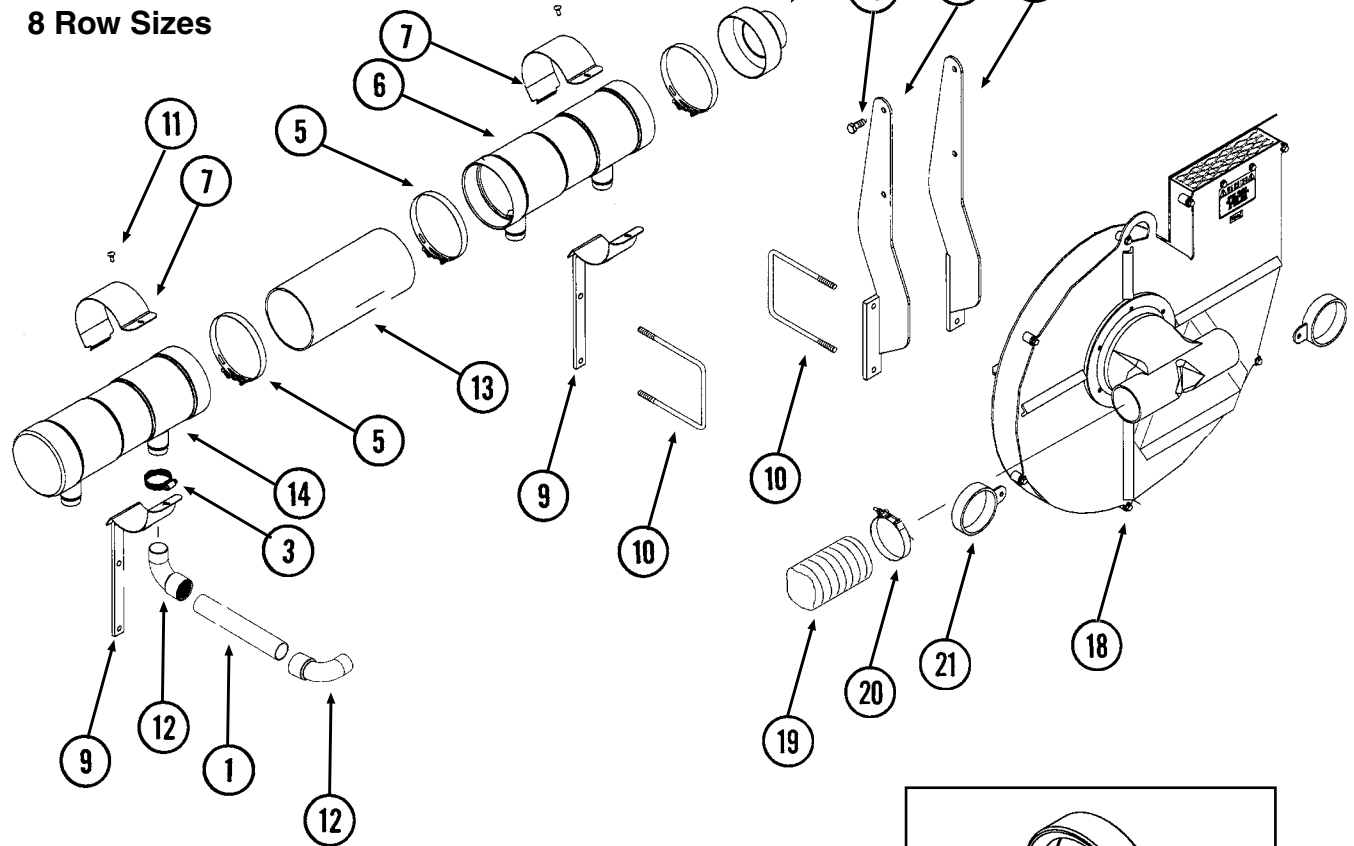
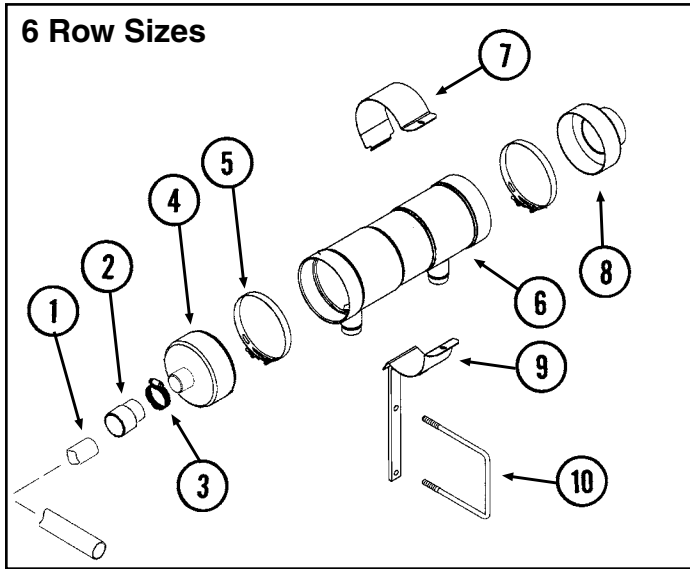

# MANIFOLDS AND DISTRIBUTION HOSES

---

ITEM	PART NO.	QTY.	DESCRIPTION
1.	GD15792-10	-	Hose, 2" x 60"
	GD15792-15	-	Hose, 2" x 120"
2.	GD14627	2	Coupler, 2", 6 Row 36"/38"/40"
3.	G10676	2	Hose Clamp, No. 36
4.	GA11065	2	End Cap, 2"
5.	G11145	4-6	T-Bolt Clamp, 7"
6.	GD15799	2	Manifold, 19 1/2" Long (Open Both Ends)
7.	GD15854	2-4	Clamp
8.	GA11061	1	End, 4"
9.	GA10808	2-4	Mount
10.	GD7145	4-6	U-Bolt, 7" x 7" x 1/2"-13
	G10228	8-12	Lock Washer, 1/2"
	G10102	8-12	Hex Nut, 1/2"-13
11.	G10312	2-4	Carriage Bolt, 5/16"-18 x 3/4"
	G10620	2-4	Serrated Flange Nut, 5/16"-18
12.	GD14626	-	Elbow, 90°, 2"
13.	GD15856-01	2	Pipe, 6" x 14", 8 Row 30"
	GD15856-02	-	Pipe, 6" x 20", 8 Row 36"/38"/40"
14.	GD15850	2	Manifold, 21" (Open One End)
15.	G10037	4	Hex Head Cap Screw, 1/2"-13 x 1 1/4"
	G10228	4	Lock Washer, 1/2"
	G10102	4	Hex Nut, 1/2"-13
16.	GA10767	1	Mount, L.H.
17.	GA10768	1	Mount, R.H.
18.		-	See "Digital Vacuum Gauge, Analog Vacuum Gauge And Vacuum Fan Assembly", Pages P32 And P33 And "Decals, Paint And Miscellaneous", Pages P74-P76
19.	GD15791-03	2	Hose, 4" x 46"
20.	G11137	4	T-Bolt Clamp, 4 1/4"
21.	GA11062	2	Guide, 4"
22.	GA10824	2	Hose Protector
23.	G10038	2	Hex Head Cap Screw, 1/2"-13 x 3" (At Transmission Assembly)
	G10216	2	Washer, 1/2" USS
	G10228	2	Lock Washer, 1/2"
	G10102	2	Hex Nut, 1/2"-13
	G10104	2	Hex Nut, 5/8"-11 (At U-Bolt On Row Unit)

# TOOLBAR ASSEMBLY

(MT40)

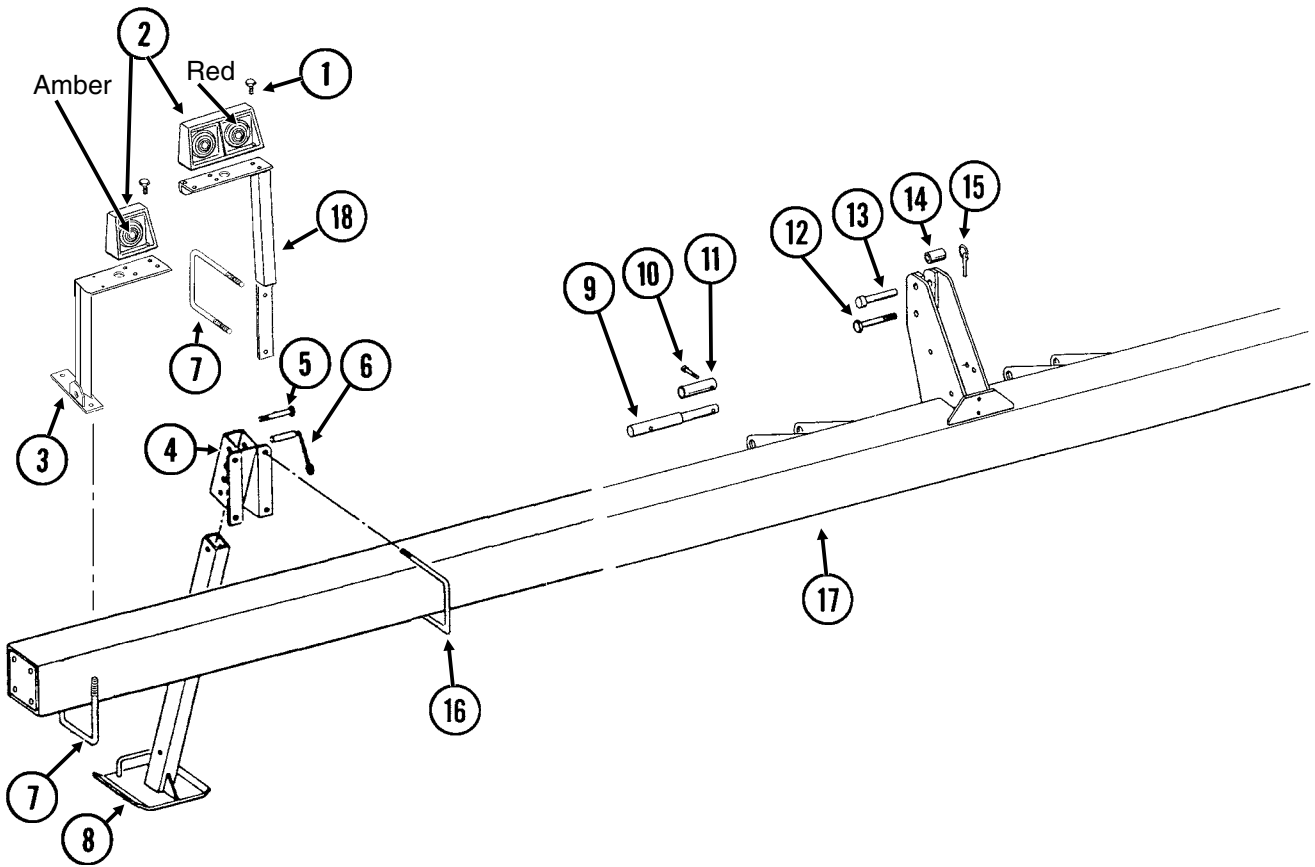

# TOOLBAR ASSEMBLY

---

ITEM	PART NO.	QTY.	DESCRIPTION
1.	G10064	16	Hex Head Cap Screw, 1/4"-20 x 1"
	G10209	16	Washer, 1/4" USS
	G10110	16	Lock Nut, 1/4"-20, Grade B
2.			See "Electrical Components", Pages P68 And P69
3.	GA6824	1	Bracket, R.H. (Shown)
	GA6823	1	Bracket, L.H.
4.	GA4707	2	Mount
5.	G10016	2	Hex Head Cap Screw, 1/2"-13 x 2"
	G10111	2	Lock Nut, 1/2"-13
6.	GA4733	2	Detent Pin W/Chain
7.	GD7145	4	U-Bolt, 7" x 7" x 1/2"-13
	G10228	8	Lock Washer, 1/2"
	G10102	8	Hex Nut, 1/2"-13
8.	GA4732	2	Parking Stand
9.	GD9750	2	Pin, 11 3/4" Long
10.	G10048	4	Hex Head Cap Screw, 3/8"-16 x 2"
	G10108	4	Lock Nut, 3/8"-16
11.	GD9749	2	Bushing, 3 3/4"
12.	G10678	1	Hex Head Cap Screw, 1"-8 x 5 1/2" (Category 2)
	G10396	1	Lock Nut, 1"-8
13.	GA6078	1	Pin, 1" x 4 1/2" (Category 3N And 3)
14.	GD8701	1	Bushing, 2"
15.	GD2557	3	Lynch Pin, 7/16"
16.	GD1114	4	U-Bolt, 7" x 7" x 5/8"-11
	G10230	8	Lock Washer, 5/8"
	G10104	8	Hex Nut, 5/8"-11
17.	A6911	-	Toolbar, 7" x 7" x 180", 6 Row 30" <b>(Non-Stock Item)</b>
	A6912	-	Toolbar, 7" x 7" x 230", 6 Row 36"/38"/40" <b>(Non-Stock Item)</b>
	A6913	-	Toolbar, 7" x 7" x 240", 8 Row 30" <b>(Non-Stock Item)</b>
	A6914	-	Toolbar, 7" x 7" x 310", 8 Row 36"/38"/40" <b>(Non-Stock Item)</b>
18.	GA10781	1	Bracket, L.H. (Shown)
	GA10782	1	Bracket, R.H.

# GROUND DRIVE WHEEL ASSEMBLY

PLA029/PLA028/PTD085/HTA014/PLA05(SFP10c/SFP14b)

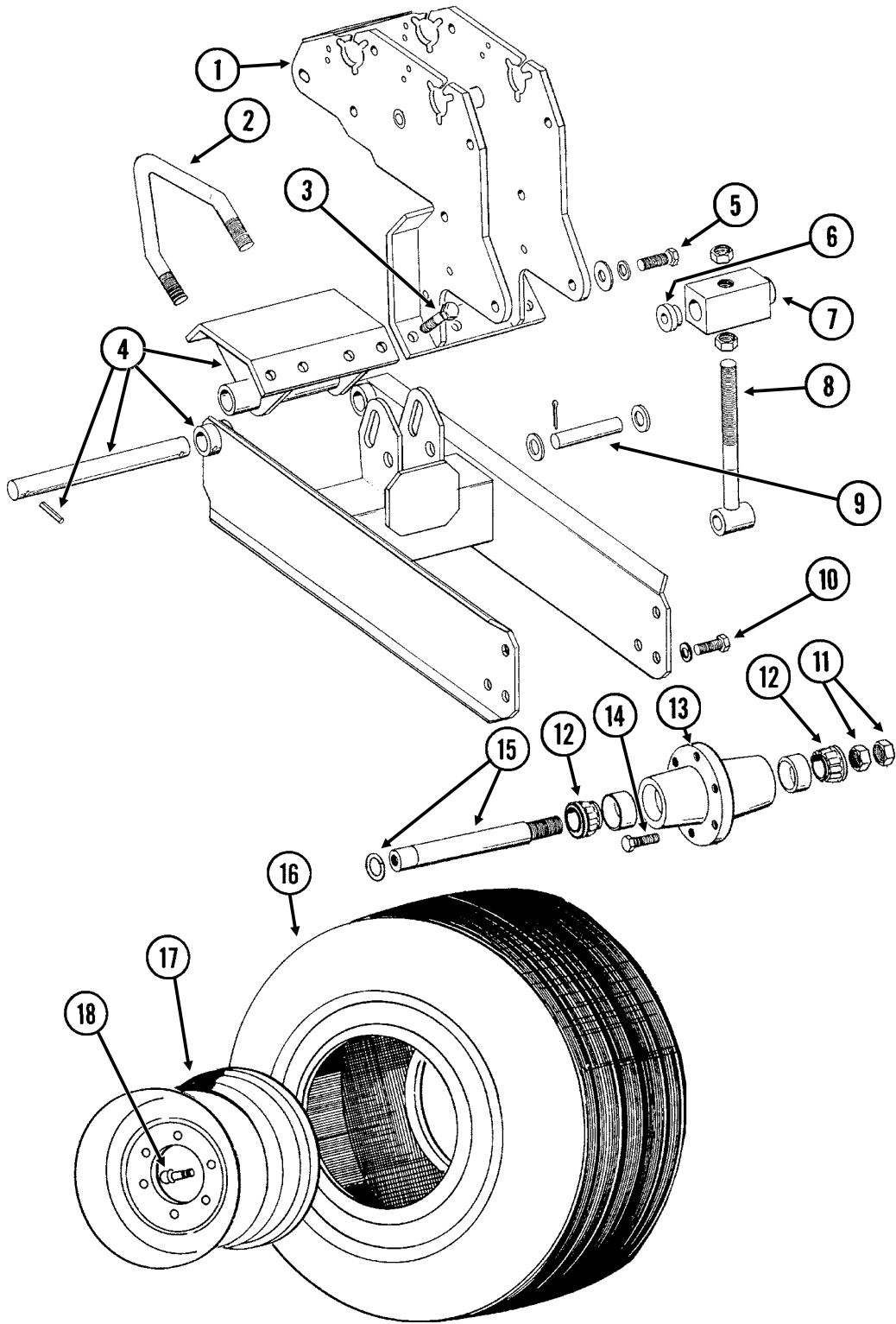

# GROUND DRIVE WHEEL ASSEMBLY

ITEM	PART NO.	QTY.	DESCRIPTION
		(Per Assy.)	
1.		-	See "Seed Rate Transmission And Module Drive Assembly", Pages P46 And P47
2.	GD8175	2	U-Bolt, 7" x 7" x 5/8"-11 (Diamond)
	GD7805	4	Special Washer, 5/8", Hardened
	G10230	4	Lock Washer, 5/8"
	G10104	4	Hex Nut, 5/8"-11
3.	G10005	4	Hex Head Cap Screw, 5/8"-11 x 1 3/4"
	GD7805	4	Special Washer, 5/8", Hardened
	G10230	4	Lock Washer, 5/8"
	G10104	4	Hex Nut, 5/8"-11
4.	GA7294	1	Arm W/Pin, Lower Clamp And Spring Pins
	GD5804	1	Pin, 1 1/4" x 12"
	GA7295	1	Clamp W/Grease Fittings
	G10641	-	Grease Fitting, 1/8" NPT
	G10610	-	Spring Pin, 3/8" x 2"
5.	G10026	2	Hex Head Cap Screw, 3/4"-10 x 2"
	G10194	2	Washer, 3/4" SAE
	G10231	2	Lock Washer, 3/4"
6.	GD10403	2	Concentric Spacer
7.	GD10328	1	Adjustment Block
8.	GA4705	1	Adjusting Screw
	G10117	2	Hex Nut, 1"-8
9.	GD7041	1	Pin, 1" x 4"
	G10082	2	Washer, 1" SAE
	G10459	2	Cotter Pin, 3/16" x 1 1/2"
10.	G10026	2	Hex Head Cap Screw, 3/4"-10 x 2"
	G10231	2	Lock Washer, 3/4"
11.	G11081	-	Hex Jam Nut, 1 1/2"-12, Grade 2
12.	GA0895	2	Bearing
13.	GA2148	1	Hub W/Cups, 6 Bolt
	GR0434	-	Cup
14.	GR0270	6	Lug Bolt, 9/16"-18
15.	GA2558	1	Spindle W/Round External Retaining Ring, 9 1/2"
	GD11490	-	Round External Retaining Ring
16.	GD0844	1	Tire, 7.60" x 15", 8 Ply (Specify Brand*)
17.	GA5196	1	Wheel W/Valve Protector, 5" x 15"
18.	GD1166	1	Valve Stem
A.	GA2147	-	Hub And Spindle Assembly (Items 11, 12, 13 And 15)
B.	GA10660	-	Ground Drive And Contact Wheel Assembly, R.H. (Items 1-18 On This Page, Items 2-15 On Pages P44 And P45, Items 1-10 And 12-40 On Pages P46 And P47 and Items 2-20 On Pages P48 And P49
	GA10661	-	Ground Drive And Contact Wheel Assembly, L.H. (Items 1-18 On This Page, Items 2-15 On Pages P44 And P45, Items 1-10 And 12-40 On Pages P46 And P47 and Items 2-20 On Pages P48 And P49

\* Specific brand requests will be supplied only as available from current KINZE® Repair Parts stock. If a specific brand requested is not in stock, the brand available will be supplied.

# CONTACT WHEEL ASSEMBLY

PLA027(SFP9dd)

R.H. Side Shown

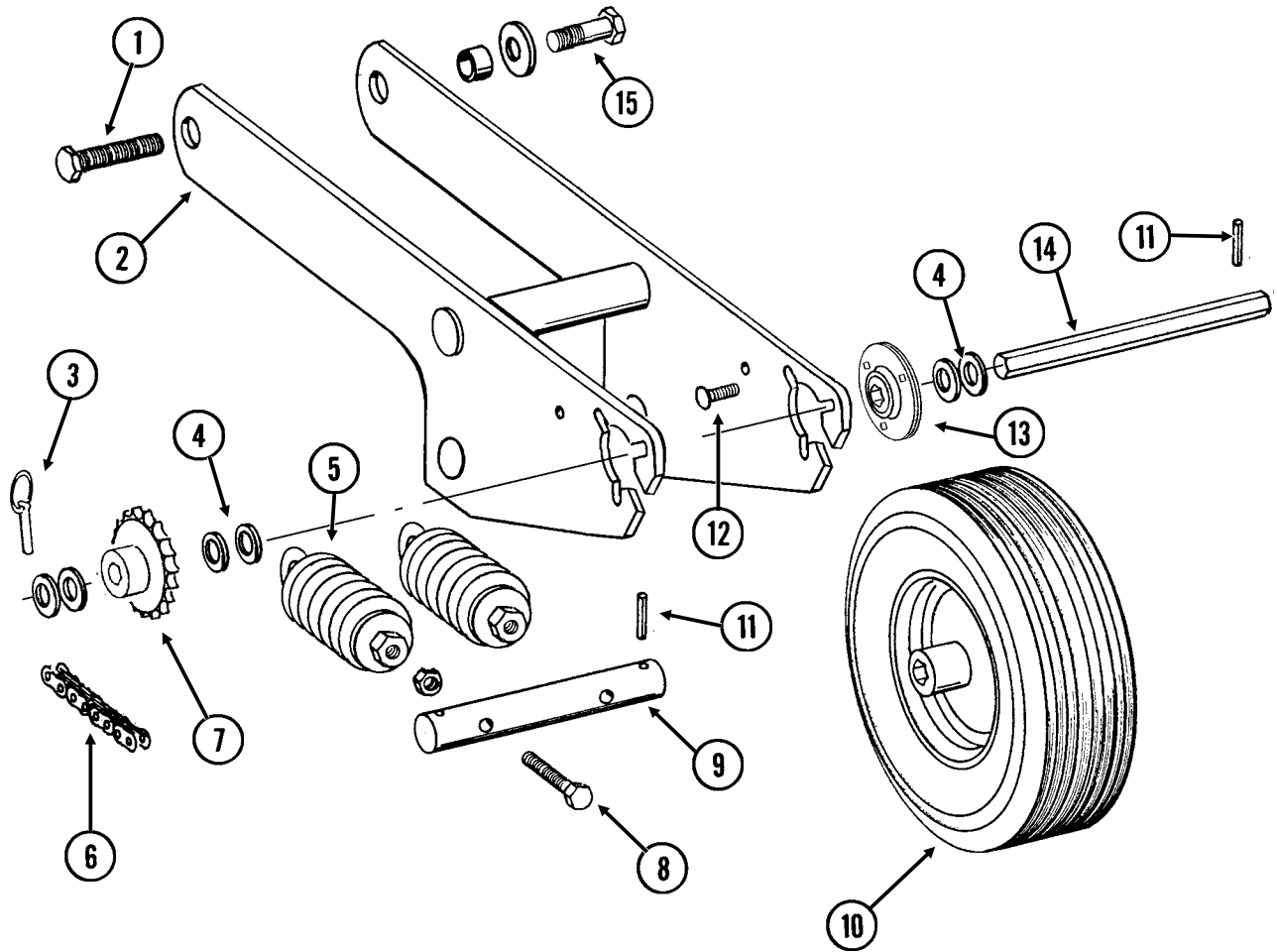



# CONTACT WHEEL ASSEMBLY

---

ITEM	PART NO.	QTY. (Per Assy.)	DESCRIPTION
1.		-	See "Module Drive", Pages P48 And P49 (Item 7)
2.	GA7297	1	Arm
3.	GD2558	1	Lynch Pin, 1/4"
4.	G10233	-	Machine Bushing, 1", 10 Gauge
5.	GA2068	2	Spring W/Plug
6.	G3310-218	1	Chain, No. 40, 218 Pitch Including Connector Link (Used With 15 And 19 Tooth Sprockets)
	G3310-224	1	Chain, No. 40, 224 Pitch Including Connector Link (Used With 30 Tooth Sprocket)
	GR0912	-	Connector Link, No. 40
7.	GA5105	-	Sprocket, 15 Tooth
	GA5107	-	Sprocket, 19 Tooth
	GA5114	1	Sprocket, 30 Tooth
8.	G10861	2	Hex Head Cap Screw, 1/2"-13 x 5", Full Thread
	G10206	2	Washer, 1/2" SAE
	G10501	2	Hex Jam Nut, 1/2"-13, Grade 2
9.	GD10329	1	Shaft
10.	GA5090	1	Tire And Rim Assembly (Specify Brand*)
	GD5753	1	Tire, 4.10" x 6" (Specify Brand*)
	GD5752	1	Inner Tube
11.	G10602	2	Spring Pin, 1/4" x 1 1/2"
12.	G10303	6	Carriage Bolt, 5/16"-18 x 1"
	G10232	6	Lock Washer, 5/16"
	G10106	6	Hex Nut, 5/16"-18
13.	GA9846	-	Flanged Bearing, 7/8" Hex Bore
14.	GD10332	1	Shaft, 7/8" x 11"
15.	G10005	1	Hex Head Cap Screw, 5/8"-11 x 1 3/4"
	GD7805	1	Special Washer, 5/8", Hardened
	GD3180-15	1	Sleeve, 5/8" I.D. x 7/8" O.D. x 1 5/32" Long
	G10107	1	Lock Nut, 5/8"-11

\* Specific brand requests will be supplied only as available from current KINZE® Repair Parts stock. If a specific brand requested is not in stock, the brand available will be supplied. Different brand tires may have different diameters. Change in tire brand may affect rates. Field checks are recommended after any change in contact tires.

# SEED RATE TRANSMISSION AND MODULE DRIVE ASSEMBLY

(SFP24ff)

R.H. Side Shown

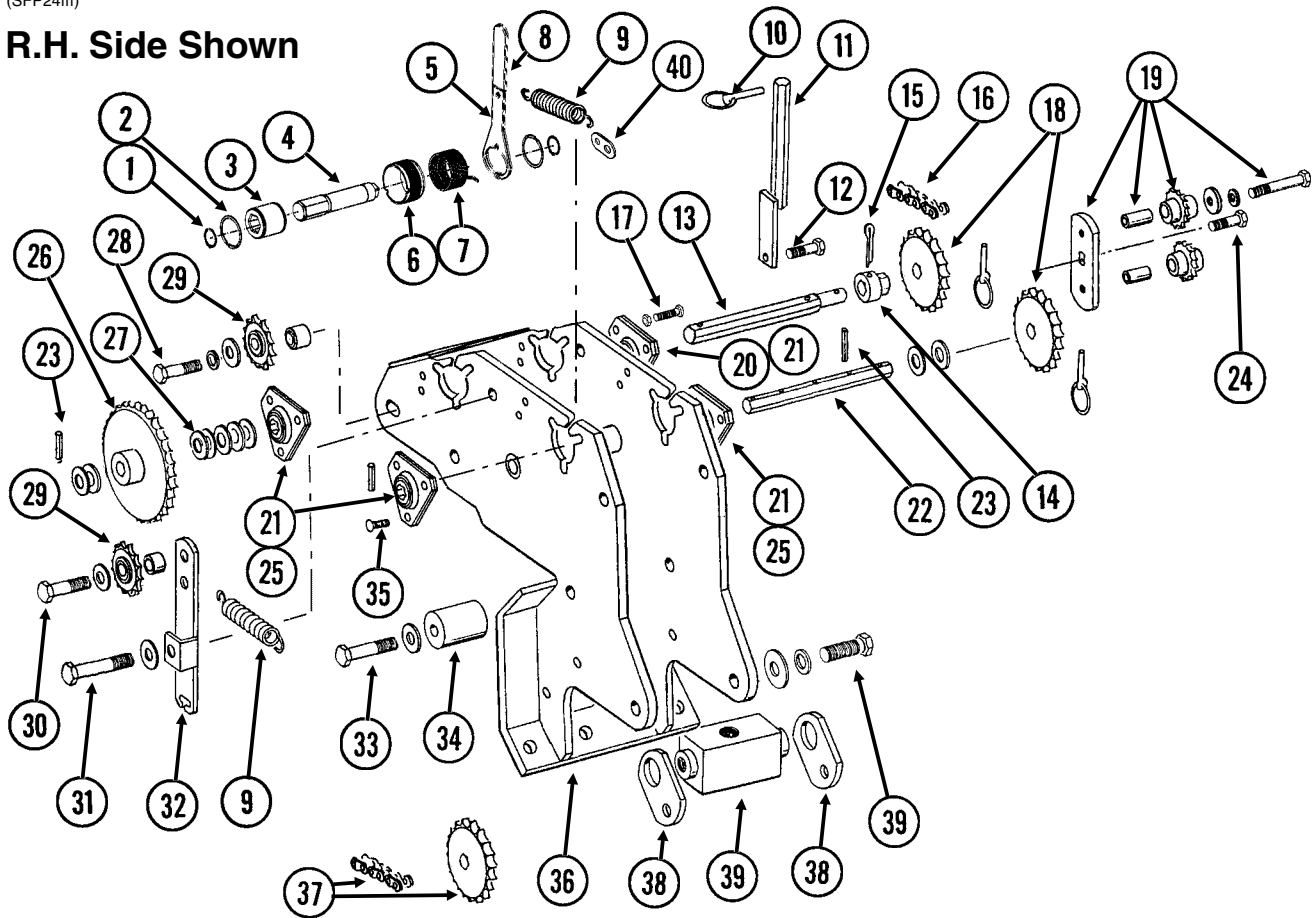

ITEM	PART NO.	QTY.	DESCRIPTION
(Per Assy.)			
1.	G11075	2	External Inverted Snap Ring, 7/8"
2.	G10496	2	External Inverted Snap Ring, 1 1/2"
3.	GD14432	1	Sleeve, 1 1/4"
4.	GD14426	1	Tightener Shaft, 3 3/8"
5.	GD14431	1	Handle
6.	GD14430	1	Release Collar, Gold, R.H. (Shown)
	GD14429	-	Release Collar, Silver, L.H.
7.	GD14414	1	Torsion Spring, R.H. (Used In L.H. Wrap Spring Wrench)
	GD14413	-	Torsion Spring, L.H. (Shown) (Used In R.H. Wrap Spring Wrench)
8.	G11078	1	Vinyl Cap
9.	GD5857	2	Spring
10.	GD2558	3	Lynch Pin, 1/4"
11.	GA11052	1	Sprocket Storage Rod
12.	G10037	1	Hex Head Cap Screw, 1/2"-13 x 1 1/4"
	G10216	1	Washer, 1/2" USS
	G10111	1	Lock Nut, 1/2"-13
13.	GD10336	1	Shaft, 7/8" x 11"
14.	GD7127	1	Shear Coupler
15.	G10462	1	Cotter Pin, 3/16" x 2"
16.	G3310-68	1	Chain, No. 40, 68 Pitch Including Connector Link
	GR0912	-	Connector Link, No. 40
17.	G10338	1	Carriage Bolt, 5/16"-18 x 1 1/4"
	G10232	1	Lock Washer, 5/16"
	G10106	1	Hex Nut, 5/16"-18
	G10109	1	Lock Nut, 5/16"-18, Grade 8

# SEED RATE TRANSMISSION AND MODULE DRIVE ASSEMBLY

ITEM	PART NO.	QTY.	DESCRIPTION
		(Per Assy.)	
18.	GA5105	1	Sprocket, 15 Tooth
	GA5106	1	Sprocket, 17 Tooth
	GA5107	2	Sprocket, 19 Tooth
	GA5108	2	Sprocket, 23 Tooth
	GA5109	1	Sprocket, 24 Tooth
	GA5110	1	Sprocket, 25 Tooth
	GA5111	1	Sprocket, 26 Tooth
	GA5112	1	Sprocket, 27 Tooth
	GA5113	1	Sprocket, 28 Tooth
19.	GA7336	1	Idler W/Bolt-On Sprockets
	GD7426	-	Sprocket, 12 Tooth
	GD1026	-	Sleeve, 1 $\frac{3}{16}$ " Long
	G10210	-	Washer, $\frac{3}{8}$ " USS
	G10229	-	Lock Washer, $\frac{3}{8}$ "
	G10047	-	Hex Head Cap Screw, $\frac{3}{8}$ "-16 x 1 $\frac{3}{4}$ "
20.	GA5548	1	Special Bearing
21.	G3400-01	4	Flangette
22.	GD10337	1	Shaft, $\frac{7}{8}$ " x 10 $\frac{1}{2}$ "
23.	G10602	7	Spring Pin, $\frac{1}{4}$ " x 1 $\frac{1}{2}$ "
24.	G11100	1	Hex Socket Button Head Cap Screw, $\frac{1}{4}$ "-20 x $\frac{1}{2}$ ", Grade 8
	G10227	1	Lock Washer, $\frac{1}{4}$ "
	G10209	1	Washer, $\frac{1}{4}$ " USS
25.	G2100-03	3	Bearing, $\frac{7}{8}$ " Hex Bore, Spherical
26.	GA5202	1	Sprocket, 34 Tooth, See "Point Row Clutch", Pages P52 And P53, For Machines Equipped With Point Row Clutches
27.	G10233	-	Machine Bushing, 1", 10 Gauge (As Required)
28.	G10038	1	Hex Head Cap Screw, $\frac{1}{2}$ "-13 x 3"
	G10128	1	Machine Bushing, $\frac{1}{2}$ ", 14 Gauge
	GB0258	1	Stepped Spacer, $\frac{7}{8}$ "
	G10216	1	Washer, $\frac{1}{2}$ " USS
	G10228	1	Lock Washer, $\frac{1}{2}$ "
	G10102	1	Hex Nut, $\frac{1}{2}$ "-13
29.	GA7154	2	Sprocket W/Bearing, 18 Tooth
30.	G10581	1	Hex Head Cap Screw, $\frac{1}{2}$ "-13 x 2 $\frac{1}{4}$ "
	G10128	1	Machine Bushing, $\frac{1}{2}$ ", 14 Gauge
	GD7889	1	Bushing. 1" O.D. x $\frac{9}{16}$ " I.D. x $\frac{7}{16}$ " Long
	G10228	1	Lock Washer, $\frac{1}{2}$ "
	G10102	1	Hex Nut, $\frac{1}{2}$ "-13
31.	G10036	1	Hex Head Cap Screw, $\frac{5}{8}$ "-11 x 4"
	GD7805	1	Special Washer, $\frac{5}{8}$ ", Hardened
	G10503	1	Hex Jam Nut, $\frac{5}{8}$ "-11, Grade 2
	G10107	1	Lock Nut, $\frac{5}{8}$ "-11
32.	GD13422	1	Idler Arm, R.H. Side Of Planter (Shown)
	GD13394	-	Idler Arm, L.H. Side Of Planter
33.	G10033	1	Hex Head Cap Screw, $\frac{1}{2}$ "-13 x 3 $\frac{1}{2}$ "
	G10206	1	Washer, $\frac{1}{2}$ " SAE
	G10228	1	Lock Washer, $\frac{1}{2}$ "
	G10102	1	Hex Nut, $\frac{1}{2}$ "-13
34.	GD10407	1	Chain Support
35.	G10303	12	Carriage Bolt, $\frac{5}{16}$ "-18 x 1"
	G10232	12	Lock Washer, $\frac{5}{16}$ "
	G10106	12	Hex Nut, $\frac{5}{16}$ "-18
36.	GA10063	1	Module
37.		-	See "Contact Drive Wheel Assembly", Page P44 And P45
38.	GD15696	2	Strap
39.		-	See "Ground Drive Wheel Assembly", Pages P42 And P43
40.	GD14595	1	Spring Tension Link
A.	G1K380	1	Wrap Spring Wrench Replacement Kit, Gold Collar, R.H. (Items 1-8 And 24) (Shown)
	G1K381	-	Wrap Spring Wrench Replacement Kit, Silver Collar, L.H. (Items 1-8 And 24)

# MODULE DRIVE

(SFP25hh)

R.H. Side Shown

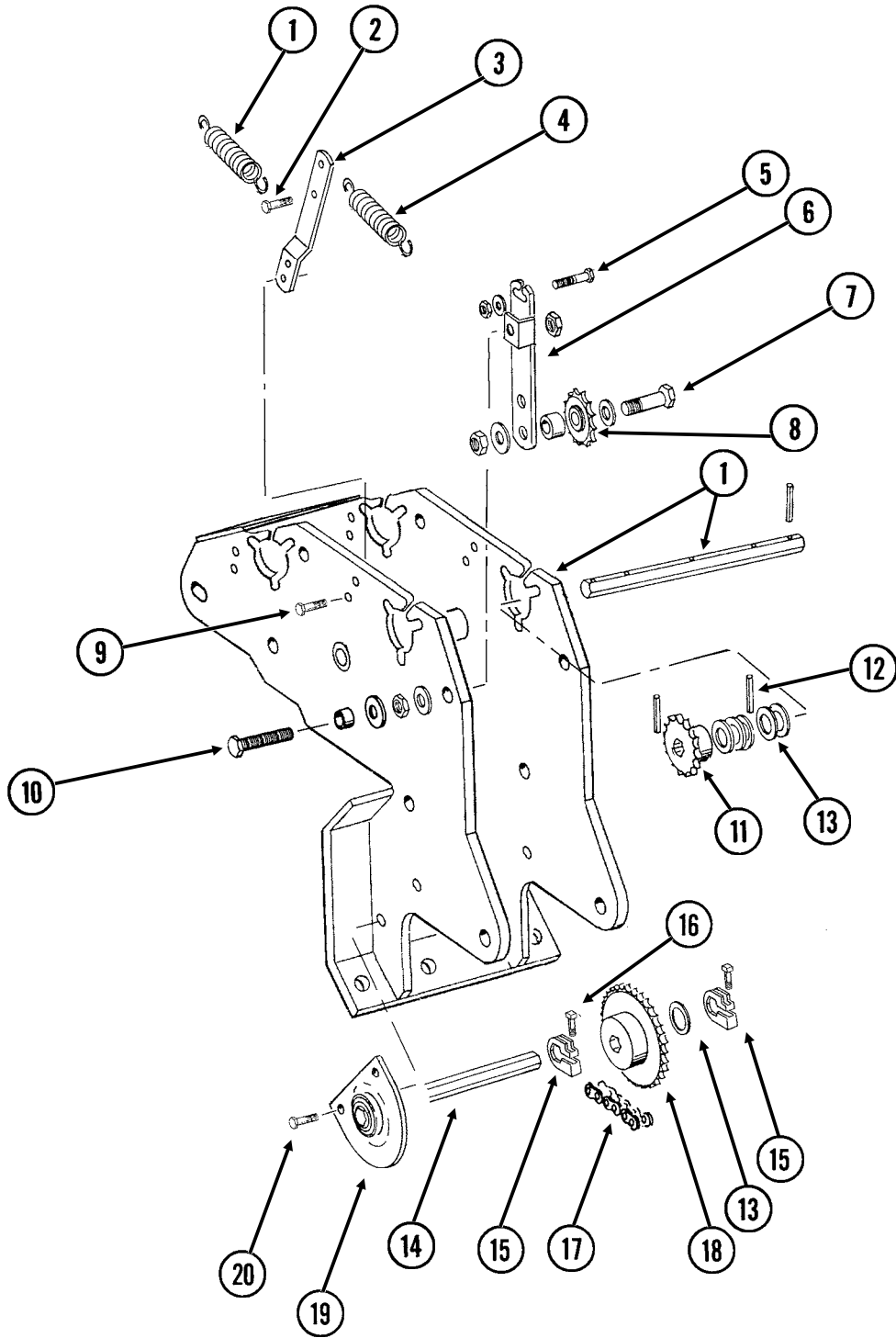

# MODULE DRIVE

ITEM	PART NO.	QTY. (Per Assy.)	DESCRIPTION
1.		-	See "Seed Rate Transmission And Module Drive Assembly", Pages P46 And P47
2.	G10040	1	Hex Head Cap Screw, 1/4"-20 x 1 3/4"
	G10103	1	Hex Nut, 1/4"-20
3.	GD5860	1	Bar
4.	GD5857	1	Spring
5.	G10069	1	Hex Head Cap Screw, 5/16"-18 x 2 1/4"
	G10219	1	Washer, 5/16" USS
	G10106	1	Hex Nut, 5/16"-18
6.	GD13394	-	Idler Arm, R.H. Side Of Planter (Shown)
	GD13422	1	Idler Arm, L.H. Side Of Planter
7.	G10581	1	Hex Head Cap Screw, 1/2"-13 x 2 1/4"
	G10128	1	Machine Bushing, 1/2", 14 Gauge
	GD7889	1	Bushing, 1" O.D. x 9/16" I.D. x 7/16" Long
	G10228	1	Lock Washer, 1/2"
	G10102	1	Hex Nut, 1/2"-13
8.	GA7154	1	Sprocket W/Bearing, 18 Tooth
9.	G10064	1	Hex Head Cap Screw, 1/4"-20 x 1"
	G10227	1	Lock Washer, 1/4"
	G10103	1	Hex Nut, 1/4"-20
10.	G11028	1	Hex Head Cap Screw, 5/8"-11 x 4 1/2", Full Thread
	GD7805	1	Special Washer, 5/8", Hardened
	GD3180-15	1	Sleeve, 5/8" I.D. x 7/8" O.D. x 15/32" Long
	G10104	1	Hex Nut, 5/8"-11
	G10205	1	Washer, 5/8" SAE
	G10107	1	Lock Nut, 5/8"-11
11.	GA5105	1	Sprocket, 15 Tooth
12.	G10602	7	Spring Pin, 1/4" x 1 1/2"
13.	G10233	1	Machine Bushing, 1", 10 Gauge
14.	GD0914-66	-	Hex Shaft, 7/8" x 66", 6 Row 30" (No Holes) (Two Per Planter)
	GD0914-86	-	Hex Shaft, 7/8" x 86", 6 Row 36"/38"/40" (No Holes) (Two Per Planter)
	GD0914-96	-	Hex Shaft, 7/8" x 96", 8 Row 30" (No Holes) (Two Per Planter)
	GD0914-126	-	Hex Shaft, 7/8" x 126", 8 Row 36"/38"/40" (No Holes) (Two Per Planter)
15.	GD11045	2	Lock Clamp
16.	G10130	2	Square Head Machine Bolt, 5/16"-18 x 1 3/4"
	G10923	2	Flange Nut, 5/16"-18, No Serration
17.	G3310-75	1	Chain, No. 40, 75 Pitch Including Connector Link And Offset Link
	GR0912	-	Connector Link, No. 40
	GR0911	-	Offset Link, No. 40
18.	GA5114	1	Sprocket, 30 Tooth
19.	GA2180	1	Hanger Bearing, 7/8" Hex Bore
20.	G10004	2	Hex Head Cap Screw, 3/8"-16 x 1 1/4"
	G10210	2	Washer, 3/8" USS
	G10229	2	Lock Washer, 3/8"
	G10101	2	Hex Nut, 3/8"-16
A.	G1K269	-	Lock Clamp Kit (Items 15 And 16)

# FRONT MOUNTED DRIVE WHEEL

(PLTR170cc)

R.H. Side Shown

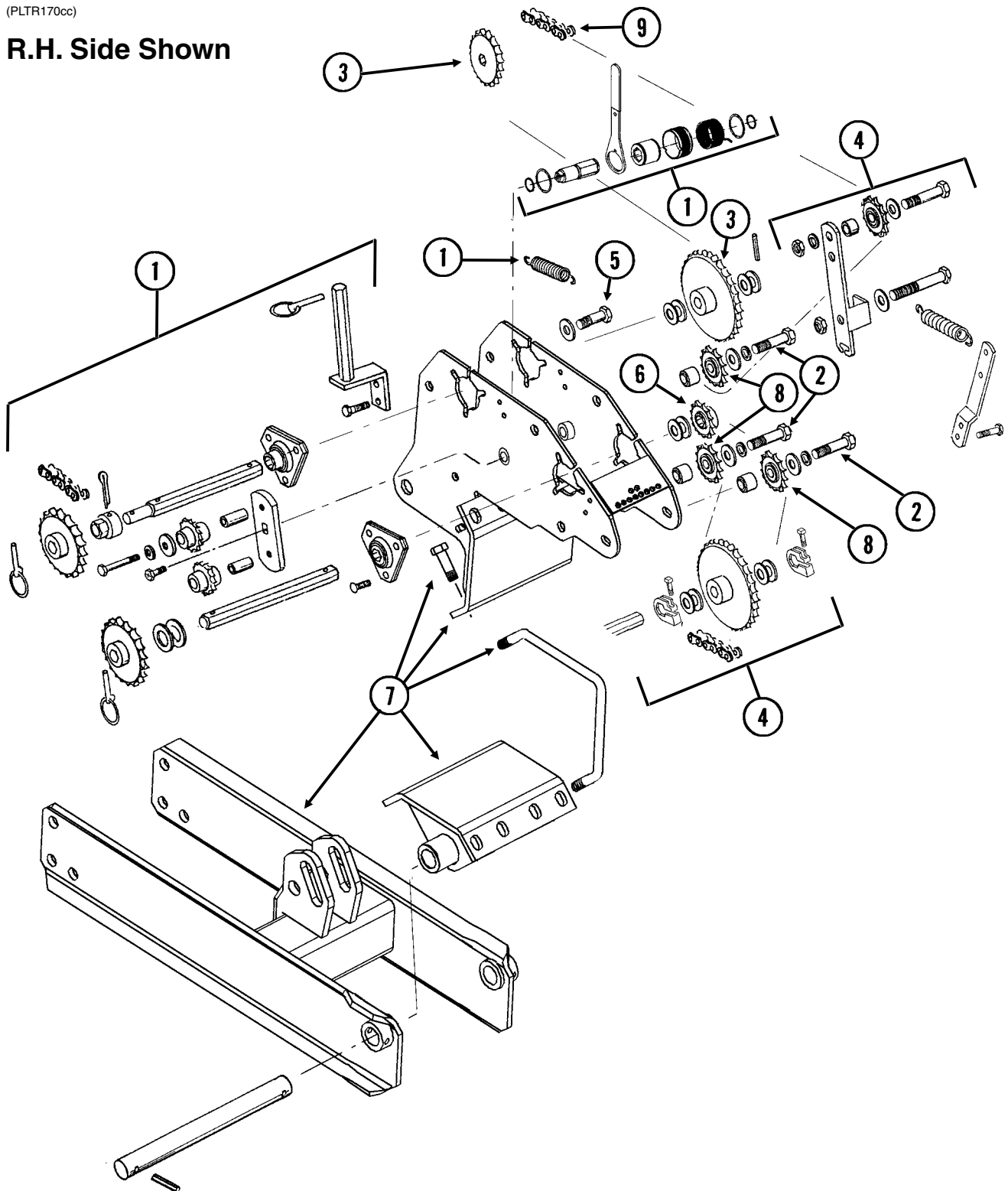

# FRONT MOUNTED DRIVE WHEEL

---

ITEM	PART NO.	QTY. (Per Assy.)	DESCRIPTION
1.		-	See "Seed Rate Transmission And Module Drive Assembly", Pages P46 And P47
2.	G10397	3	Hex Head Cap Screw, 1/2"-13 x 2 3/4"
	G10128	3	Machine Bushing, 1/2", 14 Gauge
	G10216	3	Washer, 1/2" USS
	GB0258	3	Stepped Spacer, 7/8"
	G10228	3	Lock Washer, 1/2"
	G10102	3	Hex Nut, 1/2"-13
3.		-	See "Contact Drive Wheel Assembly", Pages P44 And P45
4.		-	See "Module Drive", Pages P48 And P49
5.	G10005	2	Hex Head Cap Screw, 5/8"-11 x 1 3/4"
	GD7805	2	Special Washer, 5/8", Hardened
	GD3180-15	2	Sleeve, 5/8" I.D. x 7/8" O.D. x 1 5/32" Long
	G10107	2	Lock Nut, 5/8"-11
6.	GA5105	1	Sprocket, 15 Tooth
7.		-	See "Ground Drive Wheel Assembly", Pages P42 And P43
8.	GA7154	2	Sprocket W/Bearing, 18 Tooth
9.	G3310-204	1	Chain, No. 40, 204 Pitch Including Connector Link
	GR0912	-	Connector Link, No. 40
A.	G1K377	-	Front Drive Wheel Conversion Package (Items 2, 5 And 8 On This Page, Items 15 And 16 On Pages P48 And P49 And Items 26 And 27 On Pages P74-P76)

# POINT ROW CLUTCH

PRC019/PRC020(SFP5d/A10054)

R.H. Point Row Clutch Shown  
(Used On L.H. Side Of Planter)

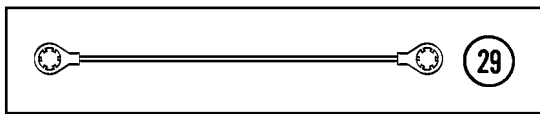
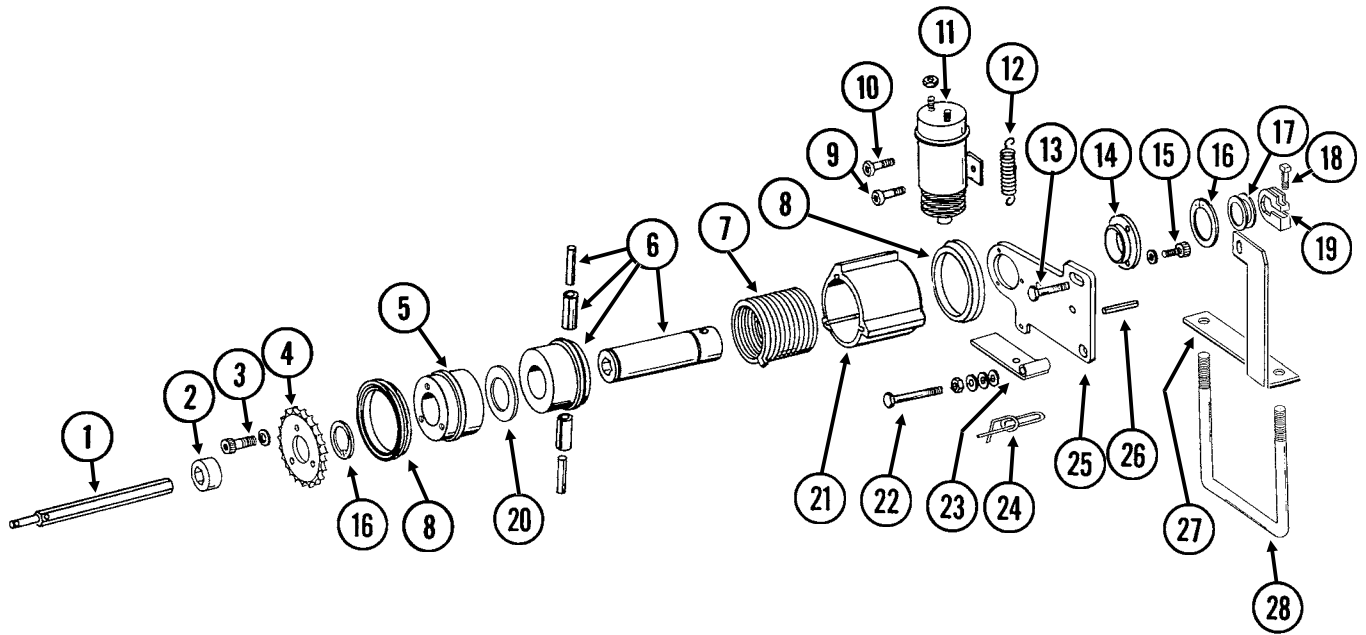



# POINT ROW CLUTCH

ITEM	PART NO.	QTY. (Per Assy.)	DESCRIPTION
1.	GD10527	1	Input Shaft, 7/8" x 15 1/2"
2.	GD10200	1	Sleeve, 3/4" Long
3.	G10023	3	Hex Head Cap Screw, 1/4"-20 x 3/4"
	G10227	3	Lock Washer, 1/4"
4.	GD10525	1	Sprocket, 34 Tooth
5.	GD10104	1	Input Hub
6.	GA7137	1	Hub/Sleeve Assembly W/Spring Pins
	G10804	-	Spring Pin, 5/32" x 7/8"
	G10765	-	Spring Pin, 1/4" x 1"
7.	GD9672	1	Spring, R.H. (Shown)
	GD9671	-	Spring, L.H.
8.	GD14512	2	V-Ring Seal
9.	G10900	1	Hex Socket Head Cap Screw, 1/4"-20 x 1 3/4", Grade 8
	G10227	1	Lock Washer, 1/4"
	G10103	2	Hex Nut, 1/4"-20
10.	G10023	1	Hex Head Cap Screw, 1/4"-20 x 3/4"
	G10227	1	Lock Washer, 1/4"
	G10103	1	Hex Nut, 1/4"-20
11.	GA8393	1	Solenoid Complete
	GR1306	1	Snap Ring
	GR1303	1	Spring
	GR1304	1	Boot
	GR1305	1	Plunger
12.	GD10123	1	Spring
13.	G10003	1	Hex Head Cap Screw, 3/8"-16 x 1 1/2"
	G10203	2	Washer, 3/8" SAE
	G10101	1	Hex Nut, 3/8"-16
14.	GD9667	1	Bushing
15.	G10253	3	Hex Socket Head Screw, No. 10-32 x 1/2"
	G10257	3	Lock Washer, No. 10
16.	G10496	2	External Inverted Snap Ring, 1 1/2"
17.	G10233	-	Machine Bushing, 1", 10 Gauge
18.	G10130	-	Square Head Machine Bolt, 5/16"-18 x 1 3/4"
	G10923	-	Flange Nut, 5/16"-18, No Serration
19.	GD11045	-	Lock Clamp
20.	GD14513	1	Felt Washer
21.	GD10102	1	Stop Collar
22.	G10049	1	Hex Head Cap Screw, 3/8"-16 x 2 1/2"
	G10101	1	Hex Nut, 3/8"-16
	G10203	1	Washer, 3/8" SAE
	G10229	2	Lock Washer, 3/8"
	G10497	1	Hex Jam Nut, 3/8"-16, Grade 2
23.	GD10510	1	Actuator Arm
24.	GD11120	1	Rue Ring Cotter, 5/16"
25.	GD10103	1	Mounting Plate
26.	G10859	1	Spring Pin, 3/16" x 2 1/4"
27.	GD10529	1	Bracket, L.H. (Shown)
	GD10528	-	Bracket, R.H.
28.	GD7145	1	U-Bolt, 7" x 7" x 1/2"-13
	G10111	2	Lock Nut, 1/2"-13
29.	GA10054	1	Ground Cable, Green
A.	G1K269	-	Lock Clamp Kit (Items 18 And 19)
B.	GA7418	-	Point Row Clutch Assembly, R.H. (Shown) (Items 3-12, 14-16, 20-26 And 29)
	GA7417	-	Point Row Clutch Assembly, L.H. (Items 3-12, 14-16, 20-26 And 29)

# POINT ROW CLUTCH ELECTRICAL COMPONENTS

(EF10b/ELC34/ELC35/EF10c/SFP6/TWL18/TWL76)

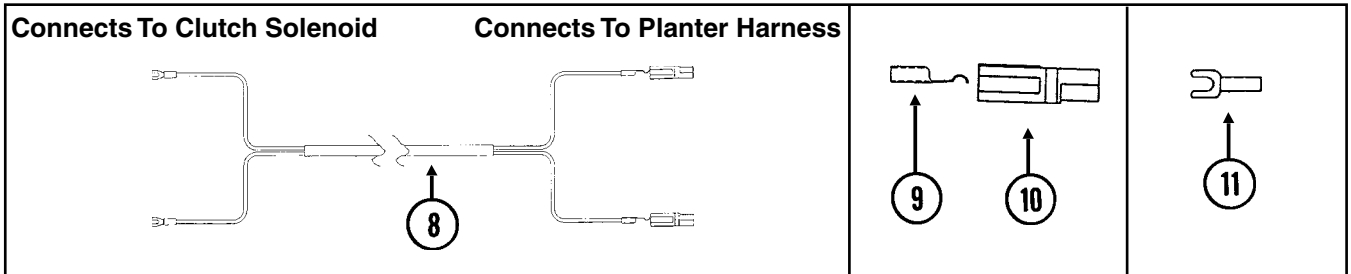
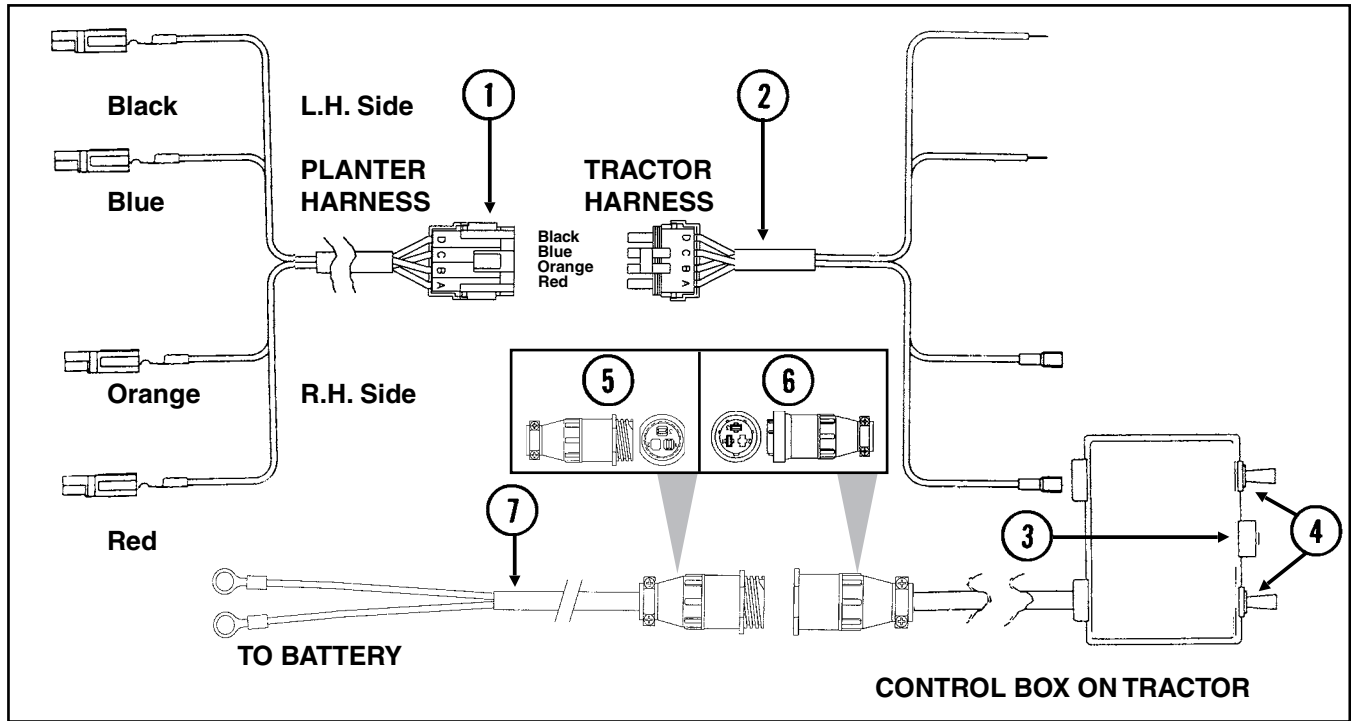

# POINT ROW CLUTCH ELECTRICAL COMPONENTS

---

ITEM	PART NO.	QTY. (Per Assy.)	DESCRIPTION
1.	GR1450	-	Harness W/4-Pin Connector, 60"
	GA8328	-	4-Pin Connector W/Female Housing, 4 Seals And 4 Pin Contacts
2.	GR1447	-	Harness W/4-Pin Connector, 152"
	GA8329	-	4-Pin Connector W/Male Housing, 4 Seals And 4 Socket Contacts
3.	GA7165	-	Circuit Breaker, 12 Amp
4.	GA7144	-	Two Position Switch
5.	G1K267	-	Power Lead Adapter Connector Kit, Includes: (1) 3-Pin Connector, (1) Cable Clamp, (3) Male Terminal Pins
6.	G1K268	-	Console Cable Connector Kit, Includes: (1) 3-Pin Connector, (1) Cable Clamp, (1) Lock Ring, (3) Female Terminal Pins
7.	GA7856	1	Power Lead Adapter
8.	GA7416	1	Wiring Harness, 288"
9.	GD9530	-	Contact
10.	GD9529	-	Housing, Black
	GD12726	-	Housing, Red
11.	G10996	-	Fork Terminal

# ROW MARKER ASSEMBLY, CONVENTIONAL 6 ROW 30"

MKR010(MKR1a)

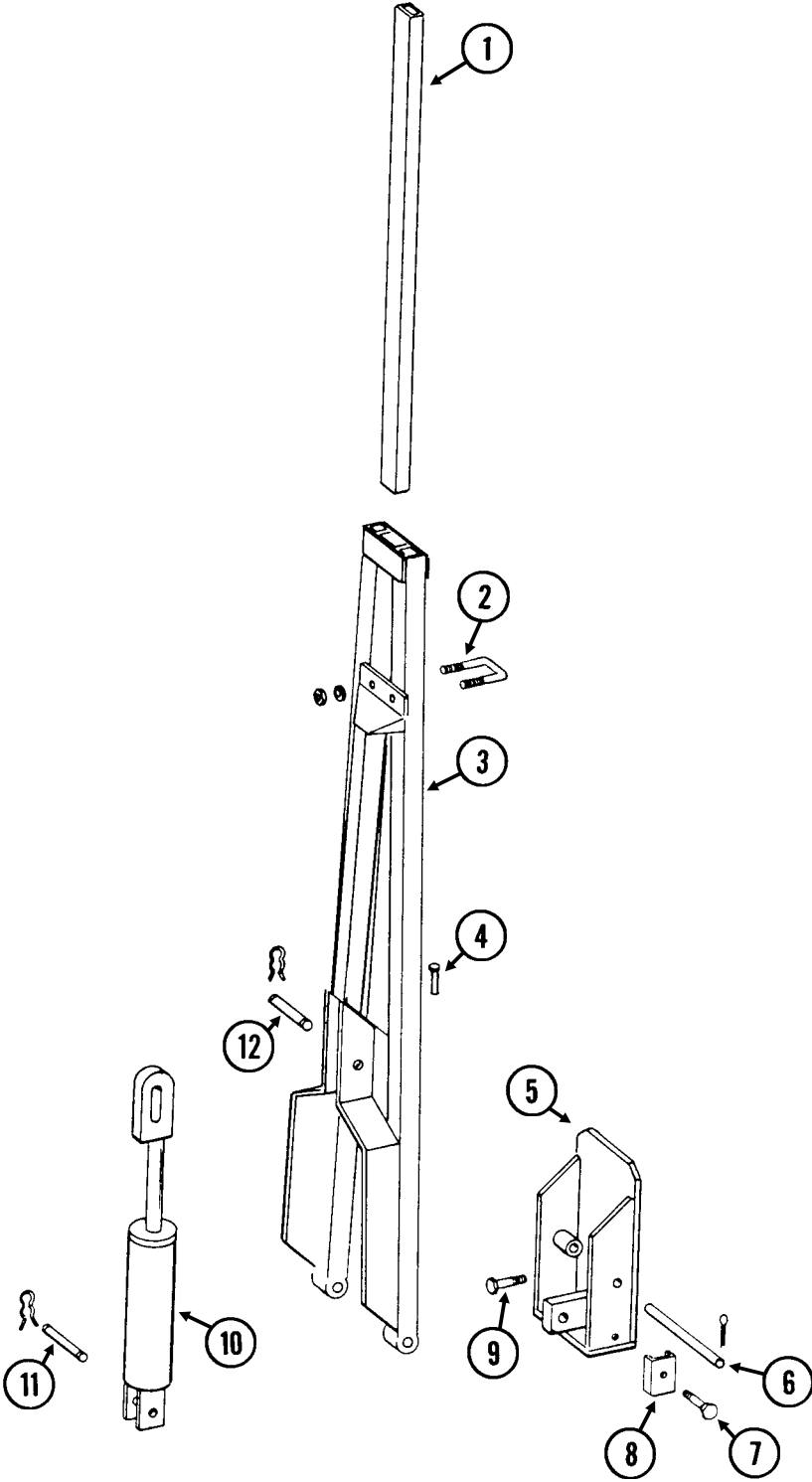

# ROW MARKER ASSEMBLY, CONVENTIONAL

## 6 ROW 30"

---

ITEM	PART NO.	QTY. (Per Assy.)	DESCRIPTION
1.	GD0453-02	1	Extension Tube, 40"
2.	GD2721	1	U-Bolt, 2" x 2" x 1/2"-13
	G10228	2	Lock Washer, 1/2"
	G10102	2	Hex Nut, 1/2"-13
3.	GA5183	-	Arm W/Grease Fittings, 58 1/2"
	G10640	-	Grease Fitting, 1/4"-28
4.	GD0462	1	Safety Lockup Pin
	G10670	1	Hair Pin Clip, No. 3
	G10187	1	Spring Pin, 5/32" x 2"
5.	GA5178	-	Mount W/Grease Fittings
	G10640	-	Grease Fitting, 1/4"-28
6.	GD0438	1	Pin, 13 1/2"
	G10460	2	Cotter Pin, 1/4" x 2"
7.	G10133	1	Hex Head Cap Screw, 5/16"-18 x 1 1/2"
	G10232	1	Lock Washer, 5/16"
	G10106	1	Hex Nut, 5/16"-18
8.	GD5892	1	Hose Clamp, 5/8" x 1 1/2" x 1 1/2"
9.	G10008	4	Hex Head Cap Screw, 5/8"-11 x 2"
	G10230	4	Lock Washer, 5/8"
10.		-	See "Row Marker Cylinder", Page P62
11.	GR0367	1	Pin, 1" x 2 7/8"
	GR0193	2	Hair Pin Clip
12.	GR0375	1	Pin, 1" x 3 1/2"
	GR0193	2	Hair Pin Clip

# ROW MARKER ASSEMBLY, TWO-FOLD LOW PROFILE 6 ROW 36"/38"/40", 8 ROW 30" AND 8 ROW 36"/38"/40"

MKR006/MKR009(MKR2/A11591)

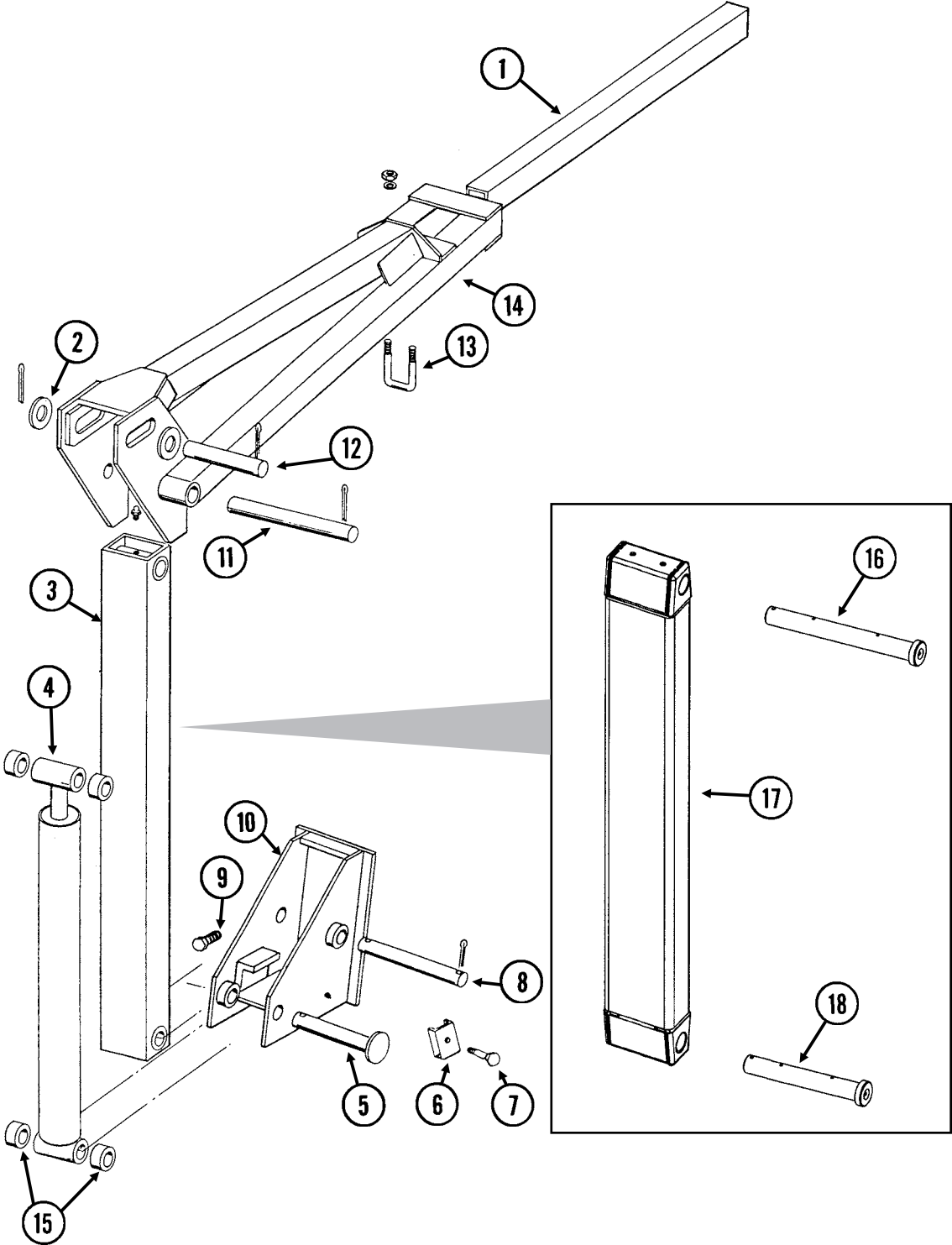

# ROW MARKER ASSEMBLY, TWO-FOLD LOW PROFILE 6 ROW 36"/38"/40", 8 ROW 30" AND 8 ROW 36"/38"/40"

---

ITEM	PART NO.	QTY. (Per Assy.)	DESCRIPTION
1.	GD0453-04	1	Extension Tube, 60", 6 Row 36"/38"/40"
	GD0453-03	-	Extension Tube, 50", 8 Row 30"
	GD0453-08	-	Extension Tube, 65", 8 Row 36"/38"/40"
2.	G10226	2	Washer, 1 ¼" SAE
3.	GA5173	1	Arm W/Grease Fittings, First Stage
	G10641	-	Grease Fitting, ⅛" NPT
4.		-	See "Row Marker Cylinder", Page P63
5.	GD15386	1	Pin, 1 ¼" x 7 ⅝"
	G10460	1	Cotter Pin, ¼" x 2"
6.	GD5875	1	Hose Clamp, ⅞" x 2 ½" x 2"
7.	G10133	1	Hex Head Cap Screw, ⅝"-18 x 1 ½"
	G10232	1	Lock Washer, ⅝"
	G10106	1	Hex Nut, ⅝"-18
	G10228	2	Lock Washer, ½"
	G10102	2	Hex Nut, ½"-13
8.	GD0652	1	Pin, 1 ¼" x 9 ½"
	G10460	2	Cotter Pin, ¼" x 2"
9.	G10879	4	Flanged 12 Point Bolt, ⅝"-11 x 2", Special Hardened Mount
10.	GA5130	1	
11.	GD3214	1	Pin, 1 ¼" x 12 ¼"
	G10460	2	Cotter Pin, ¼" x 2"
12.	GD2161	1	Pin, 1 ¼" x 8 ¼"
	G10460	2	Cotter Pin, ¼" x 2"
13.	GD2721	1	U-Bolt, 2" x 2" x ½"-13
14.	GA5190	1	Arm, Second Stage, 35", 6 Row 36"/38"/40"
	GA5188	-	Arm, Second Stage, 46", 8 Row 30"
	GA5192	-	Arm, Second Stage, 67", 8 Row 36"/38"/40"
15.	GD0752-41	-	Sleeve, 1" (If Applicable)
16.	GA11766	-	Pin W/Grease Fitting, 1 ¼" x 11 13/16"
	G10640	-	Grease Fitting, ¼"-28
17.	GA11591	-	Arm, First Stage
18.	GA11767	-	Pin W/Grease Fitting, 1 ¼" x 9 ½"
	G10640	-	Grease Fitting, ¼"-28

# ROW MARKER SPINDLE/HUB/BLADE

MKR020(MKR4)

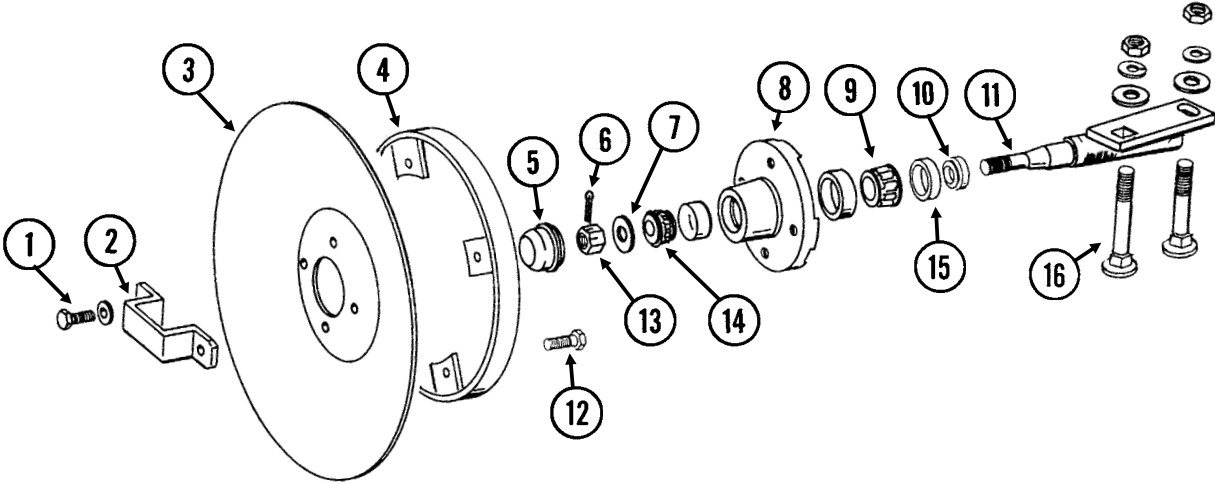



# ROW MARKER SPINDLE/HUB/BLADE

---

ITEM	PART NO.	QTY. (Per Assy.)	DESCRIPTION
1.	G10722	4	Hex Head Cap Screw, 1/2"-20 x 1"
	G10228	4	Lock Washer, 1/2"
2.	GD2597	1	Retainer
3.	GD0746	1	Disc Blade, Solid, 16" (Shown)
	GD10283	-	Disc Blade, Notched, 16" (Optional)
4.	GA5853	1	Depth Band
5.	GD0840	1	Dust Cap
6.	G10544	1	Cotter Pin, 5/32" x 1"
7.	G10724	1	Washer, 5/8" SAE
8.	GA0167	1	Hub W/Cups, 4 Bolt
	GR0151	-	Outer Cup
	GR0150	-	Inner Cup
9.	GA0245	1	Bearing
10.	GA0899	1	Rubber Seal
11.	GA1677	1	Spindle, L.H. (Shown)
	GA1676	-	Spindle, R.H.
12.	G10019	4	Hex Head Cap Screw, 5/16"-18 x 1"
	G10109	4	Lock Nut, 5/16"-18, Grade 8
13.	G10725	1	Slotted Hex Nut, 5/8"-18
14.	GA0257	1	Bearing
15.	GA0243	1	Grease Seal
16.	G10844	2	Carriage Bolt, 1/2"-13 x 3 1/2"
	G10168	2	Machine Bushing, 1/2", 7 Gauge
	G10228	2	Lock Washer, 1/2"
	G10102	2	Hex Nut, 1/2"-13
A.	GA1679	-	Hub And Spindle Assembly, L.H. (Items 1, 2, 5-11 And 13-15)
	GA1678	-	Hub And Spindle Assembly, R.H. (Items 1, 2, 5-11 And 13-15)

# ROW MARKER CYLINDER

## 6 ROW 30"

CYL030(CYL2c)

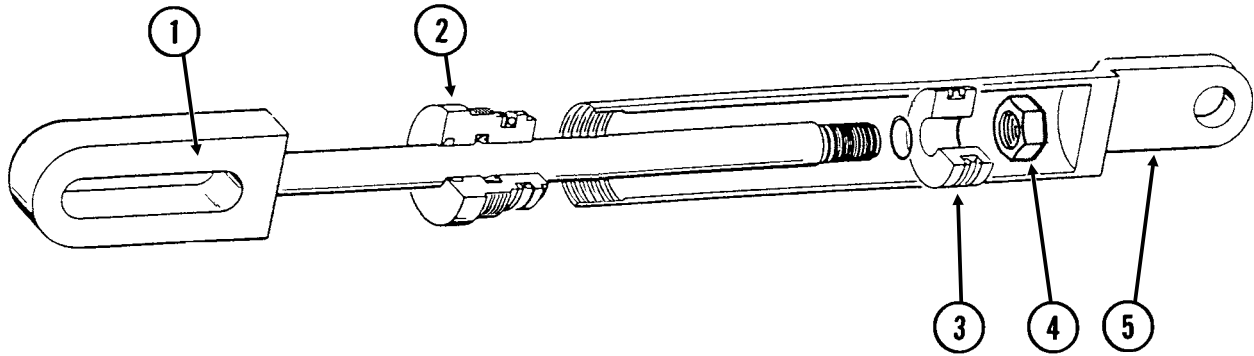

ITEM	PART NO.	QTY.	DESCRIPTION
1.	GA8918	1	Rod Assembly
2.	GD12510	1	Gland
3.	GD12511	1	Piston
4.	G10967	1	Lock Nut, 3/4"-16
5.	A8775	1	Barrel ( <b>Non-Stock Item</b> )
A.	GA8919	-	Cylinder Complete, 2" x 8" ( <i>Part Number Stamped On Barrel</i> )
B.	GR1529	-	Seal Kit, Includes: (1) T-Seal, (2) O-Rings, (1) BU Ring, (2) U-Cups, (1) Wiper, (1) IS511 Instruction

# ROW MARKER CYLINDER

## 6 ROW 36"/38"/40", 8 ROW 30" AND 8 ROW 36"/38"/40"

CYL039(CYL3e)

3/4"-16 O-Ring Ports

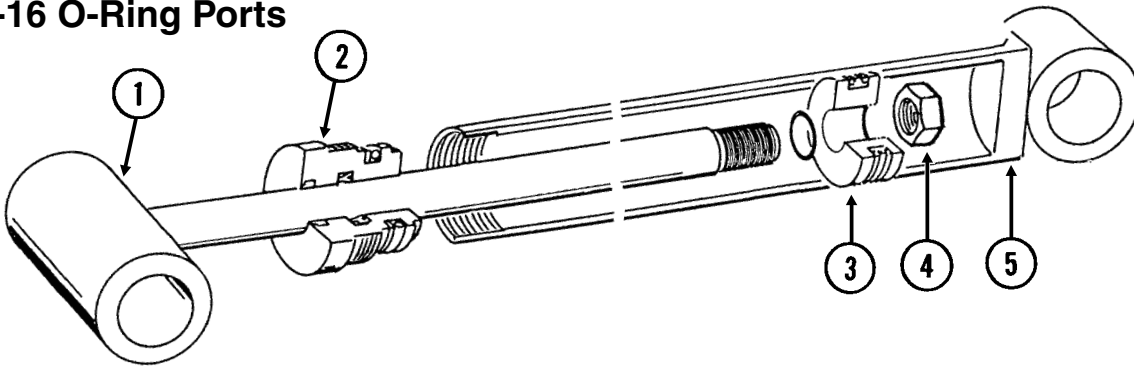

ITEM	PART NO.	QTY.	DESCRIPTION
1.	GA9440	1	Rod Assembly
2.	GD12510	1	Gland
3.	GD12511	1	Piston
4.	G10967	1	Lock Nut, 3/4"-16
5.	A9442	1	Barrel <b>(Non-Stock Item)</b>
A.	GA9443	-	Cylinder Complete, 2" x 20 1/16" <i>(Part Number Stamped On Barrel)</i>
B.	GR1529	-	Seal Kit, Includes: (1) T-Seal, (2) O-Rings, (1) BU Ring, (2) U-Cups, (1) Wiper, (1) IS511 Instruction

# ROW MARKER SEQUENCING/FLOW CONTROL VALVE

VVB025(PT9cc)

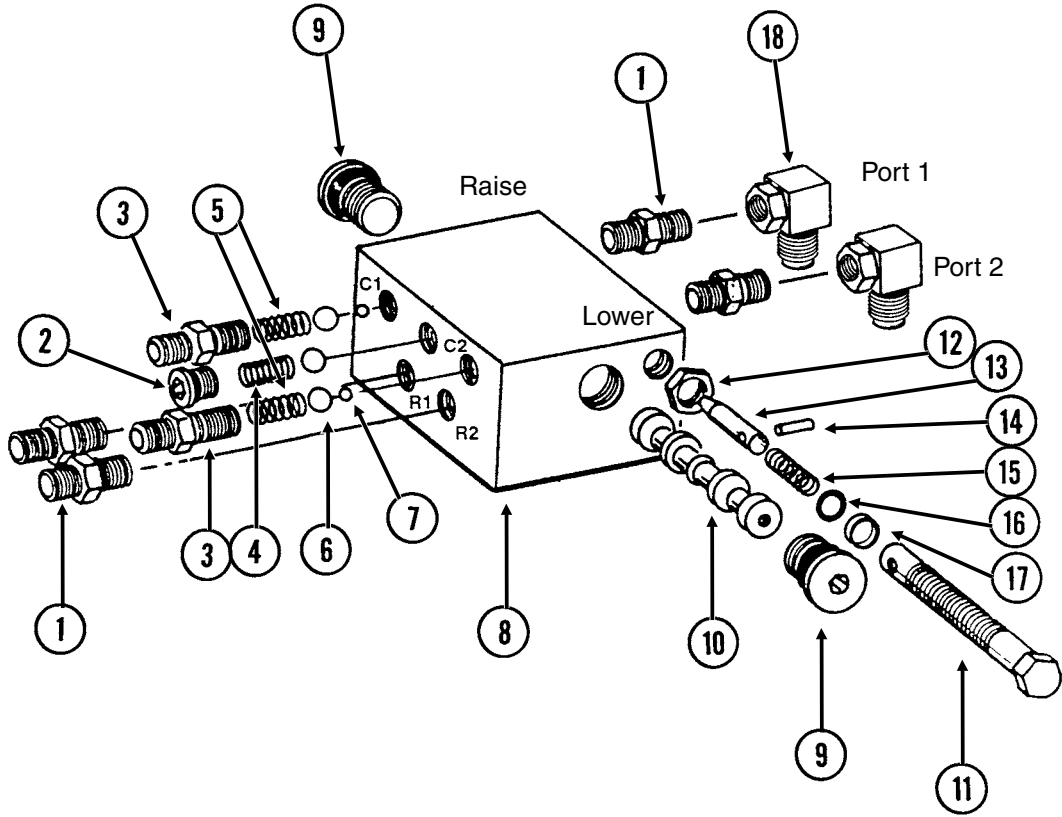

# ROW MARKER SEQUENCING/FLOW CONTROL VALVE

---

ITEM	PART NO.	QTY.	DESCRIPTION
1.	*G6400-06	4	Connector W/O-Ring, 1/16"-18 Male JIC To O-Ring
	GR1045	-	O-Ring
2.	GR1034	1	Hex Socket Plug W/O-Ring
	GR1035	-	O-Ring
3.	GR1032	2	Port Adapter W/O-Ring
	GR1045	-	O-Ring
4.	GR1033	1	Detent Spring
5.	GR1036	2	Spring
6.	GR1044	3	7/16" Check Ball
7.	GR1043	2	1/4" Steel Ball
8.		-	Valve Body ( <b>Non-Stock Item</b> )
9.	GR1047	2	Hex Socket Plug W/O-Ring
	GR1037	-	O-Ring
10.		-	Spool ( <b>Non-Stock Item</b> )
11.	GR1042	2	Adjustment Screw
12.	GR1048	2	Hex Jam Nut, 1/2"-20
13.	GR1038	2	Needle
14.	GR1039	2	Spring Pin
15.	GR1046	2	Compression Spring
16.	GR1040	2	O-Ring
17.	GR1041	2	Teflon BU Ring
18.	G6801-06	2	Elbow W/O-Ring, 90°, 1/16"-18 Male JIC To O-Ring
	GR1045	-	O-Ring
A.	GA5552	-	Valve Assembly Complete (Items 1-17)
B.	GA5572	-	Flow Control Portion Only (Items 11-17)

\*Not used on sizes with 3/8" hoses.

# ROW MARKER HYDRAULIC SYSTEM

PHS034(MT19d)

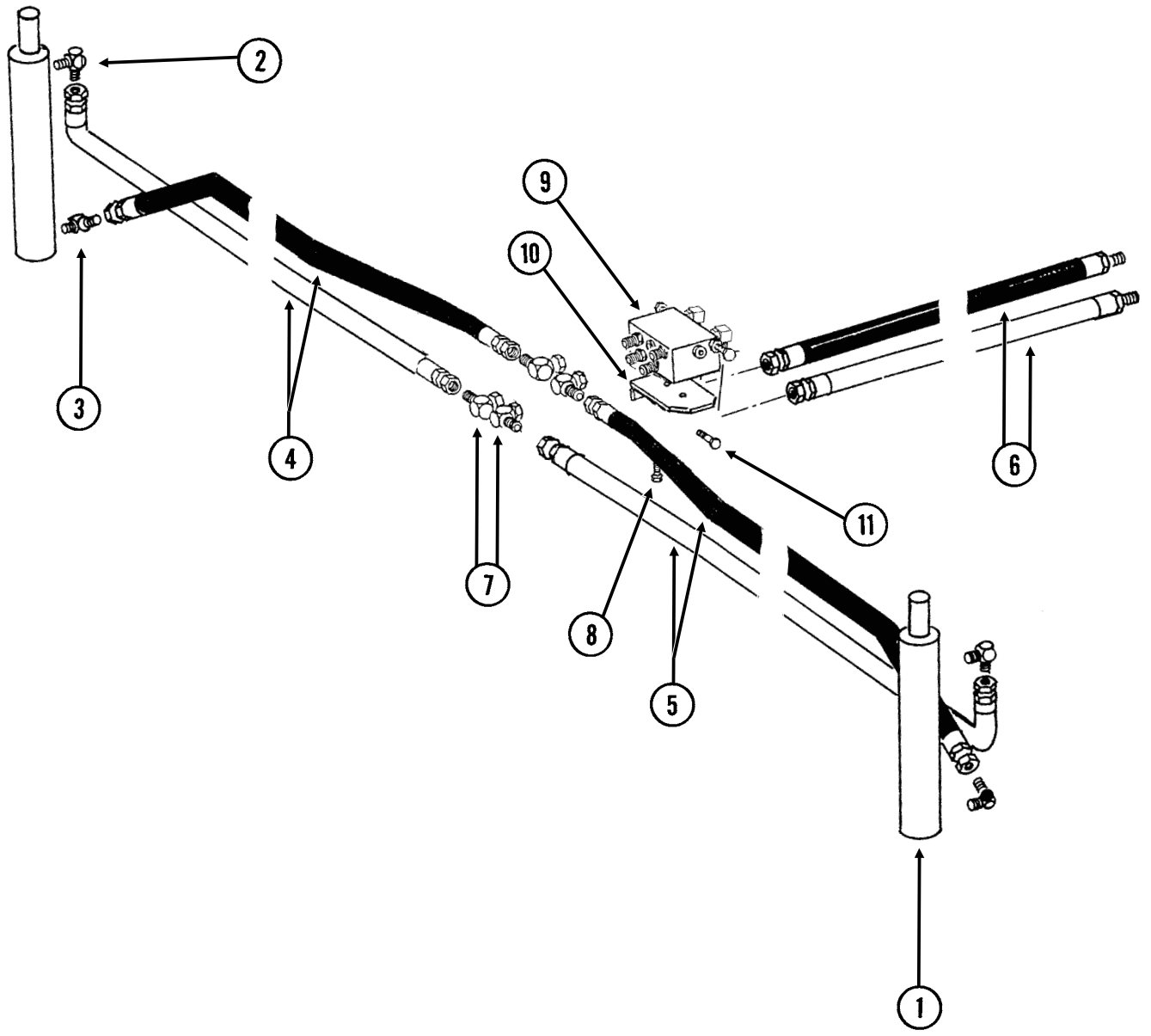

# ROW MARKER HYDRAULIC SYSTEM

ITEM	PART NO.	QTY.	DESCRIPTION
1.		-	See "Row Marker Cylinder", Pages P62 And P63
2.	G6801-06-08	2	Elbow W/O-Ring, 90°, 1/16"-18 Male JIC To 3/4"-16 O-Ring, 6 Row 30"
	GR1037	-	O-Ring
	G6801-08	-	Elbow W/O-Ring, 90°, 3/4"-16 Male JIC To O-Ring, 6 Row 36"/38"/40" And 8 Row 30"/36"/38"/40"
	GR1037	-	O-Ring
3.	G6801-06-08	2	Elbow W/O-Ring, 90°, 1/16"-18 Male JIC To 3/4"-16 O-Ring, 6 Row 30"
	GR1037	-	O-Ring
	G6400-08	-	Connector W/O-Ring, 3/4"-16 Male JIC To O-Ring, 6 Row 36"/38"/40" And 8 Row 30"/36"/38"/40"
	GR1037	-	O-Ring
	G6400-08-04	-	Connector W/O-Ring, 3/4"-16 Male JIC To 7/16"-20 O-Ring 6 Row 36"/38"/40" And 8 Row 30"/36"/38"/40"
	GR1465	-	O-Ring
4.	*A1106	-	Hose Assembly, 1/4" x 130", 6 Row 30"
	*A3114	-	Hose Assembly, 3/8" x 156", 6 Row 36"/38"/40"
	*A1049	-	Hose Assembly, 3/8" x 160", 8 Row 30"
	*A3154	-	Hose Assembly, 3/8" x 196", 8 Row 36"/38"/40"
5.	*A1168	-	Hose Assembly, 1/4" x 120", 6 Row 30"
	*A3115	-	Hose Assembly, 3/8" x 146", 6 Row 36"/38"/40"
	*A1013	-	Hose Assembly, 3/8" x 150", 8 Row 30"
	*A1028	-	Hose Assembly, 3/8" x 186", 8 Row 36"/38"/40"
6.	*A3186	2	Hose Assembly, 3/8" x 56"
7.	G6500-06	4	Swivel Elbow, 90°, 1/16"-18 Male JIC To Female, 6 Row 30"
	G6500-08-06	-	Swivel Elbow, 90°, 3/4"-16 Male JIC To 1/16"-18 Female, 6 Row 36"/38"/40" And 8 Row 30"/36"/38"/40"
8.	G10001	2	Hex Head Cap Screw, 3/8"-16 x 1"
	G10229	2	Lock Washer, 3/8"
9.			See "Row Marker Sequencing/Flow Control Valve", Pages P64 And P65
10.	GD10205	1	Mounting Angle
11.	G10017	2	Hex Head Cap Screw, 1/2"-13 x 1 1/2"
	G10111	2	Lock Nut, 1/2"-13

\* Hydraulic hose is not stocked by KINZE® Repair Parts, but can be made available on a special order basis. Call for quote.

# ELECTRICAL COMPONENTS

PFA043(PT49a/A9507a/MTR27a/ELC8)

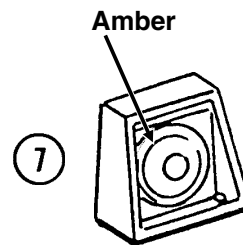
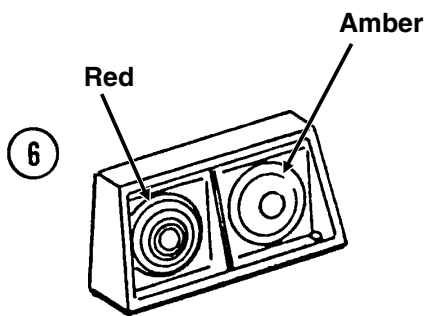
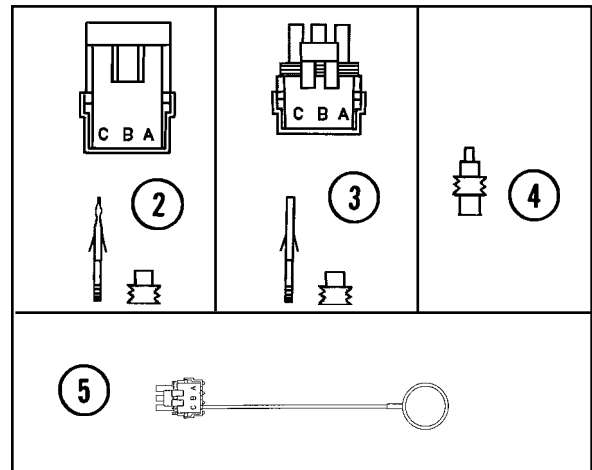
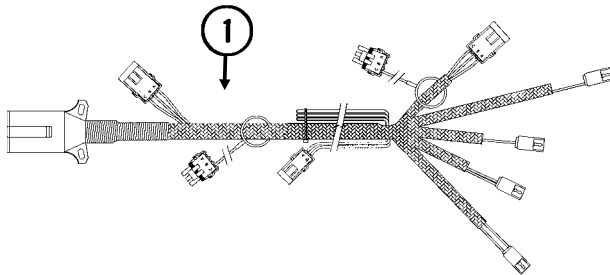

See "Toolbar Assembly", pages P40 and P41 for light brackets.

See "Digital Vacuum Gauge, Analog Vacuum Gauge And Vacuum Fan Assembly", pages P32 and P33 for those electrical components.



# ELECTRICAL COMPONENTS

---

ITEM	PART NO.	QTY.	DESCRIPTION
1.	GA9507	-	Wiring Harness W/7 Terminal Female Connector, 186", 6 Row 30" (4 Light Connections)
	GA9509	-	Wiring Harness W/7 Terminal Female Connector, 264", 6 Row 36"/38"/40", 8 Row 30"/36"/38"/40" (4 Light Connections)
	GA5385	-	7 Terminal Female Connector
2.	G1K248	-	3-Pin Female Connector Kit (Black), Includes: (3) 3-Pin Female Housings, (9) Pin Contacts, (9) Seals
3.	G1K252	-	3-Pin Male Connector Kit (Black), Includes: (3) 3-Pin Male Housings, (9) Socket Contacts, (9) Seals
4.	GD11089	-	Sealing Plug
5.	GA8047	-	Dust Plug (Black)
6.	GA6699	1	Double Light Assembly (Shown)
	GA6700	1	Double Light Assembly
	GR1203	-	Red Lens
	GR1204	-	Amber Lens
	GR1205	-	Cover
	GR1206	-	Rubber Grommet (4)
	GR1207	-	Lamp Unit
	GR1208	-	Bulb
7.	GA6701	2	Single Amber Light Assembly
	GR1204	-	Amber Lens
	GR1206	-	Rubber Grommet (2)
	GR1207	-	Lamp Unit
	GR1208	-	Bulb

# KPM I ELECTRONIC SEED MONITOR

(MTR46b/A11948)

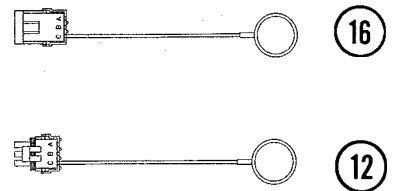
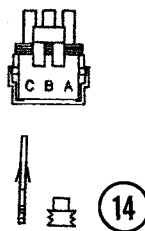
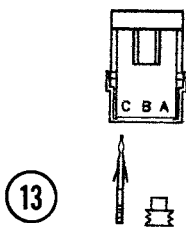
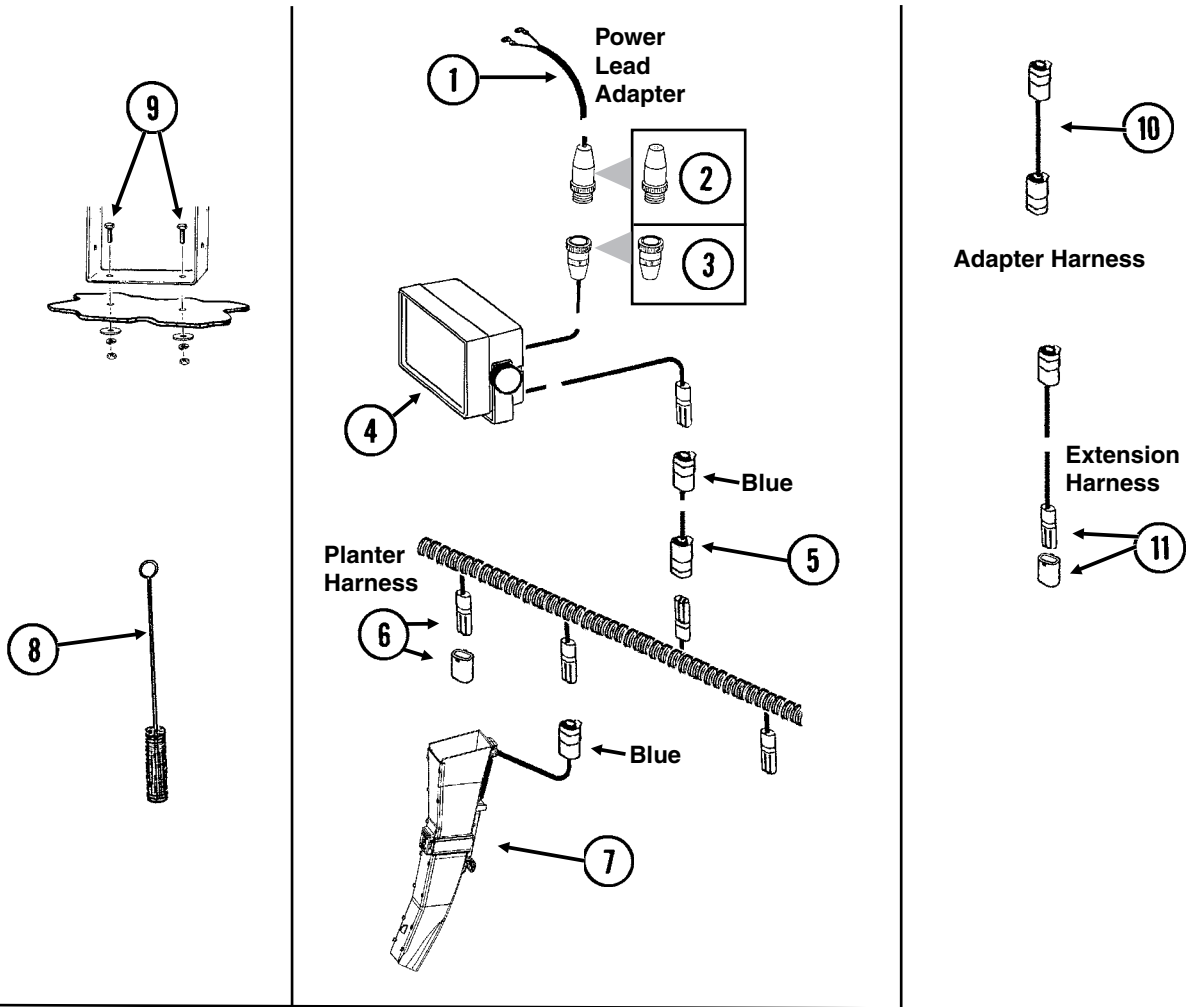

# KPM I ELECTRONIC SEED MONITOR

ITEM	PART NO.	QTY.	DESCRIPTION
1.	GA7856	1	Power Lead Adapter
2.	G1K267	-	Power Lead Adapter Connector Kit, Includes: (1) Cable Clamp, (1) 3-Pin Connector, (3) Male Terminal Pins
3.	G1K268	-	Console Cable Connector Kit, Includes: (1) Cable Clamp, (1) 3-Pin Connector, (1) Lock Ring, (3) Female Terminal Pins
4.	GA10570	1	KPM I Backlit Console W/Mounting Bracket, Fuse Holder And Fuse, Power Lead Adapter (Item 11), Brush (Item 23) And Dust Plug (Item 34)
	GR1390	-	Mounting Bracket, KPM I
	GR1392	-	Console Mounting Bracket Hardware Package (Includes 2 Knobs And 1/4" Hardware)
	GA10601	-	Fuse Holder
	GD7639	-	Fuse
5.		-	See Planter Wiring Harness, Item 1 On Pages P68 And P69
6.	GA8022	-	Planter Harness W/Dust Caps, 6 Row (9 Connectors)
	GA7850	-	Planter Harness W/Dust Caps, 8 Row (12 Connectors)
	GD11993	-	Dust Cap
7.	GA11948	-	Seed Tube W/Computerized Sensor, EdgeVac®
	GR1737	-	Sensor Only, EdgeVac®
	GA11947	-	Seed Tube (With Holes For Sensor Installation), EdgeVac®
8.	GR0594	-	Brush
9.	G10022	2	Hex Head Cap Screw, 1/4"-20 x 1/2"
	G10211	2	Washer, 1/4" SAE
	G10227	2	Lock Washer, 1/4"
	G10103	2	Hex Nut, 1/4"-20
10.	GA7857	-	Adapter Harness, 1'
11.	GA7854	-	Extension Harness W/Dust Cap, 15'
	GA7855	-	Extension Harness W/Dust Cap, 30'
	GD11993	-	Dust Cap
12.	GA8047	-	Dust Plug (Black)
	GA9979	-	Dust Plug (Blue)
13.	G1K248	-	3-Pin Female Connector Kit (Black), Includes: (3) 3-Pin Female Housings, (9) Pin Contacts, (9) Seals
	G1K362	-	3-Pin Female Connector Kit (Blue), Includes: (3) 3-Pin Female Housings, (9) Pin Contacts, (9) Seals
14.	G1K252	-	3-Pin Male Connector Kit (Black), Includes: (3) 3-Pin Male Housings, (9) Socket Contacts, (9) Seals
	G1K363	-	3-Pin Male Connector Kit (Blue), Includes: (3) 3-Pin Male Housings, (9) Socket Contacts, (9) Seals
15.	GD11089	-	Sealing Plug
16.	GA8046	-	Dust Plug (Black)
	GA9978	-	Dust Plug (Blue)

# KPM II STACK-MODE/KPM III ELECTRONIC SEED MONITORS

(MTR46c)

**Radar Distance Sensor**

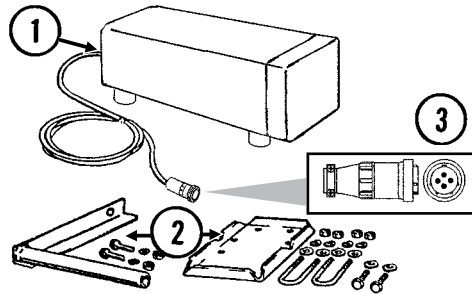

**Magnetic Distance Sensor (MDS)**

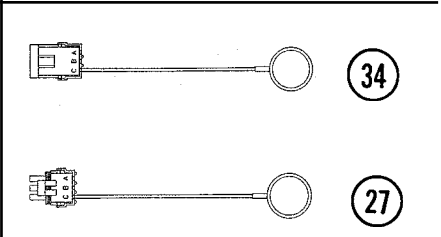
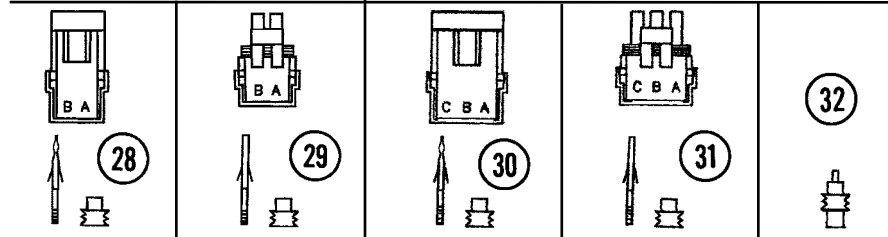
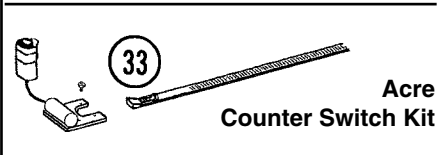
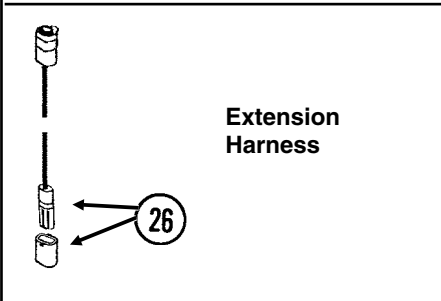
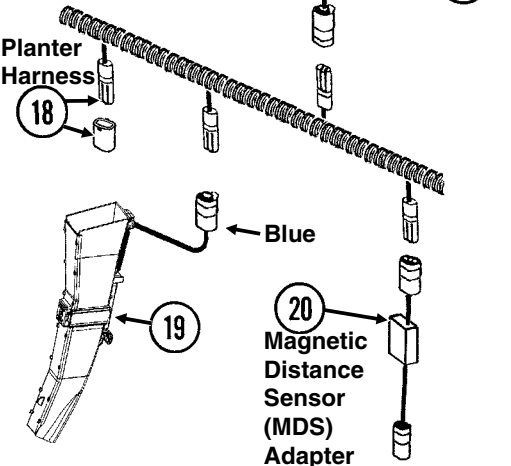
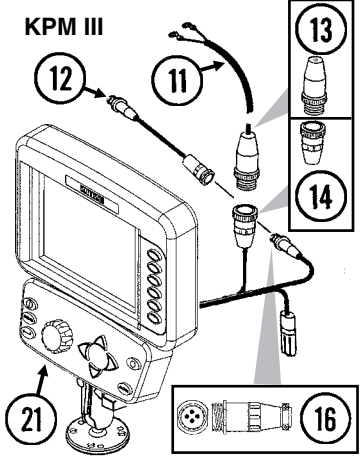
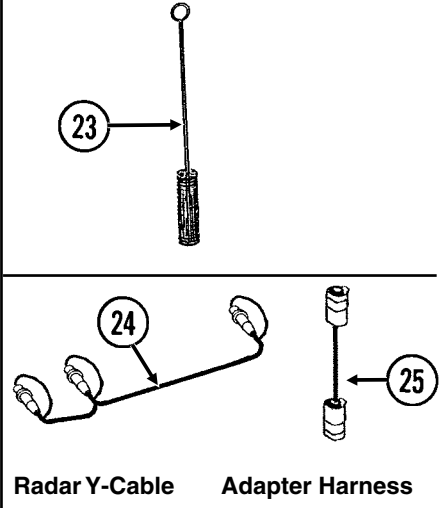
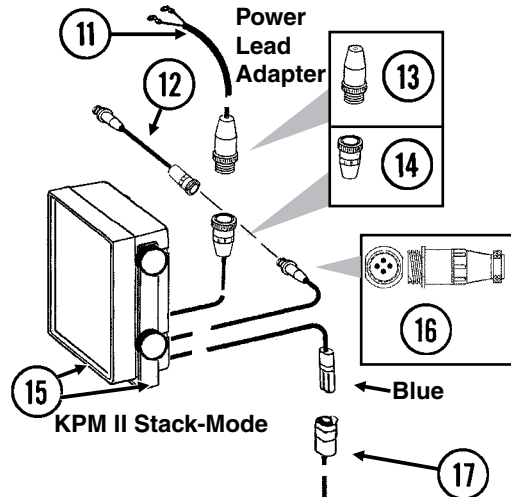
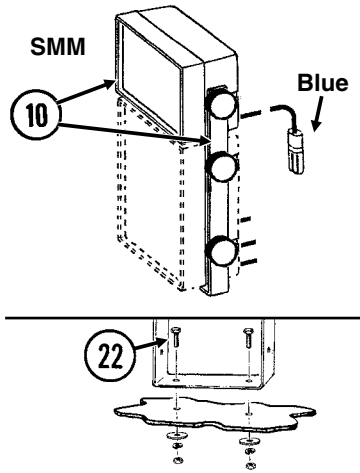
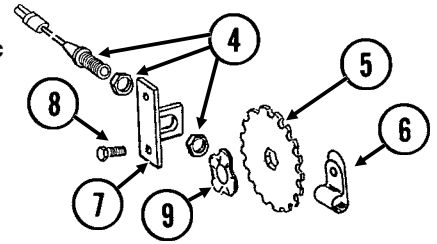

ITEM	PART NO.	QTY.	DESCRIPTION
1.	GA7858	-	Radar Distance Sensor W/20' Cable
2.	GA8026	-	Radar Sensor Pipe/Mounting Bracket Package
3.	G1K323	-	4-Pin Connector Kit W/Female Housing, Includes: (4) Pins And (1) Cable Clamp
4.	GA5600	1	Magnetic Distance Sensor
5.	GD8751	-	Magnetic Distance Sensor Pulse Wheel
6.	GD6291	-	Insulated Clamp, 3/8"
7.	GD8770	1	Bracket
8.	G10001	2	Hex Head Cap Screw, 3/8"-16 x 1"
	G10229	2	Lock Washer, 3/8"
	G10101	2	Hex Nut, 3/8"-16

# KPM II STACK-MODE/KPM III ELECTRONIC SEED MONITORS

ITEM	PART NO.	QTY.	DESCRIPTION
9.	GD8771	1	Spring Wave Washer
10.	GA9857	1	SMM Backlit Console W/Mounting Bracket And Dust Plug (Item 36)
	GR1631	-	Mounting Bracket, KPM II Stack-Mode And SMM Consoles
	GR1632	-	Console Mounting Bracket Hardware Package (Includes 2 Knobs And 1/4" Hardware)
11.	GA7856	1	Power Lead Adapter
12.	GA9144	-	Monitor/Radar Adapter Cable, 10"
13.	G1K267	-	Power Lead Adapter Connector Kit, Includes: (1) Cable Clamp, (1) 3-Pin Connector, (3) Male Terminal Pins
14.	G1K268	-	Console Cable Connector Kit, Includes: (1) Cable Clamp, (1) 3-Pin Connector, (1) Lock Ring, (3) Female Terminal Pins
15.	GA10575	-	KPM II Backlit Console W/Mounting Bracket, Fuse Holder And Fuse, Power Lead Adapter (Item 11), Brush (Item 23), Dust Plug (Item 34) And Monitor/Radar Adapter, 10" (Item 12)
	GR1391	-	Mounting Bracket, KPM II
	GR1393	-	Console Mounting Bracket Hardware Package (Includes 4 Knobs And 1/4" Hardware)
	GA10601	-	Fuse Holder
	GD7639	-	Fuse
16.	G1K322	-	4-Pin Connector Kit W/Male Housing, (4) Female Socket Contacts And (1) Cable Clamp
17.		-	Included In Light Wiring Harness, See Item 1 On Pages P68 And P69
18.	GA8022	-	Planter Harness W/Dust Caps, 6 Row (9 Connectors)
	GA7850	-	Planter Harness W/Dust Caps, 8 Row (12 Connectors)
	GD11993	-	Dust Cap
19.	GA11948	-	Seed Tube W/Computerized Sensor, EdgeVac®
	GR1737	-	Sensor Only, EdgeVac®
	GA11947	-	Seed Tube (With Holes For Sensor Installation), EdgeVac®
20.	GA7859	1	Magnetic Distance Sensor Adapter (Analog To Digital)
21.	GA11039	1	KPM III Backlit Console W/Brush (Item 23), Dust Plug (Item 34), Mounting Bracket Assembly, Console Mounting Bracket Hardware And Power Harness
	GR1761	-	Mounting Bracket Assembly, Includes: (2) Mounting Brackets, (2) Connector Halves, (1) Compression Spring, (1) Tension Knob, (1) 1/4"-20 x 1 3/4" Hex Head Cap Screw, (1) 1/4" Plastic Washer, (1) 1/4" Steel Washer
	GR1762	-	Console Mounting Bracket Hardware Package, Includes: (3) No. 10-32 x 5/8" Hex Socket Pan Head Screws, (3) No. 20 Lock Washers
	GR1764	-	Power Harness
22.	G10022	2	Hex Head Cap Screw, 1/4"-20 x 1/2"
	G10211	2	Washer, 1/4" SAE
	G10227	2	Lock Washer, 1/4"
	G10103	2	Hex Nut, 1/4"-20
23.	GR0594	-	Brush
24.	GR0586	1	Radar Y-Cable (Used To Connect Radar Distance Sensor For Multiple Functions)
25.	GA7857	-	Adapter Harness, 1'
26.	GA7854	-	Extension Harness W/Dust Cap, 15'
	GA7855	-	Extension Harness W/Dust Cap, 30'
	GD11993	-	Dust Cap
27.	GA8047	-	Dust Plug (Black)
	GA9979	-	Dust Plug (Blue)
28.	G1K321	-	2-Pin Female Connector Kit (Black), Includes: (3) 2-Pin Female Housings, (6) Pin Contacts, (6) Seals
29.	G1K320	-	2-Pin Male Connector Kit (Black), Includes: (3) 2-Pin Male Housings, (6) Socket Contacts, (6) Seals
30.	G1K248	-	3-Pin Female Connector Kit (Black), Includes: (3) 3-Pin Female Housings, (9) Pin Contacts, (9) Seals
	G1K362	-	3-Pin Female Connector Kit (Blue), Includes: (3) 3-Pin Female Housings, (9) Pin Contacts, (9) Seals
31.	G1K252	-	3-Pin Male Connector Kit (Black), Includes: (3) 3-Pin Male Housings, (9) Socket Contacts, (9) Seals
	G1K363	-	3-Pin Male Connector Kit (Blue), Includes: (3) 3-Pin Male Housings, (9) Socket Contacts, (9) Seals
32.	GD11089	-	Sealing Plug
33.	G1K249	-	Acre Counter Switch Kit
34.	GA8046	-	Dust Plug (Black)
	GA9978	-	Dust Plug (Blue)
A.	GA6147	-	Magnetic Distance Sensor And Mounting Package (Items 4-9)

# DECALS, PAINT AND MISCELLANEOUS

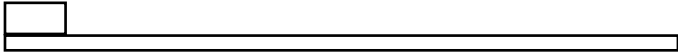

1

**WARNING**

THIS MACHINE HAS BEEN DESIGNED AND BUILT WITH YOUR SAFETY IN MIND. DO NOT MAKE ANY ALTERATIONS OR CHANGES TO THIS MACHINE. ANY ALTERATION TO THE DESIGN OR CONSTRUCTION MAY CREATE SAFETY HAZARDS.

7100-90

2

**DANGER**

THIS PLANTER IS DESIGNED TO BE DRIVEN BY GROUND TIRES ONLY. THE USE OF HYDRAULIC, ELECTRIC OR PTO DRIVES MAY CREATE SERIOUS SAFETY HAZARDS TO YOU AND THE PEOPLE NEARBY. IF YOU INSTALL SUCH DRIVES YOU MUST FOLLOW ALL APPROPRIATE SAFETY STANDARDS AND PRACTICES TO PROTECT YOU AND OTHERS NEAR THIS PLANTER FROM INJURY.

7100-89

3

**WARNING**

TO AVOID INJURY -- STAND CLEAR--KEEP OTHERS AWAY WHEN RAISING OR LOWERING MARKERS. BEFORE TRANSPORTING PLANTER FULLY EXTEND HYDRAULIC CYLINDERS AND INSTALL LOCKING PINS WHERE PROVIDED.

7100-42

4

**WARNING**

1. Read and understand the Operator's Manual.
2. Stop the tractor engine before leaving the operator's platform.
3. Keep riders off the machine.
4. Make certain everyone is clear of the machine before starting the tractor engine and operating.
5. Keep all shields in place.
6. Never lubricate, adjust, unclog or service the machine with tractor engine running.
7. Wait for all movement to stop before servicing.
8. Keep hands, feet and clothing away from moving parts.
9. Use flashing warning lights when operating on highways except when prohibited by law.

7100-46

5

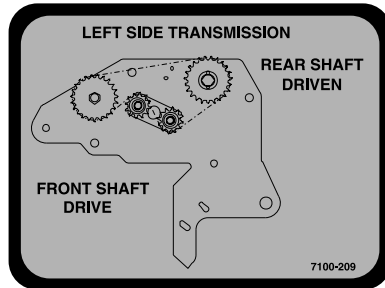

6

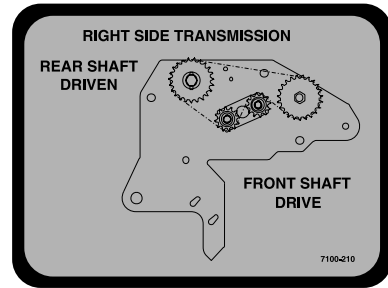

7

# KINZE

8

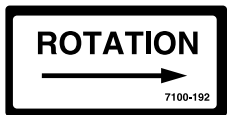

9



10

**WARNING**

AGRICULTURAL CHEMICALS CAN BE DANGEROUS. IMPROPER SELECTION OR USE CAN SERIOUSLY INJURE PERSONS, ANIMALS, PLANTS, SOIL OR OTHER PROPERTY. BE SAFE. SELECT THE RIGHT CHEMICAL FOR THE JOB. HANDLE WITH CARE. FOLLOW THE INSTRUCTIONS ON THE CONTAINER LABEL AND OF THE EQUIPMENT MANUFACTURER.

7100-115

11

USE 1 TABLESPOON POWDERED GRAPHITE WITH EACH HOPPER FILL OF SEED. SEED TREATMENT, FOREIGN MATERIAL, DIRT, OR SEED CHAFF MAY CAUSE GRADUAL REDUCTION OF SEED POPULATION. REFER TO MANUAL FOR MAINTENANCE AND CARE.

7100-153

12

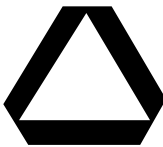

13

**NOTE**

It is the responsibility of the user to read and understand the Operator's Manual in regards to safety, operation, lubrication and maintenance before operation of this equipment.

AN OPERATOR & PARTS MANUAL IS AVAILABLE FOR THIS MACHINE.

To obtain a manual, furnish model number and serial number and contact your KINZE Dealer or KINZE Manufacturing, Inc., P.O. Box 806 Williamsburg, IA 52361-0806 USA

14

# 3110

15

TORQUE 5/8" SPINDLE BOLTS TO 120 FT/LBS. CHECK PERIODICALLY AND RE-TORQUE AS NEEDED.

7100-234

16

ROTATE KNURLED COLLAR ON WRAP SPRING TIGHTENER TO RELEASE SPRING TENSION

7100-295

17



18



19



20



21

# DECALS, PAINT AND MISCELLANEOUS



22



23

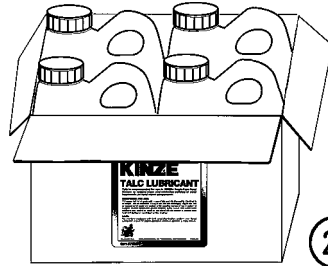

24



25

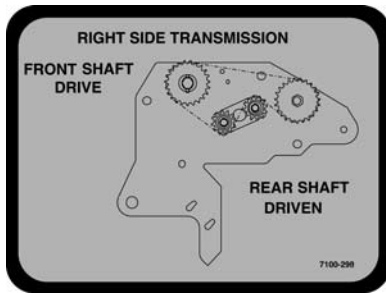

26

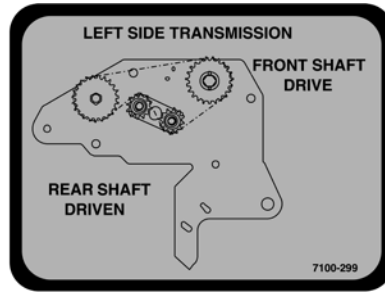

27



28



29

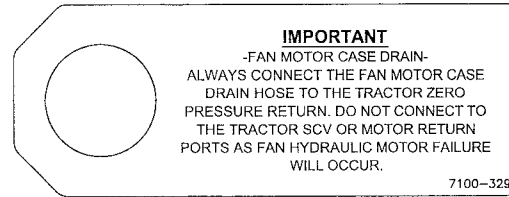

30

ITEM	PART NO.	QTY.	DESCRIPTION
1.	GD1512	-	Tie Strap, 7 1/2"
	GD2117	-	Tie Strap, 14 1/2"
2.	G7100-90	1	Decal, Warning
3.	G7100-89	2-4	Decal, Danger
4.	G7100-42	4	Decal, Warning
5.	G7100-46	1	Decal, Warning
6.	G7100-209	1	Decal, Transmission, L.H. Side
7.	G7100-210	1	Decal, Transmission, R.H. Side
8.	G7100-104	1	Decal, KINZE®, 3" x 12"
9.	G7100-192	-	Decal, Point Row Clutch Rotation
10.	G7100-247	-	Decal, Logo, 4 3/8" x 4 1/2" (2 Per Row Unit)
	G7100-252	-	Decal, Logo, 3 1/2" x 3 5/8" (Hopper Panel Extension)
11.	G7100-115	-	Decal, Warning (1 Per Granular Chemical Hopper)
12.	G7100-153	-	Decal, Information (1 Per Seed Meter)
13.	G7100-36	1	SMV Sign
14.	G7100-217	-	Decal, Note
15.	G7100-297	1	Decal, 3110
16.	G7100-234	-	Decal, Bolt Torque
17.	G7100-295	1	Decal, Spring Tension Release
18.	G7100-111	-	Decal, Oil Daily
19.	G7100-116	-	Decal, Grease Daily
20.	G7100-258	-	Reflective Decal, Red, 1 1/2" x 9", Rectangular (If Applicable)
	G7100-259	-	Reflective Decal, Amber, 1 1/2" x 9", Rectangular (If Applicable)
	G7100-260	-	Reflective Decal, Orange, 1 1/2" x 9", Rectangular (If Applicable)

# DECALS, PAINT AND MISCELLANEOUS

---

ITEM	PART NO.	QTY.	DESCRIPTION
21.	G7100-261	-	Reflective Decal, Red, 1 3/4" x 9", Die-Cut (If Applicable)
	G7100-262	-	Reflective Decal, Amber, 1 3/4" x 9", Die-Cut (If Applicable)
	G7100-263	-	Reflective Decal, Orange, 1 3/4" x 9", Die-Cut (If Applicable)
22.	GR0146MPP	-	Powdered Graphite, Twenty-Four 1 Pound Containers
23.	GR0155MPP	-	Blue Paint, Twelve Aerosol Cans
24.	GR1570MPP	-	Talc Lubricant, Four 8 Pound Containers
	GR1828	-	Talc Lubricant, 30 Pound Container
25.	GM0183	-	Operator & Parts Manual, Model 3110 (EdgeVac® Seed Metering)
26.	G7100-298	-	Decal, Transmission, R.H. Side (Front Mounted Drive Wheels)
27.	G7100-299	-	Decal, Transmission, L.H. Side (Front Mounted Drive Wheels)
28.	G7100-311	-	Decal, EdgeVac®
29.	G7100-301	2	Decal, Warning
30.	G7100-329	-	Tag, Fan Motor Case Drain



# NUMERICAL INDEX

Part No.	Page	Part No.	Page	Part No.	Page
*A1013.....	P67	G10063.....	P33	G10228.....	P7, P27, P37,
*A1028.....	P67	G10064.....	P10, P41, P49	.....	P39, P41, P47, P49,
*A1049.....	P67	G10069.....	P49	.....	P51, P57, P59, P61
*A1106.....	P67	G10082.....	P43	G10229.....	P4, P10, P11, P17,
*A1168.....	P67	G10101.....	P4, P10, P11, P19,	.....	P19, P29, P33, P47,
*A3114.....	P67	.....	P33, P49, P53, P72	.....	P49, P53, P67, P72
*A3115.....	P67	G10102.....	P9, P27, P31, P37,	G10230.....	P4, P7, P10,
*A3154.....	P67	.....	P39, P41, P49, P49,	.....	P11, P41, P43, P57
*A3186.....	P67	.....	P51, P57, P59, P61	G10231.....	P43
*A3266.....	P35	G10103.....	P19, P49,	G10232.....	P9, P45, P46,
*A3292.....	P35	.....	P53, P71, P73	.....	P47, P57, P59
*A3337.....	P35	G10104.....	P4, P11, P39,	G10233.....	P45, P47, P49, P53
*A3367.....	P35	.....	P41, P43, P49	G10253.....	P53
*A8247.....	P35	G10106.....	P9, P25, P45, P46,	G10257.....	P18, P53
*A8273.....	P35	.....	P47, P49, P57, P59	G10260.....	P15
*G6400-06.....	P65	G10107.....	P9, P10, P21,	G10303.....	P9, P23, P45, P47
A10759.....	P17	.....	P25, P31, P45,	G10304.....	P3
A6911.....	P41	.....	P47, P49, P51	G10305.....	P20
A6912.....	P41	G10108.....	P3, P12,	G10306.....	P19
A6913.....	P41	.....	P17, P33, P41	G10308.....	P10, P20
A6914.....	P41	G10109.....	P7, P9, P10,	G10309.....	P12
A8775.....	P62	.....	P23, P27, P29,	G10310.....	P19
A9442.....	P63	.....	P31, P46, P61	G10312.....	P3, P17, P39
G10001.....	P4, P9, P10,	G10110.....	P19, P41	G10315.....	P9, P10, P19
.....	P33, P67, P72	G10111.....	P10, P21, P23,	G10318.....	P25
G10002.....	P17	.....	P25, P27, P31,	G10323.....	P15
G10003.....	P3, P19, P29, P53	.....	P41, P46, P53, P67	G10325.....	P5, P17
G10004.....	P49	G10112.....	P31	G10326.....	P3
G10005.....	P31, P43, P45, P51	G10117.....	P43	G10328.....	P5
G10006.....	P9, P27	G10128.....	P47, P49, P51	G10338.....	P7, P12, P46
G10007.....	P5, P11, P31	G10130.....	P49, P53	G10348.....	P27
G10008.....	P57	G10133.....	P10, P27, P29,	G10371.....	P27
G10010.....	P7, P29, P31	.....	P31, P57, P59	G10396.....	P41
G10011.....	P31	G10152.....	P9	G10397.....	P51
G10013.....	P10	G10168.....	P61	G10400.....	P31
G10014.....	P7, P31	G10171.....	P9	G10412.....	P4, P12
G10015.....	P9	G10187.....	P57	G10427.....	P5, P9
G10016.....	P41	G10194.....	P29, P43	G10438.....	P3
G10017.....	P23, P25, P67	G10201.....	P3, P17	G10452.....	P19
G10018.....	P7, P9	G10203.....	P3, P33, P53	G10459.....	P43
G10019.....	P61	G10204.....	P5, P7	G10460.....	P57, P59
G10022.....	P71, P73	G10205.....	P31, P33, P49	G10462.....	P46
G10023.....	P17, P53	G10206.....	P29, P45, P47	G10463.....	P9
G10026.....	P43	G10207.....	P3	G10496.....	P46, P53
G10033.....	P27, P47	G10209.....	P18, P19, P41, P47	G10497.....	P53
G10036.....	P21, P47	G10210.....	P3, P9, P10, P11,	G10499.....	P33
G10037.....	P39, P46	.....	P12, P17, P47, P49	G10501.....	P27, P45
G10038.....	P37, P39, P47	G10211.....	P71, P73	G10503.....	P23, P25,
G10039.....	P23, P25, P31	G10213.....	P5, P29, P31	.....	P29, P31, P47
G10040.....	P49	G10216.....	P7, P23, P25, P37,	G10523.....	P19
G10045.....	P27	.....	P39, P46, P47, P51	G10529.....	P20
G10046.....	P31	G10219.....	P9, P23, P49	G10536.....	P23, P25
G10047.....	P3, P47	G10226.....	P59	G10544.....	P61
G10048.....	P41	G10227.....	P19, P47, P49,	G10546.....	P12, P18
G10049.....	P53	.....	P53, P71, P73	G10551.....	P3
G10061.....	P12			G10567.....	P12, P17, P18

# NUMERICAL INDEX

Part No.	Page	Part No.	Page	Part No.	Page
G10570	P18	G11073	P18	G6408-06	P37
G10572	P25	G11075	P46	G6408-12	P37
G10574	P21, P27, P31	G11078	P46	G6500-06	P36, P37, P67
G10581	P47, P49	G11081	P43	G6500-08-06	P67
G10585	P23, P25	G11098	P29	G6801-06	P65
G10597	P23, P25	G11100	P47	G6801-06-08	P67
G10599	P10, P11, P33	G11123	P33	G6801-08	P67
G10602	P12, P15, P17, P18, P45, P47, P49	G11124	P33	G6801-10	P37
G10603	P15	G11133	P33	G6801-10-12	P36
G10610	P43	G11137	P39	G6801-12	P36, P37
G10620	P3, P7, P12, P17, P39	G11145	P39	G7100-104	P75
G10621	P12, P17, P20	G11172	P15	G7100-111	P75
G10622	P5, P20	G11173	P15	G7100-115	P75
G10640	P7, P57, P59	G11209	P19	G7100-116	P75
G10641	P43, P59	G11210	P15	G7100-153	P75
G10643	P31	G11213	P15	G7100-192	P75
G10660	P18	G11215	P33	G7100-209	P75
G10669	P3	G11228	P29	G7100-210	P75
G10670	P17, P57	G11236	P29	G7100-217	P75
G10676	P39	G1K248	P69, P71, P73	G7100-234	P75
G10678	P41	G1K249	P73	G7100-247	P75
G10722	P61	G1K252	P69, P71, P73	G7100-252	P75
G10724	P61	G1K267	P55, P71, P73	G7100-258	P75
G10725	P61	G1K268	P33, P55, P71, P73	G7100-259	P75
G10730	P31	G1K269	P49, P53	G7100-260	P75
G10732	P4	G1K296	P7	G7100-261	P76
G10751	P12	G1K320	P73	G7100-262	P76
G10752	P12	G1K321	P73	G7100-263	P76
G10753	P33	G1K322	P73	G7100-295	P75
G10757	P19	G1K323	P72	G7100-297	P75
G10758	P19	G1K345	P10	G7100-298	P76
G10765	P29, P31, P53	G1K362	P71, P73	G7100-299	P76
G10801	P9, P10	G1K363	P71, P73	G7100-301	P76
G10804	P53	G1K377	P51	G7100-311	P76
G10844	P61	G1K380	P47	G7100-329	P76
G10859	P53	G1K381	P47	G7100-36	P75
G10861	P45	G1K385	P19	G7100-42	P75
G10864	P19	G1K426	P36	G7100-46	P75
G10879	P59	G1K467	P29	G7100-89	P75
G10900	P53	G2100-03	P47	G7100-90	P75
G10912	P5	G3303-104	P3	G7566X	P11
G10921	P18	G3303-108	P18	GA0167	P61
G10923	P49, P53	G3305-01	P20	GA0243	P61
G10924	P7	G3310-204	P51	GA0245	P61
G10940	P7	G3310-218	P45	GA0257	P61
G10944	P7	G3310-224	P45	GA0895	P43
G10967	P62, P63	G3310-68	P46	GA0899	P61
G10974	P29, P31	G3310-75	P49	GA10054	P53
G10996	P55	G3400-01	P47	GA10063	P47
G11007	P3	G6326X	P4	GA10137	P12
G11008	P3	G6400-06	P36, P37	GA10143	P33
G11009	P15	G6400-08	P67	GA10148	P33
G11010	P31	G6400-08-04	P67	GA10149	P36
G11015	P3	G6400-10	P37	GA10151	P12
G11028	P49	G6400-12	P37	GA10155	P12
		G6400-L-06	P37	GA10157	P3

# NUMERICAL INDEX

Part No.	Page	Part No.	Page	Part No.	Page
GA10570	P71	GA2094	P20	GA6733	P9
GA10575	P73	GA2147	P43	GA6741	P19
GA10601	P71, P73	GA2148	P43	GA6801	P9
GA10634	P13	GA2180	P49	GA6823	P41
GA10635	P33	GA2558	P43	GA6824	P41
GA10660	P43	GA4293	P37	GA6832	P27
GA10661	P43	GA4444	P17	GA6833	P27
GA10752	P33	GA4705	P43	GA6834	P27
GA10755	P15	GA4707	P41	GA6838	P27
GA10765	P33	GA4732	P41	GA6907	P19
GA10767	P39	GA4733	P41	GA7137	P53
GA10768	P39	GA5090	P45	GA7144	P55
GA10781	P41	GA5105	P45, P47, P49, P51	GA7154	P47, P49, P51
GA10782	P41	GA5106	P47	GA7165	P55
GA10799	P33	GA5107	P45, P47	GA7271	P29
GA10808	P39	GA5108	P47	GA7294	P43
GA10824	P39	GA5109	P47	GA7295	P43
GA11039	P73	GA5110	P47	GA7297	P45
GA11052	P46	GA5111	P47	GA7336	P47
GA11061	P39	GA5112	P47	GA7412	P29
GA11062	P39	GA5113	P47	GA7416	P55
GA11065	P39	GA5114	P45, P49	GA7417	P53
GA11154	P33	GA5130	P59	GA7418	P53
GA11155	P33	GA5173	P59	GA7445	P29, P31
GA11156	P33	GA5178	P57	GA7446	P27, P29, P31
GA11157	P33	GA5183	P57	GA7850	P71, P73
GA11175	P33	GA5188	P59	GA7854	P71, P73
GA11520	P21	GA5190	P59	GA7855	P71, P73
GA11591	P59	GA5192	P59	GA7856	P33, P55, P71, P73
GA11699	P33	GA5196	P43	GA7857	P71, P73
GA11766	P59	GA5202	P47	GA7858	P72
GA11767	P59	GA5385	P69	GA7859	P73
GA11911	P15	GA5548	P47	GA7949	P7
GA11934	P37	GA5552	P65	GA7975	P7
GA11935	P15	GA5572	P65	GA7976	P7
GA11947	P71, P73	GA5600	P72	GA8022	P71, P73
GA11948	P71, P73	GA5625	P21	GA8026	P72
GA11987	P33	GA5651	P4	GA8046	P71, P73
GA12133	P15	GA5654	P25, P27, P29, P31	GA8047	P69, P71, P73
GA12154	P15	GA5698	P15	GA8322	P10
GA12235	P29, P31	GA5715	P23, P25	GA8324	P5
GA12236	P27, P29, P31	GA5718	P25	GA8326	P18
GA12256	P29	GA5719	P23, P25	GA8328	P33, P55
GA1676	P61	GA5853	P61	GA8329	P33, P55
GA1677	P61	GA5892	P23	GA8364	P18
GA1678	P61	GA6078	P41	GA8371	P17
GA1679	P61	GA6147	P73	GA8393	P53
GA1720	P4	GA6171	P7, P9, P10	GA8603	P21, P31
GA2007	P12	GA6434	P10	GA8641	P21, P31
GA2012L	P5	GA6597	P10	GA8760	P29
GA2012R	P5	GA6618	P9	GA8918	P62
GA2014	P5, P9, P25, P27, P29, P31	GA6619	P9	GA8919	P62
GA2054	P9	GA6620	P9	GA9131	P31
GA2068	P45	GA6699	P69	GA9144	P73
GA2075	P19	GA6700	P69	GA9440	P63
		GA6701	P69	GA9443	P63

# NUMERICAL INDEX

Part No.	Page	Part No.	Page	Part No.	Page
GA9507	P69	GD10104	P53	GD1132	P25, P27, P29, P31
GA9509	P69	GD10123	P53	GD11413	P12, P18
GA9844	P31	GD10200	P53	GD11422	P4
GA9845	P31	GD10205	P67	GD11423	P7
GA9846	P45	GD1026	P3, P17, P47	GD11424	P17
GA9857	P73	GD10283	P61	GD1143	P20
GA9861	P31	GD10328	P43	GD1144	P20
GA9862	P31	GD10329	P45	GD1145	P20
GA9864	P31	GD1033	P3	GD11453	P7
GA9865	P31	GD10332	P45	GD11490	P43
GA9978	P71, P73	GD10336	P46	GD11508	P11
GA9979	P71, P73	GD10337	P47	GD11509	P11
GB0115	P18	GD10403	P43	GD11652	P21, P31
GB0116	P18	GD10407	P47	GD1166	P43
GB0186	P4	GD10473	P5, P9	GD11677	P21
GB0213	P31	GD10510	P53	GD11845	P3, P5, P9
GB0218	P4, P12, P31	GD10519	P29, P31	GD11936	P7
GB0239	P9, P10	GD10525	P53	GD11962	P3, P17
GB0254	P10	GD10526	P29	GD11993	P71, P73
GB0258	P47, P51	GD10527	P53	GD12510	P62, P63
GB0265	P3	GD10528	P53	GD12511	P62, P63
GB0266	P3	GD10529	P53	GD12534	P27
GB0267	P3	GD10552	P27, P29, P31	GD12726	P55
GB0268	P9, P10	GD1059L	P17	GD12817	P31
GB0274	P3	GD1059R	P17	GD12826	P31
GB0276	P7	GD1060	P17	GD12827	P31
GB0278	P12, P18	GD1061	P18	GD12829	P31
GB0282	P10	GD1063	P18	GD13361	P3
GB0285	P3	GD1065	P3	GD13394	P47, P49
GB0301	P5	GD1085	P10	GD13422	P47, P49
GB0314	P12	GD1086	P7	GD14170	P31
GB0319	P15	GD10867	P3	GD14217	P4
GB0328	P15	GD10963	P19	GD14258	P33
GB0331	P12	GD10984	P19	GD14398	P21
GB0358	P15	GD10991	P7	GD14413	P46
GB0383	P29	GD10993	P3	GD14414	P46
GB0387	P27, P29	GD11001	P3	GD14426	P46
GB0401	P29	GD11017	P5	GD14429	P46
GD0438	P57	GD11045	P49, P53	GD14430	P46
GD0453-02	P57	GD11089	P69, P71, P73	GD14431	P46
GD0453-03	P59	GD1109	P9, P10	GD14432	P46
GD0453-04	P59	GD11120	P53	GD14467	P15
GD0453-08	P59	GD1114	P4, P41	GD14468	P15
GD0462	P57	GD1115L	P19	GD14477	P15
GD0652	P59	GD1115R	P19	GD14512	P53
GD0746	P61	GD1116	P19	GD14513	P53
GD0752-41	P59	GD1118	P19	GD14536	P33
GD0840	P61	GD11219	P17	GD14541	P15
GD0844	P43	GD11239	P12, P17, P18	GD14592	P15
GD0914-126	P49	GD11240	P18	GD14595	P47
GD0914-66	P49	GD11259	P3, P5	GD14626	P39
GD0914-86	P49	GD11279	P13	GD14627	P39
GD0914-96	P49	GD11297	P18	GD14659	P19
GD10036	P4	GD11305	P17	GD14660	P33
GD10102	P53	GD11306	P5	GD14674	P23, P25, P29
GD10103	P53	GD11313	P11	GD1512	P75

# NUMERICAL INDEX

Part No.	Page	Part No.	Page	Part No.	Page
GD15386	P59	GD5875	P59	GR0434	P43
GD15663	P15	GD5892	P57	GR0586	P73
GD15696	P47	GD6291	P72	GR0594	P71, P73
GD15700	P15	GD7041	P43	GR0911	P49
GD15747	P12	GD7127	P46	GR0912	P45, P46, P49, P51
GD15789	P33	GD7145	P39, P41, P53	GR1032	P65
GD15790	P33	GD7148	P18	GR1033	P65
GD15791-03	P39	GD7258	P18	GR1034	P65
GD15792-10	P39	GD7318	P3	GR1035	P65
GD15792-15	P39	GD7426	P47	GR1036	P65
GD15799	P39	GD7639	P71, P73	GR1037	P65, P67
GD15803	P33	GD7803	P21, P31	GR1038	P65
GD15804	P33	GD7804	P21, P31	GR1039	P65
GD15849-02	P33	GD7805	P4, P10, P12, P25, P43, P45, P47, P49, P51	GR1040	P65
GD15850	P39			GR1041	P65
GD15854	P39			GR1042	P65
GD15856-01	P39	GD7817-01	P25	GR1043	P65
GD15856-02	P39	GD7817-04	P25	GR1044	P65
GD15863	P33	GD7823	P25	GR1045	P36, P37, P65
GD15970	P3	GD7889	P23, P25, P47, P49	GR1046	P65
GD16188	P37	GD7890	P23, P25	GR1047	P65
GD16224-01	P33	GD8175	P43	GR1048	P65
GD16245	P3	GD8249	P4	GR1203	P69
GD17014	P3	GD8266	P23	GR1204	P69
GD17021	P15	GD8307	P25	GR1205	P69
GD17028	P15	GD8460	P10	GR1206	P69
GD17047	P15	GD8701	P41	GR1207	P69
GD17048	P15	GD8751	P72	GR1208	P69
GD17049	P15	GD8770	P72	GR1303	P53
GD17050	P15	GD8771	P73	GR1304	P53
GD17099	P15	GD8811	P7	GR1305	P53
GD17104	P15	GD9120	P10	GR1306	P53
GD17152	P15	GD9254	P21, P31	GR1390	P71
GD17162	P15	GD9290	P9	GR1391	P73
GD17186	P15	GD9305	P9	GR1392	P71
GD17187	P15	GD9529	P55	GR1393	P73
GD2117	P75	GD9530	P55	GR1447	P55
GD2161	P59	GD9562	P9	GR1450	P55
GD2423	P19	GD9667	P53	GR1465	P67
GD2460	P20	GD9671	P53	GR1466	P37
GD2557	P41	GD9672	P53	GR1466	P37
GD2558	P45, P46	GD9715	P27	GR1467	P36, P37
GD2597	P61	GD9720	P27	GR1529	P62, P63
GD2721	P57, P59	GD9724	P27, P29, P31	GR1570MPP	P76
GD2947	P19	GD9749	P41	GR1631	P73
GD2971-10	P17	GD9750	P41	GR1632	P73
GD3180-12	P9	GM0183	P76	GR1734	P36
GD3180-15	P45, P49, P51	GR0146MPP	P76	GR1736	P33
GD3214	P59	GR0150	P61	GR1737	P71, P73
GD3612	P3	GR0151	P61	GR1761	P73
GD4086	P35	GR0155MPP	P76	GR1762	P73
GD5752	P45	GR0193	P57	GR1764	P73
GD5753	P45	GR0196	P3, P18	GR1777	P33
GD5804	P43	GR0270	P43	GR1828	P76
GD5857	P27, P46, P49	GR0367	P57		
GD5860	P49	GR0375	P57		