

# MODEL 3120 3 POINT MOUNTED PLANTER

(Mechanical Seed Metering)

## OPERATOR & PARTS MANUAL

M0190

Rev. 5/07

This manual is applicable to: Model: 3120 3 Point Mounted Planters  
Serial Number: 603562 And On

Record the model number and serial number of your planter along with date purchased:

Model Number 3120  
Serial Number \_\_\_\_\_  
Date Purchased \_\_\_\_\_

Monitor Serial No. _____
Measured Pulses Per Mile/Km (Radar Distance Sensor) _____
Measured Pulses Per Mile/Km (Magnetic Distance Sensor) _____

### SERIAL NUMBER

The serial number plate is located on the planter frame to be readily available. It is suggested that your serial number and purchase date also be recorded above.

The serial number provides important information about your planter and may be required to obtain the correct replacement part. Always provide the model number and serial number to your KINZE® Dealer when ordering parts or anytime correspondence is made with KINZE Manufacturing, Inc.

D09219901

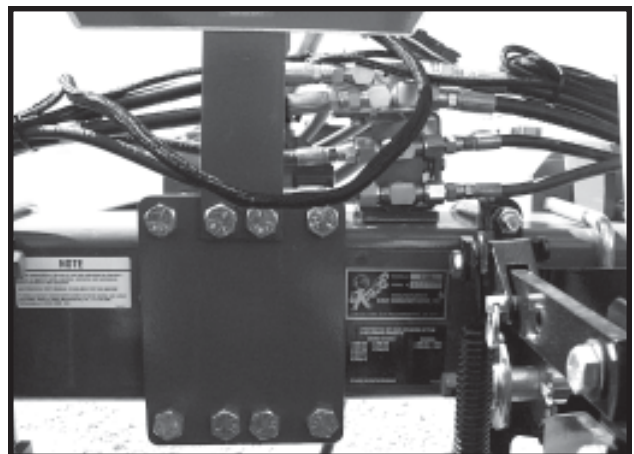



# PREDELIVERY/DELIVERY CHECKLIST

## TO THE DEALER

Predelivery service includes assembly, lubrication, adjustment and test. This service helps to ensure that the planter will be delivered to the customer ready for field use.

## PREDELIVERY CHECKLIST

After the planter has been completely assembled, use the following checklist and inspect the planter. Check off each item as it is found satisfactory or after proper adjustment is made.

- Recheck to be sure row units and optional attachments are properly spaced and assembled.
- Be sure all grease fittings are in place and lubricated.
- Check planter and make sure all working parts are moving freely, bolts are tight and cotter pins are spread.
- Check all drive chains for proper tension and alignment.
- Check for oil leaks and proper hydraulic operation.
- Check to be sure hydraulic hoses (If Applicable) are routed correctly to prevent damage to hoses.
- Inflate tires to specified PSI air pressure. Tighten wheel bolts to specified torque.
- Check to be sure all safety decals are correctly located and legible. Replace if damaged.
- Check to be sure all reflective decals and SMV sign are correctly located and visible when the planter is in transport position.
- Check to be sure safety/warning lights are installed correctly and working properly.
- Paint all parts scratched in shipment or assembly.
- Be sure all safety lockup devices are on the planter and correctly located.
- Check seed meters on test stand to ensure proper performance.

***This planter has been thoroughly checked and to the best of my knowledge is ready for delivery to the customer.***

---

(Signature Of Set-Up Person/Dealer Name/Date)

## OWNER REGISTER

Name \_\_\_\_\_ Delivery Date \_\_\_\_\_  
Street Address \_\_\_\_\_ Model No. 3120 Serial No. \_\_\_\_\_  
City, State/Province \_\_\_\_\_ Dealer Name \_\_\_\_\_  
ZIP/Postal Code \_\_\_\_\_ Dealer No. \_\_\_\_\_

## DELIVERY CHECKLIST

At the time the planter is delivered, the following checklist is to be used as a reminder of very important information which should be conveyed to the customer. Check off each item as it is fully explained to the customer.

- Advise the customer that the life expectancy of this or any other machine is dependent on regular lubrication as directed in the Operator & Parts Manual.
- Tell the customer about all applicable safety precautions.
- Along with the customer, check to be sure the reflective decals and SMV sign are clearly visible with the planter in transport position and attached to the tractor. Check to be sure safety/warning lights are in working condition. Tell the customer to check federal, state/provincial and local regulations before transporting on a road or highway.
- Give the Operator & Parts Manual to the customer and explain all operating adjustments.
- Read warranty to customer.
- Complete Warranty And Delivery Report form.

***To the best of my knowledge this machine has been delivered ready for field use and customer has been fully informed as to proper care and operation.***

---

(Signature Of Delivery Person/Dealer Name/Date)

## AFTER DELIVERY CHECKLIST

The following is a list of items we suggest to check during the first season of use of the equipment.

- Check with the customer as to the performance of the planter.
- Review with the customer the importance of proper maintenance and adherence with all safety precautions.
- Check for parts that may need to be adjusted or replaced.
- Check to be sure all safety warning signs (decals), reflective decals and SMV sign are correctly located and that decals are legible. Replace if damaged or missing.
- Check to be sure safety/warning lights are working properly.

---

(Signature Of Follow-Up Person/Dealer Name/Date)

**RETURN THIS COMPLETED FORM TO KINZE® IMMEDIATELY along with Warranty And Delivery Report.  
Retain photocopy of this form at dealership for After Delivery Check.**

*Tear Along Perforation*

# TABLE OF CONTENTS

---

<b>TO THE OWNER</b> .....	1-1
<b>WARRANTY</b> .....	1-2
<b>INTRODUCTION</b> .....	2-1
<b>SPECIFICATIONS</b> .....	3-1
<b>SAFETY PRECAUTIONS</b> .....	4-1
<b>SAFETY WARNING SIGNS</b> .....	5-1
<b>MACHINE OPERATION</b>	
Checking Granular Chemical Application Rate .....	6-78
Checking Seed Population .....	6-77
Dual Lift Assist Wheels .....	6-75
Electronic Seed Monitor System	
KPM I Monitor .....	6-11
KPM II Stack-Mode Monitor .....	6-17
KPM III Monitor .....	6-45
<b>Field Adjustments</b>	
Planting And Application Rate Charts .....	6-80
Seed Rate Transmission Adjustment .....	6-6
Field Test .....	6-76
Flow Control Valve Adjustment .....	6-75
General Planting Rate Information .....	6-79
Half Rate (2 To 1) Drive .....	6-7
Hydraulic Operation .....	6-8
Initial Preparation Of The Planter .....	6-1
Leveling The Planter .....	6-3
Metric Conversion Table .....	6-76
Parking Stand Adjustment .....	6-6
Planting Speed .....	6-76
Shear Protection .....	6-7
Row Marker Length Adjustment .....	6-10
Row Marker Speed Adjustment .....	6-9
Standard Rate Drive .....	6-7
Tire Pressure .....	6-6
Toolbar Height Adjustment .....	6-5
Tractor Preparation And Hookup .....	6-2
Tractor Requirements .....	6-1
Transporting The Planter .....	6-76
Wing Safety Pins .....	6-1

# TABLE OF CONTENTS

---

## ROW UNIT OPERATION

Brush-Type Seed Meter .....	7-5
Closing Wheel Shield (Rubber And Cast Iron “V” Closing Wheels) .....	7-2
Coulter Mounted Residue Wheels .....	7-15
Covering Discs/Single Press Wheel Adjustment .....	7-2
Drag Closing Attachment .....	7-3
Dual Gauge Wheels .....	7-10
Finger Pickup Seed Meter .....	7-4
Frame Mounted Coulter .....	7-11
Granular Chemical Bander Shield .....	7-16
Granular Chemical Banding Options .....	7-16
Granular Chemical Hopper And Drive .....	7-15
Planting Depth .....	7-1
Quick Adjustable Down Force Springs .....	7-9
Residue Wheels (For Use On Frame Mounted Coulter) .....	7-12
Row Unit Chain Routing .....	7-8
Row Unit Mounted Bed Leveler .....	7-13
Row Unit Mounted Disc Furrower .....	7-12
Row Unit Mounted No Till Coulter .....	7-14
Row Unit Mounted Residue Wheel .....	7-13
Seed Hopper .....	7-7
Seed Meter Drive Release .....	7-7
Spring Tooth Incorporator .....	7-16
“V” Closing Wheel Adjustment (Rubber And Cast Iron) .....	7-1

## LUBRICATION

Bushings .....	8-2
Drive Chains .....	8-1
Grease Fittings .....	8-4
Lubrication Symbols .....	8-1
Sealed Bearings .....	8-1
Wheel Bearings .....	8-3

# TABLE OF CONTENTS

---

## MAINTENANCE

15" Seed Opener Disc Blade/Bearing Assembly .....	9-11
Brush-Type Seed Meter Maintenance .....	9-6
Chain Tension Adjustment .....	9-2
Coulter Mounted Residue Wheels .....	9-15
Drag Closing Attachment .....	9-9
Electrical Wiring Diagram For Light Package .....	9-22
Finger Pickup Seed Meter Cleaning .....	9-4
Finger Pickup Seed Meter Inspection/Adjustment .....	9-3
Flow Control Valve Inspection .....	9-19
Frame Mounted Coulter .....	9-13
Gauge Wheel Adjustment .....	9-9
Gauge Wheel Arm Bushing And/Or Seal Replacement .....	9-10
Gauge Wheel Arm Pivot Spindle Replacement .....	9-10
Granular Chemical Attachment .....	9-16
Mounting Bolts And Hardware .....	9-1
Preparation For Storage .....	9-22
Residue Wheels (For Use On Frame Mounted Coulter) .....	9-13
Row Marker Bearing Lubrication Or Replacement .....	9-21
Row Marker Sequencing/Flow Control Valve Inspection .....	9-19
Row Unit Mounted Bed Leveler .....	9-14
Row Unit Mounted Disc Furrower .....	9-13
Row Unit Mounted No Till Coulter .....	9-15
Row Unit Mounted Residue Wheel .....	9-14
Seed Tube Guard/Inner Scraper .....	9-12
Spring Tooth Incorporator .....	9-16
Torque Values Chart .....	9-1

### Troubleshooting

Brush-Type Seed Meter Troubleshooting .....	9-8
Closing Wheel Troubleshooting .....	9-9
Finger Pickup Seed Meter Troubleshooting .....	9-5
KPM I/KPM II Stack-Mode Electronic Seed Monitor System Troubleshooting .....	9-17
KPM III Electronic Seed Monitor System Troubleshooting .....	9-18
Row Marker Operation Troubleshooting .....	9-20
Wheel Bearing Lubrication Or Replacement .....	9-21

<b>PARTS LIST INDEX .....</b>	<b>P1</b>
-------------------------------	-----------

<b>PARTS SECTION NUMERICAL INDEX .....</b>	<b>P63</b>
--	------------

# TABLE OF CONTENTS

---



# TO THE OWNER

---

KINZE Manufacturing, Inc. would like to thank you for your patronage. We appreciate your confidence in KINZE® farm machinery. Your KINZE® planter has been carefully designed to provide dependable operation in return for your investment.

**This manual has been prepared to aid you in the operation and maintenance of the planter. It should be considered a permanent part of the machine and remain with the machine when you sell it.**

It is the responsibility of the user to read and understand the Operator & Parts Manual in regards to safety, operation, lubrication and maintenance before operation of this equipment. It is the user's responsibility to inspect and service the machine routinely as directed in the Operator & Parts Manual. We have attempted to cover all areas of safety, operation, lubrication and maintenance; however, there may be times when special care must be taken to fit your conditions.

Throughout this manual the symbol  and/or the words **NOTE, IMPORTANT, CAUTION, WARNING** or **DANGER** are used to call your attention to important information. The definition of each of these terms follows:

**NOTE:** Indicates a special point of information or addresses a machine adjustment.

**IMPORTANT:** Indicates information which, if not heeded, could result in damage to the machine.



**CAUTION:** Indicates a potentially hazardous situation which, if not avoided, may result in minor or moderate personal injury.



**WARNING:** Indicates a potentially hazardous situation which, if not avoided, could result in death or serious personal injury.



**DANGER:** Indicates an imminently hazardous situation which, if not avoided, will result in death or serious personal injury.



**WARNING:** Some photos in this manual may show safety covers, shields or lockup devices removed for visual clarity. **NEVER OPERATE** the machine without all safety covers, shields and lockup devices in place.

**NOTE:** Some photos in this manual may have been taken of prototype machines. Production machines may vary in appearance.

**NOTE:** Some photos and illustrations in this manual show optional attachments installed. Contact your KINZE® Dealer for purchase of optional attachments.

# WARRANTY

---

The KINZE® Limited Warranty for your new machine is stated on the back of the retail purchaser's copy of the Warranty And Delivery Report form. Additional copies of the Limited Warranty can be obtained through your KINZE® Dealer.

Warranty, within the warranty period, is provided as part of KINZE's support program for registered KINZE® products which have been operated and maintained as described in this manual. Evidence of equipment abuse or modification beyond original factory specifications will void the warranty. Normal maintenance, service and repair is not covered by KINZE® warranty.

To register your KINZE® product for warranty, a Warranty And Delivery Report form must be completed by the KINZE® Dealer and signed by the retail purchaser, with copies to the Dealer, to the retail purchaser and to KINZE Manufacturing, Inc. Registration must be completed and sent to KINZE Manufacturing, Inc. within 30 days of delivery of the KINZE® product to the retail purchaser. KINZE Manufacturing, Inc. reserves the right to refuse warranty on serial numbered products which have not been properly registered.

If service or replacement of failed parts which are covered by the Limited Warranty are required, it is the user's responsibility to deliver the machine along with the retail purchaser's copy of the Warranty And Delivery Report to the KINZE® Dealer for service. KINZE® warranty does not include cost of travel time, mileage, hauling or labor. Any prior arrangement made between the Dealer and the retail purchaser in which the Dealer agrees to absorb all or part of this expense should be considered a courtesy to the retail purchaser.

*KINZE® warranty does not include cost of travel time, mileage, hauling or labor.*

# INTRODUCTION

---

The Model 3120 3 Point Mounted Planter is available in various sizes and row spacings and permits installation of optional row unit attachments.

## GENERAL INFORMATION

The information used in this manual was current at the time of printing. However, due to KINZE's continual attempts to improve its product, production changes may cause your machine to appear slightly different in detail. KINZE Manufacturing, Inc. reserves the right to change specifications or design without notice and without incurring obligation to install the same on machines previously manufactured.

Right hand (R.H.) and left hand (L.H.), as used throughout this manual, are determined by facing in the direction the machine will travel when in use, unless otherwise stated.

D09179909b

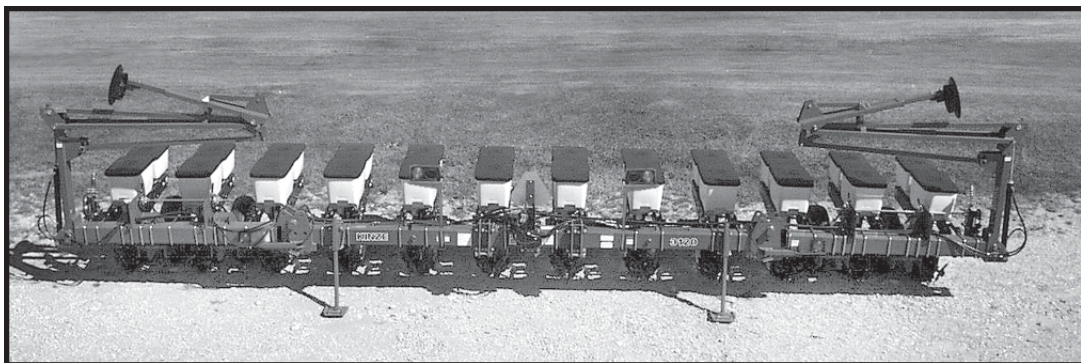

# INTRODUCTION

---

# SPECIFICATIONS

---

**BASE MACHINE TYPE** - 3 Point Mounted Vertical Folding

**SEED METER TYPE** - Mechanical Seed Metering System

**PLANTING UNIT TYPE** - Pull Row Units

**ROW SPACING** - 8 Row Wide - 36" And 38" Rows  
- 8 Row Wide - 40" Rows  
- 12 Row Narrow - 30" Rows

**DRIVE SYSTEM** - Ground drive with 7.60" x 15" 8 ply tires.  
- Two drive/gauge wheels used on 8 row machines.  
- Four drive/gauge wheels used on 12 row machine.  
- No. 2050 roller chain with spring/ratchet idlers.

**TRANSMISSIONS** - End mounted for quick sprocket adjustment.  
- No. 40 chain with spring/wrap idlers.

**HYDRAULICS** - Marker Hydraulics - Single Remote With Sequencing Valve  
- Wing Lift - Single Remote  
Additional remote required for dual lift assist wheel option.

**HITCH** - Category 2, 3N, 3

**ROW MARKERS** - Three-Fold Low Profile With Depth Band On Row Marker Blades

# SPECIFICATIONS

---

## DIMENSIONS & WEIGHTS

PLANTER SIZE	TRANSPORT WIDTH	OPERATING & TRANSPORT LENGTH	WEIGHT **
8 Row 36"/38"	18' 6"	9' 1" *	4542 lbs.
8 Row 40"	19' 0"	9' 1" *	4586 lbs.
12 Row 30"	21' 8"	9' 1" *	6150 lbs.

\* Length includes optional dual lift assist wheels.

\*\* Base machine weight includes toolbar and 3 point hitch, wheel modules with tires and wheels, seed transmission(s) with drive components, parking stands, optional row markers with hydraulic cylinders and hoses, and KINZE pull row units (closing wheel arms less closing wheels) with seed hopper and lid, and quick adjustable dual down force springs.

## MACHINE OPTIONS

- Row Marker Package
- Electronic Seed Monitors - KPM I  
KPM II Stack-Mode With Magnetic Distance Sensor Or Radar Distance Sensor  
KPM III With Magnetic Distance Sensor Or Radar Distance Sensor
- Half Rate (2 To 1) Drive Reduction Package
- Front Drive Wheel Conversion Package
- Dual Lift Assist Wheel Package
- Center Section Gauge Wheel Package (Not compatible with dual lift assist wheels on 8 row wide planters.)

## ROW UNIT OPTIONS/ATTACHMENTS

- Finger Pickup Or Brush-Type Seed Meters
- Closing Options
  - Rubber "V" Closing Wheels
  - Cast Iron "V" Closing Wheels
  - Covering Discs/Single Press Wheel
  - Drag Closing Attachment
- Dual Gauge Wheels
- Granular Chemical Application
- Hopper Panel Extension Package
- Spring Tooth Incorporator
- Row Unit Mounted No Till Coulter
- Coulter Mounted Residue Wheels
- Row Unit Mounted Disc Furrowers
- Row Unit Mounted Bed Leveler
- Row Unit Mounted Residue Wheel
- Frame Mounted Coulter
- Residue Wheel Attachments For Frame Mounted Coulter

# SAFETY PRECAUTIONS

Safe and careful operation of the tractor and planter at all times will contribute significantly to the prevention of accidents.

Since a large portion of farm accidents occur as a result of fatigue or carelessness, safety practices should be of utmost concern. Read and understand the instructions provided in this manual and on the warning signs. Review these instructions frequently! Listed below are other safety suggestions that should become common practice.

 **Never permit any persons other than the operator to ride on the tractor.**

 **Never ride on the planter or allow others to do so.**

 **Always keep hands, feet and clothing away from moving parts. Do not wear loose fitting clothing which may catch in moving parts.**

 **Do not allow anyone to stand between the hitch and towing vehicle when backing up to the planter.**

 **Be aware of bystanders, particularly children! Always look around to make sure it is safe to start the engine of the towing vehicle or move the planter. This is particularly important with higher noise levels and quiet cabs, as you may not hear people shouting.**

 **Always wear protective clothing, substantial shoes and suitable hearing and eye sight protectors applicable for the situation.**

 **Limit transport speed to 15 MPH. Transport only with farm tractor of sufficient size and horsepower. (See Machine Operation Section)**

 **Always drive at a safe speed relative to local conditions and ensure your speed is low enough for an emergency stop to be safe and secure. Keep speed to a minimum.**

 **Never allow the planter to be operated by anyone who is unfamiliar with the operation of all functions of the unit. All operators should read and thoroughly understand the instructions given in this manual prior to moving the unit.**

 **Always make sure safety/warning lights, SMV sign and reflective decals are in place and visible prior to transporting the machine on public roads. In this regard, check federal, state/provincial and local regulations.**

 **Never work under the planter while in raised position.**

 **Always make sure there are no persons near the planter when row marker assemblies are in operation.**

 **Watch for obstructions such as wires, tree limbs, etc., when folding row markers.**









 **To avoid serious injury or death, care must be taken when operating row markers around overhead power lines.**

 **Lower the planter when not in use and cycle the hydraulic control lever to relieve pressure in hoses.**

 **Before applying pressure to the hydraulic system, make sure all connections are tight and that hoses and fittings have not been damaged. Hydraulic fluid escaping under pressure can have sufficient force to penetrate skin causing injury or infection.**

 **Use a tractor equipped with a roll-over-protective-system and fasten your seat belt prior to starting the engine.**

# SAFETY PRECAUTIONS

-  Allow for unit length when making turns.
-  Reduce speed prior to turns to avoid the risk of overturning.
-  Avoid sudden uphill turns on steep slopes.
-  Always keep the tractor in gear to provide engine braking when going downhill. Do not coast.
-  This planter is designed to be **DRIVEN BY GROUND TIRES ONLY**. The use of aftermarket hydraulic, electric or PTO drives may create serious safety hazards to you and the people nearby. If you install such drives you must follow all appropriate safety standards and practices to protect you and others near this planter from injury.
-  This machine has been designed and built with your safety in mind. Do not make any alterations or changes to this machine. Any alteration to the design or construction may create safety hazards.
-  Always empty or remove all hoppers before folding planter wings.
-  Due to the transport height of the wings on vertical folding machines, watch for obstructions such as wires, tree limbs, etc.

 Never transport folding machines with lift assist wheels without the floating link in place. If not in place a sudden stop could allow the toolbar to rotate forward causing personal injury or damage to the equipment.

55702-4a

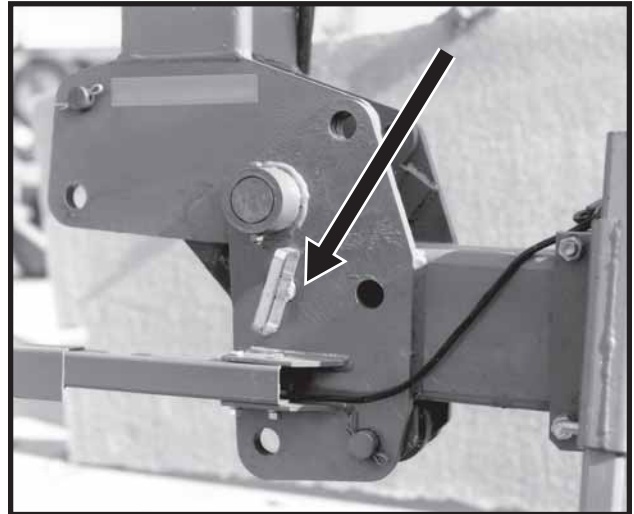

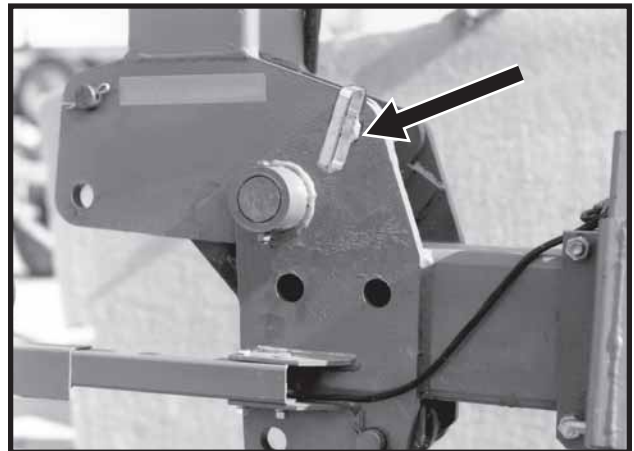

Transport Position

55702-4b



Service Position

-  Install wing safety-lock pins in transport position before transporting the planter or working around the unit. Install wing safety lock pins in service position when servicing wing fold cylinders and/or wing fold linkage.
-  Always make sure there are no persons near the planter when planter wings are being lowered from transport position.



# SAFETY PRECAUTIONS

---



If a row marker or wing lift cylinder has been disconnected or removed for any reason, do not attach the rod end of the cylinder until the cylinder is cycled several times to remove any air that may be trapped in the system.



Make sure the parked machine is on a hard, level surface.



Good maintenance is your responsibility. Poor maintenance is an invitation to trouble.



Wings must be unfolded before detaching machine from tractor.



Check to be sure all safety/warning lights are working before transporting the machine on public roads.



Be a safe and courteous driver. Always yield to oncoming traffic in all situations, including narrow bridges, intersections, etc.



Rim and tire servicing can be dangerous. Explosive separation of a tire and rim parts can cause serious injury or death.



Agricultural chemicals used with this unit can be dangerous. Improper selection or use can seriously injure persons, animals, plants, soil and other property. **BE SAFE:** Select the right chemical for the job. Handle it with care. Follow the instructions of the chemical manufacturer.



Serious injury or death can result from contact with electric lines. Use care to avoid contact with electric lines when moving or operating this machine.



Store the planter in an area away from human activity. **DO NOT** permit children to play in or around the stored unit.

# SAFETY PRECAUTIONS



# SAFETY WARNING SIGNS

The “WARNING” signs illustrated on these pages are placed on the machine to warn of hazards. The warnings found on these signs are for your personal safety and the safety of those around you. **OBSERVE THESE WARNINGS!**

- **Keep these signs clean so they can be readily observed. Wash with soap and water or cleaning solution as required.**
- **Replace “WARNING” signs should they become damaged, painted over or if they are missing.**
- **Check reflective decals and SMV sign periodically. Replace if they show loss of any of their reflective properties.**
- **When replacing decals, clean the machine surface thoroughly using soap and water or cleaning solution to remove all dirt and grease.**

**NOTE: Style and locations of SMV sign, reflective decals and safety/warning lights conform to ANSI/SAE S279.13 DEC2005 and ANSI/SAE S276.6 JAN2005.**

D09219908

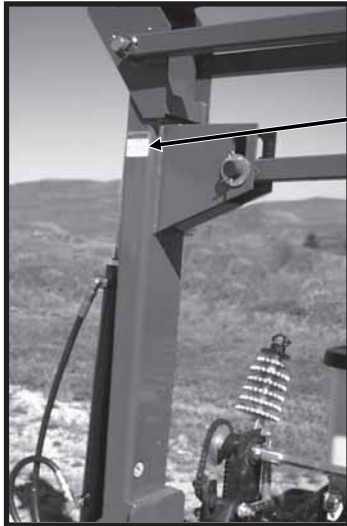

Part No. G7100-42 (Qty. 4 - Two Per Row Marker)

# SAFETY WARNING SIGNS



Part No. G7100-89 (Qty. 1)

D09129901

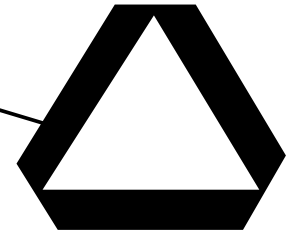

Part No. GD2199 (Qty. 1)

51803-1

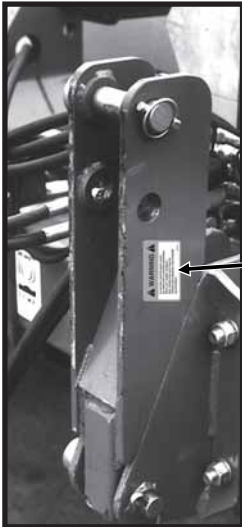

Optional Dual Lift Assist Wheel Attachment - Floating Top Mast

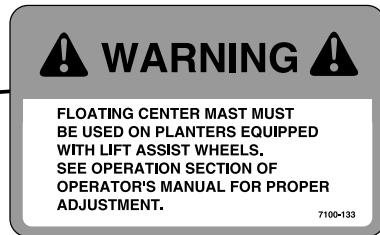

Part No. G7100-133

53761-6

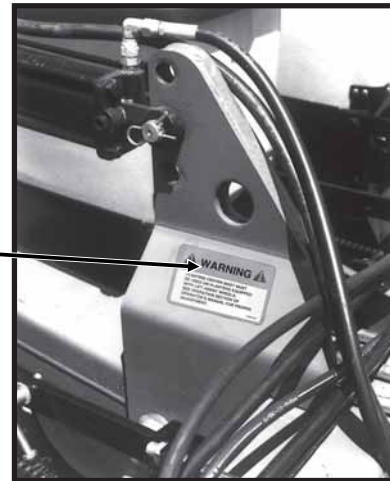

Optional Dual Lift Assist Wheel Attachment - Wheel Tower

D06039901

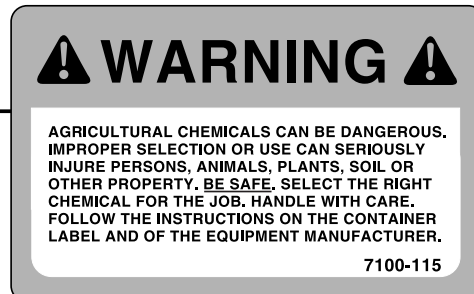

Part No. G7100-115 (1 Per Row Unit - Located On Underside Of Granular Chemical Hopper Lids)

# SAFETY WARNING SIGNS

(MT32/MT32a)

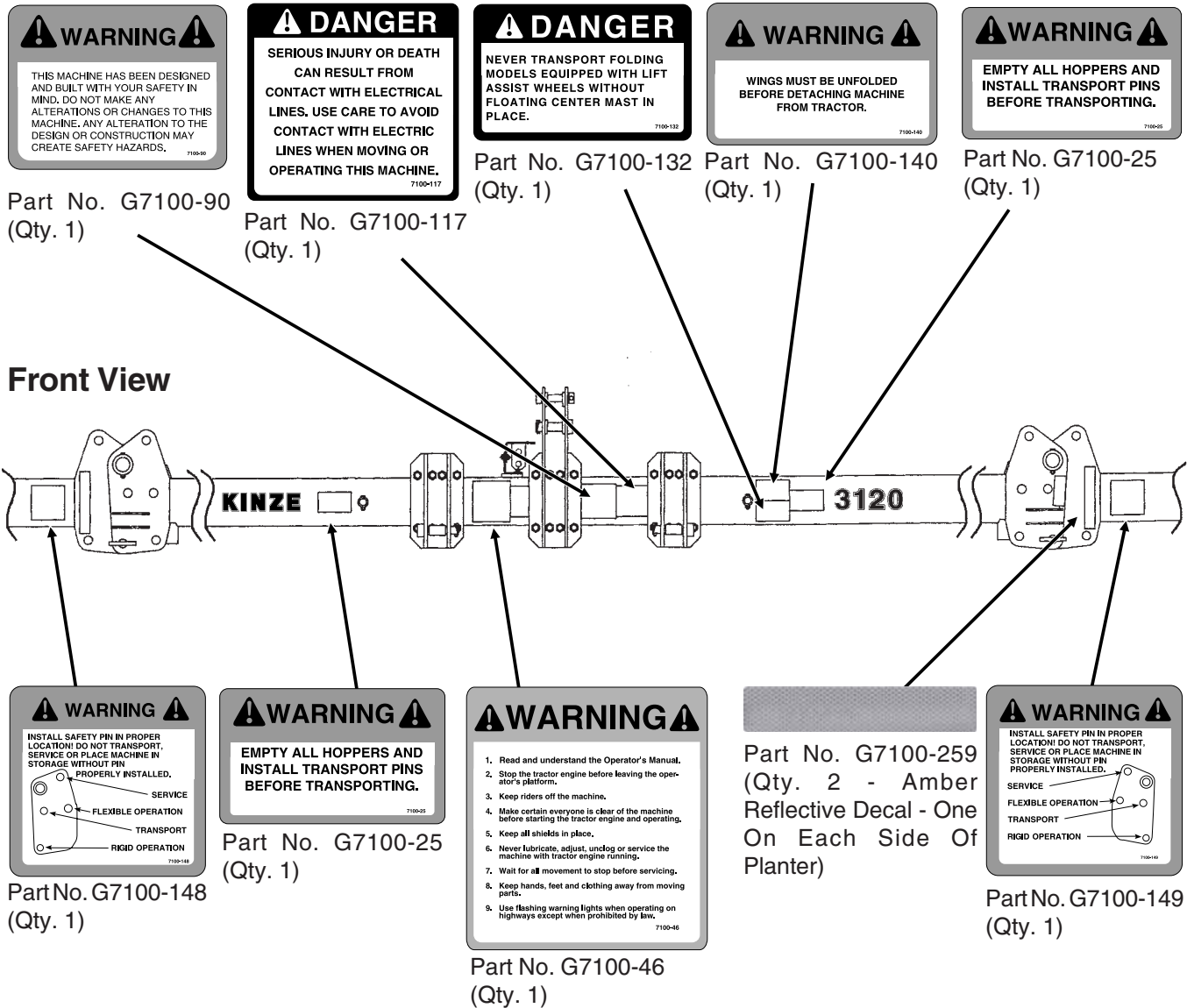
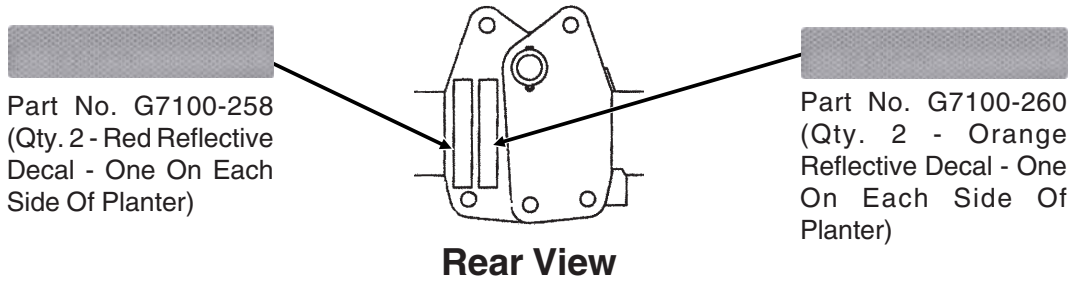

# SAFETY WARNING SIGNS

(PLTR118a)

(8 Row Shown)

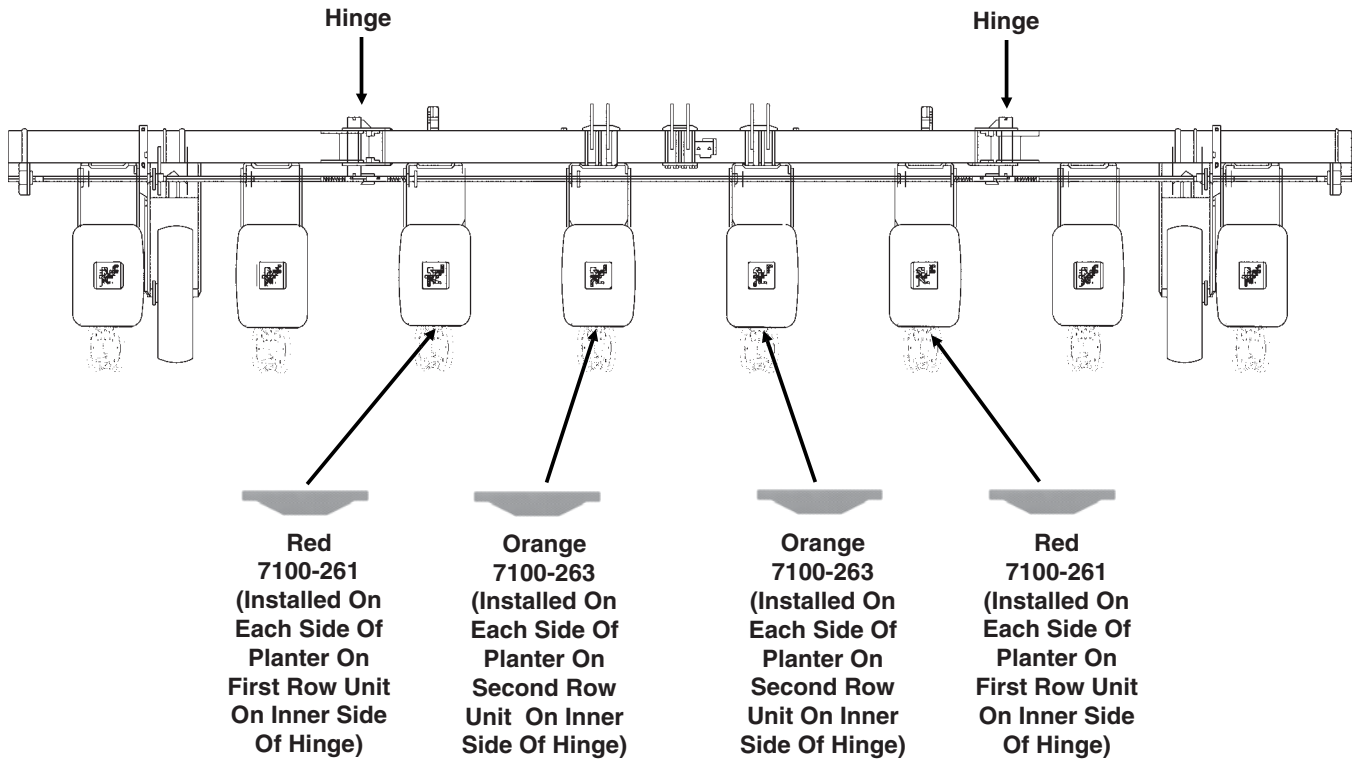

## Standard

D060800114

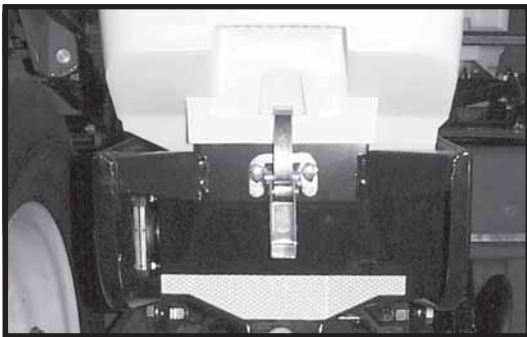

Part No. G7100-261 Red Reflective Decal Or Part No. G7100-263 Orange Reflective Decal (Qty. 1 Per Row Unit - Located On The Hopper Support As Shown Above)

## With Optional Granular Chemical

D062300102



Part No. G7100-258 Red Reflective Decal Or Part No. G7100-260 Orange Reflective Decal (Qty. 1 Per Row Unit - Located On The Granular Chemical Hopper Panel Extension As Shown Above)

# MACHINE OPERATION

The following information is general in nature and was written to aid the operator in preparation of the tractor and planter for use, and to provide general operating procedures. The operator's experience, familiarity with the machine and the following information should combine for efficient planter operation and good working habits.

**IMPORTANT:** Always raise the planter out of the ground when making sharp turns or backing up.

## WING SAFETY PINS

55702-5a

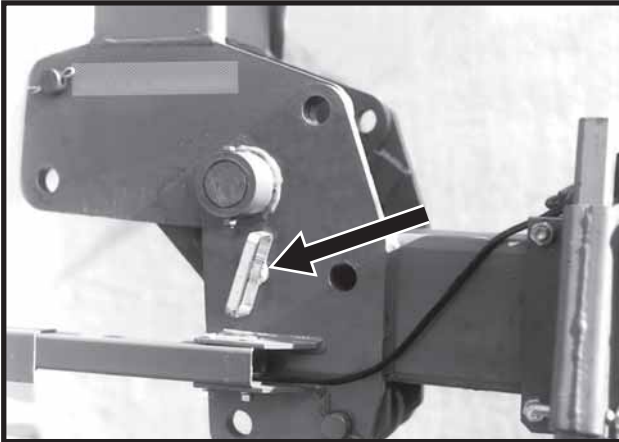

**Transport Position**

55702-7a

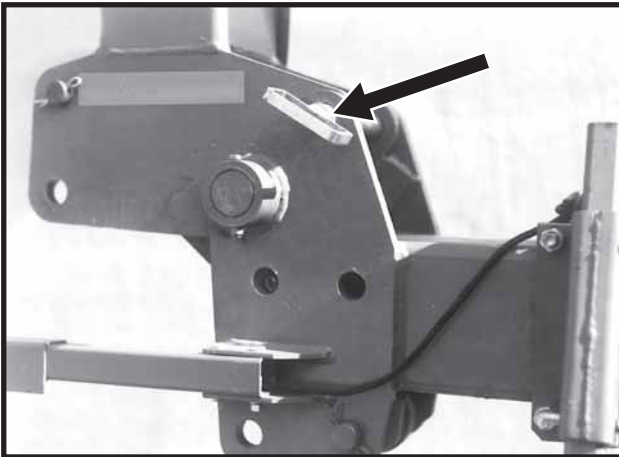

**Service Position**

The wing safety pins located in the hinge area are an added safety device. Always install the wing safety pins in the "transport" position before transporting the planter or working around the unit. Always install the wing safety pins in the "service" position when servicing the wing fold cylinder or wing fold linkage.

Install wing safety pin in "rigid" position for rigid toolbar operation and "flexible" position for wing flex operation. See "Hydraulic Operation".

Refer to decal located near each hinge for proper safety pin position for flexible operation, rigid operation, transport and service.

## INITIAL PREPARATION OF THE PLANTER

Lubricate the planter and row units per the lubrication information in this manual. Make sure all tires have been properly inflated. See "Tire Pressure". Check all drive chains for proper tension, alignment and lubrication.

## TRACTOR REQUIREMENTS

Approximate required minimum tractor horsepower (HP) required for field work is listed below:

8 Row Sizes - 75-110 HP

12 Row Sizes - 140 HP & up

**NOTE:** The tractor must have adequate 3 point hitch lift capacity to lift the weight of the machine, attachments, seed and dry chemicals. Shipping weights do not include seed, dry chemicals or additional optional attachments.

Tractor front end stability is necessary for safe efficient operation. Therefore, it may be necessary to add front ballast to your tractor for satisfactory field operation, as well as adequate transport stability. Refer to your tractor operator's manual for front ballast recommendations.

The optional Dual Lift Assist Wheel Package is recommended on some sizes of planters depending on size of tractor being used with the planter.

A quick-attaching coupler (quick hitch) is recommended for safe and easy attaching and detaching.

# MACHINE OPERATION

## TRACTOR PREPARATION AND HOOKUP

1. Set tractor rear wheel spacing at double the planter row spacing. For example: On a planter set for 36" rows, set the tractor wheel spacing at 72". On wide front end tractors set front wheel spacing equal to rear wheel spacing. Check tractor operator's manual for correct front and rear tire pressure.

2. Adjust lift links on tractor so planter will lift level from side to side and raise high enough for planter transport clearance. Set the sway blocks on the tractor in position to prevent side sway. Be sure the individual lift link arms are in the float position.

3. Back tractor up to planter. Position lower hitch pins and bushings as shown in the following diagrams for your type of tractor hitch. Line up holes and insert hitch pins and lock in place with pins provided. It may be necessary to change the length of the tractor upper link with the adjusting handle.

52926-4

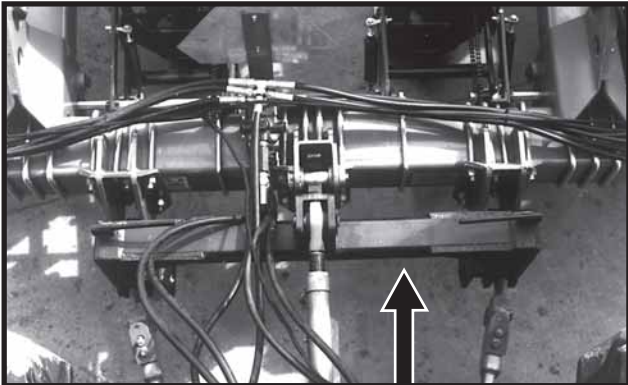

When using a quick-attaching coupler (customer supplied), match pin location to pin spacing in quick-attaching coupler.

### Lower Hitch Pins (BOLT-ON HITCH POINTS)

52567-45

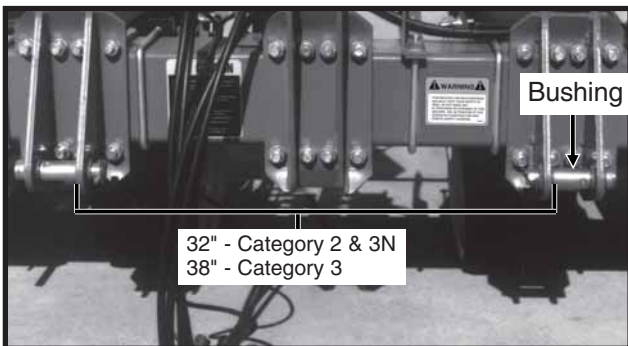

Category 2 Requires Pin Only  
Category 3N And 3 Requires Pin And Bushing

### Lower Hitch Pins (WELDED HITCH POINTS)

PFA065(PLTR76)

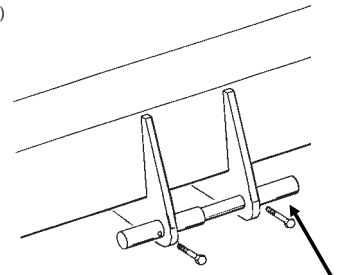

Category 2 Bushing Position

PFA066(PLTR77)

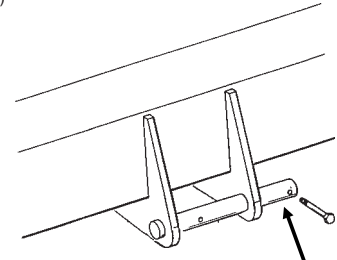

Category 3N And 3 Bushing Position

### Upper Hitch Pin

The upper hitch point has two sets of holes. The hitch pin must be positioned in the lower set of holes for use with tractors equipped with Category 2 quick-attaching coupler. The hitch pin must be positioned in the upper set of holes for use with tractors equipped with Category 3N and 3 quick-attaching coupler.

52567-49

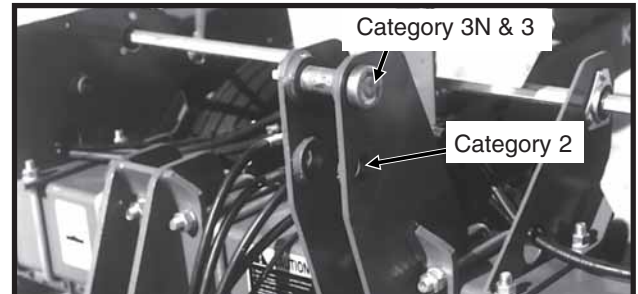

### Standard Mast (Bolt-On Mast Shown)

51803-1a

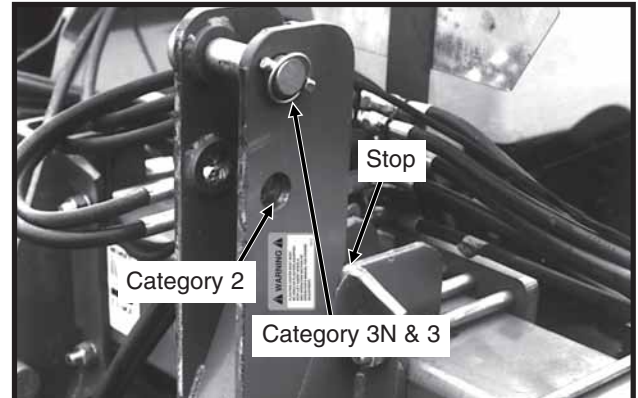

Floating Mast (Used on machines equipped with the optional Dual Lift Assist Wheel Package.)



# MACHINE OPERATION



**DANGER:** Never transport vertical folding planters with dual lift assist wheels without floating mast in place. If not in place a sudden stop could allow the toolbar to rotate forward causing serious personal injury or damage to the equipment.

4. Connect ASAE Standards 7 terminal connector for warning lights on planter to ASAE Standards receptacle on tractor. If your tractor is not equipped with an ASAE Standards receptacle, check with your tractor manufacturer for availability. Check to be sure warning lights on planter are working in conjunction with warning lights on tractor.

5. Connect hydraulic hoses to tractor ports in a sequence that is both familiar and comfortable to the operator. See "Hydraulic Operation".

Before attaching hoses, move tractor control levers back and forth to relieve any pressure in the tractor hydraulic system.

**IMPORTANT:** Always wipe hose ends to remove any dirt before connecting couplers to tractor ports.



**CAUTION:** Before the markers are operated, make sure all marker lockups are in working position.



**DANGER:** Before applying pressure to the hydraulic system, make sure all connections are tight and that hoses and fittings have not been damaged. Hydraulic fluid escaping under pressure can have sufficient force to penetrate skin causing injury or infection.

6. Raise planter slowly and watch for any interference. Remove pin from each parking stand and raise each to the transport position. Secure stands in raised position with pin in lowest hole.

7. For proper operation of the planter and row units, it is important that the planter frame and row unit parallel arms be level side-to-side and front-to-rear. The toolbar should operate at a 20"-22" height from planting surface. Tire pressure must be maintained at pressures specified and toolbar height must be adjusted equally. Check to be sure planter toolbar is level and at correct operating height. See "Leveling The Planter".



**CAUTION:** As a general safety practice and to avoid damage to the tractor hydraulic system, always lower the planter when not in use.

**NOTE:** If the planter is equipped with optional Dual Lift Assist Wheels Package, be sure to lower the rear of the planter by activating the lift assist circuit prior to lowering the front of the planter with the 3 point hitch control. When raising the planter raise the front of the planter with the 3 point hitch prior to raising the rear of the planter with the lift assist wheels.

If the lift assist is plumbed into the 3 point hitch lift circuit, adjust the flow control valve so the 3 point hitch raises ahead of the lift assist wheels when lifting the planter.

## LEVELING THE PLANTER

### Planters Not Equipped With Dual Lift Assist Wheels

1. Drive the tractor and planter on level ground.
2. Lower the planter to the ground.
3. Check to be sure toolbar height is 20"-22". See "Toolbar Height Adjustment".

(MT20a)

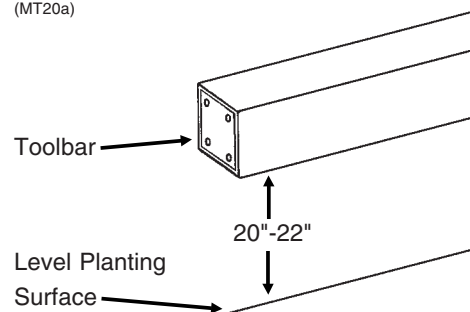

4. Check to be sure planter is level front-to-rear and row unit parallel arms are level. Adjust upper link on tractor accordingly.

52926-4

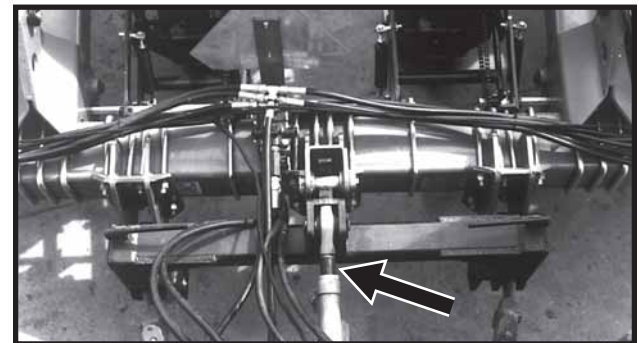

# MACHINE OPERATION

## Planters Equipped With Rear Or Front Mounted Drive Wheels And Dual Lift Assist Wheels

1. Drive the tractor and planter on level ground.
2. Begin raising the lift assist wheels by activating the lift assist circuit while at the same time lowering the planter using the 3 point hitch control.
3. Raise the dual lift assist wheels off the ground or position the lift assist circuit in float so the weight of the planter is not on the lift assist wheels.

LFD10-96a



4. Check to be sure toolbar height is 20"- 22". See "Toolbar Height Adjustment".

(MT20a)

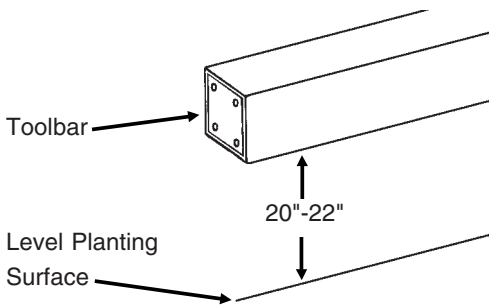

5. Check to be sure planter is level front-to-rear and row unit parallel arms are level. Adjust upper link on tractor accordingly until planter toolbar is level and floating mast is against the stop.

52926-4

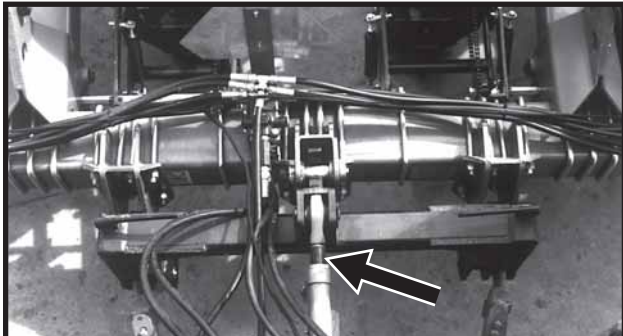

6. Lower dual lift assist wheels to rest on the ground.
7. Raise the front of the planter using the tractor's 3 point hitch.
8. Raise rear of planter using lift assist wheels.
9. Check to see if the distance between the floating mast and stop is a minimum of 3" (with planter in raised transport position).

51803-1



If adjustment is necessary, lower the planter and reposition lift assist cylinders.

To increase distance, mount lift assist cylinders in top mounting holes. To decrease distance, mount lift assist cylinders in bottom mounting holes.

51138-6a



**NOTE:** The floating mast should contact the stop only when the planter is in the planting position.

**IMPORTANT:** Raising the lift assist before the 3 point hitch may damage the lift assist wheels.

# MACHINE OPERATION

## TOOLBAR HEIGHT ADJUSTMENT

53051-39

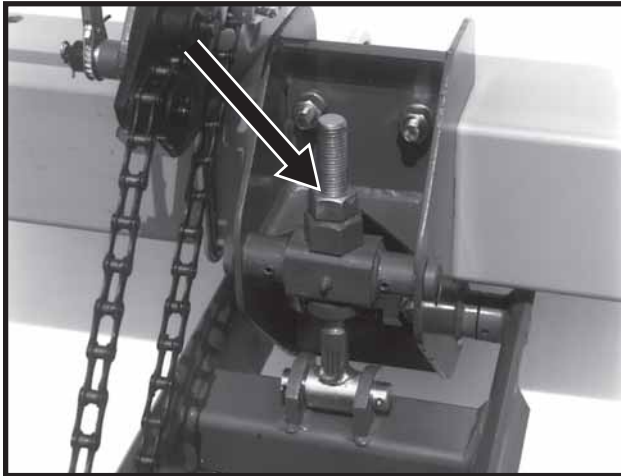

Standard Rear Mounted Drive Wheel

52607-1

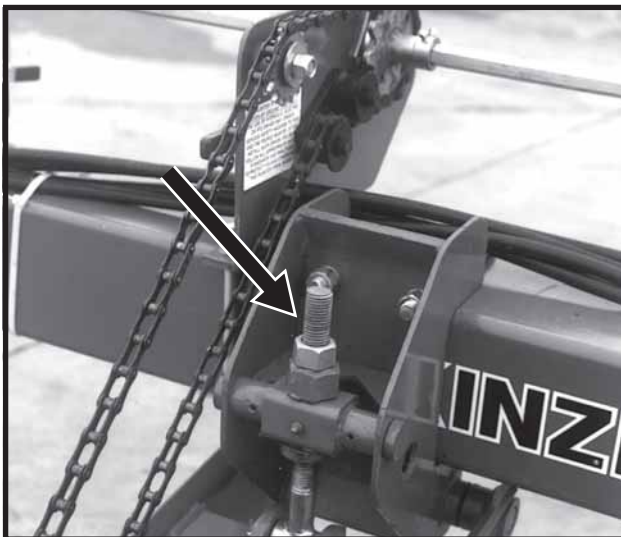

Optional Front Mounted Drive Wheel

The drive wheel assembly is designed so the wheel can be adjusted to maintain a toolbar height of 20"-22" from the planting surface in all planting situations. This is particularly useful when the planter is used for ridge planting or planting on beds. The drive wheel assembly has an adjustment range of 7". Offset No. 2050 chain links which are included with the planter will need to be added when the upper end of the range is used.

To adjust toolbar height:

1. Release drive wheel chain tension.
2. Loosen the jam nut using a 1 1/2" wrench or a 15" adjustable wrench.
3. Turn the adjusting nut using a 1 7/8" wrench or 15" adjustable wrench (clockwise to decrease frame height or counterclockwise to increase frame height).
4. Tighten the jam nut and adjust chain tension.

# MACHINE OPERATION

## PARKING STAND ADJUSTMENT

D09129906

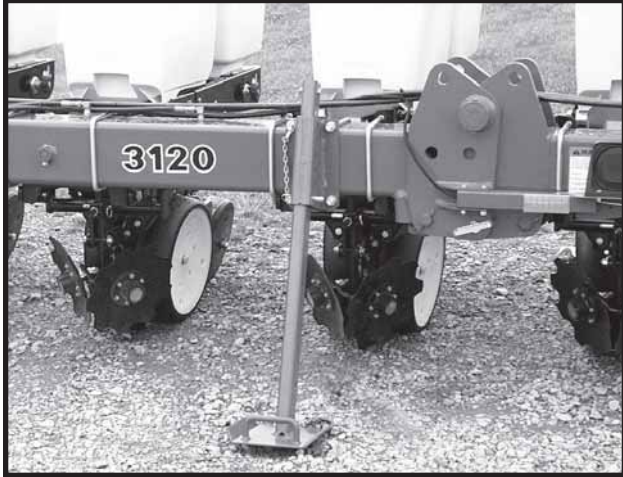

Two parking stands, located on the front side of the main frame, are standard on Model 3120 planters. The stands must be positioned so they are not directly behind the tractor tire or they will hit when the planter is raised.

Raise to top position and pin when planting. Lower and pin for parking and storage.

On planters equipped with front mounted drive wheels, parking stands are not required.

Each parking stand has six positioning holes. By using these positioning holes, you can set the main frame height from 19" to 25".

## TIRE PRESSURE

Tire pressure should be checked regularly and maintained as follows:

7.60" x 15" 8 Ply ..... 40 PSI

**IMPORTANT:** Tire pressure must be correctly maintained in all drive wheel tires to insure level and proper operation of planter. All rate charts are based on rolling radius of 7.60" x 15" tires inflated to 40 PSI.

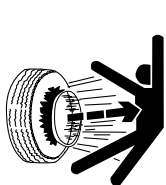

**DANGER:** Rim and tire servicing can be dangerous. Explosive separation of a tire and rim parts can cause serious injury or death.

## SEED RATE TRANSMISSION ADJUSTMENT

61048-17

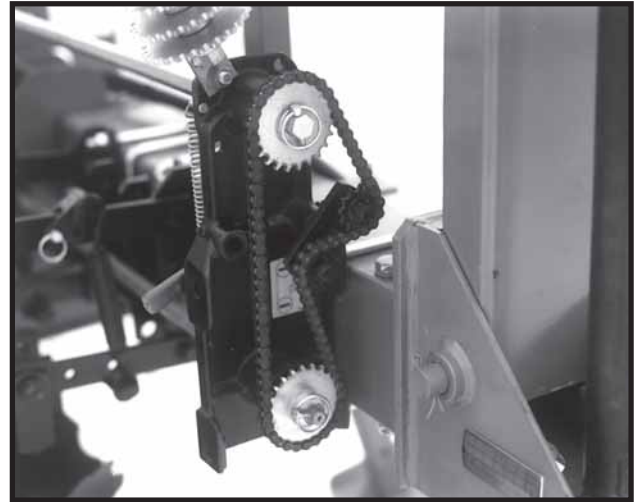

Planting population rate changes are made at the seed transmission(s). The planter transmission(s) is designed to allow simple, rapid changes of sprockets to obtain the desired planting population. By removing the lynch pins on the hexagon shafts, sprockets can be interchanged with those from the sprocket storage rod bolted to the transmission(s).

Chain tension is controlled by spring-loaded dual-sprocket idlers. The idler assembly is adjusted with a ratchet arm. This arm has a release position to remove spring tension for replacing sprockets. The amount of spring tension on the chain is controlled by the ratchet arm.

A decal positioned on each transmission illustrates proper chain routing. The planting rate charts found at the back of this section will aid you in selecting the correct sprocket combinations.

# MACHINE OPERATION

## STANDARD RATE DRIVE

D09219905

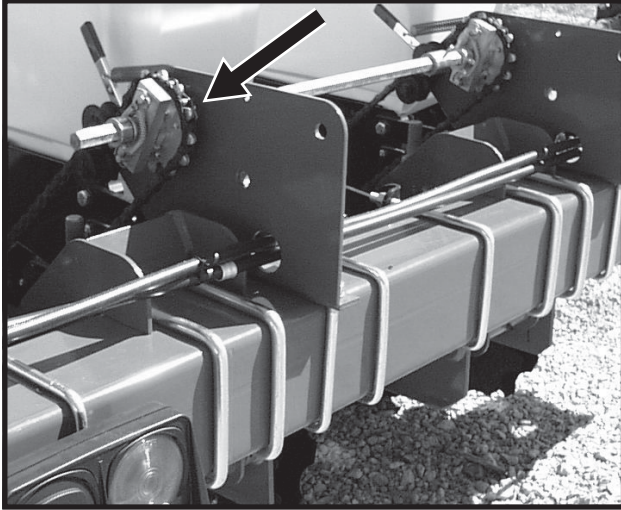

Seed planting rate charts are based on the standard rate drive. The standard rate drive uses a 12 tooth sprocket on each drive tire. Using the 48 tooth half rate (2 to 1) drive sprocket in place of the 12 tooth sprocket will reduce planting and application rates by approximately 50%. See "Half Rate (2 To 1) Drive".

## HALF RATE (2 TO 1) DRIVE

Half rate (2 to 1) drive is recommended only when desired population falls below that shown on planting rate charts. Installing the split 48 tooth half rate (2 to 1) drive reduction sprockets over the 12 tooth drive sprockets above each drive wheel will reduce the planter transmission speed and planting and application rates by approximately 50%. The 2050 drive chain must be lengthened with the chain extension supplied when 48 tooth sprockets are used.

53704-13

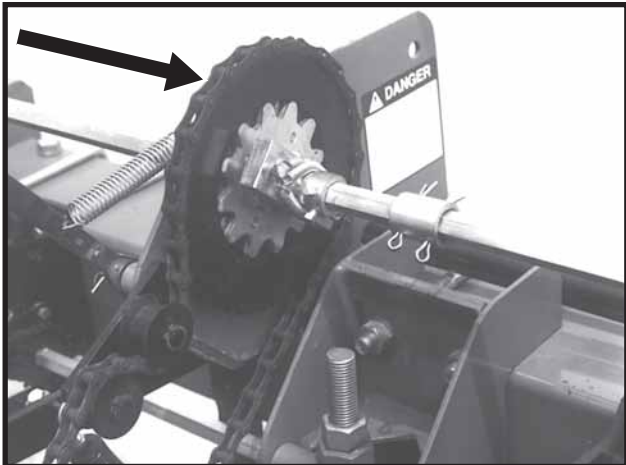

**NOTE: After each sprocket combination adjustment, make a field check to be sure you are planting at the desired rate.**

## SHEAR PROTECTION

The planter driveline and seed and granular chemical drivelines are protected from damage by shear pins.

55702-10d

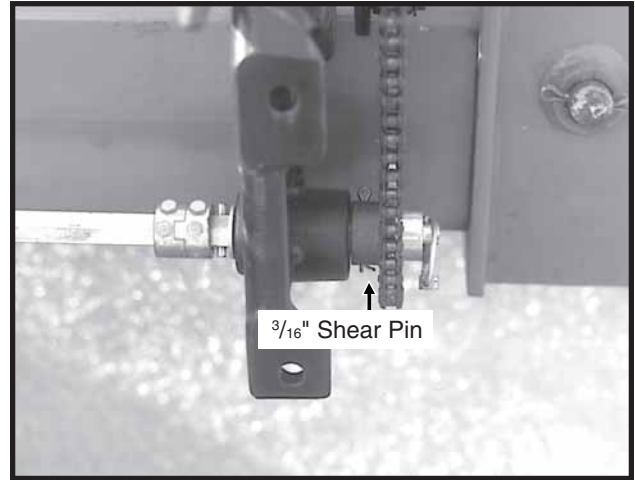

### Transmission Shaft

If excessive load should cause a pin to shear, it is important to determine where binding has occurred before replacing the pin. Replace shear pins with same size and type.

To prevent future binding or breakage of components, check driveline alignment and follow prescribed lubrication schedules.

**NOTE: Drill shaft/transmission coupler alignment is critical.**

# MACHINE OPERATION

## HYDRAULIC OPERATION

This machine is equipped with a single control valve row marker system and a separate control valve for folding the wings.

D09219907



### Single Control Valve Row Marker System

An additional control is required for the optional Dual Lift Assist Wheel Package unless it is tied into the tractor 3 point lift system. Check with your tractor dealer for parts required.

### Row Marker Hydraulic Operation

The single valve row marker system uses a sequencing valve which directs hydraulic flow to operate the markers alternately.

With the single valve row marker system, both markers can be used at the same time by first lowering one marker and moving the hydraulic control lever to the raise position and immediately returning it to the lower position. This will shift the marker control valve spool and the remaining marker will be lowered.



**WARNING:** Always stand clear of row marker assemblies and blades when planter is operating. Serious injury can result from contact with row marker blades.



**DANGER:** To avoid serious injury or death, care must be taken when operating row markers around overhead power lines.



**CAUTION:** If a row marker or wing lift cylinder has been disconnected or removed for any reason, do not attach the rod end of the cylinder until the cylinder is cycled several times to remove any air that may be trapped in the system.



**DANGER:** Serious injury or death can result from contact with electric lines. Use care to avoid contact with electric lines when moving or operating this machine.

### Folding Frame Hydraulic Operation

Vertical folding machines have the capability of folding the outer portion or wings of the planter toolbar vertically for narrower transport width. These models can be operated in the field with the wings either in the rigid position or flex position.



**WARNING:** Always make sure there are no persons near the planter when planter wings are being lowered from transport position.



**DANGER:** Serious injury or death can result from contact with electric lines. Use care to avoid contact with electric lines when moving or operating this machine.

Where flex in the frame is not required for proper row unit operation, pin the wings rigid.

55702-2a

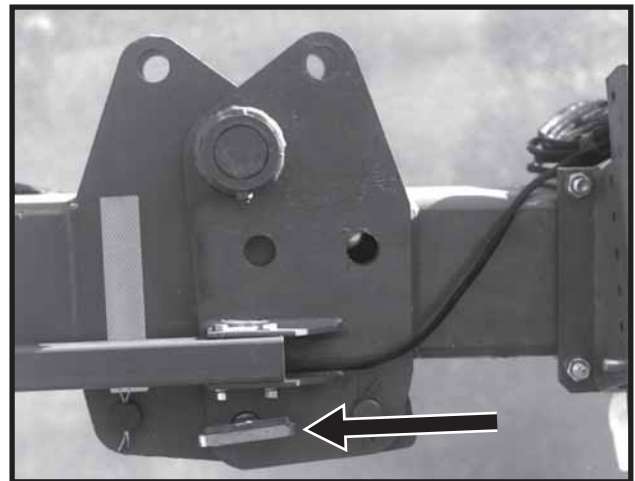

Rigid Operation Position Shown

# MACHINE OPERATION

When planting in uneven terrain or anytime additional flex is needed, the wings can be left unpinned to allow the wings to flex.

55702-20a

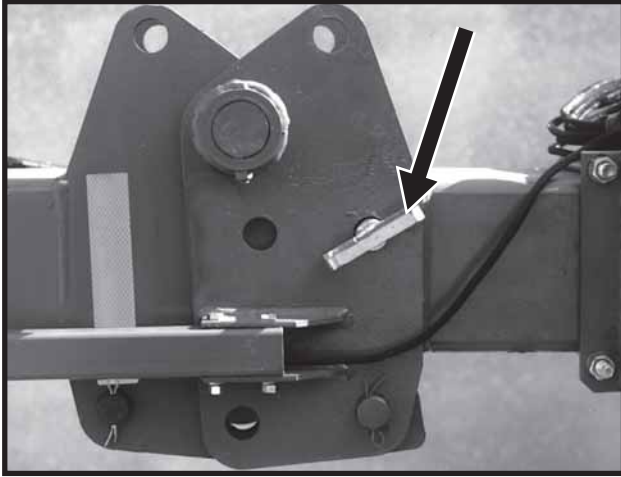

Flexible Operation Position Shown

**NOTE:** When operating with the wings in the flex position, install the wing safety pins as shown. This will limit the flex up and down to 5° and prevent the wings from flexing up far enough to disengage the drill shaft to the center units. The wing safety pins must be removed to fold the wings into the transport position.



**CAUTION:** Prior to folding the wings for transport, the markers must be folded and all hoppers located on the planter's wings emptied or removed.



**DANGER:** Wings must be unfolded before detaching machine from tractor.

## ROW MARKER SPEED ADJUSTMENT

The row marker hydraulic system includes two flow control valves. One flow control valve controls the lowering speed of both row markers and one controls the raising speed of both row markers. To adjust row marker speed, loosen the jam nut and turn the control(s) clockwise or IN to slow the travel speed and counterclockwise or OUT to increase the travel speed. The flow control(s) determine the amount of oil flow restriction through the valve(s), therefore determining travel speed of the row markers. Tighten jam nut after adjustments are complete.

55398-3

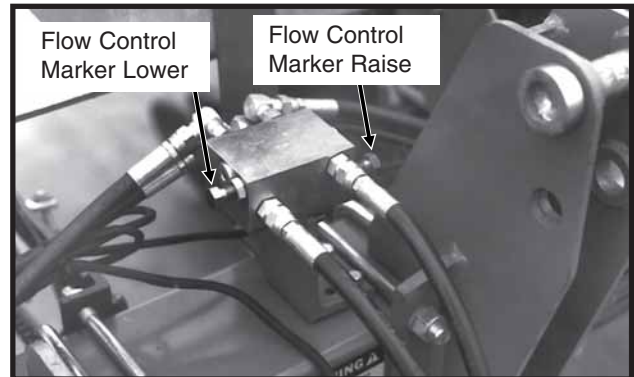

Single Valve Row Marker Hydraulic System

**IMPORTANT:** The flow controls should be properly adjusted before the marker assembly is first put into use. Excessive travel speed of the markers can damage the marker assembly.



**DANGER:** To avoid serious injury or death, care must be taken when operating row markers around overhead power lines.

**NOTE:** When oil is cold, hydraulics operate slowly. Make sure all adjustments are made with warm oil.

**NOTE:** On a tractor where the oil flow can not be controlled, the rate of flow of oil from the tractor may be greater than the rate at which the marker cylinder can accept it. The tractor hydraulic control will have to be held until the cylinder reaches the end of its stroke. This occurs most often on tractors with an open center hydraulic system.

On tractors with a closed center hydraulic system, the tractor's hydraulic flow control should be adjusted to the full flow position. If oil is restricted, the sequencing valve may not shift properly.

(PLTR78)

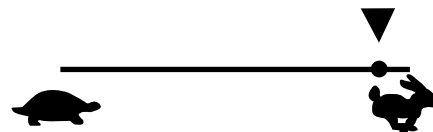

# MACHINE OPERATION

## ROW MARKER LENGTH ADJUSTMENT

To determine the correct length at which to set the row marker assemblies, multiply the number of rows by the average row spacing in inches. This provides the total planting width. Adjust the row marker extension so the distance from the marker disc blade to the center line of the planter is equal to the total planting width previously obtained. Both the planter and marker assembly should be lowered to the ground when the measurements are being taken. Measurement should be taken from the point where the blade contacts the ground. Adjust right and left row marker assemblies equally and securely tighten clamping bolts. An example of marker length adjustment follows:

Number Of Rows x Row Spacing (Inches) = Dimension Between Planter Center Line And Marker Disc Blade.

12 Rows	x	30" Row Spacing	=	360" Row Marker Dimension
---------	---	-----------------	---	---------------------------

The marker disc blade is installed so the concave side of the blade is outward to throw dirt away from the grease seals. The spindle assembly is slotted so the hub and blade can be angled to throw more or less dirt. To adjust the hub and spindle, loosen the 1/2" hardware and move the assembly as required. Tighten bolts to the specified torque.

**IMPORTANT: A marker disc blade assembly that is set at a sharper angle than necessary will add unnecessary stress to the complete marker assembly and shorten the life of bearings and blades. Set the blade angle only as needed to leave a clear mark.**

A field test is recommended to ensure the markers are properly adjusted. After the field test is made, make any minor adjustments as necessary.

60569-53



**Row Marker Disc Blade Shown With Depth Band (Standard On 8 Row Wide - Up)**

A notched marker blade is available from KINZE® Repair Parts for use in more severe no till conditions.



## KPM I ELECTRONIC SEED MONITOR

(MTR28)

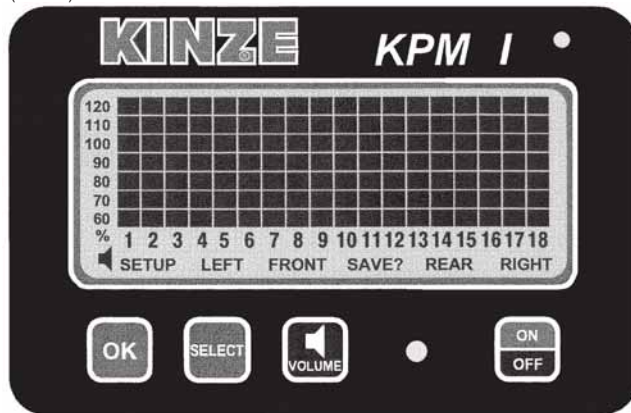

The KPM I electronic seed monitor system consists of a console, which is mounted on the tractor; seed tubes with computerized sensors, one of which is installed in each planter row unit; a primary harness\*, which connects the console to the planter harness; and a planter harness (junction Y-harness and/or harness extension where applicable), to which the individual seed tube sensors connect.

Seed flow for up to 36 rows, in two 18 row sections (left/right or rear/front), may be monitored with one monitor. For less complicated applications (18 rows or less), all rows may be programmed in one section and the other section left disabled.

The monitor system is powered by the tractor battery (requires 12 volts DC). The console receives information from each of the sensors and translates this information.

The single backlit Liquid Crystal Display (LCD) shows the active section, the number of monitored rows per section, the relative seed rate for each row (using a bar graph display) and scrolls various alarm and warning messages when an alarm condition exists. A continuous audible alarm will sound upon system malfunction or underflow conditions for any monitored row. Alarms must be acknowledged by the user. Various warnings may sound the alarm or flash one or more icons.

The monitor will power down if no activity is detected within one hour. No activity means there has been no new seed flow and no operator push key input. (If Applicable)

**\* NOTE: The primary harness, on all 3000 Series Planters, is hard-wired into the safety/warning light harness or control console harness included as standard equipment with the planter.**

Monitor Key Functions .....	6-11
LCD Functions .....	6-11
Changing The Audible Alarm Volume .....	6-12
Warnings And Alarms .....	6-12
Replacing A Faulty Sensor .....	6-13
Field Operation .....	6-14
Programming/Connecting Seed Tubes .....	6-14

### MONITOR KEY FUNCTIONS

Each key press is acknowledged by the monitor with a short beep.

#### OK

- Ends and saves the new setup during installation.
- Acknowledges and silences alarms in the operation mode.

#### SELECT

- Selects the application mode (rear/front or left/right) at the beginning of installation setup.
- Selects the active section(s) (rear, rear/front, left, right or left/right) in the operation mode.
- Has no affect on a system configured to monitor only one section.

#### VOLUME

- Pressing the key will turn the audible alarm on.
- Holding the key for periods of 2 seconds increases the volume until it reaches the maximum, at which time it rolls over to the minimum level.

#### ON/OFF

- Powers the unit on and off.

### LCD FUNCTIONS

The monitor collects data on the planting rates from all active rows and calculates an average. This average will determine the 100% mark. Seed rate for each row is then compared to the average value and the result is displayed on the bar graph.

The information regarding each section is displayed alternately every 5 seconds. While operating a system with two sections programmed, one or both sections may be selected any time. When only one section is selected, the monitor calculates the average based on the remaining active rows from that section.

**STEP 1** Press SELECT key once to show one section. The flashing icon shows the section that is not selected. The selected section is continuously displayed on the LCD.

**EXAMPLE:** The system is setup to display rear/front sections. Press SELECT key. The FRONT icon will be flashing and the REAR section will be displayed on the bargraph. After 1 minute the FRONT icon will stop flashing. The monitor will stay in this REAR only display through power down and power up. Each time the monitor is turned on while in REAR only mode, the FRONT icon will flash for 1 minute. Also if seed flow is sensed in the FRONT section while planting, the FRONT icon will resume flashing.

**STEP 2** Press SELECT key again to activate both sections.

**EXAMPLE:** Press SELECT key a second time. The information regarding each section will display alternately every 5 seconds.

For simple applications, where only one section is programmed, the display will automatically lock on that section. Pressing SELECT key will have no affect.

**NOTE:** When alternating between two sections, the display will lock on the section containing the first recognized alarm until the alarm is acknowledged by pressing the OK key or the alarm condition is removed.

## CHANGING THE AUDIBLE ALARM VOLUME

**STEP 1** Press and hold down the VOLUME key.

**STEP 2** The SETUP and VOLUME icons will turn on and the alarm will sound continuously. The intensity of the sound will change every 2 seconds. After the maximum volume is reached, the next change will set the volume to minimum and will continue to get louder every 2 seconds. When the desired volume is reached, release the key.

## WARNINGS AND ALARMS

- 1. System Alarms** - A system alarm is activated when the monitor detects a faulty sensor or one of several other communication faults.

The corresponding row number starts flashing and the alarm sounds. All segments on the corresponding bar graph are turned off. Pushing the OK key to acknowledge the warning will turn the audible alarm off. The row number will continue to flash until the alarm condition is removed. If the monitor detects a faulty sensor and there is no planting activity present, the monitor will scroll "CHECK CONNECTION".

Another type of system alarm occurs when the monitor detects a data communication bus error. The three possible data communication bus errors are:

LCD Display	Error Condition
SYS HI	The data communication lead (green) has been shorted to the power lead (white).
SYS LO	The data communication lead (green) has been shorted to the ground lead (black).
SYS EC	An internal error has been detected.

- 2. Under Flow Alarms** - If the seed rate for one or more rows is less than 55% of the calculated average, the corresponding 60% segment will stay on, the corresponding row number starts flashing and the alarm sounds. Pushing the OK key to acknowledge the alarm will turn the alarm off. The 60% segment of the bar graph remains on and the row number continues to flash until the alarm condition is corrected.

**NOTE:** All alarms present within a short time before planting stops, are frozen on the screen and the text LOW or FAIL will display on the LCD. If the under flow is between 0% and 10%, this warrants a "FAIL" condition. If the under flow is between 10% and 55%, a "LOW" condition is generated. If multiple rows have an under flow condition, "FAIL" will display if any one or more rows is between 0% and 10%. This allows the user to identify and fix the problem rows.

**NOTE: This warning will not trigger unless a minimum time of continuous planting has passed.**

**NOTE: If all the rows show a seed rate of zero, the condition will not generate an alarm. It will be assumed the planter has stopped. The row numbers and the bottom 60% segment will remain on for all selected rows.**

3. **Multiple Alarms** - If more than one alarm condition occurs at the same time, pushing the OK key will acknowledge all alarms that are currently displayed. For example, if one row on the front and one row on the rear are alarming, pushing the OK key will only acknowledge one of them. However, if there are two alarms on the front, both alarms would be acknowledged with one push of the OK key.
4. **Section Not Selected Warning** - If the monitor was programmed for two sections and only one is currently selected for display (by pressing the SELECT key), the icon of the disabled section will flash for a period of 1 minute, then turn off at each power up. If seed flow is sensed in the disabled section, the icon for that section (front, left or right) will begin to flash.
5. **Seed Planting Stopped Warning** - When the monitor detects no seed flow on all rows, the monitor will emit 3 short beeps to alert the user. This warning will occur each time the planter is stopped, each time the planter is raised at the end of a row or if the mechanical drive fails while planting.

**NOTE: This warning will not trigger unless a minimum time of continuous planting has passed.**

6. **Seed Counting Sensor In Calibration Warning** - All seed counting sensors run a self-calibration sequence on power up. While in calibration the bottom segment of each corresponding bar graph will flash if the monitor detects movement or planting activity. If the monitor does not detect this, the message "WAIT CALIBRATION" will be scrolled.

7. **Seed Counting Sensor Too Dirty Warning** - After the seed counting sensors end their internal self-calibration, the monitor may detect one or more sensors are either too dirty or blocked. If the monitor detects planting or movement, the corresponding bar graph remains flashing. The monitor will display "CLEAN SENSORS" on the LCD if no movement or planting is detected, prompting the user to clean the tubes. If the tubes are dirty, they will still show seed flow with less accuracy. If the tubes are blocked the user will get an alarm as soon as planting starts. The corresponding bar graph will remain flashing until the problem is corrected and the monitor is powered down and then powered back up.
8. **Low Battery Warning** - The monitor is constantly monitoring its input voltage to quickly detect low power conditions. If the monitor detects that the input voltage has dropped below 11.0V, it will display "LOW POWER" on the LCD, provided that the monitor does not detect planting.

**NOTE: After the alarms have been acknowledged and if the alarm condition is still present, the LCD will continue to display the alarm condition.**

## REPLACING A FAULTY SENSOR

To replace a faulty sensor; (a) disconnect the faulty sensor and check the monitor to be sure the correct sensor was disconnected, (b) turn the monitor off, (c) after a few seconds, turn the monitor back on and (d) plug in the replacement sensor. The monitor will chirp twice to acknowledge the new sensor was learned and saved.

To replace more than one faulty sensor, proceed as stated above beginning with the lowest numbered row in the rear or left section and continue to replace sensors in increasing order. Then move on to the front or right section and continue in ascending row number order.

**NOTE: If the monitor is not turned off and then on, the replacement sensor(s) will be ignored until the next power on, at which point they will be randomly learned by the monitor.**

## FIELD OPERATION

(MTR28e/MTR28c/MTR28d/MTR28b)

Press the ON/OFF key to turn the monitor on and off.



Information regarding each section is displayed alternately every 5 seconds.

### REAR/FRONT CONFIGURATION

- Press the SELECT key once to show REAR section only.
- Press the SELECT key a second time to return to each section being displayed alternately every 5 seconds.
- Press the SELECT key a third time to show REAR section only again.



### LEFT/RIGHT CONFIGURATION

- Press the SELECT key once to show LEFT section only.
- Press the SELECT key a second time to show RIGHT section only.
- Press the SELECT key a third time to return to each section being displayed alternately every 5 seconds.



**NOTE: SELECT key has no function when only a single section is being used.**

Press the VOLUME key to increase or decrease volume. See “Changing The Audible Alarm Volume”.



Press the OK key to silence alarms. See “Warnings And Alarms”.



## PROGRAMMING/CONNECTING SEED TUBES

**STEP 1** All the seed tubes w/sensors must be disconnected from the harness and the monitor must be off.

**STEP 2** Press the ON key. The monitor automatically enters the setup procedure. If the monitor was accidentally powered on with no sensors attached, the user can turn the monitor off at this point and the previous configuration is not lost.

**STEP 3** Press the SELECT key. Each time you press the SELECT key the mode will toggle between rear/front and left/right. The selected display will be solid and the configuration not currently selected will be flashing. By default the monitor starts in rear/front mode.

01229910

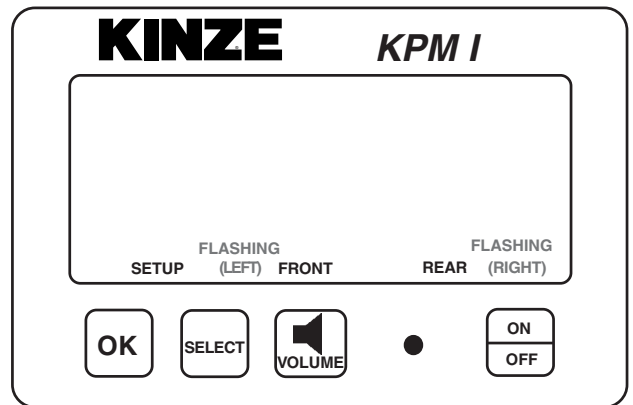

01229911

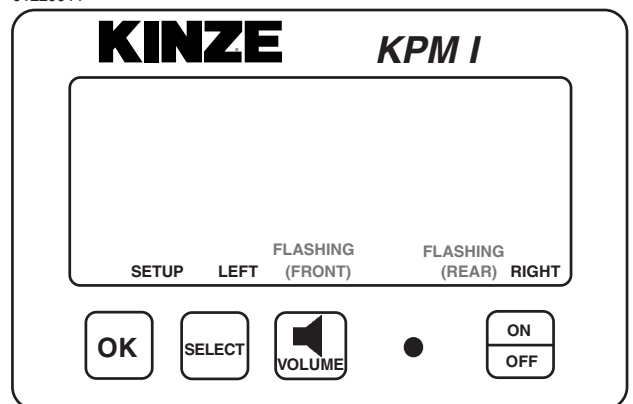

**NOTE: Model 3120 planters will use the rear configuration only.**

**STEP 4** Press and hold the OK key to confirm the selection and continue holding until the row numbers appear on the display. During confirmation, the display will alternate between “NEW” and “SYS” to alert the user that the previous configuration will be lost. With the rear/front mode selected, the monitor automatically starts with the rear section. The REAR icon shows solid and the FRONT icon starts to flash. With the left/right mode selected, the monitor automatically starts with the left section. The LEFT icon shows solid and the RIGHT icon starts to flash.

01229912

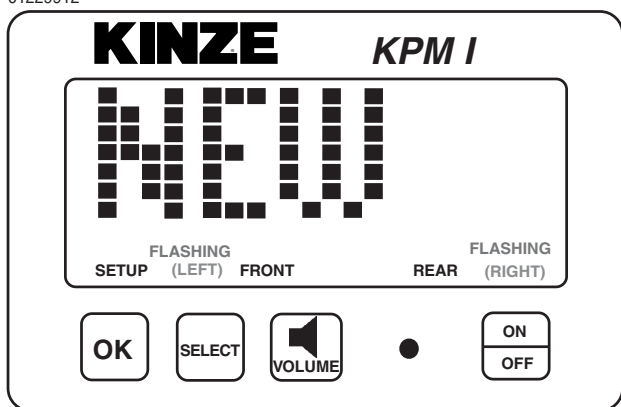

**STEP 5** Plug each seed tube w/sensor into the harness in a predetermined order. Row 1 first, row 2 second and so on up to 18 rows. When a sensor is plugged in, the corresponding row number on the LCD display will stay solid, the monitor will chirp twice and the LED (Light Emitting Diode) on the seed tube sensor will turn on for approximately 30 seconds to show connection is made. NOTE: Unless there is a faulty sensor, the installer should just have to connect the sensors in the proper order without checking the monitor is acknowledging each sensor.

01229915

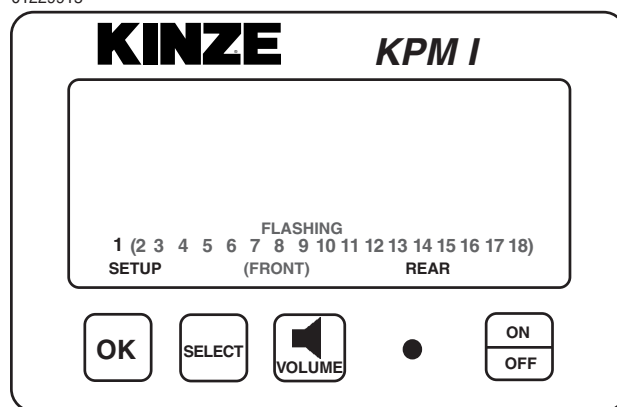

01229912a

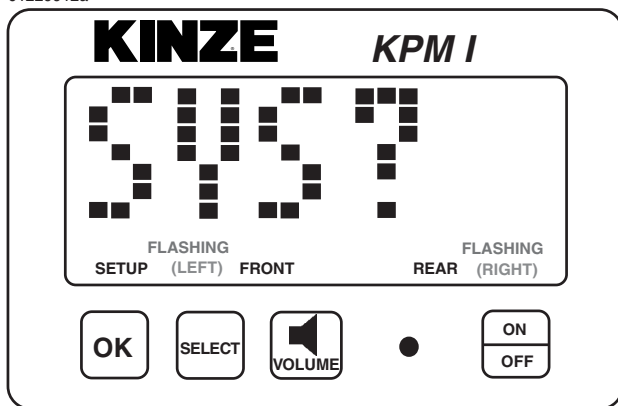

**STEP 6** When all the seed tubes w/sensors for the current section are installed, check to be sure the monitor displays solid numbers for the number of sensors connected.

01229916

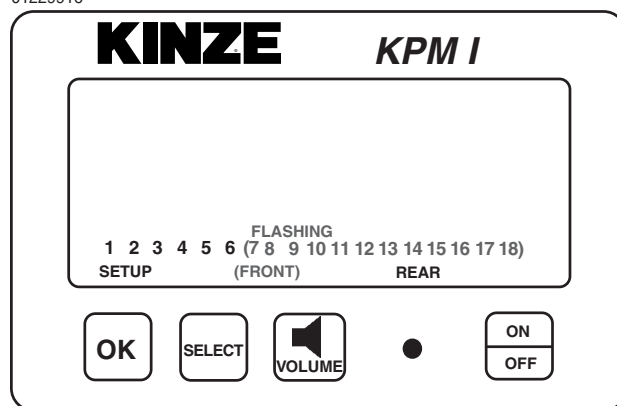

**STEP 7** If this condition is satisfied, press and hold the OK key to save the setup for the current section. The SAVE? icon will show followed by continuous short beeps indicating the monitor is preparing to save. The installer has 5 seconds to decide if he wants to save the current configuration. During this time the short beeps will sound. To complete the save, hold the OK key pressed until the word “DONE” shows on the screen followed by a long beep and the SAVE? icon turns off. When the OK key is released the monitor will continue with the second section installation.

**STEP 8** Follow STEPS 5 through 7 to install the second section. If no seed tubes are installed on the second section, press and hold the OK key until the word “DONE” shows on the screen followed by a long beep and the SAVE? icon turns off.

01229917

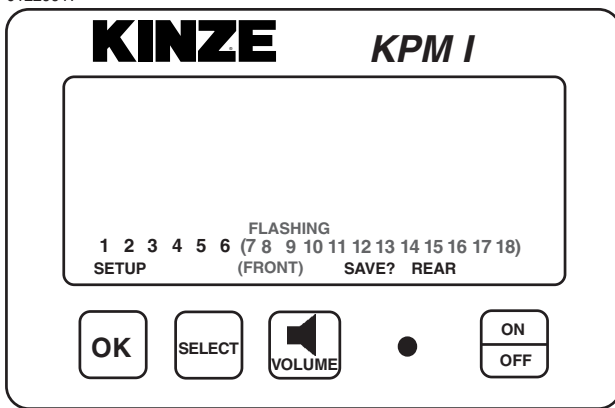

01229919

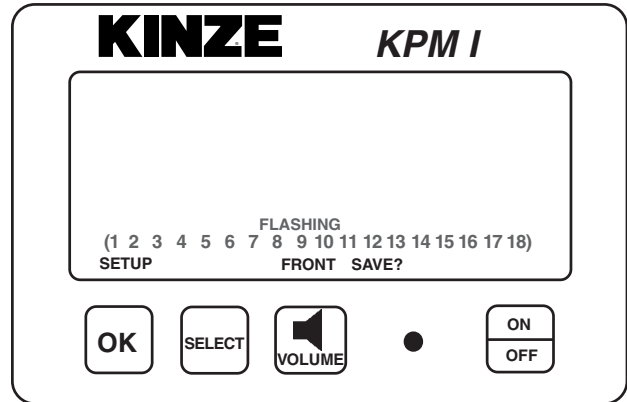

01229920

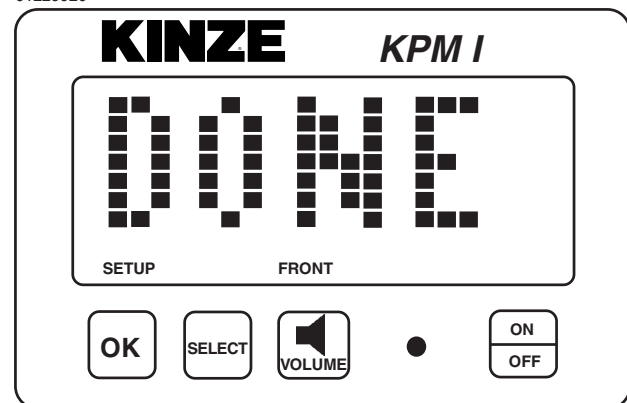

01229918

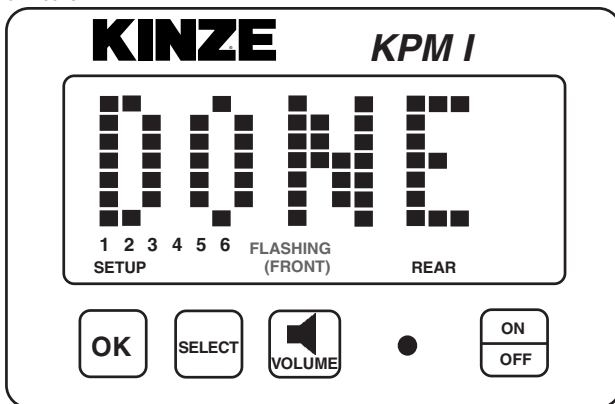

**NOTE:** Individual seed tubes may be unplugged for special situations. An alarm will sound which can be silenced by touching the OK key. The monitor will recognize each seed tube when reconnected.

**See “KPM I/KPM II Stack-Mode Electronic Seed Monitor Troubleshooting” in the Maintenance Section.**

# MACHINE OPERATION

# KPM II STACK-MODE

## KPM II STACK-MODE ELECTRONIC SEED MONITOR

(MTR41e)

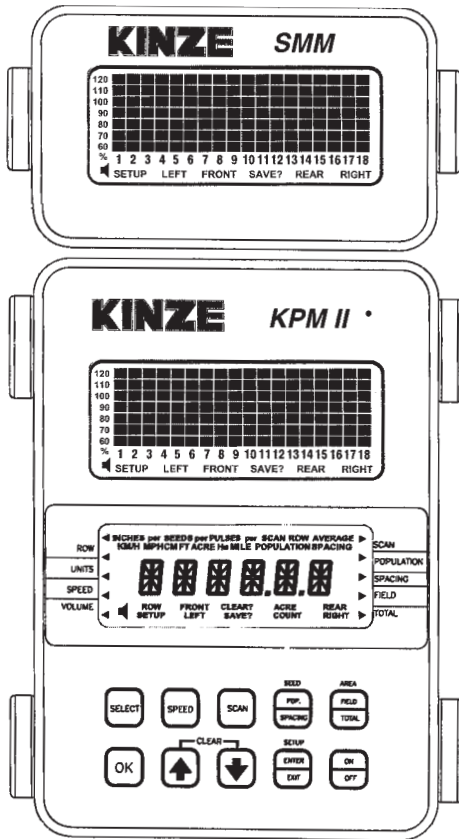

**NOTE: SMM console may not be applicable to all models.**

The KPM II Stack-Mode electronic seed monitor system consists of (a) a KPM II Stack-Mode console, which is mounted on the tractor; (b) seed tubes with sensors, one of which is installed in each planter row unit; (c) a magnetic distance sensor, which is installed on the planter, or a radar distance sensor, which is installed on the tractor; (d) shaft rotation sensors, which are installed on the planter drill shafts; and (e) a planter harness (junction Y-harness and/or extension harness where applicable), to which the individual seed tube sensors connect. The primary harness, which connects the monitor console to the planter harness, is hard-wired into the safety/warning light harness or control console harness included as standard equipment with the planter.

The software design of the KPM II Stack-Mode console allows the use of an add-on SMM console for simultaneous viewing of the seed flow bar graphs for standard and/or Interplant® System rows (up to 36 rows in two sections). A total of 72 rows may be displayed in multiple sections (rear/front, left/right or four sections). The SMM console must be used to allow utilization of the four section feature.

The monitor system is powered by the tractor battery (requires 12 volts DC). The console receives information from each of the sensors and translates this information.

The KPM II Stack-Mode console has two backlit Liquid Crystal Displays (LCD). The upper display shows the active section, the number of monitored rows per section, the relative seed rate for each row (using a bar graph display) and scrolls various alarm and warning messages when an alarm condition exists. A continuous audible alarm will sound upon system malfunction or underflow conditions for any monitored row. Alarms must be acknowledged by the user. Various warnings may sound the alarm or flash one or more icons. The lower display is used to display alphanumeric data such as row spacing, units (Metric or English), speed, volume, seed population, seed spacing, field area, total area and distance sensor pulses per mile/kilometer.

The SMM console has one backlit Liquid Crystal Display (LCD) which functions the same as the upper display on the KPM II Stack-Mode console except it does not scroll alarm and warning messages. The SMM console must be programmed into the system before printed text will display on the LCD.

The monitor system will power down if no activity is detected within one hour. No activity means there has been no new seed flow and no operator push key input.

Monitor Key Functions .....	6-18
Upper LCD Functions .....	6-19
Lower LCD Functions .....	6-20
<b>Programming</b>	
Changing The Audible Alarm Volume .....	6-22
Units (Metric Or English) .....	6-23
Row Spacing .....	6-23
Speed .....	6-25
Clearing Total Area .....	6-26
Area Counter/Speedometer Mode .....	6-27
Warnings And Alarms .....	6-27
Replacing A Faulty Sensor .....	6-28
Field Operation .....	6-29
Clearing Field Area .....	6-30
<b>Programming/Connecting SMM Console, Shaft Rotation Sensors, Seed Tubes And/Or Radar/Magnetic Distance Sensors .....</b>	<b>6-31</b>
<b>Row-By-Row Alarm Level Setting .....</b>	<b>6-43</b>

## MONITOR KEY FUNCTIONS

Push keys allow the user to select or change the operating mode, the active displays or the current configuration. Depending on the operating mode or the current display selected, some keys are valid while some are not. Each key press, if valid, is acknowledged by a short beep and an action is taken. If the key press has no action associated, the key press is considered invalid, and the user will not get any feedback.

### SELECT

- Selects the application mode (rear/front, left/right or four sections up to a maximum of 72 rows) at the beginning of installation in the setup mode.
- Selects the active section(s) (rear, rear/front, left, right or left/right) in the operation mode.
- Has no affect on a system configured to monitor only one section.
- While programming the monitor, the key will select the digit to change.

### SPEED

- Immediately displays the current ground speed.

### SCAN

- If the current average population or average spacing is displayed, this key sequentially displays the seed population/spacing on each row.
- If the display shows functions other than average seed population or spacing, pressing SCAN will sequentially display speed, average seed population and average seed spacing.
- Pressing a second time freezes the display on the current row.
- Pressing a third time restarts the sequential display.

### SEED POPULATION/SEED SPACING

- Immediately displays the average seed POPULATION and the average seed SPACING of all active rows.
- Each press alternates between seed spacing and seed population.

### AREA FIELD/AREA TOTAL

- Immediately displays the field or total area planted since the field/total area was last cleared.
- Each press alternates between field area and total area.

### OK

- Ends and saves the new setup during installation.
- Acknowledges and silences alarms in the operation mode.

### UP ARROW AND DOWN ARROW

- Scrolls sequentially through the display options on the lower LCD display.
- Freezes on the current row in the scan mode.
- Scrolls sequentially through the rows when the population scan is frozen.
- Used to enter programmable values in the programming mode.
- The UP and DOWN Arrow keys can be pressed at the same time to start the CLEAR function.

### SETUP ENTER/SETUP EXIT

- Enters and exits the programming mode.

### ON/OFF

- Powers the unit on and off.



# MACHINE OPERATION

# KPM II STACK-MODE

## UPPER LCD FUNCTIONS

(MTR29h)

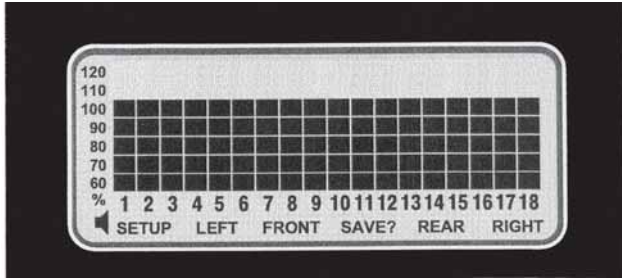

The monitor collects data on the planting rates from all active rows and calculates an average. This average will determine the 100% mark. Seed rate for each row is then compared to the average value and the result is displayed on the bar graph.

With only the KPM II Stack-Mode console programmed into the system, the information regarding each section is displayed alternately every 5 seconds. While operating a system with two sections programmed, one or both sections may be selected any time. When only one section is selected, the monitor calculates the average based on the remaining active rows from that section.

With the SMM console programmed into the system, two sections are viewed at the same time. If the system configuration is for four sections, the display will alternate every 5 seconds between a pair of sections. The select key will lock the display on rear sections. The SMM console shows RIGHT in the left/right configuration, FRONT in the rear/front configuration and FRONT RIGHT/ REAR RIGHT in four sections configuration. The KPM II Stack-Mode console shows LEFT in the left/right configuration, REAR in the rear/front configuration and FRONT LEFT/REAR LEFT in four sections configuration.

**STEP 1** Press SELECT key once to show one section. The flashing icon shows the section that is not selected. The selected section icon is continuously displayed on the LCD.

**EXAMPLE:** The system is setup to display rear section on KPM II Stack-Mode console and front section on SMM console. Press SELECT key. The FRONT icon will be flashing and the REAR section will be displayed on the bar graph. The SMM console is only backlit. After 1 minute the front row icon will stop flashing. The monitor will stay in this REAR only display through power down and power up. Each time the monitor is turned on while in REAR only mode, the FRONT icon will flash for 1 minute.

If seed flow is sensed in the FRONT section while planting, the FRONT icon will resume flashing.

When the front section is disabled, the row spacing will automatically double to maintain the proper implement width in the monitor. A 23 or 24 row 15" configuration changes to a 12 row 30" configuration with a touch of the SELECT key.

**STEP 2** Press SELECT key again to activate both sections.

For simple applications, where only one section is programmed, the display will automatically lock on that section. Pressing the SELECT key will have no affect.

**NOTE:** When alternating between two sections, the display will lock on the section containing the first recognized alarm until the alarm is acknowledged by pressing the OK key or the alarm condition is removed.

## LOWER LCD FUNCTIONS

(MTR29g)

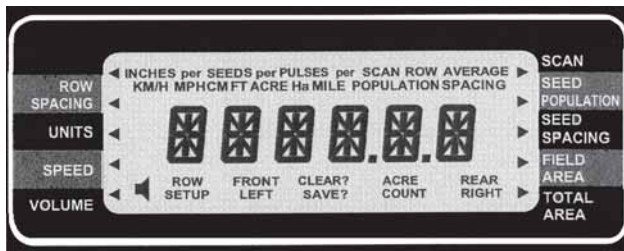

- The UP and DOWN arrow keys will sequentially change what is being displayed on the lower LCD. Pressing the UP or DOWN arrow keys will move the arrow head icon (on the left and right hand side of the display) to another item. For example, if the arrow icon is pointing to SPEED, ground speed will be displayed on the LCD. Pressing the UP arrow key will move the icon to UNITS. The display will change to display all the icons used to represent the current (English or Metric) measurement system.
- The shortcut keys SPEED, SEED POPULATION/SPACING and AREA FIELD/TOTAL allow direct access to their respective displays. For example, no matter what is currently being displayed on the lower LCD, pressing the SPEED key will change the display to the current speed. Pressing the SEED POPULATION/SPACING or AREA FIELD/TOTAL keys will alternate between the two functions assigned to those keys.
- Pressing the SCAN key while displaying seed spacing or population will cause a sequential display of each individual row. Pressing the SCAN key a second time will freeze the display on the currently displayed row. The UP or DOWN arrow keys can be used to change the currently displayed row. Pressing the SCAN key will restart the automatic advancing of the scan function.
- Pressing the SCAN key while displaying speed will cause a sequential display of speed, average planter population and average seed spacing. Pressing the SCAN key a second time will freeze the display on the currently displayed reading.

### ROW SPACING

Press the arrow keys to ROW SPACING to display the current spacing between rows in inches or centimeters. The ROW SPACING icons turn on, displaying a 3 digit, one decimal place format. In the area count mode, this function displays the implement width in feet or meters, using a 3 digit, no decimal places format.

### UNITS

Press the arrow keys to UNITS to display all the icons from the currently selected English or Metric measurement system. For the English system, the icons are: INCH, MPH, FT, ACRE and MILE. For the Metric system, the icons are: M, KM/H and Ha.

### SPEED

Press the SPEED key to display the current speed in MPH or KM/H, using a 3 digit, one decimal place format.

### VOLUME

Press the arrow keys to VOLUME to display the presently selected audible alarm volume. The SPEAKER icon turns on.

### SCAN

Press the SCAN key to display the seed spacing or seed population (see Steps 1-3 following) of each individual row. (1)Pressing the SCAN key while displaying any other function will cause the monitor to sequentially display speed, average seed population and average seed spacing. (2)Pressing the SCAN key a second time will freeze the display. (3)Pressing the SCAN key a third time restarts the sequential display. The UP and DOWN arrow keys can be used to change the current display.

# MACHINE OPERATION

# KPM II STACK-MODE

## SEED POPULATION/SEED SPACING

Each SEED POP/SPACING key press alternates between seed population and seed spacing.

Seed population displays the average number of seeds or the row average number of seeds per acre or seeds per hectare for all the active rows. The average is displayed using a 6 digits, no decimal places format. The AVERAGE POPULATION icon will turn on. When in the scan mode, the scan arrow and SCAN ROW POPULATION will appear. The ROW number icon and the current row will be displayed on the left and the population will be displayed on the right in 1000's using 3 digits, one decimal place (e.g. 32.9 means 32,900). When in scan freeze mode, the scan arrow and ROW POPULATION will turn on (scan arrow may be flashing). The UP and DOWN keys may be used to lock on the desired row.

Seed spacing displays the average distance or the row average distance between seeds for all active rows in inches per seed or centimeters per seed using a 3 digit, one decimal place format. When the average is displayed the AVERAGE SPACING icons are turned on. When in the scan mode, the scan arrow and SCAN ROW SPACING icons will appear. The ROW number icon and the current row will be displayed on the left and the spacing will be displayed on the right. The display will sequence to the next row every 5 seconds. When in scan freeze mode, the scan arrow and SPACING will turn on (scan arrow may be flashing). The UP and DOWN keys may be used to lock on the desired row.

## FIELD AREA/TOTAL AREA

Each AREA FIELD/TOTAL key press alternates between field area and total area.

Field area displays the total number of acres or hectares using a 6 digit, one decimal place format.

**NOTE: When FIELD AREA is selected, the UP or DOWN key must be held in slightly longer than normal so the monitor will not mistake this action with a CLEAR, which consists of the UP and DOWN arrow keys pressed simultaneously. A beep will sound when the function activates.**

Total area displays the total number of acres or hectares using a 6 digit, one decimal place format. The total area counter updates every time the field area counter increments. Clearing the total area counter will also clear the field area counter.

When the monitor is programmed as a rear only or rear/front configuration and shaft rotation sensors are installed, pressing the UP arrow to move beyond row spacing lights an arrow on an unlabeled area above ROW SPACING. This is the automatically set division line between the L.H. shaft sensor and the R.H. shaft sensor. The display shows the first row on the rear section and the front section assigned to the R.H. shaft rotation sensor.

**EXAMPLE: On a 12 Row 30" planter with Interplant® Package, the display would appear as follows:**

092597-21



THIS DISPLAY IS NOT ACCESSIBLE ON LEFT/RIGHT CONFIGURATIONS OR SYSTEMS WITHOUT SHAFT ROTATION SENSORS.

## PROGRAMMING - Changing The Audible Alarm Volume

**STEP 1** To enter the programming mode, press and hold the SETUP key. The monitor will emit several short beeps, followed by a long beep. On the lower LCD, the SETUP icon turns on and the arrow head icon will flash, indicating that the user can select an item to program.

**NOTE: The monitor must be in a programmable function (row spacing, units, speed, volume or area) to enter setup. The monitor will not enter setup in seed population or seed spacing.**

**STEP 2** Press the UP or DOWN arrow keys to move the flashing arrow to VOLUME. As the arrow icon moves, the lower LCD will display the current setting of the item selected.

**STEP 3** Press the OK key and the flashing arrow becomes solid and the audible alarm will sound.

**NOTE: The lower LCD will display the current volume and the SPEAKER icon is turned on. Settings are from 0 to 9.**

- Use the UP or DOWN arrow keys to change the setting. With every UP arrow key push, the alarm will increment by one step between the minimum and the maximum. If the maximum level (9) is reached the volume rolls over to the minimum level (0).
- Pressing the DOWN arrow key lowers the volume until the minimum level (0) is reached, at which point the volume rolls over to the maximum level (9).

**STEP 4** To exit without saving, press and release the OK key. The monitor will restore the lower LCD to show the setting of the item, and the arrow icon will flash, allowing the user to select another item to program.

To exit and save, press and hold the OK key. The monitor will emit several short beeps and SAVE? icon is turned on. After a short time a long beep is heard, and the lower LCD will display the word "DONE". Release the OK key. If the OK key is released BEFORE the word "DONE" is displayed, the changes WILL NOT BE SAVED. The word "DONE" MUST be displayed in order for the save to have occurred.

**NOTE: The programming mode may be exited at any time, by pressing the SETUP key. Pressing this key will return the monitor to its normal operation. All items changed and saved will come into effect immediately. Any items changed, but not saved will revert to the original programmed value.**

# MACHINE OPERATION

# KPM II STACK-MODE

## PROGRAMMING - Units (Metric Or English)

**STEP 1** To enter the programming mode, press and hold the SETUP key. The monitor will emit several short beeps, followed by a long beep. On the lower LCD, the SETUP icon turns on and the arrow head icon will flash, indicating that the user can select an item to program.

**NOTE: The monitor must be in a programmable function (row spacing, units, speed, volume or area) to enter setup. The monitor will not enter setup in seed population or seed spacing.**

**STEP 2** Press the UP or DOWN arrow keys to move the flashing arrow to UNITS. As the arrow icon moves, the lower LCD will display the current setting of the item selected.

**STEP 3** Press the OK key and the flashing arrow becomes solid and the audible alarm will sound.

**NOTE: The lower LCD will alternately display all Metric icons or all English icons, indicating the Metric or English mode respectively.**

- Use the UP or DOWN arrow keys to change the setting.

**STEP 4** To exit without saving, press and release the OK key. The monitor will restore the lower LCD to show the setting of the item, and the arrow icon will flash, allowing the user to select another item to program.

To exit and save, press and hold the OK key. The monitor will emit several short beeps and SAVE? icon is turned on. After a short time a long beep is heard, and the lower LCD will display the word "DONE". Release the OK key. If the OK key is released BEFORE the word "DONE" is displayed, the changes WILL NOT BE SAVED. The word "DONE" MUST be displayed in order for the save to have occurred.

**NOTE: The programming mode may be exited at any time, by pressing the SETUP key. Pressing this key will return the monitor to its normal operation. All items changed and saved will come into effect immediately. Any items changed, but not saved will revert to the original programmed value.**

## PROGRAMMING - Row Spacing

**STEP 1** Prior to entering the programming mode, the application mode (rear/front, left/right or four sections) must be active. If the monitor is programmed in a rear/front configuration, both sections will be active (alternating every 5 seconds if the SMM console is not used). You can then set the row spacing to the Interplant® System row spacing.

EXAMPLE: On a 12 Row 30" with Interplant® Package set the row spacing to 15.0 with front active.

When the monitor is in normal field operation mode, disabling the front section will automatically change the row spacing to 30".

**STEP 2** To enter the programming mode, press and hold the SETUP key. The monitor will emit several short beeps, followed by a long beep. On the lower LCD, the SETUP icon turns on and the arrow head icon will flash, indicating that the user can select an item to program.

**NOTE: The monitor must be in a programmable function (row spacing, units, speed, volume or area) to enter setup. The monitor will not enter setup in seed population or seed spacing.**

**STEP 3** Press the UP or DOWN arrow keys to move the flashing arrow to ROW SPACING. As the arrow icon moves, the lower LCD will display the current setting of the item selected.

**STEP 4** Press the OK key and the flashing arrow becomes solid and the audible alarm will sound.

**NOTE: The lower LCD will display the current row spacing (in inches or centimeters) and ROW SPACING icon is turned on.**

- The least significant digit of the displayed value will be blinking.
- This value can be changed by pressing either the UP or DOWN arrow keys.
- Once this digit is correct, press the MODE SELECT key and the blinking digit will move to the next significant digit, where the process can be repeated.

**NOTE:** The monitor limits the entry of row spacing to a minimum of 10.0 inches (25.4 cm) and to a maximum of 99.9 inches (253.7 cm). If the monitor is configured to a rear/front configuration, the limits change to a minimum of 5.0 inches (12.7 cm) and a maximum of 49.9 inches (126.8 cm).

**STEP 5** To exit without saving, press and release the OK key. The monitor will restore the lower LCD to show the setting of the item and the arrow icon will flash, allowing the user to select another item to program.

To exit and save, press and hold the OK key. The monitor will emit several short beeps and SAVE? icon is turned on. After a short time a long beep is heard, and the lower LCD will display the word "DONE". Release the OK key. If the OK key is released BEFORE the word "DONE" is displayed, the changes WILL NOT BE SAVED. The word "DONE" MUST be displayed in order for the save to have occurred.

To exit setup mode, press the SETUP key.

**NOTE:** The programming mode may be exited at any time, by pressing the SETUP key. Pressing this key will return the monitor to its normal operation. All items changed and saved will come into effect immediately. Any items changed, but not saved will revert to the original programmed value.

## PROGRAMMING - Speed

**STEP 1** To enter the programming mode, press and hold the SETUP key. The monitor will emit several short beeps, followed by a long beep. On the lower LCD, the SETUP icon turns on and the arrow head icon will flash, indicating that the user can select an item to program.

**NOTE: The monitor must be in a programmable function (row spacing, units, speed, volume or area) to enter setup. The monitor will not enter setup in seed population or seed spacing.**

**STEP 2** Press the UP or DOWN arrow keys to move the flashing arrow to SPEED. As the arrow icon moves, the lower LCD will display the current setting of the item selected.

**STEP 3** Press the OK key and the flashing arrow becomes solid and the audible alarm will sound. The R.H. digit on the display will be blinking.

The speed constant is used to record how many pulses are generated per mile (or kilometer) from the ground speed sensor. The lower LCD will display the current pulses per mile (or kilometer) using a 6 digit, no decimal place format. The PULSES per MILE (or PULSES per KM) icons are turned on.

**NOTE: It is highly recommended that a field calibration be done to establish the PPM/PPKM (Pulses Per Mile/Kilometer) number on a new machine installation. Several factors can affect this value such as wheel slip on the magnetic distance sensor, mounting angle and height on the radar distance sensor, etc. IT IS NOT UNCOMMON FOR THE SPEED ON THE MONITOR TO VARY SLIGHTLY FROM THE TRACTOR SPEEDOMETER. Adjusting the PPM/PPKM in the monitor to make the speed agree can cause serious errors in acre/hectare and population counts. Do field checks to verify populations and seed spacings.**

**NOTE: On new system installations, the monitor will default to 500 PPM (310 PPKM). This will have to be changed to obtain accurate readings from the monitor.**

- In field conditions, measure 330 feet ( $\frac{1}{16}$  mile) or 100 meters, depending on the unit of measurement selected.

- Pull the tractor up to the starting line.

- Press the UP and DOWN arrow keys at the same time and hold them down until the CLEAR? icon is displayed and the monitor beeps several times. When the data is actually cleared, the monitor will emit a long beep and the number of pulses is cleared.

**NOTE: If the PPM/PPKM number starts to count pulses with the tractor not moving, check the radar for vibration or other kinds of interference.**

- Drive the tractor for 330 feet ( $\frac{1}{16}$  mile) or 100 meters and stop.

- The monitor will count the number of pulses and display them.

**STEP 4** To exit without saving, press and release the OK key. The monitor will restore the lower LCD to show the previous setting of the item, and the arrow icon will flash, allowing the user to select another item to program.

To exit and save, press and hold the OK key. The monitor will emit several short beeps and SAVE? icon is turned on. After a short time a long beep is heard, and the lower LCD will display the word "DONE". Release the OK key. If the OK key is released BEFORE the word "DONE" is displayed, the changes WILL NOT BE SAVED. The word "DONE" MUST be displayed in order for the save to have occurred.

**NOTE: The programming mode may be exited at any time, by pressing the SETUP key. Pressing this key will return the monitor to its normal operation. All items changed and saved will come into effect immediately. Any items changed, but not saved will revert to the original programmed value.**

NOTE: If a discrepancy occurs and digits must be changed, follow STEPS 1 and 2 to enter the programming mode and proceed as follows:

- Press the OK key and the flashing arrow becomes solid. The least significant digit of the displayed value will be blinking.
- This value can be changed by pressing either the UP or DOWN arrow keys.
- Once this digit is correct, press the SELECT key and the blinking digit will move to the next significant digit, where the process can be repeated.

The monitor limits the entry of pulses per mile or kilometer to a minimum of 500 PPM (310 PPKM), and to a maximum of 500,000 PPM (310,686 PPKM).

KEY Action	Flashing Digit	Display Value
Press The UP Key	Right Most Digit	2031, 2032, 2033
Press The SELECT Key	Second Digit From Right	2033
Press The DOWN Key	Second Digit From Right	2023, 2013, 2003, 2093, 2083
Press The SELECT Key Twice	Left Most Digit	2083
Press The DOWN Key	Left Most Digit	1083, 0500 (Min. Value), 9500, 8500

## PROGRAMMING - Clearing Total Area

**NOTE: Clearing the total area counter will also clear the field area counter.**

**STEP 1** To enter the programming mode, press and hold the SETUP key. The monitor will emit several short beeps followed by a long beep. On the lower LCD, the SETUP icon turns on and the arrow head icon will flash, indicating that the user can select an item to program.

**NOTE: The monitor must be in a programmable function (row spacing, units, speed, volume or area) to enter setup. The monitor will not enter setup in seed population or seed spacing.**

**STEP 2** Press the UP or DOWN arrow keys to move the flashing arrow to TOTAL AREA. As the arrow icon moves, the lower LCD will display the current setting of the item selected.

**STEP 3** Press the OK key and the flashing arrow becomes solid and the audible alarm will sound.

- The lower LCD will display the total area and the ACRE (or Ha) icon turns on.
- With the flashing arrow on TOTAL AREA, press the OK key.

• To reset the counter, press the UP and DOWN arrow keys at the same time and hold them down for a short period of time to clear the data. The CLEAR? icon will be displayed and the monitor will beep several times. When the data is actually cleared, the monitor will emit a long beep, and the total area is reset to zeros. After the long beep, the previous recorded total area is not retrievable. Once cleared, the user **may not** choose to exit programming mode without saving as described in STEP 4.

**STEP 4** To exit and save, press and hold the OK key. The monitor will emit several short beeps and SAVE? icon is turned on. After a short time a long beep is heard, and the lower LCD will display the word "DONE". Release the OK key. If the OK key is released BEFORE the word "DONE" is displayed, the changes WILL NOT BE SAVED. The word "DONE" MUST be displayed in order for the save to have occurred.

**NOTE: The programming mode may be exited at any time, by pressing the SETUP key. Pressing this key will return the monitor to its normal operation. All items changed and saved will come into effect immediately. Any items changed, but not saved will revert to the original programmed value.**



## AREA COUNTER/SPEEDOMETER MODE

If the monitor is installed with only a radar distance sensor (no seed tubes attached), the monitor becomes a speedometer. If (a) the monitor is connected to a radar distance sensor, (b) the signal cable from the back of the console is connected to a sensing switch (Part No. G1K249 Acre Counter Switch Kit) instead of the seed tubes and (c) the implement width in feet (or meters) is programmed into the monitor, the monitor will function as an area counter.

The seed spacing and seed population functions are not available in this mode. If the monitor is powered down, the seed tubes connected and the monitor powered up, the monitor will again show seed population and seed spacing in inches or centimeters. Row spacing reverts back to its programmed setting.

## WARNINGS AND ALARMS

- 1. System Alarms** - A system alarm is activated when the monitor detects a faulty sensor or one of several other communication faults.

The corresponding row number starts flashing and the audible alarm sounds. All segments on the corresponding bar graph are turned off. Pushing the OK key to acknowledge the warning will turn the alarm off. The row number will continue to flash until the alarm condition is removed. If the monitor detects a faulty sensor and there is no planting activity present, the monitor will scroll "CHECK CONNECTION".

If the distance sensor is detected as faulty, the monitor will display either "PICKUP" or "RADAR", depending on the type of sensor installed, and the audible alarm will sound. The user can push the OK key to acknowledge the alarm. When the distance sensor is faulty, the monitor will change to a bar graph only mode where the rows are still displayed relative to each other. No area related information (speed, field area, total area, seed spacing or seed population) will be accumulated or displayed.

If a rotation shaft sensor is faulty, "LSHAFT", "RSHAFT" or "SHAFTS" will display.

Another type of system alarm occurs when the monitor detects a data communication bus error.

The four possible data communication bus errors are:

LCD Display	Error Condition
SYS HI	The data communication lead (green) has been shorted to the power lead (white).
SYS LO	The data communication lead (green) has been shorted to the ground lead (black).
SYS EC	An internal error has been detected.
COP	Cycled power ON/OFF to quickly.

- 2. Under Flow Alarms** - If the seed rate for one or more rows is less than 55% of the calculated average, the corresponding 60% segment will stay on, the corresponding row number starts flashing and the alarm sounds. Pushing the OK key to acknowledge the warning will turn the alarm off. The 60% segment of the bar graph remains on and the row number continues to flash until the alarm condition is corrected.

**NOTE: All alarms present within a short time before planting stops are frozen on the screen and the text LOW or FAIL will display on the LCD. If the under flow is between 0% and 10%, this warrants a "FAIL" condition. If the under flow is between 10% and 55%, a "LOW" condition is generated. If multiple rows have an under flow condition, "FAIL" will display if any one or more rows is between 0% and 10%. This allows the user to identify and fix the problem rows.**

**NOTE: This warning will not trigger unless a minimum time of continuous planting has passed.**

**NOTE: If all the rows show a seed rate of zero, the condition will not generate an alarm. It will be assumed the planter has stopped. The row numbers and the bottom 60% segment will remain on for all selected rows.**

- 3. Multiple Alarms** - If more than one alarm condition occurs at the same time, pushing the OK key will acknowledge all alarms that are currently displayed. For example, if one row on the front and one row on the rear are alarming, pushing the OK key will only acknowledge one of them. However, if there are two alarms on the front, both alarms would be acknowledged with one push of the OK key.

4. **Section Not Selected Warning** - If the monitor was programmed for two sections and only one is currently selected for display (by pressing the SELECT key), the icon of the disabled section will flash for a period of 1 minute, then turn off at each power up. If seed flow is sensed in the disabled section, the icon for that section (front, left or right) will begin to flash.
5. **Seed Planting Stopped Warning** - When the monitor detects no seed flow on all rows, the monitor will emit 3 short beeps to alert the user. This warning will occur each time the planter is stopped, each time the planter is raised at the end of a row or if the mechanical drive fails while planting.

**NOTE: This warning will not trigger unless a minimum time of continuous planting has passed.**

6. **Seed Counting Sensor In Calibration Warning** - All seed counting sensors run a self-calibration sequence on power up. While in calibration the bottom segment of each corresponding bar graph will flash if the monitor detects movement or planting activity. If the monitor does not detect this, the message "WAIT CALIBRATION" will be scrolled.
7. **Seed Counting Sensor Too Dirty Warning** - After the seed counting sensors end their internal self-calibration, the monitor may detect one or more sensors are either too dirty or blocked. If the monitor detects planting or movement, the corresponding bar graph remains flashing. The monitor will display "CLEAN SENSORS" on the top LCD if no movement or planting is detected, prompting the user to clean the tubes. If the tubes are dirty, they will still show seed flow with less accuracy. If the tubes are blocked the user will get an alarm as soon as planting starts. The corresponding bar graph will remain flashing until the problem is corrected and the monitor is powered down and then powered back up.
8. **Low Battery Warning** - The monitor is constantly monitoring its input voltage to quickly detect low power conditions. If the monitor detects that the input voltage has dropped below 11.0V, it will display "LO SYS" on the lower LCD on the KPM II Stack-Mode console, provided that the monitor does not detect speed or planting.

**NOTE: After the alarms have been acknowledged and if the alarm condition is still present, the LCD will continue to display the alarm condition.**

## REPLACING A FAULTY SENSOR

**NOTE: Stack-Mode Seed Sensors are identified by a blue 3-pin connector. Replace Stack-Mode Seed Sensors with like components only.**

To replace a faulty sensor; (a) disconnect the faulty sensor and check the monitor to be sure the correct sensor was disconnected, (b) turn the monitor off, (c) after a few seconds, turn the monitor back on and (d) plug in the replacement sensor. The monitor will chirp twice to acknowledge the new sensor was learned and saved.

To replace more than one faulty sensor, proceed as stated above for rear/front or left/right configurations beginning with the lowest numbered row in the rear or left section and continue to replace sensors in ascending order. Then move on to the front or right section and continue in ascending order. For four section configurations, begin with rear/left and continue to rear/right, then front/left and ending with front/right.

If the monitor detects a faulty distance sensor, the lower LCD will immediately move to the speed display, show the word "PICKUP" or "RADAR" depending on the distance sensor installed, and the alarm will sound.

**NOTE: If the monitor is not turned off and then on, the replacement sensor(s) will be ignored until the next power on, at which point the sensors will be randomly learned by the monitor.**

# MACHINE OPERATION

# KPM II STACK-MODE

## FIELD OPERATION

Press the ON/OFF key to turn the monitor on.



(MTR28e)

Information regarding each section is displayed alternately every 5 seconds.

### REAR/FRONT CONFIGURATION (Without SMM Console Installed)

- Press the SELECT key once to show REAR section only. (Monitor sets correct row spacing.)
- Press the SELECT key a second time to return to each section being displayed alternately every 5 seconds on KPM II Stack-Mode console. (Monitor sets correct row spacing.)
- Press the SELECT key a third time to show REAR section only again.



(MTR28c)

### REAR/FRONT CONFIGURATION (With SMM Console Installed)

- Press the SELECT key once to show REAR section only on KPM II Stack-Mode console. (Monitor sets correct row spacing.)
- Press the SELECT key a second time to show FRONT section on SMM console and REAR section on KPM II Stack-Mode console. (Monitor sets correct row spacing.)
- Press the SELECT key a third time to show REAR section only again.



(MTR28c)

### FOUR SECTION CONFIGURATION (With SMM Console Installed)

- Press the SELECT key once to show REAR and LEFT sections on KPM II Stack-Mode console and REAR and RIGHT sections on SMM console. (Monitor sets correct row spacing.)
- Press the SELECT key a second time to return to all four sections, alternating right front and right rear on SMM console and alternating left front and left rear on KPM II Stack-Mode console. (Monitor sets correct row spacing.)
- Press the SELECT key a third time to show REAR and LEFT sections on KPM II Stack-Mode console and REAR and RIGHT sections on SMM console again.



(MTR28c)

**NOTE: SELECT key has no function when only a single section is being used.**

At power up, the lower LCD will show speed (MPH or KM/H).

(MTR29g/MTR29b/MTR29a/MTR29c/MTR29f/MTR29c/MTR29f)

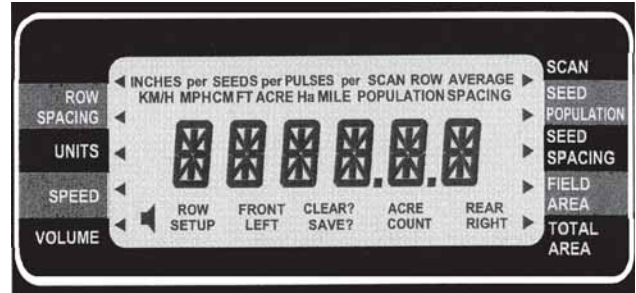

Press the UP or DOWN arrow keys to move the flashing arrow on the lower LCD to change what is displayed on the lower LCD.



Press the shortcut keys SPEED, SEED POPULATION/SEED SPACING or AREA FIELD/TOTAL for direct access to these displays.



(MTR29c/MTR29d/MTR29b/MTR29c)

Press the SEED POPULATION/SEED SPACING or AREA FIELD/TOTAL keys to alternate between the two functions assigned to that key.



Press the SEED POPULATION/SEED SPACING key to choose average seed spacing/population per acre.



Press the SCAN key to display individual rows starting at row 1.



Press the SCAN key again to lock on current row.

Press the SCAN key again to resume scrolling.

Use the UP or DOWN arrow keys to move to a particular row.



Press the SEED POPULATION/SEED SPACING key to go back to planter average.



## CLEARING FIELD AREA

(MTR29n/MTR28b)

To reset the counter, press the UP or DOWN arrow keys to move the arrow in the lower display to FIELD AREA.



Press the UP and DOWN arrow keys at the same time and hold them down for a short period of time to clear the data. The CLEAR? icon will be displayed and the monitor will beep several times. When the data is actually cleared, the monitor will emit a long beep, and the field area is reset to zero. After the long beep, the previous field area recorded is not retrievable.



**NOTE: Clearing the field area counter will not clear the total area counter. See “Programming-Clearing Total Area” for clearing total area.**

Press the OK key to silence alarms. See “Warnings And Alarms”.



# MACHINE OPERATION

# KPM II STACK-MODE

**PROGRAMMING/CONNECTING SMM CONSOLE, SHAFT ROTATION SENSORS, SEED TUBES AND/OR RADAR/MAGNETIC DISTANCE SENSORS**

**STEP 1** All sensors (including the seed tubes w/ sensors, radar, magnetic distance, SMM console and shaft rotation sensors) must be unplugged from the harness and/or console and the monitor must be off.

**NOTE:** If the monitor detects a radar sensor but no seed tubes at power up, it will automatically go into AREA COUNT mode. See “Area Counter/Speedometer Mode”.

**NOTE:** Disconnect magnetic distance sensor between MDS adapter and planter harness. **DO NOT** disconnect between MDS and MDS adapter.

01189909

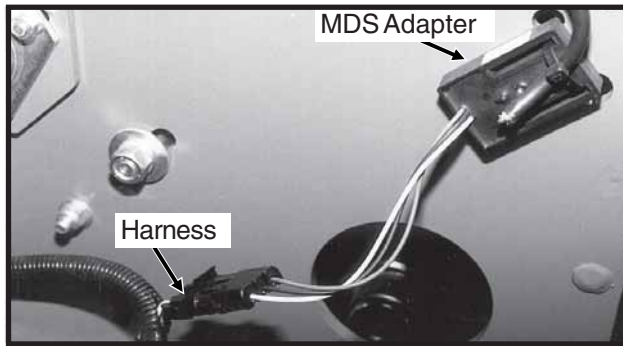

01189910



**STEP 2** Press the ON key. The monitor automatically enters the setup procedure. Monitor will scroll “NO SENSOR” on top LCD of KPM II Stack-Mode console.

**STEP 3** The monitor automatically defaults to rear/front. Press the SELECT key once for left/right and twice for four sections (front right/front left/rear right/rear left). The selected display will be solid and the configuration not currently selected will be flashing.

12060211

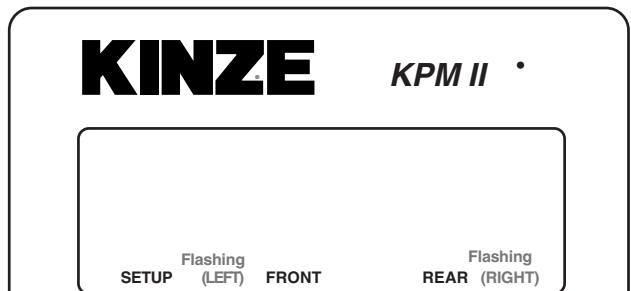

ROW	SETUP	SCAN
UNITS		SEED
SPEED		SEED
VOLUME		FIELD
		TOTAL

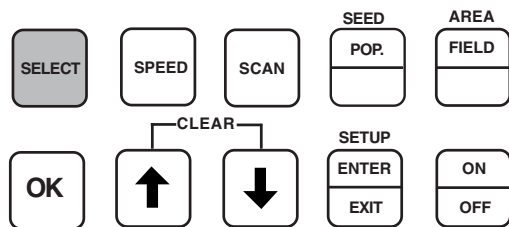

**NOTE:** SMM console may not be applicable to all models.

# MACHINE OPERATION

# KPM II STACK-MODE

12060211

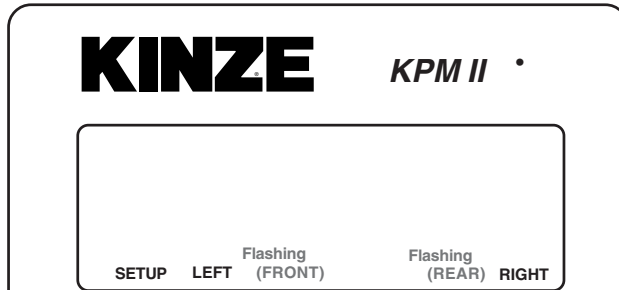
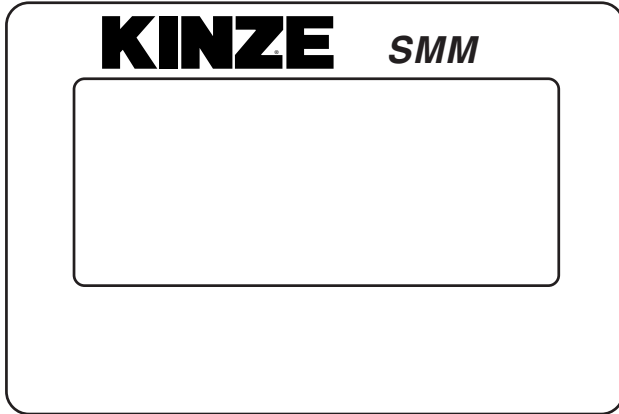

ROW	SETUP	SCAN
UNITS		SEED
SPEED		FIELD
VOLUME		TOTAL

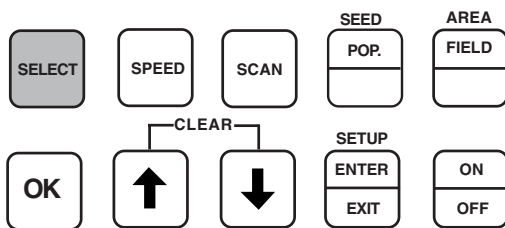

**NOTE: SMM console may not be applicable to all models.**

**NOTE: Model 3120 planters select the rear configuration.**

**STEP 4** Press and hold the OK key to confirm selection. The upper display will alternate between “NEW” and “SYS?”.

The alarm will sound four short beeps followed by one long beep. At this point your selection has been saved and row numbers will appear flashing on the upper display of the KPM II.

12060211

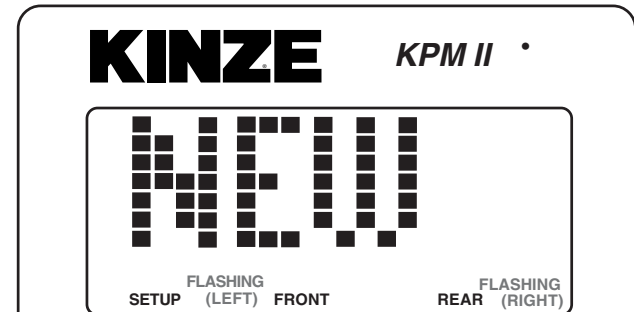

ROW SPACING	SETUP	SCAN
UNITS		SEED POPULATION
SPEED		FIELD AREA
VOLUME		TOTAL AREA

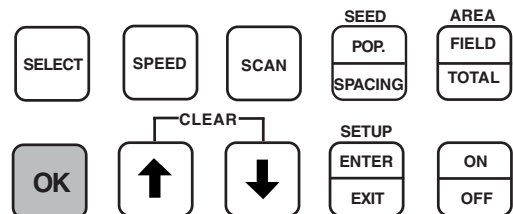

**NOTE: SMM console may not be applicable to all models.**

# MACHINE OPERATION

# KPM II STACK-MODE

**NOTE: Illustrated using rear/front configuration.** The KPM II Stack-Mode console shows LEFT in the left/right configuration, REAR in the rear/front configuration and FRONT LEFT/REAR LEFT in the four sections configuration.

**STEP 5** (If Applicable) Connect SMM console into junction Y-harness which was installed between the KPM II Stack-Mode console and the primary harness. The SMM console will show a lighted screen and KPM will show on the lower LCD.

12060211

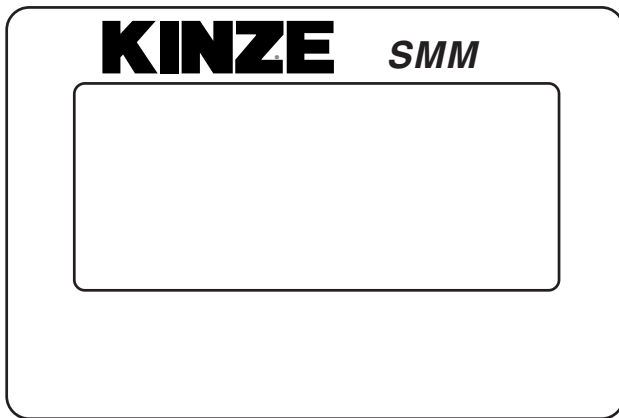

12060211

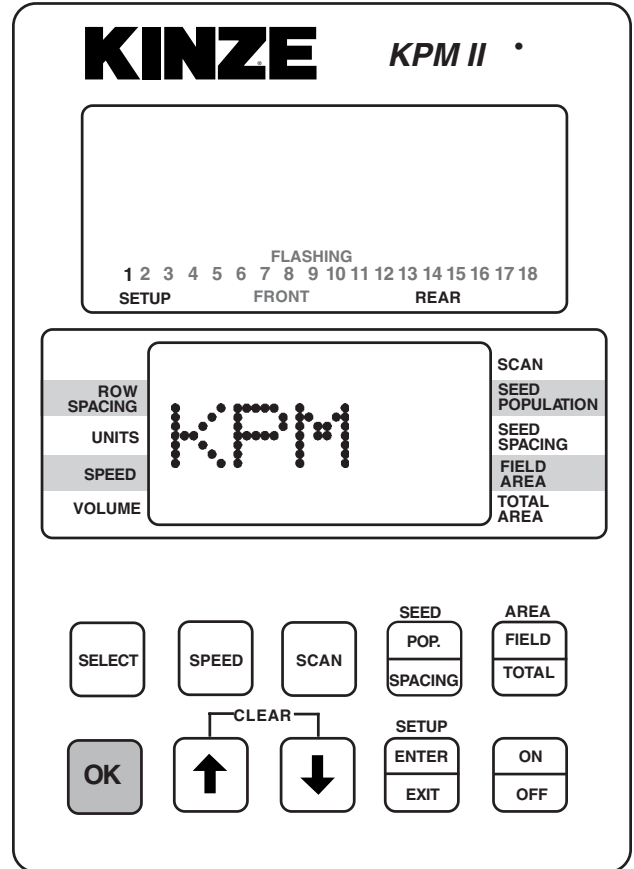
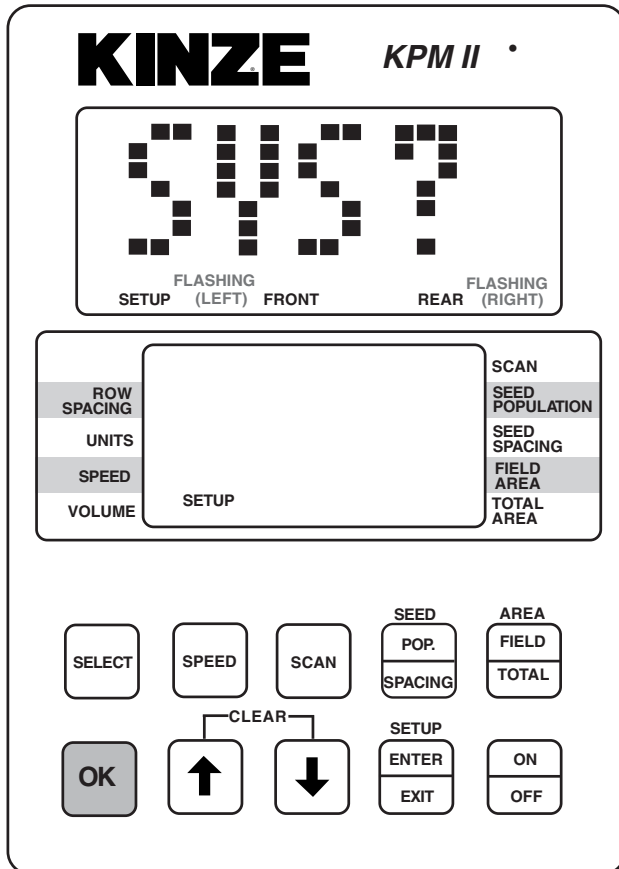

**NOTE: SMM console may not be applicable to all models.**

**NOTE: SMM console may not be applicable to all models.**

# MACHINE OPERATION

# KPM II STACK-MODE

**STEP 6** If the monitor system includes shaft rotation sensors, these should be installed at this time. Plug in the L.H. shaft first, then the R.H. shaft. L.H. and R.H. is determined by facing in the direction the machine will travel when in use.

01189906

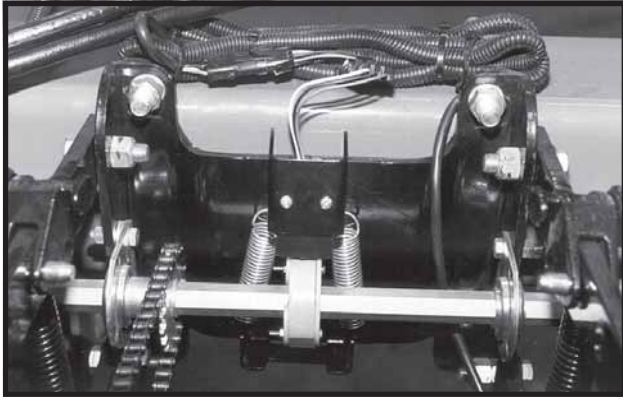

“LSHAFT” or “SHAFT 1” will display on the lower LCD when the first shaft rotation sensor is installed. “RSHAFT” or “SHAFT 2” will display when the second shaft rotation sensor is installed.

**NOTE:** Illustrated using rear/front configuration. The KPM II Stack-Mode console shows **LEFT** in the left/right configuration, **REAR** in the rear/front configuration and **FRONT LEFT/REAR LEFT** in the four sections configuration.

12060211

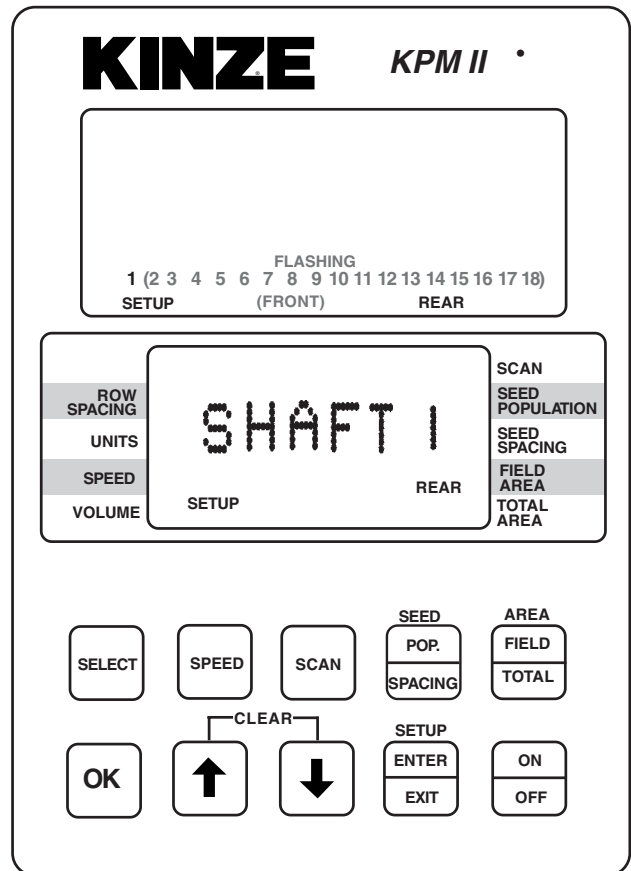

**NOTE:** SMM console may not be applicable to all models.



# MACHINE OPERATION

# KPM II STACK-MODE

## STEP 6 (Continued)

12060211

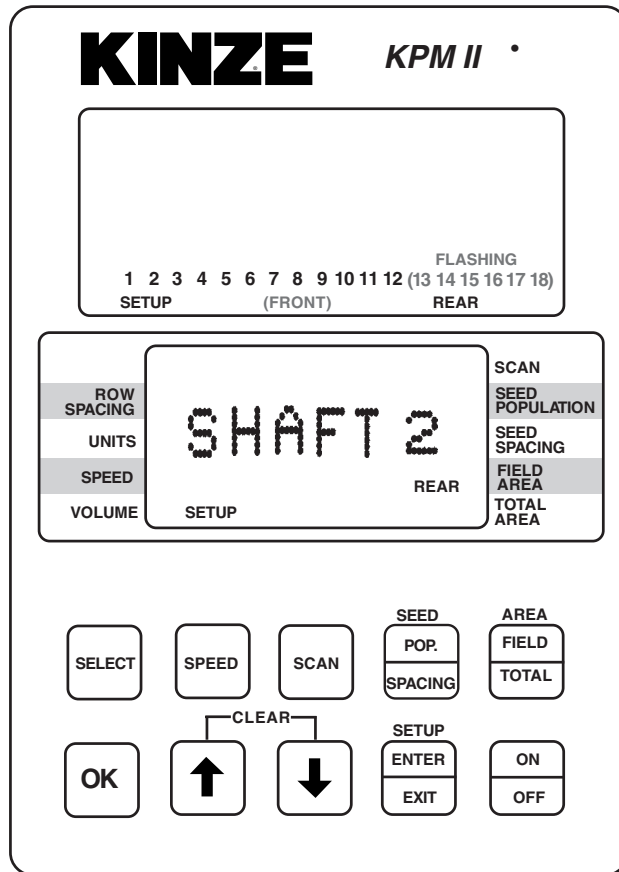

**NOTE: SMM console may not be applicable to all models.**

## STEP 7 Determine which row you want as number one and plug the seed tube w/sensor into the harness.

Continue plugging in sensors along with shaft rotation sensors if so equipped. Row 1 first, row 2 second and so on up to 18 rows. When a sensor is plugged in, the corresponding row number on the upper LCD display will stay solid, the monitor will chirp twice and a red LED (Light Emitting Diode) on the seed tube sensor will turn on for approximately 30 seconds to show connection is made.

(METR55b)

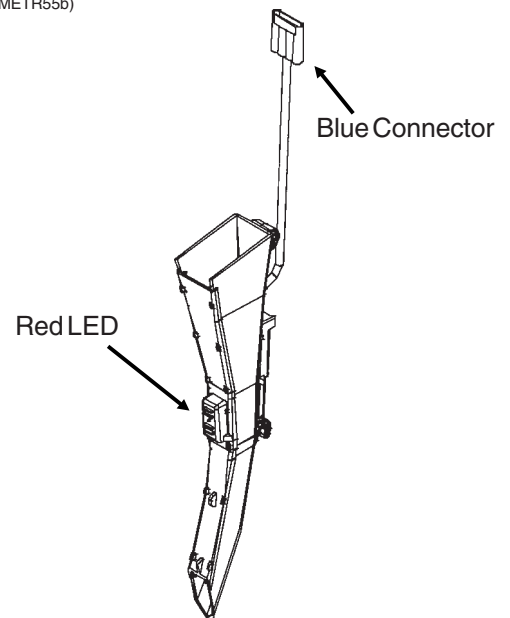

## STEP 7 (Continued)

**NOTE:** Illustrated using rear/front configuration. The KPM II Stack-Mode console shows LEFT in the left/right configuration, REAR in the rear/front configuration and REAR LEFT/FRONT LEFT in the four sections configuration.

12060211

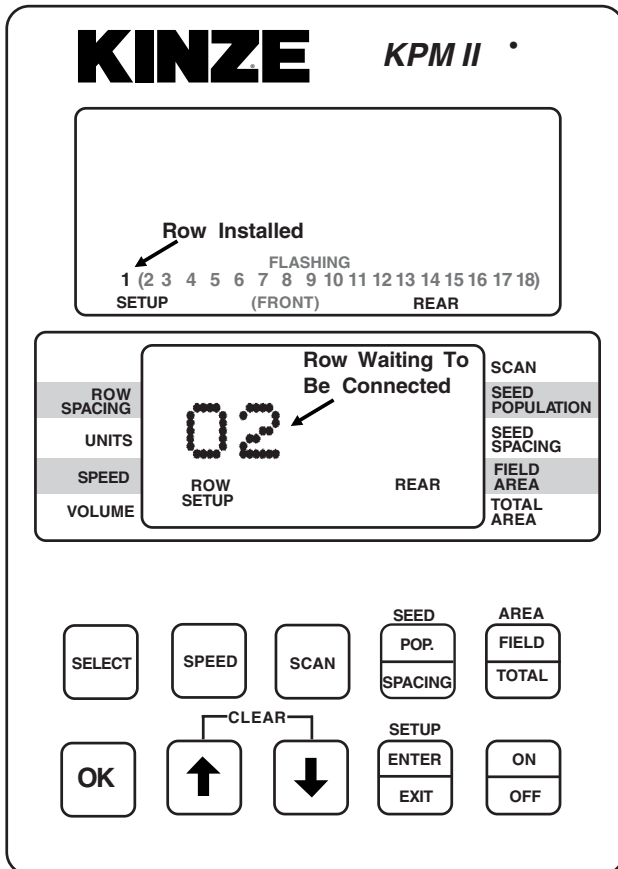

**NOTE:** SMM console may not be applicable to all models.

# MACHINE OPERATION

# KPM II STACK-MODE

**STEP 8** When all the seed tubes for the current section (rear/front, left/right or four section) are installed, check to be sure the upper LCD on the KPM II Stack-Mode console displays solid numbers for the number of seed tubes connected. Press and hold the OK key to save the setup for the current section. The SAVE? icon will display followed by continuous short beeps indicating the monitor is preparing to save. The installer has 5 seconds to decide to save the current configuration. During this time, four short beeps will sound followed by a long beep and the SAVE? icon will turn off and the word "DONE" shows on the screen. The monitor will continue to the second section installation (If Applicable).

**NOTE:** Illustrated using rear/front configuration. The KPM II Stack-Mode console shows LEFT in the left/right configuration, REAR in the rear/front configuration and FRONT LEFT/REAR LEFT in the four sections configuration.

12060211

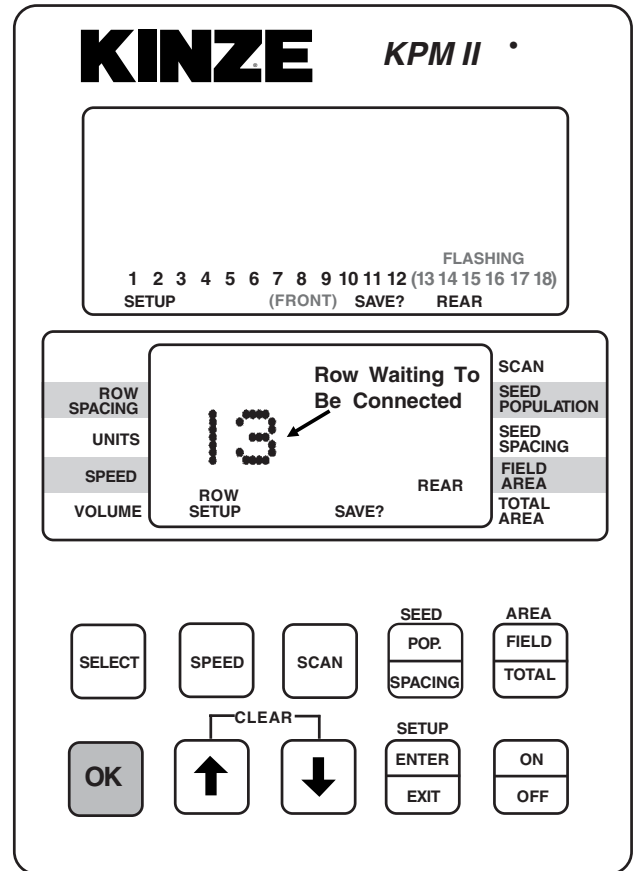

**NOTE:** SMM console may not be applicable to all models.

## STEP 8 (Continued)

12060211

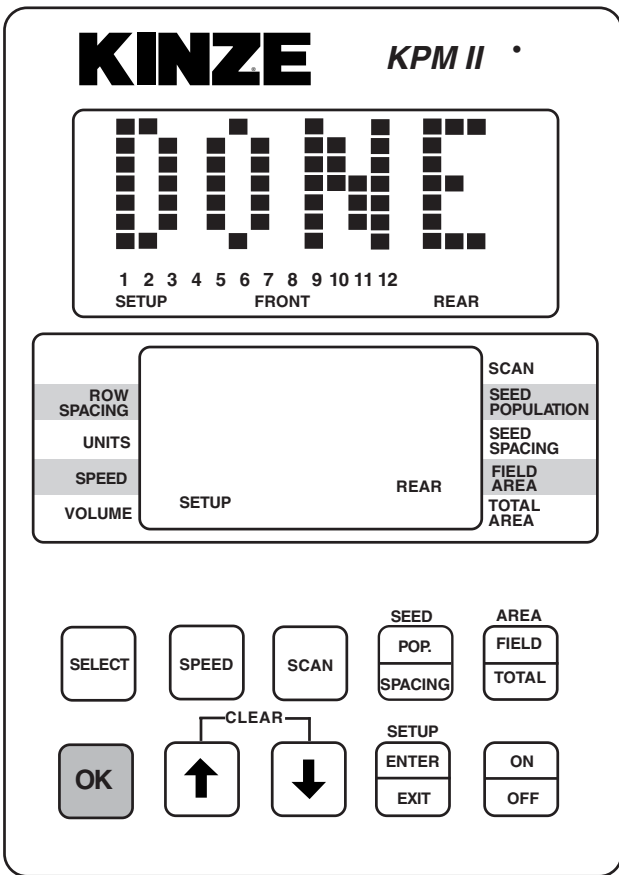

**NOTE: SMM console may not be applicable to all models.**

# MACHINE OPERATION

# KPM II STACK-MODE

**STEP 9** Follow STEPS 6, 7 and 8 to install the second, third and fourth sections (If Applicable). If no seed tubes are installed on the additional sections, press and hold the OK key. The word “DONE” will appear on upper display. The alarm will sound four short beeps followed by one long beep and the SAVE? icon turns off. The monitor has exited the setup mode. When you release the OK key the upper display will scroll “WAITING CALIBRATION”. The lower display will show “GNDSPD” and the alarm will sound continually until the distance sensor is connected. See STEP 10.

**NOTE:** The SMM console LCD remains blank (except the backlighted screen) until the entire system is saved.

**NOTE:** Illustrated using rear/front configuration. The KPM II Stack-Mode console shows LEFT in the left/right configuration, REAR in the rear/front configuration and FRONT LEFT/REAR LEFT in the four sections configuration. The SMM console shows RIGHT in the left/right configuration, FRONT in the front/rear configuration and FRONT RIGHT/REAR RIGHT in four sections configuration.

12060212

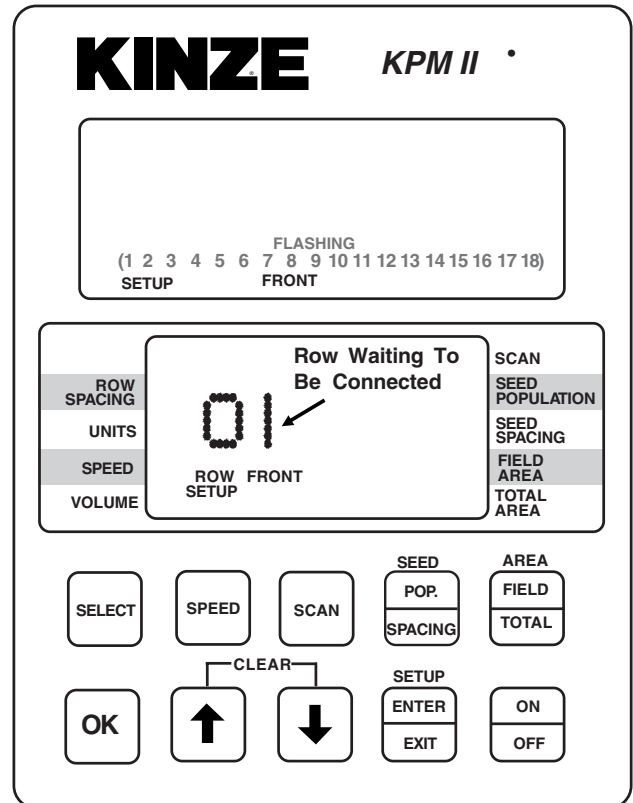

**NOTE:** SMM console may not be applicable to all models.

# MACHINE OPERATION

# KPM II STACK-MODE

## STEP 9 (Continued)

12060213

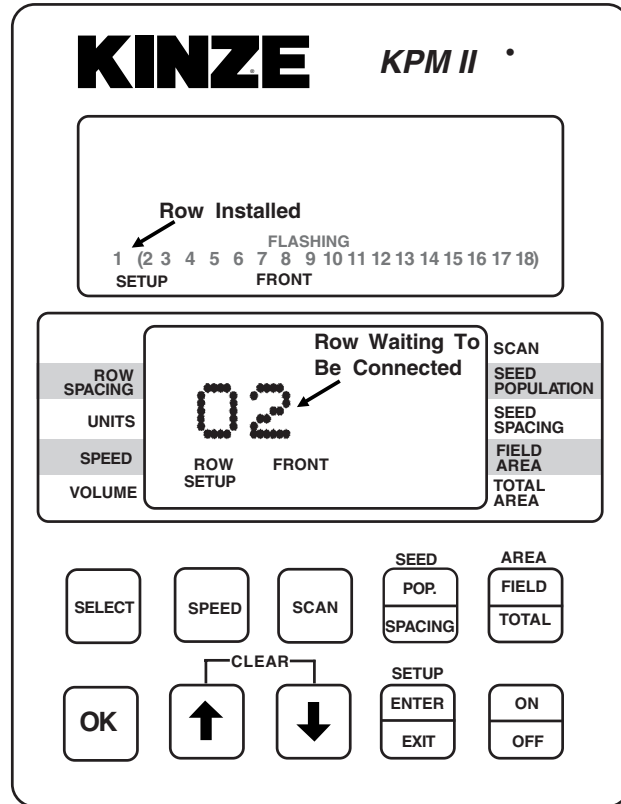
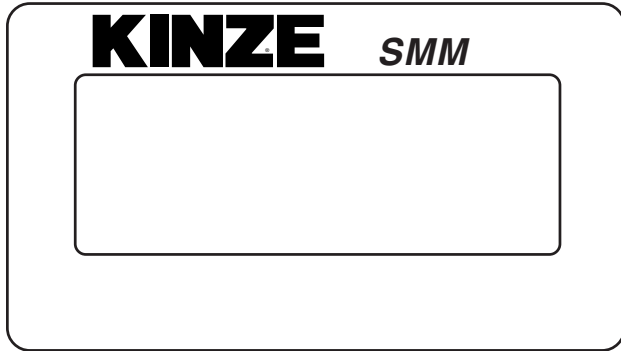

**NOTE: SMM console may not be applicable to all models.**

12060214

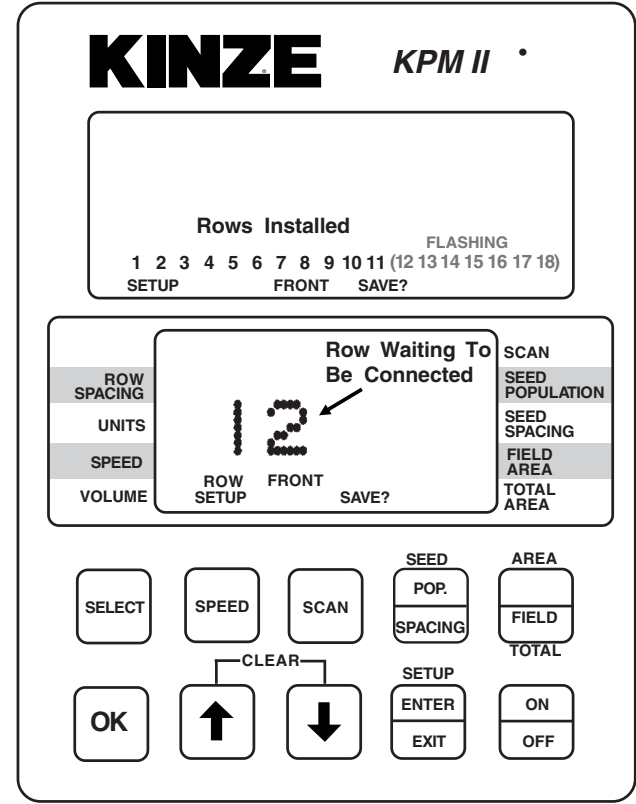
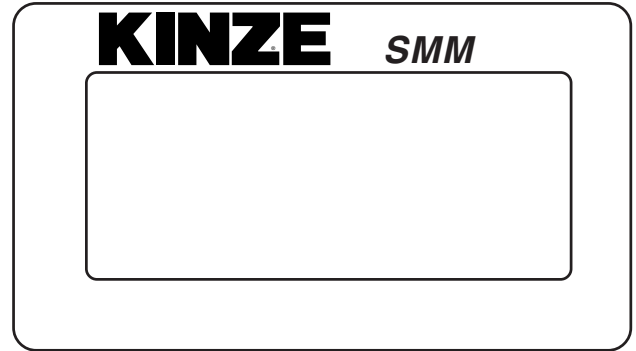

**NOTE: SMM console may not be applicable to all models.**

# MACHINE OPERATION

# KPM II STACK-MODE

## STEP 9 (Continued)

12060215

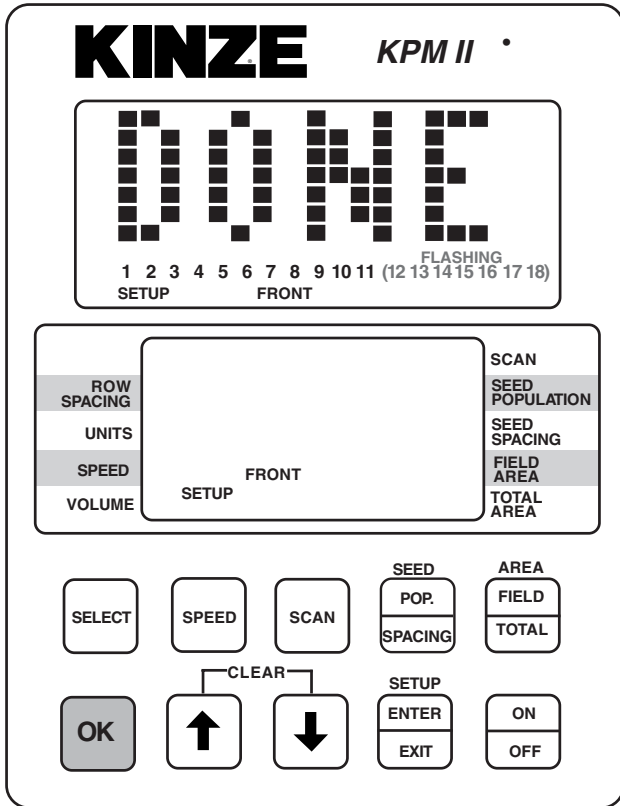
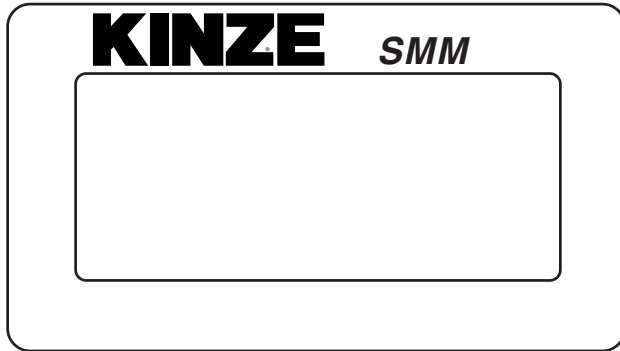

**NOTE: SMM console may not be applicable to all models.**

**STEP 10** With the lower display showing “GNDSPD”, connect the distance sensor. The monitor will display “PICKUP” if a magnetic distance sensor is connected or “RADAR” if a radar distance sensor is installed. Only one distance sensor can be connected at a time.

**NOTE: To connect the radar distance sensor, install the 10" monitor/radar adapter between the console and radar distance sensor to adapt the monitor system to various tractor radar systems. DO NOT CONNECT 10" MONITOR/RADAR ADAPTER PRIOR TO THIS STEP.**

# MACHINE OPERATION

# KPM II STACK-MODE

## STEP 10 (Continued)

**NOTE: Illustrated using rear/front configuration.** The KPM II Stack-Mode console shows LEFT in the left/right configuration, REAR in the rear/front configuration and FRONT LEFT/REAR LEFT in the four sections configuration. The SMM console shows RIGHT in the left/right configuration, FRONT in the rear/front configuration and FRONT RIGHT/REAR RIGHT in four sections configuration.

12060216

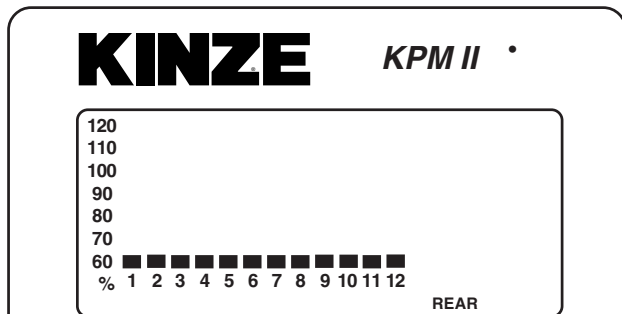
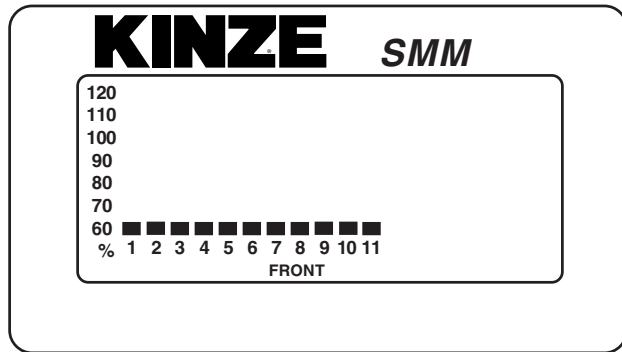

ROW SPACING	GNDSPD	SCAN
UNITS		SEED POPULATION
SPEED		SEED SPACING
VOLUME		FIELD AREA TOTAL AREA

REAR

SELECT	SPEED	SCAN	SEED POP. SPACING	AREA FIELD TOTAL
OK	CLEAR ↑	↓	SETUP ENTER EXIT	ON OFF

**NOTE: SMM console may not be applicable to all models.**

**NOTE: To reprogram the system to monitor more or less rows (up to the maximum of 18 per section, 72 total in four section configuration), all sensors must be unplugged, followed by the complete setup procedure.**

**NOTE: Individual seed tubes may be unplugged for special situations. An alarm will sound which can be silenced by touching the OK key. The monitor will recognize the seed tube(s) when reconnected.**

12060217

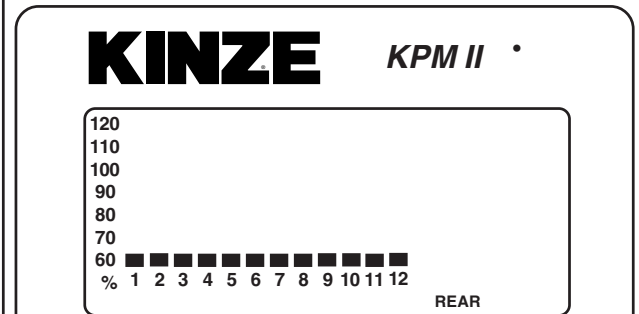
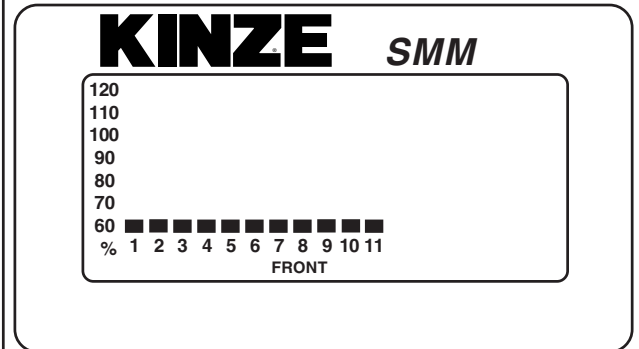

ROW SPACING	MPH 0.0	SCAN
UNITS		SEED POPULATION
SPEED		SEED SPACING
VOLUME		FIELD AREA TOTAL AREA

SELECT	SPEED	SCAN	SEED POP. SPACING	AREA FIELD TOTAL
OK	CLEAR ↑	↓	SETUP ENTER EXIT	ON OFF

**NOTE: SMM console may not be applicable to all models.**



# MACHINE OPERATION

# KPM II STACK-MODE

ROW-BY-ROW ALARM LEVEL SETTING  
 (Requires Version V2.05 Or Higher Software -  
 KPM II Stack-Mode Monitors Only)

This feature allows the audio alarm to be disabled on selected rows in applications such as planting seed corn.

**NOTE: The system should be programmed to monitor all planter rows prior to performing these steps.**

**STEP 1** Enter the programming mode by pressing and holding the SETUP key. The monitor will emit several short beeps, followed by a long beep. On the lower LCD, the SETUP icon will turn on and the arrow head icon will flash, indicating the user can select an item to program.

**NOTE: The monitor must be in a programmable function (row spacing, unit, speed, volume or area) to enter setup. The monitor will not enter setup in seed population or seed spacing.**

**STEP 2** Press the UP or DOWN arrow keys to move the flashing arrow to SEED POPULATION. As the arrow icon moves, the lower LCD will display the current setting of each item selected.

**NOTE: Illustrated using rear/front configuration. The KPM II Stack-Mode console shows LEFT in the left/right configuration, REAR in the rear/front configuration and FRONT LEFT/REAR LEFT in the four sections configuration. The SMM console shows RIGHT in the left/right configuration, FRONT in the rear/front configuration and FRONT RIGHT/REAR RIGHT in four sections configuration.**

12060218

The diagram illustrates the KINZE SMM and KPM II consoles and their control panels. The SMM console shows a bar graph for rows 1-18, with 'SETUP' and 'FRONT' labels. The KPM II console shows a bar graph for rows 1-18, with 'SETUP' and 'REAR' labels. Below the KPM II console is a control panel with a central display showing '01 AVG' and 'REAR'. The control panel includes buttons for SELECT, SPEED, SCAN, SEED POP. SPACING, AREA FIELD TOTAL, OK, CLEAR (with UP and DOWN arrows), SETUP ENTER EXIT, and ON OFF.

**NOTE: SMM console may not be applicable to all models.**

**STEP 3** Press the OK key. Row number starts flashing.

**STEP 4** Arrow UP or DOWN to desired row.

**STEP 5** Press SELECT key. "AVG" starts flashing.

**STEP 6** Arrow UP or DOWN to choose one of the following options.

HIGH - For Early Alarm (70%)  
AVG - For Standard Alarm Setting (55%)  
LOW - For Failed Alarm Only (25%)  
OFF - To Disable Row Alarm

**STEP 7** Press and hold the OK key to save alarm setting. There will be four short beeps, one long beep and the word "DONE" will appear when the save is completed.

**STEP 8** Repeat STEPS 3 through 7 for each row on which you wish to adjust the alarm setting.

**STEP 9** When finished, press the SETUP key to exit setup mode.

**NOTE:** The programming mode may be exited at any time by pressing the SETUP key. Pressing this key will return the monitor to its normal operation. All items changed and saved will come into effect immediately. Any items changed, but not saved will revert to the original programmed value.

**NOTE:** Repeat STEPS 3 through 7 to change seed monitor back to the original settings when special row-by-row alarm level settings are no longer required.

**NOTE:**

**See "Programming - Row Spacing" for programming applicable row spacing.**

**See "KPM I/KPM II Stack-Mode Electronic Seed Monitor Troubleshooting" in the Maintenance Section.**

## KPM III ELECTRONIC SEED MONITOR

D10190501



The KPM III electronic seed monitor system consists of (a) a KPM III console, which is mounted on the tractor; (b) seed tubes with sensors, one of which is installed in each planter row unit; (c) a magnetic distance sensor, which is installed on the planter or a radar distance sensor, which is installed on the tractor; (d) shaft rotation sensors (if applicable), which are installed on the planter drill shafts; and (e) planter harnesses (junction Y-harness and/or extension harness where applicable), to which the individual seed tube sensors connect. The primary harness, which connects the monitor console to the planter harness, is hard-wired into the safety/warning light harness or control console harness included as standard equipment with the planter.

The software design of the KPM III console allows simultaneous viewing of seed flow bargraphs for standard and/or Interplant® System rows (up to 36 rows).

The monitor system is powered by the tractor battery (requires 12 volts DC). The console receives information from each of the sensors and translates this information.

The KPM III console uses a single backlit Liquid Crystal Display (LCD) to show, the number of monitored rows, the relative seed rate for each row (using bargraph displays) and displays various alarm and warning messages when an alarm condition exists. A continuous audible alarm will sound upon system malfunction or underflow conditions for any monitored row. Alarms must be acknowledged by the user. Various warnings may sound the alarm or flash one or more messages. The LCD also shows alphanumeric data such as row spacing, units (Metric or English), speed (MPH or KM/H), volume, seed population, seed spacing, field area and total area.

The monitor system will power down if no activity is detected within one hour. No activity means there has been no new seed flow and no operator push key input.

<b>Monitor Key Functions</b> .....	<b>6-46</b>
<b>Configuring Planter Monitor</b> .....	<b>6-47</b>
<b>Programming/Connecting Seed Tubes, Shaft Rotation Sensors And/Or Radar/Magnetic Distance Sensors</b> .....	<b>6-49</b>
<b>Changing Volume, Contrast And Backlighting</b> .....	<b>6-51</b>
<b>Programming Interplant® Condition, Row Spacing And Units (Metric Or English)</b> .....	<b>6-52</b>
<b>Programming Row Unit Alarms Levels</b> .....	<b>6-53</b>
<b>Speed Sensor Calibration/Programming</b> .....	<b>6-54</b>
<b>Reprogramming Speed Sensor</b> .....	<b>6-55</b>
<b>Adding Interplant® Rows (If Rear Rows Have Previously Been Programmed)</b> .....	<b>6-59</b>
<b>Adding Even-Row Package (If Front Rows Have Previously Been Programmed)</b> .....	<b>6-61</b>
<b>Enabling/Disabling Interplant® Rows</b> .....	<b>6-63</b>
<b>Warnings And Alarms</b> .....	<b>6-66</b>
<b>Field Operation</b> .....	<b>6-68</b>
<b>Area Management</b> .....	<b>6-69</b>
<b>Area Counters</b> .....	<b>6-71</b>
<b>Clearing Field Area</b> .....	<b>6-72</b>
<b>Acre Count Mode</b> .....	<b>6-72</b>
<b>Replacing Faulty Sensor(s)</b> .....	<b>6-74</b>

## MONITOR KEY FUNCTIONS

Push keys allow the user to select or change the operating mode, the active displays or the current configuration. Depending on the operating mode or the current display selected, some keys may not be active. Each key press, if valid, is acknowledged by a short beep and an action is taken. If the key press has no action associated, the key press is considered invalid, and the user will not receive feedback.

D10190501

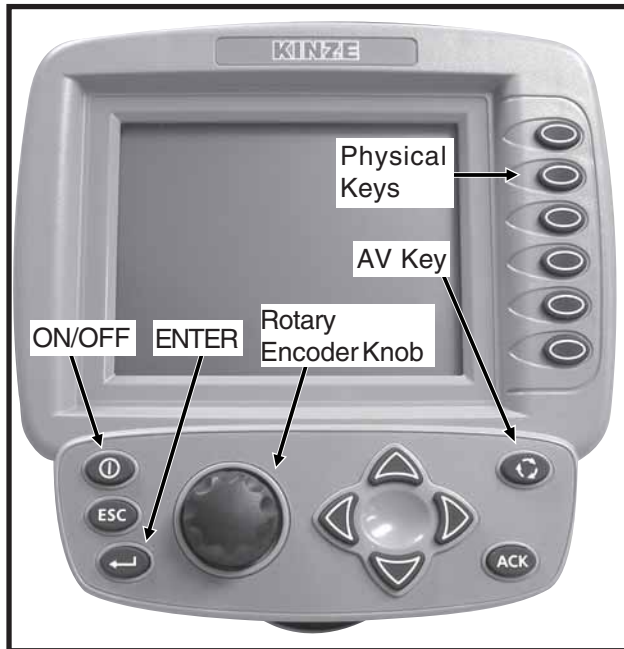

### PHYSICAL KEYS

- Located on R.H. side of console and referred to as F1, F2, F3, F4, F5 and F6
- Keys are referenced in descending order with F1 at the top and F6 at the bottom.



### ON/OFF KEY

- Powers the unit on and off.



### ESC KEY

- Used as the CANCEL (escape) key.



### ENTER KEY

- Confirms or accepts the highlighted selection.



### ROTARY ENCODER KNOB

- Turn knob clockwise to increase or counterclockwise to decrease value of item.
- Turn knob clockwise to scroll up or counterclockwise to scroll down.
- Press knob to enter selection.



### AV (AUDIO/VIDEO) KEY

- Set alarm volume.
- Adjust the contrast.
- Adjust backlighting of the LCD display.



### ACK (ACKNOWLEDGE) KEY

- Used to silence (acknowledge) the warning alarm when various error conditions occur.

**NOTE: Alarms can be viewed by pressing the STATUS key.**



### ARROW KEYS

- UP arrow key is used to increase the value of an item by one or to scroll up.
- DOWN arrow key is used to decrease the value of an item by one or to scroll down.
- LEFT arrow key multiplies the numeric value of the item by 10.
- RIGHT arrow key divides the numeric value of the item by 10.



**NOTE: Within the LCD, the black box around the smaller box as shown below indicates which field is selected/highlighted. Turning the rotary encoder knob or pressing the UP or DOWN arrow keys moves the black box. When the black box is positioned on a programmable item, such as Shaft Sensors, Speed Sensor, Front Row Units or Rear Row Units, pressing the knob or ENTER key will highlight the programmable item. A programmable item may only be changed when it is highlighted.**

D02140616

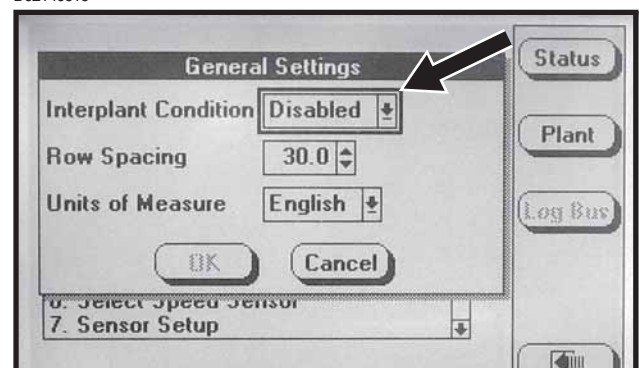

## CONFIGURING PLANTER MONITOR

When the KPM III is powered on for the first time it will go directly into the “Planter Configuration” screen (STEP 4).

**STEP 1** Press the F6 key until “Mode Selection” screen appears.

D02140614

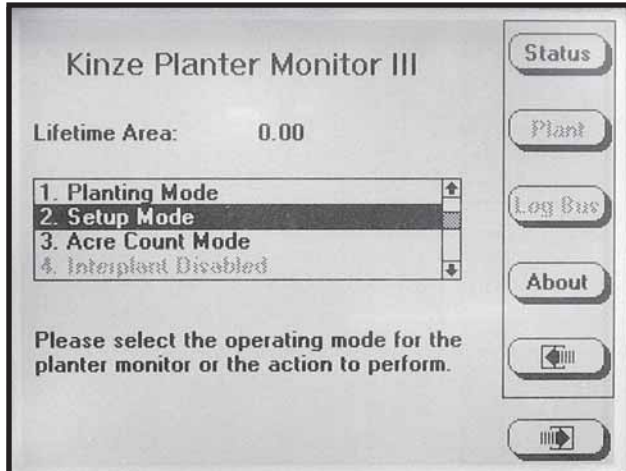

**STEP 2** Select “Setup Mode” by turning the rotary encoder knob or using the UP or DOWN arrow keys. Press the knob or ENTER key to display highlighted item.

**STEP 3** Select “Configure Planter Monitor” by turning the knob or using the UP and DOWN arrow keys. Press the knob or the ENTER key to display the highlighted item.

D02140624

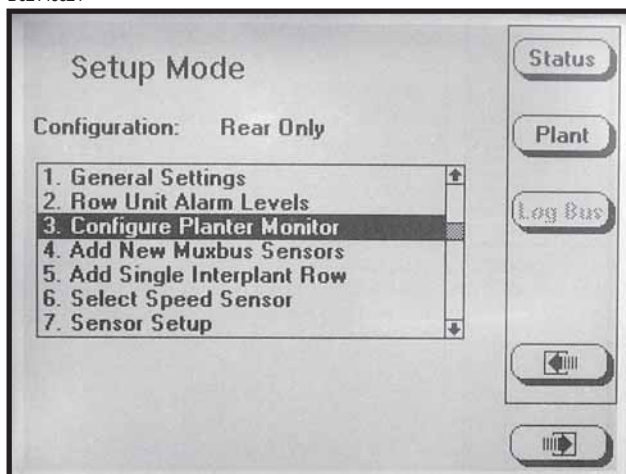

**NOTE:** The planter monitor cannot be reconfigured while planting.

**NOTE:** If the monitor has already been configured the message shown below will appear.

D02140634

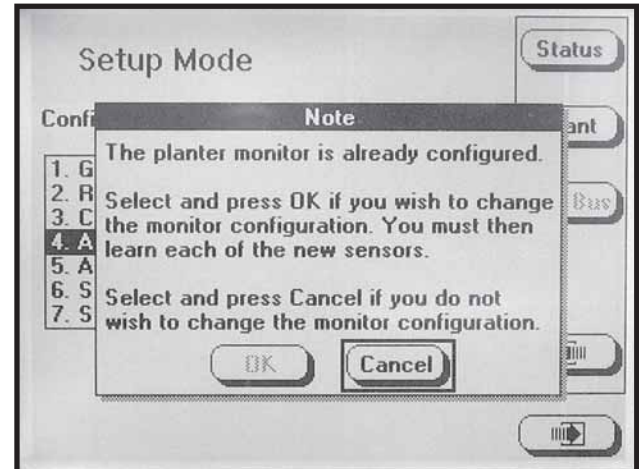

**STEP 4** Press the knob or ENTER key, to highlight the “Shaft Sensors” field. Enter the number of “Shaft Sensors” by turning the knob or using the UP or DOWN arrow keys. When the correct value is displayed press the knob or ENTER key. The black box will advance to “Speed Sensor” field.

D05310601

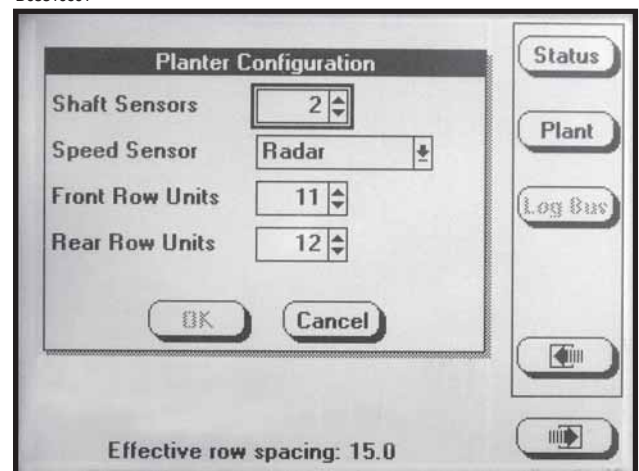

**NOTE:** The numeric value may be changed only if the item is highlighted. Turning the rotary encoder knob increases or decreases the value of the item. The UP arrow key may be used to increase the value of the item by one and the DOWN arrow key may be used to decrease the value of the field by one.

**STEP 5** Press the knob or ENTER key and a drop down menu will appear; select either “Radar” or “Coil Pick-Up” (MDS) by turning the knob or using the UP or DOWN arrow keys. When the desired selection is highlighted press the knob or ENTER key. The black box will advance to “Front Row Units” field.

D05310604

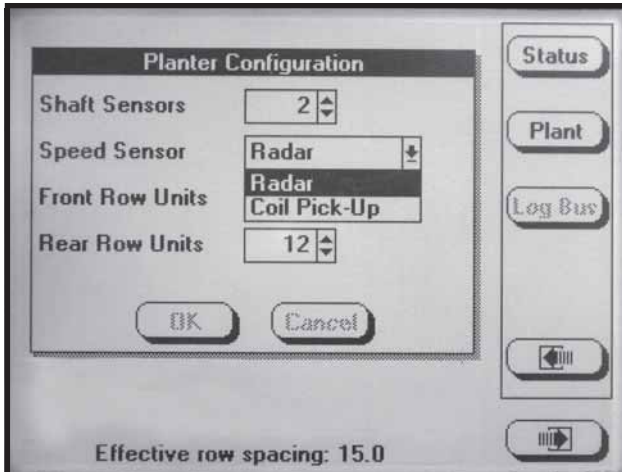

**STEP 7** Press the knob or ENTER key to highlight the “Rear Row Units” field. Turn the knob or use the UP or DOWN arrow keys to obtain correct number of pull row units. Press the knob or ENTER key when desired quantity is displayed. The black box will advance to the OK key.

D05310606

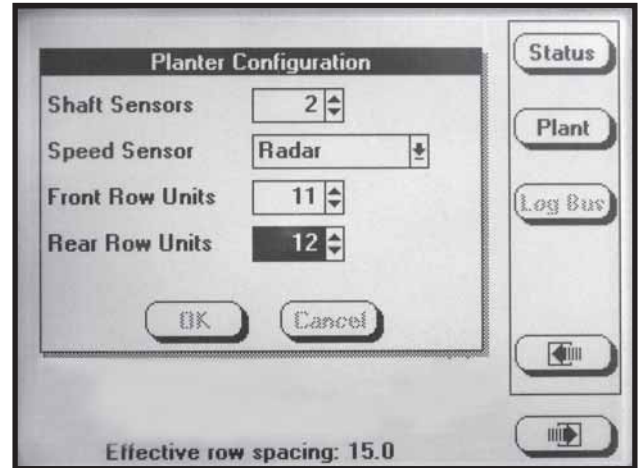

**STEP 6** If there are front rows on the planter, press the knob or ENTER key to highlight the “Front Row Units” field. Turn the knob or use the UP or DOWN arrow keys to obtain correct number of push row units. Press the knob or ENTER key when desired quantity is displayed. The black box will advance to “Rear Row Units” field. If no front rows need to be entered simply turn the knob or press the DOWN arrow key to advance to “Rear Row Units”.

**STEP 8** Press the knob or the ENTER key to save the information.

D05310607

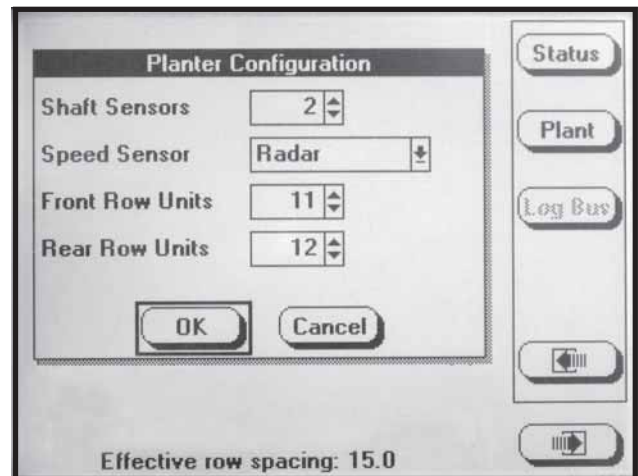

D05310605

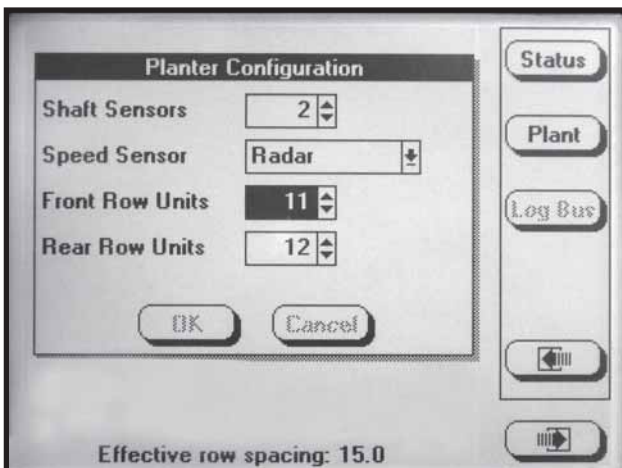

**NOTE:** To prevent the configuration from being saved press ESC or select the CANCEL button, then press the rotary encoder knob or ENTER key.

**STEP 9** The monitor screen shown below will appear.

If the new planter configuration is to be saved turn the knob or press the UP or DOWN arrow keys to select the OK button then press the knob or ENTER key to save the planter configuration into the KPM III. If the monitor configuration is not to be changed select the CANCEL key, press the knob or ENTER key to CANCEL or press the ESC key.

If OK is selected the monitor will advance to "Sensor Setup" (STEP 4 in PROGRAMMING/CONNECTING SEED TUBES, SHAFT ROTATION SENSORS AND/OR RADAR/MAGNETIC DISTANCE SENSORS section).

**NOTE: STEP 9 does not apply if configuring the monitor for the first time.**

D02140634

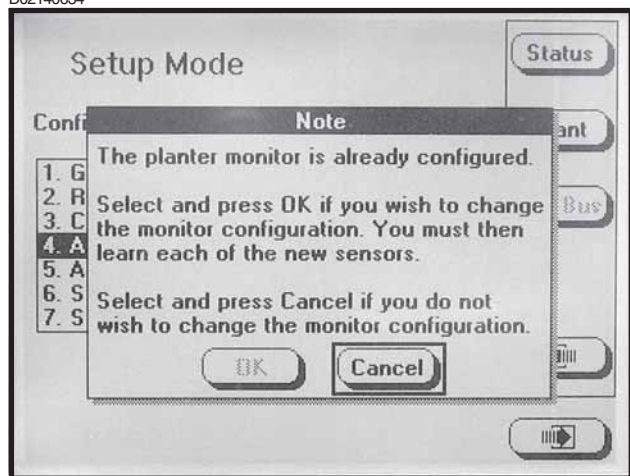

## PROGRAMMING/CONNECTING SEED TUBES, SHAFT ROTATION SENSORS AND/OR RADAR/MAGNETIC DISTANCE SENSORS

**STEP 1** To enter "Mode Selection", press F6 key until the "Mode Selection" screen appears.

**STEP 2** Select "Setup Mode" by turning the rotary encoder knob or press the UP or DOWN arrow keys. Press the knob or ENTER key to display the highlighted item.

**STEP 3** Select "Sensor Setup" by turning the knob or using the UP or DOWN arrow keys. Press the knob or ENTER key to display the highlighted item.

D02140641

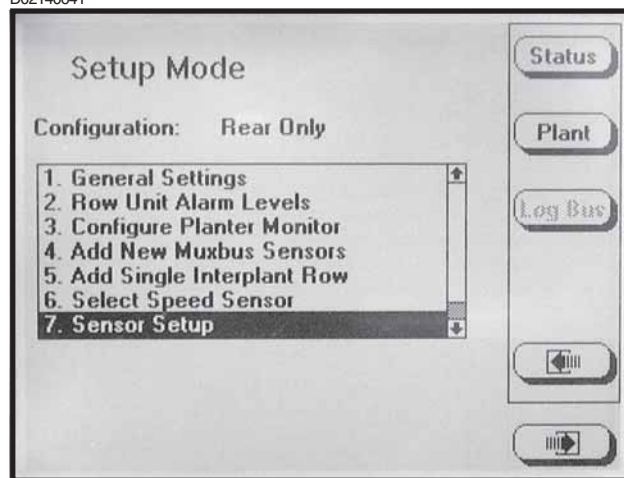

**STEP 4** Attach the planter harness to the KPM III. Do NOT connect any of the sensors to the planter harness. With [Auto Detect] selected press the INSTALL key.

D02210601a

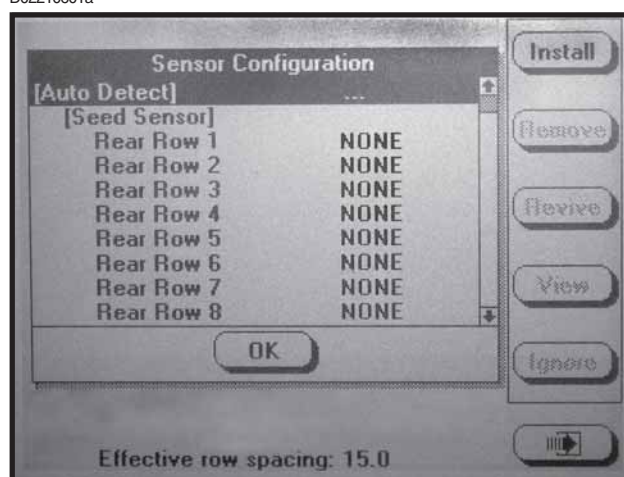

**STEP 5** Plug in the first seed sensor (row 1), working from left to right (rear row units and front next if applicable). When a sensor is connected to the planter harness wait for the monitor to acknowledge with two beeps.

Continue connecting seed sensors along with shaft rotation sensors or speed sensors. Progress will reflect on the LCD screen. The example below indicates that the last seed sensor found was Front Row 7 and the monitor is looking for the next sensor.

When all sensors are installed press the F1 key to end the installation.

D02170617

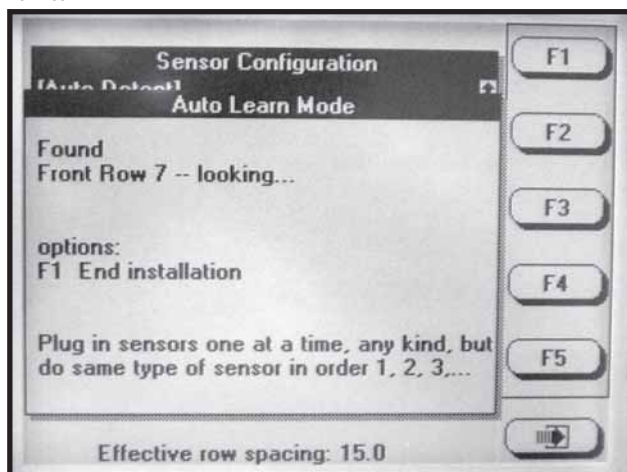

**NOTE:** After each sensor has been installed “OK” will appear after the sensor name.

D02210601b

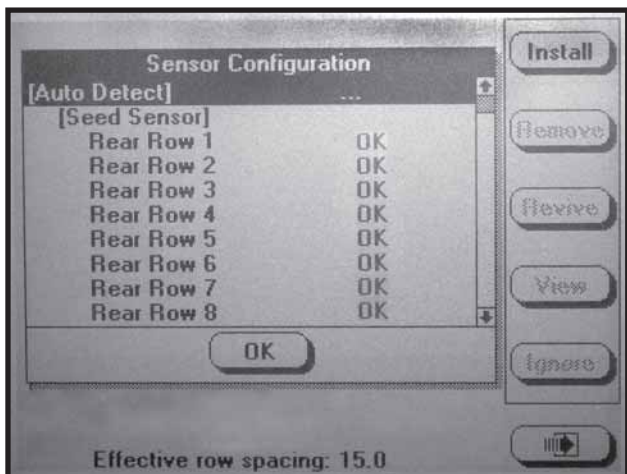

**STEP 6** If “OK” appears behind ALL sensors, press the knob or the ENTER key to save the configuration. The “Setup Mode” menu will then appear.

**NOTE:** If “NONE” appears after a sensor, the sensor was not recognized. All sensors must be disconnected from the planter harness and reconnected as described in STEP 5.

**NOTE:** If “OK slow” appears after a sensor, the sensor is able to communicate but at a slower speed. For the system to run at top speed of 9600 baud the slow sensor must be replaced.

D05310609

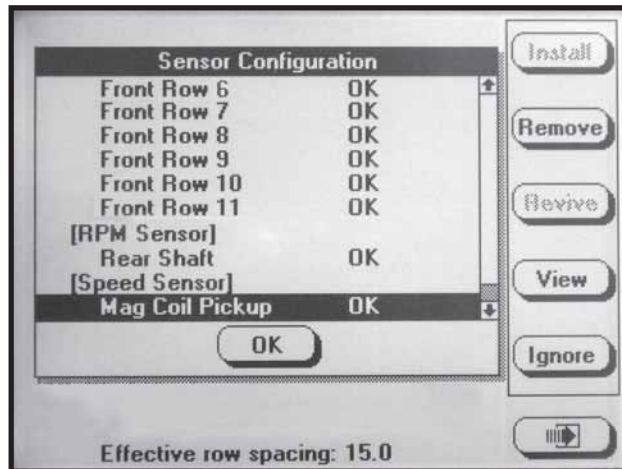

**STEP 7** To return to “Planting Mode” select the PLANT key or press the F6 key until “Planting Mode” screen appears.



## CHANGING VOLUME, CONTRAST AND BACKLIGHTING

The alarm volume and LCD screen contrast and backlighting may be adjusted at anytime, regardless of what is displayed on the screen.

**STEP 1** Press the AV key. The speaker adjustment dialog box will appear in the lower L.H. corner of the display.

D05310610

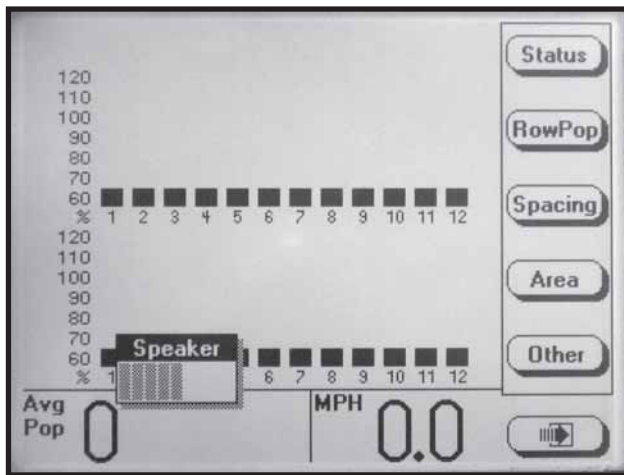

**STEP 2** Use the LEFT and RIGHT arrows or turn the rotary encoder knob to adjust the volume. The volume of the sound emitted from the speaker changes as the adjustment is being made.

**STEP 3** To adjust contrast or backlight, go to STEP 4. If finished press ENTER to save and exit.

**STEP 4** Press the AV button a second time. The contrast adjustment dialog box will appear in the lower portion of the display.

D05310611

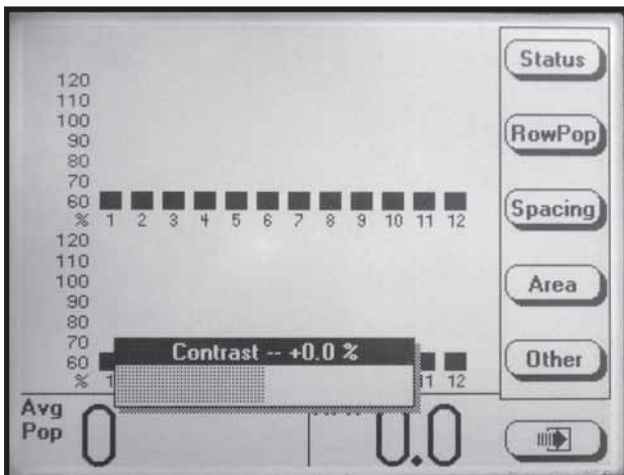

**STEP 5** Use the LEFT and RIGHT arrows or turn the knob to adjust contrast. The effect of the adjustment will be visible on the display.

**STEP 6** To adjust backlighting go to STEP 7. If finished press ENTER to save and exit.

**STEP 7** Press the AV button a third time. The backlight adjustment dialog box will appear in the lower L.H. corner of the display.

D05310612

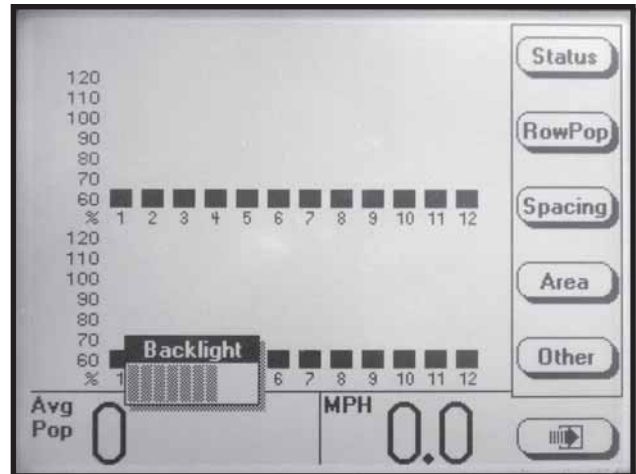

**STEP 8** Use the LEFT and RIGHT arrows or turn the knob to adjust backlighting. The effect of the adjustment will be visible on the display.

**STEP 9** Press the knob, ENTER or press the AV button a fourth time to save the volume, contrast and backlight settings. The backlight adjustment dialog box will disappear.

**PROGRAMMING INTERPLANT® CONDITION, ROW SPACING AND UNITS (Metric Or English)**

**STEP 1** To enter “Mode Selection” screen press the F6 key until “Mode Selection” screen appears.

D02140614

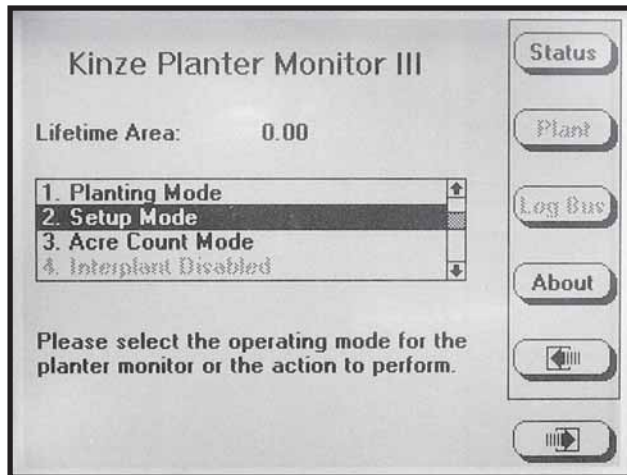

**STEP 2** Select “Setup Mode” by turning the rotary encoder knob or using the UP or DOWN arrow keys. Press the knob or ENTER key to display the highlighted item.

**STEP 3** Select “General Settings” by turning the knob or using the UP or DOWN arrow keys. Press the knob or the ENTER key to display the highlighted item.

D02140615

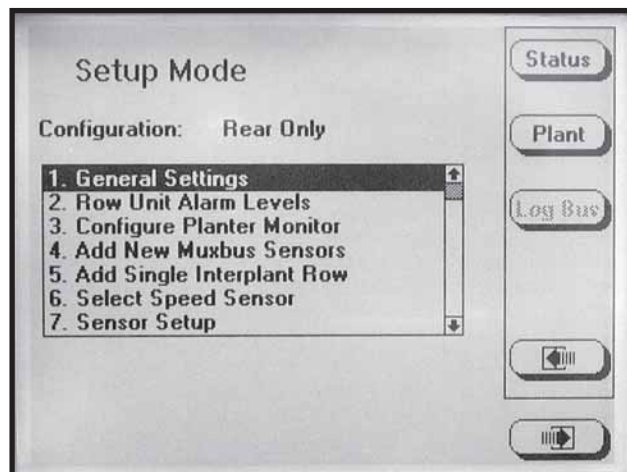

**STEP 4** Press the knob or ENTER key and a drop down menu will appear. Select either “Enabled” (push row units are being used for planting) or “Disabled” (push row units are not being used for planting and no seed rate alarms will be generated for the front rows; no bargraphs are to be displayed for the front rows and the front rows do not contribute to the average population and spacing or acre counts). Use the knob or UP or DOWN arrow keys to make selection. Press the knob or ENTER key to select highlighted item. The black box will advance to “Row Spacing” field.

D02140616

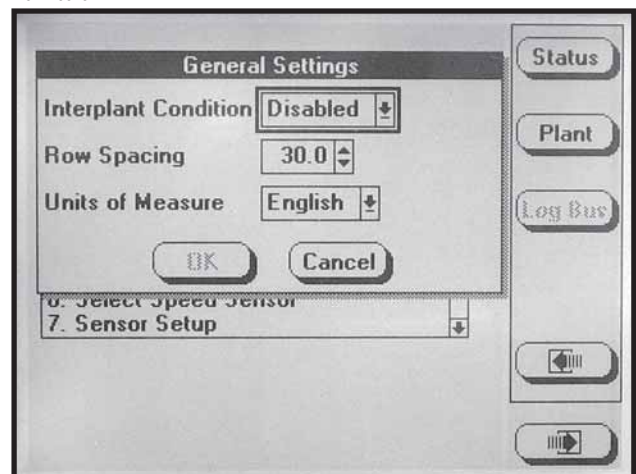

**NOTE: When English is selected inches are displayed, if Metric is selected centimeters are displayed.**

**STEP 5** Press the knob or ENTER key to enter the correct value for “Row Spacing”. Turn the knob to increase or decrease the number. The UP arrow key is used to increase the value of the item by one and the DOWN arrow key is used to decrease the value of the field by one. The LEFT arrow key multiplies the value of the item by 10 and the RIGHT arrow key divides the value of the item by 10. When the correct number has been entered press the knob or ENTER key. The black box will advance to “Units of Measure” field.

**NOTE: The narrowest row spacing the planter is equipped to plant should be entered for “Row Spacing”. Example: 12 Row 30" with Interplant, row spacing would be set to 15".**

**STEP 6** Select “Units Of Measure” field by pressing the knob or ENTER key and a drop down menu will appear. Select either “English” or “Metric” by turning the knob or using the UP or DOWN arrow keys. Press the knob or the ENTER key. The black box will advance to OK.

**STEP 7** Press the knob or ENTER key, when correct values are entered.

**STEP 8** To return to “Planting Mode” press the PLANT key.

## PROGRAMMING ROW UNIT ALARM LEVELS

The Row Unit Alarm Levels allow the thresholds for the seed rate alarms to be set. The default is 50% or Average. If the average population drops below 50% for a given row a seed rate alarm will be generated for that row unit. The alarm threshold can be set to 70%, 50%, 10% or disabled for any row.

**NOTE: When the alarm threshold is disabled for any row no seed rate alarm will be generated.**

D02140623

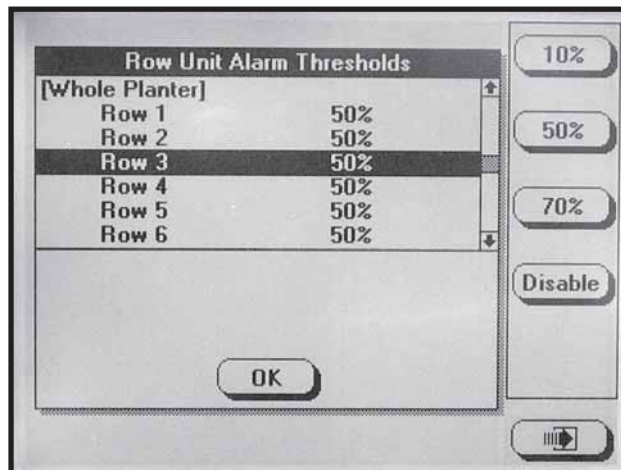

The alarm thresholds can be set for the whole planter, any planter section or individual rows.

**NOTE: A section is determined by a set of rows driven by one or more shafts, designated to a single shaft sensor.**

**STEP 1** To enter “Mode Selection”, press F6 key until the “Mode Selection” screen appears.

**STEP 2** Select “Setup Mode” by turning the rotary encoder knob or using the UP or DOWN arrow keys. Press the knob or ENTER key to display the highlighted item.

**STEP 3** Select “Row Unit Alarm Levels” by turning the knob or using the UP or DOWN arrow keys. Press the knob or ENTER key to display the highlighted item.

**STEP 4** To set alarm thresholds for whole planter, select “Whole Planter”. Press the key next to the desired threshold. When the desired threshold has been specified for all row units, press the knob or ENTER key.

To set alarm thresholds for all the rows in one section, select rear section or front section. Press the key next to the desired threshold. When the desired threshold has been specified for all row units, press the knob or ENTER key.

To set alarm thresholds for individual rows, select the desired row. Press the key next to the desired threshold. When the desired threshold has been specified for all row units, press the knob or ENTER key.

**STEP 5** To return to “Planting Mode” press the PLANT key.

## SPEED SENSOR CALIBRATION/PROGRAMMING

**STEP 1** To enter the “Speed Sensor Calibration” mode, press F6 until the “Mode Selection” screen appears. Select “Setup Mode” and press the rotary encoder knob or ENTER key. Press F6 to advance to the “Speed Sensor Calibration” screen.

The Distance Pulse Count is used to record how many pulses are generated per mile/kilometer from the ground speed sensor. The monitor will display the current pulses per mile/kilometer using a 6 digit, no decimal place format.

D02140643

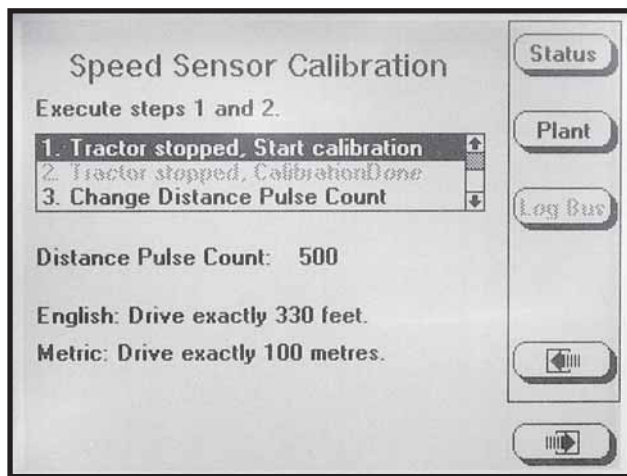

**NOTE:** A field calibration must be performed to establish the Distance Pulse Count number. Several factors can affect this value, such as wheel slip on the magnetic distance sensor. **IT IS NOT UNCOMMON FOR THE SPEED ON THE MONITOR TO VARY SLIGHTLY FROM THE TRACTOR SPEEDOMETER. Adjusting the Distance Pulse Count in the monitor to make the speed agree with the tractor can cause serious errors in acre/hectare and population/spacing readings. Do field checks to verify populations and seed spacing.**

- In field conditions, measure 330 feet or 100 meters, depending on the unit of measurement selected. Place a marker at the start point and end point.
- Pull the tractor up to the starting point.
- Select “Tractor stopped. Start calibration”.
- Press the rotary encoder knob or ENTER key to change the Distance Pulse Count on the display to 0.

**NOTE:** If the Distance Pulse Count number starts to count pulses with the tractor not moving, check radar distance sensor for vibration or other interference.

- Drive the tractor for 330 feet or 100 meters.
- The monitor will count the number of pulses and display them.
- Stop the tractor at the end point.
- Select “Tractor stopped. Calibration Done”.
- Press the knob or ENTER key.

**NOTE:** Repeat the above steps multiple times. Record and average the values. Use this average for the Distance Pulse Count number constant.

**STEP 2** Select “Change Distance Pulse Count” by turning the knob or using the DOWN arrow key. Press the knob or ENTER key.

D02200605

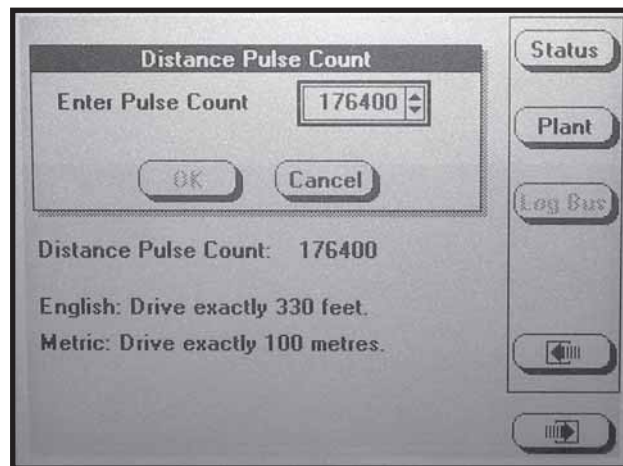

**NOTE:** The Distance Pulse Count will vary from the above example.

**STEP 3** To return to “Planting Mode” press the PLANT key.

WHEN THE CORRECT DISTANCE PULSE COUNT IS KNOWN, CALIBRATION IS NOT NEEDED AND THE FOLLOWING STEPS MAY BE USED.

**STEP 1** To enter the “Speed Sensor Calibration” screen, press F6 key until the “Mode Selection” screen appears. Select “Setup Mode” and press the rotary encoder knob or ENTER key. Press F6 key to advance to the “Speed Sensor Calibration” screen.

**STEP 2** Select “Change Distance Pulse” field by turning the knob or using the UP or DOWN arrow keys. Press the knob or ENTER key.

D02200605

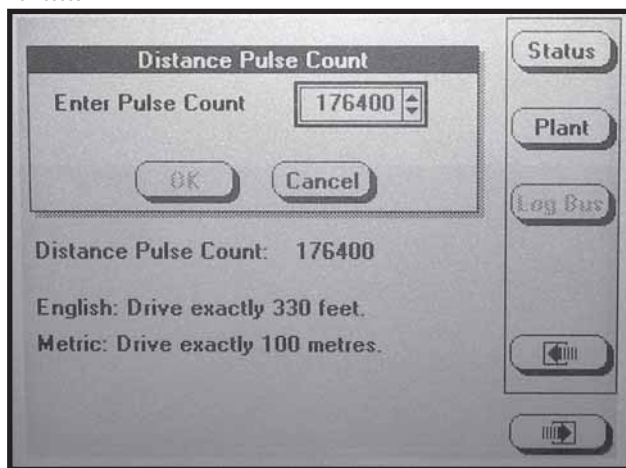

**NOTE:** The Distance Pulse Count will vary from the above example.

**STEP 3** With the “Enter Pulse Count” field selected press the knob or ENTER key.

**STEP 4** Change the Pulse Count to the desired value using the UP or DOWN arrow keys or turn the knob until the desired value is obtained. Press the knob or ENTER key.

**NOTE:** The LEFT arrow key multiplies the value of the item by 10 and the RIGHT arrow key divides the value of the item by 10.

**STEP 5** Select OK by pressing the knob or ENTER key to save the new count. Select CANCEL to retain the old value of the Distance Pulse Count.

**STEP 6** Press PLANT key to return to main planting screen.

## REPROGRAMMING SPEED SENSOR

This setting must be specified when the monitor is first configured. It will be necessary to reprogram to use an alternate speed sensor.

**NOTE:** Speed sensors may not be changed while planting.

## RADAR TO MAGNETIC DISTANCE SENSOR

**STEP 1** Press the F6 key until the “Mode Selection” screen appears. Select “Setup Mode” by turning the rotary encoder knob or using the UP or DOWN arrow keys. Press the knob or ENTER key to display the highlighted item.

D02140614

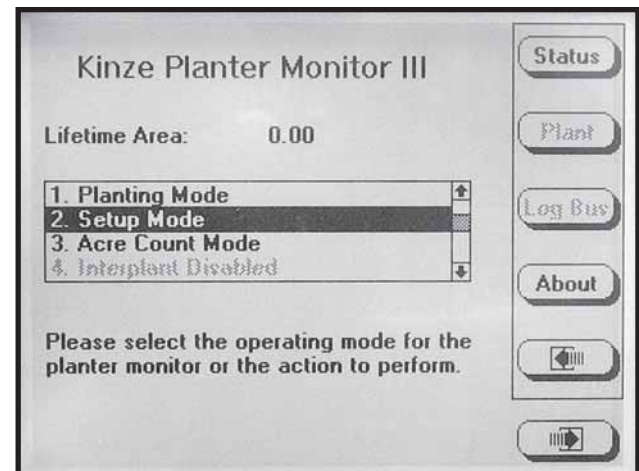

**STEP 2** Turn the knob or use the UP or DOWN arrow keys to choose “Sensor Setup”. Press the knob or ENTER key to display the highlighted item.

D02140641

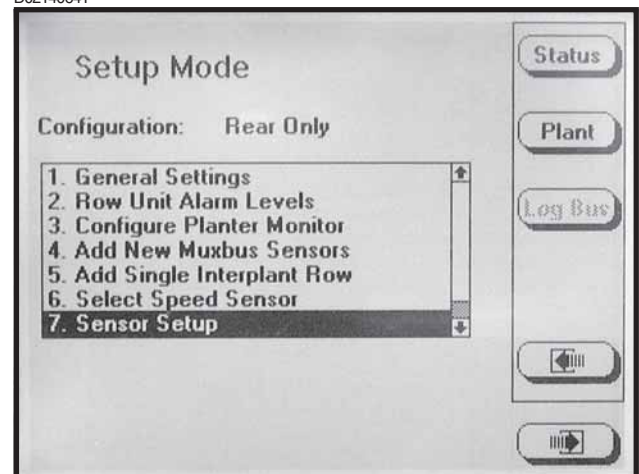

**STEP 3** Turn the knob or use the UP or DOWN arrow keys to highlight “Mag Coil Pickup”. Plug in Magnetic Distance Sensor and press the INSTALL key. Press the knob or ENTER key to save information.

D05310609a

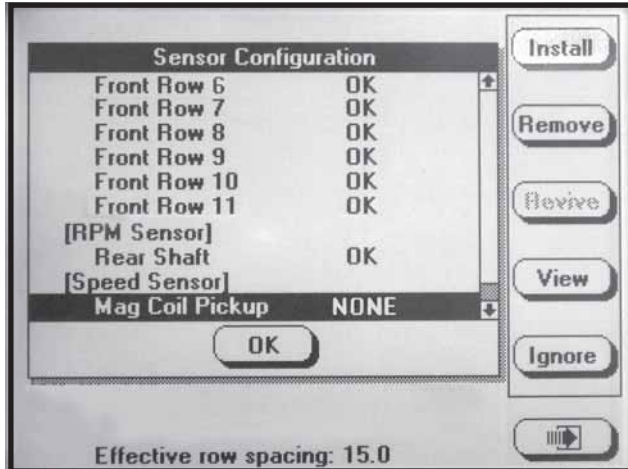

**STEP 4** Turn the knob or use the UP or DOWN arrow keys to select “Select Speed Sensor” and press the knob or ENTER key. Press the knob or ENTER key to select the “Speed Sensor” field and a drop down menu will appear. Turn the knob or use the UP or DOWN arrow keys to select “Coil Pick-Up” and press the knob or ENTER key to make selection. The black box will advance to OK press the knob or ENTER key to save the information.

D02140639

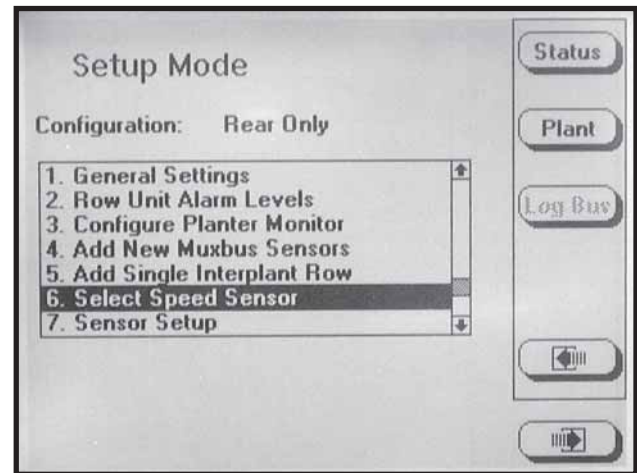

D05310609

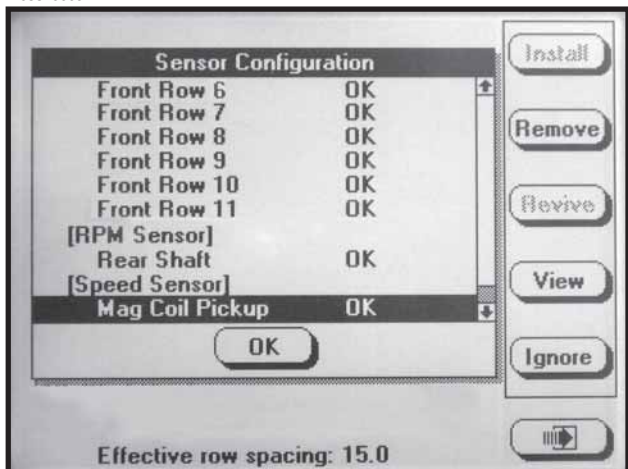

D02140639

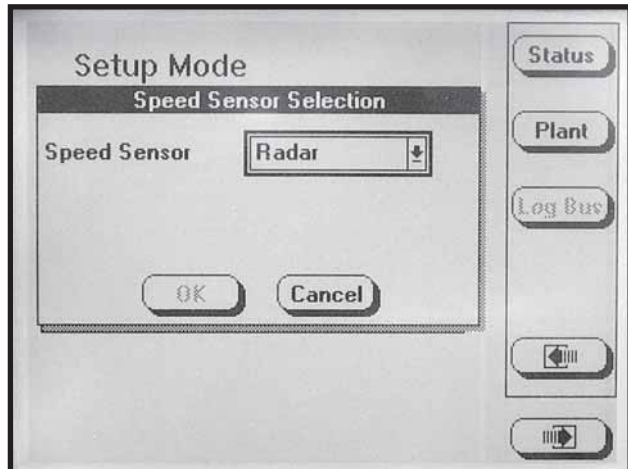

**NOTE:** To prevent the configuration from being changed select CANCEL, then press the rotary encoder knob, ENTER key or ESC key.

D06210601

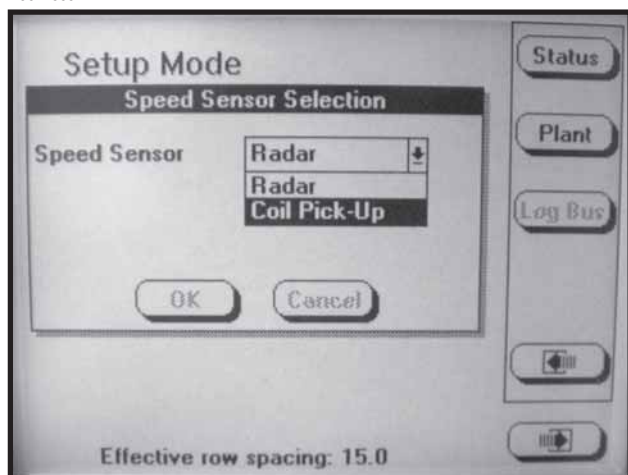

**STEP 5** Unplug the radar from the tractor.

**STEP 6** Press the PLANT key to return to main planting screen.

**NOTE:** When switching between speed sensors, verify the distance pulse count is correct for the chosen sensor. There will be significant distance pulse count variation between radar and coil pick-up sensors.

## MAGNETIC DISTANCE SENSOR TO RADAR

**STEP 1** Press the F6 key until the “Mode Selection” screen appears. Select “Setup Mode” by turning the rotary encoder knob or using the UP or DOWN arrow keys. Press the knob or ENTER key to display the highlighted item.

D02140614

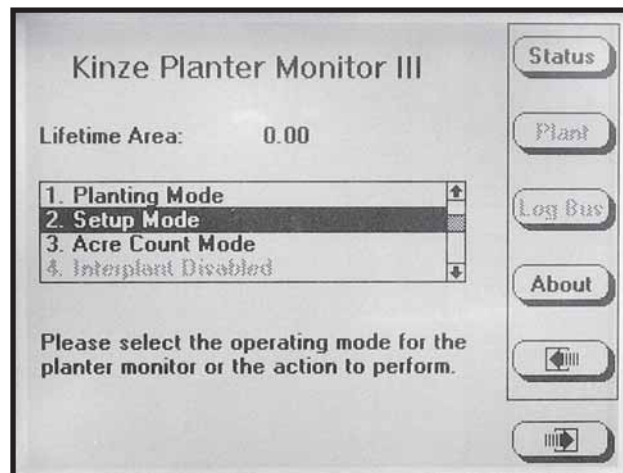

**STEP 2** Turn the knob or use the UP or DOWN arrow keys to choose “Sensor Setup”. Turn the knob or use the UP or DOWN arrow keys to highlight “Mag Coil Pickup”. Press the REMOVE key, a note will appear for confirmation select as appropriate. Unplug Magnetic Distance Sensor and press the knob or ENTER key to save the information.

D02140641

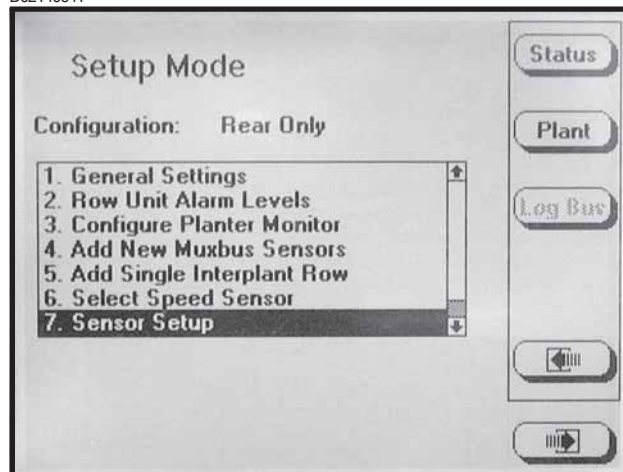

D05310609

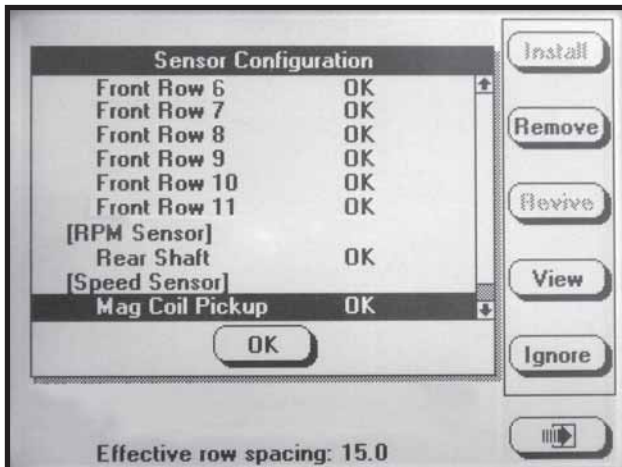

**STEP 3** Turn the knob or use the UP or DOWN arrow keys to select “Select Speed Sensor” and press the knob or ENTER key. Press the knob or ENTER key to select the “Speed Sensor” field and a drop down menu will appear. Turn the knob or use the UP or DOWN arrow keys to select “Radar” and press the knob or ENTER key to make selection.

D02140639

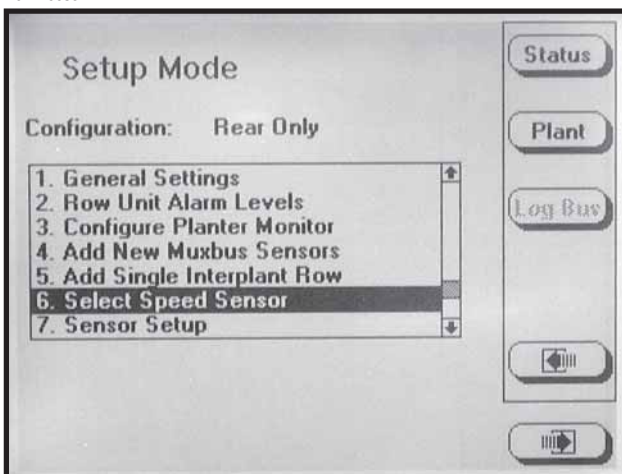

D02140639

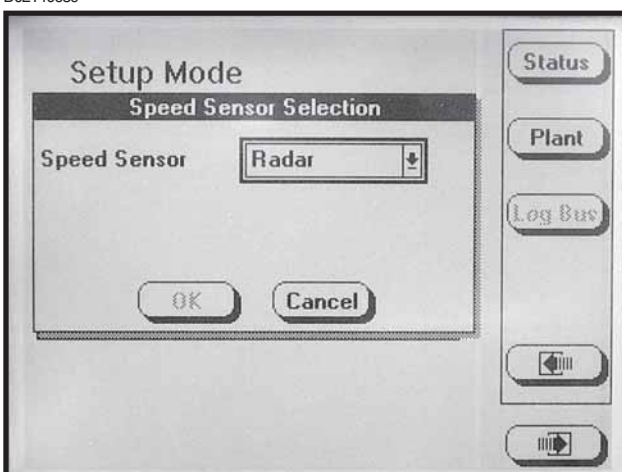

**NOTE:** To prevent the configuration from being changed select CANCEL, then press the knob, ENTER key or ESC key.

D02140640

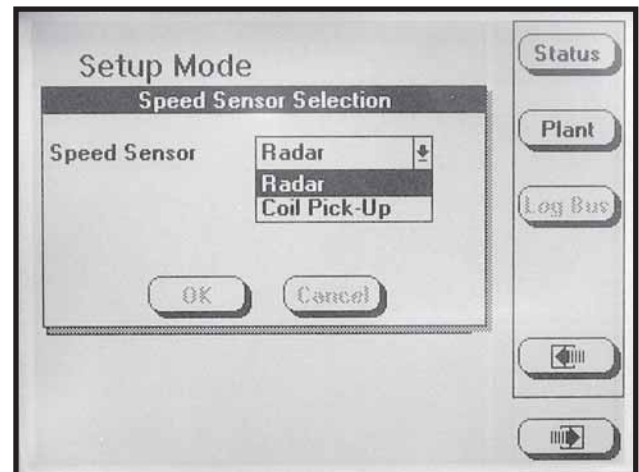

**STEP 4** Plug in the Radar and the black box will advance to OK. Press the knob or ENTER key to save the information.

**STEP 5** Press the PLANT key to return to main planting screen.

**NOTE:** When switching between speed sensors, verify the distance pulse count is correct for the chosen sensor. There will be significant distance pulse count variation between radar and magnetic distance sensors.



ADDING INTERPLANT® ROWS (If Rear Rows Have Previously Been Programmed)

**STEP 1** Press the F6 key until “Mode Selection” screen appears.

**STEP 2** Select “Setup Mode” by turning the rotary encoder knob or using the UP or DOWN arrow keys. Press the knob or ENTER key to display the highlighted item.

D02140614

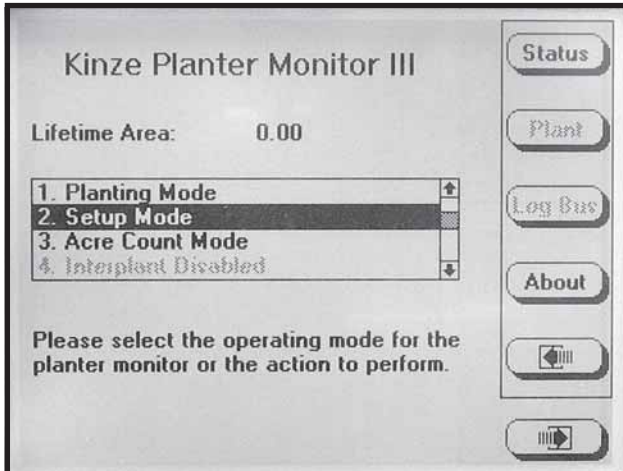

**STEP 3** Select “Add New Muxbus Sensors” by turning the knob or using the UP and DOWN arrow keys. Press the knob or ENTER key to display the highlighted item.

D02140633

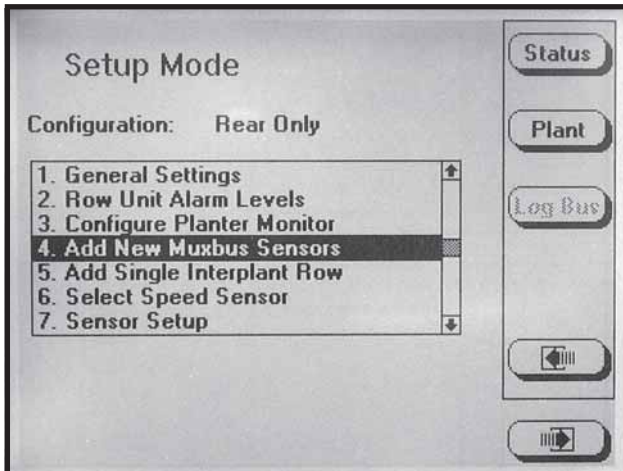

**STEP 4** The note shown below will appear. Select OK by turning the knob or using the UP or DOWN arrow keys. Press the knob or ENTER key to make the selection.

D03010601

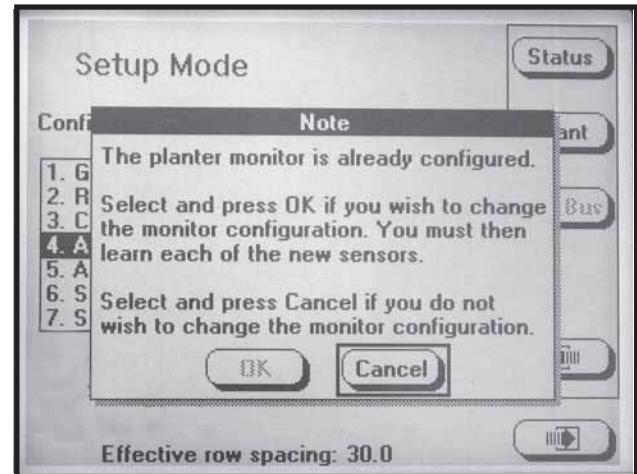

**STEP 5** Turn the knob or use the UP or DOWN arrow keys to select the “Front Row Units” field and press the knob or ENTER key to highlight the field. Turn the knob or use the UP or DOWN arrow keys to obtain the desired number of rows. When the correct value has been entered press the knob or ENTER key. The black box will advance to the OK key. Press the knob or ENTER key to save the information.

**NOTE:** To prevent the configuration from being changed select CANCEL, then press the knob, ENTER key or ESC key.

D02220674

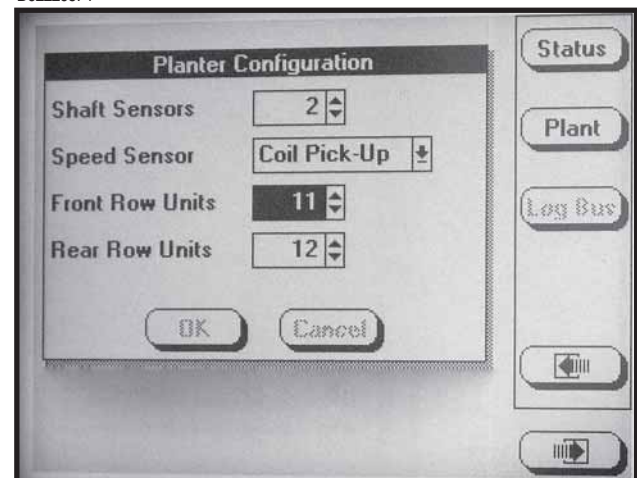

**NOTE:** Attempting to add rear rows while adding new muxbus sensors will cause the following note to appear.

D02220675

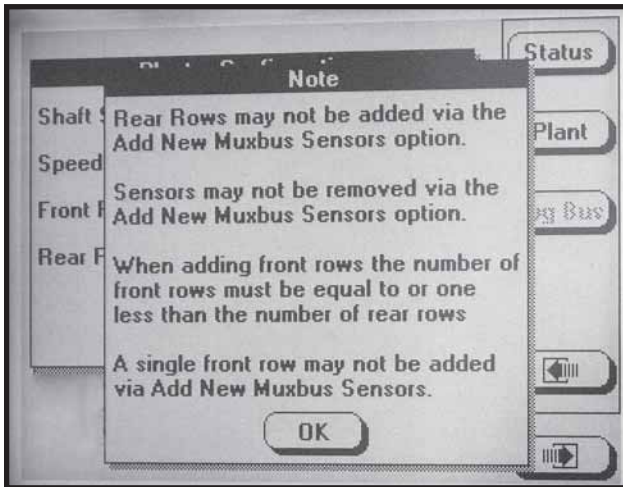

**STEP 6** The note shown below will appear. Select OK by turning the knob or using the UP or DOWN arrow keys. Press the knob or ENTER key to make the selection.

D03010603

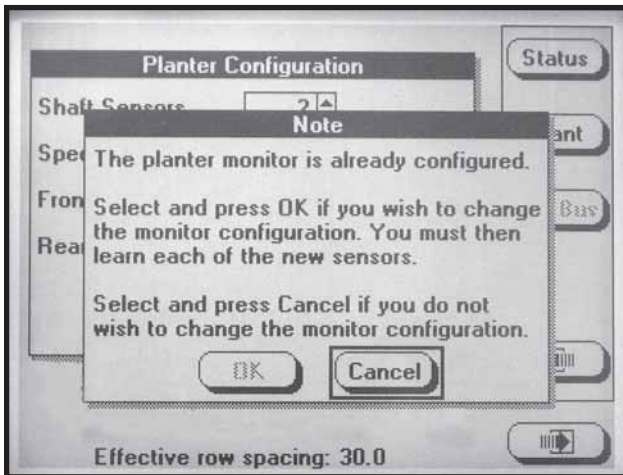

**NOTE:** To prevent the configuration from being changed select CANCEL, then press the knob, ENTER key or ESC key.

**STEP 7** The sensor configuration screen will appear. With [Auto Detect] highlighted select INSTALL. Begin to install sensors from left to right.

D02230604a

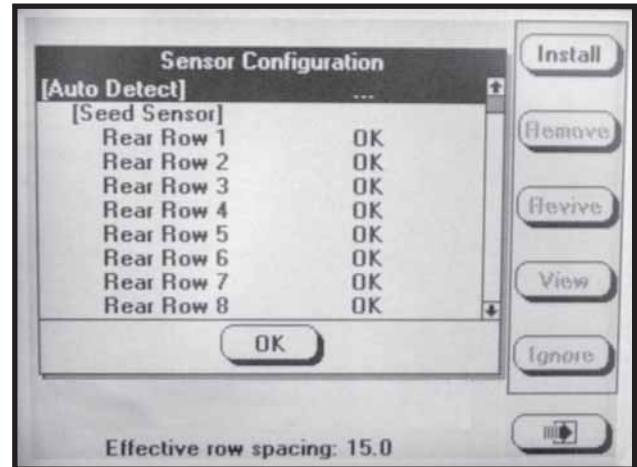

D02220672

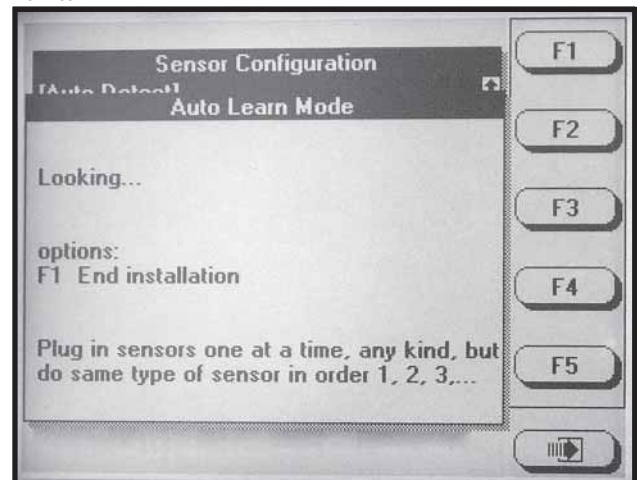

**STEP 8** When all sensors are learned select F1 to end installation. Scroll down to verify the front rows are learned. Select OK by pressing the knob or ENTER key.

**NOTE:** "OK" will appear next to each sensor if no errors are detected.

**STEP 9** Select “General Settings”, by turning the knob or using the UP or DOWN arrow keys. Press the knob or ENTER key to make the selection.

D02140615

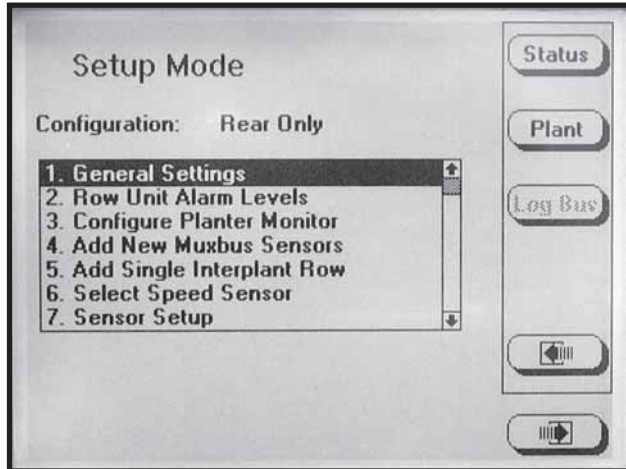

**STEP 10** Select the “Row Spacing” field by turning the knob or using the UP or DOWN arrow keys. Press the knob or ENTER key to highlight field. Adjust the row spacing to Interplant spacing by turning the knob or using the UP or DOWN arrow keys. Press the knob or ENTER key to enter the value. Then turn the knob or use the UP or DOWN arrow keys to advance to OK. Press the knob or enter key to save row spacing.

**NOTE:** To prevent the configuration from being changed select CANCEL, then press the knob, ENTER key or ESC key.

**STEP 11** To return to “Planting Mode” press the PLANT key.

ADDING EVEN-ROW PACKAGE (If Front Rows Have Previously Been Programmed)

**STEP 1** Press the F6 key until “Mode Selection” screen appears.

**STEP 2** Select “Setup Mode” by turning the rotary encoder knob or using the UP or DOWN arrow keys. Press the knob or ENTER key to display the highlighted item.

D02140614

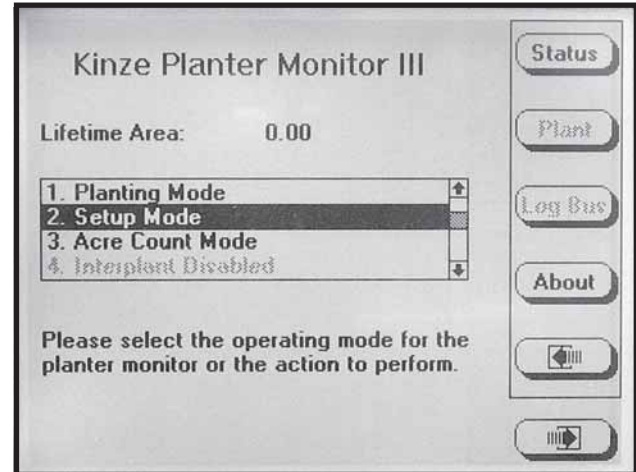

**STEP 3** Select “Add Single Interplant Row” by turning the knob or using the UP and DOWN arrow keys. Press the knob or the ENTER key to display the highlighted item.

D022206200

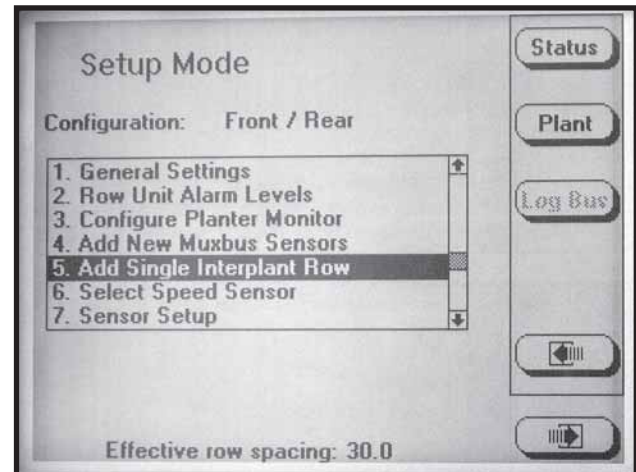

**STEP 4** To confirm the following note turn the knob or use the UP or DOWN arrow keys to select OK and then press the knob or ENTER key to confirm. If the single Interplant row is not to be added select the CANCEL key and press the knob or ENTER key to cancel or press the ESC key.

D022206201

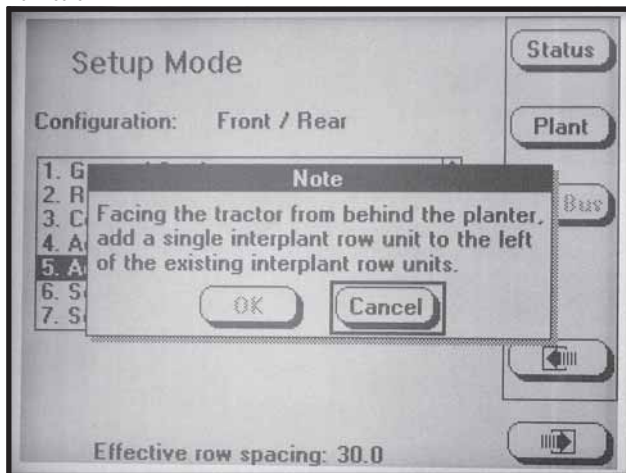

**STEP 5** To “Add Single Interplant Row” the following screen will appear.

If the single Interplant row is to be added turn the knob or use the UP or DOWN arrow keys to select OK and then press the knob or ENTER key to add the Interplant row. If the single Interplant row is not to be added select the CANCEL key and press the knob or ENTER key to cancel or press the ESC key.

D022206202

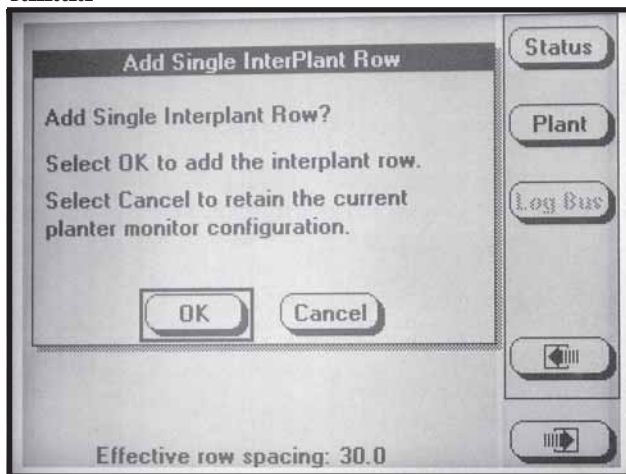

**STEP 6** The “Sensor Configuration” screen will appear. Plug in the new sensor then scroll down to highlight “Front Row 1” by turning the knob or using the UP or DOWN arrow keys. Select INSTALL to learn the new sensor. Press the knob or ENTER key to return to setup mode.

D02220670

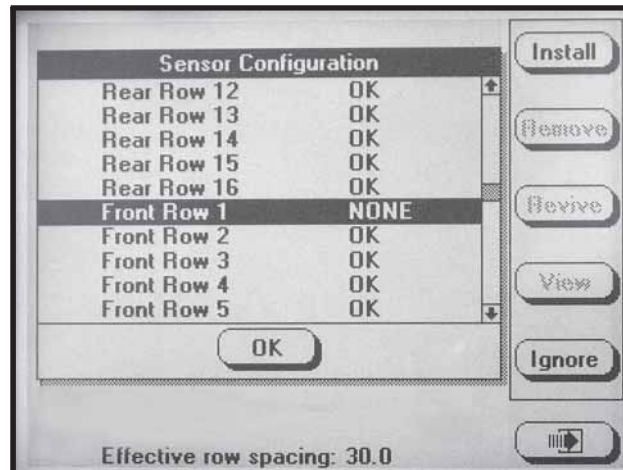

**STEP 7** To return to “Planting Mode” press the PLANT key.

## ENABLING/DISABLING INTERPLANT® ROWS

To Enable or Disable Interplant (a) press the F6 key until the “Mode Selection” screen appears, (b) turn the rotary encoder knob or use the UP or DOWN arrow keys to highlight “Disable/Enable Interplant”, (c) press the knob or ENTER key to “Disable” or “Enable” Interplant. To verify selection, the row spacing is displayed on the bottom of the screen.

D03010605a

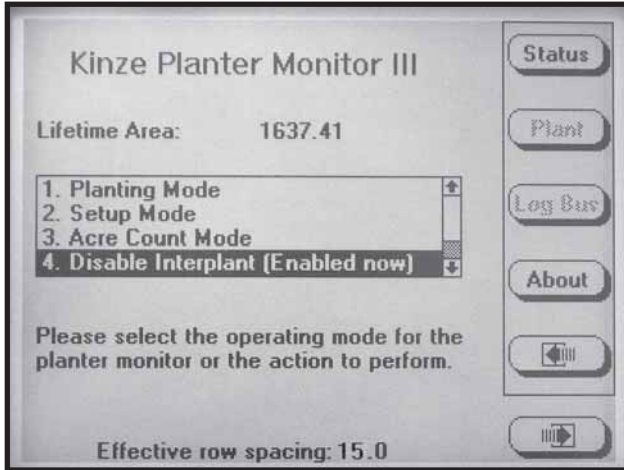

Either select the “Planting Mode” by turning the knob or using the UP arrow key and press the knob or ENTER key or press F6 to return to the “Planting Mode”.

D02240602

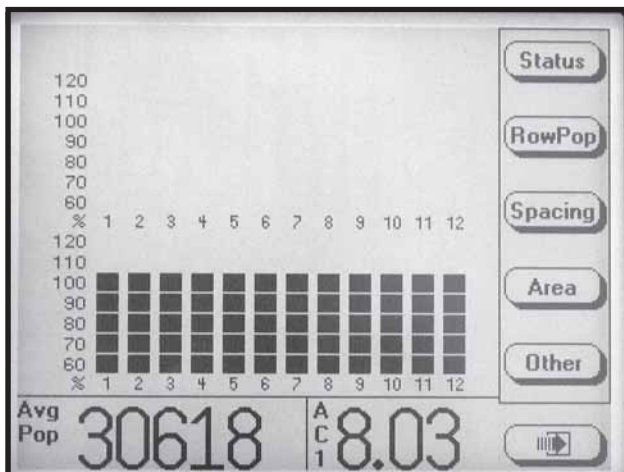

## ROW POPULATION

- Press the ROW POP key to display row population. Average planter population will be shown in the lower L.H. corner of the display.

D06310614

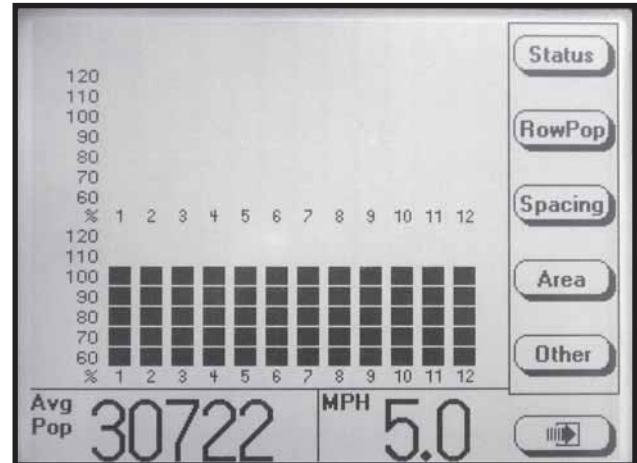

- Press the SCAN key and the monitor will scan through each row in ascending order displaying the average seed population for each row. After all rows have been scanned the average population is displayed and scan function will continue with the first rear row.

D02240604

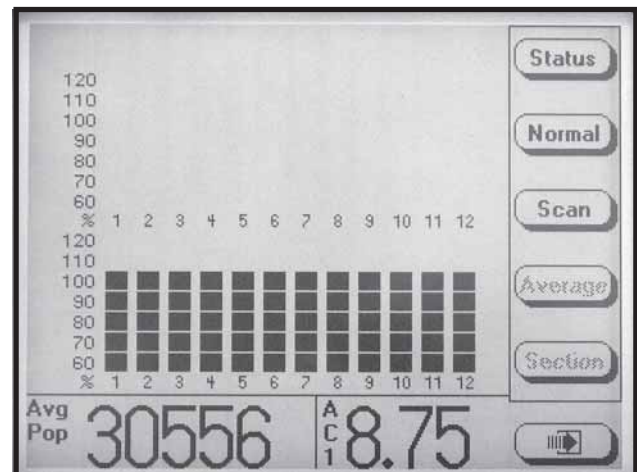

- Press the FREEZE key to stop scanning, the left display item will be frozen on a particular row. “Frzn” appears in the lower L.H. corner to indicate the display is frozen. To resume scan press the SCAN key.

**EXAMPLE: When average row population is shown, R3 indicates rear row 3, F2 indicates front row 2, etc.**

D05310615

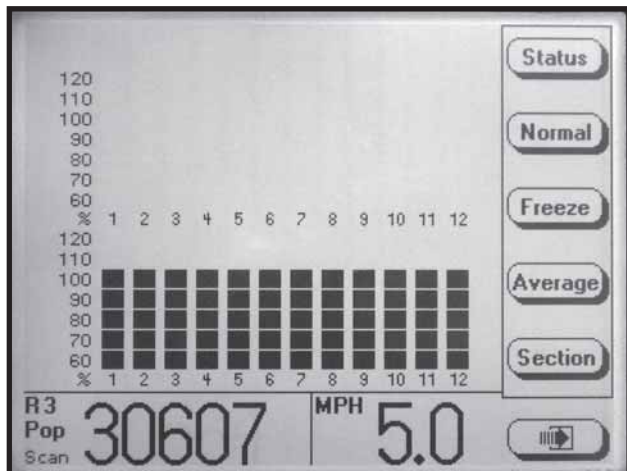

- When either Scan or Frzn is displayed in the L.H. corner the SECTION and arrow keys function as follows: (a) SECTION or RIGHT arrow key advances to the first row of the next section; (b) SECTION or LEFT arrow key selects the first row of the previous section, wrapping around to the first row of the last section when moving past the first section; (c) UP arrow key moves forward to the next row of the planter, wrapping around to the first row when moving past the last row; (d) DOWN arrow key moves backward to the previous row of the planter, wrapping around to the last row of the planter when moving past the first row.
- Press the AVERAGE key to display the average population in the bottom L.H. corner.
- Press the NORMAL key to display the normal screen for planting mode.

**NOTE: If the rows are being scanned and the AVERAGE key is selected the scan function will stop.**

## ROWSPACING

- Press the SPACING key to display seed spacing keys. Seed spacing will appear in the bottom L.H. corner of the display.

D02240602

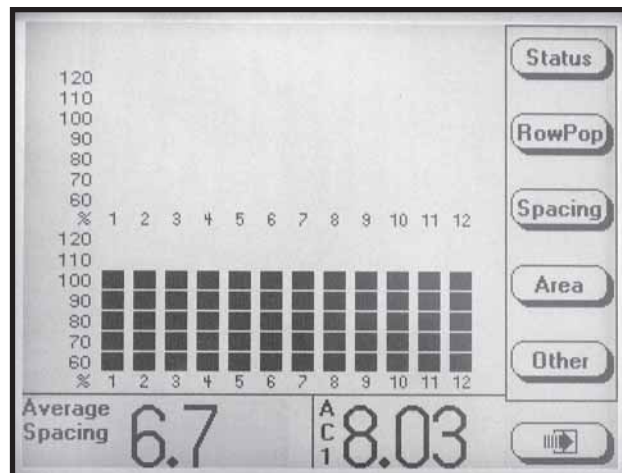

D02240605

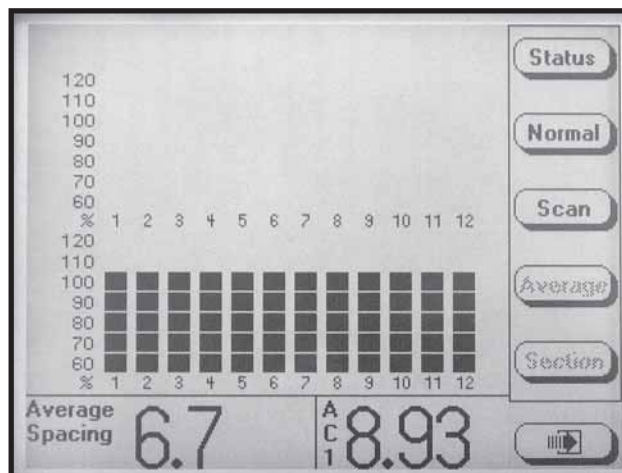

- Press the SCAN key and the monitor will scan through each row in ascending order displaying the average seed spacing for each row. Scan appears in the L.H. corner to indicate the display is scanning. After all rows have been scanned the average population is displayed and scanning will continue with the first rear row.
- Press the FREEZE key to stop scanning and the left display item will be frozen on a particular row. “Frzn” appears to indicate the display is frozen. To resume scan press the SCAN key.

- When either “Scan” or “Frzn” is displayed in the left display item the SECTION and arrow keys function as follows: (a) SECTION and RIGHT arrow key advances to the first row of the next section; (b) LEFT arrow key selects the first row of the previous section, wrapping around to the first row of the last section when moving past the first section; (c) UP arrow key moves forward to the next row of the planter, wrapping around to the first row when moving past the last row; (d) DOWN arrow key moves backward to the previous row of the planter, wrapping around to the last row of the planter when moving past the first row.
- Press the AVERAGE key to display the average seed spacing in the bottom L.H. corner.
- Press the NORMAL key to display the main planting mode.

**NOTE: If the rows are being scanned and the AVERAGE key is selected the scan function will stop.**

### SPEED/SHAFT ROTATION

- Press the OTHER key to display items available to display in the bottom R.H. corner.

- Press the SHAFT key to view the average meter shaft RPM. The value will appear in the bottom R.H. corner of the display.

**NOTE: Applicable to planters with shaft rotation sensors installed.**

D02240607

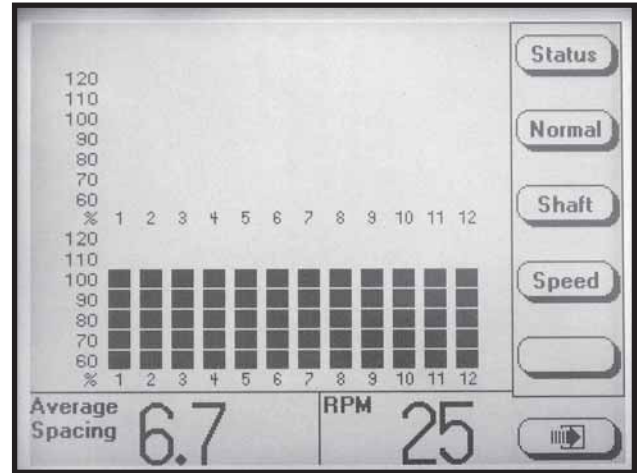

- Press the SPEED key to view the ground speed. The value will appear in the bottom R.H. corner of the display.

D02240602

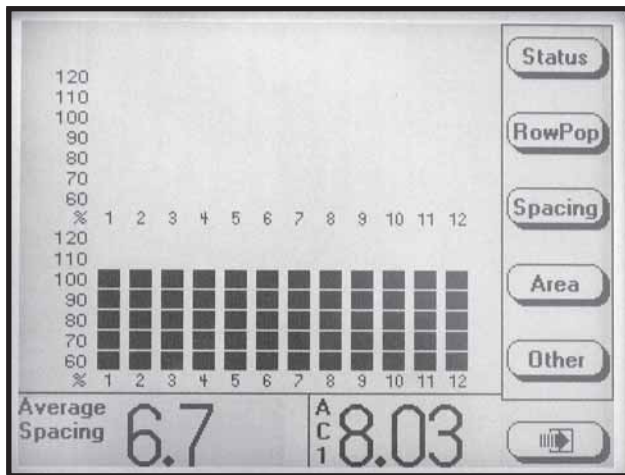

D02240608

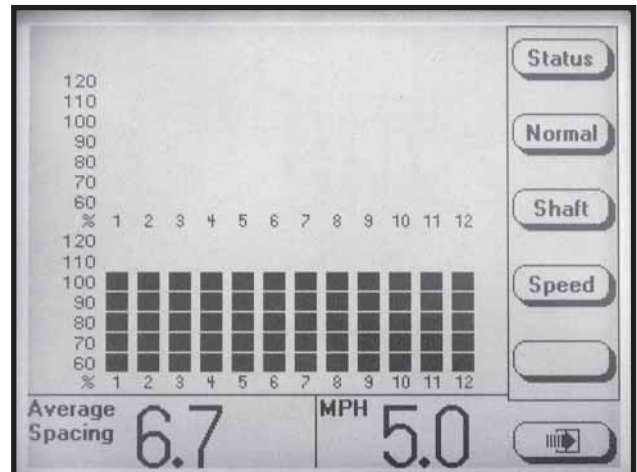

**NOTE: The appropriate units of measure will be displayed (English or Metric).**

- Press NORMAL to bring back the standard key labels.

D02240606

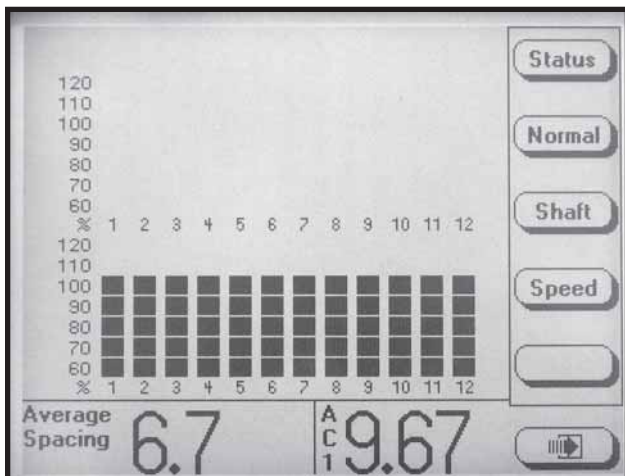

## WARNINGS AND ALARMS

- Seed Rate Alarm** - A seed rate alarm is activated whenever the row average seed population drops below the threshold set for that row.

The corresponding row on the bargraph starts flashing and the monitor emits a series of beeps that persist until the alarm is clear or the ACK button is pressed. "Seed Rate Alarm" appears in the upper left corner of the screen. The bargraph for the row drops down based on the threshold set for the alarm.

**EXAMPLE: If the threshold is 70% the lower two bargraph segments are shown. If the threshold is 50% or 10% the lowest bargraph segment is shown.**

The status message associated with an alarm contains more information about the alarm. To view the "Status Message" for a seed rate alarm, press the STATUS key.

If the sensor is detecting no seed flow it will display which row is not functioning. The alarm may be indicating a mechanical problem that is reducing the seed flow or an electrical problem causing the seed counts to be incorrect.

**NOTE: The only way to remove an alarm is to find and correct the problem. Alarms are not reported for rows that seed rate alarm thresholds have been disabled.**

**NOTE: The percentage shown in the alarm message is the percentage at the time the alarm occurred.**

- Section Not Planting** - When the monitor detects an entire section not planting, the monitor will emit three beeps to alert the user. The bargraph for the affected section flashes and is reduced to the lowest segment. An alarm message is added to the list of "Status Messages". Press the STATUS key to view the alarm message.

- Seed Counting Sensors Not Communicating With Monitor** - When the monitor detects a communication error between the sensor and the monitor, the monitor will emit two beeps to alert the user. Try to reestablish communication with sensor(s) by pressing F2. If the monitor is unable to establish communication there may be (a) a faulty sensor, (b) a poor electrical connection or (c) a cut or pinched wire harness.

D02220687

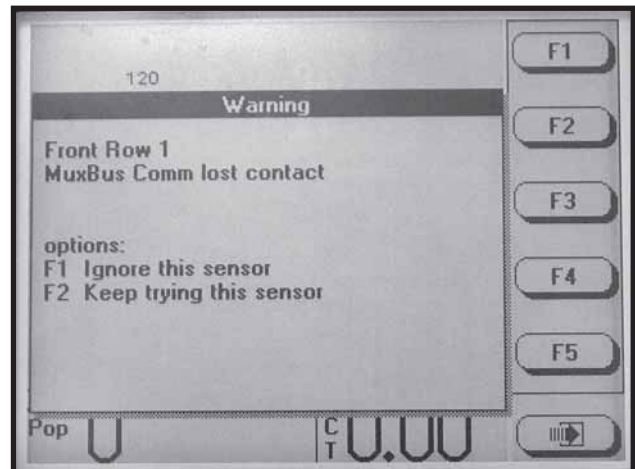

If multiple sensors have lost contact, the message will indicate which sensors have lost contact.

D02220659a

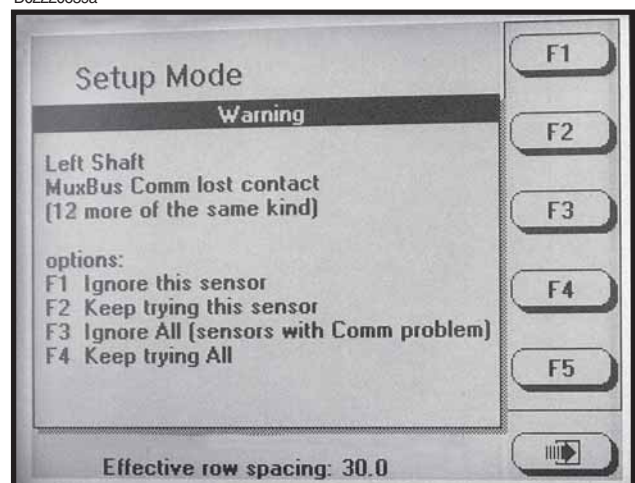

**NOTE: When it is known that a sensor or a group of sensors are faulty, F1 or F3 should be pressed. The monitor will no longer try to communicate with the sensor(s). In the planting mode the corresponding bargraphs will be grayed out in the main screen.**



D02220691

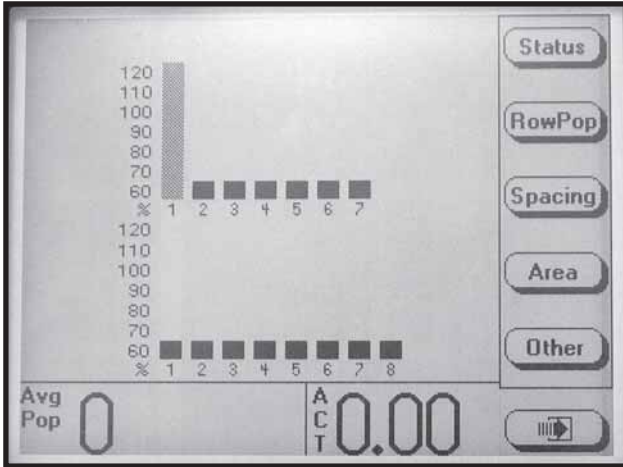

**NOTE:** If the sensors are not faulty, F2 or F4 should be pressed and the message shown below will appear when the STATUS key is pressed.

4. **Seed Counting Sensors Too Dirty Warning** - When powering on the KPM III, each of the seed sensors will do a self check. If a seed tube is too dirty, the message “Clean Or Replace Sensor As Necessary” will be displayed and the bargraph for that row will flash. The LED on the seed tube sensor will not flash. The sensor will not function until the problem is corrected.

**NOTE:** After the alarms have been acknowledged and if the alarm condition is still present, the LCD screen will continue to display the alarm condition.

5. **Wire Shorts** - When a wire is shorted any one of the messages shown below will appear, stating which wires are shorted. The short must be located and fixed to continue planting. Cycle the power on the monitor to clear the alarm.

D02220685

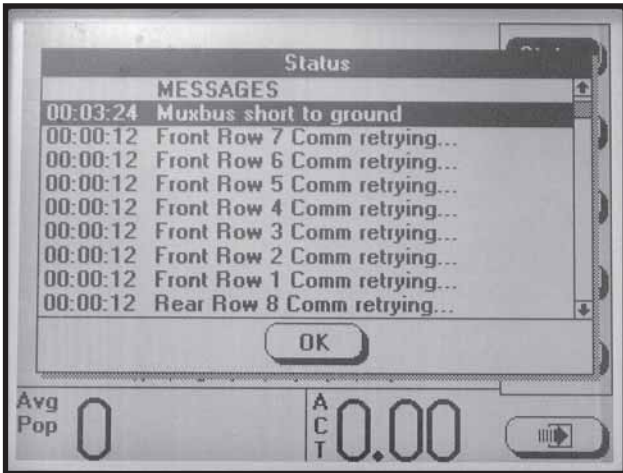

**NOTE:** If a sensor has been ignored, the sensor configuration screen will display as shown below.

D02220683

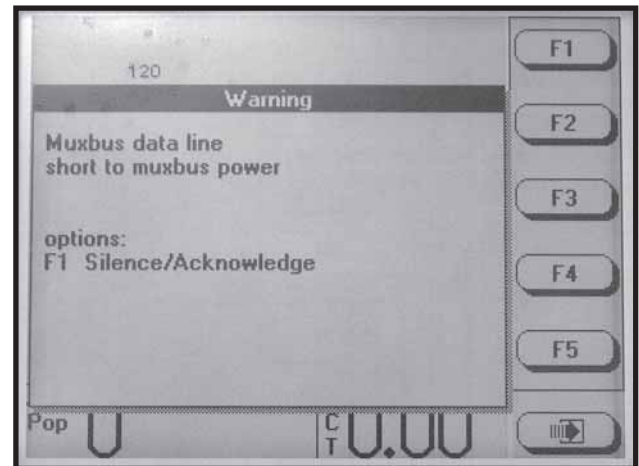

D02220684

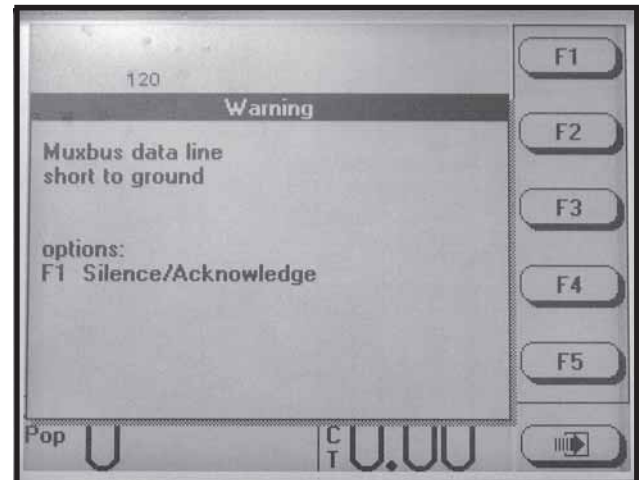

D02220692

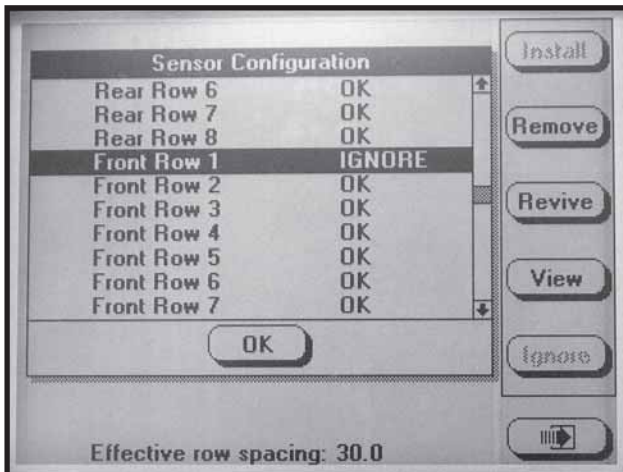

## FIELD OPERATION

Press the ON/OFF key to turn the monitor ON.

If the monitor has been configured, it will enter the normal planting mode and attempt to communicate with the seed sensors.

D02200606

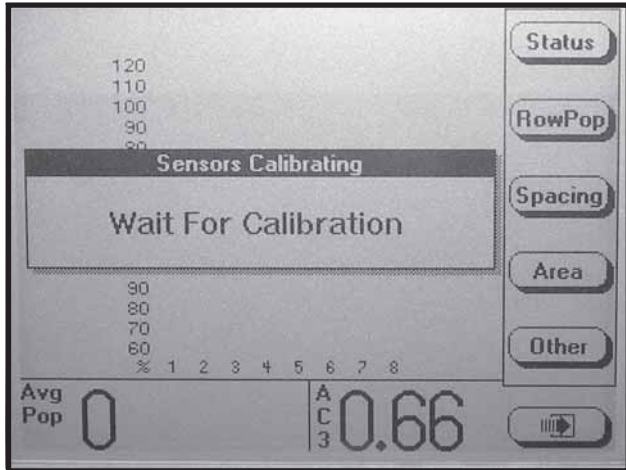

**NOTE:** Do not attempt planting before the “Wait For Calibration” message disappears. If planter is moving while sensors are calibrating alarms will be generated.

**NOTE:** If the monitor can communicate with the sensors the normal planting mode screen will be displayed.

D0220689a

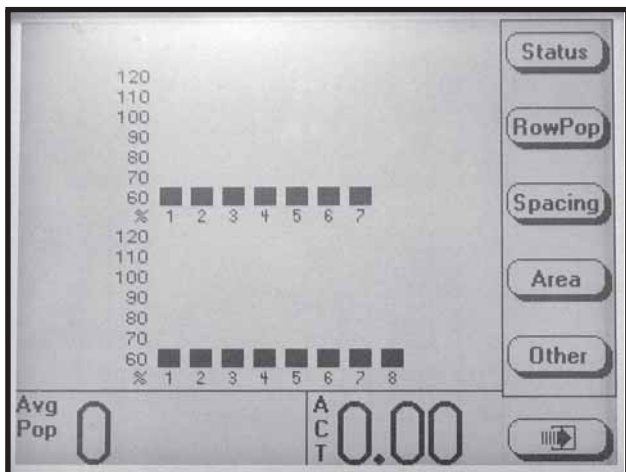

If the monitor does not detect any sensors the message shown below will appear.

D02200627

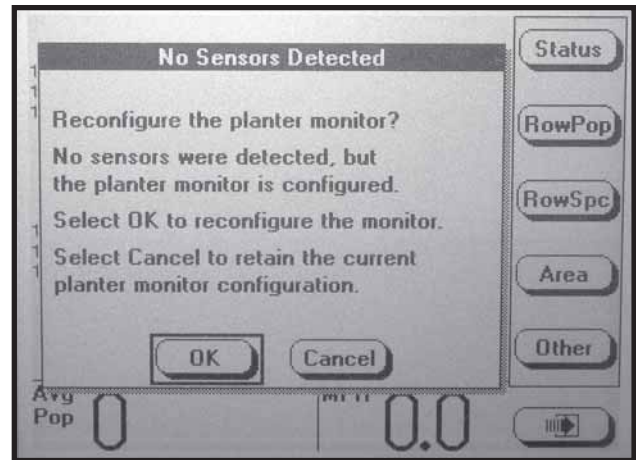

**NOTE:** Selecting OK will reconfigure the monitor requiring all sensors to be re-learned. Selecting CANCEL will maintain the current configuration and the monitor will continue trying to communicate with the sensors.

## AREA MANAGEMENT

There are 10 area counters: Total Area, Field Area and area counters 1 through 8. The Total Area is always active but may be cleared. If it is cleared, the Field Area is also cleared. Field Area and Area Counters 1 through 8 may be cleared independent of each other. They may also be started or stopped at anytime. In addition, there is a Lifetime Area Counter (located on the Mode Selection Screen) which can not be disabled or cleared by the user.

To enter the "Area Management" screen, press the F6 key until the "Area Management" screen appears.

D02210626a

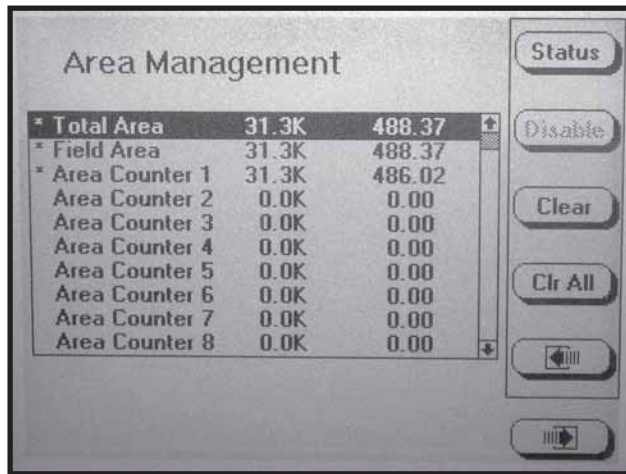

**NOTE:** Total area counter can never be disabled, but can be reset to zero (cleared).

- The asterisk next to the name of the area counter indicates the area counter is enabled and accumulating area.

**EXAMPLE:** In the photo shown above, 31.3K indicates the average seed population for the accumulated area is 31,300 seeds per unit area (acre/hectare). This number has been rounded off. The actual seed population ranges anywhere from 30,500 to 31,499 per unit area. The last column of numbers is the area accumulated (acre/hectare).

- Turn the knob or use the UP or DOWN arrow keys to highlight the desired "Area Counter".
- Press the ENABLE or DISABLE key.

**NOTE:** Up to four area counters can be enabled at one time (two area counters in addition to Total Area and Field Area). If four area counters are already enabled, disable one active area counter in order to enable a new area counter. To disable or enable area counters see next column.

**NOTE:** When a key is dimmed it does not perform any operation on the highlighted area counter.

### ENABLE AREA COUNTER

Each of the "Disabled Area Counters" may be enabled up to a total of four "Area Counters". To Enable a Disabled "Area Counter": (a) highlight the desired "Area Counter" by turning the rotary encoder knob or using the UP or DOWN arrow keys; (b) press the ENABLE key or press the knob or ENTER key and an asterisk will appear next to the "Area Counter". The Enabled "Area Counter" starts accumulating area.

### DISABLE AREA COUNTER

Each of the Enabled Area Counters may be disabled, with the exception of the Total Area Counter. To disable an enabled area counter: (a) highlight that "Area Counter"; (b) press the DISABLE key or press the rotary encoder knob or ENTER key and the asterisk next to the "Area Counter" will disappear. The "Disabled Area Counter" will no longer accumulate area.

**NOTE:** Attempts to disable an Area Counter that is currently being displayed while planting will cause the following alarm.

D02210627a

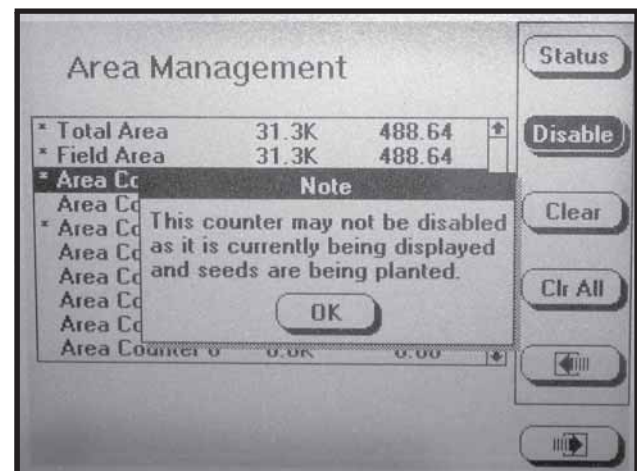

D02210626a

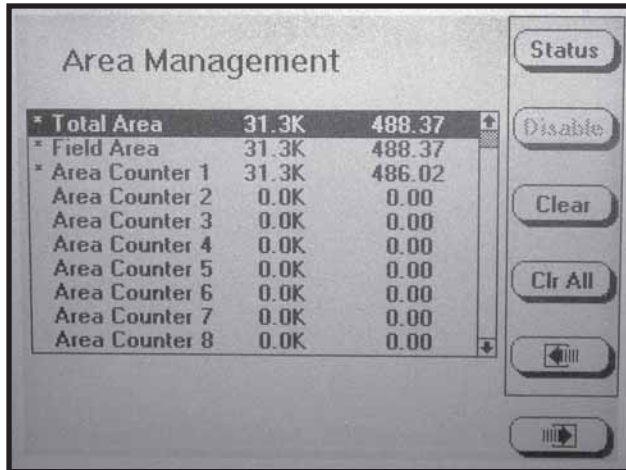

**NOTE:** If the total area is highlighted and the CLEAR key is pressed the following request for confirmation will appear.

D02200612

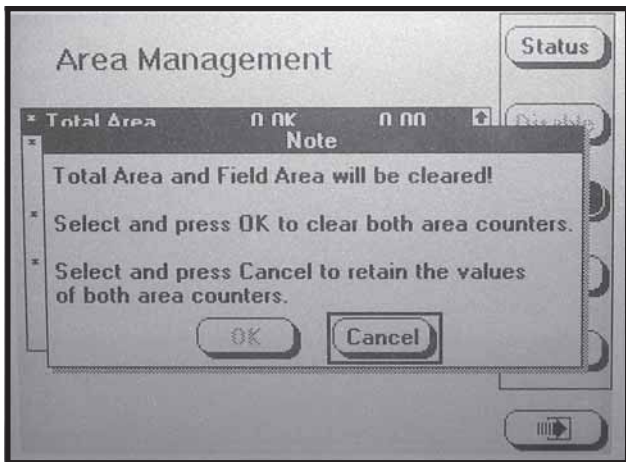

## CLEAR AREA COUNTER

Total Area, Field Area and Area Counters 1 through 8 can be cleared, whether they are Enabled or Disabled. Clearing the “Total Area” counter forces the “Field Area” counter to also be cleared. Clearing any other “Area Counter” including the “Field Area” counter clears only that counter.

**NOTE:** Lifetime Area Counter can never be cleared or disabled.

To clear an Area Counter: (a) highlight the desired area counter, by turning the rotary encoder knob or using the UP or DOWN arrow keys, (b) press the CLEAR key, (c) the request for confirmation shown below will appear, (d) turn the knob or use the UP or DOWN arrow keys to select OK or CANCEL, (e) press the knob or ENTER key to make selection.

To Clear All Area Counters except the “Total Area Counter”: (a) select the CLR ALL key; (b) a request for confirmation will appear; (c) turn the knob or use the UP or DOWN arrow keys to select either OK or CANCEL; (d) press the knob or ENTER key to confirm selection.

D02210628

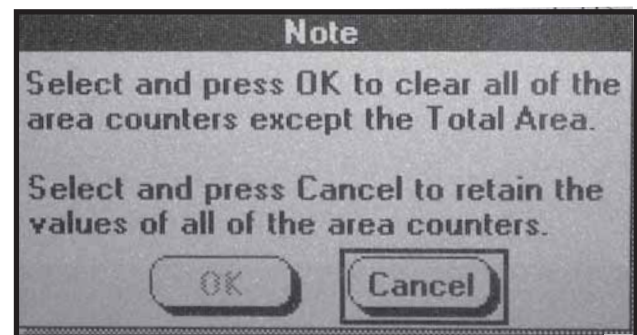

## AREA COUNTERS

**STEP 1** On the main planting screen press the AREA key.

D02240602

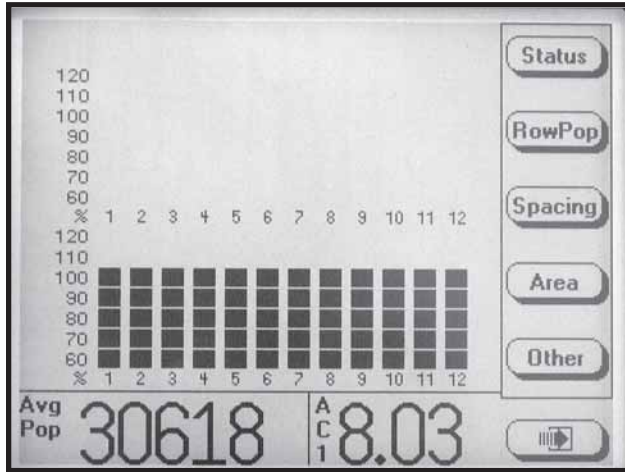

**STEP 2** Press the SELECT key to display the list of the Enabled Area Counters.

D02240603

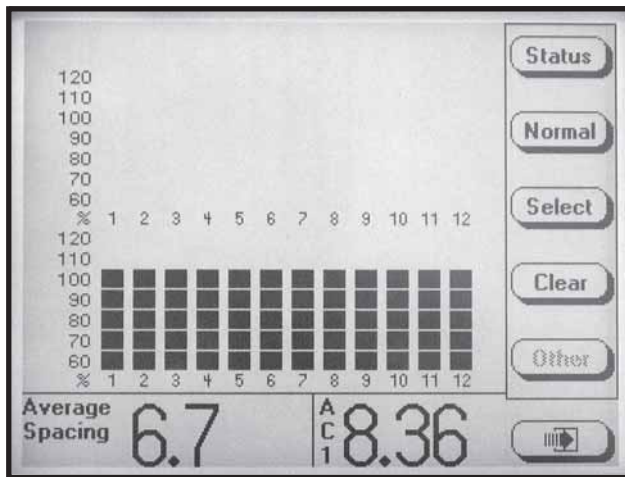

**STEP 3** To select the desired active "Area Counter" turn the knob or use the UP or DOWN arrows to highlight the desired "Area Counter".

D02240609

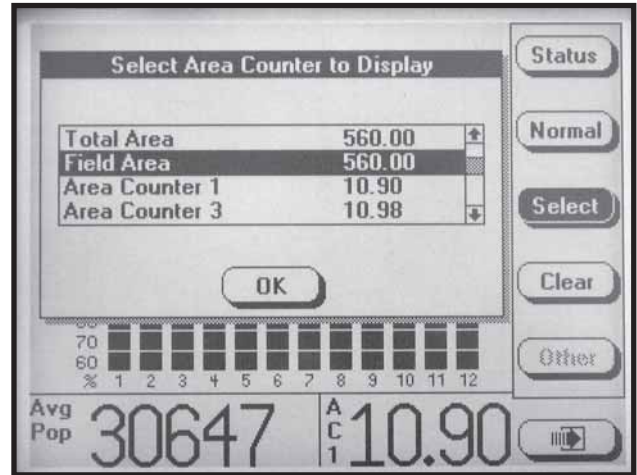

**STEP 4** Press the knob or ENTER key to select OK. The planting screen will then be displayed. Press NORMAL to display main planting screen.

D02240610

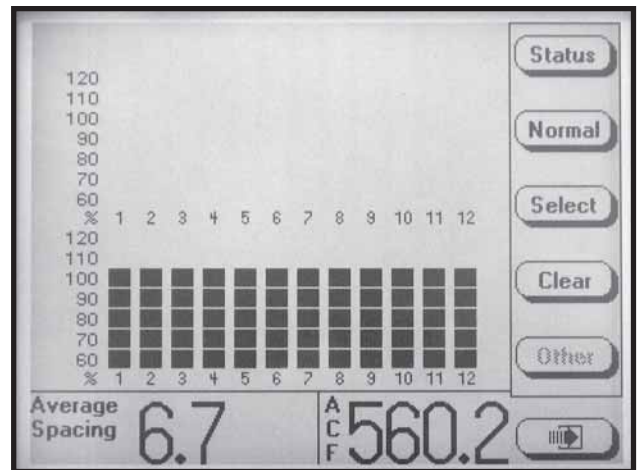

**NOTE:** The abbreviation for the selected area counter numerical value will appear in the bottom R.H. corner of the screen. In the above photo "ACF" represents "Area Counter Field".

## CLEARING FIELD AREA

To reset the counter, display the main planting screen by pressing the F6 key until it appears. Press the AREA key then select the CLEAR key, a dialog box will appear requesting confirmation to clear. Select OK or CANCEL key by turning the rotary encoder knob or using the UP or DOWN arrow keys. Press the knob or ENTER key to verify the selection.

D02210625

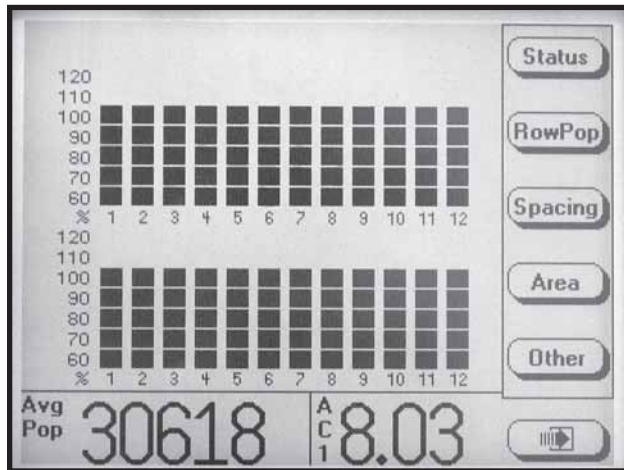

D02210625

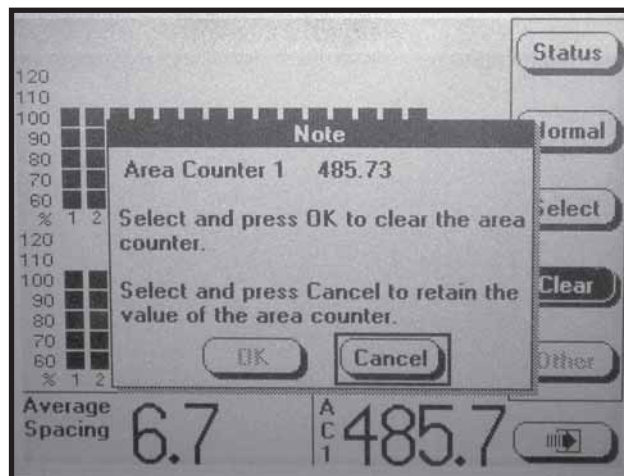

**NOTE:** Only the displayed Area Counter can be disabled.

## ACRE COUNT MODE

When a tractor is equipped with a radar distance sensor, accumulating area without a planter attached is possible. Two routes are provided to enter acre count mode: (a) Installation of an Acre Count Switch Kit or (b) entry into Acre Count Mode.

### Acre Count Switch Kit

**STEP 1** With the monitor OFF, attach an Acre Count Switch Kit to the Muxbus connector and then turn monitor ON and advance to STEP 2.

### Acre Count Mode

**STEP 1** Press the F6 key until the “Mode Selection” screen appears. Turn the rotary encoder knob or use the UP or DOWN arrow keys to select “Acre Count Mode”. Press the knob or ENTER key.

D02200618

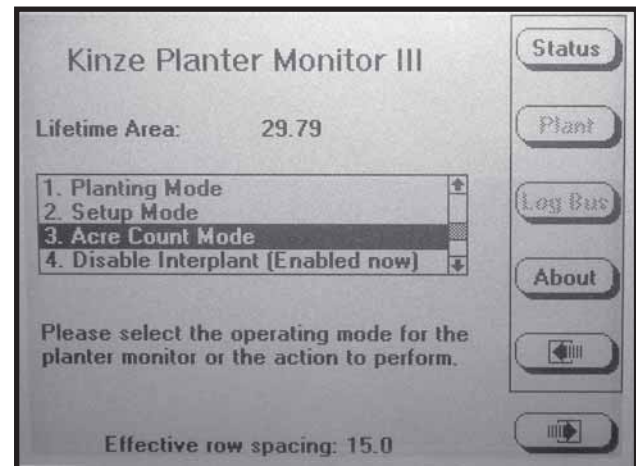

**NOTE:** If no radar unit is detected a warning will appear.

**NOTE:** If using acre count mode, area (acres or hectares) is accumulated in “Lifetime Area Counter”.

**NOTE: DO NOT BEGIN ACCUMULATING AREA IF THE RADAR UNIT HAS NOT BEEN CALIBRATED. Always check the distance pulse count value immediately after entering acre count mode and before pressing start.**

**STEP 2** In the menu, “Units & Width” will be highlighted. Press the knob or ENTER key.

D02200619

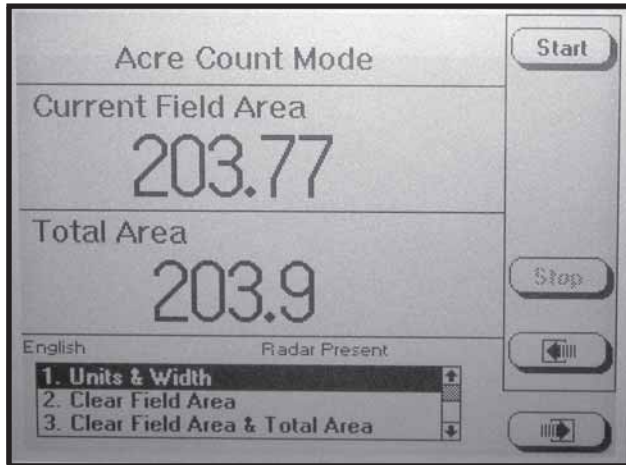

**STEP 3** A drop down menu will appear. Select the correct units of measure “English” or “Metric” by turning the knob or using the UP or DOWN arrow keys. Press the knob or ENTER key to make the selection. The black box will advance to “Implement Width” field showing implement width in feet.

D02200621



**STEP 4** Press the knob or ENTER key to highlight the field. Turn the knob or use the UP or DOWN arrow keys to select desired number in feet. When desired number is obtained press the knob or ENTER key. The black box will advance to OK key.

**NOTE: The implement width entered in acre count mode has no effect on planting mode settings.**

**STEP 5** Press the knob or ENTER key when done.

**NOTE: Tractor should be at a complete stop before starting.**

**STEP 6** To begin accumulating area press the START key.

**STEP 7** To stop accumulating area or to move to a different location, press the STOP key.

There are two counters in the Acre Count Mode (Field Area Counter and Total Area Counter). The “Field Area” counter can be cleared independent of the “Total Area” counter. Clearing the “Total Area” counter causes the “Field Area” counter to also be cleared.

- To Clear Field Area. Highlight “Clear Field Area” and press the knob or ENTER key. A note will appear verifying the decision to reset the field area to zero. Select OK and press the knob or ENTER key to clear the field to zero. Select Cancel and press the knob or the ENTER key to retain the current field value.

- To Clear Both Field Area And Total Area. Highlight the “Clear Field Area & Total Area” and press the knob or ENTER key. A note will appear to verify the decision to reset the field area and the total area to zero. Select OK and press the knob or ENTER key to clear the field to zero. Select CANCEL and press the knob or ENTER key to retain the current field value.

With planter reconnected to monitor return to normal plant screen by pressing the F6 key until the “Mode Selection” screen appears. Select “Planting Mode” by turning the knob or using the UP or DOWN arrow keys, press the knob or ENTER key.

## REPLACING FAULTY SENSOR(S)

To replace a single faulty sensor: (a) turn OFF the monitor, (b) replace the sensor, (c) turn monitor ON. It will then recognize that a single sensor has been replaced.

**NOTE: Monitor will beep twice when the new sensor(s) is learned.**

To replace more than one faulty sensor:

- STEP 1** Press F6 key until the “Mode Selection” screen appears.
- STEP 2** Select “Setup Mode” by turning the knob or press the UP or DOWN arrow keys. Press the knob or ENTER key to display the highlighted item.
- STEP 3** Select “Sensor Setup” by turning the knob or using the UP or DOWN arrow keys. Press the knob or ENTER key to display the highlighted item.

D02140641

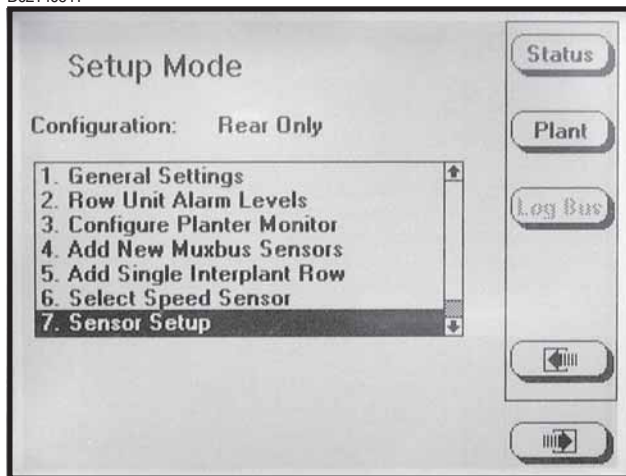

- STEP 4** Highlight faulty sensor. Press REMOVE key and unplug sensor. Plug in new sensor and press INSTALL key.

Repeat above procedure for each faulty sensor being replaced.

D02210601a

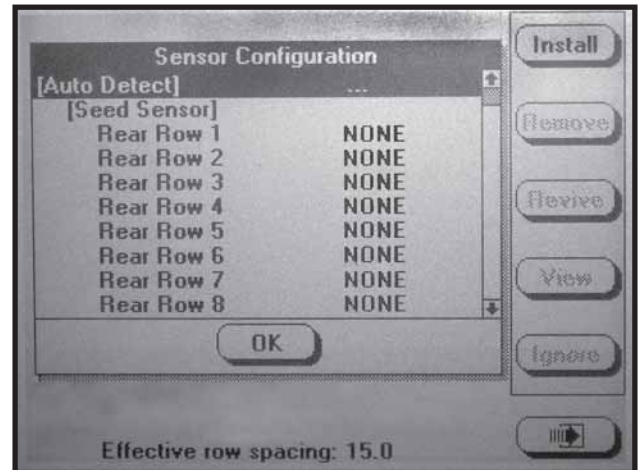

**NOTE: Highlighting a sensor and pressing VIEW gives additional information when troubleshooting a problem. If a faulty sensor has been ignored it may be highlighted in the list of sensors, press REVIVE. The monitor will try to communicate with the sensor. If successful, “OK” will appear next to the sensor.**

- STEP 5** Press the knob or ENTER key to return to “Setup Mode” screen.
- STEP 6** To return to “Planting Mode” press the PLANT key.

**See “KPM III Electronic Seed Monitor Troubleshooting” in the Maintenance Section.**



# MACHINE OPERATION

## DUAL LIFT ASSIST WHEELS

(SFP52a)

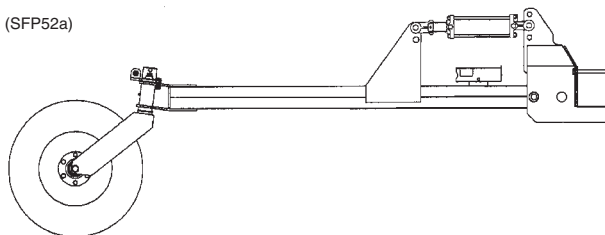

Dual lift assist wheel-equipped machines require use of a quick hitch (customer-supplied) and the top link pin is not used.

A single control valve operates the dual lift assist wheels.

When raising a planter equipped with dual lift assist wheels, the front of the planter should raise and then the back using the lift assist wheels to raise the rear of the planter. When lowering the planter, the lift assist wheels should begin to lower the rear of the planter before lowering the front of the planter. Dual lift assist wheel hydraulics can also be plumbed into the 3 point lift circuit. A flow control valve determines the correct sequence of events to allow the dual lift assist wheel cylinders to operate at the correct time in conjunction with the 3 point hitch circuit. See "Flow Control Valve Adjustment".

See "Tractor Preparation And Hookup" for additional information.

## FLOW CONTROL VALVE ADJUSTMENT

WB001(MT2)

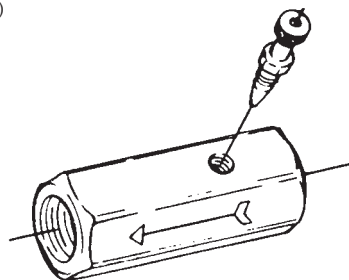

The flow control valve determines the amount of oil flow to the lift assist cylinders.

To adjust oil flow, loosen the jam nut and turn the control clockwise or "in" to restrict flow and counterclockwise or "out" to increase the flow.

# MACHINE OPERATION

## TRANSPORTING THE PLANTER



**WARNING:** Always make sure safety/warning lights, reflective decals and SMV sign are in place and visible prior to transporting the machine on public roads. In this regard, check and comply with all federal, state/provincial and local regulations.



**WARNING:** Always install all safety lockup devices before transporting the planter.

## METRIC CONVERSION TABLE

MULTIPLY	BY	TO GET
Inches (in.)	x 2.54	= centimeters (cm)
Inches (in.)	x 25.4	= millimeters (mm)
Feet (ft.)	x 30.48	= centimeters (cm)
Acres	x 0.405	= hectares (ha)
Miles per hour (mph)	x 1.609	= kilometers per hour (Km/h)
Pounds (lbs.)	x 0.453	= kilograms (kg)
Bushels (bu.)	x 35.238	= liters (l)
Gallons (gal.)	x 3.785	= liters (l)
Pounds per square inch (psi)	x 6.894	= kilopascals (kPa) (100 kPa = 1 bar)
Inch pounds (in. lbs.)	x 0.113	= newtons-meters (N•m)
Foot pounds (ft. lbs.)	x 1.356	= newtons-meters (N•m)
Centimeters (cm)	x .394	= inches (in.)
Millimeters (mm)	x .0394	= inches (in.)
Centimeters (cm)	x .0328	= feet (ft.)
Hectares (ha)	x 2.469	= acres
Kilometers per hour (Km/h)	x 0.621	= miles per hour (mph)
Kilograms (kg)	x 2.208	= pounds (lbs.)
Liters (l)	x 0.028	= bushels (bu.)
Liters (l)	x 0.264	= gallons (gal.)
Kilopascals (kPa) (100 kPa = 1 bar)	x 0.145	= pounds per square inch (psi)
Newtons-meters (N•m)	x 8.85	= inch pounds (in. lbs.)
Newtons-meters (N•m)	x 0.738	= foot pounds (ft. lbs.)

## PLANTING SPEED

Planters are designed to operate within a speed range of 2 to 8 MPH. See “Rate Charts”. Variations in ground speed will produce variations in rates. Finger pickup seed meter populations will tend to be disproportionately higher at high ground speeds.

**NOTE:** Due to a multitude of variables, seed spacing can be adversely affected at speeds above 5.5 MPH.

## FIELD TEST

With any change of field and/or planting conditions, seed size or planter adjustment, we recommend a field test be made to ensure proper seed placement and operation of row units. See “Rate Charts”, “Checking Seed Population” and “Checking Granular Chemical Application Rate” at the end of this section.

- Check the planter for fore to aft and lateral level operation. See “Leveling The Planter”.
- Check **all** row units to be certain they are running level. When planting, the row unit parallel arms should be approximately parallel to the ground.
- Check row markers for proper operation and adjustment. See “Row Marker Length Adjustment”, “Row Marker Speed Adjustment” and “Row Marker Operation”.
- Check for proper application rates and placement of granular chemicals on **all** rows. See “Checking Granular Chemical Application Rate”.
- Check for desired depth placement and seed population on **all** rows. See “Checking Seed Population”.

After the planter has been field tested, reinspect the machine.

- Hoses And Fittings
- Bolts And Nuts
- Cotter Pins And Spring Pins
- Drive Chain Alignment

# MACHINE OPERATION

## CHECKING SEED POPULATION

1. Tie up one or more sets of closing wheels by running a chain or rubber tarp strap between the hopper support panel and closing wheels. It may be necessary to decrease closing wheel arm spring tension.

(RU113g)

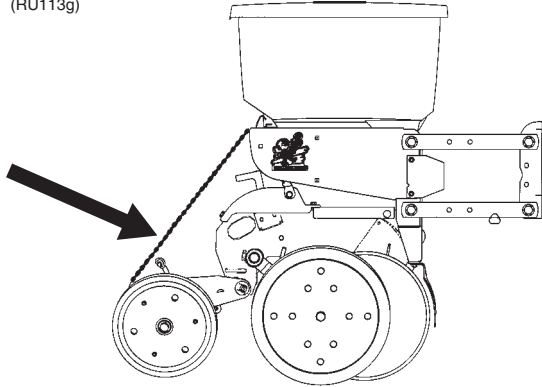

2. Plant a short distance and check to see if seed is visible in the seed trench. Adjust planting depth to a shallower setting if seed is not visible and recheck.

D020705102

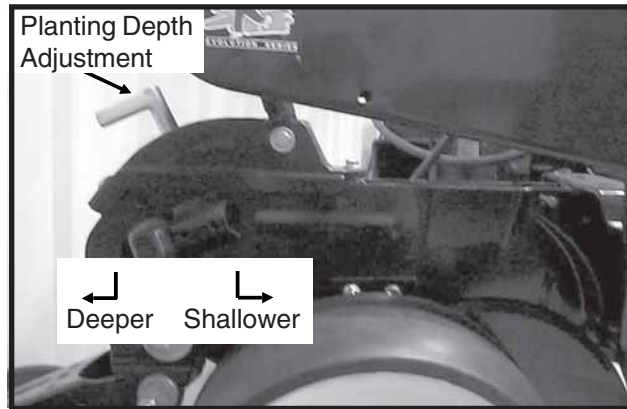

3. Measure  $\frac{1}{1000}$  of an acre. See chart for correct distance for row width being planted. For example, if planting 30" rows  $\frac{1}{1000}$  of an acre would be 17' 5".

LENGTH OF ROW IN FEET AND INCHES				
Fraction Of Acre	Row Width			
	30"	36"	38"	40"
$\frac{1}{1000}$	17' 5"	14' 6"	13' 10"	13' 1"

**NOTE:** When planting with closing wheels raised and planting depth set shallow, seeds may bounce or roll affecting seed spacing accuracy.

4. Count seeds in measured distance.
5. Multiply the number of seeds placed in  $\frac{1}{1000}$  of an acre by 1000. This will give you total population.

EXAMPLE: With 30" row spacing 17' 5" equals  $\frac{1}{1000}$  acre.

26 Seeds				
Counted	x	1000	=	26,000 Seeds Per Acre

Seed count can be affected by drive ratio between drive wheel and seed meter, tire pressure and/or seed meter malfunction.

If seed check shows the average distance between seeds in inches is significantly different than the seed rate chart indicates, first check drive ratio between drive wheel and seed meter. Check drive wheel air pressure, check for incorrect sprocket(s) in driveline and check drive and driven sprockets on transmission for proper selection.

Second, check for seed meter malfunction. For example, if spacing between kernels of corn at the transmission setting being used is 8" and a gap of 16" is observed, a finger has not functioned properly and lost its seed. If two seeds are found within a short distance of each other, the finger has metered two seeds instead of one.

See "Finger Pickup Seed Meter Troubleshooting" and/or "Brush-Type Seed Meter Troubleshooting" in the Maintenance Section of this manual.

# MACHINE OPERATION

## Determining Pounds Per Acre (Brush-Type Seed Meter)

To determine pounds per acre:

Seeds Per Acre On Chart	÷	Seeds Per Pound From Seed Tag On Bag	=	Pounds Per Acre
-------------------------------	---	---	---	-----------------------

To determine bushels per acre:

Pounds Per Acre	÷	Unit Weight Of Seed	=	Bushels Per Acre
--------------------	---	------------------------	---	---------------------

The unit weight of:

- 1 Bushel Soybeans = 60 Pounds
- 1 Bushel Milo/Grain Sorghum = 56 Pounds
- 1 Bushel Cotton = 32 Pounds

If seeds per pound information is not available the following is an average:

- 2,600 seeds per pound for medium size soybeans
- 15,000 seeds per pound for medium size  
milo/grain sorghum
- 4,500 seeds per pound for medium size cotton

If seed population check shows planting rate is significantly different than seed rate chart shows or if a particular meter is not planting accurately, see "Brush-Type Seed Meter Maintenance" and/or "Brush-Type Seed Meter Troubleshooting".

## CHECKING GRANULAR CHEMICAL APPLICATION RATE

Many things can affect the rate of delivery of granular chemicals such as temperature, humidity, speed, ground conditions, flowability of different material or any obstruction in the meter.



**WARNING: Agricultural chemicals can be dangerous if not selected and handled with care. Always read and follow directions supplied by the chemical manufacturer.**

D04159901



A field check is important to determine application rates are correct.

To check, fill insecticide and/or herbicide hoppers. Attach a calibrated vial to each granular chemical meter. Lower the planter and proceed as follows.

**NOTE: It is not necessary for seed meter clutch to be engaged during test. Disengage clutch to avoid dropping seed.**

Drive 1320 feet at planting speed. Weigh the chemical in ounces that was caught in one vial. Multiply that amount by the factor shown to determine pounds per acre.

POUNDS PER ACRE FACTOR FOR GIVEN ROW WIDTH	
Row Width	Factor
30"	0.83
36"	0.69
38"	0.65
40"	0.62

**EXAMPLE:** You are planting 30" rows. You have planted for 1320 feet at the desired planting speed. You caught 12.0 ounces of chemical in one vial. 12.0 ounces times 0.83 equals 9.96 pounds per acre.

**NOTE: It is important to check calibration of all rows.**

### Metering Gate

Use the metering gate setting for distributing insecticide or herbicide as a starting point. The charts are based on a 5 miles per hour planting speed. For speeds faster than 5 miles per hour a higher gate setting should be used. For speeds slower than 5 miles per hour a lower gate setting should be used.

# MACHINE OPERATION

## GENERAL PLANTING RATE INFORMATION

These planting rate charts are applicable to KINZE® Model 3120 3 Point Mounted Planters. See “Tire Pressure” for recommended tire pressures.

Not all row spacings listed are applicable to all model planters.

**IMPORTANT: The sprocket combinations listed in these charts are best for average conditions. Changes in sprocket combinations may be required to obtain desired planting population. TO PREVENT PLANTING MISCALCULATIONS, MAKE FIELD CHECKS TO BE SURE YOU ARE PLANTING AT THE DESIRED RATE.**

The size and shape of seed may affect the planting rate.

### Finger Pickup Corn Meter

Larger grades will generally plant more accurately at the high end of the ground speed range than smaller grades. Higher than optimum speeds may result in population rate increase or higher incidence of doubles, particularly with small seed. Medium round corn seed is most desirable for planting accuracy at optimum speed.

### Finger Pickup Oil Sunflower Meter

Larger grades will generally plant more accurately at the high end of the ground speed range than smaller grades. Higher than optimum speeds may result in population rate increase or higher incidence of doubles, particularly with small seed. No. 3 and/or No. 4 size oil sunflower seeds are recommended for use in the finger pickup seed meter equipped with oil sunflower fingers. No. 1 and/or No. 2 size confectionery sunflower seeds are recommended for use in the finger pickup seed meter equipped with corn fingers.

**NOTE: Seed additives, added to the seed in the hopper, may adversely affect performance of the finger pickup seed meter and accelerate wear. See “Finger Pickup Seed Meter” in the Row Unit Operation section.**

### Brush-Type Seed Meter (Soybean, Milo/Grain Sorghum, Acid-Delinted Cotton)

Rate charts are given in seeds per acre as well as seed spacing in inches rounded to the nearest tenth of an inch. Because of the large range in seed size, pounds per acre is not a suggested method of selecting transmission settings. When using smaller size seeds it may appear the pounds per acre is below what was expected and vice versa on large seed. To determine pounds per acre, use the formula given in “Determining Pounds Per Acre (Brush-Type Seed Meter)” in the “Checking Seed Population” section of this manual.

**NOTE: Due to a multitude of variables, seed spacing can be adversely affected at speeds above 5.5 MPH.**

**NOTE: Use of the Half Rate (2 To 1) Drive Reduction Package will reduce the planter transmission speed. The seeding rate will be approximately 50% of the chart reading when using the Half Rate (2 To 1) Drive Reduction Package. Planting speed can affect actual seeding rate. Make a field check and adjust setting in the transmission as needed to obtain the desired seed drop.**

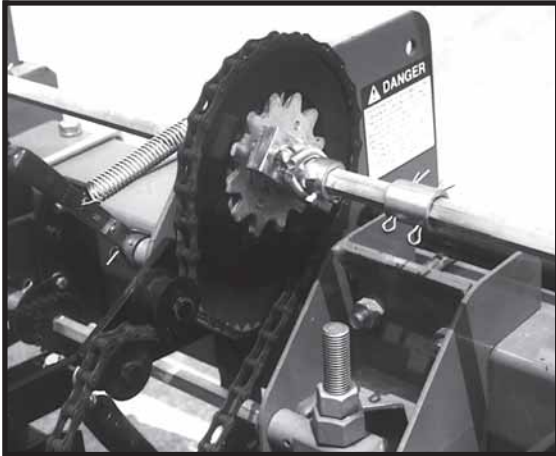
53704-12  

**EXAMPLE: 30" row spacing using 60 cell seed discs in brush-type seed meters and 17 tooth drive/ 28 tooth driven sprockets.**  
 $84,308 \div 2 = 42,154$  Population (2.5" Seed Spacing x 2 = 5" Seed Spacing)

# MACHINE OPERATION

Z195

## PLANTING RATES FOR FINGER PICKUP SEED METERS (STANDARD DRIVE) APPROXIMATE SEEDS/ACRE FOR VARIOUS ROW WIDTHS

30" Rows	36" Rows	38" Rows	40" Rows	Transmission Sprockets		Recommended Speed Range (MPH)	Average Seed Spacing In Inches
				Drive	Driven		
16,862	14,051	13,312	12,646	17	28	4 to 6	12.4
17,486	14,572	13,805	13,115	17	27	4 to 6	12.0
18,159	15,132	14,336	13,619	17	26	4 to 6	11.5
18,845	15,704	14,878	14,134	19	28	4 to 6	11.1
18,885	15,737	14,909	14,164	17	25	4 to 6	11.1
19,543	16,286	15,429	14,657	19	27	4 to 6	10.7
19,672	16,393	15,530	14,754	17	24	4 to 6	10.6
20,295	16,912	16,022	15,221	19	26	4 to 6	10.3
20,527	17,106	16,206	15,395	17	23	4 to 6	10.2
21,107	17,589	16,663	15,830	19	25	4 to 6	9.9
21,986	18,322	17,357	16,490	19	24	4 to 6	9.5
22,813	19,011	18,010	17,110	23	28	4 to 6	9.2
22,942	19,118	18,112	17,207	19	23	4 to 6	9.1
23,658	19,715	18,677	17,743	23	27	4 to 6	8.8
23,805	19,837	18,793	17,853	24	28	4 to 6	8.8
24,568	20,473	19,395	18,426	23	26	4 to 6	8.5
24,686	20,572	19,489	18,515	24	27	4 to 6	8.5
24,796	20,664	19,576	18,597	25	28	4 to 6	8.4
24,849	20,707	19,617	18,636	17	19	4 to 6	8.4
25,550	21,292	20,171	19,163	23	25	4 to 6	8.2
25,636	21,363	20,239	19,227	24	26	4 to 6	8.2
25,715	21,429	20,301	19,286	25	27	4 to 6	8.1
25,788	21,490	20,359	19,341	26	28	4 to 6	8.1
26,615	22,179	21,012	19,961	23	24	4 to 6	7.9
26,661	22,218	21,048	19,996	24	25	4 to 6	7.8
26,704	22,253	21,082	20,028	25	26	4 to 6	7.8
26,743	22,286	21,113	20,058	26	27	4 to 6	7.8
26,780	22,317	21,142	20,085	27	28	4 to 6	7.8
27,772	23,143	21,925	20,829	23	23	4 to 6	7.5
28,800	24,000	22,737	21,600	28	27	4 to 6	7.3
28,840	24,033	22,769	21,630	27	26	4 to 6	7.3
28,929	24,108	22,839	21,697	25	24	4 to 6	7.2
28,979	24,150	22,879	21,735	24	23	4 to 6	7.2
29,908	24,924	23,612	22,431	28	26	4 to 6	7.0
29,994	24,995	23,679	22,495	27	25	4 to 6	7.0
30,187	25,156	23,832	22,640	25	23	4 to 6	6.9
31,039	25,866	24,505	23,279	19	17	4 to 6	6.7
31,105	25,920	24,556	23,328	28	25	4 to 6	6.7
31,243	26,036	24,666	23,433	27	24	4 to 6	6.7
31,394	26,162	24,785	23,546	26	23	4 to 6	6.7
32,401	27,001	25,579	24,300	28	24	3 to 6	6.5
32,602	27,168	25,738	24,451	27	23	3 to 6	6.4
33,619	28,016	26,541	25,214	23	19	3 to 5.5	6.2
33,809	28,174	26,692	25,357	28	23	3 to 5.5	6.2
35,080	29,234	27,695	26,310	24	19	3 to 5.5	6.0
36,542	30,452	28,849	27,407	25	19	3 to 5	5.7
37,574	31,312	29,664	28,180	23	17	3 to 5	5.6
38,004	31,670	30,003	28,503	26	19	3 to 5	5.5
39,207	32,673	30,953	29,406	24	17	3 to 5	5.3
39,465	32,888	31,157	29,599	27	19	3 to 5	5.3
40,841	34,034	32,243	30,631	25	17	3 to 4.5	5.1
40,927	34,106	32,311	30,695	28	19	3 to 4.5	5.1
42,475	35,396	33,533	31,856	26	17	3 to 4.5	4.9
44,108	36,757	34,822	33,081	27	17	3 to 4.5	4.7
45,742	38,118	36,112	34,307	28	17	3 to 4.5	4.6

**NOTE: See "General Planting Rate Information" and "Checking Seed Population" pages for additional information. Always check seed population in the field to ensure planting rates are correct.**

# MACHINE OPERATION

Z216/RH

## PLANTING RATES FOR BRUSH-TYPE SEED METERS (STANDARD DRIVE)

### APPROXIMATE SEEDS/ACRE FOR VARIOUS ROW WIDTHS

Transmission Sprockets		60 Cell Soybean Or High-Rate Milo/ Grain Sorghum				Average Seed Spacing In Inches	48 Cell Specialty Soybean Or High-Rate Acid-Delinted Cotton				Average Seed Spacing In Inches	Speed Range (MPH)
		30" Rows	36" Rows	38" Rows	40" Rows		30" Rows	36" Rows	38" Rows	40" Rows		
Drive	Driven											
17	28	84,308	70,256	66,559	63,231	2.5	67,446	56,205	53,246	50,584	3.1	2 to 8
17	27	87,430	72,859	69,024	65,573	2.4	69,944	58,286	55,219	52,458	3.0	2 to 8
17	26	90,793	75,661	71,679	68,095	2.3	72,634	60,528	57,342	54,475	2.9	2 to 8
19	28	94,226	78,522	74,389	70,670	2.2	75,381	62,818	59,512	56,536	2.8	2 to 8
19	27	97,716	81,430	77,144	73,287	2.1	78,173	65,144	61,715	58,630	2.7	2 to 8
17	24	98,359	81,966	77,652	73,769	2.1	78,688	65,573	62,122	59,016	2.7	2 to 8
17	23	102,636	85,530	81,028	76,977	2.0	82,109	68,424	64,822	61,581	2.5	2 to 8
19	25	105,533	87,945	83,316	79,150	2.0	84,427	70,355	66,653	63,320	2.5	2 to 8
19	24	109,931	91,609	86,787	82,448	1.9	87,944	73,286	69,430	65,958	2.4	2 to 8
23	28	114,063	95,053	90,050	85,548	1.8	91,712	76,042	72,520	68,438	2.3	2 to 8
19	23	114,710	95,592	90,561	86,033	1.8	91,768	76,474	72,448	68,826	2.3	2 to 8
24	28	119,023	99,186	93,965	89,267	1.8	95,218	79,349	75,173	71,414	2.2	2 to 8
24	27	123,431	102,859	97,445	92,573	1.7	98,744	82,288	77,957	74,059	2.1	2 to 8
17	19	124,243	103,536	98,087	93,182	1.7	99,394	82,829	78,469	74,546	2.1	2 to 8
24	26	128,178	106,815	101,193	96,134	1.6	102,542	85,453	80,955	76,907	2.0	2 to 8
26	28	128,941	107,451	101,796	96,706	1.6	103,154	85,962	81,437	77,364	2.0	2 to 8
24	25	133,305	111,088	105,241	99,979	1.6	106,645	88,870	84,194	79,984	2.0	2 to 8
26	27	133,717	111,431	105,566	100,288	1.6	106,973	89,144	84,453	80,230	2.0	2 to 8
23	23	138,860	115,717	109,626	104,145	1.5	111,088	92,573	87,701	83,315	1.9	2 to 8
27	26	144,201	120,167	113,843	108,150	1.4	115,360	96,134	91,074	86,520	1.8	2 to 8
24	23	144,897	120,748	114,393	108,673	1.4	115,918	96,598	91,514	86,938	1.8	2 to 8
25	23	150,935	125,779	119,159	113,201	1.4	120,747	100,622	95,326	90,560	1.7	2 to 8
19	17	155,196	129,330	122,523	116,397	1.3	124,157	103,464	98,019	93,118	1.7	2 to 8
27	24	156,217	130,181	123,329	117,163	1.3	124,974	104,146	98,664	93,730	1.7	2 to 8
28	24	162,003	135,003	127,897	121,502	1.3	129,603	108,002	102,318	97,202	1.6	2 to 8
23	19	168,093	140,078	132,705	126,070	1.2	134,475	112,062	106,165	100,856	1.6	2 to 8
28	23	169,047	140,872	133,458	126,785	1.2	135,237	112,698	106,766	101,429	1.5	2 to 8
24	19	175,402	146,168	138,475	131,551	1.2	140,322	116,934	110,781	105,242	1.5	2 to 8
25	19	182,710	152,259	144,245	137,033	1.1	146,168	121,806	115,395	109,626	1.4	2 to 8
23	17	187,869	156,558	148,318	140,902	1.1	150,296	125,246	118,654	112,722	1.4	2 to 8
26	19	190,019	158,349	150,015	142,514	1.1	152,014	126,678	120,011	114,011	1.4	2 to 7
27	19	197,327	164,439	155,785	147,995	1.1	157,862	131,552	124,627	118,397	1.3	2 to 7
28	19	204,635	170,530	161,554	153,477	1.0	163,709	136,424	129,243	122,781	1.3	2 to 7
26	17	212,374	176,978	167,664	159,280	0.9	169,899	141,582	134,131	127,424	1.2	2 to 7
27	17	220,542	183,785	174,112	165,407	0.9	176,434	147,029	139,289	132,325	1.2	2 to 7
28	17	228,710	190,592	180,561	171,533	0.9	182,968	152,474	144,448	137,226	1.1	2 to 7

**NOTE:** See "General Planting Rate Information" and "Checking Seed Population" pages for additional information.

**NOTE:** When using the Half Rate (2 To 1) Drive Reduction Package, rates will be approximately 50% of given numbers.

**NOTE:** Always check seed population in the field to ensure planting rates are correct.

# MACHINE OPERATION

RH/Z217

## PLANTING RATES FOR BRUSH-TYPE SEED METERS (STANDARD DRIVE)

### APPROXIMATE SEEDS/ACRE FOR VARIOUS ROW WIDTHS

Transmission Sprockets		36 Cell				Average Seed Spacing In Inches	30 Cell				Average Seed Spacing In Inches	Speed Range (MPH)
		Acid-Delinted Large Cotton					Milo/Grain Sorghum Or Acid-Delinted Cotton					
Drive	Driven	30" Rows	36" Rows	38" Rows	40" Rows		30" Rows	36" Rows	38" Rows	40" Rows		
17	28	50,585	42,154	39,935	37,938	4.1	42,154	35,128	33,279	31,615	5.0	2 to 8
17	27	52,458	43,715	41,414	39,343	4.0	43,715	36,429	34,512	32,786	4.8	2 to 8
17	26	54,475	45,396	43,007	40,856	3.8	45,396	37,830	35,839	34,047	4.6	2 to 8
19	28	56,536	47,113	44,634	42,402	3.7	47,113	39,261	37,195	35,335	4.4	2 to 8
19	27	58,630	48,858	46,286	43,973	3.6	48,858	40,715	38,572	36,644	4.3	2 to 8
17	24	59,016	49,180	46,591	44,262	3.5	49,180	40,983	38,826	36,885	4.3	2 to 8
17	23	61,582	51,318	48,617	46,186	3.4	51,318	42,765	40,514	38,488	4.1	2 to 8
19	25	63,320	52,766	49,990	47,490	3.3	52,767	43,972	41,658	39,575	4.0	2 to 8
19	24	65,958	54,965	52,073	49,469	3.2	54,965	45,804	43,394	41,224	3.8	2 to 8
23	28	68,438	57,031	54,030	51,329	3.1	57,032	47,526	45,025	42,774	3.7	2 to 8
19	23	68,826	57,355	54,336	51,619	3.0	57,355	47,796	45,280	43,016	3.6	2 to 8
24	28	71,413	59,512	56,380	53,561	2.9	59,511	49,593	46,983	44,634	3.5	2 to 8
24	27	74,058	61,716	58,468	55,544	2.8	61,715	51,430	48,723	46,287	3.4	2 to 8
17	19	74,545	62,122	58,852	55,909	2.8	62,121	51,768	49,043	46,591	3.4	2 to 8
24	26	76,907	64,090	60,716	57,680	2.7	64,089	53,408	50,597	48,067	3.3	2 to 8
26	28	77,365	64,471	61,078	58,024	2.7	64,471	53,726	50,898	48,353	3.2	2 to 8
24	25	79,984	66,653	63,145	59,988	2.6	66,653	55,544	52,621	49,990	3.1	2 to 8
26	27	80,230	66,858	63,340	60,173	2.6	66,858	55,715	52,783	50,144	3.1	2 to 8
23	23	83,316	69,430	65,776	62,486	2.5	69,430	57,858	54,813	52,072	3.0	2 to 8
27	26	86,520	72,101	68,305	64,890	2.4	72,100	60,084	56,921	54,075	2.9	2 to 8
24	23	86,939	72,449	68,635	65,203	2.4	72,449	60,374	57,196	54,336	2.9	2 to 8
25	23	90,560	75,467	71,495	67,920	2.3	75,467	62,889	59,579	56,600	2.8	2 to 8
19	17	93,118	77,598	73,514	69,839	2.3	77,598	64,665	61,262	58,199	2.7	2 to 8
27	24	93,731	78,109	73,998	70,297	2.2	78,109	65,091	61,665	58,581	2.7	2 to 8
28	24	97,202	81,001	76,739	72,901	2.2	81,002	67,501	63,949	60,751	2.6	2 to 8
23	19	100,856	84,047	79,624	75,642	2.1	84,047	70,039	66,353	63,035	2.5	2 to 8
28	23	101,428	84,523	80,075	76,072	2.1	84,523	70,436	66,729	63,393	2.5	2 to 8
24	19	105,241	87,701	83,086	78,931	2.0	87,701	73,084	69,238	65,776	2.4	2 to 8
25	19	109,626	91,355	86,546	82,219	1.9	91,355	76,129	72,122	68,516	2.3	2 to 8
23	17	112,722	93,935	88,991	84,541	1.9	93,935	78,279	74,159	70,451	2.2	2 to 8
26	19	114,011	95,009	90,008	85,508	1.8	95,009	79,174	75,007	71,257	2.2	2 to 7
27	19	118,397	98,664	93,470	88,798	1.8	98,664	82,220	77,892	73,998	2.1	2 to 7
28	19	122,782	102,318	96,932	92,086	1.7	102,318	85,265	80,777	76,738	2.0	2 to 7
26	17	127,424	106,187	100,598	95,568	1.6	106,187	88,489	83,832	79,640	2.0	2 to 7
27	17	132,325	110,272	104,467	99,244	1.6	110,271	91,893	87,056	82,703	1.9	2 to 7
28	17	137,226	114,355	108,336	102,919	1.5	114,355	95,296	90,280	85,766	1.8	2 to 7

**NOTE:** See "General Planting Rate Information" and "Checking Seed Population" pages for additional information.

**NOTE:** When using the Half Rate (2 To 1) Drive Reduction Package, rates will be approximately 50% of given numbers.

**NOTE:** Always check seed population in the field to ensure planting rates are correct.



# MACHINE OPERATION

## PLANTING RATES FOR BRUSH-TYPE SEED METERS (STANDARD DRIVE) APPROXIMATE HILLS/ACRE FOR VARIOUS ROW WIDTHS

Due to variations in cotton seed size, meters equipped with the 12 cell acid-delinted hill-drop cotton discs will plant from 3 to 6 seeds per cell. Select proper disc for seed size range to be planted.

*To determine planter transmission setting, determine desired hill spacing and select the transmission ratio closest to the hill spacing in inches on the chart. To decrease population increase spacing. To increase population decrease spacing.*

*To determine population per acre, determine average seeds per hill and hills per acre by doing a field check. Measure  $\frac{1}{1000}$  of an acre ( $\frac{1}{1000}$  acre = Length of row 17' 5" for 30" row widths, 14' 6" for 36" row widths, 13' 10" for 38" row widths and 13' 1" for 40" row widths). Multiply average seeds per hill by hills per acre. EXAMPLE: 4 seeds per hill x (13 hills x 1000) = 52,000*

Transmission Sprockets Drive Driven		NUMBER OF HILLS PER ACRE 12 Cell Hill-Drop Cotton, Acid-Delinted				Average Hill Spacing In Inches	Speed Range (MPH)
		30" Rows	36" Rows	38" Rows	40" Rows		
17	28	16,862	14,051	13,312	12,646	12.4	2 to 8
17	27	17,486	14,572	13,805	13,114	12.2	2 to 8
17	26	18,158	15,132	14,336	13,619	11.5	2 to 8
19	28	18,845	15,704	14,878	14,134	11.1	2 to 8
19	27	19,543	16,286	15,429	14,658	10.7	2 to 8
17	24	19,672	16,393	15,530	14,754	10.6	2 to 8
17	23	20,527	17,106	16,206	15,395	10.2	2 to 8
19	25	21,107	17,589	16,663	15,830	9.9	2 to 8
19	24	21,986	18,322	17,358	16,490	9.5	2 to 8
23	28	22,813	19,010	18,010	17,110	9.2	2 to 8
19	23	22,942	19,118	18,112	17,206	9.1	2 to 8
24	28	23,804	19,837	18,793	17,854	8.8	2 to 8
24	27	24,686	20,572	19,489	18,515	8.5	2 to 8
17	19	24,848	20,707	19,617	18,596	8.4	2 to 8
24	26	25,636	21,363	20,239	19,227	8.2	2 to 8
26	28	25,788	21,490	20,359	19,341	8.1	2 to 8
24	25	26,661	22,218	21,048	19,996	7.8	2 to 8
26	27	26,743	22,286	21,113	20,058	7.8	2 to 8
23	23	27,772	23,143	21,925	20,829	7.5	2 to 8
27	26	28,840	24,034	22,768	21,630	7.3	2 to 8
24	23	28,980	24,150	22,878	21,734	7.2	2 to 8
25	23	30,187	25,156	23,832	22,640	6.9	2 to 8
19	17	31,039	25,866	24,505	23,280	6.7	2 to 8
27	24	31,244	26,036	24,666	23,432	6.7	2 to 8
28	24	32,401	27,000	25,580	24,300	6.5	2 to 8
23	19	33,619	28,016	26,541	25,214	6.2	2 to 8
28	23	33,809	28,174	26,692	25,357	6.2	2 to 8
24	19	35,080	29,234	27,695	26,310	6.0	2 to 8
25	19	36,542	30,452	28,849	27,406	5.7	2 to 8
23	17	37,574	31,312	29,664	28,180	5.6	2 to 8
26	19	38,004	31,670	30,003	28,503	5.5	2 to 7
27	19	39,466	32,888	31,157	29,599	5.3	2 to 7
28	19	40,927	34,106	32,311	30,695	5.1	2 to 7
26	17	42,475	35,396	33,533	31,856	4.9	2 to 7
27	17	44,108	36,757	34,822	33,081	4.7	2 to 7
28	17	45,742	38,118	36,112	34,306	4.6	2 to 7

**NOTE:** See "General Planting Rate Information" and "Checking Seed Population" pages for additional information.

**NOTE:** When using the Half Rate (2 To 1) Drive Reduction Package, rates will be approximately 50% of given numbers.

**NOTE:** Always check seed population in the field to ensure planting rates are correct.

# MACHINE OPERATION

## DRY INSECTICIDE APPLICATION RATES APPROXIMATE POUNDS/ACRE AT 5 MPH FOR VARIOUS ROW WIDTHS

Meter Setting	30" Rows	36" Rows	38" Rows	40" Rows
<b>CLAY GRANULES</b>				
10	5.1	4.3	4.0	3.8
11	5.6	4.7	4.4	4.2
12	6.3	5.3	5.0	4.7
13	7.1	5.9	5.6	5.3
14	7.9	6.6	6.2	5.9
15	8.8	7.3	6.9	6.6
16	9.9	8.3	7.8	7.4
17	11.0	9.2	8.7	8.3
18	11.8	9.8	9.3	8.9
19	13.5	11.3	10.7	10.1
20	14.6	12.2	11.5	11.0
21	16.0	13.3	12.6	12.0
22	16.9	14.1	13.3	12.7
23	17.7	14.8	14.0	13.3
24	19.4	16.2	15.3	14.6
25	21.5	17.9	17.0	16.1
26	23.7	19.8	18.7	17.8
27	24.8	20.7	19.6	18.6
28	26.2	21.8	20.7	19.7
29	28.7	23.9	22.7	21.5
30	30.5	25.4	24.1	22.9
<b>SAND GRANULES</b>				
5	3.0	2.5	2.4	2.3
6	5.0	4.2	3.9	3.8
7	5.5	4.6	4.3	4.1
8	6.5	5.4	5.1	4.9
9	8.0	6.7	6.3	6.0
10	9.2	7.7	7.3	6.9
11	10.5	8.8	8.3	7.9
12	11.5	9.6	9.1	8.6
13	13.0	10.8	10.3	9.8
14	14.5	12.1	11.4	10.9
15	16.0	13.3	12.6	12.0
16	18.0	15.0	14.2	13.5
17	20.0	16.7	15.8	15.0
18	22.5	18.8	17.8	16.9
19	25.0	20.8	19.7	18.8
20	26.5	22.1	20.9	19.9
21	28.5	23.8	22.5	21.4
22	30.5	25.4	24.1	22.9
23	33.0	27.5	26.1	24.8
24	35.5	29.6	28.0	26.6
25	38.0	31.7	30.0	28.5

**NOTE:** The chart above represents average values and should be used only as a starting point. The granular chemical flows through the given meter opening at a nearly uniform rate regardless of roller speed. Your actual rate will vary depending upon the insecticide you are using, your planting speed and your plant population. Planting speed/ground speed has the greatest effect on application rate.

Your actual rate must be checked in the field with the actual insecticide that you are using and at the speed and population at which you will be planting. See "Checking Granular Chemical Application Rate" page for additional information.



**WARNING:** Agriculture chemicals can be dangerous if not selected and handled with care. Always read and follow directions supplied by the chemical manufacturer.

# MACHINE OPERATION

---

## DRY HERBICIDE APPLICATION RATES APPROXIMATE POUNDS/ACRE AT 5 MPH FOR VARIOUS ROW WIDTHS

### CLAY GRANULES

Meter Setting	30" Rows	36" Rows	38" Rows	40" Rows
10	4.8	4.0	3.8	3.6
11	5.4	4.5	4.3	4.1
12	6.0	5.0	4.7	4.5
13	6.7	5.6	5.3	5.0
14	7.5	6.3	5.9	5.6
15	8.5	7.1	6.7	6.4
16	9.3	7.8	7.3	7.0
17	10.2	8.5	8.1	7.7
18	11.0	9.2	8.7	8.3
19	12.0	10.0	9.5	9.0
20	13.0	10.8	10.3	9.8
21	14.0	11.7	11.1	10.5
22	15.0	12.5	11.8	11.3
23	16.2	13.5	12.8	12.2
24	17.5	14.6	13.8	13.1
25	18.7	15.6	14.8	14.0
26	20.0	16.7	15.8	15.0
27	21.5	17.9	17.0	16.1
28	23.3	19.4	18.4	17.5
29	25.0	20.8	19.7	18.8
30	27.5	22.9	21.7	20.6

**NOTE:** The chart above represents average values and should be used only as a starting point. The granular chemical flows through the given meter opening at a nearly uniform rate regardless of roller speed. Your actual rate will vary depending upon the herbicide you are using, your planting speed and your plant population. Planting speed/ground speed has the greatest effect on application rate.

Your actual rate must be checked in the field with the actual herbicide that you are using and at the speed and population at which you will be planting. See "Checking Granular Chemical Application Rate" page for additional information.



**WARNING:** Agriculture chemicals can be dangerous if not selected and handled with care. Always read and follow directions supplied by the chemical manufacturer.

# MACHINE OPERATION

---

# ROW UNIT OPERATION

## PLANTING DEPTH

Planting depth is maintained by the row unit gauge wheels. To increase or decrease the planting depth, first raise the planter to remove weight from the wheels. Then push down on the depth adjustment handle and reposition it forward to decrease depth or rearward to increase planting depth. Adjust all units to the same setting initially. Then lower the planter and check operation and planting depth of all row units. It may be necessary to readjust some rows to obtain uniform operation. Available depth adjustment range is approximately 1/2" to 3 1/2".



**WARNING:** Never work under the planter while in raised position without using safety lockup devices.

D020705102

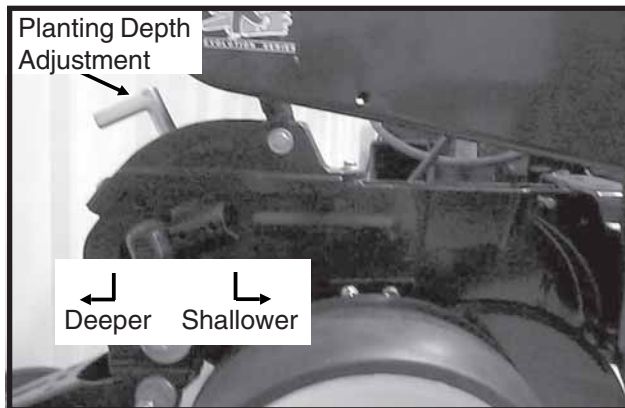

## "V" CLOSING WHEEL ADJUSTMENT (Rubber And Cast Iron)



**WARNING:** Raise planter and install safety lockup devices before making closing wheel adjustments.

After adjusting planting depth, check the operation of the "V" closing wheels. The "V" closing wheels should have enough down pressure to close the seed trench and ensure good soil to seed contact. To increase spring pressure on the closing wheels, move the 5-position quick adjustable down force lever located on the top of the closing wheel arm to the rear. Moving the lever forward decreases spring tension.

Adjust all row units to a similar setting.

LF212299-15

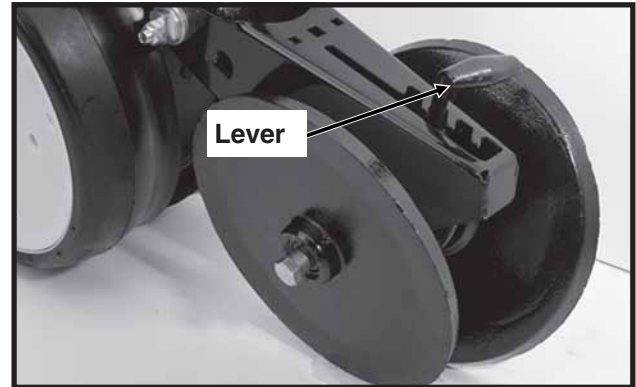

Light soil usually requires less down force at average depth (approximately 2") while heavy soil requires increased down force.

Eccentric bushings in the wheel arm stop allow for lateral adjustment of the "V" closing wheel assembly. Using a 3/4" wrench, loosen the hardware which attaches the closing wheel arm to the wheel arm stop. Using another 3/4" wrench turn the eccentric bushings until the **closing wheels are aligned with the seed trench**. Tighten hardware.

LF2122299-15

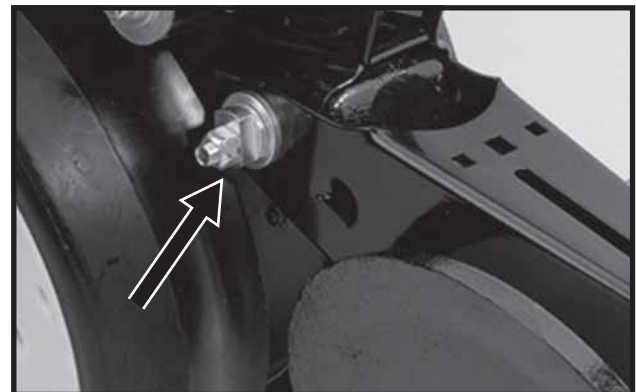

The closing wheels can be installed in two locations either "offset" (to improve residue flow) or "directly" opposite. If set "directly" opposite, the forward installation holes should be used.

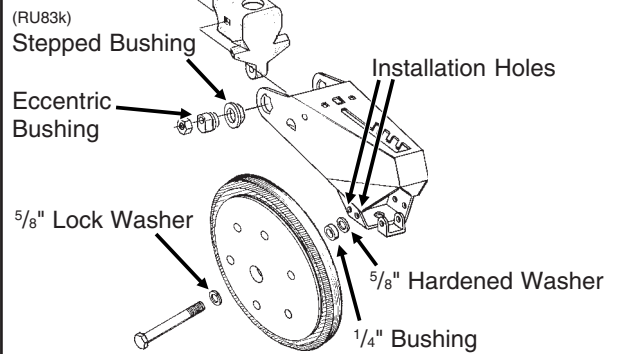

# ROW UNIT OPERATION

## CLOSING WHEEL SHIELD (Rubber And Cast Iron "V" Closing Wheels)

D11090208a

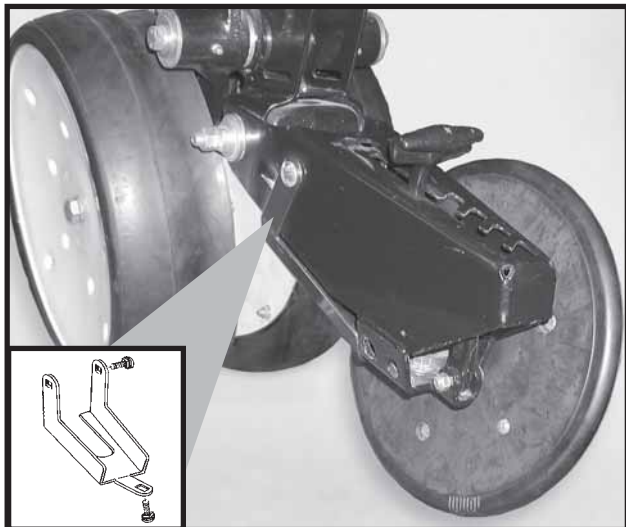

**Shown With Closing Wheel Removed For Visual Clarity**

The optional closing wheel shield is designed to be installed onto the underside of the closing wheel arm to help prevent root balls and stalks from plugging the closing wheels.

## COVERING DISCS/SINGLE PRESS WHEEL ADJUSTMENT



**WARNING:** Raise planter and install safety lockup devices before making covering discs/single press wheel adjustments.

72359-31



After adjusting planting depth, check the operation of the covering discs/single press wheels.

Initial press wheel down force setting should be with 2 1/2" between mounting arm tab and locking nut. To adjust down force spring, loosen 1/2" locking nut and turn adjusting bolt in to increase down force or out to decrease down force. Tighten locking nut against spring plug. Adjust all row units to a similar setting.

RH993(PLTR12)

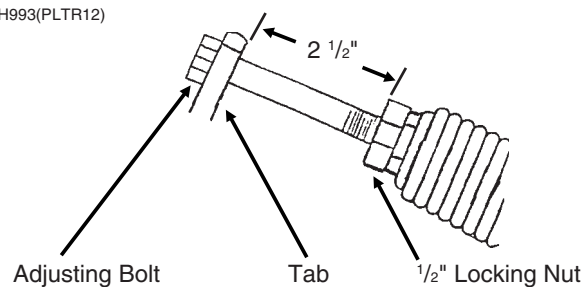

# ROW UNIT OPERATION

Eccentric bushings in the wheel arm stop allow for lateral adjustment of the covering discs/single press wheel assembly. Using a 3/4" wrench, loosen the hardware which attaches the assembly to the wheel arm stop. Using another 3/4" wrench, turn the eccentric bushings until the press wheel is aligned with the seed trench.

(RU94b)

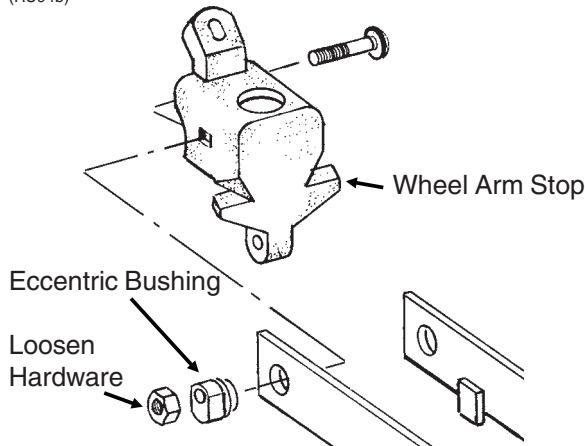

Two sets of holes in the mounting arm allow the covering discs to be located for staggered or side-by-side operation as desired.

72359-35

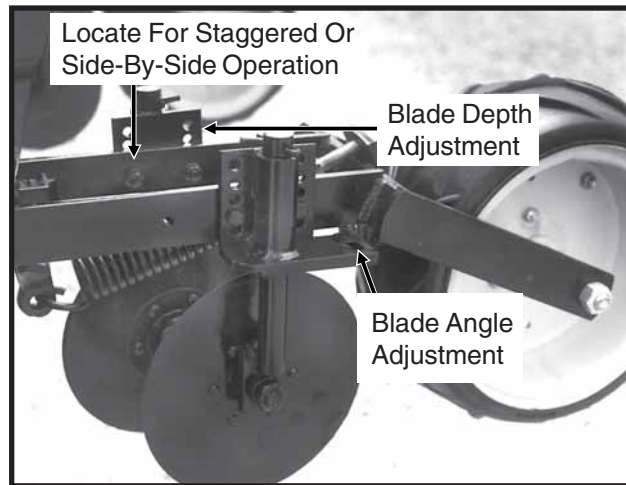

Five sets of holes in each disc bracket allow for 1/2" incremental blade depth adjustment.

Slotted holes in the disc mount and bracket allow for 0° - 15° blade angle adjustment.

Adjust covering discs on all row units to similar settings.

## DRAG CLOSING ATTACHMENT

LF212299-18

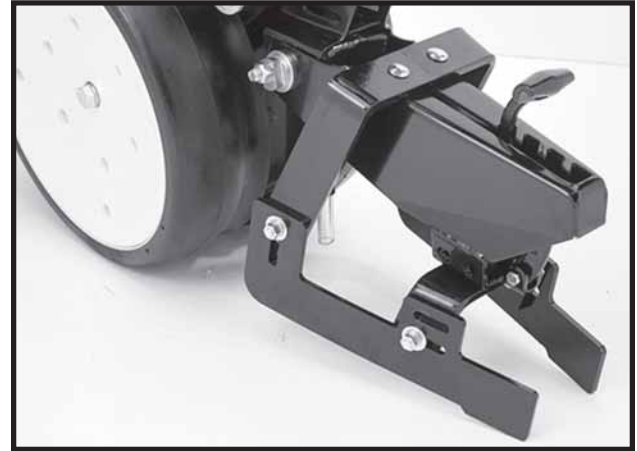

The drag closing attachment is designed to pull loose soil over the seed trench.

Front and rear adjustment is made using the slotted holes in the blades. Adjust all rows the same.

**NOTE: Use of a seed firming wheel or other seed firming device is recommended with the drag closing attachment.**

**WARNING: Raise planter and install safety lockup devices before making drag closing attachment adjustments.**

(RU90d)

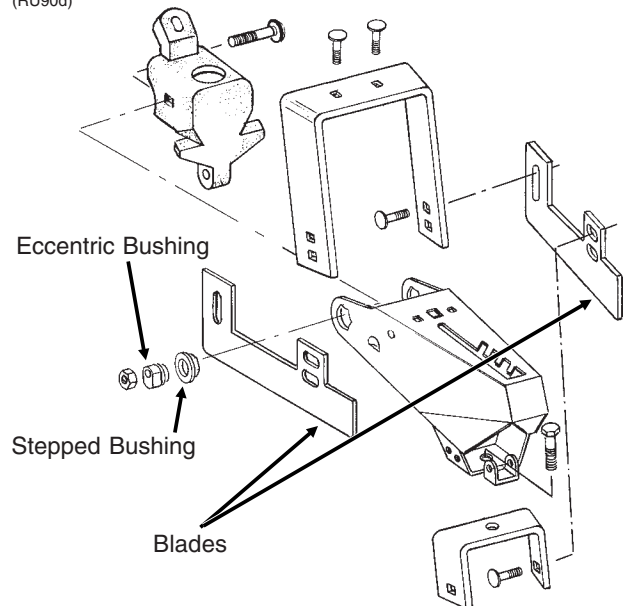

Eccentric bushings allow for lateral adjustment of the drag closing attachment. Using a 3/4" wrench, loosen the hardware which attaches the assembly to the wheel arm stop. Using another 3/4" wrench, turn the eccentric bushings until the drag closing attachment is aligned with the seed trench.

# ROW UNIT OPERATION

## FINGER PICKUP SEED METER

Refer to the planting rate chart for recommended seed drive transmission sprocket combinations.

D12220401

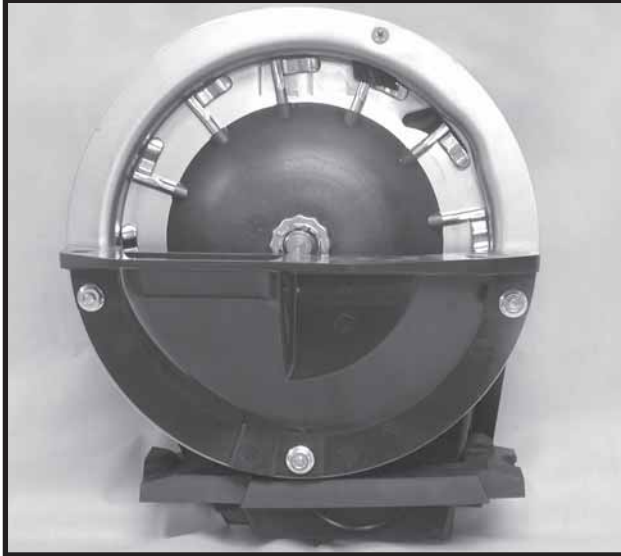

Shown With Corn Fingers Installed

The following seed fingers are available for use with the finger pickup seed meter:

(PLTR91/PLTR92/PLTR91a)

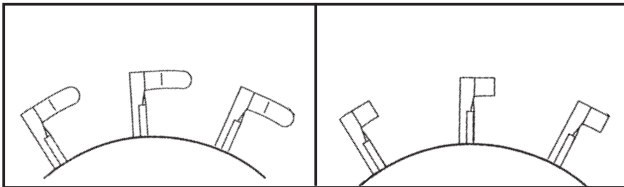

Corn Fingers

Oil Sunflower Fingers

No. 3 and/or No. 4 size oil sunflower seeds are recommended for use in the finger pickup seed meter equipped with oil sunflower fingers.

No. 1 and/or No. 2 size confectionery sunflower seeds are recommended for use in the finger pickup seed meter equipped with corn fingers.

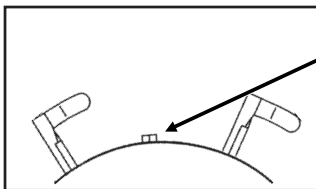

Half Rate Blank Finger

Blank fingers are used to replace alternate fingers in the finger wheel to reduce the planting rate by half while allowing the finger wheel to maintain a minimum of 40 RPM when planting low rates.

**NOTE: Always check seed population in the field to ensure planting rates are correct.**

**NOTE: Powdered graphite is recommended for finger pickup seed meter lubrication to ensure efficient operation of the mechanism and to extend the life of its components. Mix one teaspoon of powdered graphite with the seed twice daily. Apply graphite on top of seed around the outer perimeter of the hopper as shown below. Graphite application frequency and volume may need to be increased if using additional seed treatments.**

**NOTE: Do NOT apply graphite only in the center of the hopper. It will filter too quickly through the seed and not distribute as evenly as desired.**

D05230121b



**NOTE: Follow manufacturer's recommendations when applying and mixing other seed treatments. If the additive is to be applied on top of the seed, apply around the outer perimeter of the hopper as with graphite.**

See "General Planting Rate Information", "Finger Pickup Seed Meter Troubleshooting" and "Finger Pickup Seed Meter Inspection/Adjustment" for additional information.

## CLEANOUT

To maintain genetic purity, thorough seed meter cleanout is important.

To clean the seed meter, disengage the seed drive and remove the seed hopper and meter. Dump the seed from the right rear corner of the hopper into a container. Turn the seed drive several times. Invert hopper to dump seed again. Shake the hopper and listen for any remaining seed. Turn seed drive and shake and dump hopper until all seed is removed.



# ROW UNIT OPERATION

## BRUSH-TYPE SEED METER

D12220403



Shown Without Seed Disc Installed

60607-40a(PLTR13)

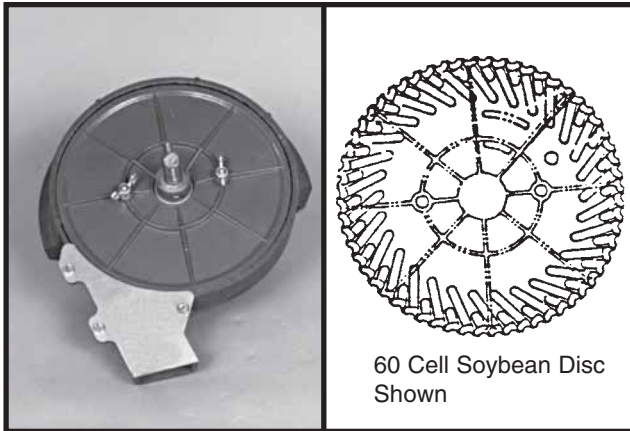

60 Cell Soybean Disc Shown

The following seed discs are available for use with the brush-type seed meter:

**Soybean:** 60 cells to meter seed sizes from 2200 to 4000 seeds per pound (Black color-coded). (PLTR14)

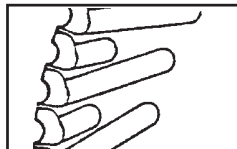

**Specialty soybean:** 48 cells to meter seed sizes from 1400 to 2200 seeds per pound (Dark blue color-coded). (PLTR15)

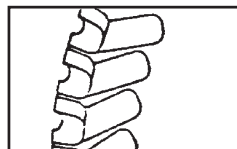

**Small milo/grain sorghum:** 30 cells to meter seed sizes from 14,000 to 20,000 seeds per pound (Red color-coded). (PLTR16)

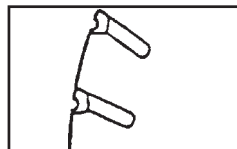

**Large milo/grain sorghum:** 30 cells to meter seed sizes from 10,000 to 16,000 seeds per pound (Light blue color-coded). (PLTR17)

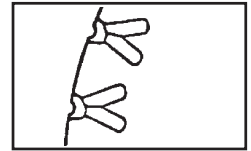

**High-rate small milo/grain sorghum:** 60 cells to meter seed sizes from 12,000 to 18,000 seeds per pound (Red color-coded). (PLTR18)

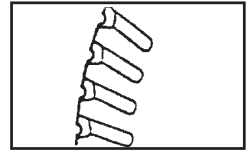

**High-rate large milo/grain sorghum:** 60 cells to meter seed sizes from 10,000 to 14,000 seeds per pound (Yellow color-coded). (PLTR19)

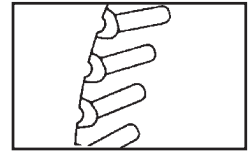

**Cotton, acid-delinted:** 30 cells to meter seed sizes from 4200 to 5200 seeds per pound (White color-coded). (PLTR20)

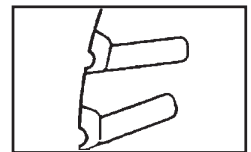

**Large cotton, acid-delinted:** 36 cells to meter seed sizes from 3800 to 4400 seeds per pound (Tan color-coded). (PLTR21)

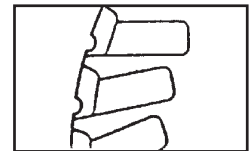

**High-rate cotton, acid-delinted:** 48 cells to meter seed sizes from 4200 to 5200 seeds per pound (Light green color-coded). (PLTR22)

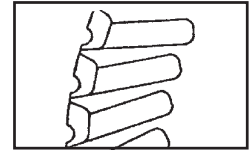

**Hill-drop cotton, acid-delinted:** 12 cells, 3 to 6 seeds/cell, to meter seed sizes from 4000 to 5200 seeds per pound (Brown color-coded). (PLTR23)

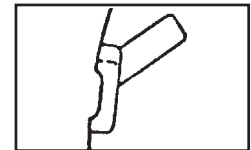

**Small hill-drop cotton, acid-delinted:** 12 cells, 3 to 6 seeds/cell, to meter seed sizes from 5000 to 6200 seeds per pound (Dark green color-coded). (PLTR23)

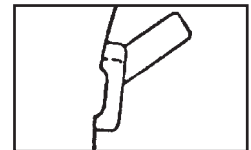

(RU14c)

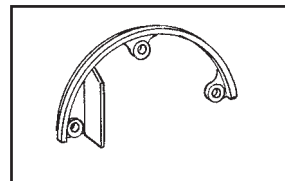

Use GD11122 upper brush retainer when using soybean and cotton discs.

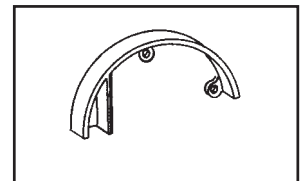

Use GD8237 upper brush retainer when using milo/grain sorghum discs.

# ROW UNIT OPERATION

When installing the seed disc onto the meter hub, turn the disc counterclockwise while tightening the two wing nuts that retain the disc. The seed disc should have only slight resistance when rotated counterclockwise after wing nuts are tight.

The brush-type seed meter attaches to the seed hopper in the same manner as the finger pickup seed meter. Secure to bottom of seed hopper with two  $\frac{5}{16}$ " thumbscrews. Tighten thumbscrews slightly with pliers. **DO NOT OVER TIGHTEN.**

Erratic seed spacing may result from misalignment between the drive coupler and seed meter input shaft. Misalignment may cause momentary stoppage of seed disc. Check alignment after initial installation. If adjustment is required, refer to "Meter Drive Adjustment" for correct procedure.

Refer to the planting rate charts in this manual for recommended seed drive transmission sprocket combinations.

One tablespoon of **powdered graphite** should be mixed with the seed each time the hoppers are filled. Regular graphite use will prolong the life of the brush-type seed meter components, improve seed spacing, and may reduce buildup of seed treatments. Apply graphite around the outer perimeter of the hopper as shown below.

D05300104b



**NOTE: Do NOT apply graphite only in the center of the hopper. It will filter too quickly through the seed and not distribute as evenly as desired.**

**NOTE: Additional graphite or talc may be required to retard buildup of seed treatments on meter components. Frequency of monitor seed tube cleaning may be affected due to use of additional graphite or talc.**

**Talc seed lubricant** may be used in lieu of or in addition to graphite to reduce seed treatment buildup on seed disc and meter components. Coat seed disc and brushes with talc before installing meter. Fill hopper  $\frac{1}{2}$  full of seed, add  $\frac{1}{4}$  cup of talc and **mix thoroughly**. Finish filling hopper, add another  $\frac{1}{4}$  cup of talc and **mix thoroughly**. Adjust rate of talc use as needed so all seeds are coated, while avoiding a buildup of talc in the bottom of the hopper. Humid conditions and/or small sized seeds with extra seed treatment may require as much as one cup of talc per hopper to prevent seed treatment buildup on seed disc and/or brushes.

**NOTE: Some liquid seed treatments or inoculants may create buildup on the seed disc or brushes. Check frequently for proper population and/or seed delivery when using any liquid seed treatment.** All seed treatment should be thoroughly mixed with the seed per the manufacturers' recommendations. Seed treatment dumped on top of the seed after the hopper is filled, and not mixed properly may cause bridging of the seed in the meter, reducing population or stopping the meter from planting.

**NOTE: Foreign material, such as hulls, stems, etc., may affect seed delivery. Clean seed is required to ensure accurate seed metering from the brush-type seed meter. Seed discs should be removed daily to check for buildup of foreign material, such as hulls, in the seed meter or the brushes.**

## CLEANOUT

To maintain genetic purity, thorough seed meter cleanout is important.

To clean the seed meter, disengage the seed drive and remove the seed hopper and meter. Dump the seed from the right rear corner of the hopper into a container. Disassemble seed disc by removing wing nuts. Empty the meter. Thoroughly inspect brushes in meter to ensure all seed is removed. Replace seed disc and install wing nuts.

# ROW UNIT OPERATION

## SEED HOPPER

LF212199-7a



Seed hopper capacity is 1.9 bushels.

When filling the seed hopper use clean seed and make certain there are no foreign objects in the hopper. **Replace hopper lids after hoppers are filled to prevent the accumulation of dust or dirt in the seed meter which will cause premature wear.** See “Finger Pickup Seed Meter” and/or “Brush-Type Seed Meter”.

Periodically empty the hoppers completely to remove any foreign material and to ensure proper seed meter operation. To empty hopper, disengage meter drive and hopper latch and lift hopper off the hopper support. See “Seed Meter Drive Release”.

## SEED METER DRIVE RELEASE

The seed meter drive is equipped with a clutch release mechanism that allows the drive to be disengaged from the seed metering unit for removal of the seed hopper. Disconnecting the drive allows the operator to check granular chemical application rates without dropping seed. It also allows one or more of the rows to be disconnected when finishing fields.

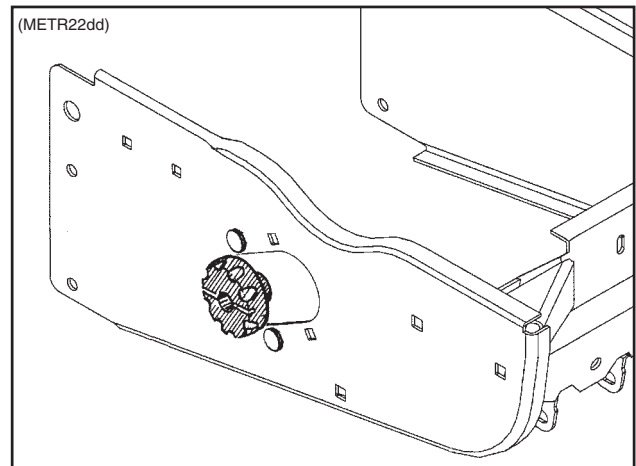

To disengage the drive, turn the knob  $\frac{1}{4}$  turn counterclockwise. To engage the drive, turn the knob  $\frac{1}{4}$  turn clockwise.

# ROW UNIT OPERATION

## ROW UNIT CHAIN ROUTING

For proper operation and to minimize wear, the row unit drive chains must be properly tensioned and aligned.

Inspect and replace weak, worn or broken springs and/or idlers and idler bushings.

**NOTE: When idler shows signs of wear, it can be reversed for prolonged use.**

D051705103

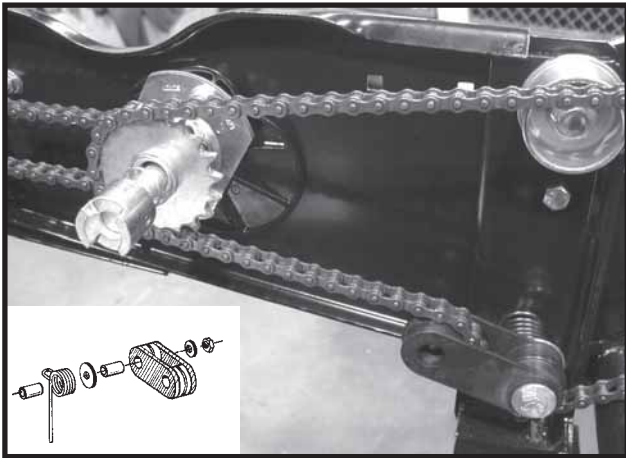

**Pull Row Unit Meter Drive**

D051705102

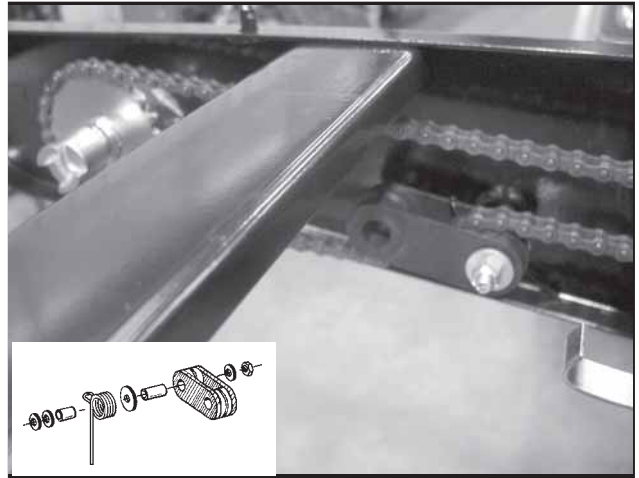

**Row Unit Granular Chemical Drive**

**NOTE: Make sure connector link is installed with closed end oriented properly as shown below.**

(PLTR24)

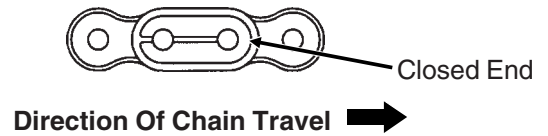

# ROW UNIT OPERATION

## QUICK ADJUSTABLE DOWN FORCE SPRINGS

Quick adjustable down force springs are designed to increase penetration in hard soil and keep the row unit from bouncing in rough field conditions.

Two springs per row, one on the L.H. parallel arms and one on the R.H. parallel arms, are used unless equipped with row unit mounted no till coulters. Four springs per row are used with row unit mounted no till coulters.

D06300305



**Two Springs Per Row (Dual)**

D07010301



**Four Springs Per Row (Quad)  
(Used Only In Conjunction With Row Unit  
Mounted No Till Coulters)**

There are four positions for spring tension adjustment. Position 1 allows for minimum down pressure and position 4 for maximum down pressure.

L0096(PLTR27e)

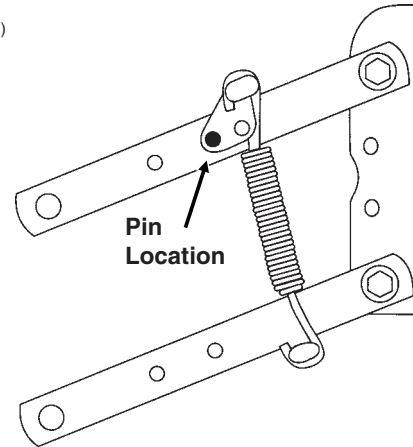

**Position 1 (Minimum)**

(PLTR28e)

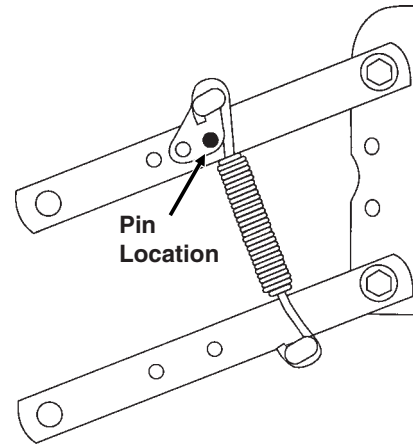

**Position 2**

(PLTR29e)

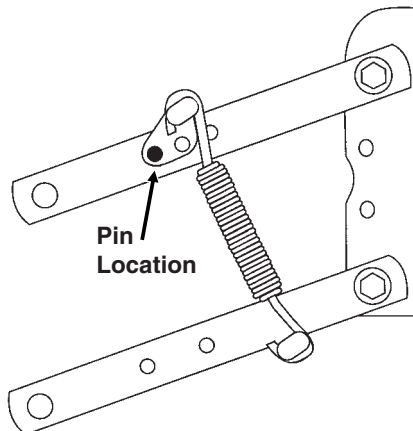

**Position 3**

# ROW UNIT OPERATION

(PLTR30e)

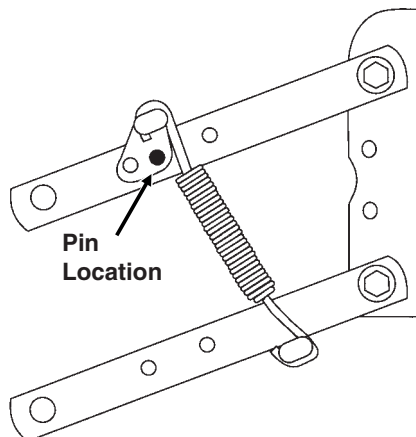

## Position 4 (Maximum)

To adjust spring tension, raise planter and remove spring mount pin at top of spring. Slide mount to desired position and install pin.

**NOTE:** It is necessary for the operator to adjust springs according to field conditions. If springs are adjusted for too much down pressure for field conditions, it is possible for the row units to lift the planter to the extent that the drive wheels do not make sufficient contact. Too much down pressure in soft field conditions can cause the row unit to run too deep.



**WARNING:** Always install safety lockup devices or lower machine to the ground before working under or around the machine.

**IMPORTANT:** Springs must always be installed with open side of spring hooks toward seed hoppers to prevent binding on spring mount adjustment pins.

## DUAL GAUGE WHEELS

Dual gauge wheels are used to provide added width for additional row unit flotation in light sandy soil.

In some applications such as narrow row widths (less than 36") or where clearance is a problem, the added width of the dual gauge wheel may prevent its use.

LF212199-1

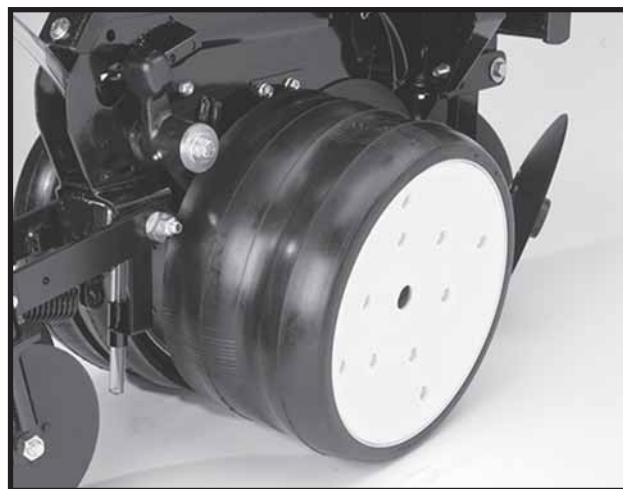

# ROW UNIT OPERATION

## FRAME MOUNTED COULTER

LF083002101

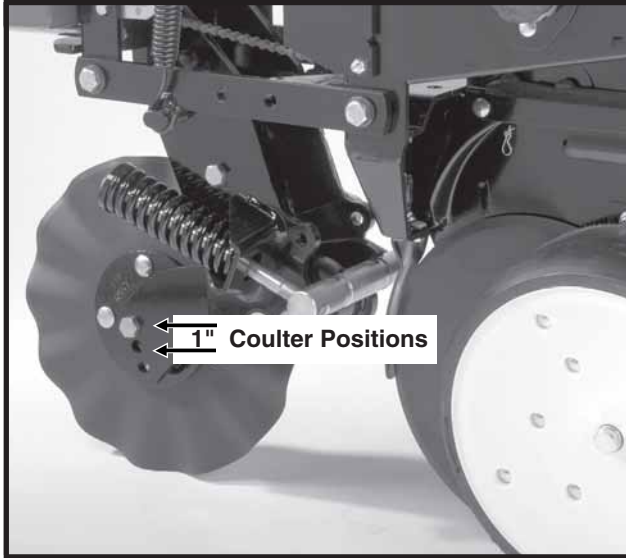

Frame mounted coulters with 1" bubbled, 1" fluted (8 flutes) or 3/4" fluted (13 flutes) blades may be used on pull row units only. (Not compatible with push row units.)

The frame mounted coulters is designed to apply necessary spring down pressure on the coulters for maximum penetration while exerting less shock load on the row unit.

The initial location of the coulters blade is in the top hole. The blade can be relocated to one of the lower two holes (1" increments) as wear occurs or if deeper operation of the blade is desired.

LF083002101

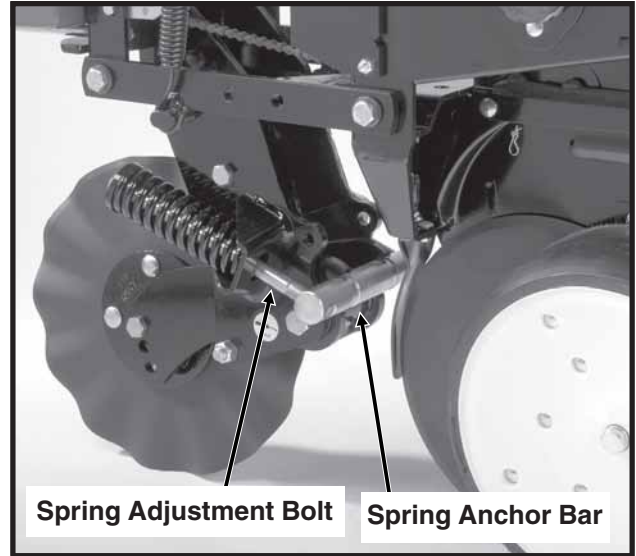

### DOWN PRESSURE ADJUSTMENT

Down force adjustment is made by tightening or loosening the two spring adjustment bolts. With the planter in raised position, turn the bolts clockwise to increase down pressure or counterclockwise to decrease down force. Set both springs the same.

Down force on the blade is shown below in lbs.

End Of Spring Adjustment Bolt Flush With Spring Anchor Bar (Shown Above)	End Of Spring Adjustment Bolt Extended 1/2" Through Spring Anchor Bar	All Threads Used (Maximum)
275 lbs.	400 lbs.	500 lbs.

**NOTE:** Avoid setting down pressure higher than is required for consistent soil penetration. Excessive pressure will increase the chances of damage to coulters components when the coulters strikes an obstacle.

# ROW UNIT OPERATION

## RESIDUE WHEELS

(For Use With Frame Mounted Coulter)

The residue wheels for use with the frame mounted coulter may be used on pull row units only.

LF083002102



The residue wheels are attached to the frame mounted coulter with two cap screws and sleeves allowing the unit to free-float. A 2-position spindle bolt mounting allows the tined wheels to be mounted interlocked or staggered. Depth adjustment is made using a spring-loaded cam and pin with 11 positions in  $\frac{1}{4}$ " increments. A high point on the cam allows the wheels to be locked up so they do not contact the ground. A weed guard, located on the inboard side of each wheel, aids in the prevention of weed wrap which can cause premature bearing failure.

(RU135i)

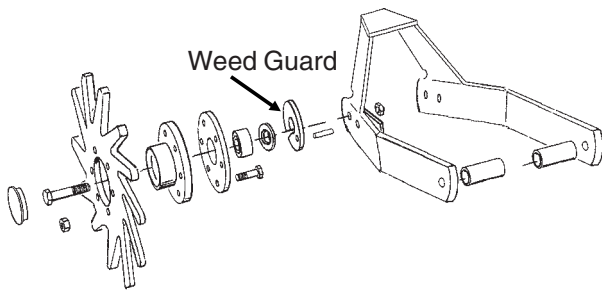

**NOTE: Opening in weed guard must point down.**

## ROW UNIT MOUNTED DISC FURROWER

The row unit mounted disc furrower is for use on pull row units only and may be equipped with either 12" solid blades or 12" notched blades.

Disc furrowers are used to clear crop residue, dirt clods and dry soil from in front of the row units for a clean and smooth seed bed. Notched blades are used for heavier residue conditions. The notched blades cut crop residue and move it aside to prevent plugging or pushing.

LF212299-22

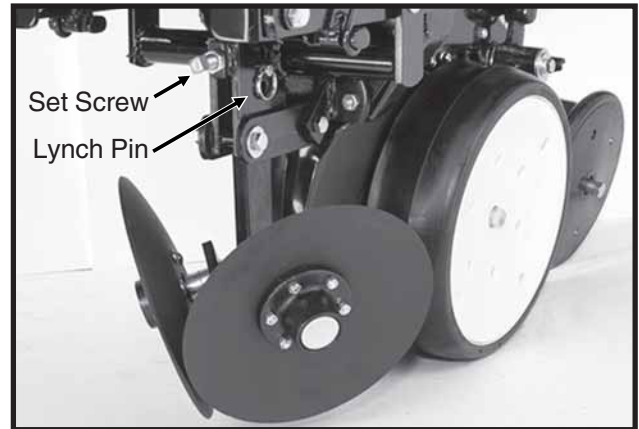

Vertical adjustment in  $\frac{1}{3}$ " increments is possible by removing the lynch pin which secures the vertical support arm and moving the support arm up or down as required. Reinstall lynch pin. Finer adjustment can be attained by removing the lynch pin and using the  $\frac{5}{8}$ " x  $2 \frac{1}{4}$ " set screw to clamp the support arm in the required position.

(RU98e)

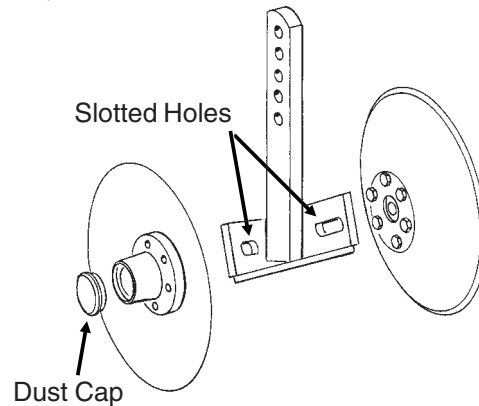

Slotted holes in the support arm where the blades are mounted allow fore and aft adjustment of the disc blades. Blades can be adjusted so the front edges meet or one blade can be moved to the rear and the other to the front of the slot so the cutting edge of one blade overlaps the edge of the other blade. The dust cap must be removed to make these adjustments.



# ROW UNIT OPERATION

## ROW UNIT MOUNTED BED LEVELER

LF212299-25a

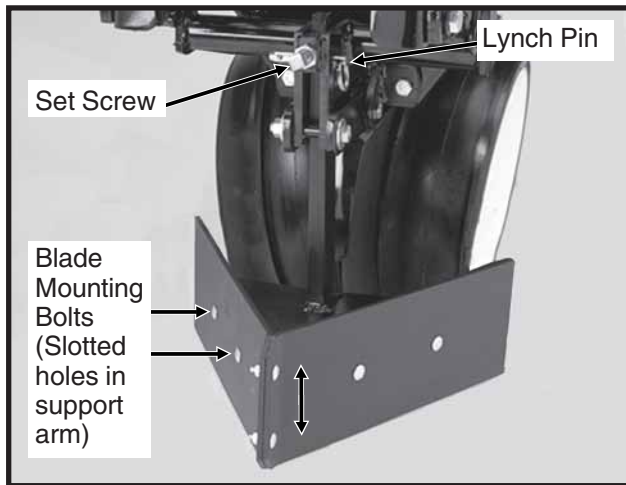

Row unit mounted bed levelers may be used on pull row units only. They are not compatible with push row units.

Vertical adjustment in  $\frac{1}{3}$ " increments is possible by removing the lynch pin which secures the vertical support arm and moving the support arm up or down as required. Re-install lynch pin. Finer adjustment can be attained by removing the lynch pin and using the  $\frac{5}{8}$ " x  $2 \frac{1}{4}$ " set screw to clamp the support arm in the required position.

Slotted holes in the support arm where the blades are mounted allow tilting of the blades. The blades can be tilted up or down at the front for desired adjustment.

**NOTE: The row unit mounted bed leveler is not compatible with row spacings less than 36".**

## ROW UNIT MOUNTED RESIDUE WHEEL

The row unit mounted residue wheel may be used on pull row units and push row units.

D101701113



Two adjustable springs on the parallel links on each residue wheel allow for down force adjustment. Position 1 as shown below provides minimum down pressure and position 3 maximum down pressure.

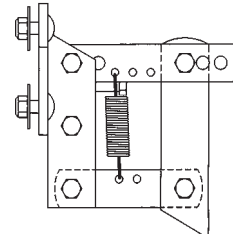

**Position 1 (Minimum)** (PLTR31a)

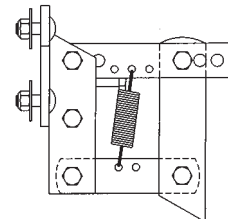

**Position 2** (PLTR32a)

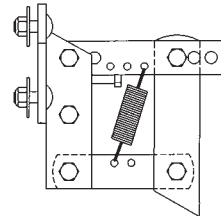

**Position 3 (Maximum)** (PLTR33a)

For additional uplift or float, position springs as shown below.

(PLTR34a)

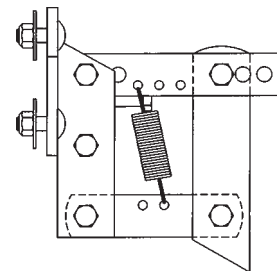

To adjust down force springs, raise the row unit out of the ground and reposition springs as shown for the desired down pressure.

# ROW UNIT OPERATION

D101701112

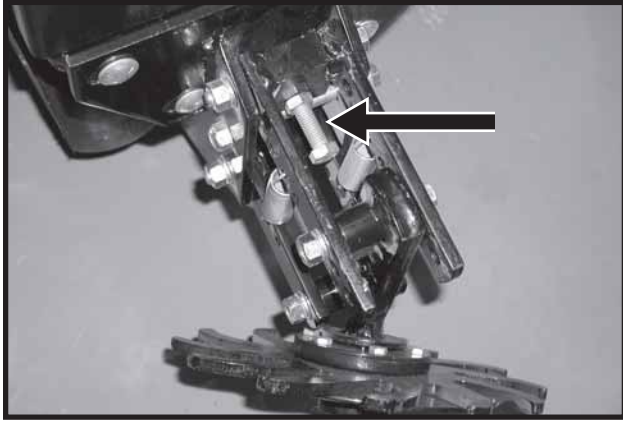

A full threaded bolt and jam nut located on the upper link allows maximum depth to be set for loose soil conditions. Initial setting should be 1 3/4" above the depth of the row unit double disc opener.

Three holes in the upper link allow for wheel angle adjustment. With the wheel mount in the most vertical position, using the rear hole in the upper link, the residue wheel is most aggressive. Moving the wheel mount to one of the forward holes reduces the aggressiveness of the wheel for use in mulch till applications where the soil is loose.

D101701202

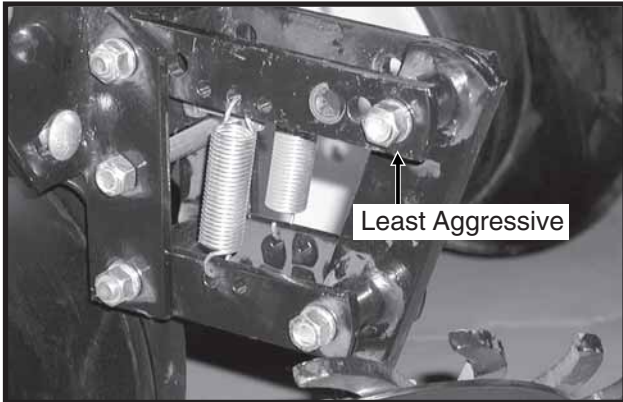

To lock the residue wheel up out of the ground, remove the 1/2" x 5" lockup bolt, raise the residue wheel and install bolt.

D011701203

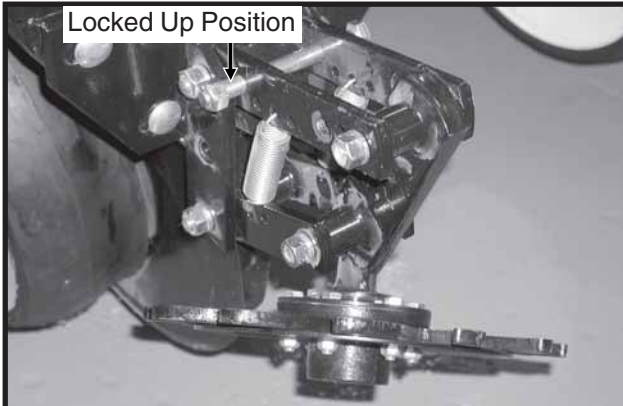

## ROW UNIT MOUNTED NO TILL COULTER

LF212299-19a



Row unit mounted no till coulters with 1" bubbled, 1" fluted (8 flutes) or 3/4" fluted (13 flutes) blades may be used on pull row units and push row units. (3/4" fluted shown)

Four quick adjustable down force springs are required per row when using row unit mounted no till coulters. See "Quick Adjustable Down Force Springs".

For proper operation, the coulters should be aligned in relation to the row unit double disc openers. The coulters assembly can be adjusted by loosening the four attaching bolts, moving coulters arm to align and tightening the four attaching bolts.

The coulters blade can be adjusted to one of four 1/2" incremental settings in the forked arm. Initial location of the coulters is in the top hole. As the coulters blade wears, the blade should be adjusted downward to one of the three lower settings to maintain the coulters blade at or slightly below the opener discs. In very hard soil conditions such as compacted wheel tracks, opener penetration and cutting of surface residue may be improved by adjusting the coulters to operate below the depth of the double disc opener blades.

Operating depth can be checked by setting the planter down on a level concrete floor and checking the relationship between the coulters blade and row unit opener blade. Make sure the planter is level and coulters is square with the planter frame and aligned with the row unit disc opener.

**NOTE: Torque 5/8" spindle hardware to 120 ft. lbs.**

# ROW UNIT OPERATION

## COULTER MOUNTED RESIDUE WHEELS

LF212299-23



Coultter mounted residue wheels are designed for use on pull row units and push row units. Row unit extension brackets are required on the four center pull row units if the planter is equipped with coultter mounted residue wheels.

The coultter mounted residue wheels are attached to the row unit mounted no till coultter with one cap screw and sleeve allowing the unit to free-float. A 2-position spindle bolt mounting allows the tined wheels to be mounted interlocked or staggered. A lock nut on the inside of the mount locks the spindle cap screw. Depth adjustment is made using a spring-loaded cam and pin with 11 positions in 1/4" increments. A high point on the cam allows the wheels to be locked up so they do not contact the ground. A weed guard, located on the inboard side of each wheel, aids in the prevention of weed wrap which can cause premature bearing failure.

(RU104tt)

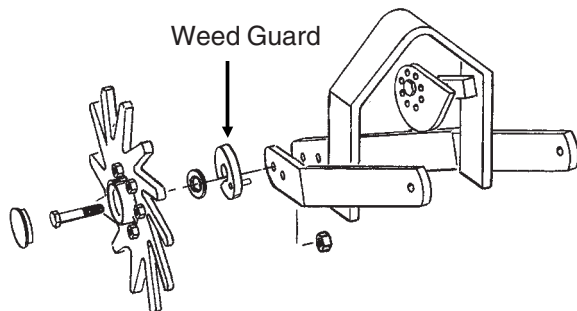

**NOTE: Opening in weed guard must point down.**

## GRANULAR CHEMICAL HOPPER AND DRIVE

LF212299-6



The granular chemical hopper has a 1.4 cubic feet capacity.

Be sure no foreign objects get into the hopper when it is being filled. Replace the hopper lids after filling the hoppers to prevent the accumulation of dirt and moisture.

The metering gate located on the bottom of the hopper regulates the application rate. See "Dry Insecticide And Dry Herbicide Application Rate Charts" in this manual. Calibrate using the chemical manufacturers' instructions.



**WARNING: Agricultural chemicals can be dangerous. Improper selection or use can seriously injure persons, animals, plants, soil or other property. BE SAFE: Select the right chemical for the job. Handle it with care. Follow the instructions on the container label and of the equipment manufacturer.**

The granular chemical clutch drive coupler and meter shaft can be disengaged and engaged by turning the throwout knob located at the rear of the hopper support panel. To engage the drive, turn the knob 1/4 turn clockwise. To disengage the drive, turn the knob 1/4 turn counterclockwise. Slotted holes in the hopper support panel and clutch housing allow for alignment adjustment between the clutch drive coupler and meter shaft.

LF212299-4

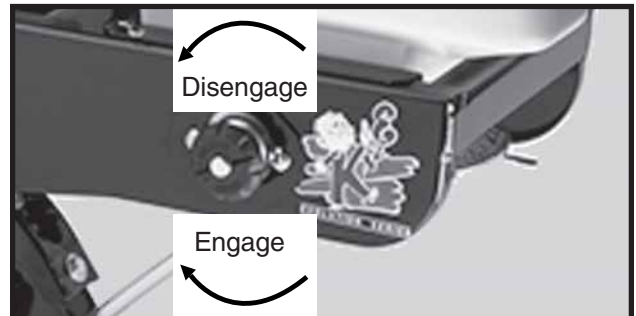

# ROW UNIT OPERATION

## GRANULAR CHEMICAL BANDING OPTIONS

Granular chemical banding options allow 4 1/2" slope-compensating banding, straight drop in-furrow placement or 14" rear banding.

**NOTE: The granular chemical rear bander is not compatible with the covering discs/single press wheel option.**

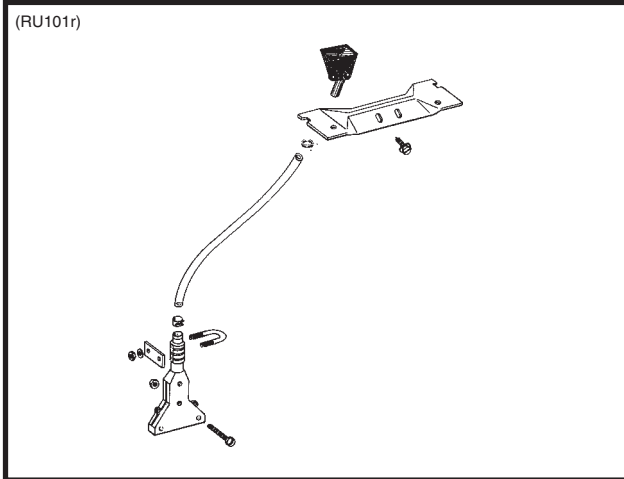

4 1/2" Slope-Compensating Bander

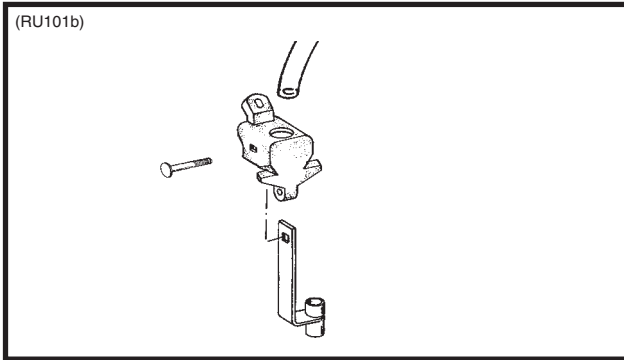

Straight Drop In-Furrow Placement

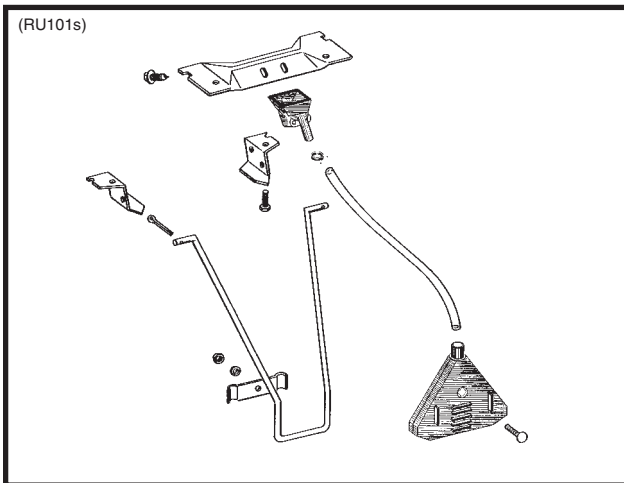

14" Rear Banding

## GRANULAR CHEMICAL BANDER SHIELD

The optional granular chemical bander shield is designed to be installed onto the underside of the wheel arm stop to shield crop residue from lodging in the granular chemical bander.

(RU83m)

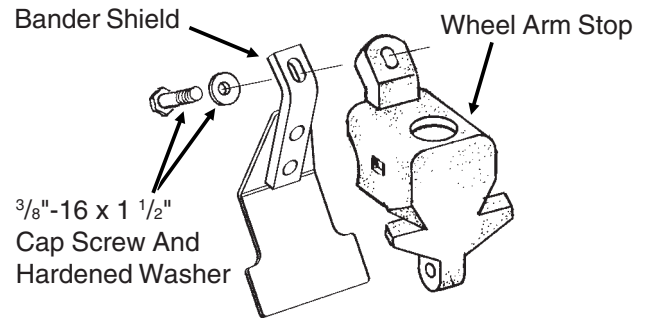

## SPRING TOOTH INCORPORATOR

The spring tooth incorporator smooths the soil behind the row unit and incorporates granular chemicals. The two mounting chains on each spring tooth incorporator should be adjusted so there is approximately 1/8" slack in the chain when the unit is lowered to planting position.

**NOTE: The spring tooth incorporator is not compatible with the covering discs/single press wheel option.**

LF212299-26

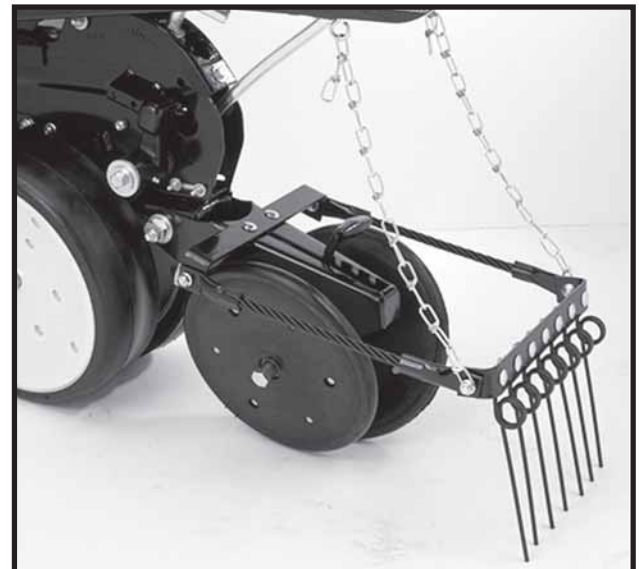

# LUBRICATION

The following pages show the locations of all lubrication points. Proper lubrication of all moving parts will help ensure efficient operation of your KINZE® planter and prolong the life of friction producing parts.

**⚠ WARNING:** Always install safety lockup devices or lower the planter to the ground before working under the machine.

## LUBRICATION SYMBOLS

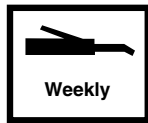
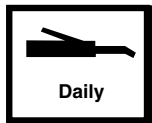

Lubricate at frequency indicated with an SAE multipurpose grease.



Lubricate at frequency indicated with a high quality SAE 10 weight oil or a quality spray lubricant.

## SEALED BEARINGS

LF212199-3

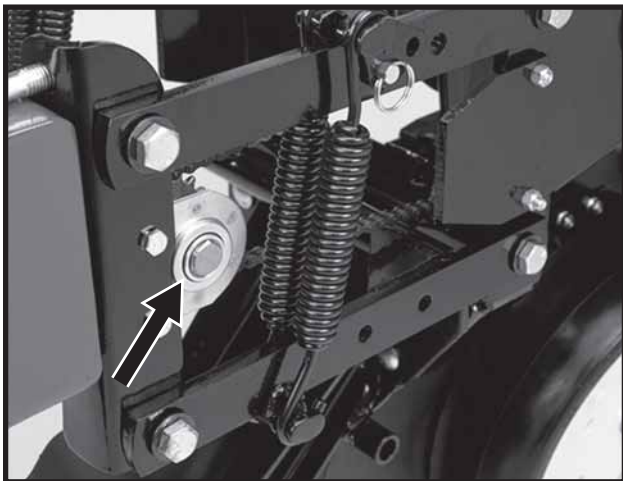

A number of sealed bearings are used on your KINZE® planter to provide trouble free operation. These are located in such areas as the drive shaft, row units and transmission bearings. Sealed bearings are lubricated for life. Due to the seals, relubrication is not practical.

## DRIVE CHAINS

All transmission and drive chains should be lubricated daily with a high quality chain lubricant. Extreme operating conditions such as dirt, temperature or speed may require more frequent lubrication. If a chain becomes stiff, it should be removed, soaked and washed in solvent to loosen and remove dirt from the joints. Then soak the chain in oil so the lubricant can penetrate between the rollers and bushings.

D051705103

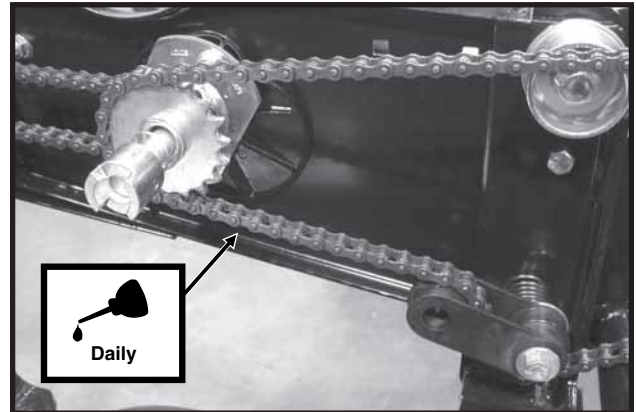

Row Unit Drive Chains

D051705102

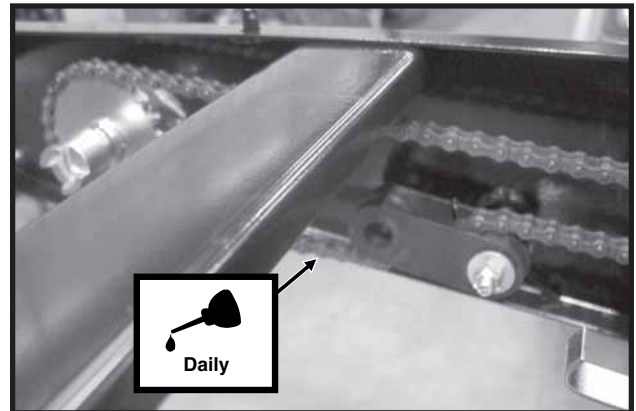

Row Unit Granular Chemical Drive Chains

D09139901

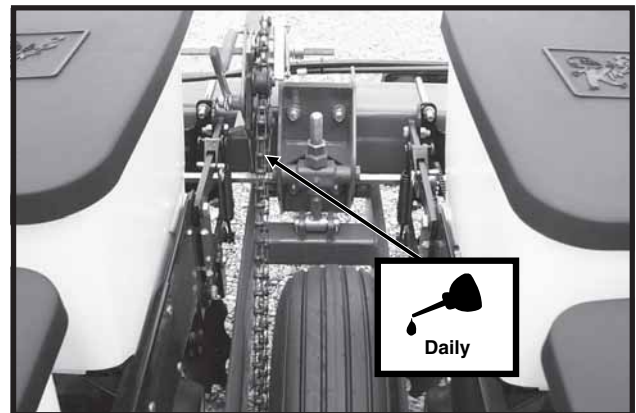

Drive Wheel Chains

# LUBRICATION

D09109917

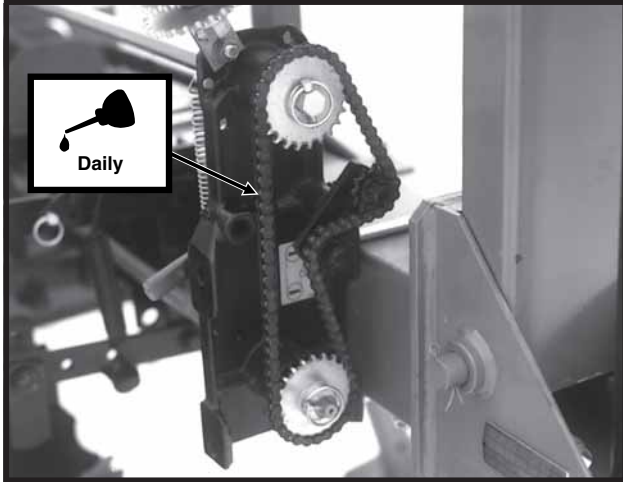

Seed Rate Transmission Chain(s)

## BUSHINGS

Lubricate bushings at the frequency indicated.

Using a torque wrench, check each bolt for proper torque. If bolt is loose, it should be removed and the bushing inspected for cracks and wear. Replace bushing if necessary. **Only hardened flat washers should be used. Replace damaged flat washers with proper part. Torque hardware to 130 ft. lbs.**

LF212199-3

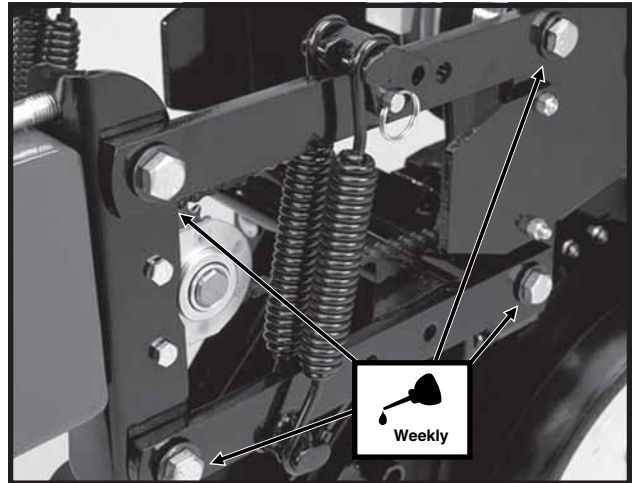

Pull Row Unit Parallel Linkages (8 Per Row)

LF212299-22

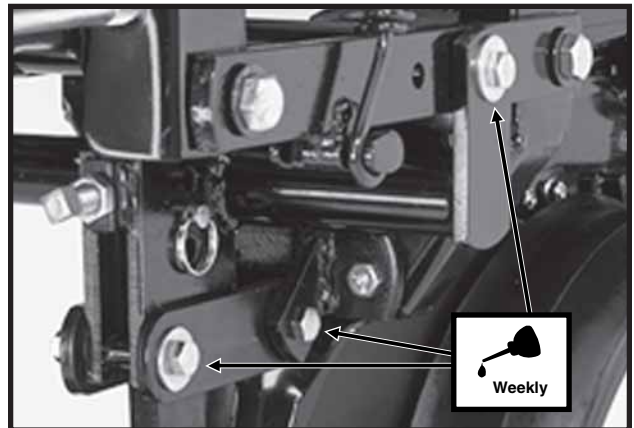

Row Unit Mounted Disc Furrower Parallel Linkages (6 Per Row)

# LUBRICATION

59386-26

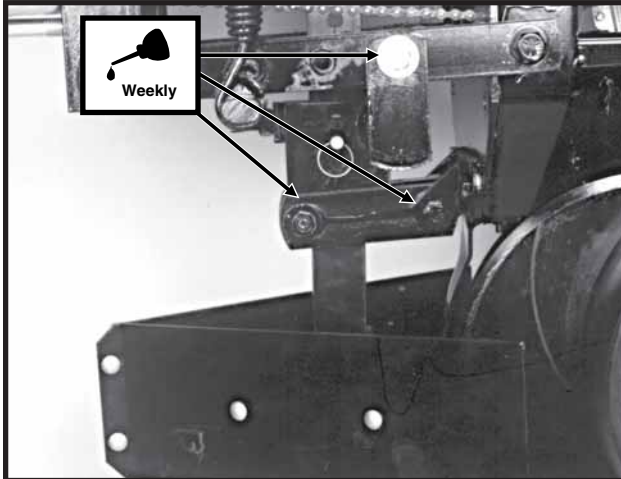

**Row Unit Mounted Bed Leveler Parallel Linkages  
(6 Per Row)**

LF212199-2

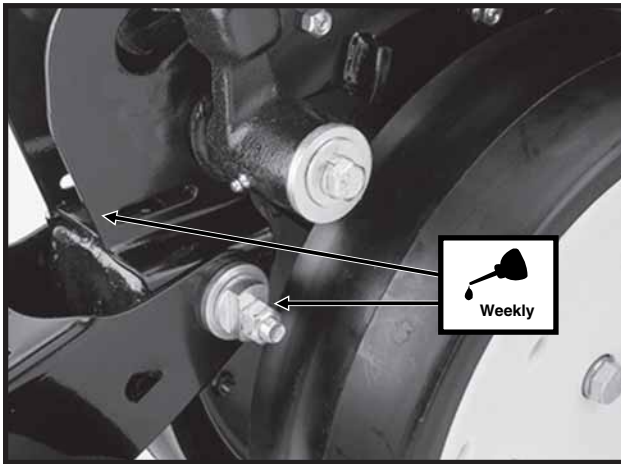

**Row Unit "V" Closing Wheel, Covering Discs/  
Single Press Wheel And/Or Drag Closing Wheel  
Eccentric Bushings (2 Per Row)**

## WHEEL BEARINGS

All wheel bearings should be repacked annually and checked for wear. This applies to all drive wheels and marker hubs.

To check for wear, raise the wheel off the ground. Check for endplay in the bearings by moving the tire side to side. Rotate the tire to check for roughness in the bearings. If bearings sound rough, the hub should be removed and the bearings inspected and replaced if necessary. See "Wheel Bearing Lubrication Or Replacement".

To repack wheel hubs, follow the procedure outlined for wheel bearing replacement with the exception that bearings and bearing cups are reused.

# LUBRICATION

## GREASE FITTINGS

Those parts equipped with grease fittings should be lubricated at the frequency indicated with an SAE multipurpose grease. Be sure to clean the fitting thoroughly before using grease gun. The frequency of lubrication recommended is based on normal operating conditions. Severe or unusual conditions may require more frequent attention.

**NOTE:** Numbers on photo below correspond with the following pages showing lubrication frequencies.

D09179909

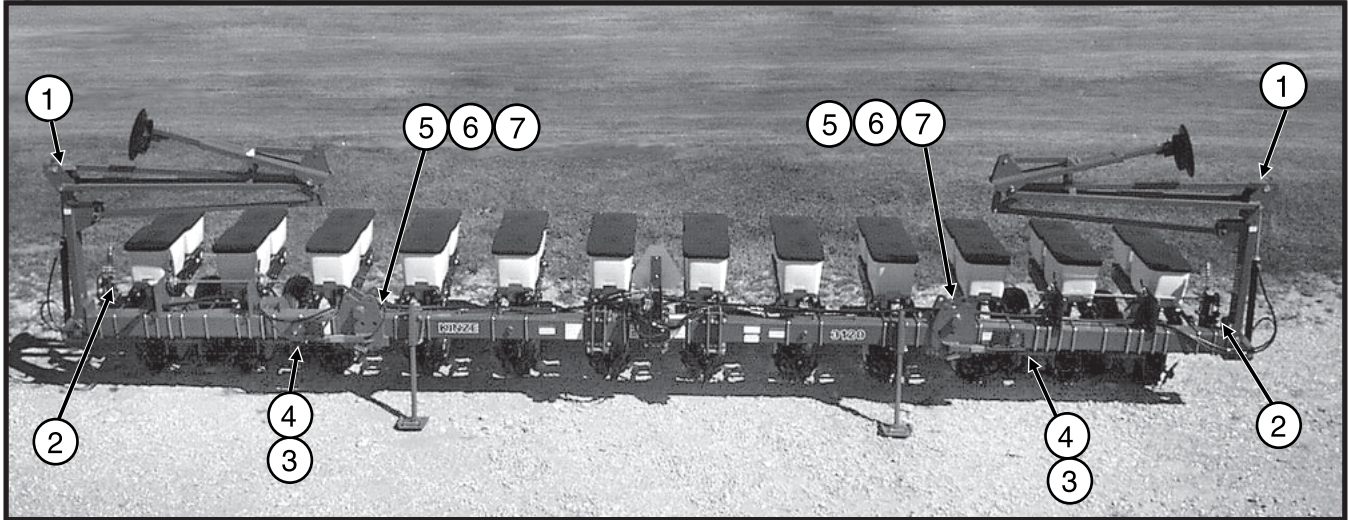

**WARNING:** Always install safety stands or lower the planter to the ground before working under or around the machine.

53555-8

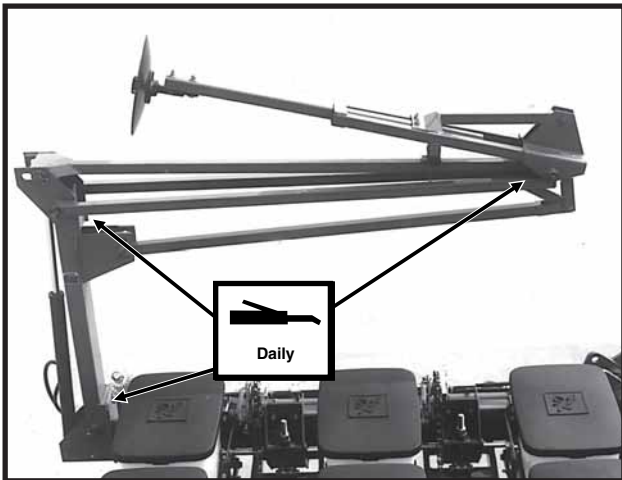

1. Low Profile Row Markers - 3 Zerks Per Assembly

61048-48a

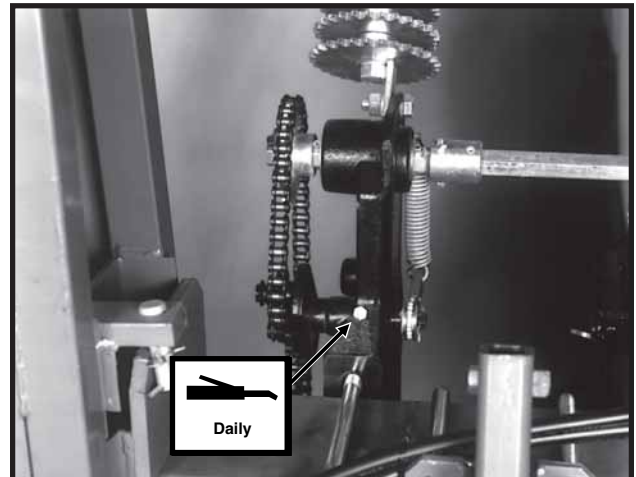

2. Seed Rate Transmission Assembly - 1 Zerk Per Idler Assembly



# LUBRICATION

52567-7

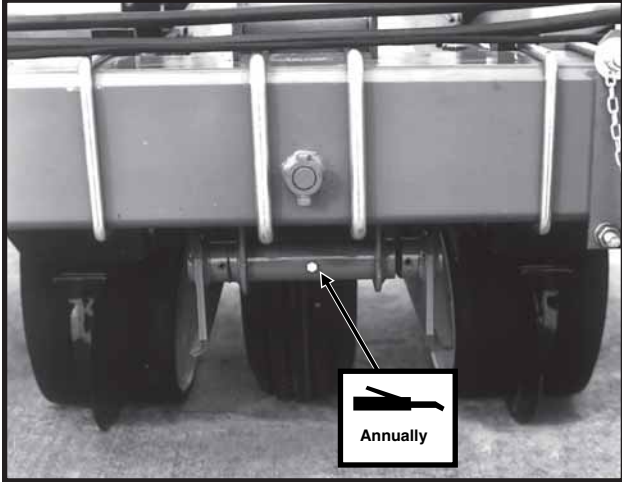

3. Wheel Module Shaft - 1 Zerk Per Module

53704-12

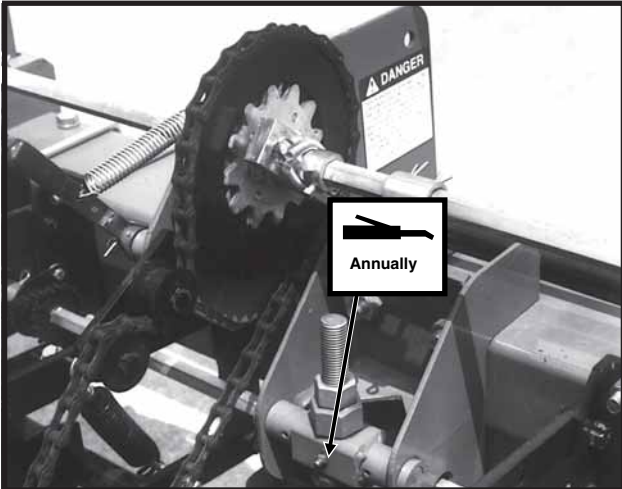

4. Wheel Module Jack Screw - 1 Zerk Per Module

51138-13

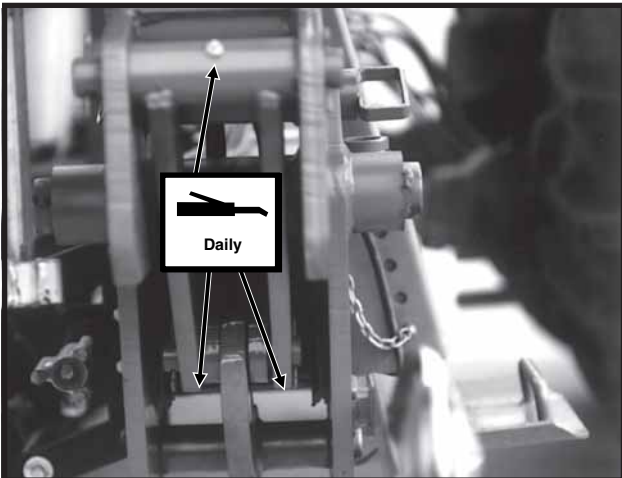

5. Wing Hinge Linkage - 3 Zerks Per Hinge

52567-28

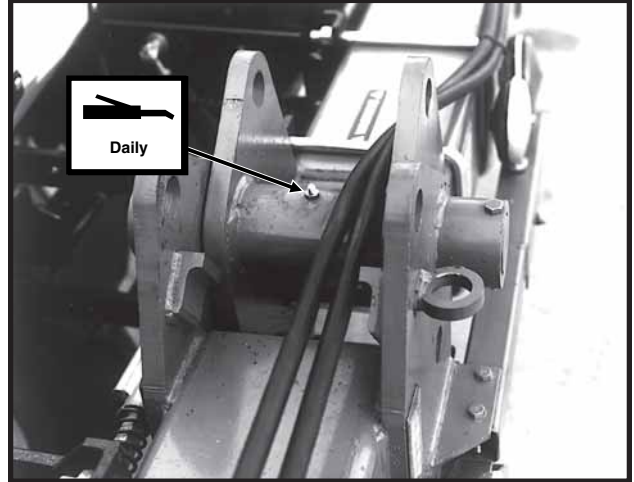

6. Wing Hinge Pin - 1 Zerk Per Hinge

53704-3a

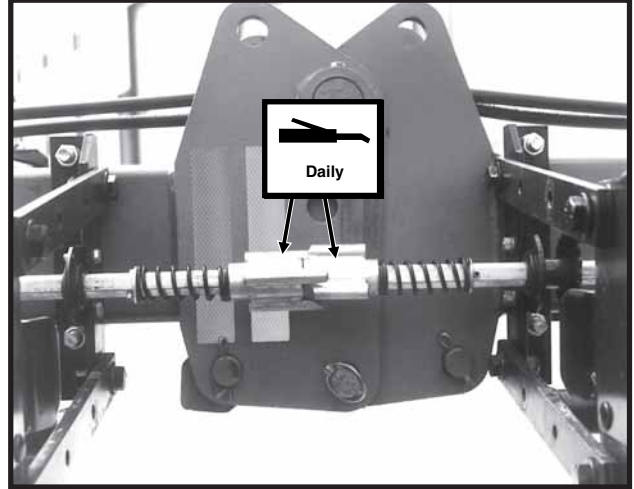

7. Drill Shaft Coupler - 2 Zerks Per Hinge Area

51138-4

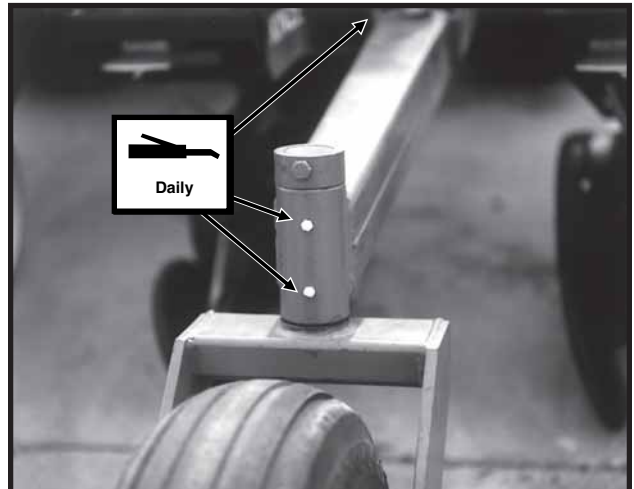

8. (If Applicable) Lift Assist Wheel Arm - 3 Zerks Per Arm Assembly (One At Wheel Tower Pivot-Not Shown)

# LUBRICATION

## Row Unit

LF212199-2

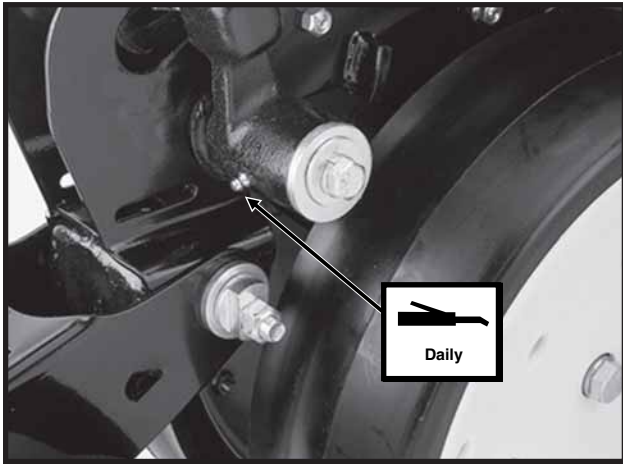

Gauge Wheel Arms - 1 Zerk Per Arm  
**(Seals in gauge wheel arm are installed with lip facing out to allow grease to purge dirt away from seal. Pump grease into arm until fresh grease appears between washers and arm.)**

LF083002101

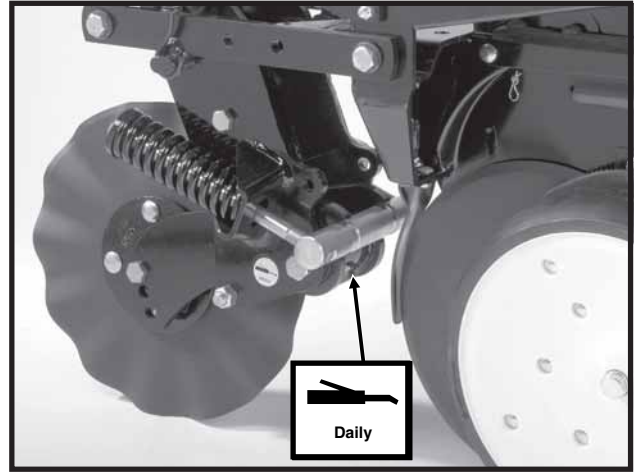

Frame Mounted Coulter - 1 Zerk Per Arm

# MAINTENANCE

## MOUNTING BOLTS AND HARDWARE

Before operating the planter for the first time, check to be sure all hardware is tight. Check all hardware again after approximately the first 50 hours of operation and at the beginning of each planting season thereafter.

All hardware used on the KINZE® planter is Grade 5 (high strength) unless otherwise noted. Grade 5 cap screws are marked with three radial lines on the head. If hardware must be replaced, be sure to replace it with hardware of equal size, strength and thread type. Refer to the torque values chart when tightening hardware.

Row Unit Parallel Linkage Bushing Hardware - 130 Ft. Lbs. (See “Bushings” in the Lubrication Section of this manual.)

5/8" No Till Coulter Spindle Hardware - 120 Ft. Lbs.

**IMPORTANT: Over tightening hardware can cause as much damage as under tightening. Tightening hardware beyond the recommended range can reduce its shock load capacity.**

### TORQUE VALUES CHART - PLATED HARDWARE

Bolt Diameter	Grade 2		Grade 5		Grade 8	
	Coarse	Fine	Coarse	Fine	Coarse	Fine
1/4"	50 In. Lbs.	56 In. Lbs.	76 In. Lbs.	87 In. Lbs.	9 Ft. Lbs.	10 Ft. Lbs.
5/16"	8 Ft. Lbs.	9 Ft. Lbs.	13 Ft. Lbs.	14 Ft. Lbs.	18 Ft. Lbs.	20 Ft. Lbs.
3/8"	15 Ft. Lbs.	17 Ft. Lbs.	23 Ft. Lbs.	26 Ft. Lbs.	33 Ft. Lbs.	37 Ft. Lbs.
7/16"	25 Ft. Lbs.	27 Ft. Lbs.	37 Ft. Lbs.	41 Ft. Lbs.	52 Ft. Lbs.	58 Ft. Lbs.
1/2"	35 Ft. Lbs.	40 Ft. Lbs.	57 Ft. Lbs.	64 Ft. Lbs.	80 Ft. Lbs.	90 Ft. Lbs.
9/16"	50 Ft. Lbs.	60 Ft. Lbs.	80 Ft. Lbs.	90 Ft. Lbs.	115 Ft. Lbs.	130 Ft. Lbs.
5/8"	70 Ft. Lbs.	80 Ft. Lbs.	110 Ft. Lbs.	125 Ft. Lbs.	160 Ft. Lbs.	180 Ft. Lbs.
3/4"	130 Ft. Lbs.	145 Ft. Lbs.	200 Ft. Lbs.	220 Ft. Lbs.	280 Ft. Lbs.	315 Ft. Lbs.
7/8"	125 Ft. Lbs.	140 Ft. Lbs.	320 Ft. Lbs.	350 Ft. Lbs.	450 Ft. Lbs.	500 Ft. Lbs.
1"	190 Ft. Lbs.	205 Ft. Lbs.	480 Ft. Lbs.	530 Ft. Lbs.	675 Ft. Lbs.	750 Ft. Lbs.
1 1/8"	265 Ft. Lbs.	300 Ft. Lbs.	600 Ft. Lbs.	670 Ft. Lbs.	960 Ft. Lbs.	1075 Ft. Lbs.
1 1/4"	375 Ft. Lbs.	415 Ft. Lbs.	840 Ft. Lbs.	930 Ft. Lbs.	1360 Ft. Lbs.	1500 Ft. Lbs.
1 3/8"	490 Ft. Lbs.	560 Ft. Lbs.	1100 Ft. Lbs.	1250 Ft. Lbs.	1780 Ft. Lbs.	2030 Ft. Lbs.
1 1/2"	650 Ft. Lbs.	730 Ft. Lbs.	1450 Ft. Lbs.	1650 Ft. Lbs.	2307 Ft. Lbs.	2670 Ft. Lbs.

**NOTE: Unplated hardware and bolts with lock nuts should be torqued approximately 1/3 higher than the above values. Bolts lubricated prior to installation should be torqued to 70% of value shown in chart.**



**GRADE 2**  
No Marks



**GRADE 5**  
3 Marks



**GRADE 8**  
6 Marks

# MAINTENANCE

## CHAIN TENSION ADJUSTMENT

The drive chains have a spring loaded idler and therefore are self-adjusting. The only adjustment needed is to shorten the chain if wear stretches the chain and reduces spring tension. The pivot point of these idlers should be checked periodically to ensure they rotate freely.

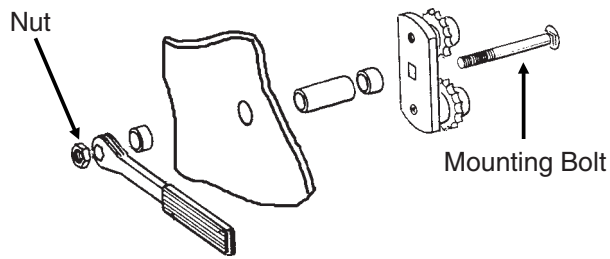

**NOTE:** The nut on the mounting bolt (on applicable idler assemblies) must be kept tight or chain tension will not be maintained and adjustment wrench will not function properly.

53051-17



52607-1



Shown With Optional Front Mounted Drive Wheel

# MAINTENANCE

## FINGER PICKUP SEED METER INSPECTION/ADJUSTMENT

To inspect or service the finger pickup seed meter, remove the meter from the seed hopper by removing the two thumbscrews which secure the mechanism to the hopper. Remove the baffle from the meter assembly by removing three cap screws. This will permit access to the finger pickup.

D04229901

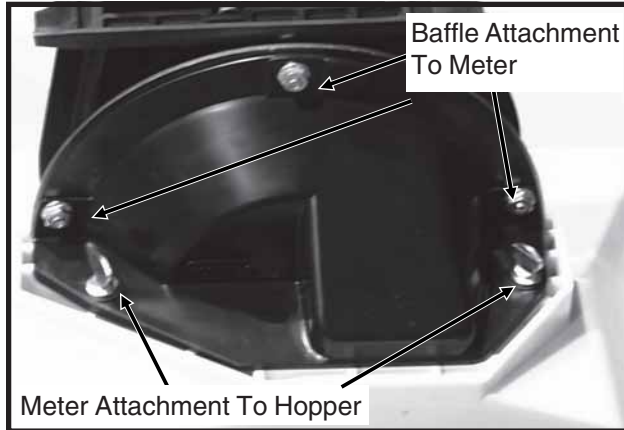

Rotate the seed meter drive by hand to ensure that the springs are holding the tabs of the fingers against the carrier plate where indicated in the photo and that the fingers are being raised in the correct area.

D12220402a

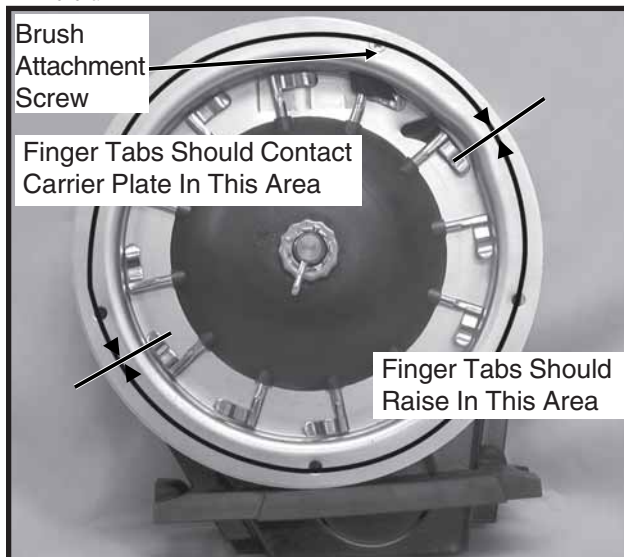

A buildup of debris or chaff may prevent proper finger operation and will require disassembly and cleaning of the finger pickup meter as follows:

1. Remove cotter pin, cover nut and adjusting nut and wave washer (If Applicable) from drive shaft.
2. Carefully lift finger holder, along with fingers and cam, off of the shaft. Clean.

D092004102

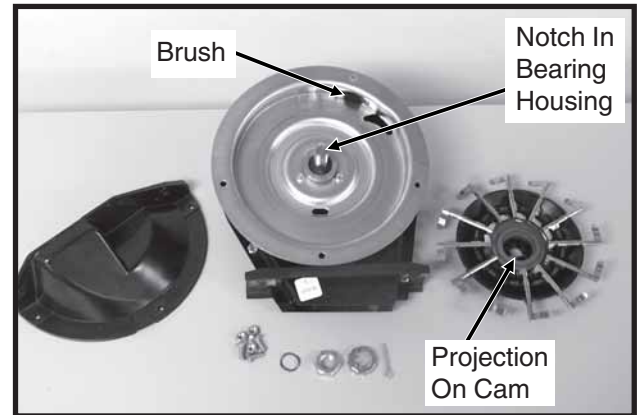

3. Check brush for wear and replace if necessary or following every 100 acres per row of operation.

**EXAMPLE:** Approximately 800 acres of corn or sunflowers on a 8 row machine or 1200 acres on an 12 row machine.

**NOTE:** It is not necessary to remove finger holder to replace brush.

4. To replace fingers or springs, remove springs from fingers and remove finger from holder by lifting it out of the friction fit slot. Under average conditions, life expectancy of these parts should be 600-900 acres per row of operation.
5. After cleaning and/or replacing defective parts, reassemble the meter in the reverse order. When replacing fingers, make sure the open end of the spring loop is toward the inside of the finger holder.

60620-22

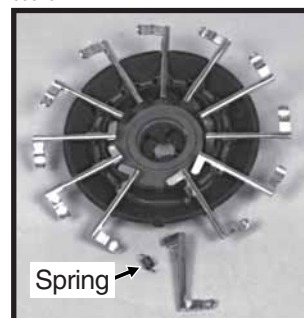

**Corn Finger Assembly**

(Position Spring Opening Toward Holder)

D07299902



**Oil Sunflower Finger Assembly**

6. Make sure fingers are installed in holder so that holder will be positioned flush with the carrier plate when assembled. A projection on the cam is designed to align with a mating notch in the bearing housing to ensure proper operation when assembled.

# MAINTENANCE

D021506100

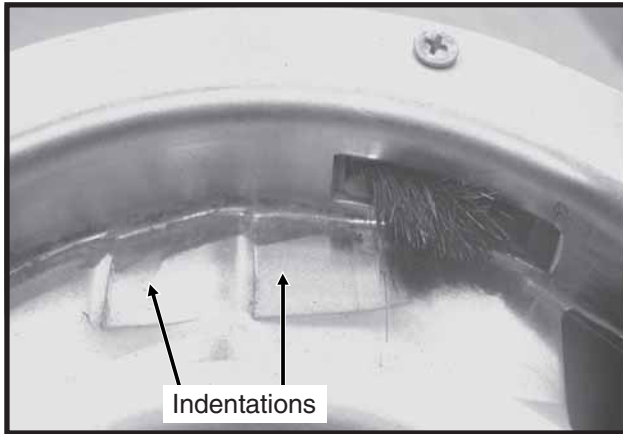

**Photo Shows Worn Carrier Plate**

- Before installing the finger holder on the carrier plate, check the indentations on the carrier plate for wear. Excessive wear of the carrier plate at the indentations will cause over planting especially when using small sizes of seed.

Inspect the carrier plate annually. Under average conditions, the life expectancy of the carrier plate should be 250-300 acres per row of operation.

- With finger holder flush against the carrier, install wave washer and adjusting nut. Tighten adjusting nut to fully compress wave washer. Then back off nut  $\frac{1}{2}$  to 2 flats ( $\frac{1}{12}$  to  $\frac{1}{3}$  turn) to obtain rolling torque of 22 to 25 inch pounds.

D07299903/D07309912

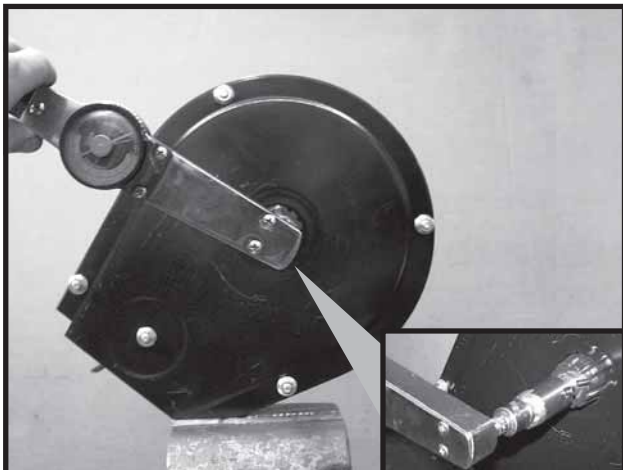

- Turn finger holder by hand to make sure it is positioned firmly against the carrier plate, but is not over tightened and can be rotated with moderate force.
- Install cover nut and cotter pin and reinstall baffle.

**NOTE: Check tightness of adjusting nut on each unit after first day of use and periodically thereafter.**

To inspect or replace the seed belt, remove the four cap screws around the edge of the housing cover and the nut from the belt idler mounting bolt.

60620-13a/60887-97

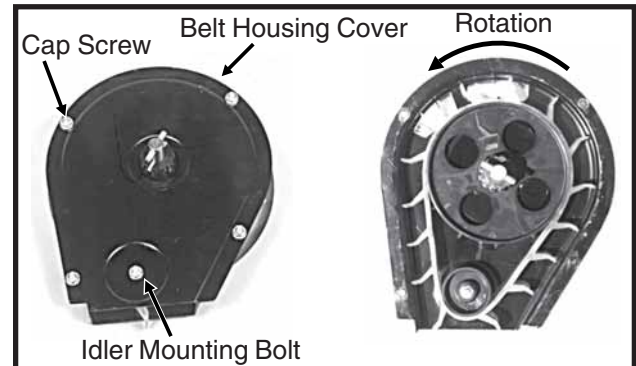

If the belt is being replaced, make sure it is installed to correctly orient the paddles as shown. A diagram molded into the drive sprocket also illustrates the correct orientation.

Reinstall the housing cover. **DO NOT TIGHTEN** hardware at this time. Wedge a screwdriver between the sprocket hub and housing cover as shown below. Pry cover down until it is centered on the belt housing and tighten hardware. Check idler alignment by rotating meter drive shaft. The seed belt should "run" centered on the idler or with only slight contact with the belt housing or cover.

**IMPORTANT: Do not over tighten hardware.**

D06200030



## FINGER PICKUP SEED METER CLEANING

- Disassemble meter.
- Blow out any foreign material present in the meter mechanism.
- Wash in mild soap and water. **DO NOT USE GASOLINE, KEROSENE OR ANY OTHER PETROLEUM BASED PRODUCT.**
- Dry thoroughly.
- Coat lightly with a rust inhibitor.
- Rotate finger assembly so finger does not touch brush.
- Reassemble and store in a dry rodent-free place.

# MAINTENANCE

## FINGER PICKUP SEED METER TROUBLESHOOTING

PROBLEM	POSSIBLE CAUSE	SOLUTION
One row not planting seed.	Drive release not engaged.	Engage drive release mechanism.
	Foreign material in hopper.	Clean hopper and finger carrier mechanism.
	Seed hopper empty.	Fill seed hopper.
	Row unit drive chain off of sprocket or broken.	Check drive chain.
Unit is skipping.	Foreign material or obstruction in meter.	Clean and inspect.
	Finger holder improperly adjusted.	Adjust to specifications. (22 to 25 in. lbs. rolling torque)
	Broken fingers.	Replace fingers and/or springs as required.
	Planting too slowly.	Increase planting speed to within recommended range.
Planting too many doubles.	Planting too fast.	Stay within recommended speed range.
	Loose finger holder.	Adjust to specifications. (22 to 25 in. lbs. rolling torque)
	Worn brush in carrier plate.	Inspect and replace if necessary.
Overplanting.	Worn carrier plate.	Inspect and replace if necessary.
	Seed hopper additive being used.	Reduce or eliminate additive or increase graphite.
Underplanting.	Seed belt installed backwards.	Remove and install correctly.
	Weak or broken springs.	Replace.
	Spring not properly installed.	Remove finger holder and correct.
	Seed belt catching or dragging.	Replace belt.
	Brush dislodging seed.	Replace brush.
Irregular or incorrect seed spacing.	Driving too fast.	Check chart for correct speed.
	Wrong tire pressure.	Inflate tires to correct air pressure.
	Drive wheels slipping.	Reduce down pressure on row unit down force springs.
	Wrong sprockets.	Check seed rate charts for correct sprocket combinations.
Seed spacing not as indicated in charts.	Wrong tire pressure.	Inflate tires to correct air pressure.
	Inconsistent seed size.	Do field check and adjust sprockets accordingly.
	Wrong sprockets.	Check chart for correct sprocket combination.
	Charts are approximate.	Slight variations due to wear in meter components and tire slippage due to field conditions may produce seed spacing variations.
	Stiff or worn drive chains.	Replace chains.
Scattering of seeds.	Planting too fast.	Reduce planting speed.
	Seed tube improperly installed.	Check seed tube installation.
	Seed tube worn or damaged.	Replace seed tube.
Seed tubes and/or openers plugging.	Allowing planter to roll backward when lowering.	Lower planter only when tractor is moving forward.
Inconsistent seed depth.	Rough seed bed.	Adjust down pressure springs. Reduce planting speed.
	Partially plugged seed tube.	Inspect and clean.
	Seed tube improperly installed.	Install properly.

# MAINTENANCE

## BRUSH-TYPE SEED METER MAINTENANCE

60607-10a

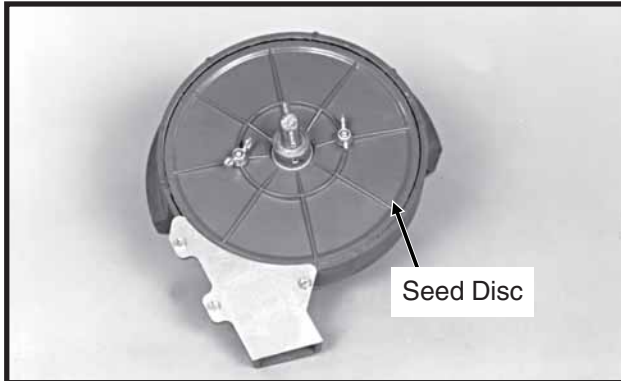

D04239911

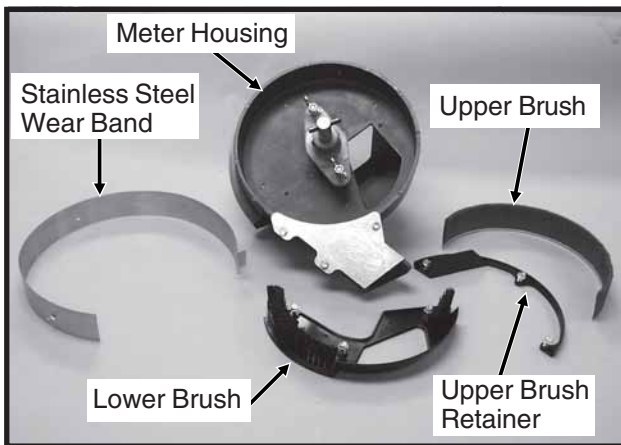

Only clean, high quality seed should be used for maximum meter accuracy. Damaged or cracked seed, hulls or foreign materials may become lodged in the upper brush and greatly reduce meter accuracy. It is suggested that the seed disc be removed daily, inspected and cleaned. Check for buildup of foreign material on the seed disc, particularly in the seed loading slots. Clean the disc by washing it with soap and water. Check for cracked seed, hulls, etc. lodged between the brush retainer and stainless steel wear band which can greatly reduce the accuracy of the meter because the upper brush will not be able to retain the seed in the seed disc pocket. Clean the brush areas of the meter housing thoroughly.

D04239912a



**IMPORTANT:** Replace hopper lids after hoppers are filled to prevent accumulation of dust or dirt in the seed meter which will cause premature wear.

### Cleaning brush-type seed meter for storage:

1. Remove meter from seed hopper by removing the two thumbscrews which secure the meter to the hopper.
2. Remove seed disc and wash with soap and water and dry thoroughly.
3. Remove upper brush by removing the three hex head screws from the brush retainer and removing brush retainer and upper brush.
4. Remove the three hex head screws from the lower brush and remove lower brush and stainless steel wear band.
5. Wash all parts and meter housing with soap and water and dry thoroughly.
6. Inspect all parts for wear and replace worn parts.
7. Reassemble meter except for seed disc. **Meter should be stored in a rodent-free space with seed disc removed.**

### Seed Disc Wear

HD112690(PLTR40b)

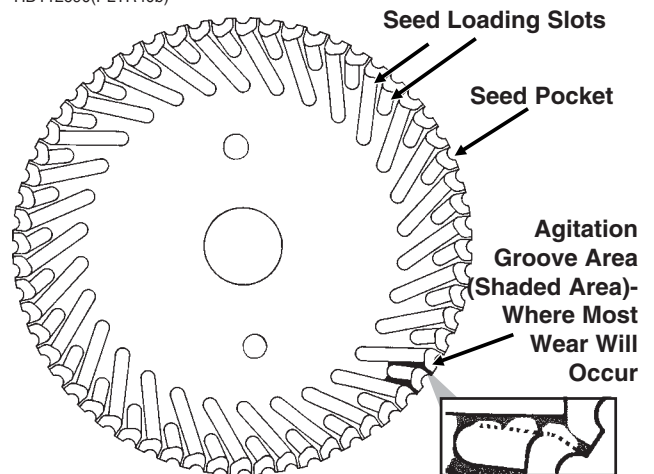

Most wear on the seed disc will be found in the agitation groove area (area between the seed loading slots). Wear will affect planting accuracy at high RPM. To measure for wear, lay a straight edge across the surface of the disc and measure the gap between the disc (at the agitation groove area) and the straight edge. If the agitation groove areas are worn in excess of .030" and accuracy starts to drop off at higher meter RPM, the seed disc should be replaced.

Estimated life expectancy of the seed disc under normal operating conditions should be approximately 200 acres per row. Severe operating conditions such as dust, lack of lubrication or abrasive seed coating could greatly reduce life expectancy of the seed disc to under 100 acres per row.



# MAINTENANCE

## Upper Brush

D12220403

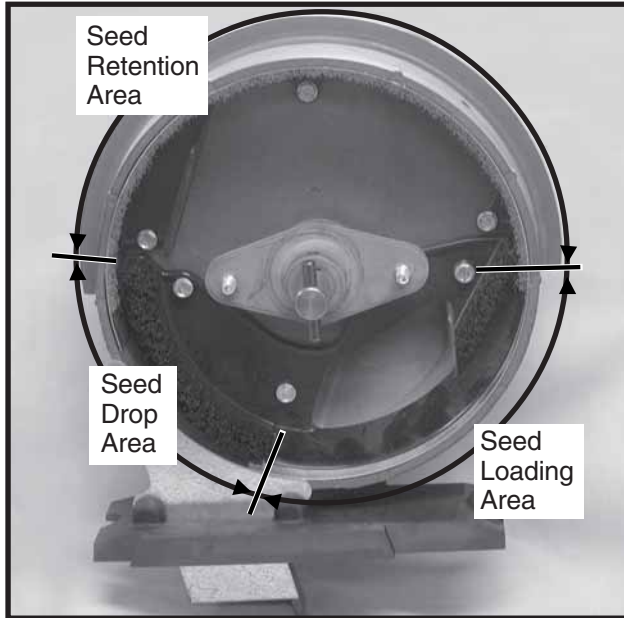

The upper brush holds seed in the seed disc pocket in the seed retention area.

The brush must apply enough pressure against the seed in the seed disc pocket as the disc rotates through the seed retention area to prevent the seed from dropping out of the disc pocket. A damaged spot, excessive wear on the brush or foreign material lodged in the brush may greatly reduce meter performance.

The upper brush should be replaced at approximately 120-400 acres per row of use or sooner if damage or excessive wear is found.

### Installation Of Upper Brush

Position upper brush into inner perimeter of seed retention area. Make sure the base of the brush is tight against the bottom of the meter housing. Install brush retainer and three hex head screws. Tighten center screw first, left screw second and right screw last.

**NOTE: Use GD11122 upper brush retainer when using soybean and cotton discs. Use GD8237 upper brush retainer when using milo/grain sorghum discs. GD11122 brush retainer shown.**

LF212299-13a



## Stainless Steel Wear Band

D04239917a



The purpose of the stainless steel wear band is to protect the meter housing from wear. The band is .030" thick and should be replaced when approximately .020" of wear is found in the primary area of wear. If the wear band is allowed to wear through or if the meter is used without the wear band in place, damage to the meter housing may occur.

Estimated life expectancy of the stainless steel wear band is 240-800 acres per row.

## Lower Brush

D04239911

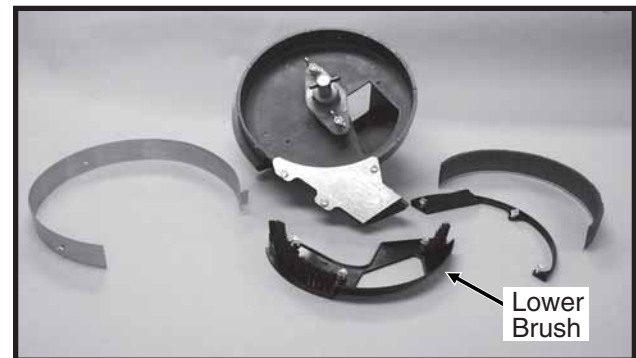

The lower brush has several functions. One function is to move seed down the seed loading slots to the seed pockets. The second function is to isolate seed in the reservoir from entering the seed tube and a third is to clean the seed loading slots.

Estimated life expectancy of the lower brush is 240-800 acres per row. The lower brush should be replaced if the bristles are deformed or missing or if there are cracks in the brush retainer.

# MAINTENANCE

## BRUSH-TYPE SEED METER TROUBLESHOOTING

PROBLEM	POSSIBLE CAUSE	SOLUTION
Low count.	Meter RPM too high.	Reduce planting speed.
	Seed sensor not picking up all seeds dropped.	Clean seed tube. Switch meter to different row. If problem stays with same row, replace sensor.
	Lack of lubrication causing seeds not to release from disc properly.	Use graphite or talc as recommended.
	Seed size too large for seed disc being used.	Switch to smaller seed or appropriate seed disc. See "Brush-Type Seed Meter" for proper seed disc for size of seed being used.
	Seed treatment buildup in meter.	Reduce amount of treatment used and/or thoroughly mix treatment with seed. Add talc.
Low count at low RPM and higher count at higher RPM.	Foreign material lodged in upper brush.	Remove seed disc and remove foreign material from between brush retainer and bristles. Clean thoroughly.
	Worn upper brush.	Replace. See "Maintenance".
Low count at higher RPM and normal count at low RPM.	Seed disc worn in the agitation groove area.	Replace disc. See "Maintenance".
High count.	Seed size too small for seed disc.	Switch to larger seed or appropriate seed disc.
	Incorrect seed rate transmission setting.	Reset transmission. Refer to proper rate chart in "Machine Operation" section of manual.
	Upper brush too wide (fanned out) for small seed size.	Replace upper brush.
High count. (Milo/Grain Sorghum)	Incorrect brush retainer being used.	Make sure GD8237 brush retainer is installed to keep upper brush from fanning out.
Upper brush laid back.	Seed treatment buildup on brush.	Remove brush. Wash with soap and water. Dry thoroughly before reinstalling. See "Maintenance".
	Buildup of foreign material at base of brush.	Remove brush retainer and brush. Clean thoroughly. Reinstall.

# MAINTENANCE

## CLOSING WHEEL TROUBLESHOOTING

PROBLEM	POSSIBLE CAUSE	SOLUTION
Closing wheel(s) leave severe imprint in soil.	Too much closing wheel down pressure.	Adjust closing wheel pressure.
Closing wheel(s) not firming soil around seed.	Insufficient closing wheel down pressure.	Adjust closing wheel pressure. Severe no till conditions may require use of cast iron closing wheels.
“V” closing wheel running on top of seed furrow.	Improper centering.	Align. See “V Closing Wheel Adjustment”.
Single closing wheel not directly over seed.	Improper centering.	Align. See “Covering Discs/Single Press Wheel Adjustment”.

## DRAG CLOSING ATTACHMENT

LF212299-18



Prior to storage of the planter, inspect each drag closing attachment and replace any worn or broken parts. Check for loose hardware and tighten as needed.

LF212199-2

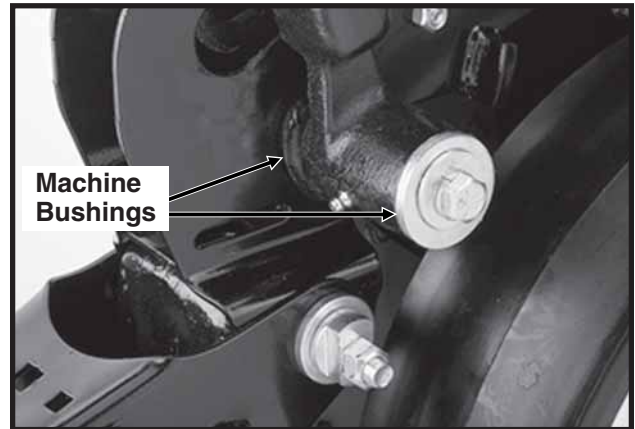

(RU113g)

## GAUGE WHEEL ADJUSTMENT

To prevent an accumulation of dirt or trash, gauge wheels should lightly contact the opener blades. Gauge wheels and opener blades should turn with only slight resistance.

To adjust clearance between gauge wheels and opener blades, add or remove machine bushings between the shank and gauge wheel arm. Store remaining machine bushings between gauge wheel arm and flat washer on outer side of gauge wheel arm.

**NOTE:** It may be desirable to space gauge wheel further from blade when operating in sticky soils.

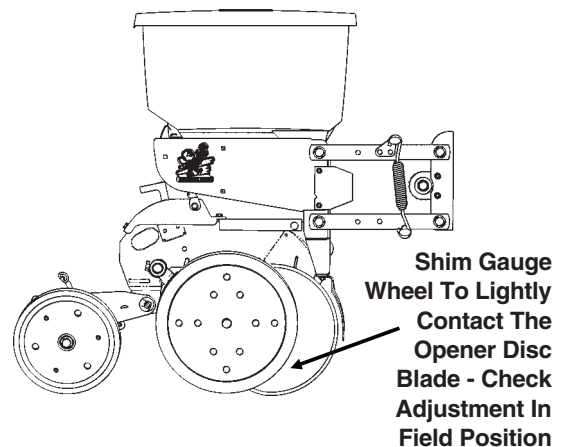

# MAINTENANCE

## GAUGE WHEEL ARM BUSHING AND/OR SEAL REPLACEMENT

(RU113g)

Gauge Wheel Arm Bushings/Seals

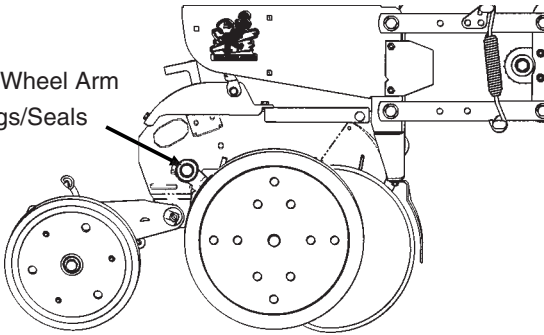

**NOTE: A Gauge Wheel Arm Bushing And Seal Driver Kit (G1K296), for use in bushing and seal replacement, is available through your KINZE® Dealer.**

**To replace gauge wheel arm assembly bushing(s) and/or seal(s):**

1. Remove gauge wheel from arm.
2. Remove the gauge wheel arm assembly from the shank assembly.
3. Remove seal and bushing and discard. Clean and dry inner bore.

(A7975/RU122)

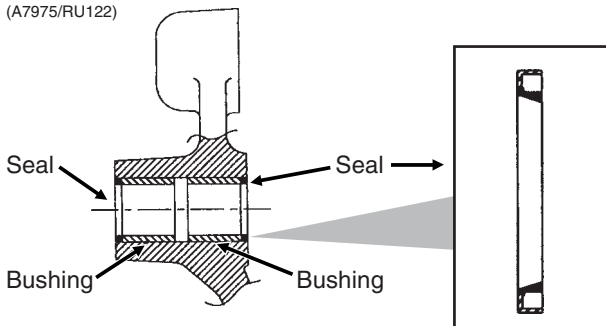

4. Drive/press replacement bushing inside bore of arm to a depth of .125" below flush.
5. Coat wiping edge of seal with grease.
6. Drive/press seal into place with lip to the outside as shown above.

**NOTE: Use extra care to protect the sealing lip during installation. Apply uniform pressure to assemble the seal into the bore of the arm. Never apply a direct hammer blow to the seal surface.**

7. Inspect gauge wheel pivot spindle.
8. Reinstall gauge wheel arm assembly and gauge wheel.

**NOTE: Special machine bushing between gauge wheel arm and gauge wheel.**

9. Shim for proper gauge wheel tire/disc blade clearance.
10. Lubricate with an SAE multipurpose grease.

## GAUGE WHEEL ARM PIVOT SPINDLE REPLACEMENT

(RU113g)

Gauge Wheel Pivot Spindle

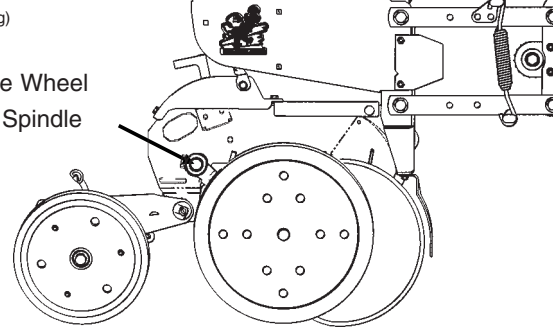

**To replace gauge wheel pivot spindle:**

1. Remove the gauge wheel and arm assemblies from the shank assembly.
2. Remove 1/2" x 3/4" cap screw that locks the pivot spindle in place and remove the spindle.

D06189902

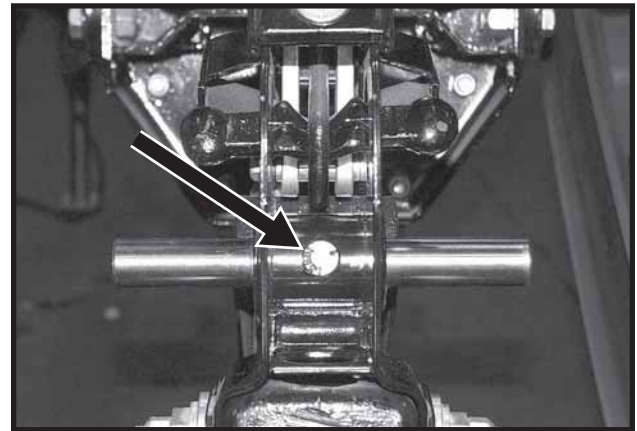

3. Install the replacement spindle and position as shown below. Exact centering is critical.

(A7966)

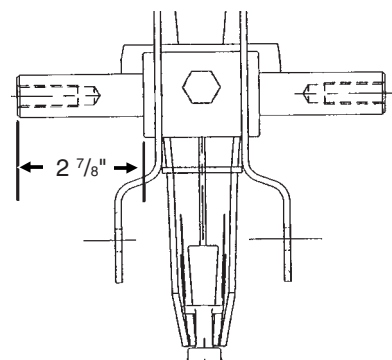

4. Install 1/2" x 3/4" cap screw and torque to lock pivot spindle in place.
5. Install gauge wheel and arm assemblies. Shim for proper gauge wheel tire/disc blade clearance.

# MAINTENANCE

## 15" SEED OPENER DISC BLADE/ BEARING ASSEMBLY

Approximately 1" - 1 1/2" of blade-to-blade contact should be maintained to properly open and form the seed trench. As the blade diameter decreases, due to wear, it will be necessary to relocate machine bushings from inside to outside to maintain approximately 1" - 1 1/2" of contact.

**NOTE: If proper blade-to-blade contact cannot be maintained after relocating machine bushings or if blade diameter wears below 14 1/2", the blades should be replaced.**

**IMPORTANT: Excessive blade contact may result in premature disc opener bearing/hub failures and excessive wear on seed tube guard/inner scraper. When properly adjusted, if one blade is held in fixed position, the opposite blade should be able to be rotated with minimal force (Less than 5 pounds force at outer edge of blade).**

(RU113g)

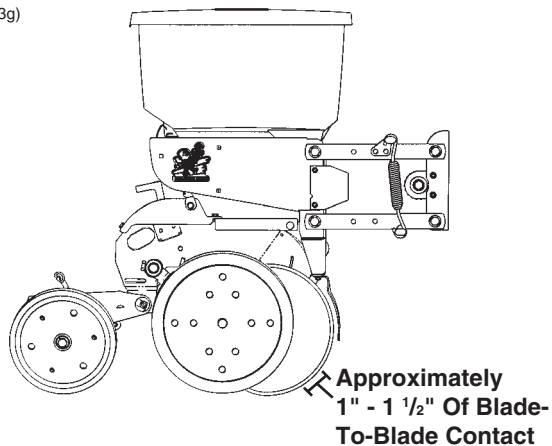

### To replace disc blade/bearing assembly:

1. Remove gauge wheel.
2. Remove scraper.
3. Remove bearing dust cap.
4. Remove cap screw, washer and disc blade/bearing assembly. The machine bushings between the shank and disc blade are used to maintain the approximate 1" - 1 1/2" of blade-to-blade contact.

**IMPORTANT: Left hand side of opener uses a left hand threaded cap screw. DO NOT OVER TIGHTEN. Damage to shank threads will require replacement of row unit shank assembly.**

5. Install machine bushing(s), new disc blade/bearing assembly, washer and cap screw. Torque 5/8"-11 Grade 5 cap screw to value shown in "Torque Values Chart".

**NOTE: Replace disc blades only with disc blades of equal thickness.**

6. Replace bearing dust cap.
7. Install scraper.
8. Install gauge wheel.

It may be necessary to replace only the bearing if there is excessive endplay or if the bearing sounds or feels rough when the disc blade is rotated.

### To replace bearing:

1. Remove gauge wheel, scraper, bearing cap, cap screw, washer and disc blade/bearing assembly.
2. Remove 1/4" rivets from bearing housing to expose bearing.
3. After installing new bearing, install three evenly spaced 1/4" cap screws into three of the six holes in the bearing housing to hold the bearing and bearing housing in place. Install rivets in the other three holes. Remove 1/4" cap screws and install rivets in those three holes.
4. Reinstall disc blade/bearing assembly, washer and cap screw. Torque 5/8"-11 cap screw to value shown in "Torque Values Chart" at the beginning of this section.
5. Replace bearing dust cap.
6. Install scraper and gauge wheel.

# MAINTENANCE

## SEED TUBE GUARD/INNER SCRAPER

The seed tube guard protects the seed tube and acts as the inner scraper for the seed opener disc blades.

Remove the seed tube and check for wear. Excessive wear on the seed tube indicates a worn seed tube guard. Replace the seed tube guard if it measures  $\frac{5}{8}$ " or less at the lower end. A new seed tube guard measures approximately  $\frac{7}{8}$ ".

LF212199-12

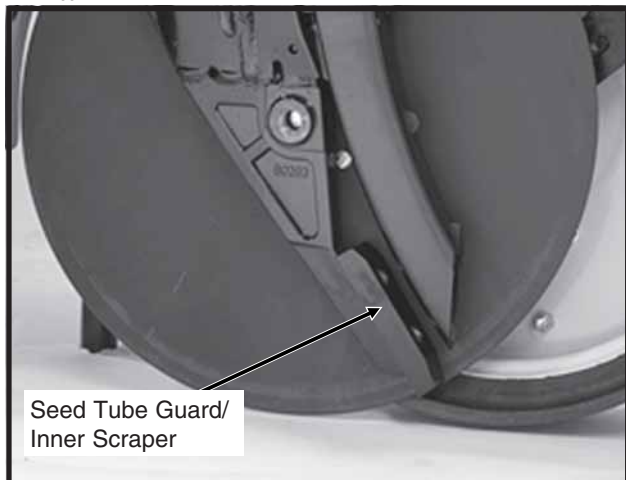

Shown With Gauge Wheel And Seed Opener Disc Blade Removed For Visual Clarity

**IMPORTANT:** No till planting or planting in hard ground conditions, especially when the planter is not equipped with no till coulters, and/or excessive blade-to-blade contact will increase seed tube guard wear and necessitate more frequent inspection and/or replacement.

To replace the seed tube guard, remove the seed tube and the two hex socket head cap screws which attach the seed tube guard. Hold the replacement seed tube guard centered between the seed opener disc blades. Install, but DO NOT tighten, the hex socket head cap screws. Using a clamp or vise-grip, squeeze the opener blades together in front of the seed tube guard. Tighten the seed tube guard retaining screws. Remove the clamps. The distance between the seed tube guard and opener blades should be equal on both sides. Reinstall seed tube.

**IMPORTANT:** Over tightening the hex socket head cap screws may damage the threads in the shank and require replacement of the shank. A seed tube guard that is worn excessively may allow the blades to wear into the row unit shank, also requiring replacement of the shank.

# MAINTENANCE

## FRAME MOUNTED COULTER

LF083002101

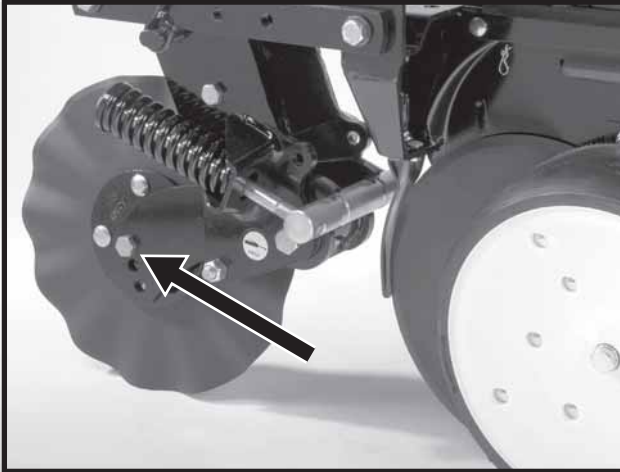

**NOTE: Torque  $\frac{5}{8}$ " spindle bolts to 120 ft. lbs.**

See "Frame Mounted Coulters" in Row Unit Operation Section of this manual for depth and spring adjustment.

When the 16" diameter coulters blade (1" fluted, 1" bubbled or  $\frac{3}{4}$ " fluted) is worn to 14  $\frac{1}{2}$ " (maximum allowable wear), it should be replaced.

## RESIDUE WHEELS (For Use With Frame Mounted Coulters)

LF083002102



The wheel hub is equipped with sealed bearings. If a bearing sounds or feels rough when the wheel is rotated, replace the bearings.

## ROW UNIT MOUNTED DISC FURROWER

LF212299-22

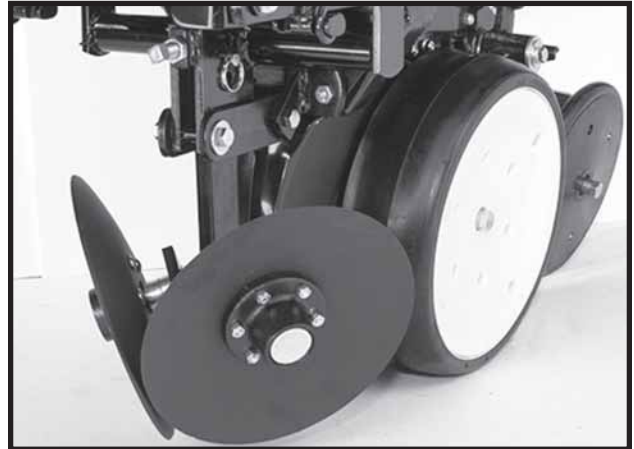

Lubricate the bushings in the support arm and mounting bracket at the frequency indicated in the Lubrication Section of this manual. Using a torque wrench, check each bolt for proper torque. If the bolt is loose, it should be removed and the bushing inspected for cracks and wear. Replace bushings as necessary. **Only hardened flat washers should be used. Replace damaged flat washers with proper part. Torque bolts to 57 ft. lbs.**

The blade hubs are equipped with sealed bearings. If bearings sound or feel rough when the blade is rotated, replace the bearings.

When the 12" diameter blades (solid or notched) are worn to 11", they should be replaced.

# MAINTENANCE

## ROW UNIT MOUNTED BED LEVELER

LF212299-25a

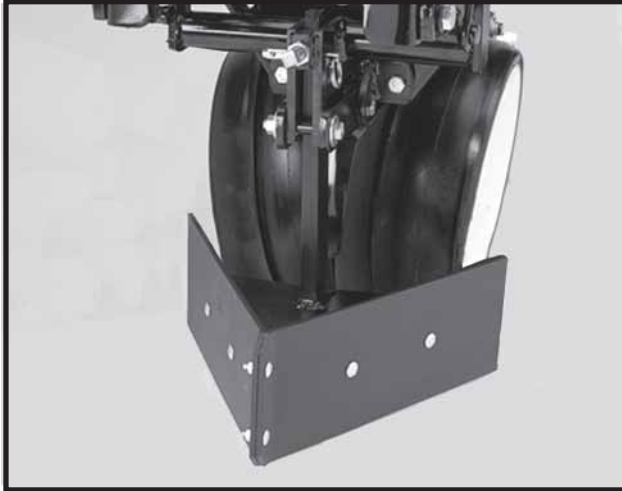

59386-26

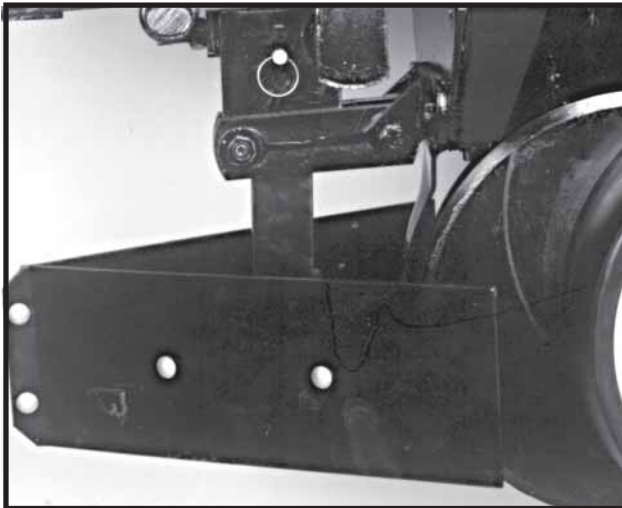

Lubricate the bushings in the mounting bracket and links at the frequency indicated in the Lubrication Section of this manual. Using a torque wrench, check each bolt for proper torque. If the bolt is loose, it should be removed and the bushing inspected for cracks and wear. Replace bushing if necessary. **Only hardened flat washers should be used. Replace damaged flat washers with proper part. Torque bolts to 57 ft. lbs.**

## ROW UNIT MOUNTED RESIDUE WHEEL

D101701113

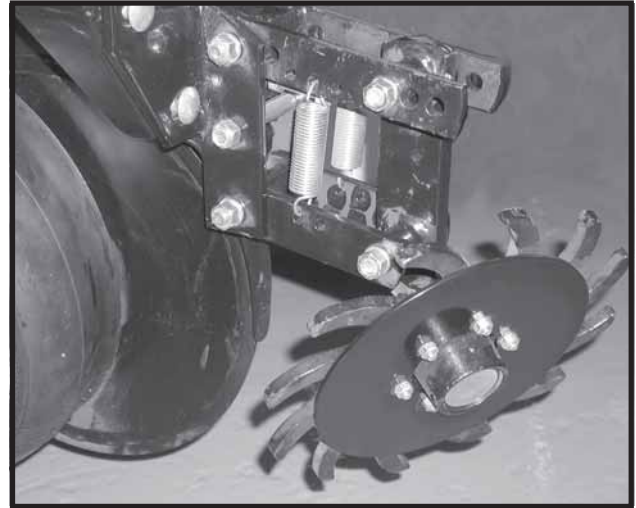

The wheel hub is equipped with sealed bearings. If a bearing sounds or feels rough when the wheel is rotated, replace the bearings.



# MAINTENANCE

## ROW UNIT MOUNTED NO TILL COULTER

LF212299-19a



Check periodically to be sure nuts and hardware are tightened to proper torque specification.

**NOTE: Torque  $\frac{5}{8}$ " spindle hardware to 120 ft. lbs.**

Be sure the couler is positioned square with the row unit and aligned in front of row unit disc opener.

The couler blade can be adjusted to one of four settings. Initially the blade is set in the highest position. As the blade wears it can be adjusted to one of the three lower settings. See "Row Unit Mounted No Till Couler" in Row Unit Operation Section of this manual.

When the 16" diameter couler blade is worn to 14  $\frac{1}{2}$ " (maximum allowable wear), it should be replaced.

## COULTER MOUNTED RESIDUE WHEELS

LF212299-23



The wheel hubs are equipped with sealed bearings. If bearings sound or feel rough when the wheel is rotated, replace the bearings.

# MAINTENANCE

## GRANULAR CHEMICAL ATTACHMENT

Prior to storage of the planter, disengage the granular chemical drive by rotating the throwout knob  $\frac{1}{4}$  turn counterclockwise. Remove the drive chain and empty and clean all granular chemical hoppers. Clean the drive chains and coat them with a rust preventive spray or submerge chains in oil. Inspect and replace any worn or broken parts.

Install hoppers and chains. Check chain alignment.

LF212299-4

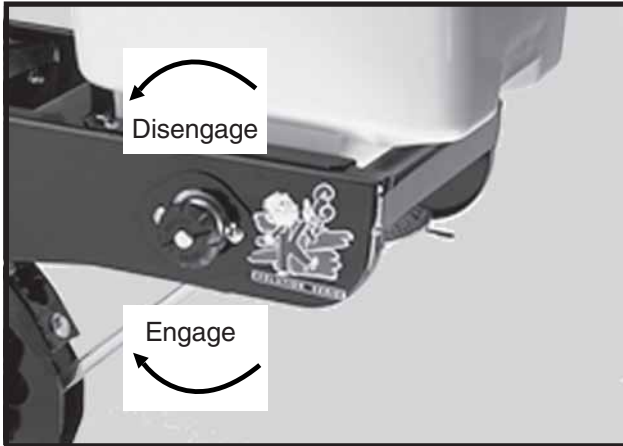

## SPRING TOOTH INCORPORATOR

Prior to storage of the planter, inspect each spring tooth incorporator and replace any worn or broken parts. Check for loose hardware and tighten as needed.

LF212299-26



# MAINTENANCE

## KPM I/KPM II STACK-MODE ELECTRONIC SEED MONITOR TROUBLESHOOTING

PROBLEM	POSSIBLE CAUSE	SOLUTION
Single sensor communication alarm comes on (alarm on with no bargraph and a flashing row number on a single row).	Faulty seed tube sensor.	Replace sensor.
	Break in the harness just before the seed tube sensor.	Inspect for break in harness and repair. If break can't be found, replace harness section.
	Dirty or corroded connector.	Clean connector.
Sensor communication alarms come on for all sensors (alarm on with no bargraphs and flashing row numbers on all rows).	Faulty monitor.	Replace monitor.
	Break in the harness just after the monitor.	Inspect for break in harness and repair. If break can't be found, replace harness section.
	Dirty or corroded connector.	Clean connector.
Sensor communication alarms come on for some sensors (alarm on with no bargraphs and flashing row numbers on all rows).	Break in the harness.	Inspect for break in harness and repair. If break can't be found, replace harness section corresponding with the alarming sensors.
	Dirty or corroded connector.	Clean connector.
Faulty monitor values (such as speed, area, etc.) being displayed. (KPM II Only)	Incorrect monitor settings.	Change settings to properly correspond to the system.
	Faulty radar/magnetic distance sensor.	Replace sensor.
	Improperly mounted radar sensor.	Properly mount sensor.
Underplanting or no planting alarm on a single sensor when planting (alarm on with a single bargraph segment on and a flashing row number on a single row).	Seed tube sensor is blocked.	Clean sensor.
	Faulty seed tube sensor.	Replace sensor.
Seed tube sensor dirty or blocked warning comes on (after calibration, bargraph keeps flashing for a single row).	Seed tube sensor is dirty.	Clean sensor.
	Faulty seed tube sensor.	Replace sensor.
LED on the seed tube sensor will not come on.	Faulty seed tube sensor.	Replace sensor.
	Dirty or corroded connector.	Clean connector.
	Break in the harness just before the sensor.	Repair harness.
Erroneous MPH readings at idle. (Radar Distance Sensor Only)	Radar sensor not located in a stable location.	Relocate to a more stable location.

# MAINTENANCE

## KPM III ELECTRONIC SEED MONITOR TROUBLESHOOTING

PROBLEM	POSSIBLE CAUSE	SOLUTION
Single sensor communication alarm comes on.	Faulty seed tube sensor.	Replace sensor.
	Break in the harness just before the seed tube sensor.	Inspect for break in harness and repair. If break can't be found, replace harness section.
	Dirty or corroded connector.	Clean connector.
Sensor communication alarms come on for all sensors.	Faulty monitor.	Replace monitor.
	Break in the harness just after the monitor.	Inspect for break in harness and repair. If break can't be found, replace harness section.
	Dirty or corroded connector.	Clean connector.
Sensor communication alarms come on for some sensors.	Break in the harness.	Inspect for break in harness and repair. If break can't be found, replace harness section corresponding with the alarming sensors.
	Dirty or corroded connector.	Clean connector.
Faulty monitor values (such as speed, area, etc.) being displayed.	Incorrect monitor settings.	Change settings to properly correspond to the system.
	Faulty radar/magnetic distance sensor.	Replace sensor.
	Improperly mounted radar sensor.	Properly mount sensor.
Underplanting or no planting alarm on a single sensor when planting (alarm on with a single bargraph segment on and a flashing row number on a single row.	Seed tube sensor is blocked.	Clean sensor.
	Faulty seed tube sensor.	Replace sensor.
	Meter not planting or underplanting.	Repair/replace meter.
	Chain broken or off sprocket.	Repair as necessary.
Seed tube sensor dirty or blocked warning comes on.	Seed tube sensor is dirty.	Clean sensor.
	Faulty seed tube sensor.	Replace sensor.
LED on the seed tube sensor will not come on.	Faulty seed tube sensor.	Replace sensor.
	Dirty or corroded connector.	Clean connector.
	Break in the harness just before the sensor.	Repair harness.
Erroneous MPH readings at idle. (Radar Distance Sensor Only)	Radar sensor not located in a stable location.	Relocate to a more stable location.

# MAINTENANCE

## FLOW CONTROL VALVE INSPECTION

The flow control valve used in the optional dual lift assist wheel hydraulic system should be adjusted for operation speed.

If the valve fails to function properly or requires frequent adjustment, the needle valve should be removed for inspection. Check for foreign material and contamination on both the valve and the seating area of the valve body. Replace any components found to be defective.

**NOTE: The dual lift assist wheels flow control must be installed with the arrow pointed toward the planter.**

**NOTE: When oil is cold, hydraulics operate slowly. Make sure all adjustments are made with warm oil.**

VVB001(MT2)

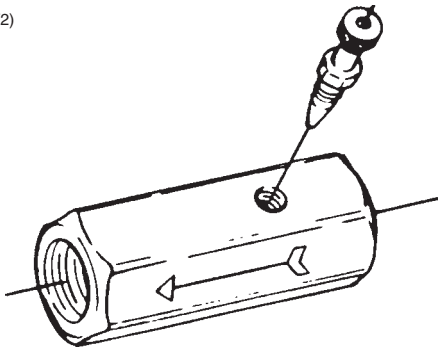

## ROW MARKER SEQUENCING/FLOW CONTROL VALVE INSPECTION

The valve block assembly consists of the row marker sequencing and flow control valves in one assembly.

The sequencing valve portion consists of a chambered body containing a spool and series of check valves to direct hydraulic oil flow. Should the valve malfunction, the components may be removed for inspection.

1. Remove valve block assembly from planter.
2. Remove detent assembly and port adapter assemblies from rear of valve block.

**IMPORTANT: Damage to the spool may occur if the detent assembly and port adapter assemblies are not removed prior to removal of the spool.**

3. Remove plug from both sides of valve block and remove spool.
4. Inspect all parts for pitting, contamination or foreign material. Also check seating surfaces inside the valve. Replace any parts found to be defective.
5. Lubricate spool with a light oil and re-install. Check to be sure spool moves freely in valve body.

**IMPORTANT: Make sure correct check ball(s) and spring are installed in each valve bore upon reassembly.**

A flow control valve is located on each side of the block assembly. The flow control valves should be adjusted for raise and lower speed as part of the assembly procedure or upon initial operation. If the valve fails to function properly or requires frequent adjustment, the needle valve should be removed for inspection. Check for foreign material and contamination. Be sure needle moves freely in adjustment screw. Replace any components found to be defective.

**NOTE: When oil is cold, hydraulics operate slowly. Make sure all adjustments are made with warm oil.**

(PLTR43)

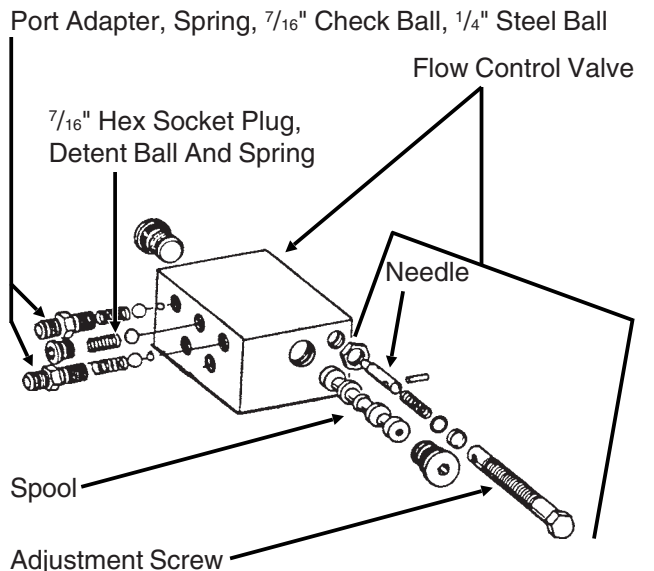

# MAINTENANCE

## ROW MARKER OPERATION TROUBLESHOOTING

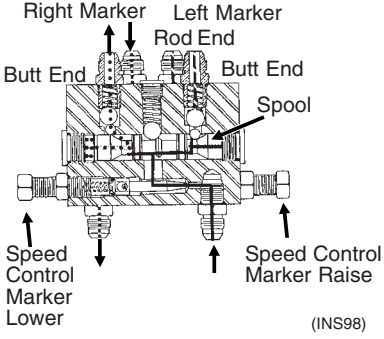
PROBLEM	POSSIBLE CAUSE	SOLUTION
<p>Same marker always operating.</p>  <p>(INS98)</p>	<p>Inadequate oil flow to sequencing valve. Most commonly associated with single valve system (lift and markers on same remote).</p>	<p><b>TEST: Raise planter and install transport lockups. Attempt to raise and lower planter. All hydraulic oil will be directed to markers. If markers function properly, the sequence valve is OK.</b> Slow raising of marker arm so the planter is up before the marker arm is completely up.</p>
	<p>Spool in sequencing valve not shifting.</p>	<p>Remove spool. Inspect for foreign material, making sure all ports in spool are open. Clean and reinstall.</p>
<p>Both markers lowering and only one raising at a time.</p>	<p>Hoses from cylinders to valve connected backwards.</p>	<p>Check hosing diagram in manual and correct.</p>
<p>Both markers lower and raise at same time</p>	<p>Foreign material under check ball in sequencing valve.</p>	<p>Remove hose fitting, spring and balls. Clean. May be desirable to remove spool and clean as well.</p>
	<p>Check ball missing or installed incorrectly in sequencing valve.</p>	<p>Disassemble and correct. See above illustration.</p>
<p>Marker (in raised position) settling down.</p>	<p>Damaged o-ring in marker cylinder or cracked piston.</p>	<p>Disassemble cylinder and inspect for damage and repair.</p>
	<p>Spool in sequencing valve not shifting completely because detent ball or spring is missing.</p>	<p>Check valve assembly and install parts as needed.</p>
	<p>Spool in sequencing valve shifting back toward center position.</p>	<p>Restrict flow of hydraulic oil from tractor to sequencing valve.</p>
<p>Neither marker will move.</p>	<p>Flow control closed too far.</p>	<p>Loosen locking nut and turn flow control adjustment bolt out or counterclockwise until desired speed is set.</p>
<p>Markers moving too fast.</p>	<p>Flow control open too far.</p>	<p>Loosen locking nut and turn flow control adjustment bolt in or clockwise until desired speed is set.</p>
<p>Sporadic marker operation speed.</p>	<p>Needle sticking open in flow control valve.</p>	<p>Remove flow control, inspect and repair or replace.</p>

# MAINTENANCE

## ROW MARKER BEARING LUBRICATION OR REPLACEMENT

1. Remove marker blade.
2. Remove dust cap from hub.
3. Remove cotter pin, nut and washer.
4. Slide hub from spindle.
5. Remove bearings and cups and discard if bearings are being replaced. Clean hub and dry. Remove bearings only and not cups if repacking.
6. Press in new bearing cups with thickest edge facing in. (Bearing replacement procedure only.)
7. Pack bearings with heavy duty wheel bearing grease thoroughly forcing grease between roller cone and bearing cage. Also fill the space between the bearing cups in the hub with grease.
8. Install rubber seal into grease seal. Place inner bearing in place and press in new rubber seal/grease seal.
9. Clean spindle and install hub.
10. Install outer bearing, washer and slotted hex nut. Tighten slotted hex nut while rotating hub until there is some drag. This assures that all bearing surfaces are in contact. Back off slotted nut to nearest locking slot and install cotter pin.
11. Fill dust caps approximately  $\frac{3}{4}$  full of wheel bearing grease and install on hub.
12. Install blade and dust cap retainer on hub and tighten evenly and securely.

(PLTR45/PLTR99/PLTR98/PLTR102)

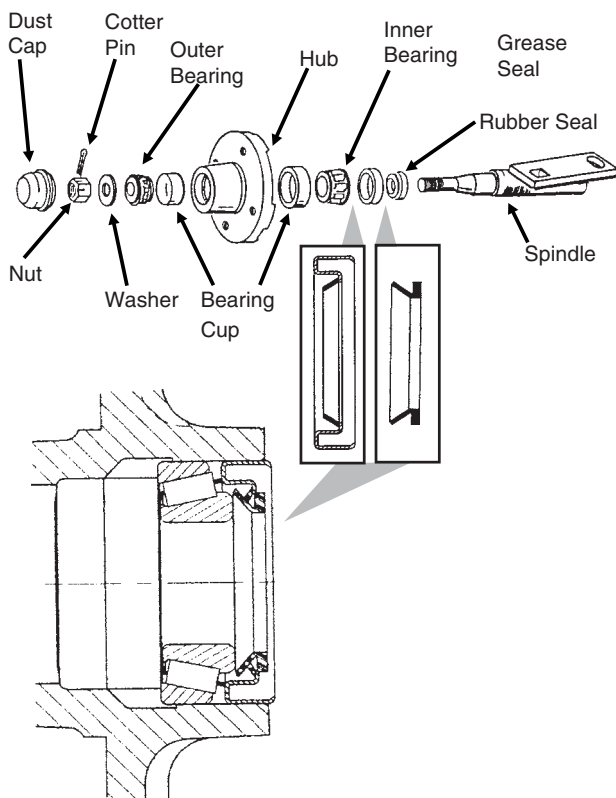

## WHEEL BEARING LUBRICATION OR REPLACEMENT

1. Raise tire clear of ground and remove wheel.
2. Remove double jam nuts and slide hub from spindle.
3. Remove bearings and cups and discard if bearings are being replaced. Clean hub and dry. Remove bearings only and not cups if repacking.
4. Press in new bearing cups with thickest edge facing in. (Bearing replacement procedure only.)
5. Pack bearings with heavy duty wheel bearing grease thoroughly forcing grease between roller cone and bearing cage. Also fill the space between the bearing cups in the hub with grease.
6. Place spacer (If Applicable) and inner bearing in place.
7. Clean spindle and install hub.
8. Install outer bearing and jam nut. Tighten jam nut while rotating hub until there is some drag. This assures that all bearing surfaces are in contact. Back off jam nut  $\frac{1}{4}$  turn or until there is only slight drag when rotating the hub. Install second jam nut to lock against first.
9. Install wheel on hub and tighten evenly and securely.

PTD057(EF35h/EF35i)

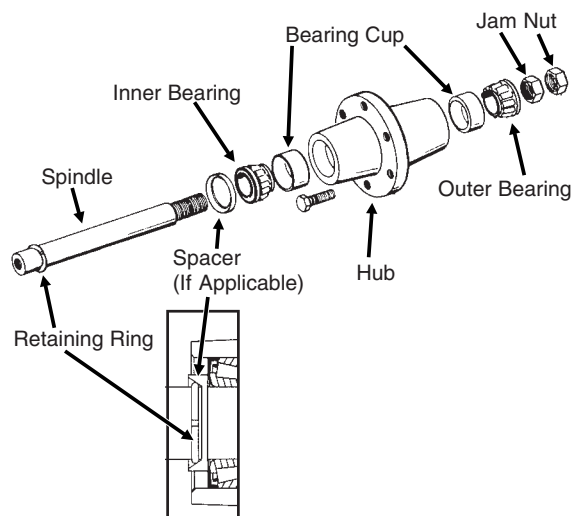

# MAINTENANCE

## PREPARATION FOR STORAGE

Store the planter in a dry sheltered area if possible.

Remove all trash that may be wrapped on sprockets or shafts and remove dirt that can draw and hold moisture.

Clean all drive chains and coat with a rust preventative spray, or remove chains and submerge in oil.

Lubricate planter and row units at all lubrication points.

Inspect the planter and row units for parts that are in need of replacement and order during the "off" season.

Make sure all seed and granular chemical hoppers are empty and clean.

Clean seed meters and store in a rodent-free, dry area.

Remove seed discs from brush-type seed meters. Clean and store meters with discs removed.

Grease or paint disc openers/blades and row marker disc blades to prevent rust.

## ELECTRICAL WIRING DIAGRAM FOR LIGHT PACKAGE

(WGN66b)

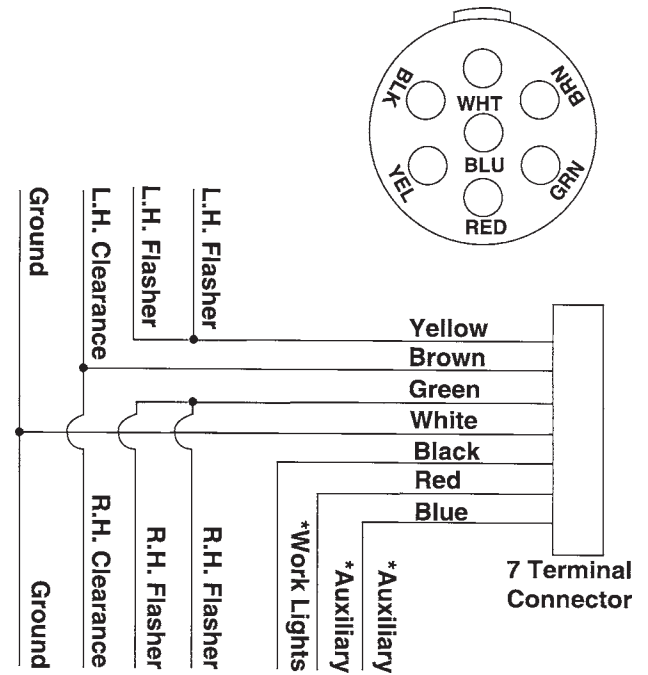

\* Optional customer-supplied auxiliary lights and wires may be wired into existing plug terminals.

(A9507a)

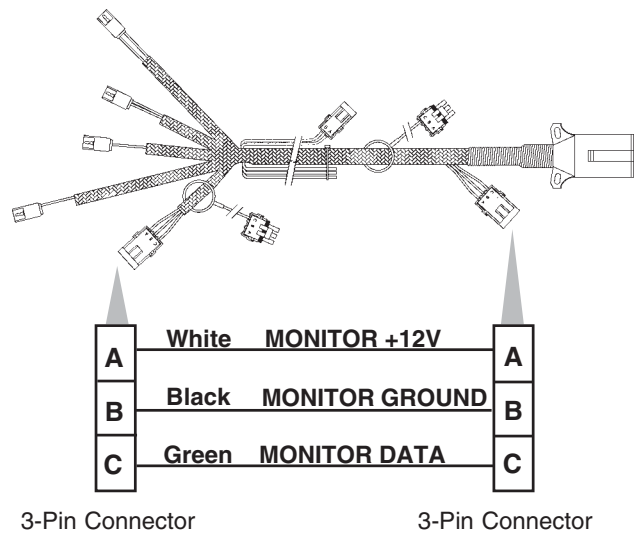

Light package supplied on the Model 3120 planter meets ASAE Standards. For the correct wiring harness to be wired into the lights on your tractor, check with the tractor manufacturer.



# PARTS LIST INDEX

---

## ROW UNIT

15" Seed Opener Disc Blade/Bearing Assembly And Scrapers .....	P5
Brush-Type Seed Meter .....	P15
Coulter Mounted Residue Wheels .....	P28
Covering Discs/Single Press Wheel .....	P8
Drag Closing Attachment .....	P11
Finger Pickup Seed Meter .....	P14
Frame Mounted Coulter W/Residue Wheels .....	P30
Gauge Wheels .....	P6
Granular Chemical Banding Options .....	P19
Granular Chemical Hopper And Hopper Panel Extension .....	P16
Granular Chemical Meter And Meter Drive .....	P18
Hopper Support And Meter Drive .....	P12
Parallel Arms, Mounting Support Plate And Quick Adjustable Down Force Springs .....	P4
Row Unit Mounted Bed Leveler .....	P22
Row Unit Mounted Disc Furrower .....	P24
Row Unit Mounted No Till Coulter .....	P21
Row Unit Mounted Residue Wheel .....	P26
Seed Hopper And Lid .....	P13
Shank Assembly, Seed Tube And Depth Adjustment .....	P2
Spring Tooth Incorporator .....	P20
"V" Closing Wheels .....	P10

## BASE MACHINE

Center Frame Assembly .....	P32
Cylinders .....	P48
Driveline .....	P40
Drive Wheel Assembly .....	P36
Dual Lift Assist W/Floating Center Mast .....	P38
Electrical Components .....	P54
Flow Control Valve .....	P51
Front Mounted Drive Wheel .....	P37
Hydraulic System .....	P52
Row Marker Assembly .....	P44
Row Marker Sequencing/Flow Control Valve .....	P51
Row Marker Spindle/Hub/Blade .....	P46
Seed Rate Transmission Assembly .....	P42
Wing And Hinge Assembly .....	P34

## ELECTRONIC SEED MONITOR

KPM I Electronic Seed Monitor .....	P56
KPM II Stack-Mode Electronic Seed Monitor .....	P58
KPM III Electronic Seed Monitor .....	P58

Decals, Paint And Miscellaneous .....	P60
---------------------------------------	-----

Numerical Index .....	P63
-----------------------	-----

# SHANK ASSEMBLY, SEED TUBE AND DEPTH ADJUSTMENT

(METR29cc)

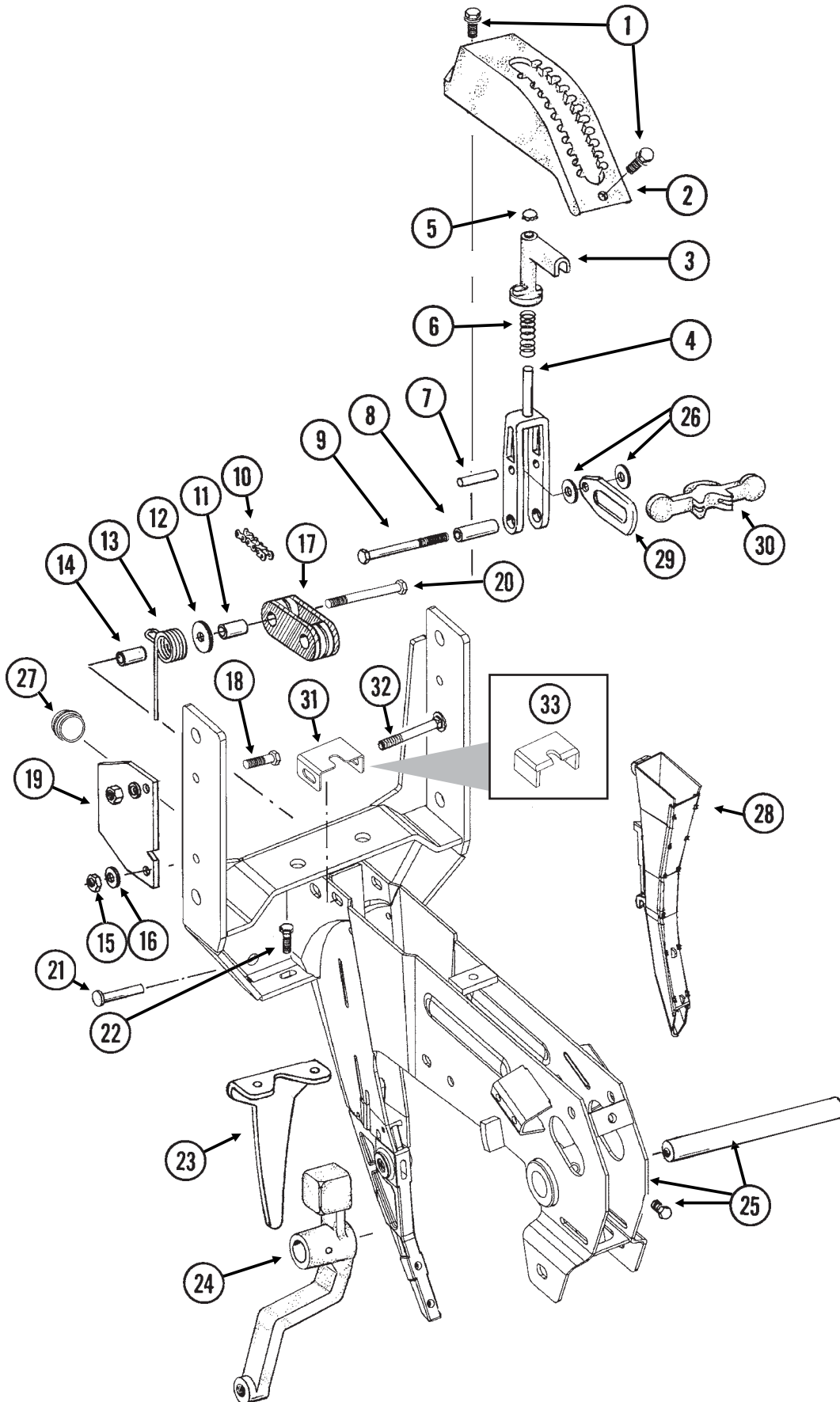

# SHANK ASSEMBLY, SEED TUBE AND DEPTH ADJUSTMENT

---

ITEM	PART NO.	QTY. (Per Row)	DESCRIPTION
1.	G11015	2	Hex Washer Head Cap Screw, $\frac{3}{8}$ "-16 x 1 $\frac{1}{4}$ "
2.	GB0274	1	Cover, Depth Adjustment
3.	GB0266	1	Handle, Depth Adjustment
4.	GB0267	1	Lever, Depth Adjustment
5.	GD3612	1	Cap Plug
6.	GD10993	1	Spring
7.	GD13361	1	Pin, $\frac{3}{8}$ " x 1 $\frac{2}{3}$ "
8.	GD11259	1	Sleeve, $\frac{3}{8}$ " I.D. x $\frac{5}{8}$ " O.D. x 1 $\frac{25}{32}$ " Long
9.	G11008	1	Hex Head Cap Screw, $\frac{3}{8}$ "-24 x 2 $\frac{1}{2}$ ", Grade 8
	G11007	1	Lock Nut, $\frac{3}{8}$ "-24, Grade C
10.	G3303-98	1	Chain, No. 41, 98 Pitch Including Connector Link
	GR0196	1	Connector Link, No. 41
11.	GD1026	1	Sleeve, 1 $\frac{3}{16}$ " Long
12.	G10201	1	Special Washer, $\frac{3}{8}$ " x 1 $\frac{1}{2}$ " O.D.
13.	GD1065	1	Idler Spring
14.	GD7318	1	Sleeve, 1" Long
15.	G10108	1	Lock Nut, $\frac{3}{8}$ "-16
16.	G10210	1	Washer, $\frac{3}{8}$ " USS
17.	GD11962	1	Idler
18.	G10003	3	Hex Head Cap Screw, $\frac{3}{8}$ "-16 x 1 $\frac{1}{2}$ "
	G10108	3	Lock Nut, $\frac{3}{8}$ "-16
19.	GD10867	2	Stop
20.	G10326	1	Hex Head Cap Screw, $\frac{3}{8}$ "-16 x 3 $\frac{3}{4}$ "
21.	G10551	1	Clevis Pin, $\frac{1}{4}$ " x 2 $\frac{1}{2}$ "
	G10669	1	Hair Pin Clip, No. 22
22.	G10312	2	Carriage Bolt, $\frac{5}{16}$ "-18 x $\frac{3}{4}$ "
	G10620	2	Serrated Flange Nut, $\frac{5}{16}$ "-18
23.	GD1033	1	Shield
24.		-	See "Gauge Wheels", Pages P6 And P7
25.	GA10157	1	Shank W/Gauge Wheel Pivot Spindle And Set Screw
	GD11001	-	Spindle
	G10438	-	Hex Head Cap Screw, $\frac{1}{2}$ "-13 x $\frac{3}{4}$ "
26.	G10207	2	Washer, $\frac{7}{8}$ " O.D. x $\frac{13}{32}$ " I.D. x .134" (If Applicable)
27.	GD11845	1	Dust Cap
28.			See "KPM I Electronic Seed Monitor And KPM II Stack-Mode/KPM III Electronic Seed Monitor", Pages P56-P59
29.	GB0285	1	Collar, Depth Adjustment
30.	GB0265	1	Pivot Link, Depth Adjustment
31.	GD15970	1	Sun Shade
32.	G10304	1	Carriage Bolt, $\frac{3}{8}$ "-16 x 3"
	G10108	1	Lock Nut, $\frac{3}{8}$ "-16
33.	GD16245	-	Sun Shade (Rubber)

# PARALLEL ARMS, MOUNTING SUPPORT PLATE AND QUICK ADJUSTABLE DOWN FORCE SPRINGS

(RU144/RU178f)

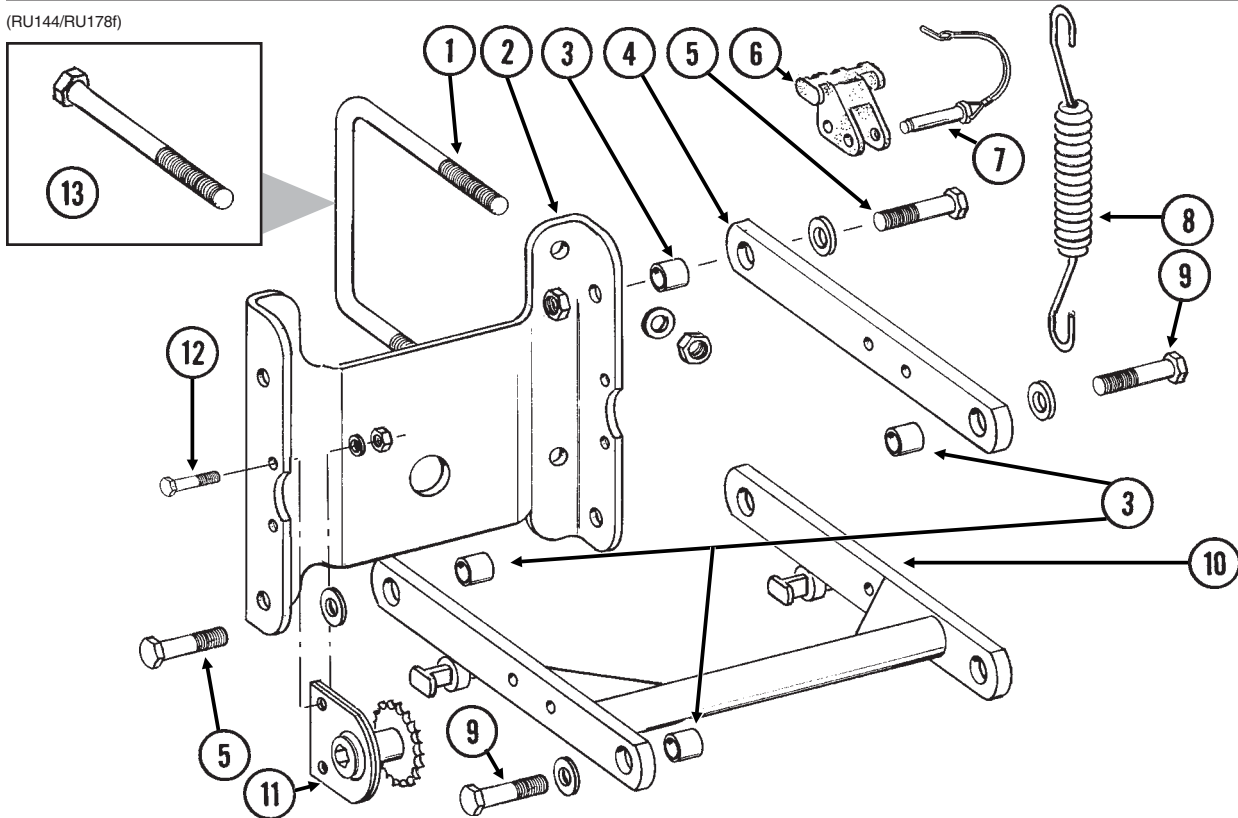

ITEM	PART NO.	QTY. (Per Row)	DESCRIPTION
1.	GD1114	2	U-Bolt, 7" x 7" x 5/8"-11
	G10230	4	Lock Washer, 5/8"
	G10104	4	Hex Nut, 5/8"-11
2.	GD10036	1	Mounting Support Plate
3.	GB0218	4	Bushing, 21/32" I.D. x 7/8" O.D. x 19/32" Long
4.	GD11422	2	Upper Parallel Arm
5.	G10732	4	Hex Head Cap Screw, 5/8"-18 x 2"
	GD7805	4	Special Washer, 5/8", Hardened
	G10412	4	Lock Nut, 5/8"-18
6.	GB0186	2	Spring Anchor
7.	GD14217	2	Tab Lock Pin, 7/16" x 1 1/2"
8.	GD8249	2-4	Spring
9.		-	See "Hopper Support And Meter Drive", Page P12
10.	GA5651	1	Lower Parallel Arm
11.	GA1720	1	Bearing/Sprocket, 7/8" Hex Bore
12.	G10004	2	Hex Head Cap Screw, 3/8"-16 x 1 1/4"
	G10229	2	Lock Washer, 3/8"
	G10101	2	Hex Nut, 3/8"-16
13.	G10152	-	Hex Head Cap Screw, 5/8"-11 x 9"
	G10205	-	Washer, 5/8" SAE
	G10230	-	Lock Washer, 5/8"
	G10104	-	Hex Nut, 5/8"-11
A.	G6326X	-	U-Bolt Package For 7" x 7" Toolbar, Includes: (2) GD1114, (4) G10230, (4) G10104

# 15" SEED OPENER DISC BLADE/BEARING ASSEMBLY AND SCRAPERS

(RU139)

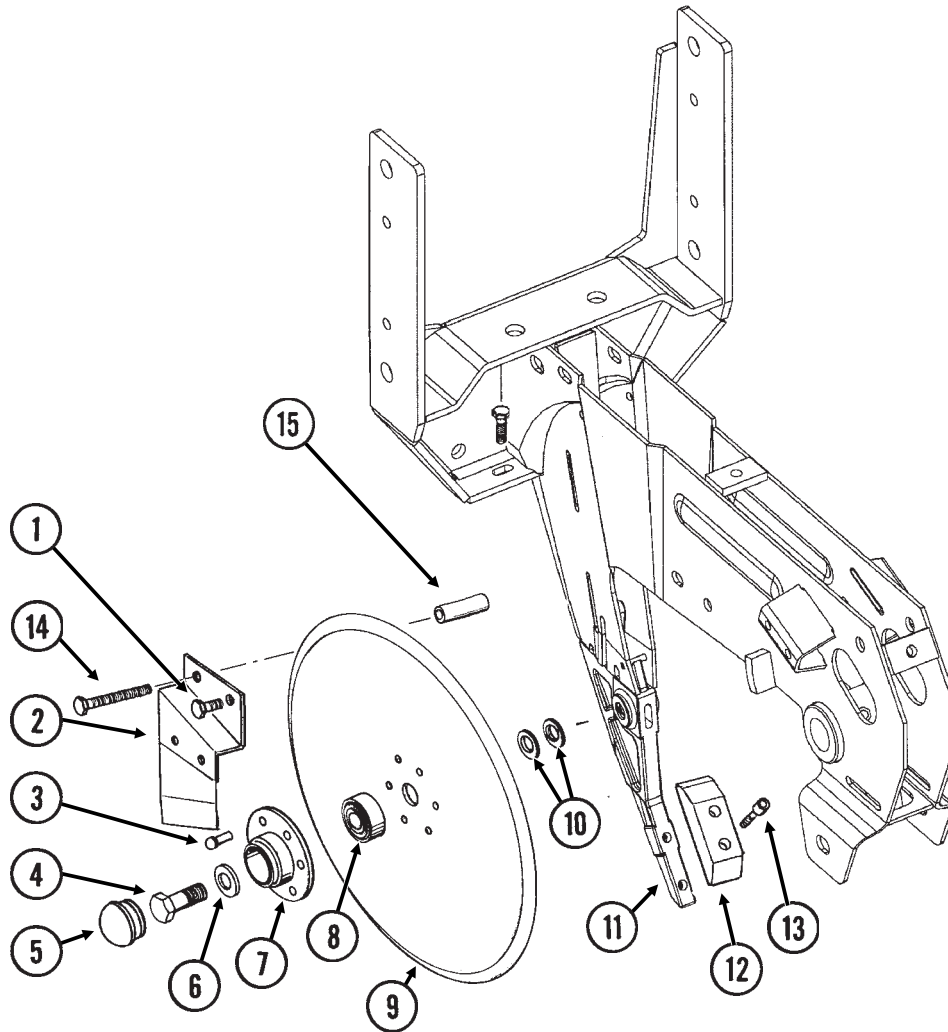

ITEM	PART NO.	QTY. (Per Row)	DESCRIPTION
1.	G10328	2	Hex Head Cap Screw, $\frac{3}{8}$ "-16 x $\frac{5}{8}$ "
	G10622	2	Serrated Flange Nut, $\frac{3}{8}$ "-16
2.	GA2012R	1	Disc Scraper, R.H.
	GA2012L	-	Disc Scraper, L.H. (Shown)
3.	G10427	12	Rivet, $\frac{1}{4}$ " x $\frac{1}{2}$ "
4.	GD11017	1	Special Hex Head Cap Screw, $\frac{5}{8}$ "-11 x $1\frac{1}{2}$ ", L.H. Threads
	G10007	1	Hex Head Cap Screw, $\frac{5}{8}$ "-11 x $1\frac{1}{2}$ "
5.	GD11845	2	Dust Cap
6.	G10204	2	Special Machine Bushing, $\frac{5}{8}$ " x 1" O.D.
7.	GD10473	2	Bearing Housing
8.	GA2014	2	Bearing
9.	GD11306	2	Disc Blade, 3.5 mm x 15"
10.	G10213	-	Machine Bushing, $\frac{5}{8}$ " (.030" Thick)(As Required)
11.		-	See "Shank Assembly", Pages P2 And P3
12.	GB0301	1	Seed Tube Guard/Inner Scraper
13.	G10912	2	Hex Socket Head Cap Screw, $\frac{5}{16}$ "-18 x 1", Grade 8
14.	G10325	1	Hex Head Cap Screw, $\frac{3}{8}$ "-16 x $2\frac{3}{4}$ "
	G10622	1	Serrated Flange Nut, $\frac{3}{8}$ "-16
15.	GD11259	1	Sleeve, $\frac{3}{8}$ " I.D. x $\frac{5}{8}$ " O.D. x $1\frac{25}{32}$ " Long
A.	GA8324	-	Disc Blade/Bearing Assembly, Less Dust Cap (Items 3 And 7-9)

# GAUGE WHEELS

(RU140)

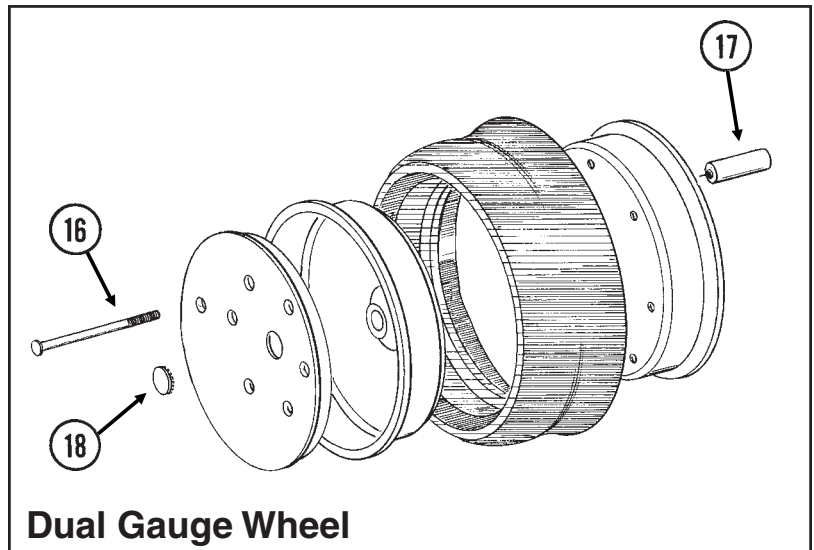
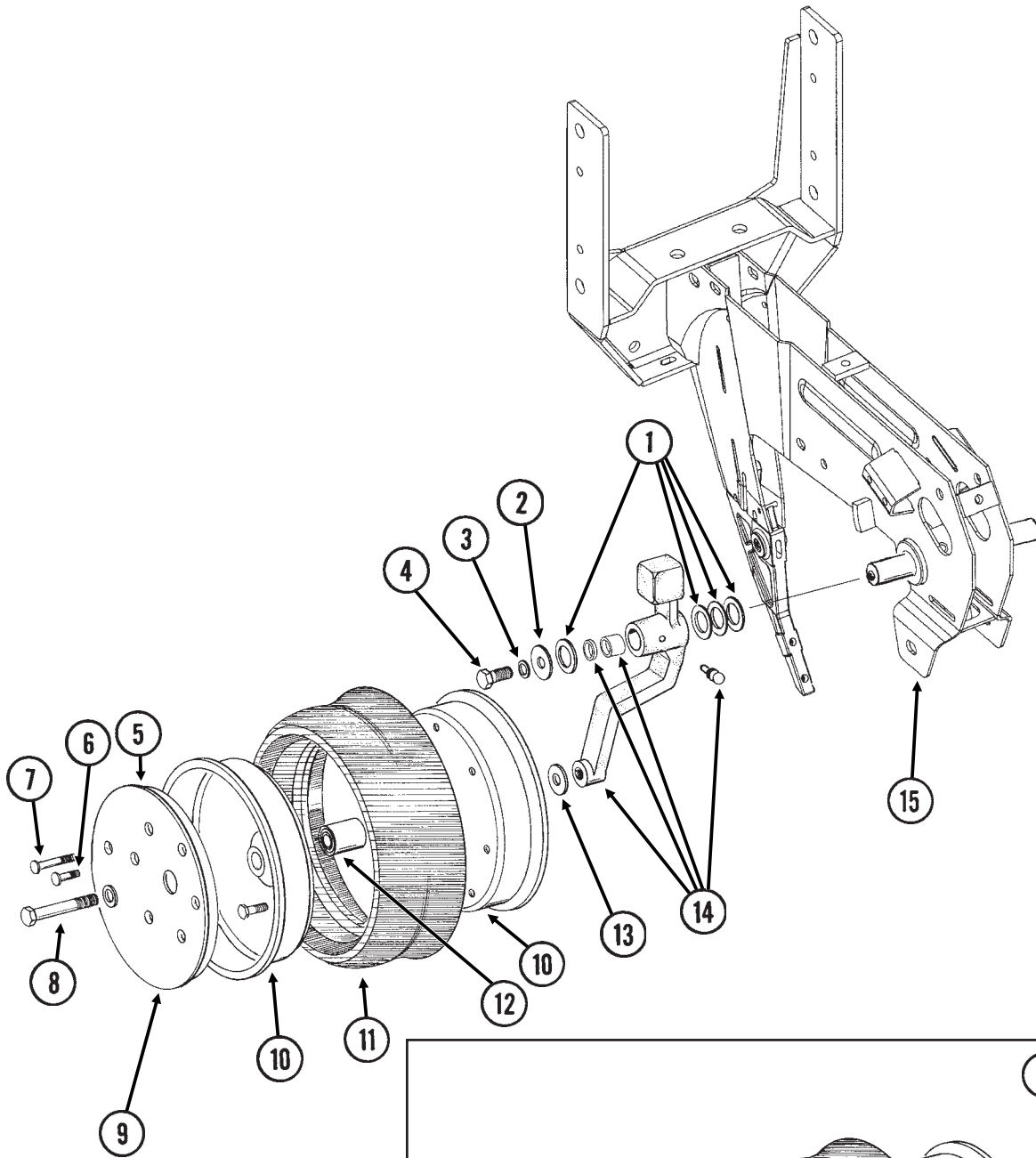

**Dual Gauge Wheel**

# GAUGE WHEELS

ITEM	PART NO.	QTY. (Per Row)	DESCRIPTION
1.	G10940	-	Machine Bushing, 1" (.048" Thick)
2.	G10216	2	Washer, 1/2" USS
3.	G10228	2	Lock Washer, 1/2"
4.	G10014	1	Hex Head Cap Screw, 1/2"-13 x 1"
5.	GD11453	2	Cover
6.	G10338	12	Carriage Bolt, 5/16"-18 x 1 1/4"
	G10620	12	Serrated Flange Nut, 5/16"-18
7.	G10924	8	Carriage Bolt, 5/16"-18 x 1 3/4"
	G10620	8	Serrated Flange Nut, 5/16"-18
8.	G10010	2	Hex Head Cap Screw, 5/8"-11 x 3"
	G10230	2	Lock Washer, 5/8"
9.	G10018	14	Hex Head Cap Screw, 5/16"-18 x 5/8"
	G10109	14	Lock Nut, 5/16"-18, Grade 8
10.	GD11423	4	Half Wheel
11.	GD1086	2	Tire
12.	GA6171	2	Bearing
13.	G10204	2	Special Machine Bushing, 5/8" x 1" O.D.
14.	GA7975	1	Wheel Arm W/Grease Fitting, Bushings And Seals, L.H. (Shown)
	GA7976	1	Wheel Arm W/Grease Fitting, Bushings And Seals, R.H.
	G10640	1	Grease Fitting, 1/4"-28 (Per Arm)
	GB0276	2	Bushing, 1" I.D. x 1 1/4" O.D. x 1" Long (Per Arm)
	GD10991	2	Seal (Per Arm)
15.		-	See "Shank Assembly", Pages P2 And P3
16.	G10944	8	Carriage Bolt, 5/16"-18 x 6" (Replaces Item 7)
	G10620	8	Serrated Flange Nut, 5/16"-18
17.	GD8811	8	Dual Gauge Wheel Sleeve, 4 1/8"
18.	GD11936	1	Plug, 1 1/8"
A.	GA7949	-	Gauge Wheel Complete (Items 5-7 And 9-12)
B.	G1K296	-	Gauge Wheel Arm Bushing And Seal Driver Kit

# COVERING DISCS/SINGLE PRESS WHEEL

RUA054/RUB026(RU94d)

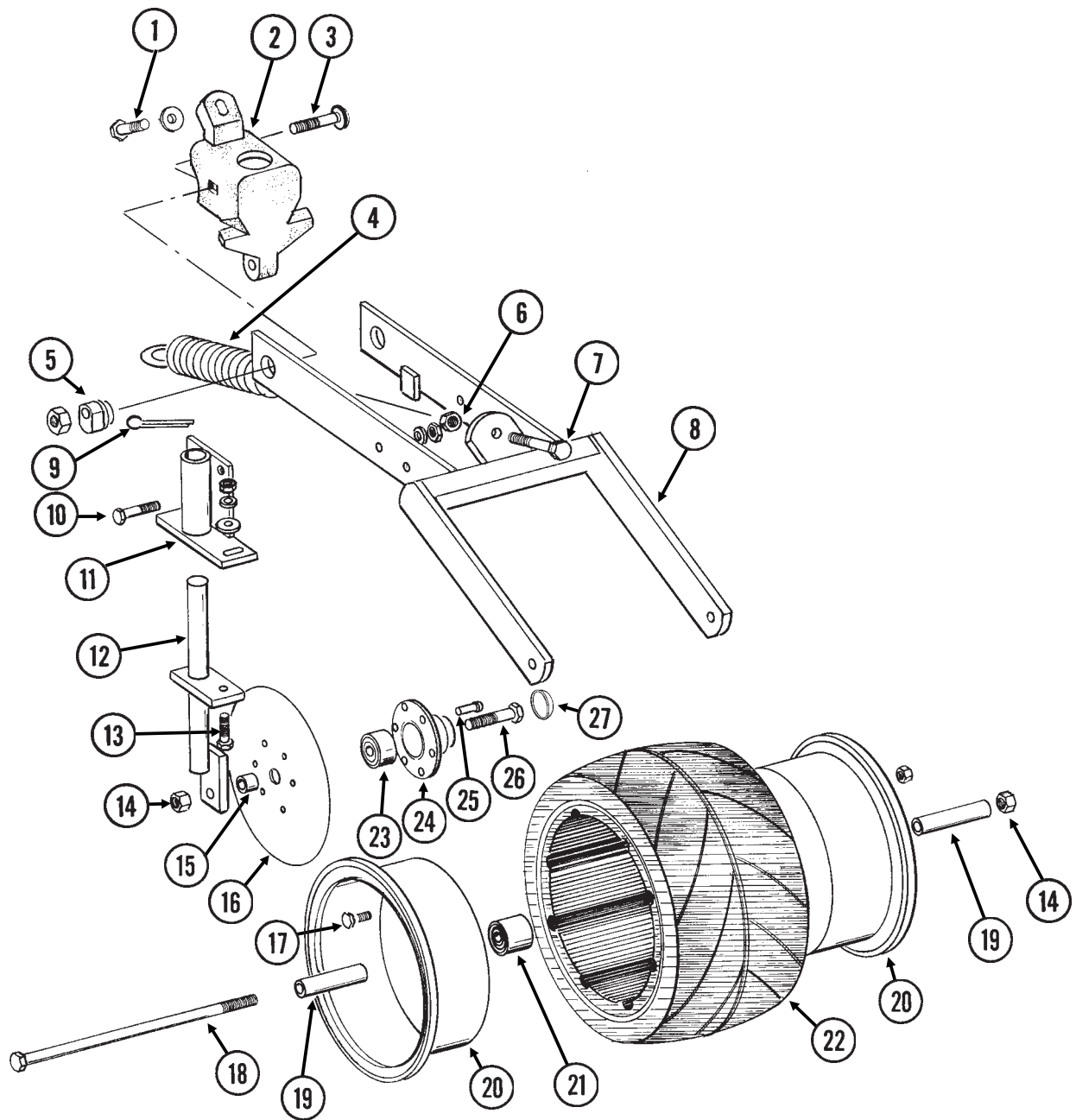



# COVERING DISCS/SINGLE PRESS WHEEL

ITEM	PART NO.	QTY. (Per Row)	DESCRIPTION
1.	G10001	1	Hex Head Cap Screw, $\frac{3}{8}$ "-16 x 1"
	G10210	1	Washer, $\frac{3}{8}$ " USS
2.	GB0268	1	Wheel Arm Stop
3.	G10801	2	Carriage Bolt, $\frac{1}{2}$ "-13 x 2 $\frac{1}{4}$ "
	G10315	-	Carriage Bolt, $\frac{1}{2}$ "-13 x 2 $\frac{1}{2}$ " (Used W/Straight Drop In-Furrow Granular Chemical Bracket)
	G10102	2	Hex Nut, $\frac{1}{2}$ "-13
4.	GA2054	1	Spring
5.	GB0239	2	Eccentric Bushing
6.	G10102	1	Hex Nut, $\frac{1}{2}$ "-13
7.	G10015	1	Adjusting Bolt, $\frac{1}{2}$ "-13 x 5"
8.	GA6619	1	Mounting Arm
9.	G10463	2	Cotter Pin, $\frac{1}{4}$ " x 1 $\frac{1}{2}$ "
10.	G10171	4	Hex Head Cap Screw, $\frac{5}{16}$ "-18 x 1 $\frac{1}{4}$ "
	G10232	4	Lock Washer, $\frac{5}{16}$ "
	G10106	4	Hex Nut, $\frac{5}{16}$ "-18
11.	GA6620	2	Bracket
12.	GA6618	2	Mount
13.	G10303	2	Carriage Bolt, $\frac{5}{16}$ "-18 x 1"
	G10219	2	Washer, $\frac{5}{16}$ " USS
	G10232	2	Lock Washer, $\frac{5}{16}$ "
	G10106	2	Hex Nut, $\frac{5}{16}$ "-18
14.	G10107	3	Lock Nut, $\frac{5}{8}$ "-11
15.	GD1109	2	Bushing, $\frac{41}{64}$ " I.D. x $\frac{7}{8}$ " O.D. x $\frac{1}{4}$ " Long
16.	GD9290	2	Disc Blade, 8"
17.	G10018	7	Hex Head Cap Screw, $\frac{5}{16}$ "-18 x $\frac{5}{8}$ "
	G10109	7	Lock Nut, $\frac{5}{16}$ "-18, Grade 8
18.	G10152	1	Hex Head Cap Screw, $\frac{5}{8}$ "-11 x 9"
19.	GD3180-12	2	Sleeve, $\frac{5}{8}$ " I.D. x $\frac{7}{8}$ " O.D. x 2 $\frac{7}{8}$ " Long
20.	GD9562	2	Half Wheel
21.	GA6171	1	Bearing
22.	GD9305	1	Tire
23.	GA2014	2	Bearing
24.	GD10473	2	Bearing Housing
25.	G10427	12	Rivet, $\frac{1}{4}$ " x $\frac{1}{2}$ "
26.	G10006	2	Hex Head Cap Screw, $\frac{5}{8}$ "-11 x 2 $\frac{1}{4}$ "
27.	GD11845	2	Dust Cap
A.	GA6733	-	Single Press Wheel Complete W/Bearing (Items 17 And 20-22)
B.	GA6801	-	Covering Disc Blade Complete W/Bearing (Items 16 And 23-25)

# "V" CLOSING WHEELS

(RU83/RU83n)

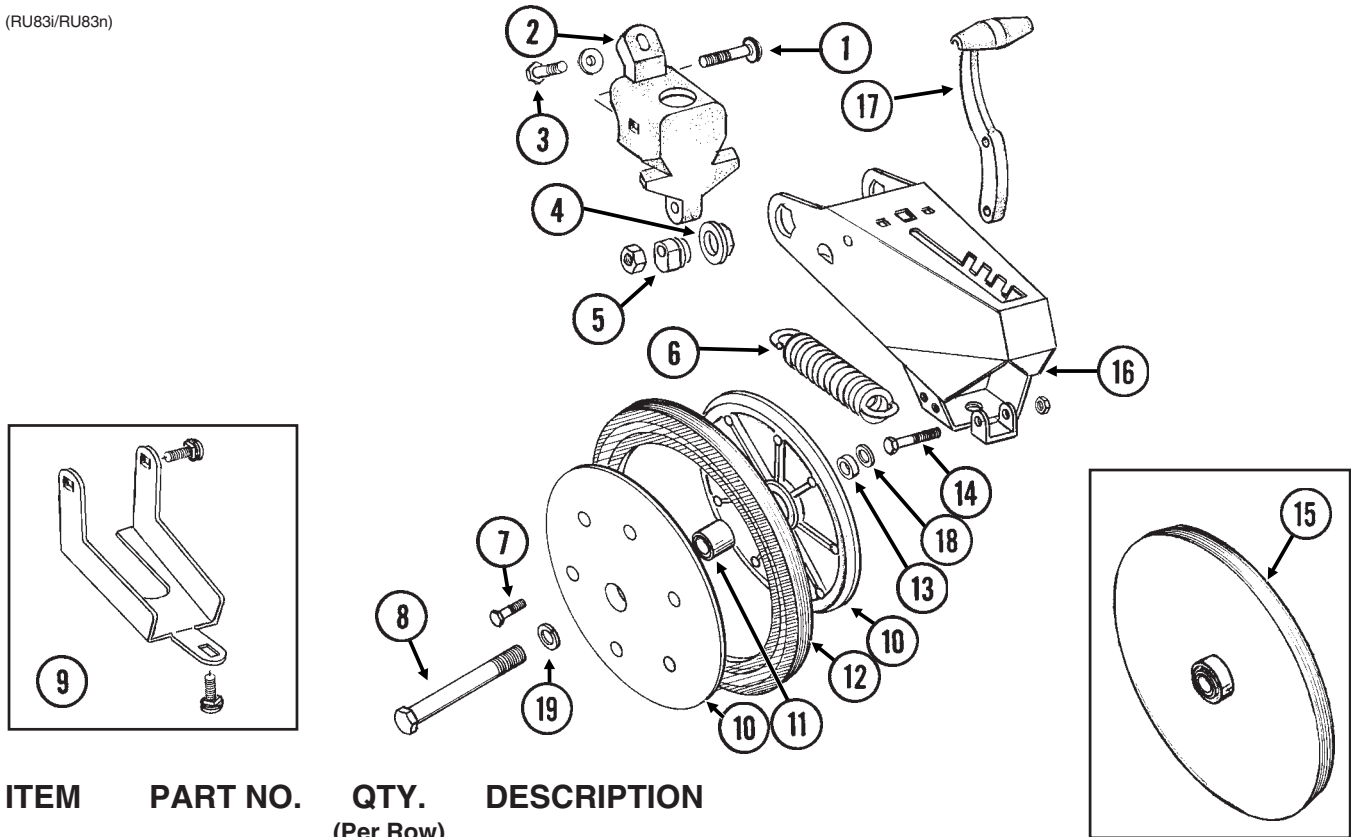

ITEM	PART NO.	QTY. (Per Row)	DESCRIPTION
1.	G10801	2	Carriage Bolt, 1/2"-13 x 2 1/4"
	G10315	-	Carriage Bolt, 1/2"-13 x 2 1/2" (Used W/Straight Drop In-Furrow Granular Chemical Bracket)
	G10111	2	Lock Nut, 1/2"-13
2.	GB0268	1	Wheel Arm Stop
3.	G10001	1	Hex Head Cap Screw, 3/8"-16 x 1"
	G10210	1	Washer, 3/8" USS
4.	GB0282	2	Stepped Bushing
5.	GB0239	2	Eccentric Bushing
6.	GD8460	1	Spring
7.	G10064	6	Hex Head Cap Screw, 1/4"-20 x 1"
8.	G10013	2	Hex Head Cap Screw, 5/8"-11 x 3 1/2"
	G10107	2	Lock Nut, 5/8"-11
9.	G1K345	-	Closing Wheel Shield Kit W/Hardware And Instruction
	G10308	2	Carriage Bolt, 3/8"-16 x 3/4"
	G10599	1	Carriage Bolt, 3/8"-16 x 1 1/4"
	G10210	1	Washer, 3/8" USS
	G10229	3	Lock Washer, 3/8"
	G10101	3	Hex Nut, 3/8"-16
10.	GD9120	4	Nylon Half Wheel
11.	GA6171	2	Bearing
12.	GD1085	2	Rubber Tire, 1" x 12"
13.	GD1109	2	Bushing, 41/64" I.D. x 7/8" O.D. x 1/4" Long
14.	G10133	1	Hex Head Cap Screw, 5/16"-18 x 1 1/2"
	G10109	1	Lock Nut, 5/16"-18, Grade 8
15.	GA6597	-	Cast Iron Closing Wheel W/Bearing
	GA6171	-	Bearing
16.	GA8322	1	Arm
17.	GB0254	1	Lever
18.	GD7805	2	Special Washer, 5/8", Hardened
19.	G10230	2	Lock Washer, 5/8"
A.	GA6434	-	Rubber Closing Wheel Complete W/Bearing (Items 7 And 10-12)

# DRAG CLOSING ATTACHMENT

RUB050(RU90c)

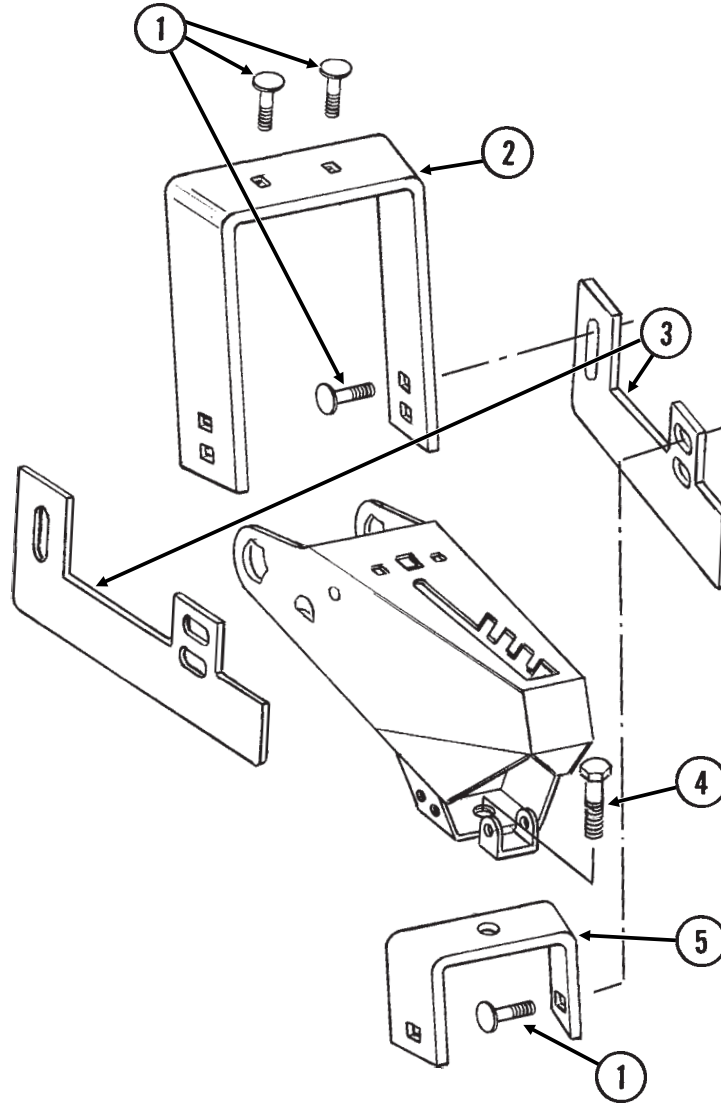

ITEM	PART NO.	QTY.	DESCRIPTION
		(Per Row)	
1.	G10599	6	Carriage Bolt, 3/8"-16 x 1 1/4"
	G10210	6	Washer, 3/8" USS
	G10229	6	Lock Washer, 3/8"
	G10101	6	Hex Nut, 3/8"-16
2.	GD11508	1	Front Bracket
3.	GD11313	2	Blade
4.	G10007	1	Hex Head Cap Screw, 5/8"-11 x 1 1/2"
	G10230	1	Lock Washer, 5/8"
	G10104	1	Hex Nut, 5/8"-11
5.	GD11509	1	Rear Bracket
A.	G7566X	-	Drag Closing Attachment Complete (Items 1-5)

# HOPPER SUPPORT AND METER DRIVE

(METR22d)

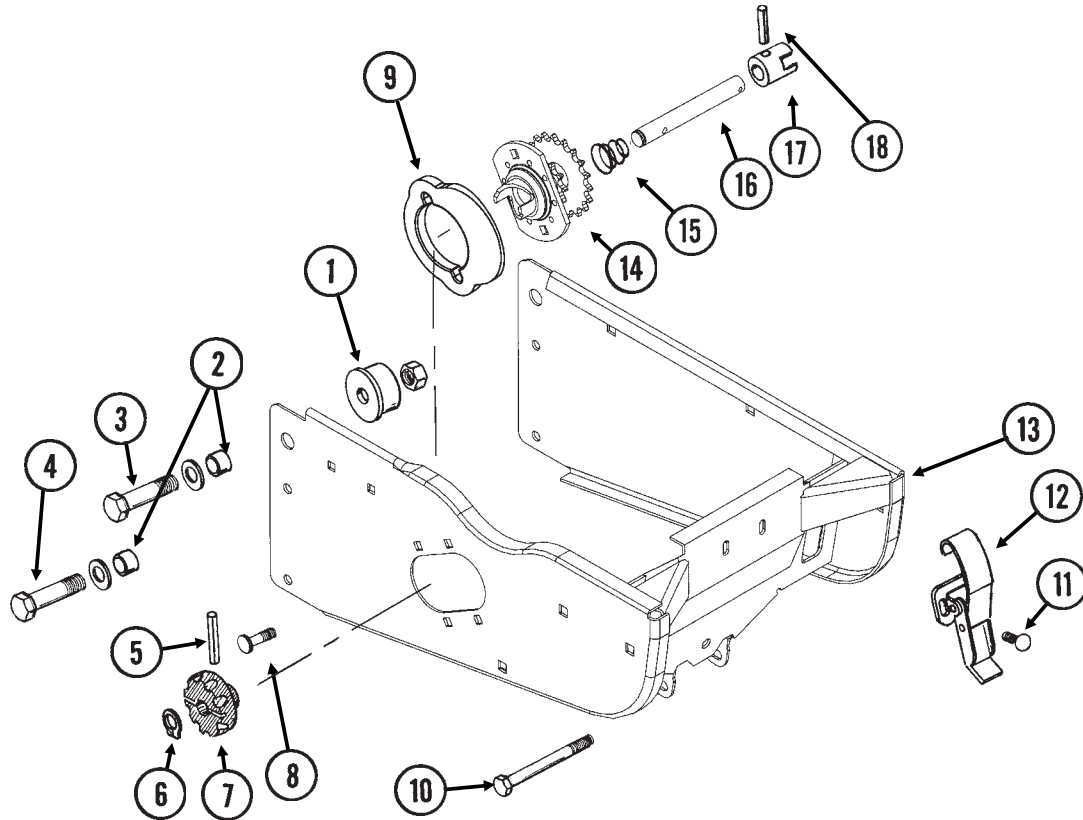

ITEM	PART NO.	QTY. (Per Row)	DESCRIPTION
1.	GB0314	2	Hopper Mount
2.	GB0218	4	Bushing, $2\frac{1}{32}$ " I.D. x $\frac{7}{8}$ " O.D. x $\frac{19}{32}$ " Long
3.	G10752	2	Hex Head Cap Screw, $\frac{5}{8}$ "-18 x $2\frac{1}{4}$ "
	GD7805	2	Special Washer, $\frac{5}{8}$ ", Hardened
	G10412	2	Lock Nut, $\frac{5}{8}$ "-18
4.	G10751	2	Hex Head Cap Screw, $\frac{5}{8}$ "-18 x $1\frac{3}{4}$ "
	GD7805	2	Special Washer, $\frac{5}{8}$ ", Hardened
	G10412	2	Lock Nut, $\frac{5}{8}$ "-18
5.	G10602	1	Spring Pin, $\frac{1}{4}$ " x $1\frac{1}{2}$ "
6.	G10567	1	External Retaining Ring, $\frac{5}{8}$ "
7.	GD11239	1	Knob
8.	G10338	2	Carriage Bolt, $\frac{5}{16}$ "-18 x $1\frac{1}{4}$ "
	G10620	2	Serrated Flange Nut, $\frac{5}{16}$ "-18
9.	GB0331	1	Clutch Adapter Plate
10.	G10061	1	Hex Head Cap Screw, $\frac{3}{8}$ "-16 x $3\frac{1}{2}$ "
	G10210	2	Washer, $\frac{3}{8}$ " USS
	G10108	1	Lock Nut, $\frac{3}{8}$ "-16
11.	G10309	2	Carriage Bolt, $\frac{1}{4}$ "-20 x $\frac{5}{8}$ ", Grade 2
	G10621	2	Serrated Flange Nut, $\frac{1}{4}$ "-20
12.	GA2007	1	Hopper Hold Down Latch
13.	GA10155	1	Hopper Support
14.	GA10137	1	Double Sprocket And Bearing, Drive Clutch, 11/19 Tooth
15.	GD11413	1	Spring
16.	GD15747	1	Shaft
17.	GB0278	1	Coupler
18.	G10546	1	Spring Pin, $\frac{3}{16}$ " x $1\frac{1}{4}$ "
A.	GA10151	-	Meter Drive Assembly, 11/19 Tooth (Items 5-7 And 14-18)

# SEED HOPPER AND LID

(RU87e/RU87a)

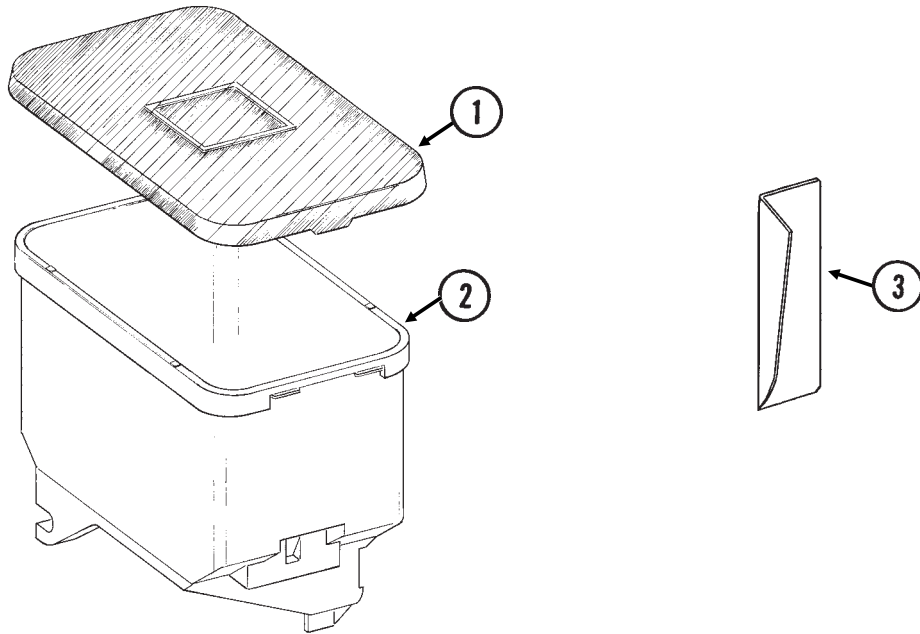

ITEM	PART NO.	QTY. (Per Row)	DESCRIPTION
1.	GD11279	1	Lid
2.	GA9714	1	Seed Hopper, Reinforced
3.	GD11747	1	Seed Reserve Baffle

# FINGER PICKUP SEED METER

RUA015/RUA056/RUA057(RU13k/RU13d)

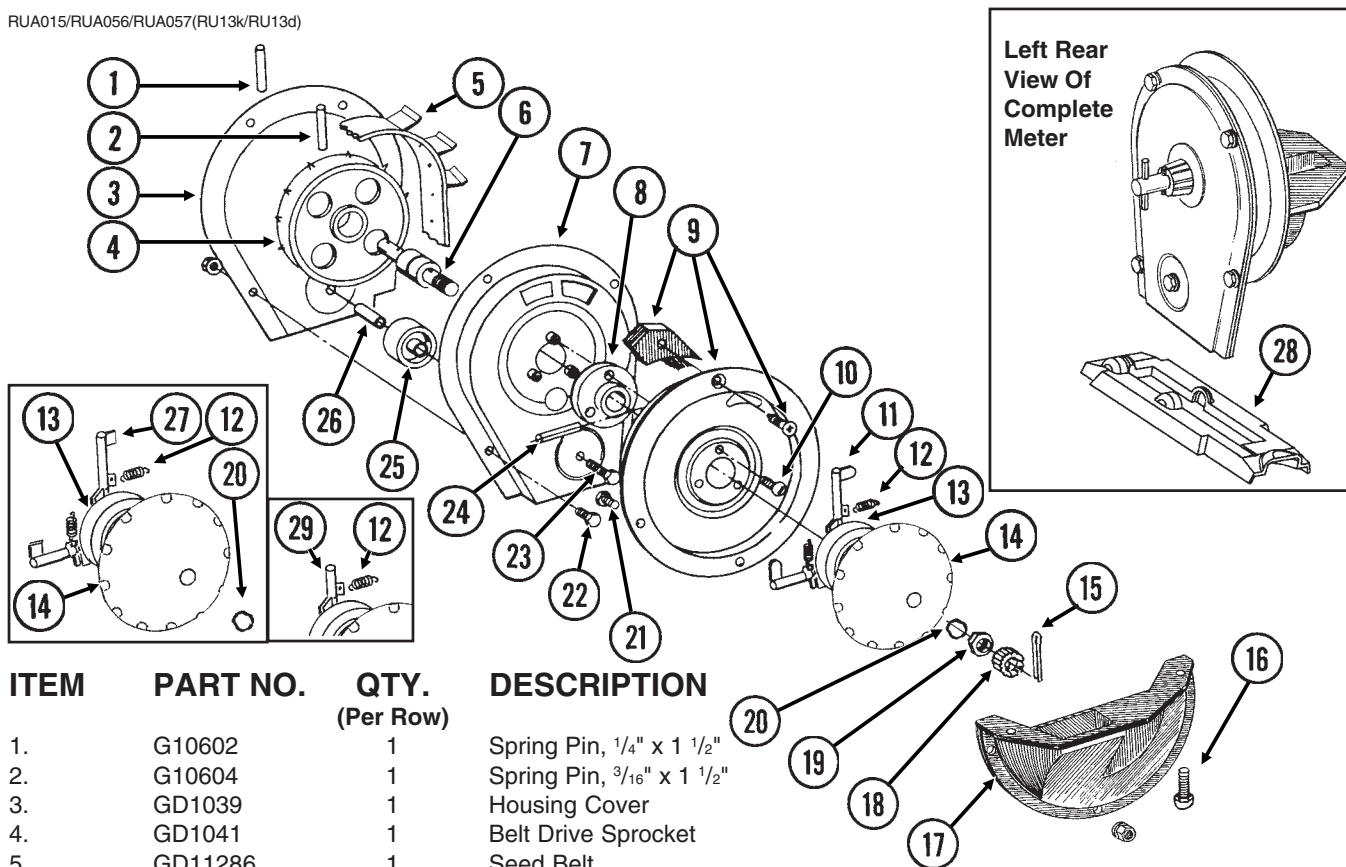

ITEM	PART NO.	QTY. (Per Row)	DESCRIPTION
1.	G10602	1	Spring Pin, 1/4" x 1 1/2"
2.	G10604	1	Spring Pin, 3/16" x 1 1/2"
3.	GD1039	1	Housing Cover
4.	GD1041	1	Belt Drive Sprocket
5.	GD11286	1	Seed Belt
6.	GA2019	1	Bearing
7.	GA2018	1	Conveyor Housing
8.	GB0110	1	Bearing Housing
9.	GR1569	1	Carrier Plate W/Brush And Screw
	GA2020	-	Brush
	G10690	-	Rolling Thread Screw, No. 10 x 3/4"
10.	G10401	3	Slotted Hex Washer Head Screw, No. 10-32 x 5/8"
11.	GD10733	12	Finger, Corn
12.	GD6501	12	Spring
13.	GB0111	1	Cam
14.	GD11528	1	Finger Holder
15.	G10470	1	Cotter Pin, 5/32" x 1"
16.	G11009	2	Locking Thumbscrew, 5/16"-18 x 3/4"
17.	GD11311	1	Seed Baffle
18.	GD1083	1	Cover Nut
19.	G10500	1	Jam Nut, 5/8"-18 UNF
20.	GA8343	1	Wave Washer, 5/8" (Triple Wave)
21.	G10020	3	Hex Head Cap Screw, 1/4"-20 x 5/8"
	G10323	3	Hex Flange Nut, 1/4"-20, No Serrations
22.	G10022	4	Hex Head Cap Screw, 1/4"-20 x 1/2"
	G10621	4	Serrated Flange Nut, 1/4"-20
23.	G10021	1	Hex Head Cap Screw, 1/4"-20 x 1 1/2"
	G10621	1	Serrated Flange Nut, 1/4"-20
24.	G10603	1	Spring Pin, 1/4" x 1 1/4"
25.	GD1042	1	Idler
26.	GB0120	1	Bushing, 17/64" I.D. x 1 1/32" Long
27.	GD10226	12	Finger, Oil Sunflower
28.	GD15698	1	Shank Cover, Finger Pickup Seed Meter
29.	GD11787	-	Half Rate Blank Finger
A.	GR1487	-	Finger Assembly, Corn (Items 11-14 And 20)
B.	GR1327	-	Finger Assembly, Oil Sunflower (Items 12-14, 20 And 27)

# BRUSH-TYPE SEED METER

RUA037/RUA056/RUA057(RU14f)

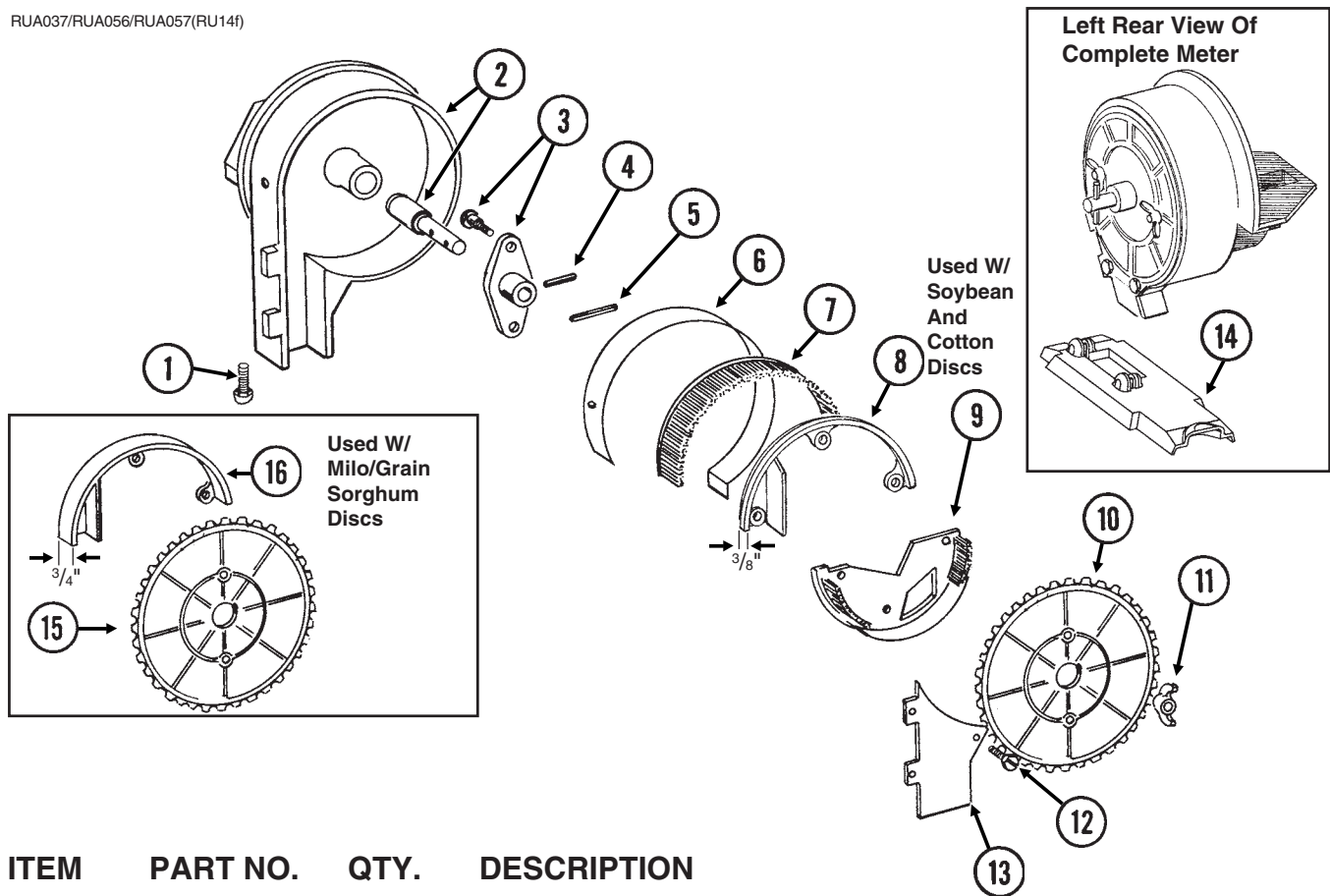

ITEM	PART NO.	QTY.	DESCRIPTION
(Per Row)			
1.	G11009	2	Locking Thumbscrew, $\frac{5}{16}$ "-18 x $\frac{3}{4}$ "
2.	GA6027	1	Housing W/Bearing
	GA5698	-	Bearing
3.	GA6038	1	Hub W/Shoulder Bolts
	GD1755	-	Shoulder Bolt, $\frac{1}{4}$ "-20 (2 Used)
4.	G10603	1	Spring Pin, $\frac{1}{4}$ " x $1\frac{1}{4}$ "
5.	G10602	1	Spring Pin, $\frac{1}{4}$ " x $1\frac{1}{2}$ "
6.	GD8778	1	Wear Strip
7.	GA5699	1	Upper Brush
8.	GD11122	1	Upper Brush Retainer (Used W/Soybean And Cotton Discs)
9.	GA5834	1	Lower Brush
10.	GA5794	-	Seed Disc, Soybean, 60 Cell, Black Color-Coded
	GA6184	-	Seed Disc, Specialty Soybean, 48 Cell, Dark Blue Color-Coded
	GA5796	-	Seed Disc, Cotton, Acid-Delinted, 30 Cell, White Color-Coded
	GA6168	-	Seed Disc, Large Cotton, Acid-Delinted, 36 Cell, Tan Color-Coded
	GA6478	-	Seed Disc, High-Rate Cotton, Acid-Delinted, 48 Cell, Light Green Color-Coded
	GA6182	-	Seed Disc, Hill-Drop Cotton, Acid-Delinted, 12 Cell, Brown Color-Coded
	GA7255	-	Seed Disc, Small Hill-Drop Cotton, Acid-Delinted, 12 Cell, Dark Green Color-Coded
11.	G10531	2	Wing Nut W/Nylon Insert, $\frac{1}{4}$ "-20
12.	G11151	9	Hex Washer Head Screw, No. 10-24 x $\frac{1}{2}$ "
	G10634	-	Slotted Tap Screw, No. 10-24 x $\frac{5}{8}$ " (Use As Required)
13.	GD7878	1	Cover
14.	GD15699	1	Shank Cover, Brush-Type Seed Meter
15.	GA5982	-	Seed Disc, Small Milo/Grain Sorghum, 30 Cell, Red Color-Coded
	GA6187	-	Seed Disc, Large Milo/Grain Sorghum, 30 Cell, Light Blue Color-Coded
	GA5795	-	Seed Disc, High-Rate Small Milo/Grain Sorghum, 60 Cell, Red Color-Coded
	GA6633	-	Seed Disc, High-Rate Large Milo/Grain Sorghum, 60 Cell, Yellow Color-Coded
16.	GD8237	-	Upper Brush Retainer (Used W/Milo/Grain Sorghum Discs)

# GRANULAR CHEMICAL HOPPER AND HOPPER PANEL EXTENSION

(METR14d)

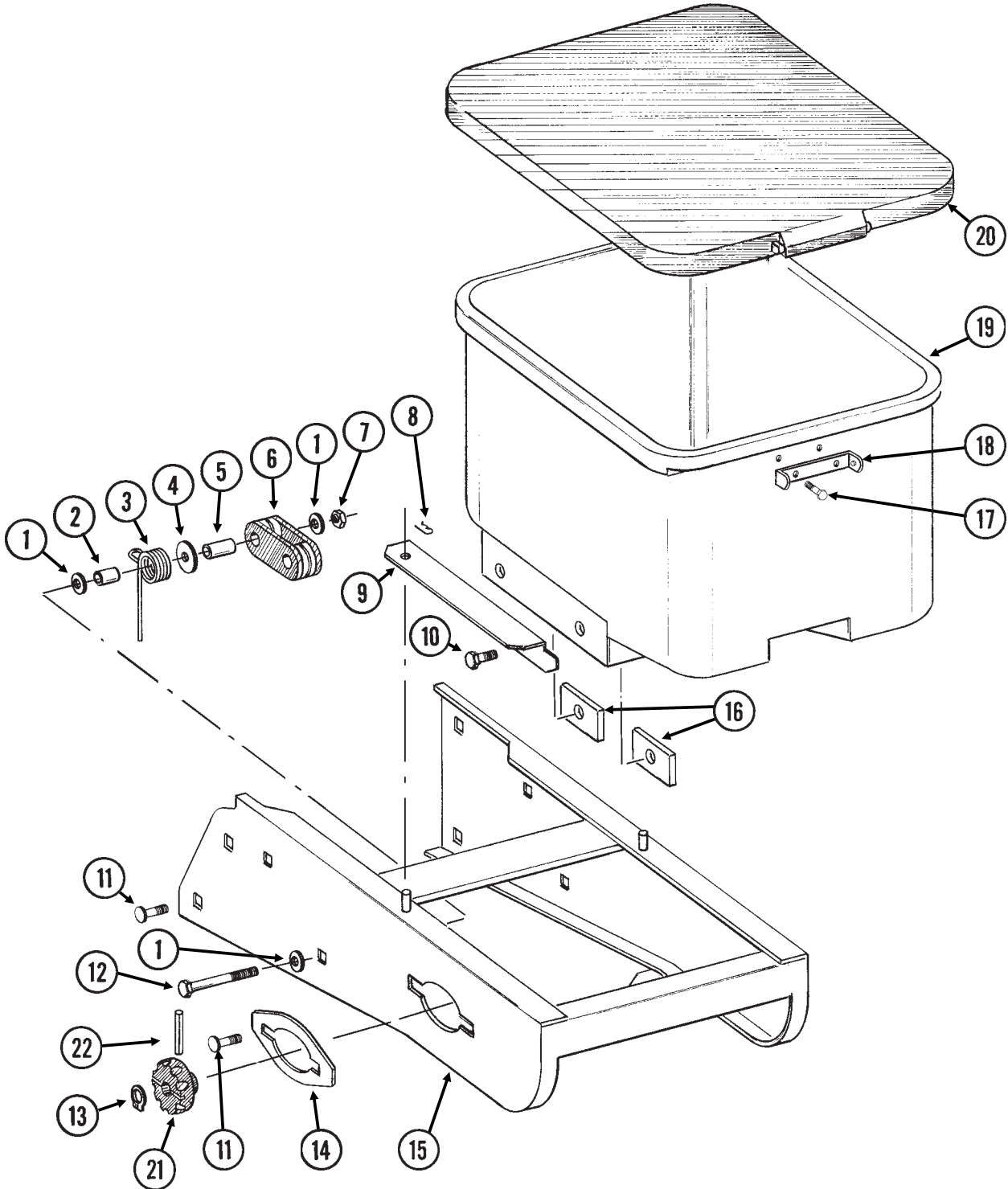



# GRANULAR CHEMICAL HOPPER AND HOPPER PANEL EXTENSION

---

ITEM	PART NO.	QTY. (Per Row)	DESCRIPTION
1.	G10210	3	Washer, $\frac{3}{8}$ " USS
2.	GD2971-10	1	Sleeve, $\frac{9}{16}$ " Long
3.	GD11219	1	Spring
4.	G10201	1	Special Washer, $\frac{3}{8}$ " x 1 $\frac{1}{2}$ " O.D.
5.	GD1026	1	Sleeve, 1 $\frac{3}{16}$ " Long
6.	GD11962	1	Idler
7.	G10108	1	Lock Nut, $\frac{3}{8}$ "-16
8.	G10670	2	Hair Pin Clip, No. 3
9.	GD1059L	1	Support, L.H. (Shown)
	GD1059R	1	Support, R.H.
10.	G10002	4	Hex Head Cap Screw, $\frac{3}{8}$ "-16 x $\frac{3}{4}$ "
	G10229	4	Lock Washer, $\frac{3}{8}$ "
11.	G10312	8	Carriage Bolt, $\frac{5}{16}$ "-18 x $\frac{3}{4}$ "
	G10620	8	Serrated Flange Nut, $\frac{5}{16}$ "-18
12.	G10325	1	Hex Head Cap Screw, $\frac{3}{8}$ "-16 x 2 $\frac{3}{4}$ "
13.	G10567	3	External Retaining Ring, $\frac{5}{8}$ "
14.	GD11305	1	Plate
15.	A10759	1	Hopper Panel Extension <b>(Non-Stock Item)</b> <b>(Sub Wholegoods Order Code 700-01099)</b>
16.	GD11424	4	Block
17.	G10023	2	Hex Head Cap Screw, $\frac{1}{4}$ "-20 x $\frac{3}{4}$ "
	G10621	2	Serrated Flange Nut, $\frac{1}{4}$ "-20
18.	GD1060	1	Hinge
19.	GA8371	1	Hopper
20.	GA4444	1	Lid
21.	GD11239	1	Knob
22.	G10602	1	Spring Pin, $\frac{1}{4}$ " x 1 $\frac{1}{2}$ "

# GRANULAR CHEMICAL METER AND METER DRIVE

RUA051/RUB028(RU91a)

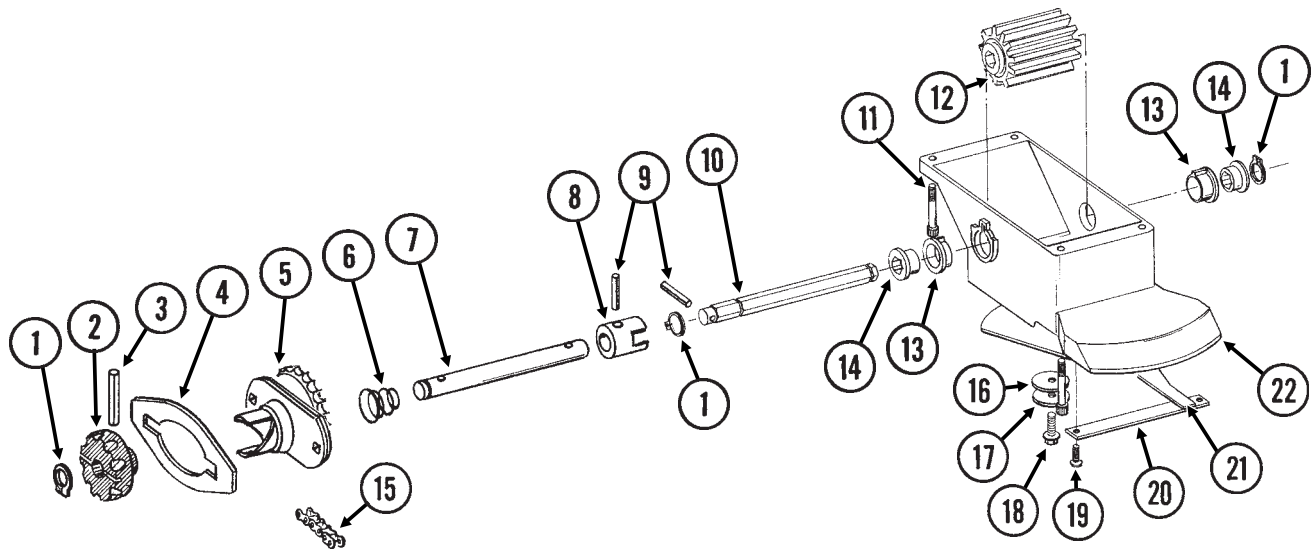

ITEM	PART NO.	QTY. (Per Row)	DESCRIPTION
1.	G10567	3	External Retaining Ring, 5/8"
2.	GD11239	1	Knob
3.	G10602	1	Spring Pin, 1/4" x 1 1/2"
4.		-	See "Granular Chemical Hopper And Hopper Panel Extension", Pages P16 And P17
5.	GA8364	1	Sprocket And Bearing, Drive Clutch, 24 Tooth
6.	GD11413	1	Spring
7.	GD11240	1	Shaft
8.	GB0278	1	Coupler
9.	G10546	2	Spring Pin, 3/16" x 1 1/4"
10.	GD11297	1	Shaft
11.	G10921	4	Hex Socket Head Cap Screw, No. 10-24 x 7/8"
	G10257	4	Lock Washer, No. 10
12.	GD7148	1	Feed Roller, Hex Bore
13.	GB0115	2	Bearing
14.	GD7258	2	Hex Bushing
15.	G3303-114	1	Chain, No. 41, 114 Pitch Including Connector Link
	GR0196	1	Connector Link, No. 41
16.	G10660	1	Wave Washer, 1/2"
17.	G10209	1	Washer, 1/4" USS
18.	G10570	1	Slotted Hex Self-Tapping Screw, 1/4"-20 x 3/4"
19.	G11073	2	Slotted Hex Self-Tapping Screw, No. 10 x 3/8"
20.	GD1061	1	Support Strap
21.	GD1063	1	Metering Gate
22.	GB0116	1	Granular Housing
A.	GA8326	-	Granular Chemical Meter Complete (Items 1, 9, 10, 12-14 And 16-22)

# GRANULAR CHEMICAL BANDING OPTIONS

RUA061/RUA073(RU101mm/RU83m)

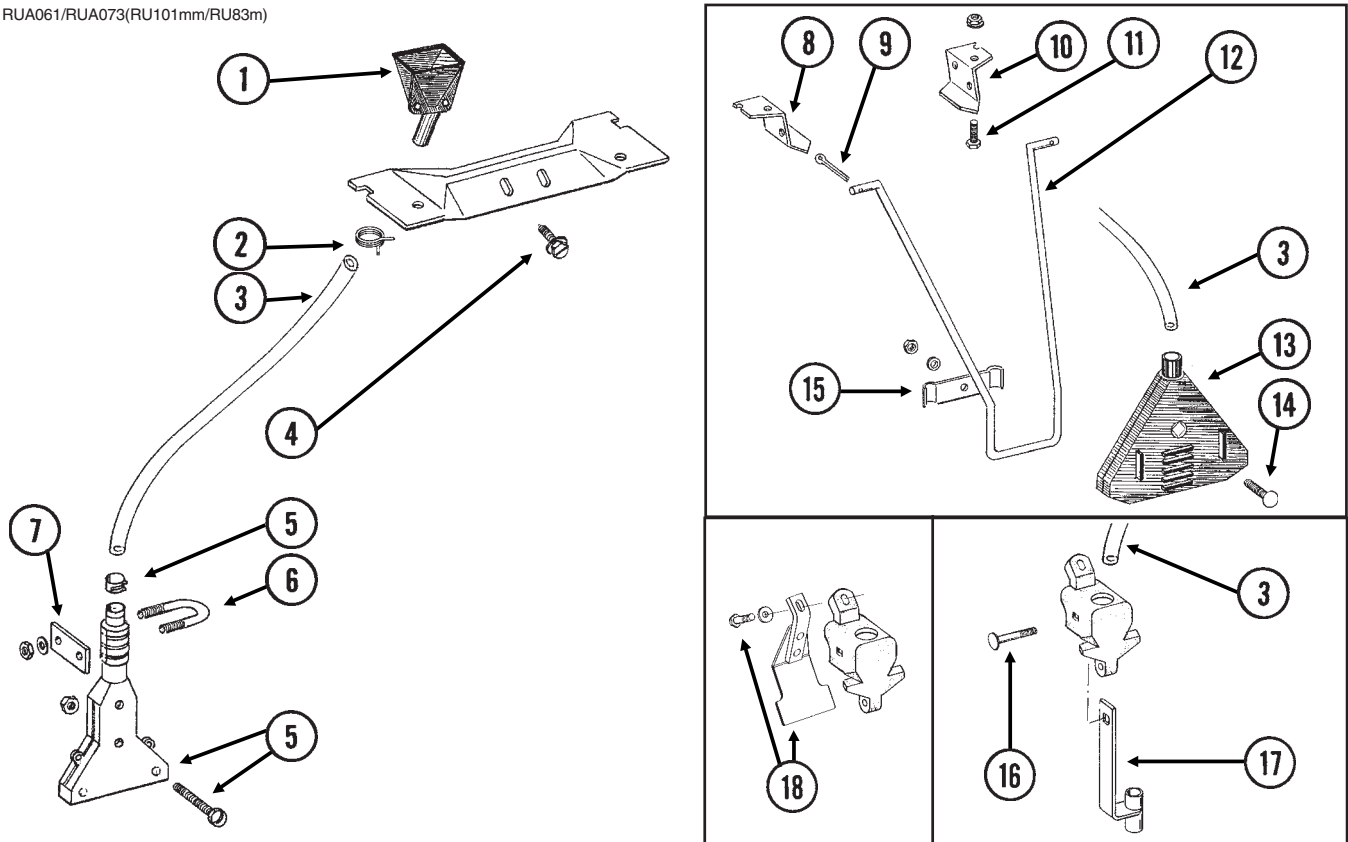

ITEM	PART NO.	QTY.	DESCRIPTION
1.	GD2423	1	Funnel
2.	G11209	1	Wire Hose Clamp, 3/4"
3.	GD2947	1	Hose, 7/16" x 28"
4.	G10523	2	Slotted Pan Head Self-Tapping Screw, No. 10 x 1/2"
5.	GA6907	1	Slope-Compensating Bander W/Hardware (4 1/2" Band Width)
	G10864	1	Uni-Clamp
	G10757	2	Pan Head Screw, No. 10-32 x 1 1/4"
	G10758	2	Hex Nut, No. 10-32
6.	GD10963	1	U-Bolt, 1 1/2" x 1 5/16" x 1/4"-20
	G10209	2	Washer, 1/4" USS
	G10110	2	Lock Nut, 1/4"-20, Grade B
7.	GD10984	1	Spacer
8.	GD1115L	-	Hanger Bracket, L.H.
9.	G10452	-	Cotter Pin, 1/8" x 1/2"
10.	GD1115R	-	Hanger Bracket, R.H.
11.	G10310	-	Carriage Bolt, 1/4"-20 x 3/4", Grade 2
	G10227	-	Lock Washer, 1/4"
	G10103	-	Hex Nut, 1/4"-20
12.	GD1116	-	Hanger
13.	GA2075	-	Diffuser, 14" Band
14.	G10306	-	Carriage Bolt, 3/8"-16 x 2"
	G10229	-	Lock Washer, 3/8"
	G10101	-	Hex Nut, 3/8"-16
15.	GD1118	-	Clamp
16.	G10315	1	Carriage Bolt, 1/2"-13 x 2 1/2" (Replaces Existing 1/2" x 2 1/4" Hardware)
17.	GA6741	1	Bracket (Straight Drop In-Furrow)
18.	G1K385	-	Bander Shield Kit W/Hardware And Instruction
	G10003	1	Hex Head Cap Screw, 3/8"-16 x 1 1/2"
	GD14659	1	Special Washer, 3/8", Hardened

# SPRING TOOTH INCORPORATOR

RUA055(RU95)

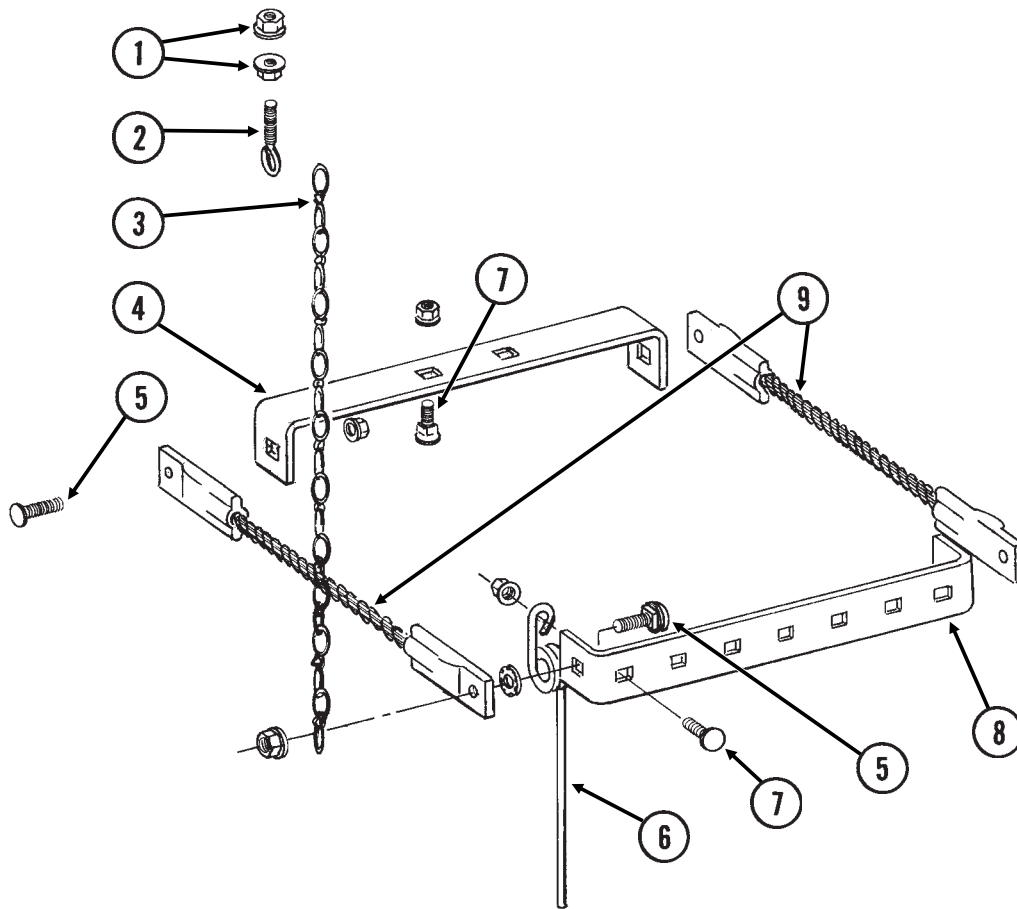

ITEM	PART NO.	QTY. (Per Row)	DESCRIPTION
1.	G10621	4	Serrated Flange Nut, 1/4"-20
2.	GD2460	2	Eyebolt, 1/4"-20
3.	G3305-01	4	Twin Loop Chain, 9 Links
4.	GD1143	1	Front Bracket
5.	G10305	4	Carriage Bolt, 3/8"-16 x 1"
	G10529	4	External Tooth Lock Washer, 3/8"
	G10622	4	Serrated Flange Nut, 3/8"-16
6.	GD1145	7	Spring Tooth
7.	G10308	9	Carriage Bolt, 3/8"-16 x 3/4"
	G10622	9	Serrated Flange Nut, 3/8"-16
8.	GD1144	1	Rear Bracket
9.	GA2094	2	Cable Assembly

# ROW UNIT MOUNTED NO TILL COULTER

RUA061(RU102/RU102c)

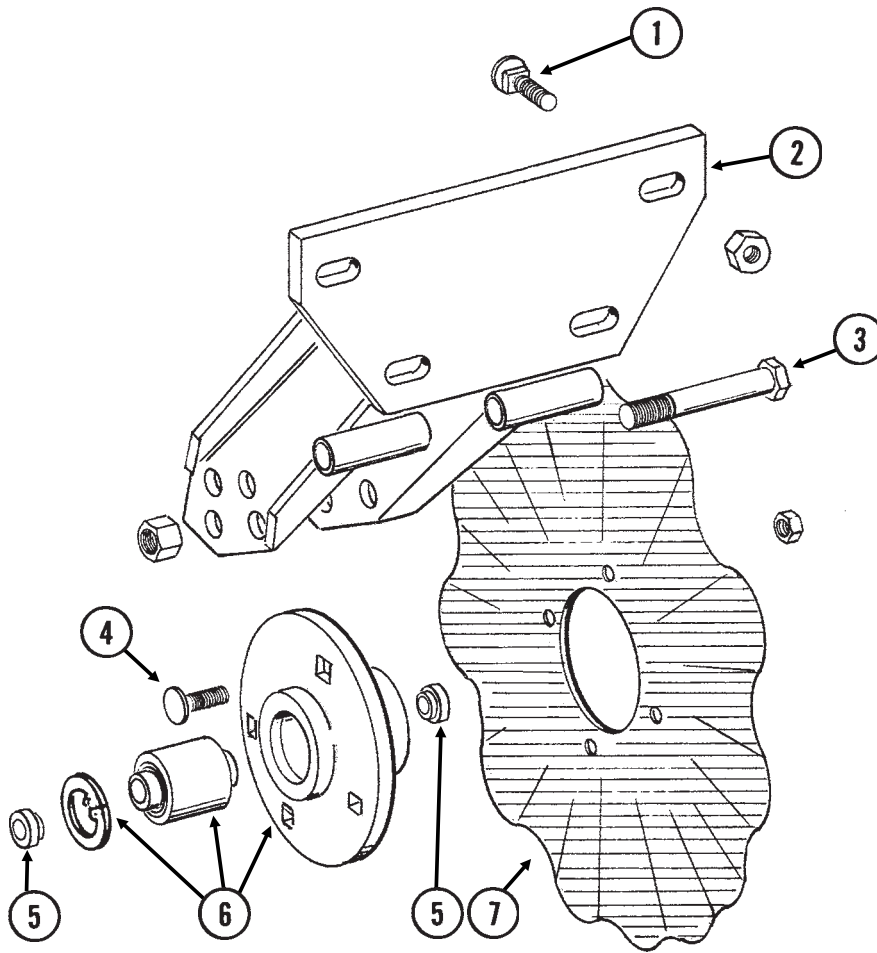

ITEM	PART NO.	QTY.	DESCRIPTION
		(Per Row)	
1.	G10574	4	Carriage Bolt, 1/2"-13 x 1 1/4"
	G10111	4	Lock Nut, 1/2"-13
2.	GA5625	1	Arm
3.	G10036	1	Hex Head Cap Screw, 5/8"-11 x 4"
	G10107	1	Lock Nut, 5/8"-11
4.	G10574	4	Carriage Bolt, 1/2"-13 x 1 1/4"
	G10111	4	Lock Nut, 1/2"-13
5.	GD11677	2	Adapter
6.	GA8641	1	Hub W/Bearing And Retaining Ring
	GA8603	-	Double Row Bearing
	GD11652	-	Retaining Ring, 2 7/16"
7.	GD7803	-	Disc Blade, Fluted, 1", 8 Flutes (Shown)
	GD7804	-	Disc Blade, Bubbled, 1"
	GD9254	-	Disc Blade, Fluted, 3/4", 13 Flutes

# ROW UNIT MOUNTED BED LEVELER

RUA059/RUA060(RU99/RU100)

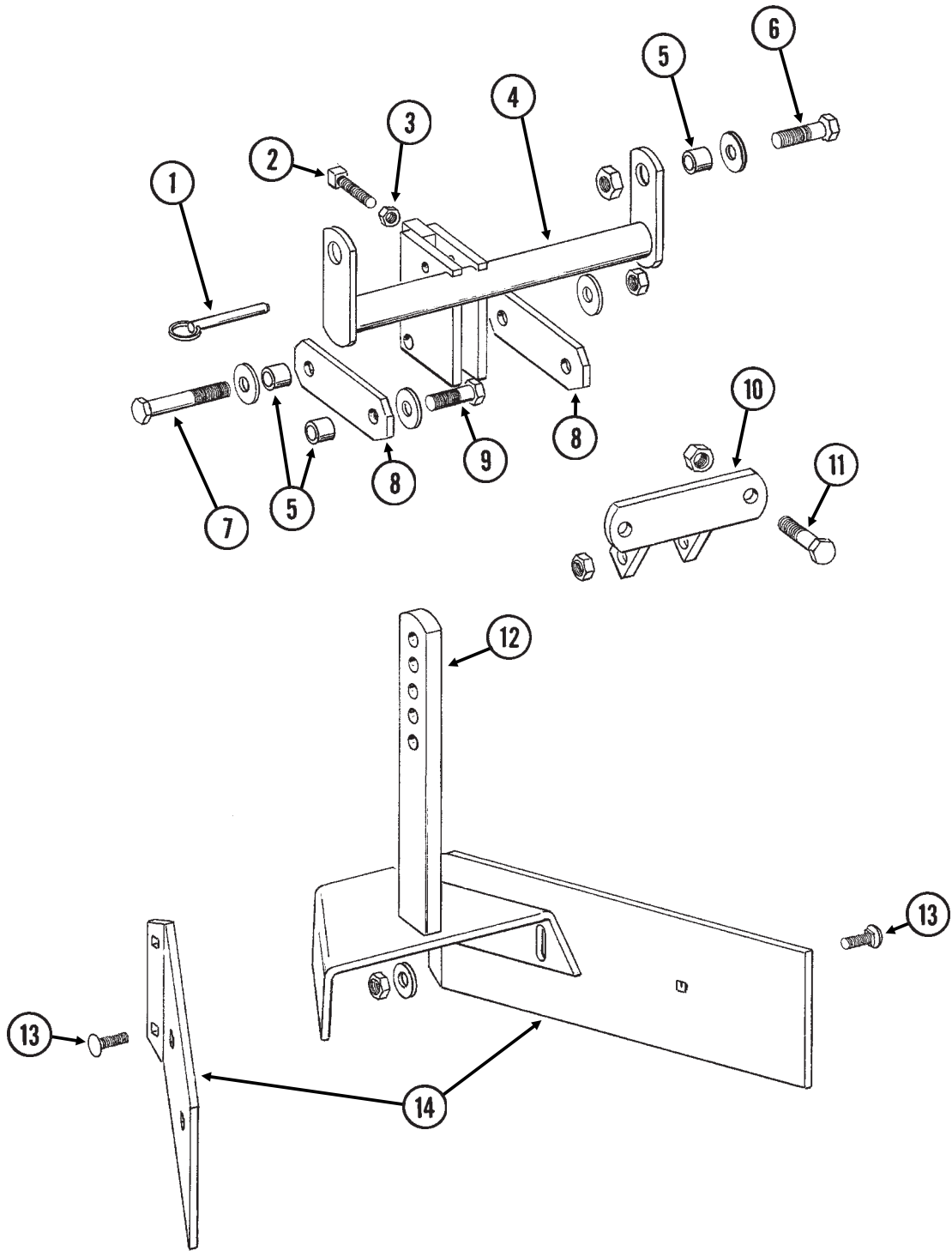

# ROW UNIT MOUNTED BED LEVELER

---

ITEM	PART NO.	QTY. (Per Row)	DESCRIPTION
1.	G10536	1	Detent Pin, 1/2" x 2 1/2" Grip
2.	G10597	1	Square Head Set Screw, 5/8"-11 x 2 1/4"
3.	G10503	1	Hex Jam Nut, 5/8"-11, Grade 2
4.	GA5719	1	Mounting Bracket
5.	GD7889	6	Bushing, 1" O.D. x 9/16" I.D. x 7/16" Long
6.	G10039	2	Hex Head Cap Screw, 1/2"-13 x 1 3/4"
	GD14674	2	Special Washer, 1/2", Hardened
	G10111	2	Lock Nut, 1/2"-13
7.	G10585	1	Hex Head Cap Screw, 1/2"-13 x 3 1/4"
	G10216	2	Washer, 1/2" USS
	G10111	1	Lock Nut, 1/2"-13
8.	GD7890	2	Link
9.	G10017	2	Hex Head Cap Screw, 1/2"-13 x 1 1/2"
	G10216	2	Washer, 1/2" USS
	G10111	2	Lock Nut, 1/2"-13
10.	GA5715	1	Anchor
11.	G10017	2	Hex Head Cap Screw, 1/2"-13 x 1 1/2"
	G10111	2	Lock Nut, 1/2"-13
12.	GA5892	1	Leveler
13.	G10303	6	Carriage Bolt, 5/16"-18 x 1"
	G10219	4	Washer, 5/16" USS
	G10109	6	Lock Nut, 5/16"-18, Grade 8
14.	GD8266	2	Blade

# ROW UNIT MOUNTED DISC FURROWER

RUA059/RUA058(RU99/RU98g)

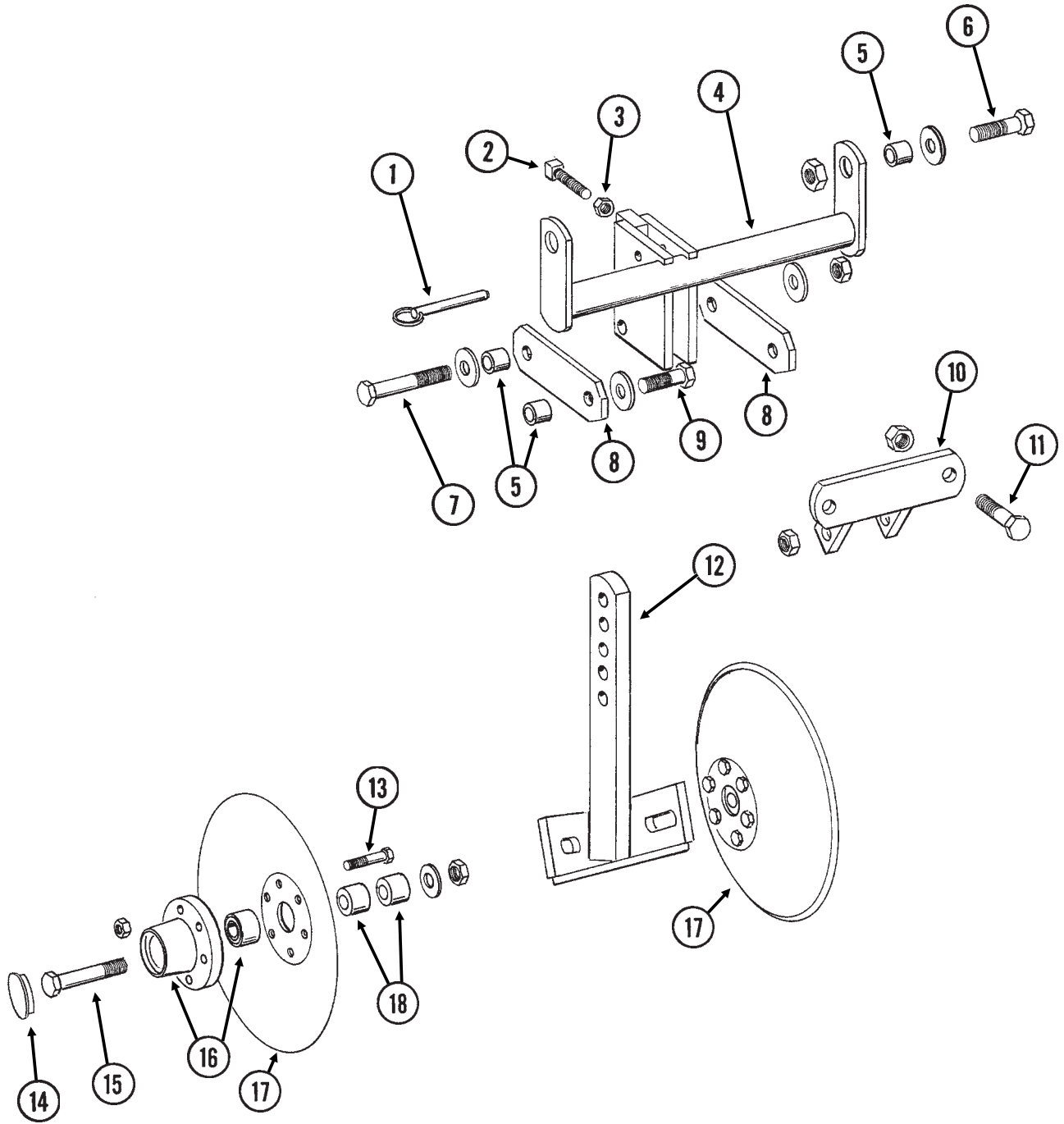



# ROW UNIT MOUNTED DISC FURROWER

---

ITEM	PART NO.	QTY. (Per Row)	DESCRIPTION
1.	G10536	1	Detent Pin, 1/2" x 2 1/2" Grip
2.	G10597	1	Square Head Set Screw, 5/8"-11 x 2 1/4"
3.	G10503	1	Hex Jam Nut, 5/8"-11, Grade 2
4.	GA5719	1	Mounting Bracket
5.	GD7889	6	Bushing, 1" O.D. x 9/16" I.D. x 7/16" Long
6.	G10039	2	Hex Head Cap Screw, 1/2"-13 x 1 3/4"
	GD14674	2	Special Washer, 1/2", Hardened
	G10111	2	Lock Nut, 1/2"-13
7.	G10585	1	Hex Head Cap Screw, 1/2"-13 x 3 1/4"
	G10216	2	Washer, 1/2" USS
	G10111	1	Lock Nut, 1/2"-13
8.	GD7890	2	Link
9.	G10017	2	Hex Head Cap Screw, 1/2"-13 x 1 1/2"
	G10216	2	Washer, 1/2" USS
	G10111	2	Lock Nut, 1/2"-13
10.	GA5715	1	Anchor
11.	G10017	2	Hex Head Cap Screw, 1/2"-13 x 1 1/2"
	G10111	2	Lock Nut, 1/2"-13
12.	GA5718	1	Support Arm
13.	G10572	6	Truss Head Slotted Machine Screw, 5/16"-18 x 7/8"
	G10106	6	Hex Nut, 5/16"-18
14.	GD1132	2	Dust Cap
15.	G10318	2	Hex Head Cap Screw, 5/8"-11 x 4 1/2"
	GD7805	2	Special Washer, 5/8", Hardened
	G10107	2	Lock Nut, 5/8"-11
16.	GA5654	2	Hub W/Bearings
	GA2014	-	Bearing
17.	GD7823	-	Disc Blade, Solid, 12" (Shown)
	GD8307	-	Disc Blade, Notched, 12"
18.	GD7817-01	2	Spacer, 1 1/16" I.D. x 3/4" Long
	GD7817-04	2	Spacer, 1 1/16" I.D. x 1/2" Long

# ROW UNIT MOUNTED RESIDUE WHEEL

(RU103d)

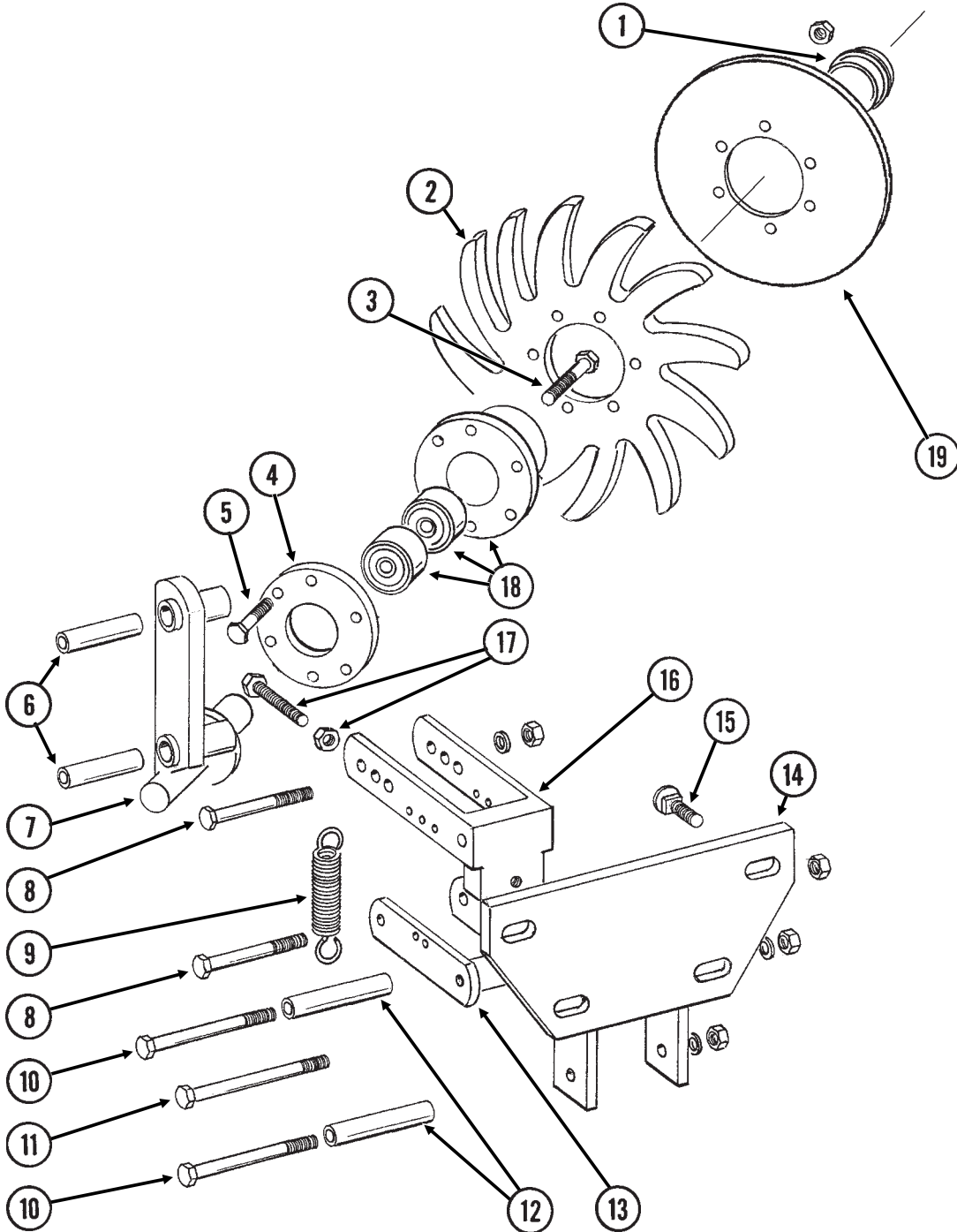

# ROW UNIT MOUNTED RESIDUE WHEEL

ITEM	PART NO.	QTY. (Per Row)	DESCRIPTION
1.	GD1132	1	Dust Cap
2.	GD10552	1	Wheel, 12 Tine, $\frac{3}{8}$ " x 12"
3.	G10006	1	Hex Head Cap Screw, $\frac{5}{8}$ "-11 x 2 $\frac{1}{4}$ "
4.	GD9724	1	Backing Plate
5.	G10133	6	Hex Head Cap Screw, $\frac{5}{16}$ "-18 x 1 $\frac{1}{2}$ "
	G10109	6	Lock Nut, $\frac{5}{16}$ "-18, Grade 8
6.	GD9720	2	Spacer, $\frac{1}{2}$ " x 2 $\frac{3}{16}$ " Long
7.	GA6838	1	Wheel Mount
8.	G10033	2	Hex Head Cap Screw, $\frac{1}{2}$ "-13 x 3 $\frac{1}{2}$ "
	G10228	2	Lock Washer, $\frac{1}{2}$ "
	G10102	2	Hex Nut, $\frac{1}{2}$ "-13
9.	GD5857	2	Spring
10.	G10045	2	Hex Head Cap Screw, $\frac{1}{2}$ "-13 x 4 $\frac{1}{2}$ "
	G10228	2	Lock Washer, $\frac{1}{2}$ "
	G10102	2	Hex Nut, $\frac{1}{2}$ "-13
11.	G10348	1	Hex Head Cap Screw, $\frac{1}{2}$ "-13 x 5" (Lockup Bolt)
	G10111	1	Lock Nut, $\frac{1}{2}$ "-13
12.	GD9715	2	Spacer, $\frac{1}{2}$ " x 3" Long
13.	GA6834	1	Lower Link
14.	GA6832	1	Mount
15.	G10574	4	Carriage Bolt, $\frac{1}{2}$ "-13 x 1 $\frac{1}{4}$ "
	G10111	4	Lock Nut, $\frac{1}{2}$ "-13
16.	GA6833	1	Upper Link
17.	G10371	1	Hex Head Cap Screw, $\frac{1}{2}$ "-13 x 3", Full Thread
	G10501	1	Hex Jam Nut, $\frac{1}{2}$ "-13, Grade 2
18.	GA5654	1	Hub W/Bearings
	GA2014	-	Bearing
19.	GD12534	-	Cover
A.	GA7446	-	Wheel Assembly, 12 Tine, R.H. (Items 2, 4, 5 And 18)

# COULTER MOUNTED RESIDUE WHEELS

RUA063(RU104uu)

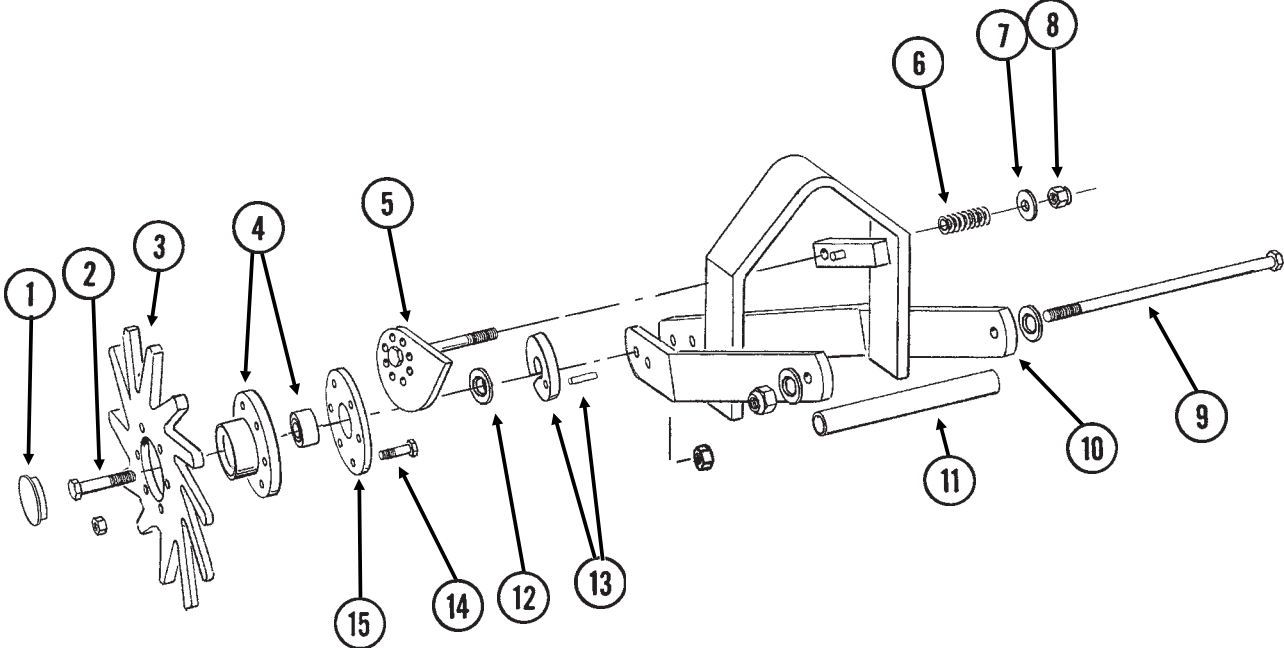

# COULTER MOUNTED RESIDUE WHEELS

---

ITEM	PART NO.	QTY. (Per Row)	DESCRIPTION
1.	GD1132	2	Dust Cap
2.	G10010	2	Hex Head Cap Screw, 5/8"-11 x 3"
	G10503	2	Hex Jam Nut, 5/8"-11, Grade 2
3.	GD10552	2	Wheel, 12 Tine, 3/8" x 12"
4.	GA5654	2	Hub W/Bearings
	GA2014	-	Bearing
5.	GA7412	1	Cam
6.	GD10519	1	Spring
7.	G10206	1	Washer, 1/2" SAE
8.	G10974	1	Lock Nut W/Nylon Insert, 1/2"-13
9.	G11098	1	Hex Head Cap Screw, 1/2"-13 x 9 1/2", Grade 8
	GD14674	2	Special Washer, 1/2", Hardened
	G10974	1	Lock Nut W/Nylon Insert, 1/2"-13
10.	GA7271	1	Mount
11.	GD10526	1	Sleeve, 7 1/2"
12.	G10213	2	Machine Bushing, 5/8" (.030" Thick)
13.	GA8760	2	Weed Guard W/Spring Pin
	G10765	-	Spring Pin, 1/4" x 1"
14.	G10133	12	Hex Head Cap Screw, 5/16"-18 x 1 1/2"
	G10109	12	Lock Nut, 5/16"-18, Grade 8
15.	GD9724	2	Backing Plate
A.	GA7446	-	Wheel Assembly, 12 Tine, R.H. (Items 3, 4, 14 And 15) (Shown)
	GA7445	-	Wheel Assembly, 12 Tine, L.H. (Items 3, 4, 14 And 15)

# FRAME MOUNTED COULTER W/RESIDUE WHEELS

(RU135c/RU135g/RU135hh)

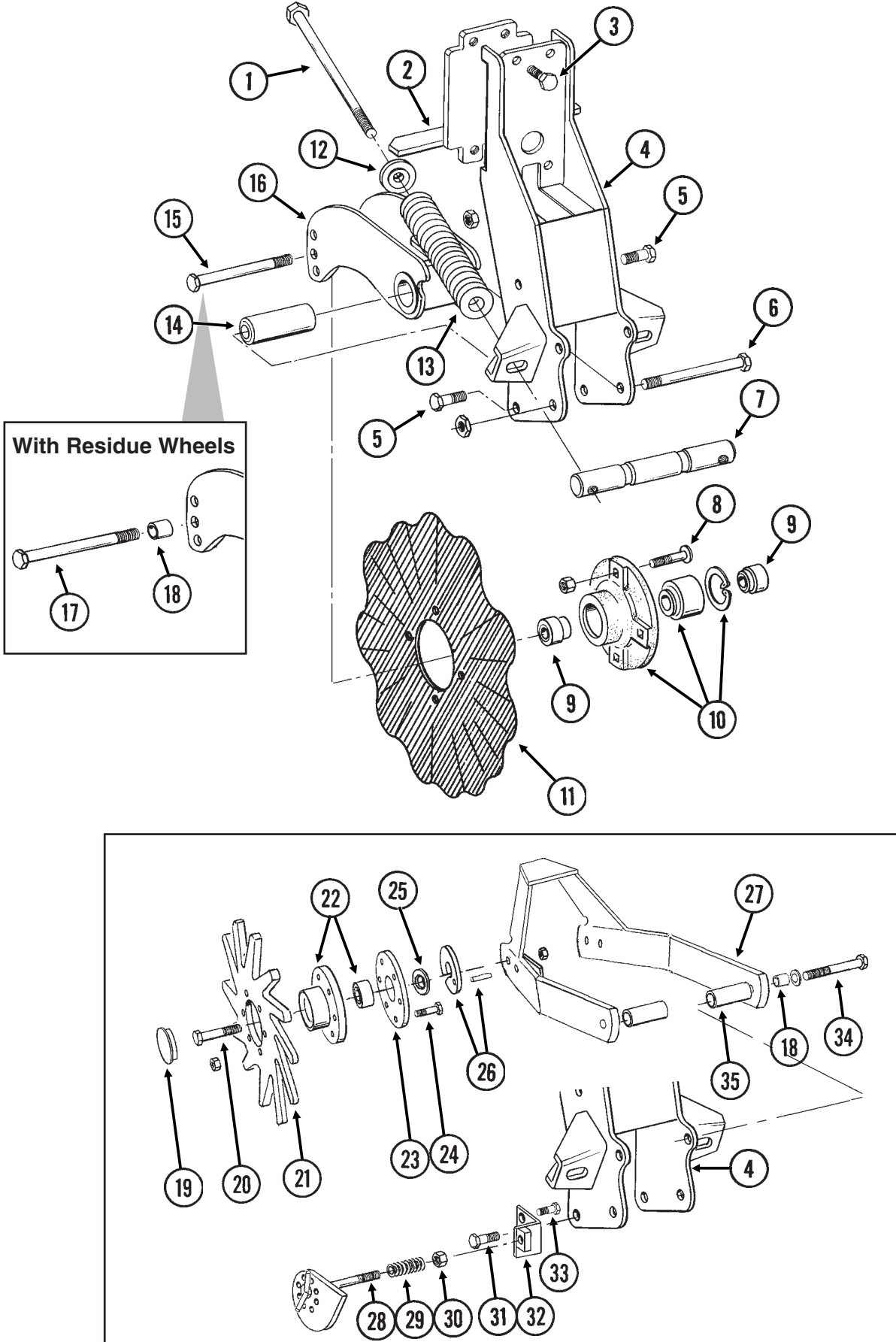

# FRAME MOUNTED COULTER W/RESIDUE WHEELS

ITEM	PART NO.	QTY. (Per Row)	DESCRIPTION
1.	G11010	2	Hex Head Cap Screw, $\frac{3}{4}$ "-10 x 12"
2.	GA9844	1	Plate W/Angle
3.	G10039	4	Hex Head Cap Screw, $\frac{1}{2}$ "-13 x 1 $\frac{3}{4}$ "
4.	GA9131	1	Coulter Frame
5.	G10007	4	Hex Head Cap Screw, $\frac{5}{8}$ "-11 x 1 $\frac{1}{2}$ "
	G10107	4	Lock Nut, $\frac{5}{8}$ "-11
6.	G10400	1	Hex Head Cap Screw, $\frac{3}{4}$ "-10 x 6 $\frac{1}{2}$ "
	G10112	1	Lock Nut, $\frac{3}{4}$ "-10
7.	GD12826	1	Spring Anchor Bar
8.	G10574	4	Carriage Bolt, $\frac{1}{2}$ "-13 x 1 $\frac{1}{4}$ "
	G10111	4	Lock Nut, $\frac{1}{2}$ "-13
9.	GD12827	2	Adapter
10.	GA8641	1	Hub W/Bearing And Retaining Ring
	GA8603	1	Double Row Bearing
	GD11652	1	Retaining Ring, 2 $\frac{7}{16}$ "
11.	GD7803	1	Disc Blade, Fluted, 1", 8 Flutes (Shown)
	GD7804	-	Disc Blade, Bubbled, 1"
	GD9254	-	Disc Blade, Fluted, $\frac{3}{4}$ ", 13 Flutes
12.	GB0213	2	Spring Seat
13.	GD12817	2	Compression Spring
14.	GD12829	1	Sleeve
15.	G10046	1	Hex Head Cap Screw, $\frac{5}{8}$ "-11 x 5"
	G10107	1	Lock Nut, $\frac{5}{8}$ "-11
16.	GA9845	1	Coulter Arm W/Grease Fitting
	G10643	-	Grease Fitting, 45°, $\frac{1}{4}$ "-28
17.	G10011	1	Hex Head Cap Screw, $\frac{5}{8}$ "-11 x 5 $\frac{1}{2}$ "
	G10107	1	Lock Nut, $\frac{5}{8}$ "-11
18.	GB0218	3	Bushing, $\frac{21}{32}$ " I.D. x $\frac{7}{8}$ " O.D. x $\frac{19}{32}$ " Long
19.	GD1132	2	Dust Cap
20.	G10010	2	Hex Head Cap Screw, $\frac{5}{8}$ "-11 x 3"
	G10503	2	Hex Jam Nut, $\frac{5}{8}$ "-11, Grade 2
21.	GD10552	2	Wheel, 12 Tine, $\frac{3}{8}$ " x 12"
22.	GA5654	2	Hub W/Bearings
	GA2014	-	Bearing
23.	GD9724	2	Backing Plate
24.	G10133	12	Hex Head Cap Screw, $\frac{5}{16}$ "-18 x 1 $\frac{1}{2}$ "
	G10109	12	Lock Nut, $\frac{5}{16}$ "-18, Grade 8
25.	G10213	2	Machine Bushing, $\frac{5}{8}$ " (.030" Thick)
26.	GA9862	2	Weed Guard W/Spring Pin
	G10765	-	Spring Pin, $\frac{1}{4}$ " x 1"
27.	GA9865	1	Mount
28.	GA9861	1	Cam
29.	GD10519	1	Spring
30.	G10974	1	Lock Nut W/Nylon Insert, $\frac{1}{2}$ "-13
31.	G10005	1	Hex Head Cap Screw, $\frac{5}{8}$ "-11 x 1 $\frac{3}{4}$ "
	G10107	4	Lock Nut, $\frac{5}{8}$ "-11
32.	GA9864	1	Support
33.	G10014	1	Hex Head Cap Screw, $\frac{1}{2}$ "-13 x 1"
	G10102	1	Hex Nut, $\frac{1}{2}$ "-13
34.	G10011	2	Hex Head Cap Screw, $\frac{5}{8}$ "-11 x 5 $\frac{1}{2}$ "
	G10205	2	Washer, $\frac{5}{8}$ " SAE
	G10730	2	Lock Nut W/Nylon Insert, $\frac{5}{8}$ "-11
35.	GD14170	2	Sleeve, 3"
A.	GA7446	-	Wheel Assembly, 12 Tine, R.H. (Items 21-24) (Shown)
	GA7445	-	Wheel Assembly, 12 Tine, L.H. (Items 21-24)

# CENTER FRAME ASSEMBLY

PFA043/PFA048/PFA055(MT4a/INS5b/PT49f)

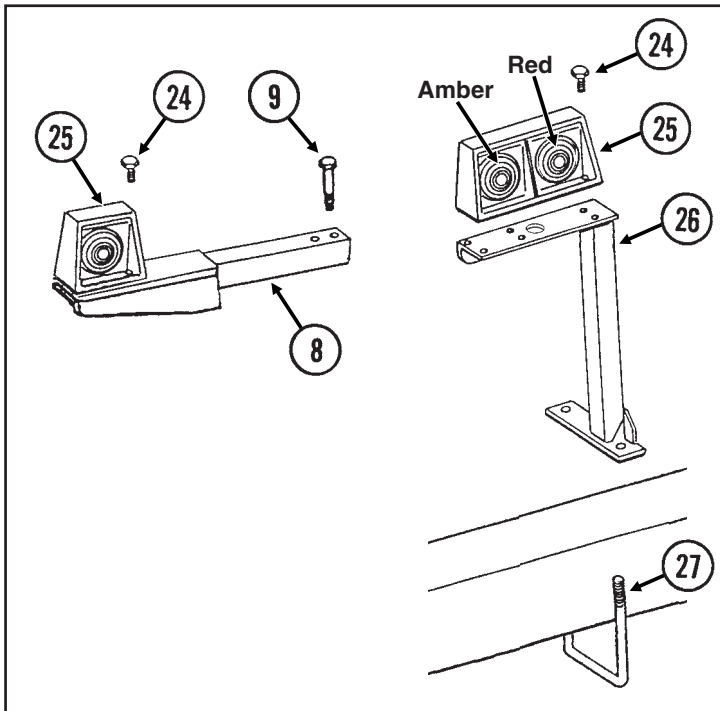
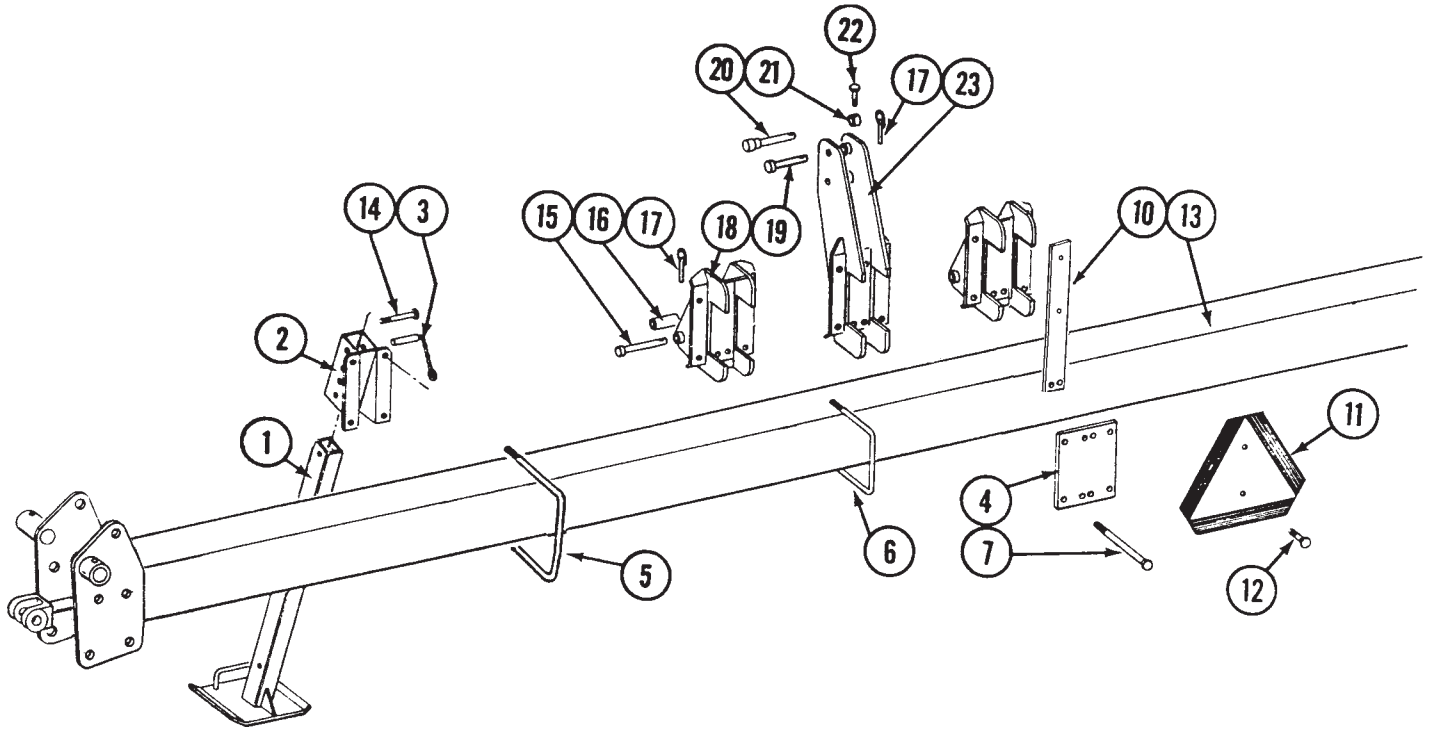



# CENTER FRAME ASSEMBLY

ITEM	PART NO.	QTY.	DESCRIPTION
1.	GA4732	2	Parking Stand
2.	GA4707	2	Mount
3.	GA4733	2	Detent Pin W/Chain
4.	D7191	-	Mounting Bar <b>(Non-Stock Item)</b>
5.	GD1114	4	U-Bolt, 7" x 7" x 5/8"-11
	G10230	8	Lock Washer, 5/8"
	G10104	8	Hex Nut, 5/8"-11
6.	GD1748	12	U-Bolt, 7" x 7" x 3/4"-10
	G10231	24	Lock Washer, 3/4"
	G10105	24	Hex Nut, 3/4"-10
7.	G10059	8	Hex Head Cap Screw, 3/4"-10 x 9 1/2"
	G10231	8	Lock Washer, 3/4"
	G10105	8	Hex Nut, 3/4"-10
8.	GA6827	1	Bracket, R.H. Side
	GA6828	1	Bracket, L.H. Side (Shown)
9.	G10325	4	Hex Head Cap Screw, 3/8"-16 x 2 3/4"
	G10229	4	Lock Washer, 3/8"
	G10101	4	Hex Nut, 3/8"-16
10.	GA5714	1	SMV Mounting Bracket
11.		-	See "Decals, Paint And Miscellaneous", Pages P60 And P61
12.	G10023	2	Hex Head Cap Screw, 1/4"-20 x 3/4"
	G10110	2	Lock Nut, 1/4"-20, Grade B
13.	A5658	1	Center Toolbar, 7" x 7" x 144", 8 Row 36"/38" <b>(Non-Stock Item)</b>
	A6538	-	Center Toolbar, 7" x 7" x 150 1/2", 8 Row 40" <b>(Non-Stock Item)</b>
	A5661	-	Center Toolbar, 7" x 7" x 183", 12 Row 30" <b>(Non-Stock Item)</b>
14.	G10016	2	Hex Head Cap Screw, 1/2"-13 x 2"
	G10111	2	Lock Nut, 1/2"-13
15.	GA4665	2	Pin
16.	GD7090	2	Bushing, Category 3
17.	GD2557	3	Lynch Pin, 7/16"
18.	GA4701	-	Lower Hitch Point
19.	GA4666	1	Pin, 1 1/4" x 4 1/2", Category 3
20.	GA4938	1	Pin, 1", Category 2
21.	GD7338	1	Bushing, 1", Category 2
22.	G10048	1	Hex Head Cap Screw, 3/8"-16 x 2"
	G10229	1	Lock Washer, 3/8"
	G10101	1	Hex Nut, 3/8"-16
23.	GA4702	1	Mast
24.	G10064	16	Hex Head Cap Screw, 1/4"-20 x 1"
	G10209	16	Washer, 1/4" USS
	G10110	16	Lock Nut, 1/4"-20, Grade B
25.			See "Electrical Components", Pages P54 And P55
26.	GA6823	1	Bracket, L.H. (Shown)
	GA6824	1	Bracket, R.H.
27.	GD7145	2	U-Bolt, 7" x 7" x 1/2"-13
	G10228	4	Lock Washer, 1/2"
	G10102	4	Hex Nut, 1/2"-13

# WING AND HINGE ASSEMBLY

PFA044/PFA043/PFA049(MT5c)

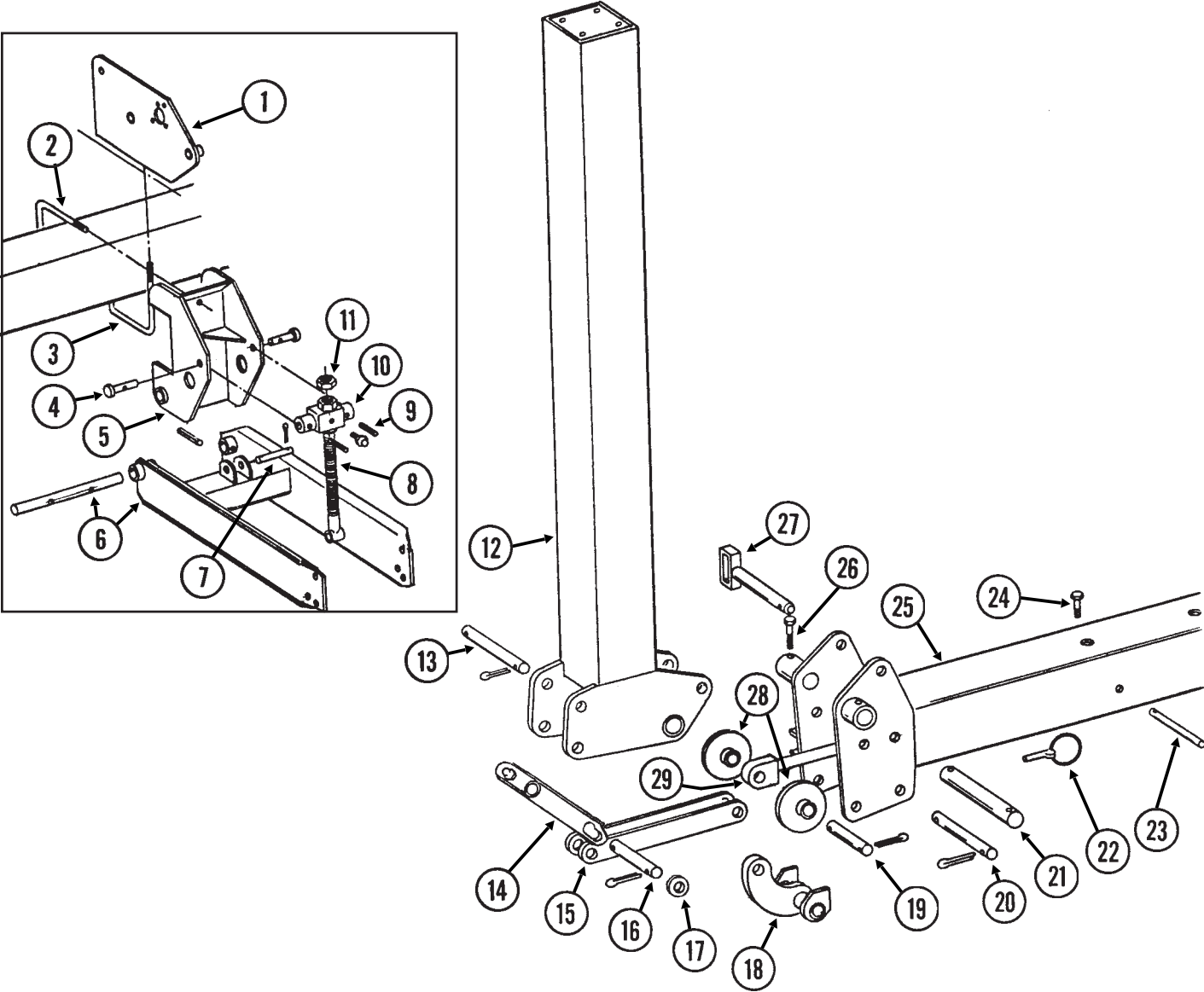

# WING AND HINGE ASSEMBLY

ITEM	PART NO.	QTY.	DESCRIPTION
1.	GA4699	1-2	Drive Plate, L.H. (Shown)
	GA4700	1-2	Drive Plate, R.H.
2.	GD1748	-	U-Bolt, 7" x 7" x 3/4"-10
	G10231	-	Lock Washer, 3/4"
	G10105	-	Hex Nut, 3/4"-10
3.	GD1114	-	U-Bolt, 7" x 7" x 5/8"-11
	G10230	-	Lock Washer, 5/8"
	G10104	-	Hex Nut, 5/8"-11
4.	GA4704	-	Pin
5.	A4703	-	Module W/Grease Fitting <b>(Non-Stock Item)</b>
	G10641	-	Grease Fitting, 1/8" NPT
6.	A4706	-	Arm W/Pin And Spring Pin <b>(Non-Stock Item)</b>
	GD7042	-	Pin, 1 1/4" x 12 1/8"
	G10610	-	Spring Pin, 3/8" x 2"
7.	GD7041	-	Pin, 1" x 4"
	G10459	-	Cotter Pin, 3/16" x 1 1/2"
8.	GA4705	2-4	Adjusting Screw
9.	G10489	4-8	Spring Pin, 3/8" x 1 1/2"
10.	GA4711	2-4	Jack Screw Mount W/Grease Fitting
	G10641	-	Grease Fitting, 1/8" NPT
11.	G10117	2-4	Hex Nut, 1"-8
12.	A4849	2	Wing W/Grease Fitting, 76", 8 Row 36"/38" <b>(Non-Stock Item)</b>
	A6537	-	Wing W/Grease Fitting, 80", 8 Row 40" <b>(Non-Stock Item)</b>
	A4851	-	Wing W/Grease Fitting, 88 1/2", 12 Row 30" <b>(Non-Stock Item)</b>
	G10641	-	Grease Fitting, 1/8" NPT
13.	GD3737	2	Pin, 1 1/4" x 8 1/2"
	G10460	4	Cotter Pin, 1/4" x 2"
14.	GA5805	2	Link
15.	GA5660	2	Link
16.	GD5841	2	Pin, 1 1/4" x 5 5/8"
	G10460	4	Cotter Pin, 1/4" x 2"
17.	G10159	8	Machine Bushing, 1 1/4", 10 Gauge
18.	GA4883	2	Link
19.	GD7861	2	Pin, 1 1/4" x 6 1/8"
	G10460	4	Cotter Pin, 1/4" x 2"
20.	GD4724	2	Pin, 1 1/4" x 10"
	G10460	4	Cotter Pin, 1/4" x 2"
21.	GD7282	2	Hinge Pin, 2 1/8" x 13"
22.	GD2557	4	Lynch Pin, 7/16"
23.	GD7302	2	Cylinder Pin, 1" x 6"
24.	G10048	2	Hex Head Cap Screw, 3/8"-16 x 2"
	G10229	2	Lock Washer, 3/8"
	G10101	2	Hex Nut, 3/8"-16
25.		-	See "Center Frame Assembly", Pages P32 And P33
26.	G10061	4	Hex Head Cap Screw, 3/8"-16 x 3 1/2"
	G10229	4	Lock Washer, 3/8"
	G10101	4	Hex Nut, 3/8"-16
27.	GA4402	2	Safety Pin, 12 3/4"
28.	GA5659	4	Wheel
29.		-	See "Wing Lift Cylinder", Page P48

# DRIVE WHEEL ASSEMBLY

PLA025(MT6f)

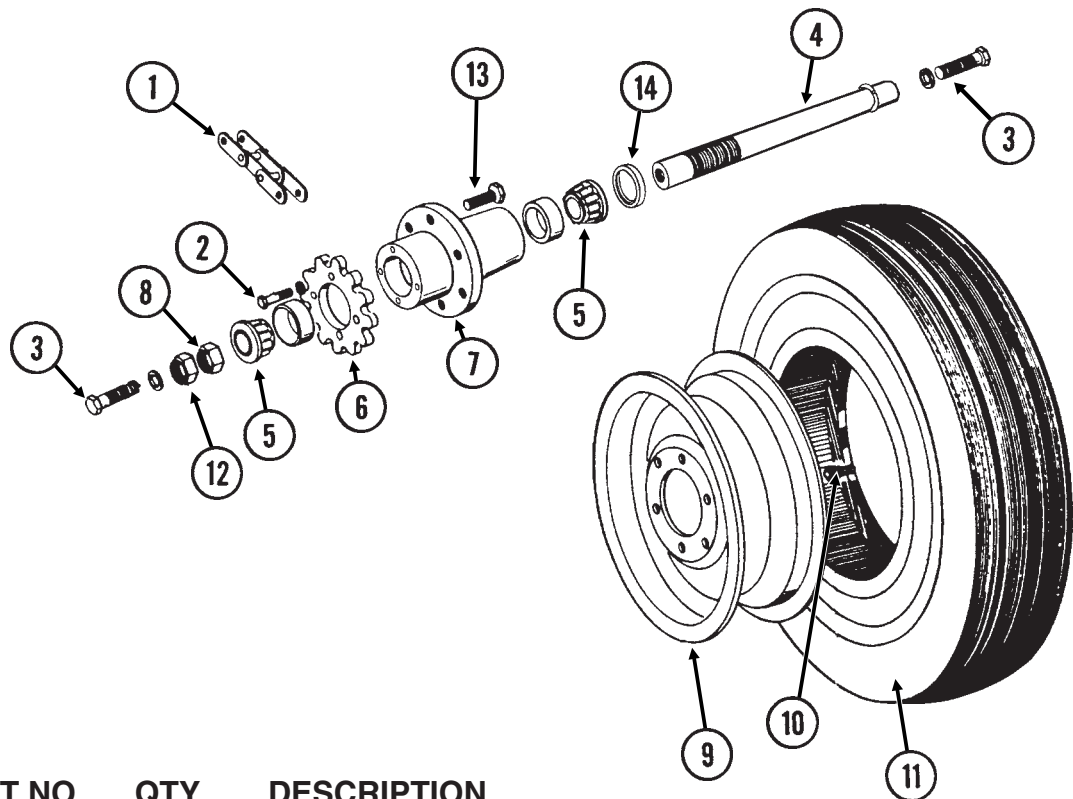

ITEM	PART NO.	QTY. (Per Assy.)	DESCRIPTION
1.	G3200-62	1	Chain, No. 2050, 62 Pitch Including Connector Link
	G3200-06	-	Chain, No. 2050, 6 Pitch Including Connector Link (Add To Chain When Using Half Rate (2 To 1) Drive Reduction Sprockets)
	GR0195	-	Connector Link, No. 2050
2.	G10019	4	Hex Head Cap Screw, $\frac{5}{16}$ "-18 x 1"
	G10232	4	Lock Washer, $\frac{5}{16}$ "
3.	G10026	2	Hex Head Cap Screw, $\frac{3}{4}$ "-10 x 2"
	G10231	2	Lock Washer, $\frac{3}{4}$ "
4.	GA4693	1	Spindle W/Round External Retaining Ring, 10 $\frac{1}{2}$ "
	GD11490	-	Round External Retaining Ring
5.	GA0895	2	Bearing
6.	G2500-17	1	Sprocket, 12 Tooth
7.	GA0926	1	Hub W/Cups, 6 Bolt
	GR0434	-	Cup
8.	G10092	1	Hex Nut, 1 $\frac{1}{2}$ "-12
9.	GA4696	1	Wheel, 5" x 15"
10.	GD1166	1	Valve Stem
11.	GD0844	1	Tire, 7.60" x 15", 8 Ply (Specify Brand*)
12.	G11081	1	Hex Jam Nut, 1 $\frac{1}{2}$ "-12, Grade 2
13.	GR0270	6	Lug Bolt, $\frac{9}{16}$ "-18
14.	GD13567	1	Spacer
A.	GA4695	-	Hub And Spindle Assembly (Items 2, 4-8, 12 And 14))
B.	GA4694	-	Tire And Rim Assembly (Items 10-12)(Specify Brand*)
C.	GA5496	-	Drive Wheel Assembly, R.H. (Items 1-14)
	GA5497	-	Drive Wheel Assembly, L.H. (Items 1-14)

\* Specific brand requests will be supplied only as available from current KINZE® stock. If a specific brand requested is not in stock, the brand available will be supplied.

# FRONT MOUNTED DRIVE WHEEL

PTD064(MT7)

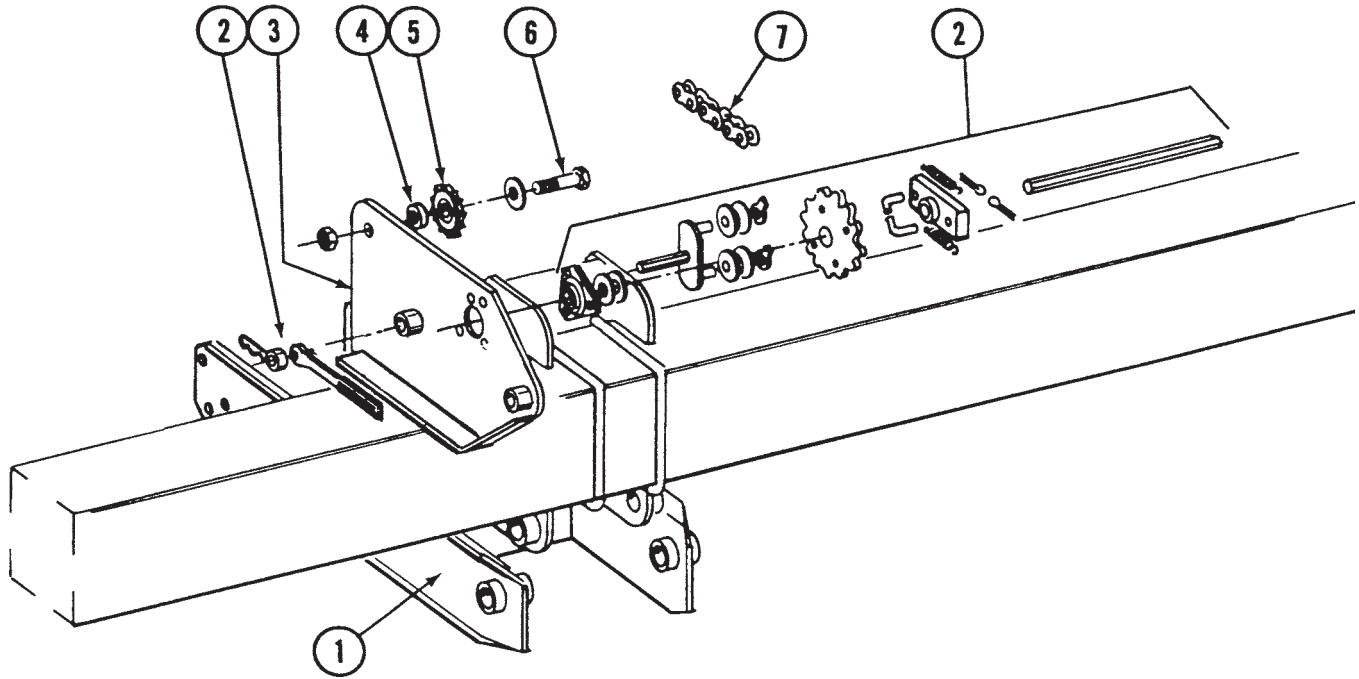

ITEM	PART NO.	QTY.	DESCRIPTION
		(Per Assy.)	
1.		-	See "Wing And Hinge Assembly", Pages P34 And P35
2.		-	See "Driveline", Pages P40 And P41
3.		-	See "Wing And Hinge Assembly", Pages P34 And P35
4.	GD7101	1	Sleeve
5.	GA0262	1	Idler Sprocket W/Bearing, 15 Tooth
6.	G10009	1	Hex Head Cap Screw, $\frac{5}{8}$ "-11 x 2 $\frac{1}{2}$ "
	G10217	-	Washer, $\frac{5}{8}$ " USS (As Required)
	G10107	1	Lock Nut, $\frac{5}{8}$ "-11
7.	G3200-22	1	Chain, No. 2050, 22 Pitch Including Connector Link (Add To Chain When Using Front Mounted Drive), See "Drive Wheel Assembly", Page P36
	GR0195	-	Connector Link, No. 2050

# DUAL LIFT ASSIST W/FLOATING CENTER MAST

PFA045/PLA015/HTA014/PFA043(MT23a/MT8d)

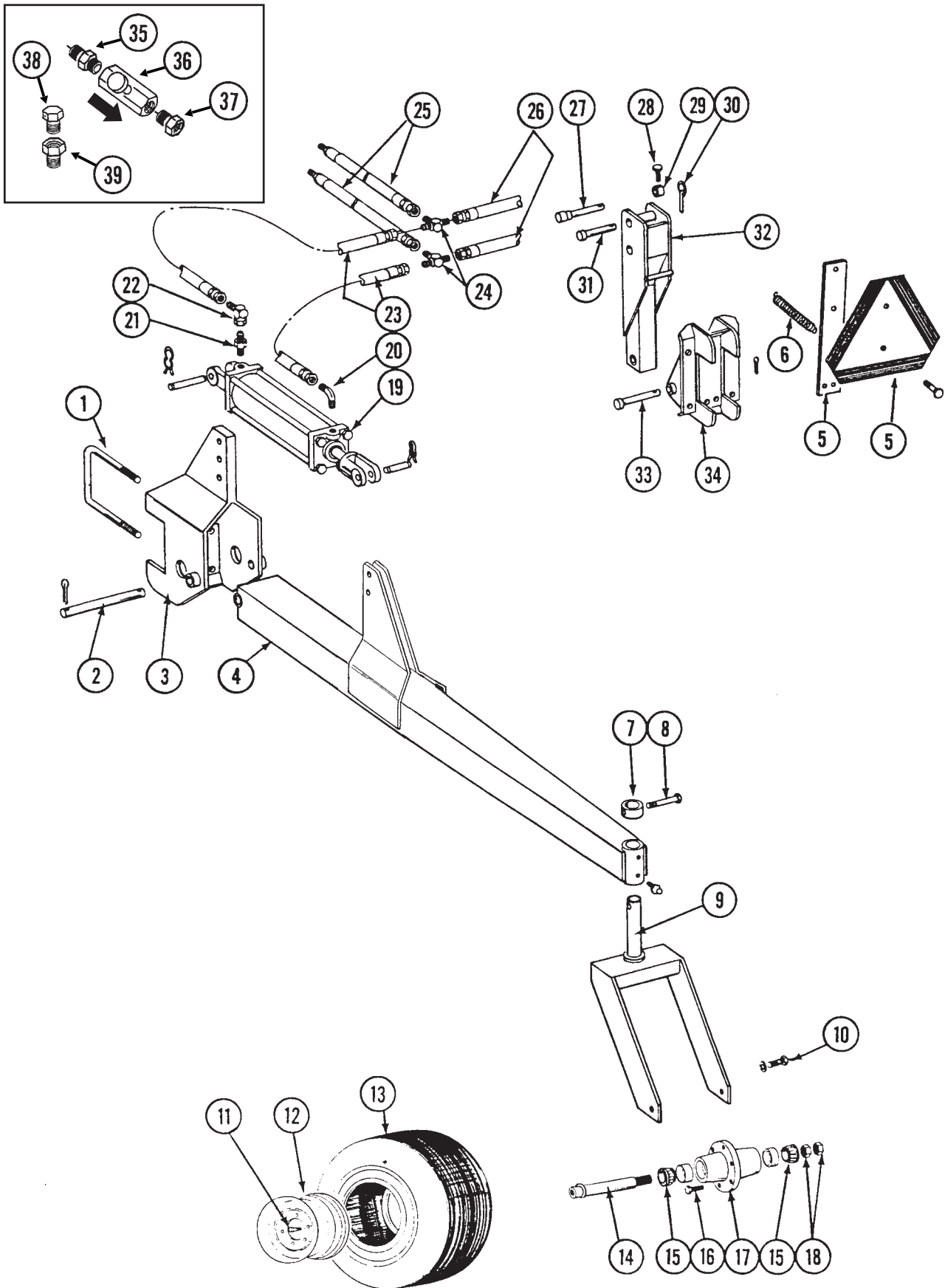

# DUAL LIFT ASSIST W/FLOATING CENTER MAST

ITEM	PART NO.	QTY.	DESCRIPTION
1.	GD1748	6	U-Bolt, 7" x 7" x 3/4"-10
	G10231	12	Lock Washer, 3/4"
	G10105	12	Hex Nut, 3/4"-10
2.	GD8311	2	Pin, 1 1/4" x 10 1/2"
	G10460	4	Cotter Pin, 1/4" x 2"
3.	A5513	-	Wheel Tower ( <b>Non-Stock Item</b> )
4.	A4713	-	Tube W/Grease Fittings ( <b>Non-Stock Item</b> )
	G10641	-	Grease Fitting, 1/8" NPT
5.		-	See "Center Frame Assembly", Pages P32 And P33
6.	GD0829	1	Spring
7.	GD7068	2	Cap
8.	G10032	2	Hex Head Cap Screw, 1/2"-13 x 3 3/4"
	G10228	2	Lock Washer, 1/2"
	G10102	2	Hex Nut, 1/2"-13
9.	GA4715	2	Caster Wheel Arm
10.	G10026	4	Hex Head Cap Screw, 3/4"-10 x 2"
	G10231	4	Lock Washer, 3/4"
11.	GD1166	2	Valve Stem
12.	GA5196	2	Wheel W/Valve Protector, 5" x 15"
13.	GD0844	2	Tire, 7.60" x 15", 8 Ply (Specify Brand**)
14.	GA2558	1	Spindle W/Round External Retaining Ring, 9 1/2"
	GD11490	-	Round External Retaining Ring
15.	GA0895	4	Bearing
16.	GR0270	12	Lug Bolt, 9/16"-18
17.	GA2148	2	Hub W/Cups, 6 Bolt
	GR0434	-	Cup
18.	G11081	-	Hex Jam Nut, 1 1/2"-12, Grade 2
19.		-	See "Dual Lift Assist Cylinder", Pages P49 And P50
20.	G2501-08-08	2	Elbow, 90°, 3/4"-16 Male JIC To 1/2" NPT
	G6801-08	-	Elbow W/O-Ring, 90°, 3/4"-16 Male JIC To O-Ring
	GR1037	-	O-Ring
21.	G2404-08-08	2	Adapter, 3/4"-16 Male JIC To 1/2" NPT
	G6400-08	-	Connector W/O-Ring, 3/4"-16 Male JIC To O-Ring
	GR1037	-	O-Ring
22.	G6500-08	2	Swivel Elbow, 90°, 3/4"-16 Male JIC To Female
23.	*A1039	2	Hose Assembly, 3/8" x 76"
24.	G2603-08	2	Tee, 3/4"-16 Male JIC
25.	*A1005	2	Hose Assembly, 3/8" x 48"
26.	*A1055	2	Hose Assembly, 3/8" x 66"
27.	GA4938	1	Pin, 1", Category 2
28.	G10048	1	Hex Head Cap Screw, 3/8"-16 x 2"
	G10229	1	Lock Washer, 3/8"
	G10101	1	Hex Nut, 3/8"-16
29.	GD7338	1	Bushing, 1", Category 2
30.	GD2557	2	Lynch Pin, 7/16"
31.	GA4666	1	Pin, 1 1/4" x 4 1/2", Category 3
32.	GA4972	1	Floating Mast
33.	GA4665	2	Pin
	G10468	2	Cotter Pin, 3/8" x 2"
34.	GA4701	-	Lower Hitch Point
35.	G2404-08-06	1	Adapter, 3/8"-16 Male JIC To 3/8" NPT
36.		-	See "Flow Control Valve", Page P51
37.	G6505-06-08	1	Connector, 3/4"-16 Female JIC To 3/8" Male NPT
38.	GA7861	2	Breather Plug, 1/2" NPT
39.	G6405-08-08	2	Connector W/O-Ring, 1/2" Female NPT To 3/4"-16 Male O-Ring
	GR1037	-	O-Ring
A.	GA2147	-	Hub And Spindle Assembly (Items 14,15,17 And 18)

\* Hydraulic hose is not stocked by KINZE® Repair Parts, but can be made available on a special order basis. Call for quote.

\*\* Specific brand requests will be supplied only as available from current KINZE® Repair Parts stock. If a specific brand requested is not in stock, the brand available will be supplied.

# DRIVELINE

(MT10b/MT29)

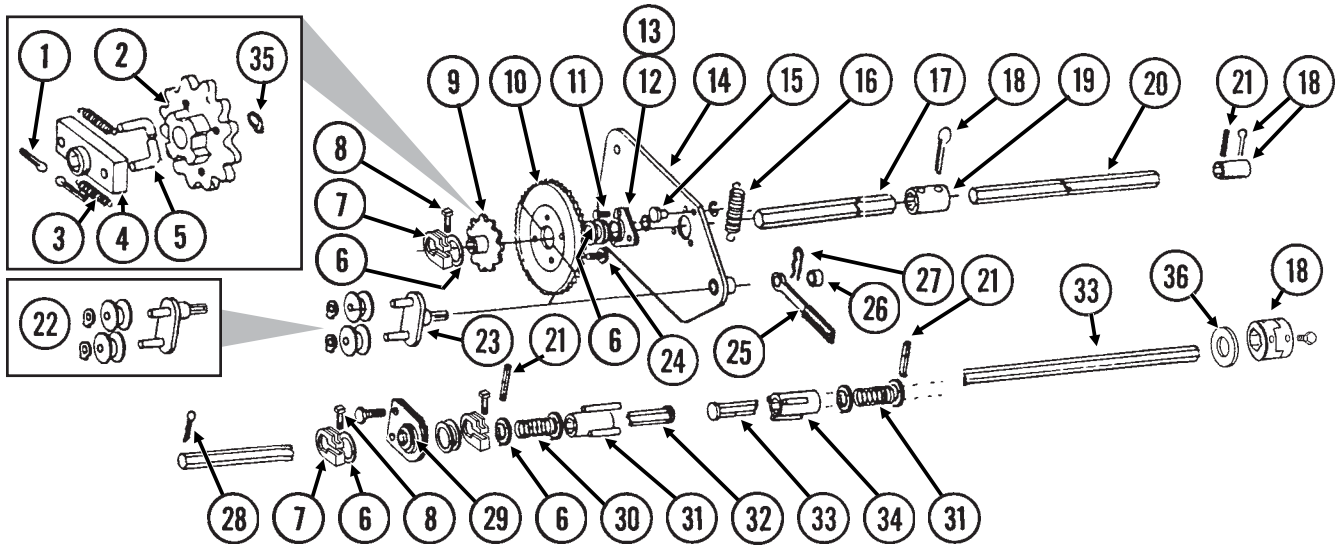

ITEM	PART NO.	QTY.	DESCRIPTION
1.	G10464	-	Cotter Pin, $\frac{3}{16}$ " x 1"
2.	GA0376	-	Sprocket, 12 Tooth, Ratchet
3.	GD1256	-	Spring
4.	GA0378	-	Block And Hub Assembly
5.	GD1255	-	L-Pin
6.	G10233	-	Machine Bushing, 1", 10 Gauge
7.	GD11045	-	Lock Clamp
8.	G10130	-	Square Head Machine Bolt, $\frac{5}{16}$ "-18 x 1 $\frac{3}{4}$ "
	G10923	-	Flange Nut, $\frac{5}{16}$ "-18, No Serration
9.	G2500-18	-	Sprocket, 12 Tooth
10.	GA2359	-	Sprocket, 48 Tooth, Half Rate (2 To 1) Drive Reduction
11.	G10303	-	Carriage Bolt, $\frac{5}{16}$ "-18 x 1"
	G10232	-	Lock Washer, $\frac{5}{16}$ "
	G10106	-	Hex Nut, $\frac{5}{16}$ "-18



# DRIVELINE

ITEM	PART NO.	QTY.	DESCRIPTION
12.	G3400-01	-	Flangette
13.	G2100-03	-	Bearing, $\frac{7}{8}$ " Hex Bore, Spherical
14.		-	See "Wing And Hinge Assembly", Pages P34 And P35
15.	G10478	-	Clevis Pin, $\frac{5}{16}$ " x 1"
	G10409	-	Retaining Ring, $\frac{5}{16}$ "
16.	GD5857	-	Spring
17.	GD5887-30	-	Hex Shaft, $\frac{7}{8}$ " x 30" (1 Hole), 12 Row 30" Only
18.		-	See "Seed Rate Transmission Assembly", Pages P42 And P43
19.	GD5886	-	Coupler, 1 $\frac{3}{4}$ "
20.	GD5887-36	2	Hex Shaft, $\frac{7}{8}$ " x 36" (1 Hole), 8 Row 36"/38"/40"
	GD6825-24	2	Hex Shaft, $\frac{7}{8}$ " x 24" (2 Holes), 12 Row 30"
21.	G10602	-	Spring Pin, $\frac{1}{4}$ " x 1 $\frac{1}{2}$ "
22.	GA5545	-	Idler W/Spools And Rings, Half Rate (2 To 1) Drive Reduction
	GD0916	-	Spool
	G10435	-	Retaining Ring
23.	GA0901	-	Idler W/Spools And Rings
	GD0916	-	Spool
	G10435	-	Retaining Ring
24.	G10002	-	Hex Head Cap Screw, $\frac{3}{8}$ "-16 x $\frac{3}{4}$ "
	G10229	-	Lock Washer, $\frac{3}{8}$ "
25.	GA4235	-	Ratchet Arm W/Protective Closure
	G10445	-	Protective Closure
26.	GD6819	-	Sleeve, $\frac{7}{16}$ "
27.	G10670	-	Hair Pin Clip, No. 3
28.	G10463	-	Cotter Pin, $\frac{1}{4}$ " x 1 $\frac{1}{2}$ "
29.	GA2180	-	Hanger Bearing, $\frac{7}{8}$ " Hex Bore
30.	GD2962	-	Spring
31.	GA5713	2	Coupler W/Grease Fitting, 6"
	G10641	-	Grease Fitting, $\frac{1}{8}$ " NPT
32.	GA5705	1	Center Section Drill Shaft, 60", R.H., 8 Row 36"/38"/40"
	GA5706	1	Center Section Drill Shaft, 50", L.H., 8 Row 36"/38"
	GA6540	-	Center Section Drill Shaft, 51", L.H., 8 Row 40"
	GA5708	-	Center Section Drill Shaft, 82", R.H., 12 Row 30"
	GA5709	-	Center Section Drill Shaft, 72", L.H., 12 Row 30"
33.	GA5704	2	Wing Drill Shaft, 68 $\frac{1}{2}$ ", 8 Row 36"/38"
	GA6539	-	Wing Drill Shaft, 72 $\frac{1}{2}$ ", 8 Row 40"
	GA5707	-	Wing Drill Shaft, 81", 12 Row 30"
34.	GA5712	2	Coupler W/Grease Fitting, 5"
	G10641	-	Grease Fitting, $\frac{1}{8}$ " NPT
35.	G10430	-	External Retaining Ring, 1 $\frac{1}{4}$ "
36.	G10226	2	Washer, 1 $\frac{1}{4}$ " SAE
A.	GA0261R	-	Ratchet Sprocket Assembly, R.H. (Items 1-6 And 35)
	GA0261L	-	Ratchet Sprocket Assembly, L.H. (Items 1-6 And 35)
B.	G1K269	-	Lock Clamp Kit (Items 7 And 8)

# SEED RATE TRANSMISSION ASSEMBLY

(MT18e)

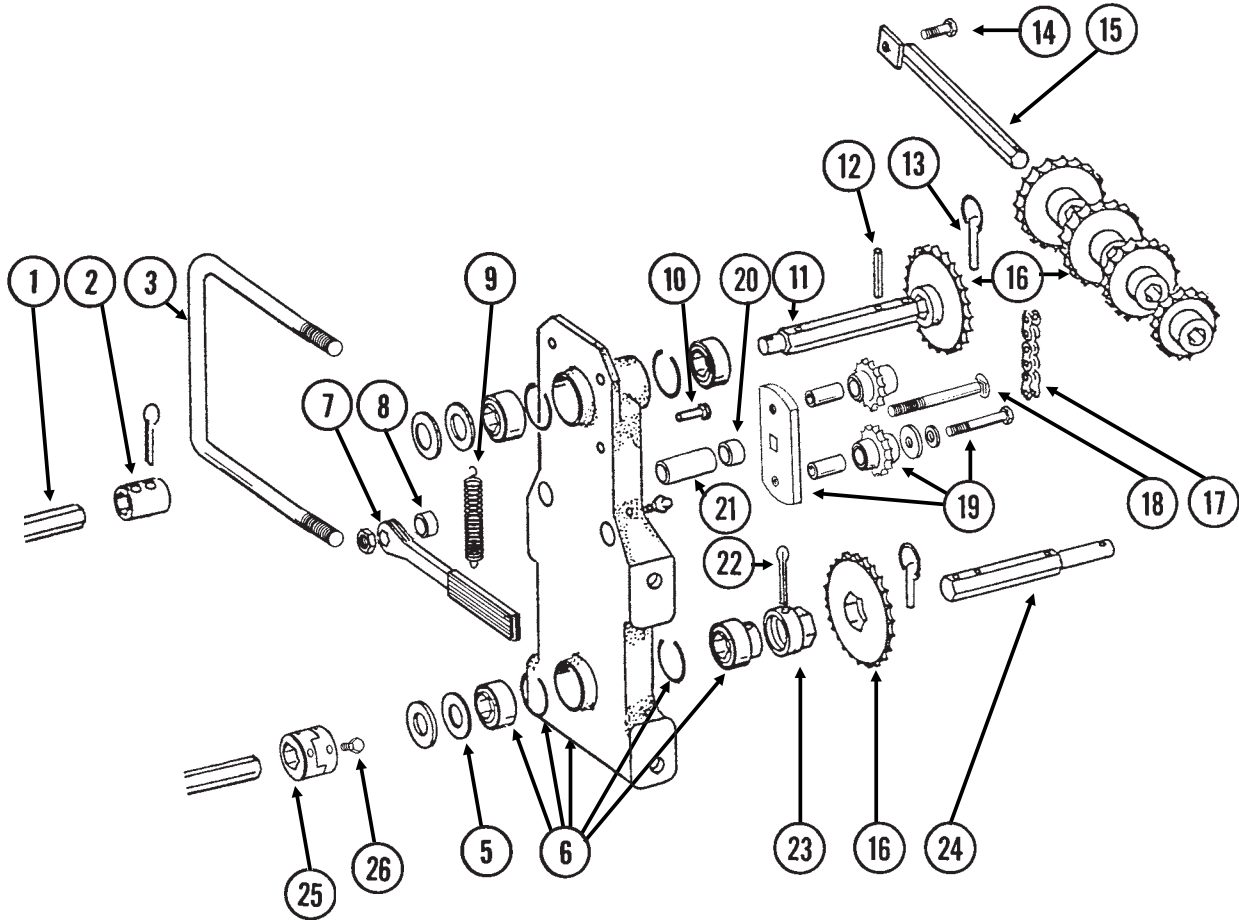

ITEM	PART NO.	QTY.	DESCRIPTION
		(Per Assy.)	
1.		-	See "Driveline", Pages P40 And P41
2.	GD5886	1	Coupler, 1 3/4"
3.	GD1114	1	U-Bolt, 7" x 7" x 5/8"-11
	G10107	2	Lock Nut, 5/8"-11
4.	G10460	2	Cotter Pin, 1/4" x 2"
5.	G10233	4	Machine Bushing, 1", 10 Gauge

# SEED RATE TRANSMISSION ASSEMBLY

ITEM	PART NO.	QTY.	DESCRIPTION
		(Per Assy.)	
6.	GA5629	1	Transmission Plate W/Bearings, Grease Fittings And Retaining Rings
	GA5116	3	Bearing, 7/8" Hex Bore, Cylindrical
	GA5624	1	Special Bearing, 7/8" Hex Bore x 1.6"
	GD6551	4	Ring
	G10640	-	Grease Fitting, 1/4"-28
7.	GA4235	1	Ratchet Arm W/Protective Closure
	G10445	-	Protective Closure
8.	GD10161	1	Spacer, 3/8"
9.	GD5857	1	Spring
10.	G10478	1	Clevis Pin, 5/16" x 1"
	G10409	1	Retaining Ring, 5/16"
11.	GD5215	1	Shaft, 7/8" x 6 3/8"
12.	G10602	3	Spring Pin, 1/4" x 1 1/2"
13.	GD2558	3	Lynch Pin, 1/4"
14.	G10037	1	Hex Head Cap Screw, 1/2"-13 x 1 1/4"
	G10228	1	Lock Washer, 1/2"
	G10102	1	Hex Nut, 1/2"-13
15.	GA5146	1	Sprocket Storage Rod
16.	GA5106	1	Sprocket, 17 Tooth
	GA5107	1	Sprocket, 19 Tooth
	GA5108	2	Sprocket, 23 Tooth
	GA5109	1	Sprocket, 24 Tooth
	GA5110	1	Sprocket, 25 Tooth
	GA5111	1	Sprocket, 26 Tooth
	GA5112	1	Sprocket, 27 Tooth
	GA5113	1	Sprocket, 28 Tooth
17.	G3310-80	1	Chain, No. 40, 80 Pitch Including Connector Link
	GR0912	-	Connector Link, No. 40
18.	G10867	1	Carriage Bolt, 1/2"-13 x 5"
	G10111	1	Lock Nut, 1/2"-13
19.	GA7336	1	Idler W/Bolt-On Sprockets
	GD7426	-	Sprocket, 12 Tooth
	GD1026	-	Sleeve, 1 3/16" Long
	G10210	-	Washer, 3/8" USS
	G10229	-	Lock Washer, 3/8"
	G10047	-	Hex Head Cap Screw, 3/8"-16 x 1 3/4"
20.	GD2734-01	1	Sleeve, 1 1/4" O.D. x 1/2" Long
21.	GD3180-16	1	Sleeve, 5/8" I.D. x 7/8" O.D. x 2 13/16" Long
22.	G10462	1	Cotter Pin, 3/16" x 2"
23.	GD7127	1	Shear Coupler
24.	GD7822	1	Shaft, 7/8" x 7"
25.	GB0287	2	Coupler
26.	G10131	4	Square Head Set Screw, 5/16"-18 x 3/4"
A.	GA5495	-	Transmission Assembly (Items 2-24)

# ROW MARKER ASSEMBLY, THREE-FOLD LOW PROFILE

(MKR8c/MKR30)

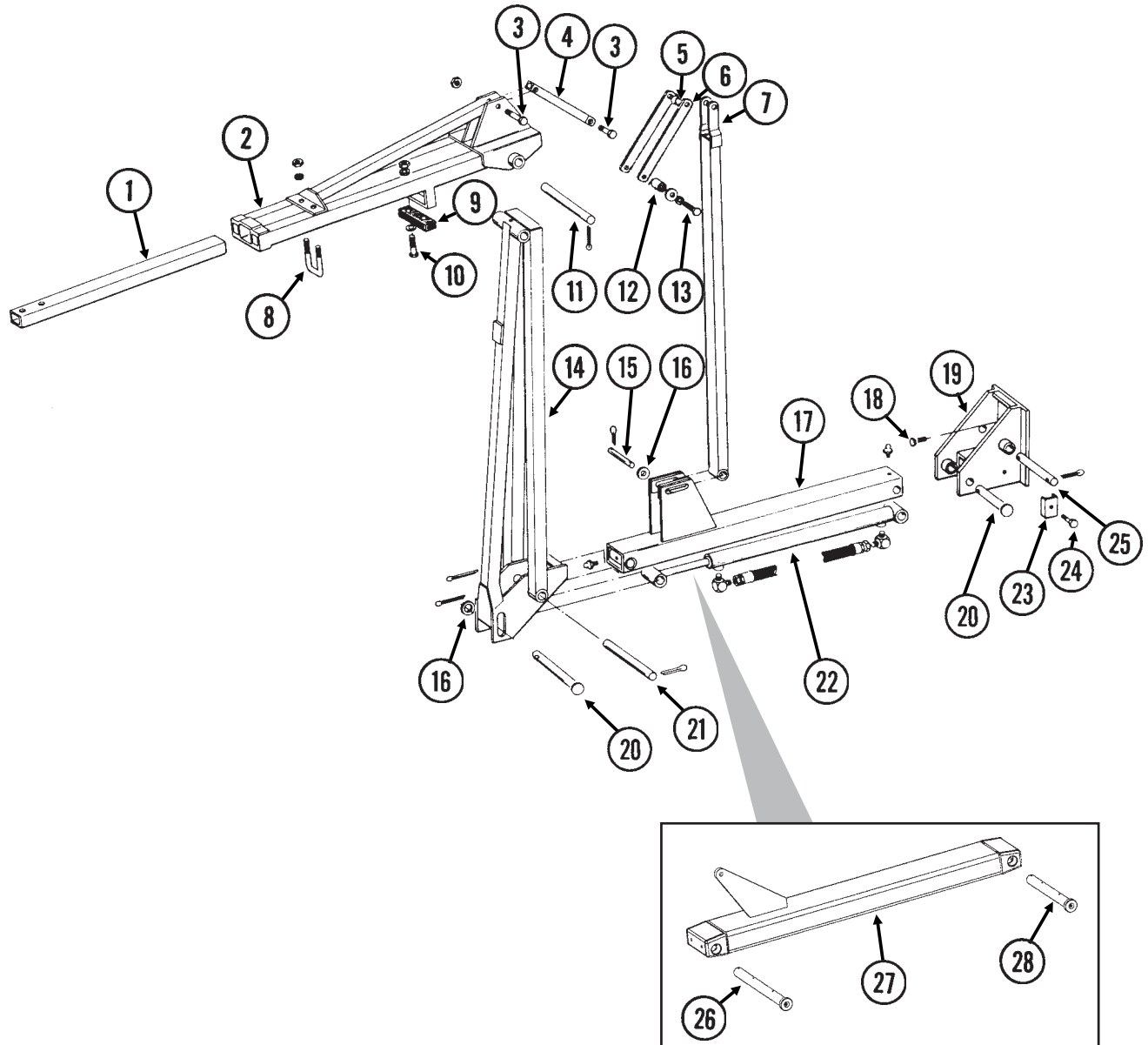

# ROW MARKER ASSEMBLY, THREE-FOLD LOW PROFILE

ITEM	PART NO.	QTY. (Per Assy.)	DESCRIPTION
1.	GD0453-05	1	Extension Tube, 55", 8 Row 36"/38"/40"
	GD0453-03	-	Extension Tube, 50", 12 Row 30"
2.	GA4905	1	Arm, Third Stage, 19 1/2", 8 Row 36"/38"/40"
	GA4887	-	Arm, Third Stage, 35", 12 Row 30"
3.	G10013	2	Hex Head Cap Screw, 5/8"-11 x 3 1/2"
	G10107	2	Lock Nut, 5/8"-11
4.	GA4894	1	Linkage, 15 1/4"
5.	GD3180-08	1	Sleeve, 5/8" I.D. x 7/8" O.D. x 1/2" Long
6.	GD8290	2	Bar
7.	GA4910	1	Linkage Tube, 54 3/4", 8 Row 36"/38"/40"
	GA4893	-	Linkage Tube, 72 3/4", 12 Row 30"
8.	GD2721	1	U-Bolt, 2" x 2" x 1/2"-13
	G10228	2	Lock Washer, 1/2"
	G10102	2	Hex Nut, 1/2"-13
9.	GA9145	1	Molded Stop, 6 1/4" Long
10.	G10047	2	Hex Head Cap Screw, 3/8"-16 x 1 3/4"
	G10210	2	Washer, 3/8" USS
	G10108	2	Lock Nut, 3/8"-16
11.	GD2697	1	Pin, 7/8" x 11"
	G10463	2	Cotter Pin, 1/4" x 1 1/2"
12.	GD7398	1	Pin
13.	G10002	1	Hex Head Cap Screw, 3/8"-16 x 3/4"
	G10229	1	Lock Washer, 3/8"
	G10210	1	Washer, 3/8" USS
14.	GA4903	1	Arm, Second Stage, 60", 8 Row 36"/38"/40"
	GA4885	-	Arm, Second Stage, 78", 12 Row 30"
15.	GD6136	1	Pin, 1 1/4" x 5"
	G10460	2	Cotter Pin, 1/4" x 2"
16.	G10226	3	Washer, 1 1/4" SAE
17.	GA4884	1	Arm W/Grease Fittings, First Stage
	G10641	-	Grease Fitting, 1/8" NPT
18.	G10879	4	Flanged 12 Point Bolt, 5/8"-11 x 2", Special Hardened
19.	GA5130	1	Mount
20.	GD15386	2	Pin, 1 1/4" x 7 5/8"
	G10460	2	Cotter Pin, 1/4" x 2"
21.	GD3214	1	Pin, 1 1/4" x 12 1/4"
	G10460	2	Cotter Pin, 1/4" x 2"
22.		-	See "Row Marker Cylinder", Page P48
23.	GD5875	1	Hose Clamp, 9/16" x 2 1/2" x 2"
24.	G10133	1	Hex Head Cap Screw, 5/16"-18 x 1 1/2"
	G10232	1	Lock Washer, 5/16"
	G10106	1	Hex Nut, 5/16"-18
25.	GD0652	1	Pin, 1 1/4" x 9 1/2"
	G10460	2	Cotter Pin, 1/4" x 2"
26.	GA11766	-	Pin W/Grease Fitting, 1 1/4" x 11 13/16"
	G10640	-	Grease Fitting, 1/4"-28
	G10463	1	Cotter Pin, 1/4" x 1 1/2"
27.	GA11594	-	Arm, First Stage
28.	GA11767	-	Pin W/Grease Fitting, 1 1/4" x 9 1/2"
	G10640	-	Grease Fitting, 1/4"-28
	G10463	1	Cotter Pin, 1/4" x 1 1/2"

# ROW MARKER SPINDLE/HUB/BLADE

MKR020(MKR4a)

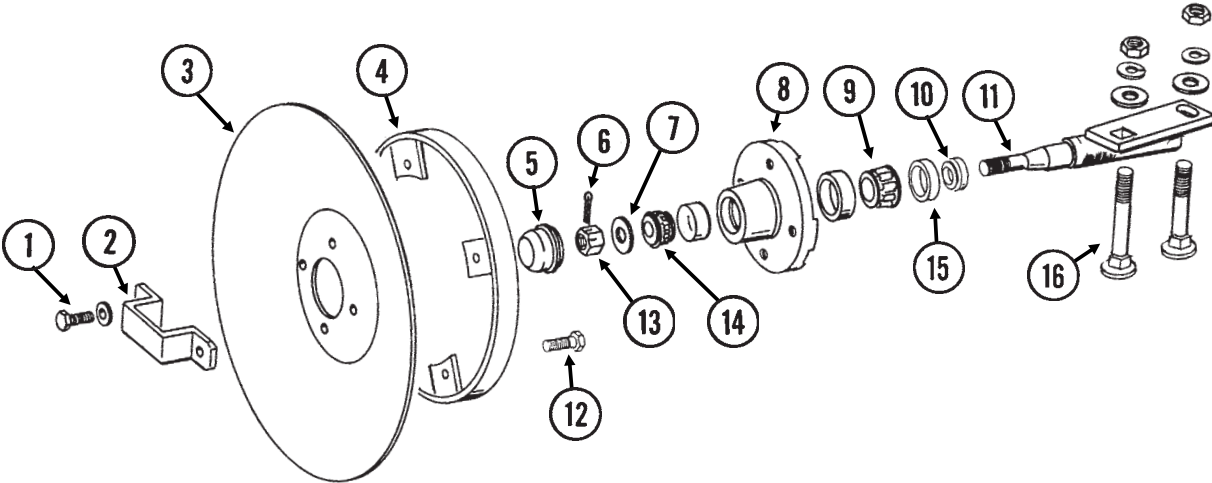

# ROW MARKER SPINDLE/HUB/BLADE

---

ITEM	PART NO.	QTY. (Per Assy.)	DESCRIPTION
1.	G10722	4	Hex Head Cap Screw, 1/2"-20 x 1"
	G10228	4	Lock Washer, 1/2"
2.	GD2597	1	Retainer
3.	GD0746	1	Disc Blade, Solid, 16" (Shown)
	GD10283	-	Disc Blade, Notched, 16" (Optional)
4.	GA5853	1	Depth Band
5.	GD0840	1	Dust Cap
6.	G10544	1	Cotter Pin, 5/32" x 1"
7.	G10724	1	Washer, 5/8" SAE
8.	GA0167	1	Hub W/Cups, 4 Bolt
	GR0151	-	Outer Cup
	GR0150	-	Inner Cup
9.	GA0245	1	Bearing
10.	GA0899	1	Rubber Seal
11.	GA1677	1	Spindle, L.H. (Shown)
	GA1676	-	Spindle, R.H.
12.	G10019	4	Hex Head Cap Screw, 5/16"-18 x 1"
	G10109	4	Lock Nut, 5/16"-18, Grade 8
13.	G10725	1	Slotted Hex Nut, 5/8"-18
14.	GA0257	1	Bearing
15.	GA0243	1	Grease Seal
16.	G10844	2	Carriage Bolt, 1/2"-13 x 3 1/2"
	G10168	2	Machine Bushing, 1/2", 7 Gauge
	G10228	2	Lock Washer, 1/2"
	G10102	2	Hex Nut, 1/2"-13
A.	GA1679	-	Hub And Spindle Assembly, L.H. (Items 1, 2, 5-11 And 13-15)
	GA1678	-	Hub And Spindle Assembly, R.H. (Items 1, 2, 5-11 And 13-15)

# ROW MARKER (CUSHION) CYLINDER

CYL039(CYL13f)

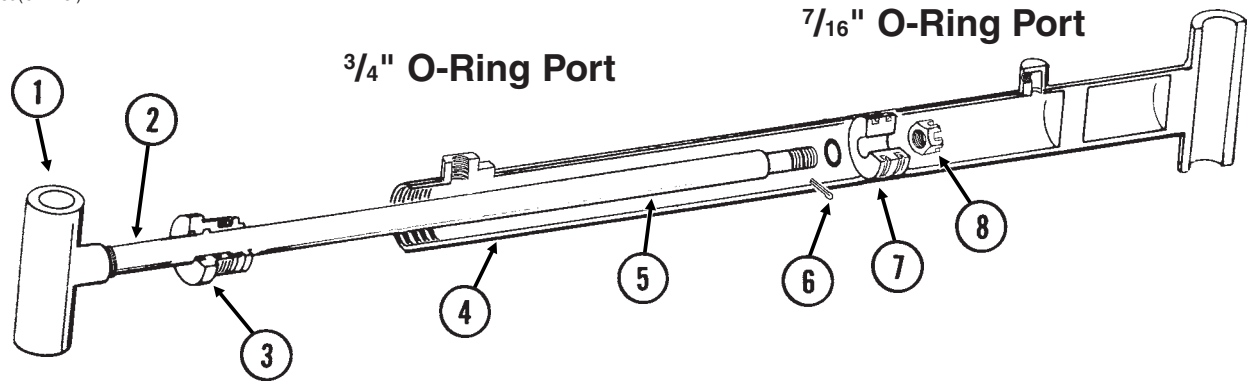

ITEM	PART NO.	QTY.	DESCRIPTION
1.	GD14308	1	Threaded Sleeve End
2.	G10526	4	Machine Bushing, 1" (.048" Thick)
3.	GD10207	1	Gland
4.	A8836	1	Barrel ( <b>Non-Stock Item</b> )
5.	GD14529	1	Rod
6.	G10827	1	Cotter Pin, 1/8" x 1 3/4"
7.	GD11983	1	Piston
8.	G10962	1	Slotted Hex Nut, 7/8"-14
A.	GA10123	-	Cylinder Complete, 2 1/2" x 20 1/16" (Part Number Stamped On Barrel)
B.	GR1521	-	Seal Kit, Includes: (1) T Seal, (2) O-Rings, (1) BU Ring, (1) U-Cup, (1) Wiper, (1) Cast Iron Ring

# WING LIFT CYLINDER

(CYL21c)

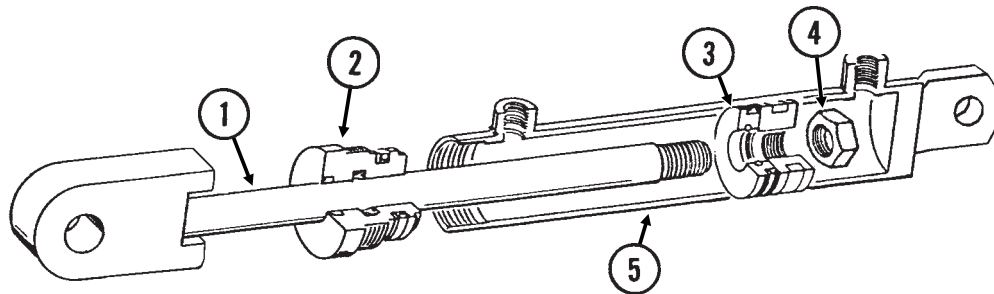

ITEM	PART NO.	QTY.	DESCRIPTION
1.	GA9020	1	Rod Assembly
2.	GD12670	1	Gland
3.	GD12672	1	Piston
4.	G10972	1	Lock Nut, 1 1/4"-12
5.	A9022	1	Barrel ( <b>Non-Stock Item</b> )
A.	GA9023	-	Cylinder Complete, 4" x 11"
B.	GR1552	-	Seal Kit, Includes: (1) T-Seal, (2) O-Rings, (1) BU Ring, (1) U-Cup, (1) Wiper, (1) Wear Ring



# DUAL LIFT ASSIST CYLINDER

CYL048(CYL22c)

1/2" NPT Ports

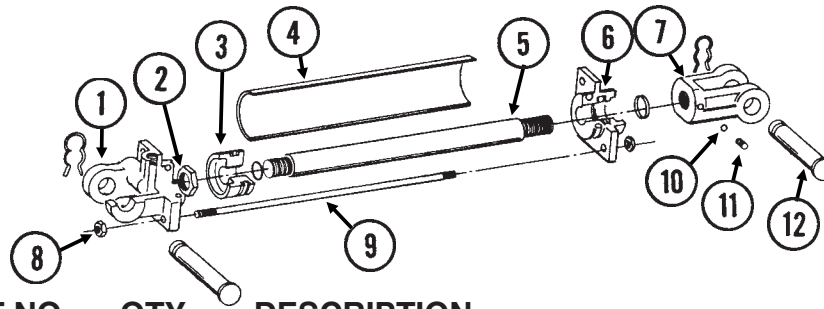

ITEM	PART NO.	QTY.	DESCRIPTION
1.	GR1027	1	Clevis
2.	GR0663	1	Hex Lock Nut, 1"-14 UNS
3.	GR1026	1	Piston
4.	R1023	1	Barrel <b>(Non-Stock Item)</b>
5.	GR0709	1	Shaft
6.	GR1025	1	Gland
7.	GR0714	1	Clevis
8.	GR0181	8	Hex Nut, 1/2"-13
9.	GR1024	4	Tie Rod
10.	GR0716	1	Nylon Ball
11.	G10072	1	Hex Socket Set Screw, 3/8"-16 x 3/8"
12.	GR0717	2	Pin W/Clip
	GR0193	-	Hair Pin Clip
A.	GA5482A	-	Cylinder Complete W/Pins And Clips, 3 1/2" x 8"
B.	GR1028	-	Seal Kit, Includes: (1) Wiper, (4) BU Rings, (4) O-Rings, (1) U-Cup

**IDENTIFICATION NOTE: "Energy" cast in clevis.**

# DUAL LIFT ASSIST CYLINDER

CYL048(CYL23)

1/2" NPT Ports

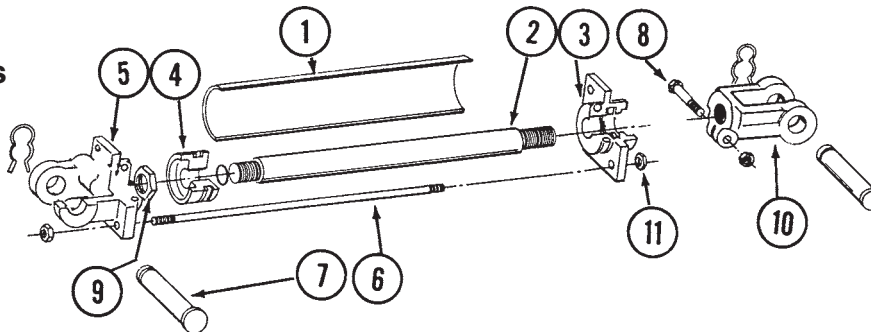

ITEM	PART NO.	QTY.	DESCRIPTION
1.	R1274	1	Barrel <b>(Non-Stock Item)</b>
2.	GR1273	1	Shaft
3.	GR1271	1	Gland
4.	GR1272	1	Piston
5.	GR1270	1	Clevis
6.	GR1024	4	Tie Rod
7.	GR0717	2	Pin W/Clip
	GR0193	-	Hair Pin Clip
8.	G10047	1	Hex Head Cap Screw, 3/8"-16 x 1 3/4"
	G10101	1	Hex Nut, 3/8"-16
9.	GR1278	1	Special Nut, 1"-14 UNS
10.	GR1276	1	Clevis
11.	GR0181	8	Hex Nut, 1/2"-13
A.	GA5482B	-	Cylinder Complete W/Pins And Clips, 3 1/2" x 8"
B.	GR1279	-	Seal Kit, Includes: (3) BU Seals, (5) O-Rings, (1) C/R Seal

**IDENTIFICATION NOTE: Decal on barrel identifies "Lion Hydraulics".**

# DUAL LIFT ASSIST CYLINDER

CYL048(CYL22c)

3/4"-16 O-Ring Ports

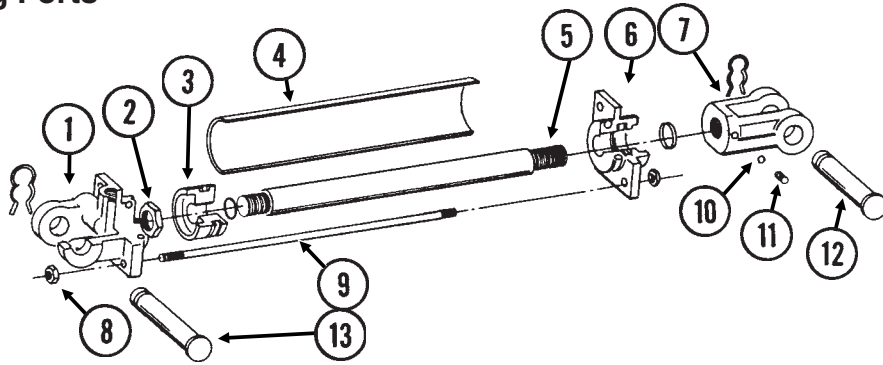

ITEM	PART NO.	QTY.	DESCRIPTION
1.	GR1511	1	Clevis
2.	G10948	1	Lock Nut, 1 1/8"-12
3.	GR1512	1	Piston
4.	R1510	-	Barrel ( <b>Non-Stock Item</b> )
5.	GR1508	1	Shaft
6.	GR1509	1	Gland
7.	GR1507	1	Clevis
8.	G10102	8	Hex Nut, 1/2"-13
9.	GR1506	4	Tie Rod
10.	GR0716	1	Nylon Ball
11.	G10072	1	Hex Socket Set Screw, 3/8"-16 x 3/8"
12.	GR1504	1	Pin W/Clip
	GR0193	-	Hair Pin Clip
13.	GR0717	1	Pin W/Clip
	GR0193	-	Hair Pin Clip
A.	GA5482C	-	Cylinder Complete W/Pins And Clips, 3 1/2" x 8"
B.	GR1505	-	Seal Kit, Includes: (1) Wiper, (2) BU Rings, (3) O-Rings, (1) U-Cup, (1) Piston Seal

**IDENTIFICATION NOTE:** "Energy" and date code "3899" (Week 38/Year 1999 or later) cast in barrel.

# ROW MARKER SEQUENCING/FLOW CONTROL VALVE

VVB025(PT9a)

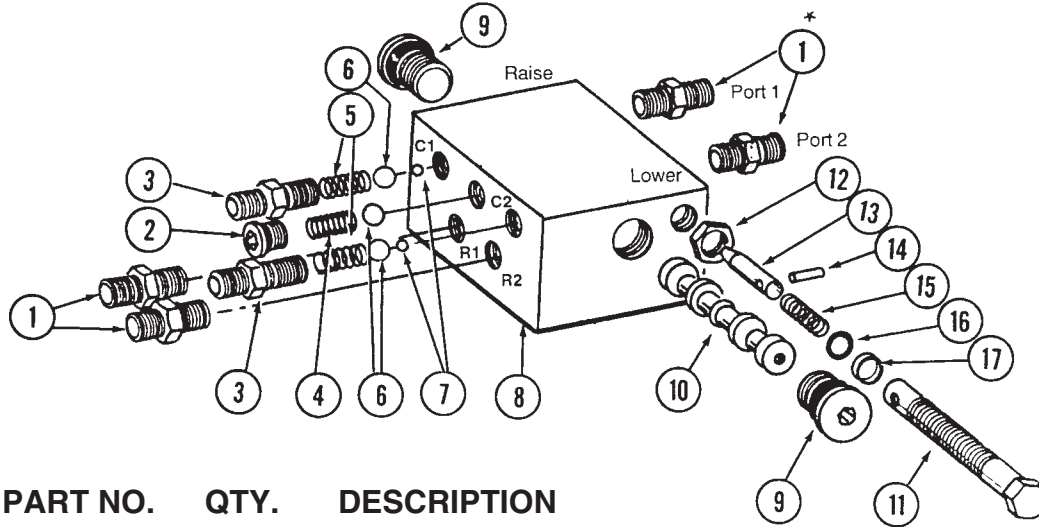

ITEM	PART NO.	QTY.	DESCRIPTION
1.	*G6400-06	4	Connector W/O-Ring, 9/16"-18 Male 37° JIC To 9/16"-18 O-Ring
	GR1045	-	O-Ring
2.	GR1034	1	Hex Socket Plug W/O-Ring
	GR1035	-	O-Ring
3.	GR1032	2	Port Adapter W/O-Ring
	GR1045	-	O-Ring
4.	GR1033	1	Detent Spring
5.	GR1036	2	Spring
6.	GR1044	3	7/16" Check Ball
7.	GR1043	2	1/4" Steel Ball
8.		-	Valve Body ( <b>Non-Stock Item</b> )
9.	GR1047	2	Hex Socket Plug W/O-Ring
	GR1037	-	O-Ring
10.		-	Spool ( <b>Non-Stock Item</b> )
11.	GR1042	2	Adjustment Screw
12.	GR1048	2	Hex Jam Nut, 1/2"-20
13.	GR1038	2	Needle
14.	GR1039	2	Spring Pin
15.	GR1046	2	Compression Spring
16.	GR1040	2	O-Ring
17.	GR1041	2	Teflon BU Ring
A.	GA5552	-	Valve Assembly Complete (Items 1-17)
B.	GA5572	-	Flow Control Portion Only (Items 11-17)

\*Not used on sizes with 3/8" hoses.

## FLOW CONTROL VALVE

VVB001(MT2)

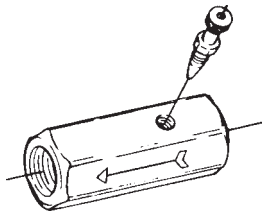

ITEM	PART NO.	QTY.	DESCRIPTION
A.	GA0270	-	Flow Control Valve W/Needle Valve ("Parker" Stamped On Valve Body)

# HYDRAULIC SYSTEM

PHS034/PHS002(PT11/MT19a)

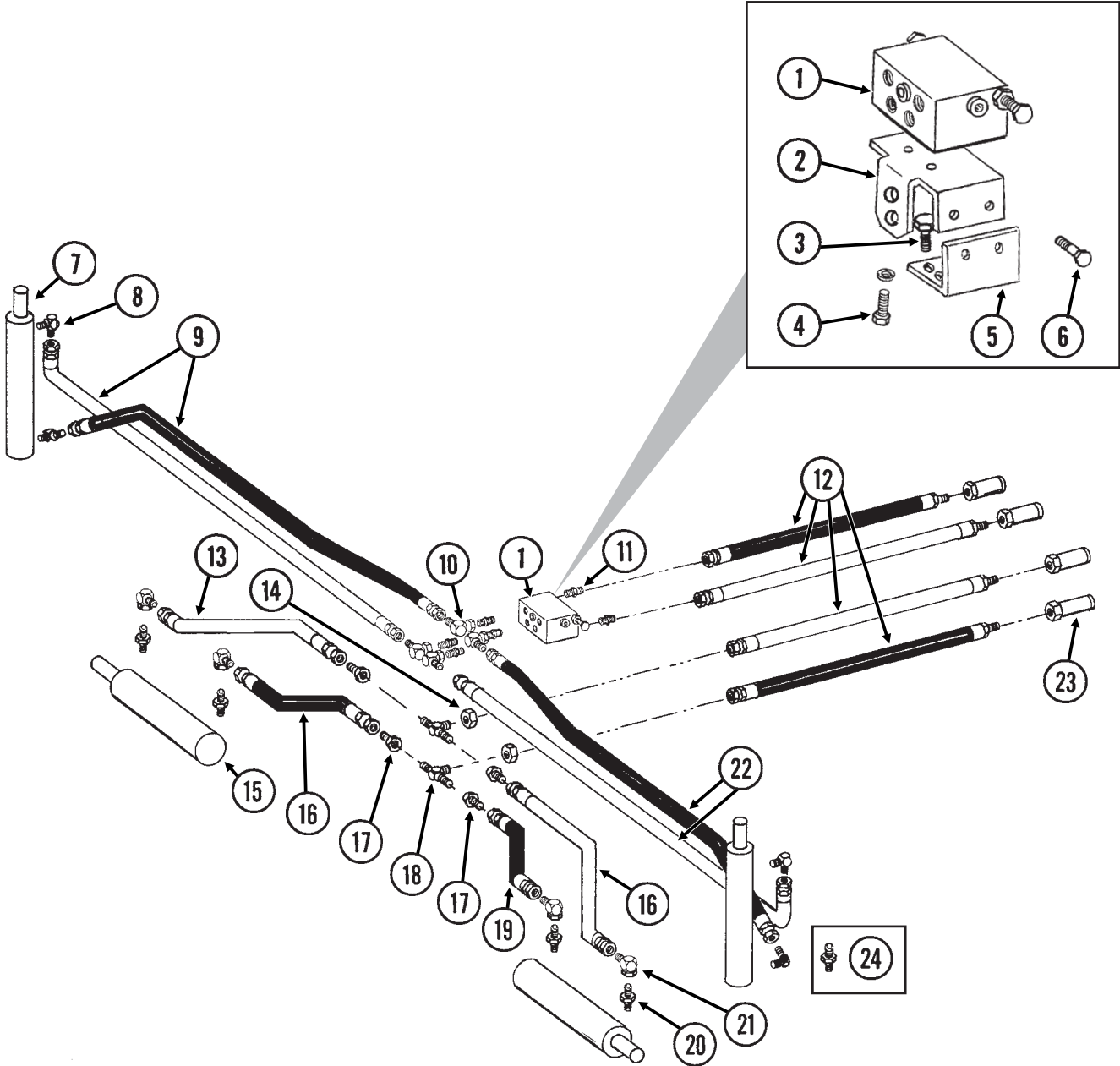

# HYDRAULIC SYSTEM

ITEM	PART NO.	QTY.	DESCRIPTION
1.		-	See "Row Marker Sequencing/Flow Control Valve", Page P51
2.	GD10224	1	Valve Mounting Angle
3.	G10001	2	Hex Head Cap Screw, $\frac{3}{8}$ "-16 x 1"
	G10210	2	Washer, $\frac{3}{8}$ " USS
	G10229	2	Lock Washer, $\frac{3}{8}$ "
4.	G10001	2	Hex Head Cap Screw, $\frac{3}{8}$ "-16 x 1"
	G10229	2	Lock Washer, $\frac{3}{8}$ "
5.	GD10223	1	Mounting Angle
6.	G10001	2	Hex Head Cap Screw, $\frac{3}{8}$ "-16 x 1"
	G10203	2	Washer, $\frac{3}{8}$ " SAE
	G10229	2	Lock Washer, $\frac{3}{8}$ "
	G10101	2	Hex Nut, $\frac{3}{8}$ "-16
7.		-	See "Row Marker Cylinder", Page P48
8.	G6801-08	4	Elbow W/O-Ring, 90°, $\frac{3}{4}$ "-16 Male JIC To O-Ring
	GR1037	-	O-Ring
9.	*A1054	2	Hose Assembly, $\frac{3}{8}$ " x 204", 8 Row 36"/38"/40"
	*A1093	-	Hose Assembly, $\frac{3}{8}$ " x 230", 12 Row 30"
10.	G6500-08-06	4	Swivel Elbow, 90°, $\frac{3}{4}$ "-16 Male JIC To $\frac{9}{16}$ "-18 Female
11.	G6400-08-06	2	Connector W/O-Ring, $\frac{3}{4}$ "-16 Male JIC To $\frac{9}{16}$ "-18 O-Ring
	GR1045	-	O-Ring
12.	*A3164	4	Hose Assembly, $\frac{3}{8}$ " x 52"
13.	*A1155	1	Hose Assembly, $\frac{1}{4}$ " x 48", 8 Row 36"/38"
	*A1153	-	Hose Assembly, $\frac{1}{4}$ " x 56", 8 Row 40"
	*A1188	-	Hose Assembly, $\frac{1}{4}$ " x 66", 12 Row 30"
14.	G306-08	2	Lock Nut, $\frac{3}{4}$ "-16
15.		-	See "Wing Lift Cylinder", Page P48
16.	*A1189	2	Hose Assembly, $\frac{1}{4}$ " x 36", 8 Row 36"/38"
	*A1132	-	Hose Assembly, $\frac{1}{4}$ " x 44", 8 Row 40"
	*A1144	-	Hose Assembly, $\frac{1}{4}$ " x 54", 12 Row 30"
17.	G2406-08-06	4	Reducer, $\frac{3}{4}$ "-16 Female JIC To $\frac{9}{16}$ "-18 Male JIC
18.	G2703-08	2	Bulkhead Tee, $\frac{3}{4}$ "-16 Male JIC
19.	*A1169	1	Hose Assembly, $\frac{1}{4}$ " x 24", 8 Row 36"/38"
	*A1181	-	Hose Assembly, $\frac{1}{4}$ " x 32", 8 Row 40"
	*A1132	-	Hose Assembly, $\frac{1}{4}$ " x 44", 12 Row 30"
20.	G6400-06-08	4	Connector W/O-Ring, $\frac{9}{16}$ "-18 Male JIC To $\frac{3}{4}$ "-16 O-Ring
	GR1037	-	O-Ring
21.	G6500-06	4	Swivel Elbow, 90°, $\frac{9}{16}$ "-18 Male JIC To Female
22.	*A1030	2	Hose Assembly, $\frac{3}{8}$ " x 192", 8 Row 36"/38"/40"
	*A1057	-	Hose Assembly, $\frac{3}{8}$ " x 216", 12 Row 30"
23.	GD4086	4	ISO Coupler
24.	G6400-08-04	2	Connector W/O-Ring, $\frac{3}{4}$ "-16 Male JIC To $\frac{7}{16}$ "-20 O-Ring
	GR1465	-	O-Ring

\*Hydraulic hose is not stocked by KINZE® Repair Parts, but can be made available on a special order basis. Call for quote.

# ELECTRICAL COMPONENTS

(A9507a/MTR27a/ELC8/PT49a/PT49h)

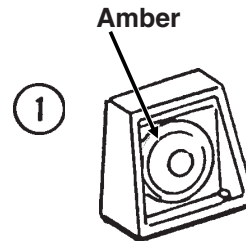
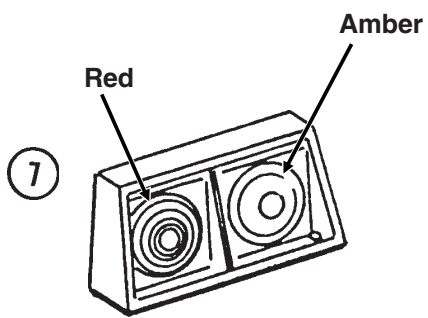
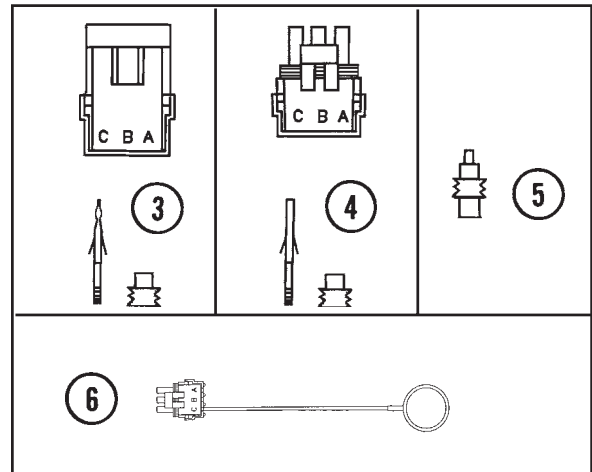
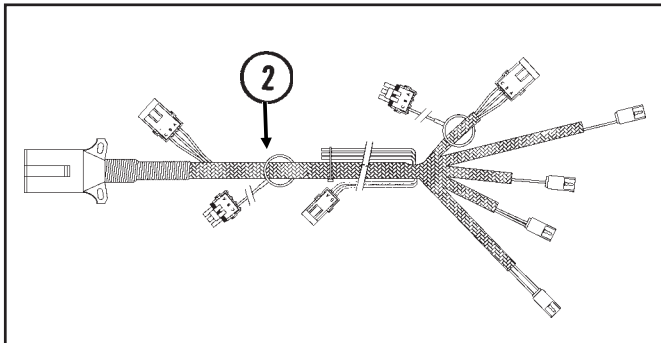

See "Center Frame Assembly", Pages P32 and P33 for light brackets.

# ELECTRICAL COMPONENTS

---

ITEM	PART NO.	QTY.	DESCRIPTION
1.	GA6701	2	Single Amber Light Assembly
	GR1204	-	Amber Lens
	GR1206	-	Rubber Grommet (2)
	GR1207	-	Lamp Unit
	GR1208	-	Bulb
2.	GA9507	-	Wiring Harness W/7 Terminal Female Connector, 186" (4 Light Connections)
	GA5385	-	7 Terminal Female Connector
3.	G1K248	-	3-Pin Female Connector Kit, Includes: (3) 3-Pin Female Housings, (9) Pin Contacts, (9) Seals
4.	G1K252	-	3-Pin Male Connector Kit, Includes: (3) 3-Pin Male Housings, (9) Socket Contacts, (9) Seals
5.	GD11089	-	Sealing Plug
6.	GA8047	-	Dust Plug (Black)
7.	GA6699	1	Double Light Assembly (Shown)
	GA6700	1	Double Light Assembly
	GR1203	-	Red Lens
	GR1204	-	Amber Lens
	GR1205	-	Cover
	GR1206	-	Rubber Grommet (4)
	GR1207	-	Lamp Unit
	GR1208	-	Bulb

# KPM I ELECTRONIC SEED MONITOR

(MTR46b)

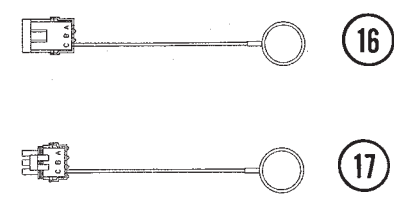
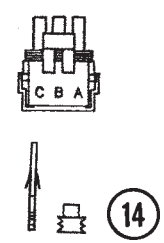
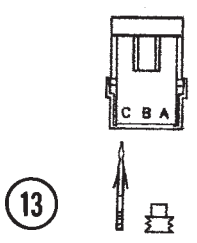
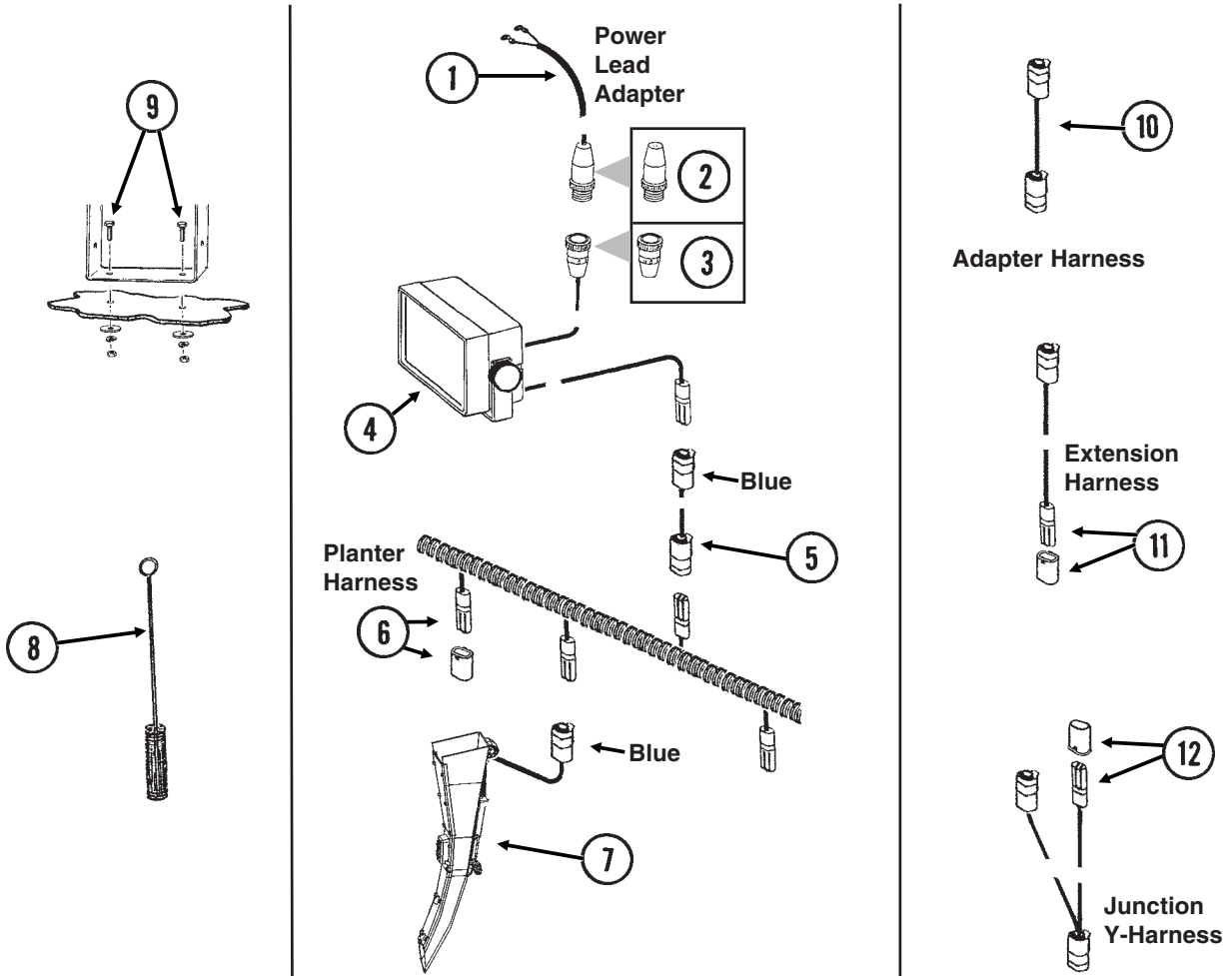



# KPM I ELECTRONIC SEED MONITOR

ITEM	PART NO.	QTY.	DESCRIPTION
1.	GA7856	1	Power Lead Adapter
2.	G1K267	-	Power Lead Adapter Connector Kit, Includes: (1) Cable Clamp, (1) 3-Pin Connector, (3) Male Terminal Pins
3.	G1K268	-	Console Cable Connector Kit, Includes: (1) Cable Clamp, (1) 3-Pin Connector, (1) Lock Ring, (3) Female Terminal Pins
4.	GA10570	1	KPM I Backlit Console W/Mounting Bracket, Fuse Holder And Fuse, Power Lead Adapter (Item 11), Brush (Item 23) And Dust Plug (Item 34)
	GR1390	-	Mounting Bracket, KPM I
	GR1392	-	Console Mounting Bracket Hardware Package (Includes 2 Knobs And 1/4" Hardware)
	GA10601	-	Fuse Holder
	GD7639	-	Fuse
5.		-	Included In Planter Wiring Harness, See Item 2 On Pages P54 And P55
6.	GA8021	-	Planter Harness W/Dust Caps, 4 Row (7 Connectors)
	GA8022	-	Planter Harness W/Dust Caps, 6 Row (9 Connectors)
	GA7850	-	Planter Harness W/Dust Caps, 8 Row (12 Connectors)
	GD11993	-	Dust Cap
7.	GA10901	-	Seed Tube W/Computerized Sensor
	GR1629	-	Sensor Only
	GA10940	-	Seed Tube (With Holes For Sensor Installation)
8.	GR0594	-	Brush
9.	G10022	2	Hex Head Cap Screw, 1/4"-20 x 1/2"
	G10211	2	Washer, 1/4" SAE
	G10227	2	Lock Washer, 1/4"
	G10103	2	Hex Nut, 1/4"-20
10.	GA7857	-	Adapter Harness, 1'
11.	GA7854	-	Extension Harness W/Dust Cap, 15'
	GA7855	-	Extension Harness W/Dust Cap, 30'
	GD11993	-	Dust Cap
12.	GA7853	-	Junction Y-Harness W/Dust Cap
	GD11993	-	Dust Cap
13.	G1K248	-	3-Pin Female Connector Kit (Black), Includes: (3) 3-Pin Female Housings, (9) Pin Contacts, (9) Seals
	G1K362	-	3-Pin Female Connector Kit (Blue), Includes: (3) 3-Pin Female Housings, (9) Pin Contacts, (9) Seals
14.	G1K252	-	3-Pin Male Connector Kit (Black), Includes: (3) 3-Pin Male Housings, (9) Socket Contacts, (9) Seals
	G1K363	-	3-Pin Male Connector Kit (Blue), Includes: (3) 3-Pin Male Housings, (9) Socket Contacts, (9) Seals
15.	GD11089	-	Sealing Plug
16.	GA8046	-	Dust Plug (Black)
	GA9978	-	Dust Plug (Blue)
17.	GA8047	-	Dust Plug (Black)
	GA9979	-	Dust Plug (Blue)

# KPM II STACK-MODE/KPM III ELECTRONIC SEED MONITORS

(MTR43nn/A10901a)

## Shaft Rotation Sensor

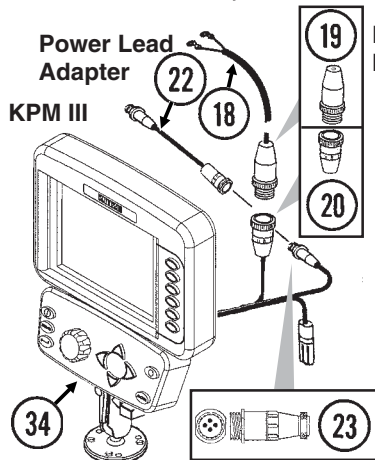
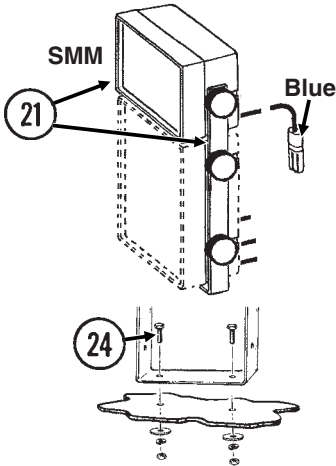
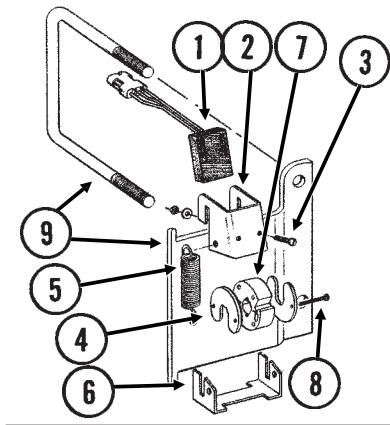

## Radar Distance Sensor

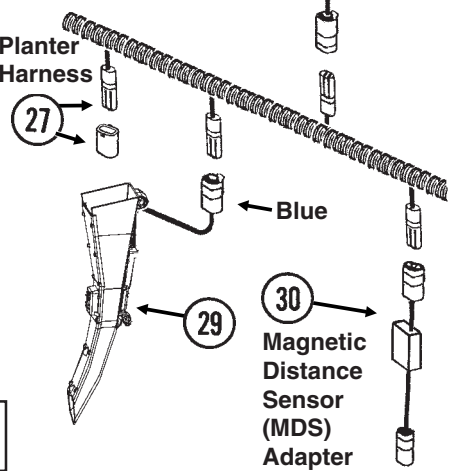
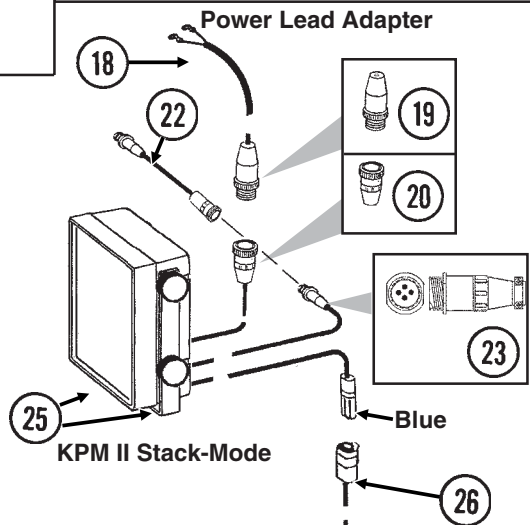
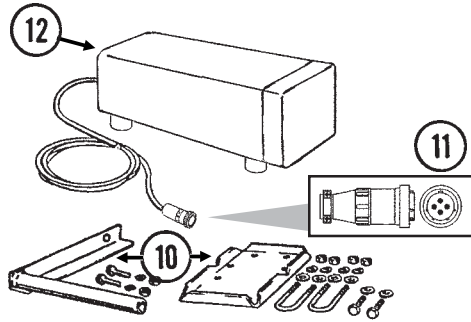

## Magnetic Distance Sensor (MDS)

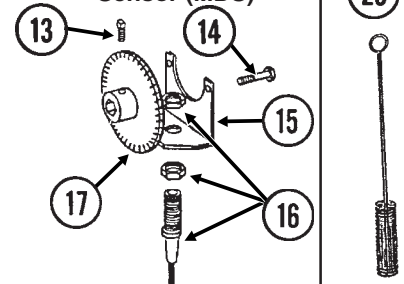

## Radar Y-Cable

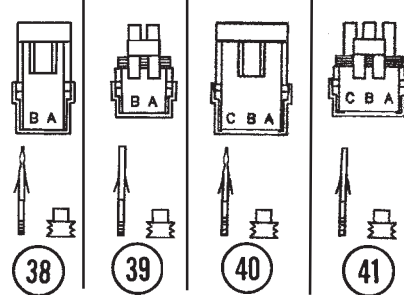
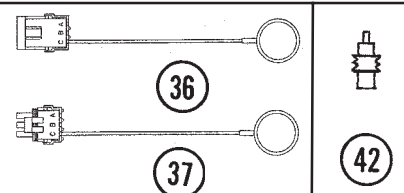
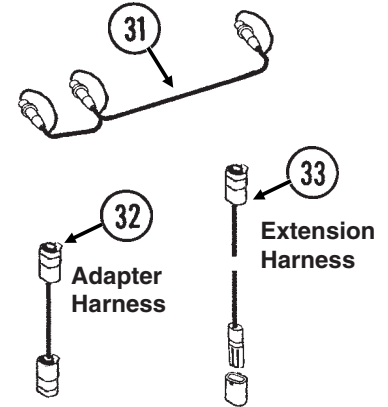

ITEM	PART NO.	QTY.	DESCRIPTION
1.	GR1415	1	Rotation Sensor
2.	GD11169	1	Mount
3.	G10757	2	Pan Head Screw, No. 10-32 x 1 1/4"
	G10243	2	Washer, No. 10 SAE
	G10758	2	Hex Nut, No. 10-32
4.	GD11474	2	Cover
5.	GD5857	2	Spring
6.	GD11170	1	Spring Mount
7.	GR1414	1	Actuator
8.	G10927	2	Pan Head Machine Screw, No. 8-32 x 1 1/4", Stainless Steel
	G10931	2	Lock Washer, No. 8, Internal/External, Stainless Steel
	G10928	2	Hex Nut, No. 8-32, Stainless Steel
9.	G1K364	-	Rotation Sensor Mount Kit, Includes: (2) Mounts, (2) GD11721 5" x 7" U-Bolts, (4) G10228 Lock Washers, (4) G10102 Hex Nuts, (1) Instruction
10.	GA8026	-	Radar Sensor Pipe/Mounting Bracket Package
11.	G1K323	-	4-Pin Connector Kit W/Female Housing, Includes: (4) Pins, (1) Cable Clamp

# KPM II STACK-MODE/KPM III ELECTRONIC SEED MONITORS

ITEM	PART NO.	QTY.	DESCRIPTION
12.	GA7858	-	Radar Distance Sensor W/20' Cable
13.	GA5549	1	Magnetic Distance Sensor Pulse Wheel
14.	G10145	1	Square Head Set Screw, 5/16"-18 x 1/2"
15.	G10171	2	Hex Head Cap Screw, 5/16"-18 x 1 1/4"
	G10232	2	Lock Washer, 5/16"
	G10106	2	Hex Nut, 5/16"-18
16.	GD7632	1	Magnetic Distance Sensor Bracket
17.	GA5600	1	Magnetic Distance Sensor
18.	GA7856	1	Power Lead Adapter
19.	G1K267	-	Power Lead Adapter Connector Kit, Includes: (1) 3-Pin Connector, (1) Cable Clamp, (3) Male Terminal Pins
20.	G1K268	-	Console Cable Connector Kit, Includes: (1) 3-Pin Connector, (1) Cable Clamp, (1) Lock Ring, (3) Female Terminal Pins
21.	GA9857	1	SMM Backlit Console W/Mounting Bracket And Dust Plug (Item 36)
	GR1631	-	Mounting Bracket, KPM II Stack-Mode And SMM Consoles
	GR1632	-	Console Mounting Bracket Hardware Package (Includes 2 Knobs And 1/4" Hardware)
22.	GA9144	-	Monitor/Radar Adapter Cable, 10"
23.	G1K322	-	4-Pin Connector Kit W/Male Housing, (4) Female Socket Contacts And (1) Cable Clamp
24.	G10022	2	Hex Head Cap Screw, 1/4"-20 x 1/2"
	G10211	2	Washer, 1/4" SAE
	G10227	2	Lock Washer, 1/4"
	G10103	2	Hex Nut, 1/4"-20
25.	GA10575	-	KPM II Backlit Console W/Mounting Bracket, Fuse Holder And Fuse, Power Lead Adapter (Item 18), Brush (Item 28), Dust Plug (Item 36) And Monitor/Radar Adapter, 10" (Item 22)
	GR1391	-	Mounting Bracket, KPM II
	GR1393	-	Console Mounting Bracket Hardware Package (Includes 4 Knobs And 1/4" Hardware)
	GA10601	-	Fuse Holder
	GD7639	-	Fuse
26.		-	Included In Tractor/Planter Wiring Harness, See Pages P54 And P55
27.	GA8021	1	Planter Harness W/Dust Caps, 4 Row (7 Connectors)
	GA8022	-	Planter Harness W/Dust Caps, 6 Row (9 Connectors)
	GA7850	-	Planter Harness W/Dust Caps, 8 Row (12 Connectors)
	GA7851	-	Planter Harness W/Dust Caps, 12 Row (16 Connectors)
	GA7852	-	Planter Harness W/Dust Caps, 16 Row (20 Connectors)
	GD11993	-	Dust Cap
28.	GR0594	-	Brush
29.	GA10901	-	Seed Tube W/Computerized Sensor
	GR1629	-	Sensor Only
	GA10940	-	Seed Tube (With Holes For Sensor Installation)
30.	GA7859	1	Magnetic Distance Sensor Adapter (Analog To Digital)
31.	GR0586	1	Radar Y-Cable (Used To Connect Radar Distance Sensor For Multiple Functions)
32.	GA7857	-	Adapter Harness, 1'
33.	GA7854	-	Extension Harness W/Dust Cap, 15'
	GA7855	-	Extension Harness W/Dust Cap, 30'
	GD11993	-	Dust Cap
34.	GA11039	1	KPM III Backlit Console W/Brush (Item 23), Dust Plug (Item 34), Mounting Bracket Assembly, Console Mounting Bracket Hardware And Power Harness
	GR1761	-	Mounting Bracket Assembly, Includes: (2) Mounting Brackets, (2) Connector Halves, (1) Compression Spring, (1) Tension Knob, (1) 1/4"-20 x 1 3/4" Hex Head Cap Screw, (1) 1/4" Plastic Washer, (1) 1/4" Steel Washer
	GR1762	-	Console Mounting Bracket Hardware Package, Includes: (3) No. 10-32 x 5/8" Hex Socket Pan Head Screws, (3) 1/4" Lock Washers
	GR1764	-	Power Harness
35.	G1K249	-	Acre Counter Switch Kit
36.	GA8046	-	Dust Plug (Black)
	GA9978	-	Dust Plug (Blue)
37.	GA8047	-	Dust Plug (Black)
	GA9979	-	Dust Plug (Blue)
38.	G1K321	-	2-Pin Female Connector Kit (Black), Includes: (3) 2-Pin Female Housings, (6) Pin Contacts, (6) Seals
39.	G1K320	-	2-Pin Male Connector Kit (Black), Includes: (3) 2-Pin Male Housings, (6) Socket Contacts, (6) Seals
40.	G1K248	-	3-Pin Female Connector Kit (Black), Includes: (3) 3-Pin Female Housings, (9) Pin Contacts, (9) Seals
	G1K362	-	3-Pin Female Connector Kit (Blue), Includes: (3) 3-Pin Female Housings, (9) Pin Contacts, (9) Seals
41.	G1K252	-	3-Pin Male Connector Kit (Black), Includes: (3) 3-Pin Male Housings, (9) Socket Contacts, (9) Seals
	G1K363	-	3-Pin Male Connector Kit (Blue), Includes: (3) 3-Pin Male Housings, (9) Socket Contacts, (9) Seals
42.	GD11089	-	Sealing Plug
A.	GA6147	-	Magnetic Distance Sensor And Mounting Package (Items 13-17 And 43)

# DECALS, PAINT AND MISCELLANEOUS

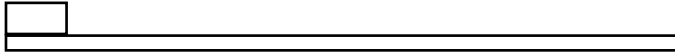

1

TORQUE 5/8" SPINDLE BOLTS TO 120 FT/LBS. CHECK PERIODICALLY AND RE-TORQUE AS NEEDED.  
7100-234

2

**! WARNING !**

EMPTY ALL HOPPERS AND INSTALL TRANSPORT PINS BEFORE TRANSPORTING.

7100-25

3

**! WARNING !**

TO AVOID INJURY -- STAND CLEAR--KEEP OTHERS AWAY WHEN RAISING OR LOWERING MARKERS. BEFORE TRANSPORTING PLANTER FULLY EXTEND HYDRAULIC CYLINDERS AND INSTALL LOCKING PINS WHERE PROVIDED.

7100-42

4

**! WARNING !**

1. Read and understand the Operator's Manual.
2. Stop the tractor engine before leaving the operator's platform.
3. Keep riders off the machine.
4. Make certain everyone is clear of the machine before starting the tractor engine and operating.
5. Keep all shields in place.
6. Never lubricate, adjust, unplug or service the machine with tractor engine running.
7. Wait for all movement to stop before servicing.
8. Keep hands, feet and clothing away from moving parts.
9. Use flashing warning lights when operating on highways except when prohibited by law.

7100-46

5

**! DANGER !**

THIS PLANTER IS DESIGNED TO BE DRIVEN BY GROUND TIRES ONLY. THE USE OF HYDRAULIC, ELECTRIC OR PTO DRIVES MAY CREATE SERIOUS SAFETY HAZARDS TO YOU AND THE PEOPLE NEARBY. IF YOU INSTALL SUCH DRIVES YOU MUST FOLLOW ALL APPROPRIATE SAFETY STANDARDS AND PRACTICES TO PROTECT YOU AND OTHERS NEAR THIS PLANTER FROM INJURY.

7100-89

6

**! WARNING !**

THIS MACHINE HAS BEEN DESIGNED AND BUILT WITH YOUR SAFETY IN MIND. DO NOT MAKE ANY ALTERATIONS OR CHANGES TO THIS MACHINE. ANY ALTERATION TO THE DESIGN OR CONSTRUCTION MAY CREATE SAFETY HAZARDS.

7100-90

7

**KINZE**

8

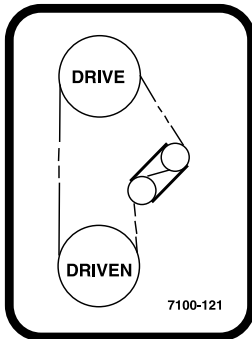

9

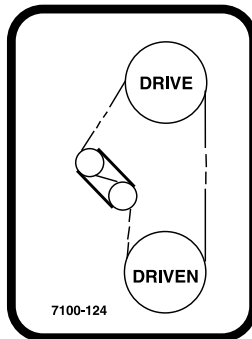

10

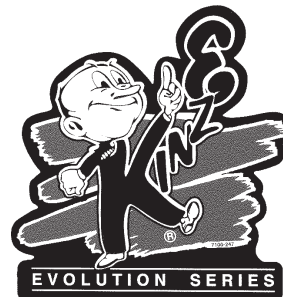

11



12

**! DANGER !**

NEVER TRANSPORT FOLDING MODELS EQUIPPED WITH LIFT ASSIST WHEELS WITHOUT FLOATING CENTER MAST IN PLACE.

7100-132

13

**! WARNING !**

AGRICULTURAL CHEMICALS CAN BE DANGEROUS. IMPROPER SELECTION OR USE CAN SERIOUSLY INJURE PERSONS, ANIMALS, PLANTS, SOIL OR OTHER PROPERTY. BE SAFE. SELECT THE RIGHT CHEMICAL FOR THE JOB. HANDLE WITH CARE. FOLLOW THE INSTRUCTIONS ON THE CONTAINER LABEL AND OF THE EQUIPMENT MANUFACTURER.

7100-115

14

**! WARNING !**

FLOATING CENTER MAST MUST BE USED ON PLANTERS EQUIPPED WITH LIFT ASSIST WHEELS. SEE OPERATION SECTION OF OPERATOR'S MANUAL FOR PROPER ADJUSTMENT.

7100-133

15

**! WARNING !**

WINGS MUST BE UNFOLDED BEFORE DETACHING MACHINE FROM TRACTOR.

7100-140

16

USE 1 TABLESPOON POWDERED GRAPHITE WITH EACH HOPPER FILL OF SEED. SEED TREATMENT, FOREIGN MATERIAL, DIRT, OR SEED CHAFF MAY CAUSE GRADUAL REDUCTION OF SEED POPULATION. REFER TO MANUAL FOR MAINTENANCE AND CARE.

7100-153

17

**! DANGER !**

SERIOUS INJURY OR DEATH CAN RESULT FROM CONTACT WITH ELECTRICAL LINES. USE CARE TO AVOID CONTACT WITH ELECTRIC LINES WHEN MOVING OR OPERATING THIS MACHINE.

7100-117

18

# DECALS, PAINT AND MISCELLANEOUS

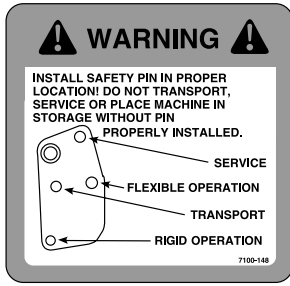

19



20

3120

21

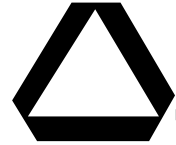

22

## NOTE

It is the responsibility of the user to read and understand the Operator's Manual in regards to safety, operation, lubrication and maintenance before operation of this equipment.

AN OPERATOR & PARTS MANUAL IS AVAILABLE FOR THIS MACHINE.

To obtain a manual, furnish model number and serial number and contact your KINZE Dealer or KINZE Manufacturing, Inc., P.O. Box 806 Williamsburg, IA 52361-0806 USA

23



24



25



26



27



28



29



30

ITEM	PART NO.	QTY.	DESCRIPTION
1.	GD1512	-	Tie Strap, 7 1/2"
	GD2117	-	Tie Strap, 14 1/2"
2.	G7100-234	-	Decal, Bolt Torque
3.	G7100-25	2	Decal, Warning
4.	G7100-42	4	Decal, Warning
5.	G7100-46	1	Decal, Warning
6.	G7100-89	2-4	Decal, Danger
7.	G7100-90	1	Decal, Warning
8.	G7100-104	1	Decal, KINZE®, 3" x 12"
9.	G7100-121	1	Decal, Transmission, R.H.
10.	G7100-124	1	Decal, Transmission, L.H.
11.	G7100-247	-	Decal, Logo, 4 3/8" x 4 1/2" (Row Unit)
	G7100-252	-	Decal, Logo, 3 1/2" x 3 5/8" (Hopper Panel Extension)
12.	GM0190	1	Operator & Parts Manual, Model 3120 (Mechanical Seed Metering System)
13.	G7100-132	1	Decal, Danger
14.	G7100-115	-	Decal, Warning (1 Per Granular Chemical Hopper)
15.	G7100-133	1-3	Decal, Warning
16.	G7100-140	1	Decal, Warning
17.	G7100-153	-	Decal, Information (1 Per Brush-Type Seed Meter)
18.	G7100-117	1	Decal, Danger
19.	G7100-148	1	Decal, Warning
20.	G7100-149	1	Decal, Warning
21.	G7100-240	1	Decal, 3120
22.	GD2199	1	SMV Sign
23.	G7100-217	-	Decal, Note
24.	GR0146MPP	-	Powdered Graphite, Twenty-Four 1 Pound Containers
25.	GR1570MPP	-	Talc Lubricant, Four 8 Pound Containers
26.	GR0155MPP	-	Blue Paint, Twelve Aerosol Cans
27.	G7100-116	-	Decal, Grease Daily
28.	G7100-111	-	Decal, Oil Daily
29.	G7100-258	-	Reflective Decal, Red, 1 1/2" x 9", Rectangular (If Applicable)
	G7100-259	-	Reflective Decal, Amber, 1 1/2" x 9", Rectangular (If Applicable)
	G7100-260	-	Reflective Decal, Orange, 1 1/2" x 9", Rectangular (If Applicable)
30.	G7100-261	-	Reflective Decal, Red, 1 3/4" x 9", Die-Cut (If Applicable)
	G7100-262	-	Reflective Decal, Amber, 1 3/4" x 9", Die-Cut (If Applicable)
	G7100-263	-	Reflective Decal, Orange, 1 3/4" x 9", Die-Cut (If Applicable)



# NUMERICAL INDEX

Part No.	Page	Part No.	Page	Part No.	Page
A1005	P39	G10037	P43	G10219	P9, P23
A1030	P53	G10039	P23, P25, P31	G10226	P41, P45
A1039	P39	G10045	P27	G10227	P19, P57, P59
A1054	P53	G10046	P31	G10228	P7, P27, P33, P39, P43, P45, P47
A1055	P39	G10047	P43, P45, P49	G10229	P4, P10, P11, P17, P19, P33, P35, P39, P41, P43, P45, P53
A1057	P53	G10048	P33, P35, P39	G10230	P4, P7, P10, P11, P33, P35
A1093	P53	G10059	P33	G10231	P33, P35, P36, P39
A1132	P53	G10061	P12, P35	G10232	P9, P36, P40, P45, P59
A1144	P53	G10064	P10, P33	G10233	P40, P42
A1153	P53	G10072	P49, P50	G10243	P58
A1155	P53	G10092	P36	G10257	P18
A1169	P53	G10101	P4, P10, P11, P19, P33, P35, P39, P49, P53	G10303	P9, P23, P40
A1181	P53	G10102	P9, P27, P31, P33, P39, P43, P45, P47, P50	G10304	P3
A1188	P53	G10103	P19, P57, P59	G10305	P20
A1189	P53	G10104	P4, P11, P33, P35	G10306	P19
A3164	P53	G10105	P33, P35, P39	G10308	P10, P20
A10759	P17	G10106	P9, P25, P40, P45, P59	G10309	P12
A4703	P35	G10107	P9, P10, P21, P25, P31, P37, P42, P45	G10310	P19
A4706	P35	G10108	P3, P12, P17, P45	G10312	P3, P17
A4713	P39	G10109	P7, P9, P10, P23, P27, P29, P31, P47	G10315	P9, P10, P19
A4849	P35	G10110	P19, P33	G10318	P25
A4851	P35	G10111	P10, P21, P23, P25, P27, P31, P33, P43	G10323	P14
A5513	P39	G10112	P31	G10325	P5, P17, P33
A5658	P33	G10117	P35	G10326	P3
A5661	P33	G10130	P40	G10328	P5
A6537	P35	G10131	P43	G10338	P7, P12
A6538	P33	G10133	P10, P27, P29, P31, P45	G10348	P27
A8836	P48	G10145	P59	G10371	P27
A9022	P48	G10152	P4, P9	G10400	P31
D7191	P33	G10159	P35	G10401	P14
G10001	P9, P10, P53	G10168	P47	G10409	P41, P43
G10002	P17, P41, P45	G10171	P9, P59	G10412	P4, P12
G10003	P3, P19	G10201	P3, P17	G10427	P5, P9
G10004	P4	G10203	P53	G10430	P41
G10005	P31	G10204	P5, P7	G10435	P41
G10006	P9, P27	G10205	P4, P31	G10438	P3
G10007	P5, P11, P31	G10206	P29	G10445	P41, P43
G10009	P37	G10207	P3	G10452	P19
G10010	P7, P29, P31	G10209	P18, P19, P33	G10459	P35
G10011	P31	G10210	P3, P9, P10, P11, P12, P17, P43, P45, P53	G10460	P35, P39, P42, P45
G10013	P10, P45	G10211	P57, P59	G10462	P43
G10014	P7, P31	G10213	P5, P29, P31	G10463	P9, P41, P45
G10015	P9	G10216	P7, P23, P25	G10464	P40
G10016	P33	G10217	P37	G10468	P39
G10017	P23, P25			G10470	P14
G10018	P7, P9			G10478	P41, P43
G10019	P36, P47			G10489	P35
G10020	P14			G10500	P14
G10021	P14			G10501	P27
G10022	P14, P57, P59			G10503	P23, P25, P29, P31
G10023	P17, P33				
G10026	P36, P39				
G10032	P39				
G10033	P27				
G10036	P21				

# NUMERICAL INDEX

Part No.	Page	Part No.	Page	Part No.	Page
G10523	P19	G10948	P50	G6500-08	P39
G10526	P48	G10962	P48	G6500-08-06	P53
G10529	P20	G10972	P48	G6505-06-08	P39
G10531	P15	G10974	P29, P31	G6801-08	P39, P53
G10536	P23, P25	G11007	P3	G7100-104	P61
G10544	P47	G11008	P3	G7100-111	P61
G10546	P12, P18	G11009	P14, P15	G7100-115	P61
G10551	P3	G11010	P31	G7100-116	P61
G10567	P12, P17, P18	G11015	P3	G7100-117	P61
G10570	P18	G11073	P18	G7100-121	P61
G10572	P25	G11081	P36, P39	G7100-124	P61
G10574	P21, P27, P31	G11098	P29	G7100-132	P61
G10585	P23, P25	G11151	P15	G7100-133	P61
G10597	P23, P25	G11209	P19	G7100-140	P61
G10599	P10, P11	G1K248	P55, P57, P59	G7100-148	P61
G10602	P12, P14, P15, P17, P18, P41, P43	G1K249	P59	G7100-149	P61
G10603	P14, P15	G1K252	P55, P57, P59	G7100-153	P61
G10604	P14	G1K267	P57, P59	G7100-217	P61
G10610	P35	G1K268	P57, P59	G7100-234	P61
G10620	P3, P7, P12, P17	G1K269	P41	G7100-240	P61
G10621	P12, P14, P17, P20	G1K320	P59	G7100-247	P61
G10622	P5, P20	G1K321	P59	G7100-25	P61
G10634	P15	G1K322	P59	G7100-252	P61
G10640	P7, P43, P45	G1K323	P58	G7100-258	P61
G10641	P35, P39, P41, P45	G1K345	P10	G7100-259	P61
G10643	P31	G1K362	P57, P59	G7100-260	P61
G10660	P18	G1K363	P57, P59	G7100-261	P61
G10669	P3	G1K364	P58	G7100-262	P61
G10670	P17, P41	G1K385	P19	G7100-263	P61
G10690	P14	G2100-03	P41	G7100-42	P61
G10722	P47	G2404-08-06	P39	G7100-46	P61
G10724	P47	G2404-08-08	P39	G7100-89	P61
G10725	P47	G2406-08-06	P53	G7100-90	P61
G10732	P4	G2500-17	P36	G7566X	P11
G10751	P12	G2500-18	P40	GA0167	P47
G10752	P12	G2501-08-08	P39	GA0243	P47
G10757	P19, P58	G2603-08	P39	GA0245	P47
G10758	P19, P58	G2703-08	P53	GA0257	P47
G10765	P29, P31	G306-08	P53	GA0261L	P41
G10801	P9, P10	G3200-06	P36	GA0261R	P41
G10827	P48	G3200-22	P37	GA0262	P37
G10844	P47	G3200-62	P36	GA0270	P51
G10864	P19	G3303-114	P18	GA0376	P40
G10867	P43	G3303-98	P3	GA0378	P40
G10879	P45	G3305-01	P20	GA0895	P36, P39
G10912	P5	G3310-80	P43	GA0899	P47
G10921	P18	G3400-01	P41	GA0901	P41
G10923	P40	G6326X	P4	GA0926	P36
G10924	P7	G6400-06	P51	GA10123	P48
G10927	P58	G6400-06-08	P53	GA10137	P12
G10928	P58	G6400-08	P39	GA10151	P12
G10931	P58	G6400-08-04	P53	GA10155	P12
G10940	P7	G6400-08-06	P53	GA10157	P3
G10944	P7	G6405-08-08	P39	GA10570	P57
		G6500-06	P53	GA10575	P59



# NUMERICAL INDEX

Part No.	Page	Part No.	Page	Part No.	Page
GA10601	P57, P59	GA4894	P45	GA5834	P15
GA10901	P57	GA4903	P45	GA5853	P47
GA10940	P57	GA4905	P45	GA5892	P23
GA11039	P59	GA4910	P45	GA5982	P15
GA11594	P45	GA4938	P33, P39	GA6027	P15
GA11766	P45	GA4972	P39	GA6038	P15
GA11767	P45	GA5106	P43	GA6147	P59
GA11947	P59	GA5107	P43	GA6168	P15
GA11948	P59	GA5108	P43	GA6171	P7, P9, P10
GA1676	P47	GA5109	P43	GA6182	P15
GA1677	P47	GA5110	P43	GA6184	P15
GA1678	P47	GA5111	P43	GA6187	P15
GA1679	P47	GA5112	P43	GA6434	P10
GA1720	P4	GA5113	P43	GA6478	P15
GA2007	P12	GA5116	P43	GA6539	P41
GA2012L	P5	GA5130	P45	GA6540	P41
GA2012R	P5	GA5146	P43	GA6597	P10
GA2014	P5, P9, P25, P27, P29, P31	GA5196	P39	GA6618	P9
GA2018	P14	GA5385	P55	GA6619	P9
GA2019	P14	GA5482A	P49	GA6620	P9
GA2020	P14	GA5482B	P49	GA6633	P15
GA2054	P9	GA5482C	P50	GA6699	P55
GA2075	P19	GA5495	P43	GA6700	P55
GA2094	P20	GA5496	P36	GA6701	P55
GA2147	P39	GA5497	P36	GA6733	P9
GA2148	P39	GA5545	P41	GA6741	P19
GA2180	P41	GA5549	P59	GA6801	P9
GA2359	P40	GA5552	P51	GA6823	P33
GA2558	P39	GA5572	P51	GA6824	P33
GA4235	P41, P43	GA5600	P59	GA6827	P33
GA4402	P35	GA5624	P43	GA6828	P33
GA4444	P17	GA5625	P21	GA6832	P27
GA4665	P33, P39	GA5629	P43	GA6833	P27
GA4666	P33, P39	GA5651	P4	GA6834	P27
GA4693	P36	GA5654	P25, P27, P29, P31	GA6838	P27
GA4694	P36	GA5659	P35	GA6907	P19
GA4695	P36	GA5660	P35	GA7255	P15
GA4696	P36	GA5698	P15	GA7271	P29
GA4699	P35	GA5699	P15	GA7336	P43
GA4700	P35	GA5704	P41	GA7412	P29
GA4701	P33, P39	GA5705	P41	GA7445	P29, P31
GA4702	P33	GA5706	P41	GA7446	P27, P29, P31
GA4704	P35	GA5707	P41	GA7850	P57, P59
GA4705	P35	GA5708	P41	GA7851	P59
GA4707	P33	GA5709	P41	GA7852	P59
GA4711	P35	GA5712	P41	GA7853	P57
GA4715	P39	GA5713	P41	GA7854	P57, P59
GA4732	P33	GA5714	P33	GA7855	P57, P59
GA4733	P33	GA5715	P23, P25	GA7856	P57, P59
GA4883	P35	GA5718	P25	GA7857	P57, P59
GA4884	P45	GA5719	P23, P25	GA7858	P59
GA4885	P45	GA5794	P15	GA7859	P59
GA4887	P45	GA5795	P15	GA7861	P39
GA4893	P45	GA5796	P15	GA7949	P7
		GA5805	P35	GA7975	P7

# NUMERICAL INDEX

Part No.	Page	Part No.	Page	Part No.	Page
GA7976	P7	GD0652	P45	GD11286	P14
GA8021	P57, P59	GD0746	P47	GD11297	P18
GA8022	P57, P59	GD0829	P39	GD11305	P17
GA8026	P58	GD0840	P47	GD11306	P5
GA8046	P57, P59	GD0844	P36, P39	GD11311	P14
GA8047	P55, P57, P59	GD0916	P41	GD11313	P11
GA8322	P10	GD10036	P4	GD1132	P25, P27, P29, P31
GA8324	P5	GD10161	P43	GD11413	P12, P18
GA8326	P18	GD10207	P48	GD11422	P4
GA8343	P14	GD10223	P53	GD11423	P7
GA8364	P18	GD10224	P53	GD11424	P17
GA8371	P17	GD10226	P14	GD1143	P20
GA8603	P21, P31	GD1026	P3, P17, P43	GD1144	P20
GA8641	P21, P31	GD10283	P47	GD1145	P20
GA8760	P29	GD1033	P3	GD11453	P7
GA9020	P48	GD1039	P14	GD11474	P58
GA9023	P48	GD1041	P14	GD11490	P36, P39
GA9131	P31	GD1042	P14	GD11508	P11
GA9144	P59	GD10473	P5, P9	GD11509	P11
GA9145	P45	GD10519	P29, P31	GD11528	P14
GA9507	P55	GD10526	P29	GD11652	P21, P31
GA9714	P13	GD10552	P27, P29, P31	GD1166	P36, P39
GA9844	P31	GD1059L	P17	GD11677	P21
GA9845	P31	GD1059R	P17	GD11747	P13
GA9857	P59	GD1060	P17	GD11787	P14
GA9861	P31	GD1061	P18	GD11845	P3, P5, P9
GA9862	P31	GD1063	P18	GD11936	P7
GA9864	P31	GD1065	P3	GD11962	P3, P17
GA9865	P31	GD10733	P14	GD11983	P48
GA9978	P57, P59	GD1083	P14	GD11993	P57, P59
GA9979	P57, P59	GD1085	P10	GD12534	P27
GB0110	P14	GD1086	P7	GD1255	P40
GB0111	P14	GD10867	P3	GD1256	P40
GB0115	P18	GD10963	P19	GD12670	P48
GB0116	P18	GD10984	P19	GD12672	P48
GB0120	P14	GD10991	P7	GD12817	P31
GB0186	P4	GD10993	P3	GD12826	P31
GB0218	P4, P12, P31	GD11001	P3	GD12827	P31
GB0239	P9, P10	GD11017	P5	GD12829	P31
GB0254	P10	GD11045	P40	GD13361	P3
GB0265	P3	GD11089	P55, P57, P59	GD13567	P36
GB0266	P3	GD1109	P9, P10	GD14170	P31
GB0267	P3	GD11122	P15	GD14217	P4
GB0268	P9, P10	GD1114	P4, P33, P35, P42	GD14308	P48
GB0274	P3	GD1115L	P19	GD14529	P48
GB0276	P7	GD1115R	P19	GD14659	P19
GB0278	P12, P18	GD1116	P19	GD14674	P29
GB0282	P10	GD11169	P58	GD1512	P61
GB0285	P3	GD11170	P58	GD15386	P45
GB0287	P43	GD1118	P19	GD15698	P14
GB0301	P5	GD11219	P17	GD15699	P15
GB0314	P12	GD11239	P12, P17, P18	GD15747	P12
GB0331	P12	GD11240	P18	GD15970	P3
GD0453-03	P45	GD11259	P3, P5	GD16245	P3
GD0453-05	P45	GD11279	P13	GD1748	P33, P35, P39

# NUMERICAL INDEX

Part No.	Page	Part No.	Page	Part No.	Page
GD1755	P15	GD7817-04	P25	GR1039	P51
GD2117	P61	GD7822	P43	GR1040	P51
GD2199	P61	GD7823	P25	GR1041	P51
GD2423	P19	GD7861	P35	GR1042	P51
GD2460	P20	GD7878	P15	GR1043	P51
GD2557	P33, P35, P39	GD7889	P23, P25	GR1044	P51
GD2558	P43	GD7890	P23, P25	GR1045	P51, P53
GD2597	P47	GD8237	P15	GR1046	P51
GD2697	P45	GD8249	P4	GR1047	P51
GD2721	P45	GD8266	P23	GR1048	P51
GD2734-01	P43	GD8290	P45	GR1203	P55
GD2947	P19	GD8307	P25	GR1204	P55
GD2962	P41	GD8311	P39	GR1205	P55
GD2971-10	P17	GD8460	P10	GR1206	P55
GD3180-08	P45	GD8778	P15	GR1207	P55
GD3180-12	P9	GD8811	P7	GR1208	P55
GD3180-16	P43	GD9120	P10	GR1270	P49
GD3214	P45	GD9254	P21, P31	GR1271	P49
GD3612	P3	GD9290	P9	GR1272	P49
GD3737	P35	GD9305	P9	GR1273	P49
GD4086	P53	GD9562	P9	GR1276	P49
GD4724	P35	GD9715	P27	GR1278	P49
GD5215	P43	GD9720	P27	GR1279	P49
GD5841	P35	GD9724	P27, P29, P31	GR1327	P14
GD5857	P27, P41, P43, P58	GM0190	P61	GR1390	P57
GD5875	P45	GR0146MPP	P61	GR1391	P59
GD5886	P41, P42	GR0150	P47	GR1392	P57
GD5887-30	P41	GR0151	P47	GR1393	P59
GD5887-36	P41	GR0155MPP	P61	GR1414	P58
GD6136	P45	GR0181	P49	GR1415	P58
GD6501	P14	GR0193	P49, P50	GR1465	P53
GD6551	P43	GR0195	P36, P37	GR1487	P14
GD6819	P41	GR0196	P3, P18	GR1504	P50
GD6825-24	P41	GR0270	P36, P39	GR1505	P50
GD7041	P35	GR0434	P36, P39	GR1506	P50
GD7042	P35	GR0586	P59	GR1507	P50
GD7068	P39	GR0594	P57, P59	GR1508	P50
GD7090	P33	GR0663	P49	GR1509	P50
GD7101	P37	GR0709	P49	GR1511	P50
GD7127	P43	GR0714	P49	GR1512	P50
GD7145	P33	GR0716	P49, P50	GR1521	P48
GD7148	P18	GR0717	P49, P50	GR1552	P48
GD7258	P18	GR0912	P43	GR1569	P14
GD7282	P35	GR1024	P49	GR1570MPP	P61
GD7302	P35	GR1025	P49	GR1629	P57
GD7318	P3	GR1026	P49	GR1631	P59
GD7338	P33, P39	GR1027	P49	GR1632	P59
GD7398	P45	GR1028	P49	GR1737	P59
GD7426	P43	GR1032	P51	GR1761	P59
GD7632	P59	GR1033	P51	GR1762	P59
GD7639	P57, P59	GR1034	P51	GR1764	P59
GD7803	P21, P31	GR1035	P51	R1023	P49
GD7804	P21, P31	GR1036	P51	R1274	P49
GD7805	P4, P10, P12, P25	GR1037	P39, P51, P53	R1510	P50
GD7817-01	P25	GR1038	P51		

