

# **OPERATOR'S MANUAL**

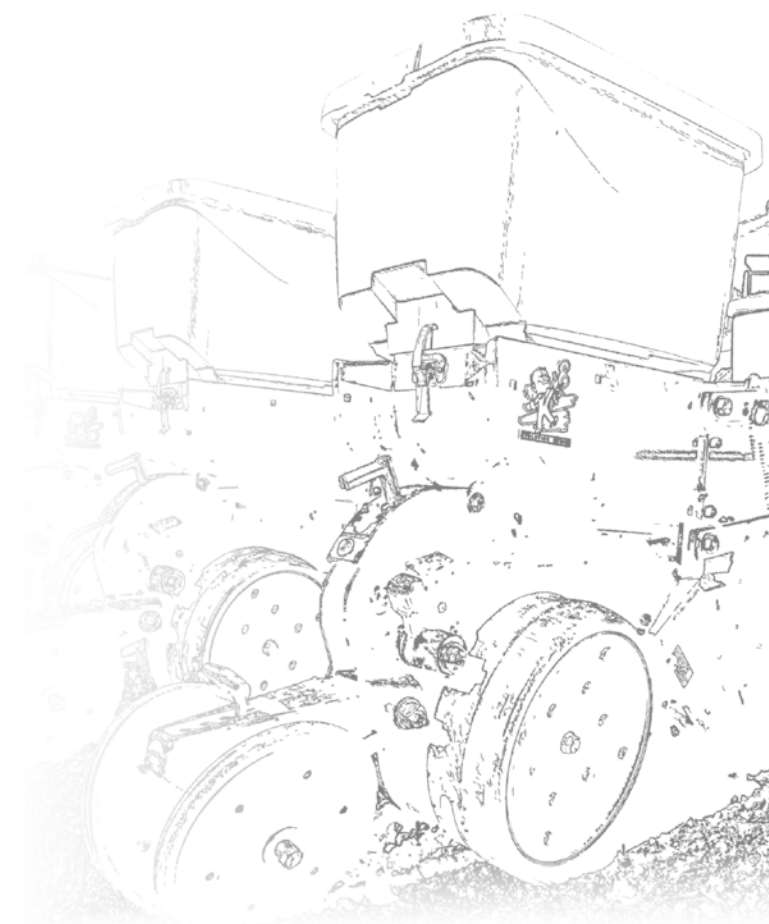

**M0245-01**

**MODEL 3140 STACK FOLD PLANTER**

**Rev. 7/14**



# MODEL 3140 STACK FOLD PLANTER OPERATOR'S MANUAL

**M0245-01**

**Rev. 7/14**

This manual is applicable to: Model 3140 Stack Fold Planter  
2013 to 2014 Production

Record the model number and serial number of your planter along with date purchased:

Model Number \_\_\_\_\_ 3140 \_\_\_\_\_

Serial Number \_\_\_\_\_

Date Purchased \_\_\_\_\_

Monitor Serial Number _____
Measured Pulses Per Mile/Km (Radar Distance Sensor) _____
Measured Pulses Per Mile/ Km (Magnetic Distance Sensor) _____

## SERIAL NUMBER

The serial number plate is located on the planter frame to be readily available. It is suggested that your serial number and purchase date also be recorded above.

The serial number provides important information about your planter and may be required to obtain the correct replacement part. Always provide the model number and serial number to your Kinze Dealer when ordering parts or anytime correspondence is made with Kinze Manufacturing, Inc.

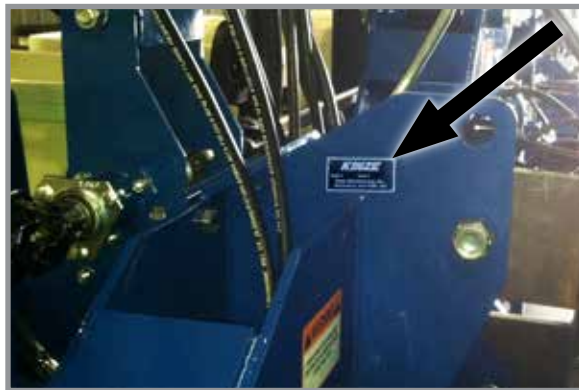

**Serial number plate location - R.H. side of 3-point mount**

**This page left blank intentionally.**

## TO THE DEALER

Predelivery service includes assembly, lubrication, adjustment, and test. This service makes sure planter is delivered to the retail customer/end user ready for field use.

## PREDELIVERY CHECKLIST

Use the following checklist and inspect planter after it is completely assembled. Check off each item found satisfactory or after proper adjustment is made.

- Row units properly spaced and optional attachments correctly assembled.
- EdgeVac components properly installed (as applicable).
- All grease fittings in place and lubricated.
- All working parts move freely, bolts are tight, and cotter pins are spread.
- Check all drive chains for proper tension and alignment.
- Check for oil leaks and proper hydraulic operation.
- Hydraulic hoses correctly routed to prevent damage.
- Inflate tires to specified air pressure and torque wheel lug bolts and lug nuts as specified in the manual.
- All safety decals correctly located and legible. Replace if damaged.
- All reflective decals and SMV sign correctly located and visible when the planter is in transport position.
- Safety/warning lights correctly installed and working properly.
- Paint all parts scratched in shipment or assembly.
- All safety lockup devices on the planter and correctly located.
- Auxiliary safety chain properly installed and hardware torqued to specification.

***This planter has been thoroughly checked and to the best of my knowledge is ready for delivery to the retail customer/end user.***

---

(Signature Of Set-Up Person/Dealer Name/Date)

## RETAIL CUSTOMER/END USER

Name \_\_\_\_\_ Delivery Date \_\_\_\_\_  
 Street Address \_\_\_\_\_ Model No. 3140 Serial No. \_\_\_\_\_  
 City, State/Province \_\_\_\_\_ Dealer Name \_\_\_\_\_  
 ZIP/Postal Code \_\_\_\_\_ Dealer No. \_\_\_\_\_

## DELIVERY CHECKLIST

Use the following checklist at time planter is delivered as a reminder of very important information which should be conveyed to retail customer/end user. Check off each item as it is fully explained.

- Check for proper operation of vacuum fan (If applicable) with tractor to be used with planter.
- Life expectancy of this or any other machine is dependent on regular lubrication as directed in the Operator Manual.
- All applicable safety precautions.
- Along with retail customer/end user, check reflective decals and SMV sign are clearly visible with planter in transport position and attached to tractor. Check safety/warning lights are in working condition. Tell retail customer/end user to check federal, state/provincial, and local regulations before towing or transporting on a road or highway.
- Give Operator Manual, Parts Manual, and all Instruction Sheets to retail customer/end user and explain all operating adjustments.
- Read warranty to retail customer/end user.
- Complete Warranty and Delivery Report form.

***To the best of my knowledge this machine has been delivered ready for field use and customer has been fully informed as to proper care and operation.***

(Signature Of Delivery Person/Dealer Name/Date)

## AFTER DELIVERY CHECKLIST

The following is a list of items we suggest to check during the first season of use of the equipment.

- Check planter performance with retail customer/end user.
- Check performance of EdgeVac or mechanical seed metering system with retail customer/end user.
- Review importance of proper maintenance and adherence to all safety precautions with retail customer/end user.
- Check for parts that may need to be adjusted or replaced.
- Check all safety decals, reflective decals, and SMV sign are correctly located as shown in the Parts Manual and that decals are legible. Replace if damaged or missing.
- Check safety/warning lights are working properly.

(Signature Of Follow-Up Person/Dealer Name/Date)

**All registrations must be submitted online at "[business.kinze.com](http://business.kinze.com)" within 5 business days of delivery.  
Retain a copy of this form for auditing purposes.**

*Tear Along Perforation*

**MACHINE OPERATION**

Initial Preparation of the Planter . . . . .	2-1
Tractor Requirements . . . . .	2-2
Tractor Preparation and Hookup . . . . .	2-2
Leveling the Planter . . . . .	2-6
Transporting Planter . . . . .	2-6
Contact Wheel Spring Adjustment . . . . .	2-6
Parking Stand Adjustment . . . . .	2-7
Wheel Module Height Adjustment . . . . .	2-7
Seed Rate Transmission Adjustment . . . . .	2-8
Wrap Spring Wrench Operation . . . . .	2-8
Contact Wheel Drive Sprockets . . . . .	2-9
Shear Protection . . . . .	2-10
Digital Vacuum Gauge Operation . . . . .	2-11
Analog Vacuum Gauge . . . . .	2-11
Vacuum Fan Motor Valve Block Assembly . . . . .	2-11
Hydraulic Operation . . . . .	2-12
Row Marker Hydraulic Operation . . . . .	2-13
Row Marker Speed Adjustment . . . . .	2-13
Row Marker Adjustments . . . . .	2-14
Wing Flex . . . . .	2-15
Wing Down Flex Cylinder . . . . .	2-16
Point Row Clutches . . . . .	2-17
Two-Speed Point Row Clutches . . . . .	2-18
Dual Lift Assist Wheels . . . . .	2-19
Accumulator . . . . .	2-19
Piston Pump Mount/Drive Spring Adjustment . . . . .	2-20
Flow Control Valve Adjustment . . . . .	2-20
Planting Speed . . . . .	2-20
Field Test . . . . .	2-21
Check Seed Population . . . . .	2-21
Determining Pounds Per Acre (Brush-Type Meter) . . . . .	2-23
Determining Bushels Per Acre . . . . .	2-23
Field Check Granular Chemical Application . . . . .	2-24

**ROW UNIT OPERATION**

Planting Depth . . . . .	3-1
“V” Closing Wheel Adjustment (Rubber or Cast Iron) . . . . .	3-1
Closing Wheel Shield (Rubber or Cast Iron “V” Closing Wheels) . . . . .	3-1
Drag Closing Attachment . . . . .	3-2
Covering Discs/Single Press Wheel Adjustment . . . . .	3-2
Seed Hoppers . . . . .	3-3
Seed Meter Drive Release . . . . .	3-3
Row Unit Extension Brackets . . . . .	3-3
Row Unit Chain Routing . . . . .	3-4
Quick Adjustable Down Force Springs Option (Standard or Heavy Duty) . . . . .	3-5

Brush-Type Seed Meter . . . . .	3-6
Finger Pickup Seed Meter . . . . .	3-7
EdgeVac Seed Meters . . . . .	3-8
Seed Meter Cleanout . . . . .	3-11
Additives . . . . .	3-12
Dual Gauge Wheels . . . . .	3-12
Frame Mounted Coulter (Pull Row) . . . . .	3-13
Residue Wheels (Frame Mounted Coulter) . . . . .	3-13
Row Unit Mounted Disc Furrower (Pull Row) . . . . .	3-14
Row Unit Mounted Bed Leveler (Pull Row) . . . . .	3-14
Row Unit Mounted Residue Wheel . . . . .	3-15
Row Unit Mounted No Till Coulter . . . . .	3-16
Coulter Mounted Residue Wheels . . . . .	3-16
Granular Chemical Hopper and Drive . . . . .	3-17
Spring Tooth Incorporator . . . . .	3-17
Granular Chemical Banding Options . . . . .	3-18
Granular Chemical Bander Shield . . . . .	3-18

**RATE CHARTS . . . . . 4-1****MONITOR OPERATION . . . . . 5-1****LUBRICATION AND MAINTENANCE**

Lubrication . . . . .	6-1
Lubrication Symbols . . . . .	6-1
Sealed Bearings . . . . .	6-1
Wrap Spring Wrench Assembly . . . . .	6-1
Drive Chains . . . . .	6-2
Bushings . . . . .	6-3
Wheel Bearings . . . . .	6-4
Grease Fittings . . . . .	6-4
Mounting Bolts and Hardware . . . . .	6-7
Tire Servicing . . . . .	6-8
Model 3140 Operating Tire Pressure . . . . .	6-8
Finger Pickup Seed Meter Inspection/Adjustment . . . . .	6-9
Cleaning Finger Pickup Seed Meter For Storage . . . . .	6-10
Brush-Type Seed Meter Maintenance . . . . .	6-11
Cleaning Brush-Type Seed Meter For Storage . . . . .	6-12
Vacuum Manifold Maintenance . . . . .	6-12
EdgeVac Seed Meter Maintenance . . . . .	6-13
EdgeVac Seed Meter Cleanout . . . . .	6-13
Chain Tension Adjustment . . . . .	6-14
Drag Closing Attachment . . . . .	6-14
Gauge Wheel Adjustment . . . . .	6-14
Gauge Wheel Arm Bushing/Seal Replacement . . . . .	6-15
Gauge Wheel Arm Pivot Spindle Replacement . . . . .	6-15
15" Seed Opener Disc Blade/Bearing Assembly . . . . .	6-16

Seed Tube Guard/Inner Scraper . . . . .	6-17
Frame Mounted Coulter . . . . .	6-17
Residue Wheels (For Use With Frame Mounted Coulter) . . . . .	6-17
Row Unit Mounted Disc Furrower . . . . .	6-18
Row Unit Mounted Bed Leveler . . . . .	6-18
Row Unit Mounted No Till Coulter . . . . .	6-18
Coulter Mounted Residue Wheels . . . . .	6-19
Row Unit Mounted Residue Wheel . . . . .	6-19
Granular Chemical Attachment . . . . .	6-19
Spring Tooth Incorporator . . . . .	6-19
Single and Two-Speed Point Row Clutch Maintenance . . . . .	6-20
Cam Follower Adjustment . . . . .	6-21
Relief Valve Cartridge . . . . .	6-22
Check Valve (Vacuum Fan) . . . . .	6-22
Flow Control Valve . . . . .	6-22
Row Marker Sequencing/Flow Control Valve Inspection . . . . .	6-23
Row Marker Bearing Lubrication or Replacement . . . . .	6-24
Wheel Bearing Repack or Replacement . . . . .	6-25
Preparation for Storage . . . . .	6-26
Electrical Wiring Diagram for Light Package . . . . .	6-27
Electrical Wiring Diagrams for Point Row Clutches . . . . .	6-28
Electrical Wiring Diagrams for Two-Speed Point Row Clutches . . . . .	6-29
Hydraulic Schematic - Vacuum Fan Motor System . . . . .	6-31
Hydraulic Schematic - Fold System . . . . .	6-32
Hydraulic Schematic - Row Marker System . . . . .	6-32
Hydraulic Schematic - Dual Lift Assist Wheel Package . . . . .	6-33
Hydraulic Schematic - Dual Lift Assist Wheel Package (Plumbed Into 3 Point Circuit) . . . . .	6-33
Hydraulic Schematic - Wing Down Flex Cylinder Package . . . . .	6-34
Hydraulic Schematic - Wing Down Flex Cylinder Package and Dual Lift Assist Wheel Package . . . . .	6-34

## TROUBLESHOOTING

Brush-Type Seed Meter . . . . .	7-1
Closing Wheel . . . . .	7-1
EdgeVac Seed Meter . . . . .	7-2
Finger Pickup Seed Meter . . . . .	7-4
KPM III Electronic Seed Monitor . . . . .	7-5
Point Row Clutch . . . . .	7-6
Row Marker Operation . . . . .	7-7



Kinze Manufacturing, Inc. would like to thank you for your patronage. We appreciate your confidence in Kinze farm machinery. Your Kinze planter has been carefully designed to provide dependable operation in return for your investment.

**This manual has been prepared to aid you in planter operation and maintenance. It should be considered a permanent part of the machine and remain with the machine when you sell it.**

It is the responsibility of the user to read and understand this Operator Manual before operating this equipment. It is the user's responsibility to inspect and service the machine routinely as directed in this Operator Manual. We have attempted to cover all areas of safety, operation, lubrication and maintenance; however, there may be times when special care must be taken to fit your conditions.

Throughout this manual the symbol  and the words **DANGER, WARNING, and CAUTION** are used to call attention to safety information that if not followed, will or could result in death or injury. **NOTICE** and **NOTE** are used to call your attention to important information. The definition of each of these terms follows:



**DANGER** Indicates a hazardous situation which, if not avoided, will result in death or serious injury.



**WARNING** Indicates a hazardous situation which, if not avoided, could result in death or serious injury.



**CAUTION**, used with the safety alert symbol, indicates a hazardous situation which, if not avoided, could result in minor or moderate injury.

**NOTICE** is used to address practices not related to personal injury.

**NOTE:** Special point of information or machine adjustment instructions.



## **WARNING**

**Read and follow all safety instructions in the equipment manual before operating or working on this equipment.**



## **WARNING**

**Some photos in this manual may show safety covers, shields or lockup devices removed for visual clarity. NEVER OPERATE machine without all safety covers, shields and lockup devices in place.**

**NOTE:** Some photos in this manual may have been taken of prototype machines. Production machines may vary in appearance.

**NOTE:** Some photos and illustrations in this manual show optional attachments installed. Contact your Kinze Dealer for purchase of optional attachments.

The Kinze Limited Warranty for your new machine is stated on the retail purchaser's copy of the Warranty And Delivery Receipt form. Additional copies of the Limited Warranty can be obtained through your Kinze Dealer.

Warranty, within the warranty period, is provided as part of Kinze's support program for registered Kinze products which have been operated and maintained as described in this manual. Evidence of equipment abuse or modification beyond original factory specifications will void the warranty. Normal maintenance, service and repair is not covered by Kinze warranty.

To register your Kinze product for warranty, a Warranty And Delivery Receipt form must be completed by the Kinze Dealer and signed by the retail purchaser, with copies to the Dealer, and to the retail purchaser. Registration must be completed and submitted to Kinze Manufacturing, Inc. within 5 business days of delivery of the Kinze product to the retail purchaser. Kinze Manufacturing, Inc. reserves the right to refuse warranty on serial numbered products which have not been properly registered.

If service or replacement of failed parts which are covered by the Limited Warranty are required, it is the user's responsibility to deliver the machine along with the retail purchaser's copy of the Warranty And Delivery Receipt to the Kinze Dealer for service. Kinze warranty does not include cost of travel time, mileage, hauling or labor. Any prior arrangement made between the Dealer and the retail purchaser in which the Dealer agrees to absorb all or part of this expense should be considered a courtesy to the retail purchaser.

*Kinze warranty does not include cost of travel time, mileage, hauling or labor.*



**Model 3140 12 Row 38" EdgeVac Planter (Less Optional Row Markers) Shown In Transport Position**

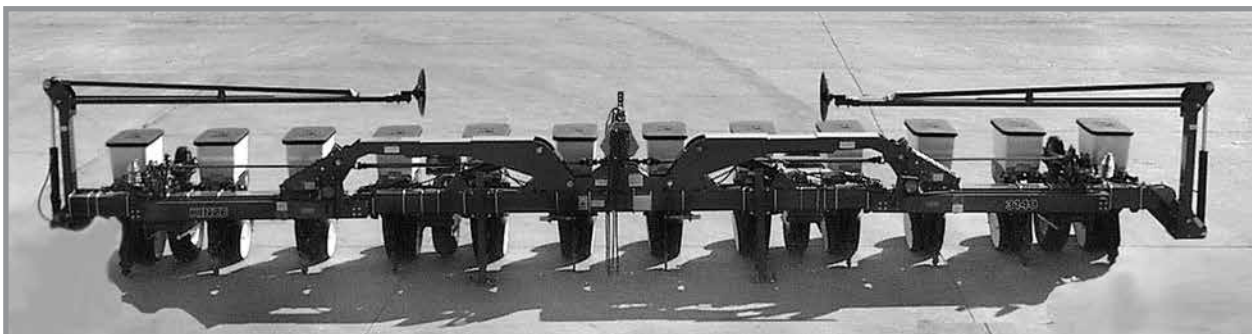

**Model 3140 12 Row 30" Mechanical Planter (With Optional Row Markers) Shown In Planting Position**

## GENERAL INFORMATION

The Model 3110 Mounted Planter is available with EdgeVac or mechanical meters, conventional hoppers, and various other options. Contact your Kinze dealer for additional options which may be available for your specific model year planter.

Information in this manual was current at time of printing. However, due to Kinze's ongoing product improvement, production changes may cause your machine to appear slightly different in detail. Kinze Manufacturing, Inc. reserves the right to change specifications or design without notice and without incurring obligation to install the same on machines previously manufactured.

Right hand (R.H.) and left hand (L.H.), as used throughout this manual, are determined by facing in the direction the machine will travel when in use, unless otherwise stated.

## SPECIFICATIONS

Planter Size	12 Row 30"	12 Row 36"/38"	12 Row 38"/40"	16 Row 30"
Width - Transport (Without Markers)	16'-1" (4.9M)	18'-5" (5.6M)	21'-1" (6.4M)	21'-1" (6.4M)
Width - Transport (Includes Markers)	17'-9" (5.4M)	19'-6" (5.9M)	22'-2" (6.8M)	23'-0" (7.0M)
Width - Planting	30'-0" (9.1M)	37'-4" (11.4M)	40'-0" (12.2M)	40'-0" (12.2M)
Height - Transport (Without Markers)	12'-6" (3.8M)	12'-6" (3.8M)	12'-6" (3.8M)	12'-6" (3.8M)
Height - Transport (With Markers)	15'-6" (4.7M)	15'-6" (4.7M)	15'-6" (4.7M)	15'-6" (4.7M)
Weight (Mechanical)	6236 lb. (2828.6 kg)	6541 lb. (2966.9 kg)	6621 lb. (3003.2 kg)	7480 lb. (3392.9 kg)
Weight (EdgeVac)	6794 lb. (3081.7 kg)	7127 lb. (3232.7 kg)	7214 lb. (3272.2 kg)	8109 lb. (3678.2 kg)
Toolbar (Mechanical)	7" x 7" x 1/4" wall	7" x 7" x 1/4" wall	7" x 7" x 3/8" wall	7" x 7" x 3/8" wall
Toolbar (EdgeVac)	7" x 7" x 3/8" wall	7" x 7" x 3/8" wall	7" x 7" x 3/8" wall	7" x 7" x 3/8" wall
Seed Capacity	1.75 bu. (EdgeVac/Hopper); 1.90 bu. (Mechanical/Hopper)			
Tires	Four 7.60" x 15" 8 ply - adjustable height			
Drive System	Two 4.10" x 6" spring-loaded contact drive tires with no. 40 chain			
Seed Transmission	Two wheel module-mounted, quick-adjust with machined sprockets and no. 40 chain			
Drive/Drill Shafts	7/8" hex drive/drill shafts			

**TRACTOR HYDRAULIC REQUIREMENTS - MECHANICAL**

Configuration	Requirements		Description
Base machine with mechanical meters	1 SCV	10 gpm	#1 SCV: Planter fold
Base machine with mechanical meters and optional row marker package	2 SCV	20 gpm	#1 SCV: Planter fold
			#2 SCV: Row markers with sequencing/flow control valve
Base machine with mechanical meters, optional row markers and dual lift assist package	3 SCV*	20 gpm	#1 SCV: Planter fold
			#2 SCV: Row markers with sequencing/flow control valve
			#3 SCV: Dual lift assist
Base machine with mechanical meters, optional row markers, dual lift assist package, and wing down flex package	4 SCV*	20 gpm	#1 SCV: Planter fold
			#2 SCV: Row markers with sequencing/flow control valve
			#3 SCV: Dual lift assist
			#4 SCV: wing down flex

\*Some options may be combined to reduce the number of SCV outlets required.

**TRACTOR HYDRAULIC REQUIREMENTS - EDGEVAC**

Configuration	Requirements		Description
Base machine with vacuum meters (external case drain required for EdgeVac hydraulic circuit)	2 SCV	25 gpm	#1 SCV: Vacuum meters
			#2 SCV: Planter fold
Base machine with vacuum meters and optional row marker package (external case drain required for EdgeVac hydraulic circuit)	3 SCV	35 gpm	#1 SCV: Vacuum metering
			#2 SCV: Planter fold
			#3 SCV: Row markers with sequencing/flow control valve
Base machine with vacuum meters, optional row marker package, and dual lift assist package option (external case drain required for EdgeVac hydraulic circuit)	3 SCV*	35 gpm	#1 SCV: Vacuum meters
			#2 SCV: Planter fold
			#3 SCV: Row markers with sequencing/flow control valve
			#4 SCV: Dual lift assist package
			#5 SCV: Wing down flex package

\*Some options may be combined to reduce the number of SCV outlets required.

1. Read and understand instructions provided in this manual and warning labels. Review these instructions frequently!
2. This machine is designed and built with your safety in mind. Do not make any alterations or changes to this machine. Any alteration to design or construction may create safety hazards.
3. A large portion of farm accidents happen from fatigue or carelessness. Safe and careful operation of tractor and planter will help prevent accidents.
4. Never allow planter to be operated by anyone unfamiliar with operation of all functions of the unit. Operators must read and thoroughly understand all instructions given in this manual before operating or working on equipment.
5. Be aware of bystanders, particularly children! Always look around to make sure it is safe to start tow vehicle engine or move planter. This is particularly important with higher noise levels and quiet cabs, as you may not hear people shouting.
6. Make sure planter weight does not exceed towing capacity of tractor, or bridge and road limits. This is critical to maintain safe control and prevent death or injury, or property and equipment damage.
7. Never ride or allow others to ride on planter.
8. Store planter in an area away from human activity. DO NOT permit children to play on or around the stored unit.
9. Keep hands, feet, and clothing away from moving parts. Do not wear loose-fitting clothing which may catch in moving parts.
10. Always wear protective clothing, shoes, gloves, hearing, and eye protection applicable for the situation.
11. Do not allow anyone to stand between tongue or hitch and towing vehicle when backing up to planter.
13. Prevent electrocution, other injuries, or property and equipment damage. Watch for obstructions such as wires, tree limbs, etc. when operating machine. Be aware of clearances during turns and when folding/unfolding planter.
14. Reinstall all guards removed for maintenance activities. Never leave guards off during operation.
15. Use of aftermarket hydraulic, electric, or PTO drives may create serious safety hazards to you and people nearby. If you install such drives, follow all appropriate safety standards and practices to protect you and others near this planter from injury.
16. Follow all federal, state/provincial, and local regulations when towing farm equipment on a public highway. Use safety chain (not an elastic or nylon/plastic tow strap) to retain connection between towing and towed machines in the event of primary attaching system separation.
17. Make sure all safety/warning lights, SMV sign, and reflective decals are in place and working properly before transporting the machine on public roads.
18. Limit towing speed to 15 MPH. Tow only with farm tractor of a minimum 90 HP. Allow for unit length when making turns.
19. Reduce speed prior to turns to avoid the risk of overturning. Always drive at a safe speed relative to local conditions and ensure your speed is slow enough for a safe emergency stop.
20. Chemical application is often an integral part of planting. Follow label instructions for proper chemical mixing, handling and container disposal methods.
21. Be familiar with safety procedures for immediate first aid should you accidentally contact chemical substances.
22. Use the proper protective clothing and safety equipment when handling chemicals.
23. Chemicals are supplied with Material Safety Data Sheets (MSDS) that provide full information about the chemical, its effects on exposure, and first aid needs in the event of an emergency. Keep your MSDS file up-to-date and available for first responders in case of emergency.
24. When servicing ground engaging components such as opening disks and firming points, use special care to avoid points and edges worn sharp during use.
25. Use professional help if you are unfamiliar with working on hydraulic systems. Pressurized hydraulic fluid can penetrate body tissue and result in death, serious infection, or other injuries.

Following are some common hazard warnings associated with this equipment. Pay close attention to all safety, operating, and maintenance information in this manual and decals applied to your equipment.

 **DANGER!**

Contacting or coming close to power lines or other high energy sources will cause death or serious injury. Keep away from power lines or high energy sources at all times.

 **WARNING**

Improperly operating or working on this equipment could result in death or serious injury. Read and follow all instructions in Operator Manual before operating or working on this equipment.

 **WARNING**

Falling equipment can cause death or serious injury. Install all lockup devices or lower planter to ground before working on equipment.

 **WARNING**

Explosive separation of rim and tire parts can cause death or serious injury. Overinflation, rim and tire servicing, improper use of rims and tires, or worn or improperly maintained tires could result in a tire explosion.

## SAFETY SIGNS AND DECALS

 **WARNING**

All safety/warning lights, reflective decals, and SMV sign must be in place and visible before transporting machine on public roads or death, serious injury, and damage to property and equipment may result. Check federal, state/provincial, and local regulations before transporting equipment on public roads.

Safety signs and decals are placed on the machine to warn of hazards and provide important operating and maintenance instructions. Information on these signs are for your personal safety and the safety of those around you. FOLLOW ALL SAFETY INSTRUCTIONS!

- Keep signs clean so they can be easily seen. Wash with soap and water or cleaning solution as required.
- Replace safety signs if damaged, painted over, or missing.
- Check reflective decals and SMV sign periodically. Replace if they show any loss of reflective properties.
- When replacing decals, clean machine surface thoroughly with soap and water or cleaning solution to remove all dirt and grease.

**NOTE:** Safety sign and decal locations are shown in the Parts Manual for this machine.

**NOTE:** Style and locations of SMV sign, reflective decals, and safety/warning lights conform to ANSI/ASABE S279.14 JUL 2008 and ANSI/ASABE S276.6 JAN 2005.

The following information is general in nature and was written to aid the operator in preparation of the tractor and planter for use, and to provide general operating procedures. The operator's experience, familiarity with the machine and the following information should combine for efficient planter operation and good working habits.

***NOTICE***

**Always raise the planter out of the ground when making sharp turns or backing up.**

The Kinze EdgeVac Seed Metering System includes seed meters, seed discs and an air system consisting of a hydraulic driven vacuum fan which draws air through manifolds and hoses and the seed meters on each row unit.



**WARNING**

**Never operate vacuum fan with cover removed.**

The dual lift assist wheel option requires a customer-supplied quick hitch to operate without the center link pin. 8 row wide planters require removal of the center section gauge wheels to accommodate dual lift assist wheels.

## **INITIAL PREPARATION OF THE PLANTER**

Lubricate the planter and row units per the lubrication information in this manual. Make sure all tires have been properly inflated. See "Tire Servicing". Check all drive chains for proper tension, alignment and lubrication.

## TRACTOR REQUIREMENTS

Approximate minimum tractor horsepower (HP) required for field work is listed below:

12 Row Narrow - 150 HP And Up

12 Row Wide And 16 Row Narrow - 180 HP And Up

**NOTE: Tractor must have adequate 3 point hitch lift capacity to lift weight of machine, attachments, seed and dry chemicals. Shipping weights do not include seed, dry chemicals or additional optional attachments.**

Tractor front end stability is necessary for safe and efficient operation. Therefore, it may be necessary to add front ballast to your tractor for satisfactory field operation, as well as adequate transport stability. Refer to your tractor operator's manual for front ballast recommendations.

### EdgeVac

A 12 volt DC electrical system is required on all sizes to operate planter safety/warning lights.

One SCV remote hydraulic outlet is required to operate the row markers, one to operate planter fold and one plus a zero pressure case drain is required to operate the seed metering system vacuum fan.

Maximum hydraulic flow rate of 13 GPM @ 2000 PSI is required to operate the seed metering system vacuum fan.

**NOTE: A Flow Control Needle Valve Kit, to provide a flow control option for tractors that are not equipped with a method for finite adjustment of hydraulic flow, is available from Kinze Repair Parts through your Kinze Dealer.**

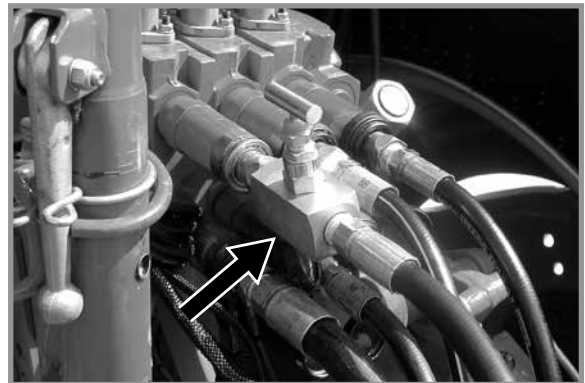

**G1K426 Needle Valve Kit**

## TRACTOR PREPARATION AND HOOKUP

1. Set tractor rear wheel spacing at double the planter row spacing. For example: On a planter set for 38" rows, set the tractor wheel spacing at 76" center-to-center. On wide front end tractors set front wheel spacing equal to rear wheel spacing. Check tractor operator's manual for correct front and rear tire pressure.
2. Adjust lift links on tractor so the planter will lift level from side to side and raise high enough for planter transport clearance. Set the sway blocks on the tractor in position to prevent side sway. Be sure the individual lift link arms are in the float position.



- Back tractor up to planter. Position lower hitch pins and bushings as shown in the following diagrams for your type of tractor hitch. Line up holes and insert hitch pins and lock in place with pins provided. It may be necessary to change the length of the upper link with the adjusting handle.

**Lower Hitch Pins**

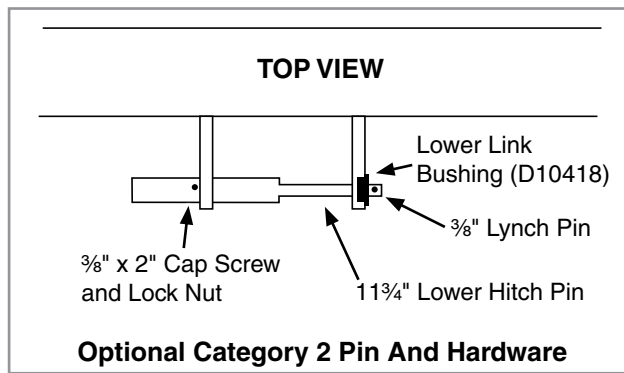
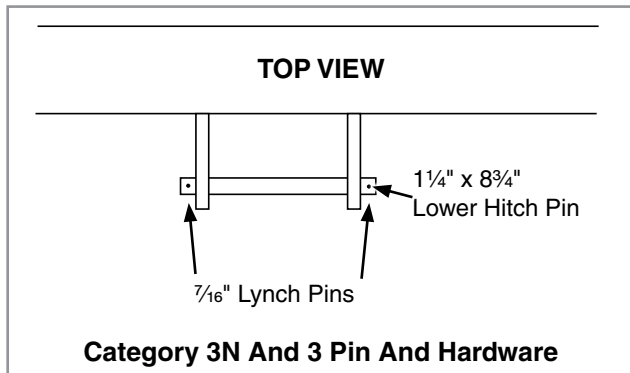

The upper hitch point has two holes. The hitch pin must be positioned in the lower hole for use with tractors equipped with Category 2 quick hitch. The lower hole is also recommended for use on tractors without a quick hitch. Some Category 2 tractors without a quick hitch are designed to accommodate the upper attaching holes. Consult tractor manufacturer.

The hitch pin must be positioned in the upper hole for use with tractors equipped with Category 3N and 3 hitches.

**Upper Hitch Pin**

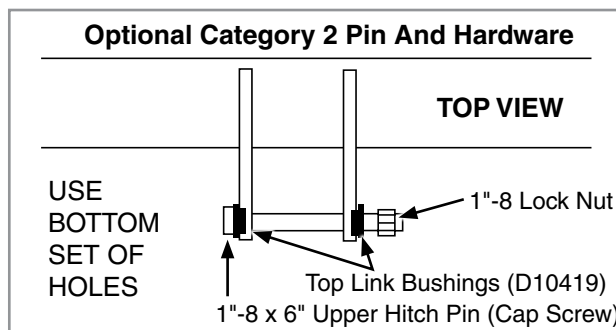
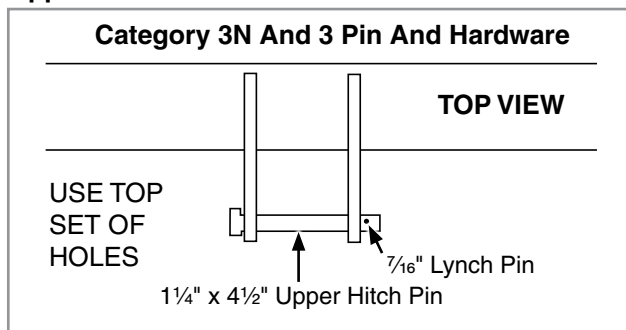

When using a quick hitch (customer-supplied), match pin location to pin spacing in the quick hitch. Adjust the tractor upper link until the quick hitch is vertical when in the planting position.

**Dual lift assist wheel equipped machines require use of a quick hitch (customer-supplied) and the top link pin is not used.**

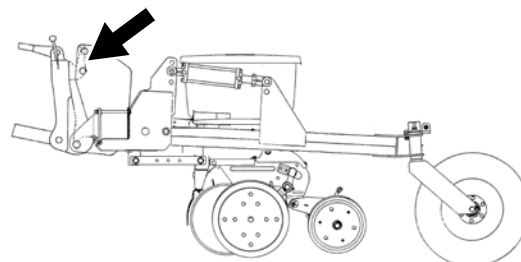

**! WARNING**

**Never transport machine with lift assist wheels without quick hitch. If this type of hitch is not in place, a sudden stop could allow the toolbar to rotate forward causing personal injury or damage to the equipment.**

4. The planter is equipped with safety/warning lights which should be used whenever the planter is being transported. The connector is a 7 terminal breakaway connector conforming to ASAE standards. If your tractor is not equipped for safety/warning lights, check with your tractor dealer.

#### EdgeVac

Connect harness on planter to digital vacuum gauge console on tractor. Connect power lead from digital vacuum gauge console to power source. A power lead adapter may be required.

### WARNING

**Pressurized hydraulic fluid can penetrate body tissue and result in death, serious infection, or other injuries. Fluid injected under skin must be IMMEDIATELY removed by a surgeon familiar with this type of injury. Make sure connections are tight and hoses and fittings are not damaged before applying system pressure. Leaks can be invisible. Keep away from suspected leaks. Relieve pressure before connecting or disconnecting tractor, searching for leaks, or performing any system maintenance.**

### NOTICE

**Wipe hose ends to remove any dirt before connecting couplers to tractor ports or contamination may cause equipment failure.**

5. Connect hydraulic hoses to tractor ports in a sequence that is both familiar and comfortable to the operator. See "Hydraulic Operation".

Before attaching hoses, move tractor SCV levers back and forth to relieve any pressure in the tractor hydraulic system.

The EdgeVac seed metering system vacuum fan operation hydraulic hoses are as follows:

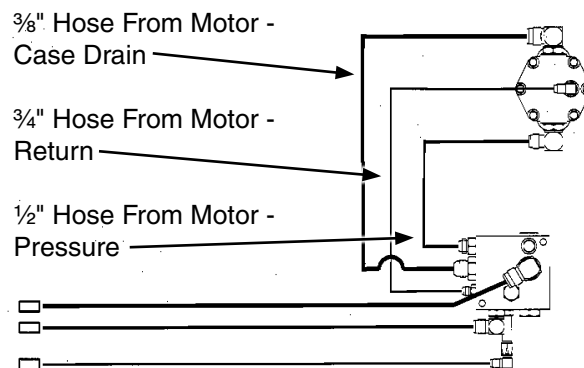

### NOTICE

**Before the markers are operated, make sure all marker lockups are in working position.**

### DANGER

**Before applying pressure to the hydraulic system, make sure all connections are tight and that hoses and fittings have not been damaged. Hydraulic fluid escaping under pressure can have sufficient force to penetrate skin causing injury or infection.**

6. With planter on a level surface, raise the planter slowly and watch for any interference.

When raising a planter equipped with dual lift assist wheels, the front of the planter should raise and then the back using the lift assist wheels to raise the rear of the planter. When lowering the planter, the lift assist wheels should begin to lower the rear of the planter before lowering the front of the planter. If the dual lift assist wheels are plumbed into the 3 point hitch lift circuit, adjust the flow control valve so the rear of the planter lowers before the front of the planter and the front of the planter raises before the rear of the planter. See "Flow Control Valve Adjustment". With planter lowered to planting position, adjust tractor linkage to level the toolbar. See "Leveling The Planter".

**With planter (equipped with dual lift assist wheels) raised for transport, maintain a minimum of 3" clearance between planter and quick hitch.**

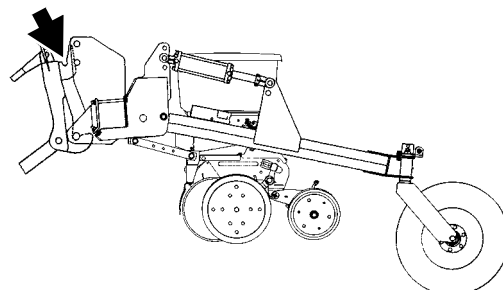

On planters equipped with the optional Dual Lift Assist Wheel Package, adjustment holes on the lift assist cylinder mounts allow for adjustment of lift height.

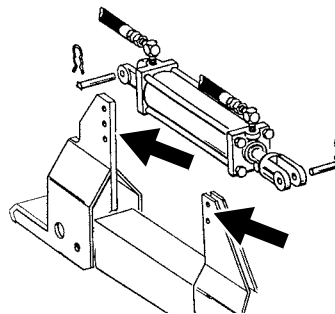

7. Remove pin from each parking stand and raise each to the transport position. Secure stands in raised position with pin in lowest hole.
8. Lower the planter so the drive wheels rest on the ground and check to be sure planter is level. Readjust top link as required to level row units. See "Leveling The Planter".

### **NOTICE**

**As a general safety practice and to avoid damage to the tractor hydraulic system, always lower the planter when not in use.**

## LEVELING THE PLANTER

For proper performance of the planter and row units, it is important that the planter frame and row unit parallel arms operate approximately level. The toolbar should operate at a 20" to 22" height, measured from the planting surface to the bottom of the toolbar.

When operating the planter, make sure the right and left lower link arms on the tractor are adjusted equally before attaching the planter. After the planter has been lowered to the correct operating height, stop the tractor and stand beside the planter and check to be sure the frame is level fore and aft. If the row units angle up or down, adjust the center link on the tractor to level the machine.

It is important for the planter to operate level laterally. Tire pressure must be maintained at pressures specified and drive wheel height must be adjusted equally. See "Wheel Module Height Adjustment".

## TRANSPORTING PLANTER

### DANGER!

**Contacting or coming close to power lines or other high energy sources will cause death or serious injury. Keep away from power lines or high energy sources at all times.**

### WARNING

**All safety/warning lights, reflective decals, and SMV sign must be in place and visible before transporting machine on public roads or death, serious injury, and damage to property and equipment may result. Check federal, state/provincial, and local regulations before transporting equipment on public roads.**

- Tow only with farm tractor rated and configured for equipment.
- Know your route and be aware of any obstructions.
- Follow all road and bridge load limit restrictions.
- Never exceed maximum transport towing speed of 20 mph (32 kph).

## CONTACT WHEEL SPRING ADJUSTMENT

There are two down pressure springs on each contact drive wheel. The spring tension is factory preset and should require no further adjustment.

The tension is set leaving 1" between the spring plug and the mounting shaft as shown below.

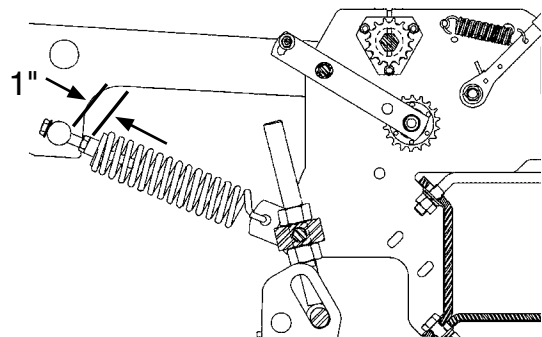

## PARKING STAND ADJUSTMENT

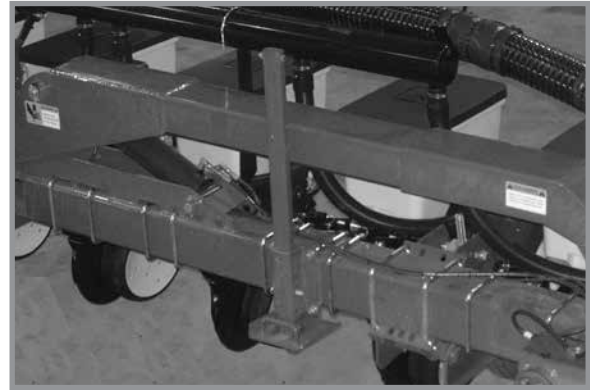
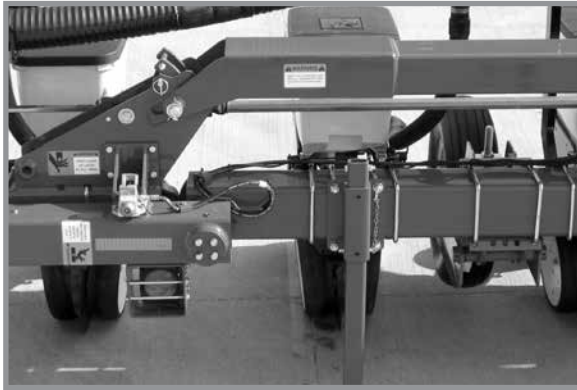

**EdgeVac Shown**

Two parking stands, located on the front side of the main frame, are standard on all Model 3140 planters. The stands must be positioned so they are not directly behind the tractor tire or they will interfere when the planter is raised.

Each parking stand has six positioning holes. By using these positioning holes, you can set the main frame parking height from 19" to 25".

Raise the stands to the top position and pin when planting; lower and pin for parking and storage.

## WHEEL MODULE HEIGHT ADJUSTMENT

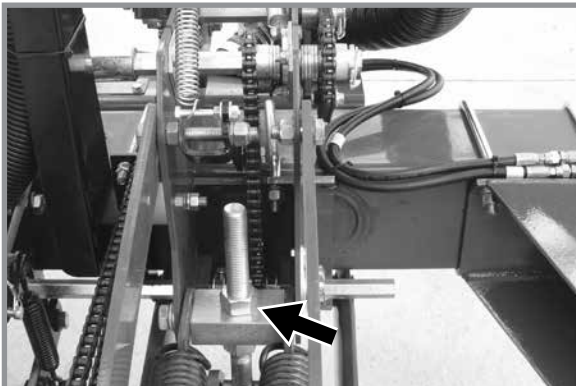

**Drive Wheel Module Assembly**

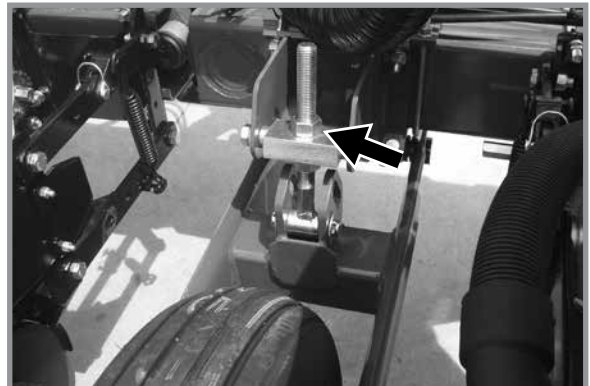

**Center Section Gauge Wheel Assembly**

The drive wheel module assembly and center section gauge wheel assembly are designed so the drive wheel height can be adjusted to maintain a frame height of 20" to 22" in all planting applications. This is particularly useful when the planter is used for ridge planting or planting on beds. The wheel module assembly has an adjustment range of 7". To adjust the wheel assembly, loosen the upper nut using a 1½" wrench or a 15" adjustable wrench and turn the lower nut using a 1½" wrench or 15" adjustable wrench (clockwise to decrease frame height or counterclockwise to increase frame height). Tighten the upper nut after adjustment is complete. Set all wheels equally.

## SEED RATE TRANSMISSION ADJUSTMENT

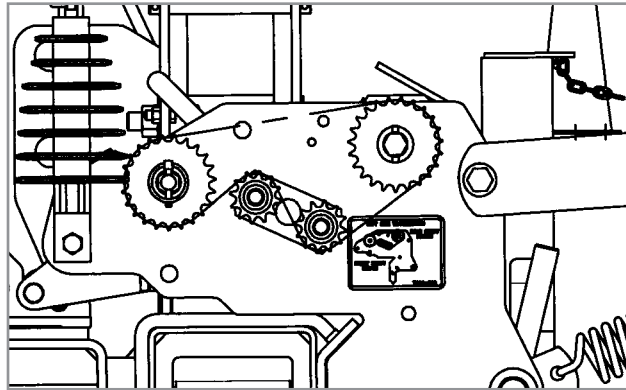

Planting population rate changes are made at the seed rate transmissions. The seed rate transmissions are designed to allow simple, rapid changes of sprockets to obtain the desired planting population. By removing the lynch pins on the hexagon shafts, sprockets can be interchanged with those from the sprocket storage rod bolted near each transmission.

Chain tension is controlled by spring-loaded, dual-sprocket idlers. The idler assembly is adjusted with a easy-release arm. This arm has a release position to remove spring tension for replacing sprockets. The amount of spring tension on the chain is controlled by the idler arm. See “Wrap Spring Wrench Operation”.

A decal positioned near each transmission illustrates proper chain routing. The planting rate charts found in “Rate Charts” will aid you in selecting the correct sprocket combinations.

## WRAP SPRING WRENCH OPERATION

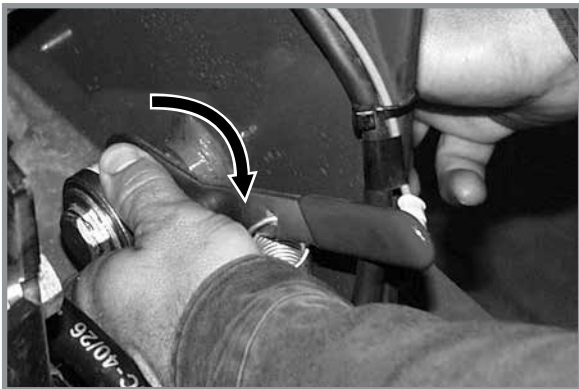

**Release Chain Tension**



**Increase Chain Tension**

Chain idlers are equipped with wrap spring wrenches. L.H. wrap spring wrenches have a blue release collar and R.H. wrap spring wrenches have a grey or black release collar.

Rotate collar on wrap spring wrench and pull handle to release chain tension.

Rotate chain idler into chain and pull handle to tension idler spring.

## CONTACT WHEEL DRIVE SPROCKETS

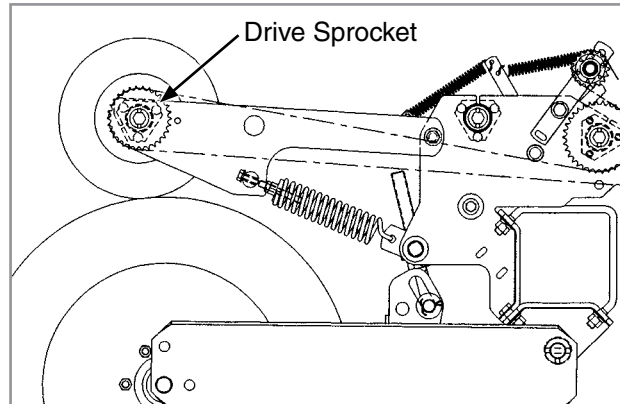

**NOTE:** 15 tooth, 19 tooth or 30 tooth drive sprockets at each contact drive wheel can be interchanged from the sprocket storage rod bolted near each transmission. The 15 and 19 tooth sprockets require use of a 218 pitch No. 40 chain. The 30 tooth sprocket requires use of a 224 pitch No. 40 chain.

Chain tension is controlled by a spring-loaded sprocket idler. The amount of spring tension on the chain is controlled by the idler arm.

The planting rate charts found in “Rate Charts” section will aid you in selecting the correct sprocket.

**NOTE:** 15, 19 and 30 tooth drive sprockets are NOT applicable to all rate charts. Check chart titles to ensure the proper rate charts are selected.

**NOTE:** After each sprocket combination adjustment, make a field test to be sure you are planting at the desired rate.

## HALF RATE (2 TO 1) DRIVE

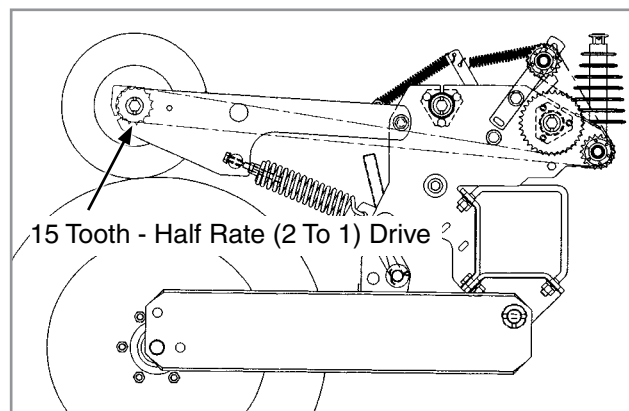

Half rate (2 to 1) drive is recommended only when the desired population falls below that shown on the planting rate charts. Replace the 30 tooth drive sprocket and shorter No. 40 110 pitch chain on each contact wheel with a 15 tooth sprocket. This will reduce the planter transmission speed and reduce planting and application rates by approximately 50%.

**NOTE:** After each sprocket combination adjustment, make a field check to be sure you are planting at the desired rate.

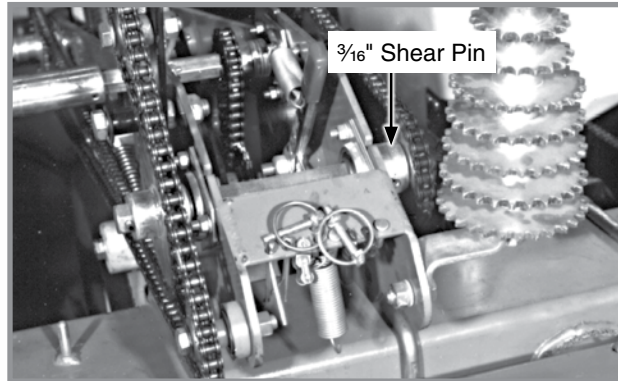
**SHEAR PROTECTION****Transmission Shaft**

The planter driveline and seed and granular chemical drivelines are protected from damage by shear pins.

If excessive load should cause a pin to shear, it is important to determine where binding has occurred before replacing the pin. Replace shear pins with same size and type.

To prevent future binding or breakage of components, check driveline alignment and follow prescribed lubrication schedules.

**NOTE: Drill shaft/transmission coupler alignment is critical.**



## DIGITAL VACUUM GAUGE OPERATION

The digital vacuum gauge console is equipped with an ON-OFF-ON type selector switch. The “FAN 1” setting should be used when the planter is equipped with one vacuum fan.

**NOTE: The toggle switch should be left in OFF position when the planter is not in use. If left in either fan position, the tractor battery will be drained.**



The digital vacuum gauge is calibrated at the factory, however, vacuum variation throughout the manifold system can occur. It may be necessary to adjust the digital readout so it agrees with the actual vacuum at the meter. With the seed discs loaded with seed, compare the digital vacuum gauge readout to the reading taken from the analog gauge or a hand held gauge at several meters along the length of the planter. The elbows located on the covers of the seed meters allow testing of meter vacuum levels without removing the vacuum hoses. If there is more difference than 1" or 2" (H<sub>2</sub>O), the digital gauge can be adjusted by inserting a small flat bladed screwdriver into the opening on the back of the digital gauge housing and turning the potentiometer until the digital gauge displays the vacuum that is present at the meter. Compare readings at 10" and 20" of vacuum.

## ANALOG VACUUM GAUGE

The analog vacuum or pressure gauge connects directly to the EdgeVac (vacuum) manifold and is teed into the digital sending units.

Only adjustment is to “zero” needle with no vacuum or pressure present. If there is a significant difference between gauge and a reading taken at meters, a different manifold location should be found to connect hose to gauge and digital sending unit.



**Analog gauge**

## VACUUM FAN MOTOR VALVE BLOCK ASSEMBLY

A pressure relief valve in the hydraulic circuit prevents build up of oil pressure over 35 PSI in case drain line when vacuum fan motor is operating. This valve will vent oil outside valve block through a drain hole in the aluminum valve block. This can occur whenever case drain is improperly connected or pressure in motor circuit builds.

See “Hydraulic Diagram - Vacuum Fan Motor System” in Lubrication and Maintenance section.

Valve block contains a check valve that prevents vacuum fan from operating in wrong direction if pressure is applied to return side of motor and allows fan to coast to a stop when tractor hydraulic control is returned to neutral position.

**NOTE: Fan turns at a reduced speed if reverse pressure is applied.**

## HYDRAULIC OPERATION

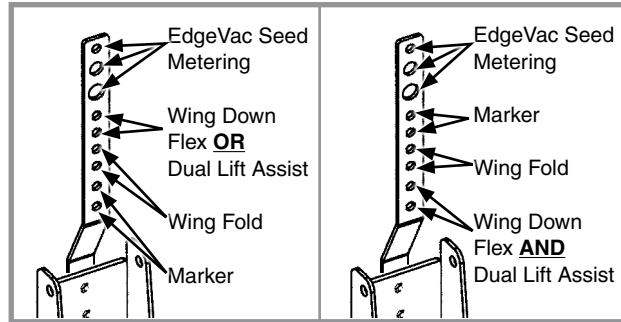

### EdgeVac

Planter may require up to four selective control valves (SCV). A single SCV is needed to fold the wings; a second SCV and case drain is required for operation of the EdgeVac seed metering system; a third SCV is required for the Row Marker Package; and a fourth SCV is required for the Dual Lift Assist Wheel Package and/or the Wing Down Flex Cylinder Package unless these are connected into the tractor 3 point lift system.

### Mechanical

Planter requires a single control valve for folding the wings. A second control valve is required for the Row Marker Package. A third valve is required for the Dual Lift Assist Wheel Package and/or the Wing Down Flex Cylinder Package unless these are connected into the tractor 3 point lift system.

### DANGER!

To avoid serious injury or death, care must be taken when operating row markers around overhead power lines.

### DANGER!

If a cylinder has been disconnected or removed for any reason, do not attach the rod end of the cylinder until the cylinder is cycled several times to remove any air that may be trapped in the system.

The wings are folded and unfolded using a single hydraulic control valve. When the wings are unfolded, the spring-actuated hydraulic latches lock the wings to the fold links so they pivot as one unit.

### NOTICE

Always be sure planter is in the fully raised position before folding the planter wings to ensure wing row units do not collide with center section seed hoppers.

## ROW MARKER HYDRAULIC OPERATION



### WARNING!

Always stand clear of marker assemblies and blades when planter is operating.



### DANGER

To avoid serious injury or death, care must be taken when operating row markers around overhead power lines.

The single valve marker system uses a sequencing valve which directs hydraulic flow to operate the markers alternately. Each time a marker is raised, the sequencing valve will direct flow to lower the opposite marker.

Both markers can be used at the same time if desired. To do this, lower the planter and the marker that has been selected. Move the tractor SCV control to the raise position and immediately return it to the lower position. This will shift the marker control valve and the remaining marker will be lowered.

## ROW MARKER SPEED ADJUSTMENT

Flow control valves located in the marker sequencing/flow control valve assembly control lowering and raising speed of markers. One flow control valve sets lowering speed of both markers and one sets raising speed of both markers. To adjust marker speed, loosen jam nut and turn control(s) clockwise, or IN to slow travel speed and counterclockwise, or OUT, to increase travel speed. Flow control(s) determine amount of oil flow restriction through valves, therefore varying travel speed of markers. Tighten jam nut after adjustments are complete.

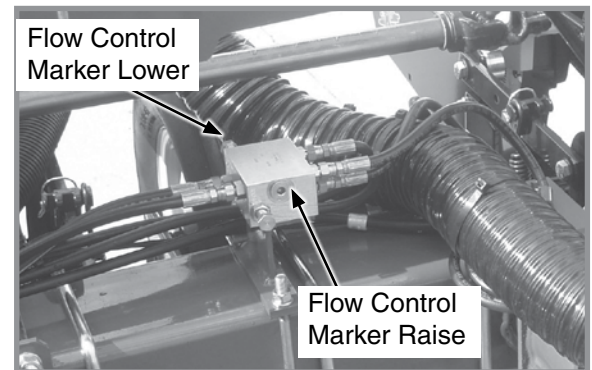

**NOTE:** Backing flow control valve out too far can cause the o-ring seal on valve to fail when hydraulics are operated.

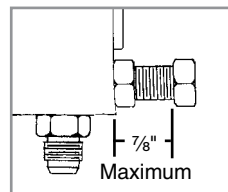

### NOTICE

The flow controls should be properly adjusted before the marker assemblies are first put into use. Excessive marker travel speed can damage the marker assembly.



### DANGER!

To avoid serious injury or death, care must be taken when operating row markers around overhead power lines.

**NOTE:** When oil is cold, hydraulics operate slowly. Make sure all adjustments are made with warm oil. Do not overtighten lock nut.

**NOTE:** On a tractor where oil flow can not be controlled, the rate of flow of oil from tractor may be greater than rate at which the marker cylinder can accept oil. Tractor hydraulic control lever will have to be held until cylinder reaches end of its stroke. This occurs most often on tractors with open center hydraulic systems. On tractors with closed center hydraulic systems, the tractor's hydraulic flow control can be set so the tractor's detent will function properly.

## ROW MARKER ADJUSTMENTS

1. Multiply number of rows by the average row spacing in inches to determine total planting width.

Row Marker Lengths	
12 Row 30"	360" (914.4 cm)
12 Row 36"	432" (1097.3 cm)
12 Row 38"	456" (1158.2 cm)
12 Row 40"	480" (1219.2 cm)
16 Row 30"	480" (1219.2 cm)

2. Lower planter and row marker assembly to ground.
3. Measure from planter center line to a point where blade contacts ground.
4. Adjust row marker extension so distance from marker disc blade to center line of planter is equal to total planting width. Adjust right and left row marker assemblies equally and securely tighten clamping bolts.

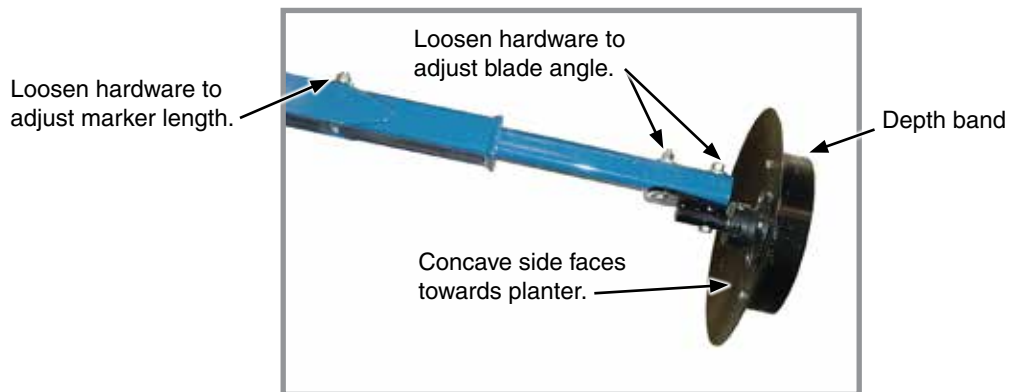

**Row marker disc blade angle adjustment**

### NOTICE

**Setting marker disc blade assembly at a sharper angle than needed adds stress to row marker assembly and shortens bearing and blade life. Set blade angle only as needed to leave a clear mark.**

Marker disc blade is installed with concave side facing inward. Spindle assembly is slotted so hub and blade can be angled to throw more or less dirt.

5. Loosen hardware and move assembly as required.
6. Tighten bolts to specified torque.
7. Do a field test to ensure markers are properly adjusted.

**NOTE: A notched marker blade is available from Kinze through your Kinze Dealer for use in more severe no till conditions.**

## WING FLEX

Two hooks located over each wing hinge area can be positioned so toolbar (a) is locked rigid, (b) so planter wings have 8° up flex or (c) with Wing Down Flex Cylinder Package (See "Wing Down Flex Cylinder") installed, so planter wings have 8° up flex and 8° down flex.

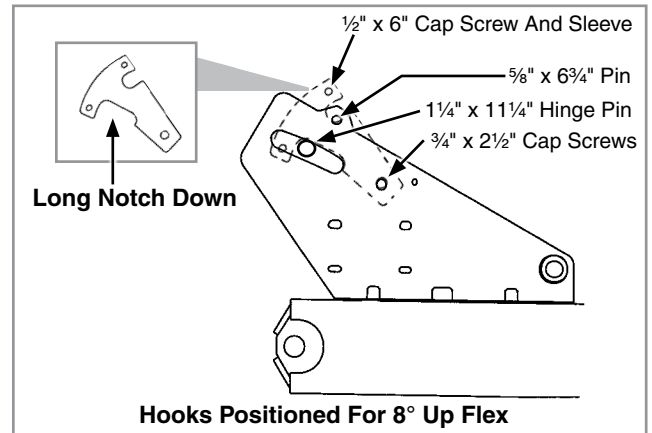
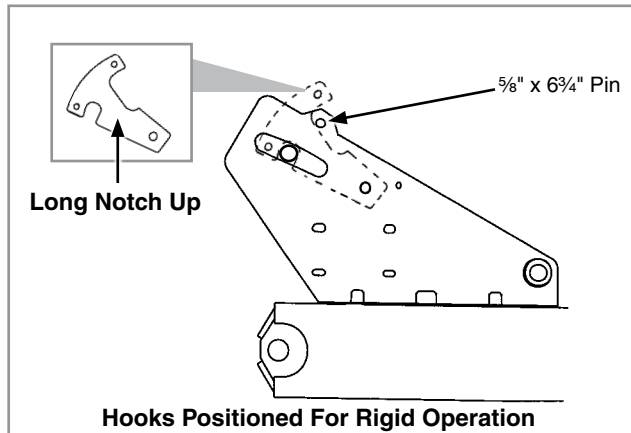

To change the hook from one position to the other:

1. Lower the planter to the ground so weight is off of the toolbar and relieve hydraulic pressure in the wing fold cylinders.
2. Remove lynch pin and 6 $\frac{3}{4}$ " pin.
3. Loosen  $\frac{3}{4}$ " hook mounting hardware and rotate the hooks back off of the hinge pin. (It may be necessary to raise the outer end of the wing up several inches to take pressure off of the hooks to allow them to rotate.)
4. Remove  $\frac{1}{2}$ " x 6" cap screw and sleeve.
5. Remove  $\frac{3}{4}$ " hook mounting hardware.
6. Install hooks in new position. Tighten  $\frac{3}{4}$ " hardware.
7. Install sleeve and  $\frac{1}{2}$ " cap screw in opposite hole.

**NOTE:** The  $\frac{3}{4}$ " hook mounting hardware should be snug, yet loose enough to allow the hooks to be rotated by hand.

8. Install 6 $\frac{3}{4}$ " pin and lynch pins.

### DANGER!

Serious injury or death can result from contact with electric lines. Use care to avoid contact with electric lines when moving or operating this machine.

### DANGER!

Wings must be unfolded before detaching machine from tractor.

### WARNING

Always install hydraulic cylinder safety lockups when servicing the machine in raised position or when transporting the machine on the road.

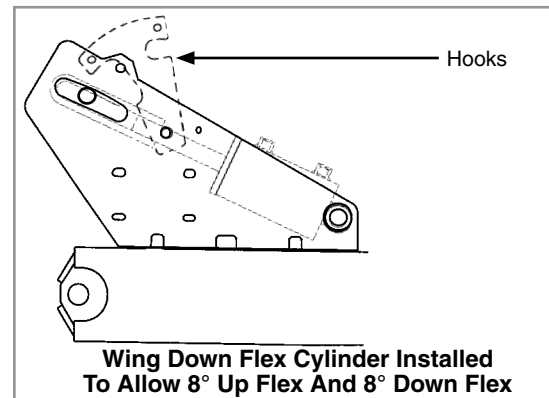
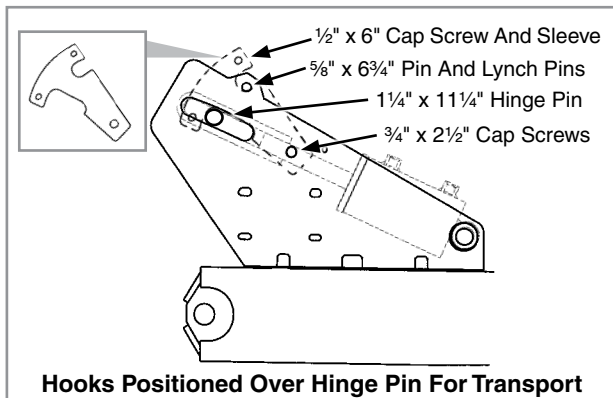
**WING DOWN FLEX CYLINDER**

To prevent the planter wings from sagging during transport should hydraulic pressure be lost, the hooks located over each hinge area should be repositioned prior to folding the planter. Apply hydraulic pressure to the wing down flex cylinders until they are completely retracted and the wings are rotated up slightly. (**3/4" hook mounting hardware should be snug, yet loose enough to allow the hooks to be rotated by hand.**) Remove lynch pin and 6 3/4" pin, rotate hooks to hook over hinge pin as shown below and reinstall 6 3/4" pin above hooks. Relieve hydraulic pressure on down flex cylinders and allow wings to come back to level. Fold planter and install lockups on wing fold cylinders. Reverse procedure to unfold planter.

**NOTICE**

**Always be sure planter is in the fully raised position before folding the planter wings to ensure wing row units do not collide with center section seed hoppers.**

## POINT ROW CLUTCHES

With the use of electric-activated clutches, which disengage the drive, either half of the planter may be shut off for finishing up fields or for long point row situations.

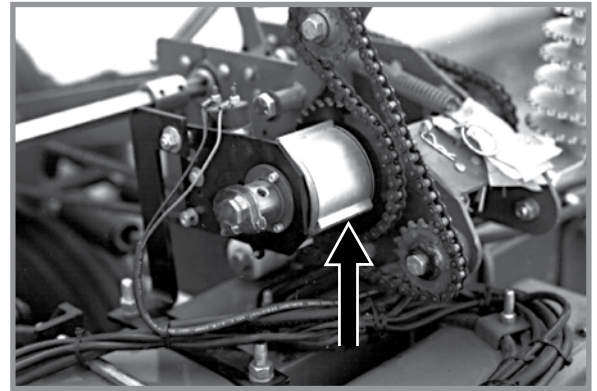

L.H. Side Of Planter Shown

The selector switch for the clutches is located in the point row clutch control box which is installed on the tractor.

**NOTE:** Switch should be left in OFF position when planter is not in use. If left in ON (left or right) position, the tractor battery will be discharged.



Point Row Clutch Control Box

**NOTE:** Since the liquid fertilizer piston pump have their own drive wheels, liquid fertilizer application will not be affected by use of the point row clutch.

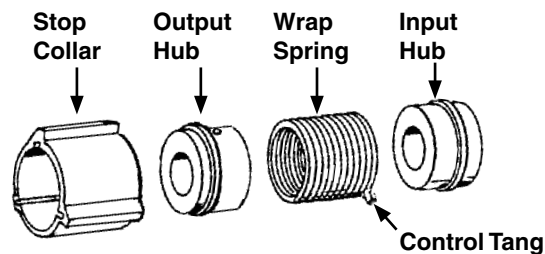

The point row clutch consists of a wrap spring riding on an input hub and an output hub. During operation the wrap spring is wrapped tightly over the hubs connecting them in a positive engagement. The greater the force of rotation the tighter the grip of the spring on the hubs. Rotation in the opposite direction or stopping the spring from rotating prevents the transmission of torque from the input hub to the output hub stopping the planter drive.

The input end of the spring is bent outward and is referred to as the control tang. The control tang fits into a slot in the stop collar that is located between the input and output hubs and over the wrap spring. If the stop collar is allowed to rotate with the input hub, the clutch is engaged. If the stop collar is stopped from rotating the control tang connected to it is forced back and the spring opens. This allows the input hub to continue rotating without transmitting torque to the output hub; therefore, stopping the planter drive.

The stop collar is controlled by the use of an electric solenoid and an actuator arm. When the selector switch on the tractor control box is in the OFF position the solenoid coil is NOT ENERGIZED and the actuator arm will not contact the stop on the stop collar allowing it to rotate with the hubs and drive the planter.

When the operational switch is in the "DISENGAGE" (right or left) position the solenoid coil IS ENERGIZED and the plunger in the solenoid coil pulls the actuator arm against the stop on the stop collar, disengaging the wrap spring and stopping the planter drive.

**TWO-SPEED POINT ROW CLUTCHES**

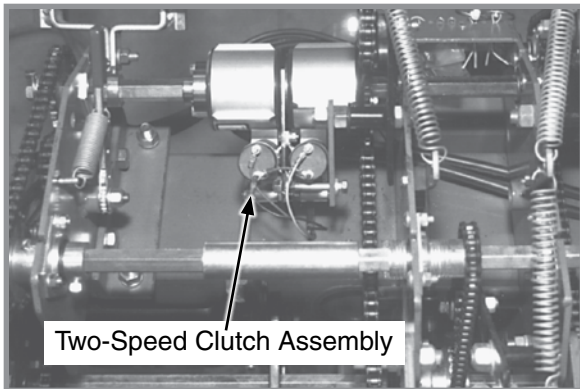

Two-Speed Clutch Assembly

Left Side Of Planter Viewed From Rear Of Planter

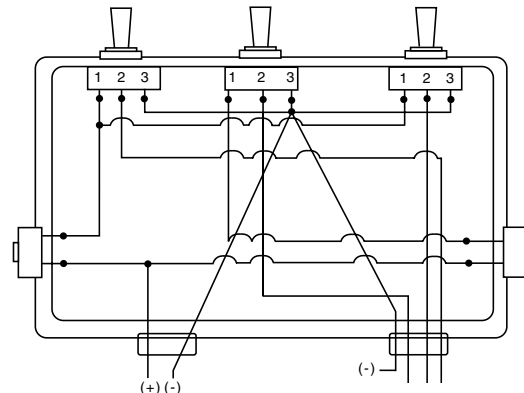

Top View Of Control Box

The optional Two-Speed Point Row Clutch Package is designed to allow on-the-go population rate adjustment as well as the capability to shut off either half of the planter for finishing up fields or for long point row situations.

The point row clutches are controlled by the point row clutch switches on the control box. The point row switch is used to shut off either the left or right half of the planter. Activating the reduced rate switch engages one solenoid on each clutch assembly and reduces the planting rate for the entire planter.

**NOTE: Point row switch should be left in OFF position and rate switch left in FULL RATE position when planter is not in use. If left in ON and/or REDUCED RATE positions, the tractor battery will be discharged.**

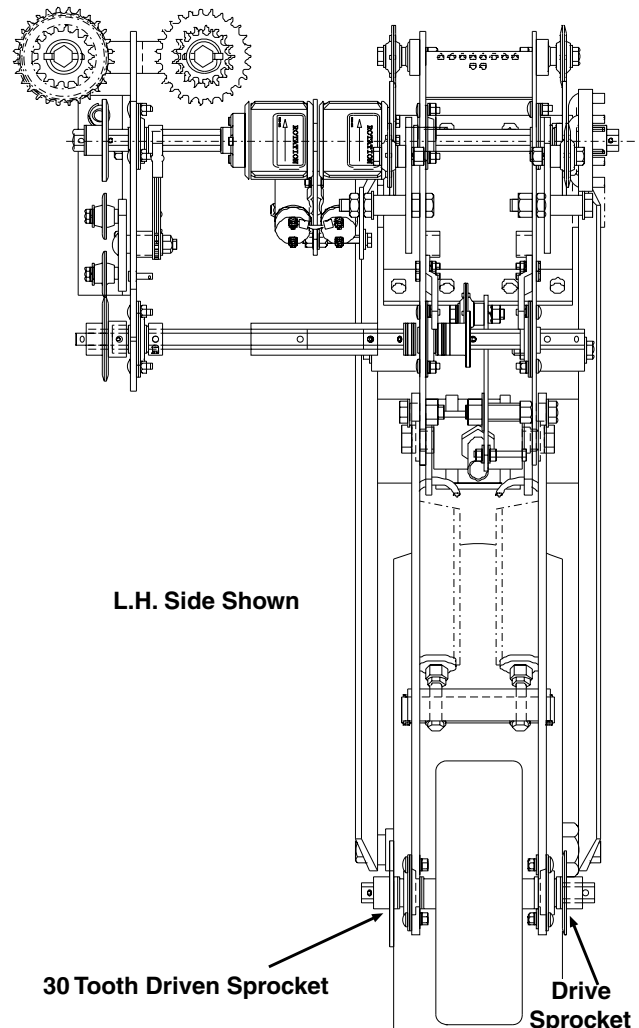

L.H. Side Shown

30 Tooth Driven Sprocket

Drive Sprocket

TRANSMISSION RATE REDUCTION		
DRIVE	DRIVEN	% REDUCTION IN POPULATION
15	30	50
17	30	43
23*	30	23
24	30	20
25*	30	17
26*	30	13
27	30	10

\* Use sprockets off seed drive transmission

7100-214

The ratio of population reduction is determined by the sprocket ratio between the drive and driven sprockets at the contact drive tire. A rate reduction decal like the one shown below is located on the wheel module.



## DUAL LIFT ASSIST WHEELS

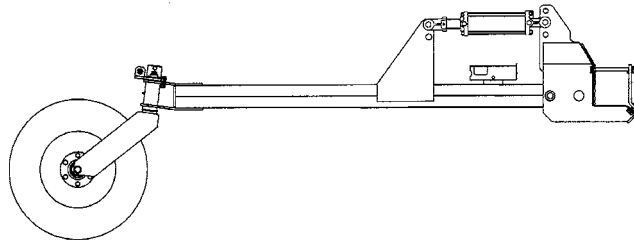

Dual lift assist wheel equipped machines require use of a quick hitch (customer-supplied) and the top link pin is not used.

A single control valve operates the dual lift assist wheels.

When raising a planter equipped with dual lift assist wheels, the front of the planter should raise and then the back using the lift assist wheels to raise the rear of the planter. When lowering the planter, the lift assist wheels should begin to lower the rear of the planter before lowering the front of the planter.

If the machine is equipped with both the Dual Lift Assist Wheel Package and Wing Down Flex Cylinder Package, a single control valve operates both options. As the dual lift assist wheel cylinders extend to raise the toolbar, the wing down flex cylinders retract to flex the wings up 5° for added clearance when turning.

The flow control valve must be adjusted so that the wing down flex cylinders start to retract before the lift assist cylinders start to raise the toolbar. This will prevent the wings from drooping as the toolbar is raised.

Dual lift assist wheels hydraulics can also be plumbed into the 3 point lift circuit. A flow control valve determines the correct sequence of events to allow the dual lift assist wheel cylinders to operate at the correct time in conjunction with the 3 point hitch lift circuit. See "Flow Control Valve Adjustment".

See "Tractor Preparation And Hookup" for additional information.

## ACCUMULATOR

An accumulator is standard in Dual Lift Assist Wheel Packages for Model 3140 Stack Folding 16 Row 30" Planters to absorb shock loads to the lift assist wheel arms during transport.

After initial dealer installation no maintenance should be necessary on the sealed system.



**WARNING**  
Do not disassemble accumulator. See dealer for service. Note manufacturer's caution decal on accumulator.

## PISTON PUMP MOUNT/DRIVE SPRING ADJUSTMENT

Adjust the pump drive tension springs by tightening the hex head adjustment bolts to maintain positive tire contact. The initial setting should result in a  $\frac{1}{8}$ " gap between coils. Tighten jam nut against spring plug to hold setting.

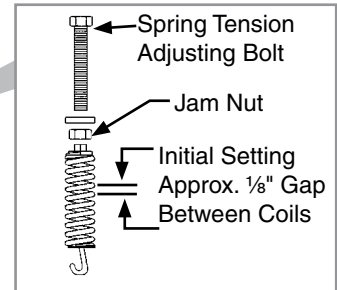
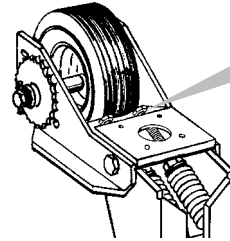

## FLOW CONTROL VALVE ADJUSTMENT

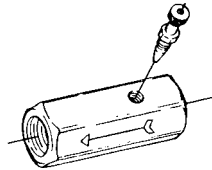

The flow control valve determines the amount of oil flow to the lift assist cylinders.

To adjust oil flow, loosen the jam nut and turn the control clockwise or "in" to restrict flow and counterclockwise or "out" to increase the flow.

## PLANTING SPEED

Planters are designed to operate within a speed range of 2 to 8 mph (3.2 - 12.8 kph). See "Rate Charts". Variations in ground speed produce variations in rates. Finger pickup seed meter populations tend to be disproportionately higher at high ground speeds.

**NOTE: Seed spacing can be adversely affected at speeds above 5.5 mph (8.8 kph).**

## FIELD TEST

Perform a field test with any change of field and/or planting conditions, seed size or planter adjustment to ensure proper seed placement and operation of row units.

- Check planter for front to rear and lateral level operation. See “Leveling the Planter”.
- Check **all** row units to be certain they are running level. Row unit parallel arms should be approximately parallel to the ground when planting.
- Check row markers for proper operation and adjustment. See “Row Marker Adjustments” and “Row Marker Speed Adjustment”.
- Check for proper application rates and placement of granular chemicals on **all** rows. See “Field Check Granular Chemical Application”.
- Check for desired depth placement and seed population on **all** rows. See “Check Seed Population” and appropriate Rate Chart.
- Check for proper application rates of fertilizer on **all** rows. See proper “Fertilizer Application Rate Chart”.

Reinspect machine after field testing.

- Hoses And Fittings
- Bolts And Nuts
- Cotter Pins And Spring Pins
- Drive Chain Alignment

## CHECK SEED POPULATION

1. Tie up one or more sets of closing wheels by running a chain or rubber tarp strap between the hopper support panel and closing wheels. It may be necessary to decrease closing wheel arm spring tension.
2. Plant a short distance and check to see if seed is visible in the seed trench. Adjust planting depth to a shallower setting if seed is not visible and recheck.

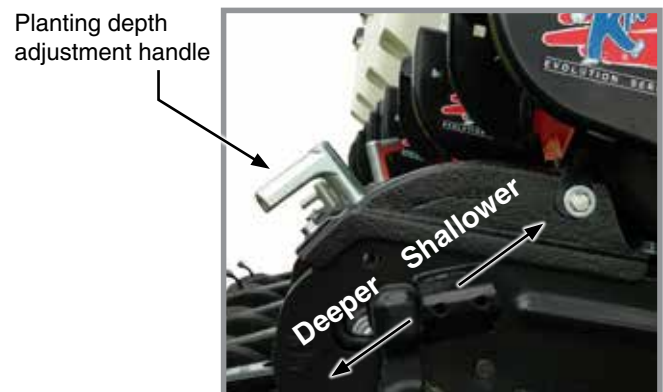
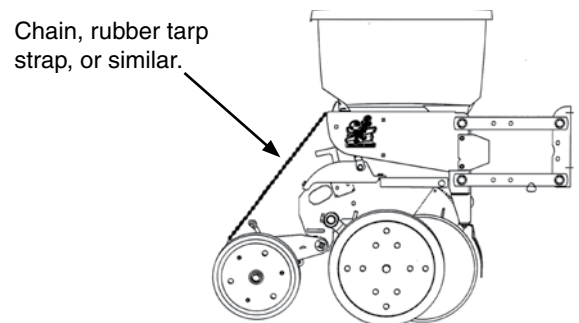

Planting depth adjustment

3. Measure  $\frac{1}{1000}$  of an acre. See chart for correct distance for row width being planted. For example, if planting 30" rows  $\frac{1}{1000}$  of an acre would be 17' 5".

$\frac{1}{1000}$ Acre Seed Population Count Row Width/Distance						
Row Width	15"	18"	19"	30"	36"	38"
Distance	34'10"	29'0"	27'8"	17'5"	14'6"	13'10"

**NOTE: Seeds may bounce or roll when planting with closing wheels raised and planting depth set shallow affecting seed spacing accuracy.**

4. Count seeds in measured distance.
5. Multiply number of seeds placed in  $\frac{1}{1000}$  of an acre by 1000. This gives total population.

EXAMPLE: 30" row spacing 17' 5" equals  $\frac{1}{1000}$  acre.  
 26 seeds counted x 1000 = 26,000 seeds per acre

Seed count can be affected by drive wheel and seed meter drive ratio, tire pressure, and/or seed meter malfunction.

1. If seed check shows average distance between seeds in inches is significantly different than seed rate chart indicates, first check drive ratio between drive wheel and seed meter. Check drive wheel air pressure, check for incorrect sprocket(s) in driveline and check drive and driven sprockets on transmission(s) for proper selection.
2. Check for seed meter malfunction. For example, if spacing between kernels of corn at the transmission setting being used is 8" and a gap of 16" is observed, a finger has lost its seed and not functioned properly. If two seeds are found within a short distance of each other, the finger has metered two seeds instead of one.
3. See "Finger Pickup Seed Meter Troubleshooting" and/or "Brush-Type Seed Meter Troubleshooting" in the Troubleshooting Section of this manual.

**DETERMINING POUNDS PER ACRE (BRUSH-TYPE METER)**

Seeds per acre ÷ Seeds per pound (from label) = Pounds per acre

If seeds per pound information is not available use the following averages:

2,600 seeds per pound for medium size soybeans

15,000 seeds per pound for medium size milo/grain sorghum

4,500 seeds per pound for medium size cotton

**DETERMINING BUSHELS PER ACRE**

Pounds per acre ÷ Seed unit weight = Bushels per acre

Average Unit Weight of:

1 Bushel Soybeans = 60 Pounds

1 Bushel Milo/Grain Sorghum = 56 Pounds

1 Bushel Cotton = 32 Pounds

If seed population check shows planting rate is significantly different than seed rate chart shows or if a particular meter is not planting accurately, see "Brush-Type Seed Meter Maintenance" and "Brush-Type Seed Meter Troubleshooting".

**FIELD CHECK GRANULAR CHEMICAL APPLICATION**

Temperature, humidity, speed, ground conditions, flowability of different material, or meter obstructions can affect granular chemical rate of delivery.

**! WARNING**

**Agricultural chemicals can cause death or serious injury to persons, animals, and plants or seriously damage soil, equipment, or property. Read and follow all chemical and equipment manufacturers labels and instructions.**

Perform a field check to determine application rates.

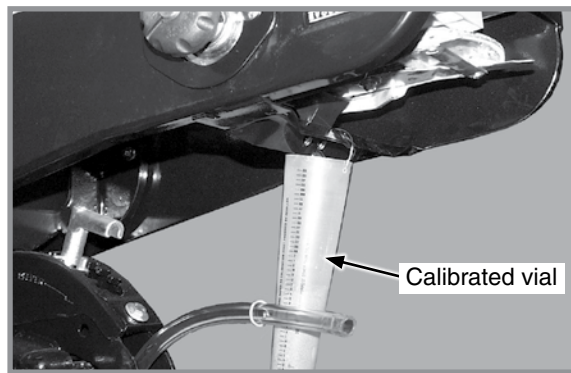

**Granular chemical field check**

1. Fill insecticide and/or herbicide hoppers.
2. Attach a calibrated vial to each granular chemical meter.

**NOTE: Disengage clutch to avoid dropping seed during test.**

3. Lower planter and drive 1320 feet at planting speed.
4. Weigh chemical in ounces caught in one vial.
5. Multiply that amount by factor shown to determine pounds per acre.

Pounds Per Acre	
Row Width	Factor
30"	.83
36"	.69
38"	.65

EXAMPLE: You are planting 30" rows. You have planted for 1320 feet at desired planting speed. You caught 12.0 ounces of chemical in one vial. 12.0 ounces times 0.83 equals 9.96 pounds per acre.

**NOTE: Check calibration of all rows.**

**METERING GATE**

Use metering gate setting as a starting point for distributing insecticide or herbicide. Charts are based on 5 mph (8 kph) planting speed. Use a higher gate setting for speeds faster than 5 mph (8 kph) and a lower setting for speeds slower than 5 mph (8 kph).

## PLANTING DEPTH

Planting depth is maintained by adjustable row unit gauge wheels. Depth adjustment range is approximately ½" to 3½".

1. Raise planter to remove weight from wheels.
2. Push down on depth adjustment handle and reposition it forward to decrease or rearward to increase planting depth. Initially adjust all units to the same setting.
3. Lower planter and check operation and planting depth of all row units. Readjust individual rows as needed for uniform operation.



Planting depth adjustment

## “V” CLOSING WHEEL ADJUSTMENT (RUBBER OR CAST IRON)

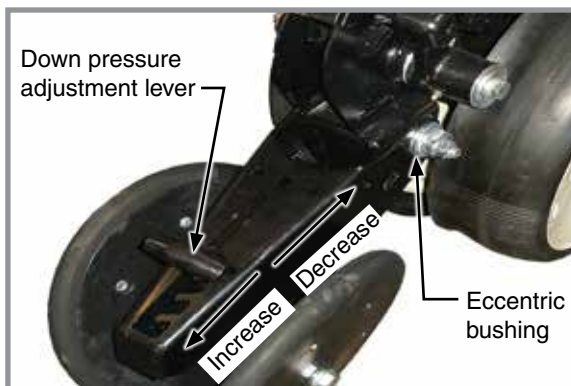

“V” Closing wheel adjustments

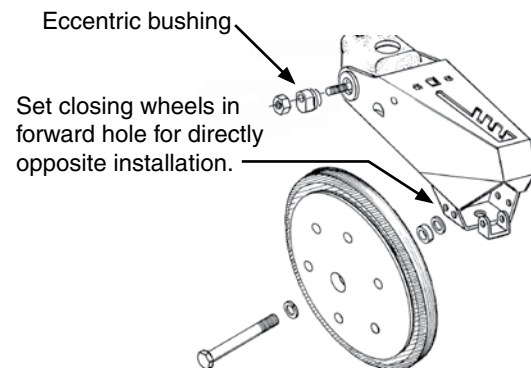

“V” closing wheels should have enough down pressure to close the seed trench and ensure good soil to seed contact. Move 5-position quick adjustable down force lever on the top of closing wheel arm to the rear to increase closing wheel spring pressure. Move lever forward to decrease pressure. Adjust all row units to a similar setting. Light soil usually requires less down force at average depth (approximately 2") while heavy soil requires increased down force.

Eccentric bushings in the wheel arm stop allow for lateral adjustment of the “V” closing wheel assembly. Use a ¾" wrench to loosen hardware attaching closing wheel arm to wheel arm stop. Use another ¾" wrench to turn eccentric bushings until **closing wheels are aligned with seed trench**. Tighten hardware.

Closing wheels can be installed “offset” (to improve residue flow) or “directly” opposite. Use forward installation holes if set “directly” opposite.

## CLOSING WHEEL SHIELD (RUBBER OR CAST IRON “V” CLOSING WHEELS)

Optional closing wheel shield is installed on underside of closing wheel arm to help prevent root balls and stalks from clogging closing wheels.

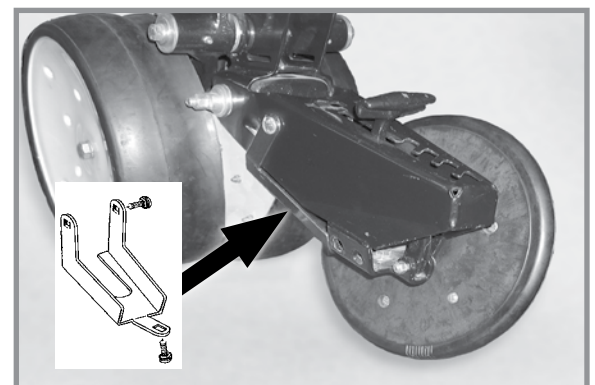

Closing wheel shield (Closing wheel removed)

### DRAG CLOSING ATTACHMENT

Drag closing attachment pulls loose soil over seed trench.

**NOTE: Use of a seed firming wheel or other seed firming device is recommended with drag closing attachment.**

Front and rear adjustment is made using slotted holes in blades. Adjust all rows the same. Wheel arm stop eccentric bushings provide lateral adjustment. Use a 3/4" wrench to loosen closing wheel arm to wheel arm stop hardware. Use another 3/4" wrench to turn eccentric bushings until drag closing attachment is aligned with seed trench. Tighten hardware.

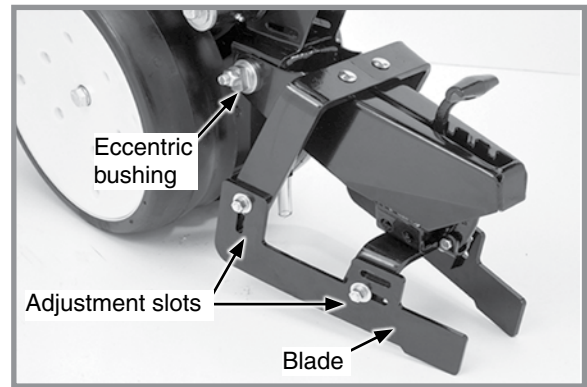

Drag closing attachment

### COVERING DISCS/SINGLE PRESS WHEEL ADJUSTMENT

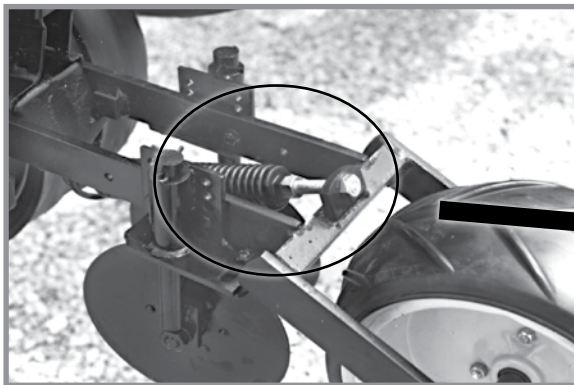

Press wheel down force adjustment

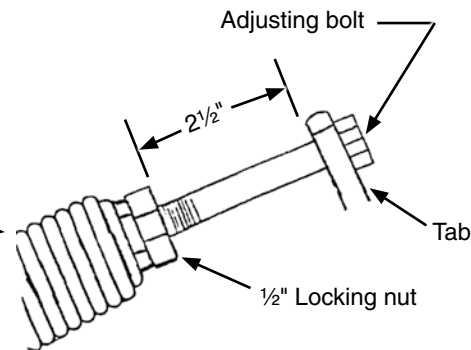

Check operation of covering discs/single press wheels after adjusting planting depth. Initial press wheel down force spring setting is 2 1/2" between mounting arm tab and locking nut. Loosen 1/2" locking nut and turn adjusting bolt in to increase down force or out to decrease down force. Tighten locking nut against spring plug. Adjust all row units to a similar setting.

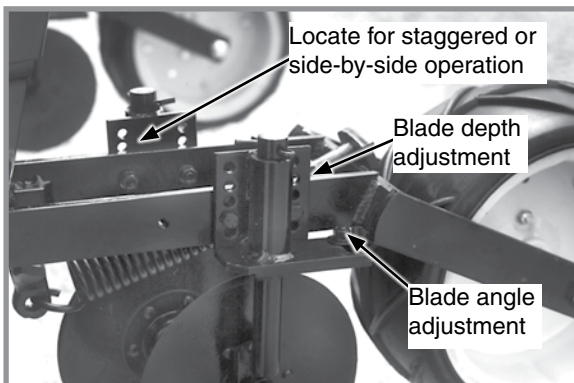

Covering disc adjustments

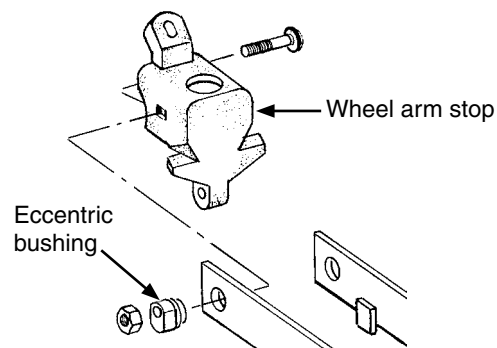

Eccentric bushings in the wheel arm stop allow for lateral adjustment of covering discs/single press wheel assembly. Use a 3/4" wrench to loosen hardware attaching closing wheel arm to wheel arm stop. Use another 3/4" wrench to turn eccentric bushings until covering discs/single press wheel assembly is aligned with seed trench. Tighten hardware. Two sets of holes in mounting arm locate covering discs for staggered or side-by-side operation. Five sets of holes in each disc bracket allow 1/2" incremental blade depth adjustment. Slotted holes in disc mount and bracket allow for 0° - 15° blade angle adjustment. Adjust covering discs on all row units to similar settings.



## SEED HOPPERS

Mechanical seed hopper has a capacity of 1.9 bushels.

EdgeVac seed hopper has a capacity of 1.75 bushels.

Use clean seed and make certain there are no foreign objects inside when filling seed hopper. **Replace hopper lids after hoppers are filled to prevent accumulation of dust or dirt in seed meter which can cause premature wear.** See "Finger Pickup Seed Meter" and/or "Brush-Type Seed Meter".

Periodically empty hoppers completely to remove any foreign objects and to ensure proper seed meter operation.

Disengage meter drive and hopper latch and lift hopper off hopper support. See "Seed Meter Drive Release".

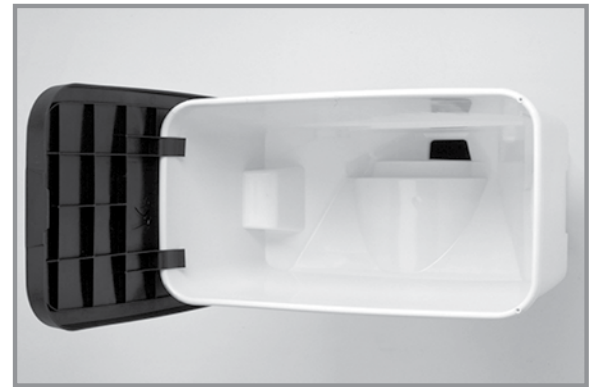

**Mechanical seed hopper**

## SEED METER DRIVE RELEASE

A clutch release mechanism disengages seed meter drive from seed meter to remove seed hopper. Disconnecting drive allows operator to check granular chemical application rates without dropping seed. It also allows one or more rows to be disconnected when finishing fields.

Turn knob ¼ turn counterclockwise to disengage or ¼ turn clockwise to engage.

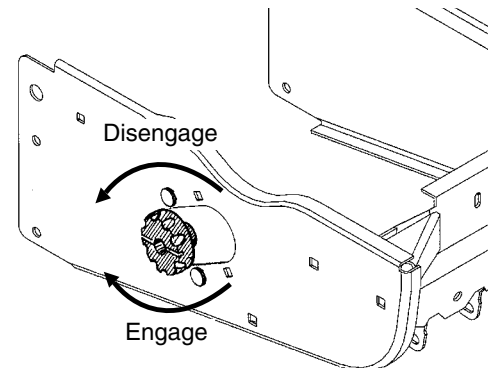

**Seed meter drive release**

## ROW UNIT EXTENSION BRACKETS

Row unit extension brackets extend row units rearward 4" to provide clearance for coulter mounted residue wheels and HD single disc fertilizer openers.

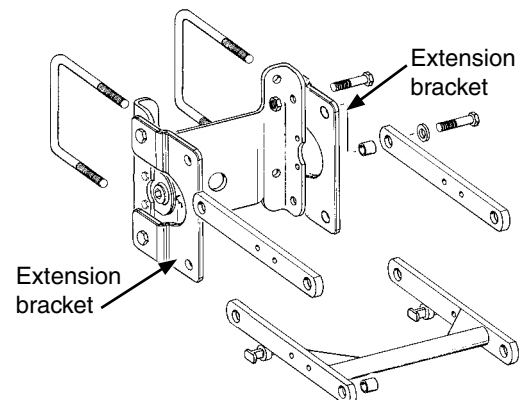

**Row unit extension brackets**

### ROW UNIT CHAIN ROUTING

Row unit drive chains must be properly tensioned and aligned for proper operation and to minimize wear.

Inspect and replace weak, worn or broken springs, idlers, and idler bushings.

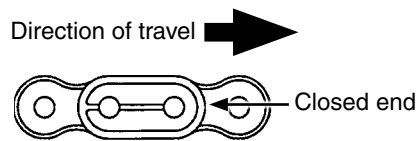

**NOTE:** Install connector link with closed end facing direction of travel.

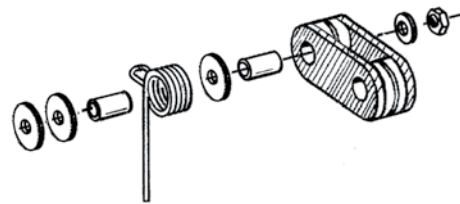

**NOTE:** Reverse idler when worn on one side for extended use.

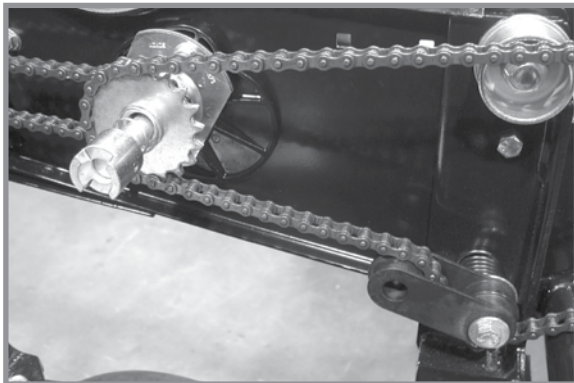

**Mechanical Pull Row Unit Meter Drive**

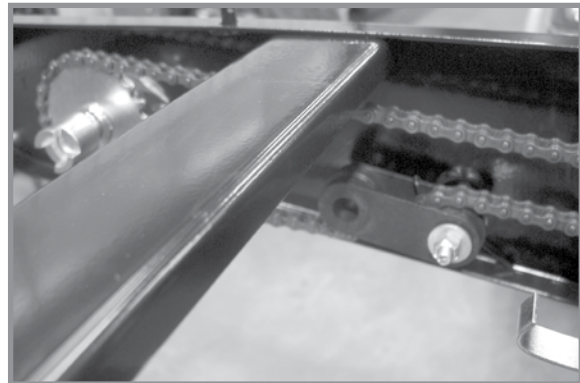

**Row Unit Granular Chemical Drive**

**QUICK ADJUSTABLE DOWN FORCE SPRINGS OPTION (STANDARD OR HEAVY DUTY)**

Standard and heavy duty quick adjustable down force springs are available in increase penetration in hard soil and keep row unit from bouncing in rough field conditions. Two springs per row, one on each side parallel arms, are used unless equipped with row unit mounted no till coulters. Row unit mounted no till coulters require four springs per row.

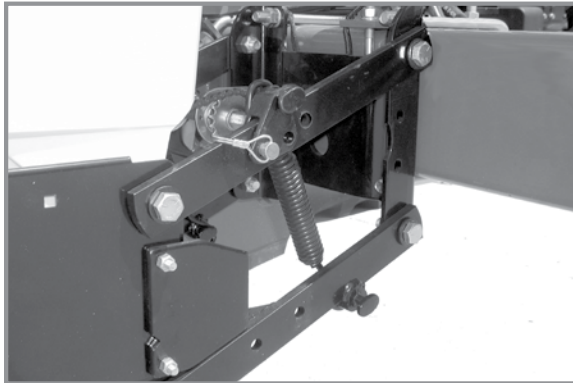

**Two springs per row (Dual)**

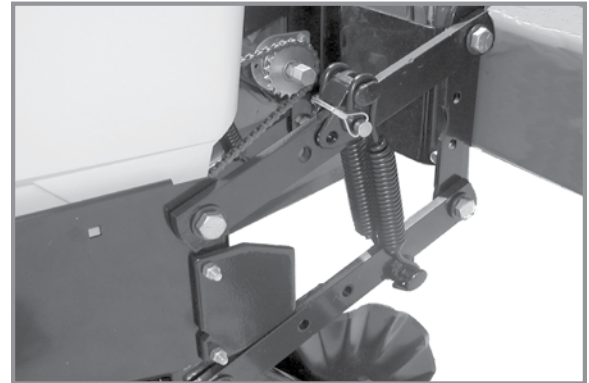

**Four springs per row (Quad)**

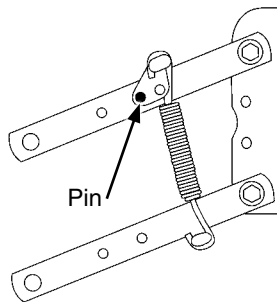

**Position 1 (Least)**

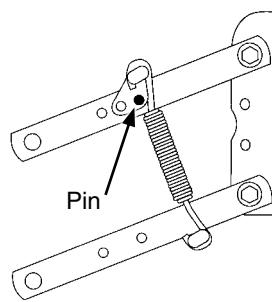

**Position 2**

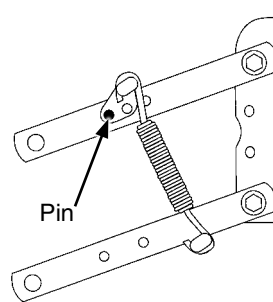

**Position 3**

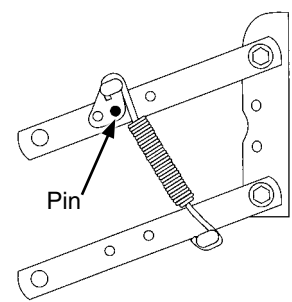

**Position 4 (Most)**

There are four positions to set down pressure spring tension.

Standard and Heavy Duty Spring Down Force Pressure*				
Position	2 Springs		4 Springs	
	Standard D8249	Heavy Duty D21337	Standard D8249	Heavy Duty D21337
1	41lb (18.6 kg)	43 lb (19.5 kg)	74 lb (33.6 kg)	80 lb (36.3 kg)
2	73 lb (33.1 kg)	86 lb (39.0 kg)	120 lb (54.4 kg)	144 lb (65.3 kg)
3	136 lb (61.7 kg)	167 lb (75.7 kg)	255 lb (115.7 kg)	307 lb (139.3 kg)
4	207 lb (93.9 kg)	249 lb (113.0 kg)	369 lb (167.4 kg)	470 lb (213.2 kg)

\*Pressure does not include weight of row unit, seed, or options.









**NOTICE**

**Springs must be installed with open side of spring hooks toward seed hoppers to prevent binding on spring mount adjustment pins.**

1. Raise planter and remove spring mount pin at top of spring.
2. Slide mount to desired position and install pin.

**NOTE: Adjust springs for field conditions. Too much down pressure in hard field conditions can cause row units to lift planter and keep drive wheels from making contact. Too much down pressure in soft field conditions can cause row unit to run too deep.**

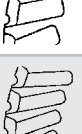
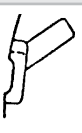
**BRUSH-TYPE SEED METER**

	<b>Crop</b>	<b>Disc Color-Code (Disc Part No.)</b>	<b>Upper Brush Retainer</b>	<b>Cells</b>	<b>Seed Size Range</b>	<b>*Lubricant</b>
	Soybean	Black (GA5794)	GD11122	60	2200 to 4000 seeds/lb.	<b>Graphite Talc</b>
	Specialty Soybean	Dark Blue (GA6184)	GD11122	48	1400 to 2200 seeds/lb.	<b>Graphite Talc</b>
	Small Milo/Grain Sorghum	Red (GA5982)	GD8237	30	14,000 to 20,000 seeds/lb.	Talc
	Large Milo Grain Sorghum	Light Blue (GA6187)	GD8237	30	10,000 to 16,000 seeds/lb.	Talc
	High-Rate Small Milo/Grain Sorghum	Red (GA5795)	GD8237	60	12,000 to 18,000 seeds/lb.	Talc
	High-Rate Large Milo/Grain Sorghum	Yellow (GA6633)	GD8237	60	10,000 to 14,000 seeds/lb.	Talc
	Cotton, Acid-Delinted	White (GA5796)	GD11122	30	4200 to 5200 seeds/lb.	Talc
	Large Cotton, Acid Delinted	Tan (GA6168)	GD11122	36	3800 to 4400 seeds/lb.	Talc
	High-Rate Cotton, Acid-Delinted	Light Green (GA6478)	GD11122	48	4200 to 5200 seeds/lb.	Talc
	Hill-Drop Cotton, Acid-Delinted	Brown (GA6182)	GD11122	12 (3 to 6 seeds/ cell)	4000 to 5200 seeds/lb.	Talc
	Small Hill-Drop Cotton, Acid-Delinted	Dark Green (GA7255)	GD11122	12 (3 to 6 seeds/ cell)	5000 to 6200 seeds/lb.	Talc

\*For More information on application rate see Additives section.

	<p><b>Use GD11122 upper brush retainer when using cotton and soybean discs.</b></p>		<p><b>Use GD8237 upper brush retainer when using milo/grain sorghum discs.</b></p>
---	---	---	--

Turn seed disc counterclockwise when installing on meter hub while tightening two wing nuts that retain disc. Seed disc should have slight resistance when rotated counterclockwise after wing nuts are tight.

Brush-type seed meter attaches to seed hopper same as finger pickup seed meter. Secure to bottom of seed hopper with two 5/16" thumbscrews. Tighten thumbscrews slightly with pliers. **DO NOT OVER TIGHTEN.**

Misalignment between drive coupler and seed meter input shaft may cause erratic seed spacing from momentary stoppage of seed disc. Check alignment and adjust as needed.

Refer to planting rate charts in this manual for recommended seed drive transmission sprocket combinations.



Shown without seed disc installed



**NOTICE**

Replace hopper lids after hoppers are filled to prevent accumulation of dust or dirt in seed meter which will cause premature wear.

**NOTE:** Clean seed is required to ensure accurate seed metering from brush-type seed meters. Remove seed discs daily and check seed meter or brushes for buildup of foreign material, such as hulls, stems, etc.

**FINGER PICKUP SEED METER**

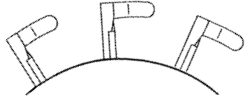
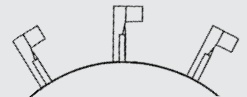











Crop	Fingers	*Lubricant
Corn	 Part No.: GR1848 - Finger Assembly, Corn	Graphite Talc
No. 1 and/or No. 2 size Confectionery Sunflower Seeds	 Part No.: GR1848 - Finger Assembly, Corn	Talc
No. 3 and/or No. 4 size Oil Sunflower Seeds	 Part No.: GR1897 - Finger Assembly, Oil	Talc
Blank fingers replace alternate fingers to reduce planting rate by half while allowing the finger wheel to maintain a minimum of 40 RPM when planting low rates.	 Part No.: GD11787 - Half Rate Blank Finger	Graphite Talc

\*For More information on application rate see Additives section.

**NOTE:** Always field check seed population to verify planting rates.

**NOTE:** Refer to planting rate charts in this manual for recommended seed drive transmission sprocket combinations.

**EDGEVAC SEED METERS**

	<b>Crop</b>	<b>Disc Color-Code (Disc Part No.)</b>	<b>Cells</b>	<b>Seed Size Range</b>	<b>Singulator Brush Setting</b>	<b>Vacuum Setting (H2O)</b>	<b>*Lubricant</b>	<b>See Notes</b>
	Corn	Light Blue (GD17049)	39	35-70 lbs./80k	5-7	18-20	Graphite Talc	4, 5
	Popcorn			2210-4200 seeds/lb.	9	18	Graphite Talc	1, 4, 5
	Low-Rate Corn	Light Green (GD17048)	24	35-70 lbs./80k	5-7	18-20	Graphite Talc	4, 5
	Low-Rate Popcorn			2210-4200 seeds/lb.	9	18	Graphite Talc	1, 4, 5
	Soybean	Black (GD14467)	60	2200-4000 seeds/lb.	5	10	Graphite Talc	1
	Soybean, High-Rate	Dark Blue (GD14468)	120	2200-4000 seeds/lb.	5	10	Graphite Talc	-
	Milo/Grain Sorghum	Yellow (GD17050)	60	10,000 - 20,000 seeds/lb.	3	20	Talc	1, 2
	Hill-Drop Cotton, Acid-Delinted	Brown (GD17187)	20 (3 seeds/ cell)	3800-4400 seeds/lb.	8	23	Talc	3
	Small Hill-Drop Cotton, Acid- Delinted	Grey (GD18095)	20 (3 seeds/ cell)	4200-4400 seeds/lb.	-	-	Talc	3
	Cotton, Acid- Delinted	Dark Green (GD17186)	54	3800-5200 seeds/lb.	8	20	Talc	3
	Dry Edible Bean, Small			1200-2500 seeds/lb.	6	18	Graphite Talc	3, 5
	Dry Edible Bean, Large	Tan (GD14477)	54	800-1200 seeds/lb.	5	18	Graphite Talc	5
	Small Cotton/ Sunflower	White (GD18098)	54	4200-5200 seeds/lb.	5	30	Talc	3
	Sugar Beets	Dark Orange (GD24805)	80	All	5-6	15-18	Graphite	1

**\*For More information on application rate see Additives section.**

Install selected seed disc. Position vacuum cover on meter by aligning keyhole slots over bolt heads. Push cover on meter and turn counter clockwise to lock in place.

**NOTES:**

1. Requires use of seed meter baffle.
2. Requires use of cleanout brush.
3. Requires use of cleanout brush w/ball-type ejector.
4. Flat seeds may require higher vacuum level.
5. Larger seeds may require lower singulator brush setting. Smaller seeds may require higher setting.

**NOTE: See “EdgeVac General Planting Rate Information” and “Check Seed Population” pages for more information. Always field check seed population to ensure planting rates are correct.**

**NOTE: Singulator brush settings are marked from 1 thru 11. Lower singulator brush settings are least aggressive. Higher singulator brush settings are most aggressive.**

**NOTE: Mixing seed sizes and shapes affects meter performance. Use consistent seed size and shape.**

**NOTE: Use 1 tablespoon powdered graphite with each hopper fill of seed. Seed treatment, foreign material, dirt or seed chaff may cause gradual reduction of seed disc fill (population). See “Additives” pages for more information.**

**NOTE: Excessive seed treatment, humidity, and light-weight seed can affect meter performance. Use ½ cup of talc with each hopper fill of seed and mix thoroughly to coat all seeds and adjust rates as needed. Use of talc aids seed flow into meter, singulation, and disc seed drop.**

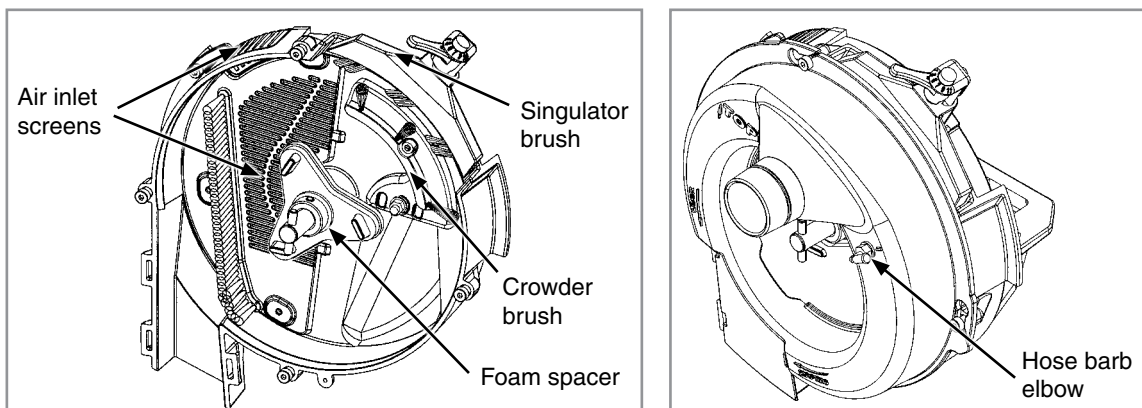

**NOTE: Foreign material in seed disc orifices, such as seed chips, hulls, stems, etc., may affect seed delivery. Clean seed ensures accurate seed metering from vacuum seed meter. Remove Seed discs daily to check for buildup of foreign material in seed disc orifices.**

Crowder brush aids in singulation of small flat seeds by crowding seeds to outer perimeter of seed disc and orienting seeds to allow singulator brush to be more effective.

Air inlet screens allow air to enter system and aids in keeping field residue or other foreign material out of meter.

Foam spacer gently preloads seed disc against vacuum cover when no vacuum is present.

3/16" hose barb elbow on seed meter vacuum cover allows measurement of vacuum level at each meter. A customer-supplied vacuum gauge is required.

See “EdgeVac Seed Meter Maintenance” and “Preparation For Storage” in Lubrication and Maintenance section for more information.

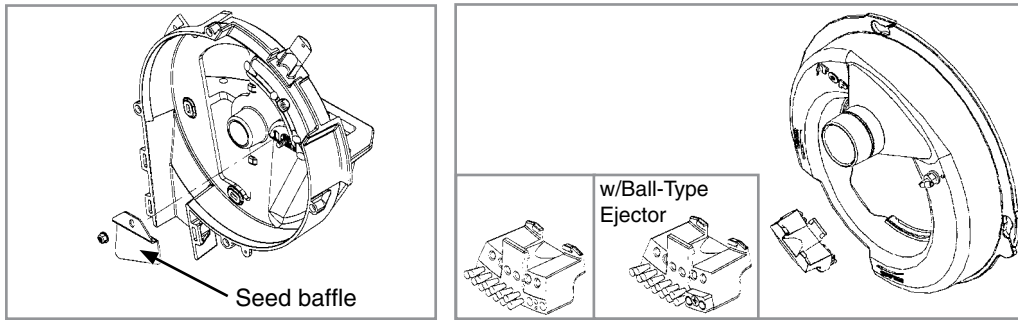

**NOTE: Damaged seed or seed containing foreign material will cause plugging of seed disc orifices and require more frequent seed meter cleanout to prevent underplanting.**

**SEED BAFFLE**

Seed baffle prevents excessive seed in meter from restricting air flow through seed. Used with 60 Cell Milo/Grain Sorghum Disc, 60 Cell Soybean Disc, 120 Cell High-Rate Soybean Disc and 39 Cell, 24 Cell Popcorn Discs, and 80 Cell Sugar Beet Discs.

**CLEANOUT BRUSH**

Cleanout brush removes foreign material and seed remnants to help prevent plugging of seed disc orifices. Used with 60 Cell Milo/Grain Sorghum Disc.

**CLEANOUT BRUSH W/BALL-TYPE EJECTOR**

Cleanout brush w/ball-type ejector ejects seed remnants from seed disc orifices. Used with 20 Cell Hill-Drop Cotton, Acid-Delinted (3 Seeds Per Cell) Discs; 54 Cell Acid-Delinted Cotton/Small Dry Edible Bean; and Small Cotton/Sunflower Discs.

***NOTICE***

**Replace hopper or tank lids after filling to prevent accumulation of dust or dirt in seed meter resulting in premature wear.**

**NOTE: Seed size, seed shape, seed treatments, travel speed, and planting rate affect meter performance.**

1. Select seed disc (and seed meter baffle, cleanout brush and/or cleanout brush w/ball-type ejector if applicable) to match crop and population.

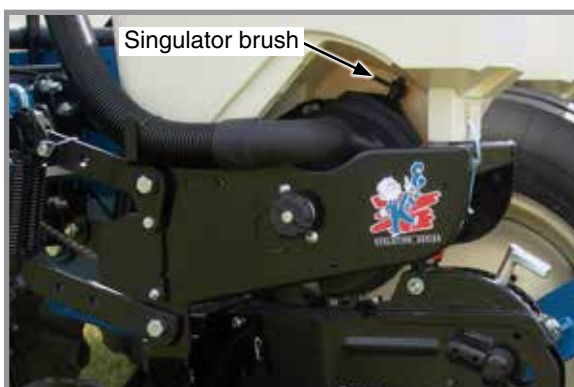

**Singulator brush adjustment location**

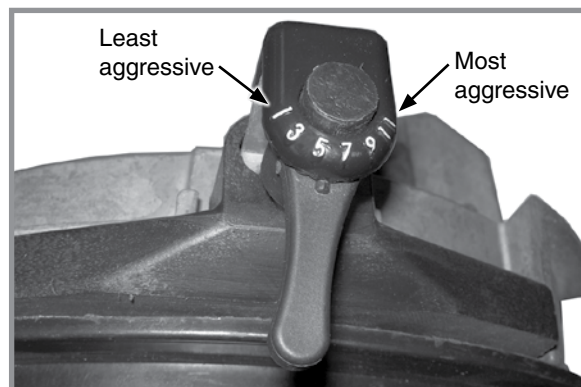

**Singulator brush adjustment lever**

2. Adjust singulator brush to initial setting. Seed size, seed shape, seed treatments, travel speed and planting rate all affect meter performance.
3. With vacuum fan running, lower planter to planting position and drive forward a short distance to load seed into seed disc cells.



- Adjust vacuum level to initial setting according to tables on page.

**NOTE: Vacuum reading will be much lower when seed disc cells are empty. Load all seed cells before setting vacuum level.**

**NOTE: Operate vacuum fan 3-5 minutes to bring oil up to normal operating temperature prior to making final vacuum level adjustment.**

- Perform optional seed disc fill check.



**Remove vacuum cover and seed disc**



**Check seed fill**

With vacuum hose connected and vacuum fan operating, remove vacuum cover and seed disc as an assembly. Inspect seed discs for proper seed fill.

See “EdgeVac Seed Metering System Troubleshooting” in Troubleshooting section.

## SEED METER CLEANOUT

**NOTE: Use of damaged seed or seed containing foreign material will cause plugging of seed cell orifices and require more frequent seed meter cleanout to prevent underplanting.**

Thorough seed meter cleanout is important to maintain genetic purity.

- Disengage seed drive and remove seed hopper and meter.
- Dump seed from right rear corner of hopper into a container.
- (Mechanical) Disassemble seed disc by removing wing nuts.  
(EdgeVac) Lay hopper on its right side. Rotate seed meter vacuum cover clockwise to align keyhole slots with bolt heads. Lift off cover. Remove seed disc.
- Empty Meter.
- Thoroughly inspect brushes in meter to ensure all seed is removed.
- Replace seed disc. (Mechanical) Install wing nuts. (EdgeVac) Install Vacuum cover.

**ADDITIVES**

The use of graphite is recommended to promote seed flow, provide lubrication for the seed meter and to help dissipate static charge buildup. Among the available dry seed lubricants graphite is the most effective and easiest to use and it requires no mechanical agitation

**CONVENTIONAL HOPPERS**

Mix one tablespoon of **powdered graphite** with seed each time hoppers are filled. Regular graphite use prolongs life of the seed meter components, improves seed spacing, and may reduce buildup of seed treatments.

**NOTE: DO NOT apply graphite only in center of hopper. It will filter too quickly through the seed and not distribute as evenly as desired.**

Apply graphite around outer perimeter of hopper.

**NOTE: Additional graphite may be required to retard buildup of seed treatments on meter components. More frequent cleaning of monitor seed tubes may be necessary due to use of additional graphite.**

**Talc seed lubricant** may be used as a drying agent in addition to graphite lubrication. The drying agent may improve seed release and/or **to retard buildup of seed treatments on meter components.**

1. Fill hopper 1/2 full of seed, add 1/4 cup (conventional) of talc and **mix thoroughly.**
2. Finish filling hopper, add another 1/4 cup (conventional) of talc and **mix thoroughly.**
3. Adjust rate of talc use as needed so all seeds are coated, while avoiding a buildup of talc in bottom of hopper.

Humid conditions and/or small sized seeds with extra seed treatment may require additional talc to maintain meter performance.

**NOTE: Liquid seed treatments or inoculants may create buildup on the seed disc or brushes. Check frequently for proper population and/or seed delivery when using any liquid seed treatment.**

Completely mix all treatments with seed following manufacturers' recommendations. Seed treatment dumped on top of seed after hopper is filled may not mix properly and cause seed bridging, reducing population or stopping meter from planting.

**DUAL GAUGE WHEELS**

Dual gauge wheels are used to provide added width for additional row unit flotation in light sandy soil.

In some applications such as narrow row widths (less than 36") or where clearance is a problem, the added width of the dual gauge wheel may prevent its use.

<b>Lubricant Application Rate</b>	
<b>Graphite</b>	
Conventional Hoppers	1 Tbs./Hopper Fill
<b>Talc</b>	
Conventional Hoppers	1/4 C.*
*Double amount of talc for sunflowers.	



**Adding graphite to conventional hopper**

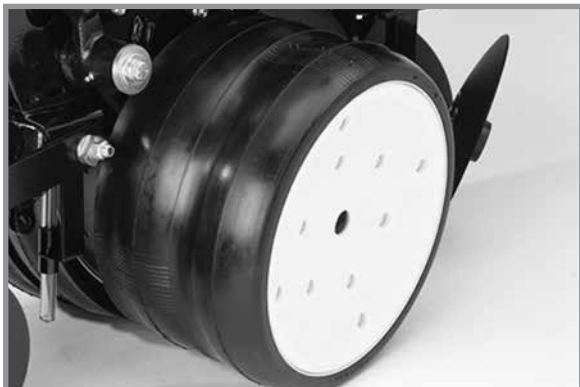

## FRAME MOUNTED COULTER (PULL ROW)

Frame mounted coulters with 1" bubbled, 1" fluted (8 flutes) or ¾" fluted (13 flutes) blades are used on pull row units only.

Springs provide down pressure on coulters for maximum penetration while exerting less shock load on row unit.

Initial coulters blade location is in top hole. Relocate blade to one of lower two holes (1" increments) as wear occurs or for deeper blade operation.

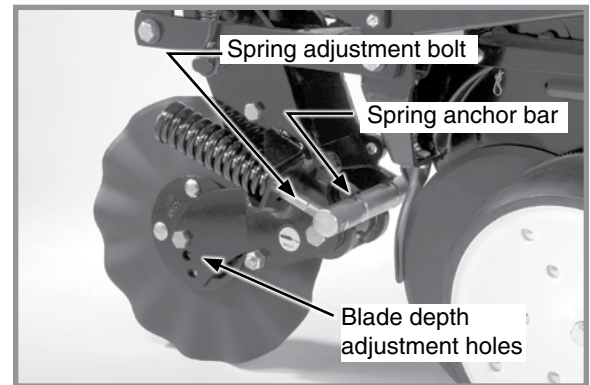

Frame mounted coulters adjustment

## DOWN PRESSURE ADJUSTMENT

### NOTICE

**Excessive down pressure can damage coulters components when coulters strikes an obstacle. Do not set down pressure higher than needed for consistent soil penetration.**

Raise planter. Turn spring adjustment bolts clockwise to increase or counterclockwise to decrease down pressure. Set both springs to specification shown in following table:

Frame Mounted Coulters Spring Downpressure Settings		
End flush with spring anchor bar	Extended ½" through spring anchor bar	All threads used
275 lb (124.7 kg)	400 lb (181.4 kg)	500 lb (226.8 kg)

## RESIDUE WHEELS (FRAME MOUNTED COULTER)

### NOTICE

**Tined wheel forward mounting positions cannot be used on four rows behind axle due to inadequate clearance.**

Residue wheels attach to frame mounted coulters with two cap screws and sleeves allowing the unit to free-float. A 2-position spindle bolt mounting positions wheels interlocked or staggered. Depth adjustment is made with a spring-loaded cam and pin with 11 positions in ¼" increments. A high point on the cam allows wheels to be locked up.

A weed guard on the inboard side of each wheel helps prevent weed wrap which can cause premature bearing failure.

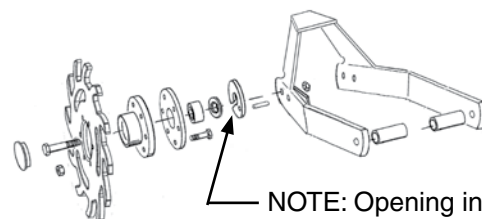

**ROW UNIT MOUNTED DISC FURROWER (PULL ROW)**

Disc furrowers are used to clear crop residue, dirt clods, and dry soil from in front of row units for a clean and smooth seed bed. The disc furrower may be equipped with 12" solid blades or 12" notched blades. Notched blades are for heavier residue conditions and cut crop residue and move it aside to prevent plugging or pushing.

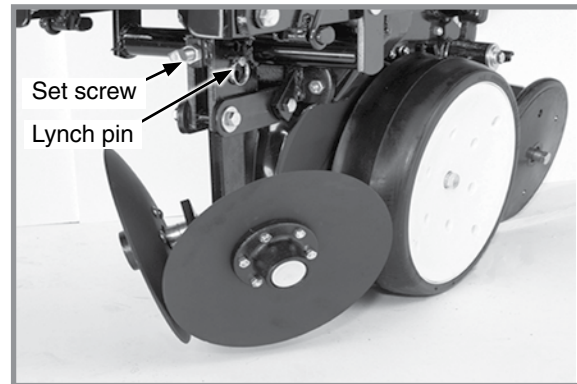
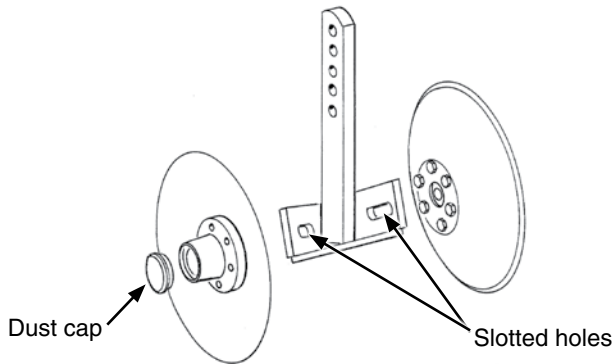

**Disc furrower adjustment**

Vertical adjustment can be made in 1/3" increments. Remove lynch pin in vertical support arm and move arm up or down. Reinstall lynch pin. Finer adjustment can be made by removing lynch pin and using 5/8" x 2 1/4" set screw to clamp support arm in position. Slotted holes in support arm allow front to rear disc blade adjustment. Blades can be adjusted so front edges meet or cutting edge of one blade overlaps edge of other blade.

**NOTE: Dust cap must be removed to make adjustments.**

**ROW UNIT MOUNTED BED LEVELER (PULL ROW)**

**NOTE: Row unit mounted bed leveler is not compatible with row spacings less than 36".**

Vertical adjustment can be made in 1/3" increments. Remove lynch pin in vertical support arm and move arm up or down. Reinstall lynch pin. Finer adjustment can be made by removing lynch pin and using 5/8" x 2 1/4" set screw to clamp support arm in position.

Slotted holes in support arm allow blade adjustment. Blades can be tilted up or down.

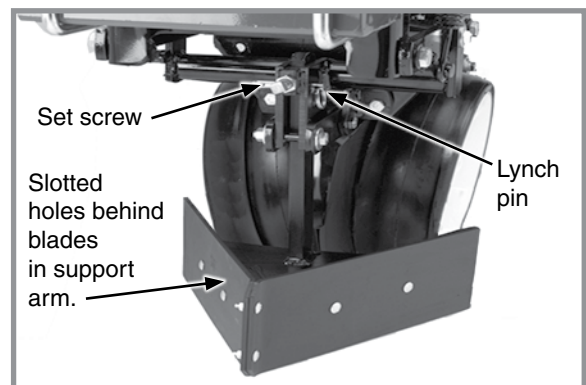

**Bed leveler adjustment**

## ROW UNIT MOUNTED RESIDUE WHEEL

Row unit mounted residue wheels are used on pull and push row units.

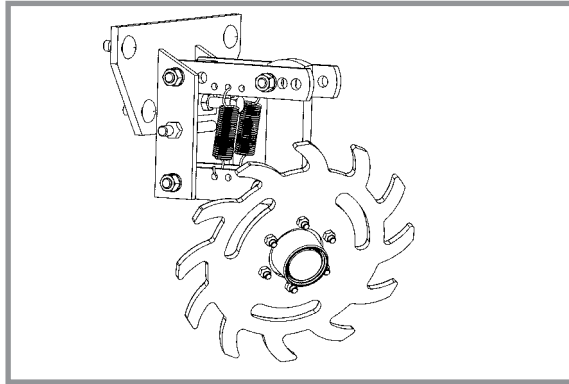

**Row Unit Mounted Residue Wheel**

Two adjustable springs on each residue wheel parallel links provide down force adjustment. Position 1 provides minimum down pressure and position 3 maximum down pressure.

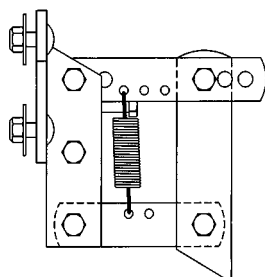

**Position 1 (Least)**

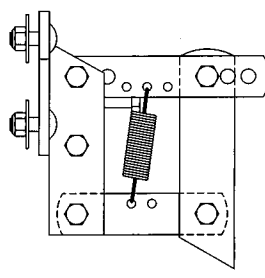

**Position 2**

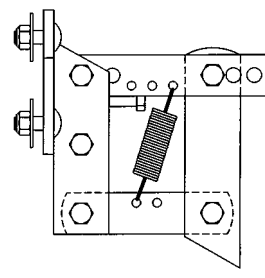

**Position 3 (Most)**

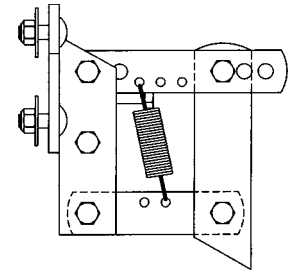

**Additional uplift or float**

Raise row unit and reposition springs to adjust down pressure.

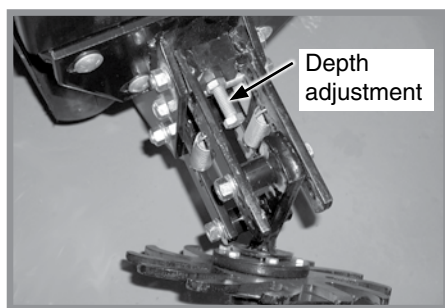

**Wheel depth adjustment**

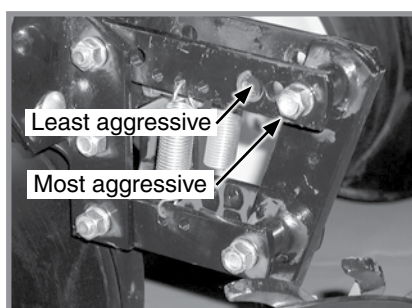

**Wheel angle adjustment**

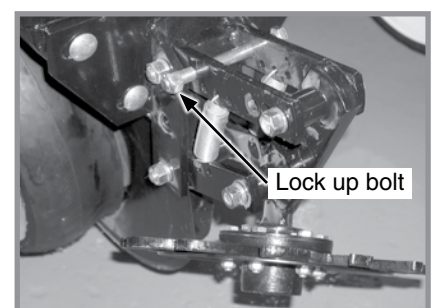

**Wheel lock up**

A full threaded bolt and jam nut located on the upper link sets maximum depth for loose soil conditions. Initial setting is 1 $\frac{3}{4}$ " above row unit double disc opener depth.

Three holes in upper link adjust wheel angle. With wheel mount in most vertical position, using the rear hole in the upper link, the residue wheel is most aggressive. Moving wheel mount to a forward hole reduces aggressiveness of residue wheel for use in mulch till applications where soil is loose.

To lock residue wheel up, remove 1/2" x 5" lockup bolt, raise residue wheel and install bolt.

## ROW UNIT MOUNTED NO TILL COULTER

Row unit mounted no till coulters with 1" bubbled, 1" fluted (8 flutes) or 3/4" fluted (13 flutes) blades may be used on pull row units and push row units (3/4" fluted shown). Four quick adjustable down force springs are required per row when using row unit mounted no till coulters. See "Quick Adjustable Down Force Springs Options".

Align coulters to row unit double disc openers. Adjust by loosening four attaching bolts, moving coulters, and tightening four attaching bolts. Coulters can be adjusted to one of four 1/2" incremental settings in the forked arm. Initial location is the top hole.

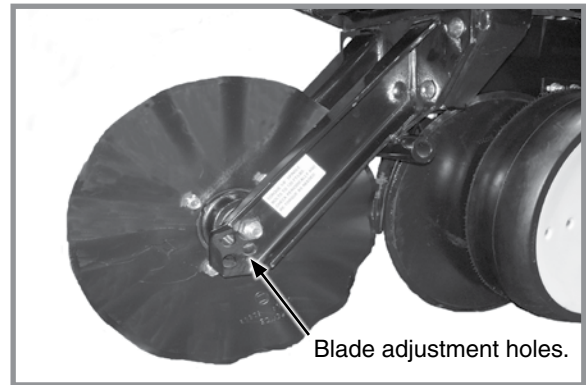

**Row Unit Mounted No Till Coulters**

Move blade as it wears to one of the three lower holes to maintain coulters at or slightly above opener discs as needed. Adjust coulters below depth of double disc opener blades in very hard soil conditions such as compacted wheel tracks to improve opener penetration and cutting of surface residue.

Check operating depth by setting planter down on a level concrete floor and checking relationship between coulters and row unit opener blade. Make sure planter is level and coulters are square with planter frame and aligned with row unit disc opener.

**NOTE: Torque 5/8" spindle hardware to 120 ft-lb (162.7 N-m).**

## COULTER MOUNTED RESIDUE WHEELS

Coulters mounted residue wheels are designed for use on pull row units and push row units. Row unit extension brackets are required on the four center pull row units if the planter is equipped with coulters mounted residue wheels.

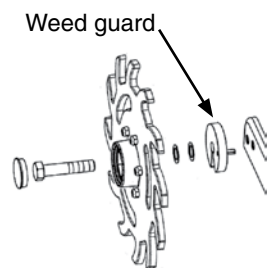

**NOTE: Opening in weed guard must face down.**



**Coulters mounted residue wheels**

Residue wheels attach to row unit mounted coulters with two cap screws and sleeves allowing unit to free-float. A 2-position spindle bolt mounting positions wheels interlocked or staggered. Depth adjustment is made with a spring-loaded cam and pin with 11 positions in 1/4" increments. A high point on the cam allows wheels to be locked up.

A weed guard on the inboard side of each wheel helps prevent weed wrap which can cause premature bearing failure.

## GRANULAR CHEMICAL HOPPER AND DRIVE

### WARNING

**Agricultural chemicals can cause death or serious injury to persons, animals, and plants or seriously damage soil, equipment, or property. Read and follow all chemical and equipment manufacturers labels and instructions.**

The granular chemical hopper has a 1.4 cubic feet capacity.

Make sure no foreign objects get into hopper when it is being filled. Replace hopper lids after filling to prevent accumulation of dirt and moisture.

A metering gate on bottom of hopper regulates the application rate. See “Dry Insecticide and Dry Herbicide Application Rate Charts” in this manual. Calibrate using chemical manufacturers’ instructions.



**Granular chemical hopper**

Granular chemical clutch drive coupler and meter shaft can be disengaged and engaged by turning throwout knob at rear of hopper support panel.

Rotate knob  $\frac{1}{4}$  turn counterclockwise to disengage and  $\frac{1}{4}$  turn clockwise to engage.

Slotted holes in hopper support panel and clutch housing allow for alignment adjustment between clutch drive coupler and meter shaft.

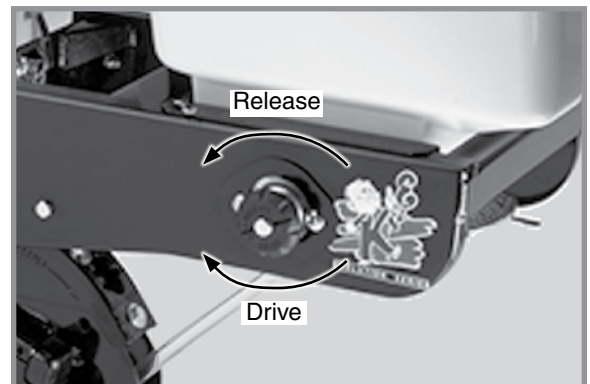

**Granular chemical drive release**

## SPRING TOOTH INCORPORATOR

Spring tooth incorporator smooths soil behind row unit and incorporates granular chemicals.

Adjust two mounting chains on each spring tooth incorporator so there is approximately  $\frac{1}{8}$ " slack in chain when unit is lowered to planting position.

**NOTE: Spring tooth incorporator is not compatible with covering discs/single press wheel option.**

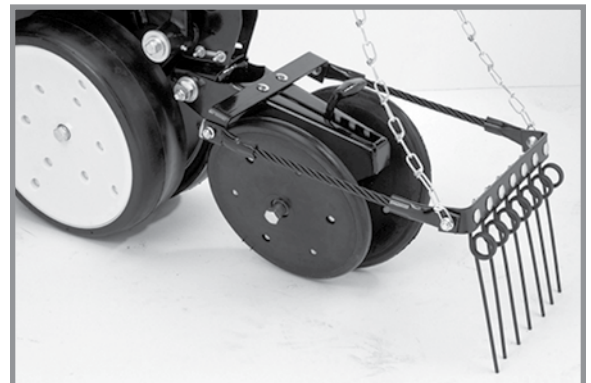

**Spring tooth incorporator**

**GRANULAR CHEMICAL BANDING OPTIONS**

Granular chemical banding options allow 4½" slope-compensating banding, straight drop in-furrow placement or 14" rear banding.

**NOTE: Granular chemical rear bander is not compatible with covering discs/single press wheel option.**

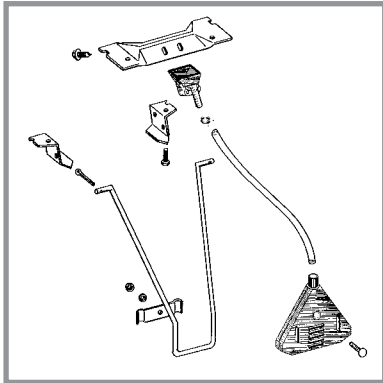

14" rear banding

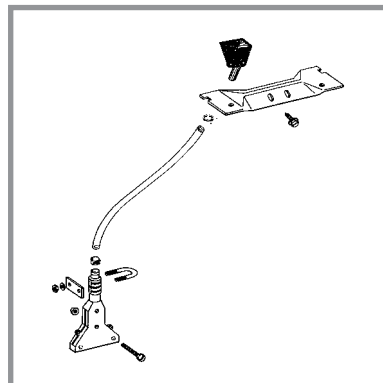

4½" slope-compensating bander

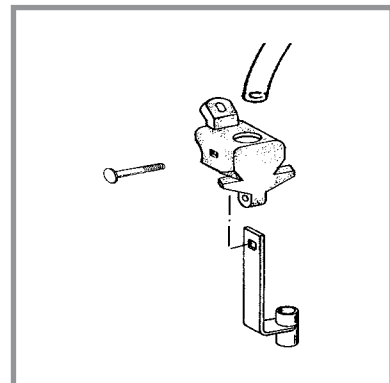

Straight drop in-furrow placement

**GRANULAR CHEMICAL BANDER SHIELD**

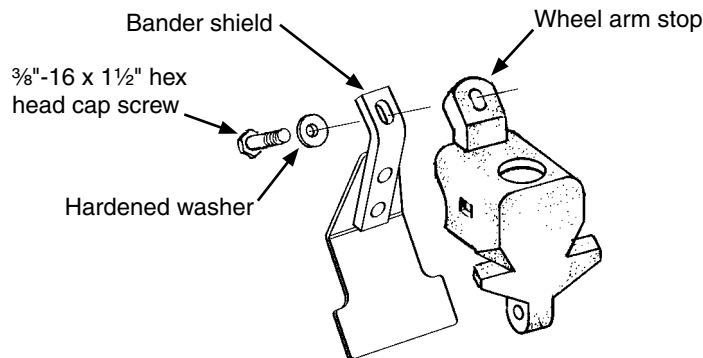

Optional granular chemical bander shield is installed on underside of wheel arm stop to shield crop residue from lodging in granular chemical bander.



## GENERAL PLANTING RATE INFORMATION

These planting rate charts apply to Kinze Model 3140 planters.

### NOTICE

**Sprocket combinations in these charts are for average conditions. Changes in sprocket combinations may be required for desired planting population. ALWAYS MAKE FIELD CHECKS TO BE SURE YOU ARE PLANTING AT DESIRED RATE.**

### NOTICE

**Seed additives added in the hopper may affect finger pickup seed meter performance and accelerate wear.**

**NOTE: Seed size and shape may affect planting rate.**

**NOTE: Not all row spacings listed apply to all size planters.**

**NOTE: Speeds above 5.5 MPH (8.8 KPH) can adversely affect seed spacing.**

## MECHANICAL

### Finger Pickup Corn Meter

Larger grades generally plant more accurately at the high end of the ground speed range than smaller grades. Higher than optimum speeds may result in population rate increase or higher incidence of doubles, particularly with small seed. Medium round corn seed is most desirable for planting accuracy at optimum speed.

### Finger Pickup Oil Sunflower Meter

Larger grades generally plant more accurately at the high end of the ground speed range than smaller grades. Higher than optimum speeds may result in population rate increase or higher incidence of doubles, particularly with small seed. No. 3 and/or No. 4 size oil sunflower seeds are recommended for use in finger pickup seed meters equipped with oil sunflower fingers. No. 1 and/or No. 2 size confectionery sunflower seeds are recommended for use in finger pickup seed meters equipped with corn fingers.

### Brush-Type Seed Meter (Soybean, Milo/Grain Sorghum, Acid-Delinted Cotton)

Rate charts are given in seeds per acre as well as seed spacing in inches rounded to nearest tenth of an inch. Because of large range in seed size, pounds per acre is not a suggested method of selecting transmission settings. Smaller size seed pounds per acre may be below what was expected and large seed pounds per acre may appear above expectations. To determine pounds per acre, use formula given in "Determining Pounds Per Acre (Brush-Type Seed Meter)" in "Check Seed Population" in Machine Operation section of this manual.

**NOTE: Planting speed can affect actual seeding rate. Make a field check and adjust transmission setting to obtain desired seed drop.**

**NOTE: Seed population per acre with 15" rows double rate for 30" rows, as well as 18" rows versus 36" rows and 19" rows versus 38" rows, at listed sprocket combination. See following pages.**

**NOTE: Half Rate (2 to 1) Drive Reduction Package may be required to obtain desired population and seed spacing when planting 15" row soybeans or other crops. Half Rate Drive with brush-type seed meters reduces planter transmission speed. Seeding rate will be approximately 50% of chart reading when using Half Rate (2 To 1) Drive Reduction Package.**

**EXAMPLE: 30" row spacing using 60 cell seed discs in brush-type seed meters.  
 $80,928 \div 2 = 40,464$  Population (2.6" Seed Spacing x 2 = 5.2" Seed Spacing)**

## EDGEVAC

**NOTE: 22, 28, and 44 tooth drive sprockets are NOT applicable to all rate charts. Check chart titles to ensure proper rate chart is selected. 22 tooth sprocket requires 114 pitch No. 40 chain. 28 tooth sprocket requires 118 pitch No. 40 chain. 44 tooth sprocket requires 126 pitch No. 40 chain.**

**NOTE: DO NOT USE 44 tooth sprockets (60 cell soybean discs) with Dry Fertilizer Package or Liquid Fertilizer Package.**

**PLANTING RATES FOR FINGER PICKUP SEED METERS (STANDARD DRIVE)  
APPROXIMATE SEEDS/ACRE FOR VARIOUS ROW WIDTHS**

30" Rows	36" Rows	38" Rows	40" Rows	Transmission Sprocket		Recomm. Speed Range (MPH)	Average Seed Spacing in Inches
				Drive	Driven		
16,186	13,488	12,778	12,139	17	28	4 to 6	12.9
16,785	13,988	13,251	12,589	17	27	4 to 6	12.5
17,431	14,526	13,761	13,073	17	26	4 to 6	12.0
18,090	15,075	14,281	13,567	19	28	4 to 6	11.6
18,128	15,107	14,312	13,596	17	25	4 to 6	11.5
18,760	15,633	14,810	14,070	19	27	4 to 6	11.1
18,883	15,736	14,908	14,162	17	24	4 to 6	11.1
19,481	16,234	15,380	14,611	19	26	4 to 6	10.7
19,704	16,420	15,556	14,778	17	23	4 to 6	10.6
20,261	16,884	15,995	15,195	19	25	4 to 6	10.3
21,104	17,587	16,662	15,829	19	24	4 to 6	9.9
21,898	18,249	17,288	16,424	23	28	4 to 6	9.5
22,022	18,352	17,386	16,517	19	23	4 to 6	9.5
22,709	18,924	17,928	17,032	23	27	4 to 6	9.2
22,850	19,042	18,040	17,138	24	28	4 to 6	9.2
23,583	19,652	18,618	17,687	23	26	4 to 6	8.9
23,697	19,747	18,708	17,772	24	27	4 to 6	8.8
23,802	19,835	18,791	17,852	25	28	4 to 6	8.8
23,853	19,877	18,831	17,889	17	19	4 to 6	8.8
24,526	20,438	19,363	18,395	23	25	4 to 6	8.5
24,608	20,507	19,427	18,456	24	26	4 to 6	8.5
24,684	20,570	19,487	18,513	25	27	4 to 6	8.5
24,755	20,629	19,543	18,566	26	28	4 to 6	8.4
25,548	21,290	20,169	19,161	23	24	4 to 6	8.2
25,592	21,327	20,205	19,194	24	25	4 to 6	8.2
25,633	21,361	20,237	19,225	25	26	4 to 6	8.2
25,671	21,393	20,267	19,254	26	27	4 to 6	8.1
25,707	21,422	20,295	19,280	27	28	4 to 6	8.1
26,659	22,216	21,046	19,994	23	23	4 to 6	7.8
27,646	23,038	21,826	20,735	28	27	4 to 6	7.6
27,684	23,070	21,856	20,763	27	26	4 to 6	7.6
27,770	23,141	21,923	20,827	25	24	4 to 6	7.5
27,818	23,181	21,961	20,863	24	23	4 to 6	7.5
28,709	23,924	22,665	21,532	28	26	4 to 6	7.3
28,791	23,993	22,730	21,594	27	25	4 to 6	7.3
28,977	24,147	22,876	21,733	25	23	4 to 6	7.2
29,795	24,829	23,522	22,346	19	17	4 to 6	7.0
29,858	24,881	23,572	22,393	28	25	4 to 6	7.0
29,991	24,993	23,677	22,493	27	24	4 to 6	7.0
30,136	25,113	23,792	22,602	26	23	4 to 6	7.0
31,102	25,918	24,554	23,326	28	24	3 to 6	6.7
31,295	26,079	24,707	23,471	27	23	3 to 6	6.7
32,271	26,893	25,477	24,203	23	19	3 to 5.5	6.5
32,454	27,045	25,622	24,341	28	23	3 to 5.5	6.5
33,674	28,062	26,585	25,256	24	19	3 to 5.5	6.2
35,077	29,231	27,693	26,308	25	19	3 to 5	6.0
36,068	30,056	28,474	27,051	23	17	2 to 5	5.8
36,480	30,400	28,800	27,360	26	19	3 to 5	5.7
37,636	31,363	29,713	28,227	24	17	3 to 5	5.6
37,883	31,570	29,908	28,413	27	19	3 to 5	5.5
39,204	32,670	30,951	29,403	25	17	3 to 4.5	5.3
39,287	32,739	31,016	29,465	28	19	3 to 4.5	5.3
40,772	33,977	32,189	30,579	26	17	3 to 4.5	5.1
42,340	35,284	33,427	31,755	27	17	3 to 4.5	4.9
43,908	36,590	34,665	32,931	28	17	3 to 4.5	4.8

**NOTE: See "General Planting Rate Information" and "Checking Seed Population" pages for additional information. Always check seed population in the field to ensure planting rates are correct.**

**PLANTING RATES FOR BRUSH-TYPE SEED METERS (STANDARD DRIVE)  
APPROXIMATE SEEDS/ACRE FOR VARIOUS ROW WIDTHS**

Transmission Sprockets		60 Cell Soybean or High-Rate Milo/Grain Sorghum				Average Seed Spacing in Inches	48 Cell Specialty Soybean or High-Rate Acid-Delinted Cotton				Average Seed Spacing in Inches	Speed Range (MPH)
Drive	Driven	30" Rows	36" Rows	38" Rows	40" Rows		30" Rows	36" Rows	38" Rows	40" Rows		
17	28	80,928	67,440	63,891	60,696	2.6	64,742	53,952	51,113	48,557	3.2	2 to 8
17	27	83,926	69,938	66,257	62,944	2.5	67,141	55,950	53,006	50,355	3.1	2 to 8
17	26	87,154	72,628	68,805	65,365	2.4	69,723	58,102	55,044	52,292	3.0	2 to 8
19	28	90,449	75,374	71,407	67,837	2.3	72,359	60,299	57,126	54,270	2.9	2 to 8
19	27	93,799	78,166	74,052	70,349	2.2	75,039	62,533	59,242	56,279	2.8	2 to 8
17	24	94,416	78,680	74,539	70,812	2.2	75,533	62,944	59,631	56,650	2.8	2 to 8
17	23	98,521	82,101	77,780	73,891	2.1	78,817	65,681	62,224	59,113	2.7	2 to 8
19	25	101,303	84,419	79,976	75,977	2.1	81,042	67,535	63,981	60,782	2.6	2 to 8
19	24	105,524	87,937	83,309	79,143	2.0	84,419	70,350	66,647	63,314	2.5	2 to 8
23	28	109,491	91,243	86,440	82,118	1.9	87,593	72,994	69,152	65,694	2.4	2 to 8
19	23	110,112	91,760	86,931	82,584	1.9	88,090	73,408	69,545	66,067	2.4	2 to 8
24	28	114,252	95,210	90,199	85,689	1.8	91,402	76,168	72,159	68,551	2.3	2 to 8
24	27	118,483	98,736	93,539	88,862	1.8	94,786	78,989	74,831	71,090	2.2	2 to 8
17	19	119,263	99,386	94,155	89,447	1.8	95,410	79,509	75,324	71,558	2.2	2 to 8
24	26	123,040	102,534	97,137	92,280	1.7	98,432	82,027	77,710	73,824	2.1	2 to 8
26	28	123,773	103,144	97,715	92,829	1.7	99,018	82,515	78,172	74,263	2.1	2 to 8
24	25	127,962	106,635	101,023	95,971	1.6	102,370	85,308	80,818	76,777	2.0	2 to 8
26	27	128,357	106,964	101,334	96,268	1.6	102,686	85,571	81,067	77,014	2.0	2 to 8
23	23	133,294	111,078	105,232	99,970	1.6	106,635	88,862	84,186	79,976	2.0	2 to 8
27	26	138,420	115,350	109,279	103,815	1.5	110,736	92,280	87,423	83,052	1.9	2 to 8
24	23	139,089	115,907	109,807	104,317	1.5	111,271	92,726	87,846	83,454	1.9	2 to 8
25	23	144,884	120,737	114,382	108,663	1.4	115,907	96,590	91,506	86,930	1.8	2 to 8
19	17	148,975	124,146	117,612	111,731	1.4	119,180	99,317	94,090	89,385	1.8	2 to 8
27	24	149,955	124,963	118,386	112,466	1.4	119,964	99,970	94,709	89,973	1.7	2 to 8
28	24	155,509	129,591	122,770	116,632	1.3	124,407	103,673	98,216	93,306	1.7	2 to 8
23	19	161,355	134,463	127,386	121,017	1.3	129,084	107,570	101,909	96,814	1.6	2 to 8
28	23	162,270	135,225	128,108	121,703	1.3	129,816	108,180	102,483	97,362	1.6	2 to 8
24	19	168,371	140,309	132,924	126,278	1.2	134,696	112,247	106,339	101,022	1.6	2 to 8
25	19	175,386	146,155	138,463	131,540	1.2	140,309	116,924	110,770	105,232	1.5	2 to 8
23	17	180,338	150,282	142,372	135,254	1.2	144,270	120,226	113,898	108,203	1.5	2 to 8
26	19	182,402	152,001	144,001	136,801	1.1	145,922	121,601	115,201	109,441	1.4	2 to 7
27	19	189,417	157,848	148,540	142,063	1.1	151,534	126,278	118,832	113,650	1.4	2 to 7
28	19	196,433	163,694	155,078	147,325	1.1	157,146	130,955	124,062	117,860	1.3	2 to 7
26	17	203,861	169,884	160,943	152,896	1.0	163,089	135,907	128,754	122,317	1.3	2 to 7
27	17	211,702	176,418	167,133	158,776	0.9	169,362	141,134	133,706	127,021	1.2	2 to 7
28	17	219,542	182,952	173,323	164,657	0.9	175,634	146,362	138,658	131,726	1.2	2 to 7

**NOTE: See "General Planting Rate Information" and "Checking Seed Population" pages for additional information.**

**NOTE: When using the Half Rate (2 to 1) Drive Reduction Package, rates will be approximately 50% of given numbers.**

**NOTE: Always check seed population in the field to ensure planting rates are correct.**

**PLANTING RATES FOR BRUSH-TYPE SEED METERS (STANDARD DRIVE)  
APPROXIMATE SEEDS/ACRE FOR VARIOUS ROW WIDTHS**

Transmission Sprockets		36 Cell Acid-Delinted Large Cotton				Average Seed Spacing In Inches	30 Cell Milo/Grain Sorghum Or Acid-Delinted Cotton				Average Seed Spacing In Inches	Speed Range (MPH)
Drive	Driven	30" Rows	36" Rows	38" Rows	40" Rows		30" Rows	36" Rows	38" Rows	40" Rows		
17	28	48,557	40,464	38,335	36,418	4.3	40,464	33,720	31,945	30,348	5.2	2 to 8
17	27	50,356	41,963	39,754	37,766	4.2	41,963	34,969	33,129	31,472	5.0	2 to 8
17	26	52,292	43,577	41,283	39,219	4.0	43,577	36,314	34,403	32,683	4.8	2 to 8
19	28	54,269	45,224	42,844	40,702	3.9	45,225	37,687	35,704	33,918	4.6	2 to 8
19	27	56,279	46,900	44,431	42,209	3.7	46,900	39,083	37,026	35,175	4.5	2 to 8
17	24	56,650	47,208	44,723	42,487	3.7	47,208	39,340	37,270	35,406	4.4	2 to 8
17	23	59,113	49,261	46,668	44,335	3.5	49,261	41,051	38,890	36,946	4.2	2 to 8
19	25	60,782	50,651	47,986	45,586	3.5	50,652	42,210	39,988	37,989	4.1	2 to 8
19	24	63,314	52,762	49,985	47,486	3.3	52,762	43,968	41,654	39,572	4.0	2 to 8
23	28	65,695	54,746	51,864	49,271	3.2	54,746	45,621	43,220	41,059	3.8	2 to 8
19	23	66,067	55,056	52,159	49,550	3.2	55,056	45,880	43,465	41,292	3.8	2 to 8
24	28	68,551	57,126	54,119	51,413	3.0	57,126	47,605	45,099	42,844	3.7	2 to 8
24	27	71,090	59,242	56,123	53,317	2.9	59,242	49,368	46,770	44,431	3.5	2 to 8
17	19	71,558	59,632	56,493	53,668	2.9	59,631	49,693	47,077	44,724	3.5	2 to 8
24	26	73,824	61,520	58,282	55,368	2.8	61,520	51,267	48,569	46,140	3.4	2 to 8
26	28	74,264	61,886	58,629	55,697	2.8	61,886	51,572	48,858	46,415	3.4	2 to 8
24	25	76,772	63,981	60,614	57,583	2.7	63,981	53,317	50,511	47,986	3.3	2 to 8
26	27	77,014	64,178	60,800	57,761	2.7	64,178	53,482	50,667	48,134	3.3	2 to 8
23	23	79,976	66,647	63,139	59,982	2.6	66,647	55,539	52,616	49,985	3.1	2 to 8
27	26	83,052	69,210	65,567	62,289	2.5	69,210	57,675	54,640	51,908	3.0	2 to 8
24	23	83,453	69,544	65,884	62,590	2.5	69,544	57,954	54,904	52,158	3.0	2 to 8
25	23	86,930	72,442	68,629	65,198	2.4	72,442	60,368	57,191	54,332	2.9	2 to 8
19	17	89,385	74,488	70,567	67,039	2.3	74,488	62,073	58,809	55,866	2.8	2 to 8
27	24	89,973	74,978	71,032	67,480	2.3	74,978	62,481	59,193	56,233	2.8	2 to 8
28	24	93,305	77,755	73,662	69,979	2.2	77,755	64,796	61,385	58,316	2.7	2 to 8
23	19	96,813	80,678	76,432	72,610	2.2	80,678	67,231	63,693	60,508	2.6	2 to 8
28	23	97,362	81,135	76,864	73,022	2.1	81,135	67,613	64,054	60,851	2.6	2 to 8
24	19	101,023	84,185	79,754	75,767	2.1	84,185	70,155	66,462	63,139	2.5	2 to 8
25	19	105,232	87,693	83,078	78,924	2.0	87,693	73,078	69,231	65,770	2.4	2 to 8
23	17	108,233	90,169	85,423	81,152	1.9	90,169	75,141	71,186	67,627	2.3	2 to 8
26	19	109,441	91,201	86,401	82,081	1.9	91,201	76,001	72,001	68,401	2.3	2 to 7
27	19	113,650	94,709	89,124	85,238	1.8	94,709	78,924	74,770	71,031	2.2	2 to 7
28	19	117,860	98,216	93,047	88,395	1.8	98,216	81,847	77,539	73,662	2.1	2 to 7
26	17	122,317	101,930	96,566	91,738	1.7	101,930	84,942	80,471	76,448	2.1	2 to 7
27	17	127,021	105,851	100,280	95,266	1.6	105,851	88,209	83,566	79,388	2.0	2 to 7
28	17	131,725	109,771	103,994	98,794	1.6	109,771	91,476	86,661	82,328	1.9	2 to 7

**NOTE: See "General Planting Rate Information" and "Checking Seed Population" pages for additional information.**

**NOTE: When using the Half Rate (2 to 1) Drive Reduction Package, rates will be approximately 50% of given numbers.**

**NOTE: Always check seed population in the field to ensure planting rates are correct.**

**PLANTING RATES FOR BRUSH-TYPE SEED METERS (STANDARD DRIVE)  
APPROXIMATE HILLS/ACRE FOR VARIOUS ROW WIDTHS**

Due to variations in cotton seed size, meters equipped with 12 cell acid-delinted hill-drop cotton discs will plant from 3 to 6 seeds per cell. Select proper disc for seed size range to be planted.

To determine planter transmission setting, determine desired hill spacing and select the transmission ratio closest to the hill spacing in inches on the chart. To decrease population increase spacing. To increase population decrease spacing.

To determine population per acre, determine average seeds per hill and hills per acre by doing a field check. Measure  $\frac{1}{1000}$  of an acre ( $\frac{1}{1000}$  acre = Length of row 17' 5" for 30" row widths, 13' 10" for 38" row widths and 13' 1" for 40" row widths). Multiply average seeds per hill by hills per acre. EXAMPLE: 4 seeds per hill x (13 hills x 1000) = 52,000

Transmission Sprockets Drive Driven		NUMBER OF HILLS PER ACRE 12 Cell Hill-Drop Cotton, Acid-Delinted				Average Hill Spacing in Inches	Speed Range (MPH)
		30" Rows	36" Rows	38" Rows	40" Rows		
17	28	16,186	13,488	12,778	12,139	12.9	2 to 8
17	27	16,785	13,988	13,251	12,588	12.5	2 to 8
17	26	17,431	14,526	13,761	13,073	12.0	2 to 8
19	28	18,090	15,075	14,281	13,568	11.6	2 to 8
19	27	18,760	15,633	14,810	14,070	11.1	2 to 8
17	24	18,883	15,736	14,908	14,163	11.1	2 to 8
17	23	19,704	16,420	15,556	14,778	10.6	2 to 8
19	25	20,261	16,884	15,995	15,196	10.3	2 to 8
19	24	21,105	17,587	16,662	15,829	9.9	2 to 8
23	28	21,898	18,249	17,288	16,424	9.5	2 to 8
19	23	22,022	18,352	17,386	16,517	9.5	2 to 8
24	28	22,850	19,042	18,040	17,138	9.2	2 to 8
24	27	23,697	19,747	18,708	17,773	8.8	2 to 8
17	19	23,853	19,877	18,831	17,890	8.8	2 to 8
24	26	24,608	20,507	19,427	18,456	8.5	2 to 8
26	28	24,755	20,629	19,543	18,566	8.4	2 to 8
24	25	25,592	21,327	20,205	19,194	8.2	2 to 8
26	27	25,671	21,393	20,267	19,254	8.1	2 to 8
23	23	26,659	22,216	21,046	19,994	7.8	2 to 8
27	26	27,684	23,070	21,856	20,763	7.6	2 to 8
24	23	27,818	23,181	21,961	20,864	7.5	2 to 8
25	23	28,977	24,147	22,876	21,733	7.2	2 to 8
19	17	29,795	24,829	23,522	22,346	7.0	2 to 8
27	24	29,991	24,993	23,677	22,493	7.0	2 to 8
28	24	31,102	25,918	24,554	23,327	6.7	2 to 8
23	19	32,271	26,893	25,477	24,204	6.5	2 to 8
28	23	32,454	27,045	25,622	24,408	6.5	2 to 8
24	19	33,674	28,062	26,585	25,256	6.2	2 to 8
25	19	35,077	29,231	27,693	26,308	6.0	2 to 8
23	17	36,068	30,056	28,474	27,051	5.8	2 to 8
26	19	36,480	30,400	28,800	27,360	5.7	2 to 7
27	19	37,883	31,570	29,908	28,413	5.5	2 to 7
28	19	39,287	32,739	31,016	29,465	5.3	2 to 7
26	17	40,772	33,977	32,189	30,579	5.1	2 to 7
27	17	42,340	35,284	33,427	31,755	4.9	2 to 7
28	17	43,908	36,590	34,665	32,932	4.8	2 to 7

NOTE: See "General Planting Rate Information" and "Checking Seed Population" pages for additional information.

NOTE: When using the Half Rate (2 to 1) Drive Reduction Package, rates will be approximately 50% of given numbers.

NOTE: Always check seed population in the field to ensure planting rates are correct.

**PLANTING RATES FOR (EDGEVAC) CORN/POPCORN 39 CELL DISC  
15 TOOTH CONTACT WHEEL DRIVE SPROCKET  
APPROXIMATE SEEDS/ACRE FOR VARIOUS ROW WIDTHS**

30" Rows	36" Rows	38" Rows	40" Rows	Transmission Sprockets		Recomm. Speed (MPH)	Average Spacing in Inches
				Drive	Driven		
23,207	19,339	18,321	17,405	15	28	4 to 6	9.0
24,066	20,055	19,000	18,050	15	27	4 to 6	8.7
24,992	20,827	19,730	18,744	15	26	4 to 6	8.4
25,992	21,660	20,520	19,494	15	25	4 to 6	8.0
26,301	21,918	20,764	19,726	17	28	4 to 6	7.9
27,075	22,562	21,375	20,306	15	24	4 to 6	7.7
27,275	22,729	21,533	20,456	17	27	4 to 6	7.7
28,252	23,543	22,304	21,189	15	23	4 to 6	7.4
28,324	23,603	22,361	21,243	17	26	4 to 6	7.4
29,395	24,496	23,207	22,046	19	28	4 to 6	7.1
29,457	24,548	23,256	22,093	17	25	4 to 6	7.1
30,484	25,403	24,066	22,863	19	27	4 to 6	6.9
30,685	25,570	24,225	23,013	17	24	4 to 6	6.8
31,656	26,380	24,992	23,742	19	26	4 to 6	6.6
32,019	26,682	25,278	24,014	17	23	4 to 6	6.5
32,923	27,436	25,992	24,692	19	25	4 to 6	6.4
34,199	28,500	27,000	25,650	15	19	4 to 6	6.1
34,294	28,579	27,075	25,721	19	24	4 to 6	6.1
35,584	29,653	28,092	26,688	23	28	4 to 6	5.9
35,786	29,821	28,252	26,839	19	23	4 to 6	5.8
36,902	30,751	29,133	27,676	23	27	4 to 6	5.7
37,131	30,942	29,314	27,848	24	28	4 to 6	5.6
38,223	31,852	30,176	28,667	15	17	4 to 6	5.5
38,506	32,088	30,400	28,880	24	27	4 to 6	5.4
38,759	32,300	30,600	29,070	17	19	4 to 6	5.4
39,854	33,211	31,464	29,890	23	25	4 to 6	5.2
40,225	33,521	31,757	30,169	26	28	4 to 6	5.2
41,514	34,595	32,775	31,136	23	24	4 to 6	5.0
41,587	34,655	32,832	31,190	24	25	4 to 6	5.0
41,772	34,810	32,978	31,329	27	28	4 to 6	5.0
43,319	36,099	34,199	32,490	23	23	4 to 6	4.8
44,924	37,436	35,466	33,693	28	27	4 to 6	4.7
44,985	37,488	35,515	33,739	27	26	4 to 6	4.6
45,203	37,669	35,686	33,902	24	23	4 to 6	4.6
46,652	38,876	36,830	34,989	28	26	4 to 6	4.5
46,785	38,987	36,935	35,089	27	25	4 to 6	4.5
47,086	39,239	37,173	35,315	25	23	4 to 6	4.4
48,416	40,346	38,223	36,312	19	17	4 to 6	4.3
48,734	40,612	38,474	36,551	27	24	4 to 6	4.3
48,970	40,808	38,660	36,727	26	23	4 to 6	4.3
50,539	42,116	39,899	37,904	28	24	4 to 6	4.1
50,853	42,378	40,147	38,140	27	23	4 to 6	4.1
52,439	43,699	41,399	39,329	23	19	4 to 6	4.0
52,737	43,947	41,634	39,552	28	23	4 to 6	4.0
54,719	45,599	43,199	41,039	24	19	4 to 6	3.8
56,999	47,499	44,999	42,749	25	19	4 to 6	3.7
58,609	48,840	46,270	43,956	23	17	4 to 6	3.6
59,279	49,399	46,799	44,459	26	19	4 to 6	3.5
61,157	50,964	48,282	45,868	24	17	4 to 6	3.4
61,559	51,299	48,599	46,169	27	19	4 to 6	3.4
63,705	53,087	50,293	47,779	25	17	4 to 6	3.3
63,839	53,199	50,399	47,879	28	19	4 to 6	3.3
66,253	55,211	52,305	49,690	26	17	4 to 6	3.2
66,423	55,352	52,439	49,817	23	15	4 to 6	3.1
68,801	57,334	54,317	51,601	27	17	4 to 6	3.0

**NOTE: See "General Planting Rate Information" and "Checking Seed Population" pages for additional information. Always check seed population in the field to ensure planting rates are correct.**

**PLANTING RATES FOR (EDGEVAC) CORN/POPCORN 39 CELL DISC  
19 TOOTH CONTACT WHEEL DRIVE SPROCKET  
APPROXIMATE SEEDS/ACRE FOR VARIOUS ROW WIDTHS**

30" Rows	36" Rows	38" Rows	40" Rows	Transmission Sprockets		Recomm. Speed (MPH)	Average Spacing In Inches
				Drive	Driven		
29,395	24,496	23,207	22,046	15	28	4 to 6	7.1
30,484	25,403	24,066	22,863	15	27	4 to 6	6.9
31,656	26,380	24,992	23,742	15	26	4 to 6	6.6
32,923	27,436	25,992	24,692	15	25	4 to 6	6.4
33,315	27,762	26,301	24,986	17	28	4 to 6	6.3
34,294	28,579	27,075	25,721	15	24	4 to 6	6.1
34,549	28,790	27,275	25,911	17	27	4 to 6	6.1
35,786	29,821	28,252	26,839	15	23	4 to 6	5.8
35,877	29,898	28,324	26,908	17	26	4 to 6	5.8
37,234	31,028	29,395	27,926	19	28	4 to 6	5.6
37,312	31,094	29,457	27,984	17	25	4 to 6	5.6
38,613	32,178	30,484	28,960	19	27	4 to 6	5.4
38,867	32,389	30,685	29,150	17	24	4 to 6	5.4
40,098	33,415	31,656	30,074	19	26	4 to 6	5.2
40,557	33,797	32,019	30,418	17	23	4 to 6	5.2
41,702	34,752	32,923	31,277	19	25	4 to 6	5.0
43,319	36,099	34,199	32,490	15	19	4 to 6	4.8
43,440	36,200	34,294	32,580	19	24	4 to 6	4.8
45,073	37,561	35,584	33,805	23	28	4 to 6	4.6
45,328	37,774	35,786	33,996	19	23	4 to 6	4.6
46,742	38,952	36,902	35,057	23	27	4 to 6	4.5
47,032	39,194	37,131	35,274	24	28	4 to 6	4.4
48,416	40,346	38,223	36,312	15	17	4 to 6	4.3
48,774	40,645	38,506	36,581	24	27	4 to 6	4.3
49,095	40,913	38,759	36,821	17	19	4 to 6	4.3
50,481	42,068	39,854	37,861	23	25	4 to 6	4.1
50,952	42,460	40,225	38,214	26	28	4 to 6	4.1
52,585	43,821	41,514	39,439	23	24	4 to 6	4.0
52,676	43,897	41,587	39,507	24	25	4 to 6	4.0
52,911	44,093	41,772	39,684	27	28	4 to 6	4.0
54,871	45,726	43,319	41,153	23	23	4 to 6	3.8
56,903	47,420	44,924	42,678	28	27	4 to 6	3.7
56,982	47,485	44,985	42,736	27	26	4 to 6	3.7
57,257	47,714	45,203	42,943	24	23	4 to 6	3.7
59,092	49,243	46,652	44,319	28	26	4 to 6	3.5
59,261	49,384	46,785	44,446	27	25	4 to 6	3.5
59,643	49,702	47,086	44,732	25	23	4 to 6	3.5
61,327	51,105	48,416	45,995	19	17	4 to 6	3.4
61,730	51,442	48,734	46,298	27	24	4 to 6	3.4
62,028	51,690	48,970	46,521	26	23	4 to 6	3.4
64,016	53,347	50,539	48,012	28	24	4 to 6	3.3
64,414	53,678	50,853	48,310	27	23	4 to 6	3.2
66,423	55,352	52,439	49,817	23	19	4 to 6	3.1
66,800	55,666	52,737	50,100	28	23	4 to 6	3.1
69,311	57,759	54,719	51,983	24	19	4 to 6	3.0
72,199	60,166	56,999	54,149	25	19	4 to 6	2.9
74,237	61,865	58,609	55,678	23	17	4 to 6	2.8
75,087	62,572	59,279	56,315	26	19	4 to 6	2.8
77,465	64,554	61,157	58,099	24	17	4 to 6	2.7
77,975	64,979	61,559	58,481	27	19	4 to 6	2.7
80,693	67,244	63,705	60,520	25	17	4 to 6	2.6
80,863	67,386	63,839	60,647	28	19	4 to 6	2.6
83,921	69,934	66,253	62,940	26	17	4 to 6	2.5
84,136	70,113	66,423	63,102	23	15	4 to 6	2.5
87,148	72,624	68,801	65,361	27	17	4 to 6	2.4

**NOTE: See "General Planting Rate Information" and "Checking Seed Population" pages for additional information. Always check seed population in the field to ensure planting rates are correct.**

**PLANTING RATES FOR (EDGEVAC) LOW-RATE CORN/POPCORN 24 CELL DISC  
15 TOOTH CONTACT WHEEL DRIVE SPROCKET  
APPROXIMATE SEEDS/ACRE FOR VARIOUS ROW WIDTHS**

30" Rows	36" Rows	38" Rows	40" Rows	Transmission Sprockets		Recomm. Speed (MPH)	Average Spacing in Inches
				Drive	Driven		
14,281	11,901	11,275	10,711	15	28	4 to 6	14.6
14,810	12,342	11,692	11,108	15	27	4 to 6	14.1
15,380	12,816	12,142	11,535	15	26	4 to 6	13.6
15,995	13,329	12,628	11,996	15	25	4 to 6	13.1
16,185	13,488	12,778	12,139	17	28	4 to 6	12.9
16,661	13,884	13,154	12,496	15	24	4 to 6	12.5
16,785	13,987	13,251	12,589	17	27	4 to 6	12.5
17,386	14,488	13,726	13,039	15	23	4 to 6	12.0
17,430	14,525	13,761	13,073	17	26	4 to 6	12.0
18,089	15,074	14,281	13,567	19	28	4 to 6	11.6
18,127	15,106	14,311	13,596	17	25	4 to 6	11.5
18,759	15,633	14,810	14,070	19	27	4 to 6	11.1
18,883	15,736	14,907	14,162	17	24	4 to 6	11.1
19,481	16,234	15,380	14,611	19	26	4 to 6	10.7
19,704	16,420	15,556	14,778	17	23	4 to 6	10.6
20,260	16,883	15,995	15,195	19	25	4 to 6	10.3
21,046	17,538	16,615	15,784	15	19	4 to 6	9.9
21,104	17,587	16,661	15,828	19	24	4 to 6	9.9
21,898	18,248	17,288	16,423	23	28	4 to 6	9.5
22,022	18,352	17,386	16,516	19	23	4 to 6	9.5
22,709	18,924	17,928	17,032	23	27	4 to 6	9.2
22,850	19,041	18,039	17,137	24	28	4 to 6	9.2
23,522	19,602	18,570	17,641	15	17	4 to 6	8.9
23,696	19,747	18,707	17,772	24	27	4 to 6	8.8
23,852	19,877	18,830	17,889	17	19	4 to 6	8.8
24,525	20,438	19,362	18,394	23	25	4 to 6	8.5
24,754	20,628	19,543	18,565	26	28	4 to 6	8.4
25,547	21,289	20,169	19,160	23	24	4 to 6	8.2
25,592	21,326	20,204	19,194	24	25	4 to 6	8.2
25,706	21,422	20,294	19,279	27	28	4 to 6	8.1
26,658	22,215	21,046	19,994	23	23	4 to 6	7.8
27,645	23,038	21,825	20,734	28	27	4 to 6	7.6
27,683	23,069	21,855	20,763	27	26	4 to 6	7.6
27,817	23,181	21,961	20,863	24	23	4 to 6	7.5
28,709	23,924	22,665	21,532	28	26	4 to 6	7.3
28,791	23,992	22,730	21,593	27	25	4 to 6	7.3
28,976	24,147	22,876	21,732	25	23	4 to 6	7.2
29,794	24,829	23,522	22,346	19	17	4 to 6	7.0
29,990	24,992	23,677	22,493	27	24	4 to 6	7.0
30,135	25,113	23,791	22,601	26	23	4 to 6	6.9
31,101	25,918	24,553	23,326	28	24	4 to 6	6.7
31,294	26,079	24,706	23,471	27	23	4 to 6	6.7
32,270	26,892	25,477	24,203	23	19	4 to 6	6.5
32,453	27,044	25,621	24,340	28	23	4 to 6	6.4
33,673	28,061	26,584	25,255	24	19	4 to 6	6.2
35,076	29,230	27,692	26,307	25	19	4 to 6	6.0
36,067	30,056	28,474	27,050	23	17	4 to 6	5.8
36,479	30,400	28,800	27,360	26	19	4 to 6	5.7
37,635	31,362	29,712	28,226	24	17	4 to 6	5.6
37,883	31,569	29,907	28,412	27	19	4 to 6	5.5
39,203	32,669	30,950	29,402	25	17	4 to 6	5.3
39,286	32,738	31,015	29,464	28	19	4 to 6	5.3
40,771	33,976	32,188	30,578	26	17	4 to 6	5.1
40,876	34,063	32,270	30,657	23	15	4 to 6	5.1
42,339	35,283	33,426	31,754	27	17	4 to 6	4.9

**NOTE: See "General Planting Rate Information" and "Checking Seed Population" pages for additional information. Always check seed population in the field to ensure planting rates are correct.**



**PLANTING RATES FOR (EDGEVAC) LOW-RATE CORN/POPCORN 24 CELL DISC  
19 TOOTH CONTACT WHEEL DRIVE SPROCKET  
APPROXIMATE HILLS/ACRE FOR VARIOUS ROW WIDTHS**

30" Rows	36" Rows	38" Rows	40" Rows	Transmission Sprockets		Recomm. Speed (MPH)	Average Spacing in Inches
				Drive	Driven		
18,089	15,074	14,281	13,567	15	28	4 to 6	11.6
18,759	15,633	14,810	14,070	15	27	4 to 6	11.1
19,481	16,234	15,380	14,611	15	26	4 to 6	10.7
20,260	16,883	15,995	15,195	15	25	4 to 6	10.3
20,501	17,084	16,185	15,376	17	28	4 to 6	10.2
21,104	17,587	16,661	15,828	15	24	4 to 6	9.9
21,261	17,717	16,785	15,945	17	27	4 to 6	9.8
22,022	18,352	17,386	16,516	15	23	4 to 6	9.5
22,078	18,399	17,430	16,559	17	26	4 to 6	9.5
22,913	19,094	18,089	17,185	19	28	4 to 6	9.1
22,961	19,135	18,127	17,221	17	25	4 to 6	9.1
23,762	19,802	18,759	17,821	19	27	4 to 6	8.8
23,918	19,932	18,883	17,939	17	24	4 to 6	8.7
24,676	20,563	19,481	18,507	19	26	4 to 6	8.5
24,958	20,798	19,704	18,719	17	23	4 to 6	8.4
25,663	21,386	20,260	19,247	19	25	4 to 6	8.1
26,658	22,215	21,046	19,994	15	19	4 to 6	7.8
26,732	22,277	21,104	20,049	19	24	4 to 6	7.8
27,737	23,114	21,898	20,803	23	28	4 to 6	7.5
27,894	23,245	22,022	20,921	19	23	4 to 6	7.5
28,764	23,970	22,709	21,573	23	27	4 to 6	7.3
28,943	24,119	22,850	21,707	24	28	4 to 6	7.2
29,794	24,829	23,522	22,346	15	17	4 to 6	7.0
30,015	25,012	23,696	22,511	24	27	4 to 6	7.0
30,212	25,177	23,852	22,659	17	19	4 to 6	6.9
31,066	25,888	24,525	23,299	23	25	4 to 6	6.7
31,355	26,129	24,754	23,516	26	28	4 to 6	6.7
32,360	26,967	25,547	24,270	23	24	4 to 6	6.5
32,416	27,013	25,592	24,312	24	25	4 to 6	6.5
32,561	27,134	25,706	24,421	27	28	4 to 6	6.4
33,767	28,139	26,658	25,325	23	23	4 to 6	6.2
35,017	29,181	27,645	26,263	28	27	4 to 6	6.0
35,066	29,221	27,683	26,299	27	26	4 to 6	6.0
35,235	29,362	27,817	26,426	24	23	4 to 6	5.9
36,364	30,304	28,709	27,273	28	26	4 to 6	5.7
36,468	30,390	28,791	27,351	27	25	4 to 6	5.7
36,703	30,586	28,976	27,527	25	23	4 to 6	5.7
37,739	31,450	29,794	28,305	19	17	4 to 6	5.5
37,988	31,656	29,990	28,491	27	24	4 to 6	5.5
38,171	31,809	30,135	28,628	26	23	4 to 6	5.5
39,395	32,829	31,101	29,546	28	24	4 to 6	5.3
39,639	33,033	31,294	29,730	27	23	4 to 6	5.3
40,876	34,063	32,270	30,657	23	19	4 to 6	5.1
41,107	34,256	32,453	30,831	28	23	4 to 6	5.1
42,653	35,544	33,673	31,990	24	19	4 to 6	4.9
44,430	37,025	35,076	33,323	25	19	4 to 6	4.7
45,685	38,070	36,067	34,263	23	17	4 to 6	4.6
46,207	38,506	36,479	34,655	26	19	4 to 6	4.5
47,671	39,726	37,635	35,753	24	17	4 to 6	4.4
47,985	39,987	37,883	35,988	27	19	4 to 6	4.4
49,657	41,381	39,203	37,243	25	17	4 to 6	4.2
49,762	41,468	39,286	37,321	28	19	4 to 6	4.2
51,643	43,036	40,771	38,733	26	17	4 to 6	4.0
51,776	43,147	40,876	38,832	23	15	4 to 6	4.0
53,630	44,691	42,339	40,222	27	17	4 to 6	3.9

**NOTE: See "General Planting Rate Information" and "Checking Seed Population" pages for additional information. Always check seed population in the field to ensure planting rates are correct.**

**PLANTING RATES FOR (EDGEVAC) SOYBEAN AND MILO/GRAIN SORGHUM 60 CELL DISCS**

**15 TOOTH CONTACT WHEEL DRIVE SPROCKET**

**APPROXIMATE SEEDS/ACRE FOR VARIOUS ROW WIDTHS**

30" Rows	36" Rows	38" Rows	40" Rows	Transmission Sprockets		Recomm. Speed (MPH)	Average Spacing in Inches
				Drive	Driven		
35,703	29,752	28,186	26,777	15	28	4 to 6	5.9
37,025	30,854	29,230	27,769	15	27	4 to 6	5.6
38,449	32,041	30,355	28,837	15	26	4 to 6	5.4
39,987	33,323	31,569	29,990	15	25	4 to 6	5.2
40,463	33,719	31,945	30,347	17	28	4 to 6	5.2
41,653	34,711	32,884	31,240	15	24	4 to 6	5.0
41,962	34,968	33,128	31,471	17	27	4 to 6	5.0
43,464	36,220	34,314	32,598	15	23	4 to 6	4.8
43,576	36,313	34,402	32,682	17	26	4 to 6	4.8
45,223	37,686	35,703	33,918	19	28	4 to 6	4.6
45,319	37,766	35,778	33,989	17	25	4 to 6	4.6
46,898	39,082	37,025	35,174	19	27	4 to 6	4.5
47,207	39,339	37,269	35,405	17	24	4 to 6	4.4
48,702	40,585	38,449	36,527	19	26	4 to 6	4.3
49,259	41,050	38,889	36,945	17	23	4 to 6	4.2
50,650	42,209	39,987	37,988	19	25	4 to 6	4.1
52,615	43,845	41,538	39,461	15	19	4 to 6	4.0
52,761	43,967	41,653	39,571	19	24	4 to 6	4.0
54,744	45,620	43,219	41,058	23	28	4 to 6	3.8
55,055	45,879	43,464	41,291	19	23	4 to 6	3.8
56,772	47,310	44,820	42,579	23	27	4 to 6	3.7
57,124	47,604	45,098	42,843	24	28	4 to 6	3.7
58,805	49,004	46,425	44,103	15	17	4 to 6	3.6
59,240	49,367	46,769	44,430	24	27	4 to 6	3.5
59,630	49,692	47,076	44,722	17	19	4 to 6	3.5
61,314	51,095	48,405	45,985	23	25	4 to 6	3.4
61,885	51,571	48,856	46,414	26	28	4 to 6	3.4
63,868	53,224	50,422	47,901	23	24	4 to 6	3.3
63,979	53,316	50,510	47,985	24	25	4 to 6	3.3
64,265	53,554	50,735	48,199	27	28	4 to 6	3.3
66,645	55,538	52,615	49,984	23	23	4 to 6	3.1
69,113	57,595	54,563	51,835	28	27	4 to 6	3.0
69,208	57,674	54,638	51,906	27	26	4 to 6	3.0
69,543	57,952	54,902	52,157	24	23	4 to 6	3.0
71,772	59,810	56,662	53,829	28	26	4 to 6	2.9
71,977	59,981	56,824	53,983	27	25	4 to 6	2.9
72,440	60,367	57,190	54,330	25	23	4 to 6	2.9
74,486	62,071	58,805	55,864	19	17	4 to 6	2.8
74,976	62,480	59,191	56,232	27	24	4 to 6	2.8
75,338	62,782	59,477	56,503	26	23	4 to 6	2.8
77,753	64,794	61,384	58,314	28	24	4 to 6	2.7
78,236	65,196	61,765	58,677	27	23	4 to 6	2.7
80,676	67,230	63,691	60,507	23	19	4 to 6	2.6
81,133	67,611	64,053	60,850	28	23	4 to 6	2.6
84,183	70,153	66,461	63,138	24	19	4 to 6	2.5
87,691	73,076	69,230	65,768	25	19	4 to 6	2.4
90,167	75,139	71,184	67,625	23	17	4 to 6	2.3
91,199	75,999	71,999	68,399	26	19	4 to 6	2.3
94,087	78,406	74,279	70,565	24	17	4 to 6	2.2
94,706	78,922	74,768	71,030	27	19	4 to 6	2.2
98,008	81,673	77,374	73,506	25	17	4 to 6	2.1
98,214	81,845	77,537	73,660	28	19	4 to 6	2.1
101,928	84,940	80,469	76,446	26	17	4 to 6	2.1
102,189	85,158	80,676	76,642	23	15	4 to 6	2.0
105,848	88,207	83,564	79,386	27	17	4 to 6	2.0

**NOTE: See "General Planting Rate Information" and "Checking Seed Population" pages for additional information. Always check seed population in the field to ensure planting rates are correct.**

**PLANTING RATES FOR (EDGEVAC) SOYBEAN AND MILO/GRAIN SORGHUM 60 CELL DISCS  
19 TOOTH CONTACT WHEEL DRIVE SPROCKET**

**APPROXIMATE SEEDS/ACRE FOR VARIOUS ROW WIDTHS**

30" Rows	36" Rows	38" Rows	40" Rows	Transmission Sprockets		Recomm. Speed (MPH)	Average Spacing in Inches
				Drive	Driven		
45,223	37,686	35,703	33,918	15	28	4 to 6	4.6
46,898	39,082	37,025	35,174	15	27	4 to 6	4.5
48,702	40,585	38,449	36,527	15	26	4 to 6	4.3
50,650	42,209	39,987	37,988	15	25	4 to 6	4.1
51,253	42,711	40,463	38,440	17	28	4 to 6	4.1
52,761	43,967	41,653	39,571	15	24	4 to 6	4.0
53,152	44,293	41,962	39,864	17	27	4 to 6	3.9
55,055	45,879	43,464	41,291	15	23	4 to 6	3.8
55,196	45,997	43,576	41,397	17	26	4 to 6	3.8
57,283	47,736	45,223	42,962	19	28	4 to 6	3.7
57,404	47,836	45,319	43,053	17	25	4 to 6	3.6
59,405	49,504	46,898	44,554	19	27	4 to 6	3.5
59,796	49,830	47,207	44,847	17	24	4 to 6	3.5
61,689	51,408	48,702	46,267	19	26	4 to 6	3.4
62,395	51,996	49,259	46,796	17	23	4 to 6	3.4
64,157	53,464	50,650	48,118	19	25	4 to 6	3.3
66,645	55,538	52,615	49,984	15	19	4 to 6	3.1
66,830	55,692	52,761	50,123	19	24	4 to 6	3.1
69,343	57,786	54,744	52,007	23	28	4 to 6	3.0
69,736	58,113	55,055	52,302	19	23	4 to 6	3.0
71,911	59,926	56,772	53,933	23	27	4 to 6	2.9
72,358	60,298	57,124	54,268	24	28	4 to 6	2.9
74,486	62,071	58,805	55,864	15	17	4 to 6	2.8
75,037	62,531	59,240	56,278	24	27	4 to 6	2.8
75,531	62,943	59,630	56,648	17	19	4 to 6	2.8
77,664	64,720	61,314	58,248	23	25	4 to 6	2.7
78,387	65,323	61,885	58,791	26	28	4 to 6	2.7
80,900	67,416	63,868	60,675	23	24	4 to 6	2.6
81,040	67,534	63,979	60,780	24	25	4 to 6	2.6
81,402	67,835	64,265	61,052	27	28	4 to 6	2.6
84,417	70,348	66,645	63,313	23	23	4 to 6	2.5
87,544	72,953	69,113	65,658	28	27	4 to 6	2.4
87,664	73,053	69,208	65,748	27	26	4 to 6	2.4
88,087	73,406	69,543	66,066	24	23	4 to 6	2.4
90,911	75,759	71,772	68,183	28	26	4 to 6	2.3
91,171	75,975	71,977	68,378	27	25	4 to 6	2.3
91,758	76,465	72,440	68,818	25	23	4 to 6	2.3
94,349	78,624	74,486	70,761	19	17	4 to 6	2.2
94,969	79,141	74,976	71,227	27	24	4 to 6	2.2
95,428	79,523	75,338	71,571	26	23	4 to 6	2.2
98,487	82,072	77,753	73,865	28	24	4 to 6	2.1
99,098	82,582	78,236	74,324	27	23	4 to 6	2.1
102,189	85,158	80,676	76,642	23	19	4 to 6	2.0
102,769	85,641	81,133	77,077	28	23	4 to 6	2.0
106,632	88,860	84,183	79,974	24	19	4 to 6	2.0
111,075	92,563	87,691	83,306	25	19	4 to 6	1.9
114,211	95,176	90,167	85,659	23	17	4 to 6	1.8
115,518	96,265	91,199	86,639	26	19	4 to 6	1.8
119,177	99,314	94,087	89,383	24	17	4 to 6	1.8
119,961	99,968	94,706	89,971	27	19	4 to 6	1.7
124,143	103,452	98,008	93,107	25	17	4 to 6	1.7
124,404	103,670	98,214	93,303	28	19	4 to 6	1.7
129,109	107,591	101,928	96,831	26	17	4 to 6	1.6
129,440	107,866	102,189	97,080	23	15	4 to 6	1.6
134,074	111,729	105,848	100,556	27	17	4 to 6	1.6

**NOTE: See "General Planting Rate Information" and "Checking Seed Population" pages for additional information. Always check seed population in the field to ensure planting rates are correct.**

**PLANTING RATES FOR (EDGEVAC) SOYBEAN 60 CELL DISC  
30 TOOTH CONTACT WHEEL DRIVE SPROCKET  
APPROXIMATE SEEDS/ACRE FOR VARIOUS ROW WIDTHS**

30" Rows	36" Rows	38" Rows	40" Rows	Transmission Sprockets		Recomm. Speed (MPH)	Average Spacing in Inches
				Drive	Driven		
71,406	59,505	56,373	53,554	15	28	4 to 6	2.9
74,050	61,708	58,461	55,538	15	27	4 to 6	2.8
76,898	64,082	60,709	57,674	15	26	4 to 6	2.7
79,974	66,645	63,138	59,981	15	25	4 to 6	2.6
80,926	67,439	63,889	60,695	17	28	4 to 6	2.6
83,306	69,422	65,768	62,480	15	24	4 to 6	2.5
83,924	69,936	66,255	62,943	17	27	4 to 6	2.5
86,928	72,440	68,628	65,196	15	23	4 to 6	2.4
87,151	72,626	68,804	65,364	17	26	4 to 6	2.4
90,447	75,372	71,406	67,835	19	28	4 to 6	2.3
90,637	75,531	71,556	67,978	17	25	4 to 6	2.3
93,797	78,164	74,050	70,348	19	27	4 to 6	2.2
94,414	78,678	74,537	70,810	17	24	4 to 6	2.2
97,404	81,170	76,898	73,053	19	26	4 to 6	2.1
98,519	82,099	77,778	73,889	17	23	4 to 6	2.1
101,301	84,417	79,974	75,975	19	25	4 to 6	2.1
105,229	87,691	83,076	78,922	15	19	4 to 6	2.0
105,521	87,935	83,306	79,141	19	24	4 to 6	2.0
109,488	91,240	86,438	82,116	23	28	4 to 6	1.9
110,109	91,758	86,928	82,582	19	23	4 to 6	1.9
113,544	94,620	89,640	85,158	23	27	4 to 6	1.8
114,249	95,207	90,196	85,687	24	28	4 to 6	1.8
117,609	98,008	92,849	88,207	15	17	4 to 6	1.8
118,480	98,734	93,537	88,860	24	27	4 to 6	1.8
119,260	99,383	94,152	89,445	17	19	4 to 6	1.8
122,627	102,189	96,811	91,970	23	25	4 to 6	1.7
123,770	103,141	97,713	92,827	26	28	4 to 6	1.7
127,737	106,447	100,845	95,802	23	24	4 to 6	1.6
127,959	106,632	101,020	95,969	24	25	4 to 6	1.6
128,530	107,108	101,471	96,397	27	28	4 to 6	1.6
133,290	111,075	105,229	99,968	23	23	4 to 6	1.6
138,227	115,189	109,127	103,670	28	27	4 to 6	1.5
138,417	115,347	109,276	103,813	27	26	4 to 6	1.5
139,086	115,905	109,804	104,314	24	23	4 to 6	1.5
143,543	119,619	113,324	107,658	28	26	4 to 6	1.5
143,954	119,961	113,648	107,965	27	25	4 to 6	1.5
144,881	120,734	114,380	108,661	25	23	4 to 6	1.4
148,971	124,143	117,609	111,729	19	17	4 to 6	1.4
149,952	124,960	118,383	112,464	27	24	4 to 6	1.4
150,676	125,563	118,955	113,007	26	23	4 to 6	1.4
155,505	129,588	122,767	116,629	28	24	4 to 6	1.3
156,471	130,393	123,530	117,353	27	23	4 to 6	1.3
161,351	134,459	127,383	121,014	23	19	4 to 6	1.3
162,266	135,222	128,105	121,700	28	23	4 to 6	1.3
168,367	140,306	132,921	126,275	24	19	4 to 6	1.2
175,382	146,152	138,459	131,536	25	19	4 to 6	1.2
180,334	150,278	142,369	135,250	23	17	4 to 6	1.2
182,397	151,998	143,998	136,798	26	19	4 to 6	1.1
188,175	156,812	148,559	141,131	24	17	4 to 6	1.1
189,413	157,844	149,536	142,059	27	19	4 to 6	1.1
196,015	163,346	154,749	147,011	25	17	4 to 6	1.1
196,428	163,690	155,075	147,321	28	19	4 to 6	1.1
203,856	169,880	160,939	152,892	26	17	4 to 6	1.0
204,378	170,315	161,351	153,284	23	15	4 to 6	1.0
211,696	176,414	167,129	158,772	27	17	4 to 6	1.0

**NOTE: See "General Planting Rate Information" and "Checking Seed Population" pages for additional information. Always check seed population in the field to ensure planting rates are correct.**

**PLANTING RATES FOR (EDGEVAC) HIGH-RATE SOYBEAN 120 CELL DISC  
15 TOOTH CONTACT WHEEL DRIVE SPROCKET  
APPROXIMATE SEEDS/ACRE FOR VARIOUS ROW WIDTHS**

30" Rows	36" Rows	38" Rows	40" Rows	Transmission Sprockets		Recomm. Speed (MPH)	Average Spacing in Inches
				Drive	Driven		
71,406	59,505	56,373	53,554	15	28	4 to 6	2.9
74,050	61,708	58,461	55,538	15	27	4 to 6	2.8
76,898	64,082	60,709	57,674	15	26	4 to 6	2.7
79,974	66,645	63,138	59,981	15	25	4 to 6	2.6
80,926	67,439	63,889	60,695	17	28	4 to 6	2.6
83,306	69,422	65,768	62,480	15	24	4 to 6	2.5
83,924	69,936	66,255	62,943	17	27	4 to 6	2.5
86,928	72,440	68,628	65,196	15	23	4 to 6	2.4
87,151	72,626	68,804	65,364	17	26	4 to 6	2.4
90,447	75,372	71,406	67,835	19	28	4 to 6	2.3
90,637	75,531	71,556	67,978	17	25	4 to 6	2.3
93,797	78,164	74,050	70,348	19	27	4 to 6	2.2
94,414	78,678	74,537	70,810	17	24	4 to 6	2.2
97,404	81,170	76,898	73,053	19	26	4 to 6	2.1
98,519	82,099	77,778	73,889	17	23	4 to 6	2.1
101,301	84,417	79,974	75,975	19	25	4 to 6	2.1
105,229	87,691	83,076	78,922	15	19	4 to 6	2.0
105,521	87,935	83,306	79,141	19	24	4 to 6	2.0
109,488	91,240	86,438	82,116	23	28	4 to 6	1.9
110,109	91,758	86,928	82,582	19	23	4 to 6	1.9
113,544	94,620	89,640	85,158	23	27	4 to 6	1.8
114,249	95,207	90,196	85,687	24	28	4 to 6	1.8
117,609	98,008	92,849	88,207	15	17	4 to 6	1.8
118,480	98,734	93,537	88,860	24	27	4 to 6	1.8
119,260	99,383	94,152	89,445	17	19	4 to 6	1.8
122,627	102,189	96,811	91,970	23	25	4 to 6	1.7
123,770	103,141	97,713	92,827	26	28	4 to 6	1.7
127,737	106,447	100,845	95,802	23	24	4 to 6	1.6
127,959	106,632	101,020	95,969	24	25	4 to 6	1.6
128,530	107,108	101,471	96,397	27	28	4 to 6	1.6
133,290	111,075	105,229	99,968	23	23	4 to 6	1.6
138,227	115,189	109,127	103,670	28	27	4 to 6	1.5
138,417	115,347	109,276	103,813	27	26	4 to 6	1.5
139,086	115,905	109,804	104,314	24	23	4 to 6	1.5
143,543	119,619	113,324	107,658	28	26	4 to 6	1.5
143,954	119,961	113,648	107,965	27	25	4 to 6	1.5
144,881	120,734	114,380	108,661	25	23	4 to 6	1.4
148,971	124,143	117,609	111,729	19	17	4 to 6	1.4
149,952	124,960	118,383	112,464	27	24	4 to 6	1.4
150,676	125,563	118,955	113,007	26	23	4 to 6	1.4
155,505	129,588	122,767	116,629	28	24	4 to 6	1.3
156,471	130,393	123,530	117,353	27	23	4 to 6	1.3
161,351	134,459	127,383	121,014	23	19	4 to 6	1.3
162,266	135,222	128,105	121,700	28	23	4 to 6	1.3
168,367	140,306	132,921	126,275	24	19	4 to 6	1.2
175,382	146,152	138,459	131,536	25	19	4 to 6	1.2
180,334	150,278	142,369	135,250	23	17	4 to 6	1.2
182,397	151,998	143,998	136,798	26	19	4 to 6	1.1
188,175	156,812	148,559	141,131	24	17	4 to 6	1.1
189,413	157,844	149,536	142,059	27	19	4 to 6	1.1
196,015	163,346	154,749	147,011	25	17	4 to 6	1.1
196,428	163,690	155,075	147,321	28	19	4 to 6	1.1
203,856	169,880	160,939	152,892	26	17	4 to 6	1.0
204,378	170,315	161,351	153,284	23	15	4 to 6	1.0
211,696	176,414	167,129	158,772	27	17	4 to 6	1.0

**NOTE: See "General Planting Rate Information" and "Checking Seed Population" pages for additional information. Always check seed population in the field to ensure planting rates are correct.**

**PLANTING RATES FOR (EDGEVAC) HIGH-RATE SOYBEAN 120 CELL DISC  
19 TOOTH CONTACT WHEEL DRIVE SPROCKET  
APPROXIMATE SEEDS/ACRE FOR VARIOUS ROW WIDTHS**

30" Rows	36" Rows	38" Rows	40" Rows	Transmission Sprockets		Recomm. Speed (MPH)	Average Spacing in Inches
				Drive	Driven		
90,447	75,372	71,406	67,835	15	28	4 to 6	2.3
93,797	78,164	74,050	70,348	15	27	4 to 6	2.2
97,404	81,170	76,898	73,053	15	26	4 to 6	2.1
101,301	84,417	79,974	75,975	15	25	4 to 6	2.1
102,507	85,422	80,926	76,880	17	28	4 to 6	2.0
105,521	87,935	83,306	79,141	15	24	4 to 6	2.0
106,303	88,586	83,924	79,727	17	27	4 to 6	2.0
110,109	91,758	86,928	82,582	15	23	4 to 6	1.9
110,392	91,993	87,151	82,794	17	26	4 to 6	1.9
114,566	95,472	90,447	85,925	19	28	4 to 6	1.8
114,807	95,673	90,637	86,106	17	25	4 to 6	1.8
118,809	99,008	93,797	89,107	19	27	4 to 6	1.8
119,591	99,659	94,414	89,693	17	24	4 to 6	1.7
123,379	102,816	97,404	92,534	19	26	4 to 6	1.7
124,791	103,992	98,519	93,593	17	23	4 to 6	1.7
128,314	106,928	101,301	96,236	19	25	4 to 6	1.6
133,290	111,075	105,229	99,968	15	19	4 to 6	1.6
133,661	111,384	105,521	100,245	19	24	4 to 6	1.6
138,685	115,571	109,488	104,014	23	28	4 to 6	1.5
139,472	116,227	110,109	104,604	19	23	4 to 6	1.5
143,822	119,852	113,544	107,866	23	27	4 to 6	1.5
144,715	120,596	114,249	108,536	24	28	4 to 6	1.4
148,971	124,143	117,609	111,729	15	17	4 to 6	1.4
150,075	125,062	118,480	112,556	24	27	4 to 6	1.4
151,062	125,885	119,260	113,297	17	19	4 to 6	1.4
155,328	129,440	122,627	116,496	23	25	4 to 6	1.3
156,775	130,646	123,770	117,581	26	28	4 to 6	1.3
161,800	134,833	127,737	121,350	23	24	4 to 6	1.3
162,081	135,067	127,959	121,561	24	25	4 to 6	1.3
162,805	135,670	128,530	122,103	27	28	4 to 6	1.3
168,834	140,695	133,290	126,626	23	23	4 to 6	1.2
175,087	145,906	138,227	131,316	28	27	4 to 6	1.2
175,328	146,107	138,417	131,496	27	26	4 to 6	1.2
176,175	146,812	139,086	132,131	24	23	4 to 6	1.2
181,822	151,518	143,543	136,366	28	26	4 to 6	1.1
182,341	151,951	143,954	136,756	27	25	4 to 6	1.1
183,516	152,930	144,881	137,637	25	23	4 to 6	1.1
188,697	157,248	148,971	141,523	19	17	4 to 6	1.1
189,939	158,282	149,952	142,454	27	24	4 to 6	1.1
190,856	159,047	150,676	143,142	26	23	4 to 6	1.1
196,973	164,145	155,505	147,730	28	24	4 to 6	1.1
198,197	165,164	156,471	148,648	27	23	4 to 6	1.1
204,378	170,315	161,351	153,284	23	19	4 to 6	1.0
205,537	171,281	162,266	154,153	28	23	4 to 6	1.0
213,264	177,720	168,367	159,948	24	19	4 to 6	1.0
222,150	185,125	175,382	166,613	25	19	4 to 6	0.9
228,423	190,352	180,334	171,317	23	17	4 to 6	0.9
231,036	192,530	182,397	173,277	26	19	4 to 6	0.9
238,354	198,629	188,175	178,766	24	17	4 to 6	0.9
239,923	199,935	189,413	179,942	27	19	4 to 6	0.9
248,286	206,905	196,015	186,214	25	17	4 to 6	0.8
248,809	207,340	196,428	186,606	28	19	4 to 6	0.8
	215,181	203,856	193,663	26	17	4 to 6	0.8
	215,733	204,378	194,160	23	15	4 to 6	0.8
	223,457	211,696	201,112	27	17	4 to 6	0.8

**NOTE: See "General Planting Rate Information" and "Checking Seed Population" pages for additional information. Always check seed population in the field to ensure planting rates are correct.**

**PLANTING RATES FOR (EDGEVAC) ACID-DELINTED HILL-DROP COTTON (3 SEEDS PER CELL), 20 CELL DISC  
15 TOOTH CONTACT WHEEL DRIVE SPROCKET  
APPROXIMATE HILLS/ACRE FOR VARIOUS ROW WIDTHS**

30" Rows	36" Rows	38" Rows	40" Rows	Transmission Sprockets		Recomm. Speed (MPH)	Average Spacing in Inches
				Drive	Driven		
11,901	9,917	9,395	8,926	15	28	4 to 6	17.6
12,342	10,285	9,743	9,256	15	27	4 to 6	16.9
12,816	10,680	10,118	9,612	15	26	4 to 6	16.3
13,329	11,108	10,523	9,997	15	25	4 to 6	15.7
13,488	11,240	10,648	10,116	17	28	4 to 6	15.5
13,884	11,570	10,961	10,413	15	24	4 to 6	15.1
13,987	11,656	11,043	10,490	17	27	4 to 6	14.9
14,488	12,073	11,438	10,866	15	23	4 to 6	14.4
14,525	12,104	11,467	10,894	17	26	4 to 6	14.4
15,074	12,562	11,901	11,306	19	28	4 to 6	13.9
15,106	12,589	11,926	11,330	17	25	4 to 6	13.8
15,633	13,027	12,342	11,725	19	27	4 to 6	13.4
15,736	13,113	12,423	11,802	17	24	4 to 6	13.3
16,234	13,528	12,816	12,176	19	26	4 to 6	12.9
16,420	13,683	12,963	12,315	17	23	4 to 6	12.7
16,883	14,070	13,329	12,663	19	25	4 to 6	12.4
17,538	14,615	13,846	13,154	15	19	4 to 6	11.9
17,587	14,656	13,884	13,190	19	24	4 to 6	11.9
18,248	15,207	14,406	13,686	23	28	4 to 6	11.5
18,352	15,293	14,488	13,764	19	23	4 to 6	11.4
18,924	15,770	14,940	14,193	23	27	4 to 6	11.0
19,041	15,868	15,033	14,281	24	28	4 to 6	11.0
19,602	16,335	15,475	14,701	15	17	4 to 6	10.7
19,652	16,376	15,515	14,739	23	26	4 to 6	10.6
19,747	16,456	15,590	14,810	24	27	4 to 6	10.6
19,835	16,529	15,659	14,876	25	28	4 to 6	10.5
19,877	16,564	15,692	14,907	17	19	4 to 6	10.5
20,438	17,032	16,135	15,328	23	25	4 to 6	10.2
20,506	17,088	16,189	15,380	24	26	4 to 6	10.2
20,569	17,141	16,239	15,427	25	27	4 to 6	10.2
20,628	17,190	16,285	15,471	26	28	4 to 6	10.1
21,289	17,741	16,807	15,967	23	24	4 to 6	9.8
21,326	17,772	16,837	15,995	24	25	4 to 6	9.8
21,361	17,801	16,864	16,020	25	26	4 to 6	9.8
21,392	17,827	16,889	16,044	26	27	4 to 6	9.8
21,422	17,851	16,912	16,066	27	28	4 to 6	9.8
22,215	18,513	17,538	16,661	23	23	4 to 6	9.4
23,038	19,198	18,188	17,278	28	27	4 to 6	9.1
23,069	19,225	18,213	17,302	27	26	4 to 6	9.1
23,141	19,284	18,269	17,356	25	24	4 to 6	9.0
23,181	19,317	18,301	17,386	24	23	4 to 6	9.0
23,924	19,937	18,887	17,943	28	26	4 to 6	8.7
23,992	19,994	18,941	17,994	27	25	4 to 6	8.7
24,147	20,122	19,063	18,110	25	23	4 to 6	8.7
24,829	20,690	19,602	18,621	19	17	4 to 6	8.4
24,881	20,734	19,643	18,661	28	25	4 to 6	8.4
24,992	20,827	19,730	18,744	27	24	4 to 6	8.4
25,113	20,927	19,826	18,834	26	23	4 to 6	8.3
25,918	21,598	20,461	19,438	28	24	4 to 6	8.1
26,079	21,732	20,588	19,559	27	23	4 to 6	8.0
26,892	22,410	21,230	20,169	23	19	4 to 6	7.8
27,044	22,537	21,351	20,283	28	23	4 to 6	7.7
28,061	23,384	22,154	21,046	24	19	4 to 6	7.5
29,230	24,359	23,077	21,923	25	19	4 to 6	7.2
30,056	25,046	23,728	22,542	23	17	4 to 6	7.0

**NOTE: See "General Planting Rate Information" and "Checking Seed Population" pages for additional information. Always check seed population in the field to ensure planting rates are correct.**

**PLANTING RATES FOR (EDGEVAC) ACID-DELINTED HILL-DROP COTTON (3 SEEDS PER CELL), 20 CELL DISC  
19 TOOTH CONTACT WHEEL DRIVE SPROCKET  
APPROXIMATE HILLS/ACRE FOR VARIOUS ROW WIDTHS**

30" Rows	36" Rows	38" Rows	40" Rows	Transmission Sprockets		Recomm. Speed (MPH)	Average Spacing in Inches
				Drive	Driven		
15,074	12,562	11,901	11,306	15	28	4 to 6	13.9
15,633	13,027	12,342	11,725	15	27	4 to 6	13.4
16,234	13,528	12,816	12,176	15	26	4 to 6	12.9
16,883	14,070	13,329	12,663	15	25	4 to 6	12.4
17,084	14,237	13,488	12,813	17	28	4 to 6	12.2
17,587	14,656	13,884	13,190	15	24	4 to 6	11.9
17,717	14,764	13,987	13,288	17	27	4 to 6	11.8
18,352	15,293	14,488	13,764	15	23	4 to 6	11.4
18,399	15,332	14,525	13,799	17	26	4 to 6	11.4
19,094	15,912	15,074	14,321	19	28	4 to 6	11.0
19,135	15,945	15,106	14,351	17	25	4 to 6	10.9
19,802	16,501	15,633	14,851	19	27	4 to 6	10.6
19,932	16,610	15,736	14,949	17	24	4 to 6	10.5
20,563	17,136	16,234	15,422	19	26	4 to 6	10.2
20,798	17,332	16,420	15,599	17	23	4 to 6	10.1
21,386	17,821	16,883	16,039	19	25	4 to 6	9.8
22,215	18,513	17,538	16,661	15	19	4 to 6	9.4
22,277	18,564	17,587	16,708	19	24	4 to 6	9.4
23,114	19,262	18,248	17,336	23	28	4 to 6	9.0
23,245	19,371	18,352	17,434	19	23	4 to 6	9.0
23,970	19,975	18,924	17,978	23	27	4 to 6	8.7
24,119	20,099	19,041	18,089	24	28	4 to 6	8.7
24,829	20,690	19,602	18,621	15	17	4 to 6	8.4
24,892	20,744	19,652	18,669	23	26	4 to 6	8.4
25,012	20,844	19,747	18,759	24	27	4 to 6	8.4
25,124	20,937	19,835	18,843	25	28	4 to 6	8.3
25,177	20,981	19,877	18,883	17	19	4 to 6	8.3
25,888	21,573	20,438	19,416	23	25	4 to 6	8.1
25,975	21,645	20,506	19,481	24	26	4 to 6	8.0
26,055	21,712	20,569	19,541	25	27	4 to 6	8.0
26,129	21,774	20,628	19,597	26	28	4 to 6	8.0
26,967	22,472	21,289	20,225	23	24	4 to 6	7.8
27,013	22,511	21,326	20,260	24	25	4 to 6	7.7
27,057	22,547	21,361	20,293	25	26	4 to 6	7.7
27,097	22,581	21,392	20,323	26	27	4 to 6	7.7
27,134	22,612	21,422	20,351	27	28	4 to 6	7.7
28,139	23,449	22,215	21,104	23	23	4 to 6	7.4
29,181	24,318	23,038	21,886	28	27	4 to 6	7.2
29,221	24,351	23,069	21,916	27	26	4 to 6	7.2
29,312	24,426	23,141	21,984	25	24	4 to 6	7.1
29,362	24,469	23,181	22,022	24	23	4 to 6	7.1
30,304	25,253	23,924	22,728	28	26	4 to 6	6.9
30,390	25,325	23,992	22,793	27	25	4 to 6	6.9
30,586	25,488	24,147	22,939	25	23	4 to 6	6.8
31,450	26,208	24,829	23,587	19	17	4 to 6	6.6
31,516	26,263	24,881	23,637	28	25	4 to 6	6.6
31,656	26,380	24,992	23,742	27	24	4 to 6	6.6
31,809	26,508	25,113	23,857	26	23	4 to 6	6.6
32,829	27,357	25,918	24,622	28	24	4 to 6	6.4
33,033	27,527	26,079	24,775	27	23	4 to 6	6.3
34,063	28,386	26,892	25,547	23	19	4 to 6	6.1
34,256	28,547	27,044	25,692	28	23	4 to 6	6.1
35,544	29,620	28,061	26,658	24	19	4 to 6	5.9
37,025	30,854	29,230	27,769	25	19	4 to 6	5.6
38,070	31,725	30,056	28,553	23	17	4 to 6	5.5

**NOTE: See "General Planting Rate Information" and "Checking Seed Population" pages for additional information. Always check seed population in the field to ensure planting rates are correct.**



**PLANTING RATES FOR (EDGEVAC) ACID-DELINTED COTTON/SMALL DRY EDIBLE BEAN 54 CELL DISC  
15 TOOTH CONTACT WHEEL DRIVE SPROCKET  
APPROXIMATE SEEDS/ACRE FOR VARIOUS ROW WIDTHS**

30" Rows	36" Rows	38" Rows	40" Rows	Transmission Sprockets		Recomm. Speed (MPH)	Average Spacing in Inches
				Drive	Driven		
32,132	26,777	25,368	24,099	15	28	4 to 6	6.5
33,323	27,769	26,307	24,992	15	27	4 to 6	6.3
34,604	28,837	27,319	25,953	15	26	4 to 6	6.0
35,988	29,990	28,412	26,991	15	25	4 to 6	5.8
36,417	30,347	28,750	27,313	17	28	4 to 6	5.7
37,488	31,240	29,596	28,116	15	24	4 to 6	5.6
37,766	31,471	29,815	28,324	17	27	4 to 6	5.5
39,118	32,598	30,882	29,338	15	23	4 to 6	5.3
39,218	32,682	30,962	29,414	17	26	4 to 6	5.3
40,701	33,918	32,132	30,526	19	28	4 to 6	5.1
40,787	33,989	32,200	30,590	17	25	4 to 6	5.1
42,209	35,174	33,323	31,656	19	27	4 to 6	5.0
42,486	35,405	33,542	31,865	17	24	4 to 6	4.9
43,832	36,527	34,604	32,874	19	26	4 to 6	4.8
44,334	36,945	35,000	33,250	17	23	4 to 6	4.7
45,585	37,988	35,988	34,189	19	25	4 to 6	4.6
47,353	39,461	37,384	35,515	15	19	4 to 6	4.4
47,485	39,571	37,488	35,613	19	24	4 to 6	4.4
49,270	41,058	38,897	36,952	23	28	4 to 6	4.2
49,549	41,291	39,118	37,162	19	23	4 to 6	4.2
51,095	42,579	40,338	38,321	23	27	4 to 6	4.1
51,412	42,843	40,588	38,559	24	28	4 to 6	4.1
52,924	44,103	41,782	39,693	15	17	4 to 6	4.0
53,316	44,430	42,092	39,987	24	27	4 to 6	3.9
53,667	44,722	42,369	40,250	17	19	4 to 6	3.9
55,182	45,985	43,565	41,387	23	25	4 to 6	3.8
55,696	46,414	43,971	41,772	26	28	4 to 6	3.8
57,481	47,901	45,380	43,111	23	24	4 to 6	3.6
57,581	47,985	45,459	43,186	24	25	4 to 6	3.6
57,838	48,199	45,662	43,379	27	28	4 to 6	3.6
59,981	49,984	47,353	44,985	23	23	4 to 6	3.5
62,202	51,835	49,107	46,652	28	27	4 to 6	3.4
62,288	51,906	49,174	46,716	27	26	4 to 6	3.4
62,588	52,157	49,412	46,941	24	23	4 to 6	3.3
64,595	53,829	50,996	48,446	28	26	4 to 6	3.2
64,779	53,983	51,141	48,584	27	25	4 to 6	3.2
65,196	54,330	51,471	48,897	25	23	4 to 6	3.2
67,037	55,864	52,924	50,278	19	17	4 to 6	3.1
67,478	56,232	53,272	50,609	27	24	4 to 6	3.1
67,804	56,503	53,530	50,853	26	23	4 to 6	3.1
69,977	58,314	55,245	52,483	28	24	4 to 6	3.0
70,412	58,677	55,588	52,809	27	23	4 to 6	3.0
72,608	60,507	57,322	54,456	23	19	4 to 6	2.9
73,020	60,850	57,647	54,765	28	23	4 to 6	2.9
75,765	63,138	59,814	56,824	24	19	4 to 6	2.8
78,922	65,768	62,307	59,191	25	19	4 to 6	2.6
81,150	67,625	64,066	60,863	23	17	4 to 6	2.6
82,079	68,399	64,799	61,559	26	19	4 to 6	2.5
84,679	70,565	66,851	63,509	24	17	4 to 6	2.5
85,236	71,030	67,291	63,927	27	19	4 to 6	2.5
88,207	73,506	69,637	66,155	25	17	4 to 6	2.4
88,393	73,660	69,784	66,294	28	19	4 to 6	2.4
91,735	76,446	72,422	68,801	26	17	4 to 6	2.3
91,970	76,642	72,608	68,978	23	15	4 to 6	2.3
95,263	79,386	75,208	71,448	27	17	4 to 6	2.2

**NOTE: See "General Planting Rate Information" and "Checking Seed Population" pages for additional information. Always check seed population in the field to ensure planting rates are correct.**

**PLANTING RATES FOR (EDGEVAC) ACID-DELINTED COTTON/SMALL DRY EDIBLE BEAN 54 CELL DISC  
19 TOOTH CONTACT WHEEL DRIVE SPROCKET  
APPROXIMATE SEEDS/ACRE FOR VARIOUS ROW WIDTHS**

30" Rows	36" Rows	38" Rows	40" Rows	Transmission Sprockets		Recomm. Speed (MPH)	Average Spacing in Inches
				Drive	Driven		
40,701	33,918	32,132	30,526	15	28	4 to 6	5.1
42,209	35,174	33,323	31,656	15	27	4 to 6	5.0
43,832	36,527	34,604	32,874	15	26	4 to 6	4.8
45,585	37,988	35,988	34,189	15	25	4 to 6	4.6
46,128	38,440	36,417	34,596	17	28	4 to 6	4.5
47,485	39,571	37,488	35,613	15	24	4 to 6	4.4
47,836	39,864	37,766	35,877	17	27	4 to 6	4.4
49,549	41,291	39,118	37,162	15	23	4 to 6	4.2
49,676	41,397	39,218	37,257	17	26	4 to 6	4.2
51,555	42,962	40,701	38,666	19	28	4 to 6	4.1
51,663	43,053	40,787	38,747	17	25	4 to 6	4.0
53,464	44,554	42,209	40,098	19	27	4 to 6	3.9
53,816	44,847	42,486	40,362	17	24	4 to 6	3.9
55,521	46,267	43,832	41,640	19	26	4 to 6	3.8
56,156	46,796	44,334	42,117	17	23	4 to 6	3.7
57,741	48,118	45,585	43,306	19	25	4 to 6	3.6
59,981	49,984	47,353	44,985	15	19	4 to 6	3.5
60,147	50,123	47,485	45,110	19	24	4 to 6	3.5
62,408	52,007	49,270	46,806	23	28	4 to 6	3.4
62,762	52,302	49,549	47,072	19	23	4 to 6	3.3
64,720	53,933	51,095	48,540	23	27	4 to 6	3.2
65,122	54,268	51,412	48,841	24	28	4 to 6	3.2
67,037	55,864	52,924	50,278	15	17	4 to 6	3.1
67,534	56,278	53,316	50,650	24	27	4 to 6	3.1
67,978	56,648	53,667	50,984	17	19	4 to 6	3.1
69,897	58,248	55,182	52,423	23	25	4 to 6	3.0
70,549	58,791	55,696	52,911	26	28	4 to 6	3.0
72,810	60,675	57,481	54,607	23	24	4 to 6	2.9
72,936	60,780	57,581	54,702	24	25	4 to 6	2.9
73,262	61,052	57,838	54,947	27	28	4 to 6	2.9
75,975	63,313	59,981	56,982	23	23	4 to 6	2.8
78,789	65,658	62,202	59,092	28	27	4 to 6	2.7
78,898	65,748	62,288	59,173	27	26	4 to 6	2.7
79,279	66,066	62,588	59,459	24	23	4 to 6	2.6
81,820	68,183	64,595	61,365	28	26	4 to 6	2.6
82,053	68,378	64,779	61,540	27	25	4 to 6	2.5
82,582	68,818	65,196	61,937	25	23	4 to 6	2.5
84,914	70,761	67,037	63,685	19	17	4 to 6	2.5
85,472	71,227	67,478	64,104	27	24	4 to 6	2.4
85,885	71,571	67,804	64,414	26	23	4 to 6	2.4
88,638	73,865	69,977	66,479	28	24	4 to 6	2.4
89,189	74,324	70,412	66,891	27	23	4 to 6	2.3
91,970	76,642	72,608	68,978	23	19	4 to 6	2.3
92,492	77,077	73,020	69,369	28	23	4 to 6	2.3
95,969	79,974	75,765	71,977	24	19	4 to 6	2.2
99,968	83,306	78,922	74,976	25	19	4 to 6	2.1
102,790	85,659	81,150	77,093	23	17	4 to 6	2.0
103,966	86,639	82,079	77,975	26	19	4 to 6	2.0
107,259	89,383	84,679	80,445	24	17	4 to 6	1.9
107,965	89,971	85,236	80,974	27	19	4 to 6	1.9
111,729	93,107	88,207	83,796	25	17	4 to 6	1.9
111,964	93,303	88,393	83,973	28	19	4 to 6	1.9
116,198	96,831	91,735	87,148	26	17	4 to 6	1.8
116,496	97,080	91,970	87,372	23	15	4 to 6	1.8
120,667	100,556	95,263	90,500	27	17	4 to 6	1.7

**NOTE: See "General Planting Rate Information" and "Checking Seed Population" pages for additional information. Always check seed population in the field to ensure planting rates are correct.**

**PLANTING RATES FOR (EDGEVAC) LARGE DRY EDIBLE BEAN 54 CELL DISC  
15 TOOTH CONTACT WHEEL DRIVE SPROCKET  
APPROXIMATE SEEDS/ACRE FOR VARIOUS ROW WIDTHS**

30" Rows	36" Rows	38" Rows	40" Rows	Transmission Sprockets		Recomm. Speed (MPH)	Average Spacing in Inches
				Drive	Driven		
32,132	26,777	25,368	24,099	15	28	4 to 6	6.5
33,323	27,769	26,307	24,992	15	27	4 to 6	6.3
34,604	28,837	27,319	25,953	15	26	4 to 6	6.0
35,988	29,990	28,412	26,991	15	25	4 to 6	5.8
36,417	30,347	28,750	27,313	17	28	4 to 6	5.7
37,488	31,240	29,596	28,116	15	24	4 to 6	5.6
37,766	31,471	29,815	28,324	17	27	4 to 6	5.5
39,118	32,598	30,882	29,338	15	23	4 to 6	5.3
39,218	32,682	30,962	29,414	17	26	4 to 6	5.3
40,701	33,918	32,132	30,526	19	28	4 to 6	5.1
40,787	33,989	32,200	30,590	17	25	4 to 6	5.1
42,209	35,174	33,323	31,656	19	27	4 to 6	5.0
42,486	35,405	33,542	31,865	17	24	4 to 6	4.9
43,832	36,527	34,604	32,874	19	26	4 to 6	4.8
44,334	36,945	35,000	33,250	17	23	4 to 6	4.7
45,585	37,988	35,988	34,189	19	25	4 to 6	4.6
47,353	39,461	37,384	35,515	15	19	4 to 6	4.4
47,485	39,571	37,488	35,613	19	24	4 to 6	4.4
49,270	41,058	38,897	36,952	23	28	4 to 6	4.2
49,549	41,291	39,118	37,162	19	23	4 to 6	4.2
51,095	42,579	40,338	38,321	23	27	4 to 6	4.1
51,412	42,843	40,588	38,559	24	28	4 to 6	4.1
52,924	44,103	41,782	39,693	15	17	4 to 6	4.0
53,316	44,430	42,092	39,987	24	27	4 to 6	3.9
53,667	44,722	42,369	40,250	17	19	4 to 6	3.9
55,182	45,985	43,565	41,387	23	25	4 to 6	3.8
55,696	46,414	43,971	41,772	26	28	4 to 6	3.8
57,481	47,901	45,380	43,111	23	24	4 to 6	3.6
57,581	47,985	45,459	43,186	24	25	4 to 6	3.6
57,838	48,199	45,662	43,379	27	28	4 to 6	3.6
59,981	49,984	47,353	44,985	23	23	4 to 6	3.5
62,202	51,835	49,107	46,652	28	27	4 to 6	3.4
62,288	51,906	49,174	46,716	27	26	4 to 6	3.4
62,588	52,157	49,412	46,941	24	23	4 to 6	3.3
64,595	53,829	50,996	48,446	28	26	4 to 6	3.2
64,779	53,983	51,141	48,584	27	25	4 to 6	3.2
65,196	54,330	51,471	48,897	25	23	4 to 6	3.2
67,037	55,864	52,924	50,278	19	17	4 to 6	3.1
67,478	56,232	53,272	50,609	27	24	4 to 6	3.1
67,804	56,503	53,530	50,853	26	23	4 to 6	3.1
69,977	58,314	55,245	52,483	28	24	4 to 6	3.0
70,412	58,677	55,588	52,809	27	23	4 to 6	3.0
72,608	60,507	57,322	54,456	23	19	4 to 6	2.9
73,020	60,850	57,647	54,765	28	23	4 to 6	2.9
75,765	63,138	59,814	56,824	24	19	4 to 6	2.8
78,922	65,768	62,307	59,191	25	19	4 to 6	2.6
81,150	67,625	64,066	60,863	23	17	4 to 6	2.6
82,079	68,399	64,799	61,559	26	19	4 to 6	2.5
84,679	70,565	66,851	63,509	24	17	4 to 6	2.5
85,236	71,030	67,291	63,927	27	19	4 to 6	2.5
88,207	73,506	69,637	66,155	25	17	4 to 6	2.4
88,393	73,660	69,784	66,294	28	19	4 to 6	2.4
91,735	76,446	72,422	68,801	26	17	4 to 6	2.3
91,970	76,642	72,608	68,978	23	15	4 to 6	2.3
95,263	79,386	75,208	71,448	27	17	4 to 6	2.2

**NOTE: See "General Planting Rate Information" and "Checking Seed Population" pages for additional information. Always check seed population in the field to ensure planting rates are correct.**

**PLANTING RATES FOR (EDGEVAC) LARGE DRY EDIBLE BEAN 54 CELL DISC  
19 TOOTH CONTACT WHEEL DRIVE SPROCKET  
APPROXIMATE SEEDS/ACRE FOR VARIOUS ROW WIDTHS**

30" Rows	36" Rows	38" Rows	40" Rows	Transmission Sprockets		Recomm. Speed (MPH)	Average Spacing in Inches
				Drive	Driven		
40,701	33,918	32,132	30,526	15	28	4 to 6	5.1
42,209	35,174	33,323	31,656	15	27	4 to 6	5.0
43,832	36,527	34,604	32,874	15	26	4 to 6	4.8
45,585	37,988	35,988	34,189	15	25	4 to 6	4.6
46,128	38,440	36,417	34,596	17	28	4 to 6	4.5
47,485	39,571	37,488	35,613	15	24	4 to 6	4.4
47,836	39,864	37,766	35,877	17	27	4 to 6	4.4
49,549	41,291	39,118	37,162	15	23	4 to 6	4.2
49,676	41,397	39,218	37,257	17	26	4 to 6	4.2
51,555	42,962	40,701	38,666	19	28	4 to 6	4.1
51,663	43,053	40,787	38,747	17	25	4 to 6	4.0
53,464	44,554	42,209	40,098	19	27	4 to 6	3.9
53,816	44,847	42,486	40,362	17	24	4 to 6	3.9
55,521	46,267	43,832	41,640	19	26	4 to 6	3.8
56,156	46,796	44,334	42,117	17	23	4 to 6	3.7
57,741	48,118	45,585	43,306	19	25	4 to 6	3.6
59,981	49,984	47,353	44,985	15	19	4 to 6	3.5
60,147	50,123	47,485	45,110	19	24	4 to 6	3.5
62,408	52,007	49,270	46,806	23	28	4 to 6	3.4
62,762	52,302	49,549	47,072	19	23	4 to 6	3.3
64,720	53,933	51,095	48,540	23	27	4 to 6	3.2
65,122	54,268	51,412	48,841	24	28	4 to 6	3.2
67,037	55,864	52,924	50,278	15	17	4 to 6	3.1
67,534	56,278	53,316	50,650	24	27	4 to 6	3.1
67,978	56,648	53,667	50,984	17	19	4 to 6	3.1
69,897	58,248	55,182	52,423	23	25	4 to 6	3.0
70,549	58,791	55,696	52,911	26	28	4 to 6	3.0
72,810	60,675	57,481	54,607	23	24	4 to 6	2.9
72,936	60,780	57,581	54,702	24	25	4 to 6	2.9
73,262	61,052	57,838	54,947	27	28	4 to 6	2.9
75,975	63,313	59,981	56,982	23	23	4 to 6	2.8
78,789	65,658	62,202	59,092	28	27	4 to 6	2.7
78,898	65,748	62,288	59,173	27	26	4 to 6	2.7
79,279	66,066	62,588	59,459	24	23	4 to 6	2.6
81,820	68,183	64,595	61,365	28	26	4 to 6	2.6
82,053	68,378	64,779	61,540	27	25	4 to 6	2.5
82,582	68,818	65,196	61,937	25	23	4 to 6	2.5
84,914	70,761	67,037	63,685	19	17	4 to 6	2.5
85,472	71,227	67,478	64,104	27	24	4 to 6	2.4
85,885	71,571	67,804	64,414	26	23	4 to 6	2.4
88,638	73,865	69,977	66,479	28	24	4 to 6	2.4
89,189	74,324	70,412	66,891	27	23	4 to 6	2.3
91,970	76,642	72,608	68,978	23	19	4 to 6	2.3
92,492	77,077	73,020	69,369	28	23	4 to 6	2.3
95,969	79,974	75,765	71,977	24	19	4 to 6	2.2
99,968	83,306	78,922	74,976	25	19	4 to 6	2.1
102,790	85,659	81,150	77,093	23	17	4 to 6	2.0
103,966	86,639	82,079	77,975	26	19	4 to 6	2.0
107,259	89,383	84,679	80,445	24	17	4 to 6	1.9
107,965	89,971	85,236	80,974	27	19	4 to 6	1.9
111,729	93,107	88,207	83,796	25	17	4 to 6	1.9
111,964	93,303	88,393	83,973	28	19	4 to 6	1.9
116,198	96,831	91,735	87,148	26	17	4 to 6	1.8
116,496	97,080	91,970	87,372	23	15	4 to 6	1.8
120,667	100,556	95,263	90,500	27	17	4 to 6	1.7

**NOTE: See "General Planting Rate Information" and "Checking Seed Population" pages for additional information. Always check seed population in the field to ensure planting rates are correct.**

**PLANTING RATES FOR (EDGEVAC) SUGAR BEETS 80 CELL DISC  
22 TOOTH CONTACT WHEEL DRIVE SPROCKET  
APPROXIMATE SEEDS/ACRE FOR VARIOUS ROW WIDTHS**

30" Rows	Transmission Sprockets		Recomm. Speed Range (MPH)	Average Seed Spacing In Inches
	Drive	Driven		
47,608	15	28	4 to 6	4.4
49,370	15	27	4 to 6	4.2
51,270	15	26	4 to 6	4.1
53,321	15	25	4 to 6	3.9
53,955	17	28	4 to 6	3.9
55,543	15	24	4 to 6	3.8
55,953	17	27	4 to 6	3.8
57,957	15	23	4 to 6	3.6
58,105	17	26	4 to 6	3.6
60,304	19	28	4 to 6	3.5
60,431	17	25	4 to 6	3.5
62,535	19	27	4 to 6	3.4
62,948	17	24	4 to 6	3.3
64,942	19	26	4 to 6	3.2
65,684	17	23	4 to 6	3.2
67,538	19	25	4 to 6	3.1
70,158	15	19	4 to 6	3.0
70,353	19	24	4 to 6	3.0
72,999	23	28	4 to 6	2.9
73,411	19	23	4 to 6	2.8
75,703	23	27	4 to 6	2.8
76,172	24	28	4 to 6	2.7
78,412	15	17	4 to 6	2.7
78,993	24	27	4 to 6	2.6
79,514	17	19	4 to 6	2.6
81,758	23	25	4 to 6	2.5
82,519	26	28	4 to 6	2.5
85,165	23	24	4 to 6	2.4
85,313	24	25	4 to 6	2.4
85,694	27	28	4 to 6	2.4
88,868	23	23	4 to 6	2.3
92,158	28	27	4 to 6	2.3
92,285	27	26	4 to 6	2.2
92,730	24	23	4 to 6	2.2
95,703	28	26	4 to 6	2.2
95,977	27	25	4 to 6	2.2
96,595	25	23	4 to 6	2.1
99,323	19	17	4 to 6	2.1
99,975	27	24	4 to 6	2.1
100,459	26	23	4 to 6	2.1
103,678	28	24	4 to 6	2.0
104,322	27	23	4 to 6	2.0
107,575	23	19	4 to 6	2.0
108,187	28	23	4 to 6	2.0
112,254	24	19	4 to 6	1.9
116,931	25	19	4 to 6	1.8
120,232	23	17	4 to 6	1.8
121,608	26	19	4 to 6	1.7
125,461	24	17	4 to 6	1.7
126,285	27	19	4 to 6	1.7
130,687	25	17	4 to 6	1.6
130,962	28	19	4 to 6	1.6
135,914	26	17	4 to 6	1.6
136,263	23	15	4 to 6	1.5
141,143	27	17	4 to 6	1.5

**NOTE: See "General Planting Rate Information" and "Check Seed Population" pages for more information. Always field check seed population to verify planting rates.**

**PLANTING RATES FOR (EDGEVAC) SUGAR BEETS 80 CELL DISC  
15 TOOTH CONTACT WHEEL DRIVE SPROCKET/19 TOOTH REVERSE DRIVEN SPROCKETS  
APPROXIMATE SEEDS/ACRE FOR VARIOUS ROW WIDTHS**

30" Rows	Transmission Sprockets		Recomm. Speed Range (MPH)	Average Seed Spacing In Inches
	Drive	Driven		
22,006	15	28	4 to 6	9.5
22,821	15	27	4 to 6	9.2
23,699	15	26	4 to 6	8.9
24,647	15	25	4 to 6	8.4
24,940	17	28	4 to 6	8.3
25,674	15	24	4 to 6	8.1
25,863	17	27	4 to 6	8.1
26,790	15	23	4 to 6	7.8
26,858	17	26	4 to 6	7.8
27,874	19	28	4 to 6	7.5
27,933	17	25	4 to 6	7.5
28,906	19	27	4 to 6	7.3
29,097	17	24	4 to 6	7.2
30,018	19	26	4 to 6	7.0
30,362	17	23	4 to 6	6.9
31,219	19	25	4 to 6	6.7
32,429	15	19	4 to 6	6.4
32,520	19	24	4 to 6	6.4
33,743	23	28	4 to 6	6.2
33,933	19	23	4 to 6	6.1
34,992	23	27	4 to 6	6.0
35,210	24	28	4 to 6	5.9
36,245	15	17	4 to 6	5.8
36,513	24	27	4 to 6	5.7
36,754	17	19	4 to 6	5.7
37,791	23	25	4 to 6	5.5
38,143	26	28	4 to 6	5.5
39,366	23	24	4 to 6	5.3
39,435	24	25	4 to 6	5.3
39,611	27	28	4 to 6	5.3
41,078	23	23	4 to 6	5.1
42,599	28	27	4 to 6	5.0
42,657	27	26	4 to 6	4.9
42,863	24	23	4 to 6	4.9
44,237	28	26	4 to 6	4.7
44,364	27	25	4 to 6	4.7
44,650	25	23	4 to 6	4.6
45,911	19	17	4 to 6	4.5
46,212	27	24	4 to 6	4.5
46,436	26	23	4 to 6	4.5
47,924	28	24	4 to 6	4.3
48,221	27	23	4 to 6	4.3
49,725	23	19	4 to 6	4.2
50,008	28	23	4 to 6	4.2
51,888	24	19	4 to 6	4.0
54,050	25	19	4 to 6	3.9
55,575	23	17	4 to 6	3.8
56,212	26	19	4 to 6	3.7
57,992	24	17	4 to 6	3.6
58,373	27	19	4 to 6	3.6
60,408	25	17	4 to 6	3.5
60,535	28	19	4 to 6	3.5
62,824	26	17	4 to 6	3.4
62,985	23	15	4 to 6	3.3
65,241	27	17	4 to 6	3.2

**NOTE: See "General Planting Rate Information" and "Check Seed Population" pages for more information. Always field check seed population to verify planting rates.**

**DRY INSECTICIDE APPLICATION RATE APPROXIMATE POUNDS/ACRE  
AT 5 MPH FOR VARIOUS ROW WIDTHS**

Meter Setting	30" Rows	36" Rows	38" Rows	40" Rows
<b>CLAY GRANULES</b>				
10	4.9	4.1	3.9	3.7
11	5.4	4.5	4.3	4.1
12	6.1	5.1	4.8	4.6
13	6.9	5.7	5.4	5.2
14	7.7	6.4	6.0	5.8
15	8.5	7.1	6.7	6.4
16	9.6	8.0	7.6	7.2
17	10.7	8.9	8.4	8.0
18	11.4	9.5	9.0	8.6
19	13.1	10.9	10.3	9.8
20	14.2	11.8	11.2	10.7
21	15.5	12.9	12.3	11.6
22	16.4	13.7	12.9	12.3
23	17.2	14.3	13.6	12.9
24	18.8	15.7	14.9	14.1
25	20.9	17.4	16.5	15.7
26	23.0	19.2	18.1	17.3
27	24.1	20.0	19.0	18.1
28	25.4	21.2	20.1	19.1
29	27.8	23.2	22.0	20.9
30	29.6	24.7	23.4	22.2

<b>SAND GRANULES</b>				
5	2.9	2.4	2.3	2.2
6	4.9	4.0	3.8	3.7
7	5.3	4.4	4.2	3.9
8	6.3	5.3	5.0	4.8
9	7.8	6.5	6.1	5.9
10	8.9	7.4	7.0	6.7
11	10.2	8.5	8.0	7.7
12	11.2	9.3	8.8	8.4
13	12.6	10.5	10.0	9.5
14	14.1	11.7	11.1	10.6
15	15.5	12.9	12.3	11.6
16	17.5	14.6	13.8	13.1
17	19.4	16.2	15.3	14.6
18	21.8	18.2	17.2	16.4
19	24.3	20.2	19.1	18.2
20	25.7	21.4	20.3	19.3
21	27.6	23.0	21.8	20.7
22	29.6	24.7	23.4	22.2
23	32.0	26.7	25.3	24.0
24	34.4	28.7	27.2	25.8
25	36.9	30.7	29.1	26.7

**NOTE:** The chart above represents average values and should be used only as a starting point. The granular chemical flows through the given meter opening at a nearly uniform rate regardless of roller speed. Your actual rate will vary depending upon the insecticide you are using, your planting speed and your plant population. Planting speed/ground speed has the greatest effect on application rate.

Your actual rate must be checked in the field with the actual insecticide that you are using and at the speed and population at which you will be planting. See "Checking Granular Chemical Application Rate" page for additional information.



**WARNING**

Agricultural chemicals can be dangerous if not selected and handled with care.  
Always read and follow directions supplied by the chemical manufacturer.

**DRY HERBICIDE APPLICATION RATES**  
**APPROXIMATE POUNDS/ACRE AT 5 MPH FOR VARIOUS ROW WIDTHS**  
**CLAY GRANULES**

Meter Setting	30" Rows	36" Rows	38" Rows	40" Rows
10	4.7	3.9	3.7	3.5
11	5.2	4.4	4.1	3.9
12	5.8	4.9	4.6	4.4
13	6.5	5.4	5.1	4.9
14	7.3	6.1	5.7	5.5
15	8.2	6.9	6.5	6.2
16	9.0	7.5	7.1	6.8
17	9.9	8.2	7.8	7.4
18	10.7	8.9	8.4	8.0
19	11.6	9.7	9.2	8.7
20	12.6	10.5	10.0	9.5
21	13.6	11.3	10.7	10.2
22	14.6	12.1	11.5	11.0
23	15.7	13.1	12.4	11.8
24	17.0	14.1	13.4	12.8
25	18.1	15.1	14.3	13.6
26	19.4	16.2	15.3	14.6
27	20.9	17.4	16.5	15.7
28	22.6	18.8	17.8	17.0
29	24.3	20.2	19.1	18.2
30	26.7	22.2	21.1	20.0

**NOTE:** The chart above represents average values and should be used only as a starting point. The granular chemical flows through the given meter opening at a nearly uniform rate regardless of roller speed. Your actual rate will vary depending upon the herbicide you are using, your planting speed and your plant population. Planting speed/ground speed has the greatest effect on application rate.

Your actual rate must be checked in the field with the actual herbicide that you are using and at the speed and population at which you will be planting. See "Checking Granular Chemical Application Rate" page for additional information.

 **WARNING**

Agricultural chemicals can be dangerous if not selected and handled with care. Always read and follow directions supplied by the chemical manufacturer.



**KPM III ELECTRONIC SEED MONITOR VER. 3.1**

**INTRODUCTION**



The KPM III electronic seed monitor system consists of:

- A tractor mounted KPM III console powered by tractor 12 VDC battery receives and displays information from planter mounted sensors.
- Seed tube and sensor installed in each planter row unit.
- A magnetic distance sensor installed on planter or a radar distance sensor installed on tractor.
- Shaft rotation sensors (if applicable) installed on planter drill shafts.
- Vacuum, pneumatic down pressure, ASD, and hydraulic level/temperature (If applicable), installed on planter.
- Planter harnesses (junction Y-harness and extension harness where applicable), to which the individual seed tube sensors connect.  
The primary harness, which connects the monitor console to the planter harness, is hard-wired into the safety/warning light harness or control console harness included as standard equipment with the planter.

The KPM III console uses a backlit Liquid Crystal Display (LCD) to show number of monitored rows, relative seed rate for each row (using bargraph displays), and alarm and warning messages. A continuous audible alarm sounds upon system malfunction or underflow conditions for any monitored row. Alarms must be acknowledged. Various warnings also sound an alarm or flash one or more messages. The LCD displays row spacing, units (Metric or English), speed (MPH or KM/H), volume, seed population, seed spacing, field area, and total area.

KPM III software allows simultaneous viewing of seed flow bargraphs for standard and Interplant System rows (up to 36 rows).

The monitor system powers down if there is no new seed flow or operator push key input within one hour.

Acre Count Mode . . . . .	5-16	General Settings (Programming Interplant condition, row spacing and units) (Metric or English) . . . . .	5-5
Adding Even-Row Package (Front Rows Previously Programmed) . . . . .	5-10	Monitor Key Functions . . . . .	5-2
Adding Interplant Rows (Rear Rows Previously Programmed Only) . . . . .	5-9	Programming/Connecting Seed Tubes, Shaft Rotation Sensors, and/or Radar/Magnetic Distance Sensors . . . . .	5-13
Area Counters . . . . .	5-25	Programming Row Unit Alarm Levels . . . . .	5-7
Area Management . . . . .	5-24	Replacing Faulty Sensor(s) . . . . .	5-26
Changing Volume, Contrast, and Backlighting with AV Key . . . . .	5-3	Reprogramming Speed Sensor . . . . .	5-11
Clearing Field Area . . . . .	5-26	Seed Meter Settings . . . . .	5-6
Configuring Planter Monitor . . . . .	5-3	Speed Sensor Calibration/Programming . . . . .	5-14
Data Logging Mode . . . . .	5-8	Test Mode . . . . .	5-17
Enabling/Disabling Interplant Rows . . . . .	5-17	Warnings and Alarms . . . . .	5-21
Field Operation . . . . .	5-23		

**MONITOR KEY FUNCTIONS**

Push keys select or change operating mode, active displays, or the current configuration. Depending on operating mode or current display selected, some keys may not be active. Each valid key press is acknowledged by a short beep and an action is taken. If a key press has no action associated, it is considered invalid, and there is no feedback.

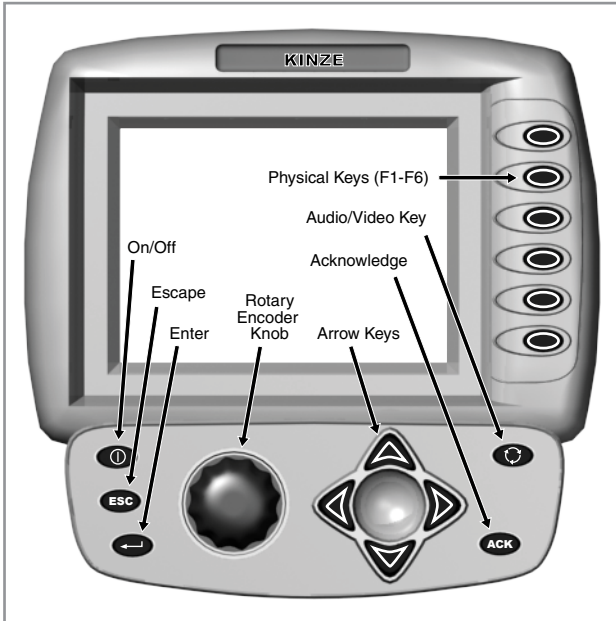

**PHYSICAL KEYS**

- Located on R.H. side of console and referred to as F1, F2, F3, F4, F5 and F6
- Keys are referenced in descending order with F1 at the top and F6 at the bottom.

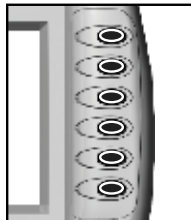

**ON/OFF KEY**

- Powers the unit on and off.



**ESC KEY**

- Used as the CANCEL (escape) key.



**ENTER KEY**

- Confirms or accepts the highlighted selection.



**ROTARY ENCODER KNOB**

- Turn knob clockwise to increase or counterclockwise to decrease value of item.
- Turn knob clockwise to scroll up or counterclockwise to scroll down.
- Press knob to enter selection.

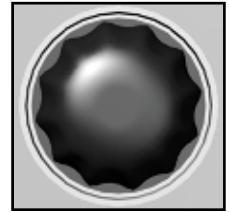

**AV (AUDIO/VIDEO) KEY**

- Set alarm volume.
- Adjust the contrast.
- Adjust backlighting of the LCD display. Can be used at any time.



**ACK (ACKNOWLEDGE) KEY**

- Used to silence (acknowledge) the warning alarm when various error conditions occur.
- NOTE: Alarms can be viewed by pressing the STATUS key.**



**ARROW KEYS**

- UP arrow key is used to move up.
- DOWN arrow key is used to move down.
- LEFT arrow key is used to move to the left.
- RIGHT arrow key is used to move to the right.



**NOTE: Within the LCD, the black box around the smaller box as shown below indicates which field is selected/highlighted. Turning the rotary encoder knob or pressing the UP or DOWN arrow keys moves the black box. When the black box is positioned on a programmable item, such as Shaft Sensors, Speed Sensor, Front Row Units or Rear Row Units, pressing the knob or ENTER key will highlight the programmable item. A programmable item may only be changed when it is highlighted.**

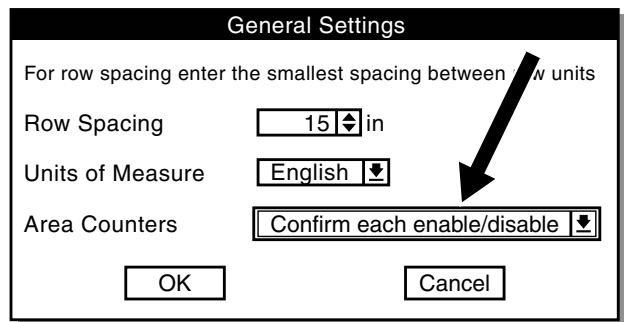

**CHANGING VOLUME, CONTRAST, AND BACKLIGHTING WITH AV KEY**

Alarm, volume, LCD screen contrast, and backlighting may be adjusted at any time, regardless of what is displayed on screen.

STEP 1 Press AV key. Contrast adjustment dialog box appears in center of display.

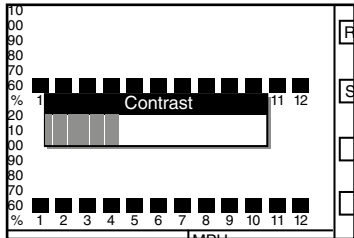

STEP 2 Use arrow keys or turn rotary encoder knob to adjust contrast. Adjustment will be visible on the screen.

STEP 3 To adjust speaker or backlight, go to STEP 4. If finished press Enter key to save and exit.

STEP 4 Press AV button a second time. The Backlight adjustment dialog box will appear in center of the display.

STEP 5 Use arrow keys or turn knob to adjust backlighting. The effect of the adjustment will be visible on display.

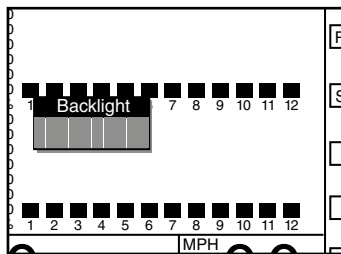

STEP 6 To adjust speaker go to STEP 7. If finished press Enter key to save and exit.

STEP 7 Press AV button a third time. Speaker adjustment dialog box will appear in center of display.

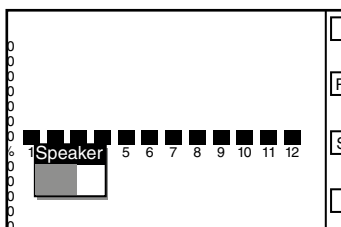

STEP 8 Use arrow keys or turn knob to adjust speaker volume. Volume of sound emitted from speaker changes as adjustment is made.

STEP 9 Press knob, Enter key or press AV button a fourth time to save volume, contrast, and backlight settings.

**CONFIGURING PLANTER MONITOR**

When the KPM III is powered on for the first time it will go directly into the Planter Configuration screen (STEP 4).

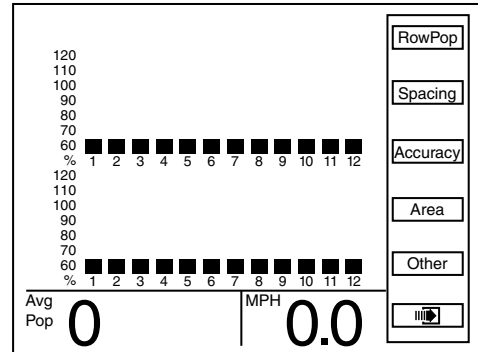

**NOTE: Planter Configuration screen displays planter rows as programmed into KPM III software. The above screen shows 12 front (Interplant) rows and 12 rear rows. If the KPM III were programmed for 8 front (Interplant) rows and 8 rear rows the screen would display 8 front and 8 rear rows.**

STEP 1 Press the F6 key until Mode Selection screen appears.

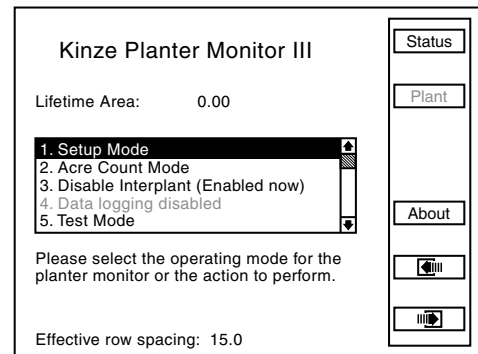

**NOTE: There are 5 choices on the Mode Selection screen;**

1. Setup mode
2. Acre count mode
3. Disable Interplant (Enabled now) mode
4. Data logging mode
5. Test mode

STEP 2 Select "1. Setup Mode" by turning the rotary encoder knob or using the arrow keys. Press the knob or Enter key to display the highlighted item.

**NOTE: There are 10 choices on the Setup Mode screen;**

1. General Settings
2. Seed Meter Settings
3. Row Unit Alarm Levels
4. Setup Data Logging
5. Configure Planter Monitor
6. Add New Muxbus Sensors
7. Add Single Interplant® Row
8. Select Speed Sensor
9. Sensor Setup
10. Calibrate Speed Sensor

STEP 3 Select "5. Configure Planter Monitor" by turning the knob or using the arrow keys. Press the knob or the Enter key to display the highlighted item.

**NOTE: Press F2 key next to Plant any time Plant option is available to return to Planter Configuration screen.**

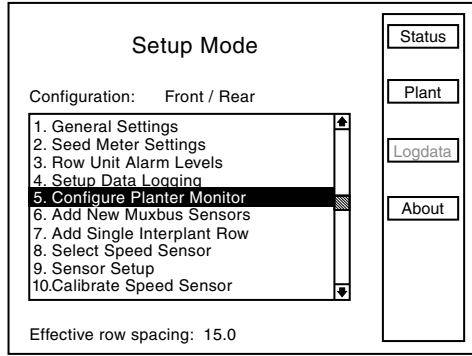

**NOTE: Planter monitor cannot be reconfigured while planting.**

STEP 4 If there are front rows (Interplant) on planter, press knob or Enter key to highlight "Front Rows" field. A drop down number pad appears. Turn knob or use arrow keys to highlight correct value then press knob to select number. For numbers containing more than one digit select one digit at a time. When desired quantity is displayed above number pad press Enter key to return to "Kinze Planter Configuration" screen. If planter has no front rows turn knob or press arrow keys to advance to "Rear Rows".

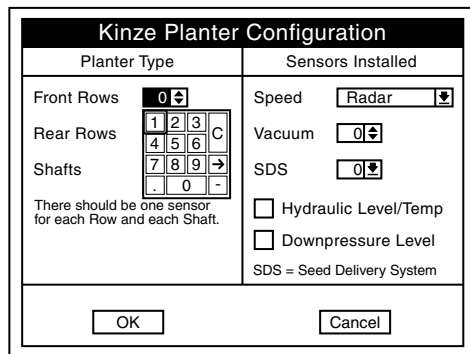

STEP 5 Press knob or Enter key to select "Rear Rows" field. A drop down number pad appears. Turn knob or use arrow keys to highlight correct value then press knob to select number. For numbers containing more than one digit select one digit at a time. When desired quantity is displayed above number pad, press Enter key to return to "Kinze Planter Configuration" screen.

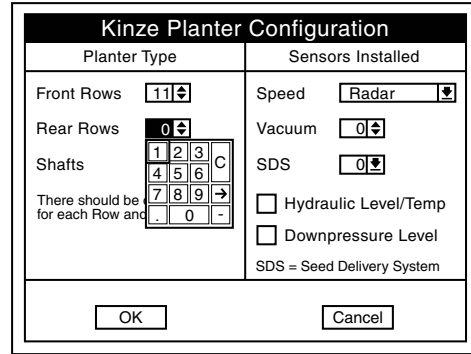

STEP 6 Rotate knob or use arrow keys to advance to "Shafts" field. Press knob or Enter key to select "Shaft" field. A drop down menu appears. Turn knob or use arrow keys to highlight number of "Shafts". When correct value is displayed, press knob or Enter key to return to "Kinze Planter Configuration" screen.

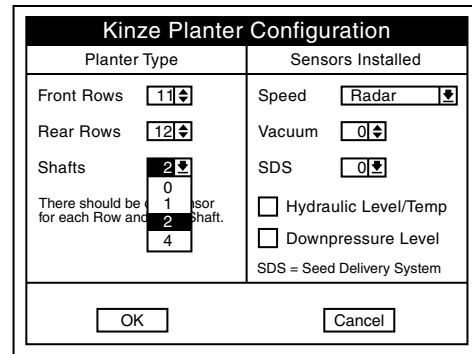

STEP 7 Turn knob or use arrow keys to move to "Speed" field. Press knob or Enter key and a drop down menu displays. Select "Radar" or "Coil Pick-Up" (MDS) by turning knob or using arrow keys. When desired selection is highlighted press knob or Enter key.

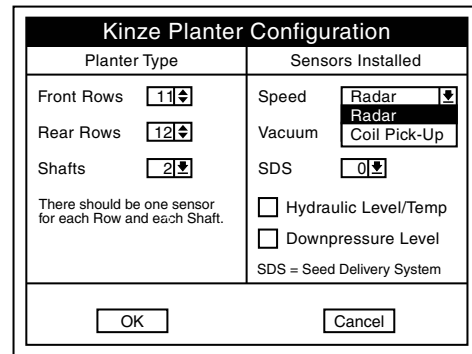

- STEP 8 If applicable, turn knob or use arrow keys to advance to "Vacuum". Press knob or Enter key and a drop down menu will appear. Select correct number of vacuum sensors by turning knob or using arrow keys. Confirm selection by pressing knob or Enter key.
- STEP 9 If applicable, turn knob or use arrow keys to advance to "SDS" (Seed Delivery System), Press knob or Enter key. A drop down menu will appear. Select correct number of SDS Sensors by turning knob or using arrow keys. Press knob or Enter key to confirm selection.
- STEP 10 If applicable, turn knob or use arrow keys to advance to "Hydraulic Level/Temp". Press knob or Enter key to select or deselect. When selected, a check mark will appear in the box.
- STEP 11 If applicable, turn knob or use arrow keys to advance to "Downpressure Level". Press knob or Enter key to select or deselect. When selected, a check mark will appear in the box.
- STEP 12 Advance to "OK" by using knob or arrow keys. Press knob or the Enter key to save information.

Kinze Planter Configuration	
Planter Type	Sensors Installed
Front Rows <input type="text" value="11"/>	Speed <input type="text" value="Radar"/>
Rear Rows <input type="text" value="12"/>	Vacuum <input type="text" value="0"/>
Shafts <input type="text" value="2"/>	SDS <input type="text" value="0"/>
There should be one sensor for each Row and each Shaft.	<input type="checkbox"/> Hydraulic Level/Temp
	<input type="checkbox"/> Downpressure Level
	SDS = Seed Delivery System
<input type="button" value="OK"/> <input type="button" value="Cancel"/>	

**NOTE: To prevent configuration from being saved select "Cancel" and press rotary encoder knob or Enter key. Display will return to "Setup Mode" screen without saving any changes.**

**NOTE: When OK is selected monitor automatically advances to Sensor Setup screen. Sensor Setup can also be selected from Setup Mode screen. Go to page 6-13 (PROGRAMMING/CONNECTING SEED TUBES, SHAFT ROTATION SENSORS AND/OR RADAR/MAGNETIC DISTANCE SENSORS)**

**GENERAL SETTINGS  
(PROGRAMMING INTERPLANT CONDITION, ROW SPACING AND UNITS) (METRIC OR ENGLISH)**

- STEP 1 Turn knob or use arrow keys to highlight "1. General Settings". Press knob or Enter key to display highlighted item.

Setup Mode

Configuration: Front / Rear

1. General Settings
2. Seed Meter Settings
3. Row Unit Alarm Levels
4. Setup Data Logging
5. Configure Planter Monitor
6. Add New Muxbus Sensors
7. Add Single Interplant Row
8. Select Speed Sensor
9. Sensor Setup
10. Calibrate Speed Sensor

Effective row spacing: 15.0

**NOTE: When English is selected inches are displayed, if Metric is selected centimeters are displayed.**

- STEP 2 Press knob or Enter key to enter correct value for "Row Spacing". A drop down number pad will appear. Turn knob or use arrow keys to highlight first digit of desired number and press knob. The number will appear in "Row Spacing" line. Turn knob or arrow keys to highlight next digit of number and press knob. Number will appear in "Row Spacing" line. When correct number is displayed in "Row Spacing" line, press Enter key to return to "General Settings" screen.

**NOTE: Enter narrowest row spacing planter is equipped to plant for "Row Spacing". Example: 12 Row 30 with Interplant, row spacing would be set to 15.**

- STEP 3 Turn knob or use arrow keys to highlight "Units of Measure" field. Select "Units of Measure" field by pressing knob or Enter key, a drop down menu will appear. Highlight "English" or "Metric" by turning knob or using arrow keys. When correct entry is highlighted, press knob or Enter key to accept unit of measure entry and return to "General Settings" screen.

- STEP 4 Turn knob or use arrow keys to highlight "Area Counters" field. Select "Area Counters" field by pressing knob or Enter key, a drop down menu will appear. Turn knob or use arrow keys to highlight "Confirm each enable/disable", "Don't confirm again today", or "Don't confirm enable/disable". When desired selection is highlighted, press knob or Enter key to accept selection and return to "General Settings" screen.

- STEP 5 Once correct values are inputted into "General Settings" screen "OK" button can be selected to save changes, or "Cancel" button can be selected to discard changes. Turn knob or use arrow keys to highlight either "OK" or "Cancel" and press knob or Enter key to return to "Setup Mode" screen.

SEED METER SETTINGS

STEP 1 Scroll to "2. Seed Meter Settings" by turning rotary encoder knob or using arrow keys. Press knob or Enter key to display highlighted item.

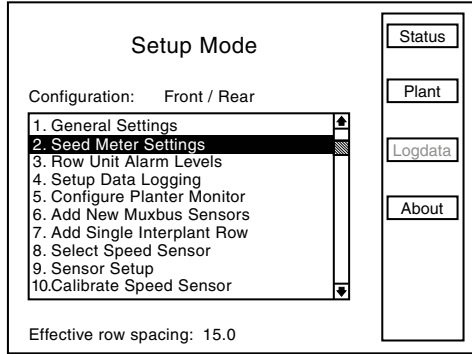

STEP 2 Select meter type by highlighting "Meter Type" and pressing knob or Enter key, then highlight "Mechanical" or "Vacuum" and press knob or enter key.

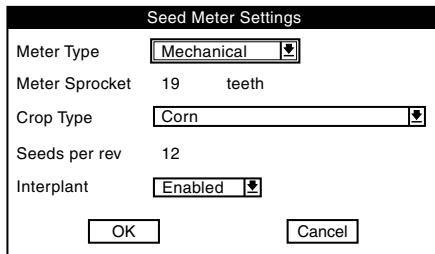
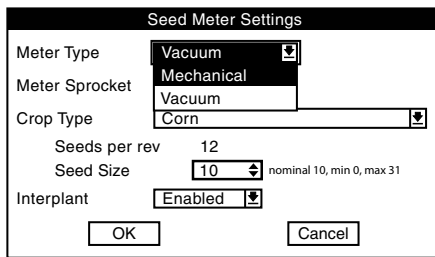

NOTE: When Mechanical "Meter Type" is selected "Meter Sprocket" automatically sets.

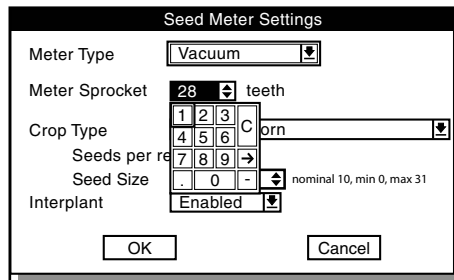

NOTE: When Vacuum "Meter Type" is selected "Meter Sprocket" automatically defaults to 28 teeth. To change "Meter Sprocket" select "Meter Sprocket" by turning knob or using arrow keys. Press knob or enter key, a drop down number pad displays. Turn knob or use arrow keys to highlight first digit of desired number and press knob. When correct number is obtain press knob or enter key.

STEP 3 Turn knob or use arrow keys to highlight "Crop Type". Press knob or Enter key to display crop drop down menu.

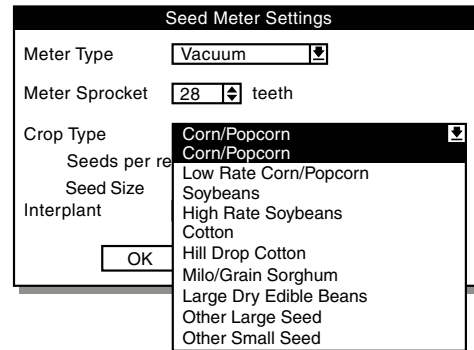

STEP 4 Turn knob or use arrows keys to highlight a crop for planting then press knob or Enter key. Once crop type is entered, "Seeds per rev" is automatically set .

A sensitivity threshold (Seed Size) ensures dust and other debris are filtered out and only actual seeds are counted. Sensitivity threshold is set to a default for a selected crop which is adequate for most conditions.

Sensitivity can be set between 0 and 31, 0 being most sensitive (counts smallest particles) and 31 least sensitive (counts large particles). Adjust threshold one value at a time until desired result is achieved. Once value is changed it becomes default for that crop.

NOTE: Adjusting threshold too high can cause monitor to miss seeds and provide inaccurate information. Always do a ground check to ensure monitor is reading accurately.

STEP 5 Select "Seed Size" and press ENTER key. A drop down number pad displays.

STEP 6 Turn knob or use arrow keys to highlight first digit of desired number. Press knob. When correct number is obtained, press knob or Enter key.

STEP 7 Turn knob or use arrow keys to highlight "Crop Type". Press knob or Enter key to display the crop drop down menu.

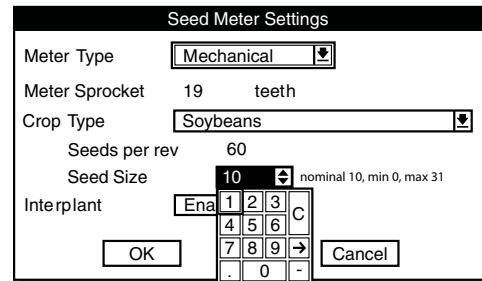

STEP 8 Turn knob or use arrows keys to highlight a crop for planting then press knob or Enter key. Once crop type is entered, the "Seeds per rev" is set automatically.

STEP 9 (If Applicable) Turn knob or use arrow keys to highlight "Interplant". Press knob or Enter key to display Interplant drop down menu.

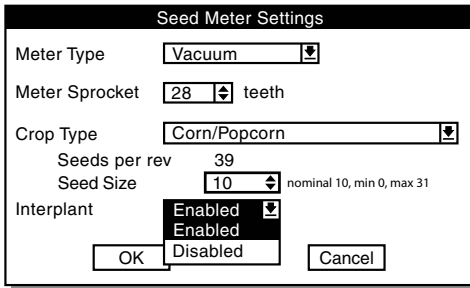

STEP 10 Turn knob or use arrow keys to highlight "enable" or "disable" and press the knob or Enter key.

STEP 11 When all changes have been made, highlight "OK" and press knob or Enter key to return to "Setup Mode" screen.

STEP 1 Select "3. Row Unit Alarm Levels" by turning knob or using arrow keys. Press knob or Enter key to display highlighted item.

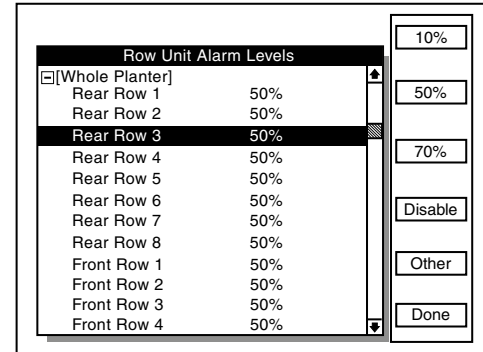

STEP 2 To set alarm thresholds for whole planter, turn knob or use arrow keys to highlight "[Whole Planter]" line. Press key next to desired threshold. When desired threshold is specified for all row units, press F6 key next to "Done".

**PROGRAMMING ROW UNIT ALARM LEVELS**

Row Unit Alarm Levels allow thresholds for seed rate alarms to be set. Default is 50% or Average. If average population drops below 50% for a given row a seed rate alarm is generated for that row unit. The alarm threshold can be set to 70%, 50%, 0% or disabled, or any custom percentage for any row.

**NOTE: When alarm threshold is disabled for any row no seed rate alarm will be generated.**

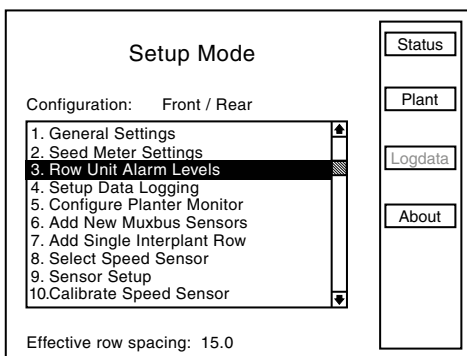

Alarm thresholds can be set for whole planter, any planter section, or individual rows.

**NOTE: A section is a set of rows driven by one or more shafts, designated to a single shaft sensor.**

**NOTE: Only configured rows appear on screen.**

To set alarm thresholds for all rows in one section, highlight desired section. Press key next to desired threshold. When desired threshold is specified for all row units, press F6 key next to "Done".

To set alarm thresholds for individual rows, highlight desired row. Press key next to desired threshold. When desired threshold is specified for all row units, press F6 key next to "Done".

To disable row unit alarm, highlight desired section or individual row. Press F4 key next to "Disable". When alarm is desired again highlight disabled section or row. Press key next to desired threshold.

To enter threshold not listed, highlight desired section or individual row. Press F5 key next to "Other". Press knob or Enter key and a drop down key pad appears. Turn knob or use arrow keys to highlight first digit of desired number and press knob. Number displays in "Enter Alarm Threshold" line. Highlight next digit of the number and press knob. Number displays in the line. When correct number is displayed, press Enter key to return to "Set Alarm Threshold" screen. Turn knob or use arrow keys to advance to "OK". Press knob or Enter key to accept threshold levels.

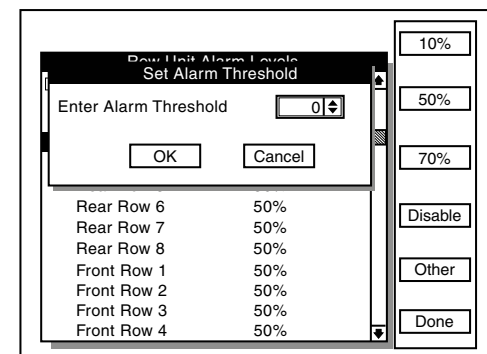

**DATA LOGGING MODE**

**STEP 1** Scroll to “4. Setup Data Logging” by turning the rotary encoder knob or using the arrow keys. Press the knob or Enter key to display the highlighted item.

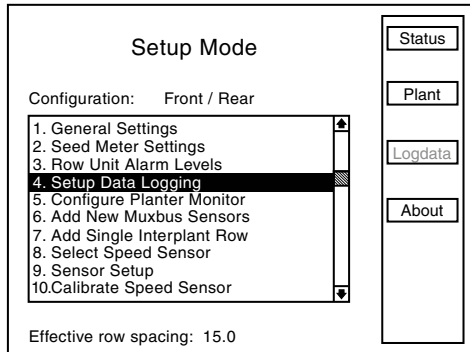

**NOTE: Data logging changes cannot be made while data is being logged. If the monitor is logging data the following warning will appear. To stop data logging and continue.**

- Press the knob or Enter key to close the warning.
- Then in the “Setup Mode” press the F3 key next to “StopLog”.

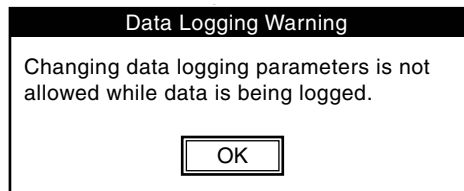

**STEP 2** Turn the knob or use the arrow keys to highlight the “Destination” box then press the knob or Enter key. Highlight the desired option either “Serial Port”, “USB Flash Drive”, or “Serial and USB” and press the knob or Enter key.

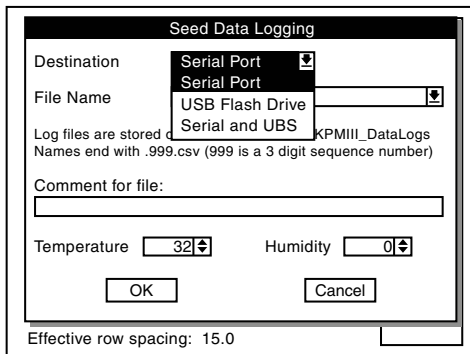

**STEP 3** Use the knob or arrow keys to highlight the “File Name” box. Press the knob or Enter key and a drop down list of the files will be displayed. Select “Add new...” to enter a file name and press the knob or enter key to display a keyboard.

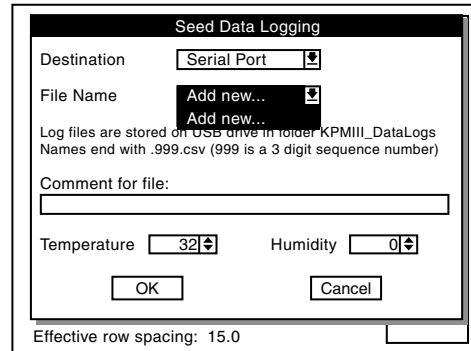

**STEP 4** Select “Add new...” to enter a file name and press the knob or enter key to display a keyboard.

**STEP 5** Add a new file name by using the drop down keyboard. Spell out the file name by highlighting each letter and pressing the knob or Enter key.

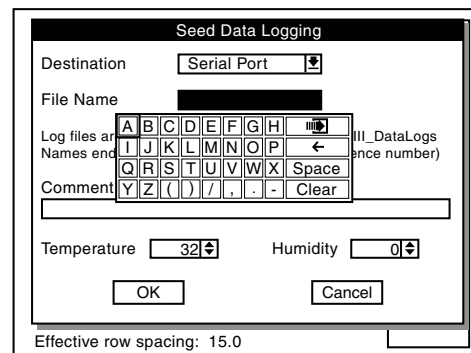

**STEP 6** Use knob or arrow keys to scroll to “Comment for file” box. Press knob or Enter key to display drop down keyboard. Use keyboard to enter a Comment for the file then press Enter key.

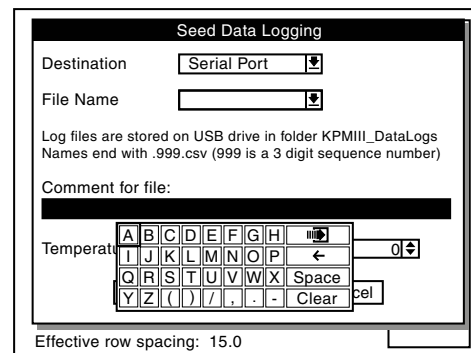



STEP 7 Use knob or arrow keys to scroll to Temperature box. Press knob or Enter key to display drop down keyboard. Use keyboard to enter temperature then press Enter key.

STEP 8 Use knob or arrow keys to scroll to Humidity box. Press knob or Enter key to display drop down keyboard. Use keyboard to enter humidity then press Enter key.

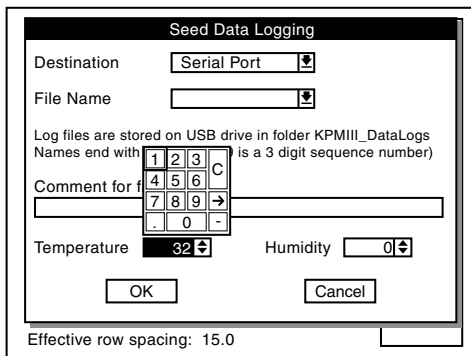

STEP 9 Use knob or arrow keys to scroll to the "OK" button and press knob or Enter key. Display returns to Setup Mode screen.

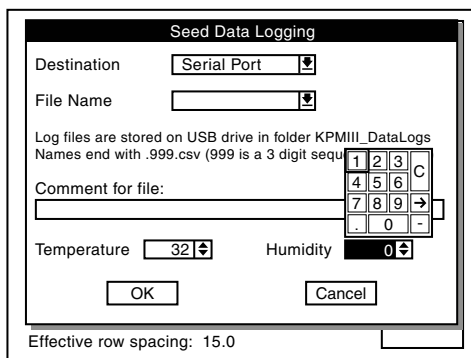

STEP 10 Press F2 key next to Plant to return to Planter configuration screen.

STEP 11 Press F3 key next to "Logdata" to begin logging.

STEP 12 Press F3 key next to "Stoplog" to end logging.

**ADDING INTERPLANT ROWS  
(REAR ROWS PREVIOUSLY PROGRAMMED ONLY)**

**NOTE: Planter monitor configuration must contain an odd number of front rows before single Interplant® row unit can be added.**

STEP 1 Highlight "6. Add New Muxbus Sensors" by turning knob or using arrow keys. Press knob or Enter key to display highlighted item.

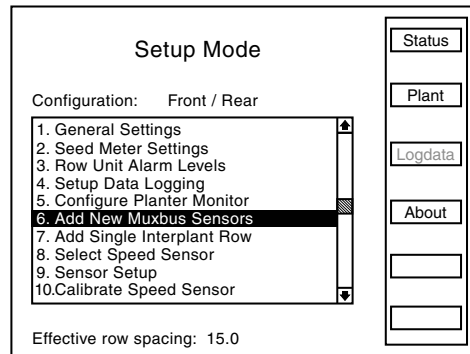

STEP 2 Note shown below displays. Highlight "OK" by turning knob or using the arrow keys. Press knob or Enter key to make selection.

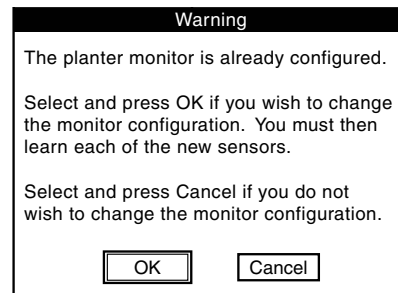

**NOTE: To prevent configuration from being changed, select Cancel, then press the knob, Enter key or ESC key.**

STEP 3 Turn knob or use arrow keys to highlight "Front Rows" field and press knob or Enter key. A drop down number pad appears.

STEP 4 Turn knob or use arrow keys to highlight first digit of desired number and press knob to select the number. For numbers containing more than one digit select one digit at a time. The number will appear in the "Front Rows" line. When correct number is displayed on "Front Rows" line, press Enter key to return to "Kinze Planter Configuration" screen.

**NOTE: To prevent configuration from being changed select Cancel, then press knob, Enter key or ESC key.**

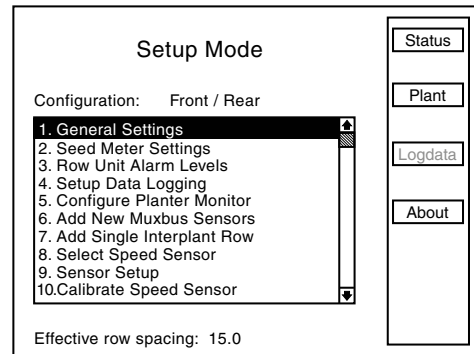
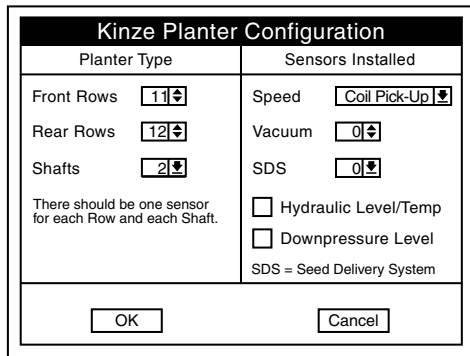

**NOTE: Attempting to add rear rows while adding new Muxbus sensors will cause the following note to appear.**

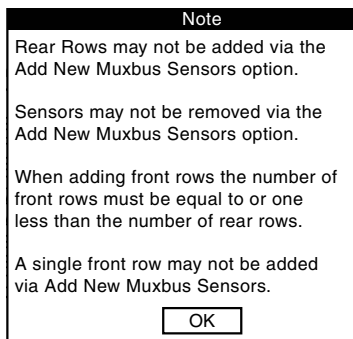

**STEP 9** Turn the knob or use the arrow keys to highlight the "Row Spacing" field. Press the knob or Enter key to make the selection. A drop down number pad will appear. Adjust the row spacing to Interplant spacing by turning the knob or use the arrow keys to highlight the correct value then press the knob to select the number, for numbers containing more than one digit select one digit at a time.

**NOTE: To prevent configuration from being changed select Cancel, then press knob, Enter key, or ESC key.**

**STEP 10** Turn knob or use arrow keys to advance to "OK" button. Press knob or Enter key to save the row spacing and return to "Setup Mode" screen.

**STEP 5** Sensor configuration screen displays. With "[Auto Detect]" highlighted press F1 key next to "Install". Install sensors from left to right the same way rear unit sensors were installed.

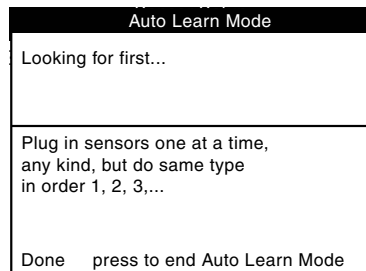

**STEP 6** When all sensors are learned select F1 to end installation. "Auto Learn Mode" box displays. Press F6 key next to "Done".

**STEP 7** Scroll down to verify front rows are learned. Select "OK" by pressing knob or Enter key. Press F6 key next to "Done". Display returns to "Setup Mode Screen".

**NOTE: "OK" displays next to each sensor if no errors are detected.**

**STEP 8** Turn knob or use arrow keys to highlight "1. General Settings". Press knob or use Enter key to make selection.

**ADDING EVEN-ROW PACKAGE  
(FRONT ROWS PREVIOUSLY PROGRAMMED)**

**STEP 1** Turn the knob or use the arrow keys to highlight "7. Add Single Interplant Row". Press the knob or the Enter key to display the highlighted item.

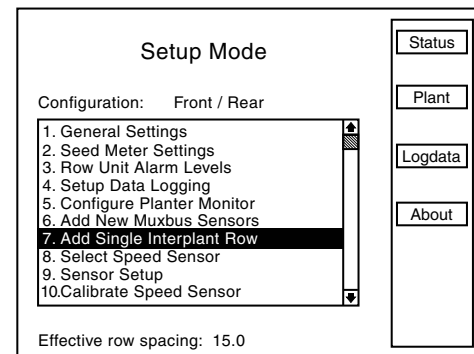

STEP 2 To confirm note below turn knob or use arrow keys to highlight “OK” button, then press knob or Enter key to confirm. If single Interplant row is not to be added select “Cancel” key and press knob or Enter key to cancel or press ESC key.

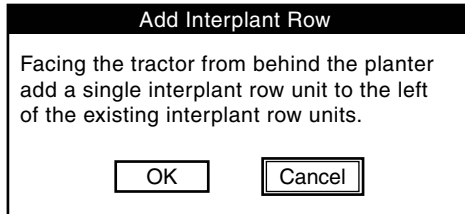

STEP 3 To “Add Single Interplant Row” following screen displays.

If single Interplant row is to be added turn knob or use arrow keys to highlight “OK” button and then press knob or Enter key to add Interplant row. If single Interplant row is not to be added select Cancel key and press knob or Enter key to cancel or press ESC key.

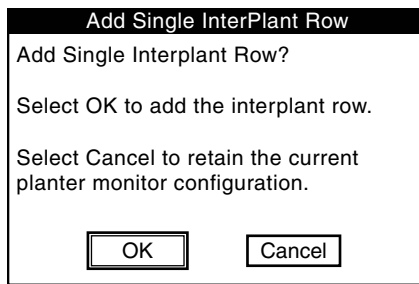

STEP 4 “Sensor Setup” screen displays. Plug in new sensor then scroll down to highlight “Front Row 1” by turning knob or using arrow keys. Press F1 key next to Install to learn new sensor.

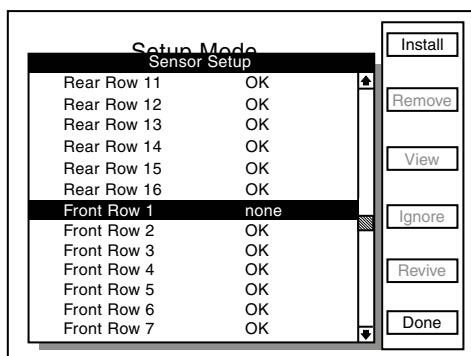

**REPROGRAMMING SPEED SENSOR**

This setting must be specified when monitor is first configured. It must be reprogrammed to use an alternate speed sensor.

**NOTE: Speed sensors may not be changed while planting.**

**RADAR TO MAGNETIC DISTANCE SENSOR**

STEP 1 Turn knob or use arrow keys to highlight “8. Select Speed Sensor”. Press knob or Enter key to display highlighted item.

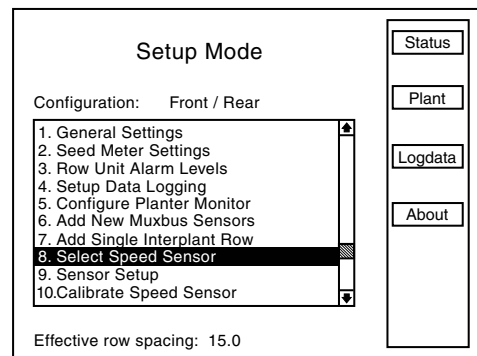

STEP 2 Press knob or Enter key, a drop down menu appears. Highlight “Coil Pick-Up” and press knob or Enter key.

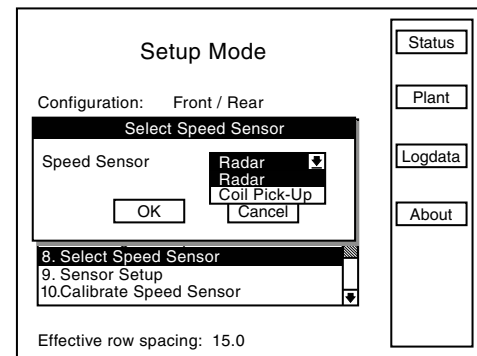

STEP 3 Turn knob or use arrow keys to highlight “OK” button and press knob or Enter key to return to “Setup Mode” screen.

STEP 4 Turn knob or use arrow keys to highlight “9. Sensor Setup” and press knob or Enter key.

STEP 5 Unplug radar from tractor.

**NOTE: To prevent configuration from being changed select Cancel, then press rotary encoder knob, Enter key, or ESC key.**

STEP 6 Plug in Magnetic Distance Sensor (MDS) and press F1 key next to Install. Press knob or Enter key to save information. Sensor Setup screen will appear.

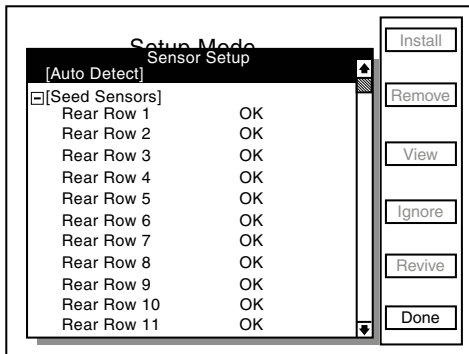

STEP 7 Turn knob or use arrow keys to scroll down to "Ground Speed Sensor".

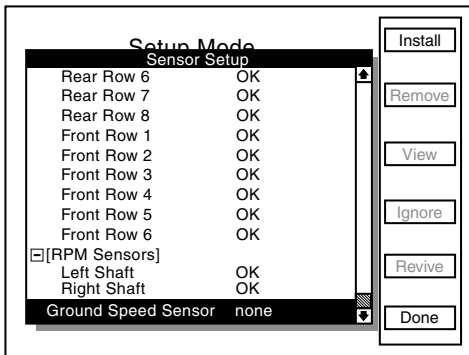

STEP 8 Press F1 key next to Install. Monitor beeps twice to confirm selection.

STEP 9 Press F6 key next to Done. Display will return to Setup Mode screen.

STEP 10 Press F2 key by "Plant" to return to Planter Configuration screen.

**NOTE:** , verify distance pulse count is correct for chosen sensor. There will be significant distance pulse count variation between radar and coil pickup sensors.

**MAGNETIC DISTANCE SENSOR (MDS) TO RADAR**

STEP 1 Turn knob or use arrow keys to choose "9. Sensor Setup". Turn knob or use arrow keys to highlight "Ground Speed Sensor". Press F2 key next to Remove to remove Ground speed Sensor.

STEP 2 Press F6 key next to Done. Display will return to Setup Mode screen.

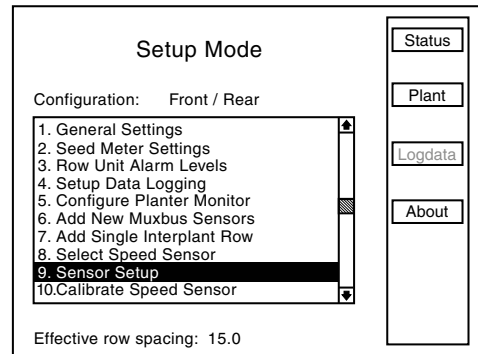

STEP 3 Turn knob or use arrow keys to highlight "8. Select Speed Sensor" and press knob or Enter key.

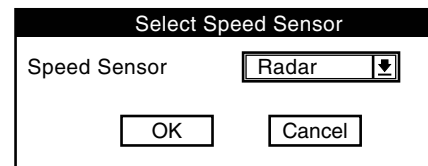

STEP 4 Press knob or Enter key to select "Speed Sensor" field. A drop down menu appears.

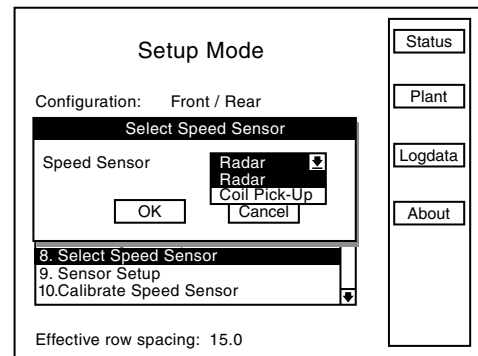

**NOTE:** To prevent configuration from being changed select Cancel, then press rotary encoder knob, Enter key or ESC key.

STEP 5 Turn knob or use arrow keys to highlight "Radar" and press knob or Enter key.

STEP 6 Turn knob or use arrow keys to highlight "OK" button and press knob or Enter key.

STEP 7 Plug in Radar, turn knob, or use arrow keys to advance to "OK". Press knob or Enter key to save the information. Display will return to Setup Mode screen.

STEP 8 Press F2 key next to Plant to return to Planter Configuration screen.

**NOTE:** Verify distance pulse count is correct for chosen sensor when switching between speed sensors. There is a significant distance pulse count variation between radar and magnetic distance sensors.

**PROGRAMMING/CONNECTING SEED TUBES, SHAFT ROTATION SENSORS, AND/OR RADAR/MAGNETIC DISTANCE SENSORS**

**NOTE:** Sensor Setup screen automatically displays after Planter Monitor is configured in Configure Planter Monitor selection in Setup Mode screen.

**IMPORTANT:** All sensors MUST be unplugged before programming begins.

**STEP 1** To access Mode Selection, press F6 key until Mode Selection screen appears.

**STEP 2** Select "1. Setup Mode" by turning rotary encoder knob or press arrow keys. Press knob or Enter key to display highlighted item.

**STEP 3** Select "9. Sensor Setup" by turning knob or using arrow keys. Press knob or Enter key to display highlighted item.

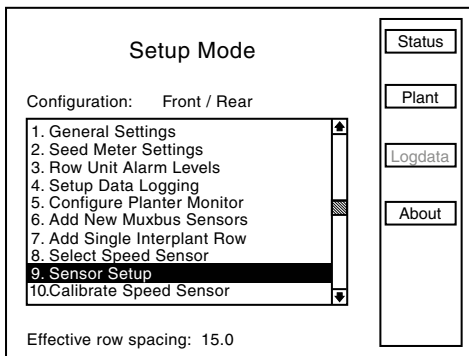

**STEP 4** Attach planter harness to KPM III. Do NOT connect any sensors to planter harness. With [Auto Detect] selected press F1 key next to Install.

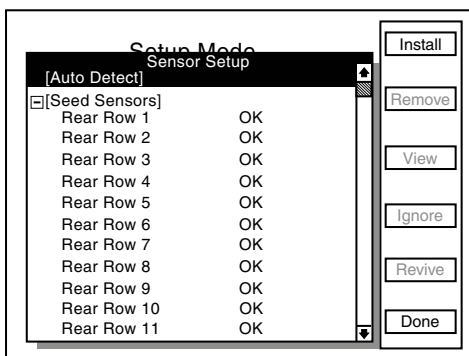

**STEP 5** Plug in first pull row unit seed sensor (row 1), working from left to right across planter. Connect interplant unit sensors after all pull row unit sensors have been connected following the same pattern. When a sensor is connected to planter harness wait for monitor to acknowledge sensor with two beeps.

**NOTE:** If monitor fails to acknowledge a sensor disconnect sensor temporarily then reconnect sensor and wait for monitor to acknowledge sensor with two beeps. If monitor still fails to acknowledge sensor try connecting a different sensor in this location.

Connect shaft rotation sensors or speed sensors the same way seed sensors were connected, making sure to work from left to right across planter.

(If applicable) plug in SDS, vacuum or PDP (pneumatic down pressure) sensors the same way seed sensors were connected.

Progress is displayed on LCD screen as sensors are connected. Example below indicates last seed sensor found was Rear Row 4 and monitor is looking for next sensor.

When all sensors are installed press F6 key to end installation and return to "Setup Mode" screen.

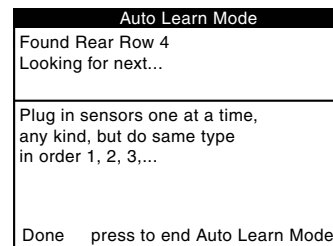

**NOTE:** After each sensor has been installed "OK" appears after sensor name on LCD screen.

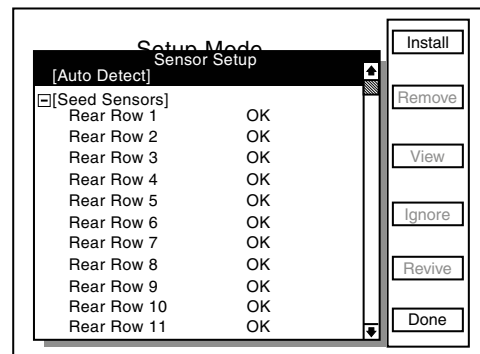

**STEP 6** When "OK" appears behind ALL sensors, press F6 key next to Done. 'Setup Mode" menu displays.

**NOTE:** If "OK slow" appears after a sensor, sensor is able to communicate but at a slower speed. For system to run at top speed of 9600 baud slow sensor must be replaced.

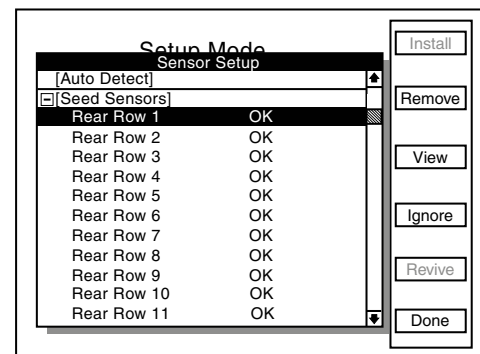

**SPEED SENSOR CALIBRATION/PROGRAMMING**

STEP 1 Turn knob or use arrow keys to highlight "10. Calibrate Speed Sensor" and press knob or Enter key.

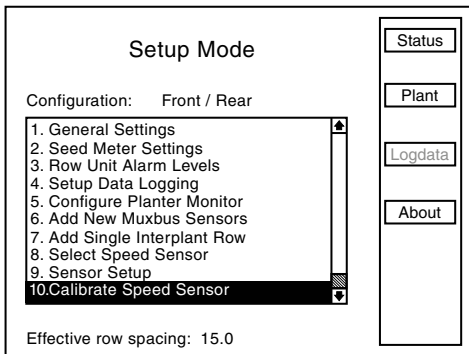

Distance Pulse Count records how many pulses are generated per mile/kilometer from the ground speed sensor.

**NOTE: A field calibration must be performed to establish Distance Pulse Count number. Several factors can affect this value, such as wheel slip on the magnetic distance sensor. IT IS NOT UNCOMMON FOR MONITOR SPEED TO VARY SLIGHTLY FROM TRACTOR SPEEDOMETER. Adjusting Distance Pulse Count in the monitor to make speed agree with tractor can cause serious errors in acre/hectare and population/spacing readings. Do field checks to verify populations and seed spacing.**

- In field conditions, measure 330 feet or 100 meters, depending on the unit of measurement selected. Place a marker at the start point and end point.
- Pull tractor up to starting point.
- Turn knob or use arrow keys to highlight "1. Tractor stopped, Start calibration" and press knob or Enter key.
- Drive tractor for 330 feet or 100 meters.
- Monitor will count number of pulses and display them.
- Stop tractor at end point.
- Turn knob or use arrow keys to highlight "2. Tractor stopped, Calibration Done" and press knob or Enter key.

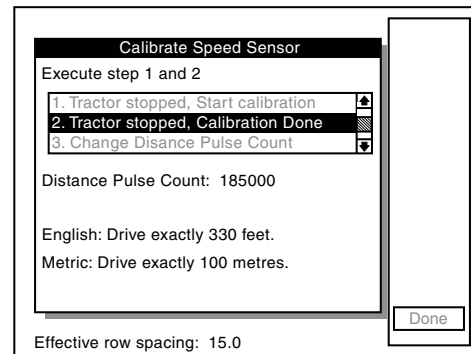

**NOTE: If warning box below appears, click OK and repeat procedure.**

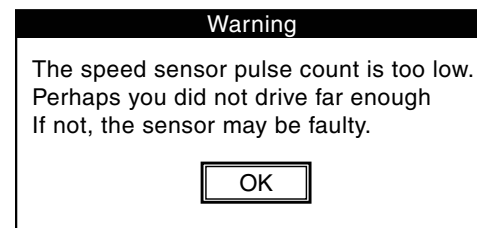
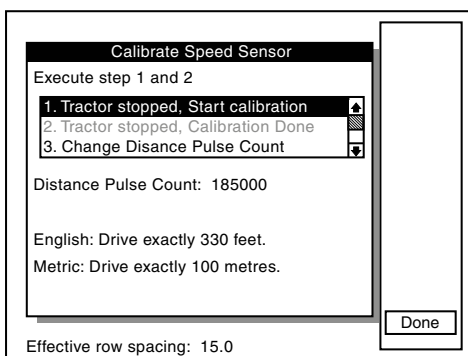

**NOTE: Repeat above steps multiple times. Record and average values. Use average for Distance Pulse Count number constant.**

**NOTE: Distance Pulse Count will vary from above example.**

When correct distance pulse count is known, calibration is not needed and the following steps may be used.

STEP 1 Turn knob or use arrow keys to highlight "10. Calibrate Speed Sensor" and press knob or Enter key

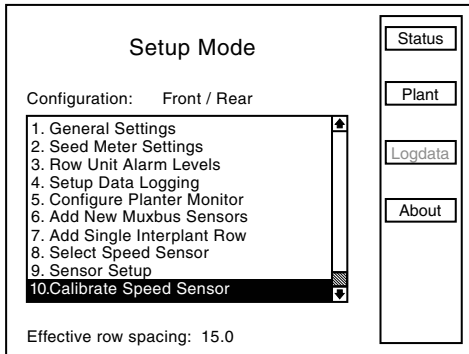

Monitor will display current pulses per mile/kilometer using a 6 digit, no decimal place format labeled "Distance Pulse Count". Turn knob or use arrow keys to highlight "Change Pulse Count" then press knob or Enter key. The "Distance Pulse Count" box will appear.

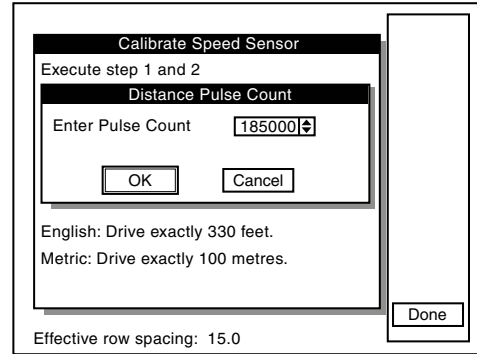

STEP 2 Turn knob or use arrow keys to highlight "3. Change Distance Pulse Count" and press knob or Enter key. Highlight "Enter Pulse Count" line and press knob or Enter key and a drop down key pad will appear.

- When "Enter Pulse Count" value is highlighted press knob or Enter key and a drop down key pad will appear. Turn knob or use arrow keys to highlight "0", zero, and press knob or Enter key. Turn knob or use arrow keys to highlight "OK" and press knob or Enter key to return to the "Calibrate Speed Sensor" screen.

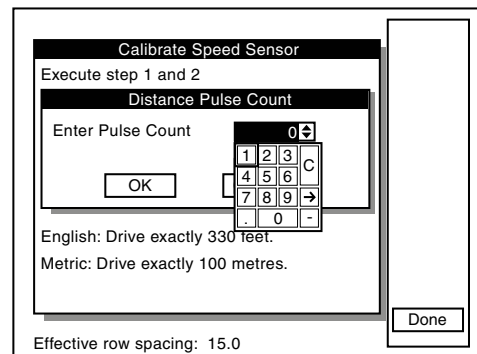
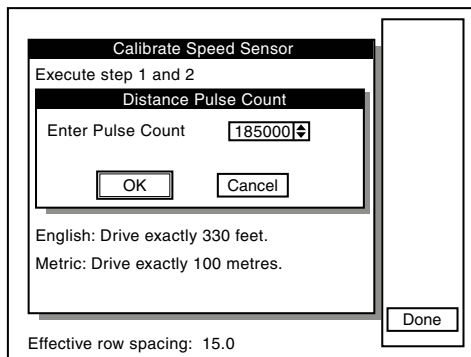

**NOTE: Distance Pulse Count will vary from above example.**

STEP 3 Turn knob or use arrow keys to highlight the first digit of the average pulse count and press the knob. The number will appear in the "Enter Pulse Count" line. Highlight the next digit of the number and press the knob. Repeat this procedure until the entire number is entered then press Enter key.

**NOTE: If Distance Pulse Count number starts to count pulses with the tractor not moving, check radar distance sensor for vibration or other interference.**

STEP 4 Turn knob or use arrow keys to highlight "OK" then press knob or Enter key to return to the "Calibrate Speed Sensor" screen.

STEP 5 Press F6 key next to "Done" to return to "Setup Mode" screen.

**ACRE COUNT MODE**

**NOTE: When a tractor is equipped with a radar distance sensor, accumulating area without a planter attached is possible.**

STEP 1 Install an "Acre Count Switch Kit".

STEP 2 Enter into "Acre Count Mode".

**Acre Count Switch Kit**

STEP 1 With monitor OFF, attach an Acre Count Switch Kit to Muxbus connector, then turn monitor "ON".

STEP 2 Press F6 key until Mode Selection screen appears. Turn rotary encoder knob or use arrow keys to highlight "2. Acre Count Mode". Press knob or Enter key.

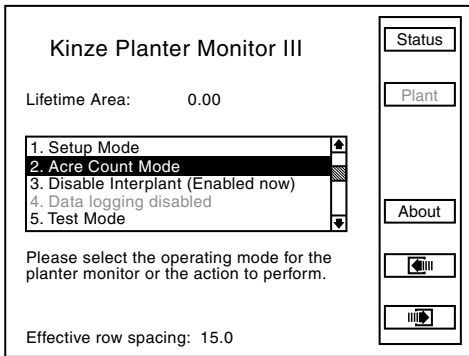

**NOTE: If radar unit is not detected a warning displays.**

**NOTE: When using the acre count mode option, area (acres or hectares) is accumulated in "Lifetime Area Counter".**

**NOTE: DO NOT BEGIN ACCUMULATING AREA IF RADAR UNIT HAS NOT BEEN CALIBRATED. Always check distance pulse count value immediately after entering acre count mode and before pressing start.**

STEP 3 Turn knob or use arrow keys to highlight "Units & Width" and press knob or Enter key.

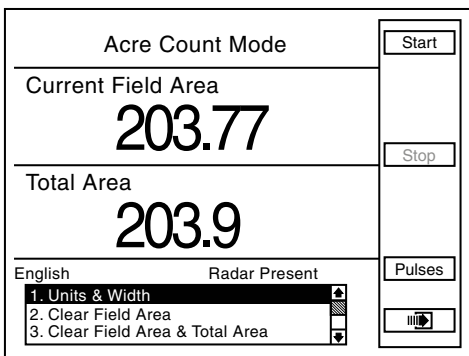

STEP 4 A box named "Acre Count General Settings" will appear. Highlight "English" or "Metric" by turning knob or using arrow keys. Press knob or Enter key to make selection.

STEP 5 Turn knob or use arrow keys to highlight "Implement Width" box and press knob or Enter key and a drop down number pad displays.

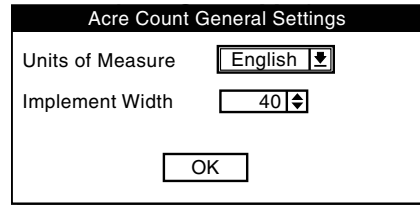

STEP 6 Turn knob or use arrow keys to highlight correct value then press knob to select number. For numbers containing more than one digit select one digit at a time. When desired quantity is displayed above number pad, press Enter key.

STEP 7 Turn knob or use arrow keys to highlight "OK" button. Press knob or Enter key to save changes.

**NOTE: Implement width entered in acre count mode has no effect on planting mode settings.**

**NOTE: Tractor should be at a complete stop before starting.**

STEP 8 To begin accumulating area press F1 key next to Start.

STEP 9 To stop accumulating area or to move to a different location, press F3 key next to Stop.

There are two counters in the Acre Count Mode (Field Area Counter and Total Area Counter). The "Field Area" counter can be cleared independent of the "Total Area" counter, however clearing "Total Area" counter also clears "Field Area" counter.

• To Clear Field Area. Highlight "Clear Field Area" and press knob or Enter key. A note will appear verifying decision to reset field area to zero. Highlight "OK" and press knob or Enter key to clear field. Highlight "Cancel" and press knob or Enter key to retain current field value.

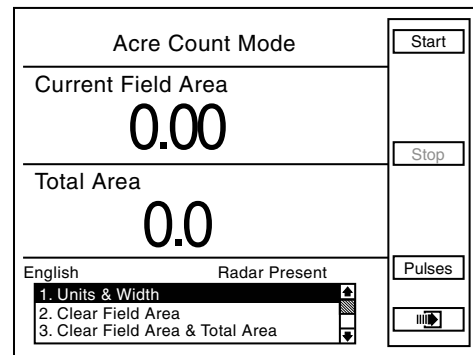

• To Clear Field Area And Total Area, highlight "Clear Field Area & Total Area" and press knob or Enter key. A note will appear to verify decision to reset field area and total area to zero. Highlight "OK" and press knob or Enter key to clear field. Highlight "Cancel" and press knob or Enter key to retain current field values.



**ENABLING/DISABLING INTERPLANT ROWS**

To Enable or Disable Interplant

- STEP 1 Return to "Planter Configuration" screen by pressing F2 key next to "Plant".
- STEP 2 Press F6 key until "Kinze Planter Monitor III" screen appears.
- STEP 3 Turn rotary encoder knob or use arrow keys to highlight "3. Disable Interplant (Enabled now)" or Enable Interplant (Disabled now).
- STEP 4 Press knob or Enter key to "Disable" or "Enable" Interplant. Row spacing is displayed on bottom of screen to verify selection.

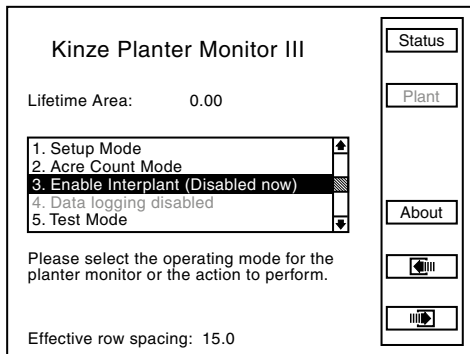
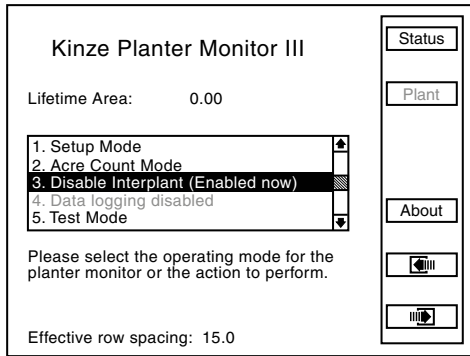

Press F6 to return to Plant screen.

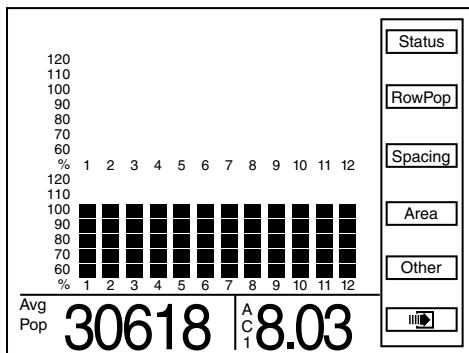

**TEST MODE**

- STEP 1 Press F6 key until Mode Selection screen appears.
- STEP 2 Select "5. Test Mode" by turning rotary encoder knob or using arrow keys. Press knob or Enter key to display highlighted item.

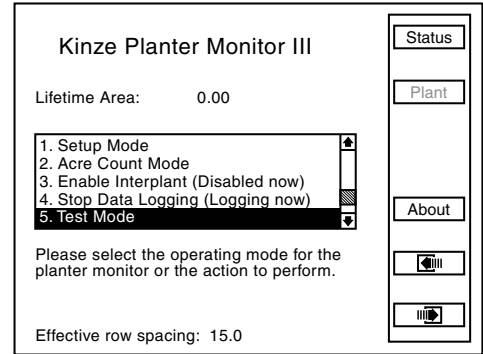

STEP 3 Press F1 key next to Start.

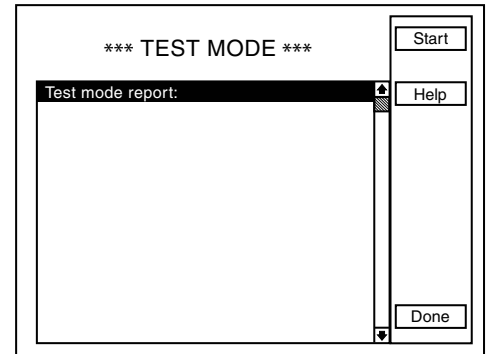

STEP 4 "Test Mode Active" box displays showing number of shaft revolutions. "End" box is highlighted. Press knob or Enter key. "Test Mode Active" box displays showing drill shaft revolutions.

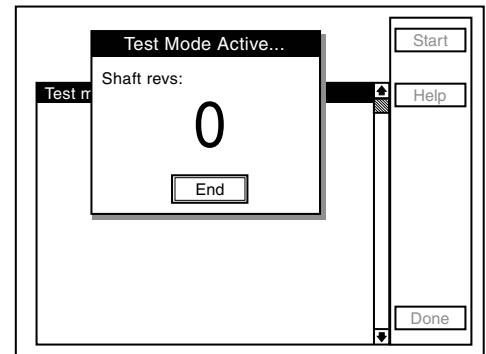

STEP 5 TEST MODE screen displays test run data (seed count) for each row.

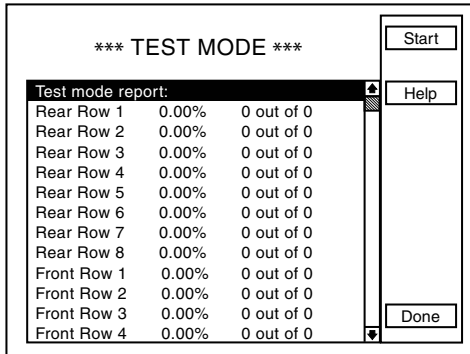

STEP 6 Begin test with tractor stopped. For EdgeVac planters, ensure vacuum is on and seed discs are full.

STEP 7 Press F1 key next to Start and plant a test strip.

STEP 8 Stop tractor and press "End". KPM III displays seed counts by row and percentage.

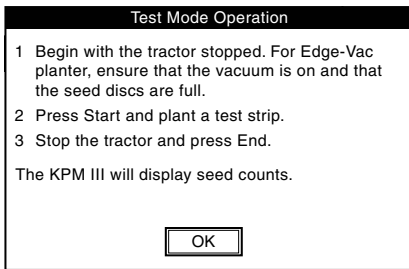

NOTE: Above instructions display on screen when F2 key next to "Help" is pressed.

STEP 9 Press F6 key next to Done. Display returns to Mode Selection screen.

**ROW POPULATION**

Press F1 key next to "RowPop" to display row population. Average planter population is shown in lower L.H. corner of display.

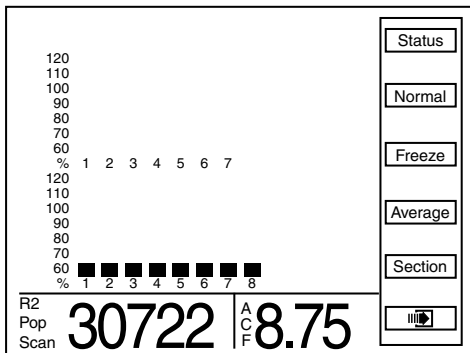

• Press F3 key next to Scan. Monitor scans through each row in ascending order displaying average seed population for each row. After all rows have been scanned, average population displays and scan function continues with first rear row.

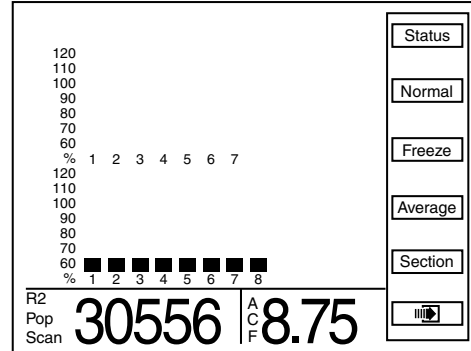

• Press F3 key next to Freeze to stop scanning. Left display item will be frozen on a particular row. "Frzn" appears in lower L.H. corner to indicate display is frozen. To resume scan press F3 key next to Scan.

EXAMPLE: When average individual row population is shown, R3 indicates rear row 3, F2 indicates front row 2, etc.

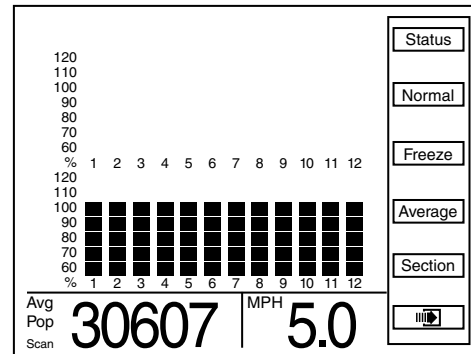

• When "Scan" or "Frzn" is displayed in L.H. corner, Section and arrow keys function as follows:

• Section, Right arrow key, or Left arrow key advances to the first rear row.

• Up arrow key moves forward to the next row of the planter, wrapping around to the first row when moving past the last row.

• Down arrow key moves backward to the previous row of the planter, wrapping around to the last row of the planter when moving past the first row.

• Press F4 key next to Average to display average population in bottom L.H. corner.

• Press F2 key next to Normal to display normal screen for Planter Configuration screen.

NOTE: If rows are being scanned and F4 key next to Average is pressed, scan function stops.

**ROW SPACING**

- Press F2 key next to Spacing to display seed spacing keys. “Average Spacing” will appear in bottom L.H. corner of display.

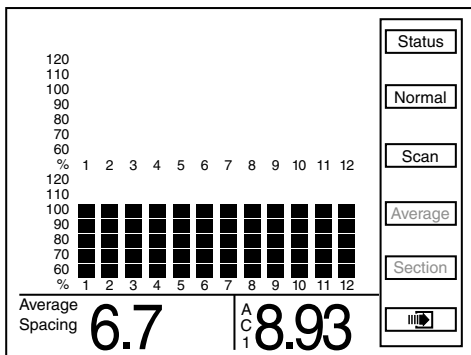
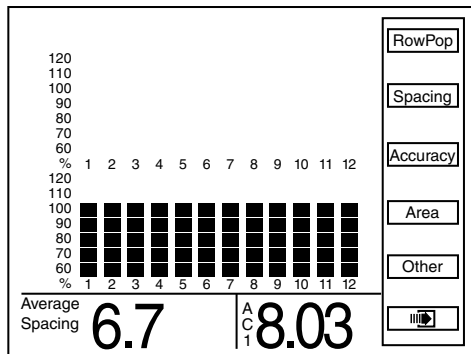

- Press F3 key next to Scan and monitor scans through each row in ascending order displaying average seed spacing for each row. Scan appears in L.H. corner to indicate display is scanning. After all rows are scanned average population is displayed and scanning continues with first rear row.

- Press F3 key next to Freeze to stop scanning, left display item will be frozen on a particular row. “Frzn” appears in lower L.H. corner to indicate display is frozen. To resume scan press F3 key next to Scan.

- When “Scan” or “Frzn” is displayed in left display item, Section and arrow keys function as follows:

- Section, Right arrow key, or Left arrow key advance to first rear row.

- Up arrow key moves forward to next row of planter, wrapping around to first row when moving past last row.

- Down arrow key moves backward to previous row of planter, wrapping around to last row of the planter when moving past the first row.

- Press F4 key next to Average to display average seed spacing in bottom L.H. corner.

- Press F2 key next to Normal to display Planter Configuration screen.

**NOTE: If rows are being scanned and F4 key next to Average is selected, scan function stops.**

**ACCURACY**

**NOTE: Soybeans will not show Skips/Multiples.**

- Press F3 key next to Accuracy to display drop down menu. Select either “Skips/Multiples” or “Accuracy”

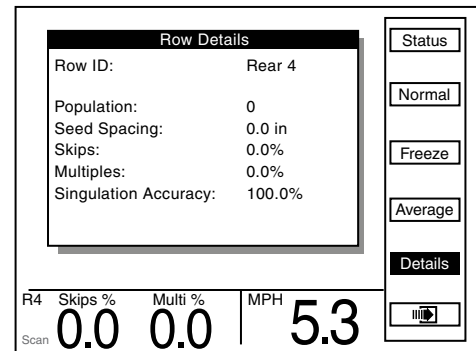
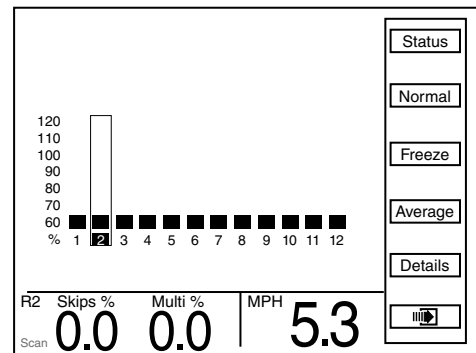
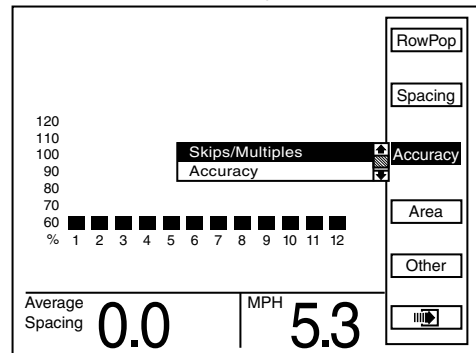

- When “Skips/Multiples” is selected average “Skips” and “Multiples” appears in the bottom L.H. corner.

- When “Accuracy” is selected average “Average Accuracy %” appears in the bottom L.H. corner.

**Example: When average individual row accuracy is shown, R3 indicates rear row 3, F2 indicates front row 2, etc.**

- Press F3 key next to Scan. Monitor scans through each row in ascending order displaying average Skips and Multiples for each row. “Scan” appears in lower L.H. corner to indicate display is scanning.

- Press F3 key next to Freeze to stop scanning. Left display item will be frozen on a particular row. “Frzn” appear in lower L.H. corner to indicated display is frozen. To resume scan press F3 key next to Scan.

- Press F5 key next to Details to display “Row Details”.

**SPEED/SHAFT ROTATION**

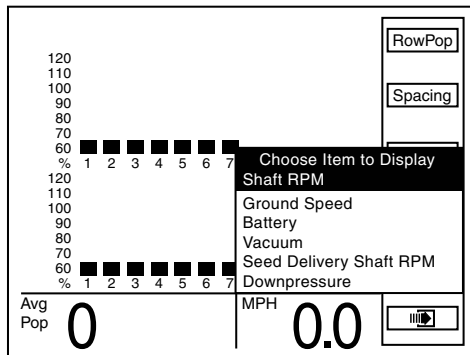
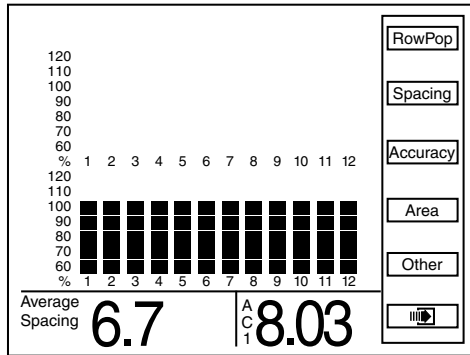

- Press F5 key next to Other for items available to display in bottom R.H. corner. Turn knob or use arrow keys to highlight “Shaft RPM”. Value appears in bottom R.H. corner of display as “RPM”.

**NOTE: Applies to planters with shaft rotation sensors installed.**

- Press F5 key next to “Other” for items available to display in bottom R.H. corner. Turn knob or use arrow keys to select “Ground Speed”. Value appears in bottom R.H. corner of display as “MPH” or “Km Per Hr”.

**NOTE: Selected units of measure display as (English or Metric).**

- Press F5 key next to “Other” for items available to display in bottom R.H. corner. Turn knob or use arrows keys to advance to “Battery” to view battery condition. Value appears in bottom R.H. corner of display as “Bat V”.

- Press F5 key next to “Other” for items available to display in bottom R.H. corner. Turn knob or use arrows keys to advance to “Vacuum” to view vacuum. Inches of vacuum appears in bottom R.H. corner of display as “VAC”.

- Press F5 key next to “Other” for items available to display in the bottom R.H. corner. Turn knob or use arrows keys to advance to “Seed Delivery Shaft RPM” to view shaft RPM. Shaft RPM appears in bottom R.H. corner of display as “RPM SDS”.

- Press F5 key next to “Other” for items available to display in bottom R.H. corner. Turn knob or use arrows keys to advance to “Downpressure” to view lbs. of down pressure. Lbs. of down pressure appears in bottom R.H. corner of the display as “LBS”.

**WARNINGS AND ALARMS**

**STEP 1** Seed Rate Alarm - A seed rate alarm is activated whenever row average seed population drops below threshold set for that row.

Corresponding row on bargraph starts flashing and monitor emits a series of beeps that persist until alarm is cleared or ACK button is pressed. "Seed Rate Alarm" appears in upper left corner of screen. Bargraph for row drops down based on threshold set for alarm.

**EXAMPLE:** If threshold is 70%, lower two bargraph segments are shown. If threshold is 50% or 10%, lowest bargraph segment is shown.

Status message associated with an alarm contains more information about the alarm. To view "Status Message" for a seed rate alarm, press F1 key next to Status.

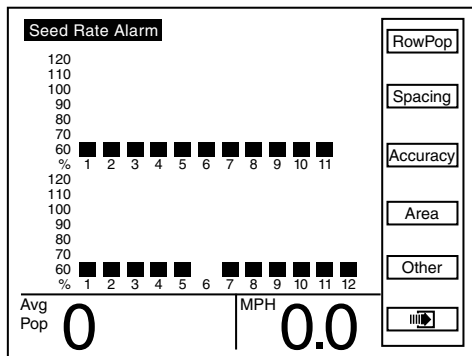

If sensor detects no seed flow it displays which row is not functioning. Alarm may be caused by a mechanical problem reducing seed flow or an electrical problem causing an incorrect seed count.

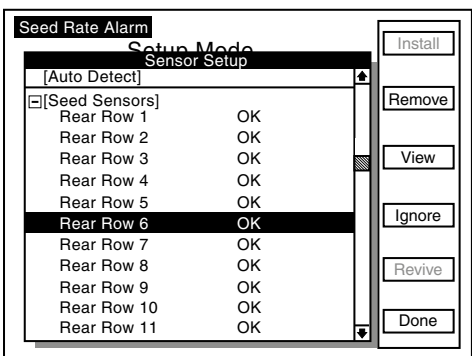

**NOTE:** Only way to remove an alarm is to find problem and correct it. Alarms are not reported for rows with seed rate alarm thresholds disabled.

**NOTE:** Percentage shown in alarm message is percentage at time alarm occurred.

Row can be removed by pressing F2 key next to Remove. A box appears asking for confirmation to remove row. "OK" box is highlighted in box.

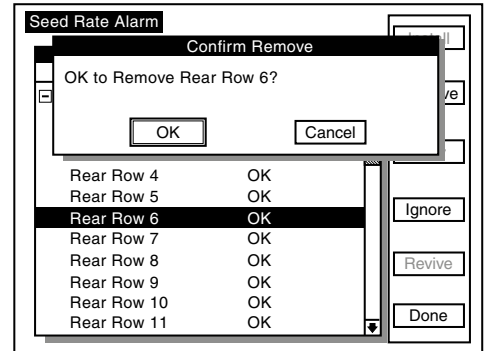

Press knob or Enter key to confirm removal. Sensor Setup screen displays "none" next to the row that was removed. Press F6 key next to "Done". The setup mode screen will appear.

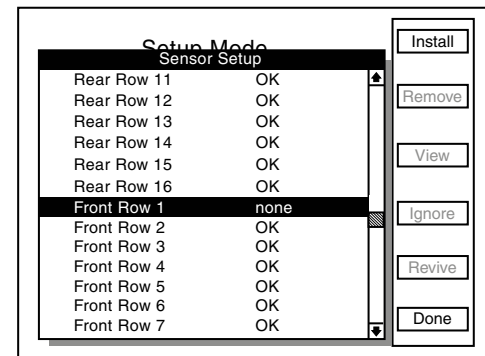

Press F2 key next to Plant to return to Planter Configuration screen.

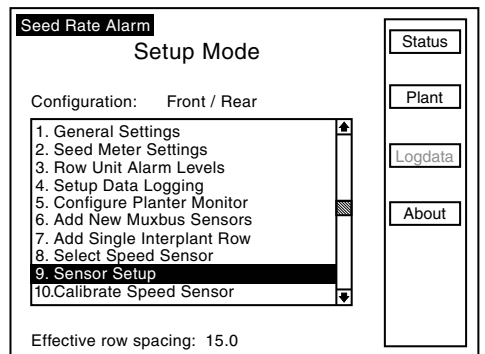

**STEP 2** Section Not Planting - If monitor detects an entire section not planting, three beeps sound. Affected section bargraph flashes and is reduced to lowest segment. An alarm message is added to list of "Status Messages". Press F1 key next to Status to view alarm message.

**STEP 3** Counting Sensors Not Communicating With Monitor - If monitor detects a communication error between sensor and monitor, monitor beeps twice.

- Try to reestablish communication with sensor(s) by pressing F2.
- If monitor is unable to establish communication there may be a faulty sensor, poor electrical connection, or a cut or pinched wire harness.

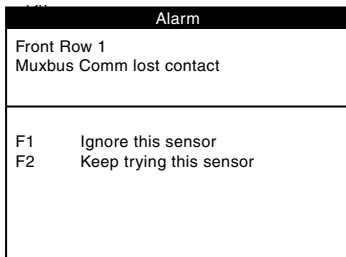

Message below shows multiple sensors with lost contact.

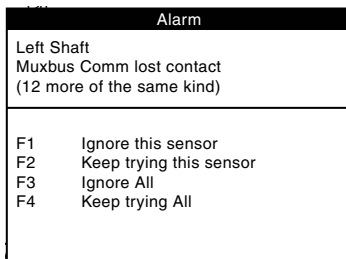

**NOTE:** When a known sensor or group of sensors are faulty, press F1 or F3. Monitor stops communication with affected sensors and corresponding bargraphs are grayed out on main "Planter Configuration" screen.

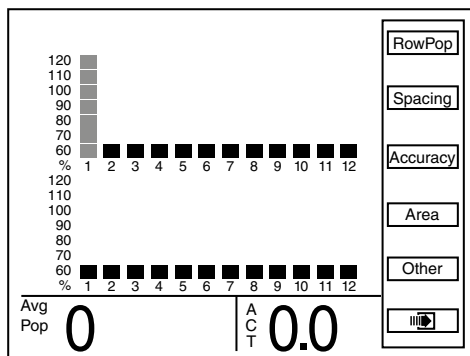

**NOTE:** Press F2 or F4 if sensors are not faulty. After pressing F2 or F4 a message similar to the one below appears when "Status" button F1 is pressed.

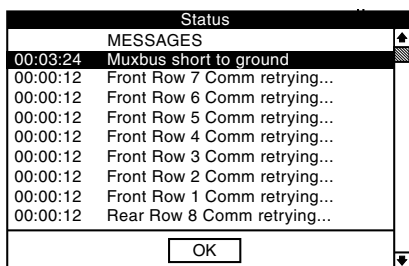

**NOTE:** If a sensor has been ignored, sensor configuration screen displays as shown below.

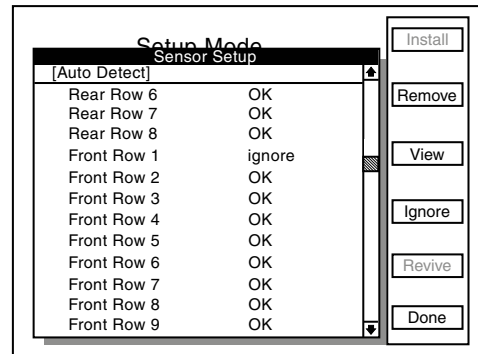

**STEP 4** Seed Counting Sensors Too Dirty Warning - When powering on KPM III, seed sensor performs a self check. If a seed tube is too dirty, the message "Clean or Replace Sensor as Necessary" displays and bargraph for that row will flash.. Sensor will not function until problem is corrected.

**NOTE:** LCD screen continues to display alarm condition after alarms are acknowledged if alarm condition is still present.

**STEP 5** Wire Shorts - When a wire is shorted, one of the messages below displays, indicating which wires are shorted. Short must be located and repaired to continue planting. Turn off and restart monitor to clear alarm.

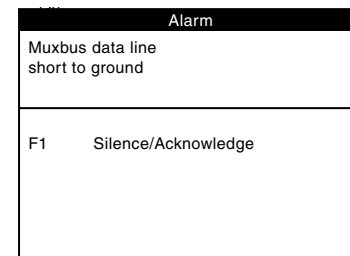
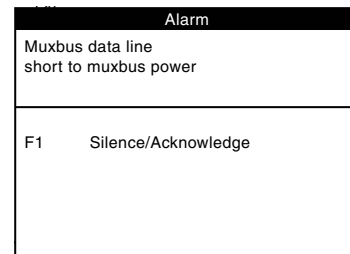

STEP 6 Add Interplant Row Error – Planter monitor configuration must contain an odd number of front rows before single Interplant row unit can be added.

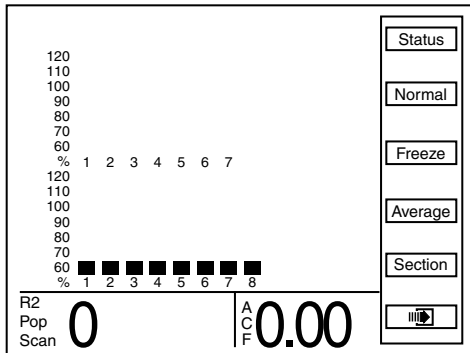

NOTE: Planter monitor configuration above has an even number of front (Interplant) rows (8).

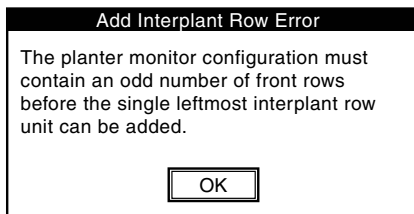

STEP 7 Sensor Present Warning – One or more sensors are present on Muxbus.

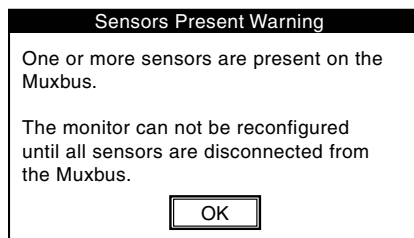

STEP 8 Alarm: Rear Row 1 wake failed – Select an option from warning box and press key next to selection.

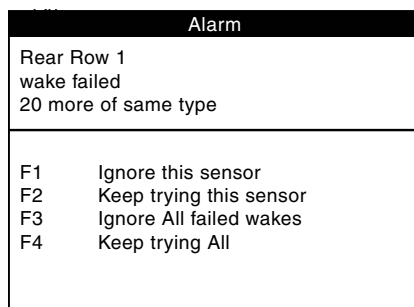

FIELD OPERATION

Press ON/OFF key to turn monitor ON.

If monitor has been configured, it will show Planter Configuration screen and attempt to communicate with seed sensors.

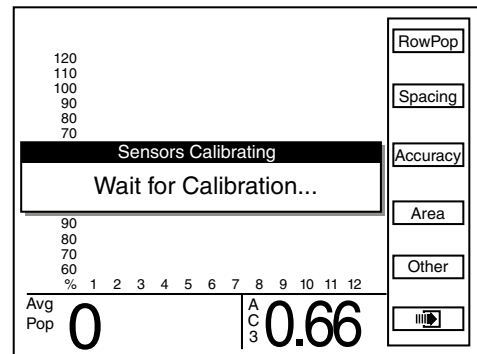

NOTE: Do not attempt planting before “Wait For Calibration” message disappears. If planter is moving while sensors are calibrating alarms will be generated.

NOTE: If monitor can communicate with sensors Planter Configuration screen displays. If monitor does not detect sensors message below displays.

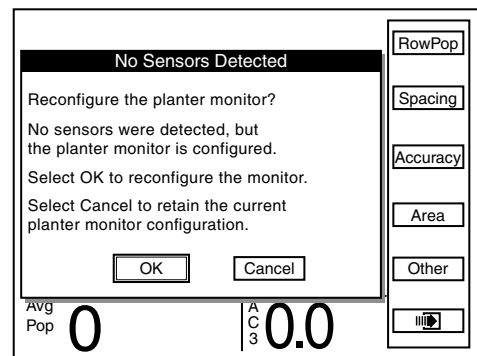
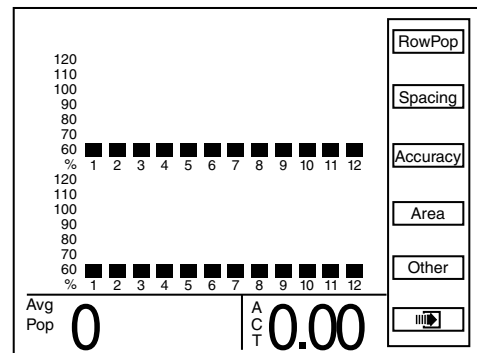

NOTE: Selecting OK reconfigures monitor requiring all sensors to be re-learned. Selecting Cancel keeps current configuration and monitor continues trying to communicate with sensors.

**AREA MANAGEMENT**

There are 42 area counters: Total Area, Field Area and Area Counters 1 through 40. Total Area is always active but may be cleared. If cleared, Field Area is also cleared. Field Area and Area Counters 1 through 40 may be cleared, started or stopped separate from each other.

In addition, there is a Lifetime Area Counter (located on Mode Selection Screen) which can not be disabled or cleared by user.

Press F6 key until "Area Management" screen displays.

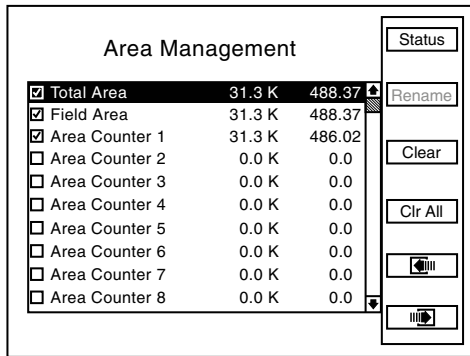

**NOTE: Total Area counter can never be disabled, but can be reset to zero (cleared).**

- Check mark (✓) in box next to name of area counter indicates area counter is enabled and accumulating area.

**EXAMPLE: In above illustration, 31.3K indicates average seed population per unit area (either acre or hectare). This number has been rounded off. Actual seed population ranges anywhere from 30,500 to 31,499 per unit area. Last column of numbers is area accumulated (acre or hectare).**

- Turn knob or use arrow keys to highlight desired area counter.
- Press F2 key next to Rename to name area. A drop down keyboard displays. Use keyboard to enter area name. Press knob or enter key to save information.

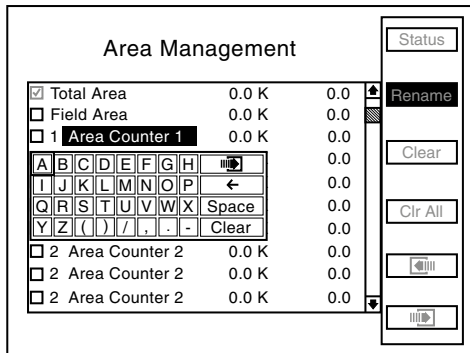

**NOTE: When a key is dimmed it does not perform any operation on highlighted area counter. • Use knob or arrow keys to highlight the "OK" button, press knob or Enter key.**

**Enable Area Counter**

- Highlight desired "Area Counter" by turning rotary encoder knob or using arrow keys.
- Press knob or Enter key. A "Confirm Area Counter Enable" box displays.

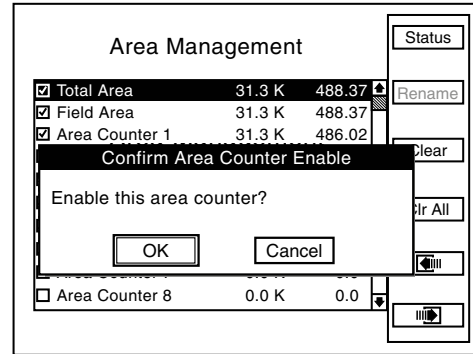

- Use knob or arrow keys to highlight "OK" button and press knob or Enter key. Enabled "Area Counter" starts accumulating area.

**Disable Area Counter**

All area counters may be disabled, except Total Area Counter.

- Highlight desired "Area Counter" by turning rotary encoder knob or using arrow keys.
- Press knob or Enter key. A "Confirm Area Counter Disable" box displays. • Use knob or arrow keys to highlight "OK" button and press knob or Enter key. Disabled "Area Counter" no longer accumulates area.

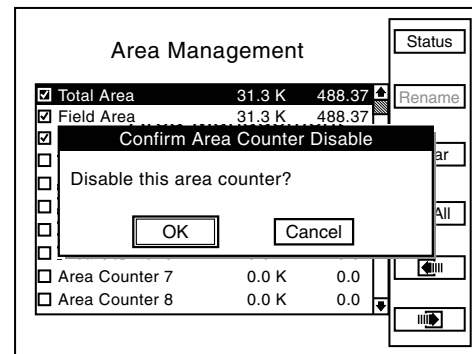

**NOTE: Attempts to disable an Area Counter that is planting will cause the following alarm.**

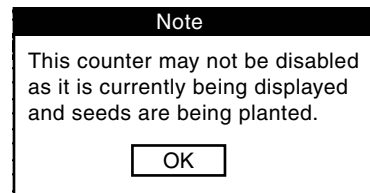



**NOTE:** If “Total area” is highlighted and F3 key next to Clear is pressed the following request for confirmation displays.

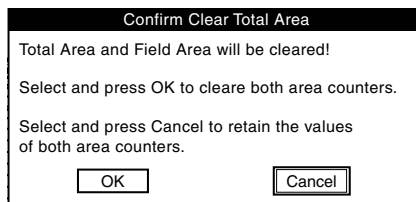

**Clear Area Counter**

Total Area, Field Area, and Area Counters 1 through 40 can be cleared, whether enabled or disabled. Clearing “Total Area” counter forces “Field Area” counter to be cleared. However, clearing an “Area Counter” including “Field Area” clears only that individual counter.

**NOTE:** Lifetime Area Counter can never be cleared or disabled.

**Clearing an Area Counter**

- STEP 1 Turn knob or use arrow keys to highlight desired area counter.
- STEP 2 Press F3 key next to “Clear”. Request for confirmation shown below displays

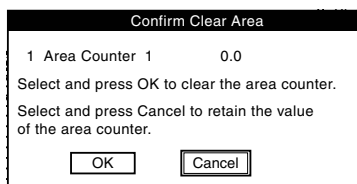

- STEP 3 Turn knob or use arrow keys to highlight “OK” or “Cancel” and press knob or Enter key to confirm selection.

**Clearing All Area Counters**

**NOTE:** This clears all area counters except the “Total Area Counter”

- STEP 1 Press F4 key next to “CLR All”. A request for confirmation displays.

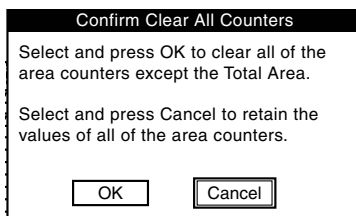

- STEP 2 Turn knob or use arrow keys to select “OK” or “Cancel” and press knob or Enter key to confirm selection.

**AREA COUNTERS**

- STEP 1 On Planter Configuration screen press F4 key next to “Area”.

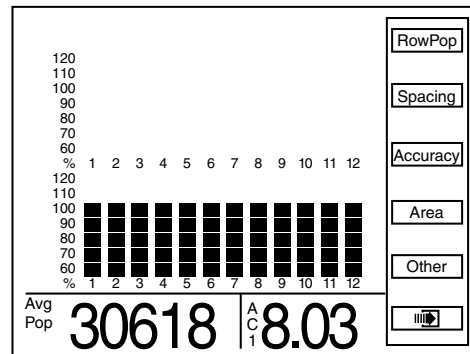

- STEP 2 Press F3 key next to “Select” to display list of area counters.

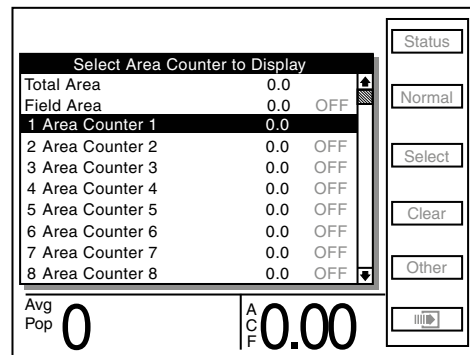

- STEP 3 Use arrow keys to highlight desired area counter to be displayed.
- STEP 4 Press knob or Enter key and “Planter Configuration” screen displays.

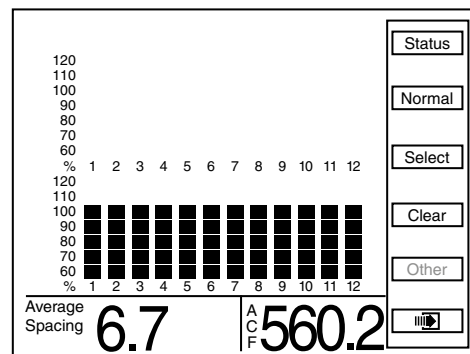

**NOTE:** Abbreviation for selected area counter appears in bottom R.H. corner of the screen. In above illustration “ACF” stands for Area Counter Field.

**CLEARING FIELD AREA**

STEP 1 Display Plant screen to reset counter.

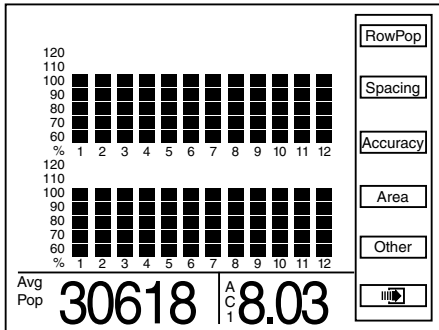

**NOTE:** If "Area" is not displayed next to F4, press F2 next to "Normal".

STEP 2 Press F4 key next to Area then press F4 key next to Clear. A dialog box displays requesting confirmation to clear.

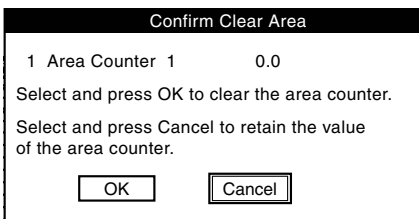

STEP 3 Highlight "OK" or "Cancel" by turning knob or using arrow keys. Press knob or Enter key to verify selection.

**NOTE:** Only displayed area counter can be cleared.

**REPLACING FAULTY SENSOR(S)**

**NOTE:** Monitor beeps twice when new sensors are learned.

STEP 1 Press F6 key until Mode Selection screen appears.

STEP 2 Highlight "1. Setup Mode" by turning knob or using arrow keys. Press knob or Enter key to display highlighted item.

STEP 3 Highlight "9. Sensor Setup" by turning knob or using arrow keys. Press knob or Enter key to display highlighted item.

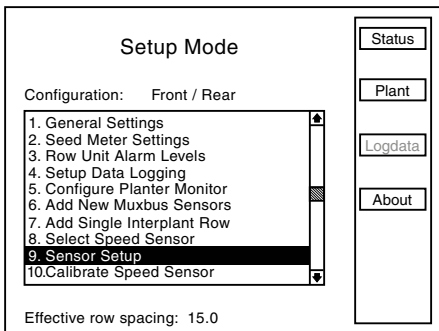

STEP 4 Turn knob or use arrow keys to highlight faulty sensor and press F2 key next to Remove.

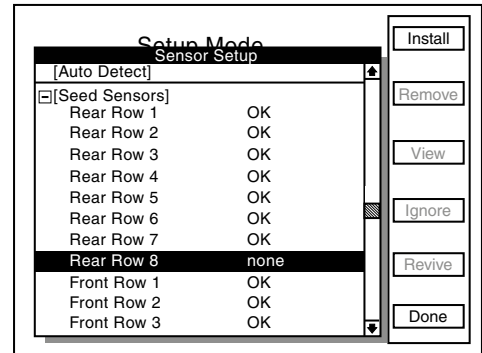

STEP 5 The following message displays. Select OK to confirm by pressing knob or Enter key. Select Cancel to exit.

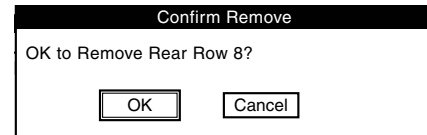

STEP 6 Unplug sensor and plug in new sensor. Press F1 key next to Install.

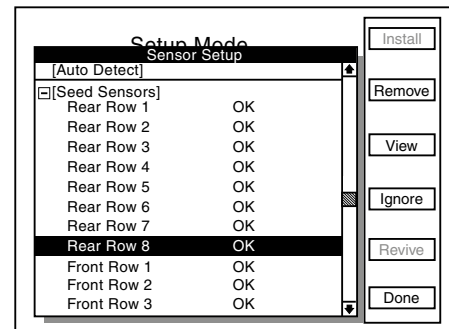

**NOTE:** Monitor beeps twice when new sensors are learned.

Repeat STEPS 1 through 6 for each faulty sensor being replaced.

**NOTE:** Highlighting a sensor and pressing F4 key next to View displays additional information for troubleshooting a problem. If a faulty sensor has been ignored it may be highlighted in list of sensors. Press F3 key next to Revive. Monitor will try to communicate with sensor. If successful, "OK" displays next to sensor.

## LUBRICATION

Following pages show locations of all lubrication points. Proper lubrication of moving parts helps ensure efficient operation of your Kinze planter and prolongs the life of friction producing parts.

### LUBRICATION SYMBOLS

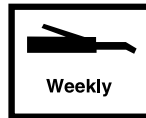
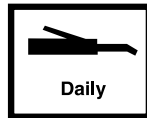

Lubricate at frequency indicated with SAE multipurpose grease.

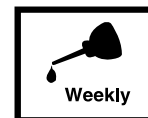

Lubricate at frequency indicated with high quality SAE 10 weight oil or spray lubricant.

### SEALED BEARINGS

Sealed bearings are used on your Kinze planter to provide trouble free operation.

These are located on drive shafts, row units, and transmission bearings. Sealed bearings are lubricated for life and are not serviceable.

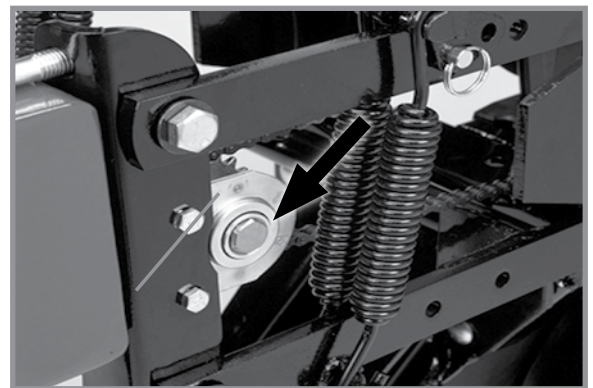

Sealed bearing (Typical)

### WRAP SPRING WRENCH ASSEMBLY

1. Remove ¼"-20 x ½" cap screw securing idler assembly to wrap spring wrench tightener shaft and
2. Remove wrap spring wrench from planter.
3. Tip wrap spring wrench on its side and lubricate with a high quality spray lubricant. Lubricant must be absorbed into wrap spring area.
4. Reinstall wrap spring wrench on planter.



Wrap spring wrench lubrication

### DRIVE CHAINS

Lubricate all transmission and drive chains daily with a high quality chain lubricant. Extreme operating conditions such as dirt, temperature, or speed may require more frequent lubrication. If a chain becomes stiff, it should be removed, soaked, and washed in solvent to loosen and remove dirt from joints. Soak chain in oil so lubricant can penetrate between rollers and bushings.

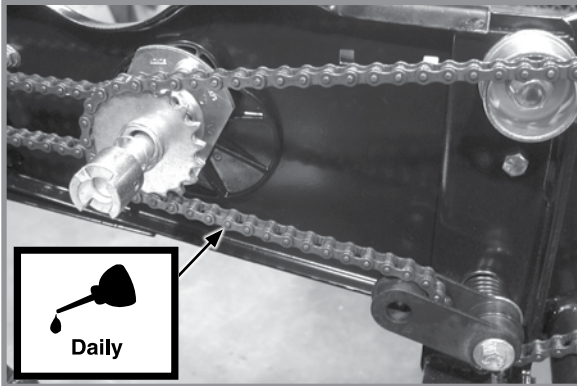

Row Unit Drive Chains (Mechanical Shown)

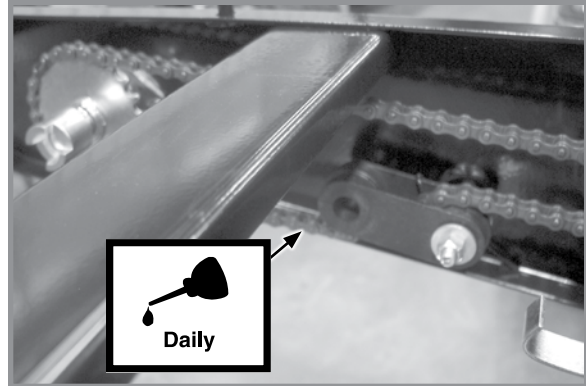

Row Unit Granular Chemical Drive Chains

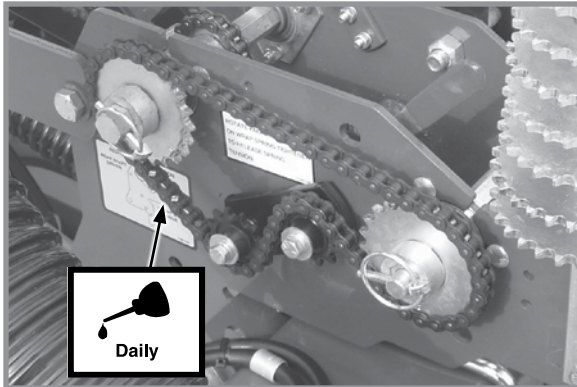

Seed Rate Transmission Drive Chains

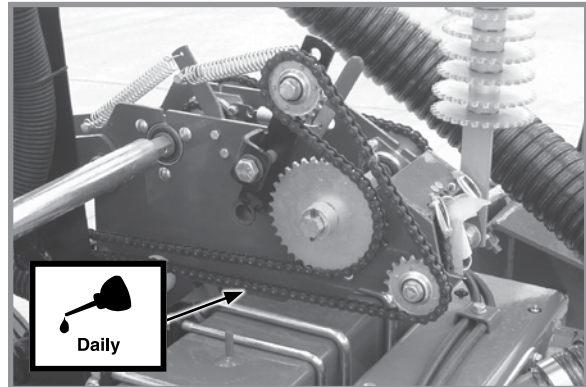

Contact Wheel Drive Chains (Without Point Row Clutches)

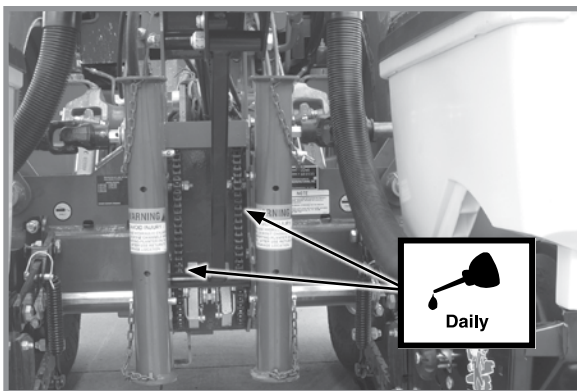

Center Drop Assembly Drive Chains

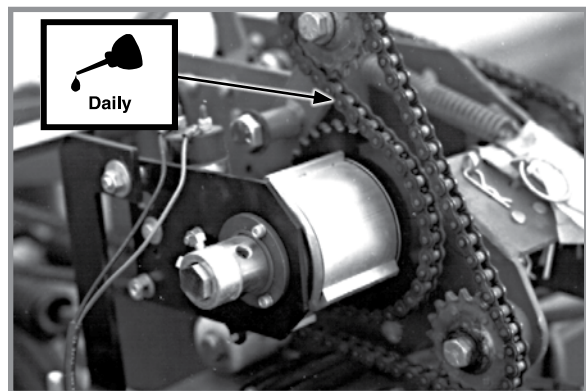

Contact Wheel Drive Chains (With Point Row Clutches)

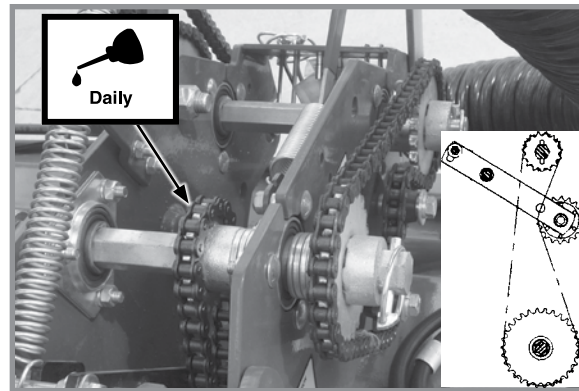

Inner Wheel Module Drive Chains

**BUSHINGS**

Lubricate bushings at frequency indicated.

Check each bolt for proper torque. If bolt is loose, removed it and inspect bushing for cracks and wear. Replace bushing if necessary. Use **only hardened flat washers**. Replace damaged flat washers with proper part. Torque hardware to 130 ft-lb (176.2 N-m).

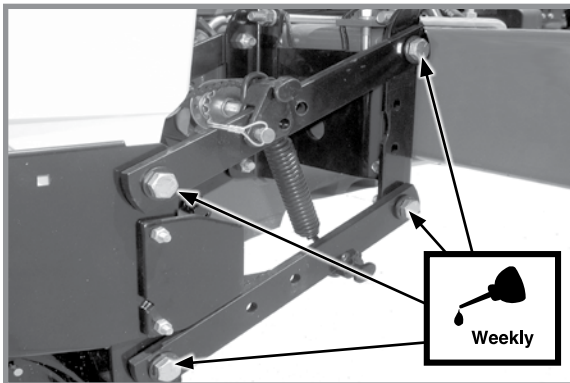

Pull row unit and/or push row unit parallel linkages (8 per row)

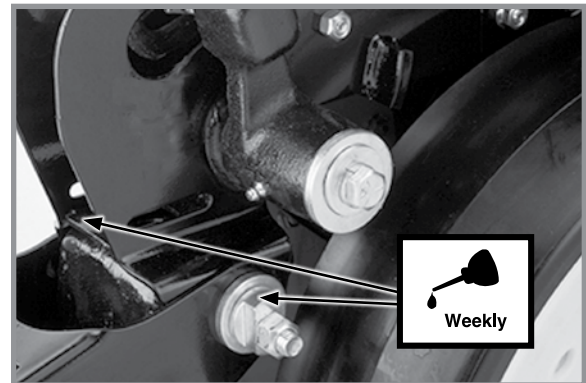

Row unit “v” closing wheel, covering discs/ single press wheel and/or drag closing wheel eccentric bushings (2 per row)

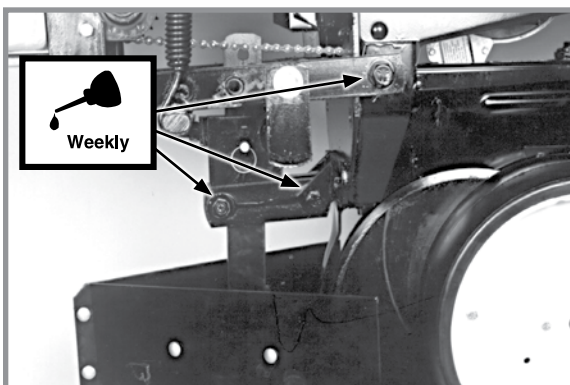

Bed leveler parallel linkages (6 per row)

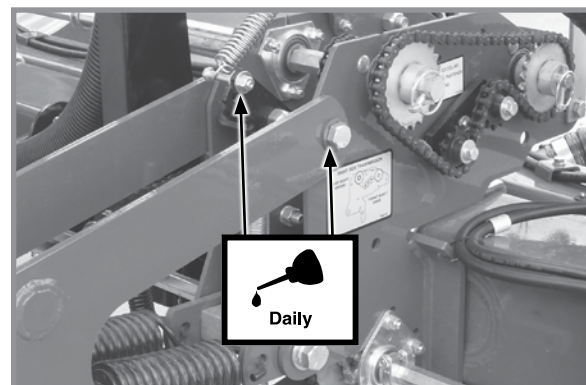

Contact Wheel Arm (2 Per Wheel Assembly)

**WHEEL BEARINGS**

All drive, transport, and marker hub wheel bearings should be repacked annually and checked for wear.

1. Raise wheel off ground.
2. Check for bearing endplay by moving wheel side to side.
3. Rotate wheel to check for bearing roughness. If bearings sound rough, remove hub and inspect bearings.

**NOTE: To repack wheel hubs, follow procedure outlined for wheel bearing replacement except bearings and bearing cups are reused.**

**GREASE FITTINGS**

Parts equipped with grease fittings should be lubricated at frequency indicated with an SAE multipurpose grease. Clean fitting thoroughly before using grease gun. Frequency of lubrication recommended is based on normal operating conditions. Severe or unusual conditions may require more frequent attention.

**NOTE: Numbers on photo below correspond to photos on following pages showing lubrication frequencies.**

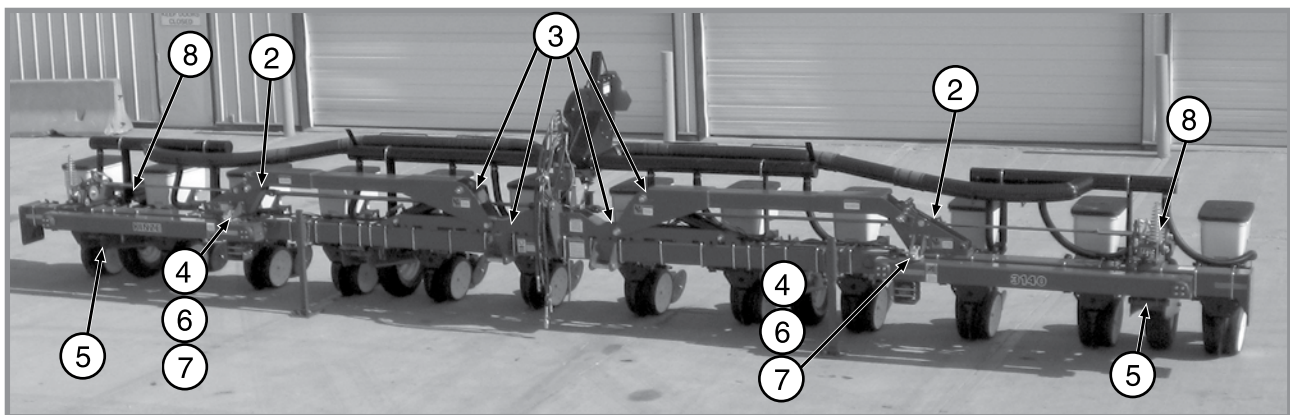

12 Row 38" Shown

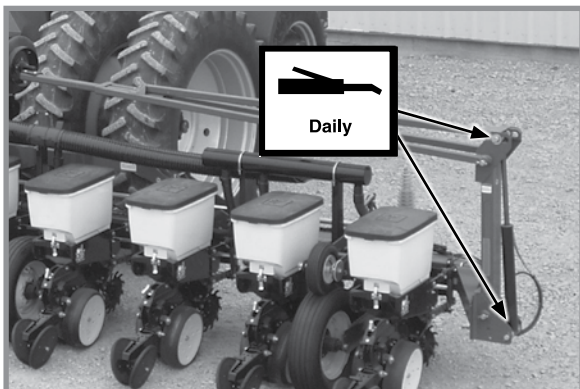

1. Row Markers - 4 Zerks Per Assembly On 8 Row 38"/40" And 12 Row 30" Sizes. 2 Zerks Per Assembly On 12 Row 36"/38", 12 Row 38"/40" And 16 Row 30" Sizes.

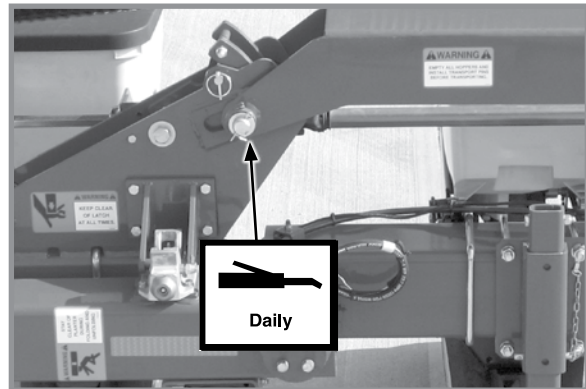

2. Wing Hinge - 2 Zerks Per Hinge Area

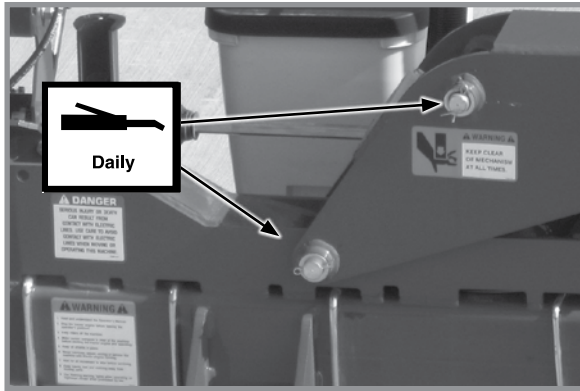

3. Center Hinge - 4 Zerks Per Hinge Area

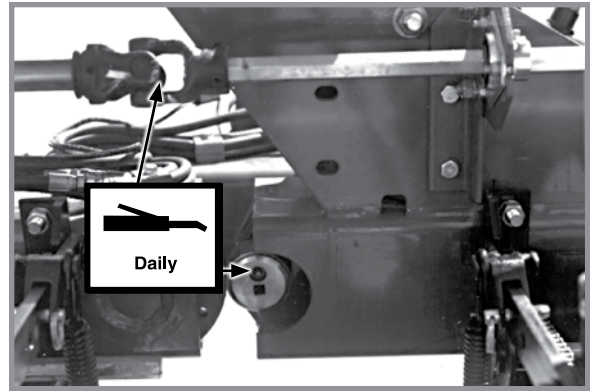

6. Cam Follower - 1 Zerk Per Cam  
7. U-Joint Assembly - 1 Zerk Per Assembly

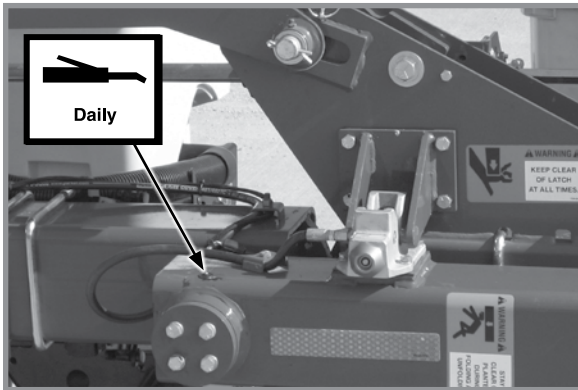

4. Link Assembly - 4 Zerks Per Link

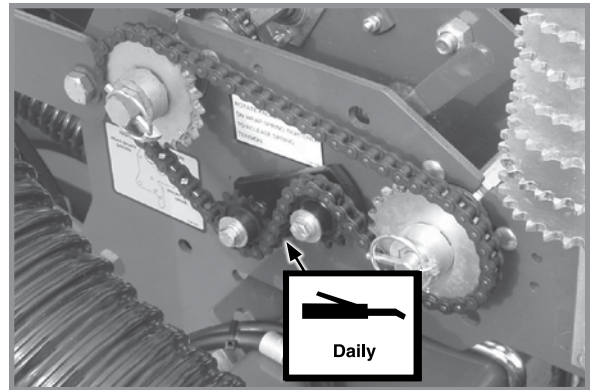

8. Seed Rate Transmission Assemblies - Zerk (Idler)

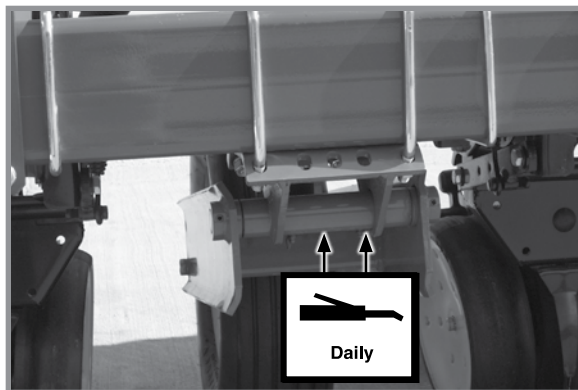

5. Drive Wheel Arm Pivot - 2 Zerks Per Pivot

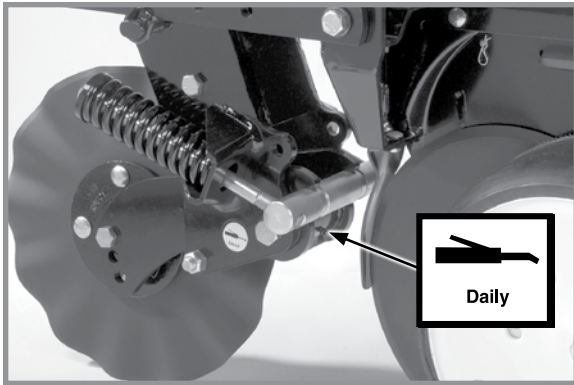

Frame mounted Coulter - 1 Per Arm

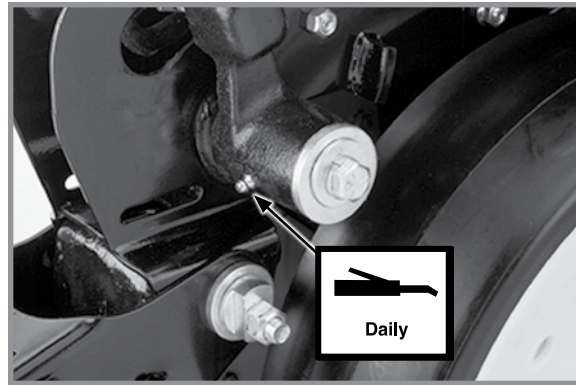

Gauge wheel arms - 1 per arm

(Seals in gauge wheel arm are installed with lip facing out to allow grease to purge dirt away from seal. Pump grease into arm until fresh grease appears between washers and arm.)

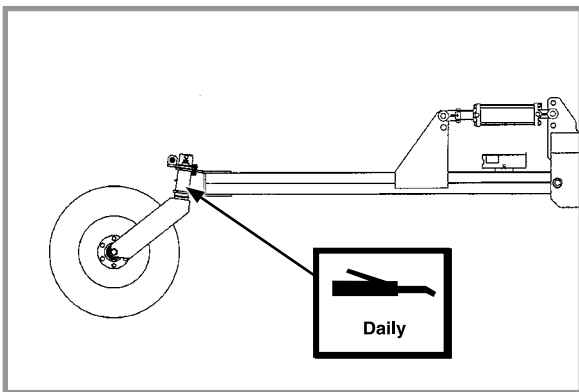

Lift Assist Arm - 1 Zerk Per Arm

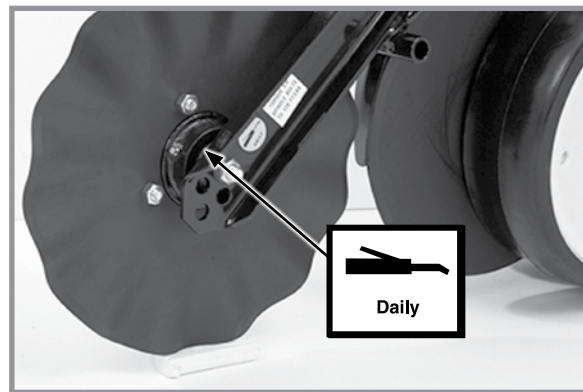

(If Applicable) Row Unit Mounted No Till Coulter Hubs- 1 Zerk Per Hub  
**(Pump grease into hub until grease comes out around the seals. Spin hub while filling with grease.)**



**MOUNTING BOLTS AND HARDWARE**



**WARNING**

Parts separation can result in death, serious injury, and damage to property and equipment. Check all hardware is tight before operating planter the first time. Check all hardware again after first 50 hours of operation and beginning of each planting season.

**NOTICE**

Over-tightening hardware can reduce its shock load capacity and cause equipment failure.

Hardware used on Kinze planters are Grade 5 (high strength) unless otherwise noted. Grade 5 cap screws are marked with three radial lines on the head. Hardware must be replaced with equal size, strength, and thread type.

**TORQUE VALUES CHART - PLATED HARDWARE**

Diameter	Grade 2 (No marks)		Grade 5 (3 marks)		Grade 8 (6 marks)	
	Coarse	Fine	Coarse	Fine	Coarse	Fine
1/4"	50 in-lb	56 in-lb	76 in-lb	87 in-lb	9 ft-lb	10 ft-lb
5/16"	8 ft-lb	9 ft-lb	13 ft-lb	14 ft-lb	18 ft-lb	20 ft-lb
3/8"	15 ft-lb	17 ft-lb	23 ft-lb	26 ft-lb	33 ft-lb	37 ft-lb
7/16"	25 ft-lb	27 ft-lb	37 ft-lb	41 ft-lb	52 ft-lb	58 ft-lb
1/2"	35 ft-lb	40 ft-lb	57 ft-lb	64 ft-lb	80 ft-lb	90 ft-lb
9/16"	50 ft-lb	60 ft-lb	80 ft-lb	90 ft-lb	115 ft-lb	130 ft-lb
5/8"	70 ft-lb	80 ft-lb	110 ft-lb	125 ft-lb	160 ft-lb	180 ft-lb
3/4"	130 ft-lb	145 ft-lb	200 ft-lb	220 ft-lb	280 ft-lb	315 ft-lb
7/8"	125 ft-lb	140 ft-lb	320 ft-lb	350 ft-lb	450 ft-lb	500 ft-lb
1"	190 ft-lb	205 ft-lb	480 ft-lb	530 ft-lb	675 ft-lb	750 ft-lb
1 1/8"	265 ft-lb	300 ft-lb	600 ft-lb	670 ft-lb	960 ft-lb	1075 ft-lb
1 1/4"	375 ft-lb	415 ft-lb	840 ft-lb	930 ft-lb	1360 ft-lb	1500 ft-lb
1 3/8"	490 ft-lb	560 ft-lb	1100 ft-lb	1250 ft-lb	1780 ft-lb	2030 ft-lb
1 1/2"	650 ft-lb	730 ft-lb	1450 ft-lb	1650 ft-lb	2307 ft-lb	2670 ft-lb

**NOTE:** Torque unplated hardware and bolts with lock nuts approximately 1/3 higher than above values. Torque bolts lubricated prior to installation to 70% of value shown in chart.

**NOTE:** Torque EdgeVac fan impeller assembly to motor shaft 5/8"-18 hex jam nut 50 ft-lb (67.8 N-m).

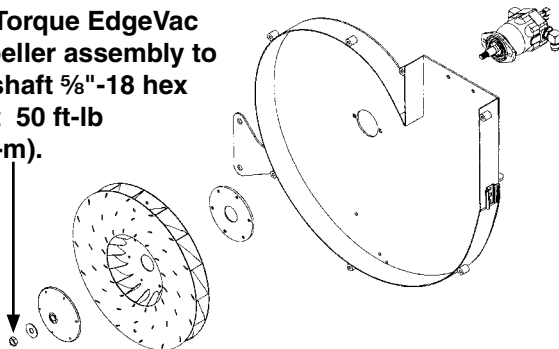

**Cylinder Rod Piston Retaining Nut Torque Chart**

	Non-Nylock Nut	Nylock Nut
1/2"-20	55-70 ft-lb (75-95 N-m)	45-55 ft-lb (61-75 N-m)
3/4"-16	115-125 ft-lb (156-169 N-m)	100-115 ft-lb (136-156 N-m)
7/8"-14	150-180 ft-lb (203-244 N-m)	130-150 ft-lb (176-203 N-m)
1"-14	275-330 ft-lb (373-447 N-m)	250-275 ft-lb (339-373 ft-lb)
1 1/8"-12	300-375 ft-lb (407-508 N-m)	275-300 ft-lb (373-407 N-m)
1 1/4"-12	300-375 ft-lb (407-508 N-m)	275-300 ft-lb (373-407 N-m)

**SPECIAL TORQUE VALUES & INSTRUCTIONS**

Row unit parallel linkage bushing hardware	130 ft-lb (176 Nm)
5/8" No till coulter spindle hardware	120 ft-lb (162 Nm)
Ground Drive Tire Lug Bolts	90 ft-lb (122 Nm)

**TIRE SERVICING**

**! WARNING**

**Explosive separation of rim and tire parts can result in death or serious injury. Rim and tire servicing, improper use of rims and tires, or worn or improperly maintained tires can cause tire explosion.**

To prevent tire explosions:

- Maintain proper tire pressure. Inflating a tire above or below the recommended pressure can cause tire damage.
- Mount tires only by properly trained personnel using proper equipment.
- Replace tires with cuts or bubbles. Replace damaged rims. Replace missing lug bolts and nuts.
- Do not weld or heat wheel assembly. Heating increases tire pressure.

**INFLATION SPECIFICATIONS**

**! WARNING**

**Over-inflation of tires can result in explosive separation of rim and tire and cause death or serious injury. Different size rims are designed for different tire pressures. Inflate to correct pressure for specific rim size.**

**MODEL 3140 OPERATING TIRE PRESSURE**

Ground Drive/Gauge 7.60" x 15" . . . . .40 psi (275.7 kPa)

Contact drive - 4.10" x 6" . . . . .50 psi (344.7 kPa)



## FINGER PICKUP SEED METER INSPECTION/ADJUSTMENT

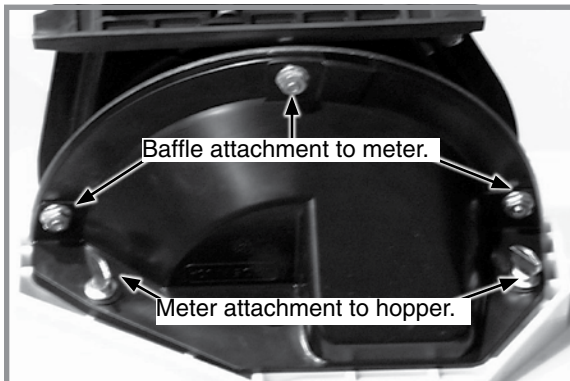

**Removing meter and baffle**

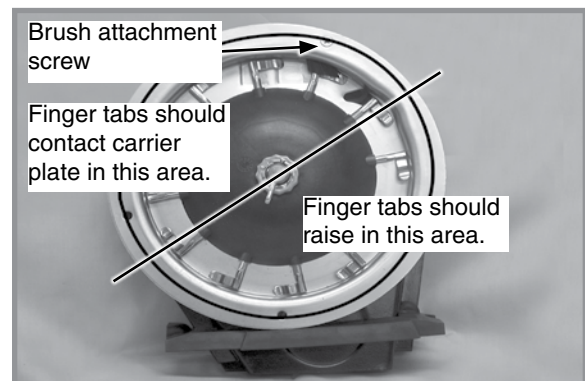

**Proper finger operation**

1. Remove two thumbscrews and meter from seed hopper and remove three cap screws and baffle from meter assembly.
2. Rotate seed meter drive by hand to ensure springs are holding tabs of fingers against carrier plate and fingers raise in correct area as shown in above photo.

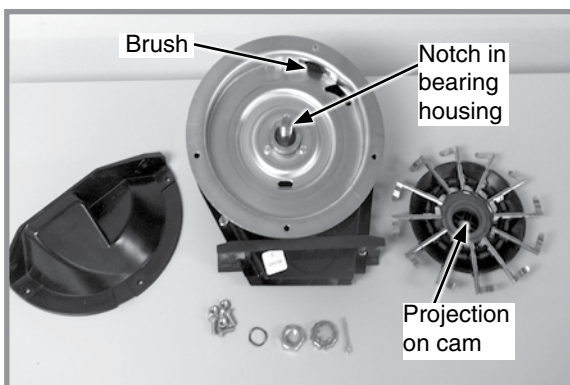

**Finger pickup meter parts**

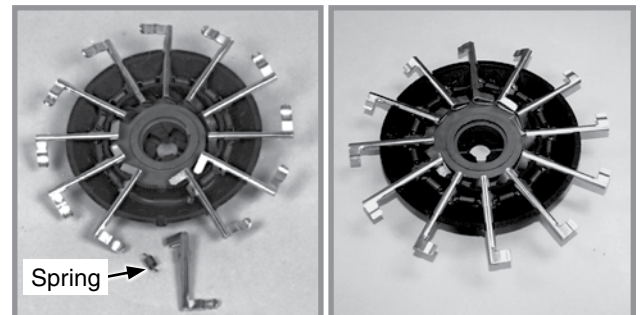

**Corn Finger Assembly**  
(Position Spring Opening  
Toward Holder)

**Oil Sunflower Finger  
Assembly**

Buildup of debris or chaff may prevent proper finger operation and requires disassembly and cleaning of finger pickup meter.

1. Remove cotter pin, cover nut and adjusting nut and wave washer (If applicable) from drive shaft.
2. Carefully lift finger holder with fingers and cam off shaft and clean.
3. Check brush for wear and replace if necessary or after every 100 acres per row of operation (Approximately 800 acres of corn or sunflowers on a 8 row machine or 1200 acres on an 12 row machine).

**NOTE: It is not necessary to remove finger holder to replace brush.**

4. Remove springs from fingers and remove finger from holder by lifting it out of friction fit slot. Life expectancy of these parts is about 600-900 acres per row of operation under average conditions.
5. Reassemble meter in reverse order after cleaning and replacing defective parts. Make sure open end of spring loop is toward inside of finger holder when replacing fingers.
6. Install fingers in holder so holder is flush with carrier plate when assembled. A cam projection aligns with a mating notch in bearing housing to ensure proper operation when assembled.

7. Check indentations on carrier plate for wear before installing finger holder on carrier plate. Excessive wear of carrier plate at indentations will cause over planting especially with small sizes of seed. Inspect carrier plate annually. Life expectancy should be 250-300 acres per row of operation under average conditions.
8. Install wave washer and adjusting nut with finger holder flush against carrier. Tighten adjusting nut to fully compress wave washer. Back off nut  $\frac{1}{2}$  to 2 flats to obtain rolling torque of 22 to 25 inch pounds.
9. Turn finger holder by hand to make sure it is firmly against carrier plate, but can be rotated with moderate force.
10. Install cover nut and cotter pin. Reinstall baffle.

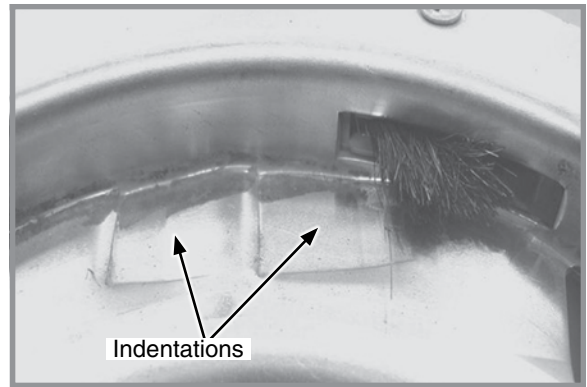
**Worn carrier plate**

**NOTE: Check adjusting nut tightness on each unit after first day of use and periodically thereafter.**

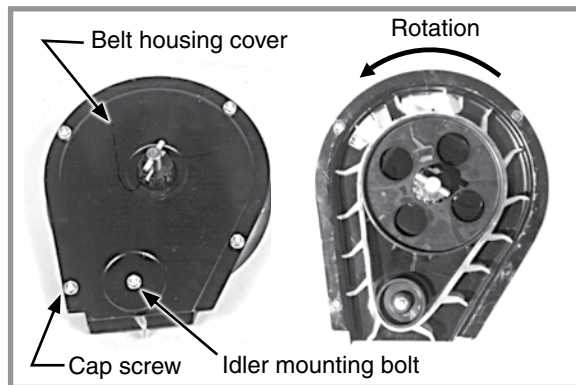
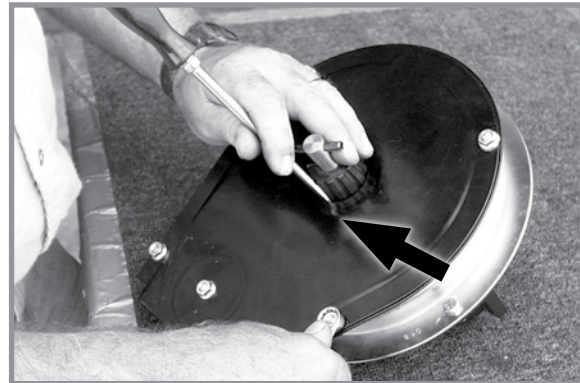
**Belt idler****Centering belt housing cover**

Remove four cap screws around edge of housing cover and nut from belt idler mounting bolt. Paddles must be correctly oriented as shown above. If belt is replaced. A diagram molded into drive sprocket shows correct orientation.

#### **NOTICE**

**Do not over-tighten hardware or components may be damaged.**

Reinstall housing cover. **DO NOT TIGHTEN** hardware. Wedge a screwdriver between sprocket hub and housing cover as shown above. Pry cover down until centered on belt housing and tighten hardware. Rotate meter drive shaft and check idler alignment. Seed belt should "run" centered on idler or with only slight contact with belt housing or cover.

### **CLEANING FINGER PICKUP SEED METER FOR STORAGE**

1. Disassemble meter and blow out any foreign material.
2. Wash **ONLY** in mild soap and water. Do not use gasoline, kerosene, or any other petroleum based product. Dry thoroughly.
3. Coat lightly with a rust inhibitor.
4. Rotate finger assembly so finger does not touch brush.
5. Reassemble and store in a dry, rodent-free location.

## BRUSH-TYPE SEED METER MAINTENANCE

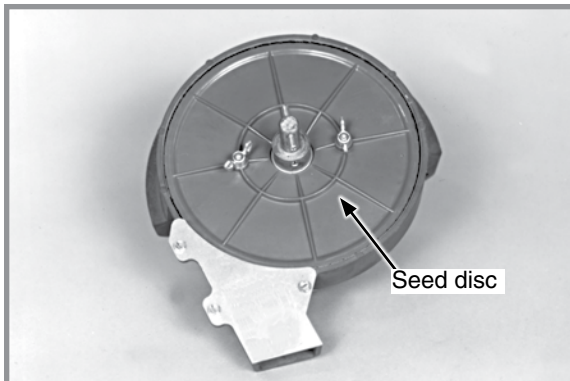

Brush-type seed meter seed disc installed

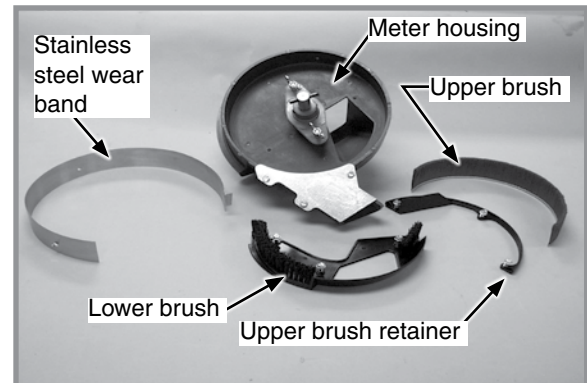

Brush-type seed meter parts

Use clean, high quality seed. Damaged or cracked seed, hulls, or foreign materials can become lodged in upper brush and greatly reduce meter accuracy. Remove seed disc daily and check for buildup of foreign material on seed disc, particularly in seed loading slots. Clean disc by washing it with soap and water. Check for cracked seed, hulls, etc. lodged between brush retainer and stainless steel wear band which can greatly reduce accuracy of the meter because upper brush will not be able to retain seed in seed disc pocket. Thoroughly clean brush areas of meter housing.

### SEED DISC WEAR

Most seed disc wear is found in the agitation groove area (area between seed loading slots). Wear affects planting accuracy at high RPM. Lay a straight edge across disc surface at agitation groove area and measure gap between disc and straight edge. If agitation groove areas are worn in excess of .030" and accuracy starts to drop off at higher meter RPM, replace seed disc. Estimated seed disc life expectancy under normal operating conditions is approximately 200 acres per row. Severe operating conditions such as dust, lack of lubrication or abrasive seed coating could reduce seed disc life expectancy to under 100 acres per row.

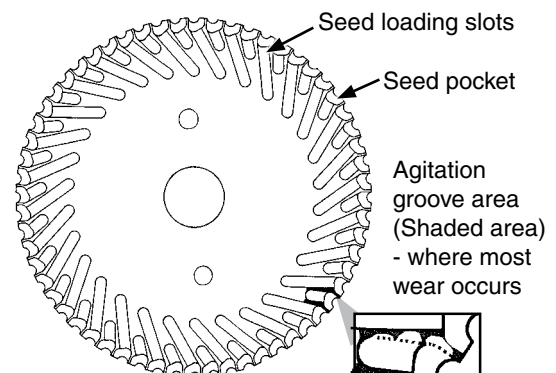

### STAINLESS STEEL WEAR BAND

#### **NOTICE**

**If wear band wears through or if meter is used without wear band in place, meter housing may be damaged.**

Stainless steel wear band protects meter housing from wear and is .030" thick. Replace wear band when there is approximately .020" of wear in primary wear area. Estimated life expectancy of stainless steel wear band is 240-800 acres per row.

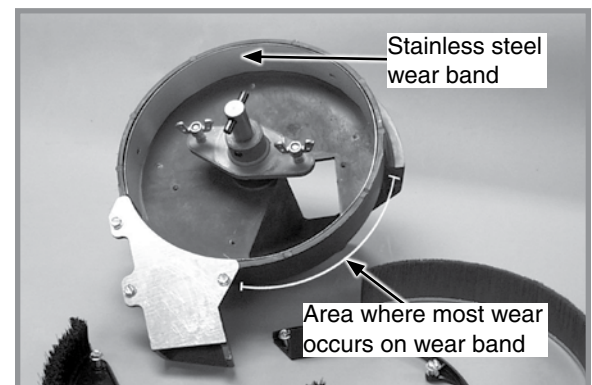

Stainless steel wear band

## UPPER BRUSH

Upper brush holds seed in seed disc pocket in seed retention area. Brush must apply enough pressure against seed in seed disc pocket as disc rotates through seed retention area to prevent seed from dropping out of disc pocket. A damaged spot, excessive brush wear, or foreign material lodged in brush may greatly reduce meter performance.

Replace upper brush at 120-400 acres per row of use or sooner if damage or excessive wear is found. Position upper brush into inner perimeter of seed retention area. Make sure base of brush is tight against bottom of meter housing. Install brush retainer and three hex head screws. Tighten screws in sequence shown in photo at right.

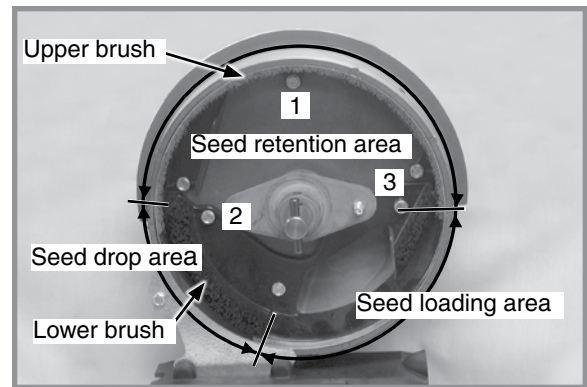

Upper brush installation

**NOTE: Use GD11122 upper brush retainer for soybean and cotton discs. Use GD8237 upper brush retainer for milo/grain sorghum discs.**

## LOWER BRUSH

Lower brush moves seed down seed loading slots to seed pockets, isolates seed in reservoir from entering seed tube, and cleans seed loading slots. Estimated lower brush life expectancy is 240-800 acres per row. Replace lower brush if bristles are deformed or missing, or if there are cracks in brush retainer.

## CLEANING BRUSH-TYPE SEED METER FOR STORAGE

1. Remove meter from seed hopper by removing two thumbscrews securing meter to hopper.
2. Remove seed disc and wash with soap and water and dry thoroughly.
3. Remove three hex head screws from brush retainer. Remove brush retainer and upper brush.
4. Remove three hex head screws from lower brush. Remove lower brush and stainless steel wear band.
5. Wash all parts and meter housing with soap and water and dry thoroughly.
6. Inspect all parts and replace worn parts.
7. Reassemble meter except for seed disc. Store meter in a dry, rodent-free space with seed disc removed.

## VACUUM MANIFOLD MAINTENANCE

Dust accumulates in manifolds and hoses during normal operation. Clean manifolds annually. Abnormally dusty planting conditions may require more frequent cleaning.

1. Remove vacuum hose from each seed meter.
2. Operate vacuum fan at full hydraulic flow from tractor for two minutes to clear manifolds, hoses, and fittings of dust and debris.
3. Shut down fan and replace hoses

## EDGEVAC SEED METER MAINTENANCE

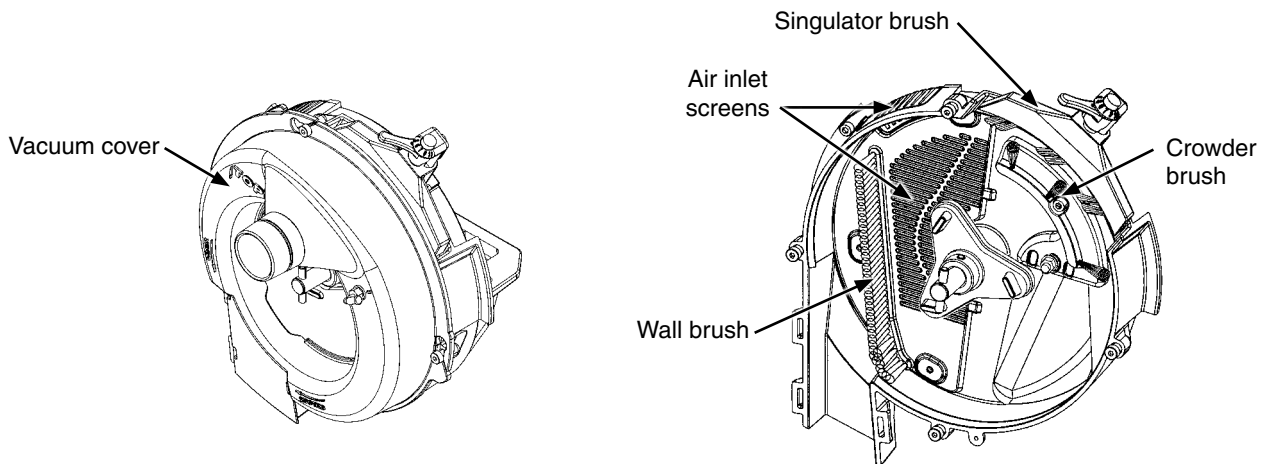

Before each planting season inspect seed discs, singulator brush, crowder brush, wall brush, and air inlet screens and clean or replace as needed.

Use clean, high quality seed for maximum meter accuracy. Damaged or cracked seed, hulls, and foreign material may become lodged in seed disc orifices and greatly reduce meter accuracy.

Inspect and clean seed discs daily checking for any buildup of foreign material and blocked orifices. If seed disc orifices are plugged frequently with seed remnants, cleanout brush or cleanout brush with ball-type ejector (if applicable) may need to be replaced. Clean seed disc by washing it with soap and water. Dry thoroughly.

Inspect singulator brush for wear after every 200 acres per row of operation. If adjustment of singulator brush does not affect meter performance or if brushes appear frayed, singulator brush may need to be replaced.

Replace seed disc or vacuum cover if abnormally high vacuum is required or if consistent operation can not be achieved.

See "Preparation For Storage" for additional EdgeVac Seed Metering System maintenance.

**NOTE: Remove seed discs from meters for annual storage and store them vertically on a dowel or pipe.**

## EDGEVAC SEED METER CLEANOUT

Thorough seed meter cleanout is important to maintain genetic purity.

1. Disengage seed drive and remove seed hopper and meter. Lay hopper on its right side.
2. Rotate vacuum cover clockwise to align key hole slots with bolt heads. Lift off cover.
3. Remove seed disc.
4. Empty meter and hopper by allowing seed to run out of meter.
5. Inspect brushes in meter to ensure all seed is removed.
6. Replace seed disc and install vacuum cover.

**NOTE: Use of damaged seed or seed containing foreign material will cause plugging of seed cell orifices and require more frequent seed meter cleanout to prevent underplanting.**

**CHAIN TENSION ADJUSTMENT**

Drive chains have spring loaded idlers and are self-adjusting. Remove link to shorten chain if wear stretches chain and reduces spring tension. Check idler pivot points to make sure they rotate freely. See “Wrap Spring Wrench Assembly” in this section for additional information.

Additional chain links are stored inside planter frame.

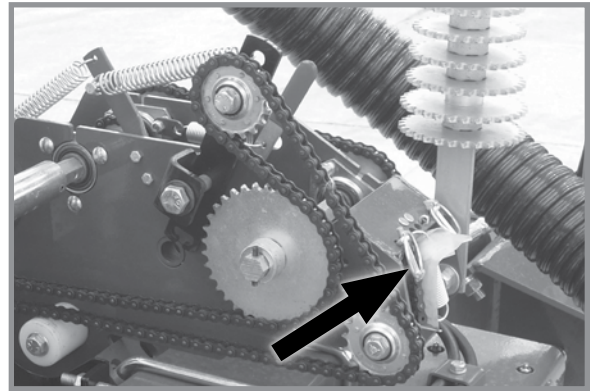

**Additional chain links**

**DRAG CLOSING ATTACHMENT**

Inspect each drag closing attachment and replace any worn or broken parts before storing planter. Check for loose hardware and tighten as needed.

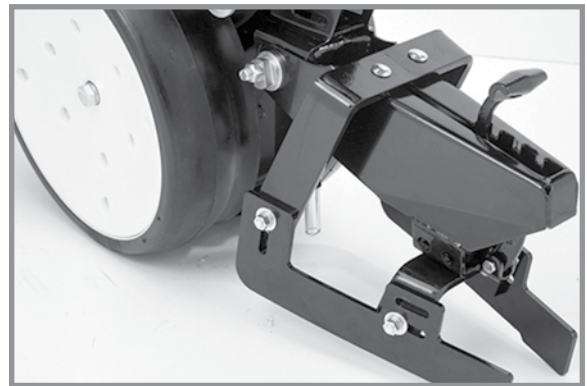

**Drag Closing Attachment**

**GAUGE WHEEL ADJUSTMENT**

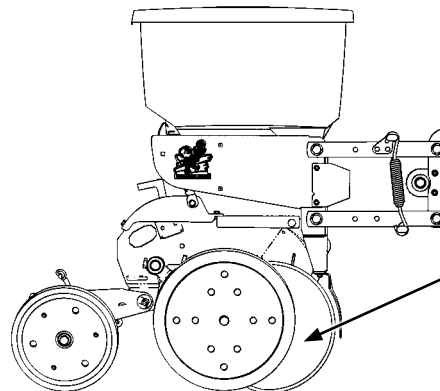
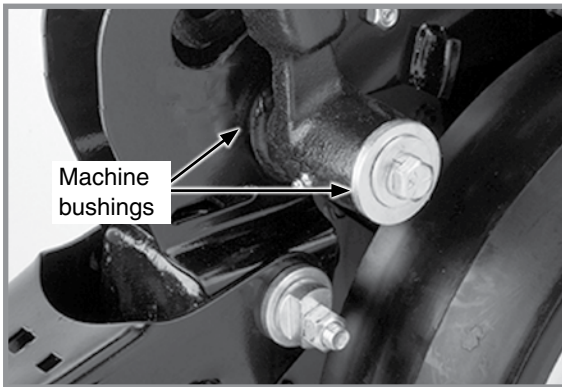

Shim gauge wheel to lightly contact opener disc blade. Check adjustment in field position.

**Gauge wheel adjustment**

Gauge wheels should lightly contact opener blades to prevent accumulation of dirt or trash. Gauge wheels and opener blades should turn with only slight resistance.

Add or remove machine bushings between shank and gauge wheel arm to adjust clearance between gauge wheels and opener blades. Store remaining machine bushings between gauge wheel arm and flat washer on outer side of gauge wheel arm.

**NOTE:** It may be desirable to space gauge wheel further from blade when operating in sticky soils.



## GAUGE WHEEL ARM BUSHING/SEAL REPLACEMENT

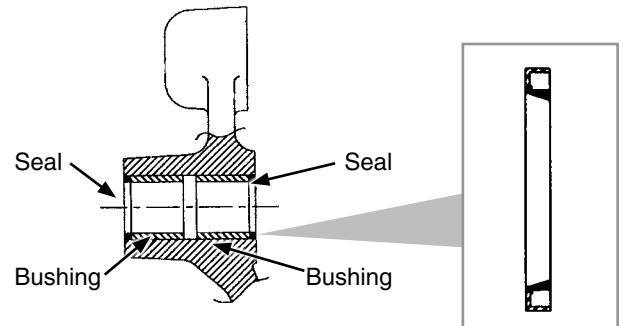
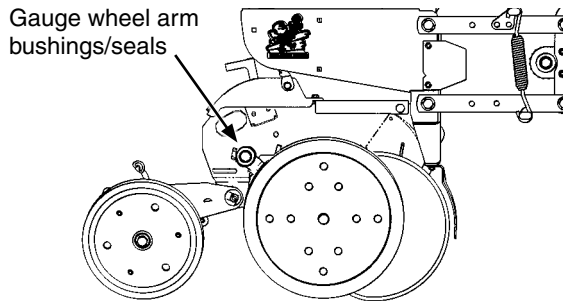

**NOTE: Gauge Wheel Arm Bushing and Seal Driver Kit (G1K296) is available through your Kinze Dealer.**

1. Remove gauge wheel from arm.
2. Remove gauge wheel arm from shank assembly.
3. Remove seal and bushing and discard. Clean and dry inner bore.
4. Drive/press replacement bushing inside bore of arm to a depth of .125" below flush.
5. Coat wiping edge of seal with grease.
6. Drive/press seal into place with lip to outside.

**NOTE: Use extra care to protect the sealing lip during installation. Apply uniform pressure to assemble the seal into the bore of the arm. Never apply a direct hammer blow to the seal surface.**

7. Inspect gauge wheel pivot spindle.
8. Reinstall gauge wheel arm assembly and gauge wheel.

**NOTE: Use special machine bushing between gauge wheel arm and gauge wheel.**

9. Shim for proper gauge wheel tire/disc blade clearance.
10. Lubricate with an SAE multipurpose grease.

## GAUGE WHEEL ARM PIVOT SPINDLE REPLACEMENT

1. Remove gauge wheel and arm assemblies from shank assembly.
2. Remove  $\frac{1}{2}$ " x  $\frac{3}{4}$ " cap screw that locks pivot spindle in place and remove spindle.
3. Install replacement spindle and position as shown. Exact centering is critical.
4. Install  $\frac{1}{2}$ " x  $\frac{3}{4}$ " cap screw and torque to lock pivot spindle in place.
5. Install gauge wheel and arm assemblies. Shim for proper gauge wheel tire/disc blade clearance.

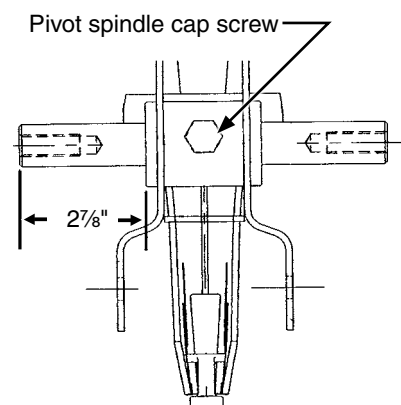

## 15" SEED OPENER DISC BLADE/BEARING ASSEMBLY

### NOTICE

Excessive blade contact may result in premature disc opener bearing/hub failures and excessive wear on seed tube guard/inner scraper. When properly adjusted, if one blade is held in fixed position, opposite blade should rotate with less than 5 pounds force at outer edge of blade.

Maintain approximately  $1" \pm \frac{1}{2}"$  of blade-to-blade contact to properly open and form seed trench. As blade diameter decreases due to wear, it is necessary to relocate machine bushings from inside to outside to maintain  $1" \pm \frac{1}{2}"$  of contact.

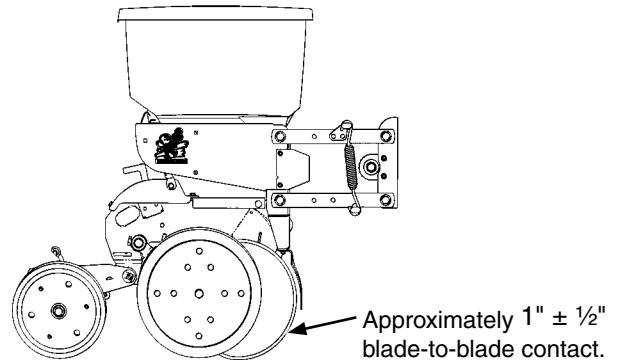

**NOTE: Proper blade clearance is critical. Blades should have  $1" \pm \frac{1}{2}"$  contact in this area. When blades are turned by hand in opposite directions against each other, there should be only light resistance to turning. Re-adjust blade scraper if necessary to center it between the blades.**

**NOTE: Replace blades if proper blade-to-blade contact cannot be maintained after relocating machine bushings or if blade diameter wears below  $14\frac{1}{2}"$ .**

### REPLACE DISC BLADE/BEARING ASSEMBLY

**NOTE: Only bearing may need to be replaced if there is excessive endplay or if bearing sounds or feels rough when disc blade is rotated.**

1. Remove gauge wheel, scraper, and bearing dust cap.
2. Remove cap screw, washer and disc blade/bearing assembly. Machine bushings between shank and disc blade are used to maintain approximate  $1" \pm \frac{1}{2}"$  of blade-to-blade contact.

### NOTICE

**Left hand side of opener uses a left hand threaded cap screw. DO NOT OVER TIGHTEN. Damage to shank threads require replacement of row unit shank assembly.**

3. Install machine bushing(s), new disc blade bearing assembly, washer and cap screw. Torque  $\frac{5}{8}"$ -11 Grade 5 cap screw to 110 ft-lb (149.14 N-m).

**NOTE: Replace disc blades only with disc blades of equal thickness.**

4. Install bearing dust cap, scraper, and gauge wheel.

### REPLACE BEARING ONLY

1. Remove gauge wheel, scraper, bearing cap, cap screw, washer and disc blade/bearing assembly.
2. Remove  $\frac{1}{4}"$  rivets from bearing housing to expose bearing.
3. Installing new bearing. install three evenly spaced  $\frac{1}{4}"$  cap screws into three of six holes in bearing housing to hold bearing and bearing housing in place. Install rivets in other three holes. Remove  $\frac{1}{4}"$  cap screws and install rivets in those three holes.
4. Reinstall disc blade/bearing assembly, washer and cap screw. Torque  $\frac{5}{8}"$ -11 cap screw to 110 ft-lb (149.14 N-m).
5. Install bearing dust cap, scraper, and gauge wheel.

## SEED TUBE GUARD/INNER SCRAPER

Seed tube guard protects seed tube and acts as inner scraper for seed opener disc blades.

Remove seed tube and check for wear. Excessive wear on seed tube indicates a worn seed tube guard. Replace seed tube guard if it measures  $\frac{5}{8}$ " or less at lower end. A new seed tube guard measures approximately  $\frac{7}{8}$ ".

**NOTE: No till planting or planting in hard ground conditions, especially when planter is not equipped with no till coulters, and/or excessive blade-to-blade contact increases seed tube guard wear and requires more frequent inspection and/or replacement.**

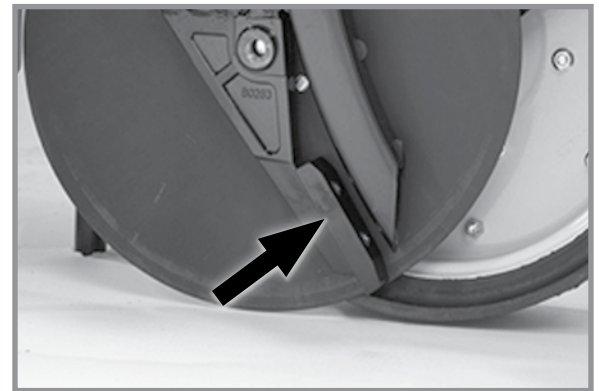

Seed tube guard/inner scraper  
(Gauge wheel/seed opener disc blade removed)

### NOTICE

**Over tightening hex socket head cap screws may damage shank threads and require replacement of shank. An excessively worn seed tube guard may allow blades to wear into row unit shank, also requiring replacement of shank.**

Remove seed tube and two hex socket head cap screws that attach seed tube guard. Hold replacement seed tube guard centered between seed opener disc blades. Install hex socket head cap screws. **DO NOT TIGHTEN**. Using a clamp or vise-grip, squeeze opener blades together in front of seed tube guard. Tighten seed tube guard retaining screws. Remove clamps. Distance between seed tube guard and opener blades should be equal on both sides. Reinstall seed tube.

## FRAME MOUNTED COULTER

**NOTE: Torque  $\frac{5}{8}$ " spindle hardware to 120 ft-lb (162.7 N-m)**

See "Frame Mounted Coulters" in Row Unit Operation section of this manual for depth and spring adjustment.

Replace 16" diameter coulters blade (1" fluted, 1" bubbled or  $\frac{3}{4}$ " fluted) when worn to 14 $\frac{1}{2}$ " (maximum allowable wear).

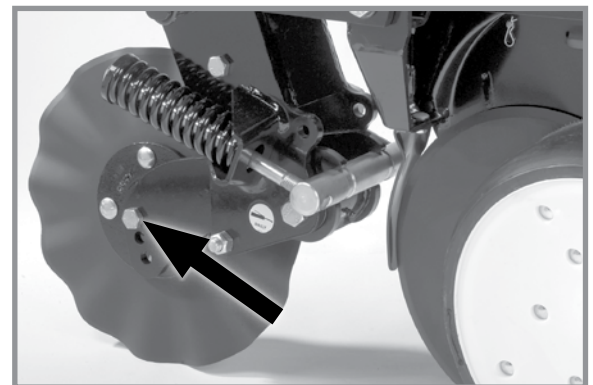

Frame mounted coulters spindle

## RESIDUE WHEELS (FOR USE WITH FRAME MOUNTED COULTER)

Wheel hub is equipped with sealed bearings. Replace bearings if a bearing sounds or feels rough when wheel is rotated.

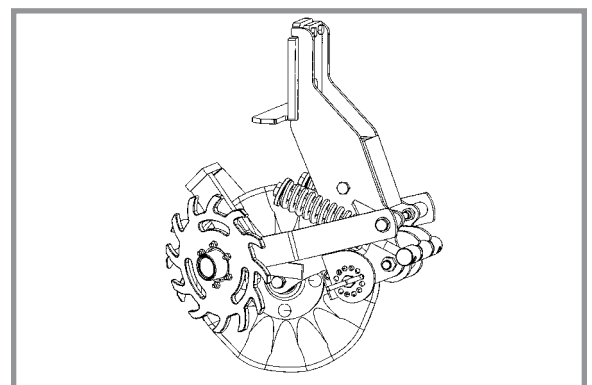

Frame mounted coulters residue wheels

### ROW UNIT MOUNTED DISC FURROWER

Lubricate bushings in support arm mounting bracket at frequency indicated in Lubrication of this section. Check each bolt for proper torque. If bolt is loose, it should be removed and bushing inspected for cracks and wear. Replace bushings as necessary.

**NOTE: Use only hardened flat washers. Replace damaged flat washers with proper part. Torque bolts to 130 ft-lb (176.2 N-m).**

Blade hubs are equipped with sealed bearings. Replace bearings if a bearing sounds or feels rough when wheel is rotated.

Replace solid or notched 12" diameter blades when worn to 11".

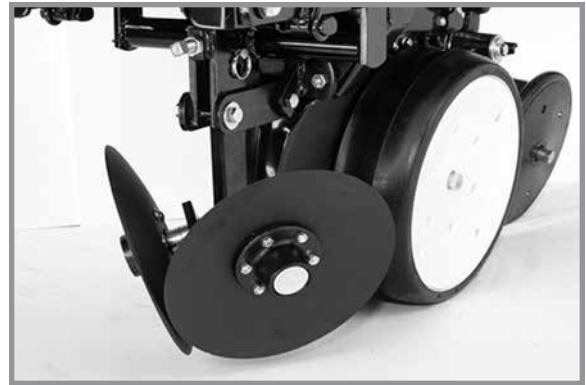

Row unit mounted disc furrower

### ROW UNIT MOUNTED BED LEVELER

Lubricate bushings in mounting bracket and links at frequency indicated in Lubrication of this section. Check each bolt for proper torque. If bolt is loose, it should be removed and bushing inspected for cracks and wear. Replace bushing if necessary.

**NOTE: Use only hardened flat washers. Replace damaged flat washers with proper part. Torque bolts to 130 ft-lb (176.2 N-m).**

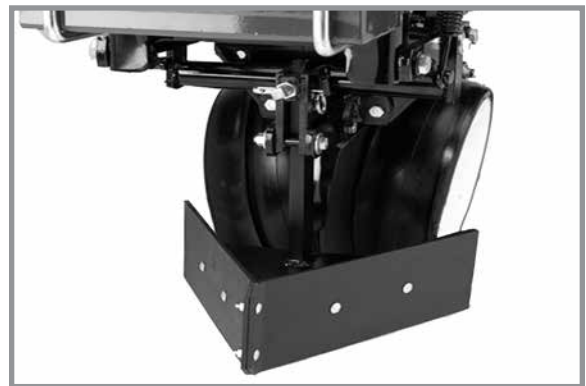

Row unit mounted bed leveler

### ROW UNIT MOUNTED NO TILL COULTER

Check nuts and hardware periodically for proper torque. Be sure coulters are positioned square with row unit and aligned in front of row unit disc opener.

**NOTE: Torque 5/8" spindle hardware to 120 ft-lb (162 N-m).**

Coulter blade can be adjusted to one of four settings. Initially blade is set in highest position. As blade wears it can be adjusted to one of three lower settings. See "Row Unit Mounted No Till Coulter" in Row Unit Operation section of this manual.

Replace 16" diameter coulters when worn to 14½".



Row unit mounted no till coulters

## COULTER MOUNTED RESIDUE WHEELS

Wheel hubs are equipped with sealed bearings. If bearings sound or feel rough when wheel is rotated, replace them.



Coultter mounted residue wheels

## ROW UNIT MOUNTED RESIDUE WHEEL

Wheel hub is equipped with sealed bearings. If a bearing sounds or feels rough when wheel is rotated, replace them.

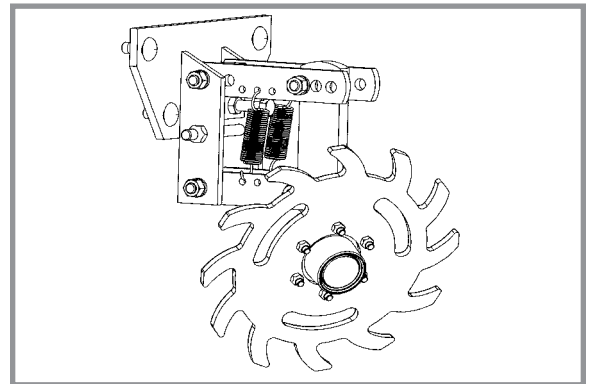

## GRANULAR CHEMICAL ATTACHMENT

Before storing planter, disengage granular chemical drive by rotating throwout knob ¼ turn counterclockwise. Remove drive chain and empty and clean all granular chemical hoppers. Clean drive chains and coat them with a rust preventive spray or submerge chains in oil. Inspect and replace worn or broken parts.

Install hoppers and chains. Check chain alignment.

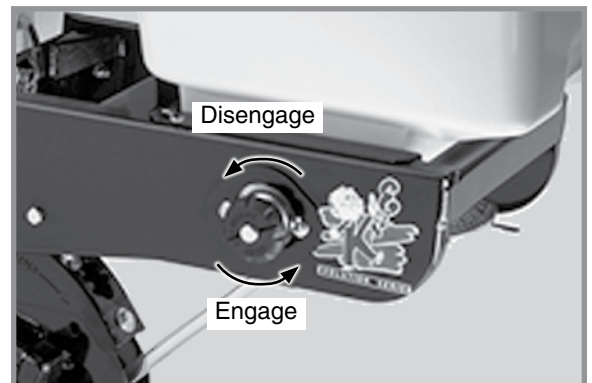

Granular chemical throwout knob

## SPRING TOOTH INCORPORATOR

Before storing planter, inspect each spring tooth incorporator and replace worn or broken parts. Check for loose hardware and tighten as needed.

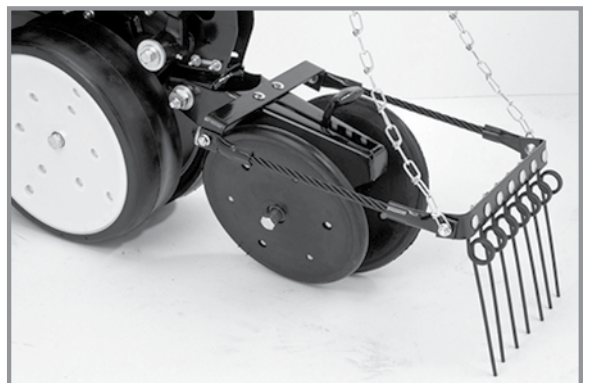

Spring tooth incorporator

**SINGLE AND TWO-SPEED POINT ROW CLUTCH MAINTENANCE**

Point row clutch is permanently lubricated and sealed and requires no periodic maintenance. Two-speed point row clutch is similar in design and operation to standard point row clutch except for two-speed function.

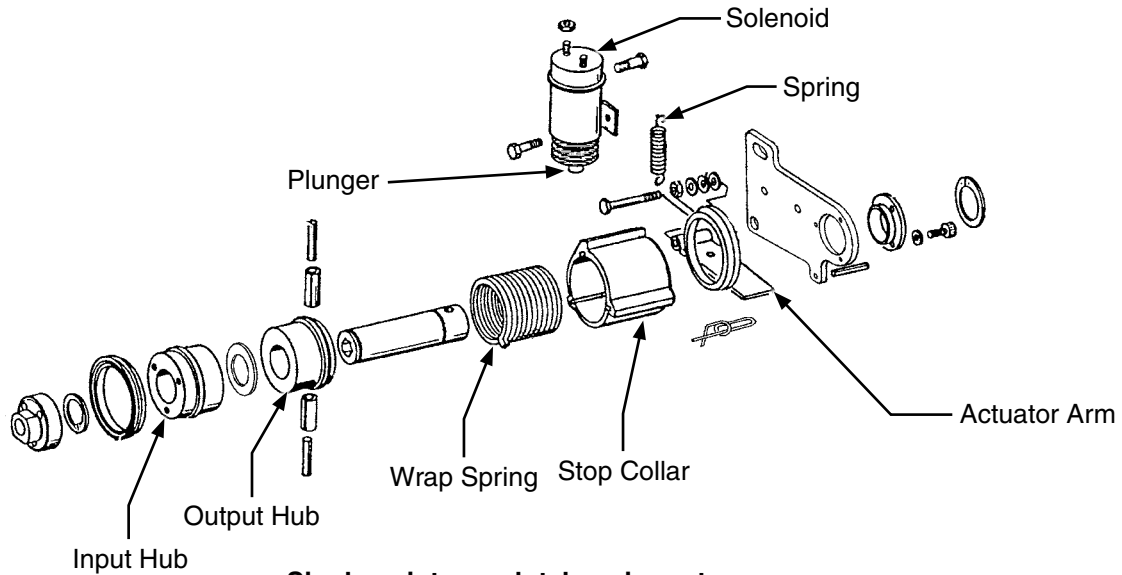

**Single point row clutch main parts**

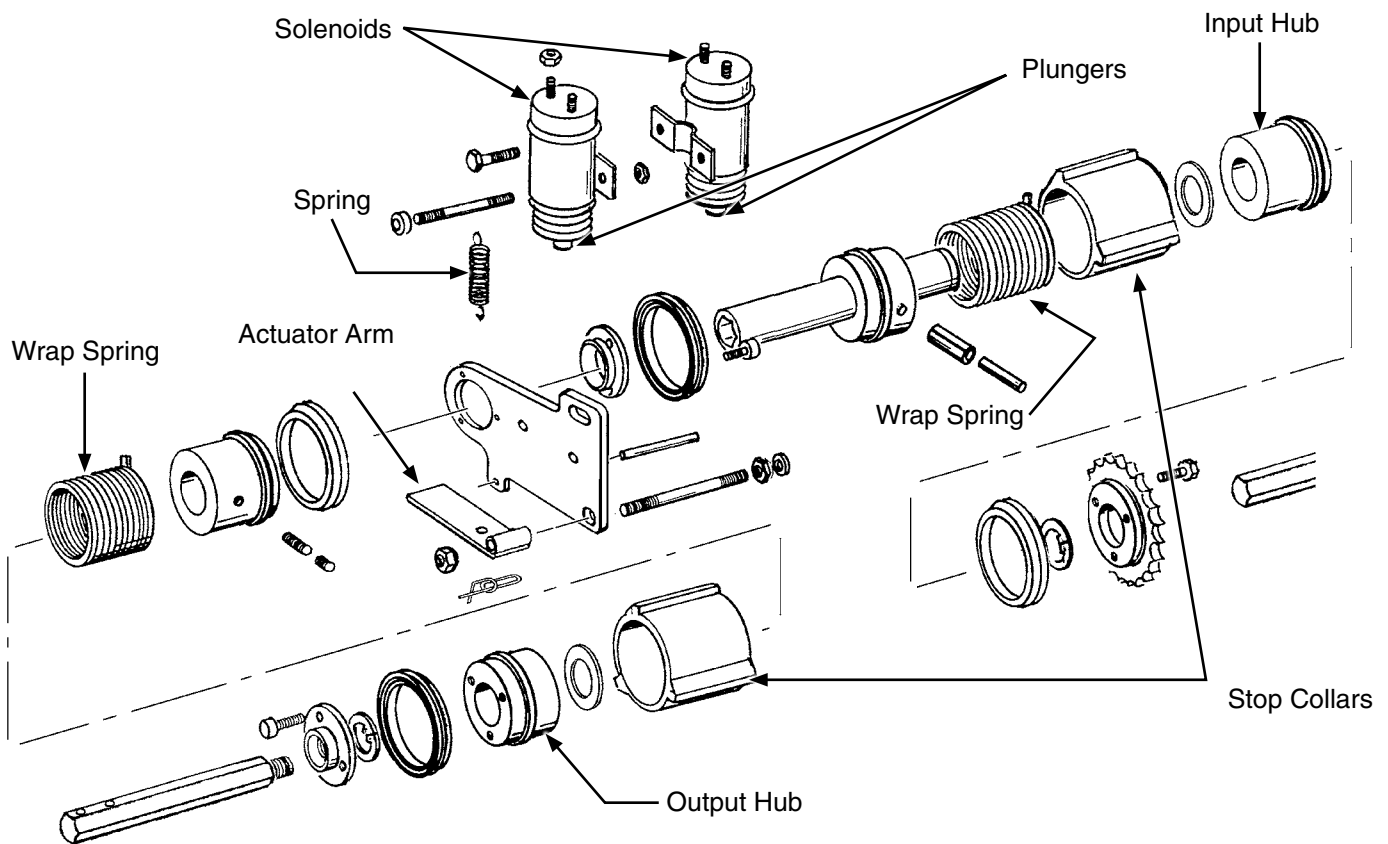

**Two-speed point row clutch main parts**

The right hand clutch operates clockwise and the left hand clutch operates counterclockwise. Therefore, some of the parts of the clutch such as the wrap spring differ from one side of the planter to the other. Be sure to use the correct repair part if a clutch must be repaired.

The control box is equipped with a resettable circuit breaker. To reset the circuit breaker, press the red button on the circuit breaker until it snaps into place. If the circuit breaker continues to trip, check to see what is causing it to trip. See "Point Row Clutch Troubleshooting".

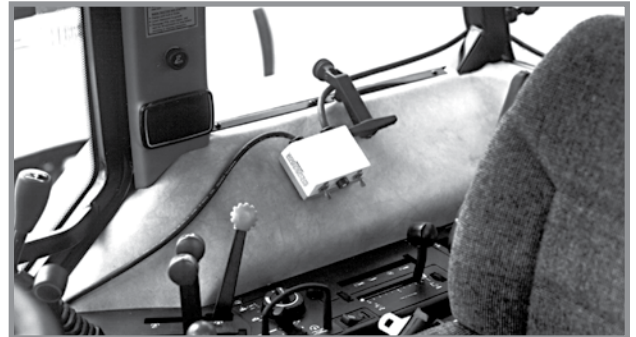

If the circuit breaker on the control box is not tripped, determine if the problem is electrical or mechanical. Place the operational switch in the RIGHT or LEFT position. Check the clutch and wiring harness for power with a test light or volt meter. If the solenoid is operating properly, the plunger on the solenoid will retract causing a clicking sound. The plunger will also be magnetized which can be checked by touching the plunger with a metal object.

#### ACTUATOR ARM ADJUSTMENT

Gap between actuator arm and stop on stop collar should be  $\frac{1}{8}$ " ( $\pm\frac{1}{32}$ ") when solenoid is NOT engaged.

Loosen nut on mounting pin and move pin in slot until there is a  $\frac{1}{8}$ " ( $\pm\frac{1}{32}$ ") gap between arm and stop on stop collar. Retighten nut.

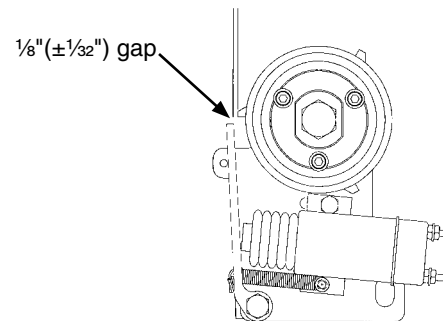

**NOTE: If the "Reduced Rate/Full Rate" functions fail to engage or disengage, see troubleshooting chart for possible cause**

#### CAM FOLLOWER ADJUSTMENT

Each wing hinge is equipped with a cam follower which floats against a curved guide on the center frame. Check cam followers periodically and maintain adjustment as shown below.

**NOTE: Always check cam follower adjustment and make cam follower adjustments with the planter on a flat surface and lowered to the planting position.**

To adjust cam followers:

1. Loosen  $\frac{3}{4}$ " cap screw on cam follower.
2. Using a  $\frac{1}{2}$ " ratchet extension, rotate and hold cam follower in place.
3. Torque  $\frac{3}{4}$ " cap screw to 150 ft. lbs.

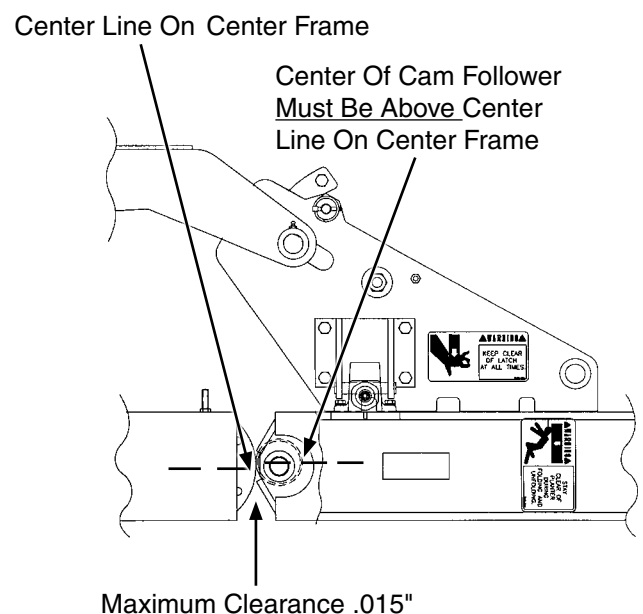

**NOTICE**

Connect hydraulic motor case drain to a case drain return line with zero pressure on tractor or hydraulic motor will be damaged. DO NOT connect hydraulic motor case drain to SCV outlet. Contact tractor manufacturer for specific details on “zero pressure return”.

**RELIEF VALVE CARTRIDGE**

Pressure relief valve located in valve block below vacuum fan motor assembly helps prevent damage to vacuum fan motor by limiting pressure in the motor case drain line. It is set to open at 35 PSI. If valve fails to function properly, it should be removed for inspection. Check for foreign material and contamination on valve and the seating area of valve body. Replace if defective.

**NOTE: Case drain pressure will build if the case drain hose to the tractor is connected where pressure is present.**

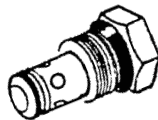
**CHECK VALVE (VACUUM FAN)**

Check valve located in valve block below vacuum fan motor assembly operates as a return line check to prevent vacuum fan motor reverse operation. Remove and inspect valve if it does not operate properly. Check for foreign material and if O-ring is leaking internally. Replace if defective.

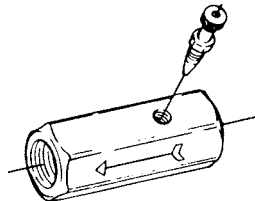
**FLOW CONTROL VALVE**

The optional dual lift assist wheels flow control valve should be adjusted as part of the assembly procedure or upon initial operation.

If the valve fails to function properly or requires frequent adjustment, the needle valve should be removed for inspection. Check for foreign material and contamination on both the valve and the seating area of the valve body. Replace any components found to be defective.

**NOTE: The flow control valve must be installed with the arrow pointed toward the planter.**

**NOTE: When oil is cold, hydraulics operate slowly. Make sure all adjustments are made with warm oil.**



## ROW MARKER SEQUENCING/FLOW CONTROL VALVE INSPECTION

### WARNING

Pressurized hydraulic fluid can penetrate body tissue and result in death, serious infection, or other injuries. Fluid injected under skin must be IMMEDIATELY removed by a surgeon familiar with this type of injury. Make sure connections are tight and hoses and fittings are not damaged before applying system pressure. Leaks can be invisible. Keep away from suspected leaks. Relieve pressure before searching for leaks or performing any system maintenance.

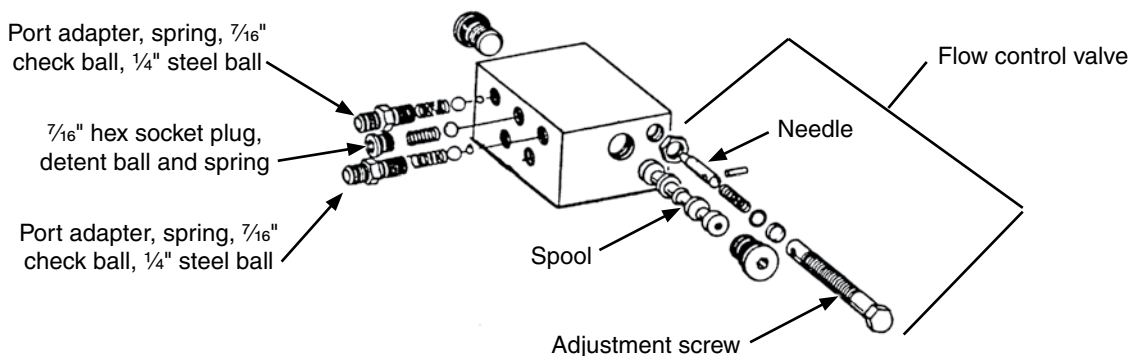

The valve block assembly consists of the row marker sequencing and flow control valves in one assembly. Sequencing valve portion consists of a chambered body containing a spool and series of check valves to direct hydraulic oil flow.

1. Remove valve block assembly from planter.
2. Remove detent assembly and port adapter assemblies from rear of valve block.

### NOTICE

**Damage to spool may occur if detent assembly and port adapter assemblies are not removed prior to removal of spool.**

3. Remove plug from both sides of valve block and remove spool.
4. Inspect all parts for pitting, contamination, or foreign material. Check seating surfaces inside valve. Replace defective parts.
5. Lubricate spool with a light oil and reinstall. Check spool moves freely in valve body.

**NOTE: Make sure correct check ball(s) and spring are installed in each valve bore upon reassembly.**

A flow control valve is located on each side of block assembly. Adjust flow control valves for raise and lower speed as part of assembly procedure or upon initial operation. If valve fails to function properly or requires frequent adjustment, remove needle valve for inspection. Check for foreign material and contamination. Make sure needle moves freely in adjustment screw. Replace defective components.

**NOTE: Hydraulics operate slowly when oil is cold. Make all adjustments with warm oil.**

## ROW MARKER BEARING LUBRICATION OR REPLACEMENT

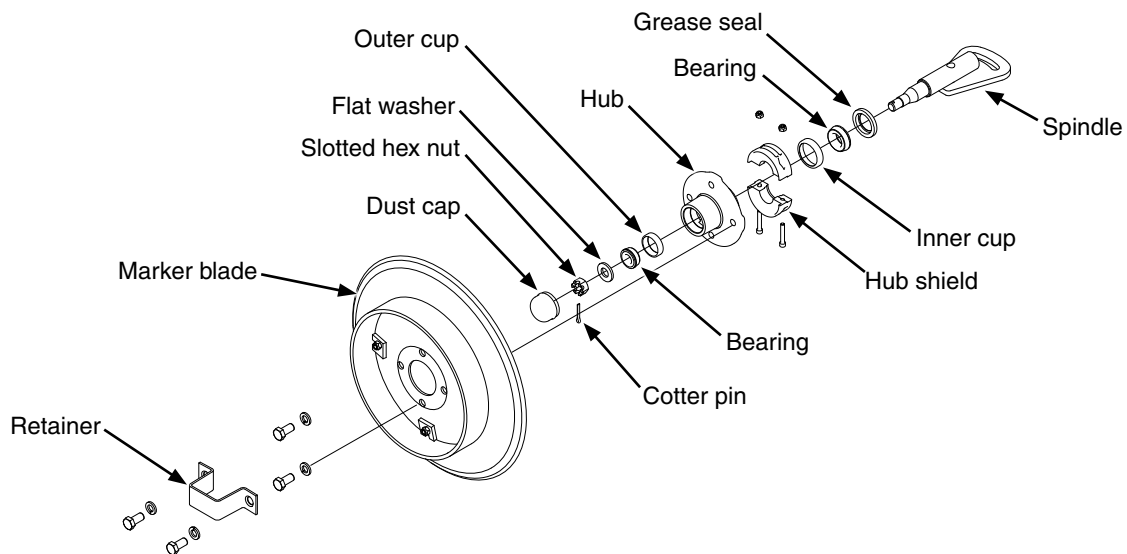

1. Remove retainer and marker blade.
2. Remove dust cap from hub.
2. Remove hub shield. Note direction of installation.
3. Remove cotter pin, slotted hex nut, and washer.
4. Slide hub from spindle.
5. Remove bearings and cups and discard if bearings are being replaced. Clean hub and dry. Remove bearings only and not cups if repacking.
6. Press in new bearing cups with thickest edge facing in. (Bearing replacement procedure only.)
7. Pack bearings with heavy duty wheel bearing grease thoroughly forcing grease between roller cone and bearing cage. Fill the space between the bearing cups in the hub with grease.
8. Install rubber seal into grease seal. Place inner bearing in place and press in new rubber seal/grease seal.
9. Clean spindle and install hub.
10. Install outer bearing, washer and slotted hex nut. Tighten slotted hex nut while rotating hub until there is some drag. This ensures all bearing surfaces are in contact. Back off slotted nut to nearest locking slot and install cotter pin.
11. Fill dust caps approximately  $\frac{3}{4}$  full of wheel bearing grease and install on hub.
12. Install hub shield.
13. Install marker blade and retainer on hub. Tighten hardware evenly.

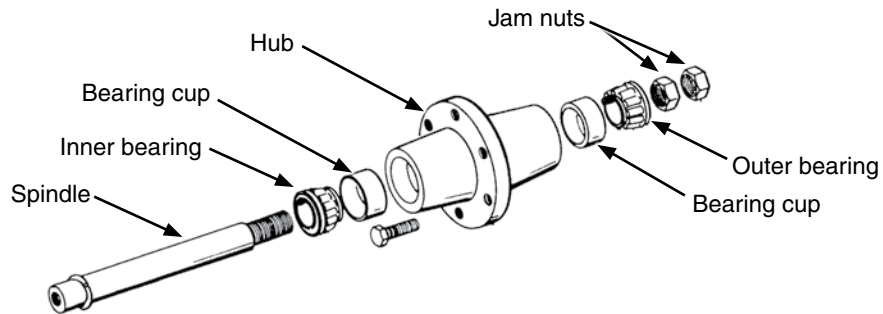
**WHEEL BEARING REPACK OR REPLACEMENT**

1. Raise tire clear of ground and remove wheel.
2. Remove double jam nuts and slide hub from spindle.
3. Remove bearings and cups and discard if bearings are being replaced. Clean hub and dry. Remove bearings only and not cups if repacking.
4. Press in new bearing cups with thickest edge facing in. (Bearing replacement procedure only.)
5. Pack bearings with heavy duty wheel bearing grease thoroughly forcing grease between roller cone and bearing cage. Fill space between bearing cups and hub with grease.
6. Place inner bearing in place.
7. Clean spindle and install hub.
8. Install outer bearing and jam nut. Tighten jam nut while rotating hub until there is some drag. This ensures all bearing surfaces are in contact. Back off jam nut  $\frac{1}{4}$  turn or until there is only slight drag when rotating hub. Install second jam nut to lock against first.
9. Install wheel on hub. Tighten hardware evenly.

**PREPARATION FOR STORAGE**

Store planter in a dry sheltered area if possible.

Remove all trash wrapped on sprockets or shafts and remove dirt that can draw and hold moisture.

Clean all drive chains and coat with a rust preventative spray, or remove chains and submerge in oil.

Lubricate planter and row units at all lubrication points.

Inspect planter for parts that in need of replacement and order during "off" season.

Make sure all seed and granular chemical hoppers are empty and clean.

Remove seed discs from seed meters, clean and store meters in a rodent-free, dry area with discs removed. Store seed discs vertically on a dowel or pipe.

Remove vacuum hose from each seed meter. Operate vacuum fan at full hydraulic flow from tractor for two minutes to clear manifolds, hoses and fittings of dust and debris.

Clean breather on analog vacuum and pressure gauges.

Disassemble, clean and grease all U-joint slides.

Grease or paint disc openers/blades and row marker disc blades to prevent rust.

Flush liquid fertilizer tanks, hoses and metering pump with clean water. See "Piston Pump Storage" if applicable.

**ELECTRICAL WIRING DIAGRAM FOR LIGHT PACKAGE**

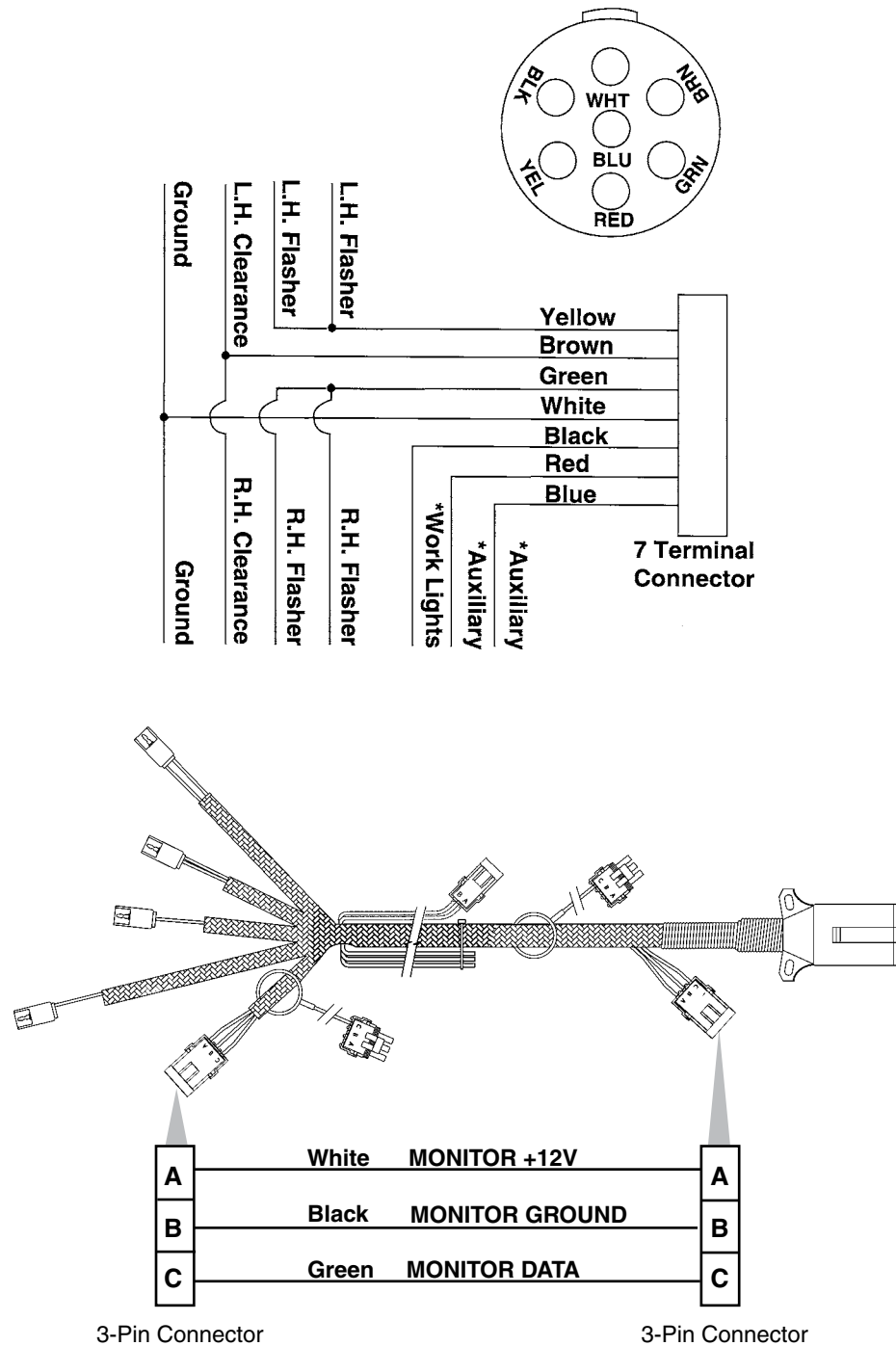

**\* Optional customer-supplied auxiliary lights and wires may be wired into existing plug terminals.**

The light package supplied on the Model 3140 planter meets ASAE Standards. For the correct wiring harness to be wired into the lights on your tractor, check with the tractor manufacturer.





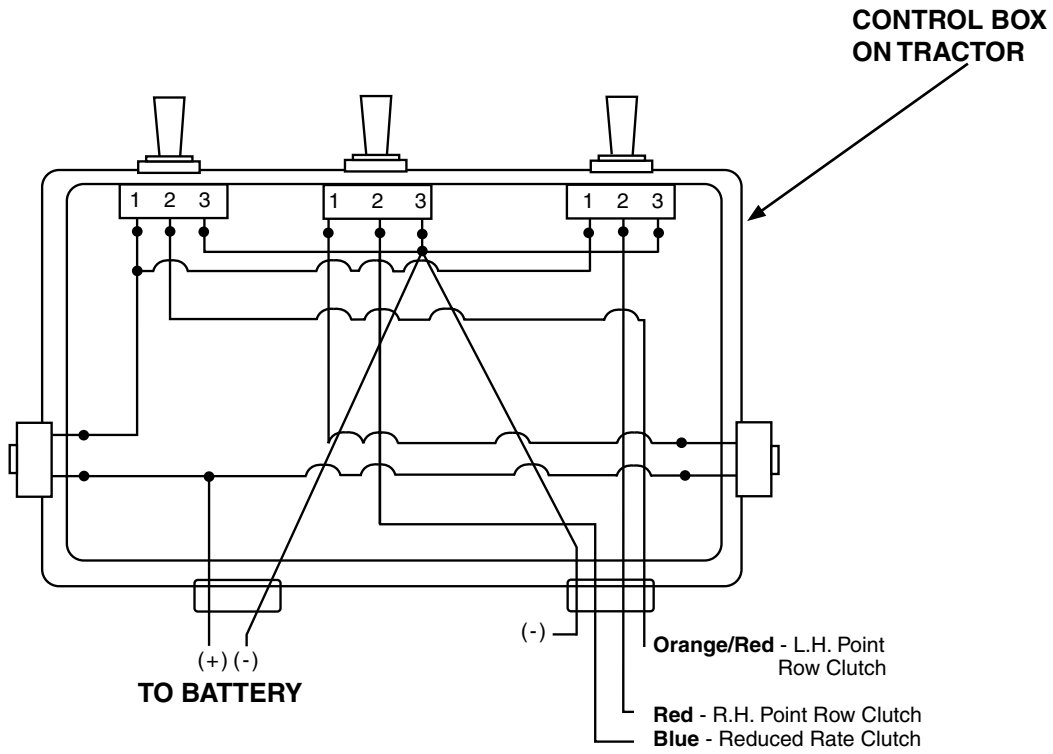

**TWO-SPEED POINT ROW CLUTCH FOR L.H. SIDE OF PLANTER SHOWN**

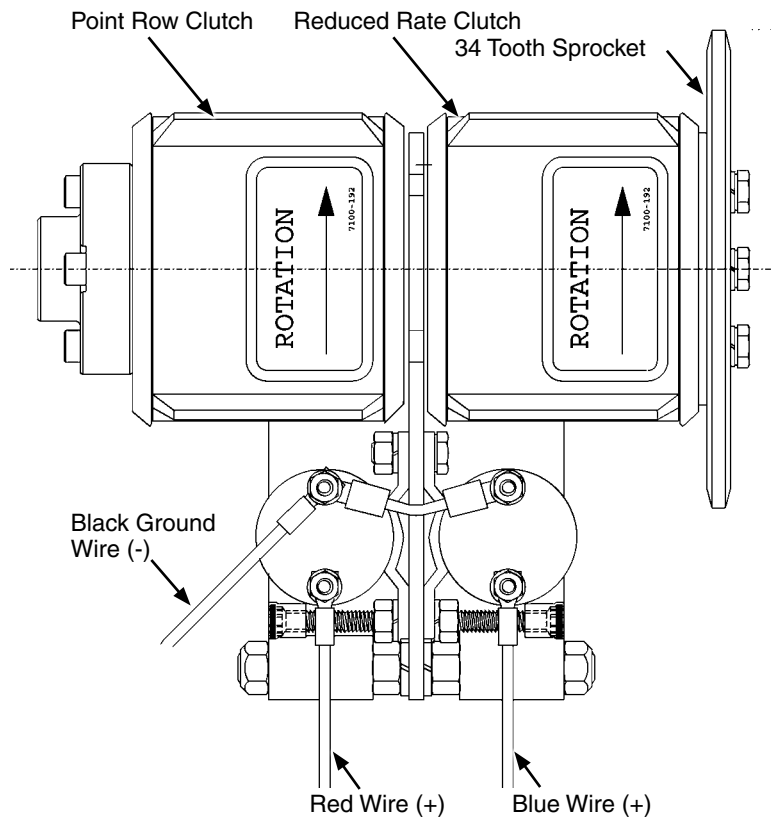



HYDRAULIC SCHEMATIC - VACUUM FAN MOTOR SYSTEM

NOTICE

Connect hydraulic motor case drain to a case drain return line with zero pressure on tractor or hydraulic motor will be damaged. DO NOT connect hydraulic motor case drain to SCV outlet. Contact tractor manufacturer for specific details on "zero pressure return".

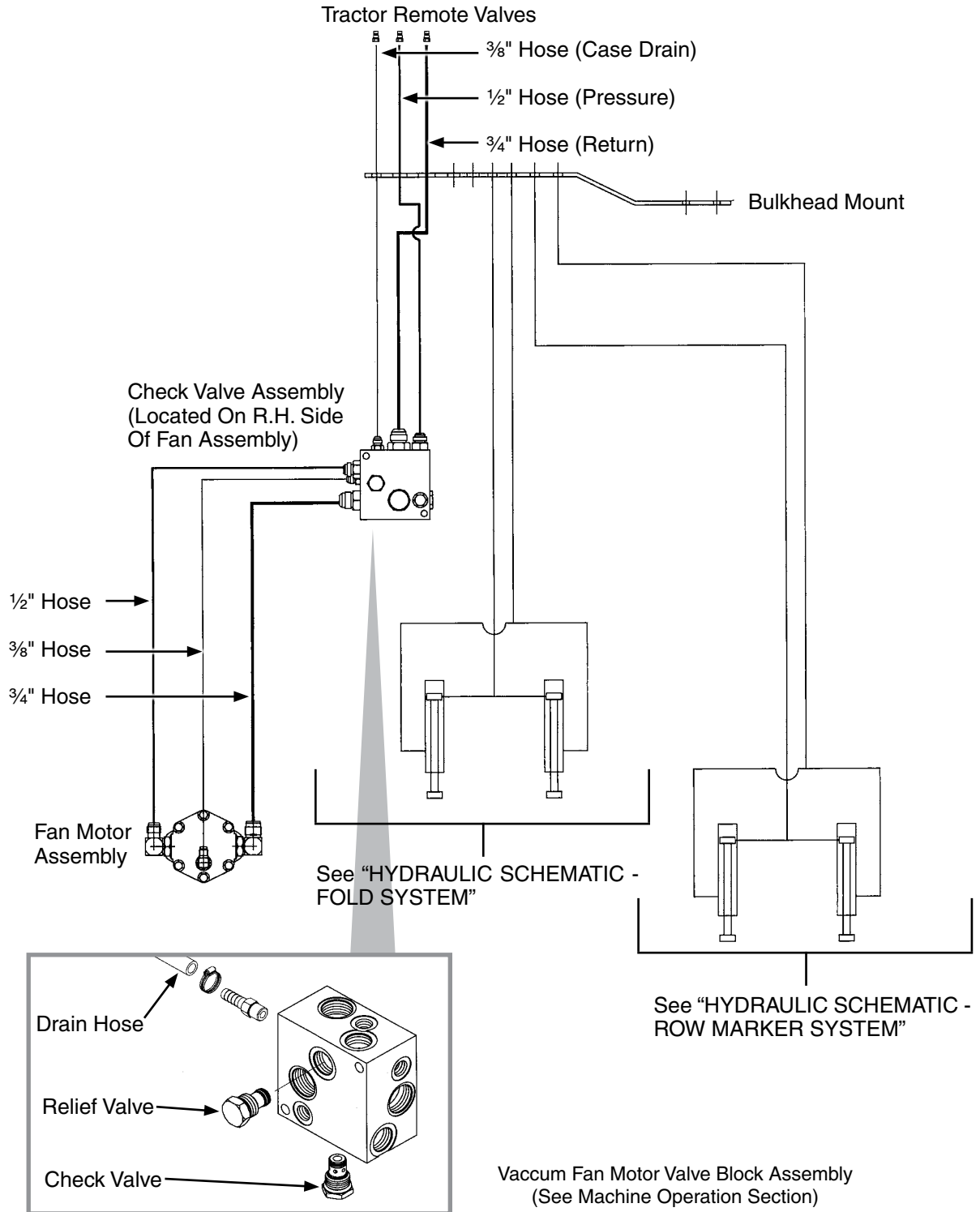

HYDRAULIC SCHEMATIC - FOLD SYSTEM

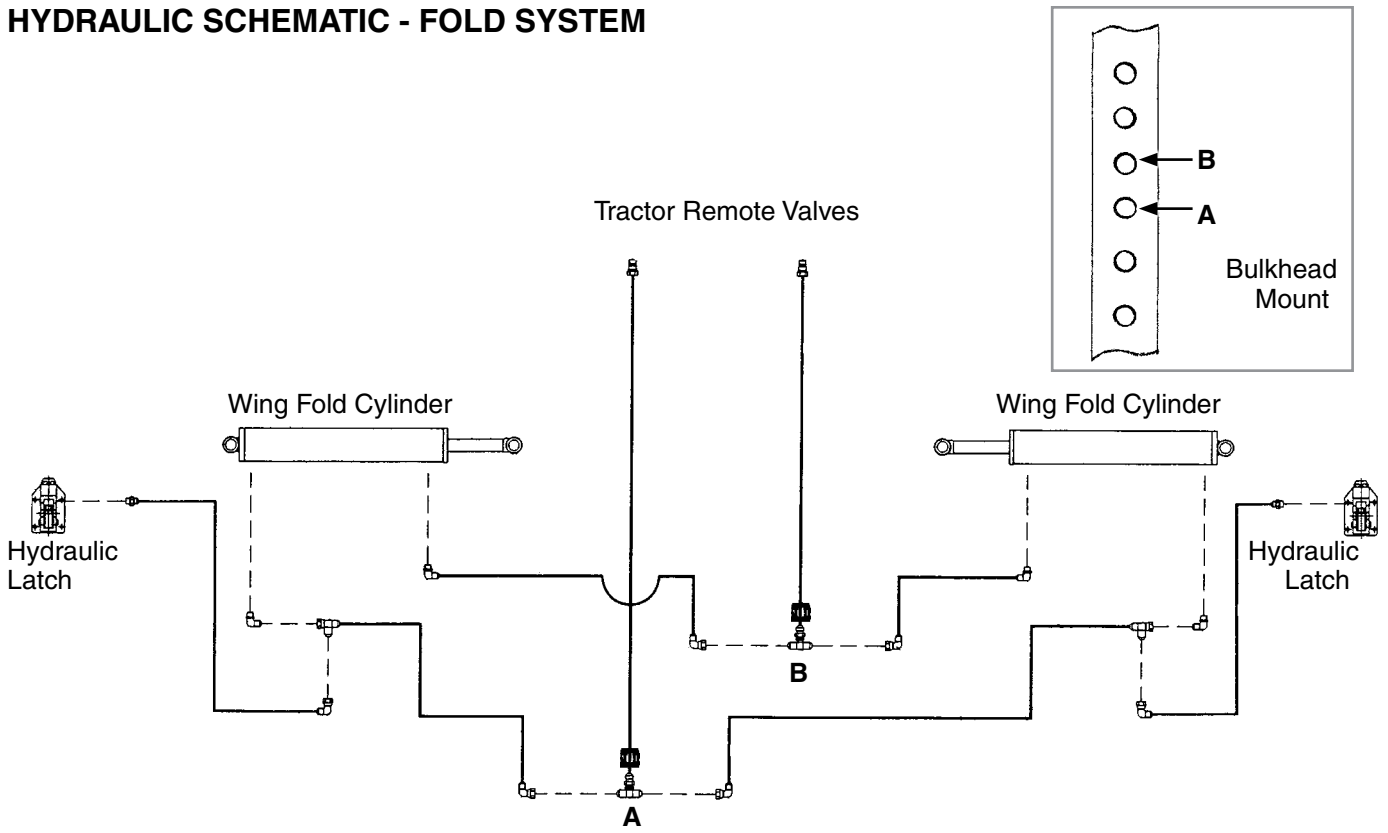

HYDRAULIC SCHEMATIC - ROW MARKER SYSTEM

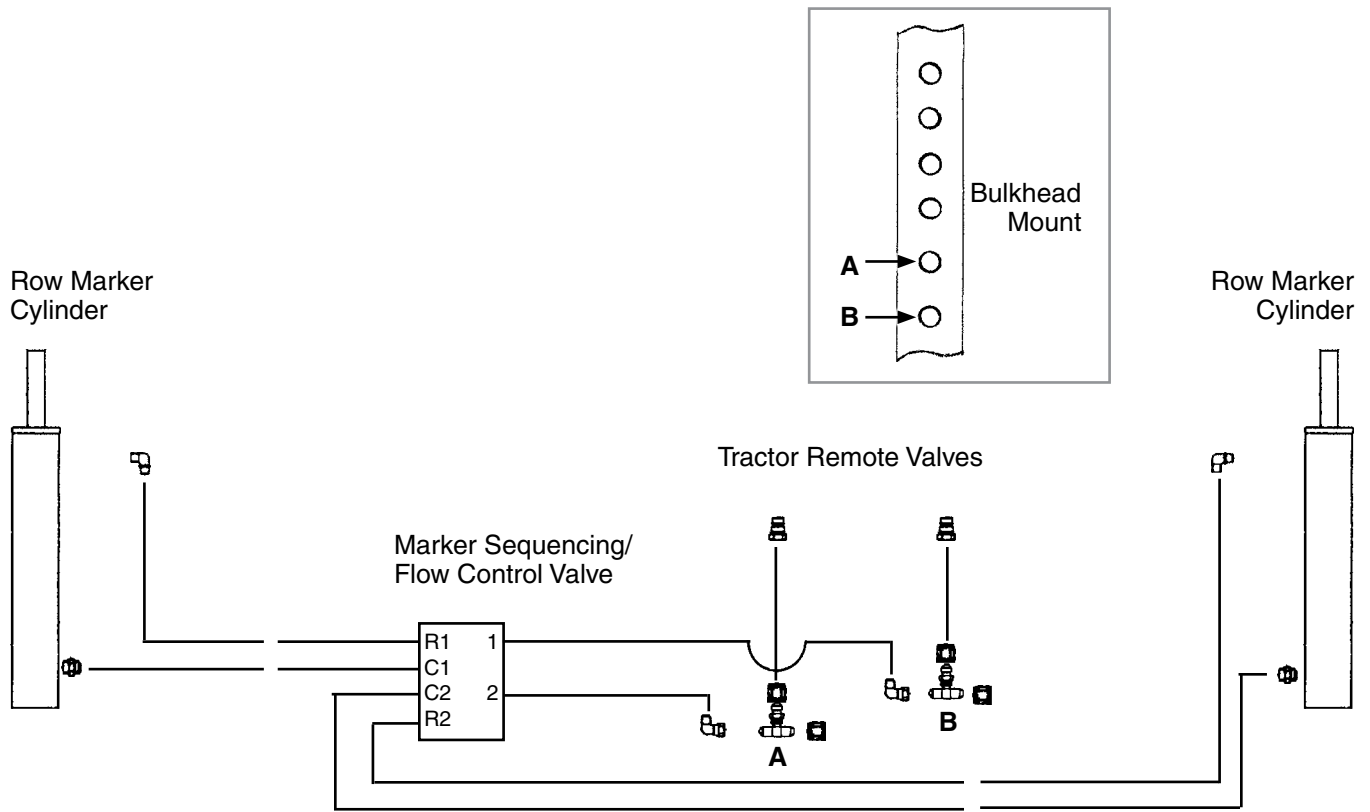

**HYDRAULIC SCHEMATIC - DUAL LIFT ASSIST WHEEL PACKAGE**

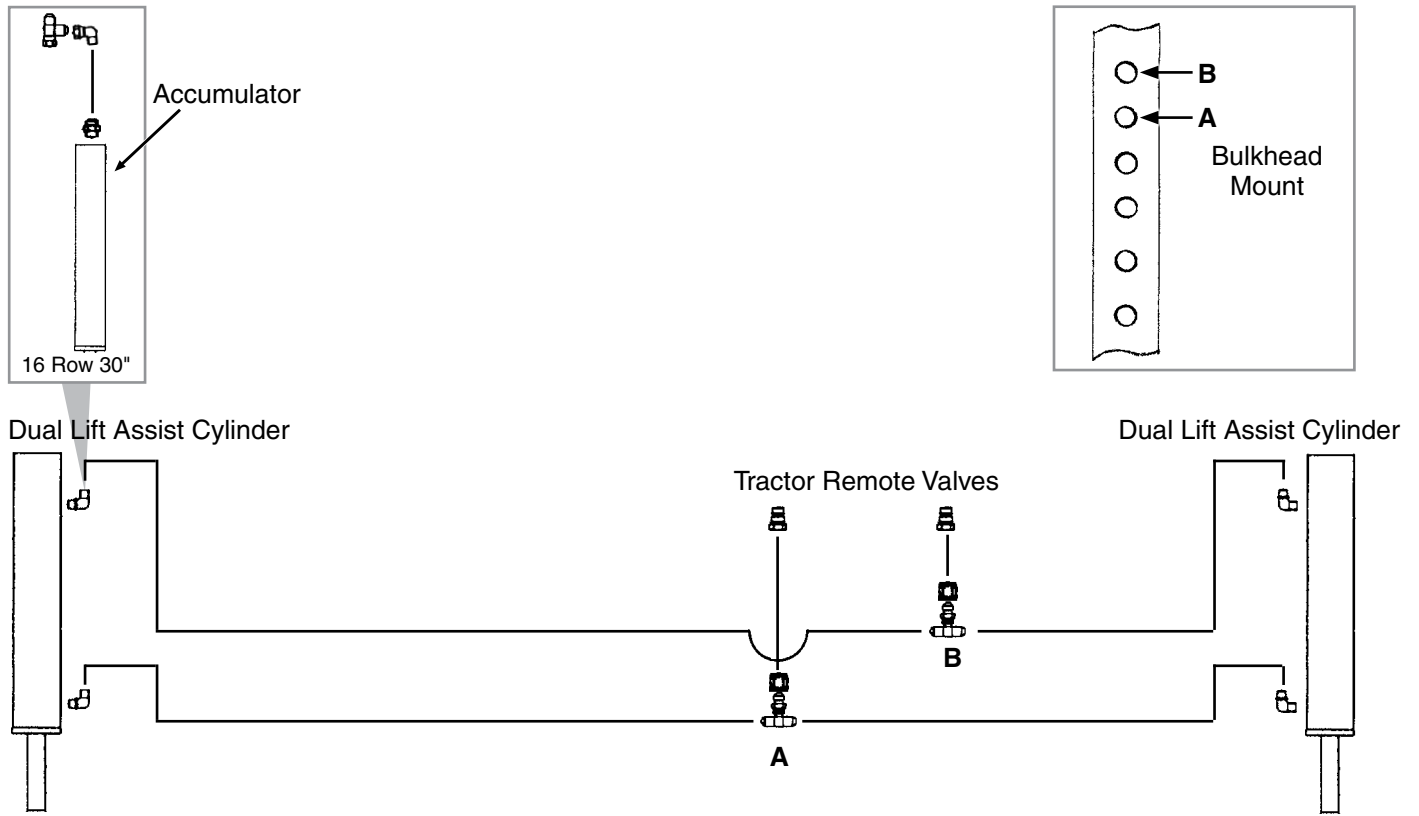

**HYDRAULIC SCHEMATIC - DUAL LIFT ASSIST WHEEL PACKAGE (PLUMBED INTO 3 POINT CIRCUIT)**

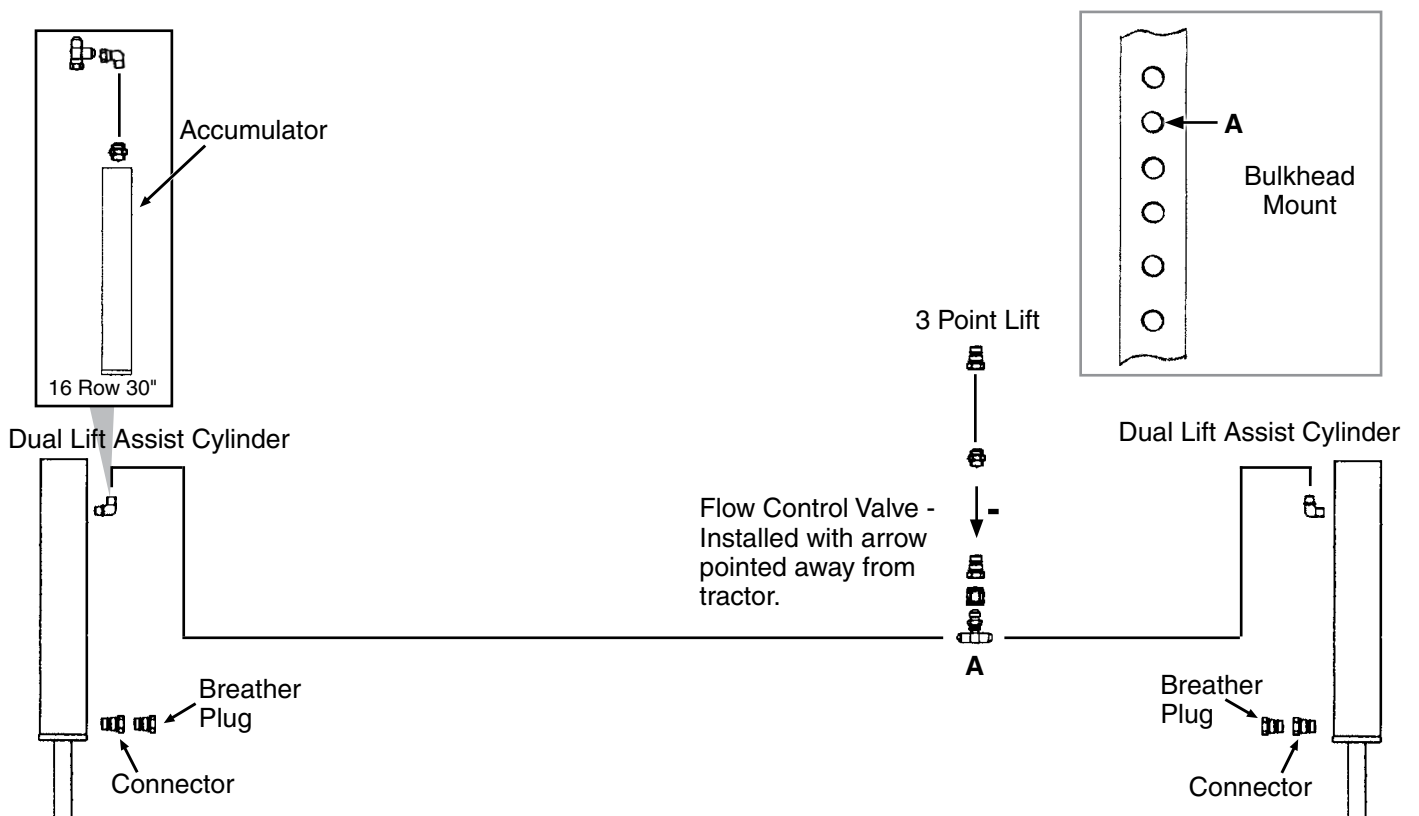

**HYDRAULIC SCHEMATIC - WING DOWN FLEX CYLINDER PACKAGE**

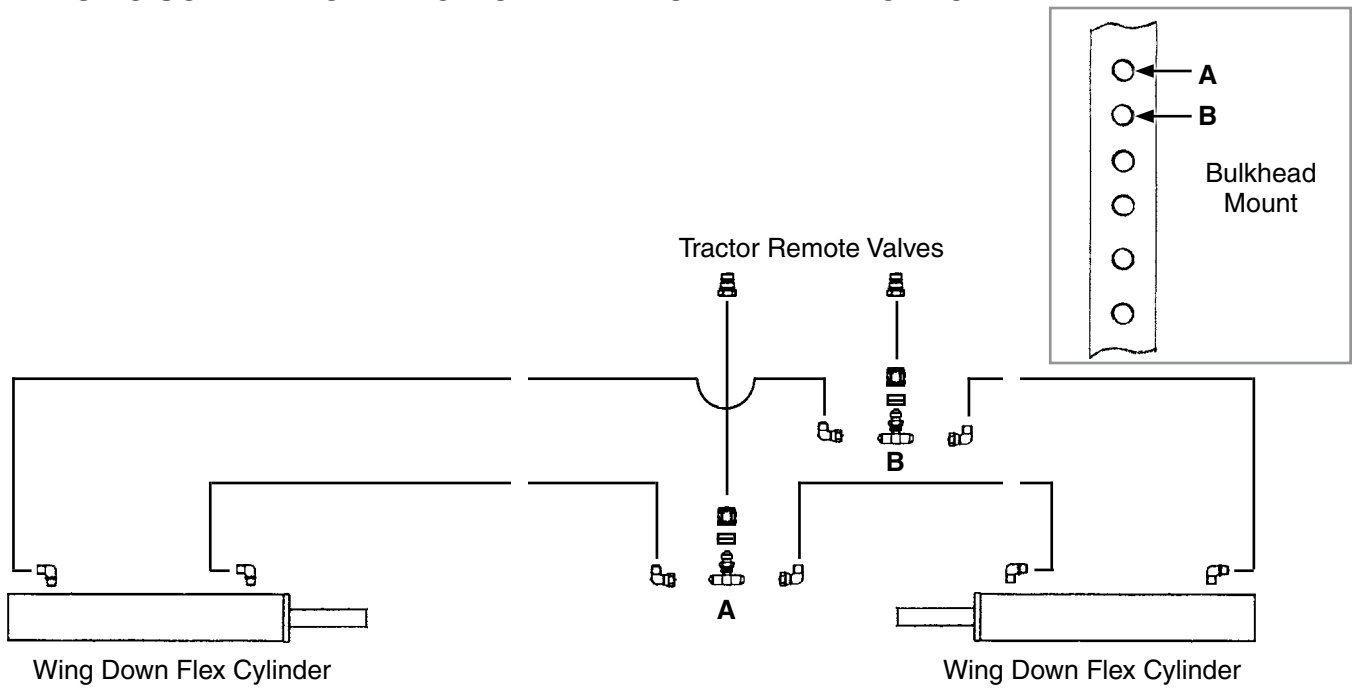

**HYDRAULIC SCHEMATIC - WING DOWN FLEX CYLINDER PACKAGE AND DUAL LIFT ASSIST WHEEL PACKAGE**

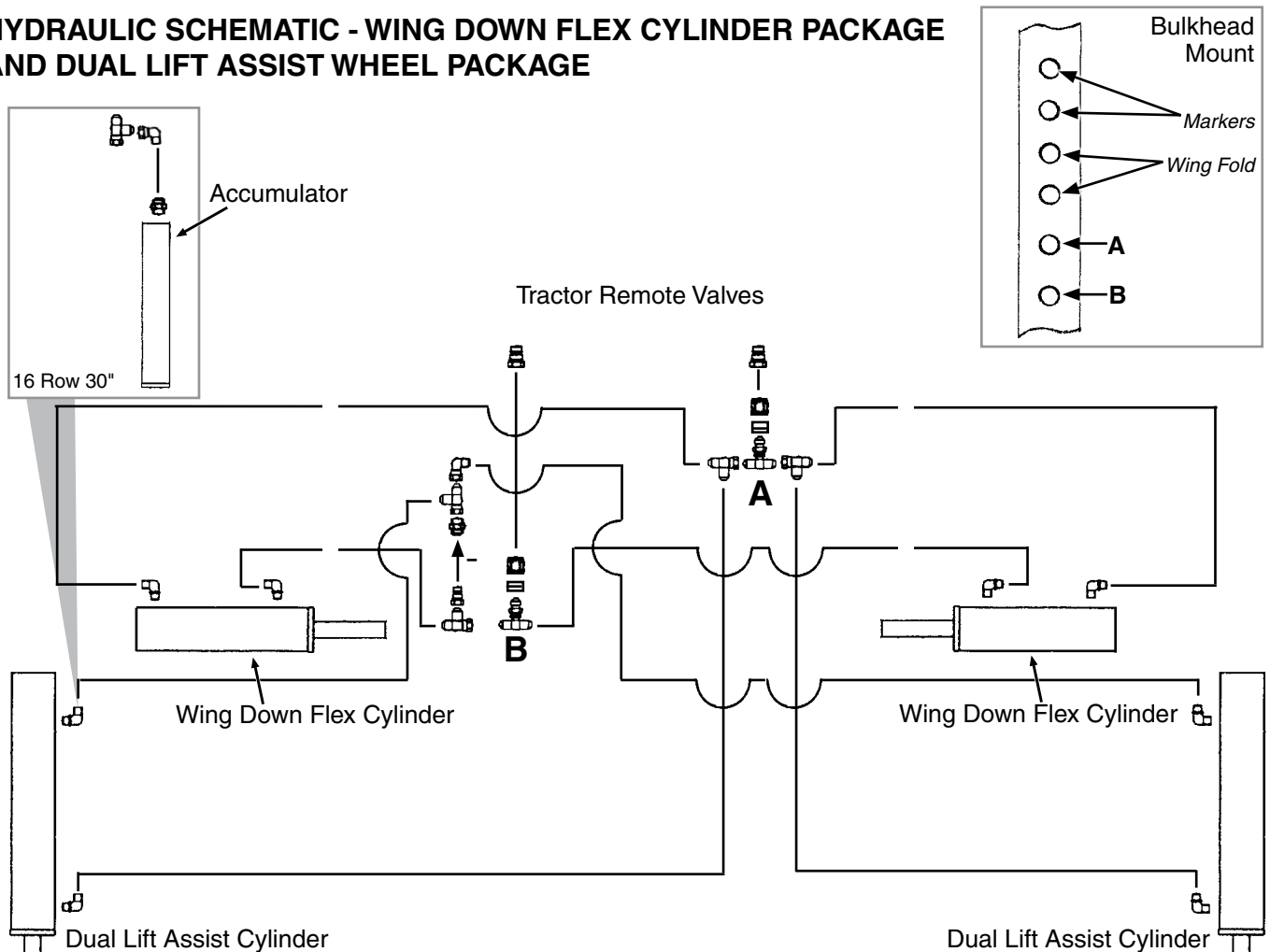

**BRUSH-TYPE SEED METER**

<b>PROBLEM</b>	<b>POSSIBLE CAUSE</b>	<b>SOLUTION</b>
Low count.	Meter RPM too high.	Reduce planting speed.
	Misalignment between drive clutch and meter.	See "Seed Meter Drive Adjustment".
	Seed sensor not picking up all seeds dropped.	Clean seed tube. Switch meter to different row. If problem stays with same row, replace sensor.
	Lack of lubrication causing seeds not to release from disc properly.	Use graphite or talc as recommended.
	Seed size too large for seed disc being used.	Switch to smaller seed or appropriate seed disc. See "Brush-Type Seed Meter" for proper seed disc for size of seed being used.
	Seed treatment buildup in meter.	Reduce amount of treatment used and/or thoroughly mix treatment with seed. Add talc.
Low count at low RPM and higher count at higher RPM.	Foreign material lodged in upper brush.	Remove seed disc and remove foreign material from between brush retainer and bristles. Clean thoroughly.
	Worn upper brush.	Replace. See "Maintenance".
Low count at higher RPM and normal count at low RPM.	Seed disc worn in the agitation groove area.	Replace disc. See "Maintenance".
High count.	Seed size too small for seed disc.	Switch to larger seed or appropriate seed disc.
	Incorrect seed rate transmission setting.	Reset transmission. Refer to proper rate chart in "Machine Operation" section of manual.
	Upper brush too wide (fanned out) for small seed size.	Replace upper brush.
High count. (Milo/Grain Sorghum)	Incorrect brush retainer being used.	Make sure GD8237 brush retainer is installed to keep upper brush from fanning out.
Upper brush laid back.	Seed treatment buildup on brush.	Remove brush. Wash with soap and water. Dry thoroughly before reinstalling. See "Maintenance".
	Buildup of foreign material at base of brush.	Remove brush retainer and brush. Clean thoroughly. Reinstall.

**CLOSING WHEEL**

<b>PROBLEM</b>	<b>POSSIBLE CAUSE</b>	<b>SOLUTION</b>
Closing wheel(s) leave severe imprint in soil.	Too much closing wheel down pressure.	Adjust closing wheel pressure.
Closing wheel(s) not firming soil around seed.	Insufficient closing wheel down pressure.	Adjust closing wheel pressure. Severe no till conditions may require use of cast iron closing wheels.
"V" closing wheel running on top of seed furrow.	Improper centering.	Align. See "V Closing Wheel Adjustment".
Single closing wheel not directly over seed.	Improper centering.	Align. See "Covering Discs/Single Press Wheel Adjustment".

## EDGEVAC SEED METER

PROBLEM	POSSIBLE CAUSE	SOLUTION
Low seed count.	Meter RPM too high.	Reduce planting rate or planting speed.
	Singulator brush setting too aggressive.	Adjust singulator brush.
	Vacuum level too low.	Increase fan speed.
	Seed sensor not picking up all seeds dropped.	Clean seed tube. Move meter to different row.
	Seeds sticking to seed disc.	Use graphite or talc to aid release.
	Seed treatment buildup in seed disc recesses.	Reduce amount of treatment used and or mix thoroughly. Add talc.
	Seed size too large for disc used.	Use appropriate disc for seed size.
	Wrong transmission setting.	Change transmission to desired rate.
	Wrong seed disc.	Use appropriate disc for seed type and size.
	Drive wheel slippage.	Compensate by adjusting transmission sprockets.
	Low tire pressure.	Adjust tire pressure to correct level.
	Failed/worn drive components.	Inspect and replace parts as required.
	Plugged orifices in seed disc.	Inspect and clean disc. Check cleanout brush. (If Applicable)
	Loss of vacuum at meter.	Check for foreign material between vacuum cover and disc. Inspect parts for wear/damage. Clean or replace as required.
	Seed bridging in hopper.	Add graphite to improve seed flow.
	Faulty vacuum gauge reading.	Repair/replace gauge.
	Dirt in vacuum manifold.	Check vacuum manifold for dirt and clean.
	Seed baffle (If Applicable) not allowing seed flow due to bridging of seed.	Thoroughly mix talc to coat all seeds. Remove seed baffle. See "Seed Meter" in Seed Meter Operation/Maintenance section.
	60 cell soybean disc not filling properly due to excessive RPM.	Replace with 120 cell soybean disc.
	Seed disc worn.	Replace.
Vacuum cover worn.	Replace.	
Not planting seed.	Seed hoppers empty.	Fill seed hopper.
	Seed tube plugged/damaged.	Clean or replace tube.
	Meter drive damaged.	Repair/replace drive components.
	Low/no vacuum.	Inspect vacuum system and repair as necessary.
	Singulator brush setting too aggressive.	Adjust singulator brush.
	Faulty vacuum gauge.	Repair/replace vacuum gauge.
	Seed bridging in hopper.	Add graphite to improve seed flow.
	Loss of vacuum at meter.	Check for foreign material between vacuum cover and disc. Inspect parts for wear/damage. Clean and/or replace as required.
	Wrong seed disc.	Use appropriate disc for seed type and size.
	Meter drive clutch not engaged.	Engage drive clutch.
	Fan not running.	Start fan.
	Dirt in vacuum manifold.	Check vacuum manifold for dirt and clean.
	Seed baffle (If Applicable) not allowing seed flow due to bridging of seed.	Thoroughly mix talc to coat all seeds. Remove seed baffle. See "Seed Meter" in Seed Meter Operation/Maintenance section.
	60 cell soybean disc not filling properly due to excessive RPM.	Replace with 120 cell soybean disc.

(Continued On Following Page)

## EDGEVAC SEED METER

PROBLEM	POSSIBLE CAUSE	SOLUTION
High seed count.	Wrong transmission setting.	Change transmission to desired rate.
	High vacuum.	Adjust vacuum level to appropriate level.
	Wrong seed disc.	Replace seed disc.
	Singulator brush setting not aggressive enough.	Adjust singulator brush.
	Worn singulator brush.	Inspect brush and replace as required.
	Seed leaking past wall brush.	Inspect wall brush condition and installation. Replace as necessary.
	Faulty vacuum gauge.	Check gauge line for dirt/obstruction. Repair/replace vacuum gauge.
Poor seed spacing.	Obstruction in seed tube.	Clean seed tube.
	Dirty/damaged seed disc.	Inspect seed disc for damage, foreign material in orifices or seed treatment buildup in recesses. Clean or replace as required.
	Wrong vacuum setting.	Adjust vacuum to appropriate level.
	Excess foreign material in seed.	Inspect and clean meter and seed discs. Use clean, undamaged seed.
	Incorrect singulator brush setting.	Adjust singulator brush to appropriate setting.
	Inconsistent driveline.	Inspect drive components for rust, misalignment, worn or damaged parts. Replace/repair as required.
	Toolbar not level or wrong height.	Adjust hitch to level toolbar and row units.
	Planting too fast for conditions.	Reduce speed.
Irregular seed population.	Rough field conditions.	Reduce speed.
	Driving too fast.	Reduce speed.
Unable to achieve desired vacuum level.	Drive wheels slipping.	Reduce speed. Decrease row unit down pressure spring settings.
	Tractor hydraulic flow set too low.	Increase flow to fan motor.
	Incorrect hydraulic connections.	Check all hydraulic connections and hose routings.
	Damaged fan components.	Inspect motor and impeller for wear/damage and repair/replace as necessary.
	Vacuum hose pinched/kinked/blocked.	Inspect air lines for any damage or obstruction. Clean air lines and manifold by removing end cap from manifold and running fan at high speed.
	Vacuum hose loose/disconnected.	Inspect and reattach all air hoses.
	Tractor not producing required hydraulic flow/pressure.	Have tractor serviced by qualified technician.
	Dirt in vacuum gauge line.	Check gauge line for dirt/obstruction and clean.

**FINGER PICKUP SEED METER**

<b>PROBLEM</b>	<b>POSSIBLE CAUSE</b>	<b>SOLUTION</b>
One row not planting seed.	Drive release not engaged.	Engage drive release mechanism.
	Foreign material in hopper.	Clean hopper and finger carrier mechanism.
	Seed hopper empty.	Fill seed hopper.
	Row unit drive chain off of sprocket or broken.	Check drive chain.
Unit is skipping.	Foreign material or obstruction in meter.	Clean and inspect.
	Finger holder improperly adjusted.	Adjust to specifications. (22 to 25 in. lbs. rolling torque)
	Broken fingers.	Replace fingers and/or springs as required.
	Planting too slowly.	Increase planting speed to within recommended range.
Planting too many doubles.	Planting too fast.	Stay within recommended speed range.
	Loose finger holder.	Adjust to specifications. (22 to 25 in. lbs. rolling torque)
	Worn brush in carrier plate.	Inspect and replace if necessary.
Overplanting.	Worn carrier plate.	Inspect and replace if necessary.
	Seed hopper additive being used.	Reduce or eliminate additive or increase graphite.
Underplanting.	Seed belt installed backwards.	Remove and install correctly.
	Weak or broken springs.	Replace.
	Spring not properly installed.	Remove finger holder and correct.
	Seed belt catching or dragging.	Replace belt.
	Brush dislodging seed.	Replace brush.
Irregular or incorrect seed spacing.	Driving too fast.	Check chart for correct speed.
	Wrong tire pressure.	Inflate tires to correct air pressure.
	Drive wheels slipping.	Reduce down pressure on row unit down force springs.
	Wrong sprockets.	Check seed rate charts for correct sprocket combinations.
Seed spacing not as indicated in charts.	Wrong tire pressure.	Inflate tires to correct air pressure.
	Inconsistent seed size.	Do field check and adjust sprockets accordingly.
	Wrong sprockets.	Check chart for correct sprocket combination.
	Charts are approximate.	Slight variations due to wear in meter components and tire slippage due to field conditions may produce seed spacing variations.
	Stiff or worn drive chains.	Replace chains.
Scattering of seeds.	Planting too fast.	Reduce planting speed.
	Seed tube improperly installed.	Check seed tube installation.
	Seed tube worn or damaged.	Replace seed tube.
Seed tubes and/or openers plugging.	Allowing planter to roll backward when lowering.	Lower planter only when tractor is moving forward.
Inconsistent seed depth.	Rough seed bed.	Adjust down pressure springs. Reduce planting speed.
	Partially plugged seed tube.	Inspect and clean.
	Seed tube improperly installed.	Install properly.



**KPM III ELECTRONIC SEED MONITOR**

<b>PROBLEM</b>	<b>POSSIBLE CAUSE</b>	<b>SOLUTION</b>
Single sensor communication alarm comes on.	Faulty seed tube sensor.	Replace sensor.
	Break in the harness just before the seed tube sensor.	Inspect for break in harness and repair. If break can't be found, replace harness section.
	Dirty or corroded connector.	Clean connector.
Sensor communication alarms come on for all sensors.	Faulty monitor.	Repair/Replace monitor.
	Break in the harness just after the monitor.	Inspect for break in harness and repair. If break can't be found, replace harness section.
	Dirty or corroded connector.	Clean connector.
Sensor communication alarms come on for some sensors.	Break in the harness.	Inspect for break in harness and repair. If break can't be found, replace harness section corresponding with the alarming sensors.
	Dirty or corroded connector.	Clean connector.
Faulty monitor values (such as speed, area, etc.) being displayed.	Incorrect monitor settings.	Change settings to properly correspond to the system.
	Faulty radar/magnetic distance sensor.	Replace sensor.
	Improperly mounted radar sensor.	Properly mount sensor.
Underplanting or no planting alarm on a single sensor when planting (alarm on with a single bargraph segment on and a flashing row number on a single row.	Seed tube sensor is blocked.	Clean sensor.
	Faulty seed tube sensor.	Replace sensor.
	Meter not planting or underplanting.	Repair/replace meter.
	Chain broken or off sprocket.	Repair as necessary.
Seed tube sensor dirty or blocked warning comes on.	Seed tube sensor is dirty.	Clean sensor.
	Faulty seed tube sensor.	Replace sensor.
LED on the seed tube sensor will not come on.	Faulty seed tube sensor.	Replace sensor.
	Dirty or corroded connector.	Clean connector.
	Break in the harness just before the sensor.	Repair harness.
Erroneous MPH readings at idle. (Radar Distance Sensor Only)	Radar sensor not located in a stable location.	Relocate to a more stable location.

## POINT ROW CLUTCH

PROBLEM	POSSIBLE CAUSE	SOLUTION
None of the clutches will disengage.	Main fuse blown in control console.	Replace defective fuse.
	Poor terminal connection in wiring harness.	Repair or replace.
	Wiring damage in wiring harness.	Repair or replace.
	Low voltage at coil. (12 volts required)	Check battery connections.
One section of planter will not re-engage.	Shear pin at seed drive transmission(s) sheared.	Replace pin with one of equal size and grade.
One clutch will not engage.	Fuses blown.	Replace defective fuses.
	Actuator arm and plunger stuck in disengaged position.	Remove, free up and reinstall.
	Actuator arm out of adjustment.	Adjust actuator arm mounting pin in slot so that actuator arm clears stop on stop collar by approximately 1/8" when clutch is rotated.
	Wrap spring broken or stretched.	Disassemble clutch and replace spring.
	Something touching the stop collar.	Check to ensure collar is free to turn with clutch.
	Clutch assembled incorrectly.	Check clutch and diagram for correct assembly.
Clutch slipping.	Wrap spring stretched.	"Lock" clutch output shaft from turning. Place torque wrench on input shaft and rotate in direction of drive. After input shaft has rotated a short distance the wrap spring should tighten onto the input hub. If slippage occurs at less than 100 ft. lbs. replace spring. If spring still slips after installing new spring, replace input hub.
Planter section will not re-engage while planter is moving forward.	Spring in actuator arm not strong enough to push arm away from stop collar when operational switch is turned to the ON position.	Remove spring from inside solenoid and stretch spring slightly or replace. Reinstall spring. If that fails, file the stop on the stop collar slightly so that the stop is not as aggressive.
Frequent solenoid burnout.	Fuses too large.	Replace fuses on front panel with 10 amp slow blow fuses.
Frequent fuse burnout.	Low voltage (12 volts required).	Check power source voltage for partially discharged battery, etc.
	Damage to wiring harness.	Locate damage and repair or replace harness.
Clutch or clutches will not disengage.	Input and output shafts out of alignment.	Align input and output shafts to prevent drag.
	Input or output shaft is pushed in too far creating a coupler.	Reposition input and output shafts.

## ROW MARKER OPERATION

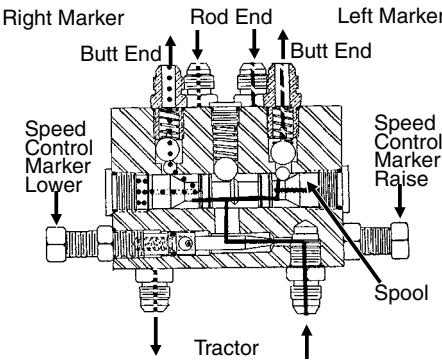
PROBLEM	POSSIBLE CAUSE	SOLUTION
Both markers lowering and only one raising at a time.	Hoses from cylinders to valve connected backwards.	Check to ensure proper hose routing. (See illustration below.)
Same marker always operating.	Spool in sequencing valve not shifting. 	Remove spool, inspect for foreign material, making sure all ports in spool are open. Clean and re-install.
Both markers lower and raise at same time.	Foreign material under check ball in sequencing valve.	Remove hose fitting, spring and balls and clean. May be desirable to remove spool and clean as well.
	Check ball missing or installed incorrectly in sequencing valve.	Disassemble and correct. See illustration in Parts Section.
Marker (in raised position) settling down.	Damaged o-ring in marker cylinder or cracked piston.	Disassemble cylinder and inspect for damage and repair.
	Spool in sequencing valve not shifting completely because detent ball or spring is missing.	Check valve assembly and install parts as needed.
	Spool in sequencing valve shifting back toward center position.	Restrict flow of hydraulic oil from tractor to sequencing valve.
Neither marker will move.	Flow control closed too far.	Loosen locking nut and turn flow control adjustment bolt out or counterclockwise until desired speed is set.
Markers moving too fast.	Flow control open too far.	Loosen locking nut and turn flow control adjustment bolt in or clockwise until desired speed is set.
Sporadic marker operation speed.	Needle sticking open in flow control valve.	Remove flow control, inspect and repair or replace.

**This page left blank intentionally.**



**Kinze Manufacturing, Inc.**

I-80 at Exit 216 North, Williamsburg, Iowa 52361