

MODEL 3400 TWIN-LINE® PLANTER OPERATOR & PARTS MANUAL

M0172

Rev. 11/02

This manual is applicable to: Model: 3400 Twin-Line® Planters
Serial Number: 625008 and on

Record the model number and serial number of your planter along with date purchased:

Model Number _____ 3400 _____

Serial Number _____

Date Purchased _____

SERIAL NUMBER

The serial number plate is located on the planter frame to be readily available. It is suggested that the serial number and purchase date also be recorded above.

The serial number provides important information about your planter and may be required to obtain the correct replacement part. Always provide the model number and serial number to your KINZE® Dealer when ordering parts or anytime correspondence is made with KINZE Manufacturing, Inc.

D06109906



KINZE®, Interplant® and Twin-Line® are registered trademarks of KINZE Manufacturing, Inc.

Rev. 11/02

PREDELIVERY/DELIVERY CHECKLIST

TO THE DEALER

Predelivery service includes assembly, lubrication, adjustment and test. This service helps to ensure that the planter will be delivered to the customer ready for field use.

PREDELIVERY CHECKLIST

After the planter has been completely assembled, use the following checklist and inspect the planter. Check off each item as it is found satisfactory or after proper adjustment is made.

- Recheck to be sure row units and optional attachments are properly spaced and assembled.
- Be sure all grease fittings are in place and lubricated.
- Check planter and make sure all working parts are moving freely, bolts are tight and cotter pins are spread.
- Check all drive chains for proper tension and alignment.
- Check for oil leaks and proper hydraulic operation.
- Check to be sure hydraulic hoses are routed correctly to prevent damage to hoses.
- Inflate tires to specified PSI air pressure. Tighten wheel bolts to specified torque.
- Check to be sure all safety decals are correctly located and legible. Replace if damaged.
- Check to be sure all reflective decals are correctly located and visible when the planter is in transport position.
- Check to be sure SMV sign is in place.
- Check to be sure safety/warning lights are installed correctly and working properly.
- Paint all parts scratched in shipment or assembly.
- Be sure all safety lockups are on the planter and correctly located.
- Check electrical wiring connections and operation.
- Check seed meters on test stand to ensure proper performance.

This planter has been thoroughly checked and to the best of my knowledge is ready for delivery to the customer.

(Signature Of Set-Up Person/Dealer Name/Date)

OWNER REGISTER

Name _____ Delivery Date _____

Street Address _____ Model No. _____ Serial No. _____

City, State/Province _____ Dealer Name _____

ZIP/Postal Code _____ Dealer No. _____

DELIVERY CHECKLIST

At the time the planter is delivered, the following checklist is to be used as a reminder of very important information which should be conveyed to the customer. Check off each item as it is fully explained to the customer.

- Advise the customer that the life expectancy of this or any other machine is dependent on regular lubrication as directed in the Operator & Parts Manual.
- Tell the customer about all applicable safety precautions.
- Along with the customer, check to be sure the reflective decals and SMV sign are clearly visible with the planter in transport position and attached to the tractor. Check to be sure safety/warning lights are in working condition. Tell the customer to check federal, state/provincial and local regulations before towing or transporting on a road or highway.
- Give the Operator & Parts Manual to the customer and explain all operating adjustments.
- Read warranty to customer.
- Complete Warranty And Delivery Report form.

To the best of my knowledge this machine has been delivered ready for field use and customer has been fully informed as to proper care and operation.

(Signature Of Delivery Person/Dealer Name/Date)

AFTER DELIVERY CHECKLIST

The following is a list of items we suggest to check during the first season of use of the equipment.

- Check with the customer as to the performance of the planter.
- Review with the customer the importance of proper maintenance and adherence with all safety precautions.
- Check for parts that may need to be adjusted or replaced.
- Check to be sure all safety decals, reflective decals and SMV sign are correctly located and legible. Replace if damaged or missing.
- Check to be sure safety/warning lights are working properly.

(Signature Of Follow-Up Person/Dealer Name/Date)

**RETURN THIS COMPLETED FORM TO KINZE® IMMEDIATELY along with Warranty And Delivery Report.
Retain photocopy of this form at dealership for After Delivery Check.**

Tear Along Perforation

TABLE OF CONTENTS

TO THE OWNER	1-1
WARRANTY	1-2
INTRODUCTION	2-1
SPECIFICATIONS	3-1
SAFETY PRECAUTIONS	4-1
SAFETY WARNING SIGNS	5-1
MACHINE OPERATION	
Checking Granular Chemical Application Rate	6-47
Checking Seed Population	6-46
Contact Drive Wheel Spring Adjustment	6-2
Electronic Seed Monitor System	
KPM I Monitor	6-12
KPM II Monitor	6-18
Fertilizer Openers And Attachments	6-40
Field Operation	6-8
Field Test	6-46
Field To Transport Sequence	6-8
General Planting Rate Information	6-48
Half Rate (2 To 1) Drive	6-4
Hydraulic/Electric Operation	6-5
Initial Preparation Of The Planter	6-1
Interplant® Clutch Sprocket	6-43
Leveling The Planter	6-2
Liquid Fertilizer Attachment	6-42
Manual Safety Lockups	6-44
Marker Length Adjustment	6-11
Marker Operation	6-10
Marker Safety Lockups	6-45
Marker Speed Adjustment	6-11
Metric Conversion Table	6-45
Planting And Application Rate Charts	6-49
Planting Speed	6-45
Respacing For 22" Rows	6-2
Shear Protection	6-4
Standard Rate Drive	6-4
Tire Pressure	6-3
Tractor Preparation And Hookup	6-1
Tractor Requirements	6-1
Transmission Adjustment	6-3
Transport Latch Locking Pin	6-44
Transport To Field Sequence	6-6
Transporting The Planter	6-45
ROW UNIT OPERATION	
Brush-Type Seed Meter	7-5
Closing Wheel Shield	7-2
Coulter Mounted Residue Wheels	7-19
Covering Discs/Single Press Wheel Adjustment	7-2
Disc Furrower (For Use With Style A Frame Mounted Coulter)	7-15
Drag Closing Attachment	7-3
Finger Pickup Seed Meter	7-4
Frame Mounted Coulters And Attachments	7-12
Granular Chemical Banding Options	7-20
Granular Chemical Hopper And Drive	7-19
Planting Depth	7-1
Interplant® Push Row Unit Clutch Sprocket	7-22
Interplant® Push Row Unit Lockups	7-21
Quick Adjustable Down Force Springs	7-10
Residue Wheels (For Use With Style B Frame Mounted Coulter)	7-15
Row Unit Chain Routing	7-9
Row Unit Mounted Disc Furrower	7-16
Row Unit Mounted No Till Coulter	7-18

TABLE OF CONTENTS

ROW UNIT OPERATION (Continued)

Row Unit Mounted Residue Wheel	7-17
Seed Hopper	7-7
Seed Meter Drive Adjustment	7-8
Seed Meter Drive Release	7-7
Spring Tooth Incorporator	7-20
“V” Closing Wheel Adjustment (Rubber And Cast Iron)	7-1

LUBRICATION

Bushings	8-3
Drive Chains	8-1
Grease Fittings	8-5
Interplant® Push Row Unit Lockups	8-2
Liquid Fertilizer Piston Pump Crankcase Oil Level	8-4
Lubrication Symbols	8-1
Sealed Bearings	8-1
Wheel Bearings	8-4

MAINTENANCE

15" Seed Opener Disc Blade/Bearing Assembly	9-10
Brush-Type Seed Meter Maintenance	9-5
Brush-Type Seed Meter Troubleshooting	9-7
Chain Tension Adjustment	9-1
Check Valve	9-16
Closing Wheel Troubleshooting	9-8
Coulter Mounted Residue Wheels	9-14
Drag Closing Attachment	9-8
Electrical Control Console Schematic	9-23
Electrical Wiring Diagram For Light Package	9-22
Electrical Wiring Harness Schematic (On Tractor)	9-24
Electrical Wiring Harness Schematic (On Planter)	9-25
Finger Pickup Seed Meter Cleaning	9-3
Finger Pickup Seed Meter Inspection/Adjustment	9-2
Finger Pickup Seed Meter Troubleshooting	9-4
Flow Control Valve Inspection	9-16
Frame Mounted Coulters And Attachments	9-11
Gauge Wheel Adjustment	9-8
Gauge Wheel Arm Bushing And/Or Seal Replacement	9-9
Gauge Wheel Assembly Pivot Spindle Replacement	9-9
Granular Chemical Attachment	9-14
Hydraulic System Schematic	9-30
KPM I/KPM II Electronic Seed Monitor Troubleshooting	9-15
Lift Circuit Troubleshooting	9-17
Marker Bearing Lubrication Or Replacement	9-19
Marker Operation Troubleshooting	9-18
Mounting Bolts And Hardware	9-1
Piston Pump Storage	9-21
Piston Pump Troubleshooting	9-21
Preparation For Storage	9-22
Push Pad Shim Replacement/Adjustment	9-20
Rotation Cylinder Circuit Troubleshooting	9-17
Row Unit Mounted Disc Furrower	9-12
Row Unit Mounted No Till Coulter	9-13
Row Unit Mounted Residue Wheel	9-13
Seed Tube Guard/Inner Scraper	9-11
Solenoid Valve Inspection	9-16
Solenoid Valve Troubleshooting	9-16
Spring Tooth Incorporator	9-14
Torque Values Chart	9-1
Transport Latch Post Wear Pad Replacement/Adjustment	9-20
Transport Wheel Bearing Replacement	9-19

PARTS LIST INDEX	P1
-------------------------------	-----------

PARTS SECTION NUMERICAL INDEX	a
--	----------

TO THE OWNER

KINZE Manufacturing, Inc. would like to thank you for your patronage. We appreciate your confidence in KINZE® farm machinery. Your KINZE® planter has been carefully designed and sturdily built to provide dependable operation in return for your investment.

This manual has been prepared to aid you in the operation and maintenance of the planter. It should be considered a permanent part of the machine and remain with the machine when you sell it.

It is the responsibility of the user to read and understand the Operator & Parts Manual in regards to safety, operation, lubrication and maintenance before operation of this equipment. It is the user's responsibility to inspect and service the machine routinely as directed in the Operator & Parts Manual. We have attempted to cover all areas of safety, operation, lubrication and maintenance; however, there may be times when special care must be taken to fit your conditions.

Throughout this manual the symbol  and/or the words **NOTE, IMPORTANT, CAUTION, WARNING or DANGER** are used to call your attention to important information. The definition of each of these terms follows:

NOTE: Indicates a special point of information or addresses a machine adjustment.

IMPORTANT: Indicates information which, if not heeded, could result in damage to the machine.



CAUTION: Indicates a potentially hazardous situation which, if not avoided, may result in minor or moderate personal injury.



WARNING: Indicates a potentially hazardous situation which, if not avoided, could result in death or serious personal injury.



DANGER: Indicates an imminently hazardous situation which, if not avoided, will result in death or serious personal injury.



WARNING: Some photos in this manual may show safety covers, shields or lockups removed for visual clarity. **NEVER OPERATE** the machine without all safety covers, shields and lockups in place.

NOTE: Some photos in this manual may have been taken of prototype machines. Production machines may vary in appearance.

NOTE: Some photos and illustrations in this manual show optional attachments installed. Contact your KINZE® Dealer for purchase of optional attachments.

WARRANTY

The KINZE® Limited Warranty for your new machine is stated on the back of the retail purchaser's copy of the Warranty And Delivery Report form. Additional copies of the Limited Warranty can be obtained through your KINZE® Dealer.

Warranty, within the warranty period, is provided as part of KINZE's support program for registered KINZE® products which have been operated and maintained as described in this manual. Evidence of equipment abuse or modification beyond original factory specifications will void the warranty. Normal maintenance, service and repair is not covered by KINZE® warranty.

To register your KINZE® product for warranty, a Warranty And Delivery Report form must be completed by the KINZE® Dealer and signed by the retail purchaser, with copies to the Dealer, to the retail purchaser and to KINZE Manufacturing, Inc. Registration must be completed and sent to KINZE Manufacturing, Inc. within 30 days of delivery of the KINZE® product to the retail purchaser. KINZE Manufacturing, Inc. reserves the right to refuse warranty on serial numbered products which have not been properly registered.

If service or replacement of failed parts which are covered by the Limited Warranty are required, it is the user's responsibility to deliver the machine along with the retail purchaser's copy of the Warranty And Delivery Report to the KINZE® Dealer for service. KINZE® warranty does not include cost of travel time, mileage, hauling or labor. Any prior arrangement made between the Dealer and the retail purchaser in which the Dealer agrees to absorb all or part of this expense should be considered a courtesy to the retail purchaser.

KINZE® warranty does not include cost of travel time, mileage, hauling or labor.

INTRODUCTION

The Model 3400 Twin-Line® Planter is available in various configurations and row spacings. Optional ultra-narrow 10" or 11" row spacings are obtainable with the addition of Interplant® push row units.

The Model 3400 Twin-Line® Planter permits installation of liquid fertilizer application equipment and various row unit attachments.

GENERAL INFORMATION

The information used in this manual was current at the time of printing. However, due to KINZE's continual attempt to improve its product, production changes may cause your machine to appear slightly different in detail. KINZE Manufacturing, Inc. reserves the right to change specifications or design without notice and without incurring obligation to install the same on machines previously manufactured.

Right hand (R.H.) and left hand (L.H.), as used throughout this manual, are determined by facing in the direction the machine will travel when in use, unless otherwise stated.

D030801111



**Shown With Planter In Raised Field Position
(Interplant® Package Installed)**

D030801115



**Shown With Planter In Transport Position
(Interplant® Package Installed)**

INTRODUCTION

SPECIFICATIONS

TYPE - Pull Type - Rigid Frame - Hydraulically rotates endwise to transport

PLANTING UNIT TYPES - Push and Pull Row Units

ROW SPACING -	Standard	Interplant® Package
	12 - 20" Rows	23 - 10" Rows
	12 - 22" Rows	23 - 11" Rows

DRIVE SYSTEM - Spring-loaded contact drive system
- Two 4.10" x 6" contact drive tires
- No. 40 chain and spring-loaded idlers
- 7/8" hex drill and drive shafts and end mounted seed transmission

TRANSPORT TIRES - Four 255 - 70R x 22.5" radial load range H tubeless rib implement tires with custom center groove

TYPE LIFT - One master cylinder - Two slave cylinders with counter balance valves

MARKERS - Independently controlled - Two-fold low profile

MACHINE OPTIONS

- Electronic Seed Monitors
KPM I
KPM II With Magnetic Distance Sensor Or Radar Distance Sensor
- Half Rate (2 To 1) Drive Reduction Package
- Interplant® Package Options
- Liquid Fertilizer With Piston Pump And Double Disc Or Notched Single Disc Fertilizer Opener Options
- Liquid Fertilizer Low Rate Check Valves Option
- Triple Transport Tire Package

ROW UNIT OPTIONS/ATTACHMENTS

- Finger Pickup Or Brush-Type Seed Meters
- Closing Options
 - Rubber "V" Closing Wheels
 - Cast Iron "V" Closing Wheels
 - Covering Discs/Single Press Wheel
 - Drag Closing Attachment
- Granular Chemical Application
- Hopper Panel Extension Package
- Spring Tooth Incorporator
- Row Unit Mounted No Till Coulter
- Row Unit Mounted Disc Furrowers
- Row Unit Mounted Residue Wheel
- Coulter Mounted Residue Wheels
- Frame Mounted Coulter - STYLE A & STYLE B
- Disc Furrowers For STYLE A Frame Mounted Coulter
- Residue Wheel Attachments For STYLE B Frame Mounted Coulter

SPECIFICATIONS

Dimensions/Operating

PLANTER SIZE	12 Row 20"	**12 Row 22"
WIDTH	22' 6"	22' 6"
LENGTH	22' 7"	22' 7"

Dimensions/Transport

PLANTER SIZE	12 Row 20"	**12 Row 22"
WIDTH Base Machine	11' 3"	11' 7"
WIDTH Push Row unit with no till coulters	12' 9"	12' 9"
LENGTH	25' 8"	25' 8"
HEIGHT	10' 6"	10' 6"

PLANTER WEIGHT	12 Row 20"	**12 Row 22"
*BASE MACHINE WEIGHT	8086 lbs.	8086 lbs.

* Base Machine weights include planter frame, row markers, drive components, tires and wheels, hydraulic cylinders and KINZE® pull row units (closing wheel arms less closing wheels).

** 3400 Twin-Line® Planters are factory assembled for 20" rows. Dealer assembly time is required to respace row units and transport tires for 22" rows.

SAFETY PRECAUTIONS

Safe and careful operation of the tractor and planter at all times will contribute significantly to the prevention of accidents.

Since a large portion of farm accidents occur as a result of fatigue or carelessness, safety practices should be of utmost concern. Read and understand the instructions provided in this manual and on the warning signs. Review these instructions frequently! Listed below are other safety suggestions that should become common practice.

 **Never allow the planter to be operated by anyone who is unfamiliar with the operation of all functions of the unit. All operators should read and thoroughly understand the instructions given in this manual prior to moving the unit.**

 **Never permit any persons other than the operator to ride on the tractor.**

 **Never ride on the planter or allow others to do so.**

 **Always make sure there are no persons near the planter when marker assemblies are in operation or when rotating the planter.**

 **Always keep hands, feet and clothing away from moving parts. Do not wear loose-fitting clothing which may catch in moving parts.**

 **Always wear protective clothing, substantial shoes and suitable hearing and eye sight protectors applicable for the situation.**

 **Do not allow anyone to stand between the tongue or hitch and the towing vehicle when backing up to the planter.**

 **Use a tractor equipped with a roll-over-protective-system and fasten your seat belt prior to starting the engine.**

 **Be aware of bystanders, particularly children! Always look around to make sure it is safe to start the engine of the towing vehicle or move the planter. This is particularly important with higher noise levels and quiet cabs, as you may not hear people shouting.**

 **Install safety lockups on markers prior to transporting the planter or working around the unit.**

D060999113

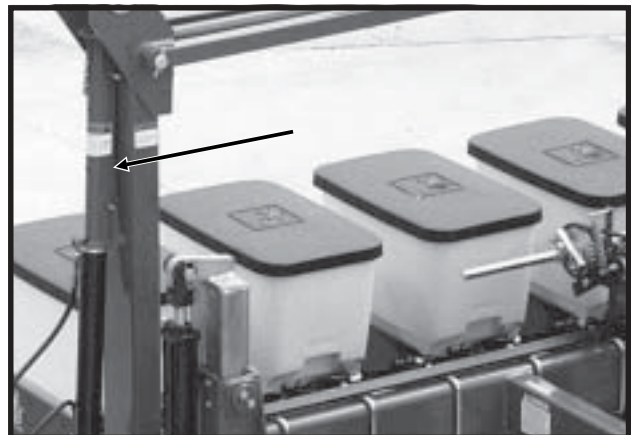

 **Watch for obstructions such as wires, tree limbs, etc., when folding markers.**

 **Care must be taken when operating row markers around overhead power lines.**

 **Never work under the planter while in raised position without using safety lockups.**

 **This planter is designed to be DRIVEN BY GROUND TIRES ONLY. The use of hydraulic, electric or PTO drives may create serious safety hazards to you and the people nearby. If you install such drives you must follow all appropriate safety standards and practices to protect you and others near this planter from injury.**

SAFETY PRECAUTIONS

 Always install safety lockups on center lift cylinders and transport latch locking pin before transporting planter.

D063099114

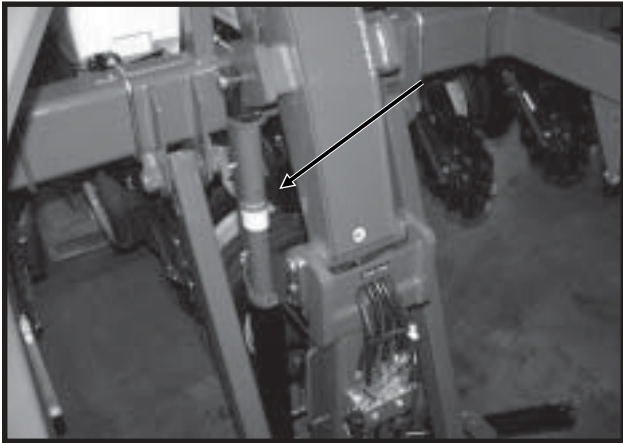

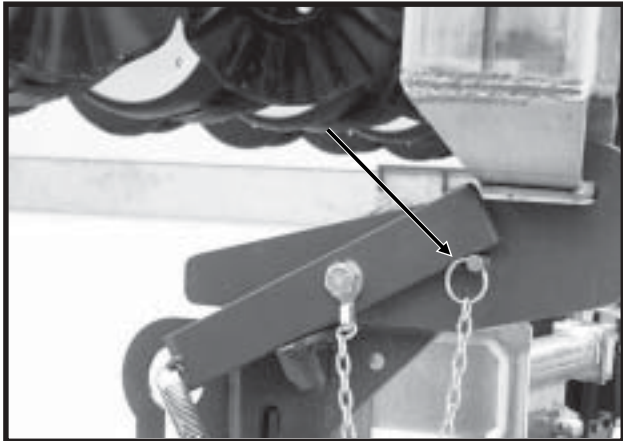

Safety Lockups On Center Lift Cylinders

D060999107



Transport Latch Locking Pin

 Before operating the planter for the first time and periodically thereafter, check to be sure the lug nuts on the transport wheels are tight. This is especially important if the planter is to be transported for a long distance.

 If the planter is going to be transported on a public highway, a safety chain should be obtained and installed. Always follow federal, state/provincial and local regulations regarding a safety chain when towing farm equipment on a public highway. Only a safety chain (not an elastic or nylon/plastic tow strap) should be used to retain the connection between the towing and towed machines in the event of separation of the primary attaching system.

 This machine has been designed and built with your safety in mind. Do not make any alterations or changes to this machine. Any alteration to the design or construction may create safety hazards.

 Check to be sure all safety/warning lights are working before transporting the machine on public roads.

 Avoid transporting planter with hoppers loaded whenever possible. When it is necessary to transport the planter with the hoppers loaded, the added weight should be distributed evenly on the planter frame before rotating the planter.

 Limit towing speed to 15 MPH. Tow only with farm tractor of a minimum 90 HP.

 Always make sure safety/warning lights, reflective decals and SMV sign are in place and visible prior to transporting the machine on public roads. In this regard, check federal, state/provincial and local regulations.

 Allow for unit length when making turns.

 Always drive at a safe speed relative to local conditions and ensure your speed is low enough for an emergency stop to be safe and secure. Keep speed to a minimum.

 Reduce speed prior to turns to avoid the risk of overturning.

 Always keep the tractor in gear to provide engine braking when going downhill. Do not coast.

 Avoid sudden uphill turns on steep slopes.

 Be a safe and courteous driver. Always yield to oncoming traffic in all situations, including narrow bridges, intersections, etc.

SAFETY PRECAUTIONS



Rim and tire servicing can be dangerous. Explosive separation of a tire and rim parts can cause serious injury or death.



Agricultural chemicals used with this unit can be dangerous. Improper selection or use can seriously injure persons, animals, plants, soil and other property. **BE SAFE:** Select the right chemical for the job. Handle it with care. Follow the instructions of the chemical manufacturer.



Store the planter in an area away from human activity. **DO NOT** permit children to play in or around the stored unit.



Make sure the parked machine is on a hard, level surface. Wheel chocks may be needed to prevent unit from rolling.



Good maintenance is your responsibility. Poor maintenance is an invitation to trouble.

SAFETY PRECAUTIONS

SAFETY WARNING SIGNS

The “WARNING” signs illustrated on these pages are placed on the machine to warn of hazards. The warnings found on these signs are for your personal safety and the safety of those around you. OBSERVE THESE WARNINGS!

- Keep these signs clean so they can be readily observed. Wash with soap and water or cleaning solution as required.
- Replace “WARNING” signs should they become damaged, painted over or if they are missing.
- Check reflective decals and SMV sign periodically. Replace if they show loss of any of their reflective property.
- When replacing decals, clean the machine surface thoroughly using soap and water or cleaning solution to remove all dirt and grease.

NOTE: The production date of the machine will determine style and locations of reflectors and/or reflective decals and safety/warning lights to conform to ANSI/ASAE S279.10 OCT 98.

D060999127



Part No. G7100-42 (Qty. 2 Per Marker)

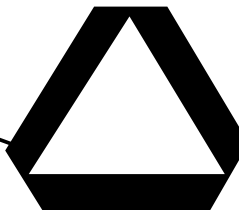

Part No. GD2199 (Qty. 1)

D060999113

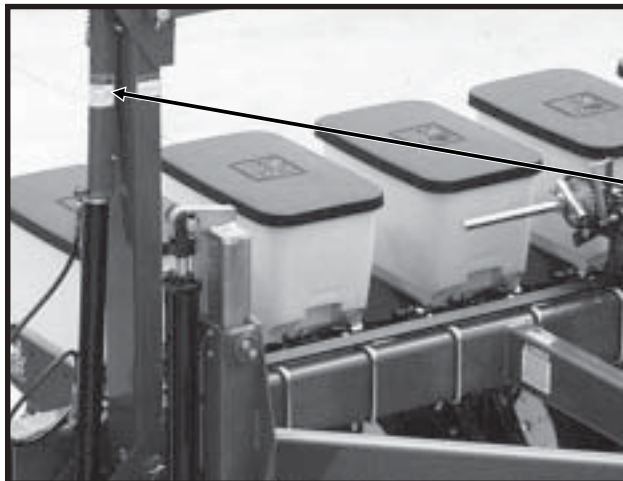

Part No. G7100-83 (Qty. 1 Per Marker Lockup)

SAFETY WARNING SIGNS



Part No. G7100-56 (Qty. 1)



Part No. G7100-43 (Qty. 1)

D060999108a

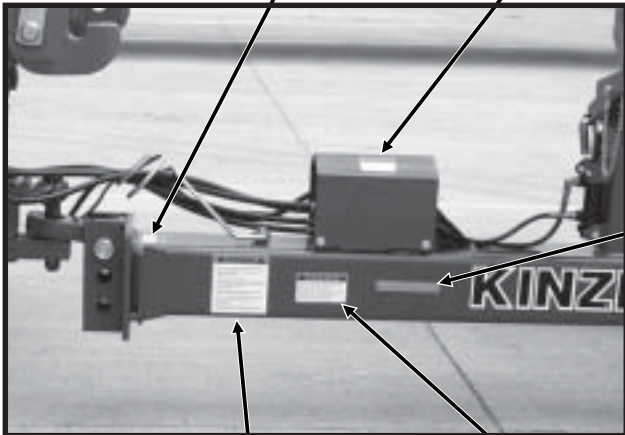

Part No. G7100-259 Amber Reflective Decal (Qty. 2 - One Located On Each Side Of The Hitch) (If Applicable)

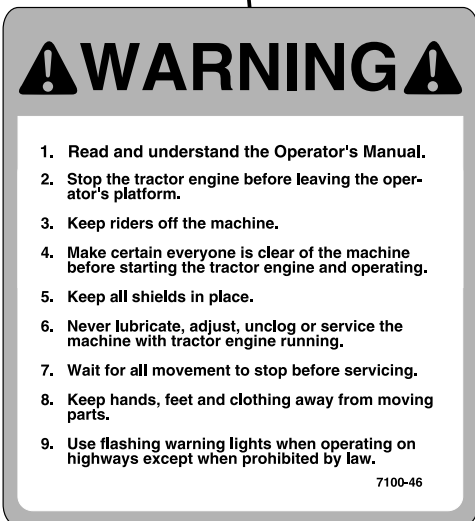

Part No. G7100-46 (Qty. 1)



Part No. G7100-90 (Qty. 1)

SAFETY WARNING SIGNS

D030801111

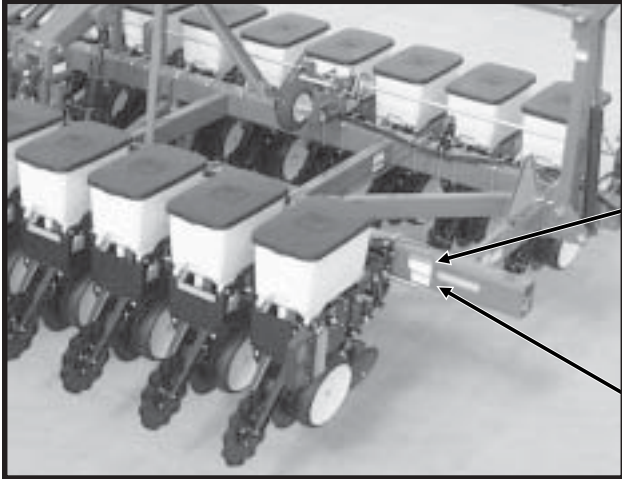

Part No. G7100-68 (Qty. 2 - One On Each Side Of Planter)



Part No. G7100-75 (Qty. 2 - One On Each Side Of Planter)

D06109905

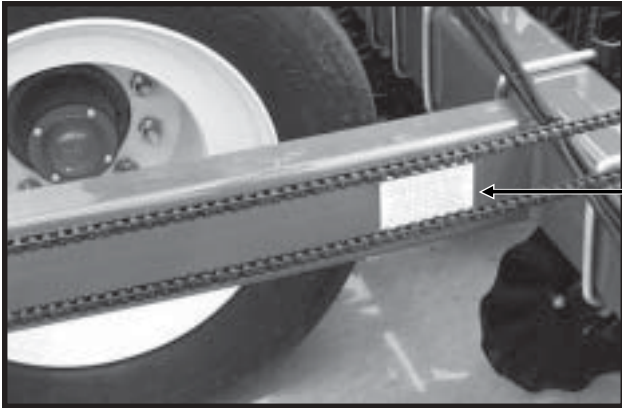

Part No. G7100-89 (Qty. 2 - One On Each Side Of Planter)

D060999127

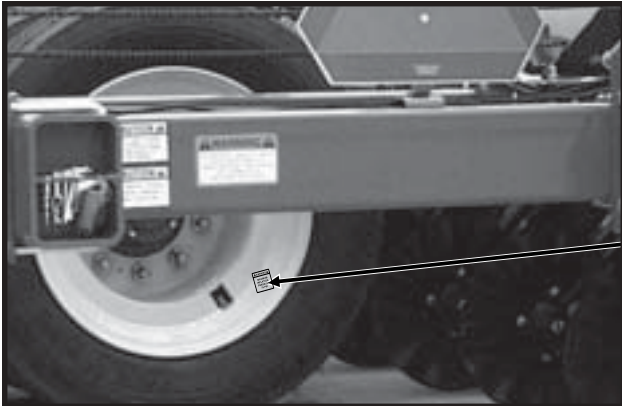

Part No. G7100-219 (Qty. 4 - One On Each Transport Wheel Rim)

SAFETY WARNING SIGNS



Part No. G7100-63 (Qty. 2 - One On Each Side Of Planter)



Part No. G7100-68 (Qty. 2 - One On Each Side Of Planter)

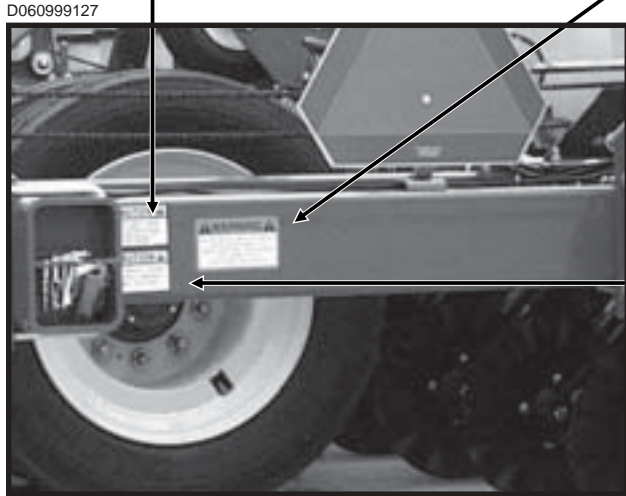

Part No. G7100-75 (Qty. 2 - One On Each Side Of Planter)

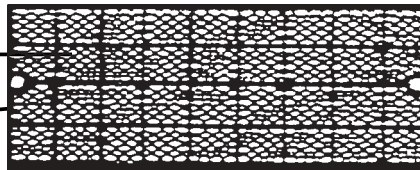

Part No. G7200-03 Red Reflector (Qty. 2 - Rear Of Planter In Transport) (If Applicable)

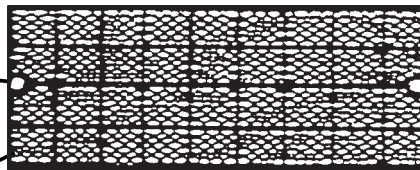
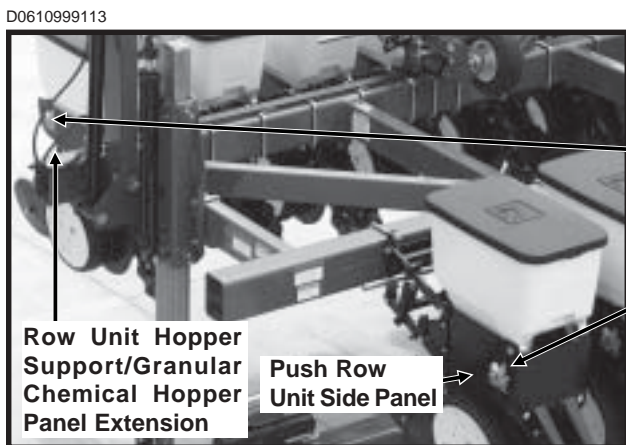

Part No. G7200-04 Amber Reflector (Qty. 1 - Front Of Planter In Transport On Outer Most Edge Of Row Unit Hopper Support/Qty. 1 - Front Of Planter In Transport On Outer Most Edge Of Push Row Unit Side Panel When Equipped With Interplant® Package) (If Applicable)

SAFETY WARNING SIGNS



D06109906

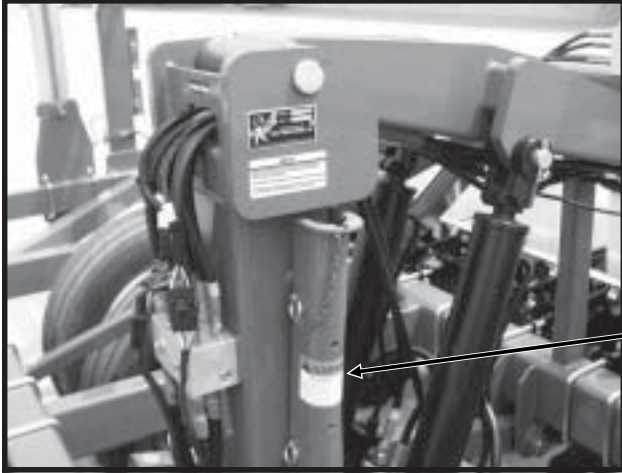

Part No. G7100-83 (Qty. 2 - One On Each Center Lift/Slave Cylinder Safety Lockup)

D06039901



Part No. G7100-115 (1 Per Row Unit - Located On Underside Of Optional Granular Chemical Hopper Lid)

D06099911

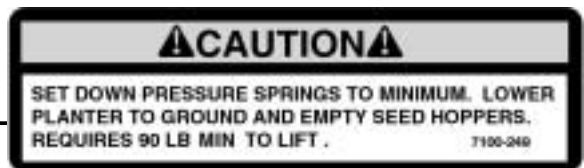

Part No. G7100-249 (Qty. 1 - Interplant® Push Row Unit Lift Lever)

SAFETY WARNING SIGNS



(PLTR147K)

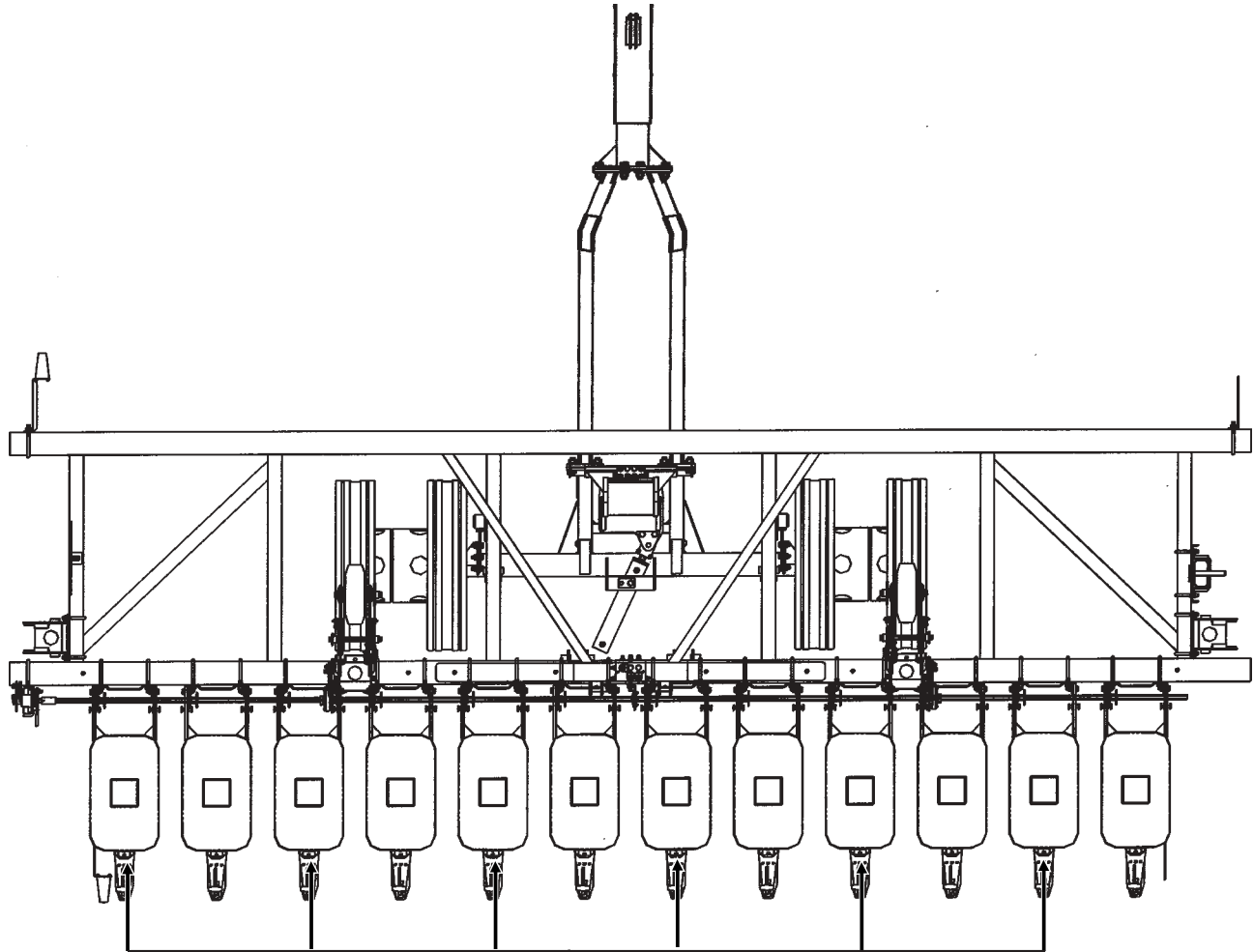

Part No. G7100-262 Amber Reflective Decal
(Qty. 6 - Located On The Hopper Support On Every
Other Row Unit Beginning On The L.H. End Of The
Planter) **(Standard)** (If Applicable)

D060800114

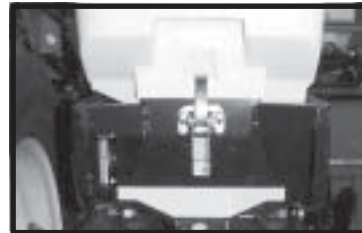

Part No. G7100-259 Amber Reflective Decal
(Qty. 6 - Located On The Granular Chemical Hopper
Panel Extension On Every Other Row Unit Beginning On
The L.H. End Of The Planter)
(With Optional Granular Chemical)
(If Applicable)

D062300102



SAFETY WARNING SIGNS



(PLTR163/RU120d/PLTR161/PLTR162)

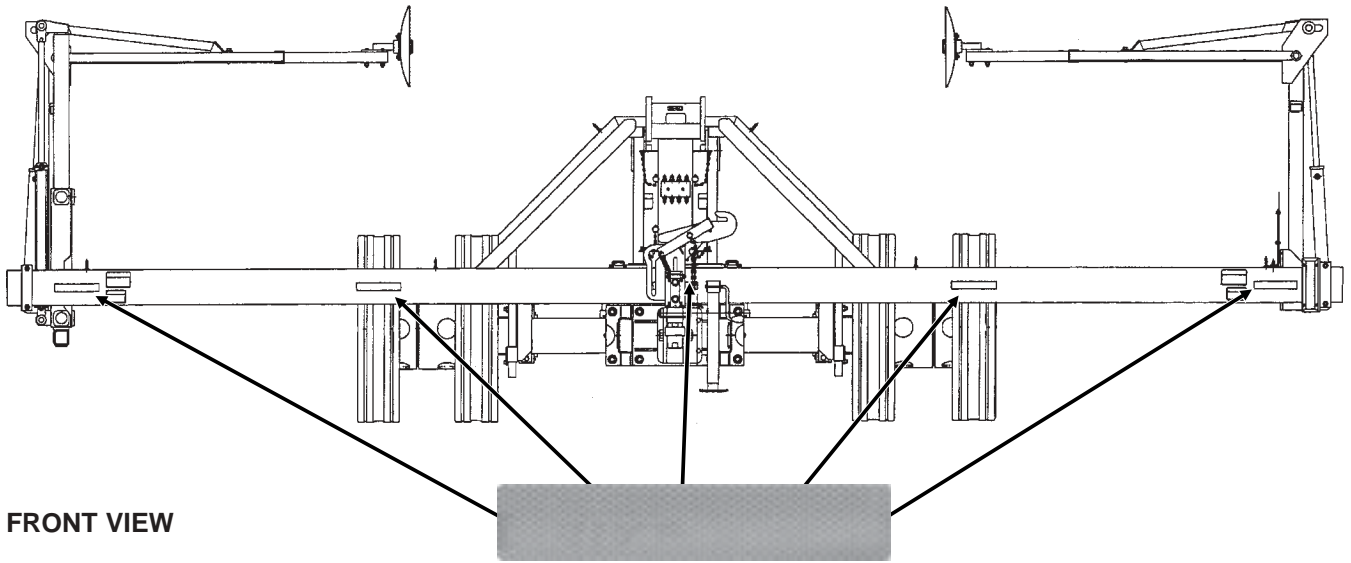

FRONT VIEW

Part No. G7100-259 Amber Reflective Decal (Qty. 5)
(If Applicable)

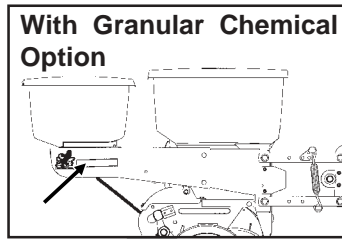

Part No. G7100-259 Amber Reflective Decal
(Qty. 2 - Located On The R.H. End Of
The Planter - Forward-Facing In
Transport Position) (If Applicable)

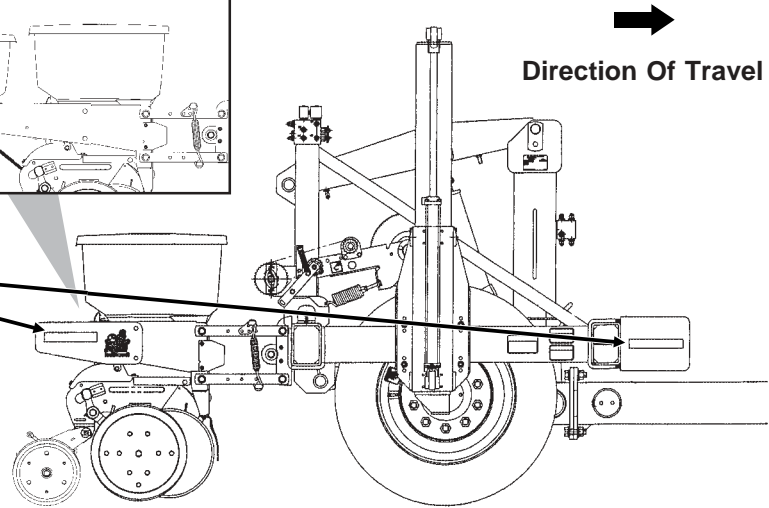

Part No. G7100-258 Red Reflective Decal (Qty. 2)

Part No. G7100-260 Orange Reflective Decal (Qty. 2)

(Located On The L.H. End Of The
Planter - Rear-Facing In Transport
Position) (If Applicable)

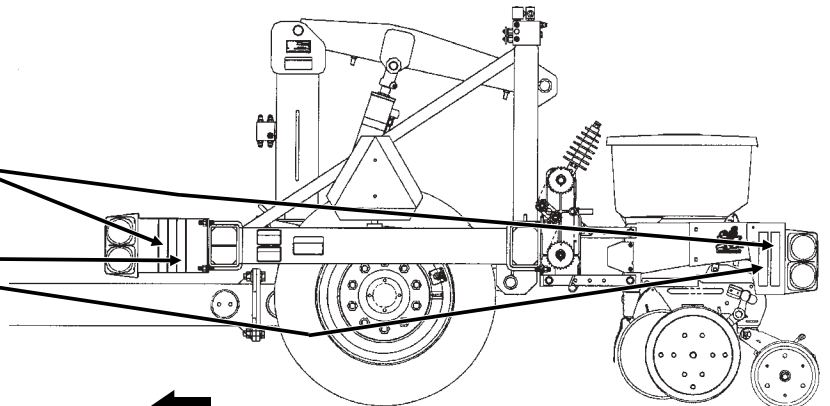

Direction Of Travel

SAFETY WARNING SIGNS



(PLTR159b/PLTR147)

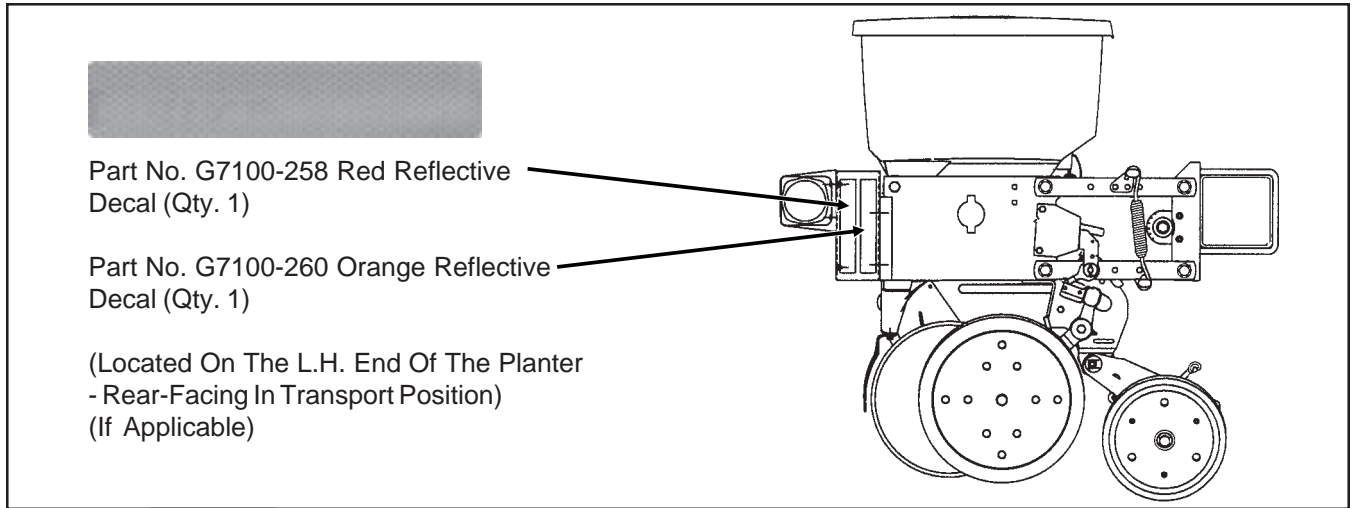

D020101103



WITH INTERPLANT® OPTION

Part No. G7100-259 Amber Reflective Decal (Qty. 5 - Located On The Front Of Every Other Push Row Unit Starting On The Second Row In - Side-Facing In Transport Position) (If Applicable)

Part No. G7100-259 Amber Reflective Decal (Qty. 1 - Located On The Push Row Unit Side Panel - Forward-Facing In Transport Position) (If Applicable)

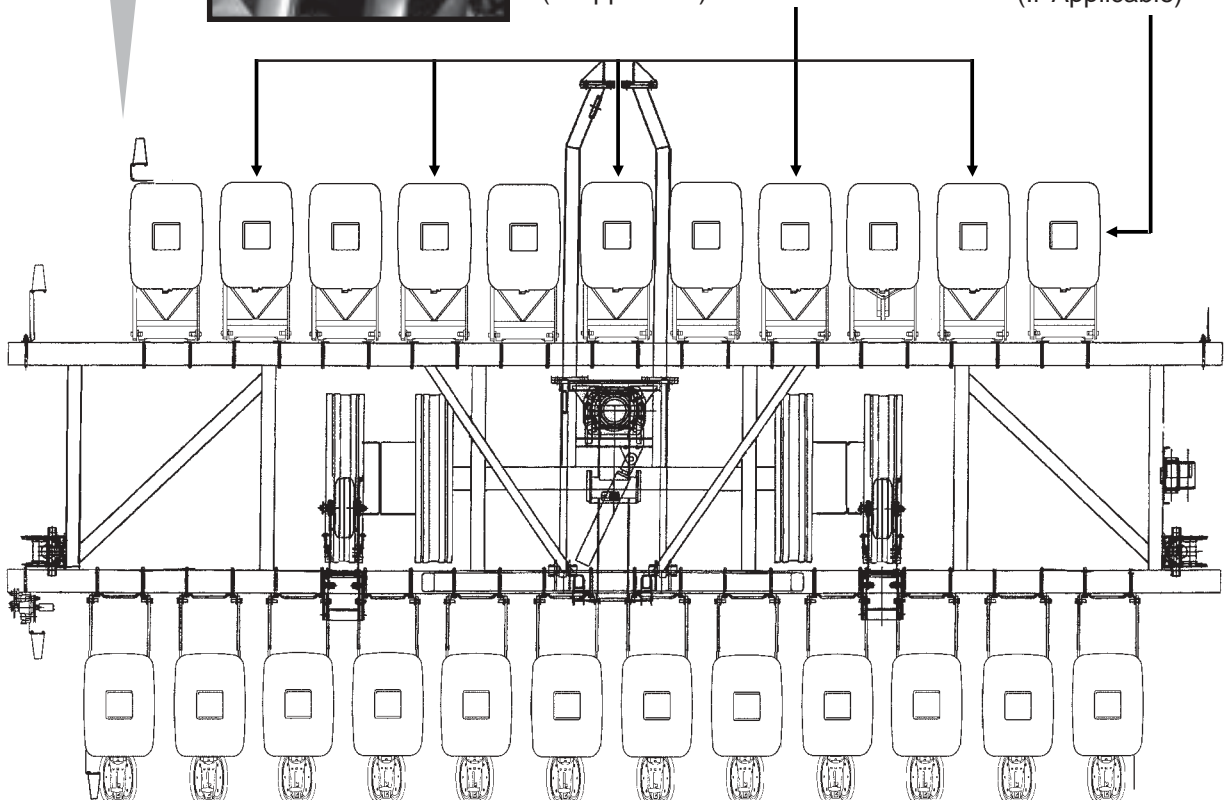

MACHINE OPERATION

The following information is general in nature and was written to aid the operator in preparation of the tractor and planter for use, and to provide general operating procedures. The operator's experience, familiarity with the machine and the following information should combine for efficient planter operation and good working habits.

IMPORTANT: Always raise the planter out of the ground when making sharp turns or backing up.

INITIAL PREPARATION OF THE PLANTER

Lubricate the planter and row units per the lubrication information in this manual. Make sure all tires have been properly inflated. Check all drive chains for proper tension, alignment and lubrication.

TRACTOR REQUIREMENTS

Consult your dealer for information on horsepower requirements and tractor compatibility. Requirements will vary with planter options, tillage and terrain. Two dual remote hydraulic outlets (SCV) are required on all sizes. A 12 volt DC electrical system is required on all sizes.

TRACTOR PREPARATION AND HOOKUP

D060999108a

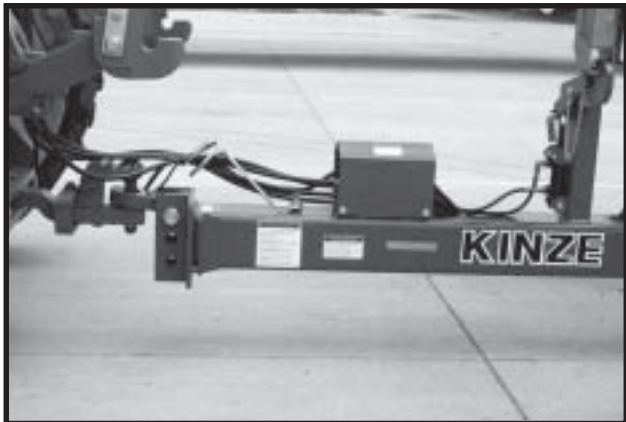

1. Adjust tractor drawbar to 13-17 inches above the ground. Adjust the drawbar so the hitch pin hole is directly below the center line of the PTO shaft. Make sure the drawbar is in a stationary position.
2. Install control console on tractor in a convenient location within reach of the operator and close to the hydraulic controls. Mount control console securely and route power cord to the power source.

The control console operates on 12 volt DC only. If two 12 volt batteries are connected in series, ALWAYS make power connection on battery which is grounded to tractor chassis.

If two 6 volt batteries are connected in series, make sure power connection provides 12 volt DC across the positive terminal on one battery and negative terminal of the second battery.

3. Back tractor to planter and connect with 1 1/4" - 1 1/2" diameter hitch pin. If the tractor is not equipped with a hitch pin locking device, make sure hitch pin is secured with a locking pin or cotter pin.
4. Connect hydraulic hoses to tractor ports in a sequence which is both familiar and comfortable to the operator.

The hydraulic hoses are color coded as follows:

Red AA - Lift Functions (Return)

Red BB - Lift Functions (Pressure)

Blue AA - Marker And Fold/Unfold Functions (Return)

Blue BB - Marker And Fold/Unfold Functions (Pressure)



DANGER: Before applying pressure to the hydraulic system, make sure all connections are tight and hoses and fittings have not been damaged. Hydraulic fluid escaping under pressure can have sufficient force to penetrate skin, causing injury or infection.

IMPORTANT: Always wipe hose ends to remove any dirt before connecting couplers to tractor ports.

5. Connect cable on planter to control console cable on tractor. Connect ASAE Standards 7 terminal connector for warning lights on planter to ASAE Standards receptacle on tractor. If your tractor is not equipped with an ASAE Standards receptacle, check with your tractor manufacturer for availability. Check to be sure warning lights on planter are working in conjunction with warning lights on tractor.
6. Remove jack and remount horizontally on storage bracket.

D102999101

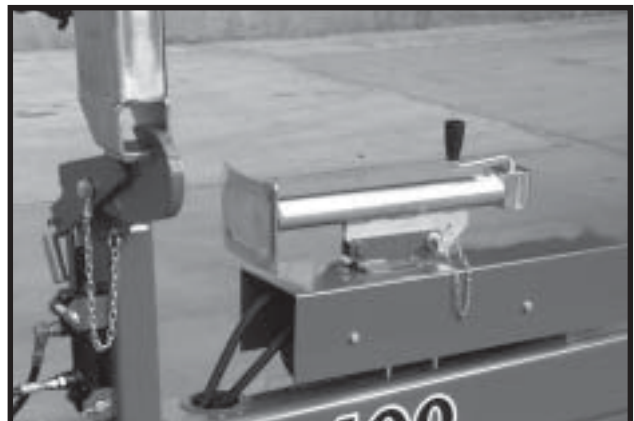

MACHINE OPERATION

- Lower planter to the planting position and check to be sure the hitch is level. If hitch slopes up or down, disconnect planter and adjust hitch clevis up or down as necessary.

NOTE: If using an auxiliary attaching system to retain the connection between the planter and tractor hitch, be sure the auxiliary attaching system is of sufficient strength and length and correctly attached. An auxiliary attaching system (safety chain) is available from KINZE® through your KINZE® Dealer. Attach safety chain using clevis mounting hole on planter hitch.

LEVELING THE PLANTER

For proper operation of the planter and row units, it is important that the planter frame and row unit parallel arms be approximately level. The toolbar should operate at a 20"-22" height, measured to the bottom of the toolbar.

Unless the tractor drawbar is adjustable for height, the fore and aft level adjustment must be maintained by the position of the hitch clevis. Three holes in the hitch bracket allow the clevis to be raised or lowered. In addition, the clevis may be turned over for a finer adjustment between mounting holes. When installing clevis mounting bolt, make sure lock nut is tightened to proper torque setting.

D060999108a

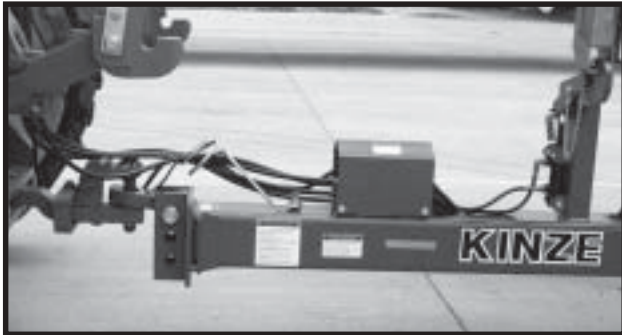

With the planter lowered to proper operating depth, check to be sure the frame is level fore and aft. Recheck once planter is in the field.

D060999127

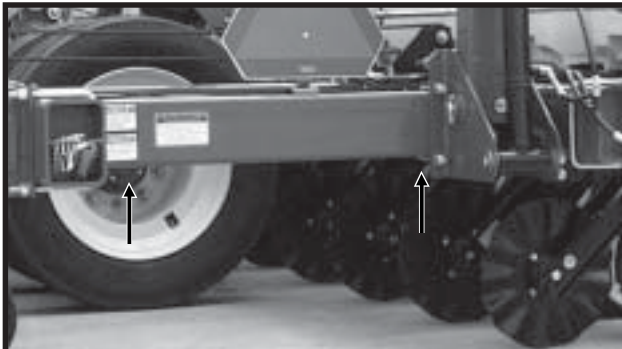

It is important for the planter to operate level laterally. Tire pressure must be maintained at pressures specified. See "Tire Pressure".

CONTACT DRIVE WHEEL SPRING ADJUSTMENT

There are two down pressure springs on each contact drive wheel. The down pressure is factory preset and should need no further adjustment.

The spring tension is set leaving 2" between the spring plug and the bolt head.

D06109905

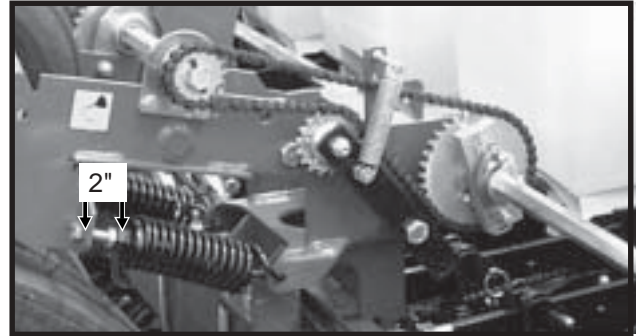

RESPACING FOR 22" ROWS

Model 3400 planters are factory assembled for 20" rows. Row units and transport tires require dealer assembly to respace for 22" rows.

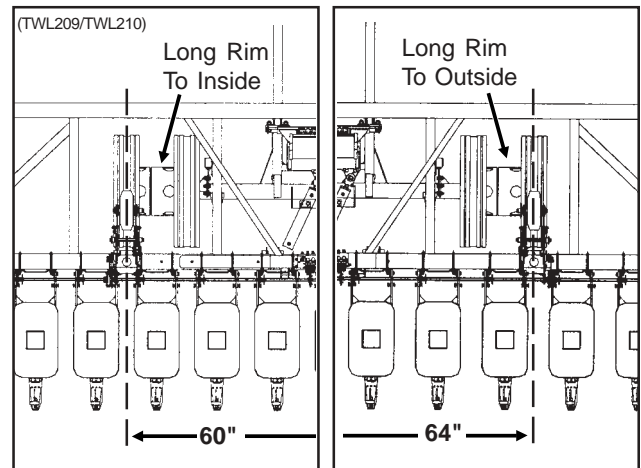

20" ROW SPACING

22" ROW SPACING

With the planter in transport position, jack the tires off the ground and install blocks to safely support the planter during resspacing procedure. On R.H. side of planter, move outside tire/rim assembly to the inside. Repeat procedure on L.H. side of planter.

Relocate the row units to 22" spacing. Slide each contact tire outward slightly to center over the transport tire.

Remove safety blocks and lower planter to the ground.

See "Marker Length Adjustment" for adjusting markers for 22" row spacing.

MACHINE OPERATION

TIRE PRESSURE

D06109909

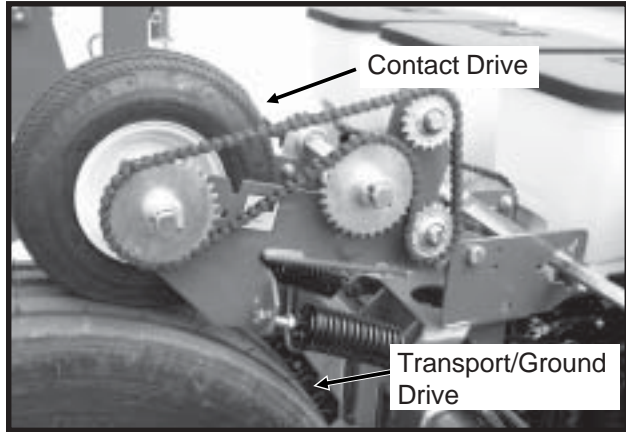

Tire pressure should be checked regularly and maintained as follows:

Transport/Ground Drive 255-70R x 22.5" 75 PSI
Contact Drive 4.10" x 6" 50 PSI

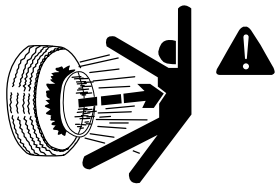

DANGER: Rim and tire servicing can be dangerous. Explosive separation of tire and rim parts can cause serious injury or death.

Do not attempt to mount a tire unless you have the proper equipment and experience to perform the job. This should only be done by persons properly trained and equipped to do the job.

Always maintain the correct tire pressure. **DO NOT INFLATE THE TIRES ABOVE THE RECOMMENDED PRESSURE. TIRE PRESSURE SHOULD BE MAINTAINED AS STATED ABOVE AND NOT AS STATED ON THE TIRE.**

When inflating tires, use a clip-on air chuck and extension hose long enough to allow you to stand to one side and **NOT** in front of or over the tire assembly. Use a safety cage to enclose the tire and rim assembly when inflating.

Inspect tires and wheels daily. Do not operate with low pressure, cuts, bubbles, damaged rims or missing lug bolts and nuts.

TRANSMISSION ADJUSTMENT

Planting population rate changes are made at the end mounted transmission. The planter is designed to allow simple, rapid changes in sprockets to obtain the desired planting population. By removing the lynch pins on the hexagon shafts, sprockets can be interchanged with those from the sprocket storage rod bolted to the transmission.

Chain tension is controlled by a spring-loaded dual-sprocket idler. The idler assembly is adjusted with a ratchet arm. This arm has a release position to remove spring tension for replacing sprockets. The amount of spring tension on the chain is controlled by the ratchet arm.

The planting rate charts found at the back of this section will aid you in selecting the correct sprocket combinations.

D030801116

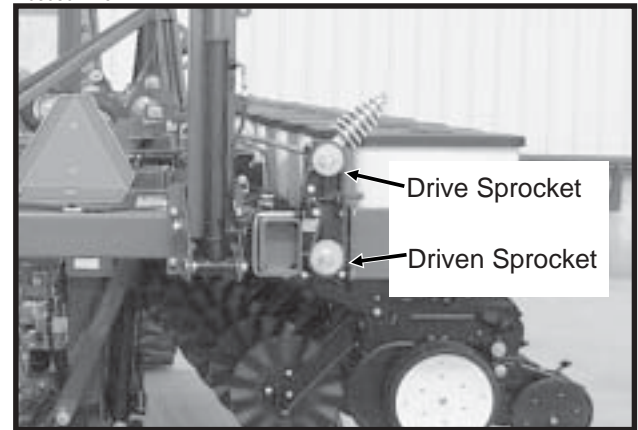

MACHINE OPERATION

STANDARD RATE DRIVE

D06109909

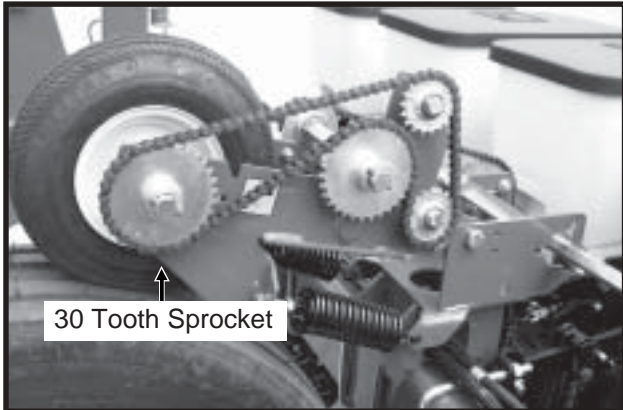

Seed planting rate charts are based on the standard rate drive unless specified otherwise. The standard rate drive uses a 30 tooth sprocket as shown above. Using the 15 tooth half rate (2 to 1) drive reduction sprocket in place of the 30 tooth sprocket will reduce the planting and application rates by approximately 50%. See "Half Rate (2 To 1) Drive".

HALF RATE (2 TO 1) DRIVE

D063099119

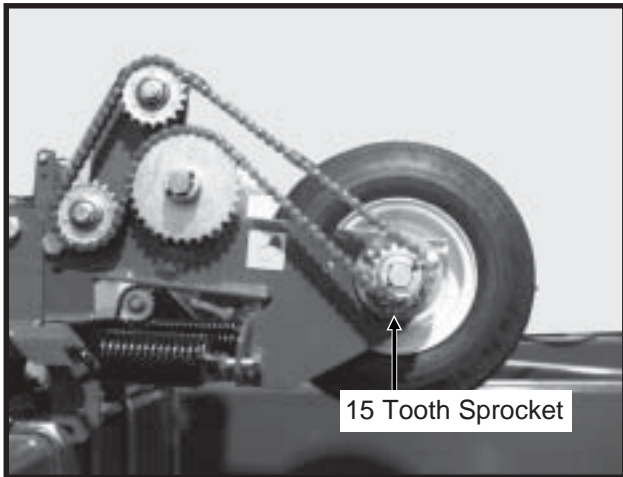

Half rate (2 to 1) drive is recommended only when desired population falls below that shown on planting rate charts. Replacing the 30 tooth drive sprocket located on the contact drive wheel, with the 15 tooth half rate (2 to 1) drive reduction sprocket will reduce the planter transmission speed and reduce planting and application rates by approximately 50%.

A 93 pitch chain is supplied with the Half Rate (2 To 1) Drive Reduction Package to allow use of the smaller 15 tooth sprocket.

NOTE: After each sprocket combination adjustment, make a field check to be sure you are planting at the desired rate.

SHEAR PROTECTION

The planter driveline, row units and fertilizer components are protected from damage by shear pins.

If excessive load should cause a pin to shear, it is important to determine where binding has occurred before replacing the pin. Replace shear pins with same size and type.

Additional shear pins can be found in the storage area located inside the forward planter toolbar.

To prevent future binding or breakage of components, check driveline alignment and follow prescribed lubrication schedules.

NOTE: Drill shaft/transmission coupler alignment is critical.

01209923

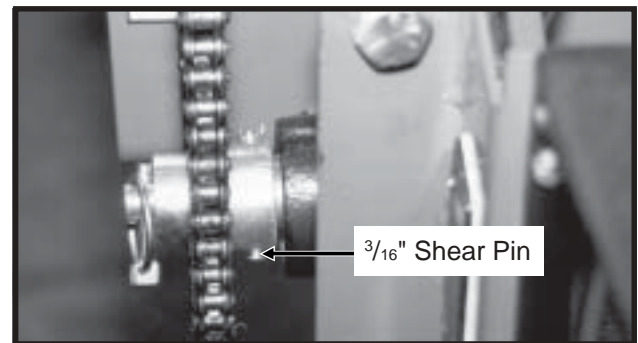

Transmission Shaft

MACHINE OPERATION

HYDRAULIC/ELECTRIC OPERATION

76746-24



Switches on the control console located on the tractor are used to raise the planter to transport position, operate the rotate function and raise and lower the row markers.

NOTE: The backlit console is equipped with a switch on the back of the console which should be used to turn off the light during extended periods of non-use.

All 3400 planters are equipped to operate from two dual remote (SCV) hydraulic outlets. One set of hydraulic outlets, in conjunction with the switch on the control console, is used to operate the raise to transport function. The second set, in conjunction with the switches on the control console, is used to operate the markers and fold/unfold functions.

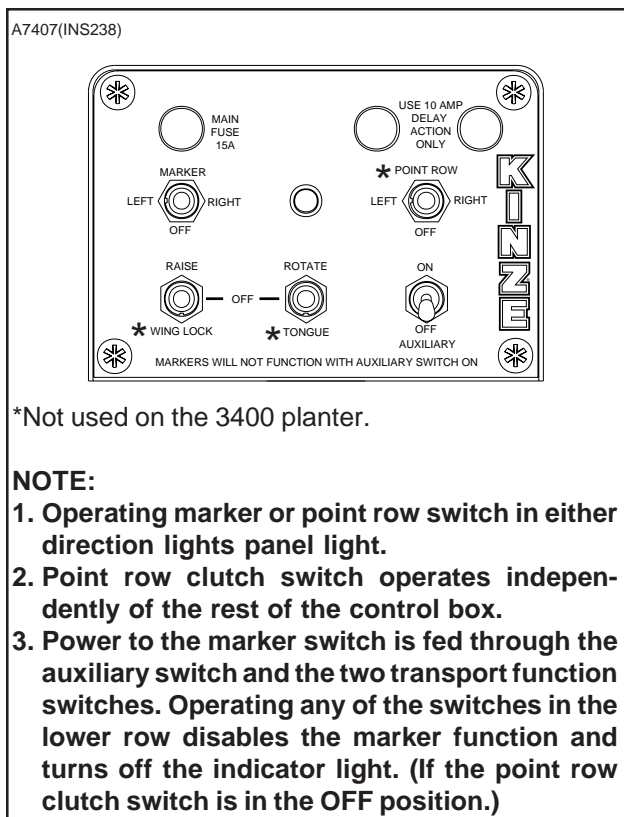

The marker and point row selector switches are an ON-OFF-ON type. Point row clutches are not available on the 3400 planter and, therefore, that switch is not used.

NOTE: For safety the marker selector switch should be placed in its OFF (center) position. An indicator light on the control box panel is ON whenever the marker circuit is energized.

The raise/wing lock and rotate/tongue (fold function) switches are MOMENTARY ON-OFF-MOMENTARY ON type and must be held in position while operating the tractor hydraulic lever. Activating a fold function switch disables the marker circuit. The wing lock and tongue functions are not used on the 3400 planter.

The auxiliary switch is an ON-OFF type switch. All 3400 planters are shipped with the auxiliary switch installed in the control console. The auxiliary switch must be in the OFF position to enable other functions to operate.

NOTE: Activating the auxiliary switch disables all other control console switches except the point row clutch switch.

NOTE: When operating in planting position, make sure the planter is lowered all the way to ensure push pads are contacting the axle. Operating with frame partially raised will increase wear on cam rollers and other components.

! DANGER: Never work under the planter while in raised position without installing safety lockups.

! WARNING: Make sure all hydraulic hoses are properly connected before operating the planter. Never connect or disconnect hydraulic hoses without first stopping the tractor engine and moving the hydraulic operating levers in both directions to relieve any pressure in the system.

NOTE: The planter will not lower when the tractor valve is in float position or in the lower position with the engine off. The planter lift cylinders are equipped with counter balance valves that require pressure from the tractor to allow them to retract.

! DANGER: Care must be taken when operating row markers around overhead power lines.

MACHINE OPERATION

TRANSPORT TO FIELD SEQUENCE

SUMMARIZED TRANSPORT TO FIELD SEQUENCE

- Remove transport latch locking pin.
- Remove manual safety lockups.
- Rotate planter to planting position.
- Lower planter to the ground.
- Rephase planter lift cylinders.
- Remove marker lockups.

NOTE: Read the following information for more detailed instructions.

D030801115

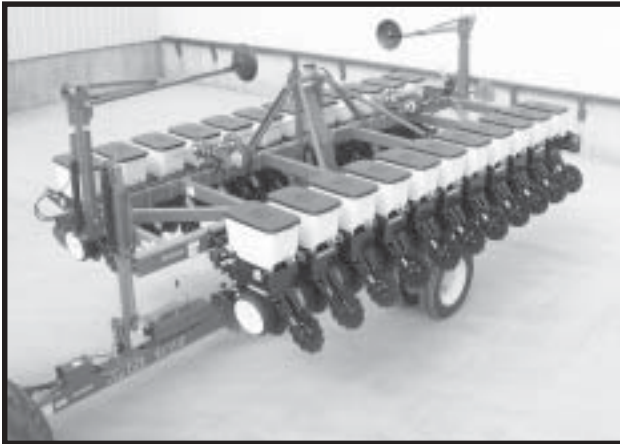

1. Remove the transport latch locking pin from the locked position and place it in the storage location.

D060999107

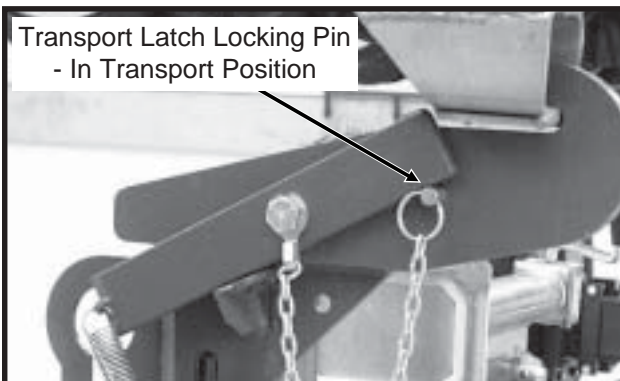

D060999116

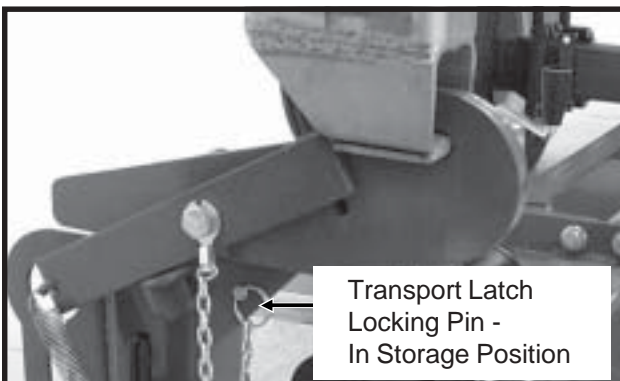

2. Remove the manual safety lockup from each center lift cylinder.

D063099114

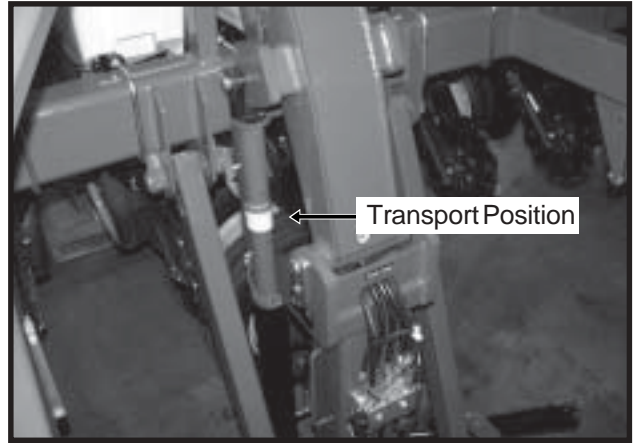

Place them in the storage location on each side of the center pivot assembly

D06109906

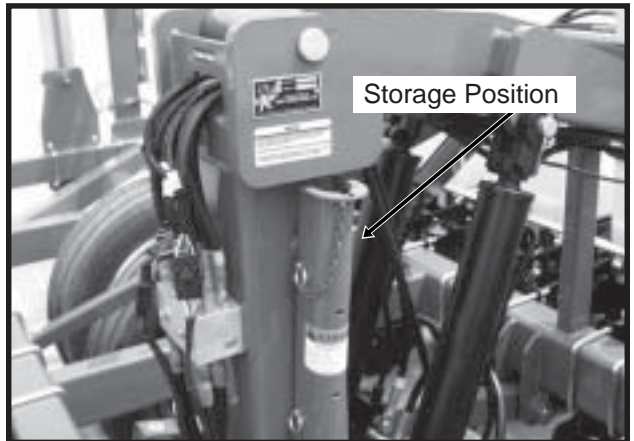

MACHINE OPERATION

3. Hold the control console switch labeled ROTATE/TONGUE in **ROTATE** and operate the hydraulic lever to unfold the planter.

76746-24

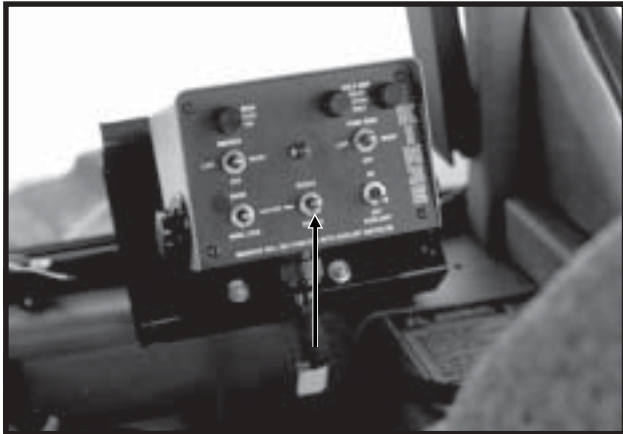

The transport latch will automatically release and the planter will rotate into planting position.

D030801114



4. Lower the planter to the ground. The planter will lower at a slower speed until transport latch post is fully raised. Hold the hydraulic lever until the planter stalls.

D030801109

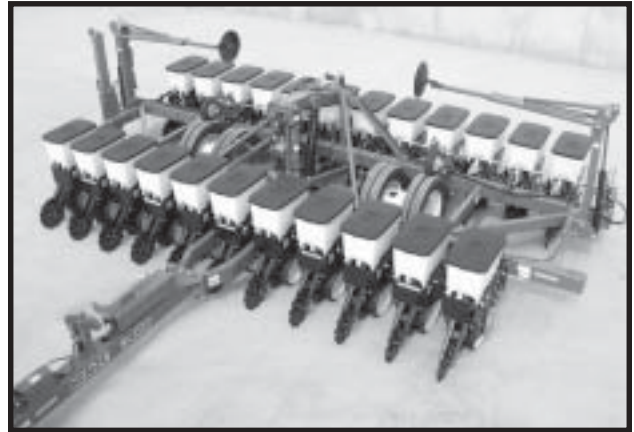

NOTE: If the planter does not stop at the proper **RAISED FIELD POSITION** during field operation, the planter lift system could be out of phase. To rephase the system, hold the control console switch labeled **RAISE** and operate the hydraulic lever to completely raise the planter. Release the **RAISE** switch and hold the hydraulic lever to lower the planter until it stalls.

5. Remove and store marker lockups.

D060999127

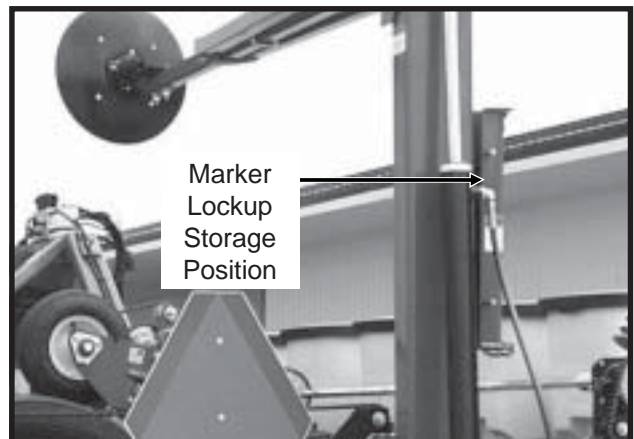

MACHINE OPERATION

FIELD OPERATION

There are two raised positions on the planter.

One is the RAISED FIELD POSITION which is when the planter is raised using only the hydraulic lever. The solenoid, located on the hitch, is not energized. The master cylinder on the hitch strokes out and the slave cylinders at the center of the planter begin to raise. In the RAISED FIELD POSITION the row units are approximately 14" off the ground. This position is used in making turns or passing over waterways during field operation.

D070899101

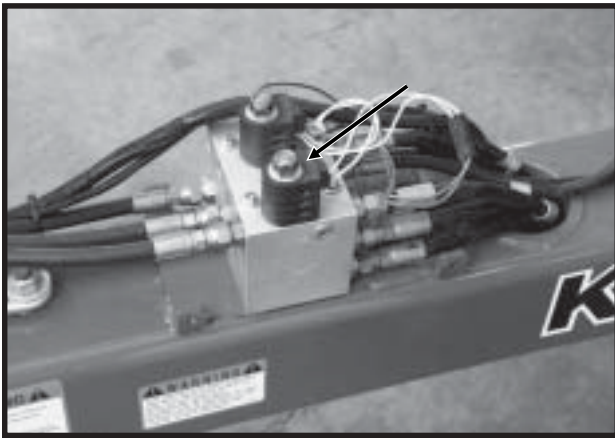

The second raised position is when the planter is raised to transport height. See "Field To Transport Sequence".

D030801111

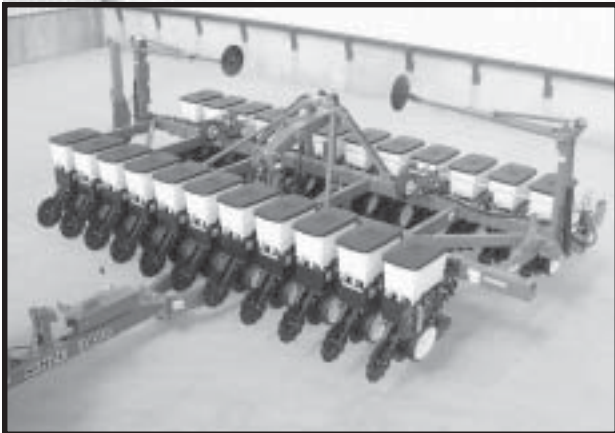

Raised Field Position

FIELD TO TRANSPORT SEQUENCE

SUMMARIZED FIELD TO TRANSPORT SEQUENCE

- Install marker lockups.
- Raise planter to fully raised position.
- Rotate planter to transport position.
- Install transport latch locking pin.
- Install manual safety lockups.

NOTE: Read the following information for more detailed instructions.

1. Install marker lockups.

D060999113

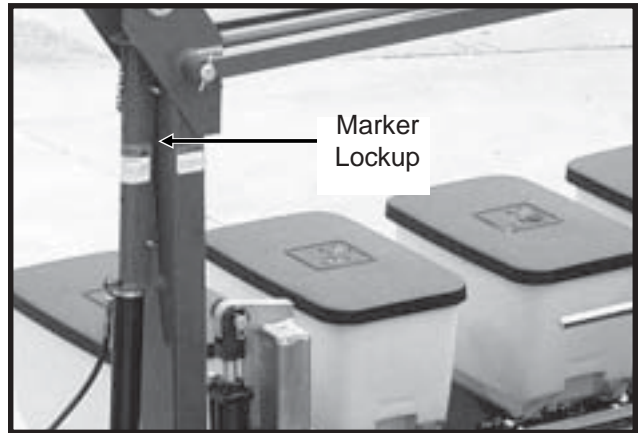

2. Hold the control console switch labeled RAISE and operate the hydraulic lever to fully raise the planter as shown below.

76746-24

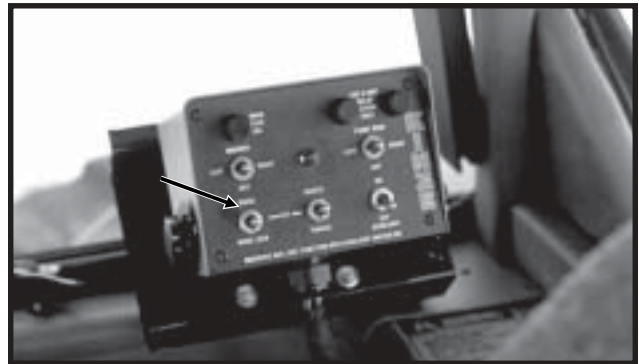

D030801113

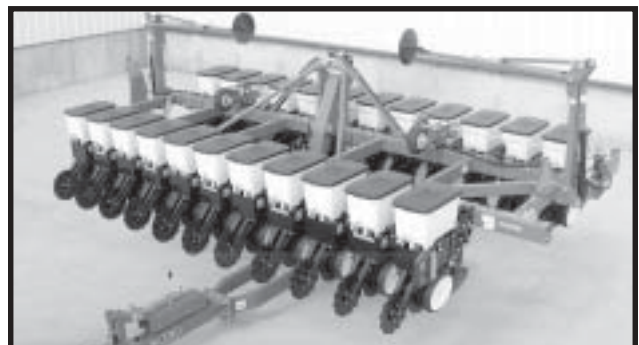

MACHINE OPERATION

3. Hold the control console switch labeled ROTATE/TONGUE in **ROTATE** and operate the hydraulic lever to rotate the planter until the transport latch is secured.

76746-24

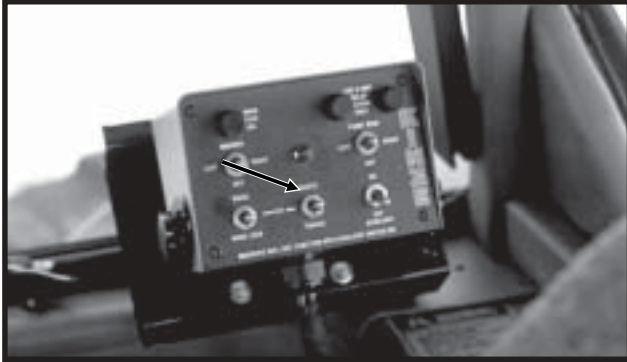

D060999116

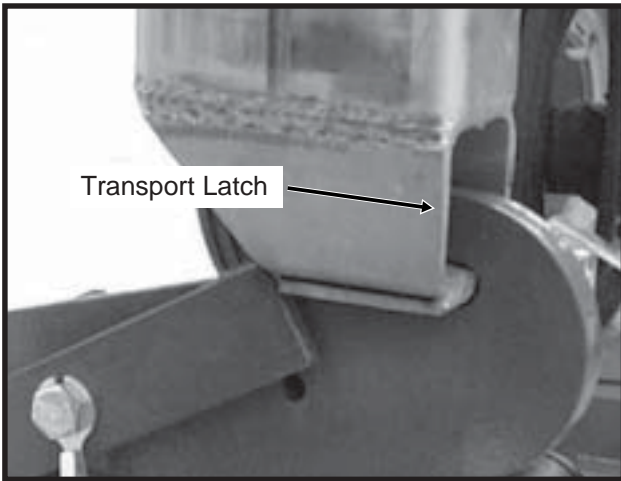

4. Install transport latch locking pin.

D060999107



5. Remove the manual safety lockups from their storage position on the side of the center pivot assembly.

D06109906



Install a lockup on each center lift cylinder.

D063099114

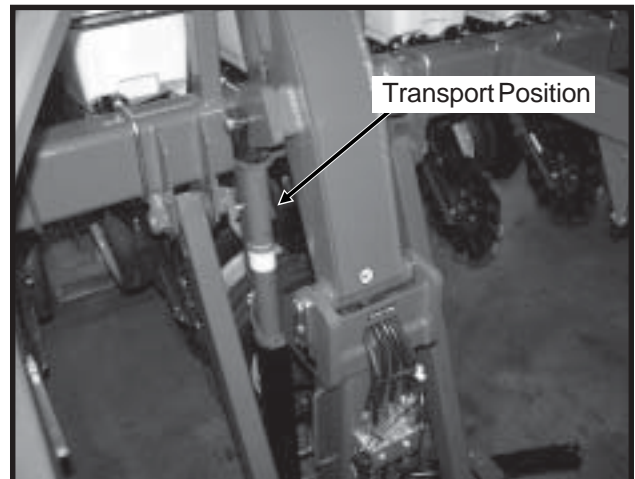

NOTE: For safety purposes it is recommended that the manual safety lockups always be installed prior to working under the planter when the planter is in the raised position or while transporting the planter.

MACHINE OPERATION

MARKER OPERATION

D06109908

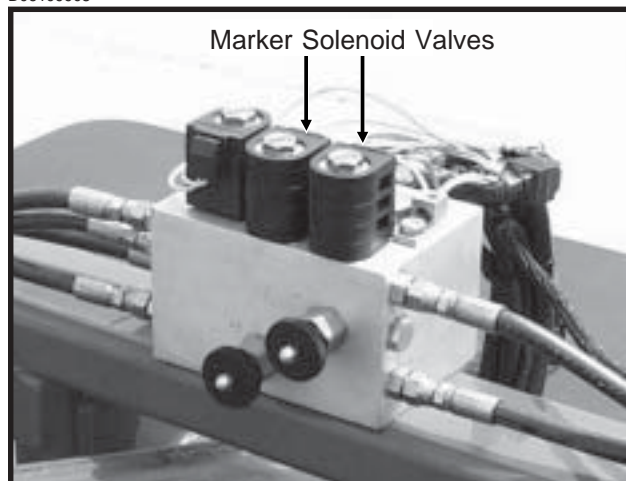

NOTE: Both markers can be lowered by operating the switch in each position and operating the hydraulic lever twice. The markers will raise simultaneously with the hydraulic lever in the raise position.

NOTE: Switch should be left in OFF position when planter is not in use. If left in ON position, it will drain the tractor battery.

If the electrical system fails to operate properly:

- Check fuse.
- Check wiring connections.
- Check control switch.
- Check solenoid. SOLENOID HOUSING WILL BE MAGNETIZED WHEN ENERGIZED.

76746-24

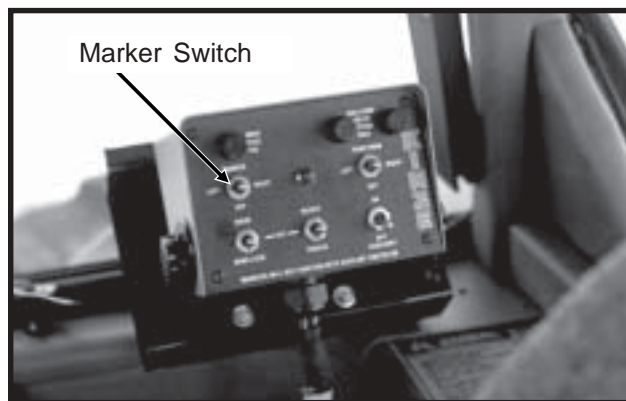

DANGER: Care must be taken when operating row markers around overhead power lines.

Three Position Selector Switch On Control Console

Two solenoid valves, located on the valve block on the center of the planter frame, along with a three position selector switch on the control console permits the operator to lower or raise the desired marker.

See "Marker Speed Adjustment".

1. On the control console, select which marker you want lowered.
2. Operate hydraulic control lever to lower marker.
3. If opposite marker is to be used next, change control switch to other side.
4. At end of field, using hydraulic control lever, raise the down marker.
5. After making the turn; using the hydraulic lever, lower the pre-selected marker.
6. Continue to follow this procedure.

MACHINE OPERATION

MARKER SPEED ADJUSTMENT

The marker hydraulic system includes two flow control valves. One flow control valve controls the lowering speed of both markers and one controls the raising speed of both markers. To adjust marker speed, loosen the jam nut and turn the control(s) clockwise, or IN, to slow the travel speed and counterclockwise, or OUT, to increase the travel speed. The flow control(s) determine the amount of oil flow restriction through the valves, therefore determining travel speed of the markers. Tighten jam nut after adjustments are complete.

D06109908

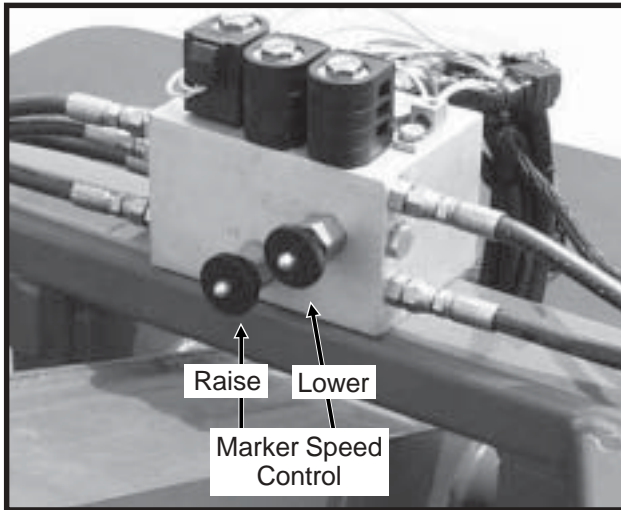

IMPORTANT: The flow controls should be properly adjusted before the marker assembly is first put into use. Excessive travel speed of the markers can damage the marker assembly.

NOTE: When oil is cold, hydraulics operate slowly. Make sure all adjustments are made with warm oil.

NOTE: On a tractor where the oil flow can not be controlled, the rate of flow of oil from the tractor may be greater than the rate at which the marker cylinder can accept the oil. The tractor hydraulic control lever will have to be held until the cylinder reaches the end of its stroke. This occurs most often on tractors with an open center hydraulic system.

On tractors equipped with flow control valves, marker speed adjustment should be made with the tractor flow controls in maximum position. After marker speed is set, the tractor flow controls can be adjusted to allow the SCV valve to stay in detent during the marker raise or lower cycle.



DANGER: Care must be taken when operating markers around overhead power lines.

MARKER LENGTH ADJUSTMENT

To determine the correct length at which to set the marker assemblies, multiply the number of rows by the average row spacing in inches. This provides the total planting width. Adjust the marker extension so the distance from the marker blade to the center line of the planter is equal to the total planting width previously obtained. Both the planter and marker assembly should be lowered to the ground when measurements are being taken. The measurement should be taken from the point where the blade contacts the ground. Adjust right and left marker assemblies equally and securely tighten clamping bolts. An example of marker length adjustment follows:

Number of rows	x	Row spacing (Inches)	=	Dimension between planter center line and marker blade.
----------------	---	----------------------	---	---

12 Rows x 20" Spacing = 240" Marker Dimension

72359-61



The marker blade is installed so the concave side of the blade is outward to throw dirt away from the grease seals. The spindle bracket is slotted so the hub and blade can be angled to throw more or less dirt. To adjust the hub and spindle, loosen the 1/2" hardware and move the bracket as required. Tighten bolts to the specified torque.

IMPORTANT: A marker blade assembly that is set at a sharper angle than necessary will add unnecessary stress to the complete marker assembly and shorten the life of bearings and blades. Set the blade angle only as needed to leave a clear mark.

A field test is recommended to ensure the markers are properly adjusted. After the field test is made, make any minor adjustments as necessary.

A notched marker blade is available from KINZE® Repair Parts for use in more severe no till conditions.

KPM I ELECTRONIC SEED MONITOR

(MTR28)

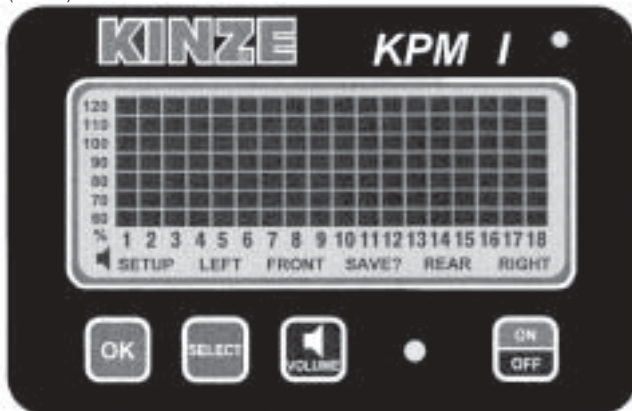

The electronic seed monitor system consists of a console, which is mounted on the tractor; seed tubes with computerized sensors, one of which is installed in each planter row unit; a primary harness*, which connects the console to the planter harness; and a planter harness (junction Y-harness and/or harness extension where applicable), to which the individual seed tube sensors connect.

Seed flow for up to 36 rows, in two 18 row sections (left/right or rear/front), may be monitored with one monitor. For less complicated applications (18 rows or less), all rows may be programmed in one section and the other section left disabled.

The monitor system is powered by the tractor battery (requires 12 volts DC). The console receives information from each of the sensors and translates this information.

The single backlit Liquid Crystal Display (LCD) shows the active section, the number of monitored rows per section, the relative seed rate for each row (using a bar graph display) and scrolls various alarm and warning messages when an alarm condition exists. A continuous audible alarm will sound upon system malfunction or underflow conditions for any monitored row. Alarms must be acknowledged by the user. Various warnings may sound the alarm or flash one or more icons.

The monitor will power down if no activity is detected within one hour. No activity means there has been no new seed flow and no operator push key input. (If Applicable)

*** NOTE: The primary harness, on all 3000 Series Planters, is hard-wired into the safety/warning light harness or control console harness included as standard equipment with the planter.**

Monitor Key Functions	6-12
LCD Functions	6-12
Changing The Audible Alarm Volume	6-13
Warnings And Alarms	6-13
Replacing A Faulty Sensor	6-14
Field Operation	6-15
Connecting Seed Tubes	6-15

MONITOR KEY FUNCTIONS

Each key press is acknowledged by the monitor with a short beep.

OK

- Ends and saves the new setup during installation.
- Acknowledges and silences alarms in the operation mode.

SELECT

- Selects the application mode (rear/front or left/right) at the beginning of installation setup.
- Selects the active section(s) (rear, rear/front, left, right or left/right) in the normal mode.
- Has no affect on a system configured to monitor only one section.

VOLUME

- Pressing the key will turn the beeper on.
- Holding the key for periods of 2 seconds increases the volume until it reaches the maximum, at which time it rolls over to the minimum level.

ON/OFF

- Powers the unit on and off.

LCD FUNCTIONS

The monitor collects data on the planting rates from all active rows and calculates an average. This average will determine the 100% mark. Seed rate for each row is then compared to the average value and the result is displayed on the bar graph.

The information regarding each section is displayed alternately every 5 seconds. While operating a system with two sections programmed, one or both sections may be selected any time. When only one section is selected, the monitor calculates the average based on the remaining active rows from that section.

STEP 1 Press SELECT key once to show one section. The flashing icon shows the section that is not selected. The selected section is continuously displayed on the LCD.

EXAMPLE: The system is setup to display rear/front sections. Press SELECT key. The FRONT icon will be flashing and the REAR section will be displayed on the bar graph. After 1 minute the front row icon will stop flashing. The monitor will stay in this REAR only display through power down and power up. Each time the monitor is turned on while in REAR only mode, the FRONT icon will flash for 1 minute. Also if seed flow is sensed in the FRONT section while planting, the FRONT icon will resume flashing.

STEP 2 Press SELECT key again to activate both sections.

EXAMPLE: Press SELECT key a second time. The information regarding each section will display alternately every 5 seconds.

For simple applications, where only one section is programmed, the display will automatically lock on that section. Pressing SELECT key will have no affect.

NOTE: When alternating between two sections, the display will lock on the section containing the first recognized alarm until the alarm is acknowledged by pressing the OK key or the alarm condition is removed.

CHANGING THE AUDIBLE ALARM VOLUME

STEP 1 Press and hold down the VOLUME key.

STEP 2 The SETUP and VOLUME icons will turn on and the beeper will sound continuously. The intensity of the sound will change every 2 seconds. After the maximum volume is reached, the next change will set the volume to minimum and will continue to get louder every 2 seconds. When the desired volume is reached, release the key.

WARNINGS AND ALARMS

- 1. System Alarms** - A system alarm is activated when the monitor detects a faulty sensor or one of several other communication faults.

The corresponding row number starts flashing and the beeper sounds. All segments on the corresponding bar graph are turned off. Pushing the OK key to acknowledge the alarm will turn the beeper off. The row number will continue to flash until the alarm condition is removed. If the monitor detects a faulty sensor and there is no planting activity present, the monitor will scroll "CHECK CONNECTION".

Another type of system alarm occurs when the monitor detects a data communication bus error. The three possible data communication bus errors are:

LCD Display	Error Condition
SYS HI	The data communication lead (green) has been shorted to the power lead (white).
SYS LO	The data communication lead (green) has been shorted to the ground lead (black).
SYS EC	An internal error has been detected.

- 2. Under Flow Alarms** - If the seed rate for one or more rows is less than 55% of the calculated average, the corresponding 60% segment will stay on, the corresponding row number starts flashing and the alarm sounds. Pushing the OK key to acknowledge the alarm will turn the alarm off. The 60% segment of the bar graph remains on and the row number continues to flash until the alarm condition is corrected.

NOTE: All alarms present within a short time before planting stops, are frozen on the screen and the text LOW or FAIL will display on the LCD. If the under flow is between 0% and 10%, this warrants a "FAIL" condition. If the under flow is between 10% and 55%, a "LOW" condition is generated. If multiple rows have an under flow condition, "FAIL" will display if any one or more rows is between 0% and 10%. This allows the user to identify and fix the problem rows.

NOTE: This warning will not trigger unless a minimum time of continuous planting has passed.

NOTE: If all the rows show a seed rate of zero, the condition will not generate an alarm. It will be assumed the planter has stopped. The row numbers and the bottom 60% segment will remain on for all selected rows.

3. **Multiple Alarms** - If more than one alarm condition occurs at the same time, pushing the OK key will acknowledge all alarms that are currently displayed. For example, if one row on the front and one row on the rear are alarming, pushing the OK key will only acknowledge one of them. However, if there are two alarms on the front, both alarms would be acknowledged with one push of the OK key.
4. **Section Not Selected Warning** - If the monitor was programmed for two sections and only one is currently selected for display (by pressing the SELECT key), the icon of the disabled section will flash for a period of 1 minute, then turn off at each power up. If seed flow is sensed in the disabled section, the icon for that section (front, left or right) will begin to flash.
5. **Seed Planting Stopped Warning** - When the monitor detects no seed flow on all rows, the monitor will emit 3 short beeps to alert the user. This warning will occur each time the planter is stopped, each time the planter is raised at the end of a row or if the mechanical drive fails while planting.

NOTE: This warning will not trigger unless a minimum time of continuous planting has passed.

6. **Seed Counting Sensor In Calibration Warning** - All seed counting sensors run a self-calibration sequence on power up. While in calibration the bottom segment of each corresponding bar graph will flash if the monitor detects movement or planting activity. If the monitor does not detect this, the message "WAIT CALIBRATION" will be scrolled.

7. **Seed Counting Sensor Too Dirty Warning** - After the seed counting sensors end their internal self-calibration, the monitor may detect one or more sensors are either too dirty or blocked. If the monitor detects planting or movement, the corresponding bar graph remains flashing. The monitor will display "CLEAN SENSORS" on the LCD if no movement or planting is detected, prompting the user to clean the tubes. If the tubes are dirty, they will still show seed flow with less accuracy. If the tubes are blocked the user will get an alarm as soon as planting starts. The corresponding bar graph will remain flashing until the problem is corrected and the monitor is powered down and then powered back up.
8. **Low Battery Warning** - The monitor is constantly monitoring its input voltage to quickly detect low power conditions. If the monitor detects that the input voltage has dropped below 10.5V, it will display "LOW POWER" on the LCD, provided that the monitor does not detect planting.

NOTE: After the alarms have been acknowledged and if the alarm condition is still present, the LCD will continue to display the alarm condition.

REPLACING A FAULTY SENSOR

To replace a faulty sensor; (a) turn the monitor off, (b) disconnect the faulty sensor, (c) turn the monitor back on and (d) plug in the replacement sensor. The monitor will chirp twice to acknowledge the new sensor was learned and saved.

To replace more than one faulty sensor, proceed as stated above beginning with the lowest numbered row in the rear or left section and continue to replace sensors in increasing order. Then move on to the front or right section and continue in ascending row number order.

NOTE: If the monitor is not turned off and then on, the replacement sensor(s) will be ignored until the next power on, at which point they will be randomly learned by the monitor.

FIELD OPERATION

(MTR28e/MTR28c/MTR28d/MTR28b)

Press the ON/OFF key to turn the monitor on and off.



Information regarding each section is displayed alternately every 5 seconds.

REAR/FRONT CONFIGURATION

- Press the SELECT key once to show REAR section only.
- Press the SELECT key a second time to return to each section being displayed alternately every 5 seconds.
- Press the SELECT key a third time to show REAR section only again.



LEFT/RIGHT CONFIGURATION

- Press the SELECT key once to show LEFT section only.
- Press the SELECT key a second time to show RIGHT section only.
- Press the SELECT key a third time to return to each section being displayed alternately every 5 seconds.



NOTE: SELECT key has no function when only a single section is being used.

Press the VOLUME key to increase or decrease volume. See "Changing The Audible Alarm Volume".



Press the OK key to silence alarms. See "Warnings And Alarms".



CONNECTING SEED TUBES

STEP 1 All the seed tubes w/sensors must be disconnected from the harness and the monitor must be off.

STEP 2 Press the ON key. The monitor automatically enters the setup procedure. If the monitor was accidentally powered on with no sensors attached, the user can turn the monitor off at this point and the previous configuration is not lost.

STEP 3 Press the SELECT key. Each time you press the SELECT key the mode will toggle between rear/front and left/right. The selected display will be solid and the configuration not currently selected will be flashing. By default the monitor starts in rear/front mode.

01229910

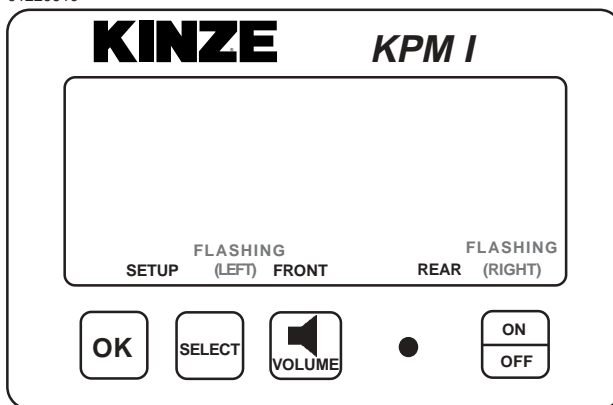

01229911

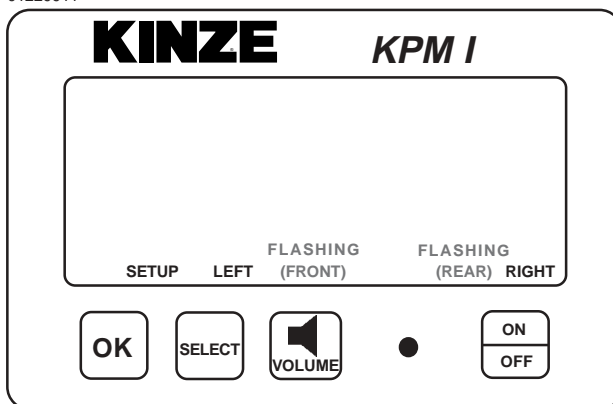

NOTE: Model 3400 20" and 22" planters will use the rear configuration only. When Interplant® Package rows are in use, select the rear/front configurations. When all rows can be viewed on a single display (rear), pressing the select key has no function.

STEP 4 Press and hold the OK key to confirm the selection and continue holding until the row numbers appear on the display. During confirmation, the display will alternate between “NEW” and “SYS” to alert the user that the previous configuration will be lost. With the rear/front mode selected, the monitor automatically starts with the rear section. The REAR icon shows solid and the FRONT icon starts to flash. With the left/right mode selected, the monitor automatically starts with the left section. The LEFT icon shows solid and the RIGHT icon starts to flash.

01229912

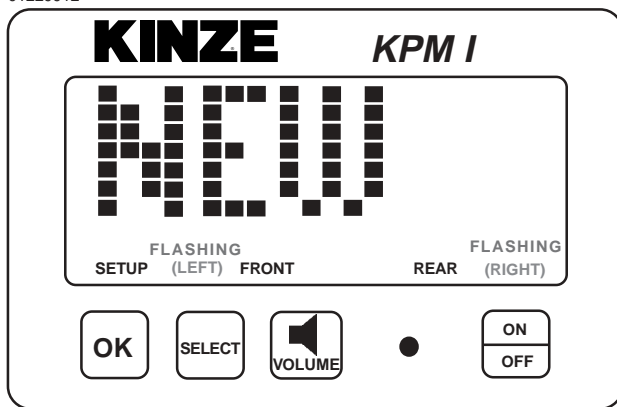

STEP 5 Plug each seed tube w/sensor into the harness in a predetermined order. Row 1 first, row 2 second and so on up to 18 rows. When a sensor is plugged in, the corresponding row number on the LCD display will stay solid, the monitor will chirp twice and the LED (Light Emitting Diode) on the seed tube sensor will turn on for approximately 30 seconds to show connection is made. NOTE: Unless there is a faulty sensor, the installer should just have to connect the sensors in the proper order without checking the monitor is acknowledging each sensor.

01229915

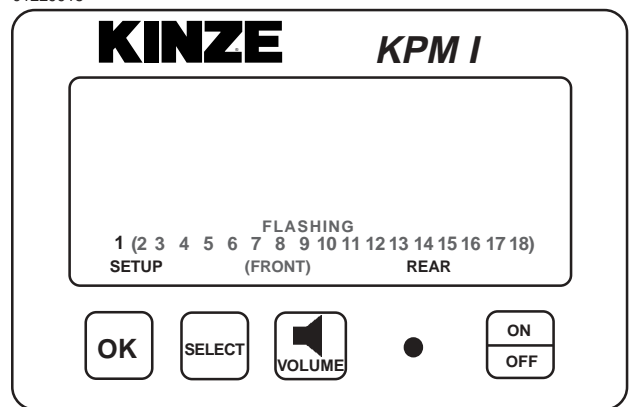

01229912a

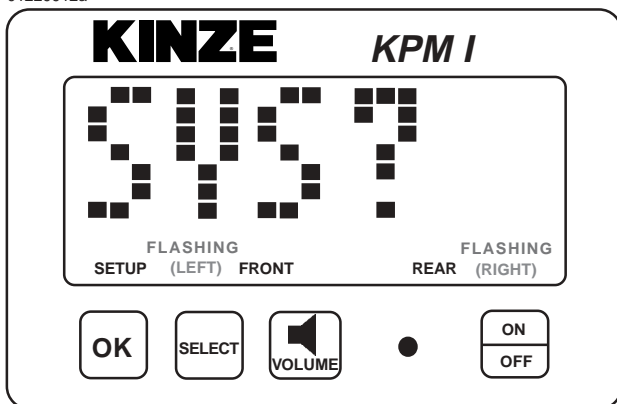

STEP 6 When all the seed tubes w/sensors for the current section are installed, check to be sure the monitor displays solid numbers for the number of sensors connected.

01229916

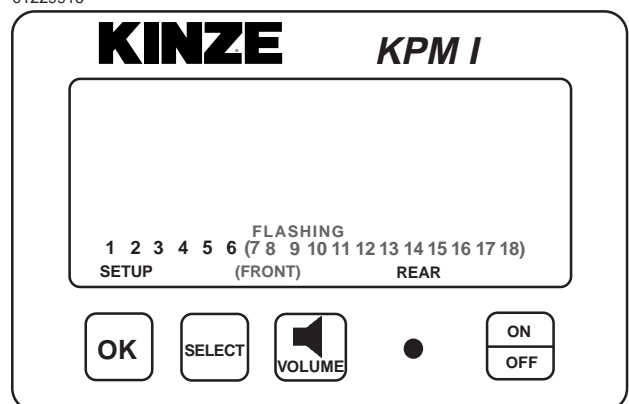

STEP 7 If this condition is satisfied, press and hold the OK key to save the setup for the current section. The SAVE? icon will show followed by continuous short beeps indicating the monitor is preparing to save. The installer has 5 seconds to decide if he wants to save the current configuration. During this time the short beeps will sound. To complete the save, hold the OK key pressed until the word “DONE” shows on the screen followed by a long beep and the SAVE? icon turns off. When the OK key is released the monitor will continue with the second section installation.

01229917

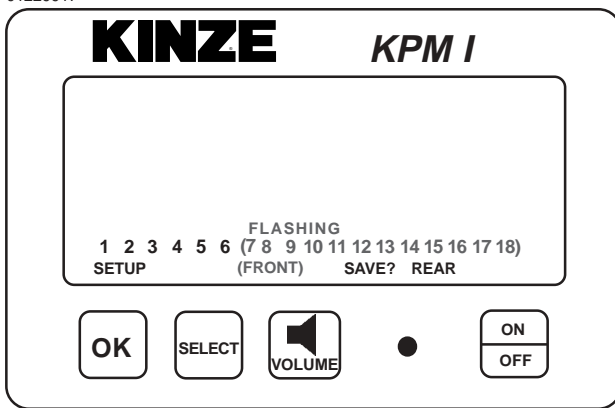

STEP 8 Follow STEPS 5 through 7 to install the second section. If no seed tubes are installed on the second section, press and hold the OK key until the word “DONE” shows on the screen followed by a long beep and the SAVE? icon turns off.

01229919

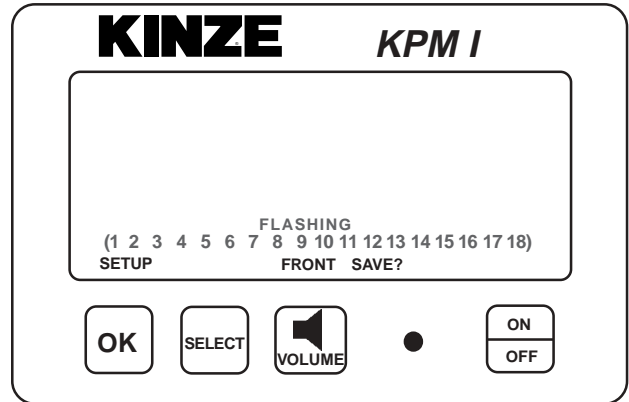

01229920

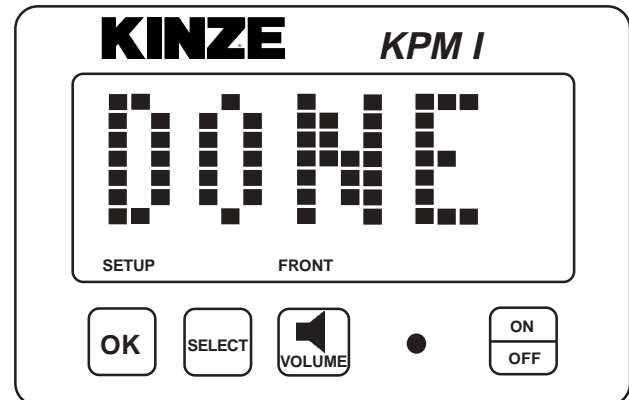

01229918

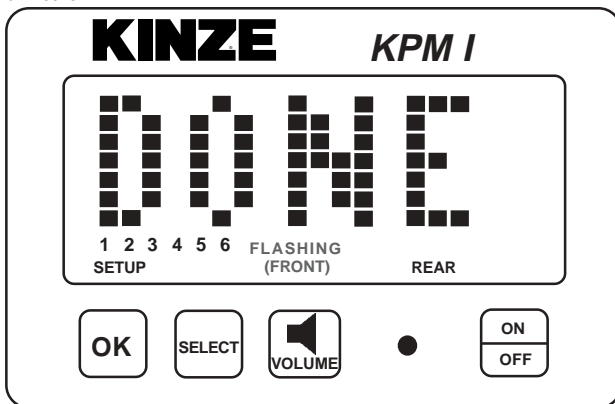

NOTE: Individual seed tubes may be unplugged for special situations. An alarm will sound which can be silenced by touching the OK key. The monitor will recognize each seed tube when reconnected.

KPM II ELECTRONIC SEED MONITOR

(MTR29)

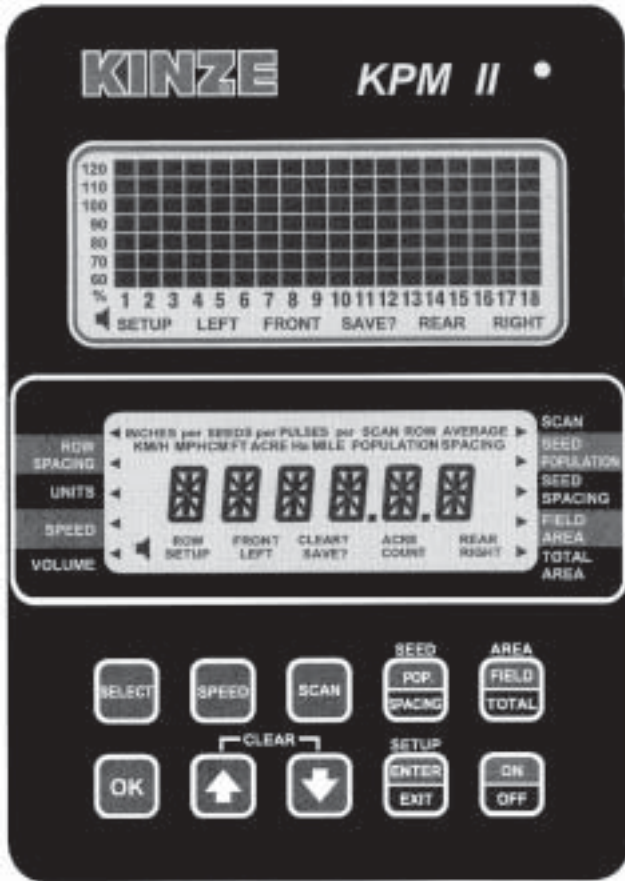

The electronic seed monitor system consists of a console, which is mounted on the tractor; seed tubes with computerized sensors, one of which is installed in each planter row unit; a primary harness*, which connects the console to the planter harness; and a planter harness (junction Y-harness and/or harness extensions where applicable) to which the individual seed tube sensors and rotation sensors connect. The monitor works with a magnetic (pickup) distance sensor or radar distance sensor.

* **NOTE:** The primary harness, on all 3000 Series Planters, is hard-wired into the safety/warning light harness or control console harness included as standard equipment with the planter.

Seed flow for up to 36 rows, in two 18 row sections (left/right or rear/front), may be monitored with one monitor. For less complicated applications (18 rows or less), all rows may be programmed in one section and the other left disabled.

The monitor system is powered by the tractor battery (requires 12 volts DC). The console receives information from each of the sensors and translates this information.

The console has two backlit Liquid Crystal Displays (LCD). The upper display shows the active section, the number of monitored rows per section, the relative seed rate for each row (using a bar graph display) and scrolls various alarm and warning messages when an alarm condition exists. A continuous audible alarm will sound upon system malfunction or underflow conditions for any monitored row. Alarms must be acknowledged by the user. Various warnings may sound the alarm or flash one or more icons. The lower display is used to display alphanumeric data such as row spacing, units (Metric or English), speed, volume, seed population, seed spacing, field area, total area and distance sensor pulses per mile/kilometer.

The monitor will power down if no activity is detected within one hour. No activity means there has been no new seed flow and no operator push key input. (If Applicable)

Monitor Key Functions	6-19
Upper LCD Functions	6-20
Lower LCD Functions	6-21
Programming	
Changing The Audible Alarm Volume	6-23
Units (Metric Or English)	6-24
Row Spacing	6-24
Speed	6-26
Clearing Total Area	6-27
Area Counter/Speedometer Mode	6-28
Warnings And Alarms	6-28
Replacing A Faulty Sensor	6-29
Field Operation	6-29
Clearing Field Area	6-30
Connecting Seed Tubes, Radar/Magnetic Distance Sensors And/Or Shaft Rotation Sensors	6-31
Row-By-Row Alarm Level Setting	6-39

MONITOR KEY FUNCTIONS

Push keys allow the user to select or change the operating mode, the active displays or the current configuration. Depending on the operating mode or the current display selected, some keys are valid while some are not. Each key press if valid is acknowledged by a short beep and an action is taken. If the key press has no action associated, the key press is considered invalid and the user will not get any feedback.

SELECT

- Selects the application mode (rear/front or left/right) at the beginning of installation in the setup mode.
- Selects the active section(s) (rear, rear/front, left, right or left/right) in the normal mode.
- Has no affect on a system configured to monitor only one section.
- While programming the monitor, the key will select the digit to change.

SPEED

- Immediately displays the current ground speed.

SCAN

- If the current average population or average spacing is displayed, this key sequentially displays the seed population/spacing on each row.
- If the display shows functions other than average seed population or spacing, pressing SCAN will sequentially display speed, average seed population and average seed spacing.
- Pressing a second time freezes the display on the current row.
- Pressing a third time restarts the sequential display.

SEED POPULATION/SEED SPACING

- Immediately displays the average seed POPULATION and the average seed SPACING of all active rows.
- Each press alternates between seed spacing and seed population.

AREA FIELD/AREA TOTAL

- Immediately displays the field and total area planted since the field/total area was last cleared.
- Each press alternates between field area and total area.

OK

- Ends and saves the new setup during installation.
- Acknowledges and silences alarms in the operation mode.

UP ARROW AND DOWN ARROW

- Scrolls sequentially through the display options on the lower LCD display.
- Freezes on the current row in the scan mode.
- Scrolls sequentially through the rows when the population scan is frozen.
- Used to enter programmable values in the programming mode.
- The Up and Down Arrow keys can be pressed at the same time to start the CLEAR function.

SETUP ENTER/SETUP EXIT

- Enters and exits the programming mode.

ON/OFF

- Powers the unit on and off.

UPPER LCD FUNCTIONS

(MTR29H)

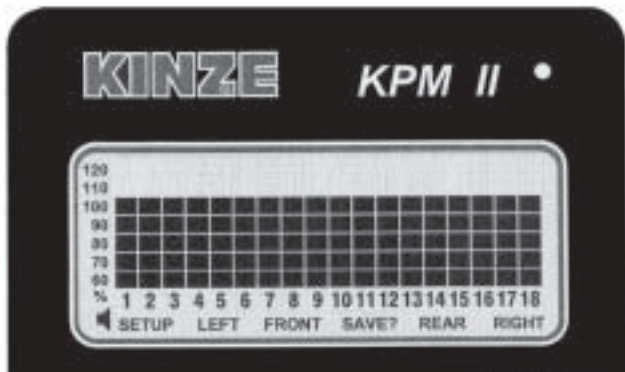

The monitor collects data on the planting rates from all active rows and calculates an average. This average will determine the 100% mark. Seed rate for each row is then compared to the average value and the result is displayed on the bar graph.

The information regarding each section is displayed alternately every 5 seconds. While operating a system with two sections programmed, one or both sections may be selected any time. When only one section is selected, the monitor calculates the average based on the remaining active rows from that section.

STEP 1 Press SELECT key once to show one section. The flashing icon shows the section that is not selected. The selected section icon is continuously displayed on the LCD.

EXAMPLE: The system is setup to display rear/front sections. Press SELECT key. The FRONT icon will be flashing and the REAR section will be displayed on the bar graph. After 1 minute the front row icon will stop flashing. The monitor will stay in this REAR only display through power down and power up. Each time the monitor is turned on while in REAR only mode, the FRONT icon will flash for 1 minute. Also if seed flow is sensed in the FRONT section while planting, the FRONT icon will resume flashing.

When the front section is disabled, the row spacing will automatically double to maintain the proper implement width in the monitor. A 23 row 15" configuration changes to a 12 row 30" configuration with a touch of the SELECT key.

STEP 2 Press SELECT key again to activate both sections.

EXAMPLE: Press SELECT key a second time. The information regarding each section will display alternately every 5 seconds.

For simple applications, where only one section is programmed, the display will automatically lock on that section. Pressing the SELECT key will have no affect.

NOTE: When alternating between two sections, the display will lock on the section containing the first recognized alarm until the alarm is acknowledged by pressing the OK key or the alarm condition is removed.

LOWER LCD FUNCTIONS

(MTR29g)



- The UP and DOWN arrow keys will sequentially change what is being displayed on the lower LCD. Pressing the UP or DOWN arrow keys will move the arrow head icon (on the left and right hand side of the display) to another item. For example, if the arrow icon is pointing to SPEED, ground speed will be displayed on the LCD. Pressing the UP arrow key will move the icon to UNITS. The display will change to display all the icons used to represent the current (English or Metric) measurement system.
- The shortcut keys SPEED, SEED POPULATION/SPACING and AREA FIELD/TOTAL allow direct access to their respective displays. For example, no matter what is currently being displayed on the lower LCD, pressing the SPEED key will change the display to the current speed. Pressing the SEED POPULATION/SPACING or AREA FIELD/TOTAL keys will alternate between the two functions assigned to that key.
- Pressing the SCAN key while displaying seed spacing or population will cause a sequential display of each individual row. Pressing the SCAN key a second time will freeze the display on the currently displayed row. The UP or DOWN arrow keys can be used to change the currently displayed row. Pressing the SCAN key will restart the automatic advancing of the scan function.
- Pressing the SCAN key while displaying speed will cause a sequential display of speed, average planter population and average seed spacing. Pressing the SCAN key a second time will freeze the display on the currently displayed reading.

ROW SPACING

Press the arrow keys to ROW SPACING to display the current spacing between rows in inches or centimeters. The ROW SPACING icons turn on, displaying a 3 digit, one decimal place format. In the acre counter mode, this function displays the implement width in feet or meters, using a 3 digit, no decimal places format.

UNITS

Press the arrow keys to UNITS to display all the icons from the currently selected English or Metric measurement system. For the English system, the icons are: INCH, MPH, FT, ACRE and MILE. For the Metric system, the icons are: M, KM/H and Ha.

SPEED

Press the SPEED key to display the current speed in MPH or KM/H, using a 3 digit, one decimal place format.

VOLUME

Press the arrow keys to VOLUME to display the presently selected audible alarm volume. The SPEAKER icon turns on.

SCAN

Press the SCAN key to display the seed spacing or seed population (see below) of each individual row. (1)Pressing the SCAN key while displaying any other function will cause the monitor to sequentially display speed, average seed population and average seed spacing. (2)Pressing the SCAN key a second time will freeze the display. (3)Pressing the SCAN key a third time restarts the sequential display. The UP and DOWN arrow keys can be used to change the current display.

SEED POPULATION/SEED SPACING

Each SEED POP/SPACING key press alternates between seed population and seed spacing.

Seed population displays the average number of seeds or the row average number of seeds per acre or seeds per hectare for all the active rows. The average is displayed using a 6 digits, no decimal places format. The AVERAGE POPULATION icon will turn on. When in the scan mode, the scan arrow and SCAN ROW POPULATION will appear. The ROW number icon and the current row will be displayed on the left and the population will be displayed on the right in 1000's using 3 digits, one decimal place (e.g. 32.9 means 32,900). When in scan freeze mode, the scan arrow and ROW POPULATION will turn on (scan arrow may be flashing). The UP and DOWN keys may be used to lock on the desired row.

Seed spacing displays the average distance or the row average distance between seeds for all active rows in inches per seed or centimeters per seed, using a 3 digit, one decimal place format. When the average is displayed the AVERAGE SPACING icons are turned on. When in the scan mode, the scan arrow and SCAN ROW SPACING icons will appear. The ROW number icon and the current row will be displayed on the left and the spacing will be displayed on the right. The display will sequence to the next row every 5 seconds. When in scan freeze mode, the scan arrow and SPACING will turn on (scan arrow may be flashing). The UP and DOWN keys may be used to lock on the desired row.

FIELD AREA/TOTAL AREA

Each AREA FIELD/TOTAL key press alternates between field area and total area.

Field area displays the total number of acres or hectares, using a 6 digit, one decimal place format.

NOTE: When FIELD AREA is selected, the UP or DOWN key must be held in slightly longer than normal so the monitor will not mistake this action with a CLEAR, which consists of the UP and DOWN arrow keys pressed simultaneously. A beep will sound when the function activates.

Total area displays the total number of acres or hectares, using a 6 digit, one decimal place format. The total area counter updates every time the field area counter increments. Clearing the total area counter will also clear the field area counter.

When the monitor is programmed as a rear only or rear/front configuration and shaft rotation sensors are installed, pressing the up arrow to move beyond row spacing lights an arrow on an unlabeled area above ROW SPACING. This is the automatically set division line between the L.H. shaft sensor and the R.H. shaft sensor. The display shows the first row on the rear section and the front section assigned to the R.H. shaft rotation sensor.

EXAMPLE: On a 12 row 30" planter with Interplant® Package, the display would appear as follows:

092597-21



THIS DISPLAY IS NOT ACCESSIBLE ON LEFT/RIGHT CONFIGURATIONS OR SYSTEMS WITHOUT SHAFT ROTATION SENSORS.

PROGRAMMING - Changing The Audible Alarm Volume

STEP 1 To enter the programming mode, press and hold the SETUP key. The monitor will emit several short beeps, followed by a long beep. On the lower LCD, the SETUP icon turns on and the arrow head icon will flash, indicating that the user can select an item to program.

NOTE: The monitor must be in a programmable function (row spacing, units, speed, volume or area) to enter setup. The monitor will not enter setup in seed population or seed spacing.

STEP 2 Press the UP or DOWN arrow keys to move the flashing arrow to VOLUME. As the arrow icon moves, the lower LCD will display the current setting of the item selected.

STEP 3 Press the OK key and the flashing arrow becomes solid and the beeper will sound.

NOTE: The lower LCD will display the current volume and the SPEAKER icon is turned on. Settings are from 0 to 9.

- Use the UP or DOWN arrow keys to change the setting. With every UP arrow key push, the beeper will increment by one step between the minimum and the maximum. If the maximum level (9) is reached the volume rolls over to the minimum level (0).
- Pressing the DOWN arrow key lowers the volume until the minimum level (0) is reached, at which point the volume rolls over to the maximum level (9).

STEP 4 To exit without saving, press and release the OK key. The monitor will restore the lower LCD to show the setting of the item, and the arrow icon will flash, allowing the user to select another item to program.

To exit and save, press and hold the OK key. The monitor will emit several short beeps and SAVE? icon is turned on. After a short time a long beep is heard, and the lower LCD will display the word "DONE". Release the OK key. If the OK key is released BEFORE the word "DONE" is displayed, the changes WILL NOT BE SAVED. The word "DONE" MUST be displayed in order for the save to have occurred.

NOTE: The programming mode may be exited at any time, by pressing the SETUP key. Pressing this key will return the monitor to its normal operation. All items changed and saved will come into affect immediately. Any items changed, but not saved will revert to the original programmed value.

PROGRAMMING - Units (Metric Or English)

STEP 1 To enter the programming mode, press and hold the SETUP key. The monitor will emit several short beeps, followed by a long beep. On the lower LCD, the SETUP icon turns on and the arrow head icon will flash, indicating that the user can select an item to program.

NOTE: The monitor must be in a programmable function (row spacing, units, speed, volume or area) to enter setup. The monitor will not enter setup in seed population or seed spacing.

STEP 2 Press the UP or DOWN arrow keys to move the flashing arrow to UNITS. As the arrow icon moves, the lower LCD will display the current setting of the item selected.

STEP 3 Press the OK key and the flashing arrow becomes solid and the beeper will sound.

NOTE: The lower LCD will alternately display all Metric icons or all English icons, indicating the Metric or English mode respectively.

- Use the UP or DOWN arrow keys to change the setting.

STEP 4 To exit without saving, press and release the OK key. The monitor will restore the lower LCD to show the setting of the item, and the arrow icon will flash, allowing the user to select another item to program.

To exit and save, press and hold the OK key. The monitor will emit several short beeps and SAVE? icon is turned on. After a short time a long beep is heard, and the lower LCD will display the word "DONE". Release the OK key. If the OK key is released BEFORE the word "DONE" is displayed, the changes WILL NOT BE SAVED. The word "DONE" MUST be displayed in order for the save to have occurred.

NOTE: The programming mode may be exited at any time, by pressing the SETUP key. Pressing this key will return the monitor to its normal operation. All items changed and saved will come into affect immediately. Any items changed, but not saved will revert to the original programmed value.

PROGRAMMING - Row Spacing

STEP 1 Prior to entering the programming mode, the application mode (rear/front or left/right) must be active. If the monitor is programmed in a rear/front configuration, both sections will be active (alternating every 5 seconds). You can then set the row spacing to the Interplant® row spacing.

EXAMPLE: On a 12 row 30" with Interplant® Package set the row spacing to 15.0 with front active.

When the monitor is in normal field operation mode, disabling the front section will automatically change the row spacing to 30".

STEP 2 To enter the programming mode, press and hold the SETUP key. The monitor will emit several short beeps, followed by a long beep. On the lower LCD, the SETUP icon turns on and the arrow head icon will flash, indicating that the user can select an item to program.

NOTE: The monitor must be in a programmable function (row spacing, units, speed, volume or area) to enter setup. The monitor will not enter setup in seed population or seed spacing.

STEP 3 Press the UP or DOWN arrow keys to move the flashing arrow to ROW SPACING. As the arrow icon moves, the lower LCD will display the current setting of the item selected.

STEP 4 Press the OK key and the flashing arrow becomes solid and the beeper will sound.

NOTE: The lower LCD will display the current row spacing (in inches or centimeters) and ROW SPACING icon is turned on.

- The least significant digit of the displayed value will be blinking.
- This value can be changed by pressing either the UP or DOWN arrow keys.
- Once this digit is correct, press the MODE SELECT key and the blinking digit will move to the next significant digit, where the process can be repeated.

NOTE: The monitor limits the entry of row spacing to a minimum of 10.0 inches (25.4 cm) and to a maximum of 99.9 inches (253.7 cm). If the monitor is configured to a rear/front configuration, the limits change to a minimum of 5.0 inches (12.7 cm) and a maximum of 49.9 inches (126.8 cm).

STEP 5 To exit without saving, press and release the OK key. The monitor will restore the lower LCD to show the setting of the item and the arrow icon will flash, allowing the user to select another item to program.

To exit and save, press and hold the OK key. The monitor will emit several short beeps and SAVE? icon is turned on. After a short time a long beep is heard, and the lower LCD will display the word "DONE". Release the OK key. If the OK key is released BEFORE the word "DONE" is displayed, the changes WILL NOT BE SAVED. The word "DONE" MUST be displayed in order for the save to have occurred.

To exit setup mode, press the SETUP key.

NOTE: The programming mode may be exited at any time, by pressing the SETUP key. Pressing this key will return the monitor to its normal operation. All items changed and saved will come into affect immediately. Any items changed, but not saved will revert to the original programmed value.

PROGRAMMING - Speed

STEP 1 To enter the programming mode, press and hold the SETUP key. The monitor will emit several short beeps, followed by a long beep. On the lower LCD, the SETUP icon turns on and the arrow head icon will flash, indicating that the user can select an item to program.

NOTE: The monitor must be in a programmable function (row spacing, units, speed, volume or area) to enter setup. The monitor will not enter setup in seed population or seed spacing.

STEP 2 Press the UP or DOWN arrow keys to move the flashing arrow to SPEED. As the arrow icon moves, the lower LCD will display the current setting of the item selected.

STEP 3 Press the OK key and the flashing arrow becomes solid and the beeper will sound.

The speed constant is used to record how many pulses are generated per mile (or kilometer) from the ground speed sensor. The lower LCD will display the current pulses per mile (or kilometer), using a 6 digit, no decimal place format. The PULSES per MILE (or PULSES per KM) icons are turned on.

NOTE: It is highly recommended that a field calibration be done to establish the PPM (Pulses Per Mile) number on a new machine installation. Several factors can affect this value such as wheel slip on the magnetic distance sensor, mounting angle and height on the radar distance sensor, etc. IT IS NOT UNCOMMON FOR THE MPH ON THE MONITOR TO VARY SLIGHTLY FROM THE TRACTOR SPEEDOMETER. *Adjusting the PPM in the monitor to make the MPH or Km/h readings agree can cause serious errors in acre/hectare and population counts.* Do field checks to verify populations and seed spacings.

NOTE: On new system installations, the monitor will default to 500 PPM. This will have to be changed to obtain accurate readings from the monitor.

- In field conditions, measure 330 feet ($\frac{1}{16}$ mile) or 100 meters, depending on the unit of measurement selected.

- Pull the tractor up to the starting line.

- Press the UP and DOWN arrow keys at the same time and hold them down until the CLEAR? icon is displayed and the monitor beeps several times. When the data is actually cleared, the monitor will emit a long beep and the number of pulses is cleared.

- Drive the tractor for 330 feet ($\frac{1}{16}$ mile) or 100 meters and stop.

- The monitor will count the number of pulses and display them.

STEP 4 To exit without saving, press and release the OK key. The monitor will restore the lower LCD to show the setting of the item, and the arrow icon will flash, allowing the user to select another item to program.

To exit and save, press and hold the OK key. The monitor will emit several short beeps and SAVE? icon is turned on. After a short time a long beep is heard, and the lower LCD will display the word "DONE". Release the OK key. If the OK key is released BEFORE the word "DONE" is displayed, the changes WILL NOT BE SAVED. The word "DONE" MUST be displayed in order for the save to have occurred.

NOTE: The programming mode may be exited at any time, by pressing the SETUP key. Pressing this key will return the monitor to its normal operation. All items changed and saved will come into affect immediately. Any items changed, but not saved will revert to the original programmed value.

NOTE: If a discrepancy occurs and digits must be changed, follow STEPS 1 and 2 to enter the programming mode and proceed as follows:

- Press the OK key and the flashing arrow becomes solid. The least significant digit of the displayed value will be blinking.
- This value can be changed by pressing either the UP or DOWN arrow keys.
- Once this digit is correct, press the SELECT key and the blinking digit will move to the next significant digit, where the process can be repeated.

The monitor limits the entry of pulses per mile or kilometer to a minimum of 500 PPM (310 PPKM), and to a maximum of 500,000 PPM (310,686 PPKM).

KEY Action	Flashing Digit	Display Value
Press The UP Key	Right Most Digit	2031, 2032, 2033
Press The SELECT Key	Second Digit From Right	2033
Press The DOWN Key	Second Digit From Right	2023, 2013, 2003, 2093, 2083
Press The SELECT Key Twice	Left Most Digit	2083
Press The DOWN Key	Left Most Digit	1083, 0500 (Min. Value), 9500, 8500

PROGRAMMING - Clearing Total Area

NOTE: Clearing the total area counter will also clear the field area counter.

STEP 1 To enter the programming mode, press and hold the SETUP key. The monitor will emit several short beeps followed by a long beep. On the lower LCD, the SETUP icon turns on and the arrow head icon will flash, indicating that the user can select an item to program.

NOTE: The monitor must be in a programmable function (row spacing, units, speed, volume or area) to enter setup. The monitor will not enter setup in seed population or seed spacing.

STEP 2 Press the UP or DOWN arrow keys to move the flashing arrow to TOTAL AREA. As the arrow icon moves, the lower LCD will display the current setting of the item selected.

STEP 3 Press the OK key and the flashing arrow becomes solid and the beeper will sound.

- The lower LCD will display the total area and the ACRE (or Ha) icon turns on.
- With the flashing arrow on TOTAL AREA, press the OK key.

• To reset the counter, press the UP and DOWN arrow keys at the same time and hold them down for a short period of time to clear the data. The CLEAR? icon will be displayed and the monitor will beep several times. When the data is actually cleared, the monitor will emit a long beep, and the total area is reset to zeros. After the long beep, the previous recorded total area is not retrievable. Once cleared, the user **may not** choose to exit programming mode without saving as described in STEP 4.

STEP 4 To exit and save, press and hold the OK key. The monitor will emit several short beeps and SAVE? icon is turned on. After a short time a long beep is heard, and the lower LCD will display the word "DONE". Release the OK key. If the OK key is released BEFORE the word "DONE" is displayed, the changes WILL NOT BE SAVED. The word "DONE" MUST be displayed in order for the save to have occurred.

NOTE: The programming mode may be exited at any time, by pressing the SETUP key. Pressing this key will return the monitor to its normal operation. All items changed and saved will come into affect immediately. Any items changed, but not saved will revert to the original programmed value.

AREA COUNTER/SPEEDOMETER MODE

If the monitor is installed with only a radar distance sensor (no seed tubes attached), the monitor becomes a speedometer. If (a) the monitor is connected to a radar distance sensor, (b) the signal cable from the back of the console is connected to a sensing switch (Part No. G1K249 Acre Counter Switch Kit) instead of the seed tubes and (c) the implement width in feet (or meters) is programmed into the monitor, the monitor will function as an acre counter.

The seed spacing and seed population functions are not available in this mode. If the monitor is powered down, the seed tubes connected and the monitor powered up, the monitor will again show seed population and seed spacing in inches or centimeters. Row spacing reverts back to its programmed setting.

WARNINGS AND ALARMS

- 1. System Alarms** - A system alarm is activated when the monitor detects a faulty sensor or one of several other communication faults.

The corresponding row number starts flashing and the beeper sounds. All segments on the corresponding bar graph are turned off. Pushing the OK key to acknowledge the alarm will turn the beeper off. The row number will continue to flash until the alarm condition is removed. If the monitor detects a faulty sensor and there is no planting activity present, the monitor will scroll "CHECK CONNECTION".

If the distance sensor is detected as faulty, the monitor will display either "PICKUP" or "RADAR", depending on the type of sensor installed, and the audible alarm will sound. The user can push the OK key to acknowledge the alarm. When the distance sensor is faulty, the monitor will change to a bar graph only mode where the rows are still displayed relative to each other. No area related information (speed, field area, total area, seed spacing or seed population) will be accumulated or displayed.

If a rotation shaft sensor is faulty, LSHAFT, RSHAFT or SHAFTS will display.

Another type of system alarm occurs when the monitor detects a data communication bus error.

The three possible data communication bus errors are:

LCD Display	Error Condition
SYS HI	The data communication lead (green) has been shorted to the power lead (white).
SYS LO	The data communication lead (green) has been shorted to the ground lead (black).
SYS EC	An internal error has been detected.

- 2. Under Flow Alarms** - If the seed rate for one or more rows is less than 55% of the calculated average, the corresponding 60% segment will stay on, the corresponding row number starts flashing and the alarm sounds. Pushing the OK key to acknowledge the alarm will turn the alarm off. The 60% segment of the bar graph remains on and the row number continues to flash until the alarm condition is corrected.

NOTE: All alarms present within a short time before planting stops are frozen on the screen and the text LOW or FAIL will display on the LCD. If the under flow is between 0% and 10%, this warrants a "FAIL" condition. If the under flow is between 10% and 55%, a "LOW" condition is generated. If multiple rows have an under flow condition, "FAIL" will display if any one or more rows is between 0% and 10%. This allows the user to identify and fix the problem rows.

NOTE: This warning will not trigger unless a minimum time of continuous planting has passed.

NOTE: If all the rows show a seed rate of zero, the condition will not generate an alarm. It will be assumed the planter has stopped. The row numbers and the bottom 60% segment will remain on for all selected rows.

- 3. Multiple Alarms** - If more than one alarm condition occurs at the same time, pushing the OK key will acknowledge all alarms that are currently displayed. For example, if one row on the front and one row on the rear are alarming, pushing the OK key will only acknowledge one of them. However, if there are two alarms on the front, both alarms would be acknowledged with one push of the OK key.

4. **Section Not Selected Warning** - If the monitor was programmed for two sections and only one is currently selected for display (by pressing the SELECT key), the icon of the disabled section will flash for a period of 1 minute, then turn off at each power up. If seed flow is sensed in the disabled section, the icon for that section (front, left or right) will begin to flash.
5. **Seed Planting Stopped Warning** - When the monitor detects no seed flow on all rows, the monitor will emit 3 short beeps to alert the user. This warning will occur each time the planter is stopped, each time the planter is raised at the end of a row or if the mechanical drive fails while planting.

NOTE: This warning will not trigger unless a minimum time of continuous planting has passed.

6. **Seed Counting Sensor In Calibration Warning** - All seed counting sensors run a self-calibration sequence on power up. While in calibration the bottom segment of each corresponding bar graph will flash if the monitor detects movement or planting activity. If the monitor does not detect this, the message "WAIT CALIBRATION" will be scrolled.
7. **Seed Counting Sensor Too Dirty Warning** - After the seed counting sensors end their internal self-calibration, the monitor may detect one or more sensors are either too dirty or blocked. If the monitor detects planting or movement, the corresponding bar graph remains flashing. The monitor will display "CLEAN SENSORS" on the top LCD if no movement or planting is detected, prompting the user to clean the tubes. If the tubes are dirty, they will still show seed flow with less accuracy. If the tubes are blocked the user will get an alarm as soon as planting starts. The corresponding bar graph will remain flashing until the problem is corrected and the monitor is powered down and then powered back up.
8. **Low Battery Warning** - The monitor is constantly monitoring its input voltage to quickly detect low power conditions. If the monitor detects that the input voltage has dropped below 11.0V, it will display "LO SYS" on the lower LCD, provided that the monitor does not detect speed or planting.

NOTE: After the alarms have been acknowledged and if the alarm condition is still present, the LCD will continue to display the alarm condition.

REPLACING A FAULTY SENSOR

To replace a faulty sensor; (a) turn the monitor off, (b) disconnect the faulty sensor, (c) turn the monitor back on and (d) plug in the replacement sensor. The monitor will chirp twice to acknowledge the new sensor was learned and saved.

To replace more than one faulty sensor, proceed as stated above beginning with the lowest numbered row in the rear/left section and continue to replace sensors in ascending order. Then move on to the front/right section and continue in ascending order.

If the monitor detects a faulty distance sensor, the lower LCD will immediately move to the speed display, show the word "PICKUP" or "RADAR" depending on the distance sensor installed, and the alarm will sound.

NOTE: If the monitor is not turned off and then on, the replacement sensor(s) will be ignored until the next power on, at which point the sensors will be randomly learned by the monitor.

FIELD OPERATION

Press the ON/OFF key to turn the monitor on and off.



(MTR28e)

Information regarding each section is displayed alternately every 5 seconds.

REAR/FRONT CONFIGURATION

- Press the SELECT key once to show REAR section only. (Monitor sets correct row spacing.)
- Press the SELECT key a second time to return to each section being displayed alternately every 5 seconds. (Monitor sets correct row spacing.)
- Press the SELECT key a third time to show REAR section only again.



(MTR28c)

LEFT/RIGHT CONFIGURATION (If Applicable)

- Press the SELECT key once to show LEFT section only.
- Press the SELECT key a second time to show RIGHT section only.
- Press the SELECT key a third time to return to each section being displayed alternately every 5 seconds.



(MTR28c)

NOTE: SELECT key has no function when only a single section is being used.

At power up, the lower LCD will show speed (MPH or Km/h).

(MTR29g/MTR29b/MTR29a/MTR29c/MTR29f/MTR29c/MTR29f)

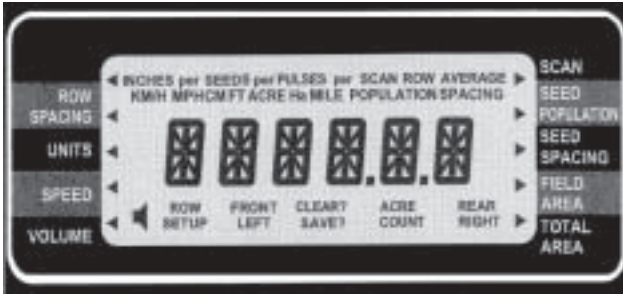

Press the UP or DOWN arrow keys to move the flashing arrow on the lower LCD to change what is displayed on the lower LCD.



Press the shortcut keys SPEED, SEED POPULATION/SEED SPACING or AREA FIELD/TOTAL for direct access to these displays.



(MTR29c/MTR29d/MTR29b/MTR29c)

Press the SEED POPULATION/SEED SPACING or AREA FIELD/TOTAL keys to alternate between the two functions assigned to that key.



Press the SEED POPULATION/SEED SPACING key to choose average seed spacing/population per acre.



Press the SCAN key to display individual rows starting at row 1.



Press the SCAN key again to lock on current row.

Press the SCAN key again to resume scrolling.

Use the UP or DOWN arrow keys to move to a particular row.



Press the SEED POPULATION/SEED SPACING key to go back to planter average.



CLEARING FIELD AREA

(MTR29n/MTR28b)

To reset the counter, press the UP or DOWN arrow keys to move the arrow in the lower display to FIELD AREA.



Press the UP and DOWN arrow keys at the same time and hold them down for a short period of time to clear the data. The CLEAR? icon will be displayed and the monitor will beep several times. When the data is actually cleared, the monitor will emit a long beep, and the field area is reset to zero. After the long beep, the previous field area recorded is not retrievable.



NOTE: Clearing the field area counter will not clear the total area counter. See "Programming-Clearing Total Area" for clearing total area.

Press the OK key to silence alarms. See "Warnings And Alarms".



CONNECTING SEED TUBES, RADAR/MAGNETIC DISTANCE SENSORS AND/OR SHAFT ROTATION SENSORS

STEP 1 All the seed tubes w/sensors (including the radar, magnetic distance and shaft rotation sensors) must be unplugged from the harness and/or console and the monitor must be off.

NOTE: If the monitor detects a radar sensor but no seed tubes at power up, it will automatically go into AREA COUNT mode. See “Area Counter/Speedometer Mode”.

NOTE: Disconnect magnetic distance sensor between MDS adapter and planter harness. DO NOT disconnect between MDS and MDS adapter.

01189909

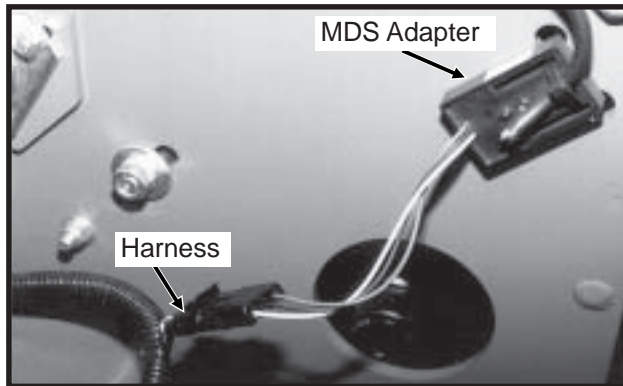

01189910

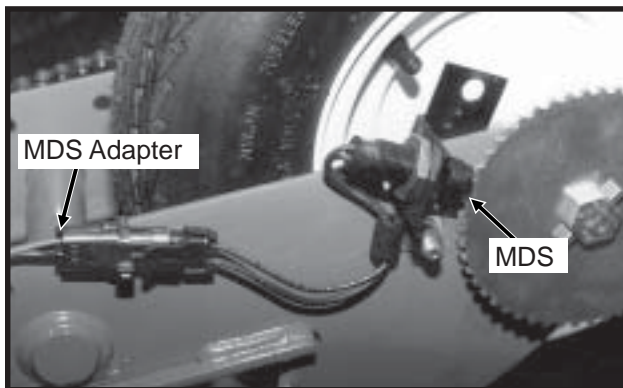

STEP 2 Press the ON key. The monitor automatically enters the setup procedure.

STEP 3 The monitor automatically defaults to front/rear. Press the SELECT key. Each time you press the SELECT key the mode will toggle between rear/front and left/right. The selected display will be solid and the configuration not currently selected will be flashing. By default the monitor starts in the rear/front mode.

01139923

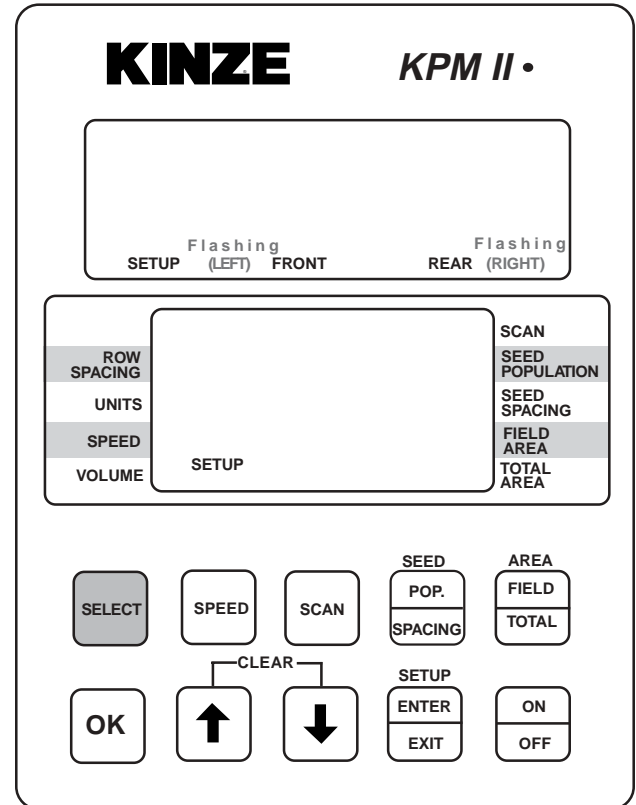

01139924

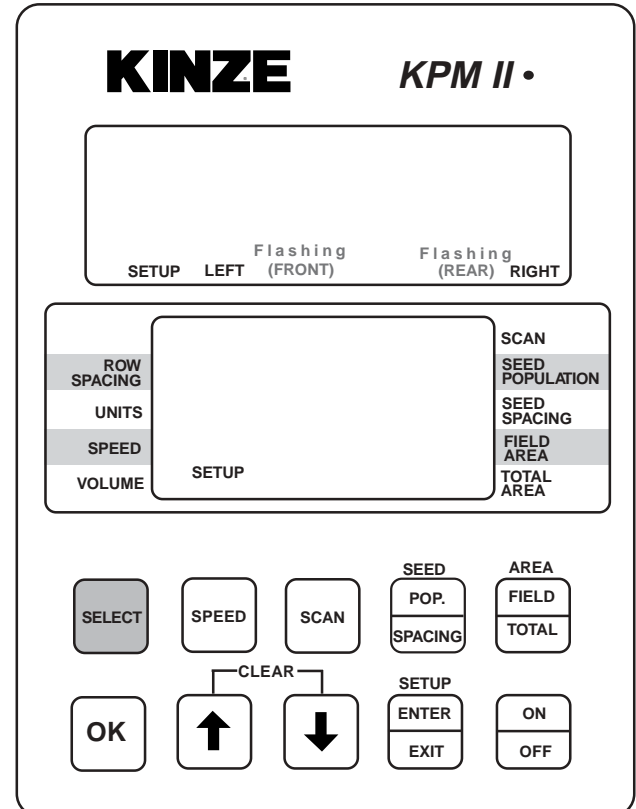

NOTE: Model 3400 20" and 22" planters will use the rear configuration only. When Interplant® Package rows are in use, select the rear/front configurations.

STEP 4 Press and hold the OK key to confirm selection. The upper display will alternate between “NEW” and “SYS?”.

The alarm will sound four short beeps followed by one long beep. At this point your selection has been saved and row numbers will appear flashing on the upper display.

01139922

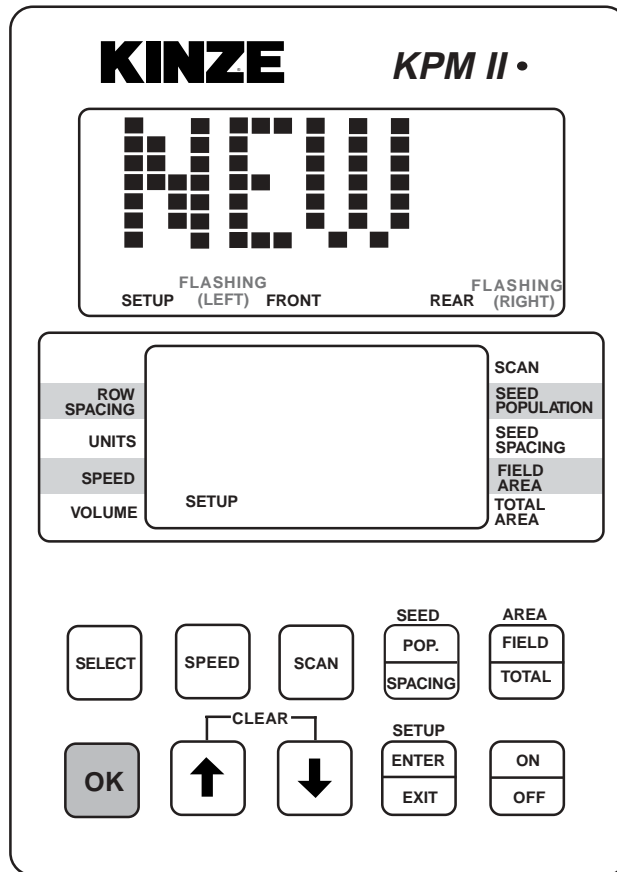

01139922

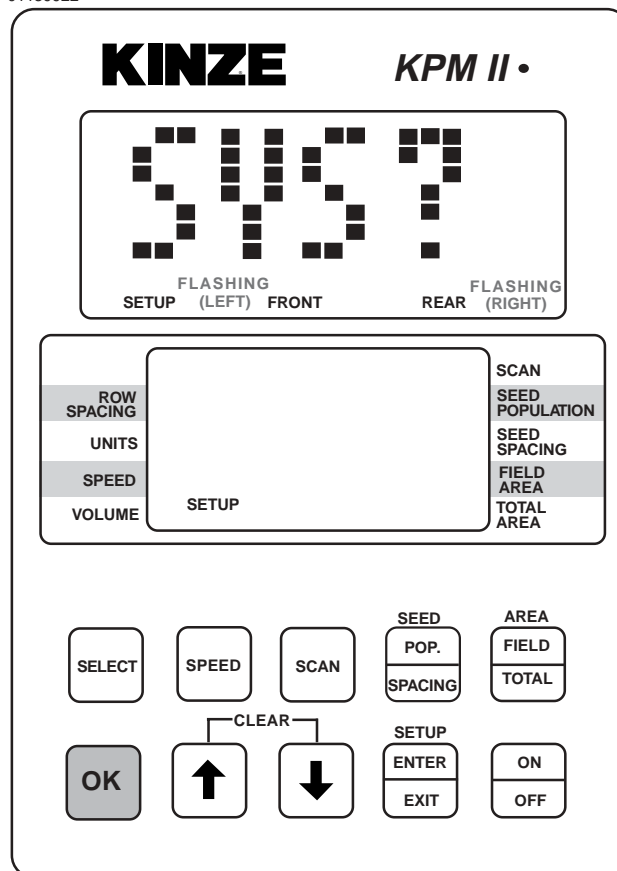

STEP 5 Determine which row you want as number one and plug the seed tube w/sensor into the harness.

Continue plugging in sensors along with shaft rotation sensors if so equipped. Row 1 first, row 2 second and so on up to 18 rows. When a sensor is plugged in, the corresponding row number on the upper LCD display will stay solid, the monitor will chirp twice and a red LED (Light Emitting Diode) on the seed tube sensor will turn on for approximately 30 seconds to show connection is made.

D04219901

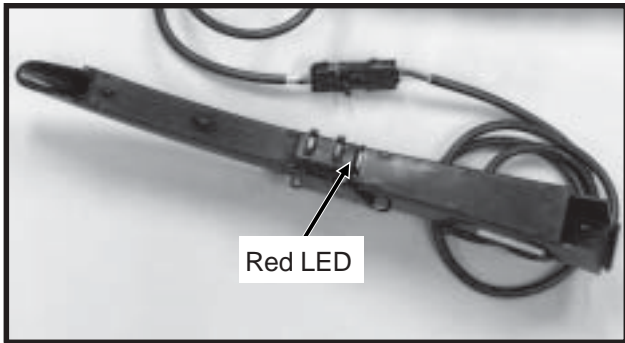

01139921

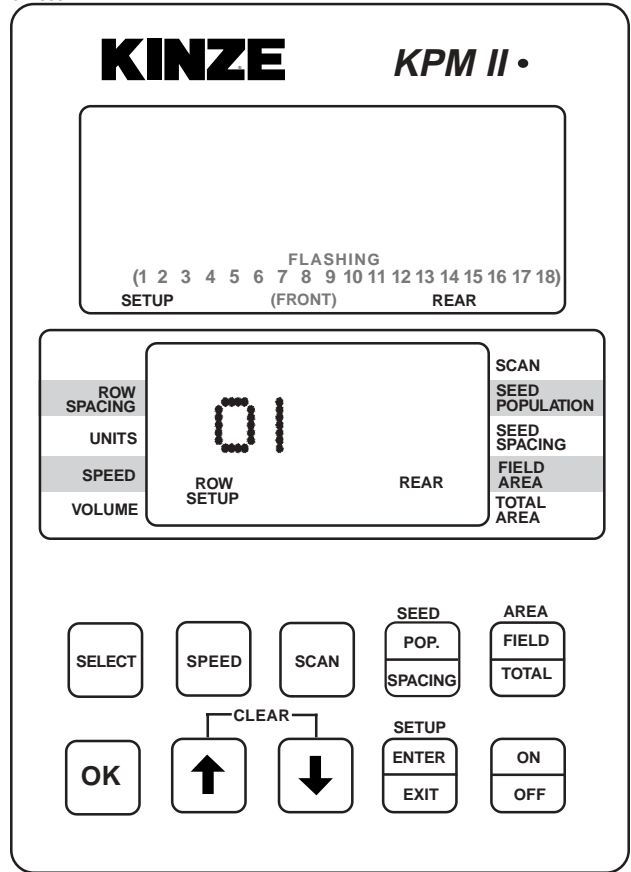

01139911

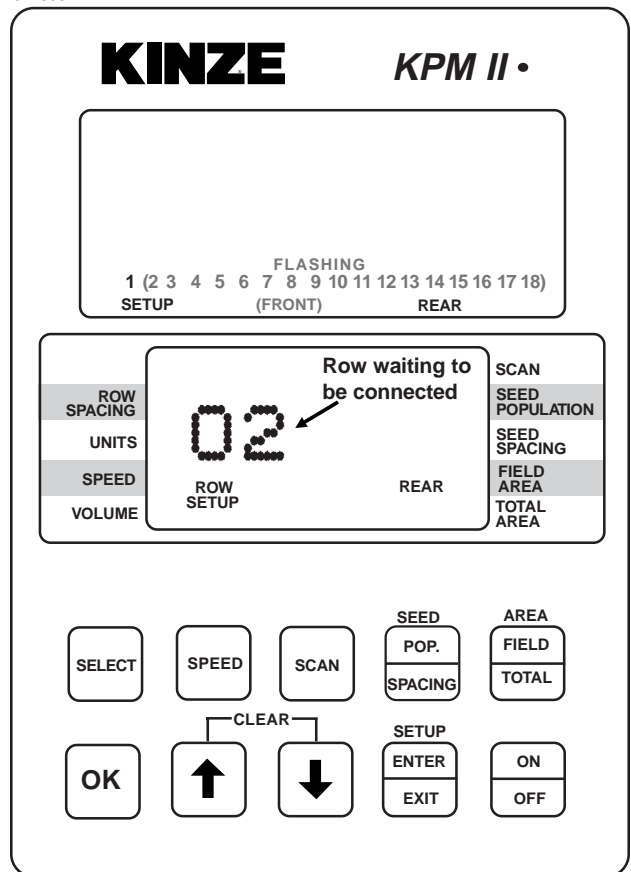

STEP 6 If the monitor system includes shaft rotation sensors, these can be installed at any time as the seed tubes are connected. The first shaft rotation sensor installed will be assigned to the rows on the L.H. half of the planter and the second shaft rotation sensor connected will be assigned to the rows on the R.H. half of the planter.

01189906

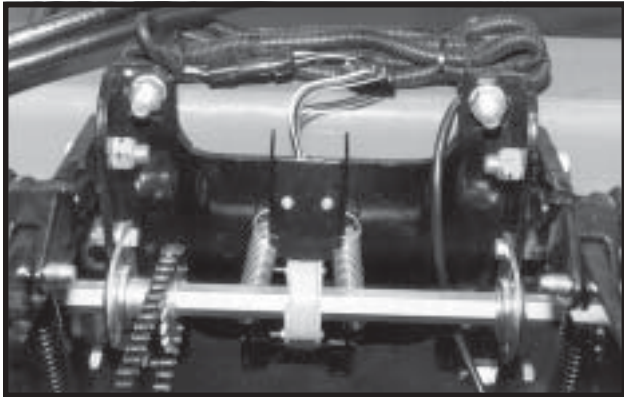

“LSHAFT” will display on the lower LCD when the first shaft rotation sensor is installed. “RSHAFT” will display when the second shaft rotation sensor is installed.

01139919

KINZE
KPM II •

FLASHING

1 (2 3 4 5 6 7 8 9 10 11 12 13 14 15 16 17 18)

SETUP(FRONT)REAR

ROW SPACING
UNITS
SPEED
VOLUME

LSHAFT

SCAN
SEED POPULATION
SEED SPACING
FIELD AREA
TOTAL AREA

SELECT	SPEED	SCAN	SEED POP. SPACING	AREA FIELD TOTAL
OK	CLEAR		SETUP ENTER EXIT	ON OFF
	↑	↓		

01139916

KINZE
KPM II •

FLASHING

1 2 3 4 5 6 7 8 9 10 11 12 (13 14 15 16 17 18)

SETUP(FRONT)REAR

ROW SPACING
UNITS
SPEED
VOLUME

RSHAFT

SCAN
SEED POPULATION
SEED SPACING
FIELD AREA
TOTAL AREA

SELECT	SPEED	SCAN	SEED POP. SPACING	AREA FIELD TOTAL
OK	CLEAR		SETUP ENTER EXIT	ON OFF
	↑	↓		

STEP 7 When all the seed tubes for the current section (Rear/Front or Left/Right) are installed, check to be sure the monitor displays solid numbers for the number of seed tubes connected. Press and hold the **OK** key to save the setup for the current section. The **SAVE?** icon will display followed by continuous short beeps indicating the monitor is preparing to save. The installer has 5 seconds to decide to save the current configuration. During this time, four short beeps will sound followed by a long beep and the **SAVE?** icon will turn off and the word **"DONE"** shows on the screen. The monitor will continue to the second section installation (If Applicable).

01139914

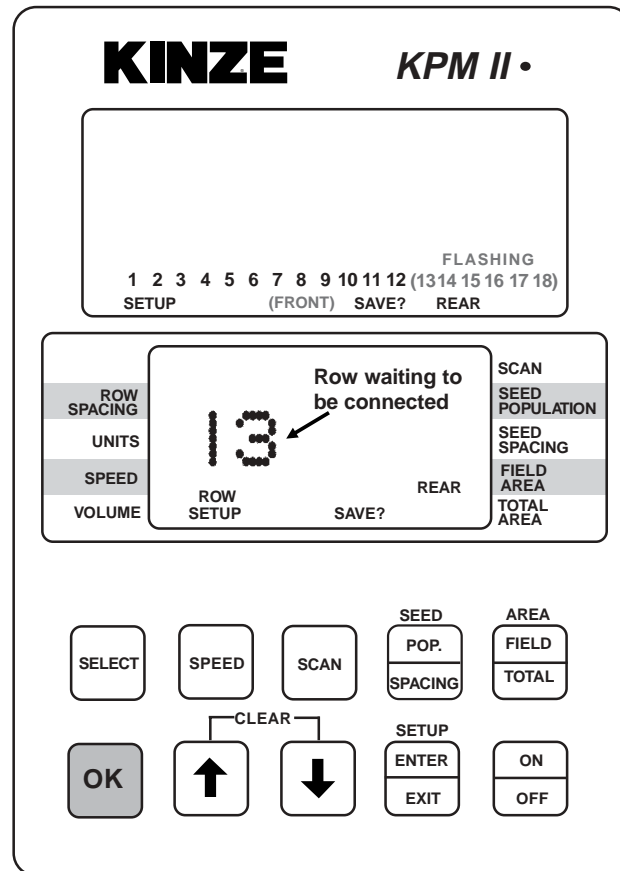

01139913

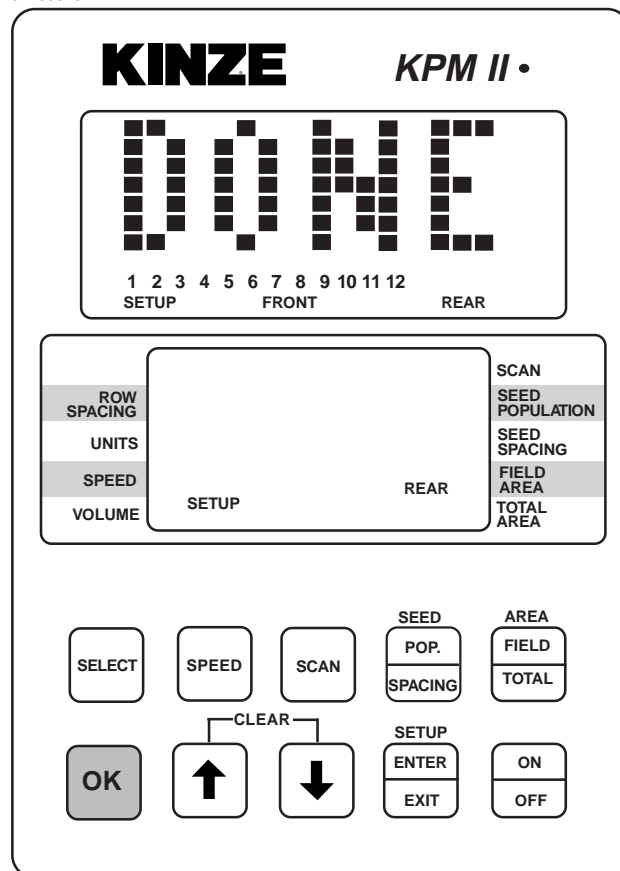

STEP 8 Follow STEPS 5 through 7 to install the second section. If no seed tubes are installed on the second section, press and hold the OK key. The word "DONE" will appear on upper display. The alarm will sound four short beeps followed by one long beep and the SAVE? icon turns off. The monitor has exited the setup mode. When you release the OK key the upper display will scroll "WAITING CALIBRATION". The lower display will show "GNDSPD" and the alarm will sound continually until the distance sensor is connected. See STEP 9.

01139912

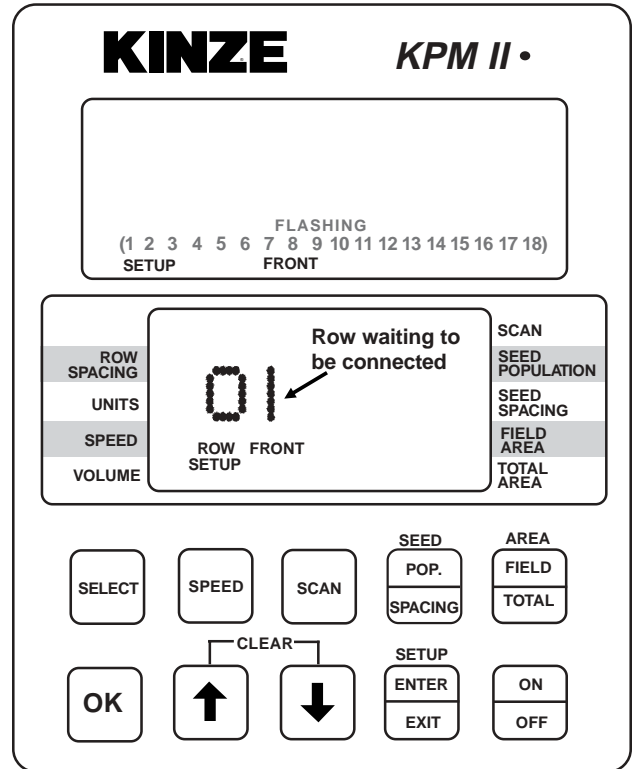

01139920

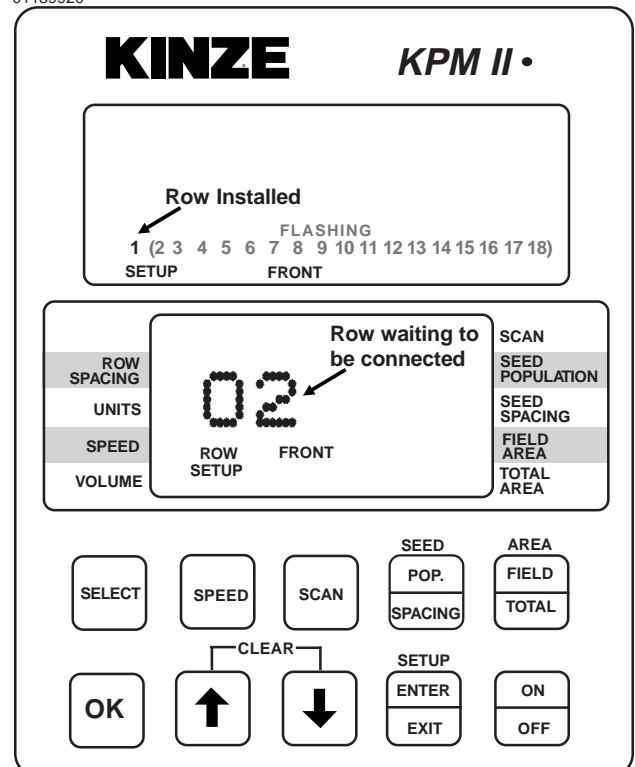

STEP 8 (Continued)

01139910

KINZE
KPM II •

Rows Installed

1 2 3 4 5 6 7 8 9 10 11 (12 13 14 15 16 17 18)

FLASHING

SETUP FRONT SAVE?

ROW SPACING
UNITS
SPEED
VOLUME

Row waiting to be connected

ROW SETUP FRONT SAVE?

SCAN
SEED POPULATION
SEED SPACING
FIELD AREA
TOTAL AREA

SELECT

SPEED

SCAN

SEED POP. SPACING

AREA FIELD TOTAL

OK

↑

↓

SETUP ENTER EXIT

ON OFF

01139910a

KINZE
KPM II •

DONE

1 2 3 4 5 6 7 8 9 10 11 (12 13 14 15 16 17 18)

FLASHING

SETUP FRONT

ROW SPACING
UNITS
SPEED
VOLUME

FRONT

SETUP

SCAN
SEED POPULATION
SEED SPACING
FIELD AREA
TOTAL AREA

SELECT

SPEED

SCAN

SEED POP. SPACING

AREA FIELD TOTAL

OK

↑

↓

SETUP ENTER EXIT

ON OFF

STEP 9 With the lower display showing “GNDSPD”, connect the distance sensor. The monitor will display “PICKUP” if a magnetic distance sensor is connected or “RADAR” if a radar distance sensor is installed. Only one distance sensor can be connected at a time.

NOTE: To connect the radar distance sensor, install the 10" monitor/radar adapter between the console and radar distance sensor to adapt the monitor system to various tractor radar systems.

NOTE: To reprogram the system to monitor more or less rows (up to the maximum of 18 per section, 36 total), all sensors must be unplugged, followed by the complete setup procedure.

NOTE: Individual seed tubes may be unplugged for special situations. An alarm will sound which can be silenced by touching the OK key. The monitor will recognize the seed tube(s) when reconnected.

10250115

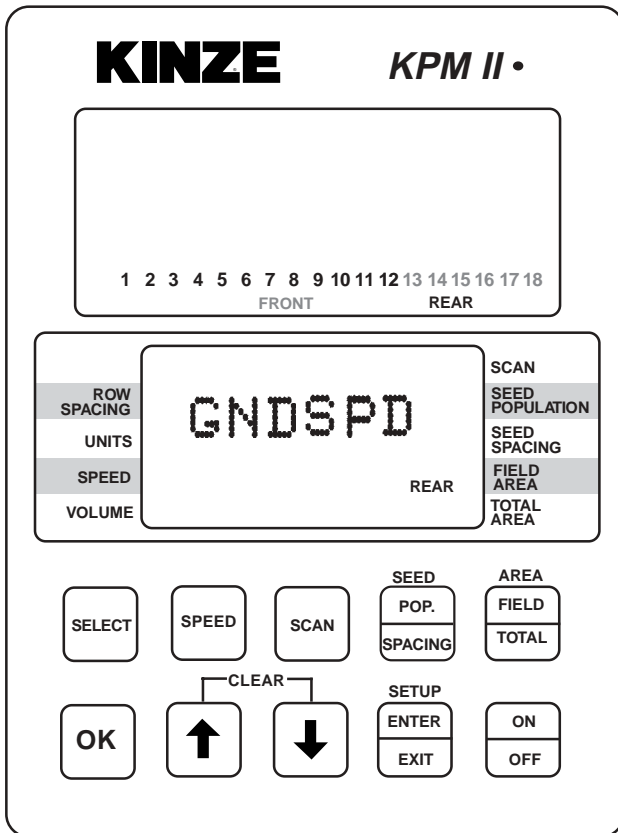

01139909

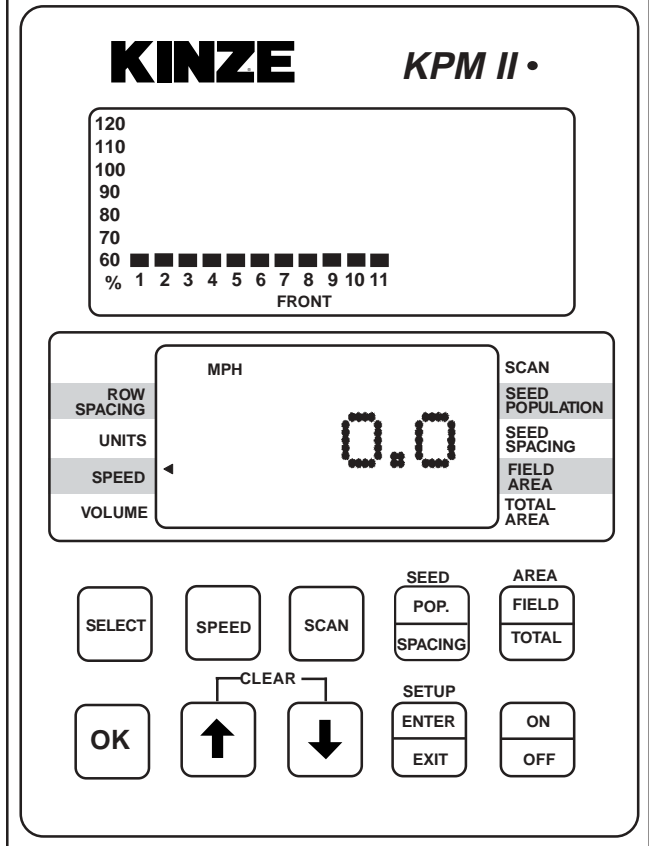

ROW-BY-ROW ALARM LEVEL SETTING
*(Requires Version V0.06 or higher Software -
 KPM II Console Only)*

This feature allows the audio alarm to be disabled on selected rows in applications such as planting seed corn.

NOTE: The seed monitor should be programmed to monitor all planter rows prior to performing these steps.

STEP 1 Enter the programming mode by pressing and holding the SETUP key. The monitor will emit several short beeps, followed by a long beep. On the lower LCD, the SETUP icon will turn on and the arrow head icon will flash, indicating the user can select an item to program.

NOTE: The monitor must be in a programmable function (row spacing, unit, speed, volume or area) to enter setup. The monitor will not enter setup in seed population or seed spacing.

STEP 2 Press the UP or DOWN arrow keys to move the flashing arrow to SEED POPULATION. As the arrow icon moves, the lower LCD will display the current setting of each item selected.

STEP 3 Press the OK key. Row number starts flashing.

STEP 4 Arrow UP or DOWN to desired row.

STEP 5 Press SELECT key. "AVG" starts flashing.

STEP 6 Arrow UP or DOWN to choose one of the following options.

- HIGH - For Early Alarm (70%)
- AVG - For Standard Alarm Setting (55%)
- LOW - For Failed Alarm Only (25%)
- OFF - To Disable Row Alarm

STEP 7 Press and hold the OK key to save alarm setting. There will be four short beeps, one long beep and the word "DONE" will appear when the save is completed.

STEP 8 Repeat STEPS 3 through 7 for each row on which you wish to adjust the alarm setting.

STEP 9 When finished, press the SETUP key to exit setup mode.

NOTE: The programming mode may be exited at any time by pressing the SETUP key. Pressing this key will return the monitor to its normal operation. All items changed and saved will come into effect immediately. Any items changed, but not saved will revert to the original programmed value.

NOTE: Repeat STEPS 3 through 7 to change seed monitor back to the original settings when special row-by-row alarm level settings are no longer required.

NOTE:
 See "Programming - Row Spacing" for programming applicable row spacing.

See "KPM I/KPM II Electronic Seed Monitor Troubleshooting" in the Maintenance Section.

04130116

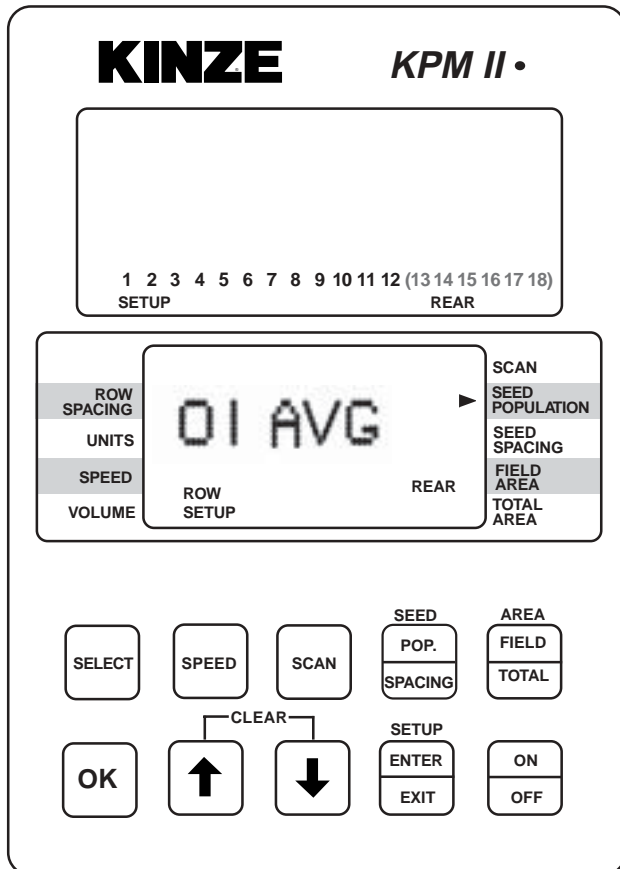

DOUBLE DISC FERTILIZER OPENER

The double disc fertilizer openers should be positioned during assembly **to place fertilizer no closer than 2" to either side of the row.** If the planter frame is level and at proper 20" operating height, fertilizer depth will be approximately 4". Soil conditions can affect depth slightly.

The down pressure spring is factory preset at 250 lbs. down pressure but may be adjusted for various soil conditions. To adjust spring tension, loosen the jam nut with a $1\frac{5}{16}$ " wrench and use a 1" wrench to turn the adjustment bolt clockwise to increase tension or counterclockwise to decrease tension. Securely tighten the jam nut upon completion of tension adjustment. Do not attempt to set opener depth with spring pressure. The opener is designed to operate against a depth stop and spring up when encountering a foreign object or hard ground.

IMPORTANT: Do not operate the double disc openers at full down pressure tension when planting in rocky ground. Chipping of the disc blades will occur.

A gap of $\frac{1}{32}$ " to $\frac{1}{16}$ " should be maintained between the opener blades at the closest point. Blade adjustment is made by moving inside spacer washers to the outer side of the blade. After making this adjustment, check to be sure bearing assembly rivets are not contacting the shank.

D06259919

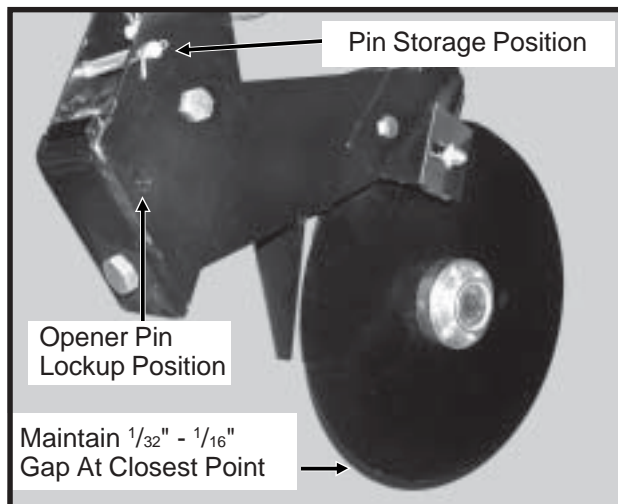

The outer scrapers on each disc blade may also be adjusted to make up for wear that may occur. Make sure the scrapers are adjusted to allow only slight contact with the blades.

The opener assembly is designed to be locked in a raised position when the fertilizer attachment is not in use or during storage. To lock the opener up, first raise the planter and place blocks under the openers. Then lower the planter until the hole in the pivot section aligns with the hole in the mounting bracket. Remove the lockup pin from the storage position in the mounting bracket and install it through the lockup hole and secure with cotter pins.



WARNING: Always install all cylinder lockup devices before working under the unit.

MACHINE OPERATION

NOTCHED SINGLE DISC FERTILIZER OPENER - STYLE A

The notched single disc fertilizer opener is designed for use in minimum and no till planting situations. Placement of fertilizer with the 16 ³/₄" diameter notched single disc fertilizer opener is recommended at 2 ¹/₂" - 3" from the row. **Never locate the opener to place fertilizer closer than 2".**

Adjust blade depth on each row using the cap screws and jam nuts located on the opener pivot shaft. The blade can be adjusted to allow a maximum 4" operating depth. Be sure the spring pin holes in the pivot post remain parallel with the opener mounting plate. Check fertilizer hose clearance after adjusting opener depth by swiveling the opener left and right. Torque cap screws and jam nuts to 57 ft. lbs.

The opener spring is factory preset at 350 lbs. and is not adjustable.



WARNING: Spring under pressure. DO NOT disassemble.

Adjust knife/scrapper leading edge contact on each row so blade will turn by hand with slight resistance, but will not coast or freewheel. In dry loose soil, knife/scrapper adjustment is critical. If adjustment is not maintained, soil or residue may wedge causing the blade to push. If the knife/scrapper is adjusted too tight, the blade will not turn causing the blade to push soil and residue. Knife/scrapper leading edge adjustment is made using the two lower ³/₈" mounting carriage bolts and pivot pad on the knife/scrapper. Because of blade runout, rotate blade one full revolution after adjustment. Readjust knife/scrapper-to-blade contact at tight spot as required. **Never strike the knife/scrapper with a heavy object or damage may occur.**

Adjust drop tube on each row using the slotted mounting holes in the drop tube. Adjust drop tube so it is protected by the knife/scrapper from soil contact and wear. The liquid drop tube should be adjusted as far from the opener blade as possible while keeping it behind the knife/scrapper. This adjustment prevents the liquid fertilizer from contacting the opener blade.

(FRTZ155e)

← **DIRECTION OF TRAVEL**

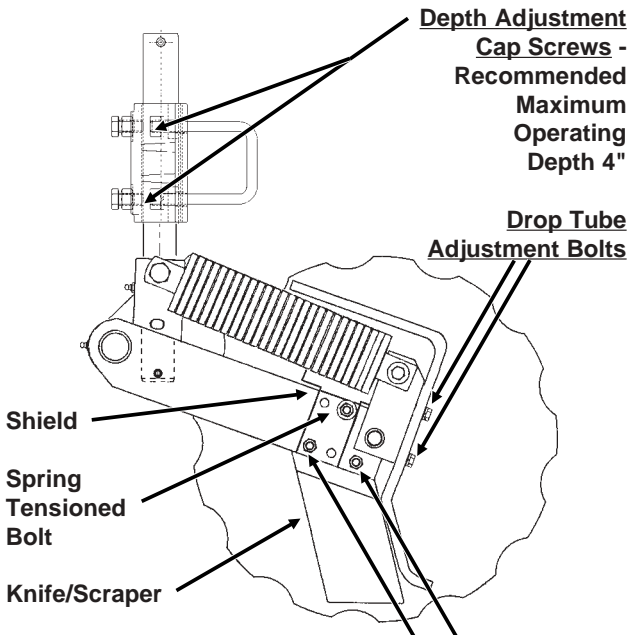

Knife/Scrapper Leading Edge Adjustment Bolts (If not equipped with a shield and spring tensioned bolt, the third knife/scrapper attachment bolt is also an adjustment bolt.)

MACHINE OPERATION

NOTCHED SINGLE DISC FERTILIZER OPENER - STYLE B

The notched single disc fertilizer opener is designed for use in minimum and no till planting situations. Placement of fertilizer with the 16^{3/4}" diameter notched single disc fertilizer opener is recommended at 2 1/2" - 3" from the row. The opener is designed to hold the blade at a set-angle so the knife and drop tube run in the shadow of the blade. **Never locate the opener to place fertilizer closer than 2".**



WARNING: Spring under pressure. DO NOT disassemble.

(FRTZ210g/B0297)

Depth Adjustment Cap Screws - Recommended Maximum Operating Depth 4" (Middle Bolt Holds Blade Angle But Must Be Loosened To Adjust Depth And Tightened First To Set Blade Angle)

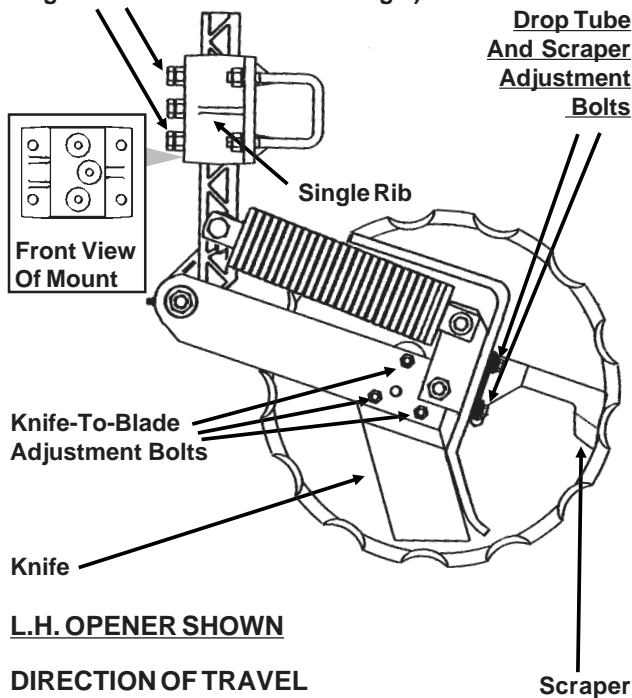

L.H. OPENER SHOWN

DIRECTION OF TRAVEL



Adjust knife-to-blade contact on each fertilizer opener so blade will turn by hand with slight resistance, but will not coast or freewheel. In dry loose soil the knife adjustment is critical. If adjustment is not maintained, soil or residue may wedge between knife and blade, resulting in the blade not turning. If the knife is adjusted too tight, the blade will not turn causing the blade to push soil and residue. **Knife adjustment is made using the three 3/8" mounting carriage bolts** and pivot pad on the knife. Because of blade runout, rotate blade one full revolution after adjustment. Readjust knife to the blade's tight spot as needed. **Never strike the knife with a heavy object or damage may occur.**

Using the slotted mounting holes in the drop tube mount, **adjust fertilizer drop tube** so it is protected from soil contact and wear behind the knife. The liquid drop tube should be adjusted 1/4"-3/8" from the opener blade while keeping it behind the knife. **Adjust scraper** to just touch the opener blade. As the mounting hardware is tightened, the scraper is drawn tighter to the blade. After adjustment, rotate opener blade to be sure blade will turn by hand with slight resistance, but will not coast or freewheel.

Adjust blade depth on each row using the cap screws and jam nuts located on the opener mount. The blade can be adjusted to allow a maximum 4" blade depth. Check fertilizer hose clearance (If Applicable) after adjusting opener depth. Torque cap screws and jam nuts to 57 ft. lbs.

NOTE: The blade runs through the ground at an angle relative to the direction of travel. For this reason and to ensure proper operation, the cast mount should be oriented so the single rib is on the same side of the blade as the drop tube.

NOTE: Recommended maximum operating depth is 4". To adjust depth: (a) Loosen depth adjustment cap screws. (b) Adjust depth. (c) Tighten middle cap screw to hold blade angle. (d) Tighten upper and lower cap screws.

LIQUID FERTILIZER ATTACHMENT

NOTE: An optional low rate check valve is available for installation in-line between the liquid fertilizer piston pump and the liquid fertilizer openers to ensure equal distribution of product at low rates. The check valve also eliminates the need for an anti-siphon loop if the valve is installed as close as possible to the fertilizer opener drop tube.

(FRTZ208)

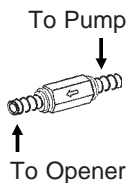

PISTON PUMP

69045-6

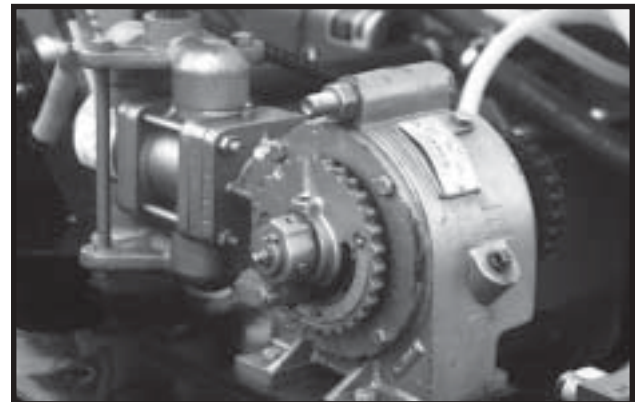

If the machine is equipped with the piston pump option, the rate of liquid fertilizer application is determined by the piston pump settings.

MACHINE OPERATION

The delivery rate chart found at the end of this section provides an approximate application rate only. Actual delivery will vary with temperature and the particular fertilizer being used.

To adjust delivery rate, loosen the $\frac{3}{8}$ " lock nut that secures the arm with the pointer and rotate the scale flange until the pointer is over the desired scale setting. The adjustment wrench will facilitate rotation of the scale flange. Tighten the $\frac{3}{8}$ " lock nut being careful not to over tighten.

(PLTR9)

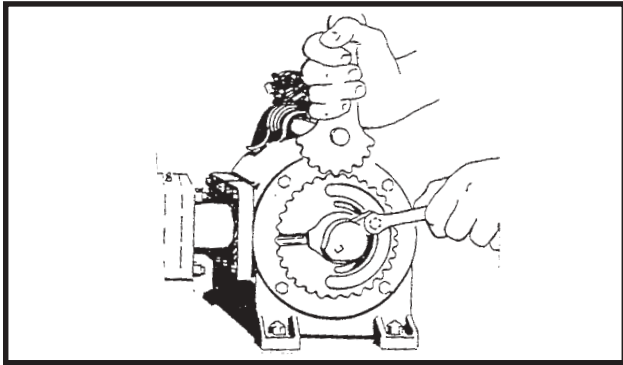

The operator and instruction manual shipped with the pump and flow divider should be kept and stored with this manual for future reference.

NOTE: Periodically check flow to all rows. If one or more lines are plugged, set rate will be delivered to remaining rows.

PISTON PUMP CONTACT DRIVE WHEEL SPRING ADJUSTMENT

(A8482a)

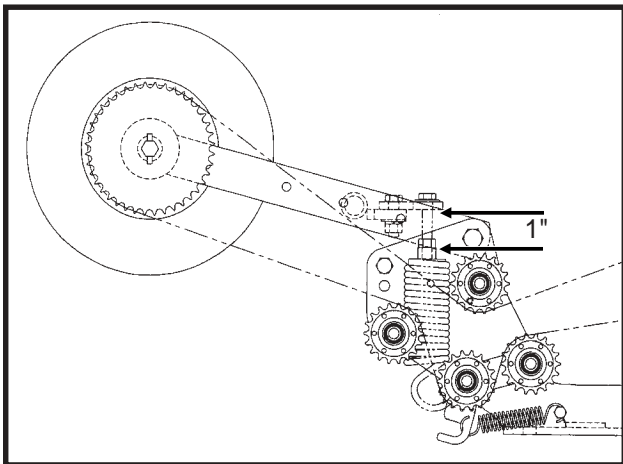

There is one down pressure spring on the piston pump contact drive wheel. The initial spring tension is set leaving 1" between the bottom of the mounting plate and the plug on the top of the spring.

CLEANING

The tanks and all hoses are made of sturdy plastic and rubber to resist corrosion. However, the tanks, hoses and metering pump should be thoroughly cleaned with water at the end of the planting season or prior to an extended period of non-use. Do not allow fertilizer to crystalize due to cold temperature or evaporation.

The strainer, located between the piston pump and ball valve (On machines equipped with the piston pump.), should be taken apart and cleaned daily. Remove the end cap to clean the screen.

(INS220)

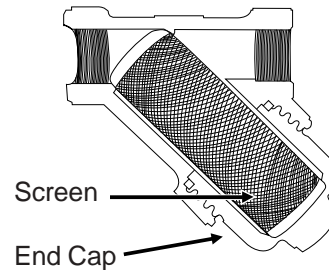

See "Piston Pump Storage" (If Applicable) in the Maintenance Section of this manual.

INTERPLANT® CLUTCH SPROCKET

01239905

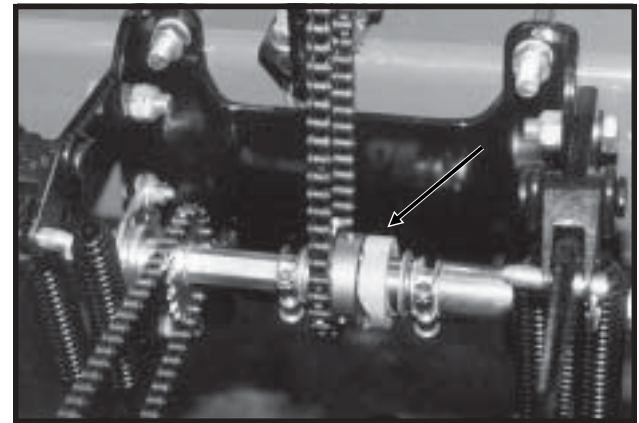

The clutch sprocket is designed to allow the push row unit drill shaft to be disengaged when only the pull row units are being used.

To engage or disengage the push row unit drill shaft using the clutch sprocket, rotate the knurled collar on the clutch sprocket $\frac{1}{4}$ turn. Then using a $\frac{7}{8}$ " wrench on the drill shaft, rock the drill shaft slightly to take pressure off of the spring loaded pins in the clutch to allow the clutch to engage or disengage.



DANGER: Always install all safety lockups or lower planter to the ground before working under or around the machine.

MACHINE OPERATION

MANUAL SAFETY LOCKUPS

Never allow anyone to work around or under the planter without first installing the manual safety lockups. When transporting the planter use the manual safety lockups for added safety.

D063099114

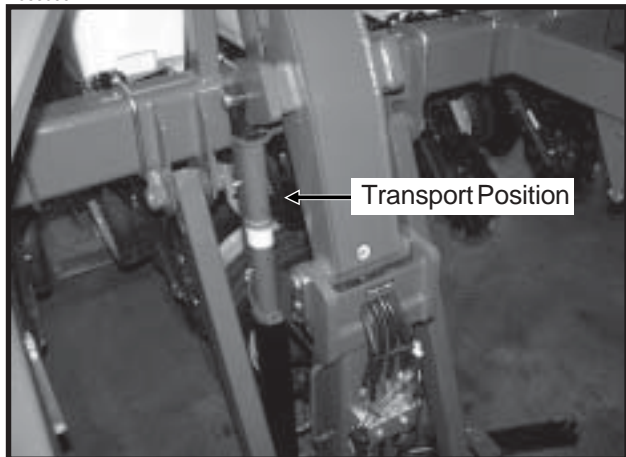

Manual Safety Lockups In Transport Position

D06109906

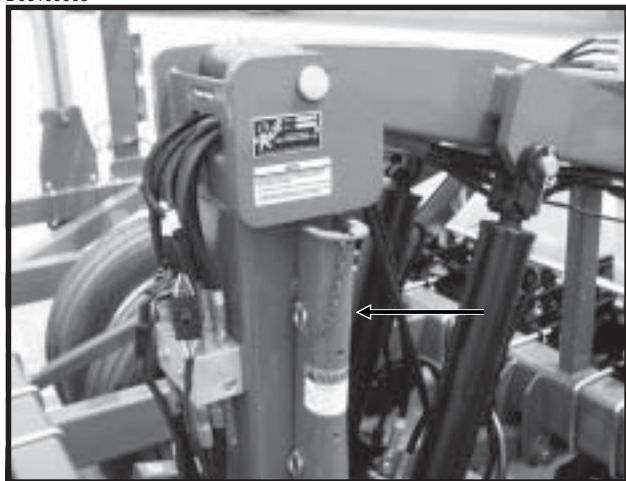

Manual Safety Lockups In Storage Location

For field operation remove the manual safety lockups and store on the side of the center pivot assembly.

TRANSPORT LATCH LOCKING PIN

The transport latch locking pin when installed will prevent the latch bar from disengaging and allowing the planter frame to swing out of the transport position. Never transport the planter without installing the transport latch locking pin.

D060999107



Transport Latch Locking Pin Installed For Transport

D060999117



Transport Latch Locking Pin Stored For Field Operation

For field operation remove the transport latch locking pin and store in the location provided on the latch post.

MACHINE OPERATION

MARKER SAFETY LOCKUP

D060999113



Install safety lockups over marker cylinder rods when transporting the planter or working around the planter. When lockups are not in use, store in the storage position provided on the first stage marker arm.

 **DANGER:** To avoid serious injury, keep others away when raising or lowering markers.

TRANSPORTING THE PLANTER

 **WARNING:** Always make sure safety/warning lights, reflective decals and SMV sign are in place and visible prior to transporting the machine on public roads. In this regard, check federal, state/provincial and local regulations.

CAUTION: Avoid transporting planter with hoppers loaded whenever possible. When it is necessary to transport the planter with the hoppers loaded, the added weight should be distributed evenly on the planter frame before rotating the planter.

 **WARNING:** Always install all safety lockups prior to transporting the planter.

METRIC CONVERSION TABLE

Multiply	By	To Get
Inches (in.)	x 2.54	= centimeters (cm)
Inches (in.)	x 25.4	= millimeters (mm)
Feet (ft.)	x 30.48	= centimeters (cm)
Acres	x 0.405	= hectares (ha)
Miles per hour (mph)	x 1.609	= kilometers per hour (Km/h)
Pounds (lbs.)	x 0.453	= kilograms (kg)
Bushels (bu.)	x 35.238	= liters (l)
Gallons (gal.)	x 3.785	= liters (l)
Pounds per square inch (psi)	x 6.894	= kilopascals (kPa) (100 kPa = 1 bar)
Inch pounds (in. lbs.)	x 0.113	= newtons-meters (N•m)
Foot pounds (ft. lbs.)	x 1.356	= newtons-meters (N•m)
Centimeters (cm)	x .394	= inches (in.)
Millimeters (mm)	x .0394	= inches (in.)
Centimeters (cm)	x .0328	= feet (ft.)
Hectares (ha)	x 2.469	= acres
Kilometers per hour (Km/h)	x 0.621	= miles per hour (mph)
Kilograms (kg)	x 2.208	= pounds (lbs.)
Liters (l)	x 0.028	= bushels (bu.)
Liters (l)	x 0.264	= gallons (gal.)
Kilopascals (kPa) (100 kPa = 1 bar)	x 0.145	= pounds per square inch (psi)
Newtons-meters (N•m)	x 8.85	= inch pounds (in. lbs.)
Newtons-meters (N•m)	x 0.738	= foot pounds (ft. lbs.)

PLANTING SPEED

Planters are designed to operate within a speed range of 2 to 8 MPH. See “Planting And Application Rate Charts”. Variations in ground speed will produce variations in rates. Finger pickup seed meter populations will tend to be disproportionately higher at high ground speeds.

NOTE: Due to a multitude of variables, seed spacing can be adversely affected at speeds above 5.5 MPH.

MACHINE OPERATION

FIELD TEST

With any change of field and/or planting conditions, seed size or planter adjustment, we recommend a field test be made to ensure proper seed placement and operation of row units. See "Rate Charts", "Checking Seed Population" and "Checking Granular Chemical Application Rate" at end of this section.

- Check the planter for fore to aft and lateral level operation. See "Leveling The Planter".
- Check **all** row units to be certain they are running level. When planting, the row unit parallel arms should be approximately parallel to the ground.
- Check row markers for proper operation and adjustment. See "Marker Length Adjustment" and marker speed adjustment in "Hydraulic Operation".
- Check for proper application rates and placement of granular chemicals on all rows. See "Checking Granular Chemical Application Rate".
- Check for desired depth placement and seed population on **all** rows. See "Checking Seed Population".
- Check for proper application rates of fertilizer on **all** rows. See proper "Fertilizer Application Rate Chart".

After the planter has been field tested, reinspect the machine.

- Hoses and fittings
- Bolts and nuts
- Cotter pins and spring pins
- Drive chain alignment

CHECKING SEED POPULATION

1. Tie up one or more sets of closing wheels by running a chain or rubber tarp strap between the hopper support panel and closing wheels. It may be necessary to decrease closing wheel arm spring tension.

(RU113b)

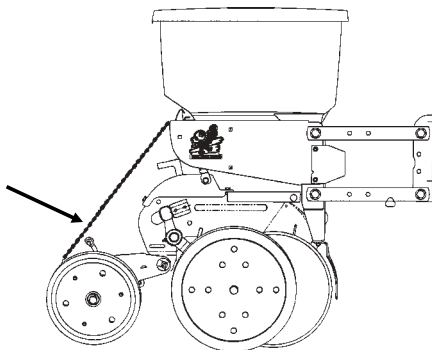

2. Plant a short distance and check to see if seed is visible in the seed trench. Adjust planting depth to a shallower setting if seed is not visible and recheck.

04059914a

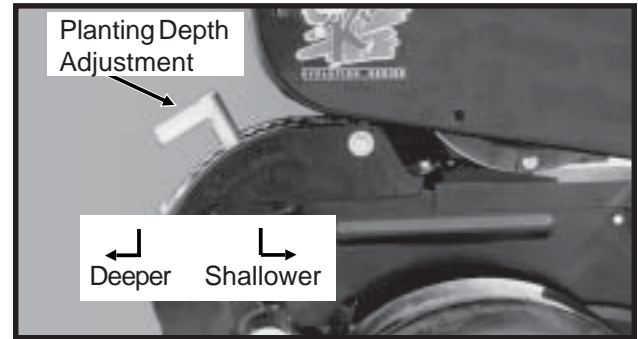

3. Measure $\frac{1}{1000}$ of an acre. See chart for correct distance for row width being planted. For example, if planting 20" rows $\frac{1}{1000}$ of an acre would be 26' 2".

LENGTH OF ROW IN FEET AND INCHES				
Fraction Of Acre	Row Width			
	10"	11"	20"	22"
$\frac{1}{1000}$	52' 3"	47' 6"	26' 2"	23' 9"

NOTE: When planting with closing wheels raised and planting depth set shallow, seeds may bounce or roll affecting seed spacing accuracy.

4. Count seeds in measured distance.
5. Multiply the number of seeds placed in $\frac{1}{1000}$ of an acre by 1000. This will give you total population.

EXAMPLE: With 20" row spacing 26' 2" equals $\frac{1}{1000}$ acre.

26 Seeds Counted	x	1000	=	26,000 Seeds Per Acre
------------------	---	------	---	-----------------------

Seed count can be affected by drive ratio between drive wheel and seed meter, tire pressure and/or seed meter malfunction.

If seed check shows the average distance between seeds in inches is significantly different than the seed rate chart indicates, first check drive ratio between drive wheel and seed meter. Check drive wheel air pressure, check for incorrect sprocket(s) in drive line and check drive and driven sprockets on transmission for proper selection.

Second, check for seed meter malfunction. For example, if spacing between kernels of corn at the transmission setting being used is 8" and a gap of 16" is observed, a finger has lost its seed and not functioned properly. If two seeds are found within a short distance of each other, the finger has metered two seeds instead of one.

See "Finger Pickup Seed Meter Troubleshooting" and/or "Brush-Type Seed Meter Troubleshooting" in the Maintenance Section of this manual.

MACHINE OPERATION

Determining Pounds Per Acre (Brush-Type Seed Meter)

To determine pounds per acre:

Seeds Per Acre On Chart	÷	Seeds Per Pound From Seed Tag On Bag	=	Pounds Per Acre
-------------------------------	---	---	---	-----------------------

To determine bushels per acre:

Pounds Per Acre	÷	Unit Weight Of Seed	=	Bushels Per Acre
--------------------	---	------------------------	---	---------------------

The unit weight of:

- 1 Bushel Soybeans = 60 Pounds
- 1 Bushel Milo/Grain Sorghum = 56 Pounds
- 1 Bushel Cotton = 32 Pounds

If seeds per pound information is not available the following is an average:

- 2,600 seeds per pound for medium size soybeans
- 15,000 seeds per pound for medium size milo/
grain sorghum
- 4,500 seeds per pound for medium size cotton

If seed check shows planting rate is significantly different than seed rate chart shows or if a particular meter is not planting accurately, see “Brush-Type Seed Meter Maintenance” and “Brush-Type Seed Meter Troubleshooting”.

CHECKING GRANULAR CHEMICAL APPLICATION RATE

Many things can affect the rate of delivery of granular chemicals such as temperature, humidity, speed, ground conditions, flowability of different material or any obstruction in the meter.



WARNING: Agricultural chemicals can be dangerous if not selected and handled with care. Always read and follow directions supplied by the chemical manufacturer.

A field check is important to determine correct application rates.

D05149901



To check, fill insecticide and/or herbicide hoppers. Attach a calibrated vial to each granular chemical meter. Lower the planter and proceed as follows.

NOTE: It is not necessary for seed meter clutch to be engaged during test. Disengage clutch to avoid dropping seed.

Drive 1320 feet at planting speed. Weigh the chemical in ounces that was caught in one vial. Multiply that amount by the factor shown to determine pounds per acre.

POUNDS PER ACRE FACTOR FOR GIVEN ROW WIDTH	
Row Width	Factor
20"	1.25
22"	1.13

EXAMPLE: You are planting 20" rows. You have planted for 1320 feet at the desired planting speed. You caught 12.0 ounces of chemical in one vial. 12.0 ounces times 1.25 equals 15.0 pounds per acre.

NOTE: It is important to check calibration of all rows.

Metering Gate

Use the metering gate setting for distributing insecticide or herbicide as a starting point. The charts are based on a 5 miles per hour planting speed. For speeds faster than 5 miles per hour a higher gate setting should be used. For speeds slower than 5 miles per hour a lower gate setting should be used.

MACHINE OPERATION

GENERAL PLANTING RATE INFORMATION

These planting rate charts are applicable to KINZE® Model 3400 Twin-Line® Planters. See "Tire Pressure" for recommended tire pressures.

Not all row spacings listed are applicable to all size planters.

IMPORTANT: The sprocket combinations listed in these charts are best for average conditions. Changes in sprocket combinations may be required to obtain desired planting population. TO PREVENT PLANTING MISCALCULATIONS, MAKE FIELD CHECKS TO BE SURE YOU ARE PLANTING AT THE DESIRED RATE.

The size and shape of seed may affect the planting rate.

Finger Pickup Corn Meter

Larger grades will generally plant more accurately at the high end of the ground speed range than smaller grades. Higher than optimum speeds may result in population rate increase or higher incidence of doubles, particularly with small seed. Medium round corn seed is most desirable for planting accuracy at optimum speed.

Finger Pickup Oil Sunflower Meter

Larger grades will generally plant more accurately at the high end of the ground speed range than smaller grades. Higher than optimum speeds may result in population rate increase or higher incidence of doubles, particularly with small seed. No. 3 and/or No. 4 size oil sunflower seeds are recommended for use in the finger pickup seed meter equipped with oil sunflower fingers. No. 1 and/or No. 2 size confectionary sunflower seeds are recommended for use in the finger pickup seed meter equipped with corn fingers.

NOTE: Seed additives, added to the seed in the hopper, may adversely affect performance of the finger pickup seed meter and accelerate wear. See "Finger Pickup Seed Meter" in the Row Unit Operation section.

Brush-Type Seed Meter (Soybean, Milo/Grain Sorghum, Acid-Delinted Cotton)

Rate charts are given in seeds per acre as well as seed spacing in inches rounded to the nearest tenth of an inch. Because of the large range in seed size, pounds per acre is not a suggested method of selecting transmission settings. When using smaller size seeds it may appear the pounds per acre is below what was expected and vice versa on large seed. To determine pounds per acre, use the formula given in "Determining Pounds Per Acre (Brush-Type Seed Meter)" in the "Checking Seed Population" section of this manual.

NOTE: Due to a multitude of variables, seed spacing can be adversely affected at speeds above 5.5 MPH.

Seed population per acre with **10" rows will be double the rate for 20" rows**, as well as 11" rows versus 22", at the listed sprocket combination. See pages 6-49 and 6-50.

In some cases when planting 10"-11" row soybeans, milo/grain sorghum or cotton, a **Half Rate (2 To 1) Drive Reduction Package** may be required to obtain the desired population and seed spacing.

NOTE: Use of the Half Rate (2 To 1) Drive Reduction Package will reduce the planter transmission speed. The seeding rate will be approximately 50% of the chart reading when using the Half Rate (2 To 1) Drive Reduction Package. Planting speed can affect actual seeding rate. Make a field check and adjust setting on the transmission as needed to obtain the desired seed drop.

D063099119

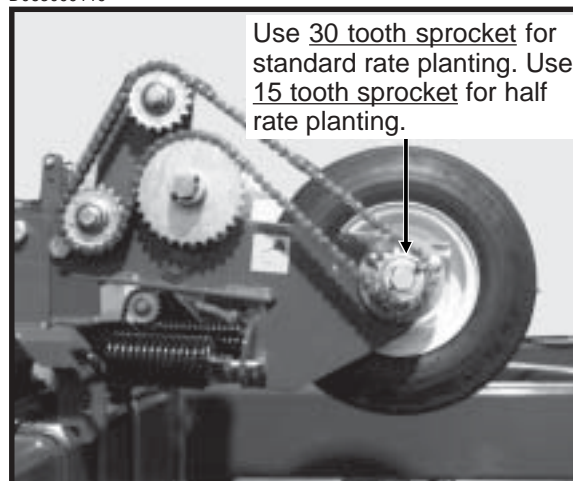

MACHINE OPERATION

PLANTING RATES FOR FINGER PICKUP SEED METERS (STANDARD DRIVE) APPROXIMATE SEEDS/ACRE FOR VARIOUS ROW WIDTHS

20" Rows	22" Rows	Transmission Sprockets		Recomm. Speed Range (MPH)	Average Seed Spacing In Inches
		Drive	Driven		
24,279	22,013	17	28	4 to 6	12.9
25,178	22,828	17	27	4 to 6	12.5
26,147	23,706	17	26	4 to 6	12.0
27,135	24,602	19	28	4 to 6	11.6
27,192	24,654	17	25	4 to 6	11.5
28,140	25,514	19	27	4 to 6	11.1
28,325	25,681	17	24	4 to 6	11.1
29,222	26,494	19	26	4 to 6	10.7
29,556	26,797	17	23	4 to 6	10.6
30,392	27,555	19	25	4 to 6	10.3
31,656	28,701	19	24	4 to 6	9.9
32,847	29,781	23	28	4 to 6	9.5
33,033	29,950	19	23	4 to 6	9.5
34,064	30,884	23	27	4 to 6	9.2
34,275	31,076	24	28	4 to 6	9.2
35,375	32,073	23	26	4 to 6	8.9
35,546	32,228	24	27	4 to 6	8.8
35,703	32,371	25	28	4 to 6	8.8
35,780	32,440	17	19	4 to 6	8.8
36,789	33,355	23	25	4 to 6	8.5
36,912	33,467	24	26	4 to 6	8.5
37,026	33,570	25	27	4 to 6	8.5
37,133	33,667	26	28	4 to 6	8.4
38,322	34,745	23	24	4 to 6	8.2
38,388	34,805	24	25	4 to 6	8.2
38,450	34,861	25	26	4 to 6	8.2
38,507	34,913	26	27	4 to 6	8.1
38,561	34,962	27	28	4 to 6	8.1
39,989	36,256	23	23	4 to 6	7.8
41,469	37,599	28	27	4 to 6	7.6
41,526	37,650	27	26	4 to 6	7.6
41,655	37,767	25	24	4 to 6	7.5
41,727	37,832	24	23	4 to 6	7.5
43,064	39,044	28	26	4 to 6	7.3
43,187	39,156	27	25	4 to 6	7.3
43,466	39,409	25	23	4 to 6	7.2
44,693	40,521	19	17	4 to 6	7.0
44,787	40,607	28	25	4 to 6	7.0
44,987	40,788	27	24	4 to 6	7.0
45,204	40,985	26	23	4 to 6	7.0
46,653	42,299	28	24	3 to 6	6.7
46,943	42,561	27	23	3 to 6	6.7
48,407	43,889	23	19	3 to 5.5	6.5
48,681	44,137	28	23	3 to 5.5	6.5
50,511	45,797	24	19	3 to 5.5	6.2
52,616	47,705	25	19	3 to 5	6.0
54,102	49,052	23	17	2 to 5	5.8
54,720	49,613	26	19	3 to 5	5.7
56,454	51,185	24	17	3 to 5	5.6
56,825	51,521	27	19	3 to 5	5.5
58,806	53,317	25	17	3 to 4.5	5.3
59,931	53,430	28	19	3 to 4.5	5.3
61,158	55,450	26	17	3 to 4.5	5.1
63,510	57,582	27	17	3 to 4.5	4.9
65,862	59,715	28	17	3 to 4.5	4.8

NOTE: See "General Planting Rate Information" and "Checking Seed Population" pages for additional information. Always check seed population in the field to ensure planting rates are correct.

MACHINE OPERATION

Z214/RH

PLANTING RATES FOR BRUSH-TYPE SEED METERS (STANDARD DRIVE)

APPROXIMATE SEEDS/ACRE FOR 20"/22" ROW WIDTHS

Transmission Sprockets		60 Cell Soybean Or High-Rate Milo/ Grain Sorghum		Average Seed Spacing In Inches	48 Cell Specialty Soybean Or High-Rate Acid-Delinted Cotton		Average Seed Spacing In Inches	Speed Range (MPH)
Drive	Driven	20" Rows	22" Rows		20" Rows	22" Rows		
17	28	121,392	110,062	2.6	97,113	88,049	3.2	2 to 8
17	27	125,889	114,139	2.5	100,712	91,312	3.1	2 to 8
17	26	130,731	118,529	2.5	104,712	94,823	3.0	2 to 8
19	28	135,674	123,011	2.3	108,593	98,408	2.9	2 to 8
19	27	140,699	127,567	2.2	112,559	102,053	2.8	2 to 8
17	24	141,624	128,406	2.2	113,300	102,725	2.8	2 to 8
17	23	147,782	133,989	2.1	118,226	107,191	2.7	2 to 8
19	25	151,955	137,772	2.1	121,563	110,217	2.6	2 to 8
19	24	158,286	143,513	2.0	126,629	114,810	2.5	2 to 8
23	28	164,237	148,908	1.9	131,390	119,126	2.4	2 to 8
19	23	165,168	149,752	1.9	132,135	119,802	2.4	2 to 8
24	28	171,379	155,383	1.8	137,103	124,307	2.3	2 to 8
24	27	177,725	161,137	1.8	142,179	128,909	2.2	2 to 8
17	19	178,895	162,198	1.8	143,115	129,758	2.2	2 to 8
24	26	184,560	167,334	1.7	147,648	133,868	2.1	2 to 8
26	28	185,660	168,331	1.7	148,527	134,664	2.1	2 to 8
24	25	191,943	174,028	1.6	153,555	139,223	2.0	2 to 8
26	27	192,536	174,566	1.6	154,029	139,653	2.0	2 to 8
23	23	199,941	181,280	1.6	159,953	145,024	2.0	2 to 8
27	26	207,630	188,251	1.5	166,104	150,601	1.9	2 to 8
24	23	208,634	189,161	1.5	166,907	151,329	1.9	2 to 8
25	23	217,326	197,042	1.4	173,861	157,634	1.8	2 to 8
19	17	223,463	202,606	1.4	178,770	162,085	1.8	2 to 8
27	24	224,933	203,939	1.4	179,946	163,151	1.7	2 to 8
28	24	233,264	211,492	1.3	186,661	169,194	1.7	2 to 8
23	19	242,033	219,443	1.3	193,626	175,554	1.6	2 to 8
28	23	243,405	220,687	1.3	194,724	176,550	1.6	2 to 8
24	19	252,557	228,985	1.2	202,044	183,187	1.6	2 to 8
25	19	263,079	238,525	1.2	210,464	190,820	1.5	2 to 8
23	17	270,507	245,260	1.2	216,405	196,207	1.5	2 to 8
26	19	273,603	248,067	1.1	218,883	198,454	1.4	2 to 7
27	19	284,126	257,607	1.1	227,301	206,086	1.4	2 to 7
28	19	294,650	267,149	1.1	235,719	213,719	1.3	2 to 7
26	17	305,792	277,251	1.0	244,634	221,801	1.3	2 to 7
27	17	317,553	289,915	0.9	245,043	230,332	1.2	2 to 7
28	17	329,313	298,577	0.9	263,451	238,862	1.2	2 to 7

NOTE: See "General Planting Rate Information" and "Checking Seed Population" pages for additional information.

NOTE: When using the Half Rate (2 To 1) Drive Reduction Package, rates will be approximately 50% of given numbers.

NOTE: Always check seed population in the field to ensure planting rates are correct.

MACHINE OPERATION

Z214/RH

PLANTING RATES FOR BRUSH-TYPE SEED METERS (STANDARD DRIVE)

APPROXIMATE SEEDS/ACRE FOR 10"/11" ROW WIDTHS

Transmission Sprockets		60 Cell Soybean Or High-Rate Milo/ Grain Sorghum		Average Seed Spacing In Inches	48 Cell Specialty Soybean Or High-Rate Acid-Delinted Cotton		Average Seed Spacing In Inches	Speed Range (MPH)
Drive	Driven	10" Rows	11" Rows		10" Rows	11" Rows		
17	28	242,784	220,124	2.6	194,226	176,098	3.2	2 to 8
17	27	251,778	228,278	2.5	201,424	182,624	3.1	2 to 8
17	26	261,462	237,058	2.4	209,424	189,646	3.0	2 to 8
19	28	271,348	246,022	2.3	217,078	196,816	2.9	2 to 8
19	27	281,398	255,134	2.2	225,118	204,106	2.8	2 to 8
17	24	283,248	256,812	2.2	226,600	205,450	2.8	2 to 8
17	23	295,564	267,978	2.1	236,452	214,382	2.7	2 to 8
19	25	303,910	275,544	2.1	243,126	220,434	2.6	2 to 8
19	24	316,572	287,026	2.0	253,258	229,620	2.5	2 to 8
23	28	328,474	297,816	1.9	262,780	238,252	2.4	2 to 8
19	23	330,336	299,504	1.9	264,270	239,604	2.4	2 to 8
24	28	342,758	310,766	1.8	274,206	248,614	2.3	2 to 8
24	27	355,450	322,274	1.8	284,358	257,818	2.2	2 to 8
17	19	357,790	324,396	1.8	286,230	259,516	2.2	2 to 8
24	26	369,120	334,668	1.7	295,296	267,736	2.1	2 to 8
26	28	371,320	336,662	1.7	297,054	269,328	2.1	2 to 8
24	25	383,886	348,056	1.6	307,110	278,446	2.0	2 to 8
26	27	385,072	349,132	1.6	308,058	279,306	2.0	2 to 8
23	23	399,882	362,560	1.6	319,906	290,048	2.0	2 to 8
27	26	415,260	376,502	1.5	332,208	301,202	1.9	2 to 8
24	23	417,268	378,322	1.5	333,814	302,658	1.9	2 to 8
25	23	434,652	394,084	1.4	347,722	315,268	1.8	2 to 8
19	17	446,926	405,212	1.4	357,540	324,170	1.8	2 to 8
27	24	449,866	407,878	1.4	359,862	326,302	1.7	2 to 8
28	24	466,528	422,984	1.3	373,322	338,388	1.7	2 to 8
23	19	484,066	438,886	1.3	387,252	351,108	1.6	2 to 8
28	23	486,810	441,374	1.3	389,448	353,100	1.6	2 to 8
24	19	505,114	457,970	1.2	404,088	366,374	1.6	2 to 8
25	19	526,158	477,050	1.2	420,928	381,640	1.5	2 to 8
23	17	541,014	490,520	1.2	432,810	392,414	1.5	2 to 8
26	19	547,206	496,134	1.1	437,766	396,908	1.4	2 to 7
27	19	568,252	515,214	1.1	454,602	412,172	1.4	2 to 7
28	19	589,300	534,298	1.1	471,438	427,438	1.3	2 to 7
26	17	611,584	554,502	1.0	489,268	443,602	1.3	2 to 7
27	17	635,106	579,830	0.9	490,086	460,664	1.2	2 to 7
28	17	658,626	597,154	0.9	526,902	477,724	1.2	2 to 7

NOTE: See "General Planting Rate Information" and "Checking Seed Population" pages for additional information.

NOTE: When using the Half Rate (2 To 1) Drive Reduction Package, rates will be approximately 50% of given numbers.

NOTE: Always check seed population in the field to ensure planting rates are correct.

MACHINE OPERATION

RH/Z215

PLANTING RATES FOR BRUSH-TYPE SEED METERS (STANDARD DRIVE)

APPROXIMATE SEEDS/ACRE FOR VARIOUS ROW WIDTHS

Transmission Sprockets		36 Cell		Average Seed Spacing In Inches	30 Cell		Average Seed Spacing In Inches	Speed Range (MPH)
		Acid-Delinted Large Cotton			Milo/Grain Sorghum Or Acid-Delinted Cotton			
Drive	Driven	20" Rows	22" Rows		20" Rows	22" Rows		
17	28	72,836	66,038	4.3	60,696	55,031	5.2	2 to 8
17	27	75,534	68,484	4.2	62,945	57,070	5.0	2 to 8
17	26	78,438	71,117	4.0	65,366	59,265	4.8	2 to 8
19	28	81,404	73,806	3.9	67,838	61,506	4.6	2 to 8
19	27	84,419	76,539	3.7	70,350	63,784	4.5	2 to 8
17	24	84,975	77,044	3.7	70,812	64,203	4.4	2 to 8
17	23	88,670	80,394	3.5	73,892	66,995	4.2	2 to 8
19	25	91,173	82,664	3.5	75,978	68,887	4.1	2 to 8
19	24	94,971	86,107	3.3	79,143	71,756	4.0	2 to 8
23	28	98,543	89,345	3.2	82,119	74,455	3.8	2 to 8
19	23	99,101	89,851	3.2	82,584	74,876	3.8	2 to 8
24	28	102,827	93,229	3.0	85,689	77,691	3.7	2 to 8
24	27	106,635	96,682	2.9	88,863	80,569	3.5	2 to 8
17	19	107,337	97,319	2.9	89,447	81,098	3.5	2 to 8
24	26	110,736	100,401	2.8	99,280	83,667	3.4	2 to 8
26	28	111,396	100,999	2.8	92,829	84,165	3.4	2 to 8
24	25	115,158	104,410	2.7	95,972	87,014	3.3	2 to 8
26	27	115,521	104,739	2.7	96,267	87,282	3.3	2 to 8
23	23	119,964	108,767	2.6	99,971	90,640	3.1	2 to 8
27	26	124,578	112,951	2.5	103,815	94,126	3.0	2 to 8
24	23	125,180	113,496	2.5	104,316	94,580	3.0	2 to 8
25	23	130,395	118,225	2.4	108,663	98,521	2.9	2 to 8
19	17	134,078	121,564	2.3	111,732	101,304	2.8	2 to 8
27	24	134,960	122,363	2.3	112,467	101,970	2.8	2 to 8
28	24	139,958	126,895	2.2	116,633	105,747	2.7	2 to 8
23	19	145,220	131,666	2.2	121,017	109,722	2.6	2 to 8
28	23	146,043	132,412	2.1	121,703	110,344	2.6	2 to 8
24	19	151,535	137,391	2.1	126,278	114,492	2.5	2 to 8
25	19	157,848	143,116	2.0	131,540	119,262	2.4	2 to 8
23	17	162,350	147,197	1.9	135,254	122,630	2.3	2 to 8
26	19	164,162	148,840	1.9	136,802	124,033	2.3	2 to 7
27	19	170,475	154,564	1.8	142,064	128,804	2.2	2 to 7
28	19	176,790	160,290	1.8	147,324	133,574	2.1	2 to 7
26	17	183,476	166,351	1.7	152,895	138,625	2.1	2 to 7
27	17	190,532	172,749	1.6	158,777	143,957	2.0	2 to 7
28	17	197,588	179,146	1.6	164,657	149,289	1.9	2 to 7

NOTE: See "General Planting Rate Information" and "Checking Seed Population" pages for additional information.

NOTE: When using the Half Rate (2 To 1) Drive Reduction Package, rates will be approximately 50% of given numbers.

NOTE: Always check seed population in the field to ensure planting rates are correct.

MACHINE OPERATION

PLANTING RATES FOR BRUSH-TYPE SEED METERS (STANDARD DRIVE) APPROXIMATE HILLS/ACRE FOR VARIOUS ROW WIDTHS

Due to variations in cotton seed size, meters equipped with 12 cell acid-delinted hill-drop cotton discs will plant from 3 to 6 seeds per cell. Select proper disc for seed size range to be planted.

To determine planter transmission setting, determine desired hill spacing and select the transmission ratio closest to the hill spacing in inches on the chart. To decrease population increase spacing. To increase population decrease spacing.

To determine population per acre, determine average seeds per hill and hills per acre by doing a field check. Measure $\frac{1}{1000}$ of an acre (1/1000 acre = Length of row 26' 2" for 20" row widths, and 23' 9" for 22" row widths). Multiply average seeds per hill by hills per acre. EXAMPLE: 4 seeds per hill x (13 hills x 1000) = 52,000

Transmission Sprockets Drive Driven		NUMBER OF HILLS PER ACRE 12 Cell Hill-Drop Cotton, Acid-Delinted		Average Hill Spacing In Inches	Speed Range (MPH)
		20" Rows	22" Rows		
17	28	24,279	22,013	12.9	2 to 8
17	27	25,178	22,828	12.5	2 to 8
17	26	26,147	23,706	12.0	2 to 8
19	28	27,135	24,602	11.6	2 to 8
19	27	28,140	25,514	11.1	2 to 8
17	24	28,325	25,681	11.1	2 to 8
17	23	29,556	26,797	10.6	2 to 8
19	25	30,392	27,555	10.3	2 to 8
19	24	31,658	28,703	9.9	2 to 8
23	28	32,847	29,781	9.5	2 to 8
19	23	33,033	29,950	9.5	2 to 8
24	28	34,275	31,076	9.2	2 to 8
24	27	35,546	32,228	8.8	2 to 8
17	19	35,780	32,440	8.8	2 to 8
24	26	36,912	33,467	8.5	2 to 8
26	28	37,133	33,667	8.4	2 to 8
24	25	38,388	34,805	8.2	2 to 8
26	27	38,507	34,913	8.1	2 to 8
23	23	39,989	36,256	7.8	2 to 8
27	26	41,526	37,650	7.6	2 to 8
24	23	41,727	37,832	7.5	2 to 8
25	23	43,466	39,409	7.2	2 to 8
19	17	44,693	40,521	7.0	2 to 8
27	24	44,987	40,788	7.0	2 to 8
28	24	46,653	42,299	6.7	2 to 8
23	19	48,407	43,889	6.5	2 to 8
28	23	48,681	44,137	6.5	2 to 8
24	19	50,511	45,797	6.2	2 to 8
25	19	52,616	47,705	6.0	2 to 8
23	17	54,102	49,052	5.8	2 to 8
26	19	54,720	49,613	5.7	2 to 7
27	19	56,825	51,521	5.5	2 to 7
28	19	58,931	53,430	5.3	2 to 7
26	17	61,158	55,450	5.1	2 to 7
27	17	63,510	57,582	4.9	2 to 7
28	17	65,862	59,715	4.8	2 to 7

NOTE: See "General Planting Rate Information" and "Checking Seed Population" pages for additional information.

NOTE: When using the Half Rate (2 To 1) Drive Reduction Package, rates will be approximately 50% of given numbers.

NOTE: Always check seed population in the field to ensure planting rates are correct.

MACHINE OPERATION

DRY INSECTICIDE APPLICATION RATES APPROXIMATE POUNDS/ACRE AT 5 MPH FOR VARIOUS ROW WIDTHS

Meter Setting	20" Rows	22" Rows
CLAY GRANULES		
10	7.4	6.7
11	8.1	7.3
12	9.2	8.3
13	10.4	9.4
14	11.6	10.5
15	12.8	11.6
16	14.4	13.1
17	16.1	14.6
18	17.1	15.5
19	19.7	17.8
20	21.3	19.3
21	23.3	21.1
22	24.6	22.3
23	25.8	23.4
24	28.2	25.6
25	31.4	28.4
26	34.5	31.3
27	36.2	32.8
28	38.1	34.5
29	41.7	37.8
30	44.4	40.3
SAND GRANULES		
5	4.4	3.9
6	7.4	6.7
7	8.0	7.2
8	9.5	8.6
9	11.7	10.6
10	13.4	12.1
11	15.3	13.9
12	16.8	15.2
13	18.9	17.1
14	21.2	19.2
15	23.3	21.1
16	26.6	23.8
17	29.1	26.4
18	32.7	29.7
19	36.5	33.1
20	38.6	35.0
21	41.4	37.5
22	44.4	40.3
23	48.0	43.5
24	51.6	46.8
25	55.4	50.2

NOTE: The above chart represents average values and should be used only as a starting point. The granular chemical flows through the given meter opening at a nearly uniform rate regardless of roller speed. Your actual rate will vary depending upon the insecticide you are using, your planting speed and your plant population. Planting speed/ground speed has the greatest effect on application rate.

Your actual rate must be checked in the field with the actual insecticide that you are using and at the speed and population at which you will be planting. See "Checking Granular Chemical Application Rate" page for additional information.



WARNING: Agricultural chemicals can be dangerous if not selected and handled with care. Always read and follow directions supplied by the chemical manufacturer.

MACHINE OPERATION

DRY HERBICIDE APPLICATION RATES

APPROXIMATE POUNDS/ACRE AT 5 MPH FOR VARIOUS ROW WIDTHS

CLAY GRANULES

Meter Setting	20" Rows	22" Rows
10	7.1	6.4
11	7.8	7.1
12	8.7	7.9
13	9.8	8.8
14	11.0	9.9
15	12.3	11.2
16	13.5	12.2
17	14.9	13.5
18	16.1	14.6
19	17.4	15.8
20	18.9	17.1
21	20.4	18.5
22	21.9	19.9
23	23.6	21.4
24	25.5	23.1
25	27.2	24.6
26	29.1	26.4
27	31.4	28.4
28	33.9	30.7
29	36.5	33.1
30	40.1	36.3

NOTE: The above chart represents average values and should be used only as a starting point. The granular chemical flows through the given meter opening at a nearly uniform rate regardless of roller speed. Your actual rate will vary depending upon the herbicide you are using, your planting speed and your plant population. Planting speed/ground speed has the greatest effect on application rate.

Your actual rate must be checked in the field with the actual herbicide that you are using and at the speed and population at which you will be planting. See "Checking Granular Chemical Application Rate" page for additional information.



WARNING: Agricultural chemicals can be dangerous if not selected and handled with care. Always read and follow directions supplied by the chemical manufacturer.

MACHINE OPERATION

LIQUID FERTILIZER PISTON PUMP APPLICATION RATES

GALLONS PER ACRE

Applies To Model LM-2455-R Pump With 18 Tooth Sprocket

Pump Setting	1	2	3	4	5	6	7	8	9	10
12 Row 20"	7.7	15.6	23.3	30.9	38.7	46.5	54.3	62.0	69.8	77.6
12 Row 22"	7.1	14.6	21.7	28.8	36.1	43.4	50.7	57.8	65.1	72.4

Above chart is for planters equipped with contact drive and the Model LM-2455-R (GA8069) piston pump. See "Tire Pressure" for recommended tire pressures. Chart is based on average wheel slippage and liquid viscosities.

Measure and weigh one gallon of actual fertilizer solution to determine exact application rate. This chart was calculated based on a solution weighing ten pounds per gallon.

NOTE: Fertilizer application rates can vary from the above chart. To prevent application miscalculations, make field checks to be sure you are applying fertilizer to all rows at the desired rate.

NOTE: Flow to all rows should be checked periodically. If one or more lines are plugged, the desired rate will be delivered to the remaining rows keeping total application rate at desired rate.

To check the exact number of gallons your fertilizer attachment will actually deliver on a 20" row spacing, proceed as follows:

Remove the hose from one of the fertilizer openers and insert it into a collection container which has been secured to the planter frame. Engage the fertilizer attachment and drive forward for 262'. Measure the fluid ounces caught in the container and multiply that amount by 100. Divide that amount by 128. The result will be the gallons of fertilizer delivered per acre when planting in 20" rows. Rinse the collection container and repeat test on other rows if necessary. To convert this delivery rate for wider rows, multiply by the following conversion factor:

22" multiply by 0.91

ROW UNIT OPERATION

PLANTING DEPTH

Planting depth is maintained by the row unit gauge wheels. To increase or decrease the planting depth, first raise the planter to remove weight from the wheels. Then push down on the depth adjustment handle and reposition it forward to decrease depth or rearward to increase planting depth. Adjust all units to the same setting initially. Then lower the planter and check operation and planting depth of all row units. It may be necessary to readjust some rows to obtain uniform operation. Available depth adjustment range is approximately 1/2" to 3 1/2".



WARNING: Never work under the planter while in raised position without using safety lockups.

04059914a

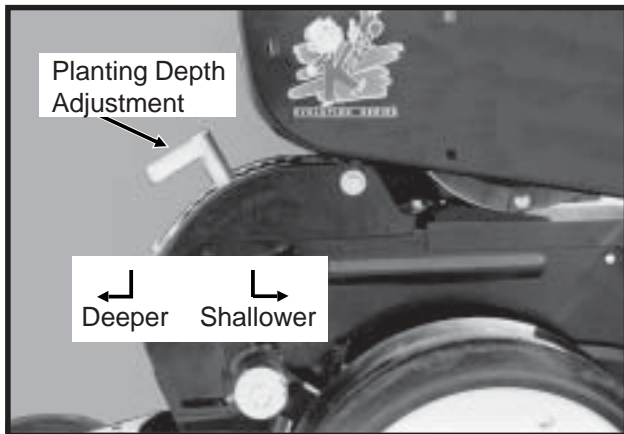

"V" CLOSING WHEEL ADJUSTMENT (Rubber And Cast Iron)



WARNING: Raise planter and install safety lockups before making closing wheel adjustments.

After adjusting planting depth, check the operation of the "V" closing wheels. The "V" closing wheels should have enough down pressure to close the seed trench and ensure good soil to seed contact. To increase spring pressure on the closing wheels, move the 5-position quick adjustable down force lever located on the top of the closing wheel arm to the rear. Moving the lever forward decreases spring tension.

Adjust all row units to a similar setting.

LF212299-15

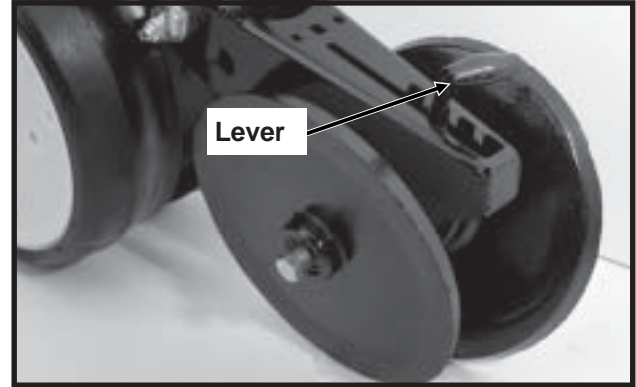

Light soil usually requires less down force at average depth (approximately 2") while heavy soil requires increased down force.

Eccentric bushings in the wheel arm stop allow for lateral adjustment of the "V" closing wheel assembly. Using a 3/4" wrench, loosen the hardware which attaches the closing wheel arm to the wheel arm stop. Using another 3/4" wrench turn the eccentric bushings until the **closing wheels are aligned with the seed trench**. Tighten hardware.

LF212299-15

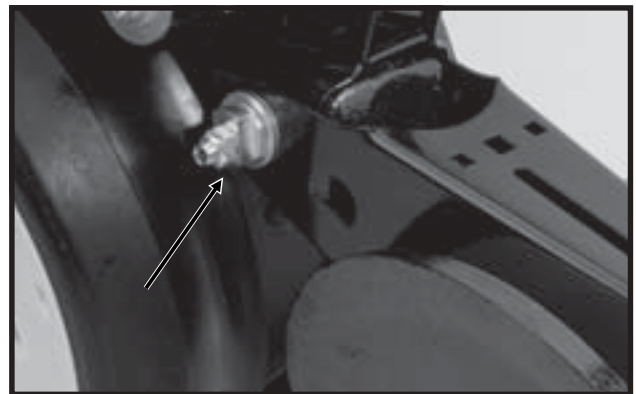

Bushings used for installation of the closing wheels can be moved from side to side for closing wheel spacing adjustment and the closing wheels can be installed in two locations either "offset" (to improve residue flow) or "directly" opposite. If set "directly" opposite, the forward installation holes should be used. Under normal conditions the narrow position is preferred.

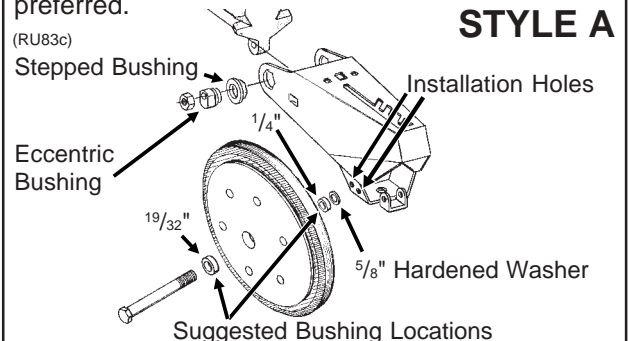

ROW UNIT OPERATION

The closing wheels can be installed in two locations either "offset" (to improve residue flow) or "directly" opposite. If set "directly" opposite, the forward installation holes should be used.

STYLE B

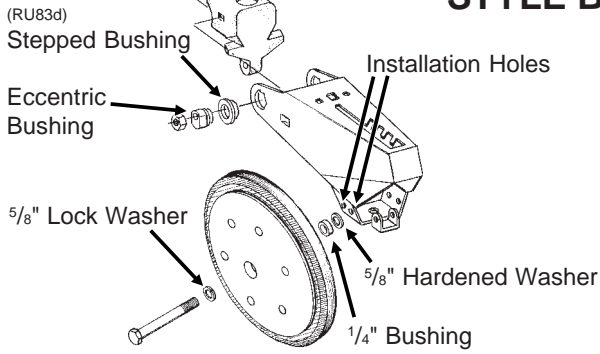

CLOSING WHEEL SHIELD (Rubber And Cast Iron "V" Closing Wheels)

D11090208a

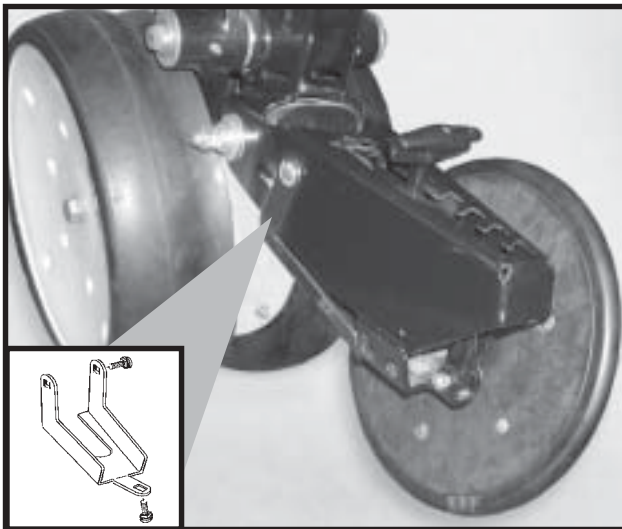

Shown With Closing Wheel Removed For Visual Clarity

The optional closing wheel shield is designed to be installed onto the underside of the closing wheel arm to help prevent root balls and stalks from plugging the closing wheels.

COVERING DISCS/SINGLE PRESS WHEEL ADJUSTMENT



WARNING: Raise planter and install safety lockups before making covering discs/single press wheel adjustments.

72359-31



After adjusting planting depth, check the operation of the covering discs/single press wheels.

Initial press wheel down force setting should be with 2 1/2" between mounting arm tab and locking nut. To adjust down force spring, loosen 1/2" locking nut and turn adjusting bolt in to increase down force or out to decrease down force. Tighten locking nut against spring plug. Adjust all row units to a similar setting.

RH993(PLTR12)

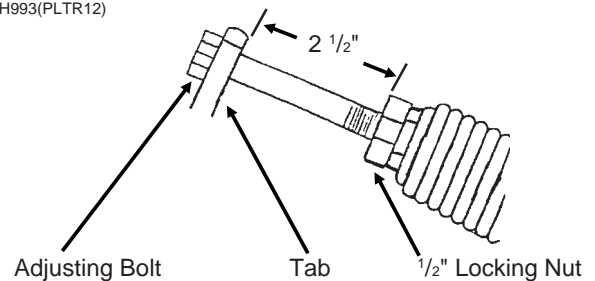

ROW UNIT OPERATION

Eccentric bushings in the wheel arm stop allow for lateral adjustment of the covering discs/single press wheel assembly. Using a $\frac{3}{4}$ " wrench, loosen the hardware which attaches the assembly to the wheel arm stop. Using another $\frac{3}{4}$ " wrench, turn the eccentric bushings until the press wheel is aligned with the seed trench.

(RU94b)

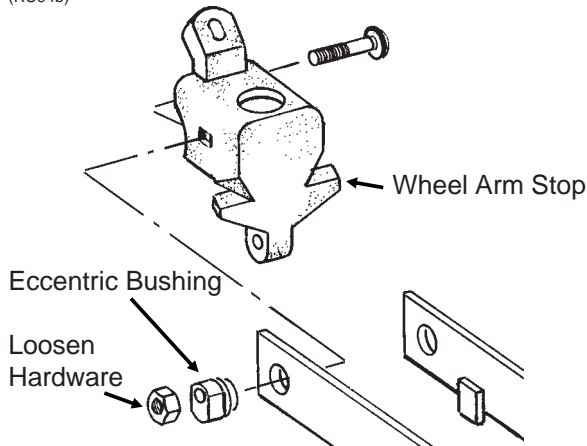

Two sets of holes in the mounting arm allow the covering discs to be located for staggered or side-by-side operation as desired.

72359-35

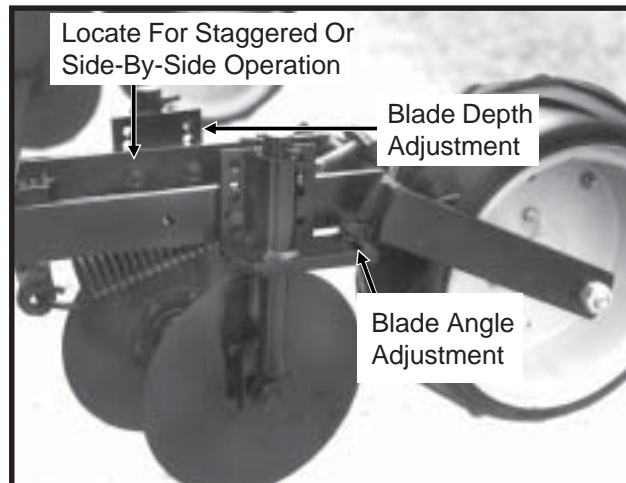

Five sets of holes in each disc bracket allow for $\frac{1}{2}$ " incremental blade depth adjustment.

Slotted holes in the disc mount and bracket allow for $0^\circ - 15^\circ$ blade angle adjustment.

Adjust covering discs on all row units to similar settings.

DRAG CLOSING ATTACHMENT

LF212299-18

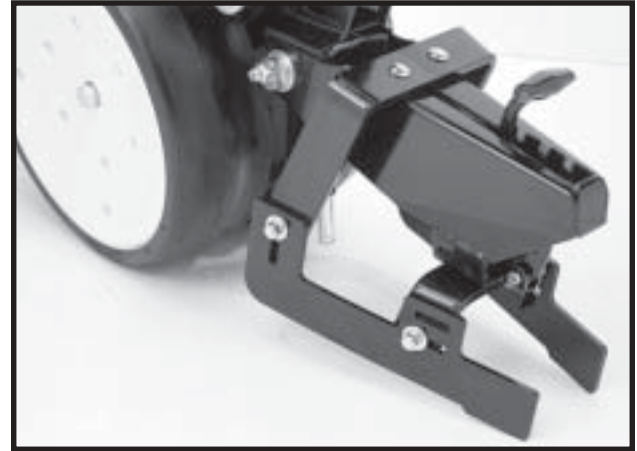

The drag closing attachment is designed to pull loose soil over the seed trench.

Front and rear adjustment is made using the slotted holes in the blades. Adjust all rows the same.

NOTE: Use of a seed firming wheel or other seed firming device is recommended with the drag closing attachment.

WARNING: Raise planter and install safety lockups before making drag closing attachment adjustments.

(RU90b)

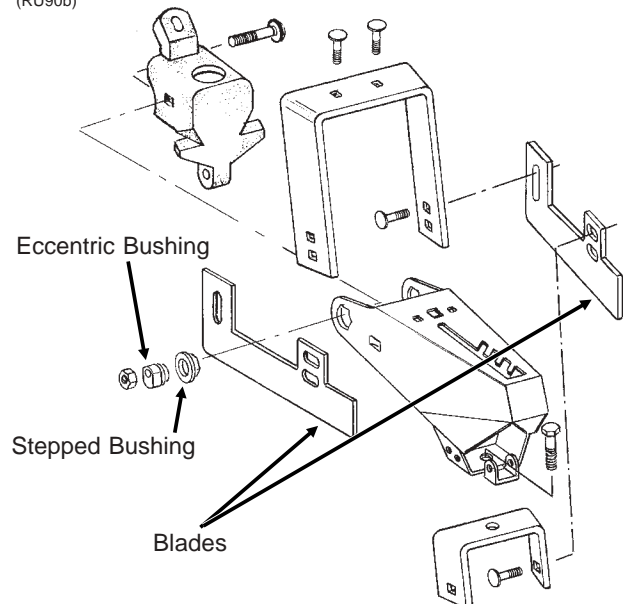

Eccentric bushings allow for lateral adjustment of the drag closing attachment. Using a $\frac{3}{4}$ " wrench, loosen the hardware which attaches the assembly to the wheel arm stop. Using another $\frac{3}{4}$ " wrench, turn the eccentric bushings until the drag closing attachment is aligned with the seed trench.

ROW UNIT OPERATION

FINGER PICKUP SEED METER

Refer to the planting rate chart for recommended seed drive transmission sprocket combinations.

D05030001

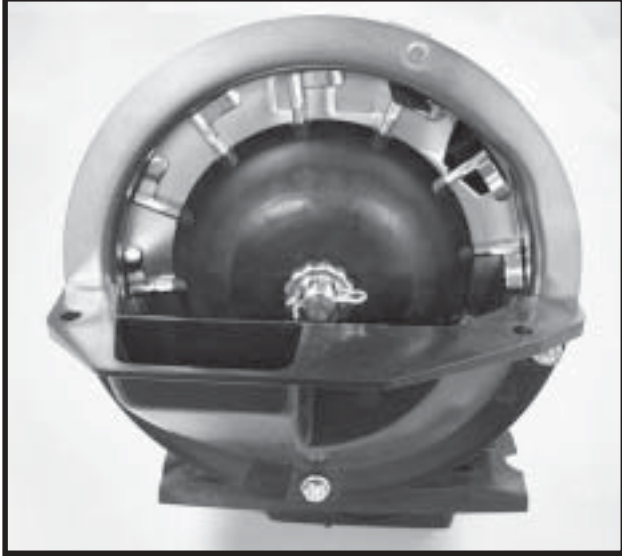

Shown With Corn Fingers Installed

The following seed fingers are available for use with the finger pickup seed meter:

(PLTR91/PLTR92/PLTR91a)

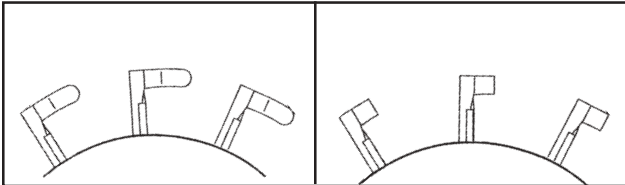

Corn Fingers

Oil Sunflower Fingers

No. 3 and/or No. 4 size oil sunflower seeds are recommended for use in the finger pickup seed meter equipped with oil sunflower fingers.

No. 1 and/or No. 2 size confectionary sunflower seeds are recommended for use in the finger pickup seed meter equipped with corn fingers.

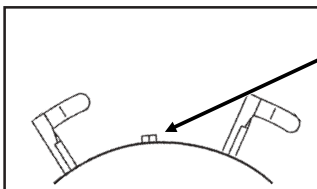

Half Rate Blank Finger

Blank fingers are used to replace alternate fingers in the finger wheel to reduce the planting rate by half while allowing the finger wheel to maintain a minimum of 40 RPM when planting low rates.

NOTE: Always check seed population in the field to ensure planting rates are correct.

NOTE: Powdered graphite is recommended for finger pickup seed meter lubrication to ensure efficient operation of the mechanism and to extend the life of its components. Mix one teaspoon of powdered graphite with the seed twice daily. Apply graphite on top of seed around the outer perimeter of the hopper as shown below. Graphite application frequency and volume may need to be increased if using additional seed treatments.

NOTE: Do NOT apply graphite only in the center of the hopper. It will filter too quickly through the seed and not distribute as evenly as desired.

D05230121b



NOTE: Follow manufacturer's recommendations when applying and mixing other seed treatments. If the additive is to be applied on top of the seed, apply around the outer perimeter of the hopper as with graphite.

See "General Planting Rate Information", "Finger Pickup Seed Meter Troubleshooting" and "Finger Pickup Seed Meter Inspection/Adjustment" for additional information.

CLEANOUT

To maintain genetic purity, thorough seed meter cleanout is important.

To clean the seed meter, disengage the seed drive and remove the seed hopper and meter. Dump the seed from the right rear corner of the hopper into a container. Turn the seed drive several times. Invert hopper to dump seed again. Shake the hopper and listen for any remaining seed. Turn seed drive and shake and dump hopper until all seed is removed.

ROW UNIT OPERATION

BRUSH-TYPE SEED METER

LF212299-13a



Shown Without Seed Disc Installed

60607-40a(PLTR13)

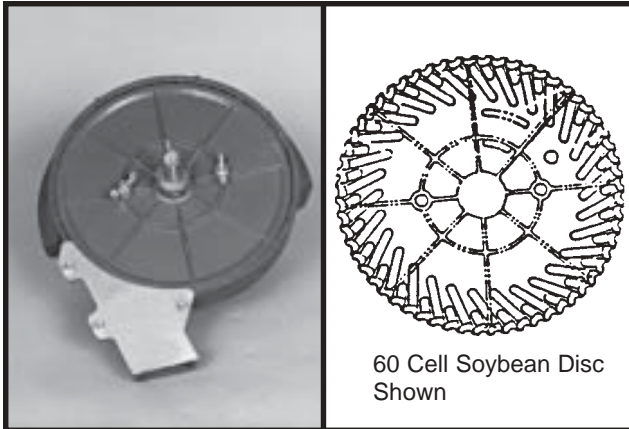

60 Cell Soybean Disc Shown

The following seed discs are available for use with the brush-type seed meter:

Soybean: 60 cells to meter seed sizes from 2200 to 4000 seeds per pound (Black color-coded).

(PLTR14)

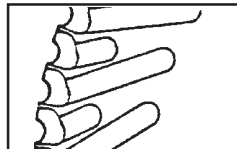

Specialty soybean: 48 cells to meter seed sizes from 1400 to 2200 seeds per pound (Dark blue color-coded).

(PLTR15)

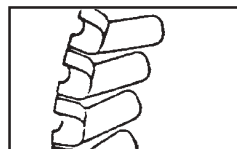

Small milo/grain sorghum: 30 cells to meter seed sizes from 14,000 to 20,000 seeds per pound (Red color-coded).

(PLTR16)

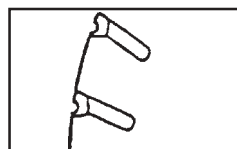

Large milo/grain sorghum:

30 cells to meter seed sizes from 10,000 to 16,000 seeds per pound (Light blue color-coded).

(PLTR17)

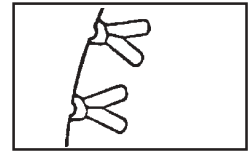

High-rate small milo/grain sorghum:

60 cells to meter seed sizes from 12,000 to 18,000 seeds per pound (Red color-coded).

(PLTR18)

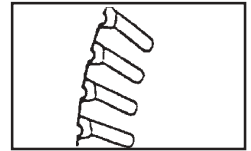

High-rate large milo/grain sorghum:

60 cells to meter seed sizes from 10,000 to 14,000 seeds per pound (Yellow color-coded).

(PLTR19)

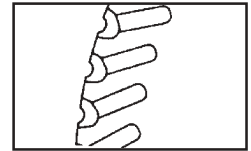

Cotton, acid-delinted: 30 cells to meter seed sizes from 4200 to 5200 seeds per pound (White color-coded).

(PLTR20)

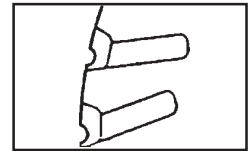

Large cotton, acid-delinted:

36 cells to meter seed sizes from 3800 to 4400 seeds per pound (Tan color-coded).

(PLTR21)

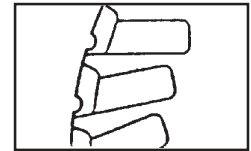

High-rate cotton, acid-delinted:

48 cells to meter seed sizes from 4200 to 5200 seeds per pound (Light green color-coded).

(PLTR22)

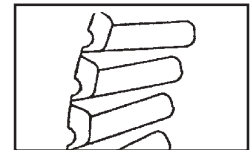

Hill-drop cotton, acid-delinted: 12 cells, 3 to 6 seeds/cell, to meter seed sizes from 4000 to 5200 seeds per pound (Brown color-coded).

(PLTR23)

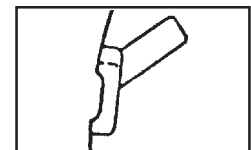

Small hill-drop cotton, acid-delinted: 12 cells, 3 to 6 seeds/cell, to meter seed sizes from 5000 to 6200 seeds per pound (Dark green color-coded).

(PLTR23)

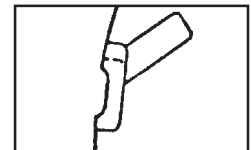

(RU14c)

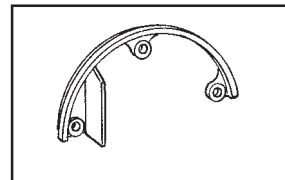

Use GD11122 upper brush retainer when using soybean and cotton discs.

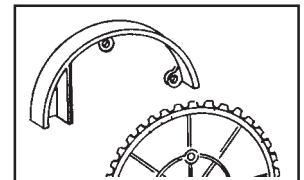

Use GD8237 upper brush retainer when using milo/grain sorghum discs.

ROW UNIT OPERATION

When installing the seed disc onto the meter hub, turn the disc counterclockwise while tightening the two wing nuts that retain the disc. The seed disc should have only slight resistance when rotated counterclockwise after wing nuts are tight.

The brush-type seed meter attaches to the seed hopper in the same manner as the finger pickup seed meter. Secure to bottom of seed hopper with two $\frac{5}{16}$ " thumbscrews. Tighten thumbscrews slightly with pliers. **DO NOT OVER TIGHTEN.**

Erratic seed spacing may result from misalignment between the drive coupler and seed meter input shaft. Misalignment may cause momentary stoppage of seed disc. Check alignment after initial installation. If adjustment is required, refer to "Meter Drive Adjustment" for correct procedure.

Refer to the planting rate charts in this manual for recommended seed drive transmission sprocket combinations.

One tablespoon of **powdered graphite** should be mixed with the seed each time the hoppers are filled. Regular graphite use will prolong the life of the brush-type seed meter components, improve seed spacing, and may reduce buildup of seed treatments. Apply graphite around the outer perimeter of the hopper as shown below.

D05300104b



NOTE: Do NOT apply graphite only in the center of the hopper. It will filter too quickly through the seed and not distribute as evenly as desired.

NOTE: Additional graphite or talc may be required to retard buildup of seed treatments on meter components. Frequency of monitor seed tube cleaning may be affected due to use of additional graphite or talc.

Talc seed lubricant may be used in lieu of or in addition to graphite to reduce seed treatment buildup on seed disc and meter components. Coat seed disc and brushes with talc before installing meter. Fill hopper $\frac{1}{2}$ full of seed, add $\frac{1}{4}$ cup of talc and **mix thoroughly**. Finish filling hopper, add another $\frac{1}{4}$ cup of talc and **mix thoroughly**. Adjust rate of talc use as needed so all seeds are coated, while avoiding a buildup of talc in the bottom of the hopper. Humid conditions and/or small sized seeds with extra seed treatment may require as much as one cup of talc per hopper to prevent seed treatment buildup on seed disc and/or brushes.

NOTE: Some liquid seed treatments or inoculants may create buildup on the seed disc or brushes. Check frequently for proper population and/or seed delivery when using any liquid seed treatment. All seed treatment should be thoroughly mixed with the seed per the manufacturers' recommendations. Seed treatment dumped on top of the seed after the hopper is filled, and not mixed properly may cause bridging of the seed in the meter, reducing population or stopping the meter from planting.

NOTE: Foreign material, such as hulls, stems, etc., may affect seed delivery. Clean seed is required to ensure accurate seed metering from the brush-type seed meter. Seed discs should be removed daily to check for buildup of foreign material, such as hulls, in the seed meter or the brushes.

CLEANOUT

To maintain genetic purity, thorough seed meter cleanout is important.

To clean the seed meter, disengage the seed drive and remove the seed hopper and meter. Dump the seed from the right rear corner of the hopper into a container. Remove seed disc by loosening wing nuts. Empty the meter. Thoroughly inspect brushes in meter to ensure all seed is removed. Replace seed disc and install wing nuts.

ROW UNIT OPERATION

SEED HOPPER

LF212199-7a



The seed hopper has a capacity of 1.9 bushels.

When filling the seed hopper use clean seed and make certain there are no foreign objects in the hopper. **Replace hopper lids after hoppers are filled to prevent the accumulation of dust or dirt in the seed meter which will cause premature wear.** See "Finger Pickup Seed Meter Lubrication" and/or "Brush-Type Seed Meter Lubrication".

Periodically empty the hoppers completely to remove any foreign objects and to ensure proper seed meter operation. To empty hopper, disengage meter drive and hopper latch and lift hopper off the hopper support. See "Seed Meter Drive Release".

SEED METER DRIVE RELEASE

The seed meter drive is equipped with a clutch release mechanism that allows the drive to be disengaged from the seed metering unit for removal of the seed hopper. Disconnecting the drive allows the operator to check granular chemical application rates without dropping seed. It also allows one or more of the rows to be disconnected when finishing fields.

D04199906

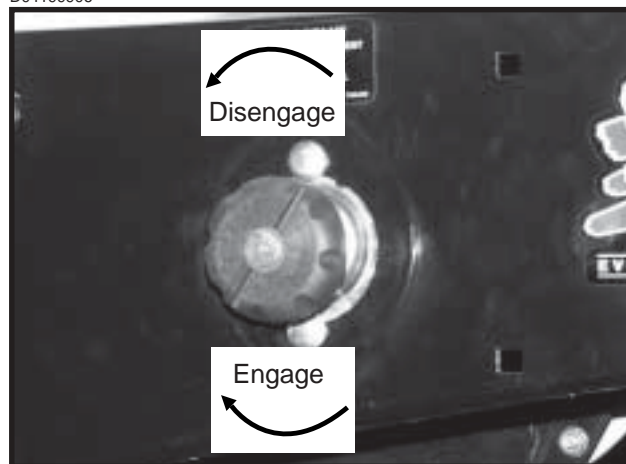

To disengage the drive, turn the knob $\frac{1}{4}$ turn counter-clockwise. To engage the drive, turn the knob $\frac{1}{4}$ turn clockwise.

ROW UNIT OPERATION

SEED METER DRIVE ADJUSTMENT

NOTE: The seed meter drive coupler must be properly aligned with the meter input shaft.

Improper alignment between the drive coupler and input shaft of the meter can cause the meter housing to flex as the meter rotates. This continual flexing of the meter housing can cause damage to the housing. Any time the hopper support panel is removed or replaced, vertical and horizontal alignment should be checked.

Erratic seed spacing may result from misalignment between the drive coupler and seed meter input shaft. Misalignment may cause momentary stoppage of brush-type meter seed disc. Check alignment after initial installation.

Although the meter drive has a self-aligning feature, the slotted mounting hole in the hopper support panel and clutch plate allow for alignment adjustment between the drive coupler and meter shaft. If the drive clutch is centered in the hole in the hopper support panel the drive should be in alignment.

D04209903

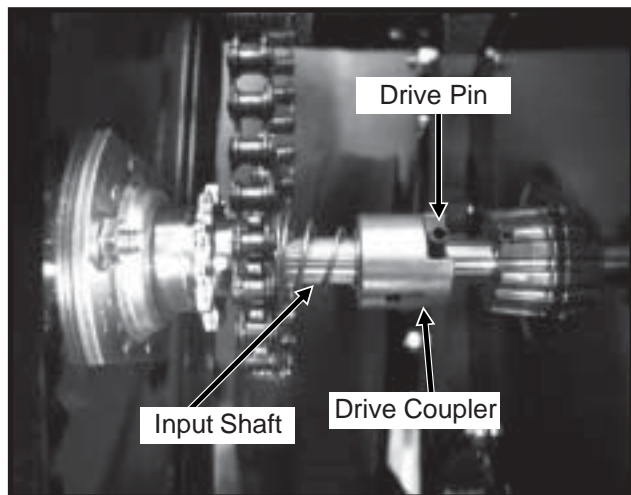

To check alignment:

- Engage drive coupler over pin on meter shaft.
- Drive shaft on clutch should be centered in sprocket bore.
- If adjustment is needed, proceed as follows.

To adjust drive clutch:

- Slightly loosen both $\frac{5}{16}$ " carriage bolts.
- Move clutch assembly to correct any misalignment.
- Tighten both $\frac{5}{16}$ " carriage bolts.

NOTE: Removing chain idler tension will allow easier clutch alignment adjustments.

D04199906

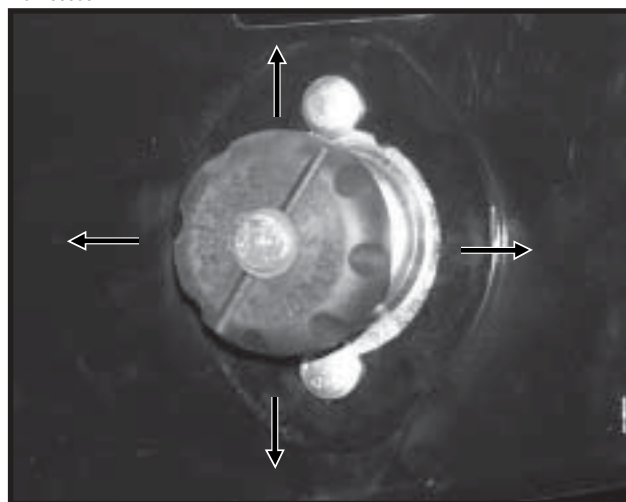

ROW UNIT OPERATION

ROW UNIT CHAIN ROUTING

For proper operation and to minimize wear, the row unit drive chains must be properly tensioned and aligned.

Inspect and replace weak, worn or broken springs and/or idlers and idler bushings.

NOTE: When idler shows signs of wear, it can be reversed for prolonged use.

LF212199-5a(RU80g)

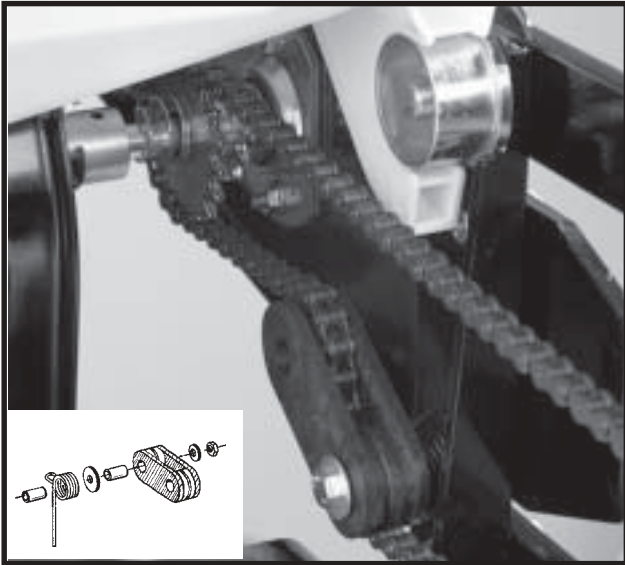

Pull Row Unit Meter Drive

D04209901a(RU80g)

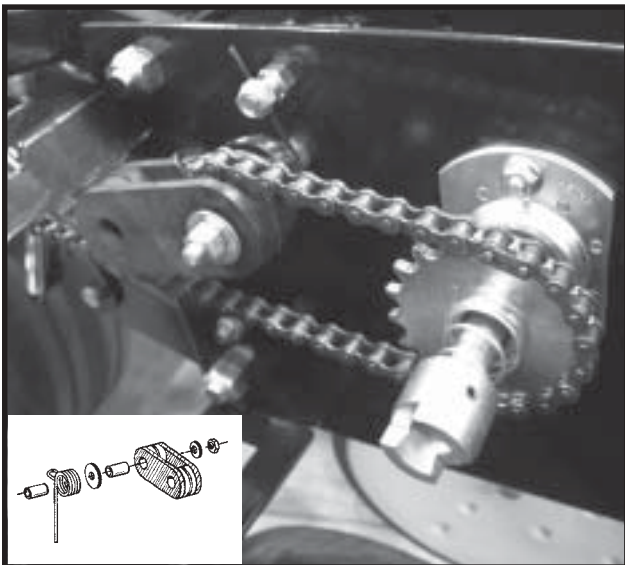

Push Row Unit Meter Drive

D05139901b(RU92l)

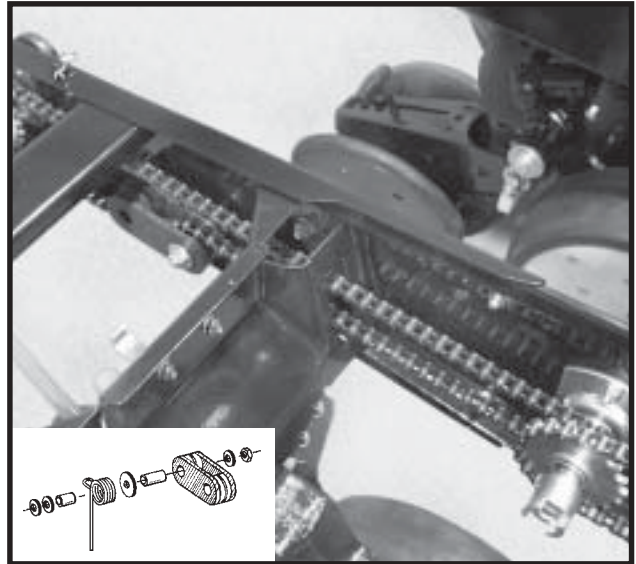

Row Unit Granular Chemical Drive

NOTE: Make sure connector link is installed with closed end oriented properly as shown below.

(PLTR24)



Direction Of Chain Travel →

ROW UNIT OPERATION

QUICK ADJUSTABLE DOWN FORCE SPRINGS

Quick adjustable down force springs are designed to increase penetration in hard soil and keep the row unit from bouncing in rough field conditions.

Two springs per row, one on the L.H. parallel arms and one on the R.H. parallel arms, are used unless equipped with row unit mounted no till coulters. Four springs per row are used with row unit mounted no till coulters.

LF212199-3a

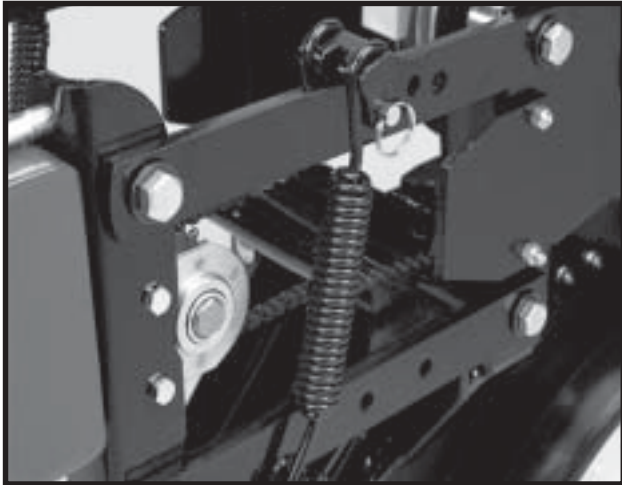

Two Springs Per Row (Dual)

LF212199-3

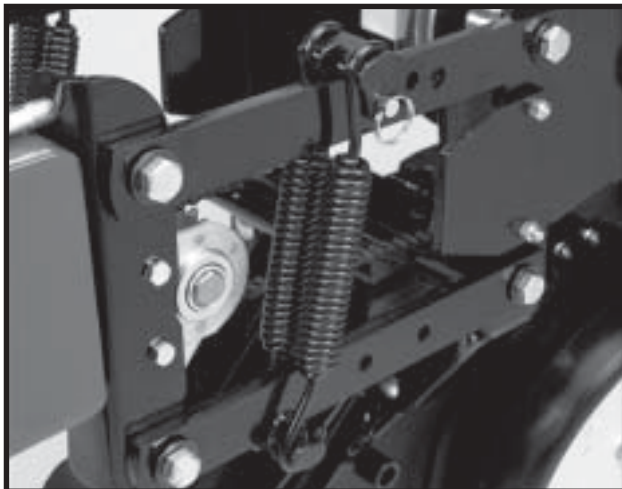

**Four Springs Per Row (Quad)
(Used Only In Conjunction With Row Unit
Mounted No Till Coulters)**

There are four positions for spring tension adjustment. Position 1 allows for minimum down pressure and position 4 for maximum down pressure.

L0096(PLTR27e)

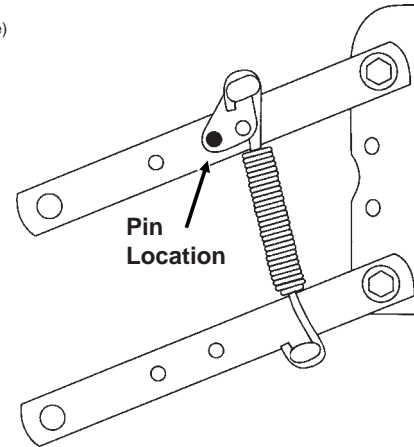

Position 1 (Minimum)

(PLTR28e)

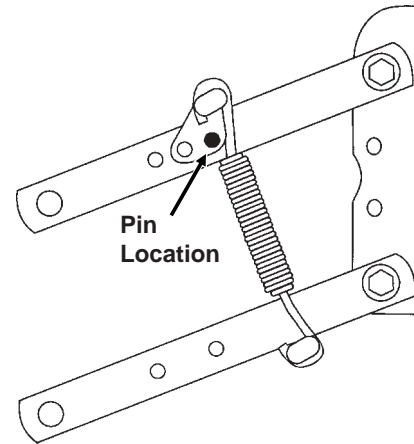

Position 2

(PLTR29e)

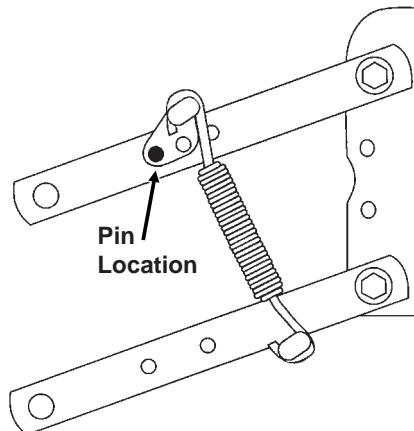

Position 3

ROW UNIT OPERATION

(PLTR30e)

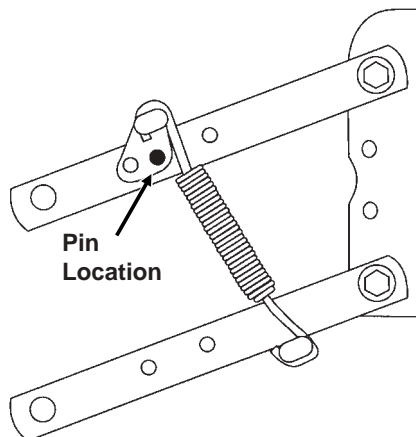

Position 4 (Maximum)

To adjust spring tension, raise planter and remove spring mount pin at top of spring. Slide mount to desired position and install pin.

NOTE: It is necessary for the operator to adjust springs according to field conditions. If springs are adjusted for too much down pressure for field conditions, it is possible for the row units to lift the planter to the extent that the drive wheels do not make sufficient contact. Too much down pressure in soft field conditions can cause the row unit to run too deep.



WARNING: Always install safety lockups or lower machine to the ground before working under or around the machine.

NOTE: Springs must always be installed with open side of spring hooks toward seed hopper to prevent binding on spring mount adjustment pin.

ROW UNIT OPERATION

FRAME MOUNTED COULTER - STYLE A

LF212299-20

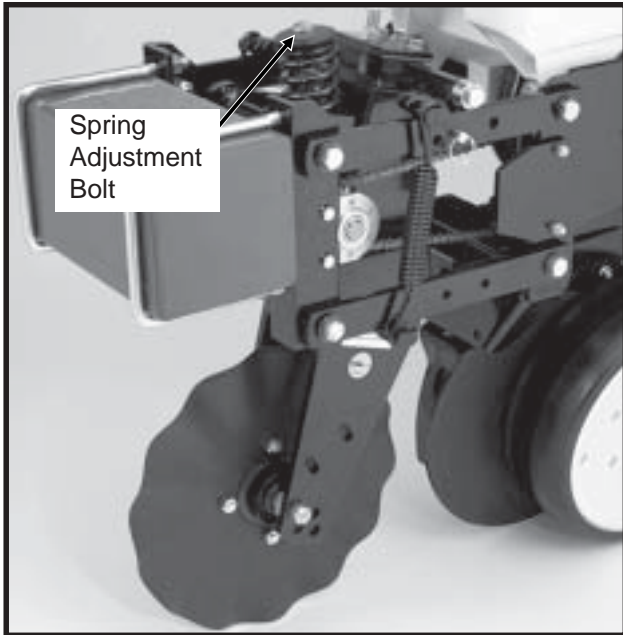

Frame mounted coulters with 1" bubbled, 1" fluted (8 flutes) or $\frac{3}{4}$ " fluted (13 flutes) blades may be used on pull row units only. (Not compatible with push row units.)

The frame mounted couler is designed to allow required spring down pressure on the couler for maximum penetration while exerting less shock load on the row unit.

The frame mounted couler can be used with or without the depth control bar installed. In most applications, especially in rocky planting conditions, the depth control bar **should not be used**. Use of the depth control bar transfers down force from the couler to the row unit making less down force available to the couler blade.

DEPTH ADJUSTMENT (Without Depth Control Bar Installed)

56314-14a

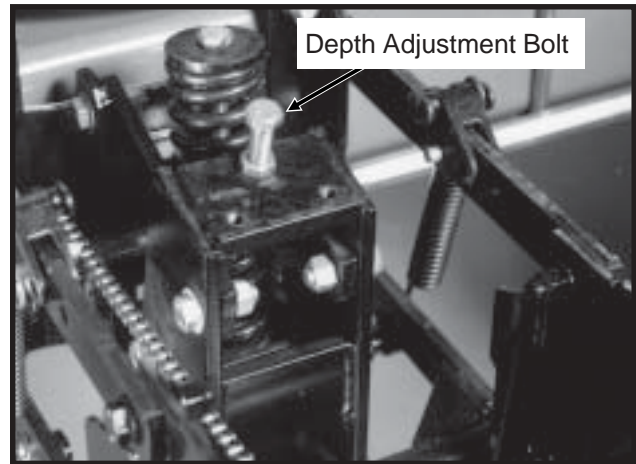

When the depth control bar is not used, operating depth of the couler blade is determined by adjusting the depth adjustment bolt and positioning of the blade assembly in the fork mount. The depth adjustment bolt will stop downward travel of the couler arm assembly. One turn of the adjusting bolt will change depth setting approximately $\frac{1}{4}$ ". Initial setting of the depth adjustment bolt should be with approximately $1\frac{3}{8}$ " of thread showing. With this setting and the toolbar height at 20", the couler depth will be approximately 2" with couler mounting spindle in top hole. Turn the adjustment bolt clockwise to decrease operating depth. Turn the depth adjustment bolt counterclockwise to increase operating depth.

LF212299-20

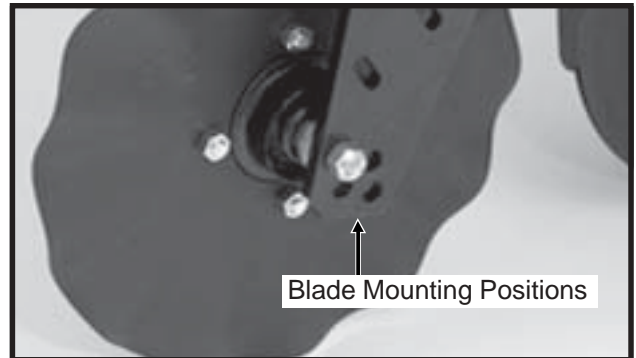

ROW UNIT OPERATION

DEPTH ADJUSTMENT

(With Depth Control Bar Installed)

LF212199-4

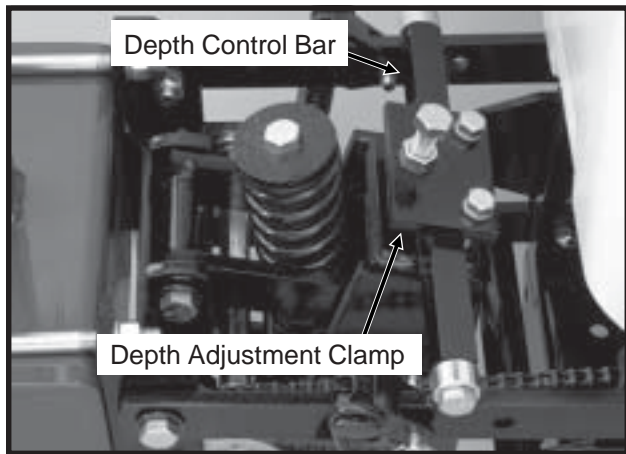

In certain applications it is desirable to use the depth control bar. In uneven terrain, use of the depth control bar allows greater depth control. The up and down movement of the row unit allows the coulters to move up and down at a rate of approximately $\frac{1}{2}$ that of the row unit, maintaining a more uniform operating depth. When using the disc furrower attachment, the depth control bar should always be used, as operating depth of the coulters is critical for the disc furrowers to operate with minimal gouging.

When using the depth control bar, down force springs must be located in the forward position and the depth adjustment bolt used only to attach the depth adjustment clamp to the coulters assembly. Operating depth of the coulters blade is adjusted by positioning the blade assembly in the fork mount. Four blade mounting adjustment positions are available at $\frac{1}{2}$ " increments. Initial position of the blade assembly should be in the top hole. This position will locate the coulters blade approximately $\frac{1}{4}$ " deeper than the row unit opener blade. In heavy residue it may be desirable to position the blade assembly in the second position to insure that the residue is cut and not forced down into the seed zone. Additional holes are used to compensate for coulters blade wear.

LF212299-20

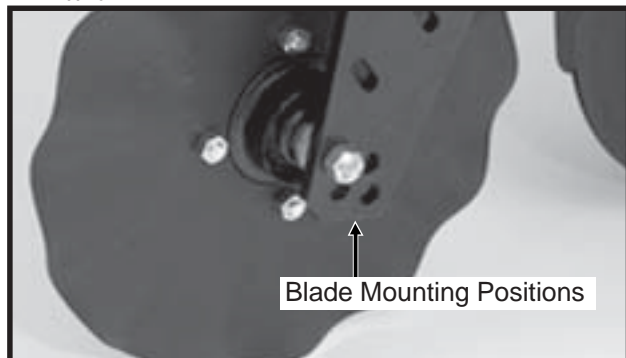

SPRING ADJUSTMENT

Down force adjustment is made by tightening or loosening the spring adjustment bolt. With the planter in the raised position, turn the bolt clockwise to increase down force or counterclockwise to decrease down force. Set all rows equally.

Compressed Spring Length (Including Washer)	Pounds Down Pressure With Blade $\frac{1}{2}$ " Above Maximum Down Position	Pounds Down Pressure With Blade 4" Above Maximum Down Position
13 $\frac{5}{16}$ "	90	230
12 $\frac{5}{16}$ "	190	330
Suggested initial setting.		
11 $\frac{5}{16}$ "	300	430

A5649rev.(PLTR44)

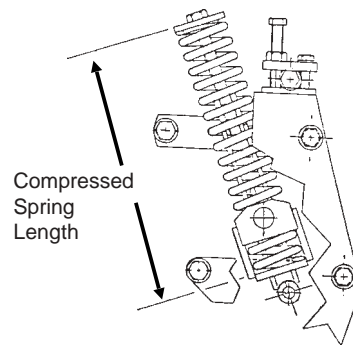

IMPORTANT: Excessive down force may cause increased wear on components.

COULTERS BLADE ADJUSTMENT

The coulters blade can be aligned with the row unit disc opener by moving the spacer washers from one side of the coulters blade hub to the other.

56314-12

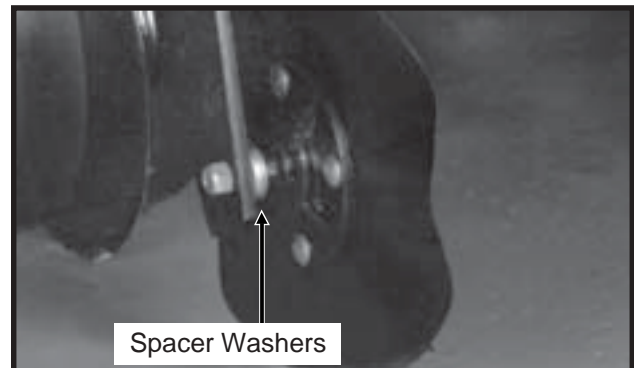

Field adjustment should be made as needed. Operating height of the planter frame will affect operating depth of the frame mounted coulters.

NOTE: Torque $\frac{5}{8}$ " spindle bolts to 120 ft. lbs.

ROW UNIT OPERATION

FRAME MOUNTED COULTER - STYLE B

LF083002101

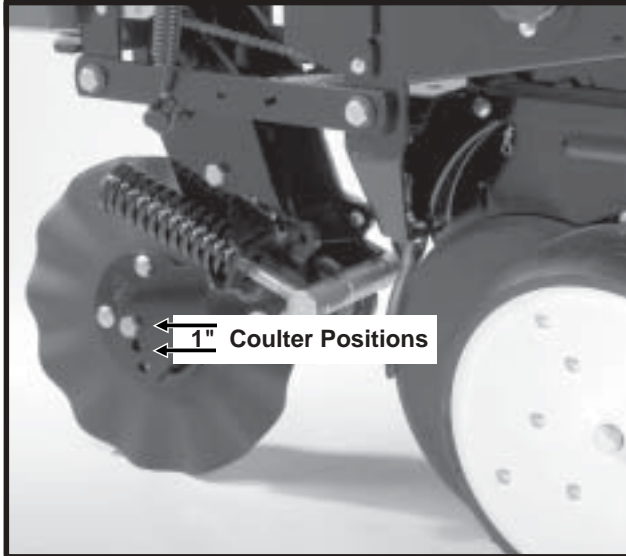

Frame mounted coulters with 1" bubbled, 1" fluted (8 flutes) or 3/4" fluted (13 flutes) blades may be used on pull row units only. (Not compatible with push row units.)

The frame mounted coulters is designed to apply necessary spring down pressure on the coulters for maximum penetration while exerting less shock load on the row unit.

The initial location of the coulters blade is in the top hole. The blade can be relocated to one of the lower two holes (1" increments) as wear occurs or if deeper operation of the blade is desired.

LF083002101

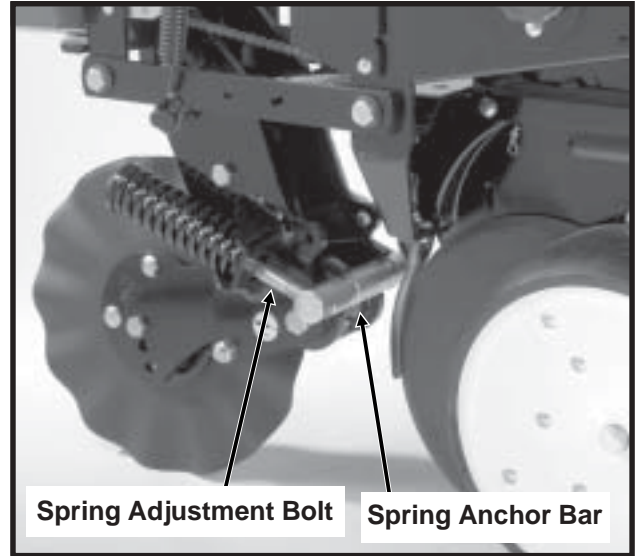

DOWN PRESSURE ADJUSTMENT

Down force adjustment is made by tightening or loosening the two spring adjustment bolts. With the planter in raised position, turn the bolts clockwise to increase down pressure or counterclockwise to decrease down force. Set both springs the same.

Down force on the blade is shown below in lbs.

End Of Spring Adjustment Bolt Flush With Spring Anchor Bar (Shown Above)	End Of Spring Adjustment Bolt Extended 1/2" Through Spring Anchor Bar	All Threads Used (Maximum)
275 lbs.	400 lbs.	500 lbs.

NOTE: Avoid setting down pressure higher than is required for consistent soil penetration. Excessive pressure will increase the chances of damage to coulters components when the coulters strikes an obstacle.

ROW UNIT OPERATION

DISC FURROWER

(For Use With Style A Frame Mounted Coulter)

The disc furrower for use with the frame mounted coulter may be equipped with either 12" solid blades or 12" notched blades.

Disc furrowers are used to clear crop residue, dirt clods and dry soil from in front of the row units for a clean and smooth seed bed. Notched blades are used for heavier residue conditions. The notched blades cut crop residue and move it aside to prevent plugging or pushing.

56314-19

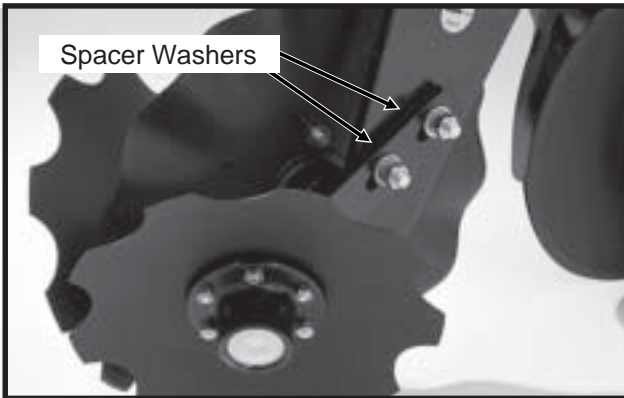

Blades can be adjusted so front edges meet by adding spacer washers between the disc furrower arm and frame mounted coulter fork mount.

Slotted holes in the frame mounted coulter fork mount and in the disc furrower arm allow for vertical and horizontal adjustment. Blades can be adjusted so the front edges meet or one blade can be moved to the rear and the other to the front of the slot so the cutting edge of one blade overlaps the edge of the other blade.

56314-17a

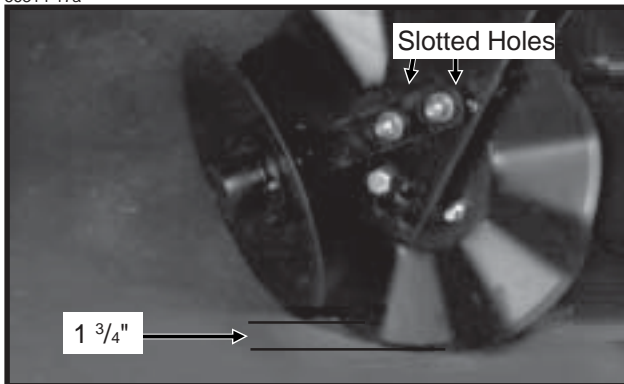

Initial setting for each disc furrower blade is 1 3/4" shallower than the coulter blade. Further adjustment may be desired for various applications.

NOTE: The depth control bar should always be used when the frame mounted coulter is equipped with disc furrowers.

RESIDUE WHEELS

(For Use With Style B Frame Mounted Coulter)

The residue wheels for use with the frame mounted coulter may be used on pull row units only.

LF083002102

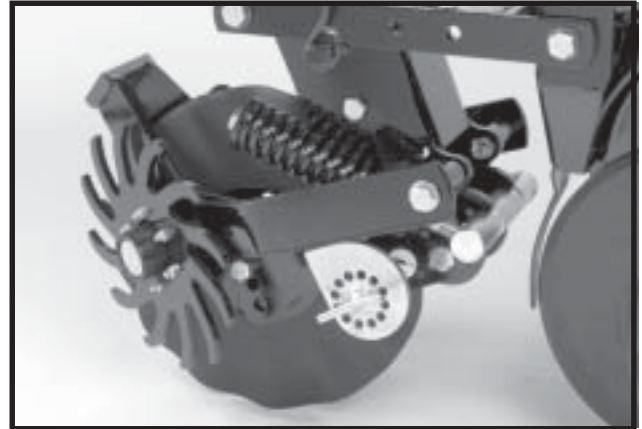

The residue wheels are attached to the frame mounted coulter with two cap screws and sleeves allowing the unit to free-float. A 2-position spindle bolt mounting allows the tined wheels to be mounted interlocked or staggered. Depth adjustment is made using a spring-loaded cam and pin with 11 positions in 1/4" increments. A high point on the cam allows the wheels to be locked up so they do not contact the ground. A weed guard, located on the inboard side of each wheel, aids in the prevention of weed wrap which can cause premature bearing failure.

(RU135d)

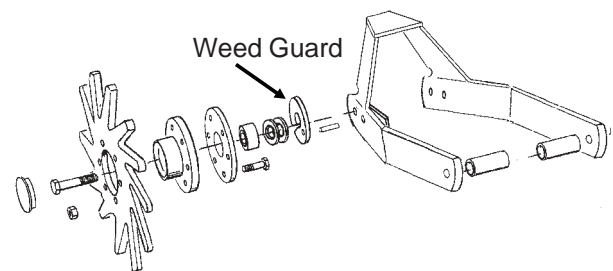

NOTE: Opening in weed guard must point down.

ROW UNIT OPERATION

ROW UNIT MOUNTED DISC FURROWER

The row unit mounted disc furrower is for use on pull row units only (not compatible with Interplant® push row units). The disc furrower may be equipped with either 12" solid blades or 12" notched blades.

Disc furrowers are used to clear crop residue, dirt clods and dry soil from in front of the row units for a clean and smooth seed bed. Notched blades are used for heavier residue conditions. The notched blades cut crop residue and move it aside to prevent plugging or pushing.

LF212299-22

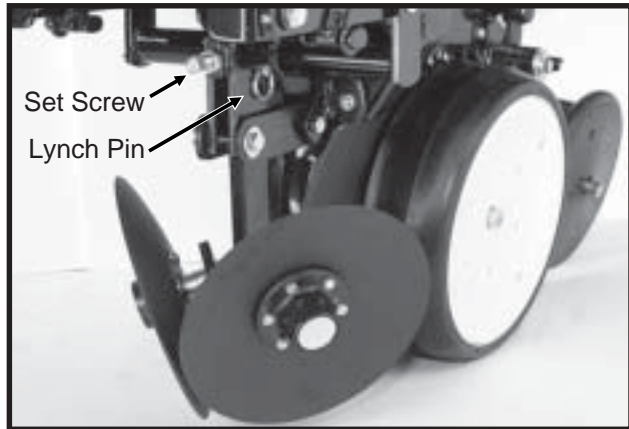

Vertical adjustment in $\frac{1}{3}$ " increments is possible by removing the lynch pin which secures the vertical support arm and moving the support arm up or down as required. Re-install lynch pin. Finer adjustment can be attained by removing the lynch pin and using the $\frac{5}{8}$ " x $2 \frac{1}{4}$ " set screw to clamp the support arm in the required position.

(RU98e)

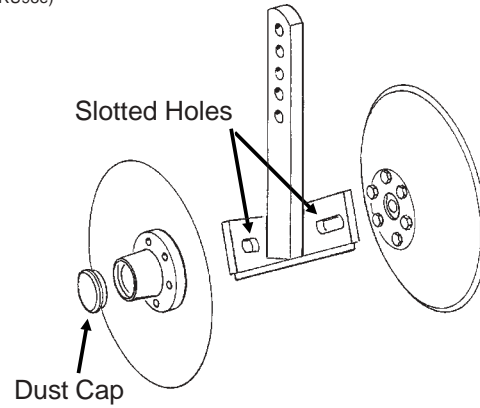

Slotted holes in the support arm where the blades are mounted allow fore and aft adjustment of the disc blades. Blades can be adjusted so the front edges meet or one blade can be moved to the rear and the other to the front of the slot so the cutting edge of one blade overlaps the edge of the other blade. The dust cap must be removed to make these adjustments.

ROW UNIT OPERATION

ROW UNIT MOUNTED RESIDUE WHEEL

The row unit mounted residue wheel may be used on pull row units and push row units.

D101701113



Two adjustable springs on the parallel links on each residue wheel allow for down force adjustment. Position 1 as shown below provides minimum down pressure and position 3 maximum down pressure.

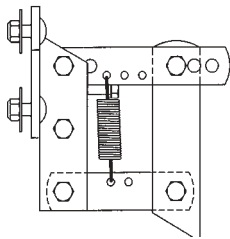

Position 1 (Minimum)(PLTR31a)

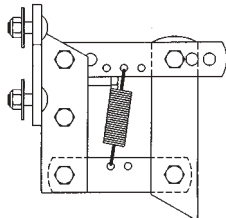

Position 2 (PLTR32a)

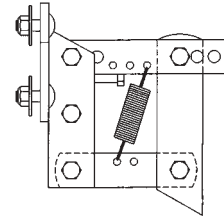

Position 3 (Maximum)(PLTR33a)

For additional uplift or float, position springs as shown below.

(PLTR34a)

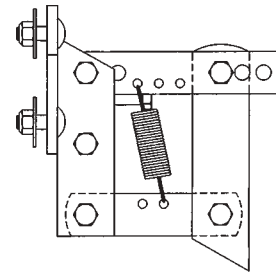

To adjust down force springs, raise the row unit out of the ground and reposition springs as shown for the desired down pressure.

ROW UNIT OPERATION

D101701112

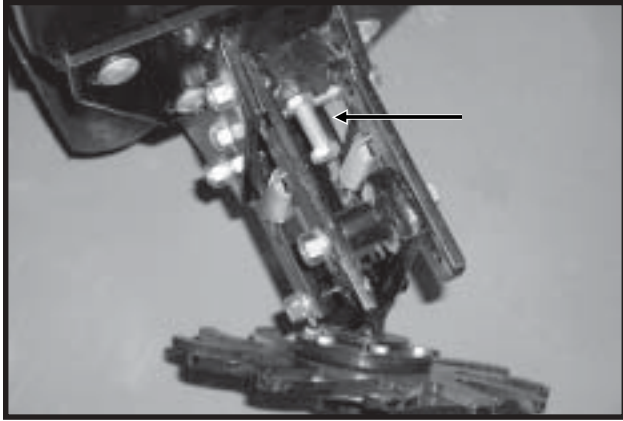

A full threaded bolt and jam nut located on the upper link allows maximum depth to be set for loose soil conditions. Initial setting should be 1 3/4" above the depth of the row unit double disc opener.

Three holes in the upper link allow for wheel angle adjustment. With the wheel mount in the most vertical position, using the rear hole in the upper link, the residue wheel is most aggressive. Moving the wheel mount to one of the forward holes reduces the aggressiveness of the wheel for use in mulch till applications where the soil is loose.

D101701202

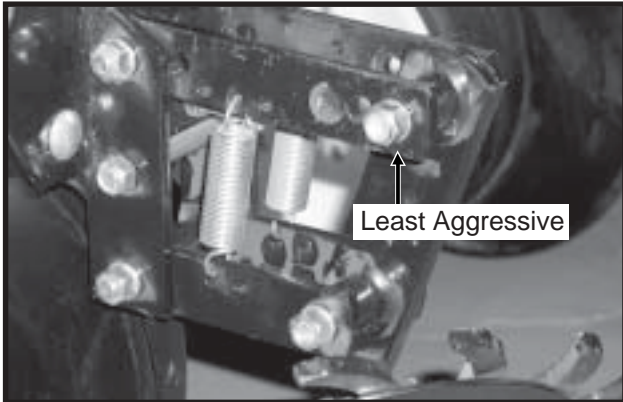

To lock the residue wheel up out of the ground, remove the 1/2" x 5" lockup bolt, raise the residue wheel and install bolt.

D011701203

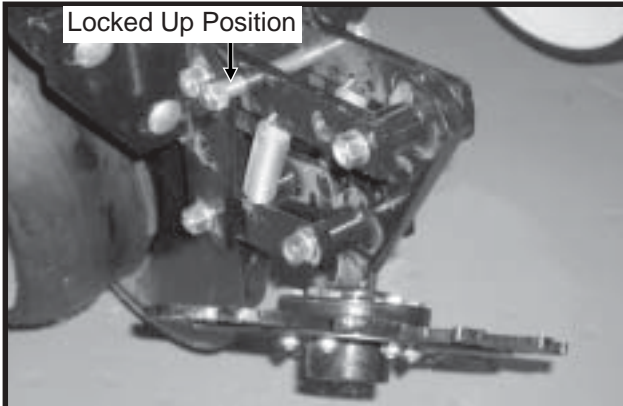

ROW UNIT MOUNTED NO TILL COULTER

LF212299-19a

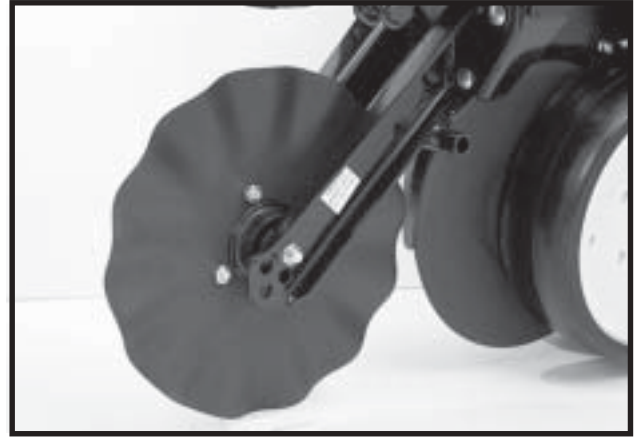

Row unit mounted no till coulters with 1" bubbled, 1" fluted (8 flutes) or 3/4" fluted (13 flutes) blades may be used on pull row units and push row units. (3/4" fluted shown)

Four quick adjustable down force springs are required per row when using row unit mounted no till coulters. See "Quick Adjustable Down Force Springs".

For proper operation, the coulters should be aligned in relation to the row unit double disc openers. The coulters assembly can be adjusted by loosening the four attaching bolts, moving coulters arm to align and tightening the four attaching bolts.

The coulters blade can be adjusted to one of four 1/2" incremental settings in the forked arm. Initial location of the coulters is in the top hole. As the coulters blade wears, the blade should be adjusted downward to one of the three lower settings to maintain the coulters blade at or slightly below the opener discs. In very hard soil conditions such as compacted wheel tracks, opener penetration and cutting of surface residue may be improved by adjusting the coulters to operate below the depth of the double disc opener blades.

Operating depth can be checked by setting the planter down on a level concrete floor and checking the relationship between the coulters blade and row unit opener blade. Make sure the planter is level and coulters is square with the planter frame and aligned with the row unit disc opener.

NOTE: Torque 5/8" spindle bolts to 120 ft. lbs.

ROW UNIT OPERATION

COULTER MOUNTED RESIDUE WHEELS

LF212299-23



Coultter mounted residue wheels are designed for use on pull row units and push row units.

The coultter mounted residue wheels are attached to the row unit mounted no till coultter with one cap screw and sleeve allowing the unit to free-float. A 2-position spindle bolt mounting allows the tined wheels to be mounted interlocked or staggered. Depth adjustment is made using a spring-loaded cam and pin with 11 positions in 1/4" increments. A high point on the cam allows the wheels to be locked up so they do not contact the ground. A weed guard, located on the inboard side of each wheel, aids in the prevention of weed wrap which can cause premature bearing failure.

(RU104n)

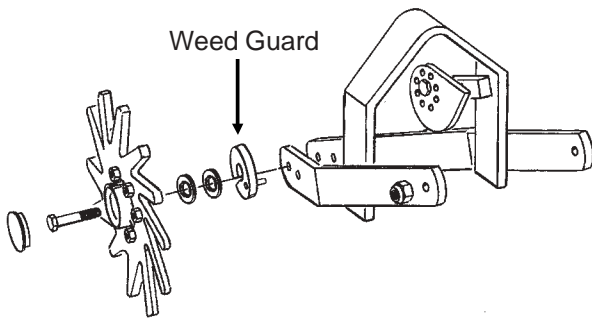

NOTE: Opening in weed guard must point down.

GRANULAR CHEMICAL HOPPER AND DRIVE

LF212299-6



The granular chemical hopper has a 1.4 cubic feet capacity.

Be sure no foreign objects get into the hopper when it is being filled. Replace the hopper lids after filling the hoppers to prevent the accumulation of dirt and moisture.

The metering gate located on the bottom of the hopper regulates the application rate. See "Dry Insecticide And Dry Herbicide Application Rate Charts" in this manual. Calibrate using the chemical manufacturers' instructions.



WARNING: Agricultural chemicals can be dangerous. Improper selection or use can seriously injure persons, animals, plants, soil or other property. BE SAFE: Select the right chemical for the job. Handle it with care. Follow the instructions on the container label.

The granular chemical clutch drive coupler and meter shaft can be disengaged and engaged by turning the throwout knob located at the rear of the hopper support panel. To engage the drive, turn the knob 1/4 turn clockwise. To disengage the drive, turn the knob 1/4 turn counterclockwise. Slotted holes in the hopper support panel and clutch housing allow for alignment adjustment between the clutch drive coupler and meter shaft.

LF212299-4

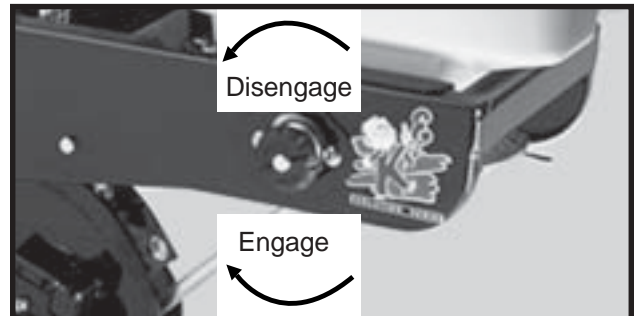

ROW UNIT OPERATION

GRANULAR CHEMICAL BANDING OPTIONS

Granular chemical banding options allow 4 1/2" slope-compensating banding, straight drop in-furrow placement or 14" rear banding.

NOTE: The granular chemical rear bander is not compatible with the covering discs/single press wheel option.

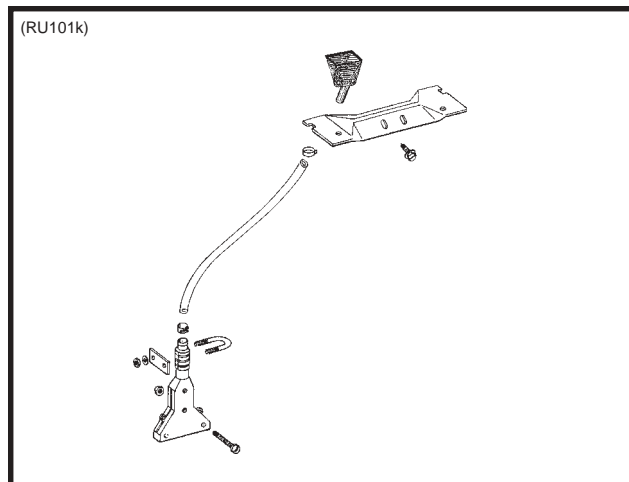

4 1/2" Slope-Compensating Bander

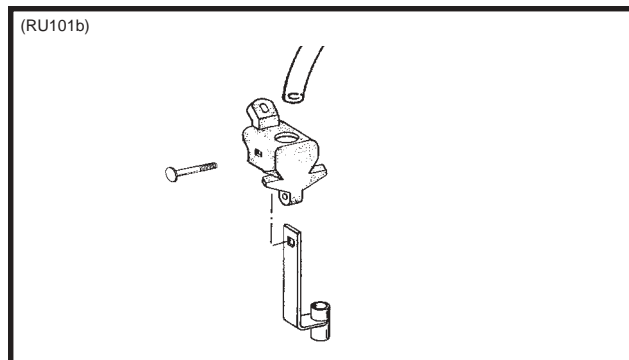

Straight Drop In-Furrow Placement

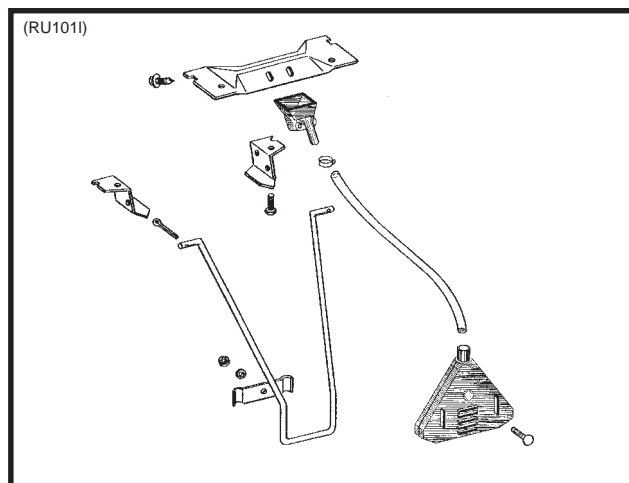

14" Rear Banding

SPRING TOOTH INCORPORATOR

The spring tooth incorporator smooths the soil behind the row unit and incorporates granular chemicals. The two mounting chains on each spring tooth incorporator should be adjusted so there is approximately 1/8" slack in the chain when the unit is lowered to planting position.

NOTE: The spring tooth incorporator is not compatible with the covering discs/single press wheel option.

LF212299-26

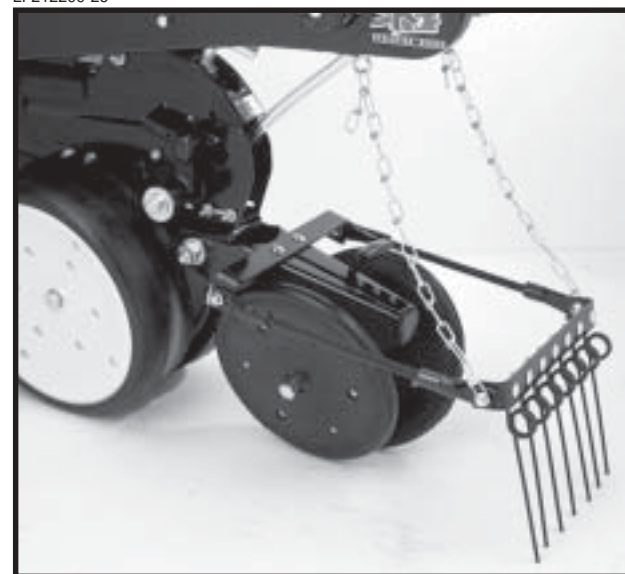

ROW UNIT OPERATION

INTERPLANT® PUSH ROW UNIT LOCK-UPS

Push row unit lockups are designed to allow the push row units to be locked in the raised position.



WARNING: Always install all safety lock-ups or lower planter to the ground before working under or around the machine.

D06099904

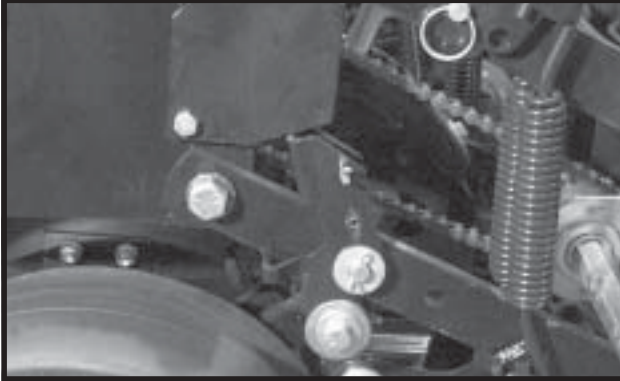

Push Row Unit Locked In Raised Position

D06099906

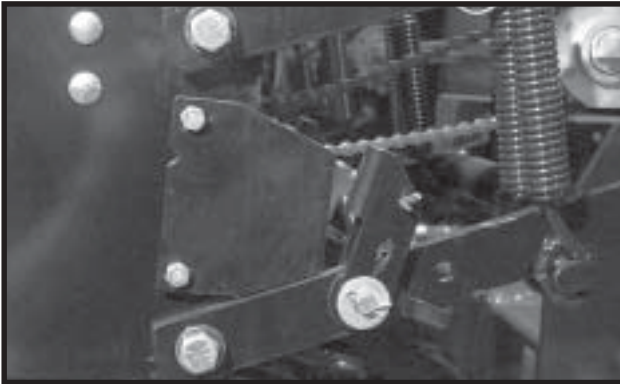

Lockup Released For Field Operation

D060499112a

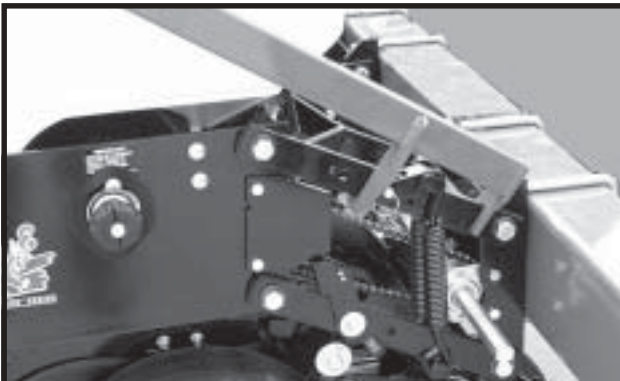

Lift Lever Positioned To Lift Push Row Unit

To lock in raised position:

1. Set row unit down pressure springs to minimum setting.
2. Lower the planter to the planting position.
3. Empty seed hoppers.
4. On each push row unit lockup, flip the spring tab forward.

D060499108

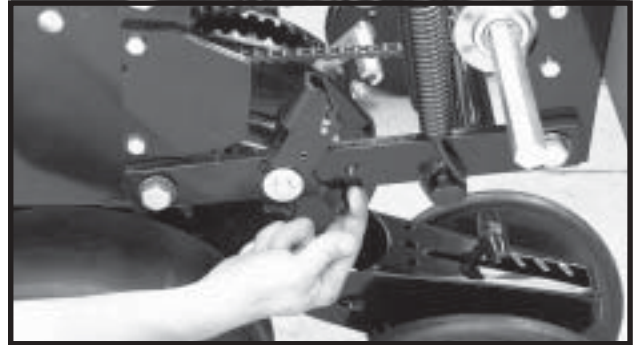

5. Using the lift lever, raise the push row unit to allow the spring loaded lockups to snap into locked position under the row unit stops.
6. Repeat Steps 4 and 5 on remaining push row units.

To release lockups:

1. Lower the planter to the planting position.
2. On each push row unit lockup, flip the spring tab rearward.

D060499107

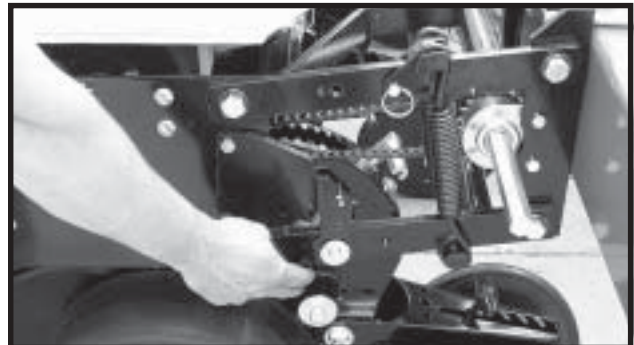

3. Using the lift lever, raise the push row unit to allow the spring loaded lockups to snap out of locked position. Lower row unit to the ground.
4. Repeat Step 3 on remaining push row units.

D070699109

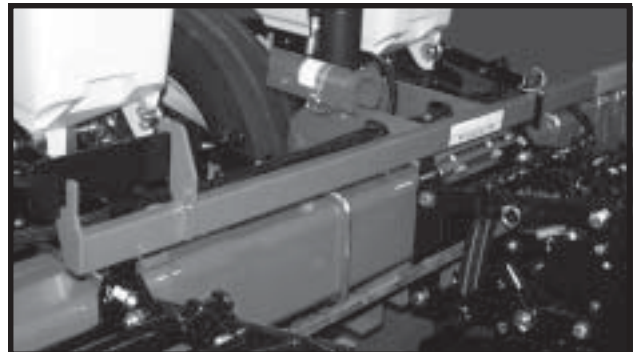

Lift Lever In Storage Location

ROW UNIT OPERATION

INTERPLANT® PUSH ROW UNIT CLUTCH SPROCKET

06309716

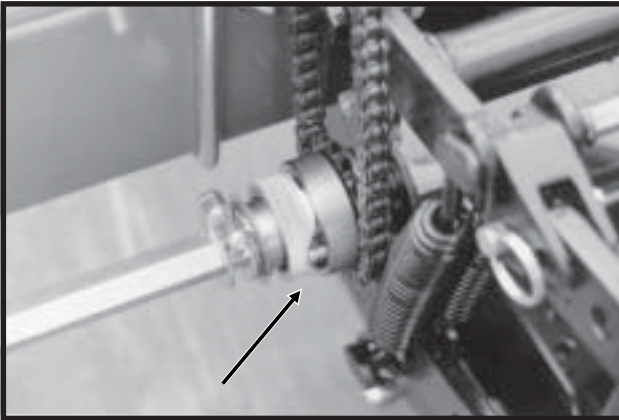

The push row unit clutch sprocket is designed to allow the push row unit drill shaft to be disengaged when only the pull row units are being used.

To disengage the push row unit drill shaft using the clutch sprocket, rotate the knurled collar on the clutch sprocket $\frac{1}{4}$ turn. Then using a $\frac{7}{8}$ " wrench on the drill shaft, rock the drill shaft slightly to take pressure off of the spring loaded pins in the clutch to allow the pins to "pop" out, disengaging the drive. To engage the drive, rotate the knurled collar $\frac{1}{4}$ turn and turn the drill shaft with a $\frac{7}{8}$ " wrench until the drive pins engage the drive sprocket.



WARNING: Always install all safety lock-ups or lower planter to the ground before working under or around the machine.

LUBRICATION

The following pages show the locations of all lubrication points. Proper lubrication of all moving parts will help ensure efficient operation of your KINZE® planter and prolong the life of friction producing parts.

! WARNING: Always install safety lockups or lower to the ground before working under the machine.

LUBRICATION SYMBOLS

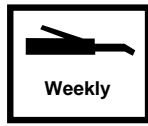
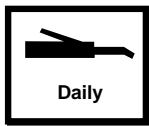

Lubricate at frequency indicated with an SAE multipurpose type grease.



Lubricate at frequency indicated with a high quality SAE 10 weight oil or a quality spray lubricant.

SEALED BEARINGS

LF212199-3

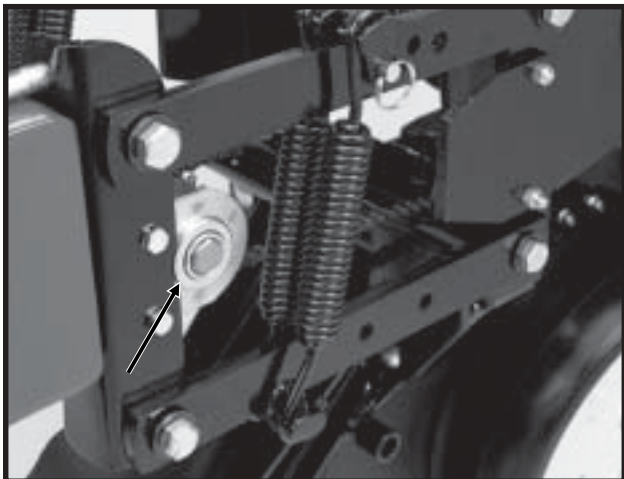

A number of sealed bearings are used on your KINZE® planter to provide trouble free operation. These are located in such areas as the drive shaft, row units and transmission bearings. Sealed bearings are lubricated for life. Due to the seals, relubrication is not practical.

DRIVE CHAINS

All transmission and drive chains should be lubricated daily with a high quality chain lubricant. Extreme operating conditions such as dirt, temperature or speed may require more frequent lubrication. If a chain becomes stiff, it should be removed, soaked and washed in solvent to loosen and remove dirt from the joints. Then soak the chain in oil so the lubricant can penetrate between the rollers and bushings.

LF212199-5a

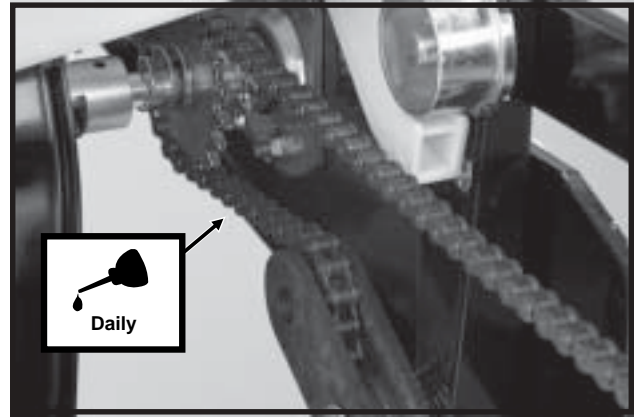

Pull Row Unit Drive Chains

D05139901b

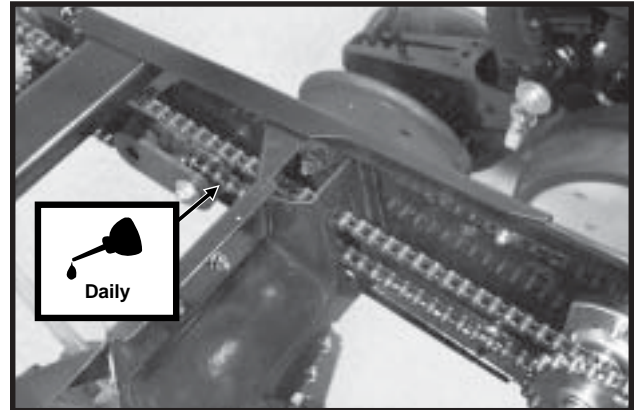

Row Unit Granular Chemical Drive Chains

D04209901a

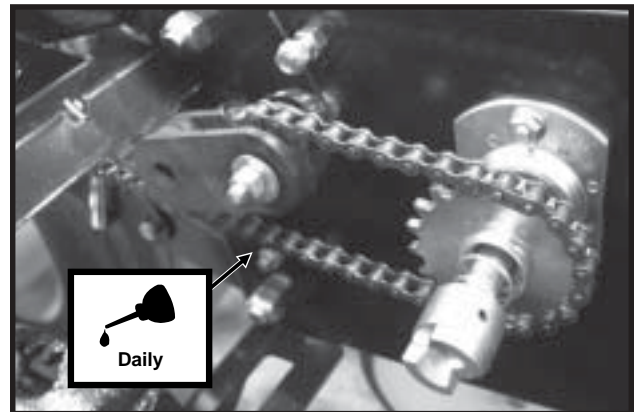

Push Row Unit Drive Chains

LUBRICATION

D060999127

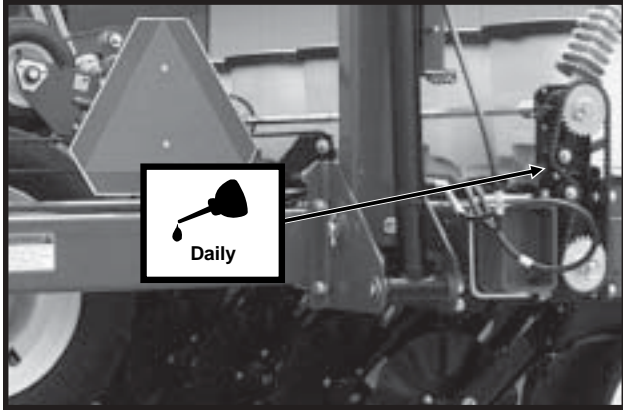

Planter Transmission Drive Chain

01239906

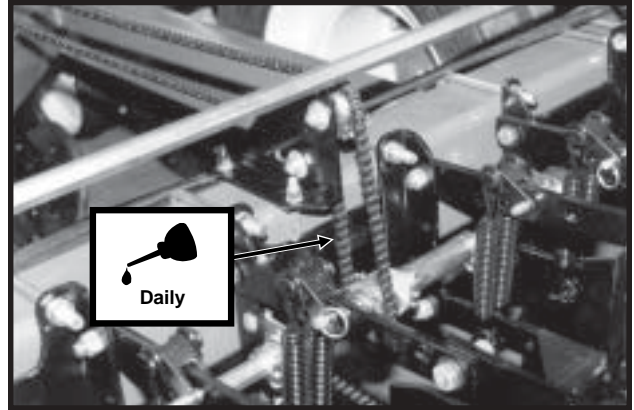

Push Row Unit Drive Chain

D06109909

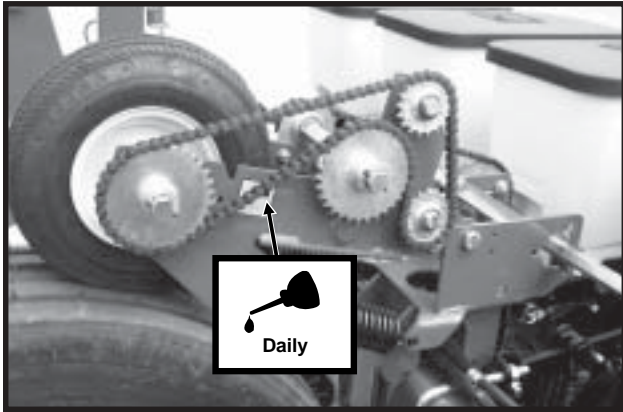

Contact Wheel Drive Chain(s)

(FRTZ198)

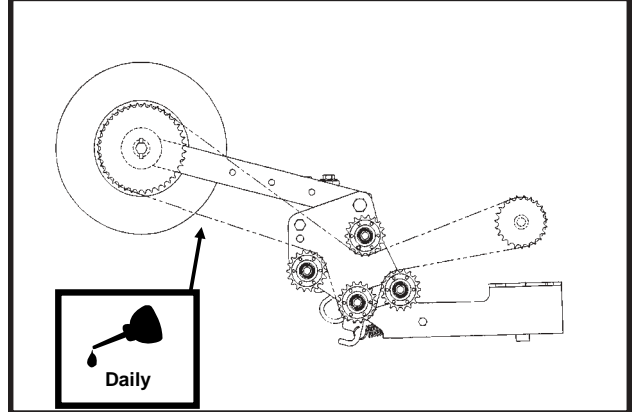

Liquid Fertilizer Drive Chain (Piston Pump)

D06109905

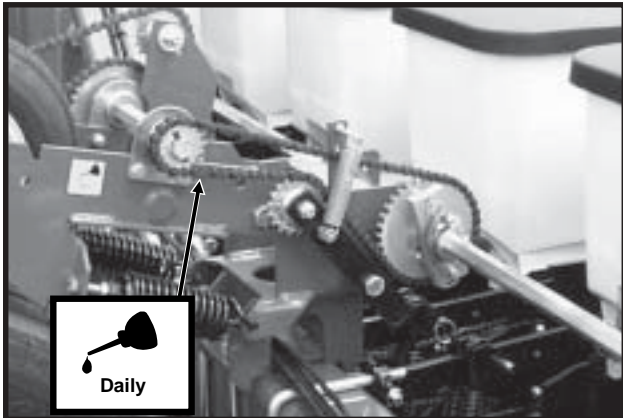

Contact Wheel Driven Chain(s)

INTERPLANT® PUSH ROW UNIT LOCKUPS

D06099906

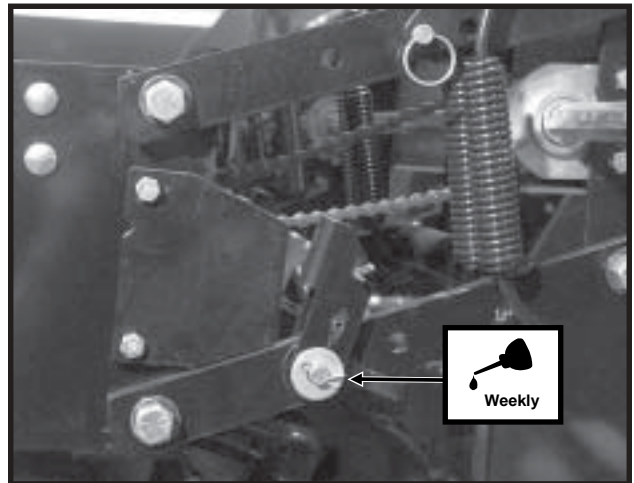

2 Per Row

LUBRICATION

BUSHINGS

Lubricate bushings at the frequency indicated.

Using a torque wrench, check each bolt for proper torque. If bolt is loose, it should be removed and the bushing inspected for cracks and wear. Replace bushing if necessary **Only hardened flat washers should be used. Replace damaged flat washers with proper part. Torque bolts to 130 ft. lbs.**

LF212299-22

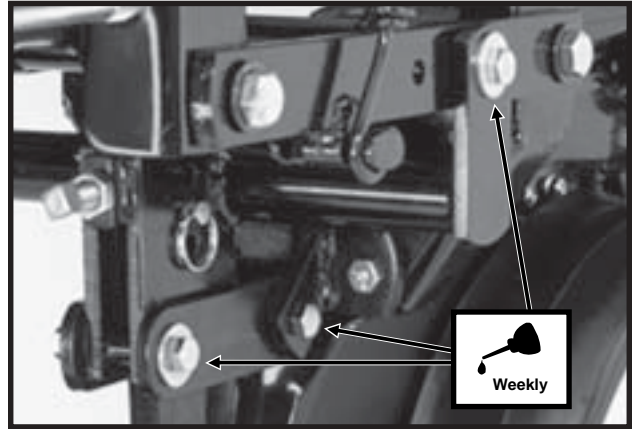

Row Unit Mounted Disc Furrower Parallel Linkage (6 Per Row)

LF212199-3

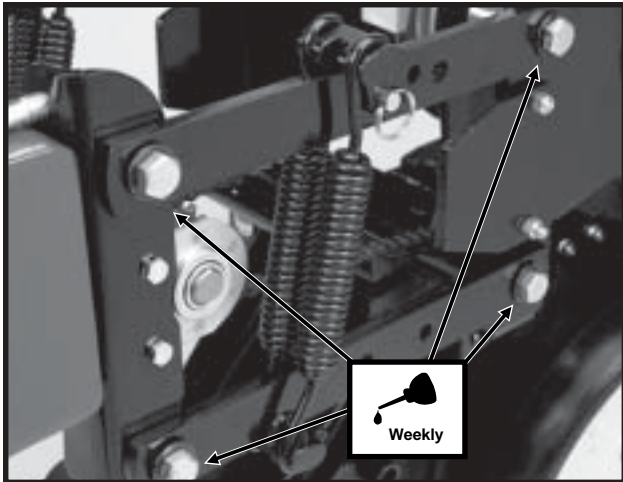

Pull Row Unit And/Or Push Row Unit Parallel Linkage (8 Per Row)

LF212199-2

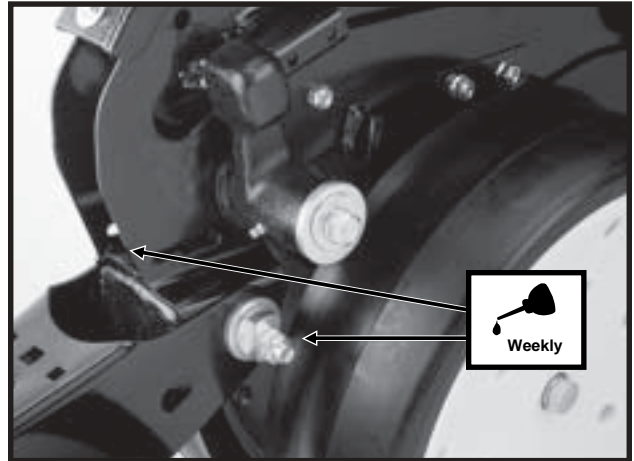

Row Unit "V" Closing Wheel, Covering Discs/ Single Press Wheel And/Or Drag Closing Wheel Eccentric Bushings (2 Per Row)

D06189901

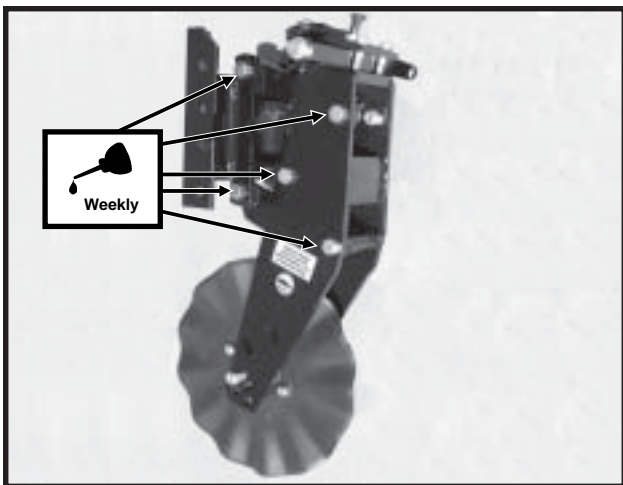

Frame Mounted Coulter Parallel Linkage - STYLE A (10 Per Row)

Shown not installed on row unit for visual clarity.

D060999107

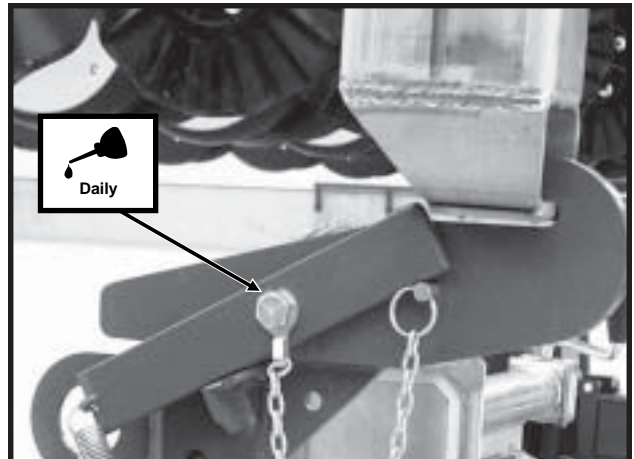

Transport Latch (1 Location)

LUBRICATION

D06109909

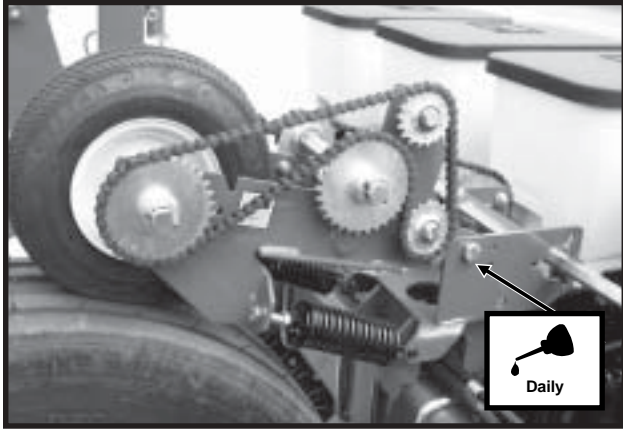

Contact Drive Wheel Arm (2 Per Wheel Assembly)

(FRTZ198)

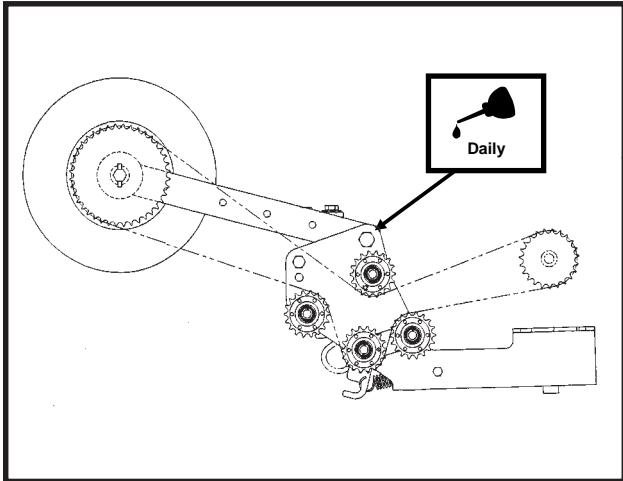

Optional Piston Pump Drive Wheel Arm Assembly (2 Per Wheel Assembly)

WHEEL BEARINGS

The transport wheel hubs are equipped with grease fittings. Pump grease into the hub until grease comes out around the seals. See "Grease Fittings" for lubrication frequency.

All wheel bearings should be repacked annually and checked for wear. This applies to all drive wheels, transport wheels and marker hubs.

To check for wear, lift the wheel off the ground. Check for endplay in the bearings by moving the tire in and out. Rotate the tire to check for roughness in the bearings. If bearings sound rough, the hub should be removed and the bearings inspected and replaced if necessary. See "Wheel Bearing Lubrication Or Replacement".

To repack wheel hubs, follow the procedure outlined for wheel bearing replacement with the exception that bearings and bearing cups are reused.

LIQUID FERTILIZER PISTON PUMP CRANKCASE OIL LEVEL

12229799

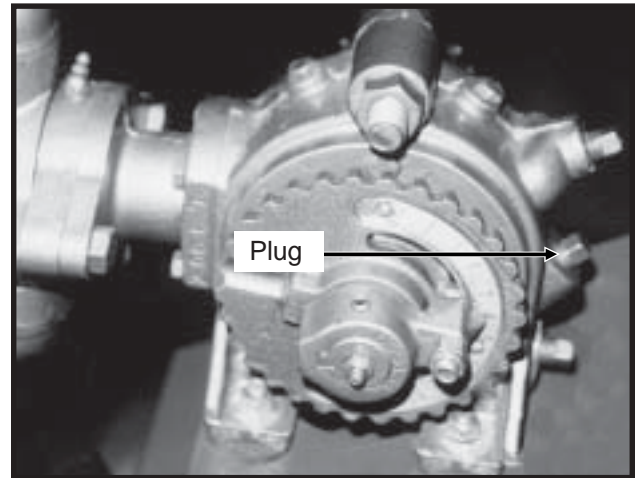

Check crankcase oil daily and maintain at plug level. Fill as needed with EP 90 weight gear oil. Total oil capacity is approximately $\frac{3}{4}$ pint.

Refer to operator and instruction manual supplied with the pump and flow divider for additional information.

LUBRICATION

GREASE FITTINGS

Those parts equipped with grease fittings should be lubricated at the frequency indicated with an SAE multipurpose type grease. Be sure to clean the fitting thoroughly before using grease gun. The frequency of lubrication recommended is based on normal operating conditions. Severe or unusual conditions may require more frequent attention.



WARNING: Always install safety lockups or lower to the ground before working under or around the machine.

NOTE: Numbers on illustration below correspond to photos on following pages showing lubrication frequencies.

(PLTR147k)

12 Row 20" Shown

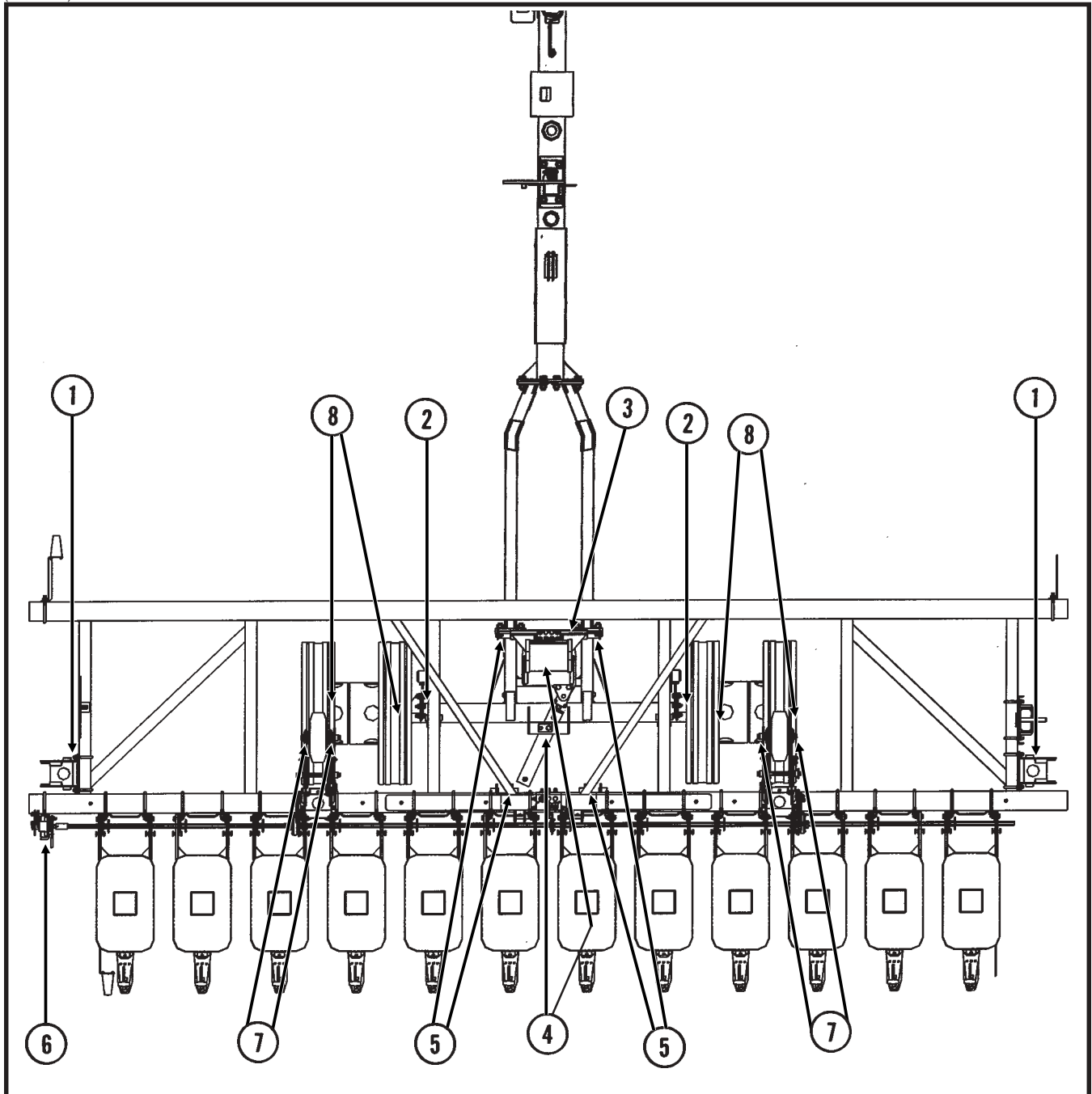

LUBRICATION

D06099120

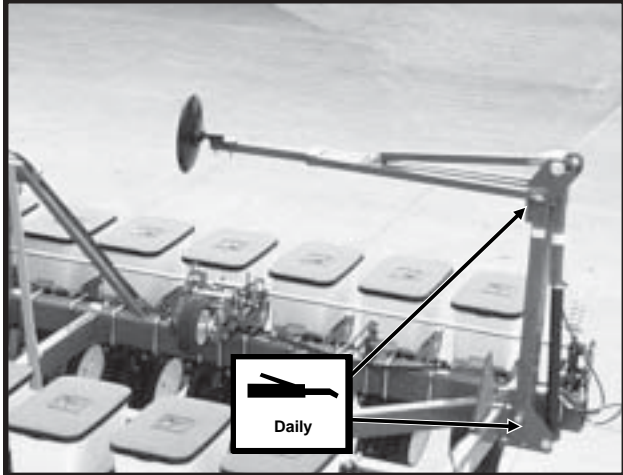

1. Marker Assemblies - 2 Zerks Per Assembly

01199919a

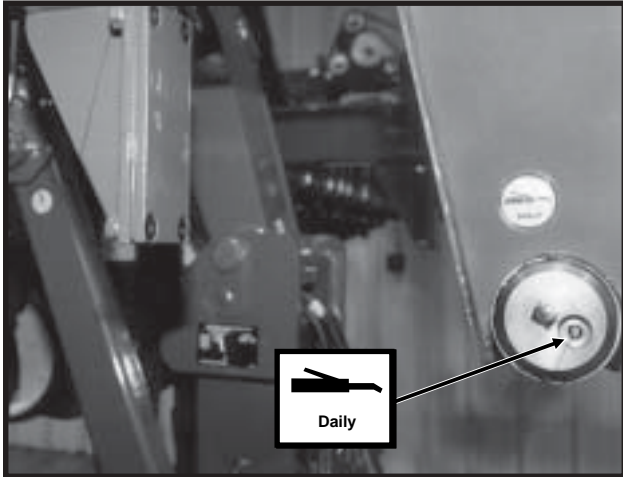

2. Cam Follower - 1 Zerk Per Follower

01199914

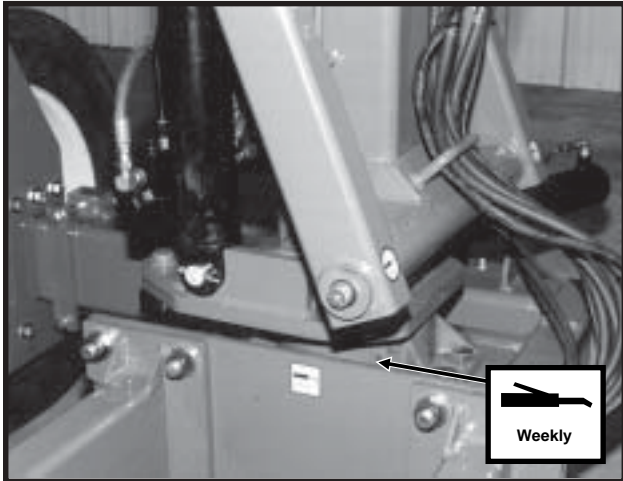

3. Center Pivot Hub - 1 Zerk

01209912

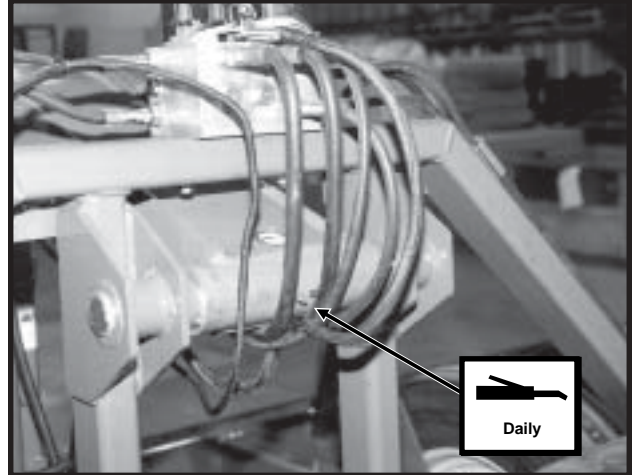

4. Upper Lift Arm - 2 Zerks

D06109907

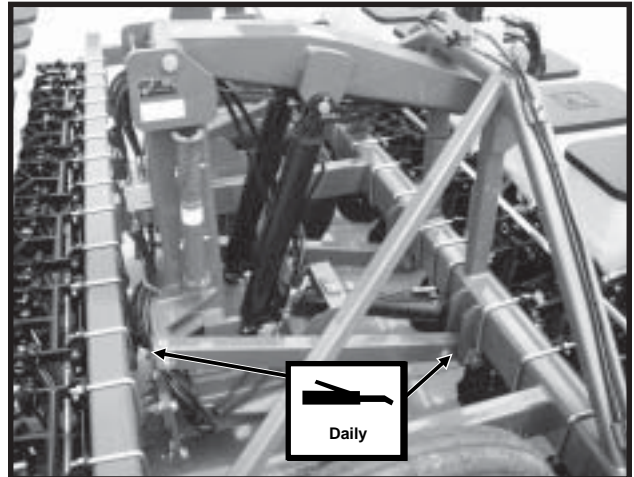

5. Lower Lift Arms - 2 Zerks Per Arm

01209904

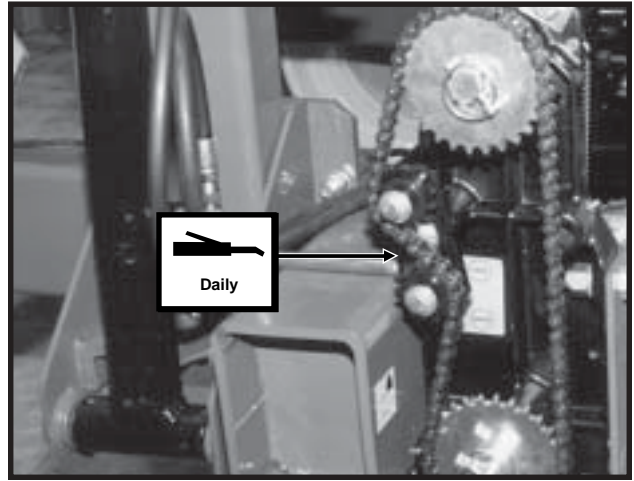

6. Transmission Assembly - 1 Zerk

LUBRICATION

D06109909

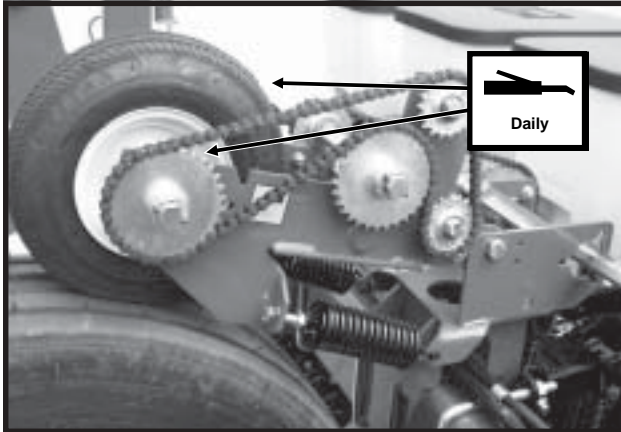

7. (If Applicable) Contact Wheel Bearing - 2 Zerks Per Arm Assembly **(Rotate tire while filling with grease.)**

D06109905

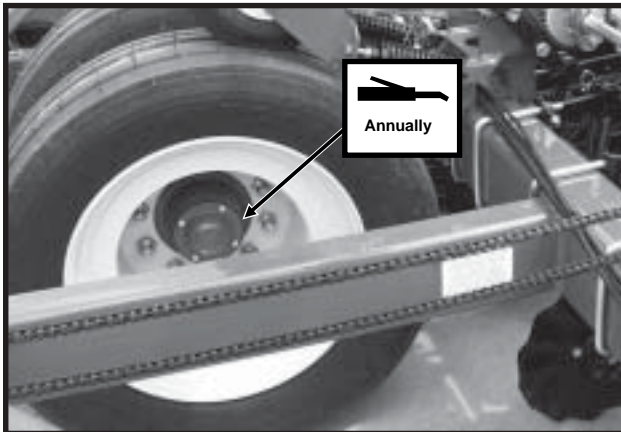

8. Transport Wheel Bearings - 1 Zerk Per Hub

Row Unit

LF212199-2

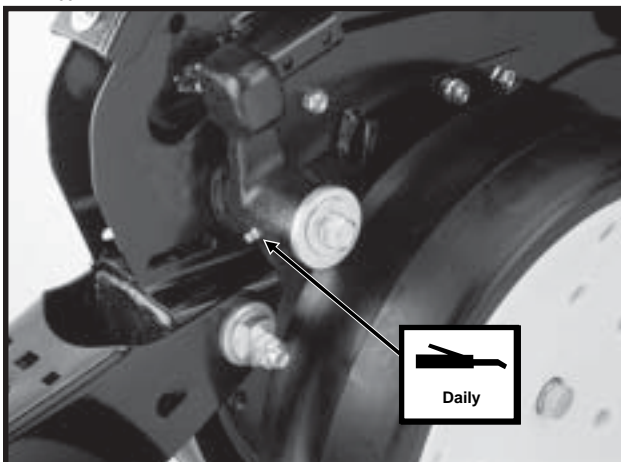

Gauge Wheel Arms - 1 Zerk Per Arm
(Seals in gauge wheel arm are installed with lip facing out to allow grease to purge dirt away from seal. Pump grease into arm until fresh grease appears between washers and arm.)

LF212299-19

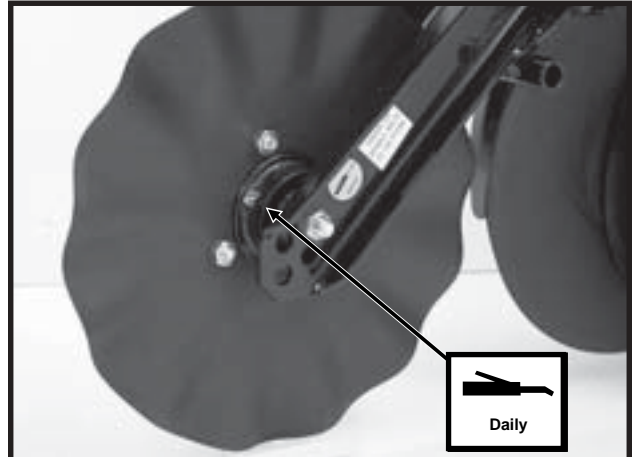

(If Applicable) Row Unit Mounted No Till Coulters Hubs - 1 Zerk Per Hub
(Pump grease into hub until grease comes out around the seals. Spin hub while filling with grease.)

56673-6

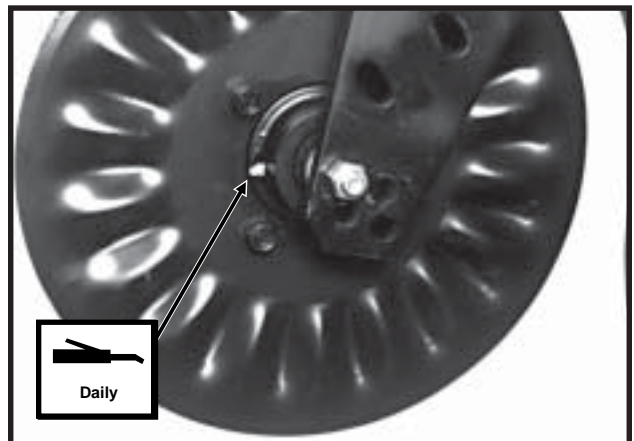

(If Applicable) Frame Mounted Coulters Hubs - STYLE A - 1 Zerk Per Hub
(Pump grease into hub until grease comes out around the seals. Spin hub while filling with grease.)

LF083002101

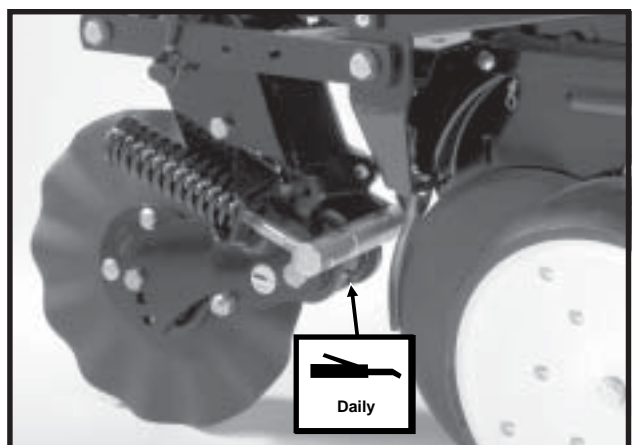

(If Applicable) Frame Mounted Coulters - STYLE B - 1 Zerk Per Arm

LUBRICATION

Fertilizer Openers

D05189901

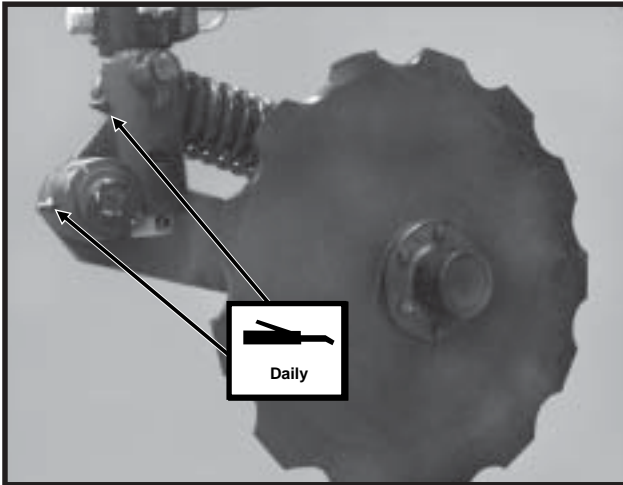

Notched Single Disc Fertilizer Opener - STYLE A - 2 Zerks

D06259919

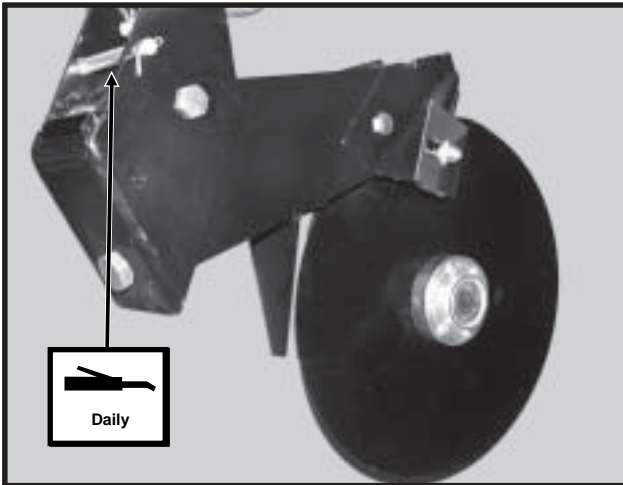

Double Disc Fertilizer Opener - 1 Zerk

D060801304

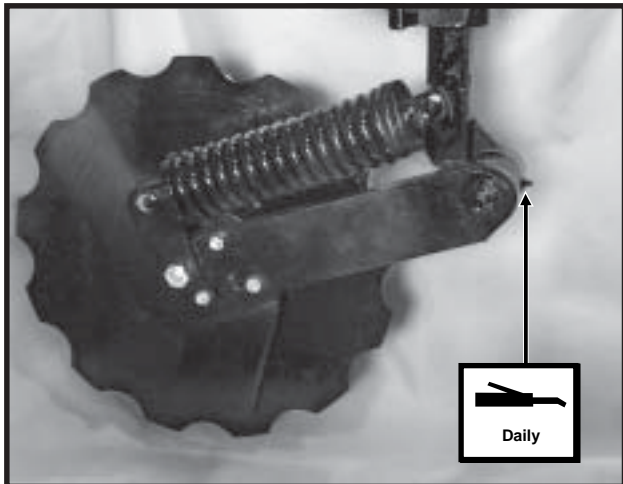

Notched Single Disc Fertilizer Opener - STYLE B - 1 Zerk

Liquid Fertilizer Attachment

12229799

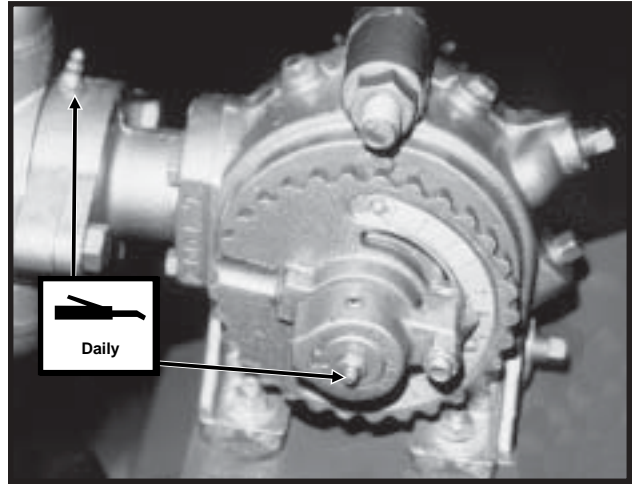

Piston Pump - 2 Zerks (Fill zerk on outboard stuffing box until lubricant seeps out of drain hole in bottom.)

MAINTENANCE

MOUNTING BOLTS AND HARDWARE

Before operating the planter for the first time, check to be sure all hardware is tight. Check all hardware again after approximately the first 50 hours of operation and at the beginning of each planting season thereafter.

All hardware used on the KINZE® planter is Grade 5 (high strength) unless otherwise noted. Cap screws are marked with three radial lines on the head. If hardware must be replaced, be sure to replace it with hardware of equal size, strength and thread type. Refer to the torque values chart when tightening bolts.

Row unit parallel linkage bushing bolts - 130 Ft. Lbs. (See "Bushings" in the Lubrication Section of this manual.)

IMPORTANT: Over tightening hardware can cause as much damage as under tightening. Tightening hardware beyond the recommended range can reduce its shock load capacity.



WARNING: Before operating the planter for the first time and periodically thereafter, check to be sure the lug nuts on the transport wheels are tight. This is especially important if the planter is to be transported for a long distance.

Transport Tire Lug Nuts - 425 Ft. Lbs.
⁵/₈" No Till Coulter Spindle Bolts - 120 Ft. Lbs.

TORQUE VALUES CHART - PLATED HARDWARE

Bolt Diameter	Grade 2		Grade 5		Grade 8	
	Coarse	Fine	Coarse	Fine	Coarse	Fine
1/4"	50 In. Lbs.	56 In. Lbs.	76 In. Lbs.	87 In. Lbs.	9 Ft. Lbs.	10 Ft. Lbs.
5/16"	8 Ft. Lbs.	9 Ft. Lbs.	13 Ft. Lbs.	14 Ft. Lbs.	18 Ft. Lbs.	20 Ft. Lbs.
3/8"	15 Ft. Lbs.	17 Ft. Lbs.	23 Ft. Lbs.	26 Ft. Lbs.	33 Ft. Lbs.	37 Ft. Lbs.
7/16"	25 Ft. Lbs.	27 Ft. Lbs.	37 Ft. Lbs.	41 Ft. Lbs.	52 Ft. Lbs.	58 Ft. Lbs.
1/2"	35 Ft. Lbs.	40 Ft. Lbs.	57 Ft. Lbs.	64 Ft. Lbs.	80 Ft. Lbs.	90 Ft. Lbs.
9/16"	50 Ft. Lbs.	60 Ft. Lbs.	80 Ft. Lbs.	90 Ft. Lbs.	115 Ft. Lbs.	130 Ft. Lbs.
5/8"	70 Ft. Lbs.	80 Ft. Lbs.	110 Ft. Lbs.	125 Ft. Lbs.	160 Ft. Lbs.	180 Ft. Lbs.
3/4"	130 Ft. Lbs.	145 Ft. Lbs.	200 Ft. Lbs.	220 Ft. Lbs.	280 Ft. Lbs.	315 Ft. Lbs.
7/8"	125 Ft. Lbs.	140 Ft. Lbs.	320 Ft. Lbs.	350 Ft. Lbs.	450 Ft. Lbs.	500 Ft. Lbs.
1"	190 Ft. Lbs.	205 Ft. Lbs.	480 Ft. Lbs.	530 Ft. Lbs.	675 Ft. Lbs.	750 Ft. Lbs.
1 1/8"	265 Ft. Lbs.	300 Ft. Lbs.	600 Ft. Lbs.	670 Ft. Lbs.	960 Ft. Lbs.	1075 Ft. Lbs.
1 1/4"	375 Ft. Lbs.	415 Ft. Lbs.	840 Ft. Lbs.	930 Ft. Lbs.	1360 Ft. Lbs.	1500 Ft. Lbs.
1 3/8"	490 Ft. Lbs.	560 Ft. Lbs.	1100 Ft. Lbs.	1250 Ft. Lbs.	1780 Ft. Lbs.	2030 Ft. Lbs.
1 1/2"	650 Ft. Lbs.	730 Ft. Lbs.	1450 Ft. Lbs.	1650 Ft. Lbs.	2307 Ft. Lbs.	2670 Ft. Lbs.

NOTE: Unplated hardware and bolts with lock nuts should be torqued approximately 1/3 higher than the above values. Bolts lubricated prior to installation should be torqued to 70% of value shown in chart.



GRADE 2
No Marks



GRADE 5
3 Marks



GRADE 8
6 Marks

CHAIN TENSION ADJUSTMENT

The drive chains have a spring loaded idler and therefore are self-adjusting. The only adjustment needed is to shorten the chain if wear stretches the chain and reduces spring tension. The pivot point of these idlers should be checked periodically to ensure they rotate freely.

(MT18a)

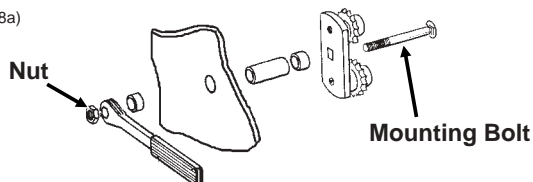

NOTE: The nut on the mounting bolt (on applicable idler assemblies) must be kept tight or chain tension will not be maintained and adjustment wrench will not function properly.

Additional chain links can be found in the storage area located inside the forward planter toolbar.

1239909

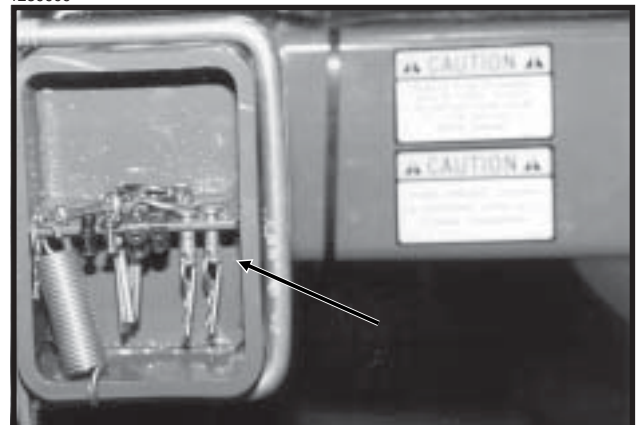

MAINTENANCE

FINGER PICKUP SEED METER INSPECTION/ADJUSTMENT

To inspect or service the finger pickup seed meter, remove the meter from the seed hopper by removing the two thumbscrews which secure the mechanism to the hopper. Remove the baffle from the meter assembly by removing three cap screws. This will permit access to the finger pickup.

D04229901

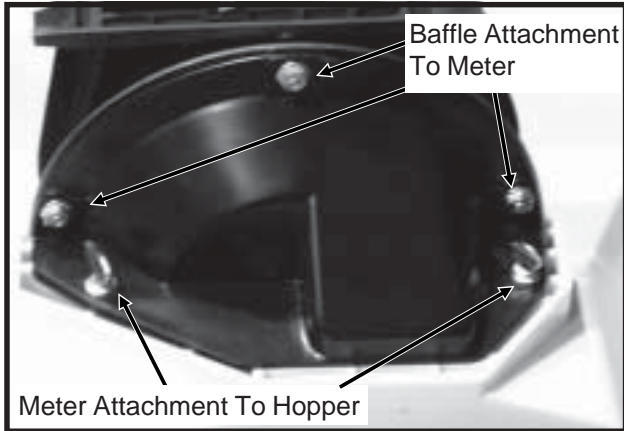

Rotate the seed meter drive by hand to ensure that the springs are holding the tabs of the fingers against the carrier plate where indicated in the photo and that the fingers are being raised in the correct area.

D05030002a

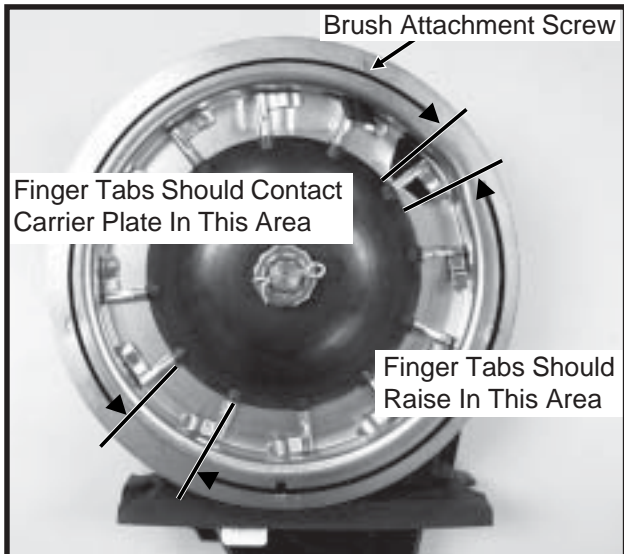

A build-up of debris or chaff may prevent proper finger operation and will require disassembly and cleaning of the finger pickup meter as follows:

1. Remove cotter pin, cover nut and adjusting nut and wave washer (If Applicable) from drive shaft.
2. Carefully lift finger holder, along with fingers and cam, off of the shaft. Clean.

60620-3b

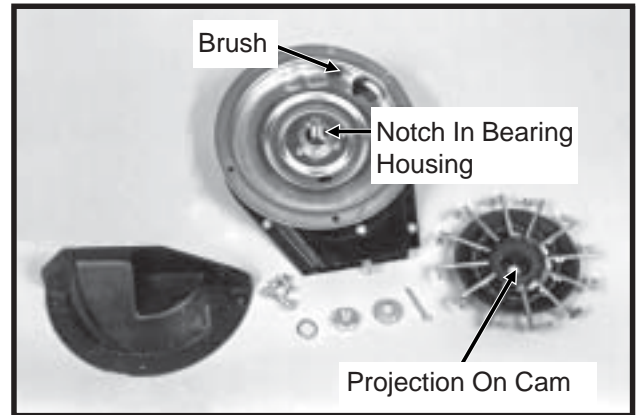

3. Check brush for wear and replace if necessary or following every 100 acres per row of operation.

EXAMPLE: Approximately 800 acres of corn or sunflowers on a 8 row machine or 1200 acres on an 12 row machine.

NOTE: It is not necessary to remove finger holder to replace brush.

4. To replace fingers or springs, remove springs from fingers and remove finger from holder by lifting it out of the friction fit slot. Under average conditions, life expectancy of these parts should be 600-900 acres per row of operation.
5. After cleaning and/or replacing defective parts, reassemble the meter in the reverse order. When replacing fingers, make sure the open end of the spring loop is toward the inside of the finger holder.

60620-22

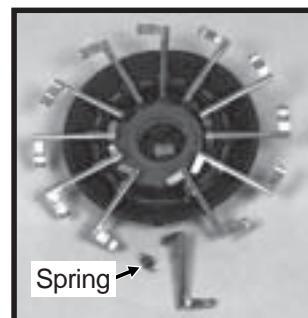

Corn Finger Assembly
(Position Spring Opening Toward Holder)

D07299902



Oil Sunflower Finger Assembly

6. Make sure fingers are installed in holder so that holder will be positioned flush with the carrier plate when assembled. A projection on the cam is designed to align with a mating notch in the bearing housing to ensure proper operation when assembled.

MAINTENANCE

50725-4

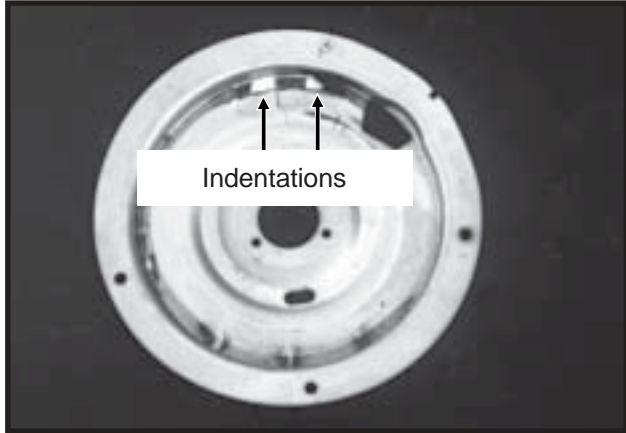

Photo Shows Worn Carrier Plate

- Before installing the finger holder on the carrier plate, check the indentations on the carrier plate for wear. Excessive wear of the carrier plate at the indentations will cause over planting especially when using small sizes of seed.

Inspect the carrier plate annually. Under average conditions, the life expectancy of the carrier plate should be 250-300 acres per row of operation.

- With finger holder flush against the carrier, install wave washer and adjusting nut. Tighten adjusting nut to fully compress wave washer. Then back off nut $\frac{1}{2}$ to 2 flats ($\frac{1}{12}$ to $\frac{1}{3}$ turn) to obtain rolling torque of 22 to 25 inch pounds.

D07299903/D07309912

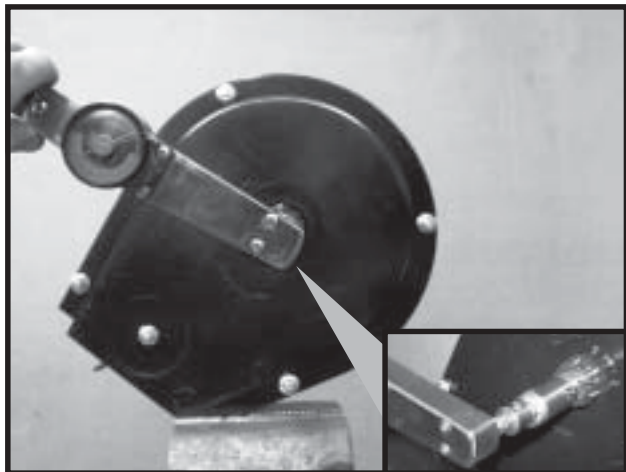

- Turn finger holder by hand to make sure it is positioned firmly against the carrier plate, but is not over tightened and can be rotated with moderate force.
- Install cover nut and cotter pin and reinstall baffle.

NOTE: Check tightness of adjusting nut on each unit after first day of use and periodically thereafter.

To inspect or replace the seed belt, remove the four cap screws around the edge of the housing cover and the nut from the belt idler mounting bolt.

60620-13a/60887-97

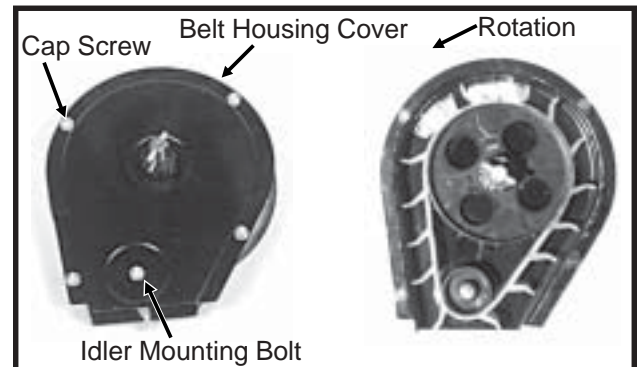

If the belt is being replaced, make sure it is installed to correctly orient the paddles as shown. A diagram molded into the drive sprocket also illustrates the correct orientation.

Reinstall the housing cover. **DO NOT TIGHTEN** hardware at this time. Wedge a screwdriver between the sprocket hub and housing cover as shown below. Pry cover down until it is centered on the belt housing and tighten hardware. Check idler alignment by rotating meter drive shaft. The seed belt should “run” centered on the idler or with only slight contact with the belt housing or cover.

IMPORTANT: Do not over tighten hardware.

D06200030



FINGER PICKUP SEED METER CLEANING

- Disassemble meter.
- Blow out any foreign material present in the meter mechanism.
- Wash in mild soap and water. **DO NOT USE GASOLINE, KEROSENE OR ANY OTHER PETROLEUM BASED PRODUCT.**
- Dry thoroughly.
- Coat lightly with a rust inhibitor.
- Reassemble and store in a dry place.

MAINTENANCE

FINGER PICKUP SEED METER TROUBLESHOOTING

PROBLEM	POSSIBLE CAUSE	SOLUTION
One row not planting seed.	Drive release not engaged.	Engage drive release mechanism.
	Foreign material in hopper.	Clean hopper and finger carrier mechanism.
	Seed hopper empty.	Fill seed hopper.
	Row unit drive chain off of sprocket or broken.	Check drive chain.
Drive release does not engage properly.	Drive release shaft is not aligned properly with meter drive shaft.	Align drive mechanism. See "Seed Meter Drive Adjustment".
Unit is skipping.	Foreign material or obstruction in meter.	Clean and inspect.
	Finger holder improperly adjusted.	Adjust to specifications. (22 to 25 in. lbs. rolling torque)
	Broken fingers.	Replace fingers and/or springs as required.
	Planting too slowly.	Increase planting speed to within recommended range.
Planting too many doubles.	Planting too fast.	Stay within recommended speed range.
	Loose finger holder.	Adjust to specifications. (22 to 25 in. lbs. rolling torque)
	Worn brush in carrier plate.	Inspect and replace if necessary.
Overplanting.	Worn carrier plate. Seed hopper additive being used.	Inspect and replace if necessary. Reduce or eliminate additive or increase graphite.
Underplanting.	Seed belt installed backwards.	Remove and install correctly.
	Weak or broken springs.	Replace.
	Spring not properly installed.	Remove finger holder and correct.
	Seed belt catching or dragging.	Replace belt.
	Brush dislodging seed.	Replace brush.
Irregular or incorrect seed spacing.	Driving too fast.	Check chart for correct speed.
	Wrong tire pressure.	Inflate tires to correct air pressure.
	Drive wheels slipping.	Reduce down pressure on row unit down force springs.
	Wrong sprockets.	Check seed rate charts for correct sprocket combinations.
Seed spacing not as indicated in charts.	Wrong tire pressure.	Inflate tires to correct air pressure.
	Inconsistent seed size.	Do field check and adjust sprockets accordingly.
	Wrong sprockets.	Check chart for correct sprocket combination.
	Charts are approximate.	Slight variations due to wear in meter components and tire slippage due to field conditions may produce seed spacing variations.
	Stiff or worn drive chains.	Replace chains.
Scattering of seeds.	Planting too fast.	Reduce planting speed.
	Seed tube improperly installed.	Check seed tube installation.
	Seed tube worn or damaged.	Replace seed tube.
Seed tubes and/or openers plugging.	Allowing planter to roll backward when lowering.	Lower planter only when tractor is moving forward.
Inconsistent seed depth.	Rough seed bed.	Adjust down pressure springs. Reduce planting speed.
	Partially plugged seed tube.	Inspect and clean.
	Seed tube improperly installed.	Install properly.

MAINTENANCE

BRUSH-TYPE SEED METER MAINTENANCE

60607-10a

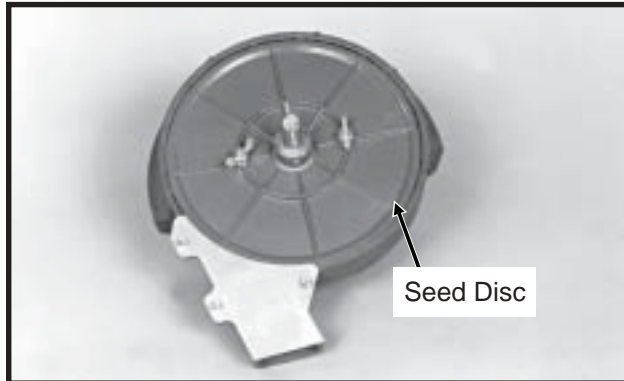

D04239911

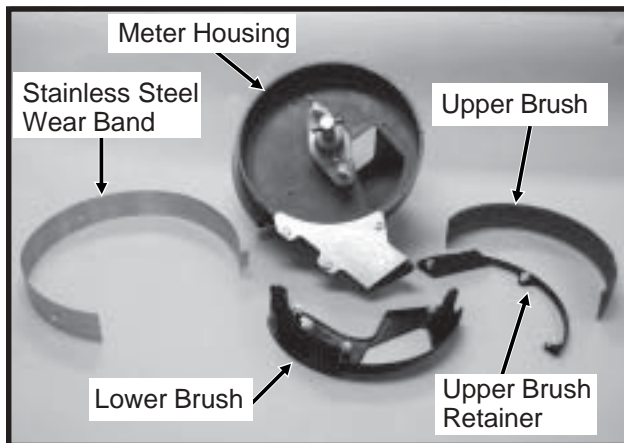

Only clean, high quality seed should be used for maximum meter accuracy. Damaged or cracked seed, hulls or foreign materials may become lodged in the upper brush and greatly reduce meter accuracy. It is suggested that the seed disc be removed daily, inspected and cleaned. Check for buildup of foreign material on the seed disc, particularly in the seed loading slots. Clean the disc by washing it with soap and water. Check for cracked seed, hulls, etc. lodged between the brush retainer and stainless steel wear band which can greatly reduce the accuracy of the meter because the upper brush will not be able to retain the seed in the seed disc pocket. Clean the brush areas of the meter housing thoroughly.

D04239912a



IMPORTANT: Replace hopper lids after hoppers are filled to prevent accumulation of dust or dirt in the seed meter which will cause premature wear.

Cleaning brush-type seed meter for storage:

1. Remove meter from seed hopper by removing the two thumbscrews which secure the meter to the hopper.
2. Remove seed disc and wash with soap and water and dry thoroughly.
3. Remove upper brush by removing the three hex head screws from the brush retainer and removing brush retainer and upper brush.
4. Remove the three hex head screws from the lower brush and remove lower brush and stainless steel wear band.
5. Wash all parts and meter housing with soap and water and dry thoroughly.
6. Inspect all parts for wear and replace worn parts.
7. Reassemble meter except for seed disc. **Meter should be stored in a rodent-free space with seed disc removed.**

Seed Disc Wear

HD112690(PLTR40b)

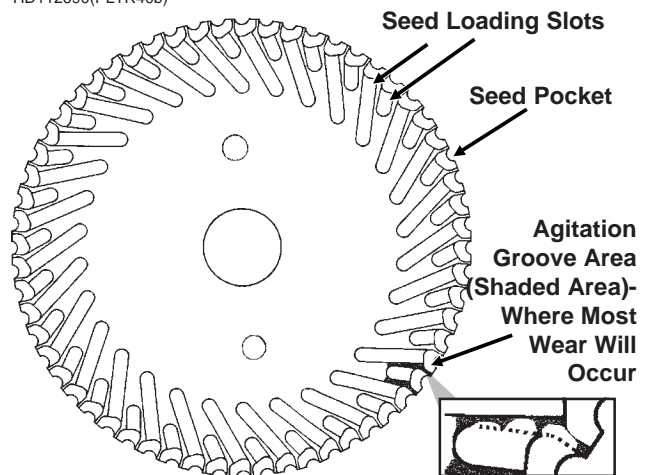

Most wear on the seed disc will be found in the agitation groove area (area between the seed loading slots). Wear will affect planting accuracy at high RPM. To measure for wear, lay a straight edge across the surface of the disc and measure the gap between the disc (at the agitation groove area) and the straight edge. If the agitation groove areas are worn in excess of .030" and accuracy starts to drop off at higher meter RPM, the seed disc should be replaced.

Estimated life expectancy of the seed disc under normal operating conditions should be approximately 200 acres per row. Severe operating conditions such as dust, lack of lubrication or abrasive seed coating could reduce life expectancy of the seed disc to under 100 acres per row.

MAINTENANCE

Upper Brush

LF212299-13a

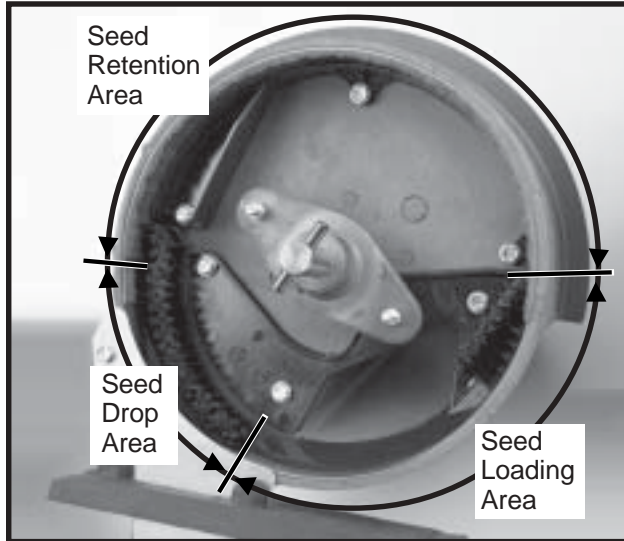

The upper brush holds seed in the seed disc pocket in the seed retention area.

The brush must apply enough pressure against the seed in the seed disc pocket as the disc rotates through the seed retention area to prevent the seed from dropping out of the disc pocket. A damaged spot, excessive wear on the brush or foreign material lodged in the brush may greatly reduce meter performance.

The upper brush should be replaced at approximately 120-400 acres per row of use or sooner if damage or excessive wear is found.

Installation Of Upper Brush

Position upper brush into inner perimeter of seed retention area. Make sure the base of the brush is tight against the bottom of the meter housing. Install brush retainer and three hex head screws. Tighten center screw first, left screw second and right screw last.

NOTE: Use GD11122 upper brush retainer when using soybean and cotton discs. Use GD8237 upper brush retainer when using milo/grain sorghum discs. GD11122 brush retainer shown.

LF212299-13a

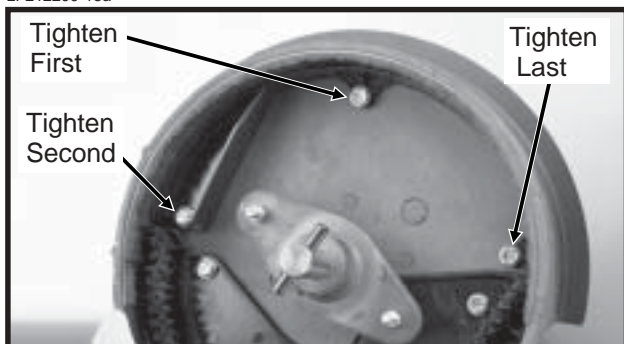

Stainless Steel Wear Band

D04239917a

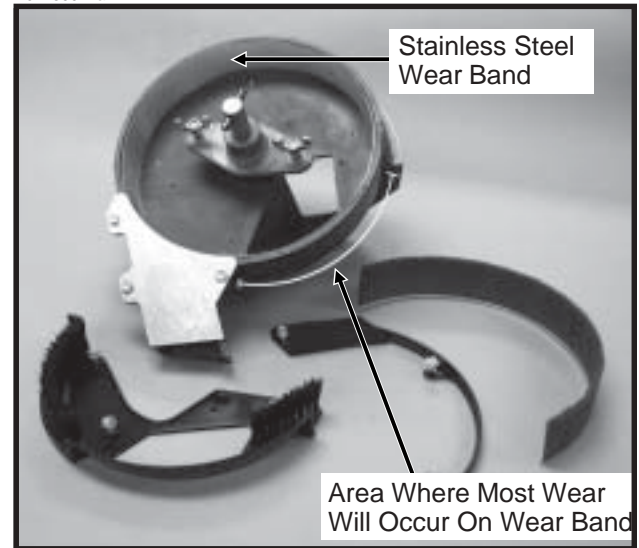

The purpose of the stainless steel wear band is to protect the meter housing from wear. The band is .030" thick and should be replaced when approximately .020" of wear is found in the primary area of wear. If the wear band is allowed to wear through or if the meter is used without the wear band in place, damage to the meter housing may occur.

Estimated life expectancy of the stainless steel wear band is 240-800 acres per row.

Lower Brush

D04239911

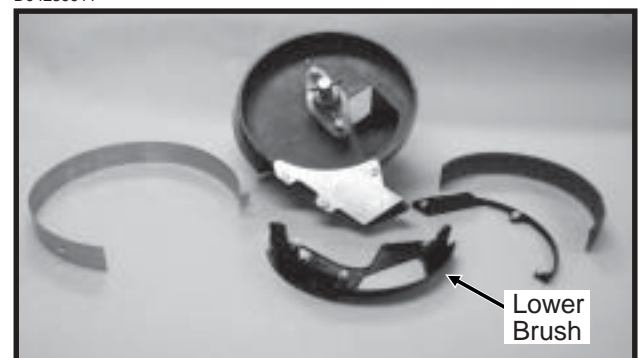

The lower brush has several functions. One function is to move seed down the seed loading slots to the seed pockets. The second function is to isolate seed in the reservoir from entering the seed tube and a third is to clean the seed loading slots.

Estimated life expectancy of the lower brush is 240-800 acres per row. The lower brush should be replaced if the bristles are deformed or missing or if there are cracks in the brush retainer.

MAINTENANCE

BRUSH-TYPE SEED METER TROUBLESHOOTING

PROBLEM	POSSIBLE CAUSE	SOLUTION
Low count.	Meter RPM too high.	Reduce planting speed.
	Misalignment between drive clutch and meter.	See "Seed Meter Drive Adjustment".
	Seed sensor not picking up all seeds dropped.	Clean seed tube. Switch meter to different row. If problem stays with same row, replace sensor.
	Lack of lubrication causing seeds not to release from disc properly.	Use graphite or talc as recommended.
	Seed size too large for seed disc being used.	Switch to smaller seed or appropriate seed disc. See "Brush-Type Seed Meter" for proper seed disc for size of seed being used.
	Seed treatment buildup in meter.	Reduce amount of treatment used and/or thoroughly mix treatment with seed. Add talc.
Low count at low RPM and higher count at higher RPM.	Foreign material lodged in upper brush.	Remove seed disc and remove foreign material from between brush retainer and bristles. Clean thoroughly.
	Worn upper brush.	Replace. See "Maintenance".
Low count at higher RPM and normal count at low RPM.	Seed disc worn in the agitation groove area.	Replace disc. See "Maintenance".
High count.	Seed size too small for seed disc.	Switch to larger seed or appropriate seed disc.
	Incorrect seed rate transmission setting.	Reset transmission. Refer to proper rate chart in "Machine Operation" section of manual.
	Upper brush too wide (fanned out) for small seed size.	Replace upper brush.
High count. (Milo/Grain Sorghum)	Incorrect brush retainer being used.	Make sure GD8237 brush retainer is installed to keep upper brush from fanning out.
Upper brush laid back.	Seed treatment buildup on brush.	Remove brush. Wash with soap and water. Dry thoroughly before reinstalling. See "Maintenance".
	Buildup of foreign material at base of brush.	Remove brush retainer and brush. Clean thoroughly. Reinstall.

MAINTENANCE

CLOSING WHEEL TROUBLESHOOTING

PROBLEM	POSSIBLE CAUSE	SOLUTION
Closing wheel(s) leave severe imprint in soil.	Too much closing wheel down pressure.	Adjust closing wheel pressure.
Closing wheel(s) not firming soil around seed.	Insufficient closing wheel down pressure.	Adjust closing wheel pressure. Severe no till conditions may require use of cast iron closing wheels.
"V" closing wheel running on top of seed furrow.	Improper centering.	Align. See "V Closing Wheel Adjustment".
Single closing wheel not directly over seed.	Improper centering.	Align. See "Covering Discs/Single Press Wheel Adjustment".

DRAG CLOSING ATTACHMENT

LF212299-18

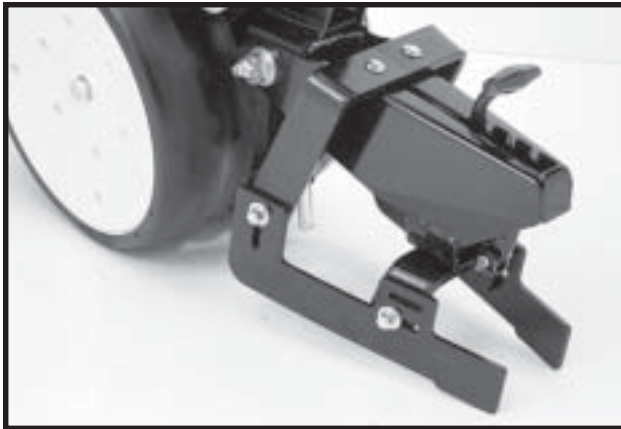

Prior to storage of the planter, inspect each drag closing attachment and replace any worn or broken parts. Check for loose hardware and tighten as needed.

GAUGE WHEEL ADJUSTMENT

To prevent an accumulation of dirt or trash, gauge wheels should lightly contact the opener blades. Gauge wheels and opener blades should turn with only slight resistance.

To adjust clearance between gauge wheels and opener blades, add or remove machine bushings between the shank and gauge wheel arm. Store remaining machine bushings between gauge wheel arm and flat washer on outer side of gauge wheel arm.

NOTE: It may be desirable to space gauge wheel further from blade when operating in sticky soils.

LF212199-2

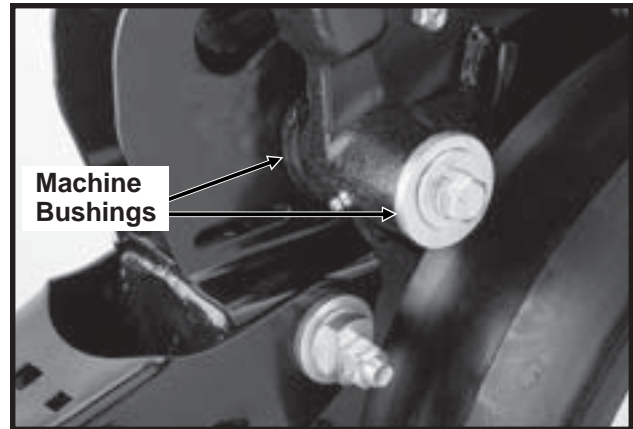

(RU113)

Machine Bushings - Minimum 2 Between Arm And Shank/ Minimum 1 Between Arm And Bolt Head

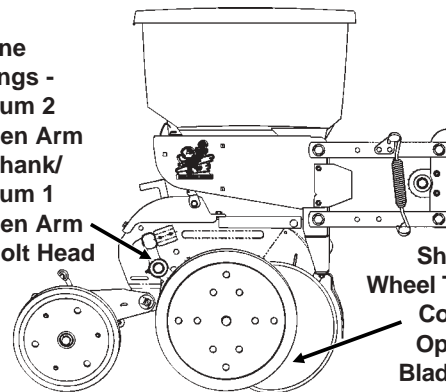

Shim Gauge Wheel To Lightly Contact The Opener Disc Blade - Check Adjustment In Field Position

MAINTENANCE

GAUGE WHEEL ARM BUSHING AND/OR SEAL REPLACEMENT

(RU113)

Gauge Wheel Arm Bushings/Seals

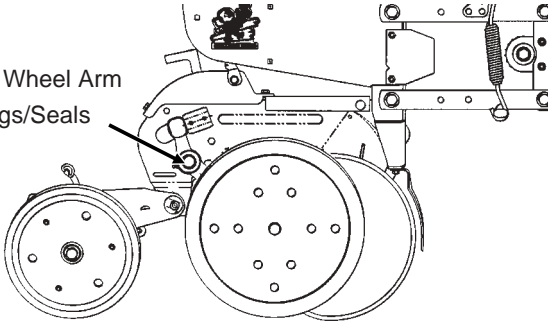

NOTE: A Gauge Wheel Arm Bushing And Seal Driver Kit (G1K296), for use in bushing and seal replacement, is available through your KINZE® Dealer.

To replace gauge wheel arm assembly bushing(s) and/or seal(s):

1. Remove gauge wheel from arm.
2. Remove the gauge wheel arm assembly from the shank assembly.
3. Remove seal and bushing and discard. Clean and dry inner bore.

(A7975/RU122)

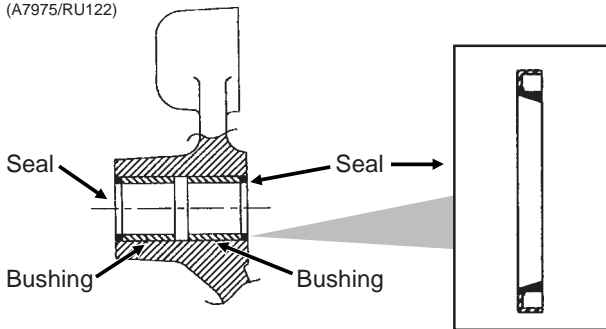

4. Drive/press replacement bushing inside bore of arm to a depth of .125" below flush.
5. Coat wiping edge of seal with grease.
6. Drive/press seal into place with lip to the outside as shown above.

NOTE: Use extra care to protect the sealing lip during installation. Apply uniform pressure to assemble the seal into the bore of the arm. Never apply a direct hammer blow to the seal surface.

7. Inspect gauge wheel pivot spindle.
8. Reinstall gauge wheel arm assembly and gauge wheel.

NOTE: Special machine bushing between gauge wheel arm and gauge wheel.

9. Shim for proper gauge wheel tire/disc blade clearance.
10. Lubricate with an SAE multipurpose type grease.

GAUGE WHEEL ARM PIVOT SPINDLE REPLACEMENT

(RU113)

Gauge Wheel Pivot Spindle

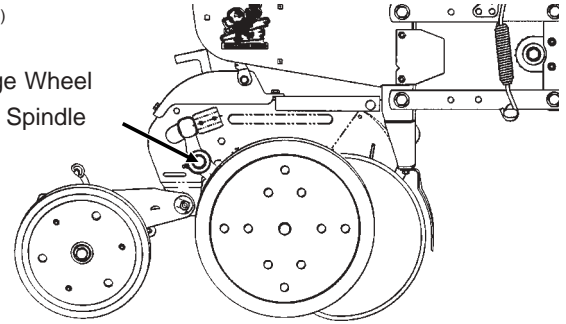

To replace gauge wheel pivot spindle:

1. Remove the gauge wheel and arm assemblies from the shank assembly.
2. Remove 1/2" x 3/4" cap screw that locks the pivot spindle in place and remove the spindle.

D06189902

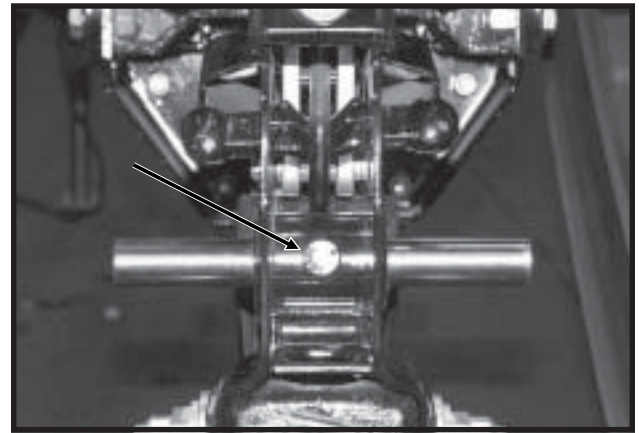

3. Install the replacement spindle and position as shown below. Exact centering is critical.

(A7966)

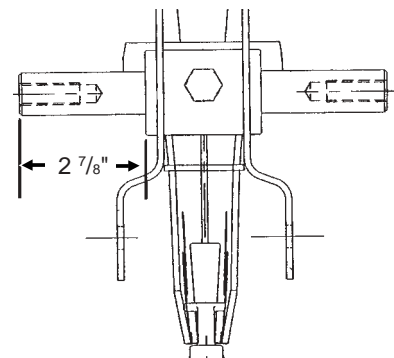

4. Install 1/2" x 3/4" cap screw and torque to lock pivot spindle in place.
5. Install gauge wheel and arm assemblies. Shim for proper gauge wheel tire/disc blade clearance.

MAINTENANCE

15" SEED OPENER DISC BLADE/ BEARING ASSEMBLY

Approximately 1"-1 1/2" of blade-to-blade contact should be maintained to properly open and form the seed trench. As the blade diameter decreases, due to wear, it will be necessary to relocate machine bushings from inside to outside to maintain approximately 1"-1 1/2" of contact.

NOTE: If proper blade-to-blade contact cannot be maintained after relocating machine bushings or if blade diameter wears below 14 1/2", the blade should be replaced.

IMPORTANT: Excessive blade contact may result in premature disc opener bearing/hub failures and excessive wear on seed tube guard/inner scraper. When properly adjusted, if one blade is held in fixed position, the opposite blade should be able to be rotated with minimal force. (Less than 5 pounds force at outer edge of blade.)

(RU113)

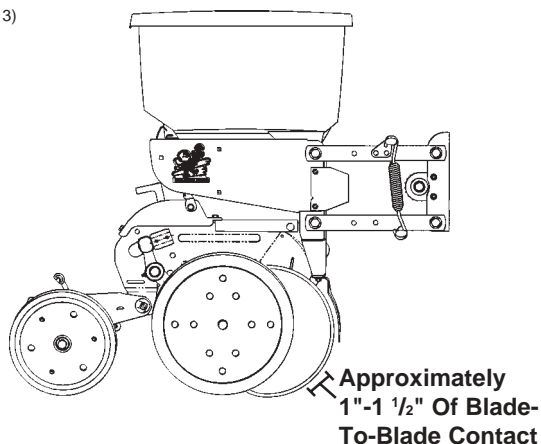

To replace disc blade/bearing assembly:

1. Remove gauge wheel.
2. Remove scraper.
3. Remove bearing dust cap.
4. Remove cap screw, washer and disc blade/bearing assembly. The machine bushings between the shank and disc blade are used to maintain the approximate 1"-1 1/2" of blade-to-blade contact.

IMPORTANT: Left hand side of opener uses a left hand threaded cap screw. DO NOT OVER TIGHTEN. Damage to shank threads will require replacement of row unit shank assembly.

5. Install machine bushing(s), new disc blade/bearing assembly, washer and cap screw. Torque 5/8"-11 Grade 5 cap screw to value shown in "Torque Values Chart".

NOTE: Replace disc blade only with disc blade of equal thickness.

6. Replace bearing dust cap.
7. Install scraper.
8. Install gauge wheel.

It may be necessary to replace only the bearing if there is excessive endplay or if the bearing sounds or feels rough when the disc blade is rotated.

To replace bearing:

1. Remove gauge wheel, scraper, bearing cap, cap screw, washer and disc blade/bearing assembly.
2. Remove 1/4" rivets from bearing housing to expose bearing.
3. After installing new bearing, install three evenly spaced 1/4" cap screws into three of the six holes in the bearing housing to hold the bearing and bearing housing in place. Install rivets in the other three holes. Remove 1/4" cap screws and install rivets in those three holes.
4. Reinstall disc blade/bearing assembly, washer and cap screw. Torque 5/8"-11 cap screw to value shown in "Torque Values Chart" at the beginning of this section.
5. Replace bearing dust cap.
6. Install scraper and gauge wheel.

MAINTENANCE

SEED TUBE GUARD/INNER SCRAPER

The seed tube guard protects the seed tube and acts as the inner scraper for the seed opener disc blades.

Remove the seed tube and check for wear. Excessive wear on the seed tube indicates a worn seed tube guard. Replace the seed tube guard if it measures $\frac{5}{8}$ " or less at the lower end. A new seed tube guard measures approximately $\frac{7}{8}$ ".

LF212199-12

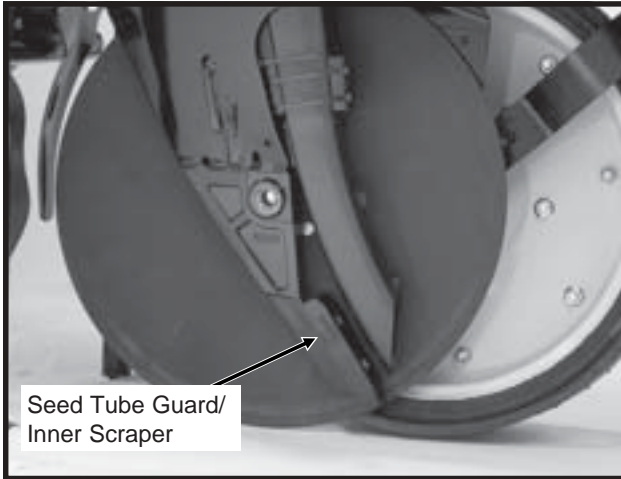

Shown With Gauge Wheel And Seed Opener Disc Blade Removed For Visual Clarity

IMPORTANT: No till planting or planting in hard ground conditions, especially when the planter is not equipped with no till coulters, and/or excessive blade-to-blade contact will increase seed tube guard wear and necessitate more frequent inspection and/or replacement.

To replace the seed tube guard, remove the seed tube and the two hex socket head cap screws which attach the seed tube guard. Hold the replacement seed tube guard centered between the seed opener disc blades. Install, but DO NOT tighten, the hex socket head cap screws. Using a clamp or vise-grip, squeeze the opener blades together in front of the seed tube guard. Tighten the seed tube guard retaining screws. Remove the clamps. The distance between the seed tube guard and opener blades should be equal on both sides. Reinstall seed tube.

IMPORTANT: Over tightening the hex socket head cap screws may damage the threads in the shank and require replacement of the shank. A seed tube guard that is worn excessively may allow the blades to wear into the row unit shank, also requiring replacement of the shank.

FRAME MOUNTED COULTER - STYLE A

LF212299-20

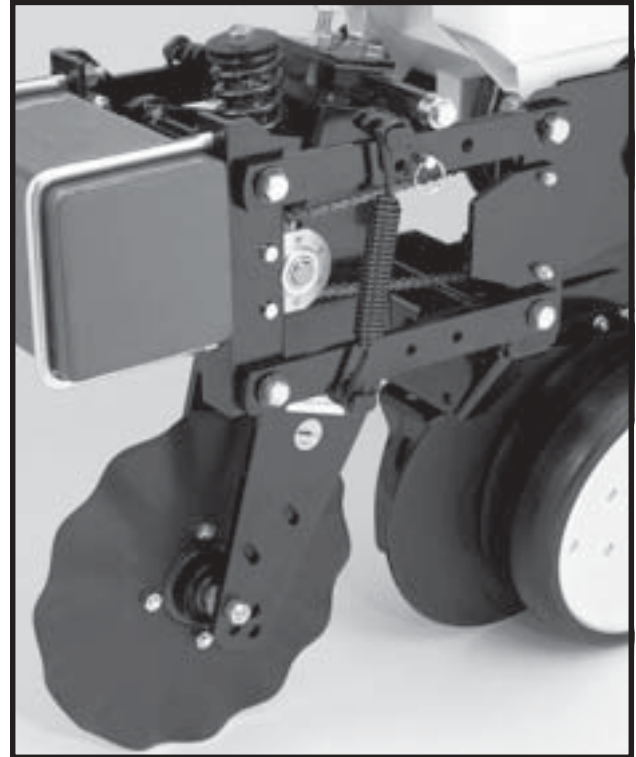

If properly maintained and lubricated (If Applicable) the bearings in the frame mounted coulters hub may never need to be replaced. Lubricate (If Applicable) at frequency indicated in the Lubrication Section of this manual. Check periodically to be sure nuts and hardware are tightened to proper torque specification. Be sure the coulters are positioned square with the planter frame and aligned in front of row unit disc opener.

NOTE: Torque $\frac{5}{8}$ " spindle bolts to 120 ft. lbs.

See "Frame Mounted Coulters" in Row Unit Operation Section of this manual for depth and spring adjustment.

When the 16" diameter coulters blade (1" fluted, 1" bubbled or $\frac{3}{4}$ " fluted) is worn to 14 $\frac{1}{2}$ " (maximum allowable wear), it should be replaced.

(If Applicable) Timely lubrication at the frequency indicated in the Lubrication Section of this manual is necessary to purge moisture and dirt from bearing and seal. This will also lubricate the seal. Add grease until it comes out around the seal.

MAINTENANCE

FRAME MOUNTED COULTER - STYLE B

LF083002101

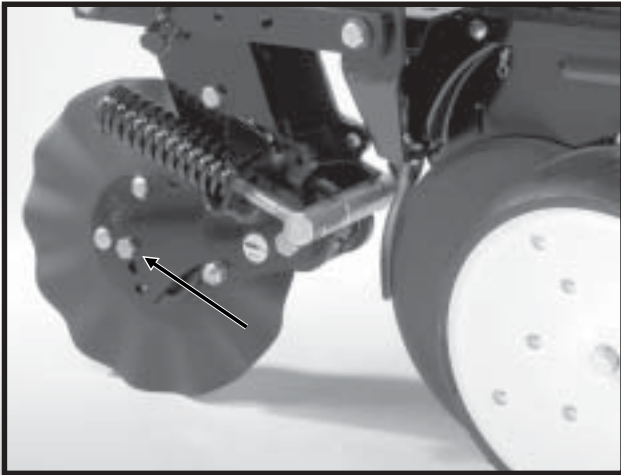

NOTE: Torque $\frac{5}{8}$ " spindle bolts to 120 ft. lbs.

See "Frame Mounted Coultter - Style B" in Row Unit Operation Section of this manual for depth and spring adjustment.

When the 16" diameter coultter blade (1" fluted, 1" bubbled or $\frac{3}{4}$ " fluted) is worn to 14 $\frac{1}{2}$ " (maximum allowable wear), it should be replaced.

DISC FURROWER (For Use With Style A Frame Mounted Coultter)

LF212299-21

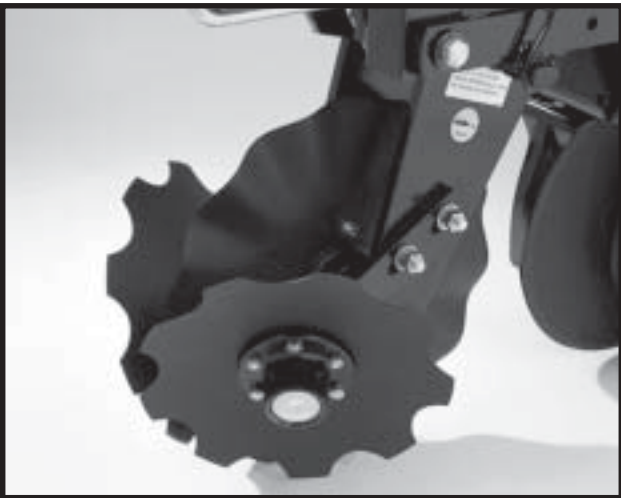

The blade hubs are equipped with sealed bearings. If bearings sound or feel rough when the blade is rotated, replace the bearings.

When the 12" diameter blades (solid or notched) are worn to 11", they should be replaced.

RESIDUE WHEELS (For Use With Style B Frame Mounted Coultter)

LF083002102

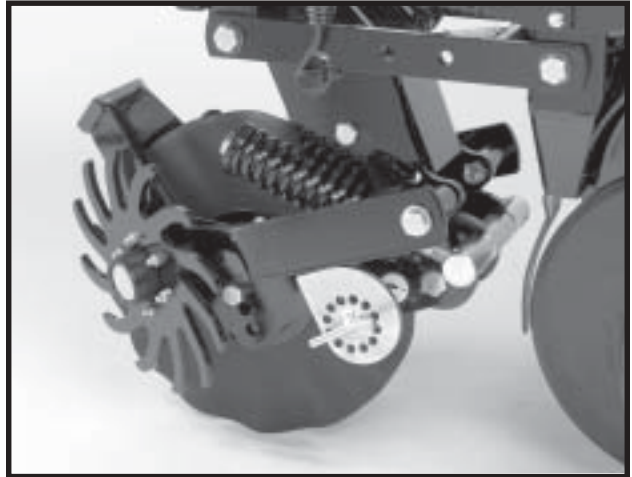

The wheel hub is equipped with sealed bearings. If bearings sound or feel rough when the wheel is rotated, replace the bearings.

ROW UNIT MOUNTED DISC FURROWER

LF212299-22

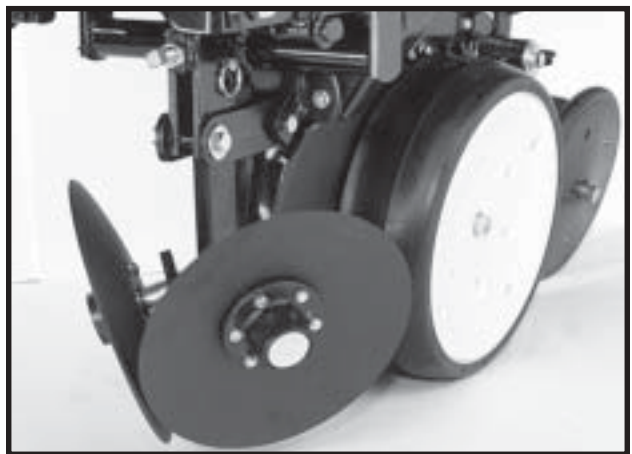

Lubricate the bushings in the support arm and mounting bracket at the frequency indicated in the Lubrication Section of this manual. Using a torque wrench, check each bolt for proper torque. If the bolt is loose, it should be removed and the bushing inspected for cracks and wear. Replace bushings as necessary. **Only hardened flat washers should be used. Replace damaged flat washers with proper part. Torque bolts to 130 ft. lbs.**

The blade hubs are equipped with sealed bearings. If bearings sound or feel rough when the blade is rotated, replace the bearings.

When the 12" diameter blades (solid or notched) are worn to 11", they should be replaced.

MAINTENANCE

ROW UNIT MOUNTED RESIDUE WHEEL

D101701113



The wheel hub is equipped with sealed bearings. If bearings sound or feel rough when the wheel is rotated, replace the bearings.

ROW UNIT MOUNTED NO TILL COULTER

LF212299-19a

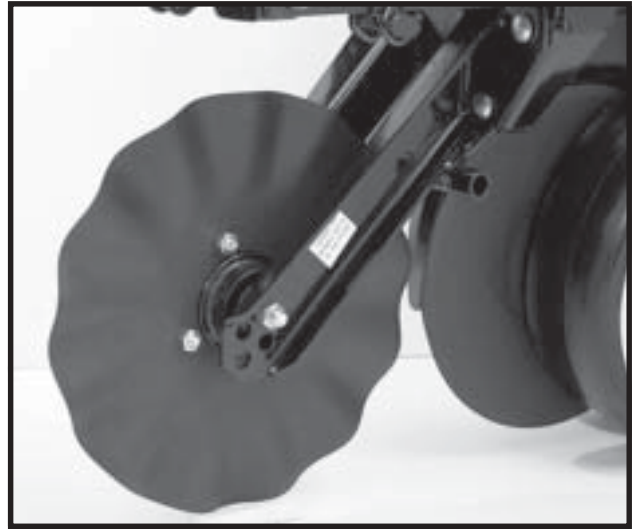

Lubricate (If Applicable) at frequency indicated in the Lubrication Section of this manual. Check periodically to be sure nuts and hardware are tightened to proper torque specification.

NOTE: Torque $\frac{5}{8}$ " spindle bolts to 120 ft. lbs.

Be sure the coulters is positioned square with the row unit and aligned in front of row unit disc opener.

The coulters blade can be adjusted to one of four settings. Initially the blade is set in the highest position. As the blade wears it can be adjusted to one of the three lower settings. See "Row Unit Mounted No Till Coulters" in Row Unit Operation Section of this manual.

When the 16" diameter coulters blade is worn to 14 $\frac{1}{2}$ " (maximum allowable wear), it should be replaced.

(If Applicable) Timely lubrication at the frequency indicated in the Lubrication Section of this manual is necessary to purge moisture and dirt from bearings and seals. This will also lubricate the seals. Add grease until it comes out around the seals. Spin hub while filling with grease.

MAINTENANCE

COULTER MOUNTED RESIDUE WHEELS

LF212299-23

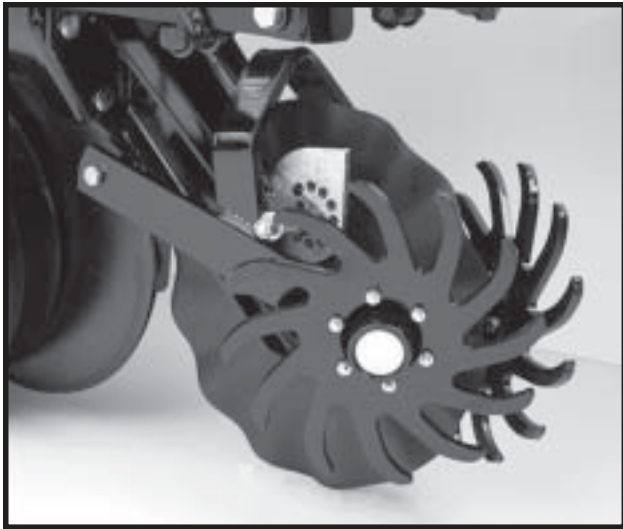

The wheel hubs are equipped with sealed bearings. If bearings sound or feel rough when the wheel is rotated, replace the bearings.

GRANULAR CHEMICAL ATTACHMENT

Prior to storage of the planter, disengage the granular chemical drive by rotating the throwout knob $\frac{1}{4}$ turn counterclockwise. Remove the drive chain and empty and clean all granular chemical hoppers. Clean the drive chains and coat them with a rust preventive spray or submerge chains in oil. Inspect and replace any worn or broken parts.

Install hoppers and chains. Check chain alignment.

LF212299-4

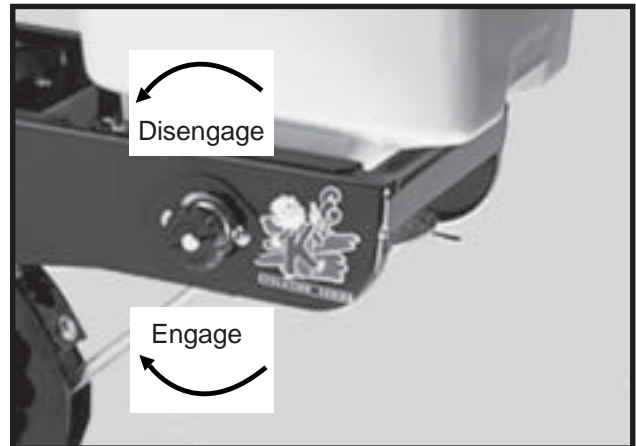

SPRING TOOTH INCORPORATOR

Prior to storage of the planter, inspect each spring tooth incorporator and replace any worn or broken parts. Check for loose hardware and tighten as needed.

LF212299-26

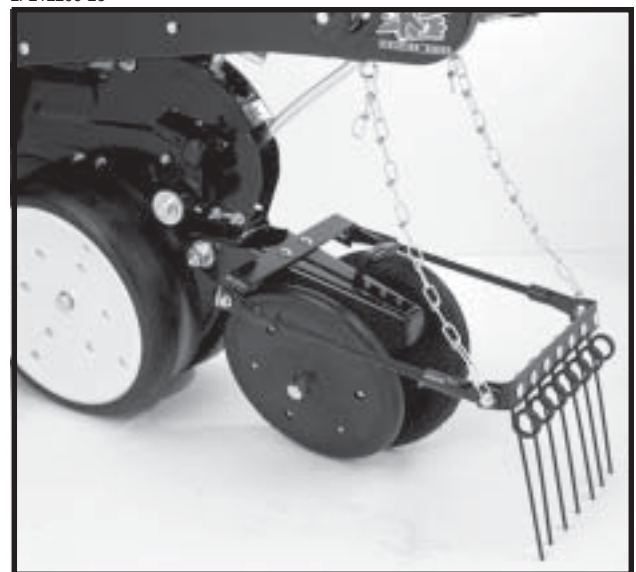

MAINTENANCE

KPM I/KPM II ELECTRONIC SEED MONITOR TROUBLESHOOTING

PROBLEM	POSSIBLE CAUSE	SOLUTION
Single sensor communication alarm comes on (alarm on with no bar graph and a flashing row number on a single row).	Faulty seed tube sensor.	Replace sensor.
	Break in the harness just before the seed tube sensor.	Inspect for break in harness and repair. If break can't be found, replace harness section.
	Dirty or corroded connector.	Clean connector.
Sensor communication alarms come on for all sensors (alarm on with no bar graphs and flashing row numbers on all rows).	Faulty monitor.	Replace monitor.
	Break in the harness just after the monitor.	Inspect for break in harness and repair. If break can't be found, replace harness section.
	Dirty or corroded connector.	Clean connector.
Sensor communication alarms come on for some sensors (alarm on with no bar graphs and flashing row numbers on all rows).	Break in the harness.	Inspect for break in harness and repair. If break can't be found, replace harness section corresponding with the alarming sensors.
	Dirty or corroded connector.	Clean connector.
Faulty monitor values (such as speed, area, etc.) being displayed. (KPM II Only)	Incorrect monitor settings.	Change settings to properly correspond to the system.
	Faulty radar/magnetic distance sensor.	Replace sensor.
	Improperly mounted radar sensor.	Properly mount sensor.
Underplanting or no planting alarm on a single sensor when planting (alarm on with a single bar graph segment on and a flashing row number on a single row).	Seed tube sensor is blocked.	Clean sensor.
	Faulty seed tube sensor.	Replace sensor.
Seed tube sensor dirty or blocked warning comes on (after calibration, bar graph keeps flashing for a single row).	Seed tube sensor is dirty.	Clean sensor.
	Faulty seed tube sensor.	Replace sensor.
LED on the seed tube sensor will not come on.	Faulty seed tube sensor.	Replace sensor.
	Dirty or corroded connector.	Clean connector.
	Break in the harness just before the sensor.	Repair harness.
Erroneous MPH readings at idle. (Radar Distance Sensor Only)	Radar sensor not located in a stable location.	Relocate to a more stable location.

MAINTENANCE

SOLENOID VALVE INSPECTION

The solenoid valve consists of a chambered body containing a cartridge valve which is activated by an electrical coil.

If the solenoid or solenoids fail to operate, first determine if the problem is electrical or hydraulic. If the valve is working properly, a click will be heard when the solenoid coil is energized. This will be the valve stem opening up. If no sound is heard, check the solenoid coil by touching the top of the coil housing with a metallic object such as a pliers or screwdriver. If the coil is working properly, the coil housing will be strongly magnetized when energized. If the voltage to the coil is low, the coil will be weakly magnetized when energized and no click will be heard.

VVB019(PLTR55)

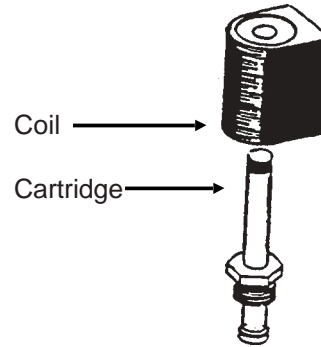

SOLENOID VALVE TROUBLESHOOTING

PROBLEM	POSSIBLE CAUSE	SOLUTION
None of the solenoids will operate.	Low Voltage.	Must be connected to 12 volt DC only. Negative ground.
	Blown fuse.	Replace fuse in control console on tractor with AGC-15 amp only.
	Battery connection.	Clean and tighten.
	Wiring harness damaged.	Repair or replace.
One solenoid valve will not operate.	Bad switch.	Replace on control panel.
	Cut wire in harness.	Locate and repair.
	Bad coil.	Replace.
	Poor connection at coil.	Check.
Valve operating when not energized.	Valve stem stuck open.	Replace cartridge.
	O-ring leaking.	Install new o-ring kit.
	Foreign material under poppet.	Remove cartridge and clean.

FLOW CONTROL VALVE INSPECTION

VVB020(TWL28)

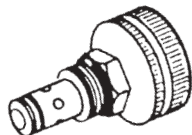

The flow control valves should be adjusted for row marker raise and lower speed as part of the assembly procedure or upon initial operation. If the valve fails to function properly or requires frequent adjustment, it should be removed for inspection. Check for foreign material and contamination on both the valve and the seating area of the valve body. Replace any components found to be defective.

CHECK VALVE

VVB020(TWL30a)

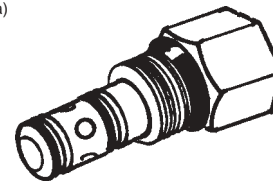

The check valve, located in the valve block on the planter hitch, traps oil flow in the planter lift system to hold the toolbar tight against the axle during field operation. Hydraulic pressure from the tractor is required to lift the toolbar. Consult your KINZE® Dealer for service.

MAINTENANCE

LIFT CIRCUIT TROUBLESHOOTING

PROBLEM	POSSIBLE CAUSE	SOLUTION
Planter will raise to raised field position, but will not raise to transport position.	Solenoid valve coil in port V3 is not energized.	Be sure control console switch is in RAISE position to energize solenoid coil in port V3. Check control console fuse by moving auxiliary switch to ON position. If red light comes on the fuse is OK. Return auxiliary to OFF position. Check for poor wire connection or damaged wire and repair. Solenoid valve coil is defective. All solenoid valves used on the planter are the same. Switch the solenoid coil with one you know is working. If this cures the problem, replace defective coil.
	Solenoid valve cartridge in port V3 is stuck closed.	All solenoid valves used on the planter are the same. Switch the solenoid cartridge with one you know is working. If this cures the problem, replace defective cartridge.
Planter will not raise.	Tractor may have hydraulic problem.	Repair tractor hydraulics.
	Planter may be overloaded with hopper extensions and/or extra fertilizer tanks, coulters or non-KINZE® approved attachments.	Remove weight.

ROTATION CYLINDER CIRCUIT TROUBLESHOOTING

PROBLEM	POSSIBLE CAUSE	SOLUTION
Cylinder does not extend or retract.	Solenoid valve coil in port V1 defective.	Check switch on control console. Replace if defective. Check coil ground wire. Check for poor connection or damaged wire.
	Solenoid valve cartridge in port V1 is stuck closed.	Replace cartridge. Test cartridge by switching with one you know is working properly. Try cartridge from port V1 which is the raise-to-transport cartridge.

NOTE: One set of hydraulic outlets, in conjunction with the switches on the control console, are used to operate the markers and rotation function. The rotation function is controlled by one solenoid valve located in the valve block on the planter hitch. Energize the solenoid valve to operate the rotation function.

MAINTENANCE

MARKER OPERATION TROUBLESHOOTING

PROBLEM	POSSIBLE CAUSE	SOLUTION
Right marker lowering slower than left marker.	Solenoid valve cartridge in port V2 not opening completely.	Switch cartridge with one in port V1. If problem follows cartridge, replace cartridge.
	Hose pinched or collapsed.	Inspect hose routing. Replace or repair hoses as required.
Left marker lowering slower than right marker.	Solenoid valve cartridge in port V1 not opening completely.	Switch cartridge with one in port V2. If problem follows cartridge, replace cartridge.
	Hose pinched or collapsed.	Inspect hose routing. Replace or repair hoses as required.
Both markers lowering.	Solenoid valve cartridge stuck open. If marker switch is in the left marker position, the right cartridge (V2) is defective. If the marker switch is in the right marker position, the left cartridge (V1) is defective.	Replace solenoid valve cartridge.
Neither marker will lower.	Blown fuse.	Check red light on control console. It should be on if switch is on. If light is not on, switch to opposite marker position. If light comes on, switch may be defective. Replace switch. Otherwise replace fuse.
	Coils at V2 and V1 not energized.	Poor ground on wire, bad wire connection or damaged wire. Repair as required.
	Marker flow control valve closed too far.	See Operation Section for adjustment.
Neither marker will raise.	Marker flow control valve closed too far.	See Operation Section for adjustment.
Right marker will not lower.	Solenoid coil in port V2 not energized.	Check switch on control console. Replace if defective. Check coil ground wire. Check for poor connection or damaged wire.
	Solenoid cartridge in port V2 stuck closed.	Switch cartridge with one on the planter you know is operating properly. If right marker lowers, replace defective cartridge.
Left marker will not lower.	Solenoid coil in port V1 not energized.	Check switch on control console. Replace if defective. Check coil ground wire. Check for poor connection or damaged wire.
	Solenoid cartridge in port V1 stuck closed.	Switch cartridge with one on the planter you know is operating properly. If left marker lowers, replace defective cartridge.
Markers traveling too fast and damaging pivot at rod end of marker cylinders.	Marker flow control valve out of adjustment.	See Operation Section for adjustment.

MAINTENANCE

MARKER BEARING LUBRICATION OR REPLACEMENT

1. Remove marker blade.
2. Remove dust cap from hub.
3. Remove cotter pin, nut and washer.
4. Slide hub from spindle.
5. Remove bearings and cups and discard if bearings are being replaced. Clean hub and dry. Remove bearings only and not cups if repacking.
6. Press in new bearing cups with thickest edge facing in. (Bearing replacement procedure only.)
7. Pack bearings with heavy duty wheel bearing grease thoroughly forcing grease between roller cone and bearing cage. Also fill the space between the bearing cups in the hub with grease.
8. Install rubber seal into grease seal. Place inner bearing in place and press in new rubber seal/grease seal.
9. Clean spindle and install hub.
10. Install outer bearing, washer and slotted hex nut. Tighten slotted hex nut while rotating hub until there is some drag. This assures that all bearing surfaces are in contact. Back off slotted nut to nearest locking slot and install cotter pin.
11. Fill dust caps approximately $\frac{3}{4}$ full of wheel bearing grease and install on hub with attachment bolts.
12. Install blade and dust cap retainer on hub and tighten evenly and securely.

(PLTR45/PLTR99/PLTR98/PLTR102)

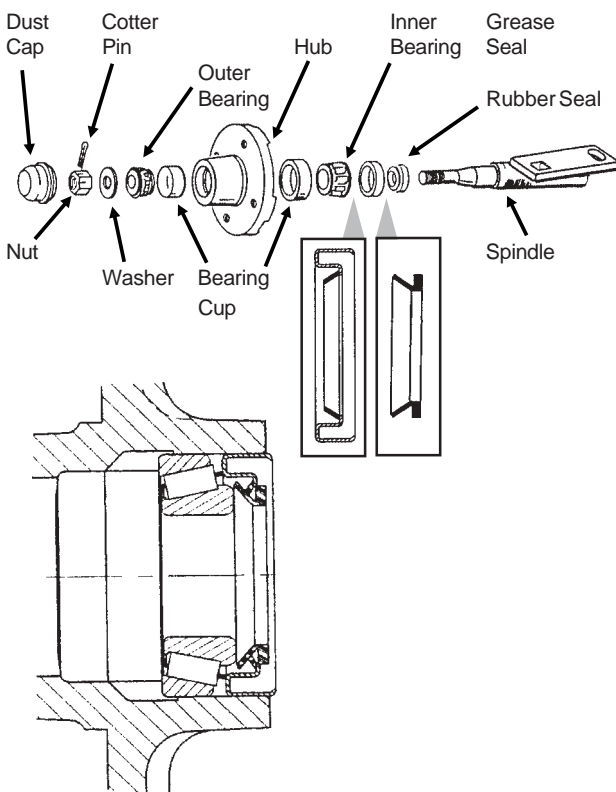

TRANSPORT WHEEL BEARING REPLACEMENT

1. Raise tires clear of ground and remove wheels.
2. Remove dust cap attachment hardware and remove cap from wheel hub.
3. Remove cotter pin, axle nut and 2" washer.
4. Slide hub from axle spindle, using a hub puller if necessary.
5. Remove bearings and cups from hub and discard. Thoroughly clean and dry wheel hub.
6. Press in new bearing cups with thickest edges facing in.
7. Pack bearing with heavy-duty wheel bearing grease, thoroughly forcing grease between roller cone and bearing cage. Also fill the space between the bearing cups in the hub with grease.
8. Place inner bearing in hub and press in new grease seal with lip pointing towards bearing.
9. Clean axle spindle and install hub.
10. Install outer bearing, 2" washer and slotted hex nut. Tighten slotted hex nut while rotating the hub until there is some drag. This assures that all bearing surfaces are in contact. Back off slotted nut to nearest locking slot and install cotter pin. Check for endplay in bearings.
11. Fill dust cap half full of wheel bearing grease and install on hub with attachment bolts.
12. Install wheels and remove jack. Torque inner and outer budd nuts to 450-500 ft. lbs.

HTA002(PLTR149)

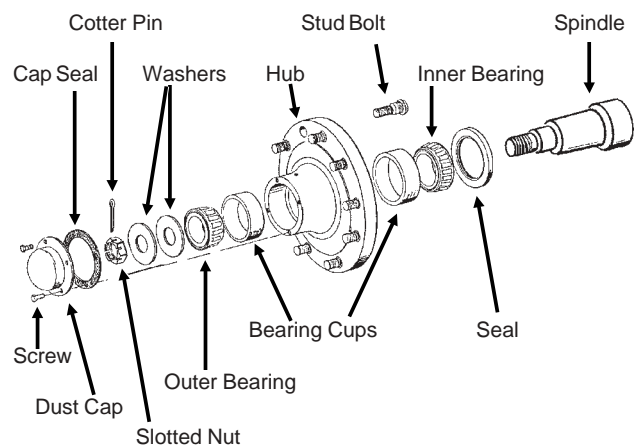

MAINTENANCE

TRANSPORT LATCH POST WEAR PAD REPLACEMENT/ADJUSTMENT

D060999113

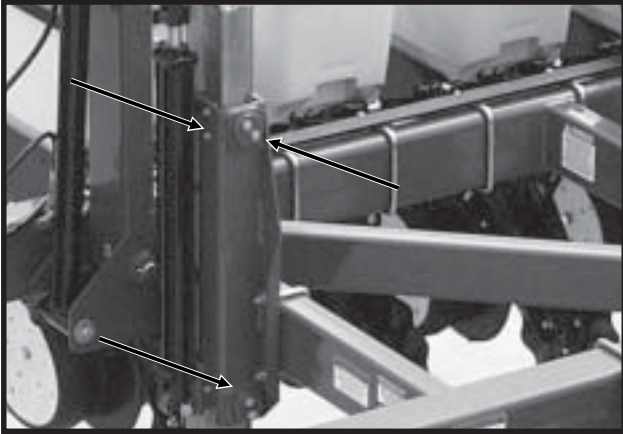

The transport latch post assembly consists of a plated tubular post equipped with two stationary and six adjustable wear pad assemblies. Each adjustable wear pad assembly consists of a poly wear pad, a threaded adjustment plug and a cap. The assembly is held in place by the threaded adjustment plug and locked in position by the cap and two 1/2" hex head cap screws.

Check wear and pad adjustment annually.

To check wear pad adjustment, visually inspect all six adjustable assemblies. Each wear pad should lightly contact the plated post. If adjustment is necessary, loosen two 1/2" cap screws on cap. Hand tighten wear pad assembly until poly pad lightly contacts post. Retighten 1/2" cap screws to 25-30 ft. lbs.

(TWL69a)

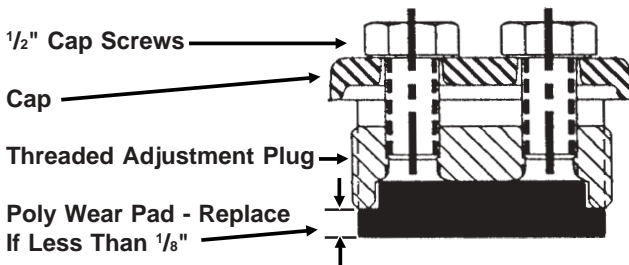

CAUTION: DO NOT OVER TIGHTEN WEAR PADS. OVER TIGHTENING WILL CAUSE PREMATURE WEAR.

PUSH PAD SHIM REPLACEMENT/ADJUSTMENT

D06109911

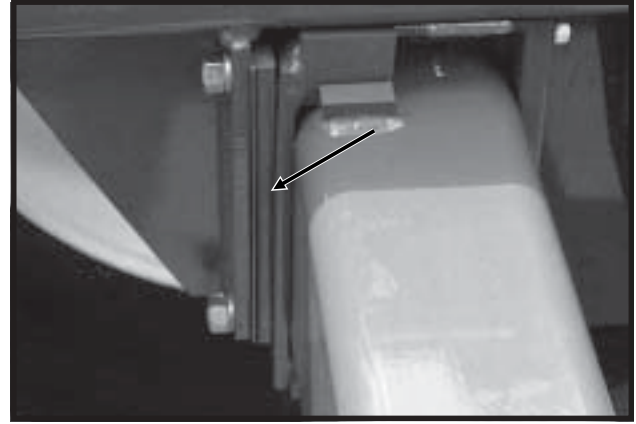

Shims on the push pads on the planter frame can be added or removed to adjust planter frame height.

Frame height is correct when distance between frame and top of axle measured just in front of push pads is 2" - 2 3/4".

MAINTENANCE

PISTON PUMP STORAGE

12229799

IMPORTANT: KEEP AIR OUT OF PUMP! This is the only way to prevent corrosion. Even for short periods of storage, the entrance of air into the pump, will cause RAPID AND SEVERE CORROSION.

Overnight Storage

SUSPENSION FERTILIZER must be flushed from the pump for ANY storage period.

Winter Storage

1. Flush pump thoroughly with 5 to 10 gallons of fresh water and circulate until all corrosive salts are dissolved in the pump.
2. With the pump set on 10, draw in a mixture of half diesel fuel and half 10 weight oil until the discharge is clean. Then plug inlet and outlet.

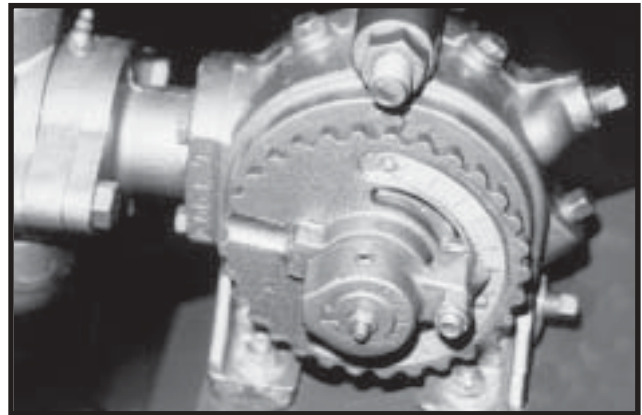

PISTON PUMP TROUBLESHOOTING

PROBLEM	POSSIBLE CAUSE	SOLUTION
Pump hard or impossible to prime.	Valves fouled or in wrong place.	Inspect and clean valves.
	Air leak in suction line.	Repair leak.
	Pump set too low.	Adjust pump setting.
	Packing washers worn out.	Replace.
Low metering.	Valves fouled or in wrong place.	Inspect and clean valves.
	Air leak in suction line.	Repair leak.
	Pump set too low.	Adjust pump setting.
	Broken valve spring.	Replace spring.
Over meters.	Broken discharge valve spring.	Replace spring.
	Trash under valves.	Inspect and clean valves.
	Improper rate setting.	Adjust pump setting.
Leaks through when stopped.	Broken discharge valve spring.	Replace spring.
	Trash under valves.	Inspect and clean valves.
Fertilizer solution leaking under stuffing box.	Packing washers worn out.	Replace.
Pump using excessive oil.	Oil seals or o-ring worn and leaking.	Replace.
Pump operates noisily.	Crankcase components worn excessively.	Inspect and replace if necessary.

MAINTENANCE

PREPARATION FOR STORAGE

Store the planter in a dry sheltered area if possible.

Remove all trash that may be wrapped on sprockets or shafts and remove dirt that can draw and hold moisture.

Clean all drive chains and coat with a rust preventative spray, or remove chains and submerge in oil.

Lubricate planter and row units at all lubrication points.

If possible, remove weight from all tires particularly if the unit is stored outdoors, in which case it is best to remove wheels and tires for storage in a cool, dry area.

Inspect the planter for parts that are in need of replacement and order during the "off" season.

Make sure all seed and granular chemical hoppers are empty and clean.

Clean seed meters and store in a rodent-free, dry area.

Remove seed discs from brush-type seed meters, clean and store meters with discs removed.

Grease exposed areas of cylinder rods before storing planter.

Grease or paint disc openers/blades and marker blades to prevent rust.

Flush liquid fertilizer tanks, hoses and metering pumps with clear water. See "Piston Pump Storage" if applicable.

ELECTRICAL WIRING DIAGRAM FOR LIGHT PACKAGE

Light package supplied on the Model 3400 Twin-Line® Planter meets ASAE Standards. For the correct wiring harness to be wired into the lights on your tractor, check with the tractor manufacturer.

69922-35



Prior To Serial No. 625040

(WGN66a/WGN66b/A8430c/A8430d)

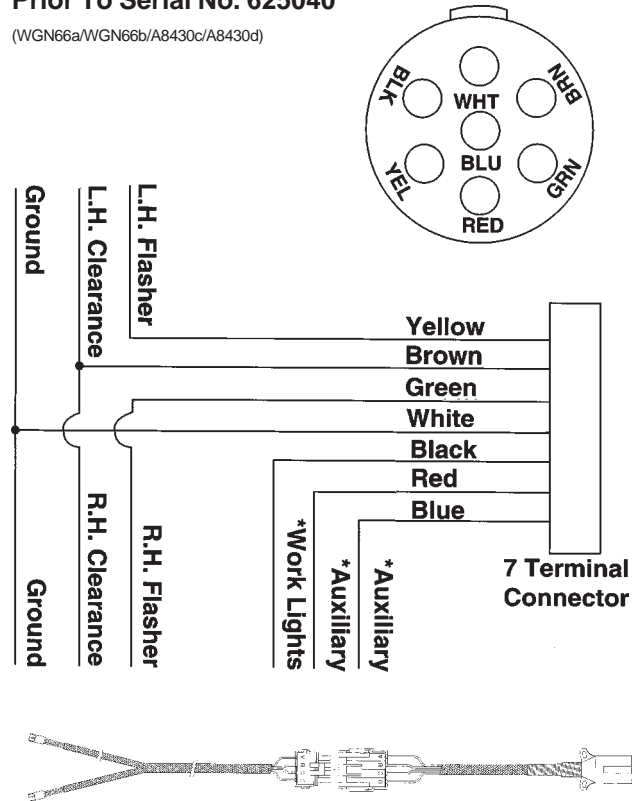

Serial No. 625040 And On

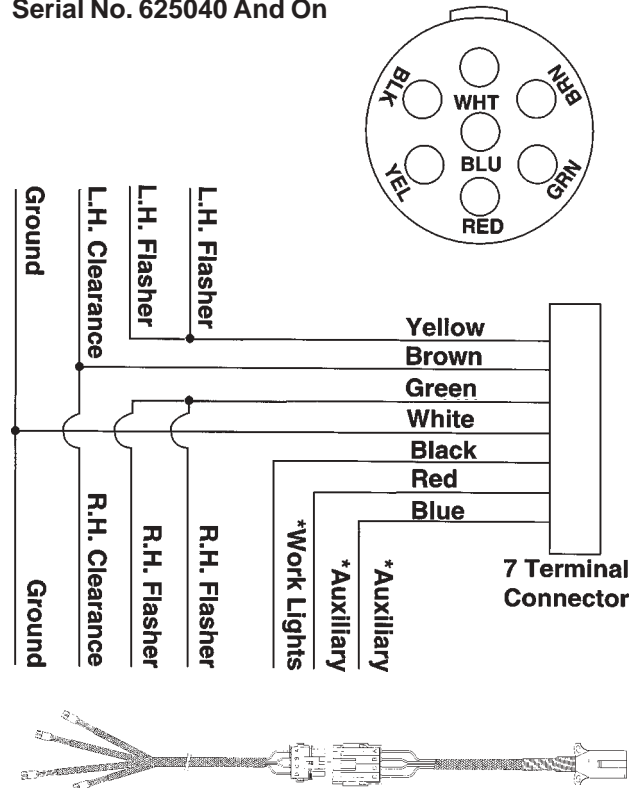

*Optional customer-supplied auxiliary lights and wires may be wired into existing plug terminals.

MAINTENANCE

ELECTRICAL CONTROL CONSOLE SCHEMATIC

IMPORTANT: Before doing any electrical work, disconnect the control console from the tractor battery. Keep wiring harnesses away from high temperature areas or sharp edges. **DO NOT** route the wiring harnesses along battery cables. Use tie straps to keep wire harness away from moving parts on tractor and planter. Be sure ground connections to the tractor frame are clean to provide good electrical contact.

A7407(PLTR82a)

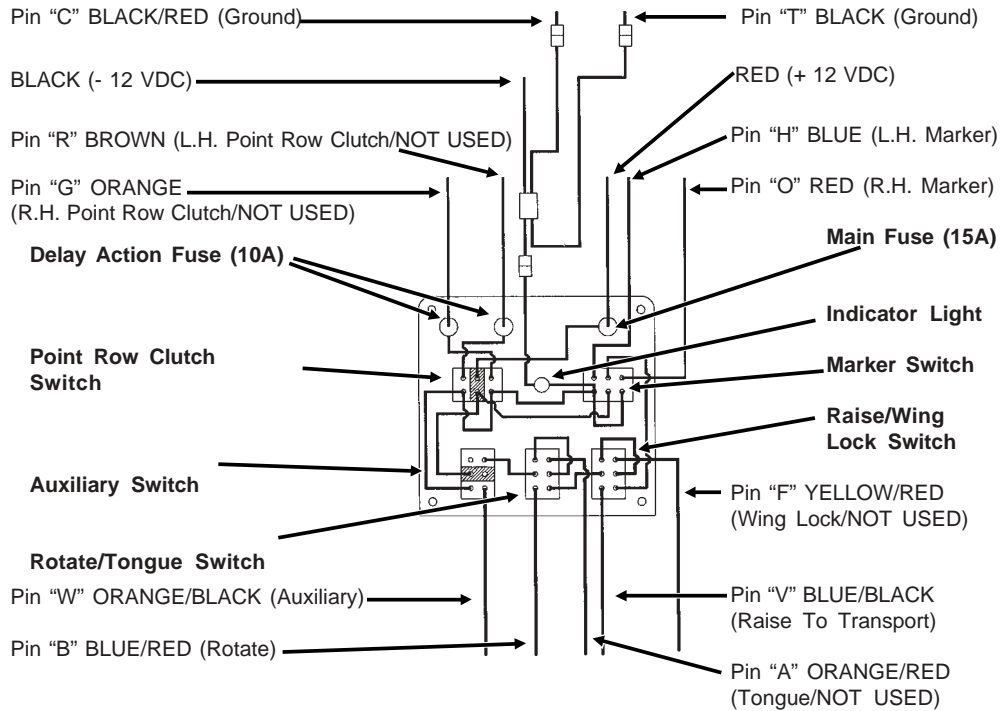

A7407(INS238)

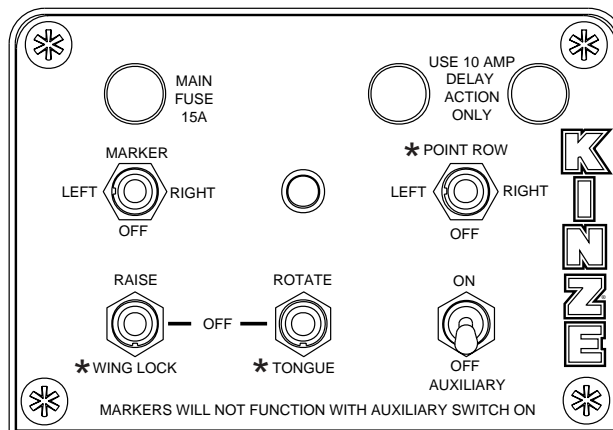

NOTE:

1. Operating marker or point row switch in either direction lights panel light.
2. Point row clutch switch operates independently of the rest of the control box.
3. Power to the marker switch is fed through the auxiliary switch and the two transport function switches. Operating any of the switches in the lower row disables the marker function and turns off the panel light. (If the point row clutch switch is in the OFF position.)

*Not used on Model 3400 planter.

MAINTENANCE

ELECTRICAL WIRING HARNESS SCHEMATIC (On Tractor)

A7368(ELC10C/ELC13)

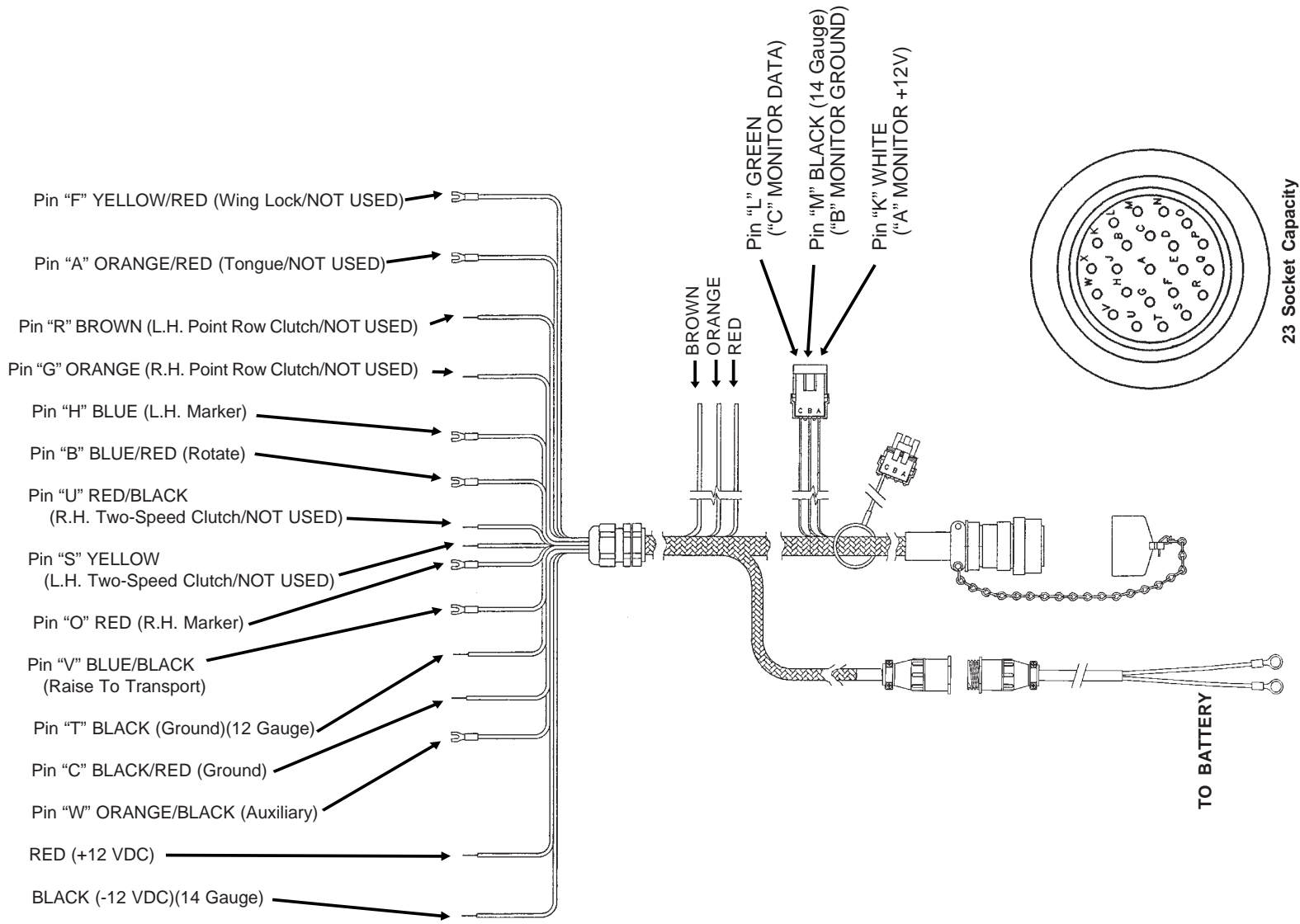

MAINTENANCE

ELECTRICAL WIRING HARNESS SCHEMATIC (On Planter) - Prior To Serial No. 625040

(ELC13/A8432a)

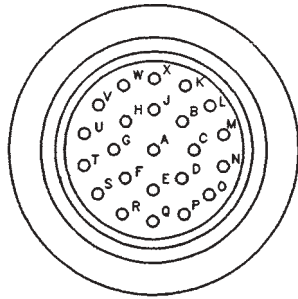

23 Pin Capacity

Connects To Second Harness
At JUNCTION BLOCK Located
On Front Of Center Pivot

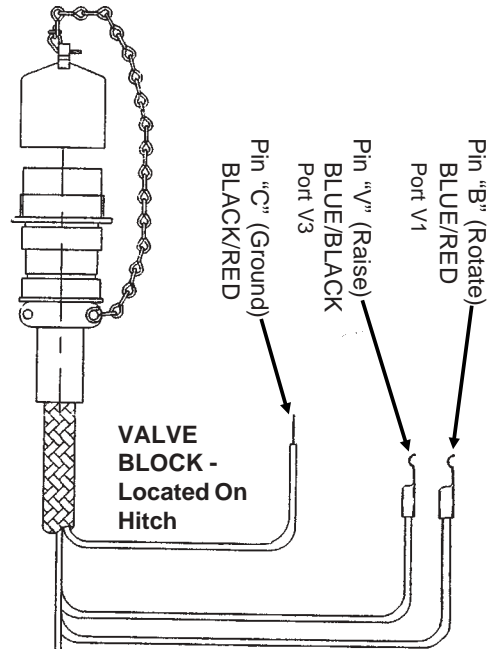
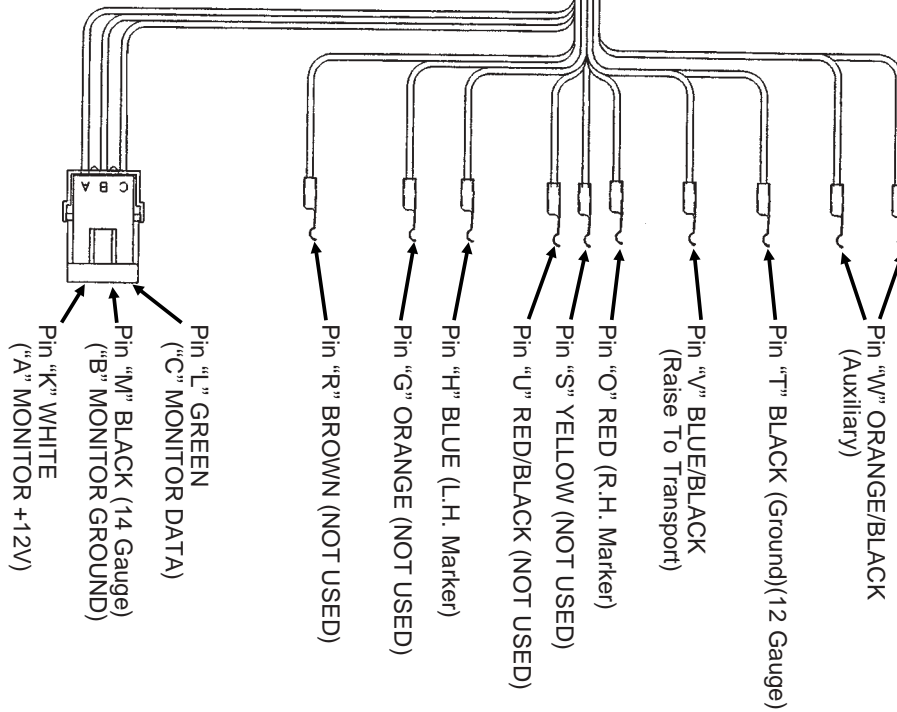

MAINTENANCE

ELECTRICAL WIRING HARNESS SCHEMATIC (On Planter) Prior To Serial No. 625040

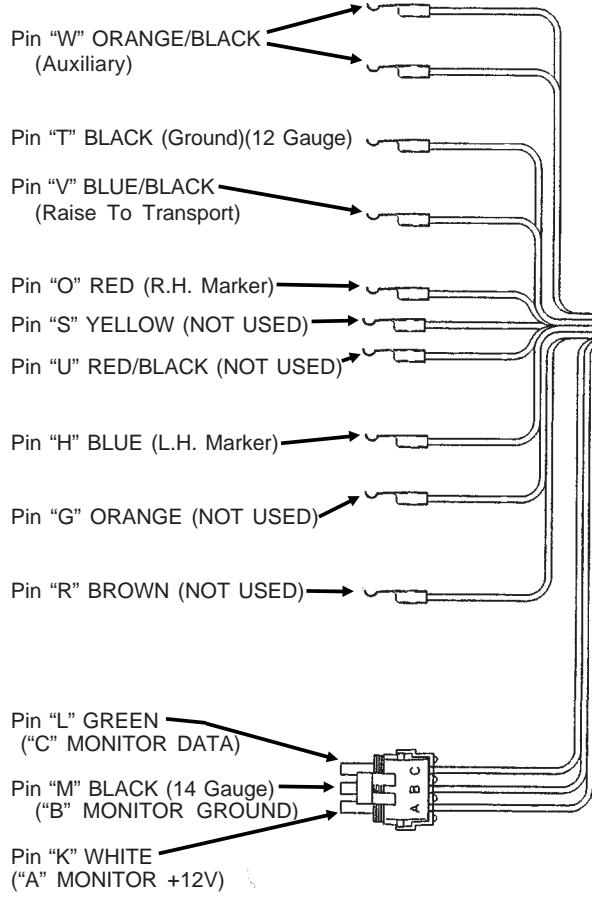

Connects To Second Harness
At JUNCTION BLOCK Located
On Front Of Center Pivot

VALVE BLOCK - Located
On Rear Center Frame

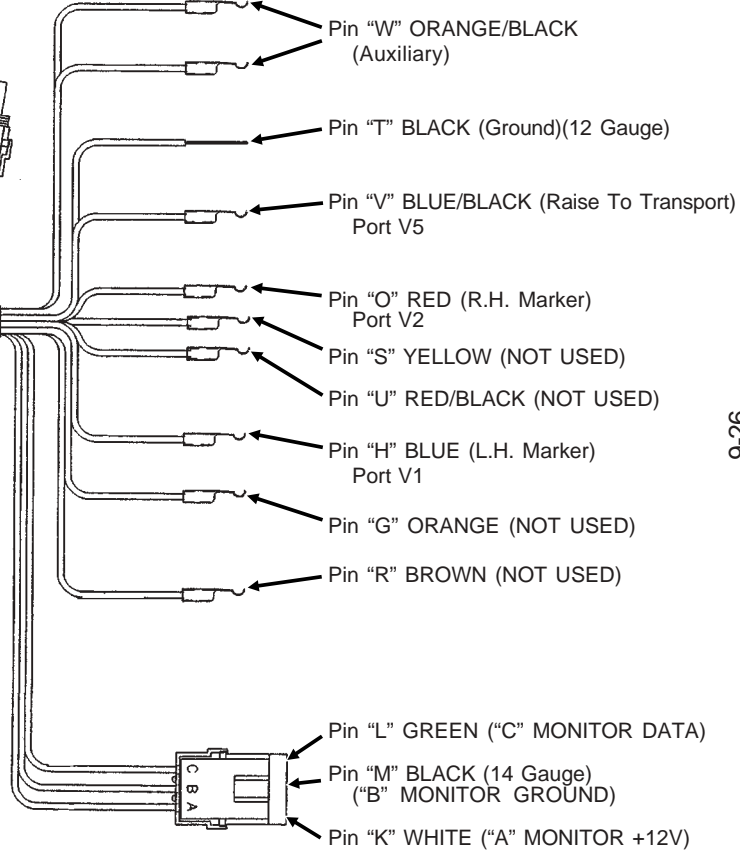

(A8433)

MAINTENANCE

ELECTRICAL WIRING HARNESS SCHEMATIC (On Planter) - Serial No. 625040 And On

(ELC13/A9530)

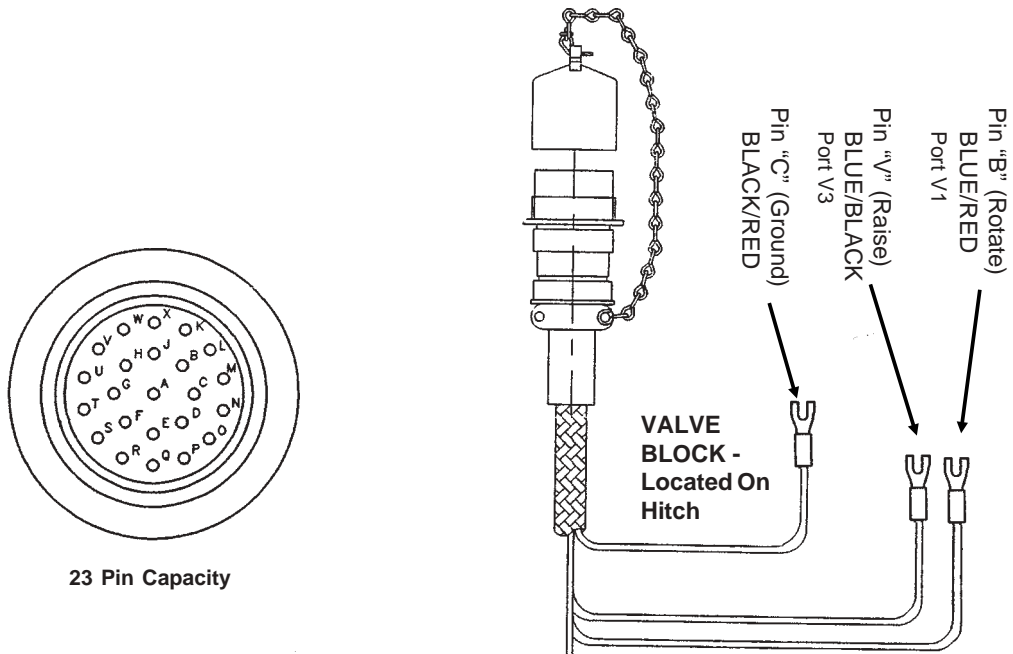

23 Pin Capacity

Connects To Second Harness At JUNCTION BLOCK Located On Front Of Center Pivot

For additional information see planter wiring layout on page 9-29

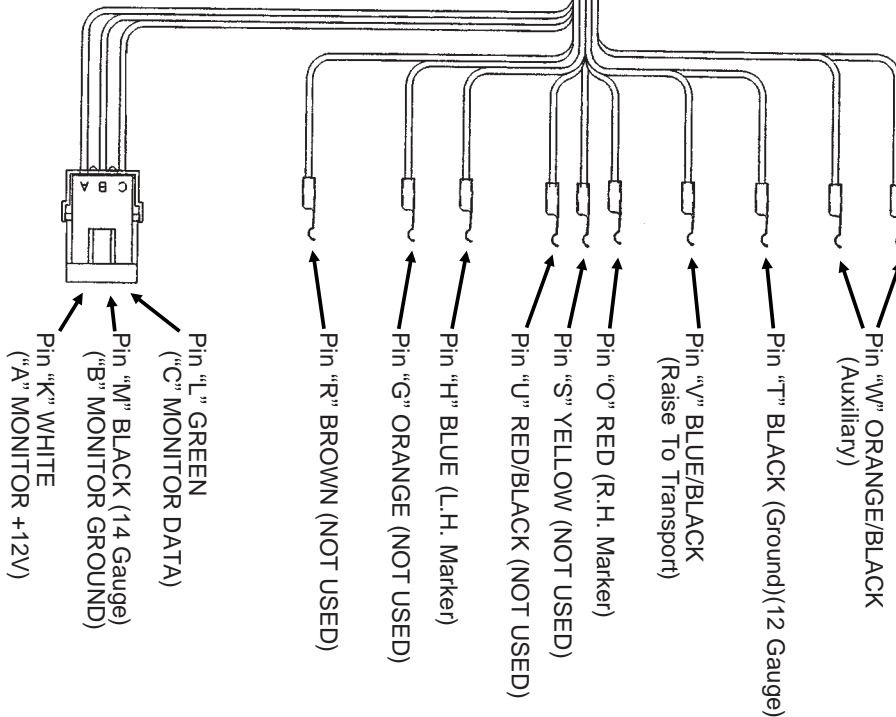

MAINTENANCE

ELECTRICAL WIRING HARNESS SCHEMATIC (On Planter) - Serial No. 625040 And On

(A9531)

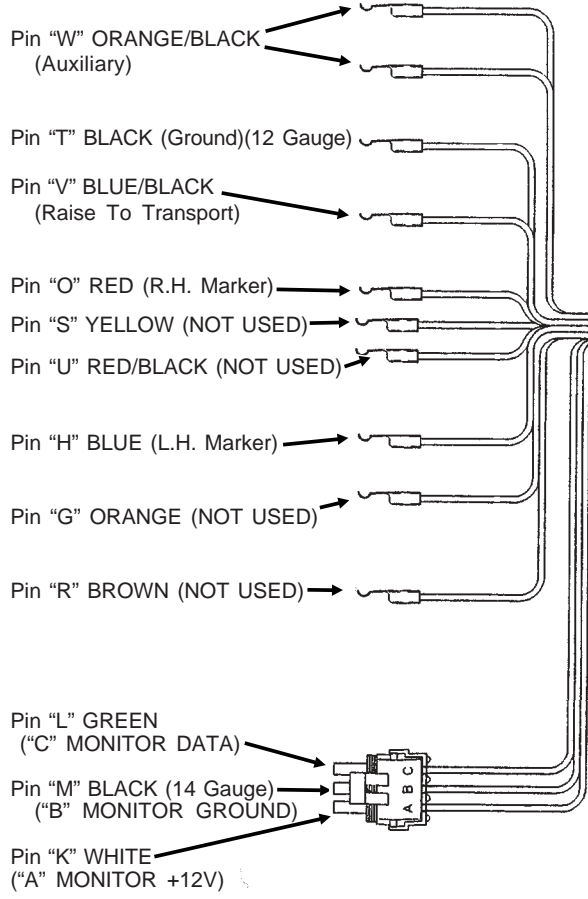

For additional information see planter wiring layout on page 9-29

Connects To Second Harness At JUNCTION BLOCK Located On Front Of Center Pivot

VALVE BLOCK - Located On Rear Center Frame

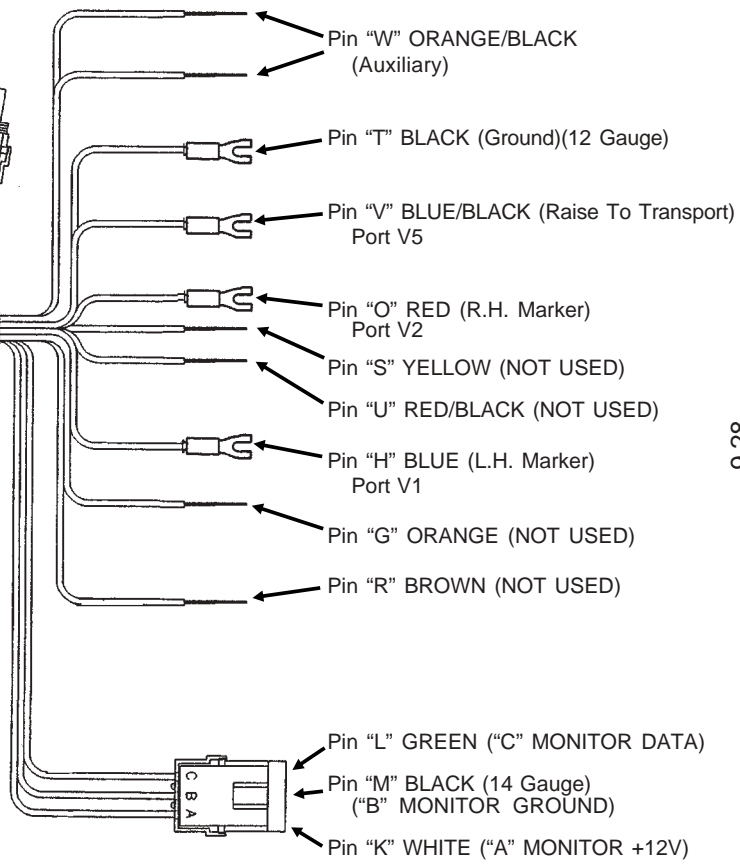

MAINTENANCE

PLANTER WIRING LAYOUT - Serial No. 625040 And On

(ELC40)

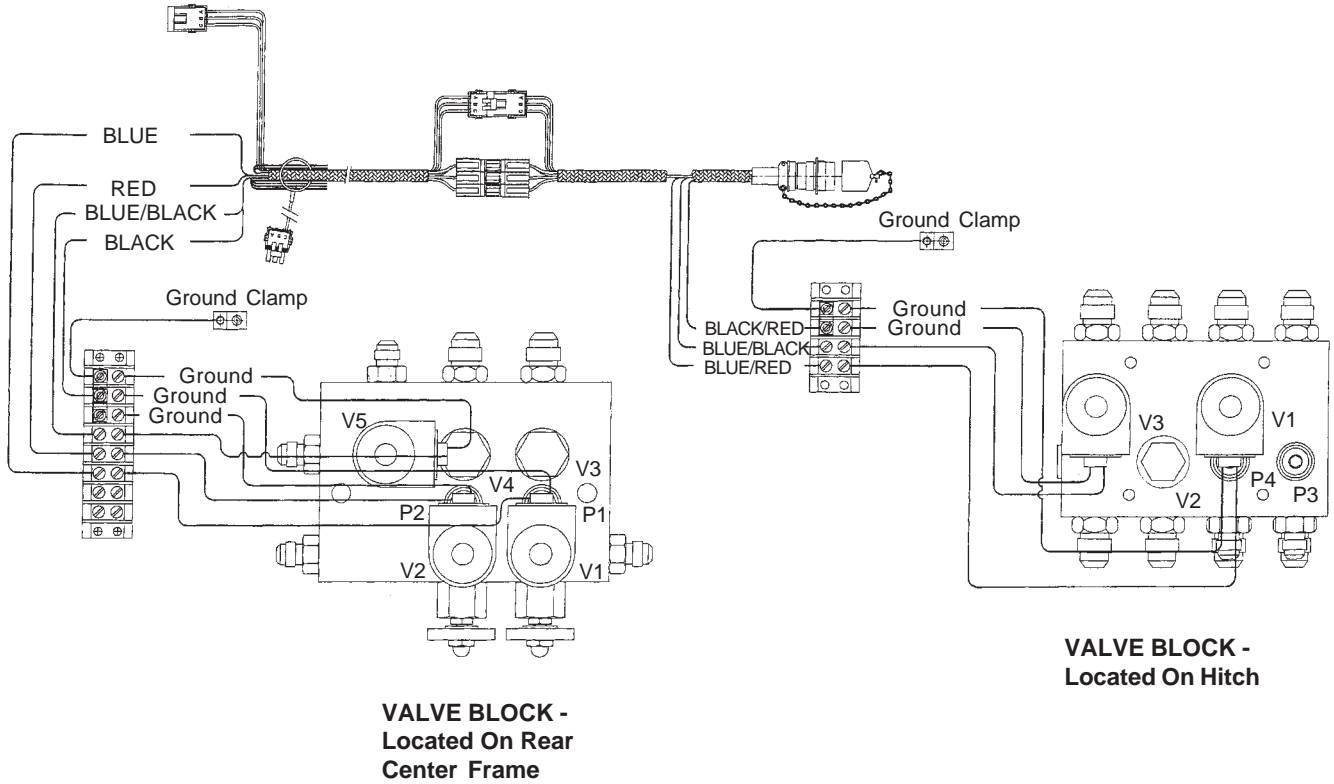

MAINTENANCE

HYDRAULIC SYSTEM SCHEMATIC

(TWL185/TWL164a/TWL160/TWL161/TWL163/TWL162/TWL158c/TWL158b)

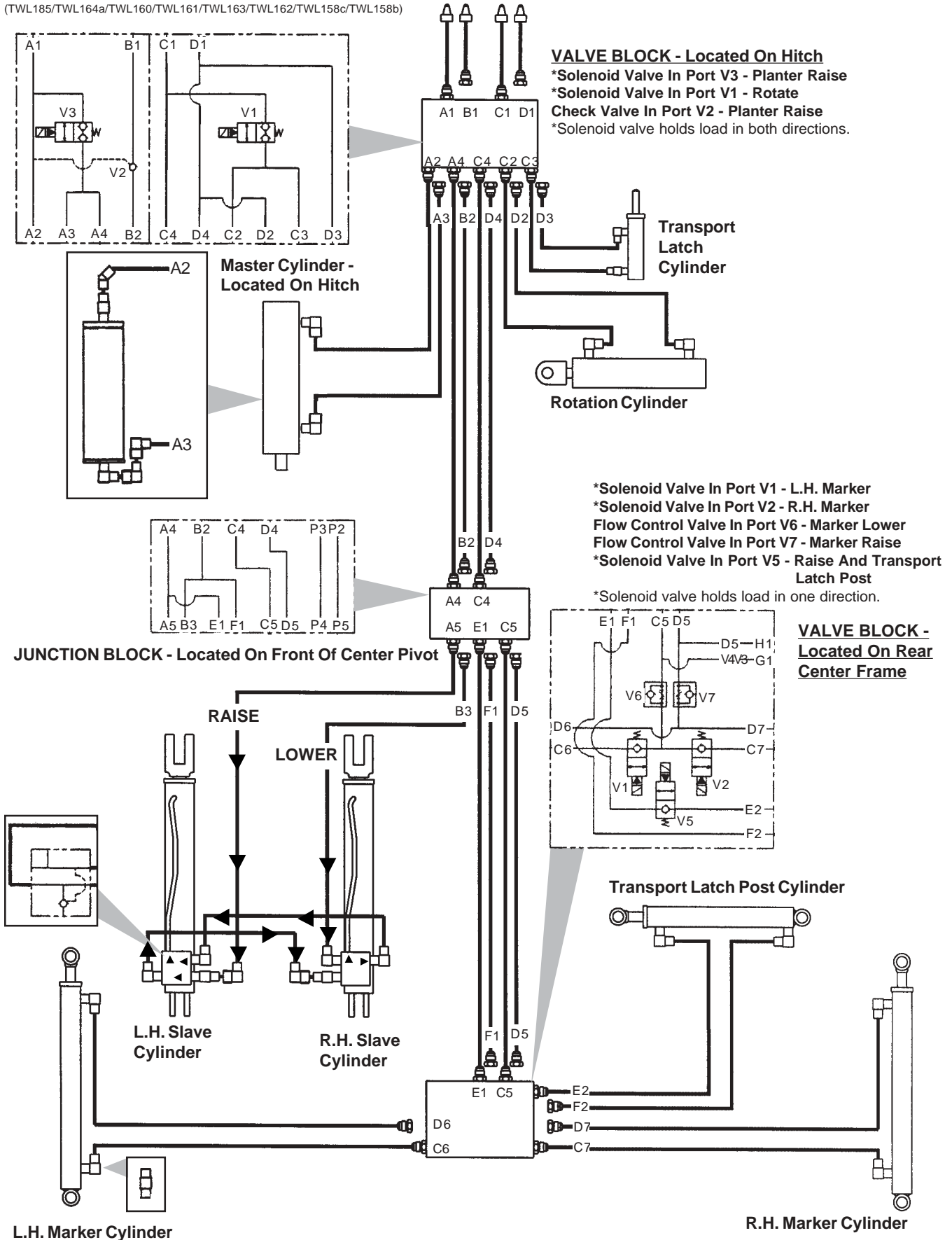

PARTS LIST INDEX

ROW UNIT

15" Seed Opener Disc Blade/Bearing Assembly And Scrapers	P5
Brush-Type Seed Meter	P15
Coulter Mounted Residue Wheels	P26
Covering Discs/Single Press Wheel	P8
Drag Closing Attachment	P11
Finger Pickup Seed Meter	P14
Frame Mounted Coulter W/Disc Furrower	P28
Frame Mounted Coulter W/Residue Wheels	P30
Gauge Wheels	P6
Granular Chemical Banding Options	P19
Granular Chemical Hopper And Hopper Panel Extension	P16
Granular Chemical Meter And Meter Drive	P18
Hopper Support And Meter Drive	P12
Interplant® Push Row Unit	P32
Parallel Arms, Mounting Support Plate And Quick Adjustable Down Force Springs	P4
Row Unit Mounted Disc Furrower	P22
Row Unit Mounted No Till Coulter	P21
Row Unit Mounted Residue Wheel	P24
Seed Hopper And Lid	P13
Shank Assembly, Seed Tube And Depth Adjustment	P2
Spring Tooth Incorporator	P20
"V" Closing Wheels	P10

BASE MACHINE

Axle And Transport/Ground Drive Wheel Assembly	P48
Center Pivot	P46
Check Valve	P75
Contact Drive Wheel Assembly	P50
Cylinders	P59
Driveline	P52
Electrical Components	P78
Flow Control Valve	P75
Frame Lift Linkage	P44
Hitch	P34
Hitch Extensions	P40
Hydraulic System	P76
Junction Block - Located On Front Of Center Pivot	P73
Marker Assembly	P56
Marker Spindle/Hub/Blade	P58
Planter Frame	P42
Safety Chain	P34
Solenoid Valves	P74
Transmission	P55
Transport Latch Post	P38
Valve Block - Located On Hitch	P69
Valve Block - Located On Rear Center Frame	P71

ELECTRONIC SEED MONITOR

KPM I/KPM II Electronic Seed Monitor	P82
--	-----

INTERPLANT® SYSTEM

Interplant® Push Row Unit	P32
Interplant® Driveline	P84

FERTILIZER

Fertilizer Openers And Mounts	P86
Liquid Fertilizer	P92

Decals, Paint And Miscellaneous	P104
---------------------------------------	------

Numerical Index	a
-----------------------	---

SHANK ASSEMBLY, SEED TUBE AND DEPTH ADJUSTMENT

RUB023/RUB024RUB022(RU80i)

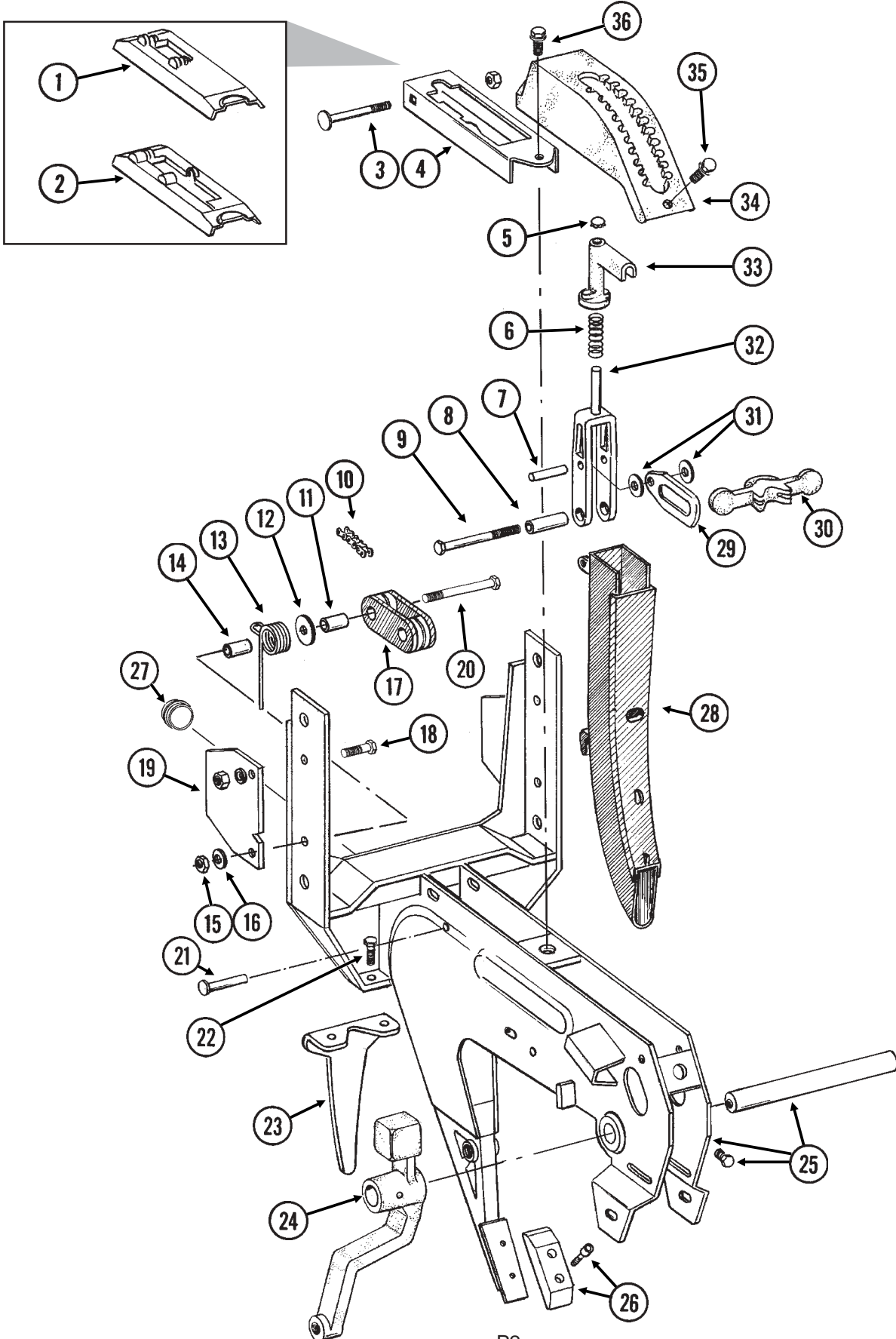

SHANK ASSEMBLY, SEED TUBE AND DEPTH ADJUSTMENT

ITEM	PART NO.	QTY. (Per Row)	DESCRIPTION
1.		-	Shank Cover, See "Brush-Type Seed Meter", Page P15
2.		-	Shank Cover, See "Finger Pickup Seed Meter", Page P14
3.	G10304	1	Carriage Bolt, $\frac{3}{8}$ "-16 x 3"
	G10108	1	Lock Nut, $\frac{3}{8}$ "-16
4.	GD10986	1	Cover
5.	GD3612	1	Cap Plug
6.	GD10993	1	Spring
7.	GD13361	1	Pin, $\frac{3}{8}$ " x 1 $\frac{2}{3}$ "
8.	GD11259	1	Sleeve, $\frac{3}{8}$ " I.D. x $\frac{5}{8}$ " O.D. x 1 $\frac{25}{32}$ " Long
9.	G11008	1	Hex Head Cap Screw, $\frac{3}{8}$ "-24 x 2 $\frac{1}{2}$ ", Grade 8
	G11007	1	Lock Nut, $\frac{3}{8}$ "-24, Grade C
10.	G3303-98	1	Chain, No. 41, 98 Pitch Including Connector Link
	GR0196	1	Connector Link, No. 41
11.	GD1026	1	Sleeve, 1 $\frac{3}{16}$ " Long
12.	G10201	1	Special Washer, $\frac{3}{8}$ " x 1 $\frac{1}{2}$ " O.D.
13.	GD1065	1	Idler Spring
14.	GD7318	1	Sleeve, 1" Long
15.	G10108	1	Lock Nut, $\frac{3}{8}$ "-16
16.	G10210	1	Washer, $\frac{3}{8}$ " USS
17.	GD11962	1	Idler
18.	G10003	3	Hex Head Cap Screw, $\frac{3}{8}$ "-16 x 1 $\frac{1}{2}$ "
	G10108	3	Lock Nut, $\frac{3}{8}$ "-16
19.	GD10867	2	Stop
20.	G10326	1	Hex Head Cap Screw, $\frac{3}{8}$ "-16 x 3 $\frac{3}{4}$ "
21.	G10551	1	Clevis Pin, $\frac{1}{4}$ " x 2 $\frac{1}{2}$ "
	G10669	1	Hair Pin Clip, No. 22
22.	G10312	2	Carriage Bolt, $\frac{5}{16}$ "-18 x $\frac{3}{4}$ "
	G10620	2	Flange Nut, $\frac{5}{16}$ "-18
23.	GD1033	1	Shield
24.		-	See "Gauge Wheels", Pages P6 And P7
25.	GA7965	1	Shank W/Gauge Wheel Pivot Spindle And Set Screw
	GD11001	-	Spindle
	G10438	-	Hex Head Cap Screw, $\frac{1}{2}$ "-13 x $\frac{3}{4}$ "
26.		-	See "15" Seed Opener Disc Blade/Bearing Assembly And Scrapers", Page P5
27.	GD11845	1	Dust Cap
28.	GD1130	-	Seed Tube (No Monitor) See "KPM I/KPM II Electronic Seed Monitor" For Seed Tube With Sensor, Pages P82 And P83
29.	GB0285	1	Collar, Depth Adjustment
30.	GB0265	1	Pivot Link, Depth Adjustment
31.	G10207	2	Washer, $\frac{7}{8}$ " O.D. x $\frac{13}{32}$ " I.D. x .134" (If Applicable)
32.	GB0267	1	Lever, Depth Adjustment
33.	GB0266	1	Handle, Depth Adjustment
34.	GB0274	1	Cover, Depth Adjustment
35.	G10985	1	Hex Washer Head Cap Screw, $\frac{3}{8}$ "-16 x 1"
36.	G11015	1	Hex Washer Head Cap Screw, $\frac{3}{8}$ "-16 x 1 $\frac{1}{4}$ "

PARALLEL ARMS, MOUNTING SUPPORT PLATE AND QUICK ADJUSTABLE DOWN FORCE SPRINGS

RUB021/RUB022(RU78e/RU79a)

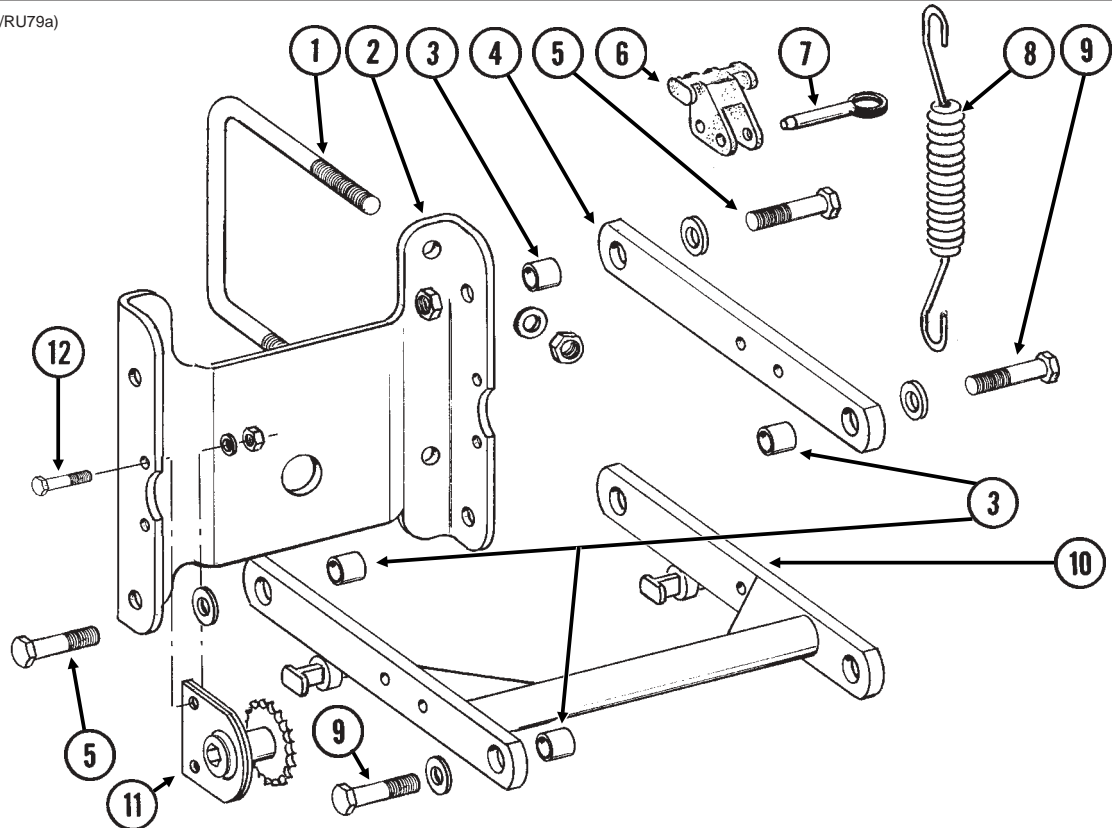

ITEM	PART NO.	QTY. (Per Row)	DESCRIPTION
1.	GD1113	-	U-Bolt, 5" x 7" x 5/8"-11
	G10230	4	Lock Washer, 5/8"
	G10104	4	Hex Nut, 5/8"-11
2.	GD10036	1	Mounting Support Plate
3.	GB0218	4	Bushing, 21/32" I.D. x 7/8" O.D. x 19/32" Long
4.	GD11422	2	Upper Parallel Arm
5.	G10732	4	Hex Head Cap Screw, 5/8"-18 x 2"
	GD7805	4	Special Washer, 5/8", Hardened
	G10412	4	Lock Nut, 5/8"-18
6.	GB0186	2	Spring Anchor
7.	G10545	2	Detent Pin, 1/2" x 1 1/3" Grip
8.	GD8249	2-4	Spring
9.		-	See "Hopper Support And Meter Drive", Page P12
10.	GA5651	1	Lower Parallel Arm
11.	GA1720	1	Bearing/Sprocket, 7/8" Hex Bore
12.	G10001	2	Hex Head Cap Screw, 3/8"-16 x 1"
	G10229	2	Lock Washer, 3/8"
	G10101	2	Hex Nut, 3/8"-16
A.	G6325X	-	U-Bolt Package For 5" x 7" Toolbar, Includes: (2) GD1113, (4) G10230, (4) G10104

15" SEED OPENER DISC BLADE/BEARING ASSEMBLY AND SCRAPERS

RUB023/RUB025(RU82e)

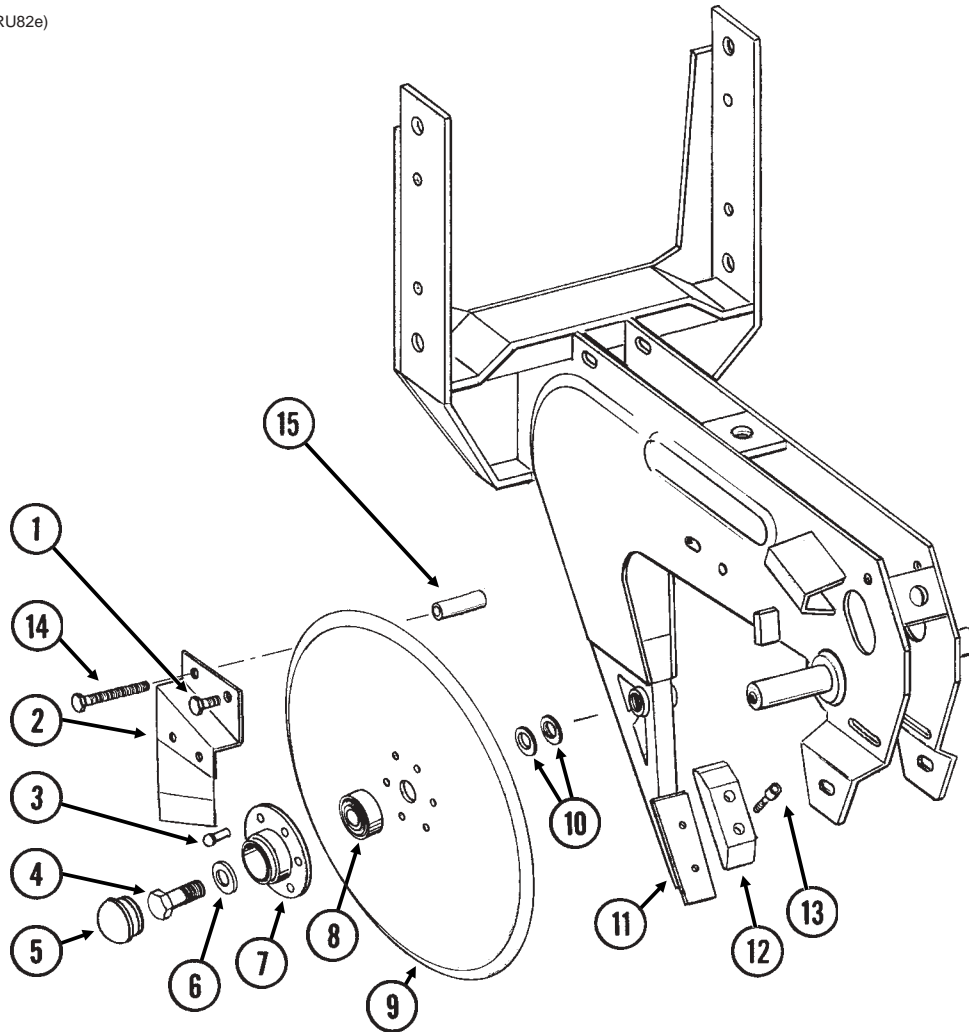

ITEM	PART NO.	QTY. (Per Row)	DESCRIPTION
1.	G10328	2	Hex Head Cap Screw, $\frac{3}{8}$ "-16 x $\frac{5}{8}$ "
	G10622	2	Flange Nut, $\frac{3}{8}$ "-16
2.	GA2012R	1	Disc Scraper, R.H.
	GA2012L	-	Disc Scraper, L.H. (Shown)
3.	G10427	12	Rivet, $\frac{1}{4}$ " x $\frac{1}{2}$ "
4.	GD11017	1	Special Hex Head Cap Screw, $\frac{5}{8}$ "-11 x 1 $\frac{1}{2}$ ", L.H. Thread
	G10007	1	Hex Head Cap Screw, $\frac{5}{8}$ "-11 x 1 $\frac{1}{2}$ "
5.	GD11845	2	Dust Cap
6.	G10204	2	Special Machine Bushing, $\frac{5}{8}$ " x 1" O.D.
7.	GD10473	2	Bearing Housing
8.	GA2014	2	Bearing
9.	GD11306	2	Disc Blade, 3.5mm x 15"
10.	G10213	-	Machine Bushing, $\frac{5}{8}$ " (.030" Thick)(As Required)
11.		-	See "Shank Assembly", Pages P2 And P3
12.	GB0301	1	Seed Tube Guard/Inner Scraper
13.	G10912	2	Hex Socket Head Cap Screw, $\frac{5}{16}$ "-18 x 1", Grade 8
14.	G10325	1	Hex Head Cap Screw, $\frac{3}{8}$ "-16 x 2 $\frac{3}{4}$ "
	G10622	1	Flange Nut, $\frac{3}{8}$ "-16
15.	GD11259	1	Sleeve, $\frac{3}{8}$ " I.D. x $\frac{5}{8}$ " O.D. x 1 $\frac{25}{32}$ " Long
A.	GA8324	-	Disc Blade And Bearing Assembly, Less Bearing Cap (Items 3 And 7-9)

GAUGE WHEELS

RUB027/RUB023(RU84a/RU84b)

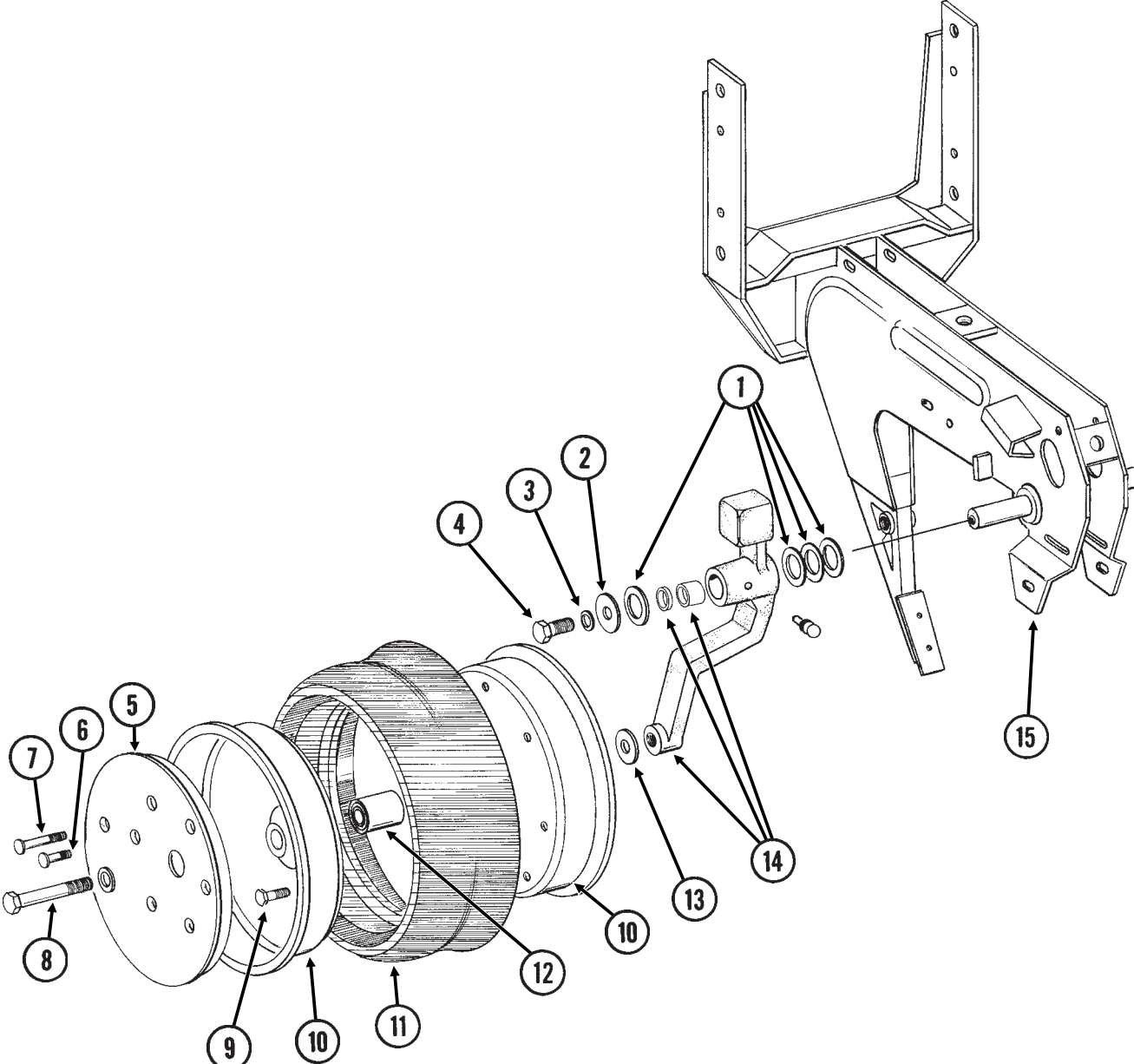

GAUGE WHEELS

ITEM	PART NO.	QTY. (Per Row)	DESCRIPTION
1.	G10940	-	Machine Bushing, 1" (.048" Thick)
2.	G10216	2	Washer, 1/2" USS
3.	G10228	2	Lock Washer, 1/2"
4.	G10014	1	Hex Head Cap Screw, 1/2"-13 x 1"
5.	GD11453	2	Cover
6.	G10338	12	Carriage Bolt, 5/16"-18 x 1 1/4"
	G10620	12	Flange Nut, 5/16"-18
7.	G10924	8	Carriage Bolt, 5/16"-18 x 1 3/4"
	G10620	8	Flange Nut, 5/16"-18
8.	G10010	2	Hex Head Cap Screw, 5/8"-11 x 3"
	G10230	2	Lock Washer, 5/8"
9.	G10018	14	Hex Head Cap Screw, 5/16"-18 x 5/8"
	G10109	14	Lock Nut, 5/16"-18
10.	GD11423	4	Half Wheel
11.	GD1086	2	Tire
12.	GA6171	2	Bearing
13.	G10204	2	Special Machine Bushing, 5/8" x 1" O.D.
14.	GA7975	1	Wheel Arm W/Grease Fitting, Bushings And Seals, L.H. (Shown)
	GA7976	1	Wheel Arm W/Grease Fitting, Bushings And Seals, R.H.
	G10640	1	Grease Fitting, 1/4"-28 (Per Arm)
	GB0276	2	Bushing, 1" I.D. x 1 1/4" O.D. x 1" Long (Per Arm)
	GD10991	2	Seal (Per Arm)
15.		-	See "Shank Assembly", Pages P2 And P3
A.	GA7949	-	Gauge Wheel Complete (Items 5-7 And 9-12)

COVERING DISCS/SINGLE PRESS WHEEL

RUA054/RUB026(RU94c)

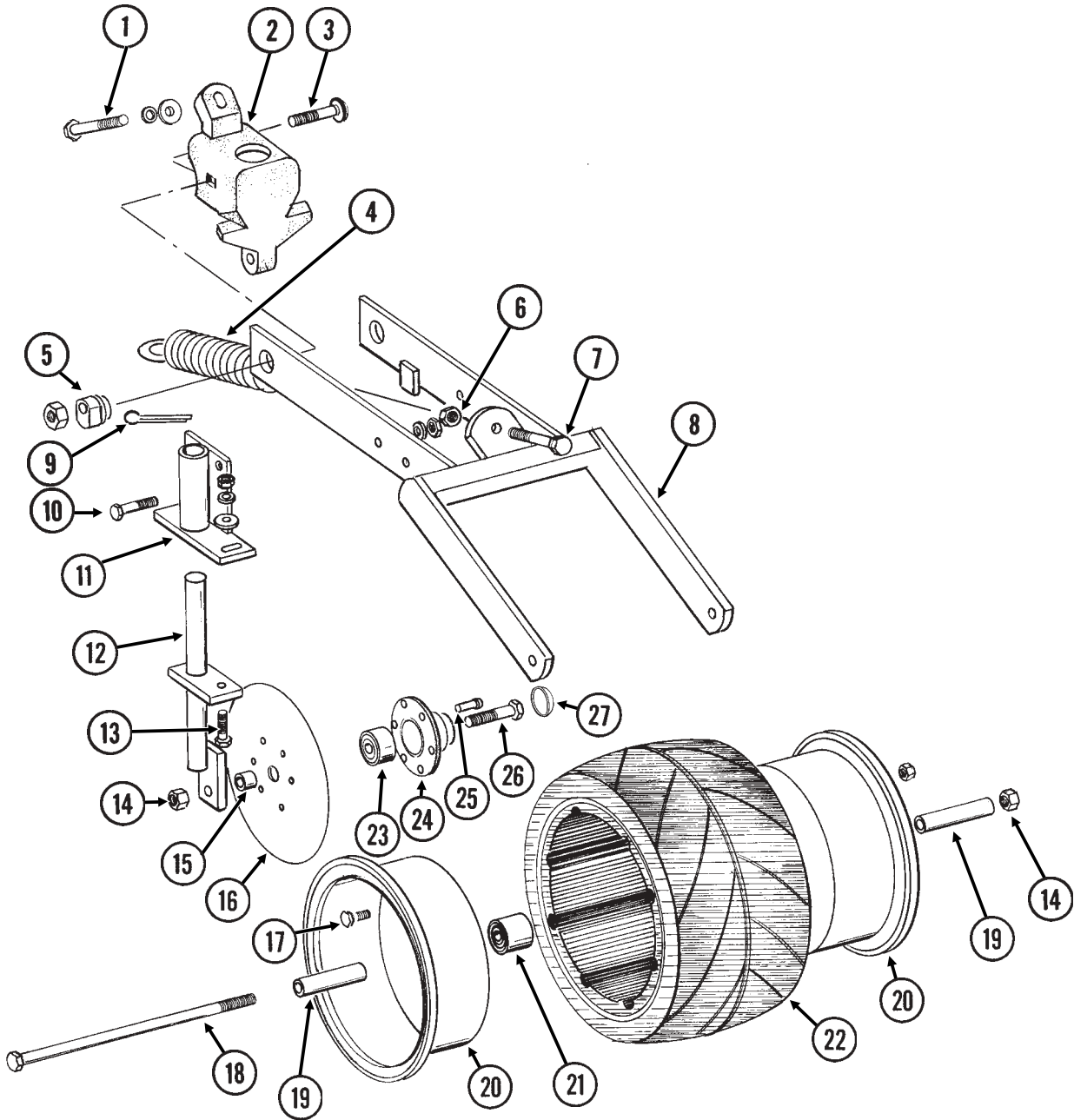

COVERING DISCS/SINGLE PRESS WHEEL

ITEM	PART NO.	QTY. (Per Row)	DESCRIPTION
1.	G10003	1	Hex Head Cap Screw, $\frac{3}{8}$ "-16 x 1 $\frac{1}{2}$ "
	G10229	1	Lock Washer, $\frac{3}{8}$ "
	G10210	2	Washer, $\frac{3}{8}$ " USS
2.	GB0268	1	Wheel Arm Stop
3.	G10801	2	Carriage Bolt, $\frac{1}{2}$ "-13 x 2 $\frac{1}{4}$ "
	G10315	-	Carriage Bolt, $\frac{1}{2}$ "-13 x 2 $\frac{1}{2}$ " (Used W/Straight Drop In-Furrow Granular Chemical Bracket)
	G10102	2	Hex Nut, $\frac{1}{2}$ "-13
4.	GA2054	1	Spring
5.	GB0239	2	Eccentric Bushing
6.	G10102	1	Hex Nut, $\frac{1}{2}$ "-13
7.	G10015	1	Adjusting Bolt, $\frac{1}{2}$ "-13 x 5"
8.	GA6619	1	Mounting Arm
9.	G10463	2	Cotter Pin, $\frac{1}{4}$ " x 1 $\frac{1}{2}$ "
10.	G10171	4	Hex Head Cap Screw, $\frac{5}{16}$ "-18 x 1 $\frac{1}{4}$ "
	G10232	4	Lock Washer, $\frac{5}{16}$ "
	G10106	4	Hex Nut, $\frac{5}{16}$ "-18
11.	GA6620	2	Bracket
12.	GA6618	2	Mount
13.	G10303	2	Carriage Bolt, $\frac{5}{16}$ "-18 x 1"
	G10219	2	Washer, $\frac{5}{16}$ " USS
	G10232	2	Lock Washer, $\frac{5}{16}$ "
	G10106	2	Hex Nut, $\frac{5}{16}$ "-18
14.	G10107	3	Lock Nut, $\frac{5}{8}$ "-11
15.	GD1109	2	Bushing, $\frac{41}{64}$ " I.D. x $\frac{7}{8}$ " O.D. x $\frac{1}{4}$ " Long
16.	GD9290	2	Disc Blade, 8"
17.	G10018	7	Hex Head Cap Screw, $\frac{5}{16}$ "-18 x $\frac{5}{8}$ "
	G10109	7	Lock Nut, $\frac{5}{16}$ "-18
18.	G10152	1	Hex Head Cap Screw, $\frac{5}{8}$ "-11 x 9"
19.	GD3180-12	2	Sleeve, $\frac{5}{8}$ " I.D. x $\frac{7}{8}$ " O.D. x 2 $\frac{7}{8}$ " Long
20.	GD9562	2	Half Wheel
21.	GA6171	1	Bearing
22.	GD9305	1	Tire
23.	GA2014	2	Bearing
24.	GD10473	2	Bearing Housing
25.	G10427	12	Rivet, $\frac{1}{4}$ " x $\frac{1}{2}$ "
26.	G10006	2	Hex Head Cap Screw, $\frac{5}{8}$ "-11 x 2 $\frac{1}{4}$ "
27.	GD11845	2	Dust Cap
A.	GA6733	-	Single Press Wheel Complete W/Bearing (Items 17 And 20-22)
B.	GA6801	-	Covering Disc Blade Complete W/Bearing (Items 16 And 23-25)

"V" CLOSING WHEELS

RUB026(RU83g/RU83i/RU83h)

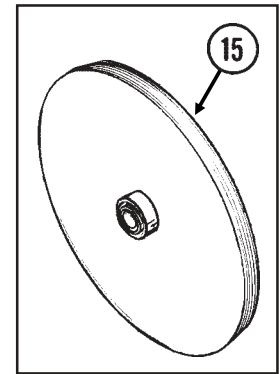
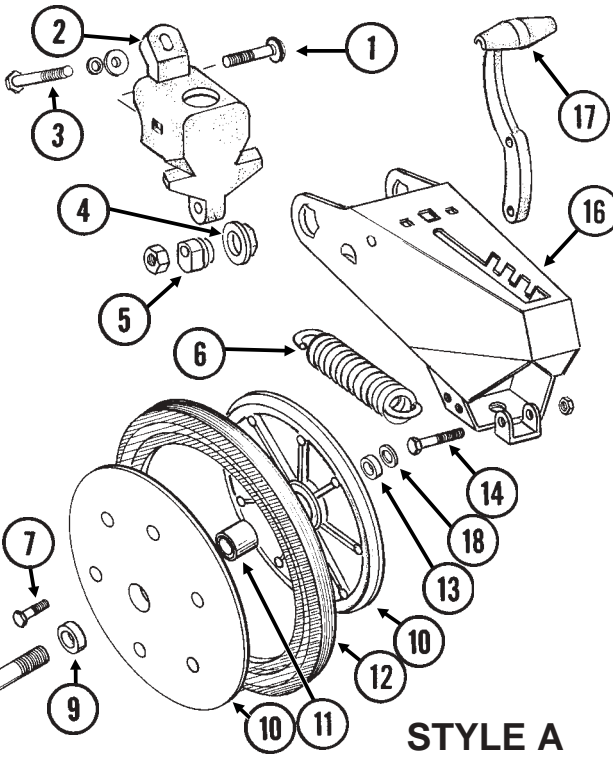
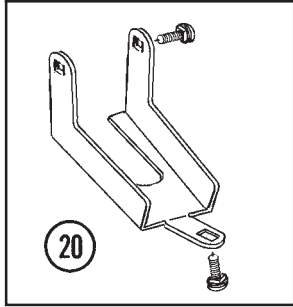
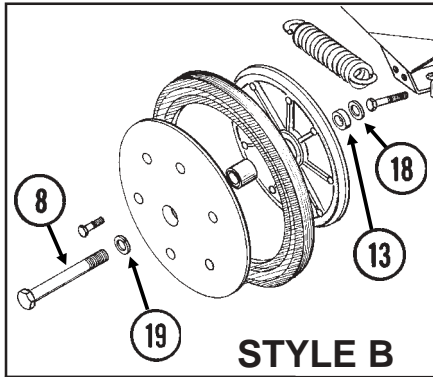

ITEM	PART NO.	QTY. (Per Row)	DESCRIPTION
1.	G10801 G10315	2 -	Carriage Bolt, 1/2"-13 x 2 1/4" Carriage Bolt, 1/2"-13 x 2 1/2" (Used W/Straight Drop In-Furrow Granular Chemical Bracket)
2.	G10111	2	Lock Nut, 1/2"-13
3.	GB0268	1	Wheel Arm Stop
4.	G10003	1	Hex Head Cap Screw, 3/8"-16 x 1 1/2"
5.	G10229	1	Lock Washer, 3/8"
6.	G10210	2	Washer, 3/8" USS
7.	GB0282	2	Stepped Bushing
8.	GB0239	2	Eccentric Bushing
9.	GD8460	1	Spring
10.	G10064	6	Hex Head Cap Screw, 1/4"-20 x 1"
11.	G10013	2	Hex Head Cap Screw, 5/8"-11 x 3 1/2"
12.	G10107	2	Lock Nut, 5/8"-11
13.	GB0218	2	Bushing, 21/32" I.D. x 7/8" O.D. x 19/32" Long
14.	GD9120	4	Nylon Half Wheel
15.	GA6171	2	Bearing
16.	GD1085	2	Rubber Tire, 1" x 12"
17.	GD1109	2	Bushing, 41/64" I.D. x 7/8" O.D. x 1/4" Long
18.	G10133	1	Hex Head Cap Screw, 5/16"-18 x 1 1/2"
19.	G10109	1	Lock Nut, 5/16"-18
20.	GA6597	-	Cast Iron Closing Wheel W/Bearing
A.	GA6171	-	Bearing
	GA8322	1	Arm
	GB0254	1	Lever
	GD7805	2	Special Washer, 5/8", Hardened
	G10230	2	Lock Washer, 5/8"
	G1K345	-	Closing Wheel Shield Kit W/Hardware And Instruction
	G10308	3	Carriage Bolt, 3/8"-16 x 3/4"
	G10210	1	Washer, 3/8" USS
	G10229	3	Lock Washer, 3/8"
	G10101	3	Hex Nut, 3/8"-16
A.	GA6434	-	Rubber Closing Wheel Complete W/Bearing (Items 7 And 10-12)

DRAG CLOSING ATTACHMENT

RUB050(RU90a)

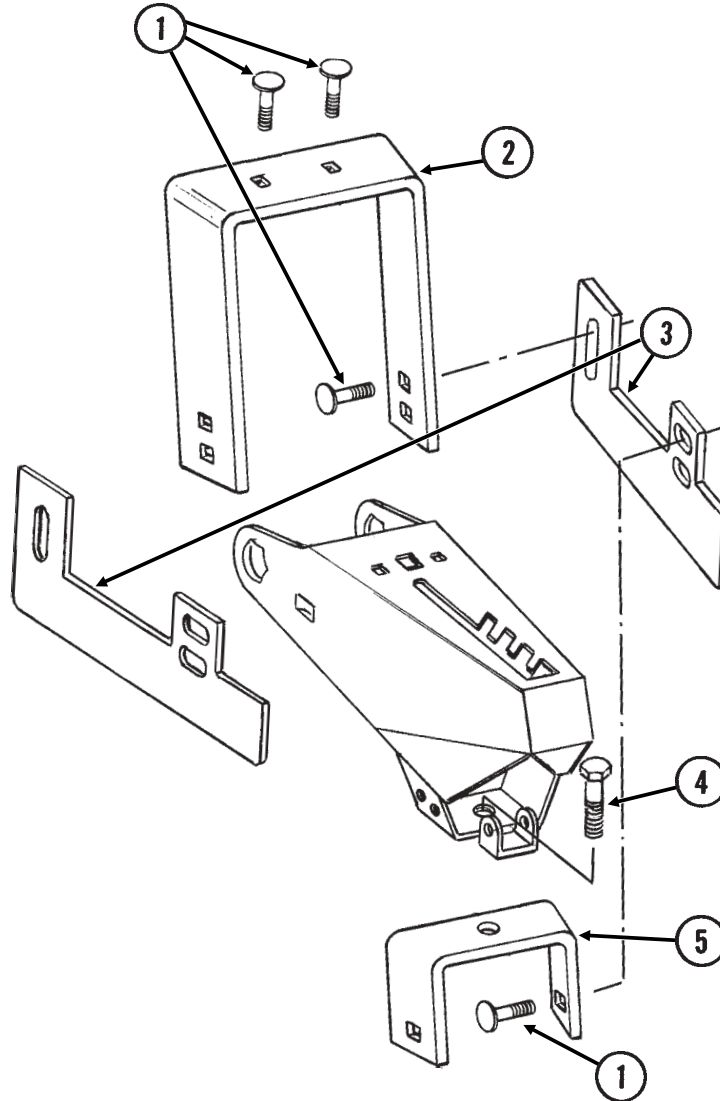

ITEM	PART NO.	QTY.	DESCRIPTION
		(Per Row)	
1.	G10599	6	Carriage Bolt, 3/8"-16 x 1 1/4"
	G10210	6	Washer, 3/8" USS
	G10229	6	Lock Washer, 3/8"
	G10101	6	Hex Nut, 3/8"-16
2.	GD11508	1	Front Bracket
3.	GD11313	2	Blade
4.	G10007	1	Hex Head Cap Screw, 5/8"-11 x 1 1/2"
	G10230	1	Lock Washer, 5/8"
	G10104	1	Hex Nut, 5/8"-11
5.	GD11509	1	Rear Bracket
A.	G7566X	-	Drag Closing Attachment Complete (Items 1-5)

HOPPER SUPPORT AND METER DRIVE

RUB028/RUB029(RU86h/RU86f)

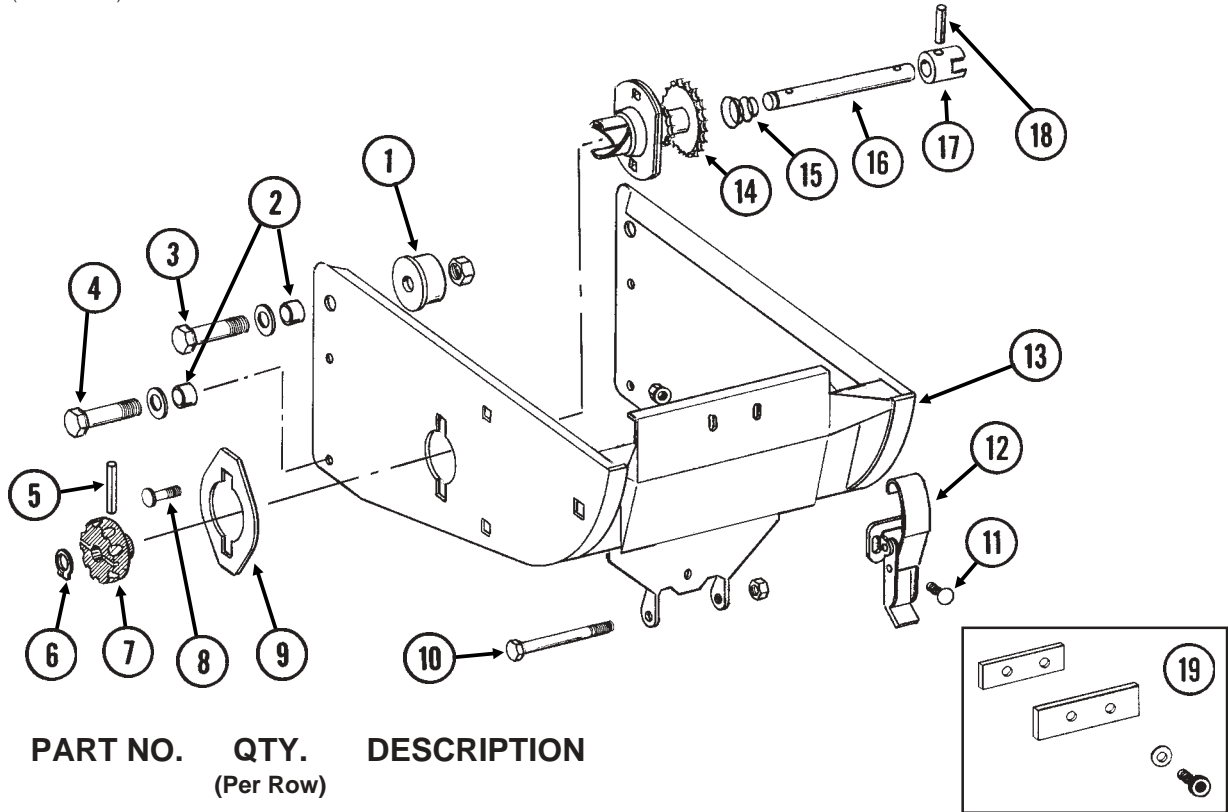

ITEM	PART NO.	QTY. (Per Row)	DESCRIPTION
1.	GB0314	2	Hopper Mount
2.	GB0218	4	Bushing, $2\frac{1}{32}$ " I.D. x $7\frac{7}{8}$ " O.D. x $1\frac{19}{32}$ " Long
3.	G10752	2	Hex Head Cap Screw, $\frac{5}{8}$ "-18 x $2\frac{1}{4}$ "
	GD7805	2	Special Washer, $\frac{5}{8}$ ", Hardened
	G10412	2	Lock Nut, $\frac{5}{8}$ "-18
4.	G10751	2	Hex Head Cap Screw, $\frac{5}{8}$ "-18 x $1\frac{3}{4}$ "
	GD7805	2	Special Washer, $\frac{5}{8}$ ", Hardened
	G10412	2	Lock Nut, $\frac{5}{8}$ "-18
5.	G10602	1	Spring Pin, $\frac{1}{4}$ " x $1\frac{1}{2}$ "
6.	G10567	1	External Retaining Ring, $\frac{5}{8}$ "
7.	GD11239	1	Knob
8.	G10338	2	Carriage Bolt, $\frac{5}{16}$ "-18 x $1\frac{1}{4}$ "
	G10620	2	Flange Nut, $\frac{5}{16}$ "-18
9.	GD11305	1	Plate
10.	G10061	1	Hex Head Cap Screw, $\frac{3}{8}$ "-16 x $3\frac{1}{2}$ "
	G10210	2	Washer, $\frac{3}{8}$ " USS
	G10108	1	Lock Nut, $\frac{3}{8}$ "-16
11.	G10309	2	Carriage Bolt, $\frac{1}{4}$ "-20 x $\frac{5}{8}$ ", Grade 2
	G10621	2	Flange Nut, $\frac{1}{4}$ "-20
12.	GA2007	1	Hopper Hold Down Latch
13.	GA8304	1	Hopper Support
14.	GA9538	1	Double Sprocket And Bearing, Drive Clutch, 11/19 Tooth
15.	GD11413	1	Spring
16.	GD10958	1	Shaft
17.	GB0278	1	Coupler
18.	G10546	1	Spring Pin, $\frac{3}{16}$ " x $1\frac{1}{4}$ "
19.	G1K312	-	Seed Hopper Support Panel Kit W/Hardware And Instruction (2 Rows)
	G10211	-	Washer, $\frac{1}{4}$ " SAE
	G10252	-	Socket Head Screw, $\frac{1}{4}$ "-20 x $\frac{7}{8}$ ", Grade 8
A.	GA9539	-	Meter Drive Assembly Complete (Items 5-7 And 14-18)

SEED HOPPER AND LID

RUA030(RU87d/RU87c/RU128/RU87a/RU87e)

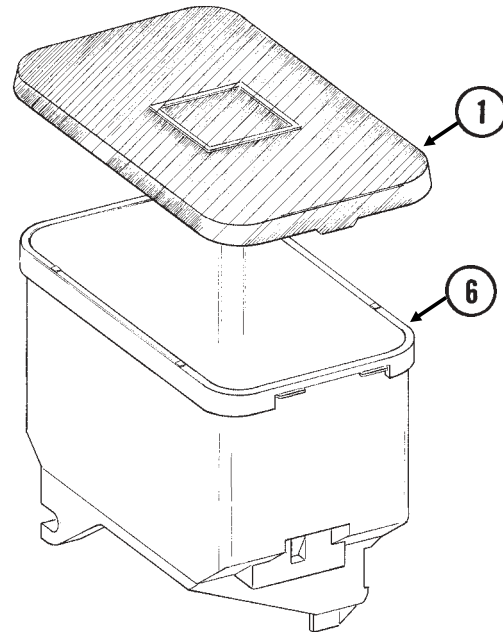
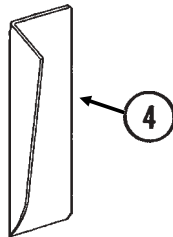
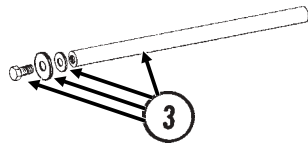
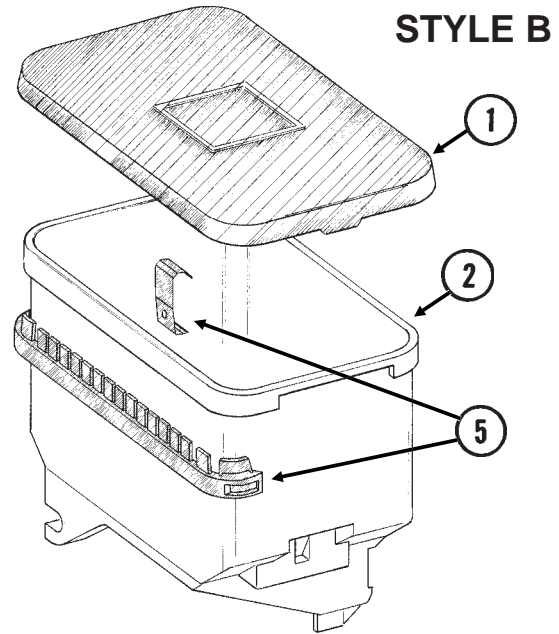
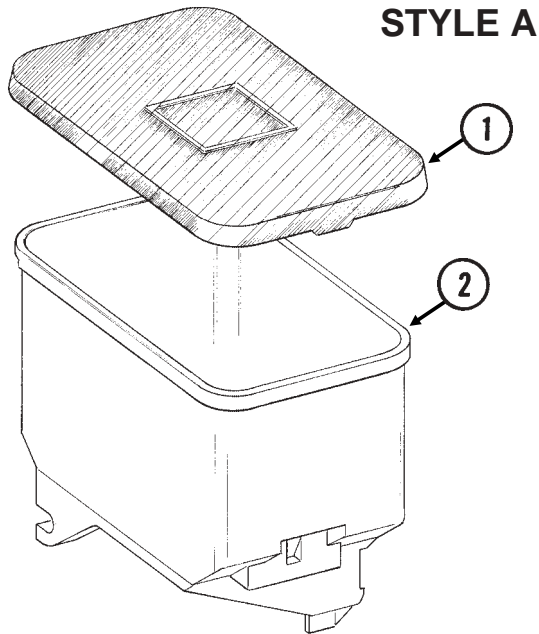

ITEM	PART NO.	QTY. (Per Row)	DESCRIPTION
1.	GD11279	1	Lid
2.	GA8370	1	Seed Hopper (Sub GA9714)
3.	G1K313	1	Seed Hopper Cross Brace Kit (STYLE A Seed Hopper)
	G10989	2	Hex Washer Head Cap Screw, $\frac{3}{8}$ "-16 x $\frac{3}{4}$ "
	G10201	2	Special Washer, $\frac{3}{8}$ " x 1 $\frac{1}{2}$ " O.D.
	G10210	2	Washer, $\frac{3}{8}$ " USS
4.	GD11747	1	Seed Reserve Baffle
5.	G1K335	1	Seed Hopper Reinforcement Kit (STYLE B Seed Hopper)
6.	GA9714	1	Seed Hopper, Reinforced

FINGER PICKUP SEED METER

RUA015/RUA056/RUA057(RU13i/RU13d)

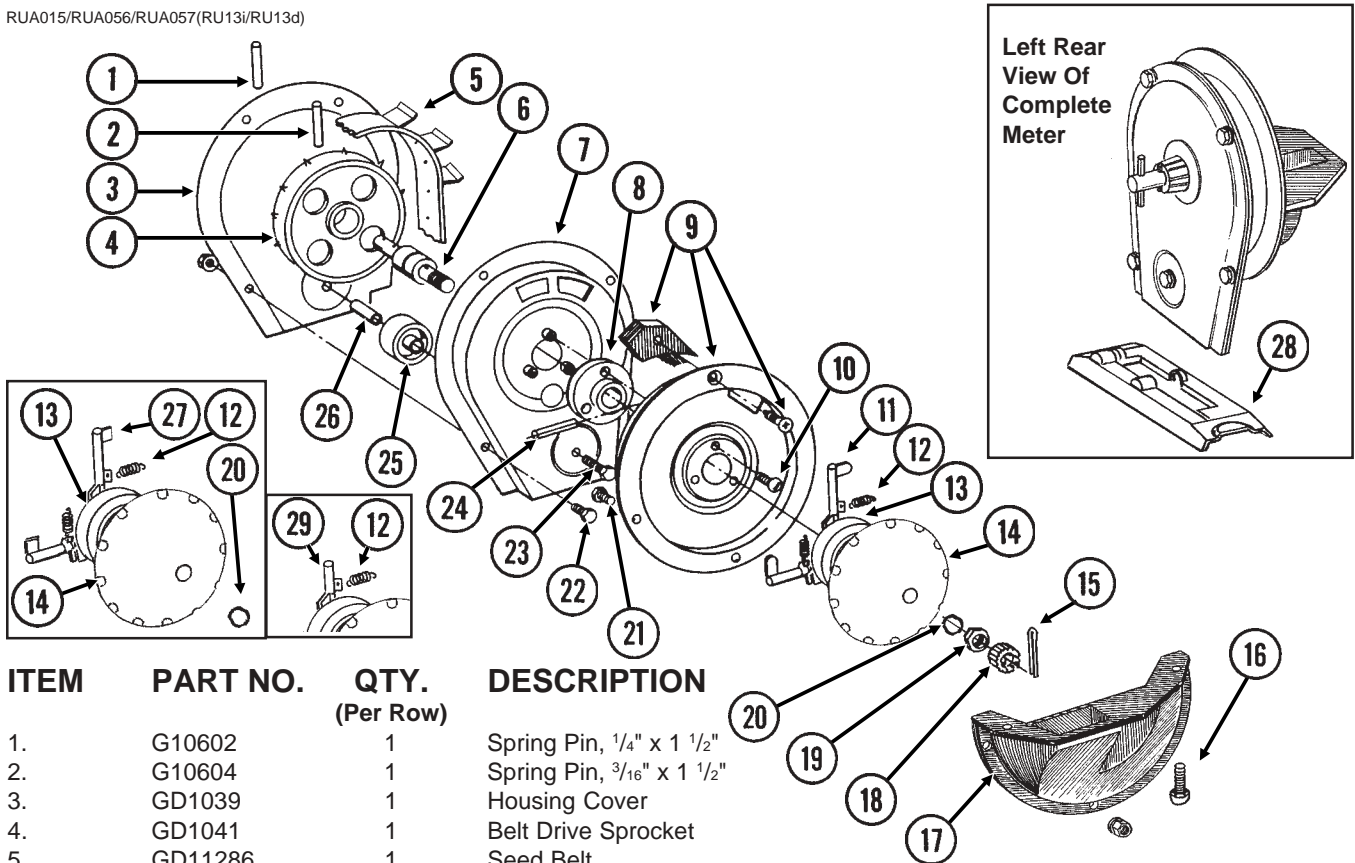

ITEM	PART NO.	QTY. (Per Row)	DESCRIPTION
1.	G10602	1	Spring Pin, 1/4" x 1 1/2"
2.	G10604	1	Spring Pin, 3/16" x 1 1/2"
3.	GD1039	1	Housing Cover
4.	GD1041	1	Belt Drive Sprocket
5.	GD11286	1	Seed Belt
6.	GA2019	1	Bearing
7.	GA2018	1	Conveyor Housing
8.	GB0110	1	Bearing Housing
9.	GR0664	1	Carrier Plate W/Brush And Screw
	GA2020	-	Brush
	G10690	-	Rolling Thread Screw, No. 10 x 3/4"
10.	G10401	3	Slotted Hex Washer Head Screw, No. 10-32 x 5/8"
11.	GD10733	12	Finger, Corn
12.	GD6501	12	Spring
13.	GB0111	1	Cam
14.	GD11528	1	Finger Holder
15.	G10470	1	Cotter Pin, 5/32" x 1"
16.	G11009	2	Locking Thumbscrew, 5/16"-18 x 3/4"
17.	GD11311	1	Seed Baffle
18.	GD1083	1	Cover Nut
19.	G10500	1	Jam Nut, 5/8"-18 UNF
20.	GA8343	1	Wave Washer, 5/8" (Triple Wave)
21.	G10020	3	Hex Head Cap Screw, 1/4"-20 x 5/8"
	G10323	3	Hex Flange Nut, 1/4"-20
22.	G10022	4	Hex Head Cap Screw, 1/4"-20 x 1/2"
	G10621	4	Flange Nut, 1/4"-20
23.	G10021	1	Hex Head Cap Screw, 1/4"-20 x 1 1/2"
	G10621	1	Flange Nut, 1/4"-20
24.	G10603	1	Spring Pin, 1/4" x 1 1/4"
25.	GD1042	1	Idler
26.	GB0120	1	Bushing, 17/64" I.D. x 1 1/32" Long
27.	GD10226	12	Finger, Oil Sunflower
28.	GD11373	1	Shank Cover, Finger Pickup Seed Meter
29.	GD11787	-	Half Rate Blank Finger

- A. GR1487 - Finger Assembly, Corn (Items 11-14 And 20)
- B. GR1327 - Finger Assembly, Oil Sunflower (Items 12-14, 20 And 27)

BRUSH-TYPE SEED METER

RUA037/RUA056/RUA057(RU14e)

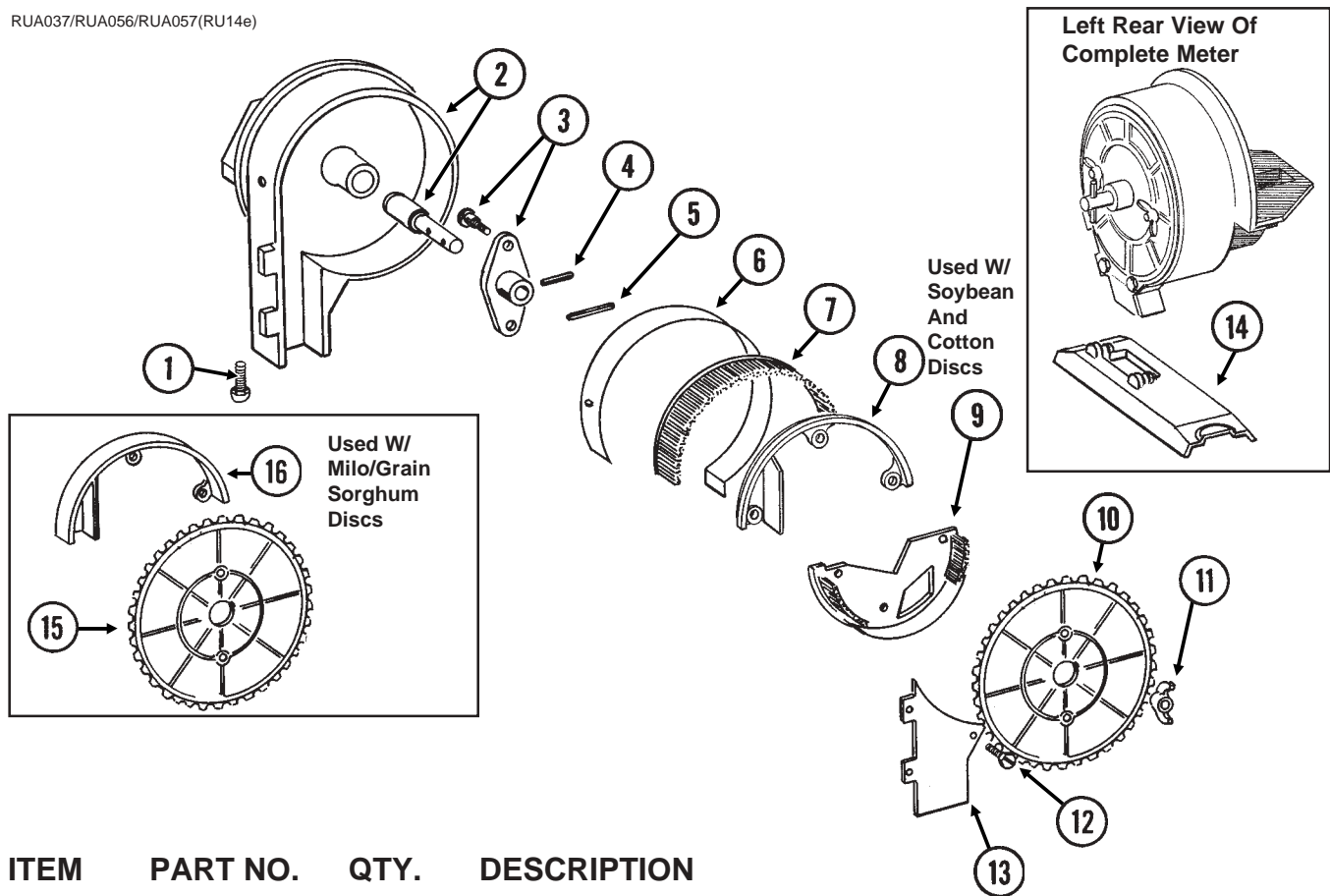

ITEM	PART NO.	QTY.	DESCRIPTION
(Per Row)			
1.	G11009	2	Locking Thumbscrew, 5/16"-18 x 3/4"
2.	GA6027	1	Housing W/Bearing
	GA5698	-	Bearing
3.	GA6038	1	Hub W/Shoulder Bolts
	GD1755	-	Shoulder Bolt, 1/4"-20 (2 Used)
4.	G10603	1	Spring Pin, 1/4" x 1 1/4"
5.	G10602	1	Spring Pin, 1/4" x 1 1/2"
6.	GD8778	1	Wear Strip
7.	GA5699	1	Upper Brush
8.	GD11122	1	Upper Brush Retainer (Used W/Soybean And Cotton Discs)
9.	GA5834	1	Lower Brush
10.	GA5794	-	Seed Disc, Soybean, 60 Cell, Black Color-Coded
	GA6184	-	Seed Disc, Specialty Soybean, 48 Cell, Dark Blue Color-Coded
	GA5796	-	Seed Disc, Cotton, Acid-Delinted, 30 Cell, White Color-Coded
	GA6168	-	Seed Disc, Large Cotton, Acid-Delinted, 36 Cell, Tan Color-Coded
	GA6478	-	Seed Disc, High-Rate Cotton, Acid-Delinted, 48 Cell, Light Green Color-Coded
	GA6182	-	Seed Disc, Hill-Drop Cotton, Acid-Delinted, 12 Cell, Brown Color-Coded
	GA7255	-	Seed Disc, Small Hill-Drop Cotton, Acid-Delinted, 12 Cell, Dark Green Color-Coded
11.	G10531	2	Nylon Insert Wing Nut, 1/4"-20
12.	G10584	9	Slotted Tap Screw, No. 10-24 x 1/2"
	G10634	-	Slotted Tap Screw, No. 10-24 x 5/8" (Use As Required)
13.	GD7878	1	Cover
14.	GD11374	1	Shank Cover, Brush-Type Seed Meter
15.	GA5982	-	Seed Disc, Small Milo/Grain Sorghum, 30 Cell, Red Color-Coded
	GA6187	-	Seed Disc, Large Milo/Grain Sorghum, 30 Cell, Light Blue Color-Coded
	GA5795	-	Seed Disc, High-Rate Small Milo/Grain Sorghum, 60 Cell, Red Color-Coded
	GA6633	-	Seed Disc, High-Rate Large Milo/Grain Sorghum, 60 Cell, Yellow Color-Coded
16.	GD8237	-	Upper Brush Retainer (Used W/Milo/Grain Sorghum Discs)

GRANULAR CHEMICAL HOPPER AND HOPPER PANEL EXTENSION

RUA052/RUA053/RUB028(RU92k)

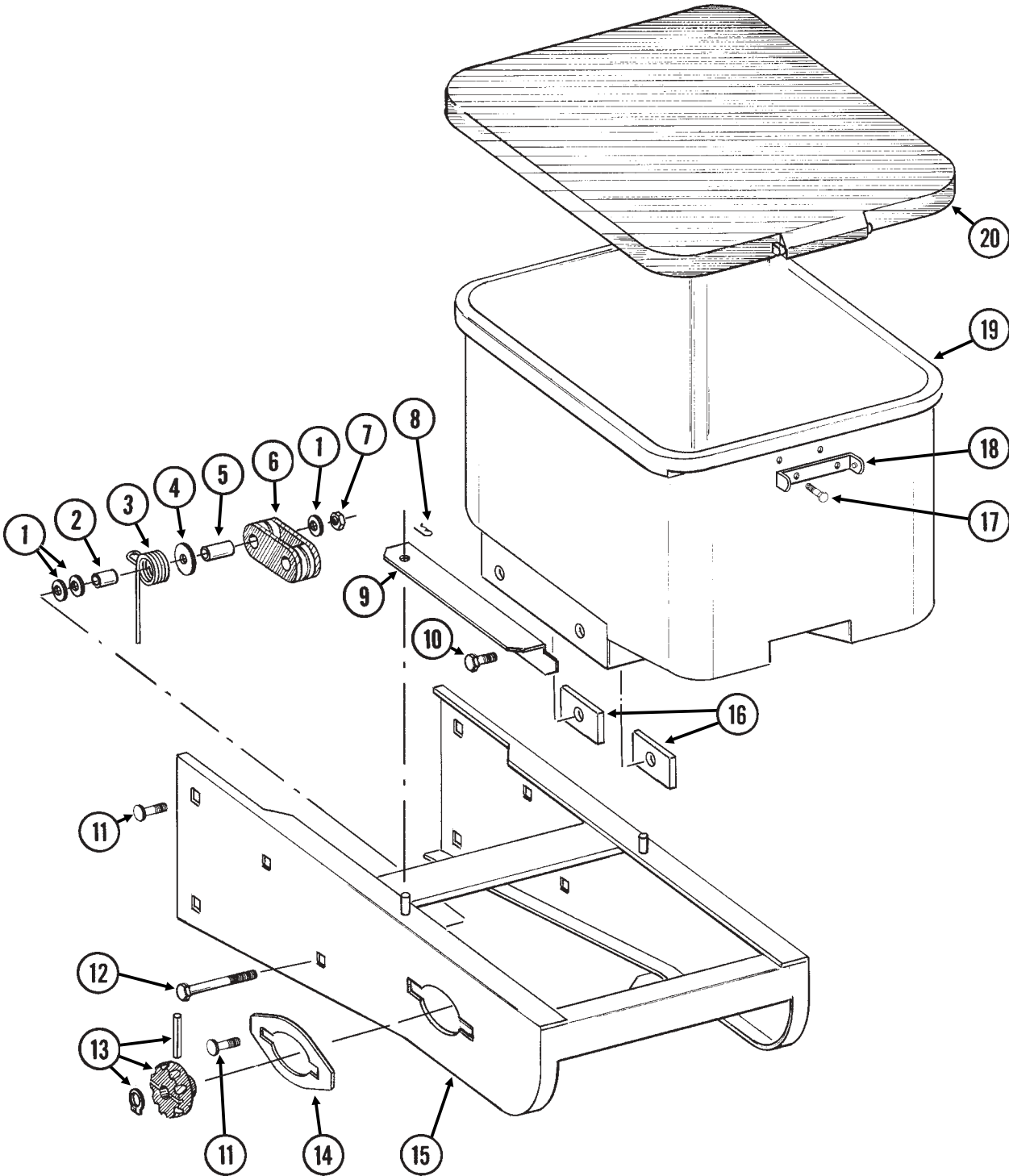

GRANULAR CHEMICAL HOPPER AND HOPPER PANEL EXTENSION

ITEM	PART NO.	QTY. (Per Row)	DESCRIPTION
1.	G10210	3	Washer, $\frac{3}{8}$ " USS
2.	GD2971-10	1	Sleeve, $\frac{9}{16}$ " Long
3.	GD11219	1	Spring
4.	G10201	1	Special Washer, $\frac{3}{8}$ " x 1 $\frac{1}{2}$ " O.D.
5.	GD1026	1	Sleeve, 1 $\frac{3}{16}$ " Long
6.	GD11962	1	Idler
7.	G10108	1	Lock Nut, $\frac{3}{8}$ "-16
8.	G10670	2	Hair Pin Clip, No. 3
9.	GD1059L	1	Support, L.H. (Shown)
	GD1059R	1	Support, R.H.
10.	G10002	4	Hex Head Cap Screw, $\frac{3}{8}$ "-16 x $\frac{3}{4}$ "
	G10229	4	Lock Washer, $\frac{3}{8}$ "
11.	G10312	8	Carriage Bolt, $\frac{5}{16}$ "-18 x $\frac{3}{4}$ "
	G10620	8	Flange Nut, $\frac{5}{16}$ "-18
12.	G10325	1	Hex Head Cap Screw, $\frac{3}{8}$ "-16 x 2 $\frac{3}{4}$ "
13.		-	See "Granular Chemical Meter And Meter Drive", Page P18
14.	GD11305	1	Plate
15.	A8422	1	Hopper Panel Extension (Non-Stock Item) (Sub Wholegoods Order Code 700-01080)
16.	GD11424	4	Block
17.	G10023	2	Hex Head Cap Screw, $\frac{1}{4}$ "-20 x $\frac{3}{4}$ "
	G10621	2	Flange Nut, $\frac{1}{4}$ "-20
18.	GD1060	1	Hinge
19.	GA8371	1	Hopper
20.	GA4444	1	Lid

GRANULAR CHEMICAL METER AND METER DRIVE

RUA051/RUB028(RU91a)

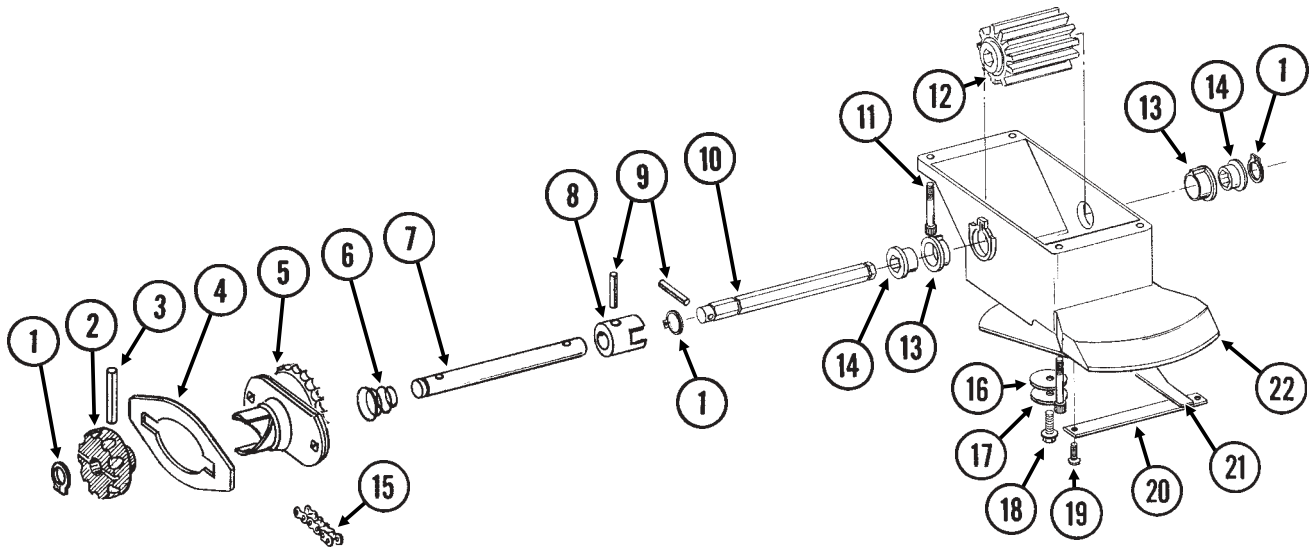

ITEM	PART NO.	QTY. (Per Row)	DESCRIPTION
1.	G10567	3	External Retaining Ring, $\frac{5}{8}$ "
2.	GD11239	1	Knob
3.	G10602	1	Spring Pin, $\frac{1}{4}$ " x 1 $\frac{1}{2}$ "
4.	-	-	See "Granular Chemical Hopper And Hopper Panel Extension", Pages P16 And P17
5.	GA8364	1	Sprocket And Bearing, Drive Clutch, 24 Tooth
6.	GD11413	1	Spring
7.	GD11240	1	Shaft
8.	GB0278	1	Coupler
9.	G10546	2	Spring Pin, $\frac{3}{16}$ " x 1 $\frac{1}{4}$ "
10.	GD11297	1	Shaft
11.	G10921	4	Hex Socket Head Cap Screw, No. 10-24 x $\frac{7}{8}$ "
	G10257	4	Lock Washer, No. 10
12.	GD7148	1	Feed Roller, Hex Bore
13.	GB0115	2	Bearing
14.	GD7258	2	Hex Bushing
15.	G3303-114	1	Chain, No. 41, 114 Pitch Including Connector Link
	GR0196	1	Connector Link, No. 41
16.	G10660	1	Wave Washer, $\frac{1}{2}$ "
17.	G10209	1	Washer, $\frac{1}{4}$ " USS
18.	G10570	1	Slotted Hex Self-Tapping Screw, $\frac{1}{4}$ "-20 x $\frac{3}{4}$ "
19.	G10521	2	Slotted Pan Head Self-Tapping Screw, No. 10 x $\frac{3}{8}$ "
20.	GD1061	1	Support Strap
21.	GD1063	1	Metering Gate
22.	GB0116	1	Granular Housing
A.	GA8326	-	Granular Chemical Meter Complete (Items 1, 9, 10, 12-14 And 16-22)

GRANULAR CHEMICAL BANDING OPTIONS

RUA061/RUA073(RU101m)

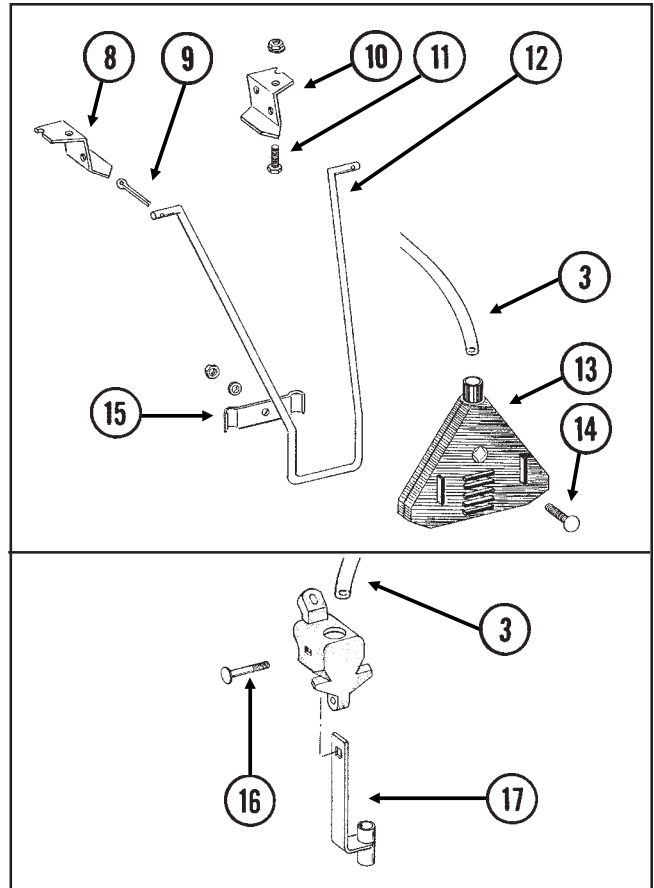
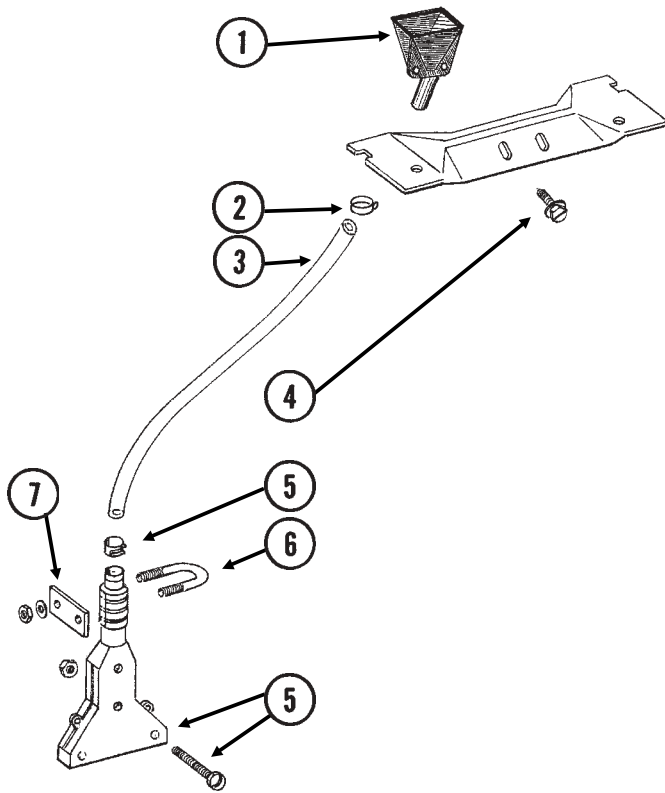

ITEM	PART NO.	QTY.	DESCRIPTION
1.	GD2423	1	Funnel
2.	G10673	1	Hose Clamp, No. 8
3.	GD2947	1	Hose, 7/16" x 28"
4.	G10523	2	Slotted Pan Head Self-Tapping Screw, No. 10 x 1/2"
5.	GA6907	1	Slope-Compensating Bander W/Hardware (4 1/2" Band Width)
	G10864	1	Uni-Clamp
	G10757	2	Pan Head Screw, No. 10-32 x 1 1/4"
	G10758	2	Hex Nut, No. 10-32
6.	GD10963	1	U-Bolt, 1 1/2" x 1 5/16" x 1/4"-20
	G10209	2	Washer, 1/4" USS
	G10110	2	Lock Nut, 1/4"-20
7.	GD10984	1	Spacer
8.	GD1115L	-	Hanger Bracket, L.H.
9.	G10452	-	Cotter Pin, 1/8" x 1/2"
10.	GD1115R	-	Hanger Bracket, R.H.
11.	G10310	-	Carriage Bolt, 1/4"-20 x 3/4", Grade 2
	G10227	-	Lock Washer, 1/4"
	G10103	-	Hex Nut, 1/4"-20
12.	GD1116	-	Hanger
13.	GA2075	-	Diffuser, 14" Band
14.	G10306	-	Carriage Bolt, 3/8"-16 x 2"
	G10229	-	Lock Washer, 3/8"
	G10101	-	Hex Nut, 3/8"-16
15.	GD1118	-	Clamp
16.	G10315	1	Carriage Bolt, 1/2"-13 x 2 1/2" (Replaces Existing 1/2" x 2 1/4" Hardware)
17.	GA6741	1	Bracket (Straight Drop In-Furrow)

SPRING TOOTH INCORPORATOR

RUA055(RU95)

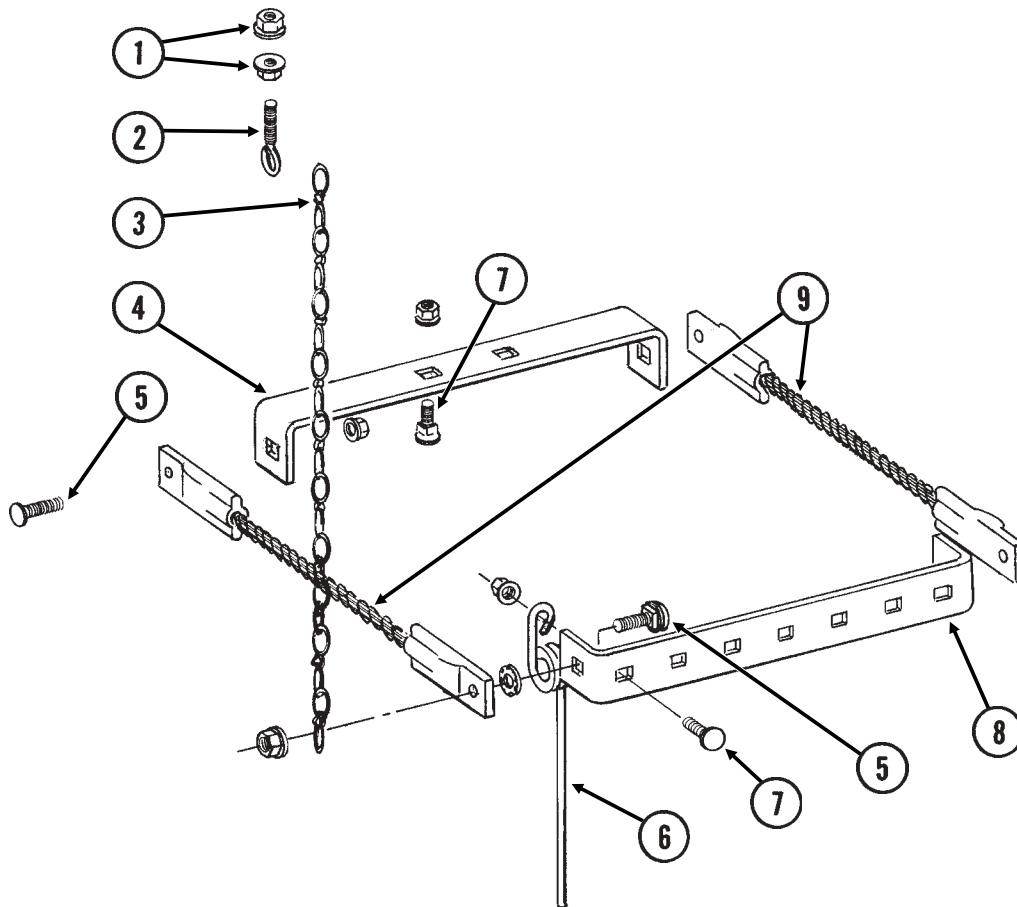

ITEM	PART NO.	QTY. (Per Row)	DESCRIPTION
1.	G10621	4	Flange Nut, 1/4"-20
2.	GD2460	2	Eyebolt, 1/4"-20
3.	G3305-01	4	Twin Loop Chain, 9 Links
4.	GD1143	1	Front Bracket
5.	G10305	4	Carriage Bolt, 3/8"-16 x 1"
	G10529	4	External Tooth Lock Washer, 3/8"
	G10622	4	Flange Nut, 3/8"-16
6.	GD1145	7	Spring Tooth
7.	G10308	9	Carriage Bolt, 3/8"-16 x 3/4"
	G10622	9	Flange Nut, 3/8"-16
8.	GD1144	1	Rear Bracket
9.	GA2094	2	Cable Assembly

ROW UNIT MOUNTED NO TILL COULTER

RUA061(RU102/RU102c)

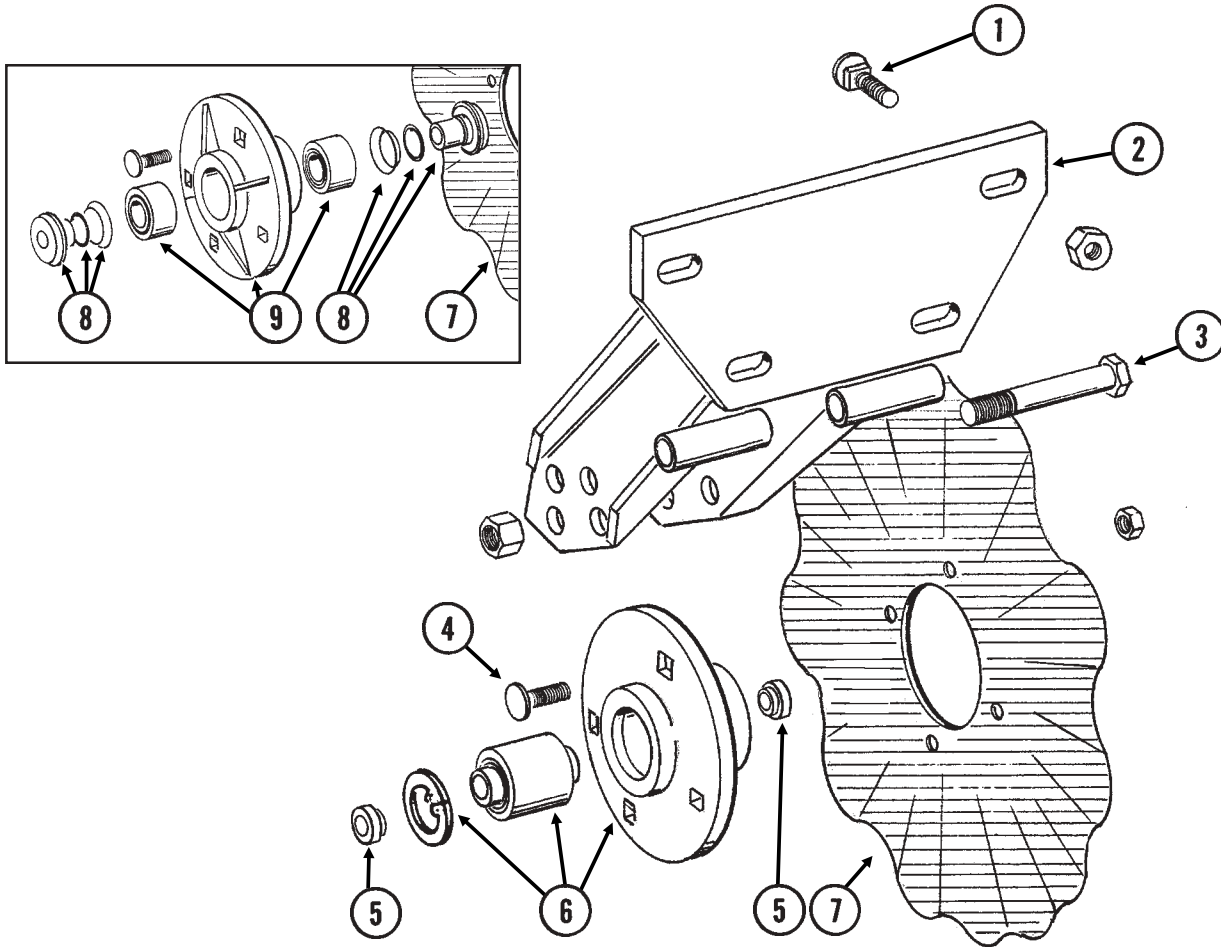

ITEM	PART NO.	QTY. (Per Row)	DESCRIPTION
1.	G10574	4	Carriage Bolt, 1/2"-13 x 1 1/4"
	G10111	4	Lock Nut, 1/2"-13
2.	GA5625	1	Arm
3.	G10036	1	Hex Head Cap Screw, 5/8"-11 x 4"
	G10107	1	Lock Nut, 5/8"-11
4.	G10574	4	Carriage Bolt, 1/2"-13 x 1 1/4"
	G10111	4	Lock Nut, 1/2"-13
5.	GD11677	2	Adapter
6.	GA8641	1	Hub W/Bearing And Retaining Ring
	GA8603	-	Double Row Bearing
	GD11652	-	Retaining Ring, 2 7/16"
7.	GD7803	-	Disc Blade, Fluted, 1", 8 Flutes (Shown)
	GD7804	-	Disc Blade, Bubbled, 1"
	GD9254	-	Disc Blade, Fluted, 3/4", 13 Flutes
8.	GB0227	2	Adapter W/O-Ring And Spring Washer
	GD8844	2	O-Ring
	GD8843	2	Spring Washer
9.	GA5640	1	Hub W/Bearings And Grease Fitting (Sub G1K289)
	GA5622	-	Bearing (2 Used Per Hub)
	G10640	-	Grease Fitting, 1/4"-28

ROW UNIT MOUNTED DISC FURROWER

RUA059/RUA058(RU99/RU98g)

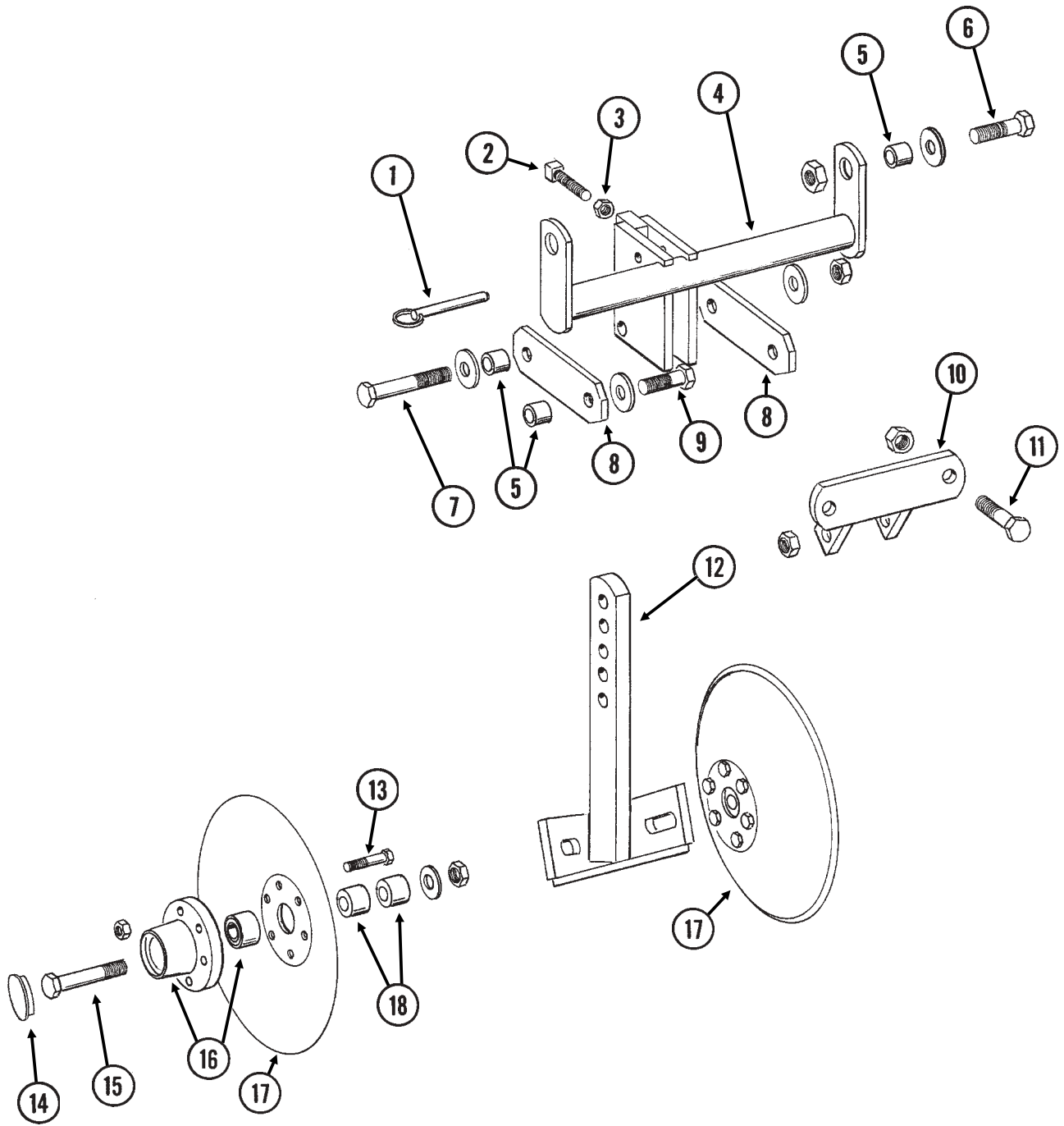

ROW UNIT MOUNTED DISC FURROWER

ITEM	PART NO.	QTY.	DESCRIPTION
		(Per Row)	
1.	G10536	1	Detent Pin, 1/2" x 2 1/2" Grip
2.	G10597	1	Square Head Set Screw, 5/8"-11 x 2 1/4"
3.	G10503	1	Hex Jam Nut, 5/8"-11, Grade 2
4.	GA5719	1	Mounting Bracket
5.	GD7889	6	Bushing
6.	G10039	2	Hex Head Cap Screw, 1/2"-13 x 1 3/4"
	G10216	2	Washer, 1/2" USS
	G10111	2	Lock Nut, 1/2"-13
7.	G10585	1	Hex Head Cap Screw, 1/2"-13 x 3 1/4"
	G10216	2	Washer, 1/2" USS
	G10111	1	Lock Nut, 1/2"-13
8.	GD7890	2	Link
9.	G10017	2	Hex Head Cap Screw, 1/2"-13 x 1 1/2"
	G10216	2	Washer, 1/2" USS
	G10111	2	Lock Nut, 1/2"-13
10.	GA5715	1	Anchor
11.	G10017	2	Hex Head Cap Screw, 1/2"-13 x 1 1/2"
	G10111	2	Lock Nut, 1/2"-13
12.	GA5718	1	Support Arm
13.	G10572	6	Truss Head Slotted Machine Screw, 5/16"-18 x 7/8"
	G10106	6	Hex Nut, 5/16"-18
14.	GD1132	2	Dust Cap
15.	G10318	2	Hex Head Cap Screw, 5/8"-11 x 4 1/2"
	GD7805	2	Special Washer, 5/8", Hardened
	G10107	2	Lock Nut, 5/8"-11
16.	GA5654	2	Hub W/Bearings
	GA2014	-	Bearing
17.	GD7823	-	Disc Blade, Solid, 12" (Shown)
	GD8307	-	Disc Blade, Notched, 12"
18.	GD7817-01	2	Spacer, 11/16" I.D. x 3/4" Long
	GD7817-04	2	Spacer, 11/16" I.D. x 1/2" Long

ROW UNIT MOUNTED RESIDUE WHEEL

(RU103d)

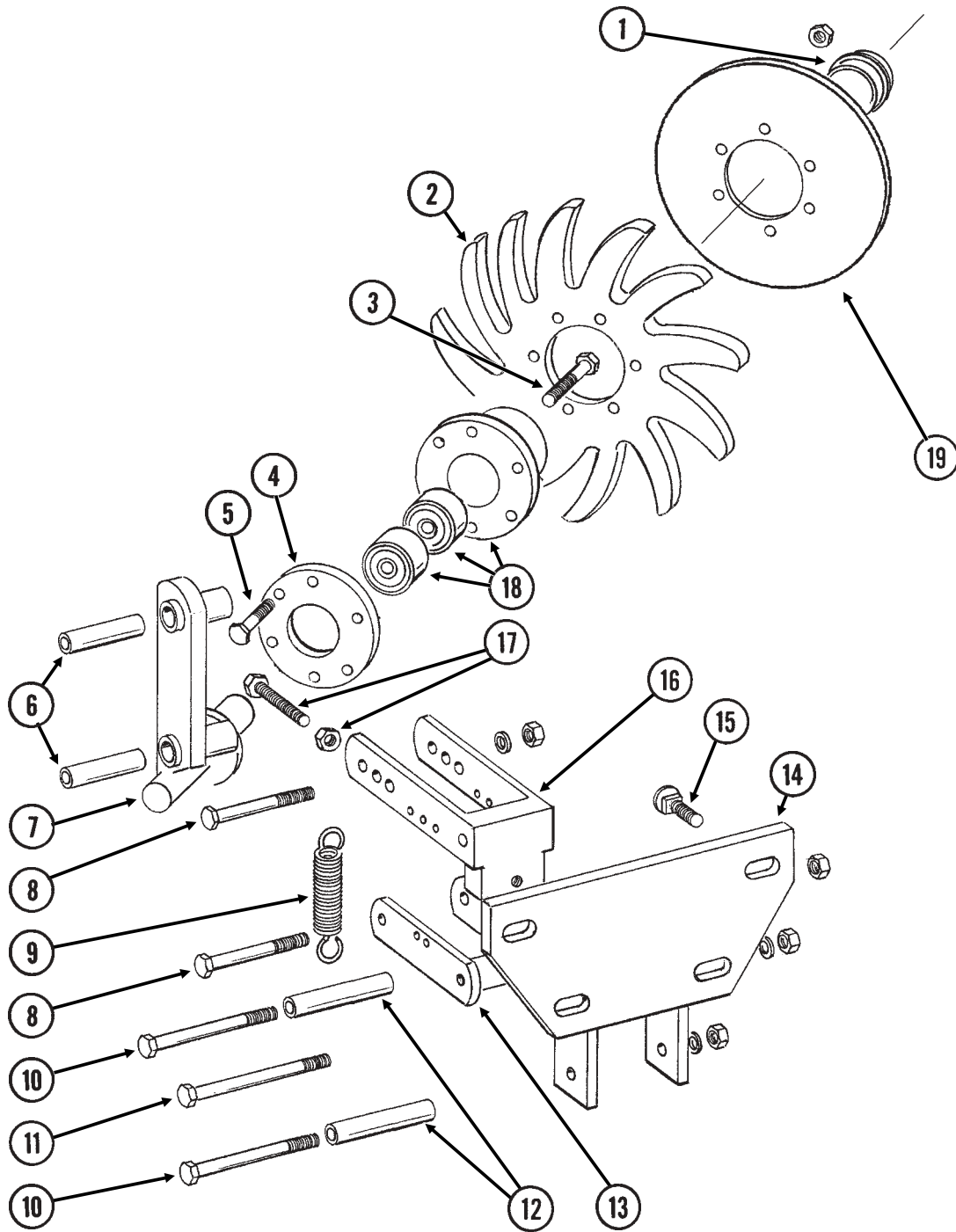

ROW UNIT MOUNTED RESIDUE WHEEL

ITEM	PART NO.	QTY. (Per Row)	DESCRIPTION
1.	GD1132	1	Dust Cap
2.	GD10552	1	Wheel, 12 Tine, $\frac{3}{8}$ " x 12"
3.	G10006	1	Hex Head Cap Screw, $\frac{5}{8}$ "-11 x 2 $\frac{1}{4}$ "
4.	GD9724	1	Backing Plate
5.	G10133	6	Hex Head Cap Screw, $\frac{5}{16}$ "-18 x 1 $\frac{1}{2}$ "
	G10109	6	Lock Nut, $\frac{5}{16}$ "-18
6.	GD9720	2	Spacer, $\frac{1}{2}$ " x 2 $\frac{3}{16}$ " Long
7.	GA6838	1	Wheel Mount
8.	G10033	2	Hex Head Cap Screw, $\frac{1}{2}$ "-13 x 3 $\frac{1}{2}$ "
	G10228	2	Lock Washer, $\frac{1}{2}$ "
	G10102	2	Hex Nut, $\frac{1}{2}$ "-13
9.	GD5857	2	Spring
10.	G10045	2	Hex Head Cap Screw, $\frac{1}{2}$ "-13 x 4 $\frac{1}{2}$ "
	G10228	2	Lock Washer, $\frac{1}{2}$ "
	G10102	2	Hex Nut, $\frac{1}{2}$ "-13
11.	G10348	1	Hex Head Cap Screw, $\frac{1}{2}$ "-13 x 5" (Lockup Bolt)
	G10111	1	Lock Nut, $\frac{1}{2}$ "-13
12.	GD9715	2	Spacer, $\frac{1}{2}$ " x 3" Long
13.	GA6834	1	Lower Link
14.	GA6832	1	Mount
15.	G10574	4	Carriage Bolt, $\frac{1}{2}$ "-13 x 1 $\frac{1}{4}$ "
	G10111	4	Lock Nut, $\frac{1}{2}$ "-13
16.	GA6833	1	Upper Link
17.	G10371	1	Hex Head Cap Screw, $\frac{1}{2}$ "-13 x 3", Full Thread
	G10501	1	Hex Jam Nut, $\frac{1}{2}$ "-13, Grade 2
18.	GA5654	1	Hub W/Bearings
	GA2014	-	Bearing
19.	GD12534	-	Cover
A.	GA7446	-	Wheel Assembly, 12 Tine (Items 2, 4, 5 And 18)

COULTER MOUNTED RESIDUE WHEELS

RUA063(RU104p)

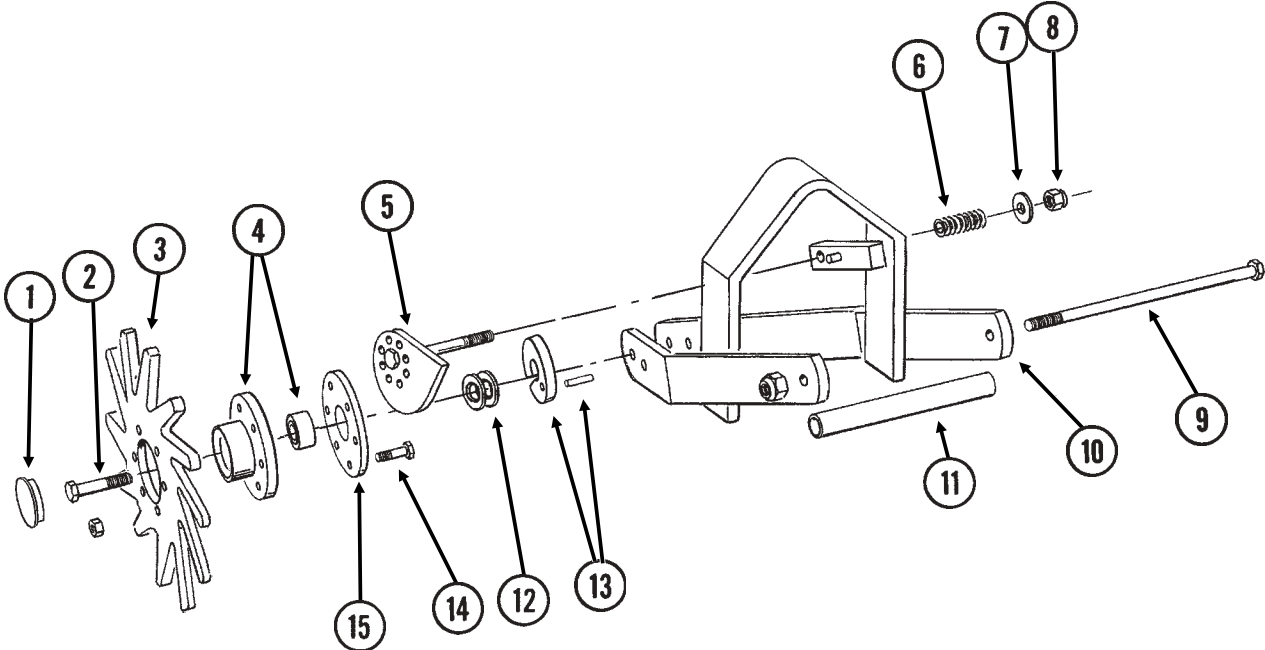

COULTER MOUNTED RESIDUE WHEELS

ITEM	PART NO.	QTY. (Per Row)	DESCRIPTION
1.	GD1132	2	Dust Cap
2.	G10009	2	Hex Head Cap Screw, $\frac{5}{8}$ "-11 x 2 $\frac{1}{2}$ "
3.	GD10552	2	Wheel, 12 Tine, $\frac{3}{8}$ " x 12"
4.	GA5654	2	Hub W/Bearings
	GA2014	-	Bearing
5.	GA7412	1	Cam
6.	GD10519	1	Spring
7.	G10206	1	Washer, $\frac{1}{2}$ " SAE
8.	G10974	1	Lock Nut W/Nylon Insert, $\frac{1}{2}$ "-13
9.	G10148	1	Hex Head Cap Screw, $\frac{1}{2}$ "-13 x 9 $\frac{1}{2}$ "
	G10974	1	Lock Nut W/Nylon Insert, $\frac{1}{2}$ "-13
10.	GA7271	1	Mount
11.	GD10526	1	Sleeve, 7 $\frac{1}{2}$ "
12.	G10213	4	Machine Bushing, $\frac{5}{8}$ " (.030" Thick)
13.	GA8760	2	Weed Guard W/Spring Pin
	G10765	-	Spring Pin, $\frac{1}{4}$ " x 1"
14.	G10133	12	Hex Head Cap Screw, $\frac{5}{16}$ "-18 x 1 $\frac{1}{2}$ "
	G10109	12	Lock Nut, $\frac{5}{16}$ "-18
15.	GD9724	2	Backing Plate
A.	GA7446	-	Wheel Assembly, 12 Tine, R.H. (Items 3, 4, 14 And 15) (Shown)
	GA7445	-	Wheel Assembly, 12 Tine, L.H. (Items 3, 4, 14 And 15)

FRAME MOUNTED COULTER W/DISC FURROWER

RUA058/RUA064/RUA070/RUA071/RUA072/RUA068(RU107f/RU107b)

STYLE A

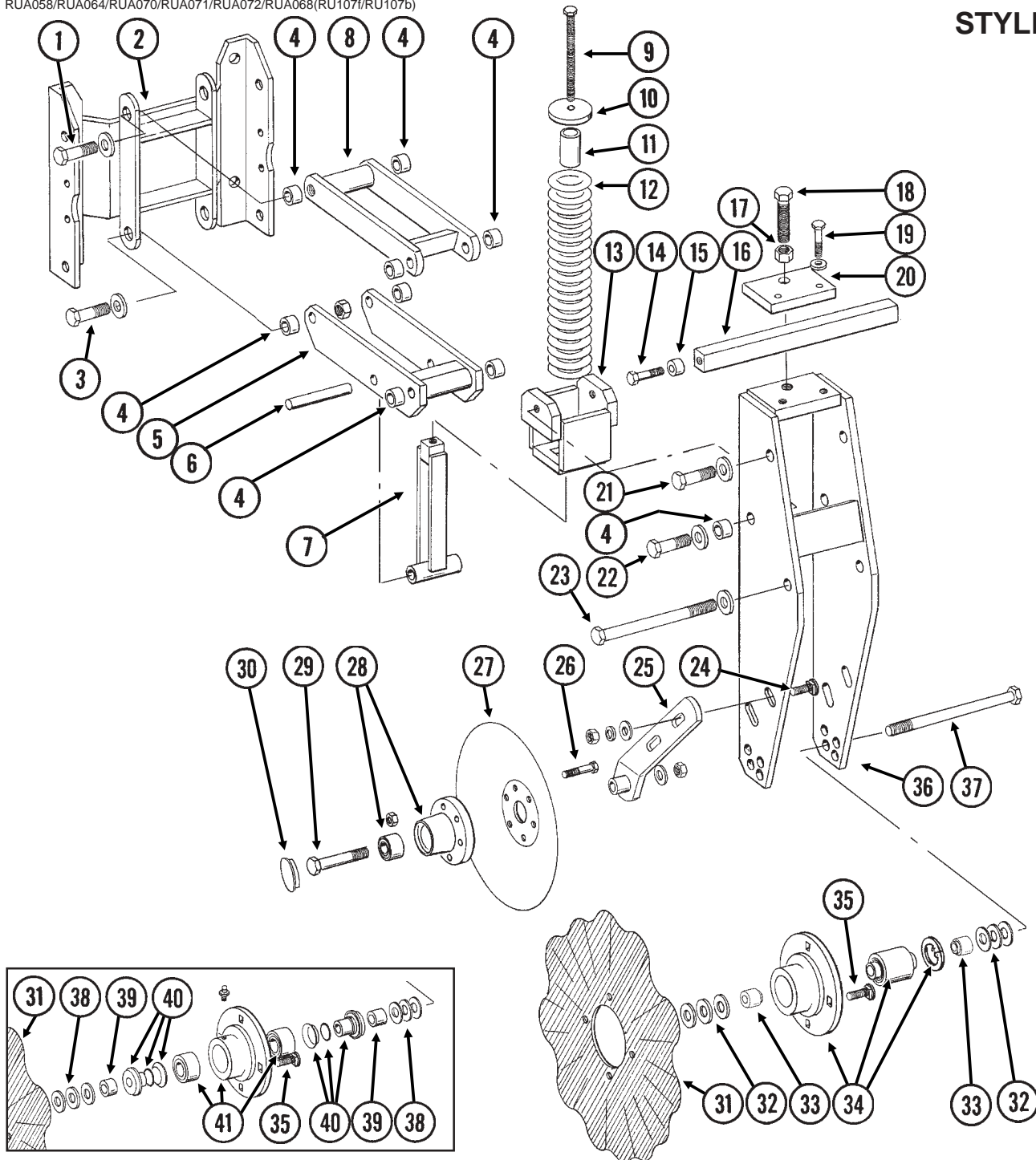

ITEM PART NO. QTY. DESCRIPTION
(Per Row)

1.	G10008	2	Hex Head Cap Screw, 5/8"-11 x 2"
	GD7805	2	Special Washer, 5/8", Hardened
2.	GA5798	1	Support Plate
3.	G10008	2	Hex Head Cap Screw, 5/8"-11 x 2"
	GD7805	2	Special Washer, 5/8", Hardened
	G10107	2	Lock Nut, 5/8"-11
4.	GB0218	10	Bushing, 21/32" I.D. x 7/8" O.D. x 19/32" Long
5.	GA5631	1	Lower Parallel Link
6.	GD7815	1	Pin, 5/8" x 4 1/4"
7.	GA5635	1	Spring Guide

FRAME MOUNTED COULTER W/DISC FURROWER

ITEM	PART NO.	QTY. (Per Row)	DESCRIPTION
8.	GA5630	1	Upper Parallel Link
9.	G10573	1	Hex Head Cap Screw, 5/8"-11 x 5 1/2", Full Thread
10.	GB0196	1	Washer
11.	GD7817-09	1	Spacer, 11/16" I.D. x 1 3/4" Long
12.	GD7831	1	Compression Spring
13.	GA5637	1	Spring Socket
14.	GD7818	2	Special Bolt
15.	GD7817-01	2	Spacer, 11/16" I.D. x 3/4" Long
16.	GD7816	1	Depth Control Bar
17.	G10104	1	Hex Nut, 5/8"-11
18.	G10582	1	Hex Head Cap Screw, 5/8"-11 x 4", Full Thread
19.	G10581	2	Hex Head Cap Screw, 1/2"-13 x 2 1/4"
	G10228	2	Lock Washer, 1/2"
20.	GD7811	1	Depth Adjustment Clamp
21.	G10008	2	Hex Head Cap Screw, 5/8"-11 x 2"
	GD7805	2	Special Washer, 5/8", Hardened
	GD1109	-	Bushing, 41/64" I.D. x 7/8" O.D. x 1/4" Long (As Required)
	G10107	1	Lock Nut, 5/8"-11
22.	G10055	2	Hex Head Cap Screw, 5/8"-11 x 1 1/4"
	GD7805	2	Special Washer, 5/8", Hardened
23.	G10012	1	Hex Head Cap Screw, 5/8"-11 x 6 1/2"
	GD7805	2	Special Washer, 5/8", Hardened
	GD1109	-	Bushing, 41/64" I.D. x 7/8" O.D. x 1/4" Long (As Required)
	G10107	1	Lock Nut, 5/8"-11
24.	G10747	4	Carriage Bolt, 1/2"-13 x 2"
	G10206	-	Washer, 1/2" SAE (As Required)
	G10228	4	Lock Washer, 1/2"
	G10102	4	Hex Nut, 1/2"-13
25.	GA5636	2	Arm
26.	G10572	12	Truss Head Slotted Machine Screw, 5/16"-18 x 7/8"
	G10106	12	Hex Nut, 5/16"-18
27.	GD7823	2	Disc Blade, Solid, 12" (Shown)
	GD8307	-	Disc Blade, Notched, 12"
28.	GA5654	2	Hub W/Bearings
	GA2014	4	Bearing
29.	G10036	2	Hex Head Cap Screw, 5/8"-11 x 4"
	G10107	2	Lock Nut, 5/8"-11
30.	GD1132	2	Dust Cap
31.	GD7803	1	Disc Blade, Fluted, 1", 8 Flutes (Shown)
	GD7804	-	Disc Blade, Bubbled, 1"
	GD9254	-	Disc Blade, Fluted, 3/4", 13 Flutes
32.	G10213	-	Machine Bushing, 5/8" (.030" Thick) (As Required)
	G10918	-	Machine Bushing, 5/8", 14 Gauge (As Required)
33.	GD11698	2	Adapter
34.	GA8641	1	Hub W/Bearing And Retaining Ring
	GA8603	-	Double Row Bearing
	GD11652	-	Retaining Ring, 2 7/16"
35.	G10574	4	Carriage Bolt, 1/2"-13 x 1 1/4"
	G10111	4	Lock Nut, 1/2"-13
36.	GA5643	1	Fork Mount
37.	G10068	1	Hex Head Cap Screw, 5/8"-11 x 6"
	G10107	1	Lock Nut, 5/8"-11
38.	G10217	-	Washer, 5/8" USS (As Required)
39.	GD7817-04	2	Spacer, 11/16" I.D. x 1/2" Long
40.	GB0227	2	Adapter W/O-Ring And Spring Washer
	GD8844	-	O-Ring
	GD8843	-	Spring Washer
41.	GA5640	1	Hub W/Bearings And Grease Fitting (Sub G1K290)
	GA5622	-	Bearing (2 Used Per Hub)
	G10640	-	Grease Fitting, 1/4"-28

FRAME MOUNTED COULTER W/RESIDUE WHEELS

(RU135c/RU135g/RU135h)

STYLE B

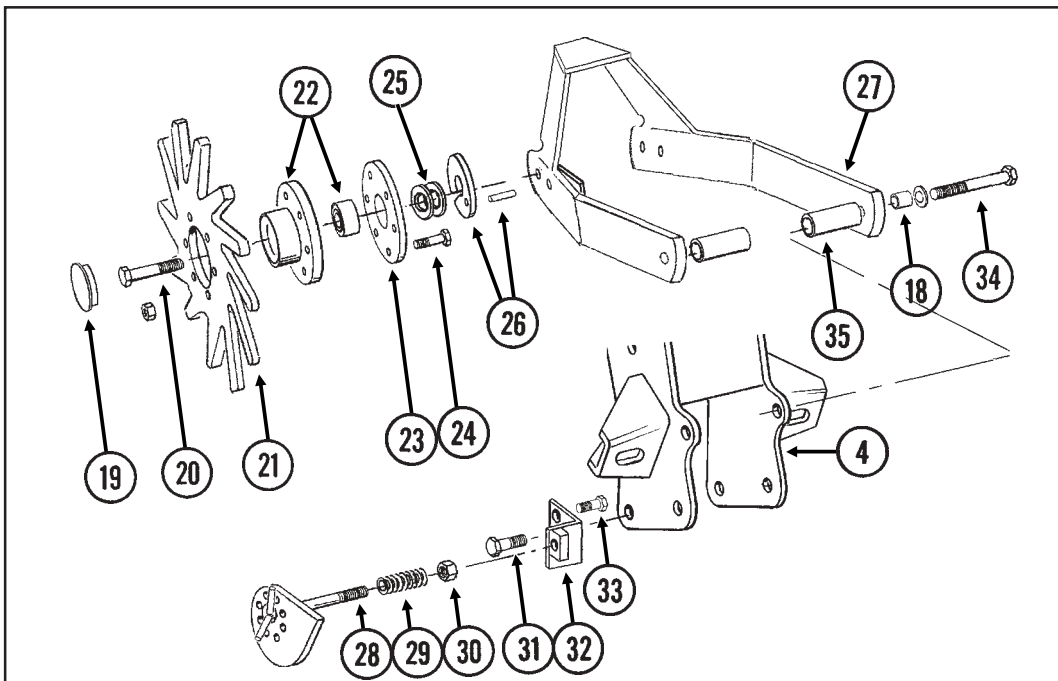
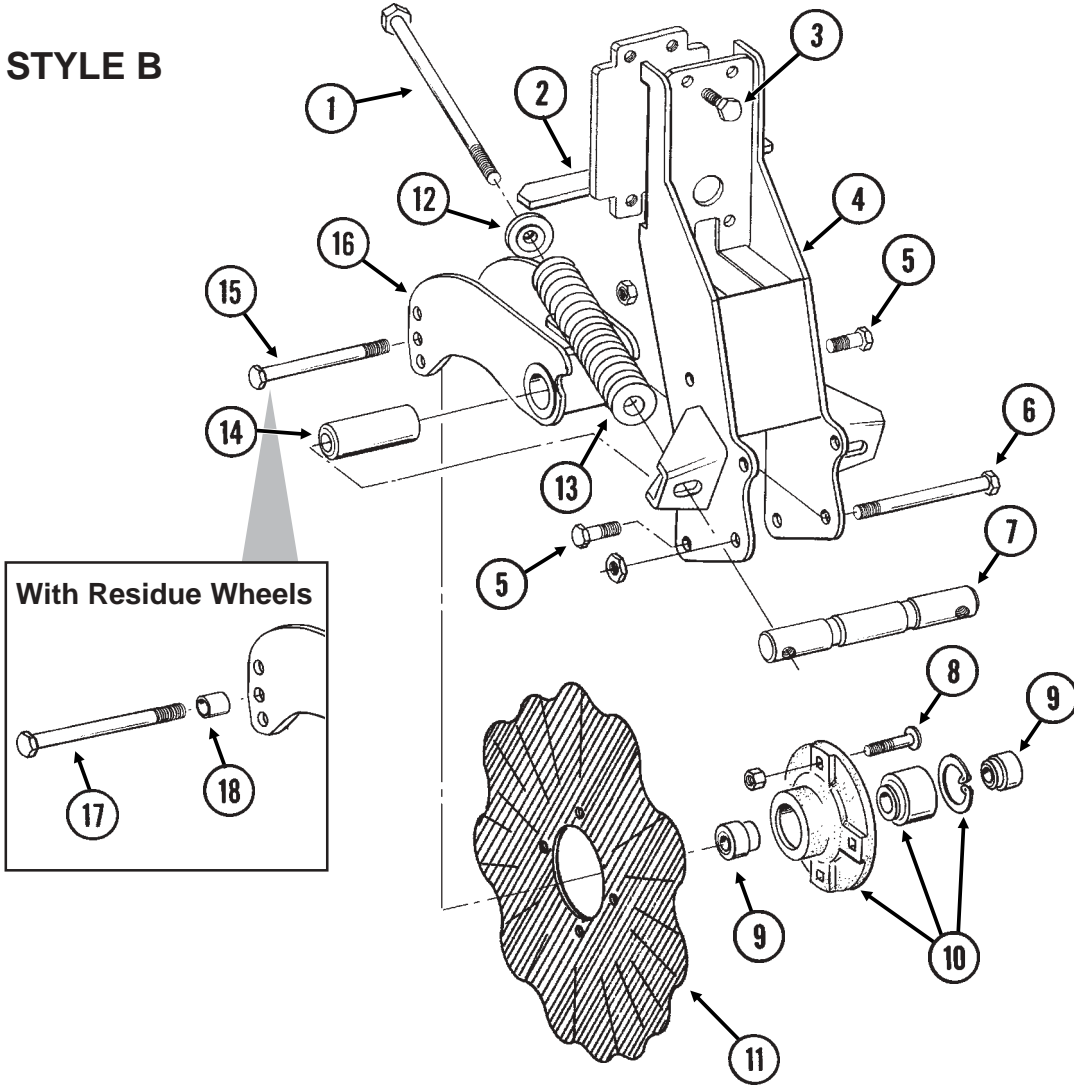

FRAME MOUNTED COULTER W/RESIDUE WHEELS

ITEM	PART NO.	QTY. (Per Row)	DESCRIPTION
1.	G11010	2	Hex Head Cap Screw, 3/4"-10 x 12"
2.	GA9844	1	Plate W/Angle
3.	G10039	4	Hex Head Cap Screw, 1/2"-13 x 1 3/4"
4.	GA9131	1	Coulter Frame
5.	G10007	4	Hex Head Cap Screw, 5/8"-11 x 1 1/2"
	G10107	4	Lock Nut, 5/8"-11
6.	G10400	1	Hex Head Cap Screw, 3/4"-10 x 6 1/2"
	G10112	1	Lock Nut, 3/4"-10
7.	GD12826	1	Spring Anchor Bar
8.	G10574	4	Carriage Bolt, 1/2"-13 x 1 1/4"
	G10111	4	Lock Nut, 1/2"-13
9.	GD12827	2	Adapter
10.	GA8641	1	Hub W/Bearing And Retaining Ring
	GA8603	1	Double Row Bearing
	GD11652	1	Retaining Ring, 2 7/16"
11.	GD7803	1	Disc Blade, Fluted, 1", 8 Flutes (Shown)
	GD7804	-	Disc Blade, Bubbled, 1"
	GD9254	-	Disc Blade, Fluted, 3/4", 13 Flutes
12.	GB0213	2	Spring Seat
13.	GD12817	2	Compression Spring
14.	GD12829	1	Sleeve
15.	G10046	1	Hex Head Cap Screw, 5/8"-11 x 5"
	G10107	1	Lock Nut, 5/8"-11
16.	GA9845	1	Coulter Arm
17.	G10011	1	Hex Head Cap Screw, 5/8"-11 x 5 1/2"
	G10107	1	Lock Nut, 5/8"-11
18.	GB0218	3	Bushing, 2 1/32" I.D. x 7/8" O.D. x 19/32" Long
19.	GD1132	2	Dust Cap
20.	G10009	2	Hex Head Cap Screw, 5/8"-11 x 2 1/2"
21.	GD10552	2	Wheel, 12 Tine, 3/8" x 12"
22.	GA5654	2	Hub W/Bearings
	GA2014	-	Bearing
23.	GD9724	2	Backing Plate
24.	G10133	12	Hex Head Cap Screw, 5/16"-18 x 1 1/2"
	G10109	12	Lock Nut, 5/16"-18
25.	G10213	4	Machine Bushing, 5/8" (.030" Thick)
26.	GA9862	2	Weed Guard W/Spring Pin
	G10765	-	Spring Pin, 1/4" x 1"
27.	GA9865	1	Mount
28.	GA9861	1	Cam
29.	GD10519	1	Spring
30.	G10974	1	Lock Nut W/Nylon Insert, 1/2"-13
31.	G10005	1	Hex Head Cap Screw, 5/8"-11 x 1 3/4"
	G10107	4	Lock Nut, 5/8"-11
32.	GA9864	1	Support
33.	G10014	1	Hex Head Cap Screw, 1/2"-13 x 1"
	G10102	1	Hex Nut, 1/2"-13
34.	G10011	2	Hex Head Cap Screw, 5/8"-11 x 5 1/2"
	G10205	2	Washer, 5/8" SAE
	G10730	2	Nylon Insert Lock Nut, 5/8"-11
35.	GD14170	2	Sleeve, 3"
A.	GA7446	-	Wheel Assembly, 12 Tine, R.H. (Items 21-24) (Shown)
	GA7445	-	Wheel Assembly, 12 Tine, L.H. (Items 21-24)

INTERPLANT® PUSH ROW UNIT

RPU011/RPU012/RPU013(RU89p/RU121/RU89i)

NOTE: Push row units use the same seed tube, row unit depth adjustment components, quick adjustable down force springs, 15" opener disc blades, gauge wheels, closing wheels, meter drive and seed hopper as the pull row unit. See those pages for common parts.

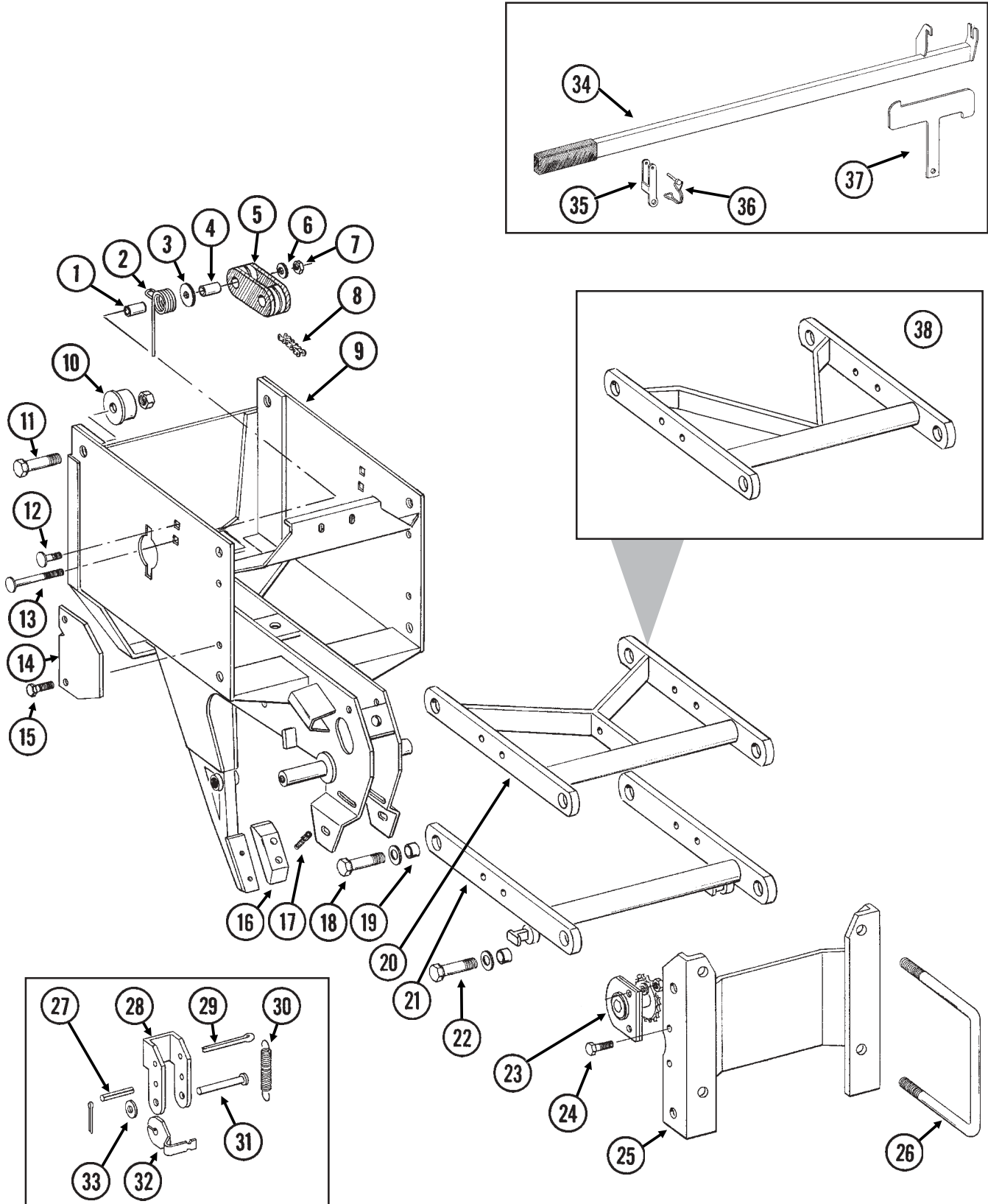

INTERPLANT® PUSH ROW UNIT

ITEM	PART NO.	QTY. (Per Row)	DESCRIPTION
1.	GD8893-01	1	Sleeve, 1 3/8" Long
2.	GD11218	1	Spring
3.	G10201	1	Special Washer, 3/8" x 1 1/2" O.D.
4.	GD1026	1	Sleeve, 1 3/16" Long
5.	GD11962	1	Idler
6.	G10210	1	Washer, 3/8" USS
7.	G10108	1	Lock Nut, 3/8"-16
8.	G3303-96	1	Chain, No. 41, 96 Pitch Including Connector Link
	GR0196	1	Connector Link, No. 41
9.	GA8037	-	Push Row Unit Shank
10.	GB0314	2	Hopper Mount
11.	G10751	2	Hex Head Cap Screw, 5/8"-18 x 1 3/4"
	G10412	2	Lock Nut, 5/8"-18
12.	G10599	1	Carriage Bolt, 3/8"-16 x 1 1/4"
	G10101	1	Hex Nut, 3/8"-16
	G10108	1	Lock Nut, 3/8"-16
13.	G10307	1	Carriage Bolt, 3/8"-16 x 3 1/2"
14.	GD10867	2	Stop
15.	G10004	4	Hex Head Cap Screw, 3/8"-16 x 1 1/4"
	G10108	4	Lock Nut, 3/8"-16
16.	GB0301	1	Seed Tube Guard/Inner Scraper
17.	G10912	2	Hex Socket Head Cap Screw, 5/16"-18 x 1", Grade 8
18.	G10751	4	Hex Head Cap Screw, 5/8"-18 x 1 3/4"
	GD7805	4	Special Washer, 5/8", Hardened
	G10412	4	Lock Nut, 5/8"-18
19.	GB0218	8	Bushing, 2 1/32" I.D. x 7/8" O.D. x 19/32" Long
20.	GA5788	1	Upper Arm
21.	GA5787	1	Lower Arm
22.	G10732	4	Hex Head Cap Screw, 5/8"-18 x 2"
	GD7805	4	Special Washer, 5/8", Hardened
	G10412	4	Lock Nut, 5/8"-18
23.	GA1720	1	Bearing/Sprocket, 7/8" Hex Bore
24.	G10004	2	Hex Head Cap Screw, 3/8"-16 x 1 1/4"
	G10229	2	Lock Washer, 3/8"
	G10101	2	Hex Nut, 3/8"-16
25.	GA5786	1	Mounting Plate
26.	GD1113	2	U-Bolt, 5" x 7" x 5/8"-11
	G10230	4	Lock Washer, 5/8"
	G10104	4	Hex Nut, 5/8"-11
27.	G10718	2	Spring Pin, 5/16" x 1 1/8"
28.	GD11264	2	Lockup
29.	G10463	2	Cotter Pin, 1/4" x 1 1/2"
30.	GD11447	2	Spring
31.	G10284	2	Clevis Pin, 1/2" x 1 1/2"
	G10456	2	Cotter Pin, 1/8" x 3/4"
32.	GD11263	2	Spring Tab
33.	G10216	2	Washer, 1/2" USS
34.	GA8651	1	Lift Lever W/Boot
	GD11649	-	Boot
35.	GD11659	1	Bracket
36.	GD9695	1	Wire Lock Pin, 1/4" x 1 3/4"
37.	GD11752	1	Mount
38.	GA8930	-	Upper Arm

HITCH AND SAFETY CHAIN

WAC011/PHA048/PHS049(WGN47e/TWL169b)

Prior To Serial No. 625025

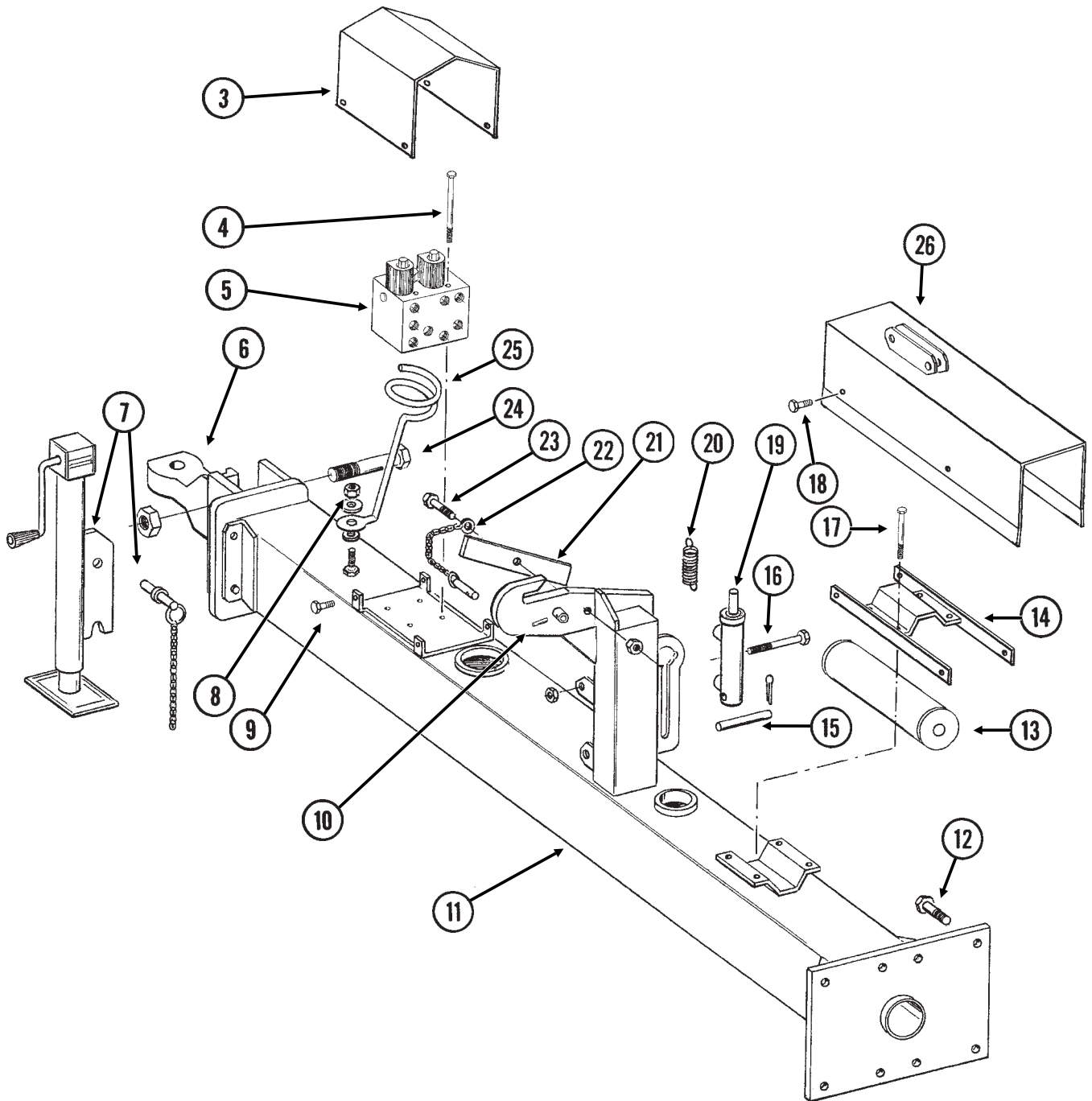
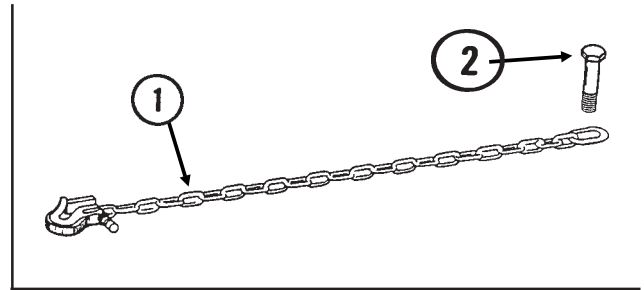

HITCH AND SAFETY CHAIN

ITEM	PART NO.	QTY.	DESCRIPTION
1.	GA7533	1	Safety Chain, 1/2"
2.	G11058	1	Hex Head Cap Screw, 1 1/4"-7 x 3"
	GD10646	1	Special Washer
	G10226	1	Washer, 1 1/4" SAE
	G10157	1	Lock Nut, 1 1/4"-7
3.	GD11510	-	Cover
4.	G10935	4	Hex Head Cap Screw, 1/4"-20 x 5"
	G10209	4	Washer, 1/4" USS
	G10227	4	Lock Washer, 1/4"
5.		-	See "Valve Block - Located On Hitch", Page P69 And P70
6.	GB0237	1	Clevis, Single
7.	GA4994	1	Jack Assembly Complete
	GA4995	-	Detent Pin Assembly
	GR0517	-	Pin
	GR0516	-	Crank Assembly
	GR0515	-	Bevel Gear
8.	G10217	1	Washer, 5/8" USS
	G10107	1	Lock Nut, 5/8"-11
9.	G10043	4	Hex Head Cap Screw, 5/16"-18 x 3/4"
	G10232	4	Lock Washer, 5/16"
	G10106	4	Hex Nut, 5/16"-18
10.	G10765	-	Spring Pin, 1/4" x 1"
11.	A8349	-	Front Hitch (Non-Stock Item)
12.	G10441	8	Hex Head Cap Screw, 7/8"-9 x 3", Grade 8
	GD10063	16	Hardened Washer, 7/8"
	G11053	8	Hex Nut, 7/8"-9, Grade 8
13.		-	See "Master Cylinder", Page P61 And P62
14.	GA8765	1	Cover Mount
15.	GD7137	1	Pin, 3/4" x 3 3/8"
	G10457	2	Cotter Pin, 5/32" x 1 1/2"
16.	G10061	1	Hex Head Cap Screw, 3/8"-16 x 3 1/2"
	GD2971-09	1	Sleeve, 2" Long
	G10229	1	Lock Washer, 3/8"
	G10101	1	Hex Nut, 3/8"-16
17.	G10063	4	Hex Head Cap Screw, 3/8"-16 x 4"
	G10229	4	Lock Washer, 3/8"
	G10101	4	Hex Nut, 3/8"-16
18.	G10001	4	Hex Head Cap Screw, 3/8"-16 x 1"
	G10229	4	Lock Washer, 3/8"
19.			See "Transport Latch Cylinder", Page P63
20.	GD5857	1	Spring
21.	GA7016	1	Catch Bar
22.	GA7022	1	Detent Pin W/Chain (Transport Latch Locking Pin)
23.	G10006	1	Hex Head Cap Screw, 5/8"-11 x 2 1/4"
	GB0218	1	Bushing, 21/32" I.D. x 7/8" O.D. x 19/32" Long
	GD5154	1	Shim, 4" x 4"
	G10107	1	Lock Nut, 5/8"-11
24.	G10169	1	Hex Head Cap Screw, 1 1/4"-7 x 6"
	G10157	1	Lock Nut, 1 1/4"-7
25.	GD8260	1	Hose Holder
26.	GA8764	1	Cover/Bracket, Jack Storage

HITCH AND SAFETY CHAIN

WAC011/PHA048/PHS049(WGN47e/TWL169c)

Serial No. 625040 And On

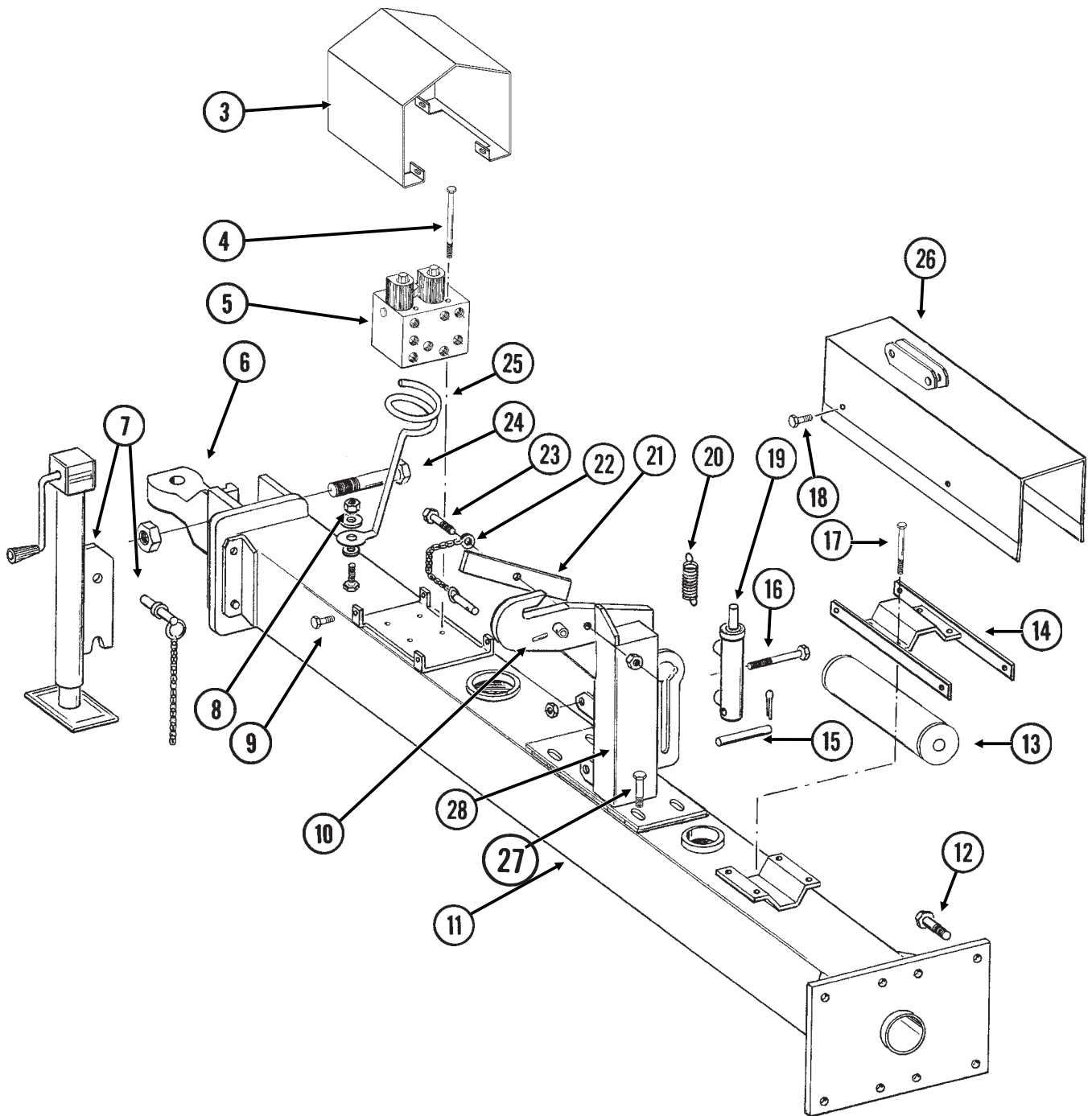
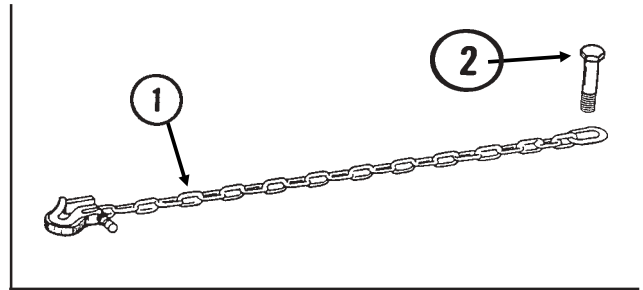

HITCH AND SAFETY CHAIN

ITEM	PART NO.	QTY.	DESCRIPTION
1.	GA7533	1	Safety Chain, 1/2"
2.	G11058	1	Hex Head Cap Screw, 1 1/4"-7 x 3"
	GD10646	1	Special Washer
	G10226	1	Washer, 1 1/4" SAE
	G10157	1	Lock Nut, 1 1/4"-7
3.	GD13397	-	Cover
4.	G10935	4	Hex Head Cap Screw, 1/4"-20 x 5"
	G10209	4	Washer, 1/4" USS
	G10227	4	Lock Washer, 1/4"
5.		-	See "Valve Block - Located On Hitch", Page P69 And P70
6.	GB0237	1	Clevis, Single
7.	GA4994	1	Jack Assembly Complete
	GA4995	-	Detent Pin Assembly
	GR0517	-	Pin
	GR0516	-	Crank Assembly
	GR0515	-	Bevel Gear
8.	G10217	1	Washer, 5/8" USS
	G10107	1	Lock Nut, 5/8"-11
9.	G10043	4	Hex Head Cap Screw, 5/16"-18 x 3/4"
	G10232	4	Lock Washer, 5/16"
	G10106	4	Hex Nut, 5/16"-18
10.	G10765	-	Spring Pin, 1/4" x 1"
11.	A9548	-	Front Hitch (Non-Stock Item)
12.	G10441	8	Hex Head Cap Screw, 7/8"-9 x 3", Grade 8
	GD10063	16	Hardened Washer, 7/8"
	G11053	8	Hex Nut, 7/8"-9, Grade 8
13.		-	See "Master Cylinder", Page P61 And P62
14.	GA8765	1	Cover Mount
15.	GD7137	1	Pin, 3/4" x 3 3/8"
	G10457	2	Cotter Pin, 5/32" x 1 1/2"
16.	G10061	1	Hex Head Cap Screw, 3/8"-16 x 3 1/2"
	GD2971-09	1	Sleeve, 2" Long
	G10229	1	Lock Washer, 3/8"
	G10101	1	Hex Nut, 3/8"-16
17.	G10063	4	Hex Head Cap Screw, 3/8"-16 x 4"
	G10229	4	Lock Washer, 3/8"
	G10101	4	Hex Nut, 3/8"-16
18.	G10001	4	Hex Head Cap Screw, 3/8"-16 x 1"
	G10229	4	Lock Washer, 3/8"
19.			See "Transport Latch Cylinder", Page P63
20.	GD5857	1	Spring
21.	GA7016	1	Catch Bar
22.	GA7022	1	Detent Pin W/Chain (Transport Latch Locking Pin)
23.	G10006	1	Hex Head Cap Screw, 5/8"-11 x 2 1/4"
	GB0218	1	Bushing, 21/32" I.D. x 7/8" O.D. x 19/32" Long
	GD5154	1	Shim, 4" x 4"
	G10107	1	Lock Nut, 5/8"-11
24.	G10169	1	Hex Head Cap Screw, 1 1/4"-7 x 6"
	G10157	1	Lock Nut, 1 1/4"-7
25.	GD8260	1	Hose Holder
26.	GA8764	1	Cover/Bracket, Jack Storage
27.	G10008	4	Hex Head Cap Screw, 5/8"-11 x 2"
	G10217	4	Washer, 5/8" USS
	G10230	4	Lock Washer, 5/8"
28.	GA9537	1	Catch Post

TRANSPORT LATCH POST

PHA049(2400m)

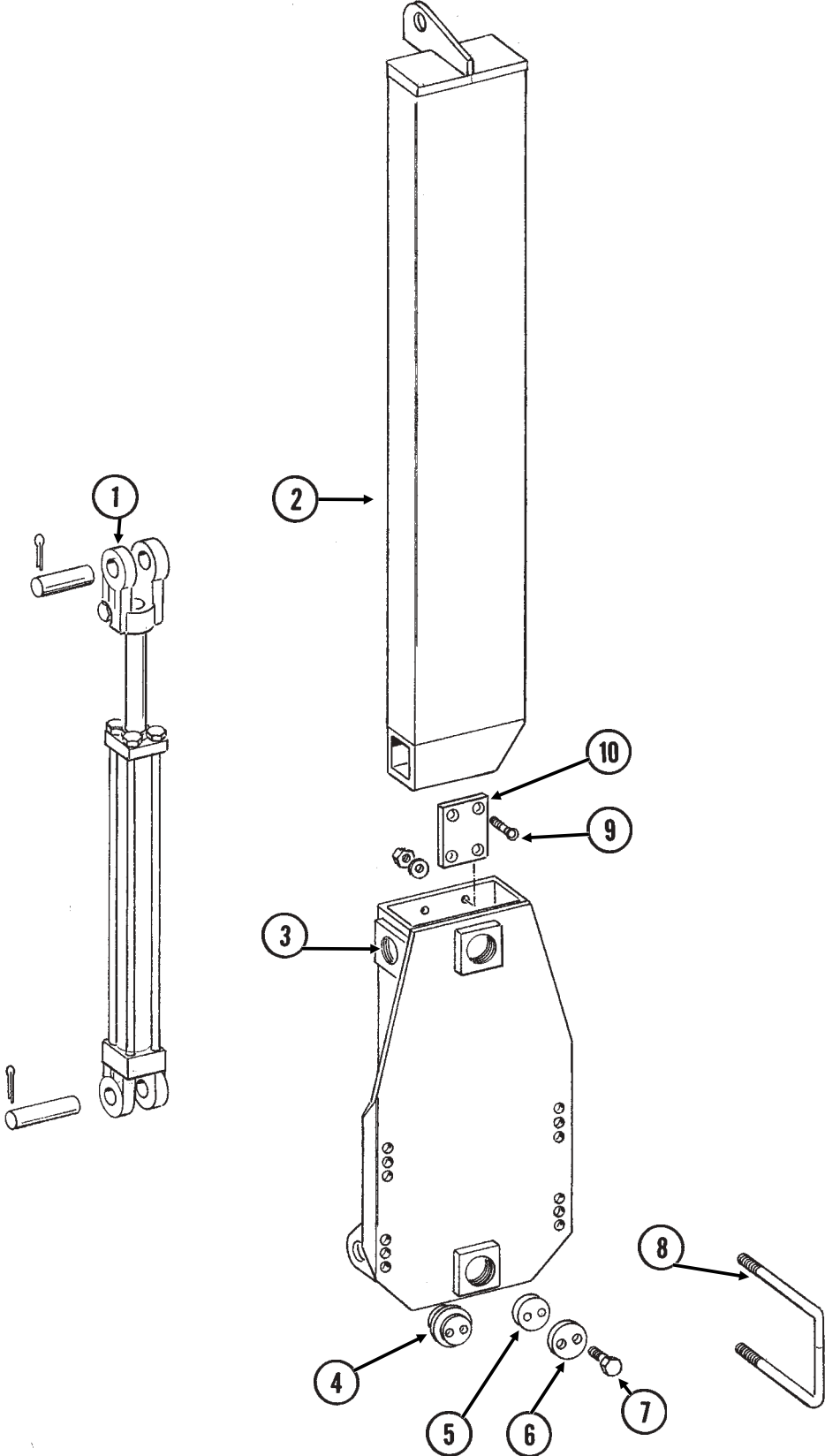

TRANSPORT LATCH POST

ITEM	PART NO.	QTY.	DESCRIPTION
1.		-	See "Transport Latch Post Cylinder", Page P64
2.	GA8356	1	Catch Post
3.	GA8357	1	Catch Mount
4.	GD9093	6	Poly Wear Pad
5.	GB0230	6	Cap
6.	GB0234	6	Adjustment Plug
7.	G10438	8	Hex Head Cap Screw, 1/2"-13 x 3/4"
	G10014	4	Hex Head Cap Screw, 1/2"-13 x 1"
8.	GD11489	2	U-Bolt, 3" x 6" x 5/8"-11
	G10230	4	Lock Washer, 5/8"
	G10104	4	Hex Nut, 5/8"-11
9.	G10934	8	Flat Head Hex Socket Cap Screw, 5/16"-18 x 1"
	G10221	8	Washer, 5/16" SAE
	G10232	8	Lock Washer, 5/16"
	G10106	8	Hex Nut, 5/16"-18
10.	GD11473	2	Pad

HITCH EXTENSIONS

PHA050/PHA051(2400L)

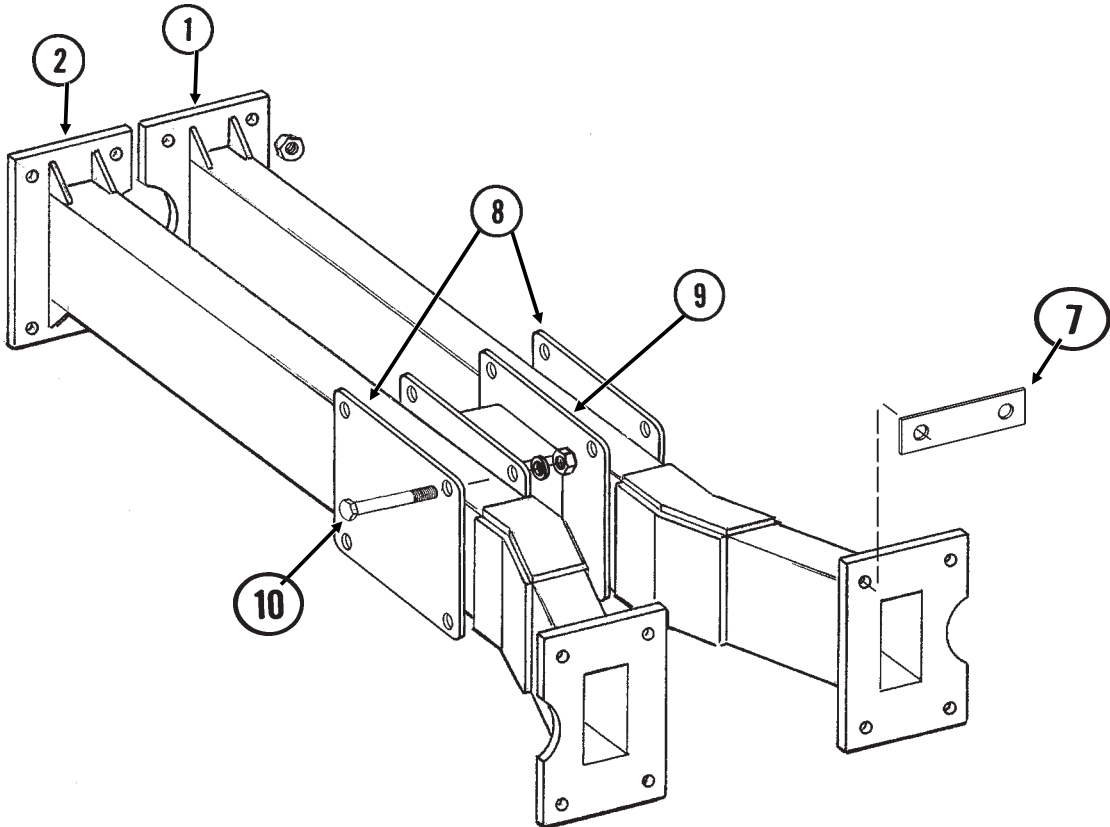
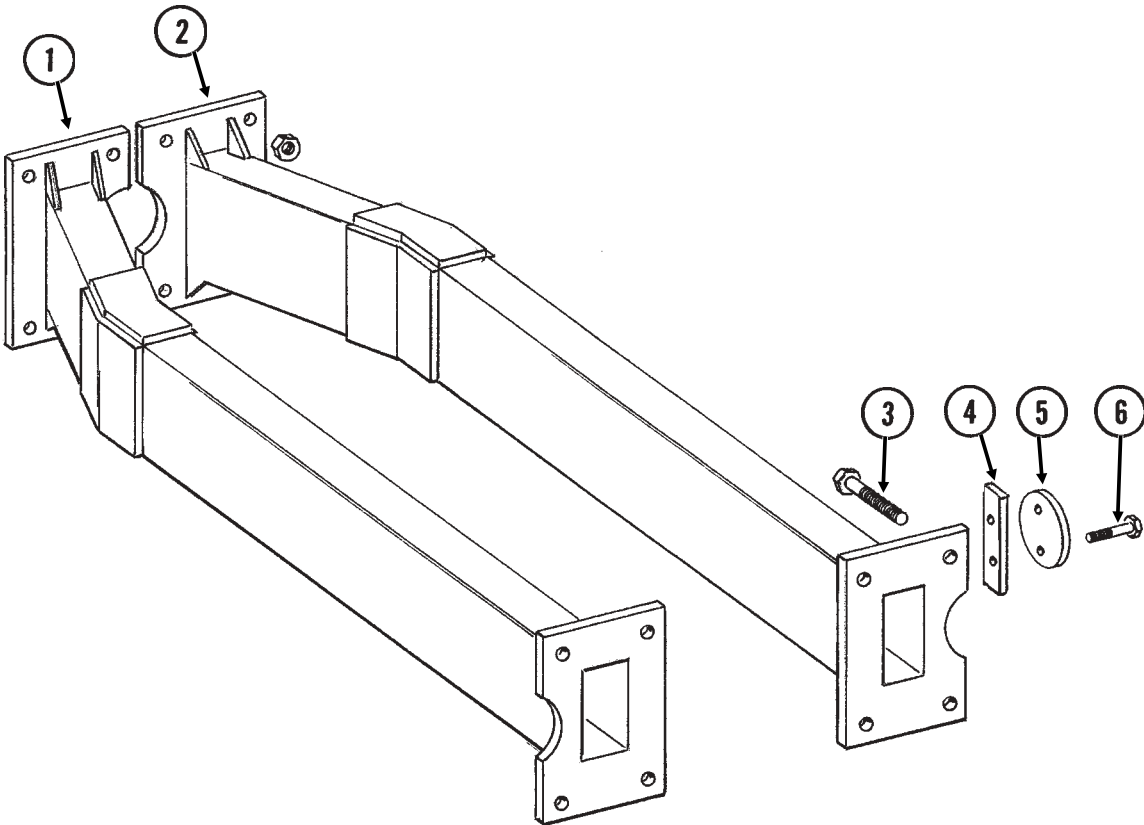

HITCH EXTENSIONS

ITEM	PART NO.	QTY.	DESCRIPTION
1.	GA8350	1	Hitch Extension, R.H.
2.	GA8362	1	Hitch Extension, L.H.
3.	G10441	8	Hex Head Cap Screw, $\frac{7}{8}$ "-9 x 3", Grade 8
	GD10063	16	Hardened Washer, $\frac{7}{8}$ "
	G10442	8	Hex Nut, $\frac{7}{8}$ "-9, Grade 8
4.	GD11512	1	Dust Cap Bar
5.	GD11507	1	Dust Cap
6.	G10048	2	Hex Head Cap Screw, $\frac{3}{8}$ "-16 x 2"
	G10229	2	Lock Washer, $\frac{3}{8}$ "
7.	GD13115	2	Spacer (If Applicable)
8.	GD14249	2	Hitch Support Plate
9.	GA9945	1	Hitch Support Assembly
10.	G10046	8	Hex Head Cap Screw, $\frac{5}{8}$ "-11 x 5"
	G10104	8	Hex Nut, $\frac{5}{8}$ "-11
	G10230	8	Lock Washer, $\frac{5}{8}$ "

PLANTER FRAME

PFA080/PFA081a/PFA081b/PFA081c/PFA084(TWL178/TWL180b/2400i/TWL179/2400j/TWL181/TWL182/RU131a)

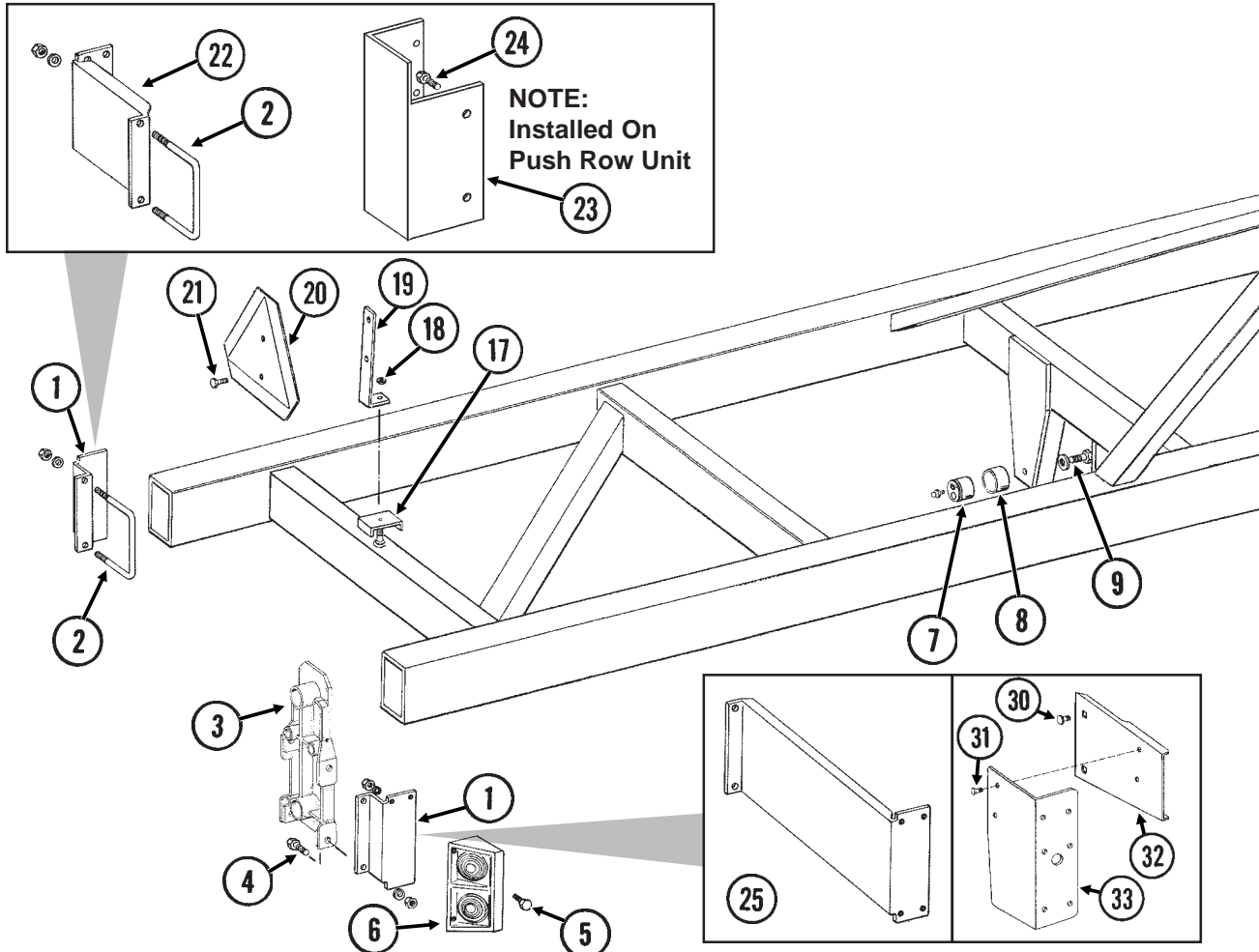

ITEM	PART NO.	QTY.	DESCRIPTION
1.	GA6792	2	Light Bracket
2.	GD1113	1-2	U-Bolt, 5" x 7" x 5/8"-11
	G10230	2-4	Lock Washer, 5/8"
	G10104	2-4	Hex Nut, 5/8"-11
3.	-	-	See "Transmission", Pages P54 And P55
4.	G10005	2	Hex Head Cap Screw, 5/8"-11 x 1 3/4"
	G10230	2	Lock Washer, 5/8"
	G10104	2	Hex Nut, 5/8"-11
5.	G10064	8	Hex Head Cap Screw, 1/4"-20 x 1"
	G10227	8	Lock Washer, 1/4"
	G10103	8	Hex Nut, 1/4"-20
6.	-	-	See "Electrical Components", Pages P78-P81
7.	GA6497	2	Cam Follower W/Grease Fitting
	G10640	-	Grease Fitting, 1/4"-28
8.	GD10532	2	Sleeve
9.	G10025	2	Hex Head Cap Screw, 3/4"-10 x 1 1/2"
	G10231	2	Lock Washer, 3/4" (If Applicable)
	GD9052	2	Special Washer, 3/4" I.D. x 2" O.D., Hardened
10.	A8352	1	Frame, 270" (Non-Stock Item)
11.	G10361	8	Flat Head Hex Socket Countersunk Cap Screw, 1/2"-13 x 1 1/2"
	G10228	8	Lock Washer, 1/2"
	G10102	8	Hex Nut, 1/2"-13
12.	GD11362	2	Push Pad
13.	GD11359	6	Shim

PLANTER FRAME

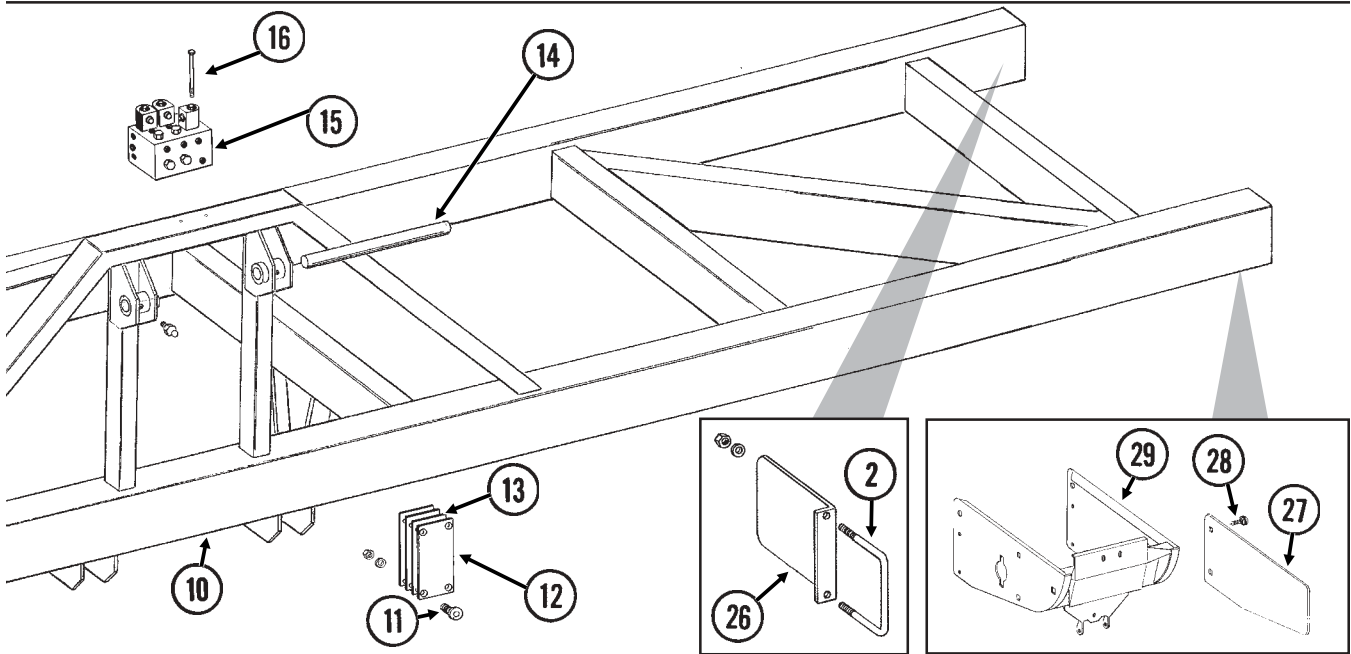

ITEM	PART NO.	QTY.	DESCRIPTION
14.	-	-	See "Frame Lift Linkage", Pages P44 And P45
15.	-	-	See "Valve Block - Located On Rear Center Frame", Page P71 And P72
16.	G10937	1	Hex Head Cap Screw, $\frac{3}{8}$ "-16 x 6 $\frac{1}{2}$ "
	G10954	1	Hex Head Cap Screw, $\frac{3}{8}$ "-16 x 7"
	G10210	2	Washer, $\frac{3}{8}$ " USS
	G10229	2	Lock Washer, $\frac{3}{8}$ "
	G10101	2	Hex Nut, $\frac{3}{8}$ "-16
17.	GD0740	-	Hose Clamp, $\frac{3}{4}$ " x 4" x 3 $\frac{1}{2}$ "
	GD5875	-	Hose Clamp, $\frac{9}{16}$ " x 2 $\frac{1}{2}$ " x 2"
18.	G10101	-	Hex Nut, $\frac{3}{8}$ "-16
19.	GD11555	-	SMV Bracket
20.	-	-	See "Decals, Paint And Miscellaneous", Pages P104-P106
21.	G10022	2	Hex Head Cap Screw, $\frac{1}{4}$ "-20 x $\frac{1}{2}$ "
	G10227	2	Lock Washer, $\frac{1}{4}$ "
	G10103	2	Hex Nut, $\frac{1}{4}$ "-20
22.	GA9061	1	Light Bracket, Short
23.	GD12703	1	Push Row Unit Light Bracket
24.	G10001	2	Hex Head Cap Screw, $\frac{3}{8}$ "-16 x 1"
	G10229	2	Lock Washer, $\frac{3}{8}$ "
	G10101	2	Hex Nut, $\frac{3}{8}$ "-16
25.	GA9062	1	Light Bracket, Long
26.	GA9063	1	Reflective Decal Bracket
27.	GD12710	1	Reflective Decal Bracket
28.	G10312	2	Carriage Bolt, $\frac{5}{16}$ "-18 x $\frac{3}{4}$ "
	G10620	2	Flange Nut, $\frac{5}{16}$ "-18
29.	-	-	See "Hopper Support And Meter Drive", Page P12
30.	G10312	-	Carriage Bolt, $\frac{5}{16}$ "-18 x $\frac{3}{4}$ "
	G10620	-	Flange Nut, $\frac{5}{16}$ "-18
31.	G10064	-	Hex Head Cap Screw, $\frac{1}{4}$ "-20 x 1"
	G10227	-	Lock Washer, $\frac{1}{4}$ "
	G10103	-	Hex Nut, $\frac{1}{4}$ "-20
32.	GD12722	1	Light Mount Extension (R.H. Wing)
33.	GD12724	1	Bracket, (R.H. Wing)
A.	G7698X	-	Push Row Unit Mounted Light Bracket Package (Items 23 And 24 On This Page And 42" Harness Extension, Item 42 on Pages P78 And P79)

FRAME LIFT LINKAGE

PFA082(MKR14c/TWL170b)

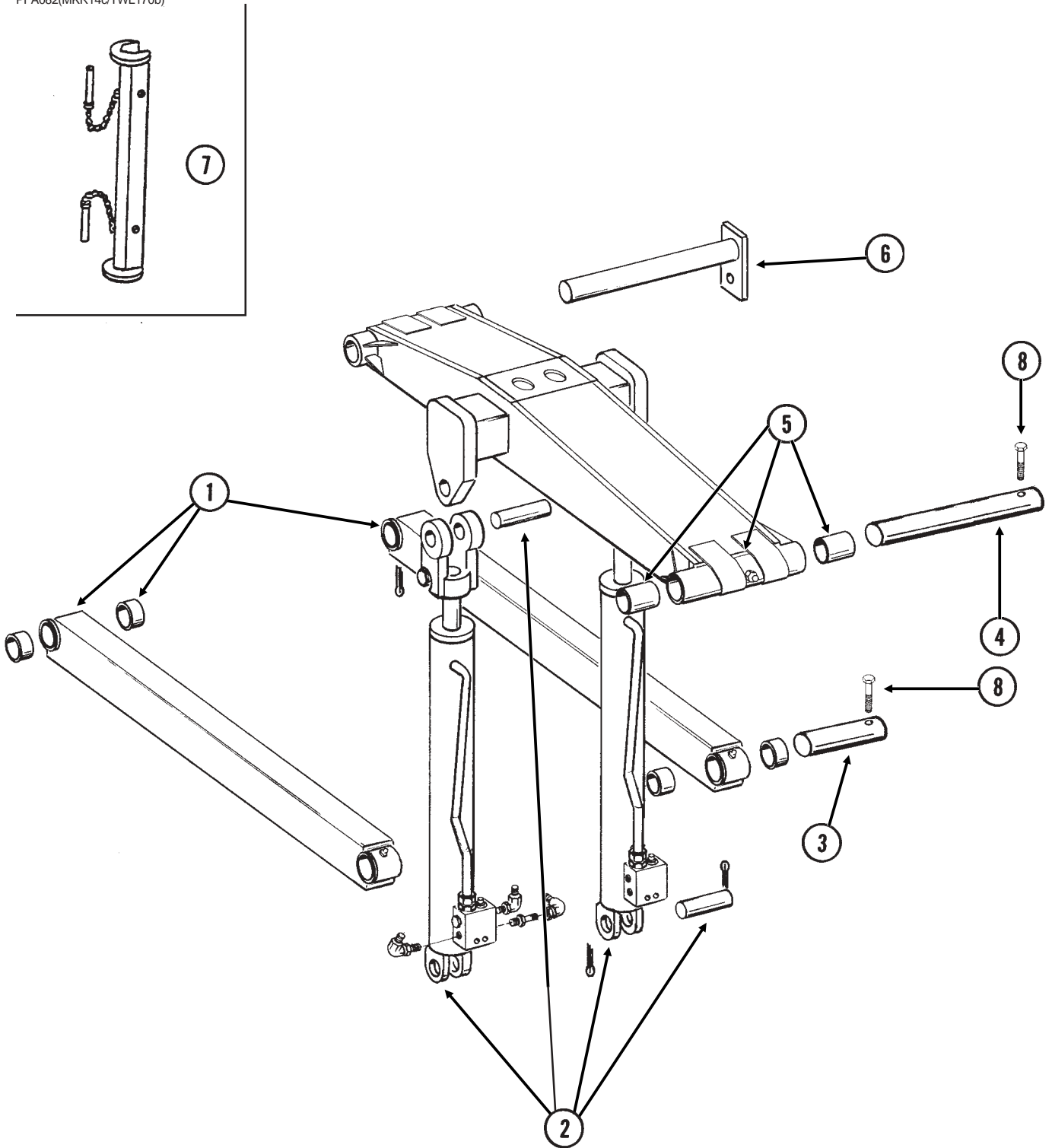

FRAME LIFT LINKAGE

ITEM	PART NO.	QTY.	DESCRIPTION
1.	GA8762	2	Lower Arm W/Grease Fittings And Bronze Bushings
	G10640	-	Grease Fitting, 1/4"-28
	GD11428	-	Bronze Bushing, 1 1/4" Wide (4 Per Arm)
2.		-	See "Slave Cylinder", Page P59 And P60
3.	GD11444	2	Pin, 1 3/4" x 7 3/8"
4.	GD11445	1	Pin, 1 3/4" x 18 1/4"
5.	GA9909	1	Upper Lift Arm W/Grease Fittings And Bronze Bushings
	G10641	-	Grease Fitting, 1/8" NPT
	G10373	-	Grease Fitting, 45°, 1/8"-27
	GD11427	-	Bronze Bushing, 2" Wide (4 Per Arm)
	GD11751	-	Steel Bushing, 1" Wide (2 Per Arm)
6.		-	See "Center Pivot", Pages P46 And P47
7.	GA8172	2	Safety Lockup W/Detent Pins, 20"
	G10536	-	Detent Pin, 1/2" x 2 1/2" Grip
8.	G10755	3	Hex Head Cap Screw, 5/16"-18 x 3"
	G10109	3	Lock Nut, 5/16"-18

CENTER PIVOT

PFA083(TWL183)

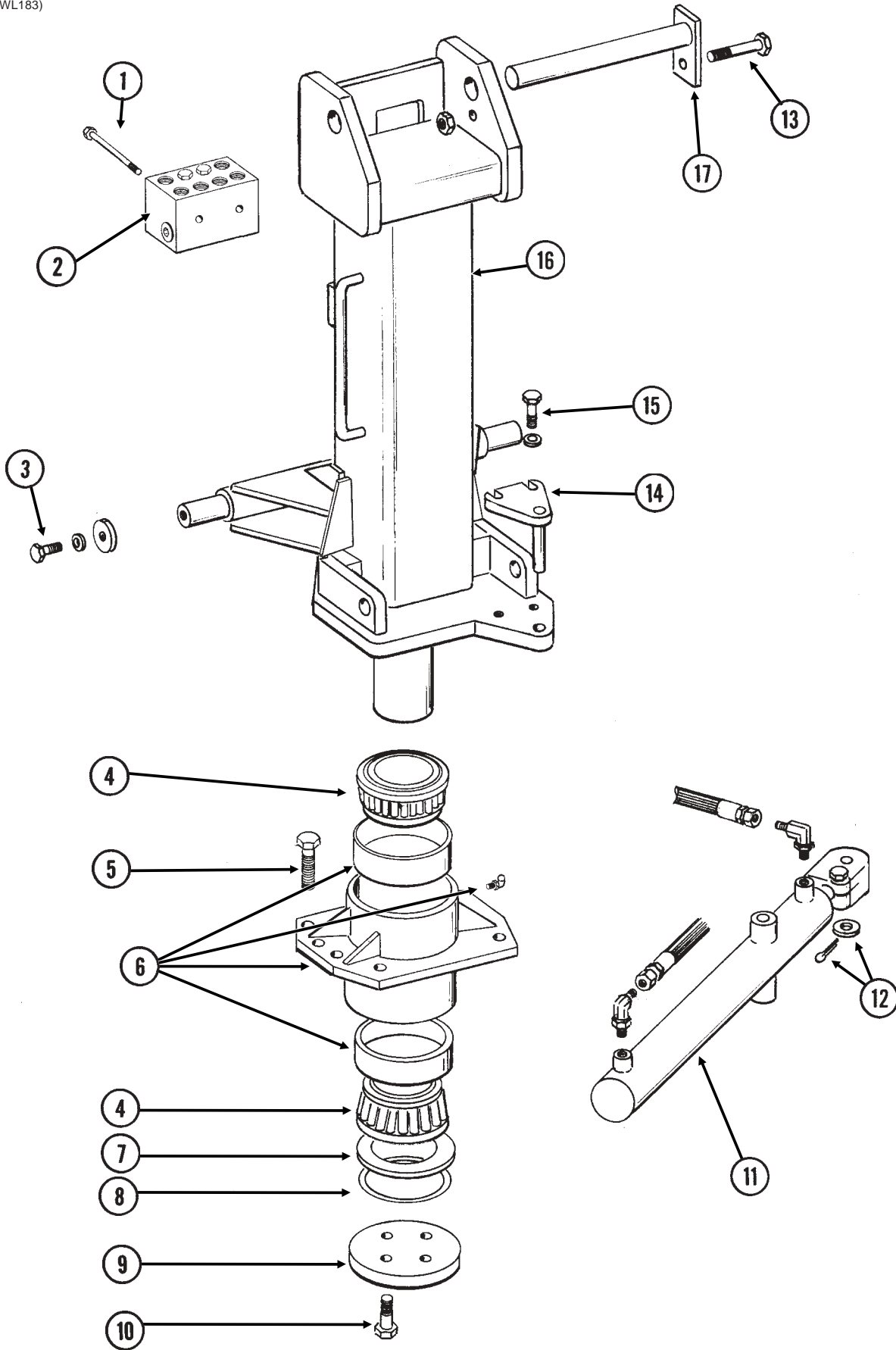

CENTER PIVOT

ITEM	PART NO.	QTY.	DESCRIPTION
1.	G10936	2	Hex Head Cap Screw, $\frac{5}{16}$ "-18 x 3 $\frac{1}{2}$ "
	G10210	2	Washer, $\frac{3}{8}$ " USS
	G10229	2	Lock Washer, $\frac{3}{8}$ "
2.		-	See "Junction Block - Located On Front Of Center Pivot", Page P73
3.	G10007	2	Hex Head Cap Screw, $\frac{5}{8}$ "-11 x 1 $\frac{1}{2}$ "
	GD11456	2	Washer, $\frac{11}{16}$ " I.D. x 2 $\frac{1}{2}$ " O.D. x $\frac{1}{4}$ " Thick
	GD7805	2	Special Washer, $\frac{5}{8}$ ", Hardened
	G10230	2	Lock Washer, $\frac{5}{8}$ "
4.	GA7096	2	Cone
5.	G10441	8	Hex Head Cap Screw, $\frac{7}{8}$ "-9 x 3", Grade 8
	GD10063	8	Hardened Washer, $\frac{7}{8}$ "
	G10442	8	Hex Nut, $\frac{7}{8}$ "-9, Grade 8
6.	GA7067	1	Bearing Housing W/Cups And Grease Fitting
	GD10011	-	Cup
	G10779	-	Grease Fitting, 90°, $\frac{1}{4}$ "-28
7.	GD10012	10	Shim, .005" Thick (As Required)
	GD10014	10	Shim, .007" Thick (As Required)
	GD10013	10	Shim, .020" Thick (As Required)
8.	GD9130	1	O-Ring
9.	GD9636	1	Bearing Cap
10.	G10027	4	Hex Head Cap Screw, $\frac{3}{4}$ "-10 x 2 $\frac{1}{2}$ "
	GD2169	4	Special Washer, $\frac{25}{32}$ " I.D. x 1 $\frac{1}{4}$ " O.D.
11.		-	See "Rotation Cylinder", Pages P65 And P66
12.	G10139	1	Washer, 1 $\frac{1}{4}$ " USS
	G10460	1	Cotter Pin, $\frac{1}{4}$ " x 2"
13.	G10016	1	Hex Head Cap Screw, $\frac{1}{2}$ "-13 x 2"
	G10228	1	Lock Washer, $\frac{1}{2}$ "
	G10102	1	Hex Nut, $\frac{1}{2}$ "-13
14.	GA8351	1	Hammer Strap
15.	G10394	2	Hex Head Cap Screw, $\frac{3}{4}$ "-16 x 2"
	GD2169	2	Special Washer, $\frac{25}{32}$ " I.D. x 1 $\frac{1}{4}$ " O.D.
	G10231	2	Lock Washer, $\frac{3}{4}$ "
16.	GA9064	1	Center Post
17.	GA8374	1	Hammer Strap

AXLE AND TRANSPORT/GROUND DRIVE WHEEL ASSEMBLY

HTA047/HTA048(2400q/TWL184/A7434)

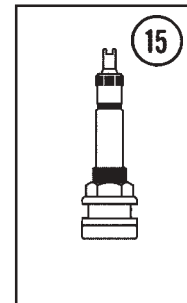
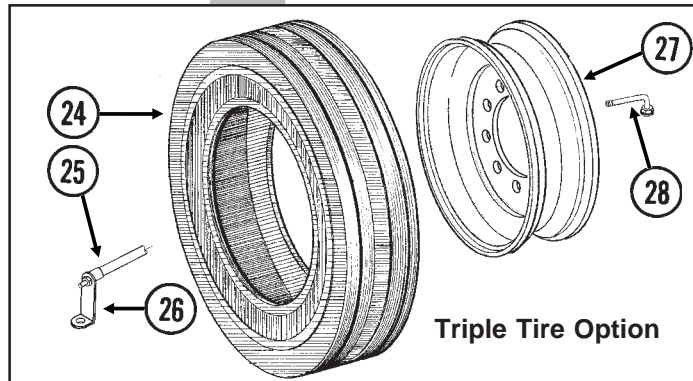
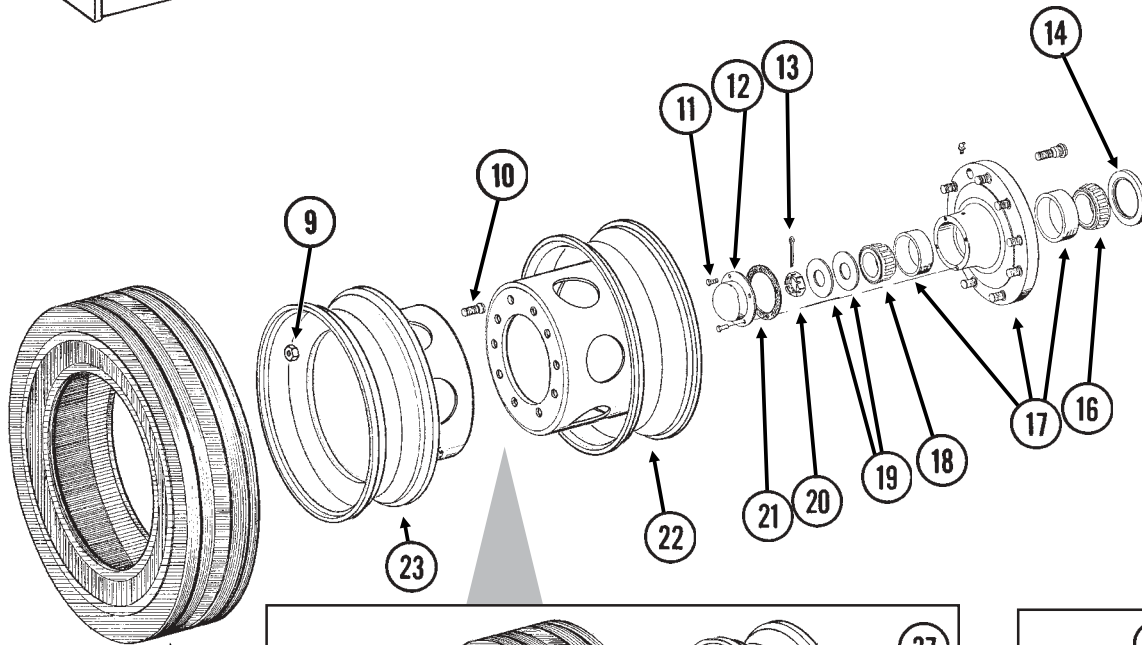
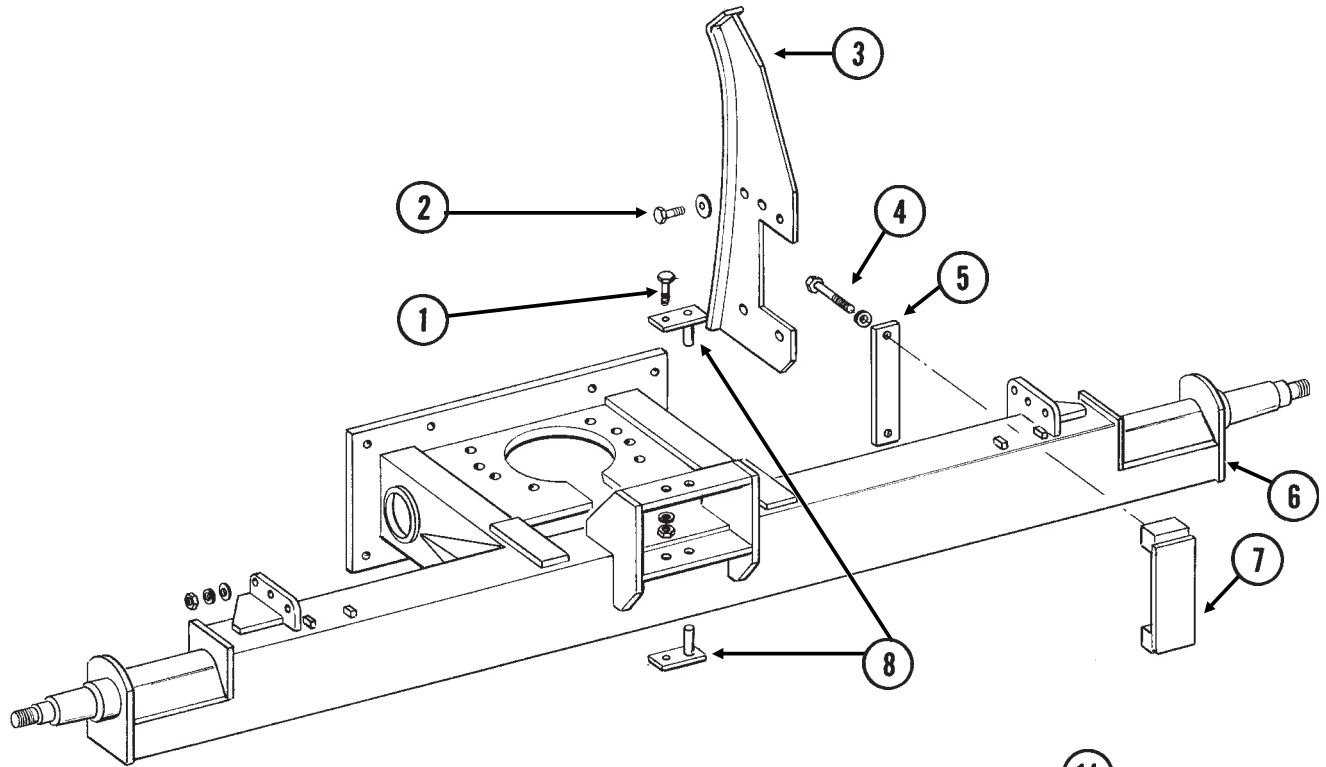

AXLE AND TRANSPORT/GROUND DRIVE WHEEL ASSEMBLY

ITEM	PART NO.	QTY. (Per Assy.)	DESCRIPTION
1.	G10017	2	Hex Head Cap Screw, 1/2"-13 x 1 1/2"
	G10228	2	Lock Washer, 1/2"
	G10102	2	Hex Nut, 1/2"-13
2.	G10008	10	Hex Head Cap Screw, 5/8"-11 x 2"
	GD7805	20	Special Washer, 5/8", Hardened
	G10107	10	Lock Nut, 5/8"-11
3.	GA8402	1	Cam Guide
4.	G10318	2	Hex Head Cap Screw, 5/8"-11 x 4 1/2"
	G10230	2	Lock Washer, 5/8"
5.	GD11454	1	Bar
6.	GA8348	1	Axle
7.	GA8383	1	Push Pad
8.	GA8405	2	Hammer Strap
9.	GD9509	10	Outer Budd Nut
10.	GD12567	10	Inner Budd Nut, 2 5/8" Long
11.	G10376	4	Hex Head Cap Screw, 5/16"-18 x 3/4"
12.	GD1529	1	Dust Cap
13.	G10460	1	Cotter Pin, 1/4" x 2"
14.	GA5988	1	Seal
15.	GA7434	1	Valve Stem
16.	GA5987	1	Inner Bearing
17.	GA5965	1	Hub W/Cups, Grease Fitting And Stud Bolts (10 Bolt)
	GR0322	-	Outer Cup
	GD8532	-	Inner Cup
	G10373	-	Grease Fitting, 45°, 1/8"-27
	GR0257	-	Bolt, 3/4"-16 x 2 1/2"
18.	GA0705	1	Outer Bearing
19.	G10139	2	Washer, 1 1/4" USS
20.	G10070	1	Slotted Hex Nut, 1 1/4"-12
21.	GD1536	1	Seal
22.	GA8354	1	Long Rim, 15 1/4" Deep
23.	GA8353	1	Short Rim, 11 1/4" Deep
24.	GD13409	2-3	Tire, 255-70R 22.5" W/O Center Rib, Tubeless (Specify Brand*)
25.	GA9056	1	Air Hose
26.	GD12704	1	Bracket
27.	GA8952	1	Center Rim Weld
28.	GA9139	1	Air Hose Elbow, 90°

* Specific brand requests will be supplied only as available from current KINZE® stock. If a specific brand requested is not in stock, the brand available will be supplied.

CONTACT DRIVE WHEEL ASSEMBLY

PLA037(TWL165b)

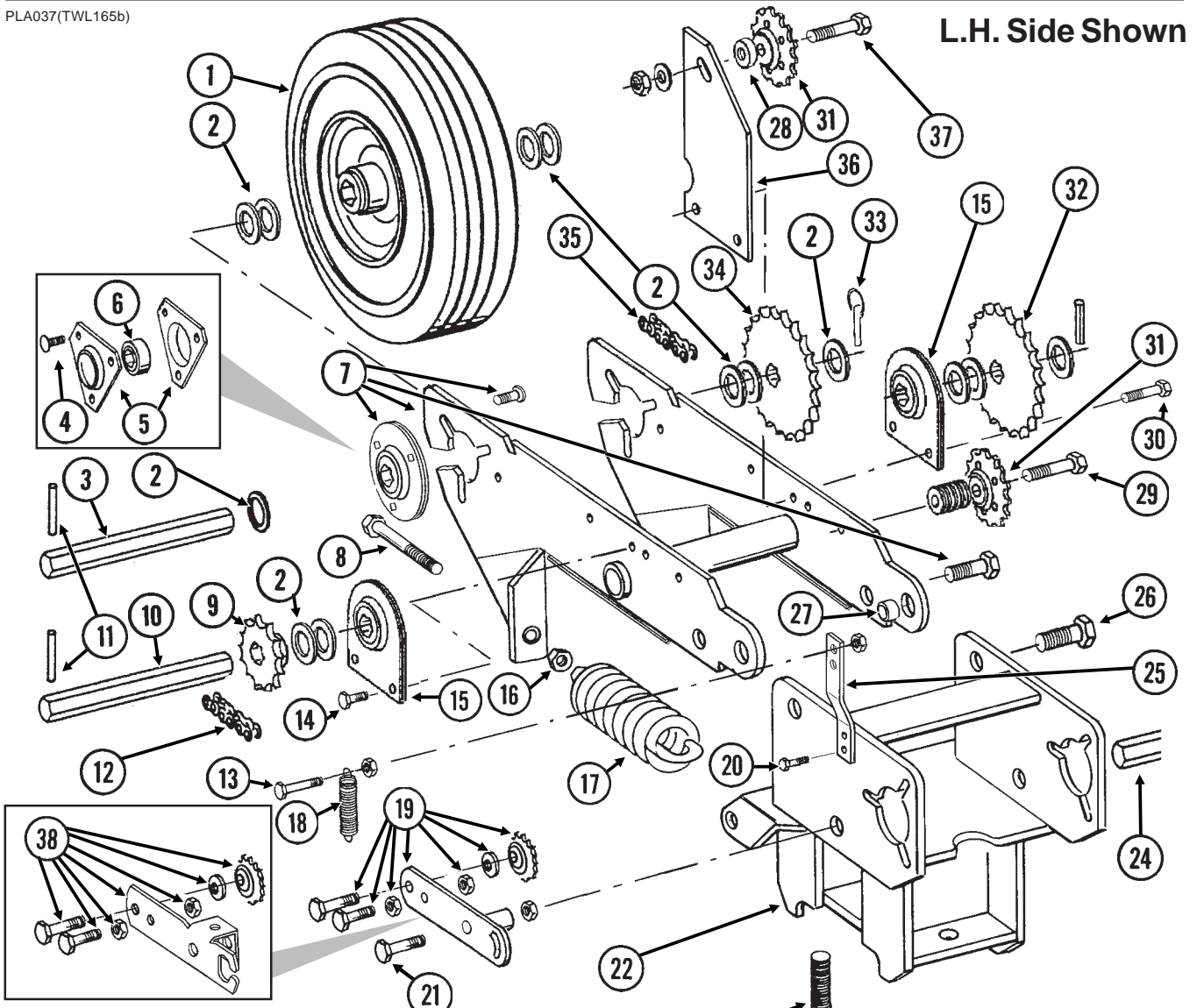

ITEM	PART NO.	QTY. (Per Wheel)	DESCRIPTION
1.	GA5090 GD5753 GD5752	- 1 1	Tire And Rim Assembly (Specify Brand*) Tire, 4.10" x 6" (Specify Brand*) Tube
2.	G10233	-	Machine Bushing, 1", 10 Gauge
3.	GD6825-10.25	1	Hex Shaft, 7/8" x 10 1/4" (2 Holes)
4.	G10303 G10219 G10232 G10106	6 6 6 6	Carriage Bolt, 5/16"-18 x 1" Washer, 5/16" USS Lock Washer, 5/16" Hex Nut, 5/16"-18
5.	G3400-01	4	Flangette
6.	G2100-03	2	Bearing, 7/8" Hex Bore, Spherical
7.	A7370 G10303 G10232 G10106 GA8789 G10971 G10055 G10107	1 6 6 6 2 - 2 2	Arm W/Flanged Bearings And Hardware (Non-Stock Item) (Sub G1K253) Carriage Bolt, 5/16"-18 x 1" Lock Washer, 5/16" Hex Nut, 5/16"-18 Flanged Bearing W/Grease Fitting, 7/8" Hex Bore (Sub GA9846) Grease Fitting, 45°, 1/4", Drive-In
8.	G10890	2	Hex Head Adjusting Bolt, 1/2"-13 x 4", Grade 2
9.	GA5105	1	Sprocket, 15 Tooth
10.	GD6825-11.375	1	Hex Shaft, 7/8" x 11 3/8" (2 Holes)
11.	G10602	4	Spring Pin, 1/4" x 1 1/2"

CONTACT DRIVE WHEEL ASSEMBLY

ITEM	PART NO.	QTY. (Per Wheel)	DESCRIPTION
12.	G3310-83	1	Chain, No. 40, 83 Pitch Including Connector Link And Offset Link
	GR0912	-	Connector Link, No. 40
	GR0911	-	Offset Link, No. 40
13.	G10746	1	Hex Head Cap Screw, 1/4"-20 x 2 3/4"
	G10103	1	Hex Nut, 1/4"-20
	G10110	1	Lock Nut, 1/4"-20
14.	G10001	3	Hex Head Cap Screw, 3/8"-16 x 1"
	G10229	3	Lock Washer, 3/8"
	G10101	3	Hex Nut, 3/8"-16
15.	GA2180	2	Hanger Bearing, 7/8" Hex Bore
16.	G10501	2	Hex Jam Nut, 1/2"-13, Grade 2
17.	GA2068	2	Spring W/Plug
18.	GD5857	1	Spring
19.	GA8477	1	Idler W/Sprocket And Hardware
	G10100	2	Hex Nut, 7/16"-14
	G10421	1	Hex Head Cap Screw, 7/16"-14 x 1 1/4"
	G10128	3	Machine Bushing, 1/2", 14 Gauge
	G10111	1	Lock Nut, 1/2"-13
	G10016	1	Hex Head Cap Screw, 1/2"-13 x 2"
	GA7154	1	Sprocket W/Bearing, 18 Tooth
20.	G10019	2	Hex Head Cap Screw, 5/16"-18 x 1"
	G10232	2	Lock Washer, 5/16"
	G10106	2	Hex Nut, 5/16"-18
21.	G10862	1	Hex Head Cap Screw, 5/8"-11 x 3 1/4"
	G10503	1	Hex Jam Nut, 5/8"-11, Grade 2
	G10107	1	Lock Nut, 5/8"-11
22.	GA8426	1	Wheel Mount
23.	GD1134	1	U-Bolt, 7" x 5" x 5/8"-11
	G10230	2	Lock Washer, 5/8"
	G10104	2	Hex Nut, 5/8"-11
24.		-	See "Driveline", Pages P52 And P53
25.	GD5860	1	Bar
26.	G10751	2	Hex Head Cap Screw, 5/8"-18 x 1 3/4"
	G10235	6	Machine Bushing, 7/8", 14 Gauge
	GD7805	2	Special Washer, 5/8" Hardened
	G10412	2	Lock Nut, 5/8"-18
27.	GB0218	2	Bushing, 21/32" I.D. x 7/8" O.D. x 19/32" Long
28.	GD11158	1	Spacer, 3/4" O.D. x 9/16" Long
29.	G10053	1	Hex Head Cap Screw, 1/2"-13 x 2 1/2"
	G10128	5	Machine Bushing, 1/2", 14 Gauge
	G10111	1	Lock Nut, 1/2"-13
30.	G10004	1	Hex Head Cap Screw, 3/8"-16 x 1 1/4"
	G10229	1	Lock Washer, 3/8"
	G10101	1	Hex Nut, 3/8"-16
31.	GA7154	2	Sprocket W/Bearing, 18 Tooth
32.	GA5114	1	Sprocket, 30 Tooth
33.	GD2558	1	Lynch Pin, 1/4"
34.	GA5114	1	Sprocket, 30 Tooth
	GA5105	1	Sprocket, 15 Tooth, Used With Half Rate (2 To 1) Drive
35.	G3310-101	1	Chain, No. 40, 101 Pitch Including Connector Link And Offset Link
	G3310-93	1	Chain, No. 40, 93 Pitch Including Connector Link And Offset Link, Used With Half Rate (2 To 1) Drive
	GR0912	-	Connector Link, No. 40
	GR0911	-	Offset Link, No. 40
36.	GD11125	1	Bar
37.	G10053	1	Hex Head Cap Screw, 1/2"-13 x 2 1/2"
	G10216	1	Washer, 1/2" USS
	G10111	1	Lock Nut, 1/2"-13
38.	GA9914	1	Idler W/Sprocket And Hardware
	G10100	2	Hex Nut, 7/16"-14
	G10421	1	Hex Head Cap Screw, 7/16"-14 x 1 1/4"
	GD11158	1	Spacer, 3/4" O.D. x 9/16" Long
	G10501	1	Hex Jam Nut, 1/2"-13, Grade 2
	G10581	1	Hex Head Cap Screw, 1/2"-13 x 2 1/4"
A.	G1K253	-	Contact Wheel Arm Replacement Kit (Item 3, 7, 8, 11 And 16)

* Specific brand requests will be supplied only as available from current KINZE® stock. If a specific brand requested is not in stock, the brand available will be supplied. Different brand tires may have different diameters. Change in tire brand could result in rate changes. To maintain consistent planting rates throughout all rows, it is recommended that all contact tires be of the same brand and be equally inflated.

DRIVELINE

PTD091(TWL166/PLTR157)

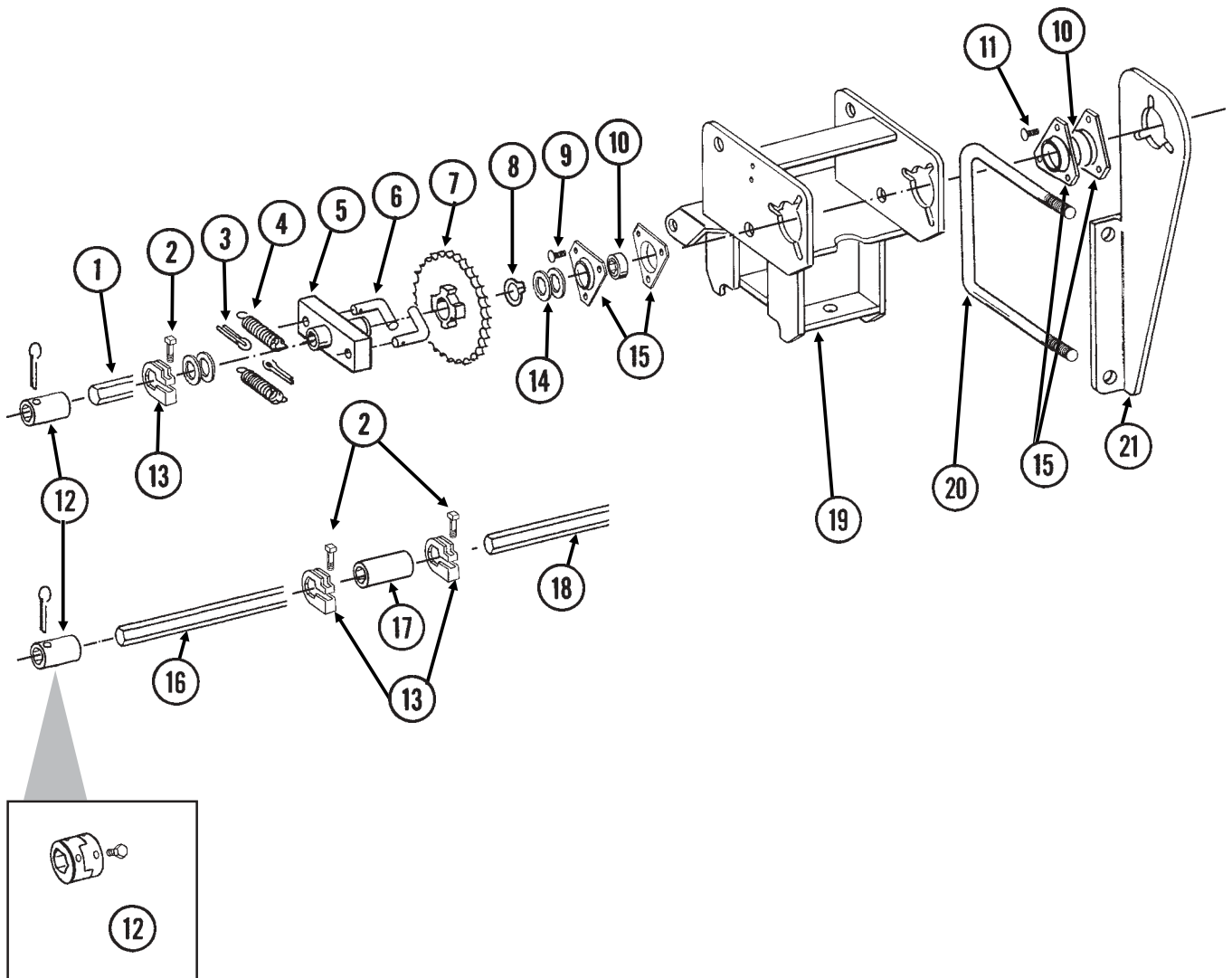

DRIVELINE

ITEM	PART NO.	QTY.	DESCRIPTION
1.	GD0914-204	1	Hex Shaft, 7/8" x 204" (No Holes)
2.	G10130	-	Square Head Machine Bolt, 5/16"-18 x 1 3/4"
	G10923	-	Flange Nut, 5/16"-18, No Serration
3.	G10464	2	Cotter Pin, 3/16" x 1"
4.	GD1256	2	Spring
5.	GA0378	1	Block And Hub Assembly
6.	GD1255	2	L-Pin
7.	GA7574	1	Sprocket W/Bushing, 34 Tooth
8.	G10430	1	External Retaining Ring, 1 1/4"
9.	G10303	6	Carriage Bolt, 5/16"-18 x 1"
	G10232	6	Lock Washer, 5/16"
	G10106	6	Hex Nut, 5/16"-18
10.	G2100-03	3	Bearing, 7/8" Hex Bore, Spherical
11.	G10303	3	Carriage Bolt, 5/16"-18 x 1"
	G10219	3	Washer, 5/16" USS
	G10232	3	Lock Washer, 5/16"
	G10106	3	Hex Nut, 5/16"-18
12.		-	See "Transmission", Pages P54 And P55
13.	GD11045	-	Lock Clamp
14.	G10233	-	Machine Bushing, 1", 10 Gauge
15.	G3400-01	6	Flangette
16.	GD0914-43	1	Hex Shaft, 7/8" x 43" (No Holes)
17.	GD1719	1	Coupler, 4"
18.	GD0914-206	1	Hex Shaft, 7/8" x 206" (No Holes)
19.		-	See "Contact Drive Wheel Assembly", Pages P50 And P51
20.	GD1113	1	U-Bolt, 5" x 7" x 5/8"-11
	G10230	2	Lock Washer, 5/8"
	G10104	2	Hex Nut, 5/8"-11
21.	GD11549	1	Center Support
A.	GA8451	-	Ratchet/Sprocket Assembly, L.H. (Items 3-8)(Shown)
	GA8450	-	Ratchet/Sprocket Assembly, R.H. (Items 3-8)
B.	G1K269	-	Lock Clamp Kit (Items 2 And 13)

TRANSMISSION

PTD091(2400h/PLTR157)

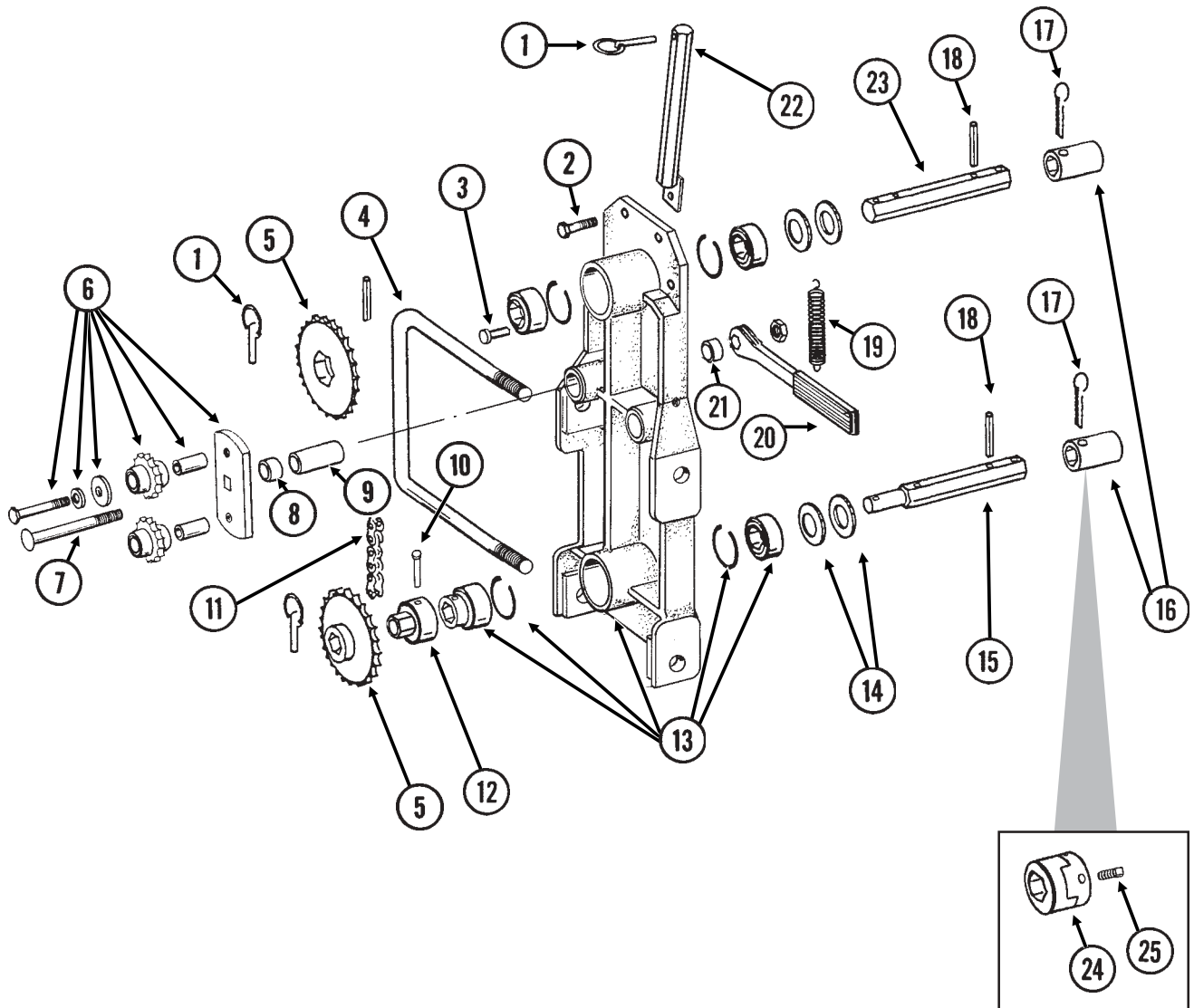

TRANSMISSION

ITEM	PART NO.	QTY.	DESCRIPTION
1.	GD2558	3	Lynch Pin, 1/4"
2.	G10017	1	Hex Head Cap Screw, 1/2"-13 x 1 1/2"
	G10228	1	Lock Washer, 1/2"
	G10102	1	Hex Nut, 1/2"-13
3.	G10478	1	Clevis Pin, 5/16" x 1"
	G10409	1	Retaining Ring, 5/16"
4.	GD1113	1	U-Bolt, 5" x 7" x 5/8"-11
	G10230	2	Lock Washer, 5/8"
	G10104	2	Hex Nut, 5/8"-11
5.	GA5106	1	Sprocket, 17 Tooth
	GA5107	1	Sprocket, 19 Tooth
	GA5108	2	Sprocket, 23 Tooth
	GA5109	1	Sprocket, 24 Tooth
	GA5110	1	Sprocket, 25 Tooth
	GA5111	1	Sprocket, 26 Tooth
	GA5112	1	Sprocket, 27 Tooth
	GA5113	1	Sprocket, 28 Tooth
6.	GA7336	1	Idler W/Bolt-On Sprockets
	GD7426	-	Sprocket, 12 Tooth
	GD1026	-	Sleeve, 1 3/16" Long
	G10210	-	Washer, 3/8" USS
	G10229	-	Lock Washer, 3/8"
	G10047	-	Hex Head Cap Screw, 3/8"-16 x 1 3/4"
7.	G10867	1	Carriage Bolt, 1/2"-13 x 5"
	G10111	1	Lock Nut, 1/2"-13
8.	GD2734-01	1	Sleeve, 1 1/4" O.D. x 1/2" Long
9.	GD3180-16	1	Sleeve, 5/8" I.D. x 7/8" O.D. x 2 13/16" Long
10.	G10821	1	Clevis Pin, 3/16" x 2"
	G10455	1	Cotter Pin, 1/16" x 1/2"
11.	G3310-80	1	Chain, No. 40, 80 Pitch Including Connector Link
	GR0912	-	Connector Link, No. 40
12.	GD7127	1	Shear Coupler
	GR0912	-	Connector Link, No. 40
13.	GA5629	1	Transmission Plate W/Bearings, Grease Fittings And Retaining Rings
	GA5116	3	Bearing, 7/8" Hex Bore, Cylindrical
	GA5624	1	Special Bearing, 7/8" Hex Bore x 1.6"
	GD6551	4	Ring
	G10640	-	Grease Fitting, 1/4"-28
14.	G10233	4	Machine Bushing, 1", 10 Gauge
15.	GD7822	1	Shaft, 7/8" x 7"
16.	GD7867	2	Coupler, 3"
17.	G10460	2	Cotter Pin, 1/4" x 2"
18.	G10602	3	Spring Pin, 1/4" x 1 1/2"
19.	GD5857	1	Spring
20.	GA4235	1	Ratchet Arm W/Protective Closure
	G10445	-	Protective Closure
21.	GD10161	1	Spacer, 3/8"
22.	GA5146	1	Sprocket Storage Rod
23.	GD5835	1	Shaft, 7/8" x 7"
24.	GB0287	2	Coupler
25.	G10131	4	Square Head Set Screw, 5/16"-18 x 3/4"

MARKER ASSEMBLY

MKR019/MKR027(MKR23)

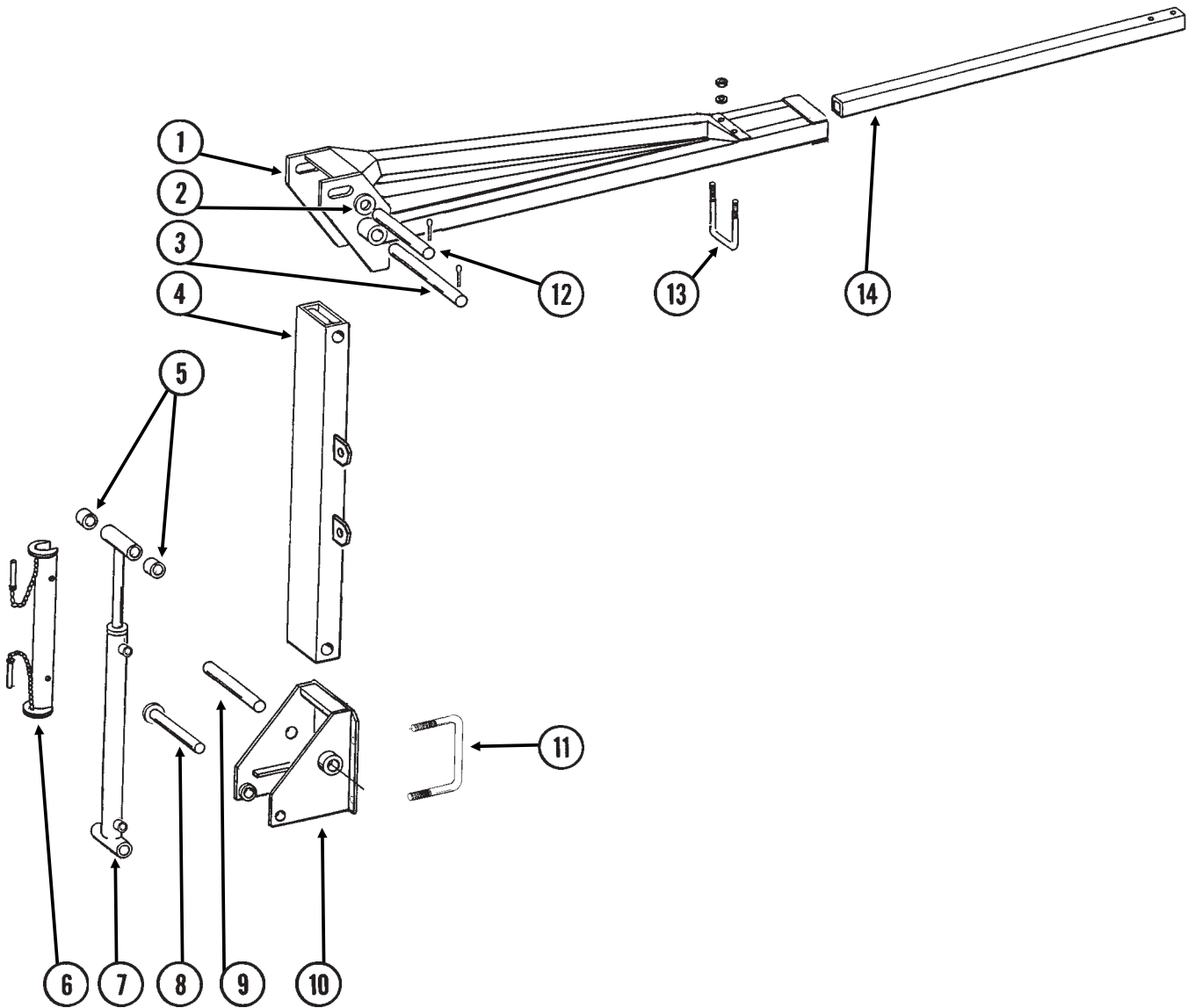

MARKER ASSEMBLY

ITEM	PART NO.	QTY.	DESCRIPTION
		(Per Assy.)	
1.	GA8472	1	Arm, Second Stage, 46"
2.	G10226	-	Washer, 1 1/4" SAE (As Required)
	G10159	-	Machine Bushing, 1 1/4", 10 Gauge (As Required)
	G10322	-	Machine Bushing, 1 1/4", 18 Gauge (As Required)
3.	GD3214	1	Pin, 1 1/4" x 12 1/4"
	G10460	2	Cotter Pin, 1/4" x 2"
4.	GA8407	1	Arm W/Grease Fittings, First Stage
	G10641	2	Grease Fitting, 1/8" NPT
5.	GD0752-41	4	Sleeve, 1"
6.	GA8170	1	Safety Lockup W/Detent Pins, 19 3/8" (Used W/2" x 20 1/16" Marker Cylinder)
	GA8876	-	Safety Lockup W/Detent Pin, 23 7/8" (Used W/2 1/2" x 20 1/16" Marker Cylinder)
	G10536	-	Detent Pin, 1/2" x 2 1/2" Grip
7.		-	See "Marker Cylinder", Pages P67 And P68
8.	GA6532	1	Pin, 1 1/4" x 7 5/8"
	G10460	1	Cotter Pin, 1/4" x 2"
9.	GD0652	1	Pin, 1 1/4" x 9 1/2"
	G10460	2	Cotter Pin, 1/4" x 2"
10.	GA8382	1	Mount
11.	GD11489	2	U-Bolt, 3" x 6" x 5/8"-11
	G10230	4	Lock Washer, 5/8"
	G10104	4	Hex Nut, 5/8"-11
12.	GD2161	1	Pin, 1 1/4" x 8 1/4"
	G10460	2	Cotter Pin, 1/4" x 2"
13.	GD2721	-	U-Bolt, 2" x 2" x 1/2"-13
	G10228	-	Lock Washer, 1/2"
	G10102	-	Hex Nut, 1/2"-13
14.	GD0453-08	-	Extension Tube, 65"

MARKER SPINDLE/HUB/BLADE

MKR020(MKR3a)

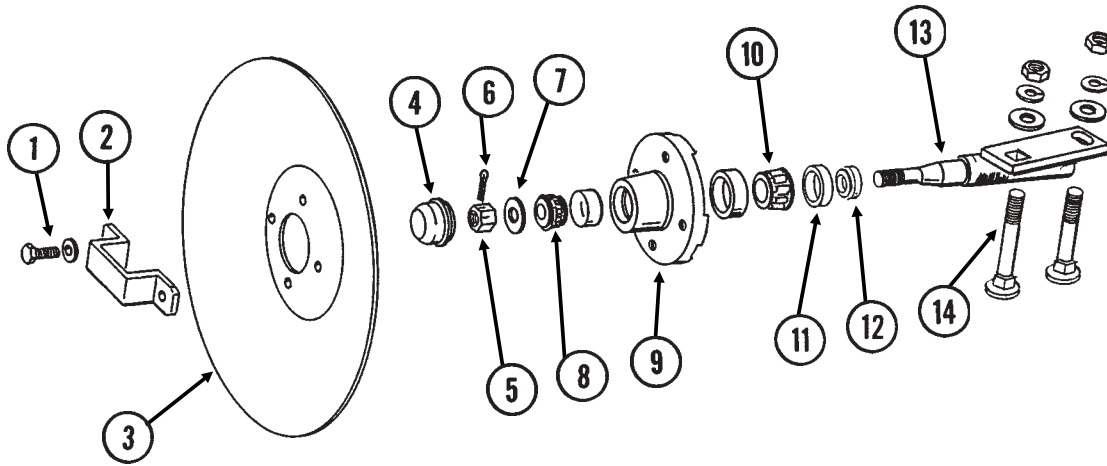

ITEM	PART NO.	QTY.	DESCRIPTION
		(Per Assy.)	
1.	G10722	4	Hex Head Cap Screw, 1/2"-20 x 1"
	G10228	4	Lock Washer, 1/2"
2.	GD2597	1	Retainer
3.	GD0746	1	Disc Blade, Solid, 16" (Shown)
	GD10283	-	Disc Blade, Notched, 16" (Optional)
4.	GD0840	1	Dust Cap
5.	G10725	1	Slotted Hex Nut, 5/8"-18
6.	G10544	1	Cotter Pin, 5/32" x 1"
7.	G10724	1	Washer, 5/8" SAE
8.	GA0257	1	Bearing
9.	GA0167	1	Hub W/Cups
	GR0151	-	Outer Cup
	GR0150	-	Inner Cup
10.	GA0245	1	Bearing
11.	GA0243	1	Grease Seal
12.	GA0899	1	Rubber Seal
13.	GA1676	1	Spindle, R.H.
	GA1677	-	Spindle, L.H. (Shown)
14.	G10844	2	Carriage Bolt, 1/2"-13 x 3 1/2"
	G10168	2	Machine Bushing, 1/2", 7 Gauge
	G10228	2	Lock Washer, 1/2"
	G10102	2	Hex Nut, 1/2"-13
A.	GA1679	-	Hub And Spindle Assembly, L.H. (Items 1, 2 And 4-13)
	GA1678	-	Hub And Spindle Assembly, R.H. (Items 1, 2 And 4-13)

SLAVE CYLINDER

CYL062(CYL54b)

Prior To Serial No. 625025

NOTE: Use With GA8745 Or GA8795 Master Cylinders

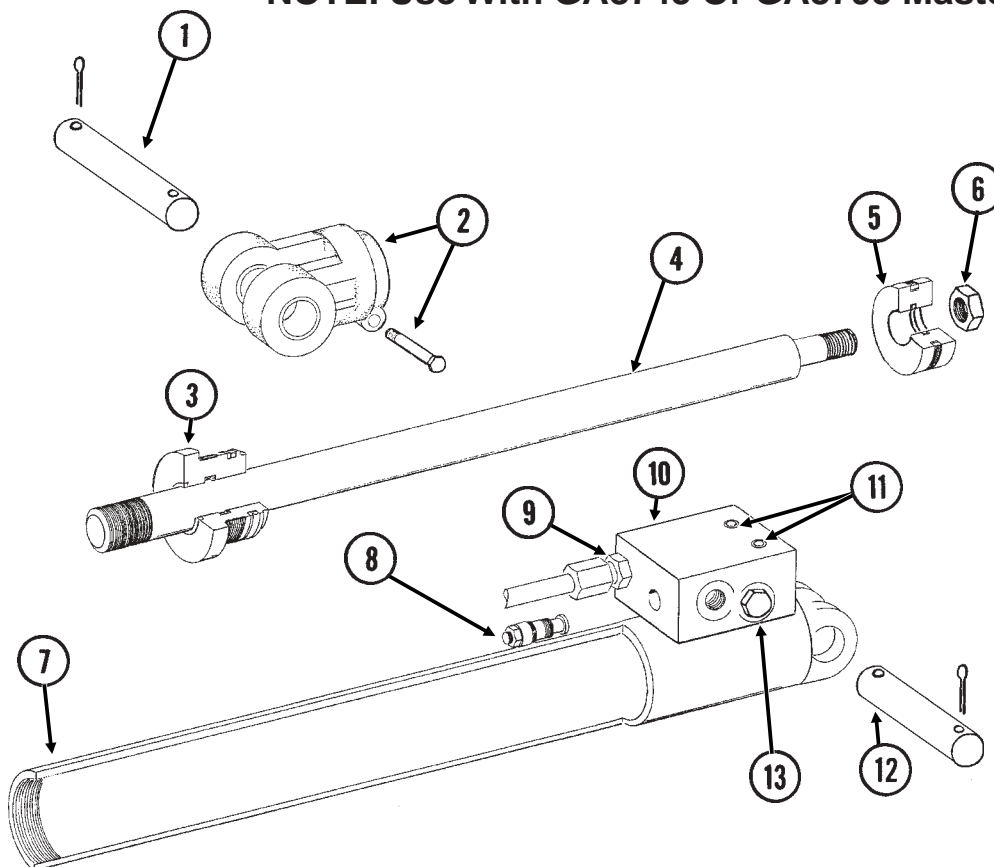

ITEM	PART NO.	QTY.	DESCRIPTION
1.	GR1287	1	Pin W/Cotter Pins
	G10460	-	Cotter Pin, 1/4" x 2"
2.	GA8130	1	Clevis W/Bushings, Cap Screw And Hex Nut
	GR1401	-	Bushing
	G10939	1	Hex Head Cap Screw, 3/8"-16 x 2 1/4"
	G10101	1	Hex Nut, 3/8"-16
3.	GD11522	1	Gland
4.	GD11521	1	Rod
5.	GD11520	1	Piston
6.	GR0983	1	Lock Nut, 1"-14
7.	A8467	1	Barrel (Non-Stock Item)
8.	GR1183	1	Counter Balance Valve
9.	G6400-08	1	Connector W/O-Ring, 3/4"-16 Male JIC To O-Ring
	GR1037	-	O-Ring
10.	GD11579	1	Block
11.	G10932	2	Hex Socket Head Cap Screw, 5/16"-18 x 2", Grade 8
12.	GR1454	1	Pin W/Cotter Pins, 1 1/4" x 3 1/2"
	G10460	-	Cotter Pin, 1/4" x 2"
13.	G6408-08	-	Plug W/O-Ring, 3/4"-16 O-Ring
	GR1037	-	O-Ring
A.	GA8181	-	Cylinder Complete, 3" x 20" <i>(Part Number Stamped On Barrel)</i>
B.	GR1453	-	Seal Kit, Includes: (1) Seal, (3) O-Rings, (1) BU Ring, (1) U-Cup, (1) Wiper

SLAVE CYLINDER

CYL062(CYL54b)

Serial No. 625025 And On

NOTE: Use With GA8896 Master Cylinder

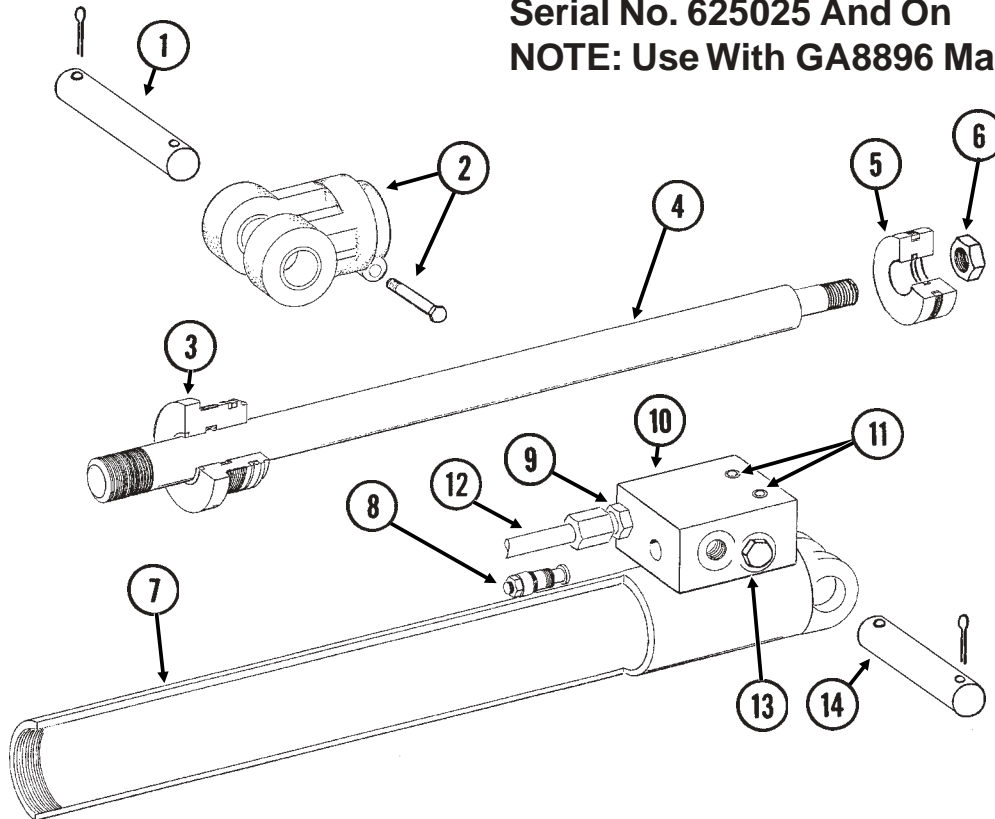

ITEM	PART NO.	QTY.	DESCRIPTION
1.	GD12585	1	Pin, 1 1/4" x 4 1/2"
	G10460	-	Cotter Pin, 1/4" x 2"
2.	GA8130	1	Clevis W/Bushings, Cap Screw And Hex Nut
	GR1401	-	Bushing
	G10939	1	Hex Head Cap Screw, 3/8"-16 x 2 1/4"
	G10101	1	Hex Nut, 3/8"-16
3.	GD12548	1	Gland
4.	GD12600	1	Rod
5.	GD12602	1	Piston
6.	G10958	1	Lock Nut, 1"-14
7.	A8986	1	Barrel (Non-Stock Item)
8.	GA8882	1	Counter Balance Valve
9.	G6400-08	1	Connector W/O-Ring, 3/4"-16 Male JIC To O-Ring
	GR1037	-	O-Ring
10.	GD11579	1	Block
11.	G10932	2	Hex Socket Head Cap Screw, 5/16"-18 x 2", Grade 8
12.	GA8984	1	Steel Hydraulic Line, 15 1/8"
13.	G6408-08	-	Plug W/O-Ring, 3/4"-16 O-Ring
	GR1037	-	O-Ring
14.	GD12790	1	Pin, 1 1/4" x 3 1/2"
	G10460	-	Cotter Pin, 1/4" x 2"
A.	GA8987	-	Cylinder Complete, 3 1/2" x 20" (Items 2-13) (Part Number Stamped On Barrel)
B.	GR1548	-	Seal Kit (For Cylinder And Counter Balance Valve), Includes: (1) Seal, (6) O-Rings, (4) BU Rings, (1) U-Cup, (1) Wiper, (1) Expander, (2) Cast Iron Rings

MASTER CYLINDER

(CYL14d)

Prior To Serial No. 625025

NOTE: Use With GA8181 Slave Cylinder

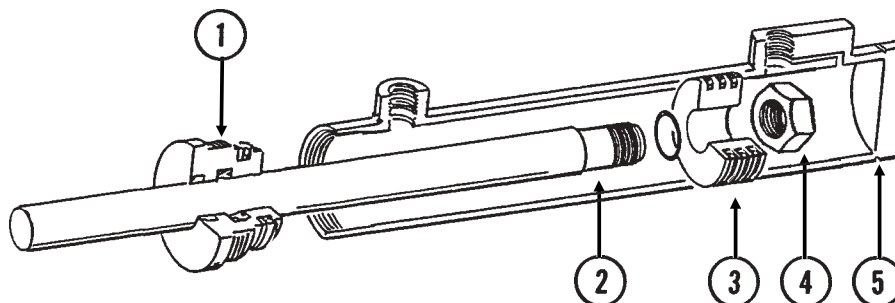

ITEM	PART NO.	QTY.	DESCRIPTION
1.	GD11513	1	Gland
2.	GD11763	1	Rod
3.	GD11294	1	Piston
4.	G10958	1	Lock Nut, 1"-14
5.	A8744	1	Barrel (Non-Stock Item)
A.	GA8745	-	Cylinder Complete, 4 1/4" x 9 3/4" <i>(Part Number Stamped On Barrel)</i>
B.	GR1496	-	Seal Kit, Includes: (2) O-Rings, (1) Piston Ring, (1) Expander, (1) BU Ring, (2) Cast Iron Rings, (1) Wiper, (1) U-Packing

MASTER CYLINDER

(CYL14d)

Prior To Serial No. 625025

NOTE: Use With GA8181 Slave Cylinder

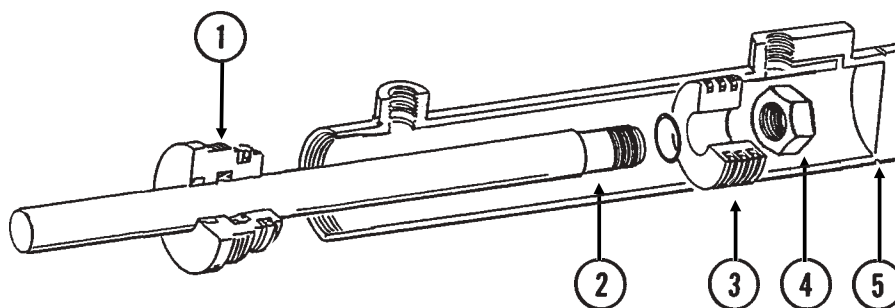

ITEM	PART NO.	QTY.	DESCRIPTION
1.	GD11835	1	Gland
2.	GD11763	1	Rod
3.	GD11294	1	Piston
4.	G10958	1	Lock Nut, 1"-14
5.	A8794	1	Barrel (Non-Stock Item)
A.	GA8795	-	Cylinder Complete, 4 1/4" x 9 3/4" <i>(Part Number Stamped On Barrel)</i>
B.	GR1496	-	Seal Kit, Includes: (2) O-Rings, (1) Piston Ring, (1) Expander, (1) BU Ring, (2) Cast Iron Rings, (1) Wiper, (1) U-Packing

MASTER CYLINDER

(CYL55a)

Serial No. 625025 And On
NOTE: Use With GA8987 Slave Cylinder

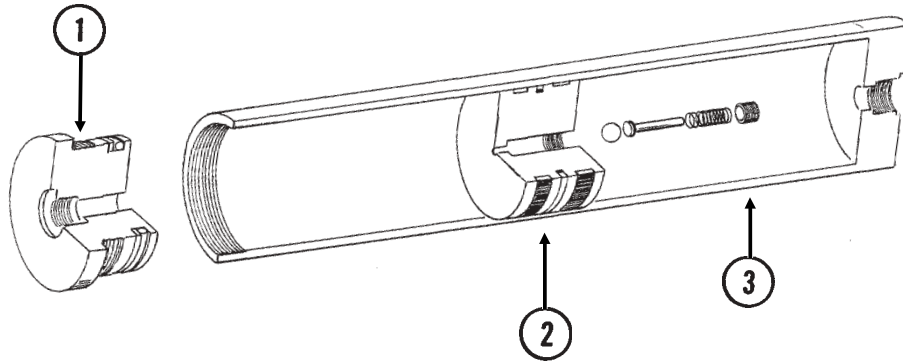

ITEM	PART NO.	QTY.	DESCRIPTION
1.	GD12606	1	Gland
2.	GA8989	1	Piston W/Rephasing Valve
	GR1169	-	Rephasing Valve Replacement Kit (Set Screw, Guide, 2 Springs And Ball)
3.	A8988	1	Barrel (Non-Stock Item)
A.	GA8896	-	Cylinder Complete, 4 1/4" x 11 1/16" <i>(Part Number Stamped On Barrel)</i>
B.	GR1549	-	Seal Kit, Includes: (1) O-Ring, (1) BU Ring, (2) Cast Iron Rings, (1) Seal, (1) Expander

TRANSPORT LATCH CYLINDER

CYL035/CYL050(CYL9b)

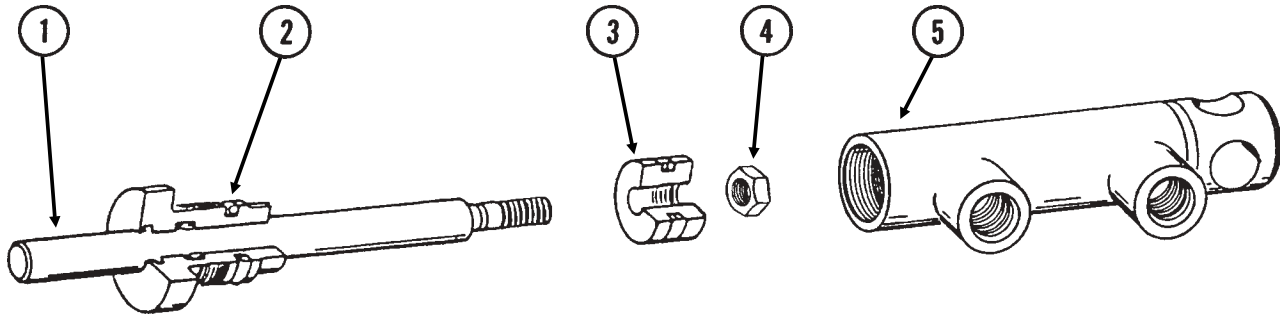

TEM	PART NO.	QTY.	DESCRIPTION
1.	GD7124	1	Rod
2.	GD7122	1	Gland
3.	GD7120	1	Piston
4.	GR0999	1	Lock Nut, 1/2"-20
5.	A6020	1	Barrel (Non-Stock Item)
A.	GA4309	-	Cylinder Complete, 1 1/2" x 2 1/2"
B.	GR1001	-	Seal Kit, Includes: (2) O-Rings, (1) U-Cup, (1) Rod Wiper, (1) Seal

TRANSPORT LATCH CYLINDER

CYL035/CYL050(CYL9c)

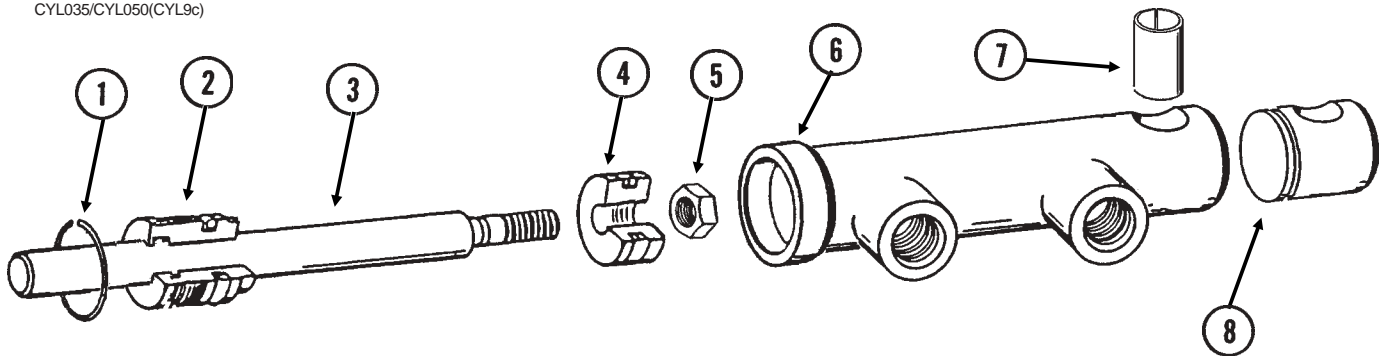

ITEM	PART NO.	QTY.	DESCRIPTION
1.	G10770	1	Internal Retaining Ring, 1 11/16"
2.	GD13170	1	Gland
3.	GD13425	1	Rod
4.	GD13172	1	Piston
5.	G11016	1	Lock Nut, 1/2"-20
6.	D13426	1	Barrel (Non-Stock Item)
7.	GD13400	1	Tension Bushing, 1" x 2"
8.	GD13173	1	End Cap
A.	GA9559	-	Cylinder Complete, 1 1/2" x 2 1/2" (Part Number Stamped On Barrel)
B.	GR1598	-	Seal Kit, Includes: (4) O-Rings, (2) BU Rings, (1) Rod Wiper, (1) T-Seal, (1) Bronze Bushing

TRANSPORT LATCH POST CYLINDER

(CYL22b)

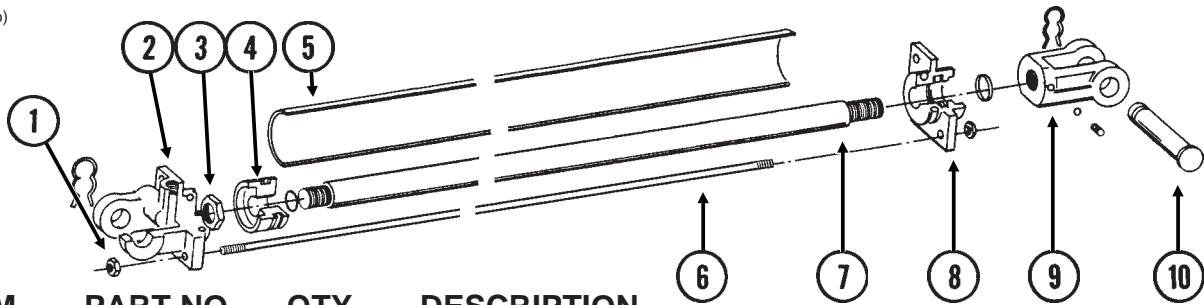

ITEM	PART NO.	QTY.	DESCRIPTION
------	----------	------	-------------

1.	GR1476	8	Tie Rod Nut
2.	GR1469	1	Clevis
3.	GR1478	1	Piston Nut
4.	GR1472	1	Piston
5.	R1474	1	Barrel (Non-Stock Item)
6.	GR1475	4	Tie Rod
7.	GR1473	1	Rod
8.	GR1470	1	Gland
9.	GR1471	1	Clevis
10.	GR1479	2	Clevis Pin W/Clip

- A. GA8456A - Cylinder Complete, 2" x 24"
 B. GR1477 - Seal Kit, Includes: (1) Seal, (5) O-Rings, (5) BU Seals

IDENTIFICATION NOTE: Decal on barrel identified "Lion Hydraulics".

TRANSPORT LATCH POST CYLINDER

(CYL22d)

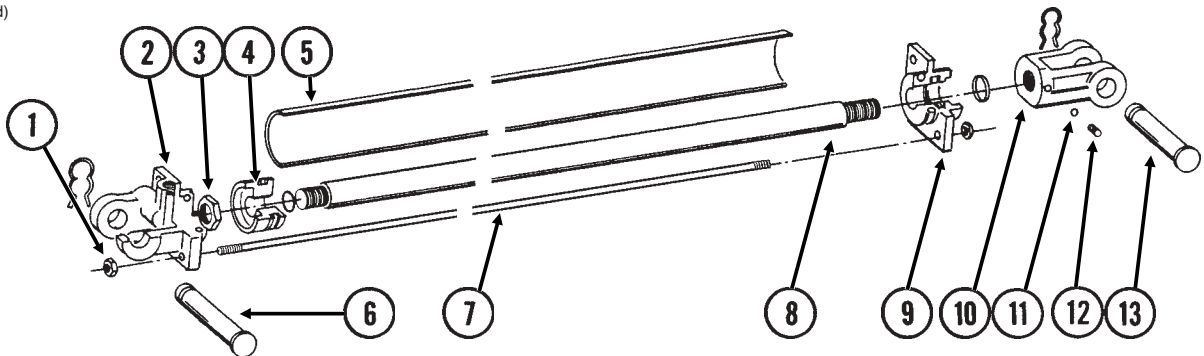

ITEM	PART NO.	QTY.	DESCRIPTION
------	----------	------	-------------

1.	G10100	8	Hex Nut, $\frac{7}{16}$ "-14
2.	GR1494	1	Clevis
3.	GR0170	1	Hex Nut, $\frac{7}{8}$ "-14
4.	GR1498	1	Piston
5.	R1500	1	Barrel (Non-Stock Item)
6.	GR1503	1	Clevis Pin W/Clip
	GR0193	-	Hair Pin Clip
7.	GR1501	4	Tie Rod
8.	GR1499	1	Rod
9.	GR1495	1	Gland
10.	GR1497	1	Clevis
11.	GR0716	1	Nylon Ball
12.	G10072	1	Hex Socket Set Screw, $\frac{3}{8}$ "-16 x $\frac{3}{8}$ "
13.	GR1504	1	Pin W/Clip
	GR0193	-	Hair Pin Clip

- A. GA8456B - Cylinder Complete, 2" x 24"
 B. GR1502 - Seal Kit, Includes: (2) Seals, (3) O-Rings, (3) BU Seals, (1) Wiper

IDENTIFICATION NOTE: "Energy" cast in clevis.

ROTATION CYLINDER

CYL061(CYL53)

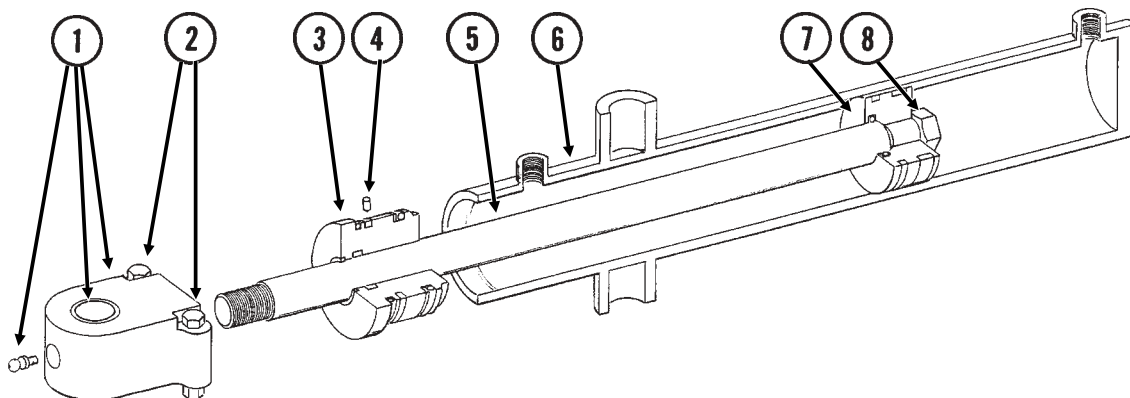

ITEM	PART NO.	QTY.	DESCRIPTION
1.	GA8497	1	Clevis W/Spring Bushing And Grease Fitting
	GR1462	-	Spring Bushing
	G10591	-	Grease Fitting, 1/4"-28 Taper
2.	G10939	2	Hex Head Cap Screw, 3/8"-16 x 2 1/4"
	G10108	2	Lock Nut, 3/8"-16
3.	GD11572	1	Gland
4.	GR1463	1	Locking Insert
5.	GD11570	1	Rod
6.	A8496	1	Barrel (Non-Stock Item)
7.	GD11571	1	Piston
8.	GR0986	1	Special Jam Nut, 1"-14
A.	GA8180	-	Cylinder Complete, 3" x 16" <i>(Part Number Stamped On Barrel)</i>
B.	GR1464	-	Seal Kit, Includes: (1) Rod Wiper, (2) Seals, (1) BU Ring, (3) O-Rings, (1) Wear Ring

ROTATION CYLINDER

CYL061(CYL53a)

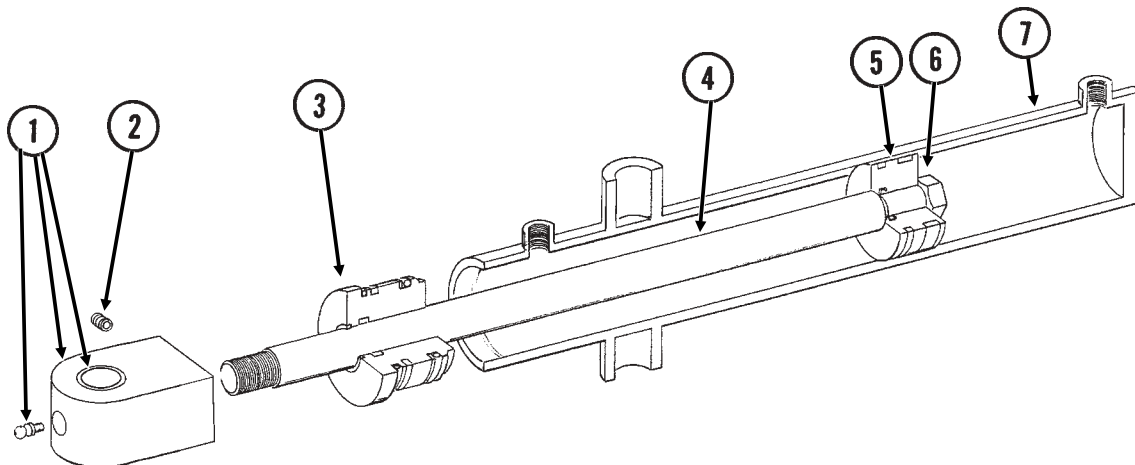

ITEM	PART NO.	QTY.	DESCRIPTION
1.	GA8497	1	Clevis W/Spring Bushing And Grease Fitting
	GR1462	-	Spring Bushing
	G10591	-	Grease Fitting, 1/4"-28 Taper
2.	G10760	2	Hex Socket Set Screw, 3/8"-16 x 1 1/2"
3.	GD12615	1	Gland
4.	GD12610	1	Rod
5.	GD12614	1	Piston
6.	G10958	1	Lock Nut, 1"-14
7.	A8991	1	Barrel (Non-Stock Item)
A.	GA8992	-	Cylinder Complete, 3" x 16" (<i>Part Number Stamped On Barrel</i>)
B.	GR1526	-	Seal Kit, Includes: (1) Wear Ring, (2) O-Rings, (1) BU Ring, (1) U-Cup, (1) Wiper, (1) T-Seal

MARKER CYLINDER

CYL039(CYL13c)

3/4"-16 O-Ring Ports

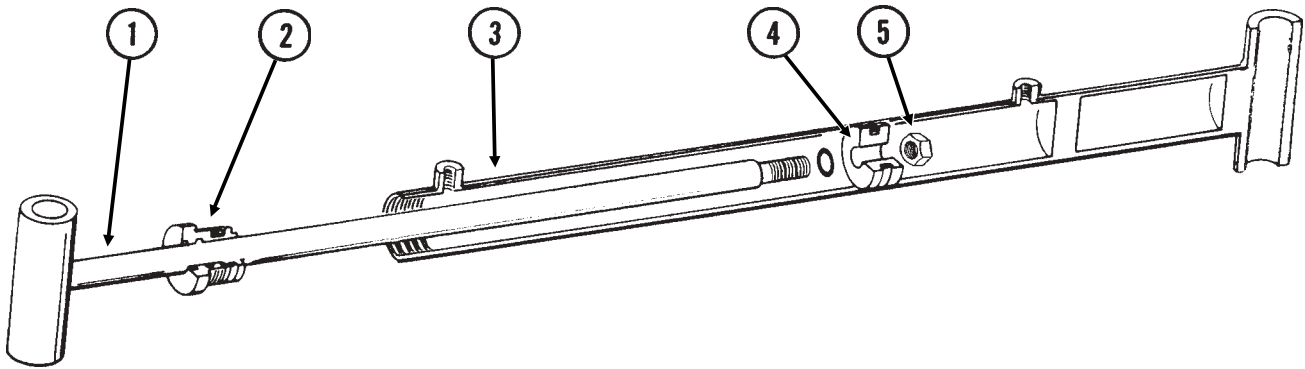

ITEM	PART NO.	QTY.	DESCRIPTION
1.	GA5459	1	Rod Assembly
2.	GD5949	1	Gland
3.	A5458	1	Barrel (Non-Stock Item)
4.	GD4632	1	Piston
5.	G10967	1	Lock Nut, 3/4"-16
A.	GA5096	-	Cylinder Complete, 2" x 20 1/16" (Part Number Stamped On Barrel)
B.	GR0927	-	Seal Kit, Includes: (1) T Seal, (2) O-Rings, (1) BU Ring, (1) U-Cup, (1) Wiper

MARKER (Cushion) CYLINDER

CYL039(CYL13d)

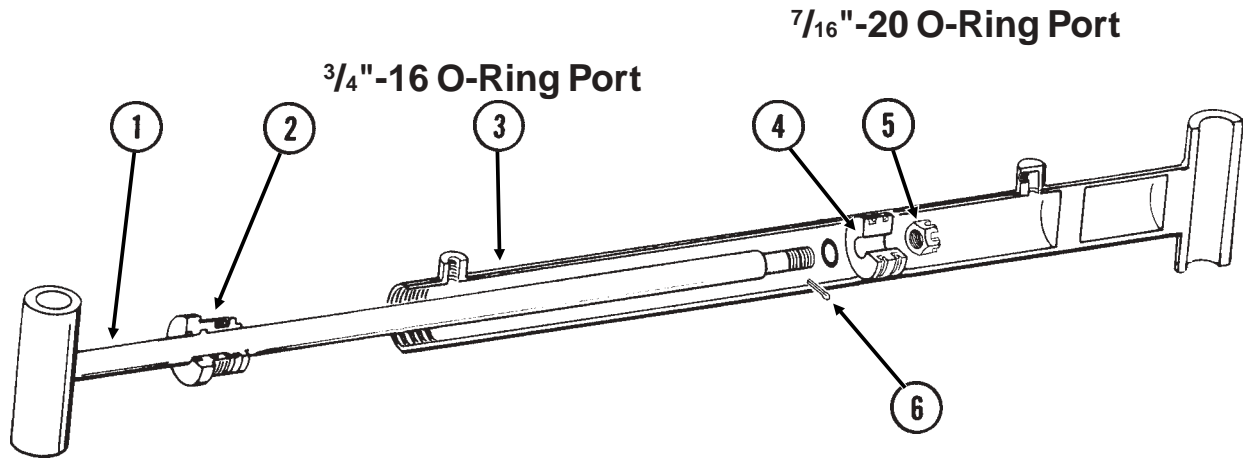

ITEM	PART NO.	QTY.	DESCRIPTION
1.	GA8835	1	Rod Assembly
2.	GD10207	1	Gland
3.	A8836	1	Barrel (Non-Stock Item)
4.	GD10206	1	Piston
5.	G10962	1	Slotted Hex Nut, $\frac{7}{8}$ "-14
6.	G10827	2	Cotter Pin, $\frac{1}{8}$ " x $1\frac{3}{4}$ "
A.	GA8837	-	Cylinder Complete, $2\frac{1}{2}$ " x $20\frac{1}{16}$ " (Part Number Stamped On Barrel)
B.	GR1309	-	Seal Kit, Includes: (1) Seal, (2) O-Rings, (1) BU Ring, (1) U-Cup, (1) Wiper, (1) Cast Iron Ring

VALVE BLOCK - LOCATED ON HITCH

PHS049(3400c)

Prior To Serial No. 625040

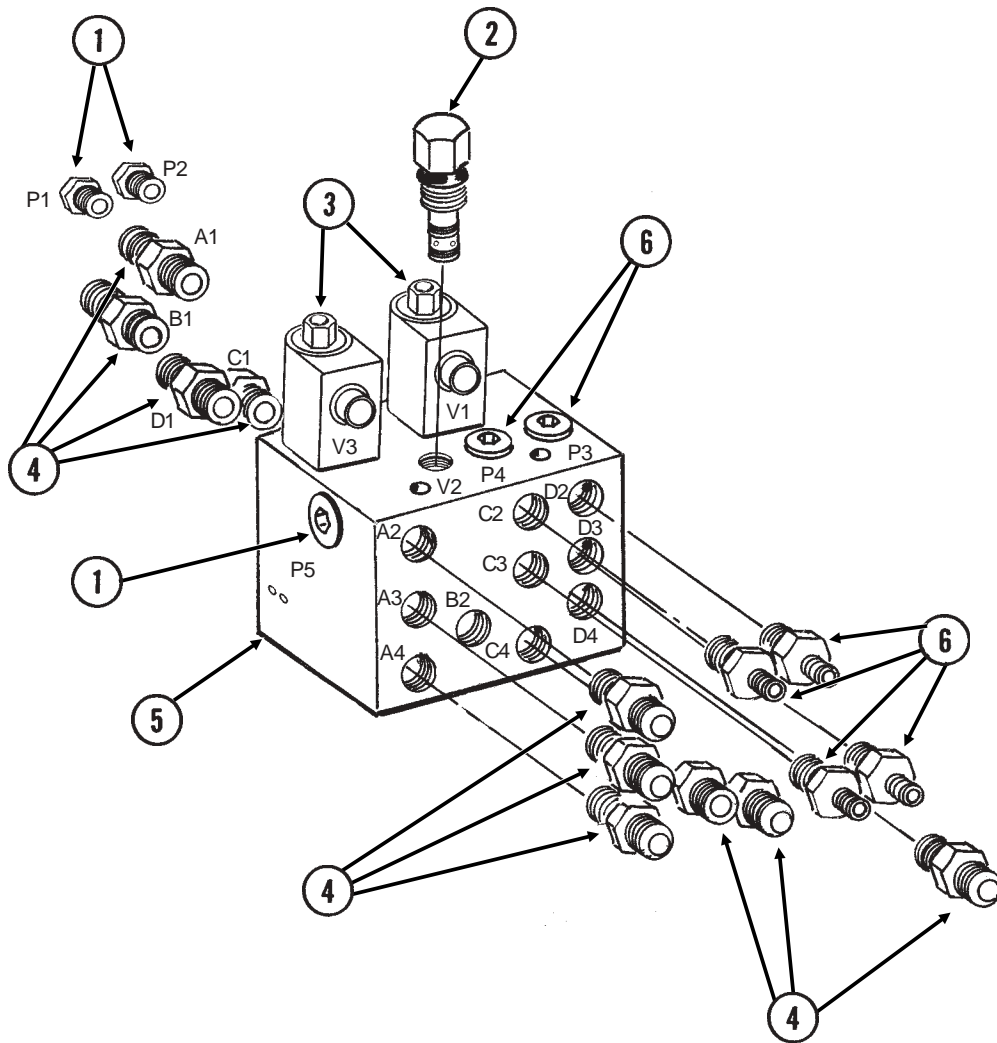

ITEM	PART NO.	QTY.	DESCRIPTION
1.	G6408-H06-O GR1045	5 -	Hex Socket Head Plug W/O-Ring, 9/16"-18 O-Ring O-Ring
2.		-	See "Check Valve", Page P75
3.		-	See "G1K276 Solenoid Valve", Page P74
4.	G6400-08 GR1037	10 -	Connector W/O-Ring, 3/4"-16 Male JIC To O-Ring O-Ring
5.	GD11460	1	Block
6.	G6400-06 GR1045	4 -	Connector W/O-Ring, 9/16"-18 Male JIC To O-Ring O-Ring

VALVE BLOCK - LOCATED ON HITCH

PHS049(3400b)

Serial No. 625040 And On

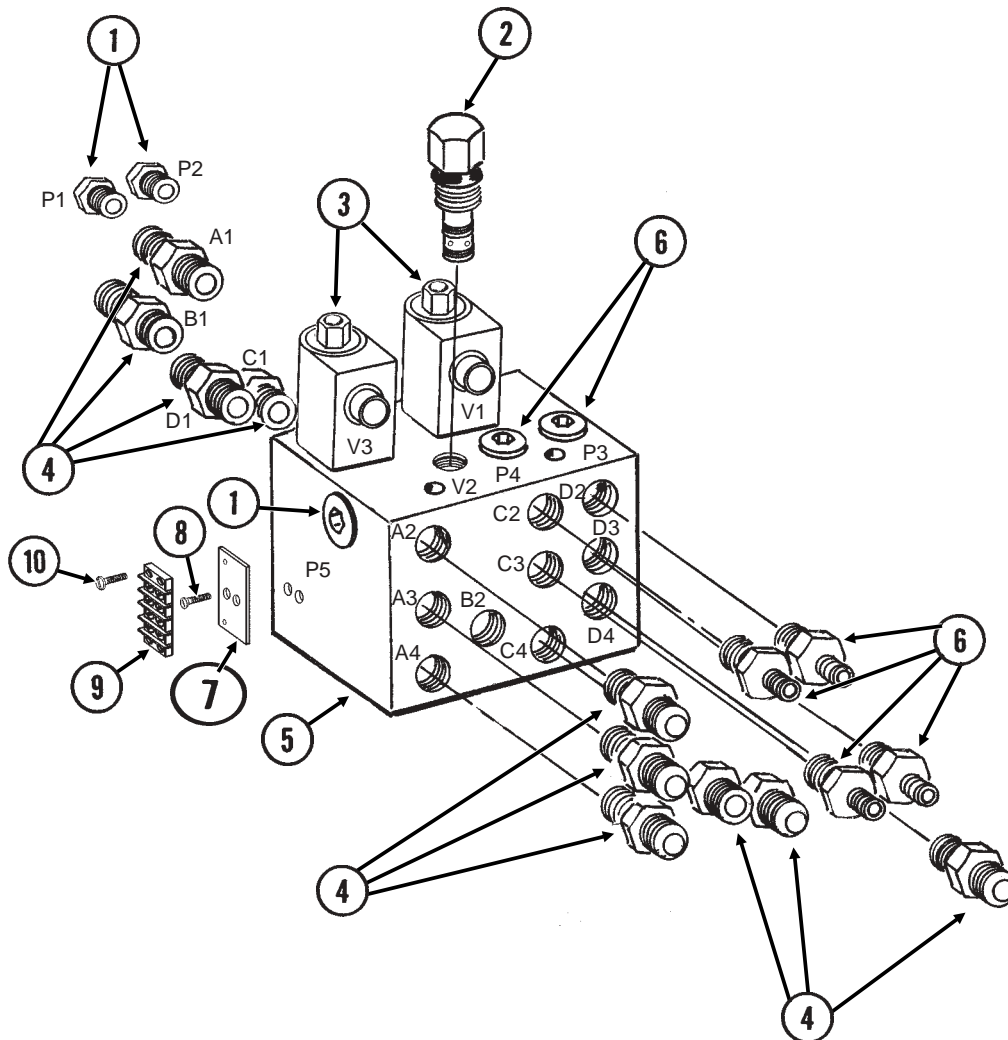

ITEM	PART NO.	QTY.	DESCRIPTION
1.	G6408-H06-O GR1045	5 -	Hex Socket Head Plug W/O-Ring, $\frac{9}{16}$ "-18 O-Ring
2.		-	See "Check Valve", Page P75
3.		-	See "G1K276 Solenoid Valve", Page P74
4.	G6400-08 GR1037	10 -	Connector W/O-Ring, $\frac{3}{4}$ "-16 Male JIC To O-Ring
5.	GD11460	1	Block
6.	G6400-06 GR1045	4 -	Connector W/O-Ring, $\frac{9}{16}$ "-18 Male JIC To O-Ring
7.	GD13395	1	Terminal Strip Mount
8.	G11001	2	Slotted Flat Head Machine Screw, No. 10-24 x $\frac{5}{8}$ ", Stainless Steel
9.	GA9510 GR1635	1 -	Terminal Strip W/Screws, No. 6, 4 Terminal
10.	G11006	2	Slotted Pan Head Machine Screw, No. 8-32 x $\frac{5}{8}$ ", Stainless Steel

VALVE BLOCK - LOCATED ON REAR CENTER FRAME

PHS050(3400d)A8455

Prior To Serial No. 625040

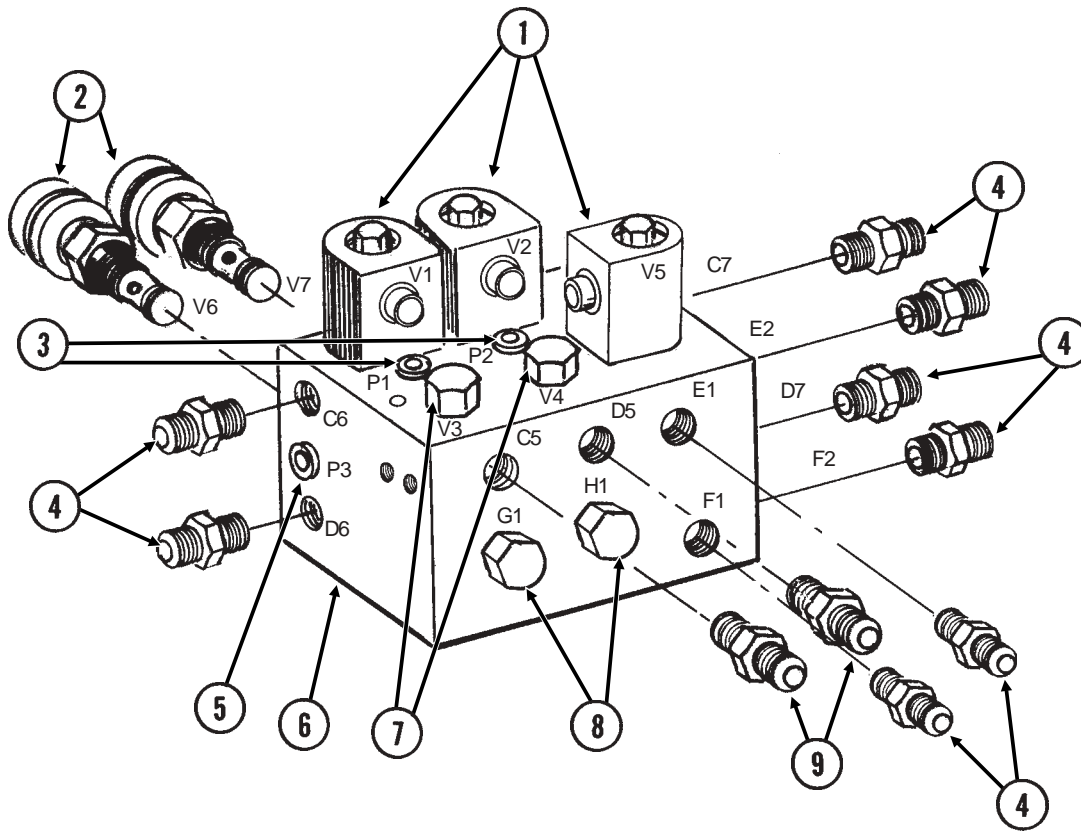

ITEM	PART NO.	QTY.	DESCRIPTION
1.		-	See "G1K275 Solenoid Valve", Page P74
2.		-	See "Flow Control Valve", Page P75
3.	G6408-H06-O	2	Hex Socket Head Plug W/O-Ring, 9/16"-18 O-Ring
	GR1045	-	O-Ring
4.	G6400-06	8	Connector W/O-Ring, 9/16"-18 Male JIC To O-Ring
	GR1045	-	O-Ring
5.	G6408-06	1	Plug W/O-Ring, 9/16"-18 O-Ring
	GR1045	-	O-Ring
6.	GD11461	1	Block
7.	G6408-10	2	Plug W/O-Ring, 7/8"-14 O-Ring
	GR1466	-	O-Ring
8.	G6408-08	2	Plug W/O-Ring, 3/4"-16 O-Ring
	GR1037	-	O-Ring
9.	G6400-08	2	Connector W/O-Ring, 3/4"-16 Male JIC To O-Ring
	GR1037	-	O-Ring

VALVE BLOCK - LOCATED ON REAR CENTER FRAME

PHS050(3400e)A8455

Serial No. 625040 And On

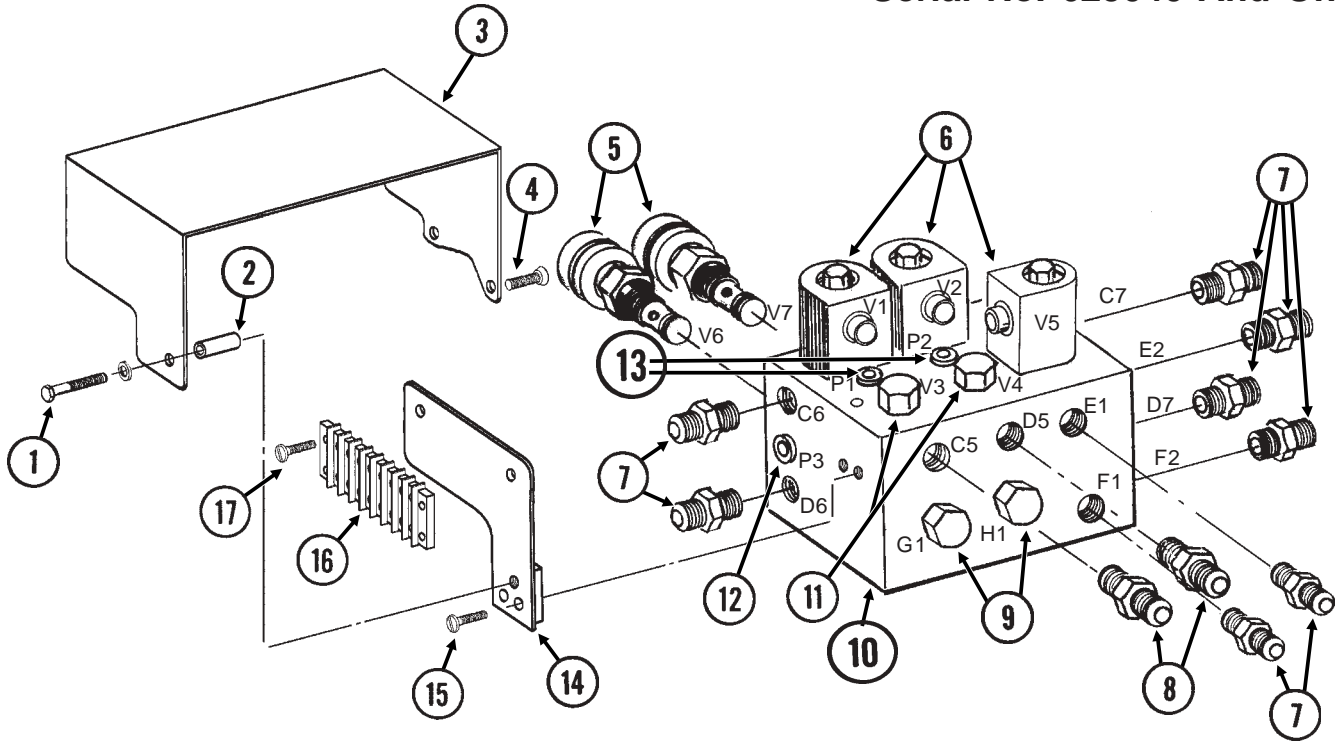

ITEM	PART NO.	QTY.	DESCRIPTION
1.	G10133	1	Hex Head Cap Screw, $\frac{5}{16}$ "-18 x $1\frac{1}{2}$ "
	G10232	1	Lock Washer, $\frac{5}{16}$ "
2.	GD8066-02	1	Sleeve, 1" Long
3.	GD13406	1	Cover
4.	G10977	2	Phillips Pan Head Machine Screw, No. 10-24 x $\frac{1}{2}$ ", Stainless Steel
5.		-	See "Flow Control Valve", Page P75
6.		-	See "G1K275 Solenoid Valve", Page P74
7.	G6400-06	8	Connector W/O-Ring, $\frac{9}{16}$ "-18 Male JIC To O-Ring
	GR1045	-	O-Ring
8.	G6400-08	2	Connector W/O-Ring, $\frac{3}{4}$ "-16 Male JIC To O-Ring
	GR1037	-	O-Ring
9.	G6408-08	2	Plug W/O-Ring, $\frac{3}{4}$ "-16 O-Ring
	GR1037	-	O-Ring
10.	GD11461	1	Block
11.	G6408-10	2	Plug W/O-Ring, $\frac{7}{8}$ "-14 O-Ring
	GR1466	-	O-Ring
12.	G6408-06	1	Plug W/O-Ring, $\frac{9}{16}$ "-18 O-Ring
	GR1045	-	O-Ring
13.	G6408-H06-O	2	Hex Socket Head Plug W/O-Ring, $\frac{9}{16}$ "-18 O-Ring
	GR1045	-	O-Ring
14.	GA9543	1	Terminal Strip Mount
15.	G11004	2	Slotted Pan Head Machine Screw, No. 10-24 x $\frac{3}{4}$ ", Stainless Steel
16.	GA9098	1	Terminal Strip W/Screws, No. 6, 8 Terminal
	GR1635	-	Screw, No. 6-32 x $\frac{1}{4}$ "
17.	G11002	2	Slotted Pan Head Machine Screw, No. 8-32 x $\frac{3}{4}$ ", Stainless Steel

JUNCTION BLOCK - LOCATED ON FRONT OF CENTER PIVOT

(2400d)

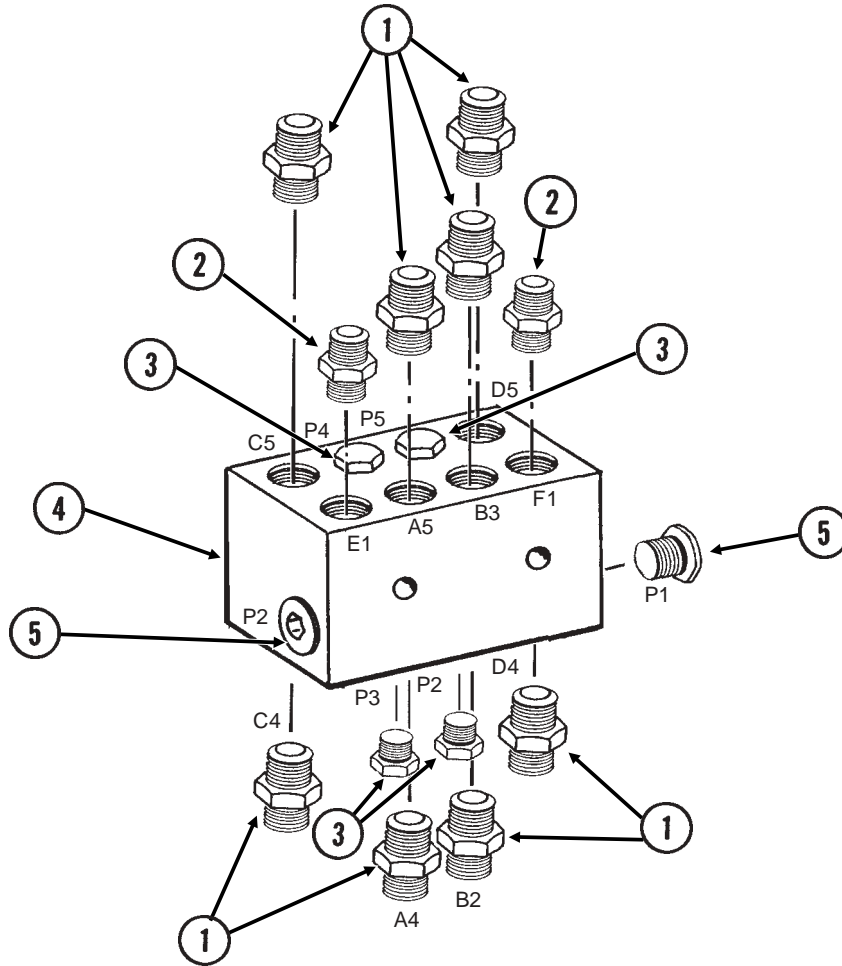

ITEM	PART NO.	QTY.	DESCRIPTION
1.	G6400-08 GR1037	8 -	Connector W/O-Ring, 3/4"-16 Male JIC To O-Ring O-Ring
2.	G6400-06 GR1045	2 -	Connector W/O-Ring, 9/16"-18 Male JIC To O-Ring O-Ring
3.	G6408-08 GR1037	4 -	Plug W/O-Ring, 3/4"-16 O-Ring O-Ring
4.	GD11459	1	Block
5.	G6408-H06-O GR1045	2 -	Hex Socket Head Plug W/O-Ring, 9/16"-18 O-Ring O-Ring

SOLENOID VALVE (G1K275)

VVB019(TWL27c/TWL18/PLTR75c/A9481)

ITEM	PART NO.	QTY.	DESCRIPTION
1.	GR0761	1	Special Hex Nut, 1/2"-20
2.	G1K274	1	Coil Kit W/Contacts, Housings And Fork Terminals
	GD9529	2	Housing, Black
	GD9530	2	Contact
	G10996	2	Fork Terminal
3.	GR0763	1	Cartridge
A.	G1K275	-	Solenoid Valve Kit W/Contacts, Housings And Fork Terminals
	GD9529	2	Housing, Black
	GD9530	2	Contact
	G10996	2	Fork Terminal
B.	GR0764	-	Seal Kit, Includes: (2) O-Rings, (1) BU Ring

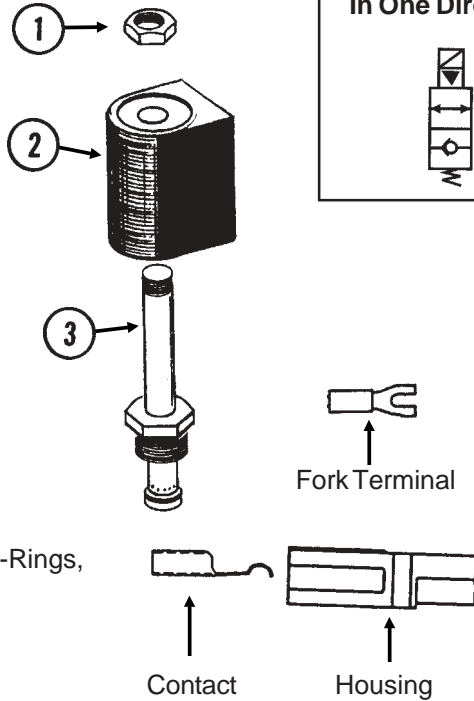

SOLENOID VALVE (G1K276)

VVB019(FF25/TWL18/PLTR75c)

ITEM	PART NO.	QTY.	DESCRIPTION
1.	GR1322	1	Special Hex Nut, 1/2"-20
2.	G1K274	1	Coil Kit W/Contacts, Housings And Fork Terminals
	GD9529	2	Housing, Black
	GD9530	2	Contact
	G10996	2	Fork Terminal
3.	GR1321	1	Cartridge
A.	G1K276	-	Solenoid Valve Kit W/Contacts, Housings And Fork Terminals
	GD9529	2	Housing, Black
	GD9530	2	Contact
	G10996	2	Fork Terminal
B.	GR0764	-	Seal Kit, Includes: (2) O-Rings, (1) BU Ring

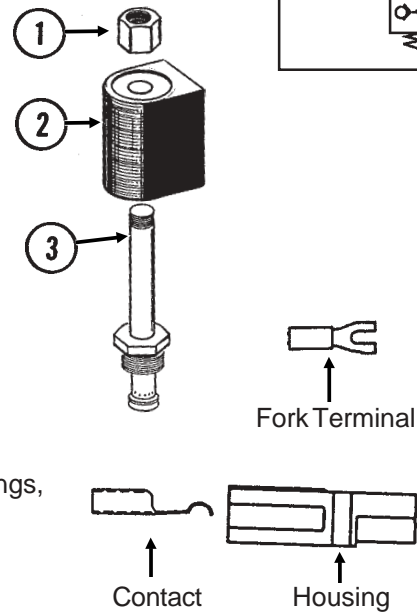

CHECK VALVE

VVB020(TWL30a)

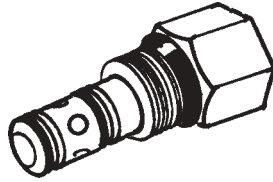

ITEM	PART NO.	QTY.	DESCRIPTION
A.	GA8406	-	Check Valve
B.	GR1468	-	Seal Kit, Includes: (4) O-Rings, (5) BU Rings

FLOW CONTROL VALVE

VVB020(TWL28)

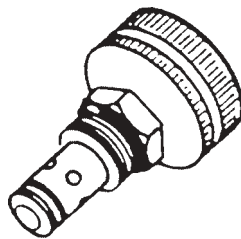

ITEM	PART NO.	QTY.	DESCRIPTION
A.	GA3413	-	Flow Control Valve
B.	GR0764	-	Seal Kit, Includes: (2) O-Rings, (1) BU Ring

HYDRAULIC SYSTEM

(TWL185/TWL158b/TWL158c)

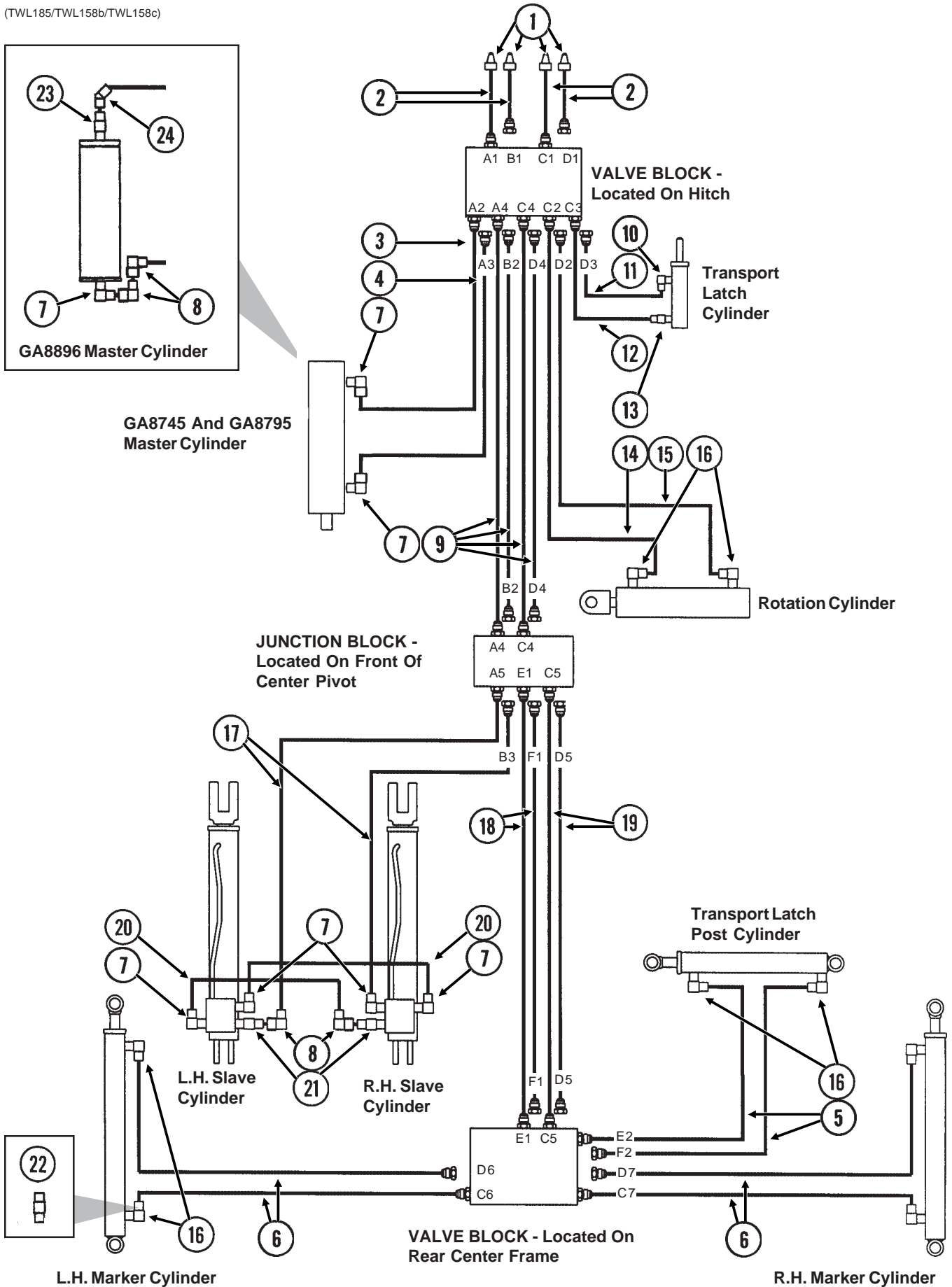

HYDRAULIC SYSTEM

ITEM	PART NO.	QTY.	DESCRIPTION
1.	GD4086	4	ISO Coupler
2.	*A3123	4	Hose Assembly, 3/8" x 72"
3.	*A1021	1	Hose Assembly, 3/8" x 56"
4.	*A3158	1	Hose Assembly, 3/8" x 46"
5.	*A7609	2	Hose Assembly, 1/4" x 164"
6.	*A7610	4	Hose Assembly, 1/4" x 175"
7.	G6801-08	5-6	Elbow W/O-Ring, 90°, 3/4"-16 Male JIC To O-Ring
	GR1037	-	O-Ring
8.	G6500-08	2-4	Swivel Elbow, 90°, 3/4"-16 Male JIC To Female
9.	*A3206	4	Hose Assembly, 3/8" x 184"
10.	G6801-06	1	Elbow W/O-Ring, 90°, 9/16"-18 Male JIC To O-Ring
	GR1045	-	O-Ring
11.	*A1169	1	Hose Assembly, 1/4" x 24"
12.	*A1192	1	Hose Assembly, 1/4" x 20"
13.	G6400-06	1	Connector W/O-Ring, 9/16"-18 Male JIC To O-Ring
	GR1045	-	O-Ring
14.	*A7606	1	Hose Assembly, 1/4" x 177"
15.	*A7607	1	Hose Assembly, 1/4" x 187"
16.	G6801-06-08	6-8	Elbow W/O-Ring, 90°, 9/16"-18 Male JIC To 3/4"-16 O-Ring
	GR1037	-	O-Ring
17.	*A1096	2	Hose Assembly, 3/8" x 50 1/2"
18.	*A1113	2	Hose Assembly, 1/4" x 80"
19.	*A3129	2	Hose Assembly, 3/8" x 79"
20.	*A1079	2	Hose Assembly, 3/8" x 24"
21.	G6400-L-08	2	Long Connector W/O-Ring, 3/4"-16 Male JIC To O-Ring
	GR1037	-	O-Ring
22.	G6400-06-04	2	Connector W/O-Ring, 9/16"-18 Male JIC To 7/16"-20 O-Ring
	GR1465	-	O-Ring
23.	G6400-08	1	Connector W/O-Ring, 3/4"-16 Male JIC To O-Ring
	GR1037	-	O-Ring
24.	G6502-08	1	Swivel Elbow, 45°, 3/4"-16 Male JIC To Female

* Hydraulic hose is not stocked by KINZE® Repair Parts, but can be made available on a special order basis. Call for quote.

ELECTRICAL COMPONENTS (Prior To Serial No. 625040)

ECP010/ECP011/ECP018/ECP023(TWL19a/TWL18/A9481/TWL23/A8430a/ELC39/ELC14/ELC3a/ELC5c/MTR27a/ELC8/A8433/A8432a/TWL20f/ELC10a/ELC4)

See "Planter Frame", pages P42 and P43, for light brackets.

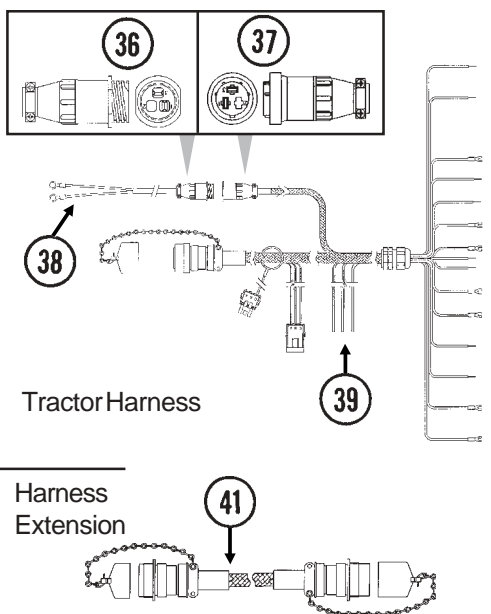
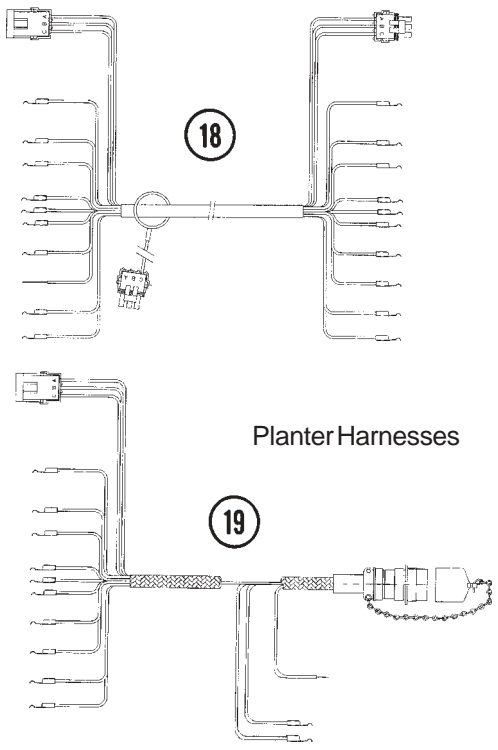
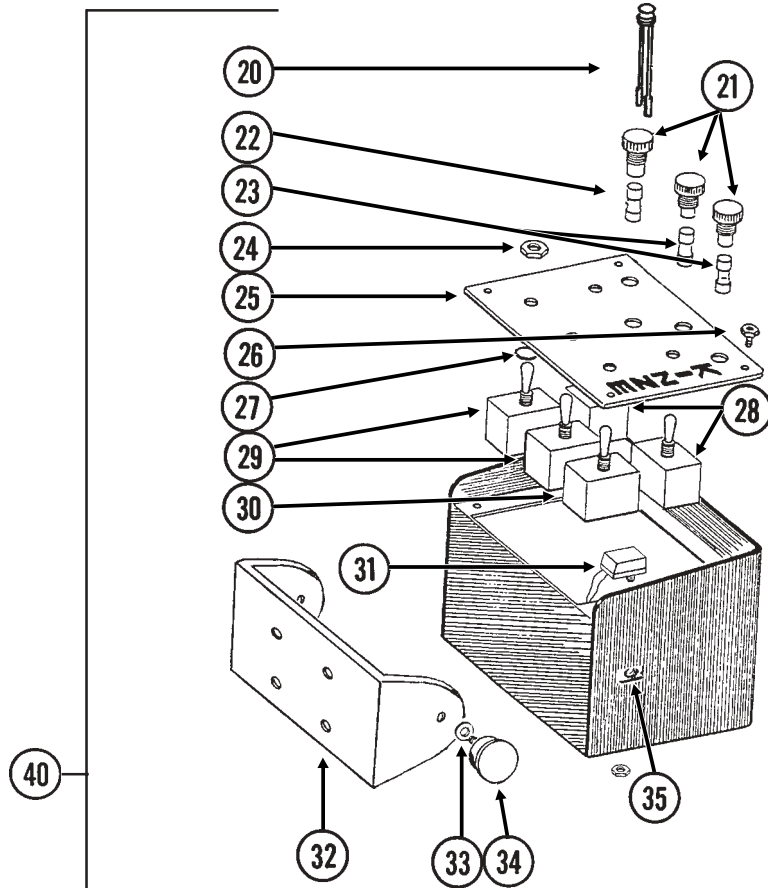
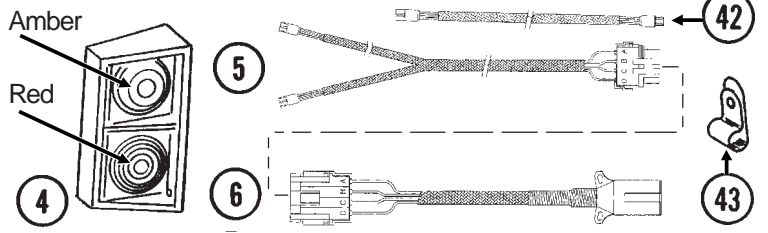
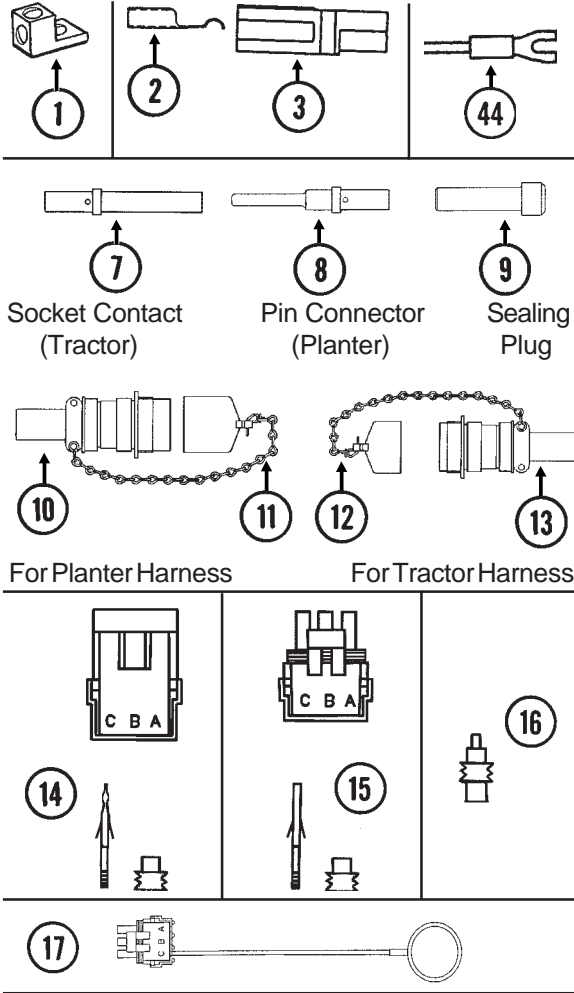

ELECTRICAL COMPONENTS (Prior To Serial No. 625040)

ITEM	PART NO.	QTY.	DESCRIPTION
1.	GA3584	-	Ground Clamp
2.	GD9530	-	Contact
3.	GD9529	-	Housing, Black
	GD12726	-	Housing, Red
4.	GA6699	1	Double Light Assembly (Shown)
	GA6700	1	Double Light Assembly
	GR1203	-	Red Lens
	GR1204	-	Amber Lens
	GR1205	-	Cover
	GR1206	-	Rubber Grommet (4)
	GR1207	-	Lamp Unit
	GR1208	-	Bulb
5.	GA8431	1	Wiring Harness W/4-Pin Connector, 208" (2 Light Connections)
	GA8329	-	4-Pin Connector W/Male Housing, 4 Seals And 4 Socket Contacts
6.	GA8430	1	Wiring Harness W/7 Terminal Female Connector And 4-Pin Connector, 282"
	GA5385	-	7 Terminal Female Connector
	GA8328	-	4-Pin Connector W/Female Housing, 4 Seals And 4 Pin Contacts
7.	GD8740	-	Socket Contact, No. 14
8.	GD8741	-	Pin Contact, No. 14
9.	GD8739	-	Sealing Plug, No. 12
10.	GA6109	1	Connector W/Cable Clamp, 23 Pin Capacity
11.	GA7862	-	Dust Cap W/Chain
12.	GA7863	-	Dust Cap W/Chain
13.	GA6108	1	Connector W/Cable Clamp, 23 Socket Capacity
14.	G1K248	-	3-Pin Female Connector Kit, Includes: (3) 3-Pin Female Housings, (9) Pin Contacts, (9) Seals
15.	G1K252	-	3-Pin Male Connector Kit (Black), Includes: (3) 3-Pin Male Housings, (9) Socket Contacts, (9) Seals
16.	GD11089	-	Sealing Plug
17.	GA8047	-	Dust Plug (Black)
18.	GA8433	1	Wiring Harness, 84"
19.	GA8432	1	Wiring Harness W/Dust Cap, 294"
20.	GA7077	1-4	Indicator Light
21.	GA2612	3-5	Fuse Holder W/Spade
22.	GD2829	1-2	Fuse, 15 Amp, Type AGC
23.	GD10243	2-6	Fuse, MOL 10 Amp Delay Action
24.	GR1363	5	Hex Face Nut, ¹⁵ / ₃₂ "-32
	GR1364	5	Internal Tooth Lock Washer, ¹⁵ / ₃₂ "
25.	GA8734	1	Cover Plate
26.	GR1292	4	Pan Head Screw, No. 8-32 x 1/2"
27.	GD3860	-	O-Ring (If Applicable)
28.	GA2528	2	Switch, 3 Position Toggle, On-Off-On
29.	GA6978	2	Switch, 3 Position Toggle, Momentary On-Off-Momentary On
30.	GA6977	1-2	Switch, 2 Position Toggle, On-Off
31.	GA8731	1	Switch, Push Button W/Transformer
32.	GD9896	1	Mounting Bracket
33.	G10211	4	Washer, 1/4" SAE
34.	GA6975	2	Knob
35.	GR1290	2	Cage Nut, 1/4"-20
36.	G1K267	-	Power Lead Adapter Connector Kit, Includes: (1) 3-Pin Connector, (1) Cable Clamp, (3) Male Terminal Pins
37.	G1K268	-	Console Cable Connector Kit, Includes: (1) 3-Pin Connector, (1) Cable Clamp, (1) Lock Ring, (3) Female Terminal Pins
38.	GA7856	1	Power Lead Adapter
39.	GA8729	1	Wiring Harness W/Dust Cap And Power Cable
40.	G7633X	-	Backlit Control Console Assembly W/Mounting Brackets, Short Harness W/Dust Cap And Power Cable
41.	GA7399	-	Harness Extension W/Dust Caps, 180"
42.	GA9096	-	Harness Extension, 42"
43.	GD6291	-	Insulated Clamp, ³ / ₈ "
44.	G10996	-	Fork Terminal

NOTE: See "KPM I/KPM II Electronic Seed Monitor" for those components.

ELECTRICAL COMPONENTS (Serial No. 625040 And On)

ECP010/ECP011/ECP018/ECP023(TWL19a/TWL18/TWL23/A8430b/ELC39/ELC14/ELC3a/ELC5c/MTR27a/ELC8/A9531/A9530/TWL20f/ELC10a/ELC4)

See "Planter Frame", pages P42 and P43, for light brackets.

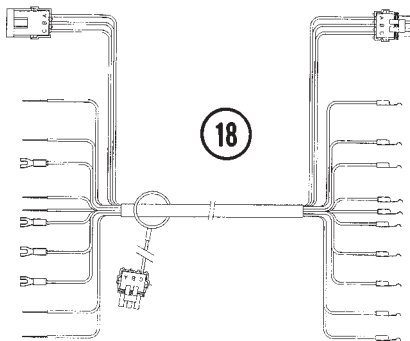
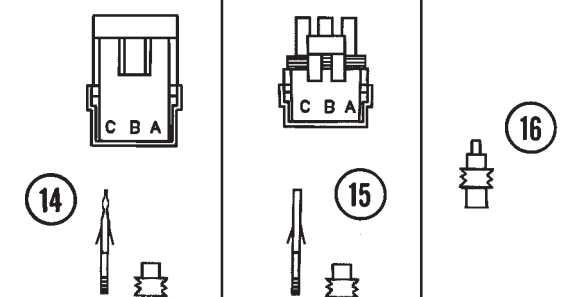
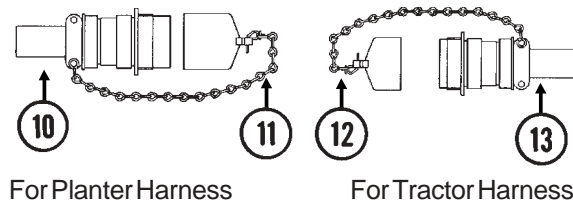
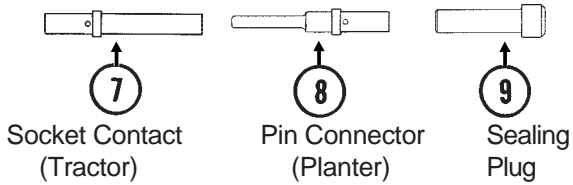
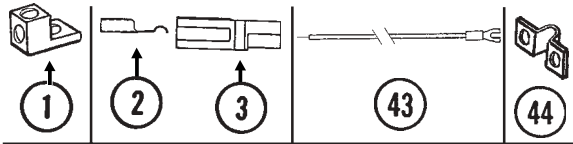

Planter Harnesses

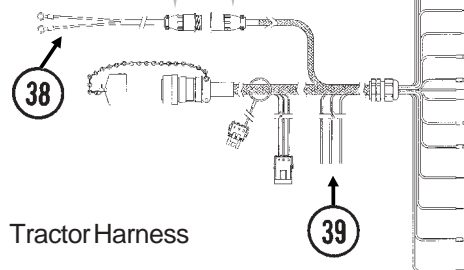
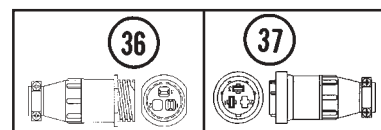
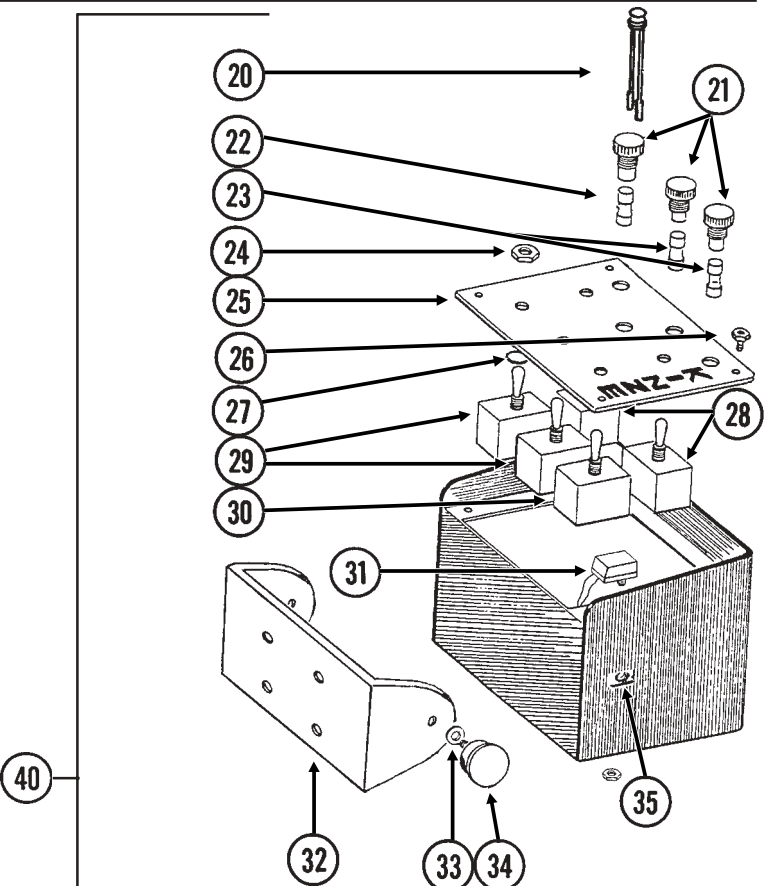
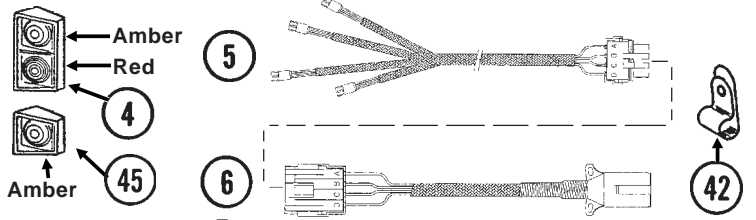
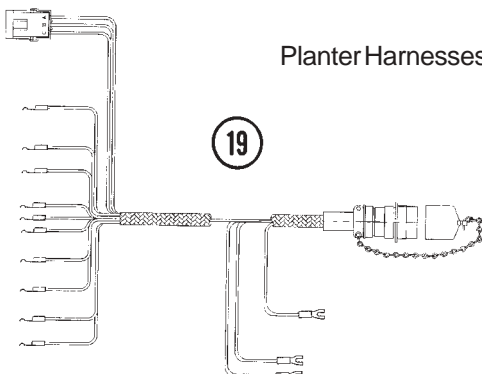

Tractor Harness

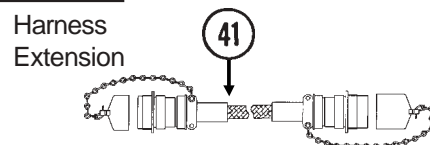

Harness Extension

ELECTRICAL COMPONENTS (Serial No. 625040 And On)

ITEM	PART NO.	QTY.	DESCRIPTION
1.	GA3584	-	Ground Clamp
2.	GD9530	-	Contact
3.	GD9529	-	Housing, Black
	GD12726	-	Housing, Red
4.	GA6699	1	Double Light Assembly (Shown)
	GA6700	1	Double Light Assembly
	GA6701	-	Single Amber Light Assembly (Shown)
	GR1203	-	Red Lens
	GR1204	-	Amber Lens
	GR1205	-	Cover
	GR1206	-	Rubber Grommet (4)
	GR1207	-	Lamp Unit
	GR1208	-	Bulb
5.	GA9529	1	Light Wiring Harness W/4-Pin Connector, 336" (4 Light Connections)
	GA8329	-	4-Pin Connector W/Male Housing, 4 Seals And 4 Socket Contacts
6.	GA8430	1	Wiring Harness W/7 Terminal Female Connector And 4-Pin Connector, 282"
	GA5385	-	7 Terminal Female Connector
	GA8328	-	4-Pin Connector W/Female Housing, 4 Seals And 4 Pin Contacts
7.	GD8740	-	Socket Contact, No. 14
8.	GD8741	-	Pin Contact, No. 14
9.	GD8739	-	Sealing Plug, No. 12
10.	GA6109	1	Connector W/Cable Clamp, 23 Pin Capacity
11.	GA7862	-	Dust Cap W/Chain
12.	GA7863	-	Dust Cap W/Chain
13.	GA6108	1	Connector W/Cable Clamp, 23 Socket Capacity
14.	G1K248	-	3-Pin Female Connector Kit, Includes: (3) 3-Pin Female Housings, (9) Pin Contacts, (9) Seals
15.	G1K252	-	3-Pin Male Connector Kit (Black), Includes: (3) 3-Pin Male Housings, (9) Socket Contacts, (9) Seals
16.	GD11089	-	Sealing Plug
17.	GA8047	-	Dust Plug (Black)
18.	GA9531	1	Hydraulic Wiring Harness, 84"
19.	GA9530	1	Hydraulic Wiring Harness W/Dust Cap, 294"
20.	GA7077	1-4	Indicator Light
21.	GA2612	3-5	Fuse Holder W/Spade
22.	GD2829	1-2	Fuse, 15 Amp, Type AGC
23.	GD10243	2-6	Fuse, MOL 10 Amp Delay Action
24.	GR1363	5	Hex Face Nut, ¹⁵ / ₃₂ "-32
	GR1364	5	Internal Tooth Lock Washer, ¹⁵ / ₃₂ "
25.	GA8734	1	Cover Plate
26.	GR1292	4	Pan Head Screw, No. 8-32 x 1/2"
27.	GD3860	-	O-Ring (If Applicable)
28.	GA2528	2	Switch, 3 Position Toggle, On-Off-On
29.	GA6978	2	Switch, 3 Position Toggle, Momentary On-Off-Momentary On
30.	GA6977	1-2	Switch, 2 Position Toggle, On-Off
31.	GA8731	1	Switch, Push Button W/Transformer
32.	GD9896	1	Mounting Bracket
33.	G10211	4	Washer, 1/4" SAE
34.	GA6975	2	Knob
35.	GR1290	2	Cage Nut, 1/4"-20
36.	G1K267	-	Power Lead Adapter Connector Kit, Includes: (1) 3-Pin Connector, (1) Cable Clamp, (3) Male Terminal Pins
37.	G1K268	-	Console Cable Connector Kit, Includes: (1) 3-Pin Connector, (1) Cable Clamp, (1) Lock Ring, (3) Female Terminal Pins
38.	GA7856	1	Power Lead Adapter
39.	GA8729	1	Wiring Harness W/Dust Cap And Power Cable
40.	G7633X	-	Backlit Control Console Assembly W/Mounting Brackets, Short Harness W/Dust Cap And Power Cable
41.	GA7399	-	Harness Extension W/Dust Caps, 180"
42.	GD6291	-	Insulated Clamp, ³ / ₈ "
43.	GA9481	-	Jumper Wire W/Fork Terminal, 13"
	G10996	-	Fork Terminal
44.	GD13310	-	Jumper
45.	GA6701	-	Single Amber Light Assembly (Planters Equipped With Interplant® Package)
	GR1204	-	Amber Lens
	GR1206	-	Rubber Grommet (2)
	GR1207	-	Lamp Unit
	GR1208	-	Bulb

NOTE: See "KPM I/KPM II Electronic Seed Monitor" for those components.

KPM I/KPM II ELECTRONIC SEED MONITOR

(MTR27vv)

Radar Distance Sensor (KPM II Only)

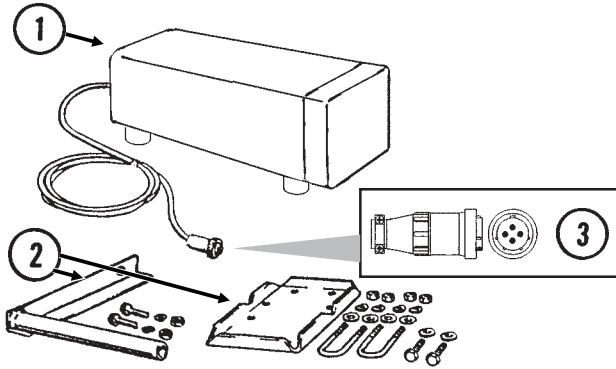

Magnetic Distance Sensor (MDS) (KPM II Only)

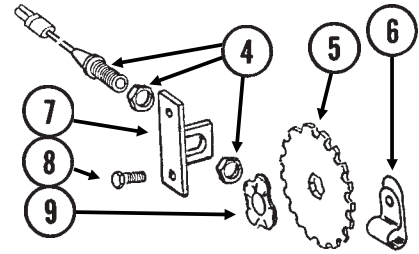

Power Lead Adapter

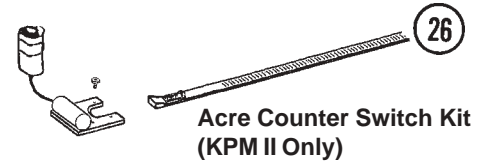
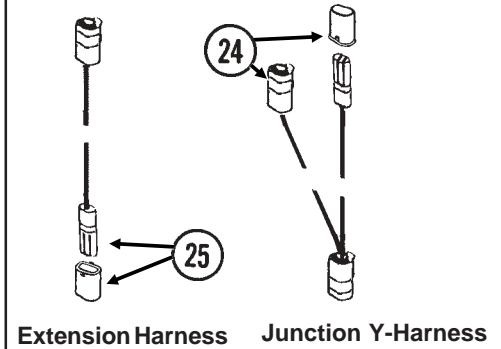
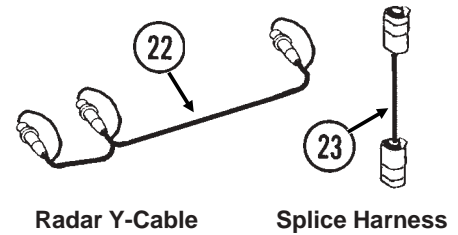
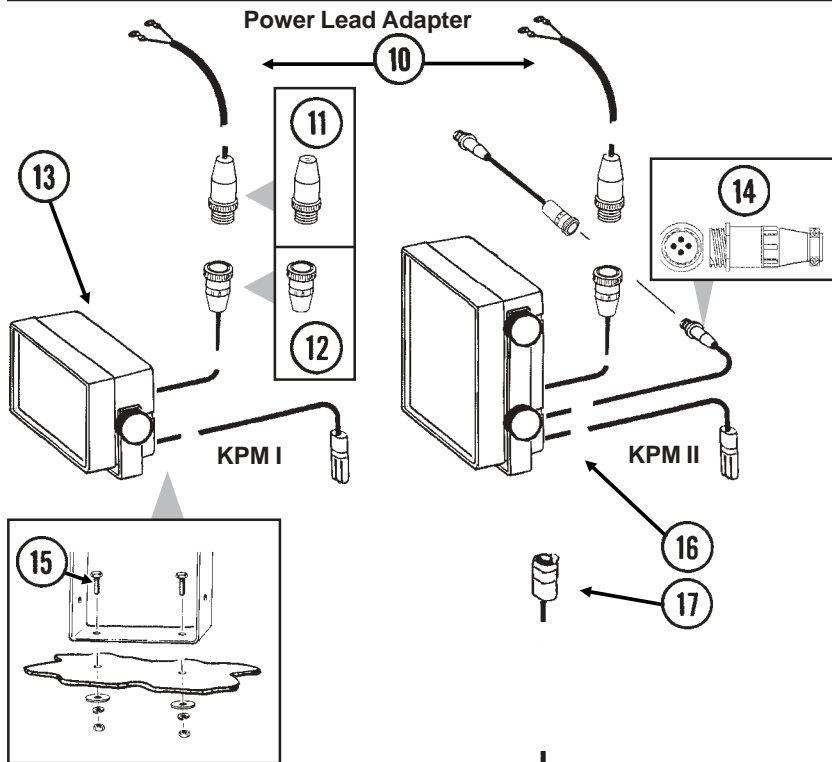

Planter Harness

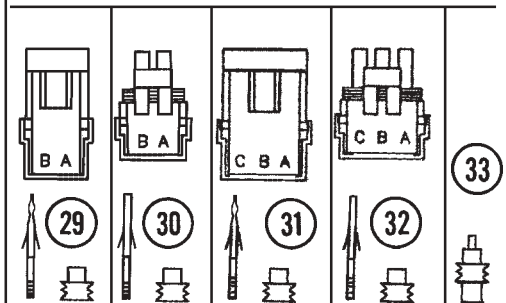
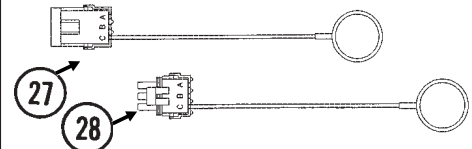
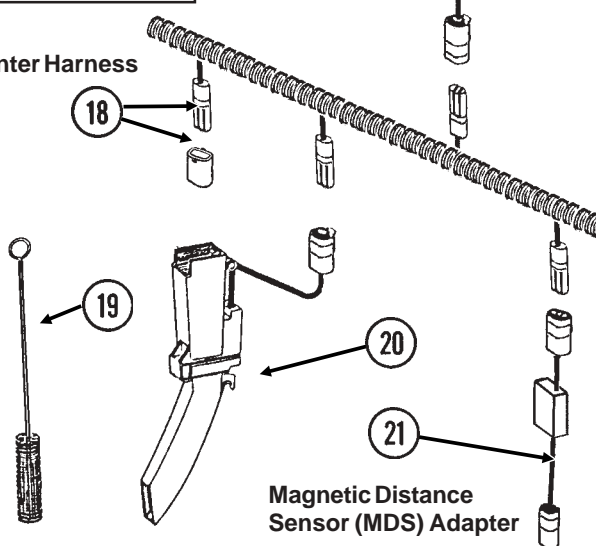

KPM I/KPM II ELECTRONIC SEED MONITOR

ITEM	PART NO.	QTY.	DESCRIPTION
1.	GA7858	-	Radar Distance Sensor W/20' Cable
2.	GA8026	-	Radar Sensor Pipe/Mounting Bracket Package
3.	G1K323	-	4-Pin Connector Kit W/Female Housing, 4 Pins And Cable Clamp
4.	GA5600	1	Magnetic Distance Sensor
5.	GD8751	-	Magnetic Distance Sensor Pulse Wheel
6.	GD6291	-	Insulated Clamp, 3/8"
7.	GD8770	1	Bracket
8.	G10004	2	Hex Head Cap Screw, 3/8"-16 x 1 1/4"
	G10229	2	Lock Washer, 3/8"
	G10101	2	Hex Nut, 3/8"-16
9.	GD8771	1	Spring Wave Washer
10.	GA7856	1	Power Lead Adapter
11.	G1K267	-	Power Lead Adapter Connector Kit, Includes: (1) Cable Clamp, (1) 3-Pin Connector, (3) Male Terminal Pins
12.	G1K268	-	Console Cable Connector Kit, Includes: (1) Cable Clamp, (1) 3-Pin Connector, (1) Lock Ring, (3) Female Terminal Pins
13.	GA8680	1	KPM I Backlit Console W/Mounting Bracket, Power Lead Adapter (Item 10), Brush (Item 19) And Dust Plug (Item 27)
	GR1390	-	Mounting Bracket, KPM I
	GR1392	-	Console Mounting Bracket Hardware Package (Includes 2 Knobs And 1/4" Hardware)
14.	G1K322	-	4-Pin Connector Kit W/Male Housing, 4 Female Socket Contacts And Cable Clamp
15.	G10022	2	Hex Head Cap Screw, 1/4"-20 x 1/2"
	G10211	2	Washer, 1/4" SAE
	G10227	2	Lock Washer, 1/4"
	G10103	2	Hex Nut, 1/4"-20
16.	GA9393	-	KPM II Backlit Console W/Mounting Bracket, Power Lead Adapter (Item 10), Brush (Item 19), Dust Plug (Item 27) And Monitor/Radar Adapter, 10" (Item 34)
	GR1391	-	Mounting Bracket, KPM II
	GR1393	-	Console Mounting Bracket Hardware Package (Includes 4 Knobs And 1/4" Hardware)
17.		-	Included In Planter And Tractor Wiring Harnesses, See Items 18 And 39, Pages P78-P81
18.	GA7851	-	Planter Harness W/Dust Caps, 12 Row (16 Connectors)
	GD11993	-	Dust Cap
19.	GR0594	-	Brush
20.	GA8495	-	Seed Tube W/Computerized Sensor
	GR1395	-	Sensor Only
	GR1461	-	Seed Tube (With Holes For Computerized Sensor Installation)
	GD2117	-	Tie Strap, 14 1/2"
21.	GA7859	1	Magnetic Distance Sensor Adapter (Analog To Digital)
22.	GR0586	1	Radar Y-Cable (Used To Connect Radar Distance Sensor For Multiple Functions)
23.	GA7857	-	Splice Harness, 1'
24.	GA7853	-	Junction Y-Harness W/Dust Cap
	GD11993	-	Dust Cap
25.	GA7854	-	Extension Harness W/Dust Cap, 15'
	GA7855	-	Extension Harness W/Dust Cap, 30'
	GD11993	-	Dust Cap
26.	G1K249	-	Acre Counter Switch Kit
27.	GA8046	-	Dust Plug (Black)
28.	GA8047	-	Dust Plug (Black)
29.	G1K321	-	2-Pin Female Connector Kit (Black), Includes: (3) 2-Pin Female Housings, (6) Pin Contacts, (6) Seals
30.	G1K320	-	2-Pin Male Connector Kit (Black), Includes: (3) 2-Pin Male Housings, (6) Socket Contacts, (6) Seals
31.	G1K248	-	3-Pin Female Connector Kit (Black), Includes: (3) 3-Pin Female Housings, (9) Pin Contacts, (9) Seals
32.	G1K252	-	3-Pin Male Connector Kit (Black), Includes: (3) 3-Pin Male Housings, (9) Socket Contacts, (9) Seals
33.	GD11089	-	Sealing Plug
34.	GA9144	-	Monitor/Radar Adapter, 10"
A.	GA6147	-	Magnetic Distance Sensor And Mounting Package (Items 4-9)

INTERPLANT® DRIVELINE

PTD073(TWL167a)

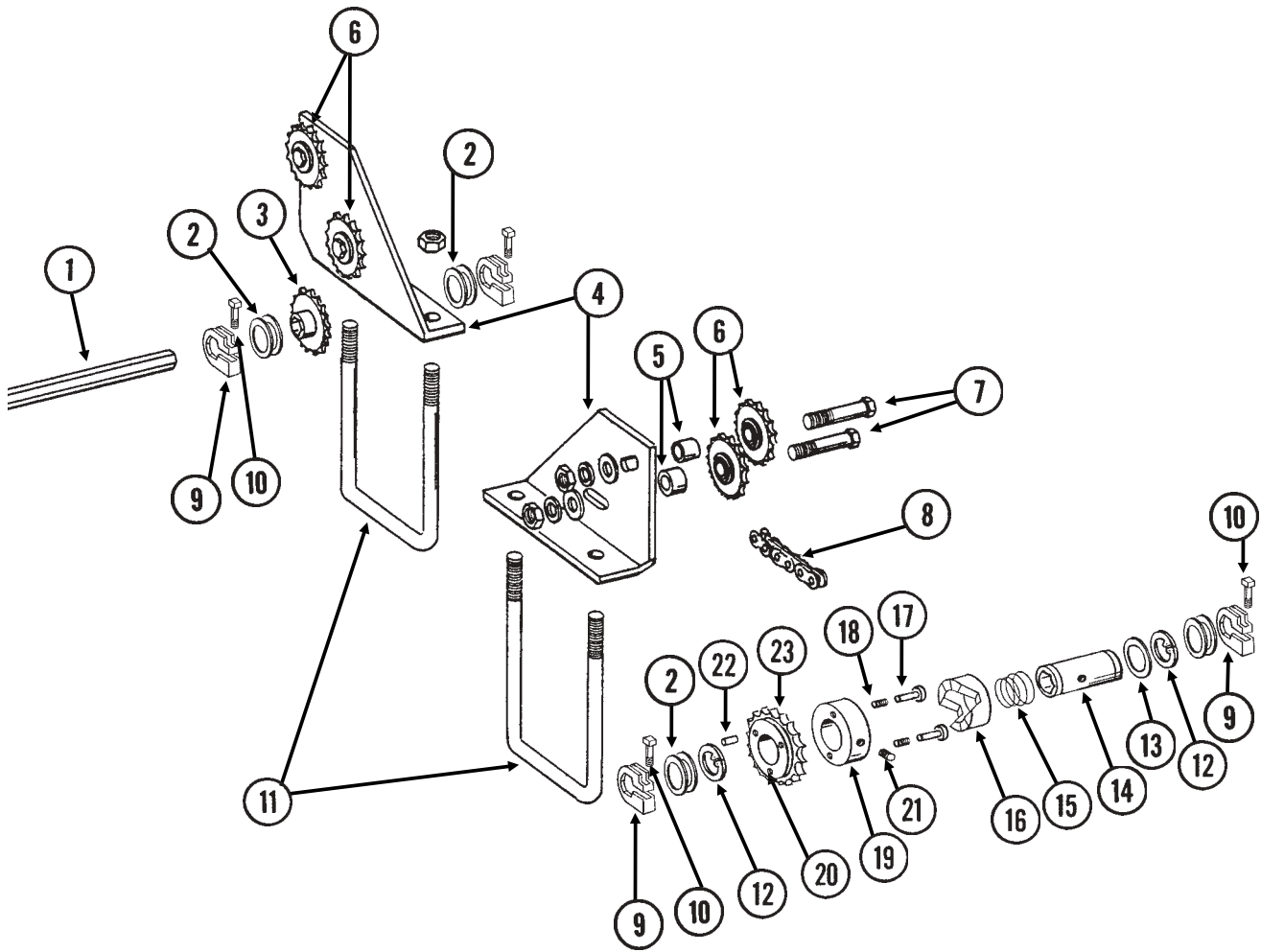

INTERPLANT® DRIVELINE

ITEM	PART NO.	QTY.	DESCRIPTION
1.	GD0914-225	-	Hex Shaft, 7/8" x 225" (No Holes)
2.	G10233	-	Machine Bushing, 1", 10 Gauge (As Required)
3.	GA5107	2	Sprocket, 19 Tooth
4.	GD11569	2	Mount
5.	GD9229	4	Spacer, 1 1/4" O.D. x 1/2" Long
6.	GA7154	-	Sprocket W/Bearing, 18 Tooth
7.	G10581	4	Hex Head Cap Screw, 1/2"-13 x 2 1/4"
	G10216	20	Washer, 1/2" USS
	G10228	4	Lock Washer, 1/2"
	G10102	4	Hex Nut, 1/2"-13
8.	G3310-328	1	Chain, No. 40, 328 Pitch Including Connector Link
	GR0912	-	Connector Link, No. 40
9.	GD11045	6	Lock Clamp
10.	G10130	6	Square Head Machine Bolt, 5/16"-18 x 1 3/4"
	G10923	6	Flange Nut, 5/16"-18, No Serration
11.	GD8306	2	U-Bolt, 7" x 5" x 1/2"-13
	G10228	4	Lock Washer, 1/2"
	G10102	-	Hex Nut, 1/2"-13
12.	G10496	2	External Inverted Snap Ring, 1 1/2"
13.	GR1411	1	Shim
14.	GR1407	1	Drive Shaft
15.	GR1408	1	Compression Spring
16.	GR1409	1	Knurled Collar
17.	GR1410	1	Pin
18.	GR1413	1	Spring
19.	GR1405	1	Lock Collar
20.	GR1406	1	Bushing
21.	G10535	1	Hex Socket Set Screw, 3/8"-16 x 3/4"
22.	G10968	1	Spring Pin, 5/32" x 7/16"
23.	GR1412	1	Sprocket, 19 Tooth
A.	GA8092	-	Clutch Sprocket Assembly, 19 Tooth (Items 12-23)
B.	G1K269	-	Lock Clamp Kit (Items 9 And 10)
C.	G1K331	-	Clutch Sprocket Kit (Items 20, 22 And 23)

DOUBLE DISC FERTILIZER OPENER AND MOUNT

(FRTZ175c/FRTZ168a/FRTZ208)

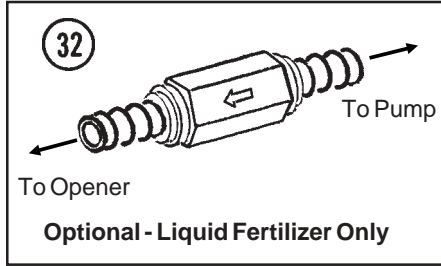
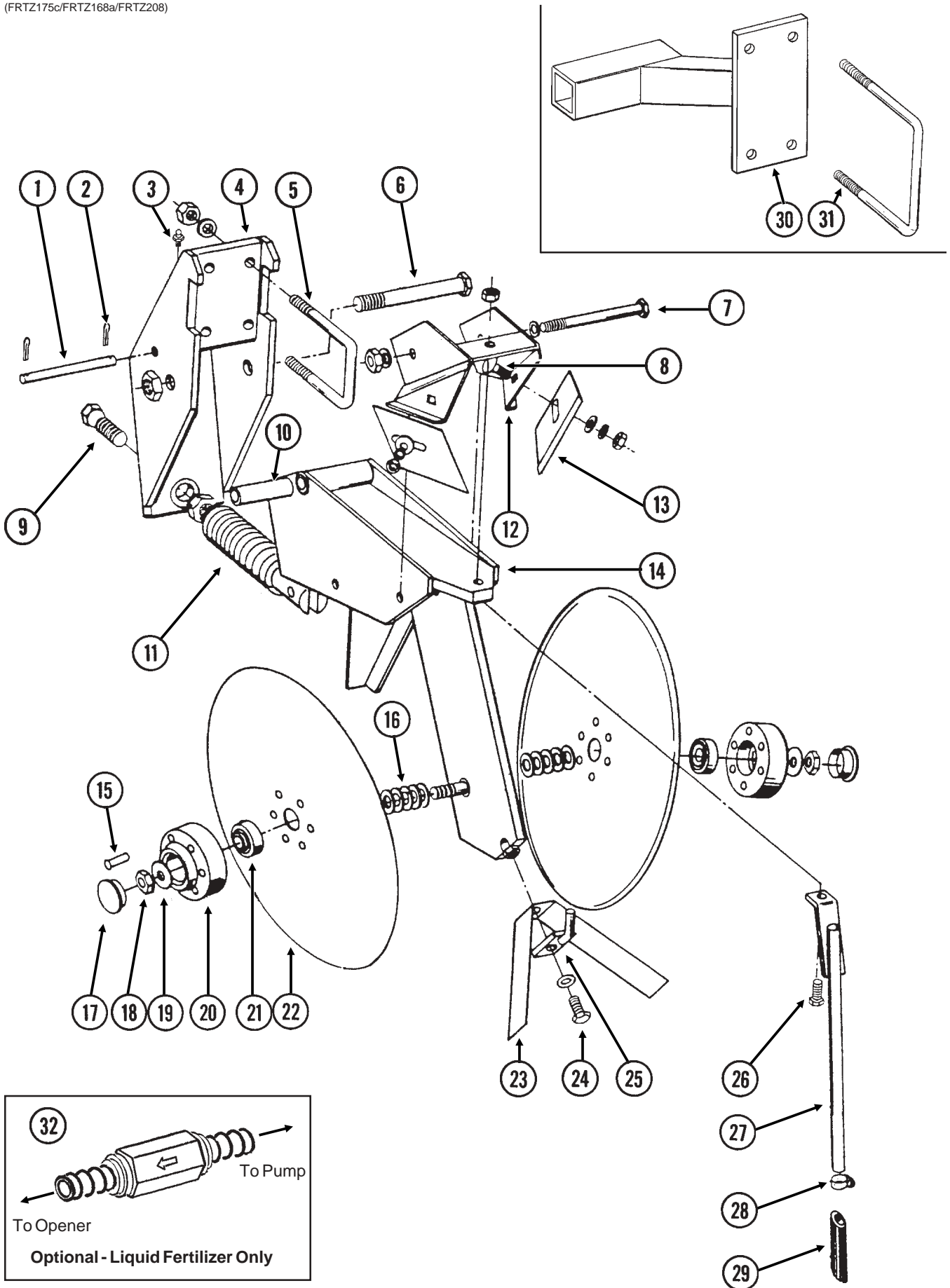

DOUBLE DISC FERTILIZER OPENER AND MOUNT

ITEM	PART NO.	QTY.	DESCRIPTION
		(Per Assy.)	
1.	GD1657	1	Lockup Pin
2.	G10451	2	Cotter Pin, 1/8" x 1"
3.	G10938	1	Grease Fitting, 1/4"-28, Taper Thread
4.	GA8483	1	Bracket
5.	GD1138	2	U-Bolt, 2 1/2" x 2 1/2" x 1/2"-13
	G10228	4	Lock Washer, 1/2"
	G10102	4	Hex Nut, 1/2"-13
6.	G10046	1	Hex Head Cap Screw, 5/8"-11 x 5"
	G10107	1	Lock Nut, 5/8"-11
7.	G10045	1	Hex Head Cap Screw, 1/2"-13 x 4 1/2"
	G10111	1	Lock Nut, 1/2"-13
8.	G10305	2	Carriage Bolt, 3/8"-16 x 1"
	G10210	2	Washer, 3/8" USS
	G10229	2	Lock Washer, 3/8"
	G10101	2	Hex Nut, 3/8"-16
9.	GD0962	1	Hex Head Adjusting Bolt, 5/8"-18 x 3 1/4"
	G10499	1	Hex Jam Nut, 5/8"-18, Grade 2
10.	GD0487	1	Bushing, 41/64" I.D. x 3 1/2" Long
11.	GA0328	1	Spring
12.	GA0810	1	Scraper Mount
13.	GD1673	2	Scraper
14.	GA9195	1	Shank
15.	G10542	12	Rivet, 1/4" x 1 5/16"
16.	G10213	-	Machine Bushing, 5/8" (.030" Thick)
17.	GD1132	2	Dust Cap
18.	G10503	1	Hex Jam Nut, 5/8"-11, Grade 2
	G10504	1	Hex Jam Nut, 5/8"-11, L.H. Thread, Grade 2
19.	G10204	2	Special Machine Bushing, 5/8" x 1" O.D.
20.	GB0134	2	Hub
21.	GA2014	2	Bearing
22.	GD11306	2	Disc Blade, 3.5mm x 15"
23.	GD2589	1	Inner Scraper
24.	G10019	1	Hex Head Cap Screw, 5/16"-18 x 1"
	G10232	1	Lock Washer, 5/16"
25.	GA0312	1	Mount
26.	G10133	1	Hex Head Cap Screw, 5/16"-18 x 1 1/2"
	G10221	-	Washer, 5/16" SAE
	G10109	1	Lock Nut, 5/16"-18
27.	GA8685	-	Drop Tube, Liquid Fertilizer
28.	G10681	-	Hose Clamp, No. 6
29.	GD11705	-	Extension
30.	GA8081	-	Opener Mount, L.H. (Shown)
	GA8080	-	Opener Mount, R.H.
31.	GD1113	2	U-Bolt, 5" x 7" x 5/8"-11
	G10230	4	Lock Washer, 5/8"
	G10104	4	Hex Nut, 5/8"-11
32.	GA8983	-	Check Valve, Low Rate
A.	GA8845	-	Disc Blade And Bearing Assembly (Items 15 And 20-22)

NOTCHED SINGLE DISC FERTILIZER OPENER AND MOUNT

(PT67/FRTZ168a/FRTZ208)

STYLE A

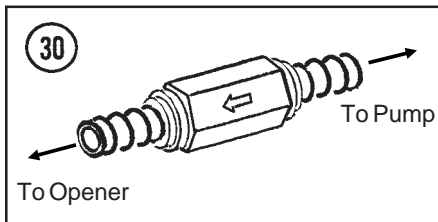
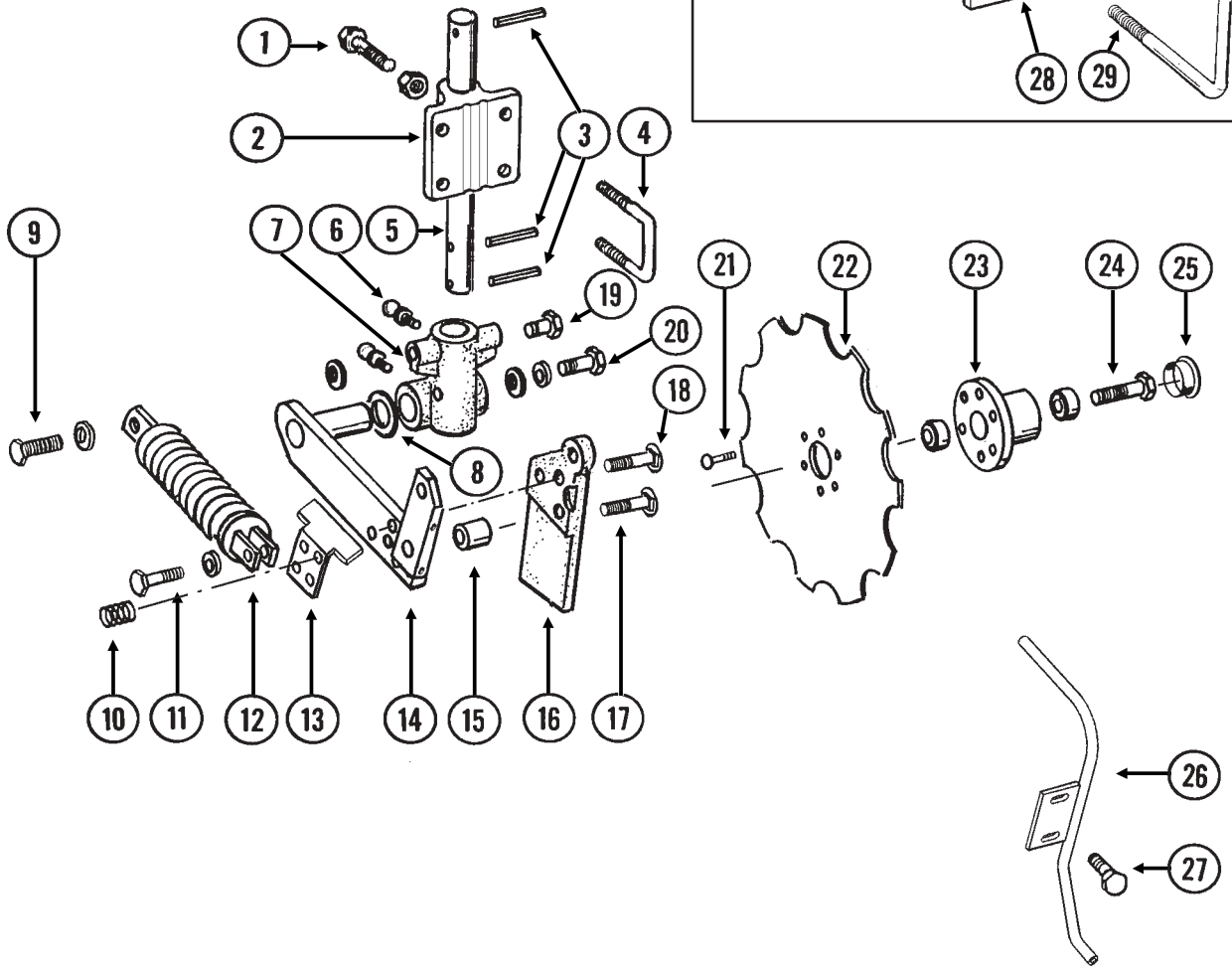

NOTCHED SINGLE DISC FERTILIZER OPENER AND MOUNT

ITEM	PART NO.	QTY.	DESCRIPTION
		(Per Assy.)	
1.	G10014	2	Hex Head Cap Screw, 1/2"-13 x 1"
	G10102	2	Hex Nut, 1/2"-13
2.	GB0270	1	Mount
3.	G10476	3	Spring Pin, 3/8" x 2 1/4"
4.	GD1138	2	U-Bolt, 2 1/2" x 2 1/2" x 1/2"-13
	G10228	4	Lock Washer, 1/2"
	G10102	4	Hex Nut, 1/2"-13
5.	GD9908	1	Shaft, 1 1/2" x 14"
6.	G10641	2	Grease Fitting, 1/8" NPT
7.	GB0250	1	Pivot
8.	G10450	2	Machine Bushing, 1 1/2", 18 Gauge
9.	GD7818	1	Special Bolt
	GD7805	2	Special Washer, 5/8", Hardened
10.	GD11106	1	Spring
11.	G10047	1	Hex Head Cap Screw, 3/8"-16 x 1 3/4"
	G10210	1	Washer, 3/8" USS
	GD1026	1	Sleeve, 1 3/16" Long
	G10108	1	Lock Nut, 3/8"-16
12.	GA6966	1	Compression Spring Assembly
13.	GD11097	1	Shield
14.	GA8007	1	Pivot Arm, L.H. (Shown)
	GA8008	-	Pivot Arm, R.H.
15.	GD7817-05	1	Spacer, 1 1/16" I.D. x 1 1/4" Long
16.	GB0249	1	Knife/Scraper, L.H. (Shown)
	GB0248	-	Knife/Scraper, R.H.
17.	G10306	2	Carriage Bolt, 3/8"-16 x 2"
	G10108	2	Lock Nut, 3/8"-16
18.	G10898	1	Carriage Bolt, 3/8"-16 x 2 3/4"
	G10210	1	Washer, 3/8" USS
	G10108	1	Lock Nut, 3/8"-16
19.	G10438	1	Hex Head Cap Screw, 1/2"-13 x 3/4"
20.	G10007	1	Hex Head Cap Screw, 5/8"-11 x 1 1/2"
	G10230	1	Lock Washer, 5/8"
	G10217	1	Washer, 5/8" USS
21.	G10886	6	Truss Head Bolt, 5/16"-18 x 1"
	G10106	6	Hex Nut, 5/16"-18
22.	GD9934	1	Disc Blade, Notched, 16 3/4"
23.	GA5654	1	Hub W/Bearings
	GA2014	-	Bearing
24.	G10013	1	Hex Head Cap Screw, 5/8"-11 x 3 1/2"
25.	GD1132	1	Dust Cap
26.	GA8398	1	Drop Tube, R.H., Liquid Fertilizer
	GA8399	-	Drop Tube, L.H., Liquid Fertilizer
27.	G10043	2	Hex Head Cap Screw, 5/16"-18 x 3/4"
	G10232	2	Lock Washer, 5/16"
	G10219	2	Washer, 5/16" USS
28.	GA8081	-	Opener Mount, L.H. (Shown)
	GA8080	-	Opener Mount, R.H.
29.	GD1113	2	U-Bolt, 5" x 7" x 5/8"-11
	G10230	4	Lock Washer, 5/8"
	G10104	4	Hex Nut, 5/8"-11
30.	GA8983	-	Check Valve, Low Rate

NOTCHED SINGLE DISC FERTILIZER OPENER AND MOUNT

FOC018(FRTZ209/FRTZ208/EF71c)

STYLE B

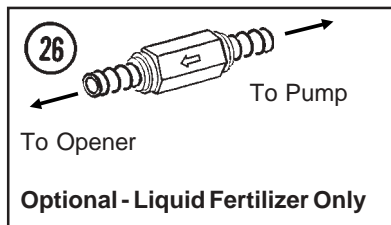
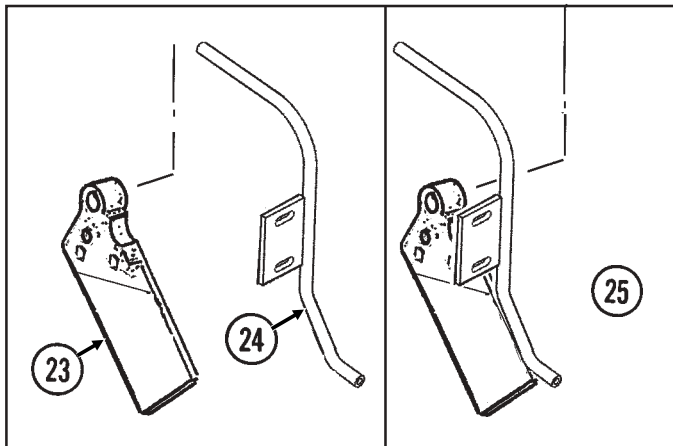
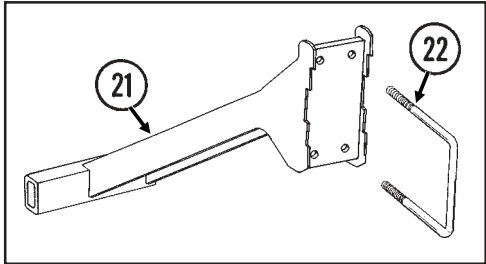
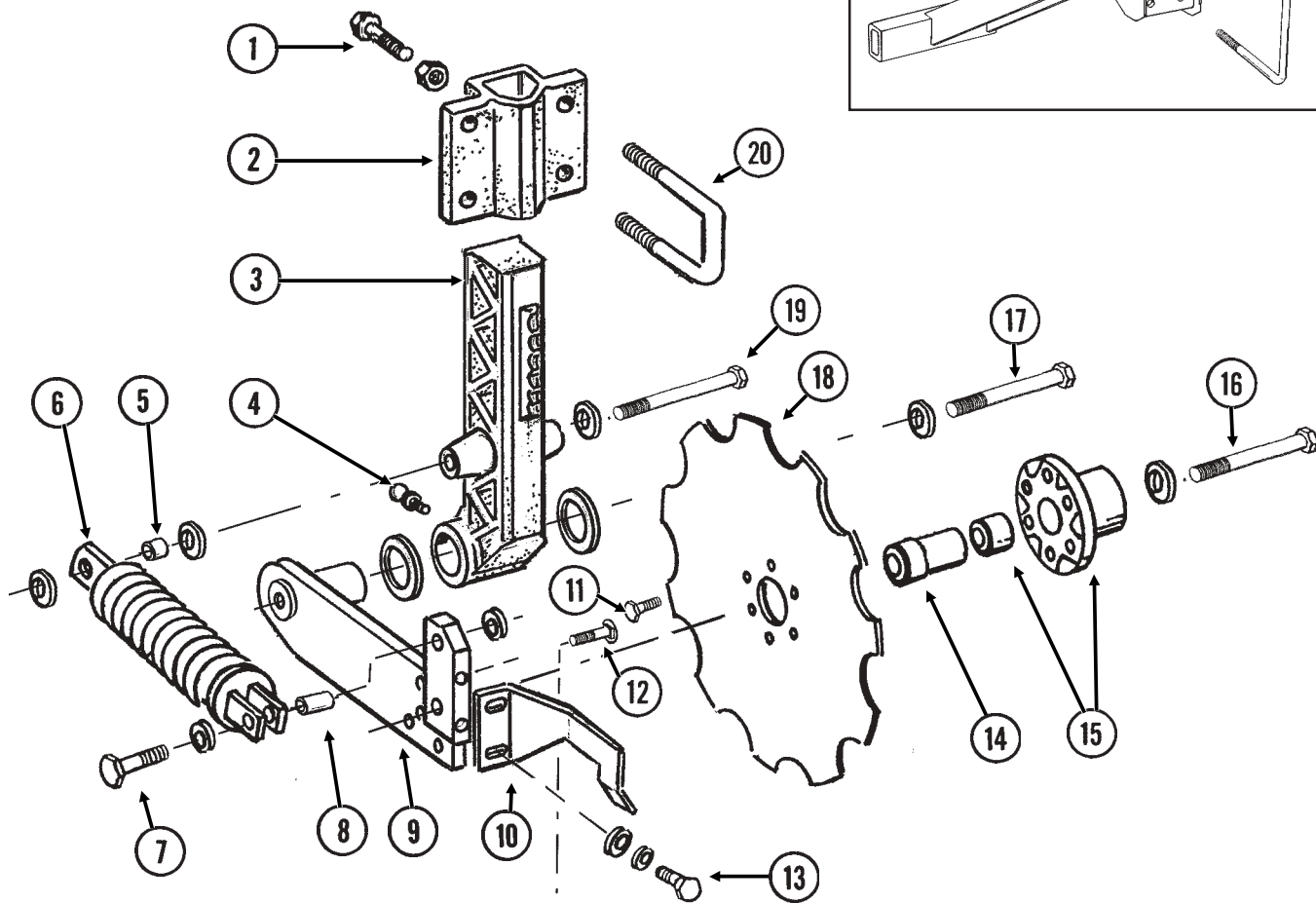

NOTCHED SINGLE DISC FERTILIZER OPENER AND MOUNT

ITEM	PART NO.	QTY.	DESCRIPTION
		(Per Assy.)	
1.	G10017	3	Hex Head Cap Screw, 1/2"-13 x 1 1/2"
	G10102	3	Hex Nut, 1/2"-13
2.	GB0297	1	Mount
3.	GB0296	1	Arm, 13 1/2"
4.	G10640	1	Grease Fitting, 1/4"-28
5.	GD12685	1	Bushing, 3/4" O.D. x 1/2" Long
6.	GA6966	1	Compression Spring Assembly
7.	G10047	1	Hex Head Cap Screw, 3/8"-16 x 1 3/4"
	G10210	2	Washer, 3/8" USS
	G10108	1	Lock Nut, 3/8"-16
8.	GD1026	1	Sleeve, 1 3/16" Long
9.	GA9433	1	Pivot Arm, L.H. (Shown)
	GA9434	-	Pivot Arm, R.H.
10.	GD11557	1	Scraper, L.H. (Shown)
	GD11558	-	Scraper, R.H.
11.	G10002	6	Hex Head Cap Screw, 3/8"-16 x 3/4"
12.	G10306	3	Carriage Bolt, 3/8"-16 x 2"
	G10108	3	Lock Nut, 3/8"-16
13.	G10991	2	Hex Head Cap Screw, 5/16"-18 x 7/8"
	G10232	2	Lock Washer, 5/16"
	G10219	6	Washer, 5/16" USS
14.	GD12679	1	Stepped Spacer, 3" Long
15.	GA9437	1	Hub W/Bearing
	GA8603	-	Double Row Bearing
16.	G10011	1	Hex Head Cap Screw, 5/8"-11 x 5 1/2"
	GD12677	1	Washer, 1 1/2" O.D., 7 Gauge, Hardened
	G10107	1	Lock Nut, 5/8"-11
17.	G10046	1	Hex Head Cap Screw, 5/8"-11 x 5"
	G10217	1	Washer, 5/8" USS
	G10450	2	Machine Bushing, 1 1/2", 18 Gauge (As Required)
	G10107	1	Lock Nut, 5/8"-11
18.	GD12676	1	Disc Blade, Notched, 16 3/4"
19.	G10871	1	Hex Head Cap Screw, 1/2"-13 x 6"
	G10206	3	Washer, 1/2" SAE
	G10111	1	Lock Nut, 1/2"-13
20.	GD13287	2	U-Bolt, 1 1/2" x 2 1/2" x 1/2"-13
	G10228	4	Lock Washer, 1/2"
	G10102	4	Hex Nut, 1/2"-13
21.	GA9457	-	Opener Mount, L.H. (Shown)
	GA9456	-	Opener Mount, R.H.
22.	GD1113	-	U-Bolt, 5" x 7" x 5/8"-11
	G10230	-	Lock Washer, 5/8"
	G10104	-	Hex Nut, 5/8"-11
23.	GB0249	1	Knife, L.H. (Shown)
	GB0248	-	Knife, R.H.
24.	GA8399	-	Drop Tube, L.H., Liquid Fertilizer (Shown)
	GA8398	1	Drop Tube, R.H., Liquid Fertilizer
25.	GA9461	1	Knife/Drop Tube, L.H., Liquid Fertilizer (Shown)
	GA9462	1	Knife/Drop Tube, R.H., Liquid Fertilizer
			(Sub GA8399 And GB0249)
			(Sub GA8398 And GB0248)
26.	GA8983	-	Check Valve, Low Rate

LIQUID FERTILIZER TANKS, SADDLES, SADDLE MOUNTS AND HOSES

LFC037/LFC038(FRTZ196)

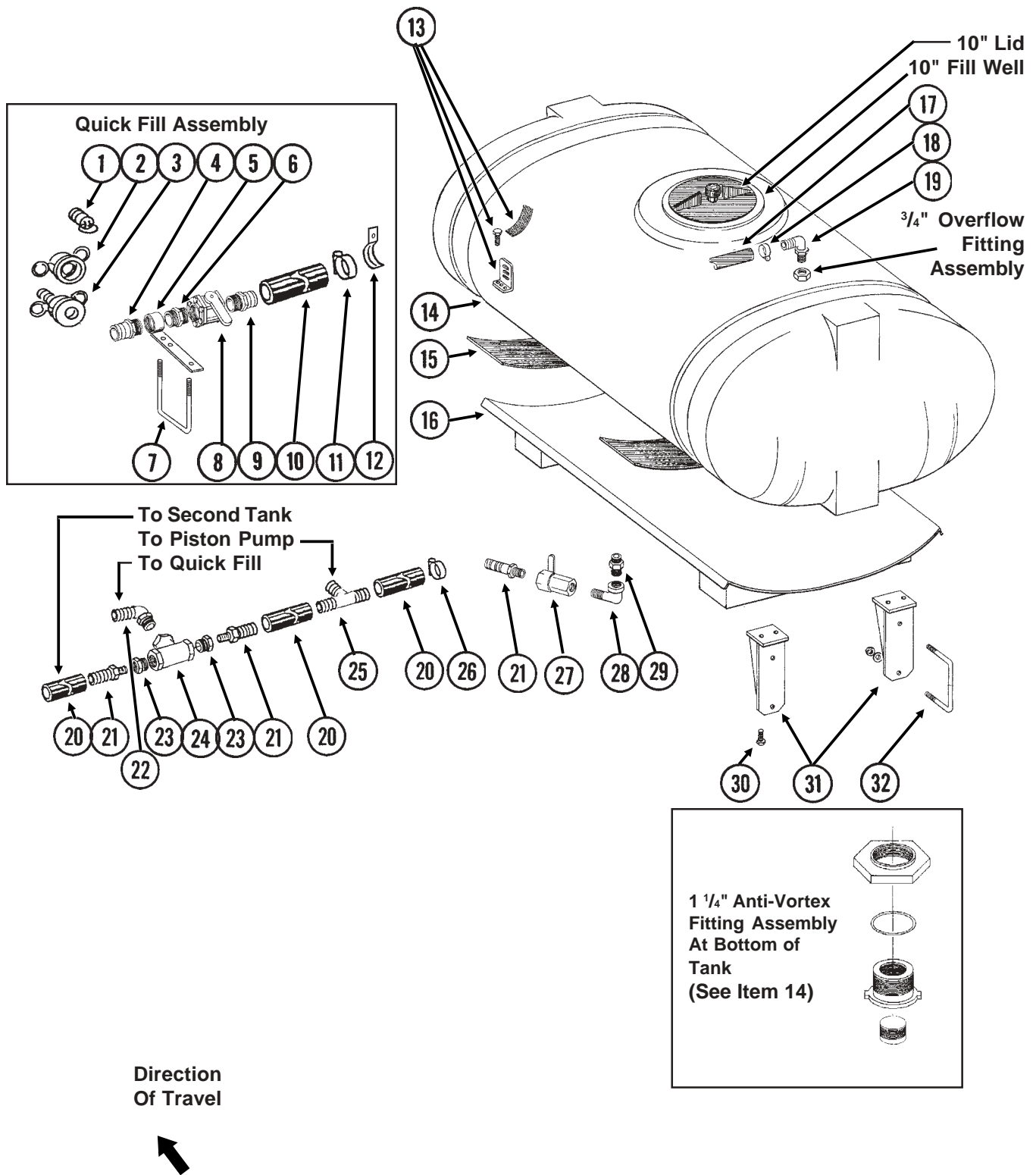

LIQUID FERTILIZER TANKS, SADDLES, SADDLE MOUNTS AND HOSES

ITEM	PART NO.	QTY.	DESCRIPTION
1.	GD10777	1	Dust Plug, 2" Male Cam Lock
2.	GD3622	1	Adapter, 2" Female NPT To Cam Lock
3.	GD3951	1	Dust Cap, 2" Cam Lock
4.	GD3623	1	Adapter, 2" Male NPT To Cam Lock
5.	GA8082	1	Quick Fill Mount, 2" NPT
6.	G10623	1	Close Nipple, 2" NPT
7.	GD1134	1	U-Bolt, 7" x 5" x 5/8"-11
	G10230	2	Lock Washer, 5/8"
	G10104	2	Hex Nut, 5/8"-11
8.	GA2660	1	Shutoff Valve, 2" NPT
9.	G10628	1	Adapter, 2" NPT To Barb
10.	G4201-04	1	Hose, 2" x 15'
11.	G10676	2	Hose Clamp, No. 36
12.	GD11235	1	Hose Clamp, 2" (If Applicable)
13.	GA8114	2	Tank Mounting Hardware Package, Includes: (2) Straps, (4) Anchors, (8) G10485, (8) G10901
	G10485	-	Hex Head Tap Bolt, 3/8"-16 x 5"
	G10901	-	Lock Nut, 3/8"-16
14.	GA8085	2	Tank W/Lid And Fittings, 200 Gallon
	GR1005	-	Fillwell, 10", Threaded (Top Of Tank)
	GR1006	-	Lid, 10", Threaded (Top Of Tank)
	GR0513	-	3/4" Polypropylene Fitting Assembly (Nut, Bushing And O-Ring) (Top Of Tank)
	GR1435	-	1 1/4" Anti-Vortex Fitting Assembly (Nut, Bushing And O-Ring) (Bottom Of Tank)
15.	GD1862	-	Pad, 8" x 14'
16.	GA8088	2	Tank Saddle
17.	G4205-11	-	Hose, 3/4" x 72" (One Per Tank)
18.	G10278	4	Hose Clamp, No. 16
19.	G10917	2	Elbow, 90°, 3/4" NPT To Barb
20.	G4200-01	1	Hose, 1 1/4" x 22'
21.	G10626	4	Adapter, 1 1/4" NPT To Barb
22.	G10630	1	Elbow, 90°, 2" NPT To Barb
23.	G10616	2	Reducing Bushing, 2" Male NPT To 1 1/4" Female
24.	G10888	1	Tee, 2" Female NPT
25.	G10633	1	Tee, 1 1/4" Barb
26.	G10674	10	Hose Clamp, No. 24
27.	GA4976	2	Shutoff Valve, 1 1/4" NPT
	GR1015	-	Body O-Ring
	GR1016	-	Stem O-Ring
	GR1017	-	Teflon Seal
	GR1018	-	Ball
	GR1019	-	Handle
28.	G10887	2	Elbow, 90°, 1 1/4" Male NPT To Female
29.	G10619	2	Close Nipple, 1 1/4" NPT
30.	G10017	16	Hex Head Cap Screw, 1/2"-13 x 1 1/2"
	G10216	32	Washer, 1/2" USS
	G10228	16	Lock Washer, 1/2"
	G10102	16	Hex Nut, 1/2"-13
31.	GA8438	8	Saddle Mount
32.	GD1113	8	U-Bolt, 5" x 7" x 5/8"-11
	G10230	16	Lock Washer, 5/8"
	G10104	16	Hex Nut, 5/8"-11

LIQUID FERTILIZER PISTON PUMP DRIVE

LFC028(TWL43j)

40 Tooth Drive Sprocket And 18 Tooth Driven Sprocket

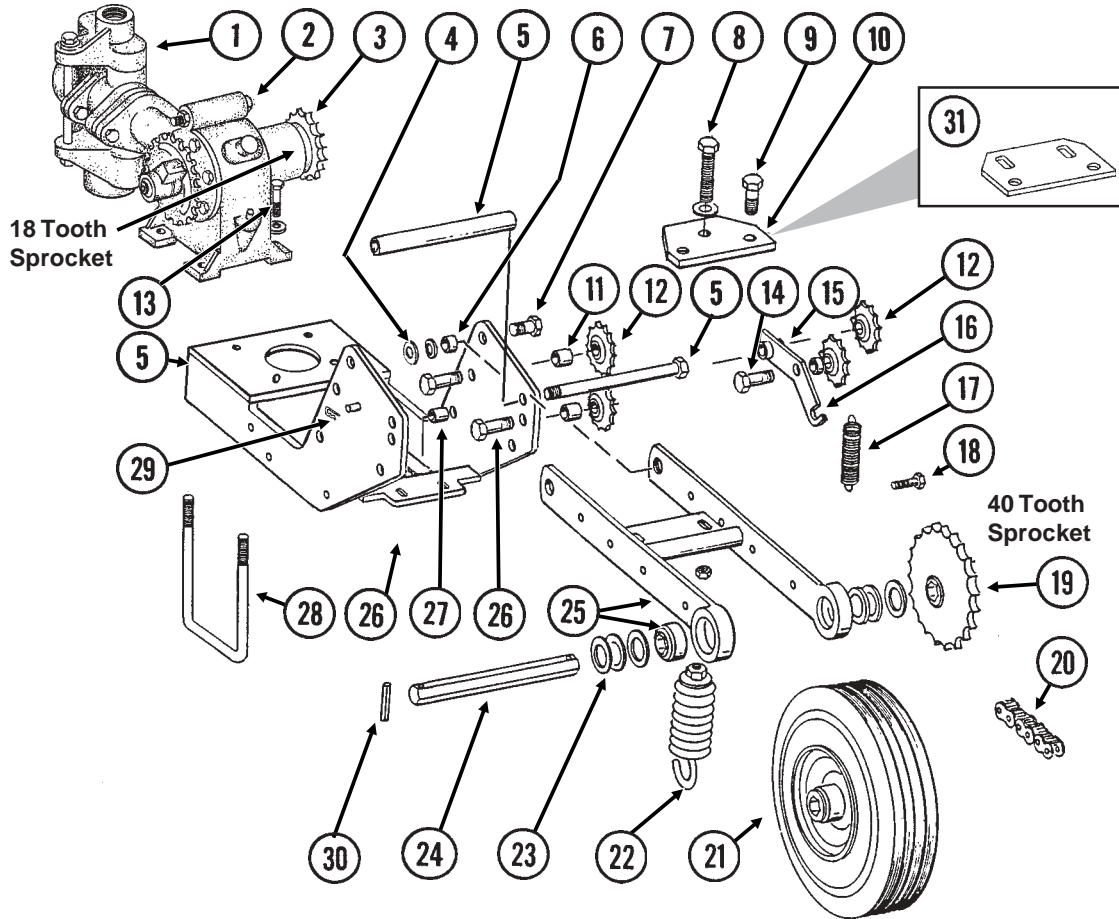

ITEM	PART NO.	QTY.	DESCRIPTION
1.		-	See "Liquid Fertilizer Piston Pump (Cylinder Assembly)", Pages P100 And P101
2.		-	See "Liquid Fertilizer Piston Pump (Crankcase Assembly)", Pages P98 And P99
3.		-	Sprocket, 18 Tooth, See "Liquid Fertilizer Piston Pump (Crankcase Assembly)", Pages P98 And P99
4.	GD7805	2	Special Washer, $\frac{5}{8}$ ", Hardened
5.	GA8486	1	Pump Mount W/Sleeve And Sleeve Mounting Hardware
	GD10165	1	Sleeve, $6 \frac{3}{4}$ "
	G10819	1	Hex Head Cap Screw, $\frac{1}{2}$ "-13 x $8 \frac{1}{2}$ "
	G10228	1	Lock Washer, $\frac{1}{2}$ "
	G10102	1	Hex Nut, $\frac{1}{2}$ "-13
6.	GB0218	2	Bushing, $\frac{21}{32}$ " I.D. x $\frac{7}{8}$ " O.D. x $\frac{19}{32}$ " Long

LIQUID FERTILIZER PISTON PUMP DRIVE

ITEM	PART NO.	QTY.	DESCRIPTION
7.	G10005	2	Hex Head Cap Screw, 5/8"-11 x 1 3/4"
	G10235	2	Machine Bushing, 7/8", 14 Gauge
	G10107	2	Lock Nut, 5/8"-11
8.	G10371	1-2	Hex Head Cap Screw, 1/2"-13 x 3", Full Thread
	G10206	1-2	Washer, 1/2" SAE
	G10102	1-2	Hex Nut, 1/2"-13
9.	G10039	2	Hex Head Cap Screw, 1/2"-13 x 1 3/4"
	G10206	2	Washer, 1/2" SAE
	G10228	2	Lock Washer, 1/2"
	G10102	2	Hex Nut, 1/2"-13
10.	GD10156	1	Spring Mount
11.	GD10007	2	Spacer, 1 1/8"
12.	GA7154	4	Sprocket W/Bearing, 18 Tooth
13.	G10003	4	Hex Head Cap Screw, 3/8"-16 x 1 1/2"
	GR1122	4	Mounting Pad
	G10210	4	Washer, 3/8" USS
	G10229	4	Lock Washer, 3/8"
	G10101	4	Hex Nut, 3/8"-16
	14.	G10016	1
G10228		1	Lock Washer, 1/2"
G10102		1	Hex Nut, 1/2"-13
15.	GD10161	1	Spacer, 3/8"
16.	GA7179	1	Idler Arm
17.	GD5857	1	Spring
18.	G10003	1	Hex Head Cap Screw, 3/8"-16 x 1 1/2"
	G10229	1	Lock Washer, 3/8"
	G10101	2	Hex Nut, 3/8"-16
19.	GA7180	1	Sprocket, 40 Tooth
20.	G3310-160	1	Chain, No. 40, 160 Pitch Including Connector Link
	GR0912	-	Connector Link, No. 40
21.	GA5090	1	Tire And Rim Assembly (Specify Brand*)
	GD5753	-	Tire, 4.10" x 6" (Specify Brand*)
	GD5752	-	Tube
22.	GA2068	1-2	Spring W/Plug
23.	G10233	5	Machine Bushing, 1", 10 Gauge
24.	GD5797	1	Hex Shaft, 7/8" x 10"
25.	GA6415	1	Wheel Arm W/Bearings
	GA5116	-	Bearing, 7/8" Hex Bore, Cylindrical
26.	G10038	3	Hex Head Cap Screw, 1/2"-13 x 3"
	G10228	3	Lock Washer, 1/2"
	G10102	3	Hex Nut, 1/2"-13
27.	GD7904-04	-	Sleeve, 1/2" x 1 1/8" Long
28.	GD1134	2	U-Bolt, 7" x 5" x 5/8"-11
	G10217	4	Washer, 5/8" USS
	G10230	4	Lock Washer, 5/8"
	G10104	4	Hex Nut, 5/8"-11
29.	G10670	1	Hair Pin Clip, No. 3
30.	G10602	2	Spring Pin, 1/4" x 1 1/2"
31.	GD13268	-	Spring Mount

* Specific brand requests will be supplied only as available from current KINZE® stock. If a specific brand requested is not in stock, the brand available will be supplied. Different brand tires may have different diameters. Change in tire brand could result in rate changes.

LIQUID FERTILIZER FLOW DIVIDER MOUNT AND HOSES

(FRTZ176c/FRTZ176i)

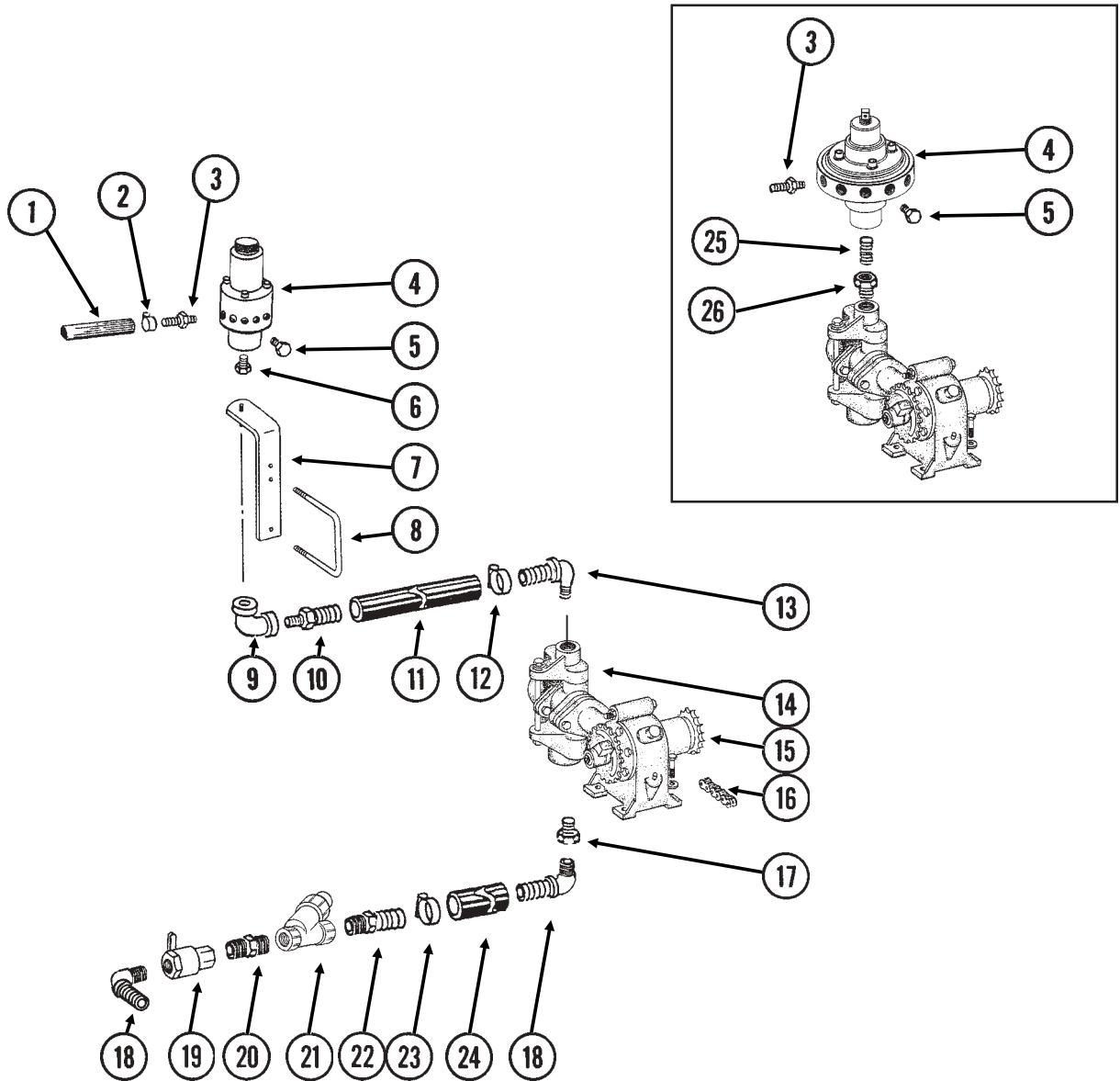

LIQUID FERTILIZER FLOW DIVIDER MOUNT AND HOSES

ITEM	PART NO.	QTY.	DESCRIPTION
1.	G4301-06	1	Hose, 3/8" x 160'
2.	G10681	24	Hose Clamp, No. 6
3.	GD11700	12	Adapter, 1/4" NPT To 3/8" Barb
4.		-	See "Liquid Fertilizer Piston Pump Flow Divider", Pages P102 And P103
5.	G10292	-	Pipe Plug, 1/4" NPT
6.	G10613	1	Reducing Bushing, 1" Male NPT To 3/4" Female (If Applicable)
7.	GA6527	1	Support, 3/4" NPT
8.	GD1113	1	U-Bolt, 5" x 7" x 5/8"-11
	G10230	2	Lock Washer, 5/8"
	G10104	2	Hex Nut, 5/8"-11
9.	G10733	1	Elbow, 90°, 3/4" Female NPT
10.	G10734	1	Adapter, 3/4" NPT To Barb
11.	G4205-03	-	Hose, 3/4" x 97"
12.	G10278	2	Hose Clamp, No. 16
13.	G10896	1	Elbow, 90°, 1" NPT To 3/4" Barb
14.		-	See "Liquid Fertilizer Piston Pump (Cylinder Assembly)", Pages P100 And P101
15.		-	See "Liquid Fertilizer Piston Pump (Crankcase Assembly)", Pages P98 And P99
16.		-	See "Liquid Fertilizer Piston Pump Drive", Pages P94 And P95
17.	G10615	1	Reducing Bushing, 1 1/2" Male NPT To 1 1/4" Female
18.	G10629	2	Elbow, 90°, 1 1/4" NPT To Barb
19.	GA4976	2	Shutoff Valve, 1 1/4" NPT
	GR1015	-	Body O-Ring
	GR1016	-	Stem O-Ring
	GR1017	-	Teflon Seal
	GR1018	-	Ball
	GR1019	-	Handle
20.	G10619	1	Close Nipple, 1 1/4" NPT
21.	GA3893	1	Strainer Complete
	GR0880	-	Screen, No. 40 Mesh
	GR0881	-	Gasket
	GR0882	-	Y-Body
	GR0883	-	End Cap
22.	G10626	2	Adapter, 1 1/4" NPT To Barb
23.	G10674	2	Hose Clamp, No. 24
24.		-	Hose, 1 1/4", See "Liquid Fertilizer Tanks, Saddles, Saddle Mounts And Hoses", Pages P92 And P93
25.	G10994	1	Close Nipple, 3/4" NPT, Stainless Steel
26.	G10995	1	Reducing Bushing, 1" Male NPT To 3/4" Female, Stainless Steel

LIQUID FERTILIZER PISTON PUMP (Crankcase Assembly) Uses 18 Tooth Sprocket

JB-L4400-991/CCU077(FRTZ172a)

Model LM-2455-R

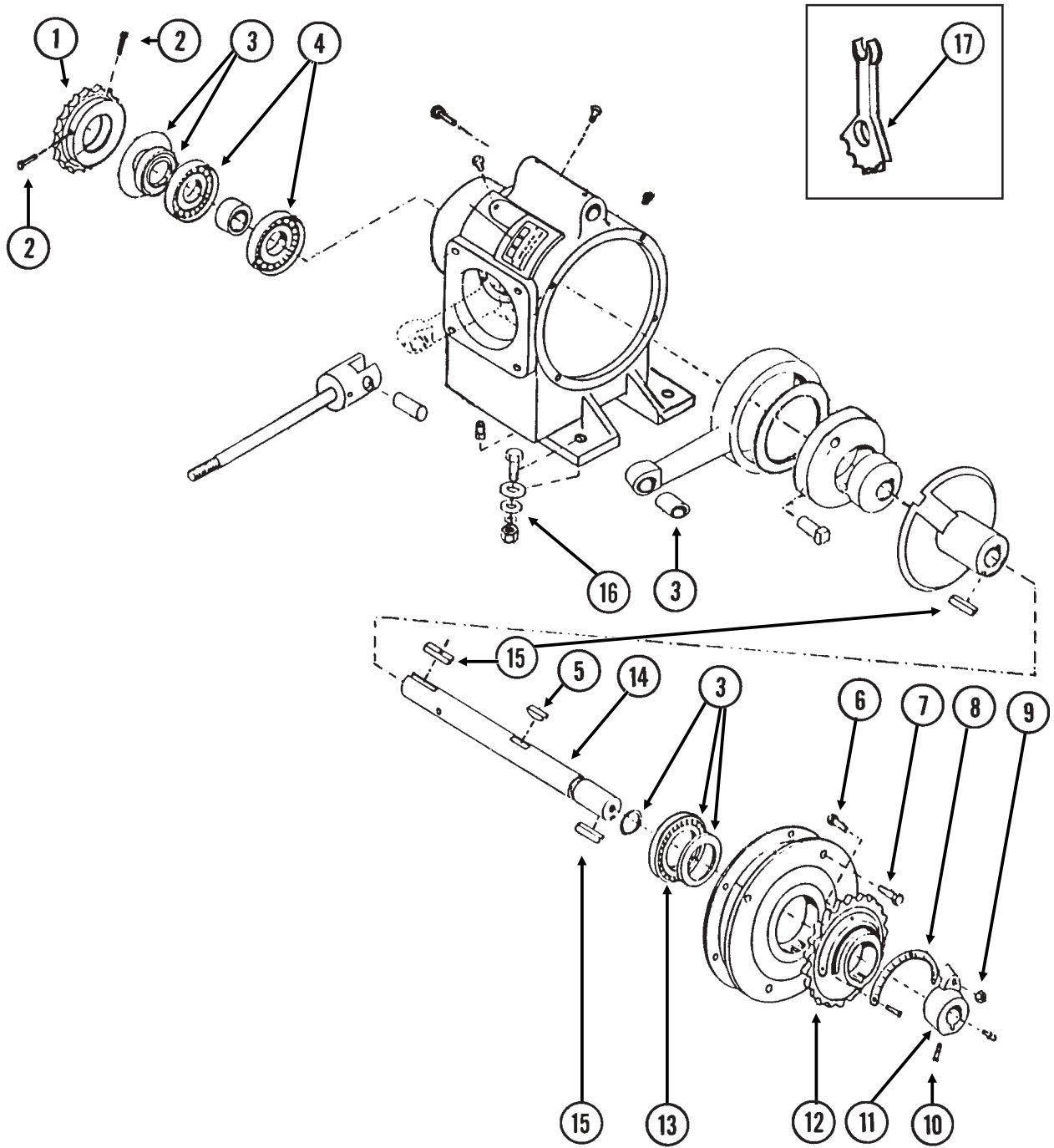

LIQUID FERTILIZER PISTON PUMP (Crankcase Assembly) Uses 18 Tooth Sprocket

ITEM	PART NO.	QTY.	DESCRIPTION
1.	GR1389	1	Sprocket, 18 Tooth
2.	G10688	2	Square Head Set Screw, $\frac{3}{8}$ "-16 x $\frac{5}{8}$ "
3.	GR1425	1	Repair Kit, Includes Item 1 On Pages P90 And P91
4.	GR1427	2	Bearing
5.	GR1420	1	Woodruff Key, $\frac{3}{8}$ "-16 x 1 $\frac{3}{4}$ "
6.	GR1167	1	Square Head Bolt, $\frac{3}{8}$ "-16 x 1 $\frac{3}{4}$ "
7.	G10043	4	Hex Head Cap Screw, $\frac{5}{16}$ "-18 x $\frac{3}{4}$ "
8.	GR1168	1	Scale
9.	G10108	1	Lock Nut, $\frac{3}{8}$ "-16
10.	G10693	3	Hex Socket Head Set Screw, $\frac{5}{16}$ "-18 x $\frac{3}{8}$ "
11.	GR1165	1	Arm
12.	GR1114	1	Flange
13.	GR1116	1	Bearing
14.	GR1421	1	Crankshaft
15.	GR1118	2	Setting Arm Key
16.		-	See "Liquid Fertilizer Piston Pump Drive", Pages P94 And P95
17.	GR1424	1	Adjustment Wrench
A.	GA8069	-	Piston Pump Complete W/18 Tooth Sprocket (LM-2455-R), Includes Crankcase Assembly On This Page And Cylinder Assembly On Pages P90 And P91

LIQUID FERTILIZER PISTON PUMP (Cylinder Assembly) Uses 18 Tooth Sprocket

JB-L2190-991(FRTZ171)

Model LM-2455-R

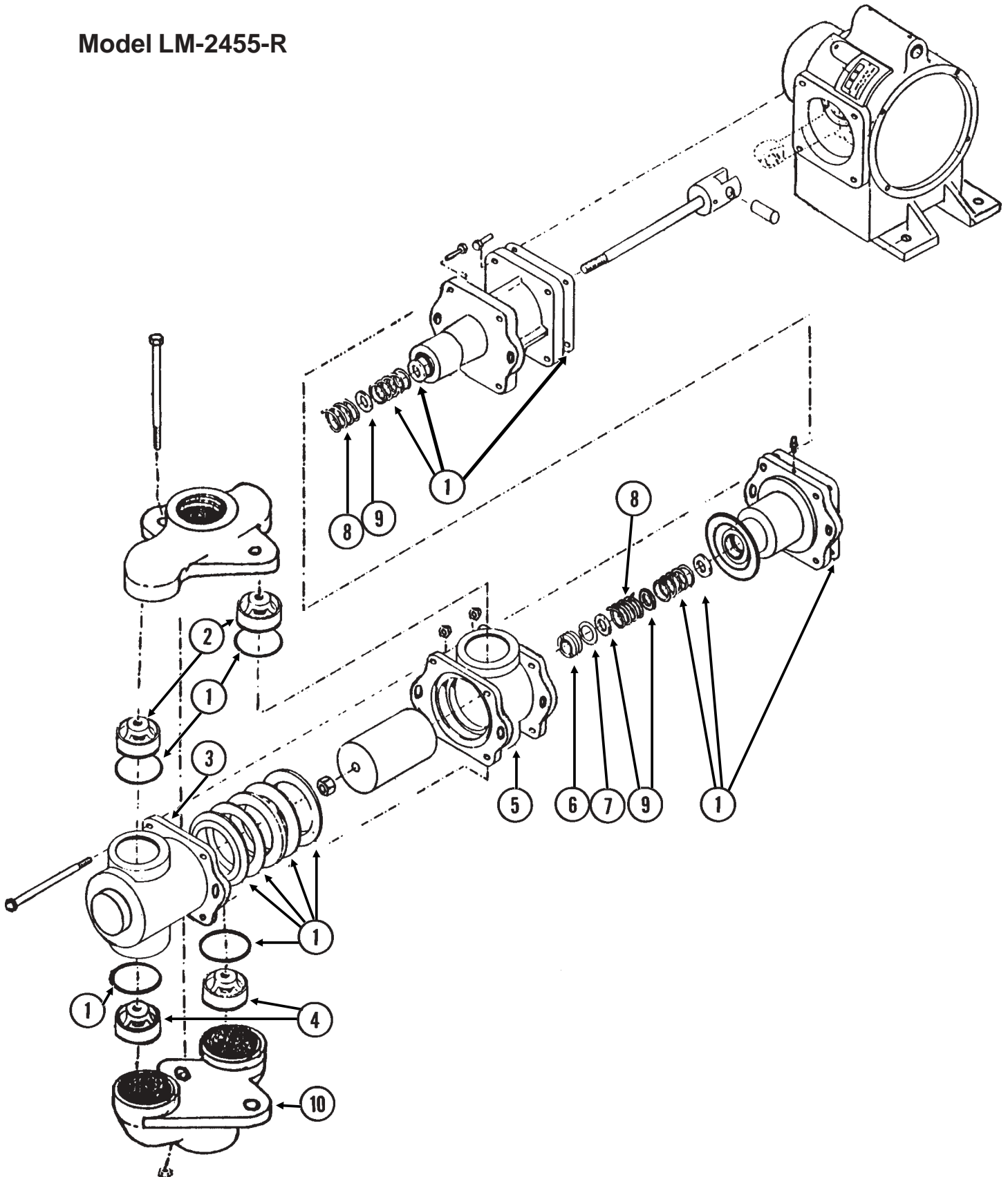

LIQUID FERTILIZER PISTON PUMP (Cylinder Assembly) Uses 18 Tooth Sprocket

ITEM	PART NO.	QTY.	DESCRIPTION
1.	GR1425	1	Repair Kit, Includes Item 3 On Pages P88 And P89
2.	GR1144	2	Discharge Valve
3.	GR1423	1	Outboard Cylinder
4.	GR1142	2	Suction Valve
5.	GR1422	1	Inboard Cylinder
6.	GR1134	1	Stuffing Box Insert
7.	GR1133	1	Retaining Ring
8.	GR1130	2	Packing Spring
9.	GR1129	3	Washer
10.	GR1451	1	Suction Manifold

LIQUID FERTILIZER PISTON PUMP FLOW DIVIDER, 16 ROW SIZE

JB-L2190-991(PT40b/FRTZ202d)

Model L-1195 Flow Divider

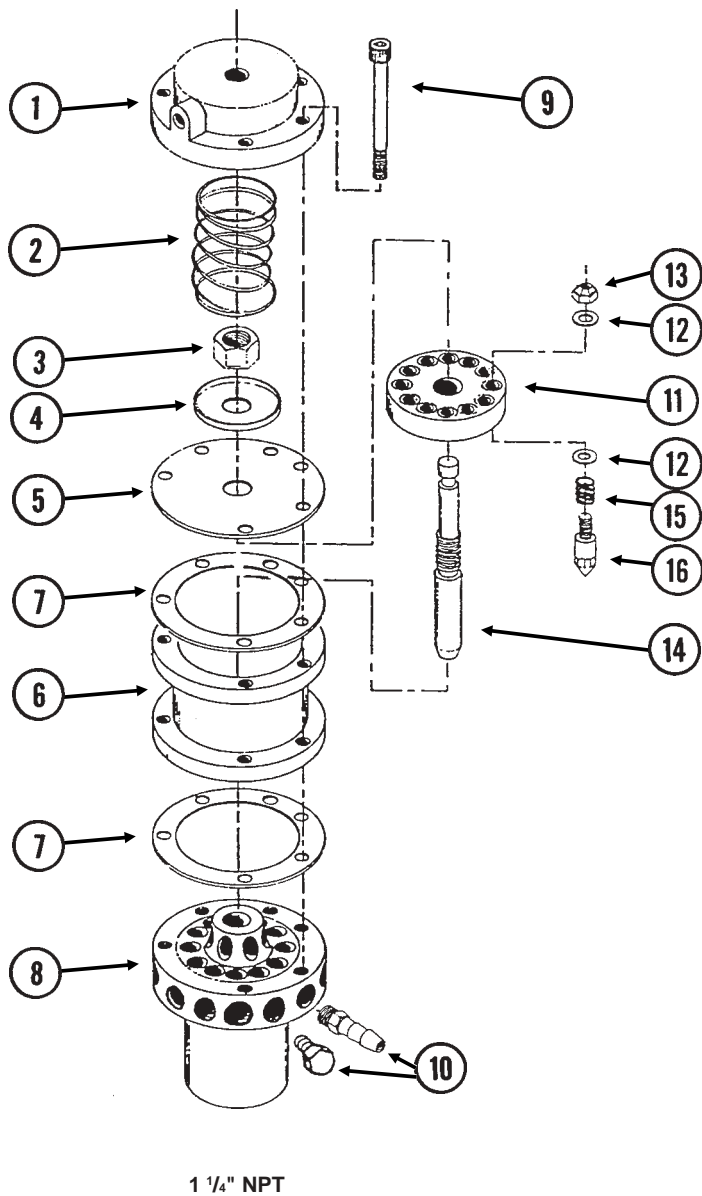

Model FD-2000 Flow Divider

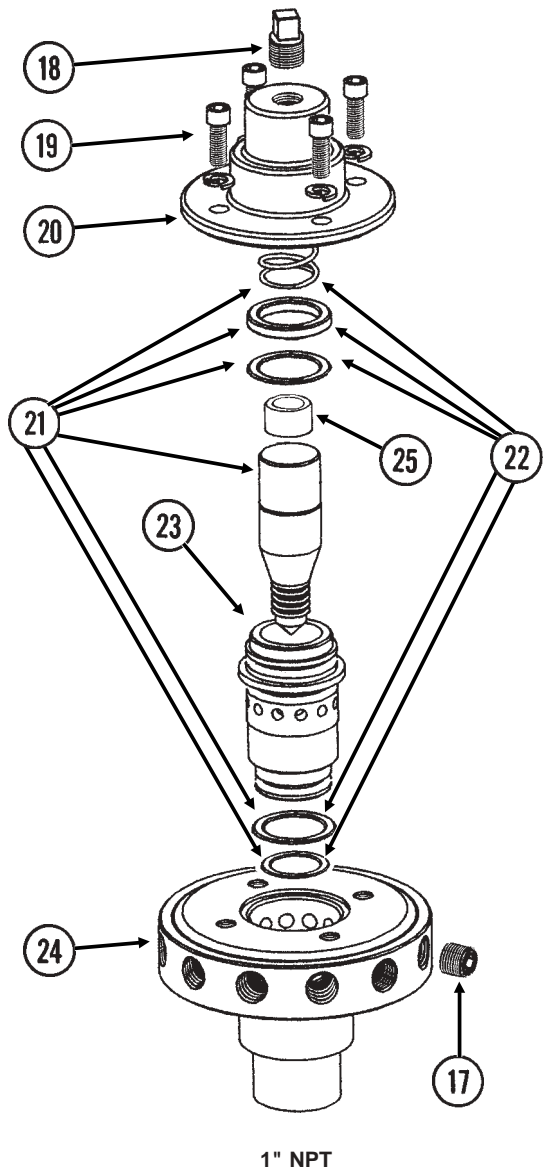

LIQUID FERTILIZER PISTON PUMP FLOW DIVIDER, 16 ROW SIZE

ITEM	PART NO.	QTY.	DESCRIPTION
1.	GR1188	1	Cap
2.	GR1189	1	Spring
3.	G10358	1	Hex Nut, $\frac{9}{16}$ "-18
4.	GR1190	1	Plate
5.	GR1191	1	Diaphragm
6.	GR1192	1	Housing
7.	GR1193	2	Gasket
8.	*	1	Manifold
9.	GR1195	6	Socket Screw, $\frac{1}{4}$ "
10.		-	See "Liquid Fertilizer Flow Divider Mount And Hoses", Pages P122 And P123
11.	*	1	Disk
12.	*	24	Stainless Steel Washer
13.	*	12	Valve Nut
14.	GR1199	1	Plunger
15.	*	12	Spring
16.	*	12	Valve
17.	G10350	4	Hex Socket Head Plug, $\frac{1}{4}$ " NPT, Stainless Steel
18.	GR1543	1	Plug
19.	GR1542	4	Hex Socket Head Screw, $\frac{1}{4}$ "-20 x $\frac{3}{4}$ ", Stainless Steel
	GR1541	4	Lock Washer, $\frac{1}{4}$ ", Stainless Steel
20.	GR1566	1	Cap
21.	GR1567	1	Needle Assembly W/Seal Kit (Item 22)
22.	GR1568	1	Seal Kit, Includes: (3) O-Rings, (1) Seal, (1) Spring
23.	GR1561	1	Sleeve
24.	GR1559	1	Body
25.	GR1574	1	Sleeve, 1" O.D. x $\frac{1}{2}$ " Long, Stainless Steel
A.	GA6570	1	Liquid Fertilizer Piston Pump Flow Divider Complete, 16 Outlet (Model L-1195) (Sub GA9407 And G10995)
B.	GA9407	1	Liquid Fertilizer Piston Pump Flow Divider Complete, 20 Outlet (Model FD-2000)

* Factory calibration required on Model L-1195. Replacement not recommended. Always be sure timing marks on disk and manifold line up.

DECALS, PAINT AND MISCELLANEOUS



1



2

WARNING

AGRICULTURAL CHEMICALS CAN BE DANGEROUS. IMPROPER SELECTION OR USE CAN SERIOUSLY INJURE PERSONS, ANIMALS, PLANTS, SOIL OR OTHER PROPERTY. BE SAFE. SELECT THE RIGHT CHEMICAL FOR THE JOB. HANDLE WITH CARE. FOLLOW THE INSTRUCTIONS ON THE CONTAINER LABEL AND OF THE EQUIPMENT MANUFACTURER.

7100-115

3



4

DANGER

SERIOUS INJURY OR DEATH CAN RESULT FROM CONTACT WITH ELECTRICAL LINES. USE CARE TO AVOID CONTACT WITH ELECTRIC LINES WHEN MOVING OR OPERATING THIS MACHINE.

7100-117

5

ATTENTION

Connect directly to **BATTERY** whenever possible

Connect black lead to negative terminal

Connect to **12 Volts Only**

7100-123

6

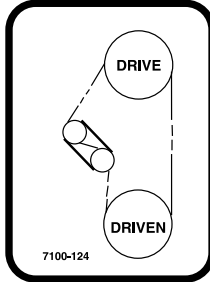

7

USE 1 TABLESPOON POWDERED GRAPHITE WITH EACH HOPPER FILL OF SEED. SEED TREATMENT, FOREIGN MATERIAL, DIRT, OR SEED CHAFF MAY CAUSE GRADUAL REDUCTION OF SEED POPULATION. REFER TO MANUAL FOR MAINTENANCE AND CARE.

7100-153

8

Twin-Line

7100-177

9

IMPORTANT

SEED METER ALIGNMENT TO DRIVE CLUTCH IS CRITICAL. REFER TO OPERATOR'S MANUAL FOR INSTRUCTIONS.

7100-248

10



11

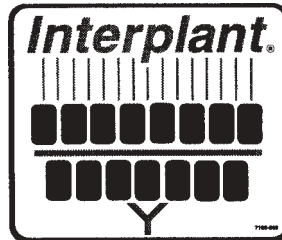

12

13

NOTE

It is the responsibility of the user to read and understand the Operator's Manual in regards to safety, operation, lubrication and maintenance before operation of this equipment.

AN OPERATOR & PARTS MANUAL IS AVAILABLE FOR THIS MACHINE.

To obtain a manual, furnish model number and serial number and contact your KINZE Dealer or KINZE Manufacturing, Inc., P.O. Box 806 Williamsburg, IA 52361-0806 USA

WARNING

MAXIMUM INFLATION PRESSURE 75 PSI

7100-119

14

KINZE 3400

TORQUE 5/8" SPINDLE BOLTS TO 120 FT/LBS. CHECK PERIODICALLY AND RE-TORQUE AS NEEDED.

7100-201

16

15

WARNING

TO AVOID INJURY -- STAND CLEAR--KEEP OTHERS AWAY WHEN RAISING OR LOWERING MARKERS. BEFORE TRANSPORTING PLANTER FULLY EXTEND HYDRAULIC CYLINDERS AND INSTALL LOCKING PINS WHERE PROVIDED.

7100-42

17

WARNING

TO AVOID INJURY -- ALWAYS LOWER PLANTER UNITS TO THE GROUND BEFORE UNHITCHING PLANTER. TONGUE CAN RAISE SUDDENLY.

7100-43

18

WARNING

1. Read and understand the Operator's Manual.
2. Stop the tractor engine before leaving the operator's platform.
3. Keep riders off the machine.
4. Make certain everyone is clear of the machine before starting the tractor engine and operating.
5. Keep all shields in place.
6. Never lubricate, adjust, unclog or service the machine with tractor engine running.
7. Wait for all movement to stop before servicing.
8. Keep hands, feet and clothing away from moving parts.
9. Use flashing warning lights when operating on highways except when prohibited by law.

7100-46

19

CAUTION

SET DOWN PRESSURE SPRINGS TO MINIMUM. LOWER PLANTER TO GROUND AND EMPTY SEED HOPPERS. REQUIRES 90 LB MIN TO LIFT.

7100-246

20

CAUTION

REAR OF PLANTER SWINGS WIDE IN TURNS. ALWAYS ALLOW SUFFICIENT ROOM TO CLEAR OBSTACLES WHEN TURNING.

7100-63

22

WARNING

TOW ONLY WITH FARM TRACTOR

7100-56

21

WARNING

NEVER WALK UNDER OR WORK ON PLANTER WHEN IT IS RAISED WITHOUT SUPPORTING THE FRAMES WITH ADDITIONAL SUPPORTS.

7100-68

23

CAUTION

AVOID UNEVEN LOADING OF HOPPERS, ESPECIALLY DURING TRANSPORT

7100-75

24

WARNING

TO AVOID INJURY

ALWAYS USE HYDRAULIC CYLINDER SAFETY LOCKOUT CHANNELS WHEN TRANSPORTING PLANTER ON THE ROAD. AFTER USE RETURN TO STORAGE LOCATION.

7100-83

25

DANGER

THIS PLANTER IS DESIGNED TO BE DRIVEN BY GROUND TIRES ONLY. THE USE OF HYDRAULIC, ELECTRIC OR PTO DRIVES MAY CREATE SERIOUS SAFETY HAZARDS TO YOU AND THE PEOPLE NEARBY. IF YOU INSTALL SUCH DRIVES YOU MUST FOLLOW ALL APPROPRIATE SAFETY STANDARDS AND PRACTICES TO PROTECT YOU AND OTHERS NEAR THIS PLANTER FROM INJURY.

7100-89

26

WARNING

THIS MACHINE HAS BEEN DESIGNED AND BUILT WITH YOUR SAFETY IN MIND. DO NOT MAKE ANY ALTERATIONS OR CHANGES TO THIS MACHINE. ANY ALTERATION TO THE DESIGN OR CONSTRUCTION MAY CREATE SAFETY HAZARDS.

7100-90

27

DECALS, PAINT AND MISCELLANEOUS

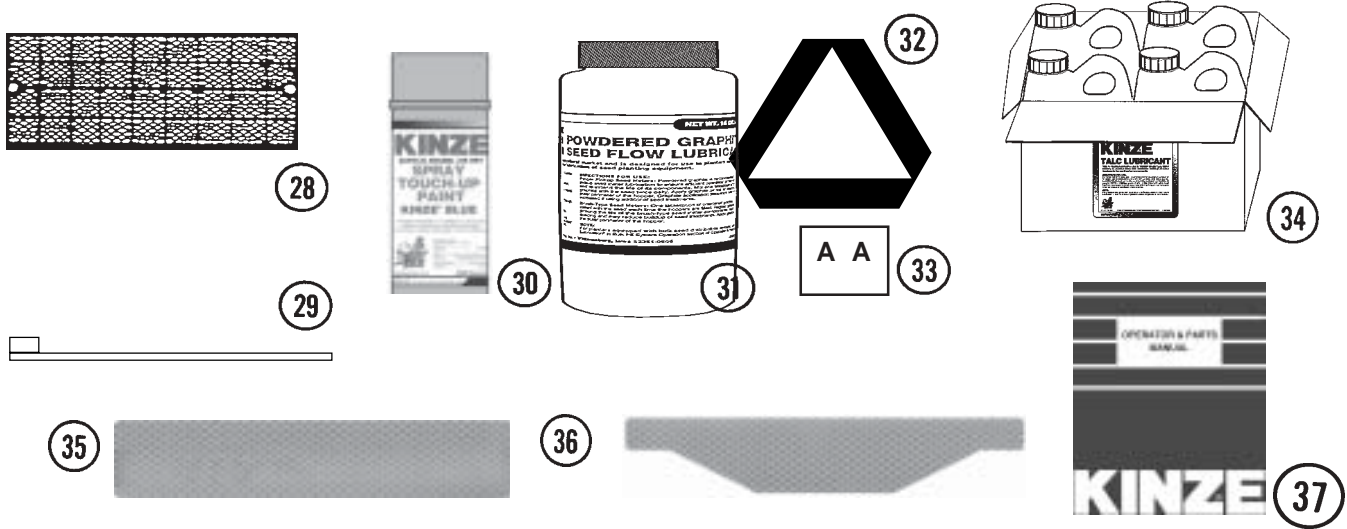

ITEM	PART NO.	QTY.	DESCRIPTION
1.	G7100-110	-	Decal, Grease Weekly
2.	G7100-111	-	Decal, Oil Daily
3.	G7100-115	-	Decal, Warning (1 Per Granular Chemical Hopper)
4.	G7100-116	-	Decal, Grease Daily
5.	G7100-117	1	Decal, Danger
6.	G7100-123	1	Decal, Attention
7.	G7100-124	1	Decal, Transmission
8.	G7100-153	-	Decal, Information (1 Per Brush-Type Seed Meter)
9.	G7100-177	1	Decal, Twin-Line®, 3/4" x 3"
10.	G7100-248	-	Decal, Meter Alignment (1 Per Row Unit)
11.	G7100-247	-	Decal, Logo, 4 3/8" x 4 1/2" (2 Per Row Unit)
	G7100-252	-	Decal, Logo, 3 1/2" x 3 5/8" (Hopper Panel Extension)
12.	G7100-208	-	Decal, Interplant®
13.	G7100-217	1	Decal, Note
14.	G7100-219	4	Decal, Warning
15.	G7100-243	2	Decal, 3400
16.	G7100-234	-	Decal, Bolt Torque (Frame Mounted Coultter)
17.	G7100-42	4	Decal, Warning
18.	G7100-43	1	Decal, Warning
19.	G7100-46	1	Decal, Warning
20.	G7100-249	-	Decal, Caution (Interplant® Push Row Unit Lift Lever)
21.	G7100-56	1	Decal, Warning
22.	G7100-63	2	Decal, Caution
23.	G7100-68	4	Decal, Warning
24.	G7100-75	4	Decal, Caution
25.	G7100-83	4	Decal, Warning
26.	G7100-89	2	Decal, Danger
27.	G7100-90	1	Decal, Warning
28.	G7200-03	2	Reflector, Red
	G7200-04	2	Reflector, Amber
29.	GD1512	-	Tie Strap, 7 1/2"
	GD2117	-	Tie Strap, 14 1/2"
	GD1162	-	Tie Strap, 28"
	GD2984	-	Tie Strap, 34"

(Continued)

DECALS, PAINT AND MISCELLANEOUS

ITEM	PART NO.	QTY.	DESCRIPTION
30.	GR0155	-	Blue Paint, Aerosol Can (Shown)
	GR0155MPP	-	Blue Paint, Twelve Aerosol Cans
31.	GR0146	-	Powdered Graphite, 1 Pound Container
	GR0146MPP	-	Powdered Graphite, Twenty-Four 1 Pound Containers
32.	GD2199	1	SMV Sign
33.	GD10057-01	-	Hose Identification Sleeve, Red AA
	GD10057-02	-	Hose Identification Sleeve, Red BB
	GD10057-03	-	Hose Identification Sleeve, Blue AA
	GD10057-04	-	Hose Identification Sleeve, Blue BB
34.	GR1570MPP	-	Talc Lubricant, Four 8 Pound Containers
35.	G7100-258	-	Reflective Decal, Red, 1 1/2" x 9", Rectangular (If Applicable)
	G7100-259	-	Reflective Decal, Amber, 1 1/2" x 9", Rectangular (If Applicable)
	G7100-260	-	Reflective Decal, Orange, 1 1/2" x 9", Rectangular (If Applicable)
36.	G7100-261	-	Reflective Decal, Red, 1 3/4" x 9", Die-Cut (If Applicable)
	G7100-262	-	Reflective Decal, Amber, 1 3/4" x 9", Die-Cut (If Applicable)
	G7100-263	-	Reflective Decal, Orange, 1 3/4" x 9", Die-Cut (If Applicable)
37.	GM0172	1	Operator & Parts Manual, Model 3400

NUMERICAL INDEX

Part No.	Page	Part No.	Page	Part No.	Page
A1021	P77	G10036	P21, P29	G10204	P5, P7, P87
A1079	P77	G10038	P95	G10205	P31
A1096	P77	G10039	P23, P31, P95	G10206	P27, P29, P91, P95
A1113	P77	G10043	P35, P37, P89, P99	G10207	P3
A1169	P77	G10045	P25, P87	G10209	P18, P19, P35, P37
A1192	P77	G10046	P31, P41, P87, P91	G10210	P3, P9, P10, P11, P12, P13, P17, P33, P43, P47, P55, P87, P89, P91, P95
A3123	P77	G10047	P55, P89, P91	G10211	P12, P79, P81, P83
A3129	P77	G10048	P41	G10213	P5, P27, P29, P31, P87
A3158	P77	G10053	P51	G10216	P7, P23, P33, P51, P85, P93
A3206	P77	G10055	P29, P50	G10217	P29, P35, P37, P89, P91, P95
A5458	P67	G10061	P12, P35, P37	G10219	P9, P50, P53, P89, P91
A6020	P63	G10063	P35, P37	G10221	P39, P87
A7370	P50	G10064	P10, P42, P43	G10226	P35, P37, P57
A7606	P77	G10068	P29	G10227	P19, P35, P37, P42, P43, P83
A7607	P77	G10070	P49	G10228	P7, P25, P29, P42, P47, P49, P55, P57, P58, P85, P87, P89, P91, P93, P94, P95
A7609	P77	G10072	P64	G10229	P4, P9, P10, P11, P17, P19, P33, P35, P37, P41, P43, P47, P51, P55, P83, P87, P95
A7610	P77	G10100	P51, P64	G10230	P4, P7, P10, P11, P33, P37, P39, P41, P42, P47, P49, P51, P53, P55, P57, P87, P89, P91, P93, P95, P97
A8349	P35	G10101	P4, P10, P11, P19, P33, P35, P37, P43, P51, P59, P60, P83, P87, P95	G10231	P42, P47
A8352	P42	G10102	P9, P25, P29, P31, P42, P47, P49, P55, P57, P58, P85, P87, P89, P91, P93, P94, P95	G10232	P9, P35, P37, P39, P50, P51, P53, P72, P87, P89, P91
A8422	P17	G10103	P19, P42, P43, P51, P83	G10233	P50, P53, P55, P85, P95
A8467	P59	G10104	P4, P11, P29, P33, P39, P41, P42, P51, P53, P55, P57, P87, P89, P91, P93, P95, P97	G10235	P51, P95
A8496	P65	G10106	P9, P23, P29, P35, P37, P39, P50, P51, P53, P89	G10252	P12
A8744	P61	G10107	P9, P10, P21, P23, P28, P29, P31, P35, P37, P49, P50, P51, P87, P91, P95	G10257	P18
A8794	P61	G10108	P3, P12, P17, P33, P65, P89, P91, P99	G10278	P93, P97
A8836	P68	G10109	P7, P9, P10, P25, P27, P31, P45, P87	G10284	P33
A8986	P60	G10110	P19, P51	G10292	P97
A8988	P62	G10111	P10, P21, P23, P25, P29, P31, P51, P55, P87, P91	G10303	P9, P50, P53
A8991	P66	G10112	P31	G10304	P3
A9548	P37	G10128	P51	G10305	P20, P87
D13426	P63	G10130	P53, P85	G10306	P19, P89, P91
G10001	P4, P35, P37, P43, P51	G10131	P55	G10307	P33
G10002	P17, P91	G10133	P10, P25, P27, P31, P72, P87	G10308	P10, P20
G10003	P3, P9, P10, P95	G10139	P47, P49	G10309	P12
G10004	P33, P51, P83	G10148	P27	G10310	P19
G10005	P31, P42, P95	G10152	P9	G10312	P3, P17, P43
G10006	P9, P25, P35, P37	G10157	P35, P37	G10315	P9, P10, P19
G10007	P5, P11, P31, P47, P89	G10159	P57	G10318	P23, P49
G10008	P28, P29, P37, P49	G10168	P58	G10322	P57
G10009	P27, P31	G10169	P35, P37	G10323	P14
G10010	P7	G10171	P9		
G10011	P31, P91	G10201	P3, P13, P17, P33		
G10012	P29				
G10013	P10, P89				
G10014	P7, P31, P39, P89				
G10015	P9				
G10016	P47, P51, P95				
G10017	P23, P49, P55, P91, P93				
G10018	P7, P9				
G10019	P51, P87				
G10020	P14				
G10021	P14				
G10022	P14, P43, P83				
G10023	P17				
G10025	P42				
G10027	P47				
G10033	P25				

NUMERICAL INDEX

Part No.	Page	Part No.	Page	Part No.	Page
G10325	P5, P17	G10573	P29	G10760	P66
G10326	P3	G10574	P21, P25, P29, P31	G10765	P27, P31, P35, P37
G10328	P5	G10581	P29, P51, P85	G10770	P63
G10338	P7, P12	G10582	P29	G10779	P47
G10348	P25	G10584	P15	G10801	P9, P10
G10358	P103	G10585	P23	G10819	P94
G10361	P42	G10591	P65	G10821	P55
G10371	P25, P95	G10591	P66	G10827	P68
G10373	P45, P49	G10597	P23	G10844	P58
G10376	P49	G10599	P11, P33	G10862	P51
G10394	P47	G10602	P12, P14, P15, P18, P50, P55, P95	G10864	P19
G10400	P31	G10603	P14, P15	G10867	P55
G10401	P14	G10604	P14	G10871	P91
G10409	P55	G10613	P97	G10886	P89
G10412	P4, P12, P33, P51	G10615	P97	G10887	P93
G10421	P51	G10616	P93	G10888	P93
G10427	P5, P9	G10619	P93, P97	G10890	P50
G10430	P53	G10620	P3, P7, P12, P17, P43	G10896	P97
G10438	P3, P39, P89	G10621	P12, P14, P17, P20	G10898	P89
G10441	P35, P37, P41, P47	G10622	P5, P20	G10901	P93
G10442	P41, P47	G10623	P93	G10912	P5, P33
G10445	P55	G10626	P93, P97	G10917	P93
G10450	P89, P91	G10628	P93	G10918	P29
G10451	P87	G10629	P97	G10921	P18
G10452	P19	G10630	P93	G10923	P53, P85
G10455	P55	G10633	P93	G10924	P7
G10456	P33	G10634	P15	G10932	P59, P60
G10457	P35, P37	G10640	P7, P21, P29, P42, P45, P55, P91	G10934	P39
G10460	P47, P49, P55, P57, P59, P60	G10641	P45, P57, P89	G10935	P35, P37
G10463	P9, P33	G10660	P18	G10936	P47
G10464	P53	G10669	P3	G10937	P43
G10470	P14	G10670	P17, P95	G10938	P87
G10476	P89	G10673	P19	G10939	P59, P60, P65
G10478	P55	G10674	P93, P97	G10940	P7
G10485	P93	G10676	P93	G10954	P43
G10496	P85	G10681	P87, P97	G10958	P60, P61, P66
G10499	P87	G10688	P99	G10962	P68
G10500	P14	G10690	P14	G10967	P67
G10501	P25, P51	G10693	P99	G10968	P85
G10503	P23, P51, P87	G10718	P33	G10971	P50
G10504	P87	G10722	P58	G10974	P27, P31
G10521	P18	G10724	P58	G10977	P72
G10523	P19	G10725	P58	G10985	P3
G10529	P20	G10730	P31	G10989	P13
G10531	P15	G10732	P4, P33	G10991	P91
G10535	P85	G10733	P97	G10994	P97
G10536	P23, P45, P57	G10734	P97	G10995	P97
G10542	P87	G10746	P51	G10996	P74, P79, P81
G10544	P58	G10747	P29	G11001	P70
G10545	P4	G10751	P12, P33, P51	G11002	P72
G10546	P12, P18	G10752	P12	G11004	P72
G10551	P3	G10755	P45	G11006	P70
G10567	P12, P18	G10757	P19	G11007	P3
G10570	P18	G10758	P19	G11008	P3
G10572	P23, P29			G11009	P14, P15
				G11010	P31

NUMERICAL INDEX

Part No.	Page	Part No.	Page	Part No.	Page
G11015	P3	G6801-06-08	P77	GA2007	P12
G11016	P63	G6801-08	P77	GA2012L	P5
G11053	P35, P37	G7100-110	P105	GA2012R	P5
G11058	P35, P37	G7100-111	P105	GA2014	P5, P9, P23, P25, P27, P29, P31, P87, P89
G1K248	P79, P81, P83	G7100-115	P105	GA2018	P14
G1K249	P83	G7100-116	P105	GA2019	P14
G1K252	P79, P81, P83	G7100-117	P105	GA2020	P14
G1K253	P51	G7100-123	P105	GA2054	P9
G1K267	P79, P81, P83	G7100-124	P105	GA2068	P51, P95
G1K268	P79, P81, P83	G7100-153	P105	GA2075	P19
G1K269	P53, P85	G7100-177	P105	GA2094	P20
G1K274	P74	G7100-208	P105	GA2180	P51
G1K275	P74	G7100-217	P105	GA2528	P79, P81
G1K276	P74	G7100-219	P105	GA2612	P79, P81
G1K312	P12	G7100-234	P105	GA2660	P93
G1K313	P13	G7100-243	P105	GA3413	P75
G1K320	P83	G7100-247	P105	GA3584	P79, P81
G1K321	P83	G7100-248	P105	GA3893	P97
G1K322	P83	G7100-249	P105	GA4235	P55
G1K323	P83	G7100-252	P105	GA4309	P63
G1K331	P85	G7100-258	P106	GA4444	P17
G1K335	P13	G7100-259	P106	GA4976	P93, P97
G1K345	P10	G7100-260	P106	GA4994	P35, P37
G2100-03	P50, P53	G7100-261	P106	GA4995	P35, P37
G3303-114	P18	G7100-262	P106	GA5090	P50, P95
G3303-96	P33	G7100-263	P106	GA5096	P67
G3303-98	P3	G7100-42	P105	GA5105	P50, P51
G3305-01	P20	G7100-43	P105	GA5106	P55
G3310-101	P51	G7100-46	P105	GA5107	P55, P85
G3310-160	P95	G7100-56	P105	GA5108	P55
G3310-328	P85	G7100-63	P105	GA5109	P55
G3310-80	P55	G7100-68	P105	GA5110	P55
G3310-83	P51	G7100-75	P105	GA5111	P55
G3310-93	P51	G7100-83	P105	GA5112	P55
G3400-01	P50, P53	G7100-89	P105	GA5113	P55
G4200-01	P93	G7100-90	P105	GA5114	P51
G4201-04	P93	G7200-03	P105	GA5116	P55, P95
G4205-03	P97	G7200-04	P105	GA5146	P55
G4205-11	P93	G7566X	P11	GA5385	P79, P81
G4301-06	P97	G7633X	P79, P81	GA5459	P67
G6325X	P4	G7698X	P43	GA5600	P83
G6400-06	P69, P70, P71, P72, P73, P77	GA0167	P58	GA5622	P21, P29
G6400-06-04	P77	GA0243	P58	GA5624	P55
G6400-08	P59, P60, P69, P70, P71, P72, P73, P77	GA0245	P58	GA5625	P21
G6400-L-08	P77	GA0257	P58	GA5629	P55
G6408-06	P71, P72	GA0312	P87	GA5630	P29
G6408-08	P59, P60, P71, P72, P73	GA0328	P87	GA5631	P28
G6408-10	P71, P72	GA0378	P53	GA5635	P28
G6408-H06-O	P69, P70, P71, P72, P73	GA0705	P49	GA5636	P29
G6500-08	P77	GA0810	P87	GA5637	P29
G6502-08	P77	GA0899	P58	GA5640	P21, P29
G6801-06	P77	GA1676	P58	GA5643	P29
		GA1677	P58	GA5651	P4
		GA1678	P58	GA5654	P23, P25, P27, P29, P31, P89
		GA1679	P58		
		GA1720	P4, P33		

NUMERICAL INDEX

Part No.	Page	Part No.	Page	Part No.	Page
GA5698	P15	GA7067	P47	GA8343	P14
GA5699	P15	GA7077	P79, P81	GA8348	P49
GA5715	P23	GA7096	P47	GA8350	P41
GA5718	P23	GA7154	P51, P85, P95	GA8351	P47
GA5719	P23	GA7179	P95	GA8353	P49
GA5786	P33	GA7180	P95	GA8354	P49
GA5787	P33	GA7255	P15	GA8356	P39
GA5788	P33	GA7271	P27	GA8357	P39
GA5794	P15	GA7336	P55	GA8362	P41
GA5795	P15	GA7399	P79, P81	GA8364	P18
GA5796	P15	GA7412	P27	GA8370	P13
GA5798	P28	GA7434	P49	GA8371	P17
GA5834	P15	GA7445	P27, P31	GA8374	P47
GA5965	P49	GA7446	P25, P27, P31	GA8382	P57
GA5982	P15	GA7533	P35, P37	GA8383	P49
GA5987	P49	GA7574	P53	GA8398	P89, P91
GA5988	P49	GA7851	P83	GA8399	P89, P91
GA6027	P15	GA7853	P83	GA8402	P49
GA6038	P15	GA7854	P83	GA8405	P49
GA6108	P79, P81	GA7855	P83	GA8406	P75
GA6109	P79, P81	GA7856	P79, P81, P83	GA8407	P57
GA6147	P83	GA7857	P83	GA8426	P51
GA6168	P15	GA7858	P83	GA8430	P79, P81
GA6171	P7, P9, P10	GA7859	P83	GA8431	P79
GA6182	P15	GA7862	P79, P81	GA8432	P79
GA6184	P15	GA7863	P79, P81	GA8433	P79
GA6187	P15	GA7949	P7	GA8438	P93
GA6415	P95	GA7965	P3	GA8450	P53
GA6434	P10	GA7975	P7	GA8451	P53
GA6478	P15	GA7976	P7	GA8456A	P64
GA6497	P42	GA8007	P89	GA8456B	P64
GA6527	P97	GA8008	P89	GA8472	P57
GA6532	P57	GA8026	P83	GA8477	P51
GA6597	P10	GA8037	P33	GA8483	P87
GA6618	P9	GA8046	P83	GA8486	P94
GA6619	P9	GA8047	P79, P81, P83	GA8495	P83
GA6620	P9	GA8068	P103	GA8497	P65, P66
GA6633	P15	GA8069	P99	GA8603	P21, P29, P31, P91
GA6699	P79, P81	GA8080	P87, P89	GA8641	P21, P29, P31
GA6700	P79, P81	GA8081	P87, P89	GA8651	P33
GA6701	P81	GA8082	P93	GA8680	P83
GA6733	P9	GA8085	P93	GA8685	P87
GA6741	P19	GA8088	P93	GA8729	P79, P81
GA6792	P42	GA8092	P85	GA8731	P79, P81
GA6801	P9	GA8114	P93	GA8734	P79, P81
GA6832	P25	GA8130	P59, P60	GA8745	P61
GA6833	P25	GA8170	P57	GA8760	P27
GA6834	P25	GA8172	P45	GA8762	P45
GA6838	P25	GA8180	P65	GA8764	P35, P37
GA6907	P19	GA8181	P59	GA8765	P35, P37
GA6966	P89, P91	GA8304	P12	GA8789	P50
GA6975	P79, P81	GA8322	P10	GA8795	P61
GA6977	P79, P81	GA8324	P5	GA8835	P68
GA6978	P79, P81	GA8326	P18	GA8837	P68
GA7016	P35, P37	GA8328	P79, P81	GA8845	P87
GA7022	P35, P37	GA8329	P79, P81	GA8876	P57

NUMERICAL INDEX

Part No.	Page	Part No.	Page	Part No.	Page
GA8882	P60	GB0196	P29	GD10226	P14
GA8896	P62	GB0213	P31	GD10243	P79, P81
GA8930	P33	GB0218	P4, P10, P12, P28, P31, P33, P35, P37, P51, P94	GD1026	P3, P17, P33, P55, P89, P91
GA8931	P103	GB0227	P21, P29	GD10283	P58
GA8952	P49	GB0230	P39	GD1033	P3
GA8983	P87, P89, P91	GB0234	P39	GD1039	P14
GA8984	P60	GB0237	P35, P37	GD1041	P14
GA8987	P60	GB0239	P9, P10	GD1042	P14
GA8989	P62	GB0248	P89, P91	GD10473	P5, P9
GA8992	P66	GB0249	P89, P91	GD10519	P27, P31
GA9056	P49	GB0250	P89	GD10526	P27
GA9061	P43	GB0254	P10	GD10532	P42
GA9062	P43	GB0265	P3	GD10552	P25, P27, P31
GA9063	P43	GB0266	P3	GD1059L	P17
GA9064	P47	GB0267	P3	GD1059R	P17
GA9096	P79	GB0268	P9, P10	GD1060	P17
GA9098	P72	GB0270	P89	GD1061	P18
GA9131	P31	GB0274	P3	GD1063	P18
GA9139	P49	GB0276	P7	GD10646	P35, P37
GA9144	P83	GB0278	P12, P18	GD1065	P3
GA9195	P87	GB0282	P10	GD10733	P14
GA9393	P83	GB0285	P3	GD10777	P93
GA9433	P91	GB0287	P55	GD1083	P14
GA9434	P91	GB0296	P91	GD1085	P10
GA9437	P91	GB0297	P91	GD1086	P7
GA9456	P91	GB0301	P5, P33	GD10867	P3, P33
GA9457	P91	GB0314	P12, P33	GD10958	P12
GA9461	P91	GD0453-08	P57	GD10963	P19
GA9462	P91	GD0487	P87	GD10984	P19
GA9481	P81	GD0652	P57	GD10986	P3
GA9510	P70	GD0740	P43	GD10991	P7
GA9529	P81	GD0746	P58	GD10993	P3
GA9530	P81	GD0752-41	P57	GD11001	P3
GA9531	P81	GD0840	P58	GD11017	P5
GA9537	P37	GD0914-204	P53	GD11045	P53, P85
GA9538	P12	GD0914-206	P53	GD11089	P79, P81, P83
GA9539	P12	GD0914-225	P85	GD1109	P9, P10, P29
GA9543	P72	GD0914-43	P53	GD11097	P89
GA9559	P63	GD0962	P87	GD11106	P89
GA9714	P13	GD10007	P95	GD11122	P15
GA9844	P31	GD10011	P47	GD11125	P51
GA9845	P31	GD10012	P47	GD1113	P4, P33, P42, P53, P55, P87, P89, P91, P93, P97
GA9861	P31	GD10013	P47	GD11158	P51
GA9862	P31	GD10014	P47	GD1115L	P19
GA9864	P31	GD10036	P4	GD1115R	P19
GA9865	P31	GD10057-01	P106	GD1116	P19
GA9909	P45	GD10057-02	P106	GD1118	P19
GA9914	P51	GD10057-03	P106	GD11218	P33
GA9945	P41	GD10057-04	P106	GD11219	P17
GB0110	P14	GD10063	P35, P37, P41, P47	GD11235	P93
GB0111	P14	GD10156	P95	GD11239	P12, P18
GB0115	P18	GD10161	P55, P95	GD11240	P18
GB0116	P18	GD10165	P94	GD11259	P3, P5
GB0120	P14	GD10206	P68	GD11263	P33
GB0134	P87	GD10207	P68		
GB0186	P4				

NUMERICAL INDEX

Part No.	Page	Part No.	Page	Part No.	Page
GD11264	P33	GD11579	P59, P60	GD13406	P72
GD11279	P13	GD1162	P105	GD13409	P49
GD11286	P14	GD11649	P33	GD13425	P63
GD11294	P61	GD11652	P21, P29, P31	GD14170	P31
GD11297	P18	GD11659	P33	GD14249	P41
GD1130	P3	GD11677	P21	GD1512	P105
GD11305	P12, P17	GD11698	P29	GD1529	P49
GD11306	P5, P87	GD11700	P97	GD1536	P49
GD11311	P14	GD11705	P87	GD1657	P87
GD11313	P11	GD11747	P13	GD1673	P87
GD1132	P23, P25, P27, P29, P31, P87, P89	GD11751	P45	GD1719	P53
GD1134	P51, P93, P95	GD11752	P33	GD1755	P15
GD11359	P42	GD11763	P61	GD1862	P93
GD11362	P42	GD11787	P14	GD2117	P83, P105
GD11373	P14	GD11835	P61	GD2161	P57
GD11374	P15	GD11845	P3, P5, P9	GD2169	P47
GD1138	P87, P89	GD11962	P3, P17, P33	GD2199	P106
GD11413	P12, P18	GD11993	P83	GD2423	P19
GD11422	P4	GD12534	P25	GD2460	P20
GD11423	P7	GD12548	P60	GD2558	P51, P55
GD11424	P17	GD1255	P53	GD2589	P87
GD11427	P45	GD1256	P53	GD2597	P58
GD11428	P45	GD12567	P49	GD2721	P57
GD1143	P20	GD12585	P60	GD2734-01	P55
GD1144	P20	GD12600	P60	GD2829	P79, P81
GD11444	P45	GD12602	P60	GD2947	P19
GD11445	P45	GD12606	P62	GD2971-09	P35, P37
GD11447	P33	GD12610	P66	GD2971-10	P17
GD1145	P20	GD12614	P66	GD2984	P105
GD11453	P7	GD12615	P66	GD3180-12	P9
GD11454	P49	GD12676	P91	GD3180-16	P55
GD11456	P47	GD12677	P91	GD3214	P57
GD11459	P73	GD12679	P91	GD3612	P3
GD11460	P69, P70	GD12685	P91	GD3622	P93
GD11461	P71, P72	GD12703	P43	GD3623	P93
GD11473	P39	GD12704	P49	GD3860	P79, P81
GD11489	P39, P57	GD12710	P43	GD3951	P93
GD11507	P41	GD12722	P43	GD4086	P77
GD11508	P11	GD12724	P43	GD4632	P67
GD11509	P11	GD12726	P79, P81	GD5154	P35, P37
GD11510	P35	GD12790	P60	GD5752	P50, P95
GD11512	P41	GD12817	P31	GD5753	P50, P95
GD11513	P61	GD12826	P31	GD5797	P95
GD11520	P59	GD12827	P31	GD5835	P55
GD11521	P59	GD12829	P31	GD5857	P25, P35, P37, P51, P55, P95
GD11522	P59	GD13115	P41	GD5860	P51
GD11528	P14	GD13170	P63	GD5875	P43
GD11549	P53	GD13172	P63	GD5949	P67
GD11555	P43	GD13173	P63	GD6291	P79, P81, P83
GD11557	P91	GD13268	P95	GD6501	P14
GD11558	P91	GD13287	P91	GD6551	P55
GD11569	P85	GD13310	P81	GD6825-10.25	P50
GD11570	P65	GD13361	P3	GD6825-11.375	P50
GD11571	P65	GD13395	P70	GD7120	P63
GD11572	P65	GD13397	P37	GD7122	P63
		GD13400	P63		

NUMERICAL INDEX

Part No.	Page	Part No.	Page	Part No.	Page
GD7124	P63	GD9530	P74, P79, P81	GR1116	P99
GD7127	P55	GD9562	P9	GR1118	P99
GD7137	P35, P37	GD9636	P47	GR1122	P95
GD7148	P18	GD9695	P33	GR1129	P101
GD7258	P18	GD9715	P25	GR1130	P101
GD7318	P3	GD9720	P25	GR1133	P101
GD7426	P55	GD9724	P25, P27, P31	GR1134	P101
GD7803	P21, P29, P31	GD9896	P79, P81	GR1142	P101
GD7804	P21, P29, P31	GD9908	P89	GR1144	P101
GD7805	P4, P10, P12, P23, P28, P29, P33, P47, P49, P51, P89, P94	GD9934	P89	GR1150	P103
GD7811	P29	GM0172	P106	GR1151	P103
GD7815	P28	GR0146	P106	GR1152	P103
GD7816	P29	GR0146MPP	P106	GR1153	P103
GD7817-01	P23, P29	GR0150	P58	GR1154	P103
GD7817-04	P23, P29	GR0151	P58	GR1155	P103
GD7817-05	P89	GR0155	P106	GR1157	P103
GD7817-09	P29	GR0155MPP	P106	GR1158	P103
GD7818	P29, P89	GR0170	P64	GR1162	P103
GD7822	P55	GR0193	P64	GR1165	P99
GD7823	P23, P29	GR0196	P3, P18, P33	GR1167	P99
GD7831	P29	GR0257	P49	GR1168	P99
GD7867	P55	GR0322	P49	GR1169	P62
GD7878	P15	GR0513	P93	GR1183	P59
GD7889	P23	GR0515	P35, P37	GR1203	P79, P81
GD7890	P23	GR0516	P35, P37	GR1204	P79, P81
GD7904-04	P95	GR0517	P35, P37	GR1205	P79, P81
GD8066-02	P72	GR0586	P83	GR1206	P79, P81
GD8237	P15	GR0594	P83	GR1207	P79, P81
GD8249	P4	GR0664	P14	GR1208	P79, P81
GD8260	P35, P37	GR0716	P64	GR1287	P59
GD8306	P85	GR0761	P74	GR1290	P79, P81
GD8307	P23, P29	GR0763	P74	GR1292	P79, P81
GD8460	P10	GR0764	P74, P75	GR1309	P68
GD8532	P49	GR0880	P97	GR1321	P74
GD8739	P79, P81	GR0881	P97	GR1322	P74
GD8740	P79, P81	GR0882	P97	GR1327	P14
GD8741	P79, P81	GR0883	P97	GR1363	P79, P81
GD8751	P83	GR0911	P51	GR1364	P79, P81
GD8770	P83	GR0912	P51, P55, P85, P95	GR1388	P103
GD8771	P83	GR0927	P67	GR1389	P99
GD8778	P15	GR0983	P59	GR1390	P83
GD8843	P21, P29	GR0986	P65	GR1391	P83
GD8844	P21, P29	GR0999	P63	GR1392	P83
GD8893-01	P33	GR1001	P63	GR1393	P83
GD9052	P42	GR1005	P93	GR1395	P83
GD9093	P39	GR1006	P93	GR1401	P59, P60
GD9120	P10	GR1015	P93, P97	GR1405	P85
GD9130	P47	GR1016	P93, P97	GR1406	P85
GD9229	P85	GR1017	P93, P97	GR1407	P85
GD9254	P21, P29, P31	GR1018	P93, P97	GR1408	P85
GD9290	P9	GR1019	P93, P97	GR1409	P85
GD9305	P9	GR1037	P59, P60, P69, P70, P71, P72, P73, P77	GR1410	P85
GD9509	P49	GR1045	P69, P70, P71, P72, P73, P77	GR1411	P85
GD9529	P74, P79, P81	GR1114	P99	GR1412	P85
				GR1413	P85
				GR1420	P99

NUMERICAL INDEX

Part No.	Page	Part No.	Page	Part No.	Page
GR1421	P99				
GR1422	P101				
GR1423	P101				
GR1424	P99				
GR1425	P99, P101				
GR1427	P99				
GR1435	P93				
GR1451	P101				
GR1453	P59				
GR1454	P59				
GR1461	P83				
GR1462	P65, P66				
GR1463	P65				
GR1464	P65				
GR1465	P77				
GR1466	P71, P72				
GR1468	P75				
GR1469	P64				
GR1470	P64				
GR1471	P64				
GR1472	P64				
GR1473	P64				
GR1475	P64				
GR1476	P64				
GR1477	P64				
GR1478	P64				
GR1479	P64				
GR1487	P14				
GR1494	P64				
GR1495	P64				
GR1496	P61				
GR1497	P64				
GR1498	P64				
GR1499	P64				
GR1501	P64				
GR1502	P64				
GR1503	P64				
GR1504	P64				
GR1526	P66				
GR1533	P103				
GR1535	P103				
GR1540	P103				
GR1541	P103				
GR1542	P103				
GR1543	P103				
GR1544	P103				
GR1545	P103				
GR1548	P60				
GR1549	P62				
GR1570MPP	P106				
GR1598	P63				
GR1635	P70, P72				
R1474	P64				
R1500	P64				