

MODEL 3600 TWIN-LINE PLANTER OPERATOR'S MANUAL

M0236

Rev. 7/14

This manual is for:

- Model 3600 Twin-Line® Planters
- 12 Row 30" and 16 Row 30" "Y" and "T" Hitch Conventional and ASD Machines; 2011 to 2014 Production Year
- 16 Row 7.5" Twin Row "Y" Hitch; 2013 to 2014 Production Year

Record model number and serial number of your planter along with date purchased:

Model Number _____ 3600 _____

Serial Number _____

Date Purchased _____

Monitor Serial Number _____

Measured Pulses Per Mile/Km (Radar Distance Sensor) _____

Measured Pulses Per Mile/ Km (Magnetic Distance Sensor) _____

SERIAL NUMBER

Record your serial number and purchase date above for quick reference.

The serial number provides important information about your planter and is required to obtain correct replacement parts. Always provide planter model and serial number to your Kinze Dealer when ordering parts or anytime correspondence is made with Kinze Manufacturing, Inc.



Serial number plate location - left side of hitch



Serial number plate location - R.H. Wing

WARRANTY

The Kinze Limited Warranty for your new machine is stated on the retail purchaser's copy of the Warranty And Delivery Receipt form. Additional copies of the Limited Warranty can be obtained through your Kinze Dealer.

Warranty, within the warranty period, is provided as part of Kinze's support program for registered Kinze products which have been operated and maintained as described in this manual. Evidence of equipment abuse or modification beyond original factory specifications will void the warranty. Normal maintenance, service and repair is not covered by Kinze warranty.

To register your Kinze product for warranty, a Warranty And Delivery Receipt form must be completed by the Kinze Dealer and signed by the retail purchaser, with copies to the Dealer, and to the retail purchaser. Registration must be completed and submitted to Kinze Manufacturing, Inc. within 5 business days of delivery of the Kinze product to the retail purchaser. Kinze Manufacturing, Inc. reserves the right to refuse warranty on serial numbered products which have not been properly registered.

If service or replacement of failed parts which are covered by the Limited Warranty are required, it is the user's responsibility to deliver the machine along with the retail purchaser's copy of the Warranty And Delivery Receipt to the Kinze Dealer for service. Kinze warranty does not include cost of travel time, mileage, hauling or labor. Any prior arrangement made between the Dealer and the retail purchaser in which the Dealer agrees to absorb all or part of this expense should be considered a courtesy to the retail purchaser.

Kinze warranty does not include cost of travel time, mileage, hauling, or labor.

GENERAL INFORMATION

The Model 3600 Twin-Line Planter is available with EdgeVac or mechanical meters, conventional hoppers or Air Seed Delivery system (ASD), Interplant, and various other options. Liquid or dry fertilizer application equipment and various row unit attachments are also available.



Model 3600 16 Row Planter with EdgeVac, Interplant, and ASD System

Information used in these instructions was current at time of printing. However, due to Kinze's ongoing product improvement, production changes may cause your machine to appear slightly different in detail. Kinze Manufacturing, Inc. reserves the right to change specifications or design without notice and without incurring obligation to install the same on machines previously manufactured.

Right hand (R.H.) and left hand (L.H.), as used throughout this manual, are determined by facing direction machine travels in use unless otherwise stated.

TO THE DEALER

Predelivery service includes assembly, lubrication, adjustment and test. This service helps ensure planter is delivered to retail customer/end user ready for field use.

PREDELIVERY CHECKLIST

Use the following checklist after planter is completely assembled. Check off each item as it is found satisfactory or after proper adjustment is made.

- Center pivot base mounting and transport wheel spindle hex head cap screws torqued to 450 ft-lb (610.1 n-m).
- Row units properly spaced and optional attachments correctly assembled.
- Row marker assemblies installed and adjusted at each end of the planter.
- EdgeVac® and ASD components properly installed (as applicable).
- All grease fittings in place and lubricated.
- All working parts move freely, bolts are tight, and cotter pins are spread.
- Check all drive chains for proper tension and alignment.
- Check for oil leaks and proper hydraulic operation.
- Hydraulic hoses correctly routed to prevent damage.
- Inflate tires to specified air pressure and torque wheel lug bolts and lug nuts as specified in the manual.
- All safety decals correctly located and legible. Replace if damaged.
- All reflective decals and SMV sign correctly located and visible when the planter is in transport position.
- Safety/warning lights correctly installed and working properly.
- Paint all parts scratched during shipment or assembly.
- All safety lockup devices on the planter and correctly located.
- Auxiliary safety chain properly installed and hardware torqued to specification.
- Vacuum fan PTO-driven pump correctly attached to the tractor. Oil reservoir filled to capacity and system inspected for leaks (If Applicable).
- Control box properly installed in tractor. All cables correctly routed and secure.

Planter has been thoroughly checked and to the best of my knowledge is ready for delivery to the customer.

(Signature Of Set-Up Person/Dealer Name/Date)

OWNER REGISTER

Name _____ Delivery Date _____

Street Address _____ Model No. 3600 Serial No. _____

City, State/Province _____ Dealer Name _____

ZIP/Postal Code _____ Dealer No. _____

DELIVERY CHECKLIST

Use the following checklist at time planter is delivered as a reminder of very important information which should be conveyed to retail customer/end user. Check off each item as it is fully explained.

- Check for proper operation of vacuum fan, ASD fan, and PTO-driven pump (If applicable) with tractor to be used with planter.
- Life expectancy of this or any other machine is dependent on regular lubrication as directed in the Operator Manual.
- All applicable safety precautions.
- Along with retail customer/end user, check reflective decals and SMV sign are clearly visible with planter in transport position and attached to tractor. Check safety/warning lights are in working condition. Tell retail customer/end user to check federal, state/provincial, and local regulations before towing or transporting on a road or highway.
- Give Operator Manual, Parts Manual, and all Instruction Sheets to retail customer/end user and explain all operating adjustments.
- Read warranty to retail customer/end user.
- Complete Warranty and Delivery Report form.

To the best of my knowledge this machine has been delivered ready for field use and customer has been fully informed as to proper care and operation.

(Signature Of Delivery Person/Dealer Name/Date)

AFTER DELIVERY CHECKLIST

The following is a list of items we suggest to check during the first season of use of the equipment.

- Check planter performance with retail customer/end user.
- Check performance of EdgeVac or mechanical seed metering system with retail customer/end user.
- Review importance of proper maintenance and adherence to all safety precautions with retail customer/end user.
- Check for parts that may need to be adjusted or replaced.
- Check all safety decals, reflective decals, and SMV sign are correctly located as shown in the Parts Manual and that decals are legible. Replace if damaged or missing.
- Check safety/warning lights are working properly.

(Signature Of Follow-Up Person/Dealer Name/Date)

**All registrations must be submitted online at "business.kinze.com" within 5 business days of delivery.
Retain a copy of this form for auditing purposes.**

Tear Along Perforation

OVERVIEW

To The Owner	1-1
Specifications	1-2
General Safety Rules	1-3
Safety Precautions	1-4

MACHINE OPERATION

Manual Safety Lockup	2-1
Row Marker Safety Lockup	2-1
Tongue Safety Pin	2-2
Transport Latch Locking Pin	2-2
Initial Preparation	2-3
Tractor Requirements	2-4
Tractor Mounted PTO Pump And Oil Cooler Option	2-4
Tractor Preparation and Hookup	2-5
Level Planter	2-7
Ridge Planting	2-8
Contact Wheel Spring Adjustment	2-9
Contact Wheel Drive Sprockets	2-9
Seed Rate Transmission Adjustment	2-10
Wrap Spring Wrench Operation	2-10
Row Unit Air Clutches	2-10
Ag Leader Electric Clutches	2-10
Hydraulic Seed Rate Drive	2-11
Hall Effect Sensor	
(Hydraulic Drive Only)	2-11
Hydraulic Weight Transfer Toolbar	2-11
Shear Protection	2-11
Hydraulic/Electric Operation	2-12
Transport to Field Sequence	2-13
Field Operation	2-15
Planting Speed	2-15
Field to Transport Sequence	2-16
EdgeVac System	2-18
Digital Vacuum Readout	2-18
Vacuum Fan Motor Valve Block Assembly	2-18
Analog Vacuum or Pressure Gauge	2-18
Air Seed Delivery (ASD) System	2-19
ASD Entrainer Access	2-19
ASD Tanks - Clean Out	2-20
ASD Scale Package Option	2-20
Kinze ISOBUS Option	2-22
KINZE Cobalt System	2-22
Ag Leader Integra Display	2-23
Planter Monitor Module (PMM)	2-23
Rock Guards	2-23

Auxiliary Work Lights Package	2-23
Row Marker Operation	2-24
Row Marker Speed Adjustment	2-25
Even-Row Push Row Unit	2-25
Row Marker Adjustments	2-26
Row Marker Even-Row Length Adjustment	2-27
Offset Hitch Adjustment	2-27
Point Row Clutches	2-28
Two-Speed Point Row Clutches	2-29
Auxiliary Hydraulic Option	2-30
Rear Trailer Hitch	2-31
Field Test	2-32
Field Check Seed Population	2-32
Determining Pounds Per Acre (Brush-Type Meter)	2-33
Determining Bushels Per Acre	2-33
Field Check Granular Chemical Application	2-34

ROW UNIT OPERATION

Planting Depth	3-1
"V" Closing Wheel Adjustment (Rubber or Cast Iron)	3-1
Closing Wheel Shield (Rubber or Cast Iron "V" Closing Wheels)	3-1
Drag Closing Attachment	3-2
Covering Discs/Single Press Wheel Adjustment	3-2
Seed Hoppers	3-3
Seed Meter Drive Release	3-3
Row Unit Extension Brackets	3-3
Row Unit Chain Routing	3-4
Quick Adjustable Down Force Springs Option (Standard or Heavy Duty)	3-5
Interplant Push Row Unit Clutch Sprocket	3-7
Interplant Push Row Unit Lockups	3-8
Interplant Push Row Unit Vacuum Hose Shutoff	3-8
Brush-Type Seed Meter	3-10
Finger Pickup Seed Meter	3-11
EdgeVac Seed Meters	3-12
Seed Meter Cleanout	3-15
Additives	3-16
Frame Mounted Coulter (Pull Row Only)	3-17
Residue Wheels (for Frame Mounted Coulter)	3-17
Row Unit Mounted Disc Furrower (Pull Row Only)	3-18
Row Unit Mounted Bed Leveler (Pull Row Only)	3-18
Row Unit Mounted Residue Wheel	3-19
Row Unit Mounted No Till Coulter	3-20
Coulter Mounted Residue Wheels	3-20
Granular Chemical Hopper and Drive	3-21
Spring Tooth Incorporator	3-21

Granular Chemical Banding Options 3-22
 Granular Chemical Bander Shield 3-22
 Interplant Push Row Unit Lockups 3-23

FERTILIZER

Double Disc Fertilizer Opener 4-1
 Notched Single Disc Opener 4-2
 Residue Wheel Attachment for Notched Single Disc
 Fertilizer Opener 4-3
 Depth/Gauge Wheel Attachment for Notched Single Disc
 Fertilizer Opener 4-3
 HD Single Disc Fertilizer Opener 4-4
 Dry Fertilizer Attachment 4-6
 Liquid Fertilizer Attachment 4-8

RATE CHARTS 5-1

LUBRICATION AND MAINTENANCE

Lubrication 6-1
 Lubrication Symbols 6-1
 Sealed Bearings 6-1
 Wrap Spring Wrench Assembly 6-1
 Air Clutch Lubrication 6-1
 Drive Chains 6-2
 Bushings 6-3
 Center Post 6-5
 U-Joint Slides 6-5
 Liquid Fertilizer Piston Pump Crankcase Oil Level 6-5
 PTO Pump Shaft Coupling (Tractor Mounted PTO Pump
 and Oil Cooler) 6-6
 Wheel Bearings 6-6
 Grease Fittings 6-6
 Mounting Bolts and Hardware 6-10
 Tire Servicing 6-12
 Finger Pickup Seed Meter Inspection/Adjustment 6-13
 Cleaning Finger Pickup Seed Meter For Storage 6-14
 Brush-Type Seed Meter Maintenance 6-15
 Cleaning Brush-Type Seed Meter For Storage 6-16
 Vacuum Manifold Maintenance 6-16
 EdgeVac Seed Meter Maintenance 6-17
 EdgeVac Seed Meter Cleanout 6-17
 Chain Tension Adjustment 6-18
 Drag Closing Attachment 6-18
 Gauge Wheel Adjustment 6-18
 Gauge Wheel Arm Bushing/Seal Replacement 6-19
 Gauge Wheel Arm Pivot Spindle Replacement 6-19
 15" Seed Opener Disc Blade/Bearing Assembly 6-20
 Seed Tube Guard/Inner Scraper 6-21

Frame Mounted Coultter 6-21
 Residue Wheels (For Use With Frame Mounted Coultter) 6-21
 Row Unit Mounted Disc Furrower 6-22
 Row Unit Mounted Bed Leveler 6-22
 Row Unit Mounted No Till Coultter 6-22
 Coultter Mounted Residue Wheels 6-23
 Row Unit Mounted Residue Wheel 6-23
 Granular Chemical Attachment 6-23
 Spring Tooth Incorporator 6-23
 Single and Two-Speed Point Row Clutch Maintenance 6-24
 Check Valve (Lift System) 6-26
 Check Valve (Vacuum Fan) 6-26
 Flow Control Valve 6-26
 Pressure Relief Valve 6-26
 Pressure Reducing Relief Valve 6-26
 Relief Valve Cartridge 6-26
 Solenoid Valve 6-26
 Row Marker Bearing Lubrication or Replacement 6-27
 Air Clutch Cleaning 6-28
 Row Marker Transport Stand Adjustment 6-29
 Wheel Bearing Repack or Replacement 6-29
 Wear Pad Field Replacement/Adjustment 6-30
 Tractor Mounted PTO Pump and Oil Cooler Option 6-33
 Fertilizer Check Valve Cleaning and Repair 6-33
 Piston Pump Storage 6-33
 Preparation for Storage 6-34
 Electrical Wiring Diagram for Light Package 6-35
 Electrical Control Console Schematic 6-36
 Electrical Wiring Harness Schematic (On Tractor) 6-37
 Electrical Wiring Harness Schematic (On Planter) 6-38
 Valve Block - Located on Hitch 6-39
 Valve Block - Located on Rear Center Frame 6-40
 Electrical Control Console Schematic (With Optional Two-Speed Point Row Clutches) and Wiring Harness at Two-Speed Point Row Clutch Solenoids 6-41
 Hydraulic System Schematic 6-42
 Wing Down Pressure Schematic (Weight Transfer Mechanism) 6-46
 Hydraulic Schematic - Vacuum Fan Motor System 6-47
 Hydraulic Schematic - Optional Tractor Driven PTO Pump and Oil Cooler System 6-47
 Airline Schematic 6-48
 Electric Clutch Schematic 6-48
 ISOBUS Implement Cable 6-49
 ISOBUS CAN Jumper Cable 6-49
 Signal 6-49
 CAN 6-49
 Wire/Color 6-49

Kinze Manufacturing, Inc. thanks you for your patronage. We appreciate your confidence in Kinze farm machinery. Your Kinze planter has been carefully designed to provide dependable operation in return for your investment.

This manual has been prepared to aid you in the operation and maintenance of the planter. It should be considered a permanent part of the machine and remain with the machine when you sell it.

It is the responsibility of the user to read and understand the Operator Manual in regards to safety, operation, lubrication and maintenance before operation of this equipment. It is the user's responsibility to inspect and service the machine routinely as directed in the Operator Manual. We have attempted to cover all areas of safety, operation, lubrication and maintenance; however, there may be times when special care must be taken to fit your conditions.

Throughout this manual the symbol  and the words **DANGER**, **WARNING**, and **CAUTION** are used to call attention to safety information that if not followed, will or could result in death or injury. **NOTICE** and **NOTE** are used to call your attention to important information. The definition of each of these terms follows:



DANGER Indicates a hazardous situation which, if not avoided, will result in death or serious injury.



WARNING Indicates a hazardous situation which, if not avoided, could result in death or serious injury.



CAUTION, used with the safety alert symbol, indicates a hazardous situation which, if not avoided, could result in minor or moderate injury.

NOTICE is used to address practices not related to personal injury.

NOTE: Special point of information or machine adjustment instructions.



WARNING

Improperly operating or working on this equipment could result in death or serious injury. Read and follow all instructions in Operator Manual before operating or working on this equipment.



WARNING

Some photos in this manual may show safety covers, shields, or lockup devices removed for visual clarity. **NEVER OPERATE OR WORK ON** machine without all safety covers, shields, and lockup devices in place as required.

NOTE: Photos in this manual may be of prototype machines. Production machines may vary in appearance.

NOTE: Some photos and illustrations in this manual show optional attachments installed. Contact your Kinze Dealer for purchase of optional attachments.

Specification	Conventional Hoppers			
	12R N 30 Y/T	12R W 36-38 Y	16R N 30 Y/T	16 R 7.5" Y
Number of Rows	12R N 30 Y/T	12R W 36-38 Y	16R N 30 Y/T	16 R 7.5" Y
Weight Empty (Mechanical)	12,780 lb (5,796.91 kg)	13,522 lb (6,133.47 kg)	15,730 lb (7,135.00 kg)	19,750 lb (8,958.45 kg)
Weight Empty (EdgeVac)	13,185 lb (5,980.62 kg)	---	16,210 lb (7,352.73 kg)	20,230 lb (9,176.17 kg)
Transport Height	11' 4" (3.5M)	11' 4" (3.5M)	11' 5" (3.5M)	11' 5" (3.5M)
Planting Length	21' 0" (6.4M)	22' 0" (6.7M)	24' 0" (7.4M)	24' 0" (7.4M)
Transport Length	36' 10" (11.3M)	45' 10" (14M)	46' 10" (14.3M)	46' 10" (14.3M)
Planting Width	31' 2" (9.5M)	37' 2" (11.4M)	41' 2" (12.6M)	41' 2" (12.6M)
Transport Width	11' 2" (3.5M)	13' 4" (4.1M)	11' 2" (3.5M)	11' 2" (3.5M)
Seed Capacity	1.75 bu. (EdgeVac/Hopper); 1.90 bu. (Mechanical/Hopper)			
Transport Tire Size	Four 255 - 70R 22.5 radial load range 'H' tubeless rib implement w/o center groove.			
Field Tire Size	7.50" x 20" 8 ply rib implement tires w/o center groove.			
Field Lift	Two master/two slave rephasing cylinders.			
Row Markers	Independently controlled, three stage, low profile, w/disk blade depth bands.			

Specification	Air Seed Delivery (ASD)		
	12R N 30 Y	16R N 30 Y	16 R 7.5" Y
Number of Rows	12R N 30 Y	16R N 30 Y	16 R 7.5" Y
Weight Empty (Mechanical)	12,660 lb (5,742.48 kg)	15,120 lb (6,858.32 kg)	21,140 lb (9,588.94 kg)
Weight Empty (EdgeVac)	13,065 lb (5,926.18 kg)	15,600 lb (7,076.04 kg)	19,620 lb (8,899.48 kg)
Transport Height	12' 6" (3.9M)	12' 6" (3.9M)	12' 6" (3.9M)
Planting Length	21' 0" (6.4M)	24' 0" (7.4M)	24' 0" (7.4M)
Transport Length	36' 10" (11.3M)	46' 10" (14.3M)	46' 10" (14.3M)
Panting Width	31' 2" (9.5M)	41' 2" (12.6M)	41' 2" (12.6M)
Transport Width	11' 2" (3.5M)	11' 2" (3.5M)	11' 2" (3.5M)
Seed Capacity	80 bu.		
ASD Fill Height (planting position)	8' 2" (2.5M)		
Transport Tire Size	Four 255 - 70R 22.5 radial load range 'H' tubeless rib implement w/o center groove.		
Wing/Lift Tire Size	7.50" x 20" 8 ply rib implement tires w/o center groove.		
Field Lift	Two master/two slave rephasing cylinders.		
Row Markers	Independently controlled, three stage, low profile, w/disk blade depth bands.		

TRACTOR HYDRAULIC REQUIREMENTS

Configuration	No Optional Pumps		Tractor Mounted PTO Pump	
	SCV	gpm min.	SCV	gpm min.
Mechanical Meter ^{1,2}	2 SCV	15 gpm min.		
EdgeVac Meter ^{1,2}	3 SCV	30 gpm min.	2 SCV	15 gpm min.
ASD (with Mechanical Meter) ³	3 SCV	25 gpm min.	2 SCV	15 gpm min.
ASD (with EdgeVac) ²	4 SCV	40 gpm min.	3 SCV	25 gpm min.
¹ Hydraulic drive adds 1 SCV + 5 gpm (mechanical) or 10 gpm (EdgeVac) min. to requirements.				
² Wing down pressure option adds 1 SCV to conventional only.				
³ Hydraulic drive not available for ASD/EdgeVac configuration.				

1. Read and understand instructions provided in this manual and warning labels. Review these instructions frequently!
2. This machine is designed and built with your safety in mind. Do not make any alterations or changes to this machine. Any alteration to design or construction may create safety hazards.
3. A large portion of farm accidents happen from fatigue or carelessness. Safe and careful operation of tractor and planter will help prevent accidents.
4. Never allow planter to be operated by anyone unfamiliar with operation of all functions of the unit. Operators must read and thoroughly understand all instructions given in this manual before operating or working on equipment.
5. Be aware of bystanders, particularly children! Always look around to make sure it is safe to start tow vehicle engine or move planter. This is particularly important with higher noise levels and quiet cabs, as you may not hear people shouting.
6. Make sure planter weight does not exceed towing capacity of tractor, or bridge and road limits. This is critical to maintain safe control and prevent death or injury, or property and equipment damage.
7. Never ride or allow others to ride on planter.
8. Store planter in an area away from human activity. DO NOT permit children to play on or around the stored unit.
9. Keep hands, feet, and clothing away from moving parts. Do not wear loose-fitting clothing which may catch in moving parts.
10. Always wear protective clothing, shoes, gloves, hearing, and eye protection applicable for the situation.
11. Do not allow anyone to stand between tongue or hitch and towing vehicle when backing up to planter.
13. Prevent electrocution, other injuries, or property and equipment damage. Watch for obstructions such as wires, tree limbs, etc. when operating machine. Be aware of clearances during turns and when folding/unfolding planter.
14. Reinstall all guards removed for maintenance activities. Never leave guards off during operation.
15. Use of aftermarket hydraulic, electric, or PTO drives may create serious safety hazards to you and people nearby. If you install such drives, follow all appropriate safety standards and practices to protect you and others near this planter from injury.
16. Follow all federal, state/provincial, and local regulations when towing farm equipment on a public highway. Use safety chain (not an elastic or nylon/plastic tow strap) to retain connection between towing and towed machines in the event of primary attaching system separation.
17. Make sure all safety/warning lights, SMV sign, and reflective decals are in place and working properly before transporting the machine on public roads.
18. Limit towing speed to 15 MPH. Tow only with farm tractor of a minimum 90 HP. Allow for unit length when making turns.
19. Reduce speed prior to turns to avoid the risk of overturning. Always drive at a safe speed relative to local conditions and ensure your speed is slow enough for a safe emergency stop.
20. Chemical application is often an integral part of planting. Follow label instructions for proper chemical mixing, handling and container disposal methods.
21. Be familiar with safety procedures for immediate first aid should you accidentally contact chemical substances.
22. Use the proper protective clothing and safety equipment when handling chemicals.
23. Chemicals are supplied with Material Safety Data Sheets (MSDS) that provide full information about the chemical, its effects on exposure, and first aid needs in the event of an emergency. Keep your MSDS file up-to-date and available for first responders in case of emergency.
24. When servicing ground engaging components such as opening disks and firming points, use special care to avoid points and edges worn sharp during use.
25. Use professional help if you are unfamiliar with working on hydraulic systems. Pressurized hydraulic fluid can penetrate body tissue and result in death, serious infection, or other injuries.

Following are some common hazard warnings associated with this equipment. Pay close attention to all safety, operating, and maintenance information in this manual and decals applied to your equipment.

 **DANGER!**

Contacting or coming close to power lines or other high energy sources will cause death or serious injury. Keep away from power lines or high energy sources at all times.

 **WARNING**

Improperly operating or working on this equipment could result in death or serious injury. Read and follow all instructions in Operator Manual before operating or working on this equipment.

 **WARNING**

Falling equipment can cause death or serious injury. Install all lockup devices or lower planter to ground before working on equipment.

 **WARNING**

Explosive separation of rim and tire parts can cause death or serious injury. Overinflation, rim and tire servicing, improper use of rims and tires, or worn or improperly maintained tires could result in a tire explosion.

SAFETY SIGNS AND DECALS

 **WARNING**

All safety/warning lights, reflective decals, and SMV sign must be in place and visible before transporting machine on public roads or death, serious injury, and damage to property and equipment may result. Check federal, state/provincial, and local regulations before transporting equipment on public roads.

Safety signs and decals are placed on the machine to warn of hazards and provide important operating and maintenance instructions. Information on these signs are for your personal safety and the safety of those around you. FOLLOW ALL SAFETY INSTRUCTIONS!

- Keep signs clean so they can be easily seen. Wash with soap and water or cleaning solution as required.
- Replace safety signs if damaged, painted over, or missing.
- Check reflective decals and SMV sign periodically. Replace if they show any loss of reflective properties.
- When replacing decals, clean machine surface thoroughly with soap and water or cleaning solution to remove all dirt and grease.

NOTE: Safety sign and decal locations are shown in the Parts Manual for this machine.

NOTE: Style and locations of SMV sign, reflective decals, and safety/warning lights conform to ANSI/ASABE S279.14 JUL 2008 and ANSI/ASABE S276.6 JAN 2005.

MANUAL SAFETY LOCKUP

WARNING

Uncontrolled machine movement can crush or cause loss of control resulting in death, serious injury, or damage to property and equipment. Install all safety lockup devices before working under or transporting this equipment.

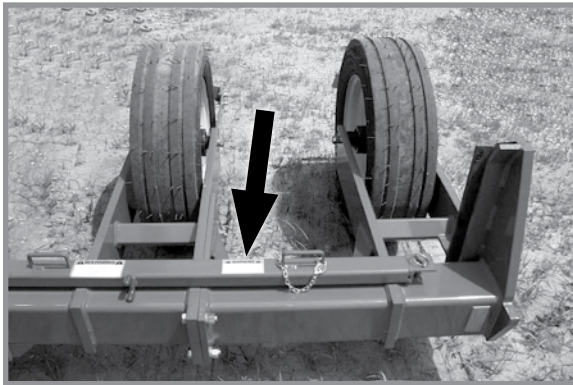

Manual safety lockup in storage position

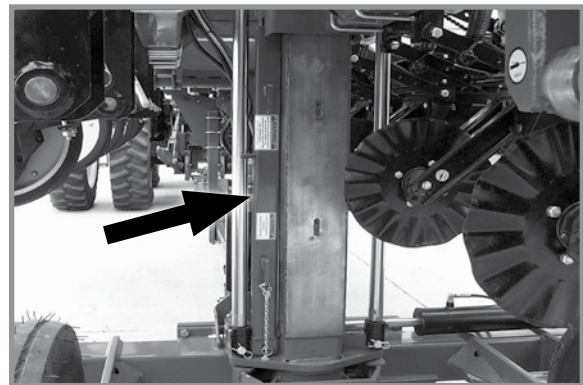

Manual safety lockup in transport position

Remove manual safety lockup and store on L.H. side of transport axle for field operation.

ROW MARKER SAFETY LOCKUP

WARNING

Row marker can lower at any time and could cause death or serious injury. Stay away from row markers! Install safety lockup device when not in use.

Always install row marker lockups when working or transporting planter.

Connect chain between marker stand and second stage of marker assembly.



Row marker safety lockup installed

! WARNING

Uncontrolled movement of equipment can cause loss of control and could result in death, serious injury, or damage to property and equipment. Install all safety pins before transporting equipment.

TONGUE SAFETY PIN



Tongue safety pin installed for transport

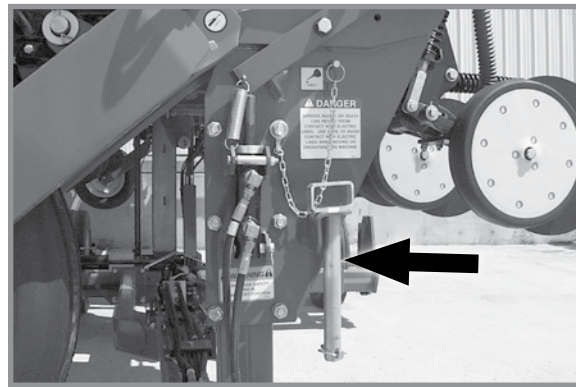

Tongue safety pin stored for field operation

Never transport planter without installing tongue safety pin. Tongue safety pin prevents tongue cylinder from retracting should hydraulic failure occur or a sudden stop be made when transporting planter.

Remove tongue safety pin and store in bracket on transport latch post at center of planter for field operation.

TRANSPORT LATCH LOCKING PIN

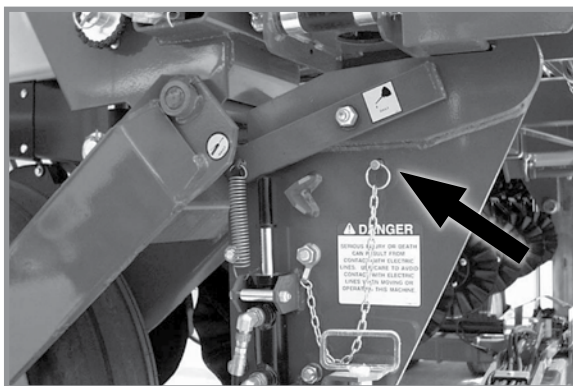

Transport latch locking pin stored for field operation

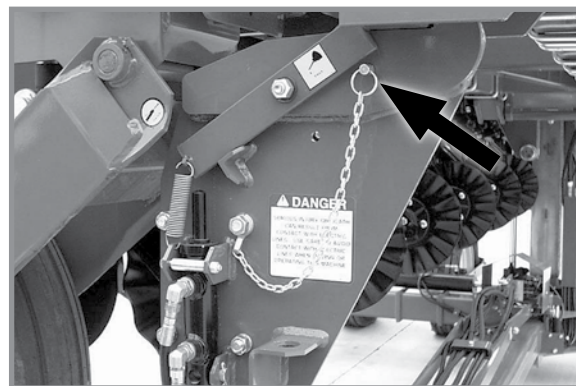

Transport latch locking pin installed for transport

Never transport planter without installing transport latch locking pin. Transport latch locking pin prevents latch bar from disengaging and allowing planter frame to swing away.

Remove transport latch locking pin and store in location provided on latch post for field operation.

INITIAL PREPARATION

Following information is general in nature to aid in preparation of tractor and planter for use, and to provide general operating procedures. Operator experience, familiarity with the machine, and the following information should combine for efficient planter operation and good working habits.

WARNING

Improperly operating or working on this equipment could result in death or serious injury. Read and follow all instructions in Operator Manual before operating or working on this equipment.

WARNING

Folding or towing planter with outer transport wheel on left side of machine removed can cause death, serious injury, or damage to property and equipment. Tipping may occur because of narrow wheel base. Outer transport wheel on left side of machine is shipped removed on non-ASD planters (not bolted on) to allow narrower width truck shipment. **DO NOT REMOVE THIS ASSEMBLY AFTER PLANTER IS ASSEMBLED FOR USE.**

WARNING

Loose transport wheel lug bolts can result in wheel separation from planter and cause death, serious injury, and damage to property and equipment. Torque transport wheel 5/8" - 18 lug bolts to 180 ft-lb (244 N-m) before operating planter for the first time and periodically after.

WARNING

Explosive separation of rim and tire can cause death or serious injury. Overinflation, rim and tire servicing, improper use of rims and tires, worn, or improperly maintained tires could result in a tire explosion.

1. Torque transport wheel 5/8" - 18 lug nuts to 180 ft-lb (244 N-m).
2. Inflate tires to the following specifications:

Transport (center section) 255-70R 22.5 ("224" rim)
75 psi (517.1 kPa) recommended/75 psi (517.1 kPa) max.

Transport (center section) 255-70R 22.5" ("276" rim)
75 psi (517.1 kPa) recommended/100 psi (689.4 kPa) max.

Ground drive (wings) 7.50" x 20" 40 psi (275.7 kPa)

Contact drive 50 psi (344.7 kPa).

Liquid fertilizer piston pump 7.60" x 15" 40 psi (275.7 kPa)

3. Lubricate planter and row units following instructions in lubrication and Maintenance section of this manual.
4. Check all drive chains for proper tension, alignment, and lubrication.

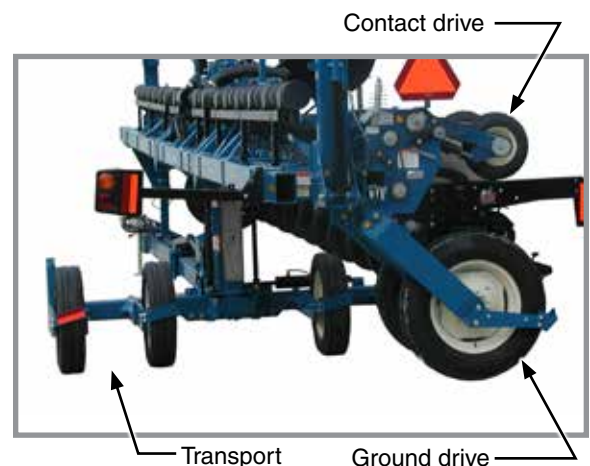

Tire locations (not all tires shown)

TRACTOR REQUIREMENTS

Consult your dealer for information on horsepower requirements and tractor compatibility. Requirements vary with planter options, tillage, and terrain.

A 12 volt DC electrical system is required on all sizes.

A minimum of two SCV remote hydraulic outlets are required on all sizes. One SCV is used for field lift and with a control console switch operates raise to transport function. A second SCV using control console operates row markers fold/unfold functions. Additional SCV's with a zero pressure case drain are needed for EdgeVac vacuum fan motor for seed metering system Air Seed Delivery, Hydraulic Drive, and Wing Down Pressure (if installed without EdgeVac or ASD).

Maximum hydraulic flow rate of 13 GPM @ 2000 PSI is required to operate EdgeVac vacuum fan motor.

TRACTOR MOUNTED PTO PUMP AND OIL COOLER OPTION

The tractor mounted PTO pump and oil cooler option is for tractors with less than required hydraulic output needed to operate hydraulic-driven vacuum fan and other planter hydraulic requirements.

A 1000 RPM PTO is required to operate the PTO-driven hydraulic pump.

PTO pump option consists of a 1 3/8"-21 or 1 1/4"-20 spline 13.5 GPM 2000 psi tractor mounted pump, planter mounted 10 gallon capacity hydraulic reservoir with spin-on 10-micron oil filter, EdgeVac fan mounted 15 GPM-rated oil cooler, and required hydraulic valves, fittings, and hoses.

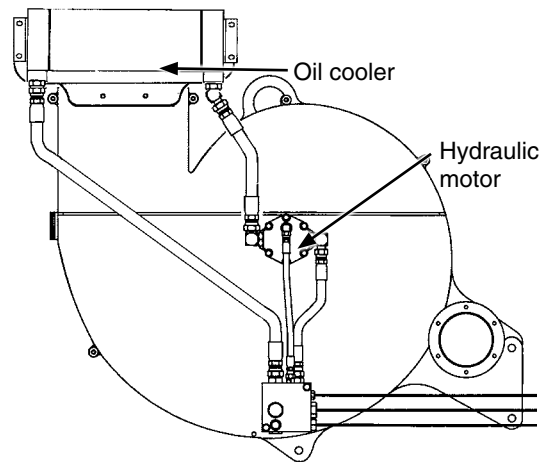

Vacuum fan assembly

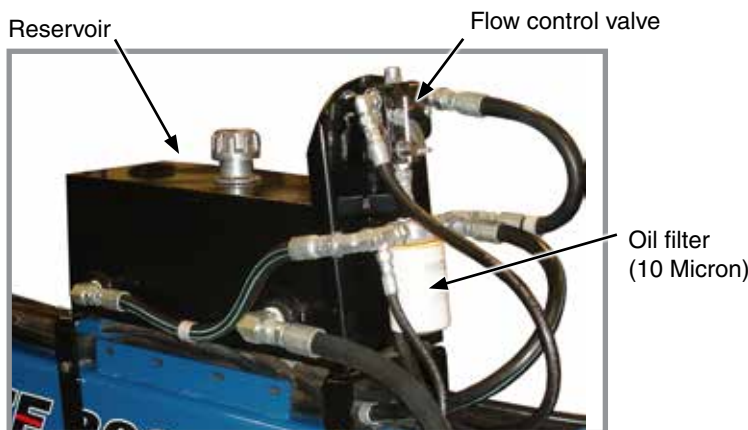

Hydraulic reservoir, flow control valve, and fittings



PTO-driven hydraulic pump (1 3/8" spline PTO pump shown)

TRACTOR PREPARATION AND HOOKUP

1. Adjust tractor drawbar 13-17 inches above ground with hitch pin hole directly below PTO shaft center line. Make sure drawbar is in a stationary position.
2. Install control console on tractor in a convenient location within easy reach of operator and close to hydraulic controls. Mount control console securely and route power cord to power source. Control console operates on 12 volt DC only. If two 12 volt batteries are connected in series, ALWAYS make power connection on battery grounded to tractor chassis.

If two 6 volt batteries are connected in series, make sure power connection provides 12 volt DC across positive terminal on one battery and negative terminal of second battery.

3. Back tractor to planter and connect with 1¼" - 1½" diameter hitch pin. If tractor is not equipped with a hitch pin locking device, make sure hitch pin is secured with a locking pin or cotter pin.

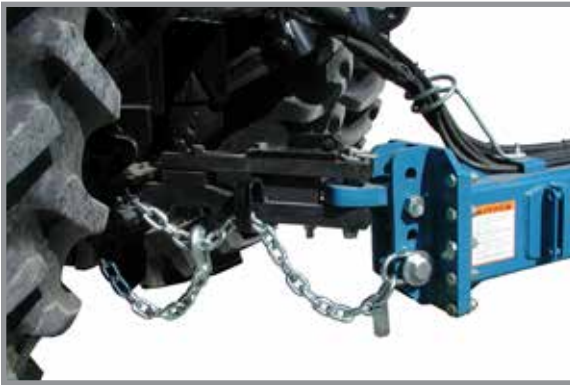

Planter/safety chain hookup to tractor

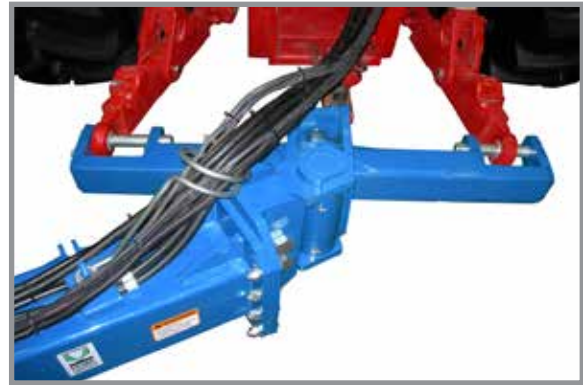

Optional 2-point hitch

NOTE: DO NOT install safety chain using clevis mounting hardware. Safety chain MUST be installed separately.

4. Safety chain must be used to keep planter and tractor connected in case of a hitch pin/drawbar failure. Attach safety chain at an unused clevis mounting hole on the planter hitch. Torque hardware to 840 ft-lb (1138.8 N-m).

NOTE: A 2-Point Hitch Option converts planter from drawn to semi-mounted and is available for use with Category 3N or 3 three-point hitch designs. Safety chain is not used with 2-point hitch.

WARNING

Pressurized hydraulic fluid can penetrate body tissue and result in death, serious infection, or other injuries. Fluid injected under skin must be IMMEDIATELY removed by a surgeon familiar with this type of injury. Make sure connections are tight and hoses and fittings are not damaged before applying system pressure. Leaks can be invisible. Keep away from suspected leaks. Relieve pressure before connecting or disconnecting tractor, searching for leaks, or performing any system maintenance.

NOTICE

Wipe hose ends to remove any dirt before connecting couplers to tractor ports or contamination may cause equipment failure.

5. Connect hydraulic hoses to tractor ports in a sequence familiar and comfortable to the operator.

NOTICE

Connect hydraulic motor case drain to a case drain return line with zero PSI on tractor. Failure to connect to a return with zero PSI will cause hydraulic motor shaft seal damage. **DO NOT** connect hydraulic motor case drain to a SCV outlet or motor return circuit connection. Contact tractor manufacturer for specific details on “zero pressure return”.

NOTICE

Always connect hydraulic motor return hose to tractor motor return port. Do not connect to tractor SCV unless through a motor spool or hydraulic motor failure can occur. If a motor return port is not available on the tractor, the SCV controlling the ASD system **MUST** be in the float position before planter is moved in planting or field raised position when ASD system is not in use.

PLANTER TO TRACTOR HYDRAULIC CONNECTIONS			
Color/Label	Machine Function	Hose Size	Function
Red AA	Field Lift	1/2"	Pressure
Red BB		1/2"	Return
Blue AA	Planter Fold & Row Marker	3/8"	Return
Blue BB		3/8"	Pressure
Black RR	Seed Rate Hydraulic Drive (EdgeVac)	3/4"	Return
Black PP		1/2"	Pressure
Black RR	Seed Rate Hydraulic Drive (Mechanical)	1/2"	Return
Black PP		3/8"	Pressure
Green RR	EdgeVac Vacuum Fan	3/4"	Return
Green PP		1/2"	Pressure
Orange CD		3/8"	Case Drain
Yellow RR	ASD System Pressure Fan	3/4"	Motor Return
Yellow PP		1/2"	Pressure
Orange CD		1/4"	Case Drain

NOTE: Set adjustable flow outlet (SCV) to full flow position.

For tractors not equipped with a method for finite adjustment of hydraulic flow, Flow Control Needle Valve Kit G1K426 is available from Kinze Repair Parts through your Kinze Dealer.



G1K426 needle valve kit

- Connect ASABE Standards 7 terminal connector for safety/warning lights on planter to ASABE Standards receptacle on tractor. If your tractor is not equipped with an ASABE Standards receptacle, check with your tractor manufacturer for availability. Check warning lights on planter work in conjunction with warning lights on tractor.

NOTE: A 12 volt battery connection is required to power the vacuum fan digital gauge. Connect "red" wire to positive (+) battery terminal and "black" wire to negative (-) battery terminal.

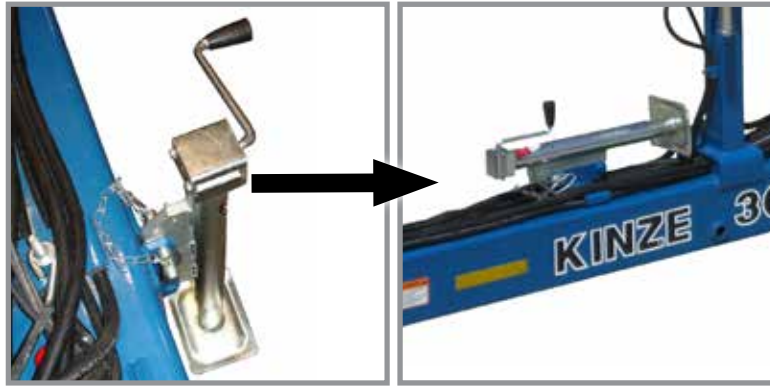

Remove and store jack

- Raise jack stand and remount horizontally on storage bracket.

LEVEL PLANTER

Lateral adjustment is maintained by tire pressure. Check tires are inflated to specification.

Front and rear level adjustment is maintained by hitch clevis position unless tractor drawbar is adjustable for height. Planter frame and row unit parallel arms must be level for proper planter and row unit operation. Bottom of toolbar should be 20" to 22" from planting surface.

- Lower planter to planting position and check planter is level front to rear. Go to step 2 if hitch is too high or low.

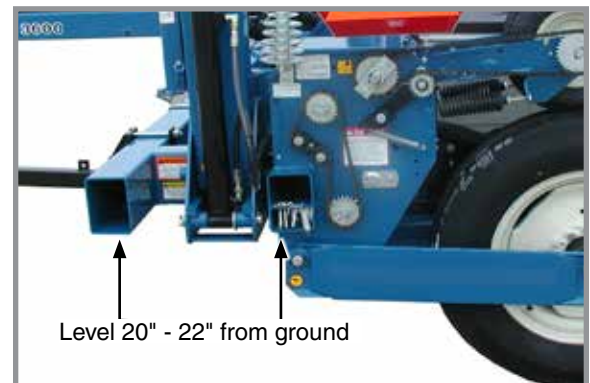

Level planter toolbars

NOTE: DO NOT install safety chain using clevis hardware. Move safety chain location if necessary.

- Remove clevis hitch hex head cap screw and lock nut using a torque wrench. Replace if off-torque is below 75 ft-lb (101.6 N-m) or there is corrosion or damage.

NOTE: Clevis must be free to move on hitch. DO NOT OVERTIGHTEN hardware.

- Align clevis to hitch holes at new location and install hex head cap screw and lock nut. Tighten lock nut until threads are fully engaged and hex head cap screw and lock nut are firmly against hitch bracket.

NOTE: On planters with push row units and no till coulters, uplift from down force springs or air springs in pneumatic down pressure system may cause wings to rise slightly in planting position. Problem may be compounded if static pressure is trapped in planter's hydraulic lift system which can cause wing cylinders to extend slightly. Operating tractor's hydraulic system in float position or moving tractor's hydraulic lever to float position briefly to relieve pressure will help maintain proper toolbar height.

4. Field check planter.

Field and actual planting conditions dictate which transport wheel setting to use so row unit parallel arms are parallel with ground. It may be necessary to lower ground drive wheels to ensure level lateral toolbar operation if transport wheels are set in one of the two lower sets of holes. Make a field check when planter is fully loaded with seed, granular chemicals, fertilizer, etc. to be sure wings are level with center frame. If wings are not level with center frame, drive wheels and/or transport wheels can be raised or lowered in wheel arms to increase or decrease planter toolbar height. Raise hitch to ensure level operation.

NOTICE

Component interference can damage equipment. Check clearance between tires and drill shaft U-joint when using top hole setting.

NOTE: To allow adequate drive force after lowering ground drive wheels, it may be necessary to lower contact drive wheel arms to lower sets of holes in wheel modules and lower down pressure springs to lower mounting rods on wheel modules.

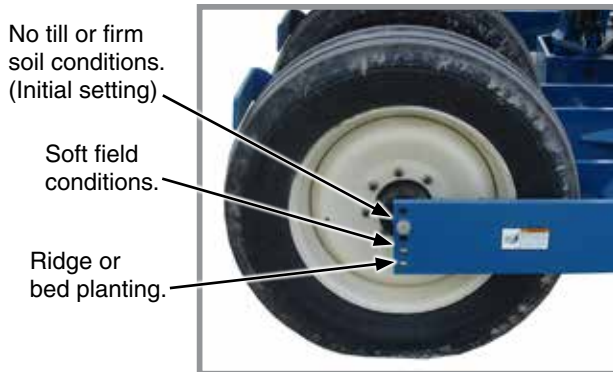

Transport wheel adjustment

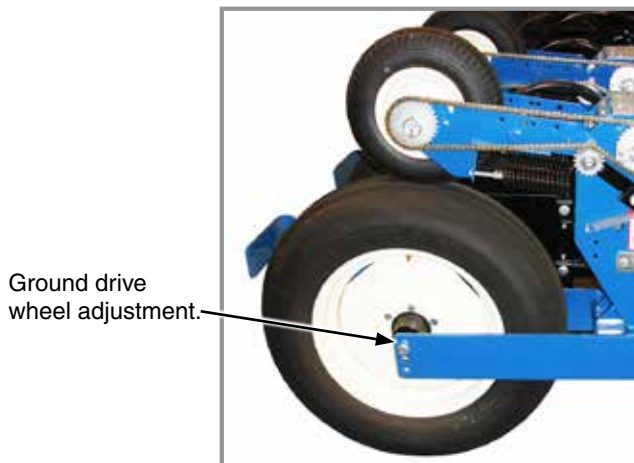
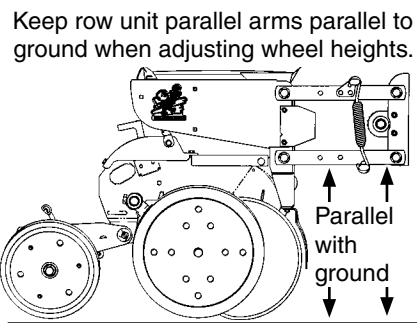

Ground drive wheel adjustment

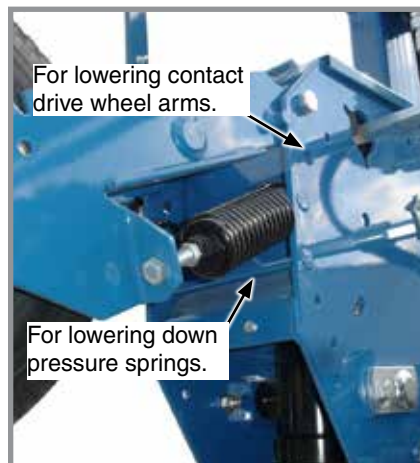

Contact drive wheel adjustment

NOTE: If setting is changed see basic adjustment procedure under “Contact Wheel Spring Adjustment”

RIDGE PLANTING

Move drive and transport wheels 2" or 4" to lower mounting holes in wheel arms when ridge planting to increase planter toolbar height. Contact drive tire must also be moved to lower set of holes in wheel module and down pressure springs hooked on lower rod. Raise hitch height to ensure level operation.

CONTACT WHEEL SPRING ADJUSTMENT

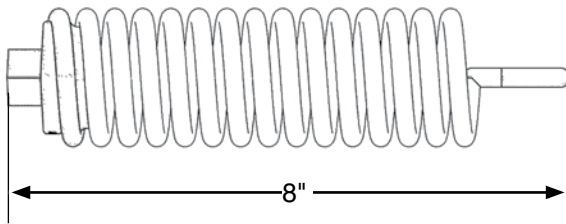

Spring length measurement (Factory setting)



Contact drive springs

There are two down pressure springs on each contact drive wheel. Spring tension is factory set to approximately 200 lb (90.7 kg) of down force at tire contact point and should require no further adjustment.

NOTE: Measurement must be taken in planting position with proper tire pressure.

CONTACT WHEEL DRIVE SPROCKETS

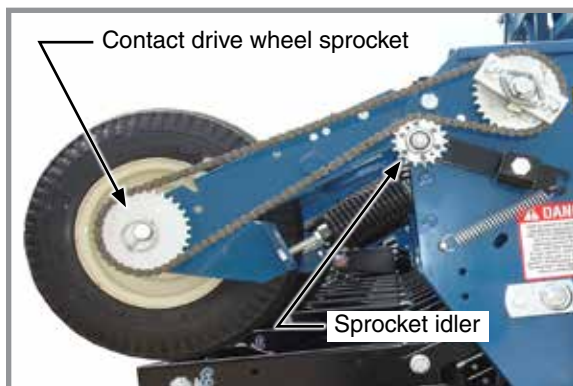

Contact wheel drive



Optional half-rate drive sprocket

Contact wheel drive works the same for mechanical or EdgeVac planters except for sprocket size. Chain tension is controlled by a spring-loaded sprocket idler. Planting rate charts in "Rate Chart" section help you select correct sprockets.

NOTE: Make a field test after each sprocket combination change to be sure you are planting at desired rate.

EDGEVAC

22 tooth, 28 tooth or 44 tooth sprockets at each contact drive wheel can be exchanged with sprockets on storage rod bolted to wheel module on each side of planter chains.

NOTE: 22, 28 and 44 tooth drive sprockets do NOT apply to all rate charts. Check chart titles to make sure proper rate chart is selected. DO NOT USE 44 tooth drive sprockets (60 cell soybean discs) with Dry Fertilizer Package or Liquid Fertilizer Squeeze Pump Package.

MECHANICAL

Seed planting rate charts are based on standard rate drive. Standard rate drive uses a 30 tooth sprocket and No. 40 118 pitch chain on each contact wheel.

Optional half-rate (2 to 1) drive is recommended only when population falls below planting rate charts. Replace 30 tooth sprocket on each contact wheel with a 15 tooth sprocket and shorter No. 40 110 pitch chain. This reduces planter transmission speed and planting and application rates by approximately 50%.

SEED RATE TRANSMISSION ADJUSTMENT

Planting population rate changes are made using seed rate transmissions at each end of planter. Seed rate transmission allows quick and easy sprocket changes to obtain desired planting population. Sprockets are exchanged with those from sprocket storage rod bolted to transmission by removing lynch pins on hexagon shafts.

A decal positioned on transmission module illustrates proper chain routing. Planting rate charts found in “Rate Chart” section help you select correct sprocket combinations.

Chain tension is controlled by a spring-loaded dual-sprocket idler adjusted with an easy-release idler arm. This arm has a release position to remove spring tension for replacing sprockets. See “Wrap Spring Wrench Operation” below.

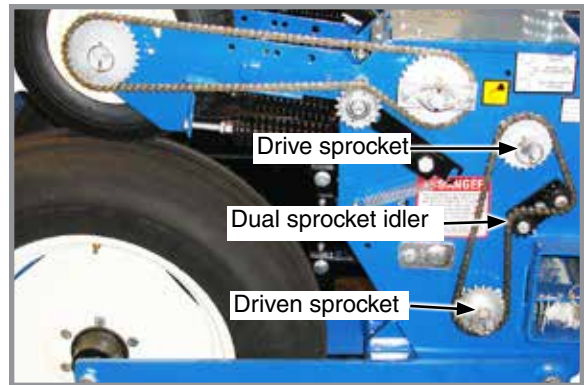

Seed rate transmission (R.H. shown)

WRAP SPRING WRENCH OPERATION

Chain idlers are equipped with wrap spring wrenches. L.H. wrap spring wrenches have a blue release collar and R.H. wrap spring wrenches have a grey or black release collar.

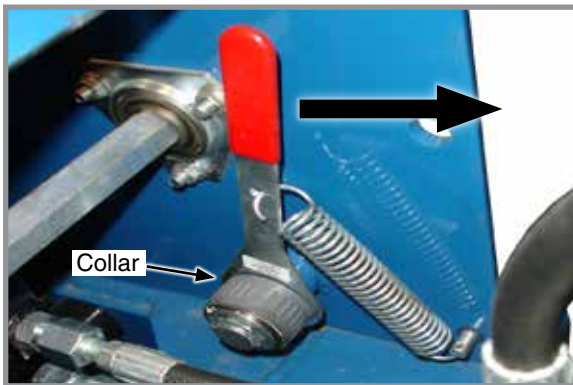

Wrap spring wrench (R.H. shown)



Chain idler tensioning

Rotate collar on wrap spring wrench and pull handle to release chain tension.

Rotate chain idler into chain and pull handle to tension idler spring.

ROW UNIT AIR CLUTCHES

Set air clutch system pressure to 50 psi (344.7 kPa).

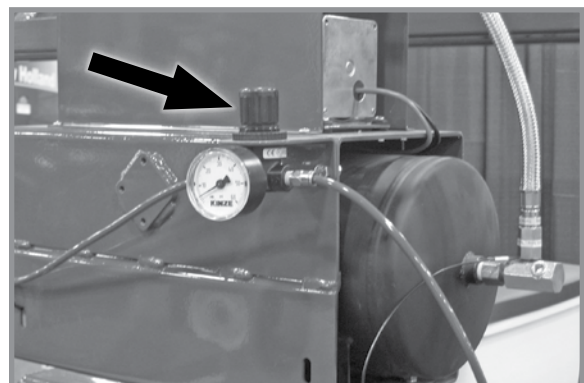

Air clutch pressure valve

AG LEADER ELECTRIC CLUTCHES

Electric clutches along with GPS can stop seed flow by turning off seed meters (and planter sections) based on field mapping and previously planted areas.

HYDRAULIC SEED RATE DRIVE

Refer to Ag Leader Integra or KINZE Cobalt operation manuals for information on setting and controlling hydraulic seed rate system.

HALL EFFECT SENSOR (HYDRAULIC DRIVE ONLY)

Set Hall effect sensor within $\frac{1}{8}$ " of pick-up disc.

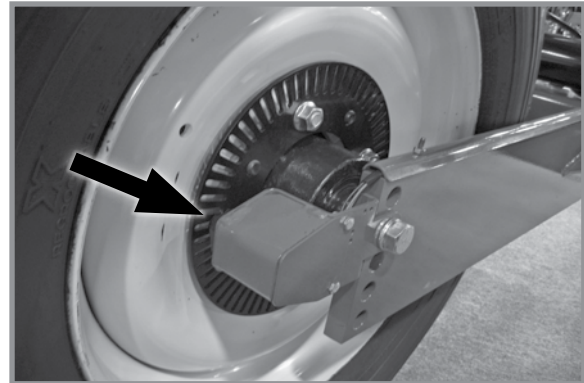

Hall effect sensor

HYDRAULIC WEIGHT TRANSFER TOOLBAR

The hydraulic weight transfer is standard on bulk fill equipped machines and optional on conventional hopper machines. The bulk fill hydraulic system powers the hydraulic weight transfer system and conventional hopper system requires an additional SCV. Pressure is set from the factory and does not require additional adjustment.

SHEAR PROTECTION

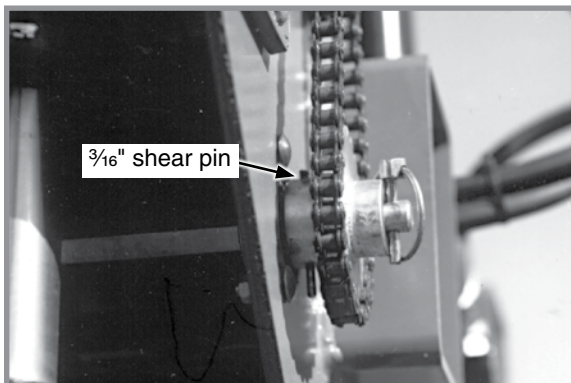

Transmission shaft

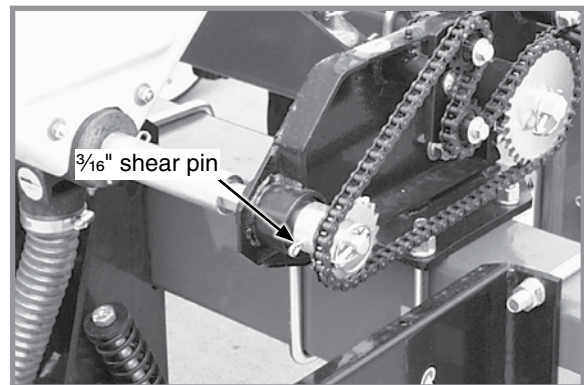

Dry fertilizer attachment transmission

Shear pins protect planter driveline and row unit components from damage.

1. Determine where binding has occurred before replacing a pin. Turn shaft by hand (with the aid of a wrench) and check for misalignment and seized parts.
2. When shaft can be turned by hand (with the aid of a wrench) replace shear pins with same size and type. Spare shear pins are stored inside ends of rear planter frame.

NOTICE

Misaligned drill shaft/transmission coupler can cause equipment damage.

3. Check driveline alignment and follow prescribed lubrication schedules to prevent component binding or breakage.

HYDRAULIC/ELECTRIC OPERATION

Control console switches and tractor's hydraulic system are used to raise planter to transport position, operate rotate and tongue extension functions, lock and release planter wings, and raise and lower row markers.

NOTE: Turn console backlighting OFF during extended periods of non-use using push button switch on back of console.



Single point row clutch control box



Two-speed point row clutch control box

Model 3600 planters operate from three dual remote (SCV) hydraulic outlets and tractor mounted control console. One SCV and a control console switch operate raise to transport function. A second SCV and control console switches operate row markers and fold/unfold functions. A third SCV operates vacuum fan motor circuit.

Marker and point row selector switches are an ON-OFF-ON type. If planter is equipped with optional Two-Speed Point Row Clutch Package, point row switch and reduced rate switch operate independently from rest of control console.

Power to marker switch is fed through auxiliary switch and two transport function switches. Operating any lower row switch disables markers and turns off marker indicator light.

Raise/wing lock and rotate/tongue (fold function) switches are MOMENTARY ON-OFF-MOMENTARY ON type and must be held in position while operating tractor hydraulic SCV control. Activating a fold function switch disables marker circuit.

WARNING

Marker selector switch must be OFF (center position) when not in use to prevent accidental extension which could result in death or serious injury, or damage to property and equipment. An indicator light on control box panel is ON whenever marker circuits or point row clutch circuits are energized.

Auxiliary switch is an ON-OFF type switch used with hydraulic marker/folding functions SCV control to operate optional attachments. Auxiliary switch must be OFF to enable other functions.

NOTE: Activating auxiliary switch disables all other control console switches except point row clutch switch.

NOTE: Lift cylinders are (port type) rephasing cylinders. Cylinders must fully retract before they rephase in lowered position. Cylinder stops can not be used.

A third SCV operates the EdgeVac seed metering system vacuum fan. See "Digital Vacuum Gauge Operation".

TRANSPORT TO FIELD SEQUENCE

Position planter in a relatively flat open area. Avoid an area with furrows, etc.

SUMMARIZED TRANSPORT TO FIELD SEQUENCE

- Remove tongue safety pin.
- Remove transport latch locking pin.
- Remove manual safety lockup.
- Rotate planter to planting position.
- Raise planter slightly to release safety hook at top of center section.
- Lower planter to ground.
- Release wing locks.
- Rephase planter lift cylinders.
- Raise planter to raised field position and retract tongue.
- Remove row marker lockups.

NOTE: Read following information for detailed instructions.

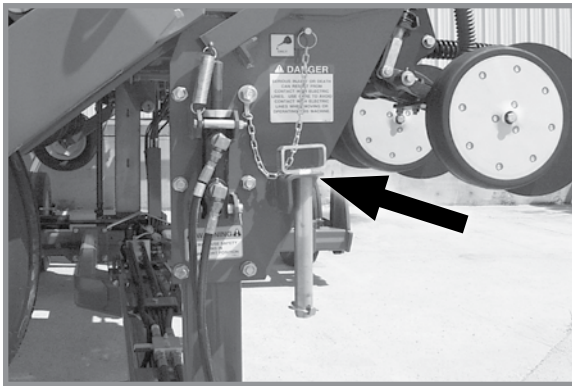

Tongue safety pin in storage position



Tongue safety pin in transport position.

1. With tongue fully extended and planter in raised transport position, remove tongue safety pin and place it in storage position.

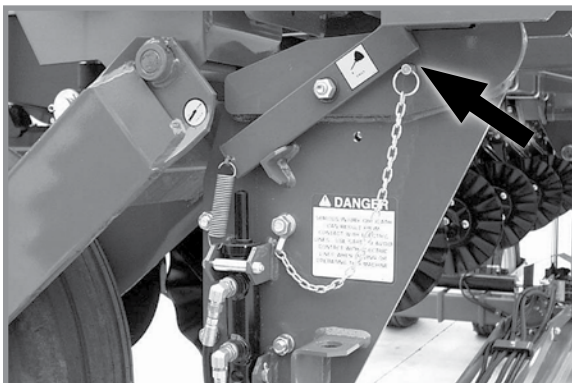

Transport latch locking pin
Locked transport position

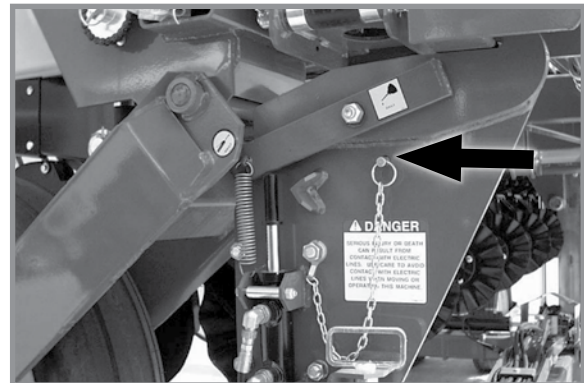

Transport latch locking pin
Storage position

2. Remove transport latch locking pin from locked position and place it in storage location.

- Remove manual safety lockup from under front center lift cylinder and place it in storage location on left side of planter axle.

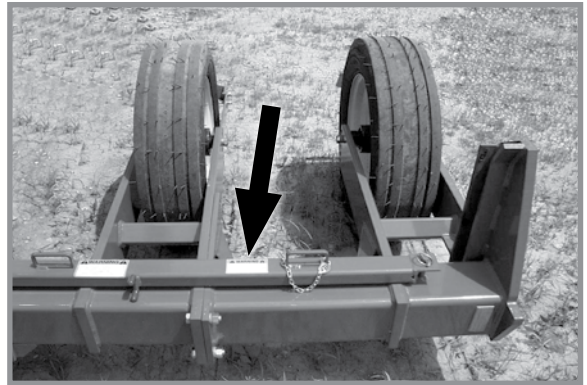

Storage position

- Hold control console “ROTATE/TONGUE” switch in “ROTATE” and operate hydraulic control to unfold planter. Transport latch automatically releases.



Rotate from transport to field

- Raise planter 1"-2". Safety hook will release and snap away from catch pin on top of pivot post.

NOTE: Raising planter too high resets hook mechanism and sequence must be repeated.

- Slowly lower planter to ground.

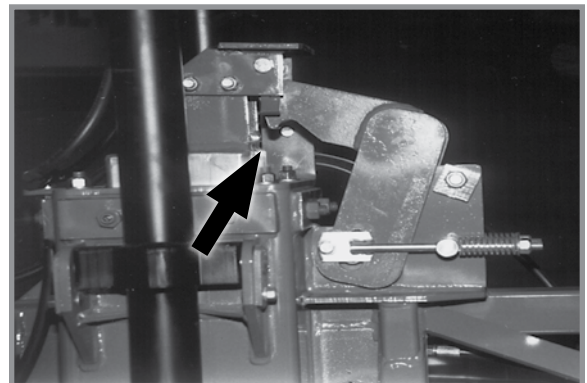

Safety hook release

- Hold control console “RAISE/WING LOCK” switch in “WING LOCK” position and operate hydraulic control to release wing locks.

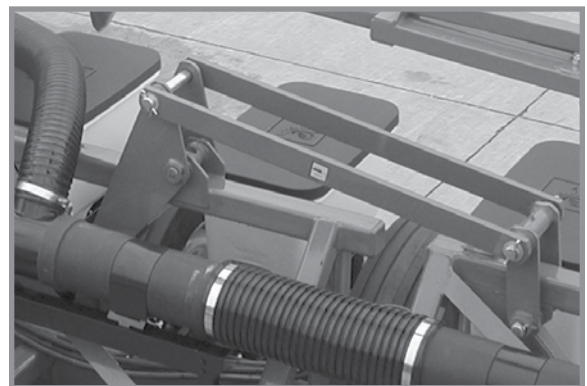

Wing lock

8. Hold hydraulic control (to lower planter) to rephase planter lift cylinders. Time to rephase system may vary due to tractor hydraulic flow and/or oil temperature. Normally 5 to 20 seconds is adequate to rephase system.
9. Raise planter to raised field position. Hold control console ROTATE/TONGUE switch in **TONGUE** and operate hydraulic control to retract tongue.
10. Remove row marker lockups.



Retract tongue



Row marker lockup

FIELD OPERATION

DANGER!

Contacting or coming close to power lines or other high energy sources will cause death or serious injury. Keep away from power lines or high energy sources at all times.

NOTICE

Raise planter out of ground when making sharp turns or backing up or equipment damage may result.

There are two raised positions on planter. Transport position is when the planter is fully raised. Raised field position is when planter wing cylinders are fully extended and center lift cylinders are at mid-stroke. In “raised field position” row units are approximately 14 inches off ground. This position is used in making turns or passing over waterways during field operation.

An oil bypass solenoid is located on top side of valve blocks on rear R.H. side of center frame. This solenoid is not energized in raised field position so wing cylinders cannot bypass oil preventing planter from raising any higher.



Raised field position

PLANTING SPEED

Planters are designed to operate in a speed range of 2 to 8 MPH. Higher ground speeds generally cause more variation in seed spacing. Speeds above 5.5 MPH are typically not recommended. See “Rate Charts”

FIELD TO TRANSPORT SEQUENCE

Position planter in a relatively flat area. Avoid areas with furrows, etc.

SUMMARIZED FIELD TO TRANSPORT SEQUENCE

- Install row marker lockups.
- Raise planter to raised field position.
- Extend tongue.
- Lock wings over center
- Raise planter to engage safety hook at top of center section into locking position.
- Lower planter onto safety hook.
- Rotate planter to transport position.
- Install tongue safety pin.
- Install transport latch locking pin.
- Install manual safety lockup.

NOTE: Read following information for detailed instructions.

1. Install row marker lockups.
2. Raise planter to raised field position using hydraulic control.



Row marker lockup

3. Hold "ROTATE/TONGUE" switch in "**TONGUE**" and operate hydraulic control until tongue is fully extended. Tongue lock latch automatically releases.

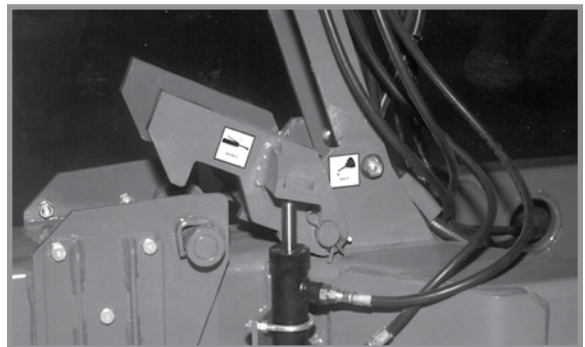

Tongue latch lock

4. Hold "RAISE/WING LOCK" switch in "**WING LOCK**" and operate hydraulic control until wing lock cylinders are fully extended and wing locks are locked over center.



Wing lock

5. Hold control console “RAISE/WING LOCK” switch in “**RAISE**” and operate hydraulic control until two center lift cylinders are fully extended and safety hook at top of center section rotates into locking position.
6. Lower planter onto safety hook using hydraulic control.

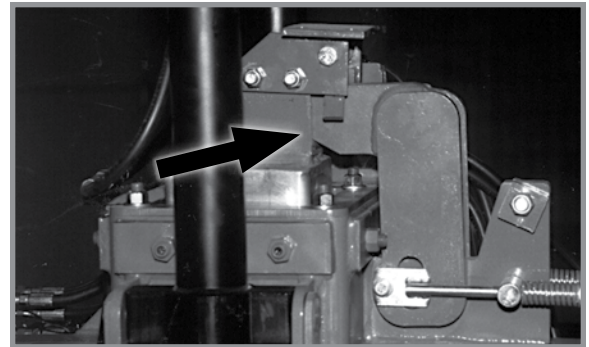

Center section safety hook

! WARNING

Uncontrolled movement of equipment can cause loss of control and could result in death, serious injury, or damage to property and equipment. Install all safety pins before transporting equipment.

7. Hold control console “ROTATE/TONGUE” switch in “**ROTATE**” and operate hydraulic control to rotate planter until transport latch is engaged.
8. Install tongue safety pin.



Tongue safety pin

9. Install transport latch locking pin.

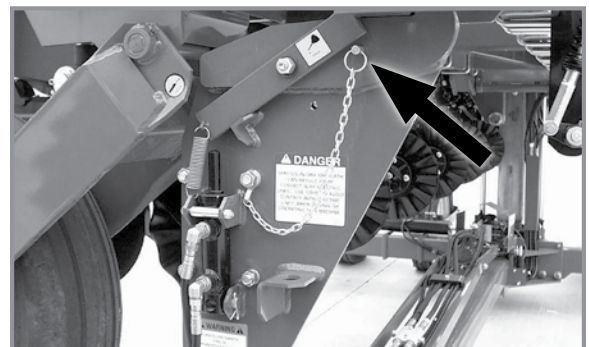

Transport latch locking pin installed

10. Remove manual safety lockup from storage location on left side of axle assembly and position it behind front center lift cylinder.

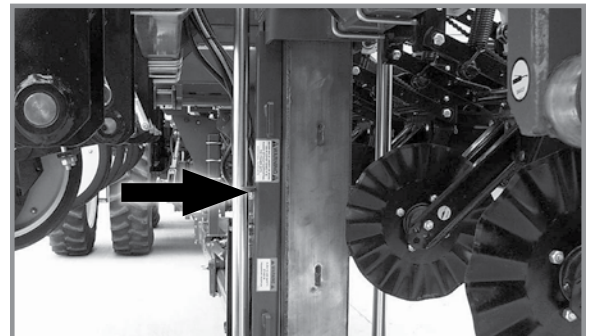

Manual safety lockup installed

EDGEVAC SYSTEM

Kinze EdgeVac seed metering system includes seed meters, seed discs, and an air system consisting of a hydraulic driven vacuum fan which draws air through manifolds, hoses, and seed meters on each row unit.

WARNING

Moving fan blades can cause amputation or severe injury. Never operate vacuum fan with cover removed.

DIGITAL VACUUM READOUT

Digital vacuum readout is incorporated into Kinze Vision and Cobalt displays. Refer to their operation manuals for instructions.

VACUUM FAN MOTOR VALVE BLOCK ASSEMBLY

A pressure relief valve in the hydraulic circuit prevents build up of oil pressure over 35 PSI in case drain line when vacuum fan motor is operating. This valve will vent oil outside valve block through a drain hole in the aluminum valve block. This can occur whenever case drain is improperly connected or pressure in motor circuit builds.

See “Hydraulic Diagram - Vacuum Fan Motor System” in Maintenance section.

Valve block contains a check valve that prevents vacuum fan from operating in wrong direction if pressure is applied to return side of motor and allows fan to coast to a stop when tractor hydraulic control is returned to neutral position.

NOTE: Fan turns at a reduced speed if reverse pressure is applied.

ANALOG VACUUM OR PRESSURE GAUGE

The analog vacuum or pressure gauge connects directly to the EdgeVac (vacuum) or ASD (pressure) manifold and is teed into the digital sending units.

Only adjustment is to “zero” needle with no vacuum or pressure present. If there is a significant difference between gauge and a reading taken at meters, a different manifold location should be found to connect hose to gauge and digital sending unit.



Analog gauge

NOTE: Analog gauges are identical EXCEPT for plug and hose barb locations in side of gauge housing. DO NOT connect EdgeVac or ASD hose to wrong gauge. Check plug and hose barb installation if readout is erratic or appears inaccurate.

AIR SEED DELIVERY (ASD) SYSTEM

CAUTION

Seed flying out of disconnected delivery tube at high velocity can cause injury. Do not disconnect delivery tubes when system is operating.

NOTICE

Foreign materials can plug system. Make sure seed is clean and free of debris when filling ASD hoppers.

NOTICE

Do not turn on system with tractor engine at full speed or system damage may occur.

NOTICE

Do not operate ASD system above maximum system operating pressure of 20 inches of water or seed bridging may occur.

1. **Before filling hoppers refer to “Row Unit Operation” for additives information.** Fill hoppers with seed, latch lids, and secure with pin.
2. Start air seed delivery system with tractor engine at idle.
3. Increase engine speed to full and set initial system pressure using flow control valve.
4. Allow system to warm up and adjust pressure if necessary.

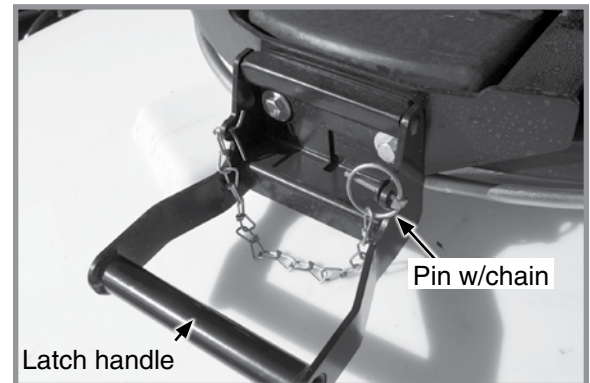

ASD tank lid latch

Recommended pressures:

- Corn – 12 inches of water
- Soybeans – 10 inches of water
- Actual pressure needed is affected by seed size, shape, and coating.

ASD ENTRAINER ACCESS

1. Shut down ASD system.
2. Loosen wing nut and turn retainer holding shutoff door in its storage location.
3. Remove rubber plug closest to area in entrainer needing attention.
4. Insert shutoff door into open slot and push into entrainer at a slight upward angle.
5. When work is complete, remove shutoff door, return door to storage location, and plug open slot.

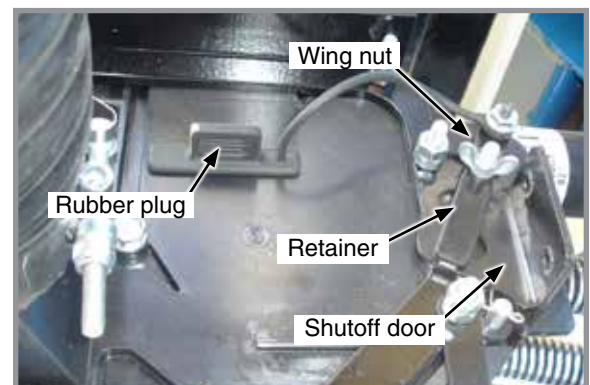

ASD entrainer (end view)

ASD TANKS - CLEAN OUT

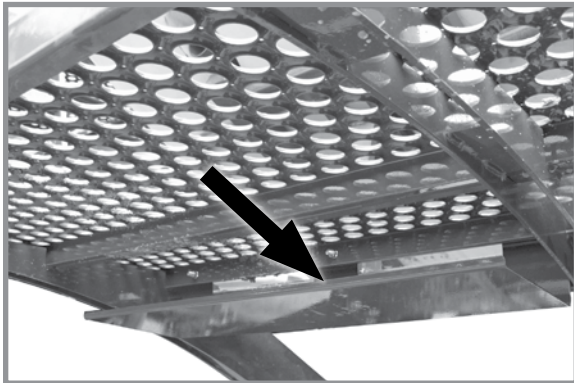

Cleanout chute storage bracket

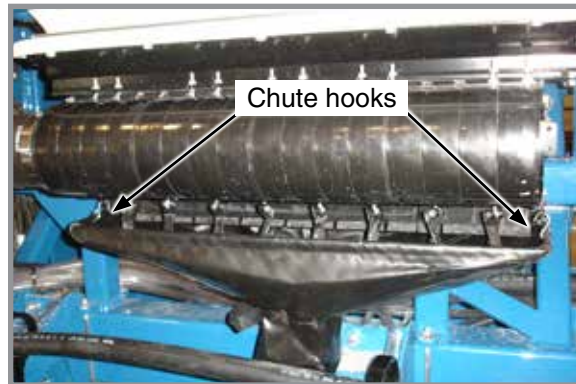

Cleanout chute installed

1. Remove ASD tank cleanout chute from storage location beneath catwalk.
2. Position tube of chute under entrainer and attach hooks on each end of entrainment assembly.
3. Open cleanout doors and empty tank.
4. Close all cleanout doors and return cleanout chute to storage location.

ASD SCALE PACKAGE OPTION

NOTICE

High-pressure water can damage display. Remove display before power washing planter.

NOTICE

Remove and store display at end of planting season. Damage from sun and weather exposure may result.

- Provides seed weight or estimated acres remaining for each ASD hopper.
- Displays total (gross) seed weight or estimated acres remaining for both hoppers combined.
- Warns operator when seed goes below a pre-defined level (when using a Kinze Vision display).

Operation of ASD Scale Package display is controlled by buttons located on its face:

- Two screen-defined selection buttons.
- Backlight ON/OFF button.
- UP/DOWN arrow buttons.
- Screen position is changed by loosening thumb screw on mount at back of monitor and repositioning screen.

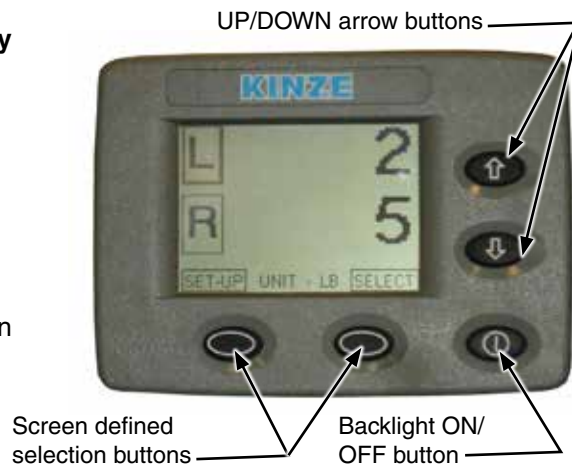

SETUP ASD SCALE PACKAGE DISPLAY

1. Press SET-UP button.
2. First setup screen displays and ALARM LEVEL box is highlighted.
3. Press SELECT button.
4. Press UP or DOWN arrows to change alarm weight level. Select BACK to save changes.
5. Press UP or DOWN arrows to highlight WEIGHT/ACRE MODE box. Press SELECT button.
6. Press UP or DOWN arrow buttons to toggle between weight or acre mode. This selection affects if values are displayed as pounds or estimated acres of seed remaining. Press BACK to save changes.
7. Press DOWN arrow to select second set-up screen.

NOTE: CALIBRATION# and SETUP# are automatic and do not need to be changed.

8. Select CONTRAST or BACKLIGHT. Use UP or DOWN arrow buttons to change levels. Press BACK to save changes.
9. Select BACK to return to main screen.



MONITOR SEED LEVELS

1. Main screen displays information for left and right hoppers.
2. Select either L or R for individual hopper status information.
3. Select BACK to return to main screen.
4. Press down arrow once or twice to display GROSS screen. Combined status information for both hoppers is shown.
5. Press down arrow again to return to main screen.



ENTER SEED INFORMATION

1. Highlight and select either L (left) or R (right) for the appropriate input screen.
2. At input screen, L or R side is indicated at left side of screen and seed weight or acres remaining is on right side.



3. Press arrow keys to select desired box; press SELECT to darken and use arrow keys to change.

NOTE: Seed information entered must be accurate for remaining estimated acres to calculate correctly.

- SEEDS/ACRE is population rate.
- SEEDS/LB value comes from seed specifications.
- ZERO is selected to zero hopper that is selected.

4. Select BACK to return to main screen.



KINZE ISOBUS OPTION

Kinze ISOBUS option consists of a planter monitor module (PMM), and planter control module (PCM). Kinze planters will communicate directly with most ISO compatible monitors.

KINZE COBALT SYSTEM

Cobalt electronic seed monitor system consists of a tractor-mounted console, seed tubes with computerized sensors installed in each planter row unit, a primary harness connecting console to planter harness, and a planter harness (junction Y-harness and/or harness extension where applicable), connected to each seed tube sensor.

Cobalt monitor is built to withstand harsh environments associated with today's agricultural industry. The weathertight enclosure seals out dirt and moisture encountered during normal operating conditions

This system is compatible with all Kinze planters, and can be transferred between multiple vehicles to maximize return on investment.

Cobalt system allows manual control of air clutches and variable population control when planter is equipped with these options. It is not GPS compatible.

NOTE: See Kinze Cobalt operator manual for installation and programming.



Kinze Cobalt display

AG LEADER INTEGRA DISPLAY

INTEGRA is a full-featured hub of any precision farming operation. A large, full-color 12.1" HD touchscreen display is easy to read and offers powerful, year-round precision farming tools. Mapping, planter and application control, yield monitoring, real-time data logging, and more – are all controlled from the cab using the Integra display.

Four video camera inputs provide operators a better view of equipment operation and safety by allowing them to view live video on the display.

NOTE: See Integra operator manual for installation and programming.



Ag Leader Integra display

PLANTER MONITOR MODULE (PMM)

The PMM Magnetic Distance Sensor Package includes a planter-mounted module enclosure with cover and mounting hardware, seed tubes w/sensors, planter harness, planter monitor cable, shaft rotation sensors and magnetic distance sensor components.

Ag Leader Integra display and associated cab harnesses are also required.



Planter monitor module (PMM)

ROCK GUARDS

Transport wheel rock guards are used on both sides of each transport wheel when planter is used in rocky conditions.

Rock guards help prevent rocks from being picked up by wheels and damaging adjoining row units.



Rock guard

AUXILIARY WORK LIGHTS PACKAGE

Auxiliary work lights package includes two 50 watt, 3" x 5" halogen flood lamps, mounting hardware, and a wiring harness to plug into existing planter light harness.

Mounting varies with ASD and conventional planters.



Auxiliary work lights

ROW MARKER OPERATION



Contacting or coming close to power lines or other high energy sources will cause death or serious injury. Keep away from power lines or high energy sources at all times.



Marker switch

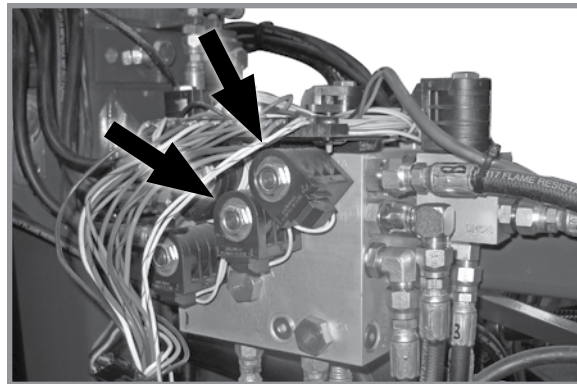

Row marker solenoid valves (Cover removed)

Two solenoid valves on valve block at rear R.H. side of center frame, and a three position selector switch on control console permit operator to lower or raise desired row marker.

NOTICE

Marker position switch must be OFF when planter is not in use or tractor battery will drain.

See "Row Marker Speed Adjustment".

1. Select which row marker to lower on control console.
2. Operate hydraulic control to lower row marker.
3. Move control switch to other side to operate opposite row marker.
4. Raise row marker at end of field using hydraulic control.
5. After turn, using the hydraulic control, lower the pre-selected row marker.
6. Continue to follow this procedure.

NOTE: Both row markers can be lowered by operating switch in each position and hydraulic control twice. Row markers raise simultaneously with hydraulic control in raise position.

If electrical system does not operate properly:

- Check fuse.
- Check wiring connections.
- Check control switch.
- Check solenoid. SOLENOID HOUSING IS MAGNETIZED WHEN ENERGIZED.

ROW MARKER SPEED ADJUSTMENT

NOTICE

Excessive row marker travel speed can damage row markers.
Adjust flow controls before row markers are first used.

Marker hydraulic system includes two flow control valves. One flow control valve sets lowering speed and one sets raising speed of both markers. Flow controls determine amount of oil flow restriction through valves, varying marker travel speed.

Loosen jam nut and turn control clockwise, or IN to slow travel speed. Turn counterclockwise, or OUT to increase travel speed. Tighten jam nut after adjustments are complete.

NOTE: Tractors with flow control valves. Make row marker speed adjustment with tractor flow controls in maximum position. After row marker speed is set, adjust tractor flow controls to allow hydraulic control to stay in detent during marker raise or lower cycle.

NOTE: Hydraulics operate slowly when oil is cold. Make all adjustments with oil warm.

NOTE: On a tractor where oil flow cannot be controlled, tractor flow rate may be greater than rate marker cylinder can accept. Hold tractor hydraulic control lever until cylinder reaches end of its stroke. This occurs most often on tractors with an open center hydraulic system.

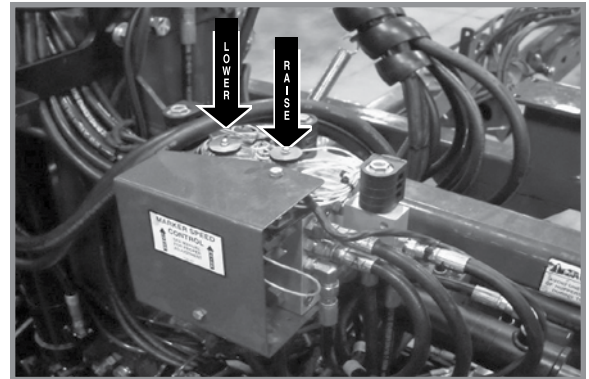

Row marker speed control adjustment

EVEN-ROW PUSH ROW UNIT

An Even-Row Push Row Unit Package is available to add one additional push row unit on outer L.H. side of front toolbar for use with Solid Row Interplant Package.

NOTE: See "Row Marker Adjustment" for determining correct length to set row marker assemblies when planting with even-row push row unit option.

NOTE: install hitch onto 2-point hitch bar using R.H. hole. If 2-Point Hitch Option is used. A 7½" offset mount is not needed. See "Offset Hitch Adjustment" for additional information.

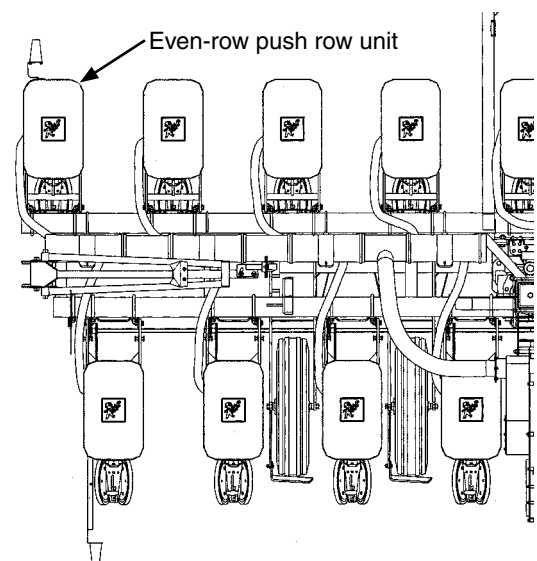

ROW MARKER ADJUSTMENTS

1. Multiply number of rows by the average row spacing in inches to determine total planting width.

Row Marker Lengths	
12 Row 30"	360" (914.4 cm)
12 Row 36"	432" (1097.3 cm)
12 Row 38"	456" (1158.2 cm)
16 Row 30"	480" (1219.2 cm)

2. Lower planter and row marker assembly to ground.
3. Measure from planter center line to a point where blade contacts ground.
4. Adjust row marker extension so distance from marker disc blade to center line of planter is equal to total planting width. Adjust right and left row marker assemblies equally and securely tighten clamping bolts.

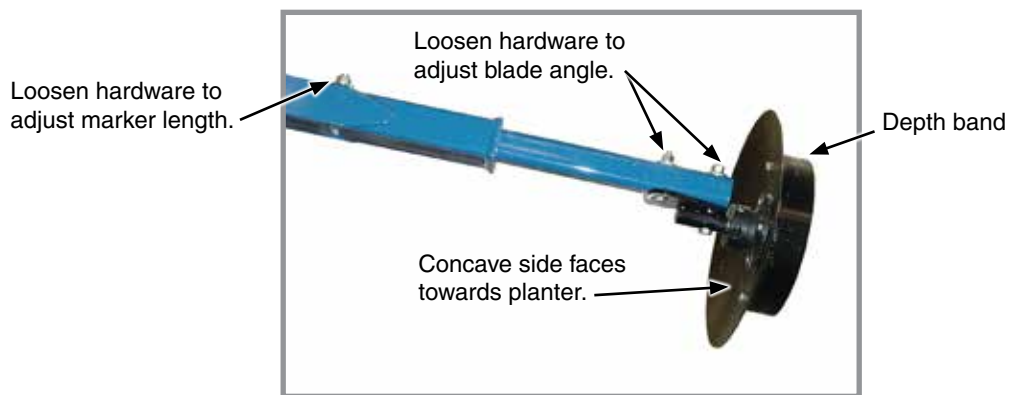

Row marker disc blade angle adjustment

NOTICE

Setting marker disc blade assembly at a sharper angle than needed adds stress to row marker assembly and shortens bearing and blade life. Set blade angle only as needed to leave a clear mark.

Marker disc blade is installed with concave side facing inward. Spindle assembly is slotted so hub and blade can be angled to throw more or less dirt.

5. Loosen hardware and move assembly as required.
6. Tighten bolts to specified torque.
7. Do a field test to ensure markers are properly adjusted.

NOTE: A notched marker blade is available from Kinze through your Kinze Dealer for use in more severe no till conditions.

ROW MARKER EVEN-ROW LENGTH ADJUSTMENT

Adjust marker extensions as shown below when using even-row push row unit option.

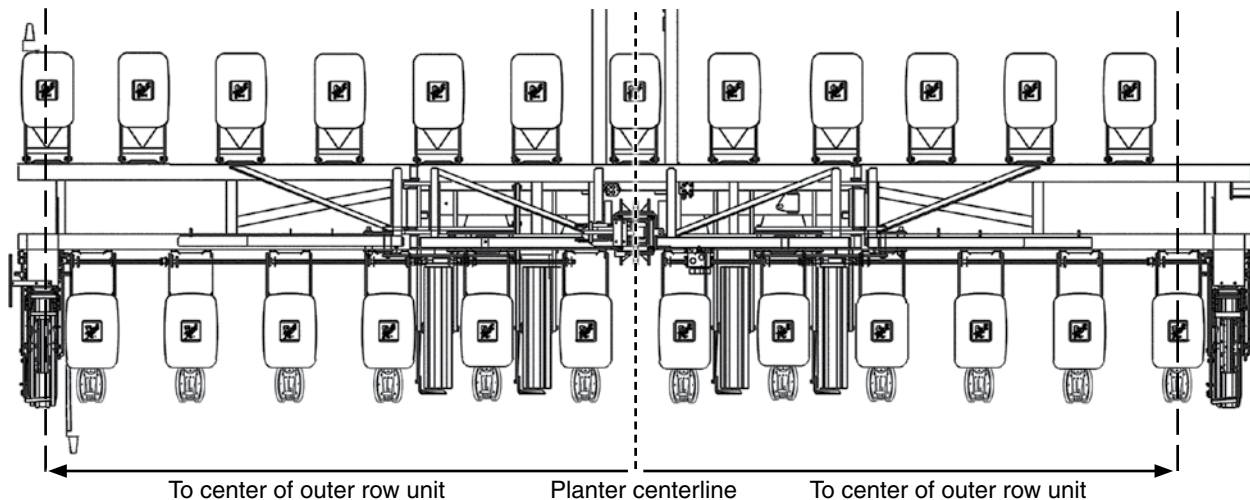

Center Of Planter To Center Of Outer Row Unit x 2 + 15" Row Spacing = Dimension Between Planter Center Line And Marker Blade

12 Row 30" With 12 Interplant Push Row Units
 (L.H. Marker 180" x 2 + 15" = 375")
 (R.H. Marker 165" x 2 + 15" = 345")

16 Row 30" With 16 Interplant Push Row Units
 (L.H. Marker 240" x 2 + 15" = 495")
 (R.H. Marker 225" x 2 + 15" = 465")

NOTE: Readjust row markers when planting 30" rows.

Number Of Rows x Row Spacing (Inches) = Dimension Between Planter Center Line And Marker Blade

12 Rows x 30" Spacing = 360" Marker Dimension
 16 Rows x 30" Spacing = 480" Marker Dimension

L.H. SIDE 30" - 7½" TWIN ROWS

Number Of Rows x Row Spacing (Inches) + ¾" Hitch Offset = Dimension Between Planter Center Line And Marker Blade

12 Rows x 30" + ¾" = 363.75"
 16 Rows x 30" + ¾" = 483.75"

R.H. SIDE 30" - 7½" TWIN ROWS

Number Of Rows x Row Spacing (Inches) - ¾" Hitch Offset = Dimension Between Planter Center Line And Marker Blade

12 Rows x 30" - ¾" = 356.25"
 16 Rows x 30" - ¾" = 476.25"

OFFSET HITCH ADJUSTMENT

If tractor hitch is offset 7½" right of tractor center line, add 7½" to marker dimension on R.H. side of planter and subtract 7½" from marker dimension on L.H. side of planter.

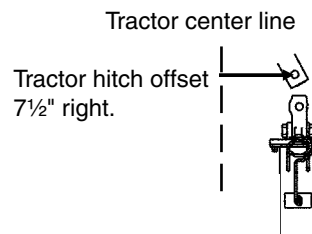

POINT ROW CLUTCHES

L.H. point row clutch switch
10 amp time delay fuse

R.H. point row clutch switch
10 amp time delay fuse



Single point row clutch control box

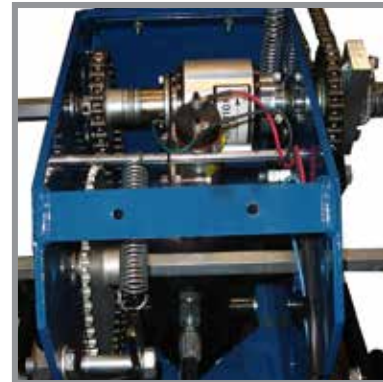

Point row clutch

Electric-activated clutches disengage drive on either half of planter for finishing up fields or for long point row situations. Clutch selector switch is located on tractor control box.

NOTICE

Switch must be OFF when planter is not in use or tractor battery will be drained.

NOTE: Liquid fertilizer piston pump has its own drive wheel and is not affected by point row clutch.

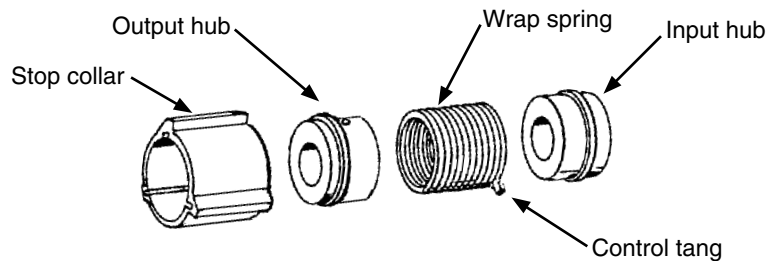

Clutch consists of a wrap spring riding on an input and output hub. Wrap spring is wrapped tightly over hubs during operation locking them together. Higher speeds create a tighter grip of spring on hubs.

Input end of spring is bent outward and is called the control tang. Control tang fits into a slot in stop collar located between input and output hubs over wrap spring. If stop collar is allowed to rotate with input hub, clutch is engaged. If stop collar is stopped from rotating, control tang connected to it is forced back and spring opens. This allows input hub to continue rotating without transmitting torque to output hub, stopping planter drive.

Stop collar is controlled by an electric solenoid and an actuator arm. When selector switch on tractor control box is OFF, solenoid coil is NOT ENERGIZED and actuator arm will not contact stop on stop collar, allowing it to rotate with hubs and drive planter.

When operational switch is in "DISENGAGE" (right or left) solenoid coil IS ENERGIZED and plunger in solenoid coil pulls actuator arm against stop on stop collar, disengaging wrap spring and stopping planter drive.

TWO-SPEED POINT ROW CLUTCHES

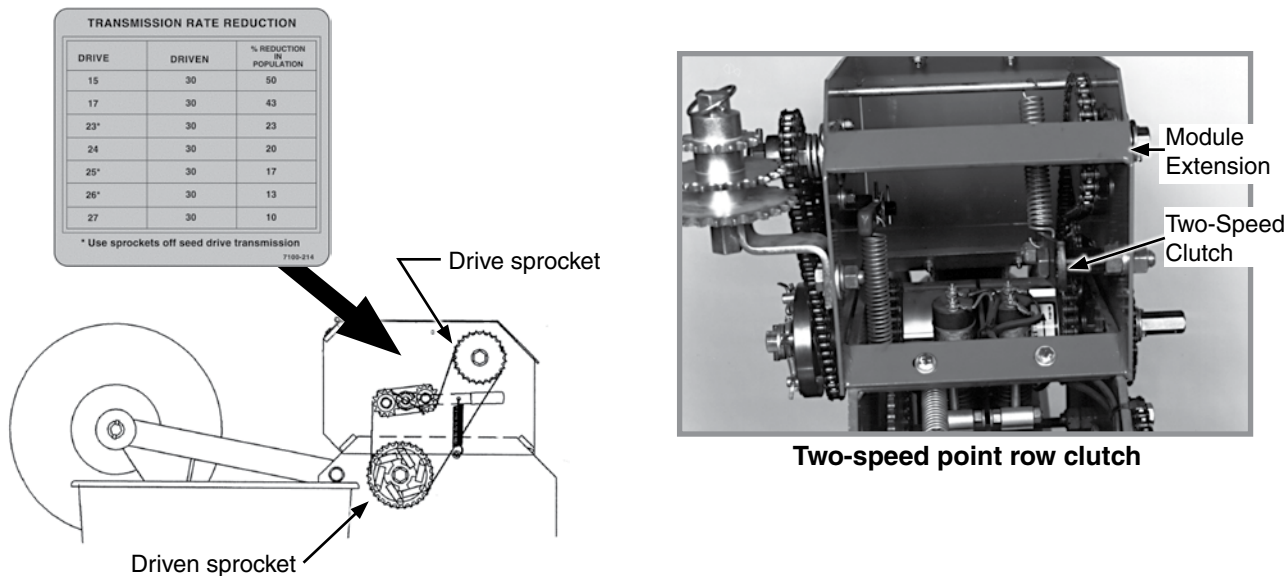

Optional Two-Speed Point Row Clutch Package allows on-the-go population rate adjustment and capability to shut off either half of planter for finishing up fields or for long point row situations.

Population reduction ratio is determined by sprocket ratio between wheel module extension drive and driven sprockets. A rate reduction decal similar to one shown above is located on wheel module extension.

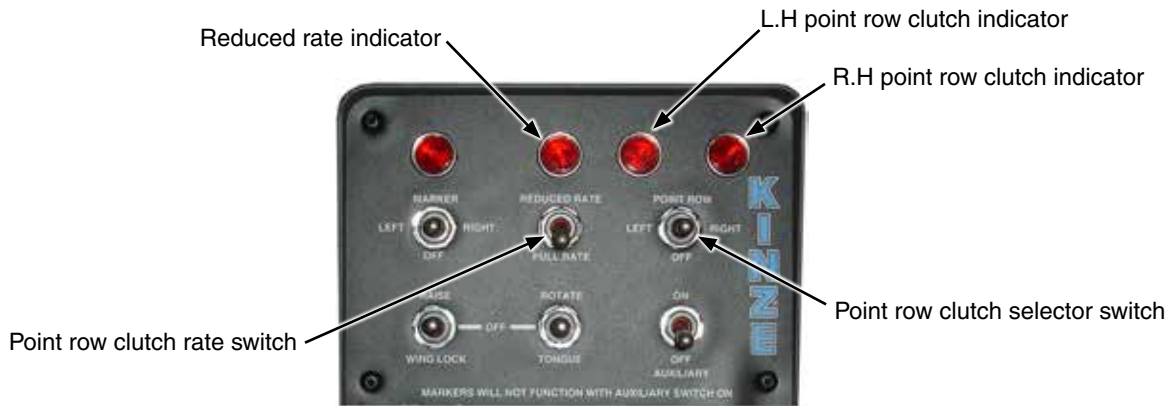

Two-speed point row clutch control box

Point row clutches are controlled by control console point row clutch switches. The point row switch shuts off left or right half of planter. Activating reduced rate switch engages one solenoid on each clutch assembly and reduces planting rate for entire planter.

NOTICE

Point row switch must be OFF and rate switch left in FULL RATE when planter is not in use or tractor battery will be drained.

NOTE: Two-speed point row clutch is located ahead of liquid fertilizer squeeze pump and/or dry fertilizer drive. Activating two-speed point row clutch reduced rate switch causes same per cent of reduction in dry or liquid fertilizer (squeeze pump) application rates. Liquid fertilizer (piston pump) application rates are not be affected because piston pump uses a dedicated drive tire.

AUXILIARY HYDRAULIC OPTION

A customer-supplied auxiliary hydraulic option provides 10 GPM of oil flow at rear of planter for powering fertilizer attachments, bulk seed handling equipment, etc. Two customer-supplied solenoid valve kits (G1K275) are required to activate auxiliary hydraulic option with control console auxiliary switch.



Auxiliary switch

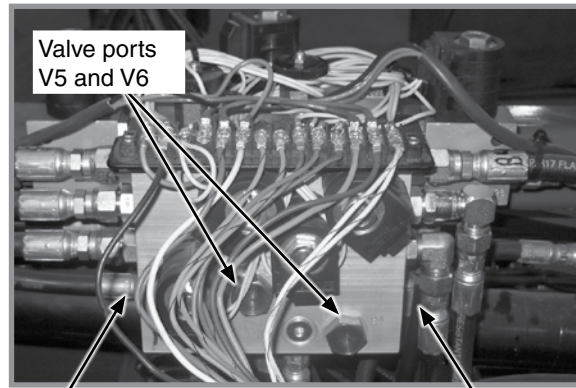

Hydraulic ports
A9 and B9

Hydraulic ports
A8 and B8

Valve block on rear center frame (Cover removed)

! WARNING

Pressurized hydraulic fluid can penetrate body tissue and result in death, serious infection, or other injuries. Fluid injected under skin must be IMMEDIATELY removed by a surgeon familiar with this type of injury. Make sure connections are tight and hoses and fittings are not damaged before applying system pressure. Leaks can be invisible. Keep away from suspected leaks. Relieve pressure before searching for leaks or performing any system maintenance.

NOTE: Place row markers in transport position and remove all pressure from hydraulic system.

Remove cover from valve block on rear center frame of planter. Remove plugs from ports V5 and V6 and install solenoid valve assemblies following installation instruction supplied with each kit. Connect power to solenoid assemblies to orange/black wire located in wiring harness connection to L.H. side of valve block.

Remove plugs from 3/4"-16 O-ring ports A8 and B8 on R.H. side of valve block or ports A9 and B9 on L.H. side of valve block. Connect customer supplied hydraulic hoses.

Refer to "Hydraulic System Schematics" and "Electrical Wiring Schematics" in Lubrication and Maintenance section of this manual for additional information.

NOTE: Auxiliary switch ON disables all other control console switches.

Before operating auxiliary system make sure marker switch on control console is OFF. Move auxiliary switch to ON. Operate hydraulic control (marker/folding functions) to engage auxiliary system.

REAR TRAILER HITCH

Rear trailer hitch can tow a 3 or 4 wheel wagon behind planter. A spring, chain, and mounting bracket supports a 1¼" feed hose from hitch to piston pump. This extra length or loop is required to allow for planter to move into transport position without stretching hose.



Trailer hitch

NOTICE

Rear trailer hitch is designed for use with piston pump only. Maximum allowable hitch weight is 200 lb (90.71 kg). Do not exceed 6,000 lb (2,721.55 kg) gross towing weight or the equivalent of a loaded 500 gal (1,892.7 L) tank and running gear or equipment can be damaged.

NOTE: Periodically check feed hose for kinks to prevent restricted delivery rate.

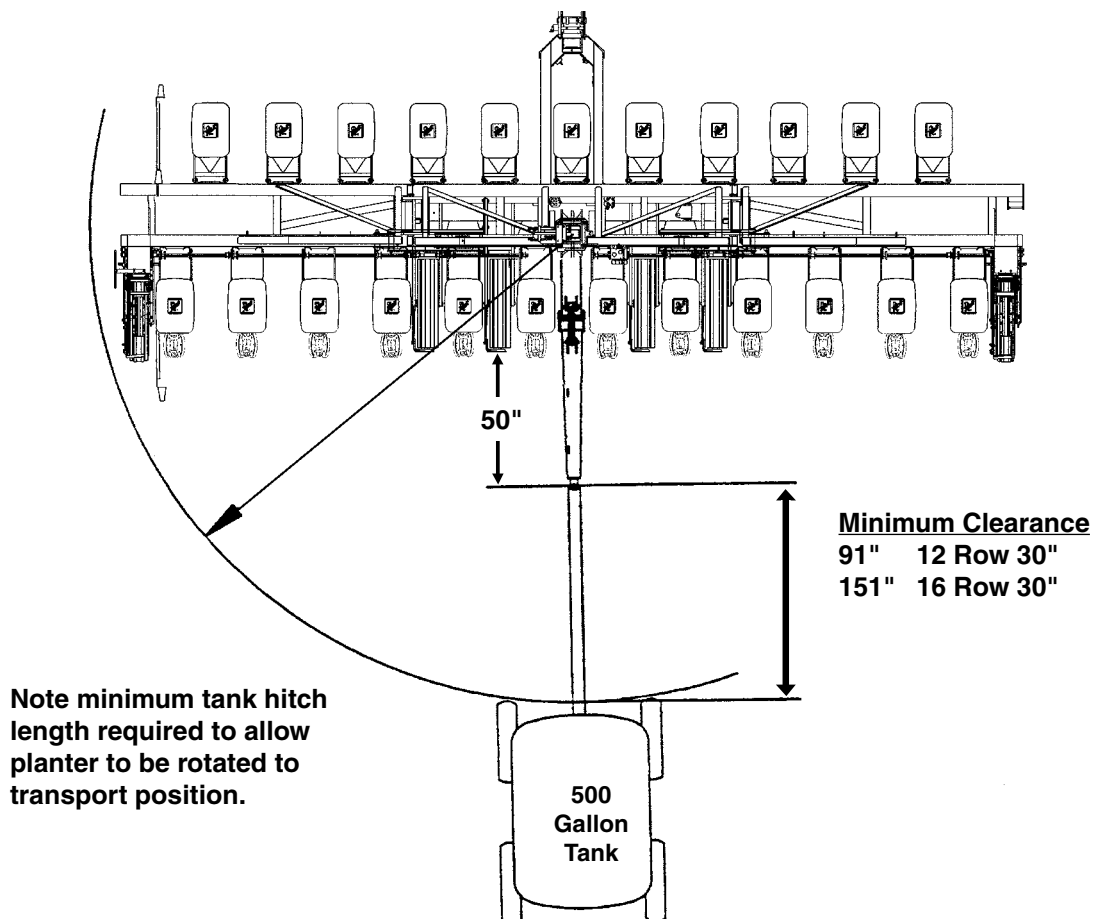

FIELD TEST

Perform a field test with any change of field and/or planting conditions, seed size or planter adjustment to ensure proper seed placement and operation of row units.

- Check planter for front to rear and lateral level operation. See “Level Planter”.
- Check **all** row units to be certain they are running level. Row unit parallel arms should be approximately parallel to the ground when planting.
- Check row markers for proper operation and adjustment. See “Row Marker Adjustment” and “Row Marker Speed Adjustment”.
- Check for proper application rates and placement of granular chemicals on **all** rows. See “Field Check Granular Chemical Application”.
- Check for desired depth placement and seed population on **all** rows. See “Field Check Seed Population” and appropriate Rate Chart.
- Check for proper application rates of fertilizer on **all** rows. See proper “Fertilizer Application Rate Chart”.

Reinspect machine after field testing.

- Hoses And Fittings
- Bolts And Nuts
- Cotter Pins And Spring Pins
- Drive Chain Alignment

FIELD CHECK SEED POPULATION

1. Tie up one or more sets of closing wheels by running a chain or rubber tarp strap between the hopper support panel and closing wheels. It may be necessary to decrease closing wheel arm spring tension.

Chain, rubber tarp strap, or similar.

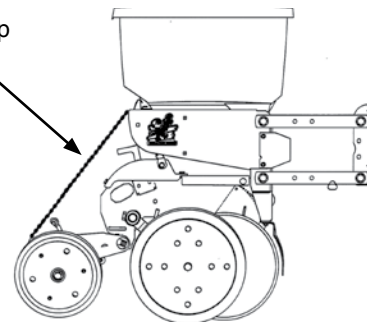

2. Plant a short distance and check to see if seed is visible in the seed trench. Adjust planting depth to a shallower setting if seed is not visible and recheck.

Planting depth adjustment handle



Planting depth adjustment

3. Measure $\frac{1}{1000}$ of an acre. See chart for correct distance for row width being planted. For example, if planting 30" rows $\frac{1}{1000}$ of an acre would be 17' 5".

$\frac{1}{1000}$ Acre Seed Population Count Row Width/Distance						
Row Width	7.5"TR/15"	18"	19"	30"	36"	38"
Distance	34'10"	29'0"	27'8"	17'5"	14'6"	13'10"

NOTE: Seeds may bounce or roll when planting with closing wheels raised and planting depth set shallow affecting seed spacing accuracy.

4. Count seeds in measured distance.
5. Multiply number of seeds placed in $\frac{1}{1000}$ of an acre by 1000. This gives total population.

EXAMPLE: With 30"-7 1/2" twin row spacing 17' 5" x 2 equals $\frac{1}{1000}$ acre.

26 Seeds Counted x 1000 x 2 = 52,000 Seeds Per Acre

EXAMPLE: 30" row spacing 17' 5" equals $\frac{1}{1000}$ acre.

26 seeds counted x 1000 = 26,000 seeds per acre

Seed count can be affected by drive wheel and seed meter drive ratio, tire pressure, and/or seed meter malfunction.

1. If seed check shows average distance between seeds in inches is significantly different than seed rate chart indicates, first check drive ratio between drive wheel and seed meter. Check drive wheel air pressure, check for incorrect sprocket(s) in driveline and check drive and driven sprockets on transmission(s) for proper selection.
2. Check for seed meter malfunction. For example, if spacing between kernels of corn at the transmission setting being used is 8" and a gap of 16" is observed, a finger has lost its seed and not functioned properly. If two seeds are found within a short distance of each other, finger has metered two seeds instead of one.
3. See "Seed Meter (Finger Pickup) Troubleshooting" or "Seed Meter (Brush-Type) Troubleshooting" in Troubleshooting Section of this manual.

DETERMINING POUNDS PER ACRE (BRUSH-TYPE METER)

Seeds per acre \div Seeds per pound (from label) = Pounds per acre

If seeds per pound information is not available use the following averages:

2,600 seeds per pound for medium size soybeans

15,000 seeds per pound for medium size milo/grain sorghum

4,500 seeds per pound for medium size cotton

DETERMINING BUSHELS PER ACRE

Pounds per acre \div Seed unit weight = Bushels per acre

Average Unit Weight of:

1 Bushel Soybeans = 60 Pounds

1 Bushel Milo/Grain Sorghum = 56 Pounds

1 Bushel Cotton = 32 Pounds

If seed population check shows planting rate is significantly different than seed rate chart shows or if a particular meter is not planting accurately, see "Brush-Type Seed Meter Maintenance" and "Seed Meter (Brush-Type) Troubleshooting".

FIELD CHECK GRANULAR CHEMICAL APPLICATION

Temperature, humidity, speed, ground conditions, flowability of different material, or meter obstructions can affect granular chemical rate of delivery.

! WARNING

Agricultural chemicals can cause death or serious injury to persons, animals, and plants or seriously damage soil, equipment, or property. Read and follow all chemical and equipment manufacturers labels and instructions.

Perform a field check to determine application rates.

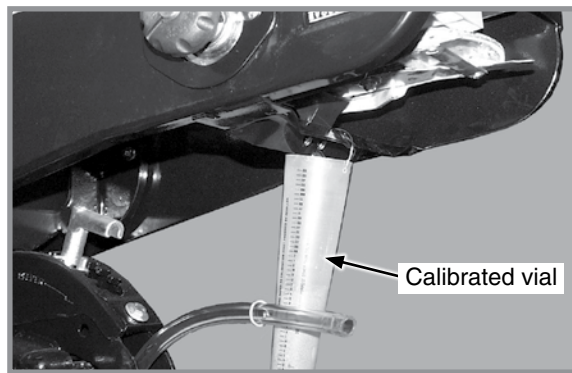

Granular chemical field check

1. Fill insecticide and/or herbicide hoppers.
2. Attach a calibrated vial to each granular chemical meter.

NOTE: Disengage clutch to avoid dropping seed during test.

3. Lower planter and drive 1320 feet at planting speed.
4. Weigh chemical in ounces caught in one vial.
5. Multiply that amount by factor shown to determine pounds per acre.

Pounds Per Acre	
Row Width	Factor
30"	.83
36"	.69
38"	.65

EXAMPLE: You are planting 30" rows. You have planted for 1320 feet at desired planting speed. You caught 12.0 ounces of chemical in one vial. 12.0 ounces times 0.83 equals 9.96 pounds per acre.

NOTE: Check calibration of all rows.

METERING GATE

Use metering gate setting as a starting point for distributing insecticide or herbicide. Charts are based on 5 mph (8 kph) planting speed. Use a higher gate setting for speeds faster than 5 mph (8 kph) and a lower setting for speeds slower than 5 mph (8 kph).

PLANTING DEPTH

Planting depth is maintained by adjustable row unit gauge wheels. Depth adjustment range is approximately ½" to 3½".

1. Raise planter to remove weight from wheels.
2. Push down on depth adjustment handle and reposition it forward to decrease or rearward to increase planting depth. Initially adjust all units to the same setting.
3. Lower planter and check operation and planting depth of all row units. Readjust individual rows as needed for uniform operation.

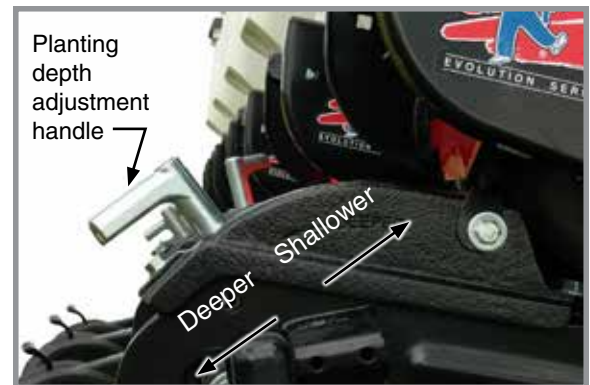

Planting depth adjustment

“V” CLOSING WHEEL ADJUSTMENT (RUBBER OR CAST IRON)

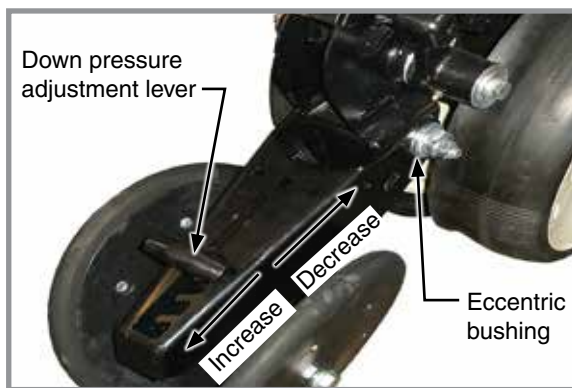

“V” Closing wheel adjustments

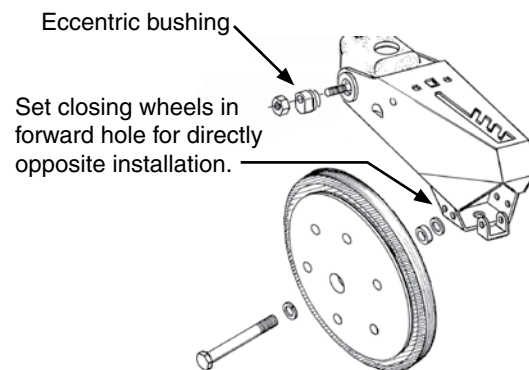

“V” closing wheels should have enough down pressure to close the seed trench and ensure good soil to seed contact. Move 5-position quick adjustable down force lever on the top of closing wheel arm to the rear to increase closing wheel spring pressure. Move lever forward to decrease pressure. Adjust all row units to a similar setting. Light soil usually requires less down force at average depth (approximately 2") while heavy soil requires increased down force.

Eccentric bushings in the wheel arm stop allow for lateral adjustment of the “V” closing wheel assembly. Use a ¾" wrench to loosen hardware attaching closing wheel arm to wheel arm stop. Use another ¾" wrench to turn eccentric bushings until **closing wheels are aligned with seed trench**. Tighten hardware.

Closing wheels can be installed “offset” (to improve residue flow) or “directly” opposite. Use forward installation holes if set “directly” opposite.

CLOSING WHEEL SHIELD (RUBBER OR CAST IRON “V” CLOSING WHEELS)

Optional closing wheel shield is installed on underside of closing wheel arm to help prevent root balls and stalks from clogging closing wheels.

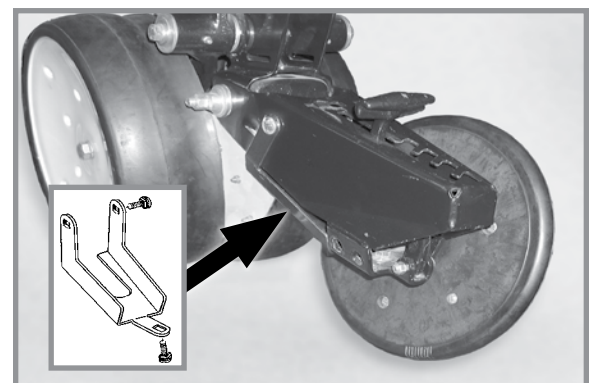

Closing wheel shield (Closing wheel removed)

DRAG CLOSING ATTACHMENT

Drag closing attachment pulls loose soil over seed trench.

NOTE: Use of a seed firming wheel or other seed firming device is recommended with drag closing attachment.

Front and rear adjustment is made using slotted holes in blades. Adjust all rows the same. Wheel arm stop eccentric bushings provide lateral adjustment. Use a 3/4" wrench to loosen closing wheel arm to wheel arm stop hardware. Use another 3/4" wrench to turn eccentric bushings until drag closing attachment is aligned with seed trench. Tighten hardware.

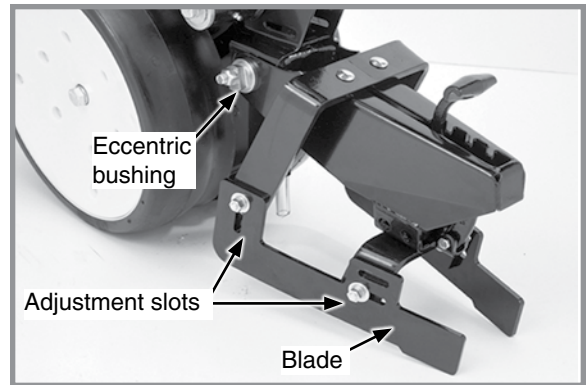

Drag closing attachment

COVERING DISCS/SINGLE PRESS WHEEL ADJUSTMENT

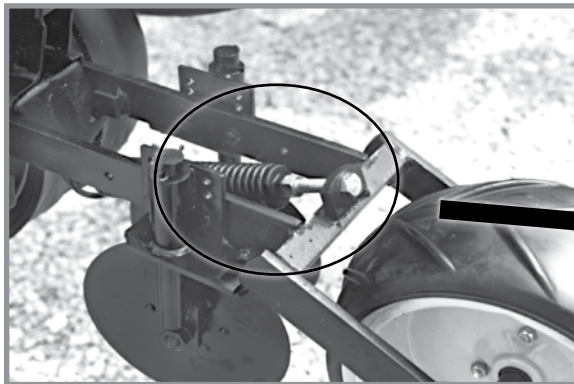

Press wheel down force adjustment

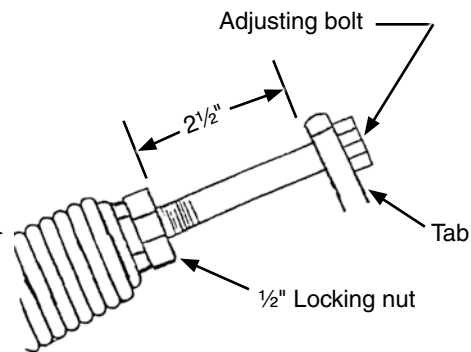

Check operation of covering discs/single press wheels after adjusting planting depth. Initial press wheel down force spring setting is 2 1/2" between mounting arm tab and locking nut. Loosen 1/2" locking nut and turn adjusting bolt in to increase down force or out to decrease down force. Tighten locking nut against spring plug. Adjust all row units to a similar setting.

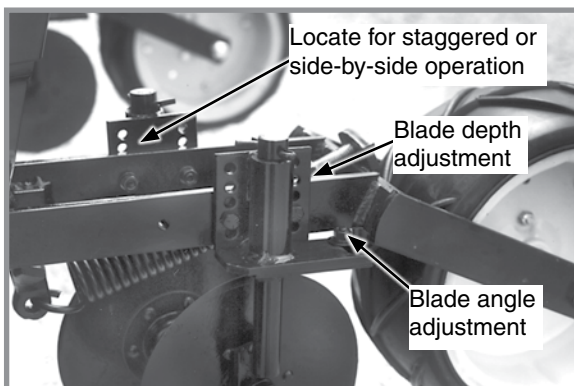

Covering disc adjustments

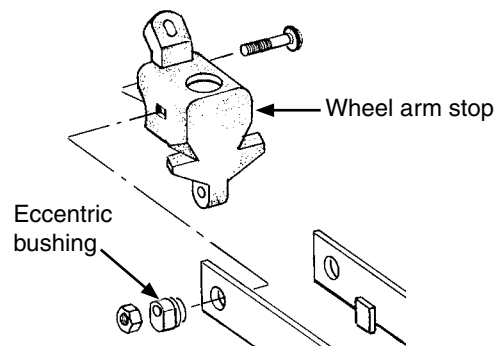

Eccentric bushings in the wheel arm stop allow for lateral adjustment of covering discs/single press wheel assembly. Use a 3/4" wrench to loosen hardware attaching closing wheel arm to wheel arm stop. Use another 3/4" wrench to turn eccentric bushings until covering discs/single press wheel assembly is aligned with seed trench. Tighten hardware. Two sets of holes in mounting arm locate covering discs for staggered or side-by-side operation. Five sets of holes in each disc bracket allow 1/2" incremental blade depth adjustment. Slotted holes in disc mount and bracket allow for 0° - 15° blade angle adjustment. Adjust covering discs on all row units to similar settings.

SEED HOPPERS

Mechanical seed hopper has a capacity of 1.9 bushels.

EdgeVac seed hopper has a capacity of 1.75 bushels.

Use clean seed and make certain there are no foreign objects inside when filling seed hopper. **Replace hopper lids after hoppers are filled to prevent accumulation of dust or dirt in seed meter which can cause premature wear.** See "Finger Pickup Seed Meter" and/or "Brush-Type Seed Meter".

Periodically empty hoppers completely to remove any foreign objects and to ensure proper seed meter operation.

Disengage meter drive and hopper latch and lift hopper off hopper support. See "Seed Meter Drive Release".

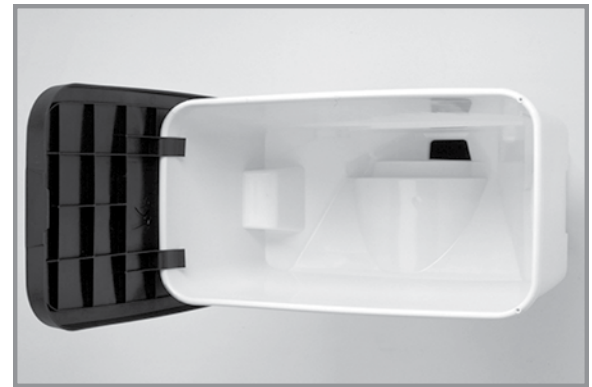

Mechanical seed hopper

SEED METER DRIVE RELEASE

A clutch release mechanism disengages seed meter drive from seed meter to remove seed hopper. Disconnecting drive allows operator to check granular chemical application rates without dropping seed. It also allows one or more rows to be disconnected when finishing fields.

Turn knob ¼ turn counterclockwise to disengage or ¼ turn clockwise to engage.

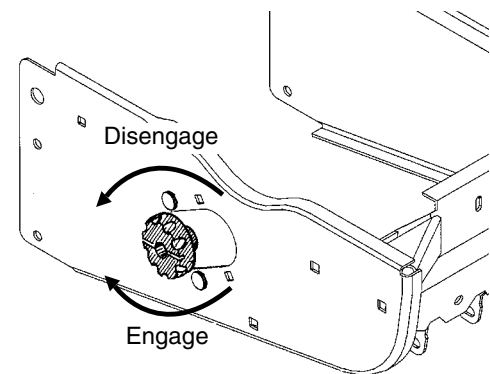

Seed meter drive release

ROW UNIT EXTENSION BRACKETS

Row unit extension brackets extend row units rearward 4" to provide clearance for coulter mounted residue wheels and HD single disc fertilizer openers.

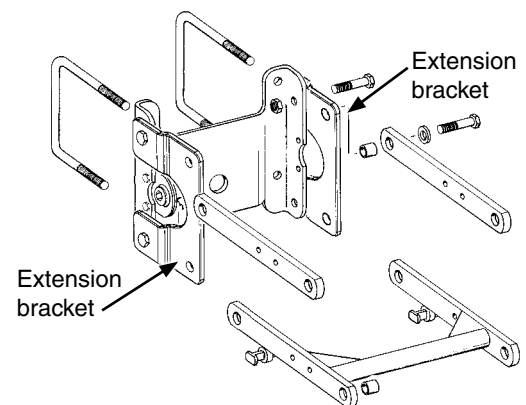

Row unit extension brackets

ROW UNIT CHAIN ROUTING

Row unit drive chains must be properly tensioned and aligned for proper operation and to minimize wear.

Inspect and replace weak, worn or broken springs, idlers, and idler bushings.

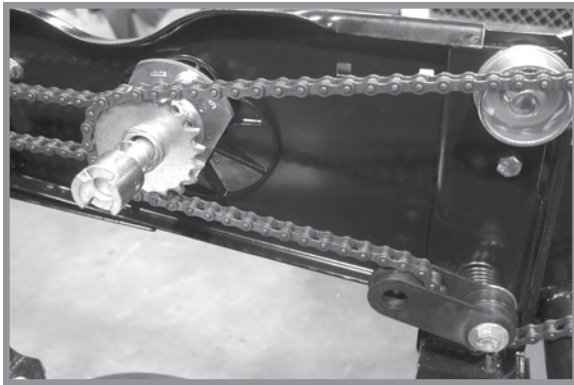

Mechanical pull row unit meter drive

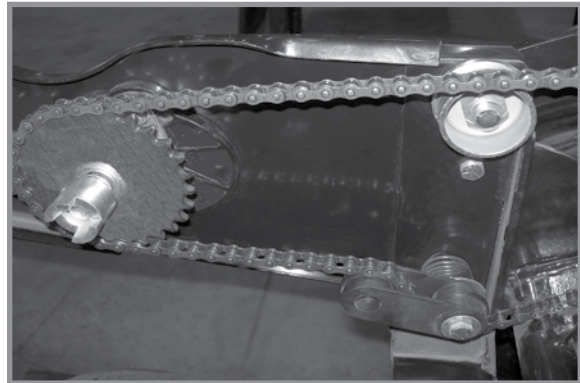

EdgeVac pull row unit meter drive



Mechanical push row unit meter drive

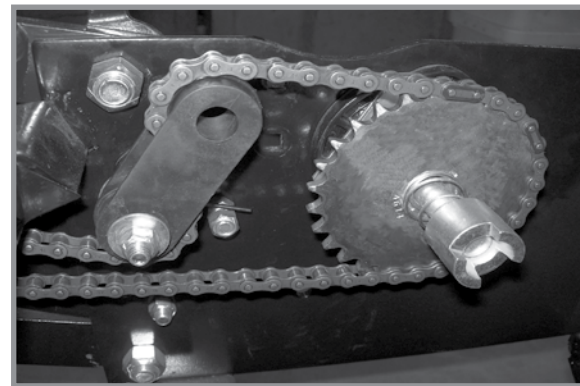

EdgeVac push row unit meter drive

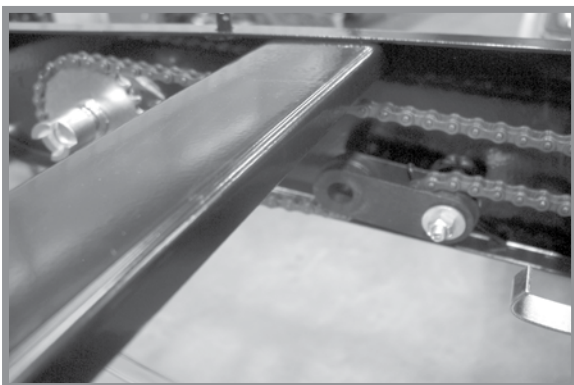

Row unit granular chemical drive

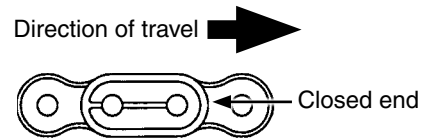

NOTE: Install connector link with closed end facing direction of travel.

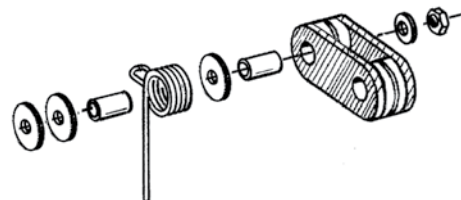

NOTE: Reverse idler when worn on one side for extended use.

QUICK ADJUSTABLE DOWN FORCE SPRINGS OPTION (STANDARD OR HEAVY DUTY)

Standard and heavy duty quick adjustable down force springs are available in increase penetration in hard soil and keep row unit from bouncing in rough field conditions. Two springs per row, one on each side parallel arms, are used unless equipped with row unit mounted no till coulters. Row unit mounted no till coulters require four springs per row.

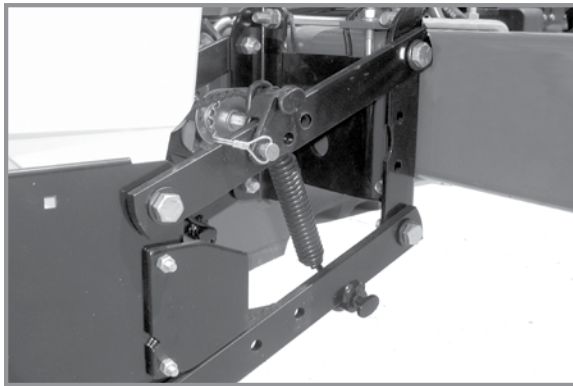

Two springs per row (Dual)

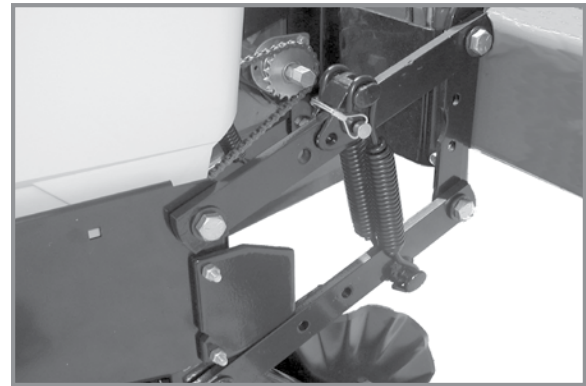

Four springs per row (Quad)

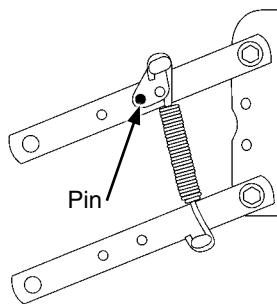

Position 1 (Least)

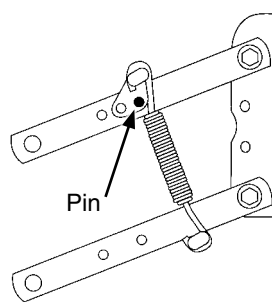

Position 2

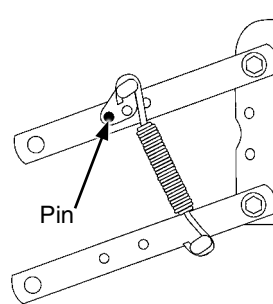

Position 3

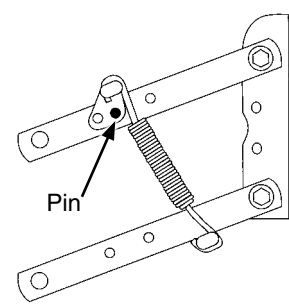

Position 4 (Most)

There are four positions to set down pressure spring tension.

Standard and Heavy Duty Spring Down Force Pressure*				
Position	2 Springs		4 Springs	
	Standard D8249	Heavy Duty D21337	Standard D8249	Heavy Duty D21337
1	41lb (18.6 kg)	43 lb (19.5 kg)	74 lb (33.6 kg)	80 lb (36.3 kg)
2	73 lb (33.1 kg)	86 lb (39.0 kg)	120 lb (54.4 kg)	144 lb (65.3 kg)
3	136 lb (61.7 kg)	167 lb (75.7 kg)	255 lb (115.7 kg)	307 lb (139.3 kg)
4	207 lb (93.9 kg)	249 lb (113.0 kg)	369 lb (167.4 kg)	470 lb (213.2 kg)

*Pressure does not include weight of row unit, seed, or options.

NOTICE

Springs must be installed with open side of spring hooks toward seed hoppers to prevent binding on spring mount adjustment pins.

1. Raise planter and remove spring mount pin at top of spring.
2. Slide mount to desired position and install pin.

NOTE: Adjust springs for field conditions. Too much down pressure in hard field conditions can cause row units to lift planter and keep drive wheels from making contact. Too much down pressure in soft field conditions can cause row unit to run too deep.

PNEUMATIC DOWN PRESSURE PACKAGE OPTION

Row unit down pressure can be adjusted on-the-go as field conditions change with pneumatic down pressure option. A cab-mounted control box adjusts pressure (Older models may have a digital readout). A planter-mounted 12 VDC air compressor with 3 gallon capacity air tank supplies air for the down pressure system.

Packages include upper and lower air spring mounting castings for pull row units (front and rear air spring mounting castings for push row units), 150 psi rated air springs, $\frac{3}{8}$ " O.D. nylon hoses, dual solenoid air valve and stainless steel, 160 psi, 2" liquid-filled gauge and planter wiring harness.

Pneumatic down pressure row unit extension brackets are required in some applications.

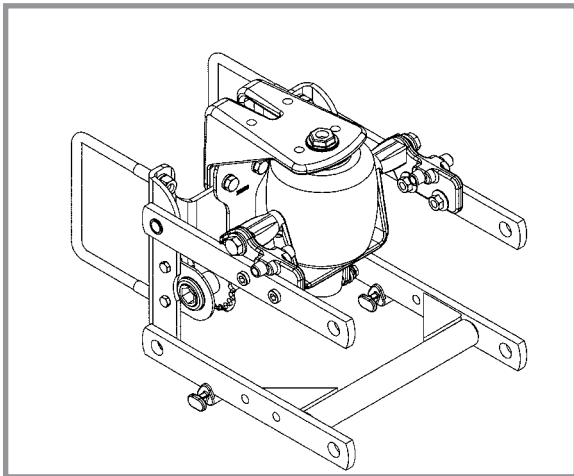

Pull row unit air spring

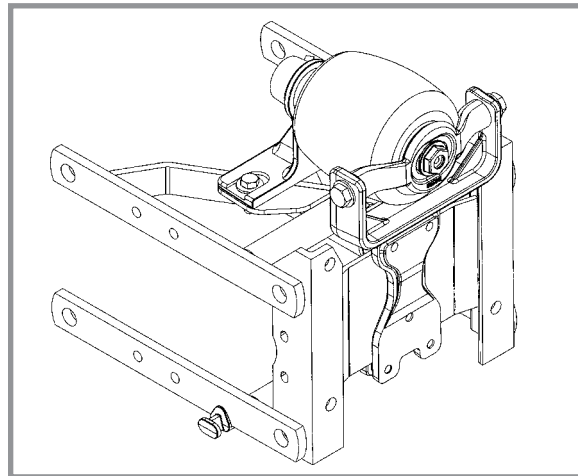

Push row unit air spring

NOTE: If additional down pressure is needed with the Pneumatic Down Pressure Package, assist springs are available through your Kinze dealer. One spring is installed on the outer side of the parallel arms on each side of the row unit as shown below.

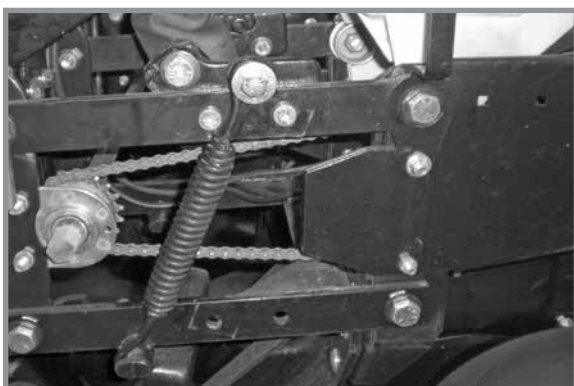

Pull row unit assist springs



Push row unit assist springs

FIELD OPERATION

NOTE: Adjust down pressure with planter lowered and row openers in ground for most accurate adjustment. Pressure can be adjusted from tractor using control console, or at planter using manual control valves on compressor assembly.



Control console

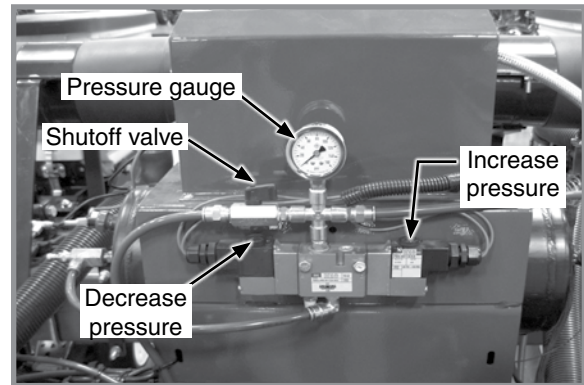

Air compressor assembly controls

ADJUST DOWN PRESSURE FROM CAB

Push toggle switch left to increase or right to decrease pressure.

ADJUST DOWN PRESSURE AT PLANTER

Push and hold decrease or increase button on compressor assembly to decrease or increase pressure.

NOTE: Value on the air pressure gauge is NOT down pressure force. Multiply air pressure (psi) by four (4) to calculate down pressure.

LOCK UP PUSH ROW UNITS EQUIPPED WITH PNEUMATIC DOWN PRESSURE SPRINGS

1. Press and hold button on solenoid until pressure gauge reads 5 PSI.
2. Lock up units. See "Interplant Push Unit Lockup" for instructions.
3. Turn shutoff valve handle perpendicular to valve body to turn off push row unit air supply.

INTERPLANT PUSH ROW UNIT CLUTCH SPROCKET

Push row unit clutch sprocket disengages interplant drive from push row unit drill shaft when only pull row units are used.

DISENGAGE

Rotate knurled collar $\frac{1}{4}$ turn. Rock drill shaft slightly using a $\frac{7}{8}$ " wrench to take pressure off of spring loaded pins in clutch to allow pins to "pop" out, disengaging drive.

ENGAGE

Rotate knurled collar $\frac{1}{4}$ turn and turn drill shaft with a $\frac{7}{8}$ " wrench until drive pins engage drive sprocket.

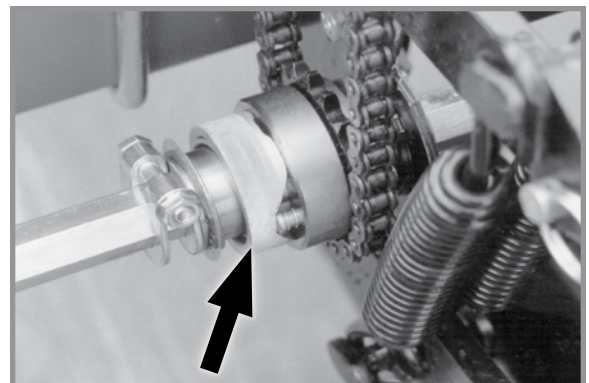

Interplant clutch sprocket

INTERPLANT PUSH ROW UNIT LOCKUPS

Push row unit lockups lock interplant row units in the raised position.



CAUTION

Improper lifting of row units can cause serious injury. An empty row unit requires minimum 90 lb (40.8 kg) lift. Set down pressure springs to minimum, lower planter to ground, and empty seed hopper before attempting to lift with this lever.

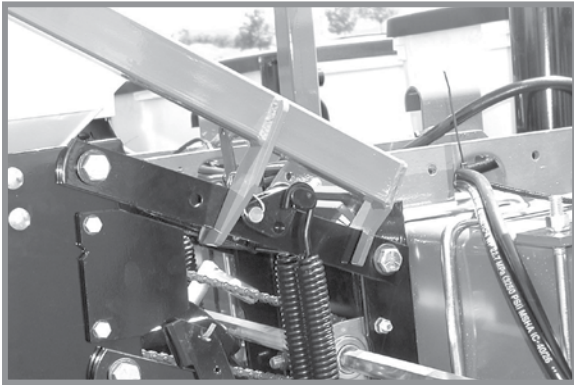

Lift lever positioned on push row unit

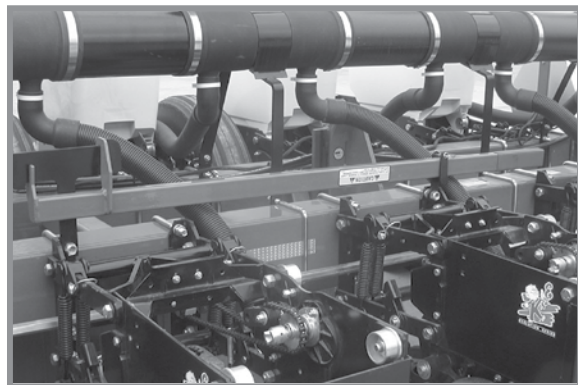

Lift lever in storage location

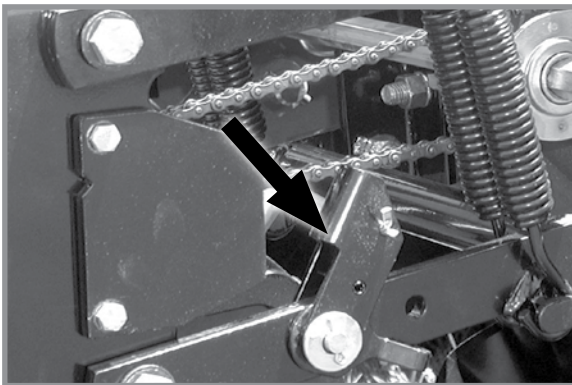

Lockup released for field operation

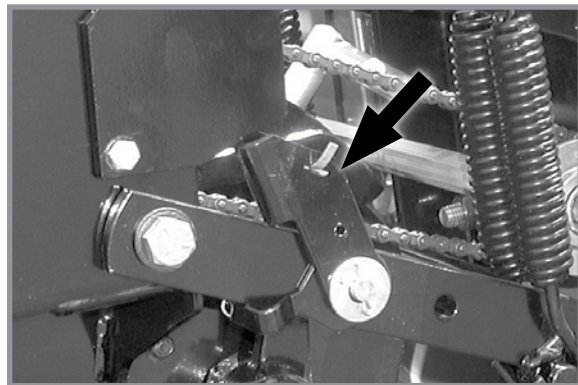

Push row unit locked in raised position

INTERPLANT PUSH ROW UNIT VACUUM HOSE SHUTOFF

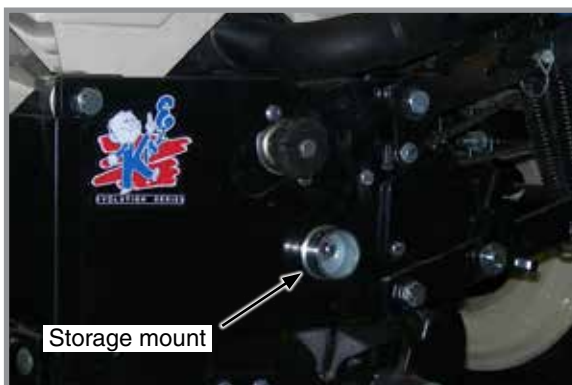

Storage mount













Interplant vacuum hose shutoff

When push row units are not used, move row unit end of 2" vacuum hose on each push row unit to storage mount located on side of shank.

This page left blank intentionally.

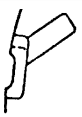
BRUSH-TYPE SEED METER

	Crop	Disc Color-Code (Disc Part No.)	Upper Brush Retainer	Cells	Seed Size Range	*Lubricant
	Soybean	Black (GA5794)	GD11122	60	2200 to 4000 seeds/lb.	Graphite Talc
	Specialty Soybean	Dark Blue (GA6184)	GD11122	48	1400 to 2200 seeds/lb.	Graphite Talc
	Small Milo/Grain Sorghum	Red (GA5982)	GD8237	30	14,000 to 20,000 seeds/lb.	Talc
	Large Milo Grain Sorghum	Light Blue (GA6187)	GD8237	30	10,000 to 16,000 seeds/lb.	Talc
	High-Rate Small Milo/Grain Sorghum	Red (GA5795)	GD8237	60	12,000 to 18,000 seeds/lb.	Talc
	High-Rate Large Milo/Grain Sorghum	Yellow (GA6633)	GD8237	60	10,000 to 14,000 seeds/lb.	Talc
	Cotton, Acid-Delinted	White (GA5796)	GD11122	30	4200 to 5200 seeds/lb.	Talc
	Large Cotton, Acid Delinted	Tan (GA6168)	GD11122	36	3800 to 4400 seeds/lb.	Talc
	High-Rate Cotton, Acid-Delinted	Light Green (GA6478)	GD11122	48	4200 to 5200 seeds/lb.	Talc
	Hill-Drop Cotton, Acid-Delinted	Brown (GA6182)	GD11122	12 (3 to 6 seeds/ cell)	4000 to 5200 seeds/lb.	Talc
	Small Hill-Drop Cotton, Acid-Delinted	Dark Green (GA7255)	GD11122	12 (3 to 6 seeds/ cell)	5000 to 6200 seeds/lb.	Talc

*For More information on application rate see Additives section.

	<p>Use GD11122 upper brush retainer when using cotton and soybean discs.</p>		<p>Use GD8237 upper brush retainer when using milo/grain sorghum discs.</p>
---	---	---	--

Turn seed disc counterclockwise when installing on meter hub while tightening two wing nuts that retain disc. Seed disc should have slight resistance when rotated counterclockwise after wing nuts are tight.

Brush-type seed meter attaches to seed hopper same as finger pickup seed meter. Secure to bottom of seed hopper with two 5/16" thumbscrews. Tighten thumbscrews slightly with pliers. **DO NOT OVER TIGHTEN.**

Misalignment between drive coupler and seed meter input shaft may cause erratic seed spacing from momentary stoppage of seed disc. Check alignment and adjust as needed.

Refer to planting rate charts in this manual for recommended seed drive transmission sprocket combinations.



Shown without seed disc installed



NOTICE

Replace hopper lids after hoppers are filled to prevent accumulation of dust or dirt in seed meter which will cause premature wear.

NOTE: Clean seed is required to ensure accurate seed metering from brush-type seed meters. Remove seed discs daily and check seed meter or brushes for buildup of foreign material, such as hulls, stems, etc.

FINGER PICKUP SEED METER

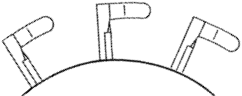
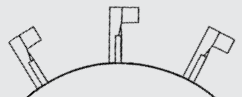









Crop	Fingers	*Lubricant
Corn	 Part No.: GR1848 - Finger Assembly, Corn	Graphite Talc
No. 1 and/or No. 2 size Confectionery Sunflower Seeds	 Part No.: GR1848 - Finger Assembly, Corn	Talc
No. 3 and/or No. 4 size Oil Sunflower Seeds	 Part No.: GR1897 - Finger Assembly, Oil	Talc
Blank fingers replace alternate fingers to reduce planting rate by half while allowing the finger wheel to maintain a minimum of 40 RPM when planting low rates.	 Part No.: GD11787 - Half Rate Blank Finger	Graphite Talc

*For More information on application rate see Additives section.

NOTE: Always field check seed population to verify planting rates.

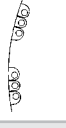
NOTE: Refer to planting rate charts in this manual for recommended seed drive transmission sprocket combinations.

EDGEVAC SEED METERS

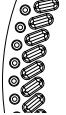
	Crop	Disc Color-Code (Disc Part No.)	Cells	Seed Size Range	Singulator Brush Setting	Vacuum Setting (H2O)	*Lubricant	See Notes
	Corn	Light Blue (GD17049)	39	35-70 lbs./80k	5-7	18-20	Graphite Talc	4, 5
	Popcorn			2210-4200 seeds/lb.	9	18	Graphite Talc	1, 4, 5
	Low-Rate Corn	Light Green (GD17048)	24	35-70 lbs./80k	5-7	18-20	Graphite Talc	4, 5
	Low-Rate Popcorn			2210-4200 seeds/lb.	9	18	Graphite Talc	1, 4, 5
	Soybean	Black (GD14467)	60	2200-4000 seeds/lb.	5	10	Graphite Talc	1
	Soybean, High-Rate	Dark Blue (GD14468)	120	2200-4000 seeds/lb.	5	10	Graphite Talc	-
	Milo/Grain Sorghum	Yellow (GD17050)	60	10,000 - 20,000 seeds/lb.	3-6	20	Talc	1, 2
	Hill-Drop Cotton, Acid-Delinted	Brown (GD17187)	20 (3 seeds/ cell)	3800-4400 seeds/lb.	8	23	Talc	3
	Small Hill-Drop Cotton, Acid- Delinted	Grey (GD18095)	20 (3 seeds/ cell)	4200-4400 seeds/lb.	-	-	Talc	3
	Cotton, Acid- Delinted	Dark Green (GD17186)	54	3800-5200 seeds/lb.	8	20	Talc	3
	Dry Edible Bean, Small			1200-2500 seeds/lb.	6	18	Graphite Talc	3, 5
	Dry Edible Bean, Large	Tan (GD14477)	54	800-1200 seeds/lb.	5	18	Graphite Talc	5
	Small Cotton/ Sunflower	White (GD18098)	54	4200-5200 seeds/lb.	5	30	Talc	3
	Sugar Beets	Dark Orange (GD24805)	80	All	5-6	15-18	Graphite	1

***For More information on application rate see Additives section.**

Install selected seed disc. Position vacuum cover on meter by aligning keyhole slots over bolt heads. Push cover on meter and turn counter clockwise to lock in place.

NOTES:

1. Requires use of seed meter baffle.
2. Requires use of cleanout brush.
3. Requires use of cleanout brush w/ball-type ejector.
4. Flat seeds may require higher vacuum level.
5. Larger seeds may require lower singulator brush setting. Smaller seeds may require higher setting.

NOTE: See “EdgeVac General Planting Rate Information” and “Check Seed Population” pages for more information. Always field check seed population to ensure planting rates are correct.

NOTE: Singulator brush settings are marked from 1 thru 11. Lower singulator brush settings are least aggressive. Higher singulator brush settings are most aggressive.

NOTE: Mixing seed sizes and shapes affects meter performance. Use consistent seed size and shape.

NOTE: Use 1 tablespoon powdered graphite with each hopper fill of seed. Seed treatment, foreign material, dirt or seed chaff may cause gradual reduction of seed disc fill (population). See “Additives” pages for more information.

NOTE: Excessive seed treatment, humidity, and light-weight seed can affect meter performance. Use ½ cup of talc with each hopper fill of seed and mix thoroughly to coat all seeds and adjust rates as needed. Use of talc aids seed flow into meter, singulation, and disc seed drop.

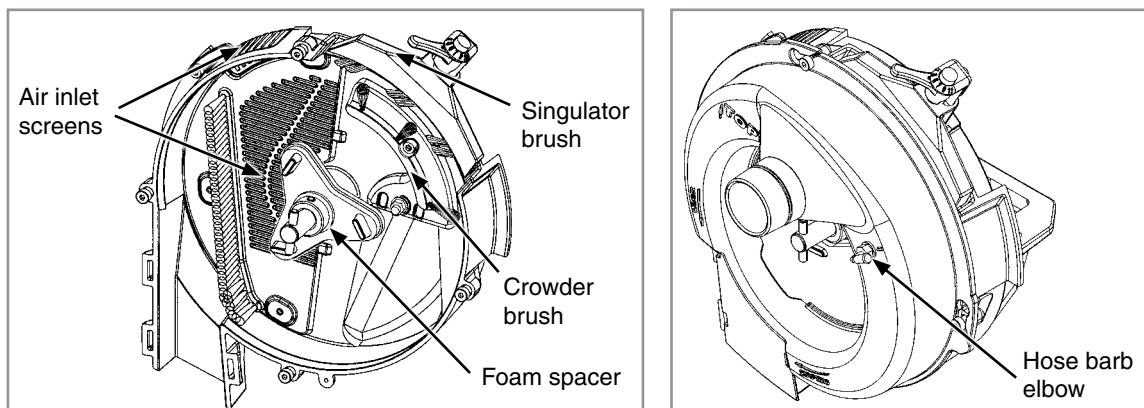

NOTE: Foreign material in seed disc orifices, such as seed chips, hulls, stems, etc., may affect seed delivery. Clean seed ensures accurate seed metering from vacuum seed meter. Remove Seed discs daily to check for buildup of foreign material in seed disc orifices.

Crowder brush aids in singulation of small flat seeds by crowding seeds to outer perimeter of seed disc and orienting seeds to allow singulator brush to be more effective.

Air inlet screens allow air to enter system and aids in keeping field residue or other foreign material out of meter.

Foam spacer gently preloads seed disc against vacuum cover when no vacuum is present.

3/16" hose barb elbow on seed meter vacuum cover allows measurement of vacuum level at each meter. A customer-supplied vacuum gauge is required.

See “EdgeVac Seed Meter Maintenance” and “Preparation For Storage” in Lubrication and Maintenance section for more information.

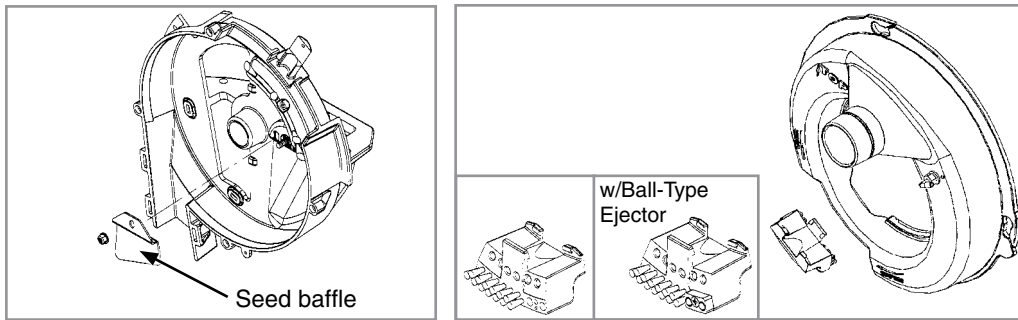

NOTE: Damaged seed or seed containing foreign material will cause plugging of seed disc orifices and require more frequent seed meter cleanout to prevent underplanting.

SEED BAFFLE

Seed baffle prevents excessive seed in meter from restricting air flow through seed. Used with 60 Cell Milo/Grain Sorghum Disc, 60 Cell Soybean Disc, 120 Cell High-Rate Soybean Disc and 39 Cell, 24 Cell Popcorn Discs, and 80 Cell Sugar Beet Disc.

CLEANOUT BRUSH

Cleanout brush removes foreign material and seed remnants to help prevent plugging of seed disc orifices. Used with 60 Cell Milo/Grain Sorghum Disc.

CLEANOUT BRUSH W/BALL-TYPE EJECTOR

Cleanout brush w/ball-type ejector ejects seed remnants from seed disc orifices. Used with 20 Cell Hill-Drop Cotton, Acid-Delinted (3 Seeds Per Cell) Discs; 54 Cell Acid-Delinted Cotton/Small Dry Edible Bean; and Small Cotton/Sunflower Discs.

NOTICE

Replace hopper or tank lids after filling to prevent accumulation of dust or dirt in seed meter resulting in premature wear.

NOTE: Seed size, seed shape, seed treatments, travel speed, and planting rate affect meter performance.

1. Select seed disc (and seed meter baffle, cleanout brush and/or cleanout brush w/ball-type ejector if applicable) to match crop and population.

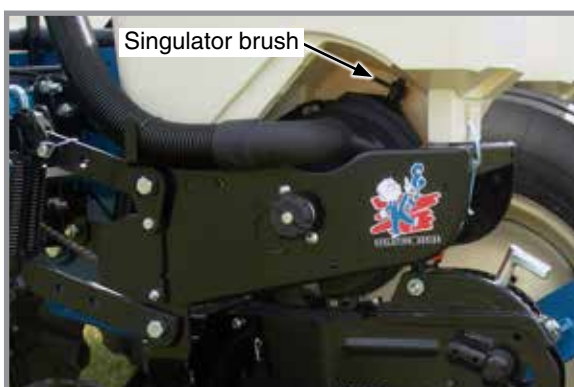

Singulator brush adjustment location

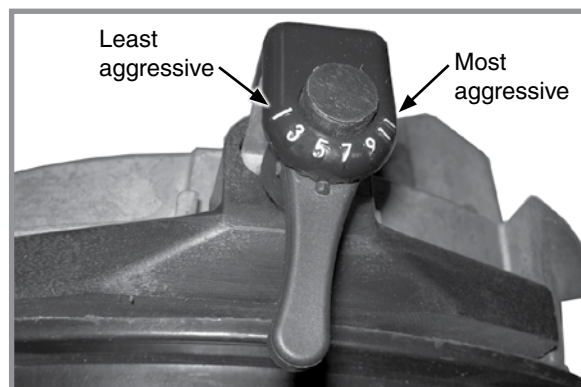

Singulator brush adjustment lever

2. Adjust singulator brush to initial setting. Seed size, seed shape, seed treatments, travel speed and planting rate all affect meter performance.
3. With vacuum fan running, lower planter to planting position and drive forward a short distance to load seed into seed disc cells.

- Adjust vacuum level to initial setting according to tables on page.

NOTE: Vacuum reading will be much lower when seed disc cells are empty. Load all seed cells before setting vacuum level.

NOTE: Operate vacuum fan 3-5 minutes to bring oil up to normal operating temperature prior to making final vacuum level adjustment.

- Perform optional seed disc fill check.



Remove vacuum cover and seed disc

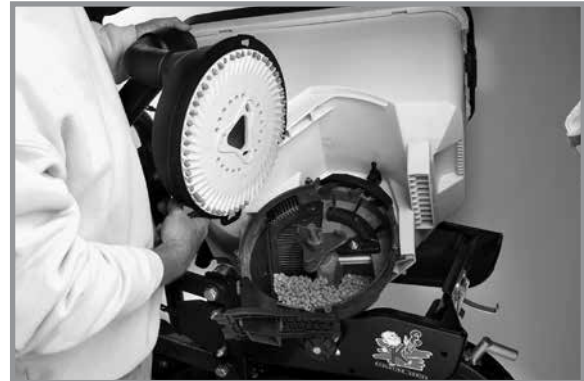

Check seed fill

With vacuum hose connected and vacuum fan operating, remove vacuum cover and seed disc as an assembly. Inspect seed discs for proper seed fill.

See “Seed Metering System (EdgeVac) Troubleshooting” in Troubleshooting section.

SEED METER CLEANOUT

NOTE: Use of damaged seed or seed containing foreign material will cause plugging of seed cell orifices and require more frequent seed meter cleanout to prevent underplanting.

Thorough seed meter cleanout is important to maintain genetic purity.

- Disengage seed drive and remove seed hopper and meter.
- Dump seed from right rear corner of hopper into a container.
- (Mechanical) Disassemble seed disc by removing wing nuts.
(EdgeVac) Lay hopper on its right side. Rotate seed meter vacuum cover clockwise to align keyhole slots with bolt heads. Lift off cover. Remove seed disc.
- Empty Meter.
- Thoroughly inspect brushes in meter to ensure all seed is removed.
- Replace seed disc. (Mechanical) Install wing nuts. (EdgeVac) Install Vacuum cover.

ADDITIVES

The use of graphite is recommended to promote seed flow, provide lubrication for the seed meter and to help dissipate static charge buildup. Among the available dry seed lubricants graphite is the most effective and easiest to use and it requires no mechanical agitation

CONVENTIONAL HOPPERS

Mix one tablespoon of **powdered graphite** with seed each time hoppers are filled. Regular graphite use prolongs life of the seed meter components, improves seed spacing, and may reduce buildup of seed treatments.

NOTE: DO NOT apply graphite only in center of hopper. It will filter too quickly through the seed and not distribute as evenly as desired.

Apply graphite around outer perimeter of hopper.

ASD HOPPERS

Mix 1 pound bottle of powdered graphite each time the bulk seed hopper is filled. Graphite should be added in layers as the bulk seed hoppers are filled. Regular graphite use prolongs life of the seed meter components, improves seed spacing, and may reduce buildup of seed treatments.



Adding graphite to conventional hopper



Adding graphite ASD hopper

NOTE: Additional graphite may be required to retard buildup of seed treatments on meter components. More frequent cleaning of monitor seed tubes may be necessary due to use of additional graphite.

Talc seed lubricant may be used as a drying agent in addition to graphite lubrication. The drying agent may improve seed release and/or **to retard buildup of seed treatments on meter components.**

1. Fill hopper $\frac{1}{2}$ full of seed, add $\frac{1}{4}$ cup (conventional); 2 pounds (ASD) of talc and **mix thoroughly**.
2. Finish filling hopper, add another $\frac{1}{4}$ cup (conventional); 2 pounds (ASD) of talc and **mix thoroughly**.
3. Adjust rate of talc use as needed so all seeds are coated, while avoiding a buildup of talc in bottom of hopper.

Humid conditions and/or small sized seeds with extra seed treatment may require additional talc to maintain meter performance.

NOTE: Liquid seed treatments or inoculants may create buildup on the seed disc or brushes. Check frequently for proper population and/or seed delivery when using any liquid seed treatment.

Completely mix all treatments with seed following manufacturers' recommendations. Seed treatment dumped on top of seed after hopper is filled may not mix properly and cause seed bridging, reducing population or stopping meter from planting.

Lubricant Application Rate	
Graphite	
Conventional Hoppers	1 Tbs./Hopper Fill
ASD Hoppers	1 Pound Bottle/Hopper
Talc	
Conventional Hoppers	$\frac{1}{4}$ C.*
ASD Hoppers	4 Pounds/Hopper*
*Double amount of talc for sunflowers.	

FRAME MOUNTED COULTER (PULL ROW ONLY)

Frame mounted coulters with 1" bubbled, 1" fluted (8 flutes) or 3/4" fluted (13 flutes) blades are used on pull row units only.

Springs provide down pressure on coulters for maximum penetration while exerting less shock load on row unit.

Initial coulters blade location is in top hole. Relocate blade to one of lower two holes (1" increments) as wear occurs or for deeper blade operation.

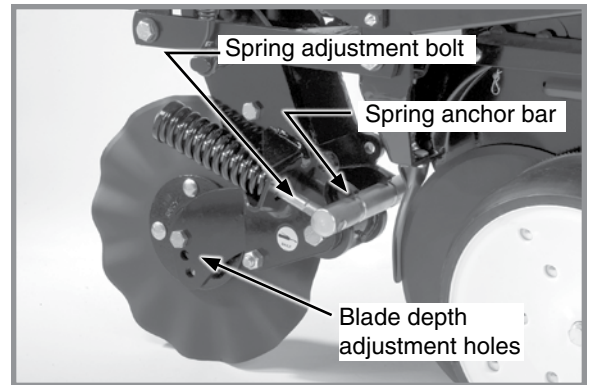

Frame mounted coulter adjustment

DOWN PRESSURE ADJUSTMENT

NOTICE

Excessive down pressure can damage coulter components when coulter strikes an obstacle. Do not set down pressure higher than needed for consistent soil penetration.

Raise planter. Turn spring adjustment bolts clockwise to increase or counterclockwise to decrease down pressure. Set both springs to specification shown in following table:

Frame Mounted Coulter Spring Downpressure Settings		
End flush with spring anchor bar	Extended 1/2" through spring anchor bar	All threads used
275 lb (124.7 kg)	400 lb (181.4 kg)	500 lb (226.8 kg)

RESIDUE WHEELS (FOR FRAME MOUNTED COULTER)

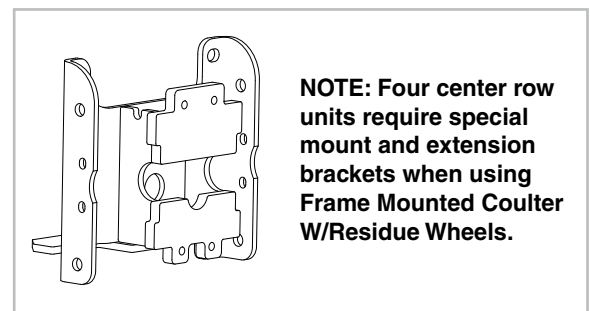
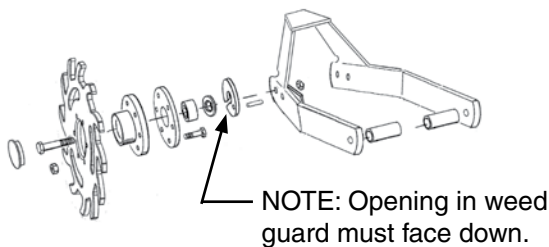

NOTICE

Tined wheel forward mounting positions cannot be used behind 3600 axles due to limited clearance.

Residue wheels attach to frame mounted coulters with two cap screws and sleeves allowing the unit to free-float. A 2-position spindle bolt mounting positions wheels interlocked or staggered. Depth adjustment is made with a spring-loaded cam and pin with 11 positions in 1/4" increments. A high point on the cam allows wheels to be locked up.

A weed guard on the inboard side of each wheel helps prevent weed wrap which can cause premature bearing failure.

ROW UNIT MOUNTED DISC FURROWER (PULL ROW ONLY)

Disc furrowers are used to clear crop residue, dirt clods, and dry soil from in front of row units for a clean and smooth seed bed. The disc furrower may be equipped with 12" solid blades or 12" notched blades. Notched blades are for heavier residue conditions and cut crop residue and move it aside to prevent plugging or pushing.

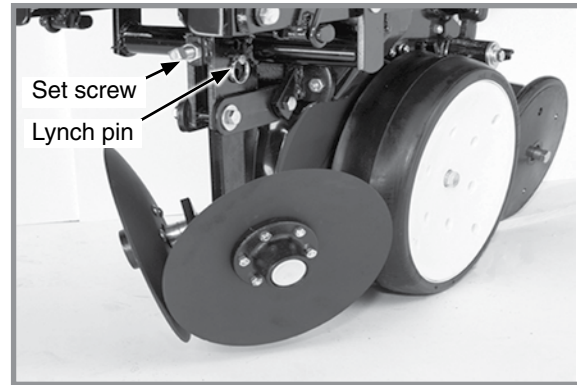
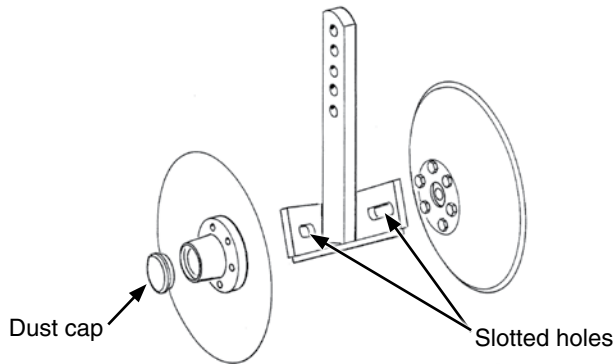

Disc furrower adjustment

Vertical adjustment can be made in $\frac{1}{3}$ " increments. Remove lynch pin in vertical support arm and move arm up or down. Reinstall lynch pin. Finer adjustment can be made by removing lynch pin and using $\frac{5}{8}$ " x $2\frac{1}{4}$ " set screw to clamp support arm in position.

Slotted holes in support arm allow front to rear disc blade adjustment. Blades can be adjusted so front edges meet or cutting edge of one blade overlaps edge of other blade.

NOTE: Dust cap must be removed to make adjustments.

ROW UNIT MOUNTED BED LEVELER (PULL ROW ONLY)

NOTE: Row unit mounted bed leveler is not compatible with row spacings less than 36".

Vertical adjustment can be made in $\frac{1}{3}$ " increments. Remove lynch pin in vertical support arm and move arm up or down. Reinstall lynch pin. Finer adjustment can be made by removing lynch pin and using $\frac{5}{8}$ " x $2\frac{1}{4}$ " set screw to clamp support arm in position.

Slotted holes in support arm allow blade adjustment. Blades can be tilted up or down.

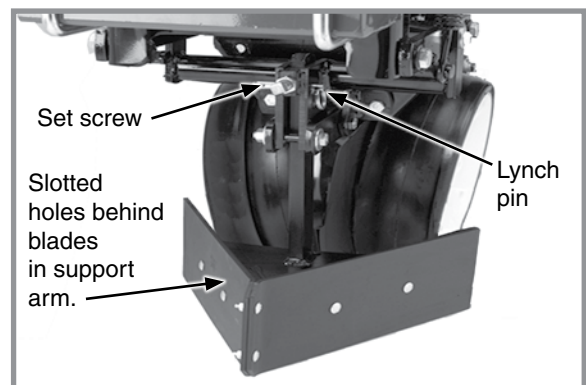

Bed leveler adjustment

ROW UNIT MOUNTED RESIDUE WHEEL

Row unit mounted residue wheels are used on pull and push row units.

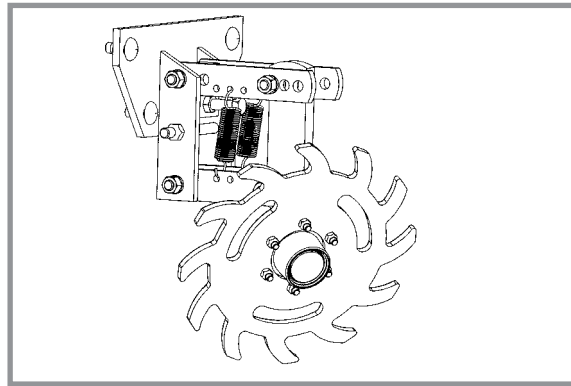

Row Unit Mounted Residue Wheel

Two adjustable springs on each residue wheel parallel links provide down force adjustment. Position 1 provides minimum down pressure and position 3 maximum down pressure.

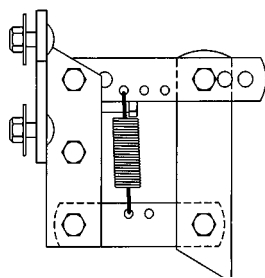

Position 1 (Least)

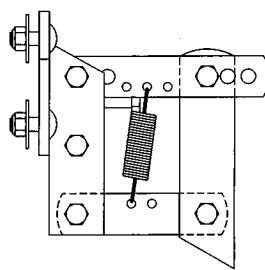

Position 2

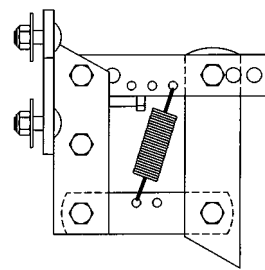

Position 3 (Most)

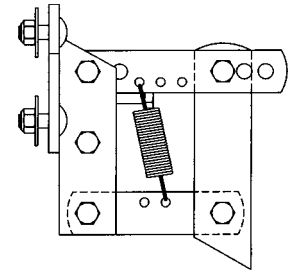

Additional uplift or float

Raise row unit and reposition springs to adjust down pressure.

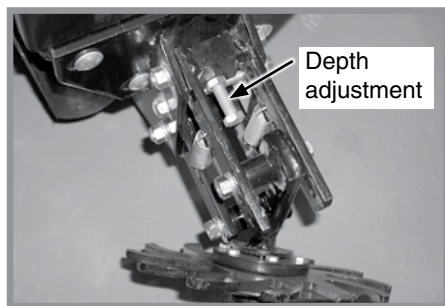

Wheel depth adjustment

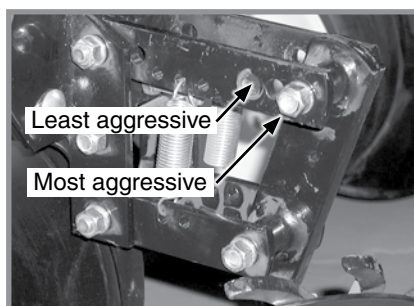

Wheel angle adjustment

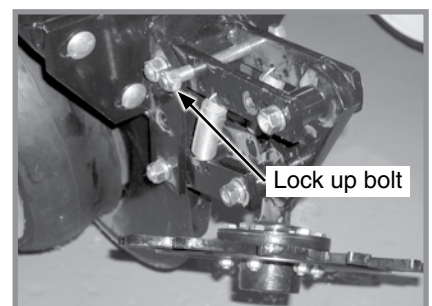

Wheel lock up

A full threaded bolt and jam nut located on the upper link sets maximum depth for loose soil conditions. Initial setting is 1 3/4" above row unit double disc opener depth.

Three holes in upper link adjust wheel angle. With wheel mount in most vertical position, using the rear hole in the upper link, the residue wheel is most aggressive. Moving wheel mount to a forward hole reduces aggressiveness of residue wheel for use in mulch till applications where soil is loose.

To lock residue wheel up, remove 1/2" x 5" lockup bolt, raise residue wheel and install bolt.

ROW UNIT MOUNTED NO TILL COULTER

Row unit mounted no till coulters with 1" bubbled, 1" fluted (8 flutes) or ¾" fluted (13 flutes) blades may be used on pull row units and push row units (¾" fluted shown). Four quick adjustable down force springs are required per row when using row unit mounted no till coulters. See "Quick Adjustable Down Force Springs Options".

Align coulters to row unit double disc openers. Adjust by loosening four attaching bolts, moving coulters, and tightening four attaching bolts. Coulters can be adjusted to one of four ½" incremental settings in the forked arm. Initial location is the top hole.

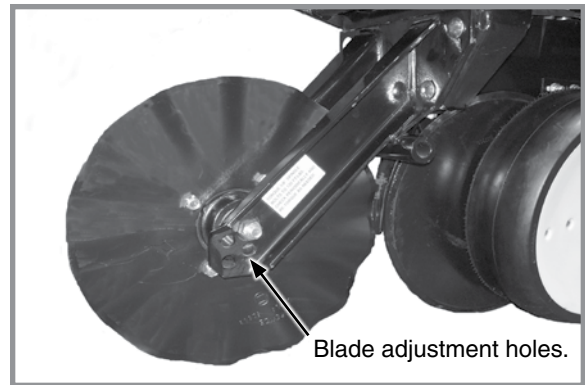

Row Unit Mounted No Till Coulters

Move blade as it wears to one of the three lower holes to maintain coulters at or slightly above opener discs as needed. Adjust coulters below depth of double disc opener blades in very hard soil conditions such as compacted wheel tracks to improve opener penetration and cutting of surface residue.

Check operating depth by setting planter down on a level concrete floor and checking relationship between coulters and row unit opener blade. Make sure planter is level and coulters are square with planter frame and aligned with row unit disc opener.

NOTE: Torque ⅝" spindle hardware to 120 ft-lb (162.7 N-m).

COULTER MOUNTED RESIDUE WHEELS

Coulters mounted residue wheels are designed for use on pull row units and push row units. Row unit extension brackets are required on the four center pull row units if the planter is equipped with coulters mounted residue wheels.

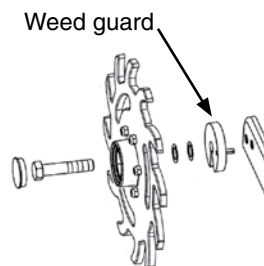

NOTE: Opening in weed guard must face down.



Coulters mounted residue wheels

Residue wheels attach to row unit mounted coulters with two cap screws and sleeves allowing unit to free-float. A 2-position spindle bolt mounting positions wheels interlocked or staggered. Depth adjustment is made with a spring-loaded cam and pin with 11 positions in ¼" increments. A high point on the cam allows wheels to be locked up.

A weed guard on the inboard side of each wheel helps prevent weed wrap which can cause premature bearing failure.

GRANULAR CHEMICAL HOPPER AND DRIVE

WARNING

Agricultural chemicals can cause death or serious injury to persons, animals, and plants or seriously damage soil, equipment, or property. Read and follow all chemical and equipment manufacturers labels and instructions.

The granular chemical hopper has a 1.4 cubic feet capacity.

Make sure no foreign objects get into hopper when it is being filled. Replace hopper lids after filling to prevent accumulation of dirt and moisture.

A metering gate on bottom of hopper regulates the application rate. See "Dry Insecticide and Dry Herbicide Application Rate Charts" in this manual. Calibrate using chemical manufacturers' instructions.



Granular chemical hopper

Granular chemical clutch drive coupler and meter shaft can be disengaged and engaged by turning throwout knob at rear of hopper support panel.

Rotate knob $\frac{1}{4}$ turn counterclockwise to disengage and $\frac{1}{4}$ turn clockwise to engage.

Slotted holes in hopper support panel and clutch housing allow for alignment adjustment between clutch drive coupler and meter shaft.

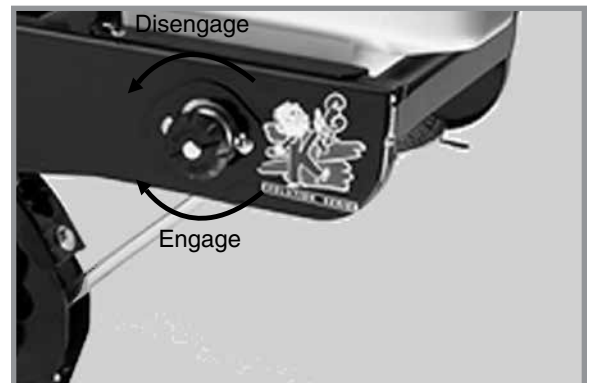

Granular chemical drive release

SPRING TOOTH INCORPORATOR

Spring tooth incorporator smooths soil behind row unit and incorporates granular chemicals.

Adjust two mounting chains on each spring tooth incorporator so there is approximately $\frac{1}{8}$ " slack in chain when unit is lowered to planting position.

NOTE: Spring tooth incorporator is not compatible with covering discs/single press wheel option.

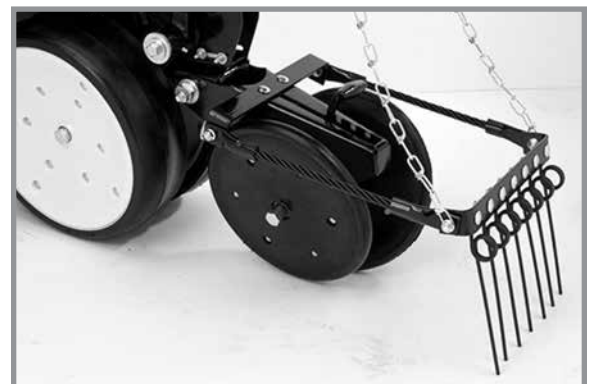

Spring tooth incorporator

GRANULAR CHEMICAL BANDING OPTIONS

Granular chemical banding options allow 4½" slope-compensating banding, straight drop in-furrow placement or 14" rear banding.

NOTE: Granular chemical rear bander is not compatible with covering discs/single press wheel option.

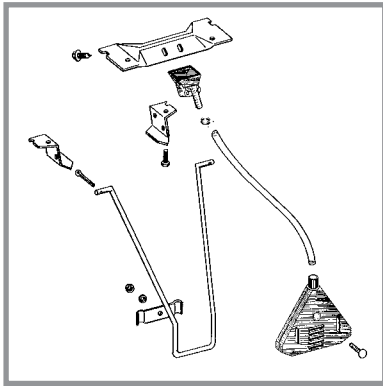

14" rear banding

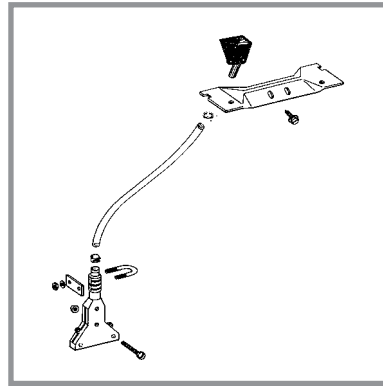

4½" slope-compensating bander

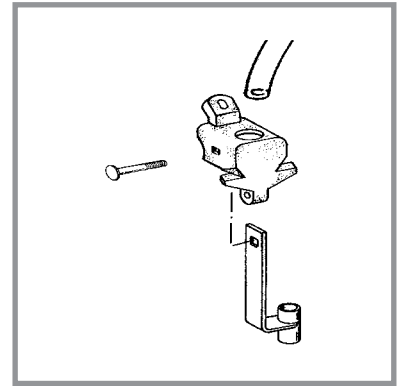

Straight drop in-furrow placement

GRANULAR CHEMICAL BANDER SHIELD

Optional granular chemical bander shield is installed on underside of wheel arm stop to shield crop residue from lodging in granular chemical bander.

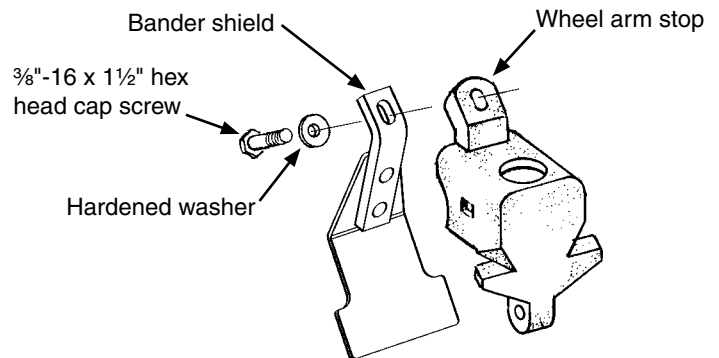

Granular chemical bander shield installation

INTERPLANT PUSH ROW UNIT LOCKUPS

Push row unit lockups are designed to allow the push row units to be locked in the raised position.

CAUTION

Improper lifting of row units can cause serious injury. An empty row unit requires minimum 84 lb (38.1 kg) lift. Set down pressure springs to minimum, lower planter to ground, and empty seed hopper before attempting to lift with this lever.

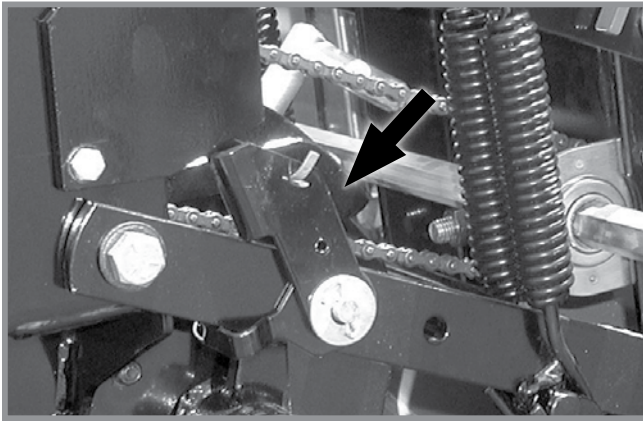

Push Row Unit Locked In Raised Position

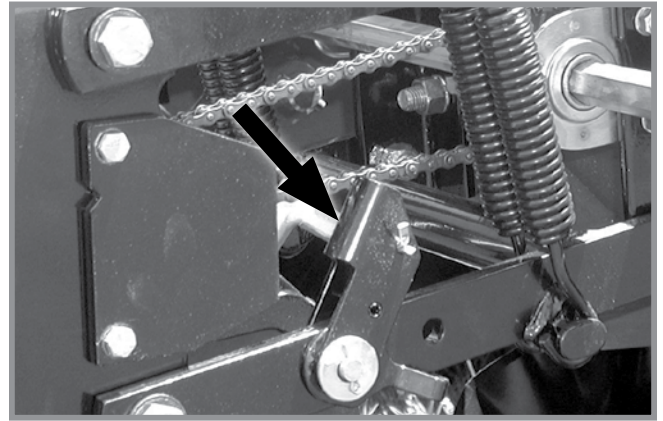

Lockup Released For Field Operation

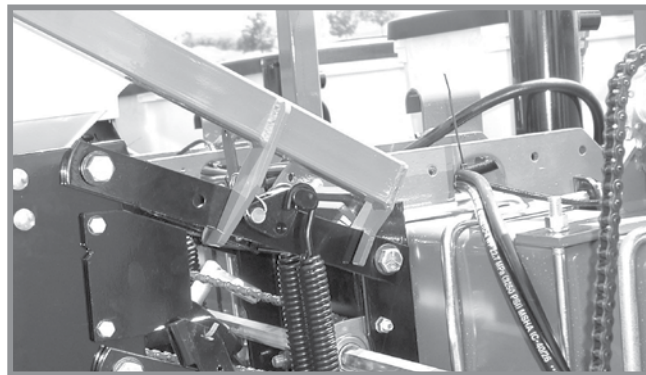

Lift lever positioned on push row unit

To lock in raised position:

1. Set row unit down pressure springs to minimum setting.
2. Lower the planter to the planting position.
3. Empty seed hoppers.
4. On each push row unit lockup, flip the spring tab forward.

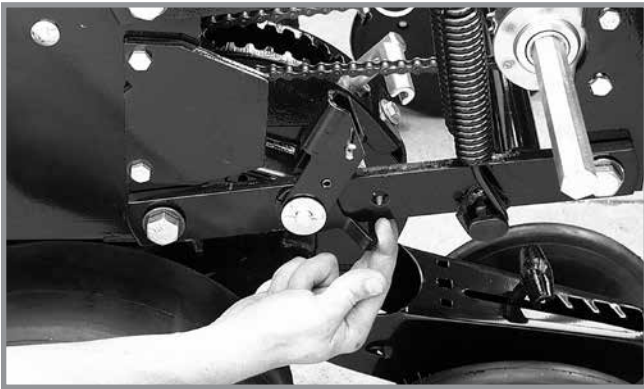

5. Using the lift lever, raise the push row unit to allow the spring loaded lockups to snap into locked position under the row unit stops.
6. Repeat Steps 4 and 5 on remaining push row units.

To release lockups:

1. Lower the planter to the planting position.
2. On each push row unit lockup, flip the spring tab rearward.

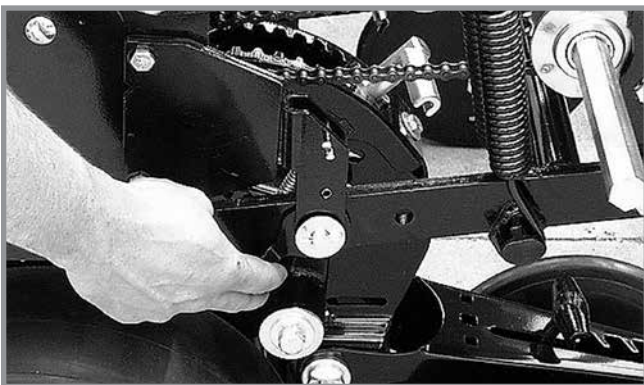

3. Using the lift lever, raise the push row unit to allow the spring loaded lockups to snap out of locked position. Lower row unit to the ground.
4. Repeat Step 3 on remaining push row units.

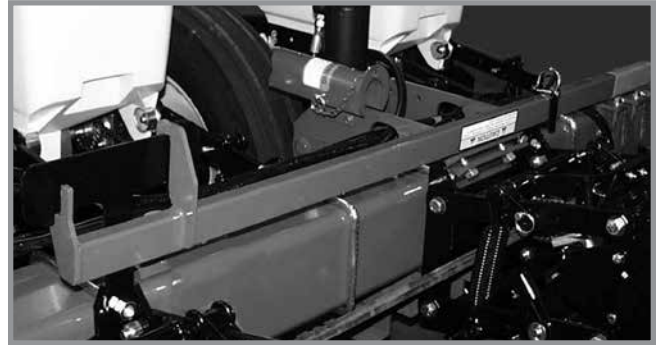
**Lift lever in storage location**

DOUBLE DISC FERTILIZER OPENER

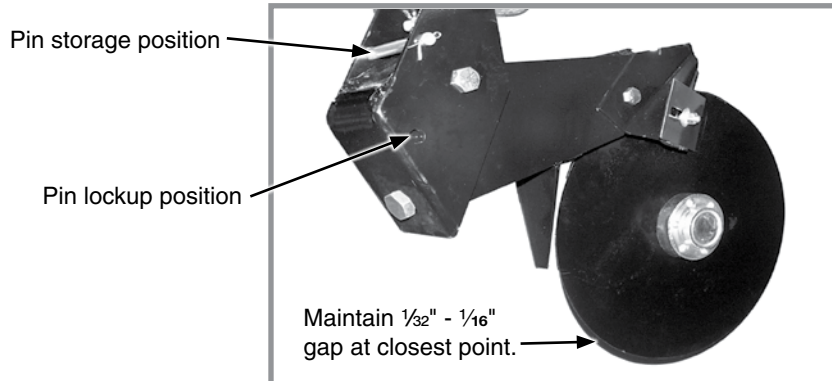

Double disc fertilizer opener

Position double disc fertilizer openers **to place fertilizer no closer than 2" to either side of row**. Fertilizer depth is approximately 4" if planter frame is level and at proper 20" operating height. Soil conditions can affect depth slightly.

NOTE: Do not set opener depth with spring pressure. Opener is designed to operate against a depth stop and spring up when encountering a foreign object or hard ground.

Down pressure spring is factory preset at 250 lb (113.4 kg) but can be adjusted for various soil conditions.

1. Loosen jam nut with a $1\frac{5}{16}$ " wrench.
2. Use a 1" wrench to turn adjustment bolt clockwise to increase tension or counterclockwise to decrease tension.
3. Tighten jam nut.

NOTICE

Do not operate double disc openers at full down pressure tension on rocky ground or disc blades will chip.

Maintain a gap of $\frac{1}{32}$ " to $\frac{1}{16}$ " between opener blades at the closest point. Blade adjustment is made by moving inside spacer washers to outer side of blade. Check bearing assembly rivets are not contacting shank after making adjustment.

Outer scrapers on each disc blade can be adjusted for wear. Make sure scrapers are adjusted to allow only slight blade contact.

Opener assembly is designed to be locked in a raised position when fertilizer attachment is not in use or during storage.

1. Raise planter and place blocks under openers.
2. Lower planter until pivot section hole aligns with mounting bracket hole.
3. Remove lockup pin from mounting bracket storage position and install through lockup hole.
4. Secure with cotter pins.

NOTCHED SINGLE DISC OPENER

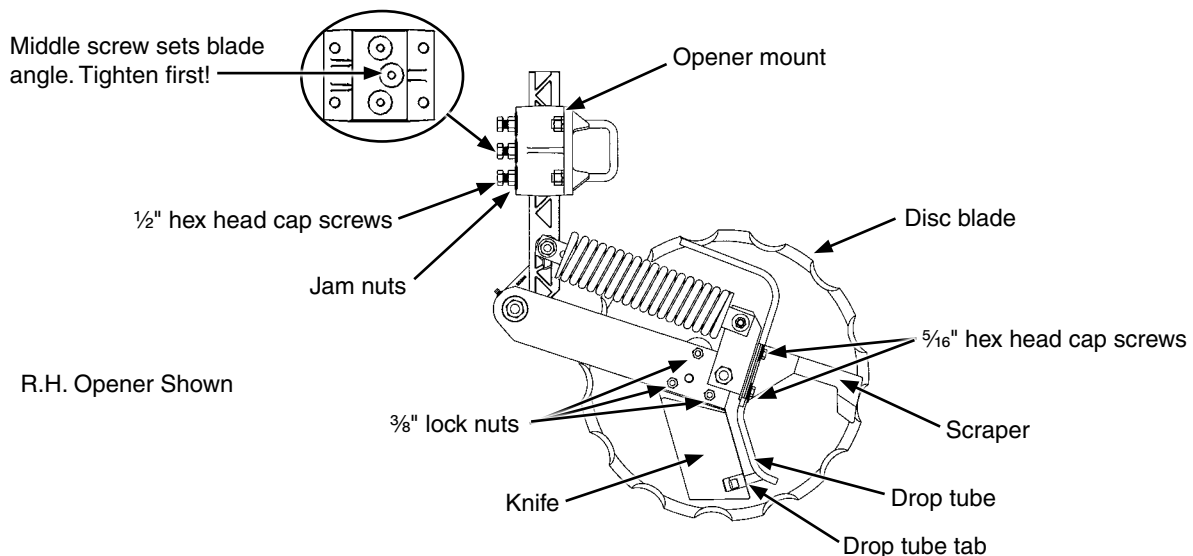

Notched single disc opener adjustments

CAUTION

Compressed spring may fly out of this assembly if attempting to disassemble and cause injury. Do not take apart this assembly.

Disc blades are sharp and can cut causing serious injury. Wear gloves when working on or turning disc blades by hand.

NOTICE

Never strike knife with heavy object. Damage to knife will occur.

If knife to disc blade clearance is too large, soil or residue can wedge between knife and blade, and blade will not turn.

1. Adjust knife to disc blade contact. Loosen or tighten $\frac{3}{8}$ " lock nuts to adjust knife's entire leading edge against disc blade. Turn blade and check for slight resistance without freewheeling. Readjust knife to blade's tight spot as needed.

NOTICE

Adjust liquid drop tube out of path of soil flow across knife. Drop tube and tab wear quickly if not correctly adjusted.

2. Adjust scraper and drop tube. Loosen two $\frac{5}{16}$ " hex head cap screws. Adjust scraper until just touching disc blade. Adjust drop tube until it is centered between knife and disc blade. Tighten screws. Turn blade and check for slight resistance without freewheeling. Repeat as needed. Insert flat bladed pry bar or screwdriver between knife and drop tube above drop tube tab. Carefully bend tube until $\frac{1}{4}$ " - $\frac{3}{8}$ " from disc blade.

NOTE: Maximum disc blade depth 4" (10.2 cm).

3. Adjust blade depth. Loosen three $\frac{1}{2}$ " hex head cap screws and jam nuts in opener mount. Adjust opener assembly up or down to desired blade depth. Tighten center hex head cap screw and jam nut first to set proper disc blade angle. Tighten remaining hex head cap screws and jam nuts. Torque hex head cap screws and jam nuts to 57 ft-lb (77.29 N-m). Check fertilizer hose clearance and adjust as necessary.

RESIDUE WHEEL ATTACHMENT FOR NOTCHED SINGLE DISC FERTILIZER OPENER



Notched single disc opener residue wheel attachment

Residue wheel attachment for notched single disc fertilizer opener is used where row unit mounted residue wheel attachments cannot be installed. Residue wheel is attached to notched single disc fertilizer opener with $\frac{5}{8}$ " x $7\frac{1}{2}$ " and $\frac{1}{2}$ " x $6\frac{1}{2}$ " hardware.

Maximum depth is set by lifting residue wheel and moving adjustment lever down to increase depth or up to decrease depth in 1" increments (in relation to blade depth setting). Adjust all rows the same. Residue wheel down force is maintained by a torsion spring and is not adjustable.

DEPTH/GAUGE WHEEL ATTACHMENT FOR NOTCHED SINGLE DISC FERTILIZER OPENER

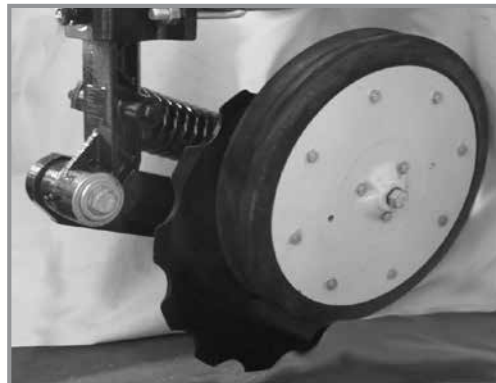

Notched single disc opener depth/gauge wheel

Depth/gauge wheel attachment for notched single disc fertilizer opener is used where additional gauging is required to maintain desired fertilizer opener depth. Depth/gauge wheel is attached to notched single disc fertilizer opener using a mounting block fastened to the pivot arm with $\frac{5}{8}$ " hardware through disc blade bearing.

Depth adjustment is made using 3 adjustment holes in depth/gauge wheel mounting block. Moving depth/gauge wheel increases/decreases depth in approximate 1" increments in relation to blade depth setting made at vertical mounting post.

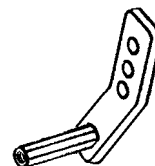

HD SINGLE DISC FERTILIZER OPENER

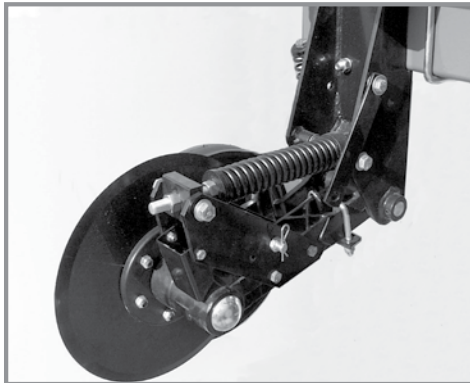

HD single disc opener

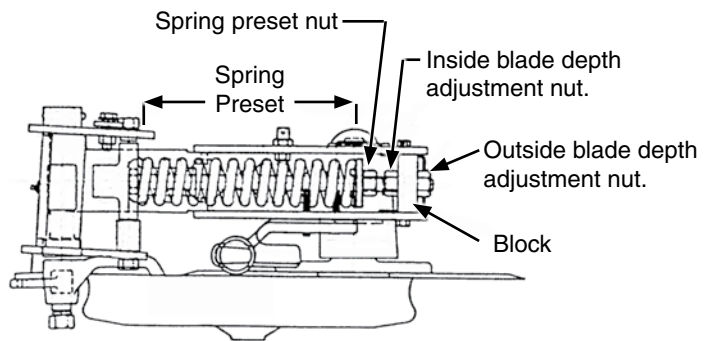

R.H. configuration shown (Overhead view)

Recommended placement of fertilizer with HD single disc fertilizer opener is 3½" - 4" from row.

NOTICE

Never place fertilizer closer than 2" to row or seeds may be damaged.

Maximum blade depth is approximately 5" with planter frame level and at 20" operating height. Soil conditions can affect depth slightly.

Raise planter to remove weight from fertilizer opener. Loosen inside adjustment nut with 1½" wrench. Turn outside nut clockwise to decrease or counterclockwise to increase blade depth. One full turn of blade depth adjustment nut changes blade depth ⅜". Tighten inside nut tight against block. Adjust all fertilizer openers to same depth.

Fertilizer opener down pressure can be adjusted from 250 lb (113.4 kg) to 640 lb (290.3 kg).

NOTICE

Do not operate HD single disc fertilizer openers at full down pressure tension on rocky ground or disc blades will chip.

NOTE: DO NOT adjust spring preset dimension less than 9½".

NOTE: Excessive down pressure can cause planter frame up-lift and affect machine performance. Planter frame should be 20" from ground in planting position. Excessive down pressure in loose soil conditions can cause openers to run too deep and push dirt ahead of opener and may stop soil press wheel and opener blade from turning.

Raise planter to remove weight from fertilizer opener. Turn spring preset nut clockwise to increase and counterclockwise to decrease down pressure. Adjust all rows to a similar setting. Minimal spring pressure for acceptable operation is recommended. See chart for spring length settings.

Adjust spring loaded dry fertilizer drop tube/scrapper periodically to maintain ⅛" gap between drop tube and opener blade. If this dimension is not maintained fertilizer may not drop in proper location.

Loosen scraper adjustment bolt. Slotted hole in scraper allows up or down adjustment.

Spring Preset	
Length	Down Pressure
11" (27.9 cm)	250 lb (113.4 kg)
10¾" (27.3 cm)	320 lb (145.1 kg)
*10½" (26.7 cm)	370 lb (167.8 kg)
10¼" (26 cm)	450 lb (204.1 kg)
10" (25.4 cm)	520 lb (235.8 kg)
9¾" (24.8 cm)	580 lb (263.1 kg)
9½" (24.1 cm)	640 lb (290.3 kg)
*Initial setting	

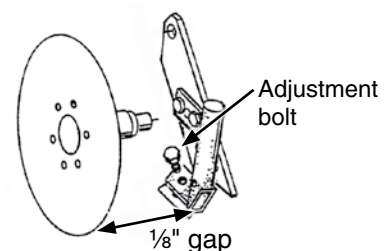

Adjust liquid drop tube/scrapper so there is slight contact between blade and scraper lower leading edge, and 1/4" clearance between liquid drop tube trailing edge and blade. Blade should turn with minimum amount of drag.

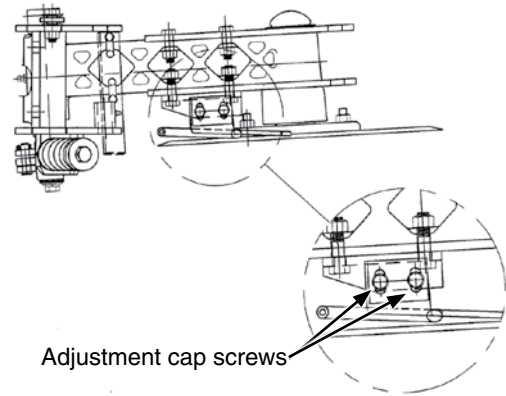

NOTE: Soil press wheel is not for gauging fertilizer opener operating depth.

Additional press wheel down pressure may be desirable in heavy moist soils. Turn press wheel spring adjustment bolt clockwise to increase down pressure.



Press wheel down pressure adjustment

HD single disc fertilizer opener can be raised and locked up when fertilizer attachment is not used or during storage.

NOTE: A lockup bar automatically raises and locks soil press wheel when blade assembly is raised.

1. Place planter in planting position.
2. Remove outside blade depth adjustment.
3. Raise planter until adjustment bolt clears adjustment block.
4. Raise spring to clear blade assembly and raise blade assembly until storage strap can be positioned on lockup pin. Install hair pin clip.
5. Reinstall depth adjustment nut and tighten

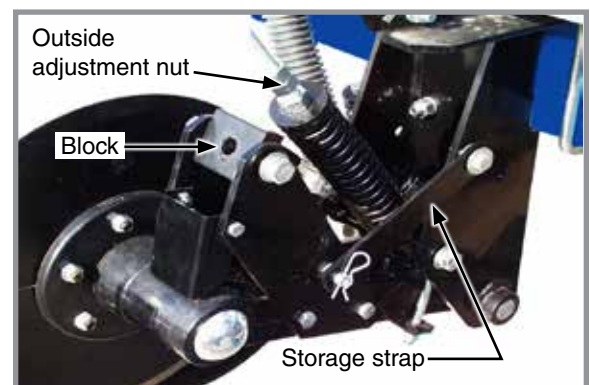

HD opener lockup

DRY FERTILIZER ATTACHMENT

WARNING

Agricultural chemicals can cause death or serious injury to persons, animals, and plants or seriously damage soil, equipment, or property. Read and follow all chemical and equipment manufacturers labels and instructions.



Dry fertilizer option installed



Fertilizer drive rate transmission

Rate of fertilizer application is determined by drive/driven sprocket combination on fertilizer drive rate transmission and auger position in the hoppers.

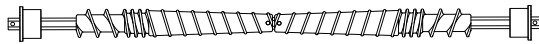

Augers positioned for high rate delivery



Augers positioned for low rate delivery

NOTE: Uneven delivery of fertilizer will occur if high rate auger position is used at too low a rate setting.

Remove ¼" stainless steel cap screws holding augers in place on shaft and reposition augers to change delivery rate.

A fertilizer transmission is located directly ahead of row unit transmission on right side of planter and allows simple, rapid changes in sprockets to obtain desired fertilizer application rates. Chain tension is controlled by a spring loaded idler adjusted with a ratchet arm located to inside of transmission. Sprockets can be changed with those on the sprocket storage rod by removing hexagon shaft pins. Fertilizer rate charts in Rate Chart section will help you select correct sprocket combinations.

NOTE: Make a field check after each sprocket combination adjustment to be sure you are applying fertilizer at desired rate.

NOTICE

Placing fertilizer too close to seeds or in excessive amounts can cause germination or seedling damage. Check with your fertilizer dealer or manufacturer for correct amount and placement.

Because dry fertilizer attachment meters granules by volume rather than weight, differences in brands, and fertilizer analysis, weight metered during actual application may vary considerably. Use chart for reference only. Use a container to catch and measure application for a better estimate.

Keep fertilizer dry during use and storage since most fertilizers easily absorb moisture. In addition to waste, deposits of fertilizer left in hopper can cause metal corrosion. Empty hoppers at end of each day.

CLEANING

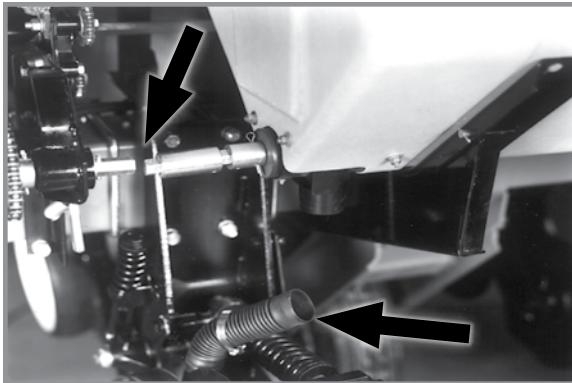
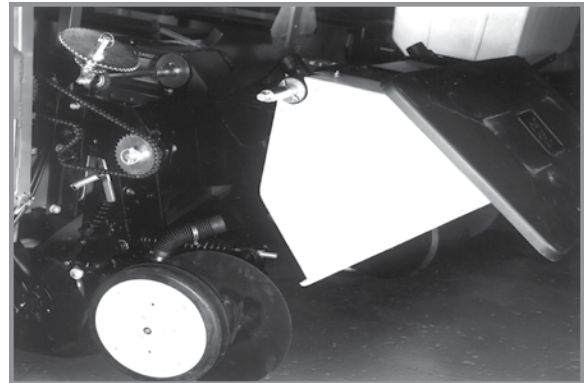
**Disconnect drive shaft and hoses****Rotate lid to back and rotate hopper forward**

Dry fertilizer hoppers tip forward for dumping and ease of cleaning. Disconnect drive shaft from transmission and/or adjacent hopper. **LOOSEN HOSE CLAMPS AND REMOVE HOSES FROM EACH HOPPER.** Remove rear $\frac{1}{2}$ " x $1\frac{1}{4}$ " cap screw from between each hopper saddle and hopper mount. Rotate each hopper lid to back side of hopper and carefully tip hopper forward. Flush all loose fertilizer from hoppers and hoses after dumping contents.

At end of planting season or when fertilizer attachment is not used for a period of time, hoppers should be disassembled, cleaned, and metal surfaces coated with a rust preventative. Remove $\frac{1}{4}$ " cotter pin and bearing from one end of shaft. Pull auger assembly from opposite end of hopper. Remove stainless steel cap screws from auger shaft and remove all auger components for cleaning. Coat all parts with rust preventative before reassembly. Reinstall auger halves in low or high rate position.

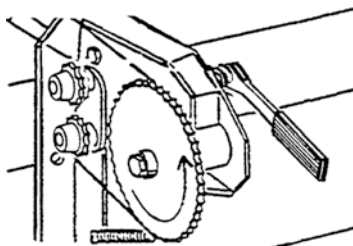
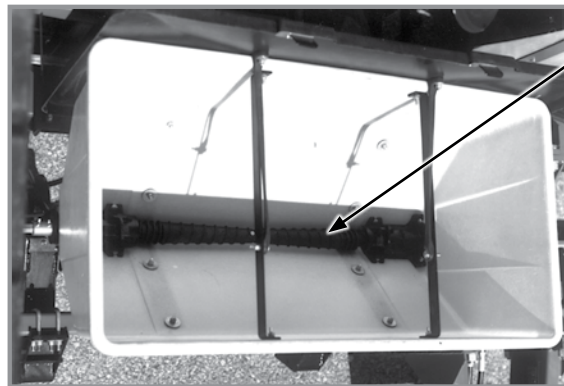
**Transmission direction of rotation**

Flighting must move chemicals from center to outside of hopper.

Auger installation

NOTE: Install auger assembly so the flighting moves material to outer openings in hopper when augers rotate in direction they turn during operation.

Slide auger assembly through outlet housing into hopper. Secure in place by reinstalling bearing and cotter pin. Rotating shaft in direction shown to see if flighting (spirals) on auger move toward ends of hopper. If not, remove auger assembly, turn 180° , and reinstall.

NOTE: Frequent lubrication of auger bearings is critical to ensure augers turn freely. Check lubrication section for frequency.

Be certain augers turn freely. If not, loosen $\frac{5}{16}$ " carriage bolts in outlet housings, rotate auger several times, and retighten carriage bolts. This allows housings and augers to realign.

NOTE: Do not operate fertilizer attachment without auger baffles in place.

Install auger baffles over augers and secure in place with two hair pin clips in each hopper.

LIQUID FERTILIZER ATTACHMENT

WARNING

Agricultural chemicals can cause death or serious injury to persons, animals, and plants or seriously damage soil, equipment, or property. Read and follow all chemical and equipment manufacturers labels and instructions.

CAUTION

Prior to 2012 production. Overfilling tank can cause siphoning, tank collapse, personal injury, and damage to property and equipment. Do not overfill tank. Do not leave planter unattended when filling tank. Close fill valve and open tank lid if siphoning occurs. Follow all chemical manufacturers first aid, cleanup, and handling instructions.

NOTICE

Placing fertilizer too close to seeds or in excessive amounts can cause germination or seedling damage. Check with your fertilizer dealer or manufacturer for correct amount and placement.



Liquid fertilizer installed on 3600 ASD

CHECK VALVES



Old style non-reparable check valve



New style reparable check valve

Optional low rate check valves are available for in-line installation between liquid fertilizer squeeze or piston pump and openers to ensure equal distribution of product at low rates. Check valves eliminate anti-siphon loops.

SQUEEZE PUMP

Squeeze pump rate of liquid fertilizer application is determined by combination of sprockets on squeeze pump drive and driven shafts. Make sure sprockets are in alignment, sprocket retaining collars are tight, and chain is properly tensioned is when changing sprocket combinations. Close all shut-off valves when planter sits overnight or for extended periods of time. It is also important to close tank valves when servicing on pump or hoses.

NOTE: Delivery rate chart in Rate Chart section of this manual provides approximate application rate only. Delivery varies with temperature and fertilizer.

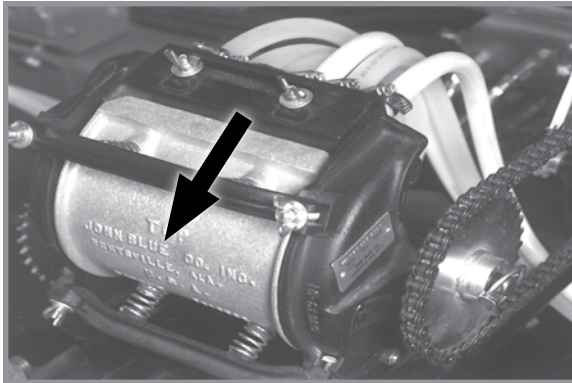

Discharge manifold rearward

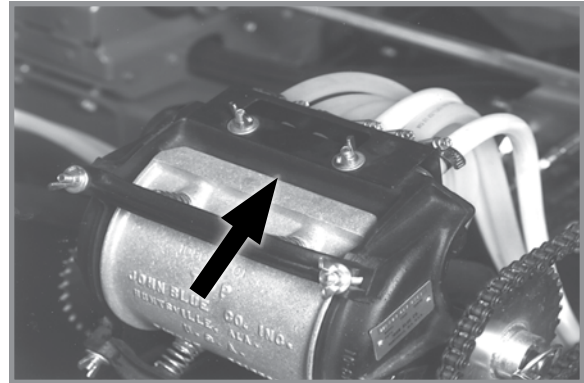

Discharge manifold forward

Discharge manifold must be repositioned rearward when not in use to prevent hose distortion and prolong hose life. Discharge manifold must be forward when pump is in operation. Loosen wing nuts and slide manifold forward and sideways or rearward as required and retighten wing nuts.

NOTICE

Avoid excessive pressure using quick fill attachment or rubber plugs installed in manifold may be forced out.

If either end pump hoses run off back plate, loosen hose clamps on intake manifold and rotate hose as follows:

1. For right hand hose (facing pump from front of planter as shown) twist hose $\frac{1}{4}$ turn to right.
2. For left hand hose (facing front of pump) twist hose $\frac{1}{4}$ turn to left.
3. Retighten hose clamps.

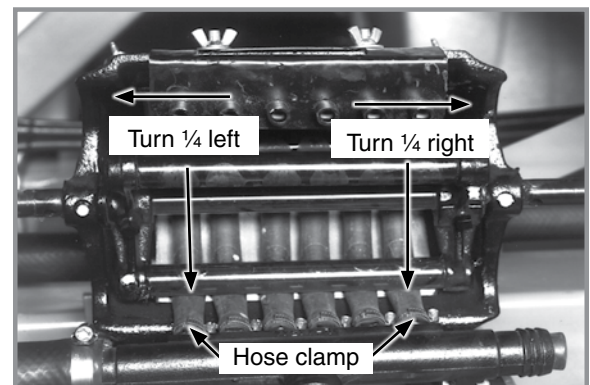

Adjusting squeeze pump end hoses

PISTON PUMP

NOTE: Keep manuals shipped with pump and flow divider with this manual.

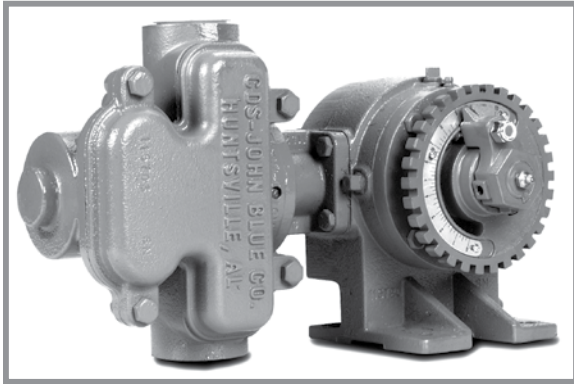

Piston pump

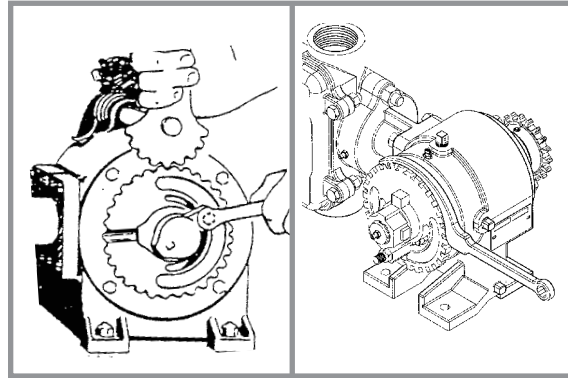

Adjusting delivery rate

NOTE: Delivery rate chart in Rate Chart section of this manual provides approximate application rate only. Delivery varies with temperature and fertilizer.

Loosen $\frac{3}{8}$ " lock nut that secures arm with pointer and rotate scale flange with adjustment wrench until pointer is over desired scale setting. Tighten $\frac{3}{8}$ " lock nut. **DO NOT OVERTIGHTEN.**

NOTE: Periodically check flow to all rows. Set rate is delivered to remaining rows if one or more lines are plugged.

PISTON PUMP GROUND DRIVE WHEEL SPRING ADJUSTMENT

Initial down pressure spring tension on piston pump ground drive wheel, is set leaving $12\frac{1}{4}$ " between the bottom of mounting plate and plug on top of spring. This dimension is taken with planter raised (tire not contacting the ground). Further adjustment can be made to fit conditions.

NOTE: Piston pump ground drive wheel assembly can be locked in raised position when not in use. Remove two cap screws that attach upper end of spring to spring mount. Reattach spring using upper holes in spring mount. Reverse procedure to reset for field use.

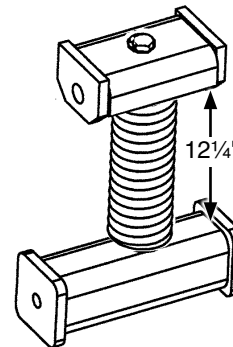

CLEANING

Clean tanks, hoses, and metering pump thoroughly with water at end of planting season or prior to an extended period of non-use. Do not allow fertilizer to crystallize from cold temperature or evaporation.

On machines equipped with piston pump, take apart and clean strainer located between piston pump and ball valve daily. Remove the end cap to clean the screen. See Piston Pump Storage in Maintenance Section of this manual.

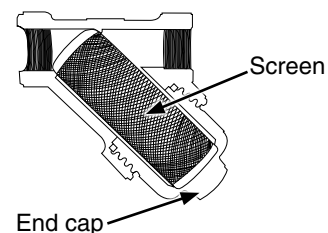

GENERAL PLANTING RATE INFORMATION

These planting rate charts apply to KINZE Model 3600 planters.

NOTICE

Sprocket combinations in these charts are for average conditions. Changes in sprocket combinations may be required for desired planting population. ALWAYS MAKE FIELD CHECKS TO BE SURE YOU ARE PLANTING AT DESIRED RATE.

NOTICE

Seed additives added in the hopper may affect finger pickup seed meter performance and accelerate wear.

NOTE: Seed size and shape may affect planting rate.

NOTE: Not all row spacings listed apply to all size planters.

NOTE: Speeds above 5.5 MPH (8.8 KPH) can adversely affect seed spacing.

MECHANICAL

Finger Pickup Corn Meter

Larger grades generally plant more accurately at the high end of the ground speed range than smaller grades. Higher than optimum speeds may result in population rate increase or higher incidence of doubles, particularly with small seed. Medium round corn seed is most desirable for planting accuracy at optimum speed.

Finger Pickup Oil Sunflower Meter

Larger grades generally plant more accurately at the high end of the ground speed range than smaller grades. Higher than optimum speeds may result in population rate increase or higher incidence of doubles, particularly with small seed. No. 3 and/or No. 4 size oil sunflower seeds are recommended for use in finger pickup seed meters equipped with oil sunflower fingers. No. 1 and/or No. 2 size confectionery sunflower seeds are recommended for use in finger pickup seed meters equipped with corn fingers.

Brush-Type Seed Meter (Soybean, Milo/Grain Sorghum, Acid-Delinted Cotton)

Rate charts are given in seeds per acre as well as seed spacing in inches rounded to nearest tenth of an inch. Because of large range in seed size, pounds per acre is not a suggested method of selecting transmission settings. Smaller size seed pounds per acre may be below what was expected and large seed pounds per acre may appear above expectations. To determine pounds per acre, use formula given in "Determining Pounds Per Acre (Brush-Type Seed Meter)" in "Check Seed Population" in Machine Operation section of this manual.

NOTE: Planting speed can affect actual seeding rate. Make a field check and adjust transmission setting to obtain desired seed drop.

NOTE: Seed population per acre with 15" rows double rate for 30" rows, as well as 18" rows versus 36" rows and 19" rows versus 38" rows, at listed sprocket combination. See following pages.

NOTE: Half Rate (2 to 1) Drive Reduction Package may be required to obtain desired population and seed spacing when planting 15" row soybeans or other crops. Half Rate Drive with brush-type seed meters reduces planter transmission speed. Seeding rate will be approximately 50% of chart reading when using Half Rate (2 To 1) Drive Reduction Package.

**EXAMPLE: 30" row spacing using 60 cell seed discs in brush-type seed meters.
 $80,928 \div 2 = 40,464$ Population (2.6" Seed Spacing x 2 = 5.2" Seed Spacing)**

EDGEVAC

NOTE: 22, 28, and 44 tooth drive sprockets are NOT applicable to all rate charts. Check chart titles to ensure proper rate chart is selected. 22 tooth sprocket requires 114 pitch No. 40 chain. 28 tooth sprocket requires 118 pitch No. 40 chain. 44 tooth sprocket requires 126 pitch No. 40 chain.

NOTE: DO NOT USE 44 tooth sprockets (60 cell soybean discs) with Dry Fertilizer Package or Liquid Fertilizer Package.

**PLANTING RATES FOR FINGER PICKUP SEED METERS (STANDARD DRIVE)
APPROXIMATE SEEDS/ACRE FOR VARIOUS ROW WIDTHS**

Transmission Drive	Sprockets Driven	7.5" Rows	30" Rows	36" Rows	38" Rows	Recomm. Speed Range (MPH)	Average Seed Spacing In Inches
17	28	32,372	16,186	13,488	12,778	4 to 6	12.9
17	27	33,570	16,785	13,988	13,251	4 to 6	12.5
17	26	34,862	17,431	14,526	13,761	4 to 6	12.0
19	28	36,180	18,090	15,075	14,281	4 to 6	11.6
17	25	36,256	18,128	15,107	14,312	4 to 6	11.5
19	27	37,520	18,760	15,633	14,810	4 to 6	11.1
17	24	37,766	18,883	15,736	14,908	4 to 6	11.1
19	26	38,962	19,481	16,234	15,380	4 to 6	10.7
17	23	39,408	19,704	16,420	15,556	4 to 6	10.6
19	25	40,522	20,261	16,884	15,995	4 to 6	10.3
19	24	42,208	21,104	17,587	16,662	4 to 6	9.9
23	28	43,796	21,898	18,249	17,288	4 to 6	9.5
19	23	44,044	22,022	18,352	17,386	4 to 6	9.5
23	27	45,418	22,709	18,924	17,928	4 to 6	9.2
24	28	45,700	22,850	19,042	18,040	4 to 6	9.2
23	26	47,166	23,583	19,652	18,618	4 to 6	8.9
24	27	47,394	23,697	19,747	18,708	4 to 6	8.8
25	28	47,604	23,802	19,835	18,791	4 to 6	8.8
17	19	47,706	23,853	19,877	18,831	4 to 6	8.8
23	25	49,052	24,526	20,438	19,363	4 to 6	8.5
24	26	49,216	24,608	20,507	19,427	4 to 6	8.5
25	27	49,368	24,684	20,570	19,487	4 to 6	8.5
26	28	49,510	24,755	20,629	19,543	4 to 6	8.4
23	24	51,096	25,548	21,290	20,169	4 to 6	8.2
24	25	51,184	25,592	21,327	20,205	4 to 6	8.2
25	26	51,266	25,633	21,361	20,237	4 to 6	8.2
26	27	51,342	25,671	21,393	20,267	4 to 6	8.1
27	28	51,414	25,707	21,422	20,295	4 to 6	8.1
23	23	53,318	26,659	22,216	21,046	4 to 6	7.8
28	27	55,292	27,646	23,038	21,826	4 to 6	7.6
27	26	55,368	27,684	23,070	21,856	4 to 6	7.6
25	24	55,540	27,770	23,141	21,923	4 to 6	7.5
24	23	55,636	27,818	23,181	21,961	4 to 6	7.5
28	26	57,418	28,709	23,924	22,665	4 to 6	7.3
27	25	57,582	28,791	23,993	22,730	4 to 6	7.3
25	23	57,954	28,977	24,147	22,876	4 to 6	7.2
19	17	59,590	29,795	24,829	23,522	4 to 6	7.0
28	25	59,716	29,858	24,881	23,572	4 to 6	7.0
27	24	59,982	29,991	24,993	23,677	4 to 6	7.0
26	23	60,272	30,136	25,113	23,792	4 to 6	7.0
28	24	62,204	31,102	25,918	24,554	3 to 6	6.7
27	23	62,590	31,295	26,079	24,707	3 to 6	6.7
23	19	64,542	32,271	26,893	25,477	3 to 5.5	6.5
28	23	64,908	32,454	27,045	25,622	3 to 5.5	6.5
24	19	67,348	33,674	28,062	26,585	3 to 5.5	6.2
25	19	70,154	35,077	29,231	27,693	3 to 5	6.0
23	17	72,136	36,068	30,056	28,474	2 to 5	5.8
26	19	72,960	36,480	30,400	28,800	3 to 5	5.7
24	17	75,272	37,636	31,363	29,713	3 to 5	5.6
27	19	75,766	37,883	31,570	29,908	3 to 5	5.5
25	17	78,408	39,204	32,670	30,951	3 to 4.5	5.3
28	19	78,574	39,287	32,739	31,016	3 to 4.5	5.3
26	17	81,544	40,772	33,977	32,189	3 to 4.5	5.1
27	17	84,680	42,340	35,284	33,427	3 to 4.5	4.9
28	17	87,816	43,908	36,590	34,665	3 to 4.5	4.8

NOTE: See "Mechanical Meter General Planting Rate Information" and "Check Seed Population" pages for more information. Always field check seed population to verify planting rates.

PLANTING RATES FOR BRUSH-TYPE SEED METERS (STANDARD DRIVE)

APPROXIMATE SEEDS/ACRE FOR 30"/36"/38" ROW WIDTHS

Transmission Sprockets		60 Cell Soybean Or High-Rate Milo/Grain Sorghum			Average Seed Spacing In Inches	48 Cell Specialty Soybean Or High-Rate Acid-Delinted Cotton			Average Seed Spacing In Inches	Speed Range (MPH)
Drive	Driven	30" Rows	36" Rows	38" Rows		30" Rows	36" Rows	38" Rows		
17	28	80,928	67,440	63,891	2.6	64,742	53,952	51,113	3.2	2 to 8
17	27	83,926	69,938	66,257	2.5	67,141	55,950	53,006	3.1	2 to 8
17	26	87,154	72,628	68,805	2.4	69,723	58,102	55,044	3.0	2 to 8
19	28	90,449	75,374	71,407	2.3	72,359	60,299	57,126	2.9	2 to 8
19	27	93,799	78,166	74,052	2.2	75,039	62,533	59,242	2.8	2 to 8
17	24	94,416	78,680	74,539	2.2	75,533	62,944	59,631	2.8	2 to 8
17	23	98,521	82,101	77,780	2.1	78,817	65,681	62,224	2.7	2 to 8
19	25	101,303	84,419	79,976	2.1	81,042	67,535	63,981	2.6	2 to 8
19	24	105,524	87,937	83,309	2.0	84,419	70,350	66,647	2.5	2 to 8
23	28	109,491	91,243	86,440	1.9	87,593	72,994	69,152	2.4	2 to 8
19	23	110,112	91,760	86,931	1.9	88,090	73,408	69,545	2.4	2 to 8
24	28	114,252	95,210	90,199	1.8	91,402	76,168	72,159	2.3	2 to 8
24	27	118,483	98,736	93,539	1.8	94,786	78,989	74,831	2.2	2 to 8
17	19	119,263	99,386	94,155	1.8	95,410	79,509	75,324	2.2	2 to 8
24	26	123,040	102,534	97,137	1.7	98,432	82,027	77,710	2.1	2 to 8
26	28	123,773	103,144	97,715	1.7	99,018	82,515	78,172	2.1	2 to 8
24	25	127,962	106,635	101,023	1.6	102,370	85,308	80,818	2.0	2 to 8
26	27	128,357	106,964	101,334	1.6	102,686	85,571	81,067	2.0	2 to 8
23	23	133,294	111,078	105,232	1.6	106,635	88,862	84,186	2.0	2 to 8
27	26	138,420	115,350	109,279	1.5	110,736	92,280	87,423	1.9	2 to 8
24	23	139,089	115,907	109,807	1.5	111,271	92,726	87,846	1.9	2 to 8
25	23	144,884	120,737	114,382	1.4	115,907	96,590	91,506	1.8	2 to 8
19	17	148,975	124,146	117,612	1.4	119,180	99,317	94,090	1.8	2 to 8
27	24	149,955	124,963	118,386	1.4	119,964	99,970	94,709	1.7	2 to 8
28	24	155,509	129,591	122,770	1.3	124,407	103,673	98,216	1.7	2 to 8
23	19	161,355	134,463	127,386	1.3	129,084	107,570	101,909	1.6	2 to 8
28	23	162,270	135,225	128,108	1.3	129,816	108,180	102,483	1.6	2 to 8
24	19	168,371	140,309	132,924	1.2	134,696	112,247	106,339	1.6	2 to 8
25	19	175,386	146,155	138,463	1.2	140,309	116,924	110,770	1.5	2 to 8
23	17	180,338	150,282	142,372	1.2	144,270	120,226	113,898	1.5	2 to 8
26	19	182,402	152,001	144,001	1.1	145,922	121,601	115,201	1.4	2 to 7
27	19	189,417	157,878	148,540	1.1	151,534	126,278	118,832	1.4	2 to 7
28	19	196,433	163,694	155,078	1.1	157,146	130,955	124,062	1.3	2 to 7
26	17	203,861	169,884	160,943	1.0	163,089	135,907	128,754	1.3	2 to 7
27	17	211,702	176,418	167,133	0.9	169,362	141,134	133,706	1.2	2 to 7
28	17	219,542	182,952	173,323	0.9	175,634	146,362	138,658	1.2	2 to 7

NOTE: See "Mechanical Meter General Planting Rate Information" and "Check Seed Population" pages for additional information.

NOTE: When using Half Rate (2 To 1) Drive Reduction Package, rates are approximately 50% of given numbers.

NOTE: Always field check seed population to ensure planting rates are correct.

**PLANTING RATES FOR BRUSH-TYPE SEED METERS (STANDARD DRIVE)
APPROXIMATE SEEDS/ACRE FOR 15"/18"/19" ROW WIDTHS**

Transmission Sprockets		60 Cell Soybean Or High-Rate Milo/Grain Sorghum			Average Seed Spacing In Inches	48 Cell Specialty Soybean Or High-Rate Acid-Delinted Cotton			Average Seed Spacing In Inches	Speed Range (MPH)
Drive	Driven	7.5" Rows or 15" Rows	18" Rows	19" Rows		7.5" Rows or 15" Rows	18" Rows	19" Rows		
17	28	161,856	134,880	127,782	2.6	129,484	107,904	102,226	3.2	2 to 8
17	27	167,852	139,876	132,514	2.5	134,282	111,900	106,012	3.1	2 to 8
17	26	174,308	145,256	137,610	2.4	139,446	116,204	110,088	3.0	2 to 8
19	28	180,898	150,748	142,814	2.3	144,718	120,598	114,252	2.9	2 to 8
19	27	187,598	156,332	148,104	2.2	150,078	125,066	118,484	2.8	2 to 8
17	24	188,832	157,360	149,078	2.2	151,066	125,888	119,262	2.8	2 to 8
17	23	197,042	164,202	155,560	2.1	157,634	131,362	124,448	2.7	2 to 8
19	25	202,606	168,838	159,952	2.1	162,084	135,070	127,962	2.6	2 to 8
19	24	211,048	175,874	166,618	2.0	168,838	140,700	133,294	2.5	2 to 8
23	28	218,982	182,486	172,880	1.9	175,186	145,988	138,304	2.4	2 to 8
19	23	220,224	183,520	173,862	1.9	176,180	146,816	139,090	2.4	2 to 8
24	28	228,504	190,420	180,398	1.8	182,804	152,336	144,318	2.3	2 to 8
24	27	236,966	197,472	187,078	1.8	189,572	157,978	149,662	2.2	2 to 8
17	19	238,526	198,772	188,310	1.8	190,820	159,018	150,648	2.2	2 to 8
24	26	246,080	205,068	194,274	1.7	196,864	164,054	155,420	2.1	2 to 8
26	28	247,546	206,288	195,430	1.7	198,036	165,030	156,344	2.1	2 to 8
24	25	255,924	213,270	202,046	1.6	204,740	170,616	161,636	2.0	2 to 8
26	27	256,714	213,928	202,668	1.6	205,372	171,142	162,134	2.0	2 to 8
23	23	266,588	222,156	210,464	1.6	213,270	177,724	168,372	2.0	2 to 8
27	26	276,840	230,700	218,558	1.5	221,472	184,560	174,846	1.9	2 to 8
24	23	278,178	231,814	219,614	1.5	222,542	185,452	175,692	1.9	2 to 8
25	23	289,768	241,474	228,764	1.4	231,814	193,180	183,012	1.8	2 to 8
19	17	297,950	248,292	235,224	1.4	238,360	198,634	188,180	1.8	2 to 8
27	24	299,910	249,926	236,772	1.4	239,928	199,940	189,418	1.7	2 to 8
28	24	311,018	259,182	245,540	1.3	248,814	207,346	196,432	1.7	2 to 8
23	19	322,710	268,926	254,772	1.3	258,168	215,140	203,818	1.6	2 to 8
28	23	324,540	270,450	256,216	1.3	259,632	216,360	204,966	1.6	2 to 8
24	19	336,742	280,618	265,848	1.2	269,392	224,494	212,678	1.6	2 to 8
25	19	350,772	292,310	276,926	1.2	280,618	233,848	221,540	1.5	2 to 8
23	17	360,676	300,564	284,744	1.2	288,540	240,452	227,796	1.5	2 to 8
26	19	364,804	304,002	288,002	1.1	291,844	243,202	230,402	1.4	2 to 7
27	19	378,834	315,756	297,080	1.1	303,068	252,556	237,664	1.4	2 to 7
28	19	392,866	327,388	310,156	1.1	314,292	261,910	248,124	1.3	2 to 7
26	17	407,722	339,768	321,886	1.0	326,178	271,814	257,508	1.3	2 to 7
27	17	423,404	352,836	334,266	0.9	338,724	282,268	267,412	1.2	2 to 7
28	17	439,084	365,904	346,646	0.9	351,268	292,724	277,316	1.2	2 to 7

NOTE: See "General Planting Rate Information" and "Check Seed Population" pages for additional information.

NOTE: When using Half Rate (2 To 1) Drive Reduction Package, rates are approximately 50% of given numbers.

NOTE: Always field check seed population to ensure planting rates are correct.

**PLANTING RATES FOR BRUSH-TYPE SEED METERS (STANDARD DRIVE)
APPROXIMATE SEEDS/ACRE FOR VARIOUS ROW WIDTHS**

Transmission Sprockets		36 Cell Acid-Delinted Large Cotton			Average Seed Spacing In Inches	30 Cell Milo/Grain Sorghum Or Acid-Delinted Cotton			Average Seed Spacing In Inches	Speed Range (MPH)
Drive	Driven	30" Rows	36" Rows	38" Rows		30" Rows	36" Rows	38" Rows		
17	28	48,557	40,464	38,335	4.3	40,464	33,720	31,945	5.2	2 to 8
17	27	50,356	41,963	39,754	4.2	41,963	34,969	33,129	5.0	2 to 8
17	26	52,292	43,577	41,283	4.0	43,577	36,314	34,403	4.8	2 to 8
19	28	54,269	45,224	42,844	3.9	45,225	37,687	35,704	4.6	2 to 8
19	27	56,279	46,900	44,431	3.7	46,900	39,083	37,026	4.5	2 to 8
17	24	56,650	47,208	44,723	3.7	47,208	39,340	37,270	4.4	2 to 8
17	23	59,113	49,261	46,668	3.5	49,261	41,051	38,890	4.2	2 to 8
19	25	60,782	50,651	47,986	3.5	50,652	42,210	39,988	4.1	2 to 8
19	24	63,314	52,762	49,985	3.3	52,762	43,968	41,654	4.0	2 to 8
23	28	65,695	54,746	51,864	3.2	54,746	45,621	43,220	3.8	2 to 8
19	23	66,067	55,056	52,159	3.2	55,056	45,880	43,465	3.8	2 to 8
24	28	68,551	57,126	54,119	3.0	57,126	47,605	45,099	3.7	2 to 8
24	27	71,090	59,242	56,123	2.9	59,242	49,368	46,770	3.5	2 to 8
17	19	71,558	59,632	56,493	2.9	59,631	49,693	47,077	3.5	2 to 8
24	26	73,824	61,520	58,282	2.8	61,520	51,267	48,569	3.4	2 to 8
26	28	74,264	61,886	58,629	2.8	61,886	51,572	48,858	3.4	2 to 8
24	25	76,772	63,981	60,614	2.7	63,981	53,317	50,511	3.3	2 to 8
26	27	77,014	64,178	60,800	2.7	64,178	53,482	50,667	3.3	2 to 8
23	23	79,976	66,647	63,139	2.6	66,647	55,539	52,616	3.1	2 to 8
27	26	83,052	69,210	65,567	2.5	69,210	57,675	54,640	3.0	2 to 8
24	23	83,453	69,544	65,884	2.5	69,544	57,954	54,904	3.0	2 to 8
25	23	86,930	72,442	68,629	2.4	72,442	60,368	57,191	2.9	2 to 8
19	17	89,385	74,488	70,567	2.3	74,488	62,073	58,806	2.8	2 to 8
27	24	89,973	74,978	71,032	2.3	74,978	62,481	59,193	2.8	2 to 8
28	24	93,305	77,755	73,662	2.2	77,755	64,796	61,385	2.7	2 to 8
23	19	96,813	80,678	76,432	2.2	80,678	67,231	63,693	2.6	2 to 8
28	23	97,362	81,135	76,864	2.1	81,135	67,613	64,054	2.6	2 to 8
24	19	101,023	84,185	79,754	2.1	84,185	70,155	66,462	2.5	2 to 8
25	19	105,232	87,693	83,078	2.0	87,693	73,078	69,231	2.4	2 to 8
23	17	108,233	90,169	85,423	1.9	90,169	75,141	71,186	2.3	2 to 8
26	19	109,441	91,201	86,401	1.9	91,201	76,001	72,001	2.3	2 to 7
27	19	113,650	94,709	89,124	1.8	94,709	78,924	74,770	2.2	2 to 7
28	19	117,860	98,216	93,047	1.8	98,216	81,847	77,539	2.1	2 to 7
26	17	122,317	101,930	96,566	1.7	101,930	84,942	80,471	2.1	2 to 7
27	17	127,021	105,851	100,280	1.6	105,851	88,209	83,566	2.0	2 to 7
28	17	131,725	109,771	103,994	1.6	109,771	91,476	86,661	1.9	2 to 7

NOTE: See "General Planting Rate Information" and "Check Seed Population" pages for additional information.

NOTE: When using Half Rate (2 To 1) Drive Reduction Package, rates are approximately 50% of given numbers.

NOTE: Always field check seed population to ensure planting rates are correct.

**PLANTING RATES FOR BRUSH-TYPE SEED METERS (STANDARD DRIVE)
APPROXIMATE HILLS/ACRE FOR VARIOUS ROW WIDTHS**

Due to variations in cotton seed size, meters equipped with 12 cell acid-delinted hill-drop cotton discs plant from 3 to 6 seeds per cell. Select proper disc for seed size range to be planted.

To determine planter transmission setting, determine desired hill spacing and select the transmission ratio closest to the hill spacing in inches on the chart. To decrease population increase spacing. To increase population decrease spacing.

To determine population per acre, determine average seeds per hill and hills per acre by doing a field check. Measure $\frac{1}{1000}$ of an acre (1/1000 acre = Length of row 17' 5" for 30" row widths, 14' 6" for 36" row widths and 13' 10" for 38" row widths). Multiply average seeds per hill by hills per acre. EXAMPLE: 4 seeds per hill x (13 hills x 1000) = 52,000

Transmission Sprockets Drive Driven		NUMBER OF HILLS PER ACRE 12 Cell Hill-Drop Cotton, Acid-Delinted			Average Hill Spacing In Inches	Speed Range (MPH)
		30" Rows	36" Rows	38" Rows		
17	28	16,186	13,488	12,778	12.9	2 to 8
17	27	16,785	13,988	13,251	12.5	2 to 8
17	26	17,431	14,526	13,761	12.0	2 to 8
19	28	18,090	15,075	14,281	11.6	2 to 8
19	27	18,760	15,633	14,810	11.1	2 to 8
17	24	18,883	15,736	14,908	11.1	2 to 8
17	23	19,704	16,420	15,556	10.6	2 to 8
19	25	20,261	16,884	15,995	10.3	2 to 8
19	24	21,105	17,587	16,662	9.9	2 to 8
23	28	21,898	18,249	17,288	9.5	2 to 8
19	23	22,022	18,352	17,386	9.5	2 to 8
24	28	22,850	19,042	18,040	9.2	2 to 8
24	27	23,697	19,747	18,708	8.8	2 to 8
17	19	23,853	19,877	18,831	8.8	2 to 8
24	26	24,608	20,507	19,427	8.5	2 to 8
26	28	24,755	20,629	19,543	8.4	2 to 8
24	25	25,592	21,327	20,205	8.2	2 to 8
26	27	25,671	21,393	20,267	8.1	2 to 8
23	23	26,659	22,216	21,046	7.8	2 to 8
27	26	27,684	23,070	21,856	7.6	2 to 8
24	23	27,818	23,181	21,961	7.5	2 to 8
25	23	28,977	24,147	22,876	7.2	2 to 8
19	17	29,795	24,829	23,522	7.0	2 to 8
27	24	29,991	24,993	23,677	7.0	2 to 8
28	24	31,102	25,918	24,554	6.7	2 to 8
23	19	32,271	26,893	25,477	6.5	2 to 8
28	23	32,454	27,045	25,622	6.5	2 to 8
24	19	33,674	28,062	26,585	6.2	2 to 8
25	19	35,077	29,231	27,693	6.0	2 to 8
23	17	36,068	30,056	28,474	5.8	2 to 8
26	19	36,480	30,400	28,800	5.7	2 to 7
27	19	37,883	31,570	29,908	5.5	2 to 7
28	19	39,287	32,739	31,016	5.3	2 to 7
26	17	40,772	33,977	32,189	5.1	2 to 7
27	17	42,340	35,284	33,427	4.9	2 to 7
28	17	43,908	36,590	34,665	4.8	2 to 7

NOTE: See "General Planting Rate Information" and "Check Seed Population" pages for additional information.

NOTE: When using Half Rate (2 To 1) Drive Reduction Package, rates are approximately 50% of given numbers.

NOTE: Always field check seed population to ensure planting rates are correct.

**PLANTING RATES FOR (EDGEVAC) CORN/POPCORN 39 CELL DISC
22 TOOTH CONTACT WHEEL DRIVE SPROCKET
APPROXIMATE SEEDS/ACRE FOR VARIOUS ROW WIDTHS**

Transmission Sprockets Drive Driven		7.5" Rows or 15" Rows	18" Rows	19" Rows	30" Rows	36" Rows	38" Rows	Recomm. Speed Range (MPH)	Average Seed Spacing In Inches
15	28	46,414	38,678	36,642	23,207	19,339	18,321	4 to 6	9.0
15	27	48,133	40,111	37,999	24,066	20,055	19,000	4 to 6	8.7
15	26	49,984	41,653	39,461	24,992	20,827	19,730	4 to 6	8.4
15	25	51,983	43,319	41,039	25,992	21,660	20,520	4 to 6	8.0
17	28	52,602	43,835	41,528	26,301	21,918	20,764	4 to 6	7.9
15	24	54,149	45,124	42,749	27,075	22,562	21,375	4 to 6	7.7
17	27	54,550	45,459	43,066	27,275	22,729	21,533	4 to 6	7.7
15	23	56,503	47,086	44,608	28,252	23,543	22,304	4 to 6	7.4
17	26	56,648	47,207	44,722	28,324	23,603	22,361	4 to 6	7.4
19	28	58,791	48,992	46,414	29,395	24,496	23,207	4 to 6	7.1
17	25	58,914	49,095	46,511	29,457	24,548	23,256	4 to 6	7.1
19	27	60,968	50,807	48,133	30,484	25,403	24,066	4 to 6	6.9
17	24	61,369	51,141	48,449	30,685	25,570	24,225	4 to 6	6.8
19	26	63,313	52,761	49,984	31,656	26,380	24,992	4 to 6	6.6
17	23	64,037	53,364	50,556	32,019	26,682	25,278	4 to 6	6.5
19	25	65,845	54,871	51,983	32,923	27,436	25,992	4 to 6	6.4
15	19	68,399	56,999	53,999	34,199	28,500	27,000	4 to 6	6.1
19	24	68,589	57,157	54,149	34,294	28,579	27,075	4 to 6	6.1
23	28	71,167	59,306	56,185	35,584	29,653	28,092	4 to 6	5.9
19	23	71,571	59,643	56,503	35,786	29,821	28,252	4 to 6	5.8
23	27	73,803	61,503	58,266	36,902	30,751	29,133	4 to 6	5.7
24	28	74,262	61,885	58,628	37,131	30,942	29,314	4 to 6	5.6
15	17	76,446	63,705	60,352	38,223	31,852	30,176	4 to 6	5.5
24	27	77,012	64,177	60,799	38,506	32,088	30,400	4 to 6	5.4
17	19	77,519	64,599	61,199	38,759	32,300	30,600	4 to 6	5.4
23	25	79,708	66,423	62,927	39,854	33,211	31,464	4 to 6	5.2
26	28	80,450	67,042	63,513	40,225	33,521	31,757	4 to 6	5.2
23	24	83,029	69,191	65,549	41,514	34,595	32,775	4 to 6	5.0
24	25	83,173	69,311	65,663	41,587	34,655	32,832	4 to 6	5.0
27	28	83,544	69,620	65,956	41,772	34,810	32,978	4 to 6	5.0
23	23	86,639	72,199	68,399	43,319	36,099	34,199	4 to 6	4.8
28	27	89,848	74,873	70,932	44,924	37,436	35,466	4 to 6	4.7
27	26	89,971	74,976	71,030	44,985	37,488	35,515	4 to 6	4.6
24	23	90,406	75,338	71,373	45,203	37,669	35,686	4 to 6	4.6
28	26	93,303	77,753	73,660	46,652	38,876	36,830	4 to 6	4.5
27	25	93,570	77,975	73,871	46,785	38,987	36,935	4 to 6	4.5
25	23	94,172	78,477	74,347	47,086	39,239	37,173	4 to 6	4.4
19	17	96,831	80,693	76,446	48,416	40,346	38,223	4 to 6	4.3
27	24	97,469	81,224	76,949	48,734	40,612	38,474	4 to 6	4.3
26	23	97,939	81,616	77,321	48,970	40,808	38,660	4 to 6	4.3
28	24	101,078	84,232	79,799	50,539	42,116	39,899	4 to 6	4.1
27	23	101,706	84,755	80,294	50,853	42,378	40,147	4 to 6	4.1
23	19	104,878	87,399	82,799	52,439	43,699	41,399	4 to 6	4.0
28	23	105,473	87,894	83,268	52,737	43,947	41,634	4 to 6	4.0
24	19	109,438	91,199	86,399	54,719	45,599	43,199	4 to 6	3.8
25	19	113,998	94,999	89,999	56,999	47,499	44,999	4 to 6	3.7
23	17	117,217	97,681	92,540	58,609	48,840	46,270	4 to 6	3.6
26	19	118,558	98,798	93,599	59,279	49,399	46,799	4 to 6	3.5
24	17	122,313	101,928	96,563	61,157	50,964	48,282	4 to 6	3.4
27	19	123,118	102,598	97,199	61,559	51,299	48,599	4 to 6	3.4
25	17	127,410	106,175	100,587	63,705	53,087	50,293	4 to 6	3.3
28	19	127,678	106,398	100,798	63,839	53,199	50,399	4 to 6	3.3
26	17	132,506	110,422	104,610	66,253	55,211	52,305	4 to 6	3.2
23	15	132,846	110,705	104,878	66,423	55,352	52,439	4 to 6	3.1
27	17	137,603	114,669	108,634	68,801	57,334	54,317	4 to 6	3.0

NOTE: See "General Planting Rate Information" and "Check Seed Population" pages for more information. Always field check seed population to verify planting rates.

**PLANTING RATES FOR (EDGEVAC) CORN/POPCORN 39 CELL DISC
28 TOOTH CONTACT WHEEL DRIVE SPROCKET
APPROXIMATE SEEDS/ACRE FOR VARIOUS ROW WIDTHS**

Transmission Sprockets Drive Driven		7.5" Rows or 15" Rows	18" Rows	19" Rows	30" Rows	36" Rows	38" Rows	Recomm. Speed Range (MPH)	Average Seed Spacing In Inches
15	28	58,791	48,992	46,414	29,395	24,496	23,207	4 to 6	7.1
15	27	60,968	50,807	48,133	30,484	25,403	24,066	4 to 6	6.9
15	26	63,313	52,761	49,984	31,656	26,380	24,992	4 to 6	6.6
15	25	65,845	54,871	51,983	32,923	27,436	25,992	4 to 6	6.4
17	28	66,629	55,524	52,602	33,315	27,762	26,301	4 to 6	6.3
15	24	68,589	57,157	54,149	34,294	28,579	27,075	4 to 6	6.1
17	27	69,097	57,581	54,550	34,549	28,790	27,275	4 to 6	6.1
15	23	71,571	59,643	56,503	35,786	29,821	28,252	4 to 6	5.8
17	26	71,755	59,796	56,648	35,877	29,898	28,324	4 to 6	5.8
19	28	74,468	62,057	58,791	37,234	31,028	29,395	4 to 6	5.6
17	25	74,625	62,187	58,914	37,312	31,094	29,457	4 to 6	5.6
19	27	77,226	64,355	60,968	38,613	32,178	30,484	4 to 6	5.4
17	24	77,734	64,778	61,369	38,867	32,389	30,685	4 to 6	5.4
19	26	80,196	66,830	63,313	40,098	33,415	31,656	4 to 6	5.2
17	23	81,114	67,595	64,037	40,557	33,797	32,019	4 to 6	5.2
19	25	83,404	69,503	65,845	41,702	34,752	32,923	4 to 6	5.0
15	19	86,639	72,199	68,399	43,319	36,099	34,199	4 to 6	4.8
19	24	86,879	72,399	68,589	43,440	36,200	34,294	4 to 6	4.8
23	28	90,145	75,121	71,167	45,073	37,561	35,584	4 to 6	4.6
19	23	90,657	75,547	71,571	45,328	37,774	35,786	4 to 6	4.6
23	27	93,484	77,904	73,803	46,742	38,952	36,902	4 to 6	4.5
24	28	94,065	78,387	74,262	47,032	39,194	37,131	4 to 6	4.4
15	17	96,831	80,693	76,446	48,416	40,346	38,223	4 to 6	4.3
24	27	97,549	81,291	77,012	48,774	40,645	38,506	4 to 6	4.3
17	19	98,191	81,825	77,519	49,095	40,913	38,759	4 to 6	4.3
23	25	100,963	84,136	79,708	50,481	42,068	39,854	4 to 6	4.1
26	28	101,904	84,920	80,450	50,952	42,460	40,225	4 to 6	4.1
23	24	105,170	87,641	83,029	52,585	43,821	41,514	4 to 6	4.0
24	25	105,353	87,794	83,173	52,676	43,897	41,587	4 to 6	4.0
27	28	105,823	88,186	83,544	52,911	44,093	41,772	4 to 6	4.0
23	23	109,742	91,452	86,639	54,871	45,726	43,319	4 to 6	3.8
28	27	113,807	94,839	89,848	56,903	47,420	44,924	4 to 6	3.7
27	26	113,963	94,969	89,971	56,982	47,485	44,985	4 to 6	3.7
24	23	114,514	95,428	90,406	57,257	47,714	45,203	4 to 6	3.7
28	26	118,184	98,487	93,303	59,092	49,243	46,652	4 to 6	3.5
27	25	118,522	98,768	93,570	59,261	49,384	46,785	4 to 6	3.5
25	23	119,285	99,404	94,172	59,643	49,702	47,086	4 to 6	3.5
19	17	122,653	102,211	96,831	61,327	51,105	48,416	4 to 6	3.4
27	24	123,460	102,883	97,469	61,730	51,442	48,734	4 to 6	3.4
26	23	124,057	103,380	97,939	62,028	51,690	48,970	4 to 6	3.4
28	24	128,033	106,694	101,078	64,016	53,347	50,539	4 to 6	3.3
27	23	128,828	107,357	101,706	64,414	53,678	50,853	4 to 6	3.2
23	19	132,846	110,705	104,878	66,423	55,352	52,439	4 to 6	3.1
28	23	133,599	111,333	105,473	66,800	55,666	52,737	4 to 6	3.1
24	19	138,622	115,518	109,438	69,311	57,759	54,719	4 to 6	3.0
25	19	144,398	120,332	113,998	72,199	60,166	56,999	4 to 6	2.9
23	17	148,475	123,729	117,217	74,237	61,865	58,609	4 to 6	2.8
26	19	150,174	125,145	118,558	75,087	62,572	59,279	4 to 6	2.8
24	17	154,930	129,109	122,313	77,465	64,554	61,157	4 to 6	2.7
27	19	155,950	129,958	123,118	77,975	64,979	61,559	4 to 6	2.7
25	17	161,386	134,488	127,410	80,693	67,244	63,705	4 to 6	2.6
28	19	161,726	134,771	127,678	80,863	67,386	63,839	4 to 6	2.6
26	17	167,841	139,868	132,506	83,921	69,934	66,253	4 to 6	2.5
23	15	168,272	140,226	132,846	84,136	70,113	66,423	4 to 6	2.5
27	17	174,297	145,247	137,603	87,148	72,624	68,801	4 to 6	2.4

NOTE: See "General Planting Rate Information" and "Check Seed Population" pages for more information. Always field check seed population to verify planting rates.

**PLANTING RATES FOR (EDGEVAC) LOW-RATE CORN/POPCORN 24 CELL DISC
22 TOOTH CONTACT WHEEL DRIVE SPROCKET
APPROXIMATE SEEDS/ACRE FOR VARIOUS ROW WIDTHS**

Transmission Sprockets		7.5" Rows or 15" Rows	18" Rows	19" Rows	30" Rows	36" Rows	38" Rows	Recomm. Speed Range (MPH)	Average Seed Spacing In Inches
Drive	Driven								
15	28	28,562	23,802	22,549	14,281	11,901	11,275	4 to 6	14.6
15	27	29,620	24,683	23,384	14,810	12,342	11,692	4 to 6	14.1
15	26	30,759	25,633	24,284	15,380	12,816	12,142	4 to 6	13.6
15	25	31,990	26,658	25,255	15,995	13,329	12,628	4 to 6	13.1
17	28	32,370	26,975	25,556	16,185	13,488	12,778	4 to 6	12.9
15	24	33,323	27,769	26,307	16,661	13,884	13,154	4 to 6	12.5
17	27	33,569	27,975	26,502	16,785	13,987	13,251	4 to 6	12.5
15	23	34,771	28,976	27,451	17,386	14,488	13,726	4 to 6	12.0
17	26	34,861	29,050	27,521	17,430	14,525	13,761	4 to 6	12.0
19	28	36,179	30,149	28,562	18,089	15,074	14,281	4 to 6	11.6
17	25	36,255	30,212	28,622	18,127	15,106	14,311	4 to 6	11.5
19	27	37,519	31,266	29,620	18,759	15,633	14,810	4 to 6	11.1
17	24	37,766	31,471	29,815	18,883	15,736	14,907	4 to 6	11.1
19	26	38,962	32,468	30,759	19,481	16,234	15,380	4 to 6	10.7
17	23	39,408	32,840	31,111	19,704	16,420	15,556	4 to 6	10.6
19	25	40,520	33,767	31,990	20,260	16,883	15,995	4 to 6	10.3
15	19	42,092	35,076	33,230	21,046	17,538	16,615	4 to 6	9.9
19	24	42,209	35,174	33,323	21,104	17,587	16,661	4 to 6	9.9
23	28	43,795	36,496	34,575	21,898	18,248	17,288	4 to 6	9.5
19	23	44,044	36,703	34,771	22,022	18,352	17,386	4 to 6	9.5
23	27	45,417	37,848	35,856	22,709	18,924	17,928	4 to 6	9.2
24	28	45,700	38,083	36,079	22,850	19,041	18,039	4 to 6	9.2
15	17	47,044	39,203	37,140	23,522	19,602	18,570	4 to 6	8.9
24	27	47,392	39,493	37,415	23,696	19,747	18,707	4 to 6	8.8
17	19	47,704	39,753	37,661	23,852	19,877	18,830	4 to 6	8.8
23	25	49,051	40,876	38,724	24,525	20,438	19,362	4 to 6	8.5
26	28	49,508	41,257	39,085	24,754	20,628	19,543	4 to 6	8.4
23	24	51,095	42,579	40,338	25,547	21,289	20,169	4 to 6	8.2
24	25	51,183	42,653	40,408	25,592	21,326	20,204	4 to 6	8.2
27	28	51,412	42,843	40,588	25,706	21,422	20,294	4 to 6	8.1
23	23	53,316	44,430	42,092	26,658	22,215	21,046	4 to 6	7.8
28	27	55,291	46,076	43,651	27,645	23,038	21,825	4 to 6	7.6
27	26	55,367	46,139	43,711	27,683	23,069	21,855	4 to 6	7.6
24	23	55,634	46,362	43,922	27,817	23,181	21,961	4 to 6	7.5
28	26	57,417	47,848	45,329	28,709	23,924	22,665	4 to 6	7.3
27	25	57,581	47,985	45,459	28,791	23,992	22,730	4 to 6	7.3
25	23	57,952	48,294	45,752	28,976	24,147	22,876	4 to 6	7.2
19	17	59,589	49,657	47,044	29,794	24,829	23,522	4 to 6	7.0
27	24	59,981	49,984	47,353	29,990	24,992	23,677	4 to 6	7.0
26	23	60,270	50,225	47,582	30,135	25,113	23,791	4 to 6	6.9
28	24	62,202	51,835	49,107	31,101	25,918	24,553	4 to 6	6.7
27	23	62,588	52,157	49,412	31,294	26,079	24,706	4 to 6	6.7
23	19	64,541	53,784	50,953	32,270	26,892	25,477	4 to 6	6.5
28	23	64,907	54,089	51,242	32,453	27,044	25,621	4 to 6	6.4
24	19	67,347	56,122	53,168	33,673	28,061	26,584	4 to 6	6.2
25	19	70,153	58,461	55,384	35,076	29,230	27,692	4 to 6	6.0
23	17	72,134	60,111	56,948	36,067	30,056	28,474	4 to 6	5.8
26	19	72,959	60,799	57,599	36,479	30,400	28,800	4 to 6	5.7
24	17	75,270	62,725	59,424	37,635	31,362	29,712	4 to 6	5.6
27	19	75,765	63,138	59,814	37,883	31,569	29,907	4 to 6	5.5
25	17	78,406	65,338	61,900	39,203	32,669	30,950	4 to 6	5.3
28	19	78,571	65,476	62,030	39,286	32,738	31,015	4 to 6	5.3
26	17	81,542	67,952	64,375	40,771	33,976	32,188	4 to 6	5.1
23	15	81,751	68,126	64,541	40,876	34,063	32,270	4 to 6	5.1
27	17	84,679	70,565	66,851	42,339	35,283	33,426	4 to 6	4.9

NOTE: See "General Planting Rate Information" and "Check Seed Population" pages for more information. Always field check seed population to verify planting rates.

**PLANTING RATES FOR (EDGEVAC) LOW-RATE CORN/POPCORN 24 CELL DISC
28 TOOTH CONTACT WHEEL DRIVE SPROCKET
APPROXIMATE HILLS/ACRE FOR VARIOUS ROW WIDTHS**

Transmission Sprockets		7.5" Rows or 15" Rows	18" Rows	19" Rows	30" Rows	36" Rows	38" Rows	Recomm. Speed Range (MPH)	Average Seed Spacing In Inches
Drive	Driven								
15	28	36,179	30,149	28,562	18,089	15,074	14,281	4 to 6	11.6
15	27	37,519	31,266	29,620	18,759	15,633	14,810	4 to 6	11.1
15	26	38,962	32,468	30,759	19,481	16,234	15,380	4 to 6	10.7
15	25	40,520	33,767	31,990	20,260	16,883	15,995	4 to 6	10.3
17	28	41,003	34,169	32,370	20,501	17,084	16,185	4 to 6	10.2
15	24	42,209	35,174	33,323	21,104	17,587	16,661	4 to 6	9.9
17	27	42,521	35,434	33,569	21,261	17,717	16,785	4 to 6	9.8
15	23	44,044	36,703	34,771	22,022	18,352	17,386	4 to 6	9.5
17	26	44,157	36,797	34,861	22,078	18,399	17,430	4 to 6	9.5
19	28	45,826	38,189	36,179	22,913	19,094	18,089	4 to 6	9.1
17	25	45,923	38,269	36,255	22,961	19,135	18,127	4 to 6	9.1
19	27	47,524	39,603	37,519	23,762	19,802	18,759	4 to 6	8.8
17	24	47,836	39,864	37,766	23,918	19,932	18,883	4 to 6	8.7
19	26	49,352	41,126	38,962	24,676	20,563	19,481	4 to 6	8.5
17	23	49,916	41,597	39,408	24,958	20,798	19,704	4 to 6	8.4
19	25	51,326	42,771	40,520	25,663	21,386	20,260	4 to 6	8.1
15	19	53,316	44,430	42,092	26,658	22,215	21,046	4 to 6	7.8
19	24	53,464	44,554	42,209	26,732	22,277	21,104	4 to 6	7.8
23	28	55,474	46,228	43,795	27,737	23,114	21,898	4 to 6	7.5
19	23	55,789	46,491	44,044	27,894	23,245	22,022	4 to 6	7.5
23	27	57,529	47,941	45,417	28,764	23,970	22,709	4 to 6	7.3
24	28	57,886	48,238	45,700	28,943	24,119	22,850	4 to 6	7.2
15	17	59,589	49,657	47,044	29,794	24,829	23,522	4 to 6	7.0
24	27	60,030	50,025	47,392	30,015	25,012	23,696	4 to 6	7.0
17	19	60,425	50,354	47,704	30,212	25,177	23,852	4 to 6	6.9
23	25	62,131	51,776	49,051	31,066	25,888	24,525	4 to 6	6.7
26	28	62,710	52,258	49,508	31,355	26,129	24,754	4 to 6	6.7
23	24	64,720	53,933	51,095	32,360	26,967	25,547	4 to 6	6.5
24	25	64,832	54,027	51,183	32,416	27,013	25,592	4 to 6	6.5
27	28	65,122	54,268	51,412	32,561	27,134	25,706	4 to 6	6.4
23	23	67,534	56,278	53,316	33,767	28,139	26,658	4 to 6	6.2
28	27	70,035	58,362	55,291	35,017	29,181	27,645	4 to 6	6.0
27	26	70,131	58,443	55,367	35,066	29,221	27,683	4 to 6	6.0
24	23	70,470	58,725	55,634	35,235	29,362	27,817	4 to 6	5.9
28	26	72,729	60,607	57,417	36,364	30,304	28,709	4 to 6	5.7
27	25	72,936	60,780	57,581	36,468	30,390	28,791	4 to 6	5.7
25	23	73,406	61,172	57,952	36,703	30,586	28,976	4 to 6	5.7
19	17	75,479	62,899	59,589	37,739	31,450	29,794	4 to 6	5.5
27	24	75,975	63,313	59,981	37,988	31,656	29,990	4 to 6	5.5
26	23	76,342	63,619	60,270	38,171	31,809	30,135	4 to 6	5.5
28	24	78,789	65,658	62,202	39,395	32,829	31,101	4 to 6	5.3
27	23	79,279	66,066	62,588	39,639	33,033	31,294	4 to 6	5.3
23	19	81,751	68,126	64,541	40,876	34,063	32,270	4 to 6	5.1
28	23	82,215	68,512	64,907	41,107	34,256	32,453	4 to 6	5.1
24	19	85,306	71,088	67,347	42,653	35,544	33,673	4 to 6	4.9
25	19	88,860	74,050	70,153	44,430	37,025	35,076	4 to 6	4.7
23	17	91,369	76,141	72,134	45,685	38,070	36,067	4 to 6	4.6
26	19	92,415	77,012	72,959	46,207	38,506	36,479	4 to 6	4.5
24	17	95,342	79,451	75,270	47,671	39,726	37,635	4 to 6	4.4
27	19	95,969	79,974	75,765	47,985	39,987	37,883	4 to 6	4.4
25	17	99,314	82,762	78,406	49,657	41,381	39,203	4 to 6	4.2
28	19	99,523	82,936	78,571	49,762	41,468	39,286	4 to 6	4.2
26	17	103,287	86,072	81,542	51,643	43,036	40,771	4 to 6	4.0
23	15	103,552	86,293	81,751	51,776	43,147	40,876	4 to 6	4.0
27	17	107,259	89,383	84,679	53,630	44,691	42,339	4 to 6	3.9

NOTE: See "General Planting Rate Information" and "Check Seed Population" pages for more information. Always field check seed population to verify planting rates.

**PLANTING RATES FOR (EDGEVAC) SOYBEAN AND MILO/GRAIN SORGHUM 60 CELL DISCS
22 TOOTH CONTACT WHEEL DRIVE SPROCKET
APPROXIMATE SEEDS/ACRE FOR VARIOUS ROW WIDTHS**

Transmission Sprockets		7.5" Rows or 15" Rows	18" Rows	19" Rows	30" Rows	36" Rows	38" Rows	Recomm. Speed Range (MPH)	Average Seed Spacing In Inches
Drive	Driven								
15	28	71,406	59,505	56,373	35,703	29,752	28,186	4 to 6	5.9
15	27	74,050	61,708	58,461	37,025	30,854	29,230	4 to 6	5.6
15	26	76,898	64,082	60,709	38,449	32,041	30,355	4 to 6	5.4
15	25	79,974	66,645	63,138	39,987	33,323	31,569	4 to 6	5.2
17	28	80,926	67,439	63,889	40,463	33,719	31,945	4 to 6	5.2
15	24	83,306	69,422	65,768	41,653	34,711	32,884	4 to 6	5.0
17	27	83,924	69,936	66,255	41,962	34,968	33,128	4 to 6	5.0
15	23	86,928	72,440	68,628	43,464	36,220	34,314	4 to 6	4.8
17	26	87,151	72,626	68,804	43,576	36,313	34,402	4 to 6	4.8
19	28	90,447	75,372	71,406	45,223	37,686	35,703	4 to 6	4.6
17	25	90,637	75,531	71,556	45,319	37,766	35,778	4 to 6	4.6
19	27	93,797	78,164	74,050	46,898	39,082	37,025	4 to 6	4.5
17	24	94,414	78,678	74,537	47,207	39,339	37,269	4 to 6	4.4
19	26	97,404	81,170	76,898	48,702	40,585	38,449	4 to 6	4.3
17	23	98,519	82,099	77,778	49,259	41,050	38,889	4 to 6	4.2
19	25	101,301	84,417	79,974	50,651	42,209	39,987	4 to 6	4.1
15	19	105,229	87,691	83,076	52,615	43,845	41,538	4 to 6	4.0
19	24	105,521	87,935	83,306	52,761	43,967	41,653	4 to 6	4.0
23	28	109,488	91,240	86,438	54,744	45,620	43,219	4 to 6	3.8
19	23	110,109	91,758	86,928	55,055	45,879	43,464	4 to 6	3.8
23	27	113,544	94,620	89,640	56,772	47,310	44,820	4 to 6	3.7
24	28	114,249	95,207	90,196	57,124	47,604	45,098	4 to 6	3.7
15	17	117,609	98,008	92,849	58,805	49,004	46,425	4 to 6	3.6
24	27	118,480	98,734	93,537	59,240	49,367	46,769	4 to 6	3.5
17	19	119,260	99,383	94,152	59,630	49,692	47,076	4 to 6	3.5
23	25	122,627	102,189	96,811	61,314	51,095	48,405	4 to 6	3.4
26	28	123,770	103,141	97,713	61,885	51,571	48,856	4 to 6	3.4
23	24	127,737	106,447	100,845	63,868	53,224	50,422	4 to 6	3.3
24	25	127,959	106,632	101,020	63,979	53,316	50,510	4 to 6	3.3
27	28	128,530	107,108	101,471	64,265	53,554	50,735	4 to 6	3.3
23	23	133,290	111,075	105,229	66,645	55,538	52,615	4 to 6	3.1
28	27	138,227	115,189	109,127	69,113	57,595	54,563	4 to 6	3.0
27	26	138,417	115,347	109,276	69,208	57,674	54,638	4 to 6	3.0
24	23	139,086	115,905	109,804	69,543	57,952	54,902	4 to 6	3.0
28	26	143,543	119,619	113,324	71,772	59,810	56,662	4 to 6	2.9
27	25	143,954	119,961	113,648	71,977	59,981	56,824	4 to 6	2.9
25	23	144,881	120,734	114,380	72,440	60,367	57,190	4 to 6	2.9
19	17	148,971	124,143	117,609	74,486	62,071	58,805	4 to 6	2.8
27	24	149,952	124,960	118,383	74,976	62,480	59,191	4 to 6	2.8
26	23	150,676	125,563	118,955	75,338	62,782	59,477	4 to 6	2.8
28	24	155,505	129,588	122,767	77,753	64,794	61,384	4 to 6	2.7
27	23	156,471	130,393	123,530	78,236	65,196	61,765	4 to 6	2.7
23	19	161,351	134,459	127,383	80,676	67,230	63,691	4 to 6	2.6
28	23	162,266	135,222	128,105	81,133	67,611	64,053	4 to 6	2.6
24	19	168,367	140,306	132,921	84,183	70,153	66,461	4 to 6	2.5
25	19	175,382	146,152	138,459	87,691	73,076	69,230	4 to 6	2.4
23	17	180,334	150,278	142,369	90,167	75,139	71,184	4 to 6	2.3
26	19	182,397	151,998	143,998	91,199	75,999	71,999	4 to 6	2.3
24	17	188,175	156,812	148,559	94,087	78,406	74,279	4 to 6	2.2
27	19	189,413	157,844	149,536	94,706	78,922	74,768	4 to 6	2.2
25	17	196,015	163,346	154,749	98,008	81,673	77,374	4 to 6	2.1
28	19	196,428	163,690	155,075	98,214	81,845	77,537	4 to 6	2.1
26	17	203,856	169,880	160,939	101,928	84,940	80,469	4 to 6	2.1
23	15	204,378	170,315	161,351	102,189	85,158	80,676	4 to 6	2.0
27	17	211,696	176,414	167,129	105,848	88,207	83,564	4 to 6	2.0

NOTE: See "General Planting Rate Information" and "Check Seed Population" pages for more information. Always field check seed population to verify planting rates.

**PLANTING RATES FOR (EDGEVAC) SOYBEAN AND MILO/GRAIN SORGHUM 60 CELL DISCS
28 TOOTH CONTACT WHEEL DRIVE SPROCKET**

APPROXIMATE SEEDS/ACRE FOR VARIOUS ROW WIDTHS

Transmission Sprockets		7.5" Rows or 15" Rows	18" Rows	19" Rows	30" Rows	36" Rows	38" Rows	Recomm. Speed Range (MPH)	Average Seed Spacing In Inches
Drive	Driven								
15	28	90,447	75,372	71,406	45,223	37,686	35,703	4 to 6	4.6
15	27	93,797	78,164	74,050	46,898	39,082	37,025	4 to 6	4.5
15	26	97,404	81,170	76,898	48,702	40,585	38,449	4 to 6	4.3
15	25	101,301	84,417	79,974	50,650	42,209	39,987	4 to 6	4.1
17	28	102,507	85,422	80,926	51,253	42,711	40,463	4 to 6	4.1
15	24	105,521	87,935	83,306	52,761	43,967	41,653	4 to 6	4.0
17	27	106,303	88,586	83,924	53,152	44,293	41,962	4 to 6	3.9
15	23	110,109	91,758	86,928	55,055	45,879	43,464	4 to 6	3.8
17	26	110,392	91,993	87,151	55,196	45,997	43,576	4 to 6	3.8
19	28	114,566	95,472	90,447	57,283	47,736	45,223	4 to 6	3.7
17	25	114,807	95,673	90,637	57,404	47,836	45,319	4 to 6	3.6
19	27	118,809	99,008	93,797	59,405	49,504	46,898	4 to 6	3.5
17	24	119,591	99,659	94,414	59,796	49,830	47,207	4 to 6	3.5
19	26	123,379	102,816	97,404	61,689	51,408	48,702	4 to 6	3.4
17	23	124,791	103,992	98,519	62,395	51,996	49,259	4 to 6	3.4
19	25	128,314	106,928	101,301	64,157	53,464	50,650	4 to 6	3.3
15	19	133,290	111,075	105,229	66,645	55,538	52,615	4 to 6	3.1
19	24	133,661	111,384	105,521	66,830	55,692	52,761	4 to 6	3.1
23	28	138,685	115,571	109,488	69,343	57,786	54,744	4 to 6	3.0
19	23	139,472	116,227	110,109	69,736	58,113	55,055	4 to 6	3.0
23	27	143,822	119,852	113,544	71,911	59,926	56,772	4 to 6	2.9
24	28	144,715	120,596	114,249	72,358	60,298	57,124	4 to 6	2.9
15	17	148,971	124,143	117,609	74,486	62,071	58,805	4 to 6	2.8
24	27	150,075	125,062	118,480	75,037	62,531	59,240	4 to 6	2.8
17	19	151,062	125,885	119,260	75,531	62,943	59,630	4 to 6	2.8
23	25	155,328	129,440	122,627	77,664	64,720	61,314	4 to 6	2.7
26	28	156,775	130,646	123,770	78,387	65,323	61,885	4 to 6	2.7
23	24	161,800	134,833	127,737	80,900	67,416	63,868	4 to 6	2.6
24	25	162,081	135,067	127,959	81,040	67,534	63,979	4 to 6	2.6
27	28	162,805	135,670	128,530	81,402	67,835	64,265	4 to 6	2.6
23	23	168,834	140,695	133,290	84,417	70,348	66,645	4 to 6	2.5
28	27	175,087	145,906	138,227	87,544	72,953	69,113	4 to 6	2.4
27	26	175,328	146,107	138,417	87,664	73,053	69,208	4 to 6	2.4
24	23	176,175	146,812	139,086	88,087	73,406	69,543	4 to 6	2.4
28	26	181,822	151,518	143,543	90,911	75,759	71,772	4 to 6	2.3
27	25	182,341	151,951	143,954	91,171	75,975	71,977	4 to 6	2.3
25	23	183,516	152,930	144,881	91,758	76,465	72,440	4 to 6	2.3
19	17	188,697	157,248	148,971	94,349	78,624	74,486	4 to 6	2.2
27	24	189,939	158,282	149,952	94,969	79,141	74,976	4 to 6	2.2
26	23	190,856	159,047	150,676	95,428	79,523	75,338	4 to 6	2.2
28	24	196,973	164,145	155,505	98,487	82,072	77,753	4 to 6	2.1
27	23	198,197	165,164	156,471	99,098	82,582	78,236	4 to 6	2.1
23	19	204,378	170,315	161,351	102,189	85,158	80,676	4 to 6	2.0
28	23	205,537	171,281	162,266	102,769	85,641	81,133	4 to 6	2.0
24	19	213,264	177,720	168,367	106,632	88,860	84,183	4 to 6	2.0
25	19	222,150	185,125	175,382	111,075	92,563	87,691	4 to 6	1.9
23	17	228,423	190,352	180,334	114,211	95,176	90,167	4 to 6	1.8
26	19	231,036	192,530	182,397	115,518	96,265	91,199	4 to 6	1.8
24	17	238,354	198,629	188,175	119,177	99,314	94,087	4 to 6	1.8
27	19	239,923	199,935	189,413	119,961	99,968	94,706	4 to 6	1.7
25	17	248,286	206,905	196,015	124,143	103,452	98,008	4 to 6	1.7
28	19	248,809	207,340	196,428	124,404	103,670	98,214	4 to 6	1.7
26	17		215,181	203,856	129,109	107,591	101,928	4 to 6	1.6
23	15		215,733	204,378	129,440	107,866	102,189	4 to 6	1.6
27	17		223,457	211,696	134,074	111,729	105,848	4 to 6	1.6

NOTE: See "General Planting Rate Information" and "Check Seed Population" pages for more information. Always field check seed population to verify planting rates.

**PLANTING RATES FOR (EDGEVAC) SOYBEAN 60 CELL DISC
44 TOOTH CONTACT WHEEL DRIVE SPROCKET
APPROXIMATE SEEDS/ACRE FOR VARIOUS ROW WIDTHS**

Transmission Sprockets		7.5" Rows or 15" Rows	18" Rows	19" Rows	30" Rows	36" Rows	38" Rows	Recomm. Speed Range (MPH)	Average Seed Spacing In Inches
Drive	Driven								
15	28	142,811	119,009	112,746	71,406	59,505	56,373	4 to 6	2.9
15	27	148,100	123,417	116,921	74,050	61,708	58,461	4 to 6	2.8
15	26	153,796	128,164	121,418	76,898	64,082	60,709	4 to 6	2.7
15	25	159,948	133,290	126,275	79,974	66,645	63,138	4 to 6	2.6
17	28	161,852	134,877	127,778	80,926	67,439	63,889	4 to 6	2.6
15	24	166,613	138,844	131,536	83,306	69,422	65,768	4 to 6	2.5
17	27	167,847	139,873	132,511	83,924	69,936	66,255	4 to 6	2.5
15	23	173,857	144,881	137,255	86,928	72,440	68,628	4 to 6	2.4
17	26	174,303	145,252	137,607	87,151	72,626	68,804	4 to 6	2.4
19	28	180,894	150,745	142,811	90,447	75,372	71,406	4 to 6	2.3
17	25	181,275	151,062	143,112	90,637	75,531	71,556	4 to 6	2.3
19	27	187,594	156,328	148,100	93,797	78,164	74,050	4 to 6	2.2
17	24	188,828	157,357	149,075	94,414	78,678	74,537	4 to 6	2.2
19	26	194,809	162,341	153,796	97,404	81,170	76,898	4 to 6	2.1
17	23	197,038	164,198	155,556	98,519	82,099	77,778	4 to 6	2.1
19	25	202,601	168,834	159,948	101,301	84,417	79,974	4 to 6	2.1
15	19	210,458	175,382	166,151	105,229	87,691	83,076	4 to 6	2.0
19	24	211,043	175,869	166,613	105,521	87,935	83,306	4 to 6	2.0
23	28	218,977	182,481	172,876	109,488	91,240	86,438	4 to 6	1.9
19	23	220,219	183,516	173,857	110,109	91,758	86,928	4 to 6	1.9
23	27	227,087	189,239	179,279	113,544	94,620	89,640	4 to 6	1.8
24	28	228,498	190,415	180,393	114,249	95,207	90,196	4 to 6	1.8
15	17	235,218	196,015	185,699	117,609	98,008	92,849	4 to 6	1.8
24	27	236,961	197,467	187,074	118,480	98,734	93,537	4 to 6	1.8
17	19	238,519	198,766	188,305	119,260	99,383	94,152	4 to 6	1.8
23	25	245,254	204,378	193,622	122,627	102,189	96,811	4 to 6	1.7
26	28	247,539	206,283	195,426	123,770	103,141	97,713	4 to 6	1.7
23	24		212,894	201,689	127,737	106,447	100,845	4 to 6	1.6
24	25		213,264	202,040	127,959	106,632	101,020	4 to 6	1.6
27	28		214,217	202,942	128,530	107,108	101,471	4 to 6	1.6
23	23		222,150	210,458	133,290	111,075	105,229	4 to 6	1.6
28	27		230,378	218,253	138,227	115,189	109,127	4 to 6	1.5
27	26		230,695	218,553	138,417	115,347	109,276	4 to 6	1.5
24	23		231,809	219,609	139,086	115,905	109,804	4 to 6	1.5
28	26		239,239	226,647	143,543	119,619	113,324	4 to 6	1.5
27	25		239,923	227,295	143,954	119,961	113,648	4 to 6	1.5
25	23		241,468	228,759	144,881	120,734	114,380	4 to 6	1.4
19	17		248,286	235,218	148,971	124,143	117,609	4 to 6	1.4
27	24		249,919	236,766	149,952	124,960	118,383	4 to 6	1.4
26	23			237,909	150,676	125,563	118,955	4 to 6	1.4
28	24			245,535	155,505	129,588	122,767	4 to 6	1.3
27	23			247,060	156,471	130,393	123,530	4 to 6	1.3
23	19				161,351	134,459	127,383	4 to 6	1.3
28	23				162,266	135,222	128,105	4 to 6	1.3
24	19				168,367	140,306	132,921	4 to 6	1.2
25	19				175,382	146,152	138,459	4 to 6	1.2
23	17				180,334	150,278	142,369	4 to 6	1.2
26	19				182,397	151,998	143,998	4 to 6	1.1
24	17				188,175	156,812	148,559	4 to 6	1.1
27	19				189,413	157,844	149,536	4 to 6	1.1
25	17				196,015	163,346	154,749	4 to 6	1.1
28	19				196,428	163,690	155,075	4 to 6	1.1
26	17				203,856	169,880	160,939	4 to 6	1.0
23	15				204,378	170,315	161,351	4 to 6	1.0
27	17				211,696	176,414	167,129	4 to 6	1.0

NOTE: Planting rates over 250,000 seeds/acre are not recommended with subject seed disc and/or drive ratio.

NOTE: See "General Planting Rate Information" and "Check Seed Population" pages for more information. Always field check seed population to verify planting rates.

**PLANTING RATES FOR (EDGEVAC) HIGH-RATE SOYBEAN 120 CELL DISC
22 TOOTH CONTACT WHEEL DRIVE SPROCKET
APPROXIMATE SEEDS/ACRE FOR VARIOUS ROW WIDTHS**

Transmission Sprockets		15" Rows	18" Rows	19" Rows	30" Rows	36" Rows	38" Rows	Recomm. Speed Range (MPH)	Average Seed Spacing In Inches
Drive	Driven								
15	28	142,811	119,009	112,746	71,406	59,505	56,373	4 to 6	2.9
15	27	148,100	123,417	116,921	74,050	61,708	58,461	4 to 6	2.8
15	26	153,796	128,164	121,418	76,898	64,082	60,709	4 to 6	2.7
15	25	159,948	133,290	126,275	79,974	66,645	63,138	4 to 6	2.6
17	28	161,852	134,877	127,778	80,926	67,439	63,889	4 to 6	2.6
15	24	166,613	138,844	131,536	83,306	69,422	65,768	4 to 6	2.5
17	27	167,847	139,873	132,511	83,924	69,936	66,255	4 to 6	2.5
15	23	173,857	144,881	137,255	86,928	72,440	68,628	4 to 6	2.4
17	26	174,303	145,252	137,607	87,151	72,626	68,804	4 to 6	2.4
19	28	180,894	150,745	142,811	90,447	75,372	71,406	4 to 6	2.3
17	25	181,275	151,062	143,112	90,637	75,531	71,556	4 to 6	2.3
19	27	187,594	156,328	148,100	93,797	78,164	74,050	4 to 6	2.2
17	24	188,828	157,357	149,075	94,414	78,678	74,537	4 to 6	2.2
19	26	194,809	162,341	153,796	97,404	81,170	76,898	4 to 6	2.1
17	23	197,038	164,198	155,556	98,519	82,099	77,778	4 to 6	2.1
19	25	202,601	168,834	159,948	101,301	84,417	79,974	4 to 6	2.1
15	19	210,458	175,382	166,151	105,229	87,691	83,076	4 to 6	2.0
19	24	211,043	175,869	166,613	105,521	87,935	83,306	4 to 6	2.0
23	28	218,977	182,481	172,876	109,488	91,240	86,438	4 to 6	1.9
19	23	220,219	183,516	173,857	110,109	91,758	86,928	4 to 6	1.9
23	27	227,087	189,239	179,279	113,544	94,620	89,640	4 to 6	1.8
24	28	228,498	190,415	180,393	114,249	95,207	90,196	4 to 6	1.8
15	17	235,218	196,015	185,699	117,609	98,008	92,849	4 to 6	1.8
24	27	236,961	197,467	187,074	118,480	98,734	93,537	4 to 6	1.8
17	19	238,519	198,766	188,305	119,260	99,383	94,152	4 to 6	1.8
23	25	245,254	204,378	193,622	122,627	102,189	96,811	4 to 6	1.7
26	28	247,539	206,283	195,426	123,770	103,141	97,713	4 to 6	1.7
23	24		212,894	201,689	127,737	106,447	100,845	4 to 6	1.6
24	25		213,264	202,040	127,959	106,632	101,020	4 to 6	1.6
27	28		214,217	202,942	128,530	107,108	101,471	4 to 6	1.6
23	23		222,150	210,458	133,290	111,075	105,229	4 to 6	1.6
28	27		230,378	218,253	138,227	115,189	109,127	4 to 6	1.5
27	26		230,695	218,553	138,417	115,347	109,276	4 to 6	1.5
24	23		231,809	219,609	139,086	115,905	109,804	4 to 6	1.5
28	26		239,239	226,647	143,543	119,619	113,324	4 to 6	1.5
27	25		239,923	227,295	143,954	119,961	113,648	4 to 6	1.5
25	23		241,468	228,759	144,881	120,734	114,380	4 to 6	1.4
19	17		248,286	235,218	148,971	124,143	117,609	4 to 6	1.4
27	24		249,919	236,766	149,952	124,960	118,383	4 to 6	1.4
26	23			237,909	150,676	125,563	118,955	4 to 6	1.4
28	24			245,535	155,505	129,588	122,767	4 to 6	1.3
27	23			247,060	156,471	130,393	123,530	4 to 6	1.3
23	19				161,351	134,459	127,383	4 to 6	1.3
28	23				162,266	135,222	128,105	4 to 6	1.3
24	19				168,367	140,306	132,921	4 to 6	1.2
25	19				175,382	146,152	138,459	4 to 6	1.2
23	17				180,334	150,278	142,369	4 to 6	1.2
26	19				182,397	151,998	143,998	4 to 6	1.1
24	17				188,175	156,812	148,559	4 to 6	1.1
27	19				189,413	157,844	149,536	4 to 6	1.1
25	17				196,015	163,346	154,749	4 to 6	1.1
28	19				196,428	163,690	155,075	4 to 6	1.1
26	17				203,856	169,880	160,939	4 to 6	1.0
23	15				204,378	170,315	161,351	4 to 6	1.0
27	17				211,696	176,414	167,129	4 to 6	1.0

NOTE: Planting rates over 250,000 seeds/acre are not recommended with subject seed disc and/or drive ratio.

NOTE: See "General Planting Rate Information" and "Check Seed Population" pages for more information. Always field check seed population to verify planting rates.

**PLANTING RATES FOR (EDGEVAC) HIGH-RATE SOYBEAN 120 CELL DISC
28 TOOTH CONTACT WHEEL DRIVE SPROCKET
APPROXIMATE SEEDS/ACRE FOR VARIOUS ROW WIDTHS**

Transmission Sprockets		15" Rows	18" Rows	19" Rows	30" Rows	36" Rows	38" Rows	Recomm. Speed Range (MPH)	Average Seed Spacing In Inches
Drive	Driven								
15	28	180,894	150,745	142,811	90,447	75,372	71,406	4 to 6	2.3
15	27	187,594	156,328	148,100	93,797	78,164	74,050	4 to 6	2.2
15	26	194,809	162,341	153,796	97,404	81,170	76,898	4 to 6	2.1
15	25	202,601	168,834	159,948	101,301	84,417	79,974	4 to 6	2.1
17	28	205,013	170,844	161,852	102,507	85,422	80,926	4 to 6	2.0
15	24	211,043	175,869	166,613	105,521	87,935	83,306	4 to 6	2.0
17	27	212,606	177,172	167,847	106,303	88,586	83,924	4 to 6	2.0
15	23	220,219	183,516	173,857	110,109	91,758	86,928	4 to 6	1.9
17	26	220,783	183,986	174,303	110,392	91,993	87,151	4 to 6	1.9
19	28	229,132	190,944	180,894	114,566	95,472	90,447	4 to 6	1.8
17	25	229,615	191,346	181,275	114,807	95,673	90,637	4 to 6	1.8
19	27	237,619	198,016	187,594	118,809	99,008	93,797	4 to 6	1.8
17	24	239,182	199,318	188,828	119,591	99,659	94,414	4 to 6	1.7
19	26	246,758	205,632	194,809	123,379	102,816	97,404	4 to 6	1.7
17	23	249,581	207,984	197,038	124,791	103,992	98,519	4 to 6	1.7
19	25		213,857	202,601	128,314	106,928	101,301	4 to 6	1.6
15	19		222,150	210,458	133,290	111,075	105,229	4 to 6	1.6
19	24		222,768	211,043	133,661	111,384	105,521	4 to 6	1.6
23	28		231,142	218,977	138,685	115,571	109,488	4 to 6	1.5
19	23		232,453	220,219	139,472	116,227	110,109	4 to 6	1.5
23	27		239,703	227,087	143,822	119,852	113,544	4 to 6	1.5
24	28		241,192	228,498	144,715	120,596	114,249	4 to 6	1.4
15	17		248,286	235,218	148,971	124,143	117,609	4 to 6	1.4
24	27			236,961	150,075	125,062	118,480	4 to 6	1.4
17	19			238,519	151,062	125,885	119,260	4 to 6	1.4
23	25			245,254	155,328	129,440	122,627	4 to 6	1.3
26	28			247,539	156,775	130,646	123,770	4 to 6	1.3
23	24				161,800	134,833	127,737	4 to 6	1.3
24	25				162,081	135,067	127,959	4 to 6	1.3
27	28				162,805	135,670	128,530	4 to 6	1.3
23	23				168,834	140,695	133,290	4 to 6	1.2
28	27				175,087	145,906	138,227	4 to 6	1.2
27	26				175,328	146,107	138,417	4 to 6	1.2
24	23				176,175	146,812	139,086	4 to 6	1.2
28	26				181,822	151,518	143,543	4 to 6	1.1
27	25				182,341	151,951	143,954	4 to 6	1.1
25	23				183,516	152,930	144,881	4 to 6	1.1
19	17				188,697	157,248	148,971	4 to 6	1.1
27	24				189,939	158,282	149,952	4 to 6	1.1
26	23				190,856	159,047	150,676	4 to 6	1.1
28	24				196,973	164,145	155,505	4 to 6	1.1
27	23				198,197	165,164	156,471	4 to 6	1.1
23	19				204,378	170,315	161,351	4 to 6	1.0
28	23				205,537	171,281	162,266	4 to 6	1.0
24	19				213,264	177,720	168,367	4 to 6	1.0
25	19				222,150	185,125	175,382	4 to 6	0.9
23	17				228,423	190,352	180,334	4 to 6	0.9
26	19				231,036	192,530	182,397	4 to 6	0.9
24	17				238,354	198,629	188,175	4 to 6	0.9
27	19				239,923	199,935	189,413	4 to 6	0.9
25	17				248,286	206,905	196,015	4 to 6	0.8
28	19				248,809	207,340	196,428	4 to 6	0.8
26	17					215,181	203,856	4 to 6	0.8
23	15					215,733	204,378	4 to 6	0.8
27	17					223,457	211,696	4 to 6	0.8

NOTE: Planting rates over 250,000 seeds/acre are not recommended with subject seed disc and/or drive ratio.

NOTE: See "General Planting Rate Information" and "Check Seed Population" pages for more information. Always field check seed population to verify planting rates.

**PLANTING RATES FOR (EDGEVAC) HILL-DROP COTTON (3 SEEDS PER CELL), 20 CELL DISC
22 TOOTH CONTACT WHEEL DRIVE SPROCKET
APPROXIMATE HILLS/ACRE FOR VARIOUS ROW WIDTHS**

Transmission Sprockets		15" Rows	18" Rows	19" Rows	30" Rows	36" Rows	38" Rows	Recomm. Speed Range (MPH)	Average Hill Spacing In inches
Drive	Driven								
15	28	23,802	19,835	18,791	11,901	9,917	9,395	4 to 6	17.6
15	27	24,683	20,569	19,487	12,342	10,285	9,743	4 to 6	16.9
15	26	25,633	21,361	20,236	12,816	10,680	10,118	4 to 6	16.3
15	25	26,658	22,215	21,046	13,329	11,108	10,523	4 to 6	15.7
17	28	26,975	22,480	21,296	13,488	11,240	10,648	4 to 6	15.5
15	24	27,769	23,141	21,923	13,884	11,570	10,961	4 to 6	15.1
17	27	27,975	23,312	22,085	13,987	11,656	11,043	4 to 6	14.9
15	23	28,976	24,147	22,876	14,488	12,073	11,438	4 to 6	14.4
17	26	29,050	24,209	22,935	14,525	12,104	11,467	4 to 6	14.4
19	28	30,149	25,124	23,802	15,074	12,562	11,901	4 to 6	13.9
17	25	30,212	25,177	23,852	15,106	12,589	11,926	4 to 6	13.8
19	27	31,266	26,055	24,683	15,633	13,027	12,342	4 to 6	13.4
17	24	31,471	26,226	24,846	15,736	13,113	12,423	4 to 6	13.3
19	26	32,468	27,057	25,633	16,234	13,528	12,816	4 to 6	12.9
17	23	32,840	27,366	25,926	16,420	13,683	12,963	4 to 6	12.7
19	25	33,767	28,139	26,658	16,883	14,070	13,329	4 to 6	12.4
15	19	35,076	29,230	27,692	17,538	14,615	13,846	4 to 6	11.9
19	24	35,174	29,312	27,769	17,587	14,656	13,884	4 to 6	11.9
23	28	36,496	30,413	28,813	18,248	15,207	14,406	4 to 6	11.5
19	23	36,703	30,586	28,976	18,352	15,293	14,488	4 to 6	11.4
23	27	37,848	31,540	29,880	18,924	15,770	14,940	4 to 6	11.0
24	28	38,083	31,736	30,065	19,041	15,868	15,033	4 to 6	11.0
15	17	39,203	32,669	30,950	19,602	16,335	15,475	4 to 6	10.7
23	26	39,304	32,753	31,029	19,652	16,376	15,515	4 to 6	10.6
24	27	39,493	32,911	31,179	19,747	16,456	15,590	4 to 6	10.6
25	28	39,670	33,058	31,318	19,835	16,529	15,659	4 to 6	10.5
17	19	39,753	33,128	31,384	19,877	16,564	15,692	4 to 6	10.5
23	25	40,876	34,063	32,270	20,438	17,032	16,135	4 to 6	10.2
24	26	41,012	34,177	32,378	20,506	17,088	16,189	4 to 6	10.2
25	27	41,139	34,282	32,478	20,569	17,141	16,239	4 to 6	10.2
26	28	41,257	34,380	32,571	20,628	17,190	16,285	4 to 6	10.1
23	24	42,579	35,482	33,615	21,289	17,741	16,807	4 to 6	9.8
24	25	42,653	35,544	33,673	21,326	17,772	16,837	4 to 6	9.8
25	26	42,721	35,601	33,727	21,361	17,801	16,864	4 to 6	9.8
26	27	42,785	35,654	33,777	21,392	17,827	16,889	4 to 6	9.8
27	28	42,843	35,703	33,824	21,422	17,851	16,912	4 to 6	9.8
23	23	44,430	37,025	35,076	22,215	18,513	17,538	4 to 6	9.4
28	27	46,076	38,396	36,376	23,038	19,198	18,188	4 to 6	9.1
27	26	46,139	38,449	36,425	23,069	19,225	18,213	4 to 6	9.1
25	24	46,281	38,568	36,538	23,141	19,284	18,269	4 to 6	9.0
24	23	46,362	38,635	36,601	23,181	19,317	18,301	4 to 6	9.0
28	26	47,848	39,873	37,775	23,924	19,937	18,887	4 to 6	8.7
27	25	47,985	39,987	37,883	23,992	19,994	18,941	4 to 6	8.7
25	23	48,294	40,245	38,127	24,147	20,122	19,063	4 to 6	8.7
19	17	49,657	41,381	39,203	24,829	20,690	19,602	4 to 6	8.4
28	25	49,762	41,468	39,286	24,881	20,734	19,643	4 to 6	8.4
27	24	49,984	41,653	39,461	24,992	20,827	19,730	4 to 6	8.4
26	23	50,225	41,854	39,652	25,113	20,927	19,826	4 to 6	8.3
28	24	51,835	43,196	40,922	25,918	21,598	20,461	4 to 6	8.1
27	23	52,157	43,464	41,177	26,079	21,732	20,588	4 to 6	8.0
23	19	53,784	44,820	42,461	26,892	22,410	21,230	4 to 6	7.8
28	23	54,089	45,074	42,702	27,044	22,537	21,351	4 to 6	7.7
24	19	56,122	46,769	44,307	28,061	23,384	22,154	4 to 6	7.5
25	19	58,461	48,717	46,153	29,230	24,359	23,077	4 to 6	7.2
23	17	60,111	50,093	47,456	30,056	25,046	23,728	4 to 6	7.0

NOTE: See "General Planting Rate Information" and "Check Seed Population" pages for more information. Always field check seed population to verify planting rates.

**PLANTING RATES FOR (EDGEVAC) HILL-DROP COTTON (3 SEEDS PER CELL), 20 CELL DISC
28 TOOTH CONTACT WHEEL DRIVE SPROCKET
APPROXIMATE HILLS/ACRE FOR VARIOUS ROW WIDTHS**

Transmission Sprockets		15" Rows	18" Rows	19" Rows	30" Rows	36" Rows	38" Rows	Recomm. Speed Range (MPH)	Average Hill Spacing In Inches
Drive	Driven								
15	28	30,149	25,124	23,802	15,074	12,562	11,901	4 to 6	13.9
15	27	31,266	26,055	24,683	15,633	13,027	12,342	4 to 6	13.4
15	26	32,468	27,057	25,633	16,234	13,528	12,816	4 to 6	12.9
15	25	33,767	28,139	26,658	16,883	14,070	13,329	4 to 6	12.4
17	28	34,169	28,474	26,975	17,084	14,237	13,488	4 to 6	12.2
15	24	35,174	29,312	27,769	17,587	14,656	13,884	4 to 6	11.9
17	27	35,434	29,529	27,975	17,717	14,764	13,987	4 to 6	11.8
15	23	36,703	30,586	28,976	18,352	15,293	14,488	4 to 6	11.4
17	26	36,797	30,664	29,050	18,399	15,332	14,525	4 to 6	11.4
19	28	38,189	31,824	30,149	19,094	15,912	15,074	4 to 6	11.0
17	25	38,269	31,891	30,212	19,135	15,945	15,106	4 to 6	10.9
19	27	39,603	33,003	31,266	19,802	16,501	15,633	4 to 6	10.6
17	24	39,864	33,220	31,471	19,932	16,610	15,736	4 to 6	10.5
19	26	41,126	34,272	32,468	20,563	17,136	16,234	4 to 6	10.2
17	23	41,597	34,664	32,840	20,798	17,332	16,420	4 to 6	10.1
19	25	42,771	35,643	33,767	21,386	17,821	16,883	4 to 6	9.8
15	19	44,430	37,025	35,076	22,215	18,513	17,538	4 to 6	9.4
19	24	44,554	37,128	35,174	22,277	18,564	17,587	4 to 6	9.4
23	28	46,228	38,524	36,496	23,114	19,262	18,248	4 to 6	9.0
19	23	46,491	38,742	36,703	23,245	19,371	18,352	4 to 6	9.0
23	27	47,941	39,951	37,848	23,970	19,975	18,924	4 to 6	8.7
24	28	48,238	40,199	38,083	24,119	20,099	19,041	4 to 6	8.7
15	17	49,657	41,381	39,203	24,829	20,690	19,602	4 to 6	8.4
23	26	49,784	41,487	39,304	24,892	20,744	19,652	4 to 6	8.4
24	27	50,025	41,687	39,493	25,012	20,844	19,747	4 to 6	8.4
25	28	50,248	41,874	39,670	25,124	20,937	19,835	4 to 6	8.3
17	19	50,354	41,962	39,753	25,177	20,981	19,877	4 to 6	8.3
23	25	51,776	43,147	40,876	25,888	21,573	20,438	4 to 6	8.1
24	26	51,949	43,291	41,012	25,975	21,645	20,506	4 to 6	8.0
25	27	52,109	43,424	41,139	26,055	21,712	20,569	4 to 6	8.0
26	28	52,258	43,549	41,257	26,129	21,774	20,628	4 to 6	8.0
23	24	53,933	44,944	42,579	26,967	22,472	21,289	4 to 6	7.8
24	25	54,027	45,022	42,653	27,013	22,511	21,326	4 to 6	7.7
25	26	54,114	45,095	42,721	27,057	22,547	21,361	4 to 6	7.7
26	27	54,194	45,161	42,785	27,097	22,581	21,392	4 to 6	7.7
27	28	54,268	45,223	42,843	27,134	22,612	21,422	4 to 6	7.7
23	23	56,278	46,898	44,430	28,139	23,449	22,215	4 to 6	7.4
28	27	58,362	48,635	46,076	29,181	24,318	23,038	4 to 6	7.2
27	26	58,443	48,702	46,139	29,221	24,351	23,069	4 to 6	7.2
25	24	58,623	48,853	46,281	29,312	24,426	23,141	4 to 6	7.1
24	23	58,725	48,937	46,362	29,362	24,469	23,181	4 to 6	7.1
28	26	60,607	50,506	47,848	30,304	25,253	23,924	4 to 6	6.9
27	25	60,780	50,650	47,985	30,390	25,325	23,992	4 to 6	6.9
25	23	61,172	50,977	48,294	30,586	25,488	24,147	4 to 6	6.8
19	17	62,899	52,416	49,657	31,450	26,208	24,829	4 to 6	6.6
28	25	63,031	52,526	49,762	31,516	26,263	24,881	4 to 6	6.6
27	24	63,313	52,761	49,984	31,656	26,380	24,992	4 to 6	6.6
26	23	63,619	53,016	50,225	31,809	26,508	25,113	4 to 6	6.6
28	24	65,658	54,715	51,835	32,829	27,357	25,918	4 to 6	6.4
27	23	66,066	55,055	52,157	33,033	27,527	26,079	4 to 6	6.3
23	19	68,126	56,772	53,784	34,063	28,386	26,892	4 to 6	6.1
28	23	68,512	57,094	54,089	34,256	28,547	27,044	4 to 6	6.1
24	19	71,088	59,240	56,122	35,544	29,620	28,061	4 to 6	5.9
25	19	74,050	61,708	58,461	37,025	30,854	29,230	4 to 6	5.6
23	17	76,141	63,451	60,111	38,070	31,725	30,056	4 to 6	5.5

NOTE: See "General Planting Rate Information" and "Check Seed Population" pages for more information. Always field check seed population to verify planting rates.

**PLANTING RATES FOR (EDGEVAC) COTTON/SMALL DRY EDIBLE BEAN 54 CELL DISC
22 TOOTH CONTACT WHEEL DRIVE SPROCKET
APPROXIMATE SEEDS/ACRE FOR VARIOUS ROW WIDTHS**

Transmission Sprockets		15" Rows	18" Rows	19" Rows	30" Rows	36" Rows	38" Rows	Recomm. Speed Range (MPH)	Average Seed Spacing In Inches
Drive	Driven								
15	28	64,265	53,554	50,735	32,132	26,777	25,368	4 to 6	6.5
15	27	66,645	55,538	52,615	33,323	27,769	26,307	4 to 6	6.3
15	26	69,208	57,674	54,638	34,604	28,837	27,319	4 to 6	6.0
15	25	71,977	59,981	56,824	35,988	29,990	28,412	4 to 6	5.8
17	28	72,834	60,695	57,500	36,417	30,347	28,750	4 to 6	5.7
15	24	74,976	62,480	59,191	37,488	31,240	29,596	4 to 6	5.6
17	27	75,531	62,943	59,630	37,766	31,471	29,815	4 to 6	5.5
15	23	78,236	65,196	61,765	39,118	32,598	30,882	4 to 6	5.3
17	26	78,436	65,364	61,923	39,218	32,682	30,962	4 to 6	5.3
19	28	81,402	67,835	64,265	40,701	33,918	32,132	4 to 6	5.1
17	25	81,574	67,978	64,400	40,787	33,989	32,200	4 to 6	5.1
19	27	84,417	70,348	66,645	42,209	35,174	33,323	4 to 6	5.0
17	24	84,973	70,810	67,084	42,486	35,405	33,542	4 to 6	4.9
19	26	87,664	73,053	69,208	43,832	36,527	34,604	4 to 6	4.8
17	23	88,667	73,889	70,000	44,334	36,945	35,000	4 to 6	4.7
19	25	91,171	75,975	71,977	45,585	37,988	35,988	4 to 6	4.6
15	19	94,706	78,922	74,768	47,353	39,461	37,384	4 to 6	4.4
19	24	94,969	79,141	74,976	47,485	39,571	37,488	4 to 6	4.4
23	28	98,540	82,116	77,794	49,270	41,058	38,897	4 to 6	4.2
19	23	99,098	82,582	78,236	49,549	41,291	39,118	4 to 6	4.2
23	27	102,189	85,158	80,676	51,095	42,579	40,338	4 to 6	4.1
24	28	102,824	85,687	81,177	51,412	42,843	40,588	4 to 6	4.1
15	17	105,848	88,207	83,564	52,924	44,103	41,782	4 to 6	4.0
24	27	106,632	88,860	84,183	53,316	44,430	42,092	4 to 6	3.9
17	19	107,334	89,445	84,737	53,667	44,722	42,369	4 to 6	3.9
23	25	110,364	91,970	87,130	55,182	45,985	43,565	4 to 6	3.8
26	28	111,393	92,827	87,942	55,696	46,414	43,971	4 to 6	3.8
23	24	114,963	95,802	90,760	57,481	47,901	45,380	4 to 6	3.6
24	25	115,163	95,969	90,918	57,581	47,985	45,459	4 to 6	3.6
27	28	115,677	96,397	91,324	57,838	48,199	45,662	4 to 6	3.6
23	23	119,961	99,968	94,706	59,981	49,984	47,353	4 to 6	3.5
28	27	124,404	103,670	98,214	62,202	51,835	49,107	4 to 6	3.4
27	26	124,575	103,813	98,349	62,288	51,906	49,174	4 to 6	3.4
24	23	125,177	104,314	98,824	62,588	52,157	49,412	4 to 6	3.3
28	26	129,189	107,658	101,991	64,595	53,829	50,996	4 to 6	3.2
27	25	129,558	107,965	102,283	64,779	53,983	51,141	4 to 6	3.2
25	23	130,393	108,661	102,942	65,196	54,330	51,471	4 to 6	3.2
19	17	134,074	111,729	105,848	67,037	55,864	52,924	4 to 6	3.1
27	24	134,956	112,464	106,545	67,478	56,232	53,272	4 to 6	3.1
26	23	135,608	113,007	107,059	67,804	56,503	53,530	4 to 6	3.1
28	24	139,955	116,629	110,491	69,977	58,314	55,245	4 to 6	3.0
27	23	140,824	117,353	111,177	70,412	58,677	55,588	4 to 6	3.0
23	19	145,216	121,014	114,644	72,608	60,507	57,322	4 to 6	2.9
28	23	146,040	121,700	115,295	73,020	60,850	57,647	4 to 6	2.9
24	19	151,530	126,275	119,629	75,765	63,138	59,814	4 to 6	2.8
25	19	157,844	131,536	124,613	78,922	65,768	62,307	4 to 6	2.6
23	17	162,301	135,250	128,132	81,150	67,625	64,066	4 to 6	2.6
26	19	164,158	136,798	129,598	82,079	68,399	64,799	4 to 6	2.5
24	17	169,357	141,131	133,703	84,679	70,565	66,851	4 to 6	2.5
27	19	170,471	142,059	134,583	85,236	71,030	67,291	4 to 6	2.5
25	17	176,414	147,011	139,274	88,207	73,506	69,637	4 to 6	2.4
28	19	176,785	147,321	139,567	88,393	73,660	69,784	4 to 6	2.4
26	17	183,470	152,892	144,845	91,735	76,446	72,422	4 to 6	2.3
23	15	183,941	153,284	145,216	91,970	76,642	72,608	4 to 6	2.3
27	17	190,527	158,772	150,416	95,263	79,386	75,208	4 to 6	2.2

NOTE: See "General Planting Rate Information" and "Check Seed Population" pages for more information. Always field check seed population to verify planting rates.

**PLANTING RATES FOR (EDGEVAC) COTTON/SMALL DRY EDIBLE BEAN/SUNFLOWER, 54 CELL DISC
28 TOOTH CONTACT WHEEL DRIVE SPROCKET
APPROXIMATE SEEDS/ACRE FOR VARIOUS ROW WIDTHS**

Transmission Sprockets		15" Rows	18" Rows	19" Rows	30" Rows	36" Rows	38" Rows	Recomm. Speed Range (MPH)	Average Seed Spacing In Inches
Drive	Driven								
15	28	81,402	67,835	64,265	40,701	33,918	32,132	4 to 6	5.1
15	27	84,417	70,348	66,645	42,209	35,174	33,323	4 to 6	5.0
15	26	87,664	73,053	69,208	43,832	36,527	34,604	4 to 6	4.8
15	25	91,171	75,975	71,977	45,585	37,988	35,988	4 to 6	4.6
17	28	92,256	76,880	72,834	46,128	38,440	36,417	4 to 6	4.5
15	24	94,969	79,141	74,976	47,485	39,571	37,488	4 to 6	4.4
17	27	95,673	79,727	75,531	47,836	39,864	37,766	4 to 6	4.4
15	23	99,098	82,582	78,236	49,549	41,291	39,118	4 to 6	4.2
17	26	99,353	82,794	78,436	49,676	41,397	39,218	4 to 6	4.2
19	28	103,110	85,925	81,402	51,555	42,962	40,701	4 to 6	4.1
17	25	103,327	86,106	81,574	51,663	43,053	40,787	4 to 6	4.0
19	27	106,928	89,107	84,417	53,464	44,554	42,209	4 to 6	3.9
17	24	107,632	89,693	84,973	53,816	44,847	42,486	4 to 6	3.9
19	26	111,041	92,534	87,664	55,521	46,267	43,832	4 to 6	3.8
17	23	112,312	93,593	88,667	56,156	46,796	44,334	4 to 6	3.7
19	25	115,483	96,236	91,171	57,741	48,118	45,585	4 to 6	3.6
15	19	119,961	99,968	94,706	59,981	49,984	47,353	4 to 6	3.5
19	24	120,294	100,245	94,969	60,147	50,123	47,485	4 to 6	3.5
23	28	124,817	104,014	98,540	62,408	52,007	49,270	4 to 6	3.4
19	23	125,525	104,604	99,098	62,762	52,302	49,549	4 to 6	3.3
23	27	129,440	107,866	102,189	64,720	53,933	51,095	4 to 6	3.2
24	28	130,244	108,536	102,824	65,122	54,268	51,412	4 to 6	3.2
15	17	134,074	111,729	105,848	67,037	55,864	52,924	4 to 6	3.1
24	27	135,067	112,556	106,632	67,534	56,278	53,316	4 to 6	3.1
17	19	135,956	113,297	107,334	67,978	56,648	53,667	4 to 6	3.1
23	25	139,795	116,496	110,364	69,897	58,248	55,182	4 to 6	3.0
26	28	141,097	117,581	111,393	70,549	58,791	55,696	4 to 6	3.0
23	24	145,620	121,350	114,963	72,810	60,675	57,481	4 to 6	2.9
24	25	145,873	121,561	115,163	72,936	60,780	57,581	4 to 6	2.9
27	28	146,524	122,103	115,677	73,262	61,052	57,838	4 to 6	2.9
23	23	151,951	126,626	119,961	75,975	63,313	59,981	4 to 6	2.8
28	27	157,579	131,316	124,404	78,789	65,658	62,202	4 to 6	2.7
27	26	157,795	131,496	124,575	78,898	65,748	62,288	4 to 6	2.7
24	23	158,557	132,131	125,177	79,279	66,066	62,588	4 to 6	2.6
28	26	163,639	136,366	129,189	81,820	68,183	64,595	4 to 6	2.6
27	25	164,107	136,756	129,558	82,053	68,378	64,779	4 to 6	2.5
25	23	165,164	137,637	130,393	82,582	68,818	65,196	4 to 6	2.5
19	17	169,828	141,523	134,074	84,914	70,761	67,037	4 to 6	2.5
27	24	170,945	142,454	134,956	85,472	71,227	67,478	4 to 6	2.4
26	23	171,771	143,142	135,608	85,885	71,571	67,804	4 to 6	2.4
28	24	177,276	147,730	139,955	88,638	73,865	69,977	4 to 6	2.4
27	23	178,377	148,648	140,824	89,189	74,324	70,412	4 to 6	2.3
23	19	183,941	153,284	145,216	91,970	76,642	72,608	4 to 6	2.3
28	23	184,984	154,153	146,040	92,492	77,077	73,020	4 to 6	2.3
24	19	191,938	159,948	151,530	95,969	79,974	75,765	4 to 6	2.2
25	19	199,935	166,613	157,844	99,968	83,306	78,922	4 to 6	2.1
23	17	205,581	171,317	162,301	102,790	85,659	81,150	4 to 6	2.0
26	19	207,933	173,277	164,158	103,966	86,639	82,079	4 to 6	2.0
24	17	214,519	178,766	169,357	107,259	89,383	84,679	4 to 6	1.9
27	19	215,930	179,942	170,471	107,965	89,971	85,236	4 to 6	1.9
25	17	223,457	186,214	176,414	111,729	93,107	88,207	4 to 6	1.9
28	19	223,928	186,606	176,785	111,964	93,303	88,393	4 to 6	1.9
26	17	232,396	193,663	183,470	116,198	96,831	91,735	4 to 6	1.8
23	15	232,991	194,160	183,941	116,496	97,080	91,970	4 to 6	1.8
27	17	241,334	201,112	190,527	120,667	100,556	95,263	4 to 6	1.7

NOTE: See "General Planting Rate Information" and "Check Seed Population" pages for more information. Always field check seed population to verify planting rates.

**PLANTING RATES FOR (EDGEVAC) LARGE DRY EDIBLE BEAN 54 CELL DISC
22 TOOTH CONTACT WHEEL DRIVE SPROCKET
APPROXIMATE SEEDS/ACRE FOR VARIOUS ROW WIDTHS**

Transmission Sprockets		15" Rows	18" Rows	19" Rows	30" Rows	36" Rows	38" Rows	Recomm. Speed Range (MPH)	Average Seed Spacing In Inches
Drive	Driven								
15	28	64,265	53,554	50,735	32,132	26,777	25,368	4 to 6	6.5
15	27	66,645	55,538	52,615	33,323	27,769	26,307	4 to 6	6.3
15	26	69,208	57,674	54,638	34,604	28,837	27,319	4 to 6	6.0
15	25	71,977	59,981	56,824	35,988	29,990	28,412	4 to 6	5.8
17	28	72,834	60,695	57,500	36,417	30,347	28,750	4 to 6	5.7
15	24	74,976	62,480	59,191	37,488	31,240	29,596	4 to 6	5.6
17	27	75,531	62,943	59,630	37,766	31,471	29,815	4 to 6	5.5
15	23	78,236	65,196	61,765	39,118	32,598	30,882	4 to 6	5.3
17	26	78,436	65,364	61,923	39,218	32,682	30,962	4 to 6	5.3
19	28	81,402	67,835	64,265	40,701	33,918	32,132	4 to 6	5.1
17	25	81,574	67,978	64,400	40,787	33,989	32,200	4 to 6	5.1
19	27	84,417	70,348	66,645	42,209	35,174	33,323	4 to 6	5.0
17	24	84,973	70,810	67,084	42,486	35,405	33,542	4 to 6	4.9
19	26	87,664	73,053	69,208	43,832	36,527	34,604	4 to 6	4.8
17	23	88,667	73,889	70,000	44,334	36,945	35,000	4 to 6	4.7
19	25	91,171	75,975	71,977	45,585	37,988	35,988	4 to 6	4.6
15	19	94,706	78,922	74,768	47,353	39,461	37,384	4 to 6	4.4
19	24	94,969	79,141	74,976	47,485	39,571	37,488	4 to 6	4.4
23	28	98,540	82,116	77,794	49,270	41,058	38,897	4 to 6	4.2
19	23	99,098	82,582	78,236	49,549	41,291	39,118	4 to 6	4.2
23	27	102,189	85,158	80,676	51,095	42,579	40,338	4 to 6	4.1
24	28	102,824	85,687	81,177	51,412	42,843	40,588	4 to 6	4.1
15	17	105,848	88,207	83,564	52,924	44,103	41,782	4 to 6	4.0
24	27	106,632	88,860	84,183	53,316	44,430	42,092	4 to 6	3.9
17	19	107,334	89,445	84,737	53,667	44,722	42,369	4 to 6	3.9
23	25	110,364	91,970	87,130	55,182	45,985	43,565	4 to 6	3.8
26	28	111,393	92,827	87,942	55,696	46,414	43,971	4 to 6	3.8
23	24	114,963	95,802	90,760	57,481	47,901	45,380	4 to 6	3.6
24	25	115,163	95,969	90,918	57,581	47,985	45,459	4 to 6	3.6
27	28	115,677	96,397	91,324	57,838	48,199	45,662	4 to 6	3.6
23	23	119,961	99,968	94,706	59,981	49,984	47,353	4 to 6	3.5
28	27	124,404	103,670	98,214	62,202	51,835	49,107	4 to 6	3.4
27	26	124,575	103,813	98,349	62,288	51,906	49,174	4 to 6	3.4
24	23	125,177	104,314	98,824	62,588	52,157	49,412	4 to 6	3.3
28	26	129,189	107,658	101,991	64,595	53,829	50,996	4 to 6	3.2
27	25	129,558	107,965	102,283	64,779	53,983	51,141	4 to 6	3.2
25	23	130,393	108,661	102,942	65,196	54,330	51,471	4 to 6	3.2
19	17	134,074	111,729	105,848	67,037	55,864	52,924	4 to 6	3.1
27	24	134,956	112,464	106,545	67,478	56,232	53,272	4 to 6	3.1
26	23	135,608	113,007	107,059	67,804	56,503	53,530	4 to 6	3.1
28	24	139,955	116,629	110,491	69,977	58,314	55,245	4 to 6	3.0
27	23	140,824	117,353	111,177	70,412	58,677	55,588	4 to 6	3.0
23	19	145,216	121,014	114,644	72,608	60,507	57,322	4 to 6	2.9
28	23	146,040	121,700	115,295	73,020	60,850	57,647	4 to 6	2.9
24	19	151,530	126,275	119,629	75,765	63,138	59,814	4 to 6	2.8
25	19	157,844	131,536	124,613	78,922	65,768	62,307	4 to 6	2.6
23	17	162,301	135,250	128,132	81,150	67,625	64,066	4 to 6	2.6
26	19	164,158	136,798	129,598	82,079	68,399	64,799	4 to 6	2.5
24	17	169,357	141,131	133,703	84,679	70,565	66,851	4 to 6	2.5
27	19	170,471	142,059	134,583	85,236	71,030	67,291	4 to 6	2.5
25	17	176,414	147,011	139,274	88,207	73,506	69,637	4 to 6	2.4
28	19	176,785	147,321	139,567	88,393	73,660	69,784	4 to 6	2.4
26	17	183,470	152,892	144,845	91,735	76,446	72,422	4 to 6	2.3
23	15	183,941	153,284	145,216	91,970	76,642	72,608	4 to 6	2.3
27	17	190,527	158,772	150,416	95,263	79,386	75,208	4 to 6	2.2

NOTE: See "General Planting Rate Information" and "Check Seed Population" pages for more information. Always field check seed population to verify planting rates.

**PLANTING RATES FOR (EDGEVAC) LARGE DRY EDIBLE BEAN 54 CELL DISC
28 TOOTH CONTACT WHEEL DRIVE SPROCKET
APPROXIMATE SEEDS/ACRE FOR VARIOUS ROW WIDTHS**

Transmission Sprockets		15" Rows	18" Rows	19" Rows	30" Rows	36" Rows	38" Rows	Recomm. Speed Range (MPH)	Average Seed Spacing In Inches
Drive	Driven								
15	28	81,402	67,835	64,265	40,701	33,918	32,132	4 to 6	5.1
15	27	84,417	70,348	66,645	42,209	35,174	33,323	4 to 6	5.0
15	26	87,664	73,053	69,208	43,832	36,527	34,604	4 to 6	4.8
15	25	91,171	75,975	71,977	45,585	37,988	35,988	4 to 6	4.6
17	28	92,256	76,880	72,834	46,128	38,440	36,417	4 to 6	4.5
15	24	94,969	79,141	74,976	47,485	39,571	37,488	4 to 6	4.4
17	27	95,673	79,727	75,531	47,836	39,864	37,766	4 to 6	4.4
15	23	99,098	82,582	78,236	49,549	41,291	39,118	4 to 6	4.2
17	26	99,353	82,794	78,436	49,676	41,397	39,218	4 to 6	4.2
19	28	103,110	85,925	81,402	51,555	42,962	40,701	4 to 6	4.1
17	25	103,327	86,106	81,574	51,663	43,053	40,787	4 to 6	4.0
19	27	106,928	89,107	84,417	53,464	44,554	42,209	4 to 6	3.9
17	24	107,632	89,693	84,973	53,816	44,847	42,486	4 to 6	3.9
19	26	111,041	92,534	87,664	55,521	46,267	43,832	4 to 6	3.8
17	23	112,312	93,593	88,667	56,156	46,796	44,334	4 to 6	3.7
19	25	115,483	96,236	91,171	57,741	48,118	45,585	4 to 6	3.6
15	19	119,961	99,968	94,706	59,981	49,984	47,353	4 to 6	3.5
19	24	120,294	100,245	94,969	60,147	50,123	47,485	4 to 6	3.5
23	28	124,817	104,014	98,540	62,408	52,007	49,270	4 to 6	3.4
19	23	125,525	104,604	99,098	62,762	52,302	49,549	4 to 6	3.3
23	27	129,440	107,866	102,189	64,720	53,933	51,095	4 to 6	3.2
24	28	130,244	108,536	102,824	65,122	54,268	51,412	4 to 6	3.2
15	17	134,074	111,729	105,848	67,037	55,864	52,924	4 to 6	3.1
24	27	135,067	112,556	106,632	67,534	56,278	53,316	4 to 6	3.1
17	19	135,956	113,297	107,334	67,978	56,648	53,667	4 to 6	3.1
23	25	139,795	116,496	110,364	69,897	58,248	55,182	4 to 6	3.0
26	28	141,097	117,581	111,393	70,549	58,791	55,696	4 to 6	3.0
23	24	145,620	121,350	114,963	72,810	60,675	57,481	4 to 6	2.9
24	25	145,873	121,561	115,163	72,936	60,780	57,581	4 to 6	2.9
27	28	146,524	122,103	115,677	73,262	61,052	57,838	4 to 6	2.9
23	23	151,951	126,626	119,961	75,975	63,313	59,981	4 to 6	2.8
28	27	157,579	131,316	124,404	78,789	65,658	62,204	4 to 6	2.7
27	26	157,795	131,496	124,575	78,898	65,748	62,288	4 to 6	2.7
24	23	158,557	132,131	125,177	79,279	66,066	62,588	4 to 6	2.6
28	26	163,639	136,366	129,189	81,820	68,183	64,595	4 to 6	2.6
27	25	164,107	136,756	129,558	82,053	68,378	64,779	4 to 6	2.5
25	23	165,164	137,637	130,393	82,582	68,818	65,196	4 to 6	2.5
19	17	169,828	141,523	134,074	84,914	70,761	67,037	4 to 6	2.5
27	24	170,945	142,454	134,956	85,472	71,227	67,478	4 to 6	2.4
26	23	171,771	143,142	135,608	85,885	71,571	67,804	4 to 6	2.4
28	24	177,276	147,730	139,955	88,638	73,865	69,977	4 to 6	2.4
27	23	178,377	148,648	140,824	89,189	74,324	70,412	4 to 6	2.3
23	19	183,941	153,284	145,216	91,970	76,642	72,608	4 to 6	2.3
28	23	184,984	154,153	146,040	92,492	77,077	73,020	4 to 6	2.3
24	19	191,938	159,948	151,530	95,969	79,974	75,765	4 to 6	2.2
25	19	199,935	166,613	157,844	99,968	83,306	78,922	4 to 6	2.1
23	17	205,581	171,317	162,301	102,790	85,659	81,150	4 to 6	2.0
26	19	207,933	173,277	164,158	103,966	86,639	82,079	4 to 6	2.0
24	17	214,519	178,766	169,357	107,259	89,383	84,679	4 to 6	1.9
27	19	215,930	179,942	170,471	107,965	89,971	85,236	4 to 6	1.9
25	17	223,457	186,214	176,414	111,729	93,107	88,207	4 to 6	1.9
28	19	223,928	186,606	176,785	111,964	93,303	88,393	4 to 6	1.9
26	17	232,396	193,663	183,470	116,198	96,831	91,735	4 to 6	1.8
23	15	232,991	194,160	183,941	116,496	97,080	91,970	4 to 6	1.8
27	17	241,334	201,112	190,527	120,667	100,556	95,263	4 to 6	1.7

NOTE: See "General Planting Rate Information" and "Check Seed Population" pages for more information. Always field check seed population to verify planting rates.

**PLANTING RATES FOR (EDGEVAC) SUGAR BEETS 80 CELL DISC
22 TOOTH CONTACT WHEEL DRIVE SPROCKET
APPROXIMATE SEEDS/ACRE FOR VARIOUS ROW WIDTHS**

Transmission Sprockets		30" Rows	Recomm. Speed Range (MPH)	Average Seed Spacing In Inches
Drive	Driven			
15	28	47,608	4 to 6	4.4
15	27	49,370	4 to 6	4.2
15	26	51,270	4 to 6	4.1
15	25	53,321	4 to 6	3.9
17	28	53,955	4 to 6	3.9
15	24	55,543	4 to 6	3.8
17	27	55,953	4 to 6	3.8
15	23	57,957	4 to 6	3.6
17	26	58,105	4 to 6	3.6
19	28	60,304	4 to 6	3.5
17	25	60,431	4 to 6	3.5
19	27	62,535	4 to 6	3.4
17	24	62,948	4 to 6	3.3
19	26	64,942	4 to 6	3.2
17	23	65,684	4 to 6	3.2
19	25	67,538	4 to 6	3.1
15	19	70,158	4 to 6	3.0
19	24	70,353	4 to 6	3.0
23	28	72,999	4 to 6	2.9
19	23	73,411	4 to 6	2.8
23	27	75,703	4 to 6	2.8
24	28	76,172	4 to 6	2.7
15	17	78,412	4 to 6	2.7
24	27	78,993	4 to 6	2.6
17	19	79,514	4 to 6	2.6
23	25	81,758	4 to 6	2.5
26	28	82,519	4 to 6	2.5
23	24	85,165	4 to 6	2.4
24	25	85,313	4 to 6	2.4
27	28	85,694	4 to 6	2.4
23	23	88,868	4 to 6	2.3
28	27	92,158	4 to 6	2.3
27	26	92,285	4 to 6	2.2
24	23	92,730	4 to 6	2.2
28	26	95,703	4 to 6	2.2
27	25	95,977	4 to 6	2.2
25	23	96,595	4 to 6	2.1
19	17	99,323	4 to 6	2.1
27	24	99,975	4 to 6	2.1
26	23	100,459	4 to 6	2.1
28	24	103,678	4 to 6	2.0
27	23	104,322	4 to 6	2.0
23	19	107,575	4 to 6	2.0
28	23	108,187	4 to 6	2.0
24	19	112,254	4 to 6	1.9
25	19	116,931	4 to 6	1.8
23	17	120,232	4 to 6	1.8
26	19	121,608	4 to 6	1.7
24	17	125,461	4 to 6	1.7
27	19	126,285	4 to 6	1.7
25	17	130,687	4 to 6	1.6
28	19	130,962	4 to 6	1.6
26	17	135,914	4 to 6	1.6
23	15	136,263	4 to 6	1.5
27	17	141,143	4 to 6	1.5

NOTE: See "General Planting Rate Information" and "Check Seed Population" pages for more information. Always field check seed population to verify planting rates.

**PLANTING RATES FOR (EDGEVAC) SUGAR BEETS 80 CELL DISC
15 TOOTH CONTACT WHEEL DRIVE SPROCKET/19 TOOTH REVERSER DRIVEN SPROCKETS
APPROXIMATE SEEDS/ACRE FOR VARIOUS ROW WIDTHS**

Transmission Sprockets		30" Rows	Recomm. Speed Range (MPH)	Average Seed Spacing In Inches
Drive	Driven			
15	28	22,006	4 to 6	9.5
15	27	22,821	4 to 6	9.2
15	26	23,699	4 to 6	8.9
15	25	24,647	4 to 6	8.4
17	28	24,940	4 to 6	8.3
15	24	25,674	4 to 6	8.1
17	27	25,863	4 to 6	8.1
15	23	26,790	4 to 6	7.8
17	26	26,858	4 to 6	7.8
19	28	27,874	4 to 6	7.5
17	25	27,933	4 to 6	7.5
19	27	28,906	4 to 6	7.3
17	24	29,097	4 to 6	7.2
19	26	30,018	4 to 6	7.0
17	23	30,362	4 to 6	6.9
19	25	31,219	4 to 6	6.7
15	19	32,429	4 to 6	6.4
19	24	32,520	4 to 6	6.4
23	28	33,743	4 to 6	6.2
19	23	33,933	4 to 6	6.1
23	27	34,992	4 to 6	6.0
24	28	35,210	4 to 6	5.9
15	17	36,245	4 to 6	5.8
24	27	36,513	4 to 6	5.7
17	19	36,754	4 to 6	5.7
23	25	37,791	4 to 6	5.5
26	28	38,143	4 to 6	5.5
23	24	39,366	4 to 6	5.3
24	25	39,435	4 to 6	5.3
27	28	39,611	4 to 6	5.3
23	23	41,078	4 to 6	5.1
28	27	42,599	4 to 6	5.0
27	26	42,657	4 to 6	4.9
24	23	42,863	4 to 6	4.9
28	26	44,237	4 to 6	4.7
27	25	44,364	4 to 6	4.7
25	23	44,650	4 to 6	4.6
19	17	45,911	4 to 6	4.5
27	24	46,212	4 to 6	4.5
26	23	46,436	4 to 6	4.5
28	24	47,924	4 to 6	4.3
27	23	48,221	4 to 6	4.3
23	19	49,725	4 to 6	4.2
28	23	50,008	4 to 6	4.2
24	19	51,888	4 to 6	4.0
25	19	54,050	4 to 6	3.9
23	17	55,575	4 to 6	3.8
26	19	56,212	4 to 6	3.7
24	17	57,992	4 to 6	3.6
27	19	58,373	4 to 6	3.6
25	17	60,408	4 to 6	3.5
28	19	60,535	4 to 6	3.5
26	17	62,824	4 to 6	3.4
23	15	62,985	4 to 6	3.3
27	17	65,241	4 to 6	3.2

NOTE: See "General Planting Rate Information" and "Check Seed Population" pages for more information. Always field check seed population to verify planting rates.

DRY FERTILIZER APPLICATION RATES (Mechanical)
APPROXIMATE RATE IN POUNDS PER ACRE

Drive Sprocket	Driven Sprocket	Low Rate Position			High Rate Position		
		30" Rows	36" Rows	38" Rows	30" Rows	36" Rows	38" Rows
15	35	29	24	23	86	71	68
15	33	33	27	26	98	82	78
15	30	36	30	28	109	90	86
19	33	41	34	33	124	104	98
19	30	45	38	36	138	114	108
15	19	52	43	41	158	132	125
30	35	56	47	44	172	143	136
30	33	60	50	47	182	152	144
33	35	63	53	50	189	158	149
35	33	70	58	56	212	177	168
33	30	73	60	57	220	184	174
19	15	84	70	66	272	227	215
30	19	104	87	82	316	263	250
33	19	115	96	91	347	290	275
35	19	122	102	97	368	307	291
30	15	132	110	104	400	334	316
33	15	145	121	115	440	367	348
35	15	154	129	122	467	389	369

See notes on following page.

DRY FERTILIZER APPLICATION RATES (EdgeVac)
22 TOOTH CONTACT WHEEL DRIVE SPROCKET
APPROXIMATE RATE IN POUNDS PER ACRE

Drive Sprocket	Driven Sprocket	Low Rate Position			High Rate Position		
		30" Rows	36" Rows	38" Rows	30" Rows	36" Rows	38" Rows
15	35	29	24	23	86	71	68
15	33	33	27	26	98	82	78
15	30	36	30	28	109	90	86
19	33	41	34	33	124	104	98
19	30	45	38	36	138	114	108
15	19	52	43	41	158	132	125
30	35	56	47	44	172	143	136
30	33	60	50	47	182	152	144
33	35	63	53	50	189	158	149
35	33	70	58	56	212	177	168
33	30	73	60	57	220	184	174
19	15	84	70	66	272	227	215
30	19	104	87	82	316	263	250
33	19	115	96	91	347	290	275
35	19	122	102	97	368	307	291
30	15	132	110	104	400	334	316
33	15	145	121	115	440	367	348
35	15	154	129	122	467	389	369

See notes on following page.

DRY FERTILIZER APPLICATION RATES (EdgeVac)

28 TOOTH CONTACT WHEEL DRIVE SPROCKET

APPROXIMATE RATE IN POUNDS PER ACRE

Drive Sprocket	Driven Sprocket	Low Rate Position			High Rate Position		
		30" Rows	36" Rows	38" Rows	30" Rows	36" Rows	38" Rows
15	35	37	30	29	109	90	86
15	33	42	34	33	124	104	99
15	30	46	38	35	138	114	109
19	33	52	43	42	157	132	124
19	30	57	48	46	175	144	137
15	19	66	54	52	200	167	158
30	35	71	60	56	218	181	172
30	33	76	63	60	231	193	182
33	35	80	67	63	239	200	189
35	33	89	73	71	269	224	213
33	30	92	76	72	279	233	220
19	15	106	89	84	345	288	272
30	19	132	110	104	400	333	317
33	19	146	122	115	440	367	348
35	19	155	129	123	466	389	369
30	15	167	139	132	507	423	400
33	15	184	153	146	557	465	441
35	15	195	163	155	592	493	467

NOTE: (Edgevac ONLY) 22, 28 and 44 tooth drive sprockets are NOT applicable to all rate charts. Check title to ensure proper rate chart is selected. DO NOT USE 44 tooth drive sprockets (60 cell soybean discs) with Dry Fertilizer Package.

NOTE: Uneven delivery may result from attempting to use rates lower than indicated by chart.

Direction
Of Rotation

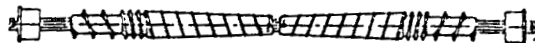

High Rate Position



Low Rate Position

Chart is for planters equipped with contact drive. See "Tire Pressure" for recommended tire pressures.

Chart calculated with a bulk density of 65 pounds per cubic foot.

NOTE: Fertilizer application rates can vary from tweights calculated in chart. Make field checks to be sure you are applying fertilizer at desired rate.

NOTE: Optional two-speed point row clutch is located ahead of dry fertilizer drive. Activating two-speed point row clutch reduced rate switch will cause same percent of reduction in dry fertilizer application rates.

To check exact number of pounds your fertilizer attachment actually delivers on a 30" row spacing, remove one spout from one fertilizer hopper and attach a container under opening. Engage fertilizer attachment and drive forward for 174'. Weigh amount of fertilizer caught in container and multiply that by 100. Result is pounds of fertilizer per acre when planting in 30" rows. To convert delivery rate for wider rows:

36" multiply by 0.83

38" multiply by 0.79

LIQUID FERTILIZER SQUEEZE PUMP APPLICATION RATES (Mechanical)

GALLONS PER ACRE

Drive	Driven	30" Rows	36" Rows	38" Rows	Drive	Driven	30" Rows	36" Rows	38" Rows
15	*62	6.1	5.1	4.8	46	*62	18.7	15.6	14.8
19	*62	7.7	6.4	6.1	15	19	19.9	16.6	15.7
15	46	8.2	6.9	6.5	32	34	23.7	19.8	18.7
19	46	10.4	8.7	8.2	34	32	26.8	22.3	21.1
15	34	11.1	9.3	8.8	19	15	31.9	26.6	25.2
15	32	11.8	9.8	9.3	46	34	34.1	28.4	26.9
32	*62	13.0	10.8	10.3	46	32	36.2	30.2	28.6
19	34	14.1	11.7	11.1	32	19	42.4	35.4	33.5
19	32	15.0	12.5	11.8	34	19	45.1	37.6	35.6
32	46	17.5	14.6	13.8	*62	34	45.9	38.3	36.3
34	46	18.6	15.5	14.7					

*Optional sprocket.

Chart is for planters equipped with contact drive and based on a solution weighing ten pounds per gallon.. Check tires for correct operating pressure.

NOTE: Fertilizer application rates can vary from the above chart. To prevent application miscalculations, make field checks to be sure you are applying fertilizer at the desired rate.

NOTE: Optional two-speed point row clutch is located ahead of liquid fertilizer squeeze pump Activating two-speed point row clutch reduced rate switch will cause same percent of reduction in liquid fertilizer (squeeze pump) application rates.

To check exact number of gallons your fertilizer attachment will actually deliver on a 30" row spacing:

1. Remove hose from one fertilizer opener and insert it into a collection container secured planter frame.
2. Engage fertilizer attachment and drive forward for 174'.
3. Measure fluid ounces caught in container and multiply by 100. Divide that amount by 128. Result is gallons of fertilizer delivered per acre when planting in 30" rows.
4. Rinse collection container and repeat test on other rows if necessary. To convert delivery rate for wider rows, multiply by following conversion factors:

36" multiply by 0.83

38" multiply by 0.79

**LIQUID FERTILIZER SQUEEZE PUMP APPLICATION RATES (EdgeVac)
22 TOOTH CONTACT WHEEL DRIVE SPROCKET**

GALLONS PER ACRE

Drive	Driven	30" Rows	36" Rows	38" Rows	Drive	Driven	30" Rows	36" Rows	38" Rows
19	62	5.7	4.7	4.5	24	17	26.1	21.8	20.6
19	46	7.6	6.4	6.0	46	30	28.4	23.6	22.4
24	46	9.7	8.0	7.6	50	30	20.8	25.7	24.3
19	30	11.7	9.8	9.2	30	17	32.6	27.2	25.8
17	23	13.7	11.4	10.8	46	24	35.5	29.5	28.0
19	23	15.3	12.7	12.1	30	15	37.0	30.8	29.2
23	24	17.7	14.8	14.0	62	30	38.2	31.9	30.2
50	46	20.1	16.8	15.9	50	23	40.2	33.5	31.7
23	19	22.4	18.7	17.7	46	19	44.8	37.3	35.4
30	23	24.1	20.1	19.0	62	24	47.8	39.8	37.7

**LIQUID FERTILIZER SQUEEZE PUMP APPLICATION RATES (EdgeVac)
28 TOOTH CONTACT WHEEL DRIVE SPROCKET**

GALLONS PER ACRE

Drive	Driven	30" Rows	36" Rows	38" Rows	Drive	Driven	30" Rows	36" Rows	38" Rows
15	62	5.7	4.7	4.5	17	15	26.7	22.2	21.1
15	46	7.7	6.4	6.1	23	19	28.5	23.7	22.5
19	46	9.7	8.1	7.7	30	23	30.7	25.6	24.2
15	30	11.8	9.8	9.3	24	17	33.2	27.7	26.2
17	30	13.3	11.1	10.5	46	30	36.1	30.1	28.5
15	23	15.4	12.8	12.1	50	30	39.2	32.7	31.0
46	62	17.5	14.6	13.8	30	17	41.5	34.6	32.8
19	23	19.4	16.2	15.4	46	24	45.1	37.6	35.6
46	50	21.7	18.0	17.1	30	15	47.1	39.2	37.2
24	23	24.6	20.5	19.4	62	30	48.7	40.5	38.4

NOTE: 22, 28 and 44 tooth drive sprockets are NOT applicable to all rate charts. Check title to ensure proper rate chart is selected. DO NOT USE 44 tooth drive sprockets (60 cell soybean discs) with Liquid Fertilizer Squeeze Pump Package.

Chart is for planters equipped with contact drive and calculated based on a solution weighing ten pounds per gallon. Check tires for correct operating pressure.

NOTE: Fertilizer application rates can vary from the above chart. To prevent application miscalculations, make field checks to be sure you are applying fertilizer at the desired rate.

NOTE: Optional two-speed point row clutch is located ahead of liquid fertilizer squeeze pump. Activating two-speed point row clutch reduced rate switch will cause same percent of reduction in liquid fertilizer (squeeze pump) application rates.

To check the exact number of gallons your fertilizer attachment will actually deliver on a 30" row spacing:

1. Remove hose from one fertilizer opener and insert it into a collection container secured planter frame.
2. Engage fertilizer attachment and drive forward for 174'.
3. Measure fluid ounces caught in container and multiply by 100. Divide that amount by 128. Result is gallons of fertilizer delivered per acre when planting in 30" rows. To convert this delivery rate for wider rows, multiply by the following conversion factors:

36" multiply by 0.83

38" multiply by 0.79

4. Rinse collection container and repeat test on other rows if necessary.

**LIQUID FERTILIZER PISTON PUMP APPLICATION RATES
GALLONS PER ACRE**

**Applies To Model NGP-7055 Pumps With 18 Tooth Sprocket
And 7.60" x 15" Ground Drive Tire**

Pump Setting	2	3	4	5	6	7	8	9	10
8 Row 36"	9.2	13.9	18.5	23.1	27.6	32.0	36.8	41.5	46.1
8 Row 38"	8.8	13.1	17.5	21.9	26.1	30.5	34.9	39.3	43.7
12 Row 30"	7.4	11.1	14.8	18.5	22.1	25.8	29.5	33.2	36.9
12 Row 36"	6.2	9.3	12.3	15.4	18.4	21.5	24.6	27.7	30.8
12 Row 38"	5.8	8.8	11.7	14.6	17.4	20.4	23.3	26.2	29.1
16 Row 30"	5.5	8.3	11.1	13.9	16.6	19.4	22.2	24.9	27.7

Chart is for planters equipped with 7.60" x 15" ground drive tire, based on 91" forward travel per wheel revolution, 48 tooth drive sprocket and 18 tooth driven sprocket on metering pump. Check tires for correct operating pressure.

Chart calculated based on a solution weighing ten pounds per gallon.

NOTE: Fertilizer application rates can vary from weights calculated in above chart. Make field checks to be sure you are applying fertilizer at desired rate.

To check the exact number of gallons your fertilizer attachment will actually deliver on a 30" row spacing:

1. Remove hose from one fertilizer opener and insert it into a collection container secured planter frame.
2. Engage fertilizer attachment and drive forward for 174'.
3. Measure fluid ounces caught in container and multiply by 100. Divide that amount by 128. Result is gallons of fertilizer delivered per acre when planting in 30" rows. To convert this delivery rate for wider rows, multiply by the following conversion factors:

36" multiply by 0.83

38" multiply by 0.79

4. Rinse collection container and repeat test on other rows if necessary.

DRY INSECTICIDE APPLICATION RATES
APPROXIMATE POUNDS/ACRE AT 5 MPH FOR VARIOUS ROW WIDTHS

Meter Setting	30" Rows	36" Rows	38" Rows
CLAY GRANULES			
10	4.9	4.1	3.9
11	5.4	4.5	4.3
12	6.1	5.1	4.8
13	6.9	5.7	5.4
14	7.7	6.4	6.0
15	8.5	7.1	6.7
16	9.6	8.0	7.6
17	10.7	8.9	8.4
18	11.4	9.5	9.0
19	13.1	10.9	10.3
20	14.2	11.8	11.2
21	15.5	12.9	12.3
22	16.4	13.7	12.9
23	17.2	14.3	13.6
24	18.8	15.7	14.9
25	20.9	17.4	16.5
26	23.0	19.2	18.1
27	24.1	20.0	19.0
28	25.4	21.2	20.1
29	27.8	23.2	22.0
30	29.6	24.7	23.4
SAND GRANULES			
5	2.9	2.4	2.3
6	4.9	4.0	3.8
7	5.3	4.4	4.2
8	6.3	5.3	5.0
9	7.8	6.5	6.1
10	8.9	7.4	7.0
11	10.2	8.5	8.0
12	11.2	9.3	8.8
13	12.6	10.5	10.0
14	14.1	11.7	11.1
15	15.5	12.9	12.3
16	17.5	14.6	13.8
17	19.4	16.2	15.3
18	21.8	18.2	17.2
19	24.3	20.2	19.1
20	25.7	21.4	20.3
21	27.6	23.0	21.8
22	29.6	24.7	23.4
23	32.0	26.7	25.3
24	34.4	28.7	27.2
25	36.9	30.7	29.1

NOTE: Chart represents average values and should be used only as a starting point. Granular chemical flows through meter opening at a nearly uniform rate regardless of roller speed. Your actual rate will vary depending on insecticide, planting speed, and plant population. Planting speed/ground speed has the greatest effect on application rate.

Field check your actual rate with insecticide you are using at speed and population you will be planting. See "Checking Granular Chemical Application Rate" in Machine Operation section for more information..

DRY HERBICIDE APPLICATION RATES
APPROXIMATE POUNDS/ACRE AT 5 MPH FOR VARIOUS ROW WIDTHS

CLAY GRANULES

Meter Setting	30" Rows	36" Rows	38" Rows
10	4.7	3.9	3.7
11	5.2	4.4	4.1
12	5.8	4.9	4.6
13	6.5	5.4	5.1
14	7.3	6.1	5.7
15	8.2	6.9	6.5
16	9.0	7.5	7.1
17	9.9	8.2	7.8
18	10.7	8.9	8.4
19	11.6	9.7	9.2
20	12.6	10.5	10.0
21	13.6	11.3	10.7
22	14.6	12.1	11.5
23	15.7	13.1	12.4
24	17.0	14.1	13.4
25	18.1	15.1	14.3
26	19.4	16.2	15.3
27	20.9	17.4	16.5
28	22.6	18.8	17.8
29	24.3	20.2	19.1
30	26.7	22.2	21.1

NOTE: Chart represents average values and should be used only as a starting point. Granular chemical flows through given meter opening at a nearly uniform rate regardless of roller speed. Your actual rate will vary depending on specific herbicide, planting speed, and plant population. Planting speed/ground speed has the greatest effect on application rate.

Field check your actual rate with herbicide you are using at speed and population you will be planting. See "Checking Granular Chemical Application Rate" in Machine Operation section for more information.

LUBRICATION

Following pages show locations of all lubrication points. Proper lubrication of moving parts helps ensure efficient operation of your Kinze planter and prolongs the life of friction producing parts.

LUBRICATION SYMBOLS

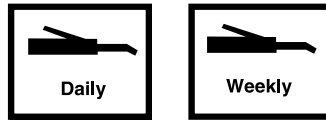

Lubricate at frequency indicated with SAE multipurpose grease.



Lubricate at frequency indicated with high quality SAE 10 weight oil or spray lubricant.

SEALED BEARINGS

Sealed bearings are used on your Kinze planter to provide trouble free operation.

These are located on drive shafts, row units, and transmission bearings. Sealed bearings are lubricated for life and are not serviceable.

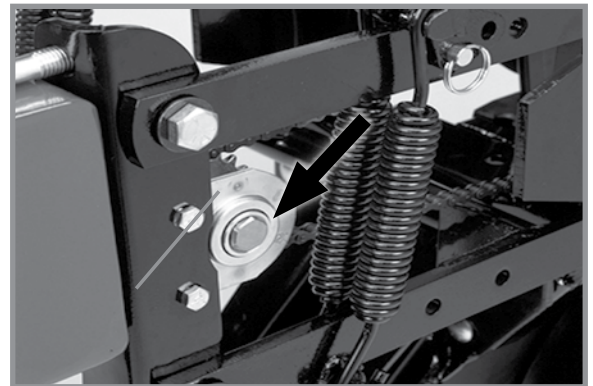

Sealed bearing (Typical)

WRAP SPRING WRENCH ASSEMBLY

1. Remove ¼"-20 x ½" cap screw securing idler assembly to wrap spring wrench tightener shaft and
2. Remove wrap spring wrench from planter.
3. Tip wrap spring wrench on its side and lubricate with a high quality spray lubricant. Lubricant must be absorbed into wrap spring area.
4. Reinstall wrap spring wrench on planter.



Wrap spring wrench lubrication

AIR CLUTCH LUBRICATION

Lubricate air clutches every 75-100 hours.

Remove Phillips head screw and spray a 1-2 second burst of silicone spray into each clutch. Reinstall screw.

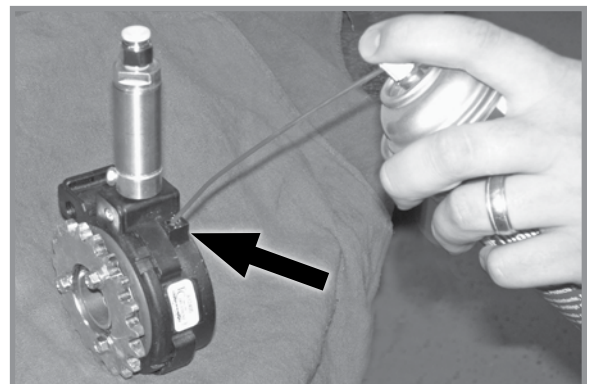

Air clutch lubrication

DRIVE CHAINS

Lubricate all transmission and drive chains daily with a high quality chain lubricant. Extreme operating conditions such as dirt, temperature, or speed may require more frequent lubrication. If a chain becomes stiff, it should be removed, soaked, and washed in solvent to loosen and remove dirt from joints. Soak chain in oil so lubricant can penetrate between rollers and bushings.

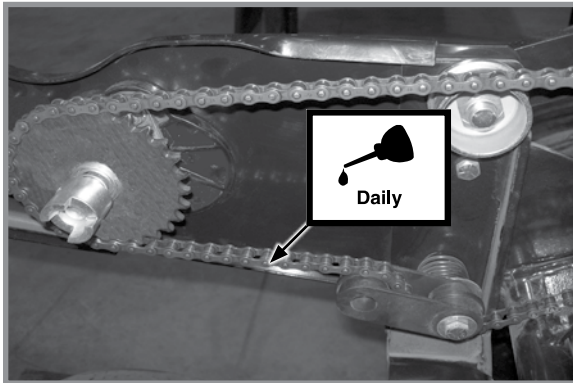

Pull row unit drive chains

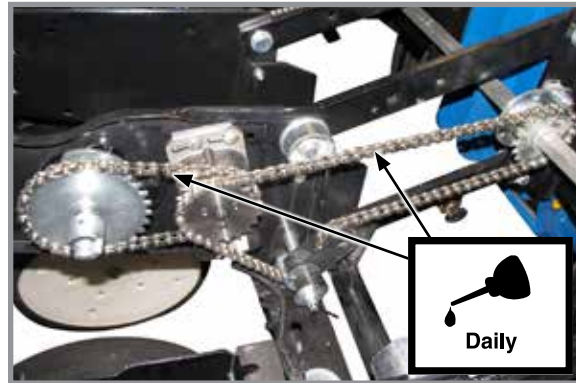

Row Unit Electric Clutches

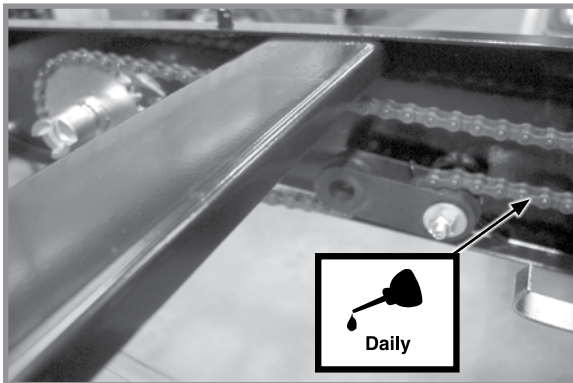

Row unit granular chemical drive chains

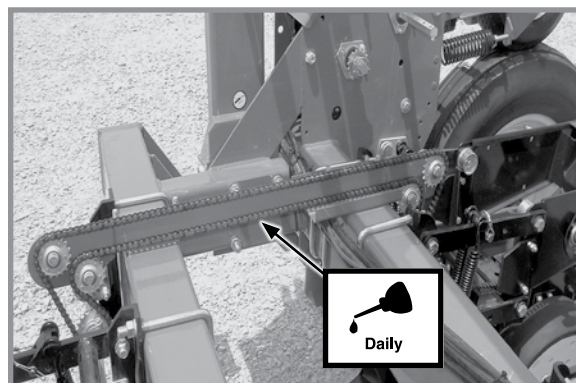

Interplant package drive chains

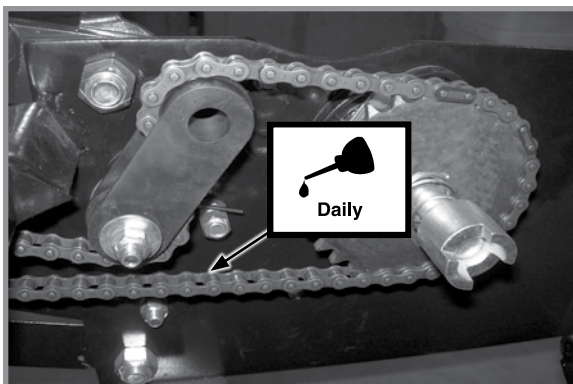

Push row unit drive chains

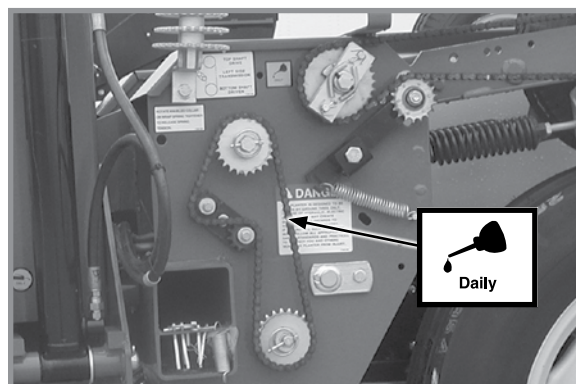

**Contact wheel drive chains
Seed rate transmission drive chains**

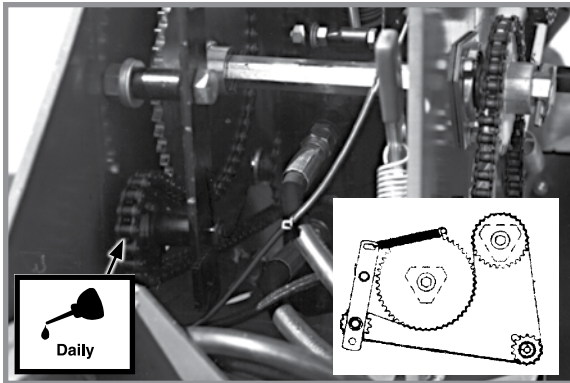

Inner wheel module drive chains

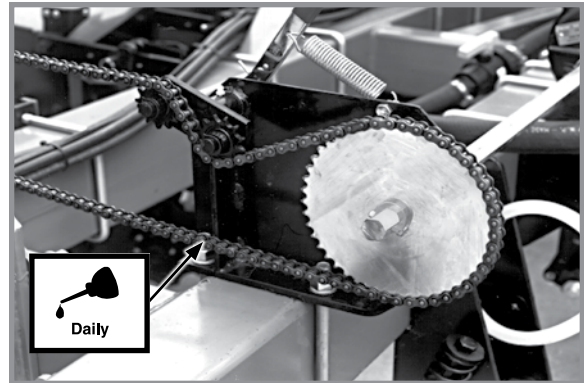

Liquid fertilizer drive chains (Squeeze pump)

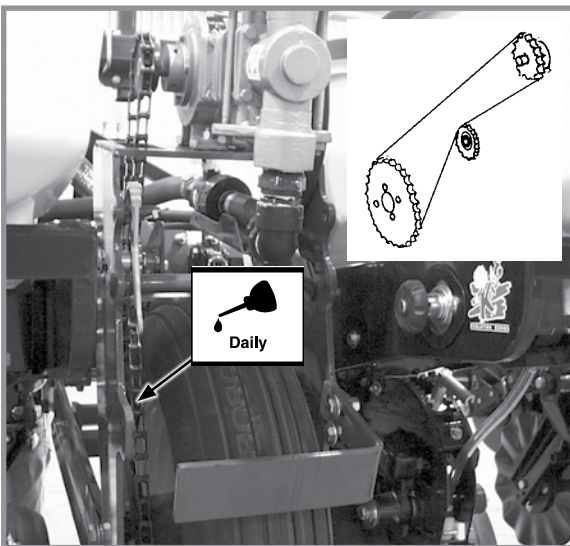

Piston pump ground drive chain

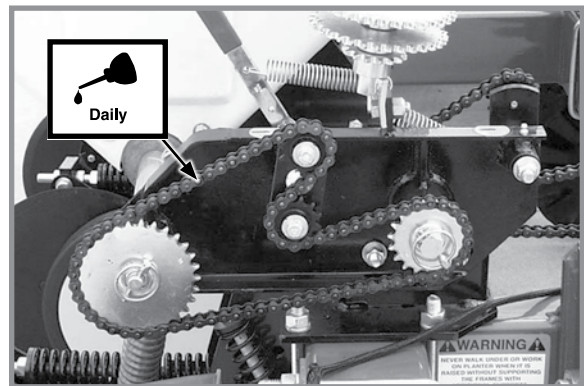

Dry fertilizer drive chains

BUSHINGS

Lubricate bushings at frequency indicated.

Check each bolt for proper torque. If bolt is loose, removed it and inspect bushing for cracks and wear. Replace bushing if necessary. Use **only hardened flat washers**. Replace damaged flat washers with proper part. Torque hardware to 130 ft-lb (176.2 N-m).

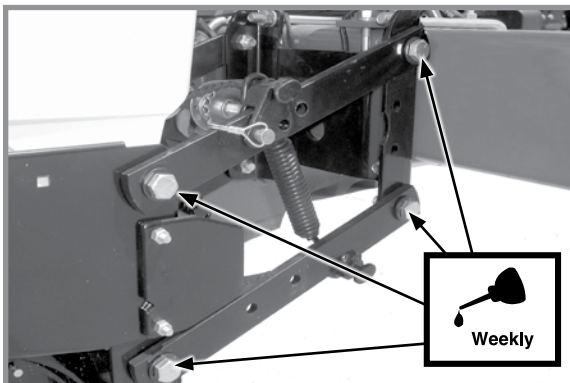

Pull row unit and/or push row unit parallel linkages (8 per row)

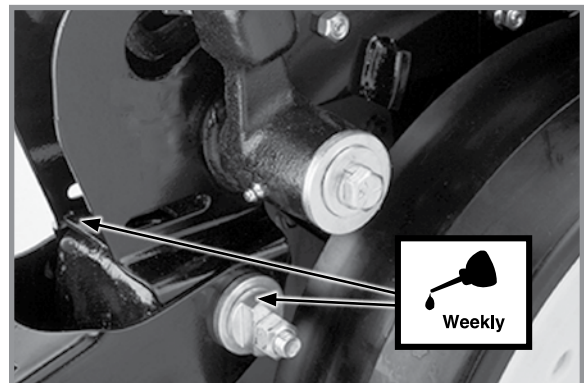

Row unit "v" closing wheel, covering discs/ single press wheel and/or drag closing wheel eccentric bushings (2 per row)

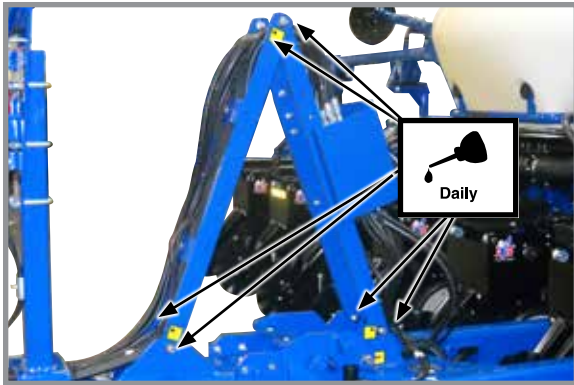

Hose take-up (6 locations)

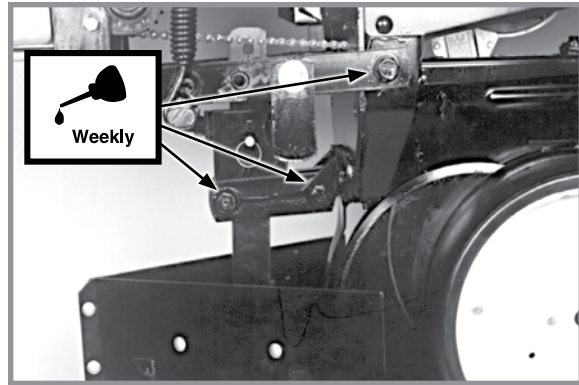

Bed leveler parallel linkages (6 per row)

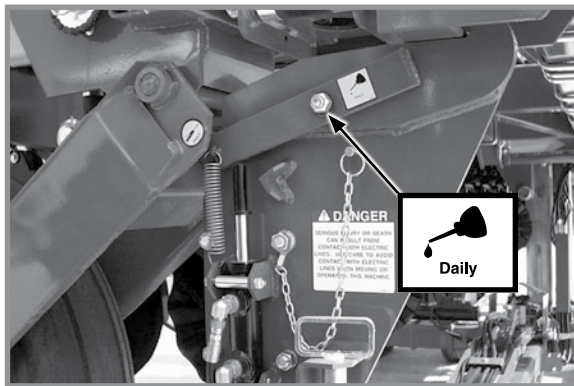

Transport latch (1 location)

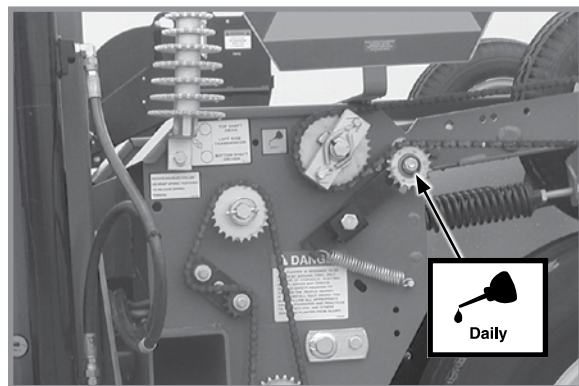

Contact wheel arm (2 per wheel assembly)

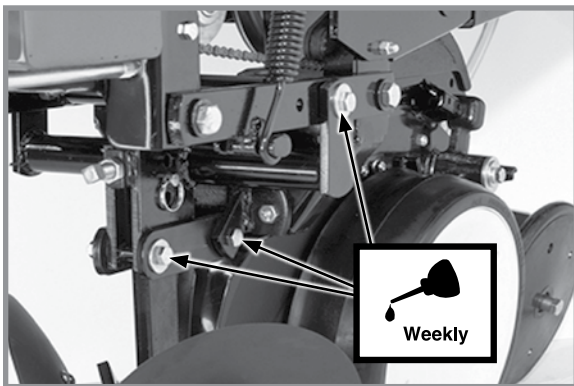

Row unit mounted disc furrower parallel linkages (6 per row)

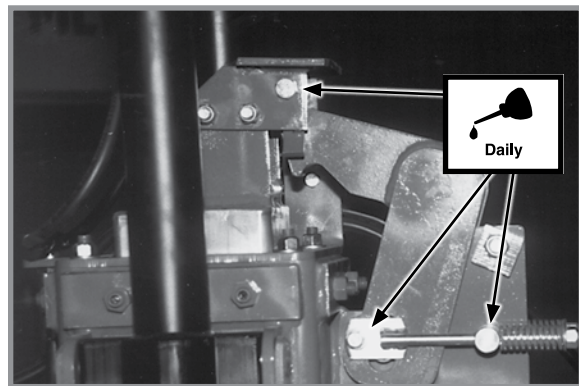

Safety hook at top of center section

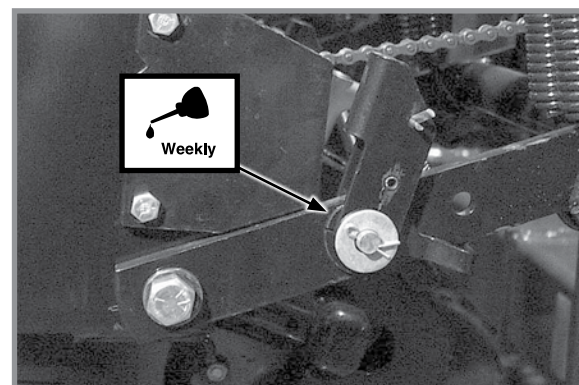

Interplant push row unit lockups - 2 per row

CENTER POST

NOTICE

Any oil or grease on center post and poly wear pads will attract dirt and accelerate wear. Do not lubricate center post and poly wear pads.

Center post is clad with stainless steel. Keep stainless steel surface clean and free of any lubrication to prolong service life.

See "Wear Pad Adjustment/Replacement" for more information.

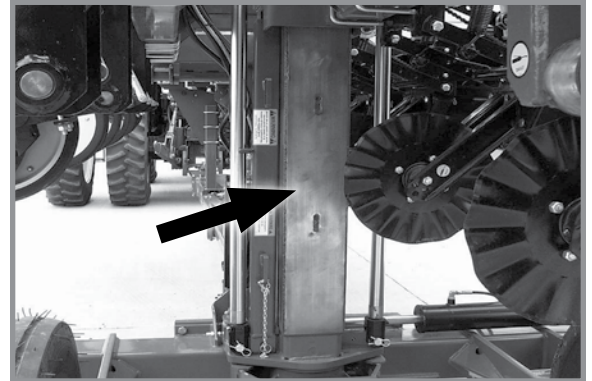

Center post

U-JOINT SLIDES

Lubricate all U-joint slides daily with a high quality lubricant.

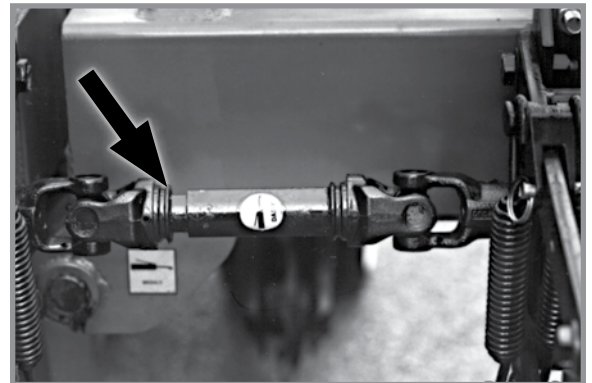

U-joint slide

LIQUID FERTILIZER PISTON PUMP CRANKCASE OIL LEVEL

Check crankcase oil daily and maintain at oil level check plug. Fill as needed with EP 90 weight gear oil. Total oil capacity is approximately $\frac{3}{4}$ pint.

Refer to operator and instruction manual supplied with pump and flow divider for more information.

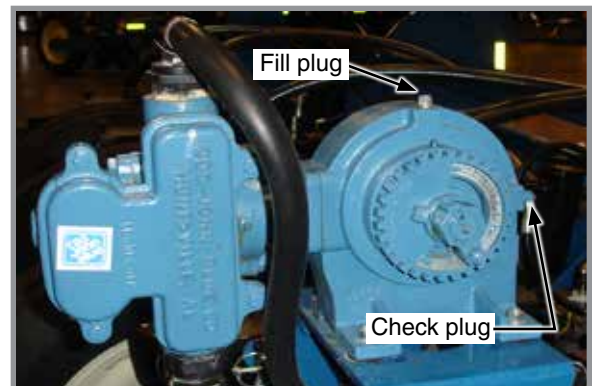

Piston pump oil fill and check plug locations

PTO PUMP SHAFT COUPLING (TRACTOR MOUNTED PTO PUMP AND OIL COOLER)

NOTE: Clean and grease PTO shaft coupling each time pump is installed.

NOTE: Apply coating of high-speed industrial coupling grease, such as Chevron® Coupling Grease, that meets AGMA CG-1 and CG-2 Standards to extend shaft spline life.

Chevron® trademark is owned by Chevron Products Company. AGMA is the acronym for the American Gear Manufacturers Association.



1 1/8"-21 spline PTO pump shown

WHEEL BEARINGS

All drive, transport, and marker hub wheel bearings should be repacked annually and checked for wear.

1. Raise wheel off ground.
2. Check for bearing endplay by moving wheel side to side.
3. Rotate wheel to check for bearing roughness. If bearings sound rough, remove hub and inspect bearings.

NOTE: To repack wheel hubs, follow procedure outlined for wheel bearing replacement except bearings and bearing cups are reused.

GREASE FITTINGS

Parts equipped with grease fittings should be lubricated at frequency indicated with an SAE multipurpose grease. Clean fitting thoroughly before using grease gun. Frequency of lubrication recommended is based on normal operating conditions. Severe or unusual conditions may require more frequent attention.

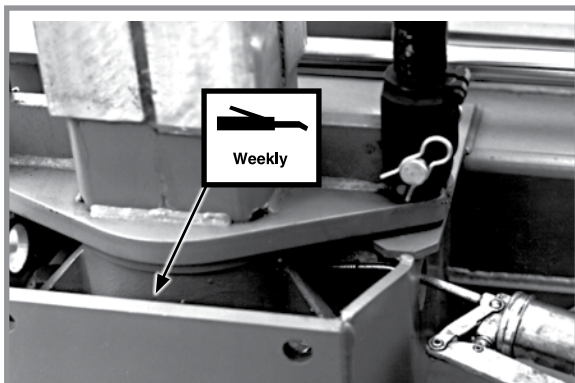

Center Pivot - 1

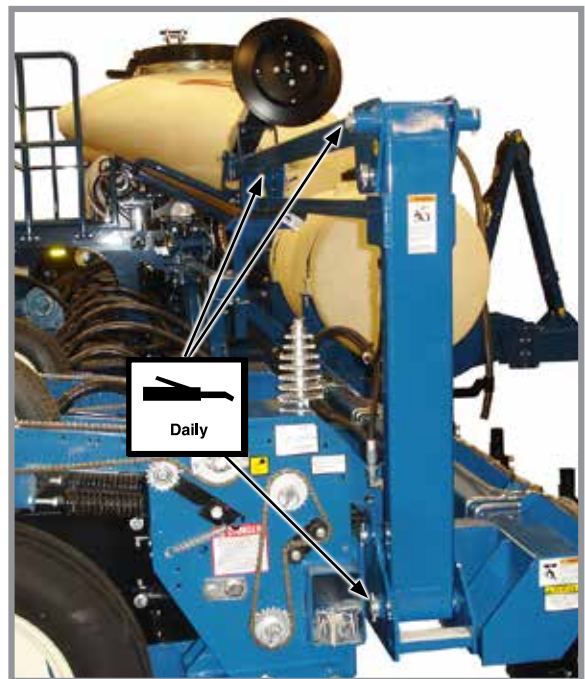

Row marker assemblies - 3 per assembly

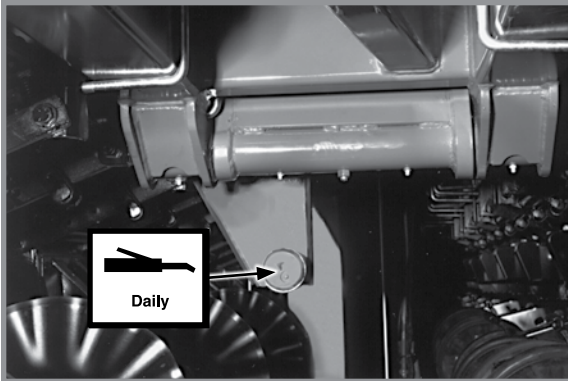

Cam follower - 1 per follower

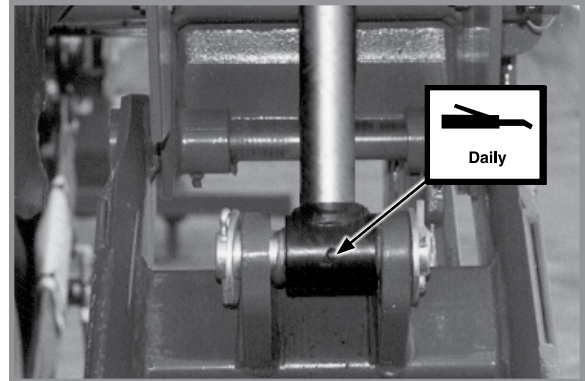

Wing lift cylinders - 1 per cylinder

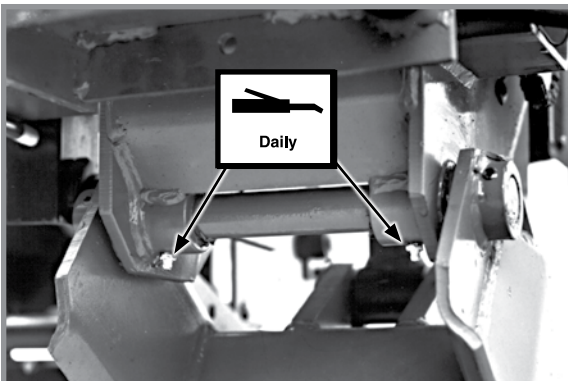

Wing wheel pivot - 2 per wheel module

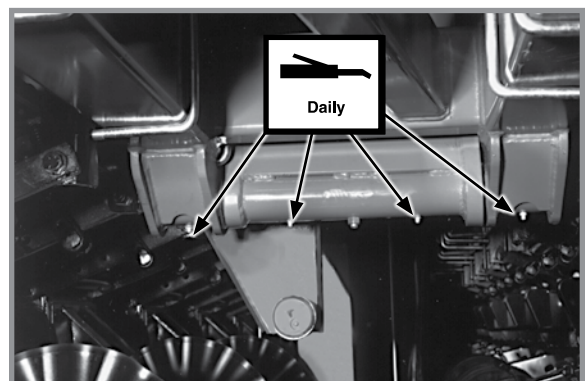

Wing hinges - 4 per wing

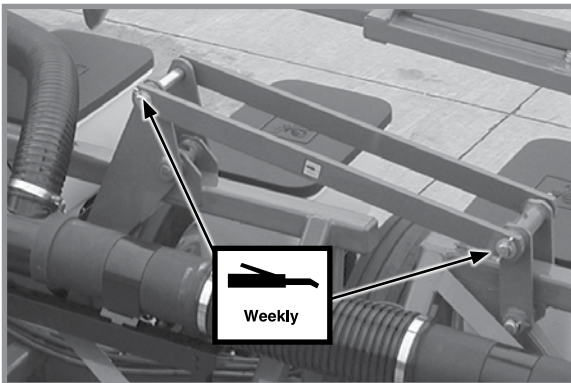

Wing locks - 3 per wing



Transport wheel bearings - 1 per hub

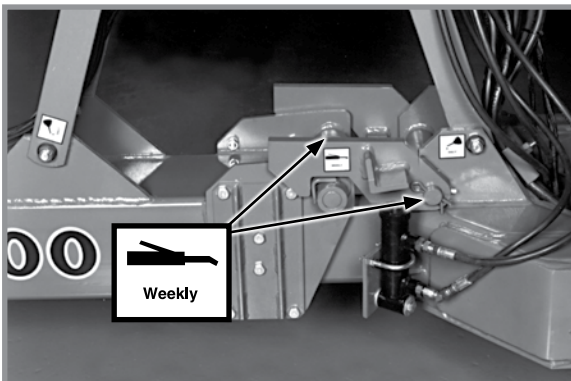

Tongue hook - 2

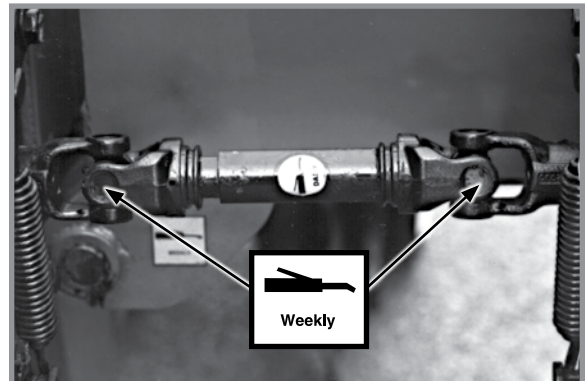

U-joints - 2 per hinge area

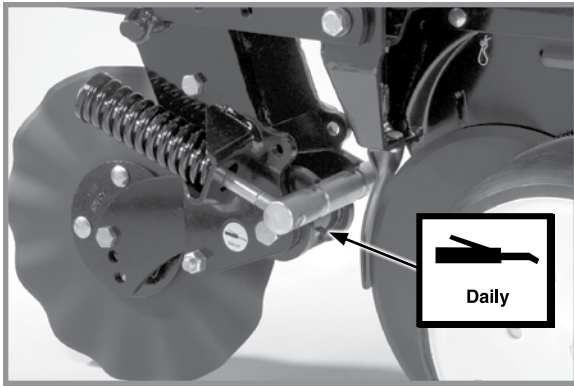

Frame mounted Coulter - 1 Per Arm

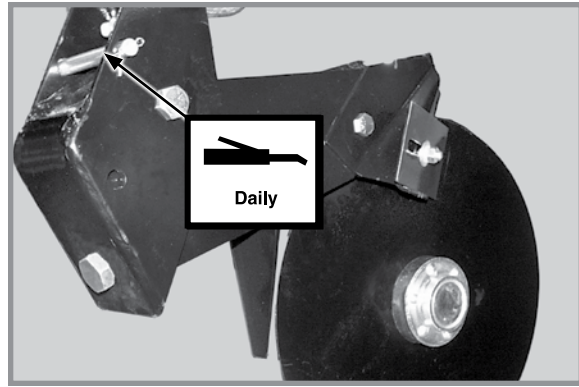

Double disc fertilizer opener - 1

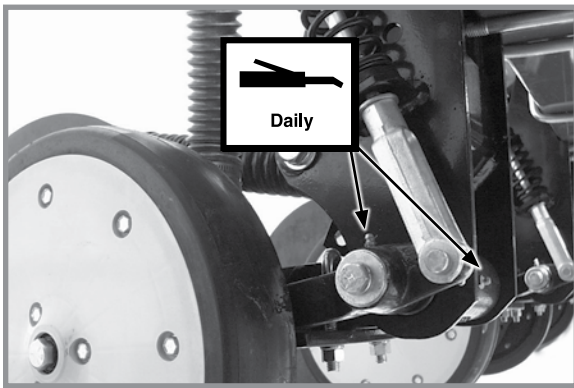

HD single disc fertilizer opener - 2
(Located on wheel arm and opener mount)

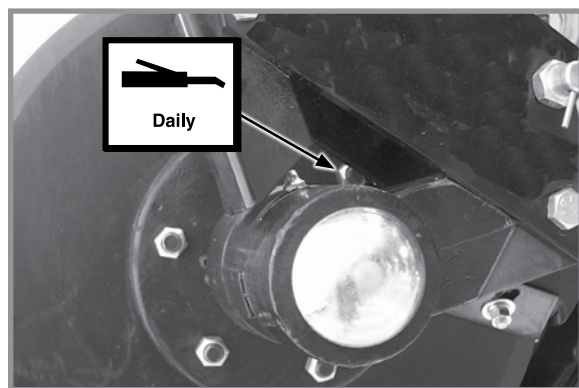

HD single disc fertilizer opener - 1
(Located on disc opener spindle hub)

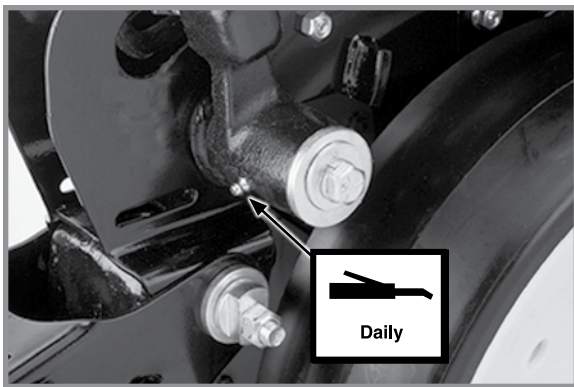

Gauge wheel arms - 1 per arm
(Seals in gauge wheel arm are installed with lip facing out to allow grease to purge dirt away from seal. Pump grease into arm until fresh grease appears between washers and arm.)

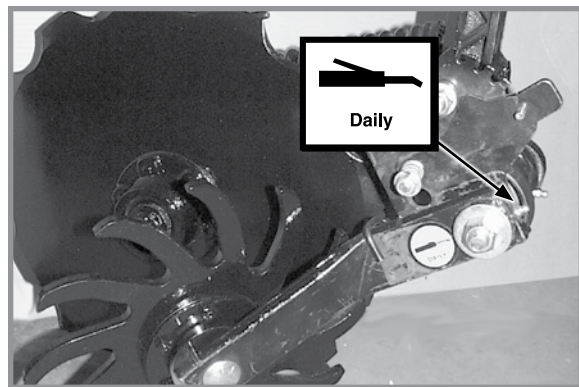

Residue wheel attachment for use with
notched single disc fertilizer opener - 1

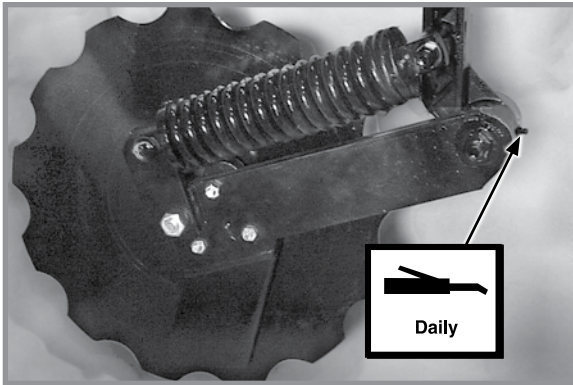

Notched single disc fertilizer opener - 1

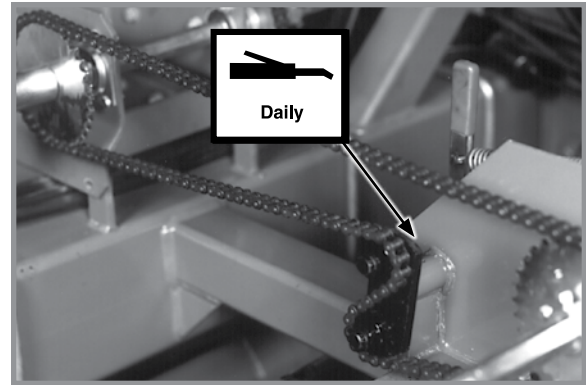

Squeeze pump drive plate - 1 per idler

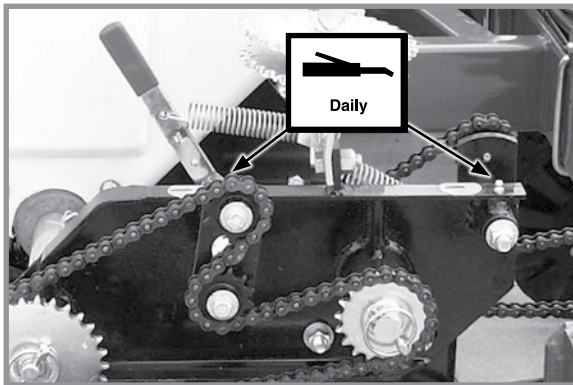

Dry fertilizer transmission - 2 per transmission

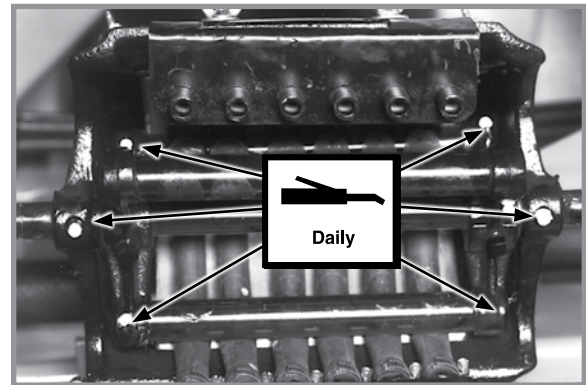

Squeeze pump - 8 per pump
NOTE: Grease fittings are on each end of roller assemblies. Rotate pump for access.

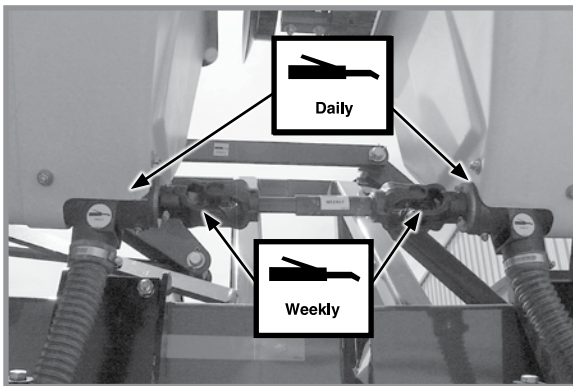

Dry fertilizer hopper - 2 per hopper
U-joint - 1 per hinge area

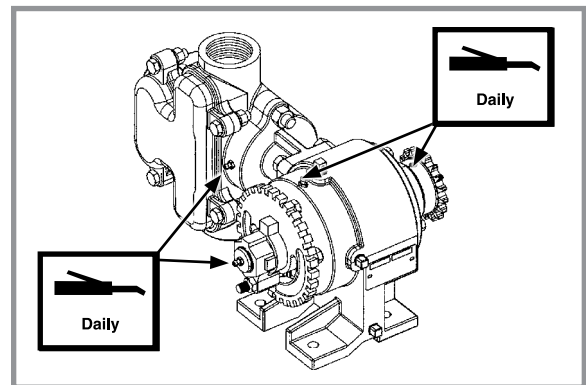

Liquid fertilizer piston pump - 4
NOTE: Fill on outboard stuffing box until lubricant seeps out of drain hole in bottom.

MOUNTING BOLTS AND HARDWARE

! WARNING



Parts separation can result in death, serious injury, and damage to property and equipment. Check all hardware is tight before operating planter the first time. Check all hardware again after first 50 hours of operation and beginning of each planting season.

NOTICE

Over-tightening hardware can reduce its shock load capacity and cause equipment failure.

Hardware used on Kinze planters are Grade 5 (high strength) unless otherwise noted. Grade 5 cap screws are marked with three radial lines on the head. Hardware must be replaced with equal size, strength, and thread type.

TORQUE VALUES CHART - PLATED HARDWARE

Diameter	Grade 2 (No marks) 		Grade 5 (3 marks) 		Grade 8 (6 marks) 	
	Coarse	Fine	Coarse	Fine	Coarse	Fine
1/4"	50 in-lb	56 in-lb	76 in-lb	87 in-lb	9 ft-lb	10 ft-lb
5/16"	8 ft-lb	9 ft-lb	13 ft-lb	14 ft-lb	18 ft-lb	20 ft-lb
3/8"	15 ft-lb	17 ft-lb	23 ft-lb	26 ft-lb	33 ft-lb	37 ft-lb
7/16"	25 ft-lb	27 ft-lb	37 ft-lb	41 ft-lb	52 ft-lb	58 ft-lb
1/2"	35 ft-lb	40 ft-lb	57 ft-lb	64 ft-lb	80 ft-lb	90 ft-lb
9/16"	50 ft-lb	60 ft-lb	80 ft-lb	90 ft-lb	115 ft-lb	130 ft-lb
5/8"	70 ft-lb	80 ft-lb	110 ft-lb	125 ft-lb	160 ft-lb	180 ft-lb
3/4"	130 ft-lb	145 ft-lb	200 ft-lb	220 ft-lb	280 ft-lb	315 ft-lb
7/8"	125 ft-lb	140 ft-lb	320 ft-lb	350 ft-lb	450 ft-lb	500 ft-lb
1"	190 ft-lb	205 ft-lb	480 ft-lb	530 ft-lb	675 ft-lb	750 ft-lb
1 1/8"	265 ft-lb	300 ft-lb	600 ft-lb	670 ft-lb	960 ft-lb	1075 ft-lb
1 1/4"	375 ft-lb	415 ft-lb	840 ft-lb	930 ft-lb	1360 ft-lb	1500 ft-lb
1 3/8"	490 ft-lb	560 ft-lb	1100 ft-lb	1250 ft-lb	1780 ft-lb	2030 ft-lb
1 1/2"	650 ft-lb	730 ft-lb	1450 ft-lb	1650 ft-lb	2307 ft-lb	2670 ft-lb

NOTE: Torque unplated hardware and bolts with lock nuts approximately 1/3 higher than above values. Torque bolts lubricated prior to installation to 70% of value shown in chart.

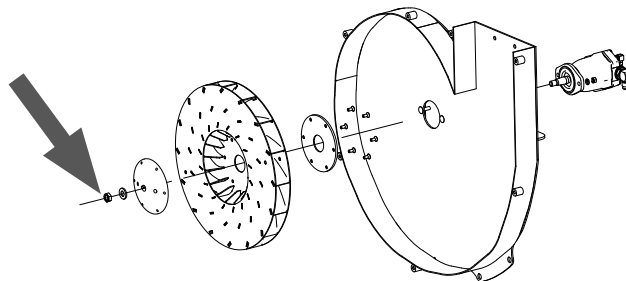

NOTE: Torque EdgeVac fan impeller assembly to motor shaft 5/8"-18 hex jam nut 50 ft-lb (67.8 N-m).

Cylinder Rod Piston Retaining Nut Torque Chart

	Non-Nylock Nut	Nylock Nut
1/2"-20	55-70 ft-lb (75-95 N-m)	45-55 ft-lb (61-75 N-m)
3/4"-16	115-125 ft-lb (156-169 N-m)	100-115 ft-lb (136-156 N-m)
7/8"-14	150-180 ft-lb (203-244 N-m)	130-150 ft-lb (176-203 N-m)
1"-14	275-330 ft-lb (373-447 N-m)	250-275 ft-lb (339-373 ft-lb)
1 1/8"-12	300-375 ft-lb (407-508 N-m)	275-300 ft-lb (373-407 N-m)
1 1/4"-12	300-375 ft-lb (407-508 N-m)	275-300 ft-lb (373-407 N-m)

TORQUE VALUES- Pneumatic Down Pressure

Diameter	Torque Value
1/8" NPT	120 in-lb Maximum
1/2"-13	180 in-lb Maximum
3/4"-16	180 in-lb Maximum

NOTE: Use these torque values with pneumatic down pressure components.

SPECIAL TORQUE VALUES

Row unit parallel linkage bushing hardware	130 ft-lb (176 Nm)
5/8" No till coulter spindle hardware	120 ft-lb (162 Nm)
Center section transport tire lug nuts	180 ft-lb
Wing ground drive tire lug bolts	90 ft-lb

TIRE SERVICING

! WARNING

Explosive separation of rim and tire parts can result in death or serious injury. Rim and tire servicing, improper use of rims and tires, or worn or improperly maintained tires can cause tire explosion.

To prevent tire explosions:

- Maintain proper tire pressure. Inflating a tire above or below the recommended pressure can cause tire damage.
- Mount tires only by properly trained personnel using proper equipment.
- Replace tires with cuts or bubbles. Replace damaged rims. Replace missing lug bolts and nuts.
- Do not weld or heat wheel assembly. Heating increases tire pressure.

INFLATION SPECIFICATIONS

! WARNING

Over-inflation of tires can result in explosive separation of rim and tire and cause death or serious injury. Different size rims are designed for different tire pressures. Inflate to correct pressure for specific rim size.

Do not exceed the following maximum pressures:

- Rims stamped with "224": 75 psi (517.1 kPa) maximum pressure.
- Rims stamped with "276": 100 psi (689.4 kPa) maximum pressure.

Transport (center section) 255-70R 22.5 ("224" rim)
 75 psi (517.1 kPa) recommended/75 psi (517.1 kPa) max.

Transport (center section) 255-70R 22.5" ("276" rim)
 75 psi (517.1 kPa) recommended/100 psi (689.4 kPa) max.

Ground drive (wings) 7.50" x 20" 40 psi (275.7 kPa)

Contact drive - 4.80" x 8" 50 psi (344.7 kPa)

Liquid fertilizer piston pump 7.60" x 15" 40 psi (275.7 kPa)

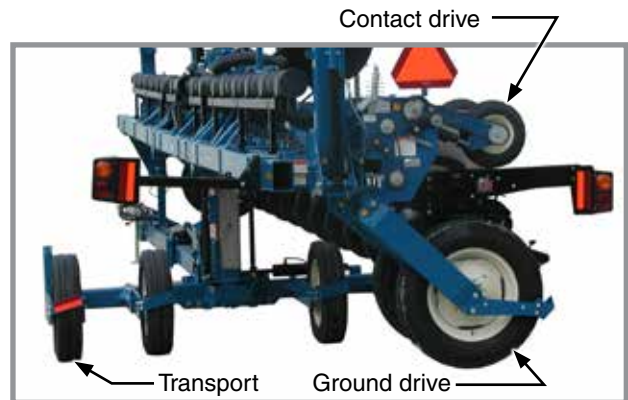

FINGER PICKUP SEED METER INSPECTION/ADJUSTMENT

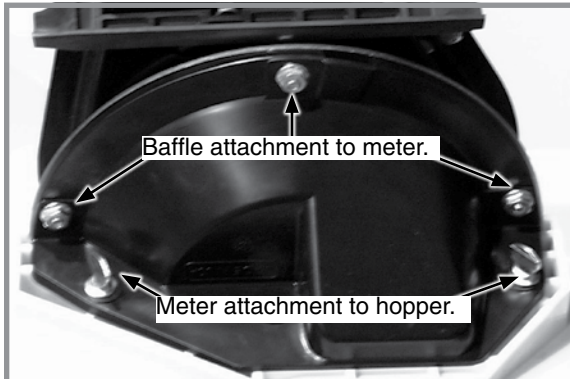

Removing meter and baffle

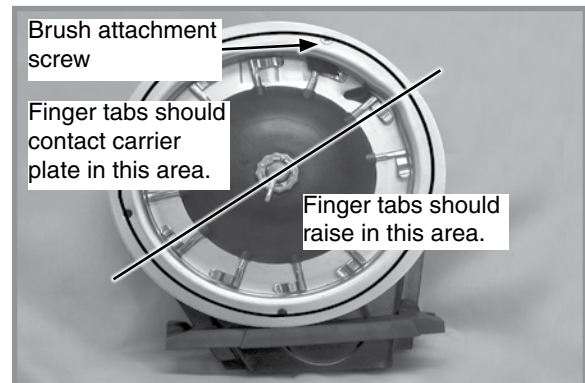

Proper finger operation

1. Remove two thumbscrews and meter from seed hopper and remove three cap screws and baffle from meter assembly.
2. Rotate seed meter drive by hand to ensure springs are holding tabs of fingers against carrier plate and fingers raise in correct area as shown in above photo.

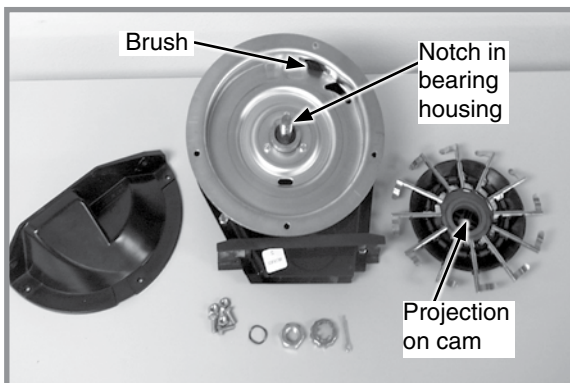

Finger pickup meter parts

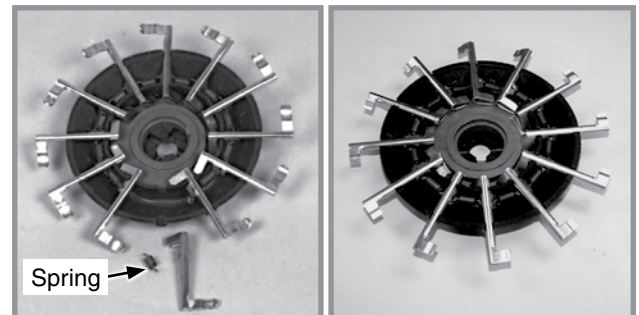

Corn Finger Assembly
(Position Spring Opening
Toward Holder)

**Oil Sunflower Finger
Assembly**

Buildup of debris or chaff may prevent proper finger operation and requires disassembly and cleaning of finger pickup meter.

1. Remove cotter pin, cover nut and adjusting nut and wave washer (If applicable) from drive shaft.
2. Carefully lift finger holder with fingers and cam off shaft and clean.
3. Check brush for wear and replace if necessary or after every 100 acres per row of operation (Approximately 800 acres of corn or sunflowers on a 8 row machine or 1200 acres on an 12 row machine).

NOTE: It is not necessary to remove finger holder to replace brush.

4. Remove springs from fingers and remove finger from holder by lifting it out of friction fit slot. Life expectancy of these parts is about 600-900 acres per row of operation under average conditions.
5. Reassemble meter in reverse order after cleaning and replacing defective parts. Make sure open end of spring loop is toward inside of finger holder when replacing fingers.
6. Install fingers in holder so holder is flush with carrier plate when assembled. A cam projection aligns with a mating notch in bearing housing to ensure proper operation when assembled.

7. Check indentations on carrier plate for wear before installing finger holder on carrier plate. Excessive wear of carrier plate at indentations will cause over planting especially with small sizes of seed. Inspect carrier plate annually. Life expectancy should be 250-300 acres per row of operation under average conditions.
8. Install wave washer and adjusting nut with finger holder flush against carrier. Tighten adjusting nut to fully compress wave washer. Back off nut $\frac{1}{2}$ to 2 flats to obtain rolling torque of 22 to 25 inch pounds.
9. Turn finger holder by hand to make sure it is firmly against carrier plate, but can be rotated with moderate force.
10. Install cover nut and cotter pin. Reinstall baffle.

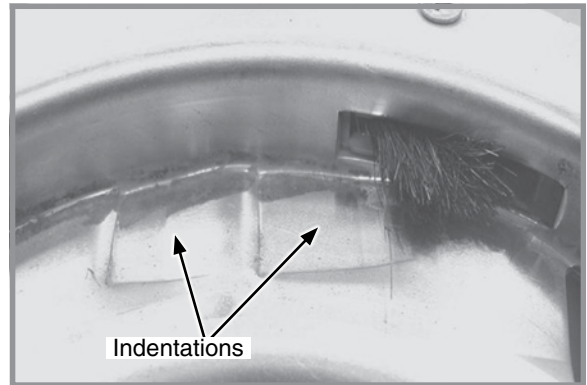
**Worn carrier plate**

NOTE: Check adjusting nut tightness on each unit after first day of use and periodically thereafter.

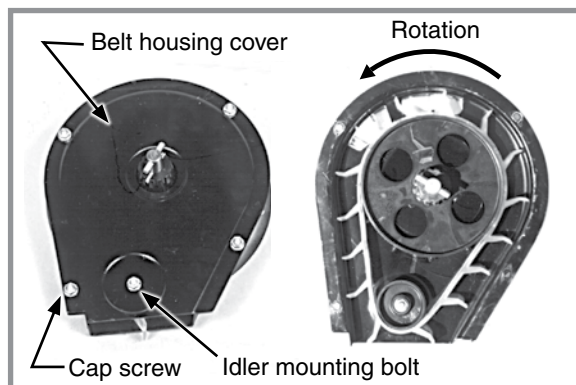
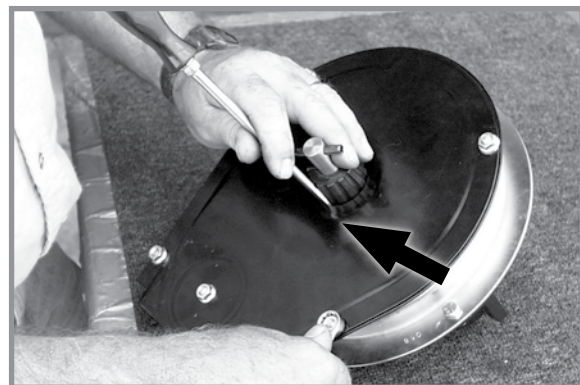
**Belt idler****Centering belt housing cover**

Remove four cap screws around edge of housing cover and nut from belt idler mounting bolt. Paddles must be correctly oriented as shown above. If belt is replaced. A diagram molded into drive sprocket shows correct orientation.

NOTICE

Do not over-tighten hardware or components may be damaged.

Reinstall housing cover. **DO NOT TIGHTEN** hardware. Wedge a screwdriver between sprocket hub and housing cover as shown above. Pry cover down until centered on belt housing and tighten hardware. Rotate meter drive shaft and check idler alignment. Seed belt should "run" centered on idler or with only slight contact with belt housing or cover.

CLEANING FINGER PICKUP SEED METER FOR STORAGE

1. Disassemble meter and blow out any foreign material.
2. Wash **ONLY** in mild soap and water. Do not use gasoline, kerosene, or any other petroleum based product. Dry thoroughly.
3. Coat lightly with a rust inhibitor.
4. Rotate finger assembly so finger does not touch brush.
5. Reassemble and store in a dry, rodent-free location.

BRUSH-TYPE SEED METER MAINTENANCE

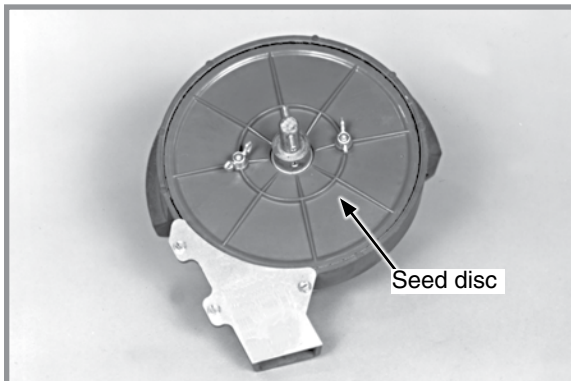

Brush-type seed meter seed disc installed

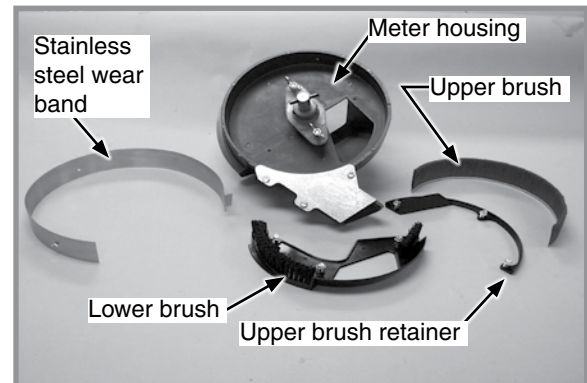

Brush-type seed meter parts

Use clean, high quality seed. Damaged or cracked seed, hulls, or foreign materials can become lodged in upper brush and greatly reduce meter accuracy. Remove seed disc daily and check for buildup of foreign material on seed disc, particularly in seed loading slots. Clean disc by washing it with soap and water. Check for cracked seed, hulls, etc. lodged between brush retainer and stainless steel wear band which can greatly reduce accuracy of the meter because upper brush will not be able to retain seed in seed disc pocket. Thoroughly clean brush areas of meter housing.

SEED DISC WEAR

Most seed disc wear is found in the agitation groove area (area between seed loading slots). Wear affects planting accuracy at high RPM. Lay a straight edge across disc surface at agitation groove area and measure gap between disc and straight edge. If agitation groove areas are worn in excess of .030" and accuracy starts to drop off at higher meter RPM, replace seed disc. Estimated seed disc life expectancy under normal operating conditions is approximately 200 acres per row. Severe operating conditions such as dust, lack of lubrication or abrasive seed coating could reduce seed disc life expectancy to under 100 acres per row.

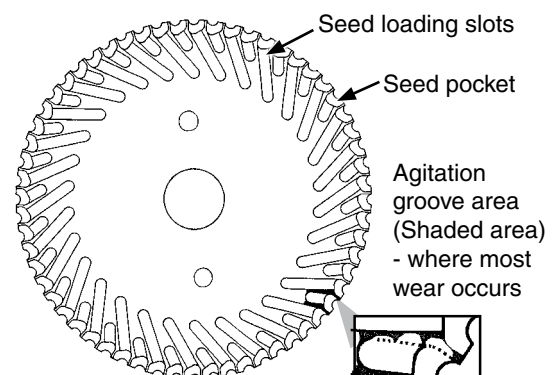

STAINLESS STEEL WEAR BAND

NOTICE

If wear band wears through or if meter is used without wear band in place, meter housing may be damaged.

Stainless steel wear band protects meter housing from wear and is .030" thick. Replace wear band when there is approximately .020" of wear in primary wear area. Estimated life expectancy of stainless steel wear band is 240-800 acres per row.

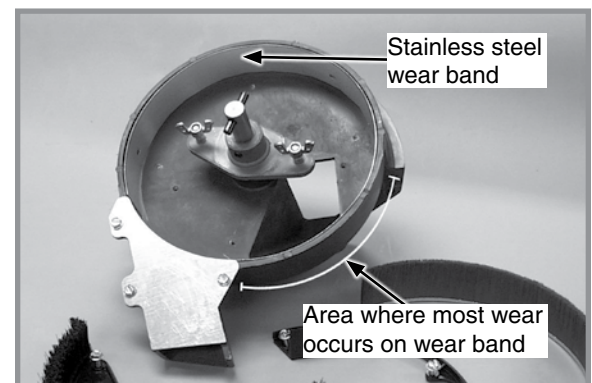

Stainless steel wear band

UPPER BRUSH

Upper brush holds seed in seed disc pocket in seed retention area. Brush must apply enough pressure against seed in seed disc pocket as disc rotates through seed retention area to prevent seed from dropping out of disc pocket. A damaged spot, excessive brush wear, or foreign material lodged in brush may greatly reduce meter performance.

Replace upper brush at 120-400 acres per row of use or sooner if damage or excessive wear is found. Position upper brush into inner perimeter of seed retention area. Make sure base of brush is tight against bottom of meter housing. Install brush retainer and three hex head screws. Tighten screws in sequence shown in photo at right.

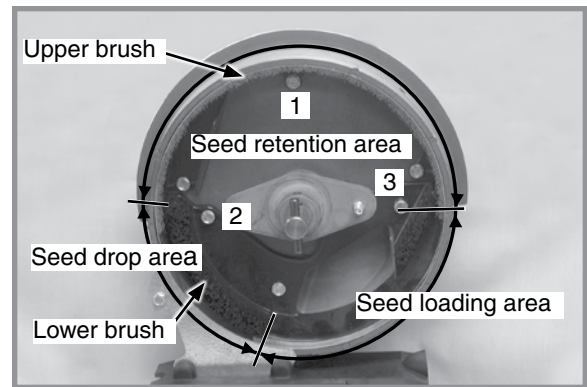

Upper brush installation

NOTE: Use GD11122 upper brush retainer for soybean and cotton discs. Use GD8237 upper brush retainer for milo/grain sorghum discs.

LOWER BRUSH

Lower brush moves seed down seed loading slots to seed pockets, isolates seed in reservoir from entering seed tube, and cleans seed loading slots. Estimated lower brush life expectancy is 240-800 acres per row. Replace lower brush if bristles are deformed or missing, or if there are cracks in brush retainer.

CLEANING BRUSH-TYPE SEED METER FOR STORAGE

1. Remove meter from seed hopper by removing two thumbscrews securing meter to hopper.
2. Remove seed disc and wash with soap and water and dry thoroughly.
3. Remove three hex head screws from brush retainer. Remove brush retainer and upper brush.
4. Remove three hex head screws from lower brush. Remove lower brush and stainless steel wear band.
5. Wash all parts and meter housing with soap and water and dry thoroughly.
6. Inspect all parts and replace worn parts.
7. Reassemble meter except for seed disc. Store meter in a dry, rodent-free space with seed disc removed.

VACUUM MANIFOLD MAINTENANCE

Dust accumulates in manifolds and hoses during normal operation. Clean manifolds annually. Abnormally dusty planting conditions may require more frequent cleaning.

1. Remove vacuum hose from each seed meter.
2. Operate vacuum fan at full hydraulic flow from tractor for two minutes to clear manifolds, hoses, and fittings of dust and debris.
3. Shut down fan and replace hoses

EDGEVAC SEED METER MAINTENANCE

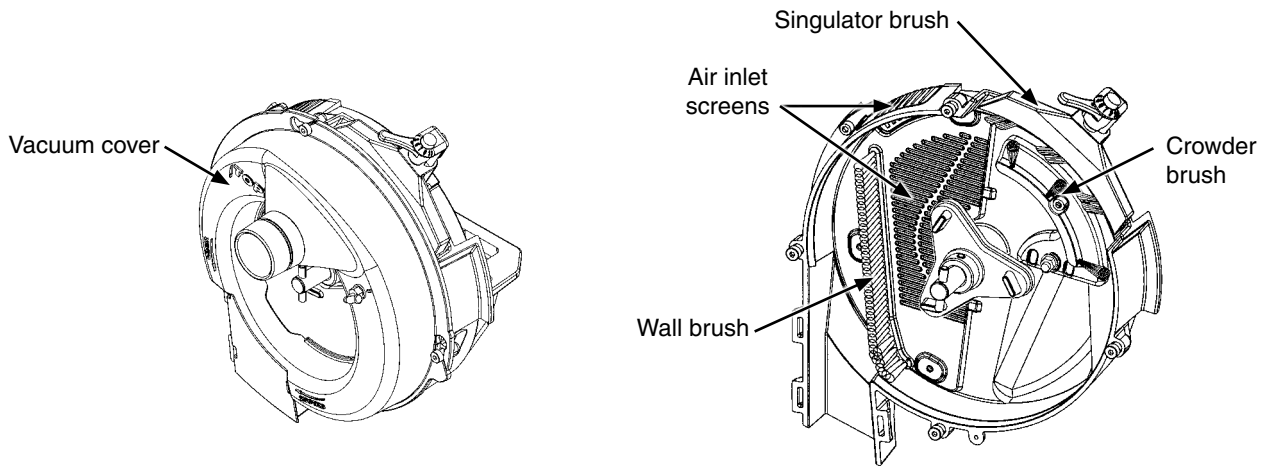

Before each planting season inspect seed discs, singulator brush, crowder brush, wall brush, and air inlet screens and clean or replace as needed.

Use clean, high quality seed for maximum meter accuracy. Damaged or cracked seed, hulls, and foreign material may become lodged in seed disc orifices and greatly reduce meter accuracy.

Inspect and clean seed discs daily checking for any buildup of foreign material and blocked orifices. If seed disc orifices are plugged frequently with seed remnants, cleanout brush or cleanout brush with ball-type ejector (if applicable) may need to be replaced. Clean seed disc by washing it with soap and water. Dry thoroughly.

Inspect singulator brush for wear after every 200 acres per row of operation. If adjustment of singulator brush does not affect meter performance or if brushes appear frayed, singulator brush may need to be replaced.

Replace seed disc or vacuum cover if abnormally high vacuum is required or if consistent operation can not be achieved.

See "Preparation For Storage" for additional EdgeVac Seed Metering System maintenance.

NOTE: Remove seed discs from meters for annual storage and store them vertically on a dowel or pipe.

EDGEVAC SEED METER CLEANOUT

Thorough seed meter cleanout is important to maintain genetic purity.

1. Disengage seed drive and remove seed hopper and meter. Lay hopper on its right side.
2. Rotate vacuum cover clockwise to align key hole slots with bolt heads. Lift off cover.
3. Remove seed disc.
4. Empty meter and hopper by allowing seed to run out of meter.
5. Inspect brushes in meter to ensure all seed is removed.
6. Replace seed disc and install vacuum cover.

NOTE: Use of damaged seed or seed containing foreign material will cause plugging of seed cell orifices and require more frequent seed meter cleanout to prevent underplanting.

CHAIN TENSION ADJUSTMENT

Drive chains have spring loaded idlers and are self-adjusting. Remove link to shorten chain if wear stretches chain and reduces spring tension. Check idler pivot points to make sure they rotate freely. See "Wrap Spring Wrench Assembly" in this section for additional information.

Additional chain links are stored inside planter frame.

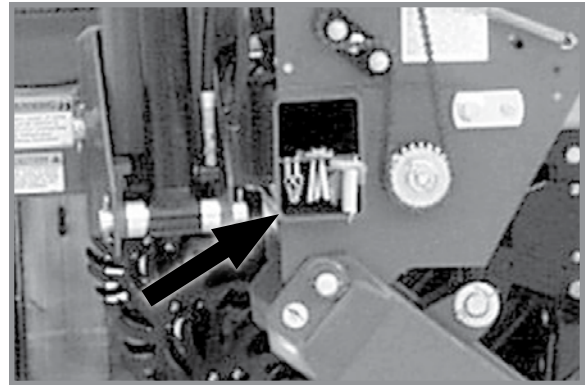

Additional chain links

DRAG CLOSING ATTACHMENT

Inspect each drag closing attachment and replace any worn or broken parts before storing planter. Check for loose hardware and tighten as needed.

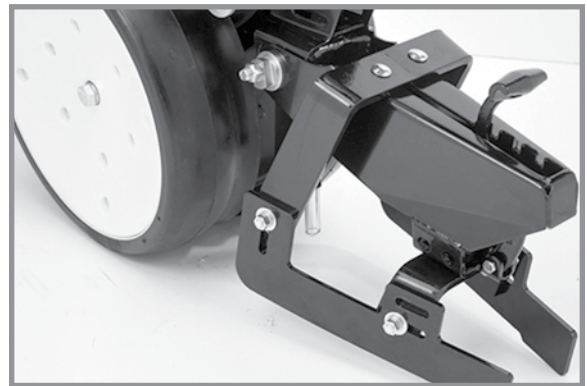

Drag Closing Attachment

GAUGE WHEEL ADJUSTMENT

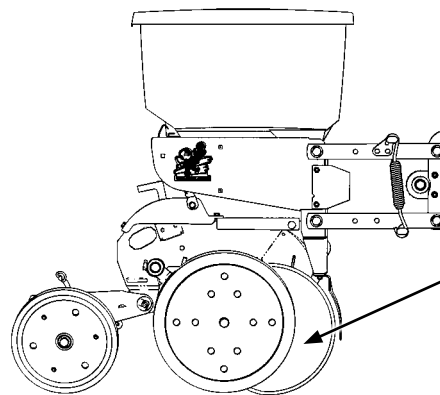
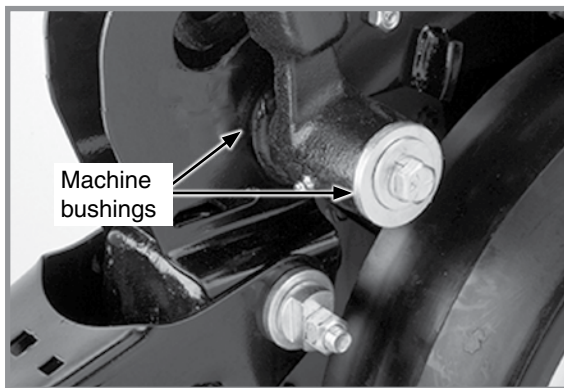

Shim gauge wheel to lightly contact opener disc blade. Check adjustment in field position.

Gauge wheel adjustment

Gauge wheels should lightly contact opener blades to prevent accumulation of dirt or trash. Gauge wheels and opener blades should turn with only slight resistance.

Add or remove machine bushings between shank and gauge wheel arm to adjust clearance between gauge wheels and opener blades. Store remaining machine bushings between gauge wheel arm and flat washer on outer side of gauge wheel arm.

NOTE: It may be desirable to space gauge wheel further from blade when operating in sticky soils.

GAUGE WHEEL ARM BUSHING/SEAL REPLACEMENT

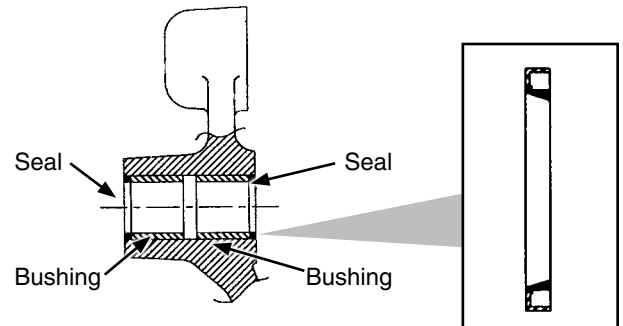
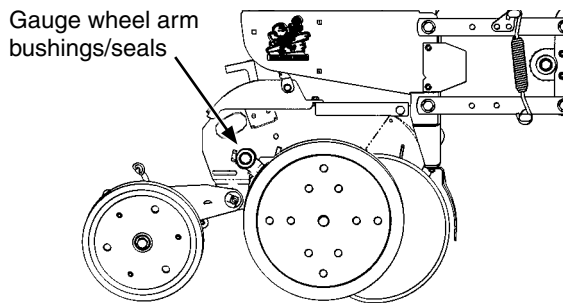

NOTE: Gauge Wheel Arm Bushing and Seal Driver Kit (G1K296) is available through your Kinze Dealer.

1. Remove gauge wheel from arm.
2. Remove gauge wheel arm from shank assembly.
3. Remove seal and bushing and discard. Clean and dry inner bore.
4. Drive/press replacement bushing inside bore of arm to a depth of .125" below flush.
5. Coat wiping edge of seal with grease.
6. Drive/press seal into place with lip to outside.

NOTE: Use extra care to protect the sealing lip during installation. Apply uniform pressure to assemble the seal into the bore of the arm. Never apply a direct hammer blow to the seal surface.

7. Inspect gauge wheel pivot spindle.
8. Reinstall gauge wheel arm assembly and gauge wheel.

NOTE: Use special machine bushing between gauge wheel arm and gauge wheel.

9. Shim for proper gauge wheel tire/disc blade clearance.
10. Lubricate with an SAE multipurpose grease.

GAUGE WHEEL ARM PIVOT SPINDLE REPLACEMENT

1. Remove gauge wheel and arm assemblies from shank assembly.
2. Remove 1/2" x 3/4" cap screw that locks pivot spindle in place and remove spindle.
3. Install replacement spindle and position as shown. Exact centering is critical.
4. Install 1/2" x 3/4" cap screw and torque to lock pivot spindle in place.
5. Install gauge wheel and arm assemblies. Shim for proper gauge wheel tire/disc blade clearance.

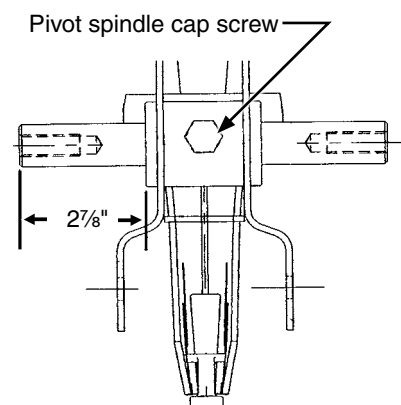

15" SEED OPENER DISC BLADE/BEARING ASSEMBLY

NOTICE

Excessive blade contact may result in premature disc opener bearing/hub failures and excessive wear on seed tube guard/inner scraper. When properly adjusted, if one blade is held in fixed position, opposite blade should rotate with less than 5 pounds force at outer edge of blade.

Maintain approximately $1" \pm \frac{1}{2}"$ of blade-to-blade contact to properly open and form seed trench. As blade diameter decreases due to wear, it is necessary to relocate machine bushings from inside to outside to maintain $1" \pm \frac{1}{2}"$ of contact.

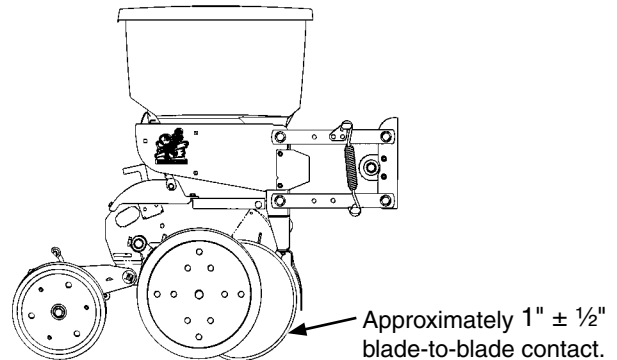

NOTE: Proper blade clearance is critical. Blades should have $1" \pm \frac{1}{2}"$ contact in this area. When blades are turned by hand in opposite directions against each other, there should be only light resistance to turning. Re-adjust blade scraper if necessary to center it between the blades.

NOTE: Replace blades if proper blade-to-blade contact cannot be maintained after relocating machine bushings or if blade diameter wears below $14\frac{1}{2}"$.

REPLACE DISC BLADE/BEARING ASSEMBLY

NOTE: Only bearing may need to be replaced if there is excessive endplay or if bearing sounds or feels rough when disc blade is rotated.

1. Remove gauge wheel, scraper, and bearing dust cap.
2. Remove cap screw, washer and disc blade/bearing assembly. Machine bushings between shank and disc blade are used to maintain approximate $1" \pm \frac{1}{2}"$ of blade-to-blade contact.

NOTICE

Left hand side of opener uses a left hand threaded cap screw. DO NOT OVER TIGHTEN. Damage to shank threads require replacement of row unit shank assembly.

3. Install machine bushing(s), new disc blade bearing assembly, washer and cap screw. Torque $\frac{5}{8}"$ -11 Grade 5 cap screw to 110 ft-lb (149.14 N-m).

NOTE: Replace disc blades only with disc blades of equal thickness.

4. Install bearing dust cap, scraper, and gauge wheel.

REPLACE BEARING ONLY

1. Remove gauge wheel, scraper, bearing cap, cap screw, washer and disc blade/bearing assembly.
2. Remove $\frac{1}{4}"$ rivets from bearing housing to expose bearing.
3. Installing new bearing. install three evenly spaced $\frac{1}{4}"$ cap screws into three of six holes in bearing housing to hold bearing and bearing housing in place. Install rivets in other three holes. Remove $\frac{1}{4}"$ cap screws and install rivets in those three holes.
4. Reinstall disc blade/bearing assembly, washer and cap screw. Torque $\frac{5}{8}"$ -11 cap screw to 110 ft-lb (149.14 N-m).
5. Install bearing dust cap, scraper, and gauge wheel.

SEED TUBE GUARD/INNER SCRAPER

Seed tube guard protects seed tube and acts as inner scraper for seed opener disc blades.

Remove seed tube and check for wear. Excessive wear on seed tube indicates a worn seed tube guard. Replace seed tube guard if it measures $\frac{5}{8}$ " or less at lower end. A new seed tube guard measures approximately $\frac{7}{8}$ ".

NOTE: No till planting or planting in hard ground conditions, especially when planter is not equipped with no till coulters, and/or excessive blade-to-blade contact increases seed tube guard wear and requires more frequent inspection and/or replacement.

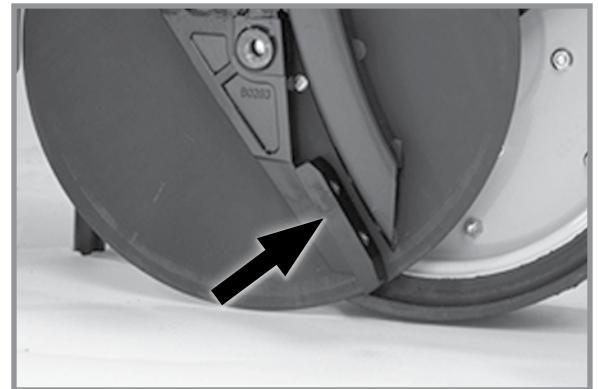

Seed tube guard/inner scraper
(Gauge wheel/seed opener disc blade removed)

NOTICE

Over tightening hex socket head cap screws may damage shank threads and require replacement of shank. An excessively worn seed tube guard may allow blades to wear into row unit shank, also requiring replacement of shank.

Remove seed tube and two hex socket head cap screws that attach seed tube guard. Hold replacement seed tube guard centered between seed opener disc blades. Install hex socket head cap screws. **DO NOT TIGHTEN.** Using a clamp or vise-grip, squeeze opener blades together in front of seed tube guard. Tighten seed tube guard retaining screws. Remove clamps. Distance between seed tube guard and opener blades should be equal on both sides. Reinstall seed tube.

FRAME MOUNTED COULTER

NOTE: Torque $\frac{5}{8}$ " spindle hardware to 120 ft-lb (162.7 N-m)

See "Frame Mounted Coulters" in Row Unit Operation section of this manual for depth and spring adjustment.

Replace 16" diameter coulters blade (1" fluted, 1" bubbled or $\frac{3}{4}$ " fluted) when worn to $14\frac{1}{2}$ " (maximum allowable wear).

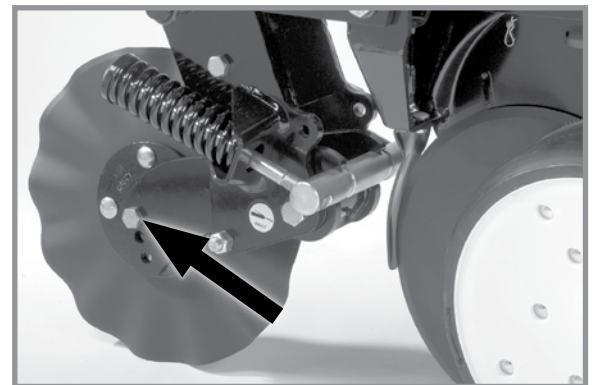

Frame mounted coulters spindle

RESIDUE WHEELS (FOR USE WITH FRAME MOUNTED COULTER)

Wheel hub is equipped with sealed bearings. Replace bearings if a bearing sounds or feels rough when wheel is rotated.

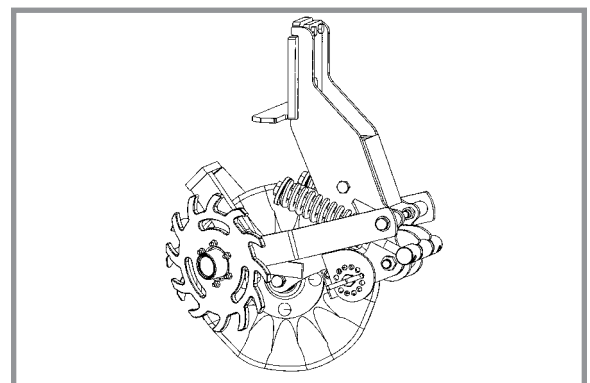

Frame mounted coulters residue wheels

ROW UNIT MOUNTED DISC FURROWER

Lubricate bushings in support arm mounting bracket at frequency indicated in Lubrication of this section. Check each bolt for proper torque. If bolt is loose, it should be removed and bushing inspected for cracks and wear. Replace bushings as necessary.

NOTE: Use only hardened flat washers. Replace damaged flat washers with proper part. Torque bolts to 130 ft-lb (176.2 N-m).

Blade hubs are equipped with sealed bearings. Replace bearings if a bearing sounds or feels rough when wheel is rotated.

Replace solid or notched 12" diameter blades when worn to 11".

ROW UNIT MOUNTED BED LEVELER

Lubricate bushings in mounting bracket and links at frequency indicated in Lubrication of this section. Check each bolt for proper torque. If bolt is loose, it should be removed and bushing inspected for cracks and wear. Replace bushing if necessary.

NOTE: Use only hardened flat washers. Replace damaged flat washers with proper part. Torque bolts to 130 ft-lb (176.2 N-m).

ROW UNIT MOUNTED NO TILL COULTER

Check nuts and hardware periodically for proper torque. Be sure coulters are positioned square with row unit and aligned in front of row unit disc opener.

NOTE: Torque $\frac{5}{8}$ " spindle hardware to 120 ft-lb (162 N-m).

Coulter blade can be adjusted to one of four settings. Initially blade is set in highest position. As blade wears it can be adjusted to one of three lower settings. See "Row Unit Mounted No Till Coulter" in Row Unit Operation section of this manual.

Replace 16" diameter coulters when worn to 14½".

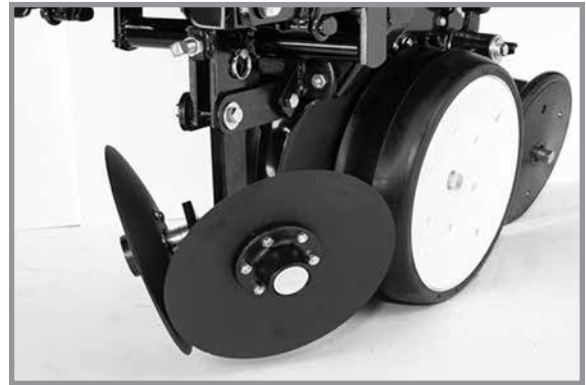

Row unit mounted disc furrower



Row unit mounted bed leveler



Row unit mounted no till coulters

COULTER MOUNTED RESIDUE WHEELS

Wheel hubs are equipped with sealed bearings. If bearings sound or feel rough when wheel is rotated, replace them.



Coulter mounted residue wheels

ROW UNIT MOUNTED RESIDUE WHEEL

Wheel hub is equipped with sealed bearings. If a bearing sounds or feels rough when wheel is rotated, replace them.

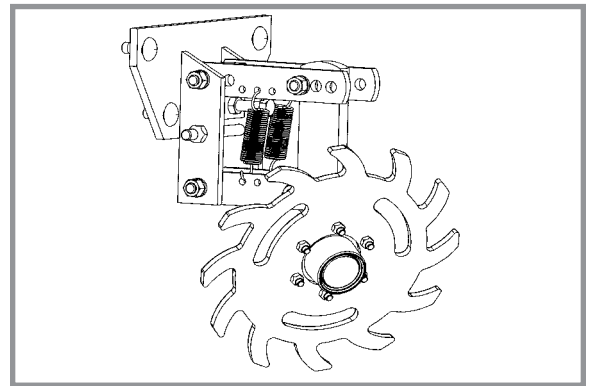

Row unit mounted residue wheels

GRANULAR CHEMICAL ATTACHMENT

Before storing planter, disengage granular chemical drive by rotating throwout knob $\frac{1}{4}$ turn counterclockwise. Remove drive chain and empty and clean all granular chemical hoppers. Clean drive chains and coat them with a rust preventive spray or submerge chains in oil. Inspect and replace worn or broken parts.

Install hoppers and chains. Check chain alignment.

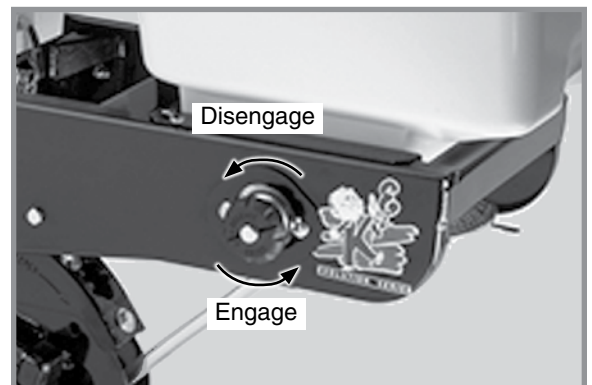

Granular chemical throwout knob

SPRING TOOTH INCORPORATOR

Before storing planter, inspect each spring tooth incorporator and replace worn or broken parts. Check for loose hardware and tighten as needed.

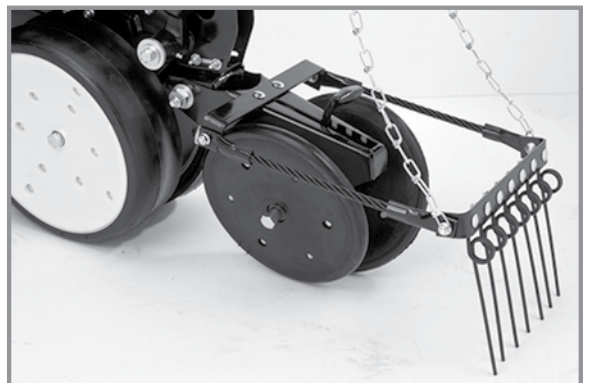

Spring tooth incorporator

SINGLE AND TWO-SPEED POINT ROW CLUTCH MAINTENANCE

Point row clutch is permanently lubricated and sealed and requires no periodic maintenance. Two-speed point row clutch is similar in design and operation to standard point row clutch except for two-speed function.

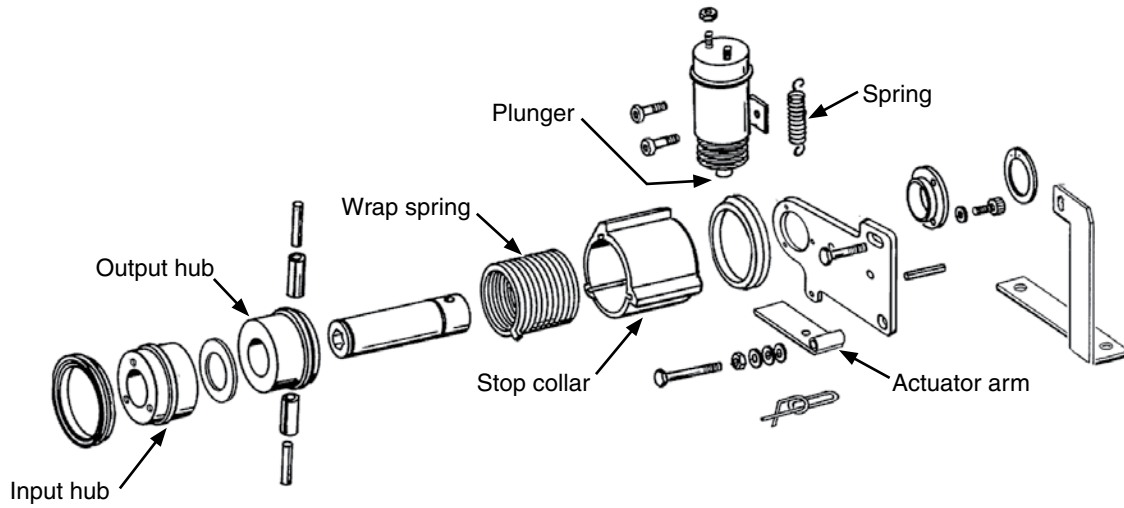

Single point row clutch main parts

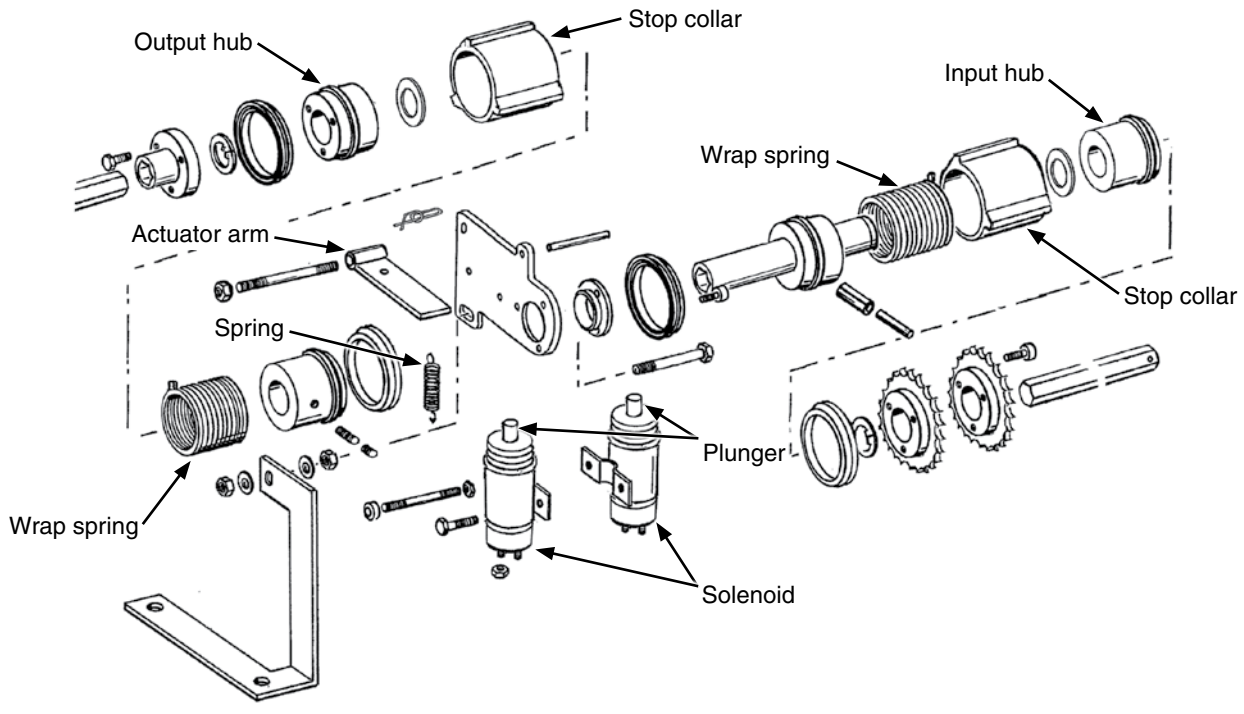

Two-speed point row clutch main parts

TESTING AND FUSE REPLACEMENT

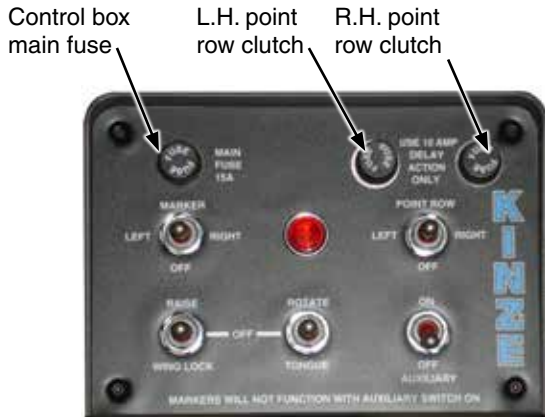

Single speed point row clutch control box
(Front View)

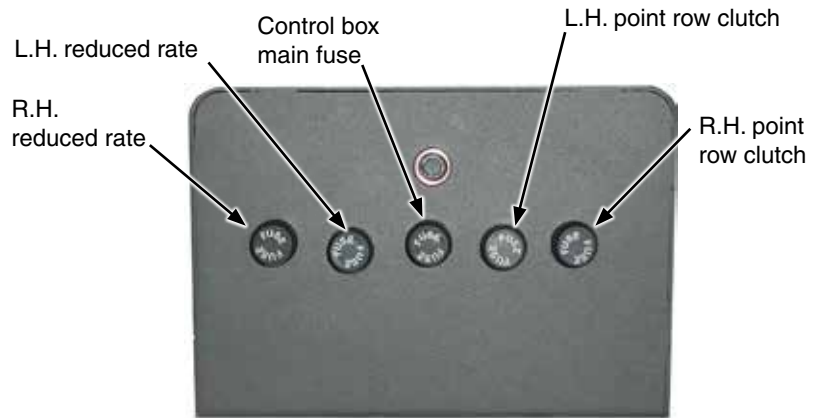

Two-speed point row clutch control box
(Rear view)

NOTE: Replace all point row fuses with MDL 10 amp slow blow fuses.

If the clutch or clutches fail to operate, first determine if problem is electrical or mechanical.

Place operation switch in RIGHT or LEFT position. Solenoid plunger will retract causing a clicking sound if it is operating properly. Touch plunger with a metal object to check if it is electrically magnetized. Check clutch and wiring harness for power with a test light or volt meter.

NOTE: R.H. clutch operates clockwise and L.H. clutch operates counterclockwise. Clutch parts such as the wrap spring are side specific. Use correct repair part if a clutch must be repaired.

Also see "Point Row Clutch Troubleshooting" in Troubleshooting section.

ACTUATOR ARM ADJUSTMENT

Gap between actuator arm and stop on stop collar should be $\frac{1}{8}$ " ($\pm\frac{1}{32}$ ") when solenoid is NOT engaged.

Loosen nut on mounting pin and move pin in slot until there is a $\frac{1}{8}$ " ($\pm\frac{1}{32}$ ") gap between arm and stop on stop collar. Retighten nut.

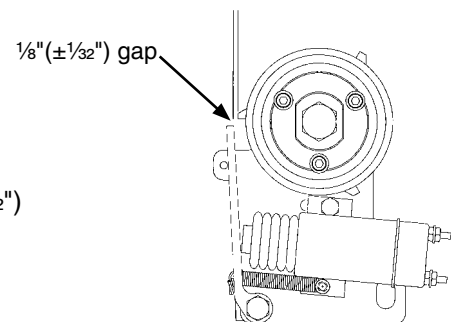

CHECK VALVE (LIFT SYSTEM)

Check valves, located in valve block on right side of center post, trap oil flow in planter's lift system to keep toolbar level during field operation. Consult your Kinze Dealer for service.

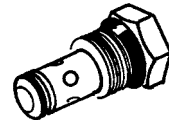

CHECK VALVE (VACUUM FAN)

Check valve located in valve block below vacuum fan motor assembly operates as a return line check to prevent vacuum fan motor reverse operation. Remove and inspect valve. If it does not operate properly. Check for foreign material and if O-ring is leaking internally. Replace if defective.

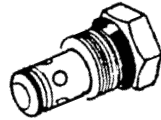

FLOW CONTROL VALVE

Flow control valves should be adjusted for row marker raise and lower speed as part of assembly procedure or upon initial operation. If valve fails to function properly or requires frequent adjustment, it should be removed for inspection. Check for foreign material and contamination on valve and seating areas of valve body. Replace defective components.

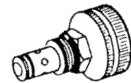

PRESSURE RELIEF VALVE

If pressure relief valve does not release tongue lock or function properly, remove valve from valve block and check for foreign material or if O-ring is leaking internally. Replace if defective.

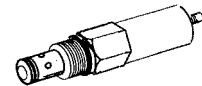

PRESSURE REDUCING RELIEF VALVE

If wings do not properly stay to ground, plumb into butt end of cylinder to test psi. Proper setting is 750 PSI.

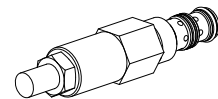

NOTICE

Connect hydraulic motor case drain to a case drain return line with zero pressure on tractor or hydraulic motor will be damaged. DO NOT connect hydraulic motor case drain to SCV outlet. Contact tractor manufacturer for specific details on "zero pressure return".

RELIEF VALVE CARTRIDGE

Pressure relief valve located in valve block below vacuum fan motor assembly helps prevent damage to vacuum fan motor by limiting pressure in the motor case drain line. It is set to open at 35 PSI. If valve fails to function properly, it should be removed for inspection. Check for foreign material and contamination on valve and the seating area of valve body. Replace if defective.



SOLENOID VALVE

Solenoid valve consists of a chambered body with an electric coil actuated cartridge valve.

If solenoid or solenoids fail to operate, first determine if problem is electrical or hydraulic. If valve is working properly, a click will be heard when solenoid coil is energized and valve stem opens. If no sound is heard, check solenoid coil by touching top of coil housing with a metallic object such as pliers or screwdriver. If coil is working properly, coil housing will be strongly magnetized when energized. If voltage to coil is low it will be weakly magnetized when energized and no click will be heard.

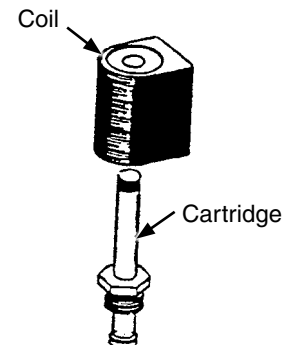

ROW MARKER BEARING LUBRICATION OR REPLACEMENT

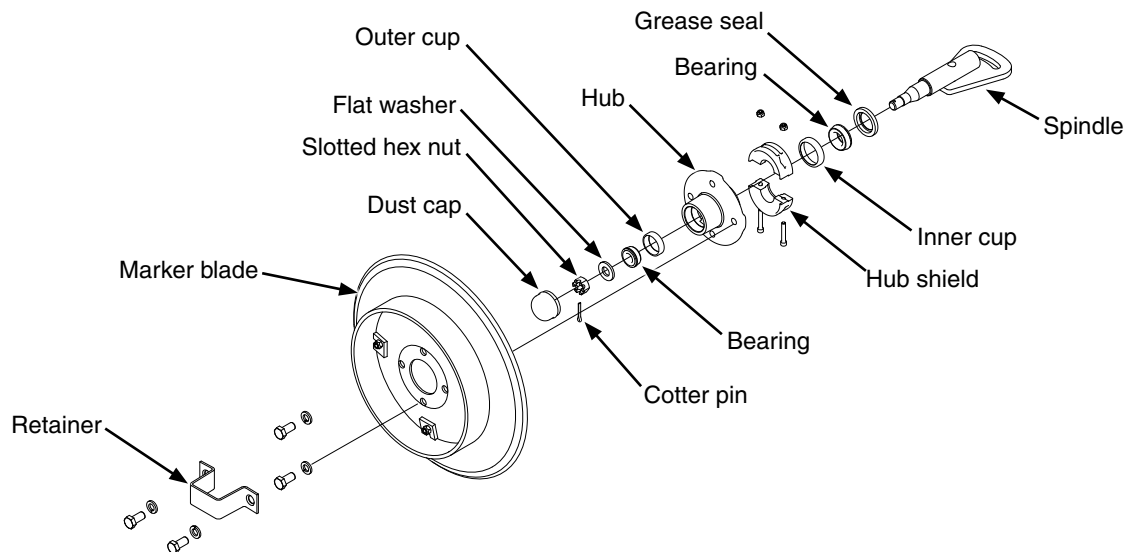

1. Remove retainer and marker blade.
2. Remove dust cap from hub.
2. Remove hub shield. Note direction of installation.
3. Remove cotter pin, slotted hex nut, and washer.
4. Slide hub from spindle.
5. Remove bearings and cups and discard if bearings are being replaced. Clean hub and dry. Remove bearings only and not cups if repacking.
6. Press in new bearing cups with thickest edge facing in. (Bearing replacement procedure only.)
7. Pack bearings with heavy duty wheel bearing grease thoroughly forcing grease between roller cone and bearing cage. Fill the space between the bearing cups in the hub with grease.
8. Install rubber seal into grease seal. Place inner bearing in place and press in new rubber seal/grease seal.
9. Clean spindle and install hub.
10. Install outer bearing, washer and slotted hex nut. Tighten slotted hex nut while rotating hub until there is some drag. This ensures all bearing surfaces are in contact. Back off slotted nut to nearest locking slot and install cotter pin.
11. Fill dust caps approximately $\frac{3}{4}$ full of wheel bearing grease and install on hub.
12. Install hub shield.
13. Install marker blade and retainer on hub. Tighten hardware evenly.

AIR CLUTCH CLEANING

(Yearly at end of planting season)

NOTE: If system is equipped with Pneumatic Down Pressure, air clutches must be removed from planter for cleaning. If system is not equipped with Pneumatic Down Pressure, air clutches can be disassembled and cleaned on planter.

At each row unit:

1. Remove meter assembly.
2. Press down collar on air fitting and remove air hose.
3. Loosen tension from chain and remove from air clutch sprocket.
4. Loosen lock clamp and slide clamp, washer, and air clutch away from chain.
5. Use a $\frac{5}{16}$ " wrench and remove sprocket from air clutch assembly.
6. Remove small Phillips-head screw from side of air clutch housing and remove housing cover.

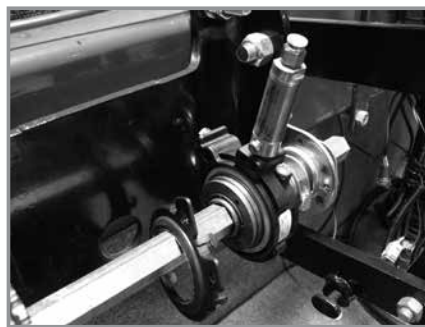
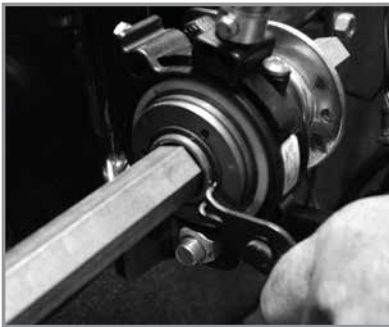

7. Expand retaining ring and remove from assembly.
8. Remove and separate sprocket hub, ratchet gear, clutch spring, and hex bushing from air clutch housing.
9. Remove debris and dirt from clutch components. Clean parts with brake cleaner or equivalent cleaner.
10. Make sure parts are completely dry. Lubricate sprocket hub, ratchet gear, clutch spring, and hex bushing with silicone spray.
11. Reverse procedure to assemble air clutch assembly.
12. Place one drop of pneumatic or light-duty hydraulic oil in air cylinder fitting before attaching air line.
13. Install meter assembly.

ROW MARKER TRANSPORT STAND ADJUSTMENT

Row marker transport stands must be correctly adjusted to allow marker cushion cylinders to function properly.

1. Raise markers to transport position.
2. Loosen mounting hardware to allow transport stands to drop down or remove transport stands.
3. With tractor engine shutoff, release hydraulic pressure on marker cylinders.
4. Locate transport stands so marker arm rests lightly on transport stand. When transport stands are correctly adjusted pin at rod end of cylinder should be loose enough to rotate and move back and forth in mounting slot.

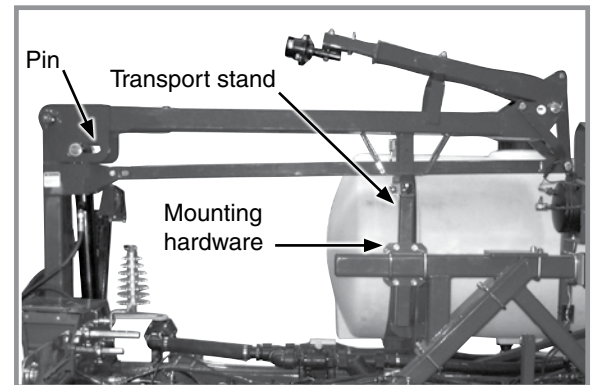

Row marker transport stand

WHEEL BEARING REPACK OR REPLACEMENT

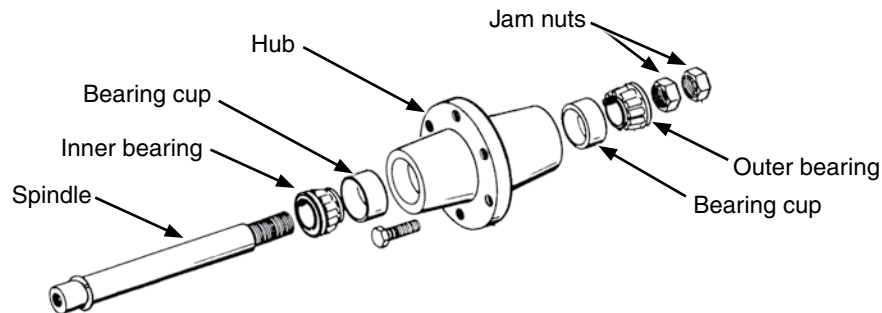

1. Raise tire clear of ground and remove wheel.
2. Remove double jam nuts and slide hub from spindle.
3. Remove bearings and cups and discard if bearings are being replaced. Clean hub and dry. Remove bearings only and not cups if repacking.
4. Press in new bearing cups with thickest edge facing in. (Bearing replacement procedure only.)
5. Pack bearings with heavy duty wheel bearing grease thoroughly forcing grease between roller cone and bearing cage. Fill space between bearing cups and hub with grease.
6. Place inner bearing in place.
7. Clean spindle and install hub.
8. Install outer bearing and jam nut. Tighten jam nut while rotating hub until there is some drag. This ensures all bearing surfaces are in contact. Back off jam nut $\frac{1}{4}$ turn or until there is only slight drag when rotating hub. Install second jam nut to lock against first.
9. Install wheel on hub. Tighten hardware evenly.

WEAR PAD FIELD REPLACEMENT/ADJUSTMENT

NOTICE

Over tightening wear pads will cause premature wear and excessive hydraulic lift pressures. Check wear pad type when replacing or adjusting. Torque wear pads to 10 ft-lb (13.6 N-m). Do not over tighten wear pads.

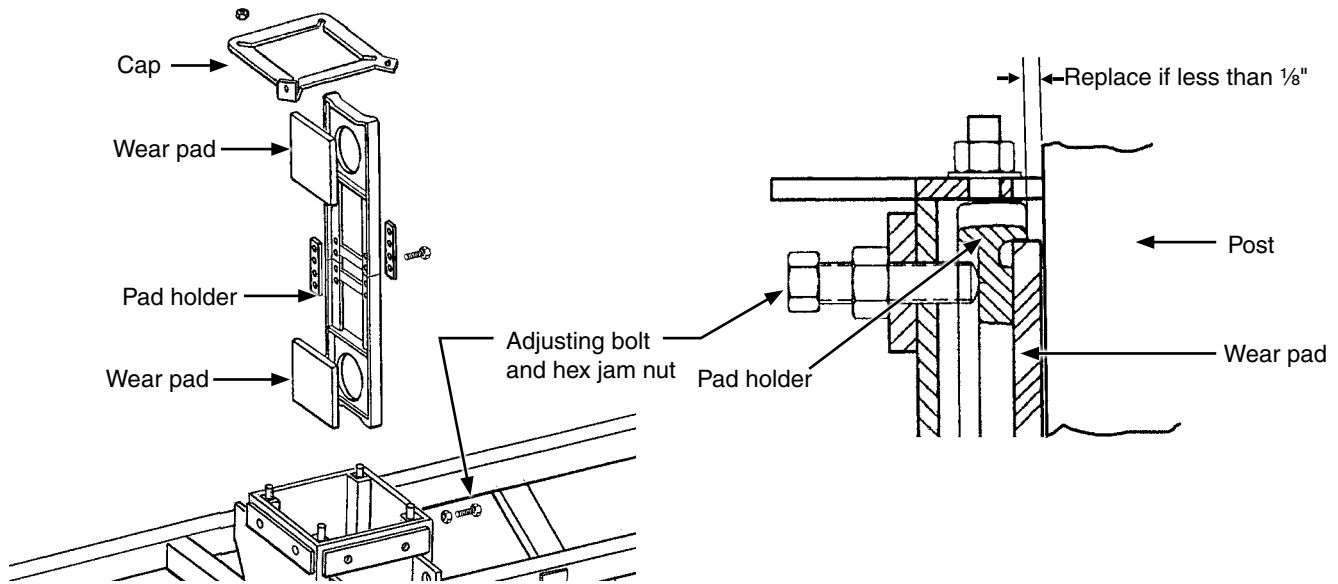

Planter center section is constructed around a steel tubular frame with four wear pad assemblies riding against a stainless steel clad center post. Two wear pads are held by a pad holder and locked in place by $\frac{3}{4}$ " adjusting bolts and hex jam nuts. Inspect pads for wear and adjustment annually to ensure center section is stabilized and planter tracks properly. Pads should make full light contact with center post when properly adjusted. Too much preload on pads will cause hydraulic lift pressure to be higher than necessary or will not allow planter to raise when loaded.

1. Position planter on a level surface and place in raised field position.

NOTE: Replace wear pad when worn to less than $\frac{1}{8}$ ". See "Pad Replacement" steps on next page.

2. Visually check four upper wear pads. Each wear pad should lightly contact stainless steel clad center post.
3. Place planter in raised transport position, install all safety lockups and visually check four lower wear pads for light contact.
4. Remove lockup and lower planter to field operation position. Loosen cap mounting nuts to allow wear pad adjustment. Loosen hex jam nuts as needed.

IMPORTANT: Cap mounting nuts MUST be loosened before adjusting wear pads.

5. Tighten pad adjusting bolts, back off, and then torque wear pads to 10 ft-lb (13.6 N-m). Hold adjusting bolt from turning and torque hex jam nuts to 200 ft-lb (271.1 N-m).
6. Operate to full height on post and recheck for zero clearance.

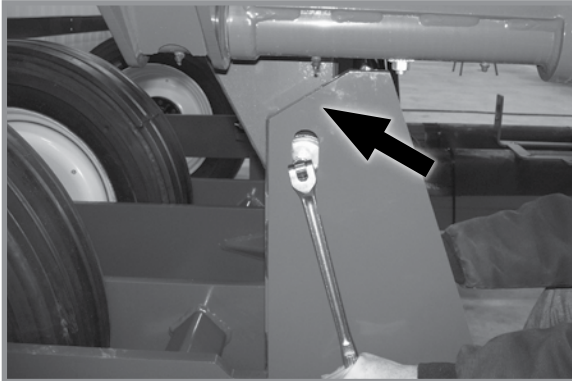
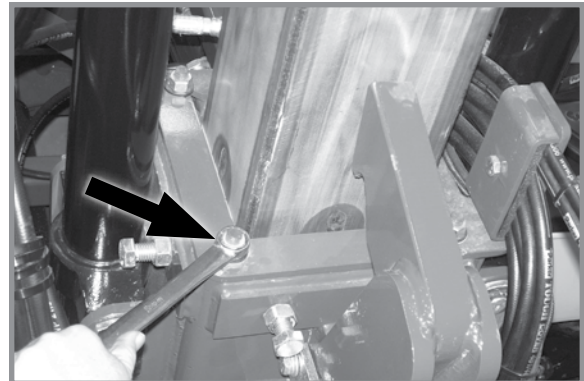
MAJOR PAD ADJUSTMENT**Loosen cam rollers****Loosen four cap mounting nuts**

1. Loosen cam rollers so they move freely.
2. Lower planter to field operation position and release wing locks. Eliminate all uplift on planter frame by backing off row unit down pressure springs and uplift on any other planter attachments.
3. Check position of center frame to axle cam roller guides. Gap between guides and frame should be the same side to side. Gap on back sides of roller guide should be equal on both sides. Final adjustment will be done later.
4. Loosen four cap mounting nuts.

IMPORTANT: Cap mounting nuts MUST be loosened before adjusting wear pads.

5. Loosen hex jam nuts and use pad adjusting bolts to position frame to center correctly.

NOTICE

Over tightening wear pads will cause premature wear and excessive hydraulic lift pressures. Torque wear pads to 10 ft-lb (13.6 N-m). Do not over tighten wear pads.

6. Tighten pad adjusting bolts, back off, and then torque wear pads to 10 ft-lb (13.6 N-m). Hold adjusting bolt from turning and torque hex jam nuts to 200 ft-lb (271.1 N-m).
7. Tighten cap mounting nuts.
8. Reset row unit down pressure and other attachments from Step 3.

PAD REPLACEMENT

1. Loosen cam rollers so they move freely as shown above.
2. Lower planter to field operation position and release wing locks.
3. Eliminate all uplift on planter frame by backing off row unit down pressure springs and uplift on any attachments.
4. Remove safety hook.
5. Disconnect hydraulic hose, remove nut on bulkhead fitting, and remove fitting from cap.

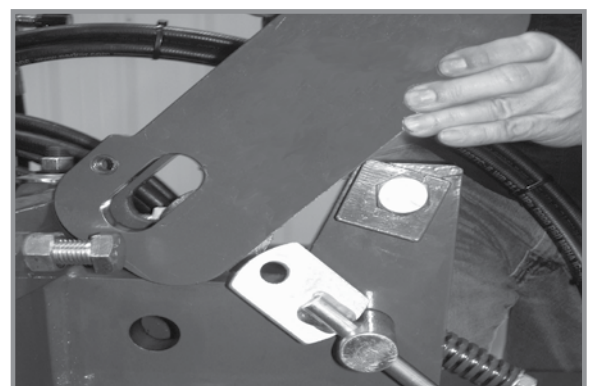
**Removing safety hook**

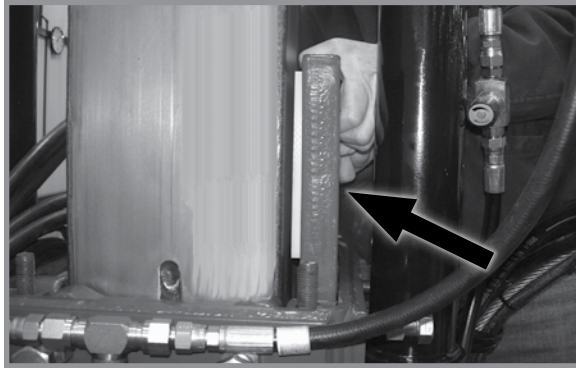

Removing pad holder assembly

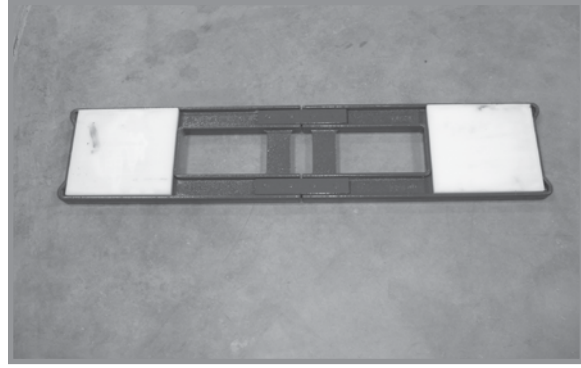

New pads in pad holder assembly

6. Loosen four cap mounting nuts and remove pad holder cap.
7. Loosen pad hex jam nuts, back pad bolts out, and remove four pad holder assemblies. Remove old pads and install new pads.

NOTE: Apply a small amount of weather stripping adhesive to hold pads in place during installation.

8. Reinstall pad hold assemblies in center section.

NOTICE

Over tightening wear pads will cause premature wear and excessive hydraulic lift pressures. Torque wear pads to 10 ft-lb (13.6 N-m). Do not over tighten wear pads.

9. Tighten pad adjusting bolts, back off, and then torque wear pads to 10 ft-lb (13.6 N-m). Hold adjusting bolt from turning and torque hex jam nuts to 200 ft-lb (271.1 N-m).
10. Reinstall cap and tighten cap mounting nuts.
11. Reinstall hydraulic hose, fittings, and safety hook.

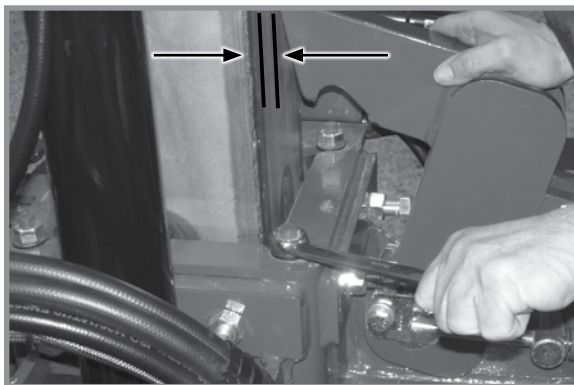

Adjust safety hook clearance to 1/4"-3/8"

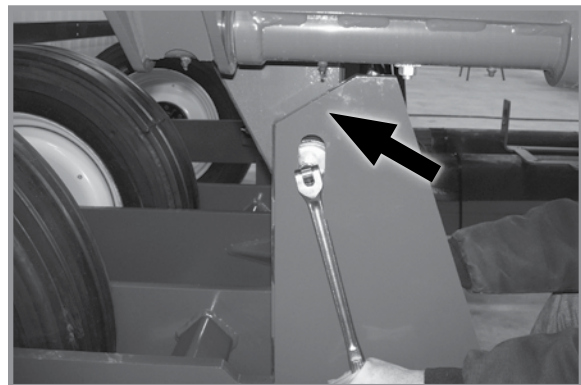

Adjust and tighten cam roller

12. Adjust stop on safety hook to 1/4"-3/8" clearance.
13. Rotate cam roller against front guide and tighten to 110 ft-lb (149.1 N-m). Make sure gap between roller guide and center frame are equal on both sides. Raise planter out of roller guides and lower back down into roller guides to be sure roller guides operate smoothly. Adjust rotation cylinder rod as needed.
14. Reset row unit down pressure and other attachments from Step 3.

TRACTOR MOUNTED PTO PUMP AND OIL COOLER OPTION

Drain reservoir, clean strainer and change filter annually.

1. Disconnect suction line (hose between reservoir and pump) from reservoir and drain. To fully drain tank, raise
2. Replace filter with good quality 10 micron filter.
3. Fill system with SAE 10W-20 multigrade wide temperature range transmission hydraulic fluid. Reservoir capacity is approximately 10 gallons.
4. Start system and run with tractor at idle and fan turned off for 1-2 minutes. Switch fan to full speed and run with tractor at idle for 1-2 minutes.
5. Check reservoir fluid level and fill as required. Hydraulic fluid level should be within 1"-2" from top of reservoir after pump has run and hydraulic hoses have been primed to allow fluid to expand when heated.
6. Bring tractor to PTO speed and adjust flow control to the desired vacuum level using the flow control valve lever.

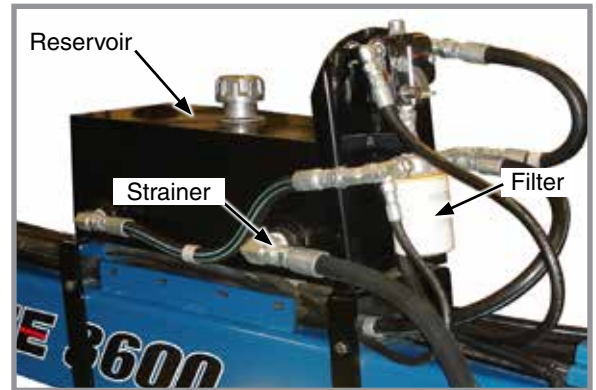

Hydraulic reservoir

FERTILIZER CHECK VALVE CLEANING AND REPAIR

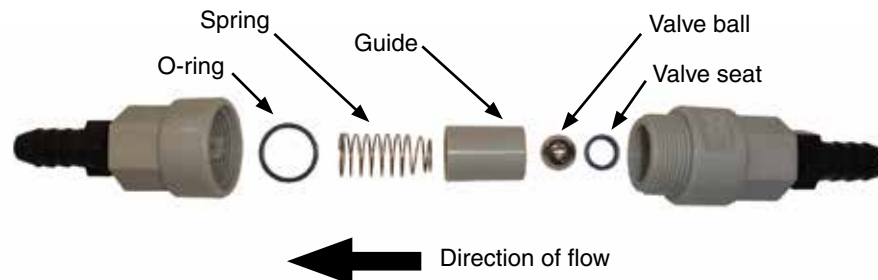

1. Unscrew valve body and separate halves. Note direction and location of parts.
2. Clean and inspect parts. Flush with clean water. Replace damaged parts.
3. Reassemble exactly as shown. O-ring and valve seat must be firmly in place inside each half of valve body.

PISTON PUMP STORAGE

NOTICE

Entrance of air into pump will cause rapid and severe corrosion. KEEP AIR OUT OF PUMP!

NOTE: SUSPENSION FERTILIZER must be flushed from pump for ANY storage period.

1. Flush pump with 5 to 10 gallons of fresh water and circulate until all corrosive salts are dissolved in pump.
2. Set pump on 10. Draw in a mixture of half diesel fuel and 10 weight oil until discharge is clean. Plug inlet and outlet.



Liquid fertilizer piston pump

PREPARATION FOR STORAGE

Store planter in a dry sheltered area if possible.

Remove all trash wrapped on sprockets or shafts and remove dirt that can draw and hold moisture.

Clean all drive chains and coat with a rust preventative spray, or remove chains and submerge in oil.

Lubricate planter and row units at all lubrication points.

Inspect planter for parts that in need of replacement and order during “off” season.

Make sure all seed and granular chemical hoppers are empty and clean.

Remove seed discs from seed meters, clean and store meters in a rodent-free, dry area with discs removed. Store seed discs vertically on a dowel or pipe.

Remove vacuum hose from each seed meter. Operate vacuum fan at full hydraulic flow from tractor for two minutes to clear manifolds, hoses and fittings of dust and debris.

Clean breather on analog vacuum and pressure gauges.

Disassemble, clean and grease all U-joint slides.

Grease or paint disc openers/blades and row marker disc blades to prevent rust.

Flush liquid fertilizer tanks, hoses and metering pump with clean water. See “Piston Pump Storage” if applicable.

Empty dry fertilizer hoppers. Clean hoppers. Disassemble and clean metering augers. Reassemble, coating all metal parts with rust preventative.

ASD System:

- Clean out ASD hopper, entrainment assembly, and delivery hoses.
- Disconnect delivery hoses from entrainer ports. Install small orange caps onto ports. Attach hoses to caps.
- Disconnect delivery hoses from air dissipator at each row unit. Install large orange caps. Attach hoses to caps.
- Check all bolts and fasteners used to assemble and attach entrainment device are tight (if applicable).
- Loosen knobs on entrainer cleanout doors to remove pressure from door gaskets.
- Inspect all seed delivery hoses and replace any that are worn, cut, or cracked.

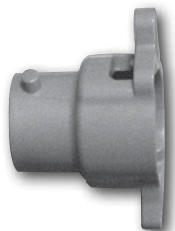

Entrainer cap

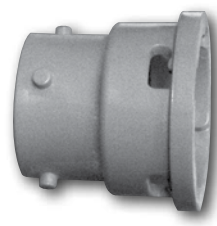

Air dissipator cap

ELECTRICAL WIRING DIAGRAM FOR LIGHT PACKAGE

Machines with double light assemblies

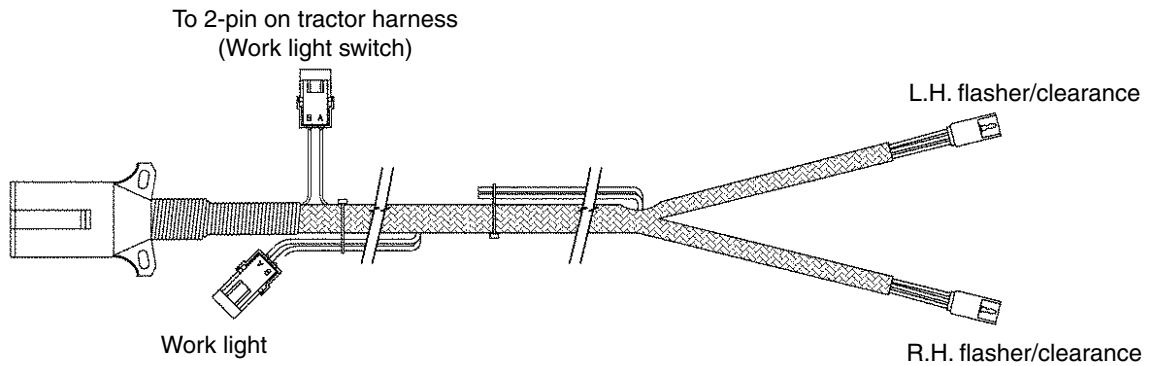
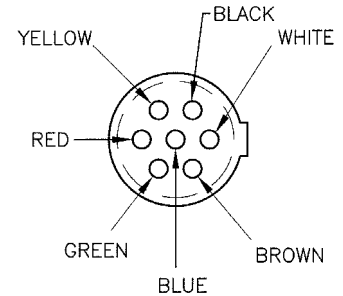
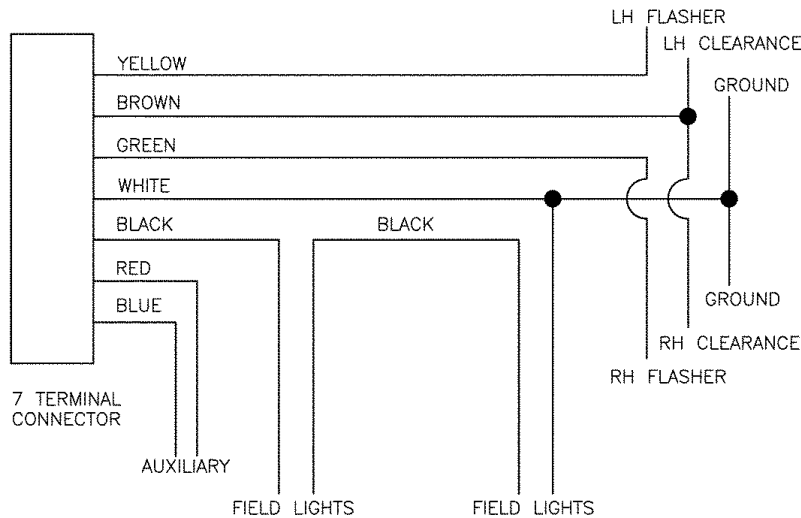

*** Optional customer-supplied auxiliary lights and wires may be wired into existing plug terminals.**

Model 3600 Twin-Line Planter safety light package meets ASAE Standards. Check with your tractor manufacturer for proper connection to your tractor.

ELECTRICAL CONTROL CONSOLE SCHEMATIC

NOTE: Disconnect control console from tractor battery before doing any electrical work. Keep wiring harnesses away from high temperature areas or sharp edges. DO NOT route wiring harnesses along battery cables. Use cable ties to keep wire harness away from moving parts on tractor and planter. Be sure tractor frame ground connections are clean to provide good electrical contact.

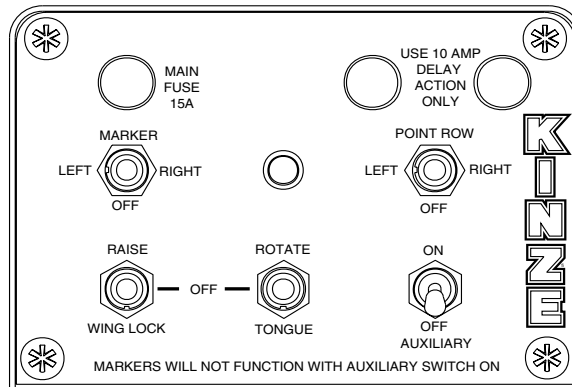
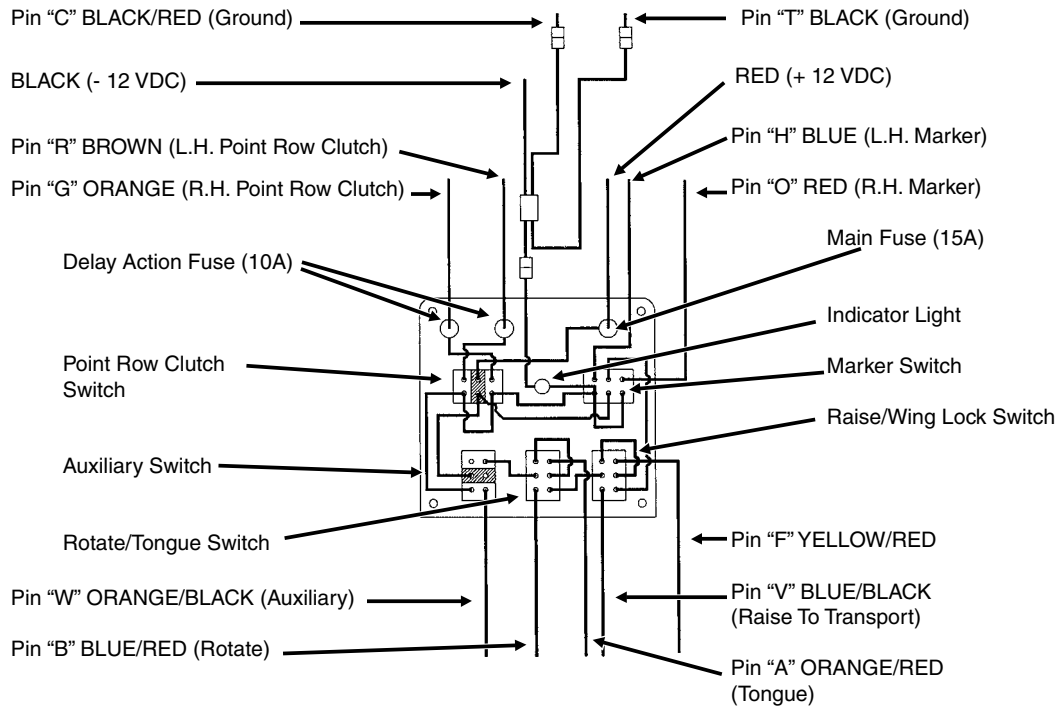

NOTE 1. Operating marker or point row switch in either direction lights panel light.

NOTE 2. Point row clutch switch operates independently from rest of control box.

NOTE 3. Power to marker switch is fed through auxiliary switch and two transport function switches. Operating any switch in lower row disables marker function and turns off panel light. (If point row clutch switch is OFF.)

See electrical control console schematic and wiring harness at two-speed point row clutch solenoids for planter equipped with optional Two-Speed Point Row Clutch Package in this section.

ELECTRICAL WIRING HARNESS SCHEMATIC (On Tractor)

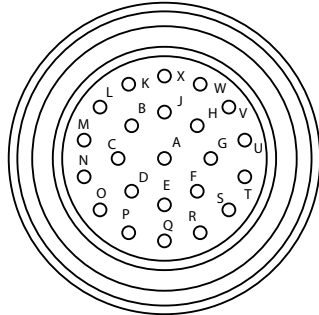

23 Socket Capacity

Pin No.	Wire Color	Function	Wire Ga.
A	Orange/Red	Tongue Raise	14
B	Blue/Red	Fold	14
C	Black/Red	Ground	14
D	White	Monitor B 12V	14
E	Green	Monitor B DATA	14
F	Yellow/Red	Wing Lock	14
G	Orange	Point Row - Right	12
H	Blue	Marker - Left	14
J	Black	Monitor B Ground	14
K	White	Monitor A 12V	14
L	Green	Monitor A Data	14
M	Black	Monitor A Ground	14
N	---	---	---
O	Red	Marker - Right	14
P	---	---	---
Q	---	---	---
R	Brown	Point Row - Left	12
S	Yellow	Reduced Rate - Left	12
T	Black	Ground	12
U	Red/Black	Reduced Rate - Right	12
V	Blue/Black	Raise to Transport	14
W	Orange/Black	Auxiliary	14
X	---	---	---

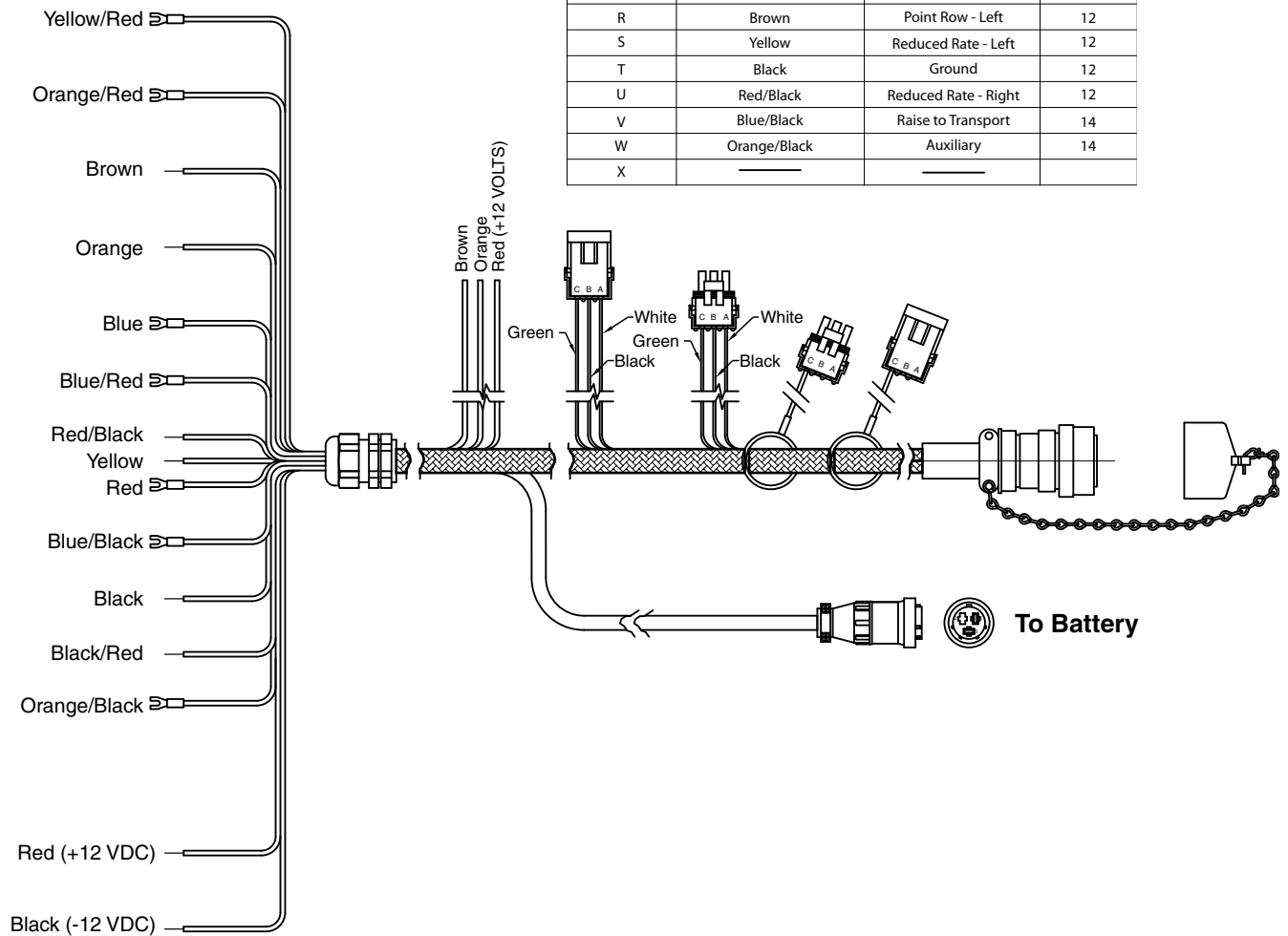

ELECTRICAL WIRING HARNESS SCHEMATIC (On Planter)

23 Socket Capacity

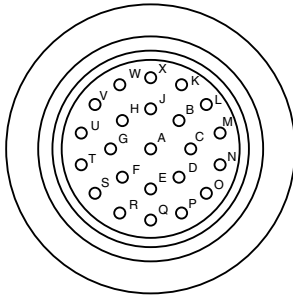

Pin No.	Wire Color	Function	Wire Ga.
A	Orange/Red	Tongue Retract/Extend	14
B	Blue/Red	Fold	14
C	Black/Red	Ground	14
D	White	Monitor B 12V	14
E	Green	Monitor B Data	14
F	Yellow/Red	Wing lock	14
G	Orange	PT. Row - Right	12
H	Blue	Marker - Left	14
J	Black	Monitor B Ground	14
K	White	Monitor A 12V	14
L	Green	Monitor A Data	14
M	Black	Monitor A Ground	14
N	---	---	---
O	Red	Marker - Right	14
P	---	---	---
Q	---	---	---
R	Brown	PT. Row - Left	12
*S	Yellow	Reduced Rate - Left	12
T	Black	Ground	12
*U	Red/Black	Reduced Rate - Right	12
V	Blue/Black	Raise to Transport	14
W	Orange/Black	Auxiliary	14
X	---	---	---

**VALVE BLOCK -
Located on rear
center frame**

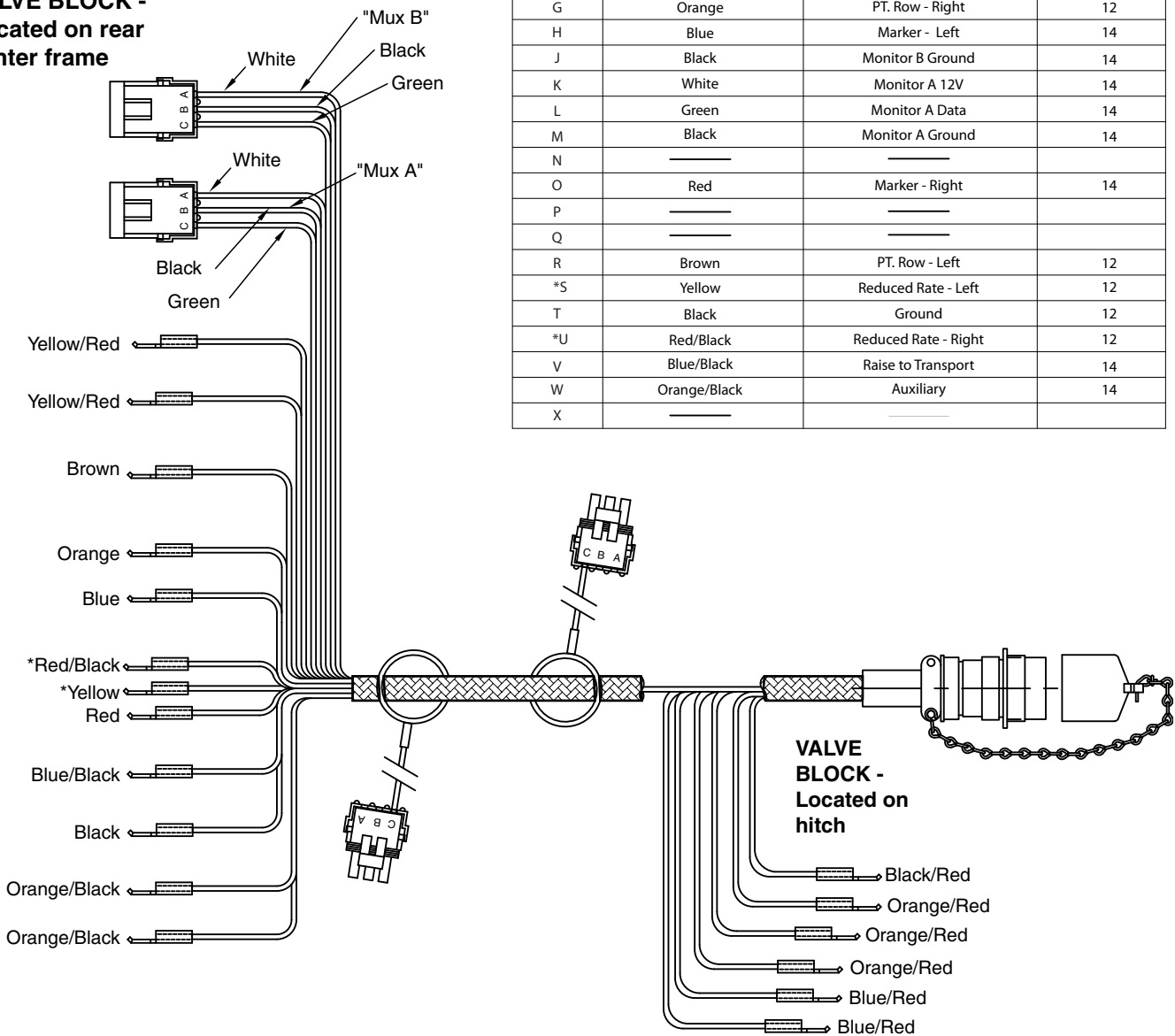

* See page 7-40 if equipped with optional two-speed point row clutch package.

VALVE BLOCK - LOCATED ON HITCH

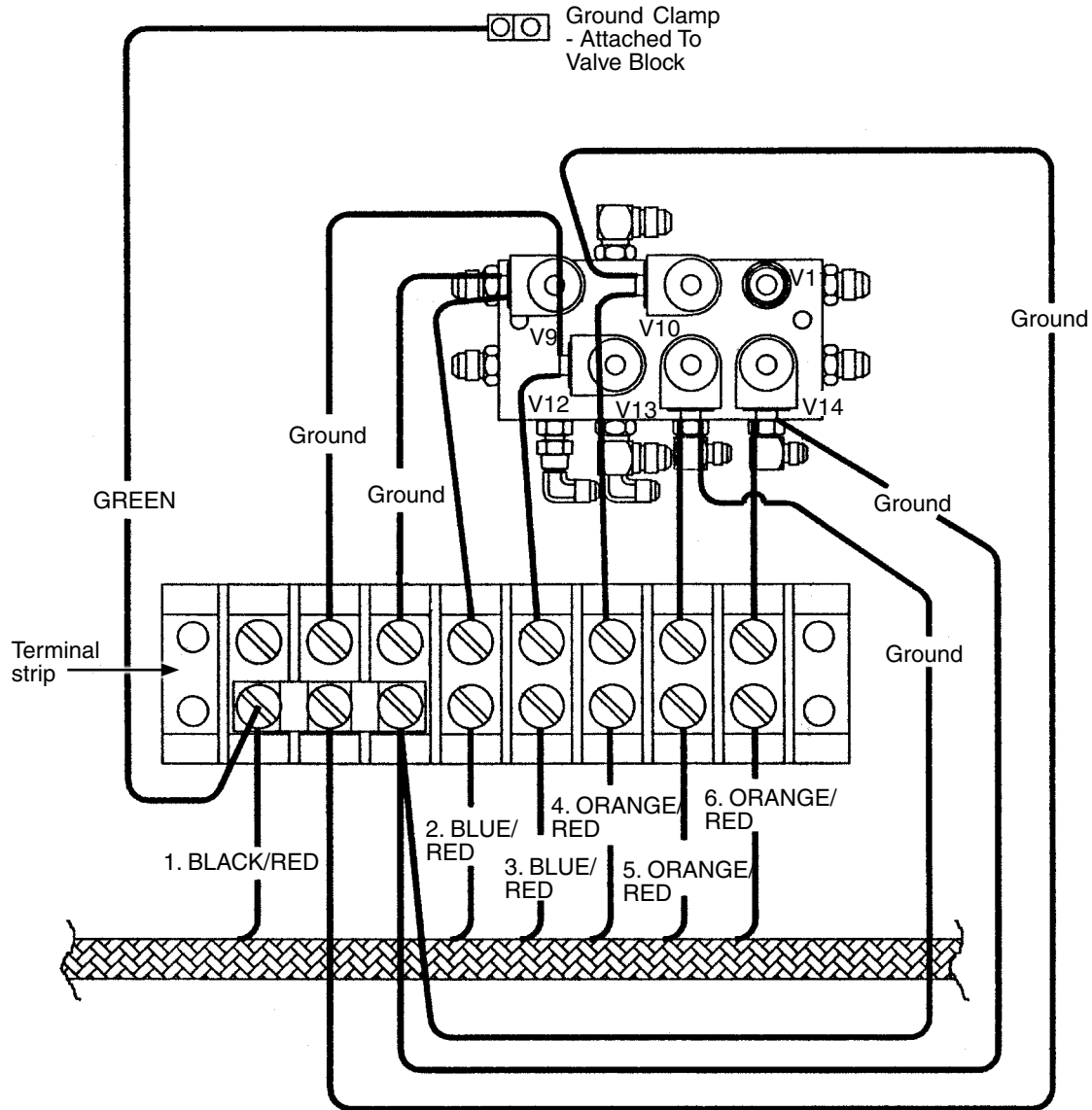

- 1. BLACK/RED - Pin "C" (Ground)
- 2. BLUE/RED - Pin "B" (Rotate) - Port V9
- 3. BLUE/RED - Pin "B" (Rotate) - Port V12
- 4. ORANGE/RED - Pin "A" (Tongue) - Port V10
- 5. ORANGE/RED - Pin "A" (Tongue) - Port V13
- 6. ORANGE/RED - Pin "A" (Tongue) - Port V14

VALVE BLOCK - LOCATED ON REAR CENTER FRAME

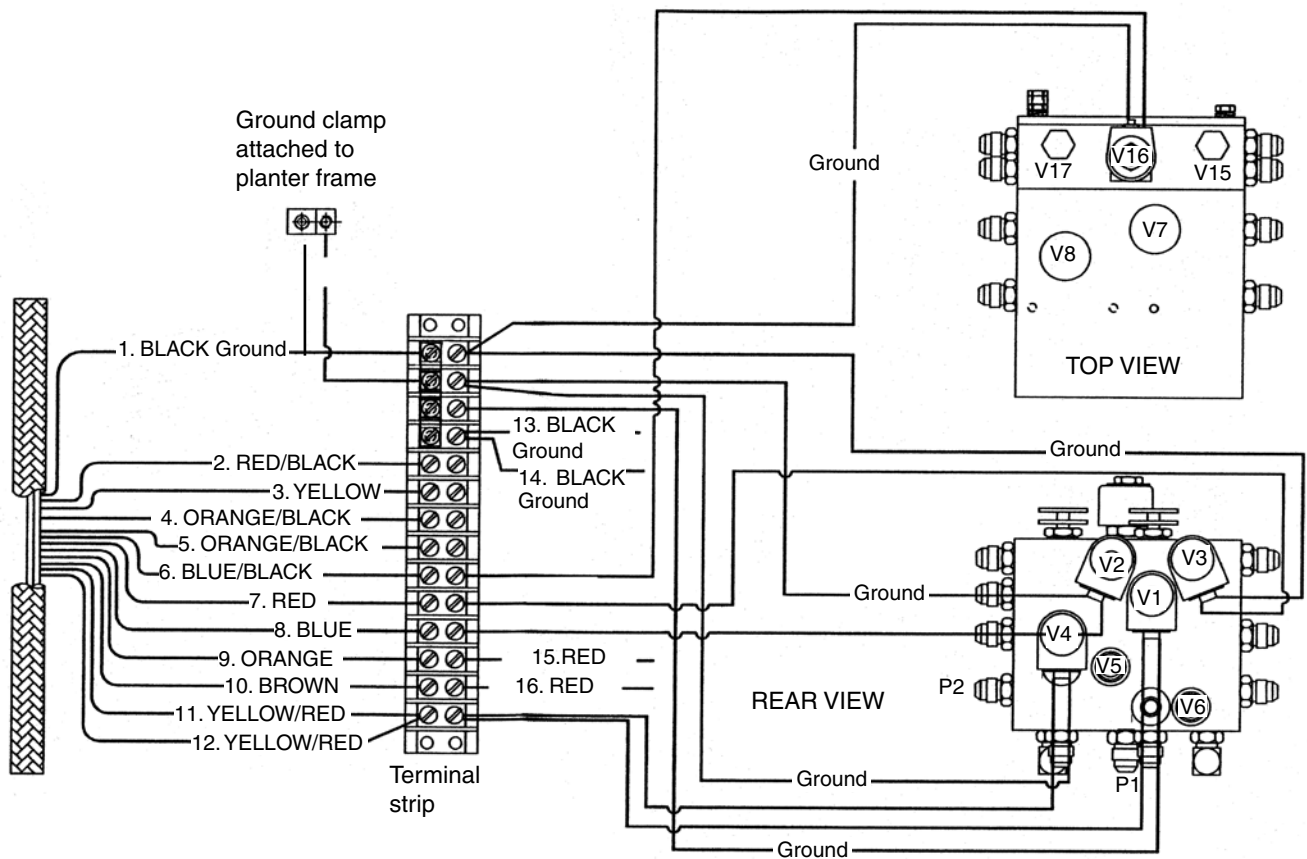

1. BLACK - Pin "T" (Ground)
2. RED/BLACK - Pin "U" (R.H. Two-Speed Clutch)*
3. YELLOW - Pin "S" (Le.H. Two-Speed Clutch)*
4. ORANGE/BLACK - Pin "W" (Auxiliary) - Ports V5 & V6
5. ORANGE/BLACK - Pin "W" (Auxiliary) - Ports V5 & V6
6. BLUE/BLACK - Pin "V" (Raise To Transport) - Port V16
7. RED - Pin "O" (R.H. Marker) - Port V1
8. BLUE - Pin "H" (L.H. Marker) - Port V2
9. ORANGE - Pin "G" (R.H. Point Row Clutch)
10. BROWN - Pin "R" (L.H. Point Row Clutch)
11. YELLOW/RED - Pin "F" (Wing Lock) - Ports V3 & V4
12. YELLOW/RED - Pin "F" (Wing Lock) - Ports V3 & V4
13. BLACK - (R.H. Point Row Ground)
14. BLACK - (L.H. Point Row Ground)
15. RED - (R.H. Point Row)
16. RED - (L.H. Point Row)

* See page 7-40 if equipped with optional Two-Speed Point Row Clutch Package.

ELECTRICAL CONTROL CONSOLE SCHEMATIC (With Optional Two-Speed Point Row Clutches) AND WIRING HARNESS AT TWO-SPEED POINT ROW CLUTCH SOLENOIDS

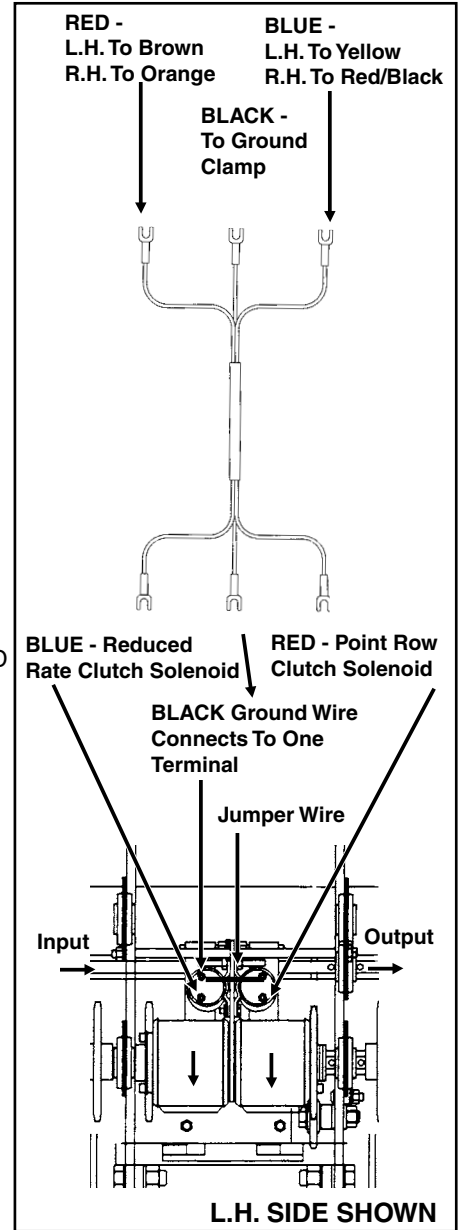
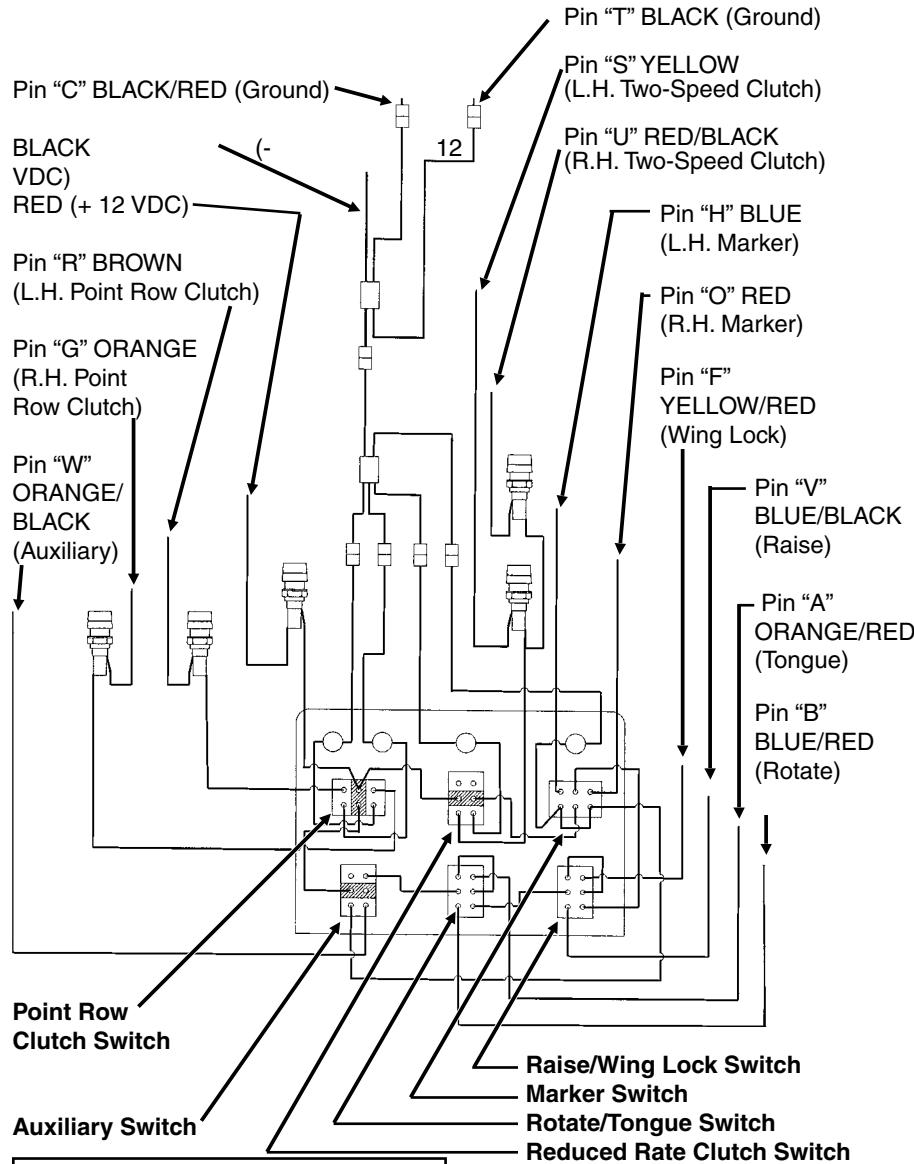

NOTE: Disconnect control console from tractor battery before doing any electrical work. Keep wiring harnesses away from high temperature areas or sharp edges. DO NOT route the wiring harnesses along battery cables. Use tie straps to keep wire harness away from moving parts on tractor and planter. Be sure ground connections to tractor frame are clean to provide good electrical contact.

NOTE:
 1. Point row and reduced rate clutch switches operate independently from rest of control console.
 2. Marker switch power is fed through auxiliary switch and two transport function switches. Operating any switches in lower row disables marker function and turns marker panel light off.

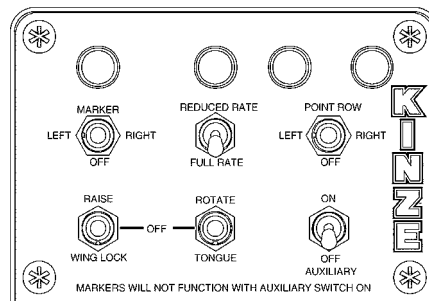

HYDRAULIC SYSTEM SCHEMATIC

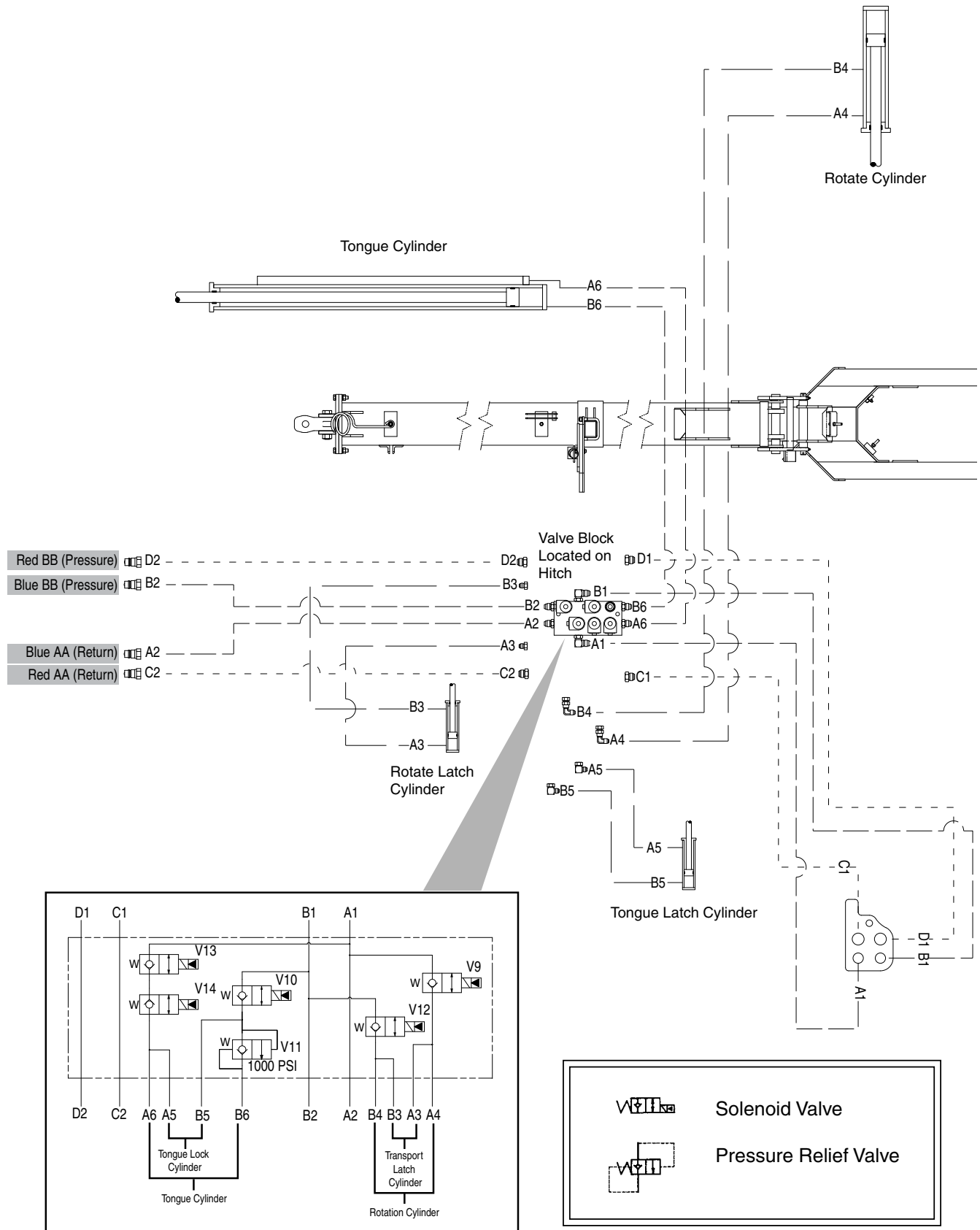

This page left blank intentionally.

Hydraulic System Schematic

12 Row (One Wing Lift Cylinder Per Wing) and 16 Row Shown (Two Wing Lift Cylinders Per Wing)

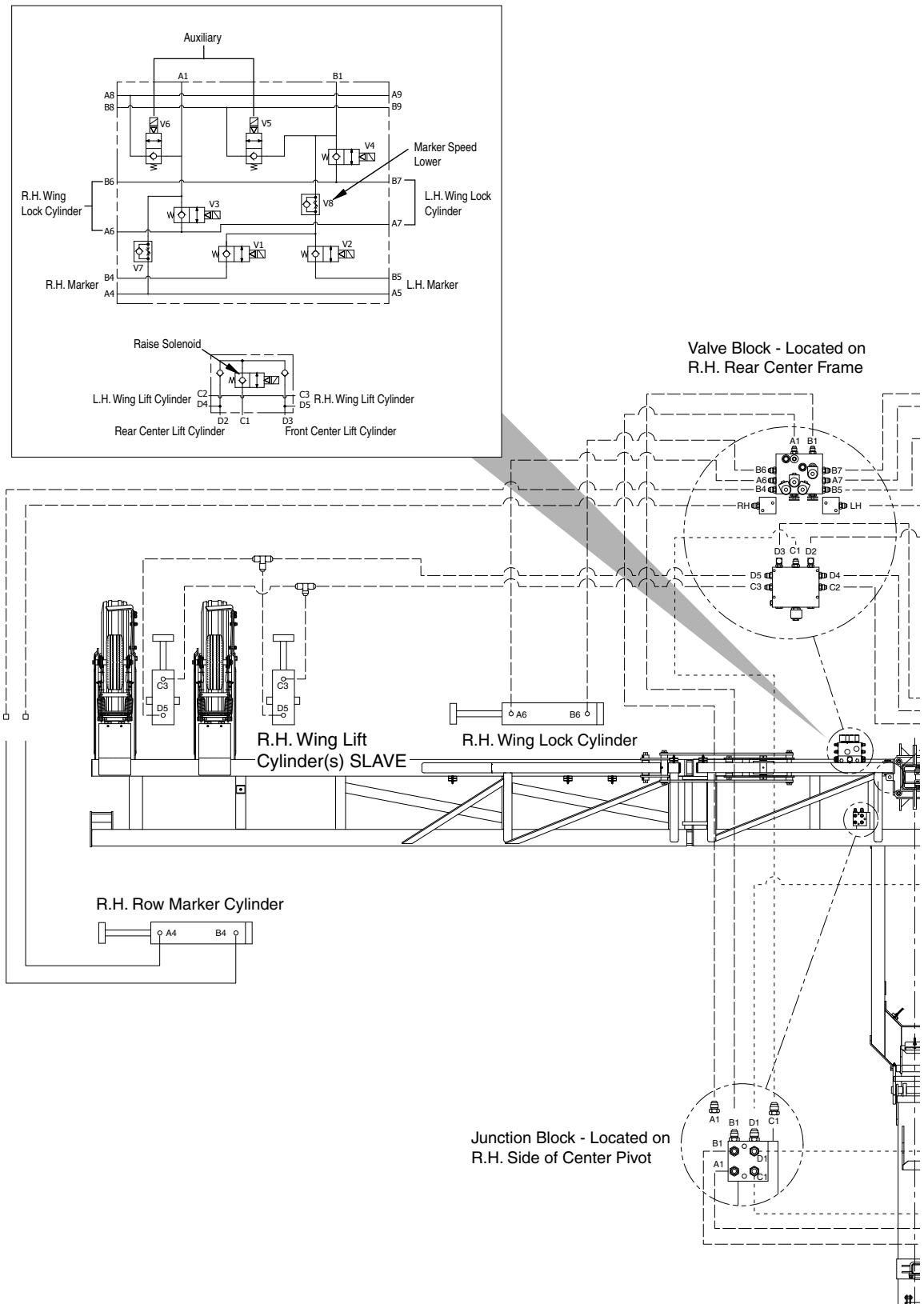

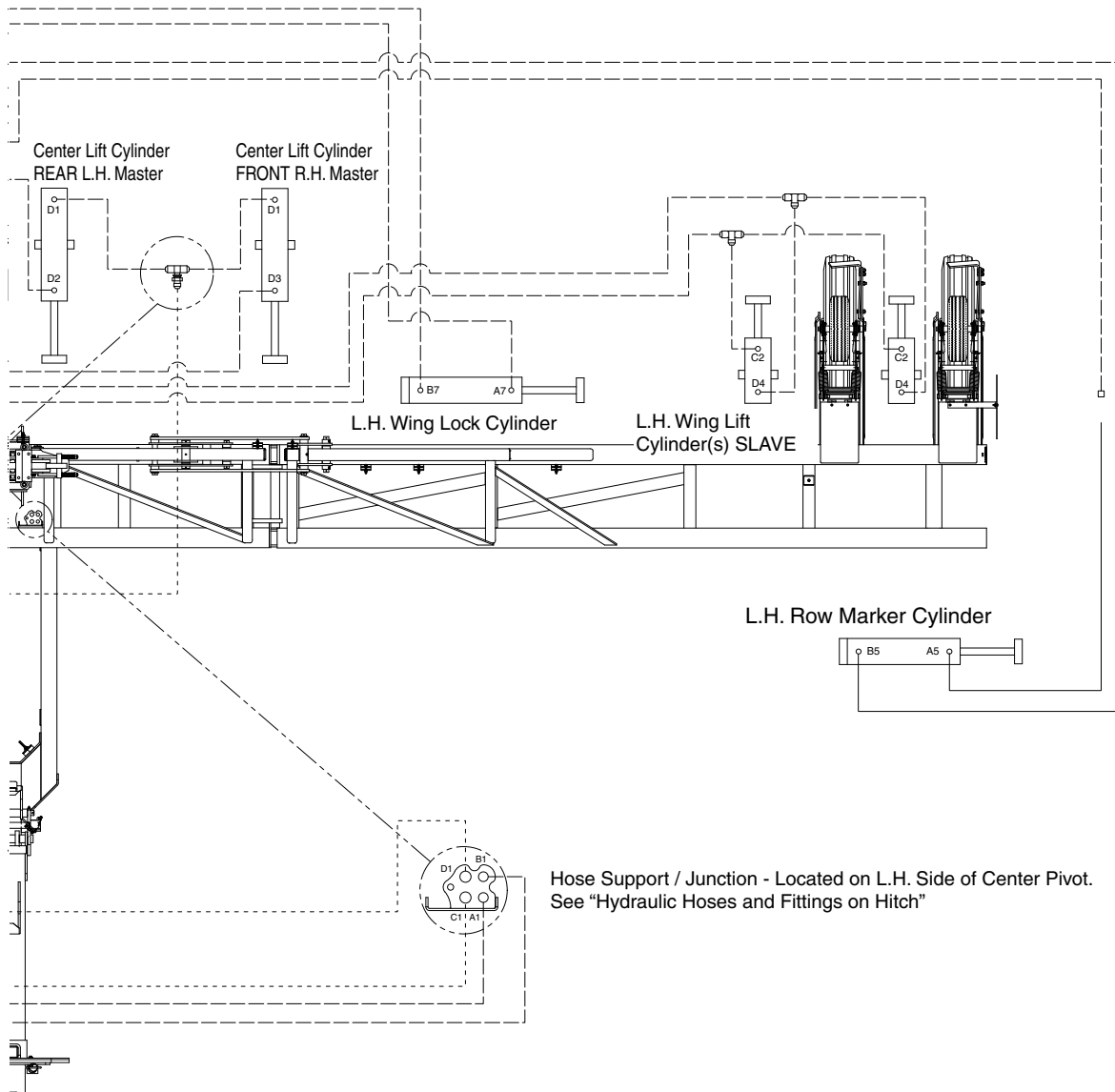
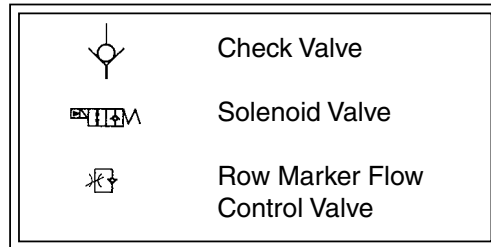

WING DOWN PRESSURE SCHEMATIC (WEIGHT TRANSFER MECHANISM)

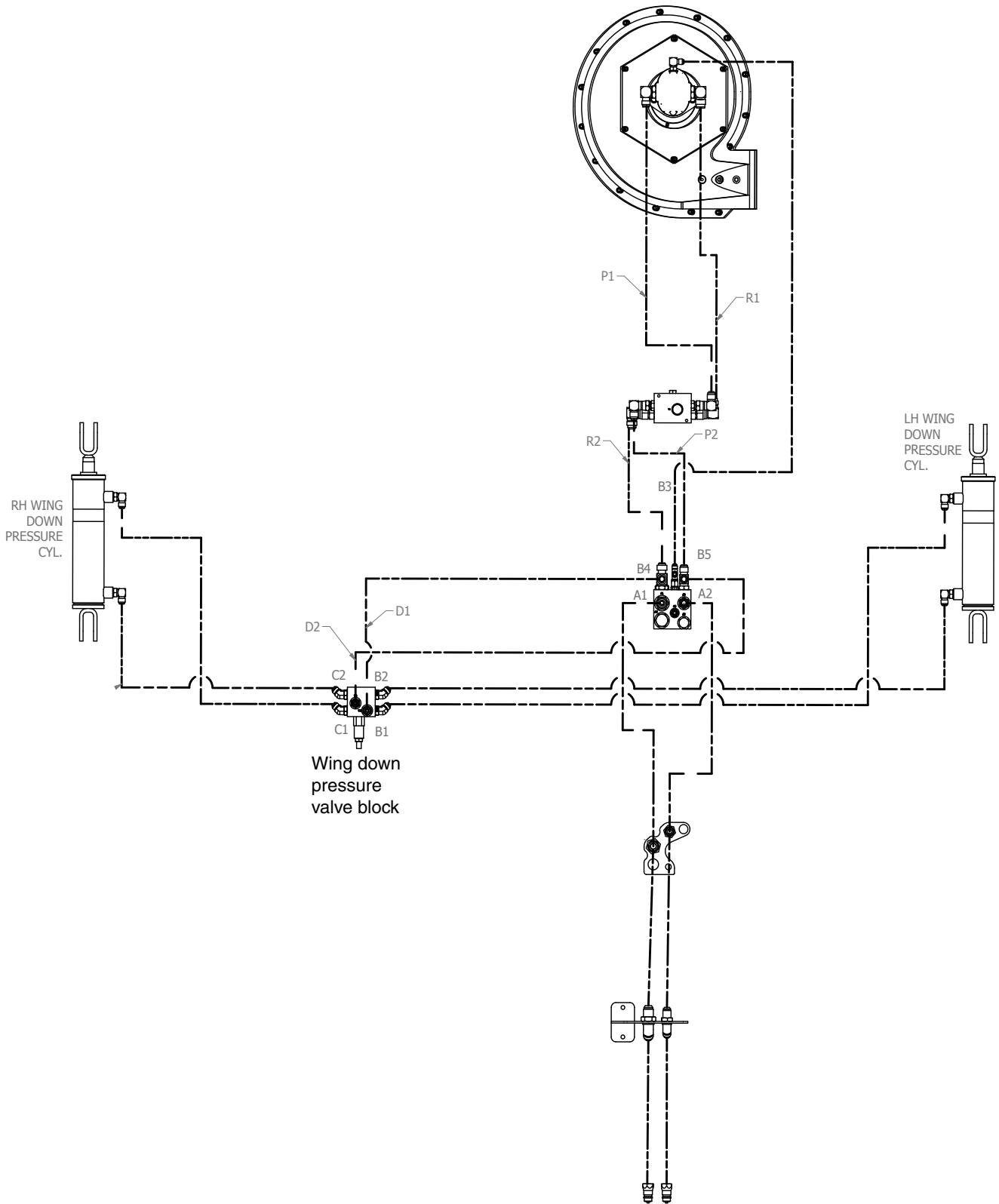

HYDRAULIC SCHEMATIC - VACUUM FAN MOTOR SYSTEM

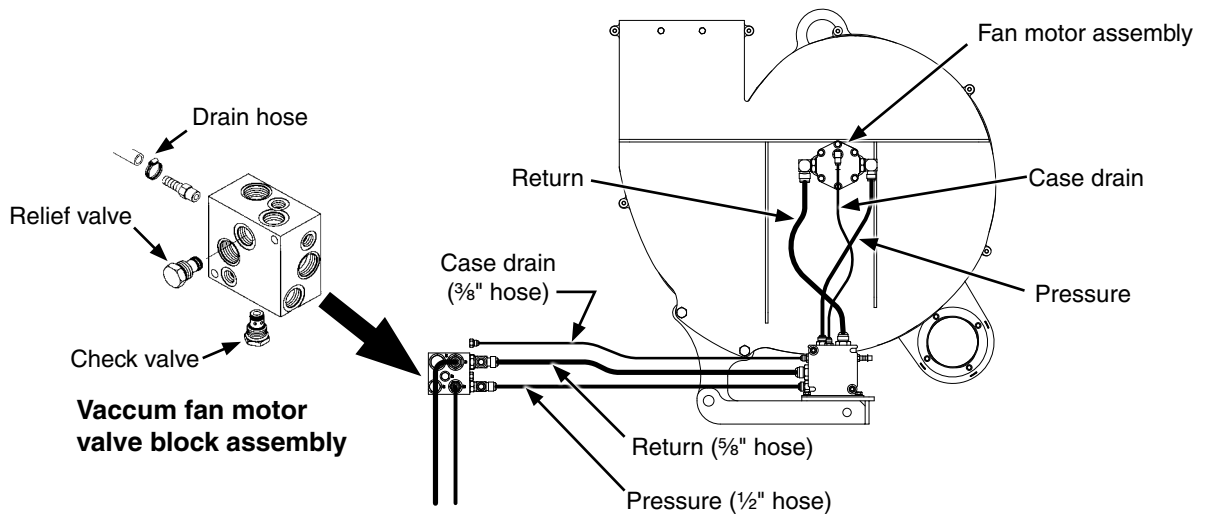

HYDRAULIC SCHEMATIC - OPTIONAL TRACTOR DRIVEN PTO PUMP AND OIL COOLER SYSTEM

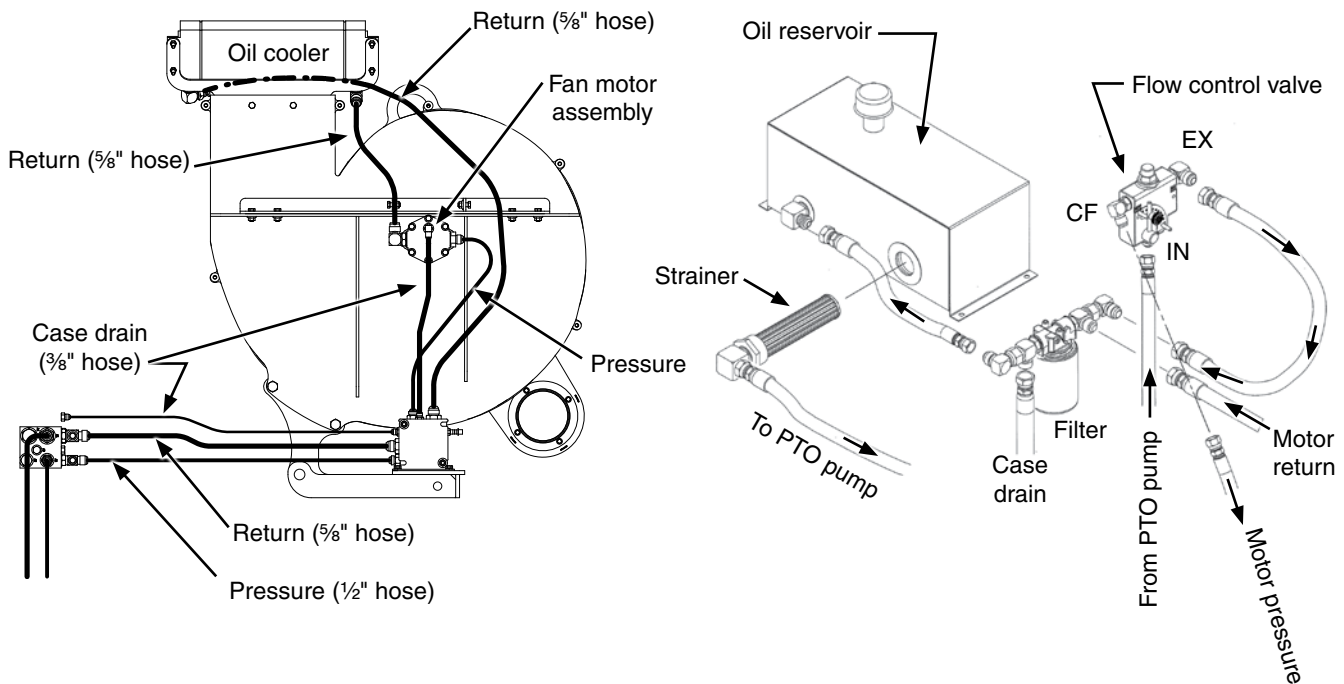

NOTICE

Failure to connect to a return with zero pressure will damage hydraulic motor. Connect hydraulic motor case drain to a case drain return line with zero pressure on tractor. DO NOT connect hydraulic motor case drain to SCV outlet. Contact tractor manufacturer for specific details on “zero pressure return”.

AIRLINE SCHEMATIC

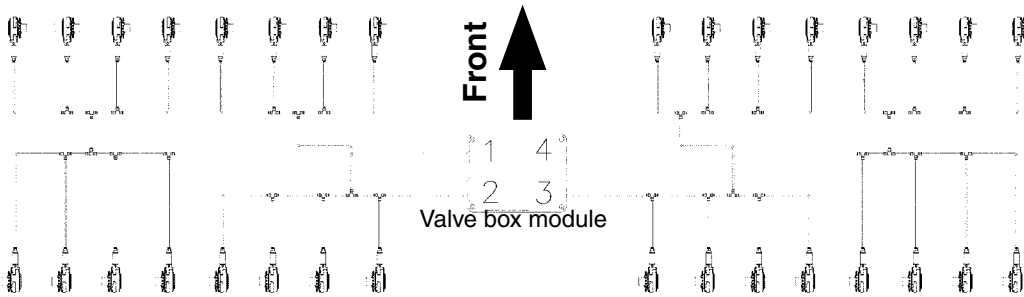
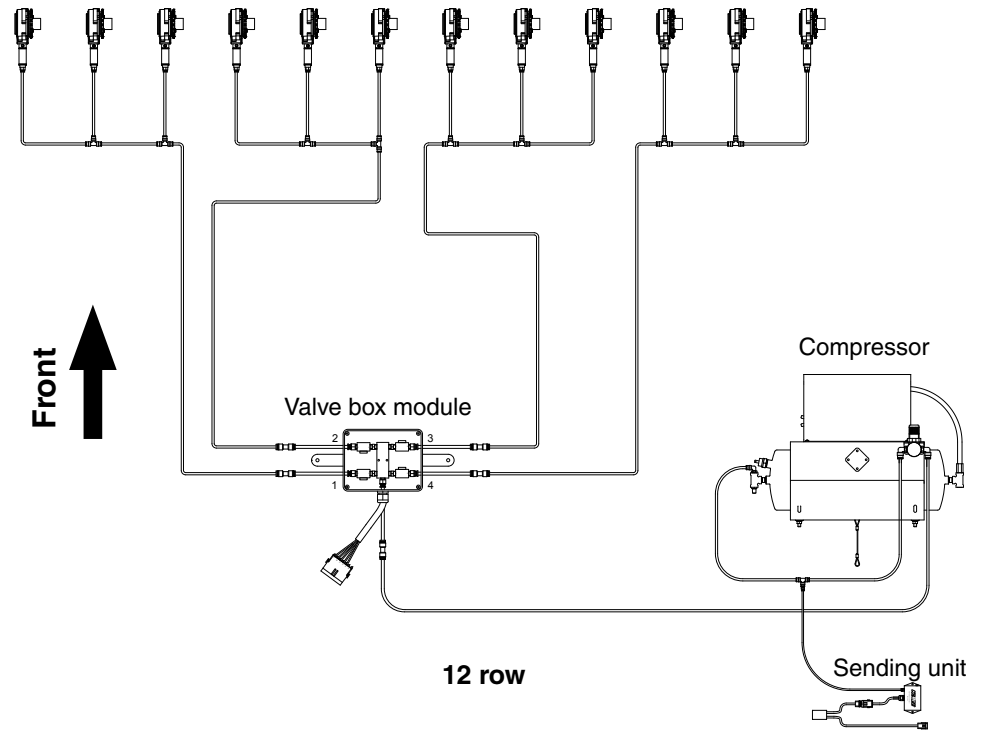

ELECTRIC CLUTCH SCHEMATIC

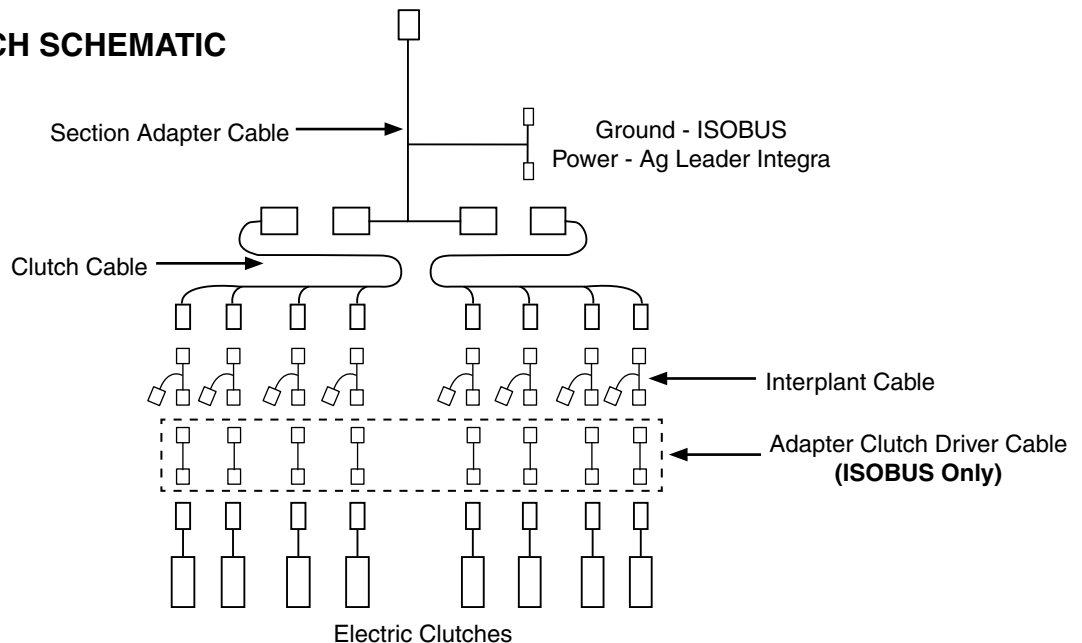

ISOBUS IMPLEMENT CABLE



Signal	ISO	Wire/Color	PMM	TBC	PCM	CAN	Mux A	Mux B
TBC Power	6	Twisted Quad Red	-	B	-	-	-	-
TBC Ground	7	Twisted Quad Black	-	D	-	-	-	-
ISO CAN H	8	Twisted Quad Yellow	31	E	-	-	-	-
ISO CAN L	9	Twisted Quad Green	32	F	-	-	-	-
ECU Power	4	Red	4, 5, 8	-	11	-	-	-
ECU Ground	2	Black	14, 15	-	12	-	-	-
LOAD Power	3	Red	-	-	1, 2, 3, 4	-	-	-
LOAD Ground	1	Black	-	-	5, 6, 7, 8	-	-	-
MUX A Power	-	Jacketed 3-Cond White	12	-	-	-	A	-
MUX A Ground	-	Jacketed 3-Cond Black	3	-	-	-	B	-
MUX A Signal	-	Jacketed 3-Cond Green	28	-	-	-	C	-
PROP CAN H	-	Twisted Pair Yellow	34	-	-	1	-	-
PROP CAN L	-	Twisted Pair Green	35	-	-	2	-	-
MUX B Power	-	Jacketed 3-Cond White	23	-	-	-	-	A
MUX B Ground	-	Jacketed 3-Cond Black	26	-	-	-	-	B
MUX B Signal	-	Jacketed 3-Cond Green	7	-	-	-	-	C

ISOBUS CAN JUMPER CABLE

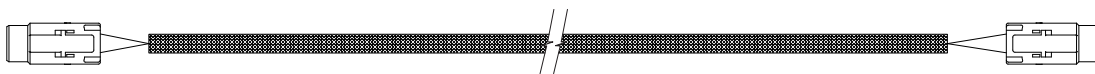

Signal	CAN	Wire/Color
CAN H	1	Twisted Pair Yellow
CAN L	2	Twisted Pair Green

PRODUCT CONTROL MODULE CABLE

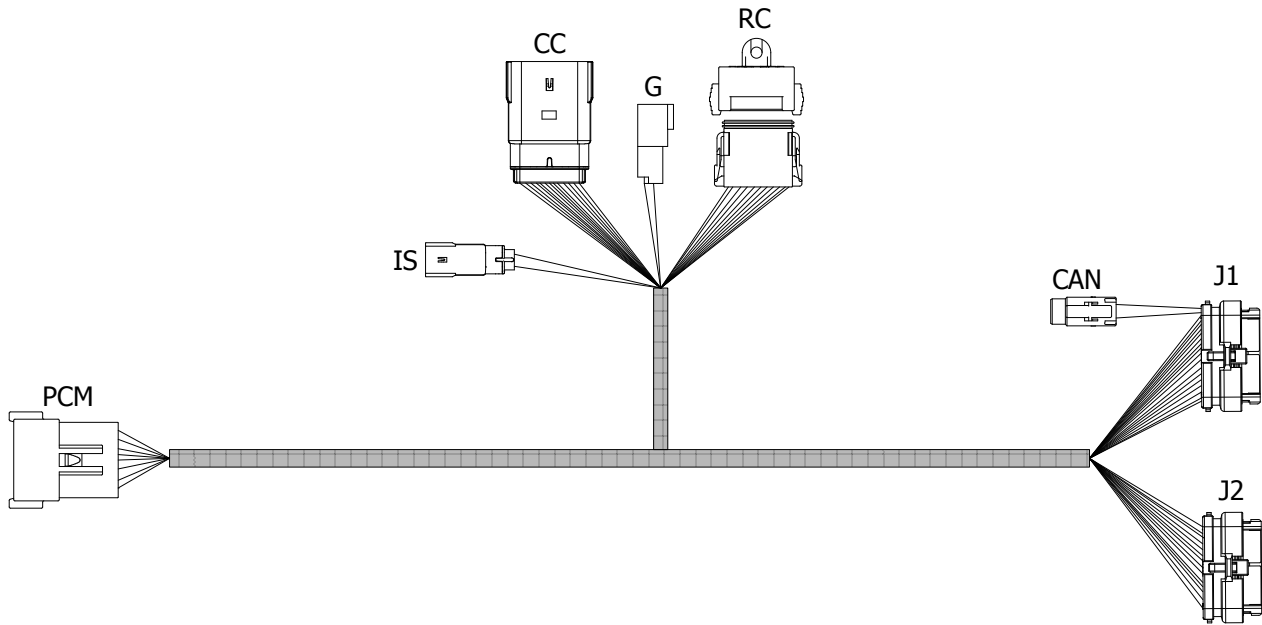

Signal	PCM	Wire/Color	J1	J2	CAN	RC	CC	IS	G
Load Power	1	Red	2	-	-	-	-	-	-
Load Power	2	Red	3	-	-	1	-	-	-
Load Power	3	Red	4	-	-	-	-	-	-
Load Power	4	Red	5	-	-	-	-	1	-
Load Ground	5	Black	-	-	-	-	-	-	1, 2
Load Ground	6	Black	14, 15	-	-	-	-	-	-
Load Ground	7	Black	16	-	-	2	-	-	-
Load Ground	8	Black	17	-	-	-	-	-	-
ECU Power	11	White/Red	11	-	-	-	-	-	-
CAN H	-	Twisted Pair Yellow	34	-	1	-	-	-	-
CAN L	-	Twisted Pair Green	33	-	2	-	-	-	-
Switch In	-	Red/Green	10	-	-	-	-	2	-
Section 1	-	White	24	-	-	-	1	-	-
Section 2	-	Green	25	-	-	-	2	-	-
Section 3	-	Orange	26	-	-	-	3	-	-
Section 4	-	Blue	27	-	-	-	4	-	-
Section 5	-	Brown	-	11	-	-	5	-	-
Section 6	-	Yellow	-	10	-	-	6	-	-
Section 7	-	Violet	-	9	-	-	7	-	-
Section 8	-	Gray	-	8	-	-	8	-	-
Section 9	-	Pink	-	7	-	-	9	-	-
Section 10	-	Tan	-	6	-	-	10	-	-
Section 11	-	Red/Green	-	5	-	-	11	-	-
Section 12	-	Black/Red	-	4	-	-	12	-	-
PWM 1 Power	-	Red/White	-	23	-	3	-	-	-
PWM 1 Ground	-	Black/White	35	-	-	4	-	-	-
PWM 2 Power	-	Red/Yellow	-	12	-	5	-	-	-
PWM 2 Ground	-	Black/Yellow	12	-	-	6	-	-	-
PWM 3 Power	-	Red/Blue	1	-	-	7	-	-	-
PWM 3 Ground	-	Black/Blue	-	24	-	8	-	-	-
Meter Speed 1	-	Green	30	-	-	9	-	-	-
Meter Speed 2	-	Green/White	29	-	-	10	-	-	-
Meter Speed 3	-	Green/Red	-	33	-	11	-	-	-

IMPLEMENT SWITCH EXTENSION CABLE

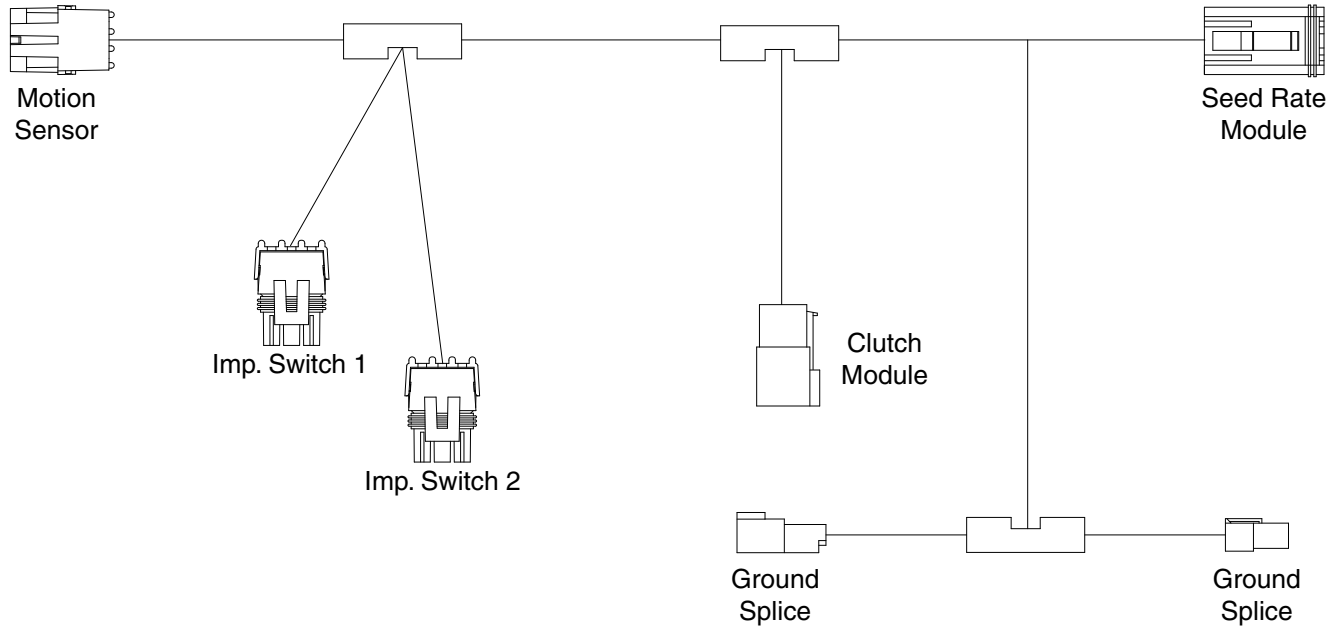

Signal	Imp. Switch 1 WP Tower 1	Imp. Switch 2 WP Tower 2	Motion Sensor WP Shroud	Color	Clutch Module Molex Recept	Seed Rate Module Deutsch Plug	Ground Splice 1	Ground Splice 2	Gauge
12V+ Power	A	A	-	Brown	1	12	-	-	16
Switch Signal	B	B	-	Green	2	10	-	-	16
Motion Signal	-	-	C	White	-	11	-	-	16
Ground	-	-	B	Black	-	6	-	-	16
12V+ Power	-	-	A	Red	-	1	-	-	16
Ground	C (Blue 16 AWG)	C (Blue 16 AWG)	-	Black	-	-	2	2	12
12V+ Power	-	-	-	Red	-	-	1	1	12

SECTION ADAPTER CABLE - 12 ROW

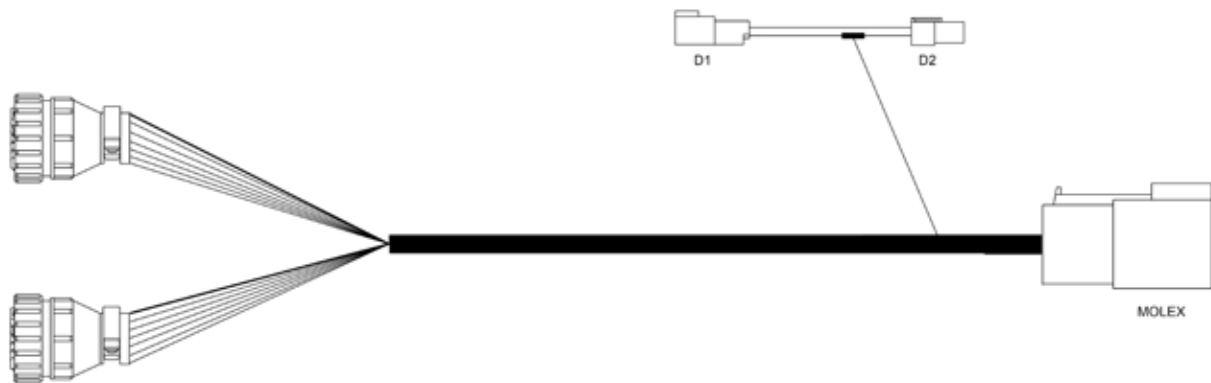

Signal	Color	AMP 1 (Left)	AMP 2 (Right)	Molex	D1	D2
High Current Power	Red	1 (16 Gauge)	1 (16 Gauge)	-	1 (12 Gauge)	1 (12 Gauge)
Ground	Black	-	-	-	2	2
Row 1, 2	Black	2, 3	-	1	-	-
Row 3, 4	Brown	4, 5	-	2	-	-
Row 5, 6	Orange	6, 7	-	3	-	-
Row 7, 8	Pink	-	6, 7	4	-	-
Row 9, 10	Green	-	4, 5	5	-	-
Row 11, 12	Yellow	-	2, 3	6	-	-

SECTION ADAPTER CABLE - 16 ROW

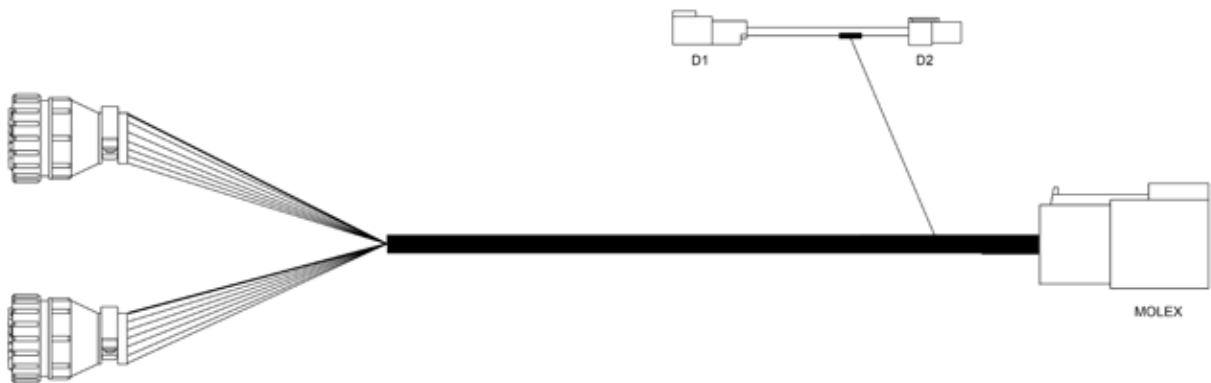

Signal	Color	AMP 1 (Left)	AMP 2 (Right)	Molex	D1	D2
High Current Power	Red	1 (16 Gauge)	1 (16 Gauge)	-	1 (12 Gauge)	1 (12 Gauge)
Ground	Black	-	-	-	2	2
Row 1, 2	Black	2, 3	-	1	-	-
Row 3, 4	Brown	4, 5	-	2	-	-
Row 5, 6	Orange	6, 7	-	3	-	-
Row 7, 8	Pink	8, 9	-	4	-	-
Row 9, 10	Green	-	8, 9	5	-	-
Row 11, 12	Yellow	-	6, 7	6	-	-
Row 13, 14	Blue	-	4, 5	7	-	-
Row 15, 16	Violet	-	2, 3	8	-	-

CLUTCH CABLE - 12 ROW

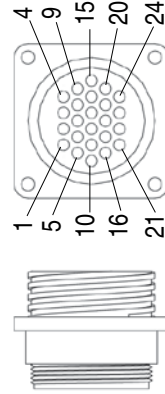
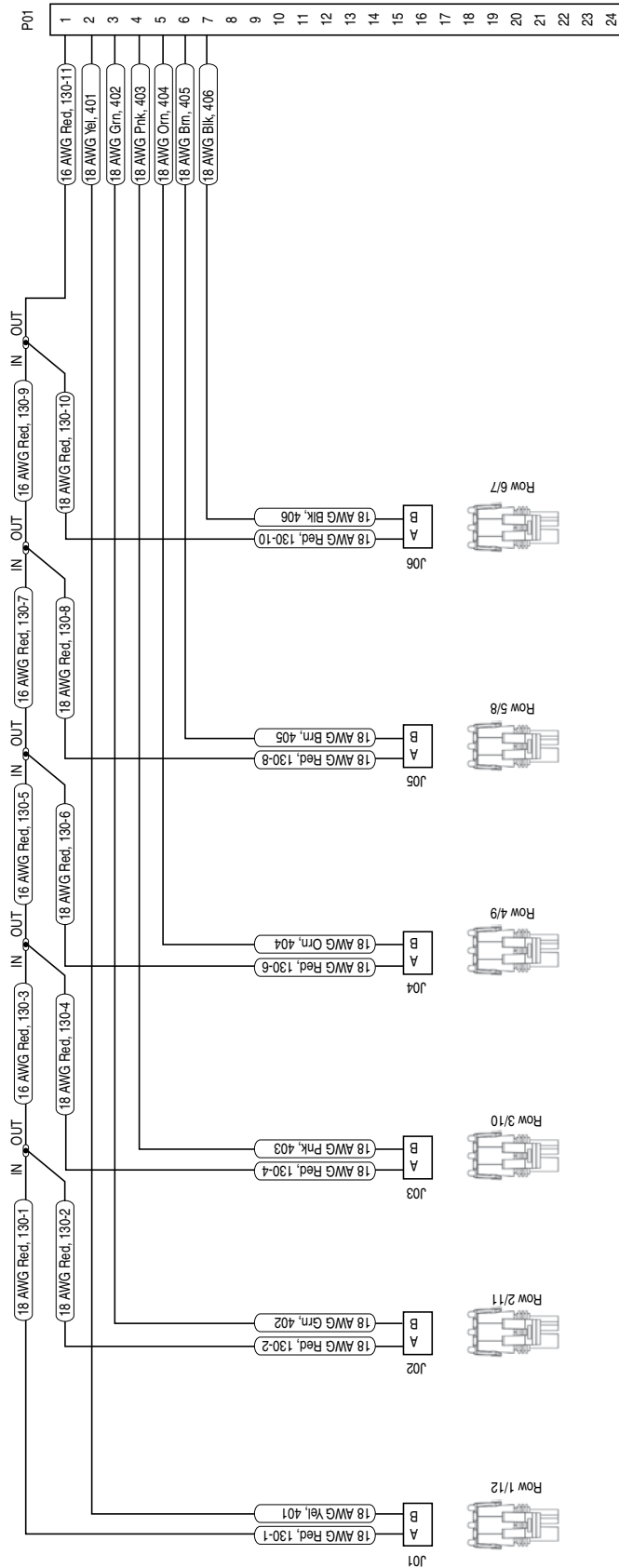

Clutch Module
Left/Right

Signal	Clutch Cable	Row 8/9	Row 7/10	Row 6/11	Row 5/12	Row 4/13	Row 3/14	Row 2/15	Row 1/16
Power	1	A	A	A	A	A	A	A	A
Row 1/16	2	-	-	-	-	-	-	-	B
Row 2/15	3	-	-	-	-	-	B	-	-
Row 3/14	4	-	-	-	-	B	-	-	-
Row 4/13	5	-	-	-	B	-	-	-	-
Row 5/12	6	-	-	-	-	-	-	-	-
Row 6/11	7	-	-	B	-	-	-	-	-
Row 7/10	8	-	B	-	-	-	-	-	-
Row 8/9	9	B	-	-	-	-	-	-	-

CLUTCH CABLE - 16 ROW

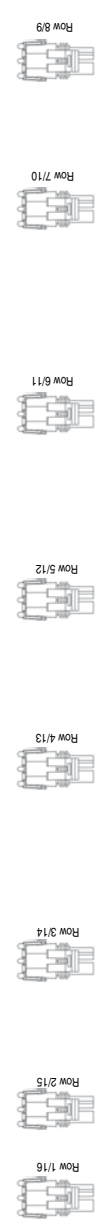
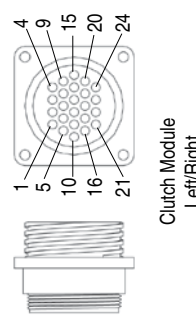
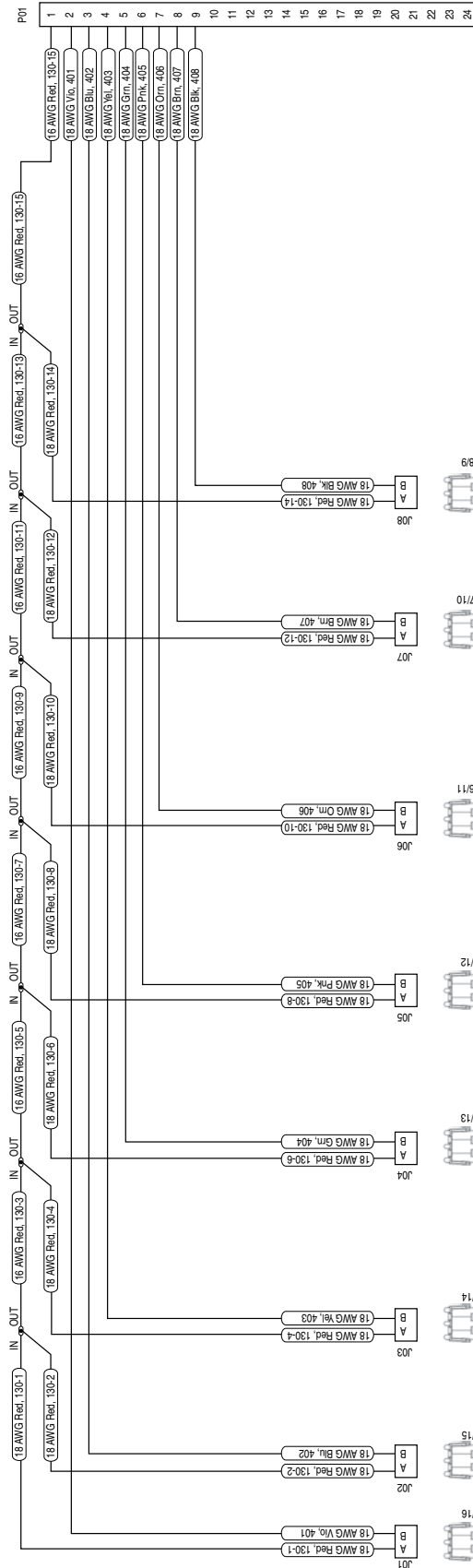

Signal	Clutch Cable	Row 8/9	Row 7/10	Row 6/11	Row 5/12	Row 4/13	Row 3/14	Row 2/15	Row 1/16
Power	1	A	A	A	A	A	A	-	-
Row 1/12	2	-	-	-	-	-	B	-	-
Row 2/11	3	-	-	-	-	-	-	-	-
Row 3/10	4	-	-	-	B	-	-	-	-
Row 4/9	5	-	-	B	-	-	-	-	-
Row 5/8	6	-	B	-	-	-	-	-	-
Row 6/7	7	B	-	-	-	-	-	-	-

AIR CLUTCH

PROBLEM	POSSIBLE CAUSE	SOLUTION
Clutches slip (effected row does not plant or skips).	Plunger in cylinder seized.	Remove air line and lubricated with pneumatic or light duty hydraulic oil.
	Worn Clutch.	Replace worn items.
	Dirt / debris buildup inside clutch.	Disassemble clean as needed. Reassemble.

AIR SEED DELIVERY (ASD)

PROBLEM	POSSIBLE CAUSE	SOLUTION
Seed does not travel through delivery tubes.	System pressure set too low.	Increase system pressure.
Seed stops flowing to row unit during planting.	Seed surging.	Shut down air seed delivery system and restart system from idle; seed should start flowing.
	Debris in system.	Insert shutoff door, open cleanout door. remove plug.
Seed does not move from entrainer at startup after exposure to water.	Seed swelled in entrainer.	Insert shutoff door, open cleanout door. remove swelled seed.

CLOSING WHEEL

PROBLEM	POSSIBLE CAUSE	SOLUTION
Closing wheel(s) leave severe imprint in soil.	Too much closing wheel down pressure.	Adjust closing wheel pressure.
Closing wheel(s) not firming soil around seed.	Not enough closing wheel down pressure.	Adjust closing wheel pressure. Severe no till conditions may require use of cast iron closing wheels.
"V" closing wheel running on top of seed furrow.	Improper centering.	Align. See "V Closing Wheel Adjustment".
Single closing wheel not directly over seed.	Improper centering.	Align. See "Covering Discs/Single Press Wheel Adjustment".

KPM III ELECTRONIC SEED MONITOR

PROBLEM	POSSIBLE CAUSE	SOLUTION
Single sensor communication alarm comes on.	Faulty seed tube sensor.	Replace sensor.
	Break in the harness just before the seed tube sensor.	Inspect for break in harness and repair. If break can't be found, replace harness section.
	Dirty or corroded connector.	Clean connector.
Sensor communication alarms come on for all sensors.	Faulty monitor.	Repair/Replace monitor.
	Break in the harness just after the monitor.	Inspect for break in harness and repair. If break can't be found, replace harness section.
	Dirty or corroded connector.	Clean connector.
Sensor communication alarms come on for some sensors.	Break in the harness.	Inspect for break in harness and repair. If break can't be found, replace harness section corresponding with alarming sensors.
	Dirty or corroded connector.	Clean connector.
Faulty monitor values (such as speed, area, etc.) being displayed.	Incorrect monitor settings.	Change settings to properly correspond to the system.
	Faulty radar/magnetic distance sensor.	Replace sensor.
	Improperly mounted radar sensor.	Properly mount sensor.
Underplanting or no planting alarm on a single sensor when planting (alarm on with a single bargraph segment on and a flashing row number on a single row.	Seed tube sensor is blocked.	Clean sensor.
	Faulty seed tube sensor.	Replace sensor.
	Meter not planting or underplanting.	Repair/replace meter.
	Chain broken or off sprocket.	Repair as necessary.
Seed tube sensor dirty or blocked warning comes on.	Seed tube sensor is dirty.	Clean sensor.
	Faulty seed tube sensor.	Replace sensor.
LED on seed tube sensor will not come on.	Faulty seed tube sensor.	Replace sensor.
	Dirty or corroded connector.	Clean connector.
	Break in the harness just before the sensor.	Repair harness.
Erroneous MPH readings at idle. (Radar Distance Sensor Only)	Radar sensor not located in a stable location.	Relocate to a more stable location.

LIFT CIRCUIT

PROBLEM	POSSIBLE CAUSE	SOLUTION
Right wing raises faster than left wing. Right wing may even raise completely before the center frame and left wing start to raise. If planter is loaded, the center frame and left wing may not be able to raise at all.	Master cylinder, located on front side of center post, leaking internally. NOTE: Make sure lift system is completely rephased.	Repair master cylinder.
Left wing raises faster than right wing. Left wing may even raise completely before the center frame and right wing start to raise. If the planter is loaded, the center frame and right wing may not be able to raise at all.	Master cylinder, located on rear side of center post, leaking internally. NOTE: Make sure the lift system is completely rephased.	Repair master cylinder.
Center frame raises, but wings do not.	Planter hydraulic circuit out of phase. Usually occurs when the planter is lowered from transport position. Solenoid valve in port V16 leaking.	Hold hydraulic control in lowering position to give the hydraulic circuit more time to rephase. Replace solenoid valve cartridge.
Center frame continues to raise after wing cylinders have reached full stroke when going to raised field position.	Solenoid valve in port V16 leaking.	Replace solenoid valve cartridge.
Planter raises to raised field position, but does not raise to transport position.	Solenoid valve coil in port V16 is not energized.	Be sure control console switch is in "raise" position to energize solenoid coil in port V16. Check control console fuse by moving auxiliary switch to ON position. If red light comes on the fuse is OK. Return auxiliary to OFF position. Check for poor wire connection or damaged wire and repair. Solenoid valve coil is defective. All solenoid valves used on the planter are the same. Switch the solenoid coil with one you know is working. If this cures the problem, replace defective coil.
	Solenoid valve cartridge in port V16 is stuck closed.	All solenoid valves used on the planter are the same. Switch the solenoid cartridge with one you know is working. If this cures the problem, replace defective cartridge.
Left wing lowering slower than center frame and right wing. If hydraulic lever is held in lowering position, left wing cylinder attempts to extend.	Check valve in port V17 leaking internally.	Remove check valve in port V17 and inspect for foreign material in valve and remove if possible. Replace check valve. If above fails, switch check valve in port V17 with check valve in port V15. If problem moves or switches to right wing, replace defective check valve.
Right wing lowering slower than center frame and left wing. If hydraulic control is held in lowering position, right wing cylinder attempts to extend.	Check valve in port V15 leaking internally.	Remove check valve in port V15 and inspect for foreign material in valve and remove if possible. Replace check valve. If above fails, switch check valve in port V15 with check valve in port V17. If problem moves or switches to right wing, replace defective check valve.
Planter does not raise or raises slowly.	Tractor may have hydraulic problem.	Switch remote outlets being used. Repair tractor hydraulics.
	Planter may be overloaded with hopper extensions and/or extra fertilizer tanks, coulters or other non-Kinze attachments.	Remove weight.
	Center pivot wear pads may be adjusted too tight and are binding on the post.	Adjust pads.
Planter will not rephase.	All cylinders not completely retracted. Caused by mechanical interference on or between planter frame and wheel lift module.	Remove interference.
	Center cylinders not retracting completely.	Lower planter and hold hydraulic lever in lower position to rephase system. Lower cylinder pins must be free to rotate in this position. If pins are tight, adjust cylinder clevises.

PISTON PUMP

PROBLEM	POSSIBLE CAUSE	SOLUTION
Pump hard or impossible to prime.	Valves fouled or in wrong place.	Inspect and clean valves.
	Air leak in suction line.	Repair leak.
	Pump set too low.	Adjust pump setting.
	Packing washers worn out.	Replace.
Low metering.	Valves fouled or in wrong place.	Inspect and clean valves.
	Air leak in suction line.	Repair leak.
	Pump set too low.	Adjust pump setting.
	Broken valve spring.	Replace spring.
Over meters.	Broken discharge valve spring.	Replace spring.
	Trash under valves.	Inspect and clean valves.
	Improper rate setting.	Adjust pump setting.
Leaks through when stopped.	Broken discharge valve spring.	Replace spring.
	Trash under valves.	Inspect and clean valves.
Fertilizer solution leaking under stuffing box.	Packing washers worn out.	Replace.
Pump using excessive oil.	Oil seals or O-ring worn and leaking.	Replace.
Pump operates noisily.	Crankcase components worn excessively.	Inspect and replace if necessary.

PTO PUMP DRIVE AND OIL COOLER OPTION

PROBLEM	POSSIBLE CAUSE	SOLUTION
Pump is squealing.	Lack of oil to pump.	Check for plugged suction strainer. Check oil level.
Oil temperature is high.	Low oil level.	Check oil level and add as required.
Desired fan speed cannot be achieved.	Low oil level.	Check oil level and add as required.
	Plugged filter.	Check and change as required.

POINT ROW CLUTCH

PROBLEM	POSSIBLE CAUSE	SOLUTION
No clutches disengage.	Main fuse blown in control console.	Replace defective fuse.
	Poor terminal connection in wiring harness.	Repair or replace.
	Wiring damage in wiring harness.	Repair or replace.
	Low voltage at coil. (12 volts required)	Check battery connections.
One section of planter will not re-engage.	Shear pin at seed drive transmission(s) sheared.	Replace pin with one of equal size and grade.
One clutch will not engage.	Fuses blown.	Replace defective fuses.
	Actuator arm and plunger stuck in disengaged position.	Remove, free up, and reinstall.
	Actuator arm out of adjustment.	Adjust actuator arm mounting pin in slot so that actuator arm clears stop on stop collar by approximately 1/8" when clutch is rotated.
	Wrap spring broken or stretched.	Disassemble clutch and replace spring.
	Something touching the stop collar.	Check to ensure collar is free to turn with clutch.
	Clutch assembled incorrectly.	Check clutch and diagram for correct assembly.
Clutch slipping.	Wrap spring stretched.	"Lock" clutch output shaft from turning. Place torque wrench on input shaft and rotate in direction of drive. After input shaft has rotated a short distance the wrap spring should tighten onto the input hub. If slippage occurs at less than 100 ft. lbs. replace spring. If spring still slips after installing new spring, replace input hub.
Planter section does not re-engage while planter is moving forward.	Spring in actuator arm not strong enough to push arm operational switch is turned to the ON position.	Remove spring from inside solenoid and stretch spring slightly or replace. Reinstall spring. If that fails, file the away from stop collar when stop on the stop collar slightly so that the stop is not as aggressive.
Frequent solenoid burnout.	Fuses too large.	Replace fuses on front panel with 10 amp slow blow fuses.
Frequent fuse burnout.	Low voltage (12 volts required).	Check power source voltage for partially discharged battery, etc.
	Damage to wiring harness.	Repair or replace harness.
Clutch or clutches will not disengage.	Input and output shafts out of alignment.	Align input and output shafts to prevent drag.
	Input or output shaft is pushed in too far creating a coupler.	Reposition input and output shafts.

ROTATION CIRCUIT

PROBLEM	POSSIBLE CAUSE	SOLUTION
Cylinder does not extend, but will retract.	Solenoid valve coil in port V12 defective.	Switch coil from port V12 with coil in port V9. If cylinder extends but will not retract, replace defective coil from port V12.
	Solenoid valve cartridge in port V12 stuck closed.	Switch cartridge from port V12 with cartridge in port V9. If cylinder extends but will not retract, replace defective cartridge from port V12.
Cylinder does not retract, but will extend.	Solenoid valve coil in port V9 defective.	Switch coil from port V9 with coil in port V12. If cylinder extends but will not retract, replace defective coil from port V9.
	Solenoid valve cartridge in port V9 stuck closed.	Switch cartridge from port V9 with cartridge in port V12. If cylinder extends but will not retract, replace defective cartridge from port V9.

ROW MARKER OPERATION

PROBLEM	POSSIBLE CAUSE	SOLUTION
Right marker lowering slower than left marker.	Solenoid valve cartridge in port V1 not opening completely.	Switch with cartridge in port V2. If problem repeats, replace cartridge.
	Hose pinched or collapsed.	Inspect hose routing. Replace or repair hoses as required.
Left marker lowering slower than right marker.	Solenoid valve cartridge in port V2 not opening completely.	Switch with cartridge in port V1. If problem repeats, replace cartridge.
	Hose pinched or collapsed.	Inspect hose routing. Replace or repair hoses as required.
Both markers lowering.	Solenoid valve cartridge stuck open. If left marker switch is selected, right cartridge (V1) is defective. If right marker switch is selected, left cartridge (V2) is defective.	Replace solenoid valve cartridge.
Neither marker lowers.	Blown fuse.	Check red light on control console. It should be on if switch is on. If light is not on, switch to opposite marker position. If light comes on, switch may be defective. Replace switch. Otherwise replace fuse.
	Coils at V1 and V2 not energized.	Poor ground on wire, bad wire connection or damaged wire. Repair as required.
	Marker flow control valve closed too far.	See Operation Section for adjustment.
Neither marker will raise.	Marker flow control valve closed too far.	See Operation Section for adjustment.
Right marker will not lower.	Solenoid coil in port V1 not energized.	Check switch on control console. Replace if defective. Check coil ground wire. Check for poor connection or damaged wire.
	Solenoid cartridge in port V1 stuck closed.	Switch cartridge with one on the planter you know is operating properly. If right marker lowers, replace defective cartridge.
Left marker will not lower.	Solenoid coil in port V2 not energized.	Check switch on control console. Replace if defective. Check coil ground wire. Check for poor connection or damaged wire.
	Solenoid cartridge in port V2 stuck closed.	Switch cartridge with one on the planter you know is operating properly. If left marker lowers, replace defective cartridge.
Markers traveling too fast and damaging rubber stop on transport stands and/or damaging pivot at rod end of marker cylinders.	Marker transport stand not adjusted correctly to allow marker cushion cylinders to operate as designed.	See "Row Marker Transport Stand Adjustment".
	Marker flow control valve needs adjustment.	See Operation Section for adjustment.

SEED METER (BRUSH-TYPE)

PROBLEM	POSSIBLE CAUSE	SOLUTION
Low count.	Meter RPM too high.	Reduce planting speed.
	Seed sensor not picking up all seeds dropped.	Clean seed tube. Switch meter to different row. If problem stays in same row, replace sensor.
	Lack of lubrication causing seeds not to release from disc properly.	Use graphite or talc as recommended.
	Seed size too large for seed disc being used.	Switch to smaller seed or appropriate seed disc. See "Brush-Type Seed Meter" for proper seed disc for size of seed being used.
	Seed treatment buildup in meter.	Reduce treatment amount used. Thoroughly mix treatment with seed. Add talc.
Low count at low RPM and higher count at higher RPM.	Foreign material lodged in upper brush.	Remove seed disc and remove foreign material from between brush retainer and bristles. Clean thoroughly.
	Worn upper brush.	Replace. See "Maintenance".
Low count at higher RPM and normal count at low RPM.	Seed disc worn in agitation groove area.	Replace disc. See "Maintenance".
High count.	Seed size too small for seed disc.	Switch to larger or appropriate seed disc.
	Incorrect seed rate transmission setting.	Reset transmission. Refer to rate charts.
	Upper brush too wide (fanned out) for small seed size.	Replace upper brush.
High count. (Milo/Grain Sorghum)	Incorrect brush retainer being used.	Make sure GD8237 brush retainer is used to keep upper brush from fanning out.
Upper brush laid back.	Seed treatment buildup on brush.	Remove brush. Wash with soap and water. Dry thoroughly before reinstalling.
	Foreign material buildup at base of brush.	Remove brush retainer and brush. Clean thoroughly. Reinstall.

SEED METER (EDGEVAC)

PROBLEM	POSSIBLE CAUSE	SOLUTION
Low seed count.	Meter RPM too high.	Reduce planting rate or planting speed.
	Singulator brush setting too aggressive.	Adjust singulator brush.
	Vacuum level too low.	Increase fan speed.
	Seed sensor not picking up all seeds dropped.	Clean seed tube. Move meter to different row.
	Seeds sticking to seed disc.	Use graphite or talc to aid release.
	Seed treatment buildup in seed disc recesses.	Reduce amount of treatment used and or mix thoroughly. Add talc.
	Seed size too large for disc used.	Use appropriate disc for seed size.
	Wrong transmission setting.	Change transmission to desired rate.
	Wrong seed disc.	Use appropriate disc for seed type and size.
	Drive wheel slippage.	Compensate by adjusting transmission sprockets.
	Low tire pressure.	Adjust tire pressure to correct level.
	Failed/worn drive components.	Inspect and replace parts as required.
	Plugged orifices in seed disc.	Inspect and clean disc. Check cleanout brush. (If Applicable)
	Loss of vacuum at meter.	Check for foreign material between vacuum cover and disc. Inspect parts for wear/damage. Clean or replace as required.
	Seed bridging in hopper.	Add graphite to improve seed flow.
	Faulty vacuum gauge reading.	Repair/replace gauge.
	Dirt in vacuum manifold.	Check vacuum manifold for dirt and clean.
	Seed baffle (If Applicable) not allowing seed flow due to bridging of seed.	Thoroughly mix talc to coat all seeds. Remove seed baffle. See "Seed Meter" in Operation/Maintenance section.
	60 cell soybean disc not filling properly due to excessive RPM.	Replace with 120 cell soybean disc.
	Seed disc worn.	Replace.
Vacuum cover worn.	Replace.	
Not planting seed.	Seed hoppers empty.	Fill seed hopper.
	Seed tube plugged/damaged.	Clean or replace tube.
	Meter drive damaged.	Repair/replace drive components.
	Low/no vacuum.	Inspect vacuum system and repair as necessary.
	Singulator brush setting too aggressive.	Adjust singulator brush.
	Faulty vacuum gauge.	Repair/replace vacuum gauge.
	Seed bridging in hopper.	Add graphite to improve seed flow.
	Loss of vacuum at meter.	Check for foreign material between vacuum cover and disc. Inspect parts for wear/damage. Clean and/or replace as required.
	Wrong seed disc.	Use appropriate disc for seed type and size.
	Meter drive clutch not engaged.	Engage drive clutch.
	Fan not running.	Start fan.
	Dirt in vacuum manifold.	Check vacuum manifold for dirt and clean.

Continued on next page.

SEED METER (EDGEVAC) - Continued

PROBLEM	POSSIBLE CAUSE	SOLUTION
Not planting seed. (Continued)	Seed baffle (If Applicable) not allowing seed flow due to bridging of seed.	Thoroughly mix talc to coat all seeds. Remove seed baffle. See "Seed Meter" in Seed Meter Operation/ Maintenance section.
	60 cell soybean disc not filling properly due to excessive RPM.	Replace with 120 cell soybean disc.
High seed count.	Wrong transmission setting.	Change transmission to desired rate.
	High vacuum.	Adjust vacuum level to appropriate level.
	Wrong seed disc.	Replace seed disc.
	Singulator brush setting not aggressive enough.	Adjust singulator brush.
	Worn singulator brush.	Inspect brush and replace as required.
	Seed leaking past wall brush.	Inspect wall brush condition and installation. Replace as necessary.
	Faulty vacuum gauge.	Check gauge line for dirt/obstruction. Repair/replace vacuum gauge.
Poor seed spacing.	Obstruction in seed tube.	Clean seed tube.
	Dirty/damaged seed disc.	Inspect seed disc for damage, foreign material in orifices or seed treatment buildup in recesses. Clean or replace.
	Wrong vacuum setting.	Adjust vacuum to appropriate level.
	Excess foreign material in seed.	Inspect and clean meter and seed discs. Use clean, undamaged seed.
	Incorrect singulator brush setting.	Adjust singulator brush to appropriate setting.
	Inconsistent driveline.	Inspect drive components for rust, misalignment, worn or damaged parts. Replace/repair as required.
	Toolbar not level or wrong height.	Adjust hitch to level toolbar and row units.
	Planting too fast for conditions.	Reduce speed.
	Rough field conditions.	Reduce speed.
Irregular seed population.	Driving too fast.	Reduce speed.
	Drive wheels slipping.	Reduce speed. Decrease row unit down pressure spring settings.
Unable to achieve desired vacuum level.	Tractor hydraulic flow set too low.	Increase flow to fan motor.
	Incorrect hydraulic connections.	Check all hydraulic connections and hose routings.
	Damaged fan components.	Inspect motor and impeller for wear/damage and repair/replace as necessary.
	Vacuum hose pinched/kinked/blocked.	Inspect air lines for any damage or obstruction. Clean air lines and manifold by removing end cap from manifold and running fan at high speed.
	Vacuum hose loose/disconnected.	Inspect and reattach all air hoses.
	Tractor not producing required hydraulic flow/pressure.	Have tractor serviced by qualified technician.
	Dirt in vacuum gauge line.	Check gauge line for dirt/obstruction and clean.

SEED METER (FINGER PICKUP)

PROBLEM	POSSIBLE CAUSE	SOLUTION
One row not planting seed.	Drive release not engaged.	Engage drive release mechanism.
	Foreign material in hopper.	Clean hopper and finger carrier mechanism.
	Seed hopper empty.	Fill seed hopper.
	Row unit drive chain off of sprocket or broken.	Check drive chain.
Unit is skipping.	Foreign material or obstruction in meter.	Clean and inspect.
	Finger holder improperly adjusted.	Adjust to specifications. (22 to 25 in. lbs. rolling torque)
	Broken fingers.	Replace fingers and/or springs as required.
	Planting too slowly.	Increase planting speed to within recommended range.
Planting too many doubles.	Planting too fast.	Stay within recommended speed range.
	Loose finger holder.	Adjust to specifications. (22 to 25 in. lbs. rolling torque)
	Worn brush in carrier plate.	Inspect and replace if necessary.
Overplanting.	Worn carrier plate.	Inspect and replace if necessary.
	Seed hopper additive being used.	Reduce or eliminate additive or increase graphite.
Underplanting.	Seed belt installed backwards.	Remove and install correctly.
	Weak or broken springs.	Replace.
	Spring not properly installed.	Remove finger holder and correct.
	Seed belt catching or dragging.	Replace belt.
	Brush dislodging seed.	Replace brush.
Irregular or incorrect seed spacing.	Driving too fast.	Check chart for correct speed.
	Wrong tire pressure.	Inflate tires to correct air pressure.
	Drive wheels slipping.	Reduce down pressure on row unit down force springs.
	Wrong sprockets.	Check seed rate charts for correct sprocket combinations.
Seed spacing not as indicated in charts.	Wrong tire pressure.	Inflate tires to correct air pressure.
	Inconsistent seed size.	Perform field check and adjust sprockets.
	Wrong sprockets.	Check chart for correct sprocket combination.
	Charts are approximate.	Slight variations due to wear in meter components and tire slippage due to field conditions may produce seed spacing variations.
	Stiff or worn drive chains.	Replace chains.
Scattering of seeds.	Planting too fast.	Reduce planting speed.
	Seed tube improperly installed.	Check seed tube installation.
	Seed tube worn or damaged.	Replace seed tube.
Seed tubes and/or openers plugging.	Allowing planter to roll backward when lowering.	Lower planter only when tractor is moving forward.
Inconsistent seed depth.	Rough seed bed.	Adjust down pressure springs. Reduce planting speed.
	Partially plugged seed tube.	Inspect and clean.
	Seed tube improperly installed.	Install properly.

SOLENOID VALVE

PROBLEM	POSSIBLE CAUSE	SOLUTION
No solenoids operate.	Low voltage.	Must be connected to 12 volt DC only. Negative ground.
	Blown fuse.	Replace control console fuse with AGC-15 amp.
	Battery connection.	Clean and tighten.
	Wiring harness damaged.	Repair or replace.
One solenoid valve will not operate.	Bad switch.	Replace on control panel.
	Cut wire in harness.	Locate and repair.
	Bad coil.	Replace.
	Poor connection at coil.	Check.
Valve operating when not energized.	Valve stem stuck open.	Replace cartridge.
	O-ring leaking.	Install new O-ring kit.
	Foreign material under poppet.	Remove and clean cartridge.

TONGUE CYLINDER CIRCUIT

PROBLEM	POSSIBLE CAUSE	SOLUTION
Tongue cylinder will not extend, but will retract.	No power to solenoid valve coil in port V10 and/or V14. Both must be energized.	Check wiring between control console and solenoid coils looking for damaged wires and poor connections.
	Solenoid valve coil defective.	Switch coil from port V13 with V10. If tongue still will not extend, switch coil from V14 with V13. It will not be necessary to remove any of the wire connections to the solenoid. All three of these solenoids are normally energized when the tongue switch is energized. Replace defective coil.
	Solenoid valve cartridges in port V10 and/or V14 stuck closed.	Switch cartridge from port V10 with cartridge in port V13. If tongue cylinder retracts, replace defective cartridge from port V10. If problem continues, switch cartridge from port V14 with cartridge in port V13. Replace defective cartridge.
Tongue cylinder will not extend but tongue lock cylinder extends.	Pressure relief valve in port V11 stuck closed or pressure setting too high. (Valve is factory set to open at 1000 PSI.)	Replace or adjust pressure relief valve. To adjust, loosen lock nut and turn counter clockwise to decrease pressure.
Tongue hook does not release before the tongue starts to extend.	Solenoid valve cartridge in port V11 stuck open or pressure setting too low. (Valve is factory set to open at 1000 PSI.)	Replace or adjust pressure relief valve. To adjust, loosen lock nut and turn clockwise to increase pressure.
Tongue cylinder will not retract, but will extend.	Solenoid valve coil in port V13 defective.	Switch coil from port V13 with coil from port V14. If coil from port V13 is bad, the tongue will extend but not retract. Replace defective coil.
	Solenoid valve cartridge in port V13 stuck closed.	Switch cartridge from port V13 with cartridge from port V14. If cartridge is bad, the tongue will extend but not retract. Replace defective cartridge.
Tongue extends with switch off.	Solenoid valve cartridge in port V10 and V14 stuck open.	Replace solenoid valve cartridge.
Tongue retracts with switch off.	Solenoid valve cartridge in port V13 stuck open.	Replace solenoid valve cartridge.
Tongue latch releases. Tongue extends slowly while planting.	Latch cylinder or tongue cylinder leaking internally.	Pressure check latch and tongue cylinders. Repair leaking cylinder(s).

WING LOCK CYLINDER CIRCUIT

PROBLEM	POSSIBLE CAUSE	SOLUTION
Cylinders will not extend or retract.	No power to the solenoid valve coils.	Auxiliary switch may be in the ON position. Must be in OFF position. Check fuse at control console. Replace fuse with 15 amp type AGC if blown. Check for poor wire connection or damaged wire. Repair as required.
Cylinders will not extend.	Solenoid valve coil in port V3 not energized.	Check for power to coil. Check coil ground wire. If OK, switch coil from port V3 with coil from port V4. If cylinders extend but will not retract, replace defective coil.
	Solenoid valve cartridge in port V3 stuck closed.	Switch cartridge in port V3 with cartridge in port V4. If cylinders extend but will not retract, replace defective cartridge.
Cylinders will not retract.	Solenoid valve coil in port V4 not energized.	Check for power to coil. Check coil ground wire. If OK, switch coil from port V4 with coil from port V3. If cylinders retract but will not extend, replace defective coil.
	Solenoid valve cartridge in port V4 stuck closed.	Switch cartridge in port V4 with cartridge in port V3. If cylinders retract but will not extend, replace defective cartridge.
Cylinders retract with the switch off.	Solenoid valve cartridge in port V4 stuck open.	Replace solenoid valve cartridge.
Cylinders extend with the switch off.	Solenoid valve cartridge in port V3 stuck open.	Replace solenoid valve cartridge.