

MODEL 3600TR
TWIN-LINE® PLANTER
(EdgeVac® Seed Metering)

OPERATOR & PARTS
MANUAL

M0211

Rev. 2/09

This manual is applicable to: Model: 3600 Twin-Line® Planters
Serial Number: 620614 and on

Record the model number and serial number of your planter along with date purchased:

Model Number _____ 3600TR _____

Serial Number _____

Date Purchased _____

Monitor Serial Number _____
Measured Pulses Per Mile/Km (Radar Distance Sensor) _____
Measured Pulses Per Mile/ Km (Magnetic Distance Sensor) _____

SERIAL NUMBER

The serial number plate is located on the planter frame to be readily available. It is suggested that your serial number and purchase date also be recorded above.

The serial number provides important information about your planter and may be required to obtain the correct replacement part. Always provide the model number and serial number to your KINZE® Dealer when ordering parts or anytime correspondence is made with KINZE Manufacturing, Inc.

D08260506



PREDELIVERY/DELIVERY CHECKLIST

TO THE DEALER

Predelivery service includes assembly, lubrication, adjustment and test. This service helps to ensure that the planter will be delivered to the customer ready for field use.

PREDELIVERY CHECKLIST

After the planter has been completely assembled, use the following checklist and inspect the planter. Check off each item as it is found satisfactory or after proper adjustment is made.

- Recheck to be sure row units are properly spaced and optional attachments are correctly assembled.
- The hardware box, containing the row unit drive chains and meter drive clutches, has been removed from the seed hopper on the L.H. side of the planter and those components have been installed. See "Row Unit Assembly And Installation Instruction".
- The row marker blade assemblies have been removed from their shipping location over the planter hitch and installed on the row marker assembly at each end of the planter. See "Row Marker Length Adjustment" in the Machine Operation Section of this manual.
- Be sure all grease fittings are in place and lubricated.
- Check planter and make sure all working parts are moving freely, bolts are tight and cotter pins are spread.
- Check all drive chains for proper tension and alignment.
- Check for oil leaks and proper hydraulic operation.
- Check to be sure hydraulic hoses are routed correctly to prevent damage.
- Inflate tires to specified PSI air pressure. Tighten wheel lug bolts and lug nuts to specified torques.
- Check to be sure all safety decals are correctly located and legible. Replace if damaged.
- Check to be sure all reflective decals and SMV sign are correctly located and visible when the planter is in transport position.
- Check to be sure safety/warning lights are installed correctly and working properly.
- Paint all parts scratched in shipment or assembly.
- Be sure all safety lockup devices are on the planter and correctly located.
- Auxiliary safety chain is properly installed and hardware is torqued to specification.
- Vacuum fan PTO-driven pump is attached correctly to the tractor. Oil reservoir is filled to capacity and system is inspected for leaks. (If Applicable)

This planter has been thoroughly checked and to the best of my knowledge is ready for delivery to the customer.

(Signature Of Set-Up Person/Dealer Name/Date)

OWNER REGISTER

Name _____ Delivery Date _____

Street Address _____ Model No. 3600TR Serial No. _____

City, State/Province _____ Dealer Name _____

ZIP/Postal Code _____ Dealer No. _____

DELIVERY CHECKLIST

At the time the planter is delivered, the following checklist is to be used as a reminder of very important information which should be conveyed to the customer. Check off each item as it is fully explained to the customer.

- Advise the customer that the life expectancy of this or any other machine is dependent on regular lubrication as directed in the Operator & Parts Manual.
- Check for proper operation of vacuum fan and PTO drive pump (If Applicable) with tractor to be used with planter.
- Tell the customer about all applicable safety precautions.
- Along with the customer, check to be sure the reflective decals and SMV sign are clearly visible with the planter in transport position and attached to the tractor. Check to be sure safety/warning lights are in working condition. Tell the customer to check federal, state/provincial and local regulations before towing or transporting on a road or highway.
- Give the Operator & Parts Manual to the customer and explain all operating adjustments.
- Read warranty to customer.
- Complete Warranty And Delivery Report form.

To the best of my knowledge this machine has been delivered ready for field use and customer has been fully informed as to proper care and operation.

(Signature Of Delivery Person/Dealer Name/Date)

AFTER DELIVERY CHECKLIST

The following is a list of items we suggest to check during the first season of use of the equipment.

- Check with the customer as to the performance of the planter.
- Check with the customer as to the performance of the EdgeVac® Seed Metering System.
- Review with the customer the importance of proper maintenance and adherence with all safety precautions.
- Check for parts that may need to be adjusted or replaced.
- Check to be sure all safety warning signs (decals), reflective decals and SMV sign are correctly located and that decals are legible. Replace if damaged or missing.
- Check to be sure safety/warning lights are working properly.

(Signature Of Follow-Up Person/Dealer Name/Date)

**RETURN THIS COMPLETED FORM TO KINZE® IMMEDIATELY along with Warranty And Delivery Report.
Retain photocopy of this form at dealership for After Delivery Check.**

Tear Along Perforation

TABLE OF CONTENTS

TO THE OWNER	1-1
WARRANTY	1-2
INTRODUCTION	2-1
SPECIFICATIONS	3-1
SAFETY PRECAUTIONS	4-1
SAFETY WARNING SIGNS	5-1
MACHINE OPERATION	
Analog Vacuum Gauge	6-18
Auxiliary Hydraulic Option	6-66
Auxiliary Work Lights Package	6-65
Checking Granular Chemical Application Rate (30" Rows Only)	6-70
Checking Seed Population	6-69
Contact Wheel Spring Adjustment	6-8
Contact Wheel Drive Sprockets	6-9
Digital Vacuum Gauge Operation	6-18
Electronic Seed Monitor System	
KPM III	6-22
Field Adjustments	
Seed Rate Transmission Adjustment	6-9
Field Operation	6-15
Field Test	6-68
Field To Transport Sequence	6-15
Hydraulic/Electric Operation	6-11
Initial Preparation Of The Planter	6-3
Leveling The Planter	6-6
Manual Safety Lockup	6-1
Metric Conversion Table	6-68
Point Row Clutches	6-63
Planting Speed	6-68
PTO Pump Drive And Oil Cooler Option	6-4
Rear Trailer Hitch	6-67
Ridge Planting	6-10
Rock Guards	6-65
Row Marker Length Adjustment	6-20
Row Marker Operation	6-19
Row Marker Safety Lockup	6-1
Row Marker Speed Adjustment	6-20
Shear Protection	6-11
Tire Pressure	6-8
Tongue Safety Pin	6-2
Tractor Preparation And Hookup	6-5
Tractor Requirements	6-3
Transport Latch Locking Pin	6-2
Transport To Field Sequence	6-12
Transporting The Planter	6-68
Two-Speed Point Row Clutches	6-64
Vacuum Fan Motor Valve Block Assembly	6-18
Wrap Spring Wrench Operation	6-10

TABLE OF CONTENTS

SEED METER OPERATION/MAINTENANCE

Field Adjustments

General Planting Rate Information	7-1
Planting And Application Rate Charts	7-5
Seed Meter Singulator Brush And Vacuum Level Adjustment	7-22
Seed Meter	7-2
Seed Meter Cleanout	7-4
Seed Meter Drive Release	7-24
Seed Meter Maintenance.....	7-25
Seed Metering System Troubleshooting	7-26
Vacuum Manifold Maintenance.....	7-25

ROW UNIT OPERATION

Closing Wheel Shield.....	8-2
Coulter Mounted Residue Wheels	8-16
Covering Discs/Single Press Wheel Adjustment	8-2
Drag Closing Attachment.....	8-3
Frame Mounted Coulter	8-11
Granular Chemical Bander Shield	8-18
Granular Chemical Banding Options	8-18
Granular Chemical Hopper And Drive	8-17
Planting Depth	8-1
Pneumatic Down Pressure Package Option.....	8-8
Push Row Unit Clutch Sprocket.....	8-20
Push Row Unit Lockups.....	8-19
Quick Adjustable Down Force Springs Option.....	8-6
Residue Wheels (For Use With Frame Mounted Coulter).....	8-12
Row Unit Chain Routing	8-5
Row Unit Extension Brackets.....	8-4
Row Unit Mounted Bed Leveler	8-13
Row Unit Mounted Disc Furrower.....	8-12
Row Unit Mounted No Till Coulter.....	8-15
Row Unit Mounted Residue Wheel.....	8-13
Seed Hopper	8-4
Spring Tooth Incorporator	8-18
"V" Closing Wheel Adjustment (Rubber And Cast Iron).....	8-1

LUBRICATION

Bushings.....	9-4
Center Post.....	9-6
Drive Chains	9-2
Grease Fittings	9-7
Lubrication Symbols	9-1
Push Row Unit Lockups.....	9-5
PTO Pump Shaft Coupling (PTO Pump Drive And Oil Cooler Option)	9-1
Sealed Bearings	9-1
U-Joint Slides.....	9-6
Wheel Bearings	9-6
Wrap Spring Wrench Assembly	9-6

TABLE OF CONTENTS

MAINTENANCE

15" Seed Opener Disc Blade/Bearing Assembly	10-6
Chain Tension Adjustment	10-2
Check Valve	10-16
Coulter Mounted Residue Wheels	10-10
Drag Closing Attachment.....	10-4
Electrical Control Console Schematic	10-30
Electrical Control Console Schematic (With Optional Two-Speed Point Row Clutches)	10-35
Electrical Wiring Diagram For Light Package.....	10-29
Electrical Wiring Harness Schematic (On Planter)	10-32
Electrical Wiring Harness Schematic (On Tractor).....	10-31
Flow Control Valve	10-17
Frame Mounted Coulter	10-7
Gauge Wheel Adjustment.....	10-4
Gauge Wheel Arm Bushing And/Or Seal Replacement	10-5
Gauge Wheel Arm Pivot Spindle Replacement	10-5
Granular Chemical Attachment.....	10-11
Hydraulic Schematic - Optional PTO Pump Drive And Oil Cooler System	10-41
Hydraulic Schematic - Planter Operation.....	10-36
Hydraulic Schematic - Vacuum Fan Motor System.....	10-40
Mounting Bolts And Hardware	10-1
Point Row Clutch Inspection	10-13
Preparation For Storage	10-28
Pressure Relief Valve.....	10-17
PTO Pump Drive And Oil Cooler Option.....	10-3
Relief Valve (Located On Vacuum Fan Motor Assembly).....	10-16
Residue Wheels (For Use With Frame Mounted Coulter).....	10-8
Row Marker Bearing Lubrication Or Replacement	10-23
Row Unit Mounted Bed Leveler	10-9
Row Unit Mounted Disc Furrower.....	10-8
Row Unit Mounted No Till Coulter.....	10-10
Row Unit Mounted Residue Wheel.....	10-9
Row Marker Transport Stand Adjustment	10-23
Seed Meter Maintenance..... <i>See "Seed Meter Operation/Maintenance" Section</i>	
Seed Tube Guard/Inner Scraper	10-7
Solenoid Valve	10-16
Spring Tooth Incorporator	10-11
Tire Pressure	10-2
Torque Values Chart	10-1

(Continued On Following Page)

TABLE OF CONTENTS

MAINTENANCE (continued)

Troubleshooting

Closing Wheel Troubleshooting	10-4
KPM III Electronic Seed Monitor Troubleshooting	10-12
Lift Circuit Troubleshooting	10-17
Point Row Clutch Troubleshooting	10-14
PTO Pump Drive And Oil Cooler Option Troubleshooting	10-3
Rotation Cylinder Circuit Troubleshooting.....	10-20
Row Marker Operation Troubleshooting	10-22
Seed Metering System Troubleshooting	See "Seed Meter Operation/ Maintenance" Section
Solenoid Valve Troubleshooting.....	10-16
Tongue Cylinder Circuit Troubleshooting	10-19
Wing Lock Cylinder Circuit Troubleshooting	10-21
Two-Speed Point Row Clutches.....	10-15
Wear Pad Replacement And Adjustment	10-25
Wheel Bearing Lubrication Or Replacement	10-24

PARTS LIST INDEX	P1
-------------------------------	-----------

PARTS SECTION NUMERICAL INDEX	P119
--	-------------

TO THE OWNER

KINZE Manufacturing, Inc. would like to thank you for your patronage. We appreciate your confidence in KINZE® farm machinery. Your KINZE® planter has been carefully designed to provide dependable operation in return for your investment.

This manual has been prepared to aid you in the operation and maintenance of the planter. It should be considered a permanent part of the machine and remain with the machine when you sell it.

It is the responsibility of the user to read and understand the Operator & Parts Manual in regards to safety, operation, lubrication and maintenance before operation of this equipment. It is the user's responsibility to inspect and service the machine routinely as directed in the Operator & Parts Manual. We have attempted to cover all areas of safety, operation, lubrication and maintenance; however, there may be times when special care must be taken to fit your conditions.

Throughout this manual the symbol  and/or the words **NOTE, IMPORTANT, CAUTION, WARNING** or **DANGER** are used to call your attention to important information. The definition of each of these terms follows:

NOTE: Indicates a special point of information or addresses a machine adjustment.

IMPORTANT: Indicates an operation or maintenance condition which, if not corrected, could result in damage to machine, property, crops or environment.



CAUTION: Indicates a potentially hazardous situation which, if not avoided, may result in minor or moderate personal injury.



WARNING: Indicates a potentially hazardous situation which, if not avoided, could result in death or serious personal injury.



DANGER: Indicates an imminently hazardous situation which, if not avoided, will result in death or serious personal injury.



WARNING: Some photos in this manual may show safety covers, shields or lockup devices removed for visual clarity. **NEVER OPERATE** the machine without all safety covers, shields and lockup devices in place.

NOTE: Some photos in this manual may have been taken of prototype machines. Production machines may vary in appearance.

NOTE: Some photos and illustrations in this manual show optional attachments installed. Contact your KINZE® Dealer for purchase of optional attachments.

WARRANTY

The KINZE® Limited Warranty for your new machine is stated on the back of the retail purchaser's copy of the Warranty And Delivery Report form. Additional copies of the Limited Warranty can be obtained through your KINZE® Dealer.

Warranty, within the warranty period, is provided as part of KINZE's support program for registered KINZE® products which have been operated and maintained as described in this manual. Evidence of equipment abuse or modification beyond original factory specifications will void the warranty. Normal maintenance, service and repair is not covered by KINZE® warranty.

To register your KINZE® product for warranty, a Warranty And Delivery Report form must be completed by the KINZE® Dealer and signed by the retail purchaser, with copies to the Dealer, to the retail purchaser and to KINZE Manufacturing, Inc. Registration must be completed and sent to KINZE Manufacturing, Inc. within 30 days of delivery of the KINZE® product to the retail purchaser. KINZE Manufacturing, Inc. reserves the right to refuse warranty on serial numbered products which have not been properly registered.

If service or replacement of failed parts which are covered by the Limited Warranty are required, it is the user's responsibility to deliver the machine along with the retail purchaser's copy of the Warranty And Delivery Report to the KINZE® Dealer for service. KINZE® warranty does not include cost of travel time, mileage, hauling or labor. Any prior arrangement made between the Dealer and the retail purchaser in which the Dealer agrees to absorb all or part of this expense should be considered a courtesy to the retail purchaser.

KINZE® warranty does not include cost of travel time, mileage, hauling or labor.

INTRODUCTION

The Model 3600TR Twin-Line® Planter is available in various configurations.

The Model 3600TR Twin-Line® Planter permits installation of various planter row unit attachments.

GENERAL INFORMATION

The information used in this manual was current at the time of printing. However, due to KINZE's ongoing product improvement, production changes may cause your machine to appear slightly different in detail. KINZE Manufacturing, Inc. reserves the right to change specifications or design without notice and without incurring obligation to install the same on machines previously manufactured.

Right hand (R.H.) and left hand (L.H.), as used throughout this manual, are determined by facing in the direction the machine will travel when in use unless otherwise stated.

D101807104



INTRODUCTION

SPECIFICATIONS

BASE MACHINE TYPE - Pull Type (Hydraulically rotates endwise to transport)

SEED METER TYPE - EdgeVac® Seed Metering System

EDGEVAC® SEED METERING SYSTEM INCLUDES -

EdgeVac® Seed Meters (Less Seed Discs), Meter Drive Clutches, No. 41 Chains, 1.75 Bu. Seed Hoppers With Lids, 20" Diameter Vacuum Fan With Mounting Components, Hydraulic Motor, Hoses And Fittings, 4" Diameter Vacuum Feed Hoses, Distribution Manifolds And 2" Diameter Vacuum Distribution Hoses

PLANTING UNIT TYPES - Push and Pull Row Units

ROW SPACING **Standard**
 12 Row Narrow - 30" - 7 ½" Twin Rows (24 Rows)
 16 Row Narrow - 30" - 7 ½" Twin Rows (32 Rows)

DRIVE SYSTEM - Spring-Loaded Contact Drive System
 - 7.50" x 20" 8 Ply Rib Implement Wing Tires - Two On 8 And 12 Row; Four On 16 Row
 - 4.80" x 8" 4 Ply Contact Drive Tires - Two On 8 And 12 Row; Four On 16 Row
 - No. 40 Roller Chain And Spring-Loaded Idlers
 - Point Row Clutches Standard On 12 And 16 Row Sizes And Optional On 8 Row Size
 - Hex Drill And Drive Shafts And End Mounted Seed Transmissions

TRANSPORT TIRES - Equipped With Four 255 - 70R 22.5" Radial Load Range H Tubeless Rib Implement Tires
 - Adjustable Height Wheels For Ridge Planting

LIFT - Master/Slave Hydraulics
 - 12 Row - 2 Center Lift (Master) Cylinders, 1 Cylinder Per Wing Wheel Module (2 Slave)
 - 16 Row - 2 Center Lift (Master) Cylinders, 1 Cylinder Per Wing Wheel Module (2 Modules Per Wing - 4 Slave Cylinders Total)

ROW MARKERS - Independently Controlled. Two-Fold, Low Profile With Depth Bands On Row Marker Disc Blades

SEED METER/VACUUM SYSTEM

- 13 GPM @ 2000 PSI
 - Zero PSI Case Drain Plus One Remote Outlet (Pressure And Return) For Vacuum Fan Hydraulic Motor

PLANTER SIZE	12 Row 30" - 7 ½" Twin Rows	16 Row 30" - 7 ½" Twin-Rows
*WEIGHT	17,003 lbs.	18,889 lbs.

* Base Machine weights include frame, row markers, drive components; tires and wheels, transport safety chain; hydraulic cylinders and hoses, 12VDC control console, KINZE® push and pull row units less closing wheels (24 on 12 Row N; 32 on 16 Row N); and seed hoppers and lids, dual quick-adjustable down force springs. EdgeVac® meters (less seed discs) and vacuum seed metering system fan, manifolds and hoses.

SPECIFICATIONS

DIMENSIONS/WEIGHTS

PLANTER SIZE	12 Row 30" - 7 ½" Twin-Rows	16 Row 30" - 7 ½" Twin-Rows
Transport Width	11' 2"	11' 2"
Transport Height	10' 8"	11' 0"
Transport Length	36' 10"	46' 10"
Operating Width	31' 2"	41' 2"
Operating Length	21' 0"	24' 0"

NOTE: L.H. transport wheel and axle stub assembly is removable for truck transport at 8' 6".

MACHINE OPTIONS

- Electronic Seed Monitors
 - KPM III With Magnetic Distance Sensor Or Radar Distance Sensor
- Two-Speed Point Row Clutch Package - Allows Half Width Planting And Reduced Rate Planting (Available Through KINZE® Repair Parts)
- Auxiliary Work Lights Package
- Rear Trailer Hitch
- Piston Pump Mount And Drive Package
- Rock Guard Package For Transport Wheel Arms
- PTO Pump Package And Oil Cooler
- 2-Point Hitch Option

ROW UNIT OPTIONS/ATTACHMENTS

- Seed Meter Discs
- Closing Wheel Options
 - Rubber "V" Closing Wheels
 - Cast Iron "V" Closing Wheels
 - Covering Discs/Single Press Wheel
 - Drag Closing Attachment
- Down Pressure Options
 - Quick Adjustable Down Force Springs
 - Pneumatic Down Pressure Package
- Granular Chemical Application
- Hopper Panel Extension Package
- Spring Tooth Incorporator
- Row Unit Extension Brackets
- Row Unit Mounted No Till Coulter
- Coulter Mounted Residue Wheels
- Row Unit Mounted Disc Furrowers
- Row Unit Mounted Bed Leveler
- Row Unit Mounted Residue Wheel
- Frame Mounted Coulter
- Residue Wheels For Frame Mounted Coulter

SAFETY PRECAUTIONS

Safe and careful operation of the tractor and planter at all times will contribute significantly to the prevention of accidents.

Since a large portion of farm accidents occur as a result of fatigue or carelessness, safety practices should be of utmost concern. Read and understand the instructions provided in this manual and on the warning signs. Review these instructions frequently! Listed below are other safety suggestions that should become common practice.

 **Never allow the planter to be operated by anyone who is unfamiliar with the operation of all functions of the unit. All operators should read and thoroughly understand the instructions given in this manual prior to moving the unit.**

 **Never permit any persons other than the operator to ride on the tractor.**

 **Never ride on the planter or allow others to do so.**

 **Always make sure there are no persons near the planter when row marker assemblies are in operation or when rotating the planter.**

 **Always keep hands, feet and clothing away from moving parts. Do not wear loose-fitting clothing which may catch in moving parts.**

 **Always wear protective clothing, substantial shoes and suitable hearing and eye sight protectors applicable for the situation.**

 **Do not allow anyone to stand between the tongue or hitch and the towing vehicle when backing up to the planter.**

 **Be aware of bystanders, particularly children! Always look around to make sure it is safe to start the engine of the towing vehicle or move the planter. This is particularly important with higher noise levels and quiet cabs, as you may not hear people shouting.**

 **Use a tractor equipped with a roll-over-protective-system and fasten your seat belt prior to starting the engine.**

 **Before operating the planter for the first time and periodically thereafter, check to be sure the lug nuts on the transport wheels are tight. This is especially important if the planter is to be transported for a long distance.**

 **Never work under the planter while in raised position without using manual safety lockup device.**

 **Install safety lockup devices on row markers prior to transporting the planter or working around the unit.**

D060299127a

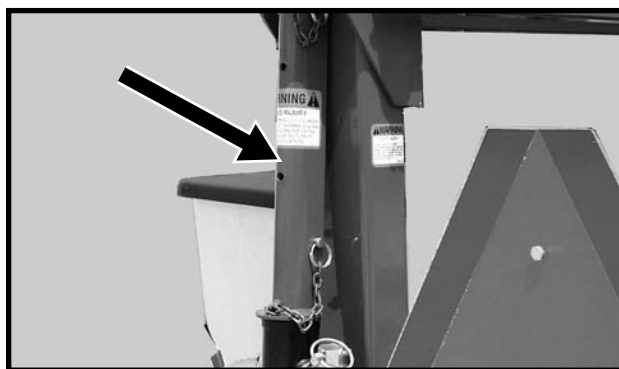

Row Marker Lockup

 **Watch for obstructions such as wires, tree limbs, etc. when folding row markers.**

 **To avoid serious injury or death, care must be taken when operating row markers around overhead power lines.**

 **The outer transport wheel on the left side of the planter is bolt-on to allow legal width truck shipment. Always install outer transport wheel assembly prior to unloading. DO NOT REMOVE THIS ASSEMBLY AFTER PLANTER IS ASSEMBLED FOR USE. DO NOT fold planter or tow planter while the outer transport wheel is removed. Tipping may occur because of narrow wheel base.**

 **This planter is designed to be DRIVEN BY GROUND TIRES ONLY. The use of aftermarket hydraulic, electric or PTO drives may create serious safety hazards to you and the people nearby. If you install such drives you must follow all appropriate safety standards and practices to protect you and others near this planter from injury.**

SAFETY PRECAUTIONS

-  Always install tongue safety pin, manual safety lockup device and transport latch locking pin before transporting planter.

D101807118

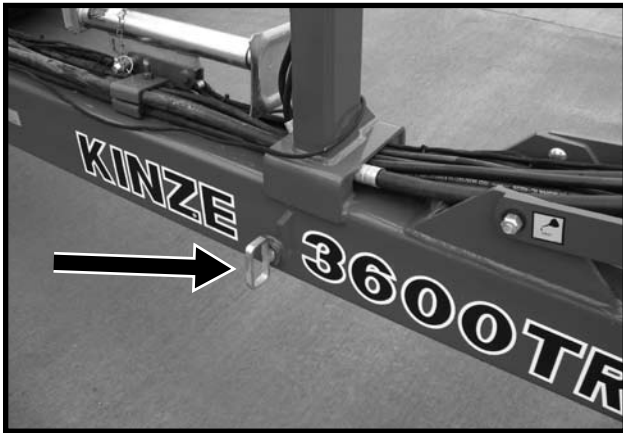

Tongue Safety Pin

D060299107

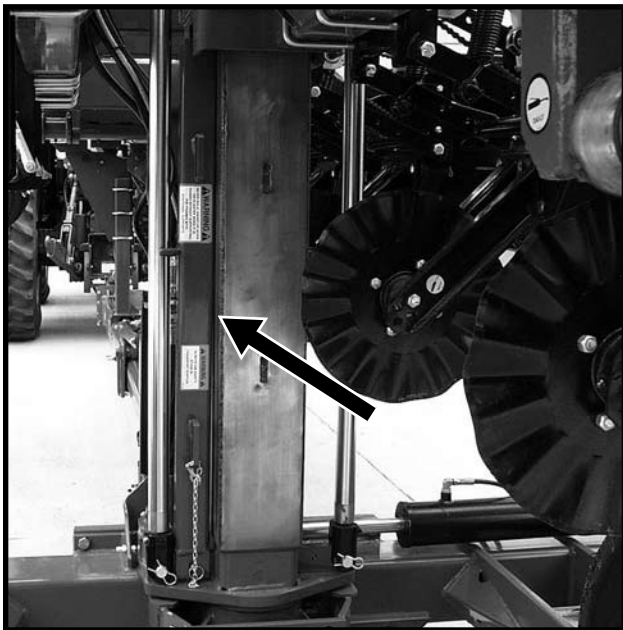

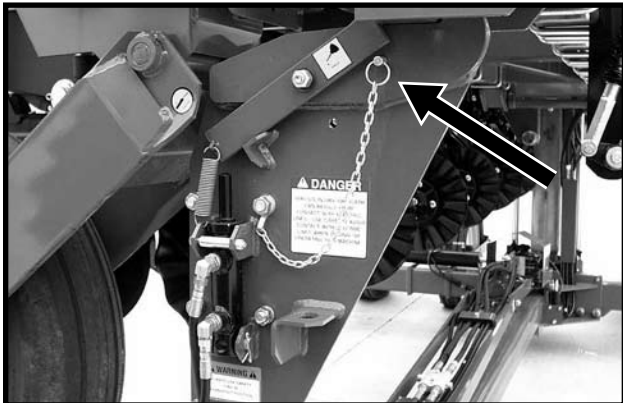

Manual Safety Lockup Device

D060299106





Transport Latch Locking Pin

-  This machine has been designed and built with your safety in mind. Do not make any alterations or changes to this machine. Any alteration to the design or construction may create safety hazards.

-  Always follow federal, state/provincial and local regulations when towing farm equipment on a public highway. Only a safety chain (not an elastic or nylon/plastic tow strap) should be used to retain the connection between the towing and towed machines in the event of separation of the primary attaching system.

-  Check to be sure all safety/warning lights are working properly before transporting the machine on public roads.

-  Avoid transporting planter with hoppers loaded whenever possible. When it is necessary to transport the planter with the hoppers loaded, the added weight should be distributed evenly on the planter frame before rotating the planter.

-  Limit towing speed to 15 MPH. Tow only with farm tractor of a minimum 90 HP.

-  Always make sure safety/warning lights, reflective decals and SMV sign are in place and visible prior to transporting the machine on public roads. In this regard, check federal, state/provincial and local regulations.

-  Allow for unit length when making turns.

-  Always drive at a safe speed relative to local conditions and ensure your speed is low enough for an emergency stop to be safe and secure. Keep speed to a minimum.

-  Reduce speed prior to turns to avoid the risk of overturning.

SAFETY PRECAUTIONS

 Always keep the tractor in gear to provide engine braking when going downhill. Do not coast.

 Avoid sudden uphill turns on steep slopes.

 Be a safe and courteous driver. Always yield to oncoming traffic in all situations, including narrow bridges, intersections, etc.

 Rim and tire servicing can be dangerous. Explosive separation of a tire and rim parts can cause serious injury or death.

 Agricultural chemicals can be dangerous. Improper selection or use can seriously injure persons, animals, plants, soil and other property. **BE SAFE:** Select the right chemical for the job. Handle it with care. Follow the instructions on the container label and of the equipment manufacturer.

 Store the planter in an area away from human activity. **DO NOT** permit children to play on or around the stored unit.

 Make sure the parked machine is on a hard, level surface. Wheel chocks may be needed to prevent unit from rolling.

 Good maintenance is your responsibility. Poor maintenance is an invitation to trouble.

 Never operate vacuum fan with cover removed.

 Always wear ear protection when working around operating vacuum fan.

 Pressurized hydraulic fluid can penetrate body tissue and result in serious infection, injury, or death. Before applying pressure to the hydraulic system, make sure all connections are tight and that hoses and fittings have not been damaged. Leaks can be invisible. Keep away from suspected leaks. Relieve pressure in the hydraulic system before searching for leaks, disconnecting hoses, or performing any other work on the system. Fluid injected under the skin must be **IMMEDIATELY** removed by a surgeon familiar with this type of injury.

SAFETY PRECAUTIONS

SAFETY WARNING SIGNS

The “WARNING” signs illustrated on these pages are placed on the machine to warn of hazards. The warnings found on these signs are for your personal safety and the safety of those around you. OBSERVE THESE WARNINGS!

- Keep these signs clean so they can be readily observed. Wash with soap and water or cleaning solution as required.
- Replace “WARNING” signs should they become damaged, painted over or if they are missing.
- Check reflective decals and SMV sign periodically. Replace if they show loss of any of their reflective properties.
- When replacing decals, clean the machine surface thoroughly using soap and water or cleaning solution to remove all dirt and grease.

NOTE: Style and locations of SMV sign, reflective decals and safety/warning lights conform to ANSI/SAE S279.13 DEC2005 and ANSI/SAE S276.6 JAN2005.

82079-2a

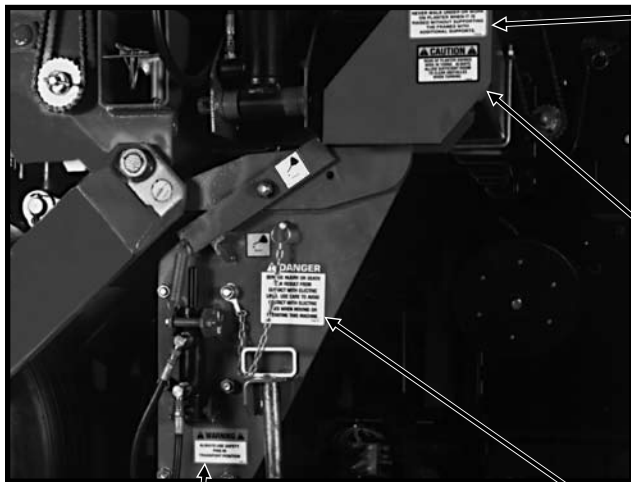

Part No. G7100-68 (Qty. 1)



Part No. G7100-63 (Qty. 1)

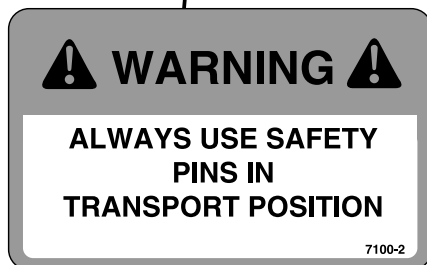

Part No. G7100-02 (Qty. 1)



Part No. G7100-117 (Qty. 1)

SAFETY WARNING SIGNS

D060299127a

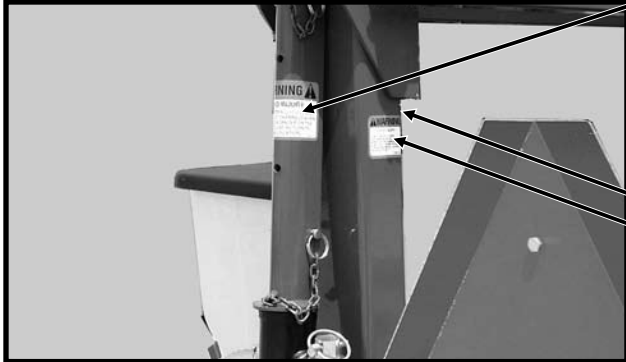

Part No. G7100-83 (Qty. 2 - One Per Row Marker)



Part No. G7100-42 (Qty. 4 - Two Per Row Marker)

D08260523

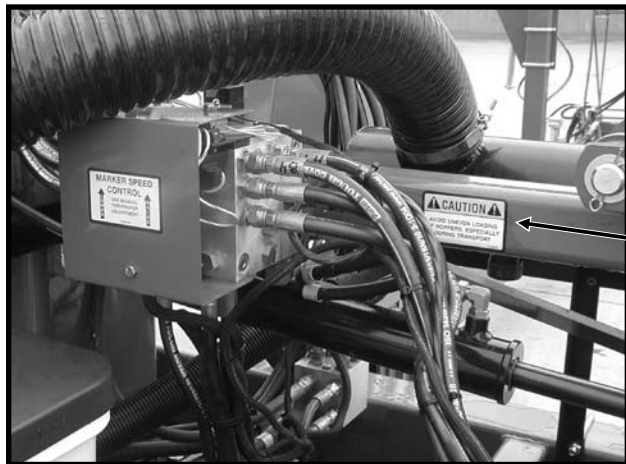

Part No. G7100-75
(Qty. 4 - Front And Rear/Left And Right)

D092702101a



Part No. G7100-302 (Qty. 1)

SAFETY WARNING SIGNS

D060299104



Part No. G7100-90 (Qty. 1)



Part No. G7100-46 (Qty. 1)

D08169904



Part No. G7100-68 (Qty. 2 - Front And Rear)



Part No. G7100-200 (Qty. 2 - Front And Rear)

SAFETY WARNING SIGNS

D060299108

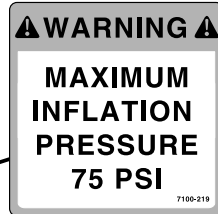
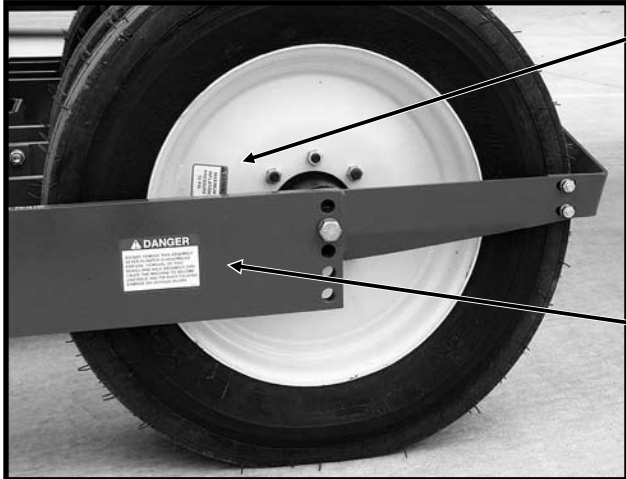

Part No. G7100-219 (Qty. 4 - One On Each Transport Wheel)



Part No. G7100-215 (Qty. 1 - Located On Rear Side Of Stub Axle)

D0205001102

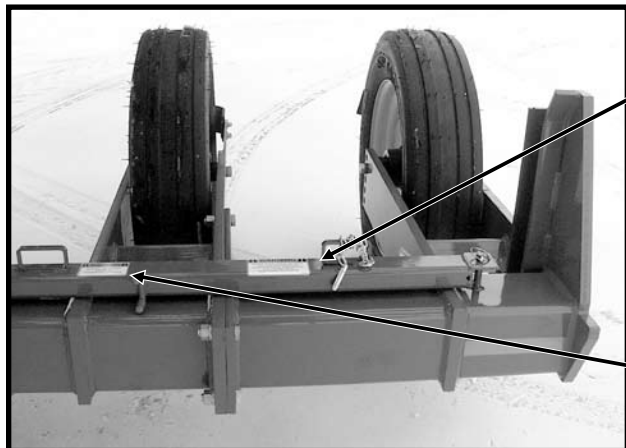

Part No. G7100-68 (Qty. 1)



Part No. G7100-200 (Qty. 1)

SAFETY WARNING SIGNS



Part No. G7100-68 (Qty. 1)



Part No. G7100-63 (Qty. 1)

D101807214

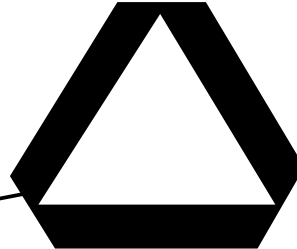
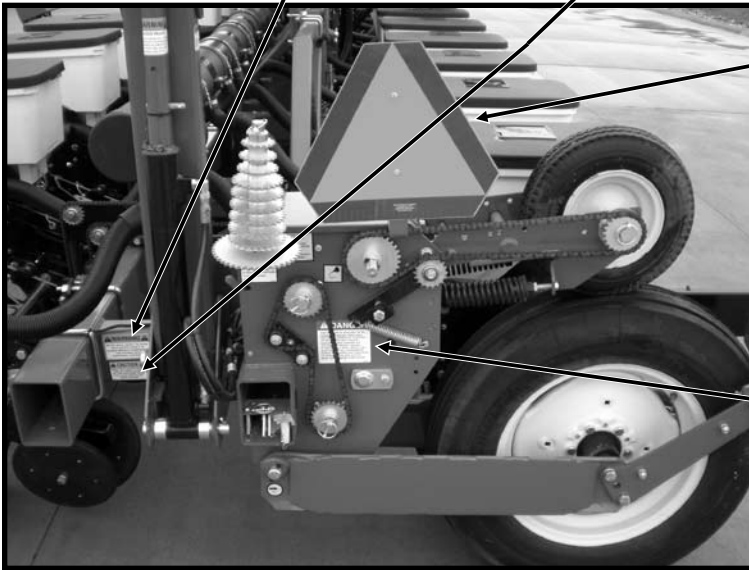

Part No. GD2199 (Qty. 1)



Part No. G7100-89 (Qty. 2 - One Located On Wheel Module At Each End Of Planter)

D08220676

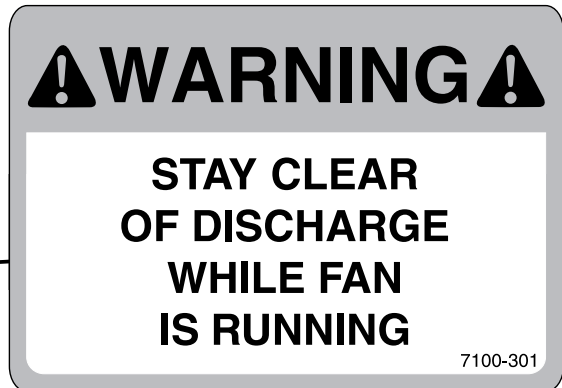

Part No. G7100-301 (Qty. 2 - One On Each Side Of Fan)

SAFETY WARNING SIGNS

(PLTR196)

12 Row 30" Shown

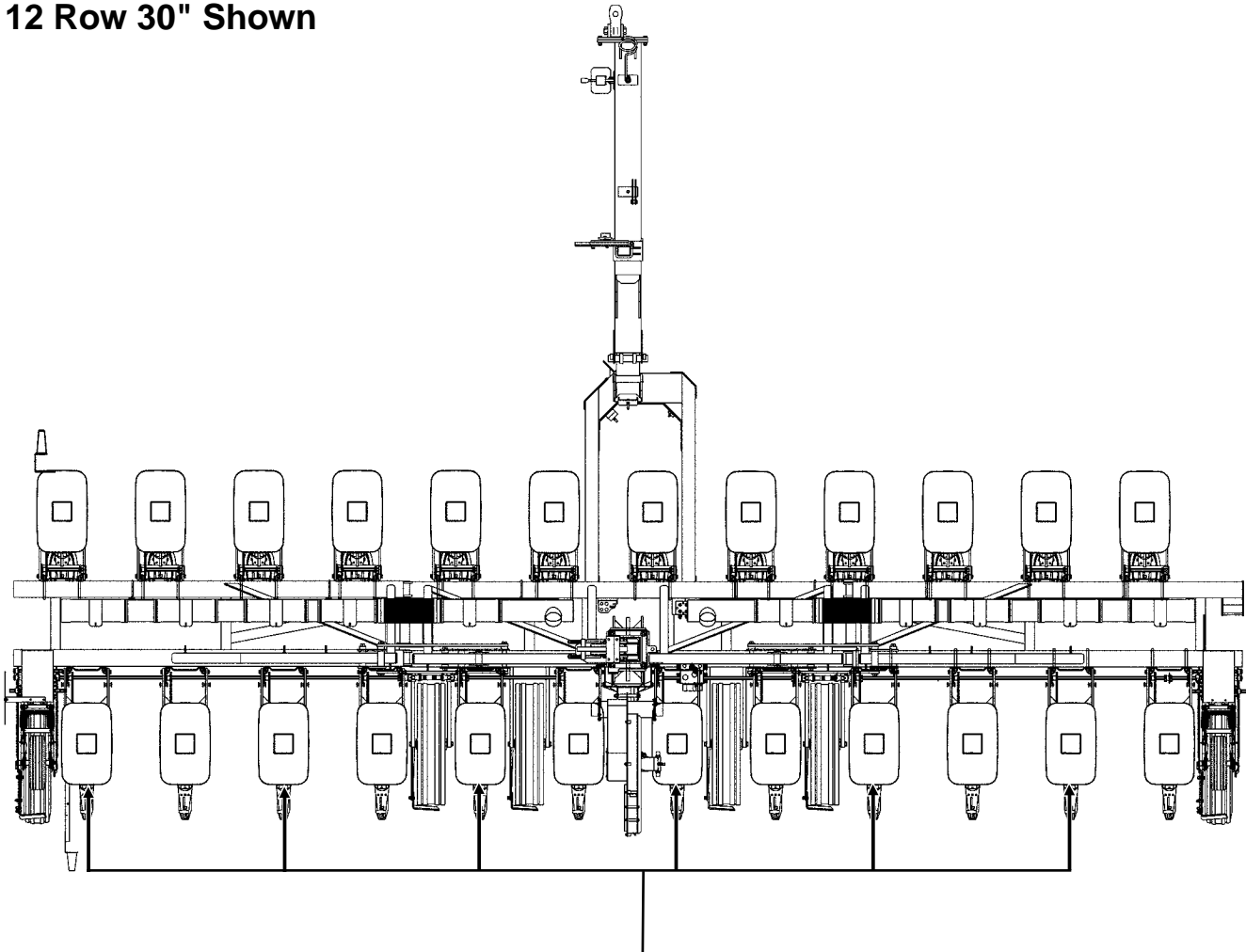

Part No. G7100-262 Amber Reflective Decal (Located On The Hopper Support On Every Other Row Unit Beginning On The 1st Row Unit On The L.H. End Of The Planter - Side-Facing In Transport Position) **(Standard)**



Part No. G7100-259 Amber Reflective Decal (Located On The Granular Chemical Hopper Panel Extension On Every Other Row Unit Beginning On The 1st Row Unit On The L.H. End Of The Planter - Side-Facing In Transport Position) **(With Optional Granular Chemical)**

D060800114

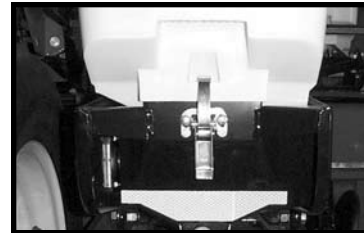

D062300102



NOTE: 4 Decals Used On 8 Row; 6 Used On 12 Row; 8 Used On 16 Row

SAFETY WARNING SIGNS

(PLTR197)

16 Row 30" Shown

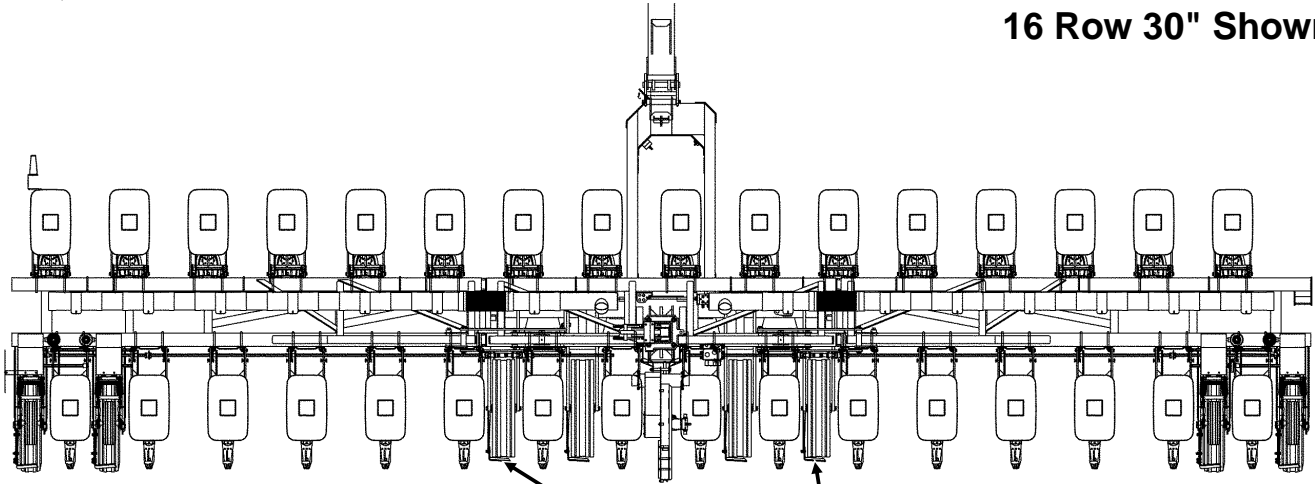

D060800115a

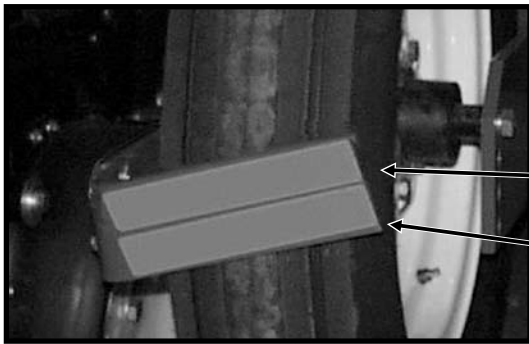

Part No. G7100-258 Red Reflective Decal
(Qty. 1 Per Outer Scraper - Located On Top)

Part No. G7100-260 Orange Reflective Decal
(Qty. 1 Per Outer Scraper - Located On Bottom)

Part No. G7100-259 Amber Reflective Decal (Located On The Front Side Of The Front Toolbar - Side-Facing In Transport Position)

NOTE: 7 Decals Used On 8 Row 36"/38"; 7 Used On 12 Row 30"; 9 Used On 12 Row 36"/38"; 9 Used On 16 Row 30" (8 Row 36"/38" Shown)

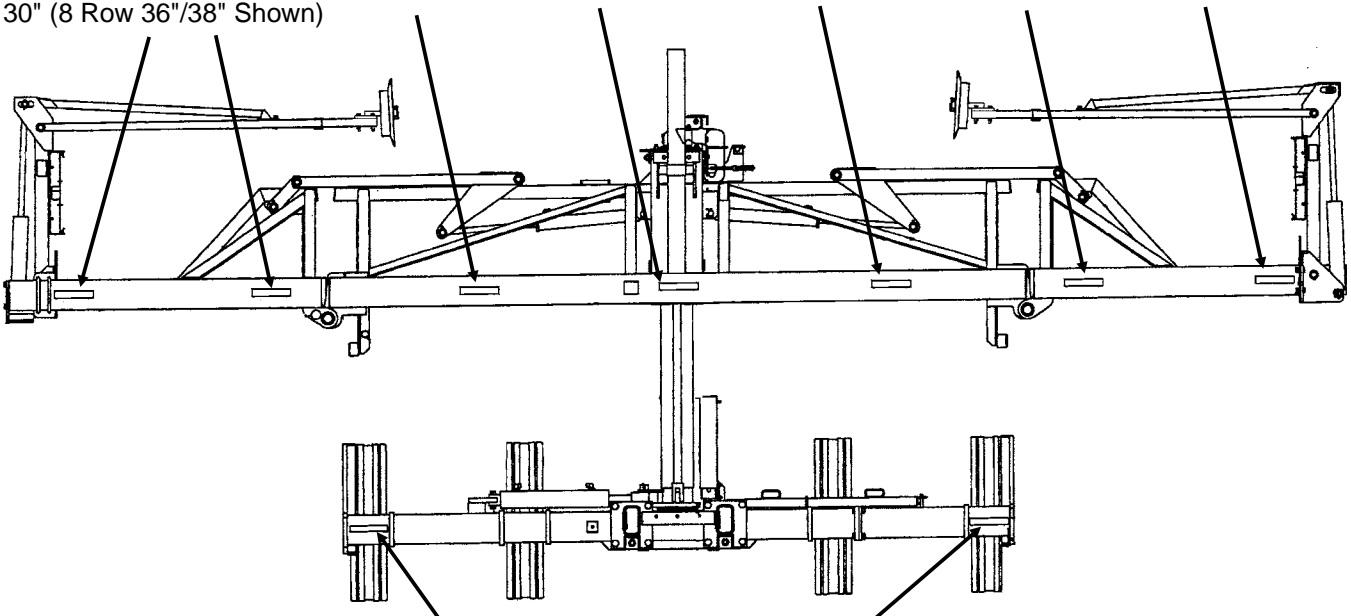

Part No. G7100-259 Amber Reflective Decal (Qty. 2 - Forward-Facing)

SAFETY WARNING SIGNS

(PLTR159e/RU120/PLTR197TTL174b/RU120e)

16 Row 30" Shown

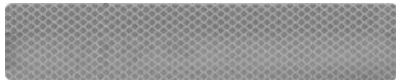

Part No. G7100-258
Red Reflective Decal (Qty. 1)

Part No. G7100-260
Orange Reflective Decal (Qty. 1)

(Located On The L.H. End Of The Planter -
- Rear-Facing In Transport Position)

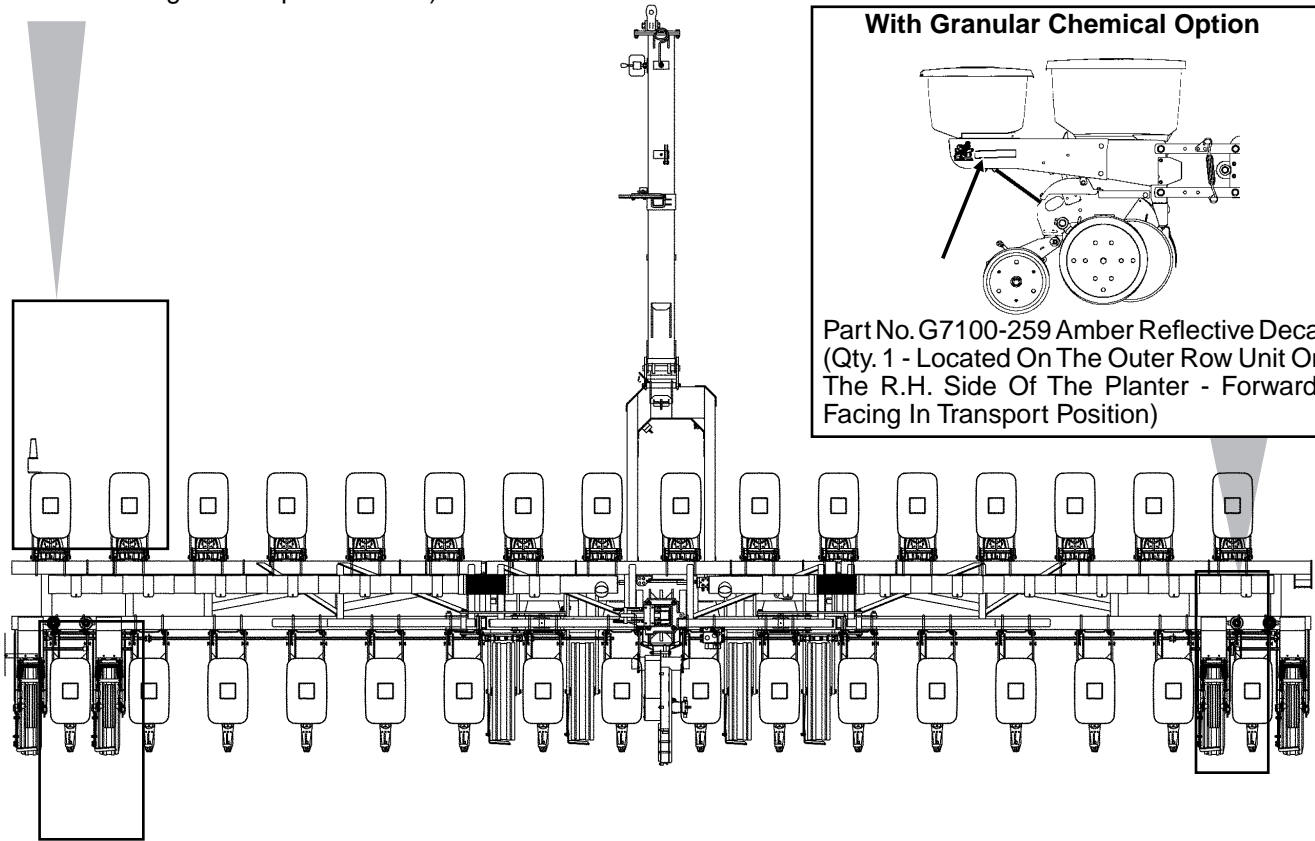
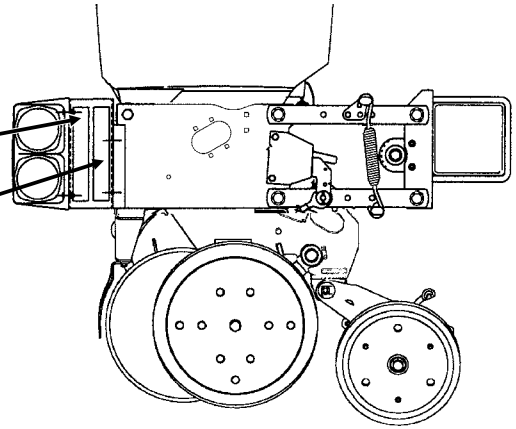

With Granular Chemical Option

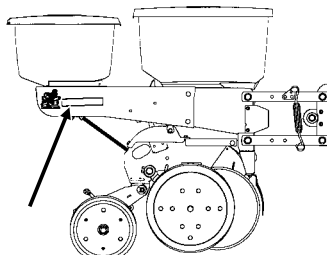

Part No. G7100-259 Amber Reflective Decal
(Qty. 1 - Located On The Outer Row Unit On
The R.H. Side Of The Planter - Forward-
Facing In Transport Position)

Part No. G7100-258 Red Reflective Decal (Qty. 1 -
Located On The Outer Row Unit On the L.H. Side Of
The Planter - Rear-Facing In Transport Position)

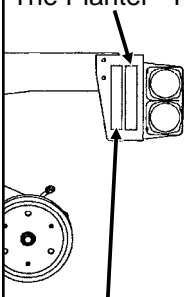

**With Granular
Chemical Option**

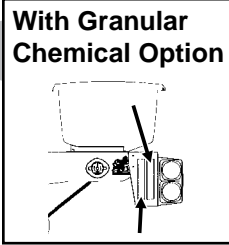

Part No. G7100-260 Orange Reflective Decal (Qty. 1
- Located On The Outer Row Unit On the L.H. Side Of
The Planter - Rear-Facing In Transport Position)

SAFETY WARNING SIGNS

(PLTR197)

PUSH ROW UNITS

D020101103



Part No. G7100-259
Amber Reflective Decal
(Qty. 6 Used On 12 Row; 8 On 16 Row - Located On The Front Of Every Other Push Row Unit Beginning With The Center Row Unit And Every Other Row Unit To Both Ends - Side-Facing In Transport Position)

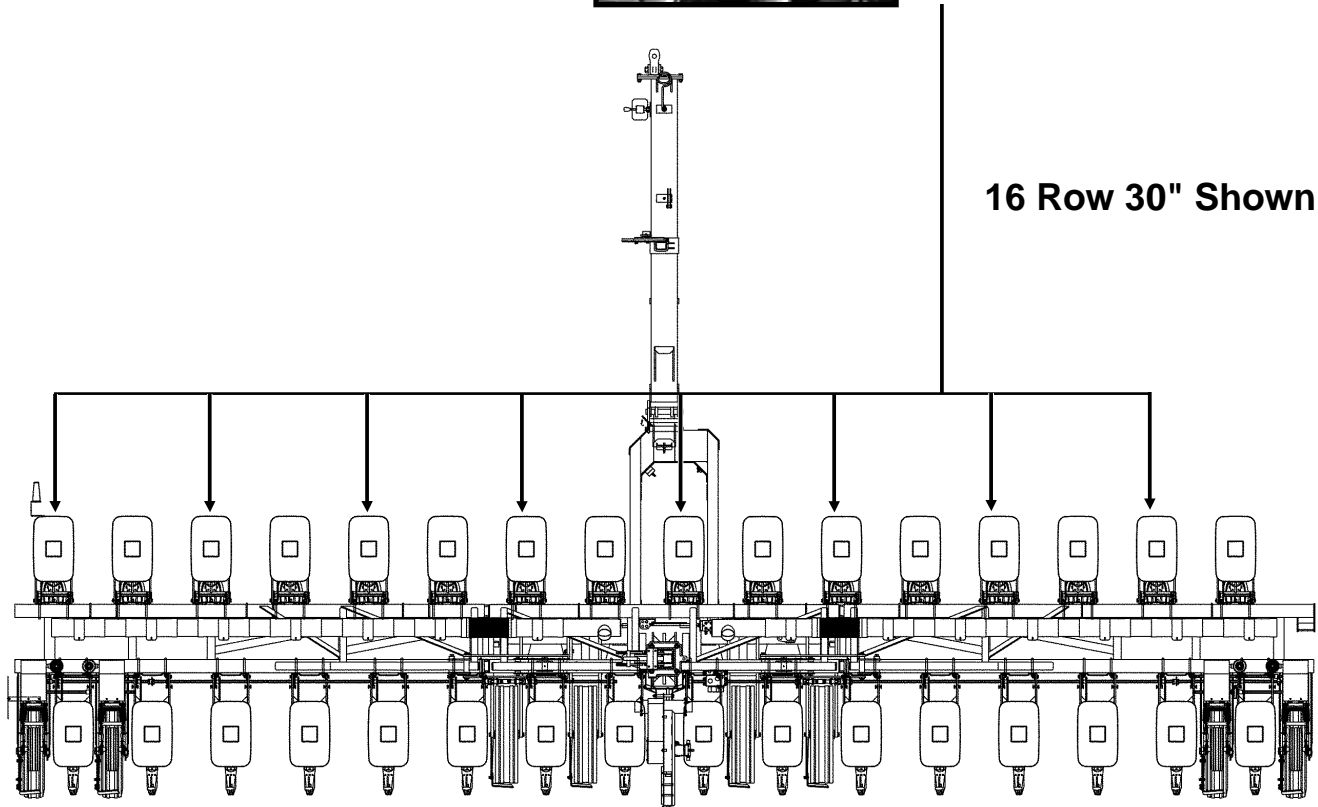

16 Row 30" Shown

SAFETY WARNING SIGNS

(TWL176)

Part No. G7100-259 Amber Reflective Decal (Qty. 2 - 1 Located On Each Side Of Hitch)

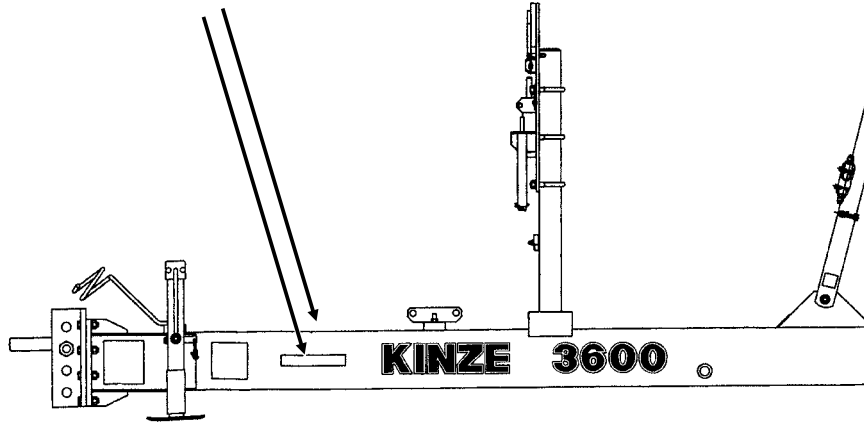

D06039901



Part No. G7100-115 (1 Per Row Unit - Located On Underside Of Optional Granular Chemical Hopper Lid)

D020501106

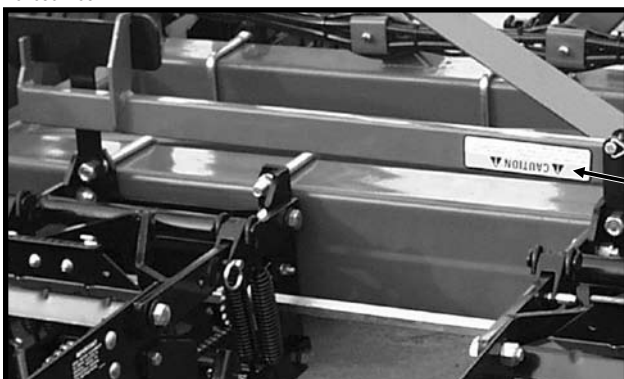

Part No. G7100-249 (Qty. 1 - Interplant® Push Row Unit Lift Lever)

MACHINE OPERATION

The following information is general in nature and was written to aid the operator in preparation of the tractor and planter for use, and to provide general operating procedures. The operator's experience, familiarity with the machine and the following information should combine for efficient planter operation and good working habits.

IMPORTANT: Always raise the planter out of the ground when making sharp turns or backing up.

The KINZE EdgeVac® Seed Metering System includes seed meters, seed discs and an air system consisting of a hydraulic driven vacuum fan which draws air through the manifolds and hoses and the seed meters on each row unit.

WARNING: Never operate vacuum fan with cover removed.

ROW MARKER SAFETY LOCKUP

Install safety lockup devices over marker cylinder rods when transporting the planter or working around the planter. When lockups are not in use, store in the storage position provided on the first stage row marker arm.

DANGER: To avoid serious injury or death, keep others away when raising or lowering row markers.

D08250007



MANUAL SAFETY LOCKUP

Never allow anyone to work around or under the planter without first securing the manual safety lockup in the locked position. When transporting the planter use the manual safety lockup for added safety.

D060299107

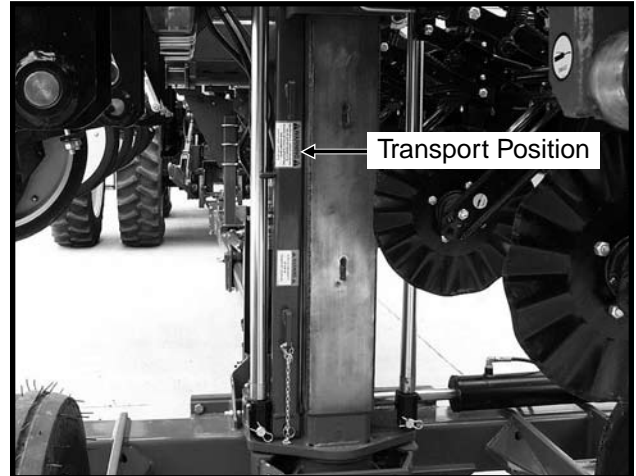

Manual Safety Lockup In Transport Position

D06189903

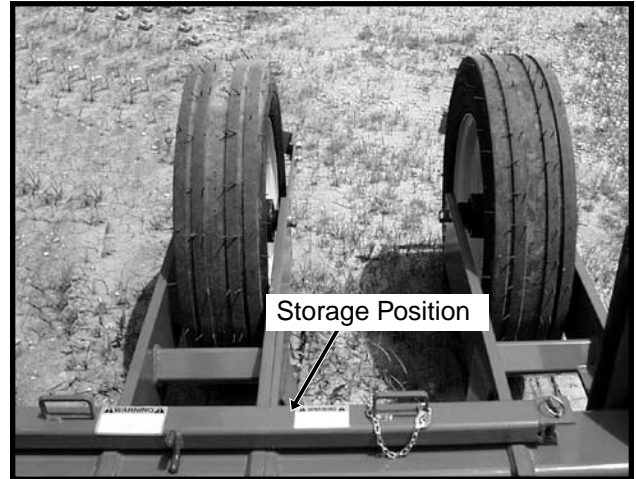

Manual Safety Lockup In Storage Position

For field operation remove the manual safety lockup and store on the L.H. side of the transport axle.

MACHINE OPERATION

TONGUE SAFETY PIN

The tongue safety pin when installed will prevent the tongue cylinder from retracting should hydraulic failure occur or a sudden stop be made when transporting the planter. Never transport the planter without installing the tongue safety pin.

D060299102

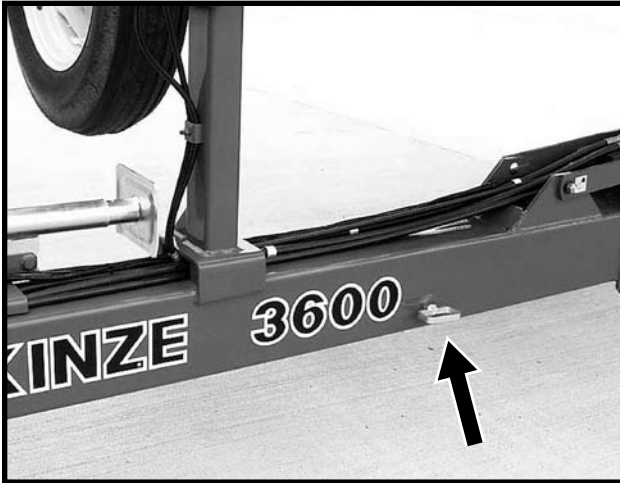

Tongue Safety Pin Installed For Transport

D062501101



Tongue Safety Pin Stored For Field Operation

For field operation remove the tongue safety pin and store in the bracket provided on the transport latch post at the center of the planter.

TRANSPORT LATCH LOCKING PIN

The transport latch locking pin when installed will prevent the latch bar from disengaging and allowing the planter frame to swing away. Never transport the planter without installing the transport latch locking pin.

D060299106

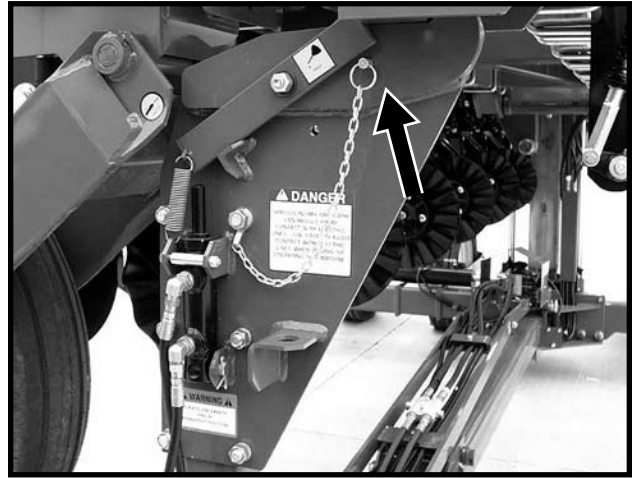

Transport Latch Locking Pin Installed For Transport

D060299216



Transport Latch Locking Pin Stored For Field Operation

For field operation remove the transport latch locking pin and store in the location provided on the latch post.

MACHINE OPERATION

INITIAL PREPARATION OF THE PLANTER

Lubricate the planter and row units per the lubrication information in this manual. Make sure all tires have been properly inflated. Check all drive chains for proper tension, alignment and lubrication.



DANGER: The outer transport wheel on the left side of the machine is shipped removed (not bolted on) to allow narrower width truck shipment. **DO NOT REMOVE THIS ASSEMBLY AFTER PLANTER IS ASSEMBLED FOR USE. DO NOT** fold planter or tow planter while the outer transport wheel is removed. Tipping may occur because of narrow wheel base.

TRACTOR REQUIREMENTS

Consult your dealer for information on horsepower requirements and tractor compatibility. Requirements will vary with planter options, tillage and terrain.

A 12 volt DC electrical system is required on all sizes.

Three SCV remote hydraulic outlets are required on all sizes. One SCV is used for field lift, and in conjunction with a switch on the control console, is used to operate the raise to transport function. The second SCV, in conjunction with the switches on the control console, is used to operate the row markers and fold/unfold functions. The third SCV plus a zero pressure case drain is used to operate the vacuum fan motor for seed metering system.

Maximum hydraulic flow rate of 13 GPM @ 2000 PSI is required to operate the vacuum fan motor.

IMPORTANT: Connect hydraulic motor case drain to a case drain return line with zero PSI on the tractor. Failure to connect to a return with zero PSI will cause damage to the hydraulic motor shaft seal. Warranty will not apply on damaged motors resulting from improper hydraulic line connection. **DO NOT** connect hydraulic motor case drain to a SCV outlet or motor return circuit connection. Contact tractor manufacturer for specific details on “zero pressure return”.

NOTE: If your tractor does not have sufficient hydraulic pump capacity, PTO pump drive and oil cooler packages are available from KINZE® through your KINZE® Dealer.

NOTE: A Flow Control Needle Valve Kit, to provide a flow control option for tractors that are not equipped with a method for finite adjustment of hydraulic flow is available from KINZE® Repair Parts through your KINZE® Dealer.

D04050604

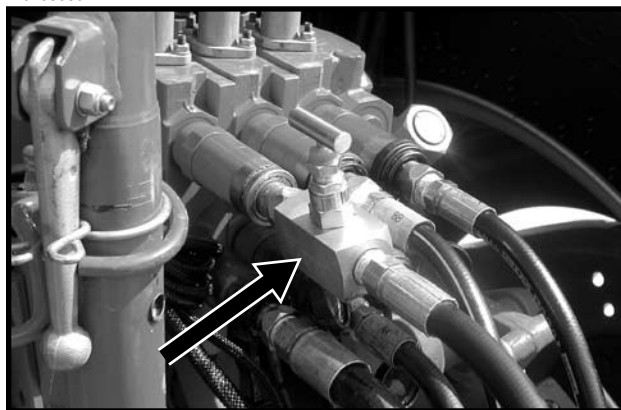

G1K426 Needle Valve Kit

MACHINE OPERATION

PTO PUMP DRIVE AND OIL COOLER OPTION

The PTO pump drive and oil cooler option is designed to accommodate tractors with less than the required hydraulic output necessary to operate the hydraulic-driven vacuum fan in addition to other planter hydraulic requirements. A 1 $\frac{3}{8}$ "-21 spline 1000 RPM PTO is required to operate the PTO-driven hydraulic pump. The option consists of a 1 $\frac{3}{8}$ "-21 spline, 13.5 GPM 2000 PSI pump, 10 gallon capacity hydraulic reservoir, 15 GPM-rated oil cooler, spin-on 10-micron oil filter and required hydraulic valves and fittings.

A 12 volt battery connection is required to power the vacuum fan digital gauge. Connect the "red" wire to the positive (+) battery terminal and the "black" wire to the negative (-) battery terminal.

(TWL290c/TWL294/PLTR177a)

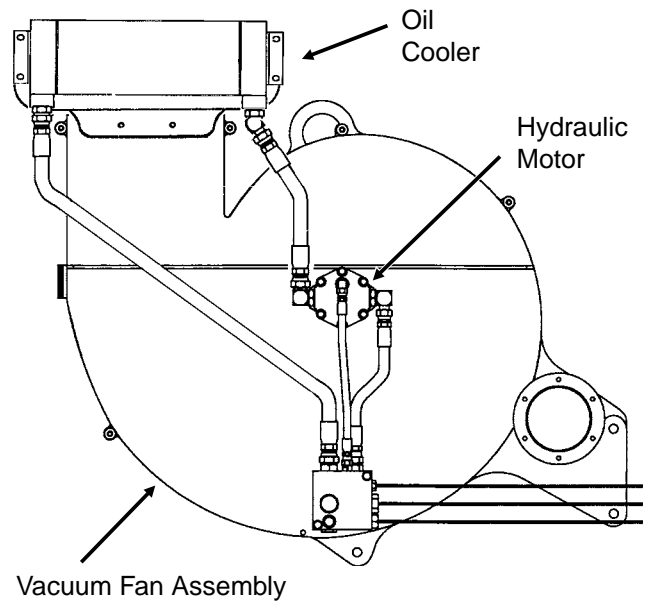

PTO-Driven Hydraulic Pump

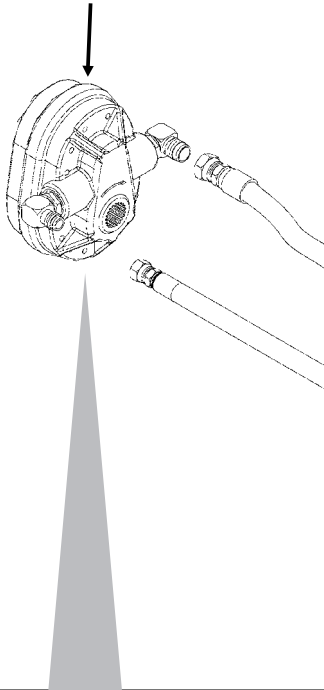

Oil Filter (10 Micron)

Flow Control Valve

Reservoir

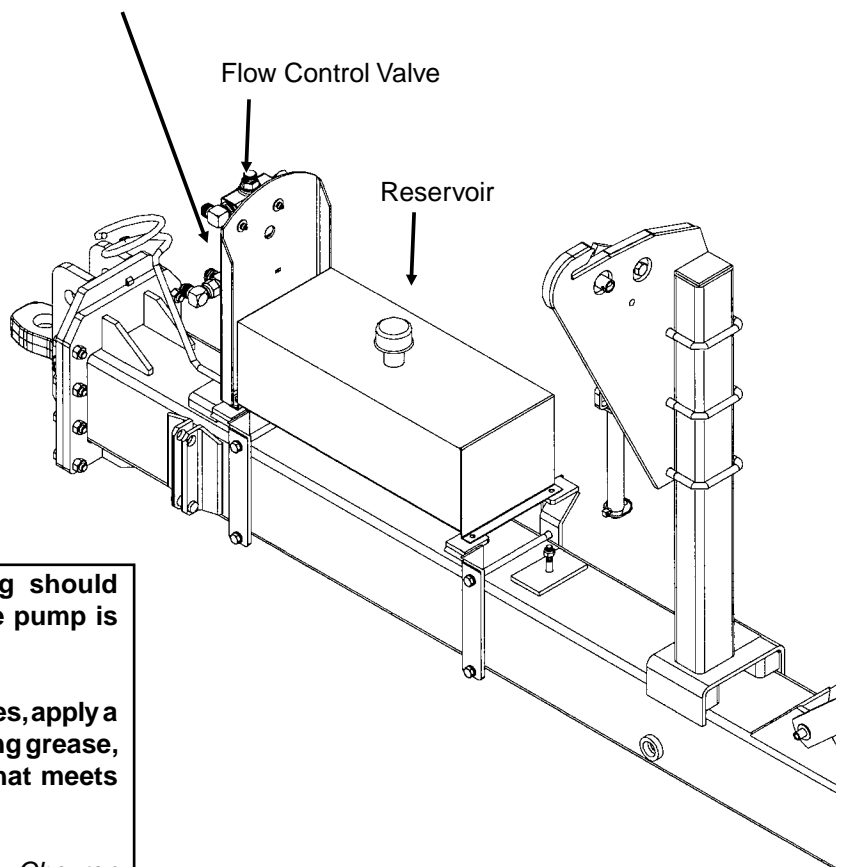

IMPORTANT: The PTO shaft coupling should be cleaned and greased each time the pump is installed.

IMPORTANT: To extend life of shaft splines, apply a coating of high-speed industrial coupling grease, such as Chevron® Coupling Grease, that meets AGMA CG-1 and CG-2 Standards.

(The Chevron® trademark is owned by Chevron Products Company. AGMA is the acronym for the American Gear Manufacturers Association)

MACHINE OPERATION

TRACTOR PREPARATION AND HOOKUP

D101807108



NOTE: A 2-Point Hitch Option, which converts the planter from drawn to semi-mounted, is available for use with Category 3N or 3 three-point hitch designs. The safety chain is not applicable with the 2-point hitch.

1. Adjust tractor drawbar to 13-17 inches above the ground. Adjust the drawbar so the hitch pin hole is directly below the center line of the PTO shaft. Make sure the drawbar is in a stationary position.
2. Install control console on tractor in a convenient location within reach of the operator and close to the hydraulic controls. Mount control console securely and route power cord to the power source.

The control console operates on 12 volt DC only. If two 12 volt batteries are connected in series, ALWAYS make power connection on the battery which is grounded to the tractor chassis.

If two 6 volt batteries are connected in series, make sure the power connection provides 12 volt DC across the positive terminal on one battery and negative terminal of the second battery.

3. Back tractor to planter and connect with 1 1/4" - 1 1/2" diameter hitch pin. If the tractor is not equipped with a hitch pin locking device, make sure hitch pin is secured with a locking pin or cotter pin.
4. The auxiliary attaching system (transport safety chain) provided with your planter should be used to ensure the connection is retained between the planter and tractor in the event of a hitch pin/drawbar failure. The safety chain is to be attached using an unused clevis mounting hole on the planter hitch. The mounting hardware should be torqued to 840 ft. lbs. Connect the hook end of the chain securely around a tractor frame member.

5. Connect hydraulic hoses to tractor ports in a sequence which is both familiar and comfortable to the operator.

The planter operation hydraulic hoses are color coded as follows:

- Red AA - Lift Functions (Return)
- Red BB - Lift Functions (Pressure)
- Blue AA - Marker And Fold/Unfold Functions (Return)
- Blue BB - Marker And Fold/Unfold Functions (Pressure)

The vacuum fan motor operation hydraulic hoses are as follows:

- 3/8" Hose From Motor - Case Drain - Green CD
- 3/4" Hose From Motor - Return - Green RR
- 1/2" Hose From Motor - Pressure - Green PP

PT79a

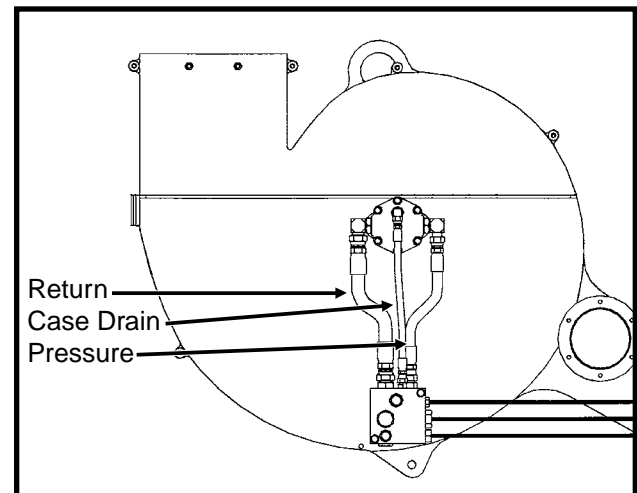

DANGER: Before applying pressure to the hydraulic system, make sure all connections are tight and that hoses and fittings have not been damaged. Hydraulic fluid escaping under pressure can have sufficient force to penetrate skin, causing injury or infection.

IMPORTANT: Always wipe hose ends to remove any dirt before connecting couplers to tractor ports.

(Continued On Following Page)

MACHINE OPERATION

6. Connect cable on planter to control console cable on tractor. Connect ASAE Standards 7 terminal connector for safety/warning lights on planter to ASAE Standards receptacle on tractor. If your tractor is not equipped with an ASAE Standards receptacle, check with your tractor manufacturer for availability. Check to be sure safety/warning lights on planter are working in conjunction with warning lights on tractor.

Connect harness on planter to digital vacuum gauge console on tractor. Connect power lead to power source. A power lead adapter may be required.

7. Raise jack and remount horizontally on storage bracket.
8. Lower planter to the planting position and check to be sure the hitch is level. If hitch slopes up or down, disconnect planter and adjust hitch clevis up or down as necessary.

LEVELING THE PLANTER

For proper performance of the planter and row units, it is important that the planter frame and row unit parallel arms operate approximately level. The toolbar should operate at a 20"-22" height, measured from the planting surface to the bottom of the toolbar.

D101807108



Four holes in the hitch bracket allow the clevis to be raised or lowered. In addition, the clevis may be turned over for a finer adjustment between mounting holes. When installing the clevis mounting bolt, make sure the lock nut is tightened to 840 ft. lbs.

D08260513

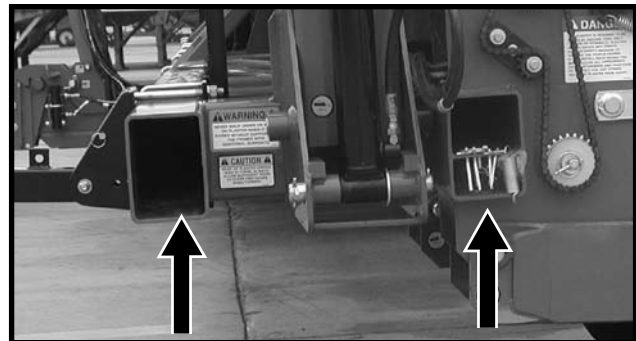

With the planter lowered to operating height, check to be sure the frame is level fore and aft. Recheck once planter is in the field.

It is important for the planter to operate level laterally. Tire pressure must be maintained at pressures specified. See "Tire Pressure".

Field and actual planting conditions will dictate which of the transport wheel settings to use to ensure row unit parallel arms are approximately parallel with the planting surface. It may also be necessary to lower the ground drive wheels to ensure level lateral toolbar operation if the transport wheels are set in one of the two lower sets of holes.

NOTE: To allow adequate drive force after lowering the ground drive wheels, it may be necessary to lower the contact drive wheel arms to the lower sets of holes in the wheel modules and lower the down pressure springs to the lower mounting rods on the wheel modules.

MACHINE OPERATION

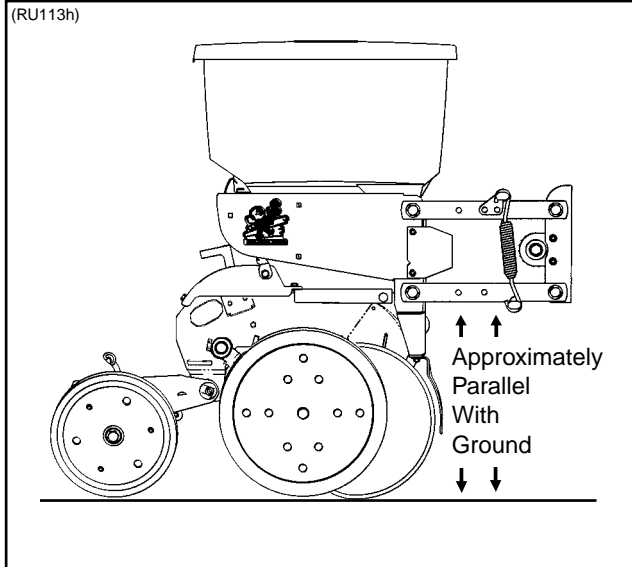

NOTE: On planters equipped with push row units and no till coulters, the uplift from the down force springs or air springs in the pneumatic down pressure system may cause the wings to rise slightly in planting position. The problem may be compounded if static pressure is trapped in the planter's hydraulic lift system which can cause the wing cylinders to extend slightly. Operating the tractor's hydraulic system in the float position or moving the tractor's hydraulic lever to the float position briefly, to relieve the pressure, will help to maintain the proper toolbar height.

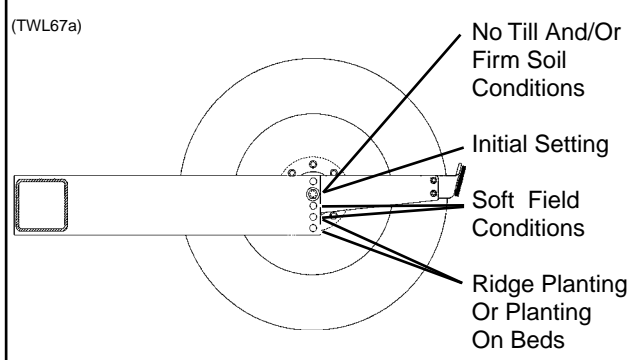

TRANSPORT WHEEL
CAUTION: When using top hole setting, check clearance between tires and drill shaft U-joint prior to operation.

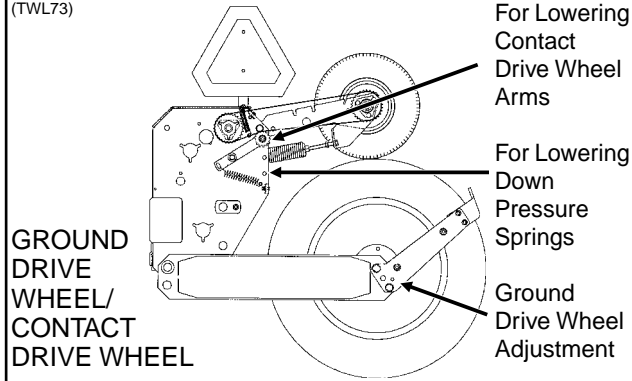

When the planter has been fully loaded with seed, granular chemicals, fertilizer, etc.; a field check should be made to be sure the wings are level with the center frame. If the wings are not level with the center frame, the drive wheels and/or transport wheels can be raised or lowered in the wheel arms to increase or decrease planter toolbar height. Hitch height should be raised accordingly to ensure level operation.

NOTE: As the lift cylinders are (port type) rephasing type, it is necessary for the cylinders to fully retract in order to rephase. Cylinder stops can not be used.

MACHINE OPERATION

CONTACT WHEEL SPRING ADJUSTMENT

D06049909

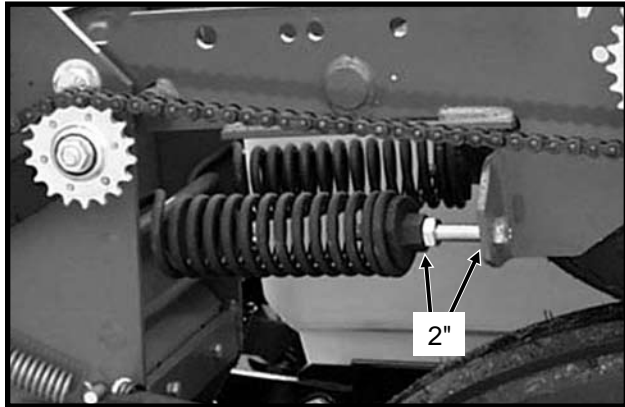

There are two down pressure springs on each contact drive wheel. The spring tension is factory preset and should require no further adjustment.

The tension is set leaving 2" between the spring plug and the bolt head.

TIRE PRESSURE

D101807136

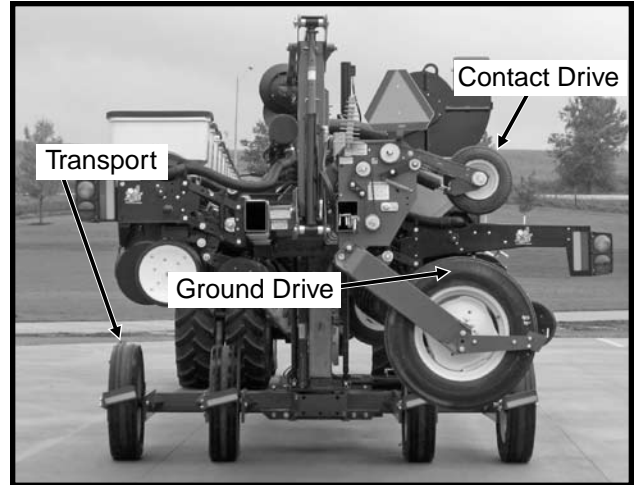

Tire pressure should be checked regularly and maintained as follows:

255-70R 22.5" Transport (Center Section) . . .	75 PSI
7.50" x 20" Ground Drive (Wings)	40 PSI
4.80" x 8" Contact Drive	50 PSI
7.60" x 15" Ground Drive (Liquid Fertilizer Piston Pump)	40 PSI

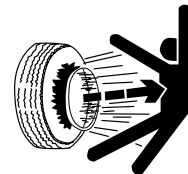

DANGER: Rim and tire servicing can be dangerous. Explosive separation of tire and rim parts can cause serious injury or death.

Do not attempt to mount a tire unless you have the proper equipment and experience to perform the job. This should only be done by persons properly trained and equipped to do the job.

Always maintain the correct tire pressures. Do not inflate the tires above the recommended pressures.

When inflating tires, use a clip-on air chuck and extension hose long enough to allow you to stand to one side and NOT in front of or over the tire assembly. Use a safety cage to enclose the tire and rim assembly when inflating.

Inspect tires and wheels daily. Do not operate with low pressure, cuts, bubbles, damaged rims or missing lug bolts and nuts.

MACHINE OPERATION

SEED RATE TRANSMISSION ADJUSTMENT

Planting population rate changes are made at each end of the planter. The seed rate transmission is designed to allow simple, rapid changes of sprockets to obtain the desired planting population. By removing the lynch pins on the hexagon shafts, sprockets can be interchanged with those from the sprocket storage rod bolted to the transmission.

Chain tension is controlled by a spring-loaded dual-sprocket idler. The idler assembly is adjusted with an easy-release idler arm. This arm has a release position to remove spring tension for replacing sprockets. The amount of spring tension on the chain is controlled by the idler arm. See "Wrap Spring Wrench Operation".

A decal positioned on the transmission module illustrates proper chain routing. The planting rate charts found in the "Seed Meter Operation/Maintenance" section will aid you in selecting the correct sprocket combinations.

D020501108

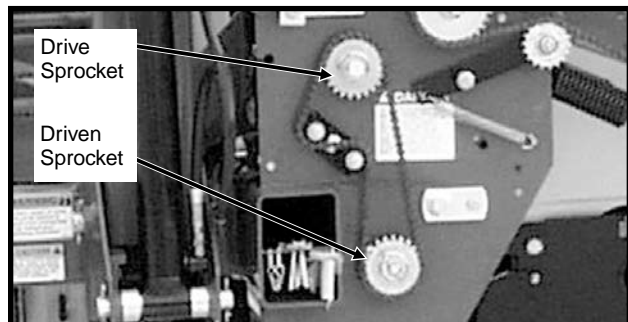

CONTACT WHEEL DRIVE SPROCKETS

D070699113a

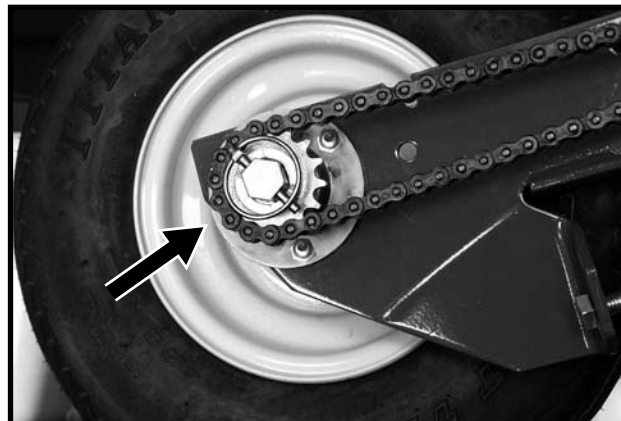

NOTE: 22 tooth, 28 tooth or 44 tooth sprockets at each contact drive wheel can be interchanged from the sprocket storage rod bolted to the wheel module on each side of the planter chains.

Chain tension is controlled by a spring-loaded sprocket idler. The amount of spring tension on the chain is controlled by the idler arm.

The planting rate charts found in the "Seed Meter Operation/Maintenance" section will aid you in selecting the correct sprocket.

NOTE: 22, 28 and 44 tooth drive sprockets are NOT applicable to all rate charts. Check chart titles to ensure the proper rate chart is selected. DO NOT USE 44 tooth drive sprockets (60 cell soybean discs) with Dry Fertilizer Package or Liquid Fertilizer Squeeze Pump Package.

NOTE: After each sprocket combination adjustment, make a field test to be sure you are planting at the desired rate.

MACHINE OPERATION

WRAP SPRING WRENCH OPERATION

The chain idler are equipped with wrap spring wrenches. Chain tension is released and/or added as shown below.

To release chain tension, rotate the knurled collar on the wrap spring wrench while rotating the chain idler away from the chain.

D10290305

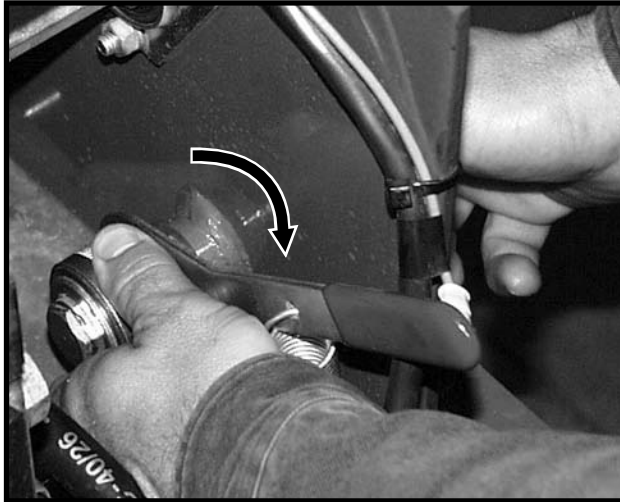

To add chain tension, rotate the chain idler into the chain while rotating the handle to tension idler spring.

D10290304



The wrap spring wrenches are made in L.H. and R.H. configurations, which can be identified by the silver or gold release collars, respectively.

RIDGE PLANTING

When ridge planting, the drive wheels and transport wheels can be lowered 2" or 4" to the lower mounting holes in the wheel arms to increase the planter toolbar height. The contact drive tire must also be lowered to the lower set of holes in the wheel module and the down pressure springs hooked on the lower rod. Hitch height should be raised accordingly to ensure level operation.

(TWL67a)

Wheel Shown Mounted In Standard Location - Lower 2" Or 4" To Lower Mounting Holes When Ridge Planting

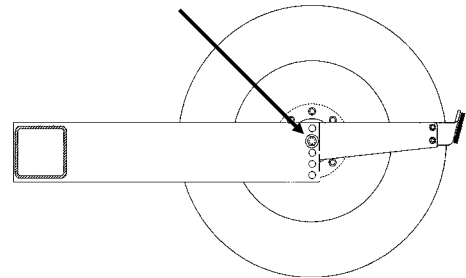

NOTE: The toolbar should operate at a 20"-22" height measured from the bottom of the toolbar to the planting surface.

MACHINE OPERATION

SHEAR PROTECTION

The planter driveline and seed and granular chemical drivelines are protected from damage by shear pins.

If excessive load should cause a pin to shear, it is important to determine where binding has occurred before replacing the pin. Replace shear pins with same size and type.

Additional shear pins can be found in the storage area located inside the rear planter frame.

To prevent future binding or breakage of components, check driveline alignment and follow prescribed lubrication schedules.

NOTE: Drill shaft/transmission coupler alignment is critical.

50981-10

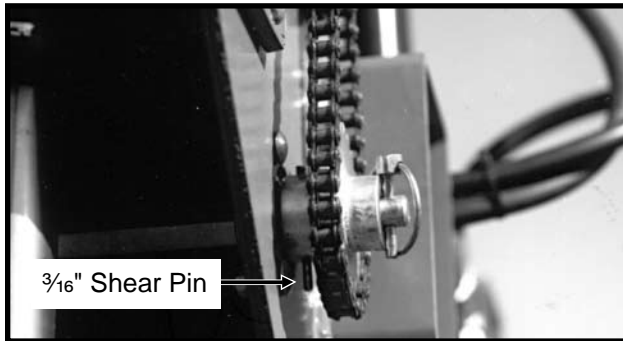

Transmission Shaft

HYDRAULIC/ELECTRIC OPERATION

76746-24

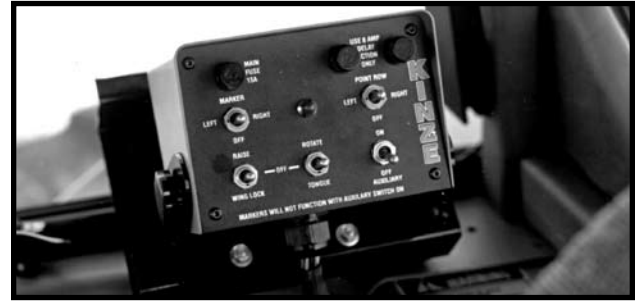

The tractor's hydraulic system and switches on the control console located on the tractor are used to raise the planter to transport position, operate the rotate and tongue extension functions, lock and release the planter wings, and raise and lower the row markers.



DANGER: To avoid serious injury or death care must be taken when operating row markers around overhead power lines.

NOTE: The backlit console is equipped with a push button switch on the back of the console which should be used to turn the console face off during extended periods of non-use.

Model 3600 planters are equipped for operation from three dual remote (SCV) hydraulic outlets. One SCV, in conjunction with a switch on the control console, is used to operate the raise to transport function. The second SCV, in conjunction with the switches on the control console, is used to operate the row markers and fold/unfold functions. The third SCV is used to operate the vacuum fan motor circuit.

The marker and point row selector switches are an ON-OFF-ON type. (NOTE: Point row clutches are optional on 8 row sizes and standard on 12 and 16 row sizes. All 3600 planters are shipped with the point row switch installed in the control console.)

If the planter is equipped with the optional Two-Speed Point Row Clutch Package, the point row switch and reduced rate switch operate independently of the rest of the control console. Power to the marker switch is fed through the auxiliary switch and the two transport function switches. Operating any of the switches in the lower row disables the marker function and turns off the indicator light for the markers.

A7435(TWL81)

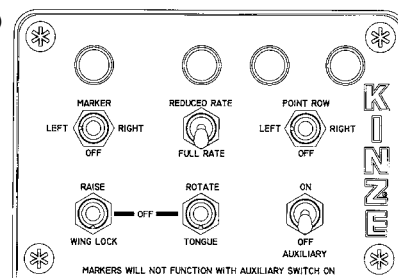

MACHINE OPERATION

The raise/wing lock and rotate/tongue (fold function) switches are MOMENTARY ON-OFF-MOMENTARY ON type and must be held in position while operating the tractor hydraulic SCV control. Activating a fold function switch disables the marker circuit.

! WARNING: To ensure the safety of the operator and others nearby, the marker selector switch should be placed in its OFF (center) position when not in use. An indicator light on the control box panel is ON whenever the marker circuits or point row clutch circuits are energized.

The auxiliary switch is an ON-OFF type switch which is used in conjunction with the hydraulic marker/folding functions SCV control to operate optional attachments. All 3600 planters are shipped with the auxiliary switch installed in the control console. The auxiliary switch must be in the OFF position to enable other functions.

NOTE: Activating the auxiliary switch disables all other control console switches except the point row clutch switch.

NOTE: The lift cylinders are (port type) rephasing cylinders. It is necessary for the cylinders to fully retract before they will rephase in the lowered position. Cylinder stops can not be used.

! WARNING: Never work under the planter while in raised position without installing safety lockup devices.

! WARNING: Make sure all hydraulic hoses are properly connected before operating the planter. Never connect or disconnect hydraulic hoses without first stopping the tractor engine and moving the hydraulic operating controls in both directions to relieve any pressure in the system.

A third SCV operates the seed metering system vacuum fan. See "Digital Vacuum Gauge Operation".

NOTE: The vacuum gauge ON/OFF switch should be left in OFF position when planter is not in use. If left in ON position, the tractor battery will be drained.

TRANSPORT TO FIELD SEQUENCE

Position the planter in a relatively flat open area. Try to avoid an area with furrows, etc.

SUMMARIZED TRANSPORT TO FIELD SEQUENCE

- Remove tongue safety pin.
- Remove transport latch locking pin.
- Remove manual safety lockup.
- Rotate planter to planting position.
- Raise planter slightly to release safety hook at top of center section.
- Lower planter to the ground.
- Release wing locks.
- Rephase planter lift cylinders.
- Raise planter to raised field position and retract tongue.
- Remove row marker lockups.

NOTE: Read the following information for more detailed instructions.

D101807139

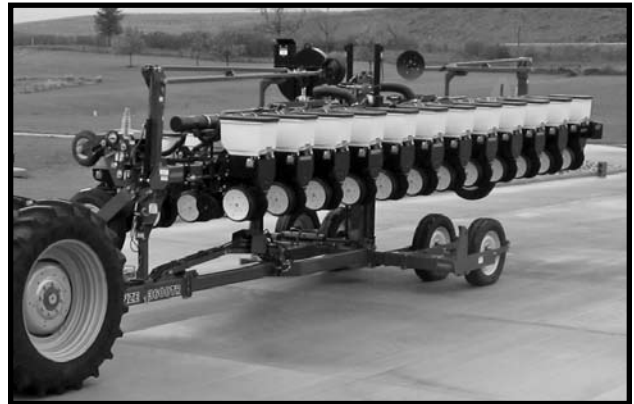

1. With the tongue fully extended and the planter in the raised transport position, remove the tongue safety pin and store it in the storage position.

D101807118

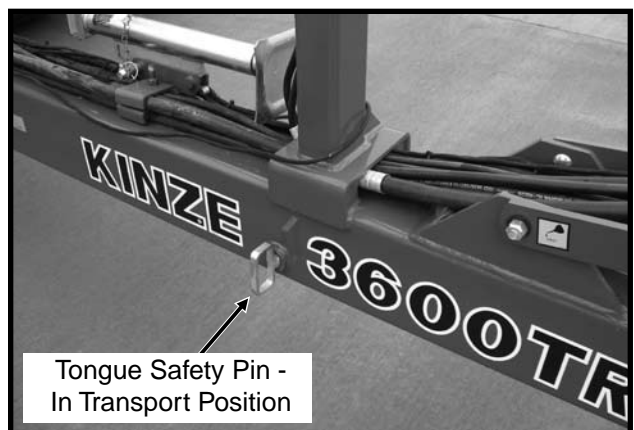

MACHINE OPERATION

D062501101



2. Remove the transport latch locking pin from the locked position and place it in the storage location.

3. Remove the manual safety lockup from under the front center lift cylinder and place it in the storage location on the left side of the planter axle.

D060299107



D060299106



D06189903

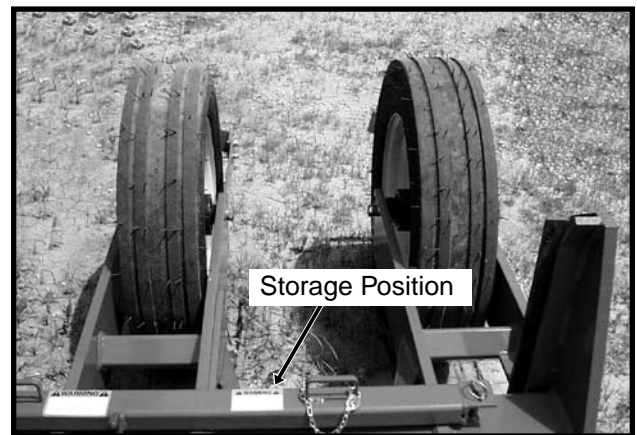

4. Hold the control console switch labeled "ROTATE/TONGUE" in "ROTATE" and operate the hydraulic control to unfold the planter. The transport latch will automatically release.

D060299216



76746-24

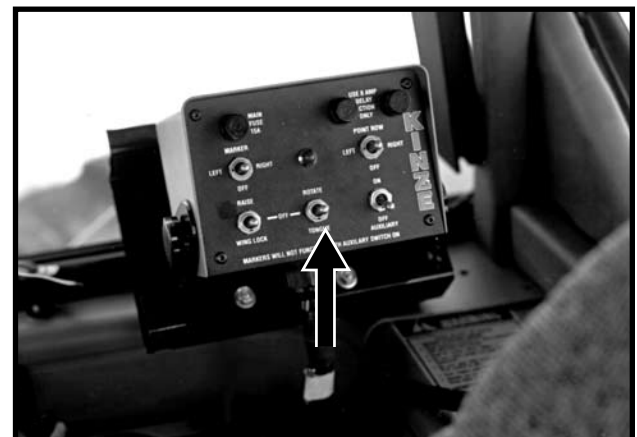

MACHINE OPERATION

D101807139

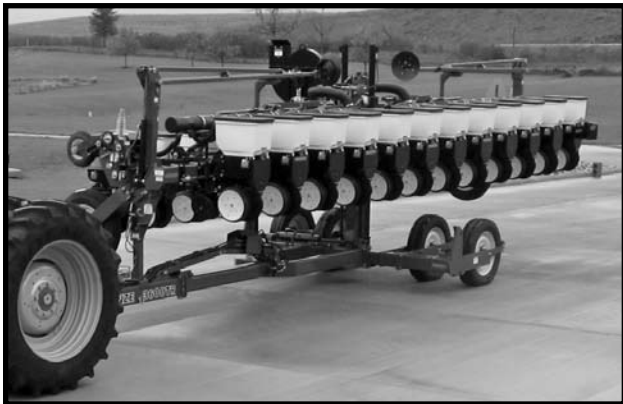

5. Raise the planter 1"-2". The safety hook will release and snap away from the catch pin on the top of the pivot post.

82316-16

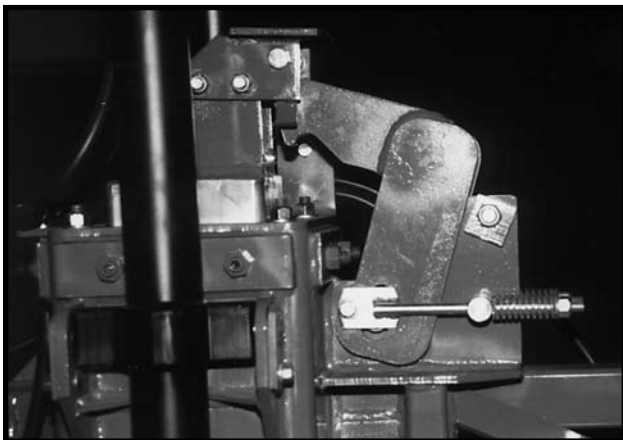

NOTE: Raising the planter too high will reset the hook mechanism and the sequence must be repeated.

6. Slowly lower the planter to the ground.

D101807111

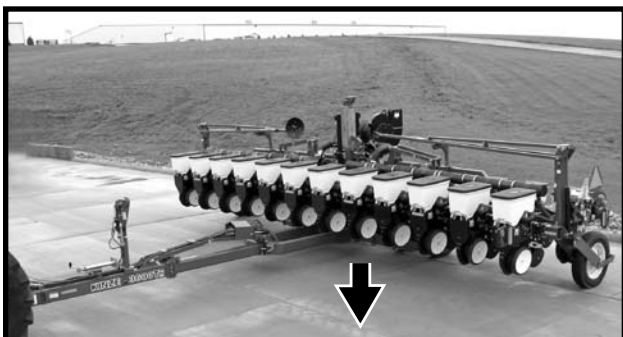

7. Hold the control console switch labeled "RAISE/WING LOCK" in "WING LOCK" position and operate the hydraulic control to release the wing locks.

D101807112



8. Hold the hydraulic control (to lower planter) to rephase the planter lift cylinders. The length of time it takes to rephase the system may vary due to tractor hydraulic flow and/or oil temperature. Normally 5 to 20 seconds is adequate to rephase the system.

9. Raise the planter to the raised field position. Hold the control console switch labeled ROTATE/TONGUE in **TONGUE** and operate the hydraulic control to retract the tongue.

D101807110

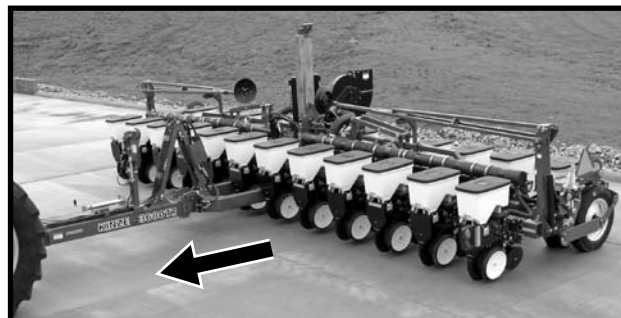

10. Remove and store row marker lockups.

D08250007



MACHINE OPERATION

FIELD OPERATION

There are two raised positions on the planter. One is the “raised field position” which is when the planter wing cylinders are fully extended and the center lift cylinders are at mid-stroke. Because the solenoid, located on the top side of the valve blocks on the rear R.H. side of the center frame, is not energized, the wing cylinders cannot bypass oil preventing the planter from raising any higher. In the “raised field position” the row units are approximately 14 inches off the ground. This position is used in making turns or passing over waterways during field operation.

D101807110



D060299126



See “Row Marker Operation” for field operation of row markers.

FIELD TO TRANSPORT SEQUENCE

Position the planter in a relatively flat area. Try to avoid an area with furrows, etc.

SUMMARIZED FIELD TO TRANSPORT SEQUENCE

- Install row marker lockups.
- Raise planter to raised field position.
- Extend tongue.
- Lock wings over center
- Raise planter to engage safety hook at top of center section into locking position.
- Lower planter onto safety hook.
- Rotate planter to transport position.
- Install tongue safety pin.
- Install transport latch locking pin.
- Install manual safety lockup.

NOTE: Read the following information for more detailed instructions.

1. Install row marker lockups.

D060299127a

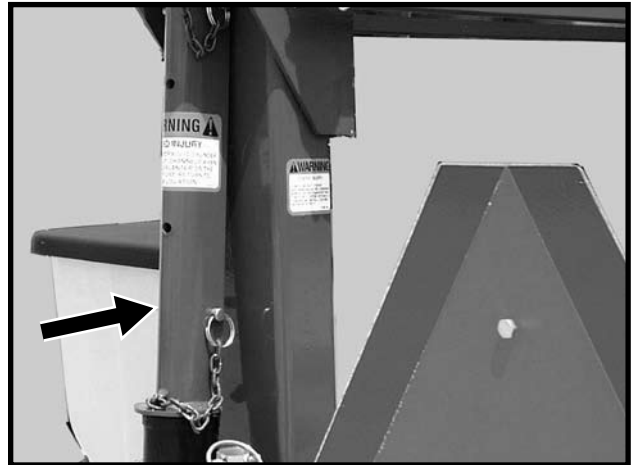

2. Using the hydraulic control, raise the planter to the raised field position as shown below.

D101807110



MACHINE OPERATION

3. Hold the control console switch labeled "ROTATE/TONGUE" in "TONGUE" and operate the hydraulic control until the tongue is fully extended. The tongue lock latch will automatically release.

D101807110

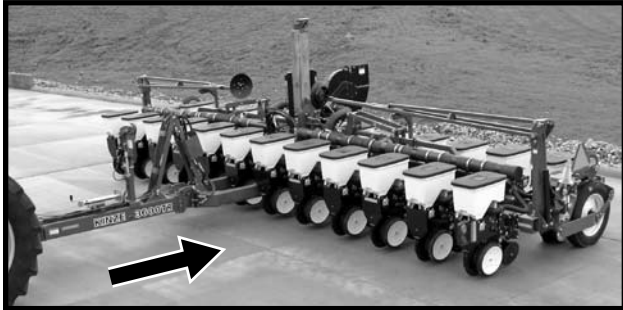

82316-20

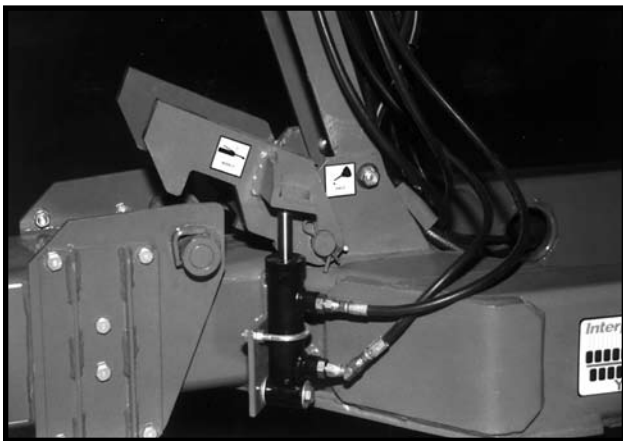

4. Hold the control console switch labeled "RAISE/WING LOCK" in "WING LOCK" and operate the hydraulic control until the wing lock cylinders are fully extended and the wing locks are locked over center.

76746-24

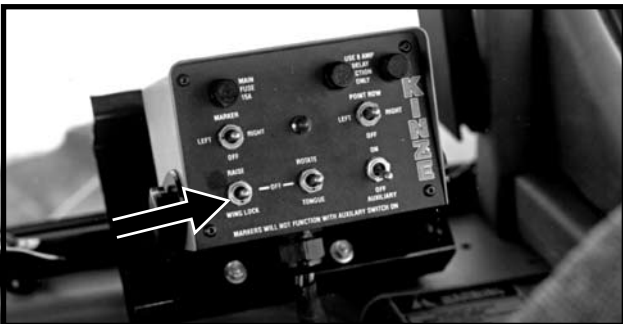

D061901109



5. Hold the control console switch labeled "RAISE/WING LOCK" in "RAISE" and operate the hydraulic control until the two center lift cylinders are fully extended and the safety hook located at the top of the center section rotates into locking position.

82316-15

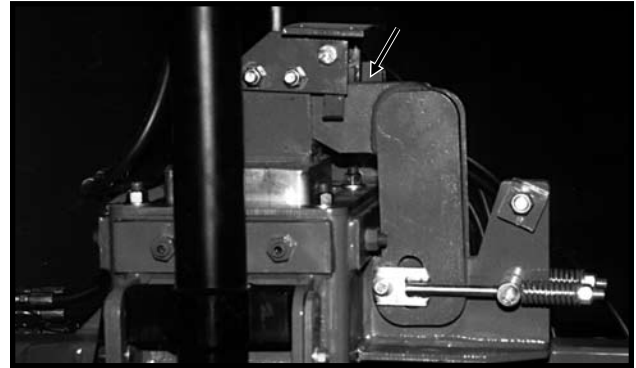

6. Using the hydraulic control, lower the planter onto the safety hook.
7. Hold the control console switch labeled "ROTATE/TONGUE" in "ROTATE" and operate the hydraulic control to rotate the planter until the transport latch is engaged.

82079-2a

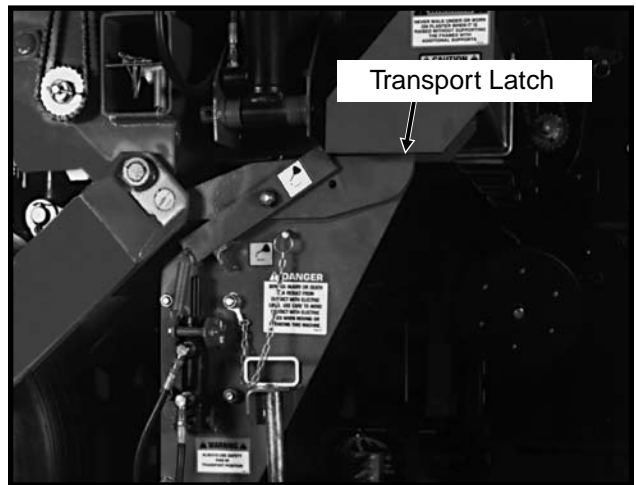

8. Install tongue safety pin.

D101807118

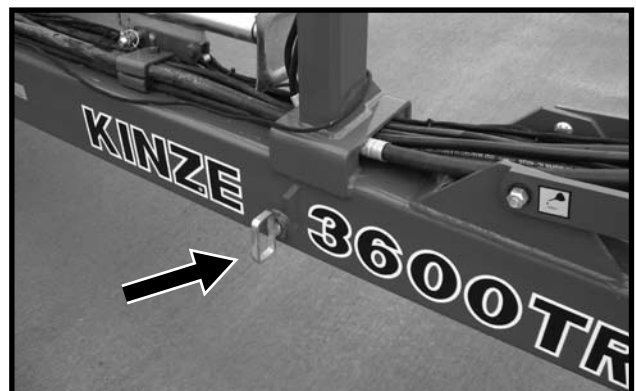

MACHINE OPERATION

9. Install transport latch locking pin.

D060299106



10. Remove manual safety bar from its storage location on the left side of the axle assembly and position it behind the front center lift cylinder.

D06189903

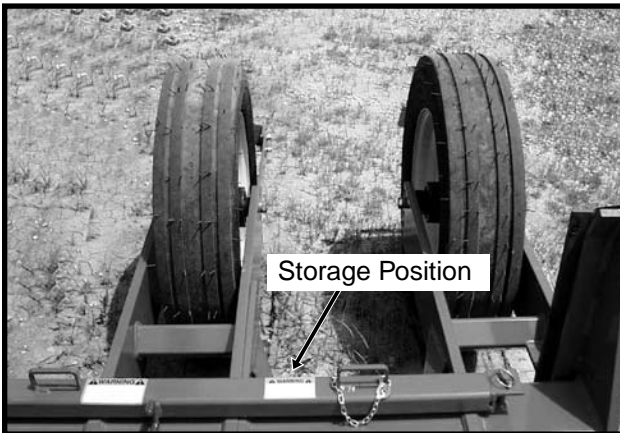

D060299107

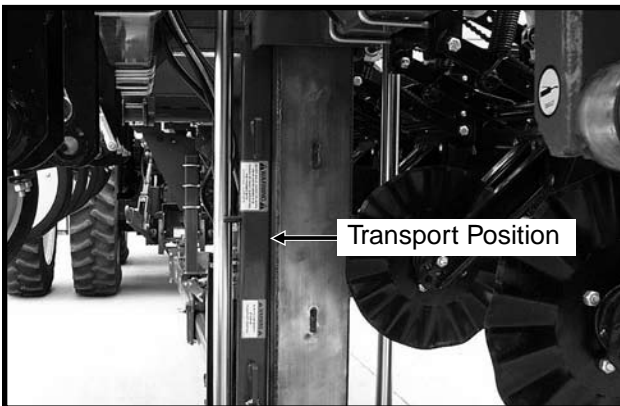

DANGER: Always install the manual safety lockup prior to working under the planter or while transporting the planter.

MACHINE OPERATION

DIGITAL VACUUM GAUGE OPERATION

The digital vacuum gauge console is equipped with an ON-OFF-ON type selector switch. The “FAN 1” setting should be used when the planter is equipped with one vacuum fan.

NOTE: The console ON/OFF switch should be left in OFF position when the planter is not in use. If left in ON position, the tractor battery will be drained.

D10240583



The digital vacuum gauge is calibrated at the factory, however, vacuum will vary throughout the manifold system and it may be necessary to adjust the digital readout so it agrees with the actual vacuum at the meter. With the seed discs loaded with seed, compare the digital vacuum gauge readout to the reading taken from the analog gauge or a hand held gauge at several meters along the length of the planter. The elbows located on the covers of the seed meters allow testing of meter vacuum levels without removing the vacuum hoses. If there is more difference than 1" or 2" (H₂O), the digital gauge can be adjusted by inserting a small flat bladed screwdriver into the opening on the back of the digital gauge housing and turning the potentiometer until the digital gauge displays the vacuum that is present at the meter. Compare readings at 10" and 20" of vacuum.

ANALOG VACUUM GAUGE

The analog vacuum gauge connects directly to the manifold. The digital vacuum gauge should then be calibrated to match that reading. See “Digital Vacuum Gauge Operation”.

D06260653



The only adjustment to the gauge is to “zero” the needle with no vacuum present. If there is a significant difference between this gauge and a reading taken at the meters, a different manifold location should be found to connect hose to the gauge.

VACUUM FAN MOTOR VALVE BLOCK ASSEMBLY

A pressure relief valve in the hydraulic circuit prevents build up of oil pressure over 35 PSI in the case drain line when the vacuum fan motor is in operation. This valve will vent oil to the outside of the valve block through a drain hole in the aluminum valve block. This can occur whenever the case drain is connected improperly or pressure in the motor circuit builds.

See “Hydraulic Diagram - Vacuum Fan Motor System” in Maintenance section.

The valve block also contains a check valve that serves two purposes. This valve (a) prevents the vacuum fan from operating in the wrong direction if pressure is applied to the return side of the motor and (b) allows the fan to coast to a stop when the tractor hydraulic control is returned to the neutral position.

NOTE: If reverse pressure is applied the fan will turn at a reduced speed.

MACHINE OPERATION

ROW MARKER OPERATION

76740-28

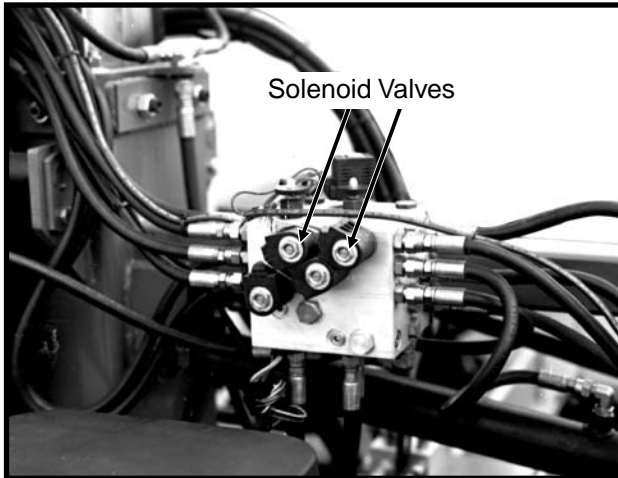

Shown With Cover Removed

D060299126

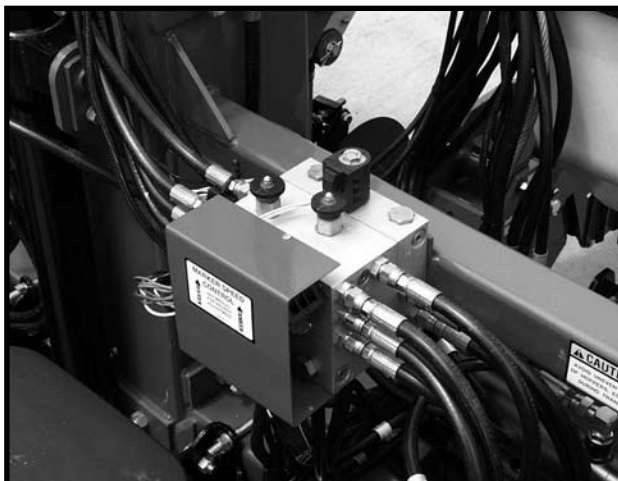

Shown With Cover Installed

76746-24

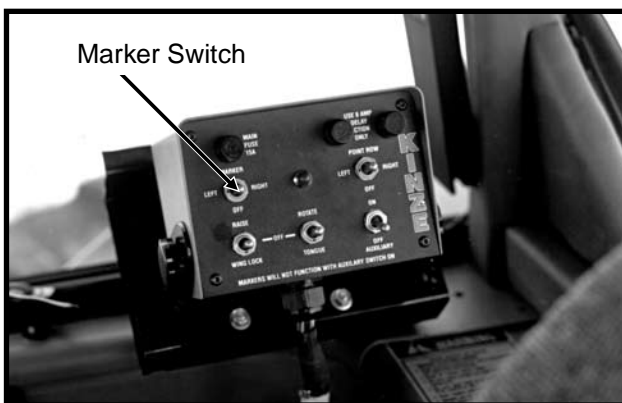

Three Position Selector Switch On Control Console

Two solenoid valves, located on the valve block on the rear R.H. side of the center frame, and a three position selector switch on the control console permit the operator to lower or raise the desired row marker.

See "Row Marker Speed Adjustment".

1. On the control console, select which row marker you want to lower.
2. Operate hydraulic control to lower row marker.
3. If opposite row marker is to be used next, change control switch to other side.
4. At end of field, using hydraulic control, raise the down row marker.
5. After making the turn, using the hydraulic control, lower the pre-selected row marker.
6. Continue to follow this procedure.

NOTE: Both row markers can be lowered by operating the switch in each position and operating the hydraulic control twice. The row markers will raise simultaneously with the hydraulic control in the raise position.

NOTE: Switch should be left in OFF position when planter is not in use. If left in ON position, it will discharge the tractor battery.

If the electrical system fails to operate properly:

- Check fuse.
- Check wiring connections.
- Check control switch.
- Check solenoid. SOLENOID HOUSING WILL BE MAGNETIZED WHEN ENERGIZED.

⚠ DANGER: To avoid serious injury or death, care must be taken when operating row markers around overhead power lines.

MACHINE OPERATION

ROW MARKER SPEED ADJUSTMENT

The marker hydraulic system includes two flow control valves. One flow control valve sets the lowering speed of both markers and one sets the raising speed of both markers. To adjust marker speed, loosen the jam nut and turn the control(s) clockwise, or IN, to slow the travel speed and counterclockwise, or OUT, to increase the travel speed. The flow control(s) determine the amount of oil flow restriction through the valves, therefore varying travel speed of the markers. Tighten jam nut after adjustments are complete.

D060299126

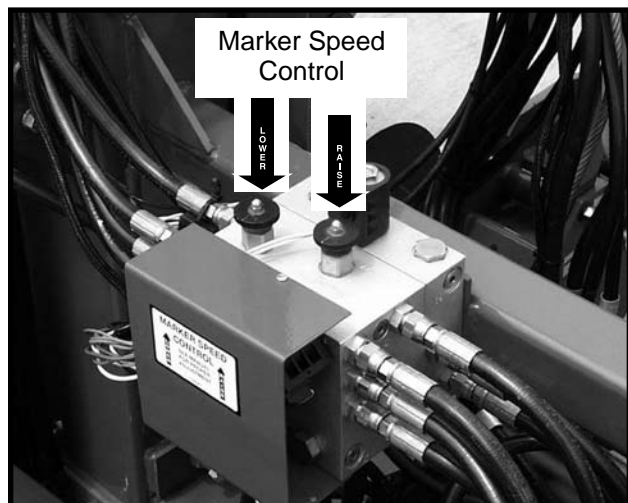

IMPORTANT: The flow controls should be properly adjusted before the row marker assembly is first put into use. Excessive row marker travel speed of the markers can damage the marker assembly.

NOTE: When oil is cold, hydraulics operate slowly. Make sure all adjustments are made with warm oil.

NOTE: On a tractor where the oil flow can not be controlled, the rate of flow of oil from the tractor may be greater than the rate at which the marker cylinder can accept the oil. The tractor hydraulic control will have to be held until the cylinder reaches the end of its stroke. This occurs most often on tractors with open center hydraulic systems.

On tractors equipped with flow control valves, row marker speed adjustment should be made with the tractor flow controls in maximum position. After row marker speed is set, the tractor flow controls can be adjusted to allow the hydraulic control to stay in detent during the marker raise or lower cycle.



DANGER: To avoid serious injury or death, care must be taken when operating row markers around power lines.

ROW MARKER LENGTH ADJUSTMENT

Both the planter and row marker assembly should be lowered to the ground when measurements are being taken. The measurement should be taken from the point where the blade contacts the ground. Adjust right and left row marker assemblies as shown on the following page. Securely tighten clamping bolts.

60569-53

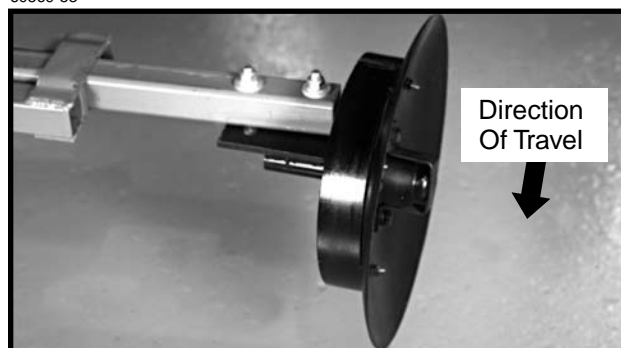

Row Marker Disc Blade Shown With Depth Band

The row marker disc blade should be installed so the concave side of the blade faces outward to throw dirt away from the grease seals. The spindle assembly is slotted so the hub and blade can be angled to throw more or less dirt. To adjust the hub and spindle, loosen the 1/2" hardware and move the assembly as required. Tighten bolts to the specified torque.

IMPORTANT: A row marker disc blade assembly that is set at a sharper angle than necessary will add unnecessary stress to the complete row marker assembly and shorten the life of bearings and blades. Set the blade angle only as needed to leave a clear mark.

A field test is recommended to ensure the row markers are properly adjusted. After the field test is made, make any minor adjustments as necessary.

Notched marker disc blade, for use in more severe no till conditions, are available from KINZE® Repair Parts through your KINZE® Dealer.

MACHINE OPERATION

L.H. SIDE 30" - 7 1/2" TWIN ROWS

Number Of Rows	Row Spacing (Inches)	3 3/4" + Hitch Offset	=	Dimension Between Planter Center Line And Marker Blade
12 Rows	x 30"	+ 3 3/4"	=	363.75"
16 Rows	x 30"	+ 3 3/4"	=	483.75"

R.H. SIDE 30" - 7 1/2" TWIN ROWS

Number Of Rows	Row Spacing (Inches)	3 3/4" - Hitch Offset	=	Dimension Between Planter Center Line And Marker Blade
12 Rows	x 30"	- 3 3/4"	=	356.25"
16 Rows	x 30"	- 3 3/4"	=	476.25"

NOTE: If using 30" row spacing remove offset hitch and install customer supplied GA9836 12 Row 30"/ GA9837 16 Row 30" hitch mount so hitch is centered with center of planter. Adjust row markers as shown below:

12 Row 30" x 30" = 360" Marker Dimension Between Planter Center Line And Marker Blade

16 Row 30" x 30" = 480" Marker Dimension Between Planter Center Line And Marker Blade

INTRODUCTION

MTR66



The KPM III electronic seed monitor system consists of

- A KPM III console, which is mounted on the tractor
- Seed tubes with sensors, one of which is installed in each planter row unit
- A magnetic distance sensor, which is installed on the planter, or a radar distance sensor, which is installed on the tractor
- Shaft rotation sensors (if applicable), which are installed on the planter drill shafts
- Vacuum, pneumatic down pressure, SDS and hydraulic level/temperature (If applicable), which are installed on the planter.
- Planter harnesses (junction Y-harness and/or extension harness where applicable), to which the individual seed tube sensors connect. The primary harness, which connects the monitor console to the planter harness, is hard-wired into the safety/warning light harness or control console harness included as standard equipment with the planter.

The software design of the KPM III console allows simultaneous viewing of seed flow bargraphs for standard and/or Interplant® System rows (up to 36 rows).

The monitor system is powered by the tractor battery. It requires 12 volts DC.

The console receives information from each of the sensors and displays this information.

The KPM III console uses a single backlit Liquid Crystal Display (LCD) to show; the number of monitored rows, the relative seed rate for each row (using bargraph displays) and displays various alarm and warning messages when an alarm condition exists. A continuous audible alarm will sound upon system malfunction or underflow conditions for any monitored row. Alarms must be acknowledged by the user. Various warnings may sound the alarm or flash one or more messages. The LCD also shows alphanumeric data such as row spacing, units (Metric or English), speed (MPH or KM/H), volume, seed population, seed spacing, field area and total area.

The monitor system will power down if no activity is detected within one hour. No activity means there has been no new seed flow and no operator push key input.

Monitor Key Functions	6-23
Changing Volume, Contrast And Backlighting	6-24
Configuring Planter Monitor	6-25
Programming Interplant® Condition, Row Spacing And Units (Metric Or English)	6-28
Seed Meter Settings	6-29
Programming Row Unit Alarms Levels	6-31
Data Logging	6-32
Adding Interplant® Rows (If Rear Rows Have Previously Been Programmed)	6-34
Adding Even-Row Package (If Front Rows Have Previously Been Programmed)	6-36
Reprogramming Speed Sensor	6-37
Programming/Connecting Seed Tubes, Shaft Rotation Sensors And/Or Radar/Magnetic Distance Sensors	6-39
Speed Sensor Calibration/Programming	6-41
Acre Count Mode	6-44
Enabling/Disabling Interplant® Rows	6-46
Test Mode	6-47
Warnings And Alarms	6-52
Field Operation	6-56
Area Management	6-57
Area Counters	6-60
Clearing Field Area	6-61
Replacing Faulty Sensor(s)	6-62

MONITOR KEY FUNCTIONS

Push keys allow the user to select or change the operating mode, the active displays or the current configuration. Depending on the operating mode or the current display selected, some keys may not be active. Each key press, if valid, is acknowledged by a short beep and an action is taken. If the key press has no action associated, the key press is considered invalid, and the user will not receive feedback.

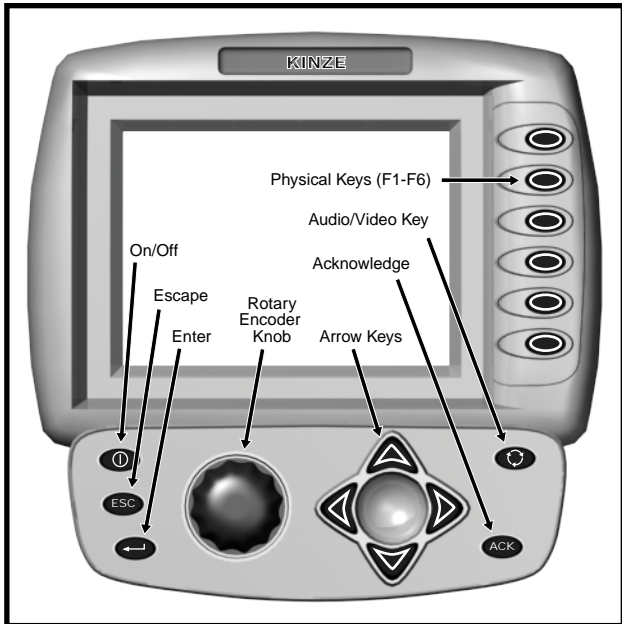

PHYSICAL KEYS

- Located on R.H. side of console and referred to as F1, F2, F3, F4, F5 and F6
- Keys are referenced in descending order with F1 at the top and F6 at the bottom.

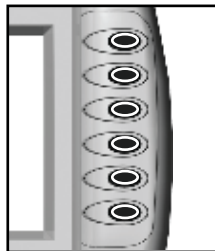

ON/OFF KEY

- Powers the unit on and off.



ESC KEY

- Used as the CANCEL (escape) key.



ENTER KEY

- Confirms or accepts the highlighted selection.



ROTARY ENCODER KNOB

- Turn knob clockwise to increase or counterclockwise to decrease value of item.
- Turn knob clockwise to scroll up or counterclockwise to scroll down.
- Press knob to enter selection.

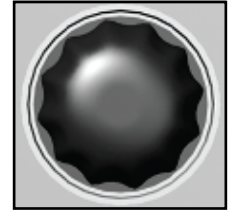

AV (AUDIO/VIDEO) KEY

- Set alarm volume.
- Adjust the contrast.
- Adjust backlighting of the LCD display. Can be used at any time.



ACK (ACKNOWLEDGE) KEY

- Used to silence (acknowledge) the warning alarm when various error conditions occur.
- NOTE: Alarms can be viewed by pressing the STATUS key.**



ARROW KEYS

- UP arrow key is used to move up.
- DOWN arrow key is used to move down.
- LEFT arrow key is used to move to the left.
- RIGHT arrow key is used to move to the right.



NOTE: Within the LCD, the black box around the smaller box as shown below indicates which field is selected/highlighted. Turning the rotary encoder knob or pressing the UP or DOWN arrow keys moves the black box. When the black box is positioned on a programmable item, such as Shaft Sensors, Speed Sensor, Front Row Units or Rear Row Units, pressing the knob or ENTER key will highlight the programmable item. A programmable item may only be changed when it is highlighted.

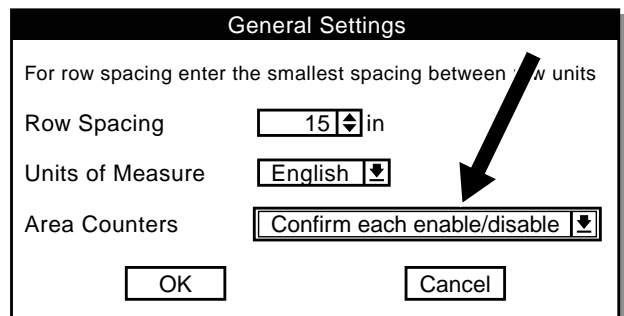

CHANGING VOLUME, CONTRAST AND BACKLIGHTING WITH THE AV KEY

The alarm, volume, LCD screen contrast, and backlighting may be adjusted at anytime, regardless of what is displayed on the screen.

STEP 1 Press the AV key. The Contrast adjustment dialog box will appear in the center of the display.

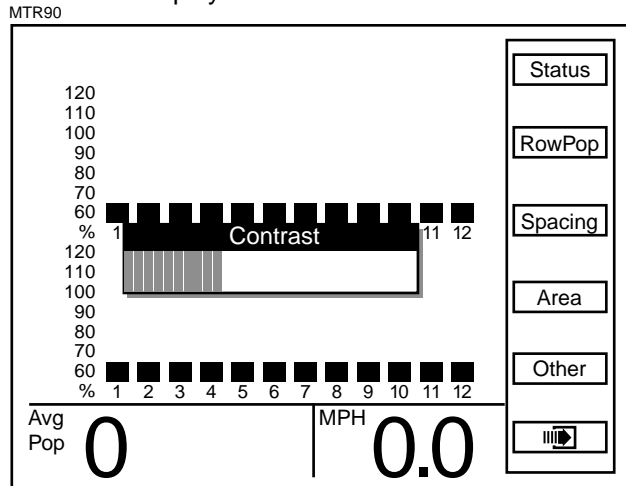

STEP 2 Use the arrow keys or turn the rotary encoder knob to adjust contrast. The adjustment will be visible on the screen.

STEP 3 To adjust speaker or backlight, go to STEP 4. If finished press the Enter key to save and exit.

STEP 4 Press the AV button a second time. The Backlight adjustment dialog box will appear in the center of the display.

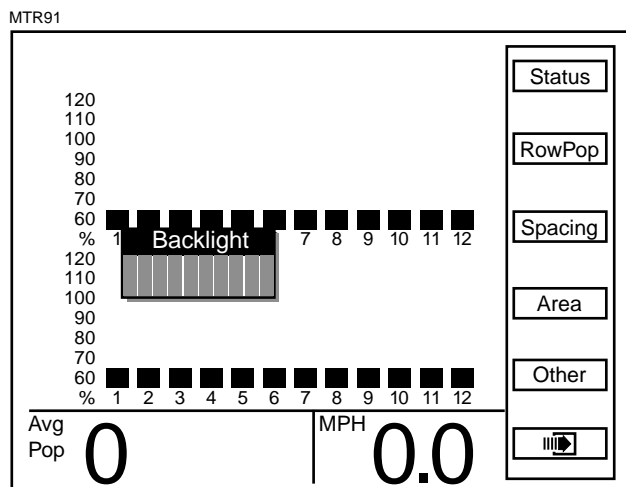

STEP 5 Use the arrow keys or turn the knob to adjust backlighting. The effect of the adjustment will be visible on the display.

STEP 6 To adjust speaker go to STEP 7. If finished press the Enter key to save and exit.

STEP 7 Press the AV button a third time. The Speaker adjustment dialog box will appear in the center of the display.

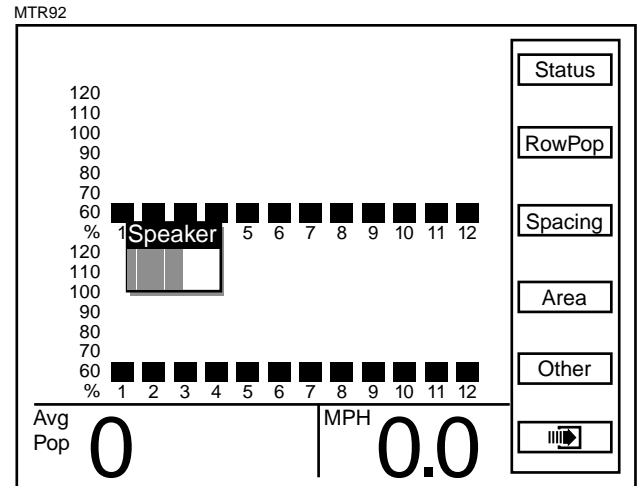

STEP 8 Use the arrow keys or turn the knob to adjust speaker volume. The volume of sound emitted from the speaker will change as adjustment is made.

STEP 9 Press the knob, Enter key or press the AV button a fourth time to save the volume, contrast and backlight settings.

CONFIGURING PLANTER MONITOR

When the KPM III is powered on for the first time it will go directly into the Planter Configuration screen (STEP 4).

MTR77

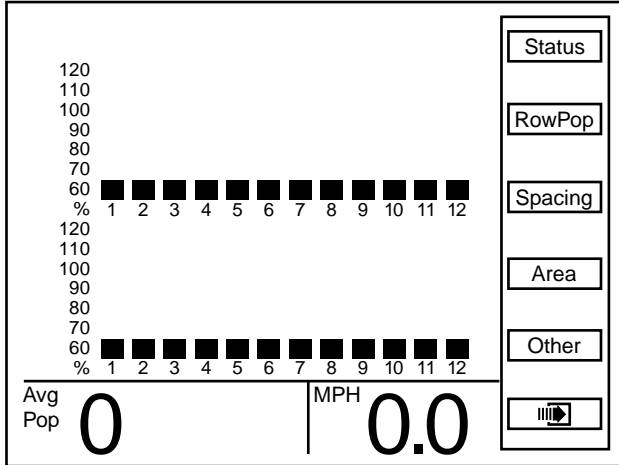

NOTE: The Planter Configuration screen displays the planter rows as programmed into the KPM III software. The above screen shows 12 front (Interplant®) rows and 12 rear rows. If the KPM III were programmed for 8 front (Interplant®) rows and 8 rear rows the screen would display 8 front and 8 rear rows.

STEP 1 Press the F6 key until Mode Selection screen appears.

MTR78

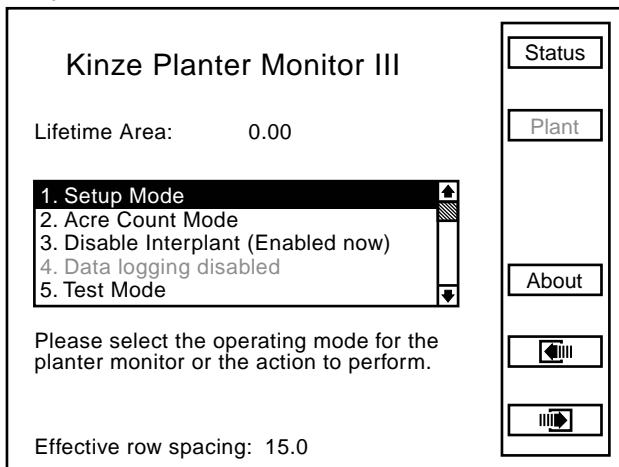

NOTE: There are 5 choices on the Mode Selection screen;

1. Setup mode
2. Acre count mode
3. Disable Interplant® (Enabled now) mode
4. Data logging mode
5. Test mode

STEP 2 Select "1. Setup Mode" by turning the rotary encoder knob or using the arrow keys. Press the knob or Enter key to display the highlighted item.

NOTE: There are 10 choices on the Setup Mode screen;

1. General Settings
2. Seed Meter Settings
3. Row Unit Alarm Levels
4. Setup Data Logging
5. Configure Planter Monitor
6. Add New Muxbus Sensors
7. Add Single Interplant® Row
8. Select Speed Sensor
9. Sensor Setup
10. Calibrate Speed Sensor

STEP 3 Select "5. Configure Planter Monitor" by turning the knob or using the arrow keys. Press the knob or the Enter key to display the highlighted item.

NOTE: Press the F2 key next to Plant any time the Plant option is available to return to the Planter Configuration screen.

MTR79

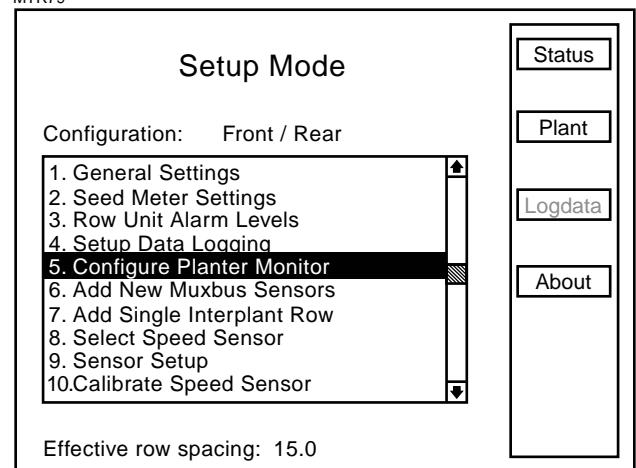

NOTE: The planter monitor cannot be reconfigured while planting.

STEP 4 If there are front rows (Interplant) on the planter, press the knob or Enter key to highlight the “Front Rows” field. A drop down number pad will appear. Turn the knob or use the arrow keys to highlight the correct value then press the knob to select the number, for numbers containing more than one digit select one digit at a time. When the desired quantity is displayed above the number pad press the Enter key to return to the “Kinze Planter Configuration” screen. If the planter has no front rows turn the knob or press the arrow keys to advance to “Rear Rows”.

MTR80

The screenshot shows the 'Kinze Planter Configuration' screen. The 'Front Rows' field is highlighted with a value of 0. A numeric keypad is visible below it. The 'Sensors Installed' section includes Speed (Radar), Vacuum (0), and SDS (0). There are checkboxes for 'Hydraulic Level/Temp' and 'Downpressure Level', and a note 'SDS = Seed Delivery System'. 'OK' and 'Cancel' buttons are at the bottom.

STEP 5 Press the knob or Enter key to select the “Rear Rows” field. A drop down number pad will appear. Turn the knob or use the arrow keys to highlight the correct value then press the knob to select the number, for numbers containing more than one digit select one digit at a time. When the desired quantity is displayed above the number pad, press the Enter key to return to the “Kinze Planter Configuration” screen.

MTR81

The screenshot shows the 'Kinze Planter Configuration' screen. The 'Rear Rows' field is highlighted with a value of 0. A numeric keypad is visible below it. The 'Front Rows' field now shows 11. The 'Sensors Installed' section and other elements are the same as in the previous screenshot.

STEP 6 Rotate the knob or use the arrow keys to advance to “Shafts” field. Press the knob or Enter key to select the “Shaft” field. A drop down menu will appear. Turn the knob or use the arrow keys to highlight the correct value then press the knob to select the number, for numbers containing more than one digit select one digit at a time. When the correct value is displayed, press the knob or Enter key to return to the “Kinze Planter Configuration” screen.

MTR82

The screenshot shows the 'Kinze Planter Configuration' screen. The 'Shafts' field is highlighted with a value of 2. A drop-down menu is open showing options 0, 1, 2, and 4. The 'Sensors Installed' section includes Speed (Radar), Vacuum (0), and SDS (0). There are checkboxes for 'Hydraulic Level/Temp' and 'Downpressure Level', and a note 'SDS = Seed Delivery System'. 'OK' and 'Cancel' buttons are at the bottom.

STEP 7 Turn the knob or use the arrow keys to advance to the “Speed” field. Press the knob or Enter key and a drop down menu will appear; select either “Radar” or “Coil Pick-Up” (MDS) by turning the knob or using the arrow keys. When the desired selection is highlighted press the knob or Enter key.

MTR83

The screenshot shows the 'Kinze Planter Configuration' screen. The 'Speed' field is highlighted with a value of Radar. A drop-down menu is open showing options Radar and Coil Pick-Up. The 'Sensors Installed' section includes Vacuum (0) and SDS (0). There are checkboxes for 'Hydraulic Level/Temp' and 'Downpressure Level', and a note 'SDS = Seed Delivery System'. 'OK' and 'Cancel' buttons are at the bottom.

STEP 8 If applicable, turn the knob or use the arrow keys to advance to “Vacuum”. Press the knob or Enter key and a drop down menu will appear. Select the correct number of vacuum sensors by turning the knob or using the arrow keys. Confirm the selection by pressing the knob or Enter key.

STEP 9 If applicable, turn the knob or use the arrow keys to advance to “SDS” (Seed Delivery System), Press the knob or Enter key. A drop down menu will appear. Select the correct number of SDS Sensors by turning the knob or using the arrow keys. Press the knob or Enter key to confirm selection.

STEP 10 If applicable, turn the knob or use the arrow keys to advance to “Hydraulic Level/Temp”. Press the knob or Enter key to select or deselect. When selected, a check mark will appear in the box.

STEP 11 If applicable, turn the knob or use the arrow keys to advance to “Downpressure Level”. Press the knob or Enter key to select or deselect. When selected, a check mark will appear in the box.

STEP 12 Advance to “OK” by using the knob or arrow keys. Press the knob or the Enter key to save the information.

MTR84

Kinze Planter Configuration	
Planter Type	Sensors Installed
Front Rows <input type="text" value="11"/>	Speed <input type="text" value="Radar"/>
Rear Rows <input type="text" value="12"/>	Vacuum <input type="text" value="0"/>
Shafts <input type="text" value="2"/>	SDS <input type="text" value="0"/>
There should be one sensor for each Row and each Shaft.	<input type="checkbox"/> Hydraulic Level/Temp <input type="checkbox"/> Downpressure Level SDS = Seed Delivery System
<input type="button" value="OK"/> <input type="button" value="Cancel"/>	

NOTE: To prevent the configuration from being saved select “Cancel” and press the rotary encoder knob or Enter key. The display will return to the “Setup Mode” screen without saving any changes.

NOTE: When OK is selected the monitor automatically advances to the Sensor Setup screen. Sensor Setup can also be selected from the Setup Mode screen. See pages 45-46 (PROGRAMMING/CONNECTING SEED TUBES, SHAFT ROTATION SENSORS AND/OR RADAR/MAGNETIC DISTANCE SENSORS)

GENERAL SETTINGS
(Programming Interplant® condition, row spacing and units) (Metric or English)

STEP 1 Turn the knob or use the arrow keys to highlight “1. General Settings”. Press the knob or the Enter key to display the highlighted item.

MTR94

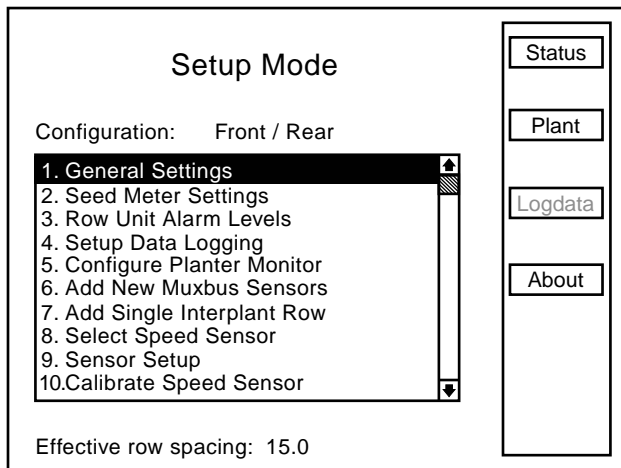

NOTE: When English is selected inches are displayed, if Metric is selected centimeters are displayed.

STEP 2 Press the knob or Enter key to enter the correct value for “Row Spacing”. A drop down number pad will appear. Turn the knob or use the arrow keys to highlight the first digit of the desired number and press the knob. The number will appear in the “Row Spacing” line. Turn the knob or use the arrow keys to highlight the next digit of the number and press the knob. The number will appear in the “Row Spacing” line. When the correct number is displayed in the “Row Spacing” line, press the Enter key to return to the “General Settings” screen.

NOTE: The narrowest row spacing the planter is equipped to plant should be entered for “Row Spacing”. Example: 12 Row 30 with Interplant®, row spacing would be set to 15.

STEP 3 Turn the knob or use the arrow keys to highlight the “Units of Measure” field. Select the “Units of Measure” field by pressing the knob or Enter key, a drop down menu will appear. Highlight either “English” or “Metric” by turning the knob or using the arrow keys. When the correct entry is highlighted, press the knob or Enter key to accept the unit of measure entry and return to the “General Settings” screen.

STEP 4 Turn the knob or use the arrow keys to highlight the “Area Counters” field. Select the “Area Counters” field by pressing the knob or Enter key, a drop down menu will appear. Turn the knob or use the arrow keys to highlight either “Confirm each enable/disable”, “Don’t confirm again today”, or “Don’t confirm enable/disable”. When the desired selection is highlighted, press the knob or Enter key to accept the selection and return to the “General Settings” screen.

STEP 5 Once the correct values have been inputted into the “General Settings” screen the “OK” button can be selected to save the changes, or the “Cancel” button can be selected to discard the changes that have been made. Turn the knob or use the arrow keys to highlight either “OK” or “Cancel” and press the knob or Enter key to return to the “Setup Mode” screen.

SEED METER SETTINGS

STEP 1 Scroll to “2. Seed Meter Settings” by turning the rotary encoder knob or using the arrow keys. Press the knob or Enter key to display the highlighted item.

MTR159

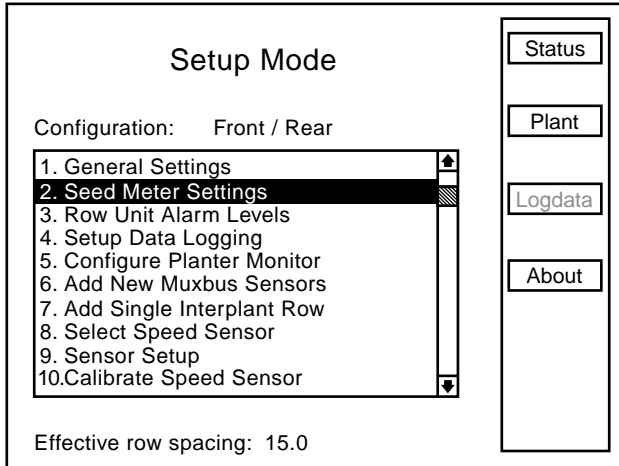

STEP 2 Select meter type by highlighting “Meter Type” and pressing the knob or Enter key, then highlight “Mechanical” or “Vacuum” and press the knob or enter key.

MTR212

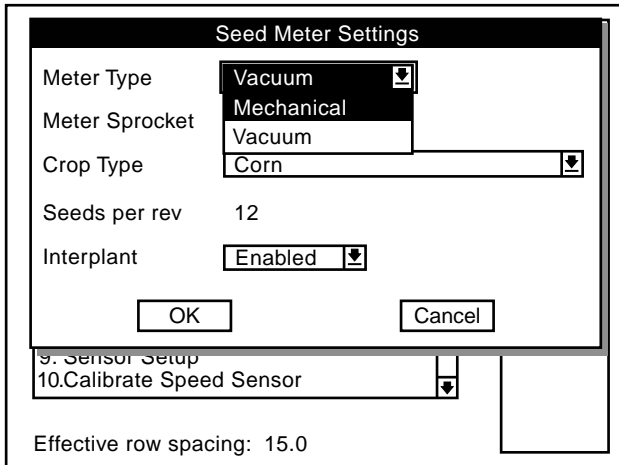

MTR210

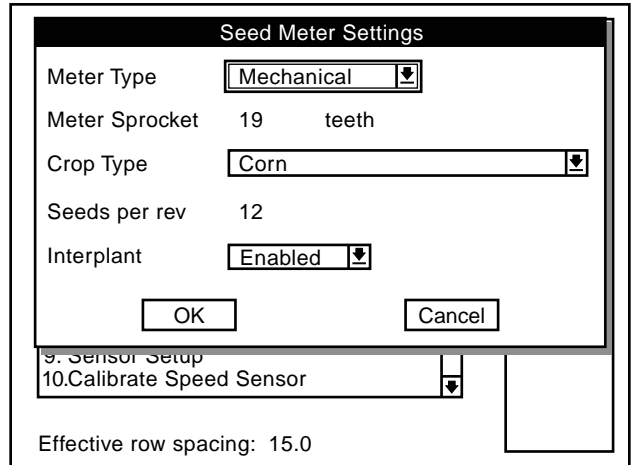

NOTE: When Mechanical “Meter Type” is selected “Meter Sprocket” automatically sets.

MTR206

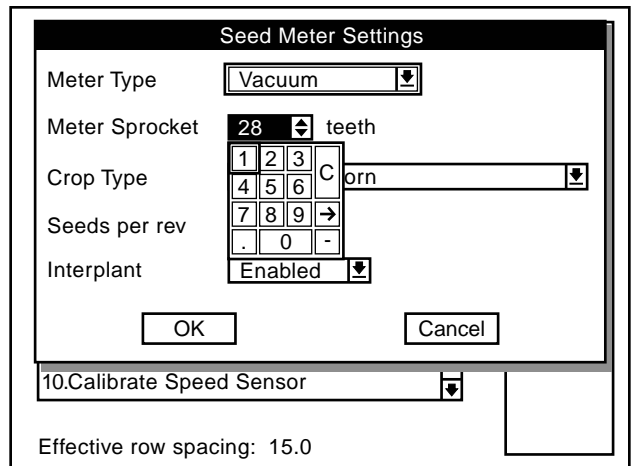

NOTE: When Vacuum “Meter Type” is selected “Meter Sprocket” automatically defaults to 28 teeth. To change “Meter Sprocket” select “Meter Sprocket” by turning the knob or using the arrow keys. Press the knob or enter key, a drop down number pad will appear. Turn the knob or use the arrow keys to highlight the first digit of the desired number and press the knob. When the correct number is obtain press the knob or enter key.

STEP 3 Turn the knob or use the arrow keys to highlight “Crop Type”. Press the knob or Enter key to display the crop drop down menu.

MTR207

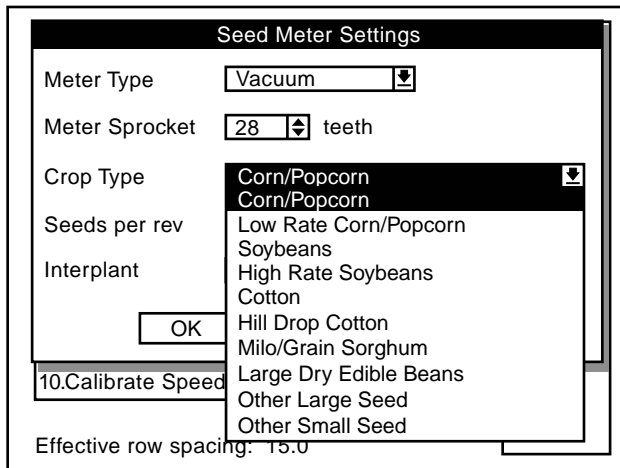

STEP 4 Turn the knob or use the arrows keys to highlight a crop for planting then press the knob or Enter key. Once crop type is entered, the “Seeds per rev” is set automatically.

STEP 5 (If Applicable) Turn the knob or use the arrow keys to highlight “Interplant”. Press the knob or Enter key to display the Interplant® drop down menu.

MTR208

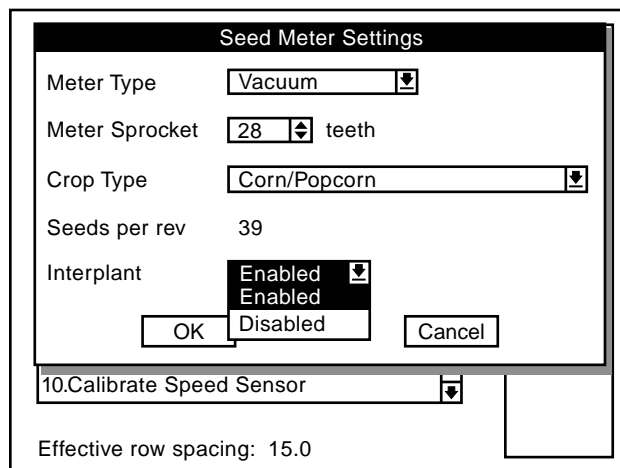

STEP 6 Turn the knob or use the arrow keys to highlight either “enable” or “disable” and press the knob or Enter key.

STEP 7 When all changes have been made, highlight “OK” and press the knob or Enter key to return to the “Setup Mode” screen.

PROGRAMMING ROW UNIT ALARM LEVELS

The Row Unit Alarm Levels allow the thresholds for the seed rate alarms to be set. The default is 50% or Average. If the average population drops below 50% for a given row a seed rate alarm will be generated for that row unit. The alarm threshold can be set to 70%, 50%, 0% or disabled, or any custom percentage desired for any row.

NOTE: When the alarm threshold is disabled for any row no seed rate alarm will be generated.

MTR96

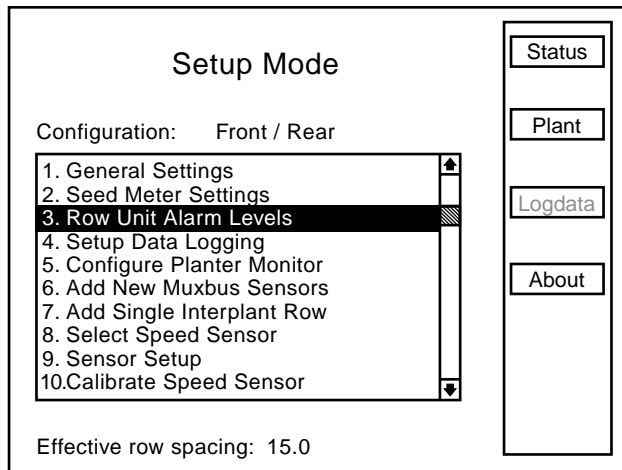

The alarm thresholds can be set for the whole planter, any planter section or individual rows.

NOTE: A section is determined by a set of rows driven by one or more shafts, designated to a single shaft sensor.

STEP 1 Select “3. Row Unit Alarm Levels” by turning the knob or using the arrow keys. Press the knob or Enter key to display the highlighted item.

MTR98

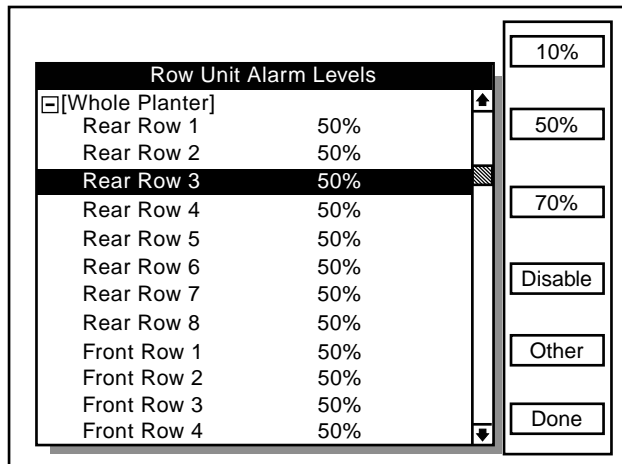

STEP 2 To set the alarm thresholds for the whole planter, turn the knob or use the arrow keys to highlight the “[Whole Planter]” line. Press the key next to the desired threshold. When the desired threshold has been specified for all row units, press the F6 key next to “Done”.

NOTE: Only configured rows will appear on the screen.

To set the alarm thresholds for all the rows in one section, highlight the desired section. Press the key next to the desired threshold. When the desired threshold has been specified for all row units, press the F6 key next to “Done”.

To set the alarm thresholds for individual rows, highlight the desired row. Press the key next to the desired threshold. When the desired threshold has been specified for all row units, press the F6 key next to “Done”.

To disable the row unit alarm, highlight the desired section or individual row. Press the F4 key next to “Disable”. When the alarm is desired again highlight the disabled section or row. Press the key next to the desired threshold.

To enter a threshold not listed, highlight the desired section or individual row. Press the F5 key next to “Other”. Press the knob or Enter key and a drop down key pad will appear. Turn the knob or use the arrow keys to highlight the first digit of the desired number and press the knob. The number will appear in the “Enter Alarm Threshold” line. Highlight the next digit of the number and press the knob. The number will appear in the line. When the correct number is displayed, press the Enter key to return to the “Set Alarm Threshold” screen. Turn the knob or use the arrow keys to advance to “OK”. Press the knob or Enter key to accept the threshold levels.

MTR99

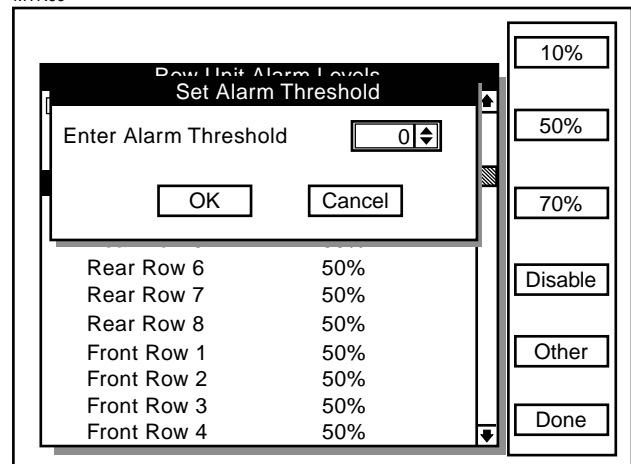

DATA LOGGING MODE

STEP 1 Scroll to “4. Setup Data Logging” by turning the rotary encoder knob or using the arrow keys. Press the knob or Enter key to display the highlighted item.

MTR164

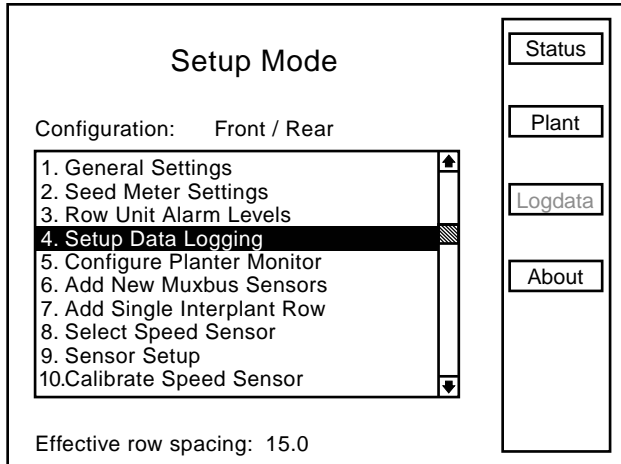

NOTE: Data logging changes cannot be made while data is being logged. If the monitor is logging data the following warning will appear. To stop data logging and continue.

- Press the knob or Enter key to close the warning.
- Then in the “Setup Mode” press the F3 key next to “StopLog”.

MTR165

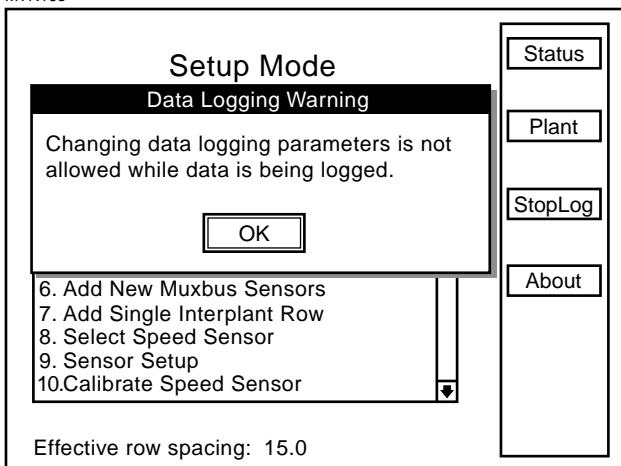

STEP 2 Turn the knob or use the arrow keys to highlight the “Destination” box then press the knob or Enter key. Highlight the desired option either “Serial Port”, “USB Flash Drive”, or “Serial and USB” and press the knob or Enter key.

MTR166

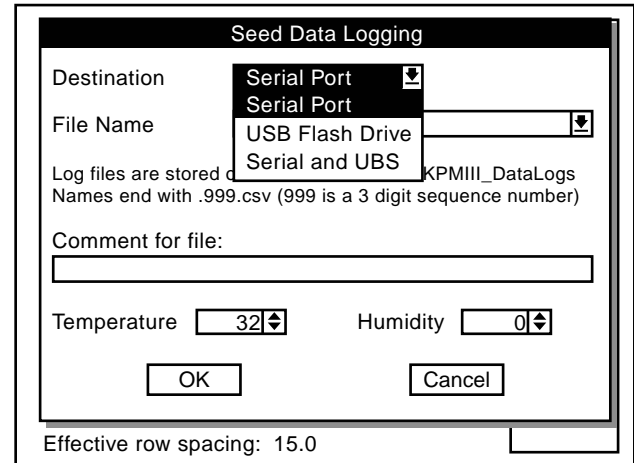

STEP 3 Use the knob or arrow keys to highlight the “File Name” box. Press the knob or Enter key and a drop down list of the files will be displayed. Select “Add new...” to enter a file name and press the knob or enter key to display a keyboard.

MTR167

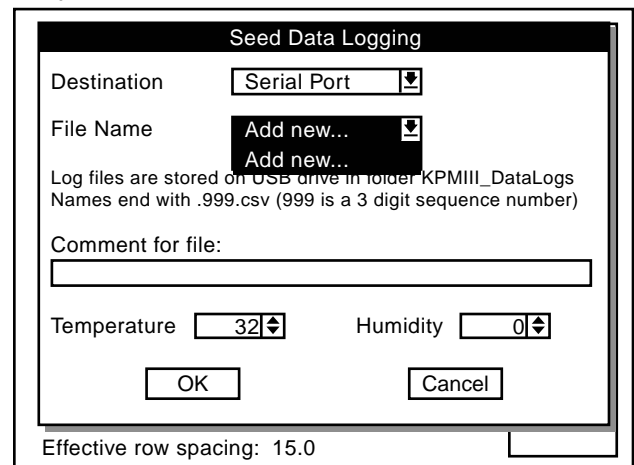

STEP 4 Select “Add new...” to enter a file name and press the knob or enter key to display a keyboard.

STEP 5 Add a new file name by using the drop down keyboard. Spell out the file name by highlighting each letter and pressing the knob or Enter key.

MTR168

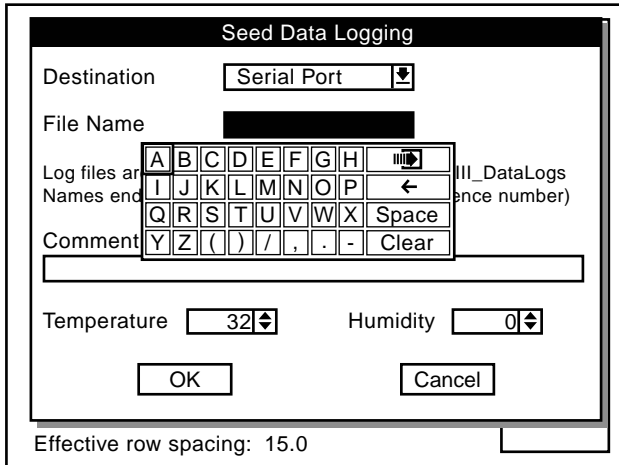

STEP 6 Use the knob or arrow keys to scroll to the “Comment for file” box. Press the knob or Enter key to display the drop down keyboard. Use the keyboard to enter a Comment for the file then press the Enter key.

MTR169

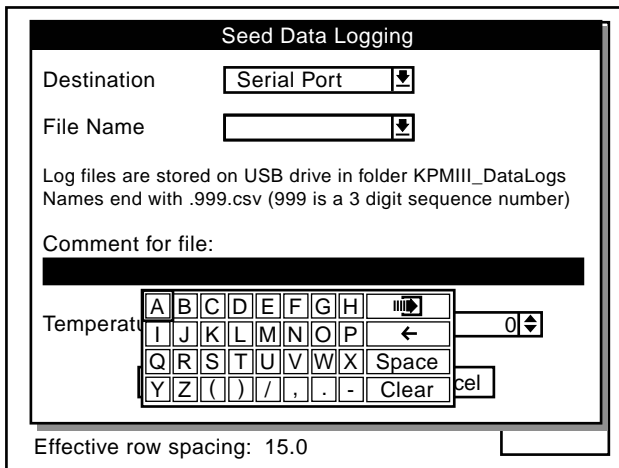

STEP 7 Use the knob or arrow keys to scroll to the Temperature box. Press the knob or Enter key to display the drop down keyboard. Use the keyboard to enter the temperature then press the Enter key.

STEP 8 Use the knob or arrow keys to scroll to the Humidity box. Press the knob or Enter key to display the drop down keyboard. Use the keyboard to enter the humidity then press the Enter key.

MTR170

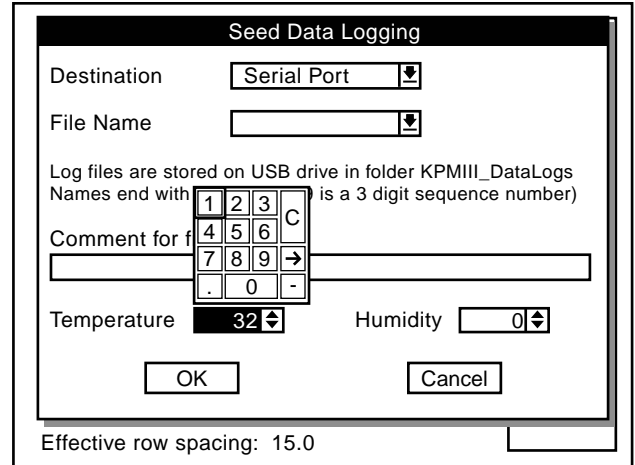

STEP 9 Use the knob or arrow keys to scroll to the “OK” button and press the knob or Enter key. The display will return to the Setup Mode screen.

MTR171

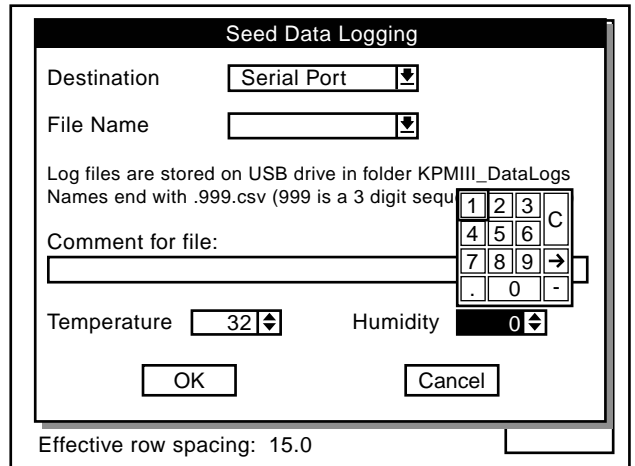

STEP 10 Press the F2 key next to Plant to return to Planter configuration screen.

STEP 11 Press the F3 key next to “Logdata” to begin logging.

STEP 12 Press the F3 key next to “Stoplog” to end logging.

ADDING INTERPLANT® ROWS (If only Rear Rows Have Previously Been Programmed)

NOTE: The planter monitor configuration must contain an odd number of front rows before the single Interplant® row unit can be added.

STEP 1 Highlight “6. Add New Muxbus Sensors” by turning the knob or using the arrow keys. Press the knob or Enter key to display the highlighted item.

MTR119

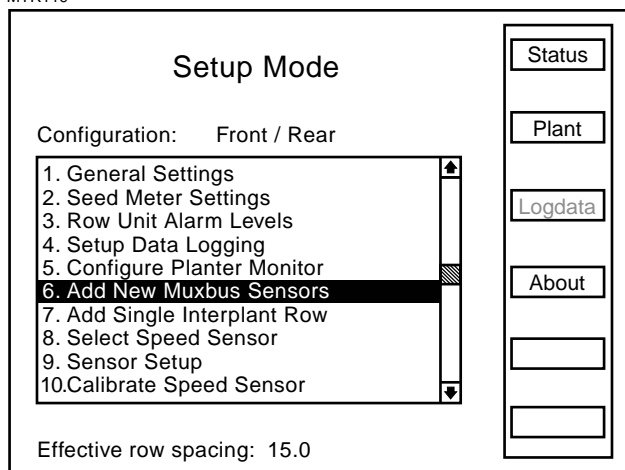

STEP 2 The note shown below will appear. Highlight “OK” by turning the knob or using the arrow keys. Press the knob or Enter key to make the selection.

MTR120

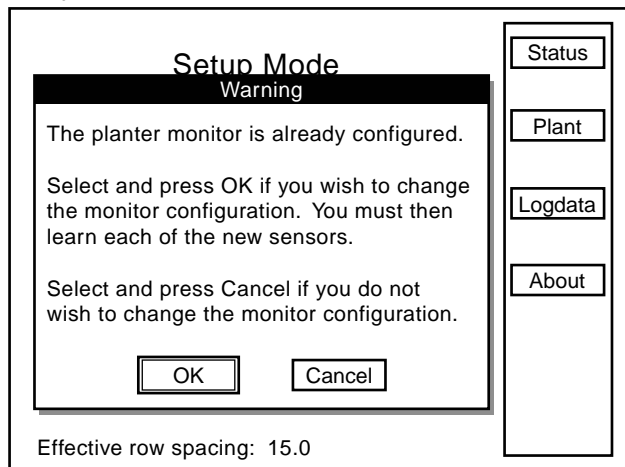

NOTE: To prevent the configuration from being changed, select Cancel, then press the knob, Enter key or ESC key.

STEP 3 Turn the knob or use the arrow keys to highlight the “Front Rows” field and press the knob or Enter key and a drop down number pad will appear.

STEP 4 Turn the knob or use the arrow keys to highlight the first digit of the desired number and press the knob to select the number, for numbers containing more than one digit select one digit at a time. The number will appear in the “Front Rows” line. When the correct number is displayed on the “Front Rows” line, press the Enter key to return to the “Kinze Planter Configuration” screen.

NOTE: To prevent the configuration from being changed select Cancel, then press the knob, Enter key or ESC key.

MTR121

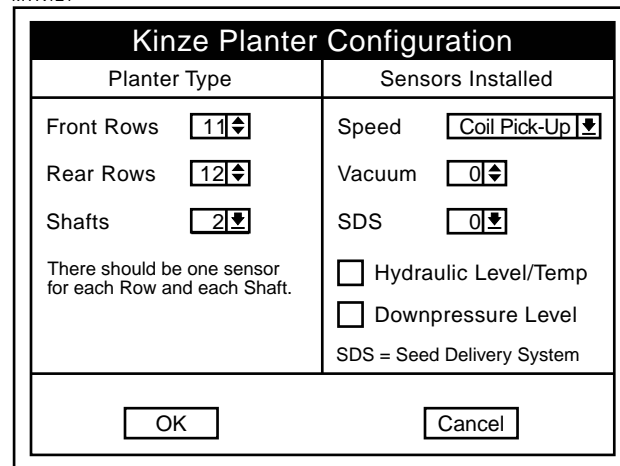

NOTE: Attempting to add rear rows while adding new Muxbus sensors will cause the following note to appear.

MTR122

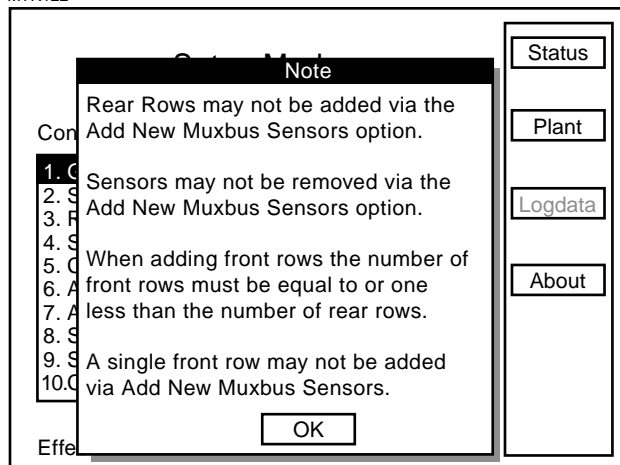

STEP 5 The sensor configuration screen will appear. With “[Auto Detect]” highlighted press the F1 key next to “Install”. Install sensors from left to right in the same way rear unit sensors were installed.

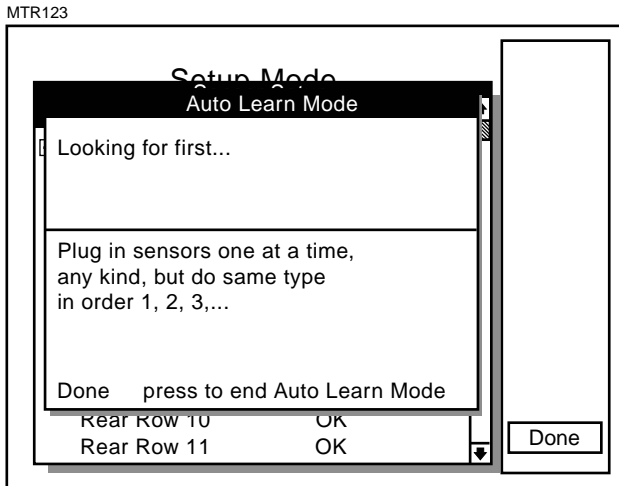

STEP 6 When all sensors are learned select F1 to end installation. The “Auto Learn Mode” box will appear. Press the F6 key next to “Done”.

STEP 7 Scroll down to verify the front rows are learned. Select “OK” by pressing the knob or the Enter key. Press the F6 key next to “Done”. The display will return to the “Setup Mode Screen”.

NOTE: “OK” will appear next to each sensor if no errors are detected.

STEP 8 Turn the knob or use the arrow keys to highlight “1. General Settings”. Press the knob or use the Enter key to make the selection.

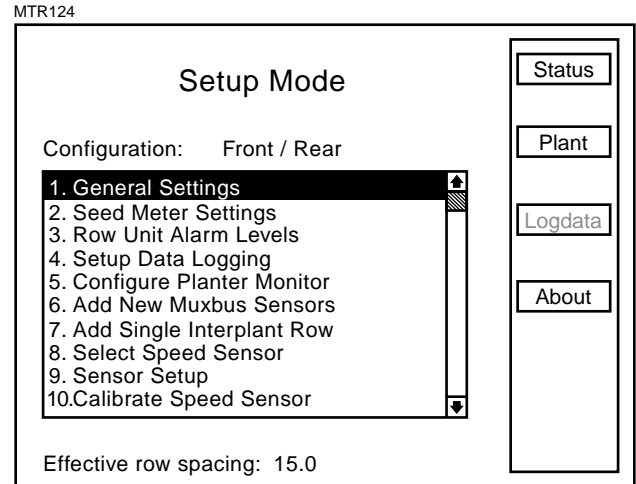

STEP 9 Turn the knob or use the arrow keys to highlight the “Row Spacing” field. Press the knob or Enter key to make the selection. A drop down number pad will appear. Adjust the row spacing to Interplant spacing by turning the knob or use the arrow keys to highlight the correct value then press the knob to select the number, for numbers containing more than one digit select one digit at a time.

NOTE: To prevent the configuration from being changed select **Cancel**, then press the knob, Enter key or ESC key.

STEP 10 Turn the knob or use the arrow keys to advance to the “OK” button. Press the knob or Enter key to save the row spacing and return to the “Setup Mode” screen.

ADDING EVEN-ROW PACKAGE (If Front Rows Have Previously Been Programmed)

STEP 1 Turn the knob or use the arrow keys to highlight “7. Add Single Interplant® Row”. Press the knob or the Enter key to display the highlighted item.

MTR126

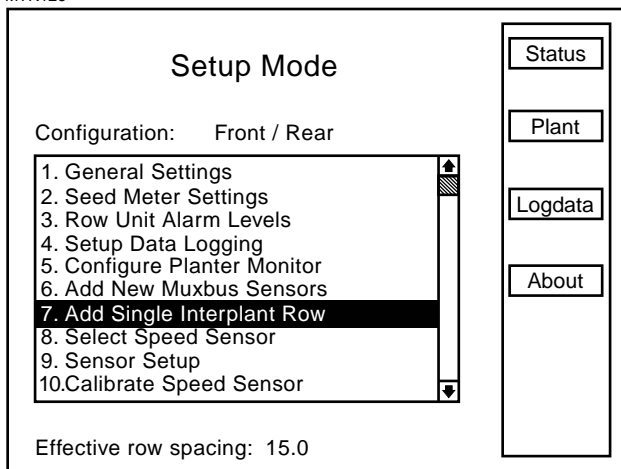

STEP 2 To confirm the note below turn the knob or use the arrow keys to highlight the “OK” button, then press the knob or Enter key to confirm. If the single Interplant® row is not to be added select the “Cancel” key and press the knob or Enter key to cancel or press the ESC key.

MTR127

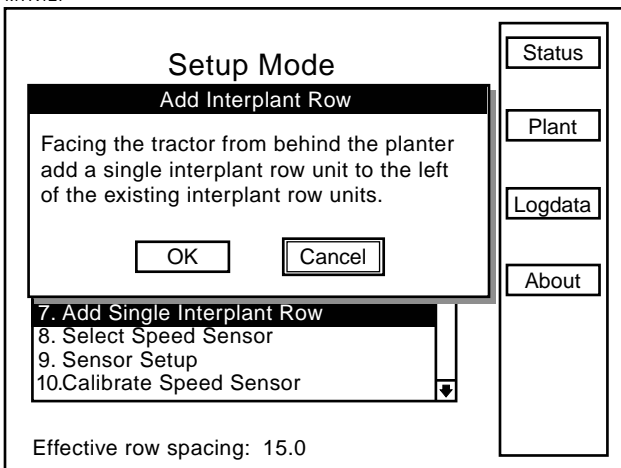

STEP 3 To “Add Single Interplant® Row” the following screen will appear.

If the single Interplant® row is to be added turn the knob or use the arrow keys to highlight the “OK” button and then press the knob or Enter key to add the Interplant® row. If the single Interplant® row is not to be added select the Cancel key and press the knob or Enter key to cancel or press the ESC key.

MTR128

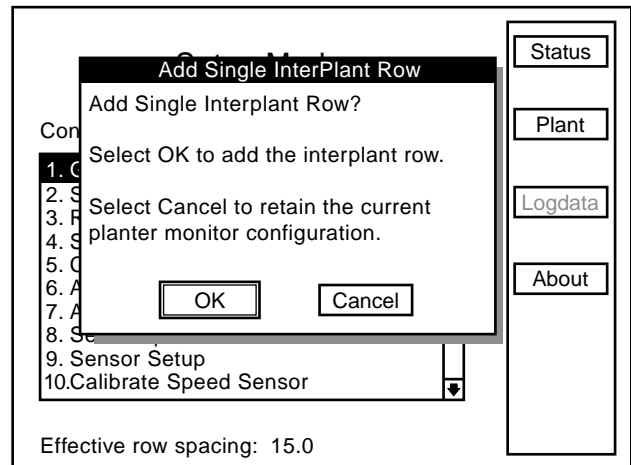

STEP 4 The “Sensor Setup” screen will appear. Plug in the new sensor then scroll down to highlight “Front Row 1” by turning the knob or using the arrow keys. Press the F1 key next to Install to learn the new sensor.

MTR129

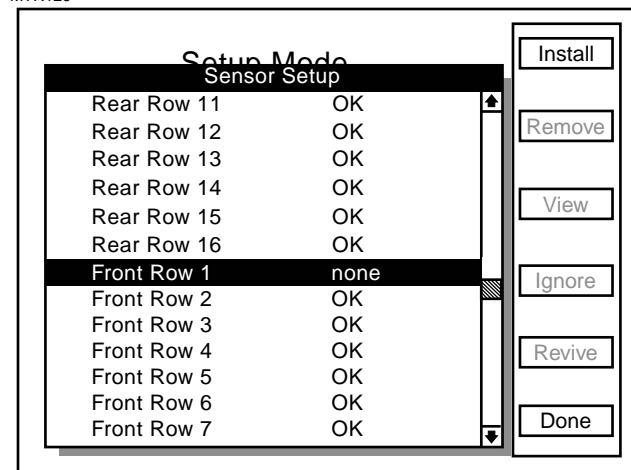

REPROGRAMMING SPEED SENSOR

This setting must be specified when the monitor is first configured. It will be necessary to reprogram to use an alternate speed sensor.

NOTE: Speed sensors may not be changed while planting.

RADAR TO MAGNETIC DISTANCE SENSOR

STEP 1 Turn the knob or use the arrow keys to highlight “8. Select Speed Sensor”. Press the knob or Enter key to display the highlighted item.

MTR109

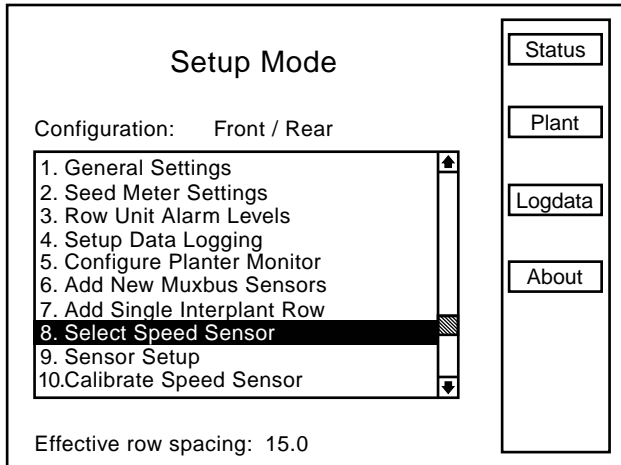

STEP 2 Press the knob or Enter key, a drop down menu will appear. Turn the knob or use the arrow keys to highlight “Coil Pick-Up” and press the knob or Enter key.

MTR110

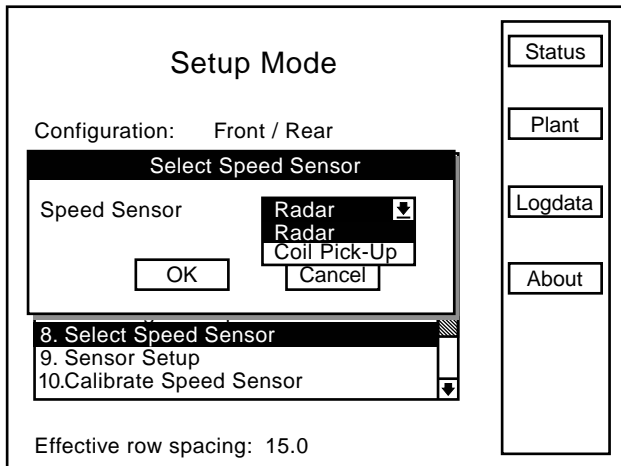

STEP 3 Turn the knob or use the arrow keys to highlight the “OK” button and press the knob or Enter key to return to the “Setup Mode” screen.

STEP 4 Turn the knob or use the arrow keys to highlight “9. Sensor Setup” and press the knob or Enter key.

STEP 5 Unplug the radar from the tractor.

NOTE: To prevent the configuration from being changed select Cancel, then press the rotary encoder knob, Enter key or ESC key.

STEP 6 Plug in Magnetic Distance Sensor (MDS) and press the F1 key next to Install. Press the knob or Enter key to save information. The Sensor Setup screen will appear.

MTR111

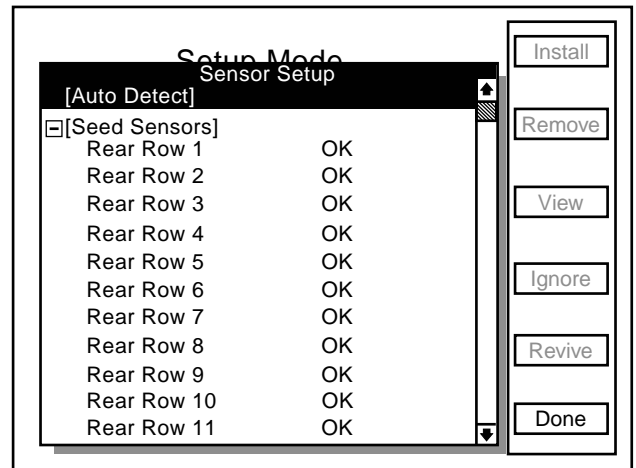

STEP 7 Turn the knob or use the arrow keys to scroll down to “Ground Speed Sensor”.

MTR112

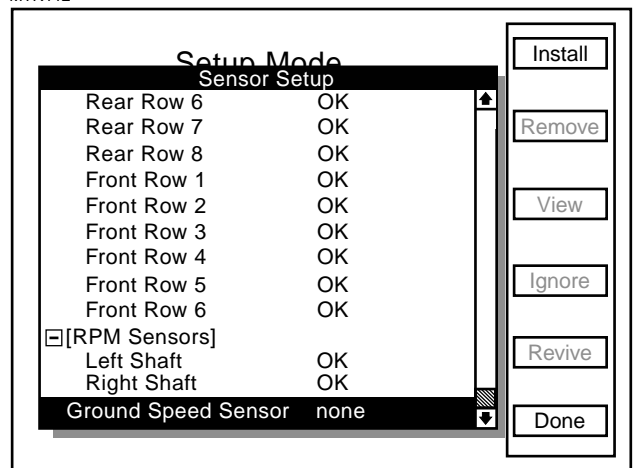

STEP 8 Press the F1 key next to Install. The monitor will beep twice to confirm selection.

STEP 9 Press the F6 key next to Done. The display will return to the Setup Mode screen.

STEP 10 Press the F2 key by "Plant" to return to the Planter Configuration screen.

NOTE: When switching between speed sensors, verify the distance pulse count is correct for the chosen sensor. There will be significant distance pulse count variation between radar and coil pick-up sensors.

MAGNETIC DISTANCE SENSOR (MDS) TO RADAR

STEP 1 Turn the knob or use the arrow keys to choose "9. Sensor Setup". Turn the knob or use the arrow keys to highlight "Ground Speed Sensor". Press the F2 key next to Remove to remove the Ground speed Sensor.

STEP 2 Press the F6 key next to Done. The display will return to the Setup Mode screen.

MTR114

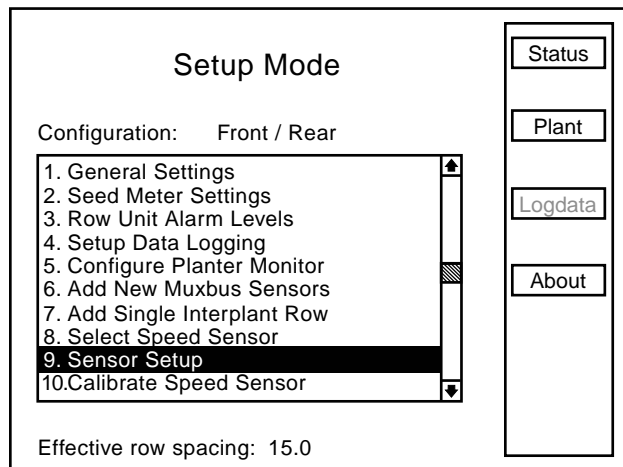

STEP 3 Turn the knob or use the arrow keys to highlight "8. Select Speed Sensor" and press the knob or Enter key.

MTR116

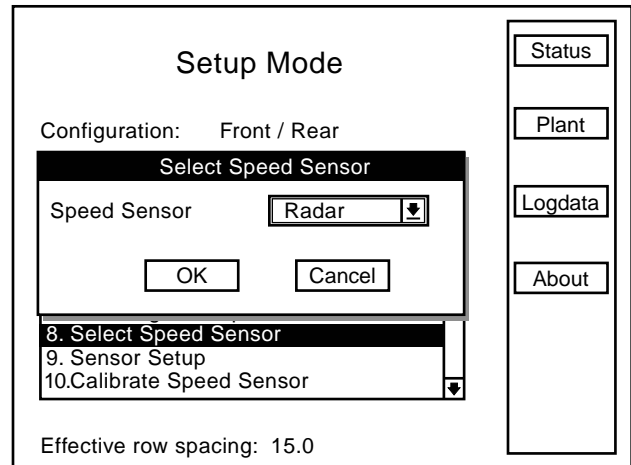

STEP 4 Press the knob or Enter key to select the "Speed Sensor" field and a drop down menu will appear.

MTR117

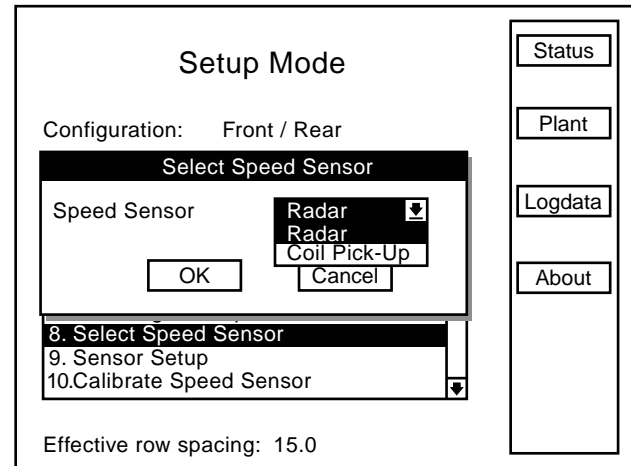

NOTE: To prevent the configuration from being changed select Cancel, then press the rotary encoder knob, Enter key or ESC key.

STEP 5 Turn the knob or use the arrow keys to highlight "Radar" and press the knob or Enter key.

STEP 6 Turn the knob or use the arrow keys to highlight the "OK" button and press the knob or Enter key.

STEP 7 Plug in Radar, turn the knob or use arrow keys to advance to "OK". Press the knob or Enter key to save the information. The display will return to the Setup Mode screen.

STEP 8 Press the F2 key next to Plant to return to Planter Configuration screen.

NOTE: When switching between speed sensors, verify the distance pulse count is correct for the chosen sensor. There will be significant distance pulse count variation between radar and magnetic distance sensors.

**PROGRAMMING/CONNECTING SEED TUBES,
SHAFT ROTATION SENSORS AND/OR RADAR/
MAGNETIC DISTANCE SENSORS**

NOTE: The **Sensor Setup** screen automatically appears after the **Planter Monitor** is configured in the **Configure Planter Monitor** selection in the **Setup Mode** screen.

IMPORTANT: All sensors **MUST** be unplugged before programming begins.

STEP 1 To access Mode Selection, press F6 key until the Mode Selection screen appears.

STEP 2 Select "1. Setup Mode" by turning the rotary encoder knob or press the arrow keys. Press the knob or Enter key to display the highlighted item.

STEP 3 Select "9. Sensor Setup" by turning the knob or using the arrow keys. Press the knob or Enter key to display the highlighted item.

STEP 4 Attach the planter harness to the KPM III. Do NOT connect any of the sensors to the planter harness. With [Auto Detect] selected press the F1 key next to Install.

MTR86

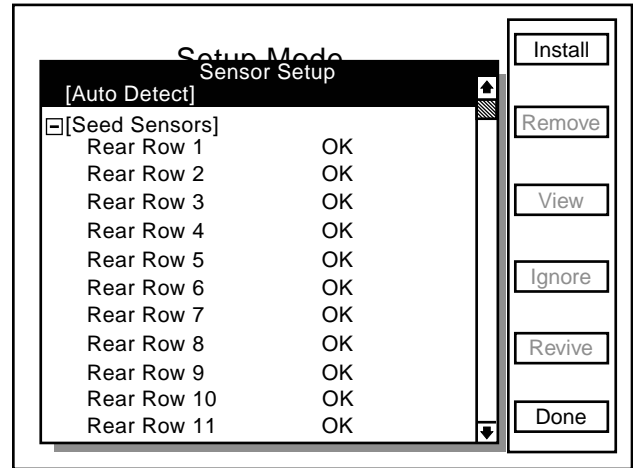

MTR85

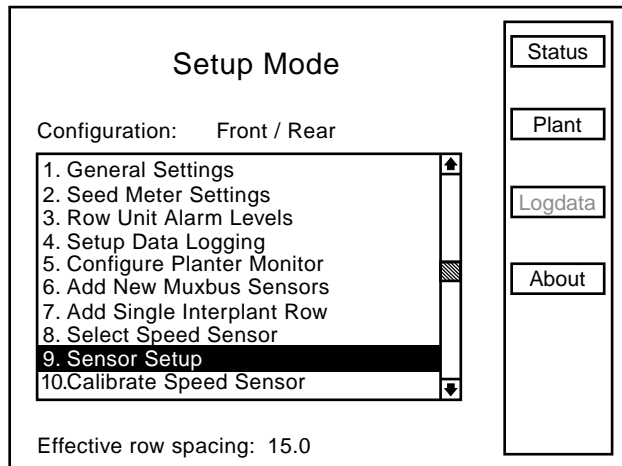

STEP 5 Plug in the first pull row unit seed sensor (row 1), working from left to right across the planter. Once all pull row unit sensors have been connected, if applicable, interplant unit sensors should be connected following the same pattern. When a sensor is connected to the planter harness wait for the monitor to acknowledge the sensor with two beeps.

NOTE: If the monitor fails to acknowledge a sensor disconnect the sensor temporarily then reconnect the sensor and wait for the monitor to acknowledge the sensor with two beeps. If the monitor still fails to acknowledge the sensor try connecting a different sensor in this location.

Connect shaft rotation sensors or speed sensors in the same way seed sensors were connected, making sure to work from left to right across the planter.

(If applicable) plug in SDS, vacuum or PDP (pneumatic down pressure) sensors in the same way seed sensors were connected.

Progress is displayed on the LCD screen as sensors are connected. The example below indicates that the last seed sensor found was Rear Row 4 and the monitor is looking for the next sensor.

When all sensors are installed press the F6 key to end the installation and return to the "Setup Mode" screen.

MTR87

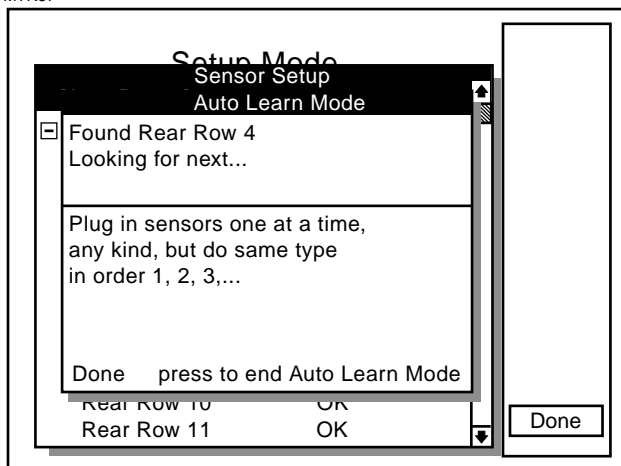

NOTE: After each sensor has been installed "OK" will appear after the sensor name on the LCD screen.

MTR86

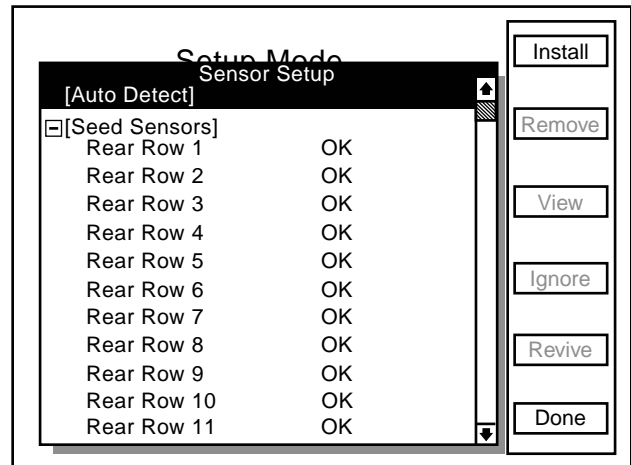

STEP 6 When "OK" appears behind ALL sensors, press the F6 key next to Done. The "Setup Mode" menu will then appear.

NOTE: If "OK slow" appears after a sensor, the sensor is able to communicate but at a slower speed. For the system to run at top speed of 9600 baud the slow sensor must be replaced.

MTR89

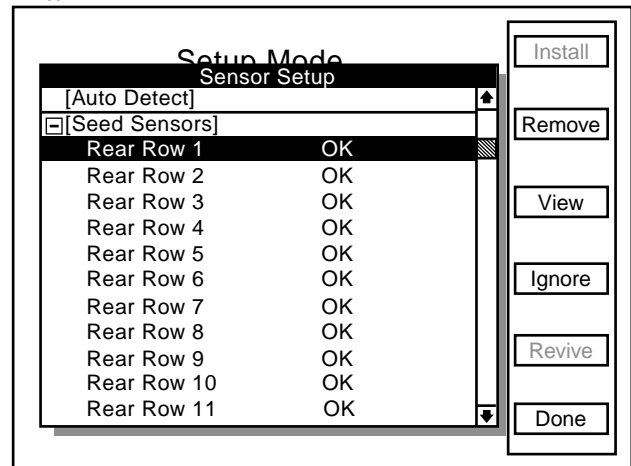

SPEED SENSOR CALIBRATION/PROGRAMMING

- STEP 1** Turn the knob or use the arrow keys to highlight "10. Calibrate Speed Sensor" and press the knob or Enter key.

MTR100

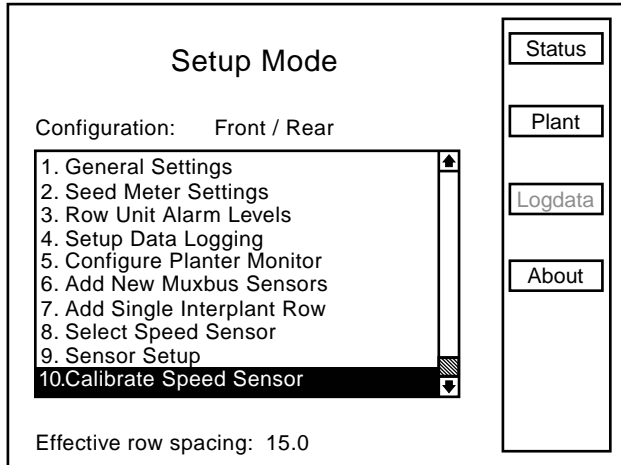

The Distance Pulse Count is used to record how many pulses are generated per mile/kilometer from the ground speed sensor.

NOTE: A field calibration must be performed to establish the Distance Pulse Count number. Several factors can affect this value, such as wheel slip on the magnetic distance sensor. IT IS NOT UNCOMMON FOR THE SPEED ON THE MONITOR TO VARY SLIGHTLY FROM THE TRACTOR SPEEDOMETER. Adjusting the Distance Pulse Count in the monit or to make the speed agree with the tractor can cause serious errors in acre/hectare and population/spacing readings. Do field checks to verify populations and seed spacing.

MTR101

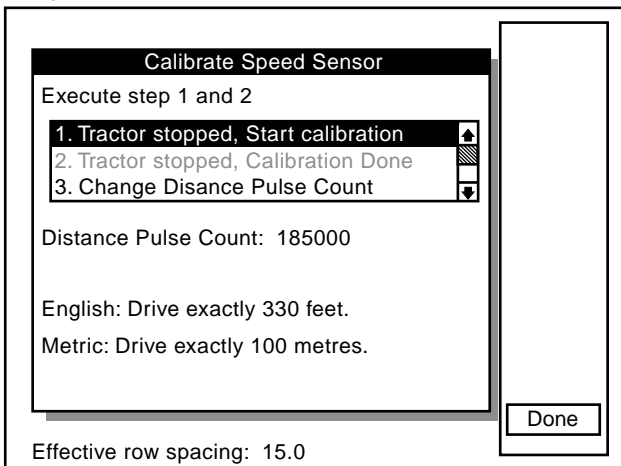

- In field conditions, measure 330 feet or 100 meters, depending on the unit of measurement selected. Place a marker at the start point and end point.

- Pull the tractor up to the starting point.
- Turn the knob or use the arrow keys to highlight "1. Tractor stopped, Start calibration" and press the knob or Enter key.
- Drive the tractor for 330 feet or 100 meters.
- The Monitor will count the number of pulses and display them.
- Stop the tractor at the end point.
- Turn the knob or use the arrow keys to highlight "2. Tractor stopped, Calibration Done" and press the knob or Enter key.

MTR104

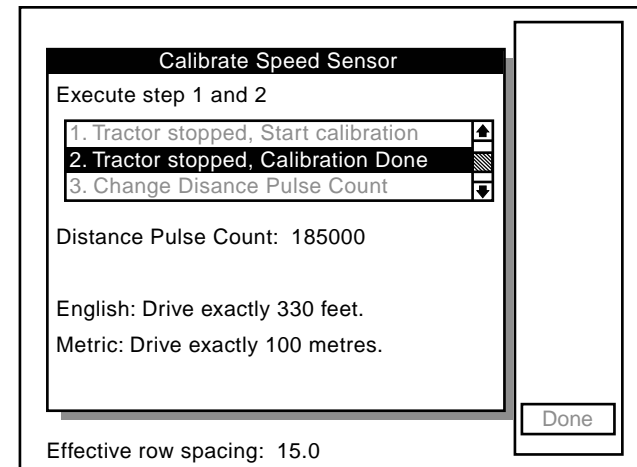

NOTE: If the warning box below appears, click OK and repeat the procedure.

MTR105

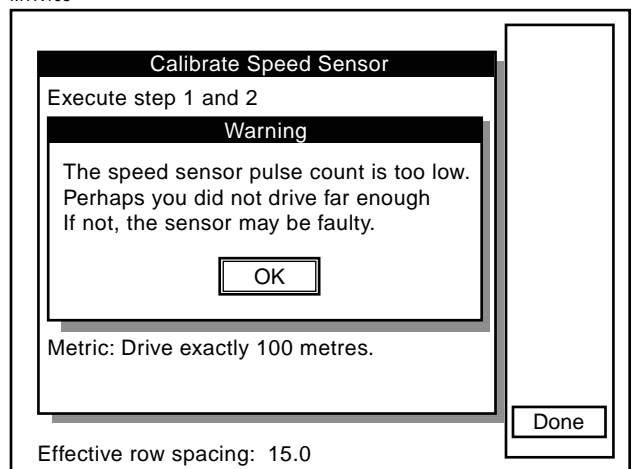

NOTE: Repeat the above steps multiple times. Record and average the values. Use this average for the Distance Pulse Count number constant.

NOTE: The Distance Pulse Count will vary from the above example.

When the correct distance pulse count is known, calibration is not needed and the following steps may be used.

STEP 1 Turn the knob or use the arrow keys to highlight "10. Calibrate Speed Sensor" and press the knob or Enter key

MTR106

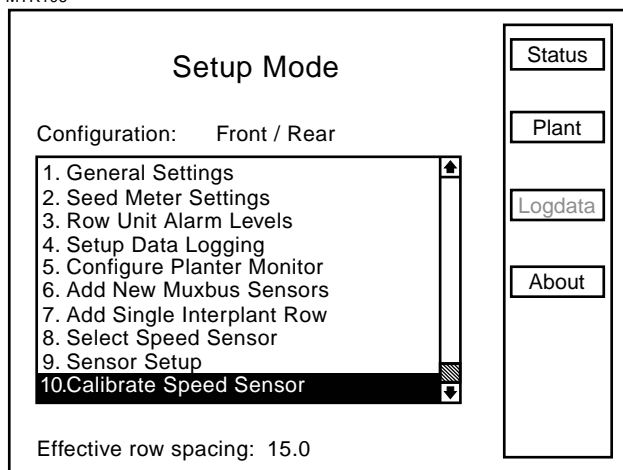

STEP 2 Turn the knob or use the arrow keys to highlight "3. Change Distance Pulse Count" and press the knob or Enter key. Highlight the "Enter Pulse Count" line and press the knob or Enter key and a drop down key pad will appear.

MTR107

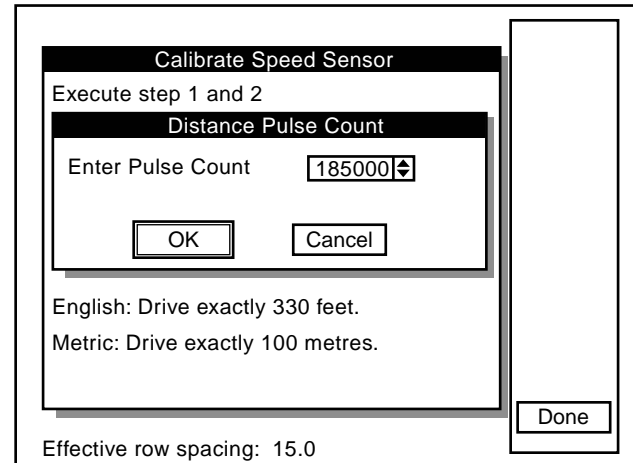

NOTE: The Distance Pulse Count will vary from the above example.

STEP 3 Turn the knob or use the arrow keys to highlight the first digit of the average pulse count and press the knob. The number will appear in the "Enter Pulse Count" line. Highlight the next digit of the number and press the knob. Repeat this procedure until the entire number is entered then press the Enter key.

STEP 4 Turn the knob or use the arrow keys to highlight "OK" then press the knob or Enter key to return to the "Calibrate Speed Sensor" screen.

STEP 5 Press F6 key next to "Done" to return to "Setup Mode" screen.

The monitor will display the current pulses per mile/kilometer using a 6 digit, no decimal place format labeled "Distance Pulse Count". Turn the knob or use the arrow keys to highlight "Change Pulse Count" then press the knob or Enter key. The "Distance Pulse Count" box will appear.

MTR102

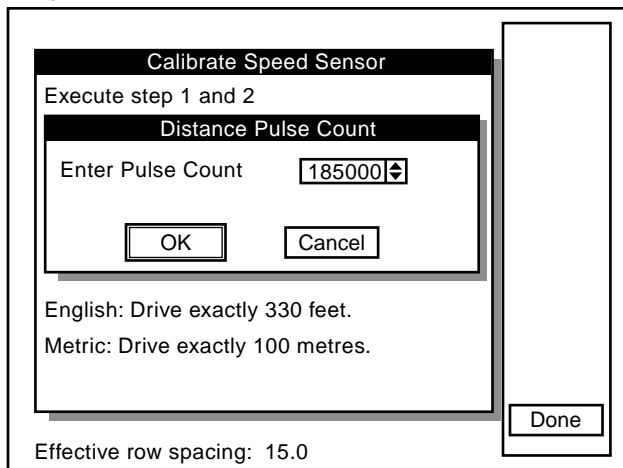

- When the "Enter Pulse Count" value is highlighted press the knob or Enter key and a drop down keypad will appear. Turn the knob or use the arrow keys to highlight "0", zero, and press the knob or Enter key. Turn the knob or use the arrow keys to highlight "OK" and press the knob or Enter key to return to the "Calibrate Speed Sensor" screen.

MTR103

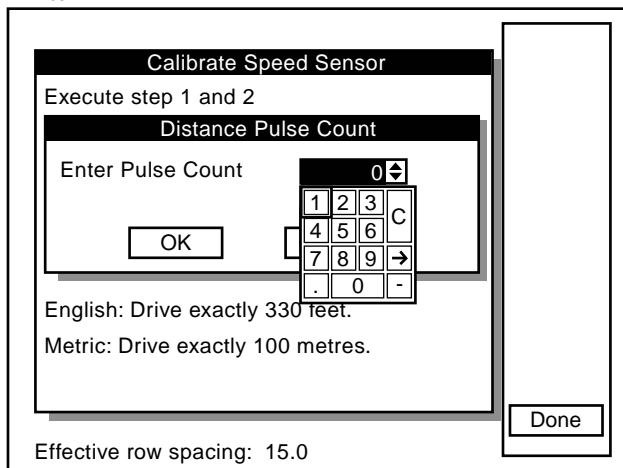

NOTE: If the Distance Pulse Count number starts to count pulses with the tractor not moving, check radar distance sensor for vibration or other interference.

ACRE COUNT MODE

NOTE: When a tractor is equipped with a radar distance sensor, accumulating area without a planter attached is possible.

STEP 1 Install an “Acre Count Switch Kit”.

STEP 2 Enter into “Acre Count Mode”.

Acre Count Switch Kit

STEP 1 With the monitor OFF, attach an Acre Count Switch Kit to the Muxbus connector and then turn monitor “ON”.

STEP 2 Press the F6 key until the Mode Selection screen appears. Turn the rotary encoder knob or use the arrow keys to highlight “2. Acre Count Mode”. Press the knob or Enter key.

MTR196

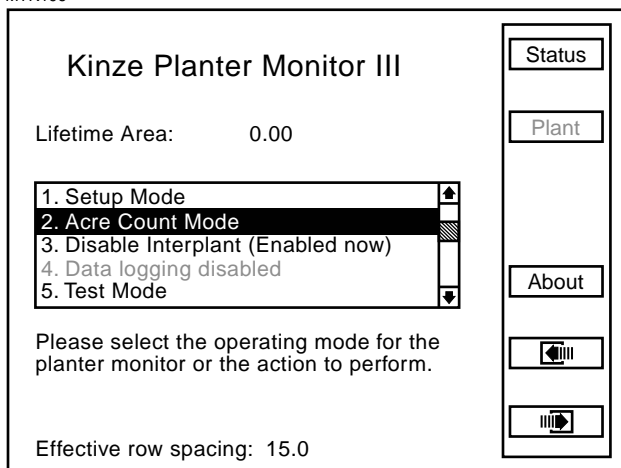

NOTE: If the radar unit is not detected a warning will appear.

NOTE: When using the acre count mode option, area (acres or hectares) is accumulated in “Lifetime Area Counter”.

NOTE: DO NOT BEGIN ACCUMULATING AREA IF THE RADAR UNIT HAS NOT BEEN CALIBRATED. Always check the distance pulse count value immediately after entering acre count mode and before pressing start.

STEP 3 Turn the knob or use the arrow keys to highlight “Units & Width” and press the knob or Enter key.

MTR197

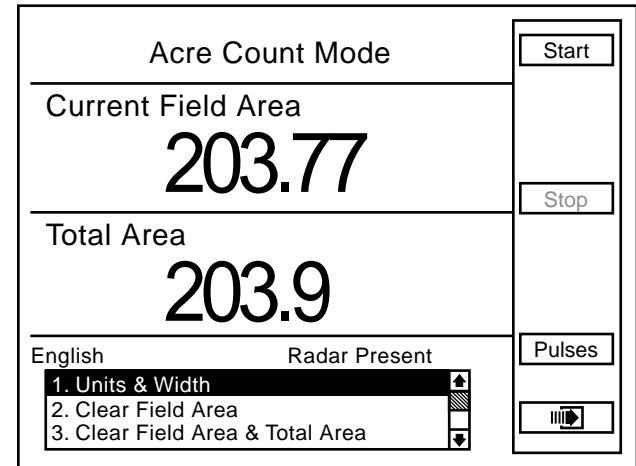

STEP 4 A box named “Acre Count General Settings” will appear. Highlight the correct units of measure “English” or “Metric” by turning the knob or using the arrow keys. Press the knob or Enter key to make the selection.

STEP 5 Turn the knob or use the arrow keys to highlight the “Implement Width” box and press the knob or Enter key and a drop down number pad will appear.

MTR198

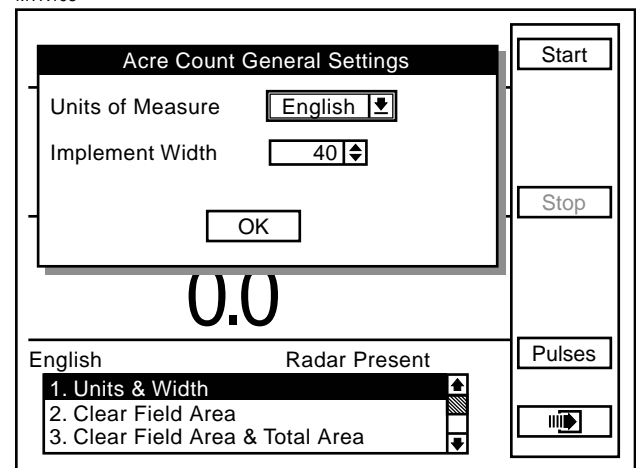

STEP 6 Turn the knob or use the arrow keys to highlight the correct value then press the knob to select the number, for numbers containing more than one digit select one digit at a time. When the desired quantity is displayed above the number pad, press the Enter key.

STEP 7 Turn the knob or use the arrow keys to highlight the “OK” button. Then press the knob or Enter key to save the changes that have been made.

NOTE: The implement width entered in acre count mode has no effect on planting mode settings.

NOTE: Tractor should be at a complete stop before starting.

STEP 8 To begin accumulating area press the F1 key next to Start.

STEP 9 To stop accumulating area or to move to a different location, press the F3 key next to Stop.

There are two counters in the Acre Count Mode (Field Area Counter and Total Area Counter). The “Field Area” counter can be cleared independent of the “Total Area” counter, however clearing the “Total Area” counter also clears the “Field Area” counter.

• To Clear Field Area. Highlight “Clear Field Area” and press the knob or Enter key. A note will appear verifying the decision to reset the field area to zero. Highlight “OK” and press the knob or Enter key to clear the field. Highlight “Cancel” and press the knob or the Enter key to retain the current field value.

MTR199

Acre Count Mode		Start
Current Field Area	0.00	Stop
Total Area	0.0	Pulses
English	Radar Present	
1. Units & Width		
2. Clear Field Area		
3. Clear Field Area & Total Area		

• To Clear Both Field Area And Total Area. Highlight “Clear Field Area & Total Area” and press the knob or Enter key. A note will appear to verify the decision to reset the field area and the total area to zero. Highlight “OK” and press the knob or Enter key to clear the field. Highlight “Cancel” and press the knob or Enter key to retain the current field values.

ENABLING/DISABLING INTERPLANT® ROWS

To Enable or Disable Interplant®

- STEP 1** Return to the “Planter Configuration” screen by pressing the F2 key next to “Plant”.
- STEP 2** Press the F6 key until the “Kinze Planter Monitor III” screen appears.
- STEP 3** Turn the rotary encoder knob or use the arrow keys to highlight “3. Disable Interplant (Enabled now) or Enable Interplant (Disabled now).
- STEP 4** Press the knob or Enter key to “Disable” or “Enable” Interplant®. To verify selection, the row spacing is displayed on the bottom of the screen.

MTR132

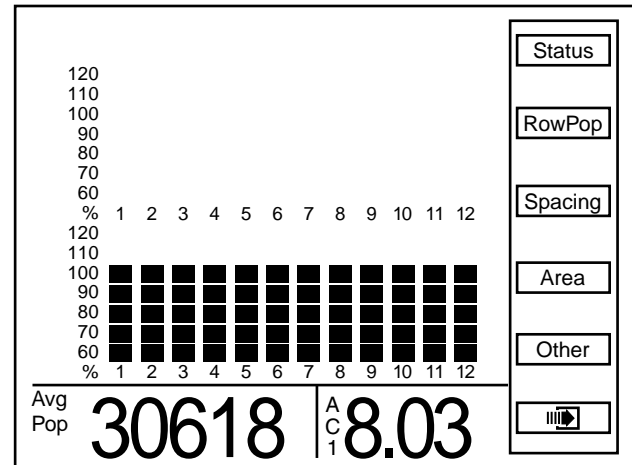

MTR130

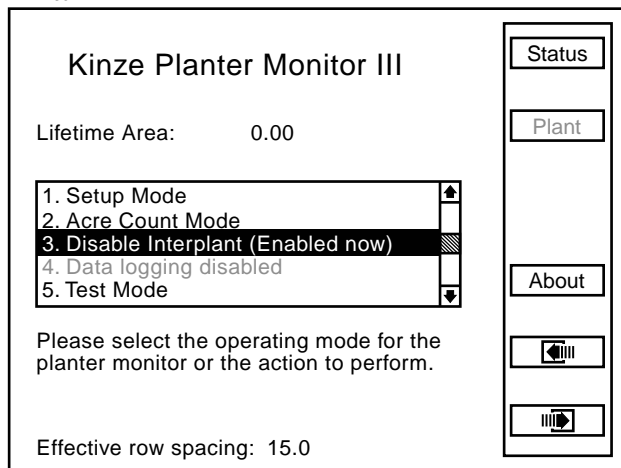

MTR131

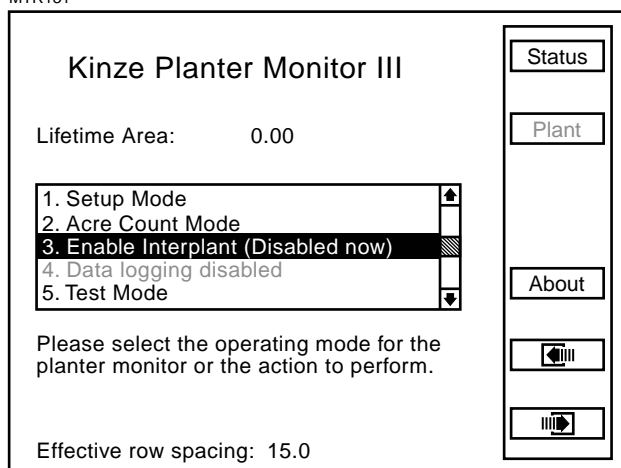

Press F6 to return to the Plant screen.

TEST MODE

STEP 1 Press the F6 key until the Mode Selection screen appears.

STEP 2 Select "5. Test Mode" by turning the rotary encoder knob or using the arrow keys. Press the knob or Enter key to display the highlighted item.

MTR173

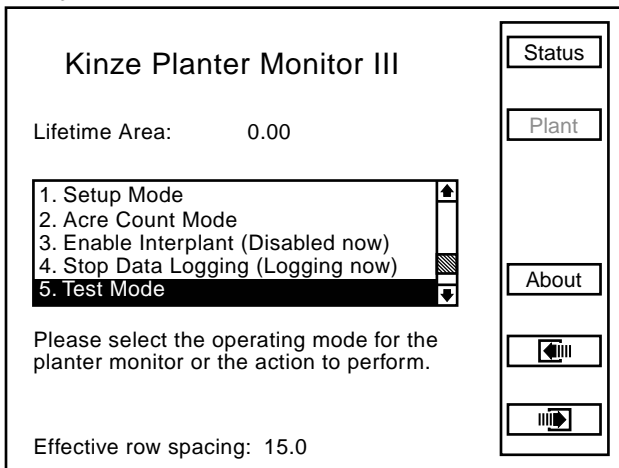

STEP 3 Press the F1 key next to Start.

MTR174

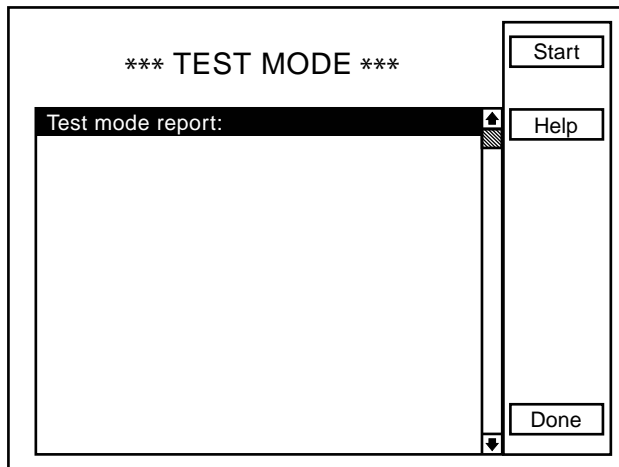

STEP 4 The "Test Mode Active" box will appear showing the number of shaft revolutions. The "End" box will be highlighted. Press the knob or Enter key. The "Test Mode Active" box will appear displaying the drill shaft revolutions.

MTR173

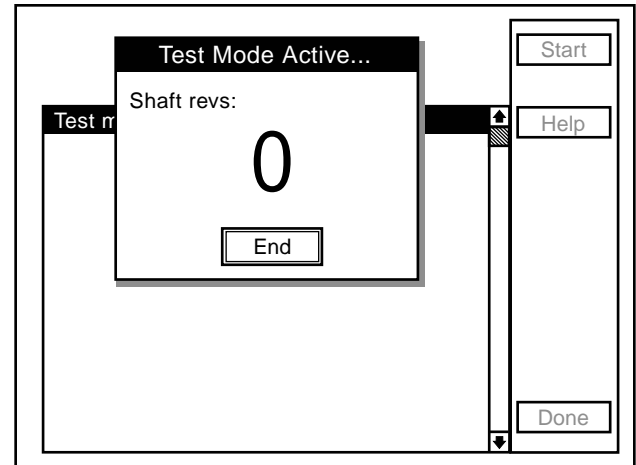

STEP 5 The TEST MODE screen displays test run data (seed count) for each row.

MTR176

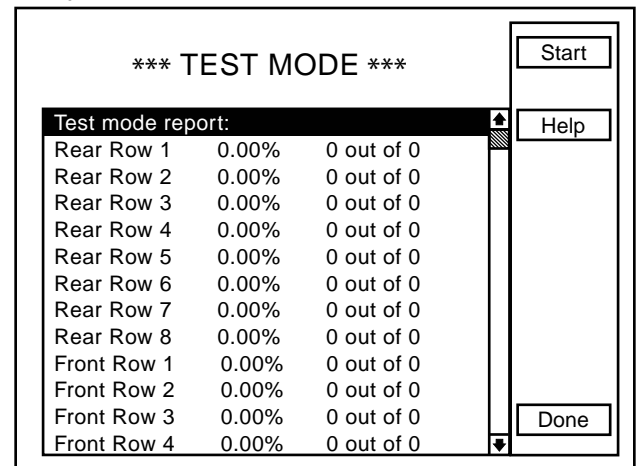

STEP 6 Begin the test with the tractor stopped. For EdgeVac planters, ensure the vacuum is on and that the seed discs are full.

STEP 7 Press the F1 key next to Start and plant a test strip.

STEP 8 Stop the tractor and press "End". The KPM III will display seed counts by row and percentage.

MTR177

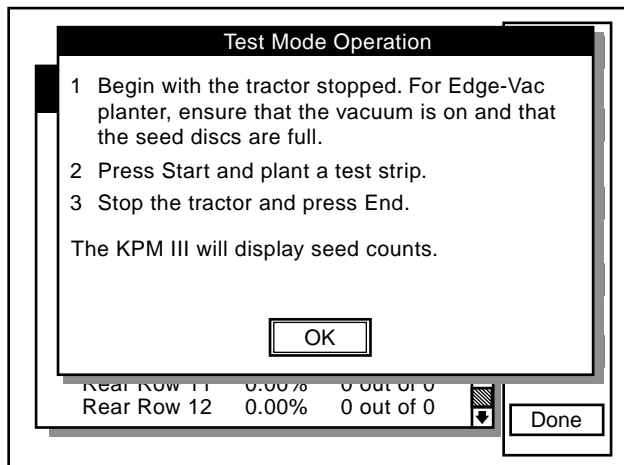

NOTE: The above instructions will display on the screen when the F2 key next to “Help” is pressed.

STEP 9 Press the F6 key next to Done. The display returns to the Mode Selection screen.

ROW POPULATION

Press the F2 key next to "RowPop" to display row population. Average planter population will be shown in the lower L.H. corner of the display.

MTR133

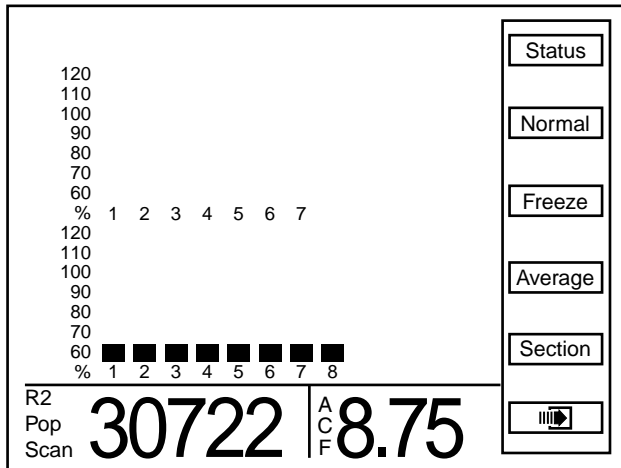

- Press the F3 key next to Scan and the monitor will scan through each row in ascending order displaying the average seed population for each row. After all rows have been scanned the average population is displayed and scan function will continue with the first rear row.

MTR134

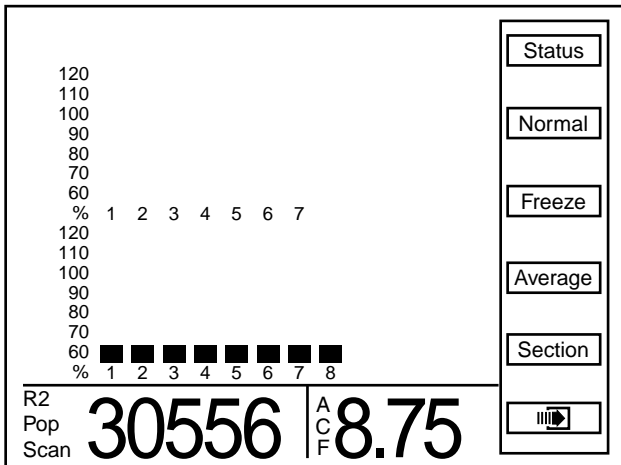

- Press the F3 key next to Freeze to stop scanning, the left display item will be frozen on a particular row. "Frzn" appears in the lower L.H. corner to indicate the display is frozen. To resume scan press the F3 key next to Scan.

EXAMPLE: When average individual row population is shown, R3 indicates rear row 3, F2 indicates front row 2, etc.

MTR135

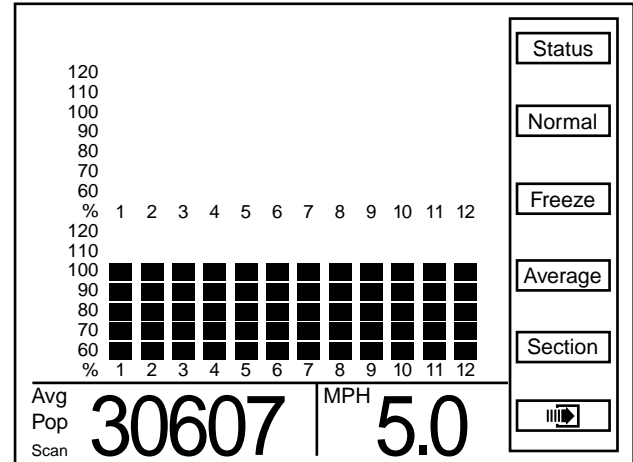

- When either "Scan" or "Frzn" is displayed in the L.H. corner, the Section and arrow keys function as follows:
 - Section, Right arrow key, or Left arrow key advances to the first rear row.
 - The Up arrow key moves forward to the next row of the planter, wrapping around to the first row when moving past the last row.
 - Down arrow key moves backward to the previous row of the planter, wrapping around to the last row of the planter when moving past the first row.
- Press the F4 key next to Average to display the average population in the bottom L.H. corner.
- Press the F2 key next to Normal to display the normal screen for the Planter Configuration screen.

NOTE: If the rows are being scanned and the F4 key next to Average is pressed the scan function will stop.

ROW SPACING

- Press the F3 key next to Spacing to display seed spacing keys. "Average Spacing" will appear in the bottom L.H. corner of the display.

MTR136

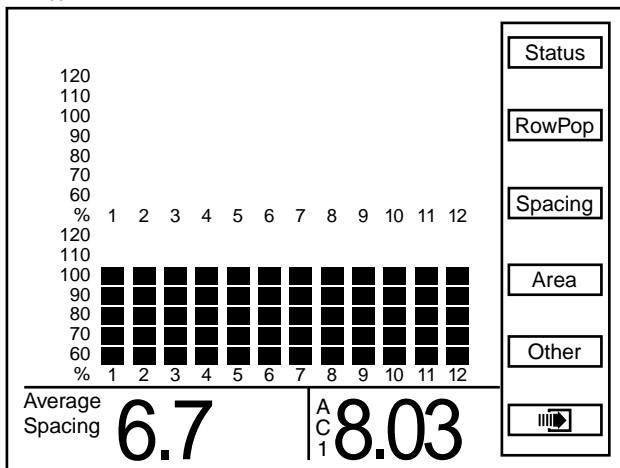

MTR137

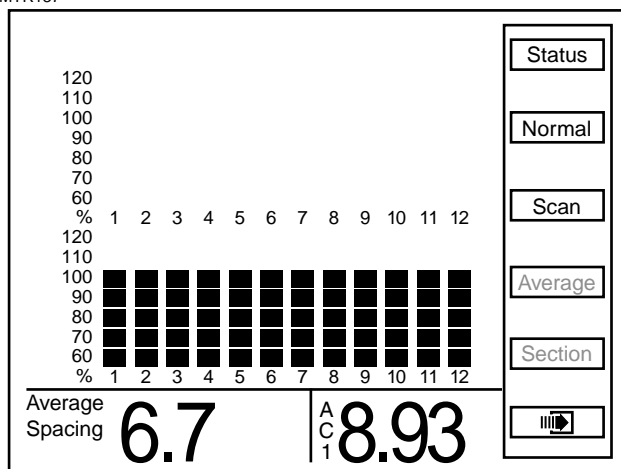

- Press the F3 key next to Scan and the monitor will scan through each row in ascending order displaying the average seed spacing for each row. Scan appears in the L.H. corner to indicate the display is scanning. After all rows have been scanned the average population is displayed and scanning will continue with the first rear row.

- Press the F3 key next to Freeze to stop scanning, the left display item will be frozen on a particular row. "Frzn" appears in the lower L.H. corner to indicate the display is frozen. To resume scan press the F3 key next to Scan.
- When either "Scan" or "Frzn" is displayed in the left display item, the Section and arrow keys function as follows:
 - Section, Right arrow key, or Left arrow key advance to the first rear row.
 - The Up arrow key moves forward to the next row of the planter, wrapping around to the first row when moving past the last row.
 - Down arrow key moves backward to the previous row of the planter, wrapping around to the last row of the planter when moving past the first row.
- Press the F4 key next to Average to display the average seed spacing in the bottom L.H. corner.
- Press the F2 key next to Normal to display the Planter Configuration screen.

NOTE: If the rows are being scanned and the F4 key next to Average is selected the scan function will stop.

SPEED/SHAFT ROTATION

MTR138

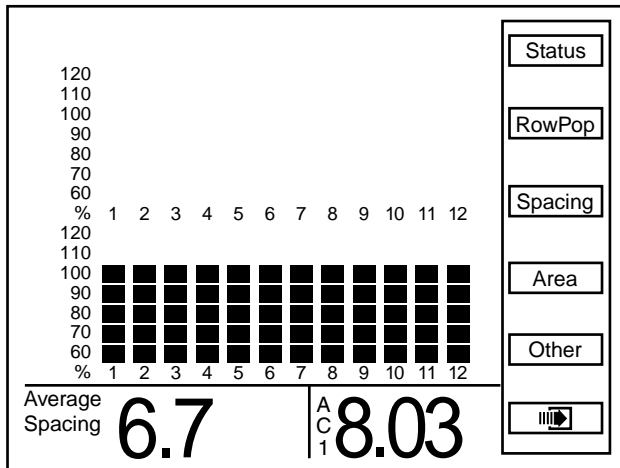

MTR209

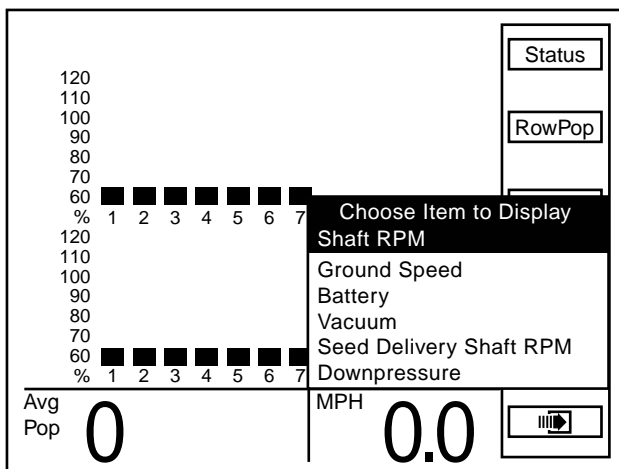

- Press the F5 key next to “Other” to display items available to display in the bottom R.H. corner. Turn the knob or use the arrows keys to advance to “Battery” to view battery condition. The value will appear in the bottom R.H. corner of the display as “Bat V”.
- Press the F5 key next to “Other” to display items available to display in the bottom R.H. corner. Turn the knob or use the arrows keys to advance to “Vacuum” to view vacuum. The inches of vacuum will appear in the bottom R.H. corner of the display as “VAC”.
- Press the F5 key next to “Other” to display items available to display in the bottom R.H. corner. Turn the knob or use the arrows keys to advance to “Seed Delivery Shaft RPM” to view shaft RPM. The shaft RPM will appear in the bottom R.H. corner of the display as “RPM SDS”.
- Press the F5 key next to “Other” to display items available to display in the bottom R.H. corner. Turn the knob or use the arrows keys to advance to “Downpressure” to view lbs. of down pressure. The lbs. of down pressure will appear in the bottom R.H. corner of the display as “LBS”.

- Press the F5 key next to Other to display items available to display in the bottom R.H. corner. Turn the knob or use the arrow keys to highlight “Shaft RPM”. The value will appear in the bottom R.H. corner of the display as “RPM”.

NOTE: Applicable to planters with shaft rotation sensors installed.

- Press the F5 key next to “Other” to display items available to display in the bottom R.H. corner. Turn the knob or use the arrow keys to select “Ground Speed”. The value will appear in the bottom R.H. corner of the display as “MPH” or “Km Per Hr”.

NOTE: The selected units of measure will be displayed (English or Metric).

WARNINGS AND ALARMS

STEP 1 Seed Rate Alarm - A seed rate alarm is activated whenever the row average seed population drops below the threshold set for that row.

The corresponding row on the bargraph starts flashing and the monitor emits a series of beeps that persist until the alarm is cleared or the ACK button is pressed. "Seed Rate Alarm" appears in the upper left corner of the screen. The bargraph for the row drops down based on the threshold set for the alarm.

EXAMPLE: If the threshold is 70% the lower two bargraph segments are shown. If the threshold is 50% or 10% the lowest bargraph segment is shown.

The status message associated with an alarm contains more information about the alarm. To view the "Status Message" for a seed rate alarm, press the F1 key next to Status.

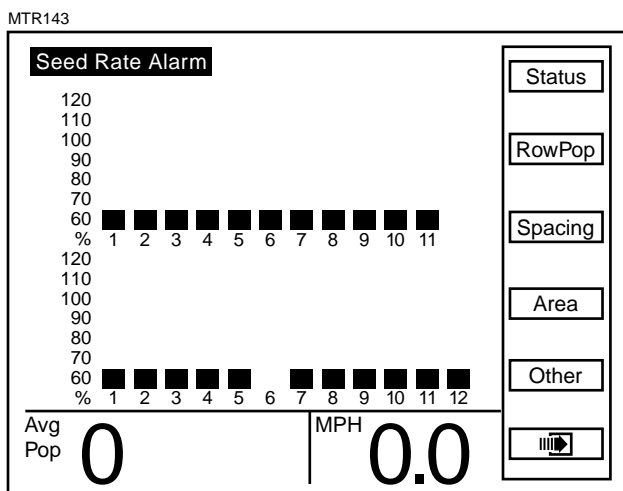

If the sensor is detecting no seed flow it will display which row is not functioning. The alarm may be caused by a mechanical problem reducing seed flow or an electrical problem causing an incorrect seed count.

MTR144

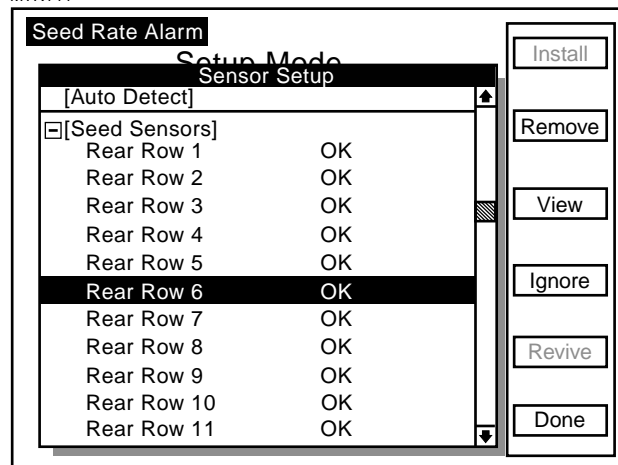

NOTE: The only way to remove an alarm is to find the problem and correct it. Alarms are not reported for rows with the seed rate alarm thresholds disabled.

NOTE: The percentage shown in the alarm message is the percentage at the time the alarm occurred.

The row can be removed by pressing the F2 key next to Remove. A box will appear asking for confirmation to remove the row. The "OK" box will be highlighted in the box.

MTR145

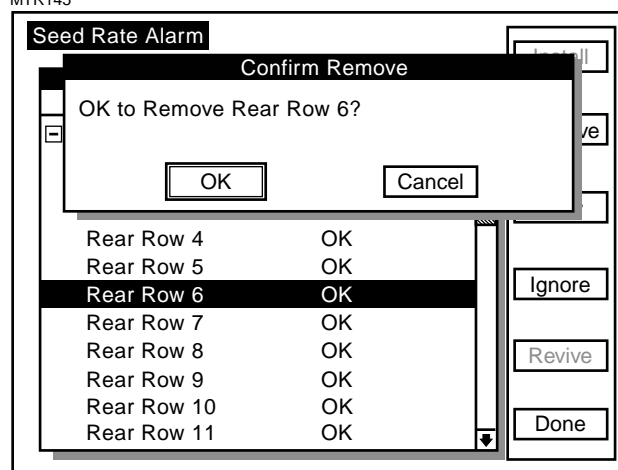

Press the knob or Enter key to confirm removal. The Sensor Setup screen will display "none" next to the row that was removed. Press the F6 key next to "Done". The setup mode screen will appear.

MTR146

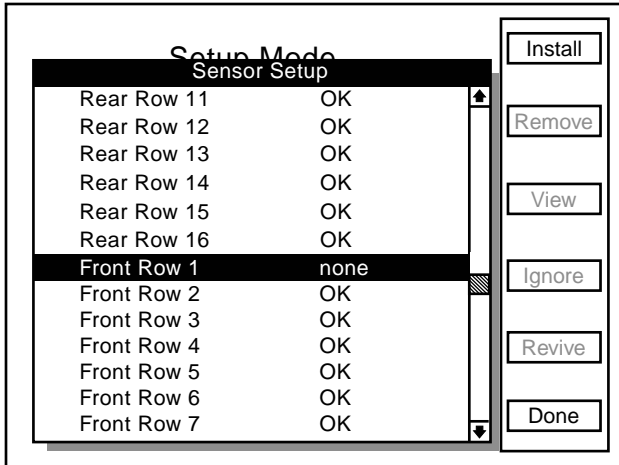

Press the F2 key next to Plant to return to the Planter Configuration screen.

MTR147

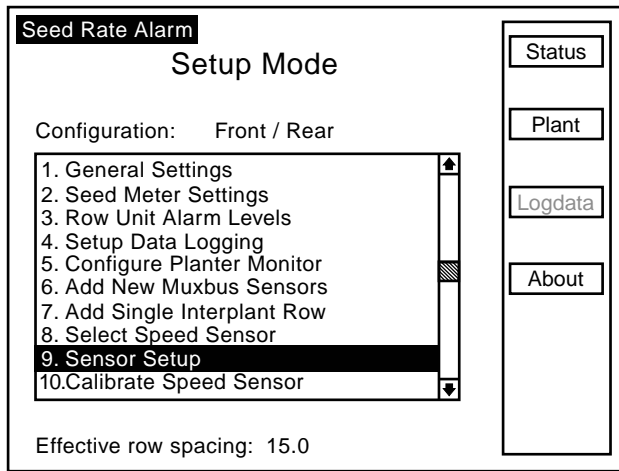

STEP 2 Section Not Planting - When the monitor detects an entire section not planting, three beeps will sound to alert the user. The bargraph for the affected section flashes and is reduced to the lowest segment. An alarm message is added to the list of "Status Messages". Press the F1 key next to Status to view the alarm message.

STEP 3 Seed Counting Sensors Not Communicating With Monitor - When the monitor detects a communication error between the sensor and the monitor, the monitor will beep twice to alert the user.

- Try to reestablish communication with sensor(s) by pressing F2.
- If the monitor is unable to establish communication there may be a faulty sensor, poor electrical connection, or a cut or pinched wire harness.

MTR148

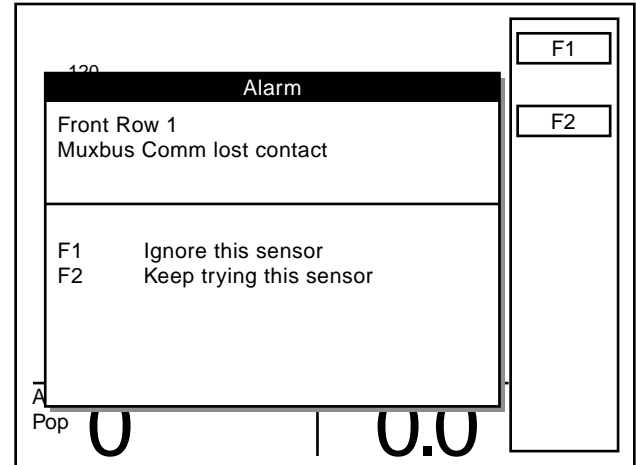

If multiple sensors have lost contact, the message will indicate which sensors have lost contact, see below.

MTR149

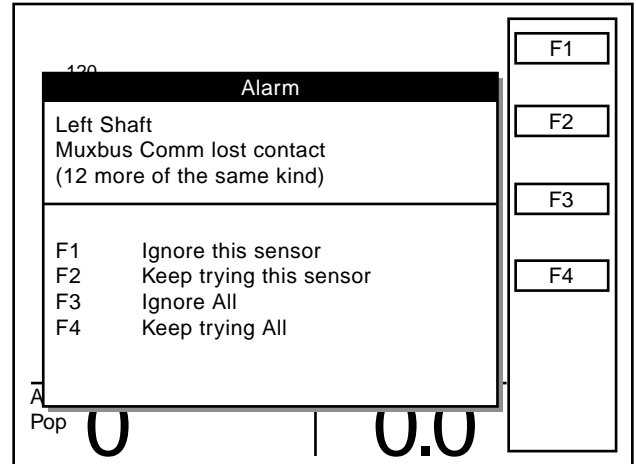

NOTE: When a known sensor or group of sensors are faulty, F1 or F3 should be pressed. The monitor will stop communication with the sensor(s) and the corresponding bargraphs will be grayed out on the main "Planter Configuration" screen as shown below.

MTR150

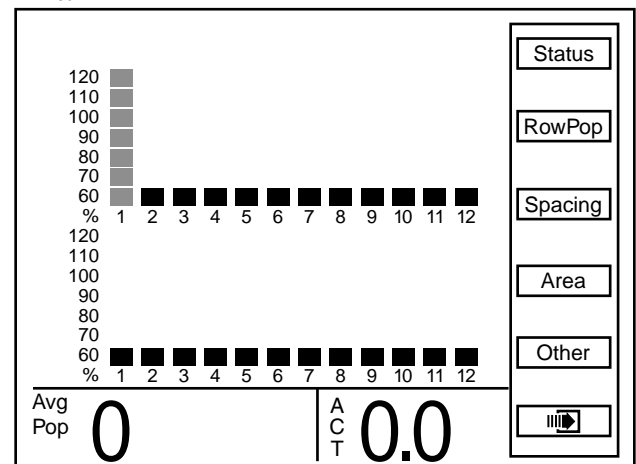

NOTE: If sensors are not faulty, F2 or F4 should be pressed. After pressing F2 or F4 a message similar to the one below will appear when the “Status” button F1 is pressed.

MTR151

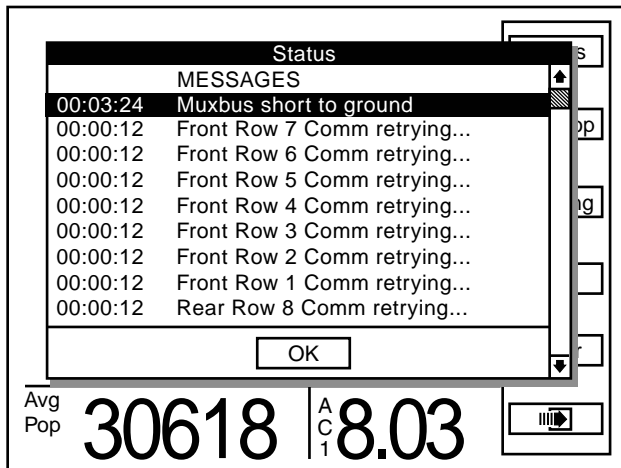

NOTE: If a sensor has been ignored, the sensor configuration screen will display as shown below.

MTR152

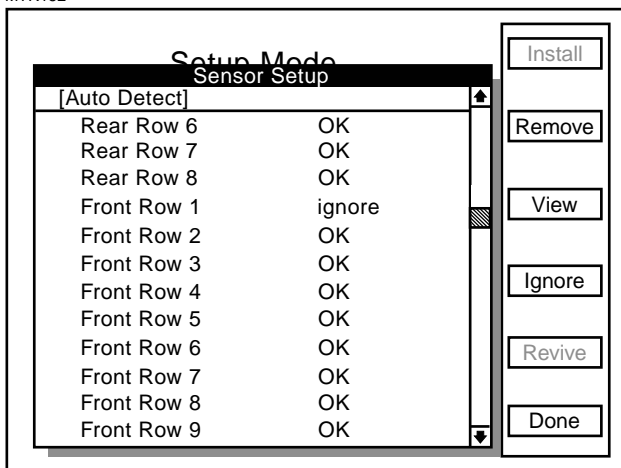

STEP 4 Seed Counting Sensors Too Dirty Warning - When powering on the KPM III, each of the seed sensors will do a self check. If a seed tube is too dirty, the message “Clean Or Replace Sensor As Necessary” will be displayed and the bargraph for that row will flash.. The sensor will not function until the problem is corrected.

NOTE: After the alarms have been acknowledged and the alarm condition still present, the LCD screen will continue to display the alarm condition.

STEP 5 Wire Shorts - When a wire is shorted, one of the messages below will appear, indicating which wires are shorted. The short must be located and repaired to continue planting. Turn off the monitor and restart it to clear the alarm.

MTR153

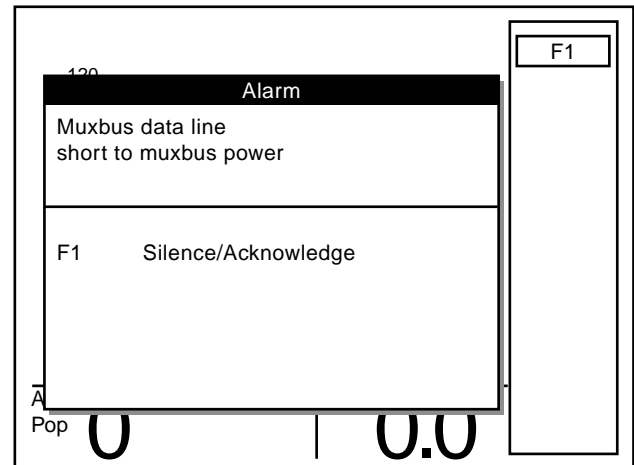

MTR154

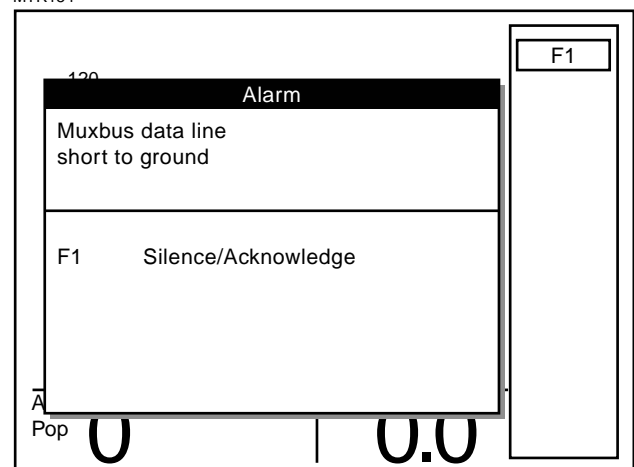

STEP 6 Add Interplant® Row Error – The planter monitor configuration must contain an odd number of front rows before the single Interplant® row unit can be added.

MTR155

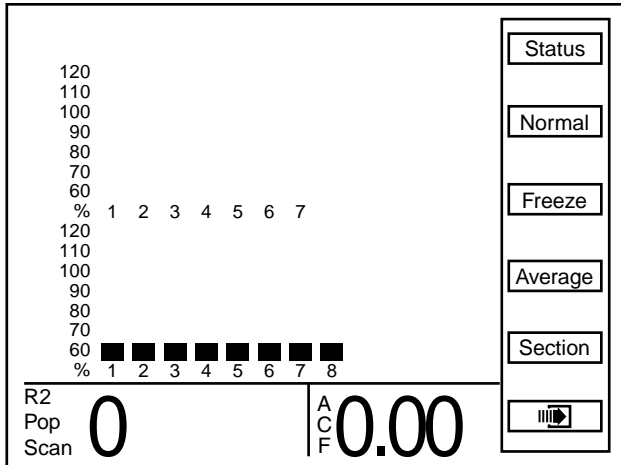

NOTE: The planter monitor configuration above has an even number of front (Interplant®) rows (8).

STEP 8 Alarm: Rear Row 1 wake failed – Select an option from the warning box and press the key next to the selection.

MTR158

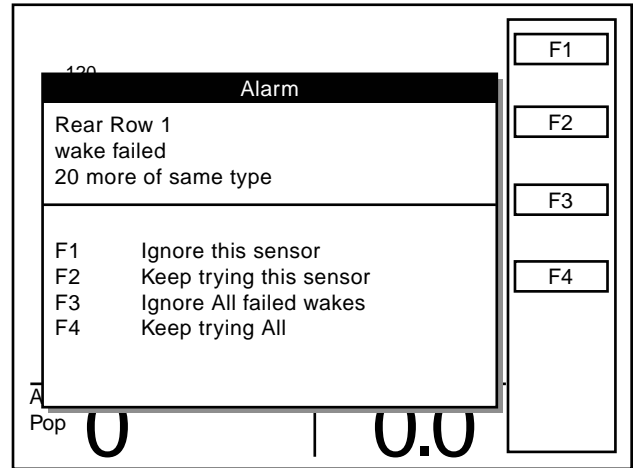

MTR156

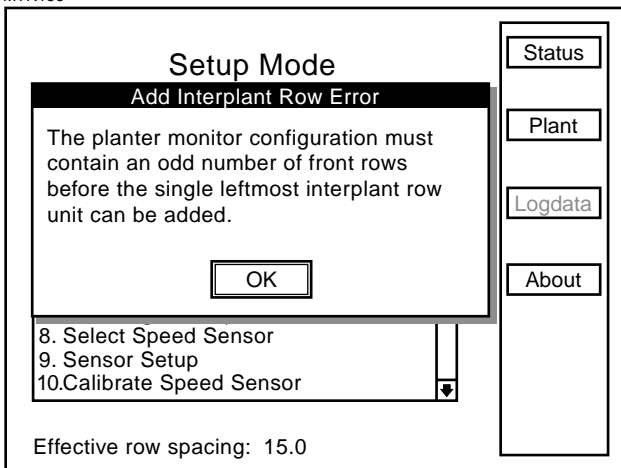

STEP 7 Sensor Present Warning – One or more sensors are present on the Muxbus.

MTR157

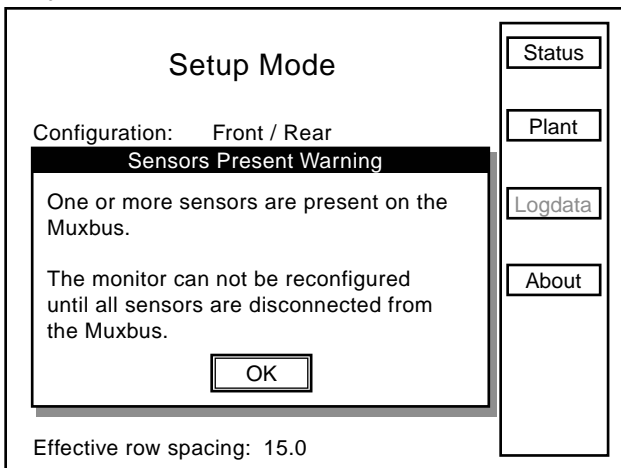

FIELD OPERATION

Press the ON/OFF key to turn the monitor ON.

If the monitor has been configured, it will show the Planter Configuration screen and attempt to communicate with the seed sensors.

MTR179

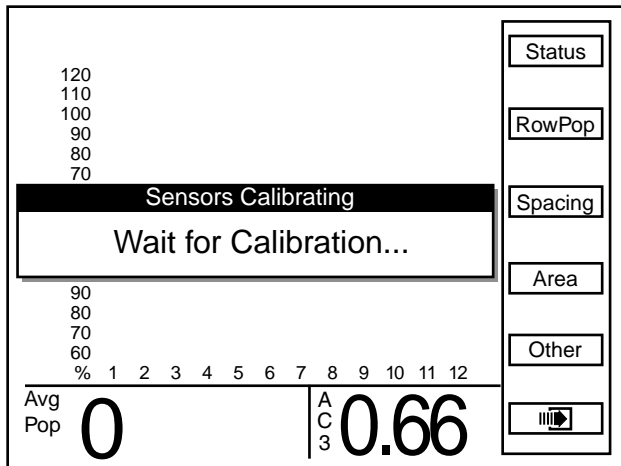

NOTE: Do not attempt planting before the "Wait For Calibration" message disappears. If the planter is moving while sensors are calibrating alarms will be generated.

NOTE: If the monitor can communicate with the sensors the Planter Configuration screen will be displayed.

MTR180

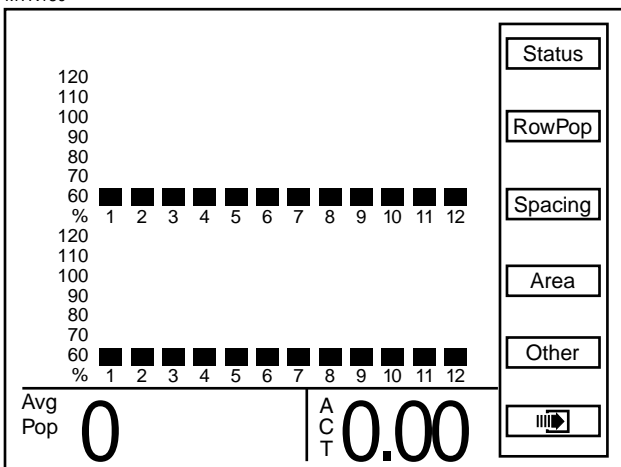

If the monitor does not detect sensors the message below will appear.

MTR181

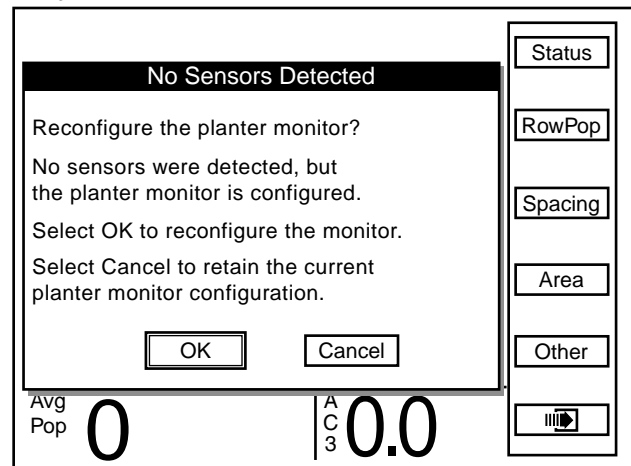

NOTE: Selecting OK will reconfigure the monitor requiring all sensors to be re-learned. Selecting Cancel will maintain the current configuration and the monitor will continue trying to communicate with the sensors.

AREA MANAGEMENT

There are 42 area counters: Total Area, Field Area and Area Counters 1 through 40. The Total Area is always active but may be cleared. If it is cleared, the Field Area is also cleared. Field Area and Area Counters 1 through 40 may be cleared, started or stopped separate from each other.

In addition, there is a Lifetime Area Counter (located on the Mode Selection Screen) which can not be disabled or cleared by the user.

To display the "Area Management" screen, press the F6 key until the "Area Management" screen appears.

MTR182

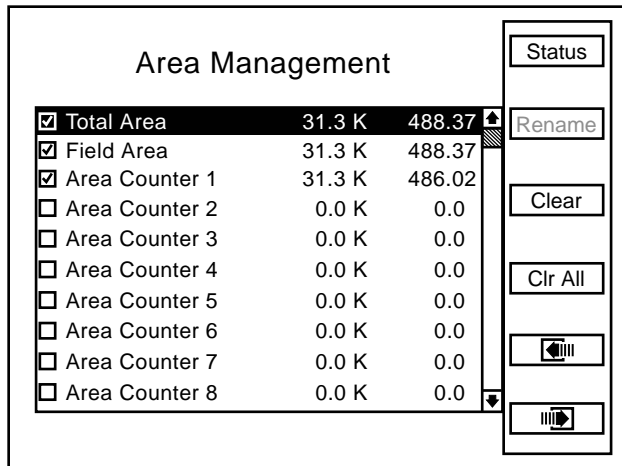

NOTE: Total Area counter can never be disabled, but can be reset to zero (cleared).

- The check mark (✓) in the box next to the name of the area counter indicates the area counter is enabled and accumulating area.

EXAMPLE: In the above illustration, 31.3K indicates average seed population per unit area (either acre or hectare). This number has been rounded off. The actual seed population ranges anywhere from 30,500 to 31,499 per unit area. The last column of numbers is the area accumulated (acre or hectare).

- Turn the knob or use the arrow keys to highlight the desired area counter.
- Press the F2 key next to Rename to name the area. A drop down keyboard will appear. Use the keyboard to enter area name, then press the knob or enter key to save information.

MTR202

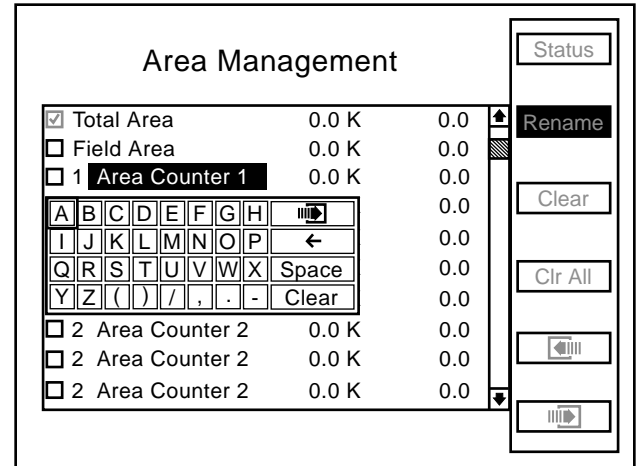

NOTE: When a key is dimmed it does not perform any operation on the highlighted area counter.

ENABLE AREA COUNTER

MTR183

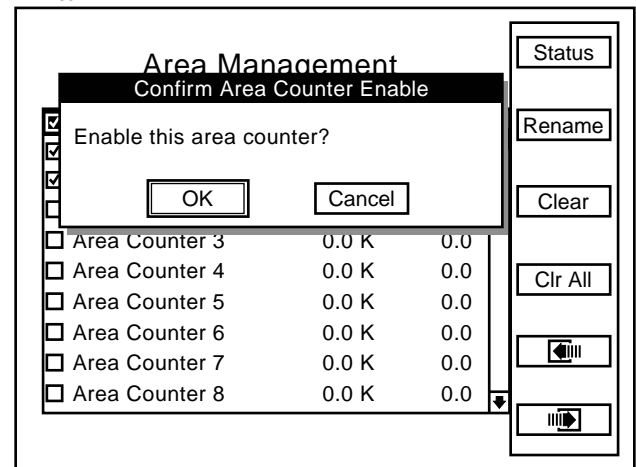

To Enable a disabled area counter:

- Highlight the desired "Area Counter" by turning the rotary encoder knob or using the arrow keys.
- Press the knob or Enter key. A "Confirm Area Counter Enable" box will appear.
- Use the knob or arrow keys to highlight the "OK" button and press the knob or Enter key. The enabled "Area Counter" will then start accumulating area.

DISABLE AREA COUNTER

All area counters may be disabled, except the Total Area Counter. To disable an enabled area counter:

- Highlight the desired “Area Counter” by turning the rotary encoder knob or using the arrow keys.
- Press the knob or Enter key. A “Confirm Area Counter Disable” box will appear.
- Use the knob or arrow keys to highlight the “OK” button and press the knob or Enter key. The disabled “Area Counter” will no longer accumulate area.

MTR184

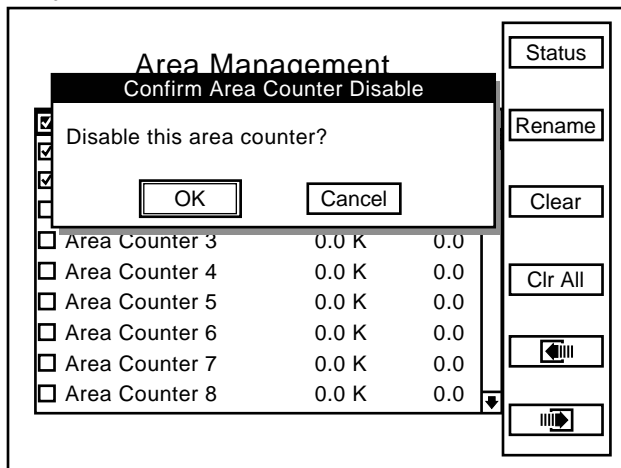

NOTE: Attempts to disable an Area Counter that is planting will cause the following alarm.

MTR185

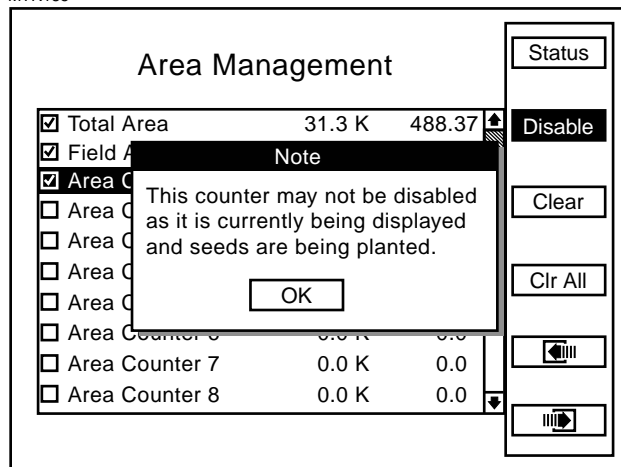

MTR186

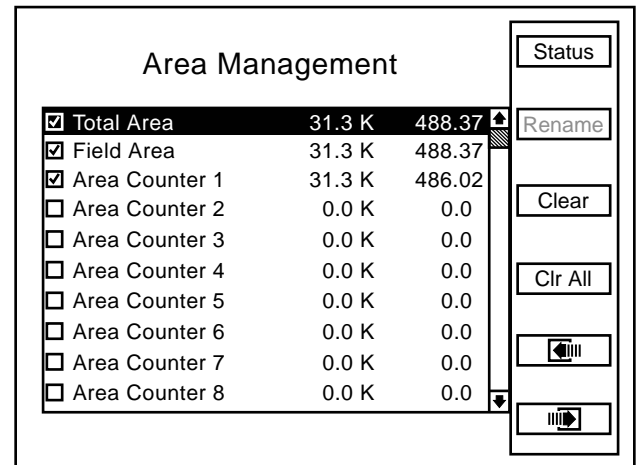

NOTE: If “Total area” is highlighted and the F3 key next to Clear is pressed the following request for confirmation will appear.

MTR187

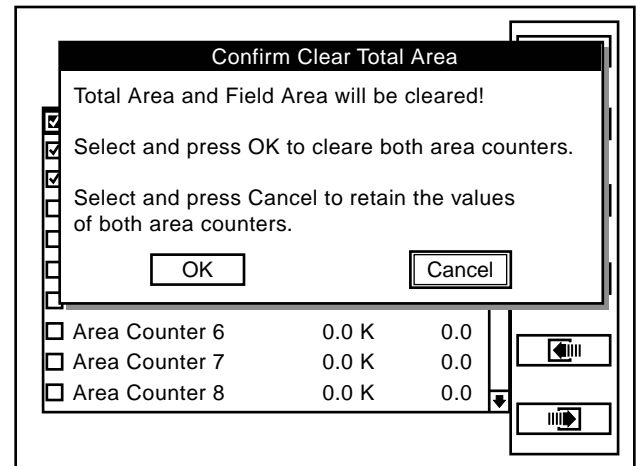

CLEAR AREA COUNTER

Total Area, Field Area and Area Counters 1 through 40 can be cleared, whether enabled or disabled. Clearing the “Total Area” counter forces the “Field Area” counter to be cleared. However, clearing an “Area Counter” including the “Field Area” clears only that individual counter.

NOTE: Lifetime Area Counter can never be cleared or disabled.

Clearing an Area Counter

- STEP 1** Turn the knob or use the arrow keys to highlight the desired area counter.
- STEP 2** Press the F3 key next to “Clear”. The request for confirmation shown below will appear.
- STEP 3** Turn the knob or use the arrow keys to highlight “OK” or “Cancel” and press the knob or Enter key to confirm the selection.

MTR188

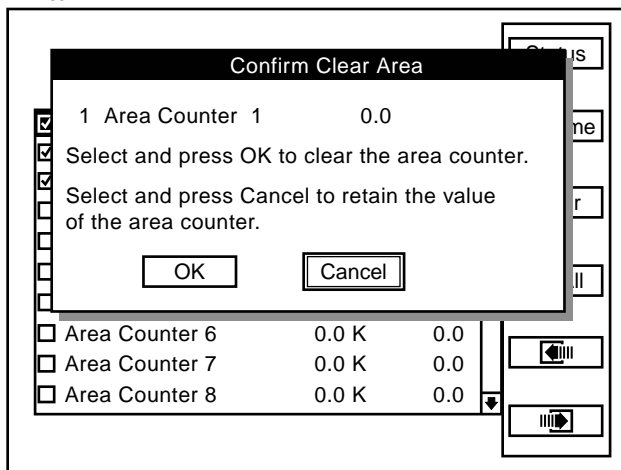

Clearing All the Area Counters

NOTE: This will clear all the area counters except the “Total Area Counter”

- STEP 1** Press the F4 key next to “CLR All”. A request for confirmation will appear.
- STEP 2** Turn the knob or use the arrow keys to select either “OK” or “Cancel” and press the knob or Enter key to make confirm the selection.

MTR189

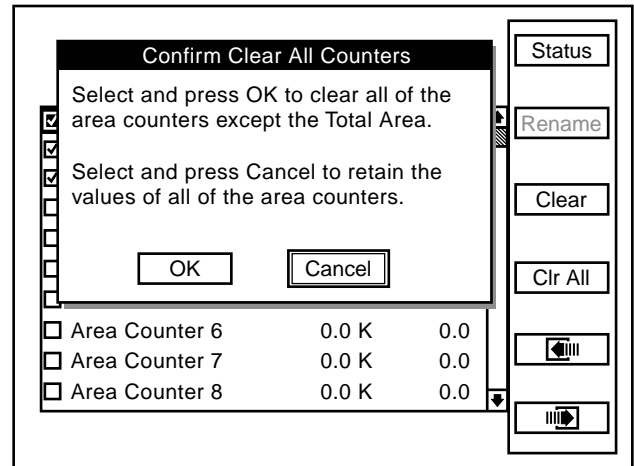

AREA COUNTERS

STEP 1 On the Planter Configuration screen press the F4 key next to “Area”.

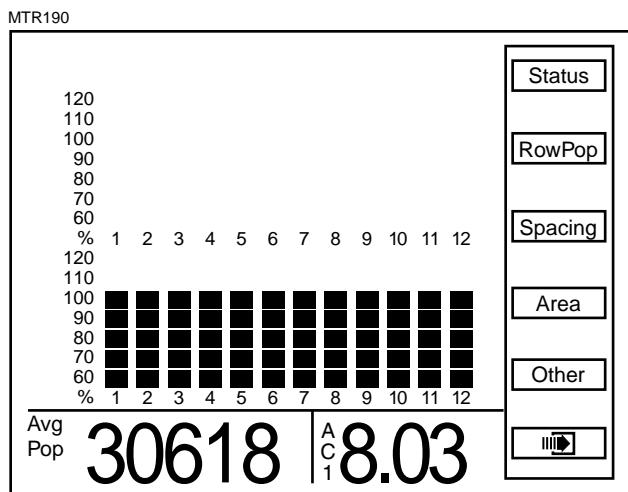

STEP 2 Press the F3 key next to “Select” to display the list of area counters.

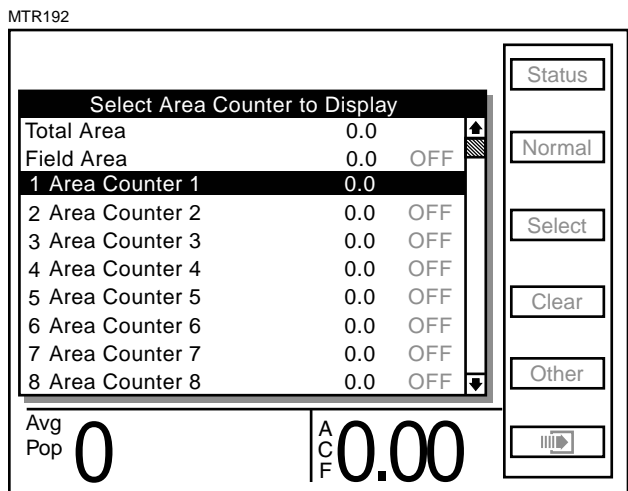

STEP 3 Use the arrow keys to highlight the desired area counter to be displayed.

STEP 4 Press the knob or Enter key and the “Planter Configuration” screen will be displayed.

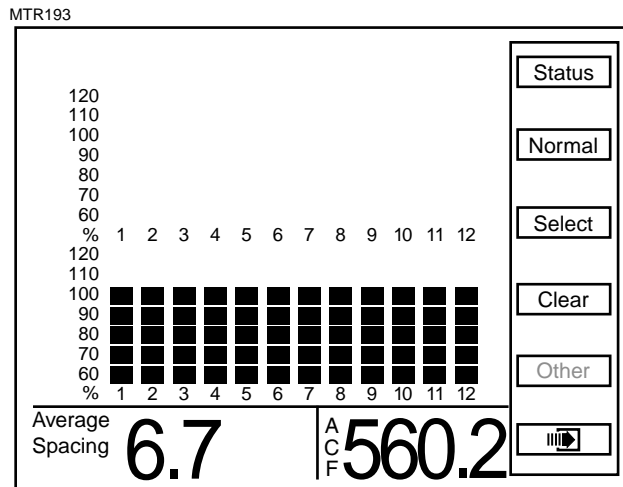

NOTE: The abbreviation for the selected area counter will appear in the bottom R.H. corner of the screen. In the above illustration “ACF” stands for Area Counter Field.

CLEARING FIELD AREA

STEP 1 To reset the counter, display the Plant screen.

NOTE: If “Area” is not displayed next to F4, press F2 next to “Normal”.

STEP 2 Press the F4 key next to Area then press the F4 key next to Clear, a dialog box will appear requesting confirmation to clear.

STEP 3 Highlight “OK” or “Cancel” by turning the knob or using the arrow keys. Press the knob or Enter key to verify the selection.

MTR194

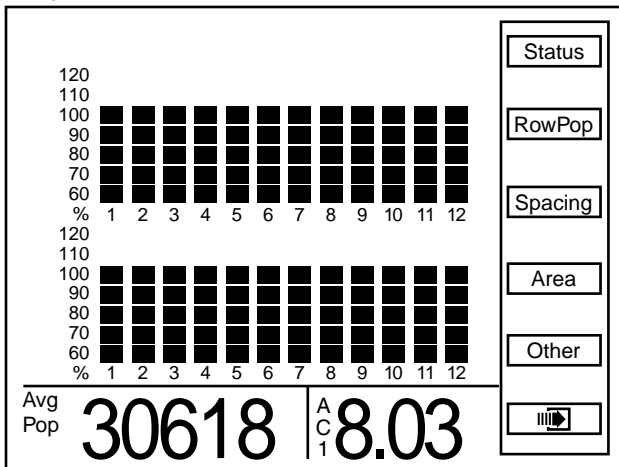

MTR195

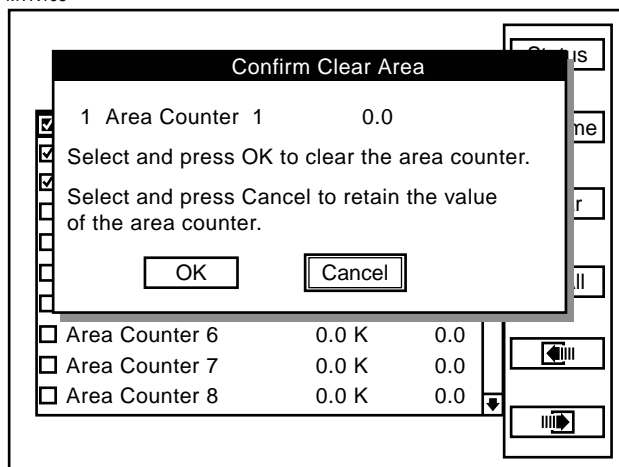

NOTE: Only the displayed area counter can be cleared.

REPLACING FAULTY SENSOR(S)

NOTE: The monitor will beep twice when the new sensor(s) is learned.

STEP 1 Press the F6 key until the Mode Selection screen appears.

STEP 2 Highlight "1. Setup Mode" by turning the knob or using the arrow keys. Press the knob or Enter key to display the highlighted item.

STEP 3 Highlight "9. Sensor Setup" by turning the knob or using the arrow keys. Press the knob or Enter key to display the highlighted item.

MTR200

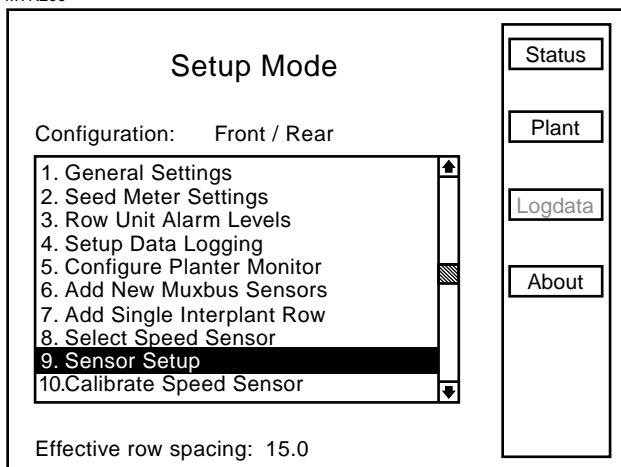

STEP 4 Turn the knob or use the arrow keys to highlight the faulty sensor and press the F2 key next to Remove.

MTR203

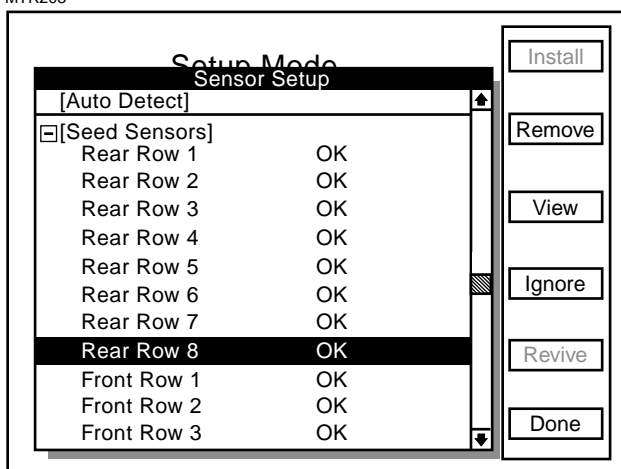

STEP 5 The following message will appear. Select OK to confirm by pressing the knob or ENTER key. Select Cancel to exit.

MTR204

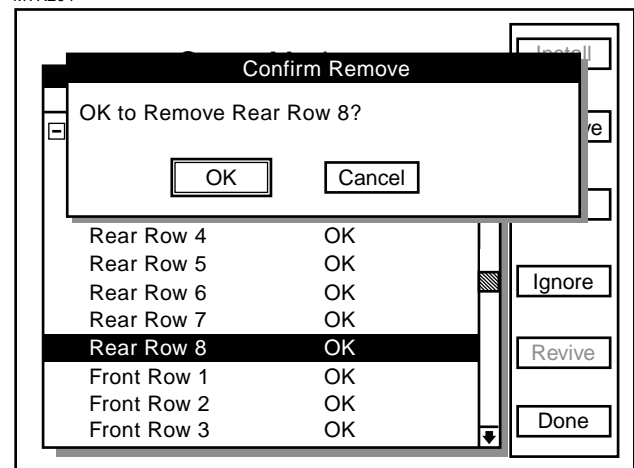

MTR205

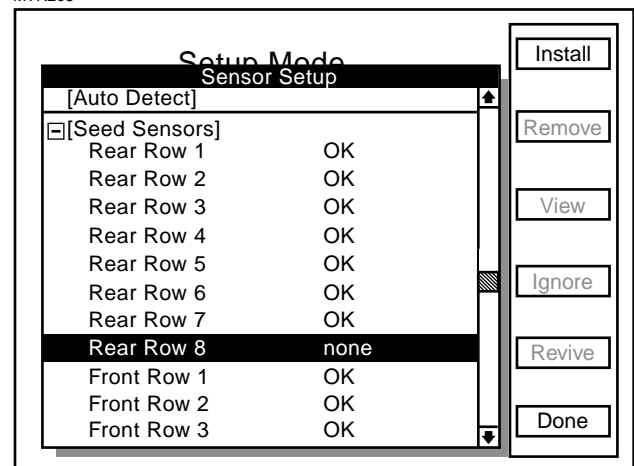

STEP 6 Unplug the sensor and plug in a new sensor. Press F1 key next to Install.

NOTE: The monitor will beep twice when the new sensor(s) is learned.

Repeat STEPS 1 through 6 for each faulty sensor being replaced.

NOTE: Highlighting a sensor and pressing the F4 key next to View displays additional information for troubleshooting a problem. If a faulty sensor has been ignored it may be highlighted in the list of sensors, press the F3 key next to Revive. The monitor will try to communicate with the sensor. If successful, "OK" will appear next to the sensor.

MACHINE OPERATION

POINT ROW CLUTCHES

(Standard on 12 and 16 Row/Optional on 8 Row)

76740-2

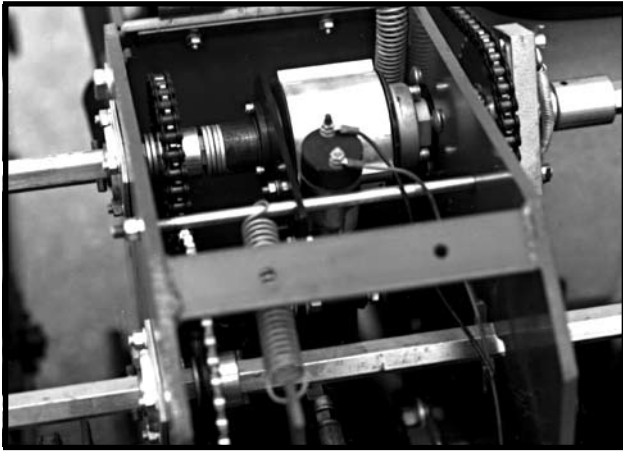

16 Row Machine Shown

With the use of electric-activated clutches, which disengage the drive, either half of the planter may be shut off for finishing up fields or long point row situations.

76746-24

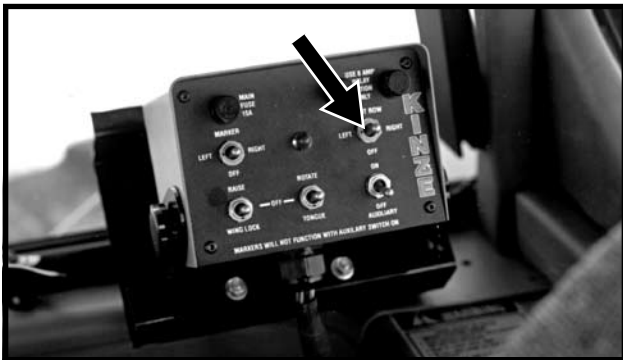

The selector switch for the clutches is located on the planter control console.

NOTE: Switch should be left in OFF position when planter is not in use. If left in ON position, the tractor battery will be drained.

NOTE: Since the liquid fertilizer piston pump have their own drive wheel, liquid fertilizer application will not be affected by use of the point row clutch.

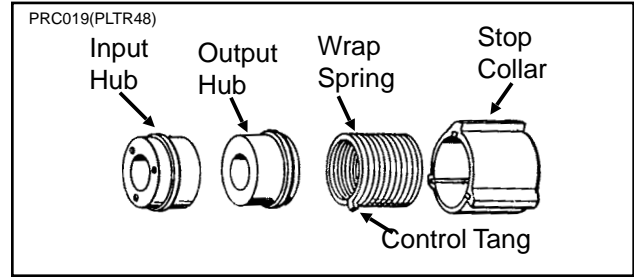

The point row clutch consists of a wrap spring riding on an input hub and an output hub. During operation the wrap spring is wrapped tightly over the hubs connecting them in a positive engagement. The greater the force of rotation the tighter the grip of the spring on the hubs.

Rotation in the opposite direction or stopping the spring from rotating prevents the transmission of torque from the input hub to the output hub, stopping the planter drive.

The input end of the spring is bent outward and is referred to as the control tang. The control tang fits into a slot in the stop collar that is located between the input and output hubs and over the wrap spring. If the stop collar is allowed to rotate with the input hub, the clutch is engaged. If the stop collar is stopped from rotating, the control tang connected to it is forced back and the spring opens. This allows the input hub to continue rotating without transmitting torque to the output hub; therefore, stopping the planter drive.

The stop collar is controlled by the use of an electric solenoid and an actuator arm. When the selector switch on the tractor control console is in the OFF position the solenoid coil is NOT ENERGIZED and the actuator arm will not contact the stop on the stop collar allowing it to rotate with the hubs and drive the planter.

When the operational switch is in the "DISENGAGE" (right or left) position the solenoid coil is ENERGIZED and the plunger in the solenoid coil retracts, allowing the actuator arm to contact the stop on the stop collar, disengaging the wrap spring and stopping the planter drive.

MACHINE OPERATION

TWO-SPEED POINT ROW CLUTCHES

81826-8

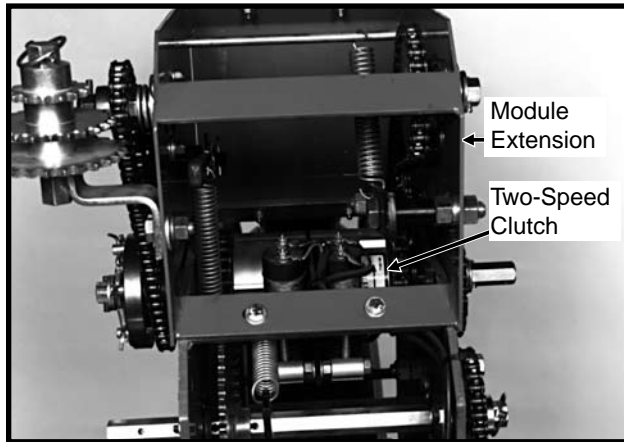

The Two-Speed Point Row Clutch Package is designed to allow on-the-go population rate adjustment as well as the capability to shutoff either half of the planter for finishing up fields or for long point row situations.

The point row clutches are controlled by the point row clutch switch on the control console. The point row switch is used to shutoff either the left or right half of the planter. Activating the reduced rate switch engages one solenoid on each clutch assembly and reduces the planting rate for the entire planter.

NOTE: Point row switch should be left in OFF position and rate switch left in FULL RATE position when planter is not in use. If left in ON and/or REDUCED RATE positions, the tractor battery will be discharged.

A7435(TWL81)

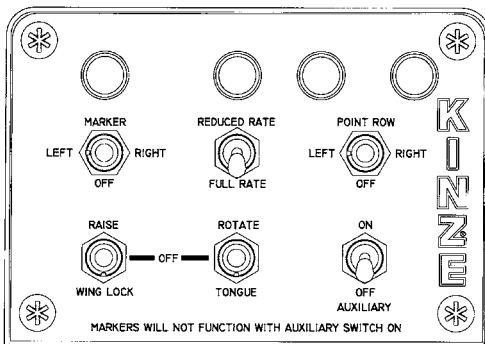

The ratio of population reduction is determined by the sprocket ratio between the drive and driven sprockets on the wheel module extension. A rate reduction decal like the one shown below is located on the wheel module extension.

(7100-214)76740-61

TRANSMISSION RATE REDUCTION		
DRIVE	DRIVEN	% REDUCTION IN POPULATION
15	30	50
17	30	43
23*	30	23
24	30	20
25*	30	17
26*	30	13
27	30	10

* Use sprockets off seed drive transmission

7100-214

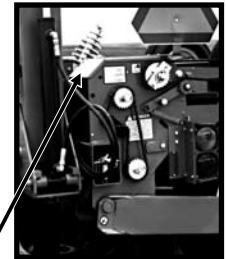

Full rate transmission shown. Two-speed clutch wheel module extension not installed.

(TWL80)

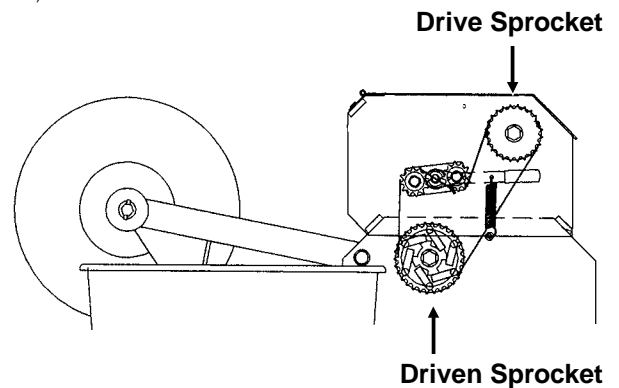

NOTE: Since the two-speed point row clutch is located ahead of the liquid fertilizer squeeze pump and/or dry fertilizer drive, activating the two-speed point row clutch reduced rate switch will cause the same per cent of reduction in dry fertilizer or liquid fertilizer (squeeze pump) application rates. Liquid fertilizer (piston pump) application rates will not be affected as the piston pump uses a dedicated drive tire.

MACHINE OPERATION

ROCK GUARDS

(PLTR49a)

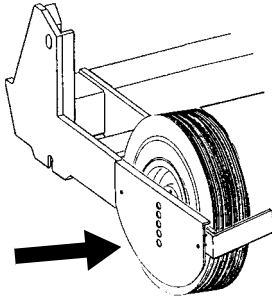

Transport wheel rock guards are designed for use on both sides of each of the four center transport wheels when the planter is used in rocky conditions. Rock guards will help prevent rocks, which can cause damage to the row units, from being picked up by the wheels.

AUXILIARY WORK LIGHTS PACKAGE

D05160505a



The optional Auxiliary Work Lights Package includes two 50 watt, 3" x 5" halogen flood lamps, hardware to mount lights at the top of one of the center lift cylinders and a wiring harness to plug into the existing planter light harness.

MACHINE OPERATION

AUXILIARY HYDRAULIC OPTION

A customer-supplied auxiliary hydraulic option may be added to provide 10 GPM of oil flow at the rear of the planter. This option may be used for powering fertilizer attachments, bulk seed handling equipment, etc. Two customer-supplied solenoid valve kits (G1K275) are required to activate the auxiliary hydraulic option using the auxiliary switch on the control console.

77612-6

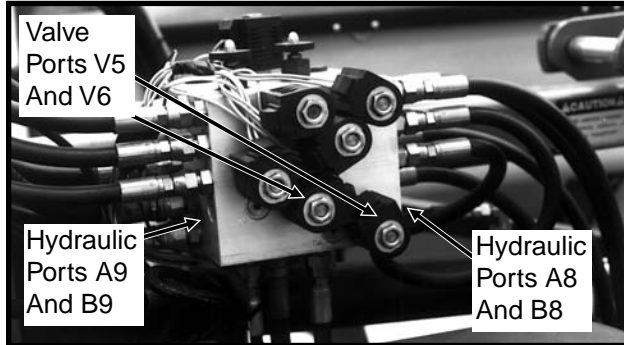

Valve Block Located On Rear Center Frame (Shown With Cover Removed)

76746-24

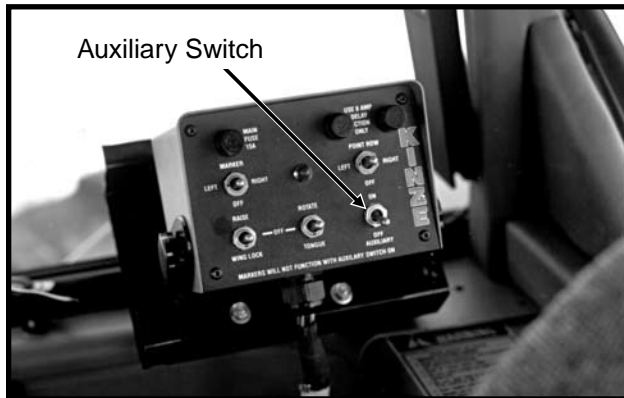

NOTE: Be sure row markers are in transport position and all pressure is removed from the hydraulic system.

Remove the cover from the valve block, located on the rear center frame of the planter. Remove plugs from ports V5 and V6 and install the solenoid valve assemblies following the installation instruction supplied with each kit. Power to the solenoid assemblies should be connected to the orange/black wire located in the wiring harness connection to the L.H. side of the valve block.

Remove plugs from 3/4"-16 O-ring ports A8 and B8 on R.H. side of valve block or ports A9 and B9 on L.H. side of valve block. Connect customer-supplied hydraulic hoses.

Refer to "Hydraulic System Schematics" and "Electrical Wiring Schematics" in the Maintenance Section of this manual for additional information.



WARNING: Before applying pressure to the hydraulic system, make sure all connections are tight and that hoses and fittings have not been damaged. Hydraulic fluid escaping under pressure can have sufficient force to penetrate skin, causing injury or infection.

Before operating the auxiliary system be sure the marker switch on the control console is in the OFF position. Move the auxiliary switch on the control console to ON position. Operate hydraulic control (marker/folding functions) to engage auxiliary system.

NOTE: Auxiliary switch left in ON position disables all other control console switches.

MACHINE OPERATION

REAR TRAILER HITCH

D07309901a



IMPORTANT: The rear trailer hitch is designed for use with piston pump only. Maximum allowable hitch weight is 200 lbs. Gross towing weight should not exceed 6000 lbs. or the equivalent of a loaded 500 gallon tank and running gear.

NOTE: Periodically check feed hose for kinks to prevent restricted delivery rate.

The Rear Trailer Hitch is used to tow a 3 or 4 wheel wagon behind the planter. A spring, chain and mounting bracket are used to support the 1 1/4" feed hose from the hitch to the piston pump. This extra length or loop is required to allow the planter to be moved into transport position without stretching the hose.

(PLTR196a)

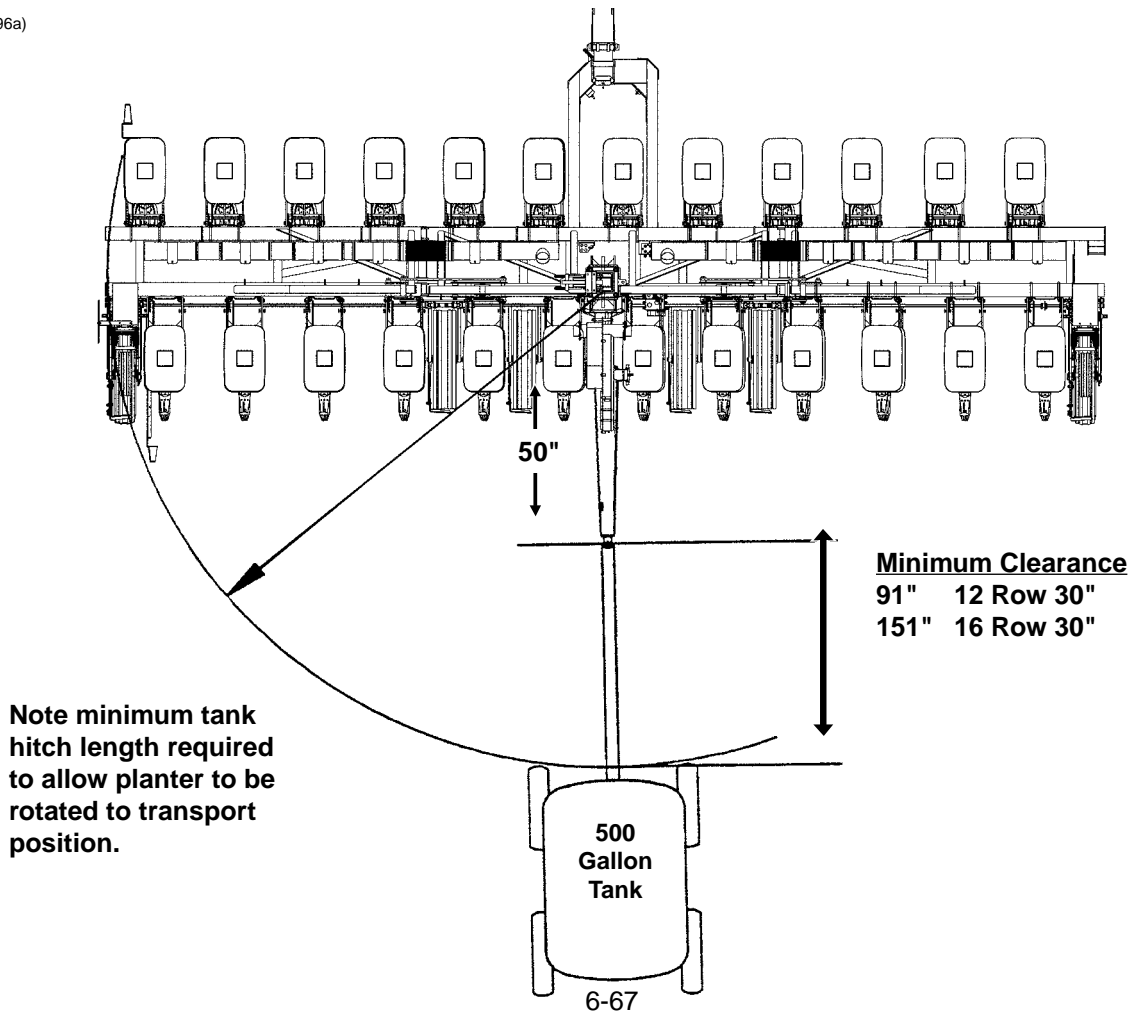

MACHINE OPERATION

TRANSPORTING THE PLANTER



WARNING: Always make sure safety/warning lights, reflective decals and SMV sign are in place and visible prior to transporting the machine on public roads. In this regard, check federal, state/provincial and local regulations.

IMPORTANT: Avoid transporting planter with hoppers loaded whenever possible. When it is necessary to transport the planter with the hoppers loaded, the added weight should be distributed evenly on the planter frame before rotating the planter.



WARNING: Install all safety lockup devices and safety locking pins before transporting the planter.

METRIC CONVERSION TABLE

MULTIPLY	BY	TO GET
Inches (in.)	x 2.54	= centimeters (cm)
Inches (in.)	x 25.4	= millimeters (mm)
Feet (ft.)	x 30.48	= centimeters (cm)
Acres	x 0.405	= hectares (ha)
Miles per hour (mph)	x 1.609	= kilometers per hour (Km/h)
Pounds (lbs.)	x 0.453	= kilograms (kg)
Bushels (bu.)	x 35.238	= liters (l)
Gallons (gal.)	x 3.785	= liters (l)
Pounds per square inch (psi)	x 6.894	= kilopascals (kPa) (100 kPa = 1 bar)
Inch pounds (in. lbs.)	x 0.113	= newtons-meters (N•m)
Foot pounds (ft. lbs.)	x 1.356	= newtons-meters (N•m)
Centimeters (cm)	x .394	= inches (in.)
Millimeters (mm)	x .0394	= inches (in.)
Centimeters (cm)	x .0328	= feet (ft.)
Hectares (ha)	x 2.469	= acres
Kilometers per hour (Km/h)	x 0.621	= miles per hour (mph)
Kilograms (kg)	x 2.208	= pounds (lbs.)
Liters (l)	x 0.028	= bushels (bu.)
Liters (l)	x 0.264	= gallons (gal.)
Kilopascals (kPa) (100 kPa = 1 bar)	x 0.145	= pounds per square inch (psi)
Newtons-meters (N•m)	x 8.85	= inch pounds (in. lbs.)
Newtons-meters (N•m)	x 0.738	= foot pounds (ft. lbs.)

PLANTING SPEED

Planters are designed to operate within a speed range of 2 to 8 MPH. Generally, higher ground speeds will cause more variation in seed spacing. Speeds above 5.5 MPH are typically not recommended. See “Planting And Application Rate Charts” in Seed Meter Operation/Maintenance section for specific recommendations.

FIELD TEST

With any change of field and/or planting conditions, seed size or planter adjustment, we recommend a field test be made to ensure proper seed placement and operation of row units. See “Planting And Application Rate Charts” in the Seed Meter Operation/Maintenance section and “Checking Seed Population” and “Checking Granular Chemical Application Rate” at end of this section.

- Check the planter for fore to aft and lateral level operation. See “Leveling The Planter”.
- Check **all** row units to be certain they are running level. When planting, the row unit parallel arms should be approximately parallel to the ground.
- Check row markers for proper operation and adjustment. See “Row Marker Length Adjustment”, “Row Marker Speed Adjustment” and “Row Marker Operation”.
- Check for proper application rates and placement of granular chemicals on **all** rows. See “Checking Granular Chemical Application Rate”.
- Check for desired depth placement and seed population on **all** rows. See “Checking Seed Population”.
- Check for proper application rates of fertilizer on **all** rows. See proper “Fertilizer Application Rate Chart”.

After the planter has been field tested, reinspect the machine.

- Hoses And Fittings
- Bolts And Nuts
- Cotter Pins And Spring Pins
- Drive Chain Alignment

MACHINE OPERATION

CHECKING SEED POPULATION

1. Tie up one or more sets of closing wheels by running a chain or rubber tarp strap between the hopper support panel and closing wheels. It may be necessary to decrease closing wheel arm spring tension.

(RU113g)

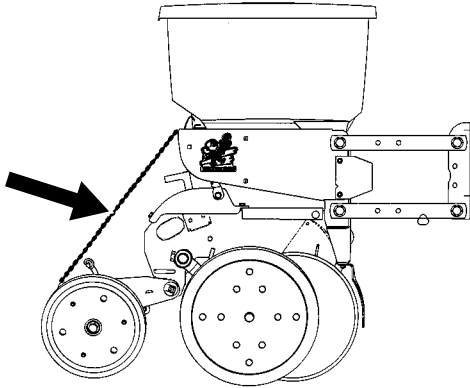

2. Plant a short distance and check to see if seed is visible in the seed trench. Adjust planting depth to a shallower setting if seed is not visible and recheck.

D020705102

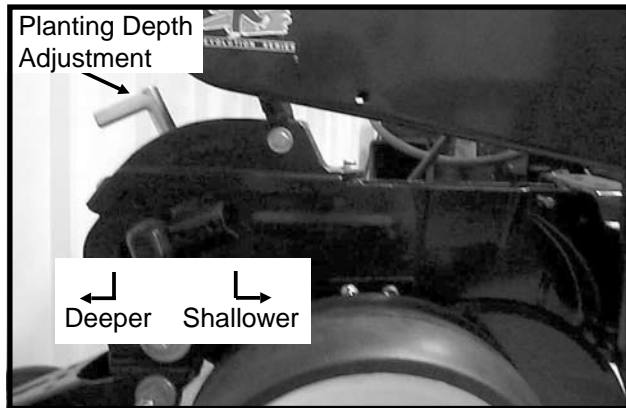

3. Measure $\frac{1}{1000}$ of an acre. See chart for correct distance for row width being planted. For example, if planting 30" rows $\frac{1}{1000}$ of an acre would be 17' 5".

LENGTH OF ROW IN FEET AND INCHES	
Fraction Of Acre	Row Width
	30"
$\frac{1}{1000}$	17' 5"

NOTE: When planting with closing wheels raised and planting depth set shallow, seeds may bounce or roll affecting seed spacing accuracy.

4. Count seeds in measured distance.
5. Multiply the number of seeds placed in $\frac{1}{1000}$ of an acre by 1000. This will give you total population.

EXAMPLE: With 30" row spacing 17' 5" equals $\frac{1}{1000}$ acre.

26 Seeds Counted	x	1000	=	26,000 Seeds Per Acre
---------------------	---	------	---	-----------------------

EXAMPLE: With 30"-7 1/2" twin row spacing 17' 5" x 2 equals $\frac{1}{1000}$ acre.

26 Seeds Counted	x	1000	x	2	=	52,000 Seeds Per Acre
---------------------	---	------	---	---	---	-----------------------

Seed count can be affected by drive ratio between drive wheel and seed meter, tire pressure and/or seed meter malfunction.

If seed check shows the average distance between seeds in inches is significantly different than the seed rate chart indicates, first check drive ratio between drive wheel and seed meter. Check drive wheel air pressure, check for incorrect sprocket(s) in driveline and check drive and driven sprockets on transmission(s) for proper selection.

Second, check for seed meter malfunction. For example, if spacing between kernels of corn at the transmission setting being used is 8" and a gap of 16" is observed, a finger has lost its seed and not functioned properly. If two seeds are found within a short distance of each other, the finger has metered two seeds instead of one.

See "Finger Pickup Seed Meter Troubleshooting" and/or "Brush-Type Seed Meter Troubleshooting" in the Maintenance Section of this manual.

MACHINE OPERATION

Determining Pounds Per Acre

To determine pounds per acre:

Seeds Per Acre On Chart	÷	Seeds Per Pound From Seed Tag On Bag	=	Pounds Per Acre
-------------------------------	---	---	---	-----------------------

To determine bushels per acre:

Pounds Per Acre	÷	Unit Weight Of Seed	=	Bushels Per Acre
--------------------	---	------------------------	---	---------------------

The unit weight of:

- 1 Bushel Soybeans = 60 Pounds
- 1 Bushel Milo/Grain Sorghum = 56 Pounds
- 1 Bushel Cotton = 32 Pounds

If seeds per pound information is not available the following is an average:

- 2,600 seeds per pound for medium size soybeans
- 15,000 seeds per pound for medium size milo/grain sorghum
- 4,500 seeds per pound for medium size cotton

If seed population check shows planting rate is significantly different than seed rate chart shows or if a particular meter is not planting accurately, see "Seed Metering System Troubleshooting" in Seed Meter Operation/Maintenance section of this manual.

CHECKING GRANULAR CHEMICAL APPLICATION RATE (30" Rows Only)

Many things can affect the rate of delivery of granular chemicals such as temperature, humidity, speed, ground conditions, flowability of different material or any obstruction in the meter.



WARNING: Agricultural chemicals can be dangerous if not selected and handled with care. Always read and follow directions supplied by the chemical manufacturer.

A field check is important to determine correct application rates.

D05149901



To check, fill insecticide and/or herbicide hoppers. Attach a calibrated vial to each granular chemical meter. Lower the planter and proceed as follows.

NOTE: It is not necessary for seed meter clutch to be engaged during test. Disengage clutch to avoid dropping seed.

Drive 1320 feet at planting speed. Weigh the chemical in ounces that was caught in one vial. Multiply that amount by the factor shown to determine pounds per acre.

POUNDS PER ACRE FACTOR FOR GIVEN ROW WIDTH	
Row Width	Factor
30"	0.83

EXAMPLE: You are planting 30" rows. You have planted for 1320 feet at the desired planting speed. You caught 12.0 ounces of chemical in one vial. 12.0 ounces times 0.83 equals 9.96 pounds per acre.

NOTE: It is important to check calibration of all rows.

Metering Gate

Use the metering gate setting for distributing insecticide or herbicide as a starting point. The charts are based on a 5 miles per hour planting speed. For speeds faster than 5 miles per hour a higher gate setting should be used. For speeds slower than 5 miles per hour a lower gate setting should be used.

SEED METER OPERATION/MAINTENANCE

GENERAL PLANTING RATE INFORMATION

These planting rate charts are applicable to KINZE® Model 3000 EdgeVac® Pull Type Planters. See "Tire Pressure" for recommended tire pressures.

IMPORTANT: The sprocket combinations listed in these charts are best for average conditions. Changes in sprocket combinations may be required to obtain desired planting population. TO PREVENT PLANTING MISCALCULATIONS, MAKE FIELD CHECKS TO BE SURE YOU ARE PLANTING AT THE DESIRED RATE.

The size and shape of seed may affect the planting rate.

The following seed discs are available for use with the KINZE® EdgeVac® Seed Metering System:

Corn/Popcorn: 39 cell. Light blue color-coded. For all seed corn grades from 35 to 70 pounds per 80,000 kernel count unit or popcorn seed size range from 2210 to 4200 seeds per pound. Also used for No. 1 sunflower seeds. *When planting popcorn this seed disc requires use of seed baffle. See "Seed Meter" on pages 7-2 and 7-3 for additional information.*

Low-Rate Corn/Popcorn: 24 cell. Light green color-coded. For all seed corn grades from 35 to 70 pounds per 80,000 kernel count unit or popcorn seed size range from 2210 to 4200 seeds per pound. Also used for No. 1 sunflower seeds. *When planting popcorn this seed disc requires use of seed baffle. See "Seed Meter" on pages 7-2 and 7-3 for additional information.*

Soybean: 60 cell. Black color-coded. Seed size range from 2200 to 4000 seeds per pound. *This seed disc requires use of seed baffle. See "Seed Meter" on pages 7-2 and 7-3 for additional information.*

Soybean, High-Rate: 120 cell. Dark blue color-coded. Seed size range from 2200 to 4000 seeds per pound. *This seed disc requires use of seed baffle. See "Seed Meter" on pages 7-2 and 7-3 for additional information.*

Milo/Grain Sorghum: 60 cell. Yellow color-coded. Seed size range from 10,000 to 20,000 seeds per pound. *This seed disc requires use of seed baffle and cleanout brush. See "Seed Meter" on pages 7-2 and 7-3 for additional information.*

Hill-Drop Cotton, Acid-Delinted (3 Seeds Per Cell): 20 cell. Brown color-coded. Cotton seed size range from 3800 to 4400 seeds per pound. *This seed disc requires use of cleanout brush w/ball-type ejector. See "Seed Meter" on pages 7-2 and 7-3 for additional information.*

Small Hill-Drop Cotton, Acid-Delinted (3 Seeds Per Cell): 20 cell. Grey color-coded. Cotton seed size range from 4200 to 5200 seeds per pound. *This seed disc requires use of cleanout brush w/ball-type ejector. See "Seed Meter" on pages 7-2 and 7-3 for additional information.*

Cotton, Acid-Delinted/Small Dry Edible Bean: 54 cell. Dark green color-coded. Cotton seed size range from 3800 to 4400 seeds per pound or dry edible bean seed size range from 1200 to 2500 seeds per pound. *This seed disc requires use of cleanout brush w/ball-type ejector. See "Seed Meter" on pages 7-2 and 7-3 for additional information.*

Small Cotton/Sunflower: 54 cell. White color-coded. Cotton seed size range from 4200 to 5200 seeds per pound or sunflower seed sizes No. 2, 3 and 4. *This seed disc requires use of cleanout brush w/ball-type ejector. See "Seed Meter" on pages 7-2 and 7-3 for additional information.*

Large Dry Edible Bean: 54 cell. Tan color-coded. Seed size range from 800 to 1200 seeds per pound.

NOTE: Due to a multitude of variables, seed spacing can be adversely affected at speeds above 5.5 MPH.

NOTE: See "Seed Meter Singulator Brush And Vacuum Level Adjustments" on page 7-23.

NOTE: 15, 19 and 30 tooth drive sprockets are NOT applicable to all rate charts. Check chart titles to ensure the proper rate chart is selected. 15 tooth sprocket(s) require use of 132 pitch No. 40 chain(s); 19 tooth sprocket(s) require use of 134 pitch chain(s); and 30 tooth sprocket(s) require use of 140 pitch chain(s).

NOTE: 22, 28 and 44 tooth drive sprockets are NOT applicable to all rate charts. Check chart titles to ensure the proper rate chart is selected. The 22 tooth sprocket requires use of 114 pitch No. 40 chain; the 28 tooth sprocket requires use of 118 pitch No. 40 chain; and the 44 tooth sprocket requires use of 126 pitch No. 40 chain.

D070699113a

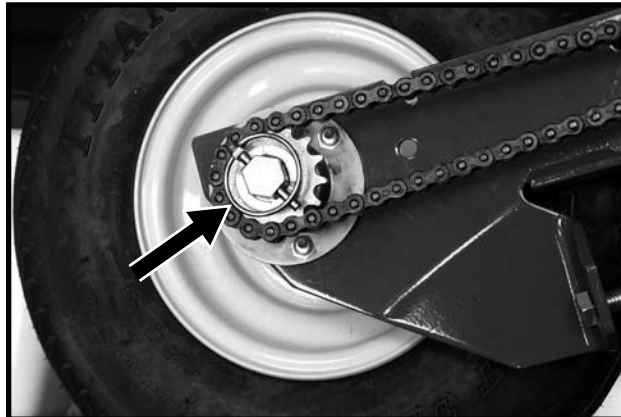

NOTE: Contact wheel drive sprocket referenced at top of each rate chart.

SEED METER OPERATION/MAINTENANCE

SEED METER

(METR71/METR71a)

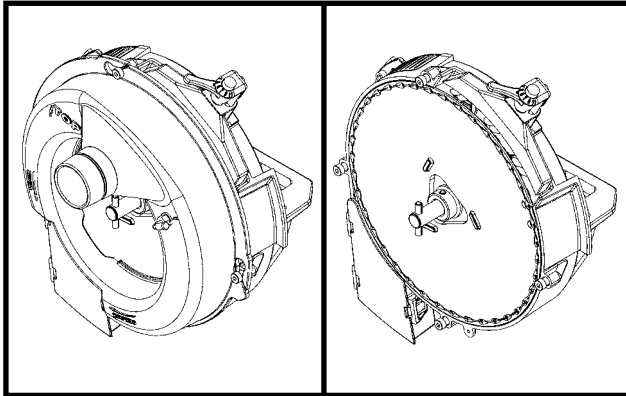

(METR70/D14467a)

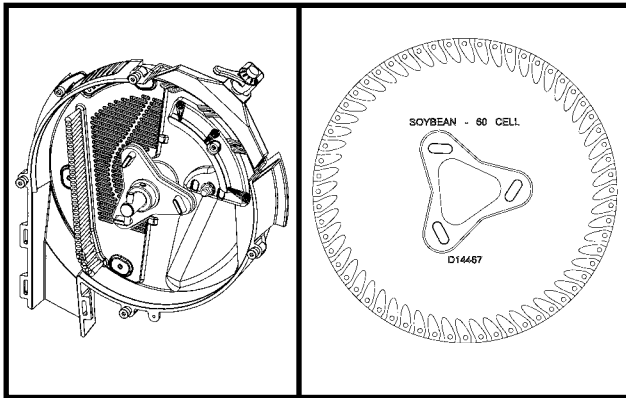

The seed discs below and at right are available for use with the KINZE® EdgeVac® Seed Metering System:

Corn/Popcorn: 39 cell. For all seed corn grades from 35 to 70 pounds per 80,000 kernel count unit. Popcorn seed size range from 2210 to 4200 seeds per pound. Also used for No. 1 sunflower seeds. (*Light blue color-coded.*) (D14465)

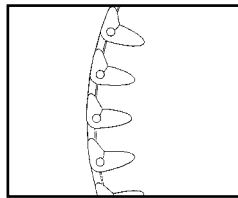

Low-Rate Corn/Popcorn: 24 cell. For all seed corn grades from 35 to 70 pounds per 80,000 kernel count unit. Popcorn seed size range from 2210 to 4200 seeds per pound. Also used for No. 1 sunflower seeds. (*Light green color-coded.*) (D16734a)

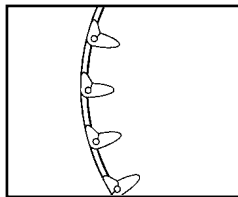

Soybean: 60 cell. Seed size range from 2200 to 4000 seeds per pound. (*Black color-coded.*)

(D14467a)

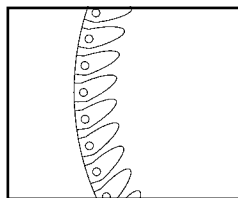

Soybean, High-Rate: 120 cell. Seed size range from 2200 to 4000 seeds per pound. (*Dark blue color-coded.*) (D14468a)

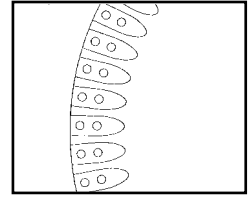

Milo/Grain Sorghum: 60 cell. Seed size range from 10,000 to 20,000 seeds per pound. (*Yellow color-coded.*) (D17050)

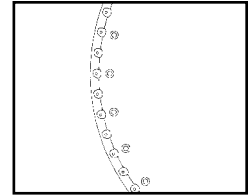

Hill-Drop Cotton, Acid-Delinted (3 Seeds Per Cell): 20 cell. Cotton seed size range from 3800 to 4400 seeds per pound. (*Brown color-coded.*) (D17187)

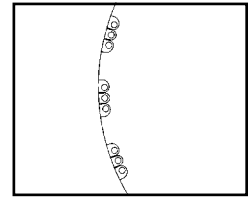

Small Hill-Drop Cotton, Acid-Delinted (3 Seeds Per Cell): 20 cell. Cotton seed size range from 4200 to 5200 seeds per pound. (*Grey color-coded.*) (D17187)

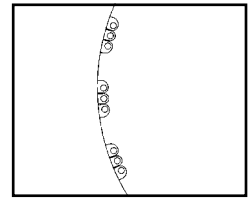

Cotton, Acid-Delinted/Small Dry Edible Bean: 54 cell. Cotton seed size range from 3800 to 4400 seeds per pound. Dry edible bean seed size range from 1200 to 2500 seeds per pound. (*Dark green color-coded.*) (D17186)

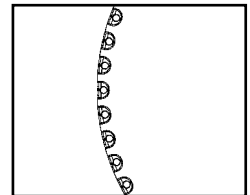

Small Cotton/Sunflower: 54 cell. Cotton seed size range from 4200 to 5200 seeds per pound. Sunflower seed sizes No. 2, 3 and 4. (*White color-coded.*) (D17186)

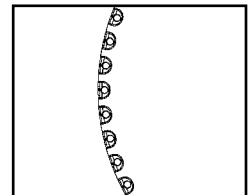

Large Dry Edible Bean: 54 cell. Seed size range from 800 to 1200 seeds per pound. (*Tan color-coded.*) (D14477)

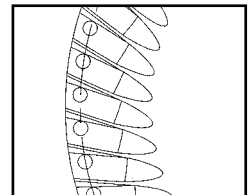

Install the selected seed disc. Position the vacuum cover on the meter by aligning the keyhole slots over the bolt heads. Push the cover on the meter and turn counter clockwise to lock in place. **See following page for additional components required with specific seed discs.**

SEED METER OPERATION/MAINTENANCE

NOTE: Use of damaged seed or seed containing foreign material will cause plugging of seed disc orifices and require more frequent seed meter cleanout to prevent underplanting.

SEED BAFFLE

- Milo/Grain Sorghum
- Soybeans
- Popcorn

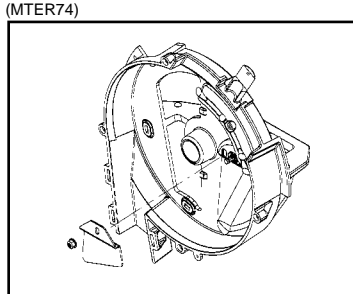

The **seed baffle** is designed to prevent excessive seed in the meter from restricting air flow through the seed. **Used with 60 Cell Milo/Grain Sorghum Disc, 60 Cell Soybean Disc, 120 Cell High-Rate Soybean Disc and 39 Cell and 24 Cell Popcorn Discs.**

CLEANOUT BRUSH

- Milo/Grain Sorghum

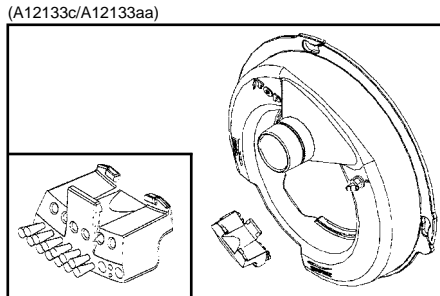

The **cleanout brush** is designed to remove foreign material and seed remnants to help prevent plugging of seed disc orifices.

Used with 60 Cell Milo/Grain Sorghum Disc.

CLEANOUT BRUSH W/BALL-TYPE EJECTOR

- Cotton
- Small Edible Beans
- No. 2, No. 3 And No. 4 Sunflowers

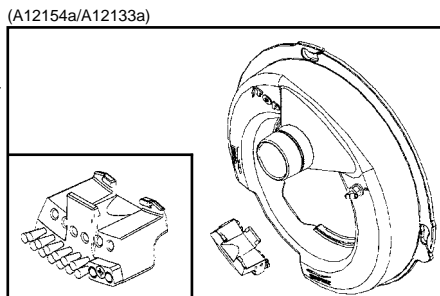

The **cleanout brush w/ball-type ejector** is designed to eject seed remnants from the seed disc orifices. **Used with 20 Cell Hill-Drop Cotton, Acid-Delinted (3 Seeds Per Cell) Discs; 54 Cell Acid-Delinted Cotton/Small Dry Edible Bean; and Small Cotton/Sunflower Discs.**

(MTER70)

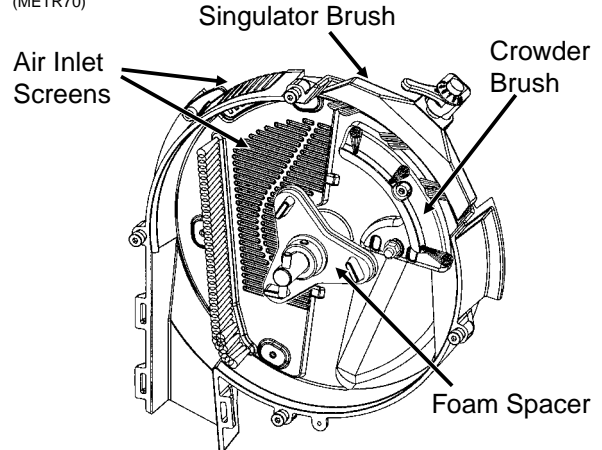

The crowder brush aids in the singulation of small flat seeds by (a) crowding seeds to the outer perimeter of the seed disc and (b) orienting seeds to allow the singulator brush to be more effective.

The air inlet screens allow air to enter the system and aids in keeping field residue or other foreign material out of the meter.

The foam spacer gently preloads the seed disc against the vacuum cover when no vacuum is present.

(MTER71)

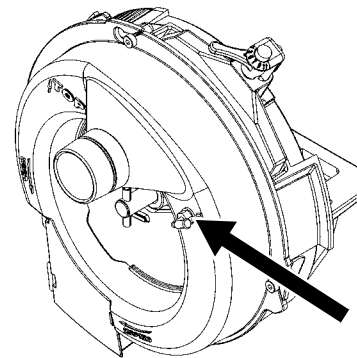

The $\frac{3}{16}$ " hose barb elbow on the seed meter vacuum cover allows measurement of vacuum level at each meter. A customer-supplied vacuum gauge is required.

See "Seed Meter Singulator Brush And Vacuum Level Adjustments", "Seed Meter Maintenance" and "Preparation For Storage" for additional EdgeVac® Seed Metering System information.

SEED METER OPERATION/MAINTENANCE

One tablespoon of **powdered graphite** should be mixed with the seed each time the hoppers are filled. Regular graphite use will prolong the life of the vacuum seed meter components, improve seed spacing, and may reduce buildup of seed treatments. Apply graphite around the outer perimeter of the hopper as shown below.

D05300104b



NOTE: DO NOT apply graphite only in the center of the hopper. It will filter too quickly through the seed and not distribute as evenly as desired.

NOTE: Additional graphite or talc may be required to retard buildup of seed treatments on meter components. More frequent cleaning of monitor seed tubes may be necessary due to use of additional graphite or talc.

Talc seed lubricant may be used in lieu of or in addition to graphite to improve seed release from the meter. Fill hopper $\frac{1}{2}$ full of seed, add $\frac{1}{4}$ cup of talc and **mix thoroughly**. Finish filling hopper, add another $\frac{1}{4}$ cup of talc and **mix thoroughly**. (For sunflowers, increase talc amount from $\frac{1}{4}$ cup to $\frac{1}{2}$ cup.) Adjust rate of talc use as needed so all seeds are coated, while avoiding a buildup of talc in the bottom of the hopper. Humid conditions and/or small sized seeds with extra seed treatment may require as much as one cup of talc per hopper to maintain meter performance.

NOTE: Some liquid seed treatments or inoculants may create buildup on the seed disc or brushes. Check frequently for proper population and/or seed delivery when using any liquid seed treatment. All seed treatment should be thoroughly mixed with the seed per the manufacturers' recommendations. Seed treatment dumped on top of the seed after the hopper is filled, and not mixed properly may cause bridging of the seed in the meter, reducing population or stopping the meter from planting.

SEED METER CLEANOUT

To maintain genetic purity, thorough seed meter cleanout is important.

To clean the seed meter, disengage the seed drive and remove the seed hopper and meter. Lay the hopper on its right side.

Disassemble seed meter by rotating vacuum cover clockwise to align key hole slots with bolt heads. Lift off cover. Remove seed disc. Empty the meter and hopper by allowing the seed to run out of the meter. Inspect brushes in meter to ensure all seed is removed. Replace seed disc and install vacuum cover.

NOTE: Use of damaged seed or seed containing foreign material will cause plugging of seed cell orifices and require more frequent seed meter cleanout to prevent underplanting.

SEED METER OPERATION/MAINTENANCE

**PLANTING RATES FOR CORN/POPCORN 39 CELL DISC
22 TOOTH CONTACT WHEEL DRIVE SPROCKET (See Page 7-1)
APPROXIMATE SEEDS/ACRE FOR VARIOUS ROW WIDTHS**

15" Rows	18" Rows	19" Rows	30" Rows	36" Rows	38" Rows	Transmission Sprockets		Recomm. Speed Range (MPH)	Average Seed Spacing In Inches
						Drive	Driven		
46,414	38,678	36,642	23,207	19,339	18,321	15	28	4 to 6	9.0
48,133	40,111	37,999	24,066	20,055	19,000	15	27	4 to 6	8.7
49,984	41,653	39,461	24,992	20,827	19,730	15	26	4 to 6	8.4
51,983	43,319	41,039	25,992	21,660	20,520	15	25	4 to 6	8.0
52,602	43,835	41,528	26,301	21,918	20,764	17	28	4 to 6	7.9
54,149	45,124	42,749	27,075	22,562	21,375	15	24	4 to 6	7.7
54,550	45,459	43,066	27,275	22,729	21,533	17	27	4 to 6	7.7
56,503	47,086	44,608	28,252	23,543	22,304	15	23	4 to 6	7.4
56,648	47,207	44,722	28,324	23,603	22,361	17	26	4 to 6	7.4
58,791	48,992	46,414	29,395	24,496	23,207	19	28	4 to 6	7.1
58,914	49,095	46,511	29,457	24,548	23,256	17	25	4 to 6	7.1
60,968	50,807	48,133	30,484	25,403	24,066	19	27	4 to 6	6.9
61,369	51,141	48,449	30,685	25,570	24,225	17	24	4 to 6	6.8
63,313	52,761	49,984	31,656	26,380	24,992	19	26	4 to 6	6.6
64,037	53,364	50,556	32,019	26,682	25,278	17	23	4 to 6	6.5
65,845	54,871	51,983	32,923	27,436	25,992	19	25	4 to 6	6.4
68,399	56,999	53,999	34,199	28,500	27,000	15	19	4 to 6	6.1
68,589	57,157	54,149	34,294	28,579	27,075	19	24	4 to 6	6.1
71,167	59,306	56,185	35,584	29,653	28,092	23	28	4 to 6	5.9
71,571	59,643	56,503	35,786	29,821	28,252	19	23	4 to 6	5.8
73,803	61,503	58,266	36,902	30,751	29,133	23	27	4 to 6	5.7
74,262	61,885	58,628	37,131	30,942	29,314	24	28	4 to 6	5.6
76,446	63,705	60,352	38,223	31,852	30,176	15	17	4 to 6	5.5
77,012	64,177	60,799	38,506	32,088	30,400	24	27	4 to 6	5.4
77,519	64,599	61,199	38,759	32,300	30,600	17	19	4 to 6	5.4
79,708	66,423	62,927	39,854	33,211	31,464	23	25	4 to 6	5.2
80,450	67,042	63,513	40,225	33,521	31,757	26	28	4 to 6	5.2
83,029	69,191	65,549	41,514	34,595	32,775	23	24	4 to 6	5.0
83,173	69,311	65,663	41,587	34,655	32,832	24	25	4 to 6	5.0
83,544	69,620	65,956	41,772	34,810	32,978	27	28	4 to 6	5.0
86,639	72,199	68,399	43,319	36,099	34,199	23	23	4 to 6	4.8
89,848	74,873	70,932	44,924	37,436	35,466	28	27	4 to 6	4.7
89,971	74,976	71,030	44,985	37,488	35,515	27	26	4 to 6	4.6
90,406	75,338	71,373	45,203	37,669	35,686	24	23	4 to 6	4.6
93,303	77,753	73,660	46,652	38,876	36,830	28	26	4 to 6	4.5
93,570	77,975	73,871	46,785	38,987	36,935	27	25	4 to 6	4.5
94,172	78,477	74,347	47,086	39,239	37,173	25	23	4 to 6	4.4
96,831	80,693	76,446	48,416	40,346	38,223	19	17	4 to 6	4.3
97,469	81,224	76,949	48,734	40,612	38,474	27	24	4 to 6	4.3
97,939	81,616	77,321	48,970	40,808	38,660	26	23	4 to 6	4.3
101,078	84,232	79,799	50,539	42,116	39,899	28	24	4 to 6	4.1
101,706	84,755	80,294	50,853	42,378	40,147	27	23	4 to 6	4.1
104,878	87,399	82,799	52,439	43,699	41,399	23	19	4 to 6	4.0
105,473	87,894	83,268	52,737	43,947	41,634	28	23	4 to 6	4.0
109,438	91,199	86,399	54,719	45,599	43,199	24	19	4 to 6	3.8
113,998	94,999	89,999	56,999	47,499	44,999	25	19	4 to 6	3.7
117,217	97,681	92,540	58,609	48,840	46,270	23	17	4 to 6	3.6
118,558	98,798	93,599	59,279	49,399	46,799	26	19	4 to 6	3.5
122,313	101,928	96,563	61,157	50,964	48,282	24	17	4 to 6	3.4
123,118	102,598	97,199	61,559	51,299	48,599	27	19	4 to 6	3.4
127,410	106,175	100,587	63,705	53,087	50,293	25	17	4 to 6	3.3
127,678	106,398	100,798	63,839	53,199	50,399	28	19	4 to 6	3.3
132,506	110,422	104,610	66,253	55,211	52,305	26	17	4 to 6	3.2
132,846	110,705	104,878	66,423	55,352	52,439	23	15	4 to 6	3.1
137,603	114,669	108,634	68,801	57,334	54,317	27	17	4 to 6	3.0

IMPORTANT: See "General Planting Rate Information" and "Checking Seed Population" pages for additional information. Always check seed population in the field to ensure planting rates are correct.

SEED METER OPERATION/MAINTENANCE

**PLANTING RATES FOR CORN/POPCORN 39 CELL DISC
28 TOOTH CONTACT WHEEL DRIVE SPROCKET (See Page 7-1)
APPROXIMATE SEEDS/ACRE FOR VARIOUS ROW WIDTHS**

15" Rows	18" Rows	19" Rows	30" Rows	36" Rows	38" Rows	Transmission Sprockets		Recomm. Speed Range (MPH)	Average Seed Spacing In Inches
						Drive	Driven		
58,791	48,992	46,414	29,395	24,496	23,207	15	28	4 to 6	7.1
60,968	50,807	48,133	30,484	25,403	24,066	15	27	4 to 6	6.9
63,313	52,761	49,984	31,656	26,380	24,992	15	26	4 to 6	6.6
65,845	54,871	51,983	32,923	27,436	25,992	15	25	4 to 6	6.4
66,629	55,524	52,602	33,315	27,762	26,301	17	28	4 to 6	6.3
68,589	57,157	54,149	34,294	28,579	27,075	15	24	4 to 6	6.1
69,097	57,581	54,550	34,549	28,790	27,275	17	27	4 to 6	6.1
71,571	59,643	56,503	35,786	29,821	28,252	15	23	4 to 6	5.8
71,755	59,796	56,648	35,877	29,898	28,324	17	26	4 to 6	5.8
74,468	62,057	58,791	37,234	31,028	29,395	19	28	4 to 6	5.6
74,625	62,187	58,914	37,312	31,094	29,457	17	25	4 to 6	5.6
77,226	64,355	60,968	38,613	32,178	30,484	19	27	4 to 6	5.4
77,734	64,778	61,369	38,867	32,389	30,685	17	24	4 to 6	5.4
80,196	66,830	63,313	40,098	33,415	31,656	19	26	4 to 6	5.2
81,114	67,595	64,037	40,557	33,797	32,019	17	23	4 to 6	5.2
83,404	69,503	65,845	41,702	34,752	32,923	19	25	4 to 6	5.0
86,639	72,199	68,399	43,319	36,099	34,199	15	19	4 to 6	4.8
86,879	72,399	68,589	43,440	36,200	34,294	19	24	4 to 6	4.8
90,145	75,121	71,167	45,073	37,561	35,584	23	28	4 to 6	4.6
90,657	75,547	71,571	45,328	37,774	35,786	19	23	4 to 6	4.6
93,484	77,904	73,803	46,742	38,952	36,902	23	27	4 to 6	4.5
94,065	78,387	74,262	47,032	39,194	37,131	24	28	4 to 6	4.4
96,831	80,693	76,446	48,416	40,346	38,223	15	17	4 to 6	4.3
97,549	81,291	77,012	48,774	40,645	38,506	24	27	4 to 6	4.3
98,191	81,825	77,519	49,095	40,913	38,759	17	19	4 to 6	4.3
100,963	84,136	79,708	50,481	42,068	39,854	23	25	4 to 6	4.1
101,904	84,920	80,450	50,952	42,460	40,225	26	28	4 to 6	4.1
105,170	87,641	83,029	52,585	43,821	41,514	23	24	4 to 6	4.0
105,353	87,794	83,173	52,676	43,897	41,587	24	25	4 to 6	4.0
105,823	88,186	83,544	52,911	44,093	41,772	27	28	4 to 6	4.0
109,742	91,452	86,639	54,871	45,726	43,319	23	23	4 to 6	3.8
113,807	94,839	89,848	56,903	47,420	44,924	28	27	4 to 6	3.7
113,963	94,969	89,971	56,982	47,485	44,985	27	26	4 to 6	3.7
114,514	95,428	90,406	57,257	47,714	45,203	24	23	4 to 6	3.7
118,184	98,487	93,303	59,092	49,243	46,652	28	26	4 to 6	3.5
118,522	98,768	93,570	59,261	49,384	46,785	27	25	4 to 6	3.5
119,285	99,404	94,172	59,643	49,702	47,086	25	23	4 to 6	3.5
122,653	102,211	96,831	61,327	51,105	48,416	19	17	4 to 6	3.4
123,460	102,883	97,469	61,730	51,442	48,734	27	24	4 to 6	3.4
124,057	103,380	97,939	62,028	51,690	48,970	26	23	4 to 6	3.4
128,033	106,694	101,078	64,016	53,347	50,539	28	24	4 to 6	3.3
128,828	107,357	101,706	64,414	53,678	50,853	27	23	4 to 6	3.2
132,846	110,705	104,878	66,423	55,352	52,439	23	19	4 to 6	3.1
133,599	111,333	105,473	66,800	55,666	52,737	28	23	4 to 6	3.1
138,622	115,518	109,438	69,311	57,759	54,719	24	19	4 to 6	3.0
144,398	120,332	113,998	72,199	60,166	56,999	25	19	4 to 6	2.9
148,475	123,729	117,217	74,237	61,865	58,609	23	17	4 to 6	2.8
150,174	125,145	118,558	75,087	62,572	59,279	26	19	4 to 6	2.8
154,930	129,109	122,313	77,465	64,554	61,157	24	17	4 to 6	2.7
155,950	129,958	123,118	77,975	64,979	61,559	27	19	4 to 6	2.7
161,386	134,488	127,410	80,693	67,244	63,705	25	17	4 to 6	2.6
161,726	134,771	127,678	80,863	67,386	63,839	28	19	4 to 6	2.6
167,841	139,868	132,506	83,921	69,934	66,253	26	17	4 to 6	2.5
168,272	140,226	132,846	84,136	70,113	66,423	23	15	4 to 6	2.5
174,297	145,247	137,603	87,148	72,624	68,801	27	17	4 to 6	2.4

IMPORTANT: See "General Planting Rate Information" and "Checking Seed Population" pages for additional information. Always check seed population in the field to ensure planting rates are correct.

SEED METER OPERATION/MAINTENANCE

**PLANTING RATES FOR LOW-RATE CORN/POPCORN 24 CELL DISC
22 TOOTH CONTACT WHEEL DRIVE SPROCKET (See Page 7-1)
APPROXIMATE SEEDS/ACRE FOR VARIOUS ROW WIDTHS**

15" Rows	18" Rows	19" Rows	30" Rows	36" Rows	38" Rows	Transmission Sprockets		Recomm. Speed Range (MPH)	Average Seed Spacing In Inches
						Drive	Driven		
28,562	23,802	22,549	14,281	11,901	11,275	15	28	4 to 6	14.6
29,620	24,683	23,384	14,810	12,342	11,692	15	27	4 to 6	14.1
30,759	25,633	24,284	15,380	12,816	12,142	15	26	4 to 6	13.6
31,990	26,658	25,255	15,995	13,329	12,628	15	25	4 to 6	13.1
32,370	26,975	25,556	16,185	13,488	12,778	17	28	4 to 6	12.9
33,323	27,769	26,307	16,661	13,884	13,154	15	24	4 to 6	12.5
33,569	27,975	26,502	16,785	13,987	13,251	17	27	4 to 6	12.5
34,771	28,976	27,451	17,386	14,488	13,726	15	23	4 to 6	12.0
34,861	29,050	27,521	17,430	14,525	13,761	17	26	4 to 6	12.0
36,179	30,149	28,562	18,089	15,074	14,281	19	28	4 to 6	11.6
36,255	30,212	28,622	18,127	15,106	14,311	17	25	4 to 6	11.5
37,519	31,266	29,620	18,759	15,633	14,810	19	27	4 to 6	11.1
37,766	31,471	29,815	18,883	15,736	14,907	17	24	4 to 6	11.1
38,962	32,468	30,759	19,481	16,234	15,380	19	26	4 to 6	10.7
39,408	32,840	31,111	19,704	16,420	15,556	17	23	4 to 6	10.6
40,520	33,767	31,990	20,260	16,883	15,995	19	25	4 to 6	10.3
42,092	35,076	33,230	21,046	17,538	16,615	15	19	4 to 6	9.9
42,209	35,174	33,323	21,104	17,587	16,661	19	24	4 to 6	9.9
43,795	36,496	34,575	21,898	18,248	17,288	23	28	4 to 6	9.5
44,044	36,703	34,771	22,022	18,352	17,386	19	23	4 to 6	9.5
45,417	37,848	35,856	22,709	18,924	17,928	23	27	4 to 6	9.2
45,700	38,083	36,079	22,850	19,041	18,039	24	28	4 to 6	9.2
47,044	39,203	37,140	23,522	19,602	18,570	15	17	4 to 6	8.9
47,392	39,493	37,415	23,696	19,747	18,707	24	27	4 to 6	8.8
47,704	39,753	37,661	23,852	19,877	18,830	17	19	4 to 6	8.8
49,051	40,876	38,724	24,525	20,438	19,362	23	25	4 to 6	8.5
49,508	41,257	39,085	24,754	20,628	19,543	26	28	4 to 6	8.4
51,095	42,579	40,338	25,547	21,289	20,169	23	24	4 to 6	8.2
51,183	42,653	40,408	25,592	21,326	20,204	24	25	4 to 6	8.2
51,412	42,843	40,588	25,706	21,422	20,294	27	28	4 to 6	8.1
53,316	44,430	42,092	26,658	22,215	21,046	23	23	4 to 6	7.8
55,291	46,076	43,651	27,645	23,038	21,825	28	27	4 to 6	7.6
55,367	46,139	43,711	27,683	23,069	21,855	27	26	4 to 6	7.6
55,634	46,362	43,922	27,817	23,181	21,961	24	23	4 to 6	7.5
57,417	47,848	45,329	28,709	23,924	22,665	28	26	4 to 6	7.3
57,581	47,985	45,459	28,791	23,992	22,730	27	25	4 to 6	7.3
57,952	48,294	45,752	28,976	24,147	22,876	25	23	4 to 6	7.2
59,589	49,657	47,044	29,794	24,829	23,522	19	17	4 to 6	7.0
59,981	49,984	47,353	29,990	24,992	23,677	27	24	4 to 6	7.0
60,270	50,225	47,582	30,135	25,113	23,791	26	23	4 to 6	6.9
62,202	51,835	49,107	31,101	25,918	24,553	28	24	4 to 6	6.7
62,588	52,157	49,412	31,294	26,079	24,706	27	23	4 to 6	6.7
64,541	53,784	50,953	32,270	26,892	25,477	23	19	4 to 6	6.5
64,907	54,089	51,242	32,453	27,044	25,621	28	23	4 to 6	6.4
67,347	56,122	53,168	33,673	28,061	26,584	24	19	4 to 6	6.2
70,153	58,461	55,384	35,076	29,230	27,692	25	19	4 to 6	6.0
72,134	60,111	56,948	36,067	30,056	28,474	23	17	4 to 6	5.8
72,959	60,799	57,599	36,479	30,400	28,800	26	19	4 to 6	5.7
75,270	62,725	59,424	37,635	31,362	29,712	24	17	4 to 6	5.6
75,765	63,138	59,814	37,883	31,569	29,907	27	19	4 to 6	5.5
78,406	65,338	61,900	39,203	32,669	30,950	25	17	4 to 6	5.3
78,571	65,476	62,030	39,286	32,738	31,015	28	19	4 to 6	5.3
81,542	67,952	64,375	40,771	33,976	32,188	26	17	4 to 6	5.1
81,751	68,126	64,541	40,876	34,063	32,270	23	15	4 to 6	5.1
84,679	70,565	66,851	42,339	35,283	33,426	27	17	4 to 6	4.9

IMPORTANT: See "General Planting Rate Information" and "Checking Seed Population" pages for additional information. Always check seed population in the field to ensure planting rates are correct.

SEED METER OPERATION/MAINTENANCE

**PLANTING RATES FOR LOW-RATE CORN/POPCORN 24 CELL DISC
28 TOOTH CONTACT WHEEL DRIVE SPROCKET (See Page 7-1)
APPROXIMATE HILLS/ACRE FOR VARIOUS ROW WIDTHS**

15" Rows	18" Rows	19" Rows	30" Rows	36" Rows	38" Rows	Transmission Sprockets		Recomm. Speed Range (MPH)	Average Seed Spacing In Inches
						Drive	Driven		
36,179	30,149	28,562	18,089	15,074	14,281	15	28	4 to 6	11.6
37,519	31,266	29,620	18,759	15,633	14,810	15	27	4 to 6	11.1
38,962	32,468	30,759	19,481	16,234	15,380	15	26	4 to 6	10.7
40,520	33,767	31,990	20,260	16,883	15,995	15	25	4 to 6	10.3
41,003	34,169	32,370	20,501	17,084	16,185	17	28	4 to 6	10.2
42,209	35,174	33,323	21,104	17,587	16,661	15	24	4 to 6	9.9
42,521	35,434	33,569	21,261	17,717	16,785	17	27	4 to 6	9.8
44,044	36,703	34,771	22,022	18,352	17,386	15	23	4 to 6	9.5
44,157	36,797	34,861	22,078	18,399	17,430	17	26	4 to 6	9.5
45,826	38,189	36,179	22,913	19,094	18,089	19	28	4 to 6	9.1
45,923	38,269	36,255	22,961	19,135	18,127	17	25	4 to 6	9.1
47,524	39,603	37,519	23,762	19,802	18,759	19	27	4 to 6	8.8
47,836	39,864	37,766	23,918	19,932	18,883	17	24	4 to 6	8.7
49,352	41,126	38,962	24,676	20,563	19,481	19	26	4 to 6	8.5
49,916	41,597	39,408	24,958	20,798	19,704	17	23	4 to 6	8.4
51,326	42,771	40,520	25,663	21,386	20,260	19	25	4 to 6	8.1
53,316	44,430	42,092	26,658	22,215	21,046	15	19	4 to 6	7.8
53,464	44,554	42,209	26,732	22,277	21,104	19	24	4 to 6	7.8
55,474	46,228	43,795	27,737	23,114	21,898	23	28	4 to 6	7.5
55,789	46,491	44,044	27,894	23,245	22,022	19	23	4 to 6	7.5
57,529	47,941	45,417	28,764	23,970	22,709	23	27	4 to 6	7.3
57,886	48,238	45,700	28,943	24,119	22,850	24	28	4 to 6	7.2
59,589	49,657	47,044	29,794	24,829	23,522	15	17	4 to 6	7.0
60,030	50,025	47,392	30,015	25,012	23,696	24	27	4 to 6	7.0
60,425	50,354	47,704	30,212	25,177	23,852	17	19	4 to 6	6.9
62,131	51,776	49,051	31,066	25,888	24,525	23	25	4 to 6	6.7
62,710	52,258	49,508	31,355	26,129	24,754	26	28	4 to 6	6.7
64,720	53,933	51,095	32,360	26,967	25,547	23	24	4 to 6	6.5
64,832	54,027	51,183	32,416	27,013	25,592	24	25	4 to 6	6.5
65,122	54,268	51,412	32,561	27,134	25,706	27	28	4 to 6	6.4
67,534	56,278	53,316	33,767	28,139	26,658	23	23	4 to 6	6.2
70,035	58,362	55,291	35,017	29,181	27,645	28	27	4 to 6	6.0
70,131	58,443	55,367	35,066	29,221	27,683	27	26	4 to 6	6.0
70,470	58,725	55,634	35,235	29,362	27,817	24	23	4 to 6	5.9
72,729	60,607	57,417	36,364	30,304	28,709	28	26	4 to 6	5.7
72,936	60,780	57,581	36,468	30,390	28,791	27	25	4 to 6	5.7
73,406	61,172	57,952	36,703	30,586	28,976	25	23	4 to 6	5.7
75,479	62,899	59,589	37,739	31,450	29,794	19	17	4 to 6	5.5
75,975	63,313	59,981	37,988	31,656	29,990	27	24	4 to 6	5.5
76,342	63,619	60,270	38,171	31,809	30,135	26	23	4 to 6	5.5
78,789	65,658	62,202	39,395	32,829	31,101	28	24	4 to 6	5.3
79,279	66,066	62,588	39,639	33,033	31,294	27	23	4 to 6	5.3
81,751	68,126	64,541	40,876	34,063	32,270	23	19	4 to 6	5.1
82,215	68,512	64,907	41,107	34,256	32,453	28	23	4 to 6	5.1
85,306	71,088	67,347	42,653	35,544	33,673	24	19	4 to 6	4.9
88,860	74,050	70,153	44,430	37,025	35,076	25	19	4 to 6	4.7
91,369	76,141	72,134	45,685	38,070	36,067	23	17	4 to 6	4.6
92,415	77,012	72,959	46,207	38,506	36,479	26	19	4 to 6	4.5
95,342	79,451	75,270	47,671	39,726	37,635	24	17	4 to 6	4.4
95,969	79,974	75,765	47,985	39,987	37,883	27	19	4 to 6	4.4
99,314	82,762	78,406	49,657	41,381	39,203	25	17	4 to 6	4.2
99,523	82,936	78,571	49,762	41,468	39,286	28	19	4 to 6	4.2
103,287	86,072	81,542	51,643	43,036	40,771	26	17	4 to 6	4.0
103,552	86,293	81,751	51,776	43,147	40,876	23	15	4 to 6	4.0
107,259	89,383	84,679	53,630	44,691	42,339	27	17	4 to 6	3.9

IMPORTANT: See "General Planting Rate Information" and "Checking Seed Population" pages for additional information. Always check seed population in the field to ensure planting rates are correct.

SEED METER OPERATION/MAINTENANCE

PLANTING RATES FOR SOYBEAN AND MILO/GRAIN SORGHUM 60 CELL DISCS

22 TOOTH CONTACT WHEEL DRIVE SPROCKET (See Page 7-1)

APPROXIMATE SEEDS/ACRE FOR VARIOUS ROW WIDTHS

15" Rows	18" Rows	19" Rows	30" Rows	36" Rows	38" Rows	Transmission Sprockets		Recomm. Speed Range (MPH)	Average Seed Spacing In Inches
						Drive	Driven		
71,406	59,505	56,373	35,703	29,752	28,186	15	28	4 to 6	5.9
74,050	61,708	58,461	37,025	30,854	29,230	15	27	4 to 6	5.6
76,898	64,082	60,709	38,449	32,041	30,355	15	26	4 to 6	5.4
79,974	66,645	63,138	39,987	33,323	31,569	15	25	4 to 6	5.2
80,926	67,439	63,889	40,463	33,719	31,945	17	28	4 to 6	5.2
83,306	69,422	65,768	41,653	34,711	32,884	15	24	4 to 6	5.0
83,924	69,936	66,255	41,962	34,968	33,128	17	27	4 to 6	5.0
86,928	72,440	68,628	43,464	36,220	34,314	15	23	4 to 6	4.8
87,151	72,626	68,804	43,576	36,313	34,402	17	26	4 to 6	4.8
90,447	75,372	71,406	45,223	37,686	35,703	19	28	4 to 6	4.6
90,637	75,531	71,556	45,319	37,766	35,778	17	25	4 to 6	4.6
93,797	78,164	74,050	46,898	39,082	37,025	19	27	4 to 6	4.5
94,414	78,678	74,537	47,207	39,339	37,269	17	24	4 to 6	4.4
97,404	81,170	76,898	48,702	40,585	38,449	19	26	4 to 6	4.3
98,519	82,099	77,778	49,259	41,050	38,889	17	23	4 to 6	4.2
101,301	84,417	79,974	50,650	42,209	39,987	19	25	4 to 6	4.1
105,229	87,691	83,076	52,615	43,845	41,538	15	19	4 to 6	4.0
105,521	87,935	83,306	52,761	43,967	41,653	19	24	4 to 6	4.0
109,488	91,240	86,438	54,744	45,620	43,219	23	28	4 to 6	3.8
110,109	91,758	86,928	55,055	45,879	43,464	19	23	4 to 6	3.8
113,544	94,620	89,640	56,772	47,310	44,820	23	27	4 to 6	3.7
114,249	95,207	90,196	57,124	47,604	45,098	24	28	4 to 6	3.7
117,609	98,008	92,849	58,805	49,004	46,425	15	17	4 to 6	3.6
118,480	98,734	93,537	59,240	49,367	46,769	24	27	4 to 6	3.5
119,260	99,383	94,152	59,630	49,692	47,076	17	19	4 to 6	3.5
122,627	102,189	96,811	61,314	51,095	48,405	23	25	4 to 6	3.4
123,770	103,141	97,713	61,885	51,571	48,856	26	28	4 to 6	3.4
127,737	106,447	100,845	63,868	53,224	50,422	23	24	4 to 6	3.3
127,959	106,632	101,020	63,979	53,316	50,510	24	25	4 to 6	3.3
128,530	107,108	101,471	64,265	53,554	50,735	27	28	4 to 6	3.3
133,290	111,075	105,229	66,645	55,538	52,615	23	23	4 to 6	3.1
138,227	115,189	109,127	69,113	57,595	54,563	28	27	4 to 6	3.0
138,417	115,347	109,276	69,208	57,674	54,638	27	26	4 to 6	3.0
139,086	115,905	109,804	69,543	57,952	54,902	24	23	4 to 6	3.0
143,543	119,619	113,324	71,772	59,810	56,662	28	26	4 to 6	2.9
143,954	119,961	113,648	71,977	59,981	56,824	27	25	4 to 6	2.9
144,881	120,734	114,380	72,440	60,367	57,190	25	23	4 to 6	2.9
148,971	124,143	117,609	74,486	62,071	58,805	19	17	4 to 6	2.8
149,952	124,960	118,383	74,976	62,480	59,191	27	24	4 to 6	2.8
150,676	125,563	118,955	75,338	62,782	59,477	26	23	4 to 6	2.8
155,505	129,588	122,767	77,753	64,794	61,384	28	24	4 to 6	2.7
156,471	130,393	123,530	78,236	65,196	61,765	27	23	4 to 6	2.7
161,351	134,459	127,383	80,676	67,230	63,691	23	19	4 to 6	2.6
162,266	135,222	128,105	81,133	67,611	64,053	28	23	4 to 6	2.6
168,367	140,306	132,921	84,183	70,153	66,461	24	19	4 to 6	2.5
175,382	146,152	138,459	87,691	73,076	69,230	25	19	4 to 6	2.4
180,334	150,278	142,369	90,167	75,139	71,184	23	17	4 to 6	2.3
182,397	151,998	143,998	91,199	75,999	71,999	26	19	4 to 6	2.3
188,175	156,812	148,559	94,087	78,406	74,279	24	17	4 to 6	2.2
189,413	157,844	149,536	94,706	78,922	74,768	27	19	4 to 6	2.2
196,015	163,346	154,749	98,008	81,673	77,374	25	17	4 to 6	2.1
196,428	163,690	155,075	98,214	81,845	77,537	28	19	4 to 6	2.1
203,856	169,880	160,939	101,928	84,940	80,469	26	17	4 to 6	2.1
204,378	170,315	161,351	102,189	85,158	80,676	23	15	4 to 6	2.0
211,696	176,414	167,129	105,848	88,207	83,564	27	17	4 to 6	2.0

IMPORTANT: See "General Planting Rate Information" and "Checking Seed Population" pages for additional information. Always check seed population in the field to ensure planting rates are correct.

SEED METER OPERATION/MAINTENANCE

PLANTING RATES FOR SOYBEAN AND MILO/GRAIN SORGHUM 60 CELL DISCS 28 TOOTH CONTACT WHEEL DRIVE SPROCKET (See Page 7-1) APPROXIMATE SEEDS/ACRE FOR VARIOUS ROW WIDTHS

15" Rows	18" Rows	19" Rows	30" Rows	36" Rows	38" Rows	Transmission Sprockets		Recomm. Speed Range (MPH)	Average Seed Spacing In Inches
						Drive	Driven		
90,447	75,372	71,406	45,223	37,686	35,703	15	28	4 to 6	4.6
93,797	78,164	74,050	46,898	39,082	37,025	15	27	4 to 6	4.5
97,404	81,170	76,898	48,702	40,585	38,449	15	26	4 to 6	4.3
101,301	84,417	79,974	50,650	42,209	39,987	15	25	4 to 6	4.1
102,507	85,422	80,926	51,253	42,711	40,463	17	28	4 to 6	4.1
105,521	87,935	83,306	52,761	43,967	41,653	15	24	4 to 6	4.0
106,303	88,586	83,924	53,152	44,293	41,962	17	27	4 to 6	3.9
110,109	91,758	86,928	55,055	45,879	43,464	15	23	4 to 6	3.8
110,392	91,993	87,151	55,196	45,997	43,576	17	26	4 to 6	3.8
114,566	95,472	90,447	57,283	47,736	45,223	19	28	4 to 6	3.7
114,807	95,673	90,637	57,404	47,836	45,319	17	25	4 to 6	3.6
118,809	99,008	93,797	59,405	49,504	46,898	19	27	4 to 6	3.5
119,591	99,659	94,414	59,796	49,830	47,207	17	24	4 to 6	3.5
123,379	102,816	97,404	61,689	51,408	48,702	19	26	4 to 6	3.4
124,791	103,992	98,519	62,395	51,996	49,259	17	23	4 to 6	3.4
128,314	106,928	101,301	64,157	53,464	50,650	19	25	4 to 6	3.3
133,290	111,075	105,229	66,645	55,538	52,615	15	19	4 to 6	3.1
133,661	111,384	105,521	66,830	55,692	52,761	19	24	4 to 6	3.1
138,685	115,571	109,488	69,343	57,786	54,744	23	28	4 to 6	3.0
139,472	116,227	110,109	69,736	58,113	55,055	19	23	4 to 6	3.0
143,822	119,852	113,544	71,911	59,926	56,772	23	27	4 to 6	2.9
144,715	120,596	114,249	72,358	60,298	57,124	24	28	4 to 6	2.9
148,971	124,143	117,609	74,486	62,071	58,805	15	17	4 to 6	2.8
150,075	125,062	118,480	75,037	62,531	59,240	24	27	4 to 6	2.8
151,062	125,885	119,260	75,531	62,943	59,630	17	19	4 to 6	2.8
155,328	129,440	122,627	77,664	64,720	61,314	23	25	4 to 6	2.7
156,775	130,646	123,770	78,387	65,323	61,885	26	28	4 to 6	2.7
161,800	134,833	127,737	80,900	67,416	63,868	23	24	4 to 6	2.6
162,081	135,067	127,959	81,040	67,534	63,979	24	25	4 to 6	2.6
162,805	135,670	128,530	81,402	67,835	64,265	27	28	4 to 6	2.6
168,834	140,695	133,290	84,417	70,348	66,645	23	23	4 to 6	2.5
175,087	145,906	138,227	87,544	72,953	69,113	28	27	4 to 6	2.4
175,328	146,107	138,417	87,664	73,053	69,208	27	26	4 to 6	2.4
176,175	146,812	139,086	88,087	73,406	69,543	24	23	4 to 6	2.4
181,822	151,518	143,543	90,911	75,759	71,772	28	26	4 to 6	2.3
182,341	151,951	143,954	91,171	75,975	71,977	27	25	4 to 6	2.3
183,516	152,930	144,881	91,758	76,465	72,440	25	23	4 to 6	2.3
188,697	157,248	148,971	94,349	78,624	74,486	19	17	4 to 6	2.2
189,939	158,282	149,952	94,969	79,141	74,976	27	24	4 to 6	2.2
190,856	159,047	150,676	95,428	79,523	75,338	26	23	4 to 6	2.2
196,973	164,145	155,505	98,487	82,072	77,753	28	24	4 to 6	2.1
198,197	165,164	156,471	99,098	82,582	78,236	27	23	4 to 6	2.1
204,378	170,315	161,351	102,189	85,158	80,676	23	19	4 to 6	2.0
205,537	171,281	162,266	102,769	85,641	81,133	28	23	4 to 6	2.0
213,264	177,720	168,367	106,632	88,860	84,183	24	19	4 to 6	2.0
222,150	185,125	175,382	111,075	92,563	87,691	25	19	4 to 6	1.9
228,423	190,352	180,334	114,211	95,176	90,167	23	17	4 to 6	1.8
231,036	192,530	182,397	115,518	96,265	91,199	26	19	4 to 6	1.8
238,354	198,629	188,175	119,177	99,314	94,087	24	17	4 to 6	1.8
239,923	199,935	189,413	119,961	99,968	94,706	27	19	4 to 6	1.7
248,286	206,905	196,015	124,143	103,452	98,008	25	17	4 to 6	1.7
248,809	207,340	196,428	124,404	103,670	98,214	28	19	4 to 6	1.7
	215,181	203,856	129,109	107,591	101,928	26	17	4 to 6	1.6
	215,733	204,378	129,440	107,866	102,189	23	15	4 to 6	1.6
	223,457	211,696	134,074	111,729	105,848	27	17	4 to 6	1.6

IMPORTANT: See "General Planting Rate Information" and "Checking Seed Population" pages for additional information. Always check seed population in the field to ensure planting rates are correct.

SEED METER OPERATION/MAINTENANCE

**PLANTING RATES FOR SOYBEAN 60 CELL DISC
44 TOOTH CONTACT WHEEL DRIVE SPROCKET (See Page 7-1)
APPROXIMATE SEEDS/ACRE FOR VARIOUS ROW WIDTHS**

15" Rows	18" Rows	19" Rows	30" Rows	36" Rows	38" Rows	Transmission Sprockets		Recomm. Speed Range (MPH)	Average Seed Spacing In Inches
						Drive	Driven		
142,811	119,009	112,746	71,406	59,505	56,373	15	28	4 to 6	2.9
148,100	123,417	116,921	74,050	61,708	58,461	15	27	4 to 6	2.8
153,796	128,164	121,418	76,898	64,082	60,709	15	26	4 to 6	2.7
159,948	133,290	126,275	79,974	66,645	63,138	15	25	4 to 6	2.6
161,852	134,877	127,778	80,926	67,439	63,889	17	28	4 to 6	2.6
166,613	138,844	131,536	83,306	69,422	65,768	15	24	4 to 6	2.5
167,847	139,873	132,511	83,924	69,936	66,255	17	27	4 to 6	2.5
173,857	144,881	137,255	86,928	72,440	68,628	15	23	4 to 6	2.4
174,303	145,252	137,607	87,151	72,626	68,804	17	26	4 to 6	2.4
180,894	150,745	142,811	90,447	75,372	71,406	19	28	4 to 6	2.3
181,275	151,062	143,112	90,637	75,531	71,556	17	25	4 to 6	2.3
187,594	156,328	148,100	93,797	78,164	74,050	19	27	4 to 6	2.2
188,828	157,357	149,075	94,414	78,678	74,537	17	24	4 to 6	2.2
194,809	162,341	153,796	97,404	81,170	76,898	19	26	4 to 6	2.1
197,038	164,198	155,556	98,519	82,099	77,778	17	23	4 to 6	2.1
202,601	168,834	159,948	101,301	84,417	79,974	19	25	4 to 6	2.1
210,458	175,382	166,151	105,229	87,691	83,076	15	19	4 to 6	2.0
211,043	175,869	166,613	105,521	87,935	83,306	19	24	4 to 6	2.0
218,977	182,481	172,876	109,488	91,240	86,438	23	28	4 to 6	1.9
220,219	183,516	173,857	110,109	91,758	86,928	19	23	4 to 6	1.9
227,087	189,239	179,279	113,544	94,620	89,640	23	27	4 to 6	1.8
228,498	190,415	180,393	114,249	95,207	90,196	24	28	4 to 6	1.8
235,218	196,015	185,699	117,609	98,008	92,849	15	17	4 to 6	1.8
236,961	197,467	187,074	118,480	98,734	93,537	24	27	4 to 6	1.8
238,519	198,766	188,305	119,260	99,383	94,152	17	19	4 to 6	1.8
245,254	204,378	193,622	122,627	102,189	96,811	23	25	4 to 6	1.7
247,539	206,283	195,426	123,770	103,141	97,713	26	28	4 to 6	1.7
	212,894	201,689	127,737	106,447	100,845	23	24	4 to 6	1.6
	213,264	202,040	127,959	106,632	101,020	24	25	4 to 6	1.6
	214,217	202,942	128,530	107,108	101,471	27	28	4 to 6	1.6
	222,150	210,458	133,290	111,075	105,229	23	23	4 to 6	1.6
	230,378	218,253	138,227	115,189	109,127	28	27	4 to 6	1.5
	230,695	218,553	138,417	115,347	109,276	27	26	4 to 6	1.5
	231,809	219,609	139,086	115,905	109,804	24	23	4 to 6	1.5
	239,239	226,647	143,543	119,619	113,324	28	26	4 to 6	1.5
	239,923	227,295	143,954	119,961	113,648	27	25	4 to 6	1.5
	241,468	228,759	144,881	120,734	114,380	25	23	4 to 6	1.4
	248,286	235,218	148,971	124,143	117,609	19	17	4 to 6	1.4
	249,919	236,766	149,952	124,960	118,383	27	24	4 to 6	1.4
		237,909	150,676	125,563	118,955	26	23	4 to 6	1.4
		245,535	155,505	129,588	122,767	28	24	4 to 6	1.3
		247,060	156,471	130,393	123,530	27	23	4 to 6	1.3
			161,351	134,459	127,383	23	19	4 to 6	1.3
			162,266	135,222	128,105	28	23	4 to 6	1.3
			168,367	140,306	132,921	24	19	4 to 6	1.2
			175,382	146,152	138,459	25	19	4 to 6	1.2
			180,334	150,278	142,369	23	17	4 to 6	1.2
			182,397	151,998	143,998	26	19	4 to 6	1.1
			188,175	156,812	148,559	24	17	4 to 6	1.1
			189,413	157,844	149,536	27	19	4 to 6	1.1
			196,015	163,346	154,749	25	17	4 to 6	1.1
			196,428	163,690	155,075	28	19	4 to 6	1.1
			203,856	169,880	160,939	26	17	4 to 6	1.0
			204,378	170,315	161,351	23	15	4 to 6	1.0
			211,696	176,414	167,129	27	17	4 to 6	1.0

NOTE: Planting rates over 250,000 seeds/acre are not recommended with subject seed disc and/or drive ratio.

IMPORTANT: See "General Planting Rate Information" and "Checking Seed Population" pages for additional information. Always check seed population in the field to ensure planting rates are correct.

SEED METER OPERATION/MAINTENANCE

**PLANTING RATES FOR HIGH-RATE SOYBEAN 120 CELL DISC
22 TOOTH CONTACT WHEEL DRIVE SPROCKET (See Page 7-1)
APPROXIMATE SEEDS/ACRE FOR VARIOUS ROW WIDTHS**

15" Rows	18" Rows	19" Rows	30" Rows	36" Rows	38" Rows	Transmission Sprockets		Recomm. Speed Range (MPH)	Average Seed Spacing In Inches
						Drive	Driven		
142,811	119,009	112,746	71,406	59,505	56,373	15	28	4 to 6	2.9
148,100	123,417	116,921	74,050	61,708	58,461	15	27	4 to 6	2.8
153,796	128,164	121,418	76,898	64,082	60,709	15	26	4 to 6	2.7
159,948	133,290	126,275	79,974	66,645	63,138	15	25	4 to 6	2.6
161,852	134,877	127,778	80,926	67,439	63,889	17	28	4 to 6	2.6
166,613	138,844	131,536	83,306	69,422	65,768	15	24	4 to 6	2.5
167,847	139,873	132,511	83,924	69,936	66,255	17	27	4 to 6	2.5
173,857	144,881	137,255	86,928	72,440	68,628	15	23	4 to 6	2.4
174,303	145,252	137,607	87,151	72,626	68,804	17	26	4 to 6	2.4
180,894	150,745	142,811	90,447	75,372	71,406	19	28	4 to 6	2.3
181,275	151,062	143,112	90,637	75,531	71,556	17	25	4 to 6	2.3
187,594	156,328	148,100	93,797	78,164	74,050	19	27	4 to 6	2.2
188,828	157,357	149,075	94,414	78,678	74,537	17	24	4 to 6	2.2
194,809	162,341	153,796	97,404	81,170	76,898	19	26	4 to 6	2.1
197,038	164,198	155,556	98,519	82,099	77,778	17	23	4 to 6	2.1
202,601	168,834	159,948	101,301	84,417	79,974	19	25	4 to 6	2.1
210,458	175,382	166,151	105,229	87,691	83,076	15	19	4 to 6	2.0
211,043	175,869	166,613	105,521	87,935	83,306	19	24	4 to 6	2.0
218,977	182,481	172,876	109,488	91,240	86,438	23	28	4 to 6	1.9
220,219	183,516	173,857	110,109	91,758	86,928	19	23	4 to 6	1.9
227,087	189,239	179,279	113,544	94,620	89,640	23	27	4 to 6	1.8
228,498	190,415	180,393	114,249	95,207	90,196	24	28	4 to 6	1.8
235,218	196,015	185,699	117,609	98,008	92,849	15	17	4 to 6	1.8
236,961	197,467	187,074	118,480	98,734	93,537	24	27	4 to 6	1.8
238,519	198,766	188,305	119,260	99,383	94,152	17	19	4 to 6	1.8
245,254	204,378	193,622	122,627	102,189	96,811	23	25	4 to 6	1.7
247,539	206,283	195,426	123,770	103,141	97,713	26	28	4 to 6	1.7
	212,894	201,689	127,737	106,447	100,845	23	24	4 to 6	1.6
	213,264	202,040	127,959	106,632	101,020	24	25	4 to 6	1.6
	214,217	202,942	128,530	107,108	101,471	27	28	4 to 6	1.6
	222,150	210,458	133,290	111,075	105,229	23	23	4 to 6	1.6
	230,378	218,253	138,227	115,189	109,127	28	27	4 to 6	1.5
	230,695	218,553	138,417	115,347	109,276	27	26	4 to 6	1.5
	231,809	219,609	139,086	115,905	109,804	24	23	4 to 6	1.5
	239,239	226,647	143,543	119,619	113,324	28	26	4 to 6	1.5
	239,923	227,295	143,954	119,961	113,648	27	25	4 to 6	1.5
	241,468	228,759	144,881	120,734	114,380	25	23	4 to 6	1.4
	248,286	235,218	148,971	124,143	117,609	19	17	4 to 6	1.4
	249,919	236,766	149,952	124,960	118,383	27	24	4 to 6	1.4
		237,909	150,676	125,563	118,955	26	23	4 to 6	1.4
		245,535	155,505	129,588	122,767	28	24	4 to 6	1.3
		247,060	156,471	130,393	123,530	27	23	4 to 6	1.3
			161,351	134,459	127,383	23	19	4 to 6	1.3
			162,266	135,222	128,105	28	23	4 to 6	1.3
			168,367	140,306	132,921	24	19	4 to 6	1.2
			175,382	146,152	138,459	25	19	4 to 6	1.2
			180,334	150,278	142,369	23	17	4 to 6	1.2
			182,397	151,998	143,998	26	19	4 to 6	1.1
			188,175	156,812	148,559	24	17	4 to 6	1.1
			189,413	157,844	149,536	27	19	4 to 6	1.1
			196,015	163,346	154,749	25	17	4 to 6	1.1
			196,428	163,690	155,075	28	19	4 to 6	1.1
			203,856	169,880	160,939	26	17	4 to 6	1.0
			204,378	170,315	161,351	23	15	4 to 6	1.0
			211,696	176,414	167,129	27	17	4 to 6	1.0

NOTE: Planting rates over 250,000 seeds/acre are not recommended with subject seed disc and/or drive ratio.

IMPORTANT: See "General Planting Rate Information" and "Checking Seed Population" pages for additional information. Always check seed population in the field to ensure planting rates are correct.

SEED METER OPERATION/MAINTENANCE

**PLANTING RATES FOR HIGH-RATE SOYBEAN 120 CELL DISC
28 TOOTH CONTACT WHEEL DRIVE SPROCKET (See Page 7-1)
APPROXIMATE SEEDS/ACRE FOR VARIOUS ROW WIDTHS**

15" Rows	18" Rows	19" Rows	30" Rows	36" Rows	38" Rows	Transmission Sprockets		Recomm. Speed Range (MPH)	Average Seed Spacing In Inches
						Drive	Driven		
180,894	150,745	142,811	90,447	75,372	71,406	15	28	4 to 6	2.3
187,594	156,328	148,100	93,797	78,164	74,050	15	27	4 to 6	2.2
194,809	162,341	153,796	97,404	81,170	76,898	15	26	4 to 6	2.1
202,601	168,834	159,948	101,301	84,417	79,974	15	25	4 to 6	2.1
205,013	170,844	161,852	102,507	85,422	80,926	17	28	4 to 6	2.0
211,043	175,869	166,613	105,521	87,935	83,306	15	24	4 to 6	2.0
212,606	177,172	167,847	106,303	88,586	83,924	17	27	4 to 6	2.0
220,219	183,516	173,857	110,109	91,758	86,928	15	23	4 to 6	1.9
220,783	183,986	174,303	110,392	91,993	87,151	17	26	4 to 6	1.9
229,132	190,944	180,894	114,566	95,472	90,447	19	28	4 to 6	1.8
229,615	191,346	181,275	114,807	95,673	90,637	17	25	4 to 6	1.8
237,619	198,016	187,594	118,809	99,008	93,797	19	27	4 to 6	1.8
239,182	199,318	188,828	119,591	99,659	94,414	17	24	4 to 6	1.7
246,758	205,632	194,809	123,379	102,816	97,404	19	26	4 to 6	1.7
249,581	207,984	197,038	124,791	103,992	98,519	17	23	4 to 6	1.7
	213,857	202,601	128,314	106,928	101,301	19	25	4 to 6	1.6
	222,150	210,458	133,290	111,075	105,229	15	19	4 to 6	1.6
	222,768	211,043	133,661	111,384	105,521	19	24	4 to 6	1.6
	231,142	218,977	138,685	115,571	109,488	23	28	4 to 6	1.5
	232,453	220,219	139,472	116,227	110,109	19	23	4 to 6	1.5
	239,703	227,087	143,822	119,852	113,544	23	27	4 to 6	1.5
	241,192	228,498	144,715	120,596	114,249	24	28	4 to 6	1.4
	248,286	235,218	148,971	124,143	117,609	15	17	4 to 6	1.4
		236,961	150,075	125,062	118,480	24	27	4 to 6	1.4
		238,519	151,062	125,885	119,260	17	19	4 to 6	1.4
		245,254	155,328	129,440	122,627	23	25	4 to 6	1.3
		247,539	156,775	130,646	123,770	26	28	4 to 6	1.3
			161,800	134,833	127,737	23	24	4 to 6	1.3
			162,081	135,067	127,959	24	25	4 to 6	1.3
			162,805	135,670	128,530	27	28	4 to 6	1.3
			168,834	140,695	133,290	23	23	4 to 6	1.2
			175,087	145,906	138,227	28	27	4 to 6	1.2
			175,328	146,107	138,417	27	26	4 to 6	1.2
			176,175	146,812	139,086	24	23	4 to 6	1.2
			181,822	151,518	143,543	28	26	4 to 6	1.1
			182,341	151,951	143,954	27	25	4 to 6	1.1
			183,516	152,930	144,881	25	23	4 to 6	1.1
			188,697	157,248	148,971	19	17	4 to 6	1.1
			189,939	158,282	149,952	27	24	4 to 6	1.1
			190,856	159,047	150,676	26	23	4 to 6	1.1
			196,973	164,145	155,505	28	24	4 to 6	1.1
			198,197	165,164	156,471	27	23	4 to 6	1.1
			204,378	170,315	161,351	23	19	4 to 6	1.0
			205,537	171,281	162,266	28	23	4 to 6	1.0
			213,264	177,720	168,367	24	19	4 to 6	1.0
			222,150	185,125	175,382	25	19	4 to 6	0.9
			228,423	190,352	180,334	23	17	4 to 6	0.9
			231,036	192,530	182,397	26	19	4 to 6	0.9
			238,354	198,629	188,175	24	17	4 to 6	0.9
			239,923	199,935	189,413	27	19	4 to 6	0.9
			248,286	206,905	196,015	25	17	4 to 6	0.8
			248,809	207,340	196,428	28	19	4 to 6	0.8
				215,181	203,856	26	17	4 to 6	0.8
				215,733	204,378	23	15	4 to 6	0.8
				223,457	211,696	27	17	4 to 6	0.8

NOTE: Planting rates over 250,000 seeds/acre are not recommended with subject seed disc and/or drive ratio.

IMPORTANT: See "General Planting Rate Information" and "Checking Seed Population" pages for additional information. Always check seed population in the field to ensure planting rates are correct.

SEED METER OPERATION/MAINTENANCE

PLANTING RATES FOR HILL-DROP COTTON (3 SEEDS PER CELL), 20 CELL DISC

22 TOOTH CONTACT WHEEL DRIVE SPROCKET (See Page 7-1)

APPROXIMATE HILLS/ACRE FOR VARIOUS ROW WIDTHS

15" Rows	18" Rows	19" Rows	30" Rows	36" Rows	38" Rows	Transmission Sprockets		Recomm. Speed Range (MPH)	Average Hill Spacing In Inches
						Drive	Driven		
23,802	19,835	18,791	11,901	9,917	9,395	15	28	4 to 6	17.6
24,683	20,569	19,487	12,342	10,285	9,743	15	27	4 to 6	16.9
25,633	21,361	20,236	12,816	10,680	10,118	15	26	4 to 6	16.3
26,658	22,215	21,046	13,329	11,108	10,523	15	25	4 to 6	15.7
26,975	22,480	21,296	13,488	11,240	10,648	17	28	4 to 6	15.5
27,769	23,141	21,923	13,884	11,570	10,961	15	24	4 to 6	15.1
27,975	23,312	22,085	13,987	11,656	11,043	17	27	4 to 6	14.9
28,976	24,147	22,876	14,488	12,073	11,438	15	23	4 to 6	14.4
29,050	24,209	22,935	14,525	12,104	11,467	17	26	4 to 6	14.4
30,149	25,124	23,802	15,074	12,562	11,901	19	28	4 to 6	13.9
30,212	25,177	23,852	15,106	12,589	11,926	17	25	4 to 6	13.8
31,266	26,055	24,683	15,633	13,027	12,342	19	27	4 to 6	13.4
31,471	26,226	24,846	15,736	13,113	12,423	17	24	4 to 6	13.3
32,468	27,057	25,633	16,234	13,528	12,816	19	26	4 to 6	12.9
32,840	27,366	25,926	16,420	13,683	12,963	17	23	4 to 6	12.7
33,767	28,139	26,658	16,883	14,070	13,329	19	25	4 to 6	12.4
35,076	29,230	27,692	17,538	14,615	13,846	15	19	4 to 6	11.9
35,174	29,312	27,769	17,587	14,656	13,884	19	24	4 to 6	11.9
36,496	30,413	28,813	18,248	15,207	14,406	23	28	4 to 6	11.5
36,703	30,586	28,976	18,352	15,293	14,488	19	23	4 to 6	11.4
37,848	31,540	29,880	18,924	15,770	14,940	23	27	4 to 6	11.0
38,083	31,736	30,065	19,041	15,868	15,033	24	28	4 to 6	11.0
39,203	32,669	30,950	19,602	16,335	15,475	15	17	4 to 6	10.7
39,304	32,753	31,029	19,652	16,376	15,515	23	26	4 to 6	10.6
39,493	32,911	31,179	19,747	16,456	15,590	24	27	4 to 6	10.6
39,670	33,058	31,318	19,835	16,529	15,659	25	28	4 to 6	10.5
39,753	33,128	31,384	19,877	16,564	15,692	17	19	4 to 6	10.5
40,876	34,063	32,270	20,438	17,032	16,135	23	25	4 to 6	10.2
41,012	34,177	32,378	20,506	17,088	16,189	24	26	4 to 6	10.2
41,139	34,282	32,478	20,569	17,141	16,239	25	27	4 to 6	10.2
41,257	34,380	32,571	20,628	17,190	16,285	26	28	4 to 6	10.1
42,579	35,482	33,615	21,289	17,741	16,807	23	24	4 to 6	9.8
42,653	35,544	33,673	21,326	17,772	16,837	24	25	4 to 6	9.8
42,721	35,601	33,727	21,361	17,801	16,864	25	26	4 to 6	9.8
42,785	35,654	33,777	21,392	17,827	16,889	26	27	4 to 6	9.8
42,843	35,703	33,824	21,422	17,851	16,912	27	28	4 to 6	9.8
44,430	37,025	35,076	22,215	18,513	17,538	23	23	4 to 6	9.4
46,076	38,396	36,376	23,038	19,198	18,188	28	27	4 to 6	9.1
46,139	38,449	36,425	23,069	19,225	18,213	27	26	4 to 6	9.1
46,281	38,568	36,538	23,141	19,284	18,269	25	24	4 to 6	9.0
46,362	38,635	36,601	23,181	19,317	18,301	24	23	4 to 6	9.0
47,848	39,873	37,775	23,924	19,937	18,887	28	26	4 to 6	8.7
47,985	39,987	37,883	23,992	19,994	18,941	27	25	4 to 6	8.7
48,294	40,245	38,127	24,147	20,122	19,063	25	23	4 to 6	8.7
49,657	41,381	39,203	24,829	20,690	19,602	19	17	4 to 6	8.4
49,762	41,468	39,286	24,881	20,734	19,643	28	25	4 to 6	8.4
49,984	41,653	39,461	24,992	20,827	19,730	27	24	4 to 6	8.4
50,225	41,854	39,652	25,113	20,927	19,826	26	23	4 to 6	8.3
51,835	43,196	40,922	25,918	21,598	20,461	28	24	4 to 6	8.1
52,157	43,464	41,177	26,079	21,732	20,588	27	23	4 to 6	8.0
53,784	44,820	42,461	26,892	22,410	21,230	23	19	4 to 6	7.8
54,089	45,074	42,702	27,044	22,537	21,351	28	23	4 to 6	7.7
56,122	46,769	44,307	28,061	23,384	22,154	24	19	4 to 6	7.5
58,461	48,717	46,153	29,230	24,359	23,077	25	19	4 to 6	7.2
60,111	50,093	47,456	30,056	25,046	23,728	23	17	4 to 6	7.0

IMPORTANT: See "General Planting Rate Information" and "Checking Seed Population" pages for additional information. Always check seed population in the field to ensure planting rates are correct.

SEED METER OPERATION/MAINTENANCE

PLANTING RATES FOR HILL-DROP COTTON (3 SEEDS PER CELL), 20 CELL DISC

28 TOOTH CONTACT WHEEL DRIVE SPROCKET (See Page 7-1)

APPROXIMATE HILLS/ACRE FOR VARIOUS ROW WIDTHS

15" Rows	18" Rows	19" Rows	30" Rows	36" Rows	38" Rows	Transmission Sprockets		Recomm. Speed Range (MPH)	Average Hill Spacing In Inches
						Drive	Driven		
30,149	25,124	23,802	15,074	12,562	11,901	15	28	4 to 6	13.9
31,266	26,055	24,683	15,633	13,027	12,342	15	27	4 to 6	13.4
32,468	27,057	25,633	16,234	13,528	12,816	15	26	4 to 6	12.9
33,767	28,139	26,658	16,883	14,070	13,329	15	25	4 to 6	12.4
34,169	28,474	26,975	17,084	14,237	13,488	17	28	4 to 6	12.2
35,174	29,312	27,769	17,587	14,656	13,884	15	24	4 to 6	11.9
35,434	29,529	27,975	17,717	14,764	13,987	17	27	4 to 6	11.8
36,703	30,586	28,976	18,352	15,293	14,488	15	23	4 to 6	11.4
36,797	30,664	29,050	18,399	15,332	14,525	17	26	4 to 6	11.4
38,189	31,824	30,149	19,094	15,912	15,074	19	28	4 to 6	11.0
38,269	31,891	30,212	19,135	15,945	15,106	17	25	4 to 6	10.9
39,603	33,003	31,266	19,802	16,501	15,633	19	27	4 to 6	10.6
39,864	33,220	31,471	19,932	16,610	15,736	17	24	4 to 6	10.5
41,126	34,272	32,468	20,563	17,136	16,234	19	26	4 to 6	10.2
41,597	34,664	32,840	20,798	17,332	16,420	17	23	4 to 6	10.1
42,771	35,643	33,767	21,386	17,821	16,883	19	25	4 to 6	9.8
44,430	37,025	35,076	22,215	18,513	17,538	15	19	4 to 6	9.4
44,554	37,128	35,174	22,277	18,564	17,587	19	24	4 to 6	9.4
46,228	38,524	36,496	23,114	19,262	18,248	23	28	4 to 6	9.0
46,491	38,742	36,703	23,245	19,371	18,352	19	23	4 to 6	9.0
47,941	39,951	37,848	23,970	19,975	18,924	23	27	4 to 6	8.7
48,238	40,199	38,083	24,119	20,099	19,041	24	28	4 to 6	8.7
49,657	41,381	39,203	24,829	20,690	19,602	15	17	4 to 6	8.4
49,784	41,487	39,304	24,892	20,744	19,652	23	26	4 to 6	8.4
50,025	41,687	39,493	25,012	20,844	19,747	24	27	4 to 6	8.4
50,248	41,874	39,670	25,124	20,937	19,835	25	28	4 to 6	8.3
50,354	41,962	39,753	25,177	20,981	19,877	17	19	4 to 6	8.3
51,776	43,147	40,876	25,888	21,573	20,438	23	25	4 to 6	8.1
51,949	43,291	41,012	25,975	21,645	20,506	24	26	4 to 6	8.0
52,109	43,424	41,139	26,055	21,712	20,569	25	27	4 to 6	8.0
52,258	43,549	41,257	26,129	21,774	20,628	26	28	4 to 6	8.0
53,933	44,944	42,579	26,967	22,472	21,289	23	24	4 to 6	7.8
54,027	45,022	42,653	27,013	22,511	21,326	24	25	4 to 6	7.7
54,114	45,095	42,721	27,057	22,547	21,361	25	26	4 to 6	7.7
54,194	45,161	42,785	27,097	22,581	21,392	26	27	4 to 6	7.7
54,268	45,223	42,843	27,134	22,612	21,422	27	28	4 to 6	7.7
56,278	46,898	44,430	28,139	23,449	22,215	23	23	4 to 6	7.4
58,362	48,635	46,076	29,181	24,318	23,038	28	27	4 to 6	7.2
58,443	48,702	46,139	29,221	24,351	23,069	27	26	4 to 6	7.2
58,623	48,853	46,281	29,312	24,426	23,141	25	24	4 to 6	7.1
58,725	48,937	46,362	29,362	24,469	23,181	24	23	4 to 6	7.1
60,607	50,506	47,848	30,304	25,253	23,924	28	26	4 to 6	6.9
60,780	50,650	47,985	30,390	25,325	23,992	27	25	4 to 6	6.9
61,172	50,977	48,294	30,586	25,488	24,147	25	23	4 to 6	6.8
62,899	52,416	49,657	31,450	26,208	24,829	19	17	4 to 6	6.6
63,031	52,526	49,762	31,516	26,263	24,881	28	25	4 to 6	6.6
63,313	52,761	49,984	31,656	26,380	24,992	27	24	4 to 6	6.6
63,619	53,016	50,225	31,809	26,508	25,113	26	23	4 to 6	6.6
65,658	54,715	51,835	32,829	27,357	25,918	28	24	4 to 6	6.4
66,066	55,055	52,157	33,033	27,527	26,079	27	23	4 to 6	6.3
68,126	56,772	53,784	34,063	28,386	26,892	23	19	4 to 6	6.1
68,512	57,094	54,089	34,256	28,547	27,044	28	23	4 to 6	6.1
71,088	59,240	56,122	35,544	29,620	28,061	24	19	4 to 6	5.9
74,050	61,708	58,461	37,025	30,854	29,230	25	19	4 to 6	5.6
76,141	63,451	60,111	38,070	31,725	30,056	23	17	4 to 6	5.5

IMPORTANT: See "General Planting Rate Information" and "Checking Seed Population" pages for additional information. Always check seed population in the field to ensure planting rates are correct.

SEED METER OPERATION/MAINTENANCE

**PLANTING RATES FOR COTTON/SMALL DRY EDIBLE BEAN 54 CELL DISC
22 TOOTH CONTACT WHEEL DRIVE SPROCKET (See Page 7-1)
APPROXIMATE SEEDS/ACRE FOR VARIOUS ROW WIDTHS**

15" Rows	18" Rows	19" Rows	30" Rows	36" Rows	38" Rows	Transmission Sprockets		Recomm. Speed Range (MPH)	Average Seed Spacing In Inches
						Drive	Driven		
64,265	53,554	50,735	32,132	26,777	25,368	15	28	4 to 6	6.5
66,645	55,538	52,615	33,323	27,769	26,307	15	27	4 to 6	6.3
69,208	57,674	54,638	34,604	28,837	27,319	15	26	4 to 6	6.0
71,977	59,981	56,824	35,988	29,990	28,412	15	25	4 to 6	5.8
72,834	60,695	57,500	36,417	30,347	28,750	17	28	4 to 6	5.7
74,976	62,480	59,191	37,488	31,240	29,596	15	24	4 to 6	5.6
75,531	62,943	59,630	37,766	31,471	29,815	17	27	4 to 6	5.5
78,236	65,196	61,765	39,118	32,598	30,882	15	23	4 to 6	5.3
78,436	65,364	61,923	39,218	32,682	30,962	17	26	4 to 6	5.3
81,402	67,835	64,265	40,701	33,918	32,132	19	28	4 to 6	5.1
81,574	67,978	64,400	40,787	33,989	32,200	17	25	4 to 6	5.1
84,417	70,348	66,645	42,209	35,174	33,323	19	27	4 to 6	5.0
84,973	70,810	67,084	42,486	35,405	33,542	17	24	4 to 6	4.9
87,664	73,053	69,208	43,832	36,527	34,604	19	26	4 to 6	4.8
88,667	73,889	70,000	44,334	36,945	35,000	17	23	4 to 6	4.7
91,171	75,975	71,977	45,585	37,988	35,988	19	25	4 to 6	4.6
94,706	78,922	74,768	47,353	39,461	37,384	15	19	4 to 6	4.4
94,969	79,141	74,976	47,485	39,571	37,488	19	24	4 to 6	4.4
98,540	82,116	77,794	49,270	41,058	38,897	23	28	4 to 6	4.2
99,098	82,582	78,236	49,549	41,291	39,118	19	23	4 to 6	4.2
102,189	85,158	80,676	51,095	42,579	40,338	23	27	4 to 6	4.1
102,824	85,687	81,177	51,412	42,843	40,588	24	28	4 to 6	4.1
105,848	88,207	83,564	52,924	44,103	41,782	15	17	4 to 6	4.0
106,632	88,860	84,183	53,316	44,430	42,092	24	27	4 to 6	3.9
107,334	89,445	84,737	53,667	44,722	42,369	17	19	4 to 6	3.9
110,364	91,970	87,130	55,182	45,985	43,565	23	25	4 to 6	3.8
111,393	92,827	87,942	55,696	46,414	43,971	26	28	4 to 6	3.8
114,963	95,802	90,760	57,481	47,901	45,380	23	24	4 to 6	3.6
115,163	95,969	90,918	57,581	47,985	45,459	24	25	4 to 6	3.6
115,677	96,397	91,324	57,838	48,199	45,662	27	28	4 to 6	3.6
119,961	99,968	94,706	59,981	49,984	47,353	23	23	4 to 6	3.5
124,404	103,670	98,214	62,202	51,835	49,107	28	27	4 to 6	3.4
124,575	103,813	98,349	62,288	51,906	49,174	27	26	4 to 6	3.4
125,177	104,314	98,824	62,588	52,157	49,412	24	23	4 to 6	3.3
129,189	107,658	101,991	64,595	53,829	50,996	28	26	4 to 6	3.2
129,558	107,965	102,283	64,779	53,983	51,141	27	25	4 to 6	3.2
130,393	108,661	102,942	65,196	54,330	51,471	25	23	4 to 6	3.2
134,074	111,729	105,848	67,037	55,864	52,924	19	17	4 to 6	3.1
134,956	112,464	106,545	67,478	56,232	53,272	27	24	4 to 6	3.1
135,608	113,007	107,059	67,804	56,503	53,530	26	23	4 to 6	3.1
139,955	116,629	110,491	69,977	58,314	55,245	28	24	4 to 6	3.0
140,824	117,353	111,177	70,412	58,677	55,588	27	23	4 to 6	3.0
145,216	121,014	114,644	72,608	60,507	57,322	23	19	4 to 6	2.9
146,040	121,700	115,295	73,020	60,850	57,647	28	23	4 to 6	2.9
151,530	126,275	119,629	75,765	63,138	59,814	24	19	4 to 6	2.8
157,844	131,536	124,613	78,922	65,768	62,307	25	19	4 to 6	2.6
162,301	135,250	128,132	81,150	67,625	64,066	23	17	4 to 6	2.6
164,158	136,798	129,598	82,079	68,399	64,799	26	19	4 to 6	2.5
169,357	141,131	133,703	84,679	70,565	66,851	24	17	4 to 6	2.5
170,471	142,059	134,583	85,236	71,030	67,291	27	19	4 to 6	2.5
176,414	147,011	139,274	88,207	73,506	69,637	25	17	4 to 6	2.4
176,785	147,321	139,567	88,393	73,660	69,784	28	19	4 to 6	2.4
183,470	152,892	144,845	91,735	76,446	72,422	26	17	4 to 6	2.3
183,941	153,284	145,216	91,970	76,642	72,608	23	15	4 to 6	2.3
190,527	158,772	150,416	95,263	79,386	75,208	27	17	4 to 6	2.2

IMPORTANT: See "General Planting Rate Information" and "Checking Seed Population" pages for additional information. Always check seed population in the field to ensure planting rates are correct.

SEED METER OPERATION/MAINTENANCE

**PLANTING RATES FOR COTTON/SMALL DRY EDIBLE BEAN/SUNFLOWER, 54 CELL DISC
28 TOOTH CONTACT WHEEL DRIVE SPROCKET (See Page 7-1)
APPROXIMATE SEEDS/ACRE FOR VARIOUS ROW WIDTHS**

15" Rows	18" Rows	19" Rows	30" Rows	36" Rows	38" Rows	Transmission Sprockets		Recomm. Speed Range (MPH)	Average Seed Spacing In Inches
						Drive	Driven		
81,402	67,835	64,265	40,701	33,918	32,132	15	28	4 to 6	5.1
84,417	70,348	66,645	42,209	35,174	33,323	15	27	4 to 6	5.0
87,664	73,053	69,208	43,832	36,527	34,604	15	26	4 to 6	4.8
91,171	75,975	71,977	45,585	37,988	35,988	15	25	4 to 6	4.6
92,256	76,880	72,834	46,128	38,440	36,417	17	28	4 to 6	4.5
94,969	79,141	74,976	47,485	39,571	37,488	15	24	4 to 6	4.4
95,673	79,727	75,531	47,836	39,864	37,766	17	27	4 to 6	4.4
99,098	82,582	78,236	49,549	41,291	39,118	15	23	4 to 6	4.2
99,353	82,794	78,436	49,676	41,397	39,218	17	26	4 to 6	4.2
103,110	85,925	81,402	51,555	42,962	40,701	19	28	4 to 6	4.1
103,327	86,106	81,574	51,663	43,053	40,787	17	25	4 to 6	4.0
106,928	89,107	84,417	53,464	44,554	42,209	19	27	4 to 6	3.9
107,632	89,693	84,973	53,816	44,847	42,486	17	24	4 to 6	3.9
111,041	92,534	87,664	55,521	46,267	43,832	19	26	4 to 6	3.8
112,312	93,593	88,667	56,156	46,796	44,334	17	23	4 to 6	3.7
115,483	96,236	91,171	57,741	48,118	45,585	19	25	4 to 6	3.6
119,961	99,968	94,706	59,981	49,984	47,353	15	19	4 to 6	3.5
120,294	100,245	94,969	60,147	50,123	47,485	19	24	4 to 6	3.5
124,817	104,014	98,540	62,408	52,007	49,270	23	28	4 to 6	3.4
125,525	104,604	99,098	62,762	52,302	49,549	19	23	4 to 6	3.3
129,440	107,866	102,189	64,720	53,933	51,095	23	27	4 to 6	3.2
130,244	108,536	102,824	65,122	54,268	51,412	24	28	4 to 6	3.2
134,074	111,729	105,848	67,037	55,864	52,924	15	17	4 to 6	3.1
135,067	112,556	106,632	67,534	56,278	53,316	24	27	4 to 6	3.1
135,956	113,297	107,334	67,978	56,648	53,667	17	19	4 to 6	3.1
139,795	116,496	110,364	69,897	58,248	55,182	23	25	4 to 6	3.0
141,097	117,581	111,393	70,549	58,791	55,696	26	28	4 to 6	3.0
145,620	121,350	114,963	72,810	60,675	57,481	23	24	4 to 6	2.9
145,873	121,561	115,163	72,936	60,780	57,581	24	25	4 to 6	2.9
146,524	122,103	115,677	73,262	61,052	57,838	27	28	4 to 6	2.9
151,951	126,626	119,961	75,975	63,313	59,981	23	23	4 to 6	2.8
157,579	131,316	124,404	78,789	65,658	62,202	28	27	4 to 6	2.7
157,795	131,496	124,575	78,898	65,748	62,288	27	26	4 to 6	2.7
158,557	132,131	125,177	79,279	66,066	62,588	24	23	4 to 6	2.6
163,639	136,366	129,189	81,820	68,183	64,595	28	26	4 to 6	2.6
164,107	136,756	129,558	82,053	68,378	64,779	27	25	4 to 6	2.5
165,164	137,637	130,393	82,582	68,818	65,196	25	23	4 to 6	2.5
169,828	141,523	134,074	84,914	70,761	67,037	19	17	4 to 6	2.5
170,945	142,454	134,956	85,472	71,227	67,478	27	24	4 to 6	2.4
171,771	143,142	135,608	85,885	71,571	67,804	26	23	4 to 6	2.4
177,276	147,730	139,955	88,638	73,865	69,977	28	24	4 to 6	2.4
178,377	148,648	140,824	89,189	74,324	70,412	27	23	4 to 6	2.3
183,941	153,284	145,216	91,970	76,642	72,608	23	19	4 to 6	2.3
184,984	154,153	146,040	92,492	77,077	73,020	28	23	4 to 6	2.3
191,938	159,948	151,530	95,969	79,974	75,765	24	19	4 to 6	2.2
199,935	166,613	157,844	99,968	83,306	78,922	25	19	4 to 6	2.1
205,581	171,317	162,301	102,790	85,659	81,150	23	17	4 to 6	2.0
207,933	173,277	164,158	103,966	86,639	82,079	26	19	4 to 6	2.0
214,519	178,766	169,357	107,259	89,383	84,679	24	17	4 to 6	1.9
215,930	179,942	170,471	107,965	89,971	85,236	27	19	4 to 6	1.9
223,457	186,214	176,414	111,729	93,107	88,207	25	17	4 to 6	1.9
223,928	186,606	176,785	111,964	93,303	88,393	28	19	4 to 6	1.9
232,396	193,663	183,470	116,198	96,831	91,735	26	17	4 to 6	1.8
232,991	194,160	183,941	116,496	97,080	91,970	23	15	4 to 6	1.8
241,334	201,112	190,527	120,667	100,556	95,263	27	17	4 to 6	1.7

IMPORTANT: See "General Planting Rate Information" and "Checking Seed Population" pages for additional information. Always check seed population in the field to ensure planting rates are correct.

SEED METER OPERATION/MAINTENANCE

**PLANTING RATES FOR LARGE DRY EDIBLE BEAN 54 CELL DISC
22 TOOTH CONTACT WHEEL DRIVE SPROCKET (See Page 7-1)
APPROXIMATE SEEDS/ACRE FOR VARIOUS ROW WIDTHS**

15" Rows	18" Rows	19" Rows	30" Rows	36" Rows	38" Rows	Transmission Sprockets		Recomm. Speed Range (MPH)	Average Seed Spacing In Inches
						Drive	Driven		
64,265	53,554	50,735	32,132	26,777	25,368	15	28	4 to 6	6.5
66,645	55,538	52,615	33,323	27,769	26,307	15	27	4 to 6	6.3
69,208	57,674	54,638	34,604	28,837	27,319	15	26	4 to 6	6.0
71,977	59,981	56,824	35,988	29,990	28,412	15	25	4 to 6	5.8
72,834	60,695	57,500	36,417	30,347	28,750	17	28	4 to 6	5.7
74,976	62,480	59,191	37,488	31,240	29,596	15	24	4 to 6	5.6
75,531	62,943	59,630	37,766	31,471	29,815	17	27	4 to 6	5.5
78,236	65,196	61,765	39,118	32,598	30,882	15	23	4 to 6	5.3
78,436	65,364	61,923	39,218	32,682	30,962	17	26	4 to 6	5.3
81,402	67,835	64,265	40,701	33,918	32,132	19	28	4 to 6	5.1
81,574	67,978	64,400	40,787	33,989	32,200	17	25	4 to 6	5.1
84,417	70,348	66,645	42,209	35,174	33,323	19	27	4 to 6	5.0
84,973	70,810	67,084	42,486	35,405	33,542	17	24	4 to 6	4.9
87,664	73,053	69,208	43,832	36,527	34,604	19	26	4 to 6	4.8
88,667	73,889	70,000	44,334	36,945	35,000	17	23	4 to 6	4.7
91,171	75,975	71,977	45,585	37,988	35,988	19	25	4 to 6	4.6
94,706	78,922	74,768	47,353	39,461	37,384	15	19	4 to 6	4.4
94,969	79,141	74,976	47,485	39,571	37,488	19	24	4 to 6	4.4
98,540	82,116	77,794	49,270	41,058	38,897	23	28	4 to 6	4.2
99,098	82,582	78,236	49,549	41,291	39,118	19	23	4 to 6	4.2
102,189	85,158	80,676	51,095	42,579	40,338	23	27	4 to 6	4.1
102,824	85,687	81,177	51,412	42,843	40,588	24	28	4 to 6	4.1
105,848	88,207	83,564	52,924	44,103	41,782	15	17	4 to 6	4.0
106,632	88,860	84,183	53,316	44,430	42,092	24	27	4 to 6	3.9
107,334	89,445	84,737	53,667	44,722	42,369	17	19	4 to 6	3.9
110,364	91,970	87,130	55,182	45,985	43,565	23	25	4 to 6	3.8
111,393	92,827	87,942	55,696	46,414	43,971	26	28	4 to 6	3.8
114,963	95,802	90,760	57,481	47,901	45,380	23	24	4 to 6	3.6
115,163	95,969	90,918	57,581	47,985	45,459	24	25	4 to 6	3.6
115,677	96,397	91,324	57,838	48,199	45,662	27	28	4 to 6	3.6
119,961	99,968	94,706	59,981	49,984	47,353	23	23	4 to 6	3.5
124,404	103,670	98,214	62,202	51,835	49,107	28	27	4 to 6	3.4
124,575	103,813	98,349	62,288	51,906	49,174	27	26	4 to 6	3.4
125,177	104,314	98,824	62,588	52,157	49,412	24	23	4 to 6	3.3
129,189	107,658	101,991	64,595	53,829	50,996	28	26	4 to 6	3.2
129,558	107,965	102,283	64,779	53,983	51,141	27	25	4 to 6	3.2
130,393	108,661	102,942	65,196	54,330	51,471	25	23	4 to 6	3.2
134,074	111,729	105,848	67,037	55,864	52,924	19	17	4 to 6	3.1
134,956	112,464	106,545	67,478	56,232	53,272	27	24	4 to 6	3.1
135,608	113,007	107,059	67,804	56,503	53,530	26	23	4 to 6	3.1
139,955	116,629	110,491	69,977	58,314	55,245	28	24	4 to 6	3.0
140,824	117,353	111,177	70,412	58,677	55,588	27	23	4 to 6	3.0
145,216	121,014	114,644	72,608	60,507	57,322	23	19	4 to 6	2.9
146,040	121,700	115,295	73,020	60,850	57,647	28	23	4 to 6	2.9
151,530	126,275	119,629	75,765	63,138	59,814	24	19	4 to 6	2.8
157,844	131,536	124,613	78,922	65,768	62,307	25	19	4 to 6	2.6
162,301	135,250	128,132	81,150	67,625	64,066	23	17	4 to 6	2.6
164,158	136,798	129,598	82,079	68,399	64,799	26	19	4 to 6	2.5
169,357	141,131	133,703	84,679	70,565	66,851	24	17	4 to 6	2.5
170,471	142,059	134,583	85,236	71,030	67,291	27	19	4 to 6	2.5
176,414	147,011	139,274	88,207	73,506	69,637	25	17	4 to 6	2.4
176,785	147,321	139,567	88,393	73,660	69,784	28	19	4 to 6	2.4
183,470	152,892	144,845	91,735	76,446	72,422	26	17	4 to 6	2.3
183,941	153,284	145,216	91,970	76,642	72,608	23	15	4 to 6	2.3
190,527	158,772	150,416	95,263	79,386	75,208	27	17	4 to 6	2.2

IMPORTANT: See "General Planting Rate Information" and "Checking Seed Population" pages for additional information. Always check seed population in the field to ensure planting rates are correct.

SEED METER OPERATION/MAINTENANCE

**PLANTING RATES FOR LARGE DRY EDIBLE BEAN 54 CELL DISC
28 TOOTH CONTACT WHEEL DRIVE SPROCKET (See Page 7-1)
APPROXIMATE SEEDS/ACRE FOR VARIOUS ROW WIDTHS**

15" Rows	18" Rows	19" Rows	30" Rows	36" Rows	38" Rows	Transmission Sprockets		Recomm. Speed Range (MPH)	Average Seed Spacing In Inches
						Drive	Driven		
81,402	67,835	64,265	40,701	33,918	32,132	15	28	4 to 6	5.1
84,417	70,348	66,645	42,209	35,174	33,323	15	27	4 to 6	5.0
87,664	73,053	69,208	43,832	36,527	34,604	15	26	4 to 6	4.8
91,171	75,975	71,977	45,585	37,988	35,988	15	25	4 to 6	4.6
92,256	76,880	72,834	46,128	38,440	36,417	17	28	4 to 6	4.5
94,969	79,141	74,976	47,485	39,571	37,488	15	24	4 to 6	4.4
95,673	79,727	75,531	47,836	39,864	37,766	17	27	4 to 6	4.4
99,098	82,582	78,236	49,549	41,291	39,118	15	23	4 to 6	4.2
99,353	82,794	78,436	49,676	41,397	39,218	17	26	4 to 6	4.2
103,110	85,925	81,402	51,555	42,962	40,701	19	28	4 to 6	4.1
103,327	86,106	81,574	51,663	43,053	40,787	17	25	4 to 6	4.0
106,928	89,107	84,417	53,464	44,554	42,209	19	27	4 to 6	3.9
107,632	89,693	84,973	53,816	44,847	42,486	17	24	4 to 6	3.9
111,041	92,534	87,664	55,521	46,267	43,832	19	26	4 to 6	3.8
112,312	93,593	88,667	56,156	46,796	44,334	17	23	4 to 6	3.7
115,483	96,236	91,171	57,741	48,118	45,585	19	25	4 to 6	3.6
119,961	99,968	94,706	59,981	49,984	47,353	15	19	4 to 6	3.5
120,294	100,245	94,969	60,147	50,123	47,485	19	24	4 to 6	3.5
124,817	104,014	98,540	62,408	52,007	49,270	23	28	4 to 6	3.4
125,525	104,604	99,098	62,762	52,302	49,549	19	23	4 to 6	3.3
129,440	107,866	102,189	64,720	53,933	51,095	23	27	4 to 6	3.2
130,244	108,536	102,824	65,122	54,268	51,412	24	28	4 to 6	3.2
134,074	111,729	105,848	67,037	55,864	52,924	15	17	4 to 6	3.1
135,067	112,556	106,632	67,534	56,278	53,316	24	27	4 to 6	3.1
135,956	113,297	107,334	67,978	56,648	53,667	17	19	4 to 6	3.1
139,795	116,496	110,364	69,897	58,248	55,182	23	25	4 to 6	3.0
141,097	117,581	111,393	70,549	58,791	55,696	26	28	4 to 6	3.0
145,620	121,350	114,963	72,810	60,675	57,481	23	24	4 to 6	2.9
145,873	121,561	115,163	72,936	60,780	57,581	24	25	4 to 6	2.9
146,524	122,103	115,677	73,262	61,052	57,838	27	28	4 to 6	2.9
151,951	126,626	119,961	75,975	63,313	59,981	23	23	4 to 6	2.8
157,579	131,316	124,404	78,789	65,658	62,202	28	27	4 to 6	2.7
157,795	131,496	124,575	78,898	65,748	62,288	27	26	4 to 6	2.7
158,557	132,131	125,177	79,279	66,066	62,588	24	23	4 to 6	2.6
163,639	136,366	129,189	81,820	68,183	64,595	28	26	4 to 6	2.6
164,107	136,756	129,558	82,053	68,378	64,779	27	25	4 to 6	2.5
165,164	137,637	130,393	82,582	68,818	65,196	25	23	4 to 6	2.5
169,828	141,523	134,074	84,914	70,761	67,037	19	17	4 to 6	2.5
170,945	142,454	134,956	85,472	71,227	67,478	27	24	4 to 6	2.4
171,771	143,142	135,608	85,885	71,571	67,804	26	23	4 to 6	2.4
177,276	147,730	139,955	88,638	73,865	69,977	28	24	4 to 6	2.4
178,377	148,648	140,824	89,189	74,324	70,412	27	23	4 to 6	2.3
183,941	153,284	145,216	91,970	76,642	72,608	23	19	4 to 6	2.3
184,984	154,153	146,040	92,492	77,077	73,020	28	23	4 to 6	2.3
191,938	159,948	151,530	95,969	79,974	75,765	24	19	4 to 6	2.2
199,935	166,613	157,844	99,968	83,306	78,922	25	19	4 to 6	2.1
205,581	171,317	162,301	102,790	85,659	81,150	23	17	4 to 6	2.0
207,933	173,277	164,158	103,966	86,639	82,079	26	19	4 to 6	2.0
214,519	178,766	169,357	107,259	89,383	84,679	24	17	4 to 6	1.9
215,930	179,942	170,471	107,965	89,971	85,236	27	19	4 to 6	1.9
223,457	186,214	176,414	111,729	93,107	88,207	25	17	4 to 6	1.9
223,928	186,606	176,785	111,964	93,303	88,393	28	19	4 to 6	1.9
232,396	193,663	183,470	116,198	96,831	91,735	26	17	4 to 6	1.8
232,991	194,160	183,941	116,496	97,080	91,970	23	15	4 to 6	1.8
241,334	201,112	190,527	120,667	100,556	95,263	27	17	4 to 6	1.7

IMPORTANT: See "General Planting Rate Information" and "Checking Seed Population" pages for additional information. Always check seed population in the field to ensure planting rates are correct.

SEED METER OPERATION/MAINTENANCE

DRY INSECTICIDE APPLICATION RATES APPROXIMATE POUNDS/ACRE AT 5 MPH FOR VARIOUS ROW WIDTHS

Meter Setting	30" Rows
CLAY GRANULES	
10	4.9
11	5.4
12	6.1
13	6.9
14	7.7
15	8.5
16	9.6
17	10.7
18	11.4
19	13.1
20	14.2
21	15.5
22	16.4
23	17.2
24	18.8
25	20.9
26	23.0
27	24.1
28	25.4
29	27.8
30	29.6
SAND GRANULES	
5	2.9
6	4.9
7	5.3
8	6.3
9	7.8
10	8.9
11	10.2
12	11.2
13	12.6
14	14.1
15	15.5
16	17.5
17	19.4
18	21.8
19	24.3
20	25.7
21	27.6
22	29.6
23	32.0
24	34.4
25	36.9

NOTE: The above chart represents average values and should be used only as a starting point. The granular chemical flows through the given meter opening at a nearly uniform rate regardless of roller speed. Your actual rate will vary depending upon the insecticide you are using, your planting speed and your plant population. Planting speed/ground speed has the greatest effect on application rate.

Your actual rate must be checked in the field with the actual insecticide that you are using and at the speed and population at which you will be planting. See "Checking Granular Chemical Application Rate" page for additional information.



WARNING: Agricultural chemicals can be dangerous if not selected and handled with care. Always read and follow directions supplied by the chemical manufacturer.

SEED METER OPERATION/MAINTENANCE

DRY HERBICIDE APPLICATION RATES

APPROXIMATE POUNDS/ACRE AT 5 MPH FOR VARIOUS ROW WIDTHS

CLAY GRANULES

Meter Setting	30" Rows
10	4.7
11	5.2
12	5.8
13	6.5
14	7.3
15	8.2
16	9.0
17	9.9
18	10.7
19	11.6
20	12.6
21	13.6
22	14.6
23	15.7
24	17.0
25	18.1
26	19.4
27	20.9
28	22.6
29	24.3
30	26.7

NOTE: The chart above represents average values and should be used only as a starting point. The granular chemical flows through the given meter opening at a nearly uniform rate regardless of roller speed. Your actual rate will vary depending upon the herbicide you are using, your planting speed and your plant population. Planting speed/ground speed has the greatest effect on application rate.

Your actual rate must be checked in the field with the actual herbicide that you are using and at the speed and population at which you will be planting. See "Checking Granular Chemical Application Rate" page for additional information.



WARNING: Agricultural chemicals can be dangerous if not selected and handled with care. Always read and follow directions supplied by the chemical manufacturer.

SEED METER OPERATION/MAINTENANCE

SEED METER SINGULATOR BRUSH AND VACUUM LEVEL ADJUSTMENTS

SEED DISC SELECTION

CROP	CELLS	SEED SIZE RANGE	COLOR-CODE
Corn	39	35 To 70 Lbs./80,000 Kernel Count Unit	Light Blue
Low-Rate Corn	24	35 To 70 Lbs./80,000 Kernel Count Unit	Light Green
Popcorn	39	2210 To 4200 Seeds/Lb.	Light Blue
Low-Rate Popcorn	24	2210 To 4200 Seeds/Lb.	Light Green
Soybean	60	2200 To 4000 Seeds/Lb.	Black
High-Rate Soybean	120	2200 To 4000 Seeds/Lb.	Dark Blue
Milo/Grain Sorghum	60	10,000 To 20,000 Seeds/Lb.	Yellow
Hill-Drop Cotton, Acid-Delinted (3 Seeds Per Cell)	20	3800 To 5200 Seeds/Lb.	Brown
Cotton, Acid-Delinted	54	3800 To 5200 Seeds/Lb.	Dark Green
Dry Edible Bean (Small)	54	1200 To 2500 Seeds/Lb.	Dark Green
Dry Edible Bean (Large)	54	800 To 1200 Seeds/Lb.	Tan

EDGEVAC® INITIAL SETTINGS

CROP	SIZE	SINGULATOR SEED DISC	VACUUM BRUSH SETTING	SETTING (H ₂ O)	SEE NOTES
Corn	35-45 Lbs./80K	Corn/Popcorn	7	20	4, 5
	45-60 Lbs./80K	Corn/Popcorn	6	20	4, 5
	60-70 Lbs./80K	Corn/Popcorn	5	20	4, 5
Popcorn	2210-4200 Seeds/Lb.	Corn/Popcorn	9	18	1, 4, 5
Soybeans	2200-4000 Seeds/Lb.	Soybean	5	10	1
Milo/Grain Sorghum	10,000-20,000 Seeds/Lb.	Milo/Grain Sorghum	7	18	1, 2
Hill-Drop Cotton	3800-5200 Seeds/Lb.	Hill-Drop Cotton	8	23	3
Cotton	3800-5200 Seeds/Lb.	Cotton	8	20	3
Edible Beans	800-1200 Seeds/Lb.	Large Edible Bean	5	18	5
	1200-2500 Seeds/Lb.	Small Edible Bean	6	18	3, 5

NOTES:

1. Requires use of seed meter baffle. Refer to page 7-3 for additional information.
2. Requires use of cleanout brush. Refer to page 7-3 for additional information.
3. Requires use of cleanout brush w/ball-type ejector. Refer to page 7-3 for additional information.
4. For flat seeds, higher vacuum level may be required.
5. Larger seeds may require a lower numbered singulator brush setting from the initial setting. Smaller seeds may require a higher numbered setting.

Refer to the planting rate charts in this manual for seed drive transmission sprocket combinations.

IMPORTANT: See “General Planting Rate Information” and “Checking Seed Population” pages for additional information. Always check seed population in the field to ensure planting rates are correct.

NOTE: Singulator brush settings are marked from 1 thru 11. The lower the singulator brush setting, the less aggressive. The higher singulator brush settings are the most aggressive. Refer to illustrations on page 7-24.

NOTE: Optimum meter performance will be attained with consistent seed size and shape. A mixture of seed sizes and shapes will affect meter performance.

NOTE: Use 1 tablespoon powdered graphite with each hopper fill of seed. Seed treatment, foreign material, dirt or seed chaff may cause gradual reduction of seed disc fill (population). See “Seed Meter”.

NOTE: Excessive seed treatment, humidity and light-weight seed can affect meter performance. Use ½ cup of talc with each hopper fill of seed and mix thoroughly so that all seeds are coated, adjust rates as needed. Use of talc will aid the seed flow into the meter, singulation and seed drop from the disc.

SEED METER OPERATION/MAINTENANCE

STEP 1 Select seed disc (and seed meter baffle, cleanout brush and/or cleanout brush w/ball-type ejector if applicable) to match crop and population.

STEP 2 Adjust the singulator brush to initial setting. Note that seed size, seed shape, seed treatments, travel speed and planting rate will all affect meter performance.

D06260660

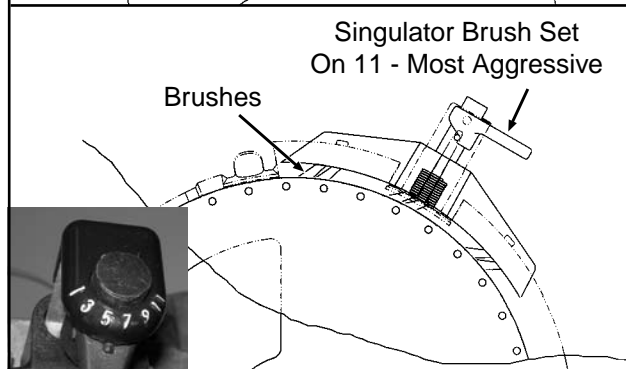
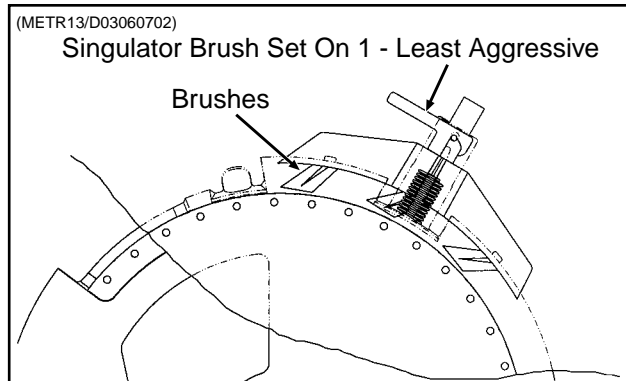
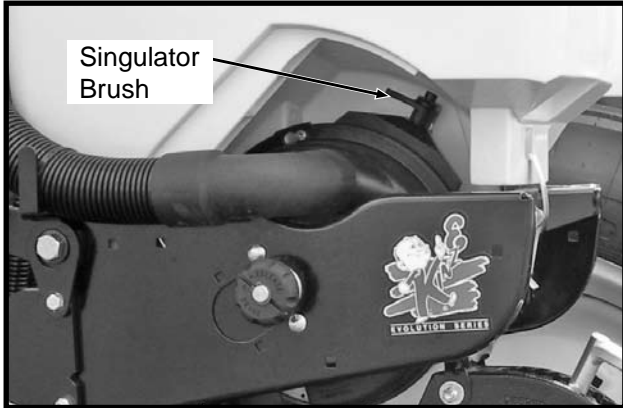

STEP 3 With vacuum fan running, lower planter to planting position and drive forward a short distance to load seed into the seed disc cells.

Adjust vacuum level to the initial setting according to the tables on preceding page. Note that seed size, seed shape, seed treatments, travel speed and planting rate will all affect meter performance.

NOTE: Vacuum reading will be much lower when seed disc cells are empty. Prior to setting vacuum level, load all seed cells.

D10240583



See “Digital Vacuum Gauge Operation” in Machine Operation section

NOTE: Operate vacuum fan 3-5 minutes to bring oil up to normal operating temperature prior to making the final vacuum level adjustment.

STEP 4 Perform optional seed disc fill check.

D101906132



D101906130



With vacuum hose connected and vacuum fan operating, remove vacuum cover and seed disc as an assembly. Inspect seed discs for proper seed fill.

See “Seed Metering System Troubleshooting” at the end of this section.

SEED METER OPERATION/MAINTENANCE

SEED METER DRIVE RELEASE

The seed meter drive is equipped with a clutch release mechanism that allows the drive to be disengaged from the seed metering unit for removal of the seed meter and mount or hopper. Disconnecting the drive allows the operator to check granular chemical application rates without dropping seed. It also allows the drive to one or more of the rows to be disconnected when finishing fields.

D011006101

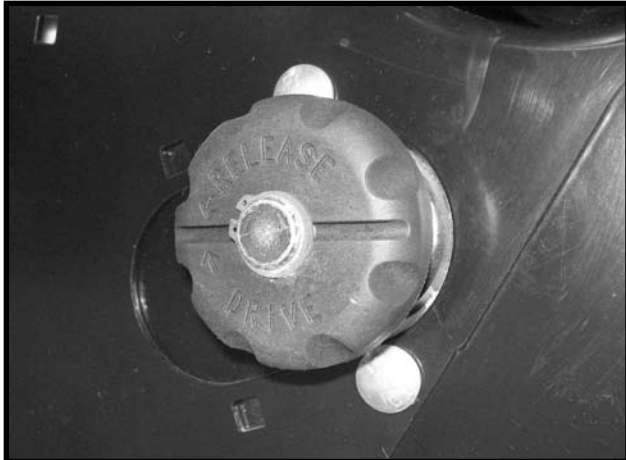

To disengage the drive, turn the knob $\frac{1}{4}$ turn counterclockwise. To engage the drive, turn the knob $\frac{1}{4}$ turn clockwise.

SEED METER OPERATION/MAINTENANCE

SEED METER MAINTENANCE

(METR71)

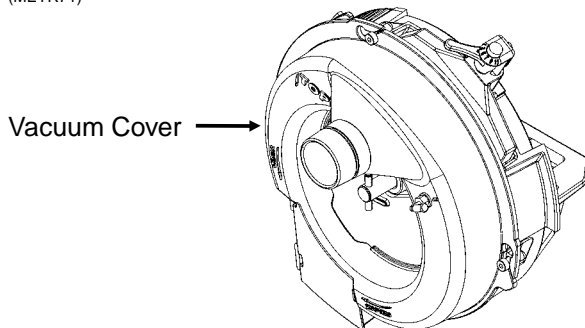

Clean, high quality seed should be used for maximum meter accuracy. Damaged or cracked seed, hulls or foreign material may become lodged in the seed disc orifices and greatly reduce meter accuracy.

It is suggested that the seed disc be inspected and cleaned daily, checking for any buildup of foreign material or any blocked orifices. Clean the seed disc by washing it with soap and water as needed. Dry thoroughly.

Inspect singulator brush for wear and replace if necessary following every 200 acres per row of operation.

The seed disc and/or vacuum cover should be replaced if abnormally high vacuum is required for consistent operation or if consistent operation can not be achieved. If adjustment of the singulator brush does not affect performance of the meter or if the brushes appear frayed, the singulator brush may need to be replaced. If the seed disc orifices are plugged frequently with seed remnants, the cleanout brush or cleanout brush with ball-type ejector (if applicable) may need to be replaced. High quality seed should be used to attain best performance.

(METR70)

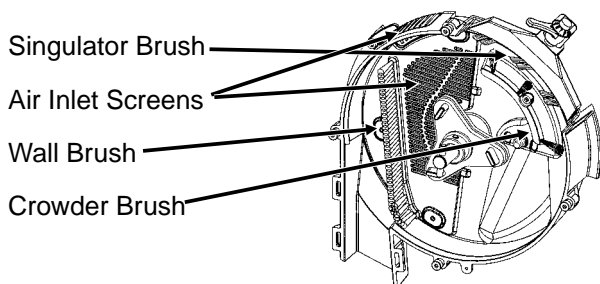

Prior to each planting season, inspect seed discs, singulator brush, crowder brush, wall brush and air inlet screens and clean or replace as needed.

See "Preparation For Storage" for additional EdgeVac® Seed Metering System maintenance.

IMPORTANT: Replace hopper lids after hoppers are filled to prevent accumulation of dust or dirt in the seed meter which will cause premature wear.

NOTE: Remove seed discs from meters for annual storage and store the seed discs vertically on a dowel or pipe.

VACUUM MANIFOLD MAINTENANCE

In the course of normal operation, dust will accumulate in manifolds and hoses. Manifolds should be cleaned annually. More frequent cleaning may be necessitated by abnormally dusty planting conditions.

Remove vacuum hose from each seed meter. Operate the vacuum fan at full hydraulic flow from the tractor for two minutes to clear manifolds, hoses and fittings of dust and debris.

SEED METER OPERATION/MAINTENANCE

SEED METERING SYSTEM TROUBLESHOOTING

PROBLEM	POSSIBLE CAUSE	SOLUTION
Low seed count.	Meter RPM too high.	Reduce planting rate or planting speed.
	Singulator brush setting too aggressive.	Adjust singulator brush.
	Vacuum level too low.	Increase fan speed.
	Seed sensor not picking up all seeds dropped.	Clean seed tube. Move meter to different row.
	Seeds sticking to seed disc.	Use graphite or talc to aid release.
	Seed treatment buildup in seed disc recesses.	Reduce amount of treatment used and or mix thoroughly. Add talc.
	Seed size too large for disc used.	Use appropriate disc for seed size.
	Wrong transmission setting.	Change transmission to desired rate.
	Wrong seed disc.	Use appropriate disc for seed type and size.
	Drive wheel slippage.	Compensate by adjusting transmission sprockets.
	Low tire pressure.	Adjust tire pressure to correct level.
	Failed/worn drive components.	Inspect and replace parts as required.
	Plugged orifices in seed disc.	Inspect and clean disc. Check cleanout brush. (If Applicable)
	Loss of vacuum at meter.	Check for foreign material between vacuum cover and disc. Inspect parts for wear/damage. Clean or replace as required.
	Seed bridging in hopper.	Add graphite to improve seed flow.
	Faulty vacuum gauge reading.	Repair/replace gauge.
	Dirt in vacuum manifold.	Check vacuum manifold for dirt and clean.
	Seed baffle (If Applicable) not allowing seed flow due to bridging of seed.	Thoroughly mix talc to coat all seeds. Remove seed baffle. See "Seed Meter" in Seed Meter Operation/Maintenance section.
	60 cell soybean disc not filling properly due to excessive RPM.	Replace with 120 cell soybean disc.
	Seed disc worn.	Replace.
Vacuum cover worn.	Replace.	
Not planting seed.	Seed hoppers empty.	Fill seed hopper.
	Seed tube plugged/damaged.	Clean or replace tube.
	Meter drive damaged.	Repair/replace drive components.
	Low/no vacuum.	Inspect vacuum system and repair as necessary.
	Singulator brush setting too aggressive.	Adjust singulator brush.
	Faulty vacuum gauge.	Repair/replace vacuum gauge.
	Seed bridging in hopper.	Add graphite to improve seed flow.
	Loss of vacuum at meter.	Check for foreign material between vacuum cover and disc. Inspect parts for wear/damage. Clean and/or replace as required.
	Wrong seed disc.	Use appropriate disc for seed type and size.
	Meter drive clutch not engaged.	Engage drive clutch.
	Fan not running.	Start fan.
	Dirt in vacuum manifold.	Check vacuum manifold for dirt and clean.

(Continued On Following Page)

SEED METER OPERATION/MAINTENANCE

SEED METERING SYSTEM TROUBLESHOOTING (Continued)

PROBLEM	POSSIBLE CAUSE	SOLUTION
Not planting seed. (Continued)	Seed baffle (If Applicable) not allowing seed flow due to bridging of seed.	Thoroughly mix talc to coat all seeds. Remove seed baffle. See "Seed Meter" in Seed Meter Operation/Maintenance section.
	60 cell soybean disc not filling properly due to excessive RPM.	Replace with 120 cell soybean disc.
High seed count.	Wrong transmission setting.	Change transmission to desired rate.
	High vacuum.	Adjust vacuum level to appropriate level.
	Wrong seed disc.	Replace seed disc.
	Singulator brush setting not aggressive enough.	Adjust singulator brush.
	Worn singulator brush.	Inspect brush and replace as required.
	Seed leaking past wall brush.	Inspect wall brush condition and installation. Replace as necessary.
	Faulty vacuum gauge.	Check gauge line for dirt/obstruction. Repair/replace vacuum gauge.
Poor seed spacing.	Obstruction in seed tube.	Clean seed tube.
	Dirty/damaged seed disc.	Inspect seed disc for damage, foreign material in orifices or seed treatment buildup in recesses. Clean or replace as required.
	Wrong vacuum setting.	Adjust vacuum to appropriate level.
	Excess foreign material in seed.	Inspect and clean meter and seed discs. Use clean, undamaged seed.
	Incorrect singulator brush setting.	Adjust singulator brush to appropriate setting.
	Inconsistent driveline.	Inspect drive components for rust, misalignment, worn or damaged parts. Replace/repair as required.
	Toolbar not level or wrong height.	Adjust hitch to level toolbar and row units.
	Planting too fast for conditions.	Reduce speed.
	Rough field conditions.	Reduce speed.
Irregular seed population.	Driving too fast.	Reduce speed.
	Drive wheels slipping.	Reduce speed. Decrease row unit down pressure spring settings.
Unable to achieve desired vacuum level.	Tractor hydraulic flow set too low.	Increase flow to fan motor.
	Incorrect hydraulic connections.	Check all hydraulic connections and hose routings.
	Damaged fan components.	Inspect motor and impeller for wear/damage and repair/replace as necessary.
	Vacuum hose pinched/kinked/blocked.	Inspect air lines for any damage or obstruction. Clean air lines and manifold by removing end cap from manifold and running fan at high speed.
	Vacuum hose loose/disconnected.	Inspect and reattach all air hoses.
	Tractor not producing required hydraulic flow/pressure.	Have tractor serviced by qualified technician.
	Dirt in vacuum gauge line.	Check gauge line for dirt/obstruction and clean.

SEED METER OPERATION/MAINTENANCE

ROW UNIT OPERATION

PLANTING DEPTH

Planting depth is maintained by the row unit gauge wheels. To increase or decrease the planting depth, first raise the planter to remove weight from the wheels. Then push down on the depth adjustment handle and reposition it forward to decrease depth or rearward to increase planting depth. Adjust all units to the same setting initially. Then lower the planter and check operation and planting depth of all row units. It may be necessary to readjust some rows to obtain uniform operation. Available depth adjustment range is approximately 1/2" to 3 1/2".



WARNING: Never work under the planter while in raised position without using safety lockup devices.

D020705102

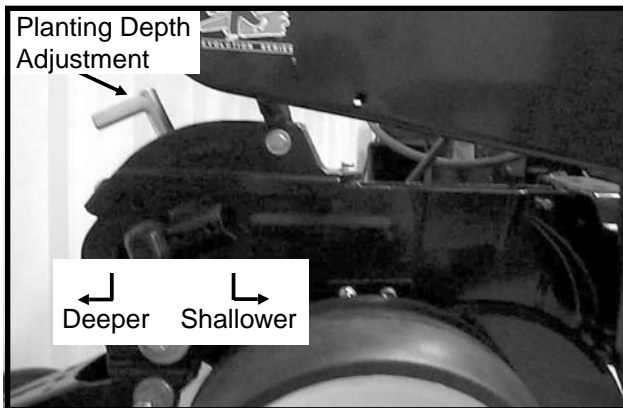

"V" CLOSING WHEEL ADJUSTMENT (Rubber And Cast Iron)



WARNING: Raise planter and install safety lockup devices before making closing wheel adjustments.

After adjusting planting depth, check the operation of the "V" closing wheels. The "V" closing wheels should have enough down pressure to close the seed trench and ensure good soil to seed contact. To increase spring pressure on the closing wheels, move the 5-position quick adjustable down force lever located on the top of the closing wheel arm to the rear. Moving the lever forward decreases spring tension.

Adjust all row units to a similar setting.

LF212299-15

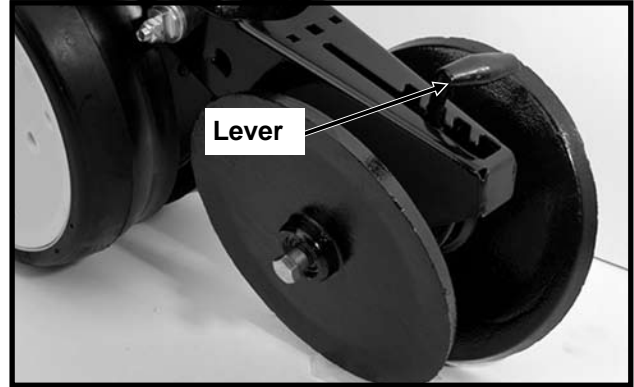

Light soil usually requires less down force at average depth (approximately 2") while heavy soil requires increased down force.

Eccentric bushings in the wheel arm stop allow for lateral adjustment of the "V" closing wheel assembly. Using a 3/4" wrench, loosen the hardware which attaches the closing wheel arm to the wheel arm stop. Using another 3/4" wrench turn the eccentric bushings until the **closing wheels are aligned with the seed trench**. Tighten hardware.

LF2122299-15

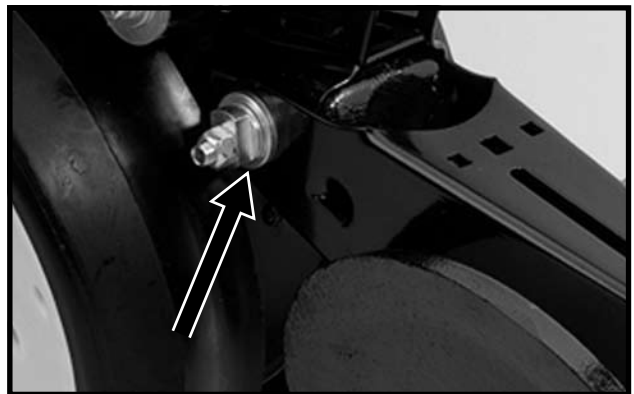

The closing wheels can be installed in two locations either "offset" (to improve residue flow) or "directly" opposite. If set "directly" opposite, the forward installation holes should be used.

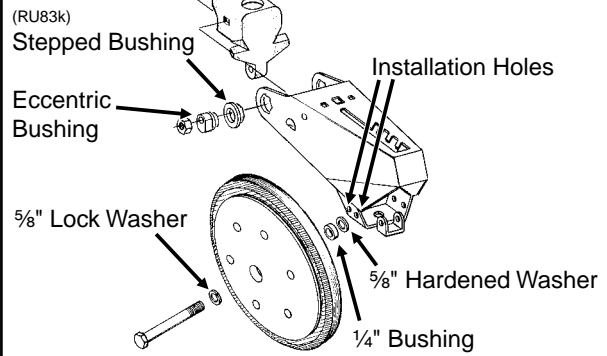

ROW UNIT OPERATION

CLOSING WHEEL SHIELD (Rubber And Cast Iron "V" Closing Wheels)

D11090208a

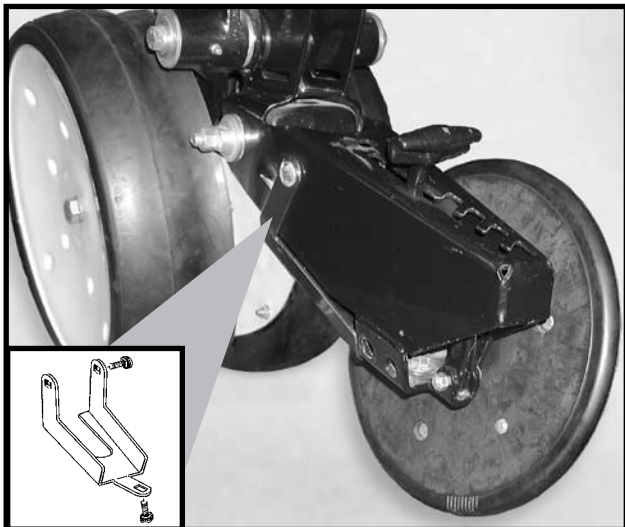

Shown With Closing Wheel Removed For Visual Clarity

The optional closing wheel shield is designed to be installed onto the underside of the closing wheel arm to help prevent root balls and stalks from plugging the closing wheels.

COVERING DISCS/SINGLE PRESS WHEEL ADJUSTMENT



WARNING: Raise planter and install safety lockup devices before making covering discs/single press wheel adjustments.

72359-31



After adjusting planting depth, check the operation of the covering discs/single press wheels.

Initial press wheel down force setting should be with 2 1/2" between mounting arm tab and locking nut. To adjust down force spring, loosen 1/2" locking nut and turn adjusting bolt in to increase down force or out to decrease down force. Tighten locking nut against spring plug. Adjust all row units to a similar setting.

RH993(PLTR12)

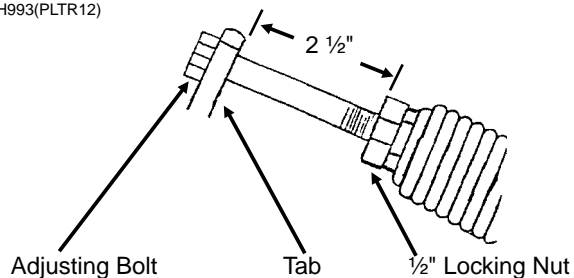

ROW UNIT OPERATION

Eccentric bushings in the wheel arm stop allow for lateral adjustment of the covering discs/single press wheel assembly. Using a 3/4" wrench, loosen the hardware which attaches the assembly to the wheel arm stop. Using another 3/4" wrench, turn the eccentric bushings until the press wheel is aligned with the seed trench.

(RU94b)

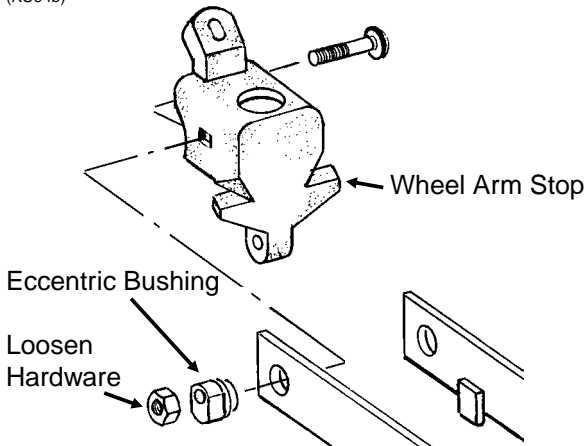

Two sets of holes in the mounting arm allow the covering discs to be located for staggered or side-by-side operation as desired.

72359-35

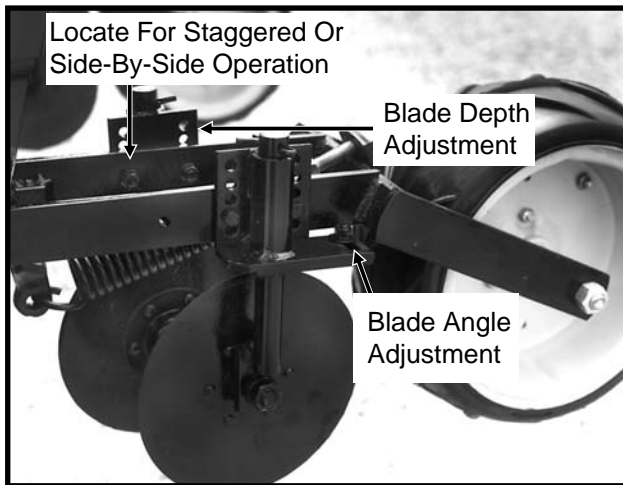

Five sets of holes in each disc bracket allow for 1/2" incremental blade depth adjustment.

Slotted holes in the disc mount and bracket allow for 0° - 15° blade angle adjustment.

Adjust covering discs on all row units to similar settings.

DRAG CLOSING ATTACHMENT

LF212299-18

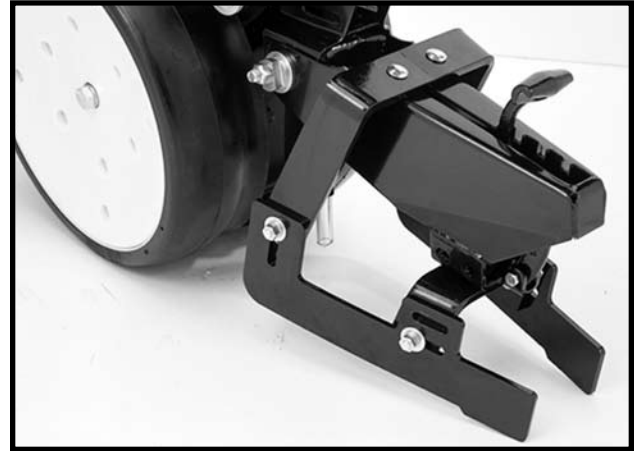

The drag closing attachment is designed to pull loose soil over the seed trench.

Front and rear adjustment is made using the slotted holes in the blades. Adjust all rows the same.

NOTE: Use of a seed firming wheel or other seed firming device is recommended with the drag closing attachment.



WARNING: Raise planter and install safety lockup devices before making drag closing attachment adjustments.

(RU90d)

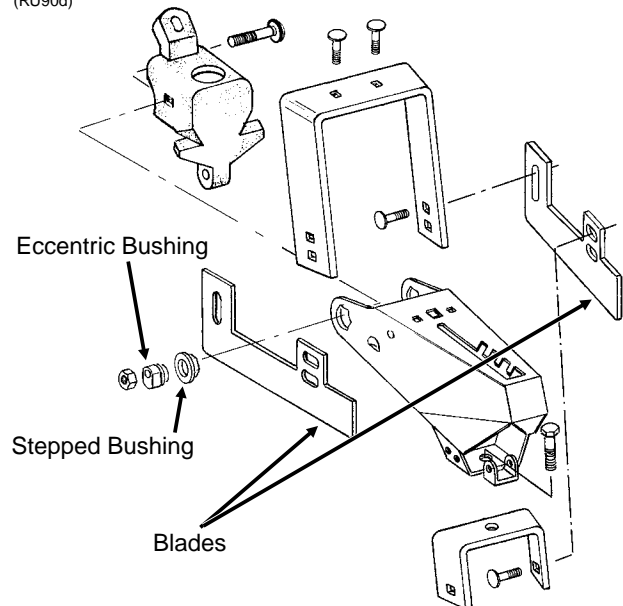

Eccentric bushings allow for lateral adjustment of the drag closing attachment. Using a 3/4" wrench, loosen the hardware which attaches the assembly to the wheel arm stop. Using another 3/4" wrench, turn the eccentric bushings until the drag closing attachment is aligned with the seed trench.

ROW UNIT OPERATION

SEED HOPPER

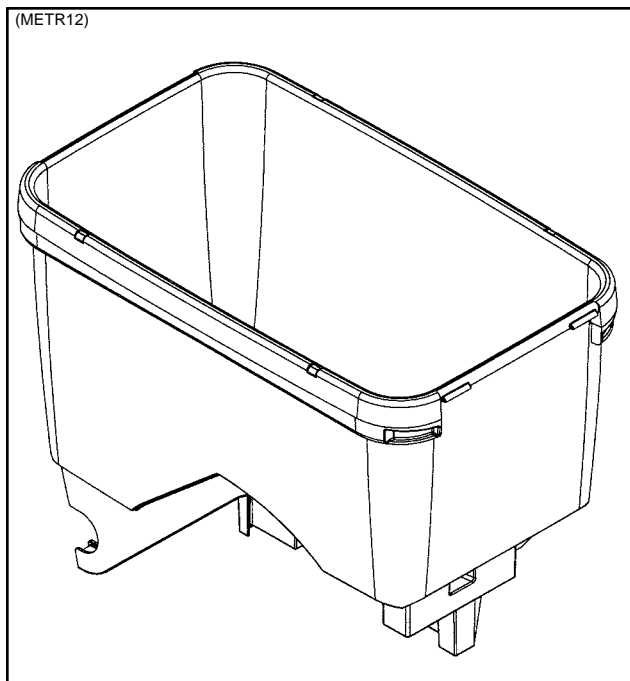

Seed hopper capacity is 1.75 bushels.

When filling the seed hopper use clean seed and make certain there are no foreign objects in the hopper. **Replace hopper lids after hoppers are filled to prevent the accumulation of dust or dirt in the seed meter which will cause premature wear.** See "Seed Meter" in Seed Meter Operation/Maintenance section.

Periodically empty the hoppers completely to remove any foreign material and to ensure proper seed meter operation. To empty hopper, disengage meter drive and hopper latch and lift hopper off the hopper support. See "Seed Meter Drive Release" in Seed Meter Operation/Maintenance section.

ROW UNIT EXTENSION BRACKETS

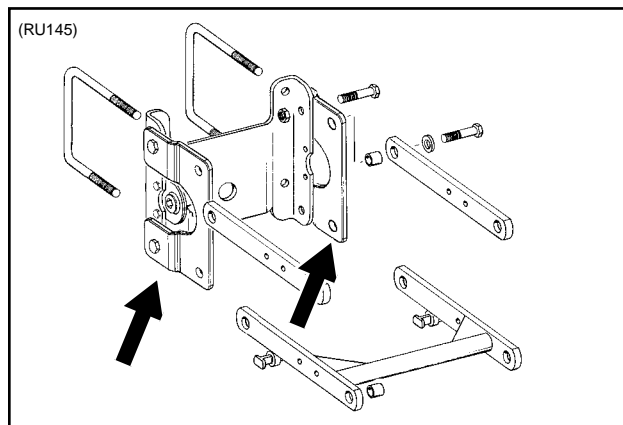

Row unit extension brackets are required on the 4 center row units if the Model 3600 planter is equipped with coulter mounted residue wheels. The brackets extend the row units rearward 4" to provide required clearance.

ROW UNIT OPERATION

ROW UNIT CHAIN ROUTING

For proper operation and to minimize wear, the row unit drive chains must be properly tensioned and aligned.

Inspect and replace weak, worn or broken springs and/or idlers and idler bushings.

NOTE: When idler shows signs of wear, it can be reversed for prolonged use.

D09280611a(RU80g)

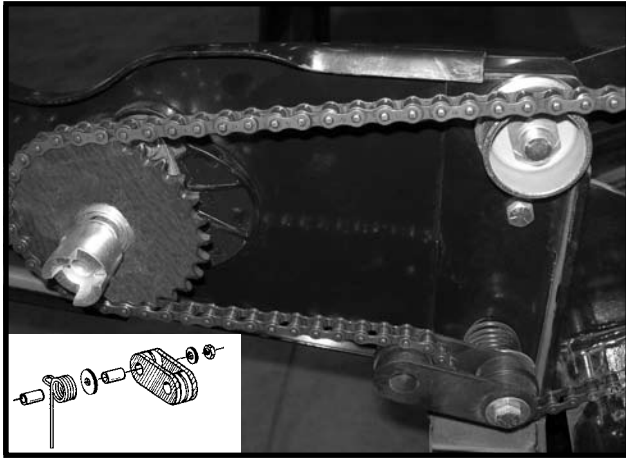

Pull Row Unit Meter Drive

D09280603a(RU80g)

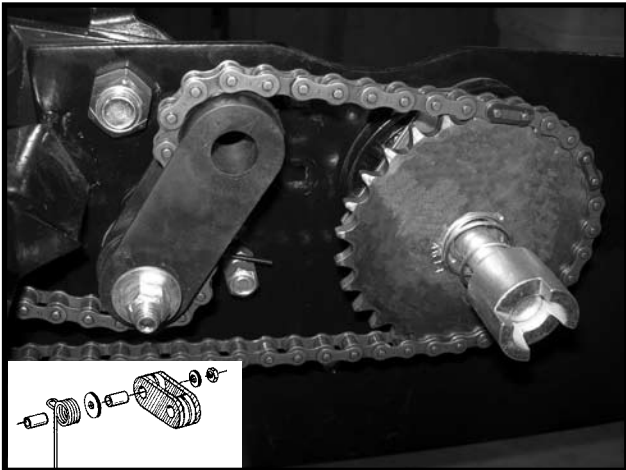

Push Row Unit Meter Drive

D051705102

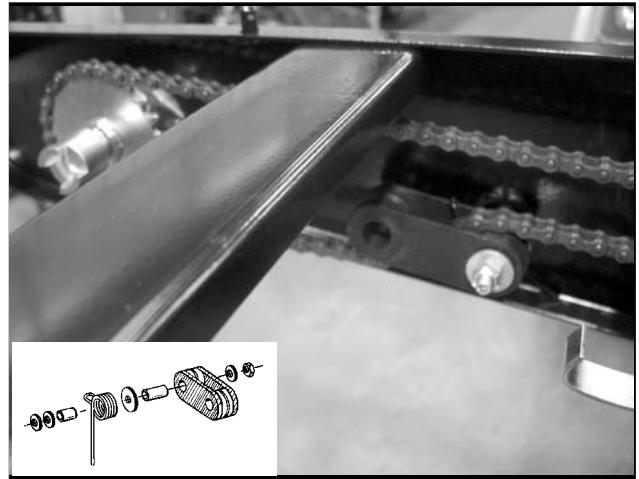

Row Unit Granular Chemical Drive

NOTE: Make sure connector link is installed with closed end oriented properly as shown below.

(PLTR24)

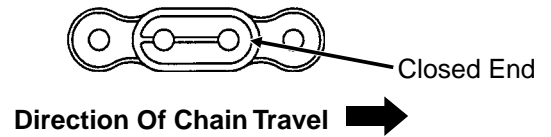

ROW UNIT OPERATION

QUICK ADJUSTABLE DOWN FORCE SPRINGS OPTION

Quick adjustable down force springs are designed to increase penetration in hard soil and keep the row unit from bouncing in rough field conditions.

Two springs per row, one on the L.H. parallel arms and one on the R.H. parallel arms, are used unless equipped with row unit mounted no till coulters. Four springs per row are used with row unit mounted no till coulters.

D06300305



Two Springs Per Row (Dual)

D07010301

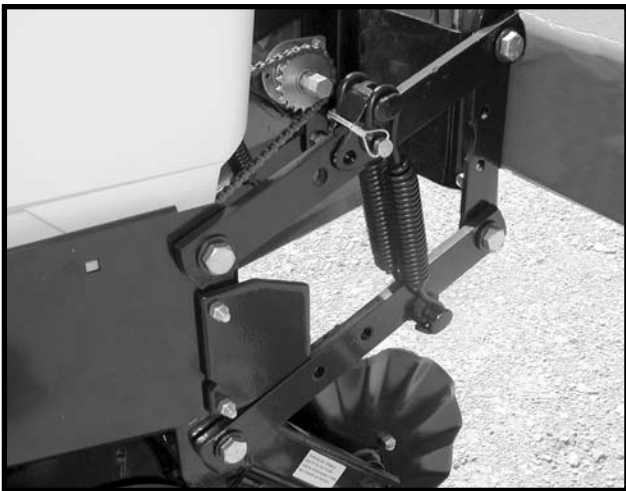

**Four Springs Per Row (Quad)
(Used Only In Conjunction With Row Unit Mounted
No Till Coulters)**

NOTE: Four springs per row are to be used with row unit mounted no till coulters only.

There are four positions for spring tension adjustment. Position 1 allows for minimum down pressure and position 4 for maximum down pressure.

L0096(PLTR27e)

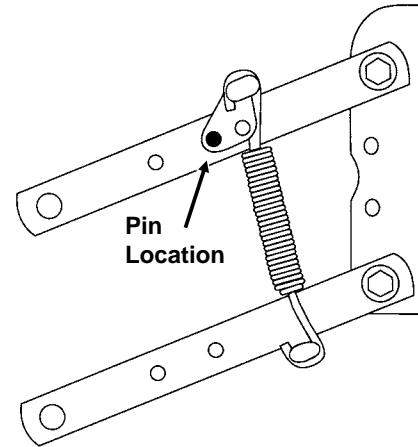

Position 1 (Minimum)

(PLTR28e)

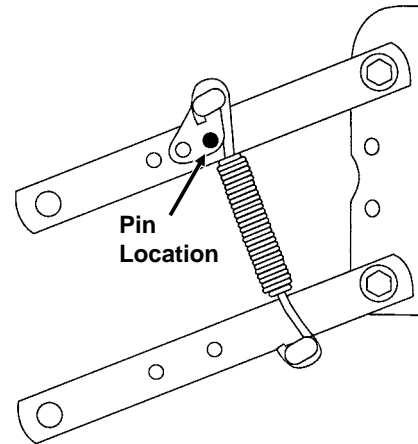

Position 2

(PLTR29e)

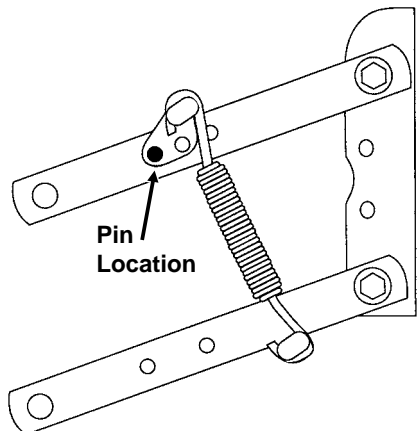

Position 3

ROW UNIT OPERATION

(PLTR30e)

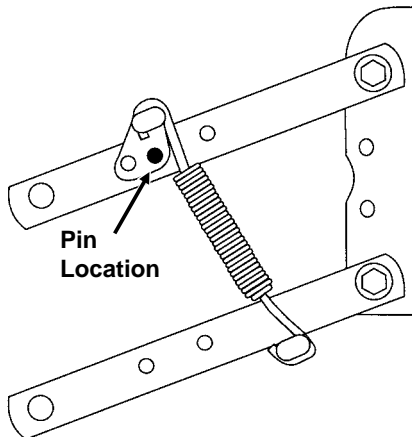

Position 4 (Maximum)

To adjust spring tension, raise planter and remove spring mount pin at top of spring. Slide mount to desired position and install pin.

NOTE: It is necessary for the operator to adjust springs according to field conditions. If springs are adjusted for too much down pressure for field conditions, it is possible for the row units to lift the planter to the extent that the drive wheels do not make sufficient contact. Too much down pressure in soft field conditions can cause the row unit to run too deep.



WARNING: Always install safety lockup devices or lower machine to the ground before working under or around the machine.

IMPORTANT: Springs must always be installed with open side of spring hooks toward the seed hoppers to prevent binding on spring mount adjustment pins.

ROW UNIT OPERATION

PNEUMATIC DOWN PRESSURE PACKAGE

With pneumatic down pressure option, the operator can vary row unit down pressure on-the-go as field conditions change. A cab-mounted digital readout displays down force (lbs.) applied. A planter-mounted 12 VDC air compressor, with 3 gallon capacity air tank, supplies air for the down pressure system.

Packages also include upper and lower air spring mounting castings for pull row units (fore and aft air spring mounting castings for push row units), 150 psi rated air springs, 3/8" O.D. nylon hoses, dual solenoid air valve and stainless steel, 160 psi, 2" liquid-filled gauge and planter wiring harness.

Pneumatic down pressure row unit extension brackets are required in some applications.

(PNE01)

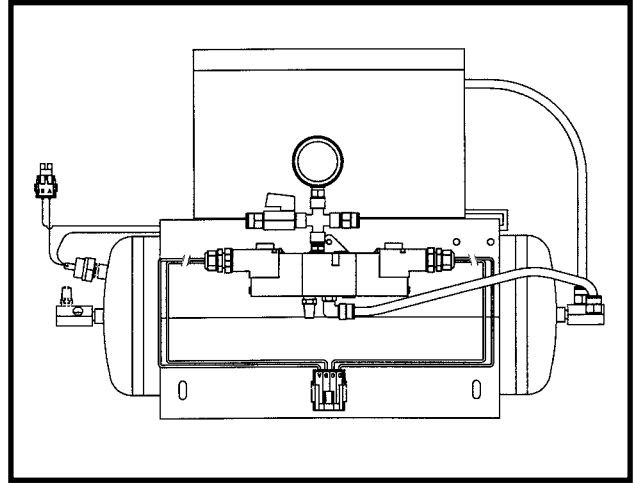

Air Compressor With Dual Solenoid Assembly

(PNE07)

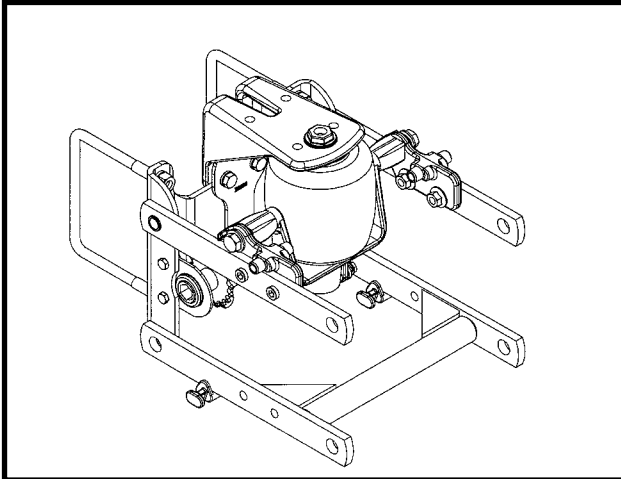

Pull Row Unit Air Spring

(A12644a)

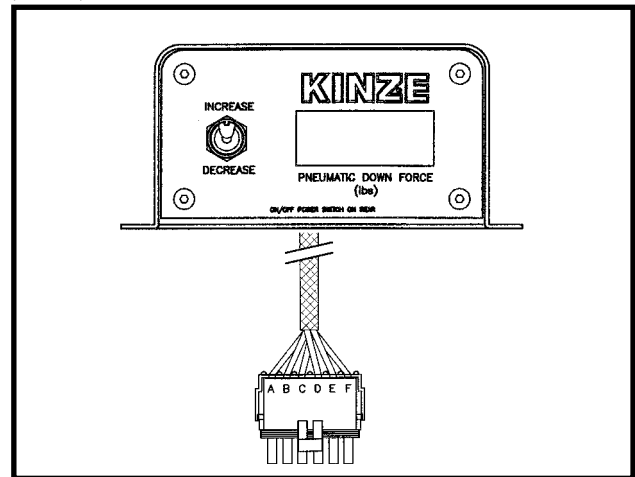

Control Console Assembly

(PNE09)

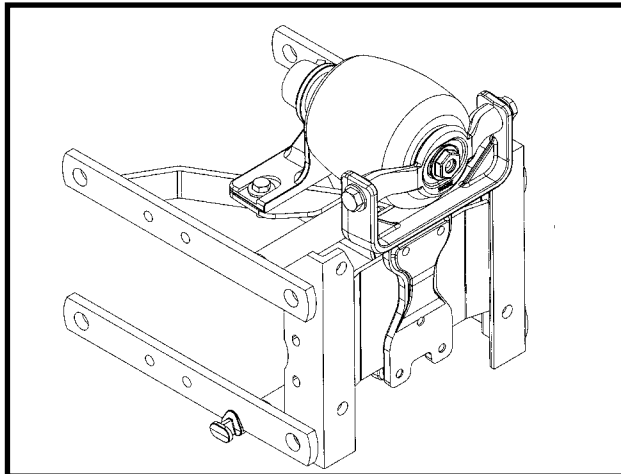

Push Row Unit Air Spring

ROW UNIT OPERATION

NOTE: If additional down pressure is needed with the Pneumatic Down Pressure Package, assist springs are available through your KINZE® dealer. One spring is installed on the outer side of the parallel arms on each side of the row unit as shown below.

D11280753a

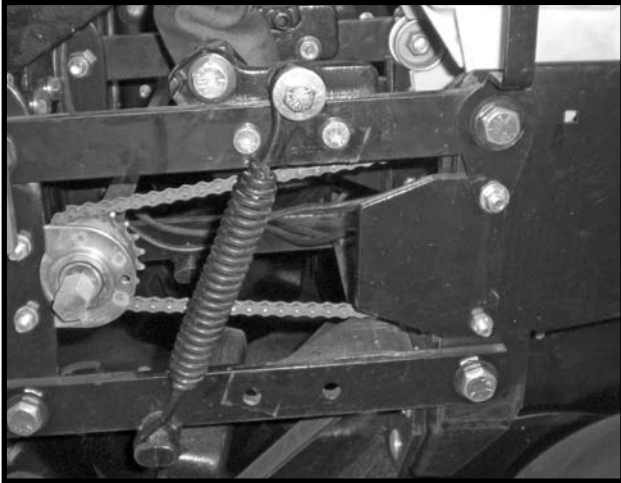

Pull Row Unit Assist Springs

D11280749a

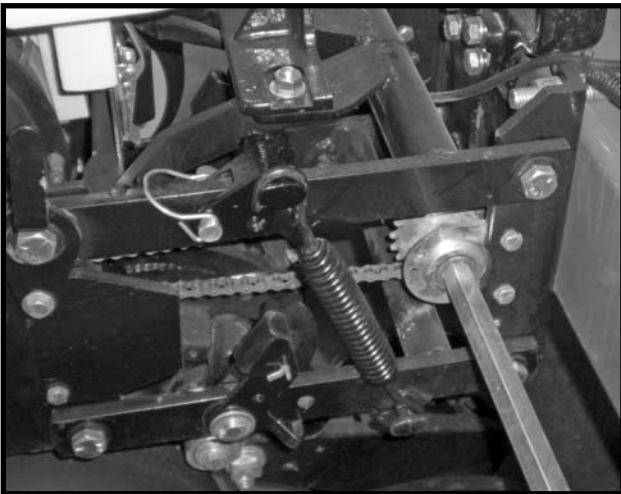

Push Row Unit Assist Springs

FIELD OPERATION

NOTE: For the most accurate adjustment, adjust down pressure with planter lowered and row openers in the ground. Pressure can be adjusted from tractor using the control console, or at planter using the manual control valves.

D112907101

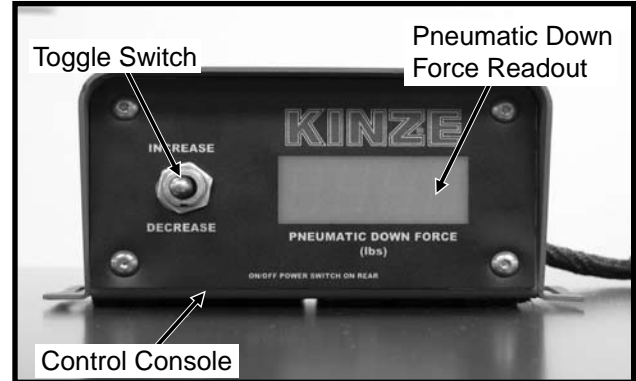

To adjust down pressure from cab:

To INCREASE pressure, push toggle switch up.

To DECREASE pressure, push toggle switch down.

The readout value on the control console is pounds of down pressure force.

To adjust down pressure from planter:

To INCREASE pressure, press and hold button on solenoid as shown below.

To DECREASE pressure, press and hold button on solenoid as shown below.

The readout value on the air pressure gauge is NOT the down pressure force value. To calculate the force value, multiply the air pressure (psi) by four (4).

D112907100

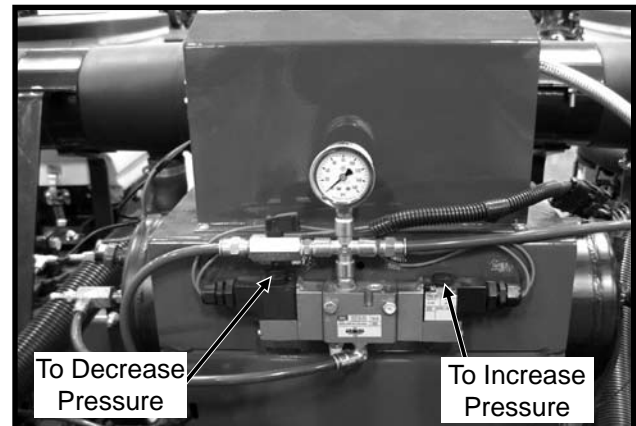

ROW UNIT OPERATION



WARNING: Always install all safety lockup devices or lower planter to the ground before working under or around the machine.

D112907100

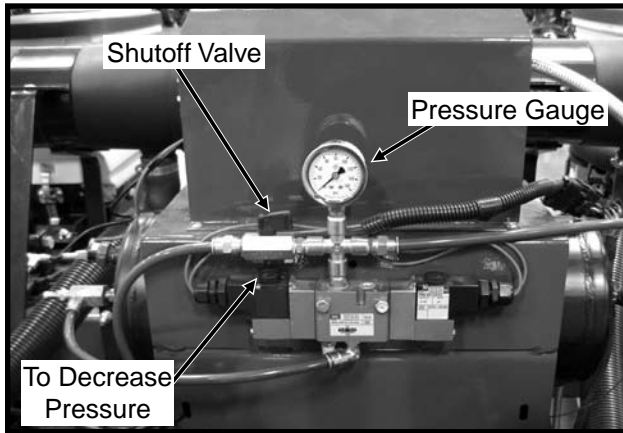

To lock up push row units equipped with pneumatic down pressure springs:

- STEP 1** Disconnect electric power supply to compressor.
- STEP 2** Press and hold button on solenoid until pressure gauge reads zero.
- STEP 3** Lock up units. See "Interplant Push Unit Lockup" for instructions.
- STEP 4** Turn the shutoff valve handle perpendicular to valve body. This turns off air supply to the push row units.

NOTE: If control console is ON and the hydraulic down force is not set to zero, compressor will start when electric power supply is reconnected.

- STEP 5** Reconnect electric power supply to compressor.

ROW UNIT OPERATION

FRAME MOUNTED COULTER

LF083002101

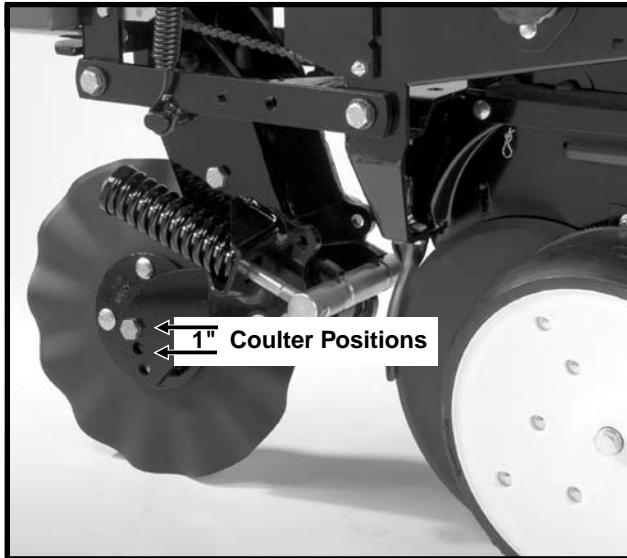

Frame mounted coulters with 1" bubbled, 1" fluted (8 flutes) or 3/4" fluted (13 flutes) blades may be used on pull row units only. (Not compatible with push row units.)

The frame mounted coulters is designed to apply necessary spring down pressure on the coulters for maximum penetration while exerting less shock load on the row unit.

The initial location of the coulters blade is in the top hole. The blade can be relocated to one of the lower two holes (1" increments) as wear occurs or if deeper operation of the blade is desired.

LF083002101

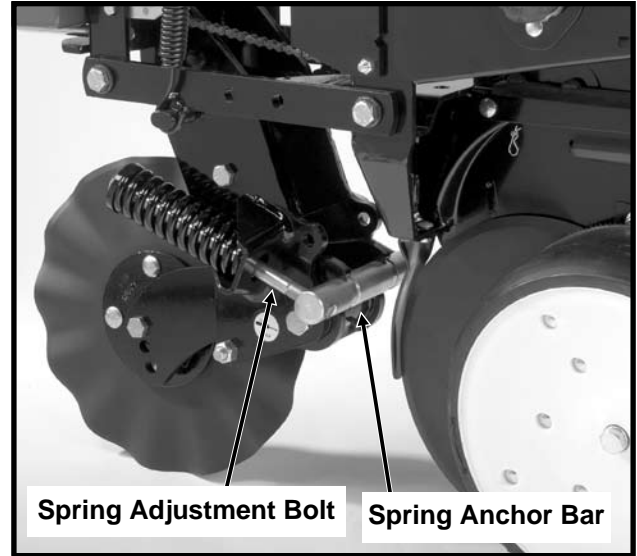

DOWN PRESSURE ADJUSTMENT

Down force adjustment is made by tightening or loosening the two spring adjustment bolts. With the planter in raised position, turn the bolts clockwise to increase down pressure or counterclockwise to decrease down force. Set both springs the same.

Down force on the blade is shown below in lbs.

End Of Spring Adjustment Bolt Flush With Spring Anchor Bar (Shown Above)	End Of Spring Adjustment Bolt Extended 1/2" Through Spring Anchor Bar	All Threads Used (Maximum)
275 lbs.	400 lbs.	500 lbs.

NOTE: Avoid setting down pressure higher than is required for consistent soil penetration. Excessive pressure will increase the chances of damage to coulters components when the coulters strikes an obstacle.

ROW UNIT OPERATION

RESIDUE WHEELS

(For Use With Frame Mounted Coulter)

The residue wheels for use with the frame mounted coulter may be used on pull row units only.

LF083002102



STYLE A Shown

The residue wheels are attached to the frame mounted coulter with two cap screws and sleeves allowing the unit to free-float. A 2-position spindle bolt mounting allows the tined wheels to be mounted interlocked or staggered. Depth adjustment is made using a spring-loaded cam and pin with 11 positions in 1/4" increments. A high point on the cam allows the wheels to be locked up so they do not contact the ground. A weed guard, located on the inboard side of each wheel, aids in the prevention of weed wrap which can cause premature bearing failure.

(RU135k)

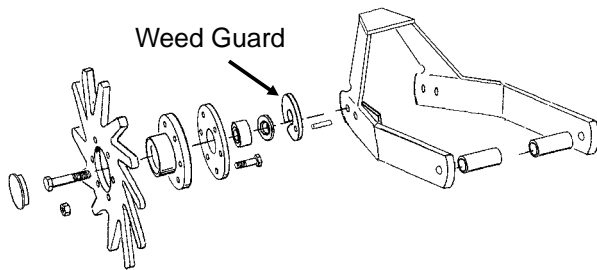

STYLE A

(RU135m)

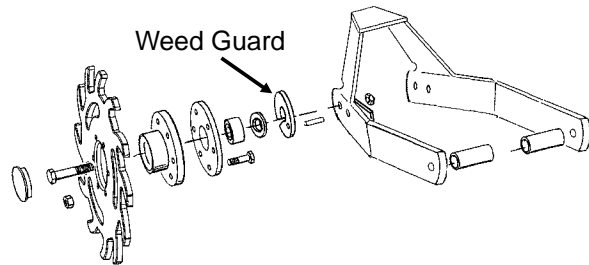

STYLE B

NOTE: Opening in weed guard must point down.

IMPORTANT: The forward mounting positions of the tined wheels can not be used on the four rows behind the axle on the 3600 machine due to inadequate clearance.

ROW UNIT MOUNTED DISC FURROWER

The row unit mounted disc furrower is for use on pull row units only (not compatible with Interplant® push row units). The disc furrower may be equipped with either 12" solid blades or 12" notched blades.

Disc furrowers are used to clear crop residue, dirt clods and dry soil from in front of the row units for a clean and smooth seed bed. Notched blades are used for heavier residue conditions. The notched blades cut crop residue and move it aside to prevent plugging or pushing.

LF212299-22

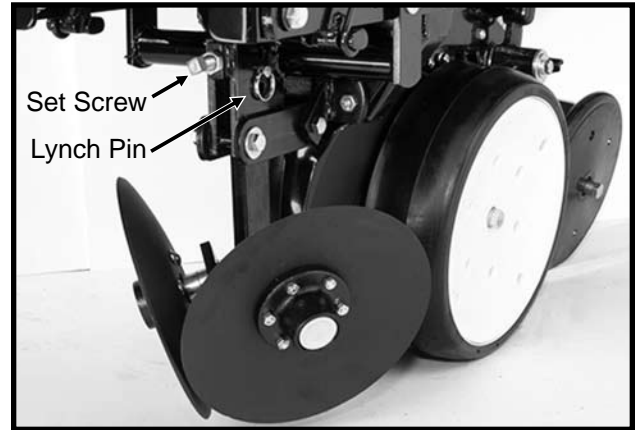

Vertical adjustment in 1/8" increments is possible by removing the lynch pin which secures the vertical support arm and moving the support arm up or down as required. Reinstall lynch pin. Finer adjustment can be attained by removing the lynch pin and using the 5/8" x 2 1/4" set screw to clamp the support arm in the required position.

(RU98e)

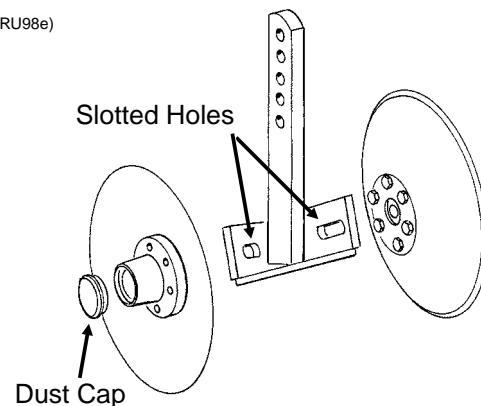

Slotted holes in the support arm where the blades are mounted allow fore and aft adjustment of the disc blades. Blades can be adjusted so the front edges meet or one blade can be moved to the rear and the other to the front of the slot so the cutting edge of one blade overlaps the edge of the other blade. The dust cap must be removed to make these adjustments.

ROW UNIT OPERATION

ROW UNIT MOUNTED BED LEVELER

LF212299-25a

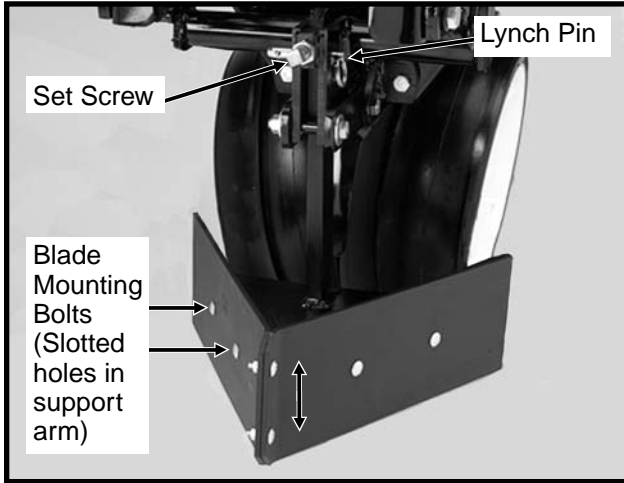

Row unit mounted bed levelers may be used on pull row units only. They are not compatible with push row units.

Vertical adjustment in $\frac{1}{8}$ " increments is possible by removing the lynch pin which secures the vertical support arm and moving the support arm up or down as required. Re-install lynch pin. Finer adjustment can be attained by removing the lynch pin and using the $\frac{5}{8}$ " x $2 \frac{1}{4}$ " set screw to clamp the support arm in the required position.

Slotted holes in the support arm where the blades are mounted allow tilting of the blades. The blades can be tilted up or down at the front for desired adjustment.

NOTE: The row unit mounted bed leveler is not compatible with row spacings less than 36".

ROW UNIT MOUNTED RESIDUE WHEEL

The row unit mounted residue wheel may be used on pull row units and push row units.

D101701113



STYLE A

(A12685)

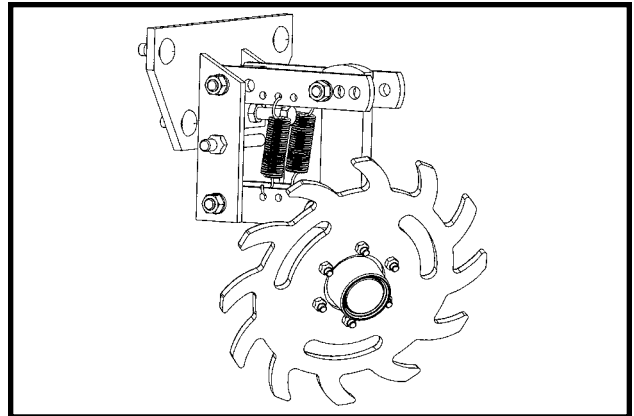

STYLE B

ROW UNIT OPERATION

Two adjustable springs on the parallel links on each residue wheel allow for down force adjustment. Position 1 as shown below provides minimum down pressure and position 3 maximum down pressure.

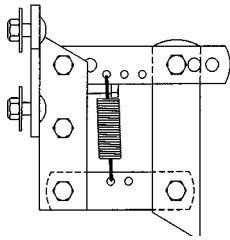

Position 1 (Minimum) (PLTR31a)

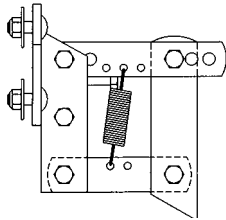

Position 2 (PLTR32a)

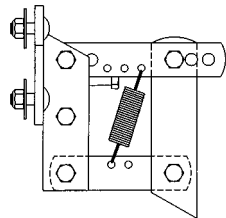

Position 3 (Maximum) (PLTR33a)

For additional uplift or float, position springs as shown below.

(PLTR34a)

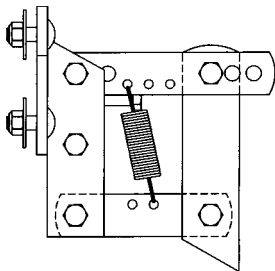

To adjust down force springs, raise the row unit out of the ground and reposition springs as shown for the desired down pressure.

D101701112

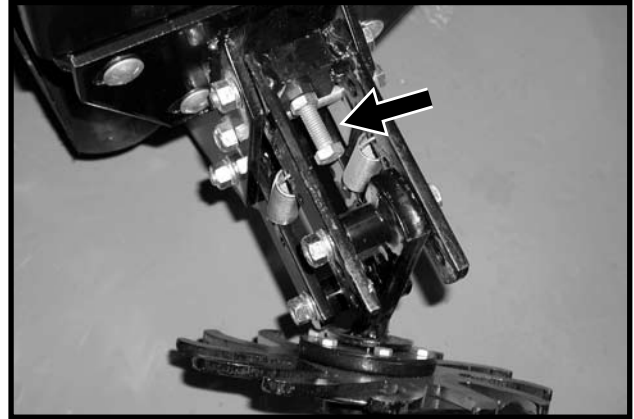

A full threaded bolt and jam nut located on the upper link allows maximum depth to be set for loose soil conditions. Initial setting should be 1 3/4" above the depth of the row unit double disc opener.

Three holes in the upper link allow for wheel angle adjustment. With the wheel mount in the most vertical position, using the rear hole in the upper link, the residue wheel is most aggressive. Moving the wheel mount to one of the forward holes reduces the aggressiveness of the wheel for use in mulch till applications where the soil is loose.

D101701202

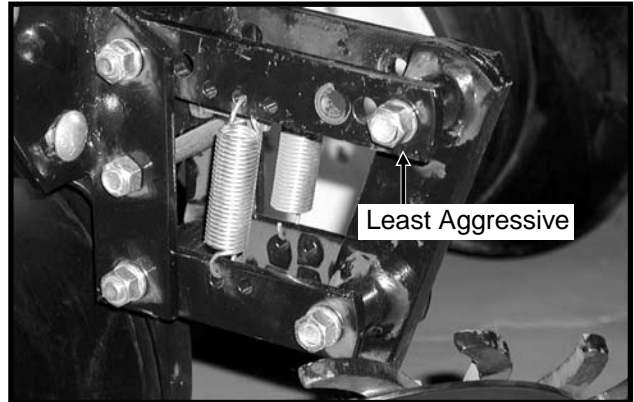

To lock the residue wheel up out of the ground, remove the 1/2" x 5" lockup bolt, raise the residue wheel and install bolt.

D011701203

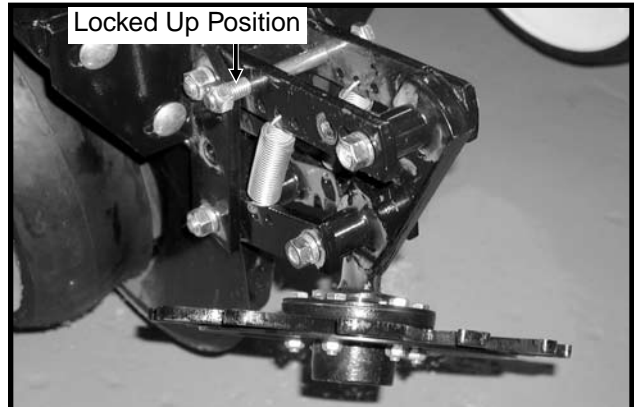

ROW UNIT OPERATION

ROW UNIT MOUNTED NO TILL COULTER

LF212299-19a

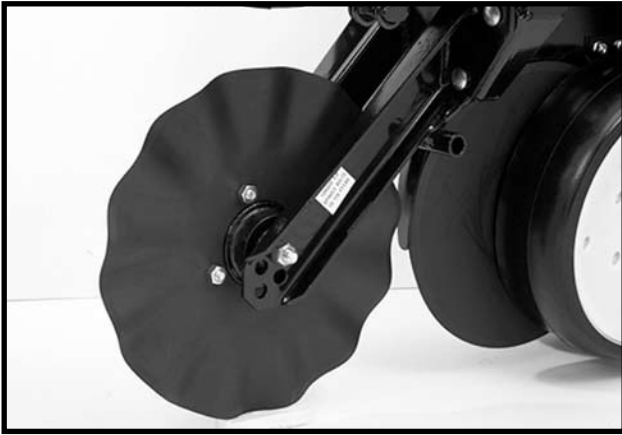

STYLE A (Two Sleeves For Installing Coupler Mounted Residue Wheels)

D05170706a



STYLE B (One Sleeve For Installing Coupler Mounted Residue Wheels)

Row unit mounted no till coulters with 1" bubbled, 1" fluted (8 flutes) or $\frac{3}{4}$ " fluted (13 flutes) blades may be used on pull row units and push row units. ($\frac{3}{4}$ " fluted shown)

Four quick adjustable down force springs are required per row when using row unit mounted no till coulters. See "Quick Adjustable Down Force Springs".

For proper operation, the couler blade should be aligned in relation to the row unit double disc openers. The couler assembly can be adjusted by loosening the four attaching bolts, moving couler arm to align and tightening the four attaching bolts.

The couler blade can be adjusted to one of four $\frac{1}{2}$ " incremental settings in the forked arm. Initial location of the couler is in the top hole. As the couler blade wears, the blade should be adjusted downward to one of the three lower settings to maintain the couler blade at or slightly below the opener discs. In very hard soil conditions such as compacted wheel tracks, opener penetration and cutting of surface residue may be improved by adjusting the couler to operate below the depth of the double disc opener blades.

Operating depth can be checked by setting the planter down on a level concrete floor and checking the relationship between the couler blade and row unit opener blade. Make sure the planter is level and couler is square with the planter frame and aligned with the row unit disc opener.

NOTE: Torque $\frac{5}{8}$ " spindle bolts to 120 ft. lbs.

ROW UNIT OPERATION

COULTER MOUNTED RESIDUE WHEELS

LF212299-23



STYLE A - Used With Style A Row Unit Mounted No Till Coultter

D05170708a



STYLE B - Used With Style B Row Unit Mounted No Till Coultter

Coultter mounted residue wheels are designed for use on pull row units and push row units. Row unit extension brackets are required on the four center pull row units if the planter is equipped with coultter mounted residue wheels.

The coultter mounted residue wheels are attached to the row unit mounted no till coultter with one cap screw and sleeve allowing the unit to free-float. A 2-position spindle bolt mounting allows the tined wheels to be mounted interlocked or staggered. Depth adjustment is made using a spring-loaded cam and pin with 11 positions in $\frac{1}{4}$ " increments. A high point on the cam allows the wheels to be locked up so they do not contact the ground. A weed guard, located on the inboard side of each wheel, aids in the prevention of weed wrap which can cause premature bearing failure.

(RU104tt)

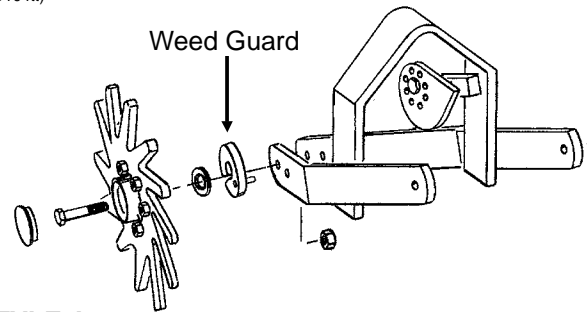

STYLE A

(RU153a)

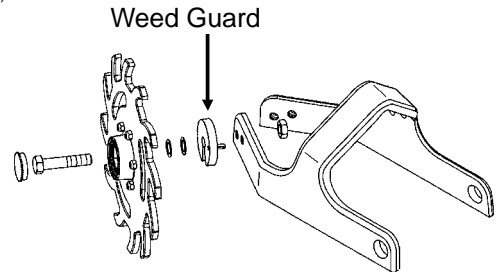

STYLE B

NOTE: Opening in weed guard must point down.

ROW UNIT OPERATION

GRANULAR CHEMICAL HOPPER AND DRIVE

LF212299-6



The granular chemical hopper has a 1.4 cubic feet capacity.

Be sure no foreign objects get into the hopper when it is being filled. Replace the hopper lids after filling the hoppers to prevent the accumulation of dirt and moisture.

The metering gate located on the bottom of the hopper regulates the application rate. See “Dry Insecticide And Dry Herbicide Application Rate Charts” in this manual. Calibrate using the chemical manufacturers’ instructions.



WARNING: Agricultural chemicals can be dangerous. Improper selection or use can seriously injure persons, animals, plants, soil or other property. BE SAFE: Select the right chemical for the job. Handle it with care. Follow the instructions on the container label and of the equipment manufacturer.

The granular chemical clutch drive coupler and meter shaft can be disengaged and engaged by turning the throwout knob located at the rear of the hopper support panel. To engage the drive, turn the knob $\frac{1}{4}$ turn clockwise. To disengage the drive, turn the knob $\frac{1}{4}$ turn counterclockwise. Slotted holes in the hopper support panel and clutch housing allow for alignment adjustment between the clutch drive coupler and meter shaft.

LF212299-4

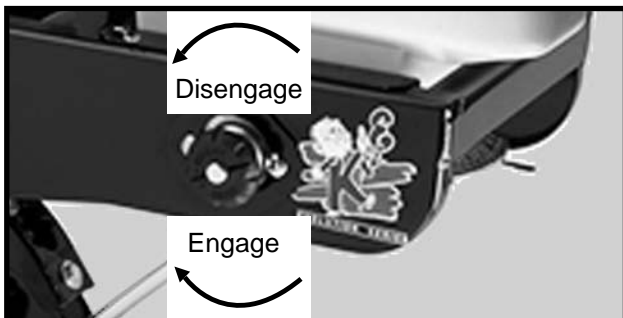

ROW UNIT OPERATION

GRANULAR CHEMICAL BANDING OPTIONS

Granular chemical banding options allow 4 1/2" slope-compensating banding, straight drop in-furrow placement or 14" rear banding.

NOTE: The granular chemical rear bander is not compatible with the covering discs/single press wheel option.

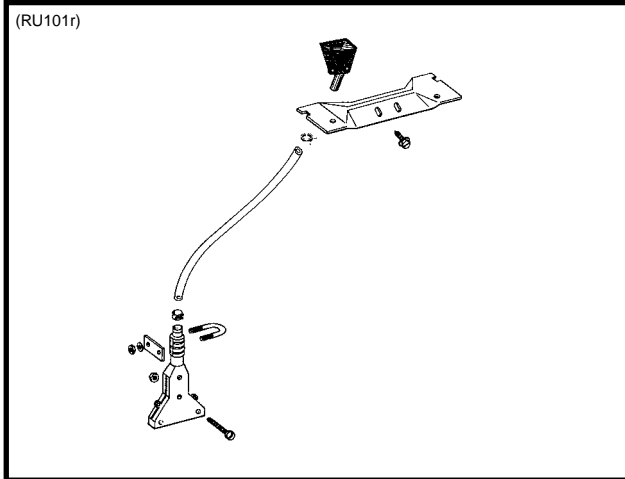

4 1/4" Slope-Compensating Bander

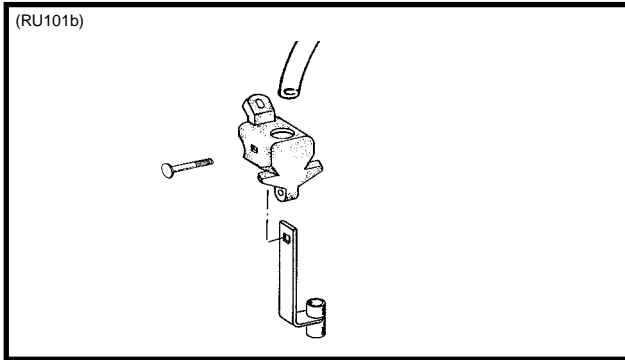

Straight Drop In-Furrow Placement

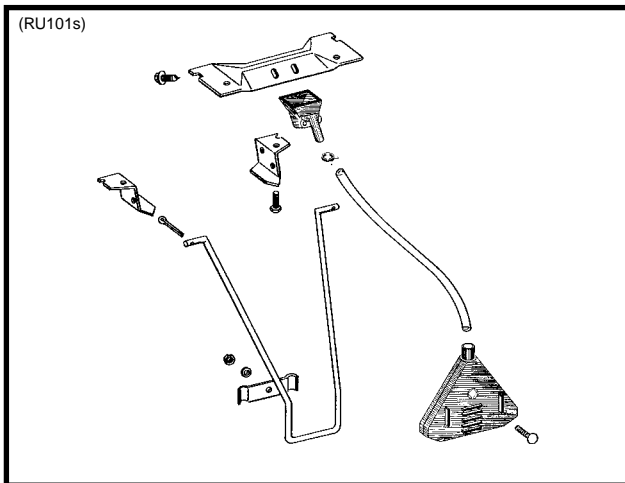

GRANULAR CHEMICAL BANDER SHIELD

The optional granular chemical bander shield is designed to be installed onto the underside of the wheel arm stop to shield crop residue from lodging in the granular chemical bander.

(RU83m)

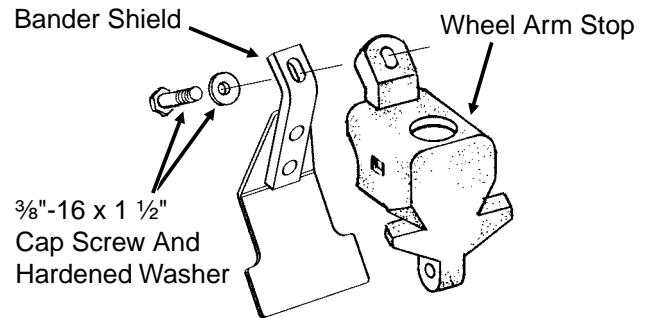

SPRING TOOTH INCORPORATOR

The spring tooth incorporator smooths the soil behind the row unit and incorporates granular chemicals. The two mounting chains on each spring tooth incorporator should be adjusted so there is approximately 1/8" slack in the chain when the unit is lowered to planting position.

NOTE: The spring tooth incorporator is not compatible with the covering discs/single press wheel option.

LF212299-26

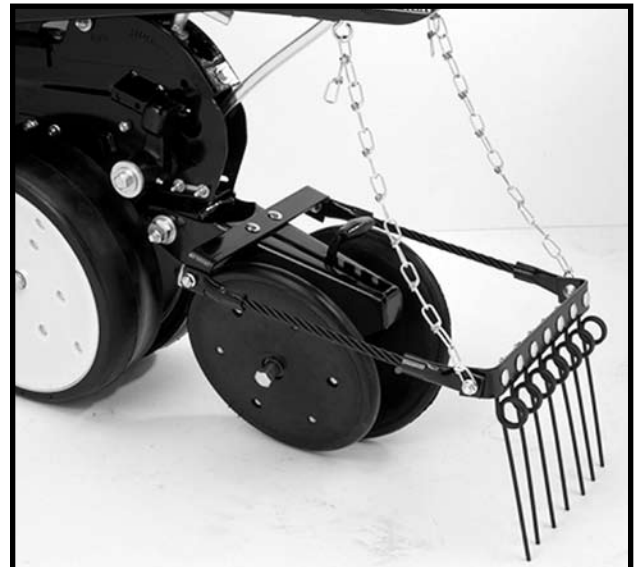

ROW UNIT OPERATION

PUSH ROW UNIT LOCKUPS

Push row unit lockups are designed to allow the push row units to be locked in the raised position.



WARNING: Always install all safety lockup devices or lower planter to the ground before working under or around the machine.

D062603106

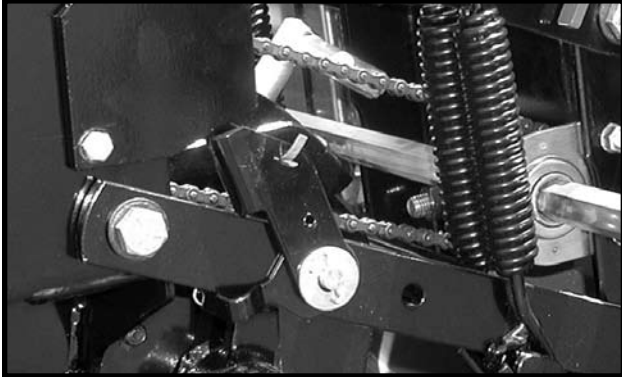

Push Row Unit Locked In Raised Position

D062603103

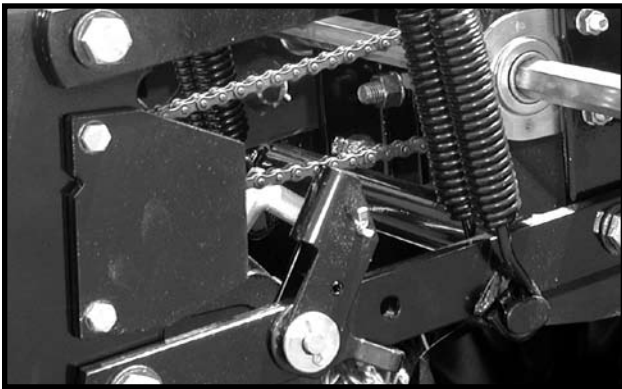

Lockup Released For Field Operation

D062603106



Lift Lever Positioned To Lift Push Row Unit

To lock in raised position:

1. Set row unit down pressure springs to minimum setting.
2. Lower the planter to the planting position.
3. Empty seed hoppers.
4. On each push row unit lockup, flip the spring tab forward.

D060499108

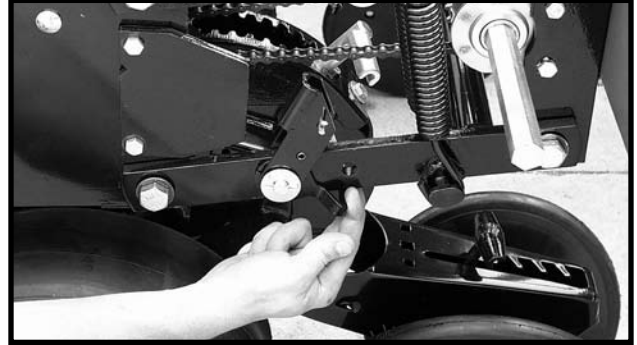

5. Using the lift lever, raise the push row unit to allow the spring loaded lockups to snap into locked position under the row unit stops.
6. Repeat Steps 4 and 5 on remaining push row units.

To release lockups:

1. Lower the planter to the planting position.
2. On each push row unit lockup, flip the spring tab rearward.

D060499107

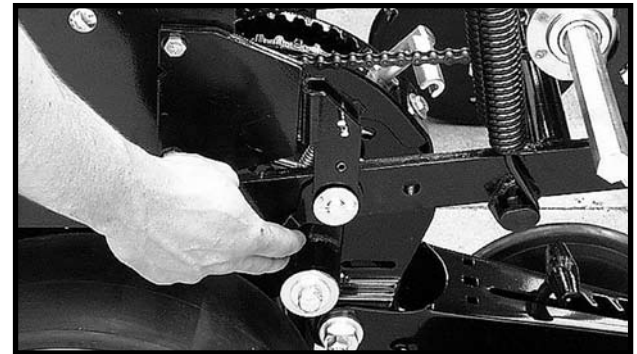

3. Using the lift lever, raise the push row unit to allow the spring loaded lockups to snap out of locked position. Lower row unit to the ground.
4. Repeat Step 3 on remaining push row units.

D070699109



Lift Lever In Storage Location

ROW UNIT OPERATION

PUSH ROW UNIT CLUTCH SPROCKET

06309716

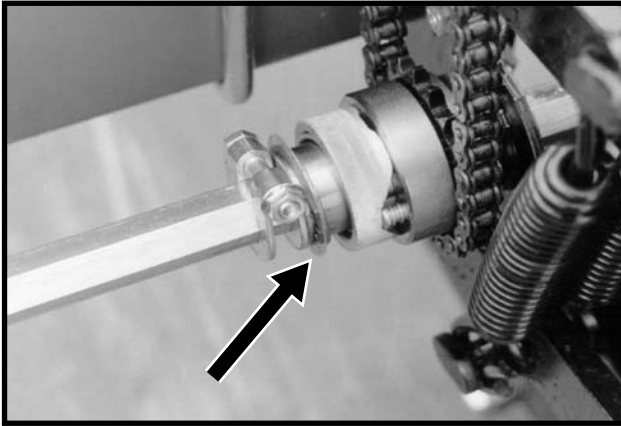

The push row unit clutch sprocket is designed to allow the push row unit drill shaft to be disengaged when only the pull row units are being used.

To disengage the push row unit drill shaft using the clutch sprocket, rotate the knurled collar on the clutch sprocket $\frac{1}{4}$ turn. Then using a $\frac{7}{8}$ " wrench on the drill shaft, rock the drill shaft slightly to take pressure off of the spring loaded pins in the clutch to allow the pins to "pop" out, disengaging the drive. To engage the drive, rotate the knurled collar $\frac{1}{4}$ turn and turn the drill shaft with a $\frac{7}{8}$ " wrench until the drive pins engage the drive sprocket.



WARNING: Always install all safety lockups or lower planter to the ground before working under or around the machine.

LUBRICATION

The following pages show the locations of all lubrication points. Proper lubrication of all moving parts will help ensure efficient operation of your KINZE® planter and prolong the life of friction producing parts.



WARNING: Always install safety lockup devices or lower the machine to the ground before working under or around the machine.

LUBRICATION SYMBOLS

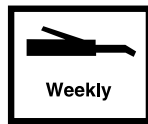
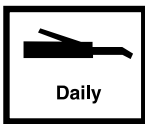

Lubricate at frequency indicated with an SAE multipurpose grease.



Lubricate at frequency indicated with a high quality SAE 10 weight oil or a quality spray lubricant.

SEALED BEARINGS

LF212199-3

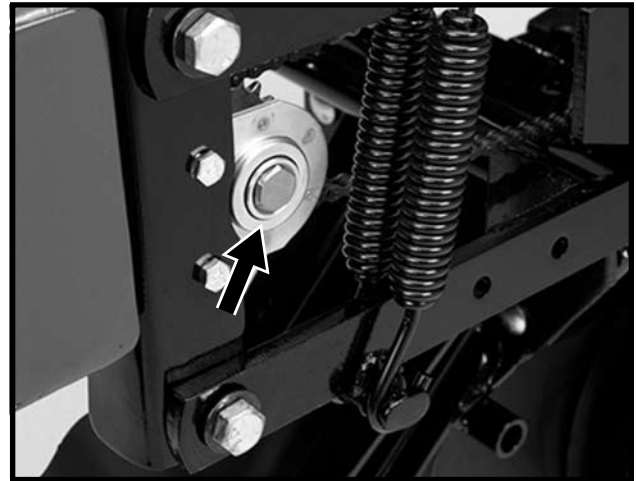

A number of sealed bearings are used on your KINZE® planter to provide trouble free operation. These are located in such areas as the drive shaft, row units and transmission bearings. Sealed bearings are lubricated for life. Due to the seals, relubrication is not practical.

PTO PUMP SHAFT COUPLING (PTO Pump Drive And Oil Cooler Option)

(TWL290c)

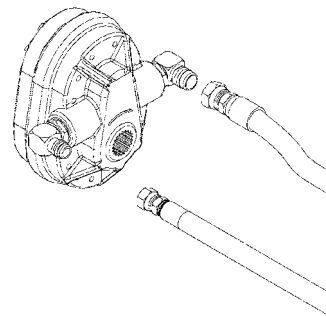

IMPORTANT: The PTO shaft coupling should be cleaned and greased each time the pump is installed.

IMPORTANT: To extend life of shaft splines, apply a coating of high-speed industrial coupling grease, such as Chevron® Coupling Grease, that meets AGMA CG-1 and CG-2 Standards.

(The Chevron® trademark is owned by Chevron Products Company. AGMA is the acronym for the American Gear Manufacturers Association)

LUBRICATION

DRIVE CHAINS

All transmission and drive chains should be lubricated daily with a high quality chain lubricant. Extreme operating conditions such as dirt, temperature or speed may require more frequent lubrication. If a chain becomes stiff, it should be removed, soaked and washed in solvent to loosen and remove dirt from the joints. Then soak the chain in oil so the lubricant can penetrate between the rollers and bushings.

D09280611a

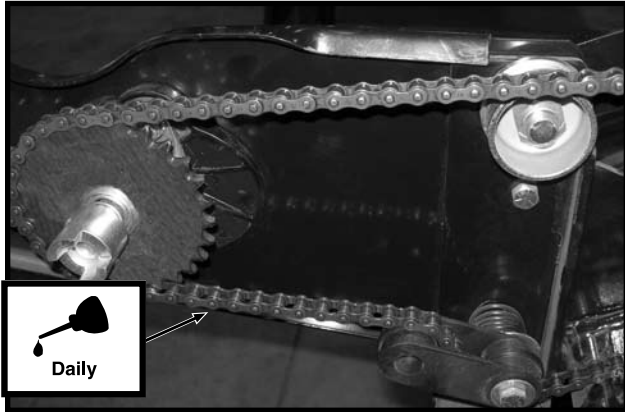

Pull Row Unit Drive Chains

D051705102

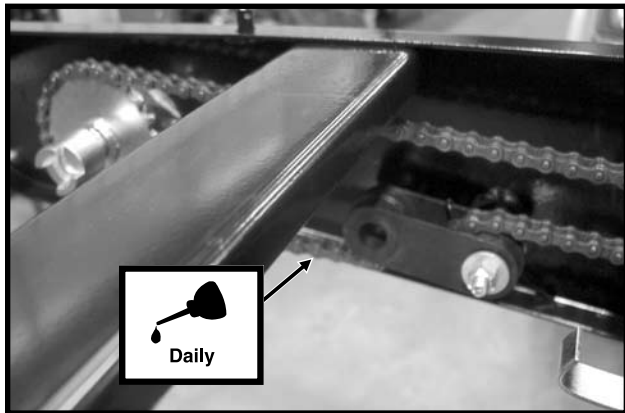

Row Unit Granular Chemical Drive Chains

D09280603a

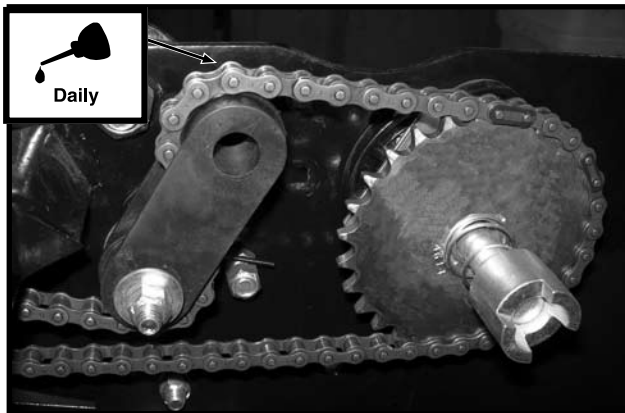

Push Row Unit Drive Chains

77387-8(PLTR52)

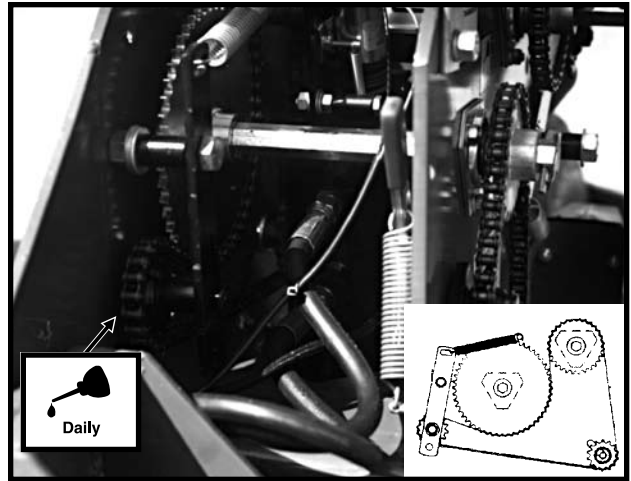

Inner Wheel Module Drive Chains

D08260513

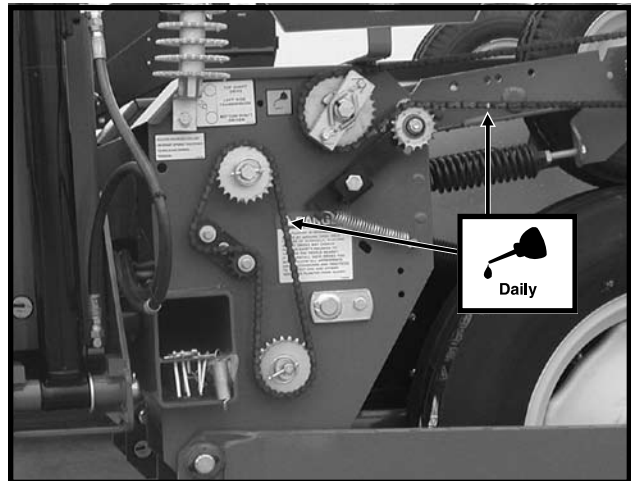

**Contact Wheel Drive Chains
Seed Rate Transmission Drive Chains**

D07140303a

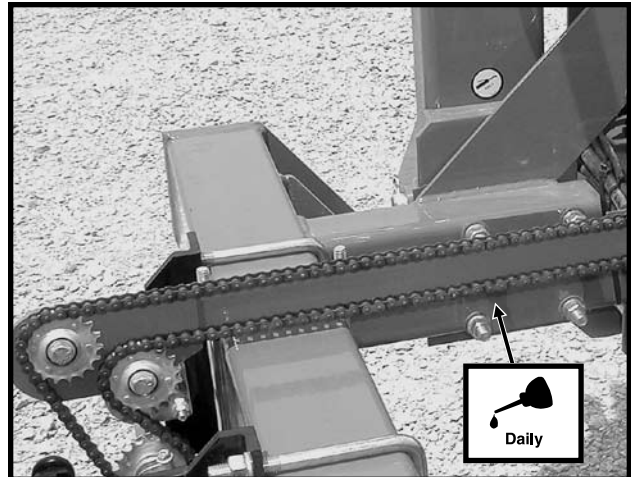

Push Row Unit Package Drive Chains

LUBRICATION

D070804112(TWL219e)

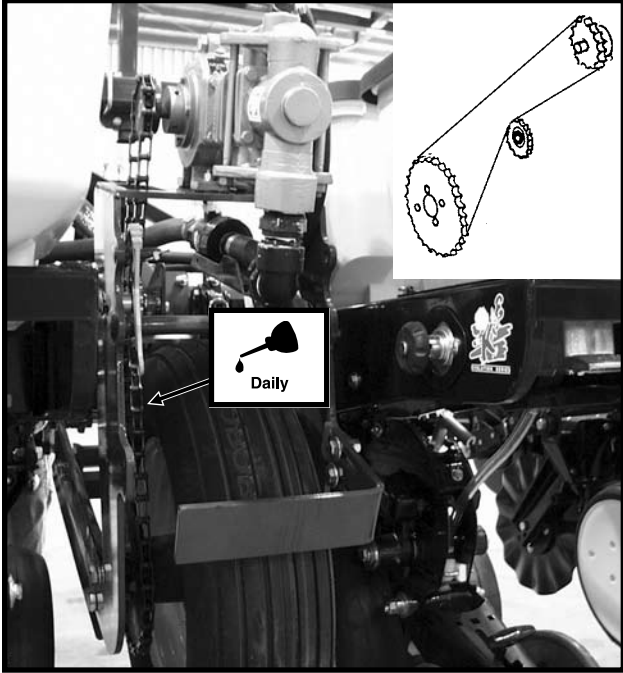

Liquid Fertilizer Ground Drive Chain (Piston Pump)

LUBRICATION

BUSHINGS

Lubricate bushings at the frequency indicated.

Using a torque wrench, check each bolt for proper torque. If bolt is loose, it should be removed and the bushing inspected for cracks and wear. Replace bushing if necessary. **Only hardened flat washers should be used. Replace damaged flat washers with proper part. Torque hardware to 130 ft. lbs.**

59386-26

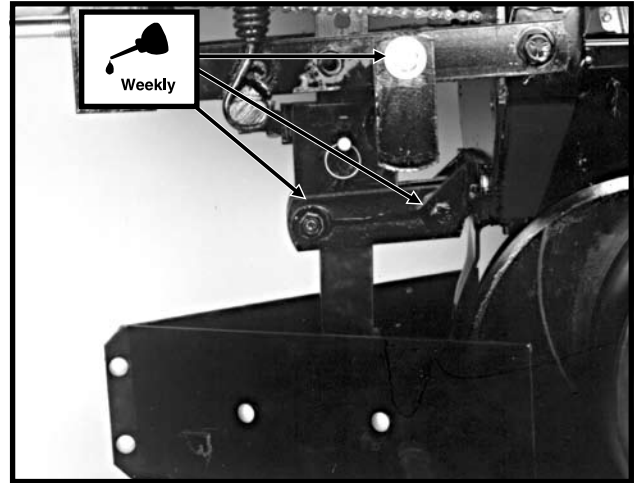

Row Unit Mounted Bed Leveler Parallel Linkages (6 Per Row)

D06300305

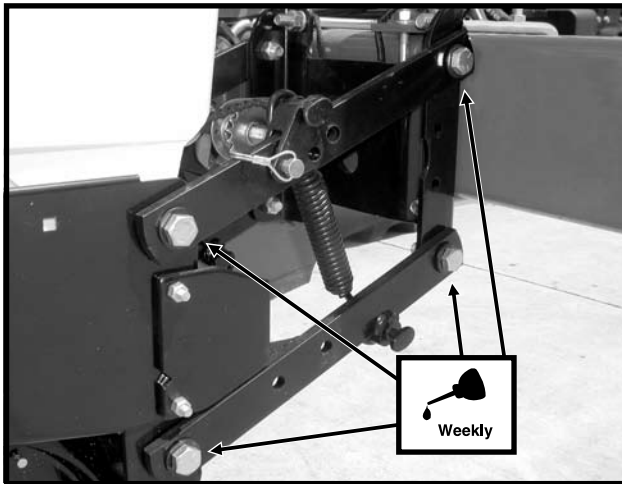

Pull Row Unit And/OR Push Row Unit Parallel Linkages (8 Per Row)

LF212199-2

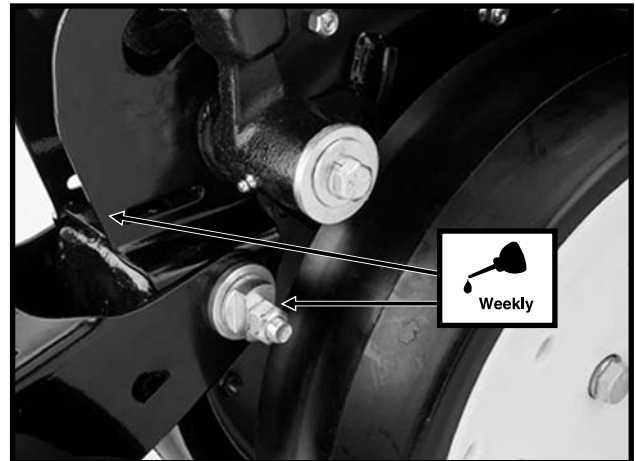

Row Unit "V" Closing Wheel, Covering Discs/ Single Press Wheel And/Or Drag Closing Wheel Eccentric Bushings (2 Per Row)

LF212299-22



Row Unit Mounted Disc Furrower Parallel Linkages (6 Per Row)

LUBRICATION

D061901128

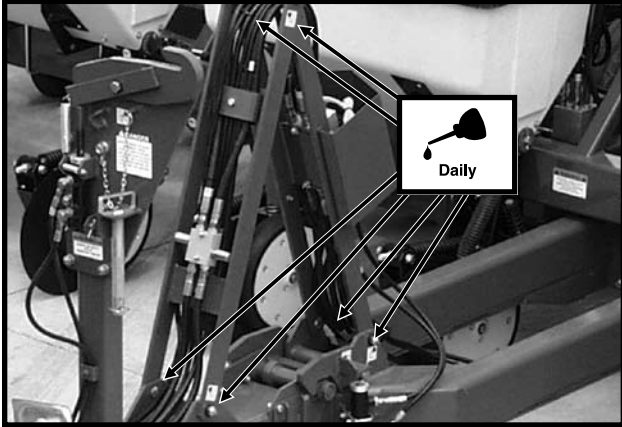

Hose Take-Up (6 Locations)

82316-16

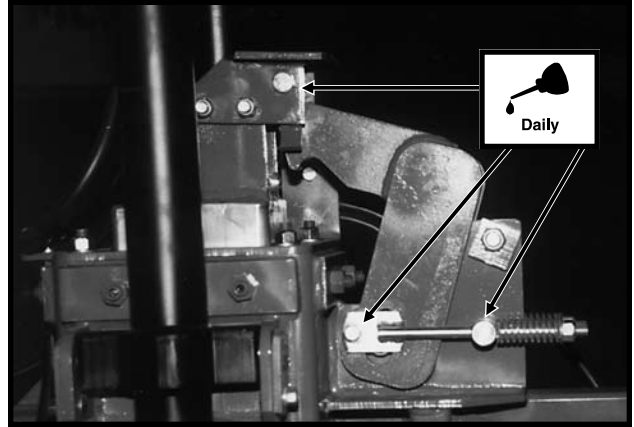

Safety Hook Located At Top Of Center Section

NOTE: CENTER POST AND POLY WEAR PADS REQUIRE NO LUBRICATION. ANY OIL OR GREASE WILL ATTRACT DIRT AND ACCELERATE WEAR ON THE CENTER POST AND ON THE POLY WEAR PADS.

D060299216



Transport Latch (1 Location)

PUSH ROW UNIT LOCKUPS

D08260513

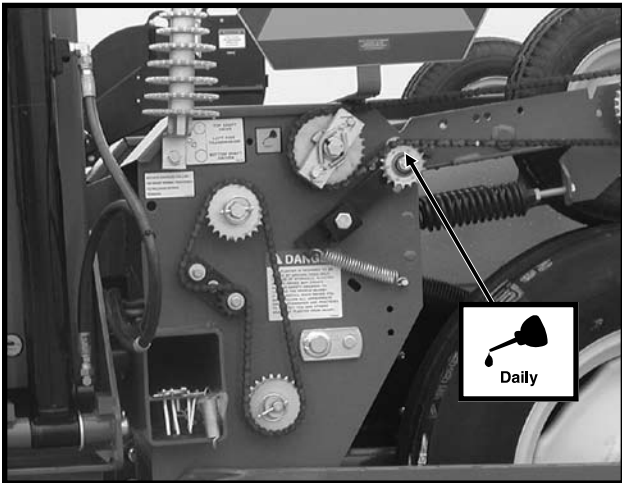

Contact Drive Wheel Arm (2 Per Wheel Assembly)

D06099906

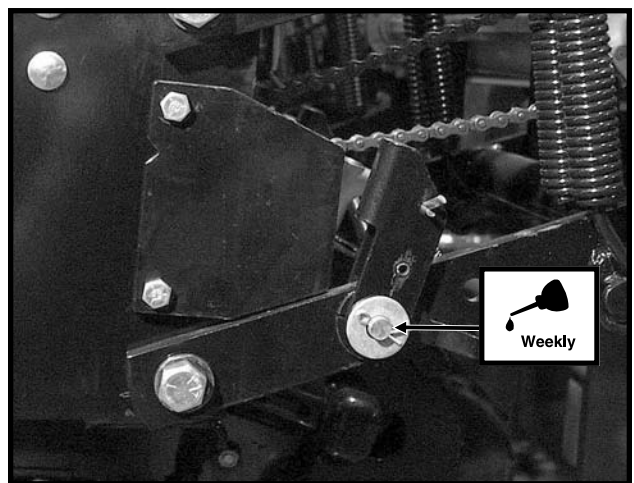

2 Per Row

LUBRICATION

WRAP SPRING WRENCH ASSEMBLY

The chain idler is equipped with a wrap spring wrench. The wrench components may require occasional lubrication to operate correctly. Disassembly is required to lubricate. (a) Remove the ¼"-20 x ½" cap screw that secures the idler with sprockets to the wrench tightener shaft. (b) Remove the wrap spring wrench from the planter. (c) Tip the wrap spring wrench on its side and lubricate using a high quality spray lubricant. Lubricant must be absorbed into the wrap spring area. (d) Reinstall wrench on planter.

D101303102



WHEEL BEARINGS

The transport wheel hubs are equipped with grease fittings. Pump grease into the hub until grease comes out around the seals. See "Grease Fittings" for lubrication frequency.

All wheel bearings should be repacked annually and checked for wear. This applies to all drive wheels, transport wheels and marker hubs.

To check for wear, lift the wheel off the ground. Check for endplay in the bearings by moving the tire side to side. Rotate the tire to check for roughness in the bearings. If bearings sound rough, the hub should be removed and the bearings inspected and replaced if necessary. See Maintenance section.

To repack wheel hubs, follow the procedure outlined for wheel bearing replacement with the exception that bearings and bearing cups are reused.

U-JOINT SLIDES

Lubricate all U-joint slides daily with a high quality lubricant.

76740-54

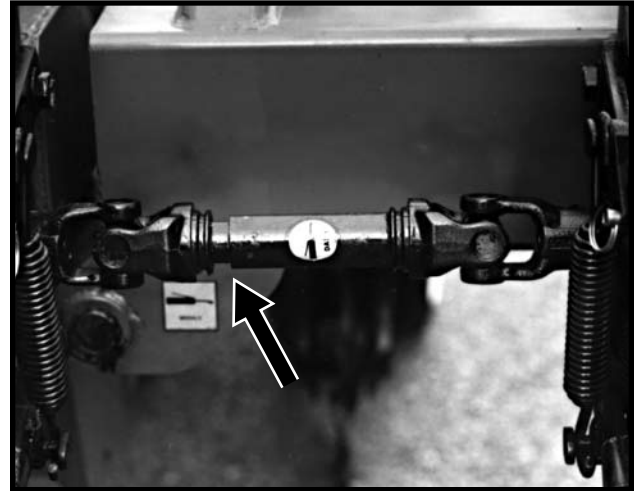

CENTER POST

D060299107



The center post is clad with stainless steel. To prolong service life keep stainless steel surface clean and free of any lubrication.

CENTER POST AND POLY WEAR PADS REQUIRE NO LUBRICATION. ANY OIL OR GREASE WILL ATTRACT DIRT AND ACCELERATE WEAR ON THE CENTER POST AND ON THE POLY WEAR PADS.

See "Wear Pad Replacement/Adjustment" for additional information.

LUBRICATION

GREASE FITTINGS

Those parts equipped with grease fittings should be lubricated at the frequency indicated with an SAE multipurpose grease. Be sure to clean the fitting thoroughly before using grease gun. The frequency of lubrication recommended is based on normal operating conditions. Severe or unusual conditions may require more frequent attention.



WARNING: Always install safety lockup devices or lower the machine to the ground before working under or around the machine.

NOTE: Numbers on below photo correspond to photos on following pages showing lubrication frequencies.

D08260501

12 Row 30" Shown

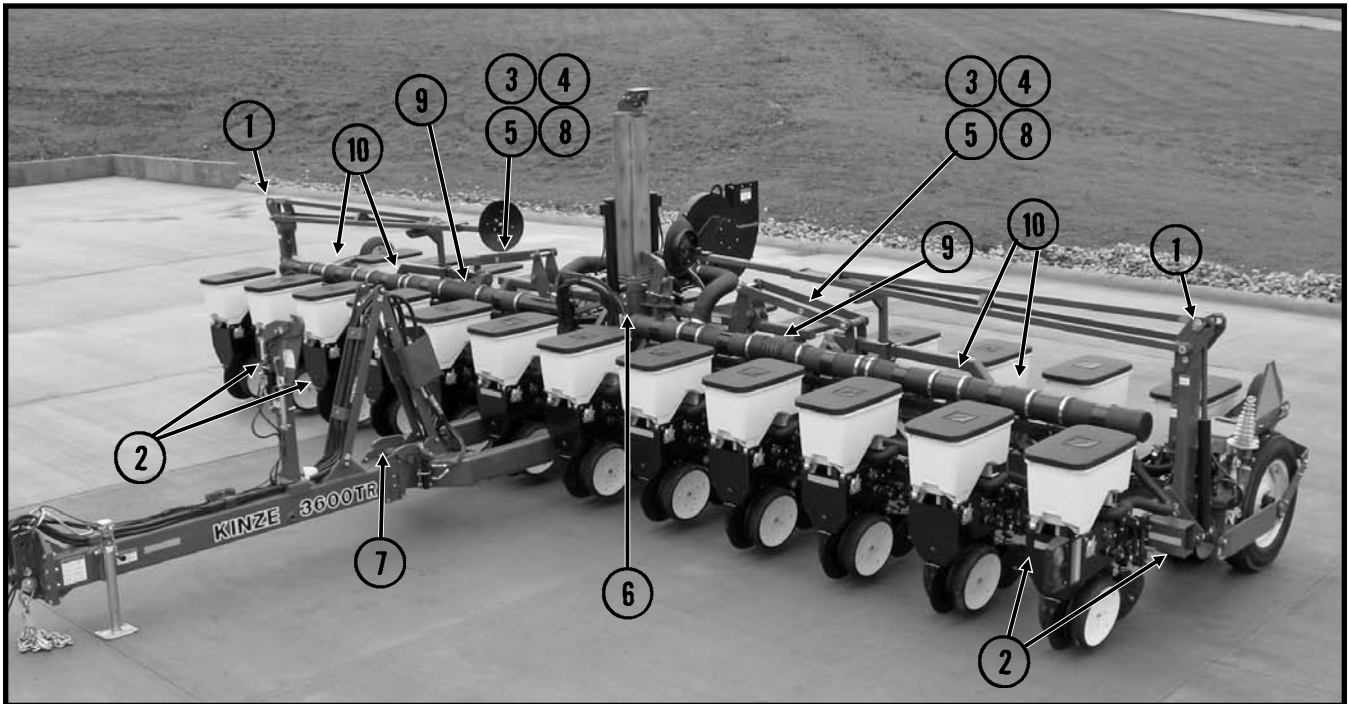

LUBRICATION

D101807104

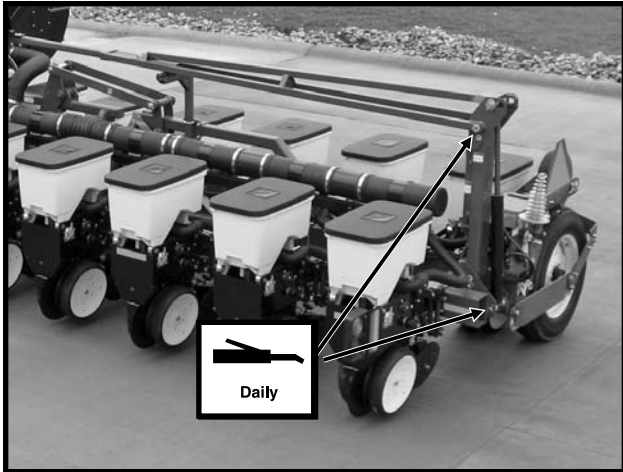

1. Row Marker Assemblies - 4 Zerks Per Assembly On 8 Row Wide And 12 Row 30". 2 Zerks Per Assembly On 12 Row Wide And 16 Row 30".

76609-17

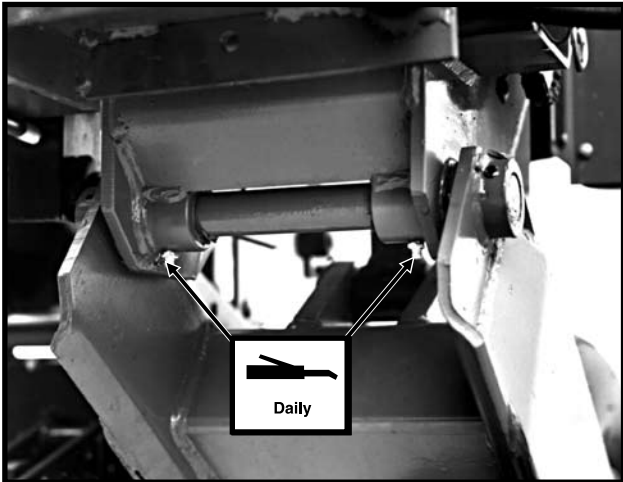

2. Wing Wheel Pivot - 2 Zerks Per Wheel Module

81439-29

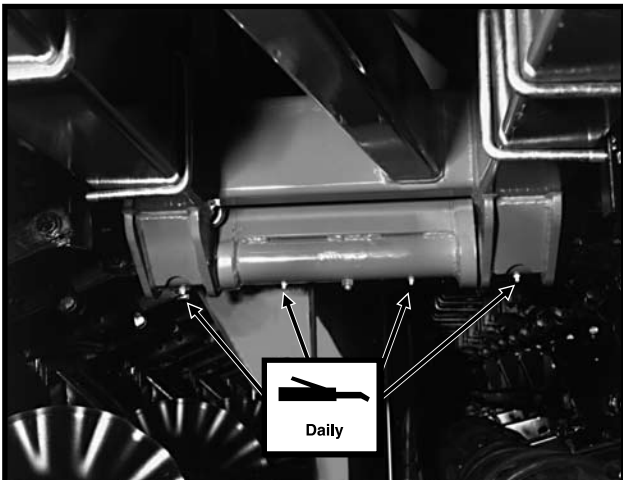

3. Wing Hinges - 4 Zerks Per Wing

D08260516

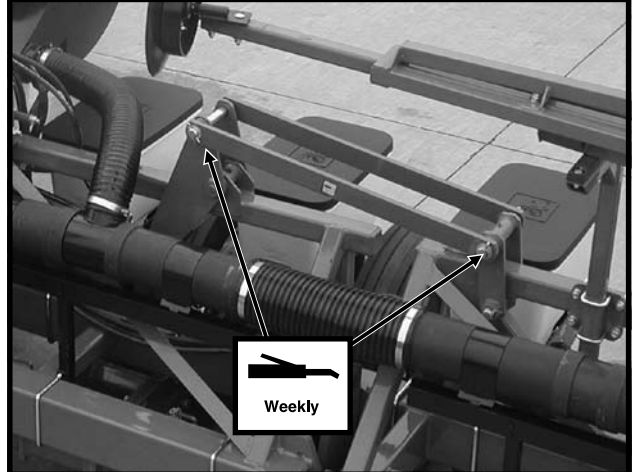

4. Wing Locks - 3 Zerks Per Wing

81439-29

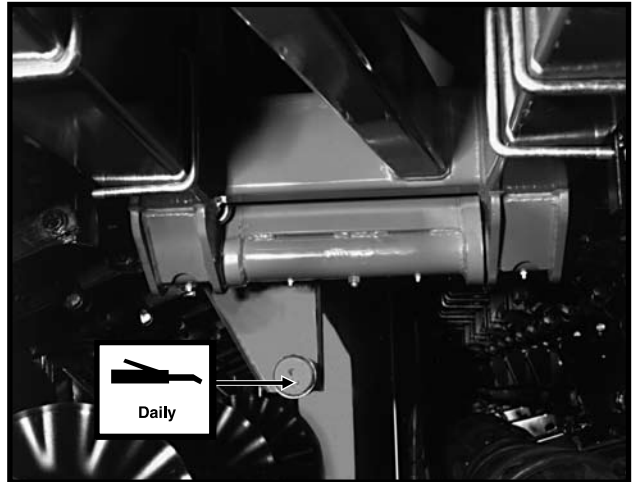

5. Cam Follower - 1 Zerk Per Follower

76609-36

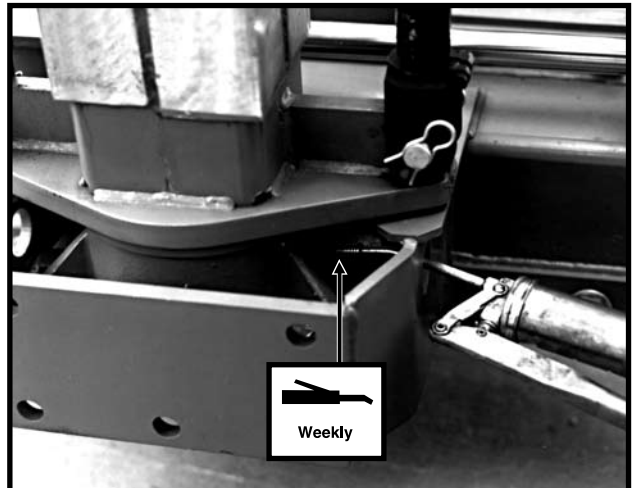

6. Center Pivot - 1 Zerk

LUBRICATION

81439-7

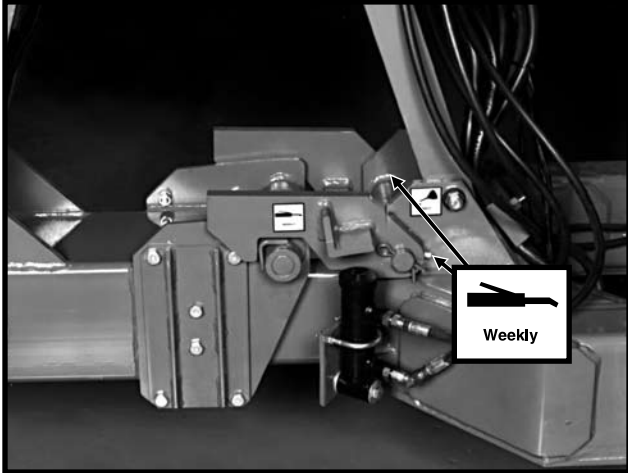

7. Tongue Hook - 2 Zerks

76740-54

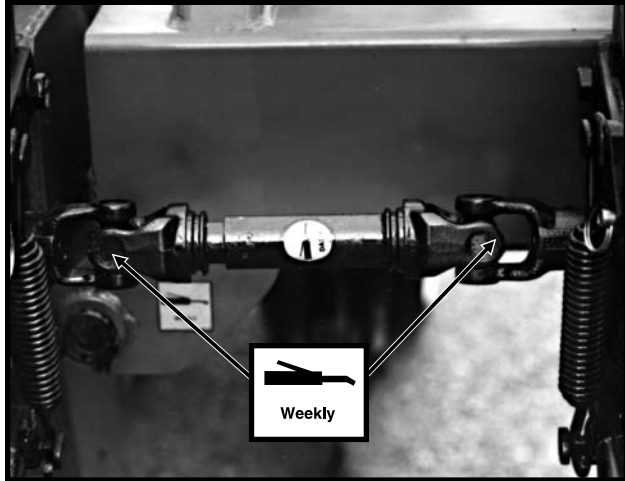

8. U-Joints - 2 Zerks Per Hinge Area

D091602101



9. Transport Wheel Bearings - 1 Zerk Per Hub

05199819a

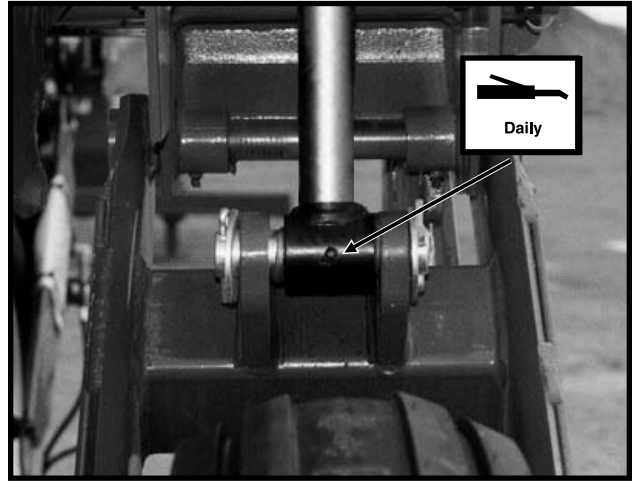

10. Wing Lift Cylinders - 1 Zerk Per Cylinder

LUBRICATION

Row Unit

LF212199-2

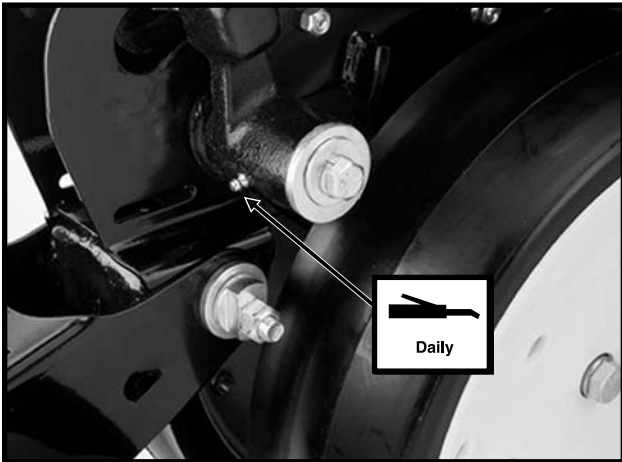

Gauge Wheel Arms - 1 Zerk Per Arm
(Seals in gauge wheel arm are installed with lip facing out to allow grease to purge dirt away from seal. Pump grease into arm until fresh grease appears between washers and arm.)

LF083002101

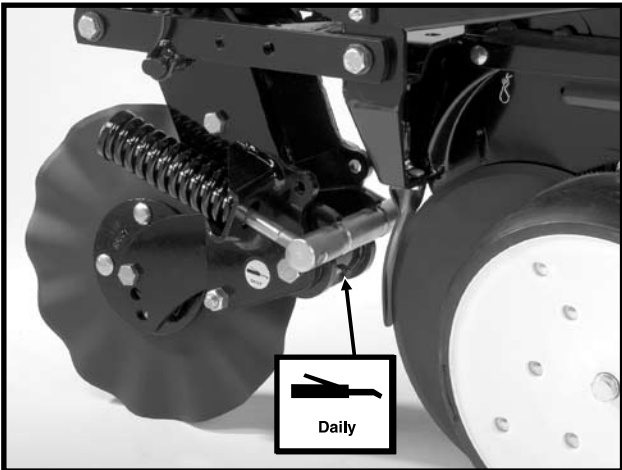

Frame Mounted Coulter - 1 Zerk Per Arm

MAINTENANCE

MOUNTING BOLTS AND HARDWARE

Before operating the planter for the first time, check to be sure all hardware is tight. Check all hardware again after approximately the first 50 hours of operation and at the beginning of each planting season thereafter.



WARNING: Before operating the planter for the first time and periodically thereafter, check to be sure the lug nuts on the transport wheels are tight. This is especially important if the planter is to be transported for a long distance.

All hardware used on the KINZE® planter is Grade 5 (high strength), unless otherwise noted. Grade 5 cap screws are marked with three radial lines on the head. If hardware must be replaced, be sure to replace it with hardware of equal size, strength and thread type. Refer to the torque values chart when tightening hardware.

Row Unit Parallel Linkage Bushing Hardware - 130 Ft. Lbs. (See “Bushings” in the Lubrication Section of this manual.)

5/8" No Till Coultter Spindle Hardware - 180 Ft. Lbs.

Center Section Transport Tire Lug Nuts - 125 Ft. Lbs.

Wing Ground Drive Tire Lug Bolts - 90 Ft. Lbs.

IMPORTANT: Over tightening hardware can cause as much damage as under tightening. Tightening hardware beyond the recommended range can reduce its shock load capacity.

IMPORTANT: Torque setting for 5/8"-18 hex jam nut that secures fan impellor assembly to motor shaft is 50 ft. lbs.

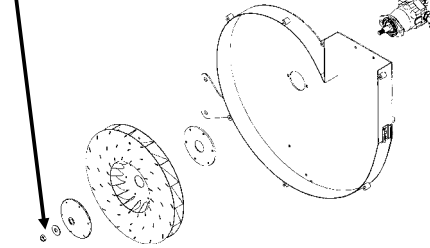

TORQUE VALUES CHART - PLATED HARDWARE

Bolt Diameter	Grade 2		Grade 5		Grade 8	
	Coarse	Fine	Coarse	Fine	Coarse	Fine
1/4"	50 In. Lbs.	56 In. Lbs.	76 In. Lbs.	87 In. Lbs.	9 Ft. Lbs.	10 Ft. Lbs.
5/16"	8 Ft. Lbs.	9 Ft. Lbs.	13 Ft. Lbs.	14 Ft. Lbs.	18 Ft. Lbs.	20 Ft. Lbs.
3/8"	15 Ft. Lbs.	17 Ft. Lbs.	23 Ft. Lbs.	26 Ft. Lbs.	33 Ft. Lbs.	37 Ft. Lbs.
7/16"	25 Ft. Lbs.	27 Ft. Lbs.	37 Ft. Lbs.	41 Ft. Lbs.	52 Ft. Lbs.	58 Ft. Lbs.
1/2"	35 Ft. Lbs.	40 Ft. Lbs.	57 Ft. Lbs.	64 Ft. Lbs.	80 Ft. Lbs.	90 Ft. Lbs.
9/16"	50 Ft. Lbs.	60 Ft. Lbs.	80 Ft. Lbs.	90 Ft. Lbs.	115 Ft. Lbs.	130 Ft. Lbs.
5/8"	70 Ft. Lbs.	80 Ft. Lbs.	110 Ft. Lbs.	125 Ft. Lbs.	160 Ft. Lbs.	180 Ft. Lbs.
3/4"	130 Ft. Lbs.	145 Ft. Lbs.	200 Ft. Lbs.	220 Ft. Lbs.	280 Ft. Lbs.	315 Ft. Lbs.
7/8"	125 Ft. Lbs.	140 Ft. Lbs.	320 Ft. Lbs.	350 Ft. Lbs.	450 Ft. Lbs.	500 Ft. Lbs.
1"	190 Ft. Lbs.	205 Ft. Lbs.	480 Ft. Lbs.	530 Ft. Lbs.	675 Ft. Lbs.	750 Ft. Lbs.
1 1/8"	265 Ft. Lbs.	300 Ft. Lbs.	600 Ft. Lbs.	670 Ft. Lbs.	960 Ft. Lbs.	1075 Ft. Lbs.
1 1/4"	375 Ft. Lbs.	415 Ft. Lbs.	840 Ft. Lbs.	930 Ft. Lbs.	1360 Ft. Lbs.	1500 Ft. Lbs.
1 3/8"	490 Ft. Lbs.	560 Ft. Lbs.	1100 Ft. Lbs.	1250 Ft. Lbs.	1780 Ft. Lbs.	2030 Ft. Lbs.
1 1/2"	650 Ft. Lbs.	730 Ft. Lbs.	1450 Ft. Lbs.	1650 Ft. Lbs.	2307 Ft. Lbs.	2670 Ft. Lbs.

NOTE: Unplated hardware and bolts with lock nuts should be torqued approximately 1/3 higher than the above values. Bolts lubricated prior to installation should be torqued to 70% of value shown in chart.



GRADE 2
No Marks



GRADE 5
3 Marks



GRADE 8
6 Marks

MAINTENANCE

CHAIN TENSION ADJUSTMENT

The drive chains have spring loaded idlers and therefore are self-adjusting. The only adjustment needed is to shorten the chain if wear stretches the chain and reduces spring tension. The pivot point of these idlers should be checked periodically to ensure they rotate freely. See "Wrap Spring Wrench Assembly" in Lubrication Section for additional information.

Additional chain links can be found in the storage box located inside the planter frame.

D020501108

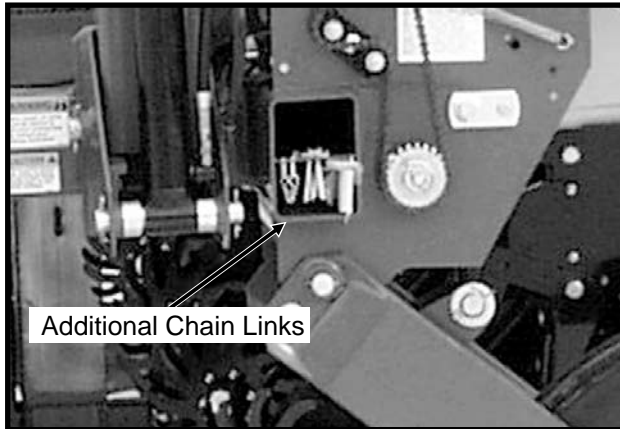

TIRE PRESSURE

D08260535

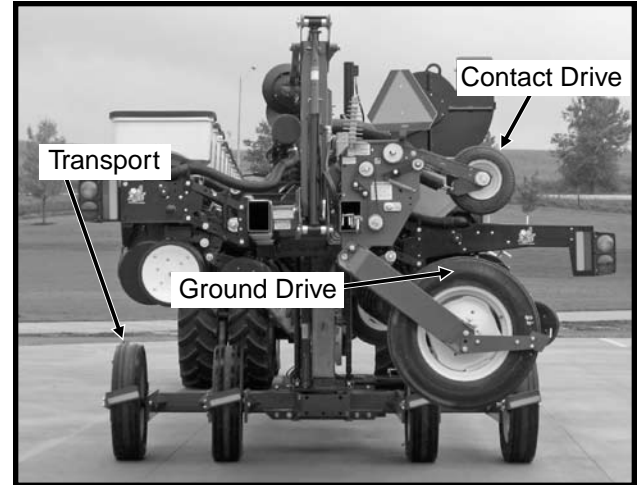

Tire pressure should be checked regularly and maintained as follows:

255-70R 22.5" Transport (Center Section)	75 PSI
7.50" x 20" Ground Drive (Wings)	40 PSI
4.80" x 8" Contact Drive	50 PSI
7.60" x 15" Ground Drive (Liquid Fertilizer Piston Pump)	40 PSI

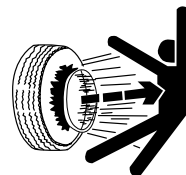

DANGER: Rim and tire servicing can be dangerous. Explosive separation of tire and rim parts can cause serious injury or death.

Do not attempt to mount a tire unless you have the proper equipment and experience to perform the job. This should only be done by persons properly trained and equipped to do the job.

Always maintain the correct tire pressures. Do not inflate the tires above the recommended pressures.

When inflating tires, use a clip-on air chuck and extension hose long enough to allow you to stand to one side and NOT in front of or over the tire assembly. Use a safety cage to enclose the tire and rim assembly when inflating.

Inspect tires and wheels daily. Do not operate with low pressure, cuts, bubbles, damaged rims or missing lug bolts and nuts.

MAINTENANCE

PTO PUMP DRIVE AND OIL COOLER OPTION

Drain the reservoir, clean strainer and change filter annually.

To drain the reservoir, disconnect the suction line (hose between reservoir and pump) from the reservoir and drain. To fully drain tank, raise the planter into field raised position. Refill system with SAE 10W-20 multigrade wide temperature range transmission hydraulic fluid. The reservoir capacity is approximately 10 gallons.

Replace filter with good quality 10 micron filter.

Start the system and allow to run with tractor at idle and the fan turned off for 1-2 minutes. Allow to run with tractor at idle and the fan at full speed for 1-2 minutes. Check reservoir fluid level and fill as required. To allow the fluid to expand when heated, the hydraulic fluid level should be within 1"-2" from the top of the reservoir after the pump has run and hydraulic hoses have been primed. Bring tractor to PTO speed and adjust flow control to the desired vacuum level using the flow control valve lever.

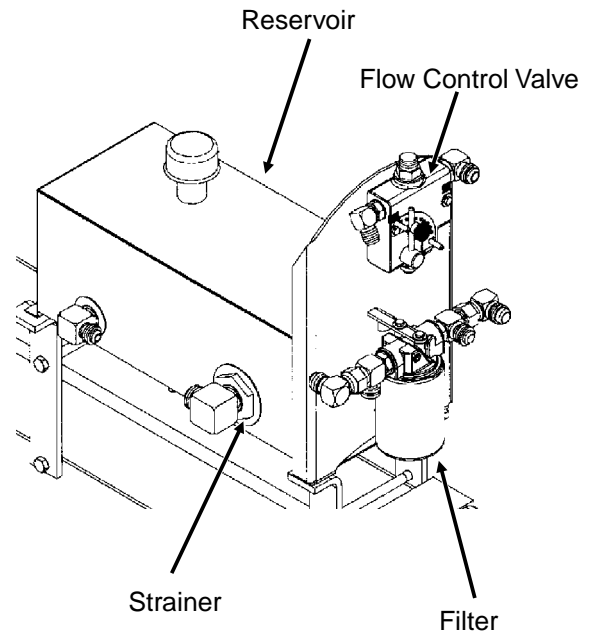

FRONT VIEW

PTO PUMP DRIVE AND OIL COOLER OPTION TROUBLESHOOTING

PROBLEM	POSSIBLE CAUSE	SOLUTION
Pump is squealing.	Lack of oil to pump.	Check for plugged suction strainer. Check oil level.
Oil temperature is high.	Low oil level.	Check oil level and add as required.
Desired fan speed cannot be achieved.	Low oil level.	Check oil level and add as required.
	Plugged filter.	Check and change as required.
Vacuum level is not displayed.	Digital vacuum gauge console power it OFF.	Turn ON.
	Cable not plugged in.	Check connection.
	Digital vacuum gauge console has no power.	Check fuse.

MAINTENANCE

CLOSING WHEEL TROUBLESHOOTING

PROBLEM	POSSIBLE CAUSE	SOLUTION
Closing wheel(s) leave severe imprint in soil.	Too much closing wheel down pressure.	Adjust closing wheel pressure.
Closing wheel(s) not firming soil around seed.	Insufficient closing wheel down pressure.	Adjust closing wheel pressure. Severe no till conditions may require use of cast iron closing wheels.
"V" closing wheel running on top of seed furrow.	Improper centering.	Align. See "V Closing Wheel Adjustment".
Single closing wheel not directly over seed.	Improper centering.	Align. See "Covering Discs/Single Press Wheel Adjustment".

DRAG CLOSING ATTACHMENT

LF212299-18



Prior to storage of the planter, inspect each drag closing attachment and replace any worn or broken parts. Check for loose hardware and tighten as needed.

LF212199-2

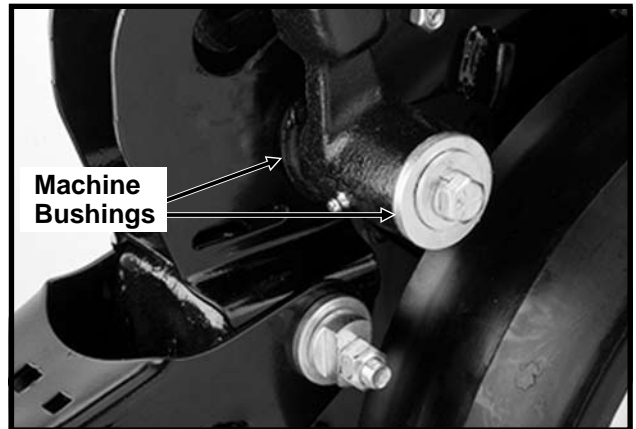

(RU113g)

GAUGE WHEEL ADJUSTMENT

To prevent an accumulation of dirt or trash, gauge wheels should lightly contact the opener blades. Gauge wheels and opener blades should turn with only slight resistance.

To adjust clearance between gauge wheels and opener blades, add or remove machine bushings between the shank and gauge wheel arm. Store remaining machine bushings between gauge wheel arm and flat washer on outer side of gauge wheel arm.

NOTE: It may be desirable to space gauge wheel further from blade when operating in sticky soils.

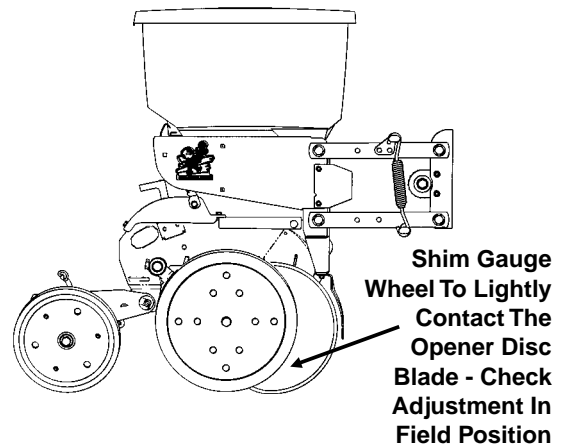

MAINTENANCE

GAUGE WHEEL ARM BUSHING AND/OR SEAL REPLACEMENT

(RU113g)

Gauge Wheel Arm Bushings/Seals

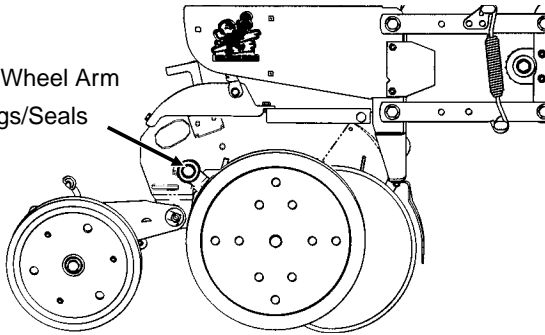

NOTE: A Gauge Wheel Arm Bushing And Seal Driver Kit (G1K296), for use in bushing and seal replacement, is available through your KINZE® Dealer.

To replace gauge wheel arm assembly bushing(s) and/or seal(s):

1. Remove gauge wheel from arm.
2. Remove the gauge wheel arm assembly from the shank assembly.
3. Remove seal and bushing and discard. Clean and dry inner bore.

(A7975/RU122)

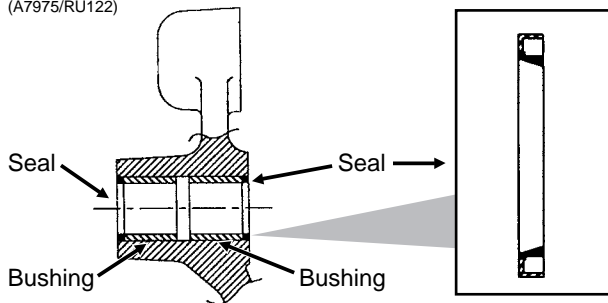

4. Drive/press replacement bushing inside bore of arm to a depth of .125" below flush.
5. Coat wiping edge of seal with grease.
6. Drive/press seal into place with lip to the outside as shown above.

NOTE: Use extra care to protect the sealing lip during installation. Apply uniform pressure to assemble the seal into the bore of the arm. Never apply a direct hammer blow to the seal surface.

7. Inspect gauge wheel pivot spindle.
8. Reinstall gauge wheel arm assembly and gauge wheel.

NOTE: Special machine bushing between gauge wheel arm and gauge wheel.

9. Shim for proper gauge wheel tire/disc blade clearance.
10. Lubricate with an SAE multipurpose grease.

GAUGE WHEEL ARM PIVOT SPINDLE REPLACEMENT

(RU113g)

Gauge Wheel Pivot Spindle

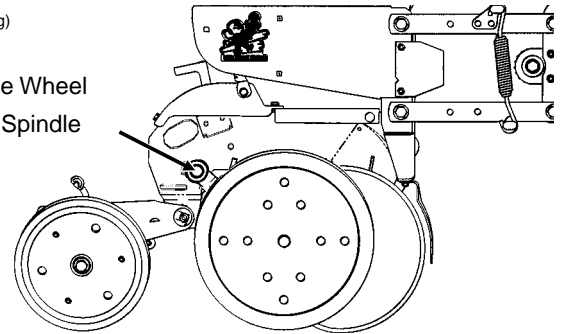

To replace gauge wheel pivot spindle:

1. Remove the gauge wheel and arm assemblies from the shank assembly.
2. Remove 1/2" x 3/4" cap screw that locks the pivot spindle in place and remove the spindle.

D06189902

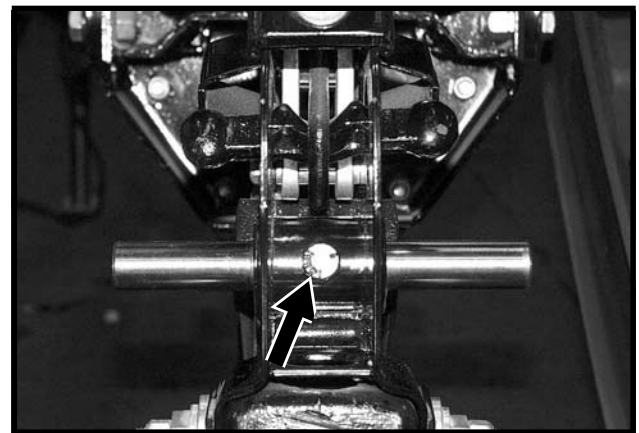

3. Install the replacement spindle and position as shown below. Exact centering is critical.

(A7966)

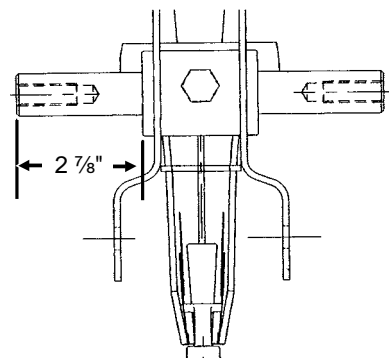

4. Install 1/2" x 3/4" cap screw and torque to lock pivot spindle in place.
5. Install gauge wheel and arm assemblies. Shim for proper gauge wheel tire/disc blade clearance.

MAINTENANCE

15" SEED OPENER DISC BLADE/ BEARING ASSEMBLY

Approximately 1" - 1 1/2" of blade-to-blade contact should be maintained to properly open and form the seed trench. As the blade diameter decreases, due to wear, it will be necessary to relocate machine bushings from inside to outside to maintain approximately 1" - 1 1/2" of contact.

NOTE: If proper blade-to-blade contact cannot be maintained after relocating machine bushings or if blade diameter wears below 14 1/2", the blades should be replaced.

IMPORTANT: Excessive blade contact may result in premature disc opener bearing/hub failures and excessive wear on seed tube guard/inner scraper. When properly adjusted, if one blade is held in fixed position, the opposite blade should be able to be rotated with minimal force (Less than 5 pounds force at outer edge of blade).

(RU113g)

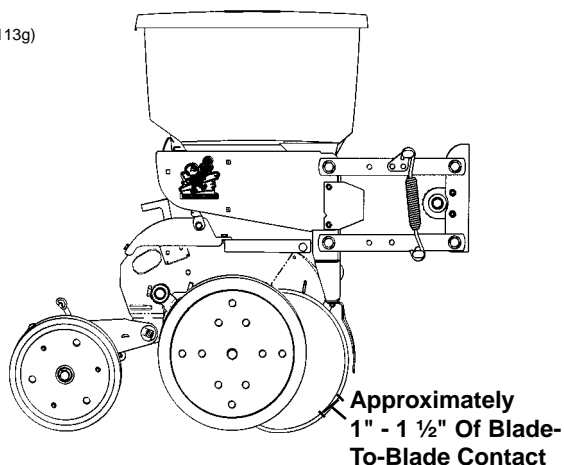

To replace disc blade/bearing assembly:

1. Remove gauge wheel.
2. Remove scraper.
3. Remove bearing dust cap.
4. Remove cap screw, washer and disc blade/bearing assembly. The machine bushings between the shank and disc blade are used to maintain the approximate 1" - 1 1/2" of blade-to-blade contact.

IMPORTANT: Left hand side of opener uses a left hand threaded cap screw. DO NOT OVERTIGHTEN. Damage to shank threads will require replacement of row unit shank assembly.

5. Install machine bushing(s), new disc blade/bearing assembly, washer and cap screw. Torque 5/8"-11 Grade 5 cap screw to value shown in "Torque Values Chart".

NOTE: Replace disc blades only with disc blades of equal thickness.

6. Replace bearing dust cap.
7. Install scraper.
8. Install gauge wheel.

It may be necessary to replace only the bearing if there is excessive endplay or if the bearing sounds or feels rough when the disc blade is rotated.

To replace bearing:

1. Remove gauge wheel, scraper, bearing cap, cap screw, washer and disc blade/bearing assembly.
2. Remove 1/4" rivets from bearing housing to expose bearing.
3. After installing new bearing, install three evenly spaced 1/4" cap screws into three of the six holes in the bearing housing to hold the bearing and bearing housing in place. Install rivets in the other three holes. Remove 1/4" cap screws and install rivets in those three holes.
4. Reinstall disc blade/bearing assembly, washer and cap screw. Torque 5/8"-11 cap screw to value shown in "Torque Values Chart" at the beginning of this section.
5. Replace bearing dust cap.
6. Install scraper and gauge wheel.

MAINTENANCE

SEED TUBE GUARD/INNER SCRAPER

The seed tube guard protects the seed tube and acts as the inner scraper for the seed opener disc blades.

Remove the seed tube and check for wear. Excessive wear on the seed tube indicates a worn seed tube guard. Replace the seed tube guard if it measures $\frac{5}{8}$ " or less at the lower end. A new seed tube guard measures approximately $\frac{7}{8}$ ".

LF212199-12

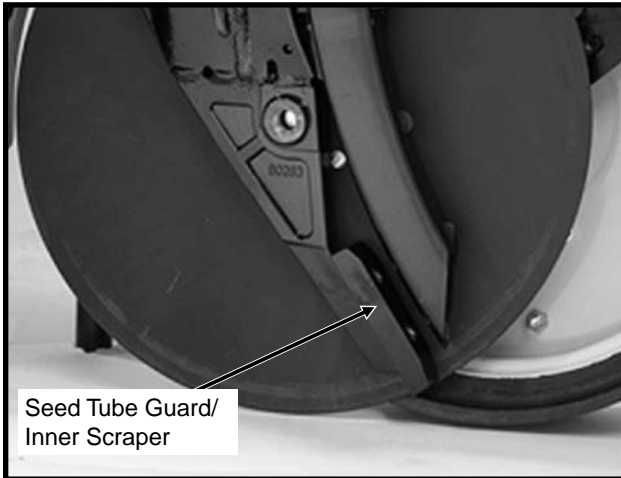

Shown With Gauge Wheel And Seed Opener Disc Blade Removed For Visual Clarity

IMPORTANT: No till planting or planting in hard ground conditions, especially when the planter is not equipped with no till coulters, and/or excessive blade-to-blade contact will increase seed tube guard wear and necessitate more frequent inspection and/or replacement.

To replace the seed tube guard, remove the seed tube and the two hex socket head cap screws which attach the seed tube guard. Hold the replacement seed tube guard centered between the seed opener disc blades. Install, but DO NOT tighten, the hex socket head cap screws. Using a clamp or vise-grip, squeeze the opener blades together in front of the seed tube guard. Tighten the seed tube guard retaining screws. Remove the clamps. The distance between the seed tube guard and opener blades should be equal on both sides. Reinstall seed tube.

IMPORTANT: Over tightening the hex socket head cap screws may damage the threads in the shank and require replacement of the shank. A seed tube guard that is worn excessively may allow the blades to wear into the row unit shank, also requiring replacement of the shank.

FRAME MOUNTED COULTER

LF083002101

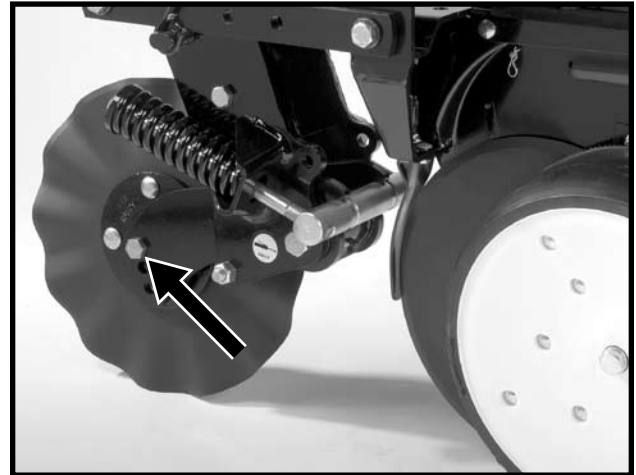

NOTE: Torque $\frac{5}{8}$ " spindle hardware to 120 ft. lbs.

See "Frame Mounted Coulters" in Row Unit Operation section of this manual for depth and spring adjustment.

When the 16" diameter coulters blade (1" fluted, 1" bubbled or $\frac{3}{4}$ " fluted) is worn to 14 $\frac{1}{2}$ " (maximum allowable wear), it should be replaced.

MAINTENANCE

RESIDUE WHEELS (For Use With Frame Mounted Coulter)

LF083002102

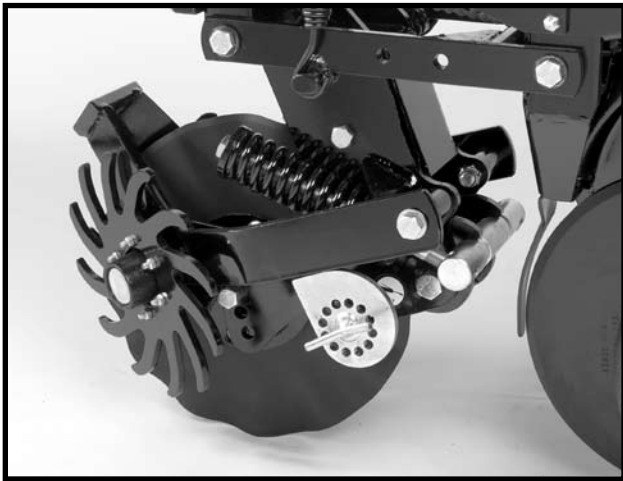

STYLE A

(RU154)

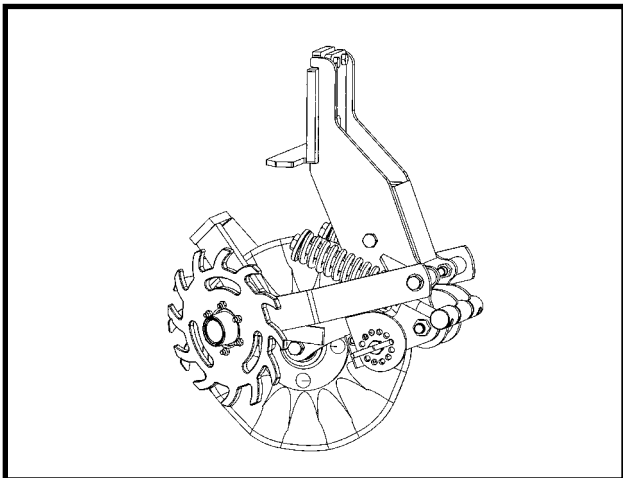

STYLE B

The wheel hub is equipped with sealed bearings. If a bearing sounds or feels rough when the wheel is rotated, replace the bearings.

ROW UNIT MOUNTED DISC FURROWER

LF212299-22

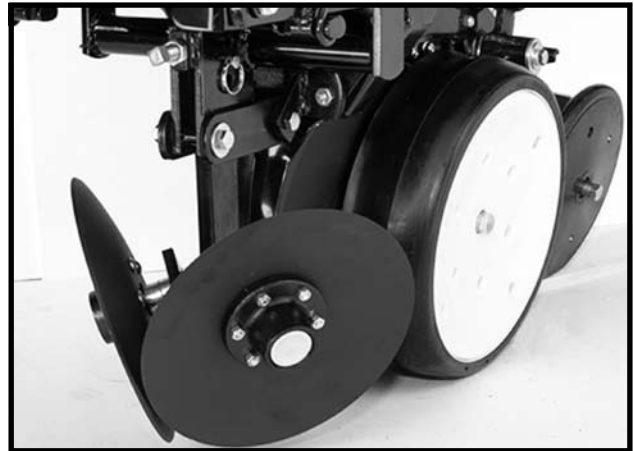

Lubricate the bushings in the support arm and mounting bracket at the frequency indicated in the Lubrication Section of this manual. Using a torque wrench, check each bolt for proper torque. If the bolt is loose, it should be removed and the bushing inspected for cracks and wear. Replace bushings as necessary. **Only hardened flat washers should be used. Replace damaged flat washers with proper part. Torque cap screws to 57 ft. lbs.**

The blade hubs are equipped with sealed bearings. If bearings sound or feel rough when the blade is rotated, replace the bearings.

When the 12" diameter blades (solid or notched) are worn to 11", they should be replaced.

MAINTENANCE

ROW UNIT MOUNTED BED LEVELER

LF212299-25a

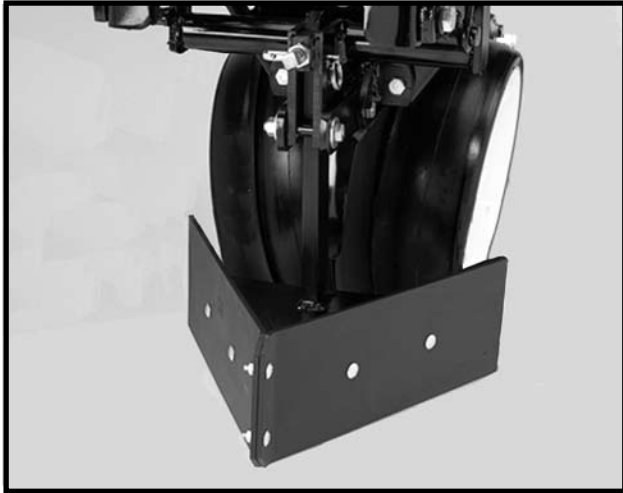

59386-26

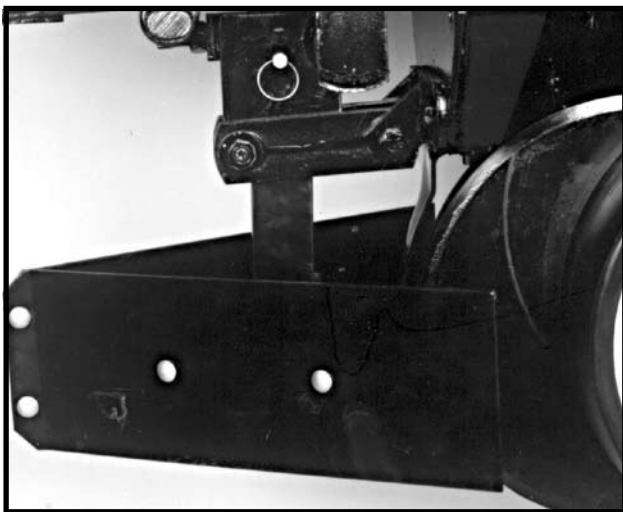

Lubricate the bushings in the mounting bracket and links at the frequency indicated in the Lubrication Section of this manual. Using a torque wrench, check each bolt for proper torque. If the bolt is loose, it should be removed and the bushing inspected for cracks and wear. Replace bushing if necessary. **Only hardened flat washers should be used. Replace damaged flat washers with proper part. Torque hardware to 130 ft. lbs.**

ROW UNIT MOUNTED RESIDUE WHEEL

D101701113



STYLE A

(A12685)

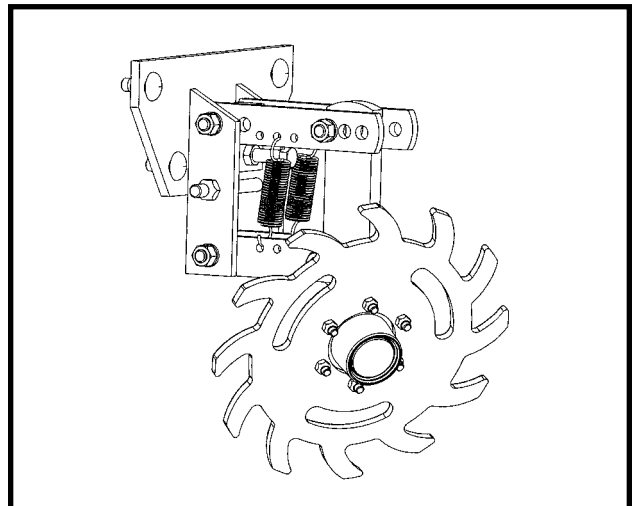

STYLE B

The wheel hub is equipped with sealed bearings. If a bearing sounds or feels rough when the wheel is rotated, replace the bearings.

MAINTENANCE

ROW UNIT MOUNTED NO TILL COULTER

LF212299-19a

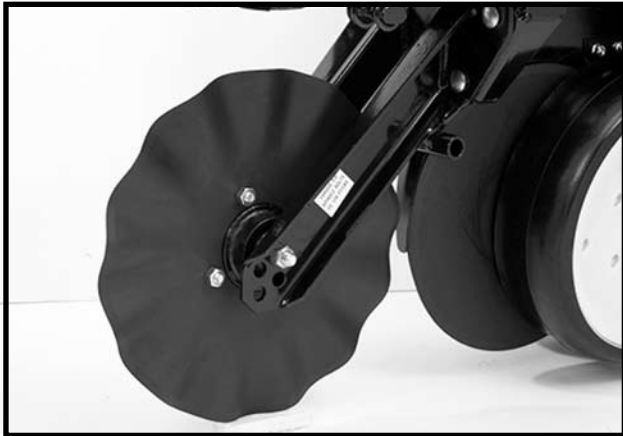

STYLE A (Two Sleeves For Installing Coulters Mounted Residue Wheels)

D05170706a

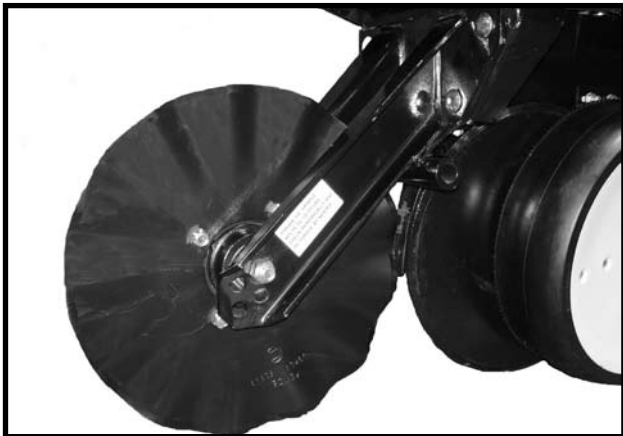

STYLE B (One Sleeve For Installing Coulters Mounted Residue Wheels)

Check periodically to be sure nuts and hardware are tightened to proper torque specification.

NOTE: Torque $\frac{5}{8}$ " spindle hardware to 120 ft. lbs.

Be sure the coulters are positioned square with the row unit and aligned in front of row unit disc opener.

The coulters blade can be adjusted to one of four settings. Initially the blade is set in the highest position. As the blade wears it can be adjusted to one of the three lower settings. See "Row Unit Mounted No Till Coulters" in Row Unit Operation section of this manual.

When the 16" diameter coulters blade is worn to 14 $\frac{1}{2}$ " (maximum allowable wear), it should be replaced.

COULTERS MOUNTED RESIDUE WHEELS

LF212299-23



STYLE A - Used With Style A Row Unit Mounted No Till Coulters

D05170708a



STYLE B - Used With Style B Row Unit Mounted No Till Coulters

The wheel hubs are equipped with sealed bearings. If bearings sound or feel rough when the wheel is rotated, replace the bearings.

MAINTENANCE

GRANULAR CHEMICAL ATTACHMENT

Prior to storage of the planter, disengage the granular chemical drive by rotating the throwout knob ¼ turn counterclockwise. Remove the drive chain and empty and clean all granular chemical hoppers. Clean the drive chains and coat them with a rust preventive spray or submerge chains in oil. Inspect and replace any worn or broken parts.

Install hoppers and chains. Check chain alignment.

LF212299-4

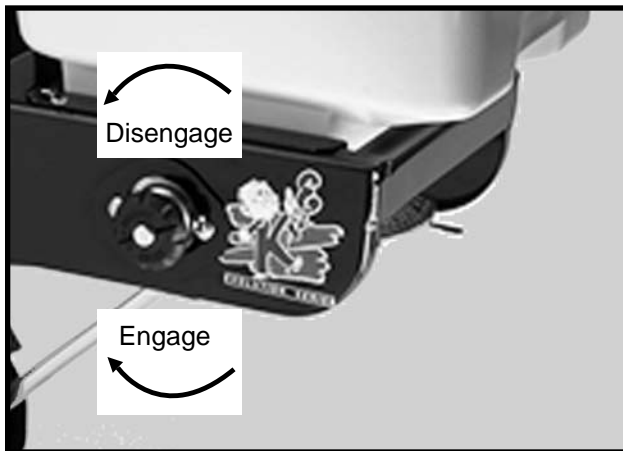

SPRING TOOTH INCORPORATOR

Prior to storage of the planter, inspect each spring tooth incorporator and replace any worn or broken parts. Check for loose hardware and tighten as needed.

LF212299-26



MAINTENANCE

KPM III ELECTRONIC SEED MONITOR TROUBLESHOOTING

PROBLEM	POSSIBLE CAUSE	SOLUTION
Single sensor communication alarm comes on.	Faulty seed tube sensor.	Replace sensor.
	Break in the harness just before the seed tube sensor.	Inspect for break in harness and repair. If break can't be found, replace harness section.
	Dirty or corroded connector.	Clean connector.
Sensor communication alarms come on for all sensors.	Faulty monitor.	Repair/Replace monitor.
	Break in the harness just after the monitor.	Inspect for break in harness and repair. If break can't be found, replace harness section.
	Dirty or corroded connector.	Clean connector.
Sensor communication alarms come on for some sensors.	Break in the harness.	Inspect for break in harness and repair. If break can't be found, replace harness section corresponding with the alarming sensors.
	Dirty or corroded connector.	Clean connector.
Faulty monitor values (such as speed, area, etc.) being displayed.	Incorrect monitor settings.	Change settings to properly correspond to the system.
	Faulty radar/magnetic distance sensor.	Replace sensor.
	Improperly mounted radar sensor.	Properly mount sensor.
Underplanting or no planting alarm on a single sensor when planting (alarm on with a single bargraph segment on and a flashing row number on a single row.	Seed tube sensor is blocked.	Clean sensor.
	Faulty seed tube sensor.	Replace sensor.
	Meter not planting or underplanting.	Repair/replace meter.
	Chain broken or off sprocket.	Repair as necessary.
Seed tube sensor dirty or blocked warning comes on.	Seed tube sensor is dirty.	Clean sensor.
	Faulty seed tube sensor.	Replace sensor.
LED on the seed tube sensor will not come on.	Faulty seed tube sensor.	Replace sensor.
	Dirty or corroded connector.	Clean connector.
	Break in the harness just before the sensor.	Repair harness.
Erroneous MPH readings at idle. (Radar Distance Sensor Only)	Radar sensor not located in a stable location.	Relocate to a more stable location.

MAINTENANCE

POINT ROW CLUTCH INSPECTION

The point row clutch is permanently lubricated and sealed and requires no periodic maintenance.

76740-2

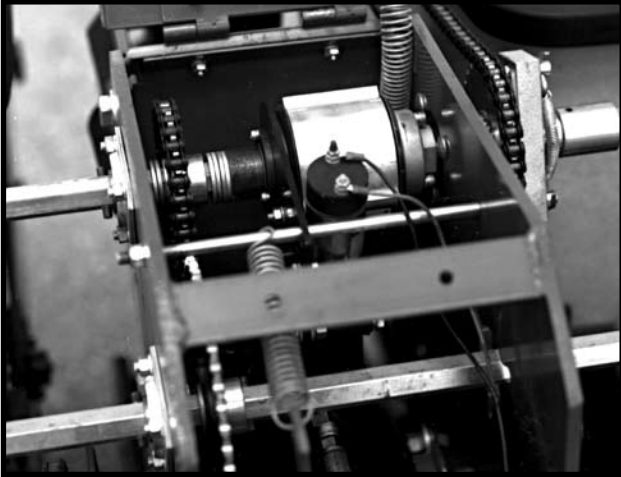

The right hand clutch operates clockwise and the left hand clutch operates counterclockwise. Therefore, some of the parts of the clutch such as the wrap spring differ from one side of the planter to the other. Be sure to use the correct repair part if a clutch must be repaired.

NOTE: The point row clutch input shaft on the R.H. side of the machine will have an "L" stamped on it and the shaft on the L.H. side of the machine will have an "R" stamped on it.

If the clutch or clutches fail to operate, first determine if the problem is electrical or mechanical. Place the operational switch in the RIGHT or LEFT position. When the switch is in the RIGHT or LEFT position and the fuse on the rear of the control console is in working condition, the red indicator light on the control console should be lighted. If light does not come on, check the fuses on the front of the control console. See "Point Row Clutch Troubleshooting" chart. If fuses are not blown, check the clutch and wiring harness for power with a test light or volt meter. If the solenoid is operating properly, the plunger on the solenoid will retract causing a clicking sound. The plunger will also be magnetized which can be checked by touching the plunger with a metal object.

NOTE: Always replace fuse with proper size and type when replacing fuse. Use MDL 10 amp slow blow fuse on front of control console.

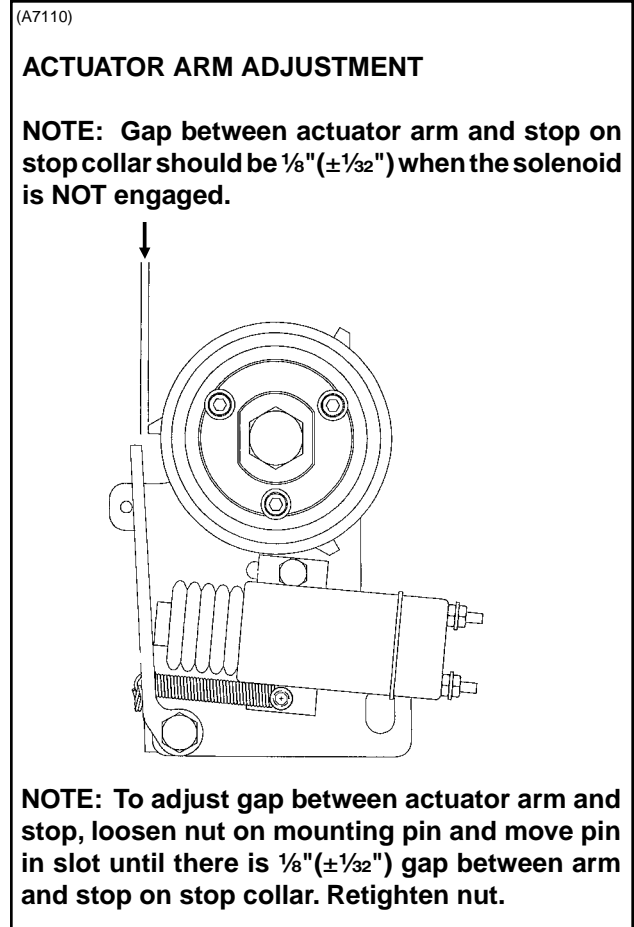
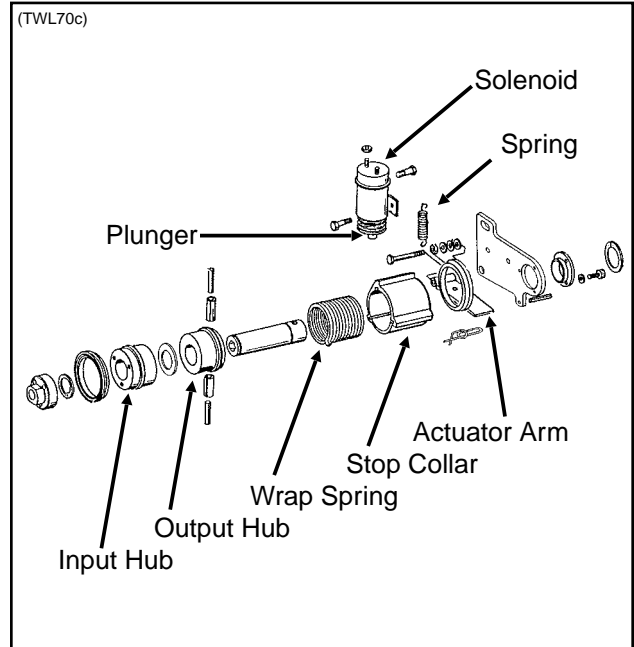

NOTE: To adjust gap between actuator arm and stop, loosen nut on mounting pin and move pin in slot until there is $\frac{1}{8}$ " ($\pm\frac{1}{32}$ ") gap between arm and stop on stop collar. Retighten nut.

MAINTENANCE

POINT ROW CLUTCH TROUBLESHOOTING

PROBLEM	POSSIBLE CAUSE	SOLUTION
None of the clutches will disengage.	Main fuse blown in control console.	Replace defective fuse.
	Poor terminal connection in wiring harness.	Repair or replace.
	Wiring damage in wiring harness.	Repair or replace.
	Low voltage at coil. (12 volts required)	Check battery connections.
One section of planter will not re-engage.	Shear pin at seed drive transmission(s) sheared.	Replace pin with one of equal size and grade.
One clutch will not engage.	Fuses blown.	Replace defective fuses.
	Actuator arm and plunger stuck in disengaged position.	Remove, free up and reinstall.
	Actuator arm out of adjustment.	Adjust actuator arm mounting pin in slot so that actuator arm clears stop on stop collar by approximately 1/8" when clutch is rotated.
	Wrap spring broken or stretched.	Disassemble clutch and replace spring.
	Something touching the stop collar.	Check to ensure collar is free to turn with clutch.
	Clutch assembled incorrectly.	Check clutch and diagram for correct assembly.
Clutch slipping.	Wrap spring stretched.	"Lock" clutch output shaft from turning. Place torque wrench on input shaft and rotate in direction of drive. After input shaft has rotated a short distance the wrap spring should tighten onto the input hub. If slippage occurs at less than 100 ft. lbs. replace spring. If spring still slips after installing new spring, replace input hub.
Planter section will not re-engage while planter is moving forward. away from stop collar when	Spring in actuator arm not strong enough to push arm Reinstall spring. If that fails, file the operational switch is turned to the ON position.	Remove spring from inside solenoid and stretch spring slightly or replace. stop on the stop collar slightly so that the stop is not as aggressive.
Frequent solenoid burnout.	Fuses too large. amp slow blow fuses.	Replace fuses on front panel with 10
Frequent fuse burnout.	Low voltage (12 volts required).	Check power source voltage for partially discharged battery, etc.
	Damage to wiring harness.	Locate damage and repair or replace harness.
Clutch or clutches will not disengage.	Input and output shafts out of alignment.	Align input and output shafts to prevent drag.
	Input or output shaft is pushed in too far creating a coupler.	Reposition input and output shafts.

MAINTENANCE

TWO-SPEED POINT ROW CLUTCHES

Optional On All Row Sizes

The two-speed point row clutch is similar in design and operation to the standard point row clutch except for the two-speed function. If a two-speed clutch or clutches fail to operate properly, refer to "Point Row Clutch Inspection" and "Point Row Clutch Troubleshooting" for additional information.

NOTE: If the "Reduced Rate/Full Rate" functions fail to engage or disengage, see troubleshooting chart for possible cause.

(FF47c)

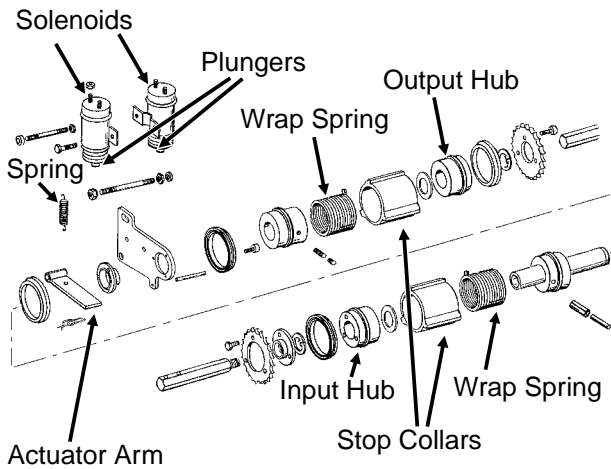

CHECK VALVE

(TWL30)

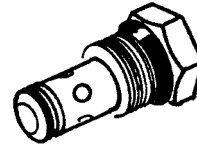

The check valves, located in the valve block on the right side of the center post, trap oil flow in the planter's lift system to keep the toolbar level during field operation. Consult your KINZE® Dealer for service.

MAINTENANCE

SOLENOID VALVE

The solenoid valve consists of a chambered body containing a cartridge valve which is activated by an electrical coil.

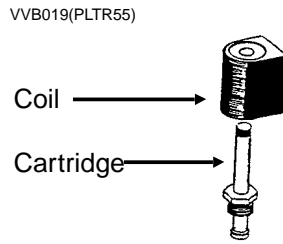

If the solenoid or solenoids fail to operate, first determine if the problem is electrical or hydraulic. If the valve is working properly, a click will be heard when the solenoid coil is energized. This will be the valve stem opening up. If no sound is heard, check the solenoid coil by touching the top of the coil housing with a metallic object such as a pliers or screwdriver. If the coil is working properly, the coil housing will be strongly magnetized when energized. If the voltage to the coil is low, the coil will be weakly magnetized when energized and no click will be heard.

CHECK VALVE

(Located In Valve Block Below Vacuum Fan Motor Assembly)

(TWL24b)

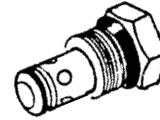

The check valve operates as a check in the return line to prevent reverse operation of the vacuum fan motor. If the valve fails to function properly, it should be removed for inspection. Check for foreign material or check to see if the o-ring is leaking internally. Replace if found to be defective.

RELIEF VALVE CARTRIDGE

(Located In Valve Block Below Vacuum Fan Motor Assembly)

(A11340)

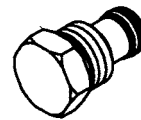

The pressure relief valve helps prevent damage to the vacuum fan motor by limiting pressure in the motor case drain line. It is set to open at 35 PSI. If the valve fails to function properly, it should be removed for inspection. Check for foreign material and contamination on both the valve and the seating area of the valve body. Replace if found to be defective.

SOLENOID VALVE TROUBLESHOOTING

PROBLEM	POSSIBLE CAUSE	SOLUTION
None of the solenoids will operate.	Low voltage.	Must be connected to 12 volt DC only. Negative ground.
	Blown fuse.	Replace fuse in control console on tractor with AGC-15 amp only.
	Battery connection.	Clean and tighten.
	Wiring harness damaged.	Repair or replace.
One solenoid valve will not operate.	Bad switch.	Replace on control panel.
	Cut wire in harness.	Locate and repair.
	Bad coil.	Replace.
	Poor connection at coil.	Check.
Valve operating when not energized.	Valve stem stuck open.	Replace cartridge.
	O-ring leaking.	Install new O-ring kit.
	Foreign material under poppet.	Remove cartridge and clean.

MAINTENANCE

FLOW CONTROL VALVE

VVB020(TWL28)

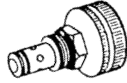

The flow control valves should be adjusted for row marker raise and lower speed as part of the assembly procedure or upon initial operation. If the valve fails to function properly or requires frequent adjustment, it should be removed for inspection. Check for foreign material and contamination on both the valve and the seating area of the valve body. Replace any components found to be defective.

PRESSURE RELIEF VALVE

VVB020(TWL29)

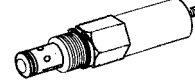

If the pressure relief valve fails to release the tongue lock or function properly, remove the valve from the valve block and check for foreign material or check to see if the O-ring is leaking internally. Replace if found to be defective.

LIFT CIRCUIT TROUBLESHOOTING

PROBLEM	POSSIBLE CAUSE	SOLUTION
Right wing raises faster than left wing. The right wing may even raise completely before the center frame and left wing start to raise. If the planter is loaded, the center frame and left wing may not be able to raise at all.	Master cylinder, located on front side of center post, leaking internally. NOTE: Make sure the lift system is completely rephased.	Repair master cylinder.
Left wing raises faster than right wing. The left wing may even raise completely before the center frame and right wing start to raise. If the planter is loaded, the center frame and right wing may not be able to raise at all.	Master cylinder, located on rear side of center post, leaking internally. NOTE: Make sure the lift system is completely rephased.	Repair master cylinder.
Center frame will raise, but wings do not.	Planter hydraulic circuit out of phase. Usually occurs when the planter is lowered from transport position. Solenoid valve in port V16 leaking.	Hold hydraulic control in lowering position to give the hydraulic circuit more time to rephase. Replace solenoid valve cartridge.
Center frame will continue to raise after the wing cylinders have reached full stroke when going to raised field position.	Solenoid valve in port V16 leaking.	Replace solenoid valve cartridge.
Planter will raise to raise field position, but will not raise to transport position.	Solenoid valve coil in port V16 is not energized.	Be sure control console switch is in "raise" position to energize solenoid coil in port V16. Check control console fuse by moving auxiliary switch to ON position. If red light comes on the fuse is OK. Return auxiliary to OFF position. Check for poor wire connection or damaged wire and repair. Solenoid valve coil is defective. All solenoid valves used on the planter are the same. Switch the solenoid coil with one you know is working. If this cures the problem, replace defective coil.

MAINTENANCE

LIFT CIRCUIT TROUBLESHOOTING (Continued)

PROBLEM	POSSIBLE CAUSE	SOLUTION
(Continued) Planter will raise to raised field position, but will not raise to transport position.	Solenoid valve cartridge in port V16 is stuck closed.	All solenoid valves used on the planter are the same. Switch the solenoid cartridge with one you know is working. If this cures the problem, replace defective cartridge.
Left wing lowering slower than center frame and right wing. If hydraulic lever is held in lowering position, the left wing cylinder will attempt to extend.	Check valve in port V17 leaking internally.	Remove check valve in port V17 and inspect for foreign material in valve and remove if possible. Replace check valve. If above fails, switch check valve in port V17 with check valve in port V15. If problem moves or switches to right wing, replace defective check valve.
Right wing lowering slower than center frame and left wing. If hydraulic control is held in lowering position, the right wing cylinder will attempt to extend.	Check valve in port V15 leaking internally.	Remove check valve in port V15 and inspect for foreign material in valve and remove if possible. Replace check valve. If above fails, switch check valve in port V15 with check valve in port V17. If problem moves or switches to right wing, replace defective check valve.
Planter will not raise or raises slowly.	Tractor may have hydraulic problem.	Switch remote outlets being used. Repair tractor hydraulics.
	Planter may be overloaded with hopper extensions and/or extra fertilizer tanks, coulters or other non-KINZE® attachments.	Remove weight.
	Center pivot wear pads may be adjusted too tight and are binding on the post.	Adjust pads.
	Relief valves on hitch leaking. Valves should hold 2500 PSI (±50 PSI).	Remove and inspect relief valve cartridge. Check for blown O-rings. Replace bad cartridge.
Planter will not rephase.	All cylinders not completely retracted. Caused by mechanical interference on or between planter frame and wheel lift module.	Remove interference.
	Center cylinders not retracting completely.	Lower planter and hold hydraulic lever in lower position to rephase system. Lower cylinder pins must be free to rotate in this position. If pins are tight, adjust cylinder clevises

MAINTENANCE

TONGUE CYLINDER CIRCUIT TROUBLESHOOTING

PROBLEM	POSSIBLE CAUSE	SOLUTION
Tongue cylinder will not extend, but will retract.	No power to solenoid valve coil in port V10 and/or V14. Both must be energized.	Check wiring between control console and solenoid coils looking for damaged wires and poor connections.
	Solenoid valve coil defective.	Switch coil from port V13 with V10. If tongue still will not extend, switch coil from V14 with V13. It will not be necessary to remove any of the wire connections to the solenoid. All three of these solenoids are normally energized when the tongue switch is energized. Replace defective coil.
	Solenoid valve cartridges in port V10 and/or V14 stuck closed.	Switch cartridge from port V10 with cartridge in port V13. If tongue cylinder retracts, replace defective cartridge from port V10. If problem continues, switch cartridge from port V14 with cartridge in port V13. Replace defective cartridge.
Tongue cylinder will not extend but tongue lock cylinder extends.	Pressure relief valve in port V11 stuck closed or pressure setting too high. (Valve is factory set to open at 1000 PSI.)	Replace or adjust pressure relief valve. To adjust, loosen lock nut and turn counter clockwise to decrease pressure.
Tongue hook does not release before the tongue starts to extend.	Solenoid valve cartridge in port V11 stuck open or pressure setting too low. (Valve is factory set to open at 1000 PSI.)	Replace or adjust pressure relief valve. To adjust, loosen lock nut and turn clockwise to increase pressure.
Tongue cylinder will not retract, but will extend.	Solenoid valve coil in port V13 defective.	Switch coil from port V13 with coil from port V14. If coil from port V13 is bad, the tongue will extend but not retract. Replace defective coil.
	Solenoid valve cartridge in port V13 stuck closed.	Switch cartridge from port V13 with cartridge from port V14. If cartridge is bad, the tongue will extend but not retract. Replace defective cartridge.
Tongue extends with the switch off.	Solenoid valve cartridge in port V10 and V14 stuck open.	Replace solenoid valve cartridge.
Tongue retracts with the switch off.	Solenoid valve cartridge in port V13 stuck open.	Replace solenoid valve cartridge.
Tongue latch releases. Tongue extends slowly while planting.	Latch cylinder or tongue cylinder leaking internally.	Pressure check latch and tongue cylinders. Repair leaking cylinder(s).

MAINTENANCE

ROTATION CYLINDER CIRCUIT TROUBLESHOOTING

PROBLEM	POSSIBLE CAUSE	SOLUTION
Cylinder does not extend, but will retract.	Solenoid valve coil in port V12 defective.	Switch coil from port V12 with coil in port V9. If cylinder extends but will not retract, replace defective coil from port V12.
	Solenoid valve cartridge in port V12 is stuck closed.	Switch cartridge from port V12 with cartridge in port V9. If cylinder extends but will not retract, replace defective cartridge from port V12.
Cylinder does not retract, but will extend.	Solenoid valve coil in port V9 defective.	Switch coil from port V9 with coil in port V12. If cylinder extends but will not retract, replace defective coil from port V9.
	Solenoid valve cartridge in port V9 is stuck closed.	Switch cartridge from port V9 with cartridge in port V12. If cylinder extends but will not retract, replace defective cartridge from port V9.

MAINTENANCE

WING LOCK CYLINDER CIRCUIT TROUBLESHOOTING

PROBLEM	POSSIBLE CAUSE	SOLUTION
Cylinders will not extend or retract.	No power to the solenoid valve coils.	Auxiliary switch may be in the ON position. Must be in OFF position. Check fuse at control console. Replace fuse with 15 amp type AGC if blown. Check for poor wire connection or damaged wire. Repair as required.
Cylinders will not extend.	Solenoid valve coil in port V3 not energized.	Check for power to coil. Check coil ground wire. If OK, switch coil from port V3 with coil from port V4. If cylinders extend but will not retract, replace defective coil.
	Solenoid valve cartridge in port V3 stuck closed.	Switch cartridge in port V3 with cartridge in port V4. If cylinders extend but will not retract, replace defective cartridge.
Cylinders will not retract.	Solenoid valve coil in port V4 not energized.	Check for power to coil. Check coil ground wire. If OK, switch coil from port V4 with coil from port V3. If cylinders retract but will not extend, replace defective coil.
	Solenoid valve cartridge in port V4 stuck closed.	Switch cartridge in port V4 with cartridge in port V3. If cylinders retract but will not extend, replace defective cartridge.
Cylinders retract with the switch off.	Solenoid valve cartridge in port V4 stuck open.	Replace solenoid valve cartridge.
Cylinders extend with the switch off.	Solenoid valve cartridge in port V3 stuck open.	Replace solenoid valve cartridge.

MAINTENANCE

ROW MARKER OPERATION TROUBLESHOOTING

PROBLEM	POSSIBLE CAUSE	SOLUTION
Right marker lowering slower than left marker.	Solenoid valve cartridge in port V1 not opening completely.	Switch cartridge with one in port V2. If problem follows cartridge, replace cartridge.
	Hose pinched or collapsed.	Inspect hose routing. Replace or repair hoses as required.
Left marker lowering slower than right marker.	Solenoid valve cartridge in port V2 not opening completely.	Switch cartridge with one in port V1. If problem follows cartridge, replace cartridge.
	Hose pinched or collapsed.	Inspect hose routing. Replace or repair hoses as required.
Both markers lowering.	Solenoid valve cartridge stuck open. If marker switch is in the left marker position, the right cartridge (V1) is defective. If the marker switch is in the right marker position, the left cartridge (V2) is defective.	Replace solenoid valve cartridge.
Neither marker will lower.	Blown fuse.	Check red light on control console. It should be on if switch is on. If light is not on, switch to opposite marker position. If light comes on, switch may be defective. Replace switch. Otherwise replace fuse.
	Coils at V1 and V2 not energized.	Poor ground on wire, bad wire connection or damaged wire. Repair as required.
	Marker flow control valve closed too far.	See Operation Section for adjustment.
Neither marker will raise.	Marker flow control valve closed too far.	See Operation Section for adjustment.
Right marker will not lower.	Solenoid coil in port V1 not energized.	Check switch on control console. Replace if defective. Check coil ground wire. Check for poor connection or damaged wire.
	Solenoid cartridge in port V1 stuck closed.	Switch cartridge with one on the planter you know is operating properly. If right marker lowers, replace defective cartridge.
Left marker will not lower.	Solenoid coil in port V2 not energized.	Check switch on control console. Replace if defective. Check coil ground wire. Check for poor connection or damaged wire.
	Solenoid cartridge in port V2 stuck closed.	Switch cartridge with one on the planter you know is operating properly. If left marker lowers, replace defective cartridge.
Markers traveling too fast and damaging rubber stop on transport stands and/or damaging pivot at rod end of marker cylinders.	Marker transport stand not adjusted correctly to allow marker cushion cylinders to operate as designed.	See "Row Marker Transport Stand Adjustment".
	Marker flow control valve out of adjustment.	See Operation Section for adjustment.

MAINTENANCE

ROW MARKER TRANSPORT STAND ADJUSTMENT

It is critical that the row marker transport stands are adjusted correctly to allow the marker cushion cylinders to function properly.

To adjust the transport stands:

1. Raise markers to transport position.
2. Loosen mounting hardware to allow transport stands to drop down or remove transport stands.
3. With tractor engine shutoff, release hydraulic pressure on marker cylinders.
4. Locate transport stands so marker arm rests lightly on transport stand. When the transport stands are correctly adjusted the pin at the rod end of the cylinder should be loose enough to rotate and move back and forth in the mounting slot.

A7102-1(TWL104)

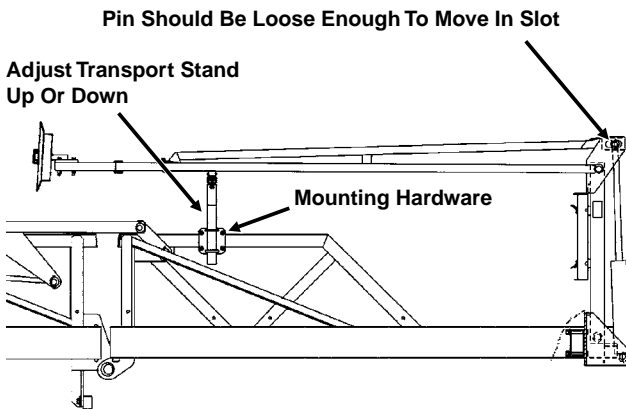

ROW MARKER BEARING LUBRICATION OR REPLACEMENT

1. Remove marker blade.
2. Remove dust cap from hub.
3. Remove cotter pin, nut and washer.
4. Slide hub from spindle.
5. Remove bearings and cups and discard if bearings are being replaced. Clean hub and dry. Remove bearings only and not cups if repacking.
6. Press in new bearing cups with thickest edge facing in. (Bearing replacement procedure only.)
7. Pack bearings with heavy duty wheel bearing grease thoroughly forcing grease between roller cone and bearing cage. Also fill the space between the bearing cups in the hub with grease.
8. Install rubber seal into grease seal. Place inner bearing in place and press in new rubber seal/grease seal.
9. Clean spindle and install hub.
10. Install outer bearing, washer and slotted hex nut. Tighten slotted hex nut while rotating hub until there is some drag. This assures that all bearing surfaces are in contact. Back off slotted nut to nearest locking slot and install cotter pin.
11. Fill dust caps approximately $\frac{3}{4}$ full of wheel bearing grease and install on hub.
12. Install blade and dust cap retainer on hub and tighten evenly and securely.

(PLTR45/PLTR99/PLTR98/PLTR102)

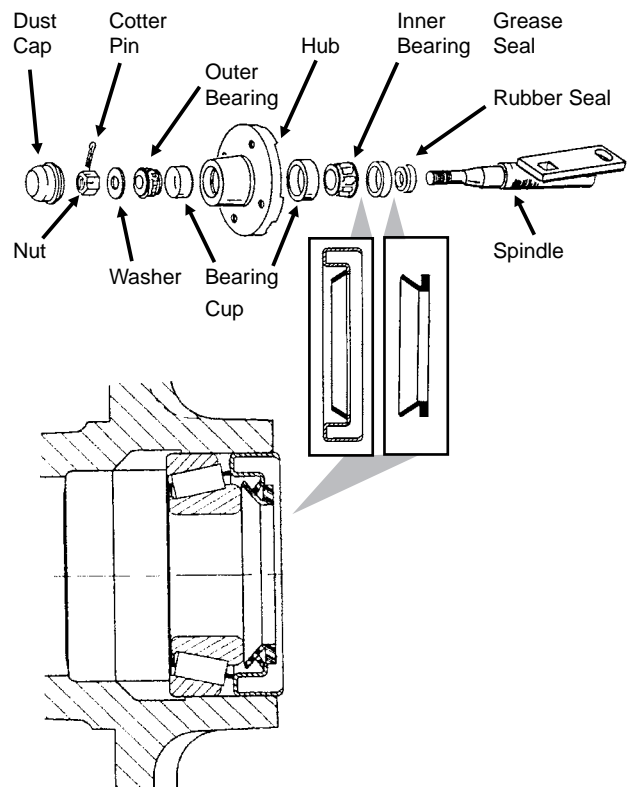

MAINTENANCE

WHEEL BEARING LUBRICATION OR REPLACEMENT

NOTE: Each transport wheel hub is equipped with a grease fitting for lubrication. The below procedure is used only for bearing replacement.

1. Raise tire clear of ground and remove wheel.
2. Remove double jam nuts and slide hub from spindle.
3. Remove bearings, seals (Where Applicable) and cups and discard if bearings are being replaced. Clean hub and dry. Remove bearings only and not cups if repacking.
4. Press in new bearing cups with thickest edge facing in. (Bearing replacement procedure only.)
5. Pack bearings with heavy duty wheel bearing grease thoroughly forcing grease between roller cone and bearing cage. Also fill the space between the bearing cups in the hub with grease.
6. Place inner bearing and seal (If Applicable) in place.
7. Clean spindle and install hub.
8. Install outer bearing, seal (If Applicable) and stepped nut. Tighten jam nut while rotating hub until there is some drag. This assures that all bearing surfaces are in contact. Back off jam nut $\frac{1}{4}$ turn or until there is only slight drag when rotating the hub. Install second jam nut to lock against first.
9. Install wheel on hub and tighten evenly and securely. Torque wheel bolts to specified torque.

(EF35e/PLTR56)

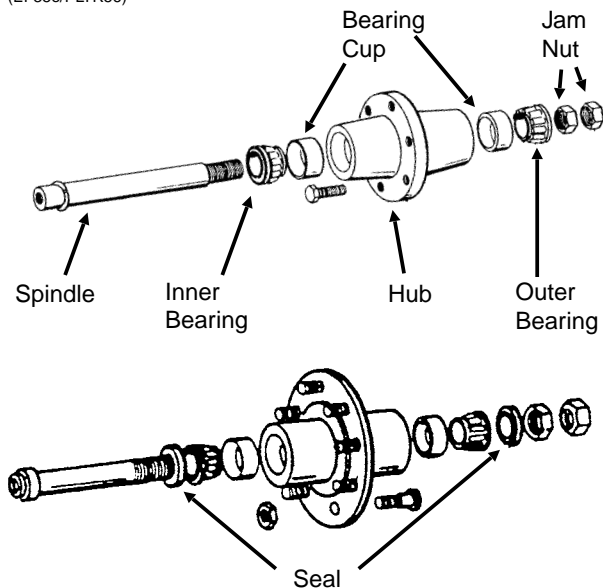

MAINTENANCE

WEAR PAD REPLACEMENT AND ADJUSTMENT

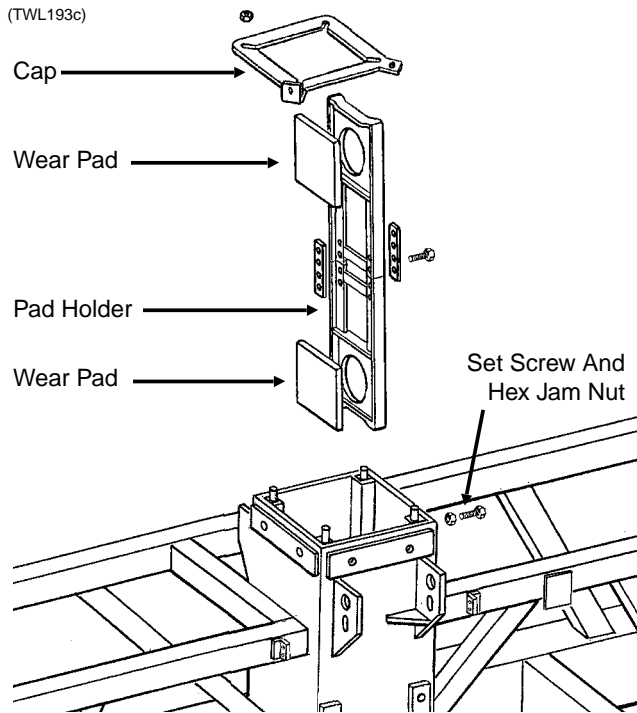

The center section of the planter is constructed around a steel tubular frame with four wear pad assemblies that ride against a stainless steel clad center post. Each wear pad assembly includes a pad holder and two wear pads. The wear pads are held by the pad holder and locked in place by $\frac{3}{4}$ " set screws and hex jam nuts.

Inspect for wear and check pad adjustment annually to ensure the center section is stabilized and the planter tracks properly. Replace any broken or missing adjustment set screws. When properly adjusted the pads should make full contact with the center post with light contact. Too much preload on the pads will cause the hydraulic lift pressure to be higher than necessary or will not allow the planter to raise when the planter is loaded.

⚠ WARNING: Always install all safety lockup devices before working under the unit.

To check adjustment and wear, position the planter on a level surface. Raise the planter to the raised field position. Visually check the four upper wear pads. Each wear pad should lightly contact the stainless steel clad center post. The maximum allowable gap between the plastic wear pad and the stainless steel post, when checked using a thickness gauge, should be no more than .060". Raise the planter to the raised transport position, install all safety lockups and visually check the four lower wear pads. Maximum allowable gap on the lower pads is .060".

(TWL109b)

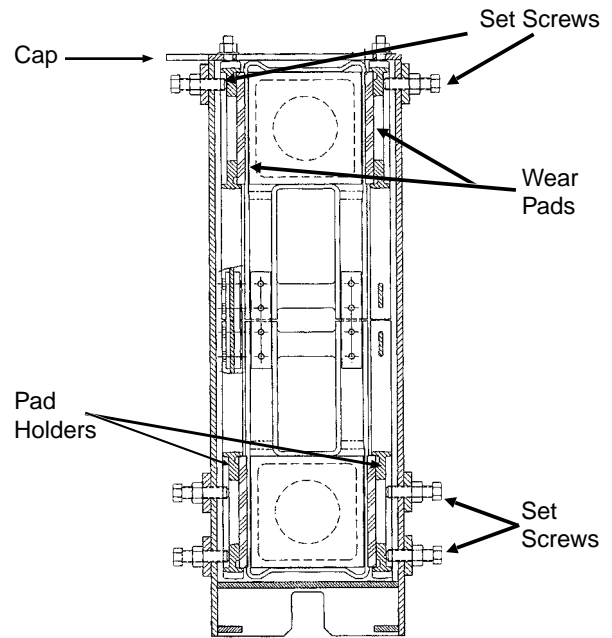

If adjustment is necessary proceed as follows: (a) Lower the planter to field operation position. It may be necessary to the loosen cap mounting nuts to allow wear pad adjustment. (b) Loosen the necessary hex jam nuts. (c) Tighten set screws until the wear pad lightly contacts the stainless steel clad center post. **DO NOT OVERTIGHTEN.** (d) Tighten hex jam nuts. (e) Recheck clearance. If clearance is not to specifications, repeat adjustment steps. (f) Torque hex jam nuts to 200 ft. lbs. Tighten cap mounting bolts if applicable.

NOTE: If exposed portion of wear pad is worn to less than $\frac{1}{8}$ " as shown below, replace the wear pad.

(TWL149a)

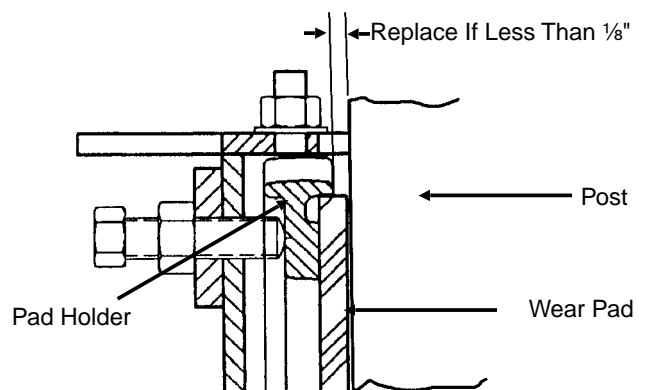

MAINTENANCE

If major adjustment or replacement is necessary proceed as follows: (a) Loosen cam rollers as shown below so they move freely. (b) Lower the planter to field operation position and release wing locks. (c) Eliminate all uplift on planter frame by backing off row unit down pressure springs and uplift on any other planter attachments.

D01190716

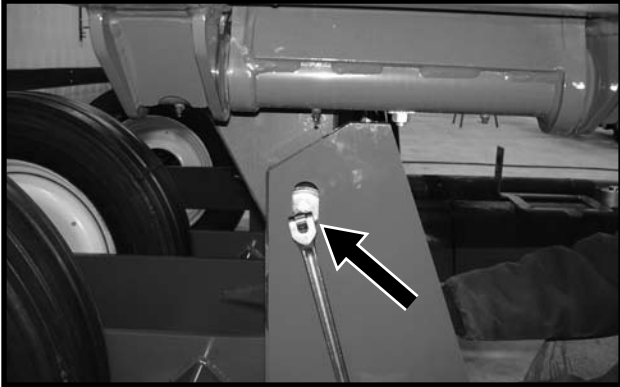

For pad adjustment only (d) Check position of center frame to axle cam roller guides. Gap between guides and frame should be the same side to side. Gap on the back sides of the roller guide should be equal on both sides. Final adjustment will be done later. (e) Loosen the four cap mounting nuts as shown below. (f) Loosen the hex jam nuts and use the pad set screws to position the frame to center correctly. (g) To adjust the pads, the pad set screws should be drawn tight, backed off and turned in until there is light contact with the pad holder. (h) Tighten hex jam nuts. (i) Torque hex jam nuts to 200 ft. lbs. (g) Tighten cap mounting nuts. (h) Reset row unit down pressure and other attachments from STEP c.

IMPORTANT: DO NOT OVERTIGHTEN WEAR PADS. OVER TIGHTENING WILL CAUSE PREMATURE WEAR AND EXCESSIVE HYDRAULIC LIFT PRESSURES.

D01190745

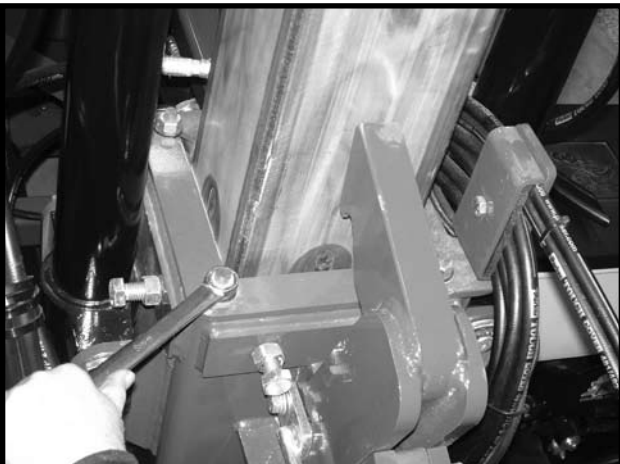

For pad replacement (d) As shown below, remove safety hook, disconnect hydraulic hose, remove nut on bulkhead fitting and remove fitting from cap..

D01190729

D01190725

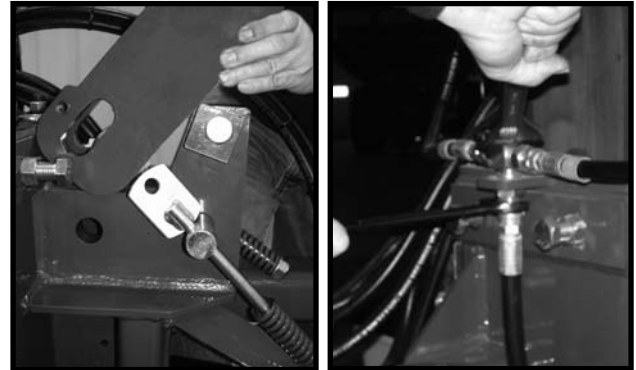

(e) Loosen the four cap mounting nuts and remove pad holder cap. (f) Loosen the pad hex jam nuts, back the pad screws out and remove the four pad holder assemblies as shown below.

D01190737



(g) Remove old pads and install new pads. NOTE: Apply a small amount of weather stripping adhesive to hold the pads in place while the pad holder is being reinstalled.

D01190739

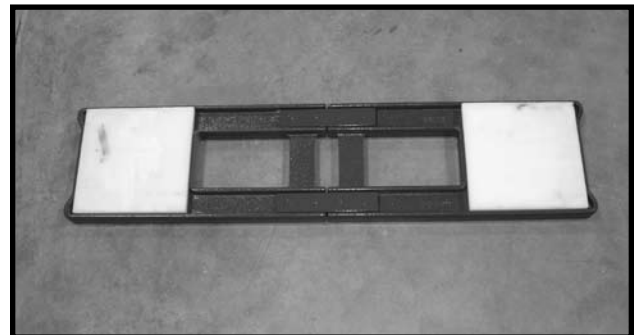

MAINTENANCE

(h) To adjust the pads, the pad set screws should be drawn tight, backed off and turned in until there is light contact with the pad holder. (i) Tighten hex jam nuts. (j) Torque hex jam nuts to 200 ft. lbs.

IMPORTANT: DO NOT OVER-TIGHTEN WEAR PADS. OVER TIGHTENING WILL CAUSE PREMATURE WEAR AND EXCESSIVE HYDRAULIC LIFT PRESSURES.

(k) Reinstall cap and tighten cap mounting nuts. (l) Reinstall hydraulic hose, fittings and safety hook.

D01190744

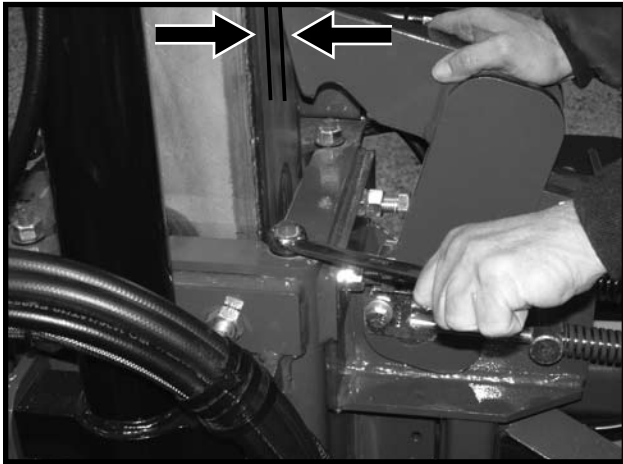

(m) Adjust stop on safety hook. Maximum clearance should be $\frac{1}{2}$ " and minimum clearance $\frac{1}{2}$ " as shown above.

D01190727



(n) Rotate cam roller against front guide and tighten to 200 ft. lbs. Make sure gap between roller guide and center frame are equal on both sides. (o) Raise planter out of the roller guides and lower back down into roller guides to be sure the roller guides operate smoothly. If not, adjust the rotation cylinder rod as shown below.

D01190731



D01190732

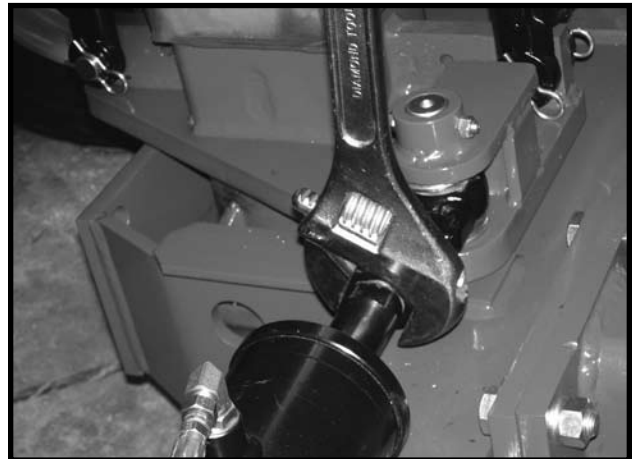

(p) Reset row unit down pressure and other attachments from STEP c.

MAINTENANCE

PREPARATION FOR STORAGE

Store the planter in a dry sheltered area if possible.

Remove all trash that may be wrapped on sprockets or shafts and remove dirt that can draw and hold moisture.

Clean all drive chains and coat with a rust preventative spray, or remove chains and submerge in oil.

Lubricate planter and row units at all lubrication points.

Inspect the planter for parts that are in need of replacement and order during the "off" season.

Make sure all seed and granular chemical hoppers are empty and clean.

Remove seed discs from seed meters, clean and store meters in a rodent-free, dry area with discs removed. Store seed discs vertically on a dowel or pipe.

Remove vacuum hose from each seed meter. Operate the vacuum fan at full hydraulic flow from the tractor for two minutes to clear manifolds, hoses and fittings of dust and debris.

Clean breather on analog vacuum gauge.

Disassemble, clean and grease all U-joint slides.

Grease or paint disc openers/blades and row marker disc blades to prevent rust.

MAINTENANCE

ELECTRICAL WIRING DIAGRAM FOR LIGHT PACKAGE

(WGN66b/A9201a)

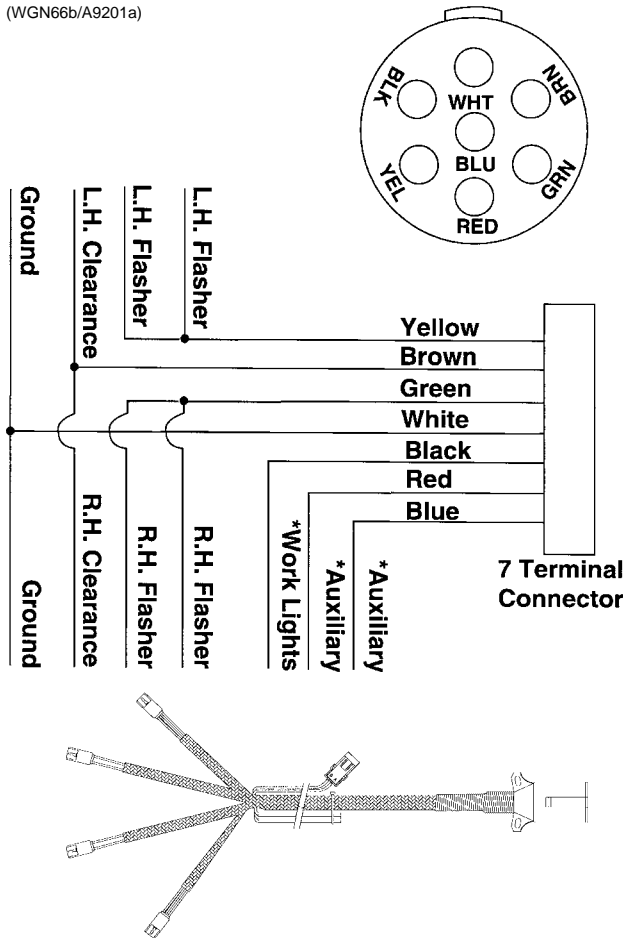

69922-35



*** Optional customer-supplied auxiliary lights and wires may be wired into existing plug terminals.**

The Light package supplied on the Model 3600TR Twin-Line® Planter meets ASAE Standards. For the correct wiring harness to be wired into the lights on your tractor, check with the tractor manufacturer.

MAINTENANCE

ELECTRICAL CONTROL CONSOLE SCHEMATIC

IMPORTANT: Before doing any electrical work, disconnect the control console from the tractor battery. Keep wiring harnesses away from high temperature areas or sharp edges. DO NOT route the wiring harnesses along battery cables. Use tie straps to keep wire harness away from moving parts on tractor and planter. Be sure ground connections to the tractor frame are clean to provide good electrical contact.

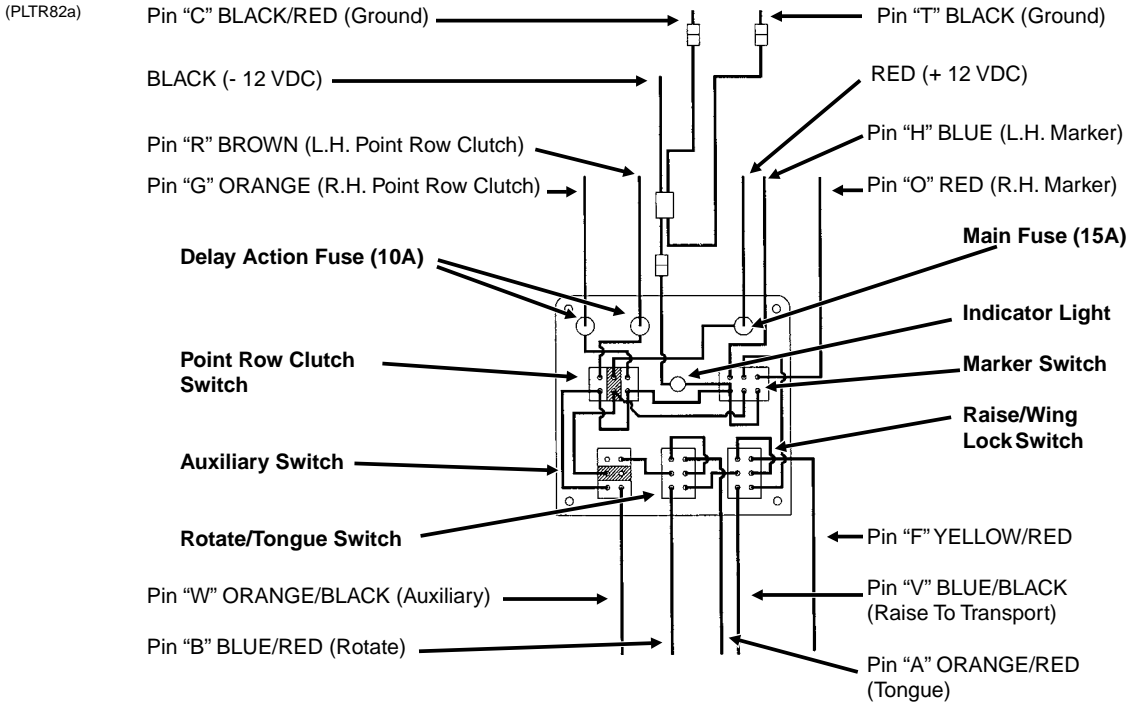

(INS238)

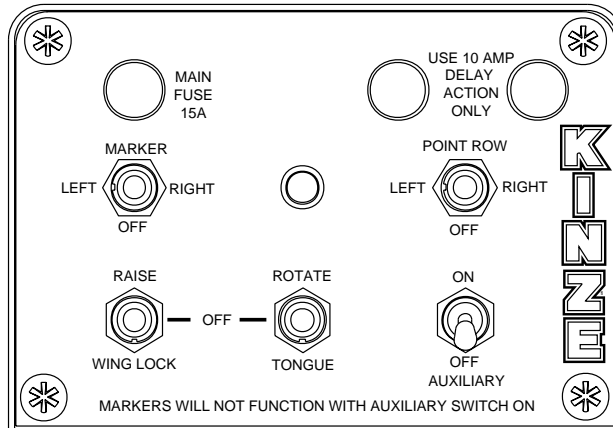

NOTE:

1. Operating marker or point row switch in either direction lights panel light.
2. Point row clutch switch operates independently of the rest of the control box.
3. Power to the marker switch is fed through the auxiliary switch and the two transport function switches. Operating any of the switches in the lower row disables the marker function and turns off the panel light. (If the point row clutch switch is in the "off" position.)

See page 10-35 for electrical control console schematic and wiring harness at two-speed point row clutch solenoids for planter equipped with the optional Two-Speed Point Row Clutch Package.

MAINTENANCE

ELECTRICAL WIRING HARNESS SCHEMATIC (On Tractor)

(ELC10c/ELC13)

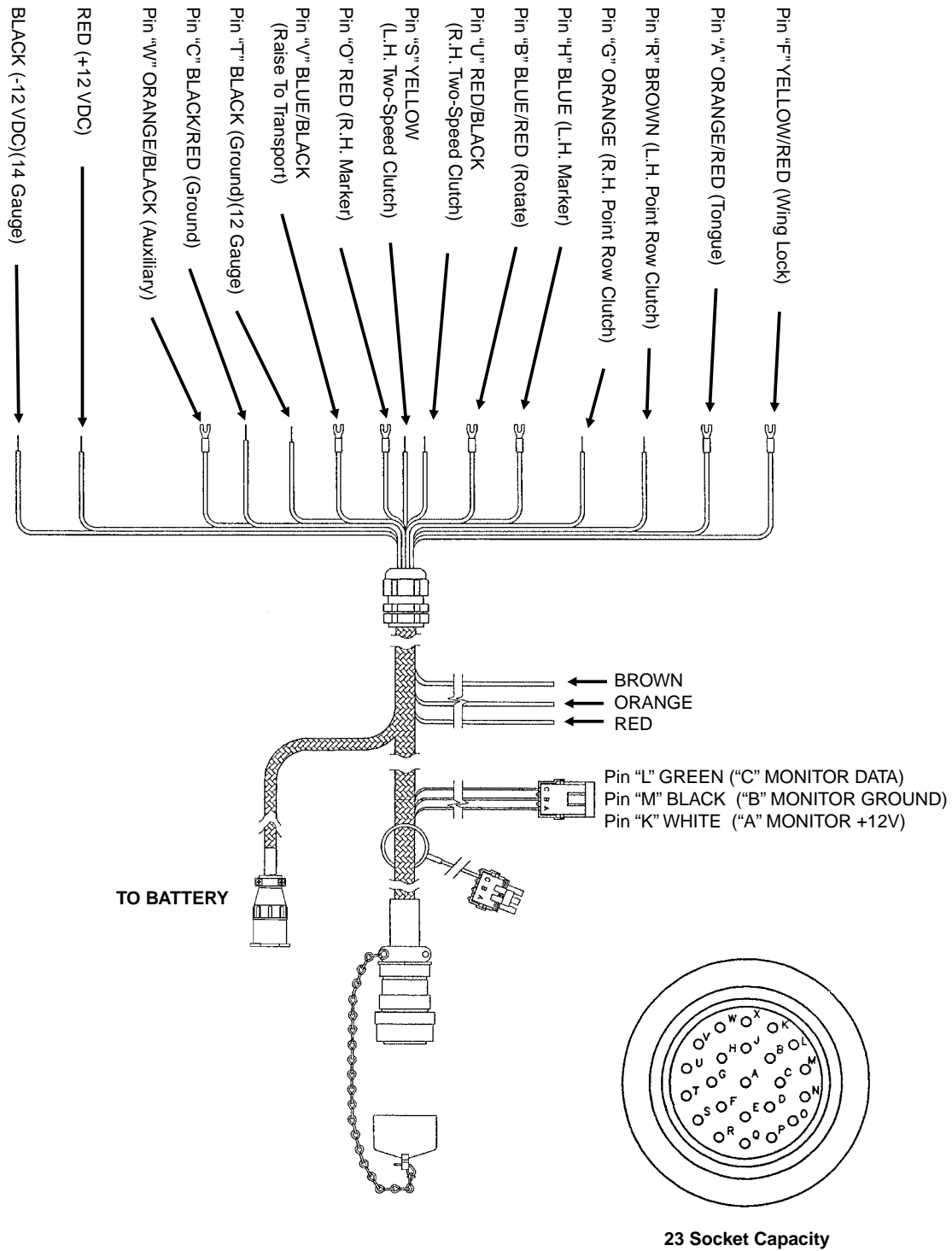

MAINTENANCE

ELECTRICAL WIRING HARNESS SCHEMATIC (On Planter)

(ELC13/ELC12b/TWL71d)

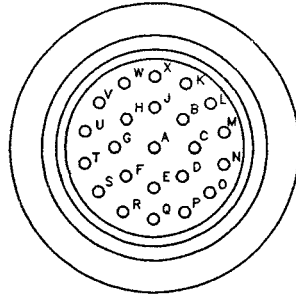

23 Pin Capacity

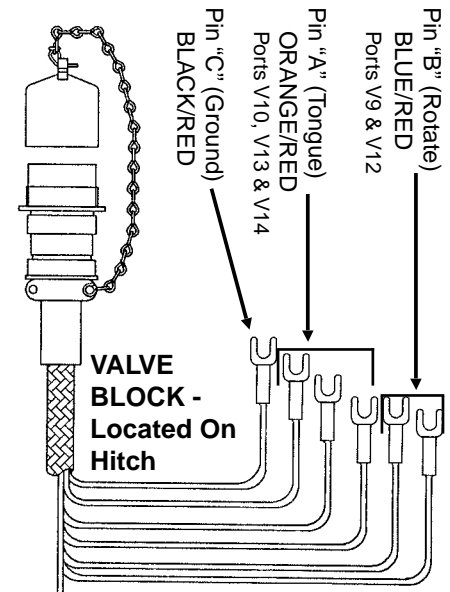

VALVE BLOCK - Located On Rear Center Frame

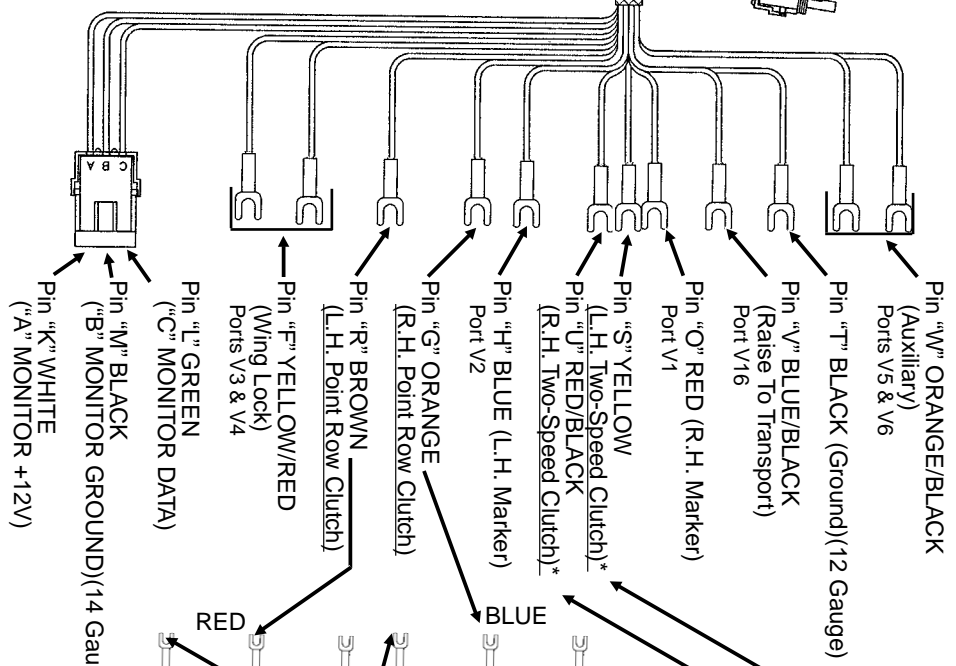

* See page 10-35 if equipped with the optional Two-Speed Point Row Clutch Package.

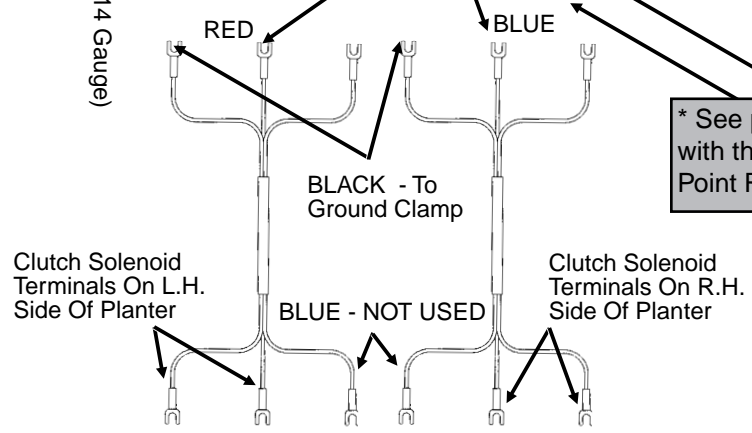

MAINTENANCE

(A7012a)

VALVE BLOCK - Located On Hitch

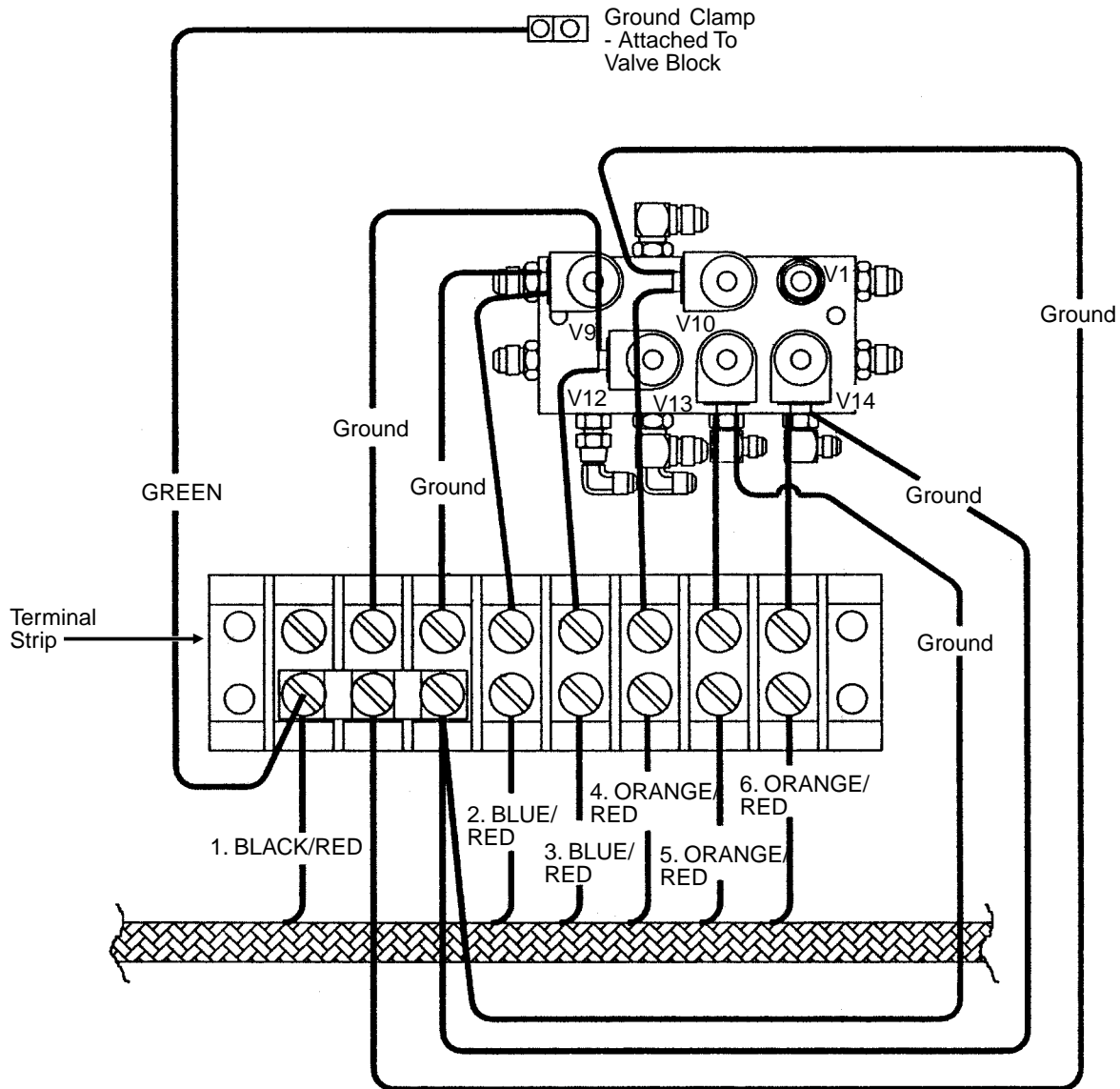

1. BLACK/RED - Pin "C" (Ground)
2. BLUE/RED - Pin "B" (Rotate) - Port V9
3. BLUE/RED - Pin "B" (Rotate) - Port V12
4. ORANGE/RED - Pin "A" (Tongue) - Port V10
5. ORANGE/RED - Pin "A" (Tongue) - Port V13
6. ORANGE/RED - Pin "A" (Tongue) - Port V14

MAINTENANCE

(A7102a)

VALVE BLOCK - Located On Rear Center Frame

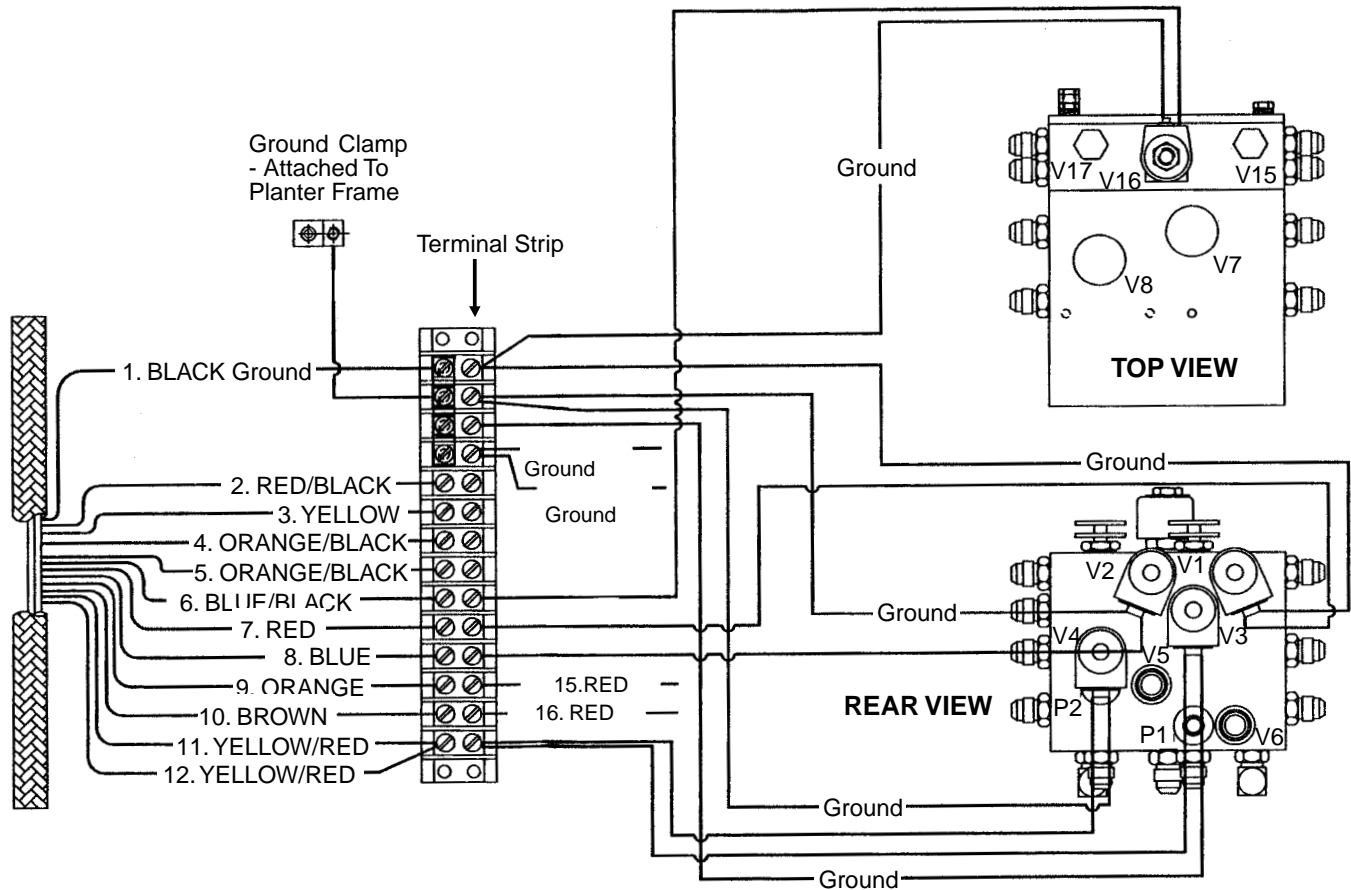

1. BLACK - Pin "T" (Ground)
2. RED/BLACK - Pin "U" (R.H. Two-Speed Clutch)*
3. YELLOW - Pin "S" (Le.H. Two-Speed Clutch)*
4. ORANGE/BLACK - Pin "W" (Auxiliary) - Ports V5 & V6
5. ORANGE/BLACK - Pin "W" (Auxiliary) - Ports V5 & V6
6. BLUE/BLACK - Pin "V" (Raise To Transport) - Port V16
7. RED - Pin "O" (R.H. Marker) - Port V1
8. BLUE - Pin "H" (L.H. Marker) - Port V2
9. ORANGE - Pin "G" (R.H. Point Row Clutch)
10. BROWN - Pin "R" (L.H. Point Row Clutch)
11. YELLOW/RED - Pin "F" (Wing Lock) - Ports V3 & V4
12. YELLOW/RED - Pin "F" (Wing Lock) - Ports V3 & V4
13. BLACK - (R.H. Point Row Ground)
14. BLACK - (L.H. Point Row Ground)
15. RED - (R.H. Point Row)
16. RED - (L.H. Point Row)

* See page 10-35 if equipped with the optional Two-Speed Point Row Clutch Package

MAINTENANCE

ELECTRICAL CONTROL CONSOLE SCHEMATIC (With Optional Two-Speed Point Row Clutches) AND WIRING HARNESS AT TWO-SPEED POINT ROW CLUTCH SOLENOIDS

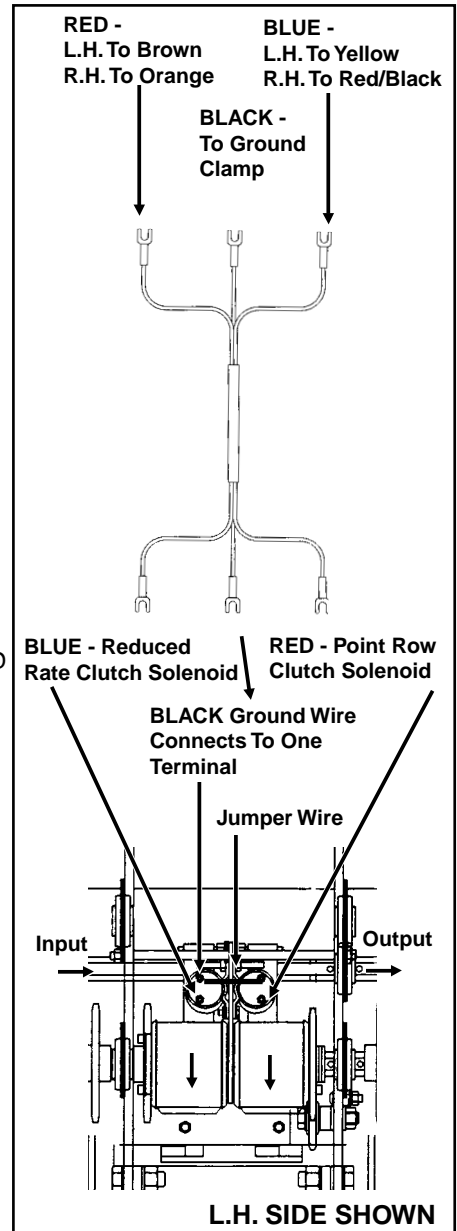
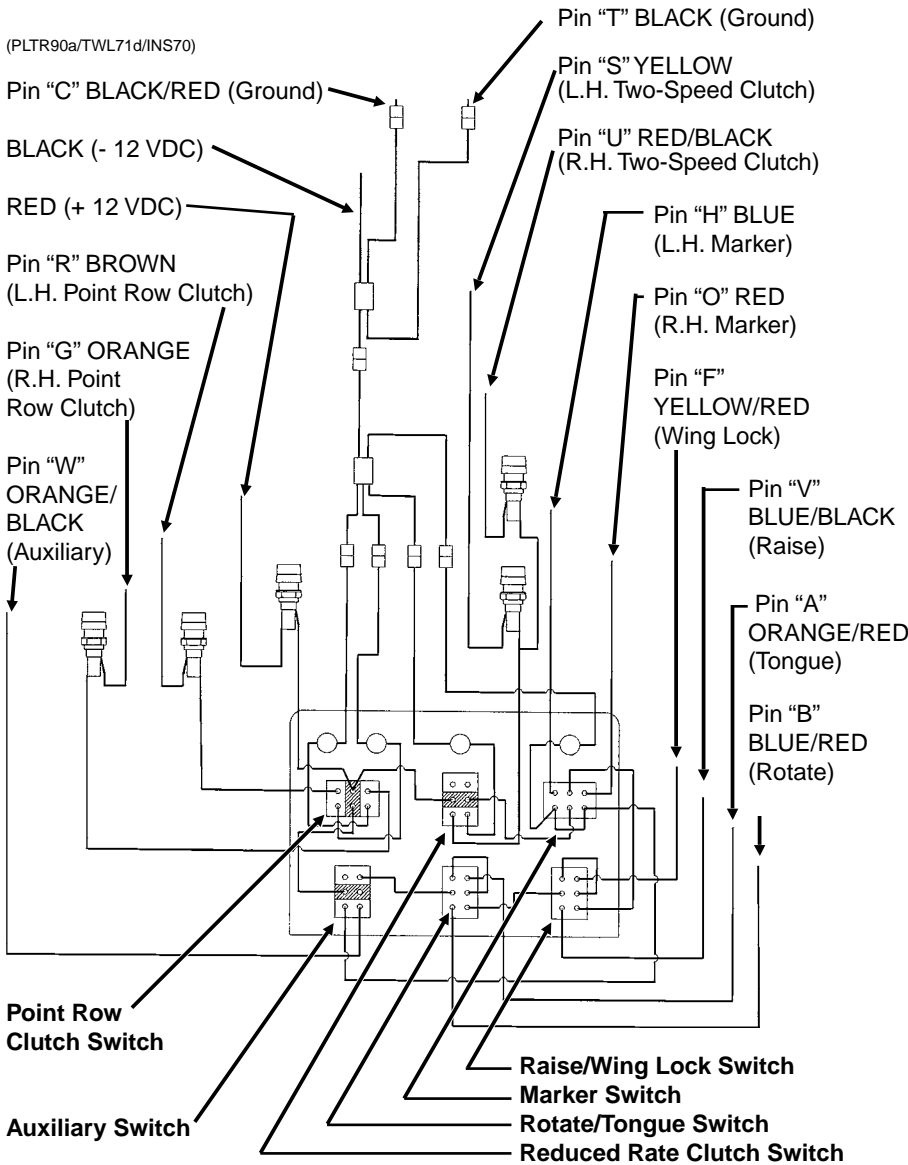

(INS260)

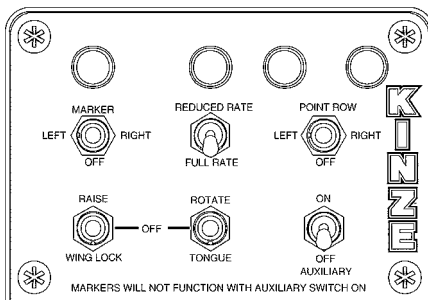

NOTE:

1. Point row and reduced rate clutch switches operate independently of the rest of the control console.
2. Power to the marker switch is fed through the auxiliary switch and the two transport function switches. Operating any of the switches in the lower row disables the marker function and turns off the panel light for the markers.

IMPORTANT: Before doing any electrical work, disconnect the control console from the tractor battery. Keep wiring harnesses away from high temperature areas or sharp edges. **DO NOT** route the wiring harnesses along battery cables. Use tie straps to keep wire harness away from moving parts on tractor and planter. Be sure ground connections to the tractor frame are clean to provide good electrical contact.

MAINTENANCE

HYDRAULIC SCHEMATIC - PLANTER OPERATION

(TWL143/TWL107/TWL111)

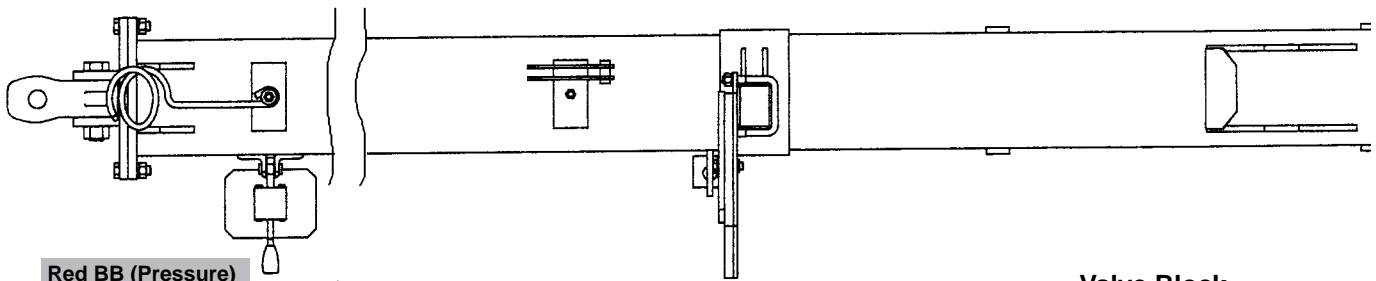
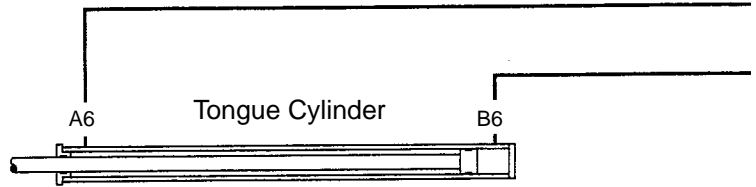

Red BB (Pressure)

D2

Blue BB (Pressure)

Blue AA (Return)

A2

Red AA (Return)

C2

Valve Block
- Located On
Hitch

D1

B1

B6

A6

A1

B5

C1

B4

A4

A5

B5

Transport Latch
Cylinder

B3

A3

Tongue Lock
Cylinder

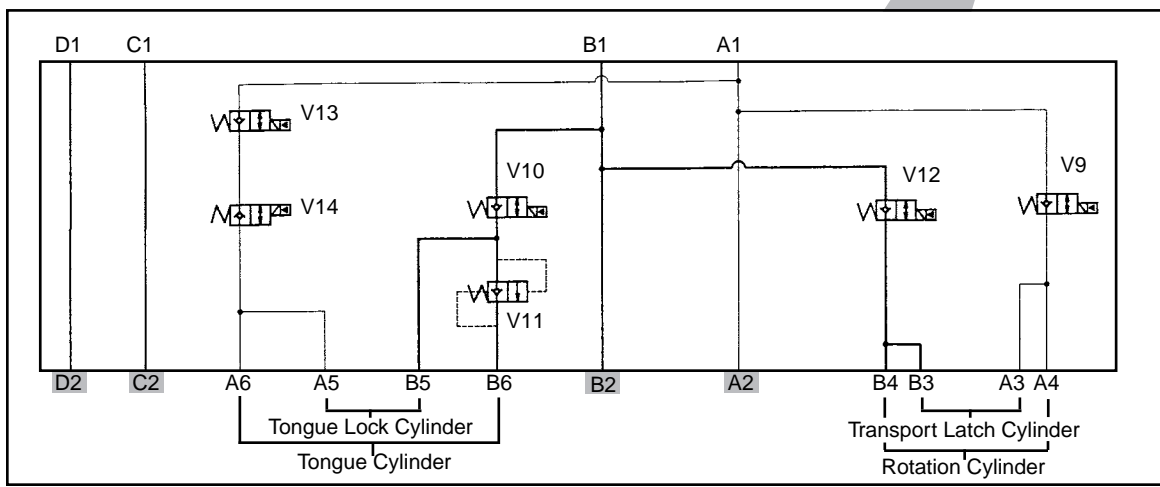

MAINTENANCE

(TWL108/TWL115)

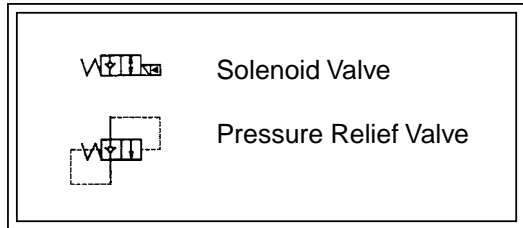
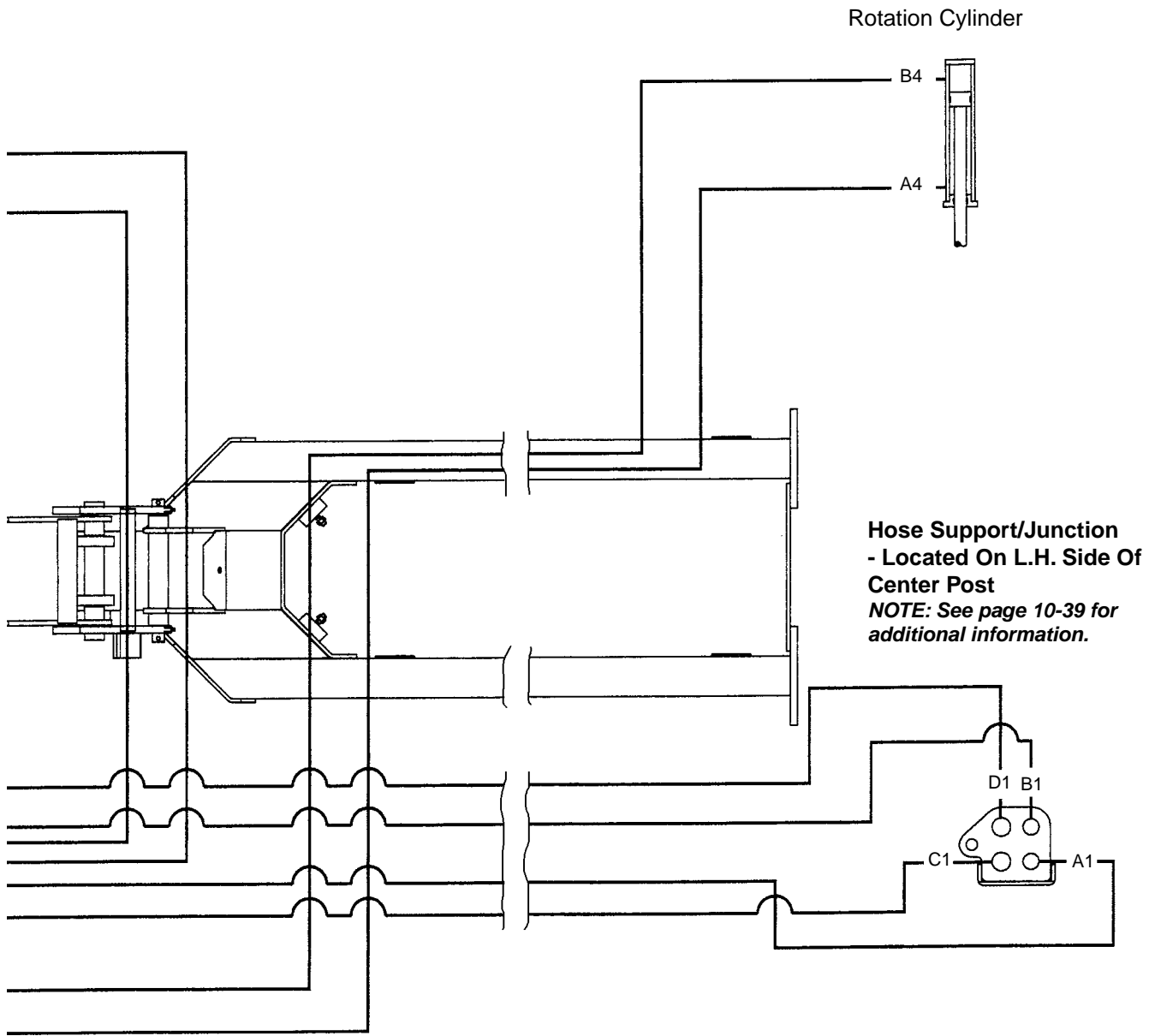

MAINTENANCE

HYDRAULIC SCHEMATIC - PLANTER OPERATION (Continued)

(TWL105/TWL113/TWL114)

16 Row Shown (Two Wing Lift Cylinders Per Wing)
 12 Row (One Wing Lift Cylinder Per Wing)

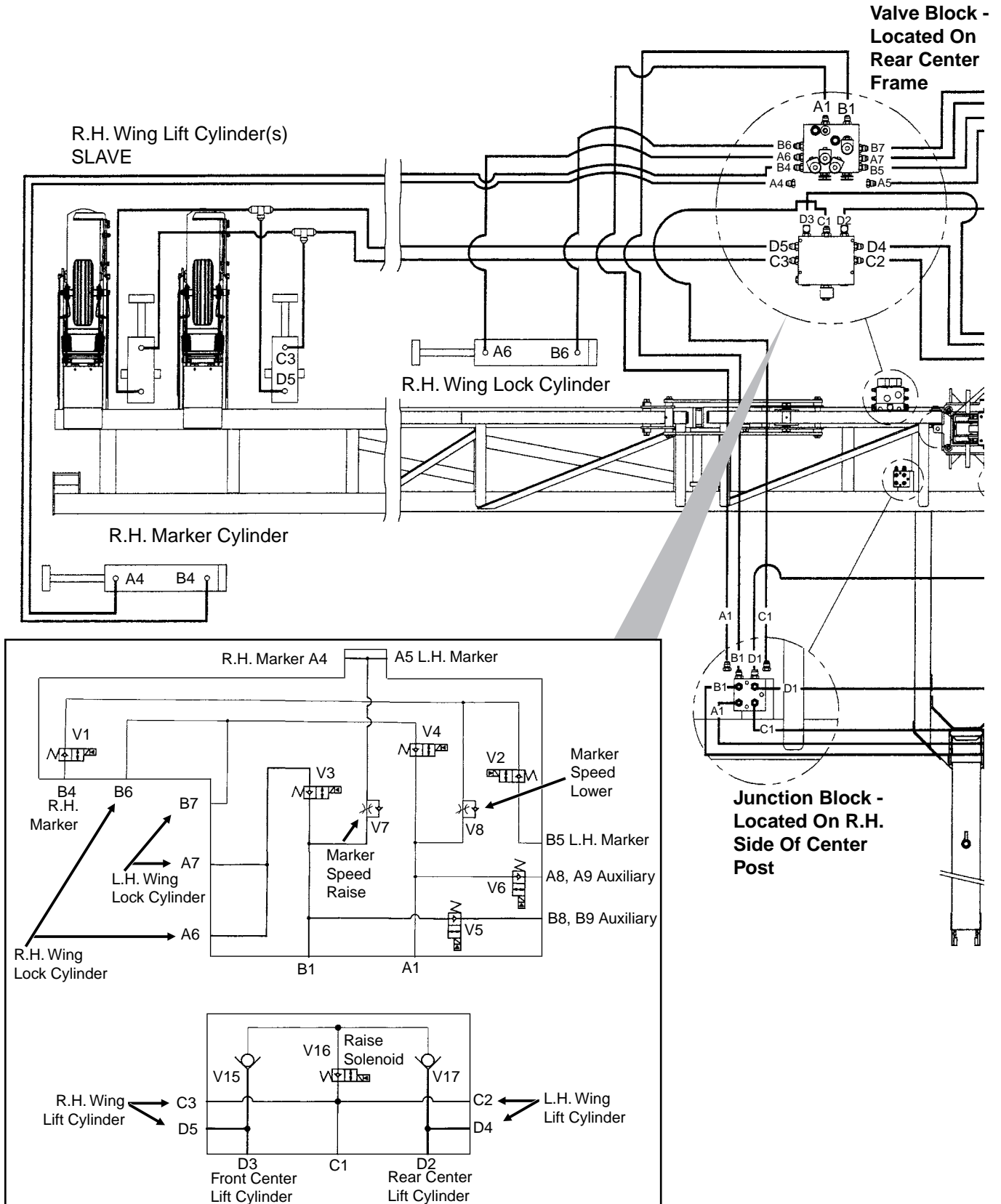

MAINTENANCE

(TWL106/TWL114)

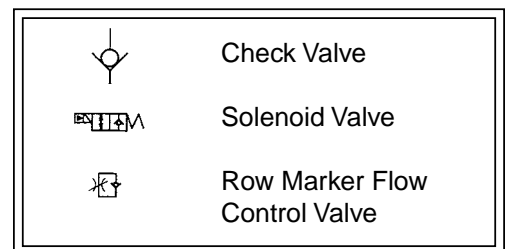
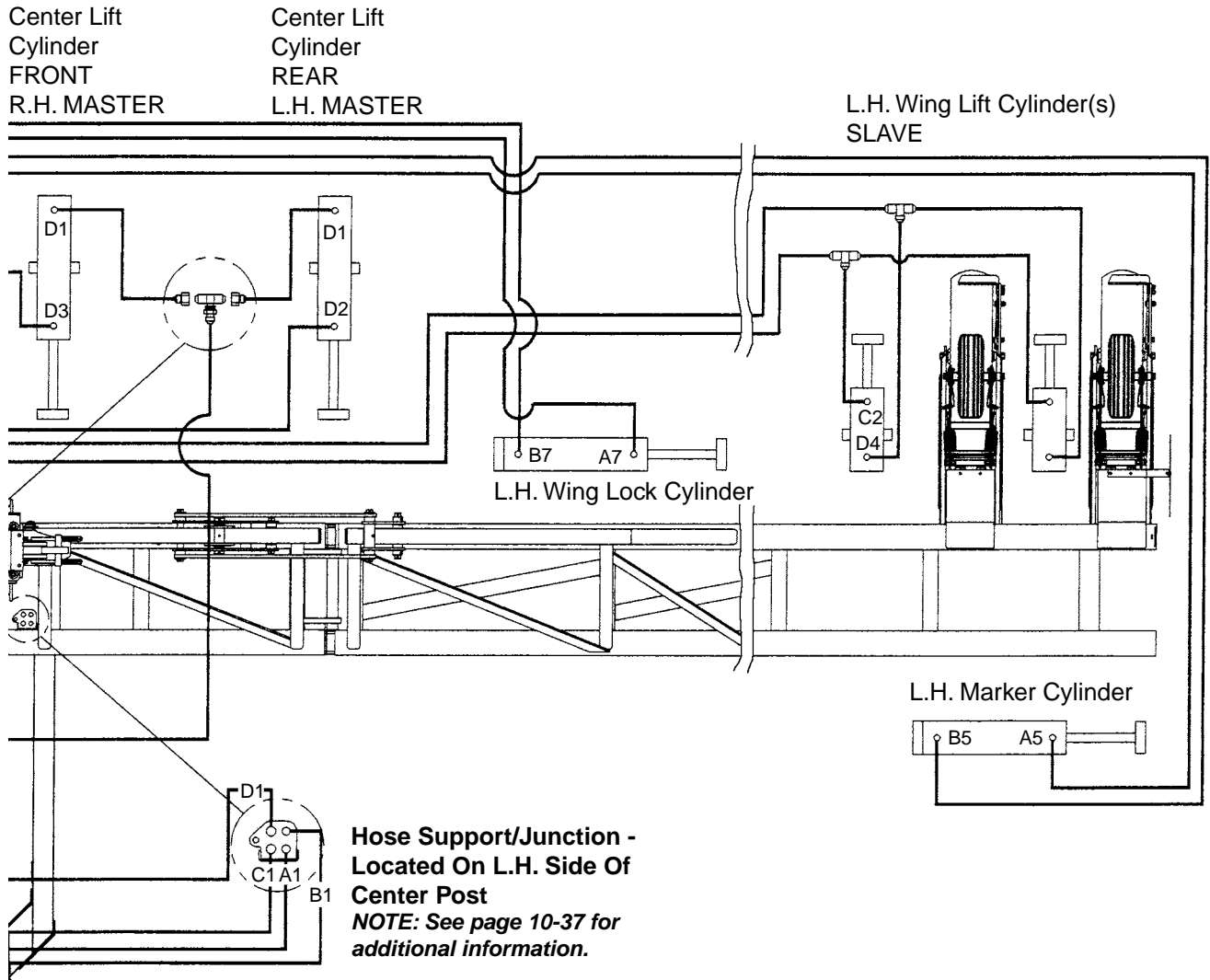

MAINTENANCE

HYDRAULIC SCHEMATIC - VACUUM FAN MOTOR SYSTEM

(PT79)

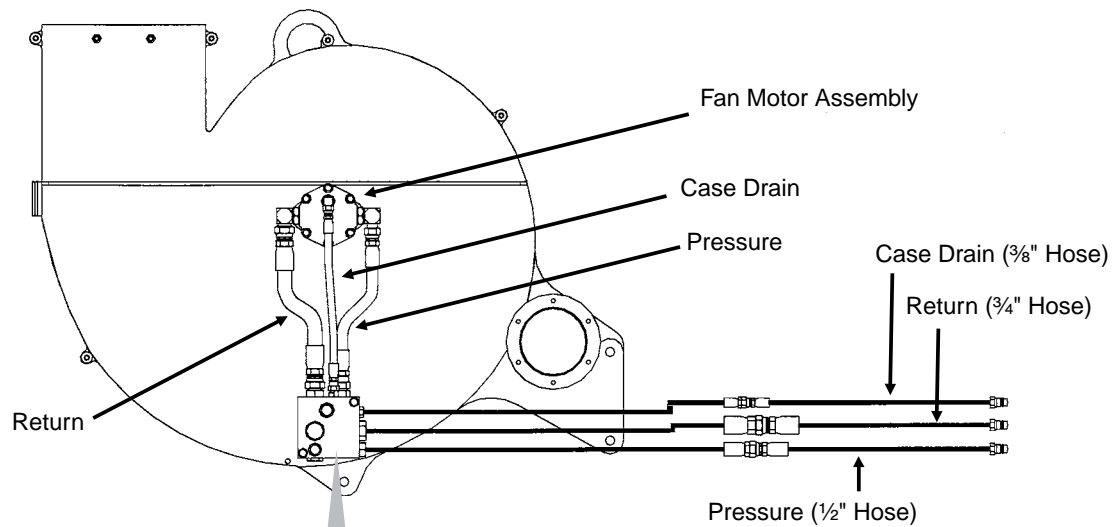

A11068bb

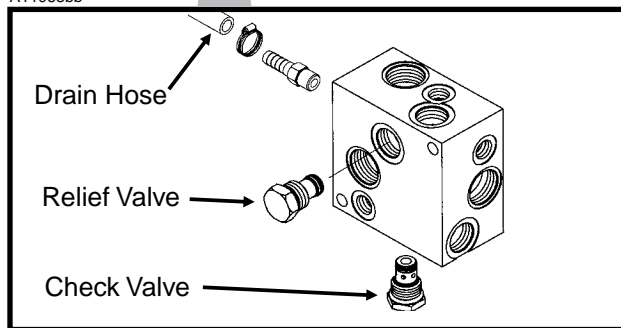

Vacuum Fan Motor Valve Block Assembly
(See Machine Operation Section)

IMPORTANT: Connect hydraulic motor case drain to a case drain return line with zero pressure on the tractor. Failure to connect to a return with zero pressure will cause damage to the hydraulic motor. **DO NOT** connect hydraulic motor case drain to SCV outlet. Contact tractor manufacturer for specific details on "zero pressure return".

MAINTENANCE

HYDRAULIC SCHEMATIC - OPTIONAL PTO PUMP DRIVE AND OIL COOLER SYSTEM

(TWL290c/PLTR177a)

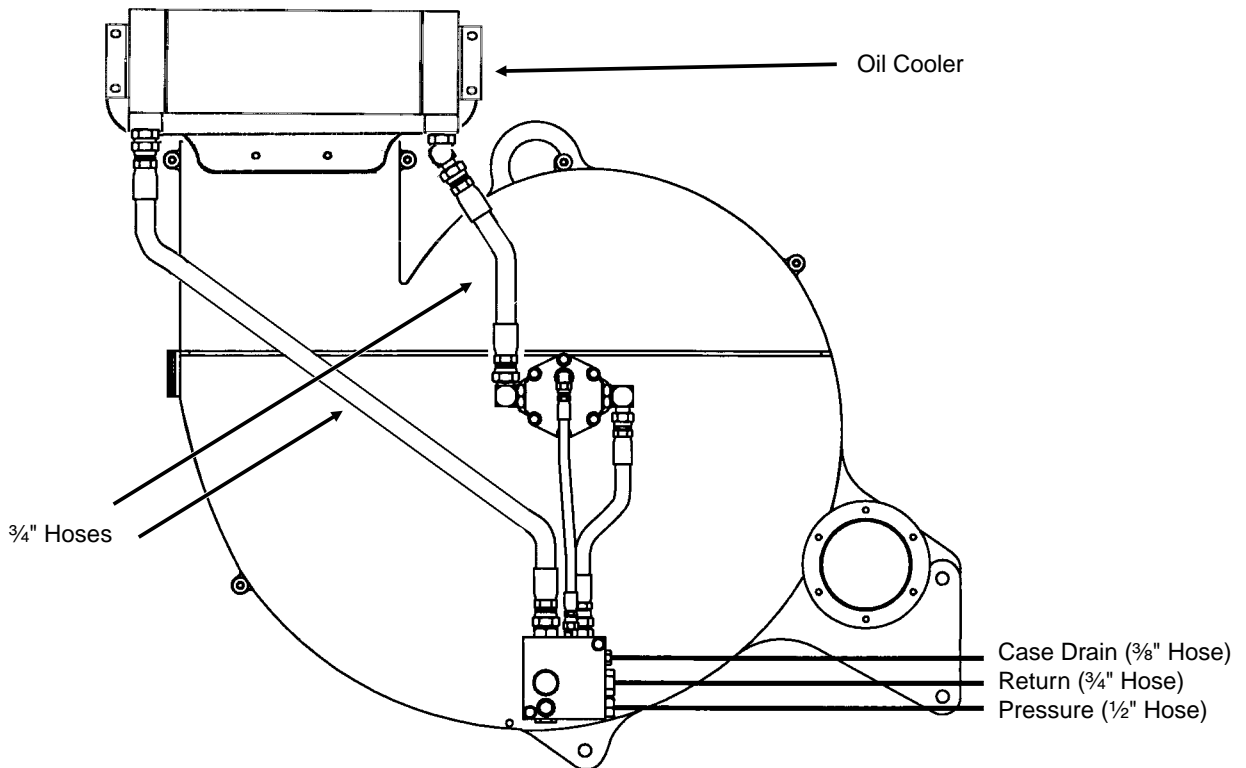
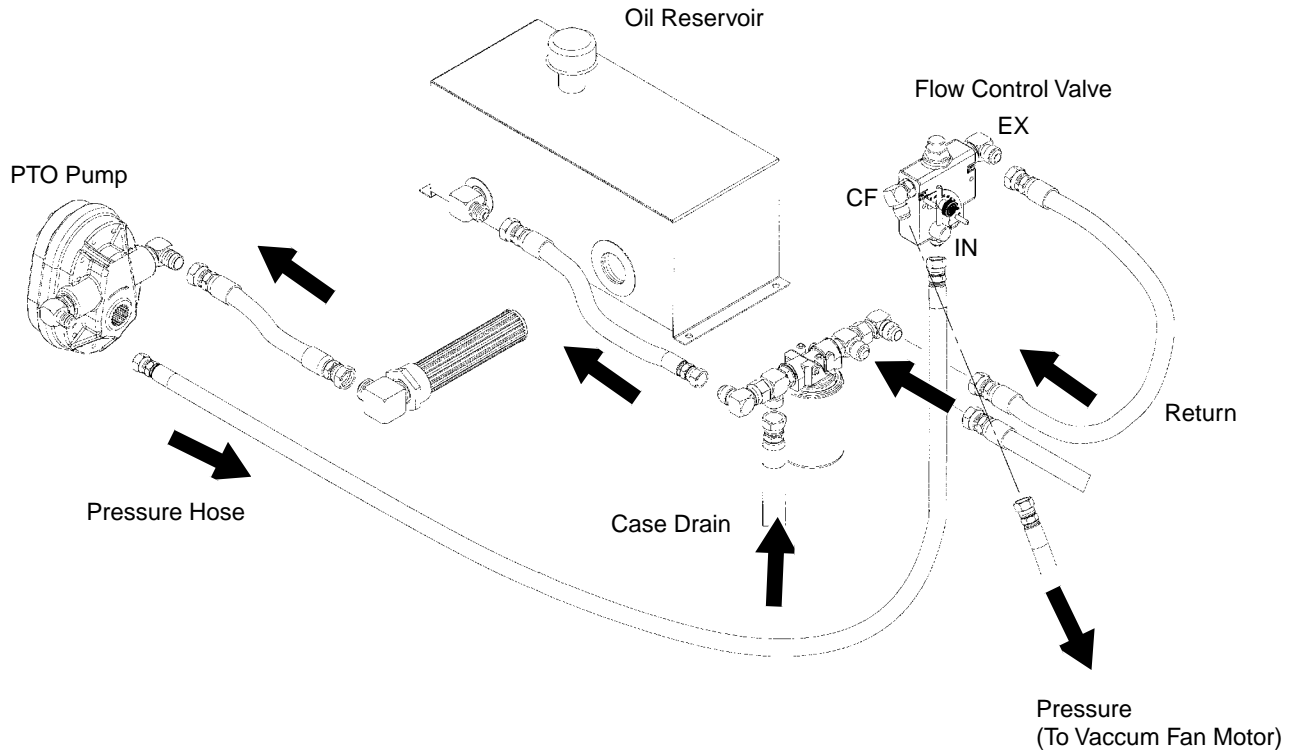

MAINTENANCE

PARTS LIST INDEX

ROW UNIT	
15" Seed Opener Disc Blade/Bearing Assembly And Scrapers	P11
Coulter Mounted Residue Wheels	P34
Covering Discs/Single Press Wheel	P14
Drag Closing Attachment.....	P17
Frame Mounted Coulter W/Residue Wheels.....	P36
Gauge Wheels	P12
Granular Chemical Banding Options	P25
Granular Chemical Hopper And Hopper Panel Extension	P22
Granular Chemical Meter And Meter Drive.....	P24
Hopper Support And Meter Drive	P18
Parallel Arms, Mounting Support Plate And Quick Adjustable Down Force Springs	P10
Parallel Arms, Mounting Support Plate And Pneumatic Down Pressure Package Option.....	P4
Pneumatic Down Pressure Control Box, Sending Unit And Harnesses	P6
Pneumatic Down Pressure Air Compressor, Dual Solenoid Assembly, Tubing And Fittings.....	P8
Row Unit Mounted Bed Leveler	P28
Row Unit Mounted Disc Furrower	P30
Row Unit Mounted No Till Coulter	P27
Row Unit Mounted Residue Wheel	P32
Seed Hopper And Lid	P19
Seed Meter	P20
Shank Assembly, Seed Tube And Depth Adjustment	P2
Spring Tooth Incorporator	P26
"V" Closing Wheels	P16
EDGEVAC® SYSTEM	
Digital Vacuum Gauge, Analog Vacuum Gauge And Vacuum Fan Assembly	P40
Manifolds And Distribution Hoses	P46
Optional Flow Control Needle Valve Kit	P44
PTO Pump Drive And Oil Cooler Option.....	P48
Vacuum Fan Hydraulic Components	P42
Vacuum Fan Hydraulic Motor Assembly	P44
Vacuum Fan Motor Valve Block Assembly (Located Below Vacuum Fan Motor Assembly)	P45
BASE MACHINE	
2-Point Hitch Option.....	P52
Axle Assembly	P64
Center Frame.....	P58
Center Pivot.....	P62
Contact Wheel And Drive Shaft(s)	P68
Cylinders.....	P88
Electrical Components.....	P104
Ground Drive Wheel	P71
Hose Take-Up	P56
Hydraulic Hoses And Fittings.....	P100
Inner Hitch	P54
Inner Module Drive	P74
Outer Hitch.....	P50
Point Row Clutch	P76
Row Marker Assemblies	P84
Row Marker Spindle/Hub/Blade.....	P83
Safety Chain	P50
Seed Rate Transmission And Row Unit Drill Shafts.....	P72
Transport Wheels/Rock Guards.....	P66
Two-Speed Point Row Clutch	P78
Two-Speed Point Row Clutch Wheel Module Extension.....	P80
Valve And Junction Blocks.....	P94
Valves (Solenoid, Flow Control, Pressure Relief, Check)	P98
Wing Frame	P60
ELECTRONIC SEED MONITOR	
KPM III Electronic Seed Monitor	P106
PUSH ROW UNIT SYSTEM	
Push Row Unit	P38
Push Row Unit Drive.....	P108
FERTILIZER	
Piston Pump Mount And Ground Drive Wheel.....	P110
Rear Trailer Hitch	P112
Decals, Paint And Miscellaneous.....	P114
Numerical Index.....	P119

SHANK ASSEMBLY, SEED TUBE AND DEPTH ADJUSTMENT

(D17014/METR29cc/A10142a/D16245)

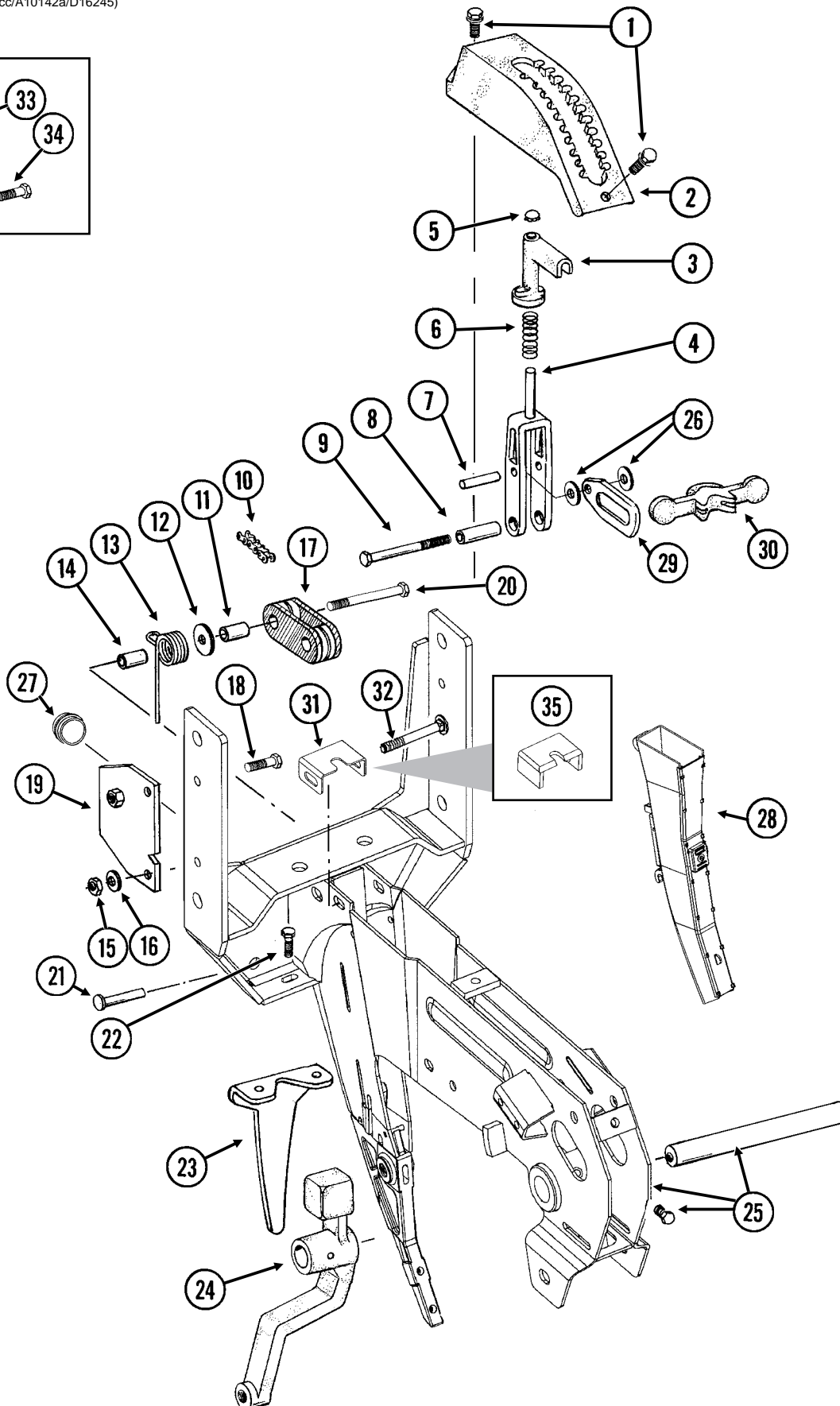
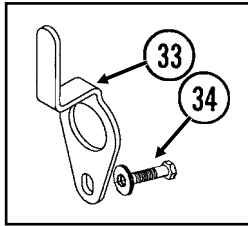

SHANK ASSEMBLY, SEED TUBE AND DEPTH ADJUSTMENT

ITEM	PART NO.	QTY. (Per Row)	DESCRIPTION
1.	G11015	2	Hex Washer Head Cap Screw, 3/8"-16 x 1 1/4"
2.	GB0274	1	Cover, Depth Adjustment
3.	GB0266	1	Handle, Depth Adjustment
4.	GB0267	1	Lever, Depth Adjustment
5.	GD3612	1	Cap Plug
6.	GD10993	1	Spring
7.	GD13361	1	Pin, 3/8" x 1 2/3"
8.	GD11259	1	Sleeve, 3/8" I.D. x 5/8" O.D. x 1 25/32" Long
9.	G11008	1	Hex Head Cap Screw, 3/8"-24 x 2 1/2", Grade 8
	G11007	1	Lock Nut, 3/8"-24, Grade C
10.	G3303-108	1	Chain, No. 41, 108 Pitch Including Connector Link
	G3303-16	1	Chain, No. 41, 16 Pitch Including Connector Link (Used W/Row Unit Extension Brackets)
	GR0196	1	Connector Link, No. 41
11.	GD1026	1	Sleeve, 1 3/16" Long
12.	G10201	1	Special Washer, 3/8" x 1 1/2" O.D.
13.	GD1065	1	Idler Spring
14.	GD7318	1	Sleeve, 1" Long
15.	G10108	1	Lock Nut, 3/8"-16
16.	G10210	1	Washer, 3/8" USS
17.	GD11962	1	Idler
18.	G10003	3	Hex Head Cap Screw, 3/8"-16 x 1 1/2"
	G10108	3	Lock Nut, 3/8"-16
19.	GD10867	2	Stop
20.	G10326	1	Hex Head Cap Screw, 3/8"-16 x 3 3/4"
21.	G10551	1	Clevis Pin, 1/4" x 2 1/2"
	G10669	1	Hair Pin Clip, No. 22
22.	G10312	2	Carriage Bolt, 5/16"-18 x 3/4"
	G10620	2	Serrated Flange Nut, 5/16"-18
23.	GD1033	1	Shield
24.		-	See "Gauge Wheels", Pages P12 And P13
25.	GA10157	1	Shank W/Gauge Wheel Pivot Spindle And Set Screw
	GD11001	-	Spindle
	G10438	-	Hex Head Cap Screw, 1/2"-13 x 3/4"
26.	G10207	2	Washer, 7/8" O.D. x 1 3/32" I.D. x .134" (If Applicable)
27.	GD11845	1	Dust Cap
28.			See KPM III Electronic Seed Monitor", Pages P106-P107
29.	GB0285	1	Collar, Depth Adjustment
30.	GB0265	1	Pivot Link, Depth Adjustment
31.	GD15970	1	Sun Shade
32.	G10304	1	Carriage Bolt, 3/8"-16 x 3"
	G10108	1	Lock Nut, 3/8"-16
33.	GD17014	1	Hose Guide
34.	G10047	1	Hex Head Cap Screw, 3/8"-16 x 1 3/4"
	G10203	2-3	Washer, 3/8" SAE
	G10108	1	Lock Nut, 3/8"-16
35.	GD16245	-	Sun Shade (Rubber)

PARALLEL ARMS, MOUNTING SUPPORT PLATE AND PNEUMATIC DOWN PRESSURE PACKAGE OPTION

(RU157a/RU159/RU157aa)

Pull Row Unit Shown

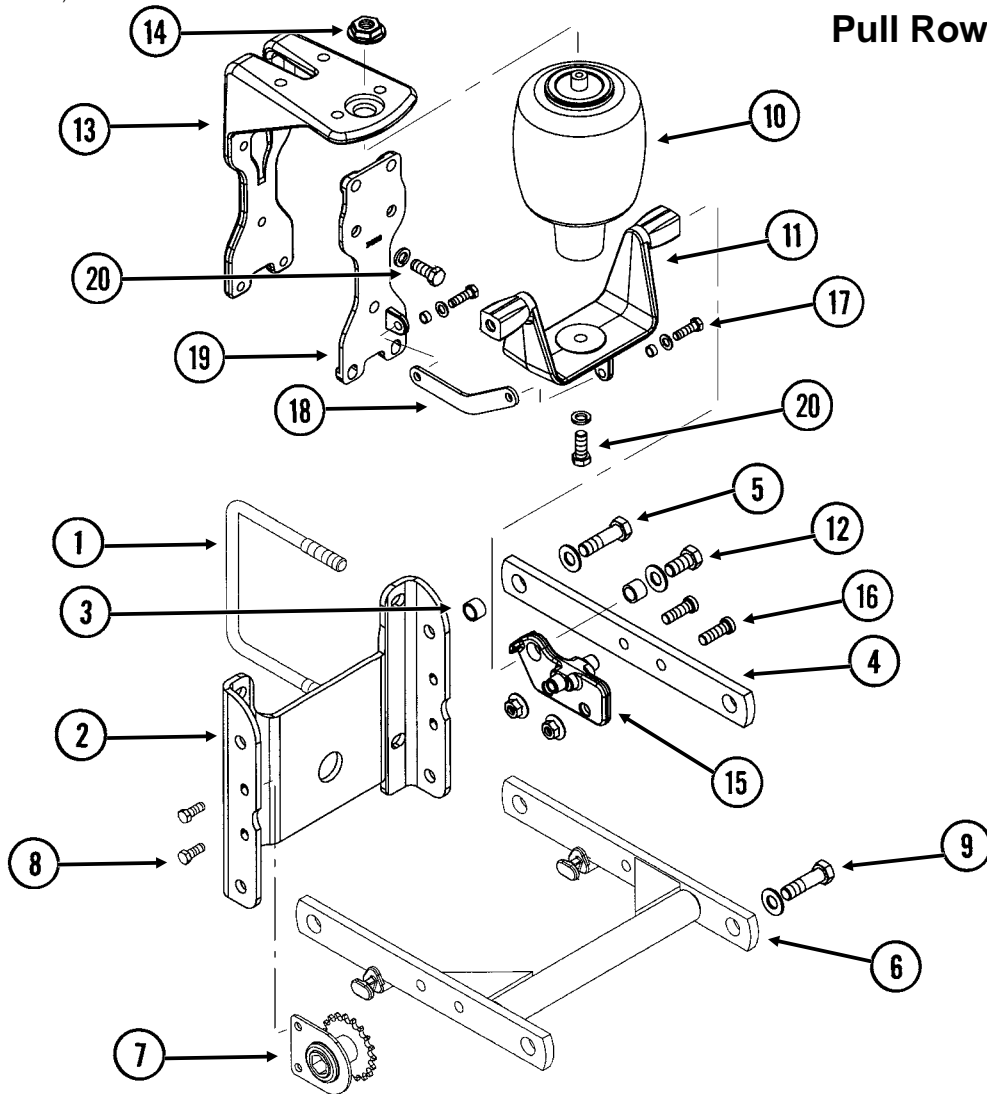

Push Row Unit Shown

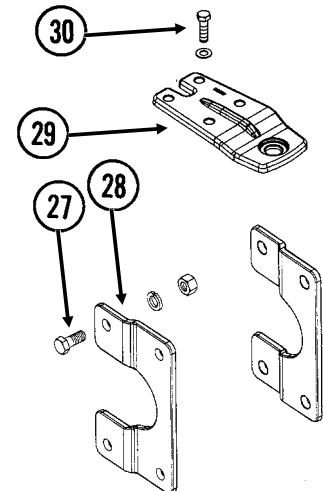
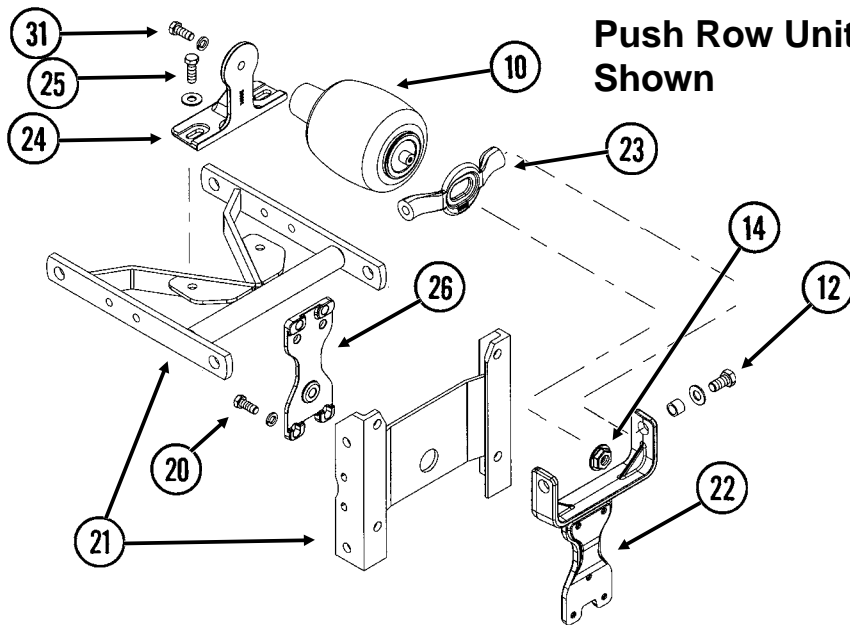

PARALLEL ARMS, MOUNTING SUPPORT PLATE AND PNEUMATIC DOWN PRESSURE PACKAGE OPTION

ITEM	PART NO.	QTY. (Per Row)	DESCRIPTION
1.	GD1113	2	U-Bolt, 5" x 7" x 5/8"-11
	G10230	4	Lock Washer, 5/8"
	G10104	4	Hex Nut, 5/8"-11
2.	GD10036	1	Mounting Support Plate
3.	GB0218	4	Bushing, 2 1/32" I.D. x 7/8" O.D. x 1 9/32" Long
4.	GD11422	2	Upper Parallel Arm
5.	G10732	4	Hex Head Cap Screw, 5/8"-18 x 2"
	GD7805	4	Special Washer, 5/8", Hardened
	G10412	4	Lock Nut, 5/8"-18
6.	GA5651	1	Lower Parallel Arm
7.	GA1720	1	Bearing/Sprocket, 7/8" Hex Bore
8.	G10001	2	Hex Head Cap Screw, 3/8"-16 x 1"
	G10229	2	Lock Washer, 3/8"
	G10101	2	Hex Nut, 3/8"-16
9.		-	See "Hopper Support And Meter Drive", Page P18
10.	GA11982	1	Air Spring Assembly
11.	GB0394	1	Saddle
12.	G11018	2	Hex Head Cap Screw, 5/8"-18 x 1 1/4"
	GD7805	2	Special Washer, 5/8", Hardened
	GD3180-30	2	Sleeve, 7/8" O.D. x 5/8" I.D. x 2 1/32"
13.	GB0396	1	Head Mount
14.	GB0397	1	Shoulder Nut, 3/4"-16
15.	GB0395	2	Bracket
16.	G11220	4	Hex Socket Cap Screw, 1/2"-13 x 1 1/2"
	G10071	4	Serrated Flange Nut, 1/2"-13
17.	G10004	2	Hex Head Cap Screw, 3/8"-16 x 1 1/4"
	G10203	2	Washer, 3/8" SAE
	GD11963-04	2	Spacer, 1/4"
	G10108	2	Lock Nut, 3/8"-16
18.	GD17794	1	Link
19.	GB0393	1	Plate
20.	G10037	7	Hex Head Cap Screw, 1/2"-13 x 1 1/4"
	G10206	2	Washer, 1/2" SAE (Lower Two Holes Only)
	G10228	7	Lock Washer, 1/2"
21.		-	See "Push Row Unit", Pages P38 And P39
22.	GB0390	1	Yoke Mount
23.	GB0392	1	Yoke
24.	GB0391	1	Mount
25.	G10017	2	Hex Head Cap Screw, 1/2"-13 x 1 1/2"
	G10216	2	Washer, 1/2" USS
	G10228	2	Lock Washer, 1/2"
	G10102	2	Hex Nut, 1/2"-11
26.	GB0389	1	Plate
27.	G10007	4	Hex Head Cap Screw, 5/8"-11 x 1 1/2"
	G10230	4	Lock Washer, 5/8"
	G10104	4	Hex Nut, 5/8"-11
28.	GB0366	2	Extension Bracket
29.	GB0398	1	Extension
30.	G10039	4	Hex Head Cap Screw, 1/2"-13 x 1 3/4"
	G10206	4	Washer, 1/2" SAE
	G10111	4	Lock Nut, 1/2"-13
31.	G10037	1	Hex Head Cap Screw, 1/2"-13 x 1 1/4"
	G10228	1	Lock Washer, 1/2"
A.	G6325X	-	U-Bolt Package For 5" x 7" Toolbar, Includes: (2) GD1113, (4) G10230, (4) G10104

PNEUMATIC DOWN PRESSURE CONTROL BOX, SENDING UNIT AND HARNESSES

(PNE01/MTR27a/ELC27b/MTR45/MTR27t)

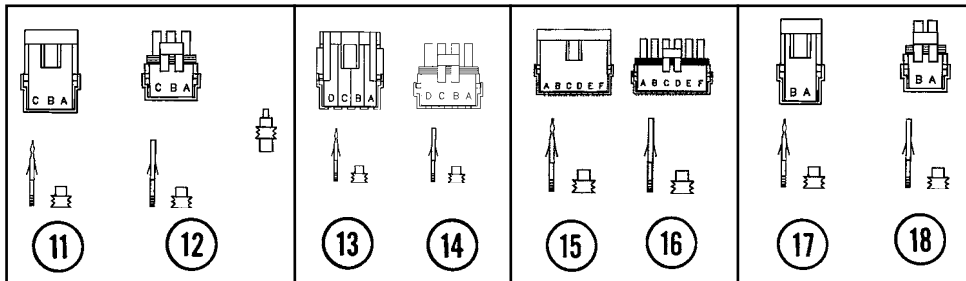
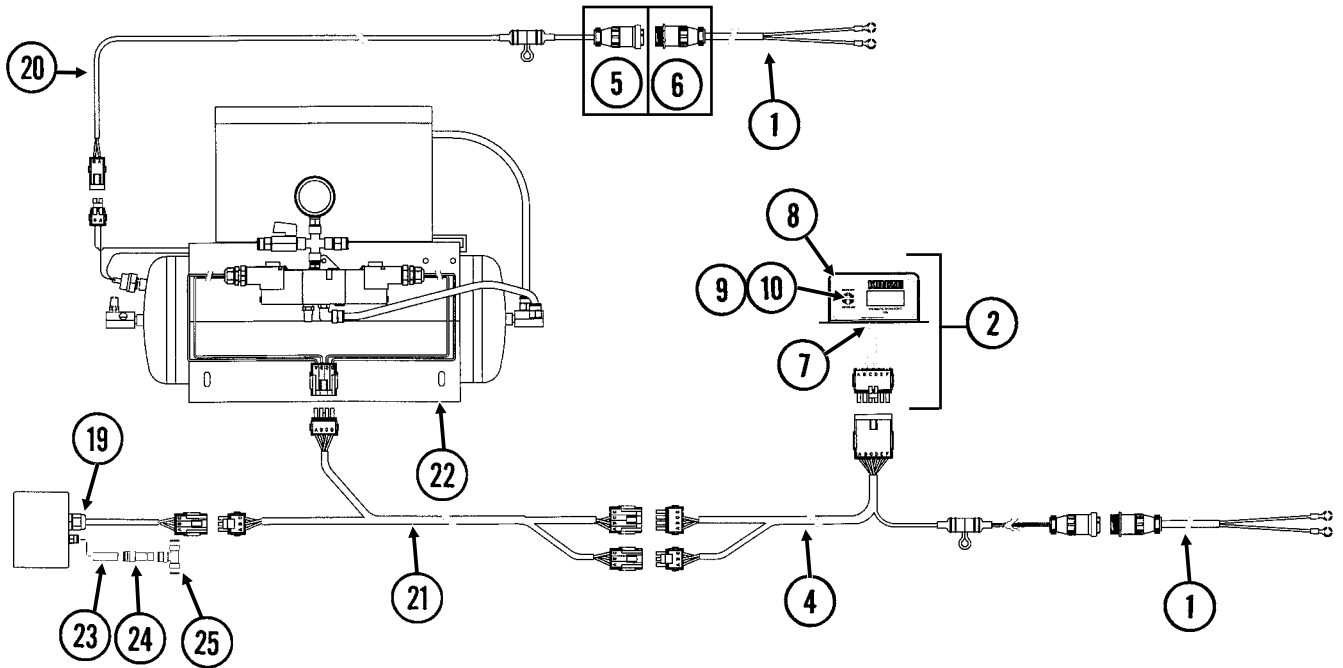

PNEUMATIC DOWN PRESSURE CONTROL BOX, SENDING UNIT AND HARNESSSES

ITEM	PART NO.	QTY.	DESCRIPTION
1.	GA7856	2	Power Lead Adapter
2.	GA12644	1	Control Console Assembly
3.	GA12646	1	Sending Unit
4.	GA12645	1	Wiring Harness W/Fuse Holder And Fuse, 206"
	GD14258	-	Fuse Holder
	GD14660	-	Fuse, 2 Amp Delay Action
5.	G1K268	-	Console Cable Connector Kit, Includes: (1) 3-Pin Connector, (1) Cable Clamp, (1) Lock Ring, (3) Female Terminal Pins
6.	G1K267	-	Console Cable Connector Kit, Includes: (1) 3-Pin Connector, (1) Cable Clamp, (3) Male Terminal Pins
7.	GA9963	1	Strain Relief
8.	GR1292	4	Pan Head Screw, No. 8-32 x 1/2"
9.	GR1363	1	Hex Face Nut, 1 5/32"-32
10.	GA6978	2	Switch, 3 Position Toggle, Momentary ON-OFF-ON
11.	G1K248	-	3-Pin Female Connector Kit (Black), Includes: (3) 3-Pin Female Housings, (9) Pin Contacts, (9) Seals
12.	G1K252	-	3-Pin Male Connector Kit (Black), Includes: (3) 3-Pin Male Housings, (9) Socket Contacts, (9) Seals
13.	GA8328	-	4-Pin Female Connector Kit, Includes: (1) 4-Pin Female Housing, (4) Pin Contacts, (4) Seals
14.	GA8329	-	4-Pin Male Connector Kit, Includes: (1) 4-Pin Male Housing, (4) Socket Contacts, (4) Seals
15.	G1K396	-	6-Pin Female Connector Kit (Black), Includes: (3) 6-Pin Female Housings, (18) Pin Contacts, (18) Seals
16.	G1K395	-	6-Pin Male Connector Kit (Black), Includes: (3) 6-Pin Male Housings, (18) Socket Contacts, (18) Seals
17.	G1K321	-	2-Pin Female Connector Kit (Black), Includes: (3) 2-Pin Female Housings, (6) Pin Contacts, (6) Seals
18.	G1K320	-	2-Pin Male Connector Kit (Black), Includes: (3) 2-Pin Male Housings, (6) Socket Contacts, (6) Seals
19.	GA9964	2	Strain Relief
20.	GA12684	1	Wiring Harness W/Fuse Holder And Fuse, 60'
	GD14258	-	Fuse Holder
	GD18275	-	Fuse, 20 Amp
21.	GA12674	1	Wiring Harness, 60'
22.		-	See "Pneumatic Down Pressure Air Compressor, Dual Solenoid Assembly, Tubing And Fittings", Pages P8 And P9
23.	GD17151-06	1	Nylon Tubing, 1/4" O. D. x 1 1/2"
24.	GD18796	1	Reducer, 3/8" To 1/4"
25.	GD18010	1	Tee, 3/8" Tube Union

PNEUMATIC DOWN PRESSURE AIR COMPRESSOR, DUAL SOLENOID ASSEMBLY, TUBING AND FITTINGS

(PNE06/PNE02/PNE05/A13169/PNE09/PNE08)

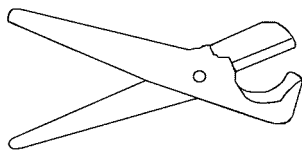
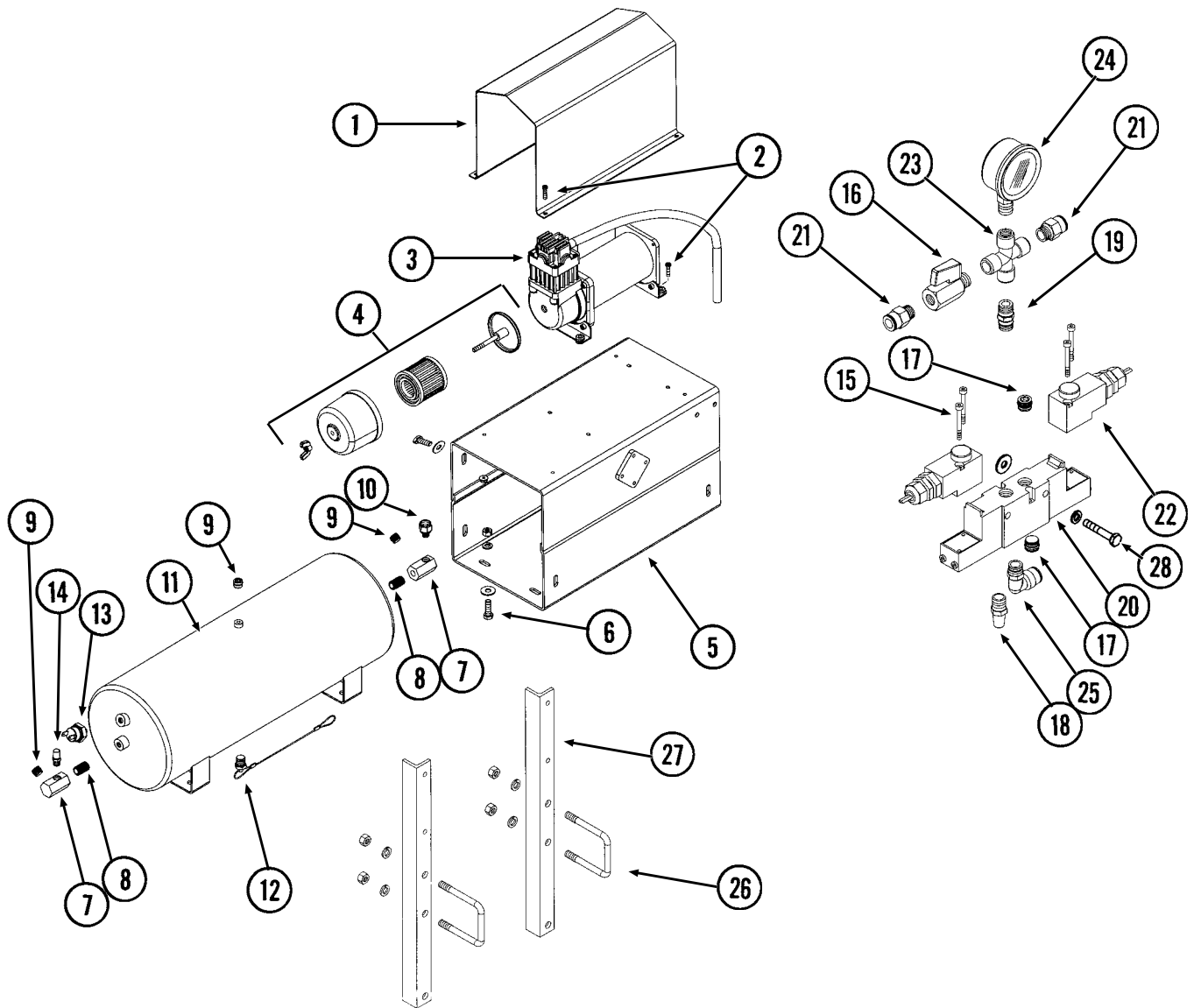

34

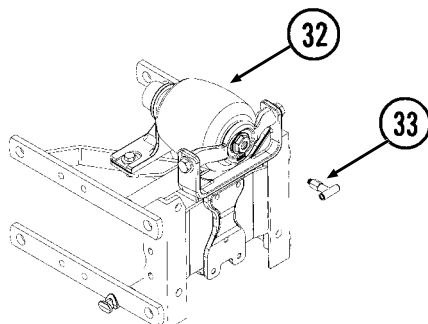

32

33

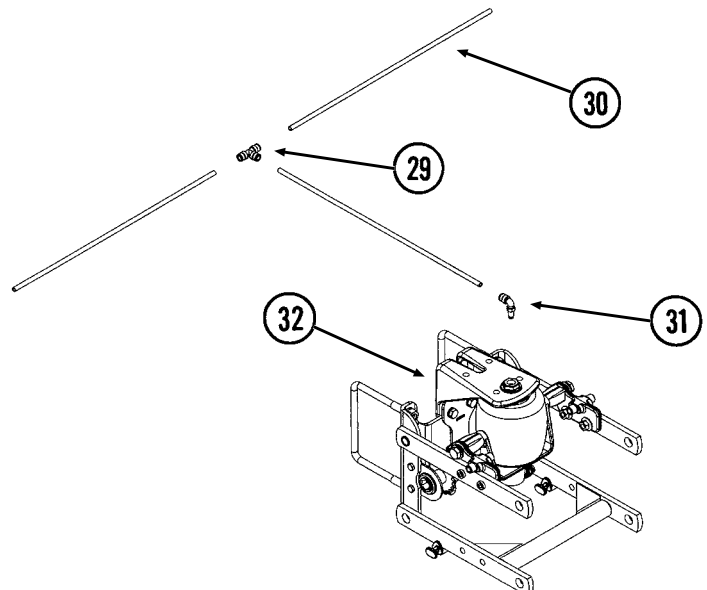

30

29

32

31

PNEUMATIC DOWN PRESSURE AIR COMPRESSOR, DUAL SOLENOID ASSEMBLY, TUBING AND FITTINGS

ITEM	PART NO.	QTY.	DESCRIPTION
1.	GD18112	1	Cover
2.	G11066	8	Phillips Pan Head Machine Screw, No. 10-24 x 3/4", Stainless Steel
	G10992	8	Serrated Flange Nut, No. 10-24
3.	GA12102	1	Air Compressor
4.	GA12404	1	Filter Assembly
	GR1809	-	Filter
5.	GA12358	1	Compressor Mount
6.	G10019	8	Hex Head Cap Screw, 5/16"-18 x 1"
	G10219	8	Washer, 5/16" USS
	G10232	8	Lock Washer, 5/16"
	G10106	8	Hex Nut, 5/16"-18
7.	GD17298	2	Manifold, 1/4" NPT
8.	GD18081	2	Close Nipple, 1/4" NPT
9.	GD17156	3	Plug, 1/4" NPT
10.	GD17144	1	Reducer, 1/8" Male To 1/4" Female
11.	GA11988	1	Tank, 3 Gallon
12.	GA11991	1	Drain, 1/4" NPT
13.	GR1778	1	Pressure Switch
14.	GA11989	1	Valve Stem, 1/8" NPT
15.	G11247	4	Slotted Pan Head Machine Screw, M4-0.7 x 8
16.	GA11992	1	Shutoff Valve, 1/4" NPT
17.	GD17156	2	Plug, 1/4" NPT
18.	GA11997	1	Breather, 1/4" NPT
19.	GD17154	1	Connector, 1/4" Male
20.	GA11993	1	Block
21.	GD17141	3	Connector, 1/4" Male
22.	GA11994	2	Solenoid
23.	GD18078	1	Female Cross, 1/4" NPT
24.	GA12104	1	Pressure Gauge, 1/4" NPT
25.	GD17143	1	Swivel Elbow, 1/4" NPT x 3/8"
26.	GD4743	2	U-Bolt, 3" x 3" x 1/2"-13
	G10228	4	Lock Washer, 1/2"
	G10102	4	Hex Nut, 1/2"-13
27.	GD18119	2	Compressor Mount
28.	G10021	2	Hex Head Cap Screw, 1/4"-20 x 1 1/2"
	G10227	2	Lock Washer, 1/4"
	G10209	2	Washer, 1/4" USS
29.	GD18010	-	Tee, 3/8" Tube Union
30.	GD17150-03	-	Nylon Tubing, 3/8" O.D. x 64', 12 Row Pull Row Units
	GD17150-04	-	Nylon Tubing, 3/8" O.D. x 86', 16 Row Pull Row Units
31.	GD18011	-	Elbow, 3/8" x 1/8" NPT Extended
32.		-	See "Parallel Arms, Mounting Support Plate And Pneumatic Down Pressure Package Option", Pages P4 And P5
33.	GD18274	-	Tee, 3/8" x 1/8" NPT Extended, Push Row Unit
34.	GA13169	1	Tube Cutter W/Blade
	GR1843	-	Blade
A.	GA12626	-	Air Compressor Assembly (Items 1-14)
B.	GA11995	-	Dual Solenoid Assembly (Items 15-25)

PARALLEL ARMS, MOUNTING SUPPORT PLATE AND QUICK ADJUSTABLE DOWN FORCE SPRINGS

RUB021/RUB022(RU78f/B0366)

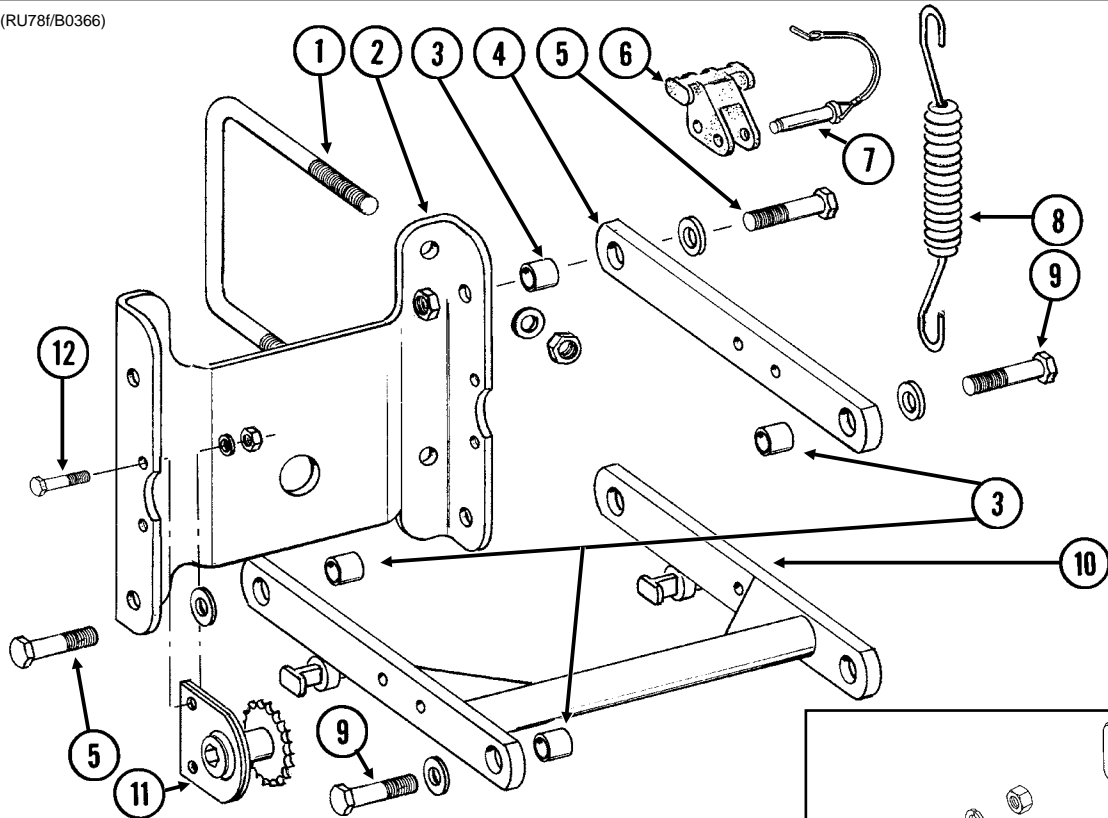

ITEM	PART NO.	QTY. (Per Row)	DESCRIPTION
1.	GD1113	2	U-Bolt, 5" x 7" x 5/8"-11
	G10230	4	Lock Washer, 5/8"
	G10104	4	Hex Nut, 5/8"-11
2.	GD10036	1	Mounting Support Plate
3.	GB0218	4	Bushing, 2 1/32" I.D. x 7/8" O.D. x 1 9/32" Long
4.	GD11422	2	Upper Parallel Arm
5.	G10732	4	Hex Head Cap Screw, 5/8"-18 x 2"
	GD7805	4	Special Washer, 5/8", Hardened
	G10412	4	Lock Nut, 5/8"-18
6.	GB0186	2	Spring Anchor
7.	GD14217	2	Tab Lock Pin, 7/16" x 1 1/2"
8.	GD8249	2-4	Spring
9.		-	See "Hopper Support And Meter Drive", Page P18
10.	GA5651	1	Lower Parallel Arm
11.	GA1720	1	Bearing/Sprocket, 7/8" Hex Bore
12.	G10001	2	Hex Head Cap Screw, 3/8"-16 x 1"
	G10229	2	Lock Washer, 3/8"
	G10101	2	Hex Nut, 3/8"-16
13.	G10007	4	Hex Head Cap Screw, 5/8"-11 x 1 1/2"
	G10230	4	Lock Washer, 5/8"
	G10104	4	Hex Nut, 5/8"-11
14.	GB0366	2	Extension Bracket
A.	G6325X	-	U-Bolt Package For 5" x 7" Toolbar, Includes: (2) GD1113, (4) G10230, (4) G10104

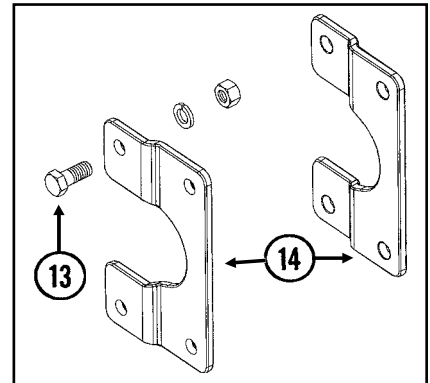

15" SEED OPENER DISC BLADE/BEARING ASSEMBLY AND SCRAPERS

(RU139)

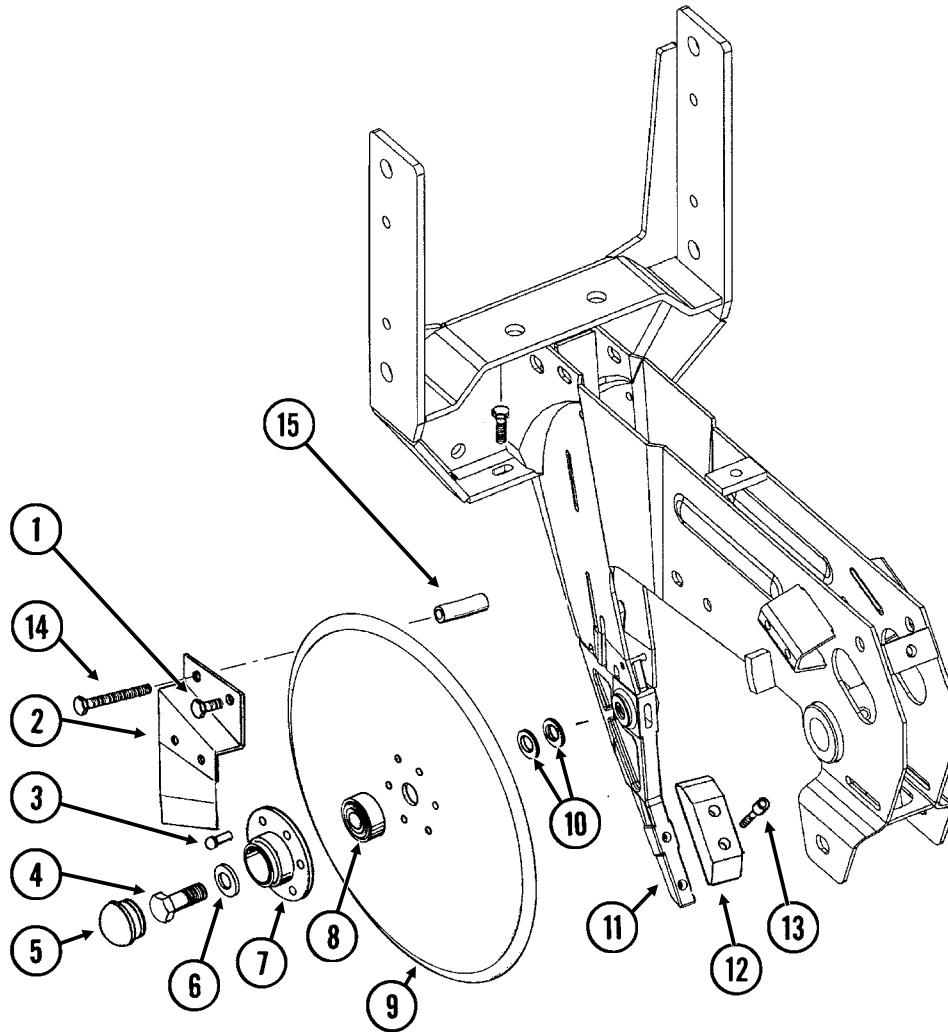

ITEM	PART NO.	QTY. (Per Row)	DESCRIPTION
1.	G10328	2	Hex Head Cap Screw, 3/8"-16 x 5/8"
	G10622	2	Serrated Flange Nut, 3/8"-16
2.	GA2012R	1	Disc Scraper, R.H.
	GA2012L	-	Disc Scraper, L.H. (Shown)
3.	G10427	12	Rivet, 1/4" x 1/2"
4.	GD11017	1	Special Hex Head Cap Screw, 5/8"-11 x 1 1/2", L.H. Threads
	G10007	1	Hex Head Cap Screw, 5/8"-11 x 1 1/2"
5.	GD11845	2	Dust Cap
6.	G10204	2	Special Machine Bushing, 5/8" x 1" O.D.
7.	GD10473	2	Bearing Housing
8.	GA2014	2	Bearing
9.	GD11306	2	Disc Blade, 3.5 mm x 15"
10.	G10213	-	Machine Bushing, 5/8" (.030" Thick)(As Required)
11.		-	See "Shank Assembly", Pages P2 And P3
12.	GB0301	1	Seed Tube Guard/Inner Scraper
13.	G10912	2	Hex Socket Head Cap Screw, 5/16"-18 x 1", Grade 8
14.	G10325	1	Hex Head Cap Screw, 3/8"-16 x 2 3/4"
	G10622	1	Serrated Flange Nut, 3/8"-16
15.	GD11259	1	Sleeve, 3/8" I.D. x 5/8" O.D. x 1 25/32" Long
A.	GA8324	-	Disc Blade/Bearing Assembly, Less Dust Cap (Items 3 And 7-9)

GAUGE WHEELS

(RU140)

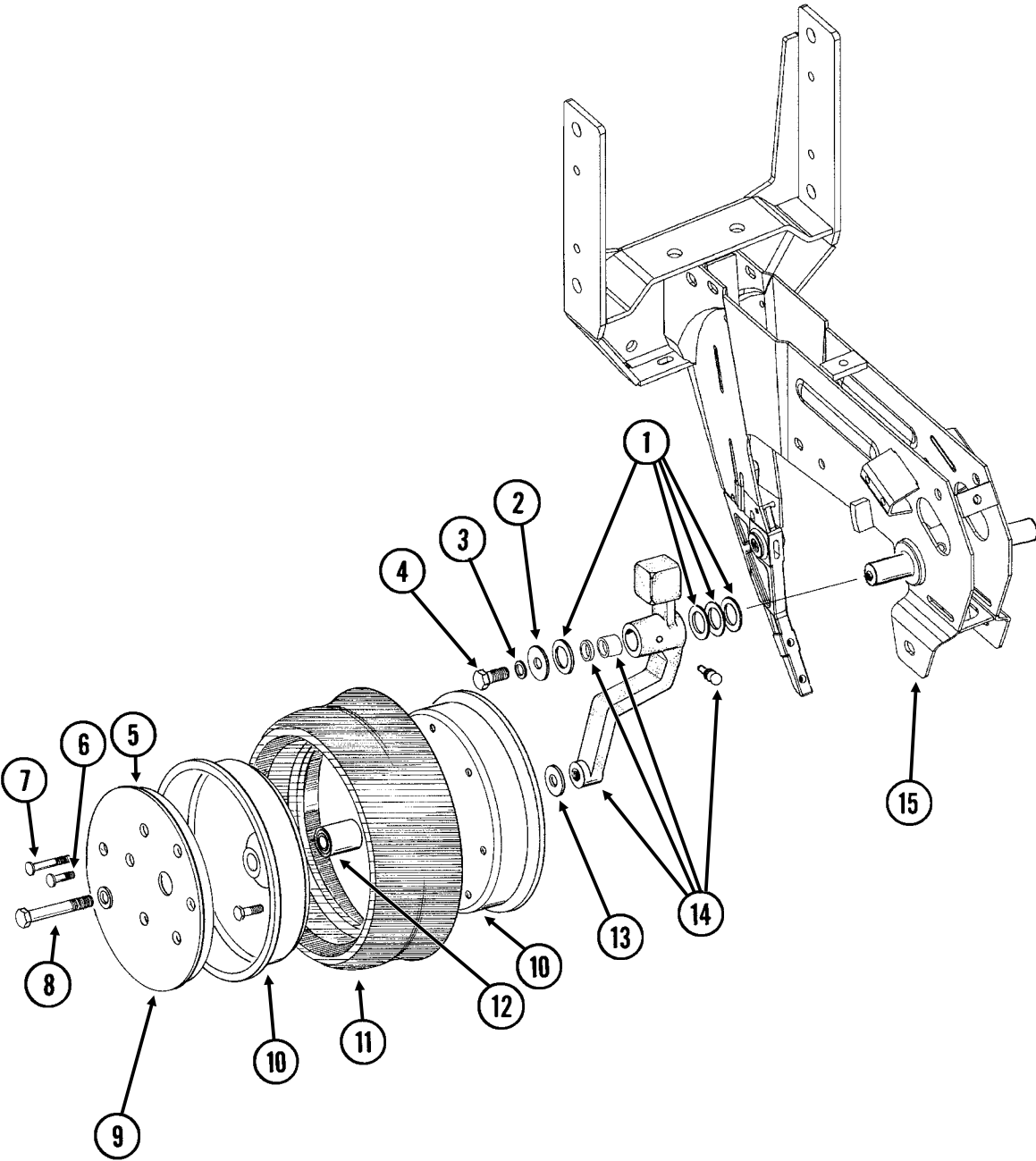

GAUGE WHEELS

ITEM	PART NO.	QTY. (Per Row)	DESCRIPTION
1.	G10940	-	Machine Bushing, 1" (.048" Thick)
2.	G10216	2	Washer, 1/2" USS
3.	G10228	2	Lock Washer, 1/2"
4.	G10014	1	Hex Head Cap Screw, 1/2"-13 x 1"
5.	GD11453	2	Cover
6.	G10338	12	Carriage Bolt, 5/16"-18 x 1 1/4"
	G10620	12	Serrated Flange Nut, 5/16"-18
7.	G10924	8	Carriage Bolt, 5/16"-18 x 1 3/4"
	G10620	8	Serrated Flange Nut, 5/16"-18
8.	G10010	2	Hex Head Cap Screw, 5/8"-11 x 3"
	G10230	2	Lock Washer, 5/8"
9.	G10018	14	Hex Head Cap Screw, 5/16"-18 x 5/8"
	G10109	14	Lock Nut, 5/16"-18, Grade 8
10.	GD11423	4	Half Wheel
11.	GD1086	2	Tire
12.	GA6171	2	Bearing
13.	G10204	2	Special Machine Bushing, 5/8" x 1" O.D.
14.	GA7975	1	Wheel Arm W/Grease Fitting, Bushings And Seals, L.H. (Shown)
	GA7976	1	Wheel Arm W/Grease Fitting, Bushings And Seals, R.H.
	G10640	1	Grease Fitting, 1/4"-28 (Per Arm)
	GB0276	2	Bushing, 1" I.D. x 1 1/4" O.D. x 1" Long (Per Arm)
	GD10991	2	Seal (Per Arm)
15.		-	See "Shank Assembly", Pages P2 And P3
A.	GA7949	-	Gauge Wheel Complete (Items 5-7 And 9-12)
B.	G1K296	-	Gauge Wheel Arm Bushing And Seal Driver Kit, Includes: (1) Seal Driver, (1) Bushing Driver, (1) Instruction

COVERING DISCS/SINGLE PRESS WHEEL

RUA054/RUB026(RU94d)

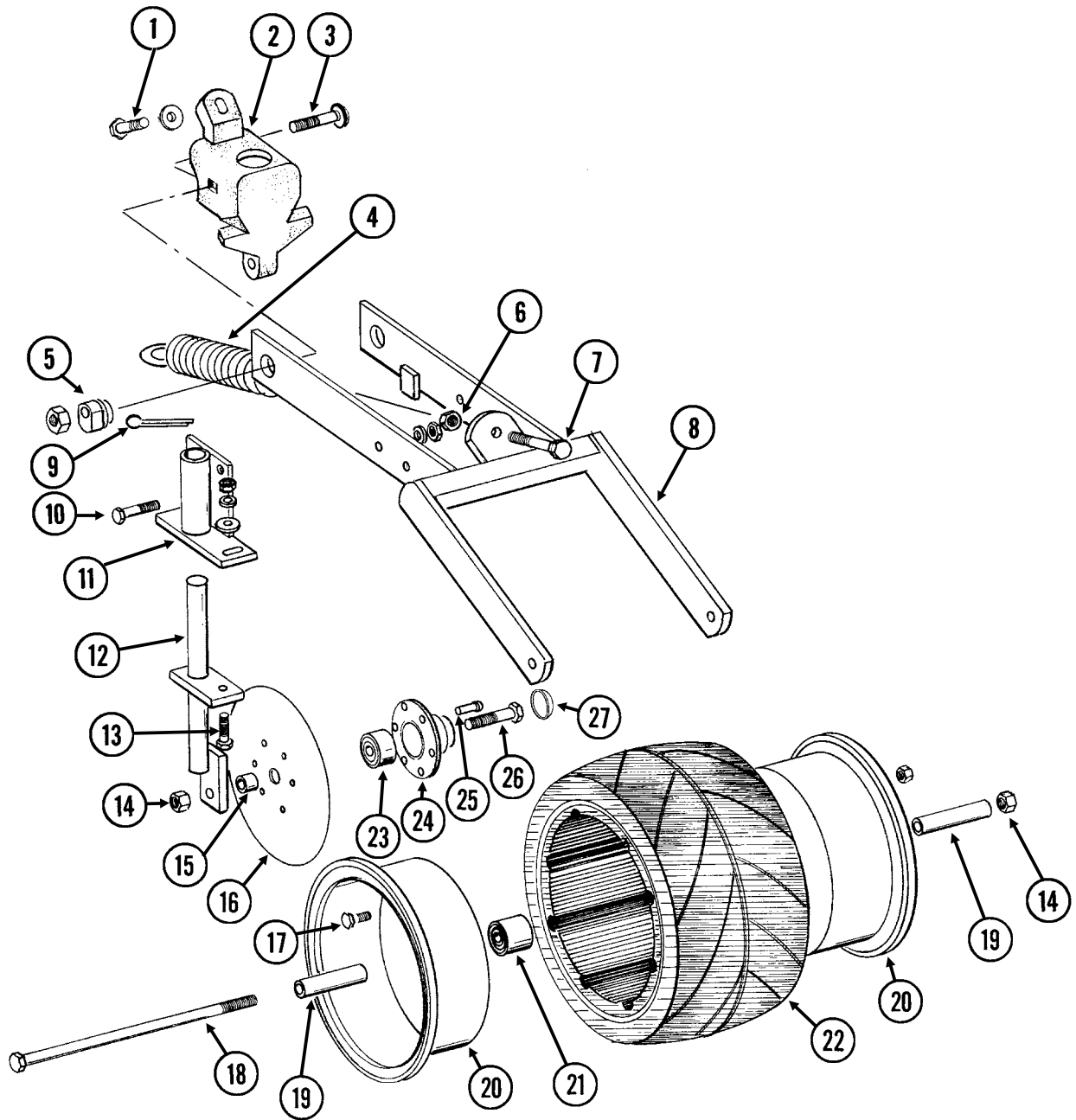

COVERING DISCS/SINGLE PRESS WHEEL

ITEM	PART NO.	QTY. (Per Row)	DESCRIPTION
1.	G10001	1	Hex Head Cap Screw, 3/8"-16 x 1"
	G10210	1	Washer, 3/8" USS
2.	GB0268	1	Wheel Arm Stop
3.	G10801	2	Carriage Bolt, 1/2"-13 x 2 1/4"
	G10315	-	Carriage Bolt, 1/2"-13 x 2 1/2" (Used W/Straight Drop In-Furrow Granular Chemical Bracket)
	G10102	2	Hex Nut, 1/2"-13
4.	GA2054	1	Spring
5.	GB0239	2	Eccentric Bushing
6.	G10102	1	Hex Nut, 1/2"-13
7.	G10015	1	Adjusting Bolt, 1/2"-13 x 5"
8.	GA6619	1	Mounting Arm
9.	G10463	2	Cotter Pin, 1/4" x 1 1/2"
10.	G10171	4	Hex Head Cap Screw, 5/16"-18 x 1 1/4"
	G10232	4	Lock Washer, 5/16"
	G10106	4	Hex Nut, 5/16"-18
11.	GA6620	2	Bracket
12.	GA6618	2	Mount
13.	G10303	2	Carriage Bolt, 5/16"-18 x 1"
	G10219	2	Washer, 5/16" USS
	G10232	2	Lock Washer, 5/16"
	G10106	2	Hex Nut, 5/16"-18
14.	G10107	3	Lock Nut, 5/8"-11
15.	GD1109	2	Bushing, 4 1/64" I.D. x 7/8" O.D. x 1/4" Long
16.	GD9290	2	Disc Blade, 8"
17.	G10018	7	Hex Head Cap Screw, 5/16"-18 x 5/8"
	G10109	7	Lock Nut, 5/16"-18, Grade 8
18.	G10152	1	Hex Head Cap Screw, 5/8"-11 x 9"
19.	GD3180-12	2	Sleeve, 5/8" I.D. x 7/8" O.D. x 2 7/8" Long
20.	GD9562	2	Half Wheel
21.	GA6171	1	Bearing
22.	GD9305	1	Tire
23.	GA2014	2	Bearing
24.	GD10473	2	Bearing Housing
25.	G10427	12	Rivet, 1/4" x 1/2"
26.	G10006	2	Hex Head Cap Screw, 5/8"-11 x 2 1/4"
27.	GD11845	2	Dust Cap
A.	GA6733	-	Single Press Wheel Complete W/Bearing (Items 17 And 20-22)
B.	GA6801	-	Covering Disc Blade Complete W/Bearing (Items 16 And 23-25)

"V" CLOSING WHEELS

(RU83i/RU83n)

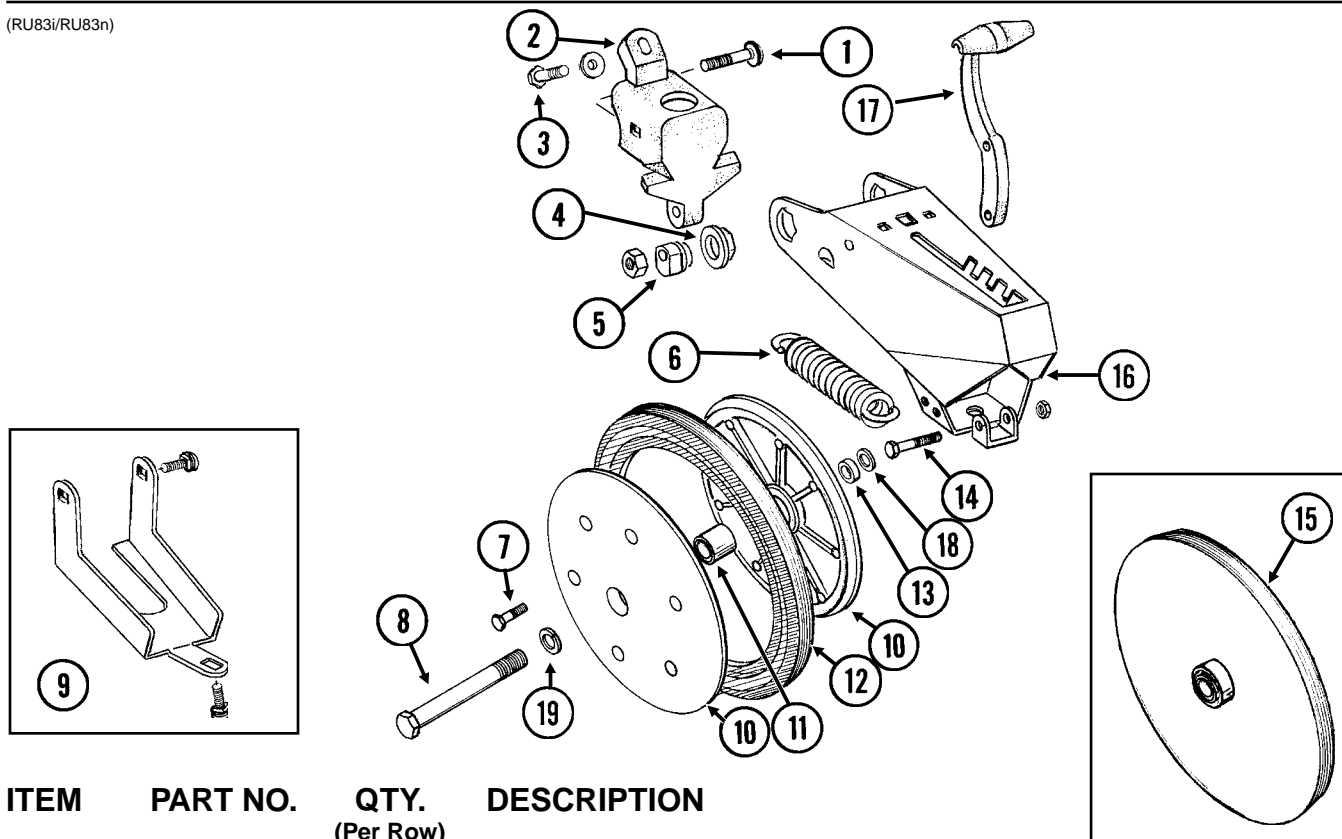

ITEM	PART NO.	QTY. (Per Row)	DESCRIPTION
1.	G10801	2	Carriage Bolt, 1/2"-13 x 2 1/4"
	G10315	-	Carriage Bolt, 1/2"-13 x 2 1/2" (Used W/Straight Drop In-Furrow Granular Chemical Bracket)
	G10111	2	Lock Nut, 1/2"-13
2.	GB0268	1	Wheel Arm Stop
3.	G10001	1	Hex Head Cap Screw, 3/8"-16 x 1"
	G10210	1	Washer, 3/8" USS
4.	GB0282	2	Stepped Bushing
5.	GB0239	2	Eccentric Bushing
6.	GD8460	1	Spring
7.	G10064	6	Hex Head Cap Screw, 1/4"-20 x 1"
8.	G10013	2	Hex Head Cap Screw, 5/8"-11 x 3 1/2"
	G10107	2	Lock Nut, 5/8"-11
9.	G1K345	-	Closing Wheel Shield Kit W/Hardware And Instruction
	G10308	2	Carriage Bolt, 3/8"-16 x 3/4"
	G10599	1	Carriage Bolt, 3/8"-16 x 1 1/4"
	G10210	1	Washer, 3/8" USS
	G10229	3	Lock Washer, 3/8"
	G10101	3	Hex Nut, 3/8"-16
10.	GD9120	4	Nylon Half Wheel
11.	GA6171	2	Bearing
12.	GD1085	2	Rubber Tire, 1" x 12"
13.	GD1109	2	Bushing, 4 1/64" I.D. x 7/8" O.D. x 1/4" Long
14.	G10133	1	Hex Head Cap Screw, 5/16"-18 x 1 1/2"
	G10109	1	Lock Nut, 5/16"-18, Grade 8
15.	GA6597	-	Cast Iron Closing Wheel W/Bearing
	GA6171	-	Bearing
16.	GA8322	1	Arm
17.	GB0254	1	Lever
18.	GD7805	2	Special Washer, 5/8", Hardened
19.	G10230	2	Lock Washer, 5/8"
A.	GA6434	-	Rubber Closing Wheel Complete W/Bearing (Items 7 And 10-12)

DRAG CLOSING ATTACHMENT

RUB050(RU90c)

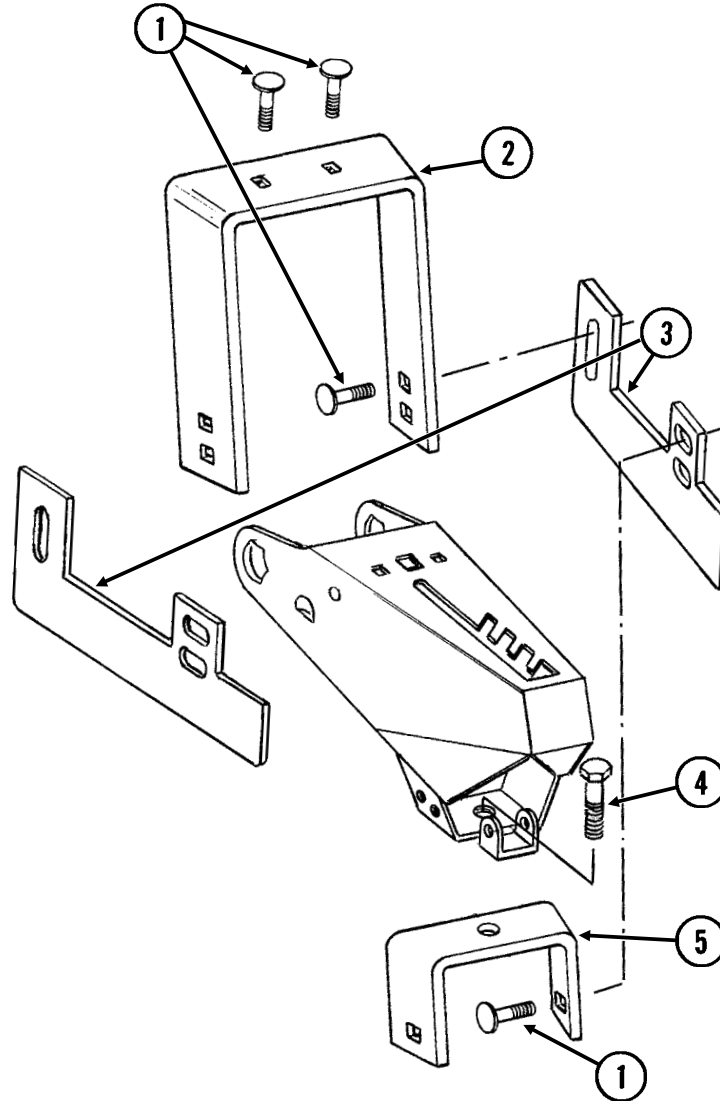

ITEM	PART NO.	QTY. (Per Row)	DESCRIPTION
1.	G10599	6	Carriage Bolt, 3/8"-16 x 1 1/4"
	G10210	6	Washer, 3/8" USS
	G10229	6	Lock Washer, 3/8"
	G10101	6	Hex Nut, 3/8"-16
2.	GD11508	1	Front Bracket
3.	GD11313	2	Blade
4.	G10007	1	Hex Head Cap Screw, 5/8"-11 x 1 1/2"
	G10230	1	Lock Washer, 5/8"
	G10104	1	Hex Nut, 5/8"-11
5.	GD11509	1	Rear Bracket
A.	G7566X	-	Drag Closing Attachment Complete (Items 1-5)

HOPPER SUPPORT AND METER DRIVE

(METR72)

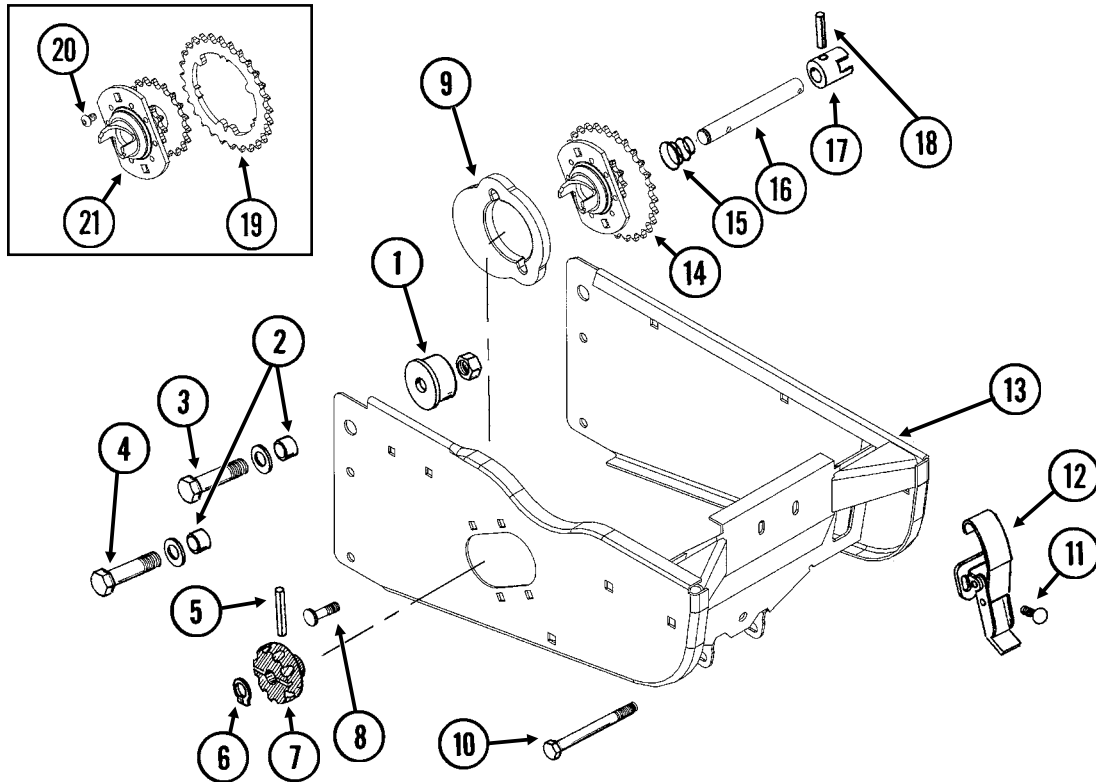

ITEM	PART NO.	QTY. (Per Row)	DESCRIPTION
1.	GB0314	2	Hopper Mount
2.	GB0218	4	Bushing, 2 ¹ / ₃₂ " I.D. x 7/8" O.D. x 1 ⁹ / ₃₂ " Long
3.	G10752	2	Hex Head Cap Screw, 5/8"-18 x 2 1/4"
	GD7805	2	Special Washer, 5/8", Hardened
	G10412	2	Lock Nut, 5/8"-18
4.	G10751	2	Hex Head Cap Screw, 5/8"-18 x 1 3/4"
	GD7805	2	Special Washer, 5/8", Hardened
	G10412	2	Lock Nut, 5/8"-18
5.	G10602	1	Spring Pin, 1/4" x 1 1/2"
6.	G10567	1	External Retaining Ring, 5/8"
7.	GD11239	1	Knob
8.	G10338	2	Carriage Bolt, 5/16"-18 x 1 1/4"
	G10620	2	Serrated Flange Nut, 5/16"-18
9.	GB0331	1	Clutch Adapter Plate
10.	G10061	1	Hex Head Cap Screw, 3/8"-16 x 3 1/2"
	G10210	2	Washer, 3/8" USS
	G10108	1	Lock Nut, 3/8"-16
11.	G10309	2	Carriage Bolt, 1/4"-20 x 5/8", Grade 2
	G10621	2	Serrated Flange Nut, 1/4"-20
12.	GA2007	1	Hopper Hold Down Latch
13.	GA10155	1	Hopper Support
14.	GA12143	1	Double Sprocket And Bearing, Drive Clutch, 11/28 Tooth
15.	GD11413	1	Spring
16.	GD15747	1	Shaft
17.	GB0278	1	Coupler
18.	G10546	1	Spring Pin, 3/16" x 1 1/4"
19.	GD17192	1	Bolt-On Sprocket, 28 Tooth
20.	G11222	3	Hex Socket Button Head Cap Screw, 5/16"-18 x 1/2", Stainless Steel
	G10620	3	Serrated Flange Nut, 5/16"-18
21.	GA10137	1	Double Sprocket And Bearing, Drive Clutch, 11/19 Tooth
A.	GA12144	-	Meter Drive Assembly, 11/28 Tooth (Items 5-7 And 14-18)

SEED HOPPER AND LID

(METR12)

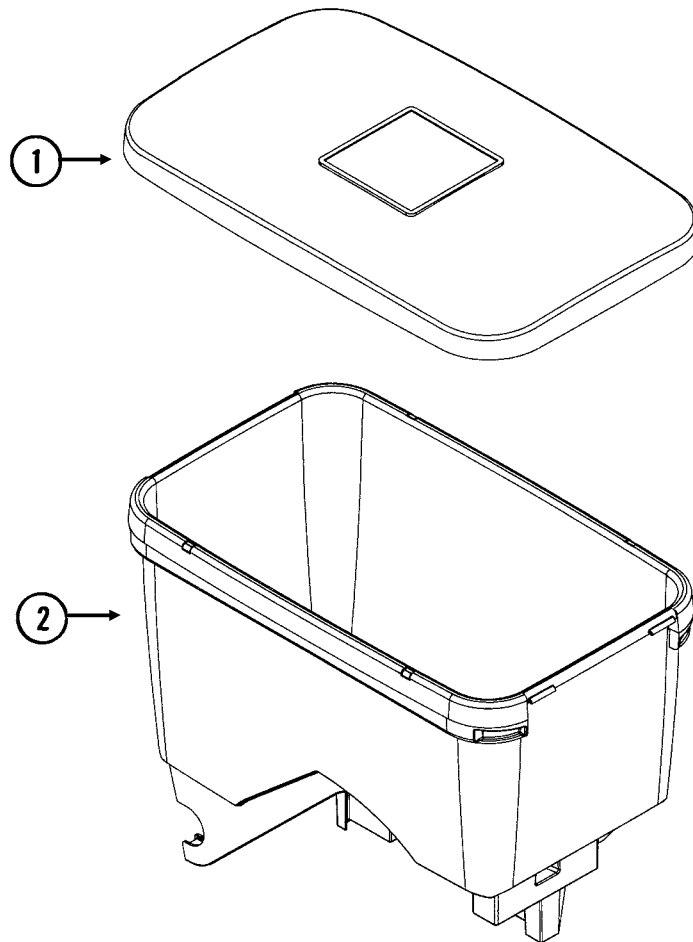



ITEM	PART NO.	QTY.	DESCRIPTION
1.	GD11279	1	Lid
2.	GA10634	1	Seed Hopper

SEED METER

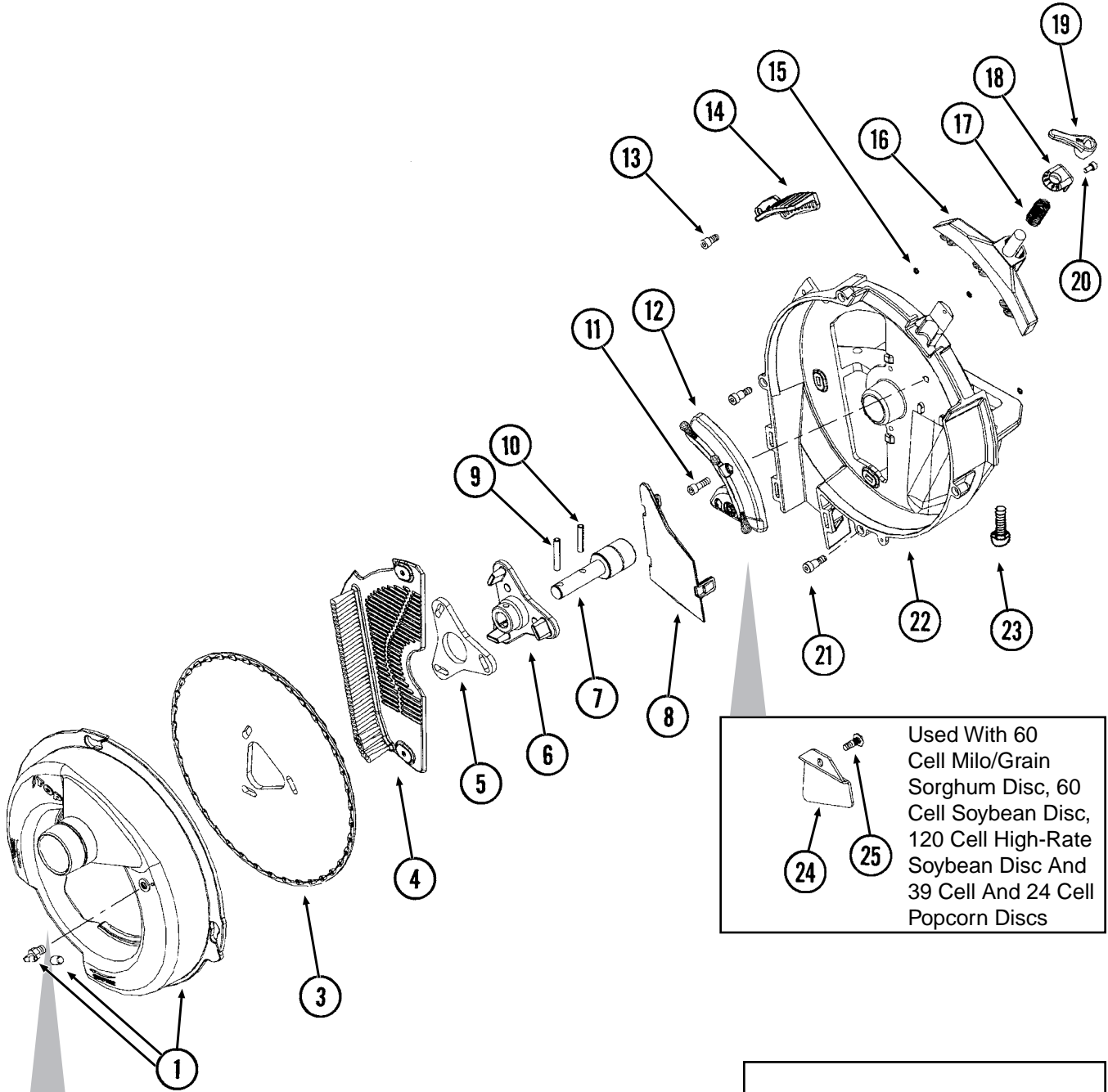
(METR69/METR65/A12133)



Used With 60 Cell Milo/Grain Sorghum Disc, 60 Cell Soybean Disc, 120 Cell High-Rate Soybean Disc And 39 Cell And 24 Cell Popcorn Discs

	<p>Used With 60 Cell Milo/Grain Sorghum Disc</p>
	<p>Used With 20 Cell Hill-Drop Acid-Delinted Cotton Discs; 54 Cell Acid-Delinted Cotton/ Small Dry Edible Bean Disc; And Small Cotton/Sunflower Disc</p>

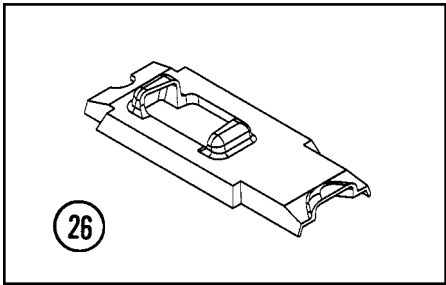

SEED METER

ITEM	PART NO.	QTY.	DESCRIPTION
1.	GA11911	1	Vacuum Cover W/Elbow And Cap
	GD17099	-	3/16" Hose Barb Elbow
	GD17152	-	Cap
2.	GA12133	1	Cleanout Brush (Used With 60 Cell Milo/Grain Sorghum Disc)
3.	GD17049	-	Seed Disc, Corn/Popcorn, 39 Cell, Light Blue Color-Coded
	GD17048	-	Seed Disc, Low-Rate Corn/Popcorn, 24 Cell, Light Green Color-Coded
	GD14467	-	Seed Disc, Soybean, 60 Cell, Black Color-Coded
	GD14468	-	Seed Disc, High-Rate Soybean, 120 Cell, Dark Blue Color-Coded
	GD17050	-	Seed Disc, Milo/Grain Sorghum, 60 Cell, Yellow Color-Coded
	GD17187	-	Seed Disc, Hill-Drop Cotton, Acid-Delinted, 3 Seeds Per Cell, 20 Cell, Brown Color-Coded
	GD18095	-	Seed Disc, Small Hill-Drop Cotton, Acid-Delinted, 20 Cell (3 Seeds Per Cell), Grey Color-Coded
	GD17186	-	Seed Disc, Cotton, Acid-Delinted/Small Dry Edible Bean, 54 Cell, Dark Green Color-Coded
	GD18098	-	Seed Disc, Small Cotton/Sunflower, 54 Cell, White Color-Coded
	GD14477	-	Seed Disc, Large Dry Edible Bean, 54 Cell, Tan Color-Coded
4.	GD17028	1	Wall Brush/Vent
5.	GD17021	1	Foam Spacer
6.	GB0328	1	Mount
7.	GA5698	1	Bearing
8.	GD14541	1	Discharge Cover
9.	G10602	1	Spring Pin, 1/4" x 1 1/2"
10.	G10603	1	Spring Pin, 1/4" x 1 1/4"
11.	G11213	1	Hex Socket Head Cap Screw, 1/4"-20 x 3/4"
12.	GA11935	1	Crowder Brush
13.	G10260	1	Hex Socket Head Cap Screw, 1/4"-20 x 1/2"
14.	GD17047	1	Air Inlet Screen
15.	GD17162	3	Push Nut, 1/8" I.D.
16.	GA10755	1	Singulator Brush
17.	GD14592	1	Spring
18.	GB0358	1	Cap
19.	GD15663	1	Brush Adjustment Lever
20.	G11173	1	Hex Socket Head Cap Screw, No. 10-24 x 3/8", Stainless Steel
21.	G11172	4	Hex Socket Head Shoulder Screw, 1/4"-20 x 3/8", Stainless Steel
22.	GB0319	1	Housing
23.	G11009	2	Locking Thumbscrew, 5/16"-18 x 3/4"
24.	GD17104	1	Seed Baffle (Used With 60 Cell Milo/Grain Sorghum Disc, 60 Cell Soybean Disc, 120 Cell High-Rate Soybean Disc And 39 Cell And 24 Cell Popcorn Discs)
25.	G11210	1	Rib Neck Bolt, 1/4"-20 x 3/4"
	G10323	1	Hex Flange Nut, 1/4"-20, No Serrations
26.	GD15700	1	Shank Cover, EdgeVac® Meter
27.	GA12154	-	Cleanout Brush W/Ball-Type Ejector (Used With 20 Cell Hill-Drop Acid-Delinted Cotton Discs And 54 Cell Acid-Delinted Cotton/Small Dry Edible Bean And Small Cotton/Sunflower Discs)

GRANULAR CHEMICAL HOPPER AND HOPPER PANEL EXTENSION

(METR14d)

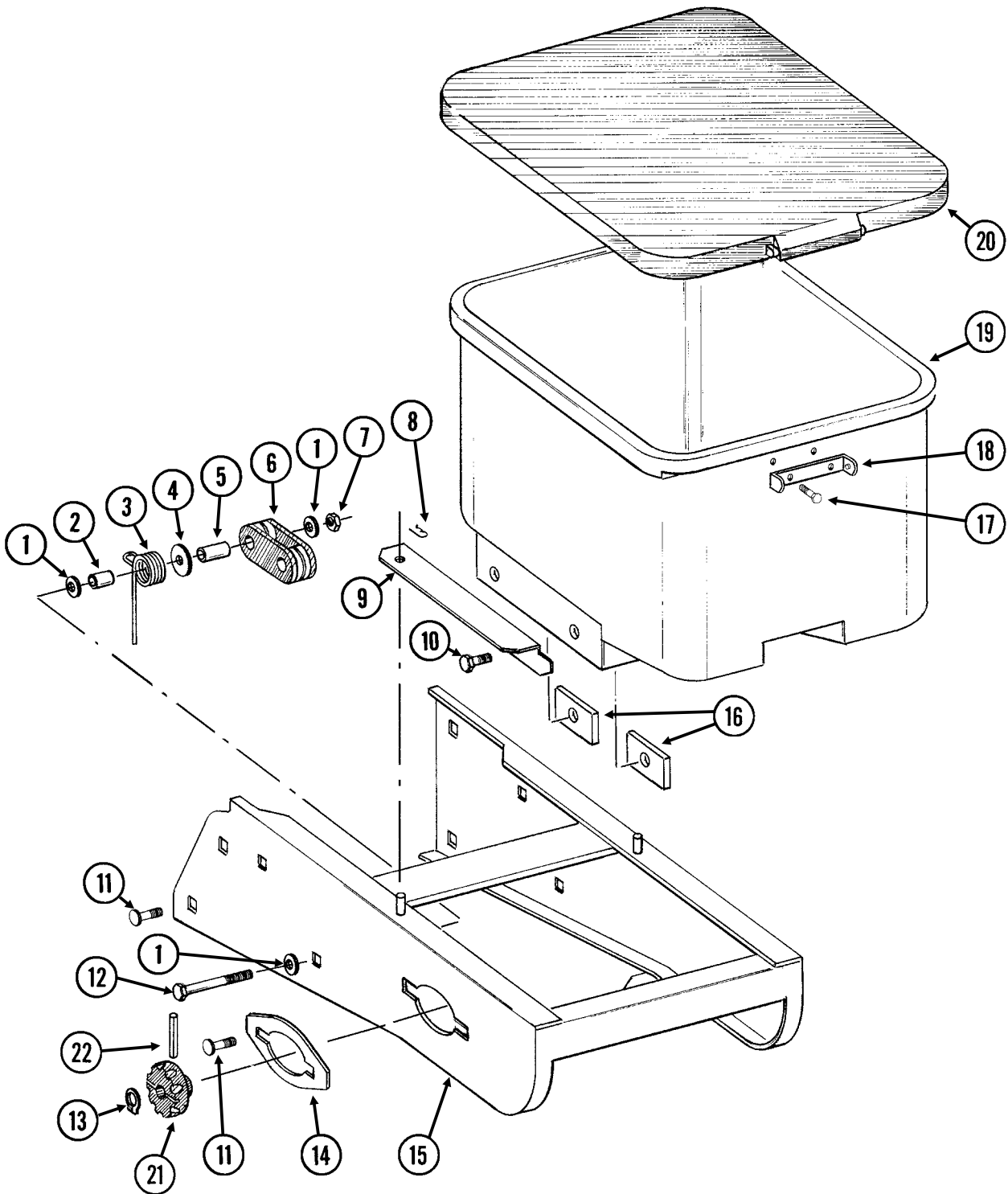

GRANULAR CHEMICAL HOPPER AND HOPPER PANEL EXTENSION

ITEM	PART NO.	QTY. (Per Row)	DESCRIPTION
1.	G10210	3	Washer, 3/8" USS
2.	GD2971-10	1	Sleeve, 9/16" Long
3.	GD11219	1	Spring
4.	G10201	1	Special Washer, 3/8" x 1 1/2" O.D.
5.	GD1026	1	Sleeve, 1 3/16" Long
6.	GD11962	1	Idler
7.	G10108	1	Lock Nut, 3/8"-16
8.	G10670	2	Hair Pin Clip, No. 3
9.	GD1059L	1	Support, L.H. (Shown)
	GD1059R	1	Support, R.H.
10.	G10002	4	Hex Head Cap Screw, 3/8"-16 x 3/4"
	G10229	4	Lock Washer, 3/8"
11.	G10312	8	Carriage Bolt, 5/16"-18 x 3/4"
	G10620	8	Serrated Flange Nut, 5/16"-18
12.	G10325	1	Hex Head Cap Screw, 3/8"-16 x 2 3/4"
13.	G10567	3	External Retaining Ring, 5/8"
14.	GD11305	1	Plate
15.	A10759	1	Hopper Panel Extension (Non-Stock Item) (Sub Wholegoods Order Code 700-01099)
16.	GD11424	4	Block
17.	G10023	2	Hex Head Cap Screw, 1/4"-20 x 3/4"
	G10621	2	Serrated Flange Nut, 1/4"-20
18.	GD1060	1	Hinge
19.	GA8371	1	Hopper
20.	GA4444	1	Lid
21.	GD11239	1	Knob
22.	G10602	1	Spring Pin, 1/4" x 1 1/2"

GRANULAR CHEMICAL METER AND METER DRIVE

RUA051/RUB028(RU91a)

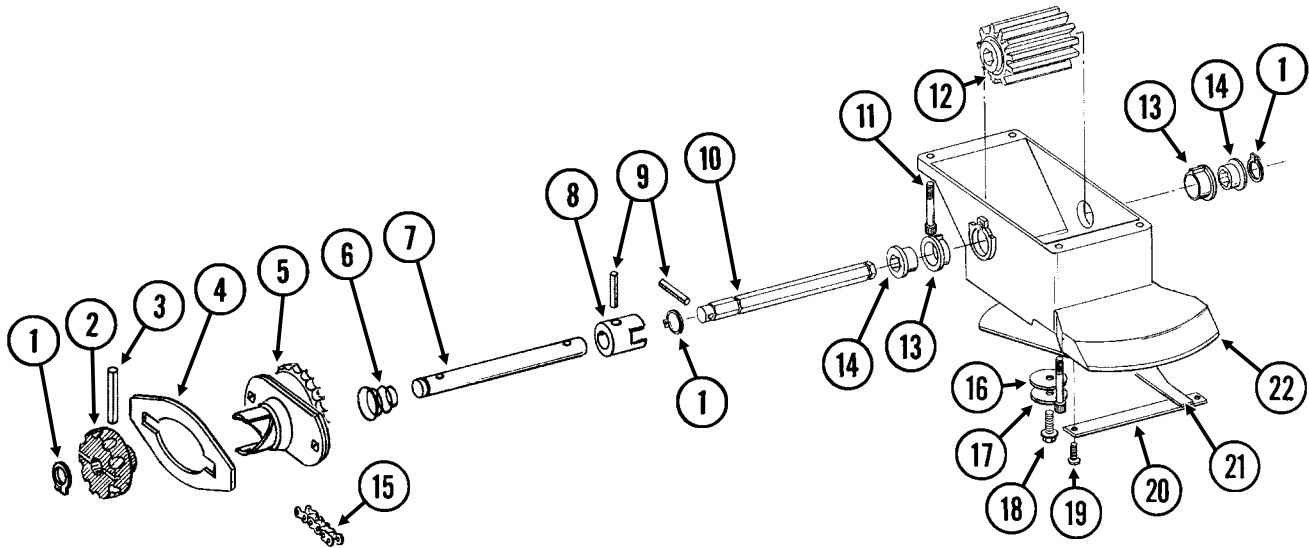

ITEM	PART NO.	QTY. (Per Row)	DESCRIPTION
1.	G10567	3	External Retaining Ring, 5/8"
2.	GD11239	1	Knob
3.	G10602	1	Spring Pin, 1/4" x 1 1/2"
4.		-	See "Granular Chemical Hopper And Hopper Panel Extension", Pages P22 And P23
5.	GA8364	1	Sprocket And Bearing, Drive Clutch, 24 Tooth
6.	GD11413	1	Spring
7.	GD11240	1	Shaft
8.	GB0278	1	Coupler
9.	G10546	2	Spring Pin, 3/16" x 1 1/4"
10.	GD11297	1	Shaft
11.	G10921	4	Hex Socket Head Cap Screw, No. 10-24 x 7/8"
	G10257	4	Lock Washer, No. 10
12.	GD7148	1	Feed Roller, Hex Bore
13.	GB0115	2	Bearing
14.	GD7258	2	Hex Bushing
15.	G3303-108	1	Chain, No. 41, 108 Pitch Including Connector Link
	GR0196	1	Connector Link, No. 41
16.	G10660	1	Wave Washer, 1/2"
17.	G10209	1	Washer, 1/4" USS
18.	G10570	1	Slotted Hex Self-Tapping Screw, 1/4"-20 x 3/4"
19.	G11073	2	Slotted Hex Self-Tapping Screw, No. 10 x 3/8"
20.	GD1061	1	Support Strap
21.	GD1063	1	Metering Gate
22.	GB0116	1	Granular Housing
A.	GA8326	-	Granular Chemical Meter Complete (Items 1, 9, 10, 12-14 And 16-22)

GRANULAR CHEMICAL BANDING OPTIONS

RUA061/RUA073(RU101mm/RU83m)

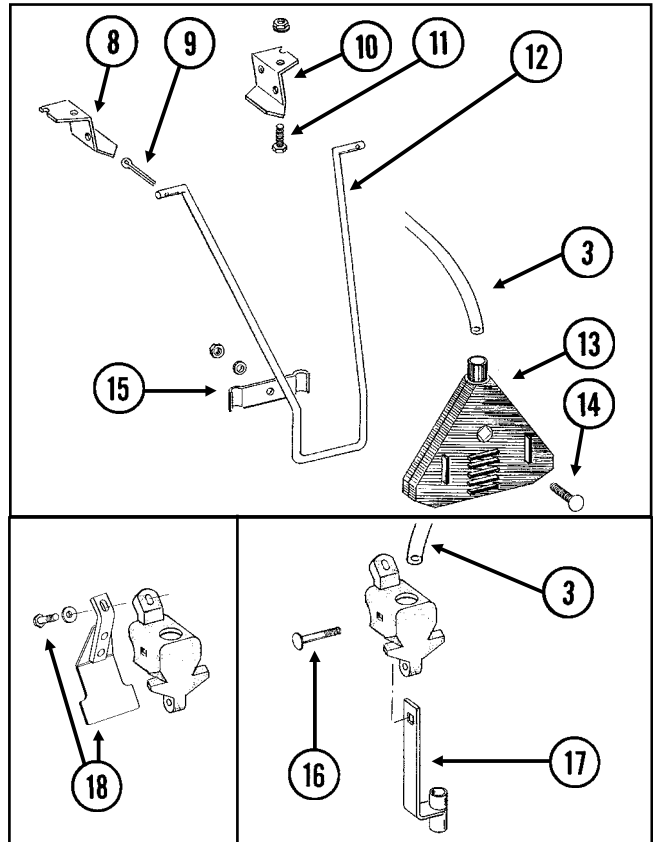
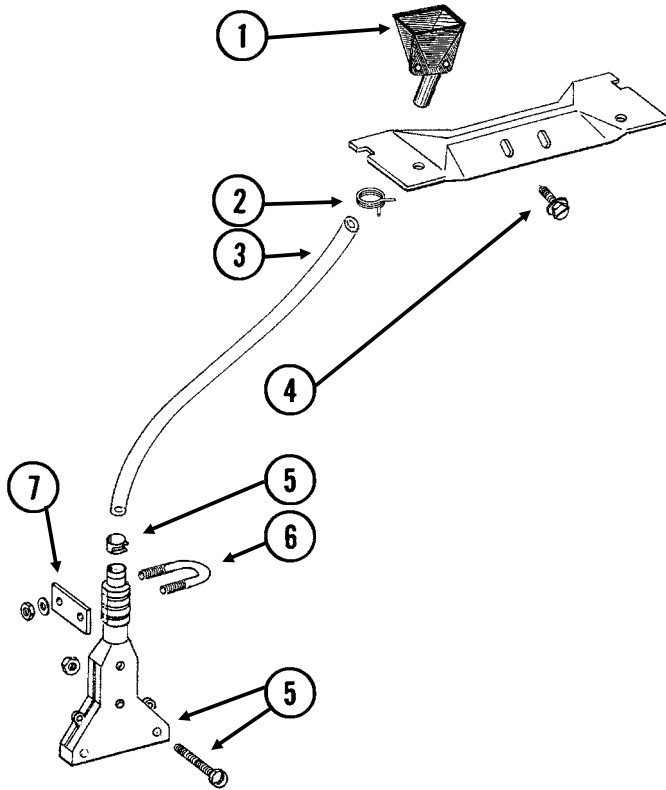

ITEM	PART NO.	QTY.	DESCRIPTION
1.	GD2423	1	Funnel
2.	G11209	1	Wire Hose Clamp, 3/4"
3.	GD2947	1	Hose, 7/16" x 28"
4.	G10523	2	Slotted Pan Head Self-Tapping Screw, No. 10 x 1/2"
5.	GA6907	1	Slope-Compensating Bander W/Hardware (4 1/2" Band Width)
	G10864	1	Uni-Clamp
	G10757	2	Pan Head Screw, No. 10-32 x 1 1/4"
	G10758	2	Hex Nut, No. 10-32
6.	GD10963	1	U-Bolt, 1 1/2" x 1 5/16" x 1/4"-20
	G10209	2	Washer, 1/4" USS
	G10110	2	Lock Nut, 1/4"-20, Grade B
7.	GD10984	1	Spacer
8.	GD1115L	-	Hanger Bracket, L.H.
9.	G10452	-	Cotter Pin, 1/8" x 1/2"
10.	GD1115R	-	Hanger Bracket, R.H.
11.	G10310	-	Carriage Bolt, 1/4"-20 x 3/4", Grade 2
	G10227	-	Lock Washer, 1/4"
	G10103	-	Hex Nut, 1/4"-20
12.	GD1116	-	Hanger
13.	GA2075	-	Diffuser, 14" Band
14.	G10306	-	Carriage Bolt, 3/8"-16 x 2"
	G10229	-	Lock Washer, 3/8"
	G10101	-	Hex Nut, 3/8"-16
15.	GD1118	-	Clamp
16.	G10315	1	Carriage Bolt, 1/2"-13 x 2 1/2" (Replaces Existing 1/2" x 2 1/4" Hardware)
17.	GA6741	1	Bracket (Straight Drop In-Furrow)
18.	G1K385	-	Bander Shield Kit W/Hardware And Instruction
	G10003	1	Hex Head Cap Screw, 3/8"-16 x 1 1/2"
	GD14659	1	Special Washer, 3/8", Hardened

SPRING TOOTH INCORPORATOR

RUA055(RU95)

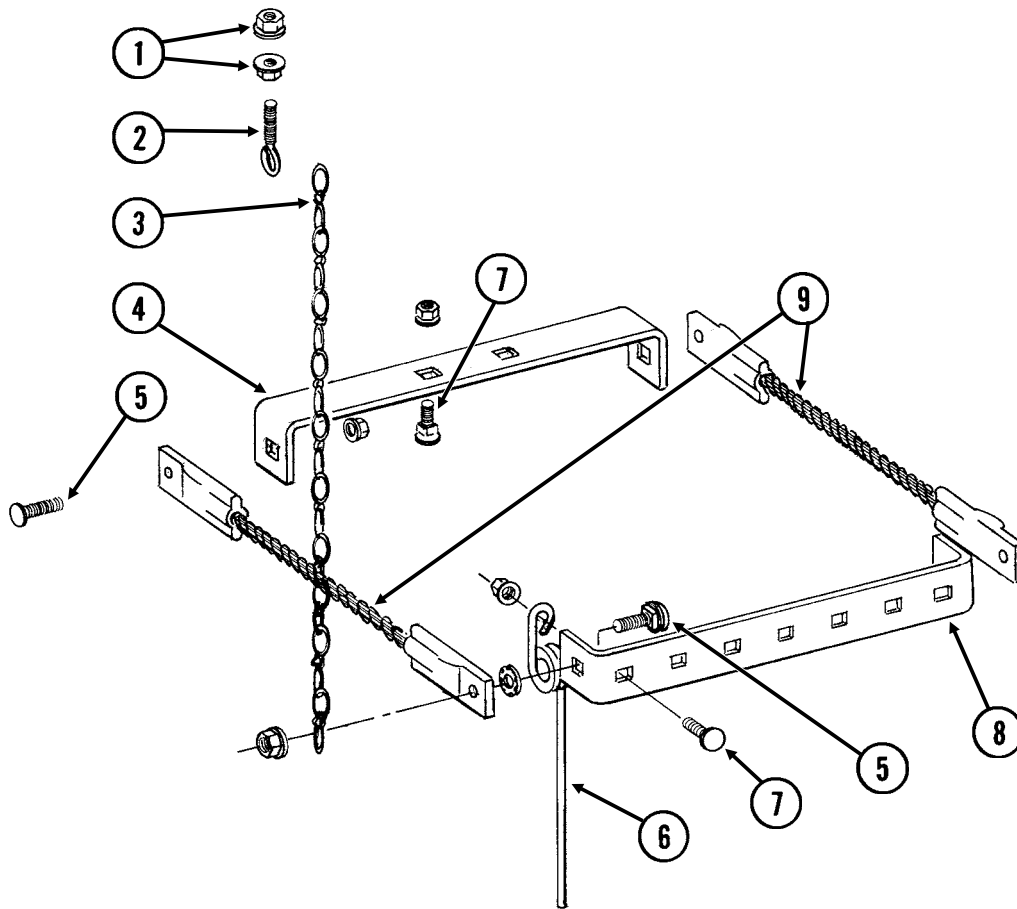

ITEM	PART NO.	QTY. (Per Row)	DESCRIPTION
1.	G10621	4	Serrated Flange Nut, 1/4"-20
2.	GD2460	2	Eyebolt, 1/4"-20
3.	G3305-01	4	Twin Loop Chain, 9 Links
4.	GD1143	1	Front Bracket
5.	G10305	4	Carriage Bolt, 3/8"-16 x 1"
	G10529	4	External Tooth Lock Washer, 3/8"
	G10622	4	Serrated Flange Nut, 3/8"-16
6.	GD1145	7	Spring Tooth
7.	G10308	9	Carriage Bolt, 3/8"-16 x 3/4"
	G10622	9	Serrated Flange Nut, 3/8"-16
8.	GD1144	1	Rear Bracket
9.	GA2094	2	Cable Assembly

ROW UNIT MOUNTED NO TILL COULTER

(D14398/RU102c/RU152)

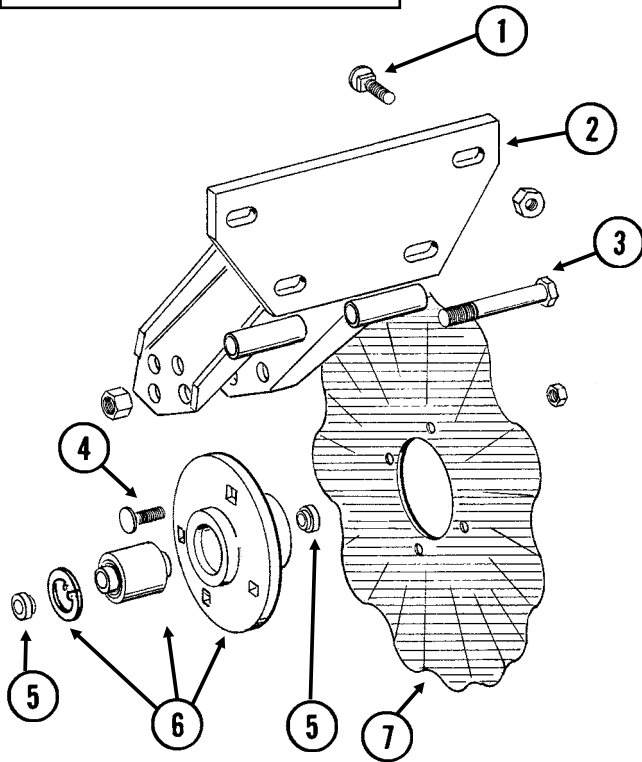
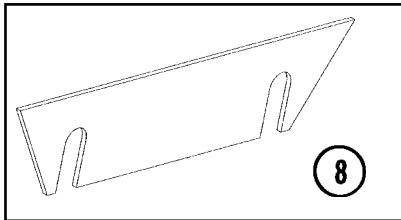

STYLE A

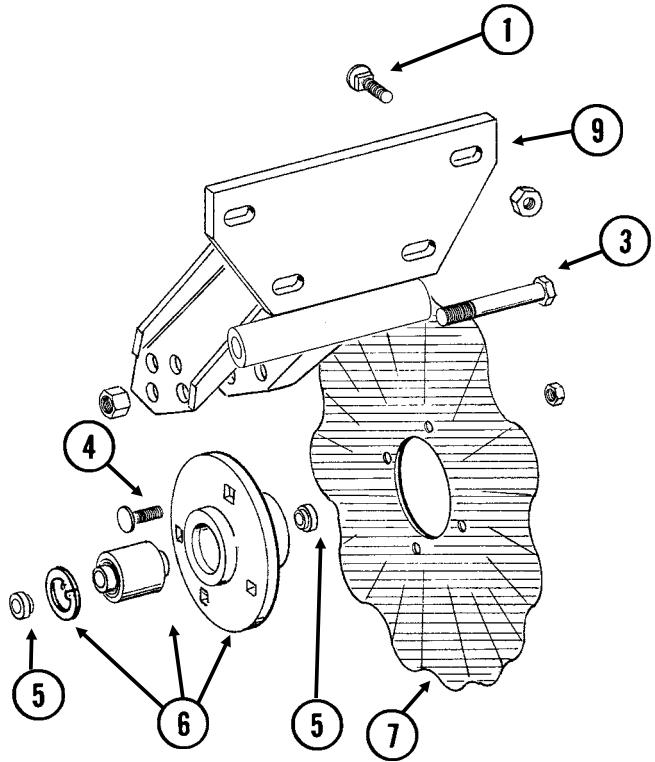

STYLE B

ITEM	PART NO.	QTY. (Per Row)	DESCRIPTION
1.	G10574	4	Carriage Bolt, 1/2"-13 x 1 1/4"
	G10111	4	Lock Nut, 1/2"-13
2.	GA5625	1	Arm (Style A)
3.	G10036	1	Hex Head Cap Screw, 5/8"-11 x 4"
	G10107	1	Lock Nut, 5/8"-11
4.	G10574	4	Carriage Bolt, 1/2"-13 x 1 1/4"
	G10111	4	Lock Nut, 1/2"-13
5.	GD11677	2	Adapter
6.	GA8641	1	Hub W/Bearing And Retaining Ring
	GA8603	-	Bearing, Double Row
	GD11652	-	Retaining Ring, 2 7/16"
7.	GD7803	-	Disc Blade, Fluted, 1", 8 Flutes (Shown)
	GD7804	-	Disc Blade, Bubbled, 1"
	GD9254	-	Disc Blade, Fluted, 3/4", 13 Flutes
	GD14398	-	Spacer
8.	GD14398	-	Spacer
9.	GA11520	1	Arm (Style B)

ROW UNIT MOUNTED BED LEVELER

RUA059/RUA060(RU99/RU100)

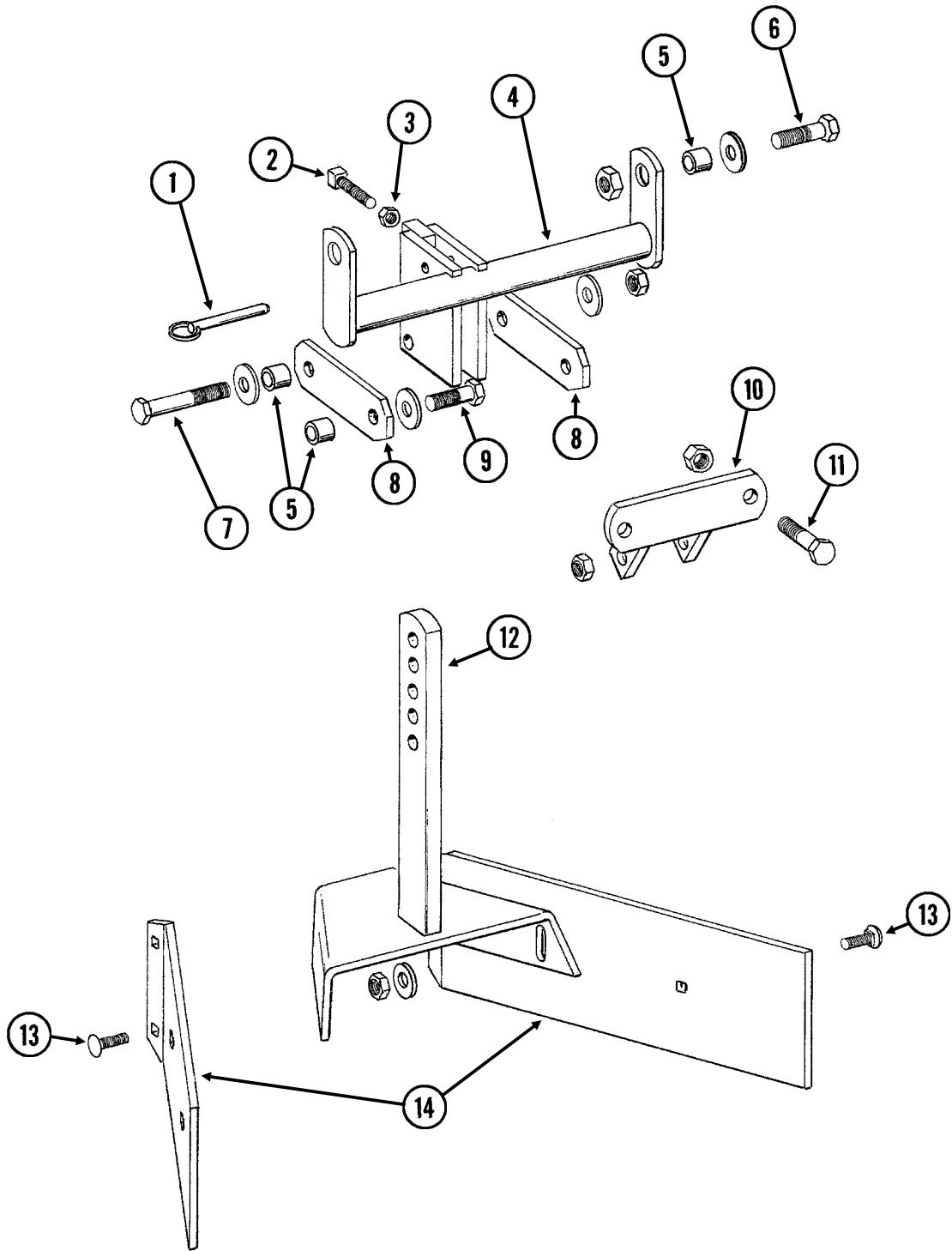

ROW UNIT MOUNTED BED LEVELER

ITEM	PART NO.	QTY. (Per Row)	DESCRIPTION
1.	G10536	1	Detent Pin, 1/2" x 2 1/2" Grip
2.	G10597	1	Square Head Set Screw, 5/8"-11 x 2 1/4"
3.	G10503	1	Hex Jam Nut, 5/8"-11, Grade 2
4.	GA5719	1	Mounting Bracket
5.	GD7889	6	Bushing, 1" O.D. x 9/16" I.D. x 7/16" Long
6.	G10039	2	Hex Head Cap Screw, 1/2"-13 x 1 3/4"
	GD14674	2	Special Washer, 1/2", Hardened
	G10111	2	Lock Nut, 1/2"-13
7.	G10585	1	Hex Head Cap Screw, 1/2"-13 x 3 1/4"
	G10216	2	Washer, 1/2" USS
	G10111	1	Lock Nut, 1/2"-13
8.	GD7890	2	Link
9.	G10017	2	Hex Head Cap Screw, 1/2"-13 x 1 1/2"
	G10216	2	Washer, 1/2" USS
	G10111	2	Lock Nut, 1/2"-13
10.	GA5715	1	Anchor
11.	G10017	2	Hex Head Cap Screw, 1/2"-13 x 1 1/2"
	G10111	2	Lock Nut, 1/2"-13
12.	GA5892	1	Leveler
13.	G10303	6	Carriage Bolt, 5/16"-18 x 1"
	G10219	4	Washer, 5/16" USS
	G10109	6	Lock Nut, 5/16"-18, Grade 8
14.	GD8266	2	Blade

ROW UNIT MOUNTED DISC FURROWER

RUA059/RUA058(RU99/RU98g)

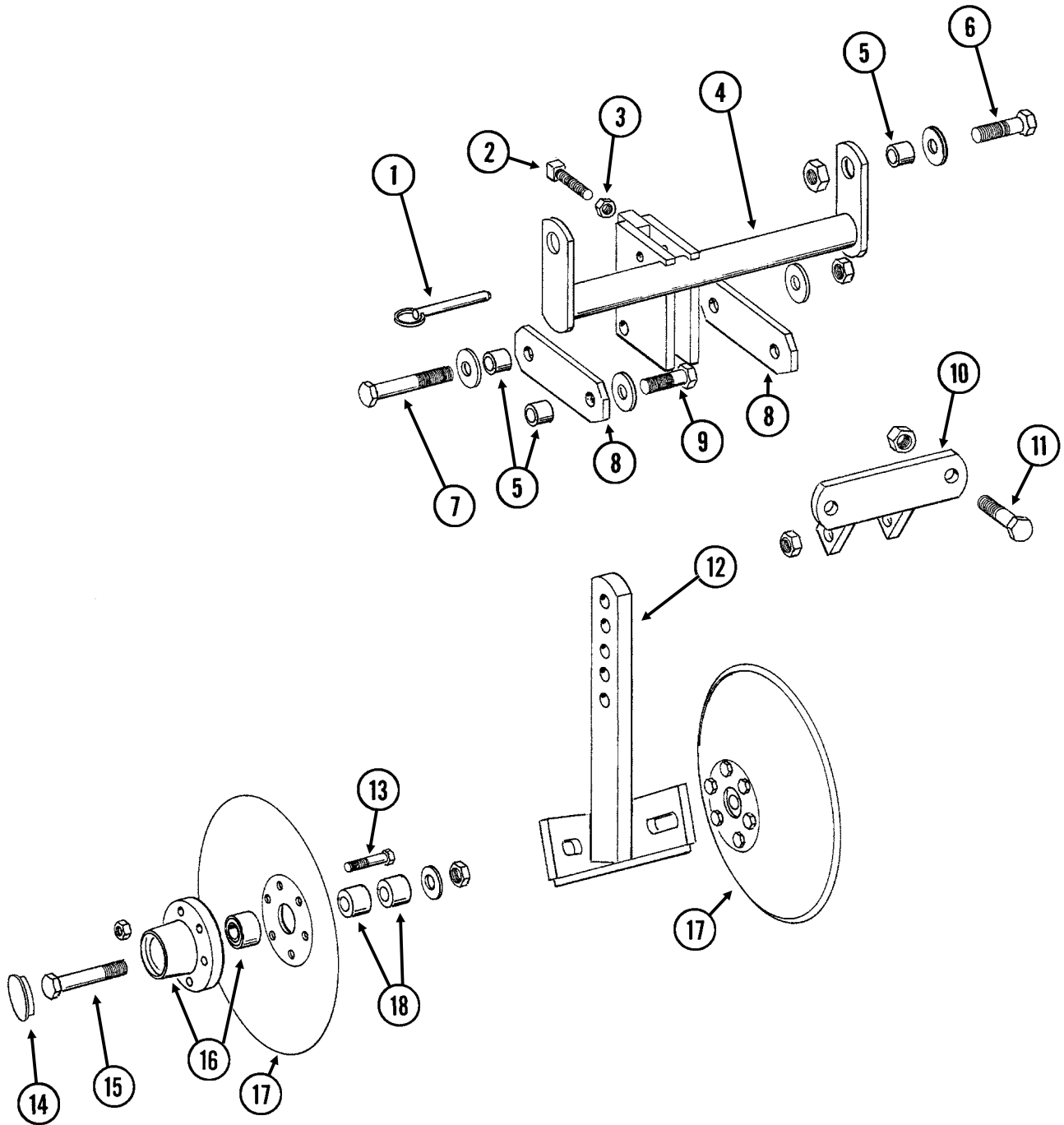

ROW UNIT MOUNTED DISC FURROWER

ITEM	PART NO.	QTY. (Per Row)	DESCRIPTION
1.	G10536	1	Detent Pin, 1/2" x 2 1/2" Grip
2.	G10597	1	Square Head Set Screw, 5/8"-11 x 2 1/4"
3.	G10503	1	Hex Jam Nut, 5/8"-11, Grade 2
4.	GA5719	1	Mounting Bracket
5.	GD7889	6	Bushing, 1" O.D. x 9/16" I.D. x 7/16" Long
6.	G10039	2	Hex Head Cap Screw, 1/2"-13 x 1 3/4"
	GD14674	2	Special Washer, 1/2", Hardened
	G10111	2	Lock Nut, 1/2"-13
7.	G10585	1	Hex Head Cap Screw, 1/2"-13 x 3 1/4"
	G10216	2	Washer, 1/2" USS
	G10111	1	Lock Nut, 1/2"-13
8.	GD7890	2	Link
9.	G10017	2	Hex Head Cap Screw, 1/2"-13 x 1 1/2"
	G10216	2	Washer, 1/2" USS
	G10111	2	Lock Nut, 1/2"-13
10.	GA5715	1	Anchor
11.	G10017	2	Hex Head Cap Screw, 1/2"-13 x 1 1/2"
	G10111	2	Lock Nut, 1/2"-13
12.	GA5718	1	Support Arm
13.	G10572	6	Truss Head Slotted Machine Screw, 5/16"-18 x 7/8"
	G10106	6	Hex Nut, 5/16"-18
14.	GD1132	2	Dust Cap
15.	G10318	2	Hex Head Cap Screw, 5/8"-11 x 4 1/2"
	GD7805	2	Special Washer, 5/8", Hardened
	G10107	2	Lock Nut, 5/8"-11
16.	GA5654	2	Hub W/Bearings
	GA2014	-	Bearing
17.	GD7823	-	Disc Blade, Solid, 12" (Shown)
	GD8307	-	Disc Blade, Notched, 12"
18.	GD7817-01	2	Spacer, 1 1/16" I.D. x 3/4" Long
	GD7817-04	2	Spacer, 1 1/16" I.D. x 1/2" Long

ROW UNIT MOUNTED RESIDUE WHEEL

(RU103dd/RU103d)

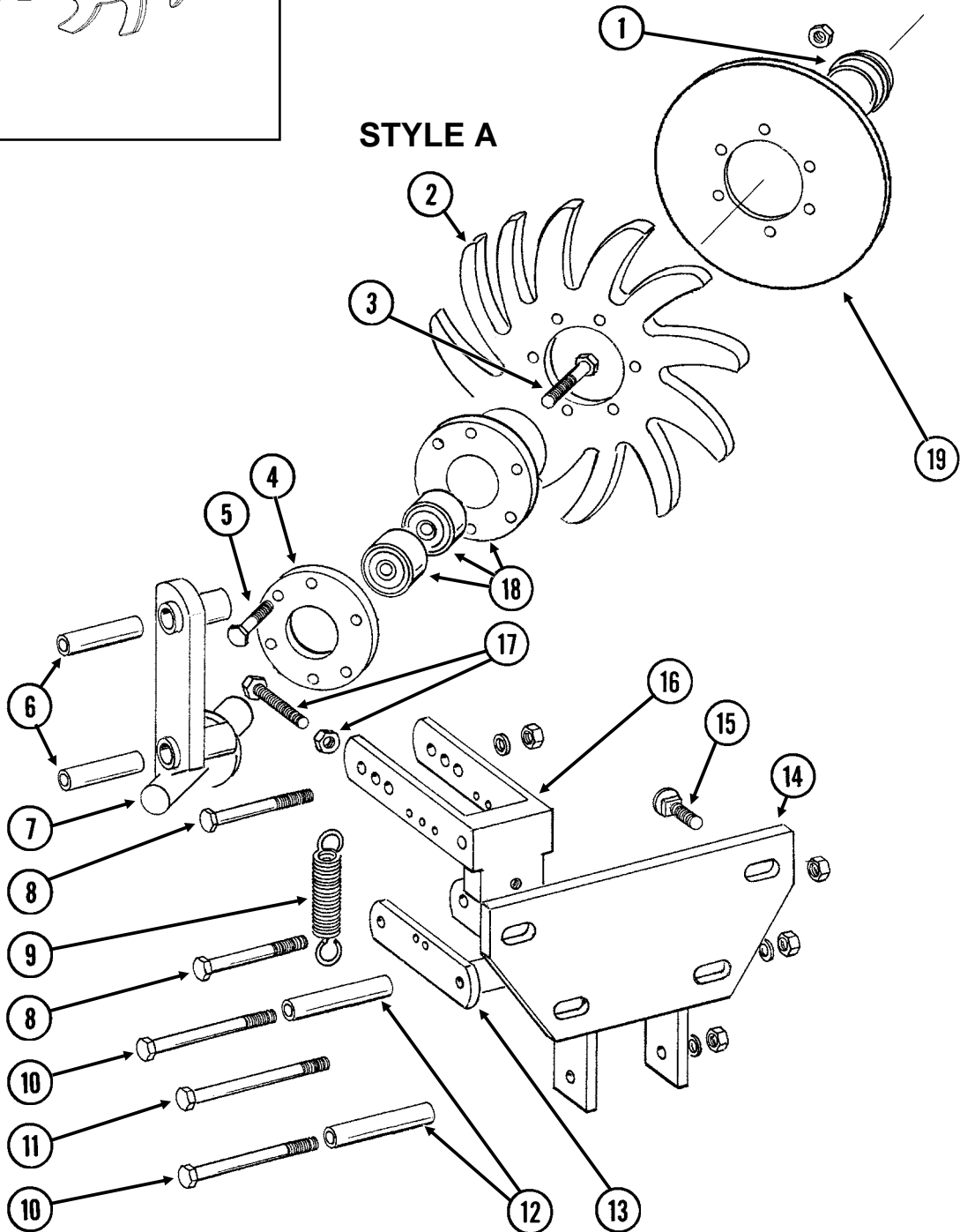
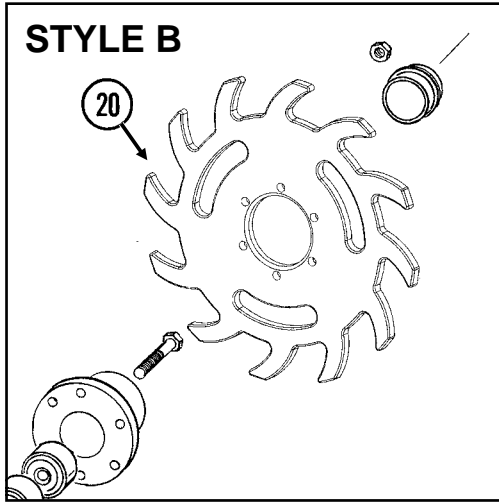

ROW UNIT MOUNTED RESIDUE WHEEL

ITEM	PART NO.	QTY. (Per Row)	DESCRIPTION
1.	GD1132	1	Dust Cap
2.	GD10552	1	Wheel, 12 Tine, $\frac{3}{8}$ " x 12"
3.	G10006	1	Hex Head Cap Screw, $\frac{5}{8}$ "-11 x 2 $\frac{1}{4}$ "
4.	GD9724	1	Backing Plate
5.	G10133	6	Hex Head Cap Screw, $\frac{5}{16}$ "-18 x 1 $\frac{1}{2}$ "
	G10109	6	Lock Nut, $\frac{5}{16}$ "-18, Grade 8
6.	GD9720	2	Spacer, $\frac{1}{2}$ " x 2 $\frac{3}{16}$ " Long
7.	GA6838	1	Wheel Mount
8.	G10033	2	Hex Head Cap Screw, $\frac{1}{2}$ "-13 x 3 $\frac{1}{2}$ "
	G10228	2	Lock Washer, $\frac{1}{2}$ "
	G10102	2	Hex Nut, $\frac{1}{2}$ "-13
9.	GD5857	2	Spring
10.	G10045	2	Hex Head Cap Screw, $\frac{1}{2}$ "-13 x 4 $\frac{1}{2}$ "
	G10228	2	Lock Washer, $\frac{1}{2}$ "
	G10102	2	Hex Nut, $\frac{1}{2}$ "-13
11.	G10348	1	Hex Head Cap Screw, $\frac{1}{2}$ "-13 x 5" (Lockup Bolt)
	G10111	1	Lock Nut, $\frac{1}{2}$ "-13
12.	GD9715	2	Spacer, $\frac{1}{2}$ " x 3" Long
13.	GA6834	1	Lower Link
14.	GA6832	1	Mount
15.	G10574	4	Carriage Bolt, $\frac{1}{2}$ "-13 x 1 $\frac{1}{4}$ "
	G10111	4	Lock Nut, $\frac{1}{2}$ "-13
16.	GA6833	1	Upper Link
17.	G10371	1	Hex Head Cap Screw, $\frac{1}{2}$ "-13 x 3", Full Thread
	G10501	1	Hex Jam Nut, $\frac{1}{2}$ "-13, Grade 2
18.	GA5654	1	Hub W/Bearings
	GA2014	-	Bearing
19.	GD12534	-	Cover
20.	GB0387	1	Wheel, 12 Tine, $\frac{3}{8}$ " x 12"
A.	GA7446	-	Wheel Assembly, 12 Tine, R.H. (Items 2, 4, 5 And 18)
B.	GA12236	-	Wheel Assembly, 12 Tine, R.H. (Items 4, 5, 18 And 20)

COULTER MOUNTED RESIDUE WHEELS

(RU104uuu/RU153)

STYLE A - Used With Style A Row Unit Mounted No Till Coulter

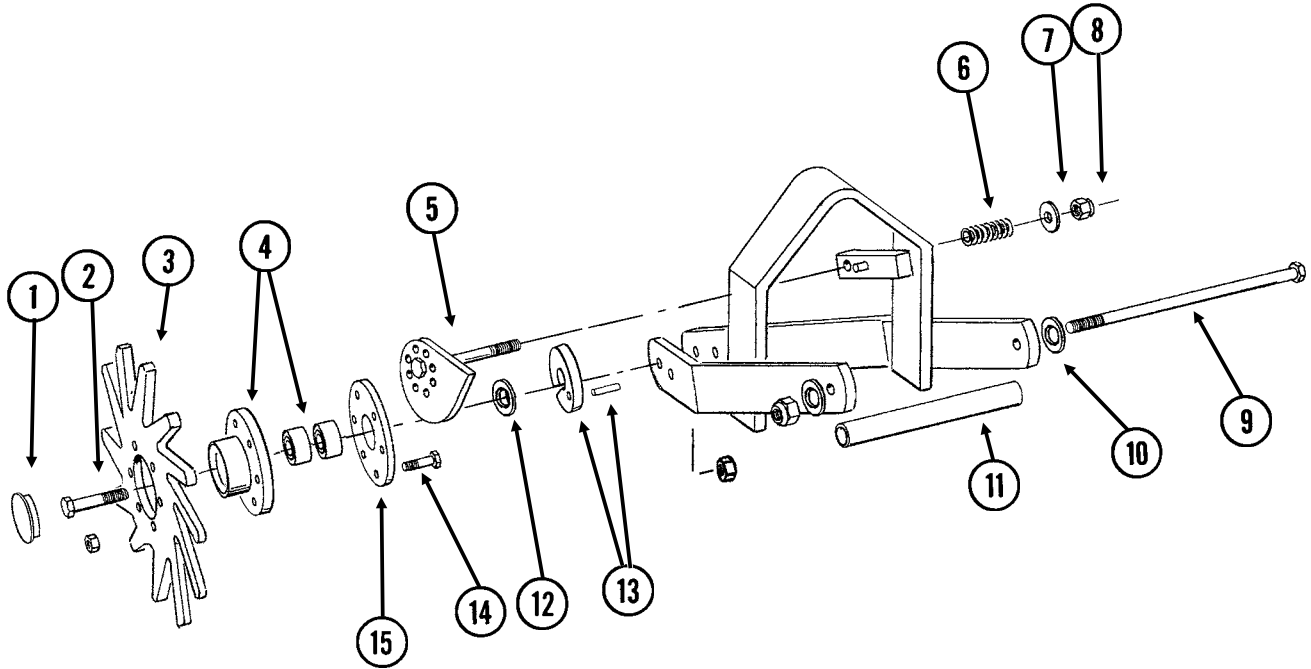

STYLE B - Used With Style B Row Unit Mounted No Till Coulter

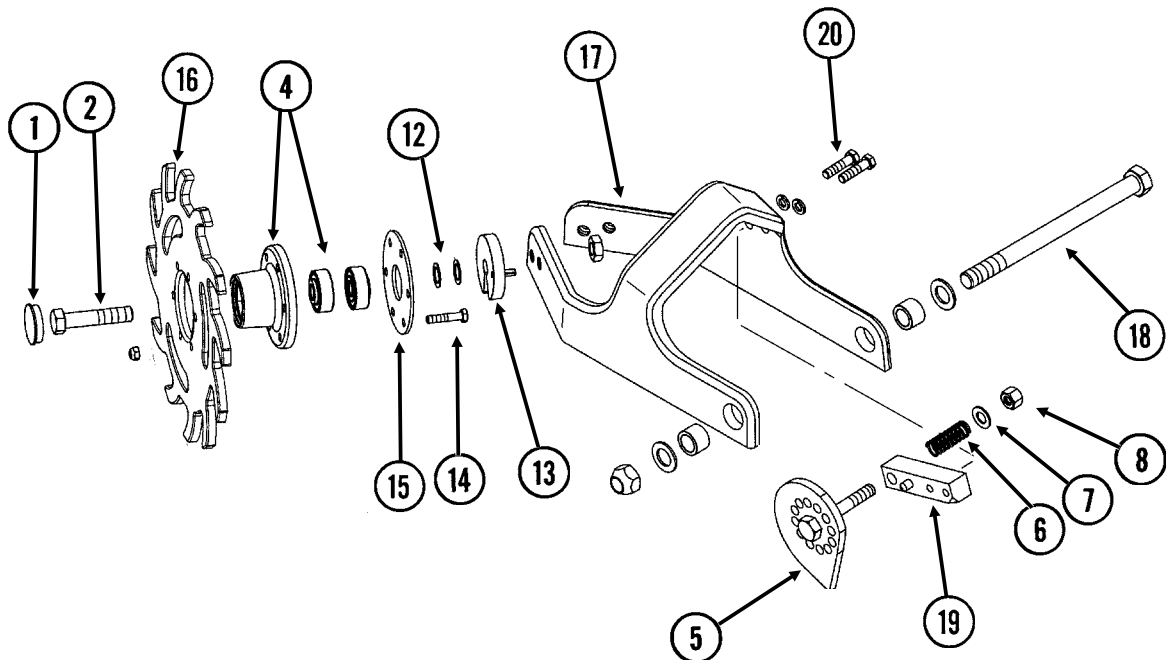

COULTER MOUNTED RESIDUE WHEELS

ITEM	PART NO.	QTY. (Per Row)	DESCRIPTION
1.	GD1132	2	Dust Cap
2.	G10010	2	Hex Head Cap Screw, 5/8"-11 x 3"
	G10503	2	Hex Jam Nut, 5/8"-11, Grade 2
3.	GD10552	2	Wheel, 12 Tine, 3/8" x 12"
4.	GA5654	2	Hub W/Bearings
	GA2014	-	Bearing
5.	GA7412	1	Cam
6.	GD10519	1	Spring
7.	G10206	1	Washer, 1/2" SAE
8.	G10974	1	Lock Nut W/Nylon Insert, 1/2"-13
9.	G11098	1	Hex Head Cap Screw, 1/2"-13 x 9 1/2", Grade 8
	GD14674	2	Special Washer, 1/2", Hardened
	G10974	1	Lock Nut W/Nylon Insert, 1/2"-13
10.	GA7271	1	Mount
11.	GD10526	1	Sleeve, 7 1/2"
12.	G10213	2-4	Machine Bushing, 5/8" (.030" Thick)
13.	GA8760	2	Weed Guard W/Spring Pin
	G10765	-	Spring Pin, 1/4" x 1"
14.	G10133	12	Hex Head Cap Screw, 5/16"-18 x 1 1/2"
	G10109	12	Lock Nut, 5/16"-18, Grade 8
15.	GD9724	2	Backing Plate
16.	GB0387	2	Wheel, 12 Tine, 3/8" x 12"
17.	GB0401	1	Mount
18.	G11236	1	Hex Head Cap Screw, 3/4"-10 x 10 1/2"
	GB0383	2	Bushing, 1 1/8" O.D. x 25/32" I.D. x 3/4" Long
	G10194	2	Washer, 3/4" SAE
	G11228	1	Lock Nut, 3/4"-10
19.	GA12256	1	Locking Pin
20.	G10003	2	Hex Head Cap Screw, 3/8"-16 x 1 1/2"
	G10229	2	Lock Washer, 3/8"
A.	GA7446	-	Wheel Assembly, 12 Tine, R.H. (Items 3, 4, 14 And 15) (Shown)
	GA7445	-	Wheel Assembly, 12 Tine, L.H. (Items 3, 4, 14 And 15)
B.	GA12236	-	Wheel Assembly, 12 Tine, R.H. (Items 4, 14, 15 And 16) (Shown)
	GA12235	-	Wheel Assembly, 12 Tine, L.H. (Items 4, 14, 15 And 16)
C.	G1K467	-	Residue Wheel Mount Kit (Items 17-20)

FRAME MOUNTED COULTER W/RESIDUE WHEELS

(RU135c/RU135g/RU153b/RU135hh)

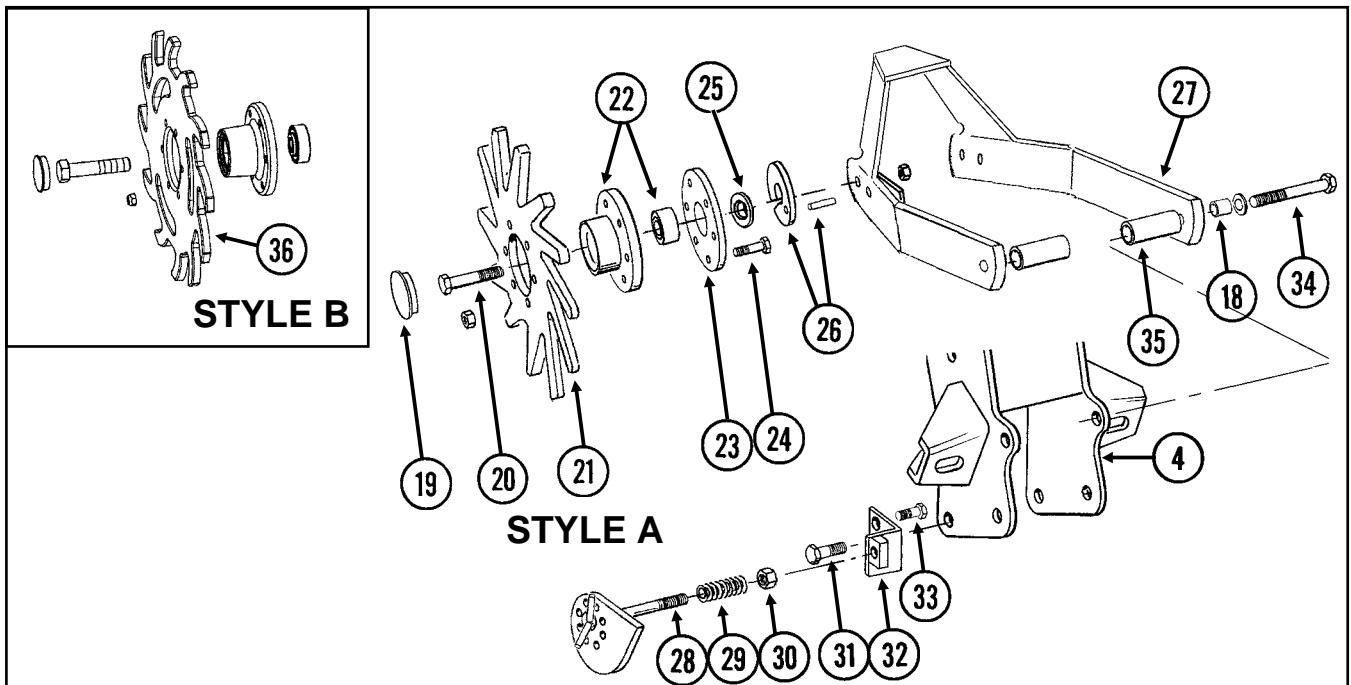
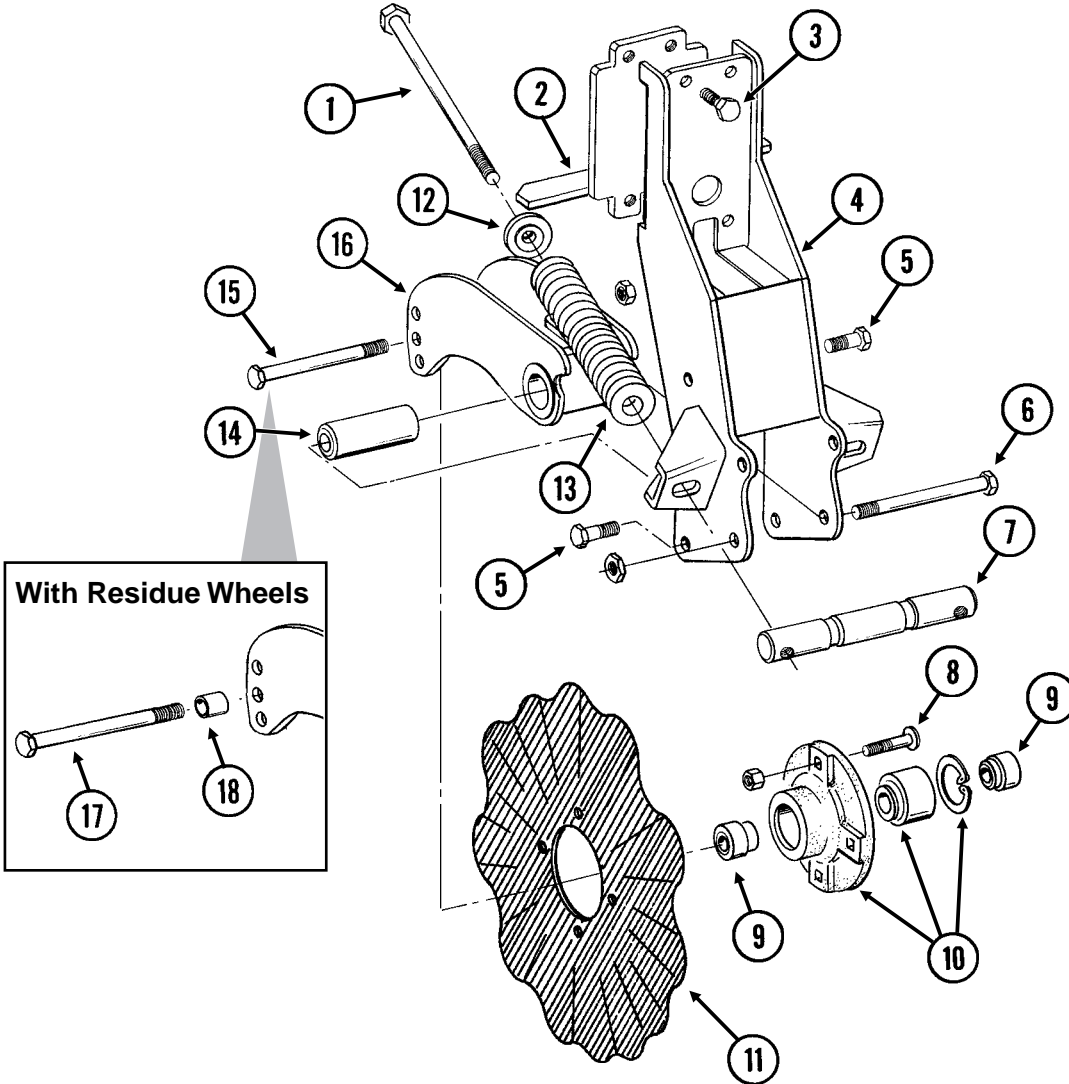

FRAME MOUNTED COULTER W/RESIDUE WHEELS

ITEM	PART NO.	QTY. (Per Row)	DESCRIPTION
1.	G11010	2	Hex Head Cap Screw, 3/4"-10 x 12"
2.	GA9844	1	Plate W/Angle
3.	G10039	4	Hex Head Cap Screw, 1/2"-13 x 1 3/4"
4.	GA9131	1	Coulter Frame
5.	G10007	4	Hex Head Cap Screw, 5/8"-11 x 1 1/2"
	G10107	4	Lock Nut, 5/8"-11
6.	G10400	1	Hex Head Cap Screw, 3/4"-10 x 6 1/2"
	G10112	1	Lock Nut, 3/4"-10
7.	GD12826	1	Spring Anchor Bar
8.	G10574	4	Carriage Bolt, 1/2"-13 x 1 1/4"
	G10111	4	Lock Nut, 1/2"-13
9.	GD12827	2	Adapter
10.	GA8641	1	Hub W/Bearing And Retaining Ring
	GA8603	1	Bearing, Double Row
	GD11652	1	Retaining Ring, 2 7/16"
11.	GD7803	1	Disc Blade, Fluted, 1", 8 Flutes (Shown)
	GD7804	-	Disc Blade, Bubbled, 1"
	GD9254	-	Disc Blade, Fluted, 3/4", 13 Flutes
12.	GB0213	2	Spring Seat
13.	GD12817	2	Compression Spring
14.	GD12829	1	Sleeve
15.	G10046	1	Hex Head Cap Screw, 5/8"-11 x 5"
	G10107	1	Lock Nut, 5/8"-11
16.	GA9845	1	Coulter Arm W/Grease Fitting
	G10643	-	Grease Fitting, 45°, 1/4"-28
17.	G10011	1	Hex Head Cap Screw, 5/8"-11 x 5 1/2"
	G10107	1	Lock Nut, 5/8"-11
18.	GB0218	3	Bushing, 2 1/32" I.D. x 7/8" O.D. x 1 9/32" Long
19.	GD1132	2	Dust Cap
20.	G10010	2	Hex Head Cap Screw, 5/8"-11 x 3"
	G10503	2	Hex Jam Nut, 5/8"-11, Grade 2
21.	GD10552	2	Wheel, 12 Tine, 3/8" x 12"
22.	GA5654	2	Hub W/Bearings
	GA2014	-	Bearing
23.	GD9724	2	Backing Plate
24.	G10133	12	Hex Head Cap Screw, 5/16"-18 x 1 1/2"
	G10109	12	Lock Nut, 5/16"-18, Grade 8
25.	G10213	2	Machine Bushing, 5/8" (.030" Thick)
26.	GA9862	2	Weed Guard W/Spring Pin
	G10765	-	Spring Pin, 1/4" x 1"
27.	GA9865	1	Mount
28.	GA9861	1	Cam
29.	GD10519	1	Spring
30.	G10974	1	Lock Nut W/Nylon Insert, 1/2"-13
31.	G10005	1	Hex Head Cap Screw, 5/8"-11 x 1 3/4"
	G10107	4	Lock Nut, 5/8"-11
32.	GA9864	1	Support
33.	G10014	1	Hex Head Cap Screw, 1/2"-13 x 1"
	G10102	1	Hex Nut, 1/2"-13
34.	G10011	2	Hex Head Cap Screw, 5/8"-11 x 5 1/2"
	G10205	2	Washer, 5/8" SAE
	G10730	2	Lock Nut W/Nylon Insert, 5/8"-11
35.	GD14170	2	Sleeve, 3"
36.	GB0386	2	Wheel, 12 Tine, 3/8" x 12"
A.	GA7446	-	Wheel Assembly, 12 Tine, R.H. (Items 21-24) (Shown)
	GA7445	-	Wheel Assembly, 12 Tine, L.H. (Items 21-24)
B.	GA12236	-	Wheel Assembly, 12 Tine, R.H. (Items 22, 23, 24 And 36) (Shown)
	GA12235	-	Wheel Assembly, 12 Tine, L.H. (Items 22, 23, 24 And 36)

PUSH ROW UNIT

(RU156c/R141dd/RU89qq/PNE31a)

NOTE: Push row units use the same seed tube, row unit depth adjustment components, quick adjustable down force springs option, 15" opener disc blades, gauge wheels, closing wheels, meter drive and seed hopper as the pull row unit. See those pages for common parts.

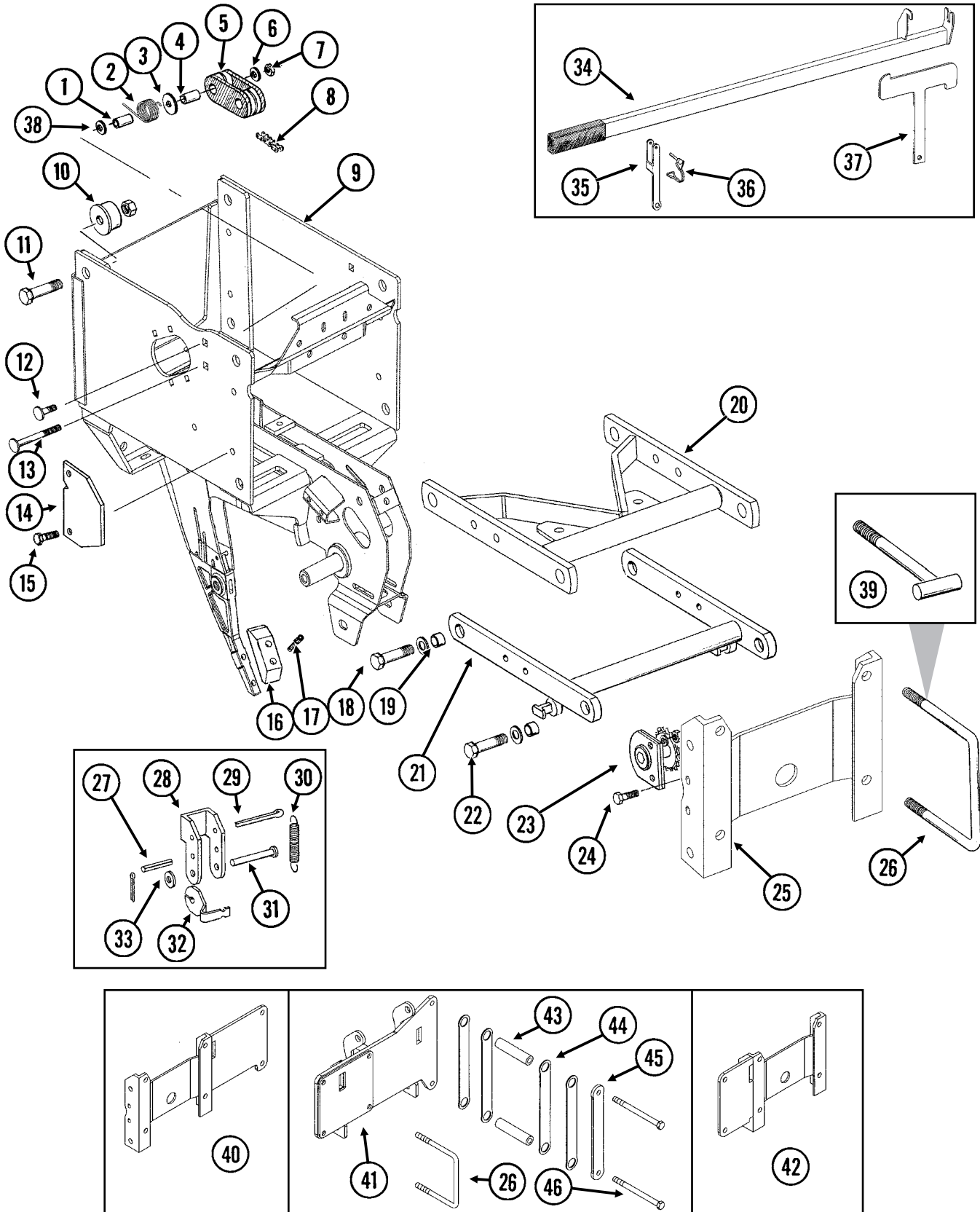

PUSH ROW UNIT

ITEM	PART NO.	QTY. (Per Row)	DESCRIPTION
1.	GD1026	1	Sleeve, 1 3/16" Long
2.	GD11218	1	Spring
3.	G10201	1	Special Washer, 3/8" x 1 1/2" O.D.
4.	GD8893-01	1	Sleeve, 1 3/8" Long
5.	GD11962	1	Idler
6.	G10210	1	Washer, 3/8" USS
7.	G10108	1	Lock Nut, 3/8"-16
8.	G3303-96	1	Chain, No. 41, 96 Pitch Including Connector Link
	GR0196	1	Connector Link, No. 41
9.	GA10161	-	Push Row Unit Shank
10.	GB0314	2	Hopper Mount
11.	G10751	2	Hex Head Cap Screw, 5/8"-18 x 1 3/4"
	G10412	2	Lock Nut, 5/8"-18
12.	G10599	1	Carriage Bolt, 3/8"-16 x 1 1/4"
	G10101	1	Hex Nut, 3/8"-16
	G10108	1	Lock Nut, 3/8"-16
13.	G10307	1	Carriage Bolt, 3/8"-16 x 3 1/2"
14.	GD10867	2	Stop
15.	G10004	4	Hex Head Cap Screw, 3/8"-16 x 1 1/4"
	G10108	4	Lock Nut, 3/8"-16
16.	GB0301	1	Seed Tube Guard/Inner Scraper
17.	G10912	2	Hex Socket Head Cap Screw, 5/16"-18 x 1", Grade 8
18.	G10751	4	Hex Head Cap Screw, 5/8"-18 x 1 3/4"
	GD7805	4	Special Washer, 5/8", Hardened
	G10412	4	Lock Nut, 5/8"-18
19.	GB0218	8	Bushing, 2 1/32" I.D. x 7/8" O.D. x 1 9/32" Long
20.	GA11969	1	Upper Arm
21.	GA5787	1	Lower Arm
22.	G10732	4	Hex Head Cap Screw, 5/8"-18 x 2"
	GD7805	4	Special Washer, 5/8", Hardened
	G10412	4	Lock Nut, 5/8"-18
23.	GA1720	1	Bearing/Sprocket, 7/8" Hex Bore
24.	G10004	2	Hex Head Cap Screw, 3/8"-16 x 1 1/4"
	G10229	2	Lock Washer, 3/8"
	G10101	2	Hex Nut, 3/8"-16
25.	GA11971	1	Mounting Plate
26.	GD1113	2	U-Bolt, 5" x 7" x 5/8"-11
	G10230	4	Lock Washer, 5/8"
	G10104	4	Hex Nut, 5/8"-11
27.	G10718	2	Spring Pin, 5/16" x 1 1/8"
28.	GD11264	2	Lockup
29.	G10463	2	Cotter Pin, 1/4" x 1 1/2"
30.	GD11447	2	Spring
31.	G10284	2	Clevis Pin, 1/2" x 1 1/2"
	G10456	2	Cotter Pin, 1/8" x 3/4"
32.	GD11263	2	Spring Tab
33.	G10216	2	Washer, 1/2" USS
34.	GA8651	1	Lift Lever W/Boot
	GD11649	-	Boot
35.	GD18073	1	Bracket
36.	GD9695	1	Wire Lock Pin, 1/4" x 1 3/4"
37.	GD18074	1	Mount
38.	G10203	1	Washer, 3/8" SAE
39.	GA9105	-	T-Bolt, 3/8"-11 x 6" (12 Row 30")
	G10230	-	Lock Washer, 5/8"
	G10104	-	Hex Nut, 5/8"-11
40.	GA12676	-	Offset Mount
41.	GA12677	-	Offset Hinge Mount
42.	GA12675	-	Offset Mount
43.	GD7817-18	2	Spacer, 1 1/16" I.D. x 5 1/2" Long
44.	GD18136	4	Pad
45.	GD18135	1	Bar
46.	G10341	-	Hex Head Cap Screw, 5/8"-11 x 8"
	G10230	-	Lock Washer, 5/8"
	G10104	-	Hex Nut, 5/8"-11

DIGITAL VACUUM GAUGE, ANALOG VACUUM GAUGE AND VACUUM FAN ASSEMBLY

(A11154/A11156/GR1736/A10765/A11158/A11699/A7856/A11155/A8329/METR68)

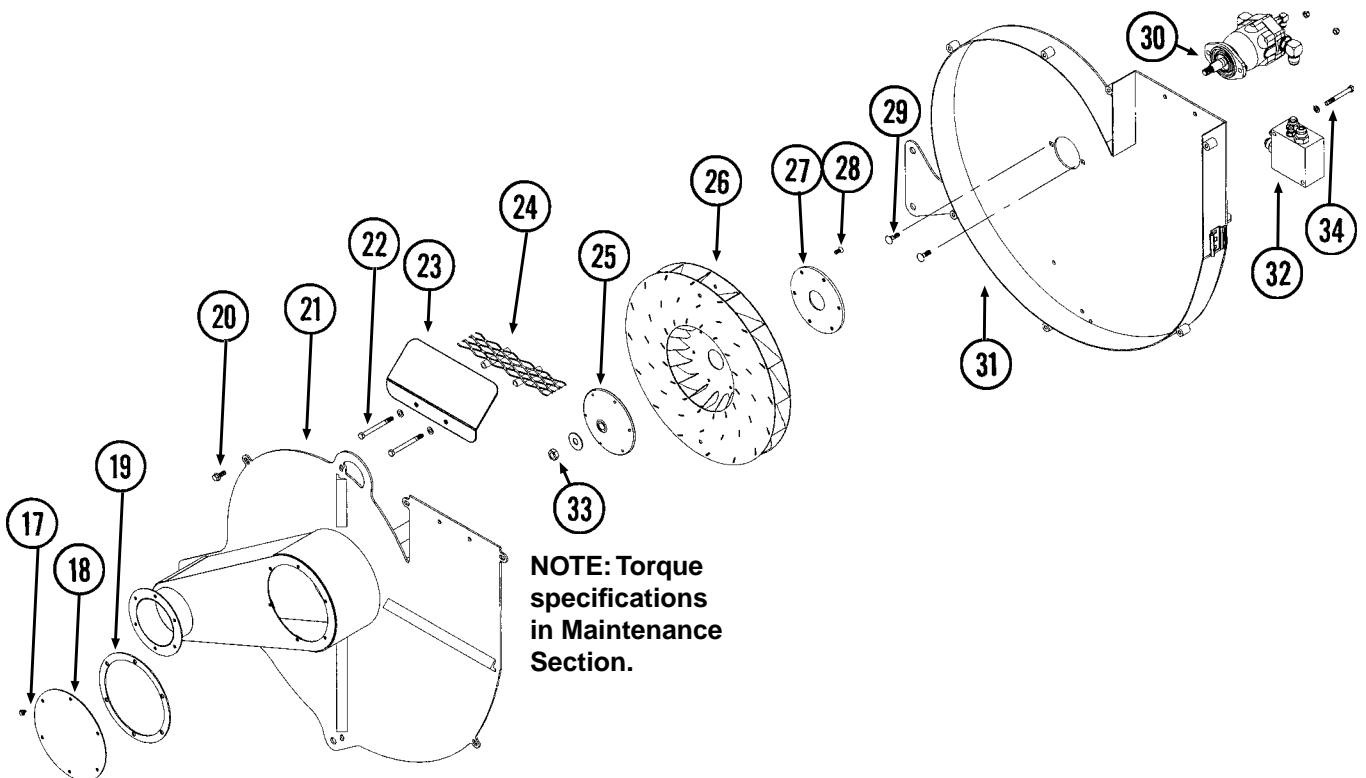
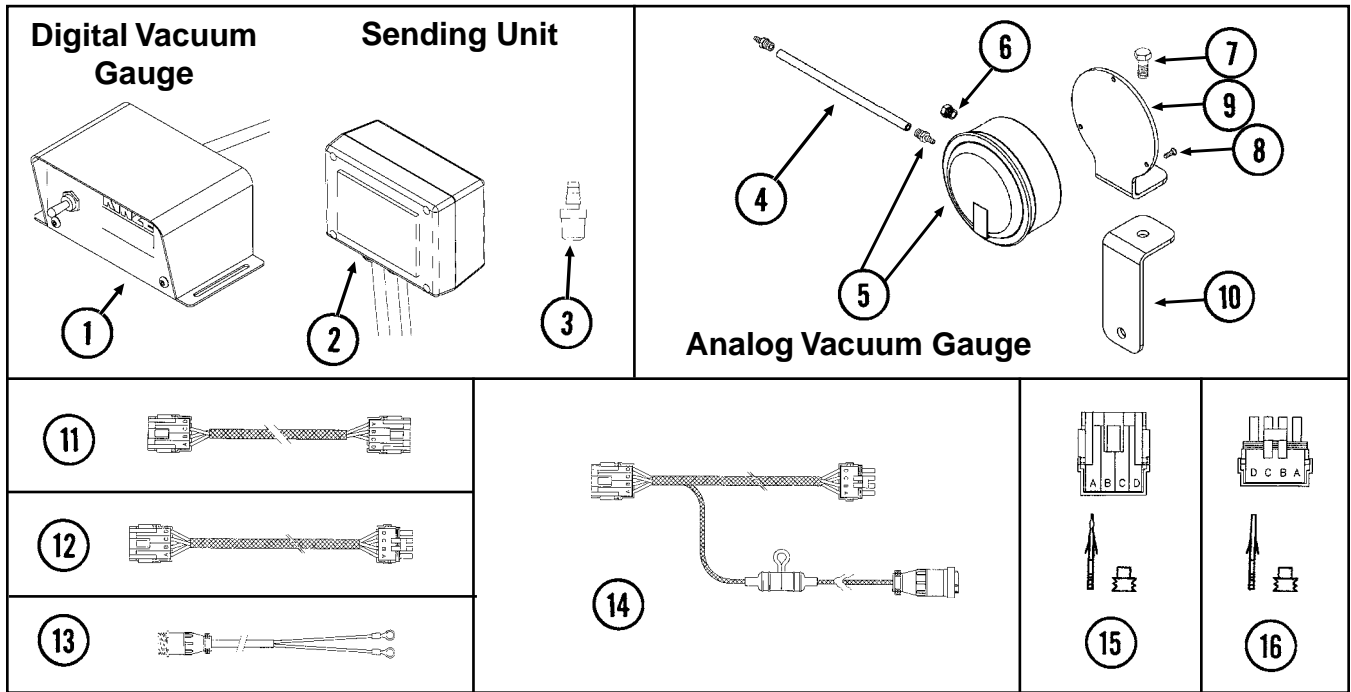

DIGITAL VACUUM GAUGE, ANALOG VACUUM GAUGE AND VACUUM FAN ASSEMBLY

ITEM	PART NO.	QTY.	DESCRIPTION
1.	GA11154	1	Digital Vacuum Gauge W/4-Pin Connector
2.	GA11156	1	Sending Unit W/1/4" Tubing And Harness W/4-Pin Male Connector
	GD16324-01	-	Clear Plastic Tubing, 1/4" x 45"
	GA9964	-	Strain Relief
3.	GR1736	1	Hose Barb, 1/8" Male NPT To Barb
4.	GD15849-02	1	Clear Plastic Tubing, 5/16" O.D. x 3/16" I.D. x 120"
5.	GA10765	1	Analog Vacuum Gauge W/Hose Barb
	GR1777	-	Hose Barb, 1/8" Male NPT To 3/16" Barb
6.	GA10799	1	Breather, 1/8" Male NPT
7.	G10001	1	Hex Head Cap Screw, 3/8"-16 x 1"
	G10108	1	Lock Nut, 3/8"-16
8.	G11215	3	Hex Socket Head Cap Screw, No. 6-32 x 3/8", Grade 8
9.	GD15804	1	Mount
10.	GD15803	1	Support
11.	GA11159	1	Harness, 550", 12 Row 30"
	GA11160	-	Harness, 670", 16 Row 30"
12.	GA11699	-	Extension Harness, 180"
13.	GA7856	-	Power Lead Adapter
14.	GA11155	1	Harness W/Fuse Holder And Fuse, 132"
	GD14258	-	Fuse Holder
	GD14660	-	Fuse, 2 Amp Delay Action
	G1K268	-	Console Cable Connector Kit, Includes: (1) 3-Pin Connector, (1) Cable Clamp, (1) Lock Ring, (3) Female Terminal Pins
15.	GA8328	-	4-Pin Female Connector Kit, Includes: (1) 4-Pin Female Housing, (4) Pin Contacts, (4) Seals
16.	GA8329	-	4-Pin Female Connector Kit, Includes: (1) 4-Pin Female Housing, (4) Pin Contacts, (4) Seals
17.	G11166	6	Whiz Lock Bolt, 1/4"-20 x 3/4"
18.	GD16233	1	Manifold
19.	GD16241	1	Gasket
20.	G11124	7	Whiz Lock Bolt, 3/8"-18 x 1"
21.	GA11086	1	Cover
22.	G10063	2	Hex Head Cap Screw, 3/8"-16 x 4"
	G10203	2	Washer, 3/8" SAE
	G10108	2	Lock Nut, 3/8"-16
23.	GD15863	1	Discharge Deflector
24.	GA11987	2	Screen
25.	GD15790	1	Hub
26.	GA10635	1	Impeller
27.	GD15789	1	Backing Plate
28.	G11133	6	Hex Socket Head Cap Screw, 5/16"-18 x 3/4", Grade 8
29.	G10599	2	Carriage Bolt, 3/8"-16 x 1 1/4"
	G10229	2	Lock Washer, 3/8"
	G10101	2	Hex Nut, 3/8"-16
30.		-	See "Vacuum Fan Hydraulic Motor Assembly", Page P44
31.	GA11085	1	Shroud
32.		-	See "Vacuum Fan Motor Valve Block Assembly (Located Below Vacuum Fan Assembly)", Page P45
33.	G10205	1	Washer, 5/8" SAE
	G10499	1	Hex Jam Nut, 5/8"-18, Grade 2
34.	G10809	2	Hex Head Cap Screw, 3/8"-16 x 3 1/4"
	G10229	2	Lock Washer, 3/8"
A.	GA11087	-	Vacuum Fan Assembly (Items 17-34 On This Page And Items 1-3, 8 And 9 On Pages P42 And P43)

VACUUM FAN HYDRAULIC COMPONENTS

(PLTR176)

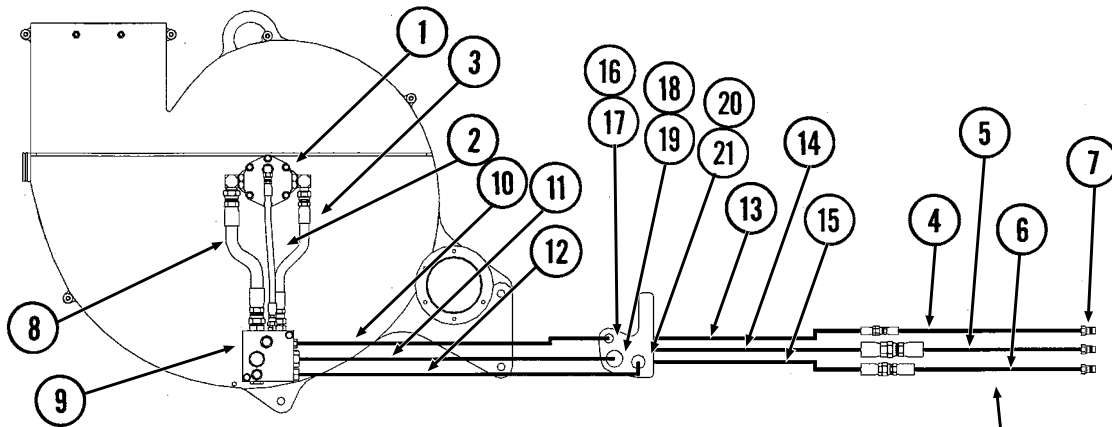

See "PTO Pump Drive And Oil Cooler Option", pages P48 and P49, if equipped with that option.

VACUUM FAN HYDRAULIC COMPONENTS

ITEM	PART NO.	QTY.	DESCRIPTION
1.		-	See "Vacuum Fan Hydraulic Motor Assembly", Page P44
2.	*A12015	1	Hose Assembly, $\frac{3}{8}$ " x 17"
3.	*A8261	1	Hose Assembly, $\frac{1}{2}$ " x 13 $\frac{1}{2}$ "
4.	*A12023	-	Hose Assembly, $\frac{3}{8}$ " x 218", 12 Row 30", "Y" Hitch
	*A12022	-	Hose Assembly, $\frac{3}{8}$ " x 268", 16 Row 30" "Y" Hitch
5.	*A3357	-	Hose Assembly, $\frac{3}{4}$ " x 218", 12 Row 30" "Y" Hitch
	*A3358	-	Hose Assembly, $\frac{3}{4}$ " x 268", 16 Row 30" "Y" Hitch
6.	*A8265	-	Hose Assembly, $\frac{1}{2}$ " x 218", 12 Row 30", "Y" Hitch
	*A8266	-	Hose Assembly, $\frac{1}{2}$ " x 268", 16 Row 30" "Y" Hitch
7.	GD4086	3	ISO Coupler
8.	*A3352	1	Hose Assembly, $\frac{3}{4}$ " x 13 $\frac{1}{2}$ "
9.		-	See "Vacuum Fan Motor Valve Block Assembly (Located Below Vacuum Fan Motor Assembly)", Page P45
10.	*A12017	1	Hose Assembly, $\frac{3}{8}$ " x 120"
11.	*A3354	1	Hose Assembly, $\frac{3}{4}$ " x 120"
12.	*A1467	1	Hose Assembly, $\frac{1}{2}$ " x 120"
13.	*A12024	1	Hose Assembly, $\frac{3}{8}$ " x 100", 12 Row 30"
	*A12021	-	Hose Assembly, $\frac{3}{8}$ " x 110", 16 Row 30"
14.	*A3355	1	Hose Assembly, $\frac{3}{4}$ " x 100", 12 Row 30"
	*A3356	-	Hose Assembly, $\frac{3}{4}$ " x 110", 16 Row 30"
15.	*A8253	1	Hose Assembly, $\frac{1}{2}$ " x 100", 12 Row 30"
	*A8263	-	Hose Assembly, $\frac{1}{2}$ " x 110", 16 Row 30"
16.	G306-06	1	Lock Nut, $\frac{9}{16}$ "-18
17.	G2700-06-06	1	Bulkhead Tube Union, $\frac{9}{16}$ "-18 Male JIC
18.	G306-12	1	Lock Nut, 1 $\frac{1}{16}$ "-12
19.	G2700-12	1	Bulkhead Tube Union, 1 $\frac{1}{16}$ "-12 Male JIC
20.	G306-10	1	Lock Nut, $\frac{7}{8}$ "-14
21.	G2700-10	1	Bulkhead Tube Union, $\frac{7}{8}$ "-14 Male JIC

* Hydraulic hose is not stocked by KINZE® Repair Parts, but can be made available on a special order basis. Call for quote.

VACUUM FAN HYDRAULIC MOTOR ASSEMBLY

(METR21a)

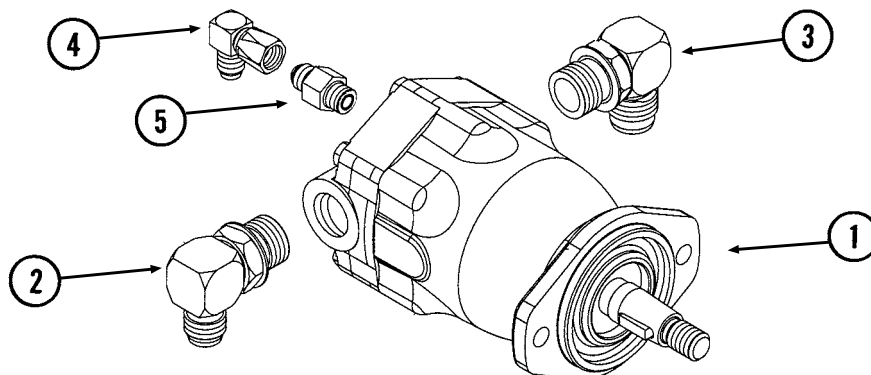

ITEM	PART NO.	QTY.	DESCRIPTION
1.	GA10149 GR1734	1 -	Hydraulic Motor Seal Kit
2.	G6801-10-12 GR1467	1 -	Elbow W/O-Ring, 90°, 7/8"-14 Male JIC To 1 1/16"-12 O-Ring O-Ring
3.	G6801-12 GR1467	1 -	Elbow W/O-Ring, 90°, 1 1/16"-12 Male JIC To O-Ring O-Ring
4.	G6500-06	1	Swivel Elbow, 90°, 9/16"-18 Male JIC To Female
5.	G6400-06 GR1045	1 -	Connector W/O-Ring, 9/16"-18 Male JIC To O-Ring O-Ring

OPTIONAL FLOW CONTROL NEEDLE VALVE KIT

(A11650)

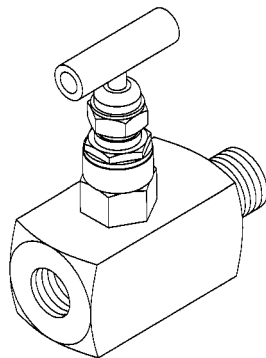

ITEM	PART NO.	QTY.	DESCRIPTION
1.	G1K426	-	Needle Valve Kit W/Instructions

VACUUM FAN MOTOR VALVE BLOCK ASSEMBLY (Located Below Vacuum Fan Motor Assembly)

(A11068d)

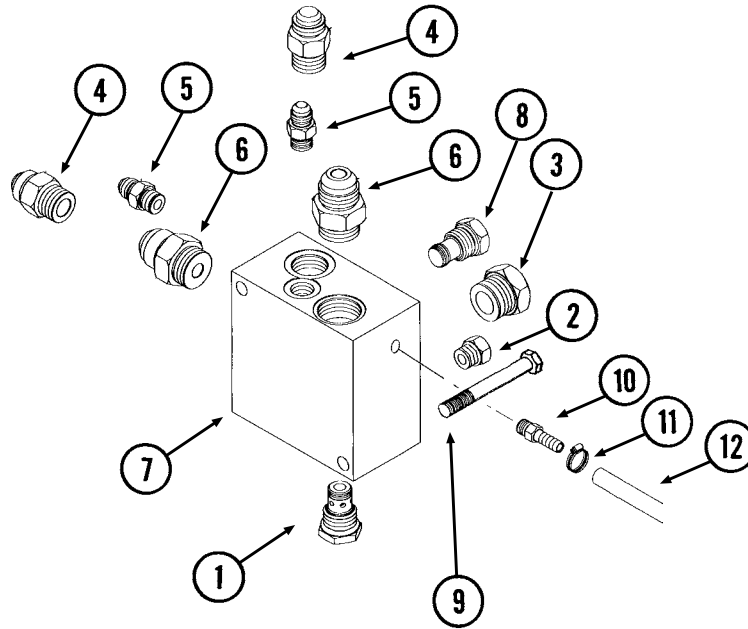

ITEM	PART NO.	QTY.	DESCRIPTION
1.	GA4293	1	Check Valve
2.	G6408-06	1	Plug W/O-Ring, 1/16"-18 O-Ring
	GR1045	-	O-Ring
3.	G6408-12	1	Plug W/O-Ring, 1 1/16"-12 O-Ring
	GR1467	-	O-Ring
4.	G6400-10	2	Connector W/O-Ring, 7/8"-14 Male JIC To O-Ring
	GR1466	-	O-Ring
5.	G6400-06	2	Connector W/O-Ring, 9/16"-18 Male JIC To O-Ring
	GR1045	-	O-Ring
6.	G6400-12	2	Connector W/O-Ring, 1 1/16"-12 Male JIC To O-Ring
	GR1467	-	O-Ring
7.	GD16188	1	Valve Block
8.	GA11934	1	Relief Valve Cartridge
9.	G10809	2	Hex Head Cap Screw, 3/8"-16 x 3 1/4"
	G10229	2	Lock Washer, 3/8"
10.	GD11700	1	Adapter, 1/4" NPT To 3/8" Barb
11.	G10681	1	Hose Clamp, No. 6
12.	GD6279-05	1	Clear Plastic Tubing, 1/16" x 60"

MANIFOLDS AND DISTRIBUTION HOSES

(PLTR175a)

12 Row 30" Shown

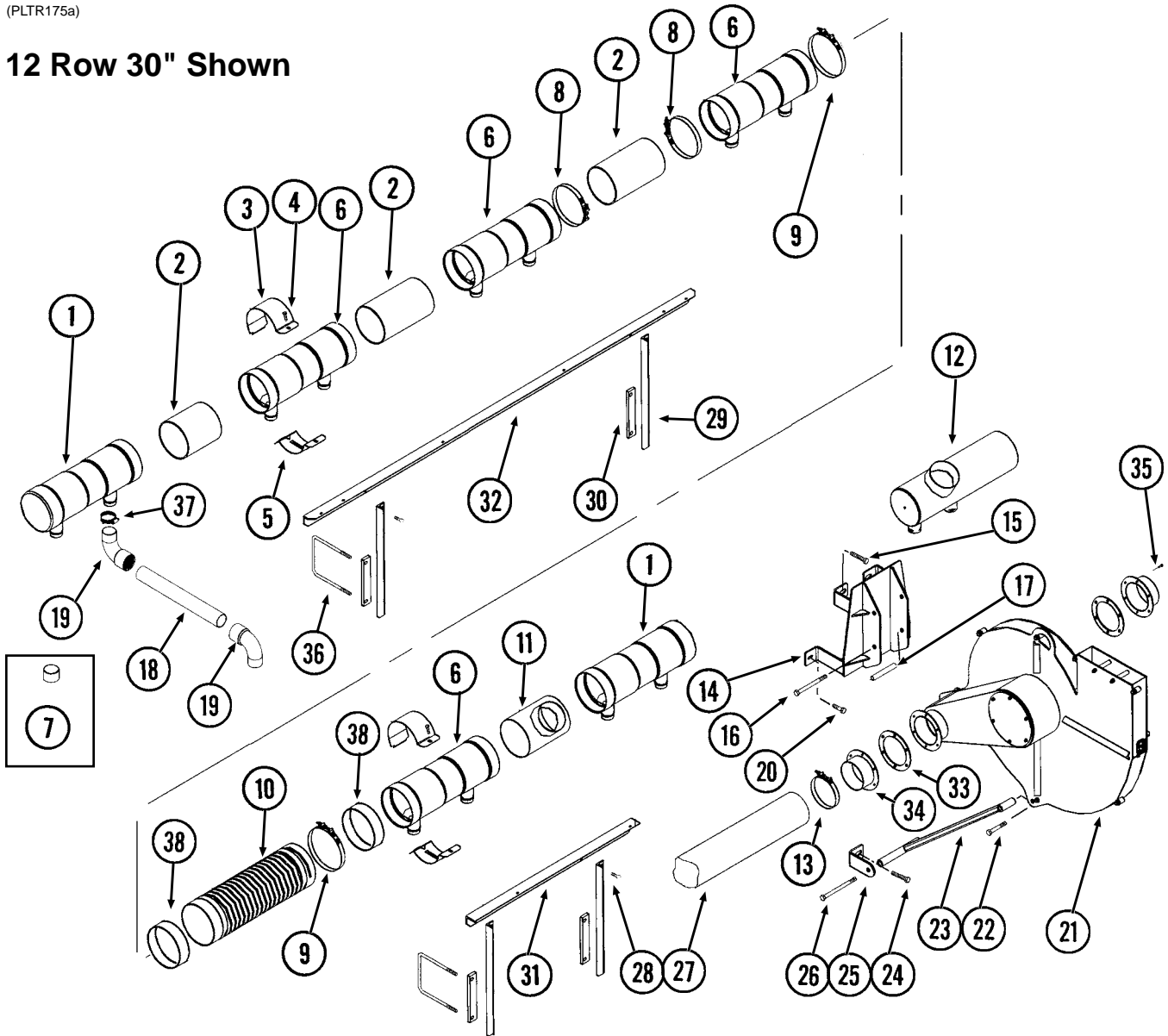

ITEM	PART NO.	QTY.	DESCRIPTION
1.	GD15850	3	Manifold, 21" (Open One End)
2.	GD15856-04	2	Pipe, 6" x 6", 12 Row 30"
	GD15856-03	4	Pipe, 6" x 11", 12 Row 30"
	GD15856-03	10	Pipe, 6" x 11", 16 Row 30"
3.	GD15854	7-15	Clamp
4.	G10312	7-15	Carriage Bolt, 5/16"-18 x 3/4"
	G10620	7-15	Serrated Flange Nut, 5/16"-18
5.	GA11164	7-15	Mount
6.	GD15799	4-12	Manifold, 21" (Open Both Ends)
7.	G11147	-	Cap, 2"
8.	G11145	7-23	T-Bolt Clamp, 7"
9.	G11194	4	T-Bolt Clamp, 7 1/4"
10.	GD16317-01	2	Hose, 7" x 21"
11.	GA12249	1	Manifold, 21 3/4", 12 Row 30" And 16 Row 30"

MANIFOLDS AND DISTRIBUTION HOSES

ITEM	PART NO.	QTY.	DESCRIPTION
12.	GA11166	1	Manifold, 21 15/16", 12 Row 30" And 16 Row 30"
13.	G11188	4	T-Bolt Clamp, 5 1/4"
14.	GA11119	1	Fan Mount
15.	G10543	2	Hex Head Cap Screw, 3/4"-10 x 3", Full Thread
	G10218	2	Washer, 3/4" USS
	G10105	2	Hex Nut, 3/4"-10
16.	G10830	2	Hex Head Cap Screw, 5/8"-11 x 7 1/2"
	G10230	2	Lock Washer, 5/8"
	G10104	2	Hex Nut, 5/8"-11
17.	GD3180-27	2	Sleeve, 5/8" I.D. x 7/8" O.D. x 5 3/4" Long
	GD3777-10	2	Sleeve, 1 3/4" x 3 1/8"
	GD3777-11	2	Sleeve, 1 3/4" x 2 1/2"
18.	GD15792-13	-	Hose, 2" x 50" (Pull Row Unit)
	GD15792-05	-	Hose, 2" x 38" (Push Row Unit)
	GD15792-12	-	Hose, 2" x 44" (Push Row Unit)
	GD15792-06	-	Hose, 2" x 42" (Push Row Unit)
19.	GD14626	16-32	Elbow, 90°, 2"
20.	G10003	2	Hex Head Cap Screw, 3/8"-16 x 1 1/2"
	G10210	3	Washer, 3/8" USS
	G10229	2	Lock Washer, 3/8"
	G10101	2	Hex Nut, 3/8"-16
21.		-	See "Digital Vacuum Gauge, Analog Vacuum Gauge And Vacuum Fan Assembly", Pages P40 And P41
22.	G10318	1	Hex Head Cap Screw, 5/8"-11 x 4 1/2"
	G10230	2	Lock Washer, 5/8"
	G10104	2	Hex Nut, 5/8"-11
23.	GA11152	1	Fan Strut
24.	G10543	2	Hex Head Cap Screw, 3/4"-10 x 3", Full Thread
	G10105	2	Hex Nut, 3/4"-10
25.	GD16295	2	Support
26.	G10953	1	Hex Head Cap Screw, 5/8"-11 x 10"
	G10218	2	Washer, 3/4" USS
	G10230	1	Lock Washer, 5/8"
	G10104	1	Hex Nut, 5/8"-11
27.	GD15867-02	2	Hose, 5" x 50"
28.	G10019	24-36	Hex Head Cap Screw, 5/16"-18 x 1"
	G10232	24-36	Lock Washer, 5/16"
	G10106	24-36	Hex Nut, 5/16"-18
29.	GD16315	8-10	Support, 21 1/2"
30.	GD16316	8-10	Spacer, 1 1/2" x 9"
31.	GD16307	1	Manifold Rail, 37 1/2", L.H. Main Frame, 12 Row 30" And 16 Row 30"
	GD16306	1	Manifold Rail, 36 1/2", R.H. Main Frame, 12 Row 30" And 16 Row 30"
32.	GD16305	2	Manifold Rail, 87 1/2", L.H. And R.H. Wing, 12 Row 30"
	GD16319	2	Manifold Rail, 142 1/2", L.H. And R.H. Wing, 16 Row 30"
33.	GD16251	2	Gasket
34.	GA11153	2	Outlet, 5"
35.	G10023	12	Hex Head Cap Screw, 1/4"-20 x 3/4"
	G10110	12	Lock Nut, 1/4"-20, Grade B
36.	GD11721	8-10	U-Bolt, 5" x 7" x 1/2"-13
	G10228	16-20	Lock Washer, 1/2"
	G10102	16-20	Hex Nut, 1/2"-13
37.	G10676	-	Hose Clamp, No. 36, Stainless Steel
38.	GD16194-01	-	Tube, 6 5/8" x 2"

PTO PUMP DRIVE AND OIL COOLER OPTION

(TWL302a/D16644/TWL1j/TWL303/PLTR177a)

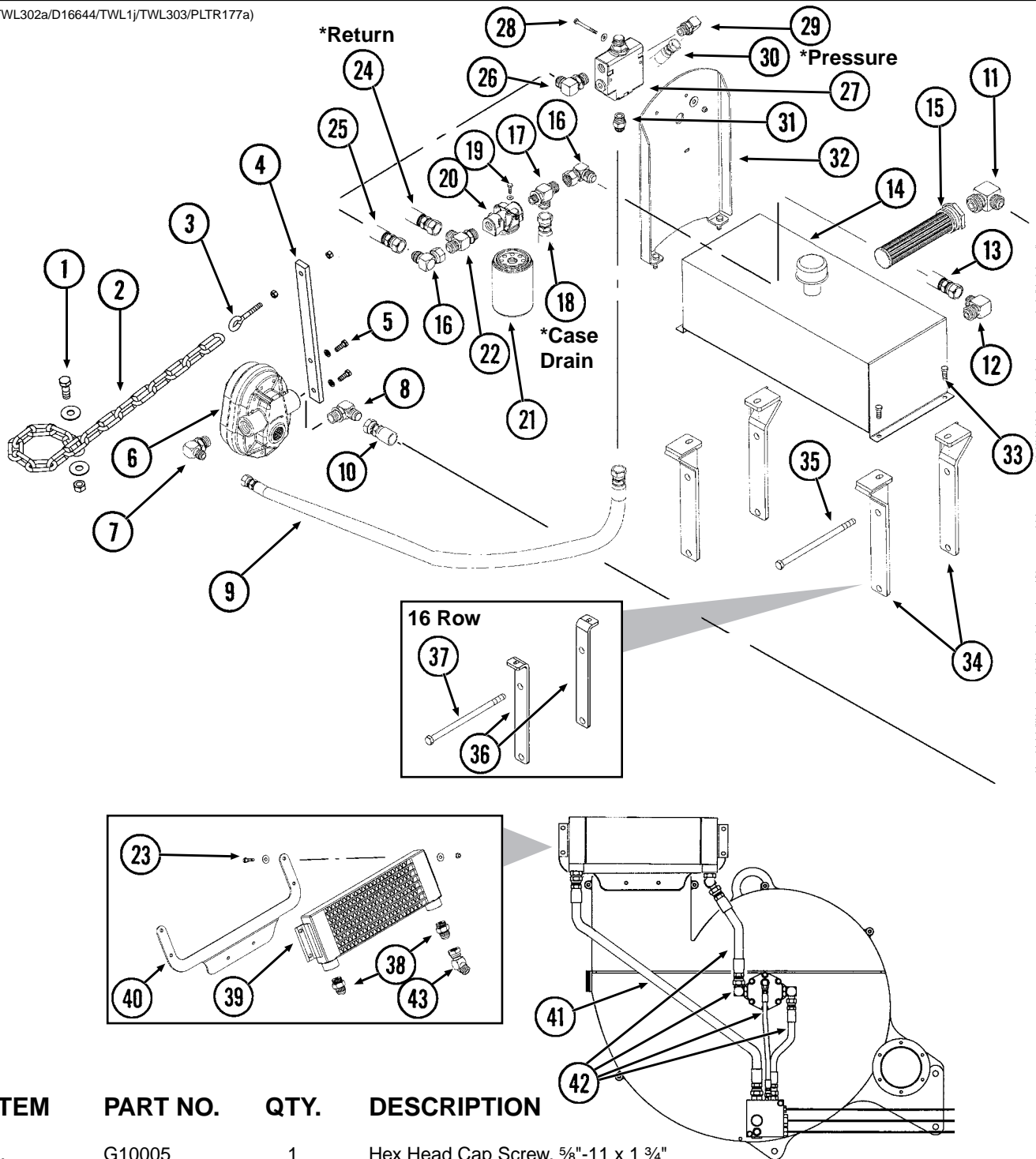

ITEM	PART NO.	QTY.	DESCRIPTION
1.	G10005	1	Hex Head Cap Screw, 5/8"-11 x 1 3/4"
	G10217	2	Washer, 5/8" USS
	G10107	1	Lock Nut, 5/8"-11
2.	G3302-09	1	Coil Chain, No. 9/0, 17 Links
3.	GD16035	1	Eyebolt, 3/8"-16 x 4"
	G10101	2	Hex Nut, 3/8"-16
4.	GD16036	1	Anti-Rotation Bracket
5.	G10001	2	Hex Head Cap Screw, 3/8"-16 x 1"
	G10229	2	Lock Washer, 3/8"
6.	GA10919	1	PTO Pump
7.	G6801-10-12	1	Elbow W/O-Ring, 90°, 7/8"-14 Male JIC To 1 1/16"-12 O-Ring
	GR1467	-	O-Ring
8.	G6801-16	1	Elbow W/O-Ring, 90°, 1 5/16"-12 Female JIC To O-Ring
	GR1786	-	O-Ring

PTO PUMP DRIVE AND OIL COOLER OPTION

ITEM	PART NO.	QTY.	DESCRIPTION
9.	*A1464	1	Hose Assembly, 1/2" x 72"
10.	*A6201	1	Hose Assembly, 1" x 72"
11.	G2501-16-20	1	Elbow, 90°, 1 5/16" Male JIC To 1 1/4" NPT
12.	G2501-12-16	1	Elbow, 90°, 1 1/16"-12 Male JIC To 1" NPT
13.	*A3371	1	Hose Assembly, 3/4" x 25"
14.	GA12802	1	Reservoir W/Breather, 10 Gallon
	GR1834	-	Breather
15.	GD16040	1	Strainer
16.	G6500-12	2	Swivel Elbow, 90°, 1 1/16"-12 Male JIC To Female
17.	G6804-12-12-08	1	Adjustable Tee W/O-Ring, 1 1/16"-12 Male JIC To 1 1/16"-12 Male O-Ring To 3/4"-16
	GR1467	-	O-Ring
18.	*A3282	-	Hose Assembly, 3/8" x 158", 12 Row 30"
	*A3283	-	Hose Assembly, 3/8" x 108", 16 Row 30"
19.	G10023	2	Hex Head Cap Screw, 1/4"-20 x 3/4"
	G10227	2	Lock Washer, 1/4"
20.	GD16038	1	Filter Head
21.	GD16037	1	Oil Filter, 10 Micron
22.	G6804-12	1	Adjustable Tee W/O-Ring, 1 1/16"-12 Male JIC To O-Ring
	GR1467	-	O-Ring
23.	G10171	4	Hex Head Cap Screw, 5/16"-18 x 1 1/4"
	G10219	8	Washer, 5/16" USS
	G10109	4	Lock Nut, 5/16"-18, Grade 8
24.	*A3675	-	Hose Assembly, 3/4" x 158", 12 Row 30"
	*A3340	-	Hose Assembly, 3/4" x 108", 16 Row 30"
25.	*A3351	1	Hose Assembly, 3/4" x 20"
26.	G6801-12-10	1	Elbow W/O-Ring, 90°, 1 1/16"-12 Male JIC To 7/8"-14 O-Ring
	GR1466	-	O-Ring
27.	GA10918	1	Flow Control Valve
28.	G10403	2	Hex Head Cap Screw, 1/4"-20 x 2 1/2"
	G10209	4	Washer, 1/4" USS
	G10110	2	Lock Nut, 1/4"-20, Grade 8
29.	G6801-10	1	Elbow W/O-Ring, 90°, 7/8"-14 Male JIC To O-Ring
	GR1466	-	O-Ring
30.	*A8283	-	Hose Assembly, 1/2" x 158", 12 Row 30"
	*A8250	-	Hose Assembly, 1/2" x 108", 16 Row 30"
31.	G6400-10	1	Connector W/O-Ring, 7/8"-14 Male JIC To O-Ring
	GR1466	-	O-Ring
32.	GA11523	1	Mounting Bracket
33.	G10001	2	Hex Head Cap Screw, 3/8"-16 x 1"
	G10210	4	Washer, 3/8" USS
	G10108	4	Lock Nut, 3/8"-16
34.	GA11544	4	Bracket, 12", 12 Row 30"
35.	G10148	4	Hex Head Cap Screw, 1/2"-13 x 9 1/2"
	G10228	4	Lock Washer, 1/2"
	G10102	4	Hex Nut, 1/2"-13
36.	GD16644	4	Bracket, 14 1/2", 16 Row 30"
37.	G11158	4	Hex Head Cap Screw, 1/2"-13 x 11 1/2"
	G10228	4	Lock Washer, 1/2"
	G10102	4	Hex Nut, 1/2"-13
38.	G6400-12	2	Connector W/O-Ring, 1 1/16"-12 Male JIC To O-Ring
	GR1467	-	O-Ring
39.	GA10917	1	Oil Cooler
40.	GD16608	1	Bracket
41.	*A3369	1	Hose Assembly, 3/4" x 40"
42.		-	See "Vacuum Fan Hydraulic Components", Pages P42 And P43
43.	G6502-12	1	Swivel Elbow, 45°, 1 1/16"-12 Male JIC To Female

* Hydraulic hose is not stocked by KINZE® Repair Parts, but can be made available on a special order basis. Call for quote.

OUTER HITCH/SAFETY CHAIN

PHA038/TWL1k/PHA025(PLTR193/WGN47a/B0292)

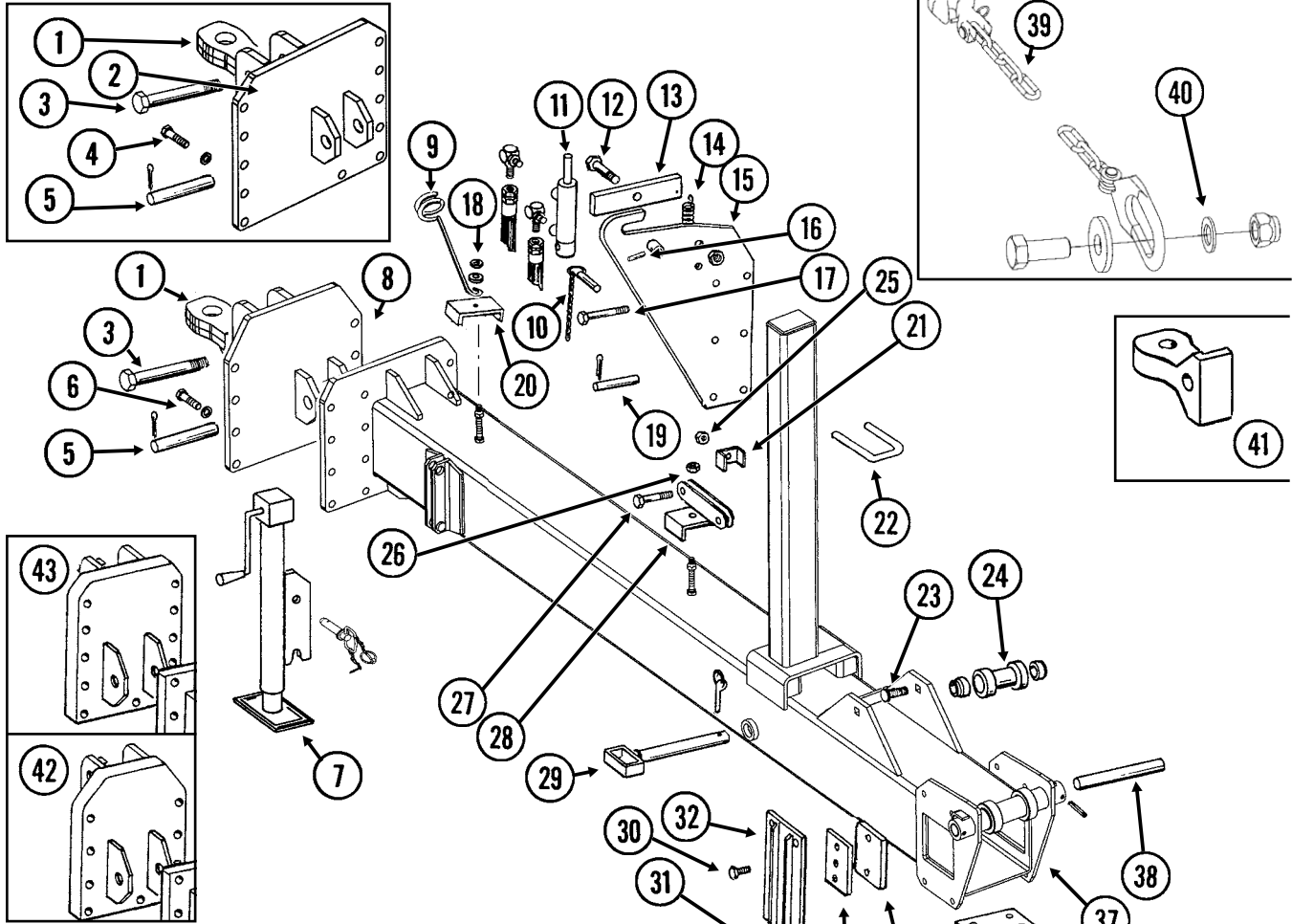

ITEM	PART NO.	QTY.	DESCRIPTION
1.	GB0237	1	Clevis, Single (1 3/4" Hole)
2.	GA12577	-	Hitch Mount, 16 Row 30"
3.	G10169	1	Hex Head Cap Screw, 1 1/4"-7 x 6"
	G10157	1	Lock Nut, 1 1/4"-7
4.	G10802	11	Hex Head Cap Screw, 3/4"-10 x 2 3/4"
	G10231	11	Lock Washer, 3/4"
	G10105	11	Hex Nut, 3/4"-10
5.	GD5173	1	Pin, 1 1/4" x 5 1/8"
	G10462	2	Cotter Pin, 3/16" x 2"
6.	G10009	9	Hex Head Cap Screw, 5/8"-11 x 2 1/2"
	G10230	9	Lock Washer, 5/8"
	G10104	9	Hex Nut, 5/8"-11
7.	GA4994	1	Jack Assembly Complete
	GA4995	-	Detent Pin Assembly
	GR0517	-	Pin
	GR0516	-	Crank Assembly
	GR0515	-	Bevel Gear Set, Includes: (2) Bevel Gears, (1) Gear Pin, (1) Groove Pin
8.	GA12584	1	Hitch Mount, 12 Row 30"
9.	GD8260	1	Hose Holder
10.	GA7022	1	Detent Pin W/Chain (Transport Latch Locking Pin)
11.			See "Transport Latch Cylinder", Page P90
12.	G10006	1	Hex Head Cap Screw, 5/8"-11 x 2 1/4"
	GB0218	1	Bushing, 2 1/32" I.D. x 7/8" O.D. x 1 9/32" Long
	GD7805	1	Special Washer, 5/8", Hardened
	G10107	1	Lock Nut, 5/8"-11
13.	GA7016	1	Catch Bar
14.	GD5857	1	Spring
15.	GA7433	1	Transport Latch
16.	G10765	-	Spring Pin, 1/4" x 1"

OUTER HITCH/SAFETY CHAIN

ITEM	PART NO.	QTY.	DESCRIPTION
17.	G10062	1	Hex Head Cap Screw, 3/8"-16 x 3"
	GD2971-09	1	Sleeve, 2" Long
	G10108	1	Lock Nut, 3/8"-16
18.	G10216	1	Washer, 1/2" USS
	G10111	1	Lock Nut, 1/2"-13
19.	GD7137	1	Pin, 3/4" x 3 3/8"
	G10457	2	Cotter Pin, 5/32" x 1 1/2"
20.	GD8188	-	Hose Clamp, 7/8" x 3" x 5 3/8"
	GD8189	-	Rubber Pad
21.	GD5892	2	Hose Clamp, 5/8" x 1 1/2" x 1 1/2"
22.	GD9953	3	U-Bolt, 3" x 4" x 5/8"-11
	G10205	1	Washer, 5/8" SAE
	G10230	6	Lock Washer, 5/8"
	G10104	6	Hex Nut, 5/8"-11
23.			See "Hose Take-Up", Pages P56 And P57
24.	GA4418	1	Roller W/Bronze Bushings, 12 Row 30"
	GA4842	-	Roller W/Bronze Bushings, 16 Row 30"
	GD6556	1	Bronze Bushing
25.	G10108	1	Lock Nut, 3/8"-16
26.	G10111	1	Lock Nut, 1/2"-13
27.	G10026	1	Hex Head Cap Screw, 3/4"-10 x 2"
	G10112	1	Lock Nut, 3/4"-10
28.	GA5842	1	Bracket, Jack Mount
	GD8189	-	Rubber Pad
29.	GA4402	1	Safety Pin, 12 3/4", 12 Row 30"
	GA4845	-	Safety Pin, 14 3/4", 16 Row 30"
	GD2558	-	Lynch Pin, 1/4"
	GD2557	-	Lynch Pin, 7/16"
30.	G10014	4	Hex Head Cap Screw, 1/2"-13 x 1"
	G10228	4	Lock Washer, 1/2"
31.	G10017	8	Hex Head Cap Screw, 1/2"-13 x 1 1/2", 12 Row 30"
	G10016	10	Hex Head Cap Screw, 1/2"-13 x 2", 16 Row 30"
	G10228	8-10	Lock Washer, 1/2"
	G10102	8-10	Hex Nut, 1/2"-13
32.	GA7029	2	Wear Mount, 12 Row 30"
	GA7084	-	Wear Mount, L.H., 16 Row 30"
	GA7085	-	Wear Mount, R.H., 16 Row 30"
	GA7083	-	Wear Pad Retainer, 16 Row 30"
33.	GD5154	-	Shim, 4" x 4" (As Required), All Sizes
	GD3501	-	Shim, 4" x 6" (As Required), 16 Row 30"
34.	GD9959	-	Wear Pad, Nylatron, 4" x 4" (As Required), All Sizes
	GD9960	-	Wear Pad, Nylatron, 4" x 6" (As Required), 16 Row 30"
35.	GD7519	3	Shim, 16 Gauge (16 Row 30" Only)
	GD7518	1	Shim, 3/8" (16 Row Only)
36.	G10014	4	Hex Head Cap Screw, 1/2"-13 x 1"
	G10228	4	Lock Washer, 1/2"
	G10216	4	Washer, 1/2" USS
37.	A12583	-	Outer Hitch, "Y", 97", 12 Row 30" (Non-Stock Item)
	A12529	-	Outer Hitch, "Y", 127 1/2", 16 Row 30" (Non-Stock Item)
38.	GD5804	1	Pin, 1 1/4" x 12", 12 Row 30"
	GD7251	1	Pin, 1 1/4" x 14", 16 Row 30"
	G10610	2	Spring Pin, 3/8" x 2"
39.	GA13594	1	Safety Chain W/Hook, 1/2"
	G1K412	-	Safety Chain Repair Kit, Includes: (1) Hook, (1) Flat Washer, (1) Latch Pin, (1) Safety Latch, (1) Spring And (1) Retaining Ring
40.	G11058	1	Hex Head Cap Screw, 1 1/4"-7 x 3"
	GD10646	1	Special Washer
	G10226	1	Washer, 1 1/4" SAE
	G10157	1	Lock Nut, 1 1/4"-7
41.	GB0292	-	Hitch Clevis, Single (2" Hole)
42.	GA9836	-	Hitch Mount, 12 Row 30"
43.	GA9837	-	Hitch Mount, 16 Row 30"

2-POINT HITCH OPTION

(A12406)

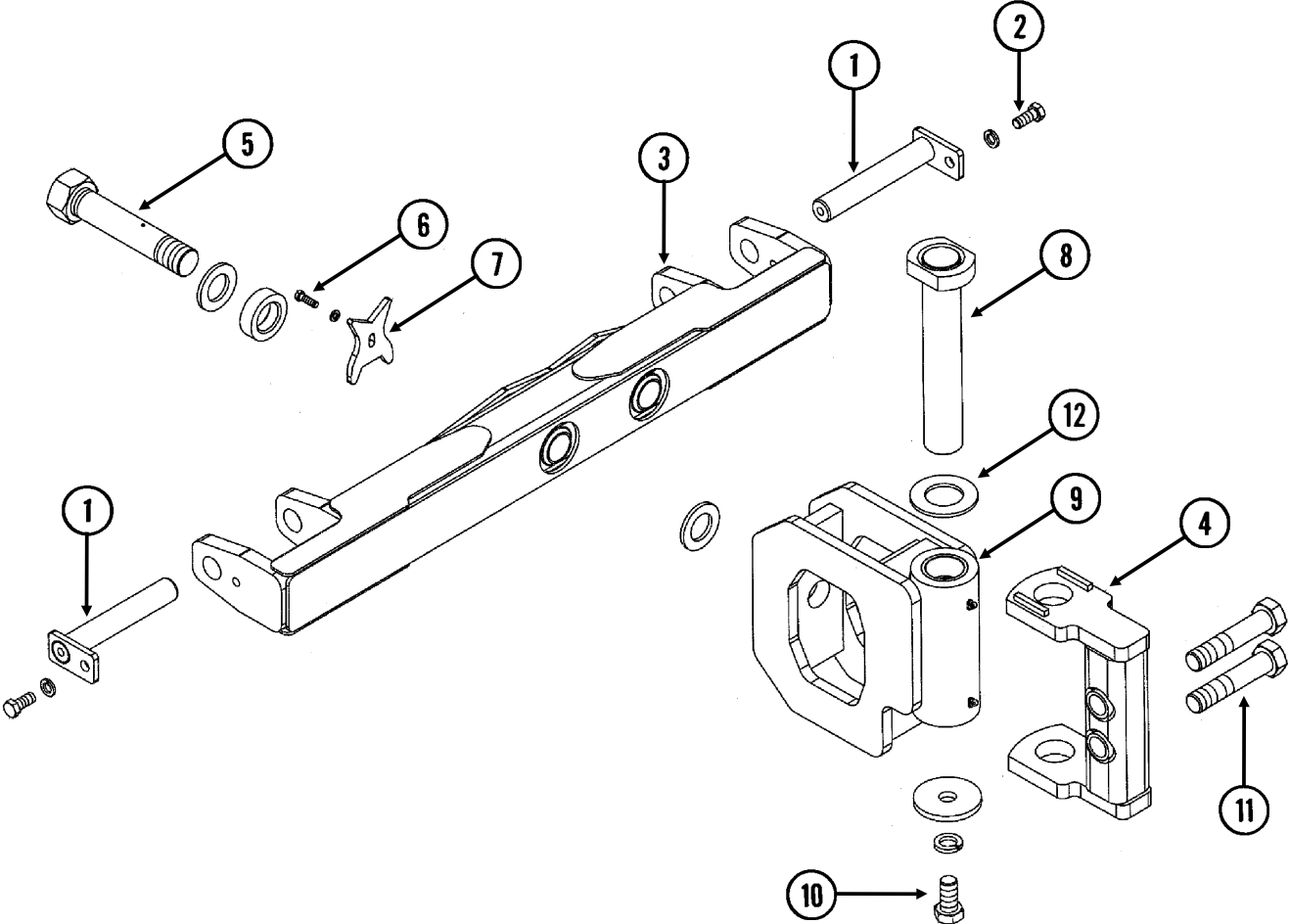

2-POINT HITCH OPTION

ITEM	PART NO.	QTY.	DESCRIPTION
1.	GA11079	2	Hammer Strap, Category 3N And 3
2.	G10007	2	Hex Head Cap Screw, 5/8"-11 x 1 1/2"
	G10230	2	Lock Washer, 5/8"
3.	GA12164	1	Hitch Bar
4.	GA12165	1	Pivot Mount
5.	GA11082	1	Pivot Bolt W/Grease Fitting, 1 3/4" x 10 3/8" (Total Length)
	G10640	-	Grease Fitting, 1/4"-28
	GD16303	2	Washer, 3" O.D. x 1 25/32" x 1/4" Thick
	GD16226	1	Sleeve, 3" O.D. x 1 25/32" x 29/32" Thick
6.	G10005	1	Hex Head Cap Screw, 5/8"-11 x 1 1/4"
	G10217	1	Washer, 5/8" USS
7.	GD15100	1	Pivot Lock
8.	GA12163	1	Pin, 13 3/8"
9.	GA11083	1	Hitch Pivot W/Bushings And Grease Fittings
	GD14562	2	Hardened Bushing, 2 3/4" O.D. x 2 1/4" I.D. x 3"
	G10779	2	Grease Fitting, 90°, 1/4"-28
10	G11223	1	Hex Head Cap Screw, 1"-8 x 2"
	G10118	1	Lock Washer, 1"
	GD17245	1	Washer, 4" O.D. x 1 1/32" I.D. x 3/8"
11.	G10169	2	Hex Head Cap Screw, 1 1/4"-7 x 6"
	G10157	2	Lock Nut, 1 1/4"-7
12.	GD15725	1	Washer, 4" O.D. x 2 1/4" I.D. x 1/4"

INNER HITCH, "Y"

PHA035/PHA037(PNE34a)

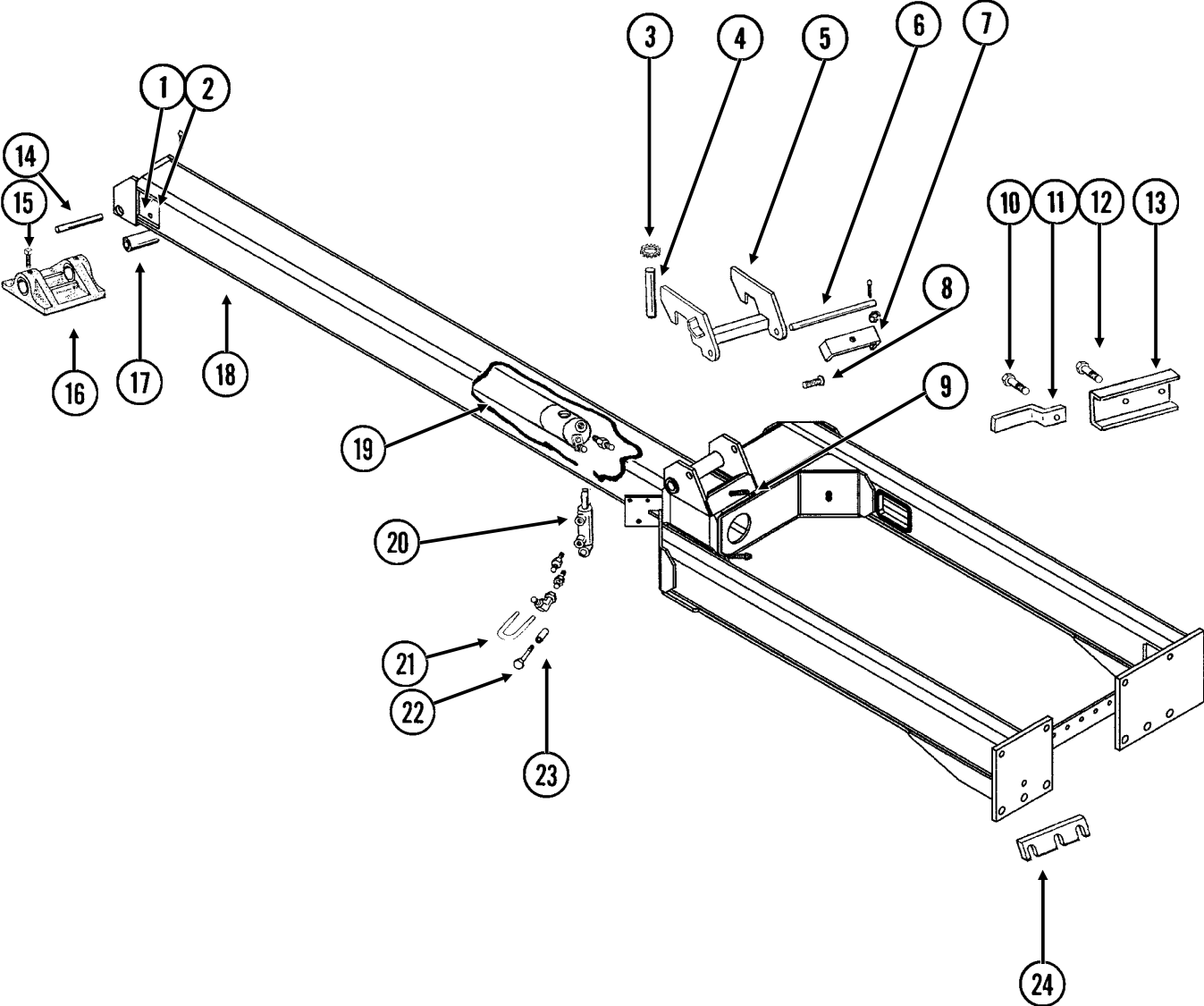

INNER HITCH, "Y"

ITEM	PART NO.	QTY.	DESCRIPTION
1.	G10014	4	Hex Head Cap Screw, 1/2"-13 x 1", 12 Row 30"
	G10017	4	Hex Head Cap Screw, 1/2"-13 x 1 1/2", 16 Row 30"
	G10228	4	Lock Washer, 1/2", 16 Row 30"
2.	GD9959	2	Wear Pad, Nylatron, 4" x 4"
	GD5154	4-6	Shim, 4" x 4"
3.	G10894	-	External Washer
4.	GD3537-17	1	Shaft, 1 1/4" x 6 3/8", 12 Row 30"
	GD3537-18	-	Shaft, 1 1/4" x 7 3/8", 16 Row 30"
5.	GA7423	1	Tongue Hook W/Grease Fittings, 12 Row 30"
	GA7424	-	Tongue Hook W/Grease Fittings, 16 Row 30"
	G10641	-	Grease Fitting, 1/8" NPT
6.	GD5804	1	Pin, 1 1/4" x 12", 8/12 Row
	GD7883	-	Pin, 1 1/4" x 14 1/2", 16 Row
	G10468	2	Cotter Pin, 3/8" x 2"
7.	GD8188	-	Hose Clamp, 7/8" x 3" x 5 3/8"
	GD8189	-	Rubber Pad
8.			See "Hose Take-Up", Pages P56 And P57
9.	G11169	1	Hex Head Cap Screw, 1/2"-13 x 3 1/2"
	G10111	1	Lock Nut, 1/2"-13
10.	G10004	1	Hex Head Cap Screw, 3/8"-16 x 1 1/4"
	G10229	1	Lock Washer, 3/8"
	G10101	1	Hex Nut, 3/8"-16
11.	GD10650	1	Hose Clamp
12.	G10003	1	Hex Head Cap Screw, 3/8"-16 x 1 1/2"
	G10210	1	Washer, 3/8" USS
	G10108	1	Lock Nut, 3/8"-16
13.	GD10664	1	Shield (If Applicable)
14.	GD5173	1	Pin, 1 1/4" x 5 1/8"
	G10462	1	Cotter Pin, 3/16" x 2"
15.	G10131	1	Square Head Set Screw, 5/16"-18 x 3/4"
16.	GB0246	1	Shoe
17.	GD3537-11	1	Shaft, 1 1/4" x 7", 8/12 Row
	GD3537-12	-	Shaft, 1 1/4" x 8", 16 Row
18.	A12582	-	Inner Hitch, 169 3/8", 12 Row 30" (Shown) (Non-Stock Item)
	A12528	-	Inner Hitch, 205 3/8", 16 Row 30" (Non-Stock Item)
19.		-	See "Tongue Cylinder", Pages P90 And P91
20.		-	See "Tongue Lock Cylinder", Page P90
21.	GD10530	1	U-Bolt, 2 1/8" x 1 7/8" x 3/8"-16
	G10229	2	Lock Washer, 3/8"
	G10101	2	Hex Nut, 3/8"-16
22.	G10585	1	Hex Head Cap Screw, 1/2"-13 x 3 1/4"
	G10216	1	Washer, 1/2" USS
	G10228	1	Lock Washer, 1/2"
	G10102	1	Hex Nut, 1/2"-13
23.	GD10538-01	1	Sleeve
24.	GD13543	1	Shim, 2 1/2" x 10", 7 Gauge
	GD13544	1	Shim, 2 1/2" x 10", 10 Gauge
	GD13545	1	Shim, 2 1/2" x 10", 12 Gauge
	GD13546	1	Shim, 2 1/2" x 10", 14 Gauge

HOSE TAKE-UP

(TWL137c)

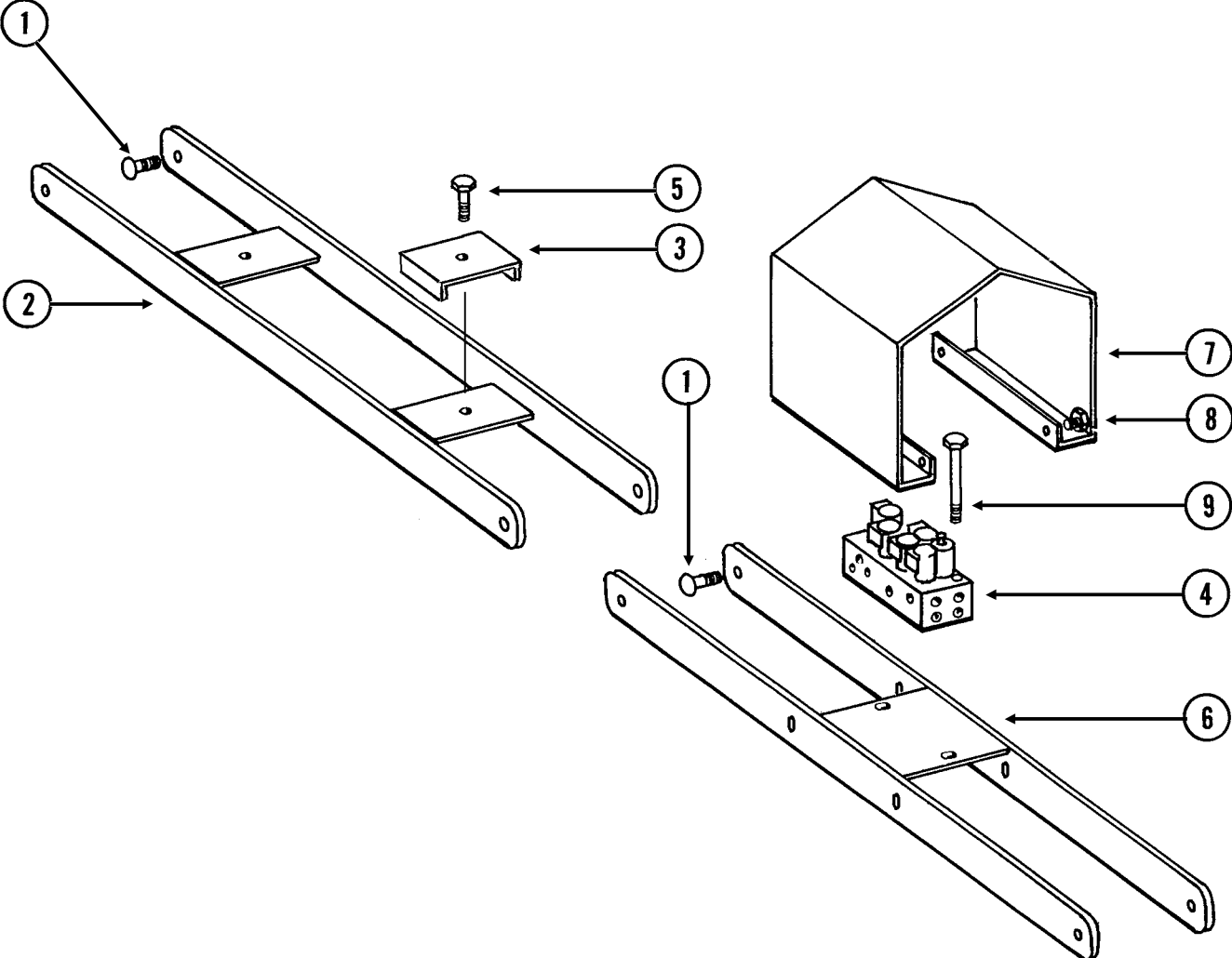

HOSE TAKE-UP

ITEM	PART NO.	QTY.	DESCRIPTION
1.	G10689	6	Carriage Bolt, 5/8"-11 x 2"
	GB0218	6	Bushing, 2 1/32" I.D. x 7/8" O.D. x 1 9/32" Long
	GD7805	6	Special Washer, 5/8", Hardened
	G10107	6	Lock Nut, 5/8"-11
2.	GA7013	-	Take-Up, 44 1/4", 12 Row 30" (Shown)
	GA7049	-	Take-Up, 56 1/4", 16 Row 30"
3.	GD8188	2	Hose Clamp, 7/8" x 3" x 5 3/8"
	GD8189	2	Rubber Pad
4.			See "Valve Block - Located On Hitch", Pages P86 And P87
5.	G10581	1	Hex Head Cap Screw, 1/2"-13 x 2 1/4"
	G10111	1	Lock Nut, 1/2"-13
6.	GA7021	-	Take-Up, 44 1/4", 12 Row 30" (Shown)
	GA7050	-	Take-Up, 56 1/4", 16 Row 30"
7.	GD9952	1	Cover
8.	G10004	4	Hex Head Cap Screw, 3/8"-16 x 1 1/4"
	G10229	4	Lock Washer, 3/8"
	G10203	8	Washer, 3/8" SAE
	G10101	4	Hex Nut, 3/8"-16
	G10172	2	Hex Head Cap Screw, 3/8"-16 x 5"
9.	G10210	2	Washer, 3/8" USS
	G10108	2	Lock Nut, 3/8"-16

CENTER FRAME

PFA070/VVB034(TWL138a)

12 ROW 30" SHOWN

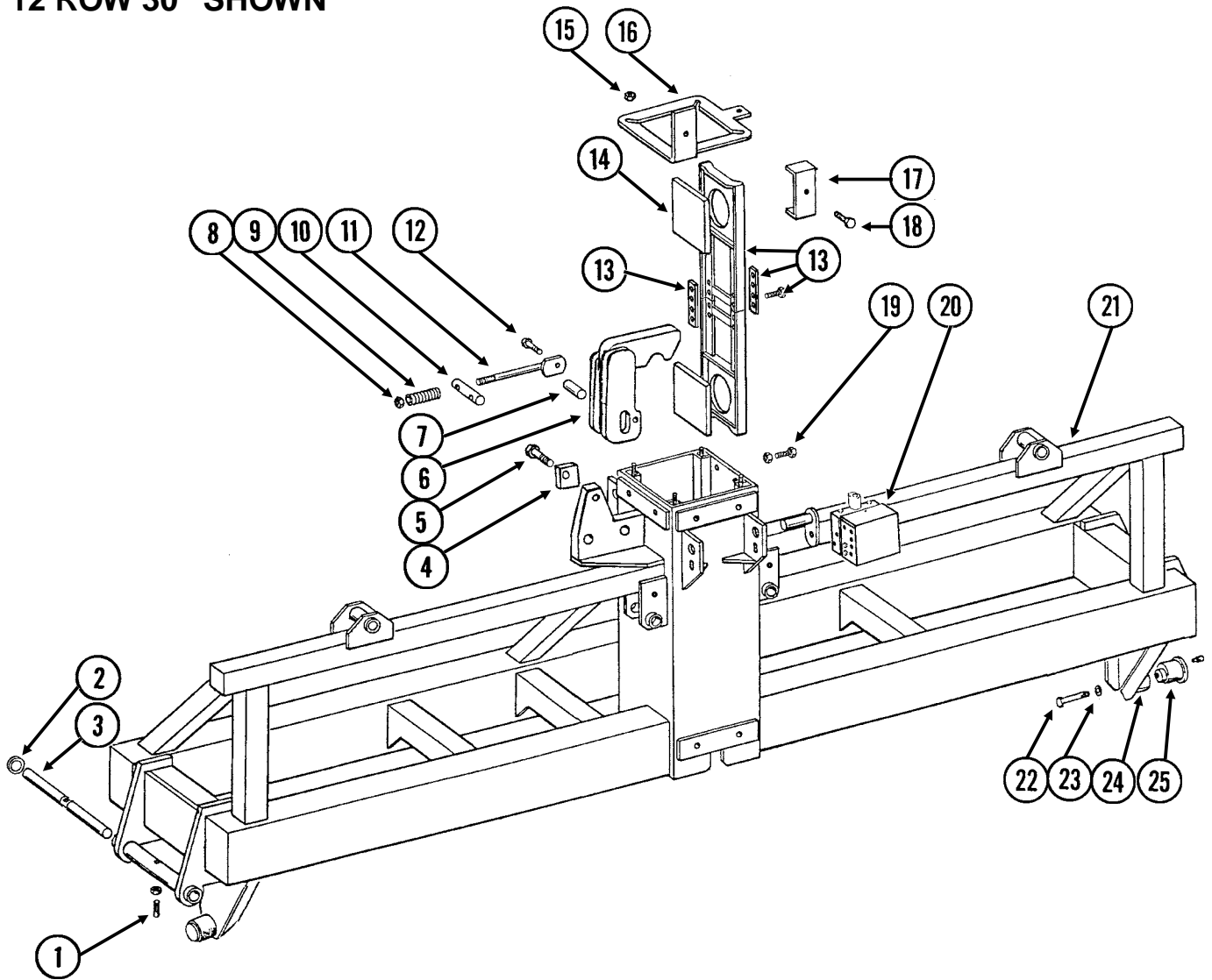

CENTER FRAME

ITEM	PART NO.	QTY.	DESCRIPTION
1.	G10102	1	Hex Nut, 1/2"-13
	G10828	1	Hex Socket Set Screw, 1/2"-13 x 1 1/4"
2.	G10404	-	Machine Bushing, 3 1/8" x 2 1/8" x 3/16" (As Required)
	G10234	-	Machine Bushing, 2 1/8", 10 Gauge (As Required)
	G10336	-	Machine Bushing, 2 1/8", 14 Gauge (As Required)
3.	GD10531	1	Hinge Pin, 2 1/8" x 25 3/4"
4.	GD10492	2	Adjustment Block
5.	G10085	-	Hex Head Cap Screw, 3/4"-10 x 3 3/4"
	G10218	-	Washer, 3/4" USS
	G10112	-	Lock Nut, 3/4"-10
6.	GA7390	-	Safety Hook
7.	GD9898	1	Pin, 1 1/4" x 2 15/16"
8.	G10205	2	Washer, 5/8" SAE
	G10107	2	Lock Nut, 5/8"-11
9.	GD10006	2	Spring
10.	GD9870	1	Pin, 1 1/4" x 6"
11.	GA6943	2	Spring Rod
12.	G10037	2	Hex Head Cap Screw, 1/2"-13 x 1 1/4"
	G10206	2	Washer, 1/2" SAE
	G10228	2	Lock Washer, 1/2"
	GD7904-02	2	Sleeve, 1/2" x 1/2" Long
13.	GA7579	4	Pad Holder W/Bars
	GD10706	-	Bar, 1 1/4" x 6" (1/4" Thick)
	GD10707	-	Bar, 1 1/4" x 6" (3/8" Thick)
	G10001	-	Hex Head Cap Screw, 3/8"-16 x 1"
14.	GD10053	8	Wear Pad, 7" x 7", 1/2" Thick
15.	GD7805	4	Special Washer, 5/8", Hardened
	G10104	4	Hex Nut, 5/8"-11
16.	GD9968	1	Cap
17.	GD8188	1	Hose Clamp, 7/8" x 3" x 5 3/8"
	GD8189	1	Rubber Pad
18.	G10053	1	Hex Head Cap Screw, 1/2"-13 x 2 1/2"
	G10228	1	Lock Washer, 1/2"
	G10102	1	Hex Nut, 1/2"-13
19.	G10543	16	Hex Head Cap Screw, 3/4"-10 x 3", Full Thread
	G10105	16	Hex Nut, 3/4"-10
20.		-	See "Valve Blocks - Located On Rear Center Frame", Page P95
21.	A7393	-	Frame W/Cam Follower Mounts, 136", 12 Row 30" And 16 Row 30" (Non-Stock Item)
	GA6929	-	Cam Follower Mount, L.H.
	GA6928	-	Cam Follower Mount, R.H.
22.	G10025	2	Hex Head Cap Screw, 3/4"-10 x 1 1/2"
23.	GD9052	2	Special Washer, 3/4" I.D. x 2" O.D., Hardened
24.	GD10532	2	Sleeve
25.	GA6497	2	Cam Follower W/Grease Fitting
	G10640	-	Grease Fitting, 1/4"-28

WING FRAME

(TWL180a/TWL139g)

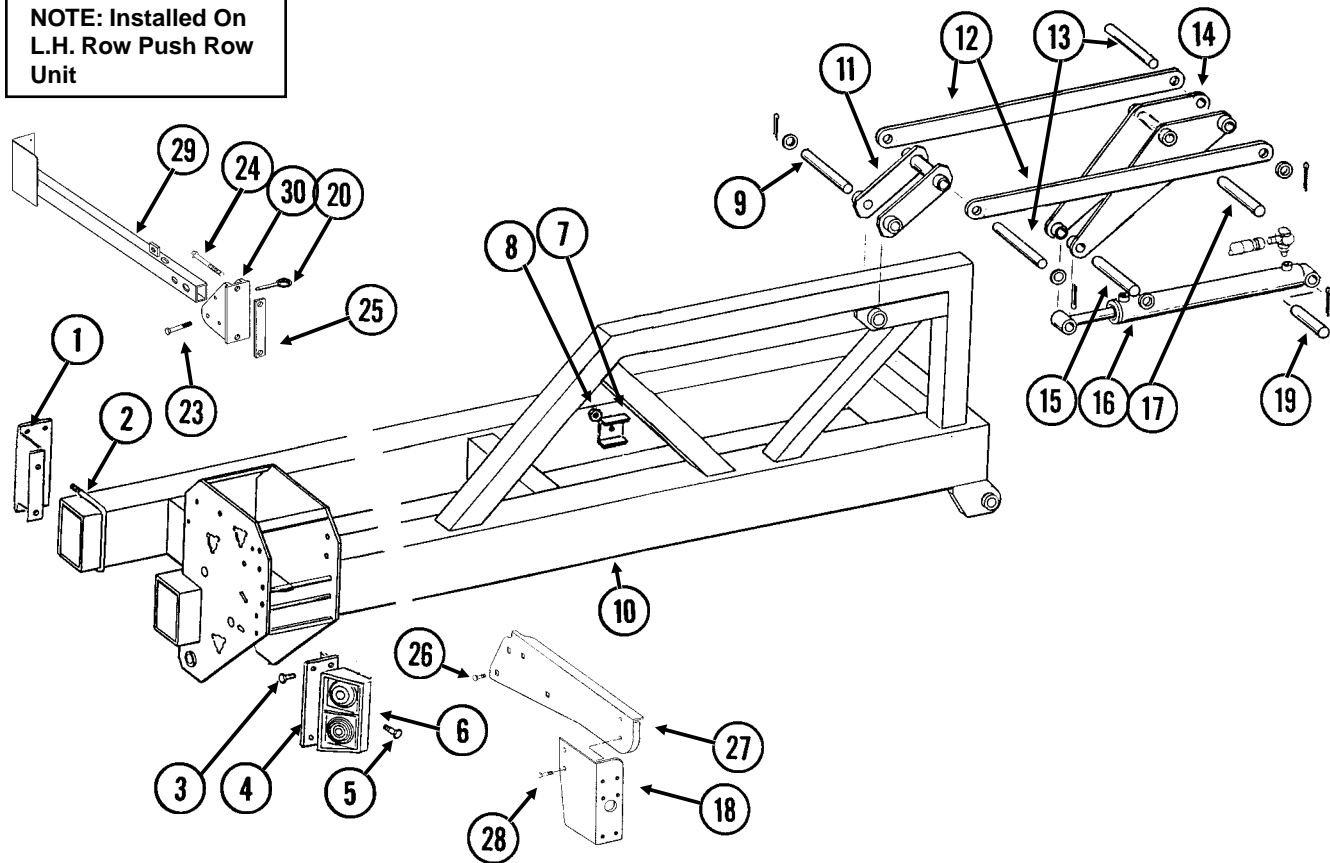
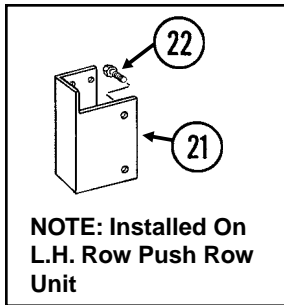

ITEM	PART NO.	QTY.	DESCRIPTION
1.	GA6792	1	Light Bracket (Wide Row Sizes Only)
2.	GD1113	1	U-Bolt, 5" x 7" x 5/8"-11
	G10230	2	Lock Washer, 5/8"
	G10104	2	Hex Nut, 5/8"-11
3.	G10001	2	Hex Head Cap Screw, 3/8"-16 x 1"
	G10210	1	Washer, 3/8" USS
	G10229	2	Lock Washer, 3/8"
	G10101	2	Hex Nut, 3/8"-16
4.	GD9681	1	Light Bracket (Wide Row Sizes Only)
5.	G10064	8	Hex Head Cap Screw, 1/4"-20 x 1"
	G10110	8	Lock Nut, 1/4"-20, Grade B
6.	-	-	See "Electrical Components", Pages P104 And P105

WING FRAME

ITEM	PART NO.	QTY.	DESCRIPTION
7.	GD5875	-	Hose Clamp, 9/16" x 2 1/2" x 2"
8.	G10108	-	Lock Nut, 3/8"-16
9.	GD9963	1	Pin, 1 1/4" x 9"
	G10460	2	Cotter Pin, 1/4" x 2"
10.	A6904	-	Wing, R.H., 119 1/4", 12 Row 30" (Non-Stock Item)
	A6905	-	Wing, L.H., 119 1/4", 12 Row 30" (Non-Stock Item)
	A6892	-	Wing, R.H., 179 1/4", 16 Row 30" (Two Wheel Towers Per Wing) (Non-Stock Item)
	A6893	-	Wing, L.H., 179 1/4", 16 Row 30" (Two Wheel Towers Per Wing) (Non-Stock Item)
11.	GA7018	1	Link
12.	GD9956	2	Strap, 41", 12 Row 30" And 16 Row 30"
13.	GD9964	2	Pin, 1 1/4" x 10 1/2"
	G10159	4	Machine Bushing, 1 1/4", 10 Gauge
	G10460	4	Cotter Pin, 1/4" x 2"
14.	GA7019	1	Toggle Link
15.	GD4108	1	Pin, 1 1/4" x 7"
	G10159	2	Machine Bushing, 1 1/4", 10 Gauge
	G10460	2	Cotter Pin, 1/4" x 2"
16.		-	See "Wing Lock Cylinder", Page P93
17.	GD9955	1	Pin, 1 1/4" x 7"
	G10606	2	Spring Pin, 1/4" x 2"
18.	GD12724	1	Bracket
19.	GD6136	2	Pin, 1 1/4" x 5"
	G10460	4	Cotter Pin, 1/4" x 2"
20.	G10874	1	Detent Pin, 1/2" x 3 1/2" Grip
21.	GA9130	1	Push Row Unit Light Bracket
22.	G10001	2	Hex Head Cap Screw, 3/8"-16 x 1"
	G10229	2	Lock Washer, 3/8"
	G10101	2	Hex Nut, 3/8"-16
23.	G10033	1	Hex Head Cap Screw, 1/2"-13 x 3 1/2"
	G10206	4	Washer, 1/2" SAE
	G10111	1	Lock Nut, 1/2"-13
24.	G10439	2	Hex Head Cap Screw, 5/8"-11 x 7"
	G10230	2	Lock Washer, 5/8"
	G10104	2	Hex Nut, 5/8"-11
25.	GD1908	1	Mounting Bracket
26.	G10312	2	Carriage Bolt, 5/16"-18 x 3/4"
	G10620	2	Serrated Flange Nut, 5/16"-18
27.	GD15950	1	Light Mount Extension
28.	G10064	2	Hex Head Cap Screw, 1/4"-20 x 1"
	G10227	2	Lock Washer, 1/4"
	G10103	2	Hex Nut, 1/4"-20
29.	GA9840	1	Light Bracket
30.	GB0309	1	Light Mount Bracket
A.	G7698X	-	Push Row Unit Mounted Light Bracket Package (Items 21 And 22 On This Page And 42" Harness Extension, Item 5 On Pages P104 And P105)

CENTER PIVOT

PFA067/PFA068(TWL7c)

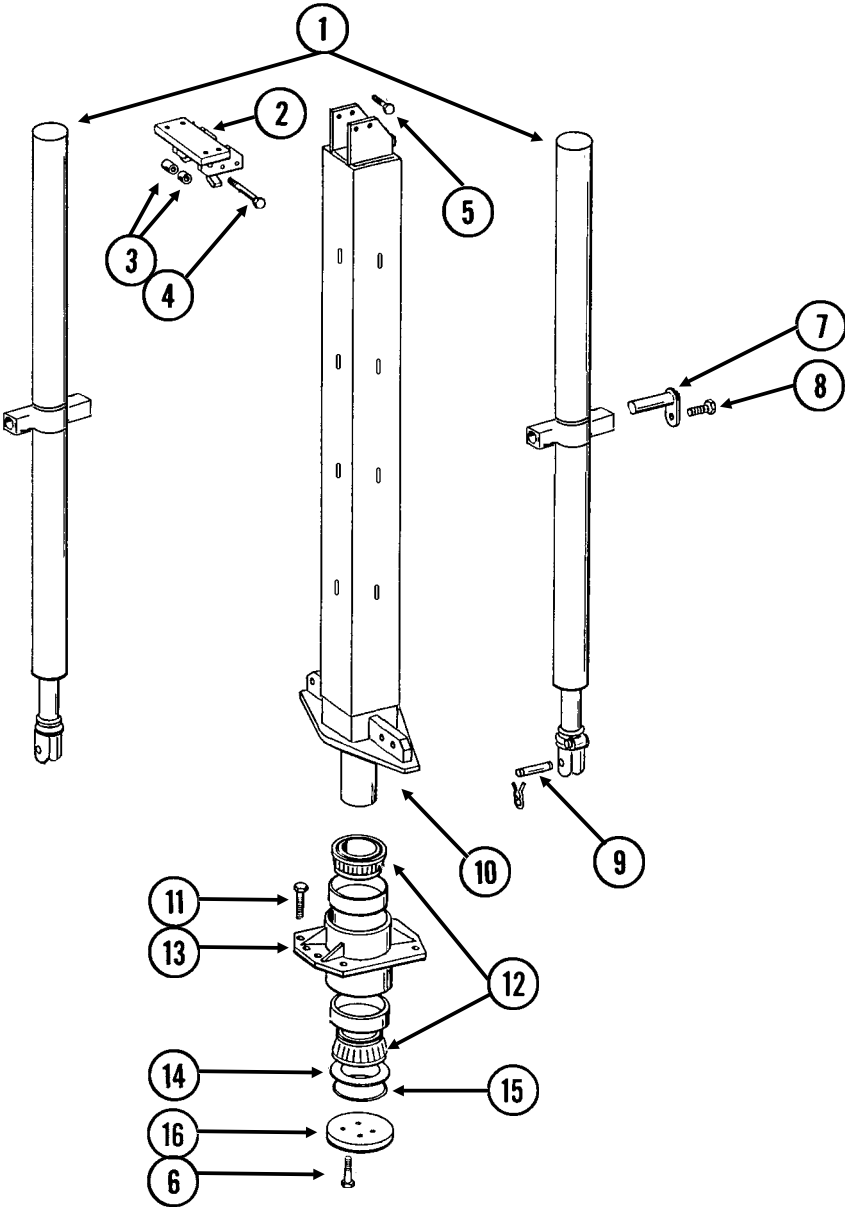

CENTER PIVOT

ITEM	PART NO.	QTY.	DESCRIPTION
1.		-	See "Center Lift Cylinder", Page P88
2.	GA6964	1	Hook Strap
3.	GD10447	1	Sleeve, 3 5/8"
	GD10446	1	Sleeve, 3 13/16"
4.	G10011	1	Hex Head Cap Screw, 5/8"-11 x 5 1/2"
	G10107	1	Lock Nut, 5/8"-11
5.	G10689	4	Carriage Bolt, 5/8"-11 x 2"
	G10107	4	Lock Nut, 5/8"-11
6.	G10027	4	Hex Head Cap Screw, 3/4"-10 x 2 1/2"
	GD2169	1	Special Washer, 25/32" I.D. x 1 1/4" O.D., Hardened
7.	GA5121	4	Pin, 2 1/8"
8.	G10017	4	Hex Head Cap Screw, 1/2"-13 x 1 1/2"
	G10216	4	Washer, 1/2" USS
	G10228	4	Lock Washer, 1/2"
	G10102	4	Hex Nut, 1/2"-13
9.	GR0375	2	Pin, 1" x 3 1/2"
	GR0193	4	Hair Pin Clip
10.	GA7540	1	Center Post
11.	G10441	8	Hex Head Cap Screw, 7/8"-9 x 3", Grade 8
	GD10063	8	Hardened Washer, 7/8"
	G11053	8	Hex Nut, 7/8"-9, Grade 8
12.	GA7096	2	Cone
13.	GA7067	1	Bearing Housing W/Cups, Less Grease Fitting
	GD10011	2	Cup
	G10779	1	Grease Fitting, 90°, 1/4"-28
14.	GD10012	-	Shim, .005" Thick (As Required)
	GD10013	-	Shim, .020" Thick (As Required)
	GD10014	-	Shim, .007" Thick (As Required)
15.	GD9130	1	O-Ring
16.	GD9636	1	Bearing Cap

AXLE ASSEMBLY

HTA043/HTA044/PFA071/PHA033/PHA034/PFA073(TWL140cc)

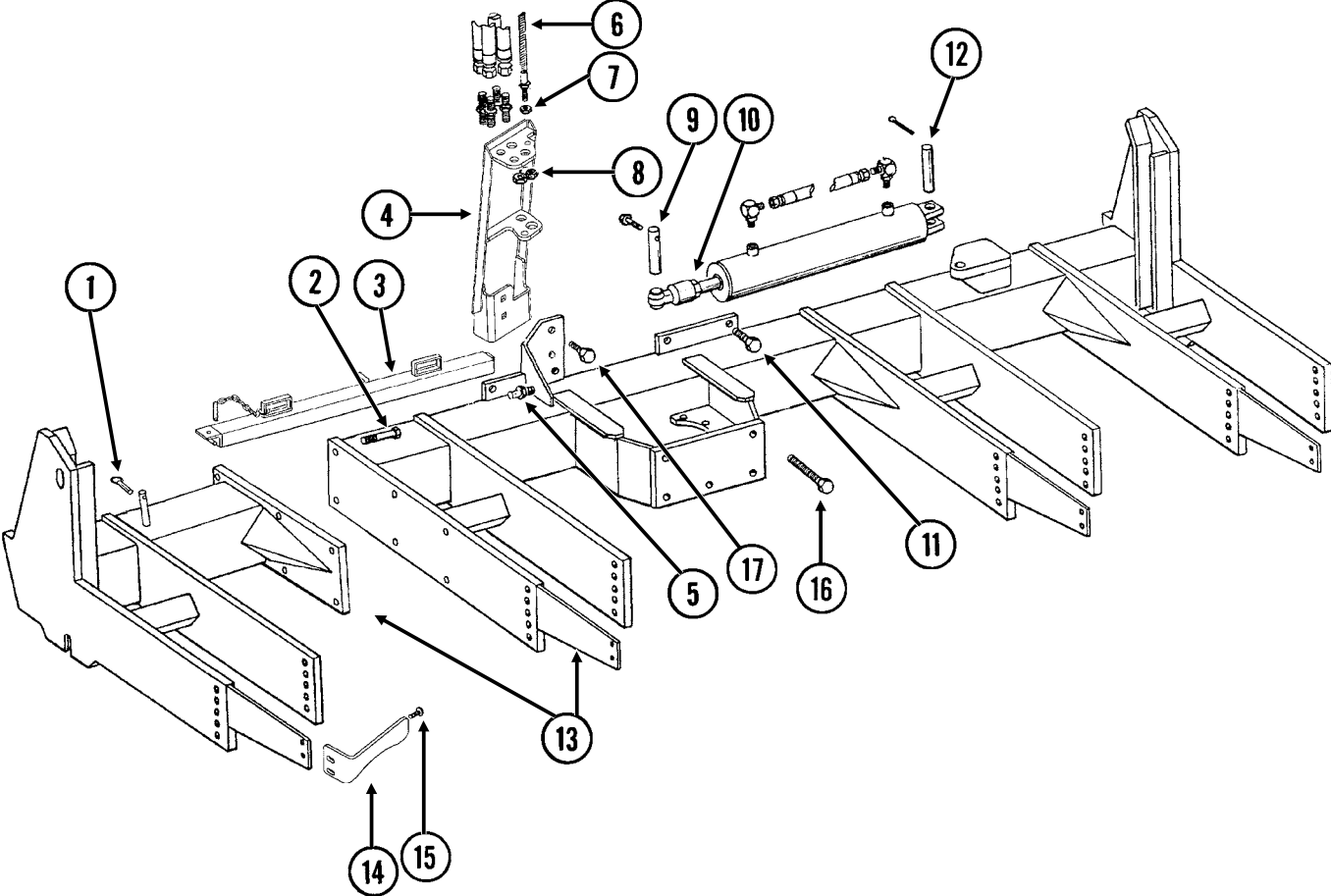

AXLE ASSEMBLY

ITEM	PART NO.	QTY.	DESCRIPTION
1.	GD2558	1	Lynch Pin, 1/4"
2.	G10802	6	Hex Head Cap Screw, 3/4"-10 x 2 3/4"
	G10028	-	Hex Head Cap Screw, 3/4"-10 x 3"
	G10231	6	Lock Washer, 3/4"
	G10105	6	Hex Nut, 3/4"-10
3.	GA7098	1	Manual Safety Lockup W/Detent Pin
	GA7022	1	Detent Pin W/Chain
4.	GA11200	1	Bulkhead Mount
5.	GD8276	1	Pin
	G10237	1	Lock Washer, 7/16"
	G10100	1	Hex Nut, 7/16"-14
6.	GA6608	-	Cable Assembly, 12 Row 30" And 16 Row 30"
7.	G10228	2	Lock Washer, 1/2"
	G10102	2	Hex Nut, 1/2"-13
8.	G306-08	2	Lock Nut, 3/4"-16
	G306-10	2	Lock Nut, 7/8"-14
9.	GD10092	1	Pin, 1 1/4" x 5 1/4"
	G10226	4	Washer, 1 1/4" SAE
	G10049	1	Hex Head Cap Screw, 3/8"-16 x 2 1/2"
	G10108	1	Lock Nut, 3/8"-16
10.		-	See "Rotation Cylinder", Page P88
11.	G10437	4	Hex Head Cap Screw, 3/4"-8 x 2 1/2", Grade 8, "Y" Hitch
	G10810	4	Hex Head Cap Screw, 3/4"-10 x 3 1/2", Grade 8, "T" Hitch
	GD2169	4	Special Washer, 25/32" I.D. x 1 1/4" O.D., Hardened
	G10436	4	Hex Nut, 3/4"-10
12.	GD10064	1	Pin, 1 1/4" x 5 1/4"
	G10460	2	Cotter Pin, 1/4" x 2"
13.	GA8062	-	Axle W/Stub Axle, 12 Row 30" And 16 Row 30"
	GA9883	-	Stub Axle, Narrow Row
14.	GD12543	-	Scraper
15.	G10636	-	Carriage Bolt, 1/2"-13 x 1 1/2"
	G10216	-	Washer, 1/2" USS
	G10228	-	Lock Washer, 1/2"
	G10102	-	Hex Nut, 1/2"-13
16.	G10808	6	Hex Head Cap Screw, 1"-8 x 10", Grade 8, "Y" Hitch
	GD10231	6	Special Washer, 1 1/16" I.D. x 2" O.D.
	G10647	6	Hex Nut, 1"-8, Grade 8
17.	G10636	-	Carriage Bolt, 1/2"-13 x 1 1/2"
	G10228	-	Lock Washer, 1/2"
	G10102	-	Hex Nut, 1/2"-13

TRANSPORT WHEELS/ROCK GUARDS

HTA032/HTA040/HTA043/HTA004(TWL141c)

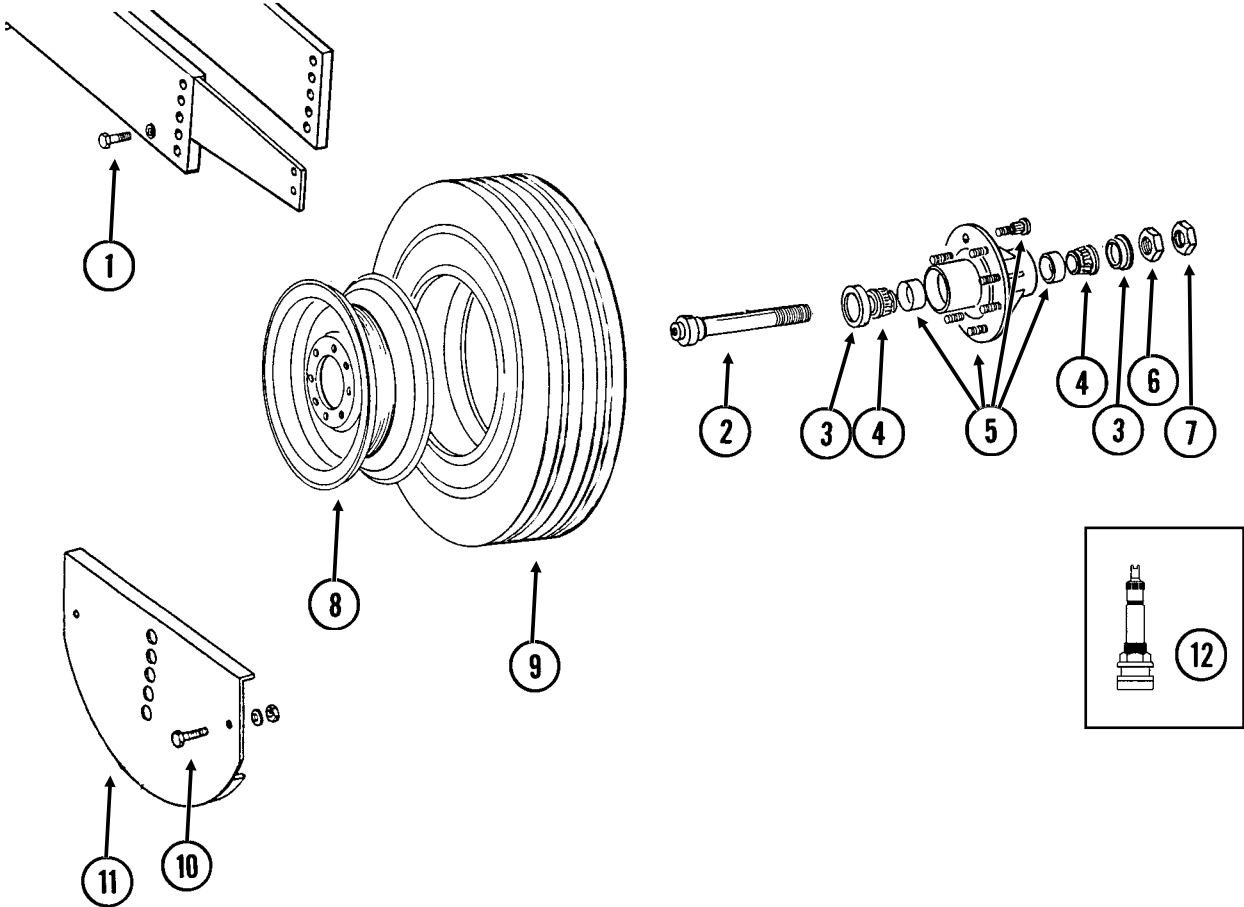

TRANSPORT WHEELS/ROCK GUARDS

ITEM	PART NO.	QTY. (Per Assy.)	DESCRIPTION
1.	G10448	2	Hex Head Cap Screw, 7/8"-9 x 2 1/2", Grade 8
	G10330	2	Lock Washer, 7/8"
2.	GA4727	1	Spindle W/Retaining Ring, 1 3/4"
	G10913	-	External Retaining Ring, 2 1/2"
3.	GA4722	2	Seal
4.	GA4723	2	Bearing
5.	GA4729	1	Hub W/Cups, Bolts, Nuts And Grease Fitting, 8 Bolt, 1 3/4" Bore
	G10640	-	Grease Fitting, 1/4"-28
	GD7079	-	Cup
	GR0528	-	Stud, 5/8"-18 x 2 1/4", Grade 8
	GR0531	-	Lug Nut, 5/8"-18 UNF
	GD7089	1	Special Nut, 1 3/4"-12 UNF
7.	GD7864	1	Special Hex Nut, 1 3/4"-12 UNF
8.	GA9544	-	Rim, 5.5" x 22.5", All Sizes
9.	GD13409	-	Tire, 255-70R 22.5" W/O Center Rib, Tubeless (Specify Brand*)
10.	G10037	-	Hex Head Cap Screw, 1/2"-13 x 1 1/4"
	G10228	-	Lock Washer, 1/2"
	G10102	-	Hex Nut, 1/2"-13
11.	GA5716	-	Rock Guard (Optional)
12.	GA7434	-	Valve Stem
A.	GA9545	-	Tire And Rim Assembly (Items 8, 9 And 12) (Specify Brand*)

* Specific brand requests will be supplied only as available from current KINZE® Repair Parts stock. If a specific brand requested is not in stock, the brand available will be supplied.

CONTACT WHEEL AND DRIVE SHAFT(S)

(PLTR155/TWL11e/TWL11k/PLTR150/TWL11f)

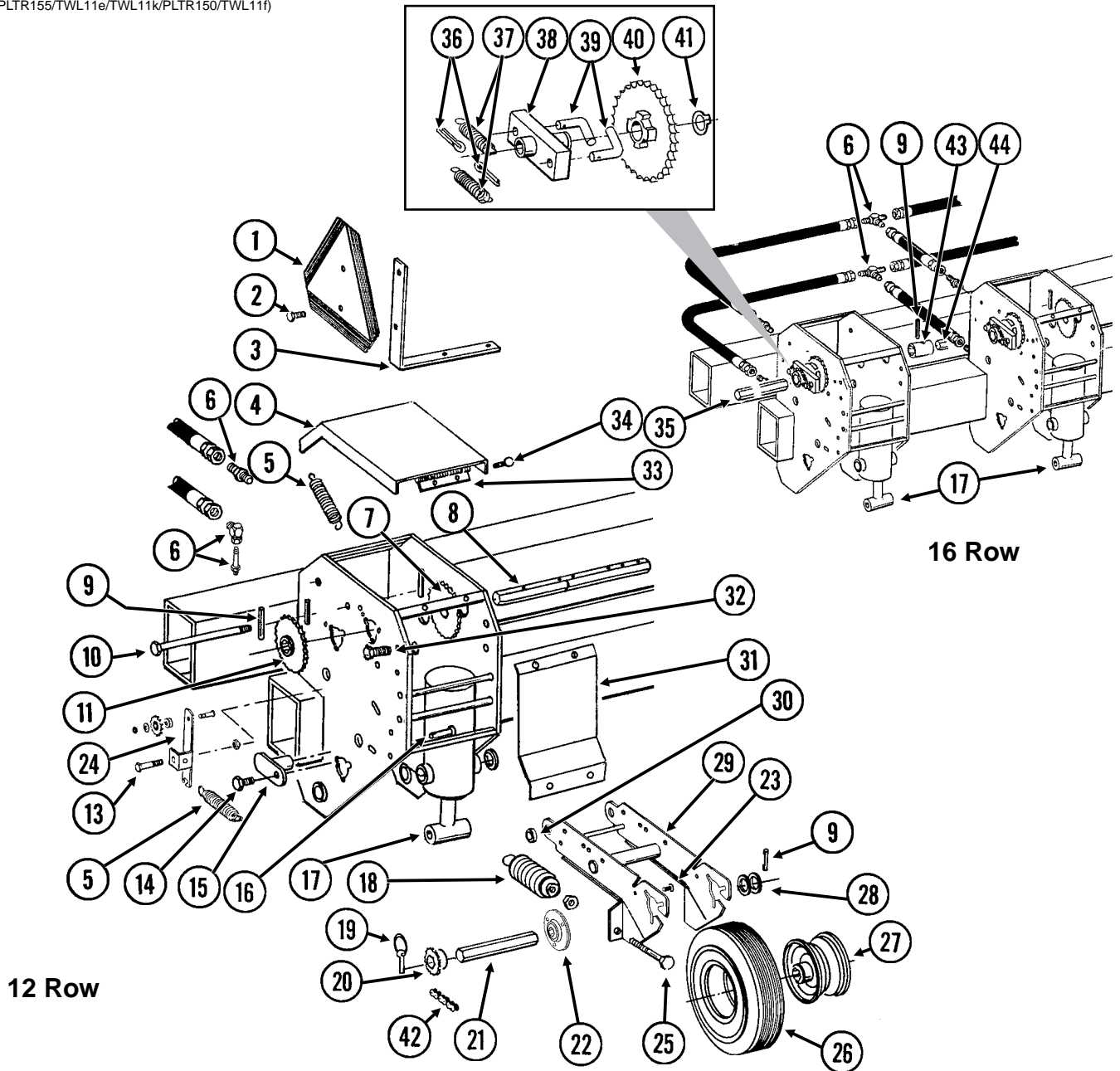

CONTACT WHEEL AND DRIVE SHAFT(S)

(TWL157/TWL156)

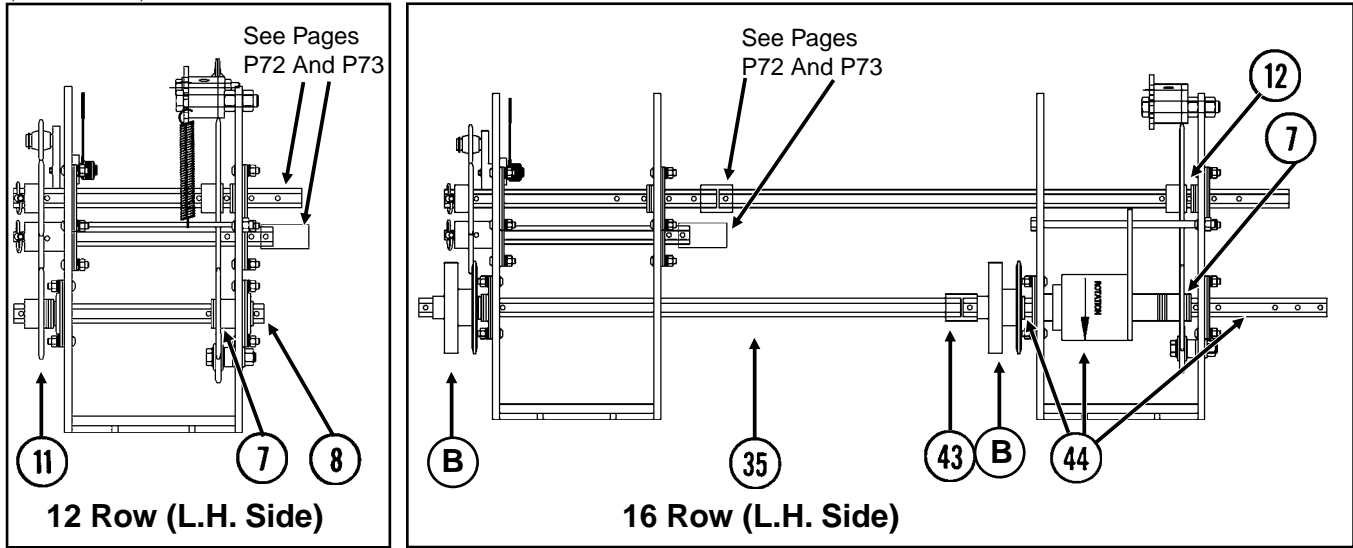

ITEM	PART NO.	QTY.	DESCRIPTION
------	----------	------	-------------

(Per Assy.)

1.	GD2199	1	SMV Sign
2.	G10022	2	Hex Head Cap Screw, 1/4"-20 x 1/2"
	G10227	2	Lock Washer, 1/4"
	G10103	2	Hex Nut, 1/4"-20
3.	GD9969	1	Bracket
4.	GD10298	1	Cover
5.	GD5857	2	Spring
6.		-	See "Hydraulic Hoses And Fittings On Planter Frame", Pages P102 And P103
7.		-	See "Inner Module Drive", Page P74 And P75
8.	GD10543	1	Hex Shaft, 7/8" x 13", See "Point Row Clutch", Pages P76 And P77 (12 Row Machines Equipped With Point Row Clutches)
9.	G10602	4	Spring Pin, 1/4" x 1 1/2"
10.	G10595	-	Hex Head Cap Screw, 3/8"-16 x 10" (Used To Secure Point Row Clutch)
	G10108	-	Lock Nut, 3/8"-16
11.	GA5114	1	Sprocket, 30 Tooth
12.	G10233	2	Machine Bushing, 1", 10 Gauge
	G10345	2	Machine Bushing, 1", 14 Gauge
13.	G10036	1	Hex Head Cap Screw, 5/8"-11 x 4"
	G10104	1	Hex Nut, 5/8"-11
	G10107	1	Lock Nut, 5/8"-11
14.	G10017	2	Hex Head Cap Screw, 1/2"-13 x 1 1/2"
	G10216	2	Washer, 1/2" USS
	G10228	2	Lock Washer, 1/2"
	G10102	2	Hex Nut, 1/2"-13
15.	GA5121	2	Pin, 2 1/8"
16.	G10870	1	Clevis Pin, 3/8" x 1"
	G10860	1	Retaining Ring, 3/8"
17.		-	See "Wing Lift Cylinder", Page P89
18.	GA2068	2	Spring W/Plug
19.	GD2558	1	Lynch Pin, 1/4"
20.	GA12192	1	Sprocket, 22 Tooth
	GA5113	1	Sprocket, 28 Tooth
	GA12191	-	Sprocket, 44 Tooth

(Continued On Following Page)

CONTACT WHEEL AND DRIVE SHAFT(S)

ITEM	PART NO.	QTY. (Per Assy.)	DESCRIPTION
(Continued)			
21.	GD6775	1	Hex Shaft, 7/8" x 11 3/4" (2 Holes)
22.	GA9846	-	Flanged Bearing, 7/8" Hex Bore
23.	G10303	6	Carriage Bolt, 5/16"-18 x 1"
	G10232	6	Lock Washer, 5/16"
	G10106	6	Hex Nut, 5/16"-18
24.	GA9553	1	Idler W/Sprocket And Hardware, L.H. Side Of Planter
	GA9554	-	Idler W/Sprocket And Hardware, R.H. Side Of Planter
	GA7154	-	Sprocket W/Bearing, 18 Tooth
	G10017	-	Hex Head Cap Screw, 1/2"-13 x 1 1/2"
	G10128	-	Machine Bushing, 1/2", 14 Gauge
	G10501	-	Hex Jam Nut, 1/2"-13, Grade 2
25.	G10890	2	Hex Head Adjusting Bolt, 1/2"-13 x 4", Grade 2
	G10501	2	Hex Jam Nut, 1/2"-13, Grade 2
26.	GD4700	1	Tire, 4.80" x 8", 4 Ply, Rib Implement (Specify Brand*)
27.	GA3553	1	Rim, 3.75" x 8"
	GD4701	-	Valve Stem
28.	G10233	-	Machine Bushing, 1", 10 Gauge
29.	GA7372	1	Wheel Arm
30.	GB0218	2	Bushing, 2 1/32" I.D. x 7/8" O.D. x 1 9/32" Long
31.	GD6895	1	Shield
32.	G10005	2	Hex Head Cap Screw, 5/8"-11 x 1 3/4"
	G10235	4	Machine Bushing, 7/8", 14 Gauge
	GD7805	2	Special Washer, 5/8", Hardened
	G10205	2	Washer, 5/8" SAE
	G10107	2	Lock Nut, 5/8"-11
33.	GD5789	1	Hinge, Female
	GD5790	1	Hinge W/Pins, Male
34.	G10064	6	Hex Head Cap Screw, 1/4"-20 x 1"
	G10209	4	Washer, 1/4" USS
	G10227	6	Lock Washer, 1/4"
	G10103	6	Hex Nut, 1/4"-20
35.	GD10099	-	Hex Shaft, 7/8" x 29 5/8"
36.	G10453	2	Cotter Pin, 3/16" x 1"
37.	GD1256	2	Spring
38.	GA0378	1	Block And Hub Assembly
39.	GD1255	2	L-Pin
40.	GA5165	1	Sprocket, 30 Tooth
41.	G10430	1	External Retaining Ring, 1 1/4"
42.	G3310-114	1	Chain, No. 40, 114 Pitch Including Connector Link (Used With 22 Tooth Sprocket)
	G3310-118	-	Chain, No. 40, 118 Pitch Including Connector Link (Used With 28 Tooth Sprocket)
	G3310-126	-	Chain, No. 40, 126 Pitch Including Connector Link (Used With 44 Tooth Sprocket)
	GR0912	-	Connector Link, No. 40
43.	GD5212	1	Coupler, 1 3/4", 16 Row 30" Only
44.		-	See "Point Row Clutch", Pages P76-P79
A.	GA3552	-	Tire And Rim Assembly (Items 26 And 27) (Specify Brand*)
B.	GA5164	-	Ratchet/Sprocket Assembly, L.H. Side Of Planter (Items 36-41)
	GA9843	-	Ratchet/Sprocket Assembly, R.H. Side Of Planter (Items 36-41)
C.	G1K324	-	Contact Wheel Arm Replacement Kit (Items 9, 21-23, 25, 28 And 29)

* Specific brand requests will be supplied only as available from current KINZE® Repair Parts stock. If a specific brand requested is not in stock, the brand available will be supplied. Different brand tires may have different diameters. Change in tire brand may affect rates. Field checks are recommended after any change in contact tires.

GROUND DRIVE WHEEL

PTD057(TWL142G/TWL142D)

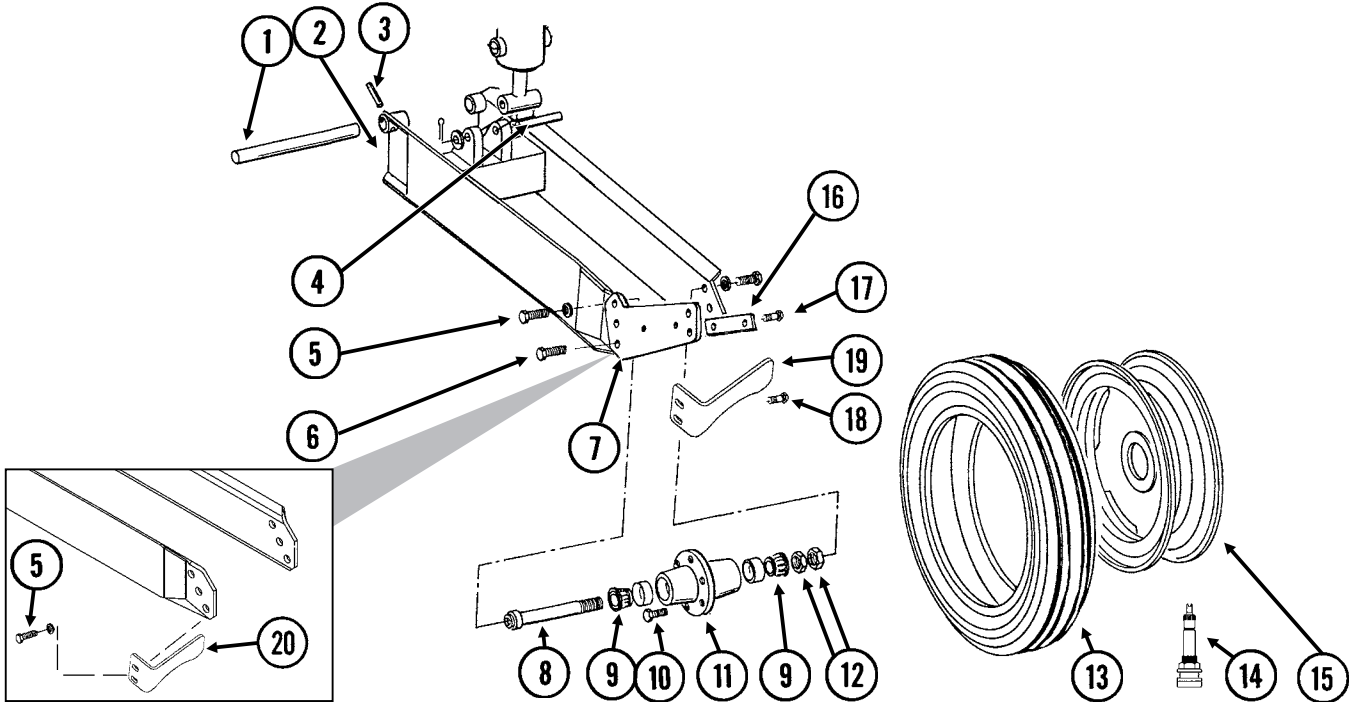

ITEM	PART NO.	QTY. (Per Assy.)	DESCRIPTION
1.	GD11695	-	Pin, 1 1/4" x 13 1/4"
2.	GA8677	1	Wheel Module
3.	G10610	-	Spring Pin, 3/8" x 2"
4.	GD5841	1	Pin, 1 1/4" x 5 5/8"
	G10226	2	Washer, 1 1/4" SAE
	G10460	2	Cotter Pin, 1/4" x 2"
5.	G10026	2	Hex Head Cap Screw, 3/4"-10 x 2"
	G10231	2	Lock Washer, 3/4"
6.	G10026	2	Hex Head Cap Screw, 3/4"-10 x 2"
	G10231	2	Lock Washer, 3/4"
	G10105	2	Hex Nut, 3/4"-10
7.	GD10128	1	Scraper Arm
8.	GA4376	1	Spindle W/Round External Retaining Ring, 10"
	GD11490	-	Round External Retaining Ring
9.	GA0895	2	Bearing
10.	GR0270	6	Lug Bolt, 9/16"-18
11.	GA2148	1	Hub W/Cups, 6 Bolt
	GR0434	-	Cup
12.	G11081	2	Hex Jam Nut, 1 1/2"-12, Grade 2
13.	GD13401	1	Tire, 7.50" x 20", 8 Ply, Tubeless W/O Center Rib (Specify Brand*)
14.	GA7434	-	Valve Stem
15.	GA2908	1	Rim, 5.5" x 20"
16.	GD10144	1	Bar Clamp
17.	G10017	2	Hex Head Cap Screw, 1/2"-13 x 1 1/2"
	G10039	1	Hex Head Cap Screw, 1/2"-13 x 1 3/4"
	G10228	2	Lock Washer, 1/2"
	G10102	2	Hex Nut, 1/2"-13
18.	G10636	2	Carriage Bolt, 1/2"-13 x 1 1/2"
	G10216	2	Washer, 1/2" USS
	G10228	2	Lock Washer, 1/2"
	G10102	2	Hex Nut, 1/2"-13
19.	GD12543	1	Scraper
20.	GA13335	1	Scraper
A.	GA7997	-	Tire And Rim Assembly (Specify Brand*) (Items 13-15)
B.	GA4377	-	Hub And Spindle Assembly (Items 8, 9, 11 And 12)

* Specific brand requests will be supplied only as available from current KINZE® Repair Parts stock. If a specific brand requested is not in stock, the brand available will be supplied.

SEED RATE TRANSMISSION AND ROW UNIT DRILL SHAFTS

(TWL14n)

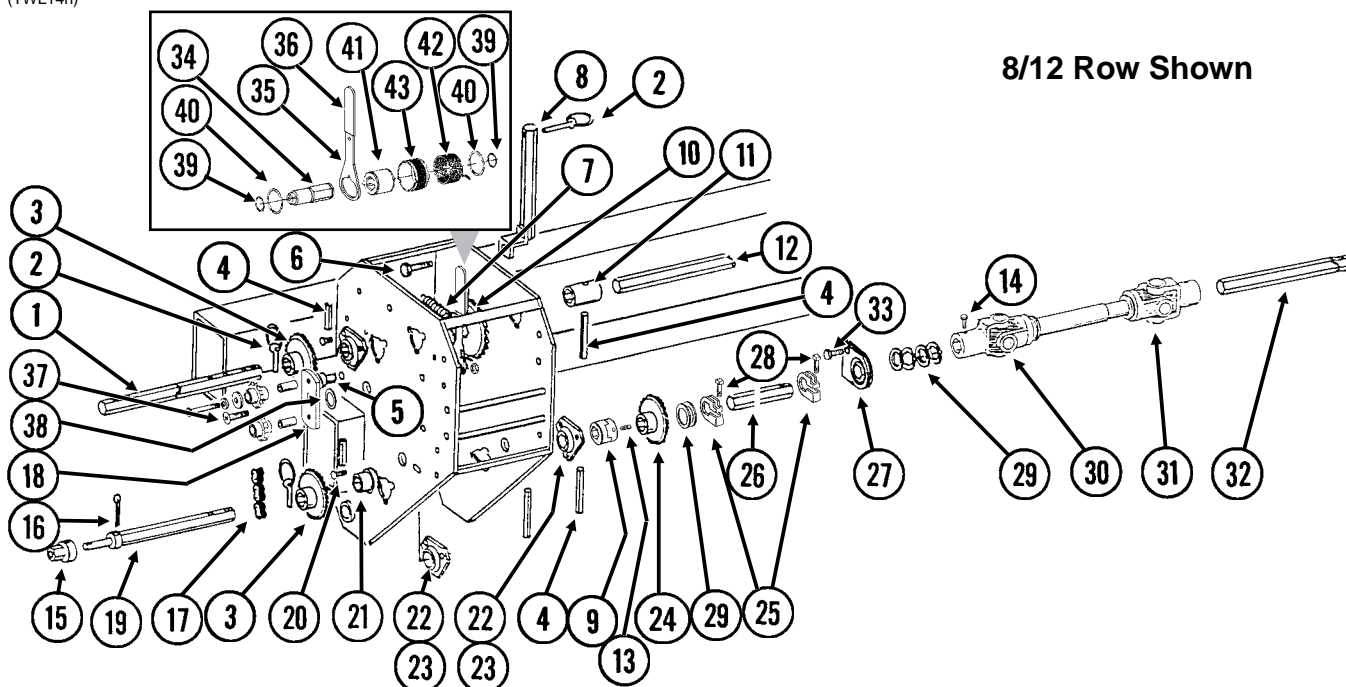

ITEM	PART NO.	QTY. (Per Side)	DESCRIPTION
1.	GD6780	1	Shaft, 7/8" x 15"
2.	GD2558	3	Lynch Pin, 1/4"
3.	GA5105	1	Sprocket, 15 Tooth
	GA5106	1	Sprocket, 17 Tooth
	GA5107	2	Sprocket, 19 Tooth
	GA5108	2	Sprocket, 23 Tooth
	GA5109	1	Sprocket, 24 Tooth
	GA5110	1	Sprocket, 25 Tooth
	GA5111	1	Sprocket, 26 Tooth
	GA5112	1	Sprocket, 27 Tooth
	GA5113	1	Sprocket, 28 Tooth
	GA5114	1	Sprocket, 30 Tooth
4.	G10602	-	Spring Pin, 1/4" x 1 1/2"
5.	G10870	1	Clevis Pin, 3/8" x 1"
	G10860	1	Retaining Ring, 3/8"
6.	G10581	1	Hex Head Cap Screw, 1/2"-13 x 2 1/4"
	GD4887-14	1	Sleeve, 1" O.D. x 9/16" I.D. x 7/8"
	G10527	2	Lock Washer, 1/2", Internal/External
	G10111	1	Lock Nut, 1/2"-13
7.	GD5857	1	Spring
8.	GA10832	1	Sprocket Storage Rod
9.	GB0287	2	Coupler
10.		-	See "Inner Module Drive", Page P74 And P75
11.	GD5212	1	Coupler, 1 3/4", 16 Row 30" Only
12.	GD10100	1	Hex Shaft, 7/8" x 31 3/8", 16 Row 30" Only
13.	G10131	4	Square Head Set Screw, 5/16"-18 x 3/4"
14.	G10688	-	Square Head Set Screw, 3/8"-16 x 5/8"
15.	GD7127	1	Shear Coupler
16.	G10462	-	Cotter Pin, 3/16" x 2"
17.	G3310-80	1	Chain, No. 40, 80 Pitch Including Connector Link
	GR0912	-	Connector Link, No. 40
18.	GA7336	1	Idler W/Bolt-On Sprockets
	GD7426	-	Sprocket, 12 Tooth
	G10047	-	Hex Head Cap Screw, 3/8"-16 x 1 3/4"
	GD1026	-	Sleeve, 1 3/16" Long
	G10210	-	Washer, 3/8" USS
	G10229	-	Lock Washer, 3/8"

SEED RATE TRANSMISSION AND ROW UNIT DRILL SHAFTS

ITEM	PART NO.	QTY. (Per Side)	DESCRIPTION
19.	GD7612	1	Shaft, 7/8" x 13 1/2"
20.	G10303	-	Carriage Bolt, 5/16"-18 x 1"
	G10232	-	Lock Washer, 5/16"
	G10106	-	Hex Nut, 5/16"-18
21.	GA5548	1	Special Bearing
22.	G3400-01	-	Flangette
23.	G2100-03	-	Bearing, 7/8" Hex Bore, Spherical
24.	GA5107	1	Sprocket, 19 Tooth, Interplant® Package Drive
25.	GD11045	-	Lock Clamp
26.	GD0914-106.5	-	Hex Shaft, 7/8" x 106 1/2" (No Holes), Wing, 12 Row 30"
	GD0914-166.75	-	Hex Shaft, 7/8" x 166 3/4" (No Holes), Wing, 16 Row 30"
27.	GA2180	-	Hanger Bearing, 7/8" Hex Bore
28.	G10130	-	Square Head Machine Bolt, 5/16"-18 x 1 3/4"
	G10923	-	Flange Nut, 5/16"-18, No Serration
29.	G10233	-	Machine Bushing, 1", 10 Gauge
30.	GA7053	1	U-Joint W/Grease Fitting, Female, 18 1/8" Long, 8 Row 36"/38" And 12 Row 36"/38"
	GA7052	-	U-Joint W/Grease Fitting, Female, 10 1/4" Long, 12 Row 30" And 16 Row 30"
	GR1557	-	Grease Fitting, 45°, Metric
	GR1298	-	Inboard Yoke And Outer Profile (18 1/4" U-Joint)
	GR1297	-	Inboard Yoke And Outer Profile (10 1/4" U-Joint)
	GR1294	-	Cross And Bearing Kit
	GR1293	-	Yoke, 7/8" Hex
31.	GA7051	-	U-Joint W/Grease Fitting, Male, 12 1/4" Long
	GR1557	-	Grease Fitting, 45°, Metric
	GR1296	-	Inner Profile
	GR1295	-	Inboard Yoke
	GR1301	-	Spring Pin, 8 mm x 50 mm
	GR1294	-	Cross And Bearing Kit
	GR1293	-	Yoke, 7/8" Hex
32.	GD0914-45	1	Hex Shaft, 7/8" x 45" (No Holes), R.H. Main Frame, 12 Row 30" And 16 Row 30"
	GD0914-35	-	Hex Shaft, 7/8" x 35" (No Holes), L.H. Main Frame, 12 Row 30" And 16 Row 30"
33.	G10004	2	Hex Head Cap Screw, 3/8"-16 x 1 1/4"
	G10229	2	Lock Washer, 3/8"
	G10101	-	Hex Nut, 3/8"-16
34.	GD14426	1	Tightener Shaft, 3 3/8"
35.	GD14431	1	Handle
36.	G11078	1	Vinyl Cap
37.	G11100	1	Hex Socket Button Head Cap Screw, 1/4"-20 x 1/2", Grade 8
	G10227	1	Lock Washer, 1/4"
	G10209	1	Washer, 1/4" USS
38.	G10235	1	Machine Bushing, 7/8", 14 Gauge
39.	G10496	2	External Inverted Snap Ring, 1 1/2"
40.	G11075	2	External Inverted Snap Ring, 7/8"
41.	GD14432	1	Sleeve, 1 1/4"
42.	GD14414	1	Torsion Spring, R.H. (Used In L.H. Wrap Spring Wrench)(Shown)
	GD14413	-	Torsion Spring, L.H. (Used In R.H. Wrap Spring Wrench)
43.	GD19344	-	Release Collar, L.H. (Shown)
	GD19343	1	Release Collar, R.H.
A.	G1K269	-	Lock Clamp Kit (Items 25 And 28)
B.	G1K381	-	Wrap Spring Wrench Replacement Kit, Silver Collar, L.H. (Items 34-43) (Shown)
	G1K380	1	Wrap Spring Wrench Replacement Kit, Gold Collar, R.H. (Items 34-43)

INNER MODULE DRIVE

PTD058/PFA046/PTD077(TWL16e)

16 Row

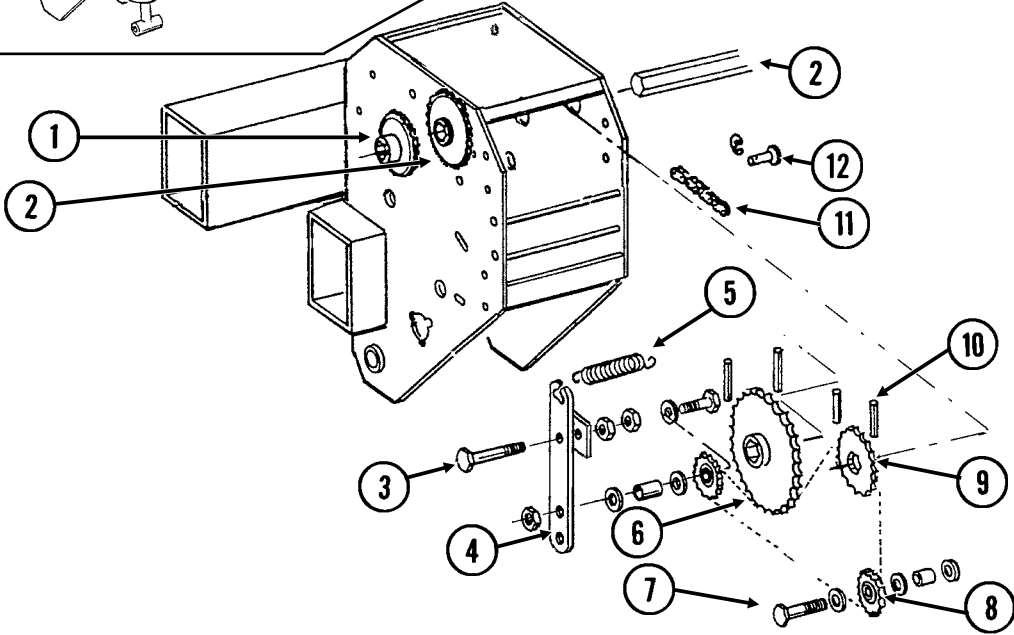
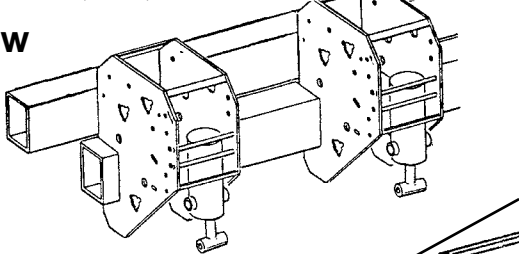

INNER MODULE DRIVE

ITEM	PART NO.	QTY.	DESCRIPTION
		(Per Module)	
1.		-	See "Seed Rate Transmission And Row Unit Drill Shafts", Pages P72 And P73
2.		-	See "Contact Wheel And Drive Shaft(s)", Pages P68-P70
3.	G10743	1	Hex Head Cap Screw, 5/8"-11 x 3 3/4"
	G10918	3	Machine Bushing, 5/8", 14 Gauge (As Required)
	G10503	1	Hex Jam Nut, 5/8"-11, Grade 2
	G10107	1	Lock Nut, 5/8"-11
4.	GA9558	1	Idler W/Sprocket And Hardware, L.H. Side Of Planter
	GA9557	-	Idler W/Sprocket And Hardware, R.H. Side Of Planter
	GA7154	-	Sprocket W/Bearing, 18 Tooth
	G10038	-	Hex Head Cap Screw, 1/2"-13 x 3"
	GD10007	-	Spacer, 1 1/8"
	G10206	-	Washer, 1/2" SAE
	G10111	-	Lock Nut, 1/2"-13
5.	GD5857	1	Spring
6.	GA5194	1	Sprocket, 50 Tooth
7.	G10581	1	Hex Head Cap Screw, 1/2"-13 x 2 1/4"
	GD7889	1	Bushing, 1" O.D. x 9/16" I.D. x 7/16" Long
	G10168	2	Machine Bushing, 1/2", 7 Gauge
	G10205	2	Washer, 5/8" SAE
	G10111	1	Lock Nut, 1/2"-13
8.	GA7154	1	Sprocket W/Bearing, 18 Tooth
9.	GA5113	1	Sprocket, 28 Tooth
10.	G10602	-	Spring Pin, 1/4" x 1 1/2"
11.	G3310-100	1	Chain, No. 40, 100 Pitch Including Connector Link
	GR0912	-	Connector Link, No. 40
12.	G10870	1	Clevis Pin, 3/8" x 1"
	G10860	1	Retaining Ring, 3/8"

POINT ROW CLUTCH

PRC019(TWL70d/TWL71d/TWL71/TWL18/
A10054)

**L.H. Point Row Clutch Shown
(Used On L.H. Side Of Planter)**

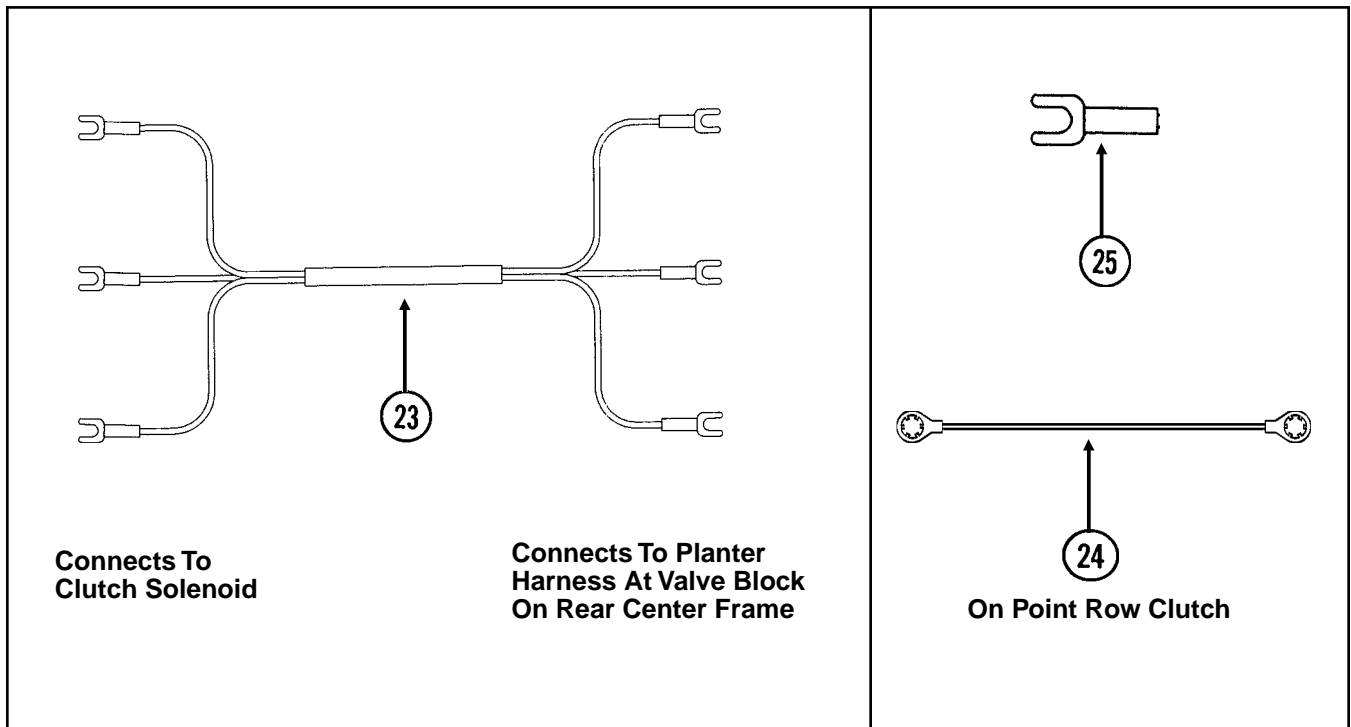
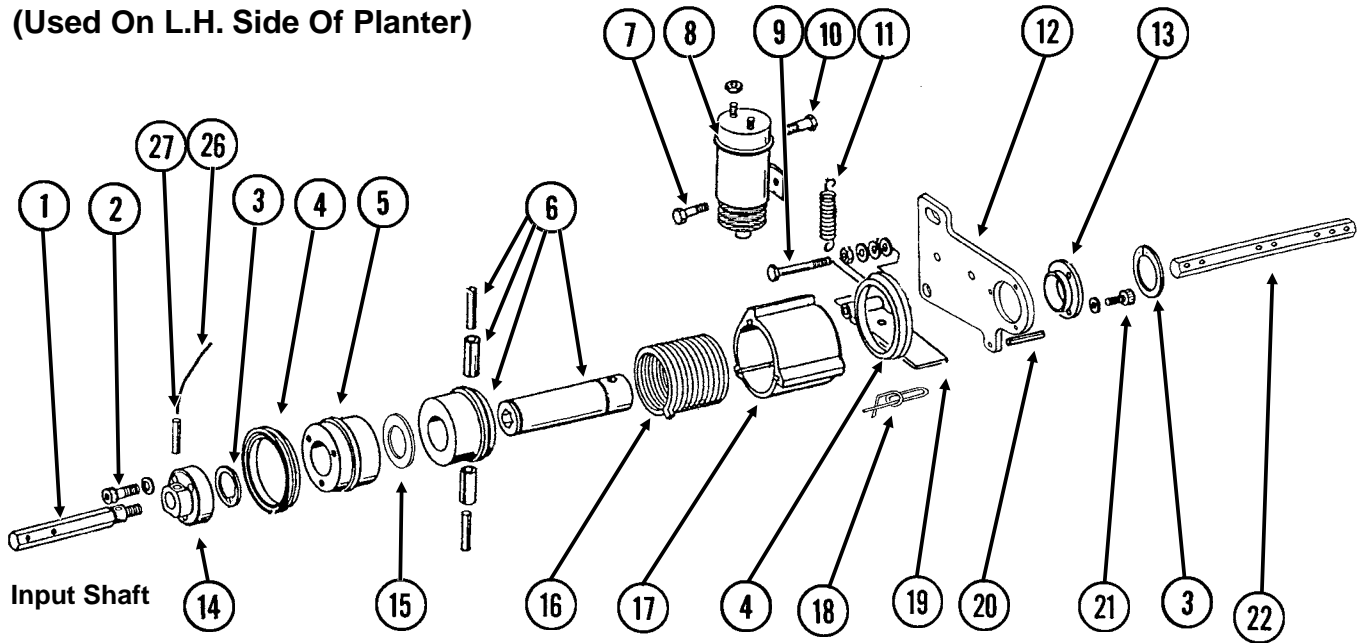

POINT ROW CLUTCH

ITEM	PART NO.	QTY. (Per Assy.)	DESCRIPTION
1.	GD10068	1	Input Shaft, R.H. Threads (Shown)
	GD10069	1	Input Shaft, L.H. Threads
2.	G10374	3	Hex Socket Head Cap Screw, 1/4"-20 x 1"
	G10227	3	Lock Washer, 1/4"
3.	G10496	2	External Inverted Snap Ring, 1 1/2"
4.	GD14512	2	V-Ring Seal
5.	GD10104	1	Input Hub
6.	GA7137	1	Hub/Sleeve Assembly W/Spring Pins
	G10765	-	Spring Pin, 1/4" x 1"
	G10804	-	Spring Pin, 5/32" x 7/8"
7.	G10023	1	Hex Head Cap Screw, 1/4"-20 x 3/4"
	G10227	1	Lock Washer, 1/4"
	G10103	1	Hex Nut, 1/4"-20
8.	GA8393	1	Solenoid Complete
	GR1306	1	Snap Ring
	GR1303	1	Spring
	GR1304	1	Boot
	GR1305	1	Plunger
9.	G10049	1	Hex Head Cap Screw, 3/8"-16 x 2 1/2"
	G10101	1	Hex Nut, 3/8"-16
	G10203	1	Washer, 3/8" SAE
	G10229	2	Lock Washer, 3/8"
	G10497	1	Hex Jam Nut, 3/8"-16, Grade 2
10.	G10900	1	Hex Socket Head Cap Screw, 1/4"-20 x 1 3/4", Grade 8
	G10227	1	Lock Washer, 1/4"
	G10103	2	Hex Nut, 1/4"-20
11.	GD10123	1	Spring
12.	GD10103	1	Mounting Plate
13.	GD9667	1	Bushing
14.	GD10070	1	Coupler W/R.H. Threads (Shown)
	GD10071	1	Coupler W/L.H. Threads
15.	GD14513	1	Felt Washer
16.	GD9671	-	Spring, L.H. (Shown)
	GD9672	-	Spring, R.H.
17.	GD10102	1	Stop Collar
18.	GD11120	1	Rue Ring Cotter, 5/16"
19.	GD10510	1	Actuator Arm
20.	G10859	1	Spring Pin, 3/16" x 2 1/4"
21.	G10253	3	Hex Socket Head Screw, No. 10-32 x 1/2"
	G10257	3	Lock Washer, No. 10
22.	GD10543	-	Hex Shaft, 7/8" x 13"
23.	GA9479	1	Wiring Harness, 228", R.H. Side, 12 Row 30"
	GA9480	-	Wiring Harness, 264", L.H. Side, 12 Row 30"
	GA9483	-	Wiring Harness, 252", R.H. Side, 16 Row 30"
	GA9482	-	Wiring Harness, 300", L.H. Side, 16 Row 30"
24.	GA10054	-	Ground Cable, Green
25.	G10996	-	Fork Terminal
26.	GD13524-01	1	Lock Wire, 10", Stainless Steel
27.	G10546	1	Spring Pin, 3/16" x 1 1/4"
A.	GA7110	-	Point Row Clutch Assembly, R.H. (R.H. Side Of Machine) (Items 1-21, 24, 26 And 27)
	GA7111	-	Point Row Clutch Assembly, L.H. (L.H. Side Of Machine) (Items 1-21, 24, 26 And 27)

TWO-SPEED POINT ROW CLUTCH

PRC023(FF47b/A7274/TWL71/TWL18/A10054)

**L.H. Two-Speed Point Row Clutch Shown
(Used On L.H. Side Of Planter)**

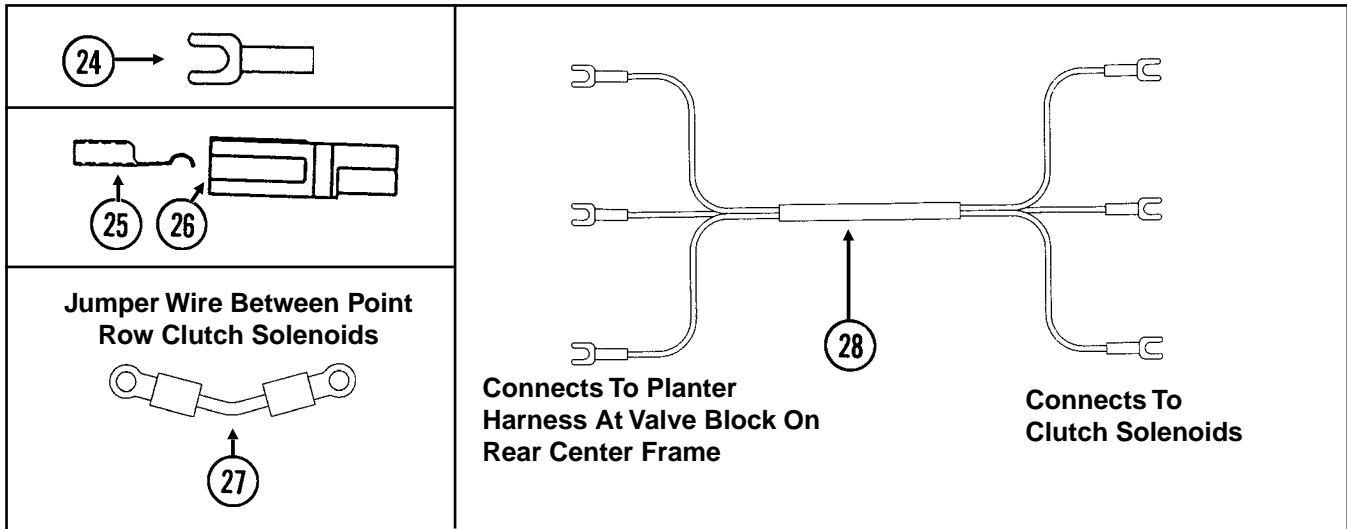
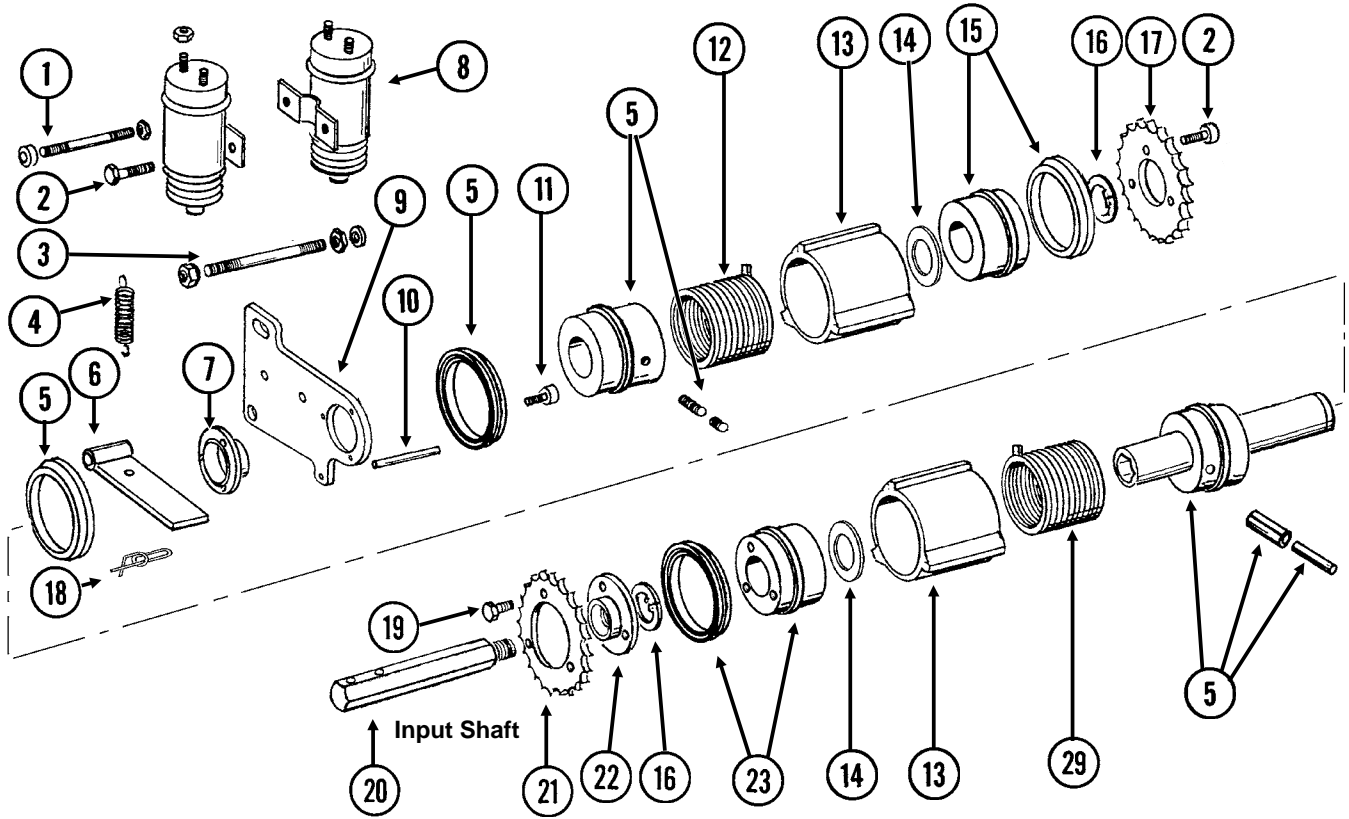

TWO-SPEED POINT ROW CLUTCH

ITEM	PART NO.	QTY. (Per Assy.)	DESCRIPTION
1.	GD10635	1	Threaded Rod, 1/4"-20 x 3 1/2"
	G10103	2	Hex Nut, 1/4"-20
	G10227	2	Lock Washer, 1/4"
	GD10282	2	Allen Nut, 1/4"-20
2.	G10023	4	Hex Head Cap Screw, 1/4"-20 x 3/4"
	G10227	4	Lock Washer, 1/4"
	G10103	1	Hex Nut, 1/4"-20
3.	GD10636	1	Threaded Rod, 3/8"-16 x 4 1/2"
	G10108	2	Lock Nut, 3/8"-16
	G10229	2	Lock Washer, 3/8"
	G10101	2	Hex Nut, 3/8"-16
4.	GD10123	2	Spring
5.	GA7463	1	Hub/Sleeve Assembly W/Seals, Sleeve, Pins And Screws
	GD10120	-	Seal
	GD10584	-	Sleeve
	G10873	-	Hex Socket Set Screw, 5/16"-18 x 3/4"
	G10872	-	Hex Socket Set Screw, 5/16"-18 x 1/4"
	G10804	-	Spring Pin, 5/32" x 7/8"
	G10765	-	Spring Pin, 1/4" x 1"
6.	GD10510	2	Actuator Arm
7.	GD10586	1	Bushing
8.	GA8393	2	Solenoid Complete
	GR1306	-	Snap Ring
	GR1303	-	Spring
	GR1304	-	Boot
	GR1305	-	Plunger
9.	GD10103	1	Mounting Plate
10.	G10859	1	Spring Pin, 3/16" x 2 1/4"
11.	G10876	3	Hex Socket Head Screw, No. 10-32 x 1/4"
12.	GD9671	2	Spring, L.H. (Shown)
13.	GD10585	2	Stop Collar
14.	GD14513	2	Felt Washer
15.	GA9572	1	Hub W/Seal
	GD10120	-	Seal
16.	G10496	2	External Inverted Snap Ring, 1 1/2"
17.	GD10579	1	Output Sprocket, 28 Tooth
18.	GD11120	2	Rue Ring Cotter, 5/16"
19.	G10374	3	Hex Socket Head Cap Screw, 1/4"-20 x 1"
	GD10588	3	Key
20.	GD10068	1	Input Shaft, R.H. Threads (Shown)
	GD10069	-	Input Shaft, L.H. Threads
21.	GD10578	1	Input Sprocket, 28 Tooth
22.	GD10638	1	Coupler W/R.H. Threads (Shown)
	GD10587	-	Coupler W/L.H. Threads
23.	GA9571	1	Hub W/Seal
	GD10120	-	Seal
24.	G10996	-	Fork Terminal
25.	GD9530	-	Contact
26.	GD9529	-	Housing, Black
	GD12726	-	Housing, Red
27.	GA7274	1	Jumper Wire W/Ring Terminals, 2 3/16"
28.	GA9479	1	Wiring Harness, 228", R.H. Side, 12 Row 30"
	GA9480	-	Wiring Harness, 264", L.H. Side, 12 Row 30"
	GA9483	-	Wiring Harness, 252", R.H. Side, 16 Row 30"
	GA9482	-	Wiring Harness, 300", L.H. Side, 16 Row 30"
29.	GD9672	-	Spring, R.H.

TWO-SPEED POINT ROW CLUTCH WHEEL MODULE EXTENSION

(TWL77g/TWL84b/TWL79a/TWL80)

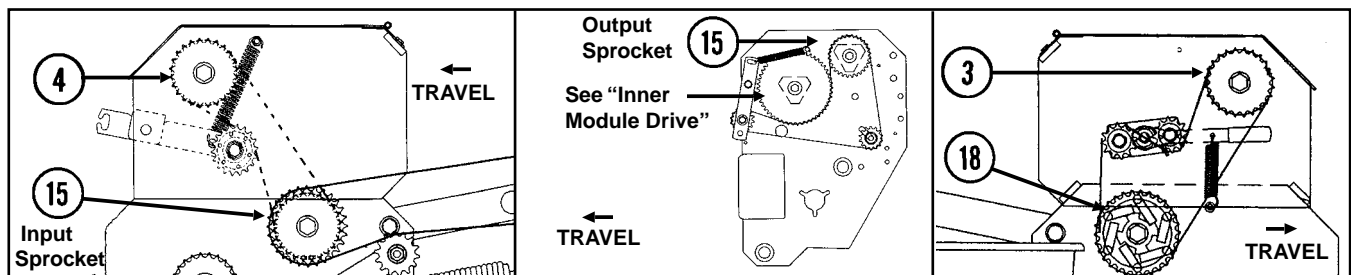
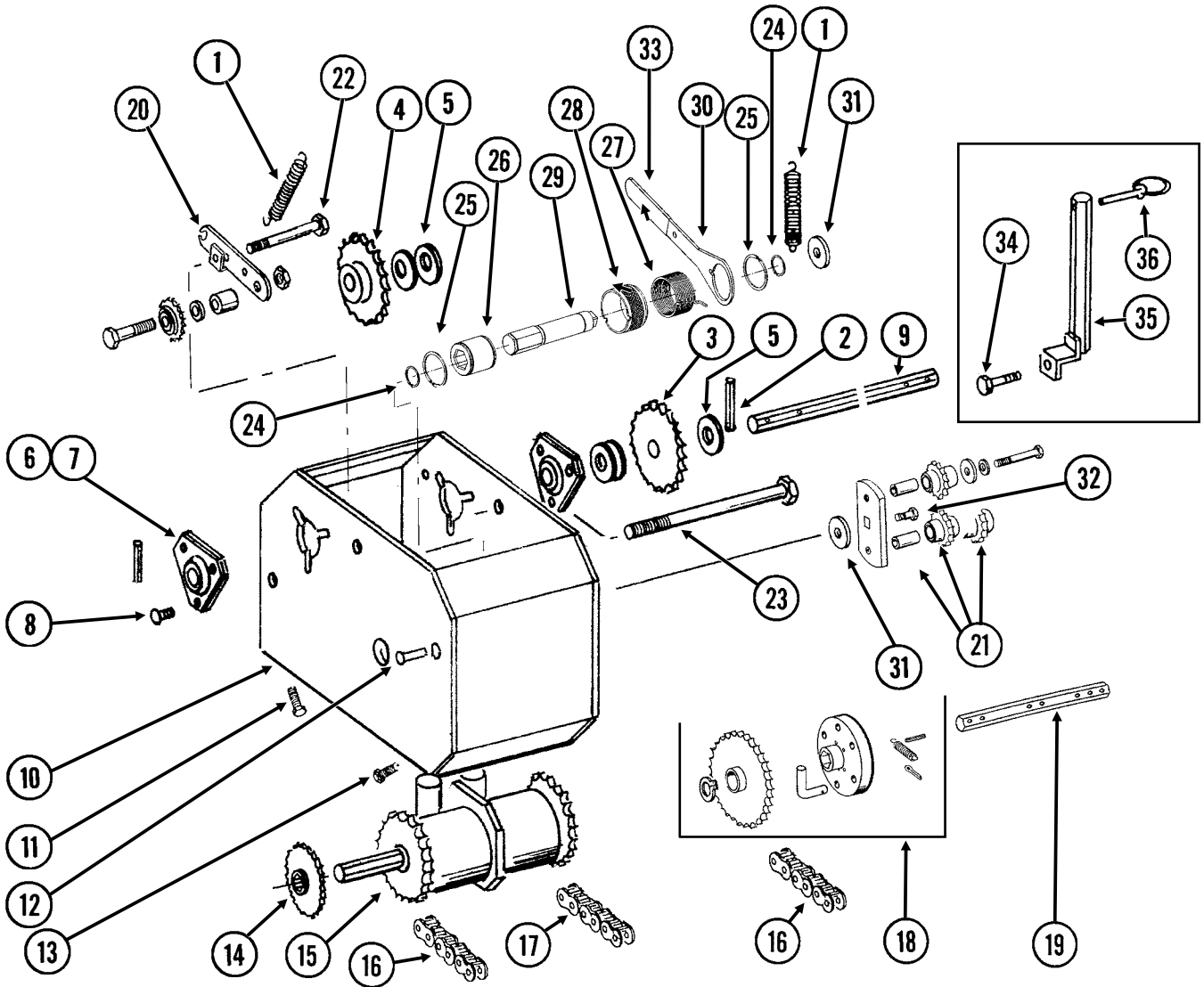

TWO-SPEED POINT ROW CLUTCH WHEEL MODULE EXTENSION

ITEM	PART NO.	QTY. (Per Assy.)	DESCRIPTION
1.	GD5857	2	Spring
2.	G10602	3	Spring Pin, 1/4" x 1 1/2"
3.	GA5109	1	Sprocket, 24 Tooth
	GA5105	1	Sprocket, 15 Tooth
	GA5106	1	Sprocket, 17 Tooth
	GA5112	1	Sprocket, 27 Tooth
	GA5108	-	Sprocket, 23 Tooth (From Transmission)
	GA5110	-	Sprocket, 25 Tooth (From Transmission)
	GA5111	-	Sprocket, 26 Tooth (From Transmission)
4.	GA5113	1	Sprocket, 28 Tooth
5.	G10233	-	Machine Bushing, 1", 10 Gauge
6.	G3400-01	-	Flangette
7.	G2100-03	-	Bearing, 7/8" Hex Bore, Spherical
8.	G10312	6	Carriage Bolt, 5/16"-18 x 3/4"
	G10232	6	Lock Washer, 5/16"
	G10106	6	Hex Nut, 5/16"-18
9.	GD10355	1	Shaft, 7/8" x 13 3/4"
10.	GA7306	1	Extension Bracket
11.	G10857	2	Hex Head Cap Screw, 1/4"-20 x 1 1/4"
	G10209	2	Washer, 1/4" USS
	G10227	2	Lock Washer, 1/4"
	G10103	2	Hex Nut, 1/4"-20
12.	G10408	1	Clevis Pin, 5/16" x 3/4"
	G10409	1	Retaining Ring, 5/16"
13.	G10064	2	Hex Head Cap Screw, 1/4"-20 x 1"
	G10209	2	Washer, 1/4" USS
	G10227	2	Lock Washer, 1/4"
	G10103	2	Hex Nut, 1/4"-20
14.		-	See "Contact Wheel And Drive Shaft(s)", Pages P68-P70
15.		-	See "Two-Speed Point Row Clutch", Pages P78 And P79
16.	G3310-74	2	Chain, No. 40, 74 Pitch Including Connector Link
	GR0912	-	Connector Link, No. 40
17.	G3310-100	1	Chain, No. 40, 100 Pitch Including Connector Link
	GR0912	-	Connector Link, No. 40
18.	GA7320	1	Overrunning Sprocket Assembly, R.H.
	GA7321	-	Overrunning Sprocket Assembly, L.H.
	G10430	1	External Retaining Ring, 1 1/4"
	GD1255	6	L-Pin
	G10546	6	Spring Pin, 3/16" x 1 1/4"
	G10470	6	Cotter Pin, 5/32" x 1"
	GD10366	6	Spring
	GA7317	1	Block
	GA7319	1	Sprocket W/Bushing, 30 Tooth
19.	GD10543	1	Hex Shaft, 7/8" x 13"
20.	GA9918	1	Idler W/Sprocket And Hardware
	GD10356	-	Bushing, 3/4" Long
	G10128	-	Machine Bushing, 1/2", 14 Gauge
	G10501	-	Hex Jam Nut, 1/2"-13, Grade 2
	G10053	-	Hex Head Cap Screw, 1/2"-13 x 2 1/2"
	GA7154	-	Sprocket W/Bearing, 18 Tooth

(Continued On Following Page)

TWO-SPEED POINT ROW CLUTCH WHEEL MODULE EXTENSION

ITEM	PART NO.	QTY. (Per Assy.)	DESCRIPTION
(Continued)			
21.	GA7336	1	Idler W/Bolt-On Sprockets
	GD7426	-	Sprocket, 12 Tooth
	GD1026	-	Sleeve, 1 3/16" Long
	G10210	-	Washer, 3/8" USS
	G10229	-	Lock Washer, 3/8"
	G10047	-	Hex Head Cap Screw, 3/8"-16 x 1 3/4"
22.	G10036	1	Hex Head Cap Screw, 5/8"-11 x 4"
	G10107	1	Lock Nut, 5/8"-11
	G10104	1	Hex Nut, 5/8"-11
23.	G10595	1	Hex Head Cap Screw, 3/8"-16 x 10"
	G10108	1	Lock Nut, 3/8"-16
24.	G10496	2	External Inverted Snap Ring, 1 1/2"
25.	G11075	2	External Inverted Snap Ring, 7/8"
26.	GD14432	1	Sleeve, 1 1/4"
27.	GD14414	1	Torsion Spring, R.H. (Used In L.H. Wrap Spring Wrench) (Shown)
	GD14413	-	Torsion Spring, L.H. (Used In R.H. Wrap Spring Wrench)
28.	GD19344	-	Release Collar, L.H. (Shown)
	GD19343	1	Release Collar, R.H.
29.	GD14426	1	Tightener Shaft, 3 3/8"
30.	GD14431	1	Handle
31.	G10235	2	Machine Bushing, 7/8", 14 Gauge
32.	G11100	1	Hex Socket Button Head Cap Screw, 1/4"-20 x 1/2", Grade 8
	G10227	1	Lock Washer, 1/4"
	G10209	1	Washer, 1/4" USS
33.	G11078	1	Vinyl Cap
34.	G10037	1	Hex Head Cap Screw, 1/2"-13 x 1 1/4"
	G10216	1	Washer, 1/2" USS
	G10228	1	Lock Washer, 1/2"
	G10102	1	Hex Nut, 1/2"-13
35.	GA7313	1	Sprocket Storage Rod
36.	GD2558	2	Lynch Pin, 1/4"
A.	G1K381	-	Wrap Spring Wrench Replacement Kit, Silver Collar, L.H. (Items 24-33) (Shown)
	G1K380	1	Wrap Spring Wrench Replacement Kit, Gold Collar, R.H. (Items 24-33)

ROW MARKER SPINDLE/HUB/BLADE

MKR020(MKR4)

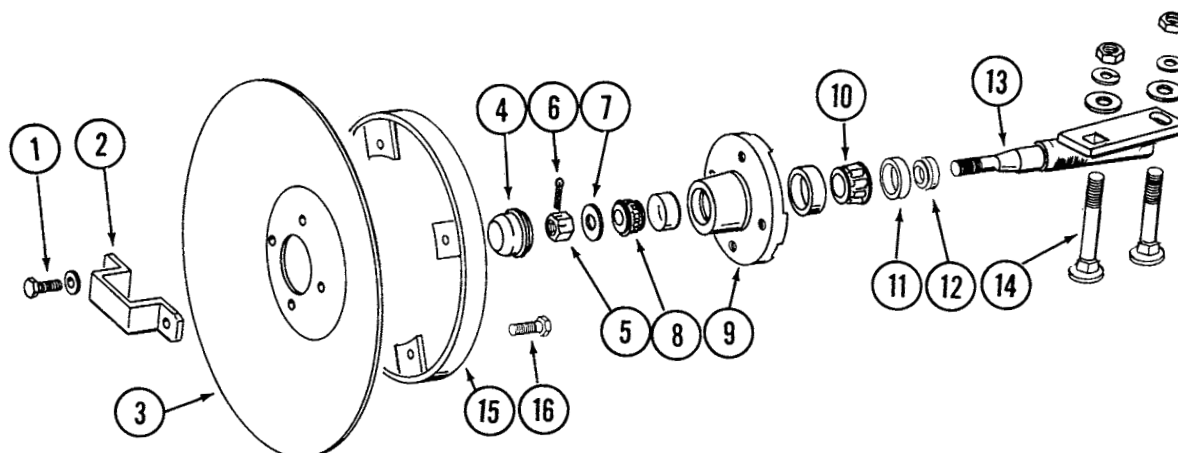

ITEM	PART NO.	QTY.	DESCRIPTION
		(Per Assy.)	
1.	G10722	4	Hex Head Cap Screw, 1/2"-20 x 1"
	G10228	4	Lock Washer, 1/2"
2.	GD2597	1	Retainer
3.	GD0746	1	Disc Blade, Solid, 16" (Shown)
	GD10283	-	Disc Blade, Notched, 16" (Optional)
4.	GD0840	1	Dust Cap
5.	G10725	1	Slotted Hex Nut, 5/8"-18
6.	G10544	1	Cotter Pin, 5/32" x 1"
7.	G10724	1	Washer, 5/8" SAE
8.	GA0257	1	Bearing
9.	GA0167	1	Hub W/Cups, 4 Bolt
	GR0151	-	Outer Cup
	GR0150	-	Inner Cup
10.	GA0245	1	Bearing
11.	GA0243	1	Grease Seal
12.	GA0899	1	Rubber Seal
13.	GA1676	1	Spindle, R.H.
	GA1677	-	Spindle, L.H. (Shown)
14.	G10844	2	Carriage Bolt, 1/2"-13 x 3 1/2"
	G10168	2	Machine Bushing, 1/2", 7 Gauge
	G10228	2	Lock Washer, 1/2"
	G10102	2	Hex Nut, 1/2"-13
15.	GA5853	1	Depth Band
16.	G10019	4	Hex Head Cap Screw, 5/16"-18 x 1"
	G10109	4	Lock Nut, 5/16"-18, Grade 8
A.	GA1679	-	Hub And Spindle Assembly, L.H. (Items 1, 2 And 4-13)
	GA1678	-	Hub And Spindle Assembly, R.H. (Items 1, 2 And 4-13)

ROW MARKER ASSEMBLY, 12 ROW 30"

MKR14ii)

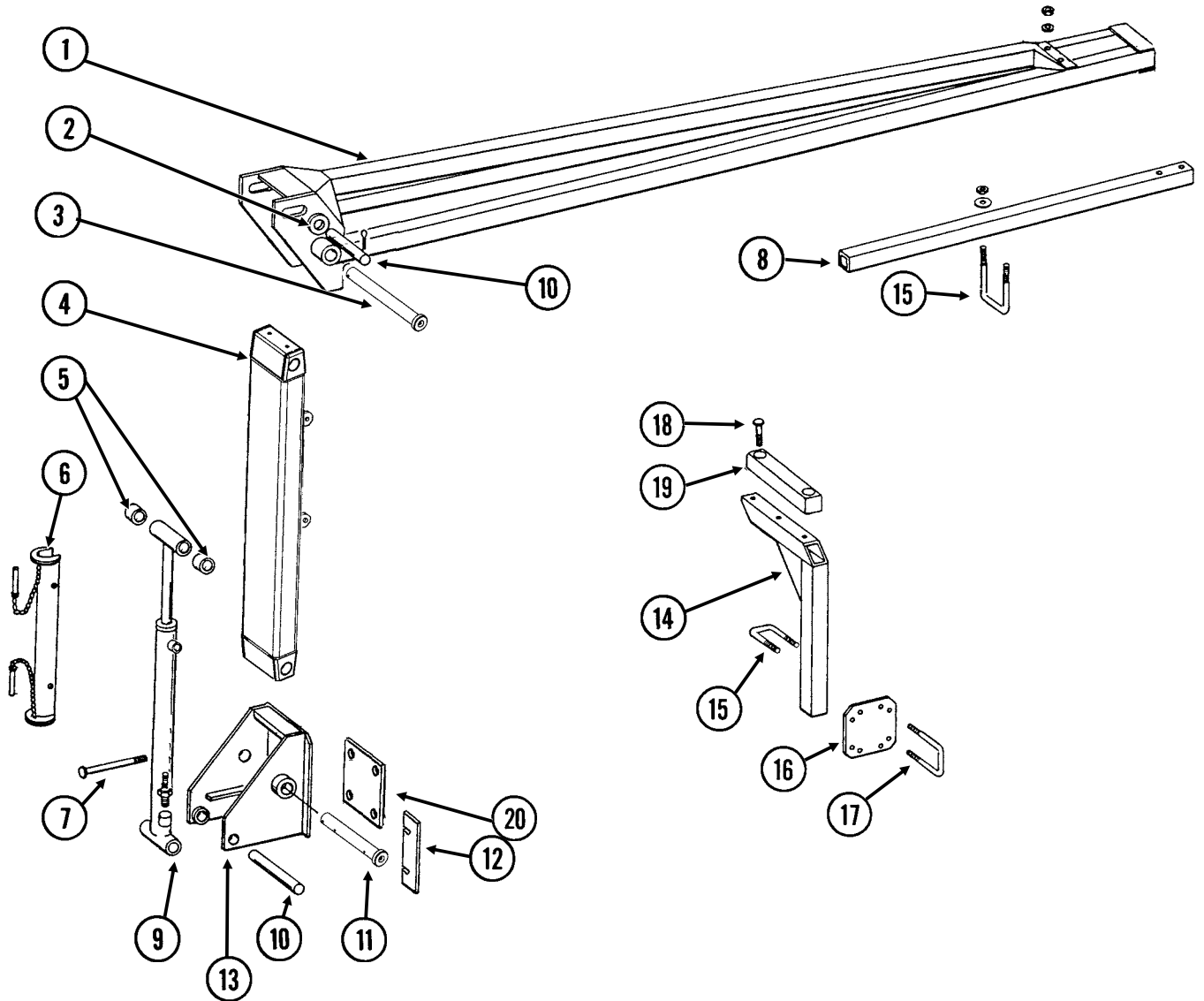

ROW MARKER ASSEMBLY, 12 ROW 30"

ITEM	PART NO.	QTY.	DESCRIPTION
		(Per Assy.)	
1.	GA4353	1	Arm W/Grease Fittings, Second Stage, 110"
	G10641	-	Grease Fitting, 1/8" NPT
2.	G10226	-	Washer, 1 1/4" SAE (As Required)
	G10159	-	Machine Bushing, 1 1/4", 10 Gauge (As Required)
	G10322	-	Machine Bushing, 1 1/4", 18 Gauge (As Required)
3.	GA11766	-	Pin W/Grease Fitting, 1 1/4" x 11 13/16"
	G10640	-	Grease Fitting, 1/4"-28
	G10463	-	Cotter Pin, 1/4" x 1 1/2"
4.	GA11590	-	Arm, First Stage
5.	GD0752-41	4	Sleeve, 1"
6.	GA8170	1	Safety Lockup W/Detent Pins, 19 3/8"
	G10536	-	Detent Pin, 1/2" x 2 1/2" Grip
7.	G10011	4	Hex Head Cap Screw, 5/8"-11 x 5 1/2" (If Applicable)
	G10046	-	Hex Head Cap Screw, 5/8"-11 x 5" (If Applicable)
	G10008	-	Hex Head Cap Screw, 5/8"-11 x 2" (If Applicable)
	GD7805	8	Special Washer, 5/8", Hardened
	G10205	-	Washer, 5/8" SAE
	G10230	4	Lock Washer, 5/8"
	G10104	4	Hex Nut, 5/8"-11
8.	GD0453-07	1	Extension Tube, 45", R.H.
	GD0453-04	-	Extension Tube, 60", L.H.
9.		-	See "Row Marker (Cushion) Cylinder", Page P93
10.	GD2161	2	Pin, 1 1/4" x 8 1/4"
	G10460	4	Cotter Pin, 1/4" x 2"
11.	GA11767	-	Pin W/Grease Fitting, 1 1/4" x 9 1/2"
	G10640	-	Grease Fitting, 1/4"-28
	G10463	-	Cotter Pin, 1/4" x 1 1/2"
12.	GD10792	-	Shim, 2 1/2" x 7 1/4", 16 Gauge (As Required)
13.	GA5130	1	Mount
14.	GA7042	1	Stand, 20" (12 Row 30" Only)
15.	GD2721	3	U-Bolt, 2" x 2" x 1/2"-13
	G10228	6	Lock Washer, 1/2"
	G10102	6	Hex Nut, 1/2"-13
16.	GD9981	1	Bar
17.	GD4743	2	U-Bolt, 3" x 3" x 1/2"-13
	G10216	4	Washer, 1/2" USS
	G10228	4	Lock Washer, 1/2"
	G10102	4	Hex Nut, 1/2"-13
18.	G10017	2	Hex Head Cap Screw, 1/2"-13 x 1 1/2"
	G10206	2	Washer, 1/2" SAE
	G10111	2	Lock Nut, 1/2"-13
19.	GA9088	-	Molded Stop, 12 1/4" Long
20.	GD13360	2	Plate, 6" x 6"

ROW MARKER ASSEMBLY, 16 ROW 30"

(MKR15ij)

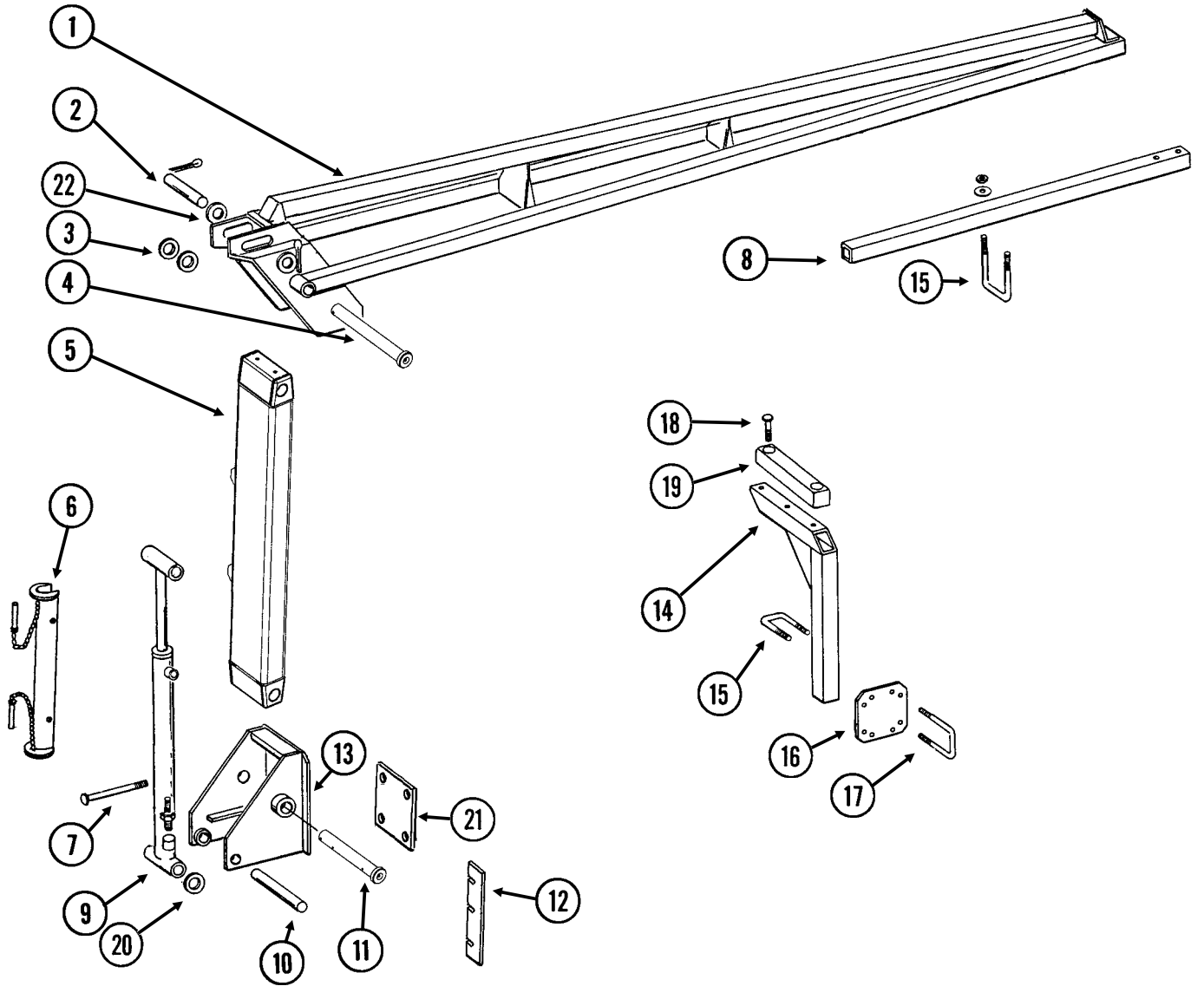

ROW MARKER ASSEMBLY, 16 ROW 30"

ITEM	PART NO.	QTY.	DESCRIPTION
		(Per Assy.)	
1.	GA7118	-	Arm, Second Stage, 172 1/4"
2.	GD1701	1	Pin, 1 1/4" x 6 1/2"
	G10460	2	Cotter Pin, 1/4" x 2"
3.	G10979	4	Special Washer, 1 1/4" (As Required)
	G10159	-	Machine Bushing, 1 1/4", 10 Gauge (As Required)
	G10322	-	Machine Bushing, 1 1/4", 18 Gauge (As Required)
4.	GA11768	-	Pin W/Grease Fitting, 1 1/4" x 13"
	G10640	-	Grease Fitting, 1/4"-28
	G10463	-	Cotter Pin, 1/4" x 1 1/2"
5.	GA11569	-	Arm, First Stage, L.H. (Shown)
	GA11568	-	Arm, First Stage, R.H.
6.	GA8170	1	Safety Lockup W/Detent Pins, 19 3/8"
	G10536	-	Detent Pin, 1/2" x 2 1/2" Grip
7.	G10012	-	Hex Head Cap Screw, 5/8"-11 x 6 1/2" (If Applicable)
	G10068	-	Hex Head Cap Screw, 5/8"-11 x 6" (If Applicable)
	G10009	-	Hex Head Cap Screw, 5/8"-11 x 2 1/2" (If Applicable)
	GD7805	8	Special Washer, 5/8", Hardened
	G10205	-	Washer, 5/8" SAE
	G10230	6	Lock Washer, 5/8"
	G10104	6	Hex Nut, 5/8"-11
8.	GD0453-09	1	Extension Tube, 75", L.H.
	GD0453-03	-	Extension Tube, 50", R.H.
9.		-	See "Row Marker (Cushion) Cylinder", Page P93
10.	GD0652	1	Pin, 1 1/4" x 9 1/2"
	G10460	2	Cotter Pin, 1/4" x 2"
11.	GA11769	-	Pin W/Grease Fitting, 1 1/4" x 11 1/2"
	G10640	-	Grease Fitting, 1/4"-28
	G10463	-	Cotter Pin, 1/4" x 1 1/2"
12.	GD10793	-	Shim, 2 1/2" x 12 1/2", 16 Gauge (As Required) (Shown)
	GD11791	-	Shim, 2 1/2" x 8 1/4", 16 Gauge (As Required)
13.	GA4877	1	Mount
14.	GA7043	1	Stand, 30"
15.	GD2721	3	U-Bolt, 2" x 2" x 1/2"-13
	G10228	6	Lock Washer, 1/2"
	G10102	6	Hex Nut, 1/2"-13
16.	GD9981	1	Bar
17.	GD4743	2	U-Bolt, 3" x 3" x 1/2"-13
	G10216	4	Washer, 1/2" USS
	G10228	4	Lock Washer, 1/2"
	G10102	4	Hex Nut, 1/2"-13
18.	G10017	2	Hex Head Cap Screw, 1/2"-13 x 1 1/2"
	G10206	2	Washer, 1/2" SAE
	G10111	2	Lock Nut, 1/2"-13
19.	GA9088	-	Molded Stop, 12 1/4" Long
20.	G10979	4	Special Washer, 1 1/4" (As Required)
21.	GD13359	2	Plate, 7" x 7"
22.	G10226	2	Washer, 1 1/4" SAE
	G10322	2	Machine Bushing, 1 1/4", 18 Gauge

ROTATION CYLINDER, ALL SIZES

(CYL11i)

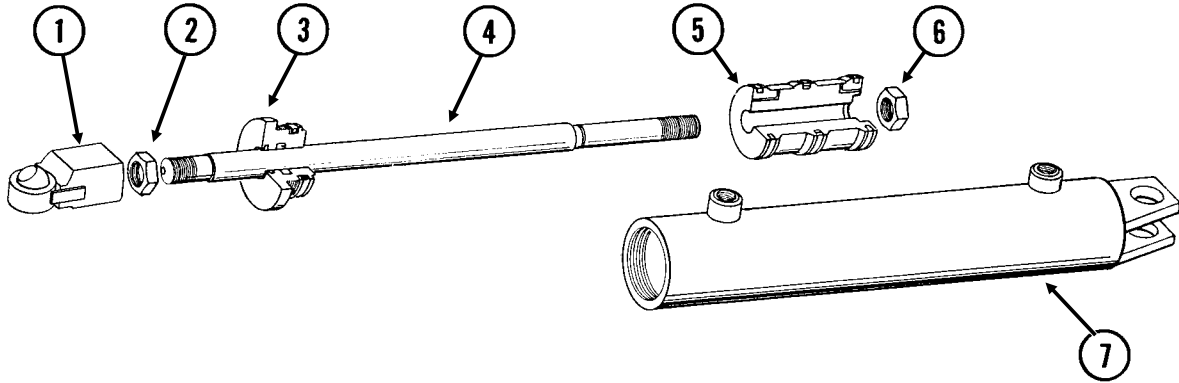

ITEM	PART NO.	QTY.	DESCRIPTION
------	----------	------	-------------

1.	GA7221	1	Threaded Ball Joint End
2.	G10509	1	Hex Jam Nut, 1 1/4"-12, Grade 2
3.	GD11988	1	Gland
4.	GD11991	1	Rod
5.	GD11992	1	Piston
6.	G10972	1	Lock Nut, 1 1/4"-12
7.	A7220	1	Barrel (Non-Stock Item)

A.	GA8904	-	Cylinder Complete, 4" x 16" (Part Number Stamped On Barrel)
B.	GR1524	-	Seal Kit, Includes: (2) O-Rings, (1) U-Cup, (1) Wiper, (1) Seal, (2) Cast Iron Rings, (1) BU Ring, (1) Expander

CENTER LIFT CYLINDER, ALL SIZES

(CYL39c)

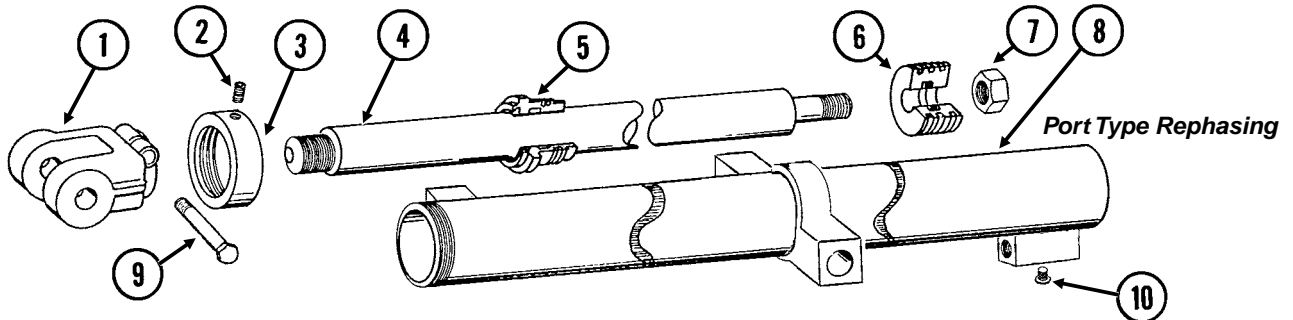

ITEM	PART NO.	QTY.	DESCRIPTION
------	----------	------	-------------

1.	GD11951	1	Clevis
2.	G10907	1	Set Screw, 1/4"-20 x 1/4"
3.	GD11193	1	Cap
4.	GD10936	1	Rod
5.	GD10211	1	Gland
6.	GD11253	1	Piston
7.	G10958	1	Lock Nut, 1"-14
8.	GA8149	1	Barrel
9.	G10939	1	Hex Head Cap Screw, 3/8"-16 x 2 1/4"
	G10108	1	Lock Nut, 3/8"-16
10.	G6408-H04-O	1	Hex Socket Head Plug W/O-Ring, 7/16"-20 O-Ring
	GR1465	1	O-Ring

A.	GA8908	-	Cylinder Complete, 3" x 48" (Part Number Stamped On Barrel)
B.	GR1428	-	Seal Kit, Includes: (2) O-Rings, (2) BU Rings, (1) Wiper, (1) U-Cup, (1) Piston Seal, (2) Cast Iron Rings, (1) Expander

WING LIFT CYLINDER, 12 ROW

CYL031/CYL011(CYL45d)

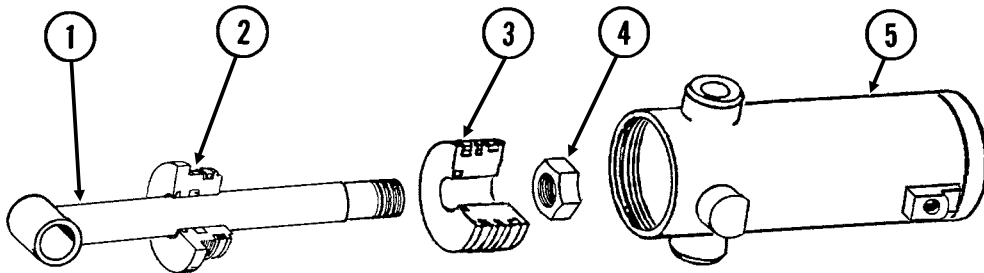

*Port Type
Rephasing*

ITEM	PART NO.	QTY	DESCRIPTION
1.	GA8320	1	Rod Assembly W/Grease Fitting
	G10640	-	Grease Fitting, 1/4"-28
2.	GD11995	1	Gland
3.	GD11994	1	Piston
4.	G10958	1	Lock Nut, 1"-14
5.	A8797	1	Barrel (Non-Stock Item)
A.	GA8909	-	Cylinder Complete, 4 1/4" x 6" (<i>Part Number Stamped On Barrel</i>)
B.	GR1523	-	Seal Kit, Includes: (1) Wiper, (2) O-Rings, (1) BU Ring, (1) U-Cup, (1) Seal, (2) Cast Iron Rings, (1) Expander

WING LIFT CYLINDER, 16 ROW

CYL031/CYL011(CYL41e)

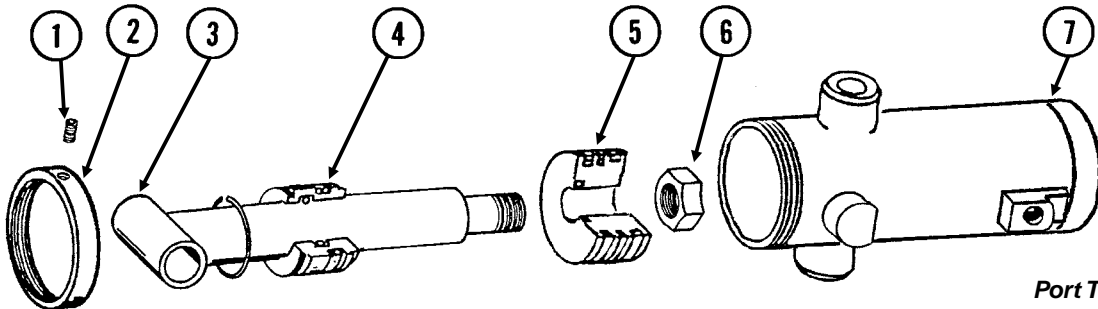

*Port Type
Rephasing*

ITEM	PART NO.	QTY.	DESCRIPTION
1.	G10907	1	Set Screw, 1/4"-20 x 1/4"
2.	GD11193	1	Cap
3.	GA8157	1	Rod Assembly W/Grease Fitting
	G10449	-	Grease Fitting, 3/16", Drive-In
4.	GD11194	1	Gland
5.	GD11253	1	Piston
6.	G10958	1	Lock Nut, 1"-14
7.	A8873	1	Barrel (Non-Stock Item)
A.	GA8874	-	Cylinder Complete, 3" x 6" (<i>Part Number Stamped On Barrel</i>)
B.	GR1417	-	Seal Kit, Includes: (2) O-Rings, (2) BU Rings, (1) Expander, (1) Wiper, (1) U-Cup, (1) Piston Seal, (2) Cast Iron Rings

TRANSPORT LATCH CYLINDER, ALL SIZES

CYL035/CYL050(CYL9c)

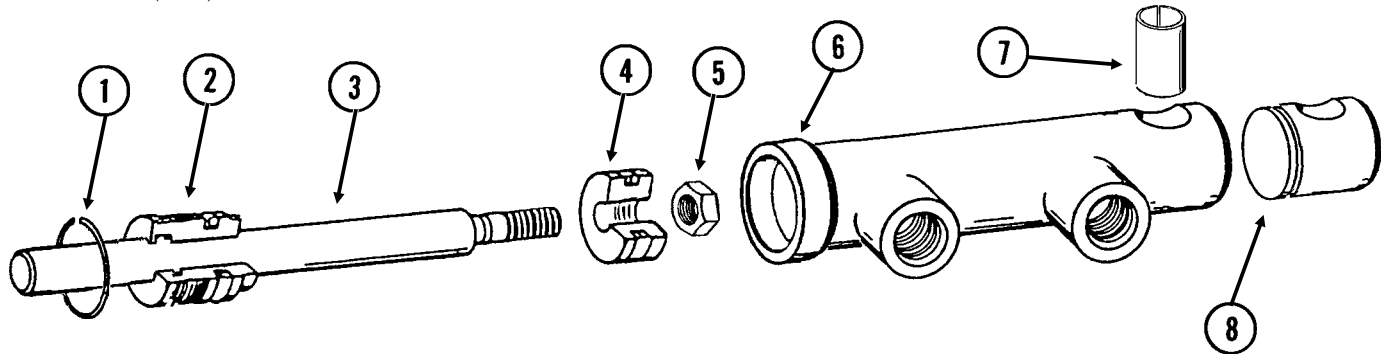

ITEM	PART NO.	QTY.	DESCRIPTION
1.	G10770	1	Internal Retaining Ring, 1 11/16"
2.	GD13170	1	Gland
3.	GD13425	1	Rod
4.	GD13172	1	Piston
5.	G11016	1	Lock Nut, 1/2"-20
6.	D13426	1	Barrel (Non-Stock Item)
7.	GD13400	1	Tension Bushing, 1" x 2" Long
8.	GD13173	1	End Cap
A.	GA9559	-	Cylinder Complete, 1 1/2" x 2 1/2" <i>(Part Number Stamped On Barrel)</i>
B.	GR1598	-	Seal Kit, Includes: (3) O-Rings, (2) BU Rings, (1) Wiper, (1) T-Seal, (1) Bronze Bushing, (1) Seal, (1) U-Cup

TONGUE LOCK CYLINDER, ALL SIZES

CYL035(CYL9d)

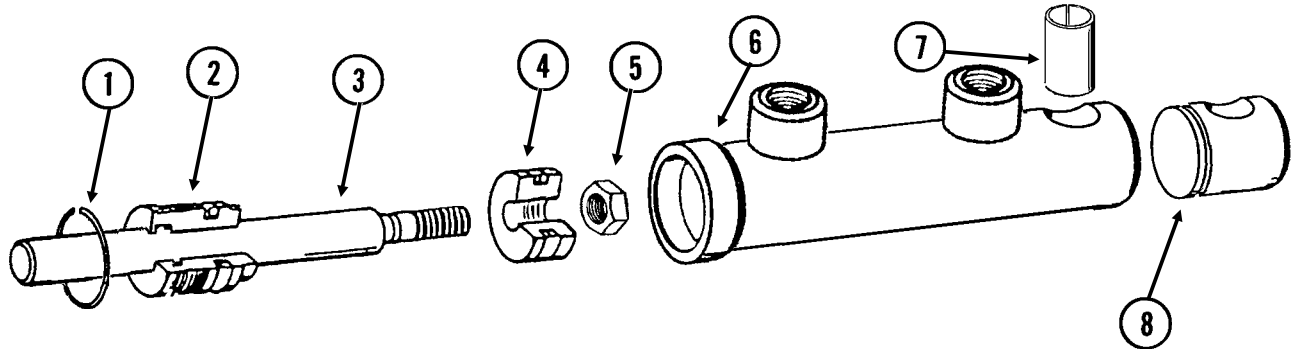

ITEM	PART NO.	QTY.	DESCRIPTION
1.	G10770	1	Internal Retaining Ring, 1 11/16"
2.	GD13170	1	Gland
3.	GD13171	1	Rod
4.	GD13172	1	Piston
5.	G11016	1	Lock Nut, 1/2"-20
6.	D13169	1	Barrel (Non-Stock Item)
7.	GD13400	1	Tension Bushing, 1" x 2" Long
8.	GD13173	1	End Cap
A.	GA9205	-	Cylinder Complete, 1 1/2" x 2 1/2" <i>(Part Number Stamped On Barrel)</i>
B.	GR1598	-	Seal Kit, Includes: (3) O-Rings, (2) BU Rings, (1) Wiper, (1) T-Seal, (1) Bronze Bushing, (1) Seal, (1) U-Cup

TONGUE CYLINDER, 12 ROW 30"

(CYL12f)

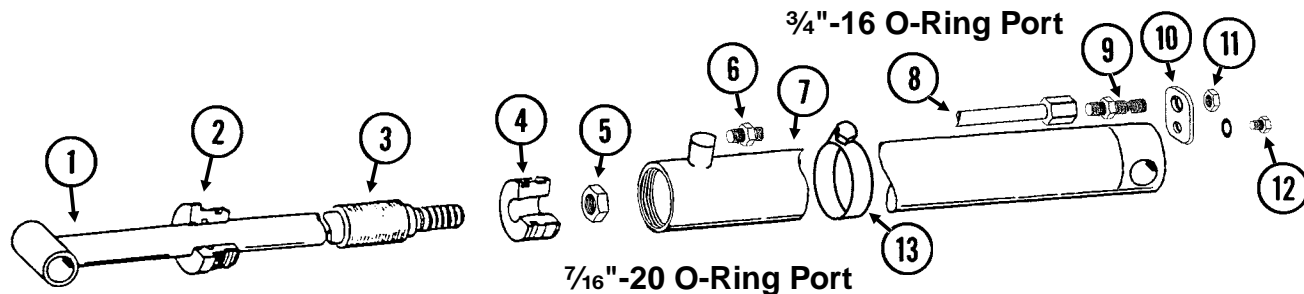

ITEM	PART NO.	QTY.	DESCRIPTION
1.	GA8893	1	Rod Assembly
2.	GD11984	1	Gland
3.	GD7147	1	Spacer
4.	GD11970	1	Piston
5.	G10972	1	Lock Nut, 1 1/4"-12
6.	G6400-08-04	1	Connector W/O-Ring, 3/4"-16 Male JIC To 7/16"-20 O-Ring
	GR1465	-	O-Ring
7.	GA8858	1	Barrel
8.	GA8978	1	Steel Hydraulic Line, 68 11/16"
9.	G2700-08	1	Bulkhead Tube Union, 3/4"-16 Male JIC
10.	GD12597	1	Bracket
11.	G306-08	1	Lock Nut, 3/4"-16
12.	G10328	1	Hex Head Cap Screw, 3/8"-16 x 5/8"
	G10229	1	Lock Washer, 3/8"
13.	G10990	1	Hose Clamp, No. 52
A.	GA8857	-	Cylinder Complete, 3" x 60" (Part Number Stamped On Barrel)
B.	GR1519	-	Seal Kit, Includes: (2) O-Rings, (1) BU Ring, (1) Wear Ring, (1) Wiper, (1) U-Cup, (1) T-Seal

TONGUE CYLINDER, 16 ROW 30"

CYL036(CYL12f)

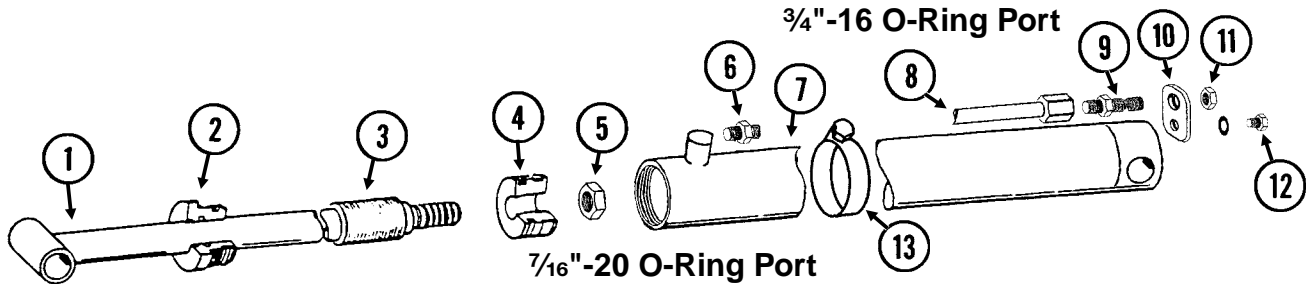

ITEM	PART NO.	QTY.	DESCRIPTION
1.	GA8859	1	Rod Assembly
2.	GD11984	1	Gland
3.	GD7147	1	Spacer
4.	GD11970	1	Piston
5.	G10972	1	Lock Nut, 1 1/4"-12
6.	G6400-08-04	1	Connector W/O-Ring, 3/4"-16 Male JIC To 7/16"-20 O-Ring
	GR1465	-	O-Ring
7.	GA8861	1	Barrel
8.	GA8979	1	Steel Hydraulic Line, 92 11/16"
9.	G2700-08	1	Bulkhead Tube Union, 3/4"-16 Male JIC
10.	GD12597	1	Bracket
11.	G306-08	1	Lock Nut, 3/4"-16
12.	G10328	1	Hex Head Cap Screw, 3/8"-16 x 5/8"
	G10229	1	Lock Washer, 3/8"
13.	G10990	1	Hose Clamp, No. 52
A.	GA8862	-	Cylinder Complete, 3" x 84" (<i>Part Number Stamped On Barrel</i>)
B.	GR1519	-	Seal Kit, Includes: (2) O-Rings, (1) BU Ring, (1) Wear Ring, (1) Wiper, (1) U-Cup, (1) T-Seal

WING LOCK CYLINDER, ALL SIZES

CYL032(CYL3f)

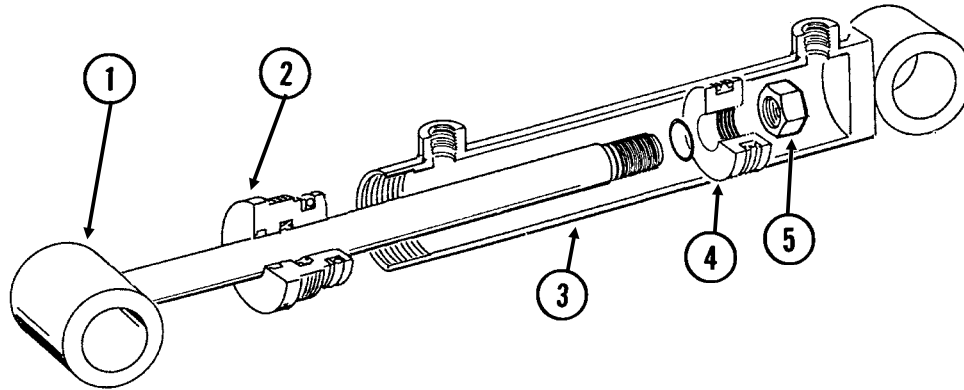

ITEM	PART NO.	QTY.	DESCRIPTION
1.	GA8898	1	Rod Assembly
2.	GD11985	1	Gland
3.	A8822	1	Barrel (Non-Stock Item)
4.	GD11986	1	Piston
5.	G10969	1	Lock Nut, 7/8"-14
A.	GA8899	-	Cylinder Complete, 2 1/2" x 20 1/16" <i>(Part Number Stamped On Barrel)</i>
B.	GR1522	-	Seal Kit, Includes: (1) T-Seal, (2) O-Rings, (1) BU Ring, (1) U-Cup, (1) Wiper

ROW MARKER (Cushion) CYLINDER, ALL SIZES

(CYL3d)

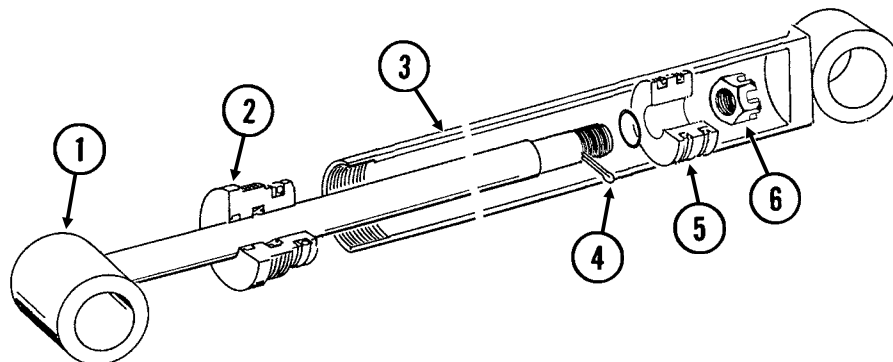

ITEM	PART NO.	QTY.	DESCRIPTION
1.	GA8871	1	Rod Assembly
2.	GD10207	1	Gland
3.	A7524	1	Barrel (Non-Stock Item)
4.	G10827	1	Cotter Pin, 1/8" x 1 3/4"
5.	GD11983	1	Piston
6.	G10962	1	Slotted Hex Nut, 7/8"-14
A.	GA8895	-	Cylinder Complete, 2 1/2" x 20 1/16" <i>(Part Number Stamped On Barrel)</i>
B.	GR1521	-	Seal Kit, Includes: (1) T-Seal, (2) O-Rings, (1) BU Ring, (1) Cast Iron Ring, (1) Wiper, (1) U-Cup

JUNCTION BLOCK - LOCATED ON R.H. SIDE OF CENTER PIVOT

VVB036(TWL24k)

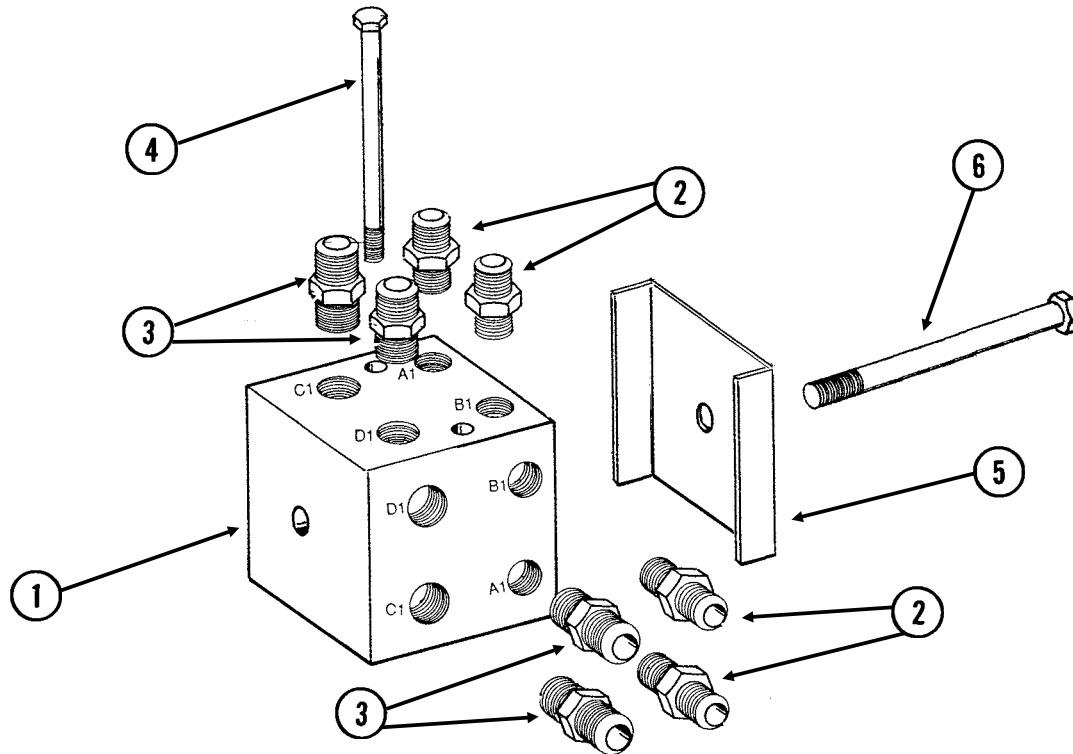

ITEM	PART NO.	QTY.	DESCRIPTION
1.	GD9971	1	Manifold Block
2.	G6400-08	4	Connector W/O-Ring, 3/4"-16 Male JIC To O-Ring
	GR1037	-	O-Ring
3.	G6400-10-08	4	Connector W/O-Ring, 7/8"-14 Male JIC To 3/4"-16 O-Ring
	GR1037	-	O-Ring
4.	G10172	2	Hex Head Cap Screw, 3/8"-16 x 5"
	G10229	2	Lock Washer, 3/8"
	G10101	2	Hex Nut, 3/8"-16
5.	GD0740	1	Hose Clamp, 3/4" x 4" x 3 1/2"
6.	G10871	1	Hex Head Cap Screw, 1/2"-13 x 6"
	G10228	1	Lock Washer, 1/2"
	G10102	1	Hex Nut, 1/2"-13

VALVE BLOCKS - LOCATED ON REAR CENTER FRAME

(IP1081)

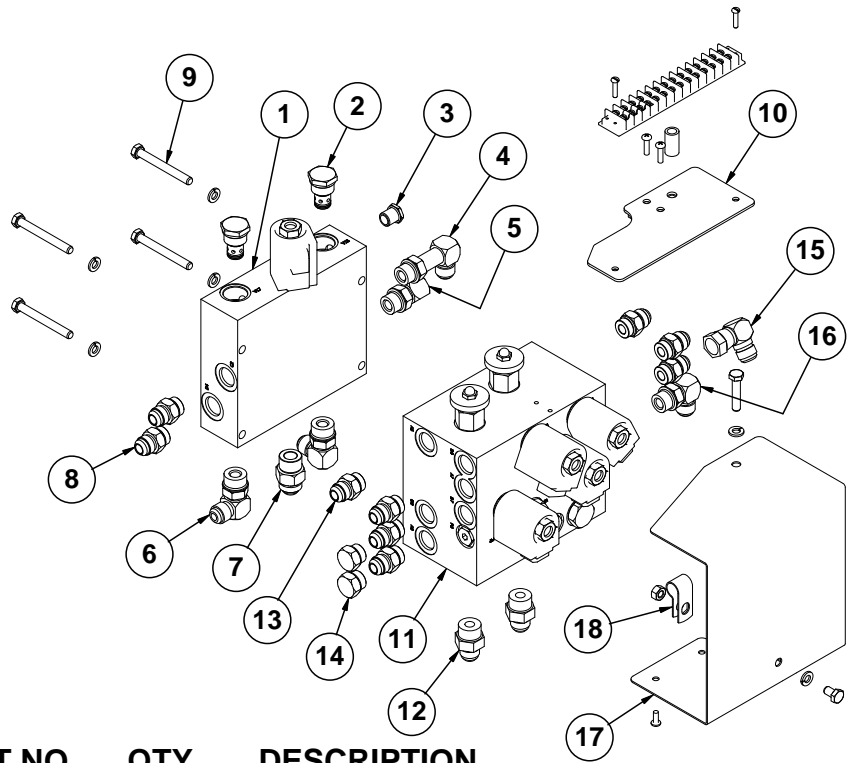

ITEM	PART NO.	QTY.	DESCRIPTION	
1.	GD9977	1	Block	
	GR1445	1	Coil	
	GR0763	1	Cartridge	
	GR0761	1	Special Hex Nut, 1/2"-20	
2.	GA4293	2	Check Valve	
	G6408-H06-0	1	Hex Socket Head Plug W/O-Ring, 9/16"-18	
3.	G6801-L-08	1	Long Elbow W/O-Ring, 90°, 3/4"-16 Male JIC To O-Ring	
	G6801-08	1	Elbow W/O-Ring, 90°, 3/4"-16 Male JIC To O-Ring	
4.	GR1037	-	O-Ring	
	G6801-08-10	2	Elbow W/O-Ring, 90°, 3/4"-16 Male JIC To 7/8"-14 O-Ring	
5.	GR1466	-	O-Ring	
	G6400-10	1	Connector W/O-Ring, 7/8"-14 Male JIC To O-Ring	
6.	GR1466	-	O-Ring	
	G6400-08	2	Connector W/O-Ring, 3/4"-16 Male JIC To O-Ring	
7.	GR1037	-	O-Ring	
	G6400-08	2	Connector W/O-Ring, 3/4"-16 Male JIC To O-Ring	
8.	GR1037	-	O-Ring	
	G10583	4	Hex Head Cap Screw, 5/16"-18 x 2 3/4"	
9.	G10232	4	Lock Washer, 5/16"	
	GA9095	1	Terminal Strip Mount	
10.	GD8066-02	1	Sleeve, 1" Long	
	G11066	2	Phillips Pan Head Machine Screw, No. 10-24 x 3/4", Stainless Steel	
	GA9097	1	Terminal Strip W/Screws, No. 6, 14 Terminal	
	GR1635	-	Screw, No. 6-32 x 1/4"	
	GD13310	3	Jumper, 7/16"	
	G11067	2	Phillips Pan Head Machine Screw, No. 8-32 x 3/4", Stainless Steel	
	11.	GD9533	1	Block
		GA3413	2	Flow Control Valve
		GR1445	4	Coil
		GR0763	4	Cartridge
GR0761		4	Special Hex Nut, 1/2"-20	
G6408-H06-0		5	Hex Socket Head Plug W/O-Ring, 9/16"-18	
G6408-10		2	Plug W/O-Ring, 7/8"-14 O-Ring	
GR1466		-	O-Ring	
G6400-08-10		2	Connector W/O-Ring, 3/4"-16 Male JIC To 7/8"-14 O-Ring	
G6400-08		7	Connector W/O-Ring, 3/4"-16 Male JIC To 7/8"-14 O-Ring	
12.	GR1466	-	O-Ring	
	G6408-08	4	Plug W/O-Ring, 3/4"-16 O-Ring	
13.	GR1037	-	O-Ring	
	G6500-08	1	Swivel Elbow, 90°, 3/4"-16 Male JIC To Female	
14.	G6801-08	1	Elbow W/O-Ring, 90°, 3/4"-16 Male JIC To O-Ring	
	GR1037	-	O-Ring	
15.	GD13146	1	Cover	
	G10133	1	Hex Head Cap Screw, 5/16"-18 x 1 1/2"	
16.	G10232	2	Lock Washer, 5/16"	
	G10977	2	Phillips Pan Head Machine Screw, No. 10-24 x 1/2", Stainless Steel	
17.	G10054	1	Hex Head Cap Screw, 5/16"-18 x 1/2"	
	GD13348	1	Insulated Clamp, 1 1/16"	
18.	G10106	1	Hex Nut, 5/16"-18	

VALVE BLOCK - LOCATED ON HITCH

VVB035(TWL26f)

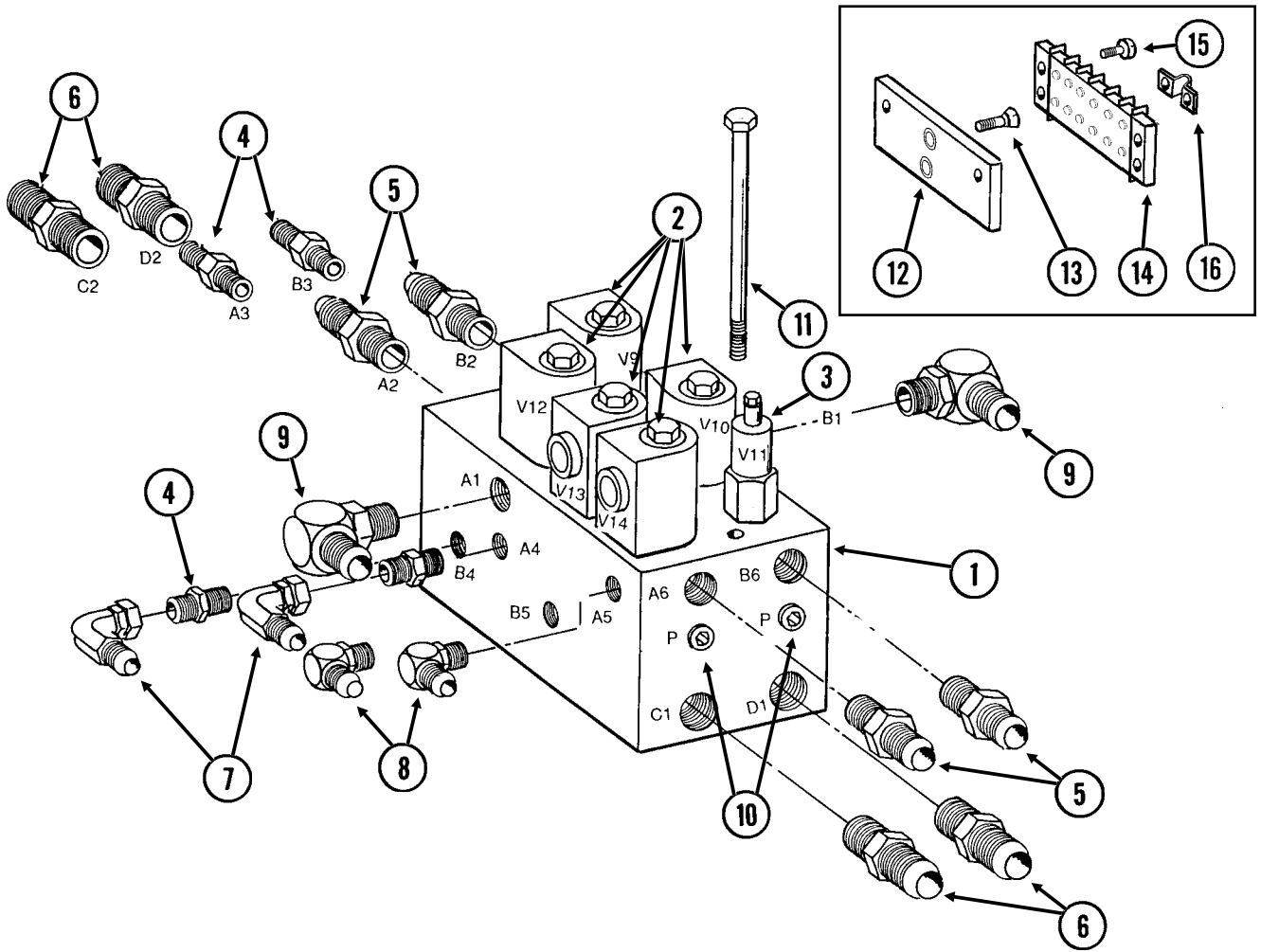

VALVE BLOCK - LOCATED ON HITCH

ITEM	PART NO.	QTY.	DESCRIPTION
1.	GD9905	1	Block
2.		-	See "Solenoid Valve", Page P98
3.		-	See "Pressure Relief Valve", Page P99
4.	G6400-06	4	Connector W/O-Ring, 9/16"-18 Male JIC To O-Ring
	GR1045	-	O-Ring
5.	G6400-08	4	Connector W/O-Ring, 3/4"-16 Male JIC To O-Ring
	GR1037	-	O-Ring
6.	G6400-10	4	Connector W/O-Ring, 7/8"-14 Male JIC To O-Ring
	GR1466	-	O-Ring
7.	G6500-06	2	Swivel Elbow, 90°, 9/16"-18 Male JIC To Female
8.	G6801-06	2	Elbow W/O-Ring, 90°, 9/16"-18 Male JIC To O-Ring
	GR1045	-	O-Ring
9.	G6801-08	2	Elbow W/O-Ring, 90°, 3/4"-16 Male JIC To O-Ring
	GR1037	-	O-Ring
10.	G6408-H06-O	2	Hex Socket Head Plug W/O-Ring, 9/16"-18 O-Ring
	GR1045	-	O-Ring
11.		-	See "Hose Take-Up", Pages P56 And P57
12.	GD12818	-	Terminal Strip Mount
13.	G11068	2	Phillips Flat Head Machine Screw, No. 10-24 x 5/8", Stainless Steel
14.	GA9098	-	Terminal Strip W/Screws, No. 6, 8 Terminal
	GR1635	-	Screw, No. 6-32 x 1/4"
15.	G11065	2	Phillips Pan Head Machine Screw, No. 8-32 x 5/8", Stainless Steel
16.		-	See "Electrical Components", Pages P104 And P105

SOLENOID VALVE

VVB019(TWL27c/TWL18/PLTR75c/A9481)

ITEM	PART NO.	QTY.	DESCRIPTION
1.	GR0761	1	Special Hex Nut, 1/2"-20
2.	G1K274	1	Coil Kit W/Contacts, Housings And Fork Terminals
	GD9529	2	Housing, Black
	GD9530	2	Contact
	G10996	2	Fork Terminal
3.	GR0763	1	Cartridge
A.	G1K275	-	Solenoid Valve Kit W/Solenoid Valve, Contacts, Housings And Fork Terminals
	GD9529	2	Housing, Black
	GD9530	2	Contact
	G10996	2	Fork Terminal
B.	GR0764	-	Seal Kit, Includes: (2) O-Rings, (1) BU Ring

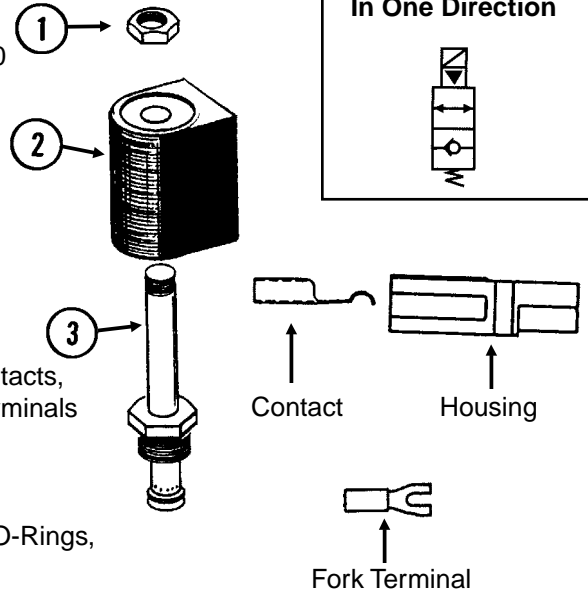

FLOW CONTROL VALVE

VVB020(TWL28)

ITEM	PART NO.	QTY.	DESCRIPTION
A.	GA3413	-	Flow Control Valve
B.	GR0764	-	Seal Kit, Includes: (2) O-Rings, (1) BU Ring

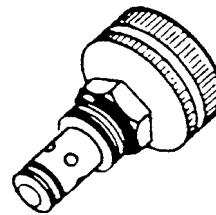

PRESSURE RELIEF VALVE

VVB020(TWL29)

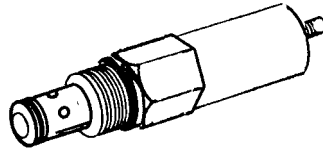

ITEM	PART NO.	QTY.	DESCRIPTION
A.	GA3407	-	Pressure Relief Valve, 1000 PSI
B.	GR0764	-	Seal Kit, Includes: (2) O-Rings, (1) BU Ring

CHECK VALVE

ITEM	PART NO.	QTY.	DESCRIPTION
A.	GA4293	-	Check Valve
B.	GR0764	-	Seal Kit, Includes: (2) O-Rings, (1) BU Ring

VVB020(TWL30)

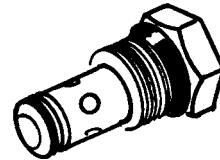

HYDRAULIC HOSES AND FITTINGS ON HITCH

(TWL107d/TWL107b)

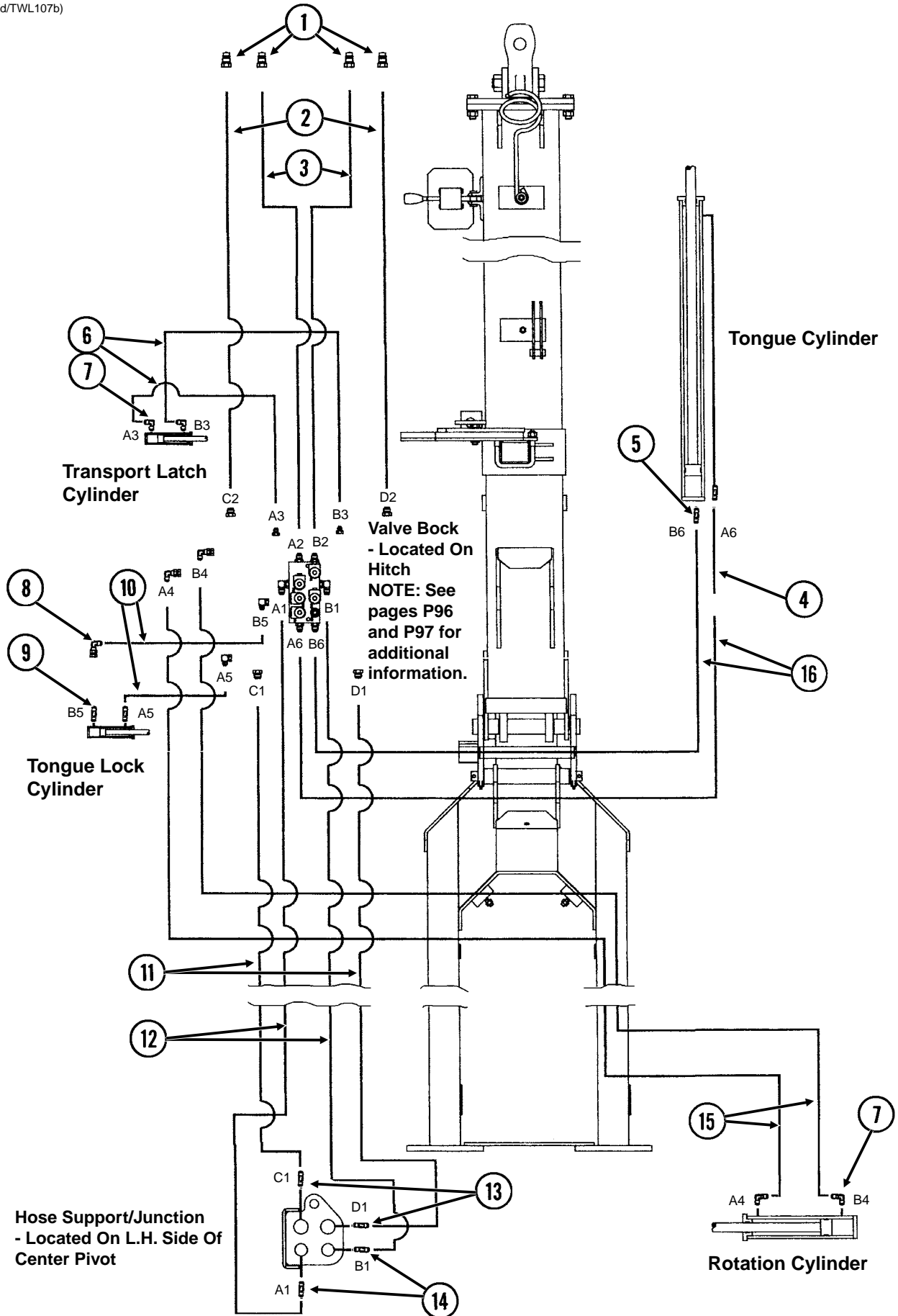

HYDRAULIC HOSES AND FITTINGS ON HITCH

ITEM	PART NO.	QTY.	DESCRIPTION
1.	GD4086	4	ISO Coupler
2.	*A1489	2	Hose Assembly, 1/2" x 191", 12 Row 30"
	*A1491	2	Hose Assembly, 1/2" x 246", 16 Row 30"
3.	*A3133	2	Hose Assembly, 3/8" x 191", 12 Row 30"
	*A3183	2	Hose Assembly, 3/8" x 246", 16 Row 30"
4.	*A3215	1	Hose Assembly, 3/8" x 72", 12 Row 30"
	*A3216	1	Hose Assembly, 3/8" x 96", 16 Row 30"
5.	G6400-08	1	Connector W/O-Ring, 3/4"-16 Male JIC To O-Ring
	GR1037	-	O-Ring
6.	*A1103	2	Hose Assembly, 1/4" x 110", 12 Row 30"
	*A1129	2	Hose Assembly, 1/4" x 168", 16 Row 30"
7.	G6801-06-08	4	Elbow W/O-Ring, 90°, 9/16"-18 Male JIC To 3/4"-16 O-Ring
	GR1037	-	O-Ring
8.	G6502-06	1	Swivel Elbow, 45°, 9/16"-18 Male JIC To Female
9.	G6400-06-08	2	Connector W/O-Ring, 9/16"-18 Male JIC To 3/4"-16 O-Ring
	GR1037	-	O-Ring
10.	*A1139	2	Hose Assembly, 1/4" x 40"
11.	*A1467	2	Hose Assembly, 1/2" x 120", 12 Row 30"
	*A1478	2	Hose Assembly, 1/2" x 128", 16 Row 30"
12.	*A1011	2	Hose Assembly, 3/8" x 125", 12 Row 30"
	*A1041	2	Hose Assembly, 3/8" x 130", 16 Row 30"
13.	G2700-10	2	Bulkhead Tube Union, 7/8"-14 Male JIC
14.	G2700-08	2	Bulkhead Tube Union, 3/4"-16 Male JIC
15.	*A1106	2	Hose Assembly, 1/4" x 130", 12 Row 30"
	*A1116	2	Hose Assembly, 1/4" x 136", 16 Row 30"
16.	*A3156	2	Hose Assembly, 3/8" x 68", 12 Row 30"
	*A3118	2	Hose Assembly, 3/8" x 80", 16 Row 30"

* Hydraulic hose is not stocked by KINZE® Repair Parts, but can be made available on a special order basis. Call for quote.

HYDRAULIC HOSES AND FITTINGS ON PLANTER FRAME

(TWL105b)

16 Row Shown (Two Wing Lift Cylinders Per Wing)
 12 Row (One Wing Lift Cylinder Per Wing)

Hose Support/Junction
 - Located On L.H. Side
 Of Center Pivot
NOTE: See pages P100
 and P101 for additional
 information.

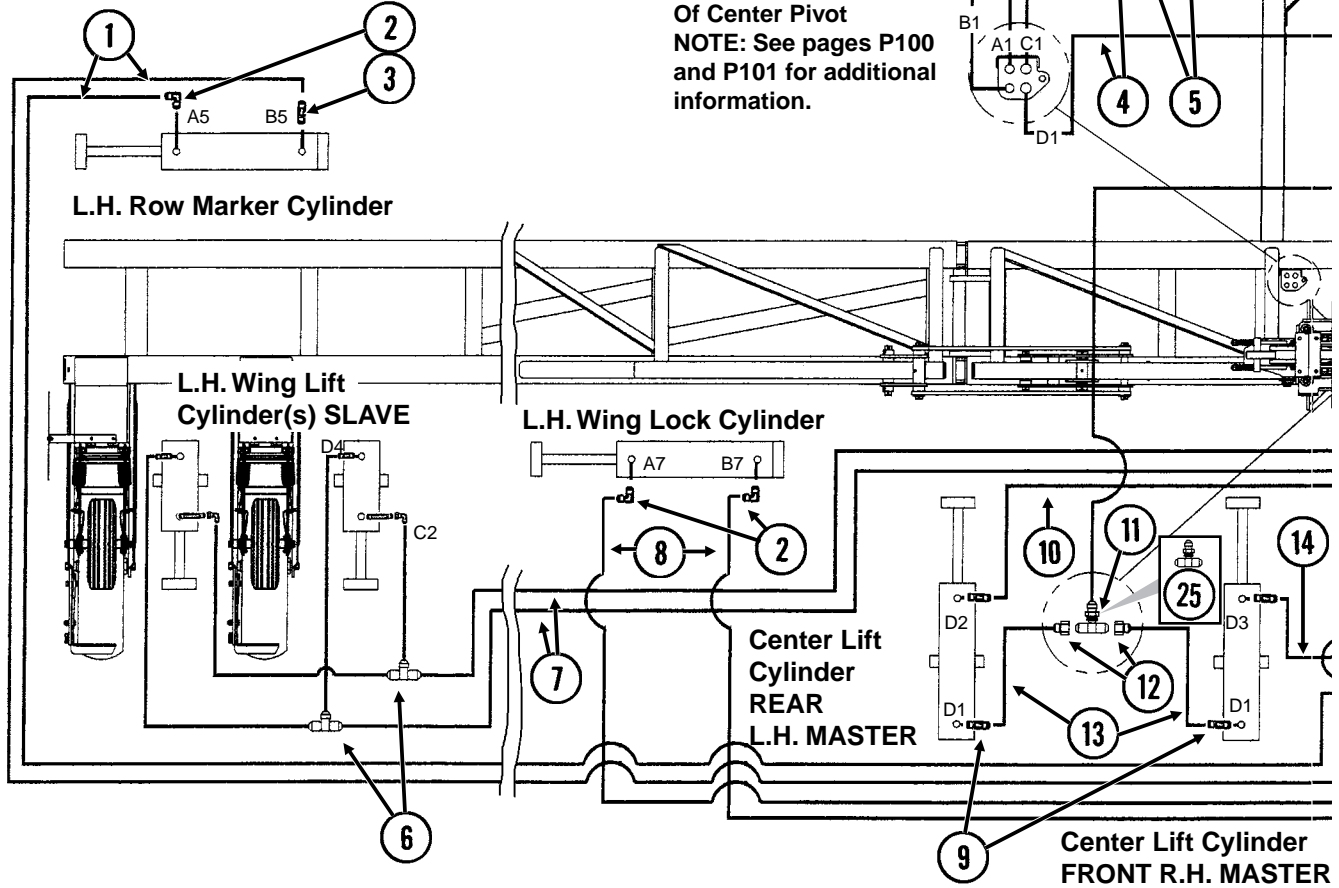

ITEM	PART NO.	QTY.	DESCRIPTION
1.	*A1034	2	Hose Assembly, 3/8" x 272", 12 Row 30"
	*A3181	2	Hose Assembly, 3/8" x 332", 16 Row 30"
2.	G6801-08	6	Elbow W/O-Ring, 90°, 3/4"-16 Male JIC To O-Ring
	GR1037	-	O-Ring
3.	G6400-08-04	2	Connector W/O-Ring, 3/4"-16 Male JIC To 7/16"-20 O-Ring
	GR1465	-	O-Ring
4.	*A8267	2	Hose Assembly, 1/2" x 58", 12 Row 30" And 16 Row 30"
5.	*A3127	2	Hose Assembly, 3/8" x 58", 12 Row 30" And 16 Row 30"
6.	G2603-08	4	Tee, 3/4"-16 Male JIC, 16 Row 30"
7.	*A1033	2	Hose Assembly, 3/8" x 250", 12 Row 30"
	*A1034	2	Hose Assembly, 3/8" x 272", 16 Row 30"
8.	*A1055	2	Hose Assembly, 3/8" x 66"
9.	G6400-08	8	Connector W/O-Ring, 3/4"-16 Male JIC To O-Ring
	GR1037	-	O-Ring
10.	*A3131	1	Hose Assembly, 3/8" x 42"
11.	G2703-10	1	Bulkhead Tee, 7/8"-14 Male JIC
12.	G2406-10-08	2	Reducer, 7/8"-14 Female JIC To 3/4"-16 Male JIC
13.	*A1076	2	Hose Assembly, 3/8" x 30"

HYDRAULIC HOSES AND FITTINGS ON PLANTER FRAME

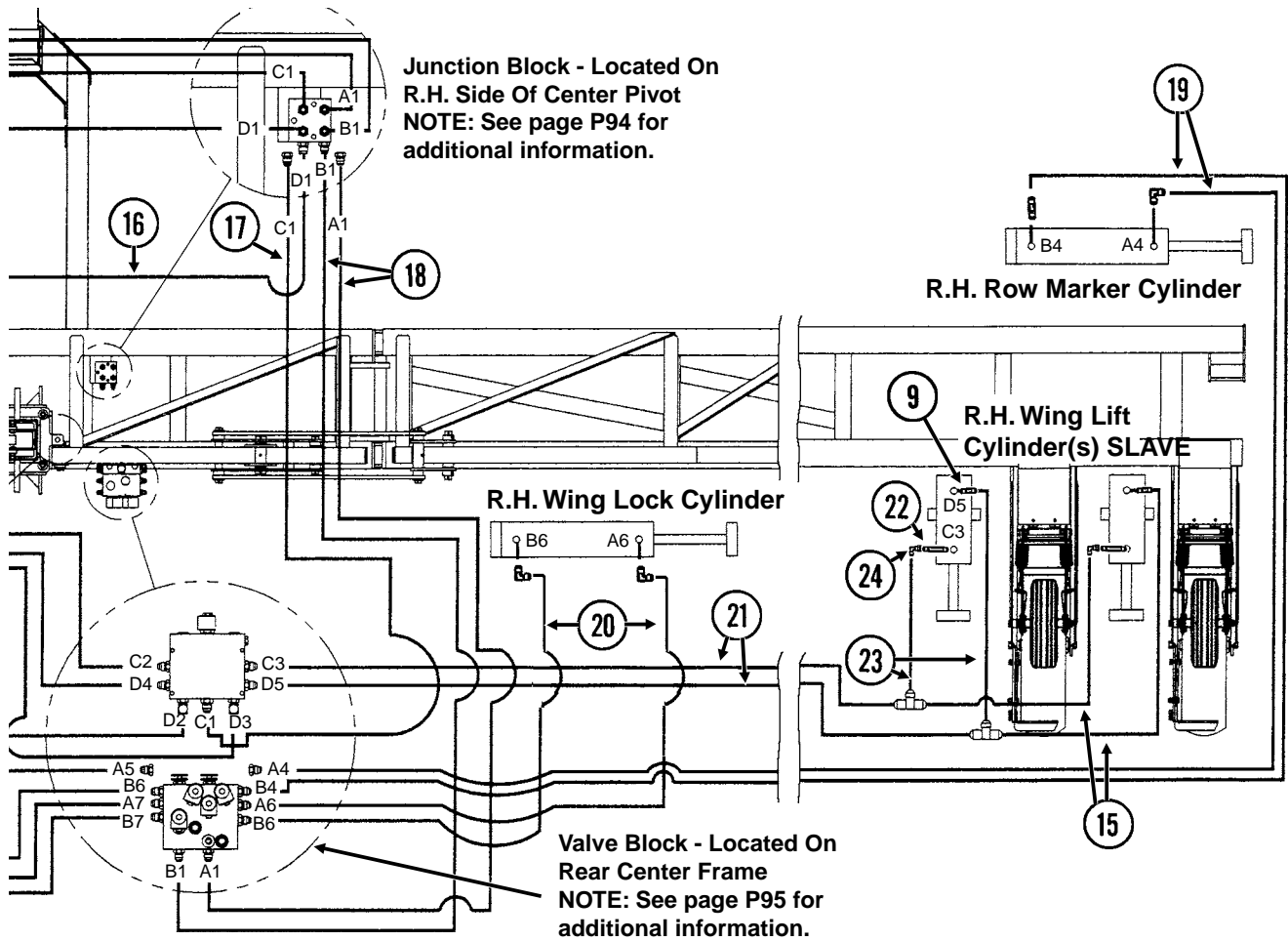

ITEM	PART NO.	QTY.	DESCRIPTION
14.	*A3128	1	Hose Assembly, 3/8" x 52"
15.	*A1018	4	Hose Assembly, 3/8" x 40", 16 Row 30"
16.	*A1404	1	Hose Assembly, 1/2" x 41"
17.	*A1424	1	Hose Assembly, 1/2" x 30"
18.	*A1076	2	Hose Assembly, 3/8" x 30"
19.	*A3163	2	Hose Assembly, 3/8" x 225", 12 Row 30"
	*A1097	2	Hose Assembly, 3/8" x 288", 16 Row 30"
20.	*A1076	2	Hose Assembly, 3/8" x 30"
21.	*A1028	2	Hose Assembly, 3/8" x 186", 12 Row 30"
	*A1057	2	Hose Assembly, 3/8" x 216", 16 Row 30"
22.	G6400-L-08	-	Long Connector W/O-Ring, 3/4"-16 Male JIC To O-Ring
	GR1037	-	O-Ring
23.	*A3122	4	Hose Assembly, 3/8" x 10 1/2", 16 Row 30"
24.	G6500-08	-	Swivel Elbow, 90°, 3/4"-16 Male JIC To Female
25.	G2703-08-08-10	-	Bulkhead Tee 7/8"-14 Male JIC To 3/4"-16 JIC

* Hydraulic hose is not stocked by KINZE® Repair Parts, but can be made available on a special order basis. Call for quote.

ELECTRICAL COMPONENTS

(TWL19a/TWL18/ELC14/ELC3a/ELC5c/MTR27a/ELC39/TWL26e/ELC8/A9481/ELC12b/MTR27v/A9689b/A10924ELC4/FF27b/FF27c/ELC38/A9201a/A9202a/TWL20g/ELC34/ELC35/ELC10c)

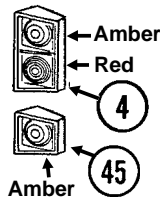
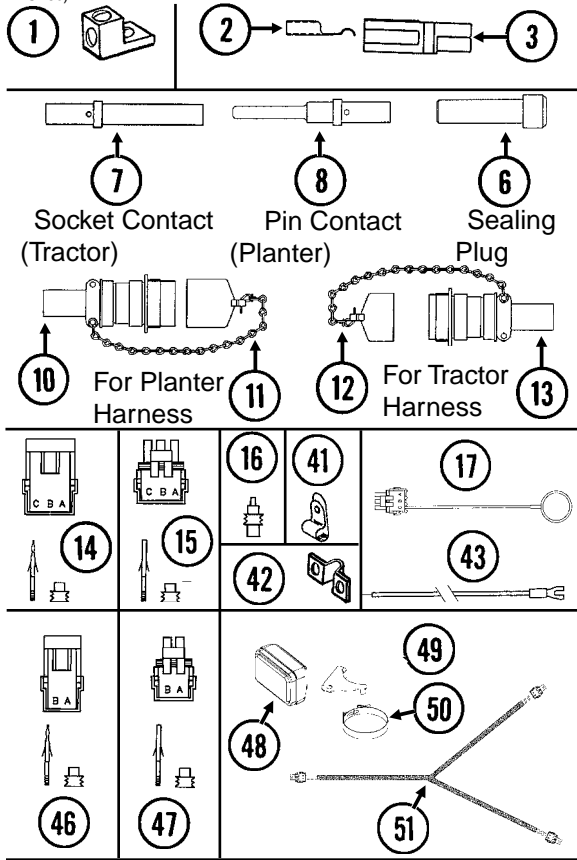

See "Wing Frame", pages P60 and P61 for light brackets.

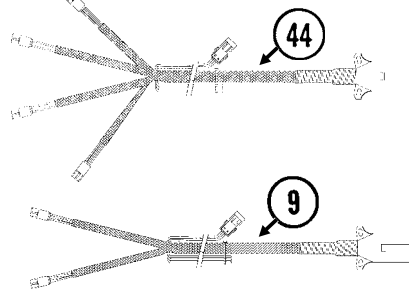

See "Digital Vacuum Gauge, Analog Vacuum Gauge And Vacuum Fan Assembly", pages P40 and P41 for vacuum gauge electrical components.

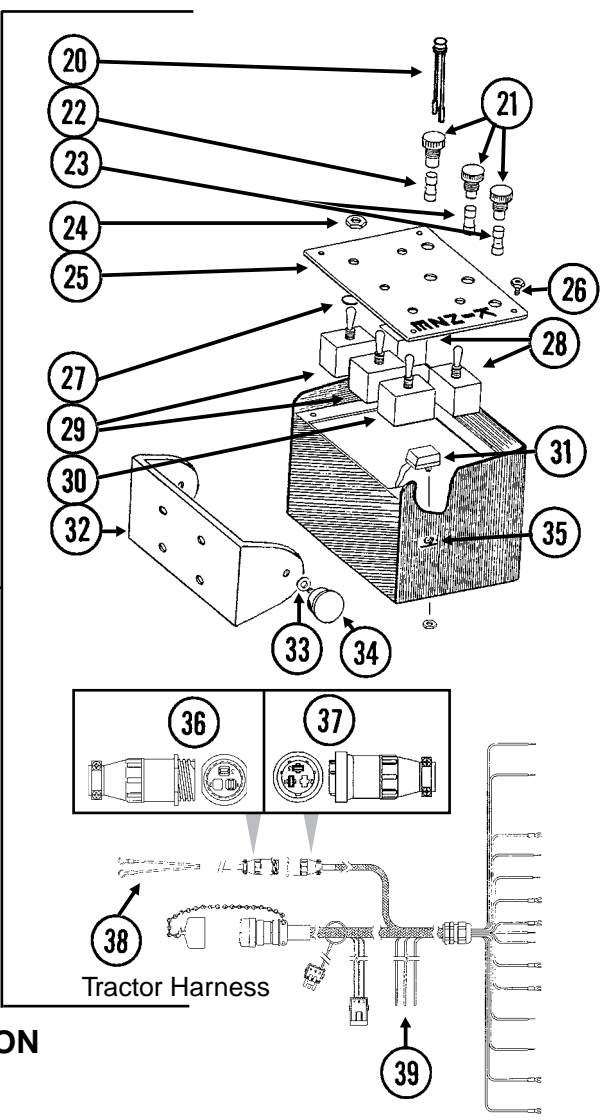
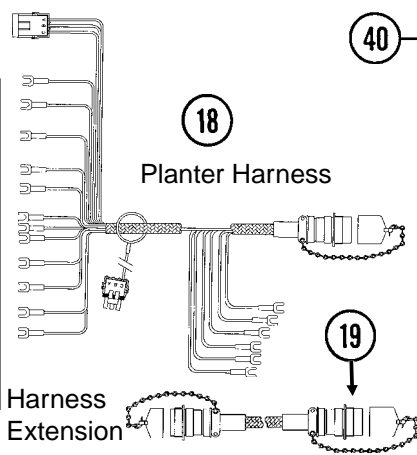

ITEM	PART NO.	QTY.	DESCRIPTION
1.	GA3584	-	Ground Clamp
2.	GD9530	-	Contact
3.	GD9529	-	Housing, Black
	GD12726	-	Housing, Red
4.	GA6699	1	Double Light Assembly (Shown)
	GA6700	1	Double Light Assembly
	GR1203	-	Red Lens
	GR1204	-	Amber Lens
	GR1205	-	Cover
	GR1206	-	Rubber Grommet (4)
	GR1207	-	Lamp Unit
	GR1208	-	Bulb
5.	GA9096	-	Harness Extension, 42"
6.	GD8739	-	Sealing Plug, No. 12
7.	GD8740	-	Socket Contact, No. 14
8.	GD8741	-	Pin Contact, No. 14

ELECTRICAL COMPONENTS

ITEM	PART NO.	QTY.	DESCRIPTION
9.	GA9202	-	Wiring Harness W/7 Terminal Female Connector, 786" (2 Light Connections), 12 Row 30"
	GA9204	-	Wiring Harness W/7 Terminal Female Connector, 882" (2 Light Connections), 16 Row 30"
	GA5385	-	7 Terminal Female Connector
10.	GA6109	1	Connector W/Cable Clamp, 23 Pin Capacity
11.	GA7862	-	Dust Cap W/Chain
12.	GA7863	-	Dust Cap W/Chain
13.	GA6108	1	Connector W/Cable Clamp, 23 Socket Capacity
14.	G1K248	-	3-Pin Female Connector Kit (Black), Includes: (3) 3-Pin Female Housings, (9) Pin Contacts, (9) Seals
15.	G1K252	-	3-Pin Male Connector Kit (Black), Includes: (3) 3-Pin Male Housings, (9) Socket Contacts, (9) Seals
16.	GD11089	-	Sealing Plug
17.	GA8047	-	Dust Plug (Black)
18.	GA9112	1	Wiring Harness W/Dust Cap, 516", 12 Row 30"
	GA9113	-	Wiring Harness W/Dust Cap, 612", 16 Row 30"
19.	GA7399	-	Harness Extension W/Dust Caps, 180"
20.	GA7077	1-4	Indicator Light
21.	GA2612	3-5	Fuse Holder W/Spade, 1 ³³ / ₅₀ "
22.	GD2829	1-2	Fuse, 15 Amp, Type AGC
23.	GD10243	2-6	Fuse, MDL 10 Amp Delay Action
24.	GR1363	5	Hex Face Nut, ¹⁵ / ₃₂ "-32
	GR1364	5	Internal Tooth Lock Washer, ¹⁵ / ₃₂ "
25.	GA8734	1	Cover Plate (Shown)
	GA8735	-	Cover Plate, Planters Equipped With Two-Speed Point Row Clutch
26.	GR1292	4	Pan Head Screw, No. 8-32 x 1/2"
27.	GD3860	-	O-Ring (If Applicable)
28.	GA2528	2	Switch, 3 Position Toggle, On-Off-On
29.	GA6978	2	Switch, 3 Position Toggle, Momentary On-Off-Momentary On
30.	GA6977	1-2	Switch, 2 Position Toggle, On-Off
31.	GA8731	1	Switch, Push Button W/Transformer
32.	GD9896	1	Mounting Bracket
33.	G10211	4	Washer, 1/4" SAE
34.	GA6975	2	Knob
35.	GR1290	2	Cage Nut, 1/4"-20
36.	G1K267	-	Console Cable Connector Kit, Includes: (1) 3-Pin Connector, (1) Cable Clamp, (3) Male Terminal Pins
37.	G1K268	-	Console Cable Connector Kit, Includes: (1) 3-Pin Connector, (1) Cable Clamp, (1) Lock Ring, (3) Female Terminal Pins
38.	GA7856	1	Power Lead Adapter
39.	GA8729	1	Wiring Harness W/Dust Cap And Power Cable
40.	G7633X	-	Backlit Control Console Assembly W/Mounting Brackets, Short Harness W/Dust Cap And Power Cable
	G7639X	-	Backlit Control Console Assembly W/Mounting Brackets, Short Harness W/Dust Cap And Power Cable (Planters Equipped With Two-Speed Point Row Clutch)
41.	GD6291	-	Insulated Clamp, ³ / ₈ "
	GD13348	-	Insulated Clamp, ¹¹ / ₁₆ "
42.	GD13310	-	Jumper, ⁷ / ₁₆ "
43.	GA9481	-	Jumper Wire W/Fork Terminal, 13"
	G10996	-	Fork Terminal
44.	GA9201	1	Wiring Harness W/7 Terminal Female Connector, 714" (4 Light Connections), 8 Row 36"/38"
	GA9203	-	Wiring Harness W/7 Terminal Female Connector, 870" (4 Light Connections), 12 Row 36"/38"
	GA5385	-	7 Terminal Female Connector
45.	GA6701	1	Single Amber Light Assembly
	GR1204	-	Amber Lens
	GR1206	-	Rubber Grommet (2)
	GR1207	-	Lamp Unit
	GR1208	-	Bulb
46.	G1K321	-	2-Pin Female Connector Kit (Black), Includes: (3) 2-Pin Female Housings, (6) Pin Contacts, (6) Seals
47.	G1K320	-	2-Pin Male Connector Kit (Black), Includes: (3) 2-Pin Male Housings, (6) Socket Contacts, (6) Seals
48.	GA9689	2	Work Light Assembly
49.	GD16046	2	Bracket, 4 1/4" x 4"
50.	G11159	1-2	T-Bolt Clamp, 3 1/2", Stainless Steel
51.	GA10924	1	Wiring Harness, 348"

NOTE: See "Point Row Clutch" or "Two-Speed Point Row Clutch" for R.H. and L.H. Wiring Harness for the point row clutches. See "KPM III Electronic Seed Monitor" for those components.

KPM III ELECTRONIC SEED MONITOR

(MTR59)

Shaft Rotation Sensor

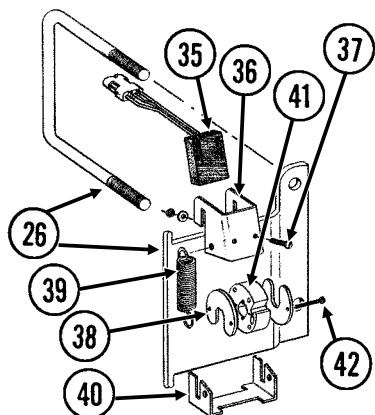

Radar Distance Sensor

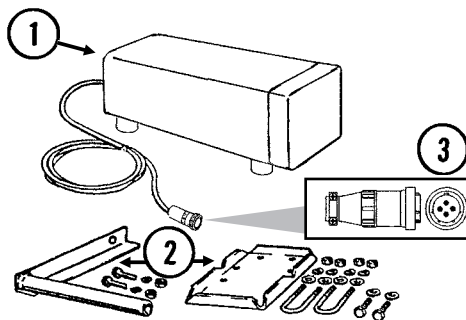

Magnetic Distance Sensor (MDS)

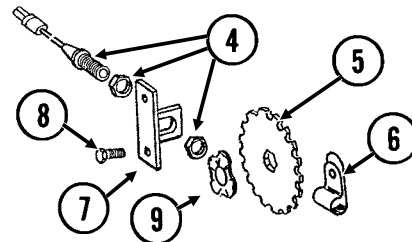

Shaft Rotation Sensor

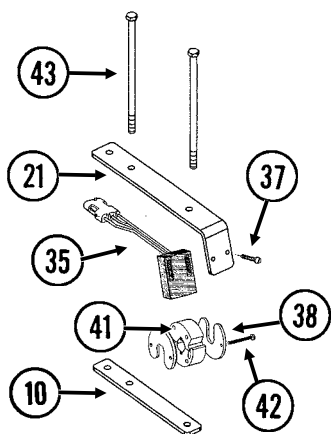

Power Lead Adapter

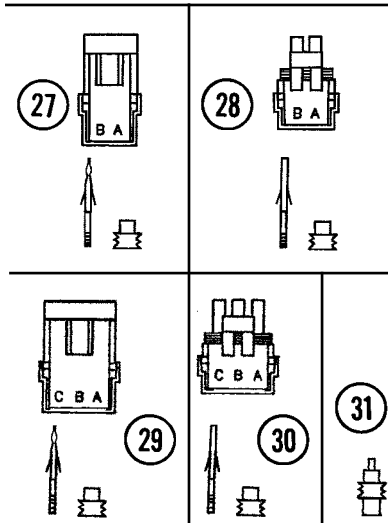
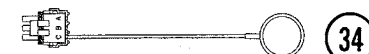
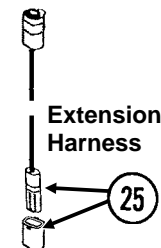
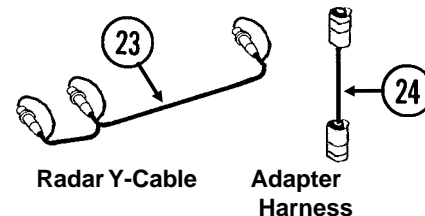
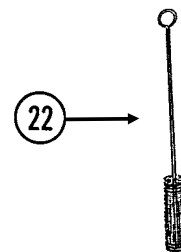
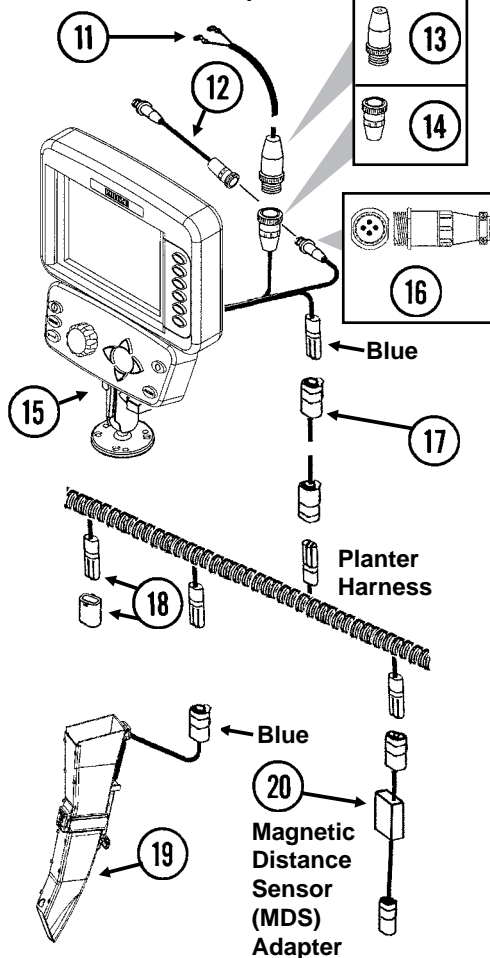

ITEM	PART NO.	QTY.	DESCRIPTION
------	----------	------	-------------

1.	GA7858	-	Radar Distance Sensor W/20' Cable
2.	GA8026	-	Radar Sensor Pipe/Mounting Bracket Package
3.	G1K323	-	4-Pin Connector Kit W/Female Housing, Includes: (4) Pins, (1) Cable Clamp
4.	GA5600	1	Magnetic Distance Sensor
5.	GD8751	-	Magnetic Distance Sensor Pulse Wheel
6.	GD6291	-	Insulated Clamp, 3/8"
7.	GD8770	1	Bracket
8.	G10001	2	Hex Head Cap Screw, 3/8"-16 x 1"
	G10229	2	Lock Washer, 3/8"
	G10101	2	Hex Nut, 3/8"-16
9.	GD8771	1	Spring Wave Washer

KPM III ELECTRONIC SEED MONITOR

ITEM	PART NO.	QTY.	DESCRIPTION
10.	GD18168	2	Mount
11.	GA7856	1	Power Lead Adapter
12.	GA9144	-	Monitor/Radar Adapter Cable, 10"
13.	G1K267	-	Console Cable Connector Kit, Includes: (1) Cable Clamp, (1) 3-Pin Connector, (3) Male Terminal Pins
14.	G1K268	-	Console Cable Connector Kit, Includes: (1) Cable Clamp, (1) 3-Pin Connector, (1) Lock Ring, (3) Female Terminal Pins
15.	GA11039	-	KPM III Backlit Console W/Brush (Item 22), Dust Plug (Item 33), Mounting Bracket Assembly, Console Mounting Bracket Hardware And Power Harness
	GA12403	-	Mounting Bracket Assembly, Includes: (2) Mounting Brackets, (2) Connector Halves, (1) Compression Spring, (1) Tension Knob, (1) ¼"-20 x 1 ¾" Hex Head Cap Screw, (1) ¼" Plastic Washer, (1) ¼" Steel Washer
	GR1762	-	Console Mounting Bracket Hardware Package, Includes: (3) No. 10-32 x ⅝" Hex Socket Pan Head Screws, (3) No. 10 Lock Washers
	GR1764	-	Power Harness
16.	G1K322	-	4-Pin Connector Kit W/Male Housing, Includes: (4) Female Socket Contacts And (1) Cable Clamp
17.		-	See Tractor/Planter Wiring Harness, Items 18 And 39 On Pages P104 And P105
18.	GA8022	-	Planter Harness W/Dust Caps, 6 Row (9 Connectors)
	GA7850	-	Planter Harness W/Dust Caps, 8 Row (12 Connectors)
	GA7851	-	Planter Harness W/Dust Caps, 12 Row (16 Connectors)
	GA7852	-	Planter Harness W/Dust Caps, 16 Row (20 Connectors)
	GD11993	-	Dust Cap
19.	GA12650	-	Seed Tube W/Computerized Sensor, EdgeVac®
	GR1737	-	Sensor Only, EdgeVac®
	GA12636	-	Seed Tube (With Holes For Sensor Installation), EdgeVac®
20.	GA7859	1	Magnetic Distance Sensor Adapter (Analog To Digital)
21.	GD18118	2	Shaft Sensor Mount
22.	GR0594	-	Brush
23.	GR0586	1	Radar Y-Cable (Used To Connect Radar Distance Sensor For Multiple Functions)
24.	GA7857	-	Adapter Harness, 1'
25.	GA7854	-	Extension Harness W/Dust Cap, 15'
	GA7855	-	Extension Harness W/Dust Cap, 30'
	GD11993	-	Dust Cap
26.	G1K364	-	Rotation Sensor Mount Kit, Includes: (2) Mounts, (2) GD11721 5" x 7" U-Bolts, (4) G10228 Lock Washers, (4) G10102 Hex Nuts, (1) Instruction
27.	G1K321	-	2-Pin Female Connector Kit (Black), Includes: (3) 2-Pin Female Housings, (6) Pin Contacts, (6) Seals
28.	G1K320	-	2-Pin Male Connector Kit (Black), Includes: (3) 2-Pin Male Housings, (6) Socket Contacts, (6) Seals
29.	G1K248	-	3-Pin Female Connector Kit (Black), Includes: (3) 3-Pin Female Housings, (9) Pin Contacts, (9) Seals
	G1K362	-	3-Pin Female Connector Kit (Blue), Includes: (3) 3-Pin Female Housings, (9) Pin Contacts, (9) Seals
30.	G1K252	-	3-Pin Male Connector Kit (Black), Includes: (3) 3-Pin Male Housings, (9) Socket Contacts, (9) Seals
	G1K363	-	3-Pin Male Connector Kit (Blue), Includes: (3) 3-Pin Male Housings, (9) Socket Contacts, (9) Seals
31.	GD11089	-	Sealing Plug
32.	G1K249	-	Acre Counter Switch Kit
33.	GA8046	-	Dust Plug (Black)
	GA9978	-	Dust Plug (Blue)
34.	GA8047	-	Dust Plug (Black)
	GA9979	-	Dust Plug (Blue)
35.	GR1415	1	Rotation Sensor
36.	GD11169	1	Mount
37.	G10757	2	Pan Head Screw, No. 10-32 x 1 ½"
	G10243	2	Washer, No. 10 SAE
	G10758	2	Hex Nut, No. 10-32
38.	GD11474	2	Cover
39.	GD5857	2	Spring
40.	GD11170	1	Spring Mount
41.	GR1414	1	Actuator
42.	G10927	2	Pan Head Machine Screw, No. 8-32 x 1 ¼", Stainless Steel
	G10931	2	Lock Washer, No. 8, Internal/External, Stainless Steel
	G10928	2	Hex Nut, No. 8-32, Stainless Steel
43.	G10686	4	Hex Head Cap Screw, ⅜"-16 x 8"
	G10229	4	Lock Washer, ⅜"
	G10101	4	Hex Nut, ⅜"-16
A.	GA6147	-	Magnetic Distance Sensor And Mounting Package (Items 4-9)

PUSH ROW UNIT DRIVE

(TWL316)

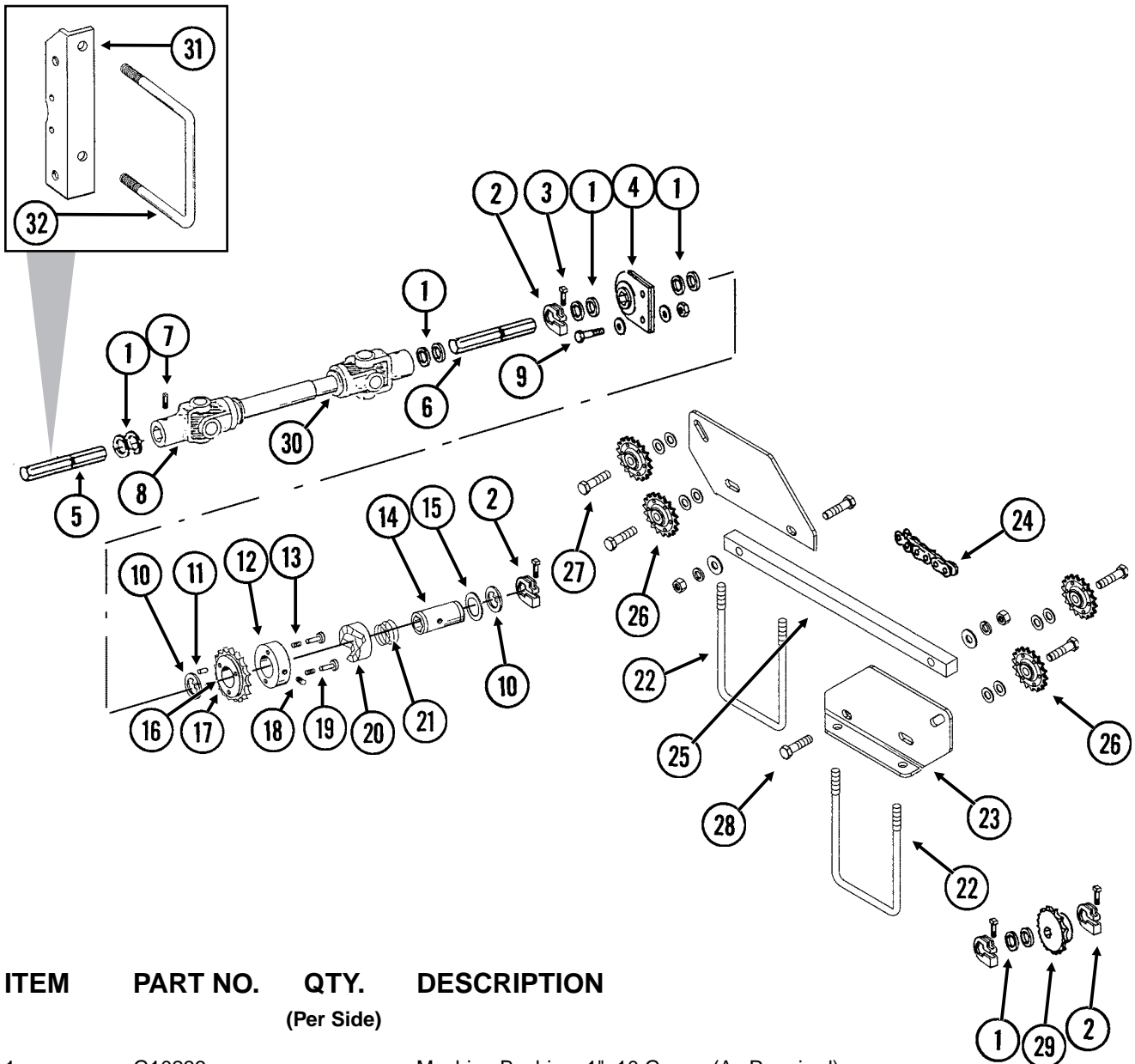

ITEM	PART NO.	QTY.	DESCRIPTION
		(Per Side)	
1.	G10233	-	Machine Bushing, 1", 10 Gauge (As Required)
2.	GD11045	-	Lock Clamp
3.	G10130	-	Square Head Machine Bolt, 5/16"-18 x 1 3/4"
	G10923	-	Flange Nut, 5/16"-18, No Serration
4.	GA2180	-	Hanger Bearing, 7/8" Hex Bore
5.	GD0914-35	1	Hex Shaft, 7/8" x 35" (No Holes), Inner R.H. Side, 12 Row 30"
	GD0914-76	1	Hex Shaft, 7/8" x 76" (No Holes), Inner L.H. Side, 12 Row 30"
	GD0914-48	-	Hex Shaft, 7/8" x 48" (No Holes), Inner R.H. Side, 16 Row 30"
	GD0914-72	-	Hex Shaft, 7/8" x 72" (No Holes), Inner L.H. Side, 16 Row 30"
6.	GD0914-90	1	Hex Shaft, 7/8" x 90" (No Holes), Outer R.H. Side, 12 Row 30"
	GD0914-107	1	Hex Shaft, 7/8" x 107" (No Holes), Outer L.H. Side, 12 Row 30"
	GD0914-128	-	Hex Shaft, 7/8" x 128" (No Holes), Outer R.H. Side, 16 Row 30"
	GD0914-166.75	-	Hex Shaft, 7/8" x 166 3/4" (No Holes), Outer L.H. Side, 16 Row 30"
7.	G10688	-	Square Head Set Screw, 3/8"-16 x 5/8"
8.	GA7052	-	U-Joint W/Grease Fitting, Female, 10 1/4" Long
	GR1557	-	Grease Fitting, 45°, Metric
	GR1297	-	Inboard Yoke And Outer Profile
	GR1294	-	Cross And Bearing Kit
	GR1293	-	Yoke, 7/8" Hex

PUSH ROW UNIT DRIVE

ITEM	PART NO.	QTY. (Per Side)	DESCRIPTION
9.	G10004	-	Hex Head Cap Screw, 3/8"-16 x 1 1/4"
	G10210	-	Washer, 3/8" USS
	G10229	-	Lock Washer, 3/8"
	G10101	-	Hex Nut, 3/8"-16
10.	G10496	2	External Inverted Snap Ring, 1 1/2"
11.	G10968	1	Spring Pin, 5/32" x 7/16"
12.	GR1405	1	Lock Collar
13.	GR1413	1	Spring
14.	GR1407	1	Drive Shaft
15.	GR1411	1	Shim
16.	GR1406	1	Bushing
17.	GR1412	1	Sprocket, 19 Tooth
18.	G10535	1	Hex Socket Set Screw, 3/8"-16 x 3/4"
19.	GR1410	1	Pin
20.	GR1409	1	Knurled Collar
21.	GR1408	1	Compression Spring
22.	GD8306	2	U-Bolt, 7" x 5" x 1/2"-13
	G10228	4	Lock Washer, 1/2"
	G10102	4	Hex Nut, 1/2"-13
23.	GD18094	2	Plate (Shown)
	GD18066	-	Plate
24.	G3310-226	1	Chain, No. 40, 226 Pitch Including Connector Link
	GR0912	-	Connector Link, No. 40
25.	GD18067	1	Brace
26.	GA7154	4	Sprocket W/Bearing, 18 Tooth
27.	G10016	4	Hex Head Cap Screw, 1/2"-13 x 2"
	G10206	8	Washer, 1/2" SAE
	G10228	4	Lock Washer, 1/2"
	G10102	4	Hex Nut, 1/2"-13
28.	G10016	2	Hex Head Cap Screw, 1/2"-13 x 2"
	G10216	2	Washer, 1/2" USS
	G10228	2	Lock Washer, 1/2"
	G10102	2	Hex Nut, 1/2"-13
29.	GA5107	2	Sprocket, 19 Tooth
30.	GA7051	1	U-Joint W/Grease Fitting, Male, 12 1/4" Long
	GR1557	-	Grease Fitting, 45°, Metric
	GR1296	-	Inner Profile
	GR1295	-	Inboard Yoke
	GR1301	-	Spring Pin, 8 mm x 50 mm
	GR1294	-	Cross And Bearing Kit
	GR1293	-	Yoke, 7/8" Hex
31.	GD11972	1	Support Angle, R.H.
32.	GD1113	-	U-Bolt, 5" x 7" x 5/8"-11
	G10230	-	Lock Washer, 5/8"
	G10104	-	Hex Nut, 5/8"-11
A.	GA8092	-	Clutch Sprocket Assembly, 19 Tooth (Items 10-21)
B.	G1K269	-	Lock Clamp Kit (Items 2 And 3)
C.	G1K331	-	Clutch Sprocket Kit (Items 11, 16 And 17)

PISTON PUMP MOUNT AND GROUND DRIVE WHEEL

(TWL219rr)

48 Tooth Drive Sprocket And 18 Tooth Driven Sprocket

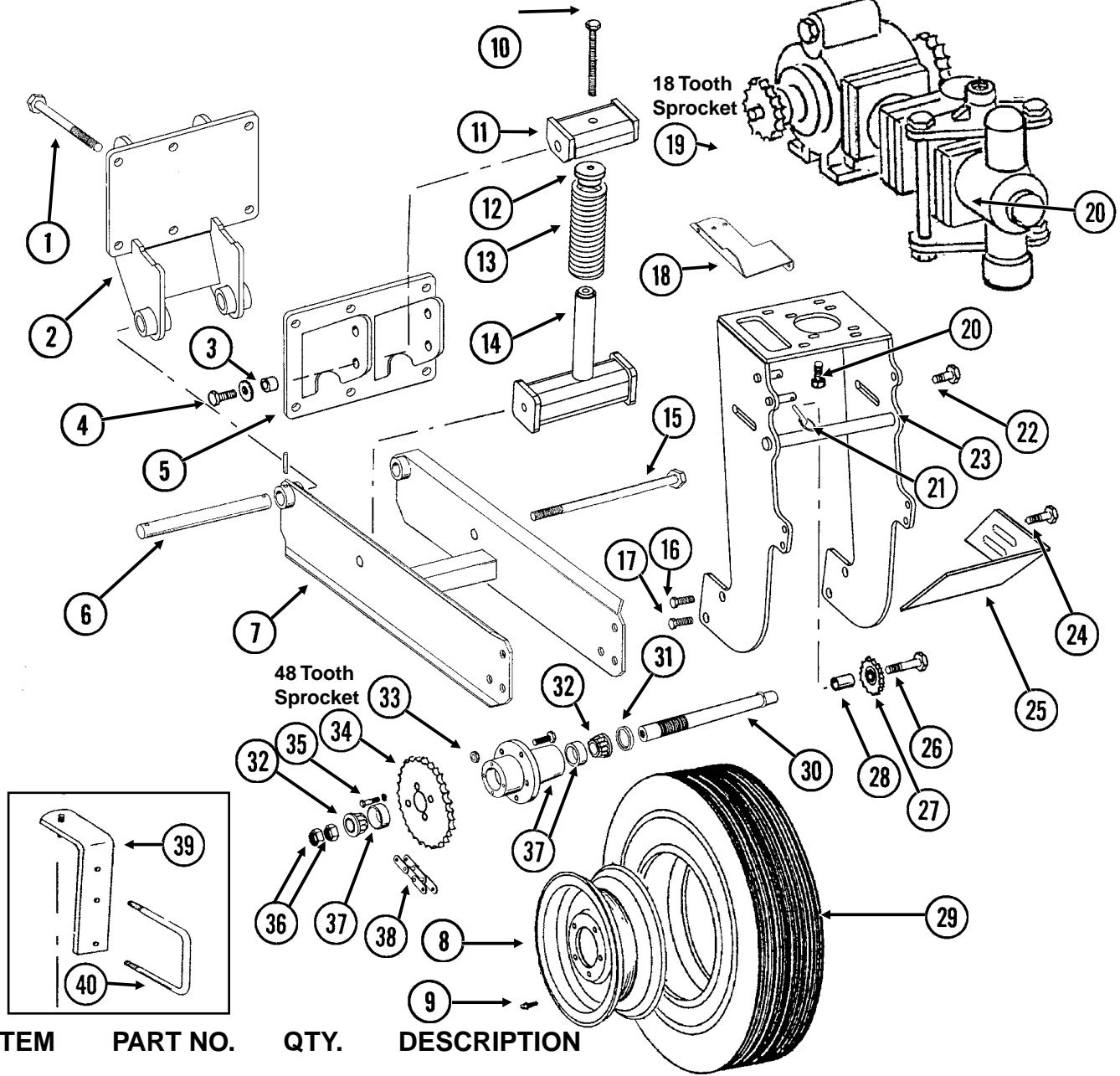

ITEM	PART NO.	QTY.	DESCRIPTION
1.	G10830	6	Hex Head Cap Screw, 5/8"-11 x 7 1/2"
	G10230	6	Lock Washer, 5/8"
	G10104	6	Hex Nut, 5/8"-11
2.	GA10624	1	Wheel Arm Mount
3.	GB0218	2	Bushing, 2 1/32" I.D. x 7/8" O.D. x 1 9/32" Long
4.	G10005	2	Hex Head Cap Screw, 5/8"-11 x 1 3/4"
	GD7805	2	Special Washer, 5/8", Hardened
	G10107	2	Lock Nut, 5/8"-11
5.	GA10622	1	Spring Mount
6.	GD2681	1	Pin, 1 1/4" x 13 1/2"
	G10460	2	Cotter Pin, 1/4" x 2"
7.	GA10621	1	Arm W/Grease Fittings
	G10641	2	Grease Fitting, 1/8" NPT
8.	GA0241	1	Wheel, 5" x 15"
9.	GD1166	1	Valve Stem

PISTON PUMP MOUNT AND GROUND DRIVE WHEEL

ITEM	PART NO.	QTY.	DESCRIPTION
10.	G10012	1	Hex Head Cap Screw, 5/8"-11 x 6 1/2"
	GD7805	1	Special Washer, 5/8", Hardened
11.	GA10908	1	Spring Mount
12.	GB0196	1	Washer
13.	GD7831	1	Compression Spring
14.	GA10907	1	Spring Guide
15.	G11122	1	Hex Head Cap Screw, 5/8"-11 x 12"
	G10107	1	Lock Nut, 5/8"-11
16.	G10026	2	Hex Head Cap Screw, 3/4"-10 x 2"
	G10231	2	Lock Washer, 3/4"
17.	G11042	2	Hex Head Cap Screw, 3/4"-10 x 1 3/4"
	G10231	2	Lock Washer, 3/4"
	G10105	2	Hex Nut, 3/4"-10
18.	GD13744	1	Hose Holder
19.	GR1146	1	Sprocket, 18 Tooth
20.		-	Customer Supplied Piston Pump
21.	GD2558	1	Lynch Pin, 1/4"
22.	G10007	2	Hex Head Cap Screw, 5/8"-11 x 1 1/2"
	G10217	2	Washer, 5/8" USS
	G10230	2	Lock Washer, 5/8"
	G10104	2	Hex Nut, 5/8"-11
23.	GA10894	1	Pump Mount
24.	G10017	2	Hex Head Cap Screw, 1/2"-13 x 1 1/2"
	G10216	2	Washer, 1/2" USS
	G10228	2	Lock Washer, 1/2"
	G10102	2	Hex Nut, 1/2"-13
25.	GD13328	1	Scraper
26.	G10013	1	Hex Head Cap Screw, 5/8"-11 x 3 1/2"
	G10205	1	Washer, 5/8" SAE
	G10230	1	Lock Washer, 5/8"
	G10104	1	Hex Nut, 5/8"-11
27.	GA0262	1	Idler Sprocket W/Bearing, 15 Tooth
28.	GD7817-05	1	Spacer, 1 1/16" I.D. x 1 1/4" Long
29.	GD0844	1	Tire, 7.60" x 15", 8 Ply (Specify Brand*)
30.	GA2559	1	Spindle
31.	GA0252	2	Seal
32.	GA0251	2	Bearing
33.	GR0267	5	Lug Nut, 1/2"-20
34.	G2500-84	1	Sprocket, 48 Tooth
35.	G10019	4	Hex Head Cap Screw, 5/16"-18 x 1"
	G10232	4	Lock Washer, 5/16"
36.	GD0831	2	Shoulder Nut, 1 1/4"-12 UNF-2A
37.	GA0547	1	Hub W/Cups And Studs, 5 Bolt
	GR0190	2	Cup
	GR0204	5	Stud
38.	G3200-62	1	Chain, No. 2050, 62 Pitch Including Connector Link
	GR0195	-	Connector Link, No. 2050
39.	GA6527	1	Mount, 3/4" NPT
40.	GD1113	1	U-Bolt, 5" x 7" x 5/8"-11
	G10230	2	Lock Washer, 5/8"
	G10104	2	Hex Nut, 5/8"-11

* Specific brand requests will be supplied only as available from current KINZE® Repair Parts stock. If a specific brand requested is not in stock, the brand available will be supplied. Different brand tires may have different diameters. Change in tire brand may affect rates. Field checks are recommended after any change in tires.

REAR TRAILER HITCH

PHA032/LFC003(TWL47a)

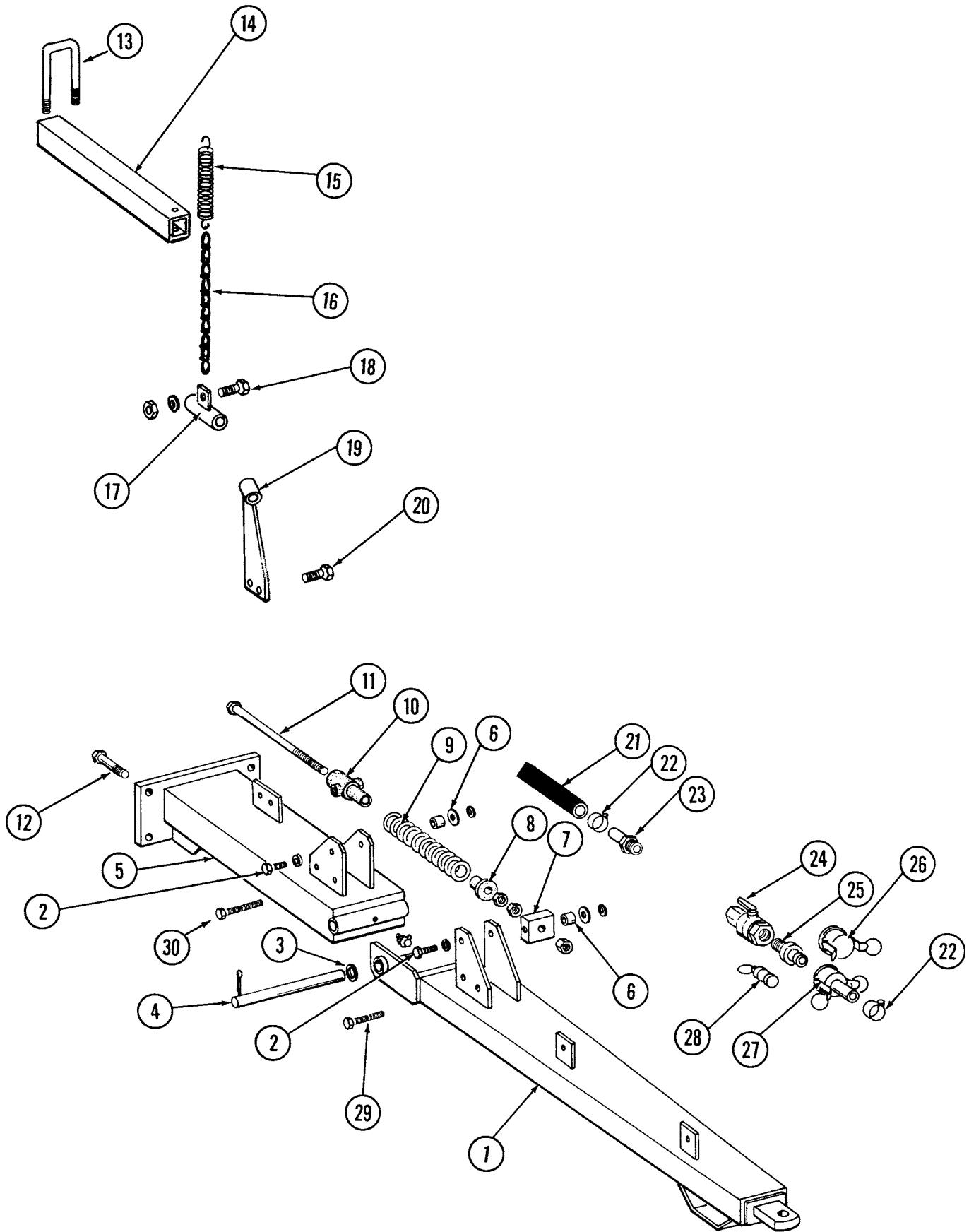

REAR TRAILER HITCH

ITEM	PART NO.	QTY.	DESCRIPTION
1.	GA6961	1	Hitch
2.	G10007	4	Hex Head Cap Screw, 5/8"-11 x 1 1/2"
	GD7805	4	Special Washer, 5/8", Hardened
	G10230	4	Lock Washer, 5/8"
3.	G10226	2	Washer, 1 1/4" SAE
4.	GD3547	1	Pin, 1 1/4" x 12 3/4"
	G10460	2	Cotter Pin, 1/4" x 2"
5.	GA6960	1	Hitch
6.	GB0218	4	Bushing, 2 1/32" I.D. x 7/8" O.D. x 1 9/32" Long
7.	GD7908	1	Tap Block
8.	GB0213	1	Spring Seat
9.	GD2115	1	Spring
10.	GB0206	1	Rod Guide
11.	GD7907	1	Special Bolt
	G10105	3	Hex Nut, 3/4"-10
12.	G10826	5	Hex Head Cap Screw, 1"-8 x 2 1/2"
	G10396	5	Lock Nut, 1"-8
13.	GD2721	2	U-Bolt, 2" x 2" x 1/2"-13
	G10228	4	Lock Washer, 1/2"
	G10102	4	Hex Nut, 1/2"-13
14.	GD10196	-	Hanger Tube
15.	GD0829	-	Spring
16.	G3305-03	-	Twin Loop Chain, 15 Links
17.	GA7209	-	Hose Support
18.	G10064	1	Hex Head Cap Screw, 1/4"-20 x 1"
	G10209	2	Washer, 1/4" USS
	G10110	1	Lock Nut, 1/4"-20, Grade B
19.	GA7208	-	Hose Support
20.	G10004	2	Hex Head Cap Screw, 3/8"-16 x 1 1/4"
	G10108	2	Lock Nut, 3/8"-16
21.	G4200-01	1	Hose, 1 1/4" x 22'
22.	G10672	6	Hose Clamp, No. 28
23.	G10626	1	Adapter, 1 1/4" NPT To Barb
24.	GA4976	1	Shutoff Valve, 1 1/4" NPT
	GR1015	-	Body O-Ring
	GR1016	-	Stem O-Ring
	GR1017	-	Teflon Seat
	GR1018	-	Ball
	GR1019	-	Handle
25.	GD1514	1	Adapter, 1 1/4" Male NPT To Cam Lock
26.	GD1515	1	Dust Cap, 1 1/4" Cam Lock
27.	GD1516	1	Adapter, 1 1/4" Barb To Female Cam Lock
28.	GD1517	1	Dust Plug, 1 1/4" Male Cam Lock
29.	G10172	1	Hex Head Cap Screw, 3/8"-16 x 5"
	G10229	1	Lock Washer, 3/8"
	G10101	1	Hex Nut, 3/8"-16
30.	G10756	1	Hex Head Cap Screw, 3/8"-16 x 6"
	G10229	1	Lock Washer, 3/8"
	G10101	1	Hex Nut, 3/8"-16

DECALS, PAINT AND MISCELLANEOUS



1



2



3



4



5



6

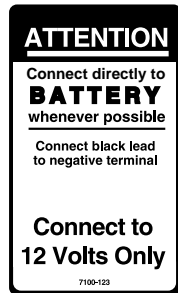

7

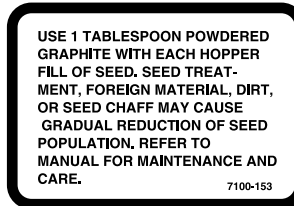

8



9

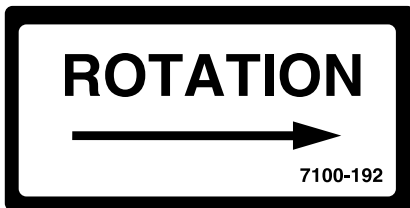

10



11



12

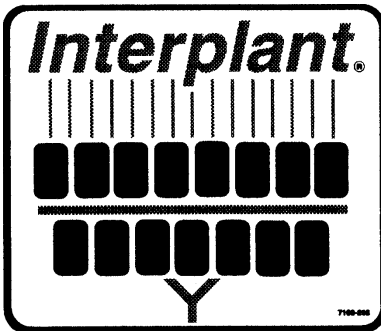

13

TRANSMISSION RATE REDUCTION

DRIVE	DRIVEN	% REDUCTION IN POPULATION
15	30	50
17	30	43
23*	30	23
24	30	20
25*	30	17
26*	30	13
27	30	10

* Use sprockets off seed drive transmission. 7100-214

14



15

NOTE

It is the responsibility of the user to read and understand the Operator's Manual in regards to safety, operation, lubrication and maintenance before operation of this equipment.

AN OPERATOR & PARTS MANUAL IS AVAILABLE FOR THIS MACHINE.

To obtain a manual, furnish model number and serial number and contact your KINZE Dealer or KINZE Manufacturing, Inc., P.O. Box 806 Williamsburg, IA 52361-0806 USA

16



17

18 TORQUE 5/8" SPINDLE BOLTS TO 120 FT/LBS. CHECK PERIODICALLY AND RE-TORQUE AS NEEDED. 7100-231



20

KINZE

3600TR

19

DECALS, PAINT AND MISCELLANEOUS

ROTATE KNURLED COLLAR
ON WRAP SPRING TIGHTENER
TO RELEASE SPRING
TENSION

7100-295

21

CAUTION

SET DOWN PRESSURE SPRINGS TO MINIMUM. LOWER
PLANTER TO GROUND AND EMPTY SEED HOPPERS.
REQUIRES 90 LB MIN TO LIFT.

7100-249

22

WARNING

TO AVOID INJURY --
STAND CLEAR--KEEP OTHERS
AWAY WHEN RAISING OR LOWERING
MARKERS. BEFORE TRANSPORTING
PLANTER FULLY EXTEND HYDRAULIC
CYLINDERS AND INSTALL LOCKING
PINS WHERE PROVIDED.

7100-42

23

WARNING

1. Read and understand the Operator's Manual.
2. Stop the tractor engine before leaving the operator's platform.
3. Keep riders off the machine.
4. Make certain everyone is clear of the machine before starting the tractor engine and operating.
5. Keep all shields in place.
6. Never lubricate, adjust, unclog or service the machine with tractor engine running.
7. Wait for all movement to stop before servicing.
8. Keep hands, feet and clothing away from moving parts.
9. Use flashing warning lights when operating on highways except when prohibited by law.

7100-46

24

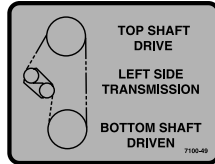

25

WARNING

USE SAFETY
CHAINS PROVIDED.
TOW ONLY WITH
FARM TRACTOR.

7100-302

26

CAUTION

REAR OF PLANTER SWINGS
WIDE IN TURNS. ALWAYS
ALLOW SUFFICIENT ROOM
TO CLEAR OBSTACLES
WHEN TURNING.

7100-63

27

WARNING

NEVER WALK UNDER OR WORK
ON PLANTER WHEN IT IS
RAISED WITHOUT SUPPORTING
THE FRAMES WITH
ADDITIONAL SUPPORTS.

7100-68

28

CAUTION

AVOID UNEVEN LOADING
OF HOPPERS, ESPECIALLY
DURING TRANSPORT

7100-75

29

WARNING

TO AVOID INJURY
ALWAYS USE HYDRAULIC CYLINDER
SAFETY LOCKOUT CHANNELS WHEN
TRANSPORTING PLANTER ON THE
ROAD. AFTER USE RETURN TO
STORAGE LOCATION.

7100-83

30

DANGER

THIS PLANTER IS DESIGNED TO BE
DRIVEN BY GROUND TIRES ONLY.
THE USE OF HYDRAULIC, ELECTRIC
OR PTO DRIVES MAY CREATE
SERIOUS SAFETY HAZARDS TO YOU
AND THE PEOPLE NEARBY. IF YOU
INSTALL SUCH DRIVES YOU MUST
FOLLOW ALL APPROPRIATE SAFETY
STANDARDS AND PRACTICES
TO PROTECT YOU AND OTHERS NEAR
THIS PLANTER FROM INJURY.

7100-89

31

WARNING

THIS MACHINE HAS BEEN DESIGNED
AND BUILT WITH YOUR SAFETY IN
MIND. DO NOT MAKE ANY
ALTERATIONS OR CHANGES TO THIS
MACHINE. ANY ALTERATION TO THE
DESIGN OR CONSTRUCTION MAY
CREATE SAFETY HAZARDS.

7100-90

32

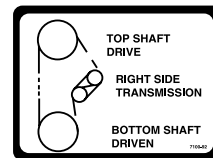

33

A A

34



35

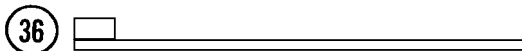

36

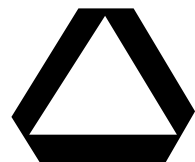

37



38



39

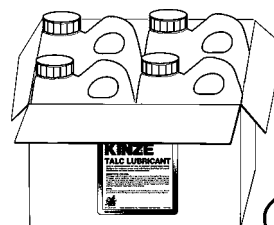

40



43

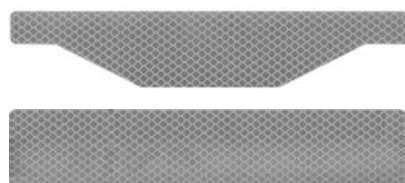

41

42

WARNING

STAY CLEAR
OF DISCHARGE
WHILE FAN
IS RUNNING

7100-301

44

IMPORTANT

-FAN MOTOR CASE DRAIN-
ALWAYS CONNECT THE FAN MOTOR CASE
DRAIN HOSE TO THE TRACTOR ZERO
PRESSURE RETURN. DO NOT CONNECT TO
THE TRACTOR SCV OR MOTOR RETURN
PORTS AS FAN HYDRAULIC MOTOR FAILURE
WILL OCCUR.

7100-329

45

DECALS, PAINT AND MISCELLANEOUS



46



47

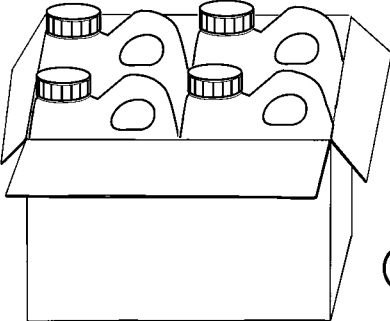

48

DECALS, PAINT AND MISCELLANEOUS

ITEM	PART NO.	QTY.	DESCRIPTION
1.	G7100-02	3	Decal, Warning
2.	G7100-110	-	Decal, Grease Weekly
3.	G7100-111	-	Decal, Oil Daily
4.	G7100-115	-	Decal, Warning (1 Per Granular Chemical Hopper)
5.	G7100-116	-	Decal, Grease Daily
6.	G7100-117	1	Decal, Danger
7.	G7100-123	1	Decal, Attention
8.	G7100-153	-	Decal, Information (1 Per Seed Meter)
9.	G7100-177	1	Decal, Twin-Line®, ¾" x 3"
10.	G7100-192	-	Decal, Point Row Clutch Rotation
11.	G7100-200	-	Decal, Warning
12.	G7100-201	1	Decal, Information
13.	G7100-208	-	Decal, Interplant®
14.	G7100-214	-	Decal, Two-Speed Point Row Clutch Rate Reduction
15.	G7100-215	1	Decal, Danger
16.	G7100-217	-	Decal, Note
17.	G7100-219	-	Decal, Warning
18.	G7100-234	-	Decal, Bolt Torque
19.	G7100-332	2	Decal, KINZE® 3600TR
20.	G7100-247	-	Decal, Logo, 4 ⅜" x 4 ½" (2 Per Row Unit)
	G7100-252	-	Decal, Logo, 3 ½" x 3 ⅝" (Hopper Panel Extension)
21.	G7100-295	-	Decal, Spring Tension Release
22.	G7100-249	-	Decal, Caution
23.	G7100-42	4	Decal, Warning
24.	G7100-46	1	Decal, Warning
25.	G7100-49	1	Decal, Left Side Transmission
26.	G7100-302	1	Decal, Warning
27.	G7100-63	2	Decal, Caution
28.	G7100-68	3	Decal, Warning
29.	G7100-75	4	Decal, Caution
30.	G7100-83	2	Decal, Warning (1 Per Marker Lockup)
31.	G7100-89	2	Decal, Danger
32.	G7100-90	1	Decal, Warning
33.	G7100-92	1	Decal, Right Side Transmission
34.	GD10057-01	-	Hose Identification Sleeve, Red AA
	GD10057-02	-	Hose Identification Sleeve, Red BB
	GD10057-03	-	Hose Identification Sleeve, Blue AA
	GD10057-04	-	Hose Identification Sleeve, Blue BB
35.	GPM0211	-	Operator & Parts Manual, Model 3600TR (EdgeVac® Seed Metering)
36.	GD1512	-	Tie Strap, 7 ½"
	GD2117	-	Tie Strap, 14 ½"
	GD1162	-	Tie Strap, 28"
	GD2984	-	Tie Strap, 34"
37.	GD2199	1	SMV Sign
38.	GR0146MPP	-	Powdered Graphite, Twenty-Four 1 Pound Containers
39.	GR0155MPP	-	Blue Paint, Twelve Aerosol Cans
40.	GR1570MPP	-	Talc Lubricant, Four 8 Pound Containers
	GR1828	-	Talc Lubricant, 30 Pound Container
41.	G7100-261	-	Reflective Decal, Red, 1 ¾" x 9", Die-Cut (If Applicable)
	G7100-262	-	Reflective Decal, Amber, 1 ¾" x 9", Die-Cut (If Applicable)
	G7100-263	-	Reflective Decal, Orange, 1 ¾" x 9", Die-Cut (If Applicable)
42.	G7100-258	-	Reflective Decal, Red, 1 ½" x 9", Rectangular (If Applicable)
	G7100-259	-	Reflective Decal, Amber, 1 ½" x 9", Rectangular (If Applicable)
	G7100-260	-	Reflective Decal, Orange, 1 ½" x 9", Rectangular (If Applicable)
43.	G7100-311	2	Decal, EdgeVac®
44.	G7100-301	2	Decal, Warning
45.	G7100-329	-	Tag, Fan Motor Case Drain
46.	G7100-338	-	Decal, Sending Unit
47.	G7100-339	-	Decal, Sending Unit
48.	GR1824MPP	-	Powdered Graphite, Four-Five Pound Containers

DECALS, PAINT AND MISCELLANEOUS

NUMERICAL INDEX

Part No.	Page	Part No.	Page	Part No.	Page
*A1011.....	P101	*A8253.....	P43	G10026.....	P51, P71, P111
*A1018.....	P103	*A8261.....	P43	G10027.....	P63
*A1028.....	P103	*A8263.....	P43	G10028.....	P65
*A1033.....	P102	*A8265.....	P43	G10033.....	P33, P61
*A1034.....	P102	*A8266.....	P43	G10036.....	P27, P69, P82
*A1041.....	P101	*A8267.....	P102	G10037.....	P5, P59, P67, P82
*A1055.....	P102	*A8283.....	P49	G10038.....	P75
*A1057.....	P103	A10759.....	P23	G10039.....	P5, P29, P31, P37, P71
*A1076.....	P102, P103	A12528.....	P55	G10045.....	P33
*A1097.....	P103	A12529.....	P51	G10046.....	P37, P85
*A1103.....	P101	A12582.....	P55	G10047.....	P3, P72, P82
*A1106.....	P101	A12583.....	P51	G10049.....	P65, P77
*A1116.....	P101	A6892.....	P61	G10053.....	P59, P81
*A1129.....	P101	A6893.....	P61	G10054.....	P95
*A1139.....	P101	A6904.....	P61	G10061.....	P18
*A12015.....	P43	A6905.....	P61	G10062.....	P51
*A12017.....	P43	A7220.....	P88	G10063.....	P41
*A12021.....	P43	A7393.....	P59	G10064.....	P16, P60, P61, P70, P81, P113
*A12022.....	P43	A7524.....	P93	G10068.....	P87
*A12023.....	P43	A8797.....	P89	G10071.....	P5
*A12024.....	P43	A8822.....	P93	G10085.....	P59
*A1404.....	P103	A8873.....	P89	G10100.....	P65
*A1424.....	P103	D13169.....	P90	G10101.....	P5, P10, P16, P17, P25, P39, P41, P47, P48, P5, P57, P60, P61, P73, P77, P79, P94, P106, P107, P109, P113
*A1464.....	P49	D13426.....	P90	G10102.....	P5, P9, P15, P33, P37, P47, P49, P51, P55, P59, P63, P65, P67, P69, P71, P82, P83, P85, P87, P94, P109, P111, P113
*A1467.....	P43, P101	G10001.....	P5, P10, P15, P16, P41, P48, P49, P59, P60, P61, P106	G10103.....	P25, P61, P69, P70, P77, P79, P81
*A1478.....	P101	G10002.....	P23	G10104.....	P5, P10, P17, P39, P47, P50, P51, P59, P60, P61, P69, P82, P85, P87, P109, P111, P113
*A1489.....	P101	G10003.....	P3, P25, P35, P47, P55	G10105.....	P47, P50, P59, P65, P71, P111, P113
*A1491.....	P101	G10004.....	P5, P39, P55, P57, P73, P109, P113	G10106.....	P9, P15, P31, P47, P70, P73, P81, P95
*A3118.....	P101	G10005.....	P37, P48, P53, P70, P110	G10107.....	P15, P16, P27, P31, P37, P48, P50, P57, P59, P63, P69, P70, P75, P82, P110, P111
*A3122.....	P103	G10006.....	P15, P33, P50	G10108.....	P3, P5, P18, P23, P39, P41, P49, P51, P55, P57, P61, P65, P69, P79, P82, P88, P113
*A3127.....	P102	G10007.....	P5, P10, P11, P17, P37, P53, P111, P113		
*A3128.....	P103	G10008.....	P85		
*A3131.....	P102	G10009.....	P50, P87		
*A3133.....	P101	G10010.....	P13, P35, P37		
*A3156.....	P101	G10011.....	P37, P63, P85		
*A3163.....	P103	G10012.....	P87, P111		
*A3181.....	P102	G10013.....	P16, P111		
*A3183.....	P101	G10014.....	P13, P37, P51, P55		
*A3215.....	P101	G10015.....	P15		
*A3216.....	P101	G10016.....	P51, P109		
*A3282.....	P49	G10017.....	P5, P29, P31, P51, P55, P63, P69, P70, P71, P85, P87, P111		
*A3283.....	P49	G10018.....	P13, P15		
*A3340.....	P49	G10019.....	P9, P47, P83, P111		
*A3351.....	P49	G10021.....	P9		
*A3352.....	P43	G10022.....	P69		
*A3354.....	P43	G10023.....	P23, P47, P49, P77, P79		
*A3355.....	P43	G10025.....	P59		
*A3356.....	P43				
*A3357.....	P43				
*A3358.....	P43				
*A3369.....	P49				
*A3371.....	P49				
*A3675.....	P49				
*A6201.....	P49				
*A8250.....	P49				

NUMERICAL INDEX

Part No.	Page	Part No.	Page	Part No.	Page
G10109.....	P13, P15, P16, P29, P33, P35, P37, P49, P83	G10227.....	P9, P25, P49, P61, P69, P70, P73, P77, P79, P81, P82	G10348.....	P33
G10110.....	P25, P47, P49, P60, P113	G10228.....	P5, P9, P13, P33, P47, P49, P51, P55, P59, P63, P65, P67, P69, P71, P82, P83, P85, P87, P94, P109, P111, P113	G10371.....	P33
G10111.....	P5, P16, P27, P29, P31, P33, P37, P51, P55, P57, P61, P72, P75, P85, P87	G10229.....	P5, P10, P16, P17, P23, P25, P35, P39, P41, P45, P47, P48, P55, P57, P60, P61, P72, P73, P77, P79, P82, P91, P92, P94, P106, P107, P109, P113	G10374.....	P77, P79
G10112.....	P37, P51, P59	G10230.....	P5, P10, P13, P16, P17, P39, P47, P50, P51, P53, P60, P61, P85, P87, P109, P110, P111, P113	G10396.....	P113
G10118.....	P53	G10231.....	P50, P65, P71, P111	G10400.....	P37
G10128.....	P70, P81	G10232.....	P9, P15, P47, P70, P73, P81, P95, P111	G10403.....	P49
G10130.....	P73, P108	G10233.....	P69, P70, P73, P81, P108	G10404.....	P59
G10131.....	P55, P72	G10234.....	P59	G10408.....	P81
G10133.....	P16, P33, P35, P37, P95	G10235.....	P70, P73, P82	G10409.....	P81
G10148.....	P49	G10237.....	P65	G10412.....	P5, P10, P18, P39
G10152.....	P15	G10243.....	P107	G10427.....	P11, P15
G10157.....	P50, P51, P53	G10253.....	P77	G10430.....	P70, P81
G10159.....	P61, P85, P87	G10257.....	P24, P77	G10436.....	P65
G10168.....	P75, P83	G10260.....	P21	G10437.....	P65
G10169.....	P50, P53	G10284.....	P39	G10438.....	P3
G10171.....	P15, P49	G10303.....	P15, P29, P70, P73	G10439.....	P61
G10172.....	P57, P94, P113	G10304.....	P3	G10441.....	P63
G10194.....	P35	G10305.....	P26	G10448.....	P67
G10201.....	P3, P23, P39	G10306.....	P25	G10449.....	P89
G10203.....	P3, P5, P39, P41, P57, P77	G10307.....	P39	G10452.....	P25
G10204.....	P11, P13	G10308.....	P16, P26	G10453.....	P70
G10205.....	P37, P41, P51, P59, P70, P75, P85, P87, P111	G10309.....	P18	G10456.....	P39
G10206.....	P5, P35, P59, P61, P75, P85, P87, P109	G10310.....	P25	G10457.....	P51
G10207.....	P3	G10312.....	P3, P23, P46, P61, P81	G10460.....	P61, P65, P71, P85, P87, P110, P113
G10209.....	P9, P24, P25, P49, P70, P73, P81, P82, P113	G10315.....	P15, P16, P25	G10462.....	P50, P55, P72
G10210.....	P3, P15, P16, P17, P18, P23, P39, P47, P49, P55, P57, P60, P72, P82, P109	G10318.....	P31, P47	G10463.....	P15, P39, P85, P87
G10211.....	P105	G10322.....	P85, P87	G10468.....	P55
G10213.....	P11, P35, P37	G10323.....	P21	G10470.....	P81
G10216.....	P5, P13, P29, P31, P39, P51, P55, P63, P65, P69, P71, P82, P85, P87, P109, P111	G10325.....	P11, P23	G10496.....	P73, P77, P79, P82, P109
G10217.....	P48, P53, P111	G10326.....	P3	G10497.....	P77
G10218.....	P47, P59	G10328.....	P11, P91, P92	G10499.....	P41
G10219.....	P9, P15, P29, P49	G10330.....	P67	G10501.....	P33, P70, P81
G10226.....	P51, P65, P71, P85, P87, P113	G10336.....	P59	G10503.....	P29, P31, P35, P37, P75
		G10338.....	P13, P18	G10509.....	P88
		G10341.....	P39	G10523.....	P25
		G10345.....	P69	G10527.....	P72
				G10529.....	P26
				G10535.....	P109
				G10536.....	P29, P31, P85, P87
				G10543.....	P47, P59
				G10544.....	P83
				G10546.....	P18, P24, P77, P81
				G10551.....	P3
				G10567.....	P18, P23, P24
				G10570.....	P24
				G10572.....	P31
				G10574.....	P27, P33, P37
				G10581.....	P57, P72, P75
				G10583.....	P95
				G10585.....	P29, P31, P55
				G10595.....	P69, P82
				G10597.....	P29, P31

NUMERICAL INDEX

Part No.	Page	Part No.	Page	Part No.	Page
G10599.....	P16, P17, P39, P41	G10860.....	P69, P72, P75	G11122.....	P111
G10602.....	P18, P21, P23, P24, P69, P72, P75, P81	G10864.....	P25	G11124.....	P41
G10603.....	P21	G10870.....	P69, P72, P75	G11133.....	P41
G10606.....	P61	G10871.....	P94	G11145.....	P46
G10610.....	P51, P71	G10872.....	P79	G11147.....	P46
G10620.....	P3, P13, P18, P23, P46, P61	G10873.....	P79	G11158.....	P49
G10621.....	P18, P23, P26	G10874.....	P61	G11159.....	P105
G10622.....	P11, P26	G10876.....	P79	G11166.....	P41
G10626.....	P113	G10890.....	P70	G11169.....	P55
G10636.....	P65, P71	G10894.....	P55	G11172.....	P21
G10640.....	P13, P53, P59, P67, P85, P87, P89	G10900.....	P77	G11173.....	P21
G10641.....	P55, P85, P110	G10907.....	P88, P89	G11188.....	P47
G10643.....	P37	G10912.....	P11, P39	G11194.....	P46
G10647.....	P65	G10913.....	P67	G11209.....	P25
G10660.....	P24	G10918.....	P75	G11210.....	P21
G10669.....	P3	G10921.....	P24	G11213.....	P21
G10670.....	P23	G10923.....	P73, P108	G11215.....	P41
G10672.....	P113	G10924.....	P13	G11220.....	P5
G10676.....	P47	G10927.....	P107	G11222.....	P18
G10681.....	P45	G10928.....	P107	G11223.....	P53
G10686.....	P107	G10931.....	P107	G11228.....	P35
G10688.....	P72, P108	G10939.....	P88	G11236.....	P35
G10689.....	P57, P63	G10940.....	P13	G11247.....	P9
G10718.....	P39	G10953.....	P47	G1K248.....	P7, P105, P107
G10722.....	P83	G10958.....	P88, P89	G1K249.....	P107
G10724.....	P83	G10962.....	P93	G1K252.....	P7, P105, P107
G10725.....	P83	G10968.....	P109	G1K267.....	P7, P105, P107
G10730.....	P37	G10969.....	P93	G1K268.....	P7, P41, P105, P107
G10732.....	P5, P10, P39	G10972.....	P88, P91, P92	G1K269.....	P73, P109
G10743.....	P75	G10974.....	P35, P37	G1K274.....	P98
G10751.....	P18, P39	G10977.....	P95	G1K275.....	P98
G10752.....	P18	G10979.....	P87	G1K296.....	P13
G10756.....	P113	G10990.....	P91, P92	G1K320.....	P7, P105, P107
G10757.....	P25, P107	G10992.....	P9	G1K321.....	P7, P105, P107
G10758.....	P25, P107	G10996.....	P77, P79, P98, P105	G1K322.....	P107
G10765.....	P35, P37, P50, P77, P79	G11007.....	P3	G1K323.....	P106
G10770.....	P90	G11008.....	P3	G1K324.....	P70
G10779.....	P53, P63	G11009.....	P21	G1K331.....	P109
G10801.....	P15, P16	G11010.....	P37	G1K345.....	P16
G10802.....	P50, P65	G11015.....	P3	G1K362.....	P107
G10804.....	P77, P79	G11016.....	P90	G1K363.....	P107
G10808.....	P65	G11018.....	P5	G1K364.....	P107
G10809.....	P41, P45	G11042.....	P111	G1K380.....	P73, P82
G10810.....	P65	G11053.....	P63	G1K381.....	P73, P82
G10826.....	P113	G11058.....	P51	G1K385.....	P25
G10827.....	P93	G11065.....	P97	G1K395.....	P7
G10828.....	P59	G11066.....	P9, P95	G1K396.....	P7
G10830.....	P47, P110	G11067.....	P95	G1K412.....	P51
G10844.....	P83	G11068.....	P97	G1K426.....	P44
G10857.....	P81	G11073.....	P24	G1K467.....	P35
G10859.....	P77, P79	G11075.....	P73, P82	G2100-03.....	P73, P81
		G11078.....	P73, P82	G2406-10-08.....	P102
		G11081.....	P71	G2500-84.....	P111
		G11098.....	P35	G2501-12-16.....	P49
		G11100.....	P73, P82	G2501-16-20.....	P49

NUMERICAL INDEX

Part No.	Page	Part No.	Page	Part No.	Page
G2603-08.....	P102	G6801-12-10	P49	GA0241	P110
G2700-06-06	P43	G6801-16.....	P48	GA0243	P83
G2700-08.....	P91, P92, P101	G6801-L-08	P95	GA0245	P83
G2700-10.....	P43, P101	G6804-12.....	P49	GA0251	P111
G2700-12.....	P43	G6804-12-12-08	P49	GA0252	P111
G2703-08-08-10	P103	G7100-02.....	P117	GA0257	P83
G2703-10.....	P102	G7100-110.....	P117	GA0262	P111
G306-06.....	P43	G7100-111.....	P117	GA0378	P70
G306-08.....	P65, P91, P92	G7100-115.....	P117	GA0547	P111
G306-10.....	P43, P65	G7100-116.....	P117	GA0895	P71
G306-12.....	P43	G7100-117.....	P117	GA0899	P83
G3200-62.....	P111	G7100-123.....	P117	GA10054	P77
G3302-09.....	P48	G7100-153.....	P117	GA10137	P18
G3303-108.....	P3, P24	G7100-177.....	P117	GA10149	P44
G3303-16.....	P3	G7100-192.....	P117	GA10155	P18
G3303-96.....	P39	G7100-200.....	P117	GA10157	P3
G3305-01.....	P26	G7100-201.....	P117	GA10161	P39
G3305-03.....	P113	G7100-208.....	P117	GA10621	P110
G3310-100.....	P75, P81	G7100-214.....	P117	GA10622	P110
G3310-114.....	P70	G7100-215.....	P117	GA10624	P110
G3310-118.....	P70	G7100-217.....	P117	GA10634	P19
G3310-126.....	P70	G7100-219.....	P117	GA10635	P41
G3310-226.....	P109	G7100-234.....	P117	GA10755	P21
G3310-74.....	P81	G7100-247.....	P117	GA10765	P41
G3310-80.....	P72	G7100-249.....	P117	GA10799	P41
G3400-01.....	P73, P81	G7100-252.....	P117	GA10832	P72
G4200-01.....	P113	G7100-258.....	P117	GA10894	P111
G6325X	P5, P10	G7100-259.....	P117	GA10907	P111
G6400-06.....	P44, P45, P97	G7100-260.....	P117	GA10908	P111
G6400-06-08	P101	G7100-261.....	P117	GA10917	P49
G6400-08.....	P94, P95, P97,P101, P102	G7100-262.....	P117	GA10918	P49
G6400-08-04	P91, P92, P102	G7100-263.....	P117	GA10919	P48
G6400-08-10	P95	G7100-295.....	P117	GA10924	P105
G6400-10.....	P45, P49, P95, P97	G7100-301.....	P117	GA11039	P107
G6400-10-08	P94	G7100-302.....	P117	GA11079	P53
G6400-12.....	P45, P49	G7100-311.....	P117	GA11082	P53
G6400-L-08	P103	G7100-329.....	P117	GA11083	P53
G6408-06.....	P45	G7100-332.....	P117	GA11085	P41
G6408-08.....	P95	G7100-338.....	P117	GA11086	P41
G6408-10.....	P95	G7100-339.....	P117	GA11087	P41
G6408-12.....	P45	G7100-42.....	P117	GA11119	P47
G6408-H04-O	P88, P95, P97	G7100-46.....	P117	GA11152	P47
G6500-06.....	P44, P97	G7100-49.....	P117	GA11153	P47
G6500-08.....	P95, P103	G7100-63.....	P117	GA11154	P41
G6500-12.....	P49	G7100-68.....	P117	GA11155	P41
G6502-06.....	P101	G7100-75.....	P117	GA11156	P41
G6502-12.....	P49	G7100-83.....	P117	GA11159	P41
G6801-06.....	P97	G7100-89.....	P117	GA11160	P41
G6801-06-08	P101	G7100-90.....	P117	GA11164	P46
G6801-08.....	P95, P97, P102	G7100-92.....	P117	GA11166	P47
G6801-08-10	P95	G7566X	P17	GA11200	P65
G6801-10.....	P49	G7633X	P105	GA11520	P27
G6801-10-12	P44, P48	G7639X	P105	GA11523	P49
G6801-12.....	P44	G7698X	P61	GA11544	P49
		GA0167	P83	GA11568	P87

NUMERICAL INDEX

Part No.	Page	Part No.	Page	Part No.	Page
GA11569	P87	GA13169	P9	GA5121	P63, P69
GA11590	P85	GA13335	P71	GA5130	P85
GA11699	P41	GA13594	P51	GA5164	P70
GA11766	P85	GA1676	P83	GA5165	P70
GA11767	P85	GA1677	P83	GA5194	P75
GA11768	P87	GA1678	P83	GA5385	P105
GA11769	P87	GA1679	P83	GA5548	P73
GA11911	P21	GA1720	P5, P10, P39	GA5600	P106
GA11934	P45	GA2007	P18	GA5625	P27
GA11935	P21	GA2012L	P11	GA5651	P5, P10
GA11969	P39	GA2012R	P11	GA5654	P31, P33, P35, P37
GA11971	P39	GA2014	P11, P15, P31, P33, P35, P37	GA5698	P21
GA11982	P5	GA2054	P15	GA5715	P29, P31
GA11987	P41	GA2068	P69	GA5716	P67
GA11988	P9	GA2075	P25	GA5718	P31
GA11989	P9	GA2094	P26	GA5719	P29, P31
GA11991	P9	GA2148	P71	GA5787	P39
GA11992	P9	GA2180	P73, P108	GA5842	P51
GA11993	P9	GA2528	P105	GA5853	P83
GA11994	P9	GA2559	P111	GA5892	P29
GA11995	P9	GA2612	P105	GA6108	P105
GA11997	P9	GA2908	P71	GA6109	P105
GA12102	P9	GA3407	P99	GA6147	P107
GA12104	P9	GA3413	P95, P98	GA6171	P13, P15, P16
GA12133	P21	GA3552	P70	GA6434	P16
GA12143	P18	GA3553	P70	GA6497	P59
GA12144	P18	GA3584	P104	GA6527	P111
GA12154	P21	GA4293	P45, P95, P99	GA6597	P16
GA12163	P53	GA4353	P85	GA6608	P65
GA12164	P53	GA4376	P71	GA6618	P15
GA12165	P53	GA4377	P71	GA6619	P15
GA12191	P69	GA4402	P51	GA6620	P15
GA12192	P69	GA4418	P51	GA6699	P104
GA12235	P35	GA4444	P23	GA6700	P104
GA12235	P37	GA4722	P67	GA6701	P105
GA12236	P33, P35, P37	GA4723	P67	GA6733	P15
GA12249	P46	GA4727	P67	GA6741	P25
GA12256	P35	GA4729	P67	GA6792	P60
GA12358	P9	GA4842	P51	GA6801	P15
GA12403	P107	GA4845	P51	GA6832	P33
GA12404	P9	GA4877	P87	GA6833	P33
GA12577	P50	GA4976	P113	GA6834	P33
GA12584	P50	GA4994	P50	GA6838	P33
GA12626	P9	GA4995	P50	GA6907	P25
GA12636	P107	GA5105	P72, P81	GA6928	P59
GA12644	P7	GA5106	P72, P81	GA6929	P59
GA12645	P7	GA5107	P72, P73, P109	GA6943	P59
GA12646	P7	GA5108	P72, P81	GA6960	P113
GA12650	P107	GA5109	P72, P81	GA6961	P113
GA12674	P7	GA5110	P72, P81	GA6964	P63
GA12675	P39	GA5111	P72, P81	GA6975	P105
GA12676	P39	GA5112	P72, P81	GA6977	P105
GA12677	P39	GA5113	P69, P72, P75, P81	GA6978	P7, P105
GA12684	P7	GA5114	P69, P72	GA7013	P57
GA12802	P49			GA7016	P50

NUMERICAL INDEX

Part No.	Page	Part No.	Page	Part No.	Page
GA7018	P61	GA7857	P107	GA9097	P95
GA7019	P61	GA7858	P106	GA9098	P97
GA7021	P57	GA7859	P107	GA9105	P39
GA7022	P50, P65	GA7862	P105	GA9112	P105
GA7029	P51	GA7863	P105	GA9113	P105
GA7042	P85	GA7949	P13	GA9130	P61
GA7043	P87	GA7975	P13	GA9131	P37
GA7049	P57	GA7976	P13	GA9144	P107
GA7050	P57	GA7997	P71	GA9201	P105
GA7051	P73, P109	GA8022	P107	GA9202	P105
GA7052	P73, P108	GA8026	P106	GA9203	P105
GA7053	P73	GA8046	P107	GA9204	P105
GA7067	P63	GA8047	P105, P107	GA9205	P90
GA7077	P105	GA8062	P65	GA9479	P77, P79
GA7083	P51	GA8092	P109	GA9480	P77, P79
GA7084	P51	GA8149	P88	GA9481	P105
GA7085	P51	GA8157	P89	GA9482	P77, P79
GA7096	P63	GA8170	P85, P87	GA9483	P77, P79
GA7098	P65	GA8320	P89	GA9544	P67
GA7110	P77	GA8322	P16	GA9545	P67
GA7111	P77	GA8324	P11	GA9553	P70
GA7118	P87	GA8326	P24	GA9554	P70
GA7137	P77	GA8328	P7, P41	GA9557	P75
GA7154	P70, P75, P81, P109	GA8329	P7, P41	GA9558	P75
GA7208	P113	GA8364	P24	GA9559	P90
GA7209	P113	GA8371	P23	GA9571	P79
GA7221	P88	GA8393	P77, P79	GA9572	P79
GA7271	P35	GA8603	P27, P37	GA9689	P105
GA7274	P79	GA8641	P27, P37	GA9836	P51
GA7306	P81	GA8651	P39	GA9837	P51
GA7313	P82	GA8677	P71	GA9840	P61
GA7317	P81	GA8729	P105	GA9843	P70
GA7319	P81	GA8731	P105	GA9844	P37
GA7320	P81	GA8734	P105	GA9845	P37
GA7321	P81	GA8735	P105	GA9846	P70
GA7336	P72, P82	GA8760	P35	GA9861	P37
GA7372	P70	GA8857	P91	GA9862	P37
GA7390	P59	GA8858	P91	GA9864	P37
GA7399	P105	GA8859	P92	GA9865	P37
GA7412	P35	GA8861	P92	GA9883	P65
GA7423	P55	GA8862	P92	GA9918	P81
GA7424	P55	GA8871	P93	GA9963	P7
GA7433	P50	GA8874	P89	GA9964	P7, P41
GA7434	P67, P71	GA8893	P91	GA9978	P107
GA7445	P35, P37	GA8895	P93	GA9979	P107
GA7446	P33, P35, P37	GA8898	P93	GB0115	P24
GA7463	P79	GA8899	P93	GB0116	P24
GA7540	P63	GA8904	P88	GB0186	P10
GA7579	P59	GA8908	P88	GB0196	P111
GA7850	P107	GA8909	P89	GB0206	P113
GA7851	P107	GA8978	P91	GB0213	P37, P113
GA7852	P107	GA8979	P92	GB0218	P5, P10, P18,
GA7854	P107	GA9088	P85, P87		P37, P39, P50,
GA7855	P107	GA9095	P95		P57, P70, P110, P113
GA7856	P7, P41, P105, P107	GA9096	P104	GB0237	P50

NUMERICAL INDEX

Part No.	Page	Part No.	Page	Part No.	Page
GB0239	P15, P16	GD0914-72	P108	GD10543	P69, P77, P81
GB0246	P55	GD0914-76	P108	GD10552	P33, P35, P37
GB0254	P16	GD0914-90	P108	GD10578	P79
GB0265	P3	GD10006	P59	GD10579	P79
GB0266	P3	GD10007	P75	GD10584	P79
GB0267	P3	GD10011	P63	GD10585	P79
GB0268	P15, P16	GD10012	P63	GD10586	P79
GB0274	P3	GD10013	P63	GD10587	P79
GB0276	P13	GD10014	P63	GD10588	P79
GB0278	P18, P24	GD10036	P5, P10	GD1059L	P23
GB0282	P16	GD10053	P59	GD1059R	P23
GB0285	P3	GD10057-01	P117	GD1060	P23
GB0287	P72	GD10057-02	P117	GD1061	P24
GB0292	P51	GD10057-03	P117	GD1063	P24
GB0301	P11, P39	GD10057-04	P117	GD10635	P79
GB0309	P61	GD10063	P63	GD10636	P79
GB0314	P18, P39	GD10064	P65	GD10638	P79
GB0319	P21	GD10068	P77, P79	GD10646	P51
GB0328	P21	GD10069	P77, P79	GD1065	P3
GB0331	P18	GD10070	P77	GD10650	P55
GB0358	P21	GD10071	P77	GD10664	P55
GB0366	P5, P10	GD10092	P65	GD10706	P59
GB0383	P35	GD10099	P70	GD10707	P59
GB0386	P37	GD10100	P72	GD10792	P85
GB0387	P33, P35	GD10102	P77	GD10793	P87
GB0389	P5	GD10103	P77, P79	GD1085	P16
GB0390	P5	GD10104	P77	GD1086	P13
GB0391	P5	GD10120	P79	GD10867	P3, P39
GB0392	P5	GD10123	P77, P79	GD10936	P88
GB0393	P5	GD10128	P71	GD10963	P25
GB0394	P5	GD10144	P71	GD10984	P25
GB0395	P5	GD10196	P113	GD10991	P13
GB0396	P5	GD10207	P93	GD10993	P3
GB0397	P5	GD10211	P88	GD11001	P3
GB0398	P5	GD10231	P65	GD11017	P11
GB0401	P35	GD10243	P105	GD11045	P73, P108
GD0453-03	P87	GD1026	P3, P23, P39, P72, P82	GD11089	P105, P107
GD0453-04	P85	GD10282	P79	GD1109	P15, P16
GD0453-07	P85	GD10283	P83	GD11120	P77, P79
GD0453-09	P87	GD10298	P69	GD1113	P5, P10, P39, P60, P109, P111
GD0652	P87	GD1033	P3	GD1115L	P25
GD0740	P94	GD10355	P81	GD1115R	P25
GD0746	P83	GD10356	P81	GD1116	P25
GD0752-41	P85	GD10366	P81	GD11169	P107
GD0829	P113	GD10446	P63	GD11170	P107
GD0831	P111	GD10447	P63	GD1118	P25
GD0840	P83	GD10473	P11, P15	GD11193	P88, P89
GD0844	P111	GD10492	P59	GD11194	P89
GD0914-106.5	P73	GD10510	P77, P79	GD11218	P39
GD0914-107	P108	GD10519	P35, P37	GD11219	P23
GD0914-128	P108	GD10526	P35	GD11239	P18, P23, P24
GD0914-166.75	P73, P108	GD10530	P55	GD11240	P24
GD0914-35	P73, P108	GD10531	P59	GD11253	P88, P89
GD0914-45	P73	GD10532	P59	GD11259	P3, P11
GD0914-48	P108	GD10538-01	P55		

NUMERICAL INDEX

Part No.	Page	Part No.	Page	Part No.	Page
GD11263	P39	GD12817	P37	GD15700	P21
GD11264	P39	GD12818	P97	GD15725	P53
GD11279	P19	GD12826	P37	GD15747	P18
GD11297	P24	GD12827	P37	GD15789	P41
GD11305	P23	GD12829	P37	GD15790	P41
GD11306	P11	GD13146	P95	GD15792-05	P47
GD11313	P17	GD13170	P90	GD15792-06	P47
GD1132	P31, P33, P35, P37	GD13171	P90	GD15792-12	P47
GD11413	P18, P24	GD13172	P90	GD15792-13	P47
GD11422	P5, P10	GD13173	P90	GD15799	P46
GD11423	P13	GD13310	P95, P105	GD15803	P41
GD11424	P23	GD13328	P111	GD15804	P41
GD1143	P26	GD13348	P95, P105	GD15849-02	P41
GD1144	P26	GD13359	P87	GD15850	P46
GD11447	P39	GD13360	P85	GD15854	P46
GD1145	P26	GD13361	P3	GD15856-03	P46
GD11453	P13	GD13400	P90	GD15856-04	P46
GD11474	P107	GD13401	P71	GD15863	P41
GD11490	P71	GD13409	P67	GD15867-02	P47
GD11508	P17	GD13425	P90	GD15950	P61
GD11509	P17	GD13524-01	P77	GD15970	P3
GD1162	P117	GD13543	P55	GD16035	P48
GD11649	P39	GD13544	P55	GD16036	P48
GD11652	P27, P37	GD13545	P55	GD16037	P49
GD1166	P110	GD13546	P55	GD16038	P49
GD11677	P27	GD13744	P111	GD16040	P49
GD11695	P71	GD14170	P37	GD16046	P105
GD11700	P45	GD14217	P10	GD16188	P45
GD11721	P47	GD14258	P7	GD16194-01	P47
GD11791	P87	GD14258	P41	GD16226	P53
GD11845	P3, P11, P15	GD14398	P27	GD16233	P41
GD11951	P88	GD14413	P73, P82	GD16241	P41
GD11962	P3	GD14414	P73, P82	GD16245	P3
GD11962	P23, P39	GD14426	P73, P82	GD16251	P47
GD11963-04	P5	GD14431	P73, P82	GD16295	P47
GD11970	P91, P92	GD14432	P73, P82	GD16303	P53
GD11972	P109	GD14467	P21	GD16305	P47
GD11983	P93	GD14468	P21	GD16306	P47
GD11984	P91, P92	GD14477	P21	GD16307	P47
GD11985	P93	GD14512	P77	GD16315	P47
GD11986	P93	GD14513	P77, P79	GD16316	P47
GD11988	P88	GD14541	P21	GD16317-01	P46
GD11991	P88	GD14562	P53	GD16319	P47
GD11992	P88	GD14592	P21	GD16324-01	P41
GD11993	P107	GD14626	P47	GD16608	P49
GD11994	P89	GD14659	P25	GD16644	P49
GD11995	P89	GD14660	P7, P41	GD1701	P87
GD12534	P33	GD14674	P29, P31, P35	GD17014	P3
GD12543	P65, P71	GD15100	P53	GD17021	P21
GD1255	P70, P81	GD1512	P117	GD17028	P21
GD1256	P70	GD1514	P113	GD17047	P21
GD12597	P91, P92	GD1515	P113	GD17048	P21
GD12724	P61	GD1516	P113	GD17049	P21
GD12726	P79, P104	GD1517	P113	GD17050	P21
		GD15663	P21	GD17099	P21

NUMERICAL INDEX

Part No.	Page	Part No.	Page	Part No.	Page
GD17104	P21	GD2971-09	P51	GD7805	P5, P10, P16, P18,
GD17141	P9	GD2971-10	P23		P31, P39, P50, P57,
GD17143	P9	GD2984	P117		P59, P70, P85, P87,
GD17144	P9	GD3180-12	P15		P110, P111, P113
GD17150-03	P9	GD3180-27	P47	GD7817-01	P31
GD17150-04	P9	GD3180-30	P5	GD7817-04	P31
GD17151-06	P7	GD3501	P51	GD7817-05	P111
GD17152	P21	GD3537-11	P55	GD7817-18	P39
GD17154	P9	GD3537-12	P55	GD7823	P31
GD17156	P9	GD3537-17	P55	GD7831	P111
GD17162	P21	GD3537-18	P55	GD7864	P67
GD17186	P21	GD3547	P113	GD7883	P55
GD17187	P21	GD3612	P3	GD7889	P29, P31, P75
GD17192	P18	GD3777-10	P47	GD7890	P29, P31
GD17245	P53	GD3777-11	P47	GD7904-02	P59
GD17298	P9	GD3860	P105	GD7907	P113
GD17794	P5	GD4086	P43, P101	GD7908	P113
GD18010	P7, P9	GD4108	P61	GD8066-02	P95
GD18011	P9	GD4700	P70	GD8188	P51, P55, P57, P59
GD18066	P109	GD4701	P70	GD8189	P51, P55, P57, P59
GD18067	P109	GD4743	P9, P85, P87	GD8249	P10
GD18073	P39	GD4887-14	P72	GD8260	P50
GD18074	P39	GD5154	P51, P55	GD8266	P29
GD18078	P9	GD5173	P50, P55	GD8276	P65
GD18081	P9	GD5212	P70, P72	GD8306	P109
GD18094	P109	GD5789	P70	GD8307	P31
GD18095	P21	GD5790	P70	GD8460	P16
GD18098	P21	GD5804	P51, P55	GD8739	P104
GD18112	P9	GD5841	P71	GD8740	P104
GD18118	P107	GD5857	P33, P50, P69,	GD8741	P104
GD18119	P9		P72, P75, P81, P107	GD8751	P106
GD18135	P39	GD5875	P61	GD8770	P106
GD18136	P39	GD5892	P51	GD8771	P106
GD18168	P107	GD6136	P61	GD8893-01	P39
GD18274	P9	GD6279-05	P45	GD9052	P59
GD18275	P7	GD6291	P105, P106	GD9120	P16
GD18796	P7	GD6556	P51	GD9130	P63
GD1908	P61	GD6775	P70	GD9254	P27, P37
GD19343	P73, P82	GD6780	P72	GD9290	P15
GD19344	P73, P82	GD6895	P70	GD9305	P15
GD2115	P113	GD7079	P67	GD9529	P79, P98, P104
GD2117	P117	GD7089	P67	GD9530	P79, P98, P104
GD2161	P85	GD7127	P72	GD9533	P95
GD2169	P63, P65	GD7137	P51	GD9562	P15
GD2199	P69, P117	GD7147	P91, P92	GD9636	P63
GD2423	P25	GD7148	P24	GD9667	P77
GD2460	P26	GD7251	P51	GD9671	P77, P79
GD2557	P51	GD7258	P24	GD9672	P77, P79
GD2558	P51, P65, P69,	GD7318	P3	GD9681	P60
	P72, P82, P111	GD7426	P72, P82	GD9695	P39
GD2597	P83	GD7518	P51	GD9715	P33
GD2681	P110	GD7519	P51	GD9720	P33
GD2721	P85, P87, P113	GD7612	P73	GD9724	P33, P35, P37
GD2829	P105	GD7803	P27, P37	GD9870	P59
GD2947	P25	GD7804	P27, P37	GD9896	P105

NUMERICAL INDEX

Part No.	Page	Part No.	Page	Part No.	Page
GD9898	P59	GR1208	P104, P105	GR1843	P9
GD9905	P97	GR1290	P105		
GD9952	P57	GR1292	P7, P105		
GD9953	P51	GR1293	P73, P108, P109		
GD9955	P61	GR1294	P73, P108, P109		
GD9956	P61	GR1295	P73, P109		
GD9959	P51, P55	GR1296	P73, P109		
GD9960	P51	GR1297	P73, P108		
GD9963	P61	GR1298	P73		
GD9964	P61	GR1301	P73, P109		
GD9968	P59	GR1303	P77, P79		
GD9969	P69	GR1304	P77, P79		
GD9971	P94	GR1305	P77, P79		
GD9977	P95	GR1306	P77, P79		
GD9981	P85, P87	GR1363	P7, P105		
GM0211	P117	GR1364	P105		
GR0146MPP	P117	GR1405	P109		
GR0150	P83	GR1406	P109		
GR0151	P83	GR1407	P109		
GR0155MPP	P117	GR1408	P109		
GR0190	P111	GR1409	P109		
GR0193	P63	GR1410	P109		
GR0195	P111	GR1411	P109		
GR0196	P3, P24, P39	GR1412	P109		
GR0204	P111	GR1413	P109		
GR0267	P111	GR1414	P107		
GR0270	P71	GR1415	P107		
GR0375	P63	GR1417	P89		
GR0434	P71	GR1428	P88		
GR0515	P50	GR1445	P95		
GR0516	P50	GR1465	P88, P91, P92, P102		
GR0517	P50	GR1466	P45, P49, P95, P97		
GR0528	P67	GR1467	P44, P45, P48, P49		
GR0531	P67	GR1519	P91, P92		
GR0586	P107	GR1521	P93		
GR0594	P107	GR1522	P93		
GR0761	P95, P98	GR1523	P89		
GR0763	P95, P98	GR1524	P88		
GR0764	P98, P99	GR1557	P73, P73, P108, P109		
GR0912	P70, P72, P75, P81, P109	GR1570MPP	P117		
GR1015	P113	GR1598	P90		
GR1016	P113	GR1635	P95, P97		
GR1017	P113	GR1734	P44		
GR1018	P113	GR1736	P41		
GR1019	P113	GR1737	P107		
GR1037	P94, P95, P97, P101, P102, P103	GR1762	P107		
GR1045	P44, P45, P97	GR1764	P107		
GR1146	P111	GR1777	P41		
GR1203	P104	GR1778	P9		
GR1204	P104, P105	GR1786	P48		
GR1205	P104	GR1809	P9		
GR1206	P104, P105	GR1824MPP	P117		
GR1207	P104, P105	GR1828	P117		
		GR1834	P49		