

MODEL 3600V
TWIN-LINE® PLANTER
(EdgeVac® Seed Metering)

OPERATOR & PARTS
MANUAL

PM0213

5/08

This manual is applicable to: Model: 3600 Twin-Line® Planters
Serial Number: 621654 and on

Record the model number and serial number of your planter along with date purchased:

Model Number _____ 3600V _____

Serial Number _____

Date Purchased _____

Monitor Serial Number _____
Measured Pulses Per Mile/Km (Radar Distance Sensor) _____
Measured Pulses Per Mile/ Km (Magnetic Distance Sensor) _____

SERIAL NUMBER

The serial number plate is located on the planter frame to be readily available. It is suggested that your serial number and purchase date also be recorded above.

The serial number provides important information about your planter and may be required to obtain the correct replacement part. Always provide the model number and serial number to your KINZE® Dealer when ordering parts or anytime correspondence is made with KINZE Manufacturing, Inc.

D05050806



PREDELIVERY/DELIVERY CHECKLIST

TO THE DEALER

Predelivery service includes assembly, lubrication, adjustment and test. This service helps to ensure that the planter will be delivered to the customer ready for field use.

PREDELIVERY CHECKLIST

After the planter has been completely assembled, use the following checklist and inspect the planter. Check off each item as it is found satisfactory or after proper adjustment is made.

- Recheck to be sure row units are properly spaced and optional attachments are correctly assembled.
- The row marker blade assemblies have been removed from their shipping location over the planter hitch and installed on the row marker assembly at each end of the planter. See "Row Marker Length Adjustment" in the Machine Operation Section of this manual.
- Be sure all grease fittings are in place and lubricated.
- Check planter and make sure all working parts are moving freely, bolts are tight and cotter pins are spread.
- Check all drive chains for proper tension and alignment.
- Check for oil leaks and proper hydraulic operation.
- Check to be sure hydraulic hoses are routed correctly to prevent damage.
- Inflate tires to specified PSI air pressure. Tighten wheel lug bolts and lug nuts to specified torques.
- Check to be sure all safety decals are correctly located and legible. Replace if damaged.
- Check to be sure all reflective decals and SMV sign are correctly located and visible when the planter is in transport position.
- Check to be sure safety/warning lights are installed correctly and working properly.
- Paint all parts scratched in shipment or assembly.
- Be sure all safety lockup devices are on the planter and correctly located.
- Auxiliary safety chain is properly installed and hardware is torqued to specification.
- Vacuum fan PTO-driven pump is attached correctly to the tractor. Oil reservoir is filled to capacity and system is inspected for leaks. (If Applicable)

This planter has been thoroughly checked and to the best of my knowledge is ready for delivery to the customer.

(Signature Of Set-Up Person/Dealer Name/Date)

OWNER REGISTER

Name _____ Delivery Date _____
Street Address _____ Model No. 3600V Serial No. _____
City, State/Province _____ Dealer Name _____
ZIP/Postal Code _____ Dealer No. _____

DELIVERY CHECKLIST

At the time the planter is delivered, the following checklist is to be used as a reminder of very important information which should be conveyed to the customer. Check off each item as it is fully explained to the customer.

- Advise the customer that the life expectancy of this or any other machine is dependent on regular lubrication as directed in the Operator & Parts Manual.
- Check for proper operation of vacuum fan and PTO drive pump (If Applicable) with tractor to be used with planter.
- Tell the customer about all applicable safety precautions.
- Along with the customer, check to be sure the reflective decals and SMV sign are clearly visible with the planter in transport position and attached to the tractor. Check to be sure safety/warning lights are in working condition. Tell the customer to check federal, state/provincial and local regulations before towing or transporting on a road or highway.
- Give the Operator & Parts Manual to the customer and explain all operating adjustments.
- Read warranty to customer.
- Complete Warranty And Delivery Report form.

To the best of my knowledge this machine has been delivered ready for field use and customer has been fully informed as to proper care and operation.

(Signature Of Delivery Person/Dealer Name/Date)

AFTER DELIVERY CHECKLIST

The following is a list of items we suggest to check during the first season of use of the equipment.

- Check with the customer as to the performance of the planter.
- Check with the customer as to the performance of the EdgeVac® Seed Metering System.
- Review with the customer the importance of proper maintenance and adherence with all safety precautions.
- Check for parts that may need to be adjusted or replaced.
- Check to be sure all safety warning signs (decals), reflective decals and SMV sign are correctly located and that decals are legible. Replace if damaged or missing.
- Check to be sure safety/warning lights are working properly.

(Signature Of Follow-Up Person/Dealer Name/Date)

**RETURN THIS COMPLETED FORM TO KINZE® IMMEDIATELY along with Warranty And Delivery Report.
Retain photocopy of this form at dealership for After Delivery Check.**

Tear Along Perforation

TABLE OF CONTENTS

TO THE OWNER	1-1
WARRANTY	1-2
INTRODUCTION	2-1
SPECIFICATIONS	3-1
SAFETY PRECAUTIONS	4-1
SAFETY WARNING SIGNS	5-1
MACHINE OPERATION	
Analog Vacuum Gauge	6-16
Auxiliary Hydraulic Option.....	6-22
Auxiliary Work Lights Package.....	6-21
Checking Seed Population.....	6-35
Digital Vacuum Gauge Operation	6-16
Electronic Seed Monitor System	
KINZE Vision® System.....	6-20
Planter Monitor Module (PMM)	6-20
Even-Row Push Row Unit.....	6-21
Fertilizer Openers And Attachments.....	6-23
Field Operation	6-13
Field Test.....	6-35
Field To Transport Sequence	6-14
Hall Effect Sensor	6-34
Hydraulic Drive	6-10
Hydraulic/Electric Operation	6-9
Initial Preparation Of The Planter.....	6-3
Leveling The Planter	6-6
Liquid Fertilizer Attachment	6-29
Liquid Fertilizer Rate Chart.....	6-32
Manual Safety Lockup	6-1
Metric Conversion Table.....	6-34
Planting Speed	6-35
PTO Pump Drive And Oil Cooler Option.....	6-4
Rear Trailer Hitch	6-33
Ridge Planting	6-8
Rock Guards.....	6-21
Row Marker Length Adjustment	6-18
Row Marker Operation.....	6-17
Row Marker Safety Lockup.....	6-1
Row Marker Speed Adjustment.....	6-18
Row Unit Air Clutches.....	6-20
Tire Pressure	6-8
Tongue Safety Pin.....	6-2
Tractor Preparation And Hookup	6-5
Tractor Requirements	6-3
Transport Latch Locking Pin	6-2
Transport To Field Sequence	6-11
Transporting The Planter	6-34
Vacuum Fan Motor Valve Block Assembly.....	6-16

TABLE OF CONTENTS

SEED METER OPERATION/MAINTENANCE

Field Adjustments

Seed Meter Singulator Brush And Vacuum Level Adjustments	7-6
General Planting Rate Information	7-1
Seed Meter	7-2
Seed Meter Cleanout	7-4
Seed Meter Drive Release	7-8
Seed Meter Maintenance.....	7-9
Seed Metering System Troubleshooting	7-10
Vacuum Manifold Maintenance.....	7-9

ROW UNIT OPERATION

Closing Wheel Shield.....	8-2
Coulter Mounted Residue Wheels	8-15
Covering Discs/Single Press Wheel Adjustment	8-2
Drag Closing Attachment.....	8-3
Frame Mounted Coulter	8-10
Interplant® Push Row Unit Clutch Sprocket	8-18
Interplant® Push Row Unit Lockups	8-17
Interplant® Push Row Unit Vacuum Hose Shutoff.....	8-18
Planting Depth	8-1
Pneumatic Down Pressure	8-7
Quick Adjustable Down Force Springs Option.....	8-5
Residue Wheels (For Use With Frame Mounted Coulter).....	8-11
Row Unit Extension Brackets.....	8-4
Row Unit Mounted Disc Furrower.....	8-11
Row Unit Mounted No Till Coulter.....	8-14
Row Unit Mounted Residue Wheel.....	8-12
Seed Hopper	8-4
Spring Tooth Incorporator	8-16
“V” Closing Wheel Adjustment (Rubber And Cast Iron).....	8-1

LUBRICATION

Air Clutches	9-1
Bushings.....	9-3
Center Post.....	9-5
Drive Chains	9-2
Grease Fittings	9-6
Interplant® Push Row Unit Lockups	9-4
Liquid Fertilizer Piston Pump Crankcase Oil Level.....	9-6
Lubrication Symbols	9-1
PTO Pump Shaft Coupling (PTO Pump Drive And Oil Cooler Option)	9-1
Sealed Bearings	9-2
U-Joint Slides.....	9-5
Wheel Bearings	9-5

TABLE OF CONTENTS

MAINTENANCE

15" Seed Opener Disc Blade/Bearing Assembly	10-6
Airline Schematic	10-38
Chain Tension Adjustment	10-2
Check Valve	10-12
Coulter Mounted Residue Wheels	10-10
Drag Closing Attachment	10-4
Electrical Control Console Schematic	10-27
Electrical Wiring Diagram For Light Package	10-26
Electrical Wiring Harness Schematic (On Planter)	10-29
Electrical Wiring Harness Schematic (On Tractor)	10-28
Flow Control Valve Inspection	10-13
Frame Mounted Coulter	10-7
Gauge Wheel Adjustment	10-4
Gauge Wheel Arm Bushing And/Or Seal Replacement	10-5
Gauge Wheel Arm Pivot Spindle Replacement	10-5
Hydraulic Schematic - Optional PTO Pump Drive And Oil Cooler System	10-37
Hydraulic Schematic - Planter Operation	10-32
Hydraulic Schematic - Vacuum Fan Motor System	10-36
Mounting Bolts And Hardware	10-1
Piston Pump Storage	10-24
Preparation For Storage	10-25
Pressure Relief Valve Inspection	10-13
PTO Pump Drive And Oil Cooler Option	10-3
Relief Valve Cartridge Inspection	10-12
Residue Wheels (For Use With Frame Mounted Coulter)	10-8
Row Marker Bearing Lubrication Or Replacement	10-19
Row Unit Mounted Disc Furrower	10-8
Row Unit Mounted No Till Coulter	10-10
Row Unit Mounted Residue Wheel	10-9
Row Marker Transport Stand Adjustment	10-19
Seed Meter Maintenance	See "Seed Meter Operation/Maintenance" Section
Seed Tube Guard/Inner Scraper	10-7
Solenoid Valve Inspection	10-12
Spring Tooth Incorporator	10-11
Tire Pressure	10-2
Torque Values Chart	10-1

Troubleshooting

Closing Wheel Troubleshooting	10-4
Lift Circuit Troubleshooting	10-13
Piston Pump Troubleshooting	10-24
PTO Pump Drive And Oil Cooler Option Troubleshooting	10-3
Rotation Cylinder Circuit Troubleshooting	10-16
Row Marker Operation Troubleshooting	10-18
Seed Metering System Troubleshooting	See "Seed Meter Operation/ Maintenance" Section
Solenoid Valve Troubleshooting	10-12
Tongue Cylinder Circuit Troubleshooting	10-15
Wing Lock Cylinder Circuit Troubleshooting	10-17
Wear Pad Replacement And Adjustment	10-21
Wheel Bearing Lubrication Or Replacement	10-20

PARTS LIST INDEX	P1
------------------------	----

PARTS SECTION NUMERICAL INDEX	P127
-------------------------------------	------

TABLE OF CONTENTS

TO THE OWNER

KINZE Manufacturing, Inc. would like to thank you for your patronage. We appreciate your confidence in KINZE® farm machinery. Your KINZE® planter has been carefully designed to provide dependable operation in return for your investment.

This manual has been prepared to aid you in the operation and maintenance of the planter. It should be considered a permanent part of the machine and remain with the machine when you sell it.

It is the responsibility of the user to read and understand the Operator & Parts Manual in regards to safety, operation, lubrication and maintenance before operation of this equipment. It is the user's responsibility to inspect and service the machine routinely as directed in the Operator & Parts Manual. We have attempted to cover all areas of safety, operation, lubrication and maintenance; however, there may be times when special care must be taken to fit your conditions.

Throughout this manual the symbol  and/or the words **NOTE, IMPORTANT, CAUTION, WARNING** or **DANGER** are used to call your attention to important information. The definition of each of these terms follows:

NOTE: Indicates a special point of information or addresses a machine adjustment.

IMPORTANT: Indicates an operation or maintenance condition which, if not corrected, could result in damage to machine, property, crops or environment.



CAUTION: Indicates a potentially hazardous situation which, if not avoided, may result in minor or moderate personal injury.



WARNING: Indicates a potentially hazardous situation which, if not avoided, could result in death or serious personal injury.



DANGER: Indicates an imminently hazardous situation which, if not avoided, will result in death or serious personal injury.



WARNING: Some photos in this manual may show safety covers, shields or lockup devices removed for visual clarity. **NEVER OPERATE** the machine without all safety covers, shields and lockup devices in place.

NOTE: Some photos in this manual may have been taken of prototype machines. Production machines may vary in appearance.

NOTE: Some photos and illustrations in this manual show optional attachments installed. Contact your KINZE® Dealer for purchase of optional attachments.

WARRANTY

The KINZE® Limited Warranty for your new machine is stated on the back of the retail purchaser's copy of the Warranty And Delivery Report form. Additional copies of the Limited Warranty can be obtained through your KINZE® Dealer.

Warranty, within the warranty period, is provided as part of KINZE's support program for registered KINZE® products which have been operated and maintained as described in this manual. Evidence of equipment abuse or modification beyond original factory specifications will void the warranty. Normal maintenance, service and repair is not covered by KINZE® warranty.

To register your KINZE® product for warranty, a Warranty And Delivery Report form must be completed by the KINZE® Dealer and signed by the retail purchaser, with copies to the Dealer, to the retail purchaser and to KINZE Manufacturing, Inc. Registration must be completed and sent to KINZE Manufacturing, Inc. within 30 days of delivery of the KINZE® product to the retail purchaser. KINZE Manufacturing, Inc. reserves the right to refuse warranty on serial numbered products which have not been properly registered.

If service or replacement of failed parts which are covered by the Limited Warranty are required, it is the user's responsibility to deliver the machine along with the retail purchaser's copy of the Warranty And Delivery Report to the KINZE® Dealer for service. KINZE® warranty does not include cost of travel time, mileage, hauling or labor. Any prior arrangement made between the Dealer and the retail purchaser in which the Dealer agrees to absorb all or part of this expense should be considered a courtesy to the retail purchaser.

KINZE® warranty does not include cost of travel time, mileage, hauling or labor.

INTRODUCTION

The Model 3600V Twin-Line® Planter is available in various configurations and row spacings. Optional Interplant® row spacing is obtainable with the addition of push row units.

The Model 3600V Twin-Line® Planter permits installation of liquid fertilizer application equipment and various row unit attachments.

GENERAL INFORMATION

The information used in this manual was current at the time of printing. However, due to KINZE's continual attempts to improve its product, production changes may cause your machine to appear slightly different in detail. KINZE Manufacturing, Inc. reserves the right to change specifications or design without notice and without incurring obligation to install the same on machines previously manufactured.

Right hand (R.H.) and left hand (L.H.), as used throughout this manual, are determined by facing in the direction the machine will travel when in use unless otherwise stated.

D05050820



INTRODUCTION

SPECIFICATIONS

BASE MACHINE TYPE - Pull Type (Hydraulically rotates endwise to transport)

SEED METER TYPE - EdgeVac® Seed Metering System

EDGEVAC® SEED METERING SYSTEM INCLUDES -

EdgeVac® Seed Meters (Less Seed Discs), Meter Drive Clutches, No. 41 Chains, 1.75 Bu. Seed Hoppers With Lids, 20" Diameter Vacuum Fan With Mounting Components, Hydraulic Motor, Hoses And Fittings, 4" Diameter Vacuum Feed Hoses, Distribution Manifolds And 2" Diameter Vacuum Distribution Hoses

PLANTING UNIT TYPES - Push and Pull Row Units

ROW SPACING	Standard	Interplant® Package
	12 Row Narrow - 30" Rows	23 - 15" Rows or 24 - 15" Rows
	16 Row Narrow - 30" Rows	31 - 15" Rows or 32 - 15" Rows

DRIVE SYSTEM - Spring-Loaded Contact Drive System
 - 7.50" x 20" 8 Ply Rib Implement Wing Tires - Two On 12 Row; Four On 16 Row
 - 4.80" x 8" 4 Ply Contact Drive Tires - Two On 12 Row; Four On 16 Row
 - No. 40 Roller Chain And Spring-Loaded Idlers

TRANSPORT TIRES - Equipped With Four 255 - 70R 22.5" Radial Load Range H Tubeless Rib Implement Tires
 - Adjustable Height Wheels For Ridge Planting

LIFT - Master/Slave Hydraulics
 - 12 Row - 2 Center Lift (Master) Cylinders, 1 Cylinder Per Wing Wheel Module (2 Slave)
 - 16 Row - 2 Center Lift (Master) Cylinders, 1 Cylinder Per Wing Wheel Module (2 Modules Per Wing - 4 Slave Cylinders Total)

ROW MARKERS - Independently Controlled. Two-Fold, Low Profile With Depth Bands On Row Marker Disc Blades

SEED METER/VACUUM SYSTEM

- 13 GPM @ 2000 PSI
 - Zero PSI Case Drain Plus One Remote Outlet (Pressure And Return) For Vacuum Fan Hydraulic Motor

PLANTER SIZE	12 Row 30"	16 Row 30"
*WEIGHT	13,233 lbs.	16,274 lbs.

* Base Machine weights include planter frame, row markers, drive components, tires and wheels, hydraulic cylinders and hoses, 12VDC control console, KINZE® pull row units (closing wheel arms less closing wheels), seed hoppers and lids, dual quick-adjustable down force springs, transport safety chain, point row clutches (12 row and larger sizes), EdgeVac® meters (less seed discs) and vacuum seed metering system fan, manifolds and hoses.

DIMENSIONS - OPERATING

PLANTER SIZE	12 Row 30"	16 Row 30"
WIDTH	31' 2"	41' 2"
LENGTH	21' 0"	24' 0"

SPECIFICATIONS

DIMENSIONS - TRANSPORT

PLANTER SIZE	12 Row 30"	16 Row 30"
WIDTH Std., Fertilizer Or Push Row Units	11' 2"	11' 2"
WIDTH Push Row Unit With No Till Coulters	11' 4"	11' 4"
Push Row Unit With No Till Coulters And Coulter Mounted Residue Wheels	11' 8"	11' 8"
LENGTH	36' 10"	46' 10"
HEIGHT	10' 8"	11' 0"

NOTE: L.H. transport wheel and axle stub assembly is removable for truck transport at 10' 3" width on wide row machines and 8' 6" on narrow row machines.

MACHINE OPTIONS

- Electronic Seed Monitors
Planter Monitor Module (PMM)
- Auxiliary Work Lights Package
- Interplant® Package
- Even-Row Push Row Unit Package
- Liquid Fertilizer Package
- Rear Trailer Hitch
- Piston Pump Mount And Drive Package
- Rock Guard Package For Transport Wheel Arms
- PTO Pump Package And Oil Cooler
- 2-Point Hitch Option

ROW UNIT OPTIONS/ATTACHMENTS

- Seed Meter Discs
- Closing Wheel Options
 - Rubber "V" Closing Wheels
 - Cast Iron "V" Closing Wheels
 - Covering Discs/Single Press Wheel
 - Drag Closing Attachment
- Down Pressure Options
 - Quick Adjustable Down Force Springs
 - Pneumatic Down Pressure Package
- Hopper Panel Extension Package
- Spring Tooth Incorporator
- Row Unit Extension Brackets
- Row Unit Mounted No Till Coulter
- Coulter Mounted Residue Wheels
- Row Unit Mounted Disc Furrowers
- Row Unit Mounted Bed Leveler
- Row Unit Mounted Residue Wheel
- Frame Mounted Coulter
- Residue Wheels For Frame Mounted Coulter

SAFETY PRECAUTIONS

Safe and careful operation of the tractor and planter at all times will contribute significantly to the prevention of accidents.

Since a large portion of farm accidents occur as a result of fatigue or carelessness, safety practices should be of utmost concern. Read and understand the instructions provided in this manual and on the warning signs. Review these instructions frequently! Listed below are other safety suggestions that should become common practice.

 **Never allow the planter to be operated by anyone who is unfamiliar with the operation of all functions of the unit. All operators should read and thoroughly understand the instructions given in this manual prior to moving the unit.**

 **Never permit any persons other than the operator to ride on the tractor.**

 **Never ride on the planter or allow others to do so.**

 **Always make sure there are no persons near the planter when row marker assemblies are in operation or when rotating the planter.**

 **Always keep hands, feet and clothing away from moving parts. Do not wear loose-fitting clothing which may catch in moving parts.**

 **Always wear protective clothing, substantial shoes and suitable hearing and eye sight protectors applicable for the situation.**

 **Do not allow anyone to stand between the tongue or hitch and the towing vehicle when backing up to the planter.**

 **Be aware of bystanders, particularly children! Always look around to make sure it is safe to start the engine of the towing vehicle or move the planter. This is particularly important with higher noise levels and quiet cabs, as you may not hear people shouting.**

 **Use a tractor equipped with a roll-over-protective-system and fasten your seat belt prior to starting the engine.**

 **Before operating the planter for the first time and periodically thereafter, check to be sure the lug nuts on the transport wheels are tight. This is especially important if the planter is to be transported for a long distance.**

 **Never work under the planter while in raised position without using manual safety lockup device.**

 **Install safety lockup devices on row markers prior to transporting the planter or working around the unit.**

D05050802

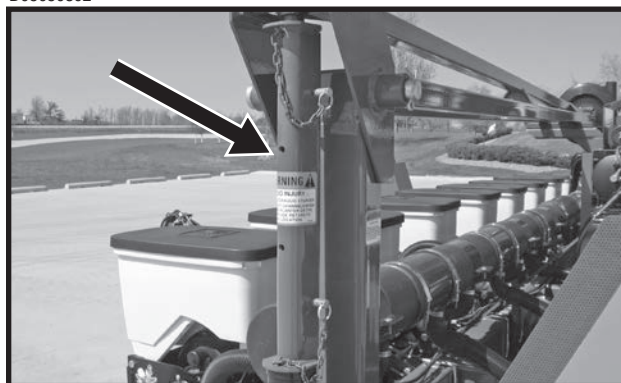

 **Watch for obstructions such as wires, tree limbs, etc. when folding row markers.**

 **To avoid serious injury or death, care must be taken when operating row markers around overhead power lines.**

 **The outer transport wheel on the left side of the planter is bolt-on to allow legal width truck shipment. Always install outer transport wheel assembly prior to unloading. DO NOT REMOVE THIS ASSEMBLY AFTER PLANTER IS ASSEMBLED FOR USE. DO NOT fold planter or tow planter while the outer transport wheel is removed. Tipping may occur because of narrow wheel base.**

SAFETY PRECAUTIONS

 Always install tongue safety pin, manual safety lockup device and transport latch locking pin before transporting planter.

D05050849

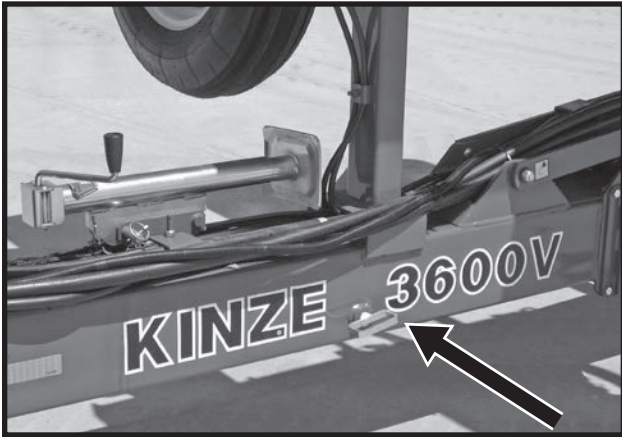

Tongue Safety Pin

D05050842

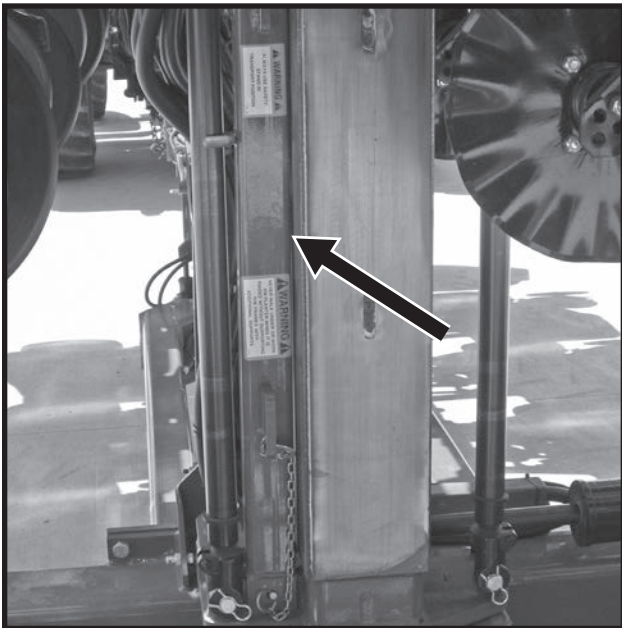

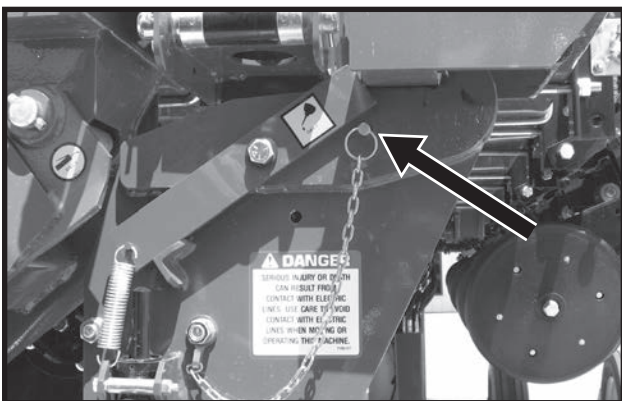

Manual Safety Lockup Device

D05050840



Transport Latch Locking Pin

 This machine has been designed and built with your safety in mind. Do not make any alterations or changes to this machine. Any alteration to the design or construction may create safety hazards.

 Always follow federal, state/provincial and local regulations when towing farm equipment on a public highway. Only a safety chain (not an elastic or nylon/plastic tow strap) should be used to retain the connection between the towing and towed machines in the event of separation of the primary attaching system.

 Check to be sure all safety/warning lights are working properly before transporting the machine on public roads.

 Avoid transporting planter with hoppers loaded whenever possible. When it is necessary to transport the planter with the hoppers loaded, the added weight should be distributed evenly on the planter frame before rotating the planter.

 Limit towing speed to 15 MPH. Tow only with farm tractor of a minimum 90 HP.

 Always make sure safety/warning lights, reflective decals and SMV sign are in place and visible prior to transporting the machine on public roads. In this regard, check federal, state/provincial and local regulations.

 Allow for unit length when making turns.

 Always drive at a safe speed relative to local conditions and ensure your speed is low enough for an emergency stop to be safe and secure. Keep speed to a minimum.

 Reduce speed prior to turns to avoid the risk of overturning.

SAFETY PRECAUTIONS

 Always keep the tractor in gear to provide engine braking when going downhill. Do not coast.

 Avoid sudden uphill turns on steep slopes.

 Be a safe and courteous driver. Always yield to oncoming traffic in all situations, including narrow bridges, intersections, etc.

 Rim and tire servicing can be dangerous. Explosive separation of a tire and rim parts can cause serious injury or death.

 Agricultural chemicals can be dangerous. Improper selection or use can seriously injure persons, animals, plants, soil and other property. **BE SAFE:** Select the right chemical for the job. Handle it with care. Follow the instructions on the container label and of the equipment manufacturer.

 Store the planter in an area away from human activity. **DO NOT** permit children to play on or around the stored unit.

 Make sure the parked machine is on a hard, level surface. Wheel chocks may be needed to prevent unit from rolling.

 Good maintenance is your responsibility. Poor maintenance is an invitation to trouble.

 Never operate vacuum fan with cover removed.

 Always wear ear protection when working around operating vacuum fan.

 Do not work on planter drive system without first shutting off the tractor or disconnecting the hydraulic lines. The hydraulic drive could start at anytime.

 Pressurized hydraulic fluid can penetrate body tissue and result in serious infection, injury, or death. Before applying pressure to the hydraulic system, make sure all connections are tight and that hoses and fittings have not been damaged. Leaks can be invisible. Keep away from suspected leaks. Relieve pressure in the hydraulic system before searching for leaks, disconnecting hoses, or performing any other work on the system. Fluid injected under the skin must be **IMMEDIATELY** removed by a surgeon familiar with this type of injury.

SAFETY PRECAUTIONS

SAFETY WARNING SIGNS

The “WARNING” signs illustrated on these pages are placed on the machine to warn of hazards. The warnings found on these signs are for your personal safety and the safety of those around you. OBSERVE THESE WARNINGS!

- Keep these signs clean so they can be readily observed. Wash with soap and water or cleaning solution as required.
- Replace “WARNING” signs should they become damaged, painted over or if they are missing.
- Check reflective decals and SMV sign periodically. Replace if they show loss of any of their reflective properties.
- When replacing decals, clean the machine surface thoroughly using soap and water or cleaning solution to remove all dirt and grease.

NOTE: Style and locations of SMV sign, reflective decals and safety/warning lights conform to ANSI/ASAE S279.13 DEC2005 and ANSI/ASAE S276.6 JAN2005.

D05050803

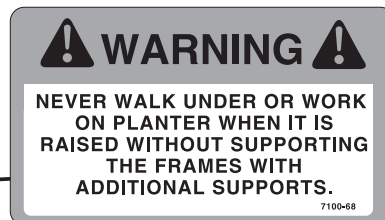
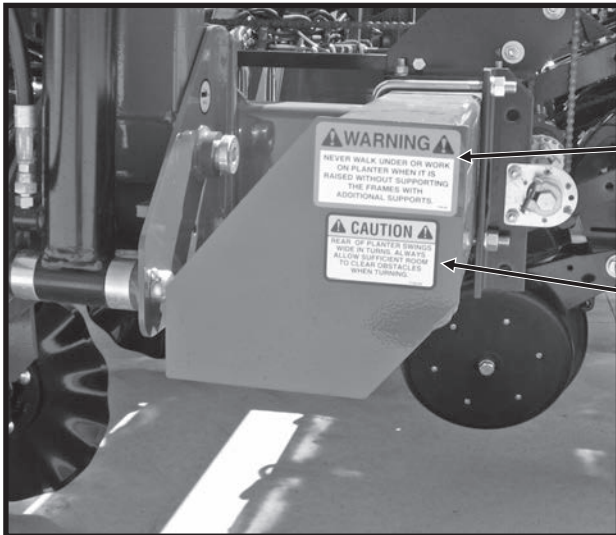

Part No. G7100-68 (Qty. 1)

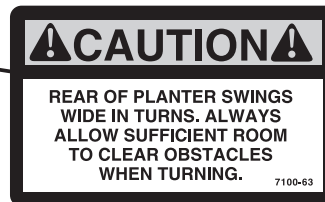

Part No. G7100-63 (Qty. 1)

D060299216

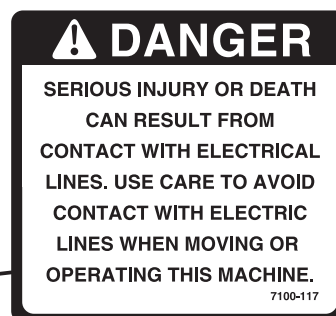

Part No. G7100-117 (Qty. 1)



Part No. G7100-02 (Qty. 1)

SAFETY WARNING SIGNS

D05050802



Part No. G7100-83 (Qty. 2 - One Per Row Marker)



Part No. G7100-42 (Qty. 4 - Two Per Row Marker)

D05050807

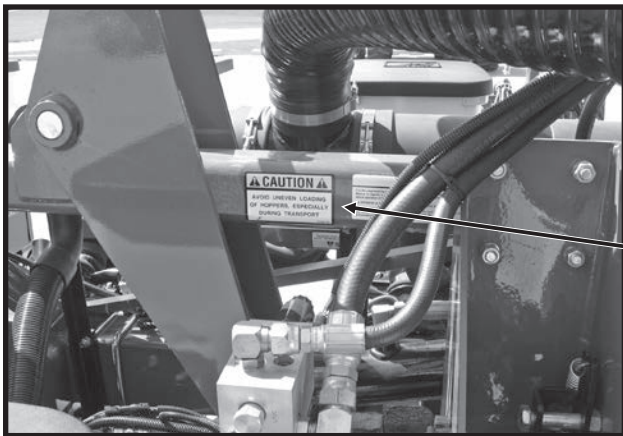

Part No. G7100-75
(Qty. 4 - Front And Rear/Left And Right)

D092702101a

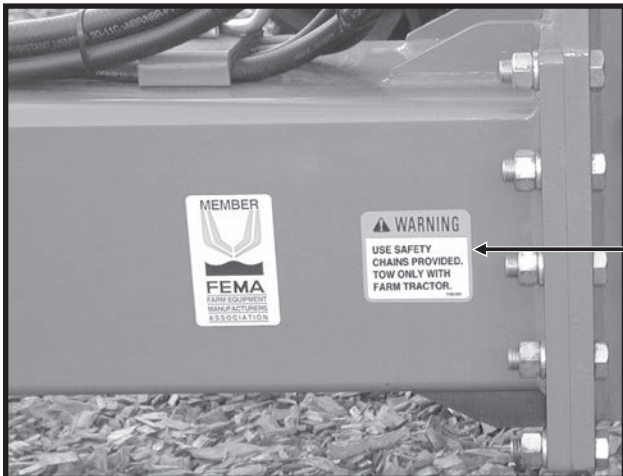

Part No. G7100-302 (Qty. 1)

SAFETY WARNING SIGNS

D05050808

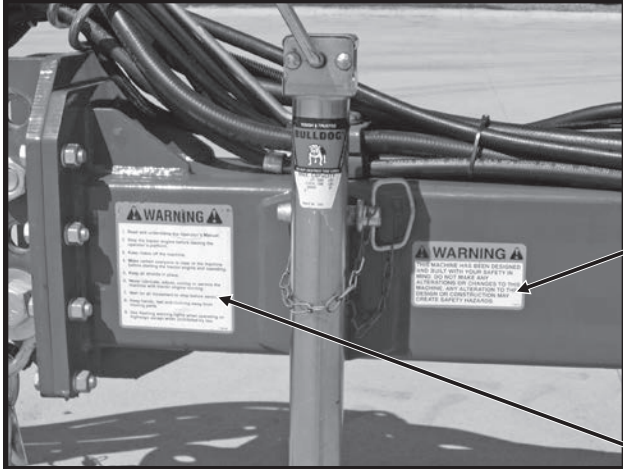

Part No. G7100-90 (Qty. 1)



Part No. G7100-46 (Qty. 1)

D05050815

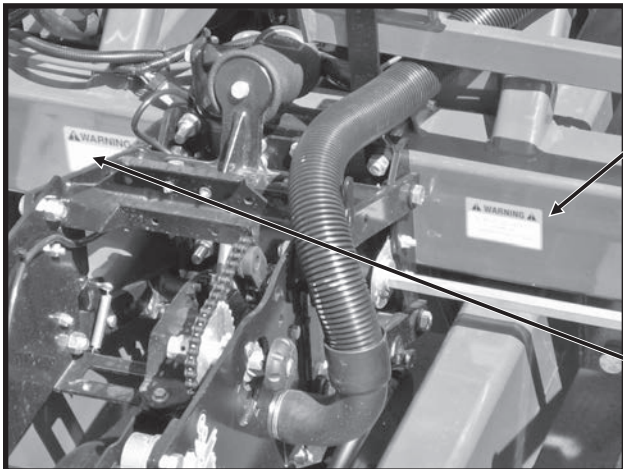

Part No. G7100-200 (Qty. 2 - Front And Rear)

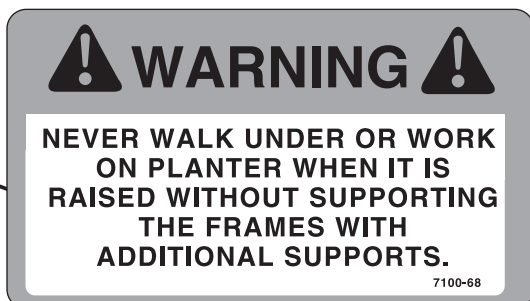

Part No. G7100-68 (Qty. 2 - Front And Rear)

SAFETY WARNING SIGNS

D060299108

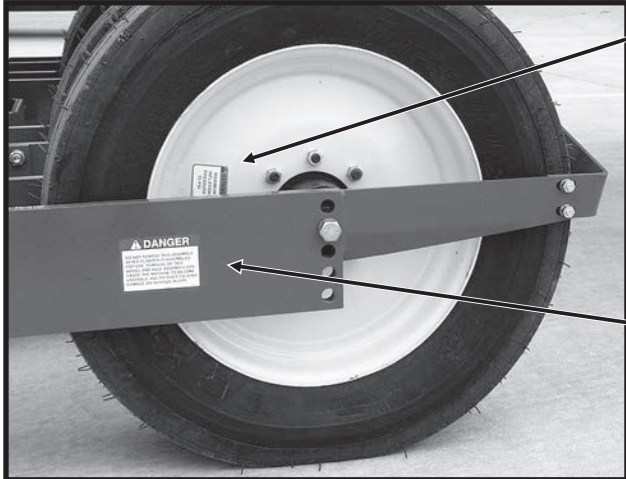

Part No. G7100-219 (Qty. 4 - One On Each Transport Wheel)



Part No. G7100-215 (Qty. 1 - Located On Rear Side Of Stub Axle)

D0205001102

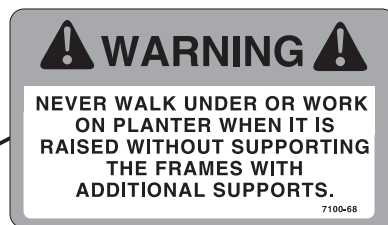
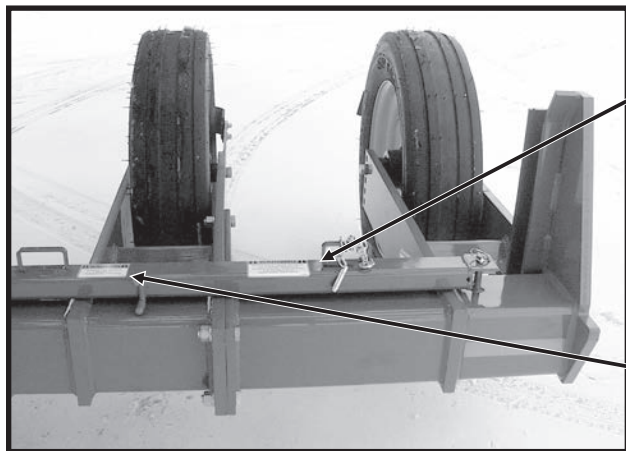

Part No. G7100-68 (Qty. 1)



Part No. G7100-200 (Qty. 1)

SAFETY WARNING SIGNS



Part No. G7100-68 (Qty. 1)



Part No. G7100-63 (Qty. 1)

D05050819



Part No. GD2199 (Qty. 1)

D08220676



Part No. G7100-301 (Qty. 2 - One On Each Side Of Fan)

SAFETY WARNING SIGNS

(PLTR174a)

12 Row 30" Shown

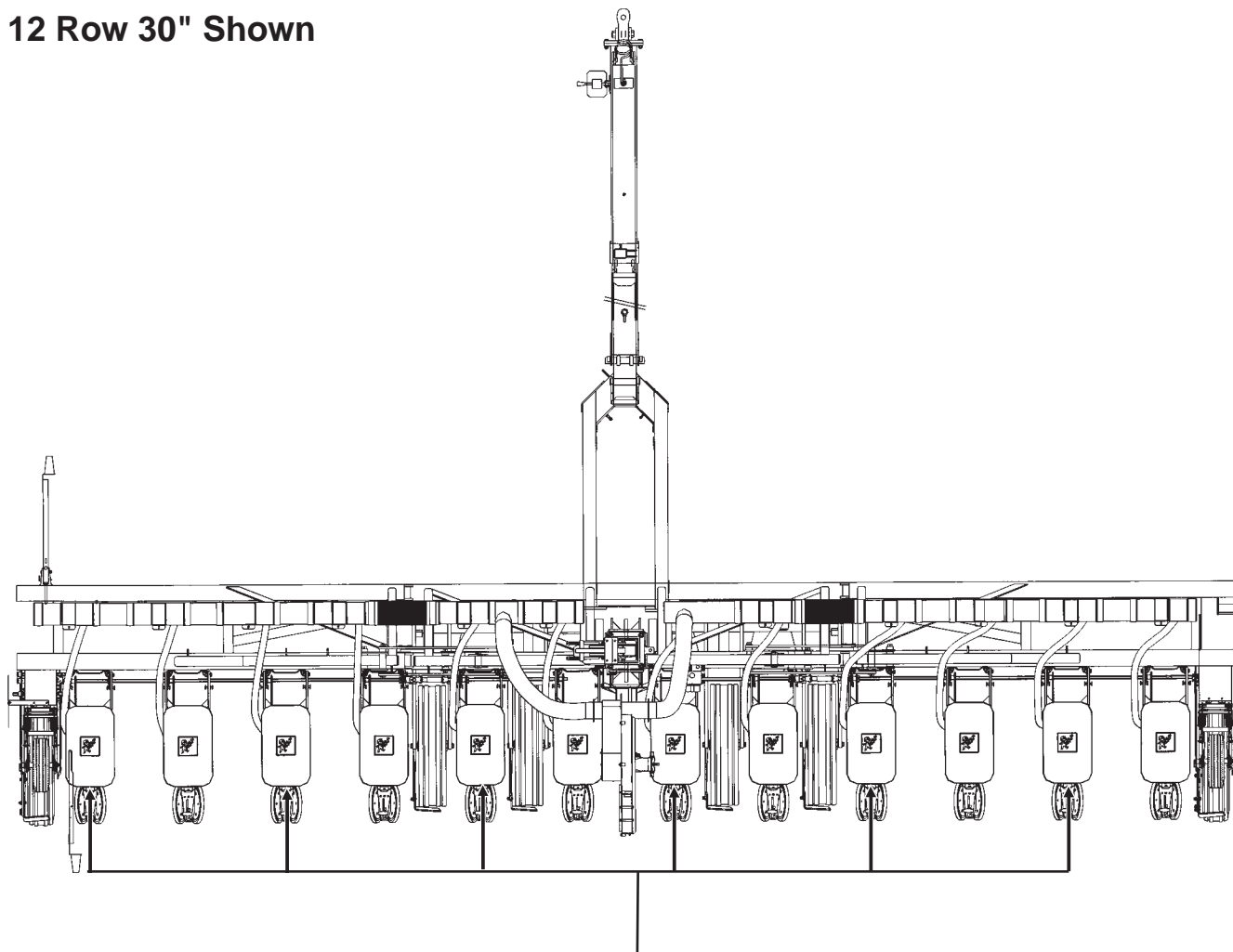

Part No. G7100-262 Amber Reflective Decal (Located On The Hopper Support On Every Other Row Unit Beginning On The 1st Row Unit On The L.H. End Of The Planter - Side-Facing In Transport Position)
(Standard)

D060800114

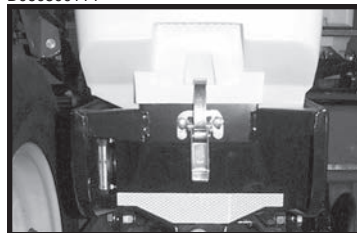

Part No. G7100-259 Amber Reflective Decal (Located On The Granular Chemical Hopper Panel Extension On Every Other Row Unit Beginning On The 1st Row Unit On The L.H. End Of The Planter - Side-Facing In Transport Position)

D062300102

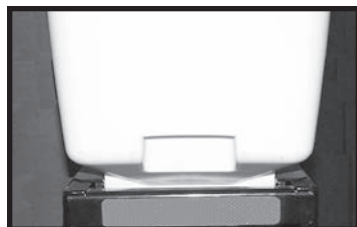

NOTE: 6 Decals Used On 12 Row; 8 Used On 16 Row

SAFETY WARNING SIGNS

(PLTR174a/TWL173a)

12 Row 30" Shown

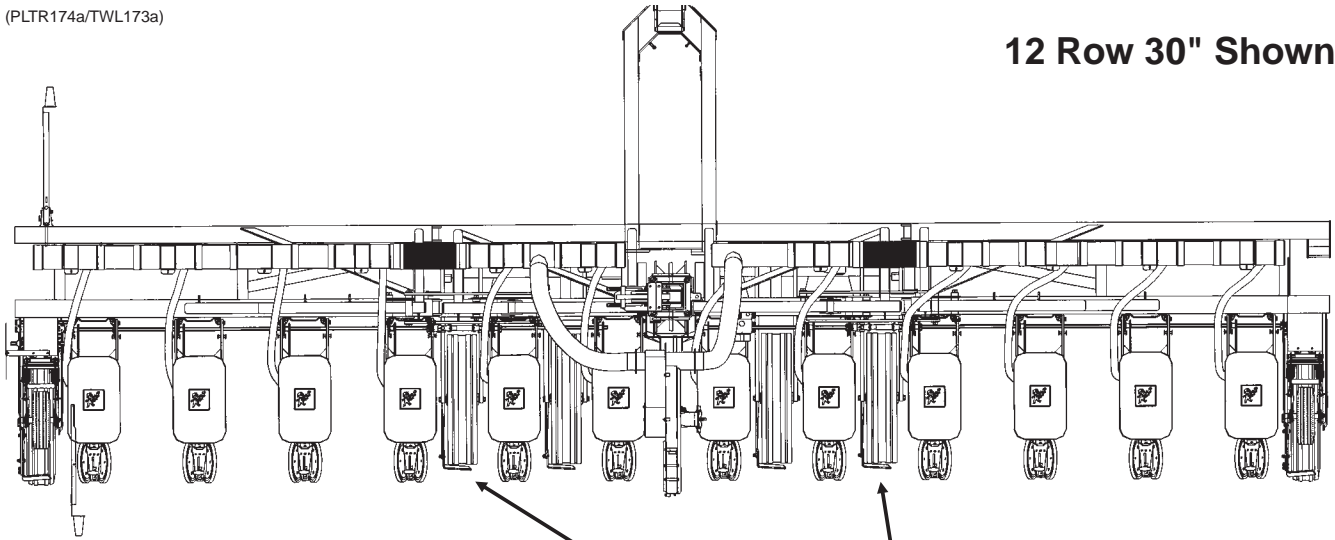

D060800115a

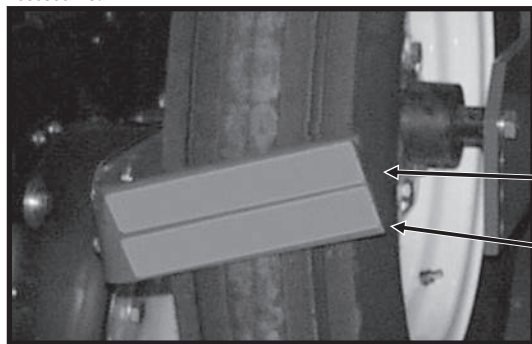

Part No. G7100-258 Red Reflective Decal
(Qty. 1 Per Outer Scraper - Located On Top)

Part No. G7100-260 Orange Reflective Decal
(Qty. 1 Per Outer Scraper - Located On Bottom)

Part No. G7100-259 Amber Reflective Decal (Located On The Front Side Of The Front Toolbar - Side-Facing In Transport Position)

NOTE: 7 Decals Used On 12 Row 30"; 9 Used On 16 Row 30" (12 Row Shown)

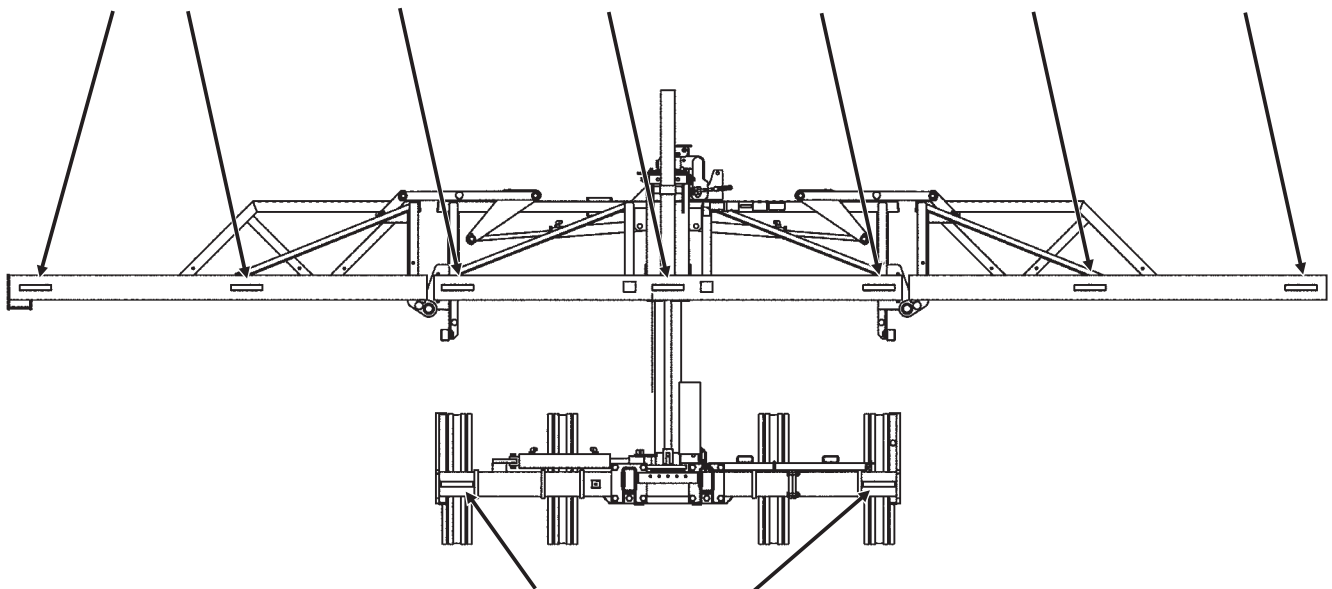

Part No. G7100-259 Amber Reflective Decal (Qty. 2 - Forward-Facing)

SAFETY WARNING SIGNS

(TWL174b/RU120e/RU130d/PLTR174a)

12 Row 30" Shown

Part No. G7100-258 Red Reflective Decal (Qty. 1 - Located On The Light Bracket On the L.H. Side Of The Planter - Rear-Facing In Transport Position)

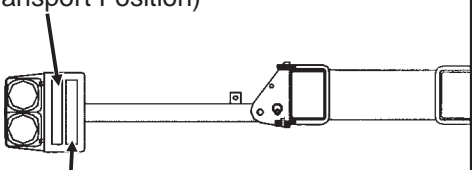

Part No. G7100-260 Orange Reflective Decal (Qty. 1 - Located On The Light Bracket On the L.H. Side Of The Planter - Rear-Facing In Transport Position)

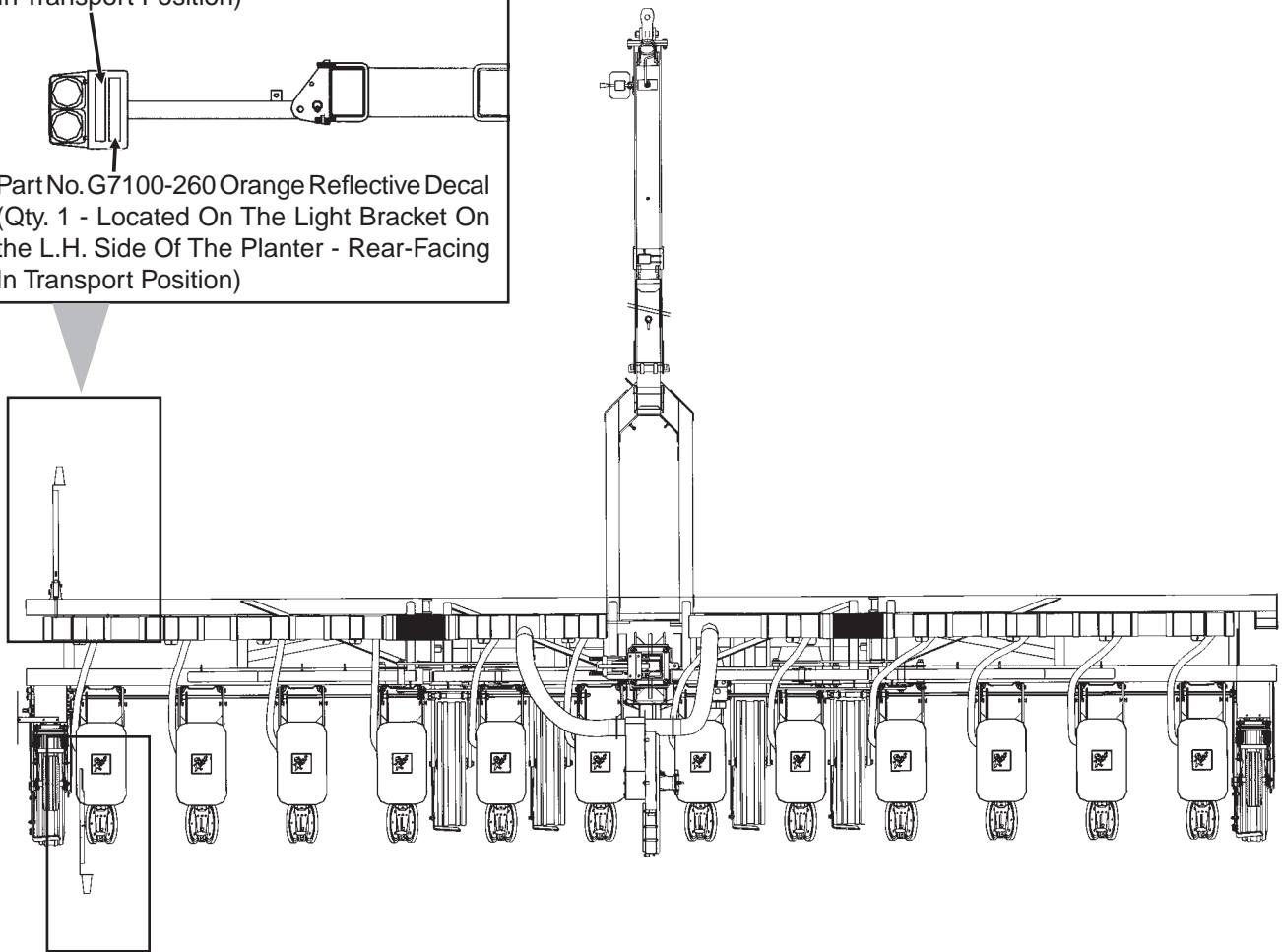

Part No. G7100-258 Red Reflective Decal (Qty. 1 - Located On The Outer Row Unit On the L.H. Side Of The Planter - Rear-Facing In Transport Position)

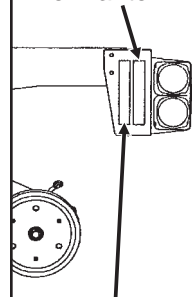

Part No. G7100-260 Orange Reflective Decal (Qty. 1 - Located On The Outer Row Unit On the L.H. Side Of The Planter - Rear-Facing In Transport Position)

SAFETY WARNING SIGNS

(TWL319)

12 Row 30" And 16 Row 30" - "Y" Hitches
Part No. G7100-259 Amber Reflective Decal (Qty. 2 - 1 Located On Each Side Of Hitch)

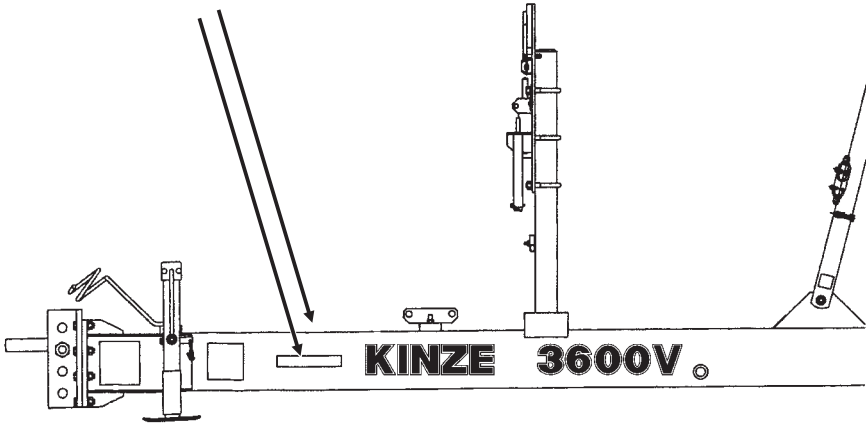

SAFETY WARNING SIGNS



(PLTR159/TWL122m/PLTR174b)

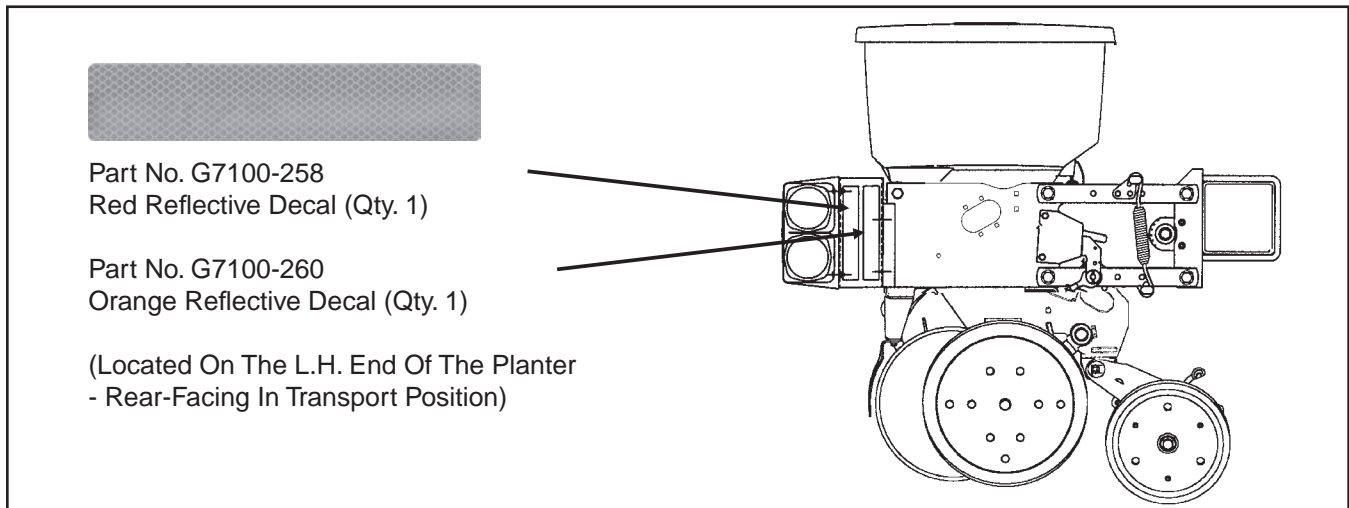

Part No. G7100-258
Red Reflective Decal (Qty. 1)

Part No. G7100-260
Orange Reflective Decal (Qty. 1)

(Located On The L.H. End Of The Planter
- Rear-Facing In Transport Position)

WITH INTERPLANT® PACKAGE OPTION

D020101103



Part No. G7100-259
Amber Reflective Decal
(Qty. 5 On 12 Row; 7 On 16 Row -
Located On The Front Of Every Other
Push Row Unit Beginning With The
Center Row Unit And Every Other
Row Unit To Both Ends - Side-Facing
In Transport Position)

Part No. G7100-259
Amber Reflective Decal
(Qty. 1 - Located On The
Front Of The Optional
Even-Row Push Row Unit
- Side-Facing In Transport
Position)

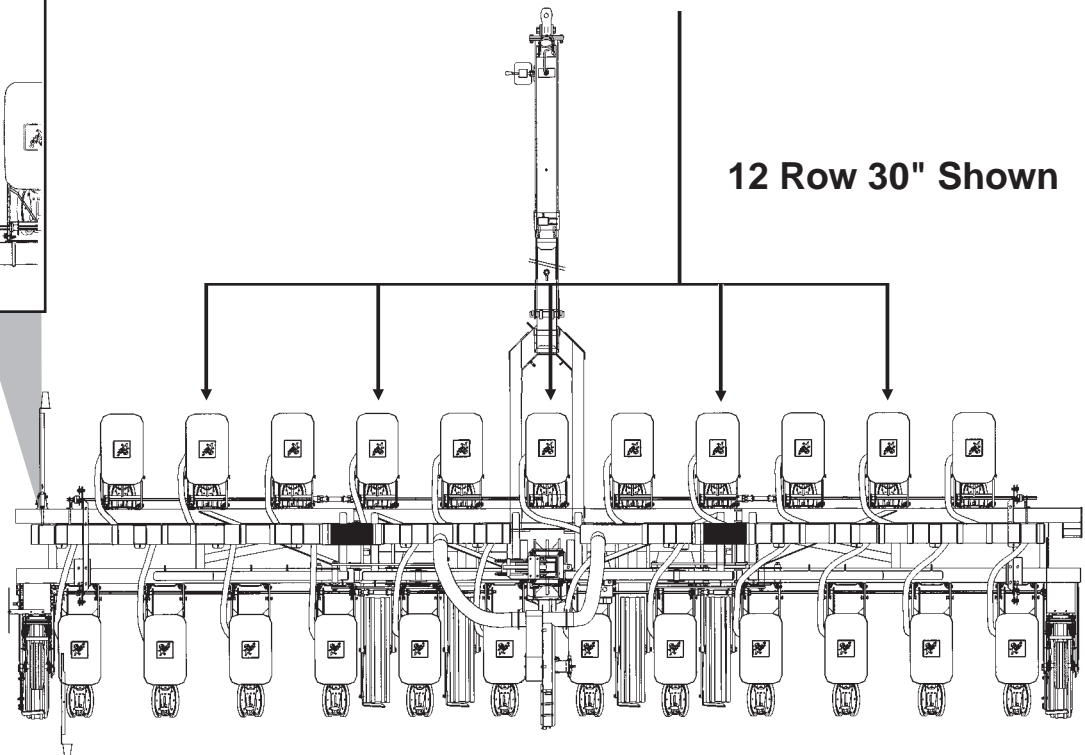
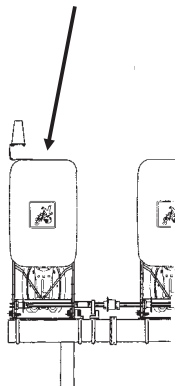

SAFETY WARNING SIGNS



D06039901



! WARNING !

AGRICULTURAL CHEMICALS CAN BE DANGEROUS. IMPROPER SELECTION OR USE CAN SERIOUSLY INJURE PERSONS, ANIMALS, PLANTS, SOIL OR OTHER PROPERTY. **BE SAFE. SELECT THE RIGHT CHEMICAL FOR THE JOB. HANDLE WITH CARE. FOLLOW THE INSTRUCTIONS ON THE CONTAINER LABEL AND OF THE EQUIPMENT MANUFACTURER.**

7100-115

Part No. G7100-115 (1 Per Row Unit - Located On Underside Of Optional Granular Chemical Hopper Lid)

D05050813

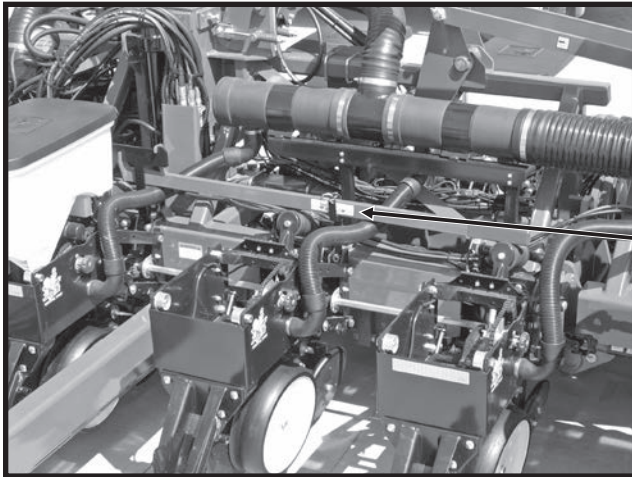

! CAUTION !

SET DOWN PRESSURE SPRINGS TO MINIMUM. LOWER PLANTER TO GROUND AND EMPTY SEED HOPPERS. **REQUIRES 90 LB MIN TO LIFT .**

7100-249

Part No. G7100-249 (Qty. 1 - Interplant® Push Row Unit Lift Lever)

SAFETY WARNING SIGNS



MACHINE OPERATION

The following information is general in nature and was written to aid the operator in preparation of the tractor and planter for use, and to provide general operating procedures. The operator's experience, familiarity with the machine and the following information should combine for efficient planter operation and good working habits.

IMPORTANT: Always raise the planter out of the ground when making sharp turns or backing up.

The KINZE EdgeVac® Seed Metering System includes seed meters, seed discs and an air system consisting of a hydraulic driven vacuum fan which draws air through the manifolds and hoses and the seed meters on each row unit.

WARNING: Never operate vacuum fan with cover removed.

ROW MARKER SAFETY LOCKUP

Install safety lockup devices over marker cylinder rods when transporting the planter or working around the planter. When lockups are not in use, store in the storage position provided on the first stage row marker arm.

DANGER: To avoid serious injury or death, keep others away when raising or lowering row markers.

D08250007

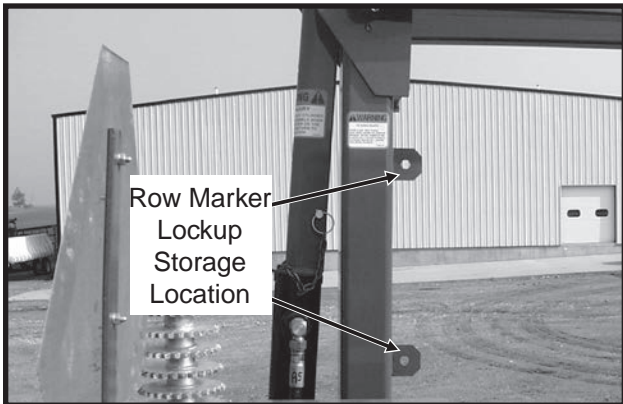

MANUAL SAFETY LOCKUP

Never allow anyone to work around or under the planter without first securing the manual safety lockup in the locked position. When transporting the planter use the manual safety lockup for added safety.

D05050842

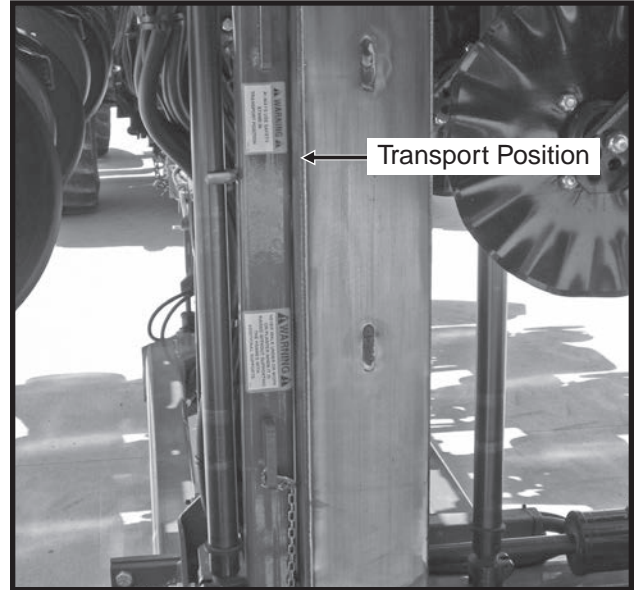

Manual Safety Lockup In Transport Position

D06189903

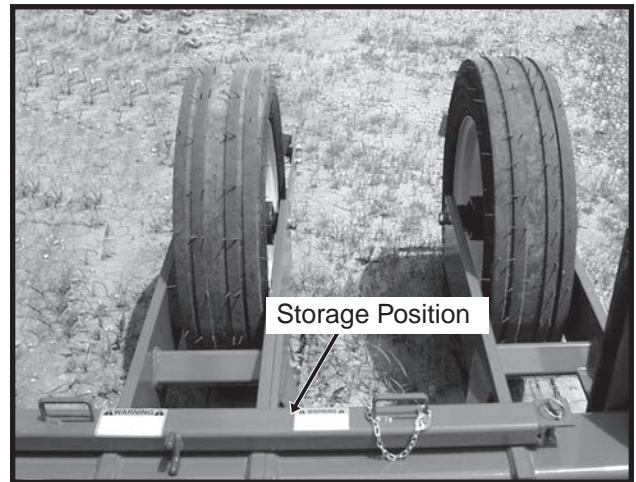

Manual Safety Lockup In Storage Position

For field operation remove the manual safety lockup and store on the L.H. side of the transport axle.

MACHINE OPERATION

TONGUE SAFETY PIN

The tongue safety pin when installed will prevent the tongue cylinder from retracting should hydraulic failure occur or a sudden stop be made when transporting the planter. Never transport the planter without installing the tongue safety pin.

D05050849

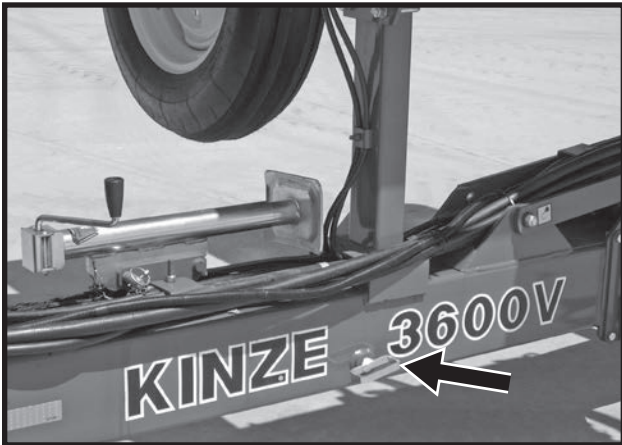

Tongue Safety Pin Installed For Transport

D062501101

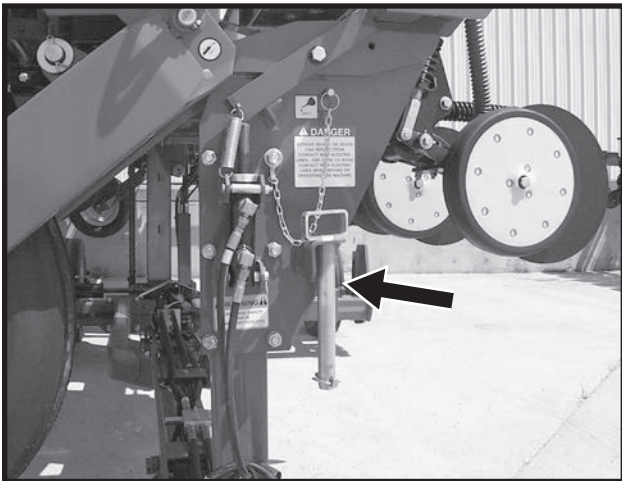

Tongue Safety Pin Stored For Field Operation

For field operation remove the tongue safety pin and store in the bracket provided on the transport latch post at the center of the planter.

TRANSPORT LATCH LOCKING PIN

The transport latch locking pin when installed will prevent the latch bar from disengaging and allowing the planter frame to swing away. Never transport the planter without installing the transport latch locking pin.

D060299106



Transport Latch Locking Pin Installed For Transport

D060299216

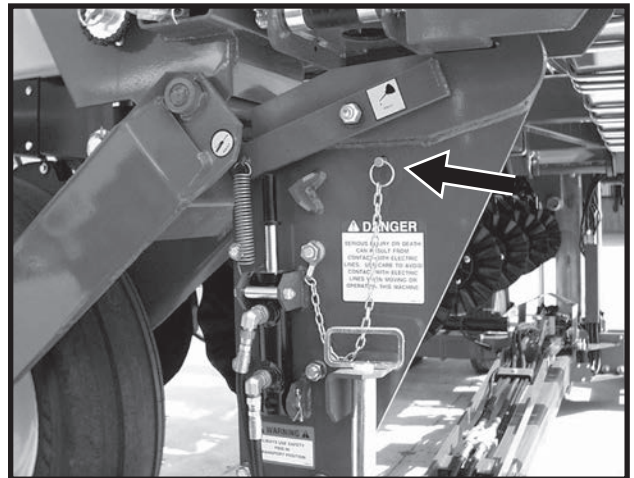

Transport Latch Locking Pin Stored For Field Operation

For field operation remove the transport latch locking pin and store in the location provided on the latch post.

MACHINE OPERATION

INITIAL PREPARATION OF THE PLANTER

Lubricate the planter and row units per the lubrication information in this manual. Make sure all tires have been properly inflated. Check all drive chains for proper tension, alignment and lubrication.



DANGER: The outer transport wheel on the left side of the machine is shipped removed (not bolted on) to allow narrower width truck shipment. **DO NOT REMOVE THIS ASSEMBLY AFTER PLANTER IS ASSEMBLED FOR USE. DO NOT** fold planter or tow planter while the outer transport wheel is removed. Tipping may occur because of narrow wheel base.

TRACTOR REQUIREMENTS

Consult your dealer for information on horsepower requirements and tractor compatibility. Requirements will vary with planter options, tillage and terrain.

3600V machine will require a minimum of 4.5 gallons per minute. A 12 volt DC electrical system is required on all sizes.

NOTE: Do not tee into hydraulic motor lines to run additional equipment.

Three SCV remote hydraulic outlets are required on all sizes. One SCV is used for field lift, and in conjunction with a switch on the control console, is used to operate the raise to transport function. The second SCV, in conjunction with the switches on the control console, is used to operate the row markers and fold/unfold functions. The third SCV plus a zero pressure case drain is used to operate the vacuum fan motor for seed metering system.

Maximum hydraulic flow rate of 13 GPM @ 2000 PSI is required to operate the vacuum fan motor.

IMPORTANT: Connect hydraulic motor case drain to a case drain return line with zero PSI on the tractor. Failure to connect to a return with zero PSI will cause damage to the hydraulic motor shaft seal. Warranty will not apply on damaged motors resulting from improper hydraulic line connection. DO NOT connect hydraulic motor case drain to a SCV outlet or motor return circuit connection. Contact tractor manufacturer for specific details on “zero pressure return”.

NOTE: If your tractor does not have sufficient hydraulic pump capacity, PTO pump drive and oil cooler packages are available from KINZE® through your KINZE® Dealer.

NOTE: A Flow Control Needle Valve Kit, to provide a flow control option for tractors that are not equipped with a method for finite adjustment of hydraulic flow is available from KINZE® Repair Parts through your KINZE® Dealer.

D04050604

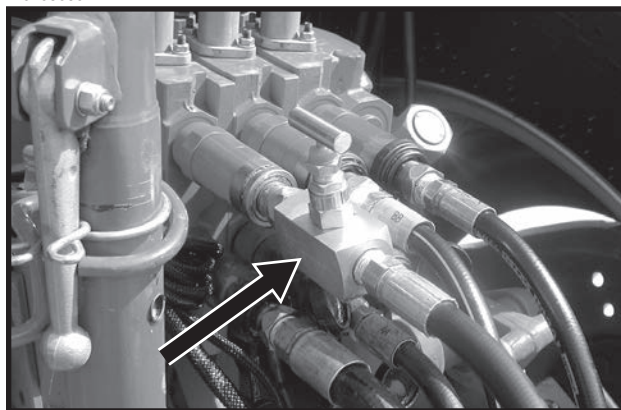

G1K426 Needle Valve Kit

MACHINE OPERATION

PTO PUMP DRIVE AND OIL COOLER OPTION

The PTO pump drive and oil cooler option is designed to accommodate tractors with less than the required hydraulic output necessary to operate the hydraulic-driven vacuum fan in addition to other planter hydraulic requirements. A 1 $\frac{3}{8}$ "-21 spline 1000 RPM PTO is required to operate the PTO-driven hydraulic pump. The option consists of a 1 $\frac{3}{8}$ "-21 spline, 13.5 GPM 2000 PSI pump, 10 gallon capacity hydraulic reservoir, 15 GPM-rated oil cooler, spin-on 10-micron oil filter and required hydraulic valves and fittings.

A 12 volt battery connection is required to power the vacuum fan digital gauge. Connect the "red" wire to the positive (+) battery terminal and the "black" wire to the negative (-) battery terminal.

(TWL290c/TWL294/PLTR177a)

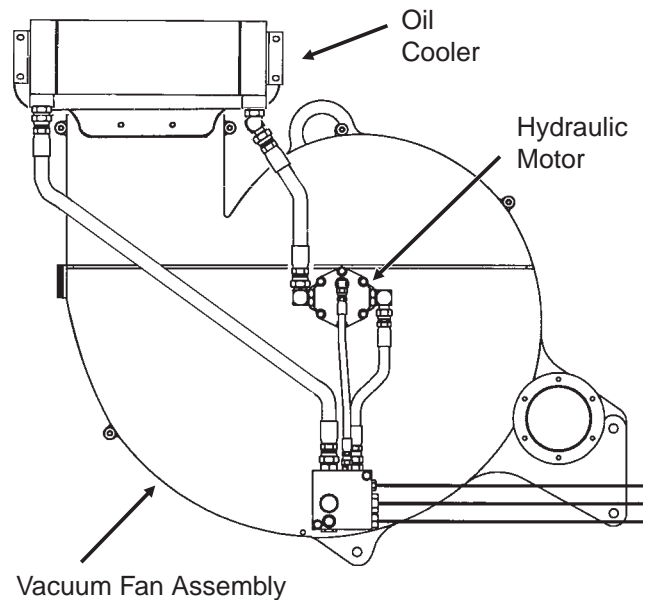

PTO-Driven Hydraulic Pump

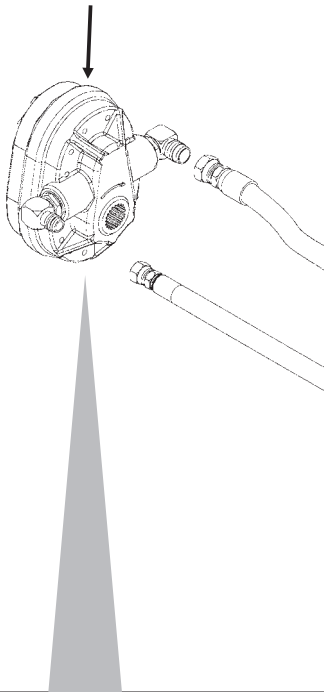

Oil Filter (10 Micron)

Flow Control Valve

Reservoir

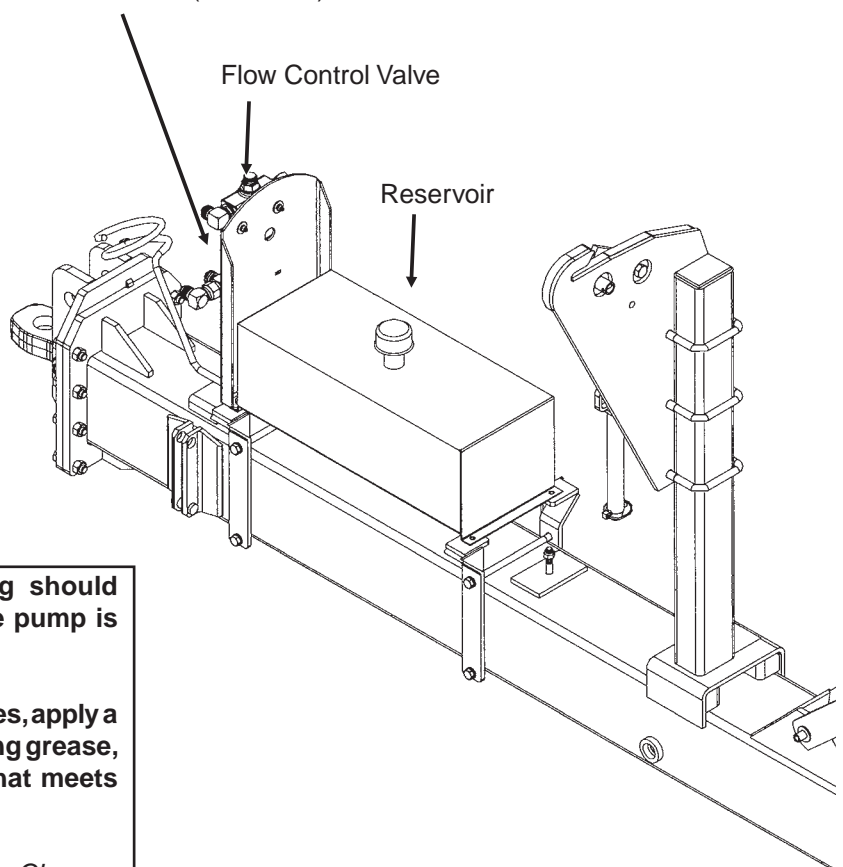

IMPORTANT: The PTO shaft coupling should be cleaned and greased each time the pump is installed.

IMPORTANT: To extend life of shaft splines, apply a coating of high-speed industrial coupling grease, such as Chevron® Coupling Grease, that meets AGMA CG-1 and CG-2 Standards.

(The Chevron® trademark is owned by Chevron Products Company. AGMA is the acronym for the American Gear Manufacturers Association)

MACHINE OPERATION

TRACTOR PREPARATION AND HOOKUP

D101602106



NOTE: A 2-Point Hitch Option, which converts the planter from drawn to semi-mounted, is available for use with Category 3N or 3 three-point hitch designs. The safety chain is not applicable with the 2-point hitch.

1. Adjust tractor drawbar to 13-17 inches above the ground. Adjust the drawbar so the hitch pin hole is directly below the center line of the PTO shaft. Make sure the drawbar is in a stationary position.
2. Install control console on tractor in a convenient location within reach of the operator and close to the hydraulic controls. Mount control console securely and route power cord to the power source.

The control console operates on 12 volt DC only. If two 12 volt batteries are connected in series, ALWAYS make power connection on the battery which is grounded to the tractor chassis.

If two 6 volt batteries are connected in series, make sure the power connection provides 12 volt DC across the positive terminal on one battery and negative terminal of the second battery.

3. Back tractor to planter and connect with 1 1/4" - 1 1/2" diameter hitch pin. If the tractor is not equipped with a hitch pin locking device, make sure hitch pin is secured with a locking pin or cotter pin.
4. The auxiliary attaching system (transport safety chain) provided with your planter should be used to ensure the connection is retained between the planter and tractor in the event of a hitch pin/drawbar failure. The safety chain is to be attached using an unused clevis mounting hole on the planter hitch. The mounting hardware should be torqued to 840 ft. lbs. Connect the hook end of the chain securely around a tractor frame member.

5. Connect hydraulic hoses to tractor ports in a sequence which is both familiar and comfortable to the operator.

The planter operation hydraulic hoses are color coded as follows:

- Red AA - Lift Functions (Return)
- Red BB - Lift Functions (Pressure)
- Blue AA - Marker And Fold/Unfold Functions (Return)
- Blue BB - Marker And Fold/Unfold Functions (Pressure)

The hydraulic motor operation hydraulic hoses are as follows:

- 3/8" Hose AA - Hydraulic Motor (Pressure)
- 1/2" Hose BB - Hydraulic Motor (Return)

The vacuum fan motor operation hydraulic hoses are as follows:

- 3/8" Hose From Motor - Case Drain
- 3/4" Hose From Motor - Return
- 1/2" Hose From Motor - Pressure

PT79a

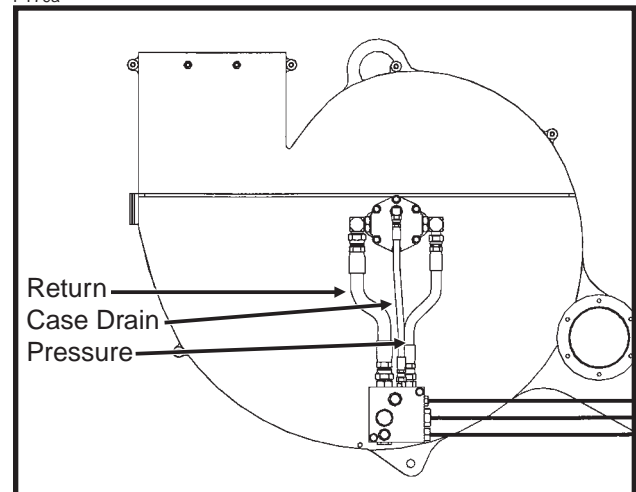

DANGER: Pressurized hydraulic fluid can penetrate body tissue and result in serious infection, injury, or death. Before applying pressure to the hydraulic system, make sure all connections are tight and that hoses and fittings have not been damaged. Leaks can be invisible. Keep away from suspected leaks. Relieve pressure in the hydraulic system before searching for leaks, disconnecting hoses, or performing any other work on the system. Fluid injected under the skin must be IMMEDIATELY removed by a surgeon familiar with this type of injury.

IMPORTANT: Always wipe hose ends to remove any dirt before connecting couplers to tractor ports.

(Continued On Following Page)

MACHINE OPERATION

6. Connect cable on planter to control console cable on tractor. Connect ASAE Standards 7 terminal connector for safety/warning lights on planter to ASAE Standards receptacle on tractor. If your tractor is not equipped with an ASAE Standards receptacle, check with your tractor manufacturer for availability. Check to be sure safety/warning lights on planter are working in conjunction with warning lights on tractor.

Connect harness on planter to digital vacuum gauge console on tractor. Connect power lead to power source. A power lead adapter may be required.

7. Raise jack and remount horizontally on storage bracket.
8. Lower planter to the planting position and check to be sure the hitch is level. If hitch slopes up or down, disconnect planter and adjust hitch clevis up or down as necessary.

LEVELING THE PLANTER

For proper performance of the planter and row units, it is important that the planter frame and row unit parallel arms operate approximately level. The toolbar should operate at a 20"-22" height, measured from the planting surface to the bottom of the toolbar.

D101602106



Four holes in the hitch bracket allow the clevis to be raised or lowered. In addition, the clevis may be turned over for a finer adjustment between mounting holes. When installing the clevis mounting bolt, make sure the lock nut is tightened to 840 ft. lbs.

D05050819

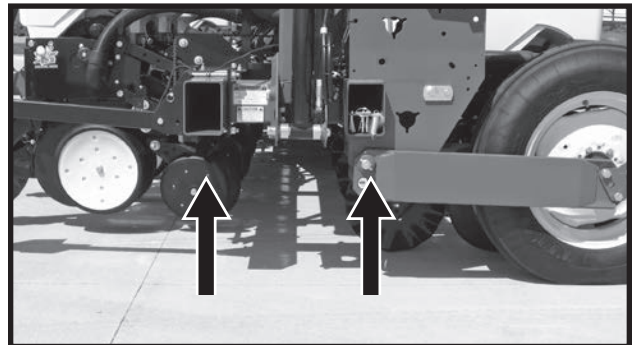

With the planter lowered to operating height, check to be sure the frame is level fore and aft. Recheck once planter is in the field.

It is important for the planter to operate level laterally. Tire pressure must be maintained at pressures specified. See "Tire Pressure".

Field and actual planting conditions will dictate which of the transport wheel settings to use to ensure row unit parallel arms are approximately parallel with the planting surface. It may also be necessary to lower the ground drive wheels to ensure level lateral toolbar operation if the transport wheels are set in one of the two lower sets of holes.

NOTE: To allow adequate drive force after lowering the ground drive wheels, it may be necessary to lower the contact drive wheel arms to the lower sets of holes in the wheel modules and lower the down pressure springs to the lower mounting rods on the wheel modules.

MACHINE OPERATION

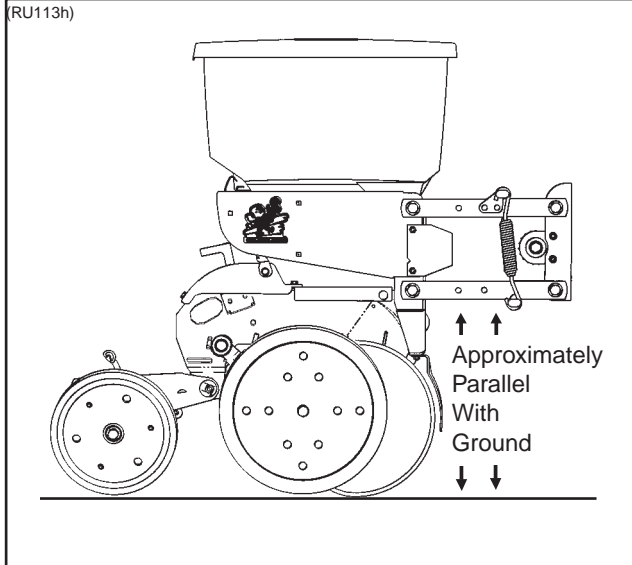

NOTE: On planters equipped with push row units and no till coulters, the uplift from the down force springs or air springs in the pneumatic down pressure system may cause the wings to rise slightly in planting position. The problem may be compounded if static pressure is trapped in the planter's hydraulic lift system which can cause the wing cylinders to extend slightly. Operating the tractor's hydraulic system in the float position or moving the tractor's hydraulic lever to the float position briefly, to relieve the pressure, will help to maintain the proper toolbar height.

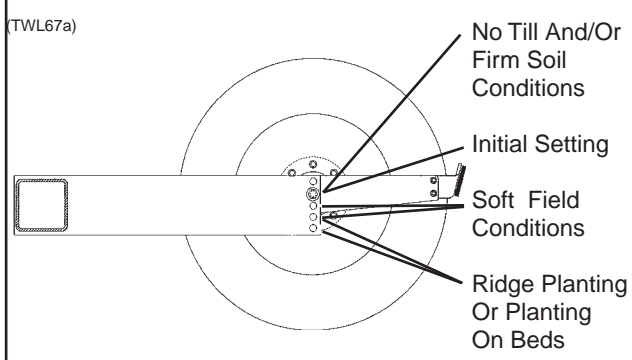

TRANSPORT WHEEL
CAUTION: When using top hole setting, check clearance between tires and drill shaft U-joint prior to operation.

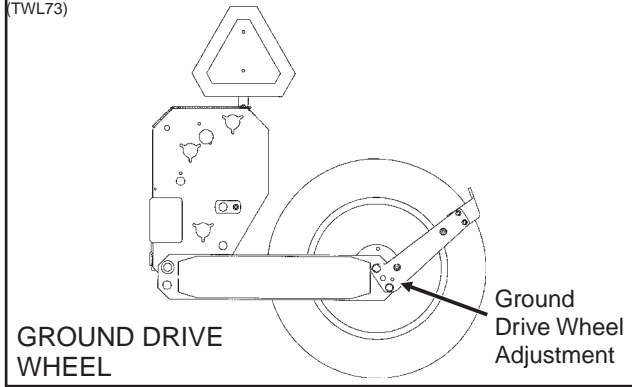

When the planter has been fully loaded with seed, fertilizer, etc.; a field check should be made to be sure the wings are level with the center frame. If the wings are not level with the center frame, the drive wheels and/or transport wheels can be raised or lowered in the wheel arms to increase or decrease planter toolbar height. Hitch height should be raised accordingly to ensure level operation.

NOTE: As the lift cylinders are (port type) rephasing type, it is necessary for the cylinders to fully retract in order to rephase. Cylinder stops can not be used.

MACHINE OPERATION

TIRE PRESSURE

D05050845

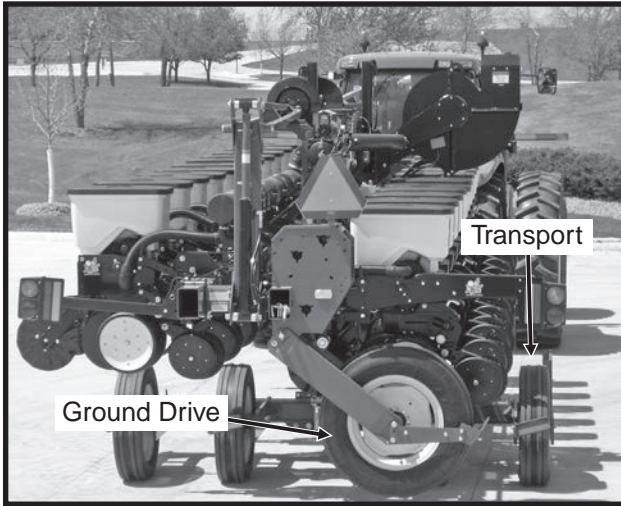

Tire pressure should be checked regularly and maintained as follows:

- 255-70R 22.5" Transport (Center Section) . . . 75 PSI
- 7.50" x 20" Ground Drive (Wings) 40 PSI
- 7.60" x 15" Ground Drive
(Liquid Fertilizer Piston Pump) 40 PSI

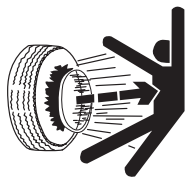

! DANGER: Rim and tire servicing can be dangerous. Explosive separation of tire and rim parts can cause serious injury or death.

Do not attempt to mount a tire unless you have the proper equipment and experience to perform the job. This should only be done by persons properly trained and equipped to do the job.

Always maintain the correct tire pressures. Do not inflate the tires above the recommended pressures.

When inflating tires, use a clip-on air chuck and extension hose long enough to allow you to stand to one side and NOT in front of or over the tire assembly. Use a safety cage to enclose the tire and rim assembly when inflating.

Inspect tires and wheels daily. Do not operate with low pressure, cuts, bubbles, damaged rims or missing lug bolts and nuts.

RIDGE PLANTING

When ridge planting, the drive wheels and transport wheels can be lowered 2" or 4" to the lower mounting holes in the wheel arms to increase the planter toolbar height. The contact drive tire must also be lowered to the lower set of holes in the wheel module and the down pressure springs hooked on the lower rod. Hitch height should be raised accordingly to ensure level operation.

(TWL67a)

Wheel Shown Mounted In Standard Location - Lower 2" Or 4" To Lower Mounting Holes When Ridge Planting

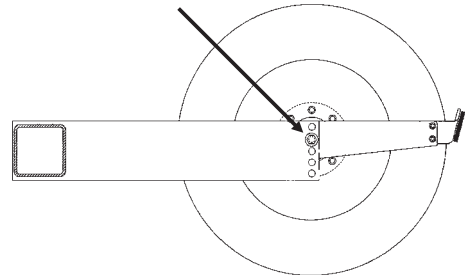

NOTE: The toolbar should operate at a 20"-22" height measured from the bottom of the toolbar to the planting surface.

MACHINE OPERATION

HYDRAULIC/ELECTRIC OPERATION

76746-24

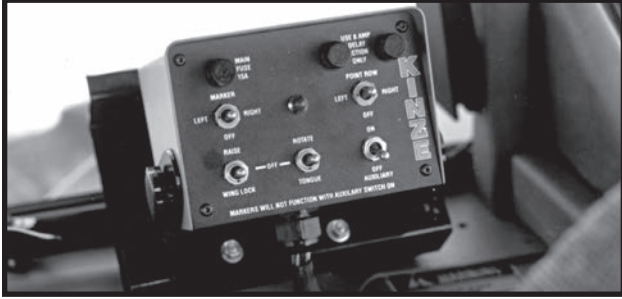

The tractor's hydraulic system and switches on the control console located on the tractor are used to raise the planter to transport position, operate the rotate and tongue extension functions, lock and release the planter wings, and raise and lower the row markers.



DANGER: To avoid serious injury or death care must be taken when operating row markers around overhead power lines.

NOTE: The backlit console is equipped with a push button switch on the back of the console which should be used to turn the console face off during extended periods of non-use.

Model 3600V planters are equipped for operation from three dual remote (SCV) hydraulic outlets. One SCV, in conjunction with a switch on the control console, is used to operate the raise to transport function. The second SCV, in conjunction with the switches on the control console, is used to operate the row markers and fold/unfold functions. The third SCV is used to operate the vacuum fan motor circuit.

The marker switches are an ON-OFF-ON type. (NOTE: All 3600V planters are shipped with the point row switch installed in the control console.)

Power to the marker switch is fed through the auxiliary switch and the two transport function switches. Operating any of the switches in the lower row disables the marker function and turns off the indicator light for the markers.

A7435(TWL81)

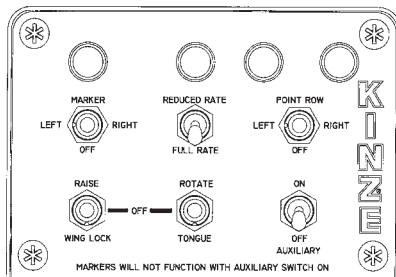

MACHINE OPERATION

The raise/wing lock and rotate/tongue (fold function) switches are MOMENTARY ON-OFF-MOMENTARY ON type and must be held in position while operating the tractor hydraulic SCV control. Activating a fold function switch disables the marker circuit.



WARNING: To ensure the safety of the operator and others nearby, the marker selector switch should be placed in its OFF (center) position when not in use. An indicator light on the control box panel is ON whenever the marker circuits or point row clutch circuits are energized.

The auxiliary switch is an ON-OFF type switch which is used in conjunction with the hydraulic marker/folding functions SCV control to operate optional attachments. All 3600 planters are shipped with the auxiliary switch installed in the control console. The auxiliary switch must be in the OFF position to enable other functions.

NOTE: Activating the auxiliary switch disables all other control console switches.

NOTE: The lift cylinders are (port type) rephasing cylinders. It is necessary for the cylinders to fully retract before they will rephase in the lowered position. Cylinder stops can not be used.



WARNING: Never work under the planter while in raised position without installing safety lockup devices.



WARNING: Make sure all hydraulic hoses are properly connected before operating the planter. Never connect or disconnect hydraulic hoses without first stopping the tractor engine and moving the hydraulic operating controls in both directions to relieve any pressure in the system.



WARNING: Do not work on planter drive system without first shutting off the tractor or disconnecting the hydraulic lines. The hydraulic drive could start at anytime.

A third SCV operates the seed metering system vacuum fan. See “Digital Vacuum Gauge Operation”.

NOTE: The vacuum gauge ON/OFF switch should be left in OFF position when planter is not in use. If left in ON position, the tractor battery will be drained.

HYDRAULIC DRIVE

When stopping in the middle of the field the drive will run a split second after the tractor and planter has come to a complete stop. To avoid the bunching of seeds in this spot shut the master switch off before coming to a complete stop.

To avoid skips when starting from a complete stop in the middle of the field, lift the planter and back-up 4-6 feet, put the planter in the ground, and continue planting. Also, when accelerating from a complete stop, do so very slowly. This will reduce the number of skips in the field when starting from a complete stop.

MACHINE OPERATION

TRANSPORT TO FIELD SEQUENCE

Position the planter in a relatively flat open area. Try to avoid an area with furrows, etc.

SUMMARIZED TRANSPORT TO FIELD SEQUENCE

- Remove tongue safety pin.
- Remove transport latch locking pin.
- Remove manual safety lockup.
- Rotate planter to planting position.
- Raise planter slightly to release safety hook at top of center section.
- Lower planter to the ground.
- Release wing locks.
- Rephase planter lift cylinders.
- Raise planter to raised field position and retract tongue.
- Remove row marker lockups.

NOTE: Read the following information for more detailed instructions.

D05050837

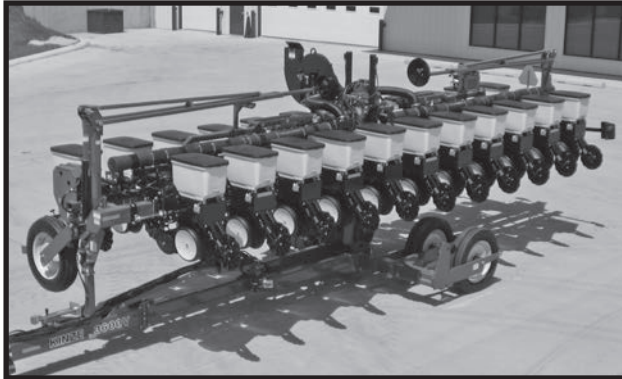

1. With the tongue fully extended and the planter in the raised transport position, remove the tongue safety pin and store it in the storage position.

D05050849

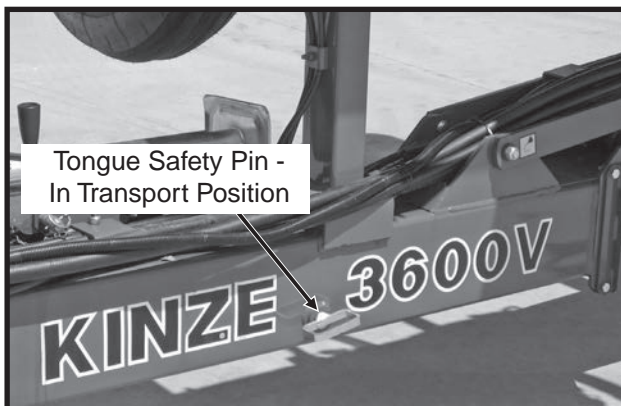

D062501101



2. Remove the transport latch locking pin from the locked position and place it in the storage location.

D060299106



D060299216



MACHINE OPERATION

- Remove the manual safety lockup from under the front center lift cylinder and place it in the storage location on the left side of the planter axle.

D05050842

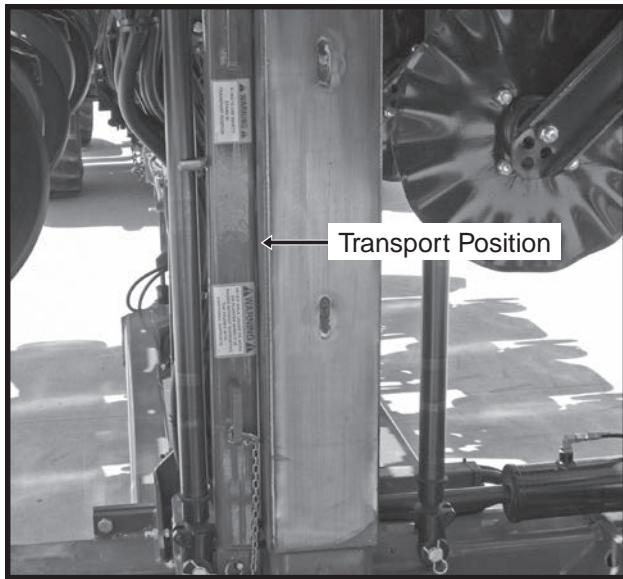

D11080614



- Raise the planter 1"-2". The safety hook will release and snap away from the catch pin on the top of the pivot post.

82316-16

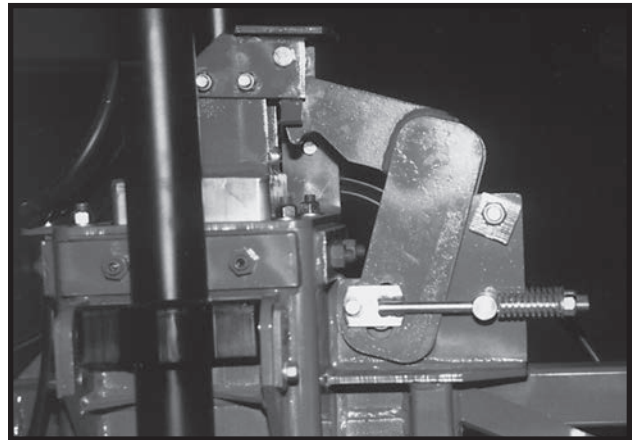

D06189903

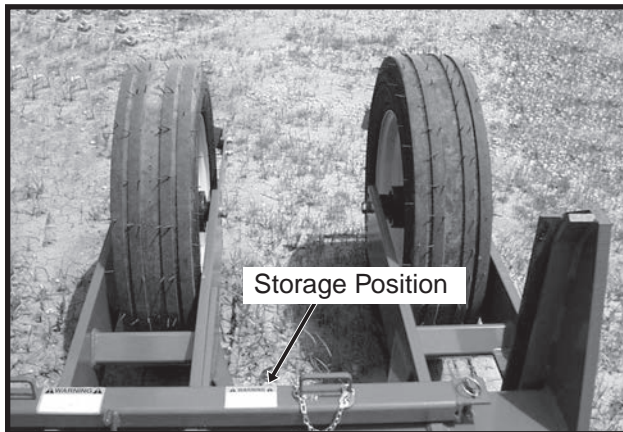

NOTE: Raising the planter too high will reset the hook mechanism and the sequence must be repeated.

- Hold the control console switch labeled "ROTATE/TONGUE" in "ROTATE" and operate the hydraulic control to unfold the planter. The transport latch will automatically release.

- Slowly lower the planter to the ground.

76746-24

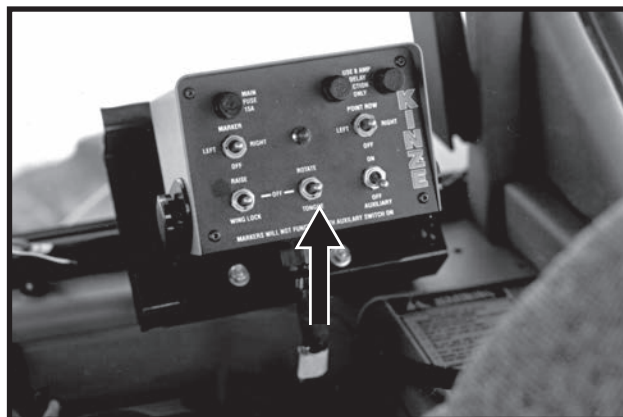

D05050834

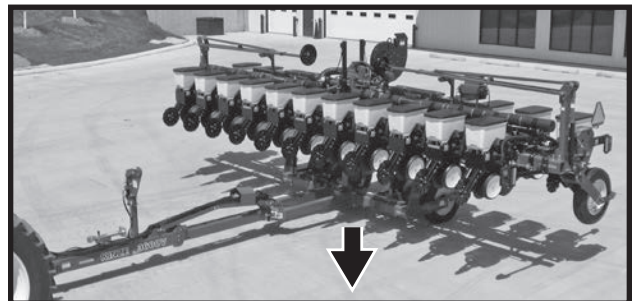

MACHINE OPERATION

7. Hold the control console switch labeled “RAISE/WING LOCK” in “**WING LOCK**” position and operate the hydraulic control to release the wing locks.

D05050827

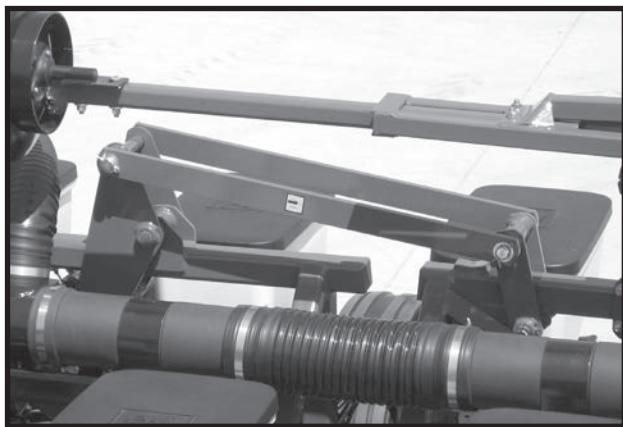

8. Hold the hydraulic control (to lower planter) to rephase the planter lift cylinders. The length of time it takes to rephase the system may vary due to tractor hydraulic flow and/or oil temperature. Normally 5 to 20 seconds is adequate to rephase the system.
9. Raise the planter to the raised field position. Hold the control console switch labeled ROTATE/TONGUE in **TONGUE** and operate the hydraulic control to retract the tongue.
10. Remove and store row marker lockups.

D08250007



FIELD OPERATION

There are two raised positions on the planter. One is the “raised field position” which is when the planter wing cylinders are fully extended and the center lift cylinders are at mid-stroke. Because the solenoid, located on the top side of the valve blocks on the rear R.H. side of the center frame, is not energized, the wing cylinders cannot bypass oil preventing the planter from raising any higher. In the “raised field position” the row units are approximately 14 inches off the ground. This position is used in making turns or passing over waterways during field operation.

D05050830



D060299126

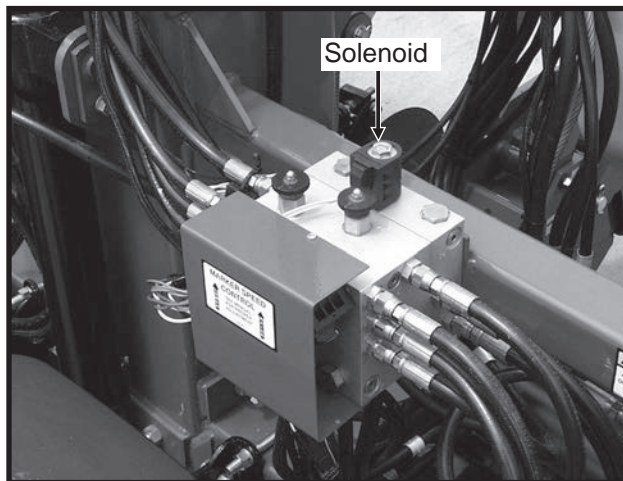

See “Row Marker Operation” for field operation of row markers.

MACHINE OPERATION

FIELD TO TRANSPORT SEQUENCE

Position the planter in a relatively flat area. Try to avoid an area with furrows, etc.

SUMMARIZED FIELD TO TRANSPORT SEQUENCE

- Install row marker lockups.
- Raise planter to raised field position.
- Extend tongue.
- Lock wings over center
- Raise planter to engage safety hook at top of center section into locking position.
- Lower planter onto safety hook.
- Rotate planter to transport position.
- Install tongue safety pin.
- Install transport latch locking pin.
- Install manual safety lockup.

NOTE: Read the following information for more detailed instructions.

1. Install row marker lockups.

D05050802

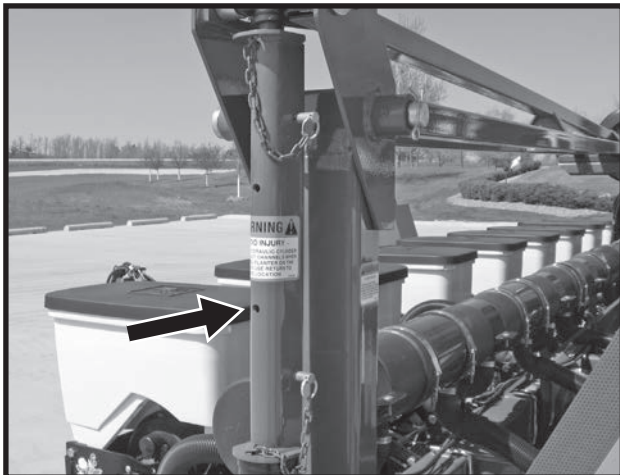

2. Using the hydraulic control, raise the planter to the raised field position as shown below.

D05050830



3. Hold the control console switch labeled "ROTATE/TONGUE" in "TONGUE" and operate the hydraulic control until the tongue is fully extended. The tongue lock latch will automatically release.

D05050830

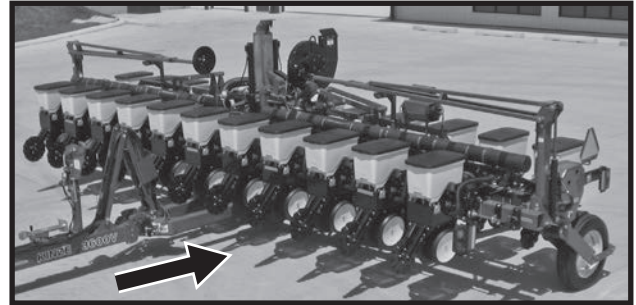

82316-20

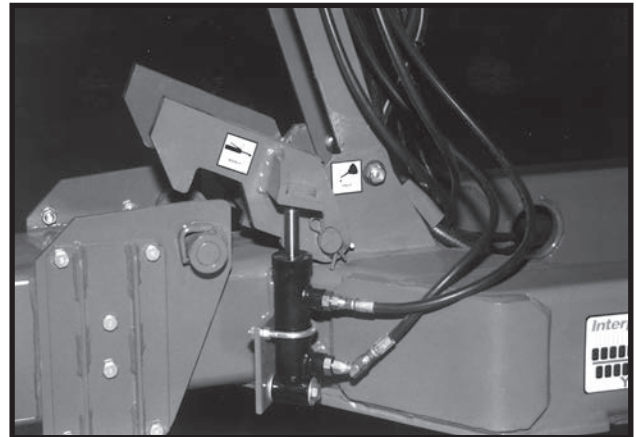

4. Hold the control console switch labeled "RAISE/WING LOCK" in "WING LOCK" and operate the hydraulic control until the wing lock cylinders are fully extended and the wing locks are locked over center.

76746-24

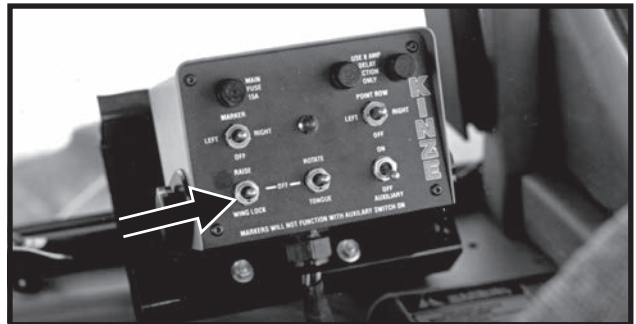

D05050828

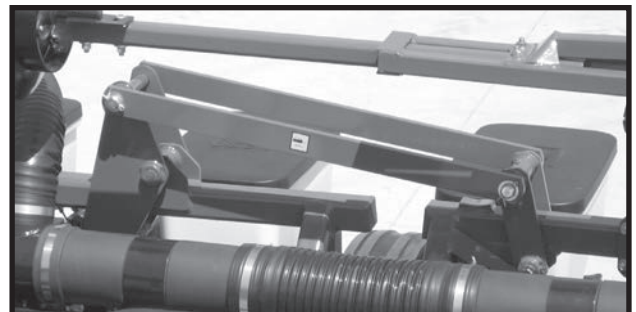

MACHINE OPERATION

5. Hold the control console switch labeled "RAISE/WING LOCK" in "RAISE" and operate the hydraulic control until the two center lift cylinders are fully extended and the safety hook located at the top of the center section rotates into locking position.

82316-15

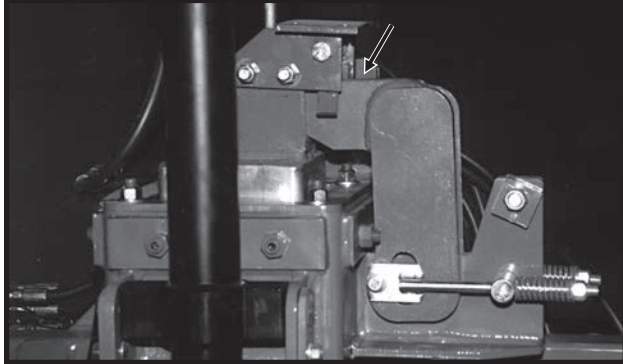

6. Using the hydraulic control, lower the planter onto the safety hook.
7. Hold the control console switch labeled "ROTATE/TONGUE" in "ROTATE" and operate the hydraulic control to rotate the planter until the transport latch is engaged.

82079-2a

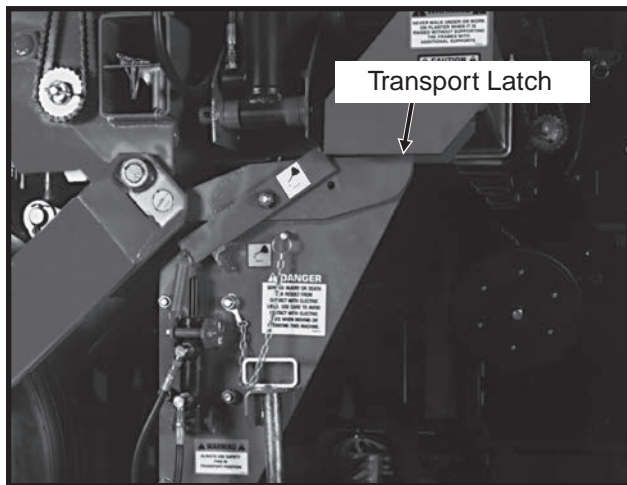

8. Install tongue safety pin.

D05050849

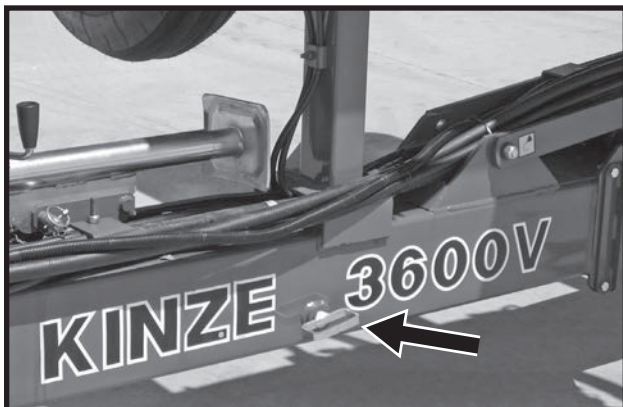

9. Install transport latch locking pin.

D060299106

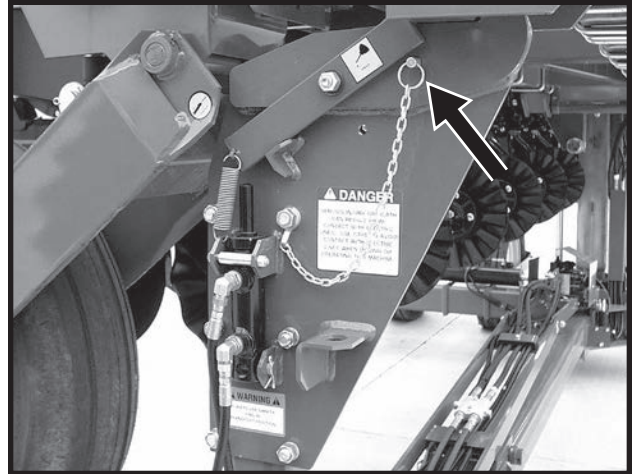

10. Remove manual safety bar from its storage location on the left side of the axle assembly and position it behind the front center lift cylinder.

D06189903

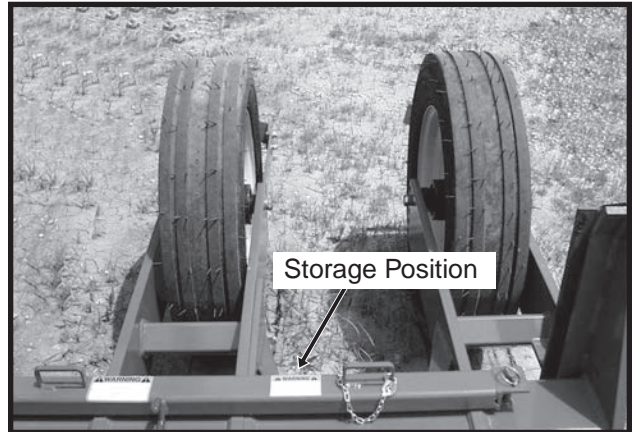

D05050842

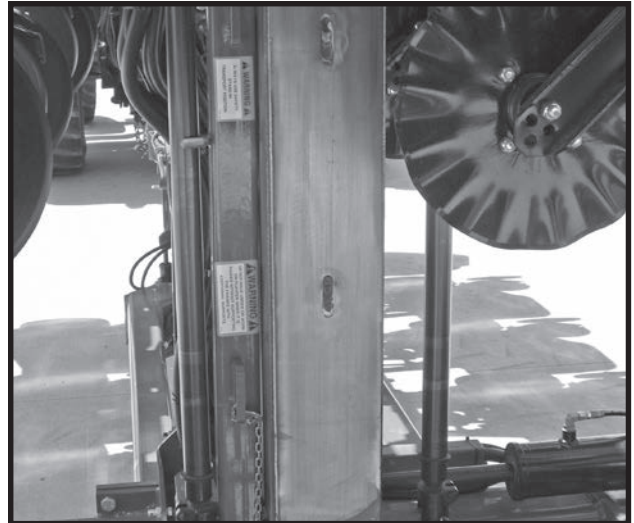

WARNING: Always install the manual safety lockup prior to working under the planter or while transporting the planter.

MACHINE OPERATION

DIGITAL VACUUM GAUGE OPERATION

The digital vacuum gauge console is equipped with an ON-OFF-ON type selector switch. The “FAN 1” setting should be used when the planter is equipped with one vacuum fan.

NOTE: The console ON/OFF switch should be left in OFF position when the planter is not in use. If left in ON position, the tractor battery will be drained.

D10240583



The digital vacuum gauge is calibrated at the factory, however, vacuum will vary throughout the manifold system and it may be necessary to adjust the digital readout so it agrees with the actual vacuum at the meter. With the seed discs loaded with seed, compare the digital vacuum gauge readout to the reading taken from the analog gauge or a hand held gauge at several meters along the length of the planter. The elbows located on the covers of the seed meters allow testing of meter vacuum levels without removing the vacuum hoses. If there is more difference than 1" or 2" (H₂O), the digital gauge can be adjusted by inserting a small flat bladed screwdriver into the opening on the back of the digital gauge housing and turning the potentiometer until the digital gauge displays the vacuum that is present at the meter. Compare readings at 10" and 20" of vacuum.

ANALOG VACUUM GAUGE

The analog vacuum gauge connects directly to the manifold. The digital vacuum gauge should then be calibrated to match that reading. See “Digital Vacuum Gauge Operation”.

D06260653

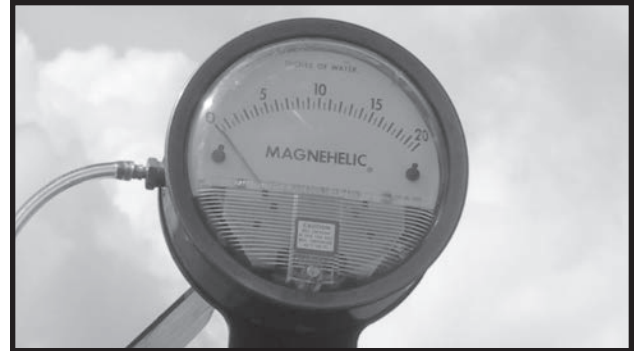

The only adjustment to the gauge is to “zero” the needle with no vacuum present. If there is a significant difference between this gauge and a reading taken at the meters, a different manifold location should be found to connect hose to the gauge.

VACUUM FAN MOTOR VALVE BLOCK ASSEMBLY

A pressure relief valve in the hydraulic circuit prevents build up of oil pressure over 35 PSI in the case drain line when the vacuum fan motor is in operation. This valve will vent oil to the outside of the valve block through a drain hole in the aluminum valve block. This can occur whenever the case drain is connected improperly or pressure in the motor circuit builds.

See “Hydraulic Diagram - Vacuum Fan Motor System” in Maintenance section.

The valve block also contains a check valve that serves two purposes. This valve (a) prevents the vacuum fan from operating in the wrong direction if pressure is applied to the return side of the motor and (b) allows the fan to coast to a stop when the tractor hydraulic control is returned to the neutral position.

NOTE: If reverse pressure is applied the fan will turn at a reduced speed.

MACHINE OPERATION

ROW MARKER OPERATION

76740-28

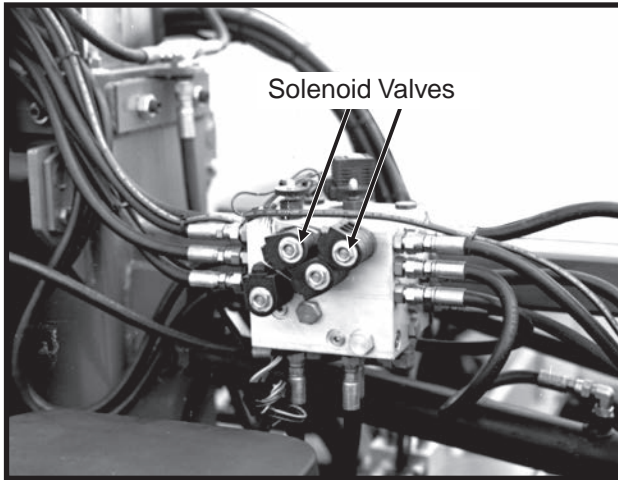

Shown With Cover Removed

D060299126

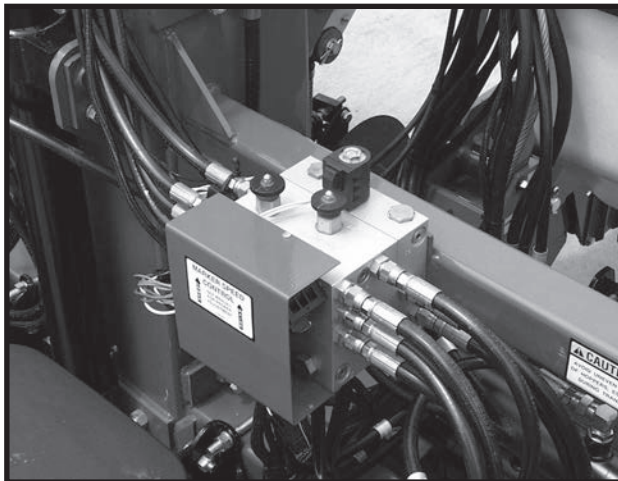

Shown With Cover Installed

76746-24

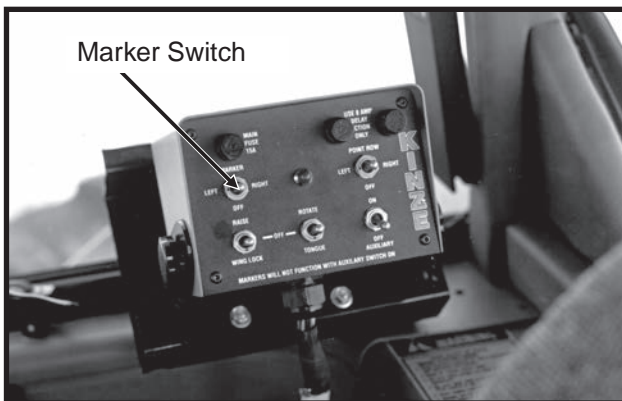

Three Position Selector Switch On Control Console

Two solenoid valves, located on the valve block on the rear R.H. side of the center frame, and a three position selector switch on the control console permit the operator to lower or raise the desired row marker.

See "Row Marker Speed Adjustment".

1. On the control console, select which row marker you want to lower.
2. Operate hydraulic control to lower row marker.
3. If opposite row marker is to be used next, change control switch to other side.
4. At end of field, using hydraulic control, raise the down row marker.
5. After making the turn, using the hydraulic control, lower the pre-selected row marker.
6. Continue to follow this procedure.

NOTE: Both row markers can be lowered by operating the switch in each position and operating the hydraulic control twice. The row markers will raise simultaneously with the hydraulic control in the raise position.

NOTE: Switch should be left in OFF position when planter is not in use. If left in ON position, it will discharge the tractor battery.

If the electrical system fails to operate properly:

- Check fuse.
- Check wiring connections.
- Check control switch.
- Check solenoid. SOLENOID HOUSING WILL BE MAGNETIZED WHEN ENERGIZED.



DANGER: To avoid serious injury or death, care must be taken when operating row markers around overhead power lines.

MACHINE OPERATION

ROW MARKER SPEED ADJUSTMENT

The marker hydraulic system includes two flow control valves. One flow control valve sets the lowering speed of both markers and one sets the raising speed of both markers. To adjust marker speed, loosen the jam nut and turn the control(s) clockwise, or IN, to slow the travel speed and counterclockwise, or OUT, to increase the travel speed. The flow control(s) determine the amount of oil flow restriction through the valves, therefore varying travel speed of the markers. Tighten jam nut after adjustments are complete.

D060299126

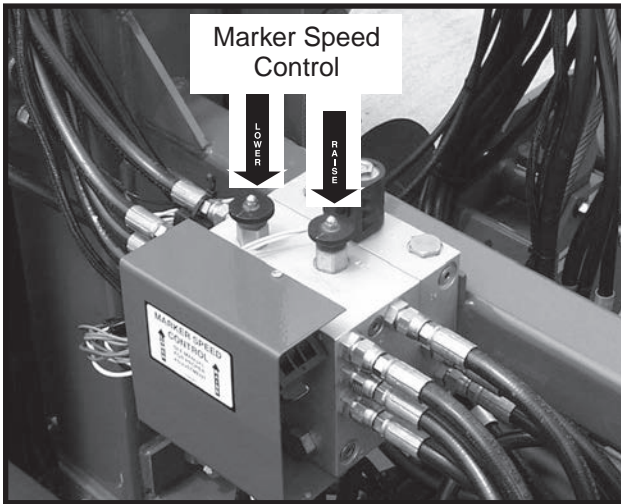

IMPORTANT: The flow controls should be properly adjusted before the row marker assembly is first put into use. Excessive row marker travel speed of the markers can damage the marker assembly.

NOTE: When oil is cold, hydraulics operate slowly. Make sure all adjustments are made with warm oil.

NOTE: On a tractor where the oil flow can not be controlled, the rate of flow of oil from the tractor may be greater than the rate at which the marker cylinder can accept the oil. The tractor hydraulic control will have to be held until the cylinder reaches the end of its stroke. This occurs most often on tractors with open center hydraulic systems.

On tractors equipped with flow control valves, row marker speed adjustment should be made with the tractor flow controls in maximum position. After row marker speed is set, the tractor flow controls can be adjusted to allow the hydraulic control to stay in detent during the marker raise or lower cycle.



DANGER: To avoid serious injury or death, care must be taken when operating row markers around power lines.

ROW MARKER LENGTH ADJUSTMENT

To determine the correct length at which to set the row marker assemblies, multiply the number of rows by the average row spacing in inches. This provides the total planting width. Adjust the marker extension so the distance from the marker disc blade to the center line of the planter is equal to the total planting width previously obtained. Both the planter and row marker assembly should be lowered to the ground when measurements are being taken. The measurement should be taken from the point where the blade contacts the ground. Adjust right and left row marker assemblies equally and securely tighten clamping bolts. An example of row marker length adjustment follows:

Number of rows	x	Row spacing (Inches)	=	Dimension Between Planter Center Line And Marker Disc Blade
-------------------	---	----------------------------	---	---

12 Rows x 30" Spacing = 360" Marker Dimension

60569-53

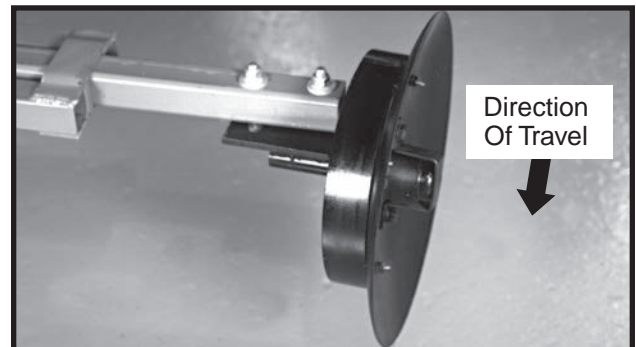

Marker Disc Blade Shown With Depth Band

The marker disc blade should be installed so the concave side of the blade faces outward to throw dirt away from the grease seals. The spindle assembly is slotted so the hub and blade can be angled to throw more or less dirt. To adjust the hub and spindle, loosen the 1/2" hardware and move the assembly as required. Tighten bolts to the specified torque.

IMPORTANT: A marker disc blade assembly that is set at a sharper angle than necessary will add unnecessary stress to the complete row marker assembly and shorten the life of bearings and blades. Set the blade angle only as needed to leave a clear mark.

A field test is recommended to ensure the markers are properly adjusted. After the field test is made, make any minor adjustments as necessary.

A notched marker disc blade, for use in more severe no till conditions, is available from KINZE® through your KINZE® Dealer. (Continued On Following Page)

MACHINE OPERATION

When using the even-row push row unit option, adjust marker extensions as shown below.

(PLTR174/INS172a/INS172)

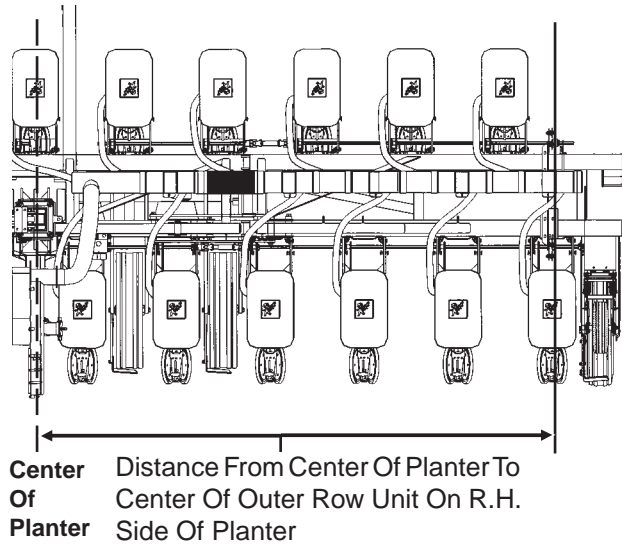
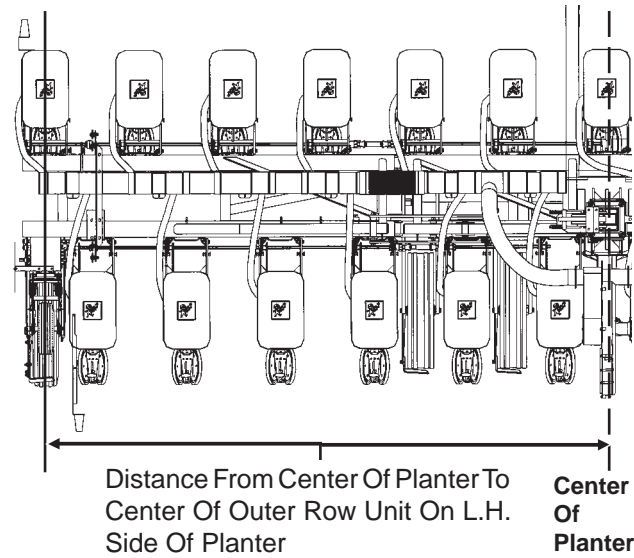

$$\begin{array}{r} \text{Center Of} \\ \text{Planter To} \\ \text{Center Of} \\ \text{Outer Row} \\ \text{Unit} \end{array} \times 2 + \begin{array}{r} 15" \\ \text{Row} \\ \text{Spacing} \end{array} = \begin{array}{r} \text{Dimension} \\ \text{Between} \\ \text{Planter Center} \\ \text{Line And} \\ \text{Marker Blade} \end{array}$$

12 Row 30" With 12 Interplant® Push Row Units
 (L.H. Marker 180" x 2 + 15" = 375")
 (R.H. Marker 165" x 2 + 15" = 345")

16 Row 30" With 16 Interplant® Push Row Units
 (L.H. Marker 240" x 2 + 15" = 495")
 (R.H. Marker 225" x 2 + 15" = 465")

NOTE: If tractor hitch is offset 7 1/2" to the right of the center line of the tractor, add 7 1/2" to the marker dimension on the R.H. side of the planter and subtract 7 1/2" from the marker dimension on the L.H. side of the planter.

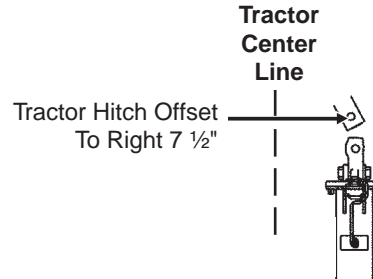

NOTE: Readjust markers when planting 30" rows.

NOTE: Readjust row markers when planting 30" rows.

$$\begin{array}{l} \text{Number Of Rows} \times \text{Row Spacing (Inches)} \\ = \\ \text{Dimension Between Planter Center Line} \\ \text{And Marker Blade} \end{array}$$

12 Rows x 30" Spacing = 360" Marker Dimension
 16 Rows x 30" Spacing = 480" Marker Dimension

MACHINE OPERATION

KINZE VISION® SYSTEM

The KINZE Vision display is a GPS-compatible universal monitor/controller for use in crop production and protection. It can easily be transferred between multiple vehicles through out the growing season to maximize your return on investment. The KINZE Vision display has its own internal memory for recording GPS and logging all information collected during various field activities. The KINZE Vision display has been built to withstand the harsh environment associated with today's agricultural industry. The weather tight enclosure is designed to seal out any dirt and moisture encountered during normal operating conditions.

NOTE: See operator manual supplied with KINZE Vision® display for installation and programming.

D012908205



PLANTER MONITOR MODULE (PMM)

The PMM Magnetic Distance Sensor Package includes a planter-mounted module enclosure with cover and mounting hardware, seed tubes w/sensors, planter harness, planter monitor cable, shaft rotation sensors and magnetic distance sensor components.

NOTE: See operator manual supplied with KINZE Vision® display for installation and programming.

D11200710a



ROW UNIT AIR CLUTCHES

Air clutch system pressure should be set at 50 psi.

D05010824

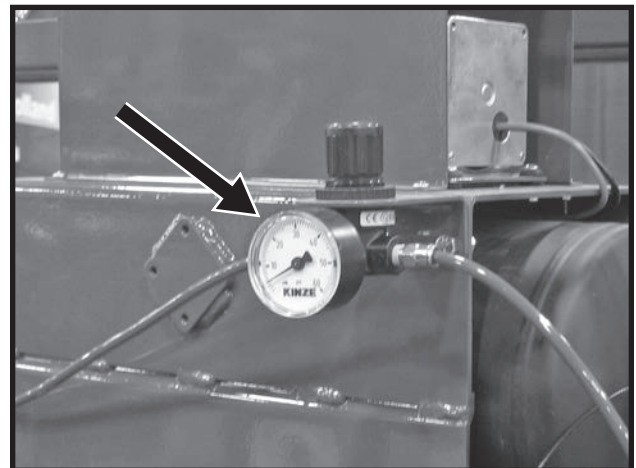

MACHINE OPERATION

ROCK GUARDS

(PLTR49a)

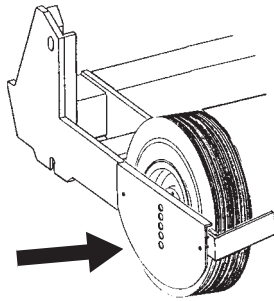

Transport wheel rock guards are designed for use on both sides of each of the four center transport wheels when the planter is used in rocky conditions. Rock guards will help prevent rocks, which can cause damage to the row units, from being picked up by the wheels.

AUXILIARY WORK LIGHTS PACKAGE

D05160505a



The optional Auxiliary Work Lights Package includes two 50 watt, 3" x 5" halogen flood lamps, hardware to mount lights at the top of one of the center lift cylinders and a wiring harness to plug into the existing planter light harness.

EVEN-ROW PUSH ROW UNIT

(PLTR132g)

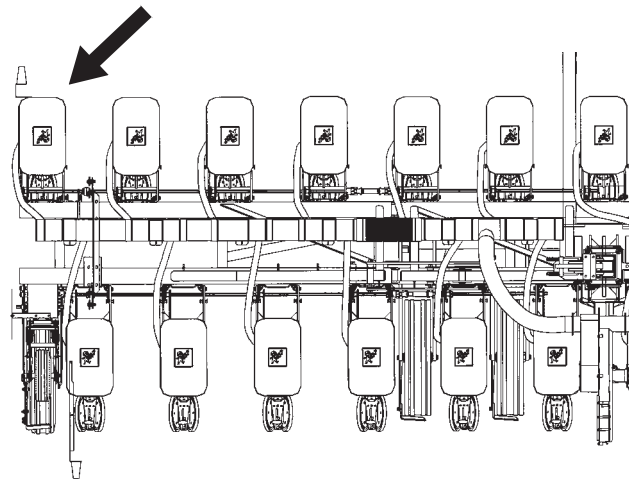

An Even-Row Push Row Unit Package is available to add one additional push row unit onto the L.H. side of the outer end of the front toolbar for use along with the Solid Row Interplant® Package.

NOTE: See "Row Marker Length Adjustment" in the Machine Operation section for determining correct length to set the row marker assemblies when planting with the even-row push row unit option.

MACHINE OPERATION

AUXILIARY HYDRAULIC OPTION

A customer-supplied auxiliary hydraulic option may be added to provide 10 GPM of oil flow at the rear of the planter. This option may be used for powering fertilizer attachments, bulk seed handling equipment, etc. Two customer-supplied solenoid valve kits (G1K275) are required to activate the auxiliary hydraulic option using the auxiliary switch on the control console.

77612-6

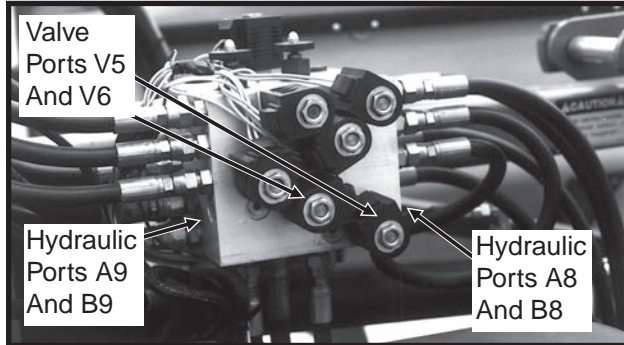

Valve Block Located On Rear Center Frame
(Shown With Cover Removed)

76746-24

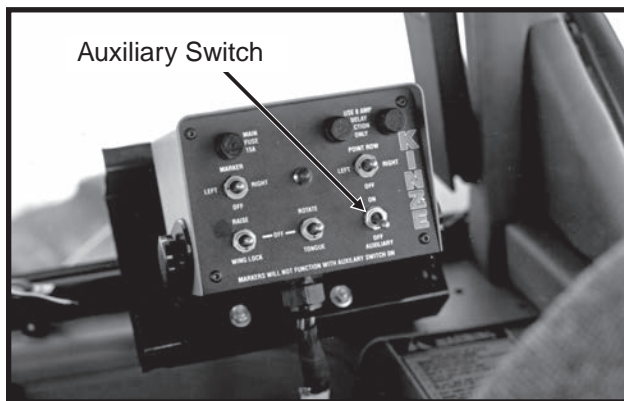

NOTE: Be sure row markers are in transport position and all pressure is removed from the hydraulic system.

Remove the cover from the valve block, located on the rear center frame of the planter. Remove plugs from ports V5 and V6 and install the solenoid valve assemblies following the installation instruction supplied with each kit. Power to the solenoid assemblies should be connected to the orange/black wire located in the wiring harness connection to the L.H. side of the valve block.

Remove plugs from 3/4"-16 O-ring ports A8 and B8 on R.H. side of valve block or ports A9 and B9 on L.H. side of valve block. Connect customer-supplied hydraulic hoses.

Refer to "Hydraulic System Schematics" and "Electrical Wiring Schematics" in the Maintenance Section of this manual for additional information.



WARNING: Pressurized hydraulic fluid can penetrate body tissue and result in serious infection, injury, or death. Before applying pressure to the hydraulic system, make sure all connections are tight and that hoses and fittings have not been damaged. Leaks can be invisible. Keep away from suspected leaks. Relieve pressure in the hydraulic system before searching for leaks, disconnecting hoses, or performing any other work on the system. Fluid injected under the skin must be **IMMEDIATELY** removed by a surgeon familiar with this type of injury.

Before operating the auxiliary system be sure the marker switch on the control console is in the OFF position. Move the auxiliary switch on the control console to ON position. Operate hydraulic control (marker/folding functions) to engage auxiliary system.

NOTE: Auxiliary switch left in ON position disables all other control console switches.

MACHINE OPERATION

DOUBLE DISC FERTILIZER OPENER

The double disc fertilizer openers should be positioned during assembly **to place fertilizer no closer than 2" to either side of the row.** If the planter frame is level and at proper 20" operating height, fertilizer depth will be approximately 4". Soil conditions can affect depth slightly.

The down pressure spring is factory preset at 250 lbs. down pressure but may be adjusted for various soil conditions. To adjust spring tension, loosen the jam nut with a $1\frac{5}{16}$ " wrench and use a 1" wrench to turn the adjustment bolt clockwise to increase tension or counterclockwise to decrease tension. Securely tighten the jam nut upon completion of tension adjustment. Do not attempt to set opener depth with spring pressure. The opener is designed to operate against a depth stop and spring up when encountering a foreign object or hard ground.

IMPORTANT: Do not operate the double disc openers at full down pressure tension when planting in rocky ground. Chipping of the disc blades will occur.

A gap of $\frac{1}{32}$ " to $\frac{1}{16}$ " should be maintained between the opener blades at the closest point. Blade adjustment is made by moving inside spacer washers to the outer side of the blade. After making this adjustment, check to be sure bearing assembly rivets are not contacting the shank.

D06259919

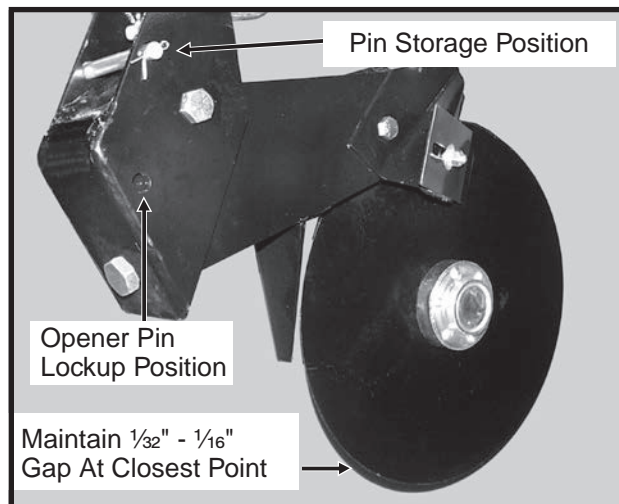

The outer scrapers on each disc blade may also be adjusted to make up for wear that may occur. Make sure the scrapers are adjusted to allow only slight contact with the blades.

The opener assembly is designed to be locked in a raised position when the fertilizer attachment is not in use or during storage. To lock the opener up, first raise the planter and place blocks under the openers. Then lower the planter until the hole in the pivot section aligns with the hole in the mounting bracket. Remove the lockup pin from the storage position in the mounting bracket and install it through the lockup hole and secure with cotter pins.



WARNING: Always install all cylinder lockup devices before working under the unit.

MACHINE OPERATION

NOTCHED SINGLE DISC FERTILIZER OPENER

The notched single disc fertilizer opener is designed for use in minimum and no till planting conditions. Placement of fertilizer with the 16 3/4" diameter notched single disc fertilizer opener is recommended at 2 1/2" - 3" from the row. The opener is designed to hold the blade at a set-angle so the knife and drop tube operate in the shadow of the blade. **Never locate the opener to place fertilizer closer than 2".**

WARNING: Spring under pressure. **DO NOT** disassemble.

(A12429a/B0297)

Depth Adjustment Cap Screws - Recommended Maximum Operating Depth 4" (Middle Cap Screw Holds Blade Angle But Must Be Loosened To Adjust Depth And Tightened First To Set Blade Angle.)

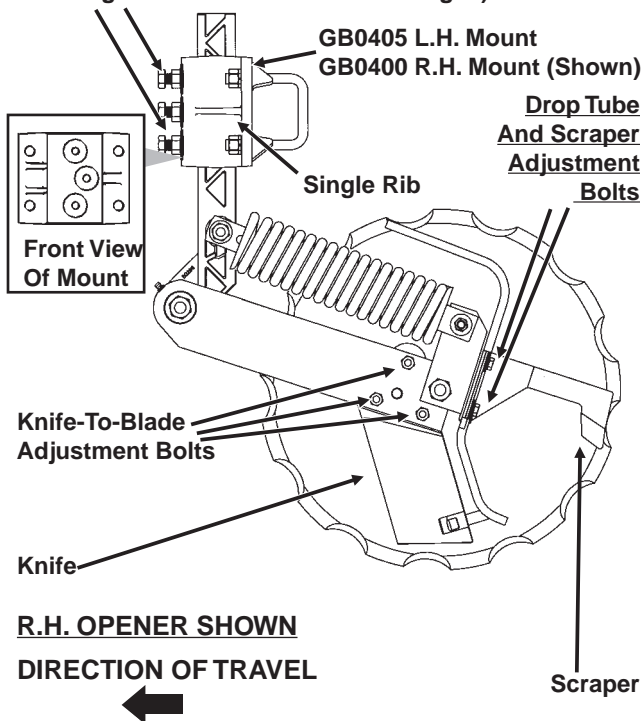

Adjust knife-to-blade contact on each fertilizer opener so blade will turn by hand with slight resistance, but will not coast or freewheel. In dry, loose soil the knife adjustment is critical. If adjustment is not maintained, soil or residue may wedge between knife and blade, resulting in the blade not turning. If the knife is adjusted too tight, the blade will not turn causing the blade to push soil and residue. **Knife adjustment is made using the three 3/8" mounting carriage bolts** and pivot pad on the knife. Because of blade runout, rotate blade one full revolution after adjustment. Readjust knife to the blade's tight spot as needed. **Never strike the knife with a heavy object or damage may occur.**

Using the slotted mounting holes in the drop tube mount, **adjust fertilizer drop tube** behind the knife so it is protected from soil contact and wear. The liquid drop tube should be adjusted 1/4" - 3/8" from the opener blade while keeping it behind the knife. Insert a flat bladed pry bar between the knife and drop tube just above the drop tube tab as shown below. Bend the tube inward toward the disc blade to obtain the desired 1/4" - 3/8" adjustment.

D01040702

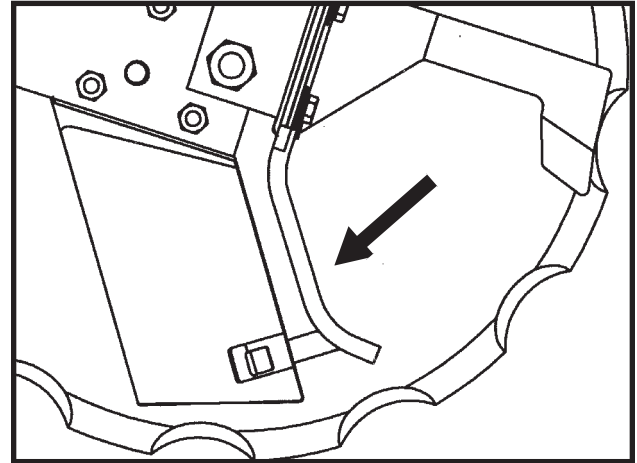

NOTE: Adjusting the liquid drop tube will ensure it is out of the path of the soil flow across the knife. Drop tube and tab will wear quickly if not adjusted correctly.

Adjust scraper to just touch the opener blade. As the mounting hardware is tightened, the scraper is drawn tighter to the blade. After adjustment, rotate opener blade to be sure blade will turn by hand with slight resistance, but will not coast or freewheel.

Adjust blade depth on each row using the cap screws and jam nuts located on the opener mount. The blade can be adjusted to allow a maximum 4" blade depth. Check fertilizer hose clearance (If Applicable) after adjusting opener depth. Torque cap screws and jam nuts to 57 ft. lbs.

MACHINE OPERATION

NOTE: The blade cuts through the soil at an angle relative to the direction of travel. For this reason and to ensure proper operation, the cast mount should be oriented so the front and bottom of the blade tilt towards the knife.

D01160802

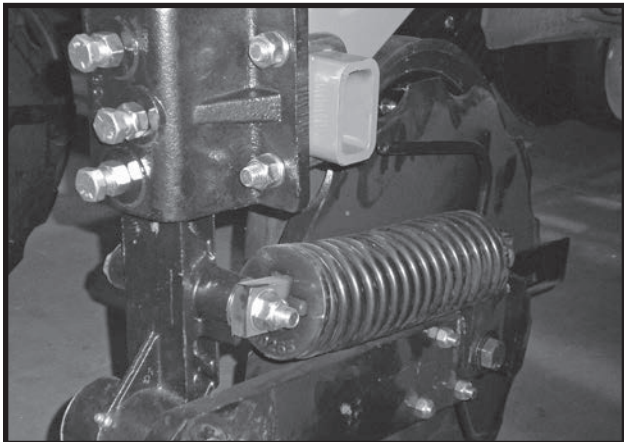

R.H. Opener (B0400)

D01160801

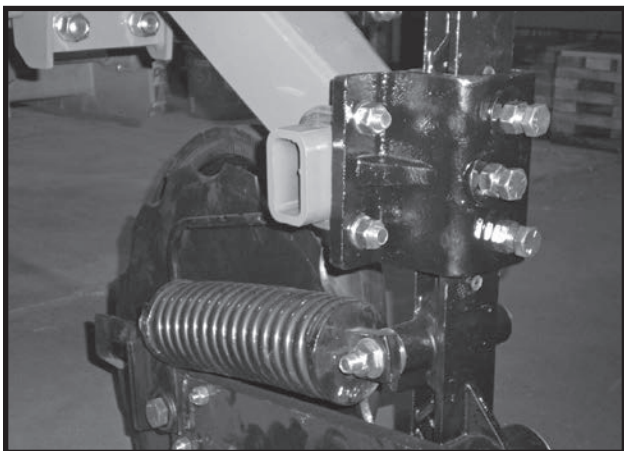

L.H. Opener (B0405)

FRTZ296

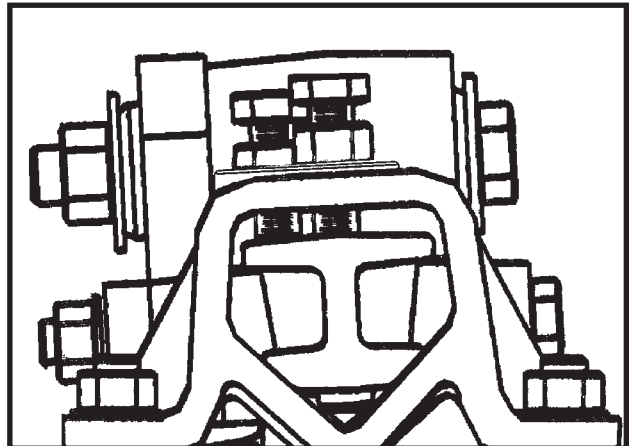

D070103100

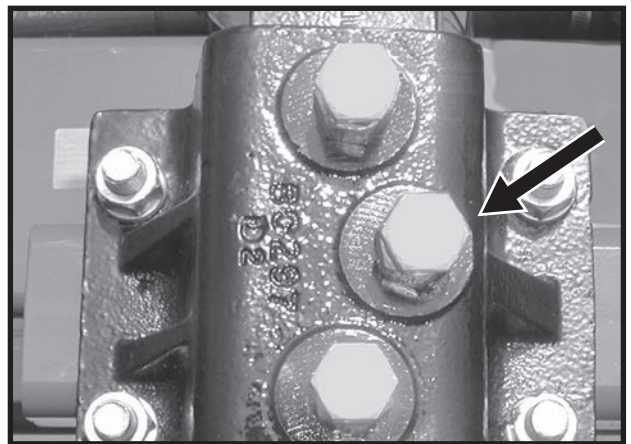

NOTE: Recommended maximum operating depth is 4". To adjust depth: (a) Loosen depth adjustment cap screws. (b) Adjust depth to desired setting. (c) Tighten upper and lower cap screws slightly to hold opener arm in place. (d) Tighten middle cap screw to set the opener arm angle. (e) Tighten upper and lower cap screws and all jam nuts.

MACHINE OPERATION

RESIDUE WHEEL ATTACHMENT FOR NOTCHED SINGLE DISC FERTILIZER OPENER

D052201104

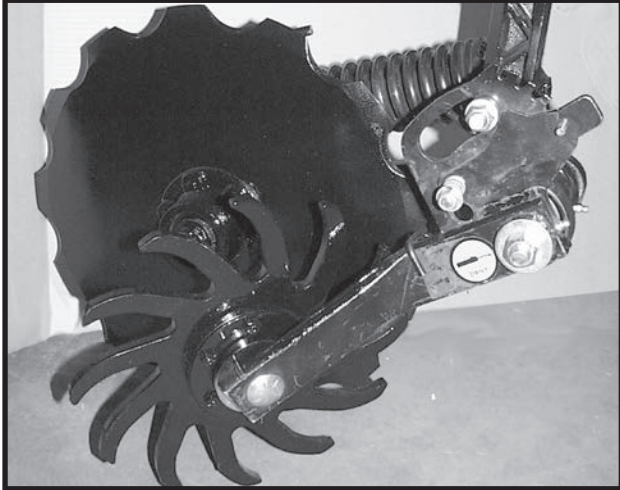

The residue wheel attachment for the notched single disc fertilizer opener is designed for applications where row unit mounted residue wheel attachments cannot be installed. The residue wheel is attached to the notched single disc fertilizer opener using $\frac{5}{8}$ " x $7\frac{1}{2}$ " and $\frac{1}{2}$ " x $6\frac{1}{2}$ " hardware.

Maximum depth is set by lifting the residue wheel and moving the adjustment lever down to increase depth or up to decrease depth in 1" increments (in relation to blade depth setting). Adjust all rows the same. Down force on the residue wheel is maintained by a torsion spring and is not adjustable.

Due to space restrictions, the residue wheel attachment for the notched single disc fertilizer opener is not applicable to Model 3600 Planters equipped with Interplant® push row units and notched single disc fertilizer openers.

DEPTH/GAUGE WHEEL ATTACHMENT FOR NOTCHED SINGLE DISC FERTILIZER OPENER

D061101202a

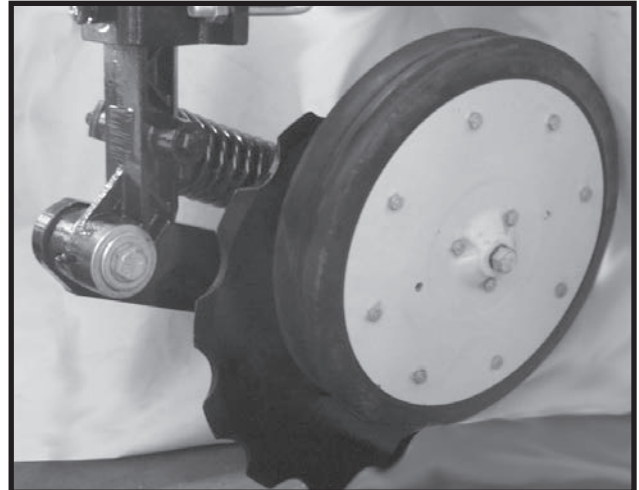

The depth/gauge wheel attachment for the notched single disc fertilizer opener is designed for use in situations where additional gauging is required to maintain desired fertilizer opener depth. The depth/gauge wheel is attached to the notched single disc fertilizer opener using a mounting block fastened to the pivot arm using $\frac{5}{8}$ " hardware through the disc blade hub w/bearing.

Depth adjustment is made by using the adjustment holes in the depth/gauge wheel mounting block.

If equipped with the depth/gauge wheel mounting block with 3 holes, moving the depth/gauge wheel increases/decreases depth in approximate 1" increments in relation to the blade depth setting made at the vertical mounting post.

(FRTZ256a)

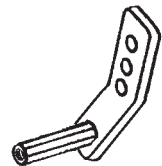

Due to space restrictions, the depth/gauge wheel attachment for the notched single disc fertilizer opener is not applicable to Model 3600 Planters equipped with Interplant® push row units and notched single disc fertilizer openers.

MACHINE OPERATION

HD SINGLE DISC FERTILIZER OPENER

D062601103

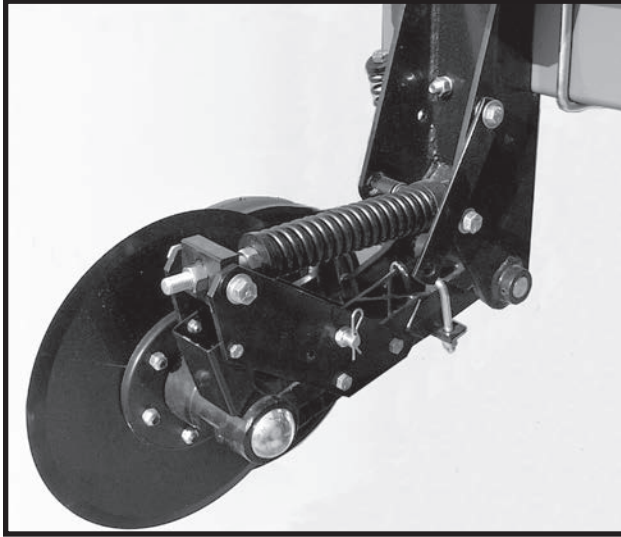

Placement of fertilizer with the HD single disc fertilizer opener is recommended at 3 1/2" - 4" from the row. **Never locate the opener to place fertilizer closer than 2".**

If planter frame is level and at 20" operating height, maximum blade depth for placement of fertilizer is approximately 5". Soil conditions can affect depth slightly.

To adjust blade depth, raise the planter to remove weight from the fertilizer opener. Loosen inside adjustment nut (A) with 1 1/8" wrench. Turn outside nut (B) clockwise to decrease blade depth or counterclockwise to increase blade depth. One full turn of the blade depth adjustment nut changes blade depth 3/8". Tighten inside nut tight against block (C). Adjust all fertilizer openers to the same depth.

L0114(PLTR3)

DIRECTION OF TRAVEL



(Overhead View)

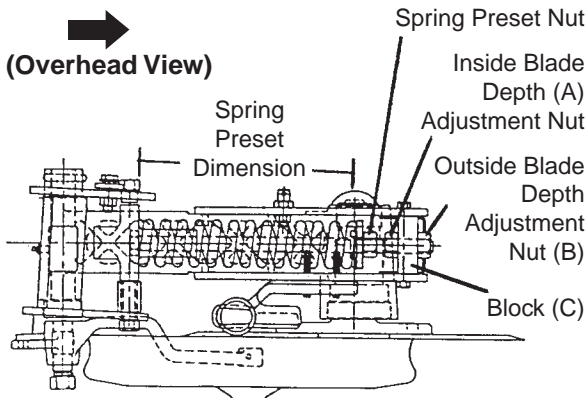

R.H. Configuration Shown

Fertilizer opener down pressure can be adjusted from 250 lbs. to 640 lbs. **To make down pressure adjustments,** raise planter to remove weight from the fertilizer opener and turn spring preset nut clockwise to increase down pressure and counterclockwise to decrease down pressure. Adjust all rows to a similar setting. Minimal spring pressure for acceptable operation is recommended. See chart for spring length setting specifications.

SPRING PRESET DIMENSION	DOWN PRESSURE (LBS.)
11"	250
10 3/4"	320
*10 1/2"	370
10 1/4"	450
10"	520
9 3/4"	580
9 1/2"	640

* Suggested initial setting.

NOTE: DO NOT adjust spring preset dimension to less than 9 1/2".

NOTE: Excessive down pressure can cause up-lift on the planter frame and affect performance of the machine. When lowered to planting position, planter frame should be at a height of approximately 20". In loose ground conditions, excessive down pressure can cause openers to run too deep and push dirt ahead of opener and may stop soil press wheel and/or opener blade from turning.



WARNING: Always install all safety lockup devices before working under the machine.

IMPORTANT: Do not operate HD single disc fertilizer openers at full down pressure tension when planting in rocky ground. Chipping or breakage of the blades will occur.

The spring loaded dry fertilizer drop tube/scrapper should be adjusted periodically to maintain 1/8" gap between drop tube and opener blade. If this dimension is not maintained the fertilizer may not drop into the proper location.

Loosen scraper adjustment bolt. Slotted hole in scraper allows up or down adjustment.

FOC016(PLTR4)

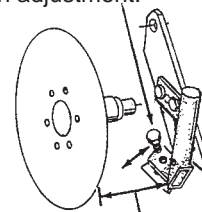

Adjust scraper to maintain 1/8" gap between drop tube and opener blade. Distance is exaggerated in above illustration.

MACHINE OPERATION

Maintain liquid fertilizer drop tube/scrapper adjustment as shown below.

(INS16a)

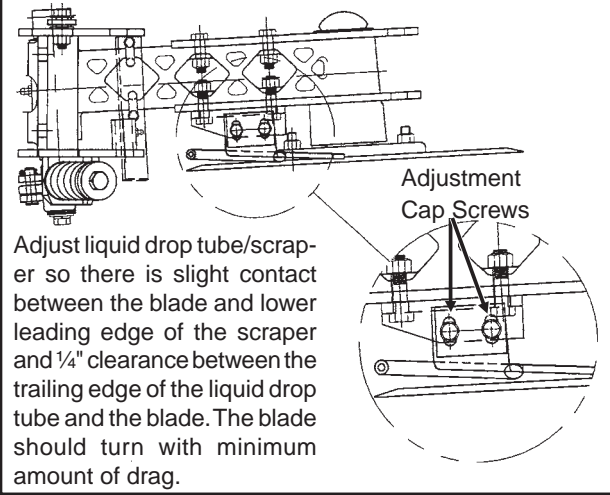

Additional press wheel down pressure may be desirable in heavy moist soils. **To increase press wheel spring pressure** turn press wheel spring adjustment bolt clockwise.

D121202101

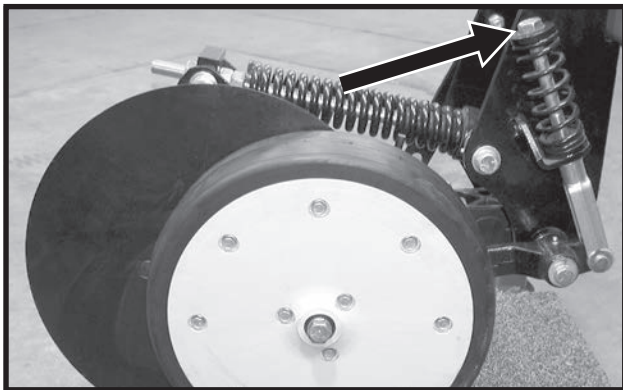

NOTE: The soil press wheel is not intended to be used for gauging fertilizer opener operating depth.

The HD single disc fertilizer opener is designed to be locked in a raised position when the fertilizer attachment is not in use or during storage.

To lock the HD single disc fertilizer opener in the raised position, proceed as follows:

STEP 1 With the planter in the planting position, remove outside blade depth adjustment nut. ("B" in illustration on previous page.)

STEP 2 Raise planter until adjustment bolt clears adjustment block.

STEP 3 Raise spring to clear blade assembly and at the same time raise blade assembly until storage strap can be positioned onto lockup pin and install hair pin clip.

STEP 4 Reinstall depth adjustment nut and tighten.

D062601102

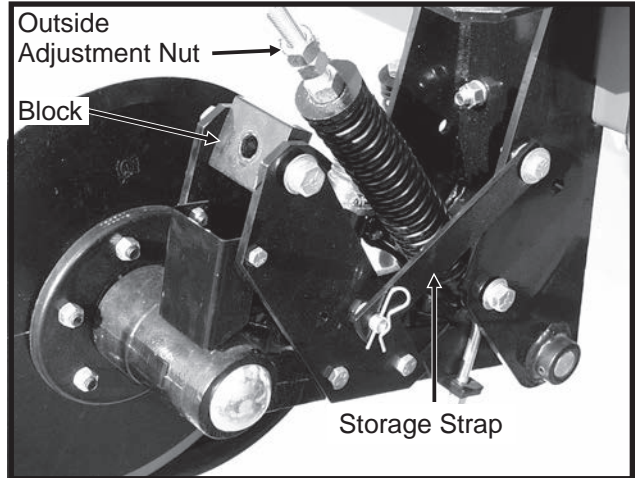

NOTE: The HD single disc fertilizer opener is equipped with a lockup bar that automatically raises and locks the soil press wheel when the blade assembly is raised.

FOC016(PLTR5b)

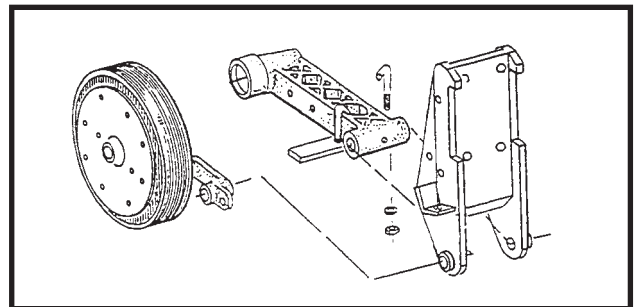

MACHINE OPERATION

LIQUID FERTILIZER ATTACHMENT

NOTE: An optional low rate check valve is available for installation in-line between the liquid fertilizer squeeze or piston pump and the liquid fertilizer openers to ensure equal distribution of product at low rates. The check valves also eliminate the need for an anti-siphon loop if the valves is installed as close as possible to the fertilizer opener drop tube.

(FRTZ208)

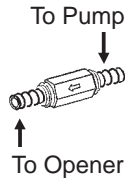

(FRTZ275)

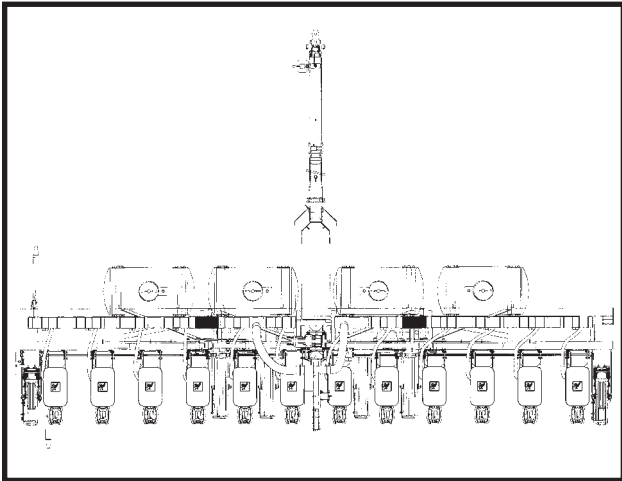

MACHINE OPERATION

OPTIONAL PISTON PUMP

NGP-7055

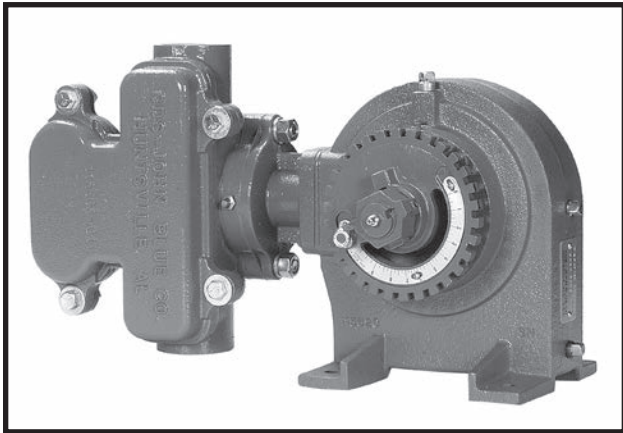

(A12330b)

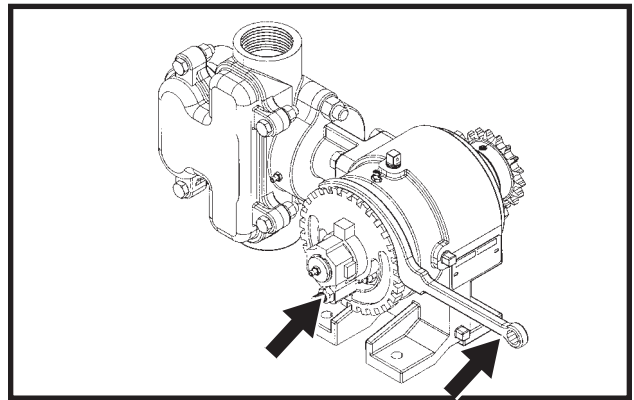

If the machine is equipped with the piston pump option, the rate of liquid fertilizer application is determined by the piston pump settings.

The delivery rate chart found at the end of this section provides an approximate application rate only. Actual delivery will vary with temperature and the particular fertilizer being used.

To adjust delivery rate, loosen the $\frac{3}{8}$ " lock nut that secures the arm with the pointer and rotate the scale flange until the pointer is over the desired scale setting. The adjustment wrench will facilitate rotation of the scale flange. Tighten the $\frac{3}{8}$ " lock nut being careful not to over tighten.

The operator and instruction manual shipped with the pump and flow divider should be kept and stored with this manual for future reference.

NOTE: Periodically check flow to all rows. If one or more lines are plugged, set rate will be delivered to remaining rows.

MACHINE OPERATION

PISTON PUMP GROUND DRIVE WHEEL SPRING ADJUSTMENT

Initial spring tension on the down pressure spring, on the piston pump ground drive wheel, is set leaving 12 1/4" between the bottom of the mounting plate and the plug on top of the spring. This dimension is taken with the planter in raised position (tire not contacting the ground). Further adjustment can be made to fit conditions.

(TWL219tt)

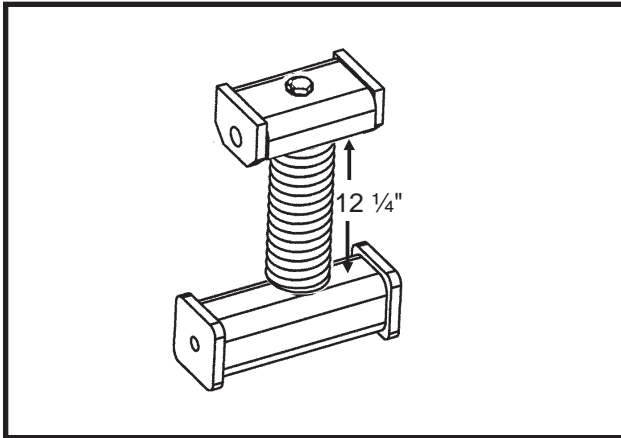

NOTE: The piston pump ground drive wheel assembly is designed to allow the assembly to be locked in raised position when not in use. Remove the two cap screws that attach the upper end of the spring to the spring mount. Reattach the spring using the upper holes in the spring mount. Reverse procedure to reset for field use.

CLEANING

The tanks and all hoses are made of sturdy plastic and rubber to resist corrosion. However, the tanks, hoses and metering pump should be thoroughly cleaned with water at the end of the planting season or prior to an extended period of non-use. Do not allow fertilizer to crystalize due to cold temperature or evaporation.

The strainer, located between the piston pump and ball valve (On machines equipped with the piston pump.), should be taken apart and cleaned daily. Remove the end cap to clean the screen.

(INS220)

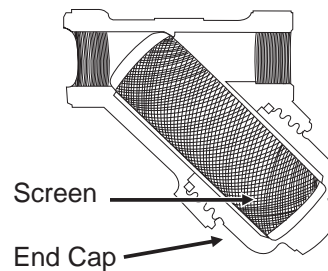

See "Piston Pump Storage" (If Applicable) in the Maintenance section of this manual.

MACHINE OPERATION

LIQUID FERTILIZER PISTON PUMP APPLICATION RATES GALLONS PER ACRE

Applies To Model LM-4405 And Model NGP-7055 Pumps With 18 Tooth Sprocket
And 7.60" x 15" Ground Drive Tire

Pump Setting	1	2	3	4	5	6	7	8	9	10
12 Row 30"	3.7	7.4	11.1	14.8	18.5	22.1	25.8	29.5	33.2	36.9
16 Row 30"	2.8	5.5	8.3	11.1	13.9	16.6	19.4	22.2	24.9	27.7

Above chart is for planters equipped with 7.60" x 15" ground drive tire, based on 91" forward travel per wheel revolution, 48 tooth drive sprocket and 18 tooth driven sprocket on metering pump. See "Tire Pressure" for recommended tire pressures. Charts are based on average wheel slippage and liquid viscosities.

Measure and weigh one gallon of actual fertilizer solution to determine exact application rate. This chart was calculated based on a solution weighing ten pounds per gallon.

NOTE: Fertilizer application rates can vary from the above chart. To prevent application miscalculations, make field checks to be sure you are applying fertilizer to all rows at the desired rate.

NOTE: Flow to all rows should be checked periodically. If one or more lines are plugged, the desired rate will be delivered to the remaining rows keeping total application rate at desired rate.

To check the exact number of gallons your fertilizer attachment will actually deliver on a 30" row spacing, proceed as follows:

Remove the hose from one of the fertilizer openers and insert it into a collection container which has been secured to the planter frame. Engage the fertilizer attachment and drive forward for 174'. Measure the fluid ounces caught in the container and multiply that amount by 100. Divide that amount by 128. The result will be the gallons of fertilizer delivered per acre when planting in 30" rows. Rinse the collection container and repeat test on other rows if necessary. To convert this delivery rate for wider rows, multiply by the following conversion:

36" multiply by 0.83

38" multiply by 0.79

MACHINE OPERATION

REAR TRAILER HITCH

D07309901a

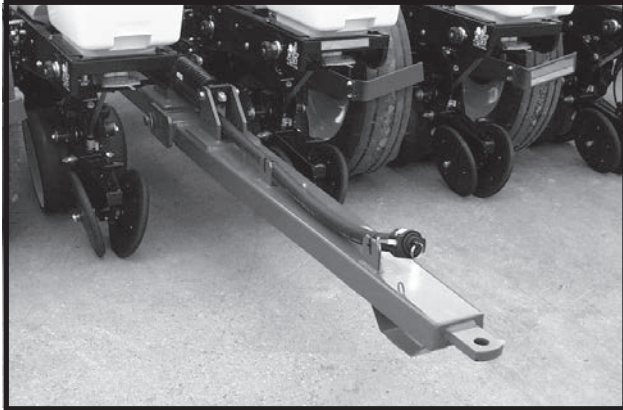

IMPORTANT: The rear trailer hitch is designed for use with piston pump only. Maximum allowable hitch weight is 200 lbs. Gross towing weight should not exceed 6000 lbs. or the equivalent of a loaded 500 gallon tank and running gear.

NOTE: Periodically check feed hose for kinks to prevent restricted delivery rate.

The Rear Trailer Hitch is used to tow a 3 or 4 wheel wagon behind the planter. A spring, chain and mounting bracket are used to support the 1 1/4" feed hose from the hitch to the piston pump. This extra length or loop is required to allow the planter to be moved into transport position without stretching the hose.

(PLTR174bb)

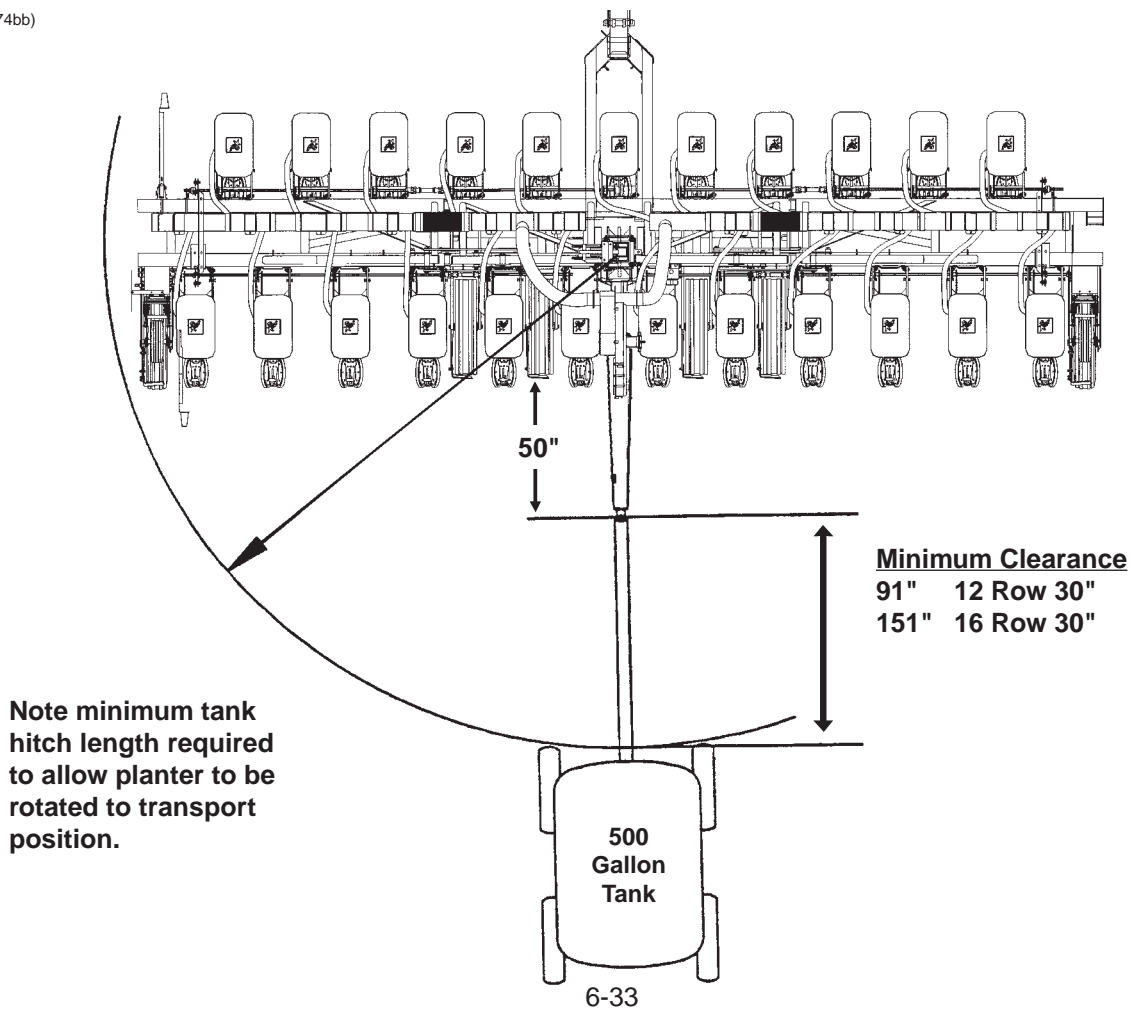

MACHINE OPERATION

TRANSPORTING THE PLANTER

WARNING: Always make sure safety/warning lights, reflective decals and SMV sign are in place and visible prior to transporting the machine on public roads. In this regard, check federal, state/provincial and local regulations.

IMPORTANT: Avoid transporting planter with hoppers loaded whenever possible. When it is necessary to transport the planter with the hoppers loaded, the added weight should be distributed evenly on the planter frame before rotating the planter.

WARNING: Install all safety lockup devices and safety locking pins before transporting the planter.

METRIC CONVERSION TABLE

MULTIPLY	BY	TO GET
Inches (in.)	x 2.54	= centimeters (cm)
Inches (in.)	x 25.4	= millimeters (mm)
Feet (ft.)	x 30.48	= centimeters (cm)
Acres	x 0.405	= hectares (ha)
Miles per hour (mph)	x 1.609	= kilometers per hour (Km/h)
Pounds (lbs.)	x 0.453	= kilograms (kg)
Bushels (bu.)	x 35.238	= liters (l)
Gallons (gal.)	x 3.785	= liters (l)
Pounds per square inch (psi)	x 6.894	= kilopascals (kPa) (100 kPa = 1 bar)
Inch pounds (in. lbs.)	x 0.113	= newtons-meters (N•m)
Foot pounds (ft. lbs.)	x 1.356	= newtons-meters (N•m)
Centimeters (cm)	x .394	= inches (in.)
Millimeters (mm)	x .0394	= inches (in.)
Centimeters (cm)	x .0328	= feet (ft.)
Hectares (ha)	x 2.469	= acres
Kilometers per hour (Km/h)	x 0.621	= miles per hour (mph)
Kilograms (kg)	x 2.208	= pounds (lbs.)
Liters (l)	x 0.028	= bushels (bu.)
Liters (l)	x 0.264	= gallons (gal.)
Kilopascals (kPa) (100 kPa = 1 bar)	x 0.145	= pounds per square inch (psi)
Newtons-meters (N•m)	x 8.85	= inch pounds (in. lbs.)
Newtons-meters (N•m)	x 0.738	= foot pounds (ft. lbs.)

HALL EFFECT SENSOR

Hall Effect sensor should be set within 1/8" of pick-up disc.

D05010806

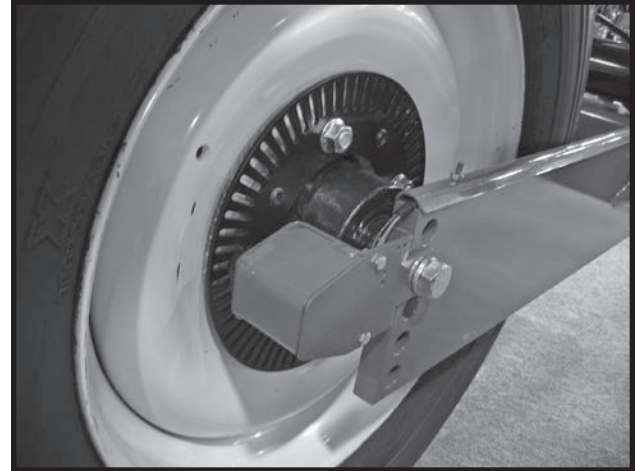

MACHINE OPERATION

PLANTING SPEED

Planters are designed to operate within a speed range of 2 to 8 MPH. Generally, higher ground speeds will cause more variation in seed spacing. Speeds above 5.5 MPH are typically not recommended. See “Planting And Application Rate Charts” in Seed Meter Operation/Maintenance section for specific recommendations.

FIELD TEST

With any change of field and/or planting conditions, seed size or planter adjustment, we recommend a field test be made to ensure proper seed placement and operation of row units. See “Planting And Application Rate Charts” in the Seed Meter Operation/Maintenance section and “Checking Seed Population” at end of this section.

- Check the planter for fore to aft and lateral level operation. See “Leveling The Planter”.
- Check **all** row units to be certain they are running level. When planting, the row unit parallel arms should be approximately parallel to the ground.
- Check row markers for proper operation and adjustment. See “Row Marker Length Adjustment”, “Row Marker Speed Adjustment” and “Row Marker Operation”.
- Check for desired depth placement and seed population on **all** rows. See “Checking Seed Population”.
- Check for proper application rates of fertilizer on **all** rows. See proper “Fertilizer Application Rate Chart”.

After the planter has been field tested, reinspect the machine.

- Hoses And Fittings
- Bolts And Nuts
- Cotter Pins And Spring Pins
- Drive Chain Alignment

CHECKING SEED POPULATION

1. Tie up one or more sets of closing wheels by running a chain or rubber tarp strap between the hopper support panel and closing wheels. It may be necessary to decrease closing wheel arm spring tension.

(RU113g)

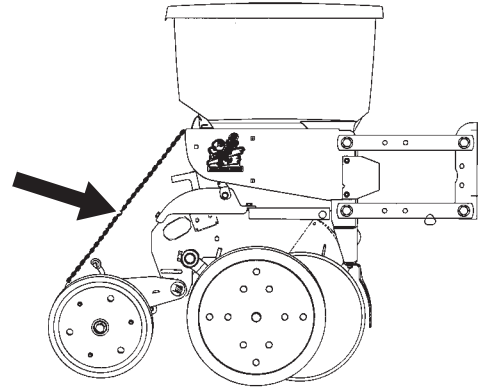

2. Plant a short distance and check to see if seed is visible in the seed trench. Adjust planting depth to a shallower setting if seed is not visible and recheck.

D020705102

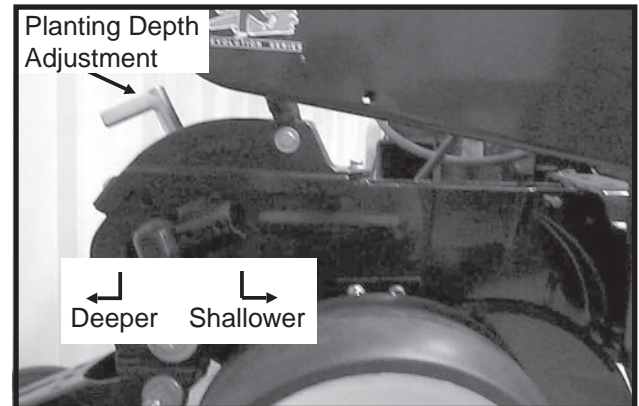

3. Measure $\frac{1}{1000}$ of an acre. See chart for correct distance for row width being planted. For example, if planting 30" rows $\frac{1}{1000}$ of an acre would be 17' 5".

LENGTH OF ROW IN FEET AND INCHES						
Fraction Of Acre	Row Width					
	15"	18"	19"	30"	36"	38"
$\frac{1}{1000}$	34' 10"	29' 0"	27' 8"	17' 5"	14' 6"	13' 10"

NOTE: When planting with closing wheels raised and planting depth set shallow, seeds may bounce or roll affecting seed spacing accuracy.

4. Count seeds in measured distance.

MACHINE OPERATION

5. Multiply the number of seeds placed in $\frac{1}{1000}$ of an acre by 1000. This will give you total population.

EXAMPLE: With 30" row spacing 17' 5" equals $\frac{1}{1000}$ acre.

26 Seeds Counted	x	1000	=	26,000 Seeds Per Acre
---------------------	---	------	---	-----------------------

Seed count can be affected by drive ratio between drive wheel and seed meter, tire pressure and/or seed meter malfunction.

If seed check shows the average distance between seeds in inches is significantly different than the seed rate chart indicates.

Check for seed meter malfunction. For example, if spacing between kernels of corn at the transmission setting being used is 8" and a gap of 16" is observed, a seed cell has lost its seed and not functioned properly. If two seeds are found within a short distance of each other, the seed cell has metered two seeds instead of one.

See "Seed Metering System Troubleshooting" in the Seed Meter Operation/Maintenance section of this manual.

Determining Pounds Per Acre

To determine pounds per acre:

Seeds Per Acre On Chart	÷	Seeds Per Pound From Seed Tag On Bag	=	Pounds Per Acre
-------------------------------	---	---	---	-----------------------

To determine bushels per acre:

Pounds Per Acre	÷	Unit Weight Of Seed	=	Bushels Per Acre
--------------------	---	------------------------	---	---------------------

The unit weight of:

- 1 Bushel Soybeans = 60 Pounds
- 1 Bushel Milo/Grain Sorghum = 56 Pounds
- 1 Bushel Cotton = 32 Pounds

If seeds per pound information is not available the following is an average:

- 2,600 seeds per pound for medium size soybeans
- 15,000 seeds per pound for medium size milo/
grain sorghum
- 4,500 seeds per pound for medium size cotton

If seed population check shows planting rate is significantly different than seed rate chart shows or if a particular meter is not planting accurately, see "Seed Metering System Troubleshooting" in Seed Meter Operation/Maintenance section of this manual.

SEED METER OPERATION/MAINTENANCE

GENERAL PLANTING RATE INFORMATION

The size and shape of seed may affect the planting rate.

The following seed discs are available for use with the KINZE® EdgeVac® Seed Metering System:

Corn/Popcorn: 39 cell. Light blue color-coded. For all seed corn grades from 35 to 70 pounds per 80,000 kernel count unit or popcorn seed size range from 2210 to 4200 seeds per pound. Also used for No. 1 sunflower seeds. *When planting popcorn this seed disc requires use of seed baffle. See "Seed Meter" on pages 7-2 and 7-3 for additional information.*

Low-Rate Corn/Popcorn: 24 cell. Light green color-coded. For all seed corn grades from 35 to 70 pounds per 80,000 kernel count unit or popcorn seed size range from 2210 to 4200 seeds per pound. Also used for No. 1 sunflower seeds. *When planting popcorn this seed disc requires use of seed baffle. See "Seed Meter" on pages 7-2 and 7-3 for additional information.*

Soybean: 60 cell. Black color-coded. Seed size range from 2200 to 4000 seeds per pound. *This seed disc requires use of seed baffle. See "Seed Meter" on pages 7-2 and 7-3 for additional information.*

Soybean, High-Rate: 120 cell. Dark blue color-coded. Seed size range from 2200 to 4000 seeds per pound. *This seed disc requires use of seed baffle. See "Seed Meter" on pages 7-2 and 7-3 for additional information.*

Milo/Grain Sorghum: 60 cell. Yellow color-coded. Seed size range from 10,000 to 20,000 seeds per pound. *This seed disc requires use of seed baffle and cleanout brush. See "Seed Meter" on pages 7-2 and 7-3 for additional information.*

Hill-Drop Cotton, Acid-Delinted (3 Seeds Per Cell): 20 cell. Brown color-coded. Cotton seed size range from 3800 to 4400 seeds per pound. *This seed disc requires use of cleanout brush w/ball-type ejector. See "Seed Meter" on pages 7-2 and 7-3 for additional information.*

Small Hill-Drop Cotton, Acid-Delinted (3 Seeds Per Cell): 20 cell. Grey color-coded. Cotton seed size range from 4200 to 5200 seeds per pound. *This seed disc requires use of cleanout brush w/ball-type ejector. See "Seed Meter" on pages 7-2 and 7-3 for additional information.*

Cotton, Acid-Delinted/Small Dry Edible Bean: 54 cell. Dark green color-coded. Cotton seed size range from 3800 to 4400 seeds per pound or dry edible bean seed size range from 1200 to 2500 seeds per pound. *This seed disc requires use of cleanout brush w/ball-type ejector. See "Seed Meter" on pages 7-2 and 7-3 for additional information.*

Large Dry Edible Bean: 54 cell. Tan color-coded. Seed size range from 800 to 1200 seeds per pound.

NOTE: Due to a multitude of variables, seed spacing can be adversely affected at speeds above 5.5 MPH.

NOTE: See "Seed Meter Singulator Brush And Vacuum Level Adjustments" on page 7-7.

SEED METER OPERATION/MAINTENANCE

SEED METER

(METR71/METR71a)

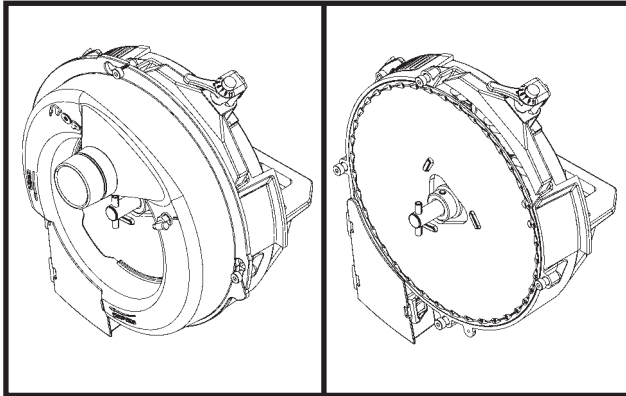

(METR70/D14467a)

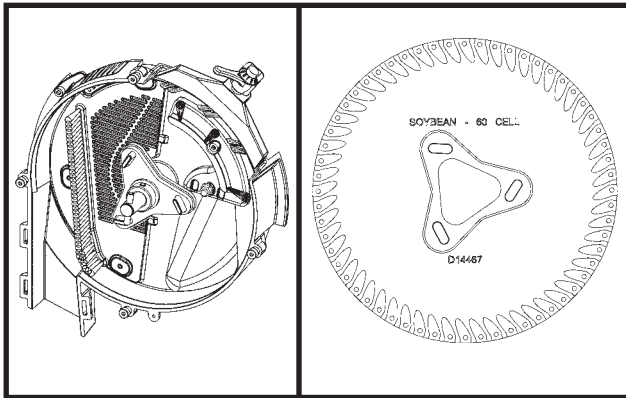

The seed discs below and at right are available for use with the KINZE® EdgeVac® Seed Metering System:

Corn/Popcorn: 39 cell. For all seed corn grades from 35 to 70 pounds per 80,000 kernel count unit. Popcorn seed size range from 2210 to 4200 seeds per pound. Also used for No. 1 sunflower seeds. (*Light blue color-coded.*) (D14465)

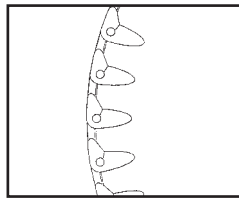

Low-Rate Corn/Popcorn: 24 cell. For all seed corn grades from 35 to 70 pounds per 80,000 kernel count unit. Popcorn seed size range from 2210 to 4200 seeds per pound. Also used for No. 1 sunflower seeds. (*Light green color-coded.*) (D16734a)

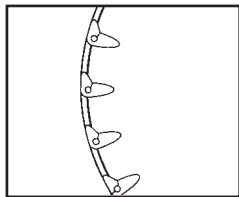

Soybean: 60 cell. Seed size range from 2200 to 4000 seeds per pound. (*Black color-coded.*)

(D14467a)

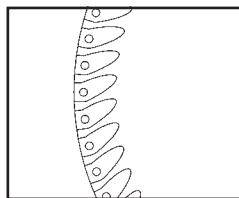

Soybean, High-Rate: 120 cell. Seed size range from 2200 to 4000 seeds per pound. (*Dark blue color-coded.*) (D14468a)

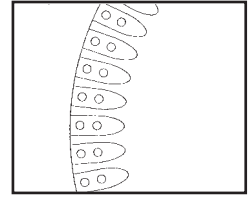

Milo/Grain Sorghum: 60 cell. Seed size range from 10,000 to 20,000 seeds per pound. (*Yellow color-coded.*) (D17050)

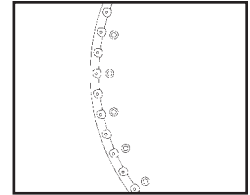

Hill-Drop Cotton, Acid-Delinted (3 Seeds Per Cell): 20 cell. Cotton seed size range from 3800 to 4400 seeds per pound. (*Brown color-coded.*) (D17187)

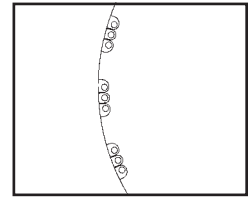

Small Hill-Drop Cotton, Acid-Delinted (3 Seeds Per Cell): 20 cell. Cotton seed size range from 4200 to 5200 seeds per pound. (*Grey color-coded.*) (D17187)

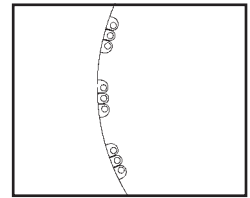

Cotton, Acid-Delinted/Small Dry Edible Bean: 54 cell. Cotton seed size range from 3800 to 4400 seeds per pound. Dry edible bean seed size range from 1200 to 2500 seeds per pound. (*Dark green color-coded.*) (D17186)

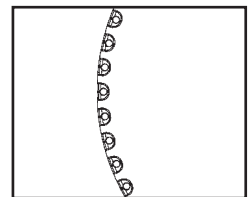

Large Dry Edible Bean: 54 cell. Seed size range from 800 to 1200 seeds per pound. (*Tan color-coded.*) (D14477)

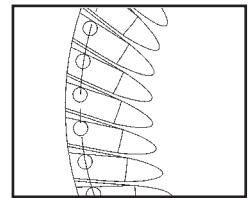

Install the selected seed disc. Position the vacuum cover on the meter by aligning the keyhole slots over the bolt heads. Push the cover on the meter and turn counter clockwise to lock in place. **See following page for additional components required with specific seed discs.**

SEED METER OPERATION/MAINTENANCE

NOTE: Use of damaged seed or seed containing foreign material will cause plugging of seed disc orifices and require more frequent seed meter cleanout to prevent underplanting.

SEED BAFFLE

- Milo/Grain Sorghum
- Soybeans
- Popcorn

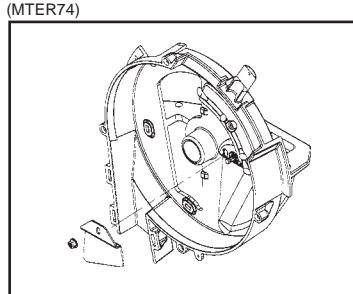

The **seed baffle** is designed to prevent excessive seed in the meter from restricting air flow through the seed. **Used with 60 Cell Milo/Grain Sorghum Disc, 60 Cell Soybean Disc, 120 Cell High-Rate Soybean Disc and 39 Cell and 24 Cell Popcorn Discs.**

CLEANOUT BRUSH

- Milo/Grain Sorghum

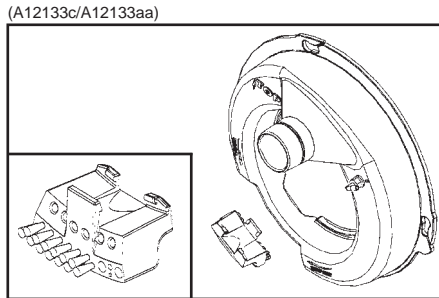

The **cleanout brush** is designed to remove foreign material and seed remnants to help prevent plugging of seed disc orifices.

Used with 60 Cell Milo/Grain Sorghum Disc.

CLEANOUT BRUSH W/BALL-TYPE EJECTOR

- Cotton
- Small Edible Beans

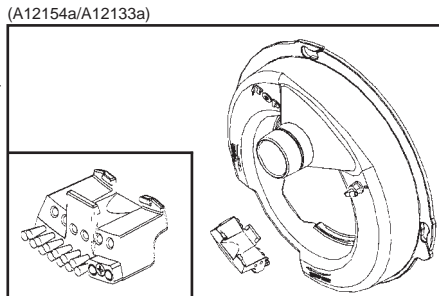

The **cleanout brush w/ball-type ejector** is designed to eject seed remnants from the seed disc orifices.

Used with 20 Cell Hill-Drop Cotton, Acid-Delinted (3 Seeds Per Cell) Discs and 54 Cell Acid-Delinted Cotton/Small Dry Edible Bean Discs.

(MTER70)

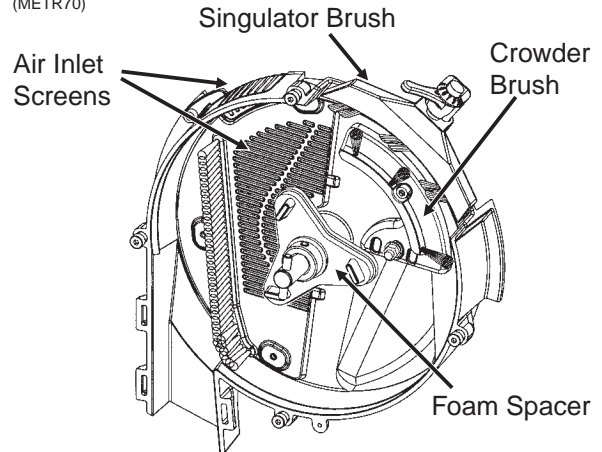

The crowder brush aids in the singulation of small flat seeds by (a) crowding seeds to the outer perimeter of the seed disc and (b) orienting seeds to allow the singulator brush to be more effective.

The air inlet screens allow air to enter the system and aids in keeping field residue or other foreign material out of the meter.

The foam spacer gently preloads the seed disc against the vacuum cover when no vacuum is present.

(MTER71)

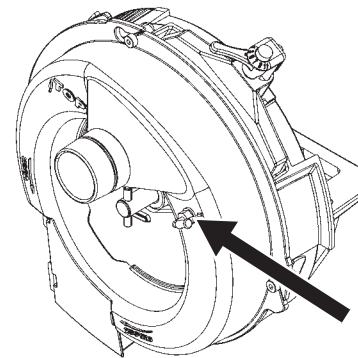

The $\frac{3}{16}$ " hose barb elbow on the seed meter vacuum cover allows measurement of vacuum level at each meter. A customer-supplied vacuum gauge is required.

See "Seed Meter Singulator Brush And Vacuum Level Adjustments", "Seed Meter Maintenance" and "Preparation For Storage" for additional EdgeVac® Seed Metering System information.

SEED METER OPERATION/MAINTENANCE

One tablespoon of **powdered graphite** should be mixed with the seed each time the hoppers are filled. Regular graphite use will prolong the life of the vacuum seed meter components, improve seed spacing, and may reduce buildup of seed treatments. Apply graphite around the outer perimeter of the hopper as shown below.

D05300104b



NOTE: DO NOT apply graphite only in the center of the hopper. It will filter too quickly through the seed and not distribute as evenly as desired.

NOTE: Additional graphite or talc may be required to retard buildup of seed treatments on meter components. More frequent cleaning of monitor seed tubes may be necessary due to use of additional graphite or talc.

Talc seed lubricant may be used in lieu of or in addition to graphite to improve seed release from the meter. Fill hopper $\frac{1}{2}$ full of seed, add $\frac{1}{4}$ cup of talc and **mix thoroughly**. Finish filling hopper, add another $\frac{1}{4}$ cup of talc and **mix thoroughly**. (For sunflowers, increase talc amount from $\frac{1}{4}$ cup to $\frac{1}{2}$ cup.) Adjust rate of talc use as needed so all seeds are coated, while avoiding a buildup of talc in the bottom of the hopper. Humid conditions and/or small sized seeds with extra seed treatment may require as much as one cup of talc per hopper to maintain meter performance.

NOTE: Some liquid seed treatments or inoculants may create buildup on the seed disc or brushes. Check frequently for proper population and/or seed delivery when using any liquid seed treatment. All seed treatment should be thoroughly mixed with the seed per the manufacturers' recommendations. Seed treatment dumped on top of the seed after the hopper is filled, and not mixed properly may cause bridging of the seed in the meter, reducing population or stopping the meter from planting.

SEED METER CLEANOUT

To maintain genetic purity, thorough seed meter cleanout is important.

To clean the seed meter, disengage the seed drive and remove the seed hopper and meter. Lay the hopper on its right side.

Disassemble seed meter by rotating vacuum cover clockwise to align key hole slots with bolt heads. Lift off cover. Remove seed disc. Empty the meter and hopper by allowing the seed to run out of the meter. Inspect brushes in meter to ensure all seed is removed. Replace seed disc and install vacuum cover.

NOTE: Use of damaged seed or seed containing foreign material will cause plugging of seed cell orifices and require more frequent seed meter cleanout to prevent underplanting.

SEED METER OPERATION/MAINTENANCE

**See “Liquid Rate Charts”
in Machine Operation section.**

SEED METER OPERATION/MAINTENANCE

SEED METER SINGULATOR BRUSH AND VACUUM LEVEL ADJUSTMENTS

SEED DISC SELECTION

CROP	CELLS	SEED SIZE RANGE	COLOR-CODE
Corn	39	35 To 70 Lbs./80,000 Kernel Count Unit	Light Blue
Low-Rate Corn	24	35 To 70 Lbs./80,000 Kernel Count Unit	Light Green
Popcorn	39	2210 To 4200 Seeds/Lb.	Light Blue
Low-Rate Popcorn	24	2210 To 4200 Seeds/Lb.	Light Green
Soybean	60	2200 To 4000 Seeds/Lb.	Black
High-Rate Soybean	120	2200 To 4000 Seeds/Lb.	Dark Blue
Milo/Grain Sorghum	60	10,000 To 20,000 Seeds/Lb.	Yellow
Hill-Drop Cotton, Acid-Delinted (3 Seeds Per Cell)	20	3800 To 5200 Seeds/Lb.	Brown
Cotton, Acid-Delinted	54	3800 To 5200 Seeds/Lb.	Dark Green
Dry Edible Bean (Small)	54	1200 To 2500 Seeds/Lb.	Dark Green
Dry Edible Bean (Large)	54	800 To 1200 Seeds/Lb.	Tan

EDGEVAC® INITIAL SETTINGS

CROP	SIZE	SINGULATOR SEED DISC	VACUUM BRUSH SETTING	SETTING (H ₂ O)	SEE NOTES
Corn	35-45 Lbs./80K	Corn/Popcorn	7	20	4, 5
	45-60 Lbs./80K	Corn/Popcorn	6	20	4, 5
	60-70 Lbs./80K	Corn/Popcorn	5	20	4, 5
Popcorn	2210-4200 Seeds/Lb.	Corn/Popcorn	9	18	1, 4, 5
Soybeans	2200-4000 Seeds/Lb.	Soybean	5	10	1
Milo/Grain Sorghum	10,000-20,000 Seeds/Lb.	Milo/Grain Sorghum	7	18	1, 2
Hill-Drop Cotton	3800-5200 Seeds/Lb.	Hill-Drop Cotton	8	23	3
Cotton	3800-5200 Seeds/Lb.	Cotton	8	20	3
Edible Beans	800-1200 Seeds/Lb.	Large Edible Bean	5	18	5
	1200-2500 Seeds/Lb.	Small Edible Bean	6	18	3, 5

NOTES:

- Requires use of seed meter baffle. Refer to page 7-3 for additional information.
- Requires use of cleanout brush. Refer to page 7-3 for additional information.
- Requires use of cleanout brush w/ball-type ejector. Refer to page 7-3 for additional information.
- For flat seeds, higher vacuum level may be required.
- Larger seeds may require a lower numbered singulator brush setting from the initial setting. Smaller seeds may require a higher numbered setting.

Refer to the planting rate charts in this manual for seed drive transmission sprocket combinations.

IMPORTANT: See “General Planting Rate Information” and “Checking Seed Population” pages for additional information. Always check seed population in the field to ensure planting rates are correct.

NOTE: Singulator brush settings are marked from 1 thru 11. The lower the singulator brush setting, the less aggressive. The higher singulator brush settings are the most aggressive. Refer to illustrations on page 7-7.

NOTE: Optimum meter performance will be attained with consistent seed size and shape. A mixture of seed sizes and shapes will affect meter performance.

NOTE: Use 1 tablespoon powdered graphite with each hopper fill of seed. Seed treatment, foreign material, dirt or seed chaff may cause gradual reduction of seed disc fill (population). See “Seed Meter”.

NOTE: Excessive seed treatment, humidity and light-weight seed can affect meter performance. Use ½ cup of talc with each hopper fill of seed and mix thoroughly so that all seeds are coated, adjust rates as needed. Use of talc will aid the seed flow into the meter, singulation and seed drop from the disc.

SEED METER OPERATION/MAINTENANCE

STEP 1 Select seed disc (and seed meter baffle, cleanout brush and/or cleanout brush w/ball-type ejector if applicable) to match crop and population.

STEP 2 Adjust the singulator brush to initial setting. Note that seed size, seed shape, seed treatments, travel speed and planting rate will all affect meter performance.

D06260660

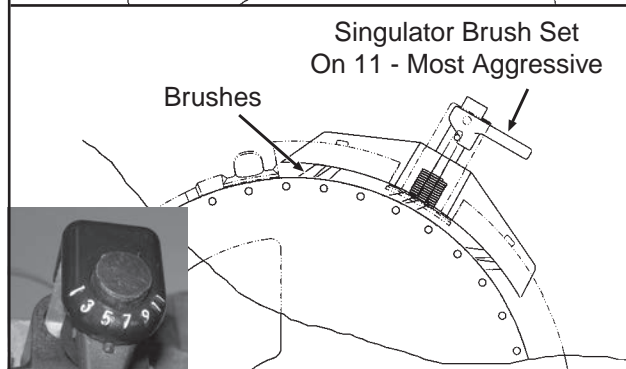
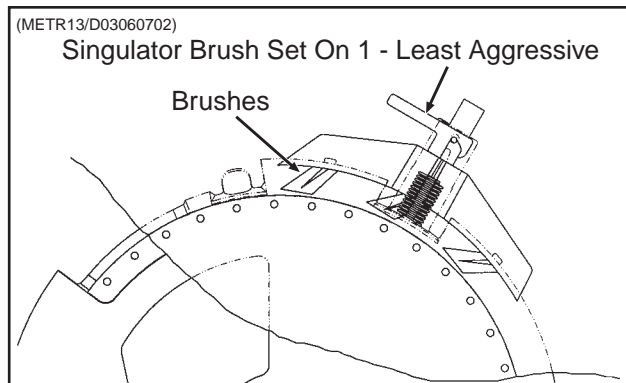
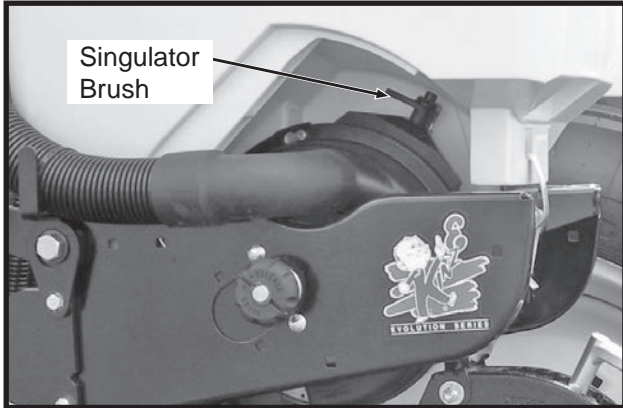

STEP 3 With vacuum fan running, lower planter to planting position and drive forward a short distance to load seed into the seed disc cells.

Adjust vacuum level to the initial setting according to the tables on preceding page. Note that seed size, seed shape, seed treatments, travel speed and planting rate will all affect meter performance.

NOTE: Vacuum reading will be much lower when seed disc cells are empty. Prior to setting vacuum level, load all seed cells.

D10240583



See “Digital Vacuum Gauge Operation” in Machine Operation section

NOTE: Operate vacuum fan 3-5 minutes to bring oil up to normal operating temperature prior to making the final vacuum level adjustment.

STEP 4 Perform optional seed disc fill check.

D101906132



D101906130



With vacuum hose connected and vacuum fan operating, remove vacuum cover and seed disc as an assembly. Inspect seed discs for proper seed fill.

See “Seed Metering System Troubleshooting” at the end of this section.

SEED METER OPERATION/MAINTENANCE

SEED METER DRIVE RELEASE

The seed meter drive is equipped with a clutch release mechanism that allows the drive to be disengaged from the seed metering unit for removal of the seed meter and mount or hopper. Disconnecting the drive allows the operator to check granular chemical application rates without dropping seed. It also allows the drive to one or more of the rows to be disconnected when finishing fields.

D011006101

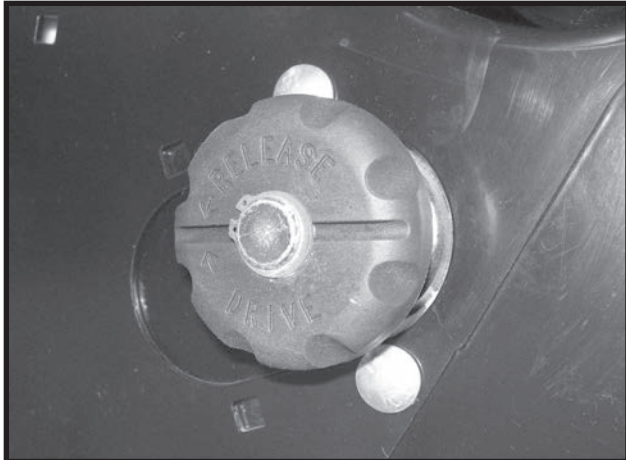

To disengage the drive, turn the knob $\frac{1}{4}$ turn counterclockwise. To engage the drive, turn the knob $\frac{1}{4}$ turn clockwise.

SEED METER OPERATION/MAINTENANCE

SEED METER MAINTENANCE

(METR71)

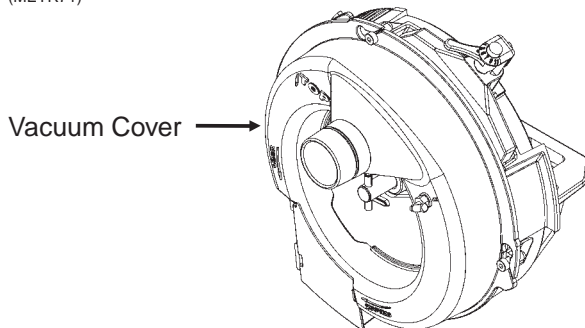

Clean, high quality seed should be used for maximum meter accuracy. Damaged or cracked seed, hulls or foreign material may become lodged in the seed disc orifices and greatly reduce meter accuracy.

It is suggested that the seed disc be inspected and cleaned daily, checking for any buildup of foreign material or any blocked orifices. Clean the seed disc by washing it with soap and water as needed. Dry thoroughly.

Inspect singulator brush for wear and replace if necessary following every 200 acres per row of operation.

The seed disc and/or vacuum cover should be replaced if abnormally high vacuum is required for consistent operation or if consistent operation can not be achieved. If adjustment of the singulator brush does not affect performance of the meter or if the brushes appear frayed, the singulator brush may need to be replaced. If the seed disc orifices are plugged frequently with seed remnants, the cleanout brush or cleanout brush with ball-type ejector (if applicable) may need to be replaced. High quality seed should be used to attain best performance.

(METR70)

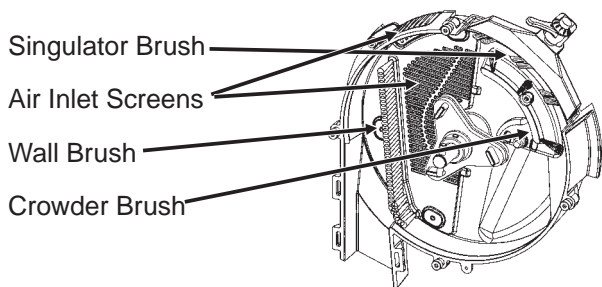

Prior to each planting season, inspect seed discs, singulator brush, crowder brush, wall brush and air inlet screens and clean or replace as needed.

See "Preparation For Storage" for additional EdgeVac® Seed Metering System maintenance.

IMPORTANT: Replace hopper lids after hoppers are filled to prevent accumulation of dust or dirt in the seed meter which will cause premature wear.

NOTE: Remove seed discs from meters for annual storage and store the seed discs vertically on a dowel or pipe.

VACUUM MANIFOLD MAINTENANCE

In the course of normal operation, dust will accumulate in manifolds and hoses. Manifolds should be cleaned annually. More frequent cleaning may be necessitated by abnormally dusty planting conditions.

Remove vacuum hose from each seed meter. Operate the vacuum fan at full hydraulic flow from the tractor for two minutes to clear manifolds, hoses and fittings of dust and debris.

SEED METER OPERATION/MAINTENANCE

SEED METERING SYSTEM TROUBLESHOOTING

PROBLEM	POSSIBLE CAUSE	SOLUTION
Low seed count.	Meter RPM too high.	Reduce planting rate or planting speed.
	Singulator brush setting too aggressive.	Adjust singulator brush.
	Vacuum level too low.	Increase fan speed.
	Seed sensor not picking up all seeds dropped.	Clean seed tube. Move meter to different row.
	Seeds sticking to seed disc.	Use graphite or talc to aid release.
	Seed treatment buildup in seed disc recesses.	Reduce amount of treatment used and or mix thoroughly. Add talc.
	Seed size too large for disc used.	Use appropriate disc for seed size.
	Wrong transmission setting.	Change transmission to desired rate.
	Wrong seed disc.	Use appropriate disc for seed type and size.
	Drive wheel slippage.	Compensate by adjusting transmission sprockets.
	Low tire pressure.	Adjust tire pressure to correct level.
	Failed/worn drive components.	Inspect and replace parts as required.
	Plugged orifices in seed disc.	Inspect and clean disc. Check cleanout brush. (If Applicable)
	Loss of vacuum at meter.	Check for foreign material between vacuum cover and disc. Inspect parts for wear/damage. Clean or replace as required.
	Seed bridging in hopper.	Add graphite to improve seed flow.
	Faulty vacuum gauge reading.	Repair/replace gauge.
	Dirt in vacuum manifold.	Check vacuum manifold for dirt and clean.
	Seed baffle (If Applicable) not allowing seed flow due to bridging of seed.	Thoroughly mix talc to coat all seeds. Remove seed baffle. See "Seed Meter" in Seed Meter Operation/Maintenance section.
	60 cell soybean disc not filling properly due to excessive RPM.	Replace with 120 cell soybean disc.
	Seed disc worn.	Replace.
Vacuum cover worn.	Replace.	
Not planting seed.	Seed hoppers empty.	Fill seed hopper.
	Seed tube plugged/damaged.	Clean or replace tube.
	Meter drive damaged.	Repair/replace drive components.
	Low/no vacuum.	Inspect vacuum system and repair as necessary.
	Singulator brush setting too aggressive.	Adjust singulator brush.
	Faulty vacuum gauge.	Repair/replace vacuum gauge.
	Seed bridging in hopper.	Add graphite to improve seed flow.
	Loss of vacuum at meter.	Check for foreign material between vacuum cover and disc. Inspect parts for wear/damage. Clean and/or replace as required.
	Wrong seed disc.	Use appropriate disc for seed type and size.
	Meter drive clutch not engaged.	Engage drive clutch.
	Fan not running.	Start fan.
Dirt in vacuum manifold.	Check vacuum manifold for dirt and clean.	

(Continued On Following Page)

SEED METER OPERATION/MAINTENANCE

SEED METERING SYSTEM TROUBLESHOOTING (Continued)

PROBLEM	POSSIBLE CAUSE	SOLUTION
Not planting seed. (Continued)	Seed baffle (If Applicable) not allowing seed flow due to bridging of seed.	Thoroughly mix talc to coat all seeds. Remove seed baffle. See "Seed Meter" in Seed Meter Operation/Maintenance section.
	60 cell soybean disc not filling properly due to excessive RPM.	Replace with 120 cell soybean disc.
High seed count.	Wrong transmission setting.	Change transmission to desired rate.
	High vacuum.	Adjust vacuum level to appropriate level.
	Wrong seed disc.	Replace seed disc.
	Singulator brush setting not aggressive enough.	Adjust singulator brush.
	Worn singulator brush.	Inspect brush and replace as required.
	Seed leaking past wall brush.	Inspect wall brush condition and installation. Replace as necessary.
	Faulty vacuum gauge.	Check gauge line for dirt/obstruction. Repair/replace vacuum gauge.
Poor seed spacing.	Obstruction in seed tube.	Clean seed tube.
	Dirty/damaged seed disc.	Inspect seed disc for damage, foreign material in orifices or seed treatment buildup in recesses. Clean or replace as required.
	Wrong vacuum setting.	Adjust vacuum to appropriate level.
	Excess foreign material in seed.	Inspect and clean meter and seed discs. Use clean, undamaged seed.
	Incorrect singulator brush setting.	Adjust singulator brush to appropriate setting.
	Inconsistent driveline.	Inspect drive components for rust, misalignment, worn or damaged parts. Replace/repair as required.
	Toolbar not level or wrong height.	Adjust hitch to level toolbar and row units.
	Planting too fast for conditions.	Reduce speed.
	Rough field conditions.	Reduce speed.
Irregular seed population.	Driving too fast.	Reduce speed.
	Drive wheels slipping.	Reduce speed. Decrease row unit down pressure spring settings.
Unable to achieve desired vacuum level.	Tractor hydraulic flow set too low.	Increase flow to fan motor.
	Incorrect hydraulic connections.	Check all hydraulic connections and hose routings.
	Damaged fan components.	Inspect motor and impeller for wear/damage and repair/replace as necessary.
	Vacuum hose pinched/kinked/ blocked.	Inspect air lines for any damage or obstruction. Clean air lines and manifold by removing end cap from manifold and running fan at high speed.
	Vacuum hose loose/disconnected.	Inspect and reattach all air hoses.
	Tractor not producing required hydraulic flow/pressure.	Have tractor serviced by qualified technician.
	Dirt in vacuum gauge line. clean.	Check gauge line for dirt/obstruction and clean.

SEED METER OPERATION/MAINTENANCE

ROW UNIT OPERATION

PLANTING DEPTH

Planting depth is maintained by the row unit gauge wheels. To increase or decrease the planting depth, first raise the planter to remove weight from the wheels. Then push down on the depth adjustment handle and reposition it forward to decrease depth or rearward to increase planting depth. Adjust all units to the same setting initially. Then lower the planter and check operation and planting depth of all row units. It may be necessary to readjust some rows to obtain uniform operation. Available depth adjustment range is approximately 1/2" to 3 1/2".



WARNING: Never work under the planter while in raised position without using safety lockup devices.

D020705102

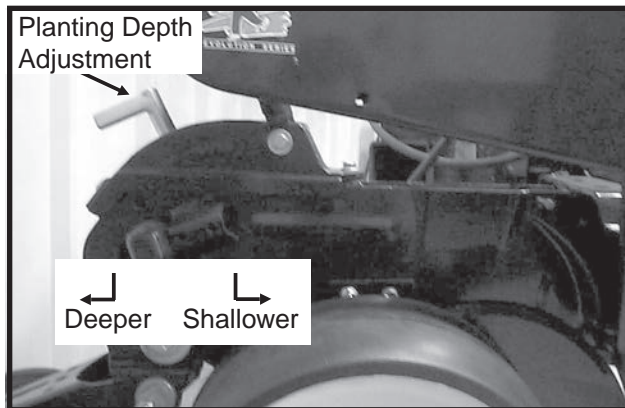

"V" CLOSING WHEEL ADJUSTMENT (Rubber And Cast Iron)



WARNING: Raise planter and install safety lockup devices before making closing wheel adjustments.

After adjusting planting depth, check the operation of the "V" closing wheels. The "V" closing wheels should have enough down pressure to close the seed trench and ensure good soil to seed contact. To increase spring pressure on the closing wheels, move the 5-position quick adjustable down force lever located on the top of the closing wheel arm to the rear. Moving the lever forward decreases spring tension.

Adjust all row units to a similar setting.

LF2122299-15

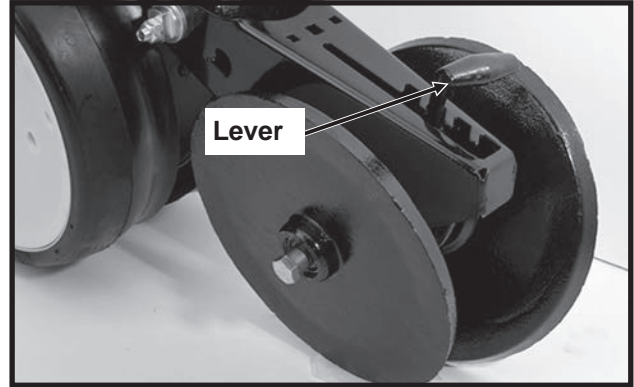

Light soil usually requires less down force at average depth (approximately 2") while heavy soil requires increased down force.

Eccentric bushings in the wheel arm stop allow for lateral adjustment of the "V" closing wheel assembly. Using a 3/4" wrench, loosen the hardware which attaches the closing wheel arm to the wheel arm stop. Using another 3/4" wrench turn the eccentric bushings until the **closing wheels are aligned with the seed trench**. Tighten hardware.

LF2122299-15

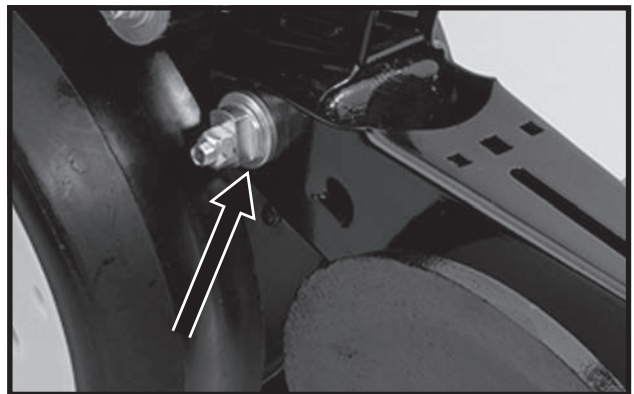

The closing wheels can be installed in two locations either "offset" (to improve residue flow) or "directly" opposite. If set "directly" opposite, the forward installation holes should be used.

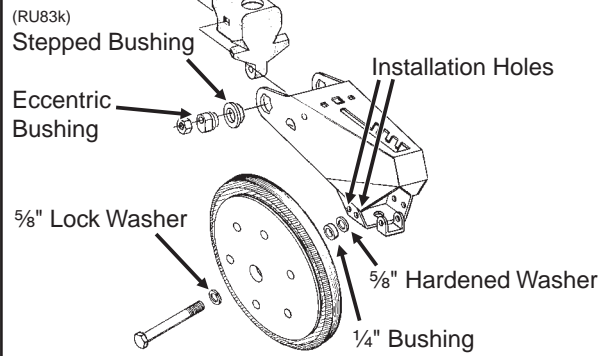

ROW UNIT OPERATION

CLOSING WHEEL SHIELD

(Rubber And Cast Iron "V" Closing Wheels)

D11090208a

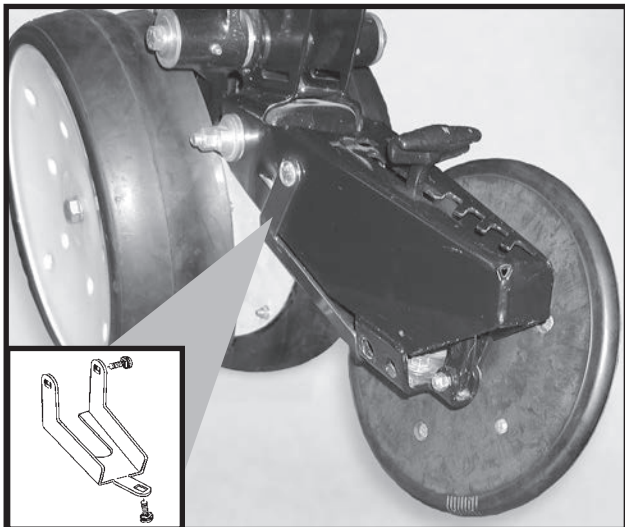

Shown With Closing Wheel Removed For Visual Clarity

The optional closing wheel shield is designed to be installed onto the underside of the closing wheel arm to help prevent root balls and stalks from plugging the closing wheels.

COVERING DISCS/SINGLE PRESS WHEEL ADJUSTMENT



WARNING: Raise planter and install safety lockup devices before making covering discs/single press wheel adjustments.

72359-31



After adjusting planting depth, check the operation of the covering discs/single press wheels.

Initial press wheel down force setting should be with 2 1/2" between mounting arm tab and locking nut. To adjust down force spring, loosen 1/2" locking nut and turn adjusting bolt in to increase down force or out to decrease down force. Tighten locking nut against spring plug. Adjust all row units to a similar setting.

RH993(PLTR12)

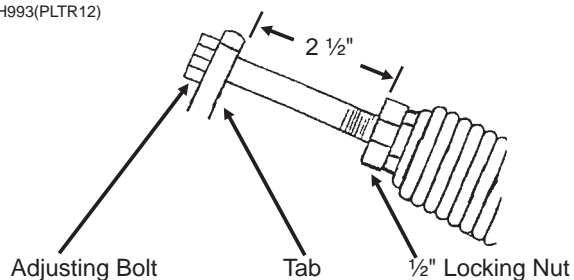

ROW UNIT OPERATION

Eccentric bushings in the wheel arm stop allow for lateral adjustment of the covering discs/single press wheel assembly. Using a 3/4" wrench, loosen the hardware which attaches the assembly to the wheel arm stop. Using another 3/4" wrench, turn the eccentric bushings until the press wheel is aligned with the seed trench.

(RU94b)

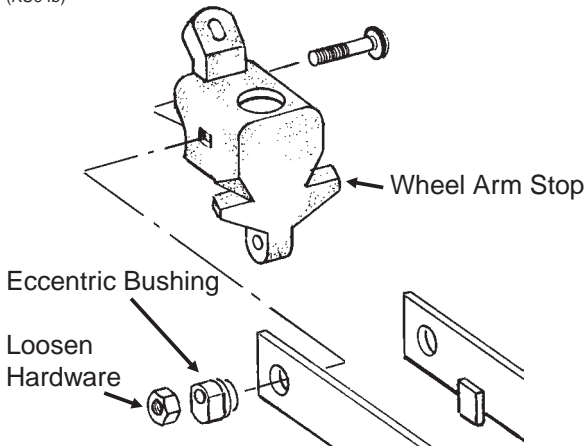

Two sets of holes in the mounting arm allow the covering discs to be located for staggered or side-by-side operation as desired.

72359-35

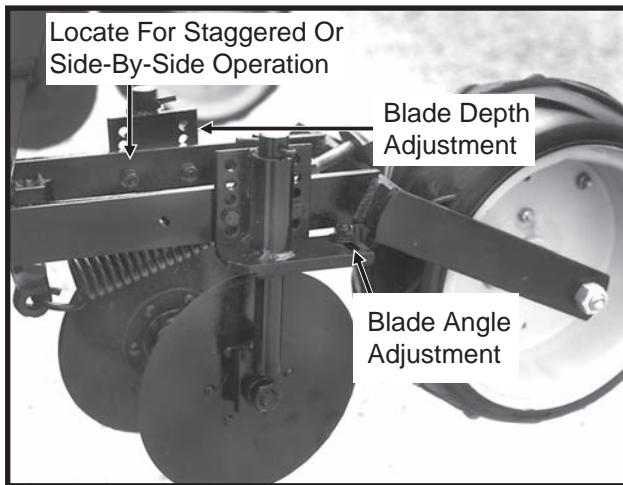

Five sets of holes in each disc bracket allow for 1/2" incremental blade depth adjustment.

Slotted holes in the disc mount and bracket allow for 0° - 15° blade angle adjustment.

Adjust covering discs on all row units to similar settings.

DRAG CLOSING ATTACHMENT

LF212299-18

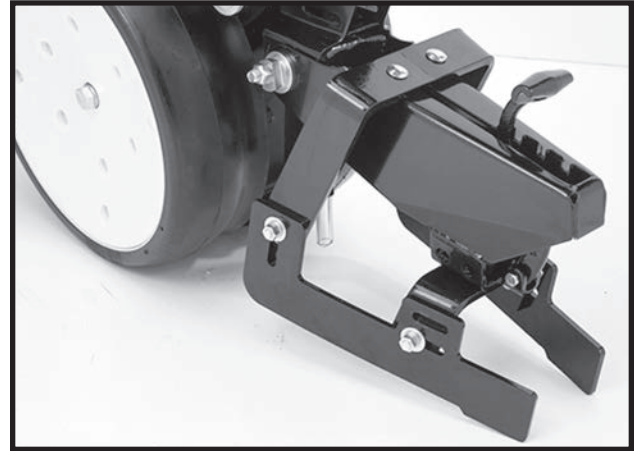

The drag closing attachment is designed to pull loose soil over the seed trench.

Front and rear adjustment is made using the slotted holes in the blades. Adjust all rows the same.

NOTE: Use of a seed firming wheel or other seed firming device is recommended with the drag closing attachment.



WARNING: Raise planter and install safety lockup devices before making drag closing attachment adjustments.

(RU90d)

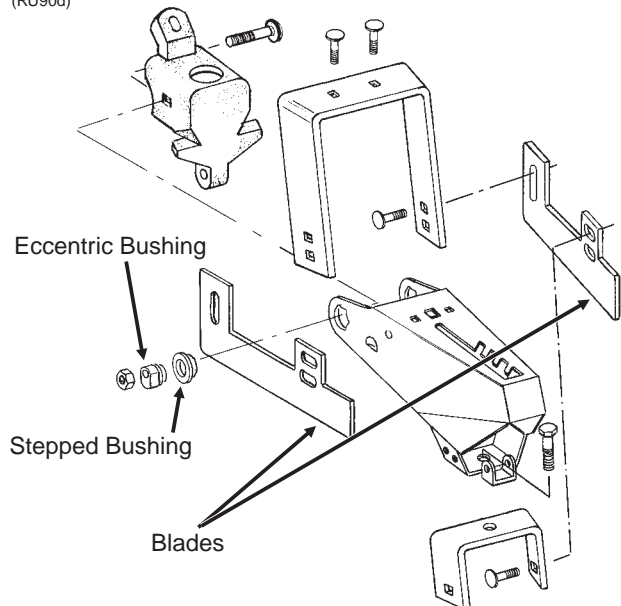

Eccentric bushings allow for lateral adjustment of the drag closing attachment. Using a 3/4" wrench, loosen the hardware which attaches the assembly to the wheel arm stop. Using another 3/4" wrench, turn the eccentric bushings until the drag closing attachment is aligned with the seed trench.

ROW UNIT OPERATION

SEED HOPPER

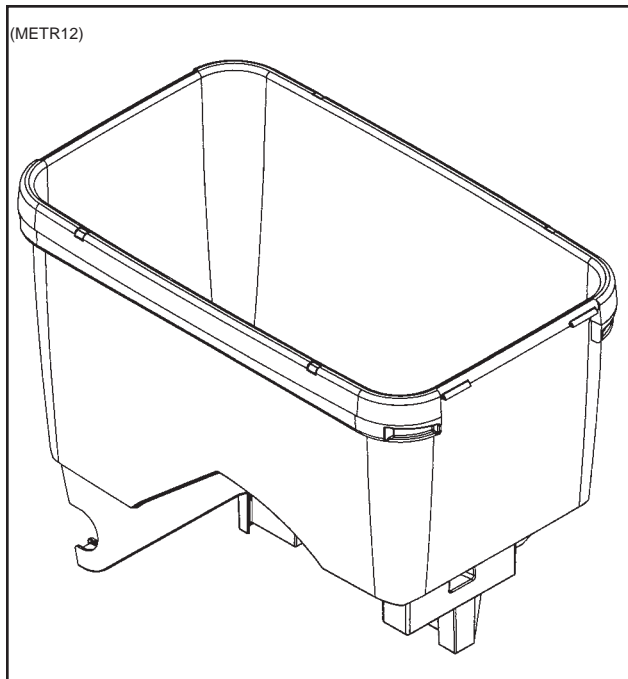

The capacity of each seed hopper is 1.75 bushels.

When filling the seed hopper use clean seed and make certain there are no foreign objects in the hopper. **Replace hopper lids after hoppers are filled to prevent the accumulation of dust or dirt in the seed meter which will cause premature wear.** See "Seed Meter" in Seed Meter Operation/Maintenance section.

Periodically empty the hoppers completely to remove any foreign material and to ensure proper seed meter operation. To empty hopper, disengage meter drive and hopper latch and lift hopper off the hopper support. See "Seed Meter Drive Release" in Seed Meter Operation/Maintenance section.

ROW UNIT EXTENSION BRACKETS

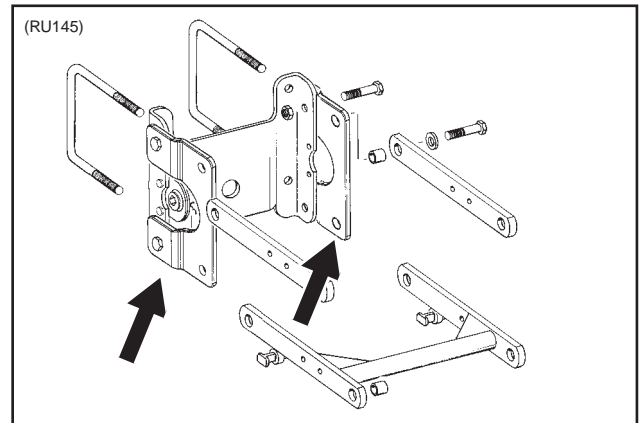

Row unit extension brackets are required on the 4 center row units if the Model 3600V planter is equipped with coulter mounted residue wheels. The brackets extend the row units rearward 4" to provide required clearance.

ROW UNIT OPERATION

QUICK ADJUSTABLE DOWN FORCE SPRINGS OPTION

Quick adjustable down force springs are designed to increase penetration in hard soil and keep the row unit from bouncing in rough field conditions.

Two springs per row, one on the L.H. parallel arms and one on the R.H. parallel arms, are used unless equipped with row unit mounted no till coulters. Four springs per row are used with row unit mounted no till coulters.

D06300305

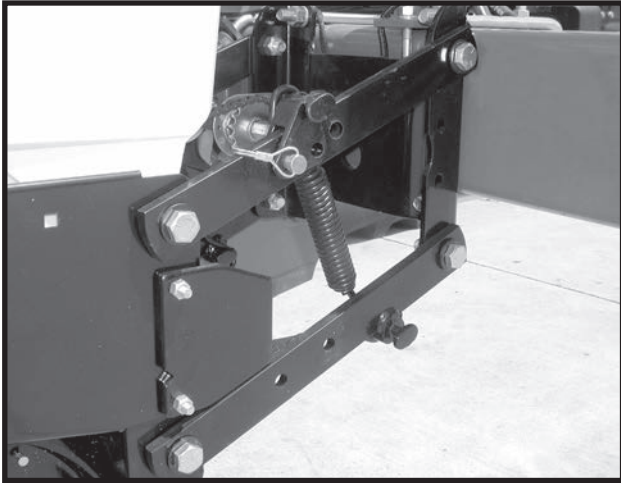

Two Springs Per Row (Dual)

D07010301

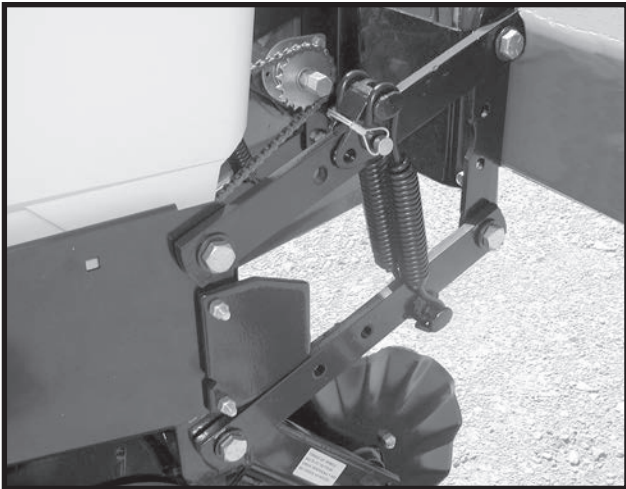

**Four Springs Per Row (Quad)
(Used Only In Conjunction With Row Unit Mounted
No Till Coulters)**

NOTE: Four springs per row are to be used with row unit mounted no till coulters only.

There are four positions for spring tension adjustment. Position 1 allows for minimum down pressure and position 4 for maximum down pressure.

L0096(PLTR27e)

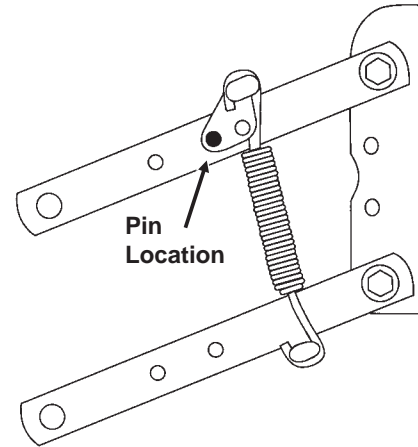

Position 1 (Minimum)

(PLTR28e)

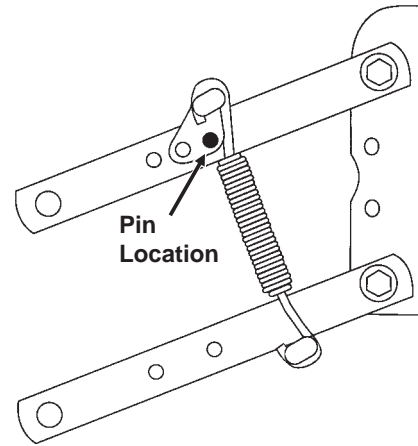

Position 2

(PLTR29e)

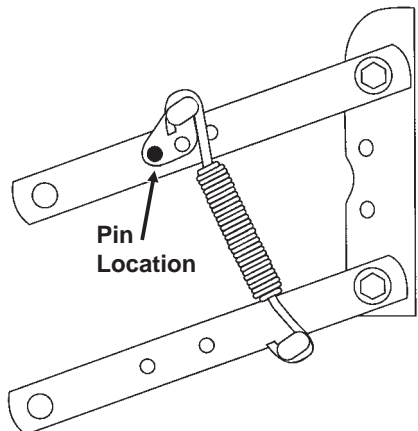

Position 3

ROW UNIT OPERATION

(PLTR30e)

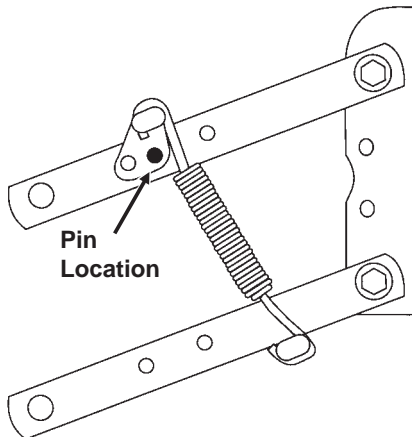

Position 4 (Maximum)

To adjust spring tension, raise planter and remove spring mount pin at top of spring. Slide mount to desired position and install pin.

NOTE: It is necessary for the operator to adjust springs according to field conditions. If springs are adjusted for too much down pressure for field conditions, it is possible for the row units to lift the planter to the extent that the drive wheels do not make sufficient contact. Too much down pressure in soft field conditions can cause the row unit to run too deep.



WARNING: Always install safety lockup devices or lower machine to the ground before working under or around the machine.

IMPORTANT: Springs must always be installed with open side of spring hooks toward the seed hoppers to prevent binding on spring mount adjustment pins.

ROW UNIT OPERATION

PNEUMATIC DOWN PRESSURE

With pneumatic down pressure option, the operator can vary row unit down pressure on-the-go as field conditions change. A cab-mounted digital readout displays down force (lbs.) applied. A planter-mounted 12 VDC air compressor, with 3 gallon capacity air tank, supplies air for the down pressure system.

Packages also include upper and lower air spring mounting castings for pull row units (fore and aft air spring mounting castings for push row units), 150 psi rated air springs, $\frac{3}{8}$ " O.D. nylon hoses, dual solenoid air valve and stainless steel, 160 psi, 2" liquid-filled gauge and planter wiring harness.

Pneumatic down pressure row unit extension brackets are required in some applications.

(PNE01e)

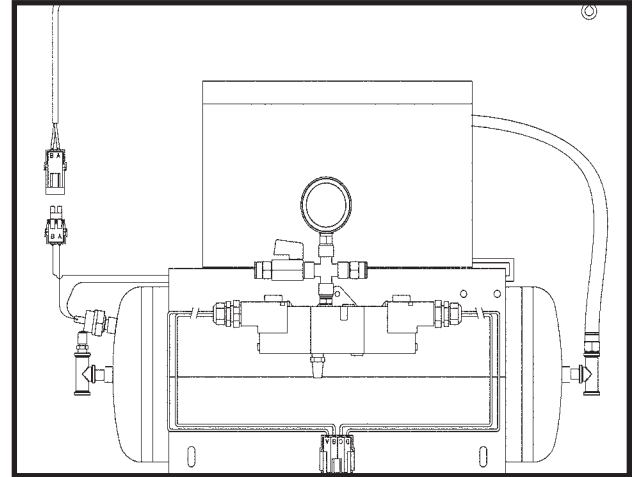

Air Compressor With Dual Solenoid Assembly

(PNE07)

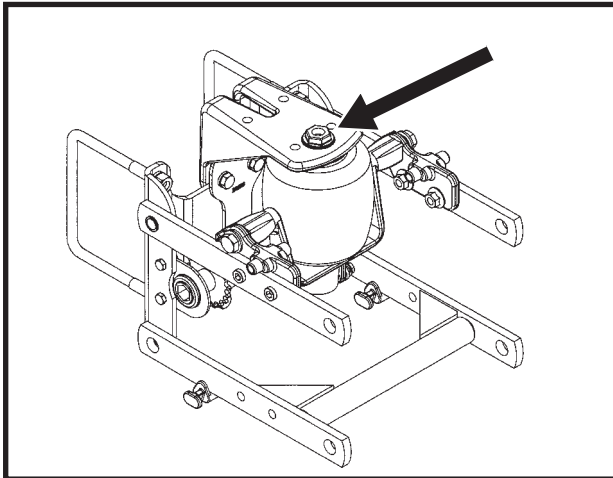

Pull Row Unit Air Spring

NOTE: Shoulder nut(s) should be torqued to 350 in. lbs. Refer to page 9-1 for additional torque values.

(A12813)

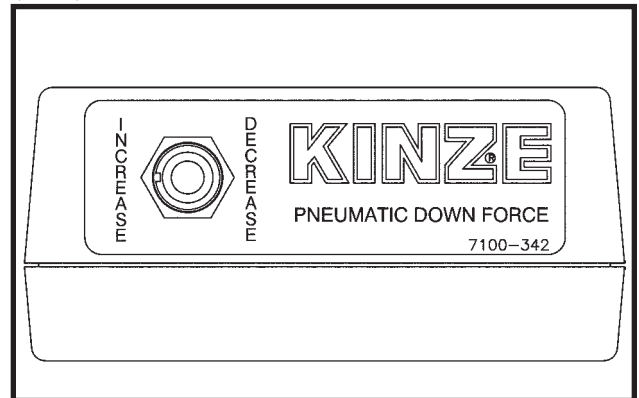

Control Box Assembly

(PNE09)

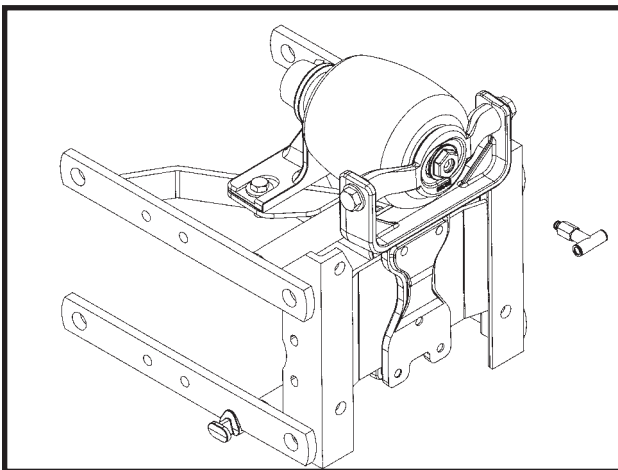

ROW UNIT OPERATION

NOTE: If additional down pressure is needed with the Pneumatic Down Pressure Package, assist springs are available through your KINZE® dealer. One spring is installed on the outer side of the parallel arms on each side of the row unit as shown below.

D11280753a

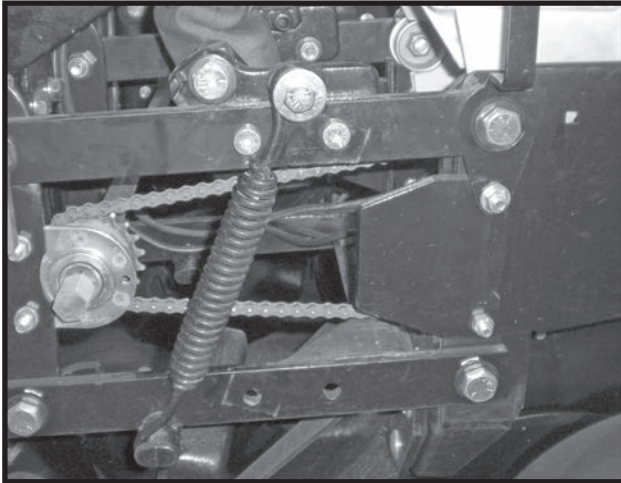

Pull Row Unit Assist Springs

D11280749a

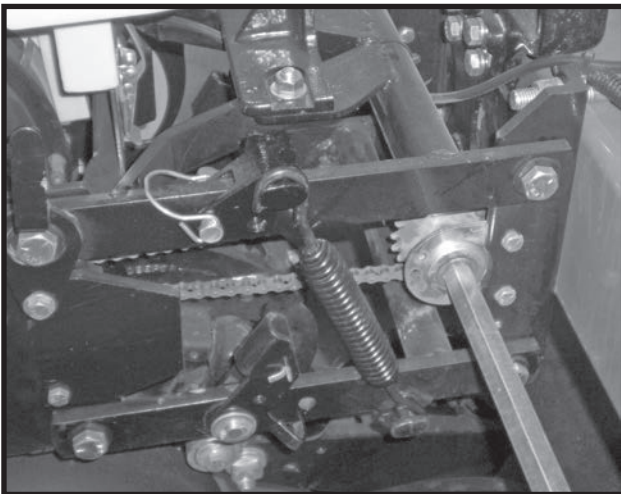

Push Row Unit Assist Springs

FIELD OPERATION

NOTE: For the most accurate adjustment, adjust down pressure with planter lowered and row openers in the ground. Pressure can be adjusted from tractor using the control console, or at planter using the manual control valves.

(A12813)

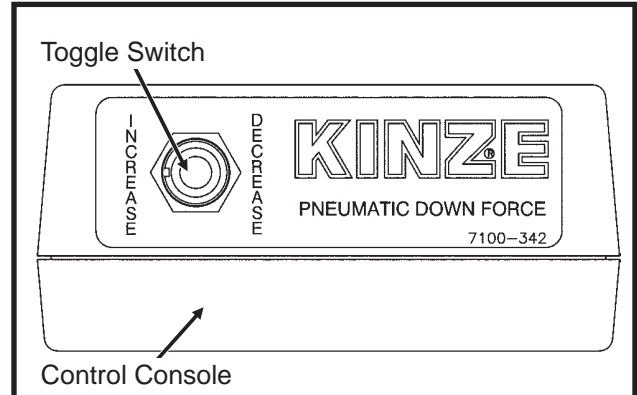

To adjust down pressure from cab:

To INCREASE pressure, push toggle switch left.

To DECREASE pressure, push toggle switch right.

To adjust down pressure from planter:

To INCREASE pressure, press and hold button on solenoid as shown below.

To DECREASE pressure, press and hold button on solenoid as shown below.

The readout value on the air pressure gauge is NOT the down pressure force value. To calculate the force value, multiply the air pressure (psi) by four (4).

D112907100

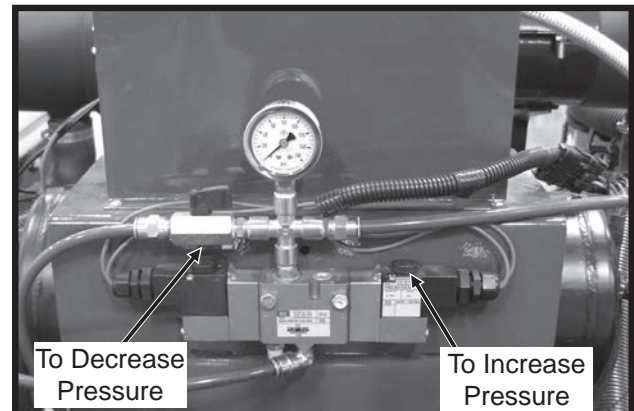

ROW UNIT OPERATION



WARNING: Always install all safety lockup devices or lower planter to the ground before working under or around the machine.

D112907100

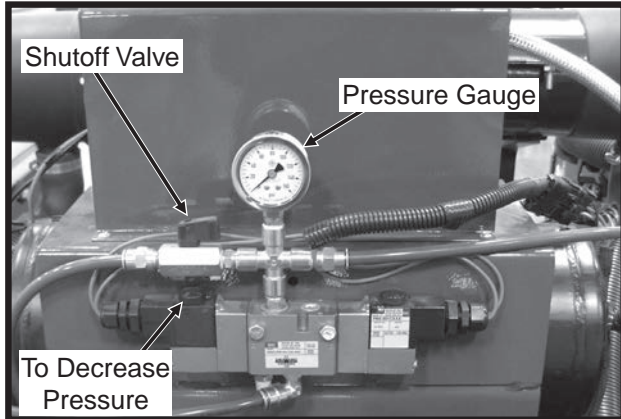

To lock up push row units equipped with pneumatic down pressure springs:

- STEP 1** Disconnect electric power supply to compressor.
- STEP 2** Press and hold button on solenoid until pressure gauge reads zero.
- STEP 3** Lock up units. See “Interplant Push Unit Lockup” for instructions.
- STEP 4** Turn the shutoff valve handle perpendicular to valve body. This turns off air supply to the push row units.

NOTE: If control console is ON and the hydraulic down force is not set to zero, compressor will start when electric power supply is reconnected.

- STEP 5** Reconnect electric power supply to compressor.

ROW UNIT OPERATION

FRAME MOUNTED COULTER

LF083002101

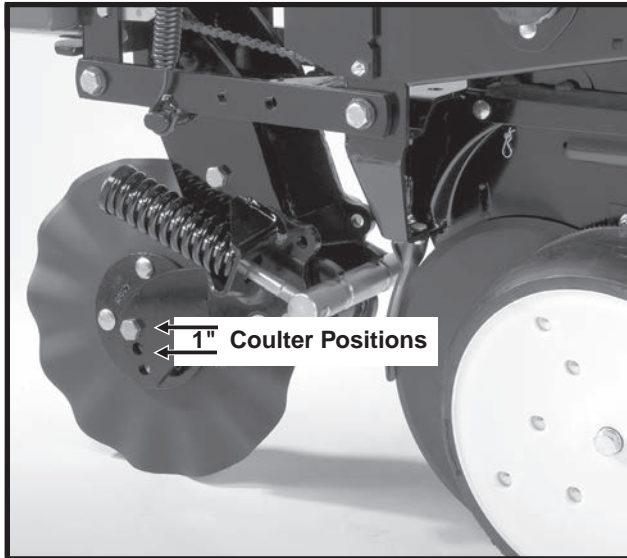

Frame mounted coulters with 1" bubbled, 1" fluted (8 flutes) or 3/4" fluted (13 flutes) blades may be used on pull row units only. (Not compatible with push row units.)

The frame mounted coulters is designed to apply necessary spring down pressure on the coulters for maximum penetration while exerting less shock load on the row unit.

The initial location of the coulters blade is in the top hole. The blade can be relocated to one of the lower two holes (1" increments) as wear occurs or if deeper operation of the blade is desired.

LF083002101

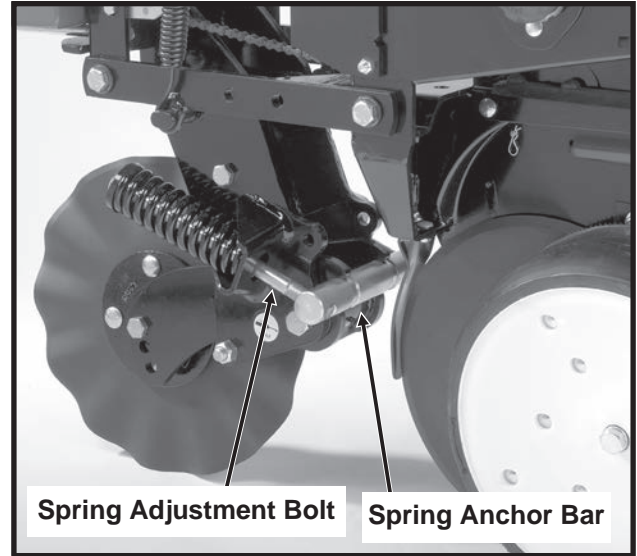

DOWN PRESSURE ADJUSTMENT

Down force adjustment is made by tightening or loosening the two spring adjustment bolts. With the planter in raised position, turn the bolts clockwise to increase down pressure or counterclockwise to decrease down force. Set both springs the same.

Down force on the blade is shown below in lbs.

End Of Spring Adjustment Bolt Flush With Spring Anchor Bar (Shown Above)	End Of Spring Adjustment Bolt Extended 1/2" Through Spring Anchor Bar	All Threads Used (Maximum)
275 lbs.	400 lbs.	500 lbs.

NOTE: Avoid setting down pressure higher than is required for consistent soil penetration. Excessive pressure will increase the chances of damage to coulters components when the coulters strikes an obstacle.

ROW UNIT OPERATION

RESIDUE WHEELS

(For Use With Frame Mounted Coulter)

The residue wheels for use with the frame mounted coulter may be used on pull row units only.

LF083002102

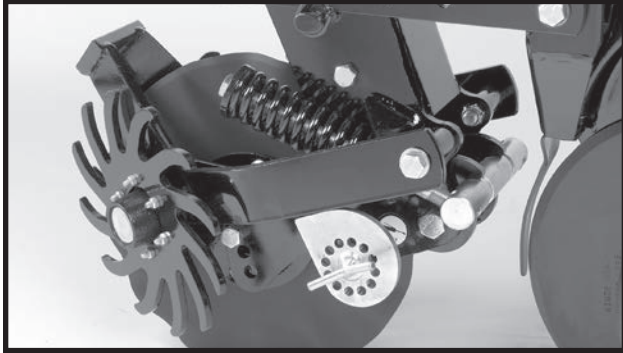

STYLE A Shown

The residue wheels are attached to the frame mounted coulter with two cap screws and sleeves allowing the unit to free-float. A 2-position spindle bolt mounting allows the tined wheels to be mounted interlocked or staggered. Depth adjustment is made using a spring-loaded cam and pin with 11 positions in $\frac{1}{4}$ " increments. A high point on the cam allows the wheels to be locked up so they do not contact the ground. A weed guard, located on the inboard side of each wheel, aids in the prevention of weed wrap which can cause premature bearing failure.

(RU135k)

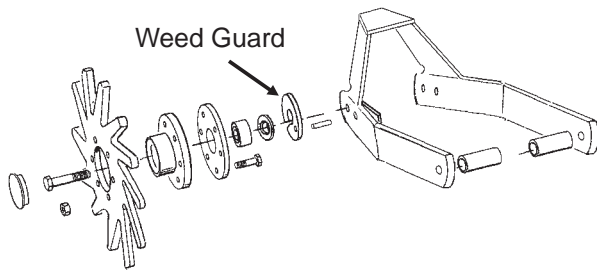

STYLE A

(RU135m)

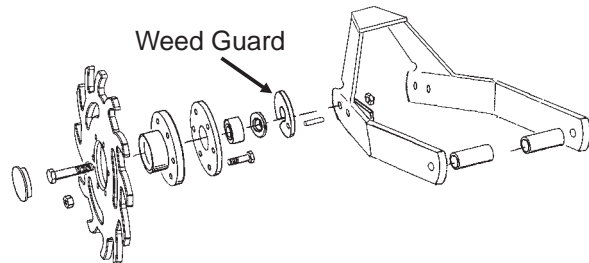

STYLE B

NOTE: Opening in weed guard must point down.

IMPORTANT: The forward mounting positions of the tined wheels can not be used on the four rows behind the axle on the 3600 machine due to inadequate clearance.

ROW UNIT MOUNTED DISC FURROWER

The row unit mounted disc furrower is for use on pull row units only (not compatible with Interplant® push row units). The disc furrower may be equipped with either 12" solid blades or 12" notched blades.

Disc furrowers are used to clear crop residue, dirt clods and dry soil from in front of the row units for a clean and smooth seed bed. Notched blades are used for heavier residue conditions. The notched blades cut crop residue and move it aside to prevent plugging or pushing.

LF212299-22

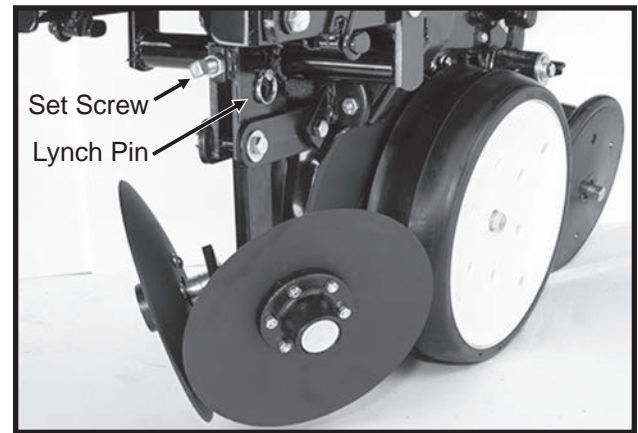

Vertical adjustment in $\frac{1}{8}$ " increments is possible by removing the lynch pin which secures the vertical support arm and moving the support arm up or down as required. Reinstall lynch pin. Finer adjustment can be attained by removing the lynch pin and using the $\frac{5}{8}$ " x $2\frac{1}{4}$ " set screw to clamp the support arm in the required position.

(RU98e)

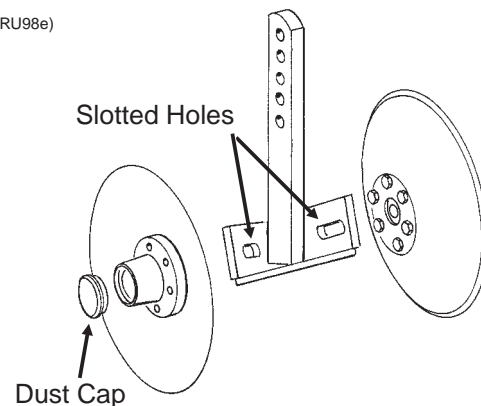

Slotted holes in the support arm where the blades are mounted allow fore and aft adjustment of the disc blades. Blades can be adjusted so the front edges meet or one blade can be moved to the rear and the other to the front of the slot so the cutting edge of one blade overlaps the edge of the other blade. The dust cap must be removed to make these adjustments.

ROW UNIT OPERATION

ROW UNIT MOUNTED RESIDUE WHEEL

The row unit mounted residue wheel may be used on pull row units and push row units.

D101701113

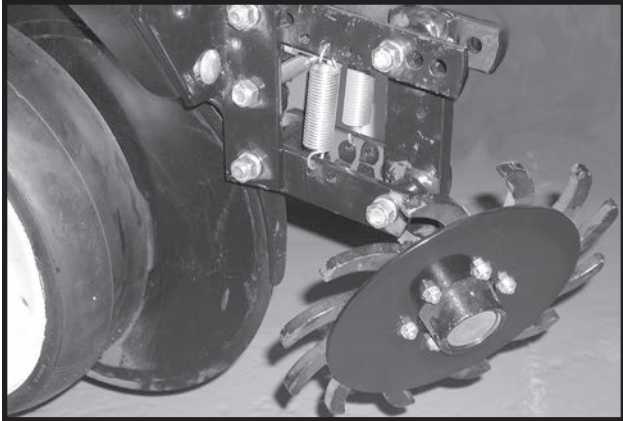

STYLE A

(A12685)

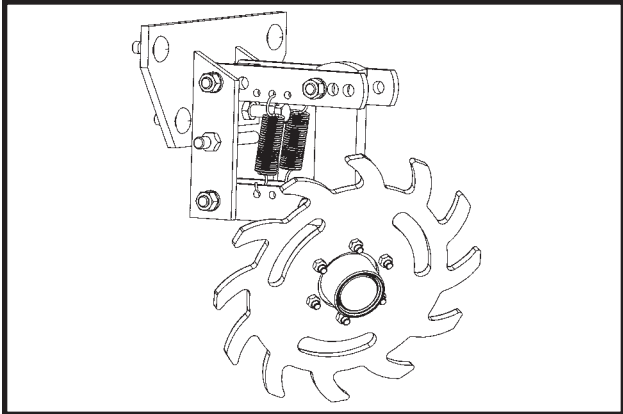

STYLE B

ROW UNIT OPERATION

Two adjustable springs on the parallel links on each residue wheel allow for down force adjustment. Position 1 as shown below provides minimum down pressure and position 3 maximum down pressure.

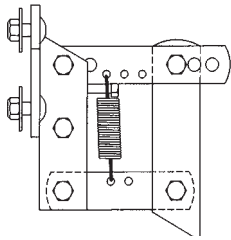

Position 1 (Minimum) (PLTR31a)

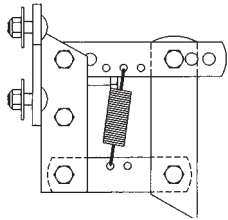

Position 2 (PLTR32a)

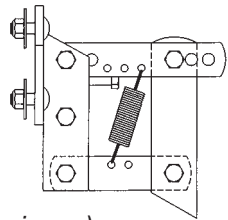

Position 3 (Maximum) (PLTR33a)

For additional uplift or float, position springs as shown below.

(PLTR34a)

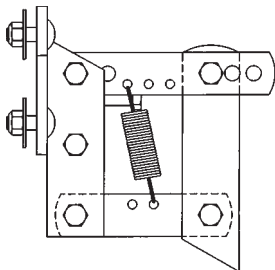

To adjust down force springs, raise the row unit out of the ground and reposition springs as shown for the desired down pressure.

D101701112

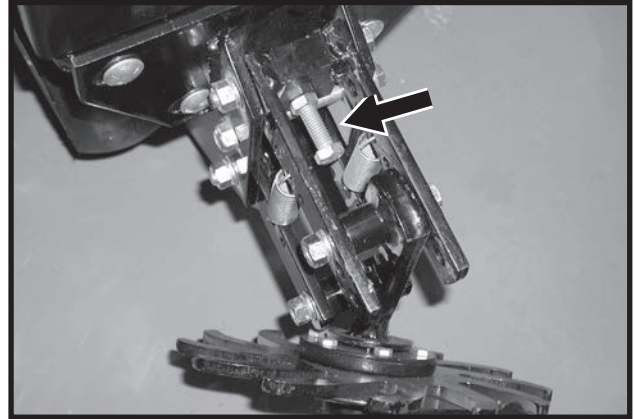

A full threaded bolt and jam nut located on the upper link allows maximum depth to be set for loose soil conditions. Initial setting should be 1 3/4" above the depth of the row unit double disc opener.

Three holes in the upper link allow for wheel angle adjustment. With the wheel mount in the most vertical position, using the rear hole in the upper link, the residue wheel is most aggressive. Moving the wheel mount to one of the forward holes reduces the aggressiveness of the wheel for use in mulch till applications where the soil is loose.

D101701202

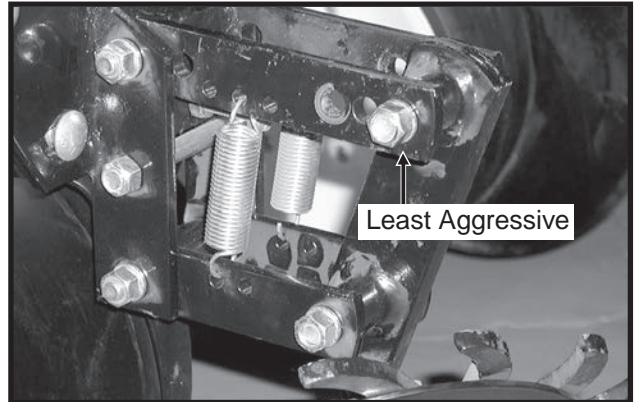

To lock the residue wheel up out of the ground, remove the 1/2" x 5" lockup bolt, raise the residue wheel and install bolt.

D011701203

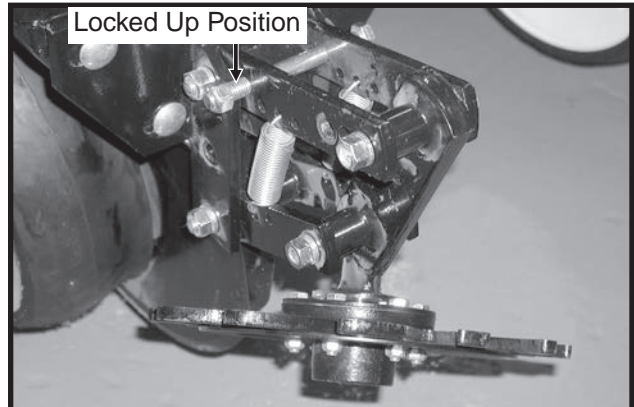

ROW UNIT OPERATION

ROW UNIT MOUNTED NO TILL COULTER

LF212299-19a

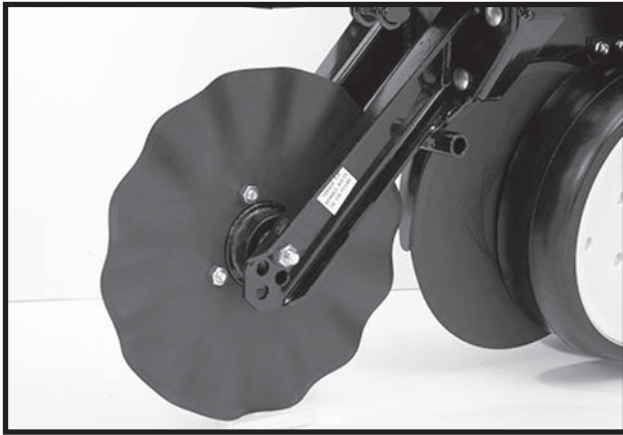

STYLE A (Two Sleeves For Installing Coulters Mounted Residue Wheels)

D05170706a



STYLE B (One Sleeve For Installing Coulters Mounted Residue Wheels)

Row unit mounted no till coulters with 1" bubbled, 1" fluted (8 flutes) or $\frac{3}{4}$ " fluted (13 flutes) blades may be used on pull row units and push row units. ($\frac{3}{4}$ " fluted shown)

Four quick adjustable down force springs are required per row when using row unit mounted no till coulters. See "Quick Adjustable Down Force Springs".

For proper operation, the coulters should be aligned in relation to the row unit double disc openers. The coulters assembly can be adjusted by loosening the four attaching bolts, moving coulters arm to align and tightening the four attaching bolts.

The coulters blade can be adjusted to one of four $\frac{1}{2}$ " incremental settings in the forked arm. Initial location of the coulters is in the top hole. As the coulters blade wears, the blade should be adjusted downward to one of the three lower settings to maintain the coulters blade at or slightly below the opener discs. In very hard soil conditions such as compacted wheel tracks, opener penetration and cutting of surface residue may be improved by adjusting the coulters to operate below the depth of the double disc opener blades.

Operating depth can be checked by setting the planter down on a level concrete floor and checking the relationship between the coulters blade and row unit opener blade. Make sure the planter is level and coulters is square with the planter frame and aligned with the row unit disc opener.

NOTE: Torque $\frac{5}{8}$ " spindle bolts to 120 ft. lbs.

ROW UNIT OPERATION

COULTER MOUNTED RESIDUE WHEELS

LF212299-23

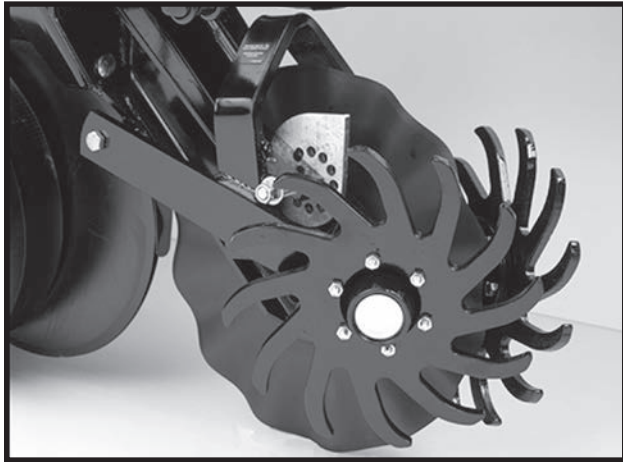

STYLE A - Used With Style A Row Unit Mounted No Till Coultter

D05170708a



STYLE B - Used With Style B Row Unit Mounted No Till Coultter

Coultter mounted residue wheels are designed for use on pull row units and push row units. Row unit extension brackets are required on the four center pull row units if the planter is equipped with coultter mounted residue wheels.

The coultter mounted residue wheels are attached to the row unit mounted no till coultter with one cap screw and sleeve allowing the unit to free-float. A 2-position spindle bolt mounting allows the tined wheels to be mounted interlocked or staggered. Depth adjustment is made using a spring-loaded cam and pin with 11 positions in 1/4" increments. A high point on the cam allows the wheels to be locked up so they do not contact the ground. A weed guard, located on the inboard side of each wheel, aids in the prevention of weed wrap which can cause premature bearing failure.

(RU104tt)

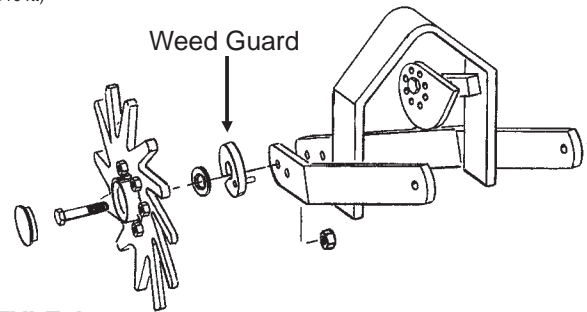

STYLE A

(RU153a)

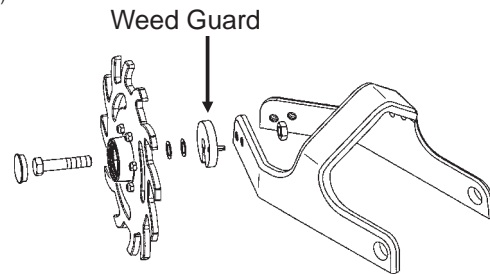

STYLE B

NOTE: Opening in weed guard must point down.

ROW UNIT OPERATION

SPRING TOOTH INCORPORATOR

The spring tooth incorporator smoothes the soil behind the row unit and incorporates granular chemicals. The two mounting chains on each spring tooth incorporator should be adjusted so there is approximately $\frac{1}{8}$ " slack in the chain when the unit is lowered to planting position.

NOTE: The spring tooth incorporator is not compatible with the covering discs/single press wheel option.

LF212299-26

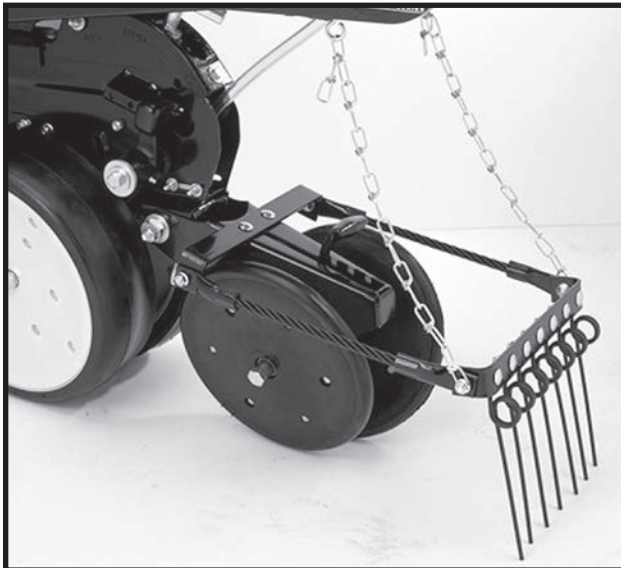

ROW UNIT OPERATION

INTERPLANT® PUSH ROW UNIT LOCKUPS

Push row unit lockups are designed to allow the push row units to be locked in the raised position.



WARNING: Always install all safety lockup devices or lower planter to the ground before working under or around the machine.

D062603106

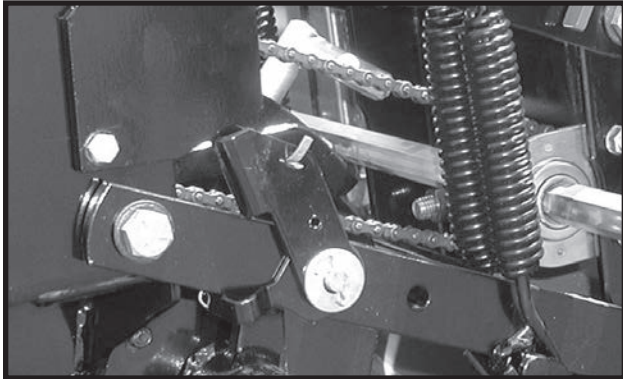

Push Row Unit Locked In Raised Position

D062603103

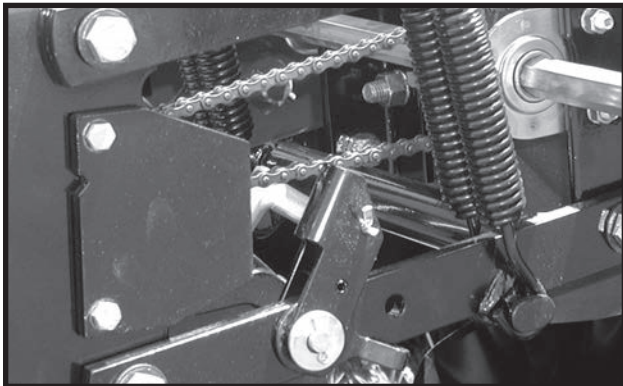

Lockup Released For Field Operation

D062603106a

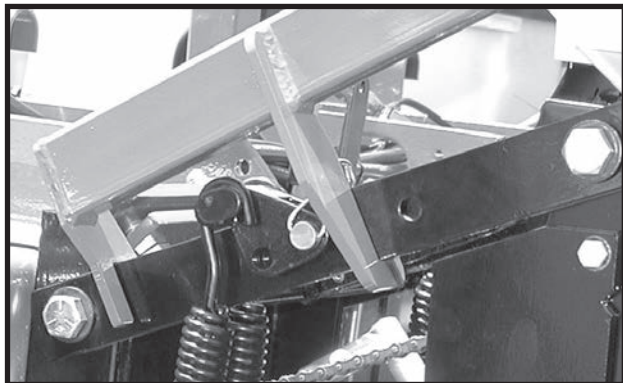

Lift Lever Positioned To Lift Push Row Unit

To lock in raised position:

1. Set row unit down pressure springs to minimum setting.
2. Lower the planter to the planting position.
3. Empty seed hoppers.
4. On each push row unit lockup, flip the spring tab forward.

D060499108

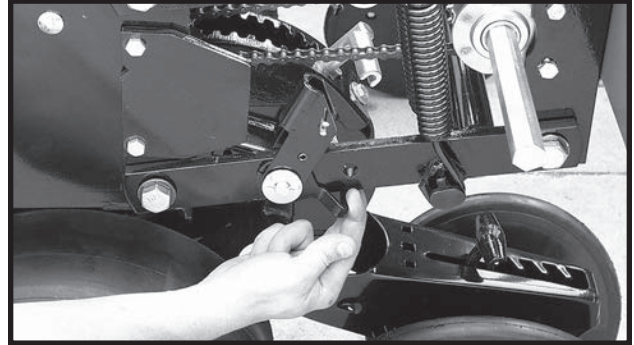

5. Using the lift lever, raise the push row unit to allow the spring loaded lockups to snap into locked position under the row unit stops.
6. Repeat Steps 4 and 5 on remaining push row units.

To release lockups:

1. Lower the planter to the planting position.
2. On each push row unit lockup, flip the spring tab rearward.

D060499107

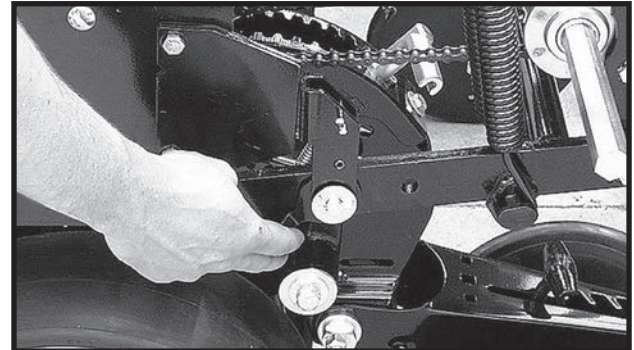

3. Using the lift lever, raise the push row unit to allow the spring loaded lockups to snap out of locked position. Lower row unit to the ground.
4. Repeat Step 3 on remaining push row units.

D08220663

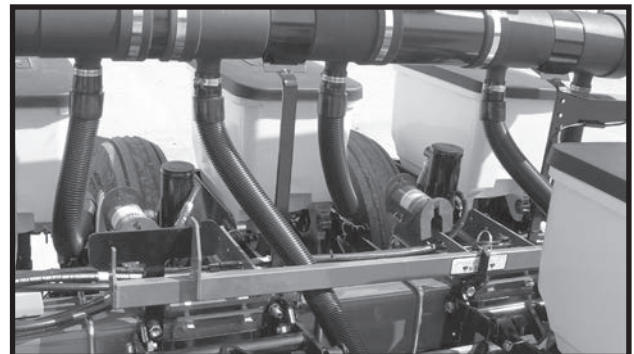

Lift Lever In Storage Location

ROW UNIT OPERATION

INTERPLANT® PUSH ROW UNIT CLUTCH SPROCKET

06309716

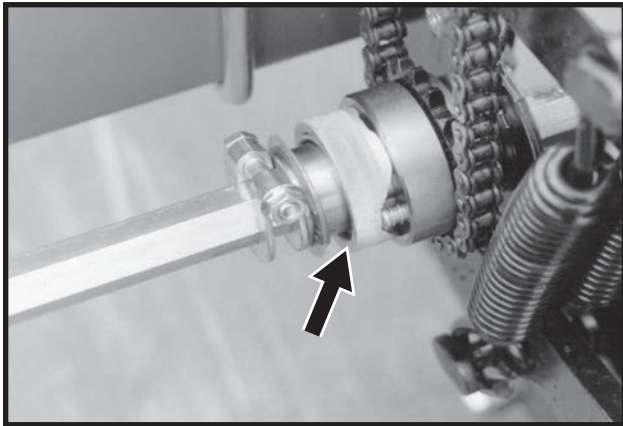

The push row unit clutch sprocket is designed to allow the push row unit drill shaft to be disengaged when only the pull row units are being used.

To disengage the push row unit drill shaft using the clutch sprocket, rotate the knurled collar on the clutch sprocket $\frac{1}{4}$ turn. Then using a $\frac{7}{8}$ " wrench on the drill shaft, rock the drill shaft slightly to take pressure off of the spring loaded pins in the clutch to allow the pins to "pop" out, disengaging the drive. To engage the drive, rotate the knurled collar $\frac{1}{4}$ turn and turn the drill shaft with a $\frac{7}{8}$ " wrench until the drive pins engage the drive sprocket.



WARNING: Always install all safety lockup devices or lower planter to the ground before working under or around the machine.

INTERPLANT® PUSH ROW UNIT VACUUM HOSE SHUTOFF

D12140617

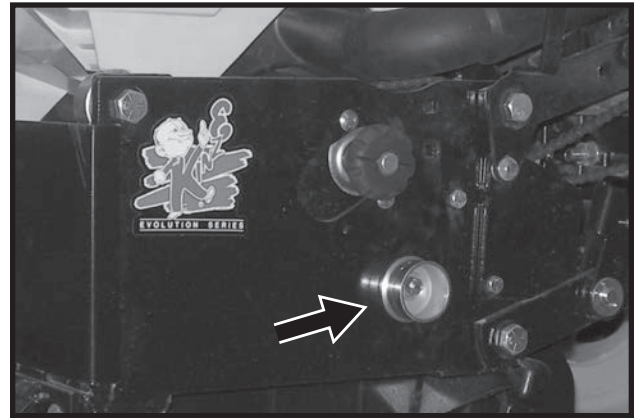

D08220662

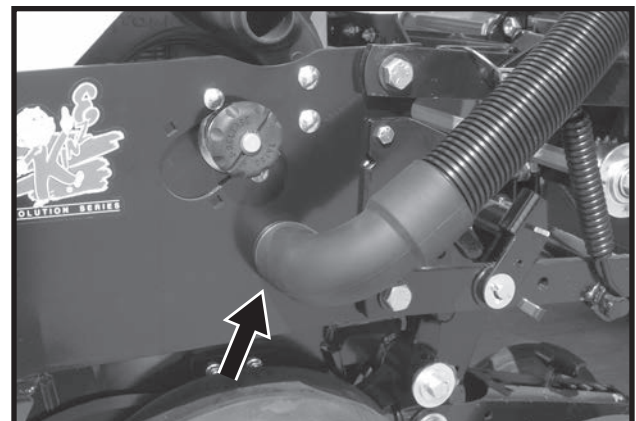

When the push row units are not being used, move the row unit end of the 2" vacuum hose on each push row unit to the storage mount located on the side of the shank as shown.



WARNING: Always install all safety lockup devices or lower machine to the ground before working under or around the machine.

LUBRICATION

The following pages show the locations of all lubrication points. Proper lubrication of all moving parts will help ensure efficient operation of your KINZE® planter and prolong the life of friction producing parts.



WARNING: Always install safety lockup devices or lower the machine to the ground before working under or around the machine.

LUBRICATION SYMBOLS



Lubricate at frequency indicated with an SAE multipurpose grease.



Lubricate at frequency indicated with a high quality SAE 10 weight oil or a quality spray lubricant.

AIR CLUTCHES

Lubricate air clutches every 75-100 hours.

Using a Phillips head screw driver remove the Phillips screw as shown and spray a 1-2 second burst of silicone spray into each clutch, then insert and retighten the screws.

D06060802

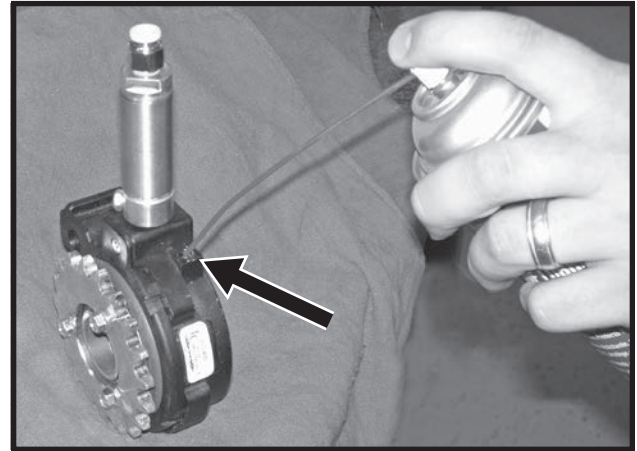

PTO PUMP SHAFT COUPLING (PTO Pump Drive And Oil Cooler Option)

(TWL290c)

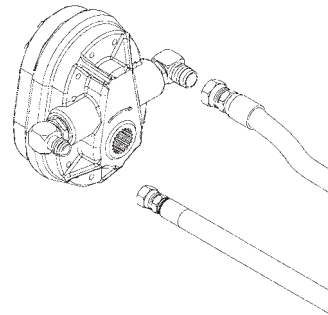

IMPORTANT: The PTO shaft coupling should be cleaned and greased each time the pump is installed.

IMPORTANT: To extend life of shaft splines, apply a coating of high-speed industrial coupling grease, such as Chevron® Coupling Grease, that meets AGMA CG-1 and CG-2 Standards.

(The Chevron® trademark is owned by Chevron Products Company. AGMA is the acronym for the American Gear Manufacturers Association)

LUBRICATION

SEALED BEARINGS

LF212199-3

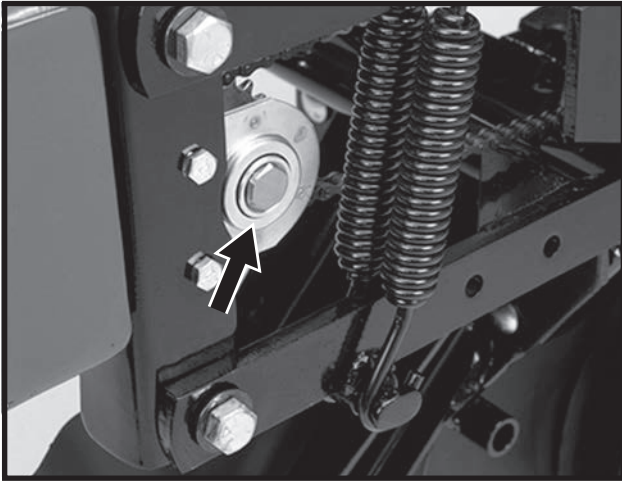

A number of sealed bearings are used on your KINZE® planter to provide trouble free operation. These are located in such areas as the drive shaft, row units and transmission bearings. Sealed bearings are lubricated for life. Due to the seals, relubrication is not practical.

DRIVE CHAINS

All transmission and drive chains should be lubricated daily with a high quality chain lubricant. Extreme operating conditions such as dirt, temperature or speed may require more frequent lubrication. If a chain becomes stiff, it should be removed, soaked and washed in solvent to loosen and remove dirt from the joints. Then soak the chain in oil so the lubricant can penetrate between the rollers and bushings.

D07140303a

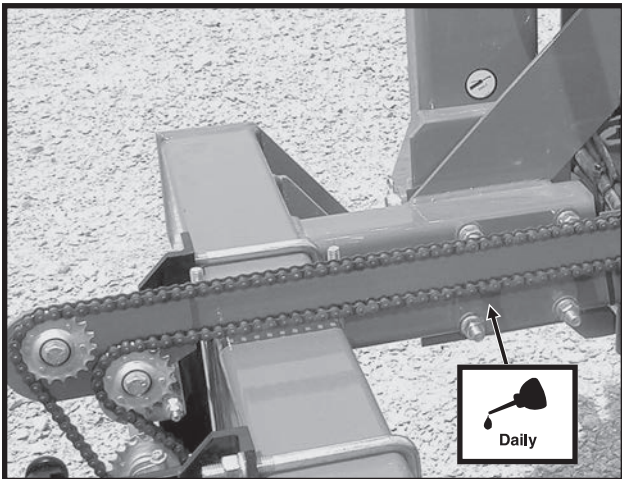

Interplant® Package Drive Chains

D070804112(TWL219e)

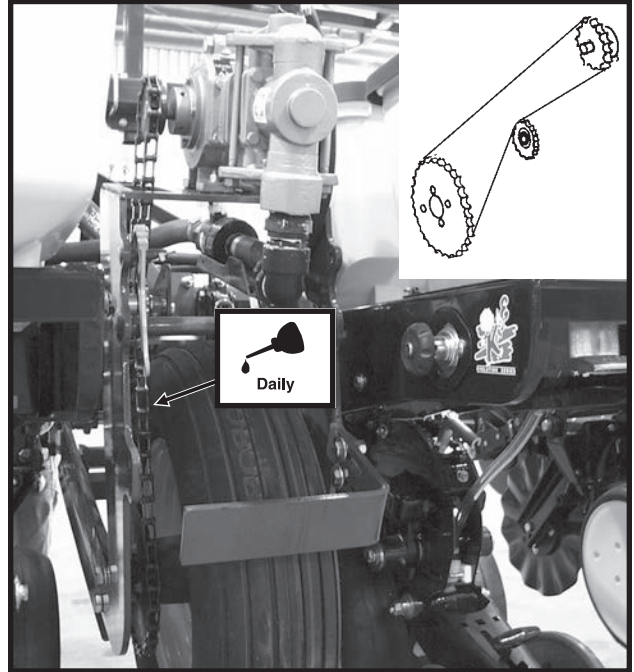

Liquid Fertilizer Ground Drive Chain (Piston Pump)

77570-46a

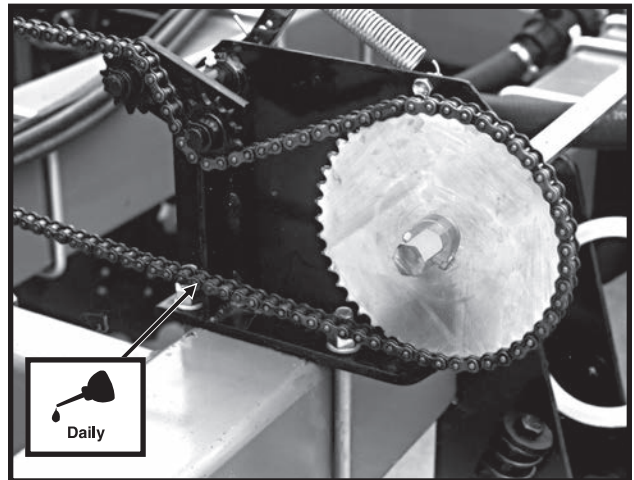

Liquid Fertilizer Drive Chains (Squeeze Pump)

LUBRICATION

BUSHINGS

Lubricate bushings at the frequency indicated.

Using a torque wrench, check each bolt for proper torque. If bolt is loose, it should be removed and the bushing inspected for cracks and wear. Replace bushing if necessary. **Only hardened flat washers should be used. Replace damaged flat washers with proper part. Torque hardware to 130 ft. lbs.**

LF212199-2

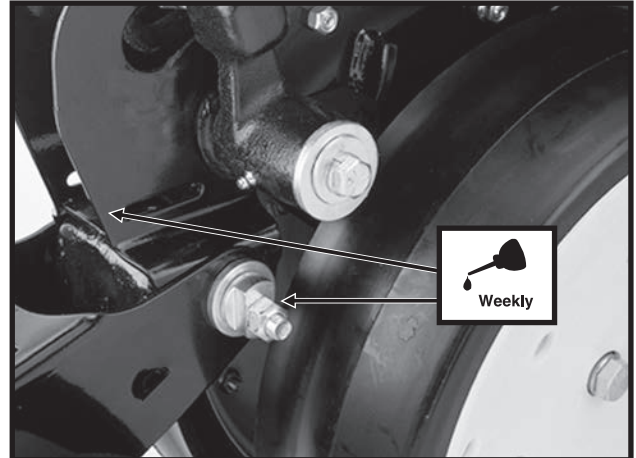

Row Unit "V" Closing Wheel, Covering Discs/
Single Press Wheel And/Or Drag Closing Wheel
Eccentric Bushings (2 Per Row)

D06300305

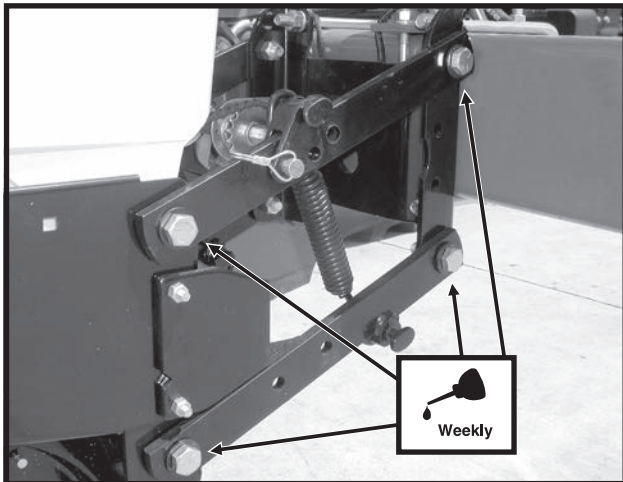

Pull Row Unit And/Or Push Row Unit Parallel
Linkages (8 Per Row)

LF212299-22



Row Unit Mounted Disc Furrower Parallel
Linkages (6 Per Row)

LUBRICATION

D061901128

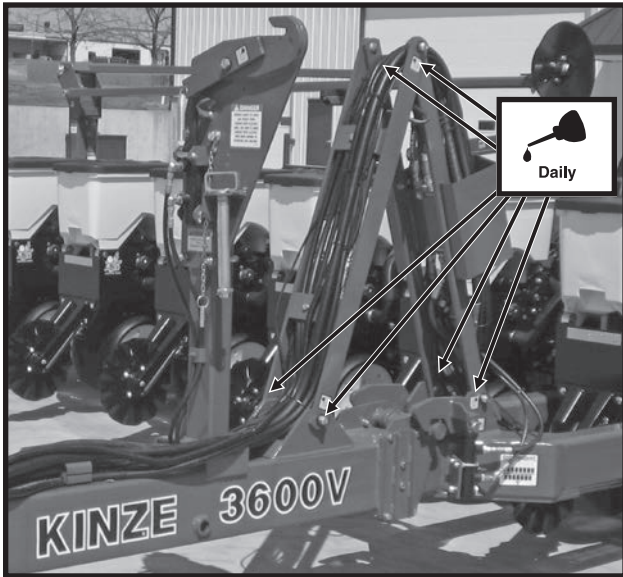

Hose Take-Up (6 Locations)

82316-16

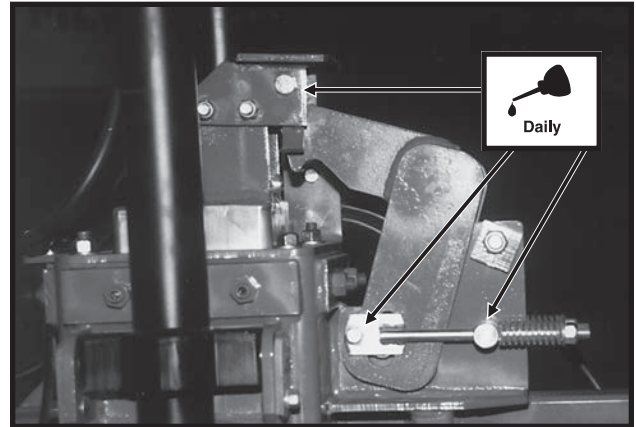

Safety Hook Located At Top Of Center Section

NOTE: CENTER POST AND POLY WEAR PADS REQUIRE NO LUBRICATION. ANY OIL OR GREASE WILL ATTRACT DIRT AND ACCELERATE WEAR ON THE CENTER POST AND ON THE POLY WEAR PADS.

D060299216



Transport Latch (1 Location)

INTERPLANT® PUSH ROW UNIT LOCKUPS

D06099906

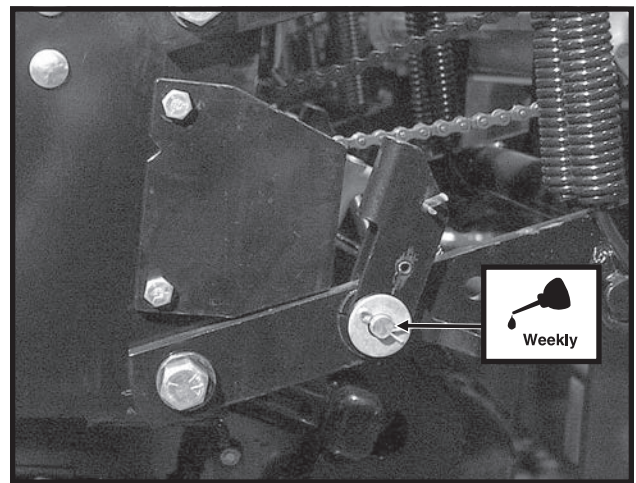

2 Per Row

LUBRICATION

WHEEL BEARINGS

The transport wheel hubs are equipped with grease fittings. Pump grease into the hub until grease comes out around the seals. See "Grease Fittings" for lubrication frequency.

All wheel bearings should be repacked annually and checked for wear. This applies to all drive wheels, transport wheels and marker hubs.

To check for wear, lift the wheel off the ground. Check for endplay in the bearings by moving the tire side to side. Rotate the tire to check for roughness in the bearings. If bearings sound rough, the hub should be removed and the bearings inspected and replaced if necessary. See Maintenance section.

To repack wheel hubs, follow the procedure outlined for wheel bearing replacement with the exception that bearings and bearing cups are reused.

U-JOINT SLIDES

Lubricate all U-joint slides daily with a high quality lubricant.

76740-54

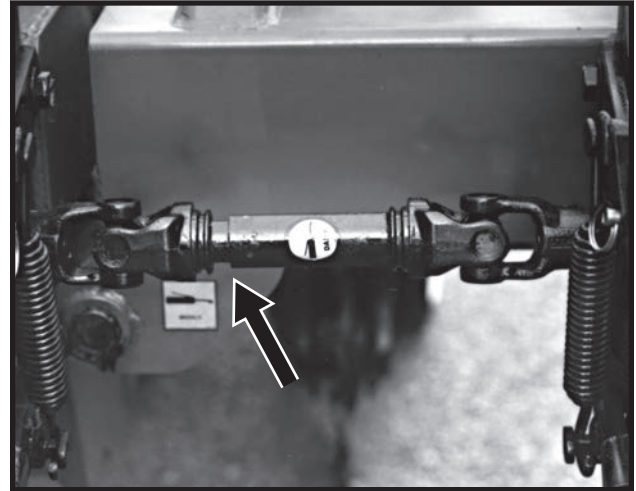

CENTER POST

D05050842



The center post is clad with stainless steel. To prolong service life keep stainless steel surface clean and free of any lubrication.

CENTER POST AND POLY WEAR PADS REQUIRE NO LUBRICATION. ANY OIL OR GREASE WILL ATTRACT DIRT AND ACCELERATE WEAR ON THE CENTER POST AND ON THE POLY WEAR PADS.

See "Wear Pad Replacement/Adjustment" for additional information.

LUBRICATION

LIQUID FERTILIZER PISTON PUMP CRANKCASE OIL LEVEL

(A12330a)

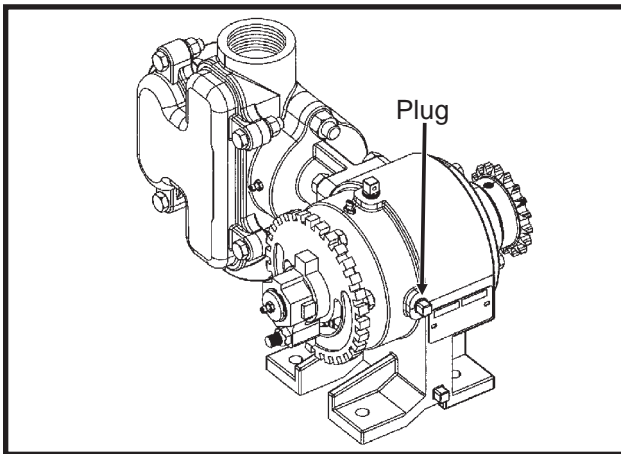

Check crankcase oil daily and maintain at plug level. Fill as needed with EP 90 weight gear oil. Total oil capacity is approximately $\frac{3}{4}$ pint.

Refer to operator and instruction manual supplied with the pump and flow divider for additional information.

GREASE FITTINGS

Those parts equipped with grease fittings should be lubricated at the frequency indicated with an SAE multipurpose grease. Be sure to clean the fitting thoroughly before using grease gun. The frequency of lubrication recommended is based on normal operating conditions. Severe or unusual conditions may require more frequent attention.



WARNING: Always install safety lockup devices or lower the machine to the ground before working under or around the machine.

NOTE: Numbers on below photo correspond to photos on following pages showing lubrication frequencies.

D05050820

12 Row 30" Shown

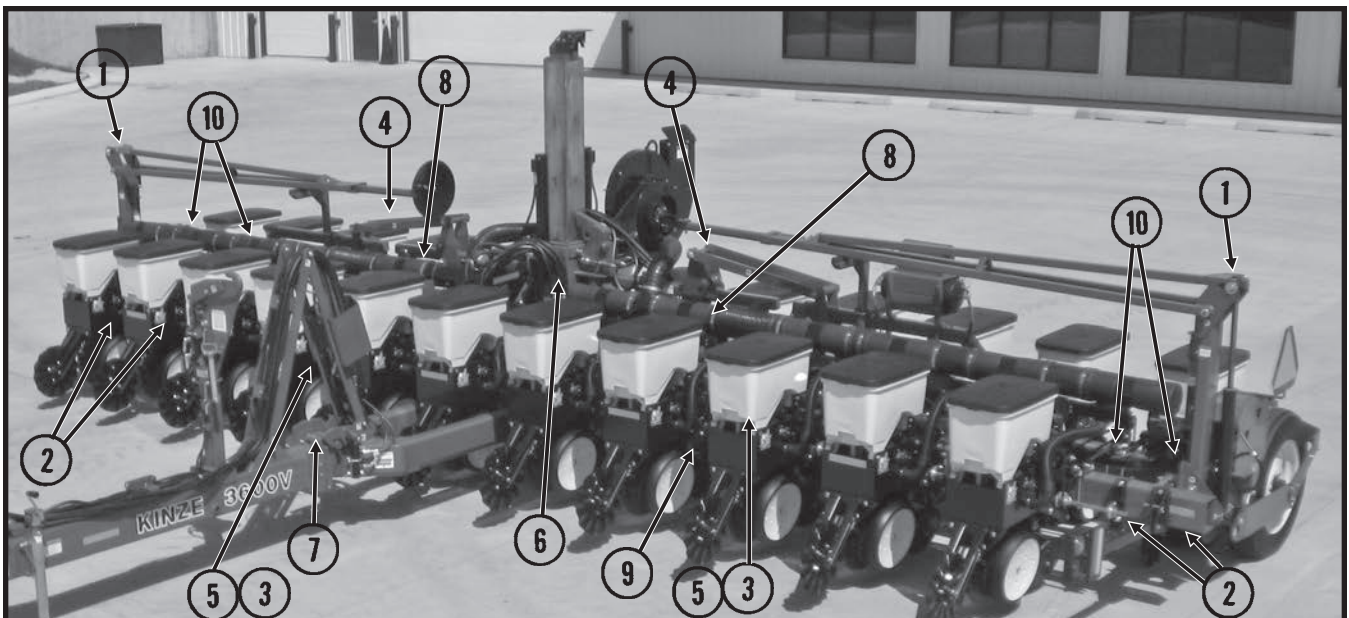

LUBRICATION

D05050832

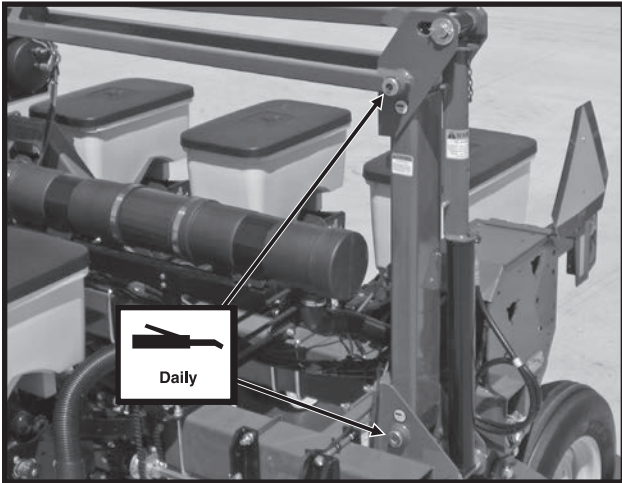

1. Row Marker Assemblies - 4 Zerks Per Assembly On 12 Row 30". 2 Zerks Per Assembly On 16 Row 30".

76609-17

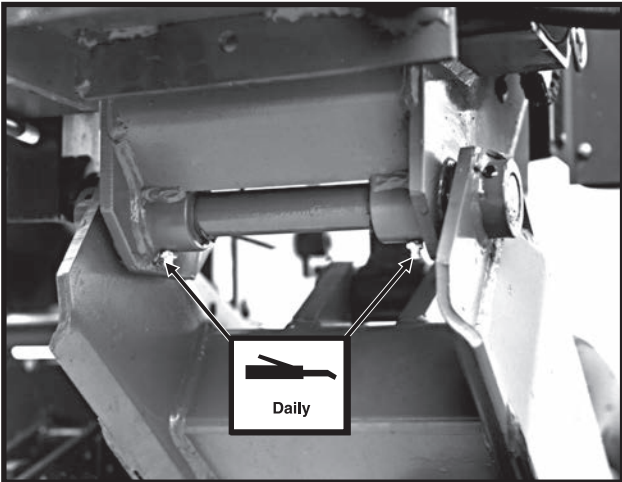

2. Wing Wheel Pivot - 2 Zerks Per Wheel Module

81439-29

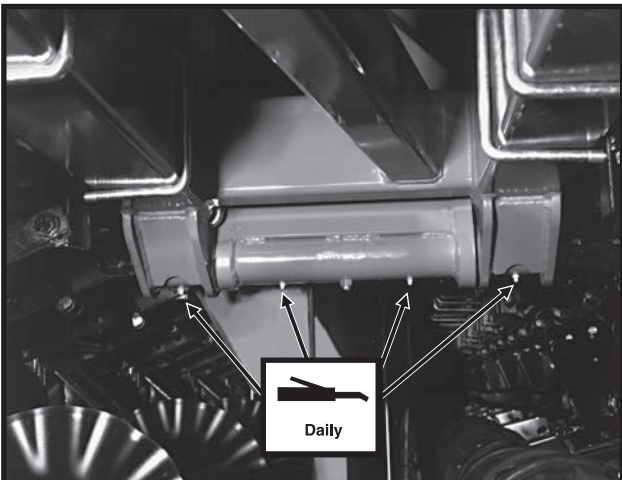

3. Wing Hinges - 4 Zerks Per Wing

D05050827

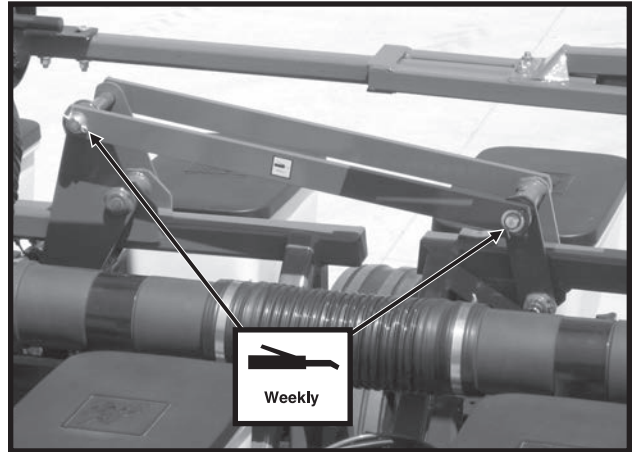

4. Wing Locks - 3 Zerks Per Wing

81439-29

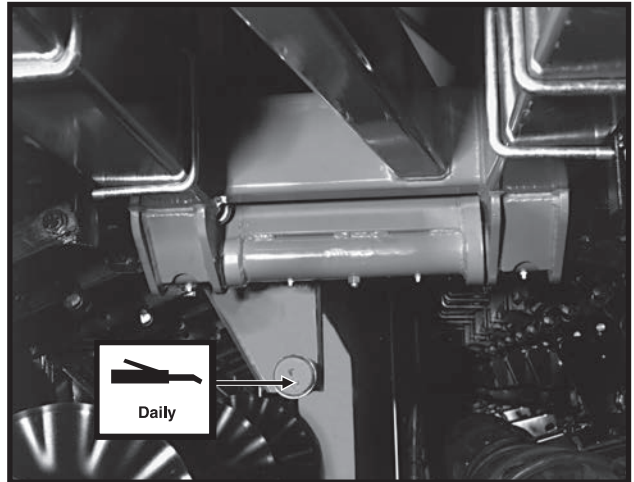

5. Cam Follower - 1 Zerk Per Follower

76609-36

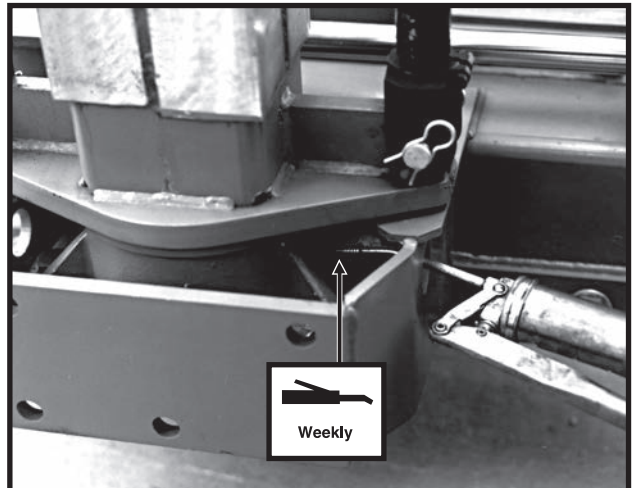

6. Center Pivot - 1 Zerk

LUBRICATION

81439-7

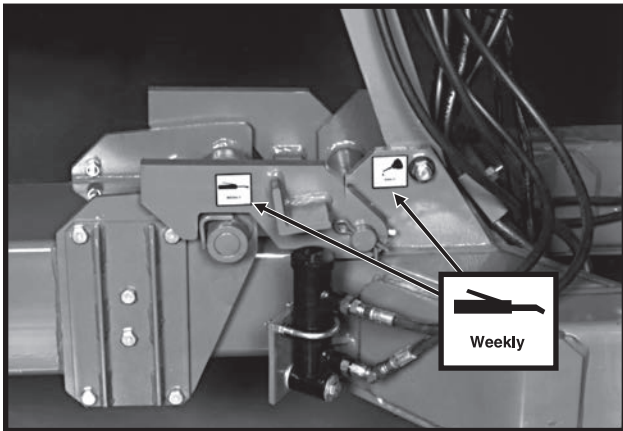

7. Tongue Hook - 2 Zerks

76740-54

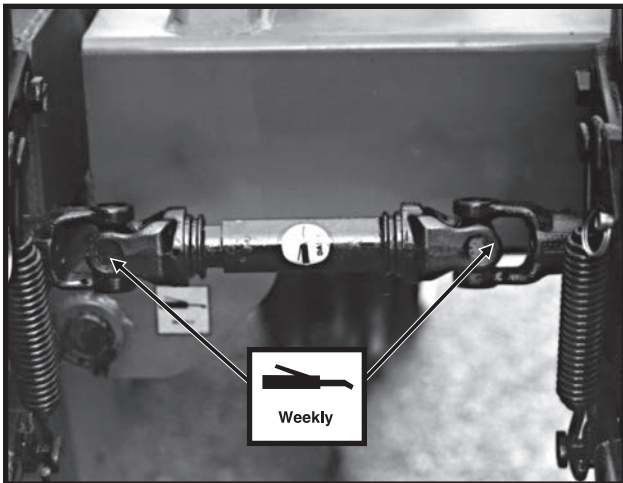

8. U-Joints - 2 Zerks Per Hinge Area

D091602101

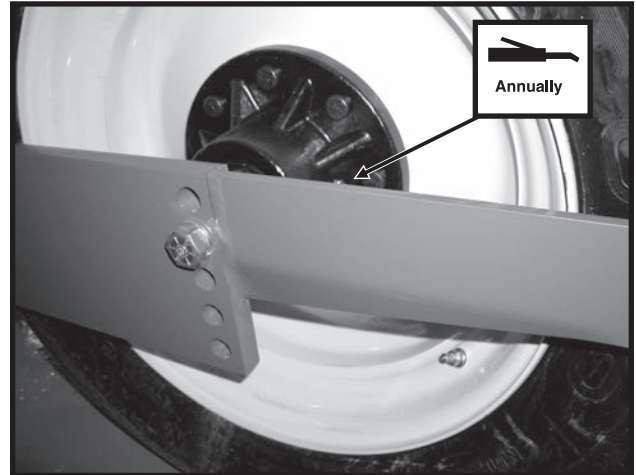

9. Transport Wheel Bearings - 1 Zerk Per Hub

05199819a

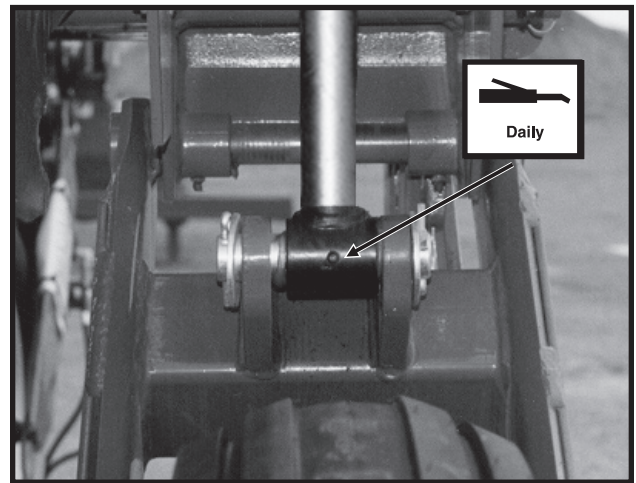

10. Wing Lift Cylinders - 1 Zerk Per Cylinder

LUBRICATION

Row Unit

LF212199-2

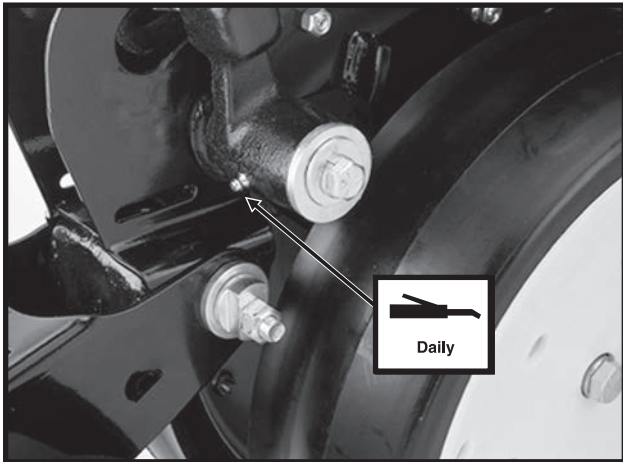

Gauge Wheel Arms - 1 Zerk Per Arm
(Seals in gauge wheel arm are installed with lip facing out to allow grease to purge dirt away from seal. Pump grease into arm until fresh grease appears between washers and arm.)

LF083002101

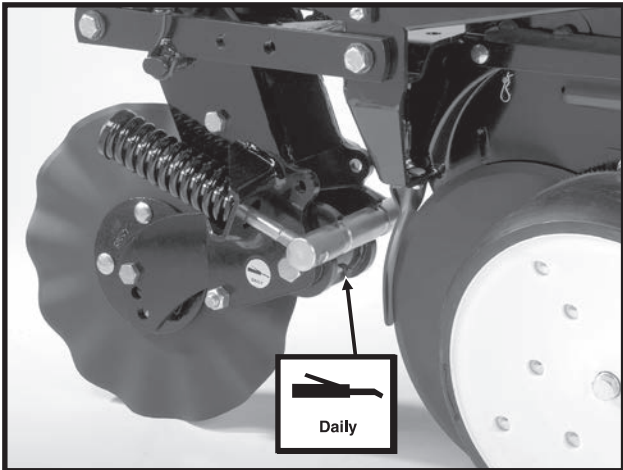

Frame Mounted Coulter - 1 Zerk Per Arm

Fertilizer Openers

D060801304

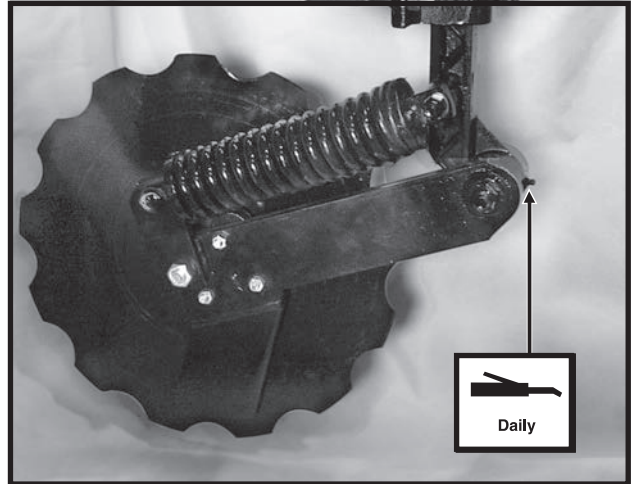

Notched Single Disc Fertilizer Opener - 1 Zerk

D05219901a

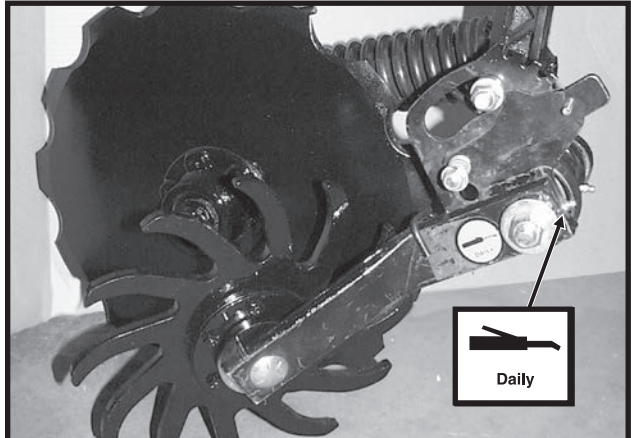

Residue Wheel Attachment For Use With Notched Single Disc Fertilizer Opener - 1 Zerk

D06259919

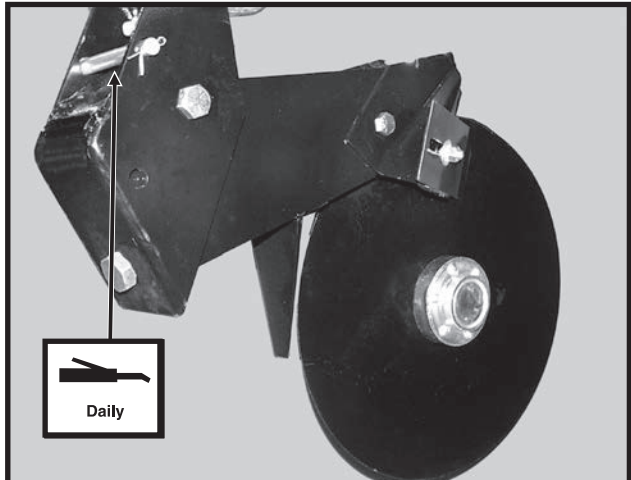

Double Disc Fertilizer Opener - 1 Zerk

LUBRICATION

D060801304

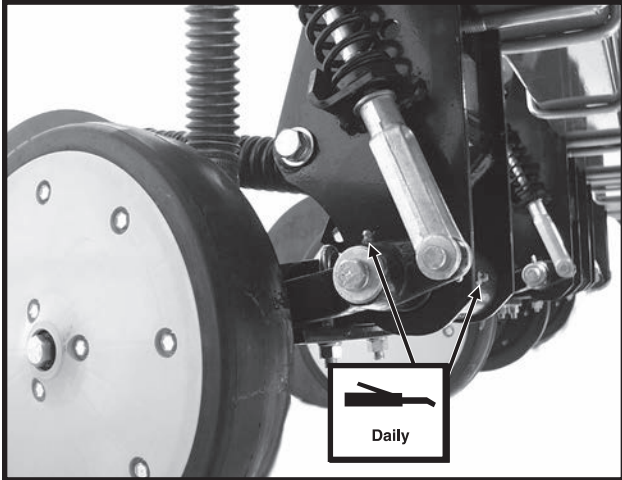

HD Single Disc Fertilizer Opener - 2 Zerks
(Located On Wheel Arm And Opener Mount)

A12335a

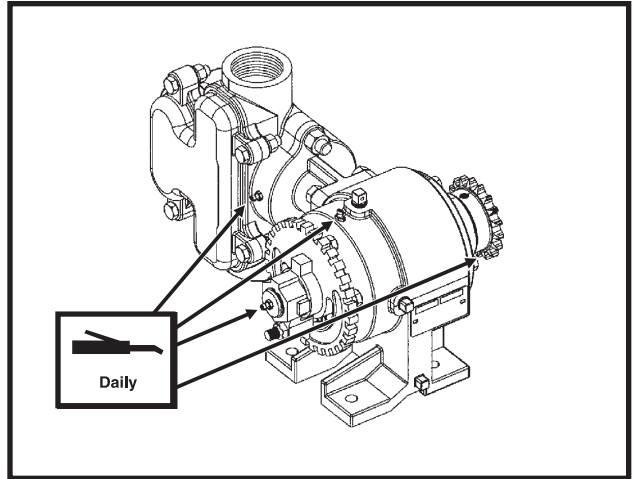

Liquid Fertilizer Piston Pump - 4 Zerks
(Fill zerk on outboard stuffing box until lubricant seeps out of drain hole in bottom.)

D060801303

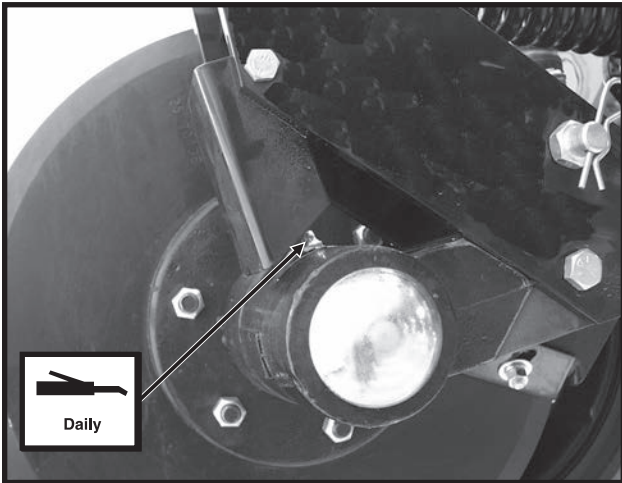

HD Single Disc Fertilizer Opener - 1 Zerk
(Located On Disc Opener Spindle Hub)

MAINTENANCE

MOUNTING BOLTS AND HARDWARE

Before operating the planter for the first time, check to be sure all hardware is tight. Check all hardware again after approximately the first 50 hours of operation and at the beginning of each planting season thereafter.

All hardware used on the KINZE® planter is Grade 5 (high strength), unless otherwise noted. Grade 5 cap screws are marked with three radial lines on the head. If hardware must be replaced, be sure to replace it with hardware of equal size, strength and thread type. Refer to the torque values chart when tightening hardware.

Row Unit Parallel Linkage Bushing Hardware - 130 Ft. Lbs. (See “Bushings” in the Lubrication Section of this manual.)

5/8" No Till Coulter Spindle Hardware - 120 Ft. Lbs.

Center Section Transport Tire Lug Nuts - 125 Ft. Lbs.

Wing Ground Drive Tire Lug Bolts - 90 Ft. Lbs.

IMPORTANT: Over tightening hardware can cause as much damage as under tightening. Tightening hardware beyond the recommended range can reduce its shock load capacity.



WARNING: Before operating the planter for the first time and periodically thereafter, check to be sure the lug nuts on the transport wheels are tight. This is especially important if the planter is to be transported for a long distance.

IMPORTANT: Torque setting for 5/8"-18 hex jam nut that secures fan impellor assembly to motor shaft is 50 ft. lbs.

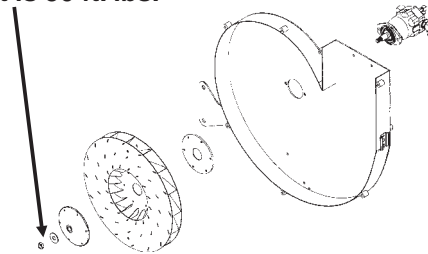

TORQUE VALUES CHART - PLATED HARDWARE

Bolt Diameter	Grade 2		Grade 5		Grade 8	
	Coarse	Fine	Coarse	Fine	Coarse	Fine
1/4"	50 In. Lbs.	56 In. Lbs.	76 In. Lbs.	87 In. Lbs.	9 Ft. Lbs.	10 Ft. Lbs.
5/16"	8 Ft. Lbs.	9 Ft. Lbs.	13 Ft. Lbs.	14 Ft. Lbs.	18 Ft. Lbs.	20 Ft. Lbs.
3/8"	15 Ft. Lbs.	17 Ft. Lbs.	23 Ft. Lbs.	26 Ft. Lbs.	33 Ft. Lbs.	37 Ft. Lbs.
7/16"	25 Ft. Lbs.	27 Ft. Lbs.	37 Ft. Lbs.	41 Ft. Lbs.	52 Ft. Lbs.	58 Ft. Lbs.
1/2"	35 Ft. Lbs.	40 Ft. Lbs.	57 Ft. Lbs.	64 Ft. Lbs.	80 Ft. Lbs.	90 Ft. Lbs.
9/16"	50 Ft. Lbs.	60 Ft. Lbs.	80 Ft. Lbs.	90 Ft. Lbs.	115 Ft. Lbs.	130 Ft. Lbs.
5/8"	70 Ft. Lbs.	80 Ft. Lbs.	110 Ft. Lbs.	125 Ft. Lbs.	160 Ft. Lbs.	180 Ft. Lbs.
3/4"	130 Ft. Lbs.	145 Ft. Lbs.	200 Ft. Lbs.	220 Ft. Lbs.	280 Ft. Lbs.	315 Ft. Lbs.
7/8"	125 Ft. Lbs.	140 Ft. Lbs.	320 Ft. Lbs.	350 Ft. Lbs.	450 Ft. Lbs.	500 Ft. Lbs.
1"	190 Ft. Lbs.	205 Ft. Lbs.	480 Ft. Lbs.	530 Ft. Lbs.	675 Ft. Lbs.	750 Ft. Lbs.
1 1/8"	265 Ft. Lbs.	300 Ft. Lbs.	600 Ft. Lbs.	670 Ft. Lbs.	960 Ft. Lbs.	1075 Ft. Lbs.
1 1/4"	375 Ft. Lbs.	415 Ft. Lbs.	840 Ft. Lbs.	930 Ft. Lbs.	1360 Ft. Lbs.	1500 Ft. Lbs.
1 3/8"	490 Ft. Lbs.	560 Ft. Lbs.	1100 Ft. Lbs.	1250 Ft. Lbs.	1780 Ft. Lbs.	2030 Ft. Lbs.
1 1/2"	650 Ft. Lbs.	730 Ft. Lbs.	1450 Ft. Lbs.	1650 Ft. Lbs.	2307 Ft. Lbs.	2670 Ft. Lbs.

NOTE: Unplated hardware and bolts with lock nuts should be torqued approximately 1/3 higher than the above values. Bolts lubricated prior to installation should be torqued to 70% of value shown in chart.



GRADE 2
No Marks



GRADE 5
3 Marks



GRADE 8
6 Marks

TORQUE VALUES- ALUMINUM

Bolt Diameter	Torque Value
1/8"	180-220 In. Lbs.
3/4"	350-400 In. Lbs.
1/2"	350-400 In. Lbs.
3/8"	350-380 In. Lbs.

NOTE: These torque values are to be used with pneumatic down pressure components.

MAINTENANCE

CHAIN TENSION ADJUSTMENT

The drive chains have spring loaded idlers and therefore are self-adjusting. The only adjustment needed is to shorten the chain if wear stretches the chain and reduces spring tension. The pivot point of these idlers should be checked periodically to ensure they rotate freely.

TIRE PRESSURE

D05050845

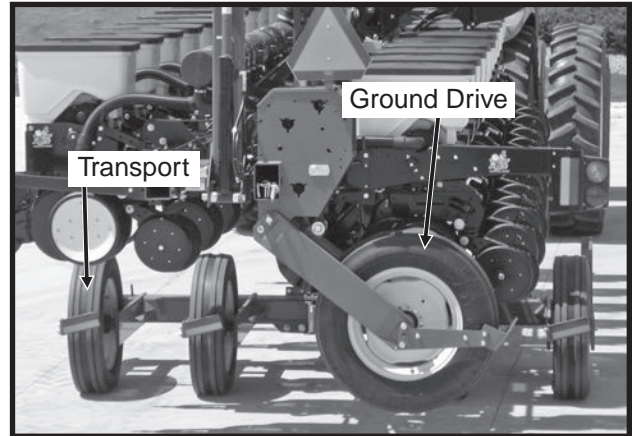

Tire pressure should be checked regularly and maintained as follows:

- 255-70R 22.5" Transport (Center Section) 75 PSI
- 7.50" x 20" Ground Drive (Wings) 40 PSI
- 7.60" x 15" Ground Drive
(Liquid Fertilizer Piston Pump) 40 PSI

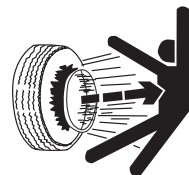

DANGER: Rim and tire servicing can be dangerous. Explosive separation of tire and rim parts can cause serious injury or death.

Do not attempt to mount a tire unless you have the proper equipment and experience to perform the job. This should only be done by persons properly trained and equipped to do the job.

Always maintain the correct tire pressures. Do not inflate the tires above the recommended pressures.

When inflating tires, use a clip-on air chuck and extension hose long enough to allow you to stand to one side and NOT in front of or over the tire assembly. Use a safety cage to enclose the tire and rim assembly when inflating.

Inspect tires and wheels daily. Do not operate with low pressure, cuts, bubbles, damaged rims or missing lug bolts and nuts.

MAINTENANCE

PTO PUMP DRIVE AND OIL COOLER OPTION

Drain the reservoir, clean strainer and change filter annually.

To drain the reservoir, disconnect the suction line (hose between reservoir and pump) from the reservoir and drain. To fully drain tank, raise the planter into field raised position. Refill system with SAE 10W-20 multigrade wide temperature range transmission hydraulic fluid. The reservoir capacity is approximately 10 gallons.

Replace filter with good quality 10 micron filter.

Start the system and allow to run with tractor at idle and the fan turned off for 1-2 minutes. Allow to run with tractor at idle and the fan at full speed for 1-2 minutes. Check reservoir fluid level and fill as required. To allow the fluid to expand when heated, the hydraulic fluid level should be within 1"-2" from the top of the reservoir after the pump has run and hydraulic hoses have been primed. Bring tractor to PTO speed and adjust flow control to the desired vacuum level using the flow control valve lever.

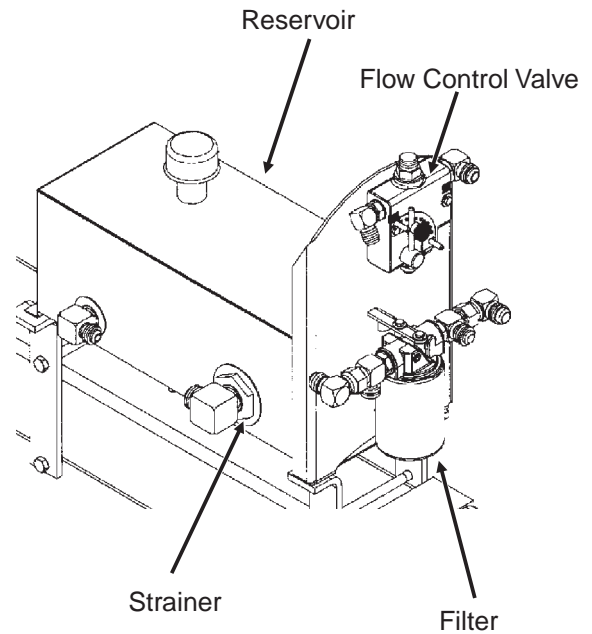

FRONT VIEW

PTO PUMP DRIVE AND OIL COOLER OPTION TROUBLESHOOTING

PROBLEM	POSSIBLE CAUSE	SOLUTION
Pump is squealing.	Lack of oil to pump.	Check for plugged suction strainer. Check oil level.
Oil temperature is high.	Low oil level.	Check oil level and add as required.
Desired fan speed cannot be achieved.	Low oil level.	Check oil level and add as required.
	Plugged filter.	Check and change as required.
Vacuum level is not displayed.	Digital vacuum gauge console power it OFF.	Turn ON.
	Cable not plugged in.	Check connection.
	Digital vacuum gauge console has no power.	Check fuse.

MAINTENANCE

CLOSING WHEEL TROUBLESHOOTING

PROBLEM	POSSIBLE CAUSE	SOLUTION
Closing wheel(s) leave severe imprint in soil.	Too much closing wheel down pressure.	Adjust closing wheel pressure.
Closing wheel(s) not firming soil around seed.	Insufficient closing wheel down pressure.	Adjust closing wheel pressure. Severe no till conditions may require use of cast iron closing wheels.
"V" closing wheel running on top of seed furrow.	Improper centering.	Align. See "V Closing Wheel Adjustment".
Single closing wheel not directly over seed.	Improper centering.	Align. See "Covering Discs/Single Press Wheel Adjustment".

DRAG CLOSING ATTACHMENT

LF212299-18

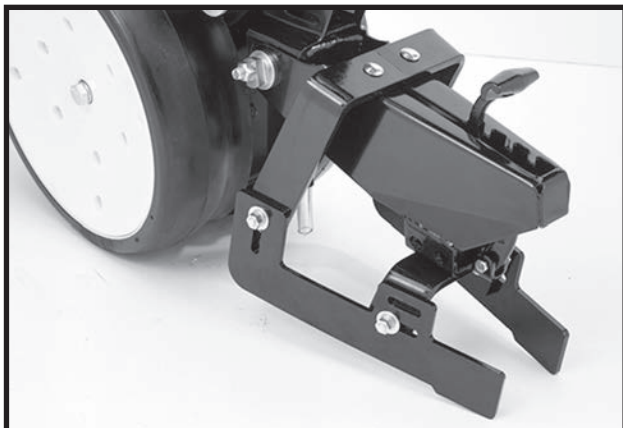

Prior to storage of the planter, inspect each drag closing attachment and replace any worn or broken parts. Check for loose hardware and tighten as needed.

LF212199-2

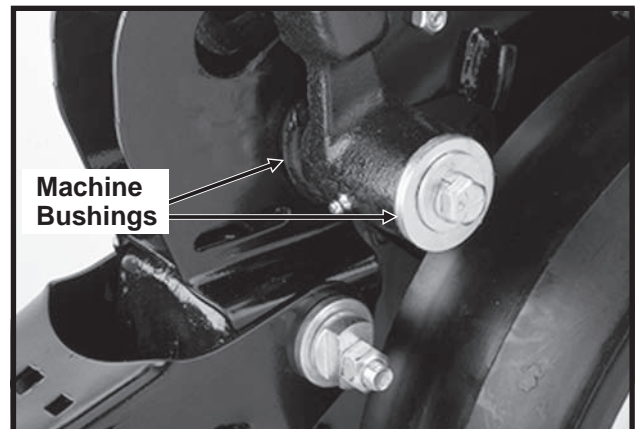

(RU113g)

GAUGE WHEEL ADJUSTMENT

To prevent an accumulation of dirt or trash, gauge wheels should lightly contact the opener blades. Gauge wheels and opener blades should turn with only slight resistance.

To adjust clearance between gauge wheels and opener blades, add or remove machine bushings between the shank and gauge wheel arm. Store remaining machine bushings between gauge wheel arm and flat washer on outer side of gauge wheel arm.

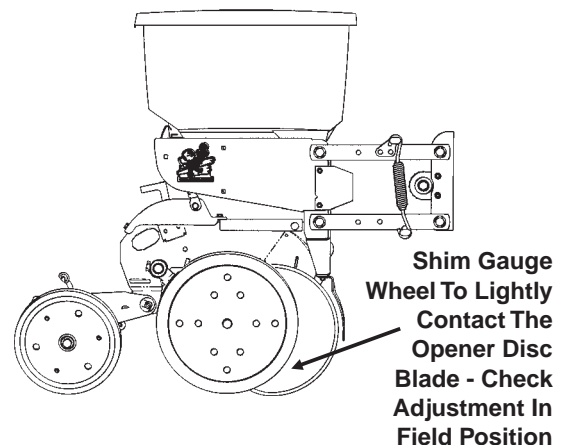

NOTE: It may be desirable to space gauge wheel further from blade when operating in sticky soils.

MAINTENANCE

GAUGE WHEEL ARM BUSHING AND/OR SEAL REPLACEMENT

(RU113g)

Gauge Wheel Arm Bushings/Seals

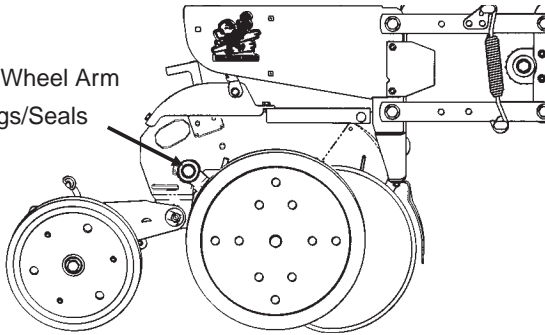

NOTE: A Gauge Wheel Arm Bushing And Seal Driver Kit (G1K296), for use in bushing and seal replacement, is available through your KINZE® Dealer.

To replace gauge wheel arm assembly bushing(s) and/or seal(s):

1. Remove gauge wheel from arm.
2. Remove the gauge wheel arm assembly from the shank assembly.
3. Remove seal and bushing and discard. Clean and dry inner bore.

(A7975/RU122)

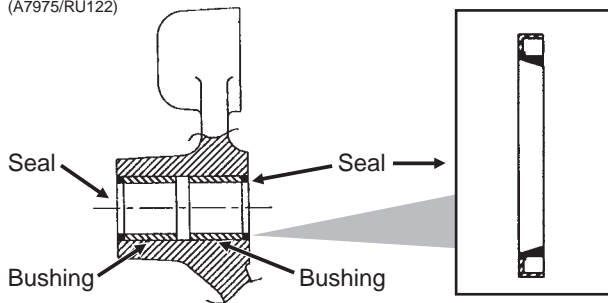

4. Drive/press replacement bushing inside bore of arm to a depth of .125" below flush.
5. Coat wiping edge of seal with grease.
6. Drive/press seal into place with lip to the outside as shown above.

NOTE: Use extra care to protect the sealing lip during installation. Apply uniform pressure to assemble the seal into the bore of the arm. Never apply a direct hammer blow to the seal surface.

7. Inspect gauge wheel pivot spindle.
8. Reinstall gauge wheel arm assembly and gauge wheel.

NOTE: Special machine bushing between gauge wheel arm and gauge wheel.

9. Shim for proper gauge wheel tire/disc blade clearance.
10. Lubricate with an SAE multipurpose grease.

GAUGE WHEEL ARM PIVOT SPINDLE REPLACEMENT

(RU113g)

Gauge Wheel Pivot Spindle

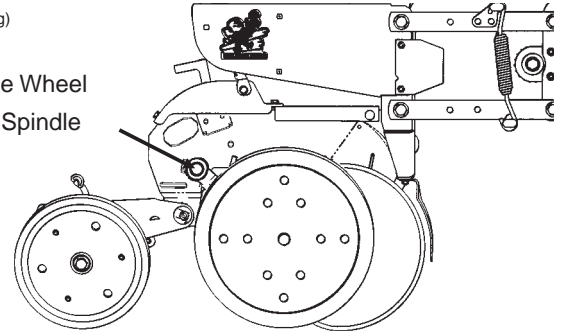

To replace gauge wheel pivot spindle:

1. Remove the gauge wheel and arm assemblies from the shank assembly.
2. Remove 1/2" x 3/4" cap screw that locks the pivot spindle in place and remove the spindle.

D06189902

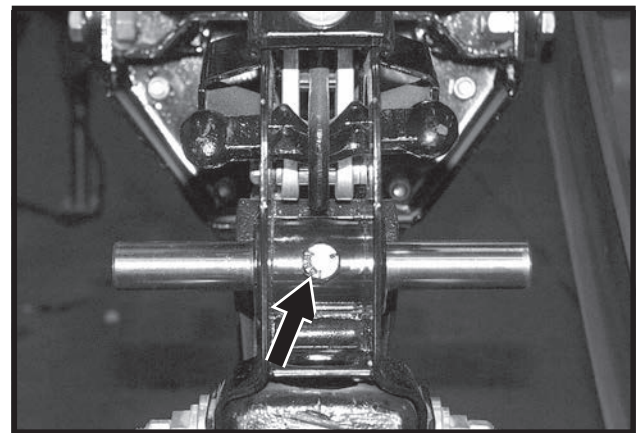

3. Install the replacement spindle and position as shown below. Exact centering is critical.

(A7966)

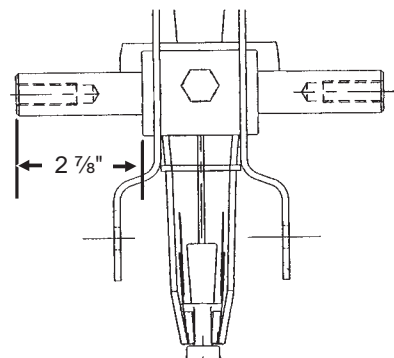

4. Install 1/2" x 3/4" cap screw and torque to lock pivot spindle in place.
5. Install gauge wheel and arm assemblies. Shim for proper gauge wheel tire/disc blade clearance.

MAINTENANCE

15" SEED OPENER DISC BLADE/ BEARING ASSEMBLY

Approximately 1" - 1 ½" of blade-to-blade contact should be maintained to properly open and form the seed trench. As the blade diameter decreases, due to wear, it will be necessary to relocate machine bushings from inside to outside to maintain approximately 1" - 1 ½" of contact.

NOTE: If proper blade-to-blade contact cannot be maintained after relocating machine bushings or if blade diameter wears below 14 ½", the blades should be replaced.

IMPORTANT: Excessive blade contact may result in premature disc opener bearing/hub failures and excessive wear on seed tube guard/inner scraper. When properly adjusted, if one blade is held in fixed position, the opposite blade should be able to be rotated with minimal force (Less than 5 pounds force at outer edge of blade).

(RU113g)

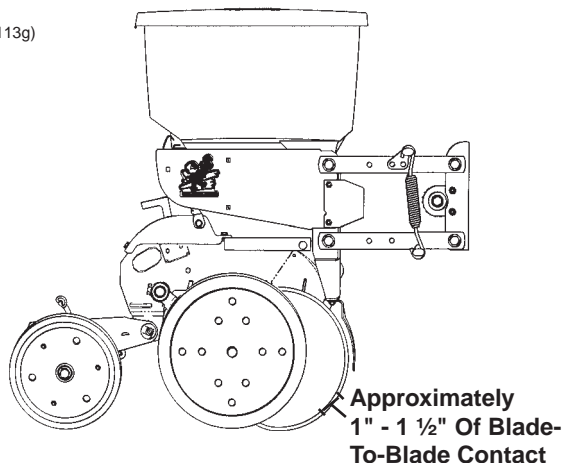

To replace disc blade/bearing assembly:

1. Remove gauge wheel.
2. Remove scraper.
3. Remove bearing dust cap.
4. Remove cap screw, washer and disc blade/bearing assembly. The machine bushings between the shank and disc blade are used to maintain the approximate 1" - 1 ½" of blade-to-blade contact.

IMPORTANT: Left hand side of opener uses a left hand threaded cap screw. DO NOT OVERTIGHTEN. Damage to shank threads will require replacement of row unit shank assembly.

5. Install machine bushing(s), new disc blade/bearing assembly, washer and cap screw. Torque ⅝"-11 Grade 5 cap screw to value shown in "Torque Values Chart".

NOTE: Replace disc blades only with disc blades of equal thickness.

6. Replace bearing dust cap.
7. Install scraper.
8. Install gauge wheel.

It may be necessary to replace only the bearing if there is excessive endplay or if the bearing sounds or feels rough when the disc blade is rotated.

To replace bearing:

1. Remove gauge wheel, scraper, bearing cap, cap screw, washer and disc blade/bearing assembly.
2. Remove ¼" rivets from bearing housing to expose bearing.
3. After installing new bearing, install three evenly spaced ¼" cap screws into three of the six holes in the bearing housing to hold the bearing and bearing housing in place. Install rivets in the other three holes. Remove ¼" cap screws and install rivets in those three holes.
4. Reinstall disc blade/bearing assembly, washer and cap screw. Torque ⅝"-11 cap screw to value shown in "Torque Values Chart" at the beginning of this section.
5. Replace bearing dust cap.
6. Install scraper and gauge wheel.

MAINTENANCE

SEED TUBE GUARD/INNER SCRAPER

The seed tube guard protects the seed tube and acts as the inner scraper for the seed opener disc blades.

Remove the seed tube and check for wear. Excessive wear on the seed tube indicates a worn seed tube guard. Replace the seed tube guard if it measures $\frac{5}{8}$ " or less at the lower end. A new seed tube guard measures approximately $\frac{7}{8}$ ".

LF212199-12

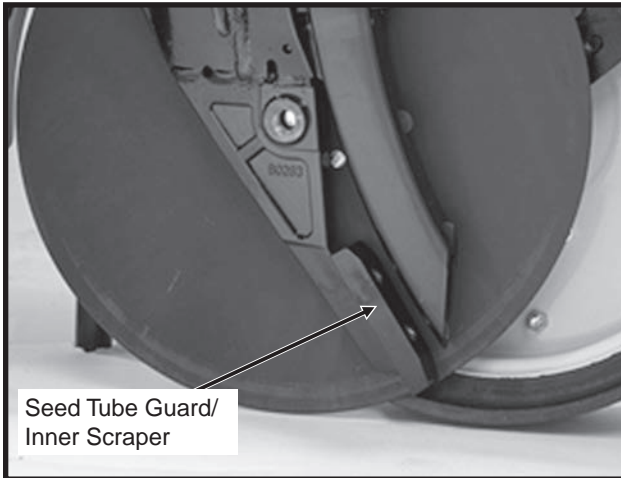

Shown With Gauge Wheel And Seed Opener Disc Blade Removed For Visual Clarity

IMPORTANT: No till planting or planting in hard ground conditions, especially when the planter is not equipped with no till coulters, and/or excessive blade-to-blade contact will increase seed tube guard wear and necessitate more frequent inspection and/or replacement.

To replace the seed tube guard, remove the seed tube and the two hex socket head cap screws which attach the seed tube guard. Hold the replacement seed tube guard centered between the seed opener disc blades. Install, but DO NOT tighten, the hex socket head cap screws. Using a clamp or vise-grip, squeeze the opener blades together in front of the seed tube guard. Tighten the seed tube guard retaining screws. Remove the clamps. The distance between the seed tube guard and opener blades should be equal on both sides. Reinstall seed tube.

IMPORTANT: Over tightening the hex socket head cap screws may damage the threads in the shank and require replacement of the shank. A seed tube guard that is worn excessively may allow the blades to wear into the row unit shank, also requiring replacement of the shank.

FRAME MOUNTED COULTER

LF083002101

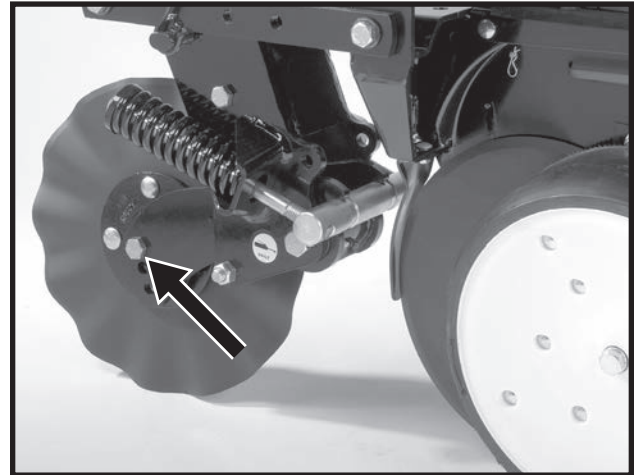

NOTE: Torque $\frac{5}{8}$ " spindle hardware to 120 ft. lbs.

See "Frame Mounted Coulters" in Row Unit Operation section of this manual for depth and spring adjustment.

When the 16" diameter coulters blade (1" fluted, 1" bubbled or $\frac{3}{4}$ " fluted) is worn to 14 $\frac{1}{2}$ " (maximum allowable wear), it should be replaced.

MAINTENANCE

RESIDUE WHEELS (For Use With Frame Mounted Coulter)

LF083002102

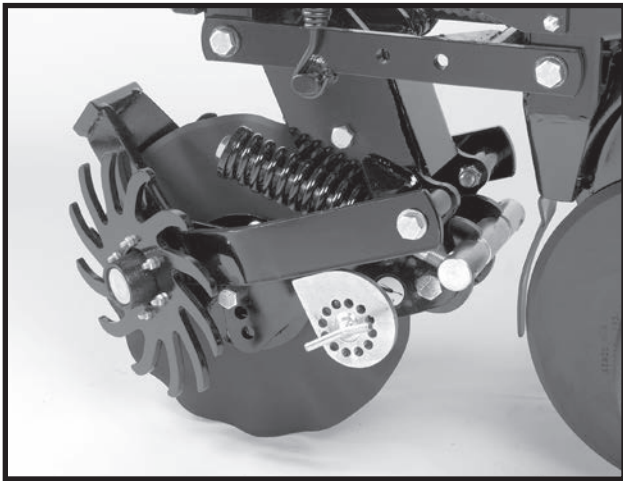

STYLE A

(RU154)

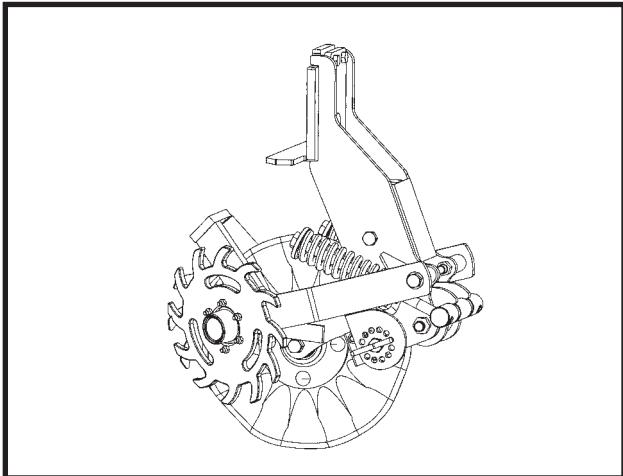

STYLE B

The wheel hub is equipped with sealed bearings. If a bearing sounds or feels rough when the wheel is rotated, replace the bearings.

ROW UNIT MOUNTED DISC FURROWER

LF212299-22

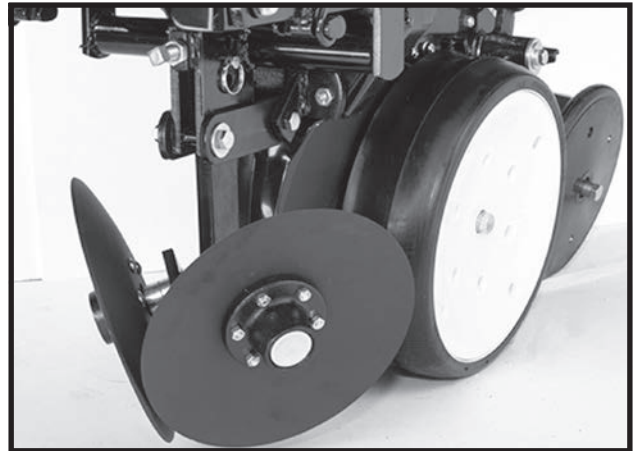

Lubricate the bushings in the support arm and mounting bracket at the frequency indicated in the Lubrication Section of this manual. Using a torque wrench, check each bolt for proper torque. If the bolt is loose, it should be removed and the bushing inspected for cracks and wear. Replace bushings as necessary. **Only hardened flat washers should be used. Replace damaged flat washers with proper part. Torque cap screws to 57 ft. lbs.**

The blade hubs are equipped with sealed bearings. If bearings sound or feel rough when the blade is rotated, replace the bearings.

When the 12" diameter blades (solid or notched) are worn to 11", they should be replaced.

MAINTENANCE

ROW UNIT MOUNTED RESIDUE WHEEL

D101701113

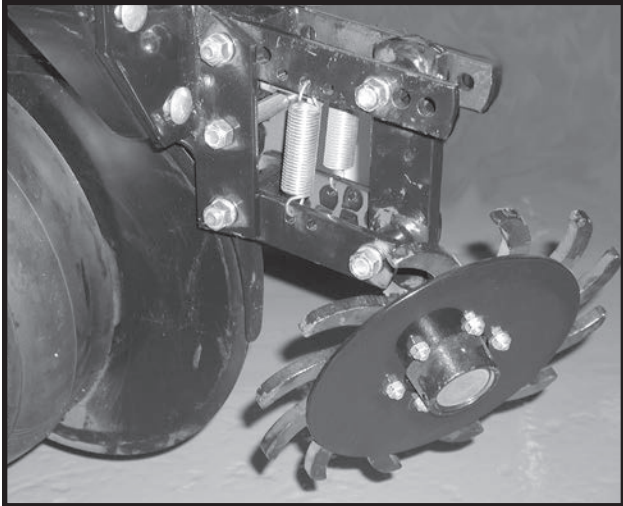

STYLE A

(A12685)

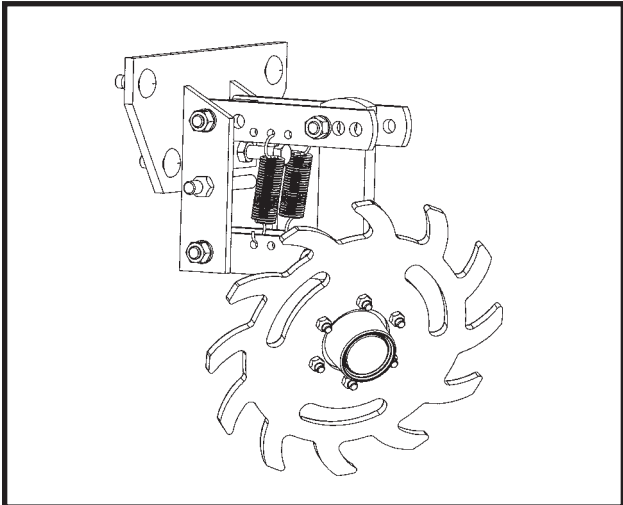

STYLE B

The wheel hub is equipped with sealed bearings. If a bearing sounds or feels rough when the wheel is rotated, replace the bearings.

MAINTENANCE

ROW UNIT MOUNTED NO TILL COULTER

LF212299-19a

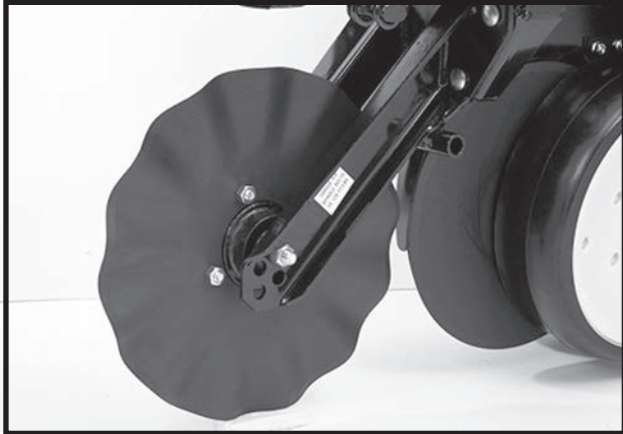

STYLE A (Two Sleeves For Installing Coulters Mounted Residue Wheels)

D05170706a

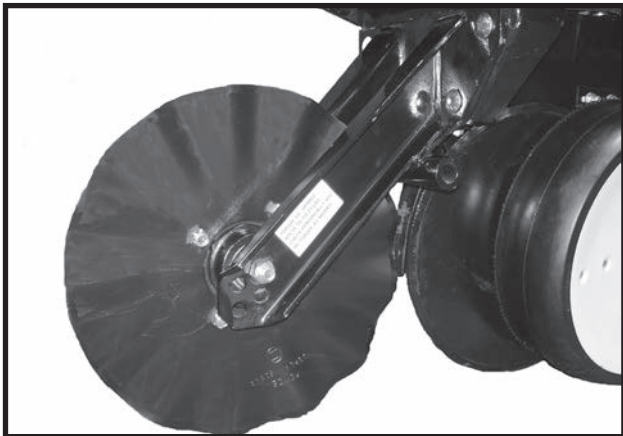

STYLE B (One Sleeve For Installing Coulters Mounted Residue Wheels)

Check periodically to be sure nuts and hardware are tightened to proper torque specification.

NOTE: Torque $\frac{5}{8}$ " spindle hardware to 120 ft. lbs.

Be sure the coulters are positioned square with the row unit and aligned in front of row unit disc opener.

The coulters blade can be adjusted to one of four settings. Initially the blade is set in the highest position. As the blade wears it can be adjusted to one of the three lower settings. See "Row Unit Mounted No Till Coulters" in Row Unit Operation section of this manual.

When the 16" diameter coulters blade is worn to 14 $\frac{1}{2}$ " (maximum allowable wear), it should be replaced.

COULTERS MOUNTED RESIDUE WHEELS

LF212299-23



STYLE A - Used With Style A Row Unit Mounted No Till Coulters

D05170708a

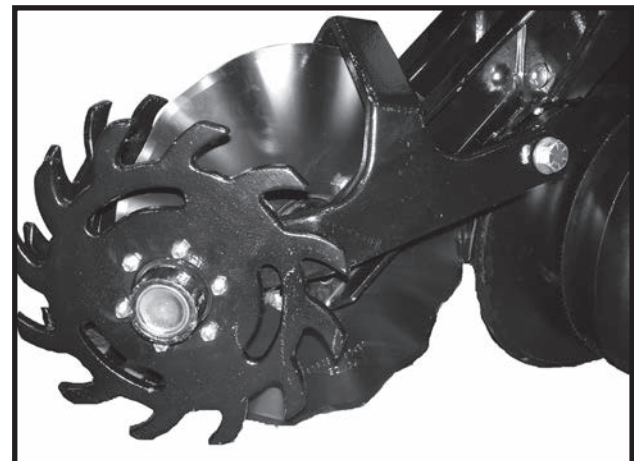

STYLE B - Used With Style B Row Unit Mounted No Till Coulters

The wheel hubs are equipped with sealed bearings. If bearings sound or feel rough when the wheel is rotated, replace the bearings.

MAINTENANCE

SPRING TOOTH INCORPORATOR

Prior to storage of the planter, inspect each spring tooth incorporator and replace any worn or broken parts. Check for loose hardware and tighten as needed.

LF212299-26

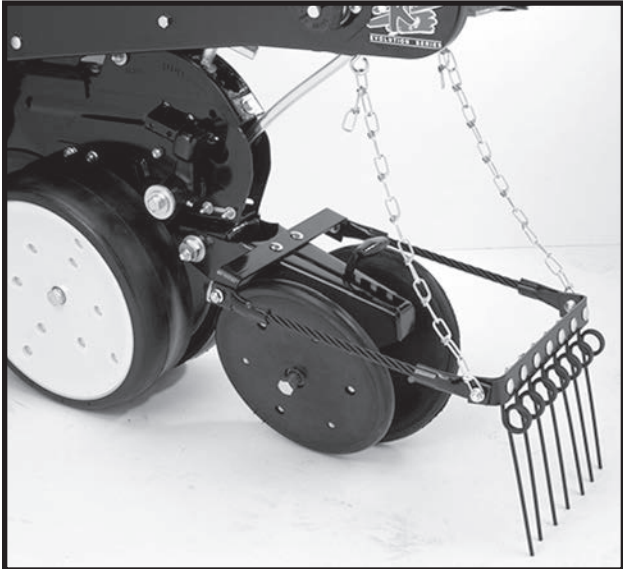

MAINTENANCE

CHECK VALVE

(TWL30)

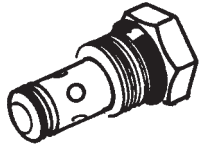

The check valves, located in the valve block on the right side of the center post, trap oil flow in the planter's lift system to keep the toolbar level during field operation. Consult your KINZE® Dealer for service.

CHECK VALVE INSPECTION (Located In Valve Block Below Vacuum Fan Motor Assembly)

(TWL24b)

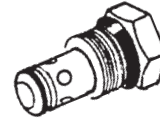

The check valve operates as a check in the return line to prevent reverse operation of the vacuum fan motor. If the valve fails to function properly, it should be removed for inspection. Check for foreign material or check to see if the o-ring is leaking internally. Replace if found to be defective.

SOLENOID VALVE INSPECTION

VVB019(PLTR55)

The solenoid valve consists of a chambered body containing a cartridge valve which is activated by an electrical coil.

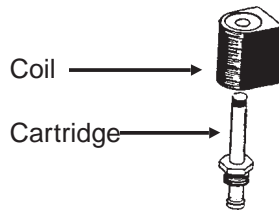

If the solenoid or solenoids fail to operate, first determine if the problem is electrical or hydraulic. If the valve is working properly, a click will be heard when the solenoid coil is energized. This will be the valve stem opening up. If no sound is heard, check the solenoid coil by touching the top of the coil housing with a metallic object such as a pliers or screwdriver. If the coil is working properly, the coil housing will be strongly magnetized when energized. If the voltage to the coil is low, the coil will be weakly magnetized when energized and no click will be heard.

RELIEF VALVE CARTRIDGE INSPECTION (Located In Valve Block Below Vacuum Fan Motor Assembly)

(A11340)



The pressure relief valve helps prevent damage to the vacuum fan motor by limiting pressure in the motor case drain line. It is set to open at 35 PSI. If the valve fails to function properly, it should be removed for inspection. Check for foreign material and contamination on both the valve and the seating area of the valve body. Replace if found to be defective.

SOLENOID VALVE TROUBLESHOOTING

PROBLEM	POSSIBLE CAUSE	SOLUTION
None of the solenoids will operate.	Low voltage.	Must be connected to 12 volt DC only. Negative ground.
	Blown fuse.	Replace fuse in control console on tractor with AGC-15 amp only.
	Battery connection.	Clean and tighten.
	Wiring harness damaged.	Repair or replace.
One solenoid valve will not operate.	Bad switch.	Replace on control panel.
	Cut wire in harness.	Locate and repair.
	Bad coil.	Replace.
	Poor connection at coil.	Check.
Valve operating when not energized.	Valve stem stuck open.	Replace cartridge.
	O-ring leaking.	Install new O-ring kit.
	Foreign material under poppet.	Remove cartridge and clean.

MAINTENANCE

FLOW CONTROL VALVE INSPECTION

VVB020(TWL28)



The flow control valves should be adjusted for row marker raise and lower speed as part of the assembly procedure or upon initial operation. If the valve fails to function properly or requires frequent adjustment, it should be removed for inspection. Check for foreign material and contamination on both the valve and the seating area of the valve body. Replace any components found to be defective.

PRESSURE RELIEF VALVE INSPECTION

VVB020(TWL29)

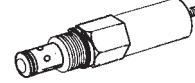

If the pressure relief valve fails to release the tongue lock or function properly, remove the valve from the valve block and check for foreign material or check to see if the O-ring is leaking internally. Replace if found to be defective.

LIFT CIRCUIT TROUBLESHOOTING

PROBLEM	POSSIBLE CAUSE	SOLUTION
Right wing raises faster than left wing. The right wing may even raise completely before the center frame and left wing start to raise. If the planter is loaded, the center frame and left wing may not be able to raise at all.	Master cylinder, located on front side of center post, leaking internally. NOTE: Make sure the lift system is completely rephased.	Repair master cylinder.
Left wing raises faster than right wing. The left wing may even raise completely before the center frame and right wing start to raise. If the planter is loaded, the center frame and right wing may not be able to raise at all.	Master cylinder, located on rear side of center post, leaking internally. NOTE: Make sure the lift system is completely rephased.	Repair master cylinder.
Center frame will raise, but wings do not.	Planter hydraulic circuit out of phase. Usually occurs when the planter is lowered from transport position. Solenoid valve in port V16 leaking.	Hold hydraulic control in lowering position to give the hydraulic circuit more time to rephase. Replace solenoid valve cartridge.
Center frame will continue to raise after the wing cylinders have reached full stroke when going to raised field position.	Solenoid valve in port V16 leaking.	Replace solenoid valve cartridge.
Planter will raise to raise field position, but will not raise to transport position.	Solenoid valve coil in port V16 is not energized.	Be sure control console switch is in "raise" position to energize solenoid coil in port V16. Check control console fuse by moving auxiliary switch to ON position. If red light comes on the fuse is OK. Return auxiliary to OFF position. Check for poor wire connection or damaged wire and repair. Solenoid valve coil is defective. All solenoid valves used on the planter are the same. Switch the solenoid coil with one you know is working. If this cures the problem, replace defective coil.

MAINTENANCE

LIFT CIRCUIT TROUBLESHOOTING (Continued)

PROBLEM	POSSIBLE CAUSE	SOLUTION
(Continued) Planter will raise to raised field position, but will not raise to transport position.	Solenoid valve cartridge in port V16 is stuck closed.	All solenoid valves used on the planter are the same. Switch the solenoid cartridge with one you know is working. If this cures the problem, replace defective cartridge.
Left wing lowering slower than center frame and right wing. If hydraulic lever is held in lowering position, the left wing cylinder will attempt to extend.	Check valve in port V17 leaking internally.	Remove check valve in port V17 and inspect for foreign material in valve and remove if possible. Replace check valve. If above fails, switch check valve in port V17 with check valve in port V15. If problem moves or switches to right wing, replace defective check valve.
Right wing lowering slower than center frame and left wing. If hydraulic control is held in lowering position, the right wing cylinder will attempt to extend.	Check valve in port V15 leaking internally.	Remove check valve in port V15 and inspect for foreign material in valve and remove if possible. Replace check valve. If above fails, switch check valve in port V15 with check valve in port V17. If problem moves or switches to right wing, replace defective check valve.
Planter will not raise or raises slowly.	Tractor may have hydraulic problem.	Switch remote outlets being used. Repair tractor hydraulics.
	Planter may be overloaded with hopper extensions and/or extra fertilizer tanks, coulters or other non-KINZE® attachments.	Remove weight.
	Center pivot wear pads may be adjusted too tight and are binding on the post.	Adjust pads.
	Relief valves on hitch leaking. Valves should hold 2500 PSI (±50 PSI).	Remove and inspect relief valve cartridge. Check for blown O-rings. Replace bad cartridge.
Planter will not rephase.	All cylinders not completely retracted. Caused by mechanical interference on or between planter frame and wheel lift module.	Remove interference.
	Center cylinders not retracting completely.	Lower planter and hold hydraulic lever in lower position to rephase system. Lower cylinder pins must be free to rotate in this position. If pins are tight, adjust cylinder clevises

MAINTENANCE

TONGUE CYLINDER CIRCUIT TROUBLESHOOTING

PROBLEM	POSSIBLE CAUSE	SOLUTION
Tongue cylinder will not extend, but will retract.	No power to solenoid valve coil in port V10 and/or V14. Both must be energized.	Check wiring between control console and solenoid coils looking for damaged wires and poor connections.
	Solenoid valve coil defective.	Switch coil from port V13 with V10. If tongue still will not extend, switch coil from V14 with V13. It will not be necessary to remove any of the wire connections to the solenoid. All three of these solenoids are normally energized when the tongue switch is energized. Replace defective coil.
	Solenoid valve cartridges in port V10 and/or V14 stuck closed.	Switch cartridge from port V10 with cartridge in port V13. If tongue cylinder retracts, replace defective cartridge from port V10. If problem continues, switch cartridge from port V14 with cartridge in port V13. Replace defective cartridge.
Tongue cylinder will not extend but tongue lock cylinder extends.	Pressure relief valve in port V11 stuck closed or pressure setting too high. (Valve is factory set to open at 1000 PSI.)	Replace or adjust pressure relief valve. To adjust, loosen lock nut and turn counter clockwise to decrease pressure.
Tongue hook does not release before the tongue starts to extend.	Solenoid valve cartridge in port V11 stuck open or pressure setting too low. (Valve is factory set to open at 1000 PSI.)	Replace or adjust pressure relief valve. To adjust, loosen lock nut and turn clockwise to increase pressure.
Tongue cylinder will not retract, but will extend.	Solenoid valve coil in port V13 defective.	Switch coil from port V13 with coil from port V14. If coil from port V13 is bad, the tongue will extend but not retract. Replace defective coil.
	Solenoid valve cartridge in port V13 stuck closed.	Switch cartridge from port V13 with cartridge from port V14. If cartridge is bad, the tongue will extend but not retract. Replace defective cartridge.
Tongue extends with the switch off.	Solenoid valve cartridge in port V10 and V14 stuck open.	Replace solenoid valve cartridge.
Tongue retracts with the switch off.	Solenoid valve cartridge in port V13 stuck open.	Replace solenoid valve cartridge.
Tongue latch releases. Tongue extends slowly while planting.	Latch cylinder or tongue cylinder leaking internally.	Pressure check latch and tongue cylinders. Repair leaking cylinder(s).

MAINTENANCE

ROTATION CYLINDER CIRCUIT TROUBLESHOOTING

PROBLEM	POSSIBLE CAUSE	SOLUTION
Cylinder does not extend, but will retract.	Solenoid valve coil in port V12 defective.	Switch coil from port V12 with coil in port V9. If cylinder extends but will not retract, replace defective coil from port V12.
	Solenoid valve cartridge in port V12 is stuck closed.	Switch cartridge from port V12 with cartridge in port V9. If cylinder extends but will not retract, replace defective cartridge from port V12.
Cylinder does not retract, but will extend.	Solenoid valve coil in port V9 defective.	Switch coil from port V9 with coil in port V12. If cylinder extends but will not retract, replace defective coil from port V9.
	Solenoid valve cartridge in port V9 is stuck closed.	Switch cartridge from port V9 with cartridge in port V12. If cylinder extends but will not retract, replace defective cartridge from port V9.

MAINTENANCE

WING LOCK CYLINDER CIRCUIT TROUBLESHOOTING

PROBLEM	POSSIBLE CAUSE	SOLUTION
Cylinders will not extend or retract.	No power to the solenoid valve coils.	Auxiliary switch may be in the ON position. Must be in OFF position. Check fuse at control console. Replace fuse with 15 amp type AGC if blown. Check for poor wire connection or damaged wire. Repair as required.
Cylinders will not extend.	Solenoid valve coil in port V3 not energized.	Check for power to coil. Check coil ground wire. If OK, switch coil from port V3 with coil from port V4. If cylinders extend but will not retract, replace defective coil.
	Solenoid valve cartridge in port V3 stuck closed.	Switch cartridge in port V3 with cartridge in port V4. If cylinders extend but will not retract, replace defective cartridge.
Cylinders will not retract.	Solenoid valve coil in port V4 not energized.	Check for power to coil. Check coil ground wire. If OK, switch coil from port V4 with coil from port V3. If cylinders retract but will not extend, replace defective coil.
	Solenoid valve cartridge in port V4 stuck closed.	Switch cartridge in port V4 with cartridge in port V3. If cylinders retract but will not extend, replace defective cartridge.
Cylinders retract with the switch off.	Solenoid valve cartridge in port V4 stuck open.	Replace solenoid valve cartridge.
Cylinders extend with the switch off.	Solenoid valve cartridge in port V3 stuck open.	Replace solenoid valve cartridge.

MAINTENANCE

ROW MARKER OPERATION TROUBLESHOOTING

PROBLEM	POSSIBLE CAUSE	SOLUTION
Right marker lowering slower than left marker.	Solenoid valve cartridge in port V1 not opening completely.	Switch cartridge with one in port V2. If problem follows cartridge, replace cartridge.
	Hose pinched or collapsed.	Inspect hose routing. Replace or repair hoses as required.
Left marker lowering slower than right marker.	Solenoid valve cartridge in port V2 not opening completely.	Switch cartridge with one in port V1. If problem follows cartridge, replace cartridge.
	Hose pinched or collapsed.	Inspect hose routing. Replace or repair hoses as required.
Both markers lowering.	Solenoid valve cartridge stuck open. If marker switch is in the left marker position, the right cartridge (V1) is defective. If the marker switch is in the right marker position, the left cartridge (V2) is defective.	Replace solenoid valve cartridge.
Neither marker will lower.	Blown fuse.	Check red light on control console. It should be on if switch is on. If light is not on, switch to opposite marker position. If light comes on, switch may be defective. Replace switch. Otherwise replace fuse.
	Coils at V1 and V2 not energized.	Poor ground on wire, bad wire connection or damaged wire. Repair as required.
	Marker flow control valve closed too far.	See Operation Section for adjustment.
Neither marker will raise.	Marker flow control valve closed too far.	See Operation Section for adjustment.
Right marker will not lower.	Solenoid coil in port V1 not energized.	Check switch on control console. Replace if defective. Check coil ground wire. Check for poor connection or damaged wire.
	Solenoid cartridge in port V1 stuck closed.	Switch cartridge with one on the planter you know is operating properly. If right marker lowers, replace defective cartridge.
Left marker will not lower.	Solenoid coil in port V2 not energized.	Check switch on control console. Replace if defective. Check coil ground wire. Check for poor connection or damaged wire.
	Solenoid cartridge in port V2 stuck closed.	Switch cartridge with one on the planter you know is operating properly. If left marker lowers, replace defective cartridge.
Markers traveling too fast and damaging rubber stop on transport stands and/or damaging pivot at rod end of marker cylinders.	Marker transport stand not adjusted correctly to allow marker cushion cylinders to operate as designed.	See "Row Marker Transport Stand Adjustment".
	Marker flow control valve out of adjustment.	See Operation Section for adjustment.

MAINTENANCE

ROW MARKER TRANSPORT STAND ADJUSTMENT

It is critical that the row marker transport stands are adjusted correctly to allow the marker cushion cylinders to function properly.

To adjust the transport stands:

1. Raise markers to transport position.
2. Loosen mounting hardware to allow transport stands to drop down or remove transport stands.
3. With tractor engine shutoff, release hydraulic pressure on marker cylinders.
4. Locate transport stands so marker arm rests lightly on transport stand. When the transport stands are correctly adjusted the pin at the rod end of the cylinder should be loose enough to rotate and move back and forth in the mounting slot.

A7102-1(TWL104)

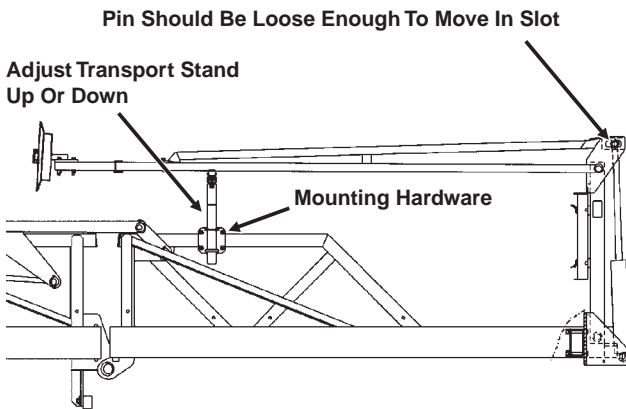

ROW MARKER BEARING LUBRICATION OR REPLACEMENT

1. Remove marker blade.
2. Remove dust cap from hub.
3. Remove cotter pin, nut and washer.
4. Slide hub from spindle.
5. Remove bearings and cups and discard if bearings are being replaced. Clean hub and dry. Remove bearings only and not cups if repacking.
6. Press in new bearing cups with thickest edge facing in. (Bearing replacement procedure only.)
7. Pack bearings with heavy duty wheel bearing grease thoroughly forcing grease between roller cone and bearing cage. Also fill the space between the bearing cups in the hub with grease.
8. Install rubber seal into grease seal. Place inner bearing in place and press in new rubber seal/grease seal.
9. Clean spindle and install hub.
10. Install outer bearing, washer and slotted hex nut. Tighten slotted hex nut while rotating hub until there is some drag. This assures that all bearing surfaces are in contact. Back off slotted nut to nearest locking slot and install cotter pin.
11. Fill dust caps approximately $\frac{3}{4}$ full of wheel bearing grease and install on hub.
12. Install blade and dust cap retainer on hub and tighten evenly and securely.

(PLTR45/PLTR99/PLTR98/PLTR102)

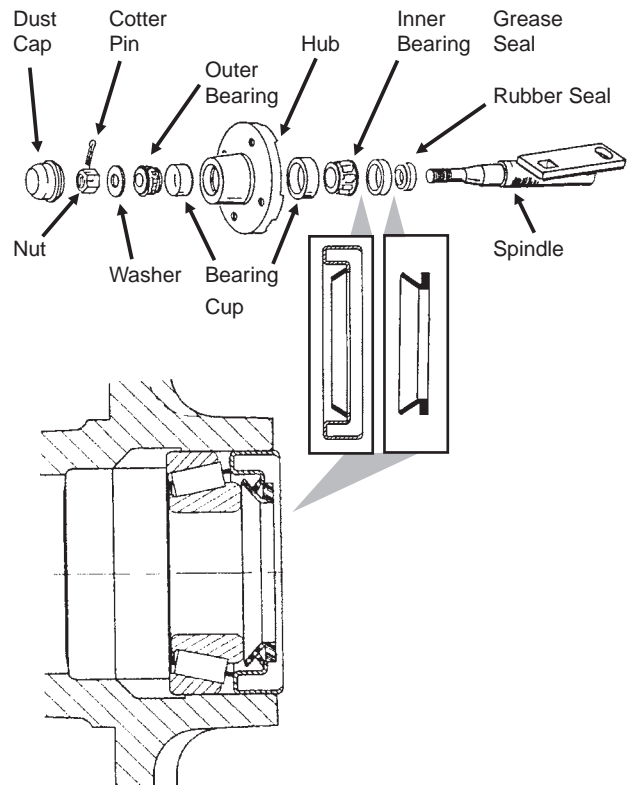

MAINTENANCE

WHEEL BEARING LUBRICATION OR REPLACEMENT

NOTE: Each transport wheel hub is equipped with a grease fitting for lubrication. The below procedure is used only for bearing replacement.

1. Raise tire clear of ground and remove wheel.
2. Remove double jam nuts and slide hub from spindle.
3. Remove bearings, seals (Where Applicable) and cups and discard if bearings are being replaced. Clean hub and dry. Remove bearings only and not cups if repacking.
4. Press in new bearing cups with thickest edge facing in. (Bearing replacement procedure only.)
5. Pack bearings with heavy duty wheel bearing grease thoroughly forcing grease between roller cone and bearing cage. Also fill the space between the bearing cups in the hub with grease.
6. Place inner bearing and seal (If Applicable) in place.
7. Clean spindle and install hub.
8. Install outer bearing, seal (If Applicable) and stepped nut. Tighten jam nut while rotating hub until there is some drag. This assures that all bearing surfaces are in contact. Back off jam nut $\frac{1}{4}$ turn or until there is only slight drag when rotating the hub. Install second jam nut to lock against first.
9. Install wheel on hub and tighten evenly and securely. Torque wheel bolts to specified torque.

(EF35e/PLTR56)

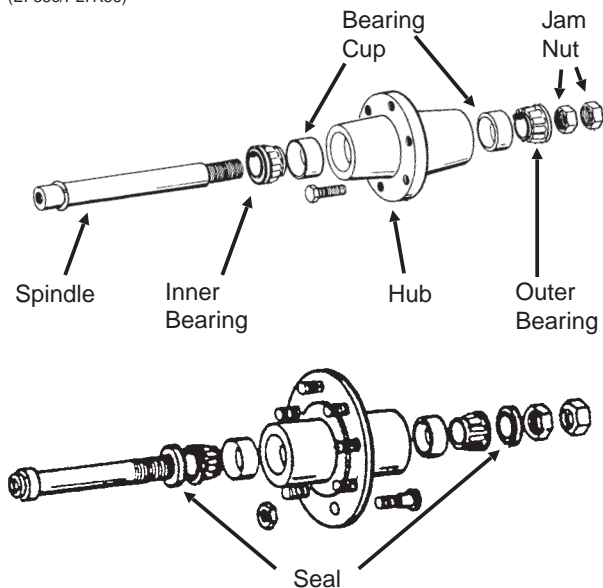

MAINTENANCE

WEAR PAD REPLACEMENT AND ADJUSTMENT

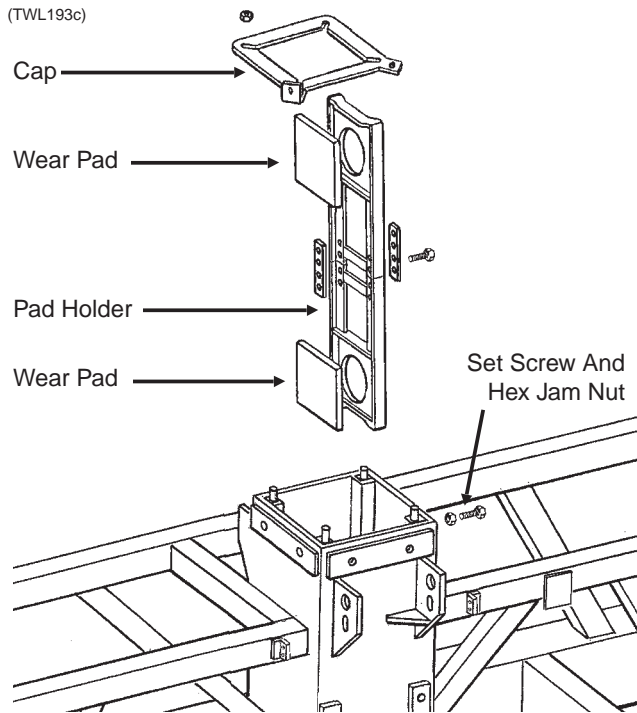

The center section of the planter is constructed around a steel tubular frame with four wear pad assemblies that ride against a stainless steel clad center post. Each wear pad assembly includes a pad holder and two wear pads. The wear pads are held by the pad holder and locked in place by $\frac{3}{4}$ " set screws and hex jam nuts.

Inspect for wear and check pad adjustment annually to ensure the center section is stabilized and the planter tracks properly. Replace any broken or missing adjustment set screws. When properly adjusted the pads should make full contact with the center post with light contact. Too much preload on the pads will cause the hydraulic lift pressure to be higher than necessary or will not allow the planter to raise when the planter is loaded.

⚠ WARNING: Always install all safety lockup devices before working under the unit.

To check adjustment and wear, position the planter on a level surface. Raise the planter to the raised field position. Visually check the four upper wear pads. Each wear pad should lightly contact the stainless steel clad center post. The maximum allowable gap between the plastic wear pad and the stainless steel post, when checked using a thickness gauge, should be no more than .060". Raise the planter to the raised transport position, install all safety lockups and visually check the four lower wear pads. Maximum allowable gap on the lower pads is .060".

(TWL109b)

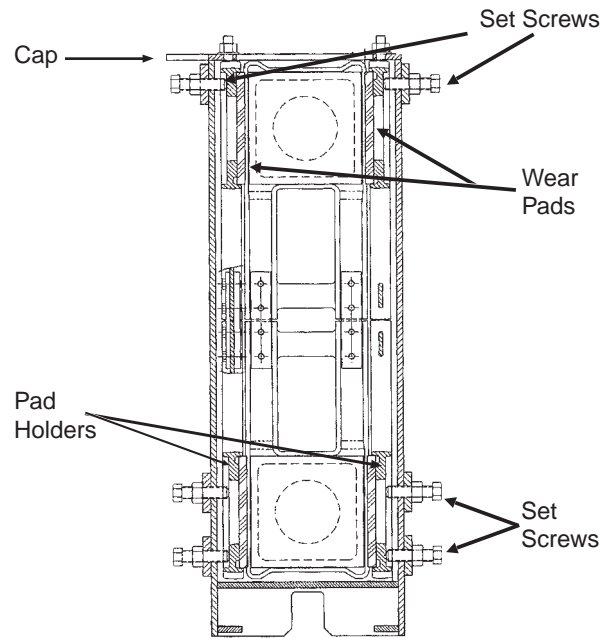

If adjustment is necessary proceed as follows: (a) Lower the planter to field operation position. It may be necessary to the loosen cap mounting nuts to allow wear pad adjustment. (b) Loosen the necessary hex jam nuts. (c) Tighten set screws until the wear pad lightly contacts the stainless steel clad center post. **DO NOT OVERTIGHTEN.** (d) Tighten hex jam nuts. (e) Recheck clearance. If clearance is not to specifications, repeat adjustment steps. (f) Torque hex jam nuts to 200 ft. lbs. Tighten cap mounting bolts if applicable.

NOTE: If exposed portion of wear pad is worn to less than $\frac{1}{8}$ " as shown below, replace the wear pad.

(TWL149a)

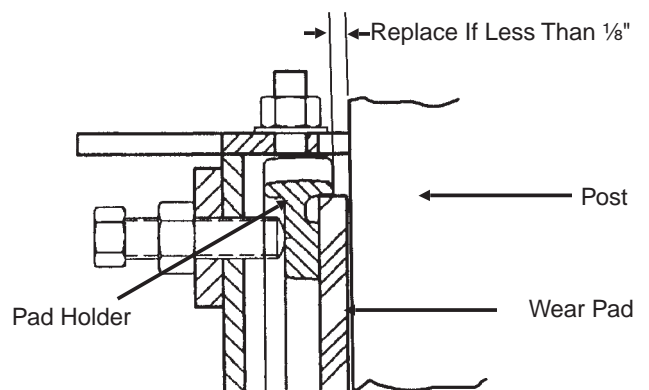

MAINTENANCE

If major adjustment or replacement is necessary proceed as follows: (a) Loosen cam rollers as shown below so they move freely. (b) Lower the planter to field operation position and release wing locks. (c) Eliminate all uplift on planter frame by backing off row unit down pressure springs and uplift on any other planter attachments.

D01190716

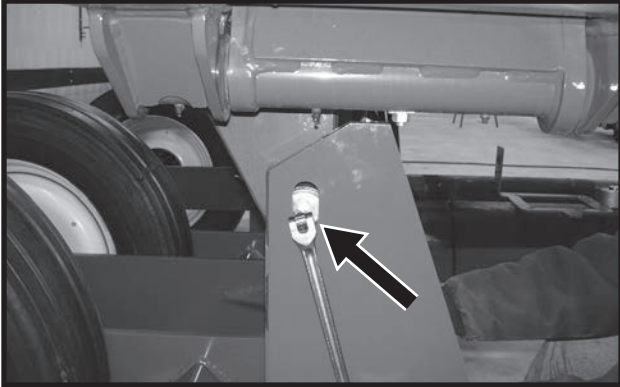

For pad adjustment only (d) Check position of center frame to axle cam roller guides. Gap between guides and frame should be the same side to side. Gap on the back sides of the roller guide should be equal on both sides. Final adjustment will be done later. (e) Loosen the four cap mounting nuts as shown below. (f) Loosen the hex jam nuts and use the pad set screws to position the frame to center correctly. (g) To adjust the pads, the pad set screws should be drawn tight, backed off and turned in until there is light contact with the pad holder. (h) Tighten hex jam nuts. (i) Torque hex jam nuts to 200 ft. lbs. (g) Tighten cap mounting nuts. (h) Reset row unit down pressure and other attachments from STEP c.

IMPORTANT: DO NOT OVERTIGHTEN WEAR PADS. OVER TIGHTENING WILL CAUSE PREMATURE WEAR AND EXCESSIVE HYDRAULIC LIFT PRESSURES.

D01190745

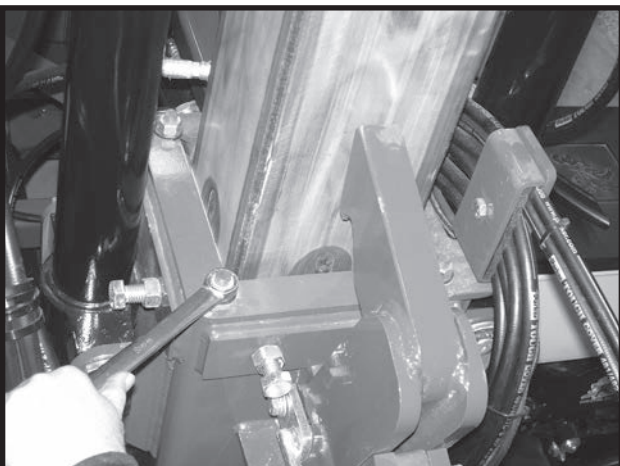

For pad replacement (d) As shown below, remove safety hook, disconnect hydraulic hose, remove nut on bulkhead fitting and remove fitting from cap..

D01190729

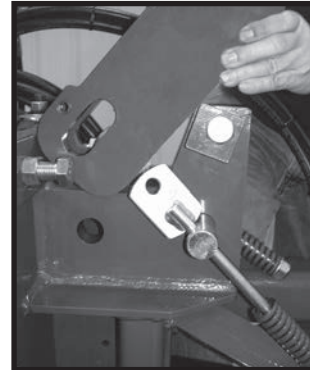

D01190725

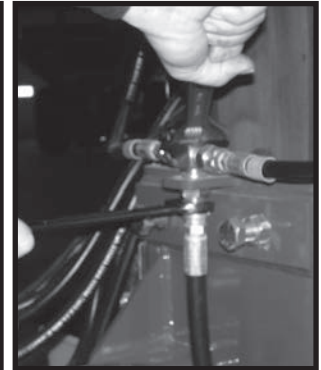

(e) Loosen the four cap mounting nuts and remove pad holder cap. (f) Loosen the pad hex jam nuts, back the pad screws out and remove the four pad holder assemblies as shown below.

D01190737

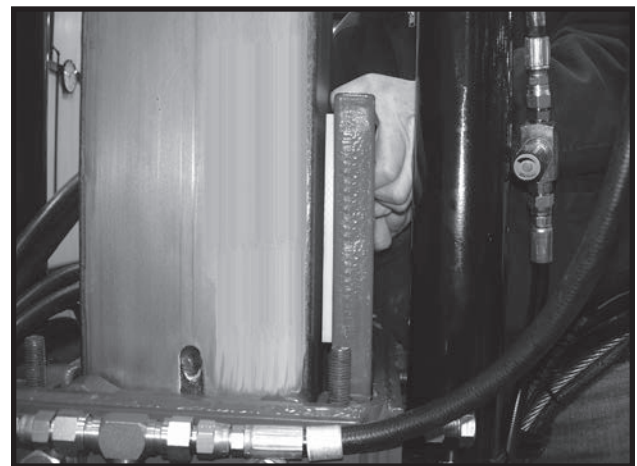

(g) Remove old pads and install new pads. NOTE: Apply a small amount of weather stripping adhesive to hold the pads in place while the pad holder is being reinstalled.

D01190739

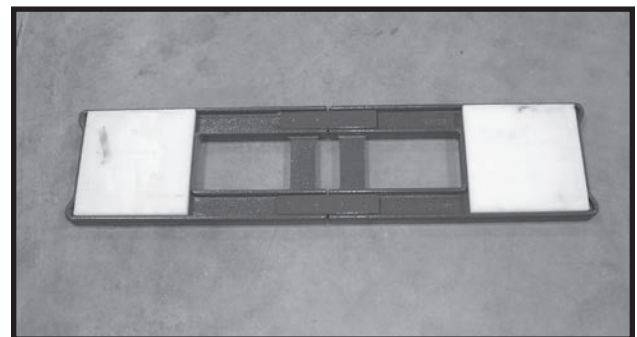

MAINTENANCE

(h) To adjust the pads, the pad set screws should be drawn tight, backed off and turned in until there is light contact with the pad holder. (i) Tighten hex jam nuts. (j) Torque hex jam nuts to 200 ft. lbs.

IMPORTANT: DO NOT OVER-TIGHTEN WEAR PADS. OVER TIGHTENING WILL CAUSE PREMATURE WEAR AND EXCESSIVE HYDRAULIC LIFT PRESSURES.

(k) Reinstall cap and tighten cap mounting nuts. (l) Reinstall hydraulic hose, fittings and safety hook.

D01190744

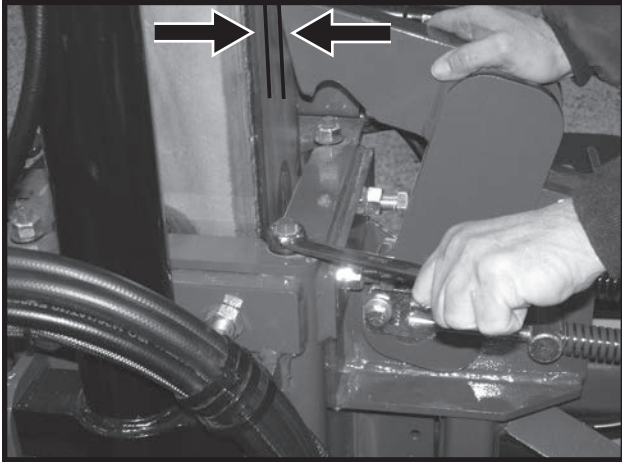

(m) Adjust stop on safety hook. Maximum clearance should be $\frac{1}{2}$ " and minimum clearance $\frac{1}{2}$ " as shown above.

D01190727

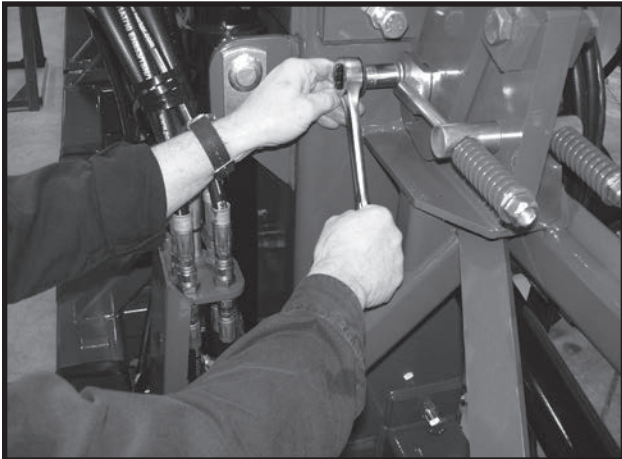

(n) Rotate cam roller against front guide and tighten to 200 ft. lbs. Make sure gap between roller guide and center frame are equal on both sides. (o) Raise planter out of the roller guides and lower back down into roller guides to be sure the roller guides operate smoothly. If not, adjust the rotation cylinder rod as shown below.

D01190731



D01190732

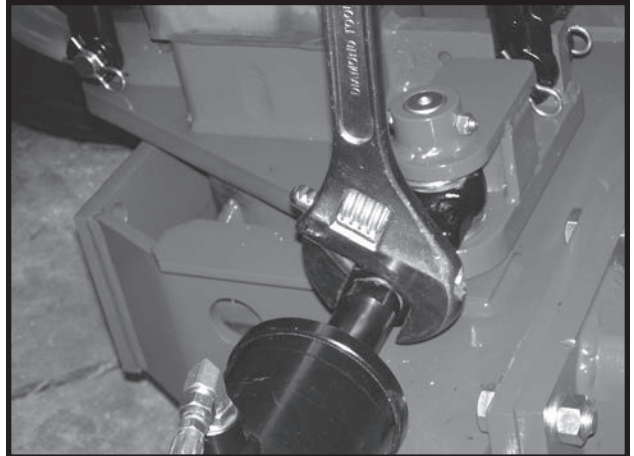

(p) Reset row unit down pressure and other attachments from STEP c.

MAINTENANCE

PISTON PUMP STORAGE

IMPORTANT: KEEP AIR OUT OF PUMP! This is the only way to prevent corrosion. Even for short periods of storage, the entrance of air into the pump, will cause RAPID AND SEVERE CORROSION.

Overnight Storage

SUSPENSION FERTILIZER must be flushed from the pump for ANY storage period.

Winter Storage

1. Flush pump thoroughly with 5 to 10 gallons of fresh water and circulate until all corrosive salts are dissolved in the pump.
2. With the pump set on 10, draw in a mixture of half diesel fuel and half 10 weight oil until the discharge is clean. Then plug inlet and outlet.

A12330a

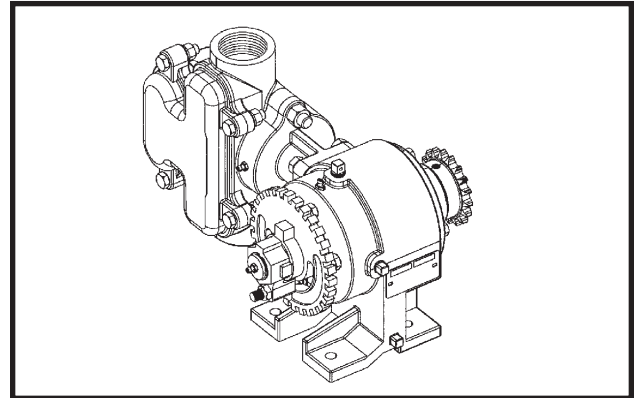

PISTON PUMP TROUBLESHOOTING

PROBLEM	POSSIBLE CAUSE	SOLUTION
Pump hard or impossible to prime.	Valves fouled or in wrong place.	Inspect and clean valves.
	Air leak in suction line.	Repair leak.
	Pump set too low.	Adjust pump setting.
	Packing washers worn out.	Replace.
Low metering.	Valves fouled or in wrong place.	Inspect and clean valves.
	Air leak in suction line.	Repair leak.
	Pump set too low.	Adjust pump setting.
	Broken valve spring.	Replace spring.
Over meters.	Broken discharge valve spring.	Replace spring.
	Trash under valves.	Inspect and clean valves.
	Improper rate setting.	Adjust pump setting.
Leaks through when stopped.	Broken discharge valve spring.	Replace spring.
	Trash under valves.	Inspect and clean valves.
Fertilizer solution leaking under stuffing box.	Packing washers worn out.	Replace.
Pump using excessive oil.	Oil seals or O-ring worn and leaking.	Replace.
Pump operates noisily.	Crankcase components worn excessively.	Inspect and replace if necessary.

MAINTENANCE

PREPARATION FOR STORAGE

Store the planter in a dry sheltered area if possible.

Remove all trash that may be wrapped on sprockets or shafts and remove dirt that can draw and hold moisture.

Clean all drive chains and coat with a rust preventative spray, or remove chains and submerge in oil.

Lubricate planter and row units at all lubrication points.

Inspect the planter for parts that are in need of replacement and order during the "off" season.

Make sure all seed hoppers are empty and clean.

Remove seed discs from seed meters, clean and store meters in a rodent-free, dry area with discs removed. Store seed discs vertically on a dowel or pipe.

Remove vacuum hose from each seed meter. Operate the vacuum fan at full hydraulic flow from the tractor for two minutes to clear manifolds, hoses and fittings of dust and debris.

Clean breather on analog vacuum gauge.

Disassemble, clean and grease all U-joint slides.

Grease or paint disc openers/blades and row marker disc blades to prevent rust.

Flush liquid fertilizer tanks, hoses and metering pump with clean water. See "Piston Pump Storage" if applicable.

MAINTENANCE

ELECTRICAL WIRING DIAGRAM FOR LIGHT PACKAGE

(WGN66a/A9202a)

STYLE A - Machines Equipped With Double Light Assemblies Only

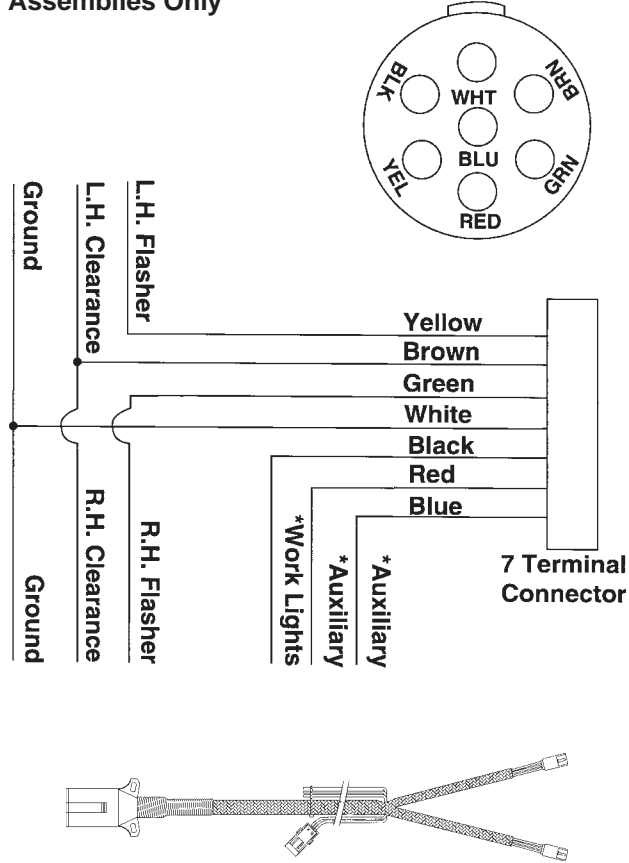

(WGN66b/A9201a)

STYLE B - Machines Equipped With Single And Double Light Assemblies

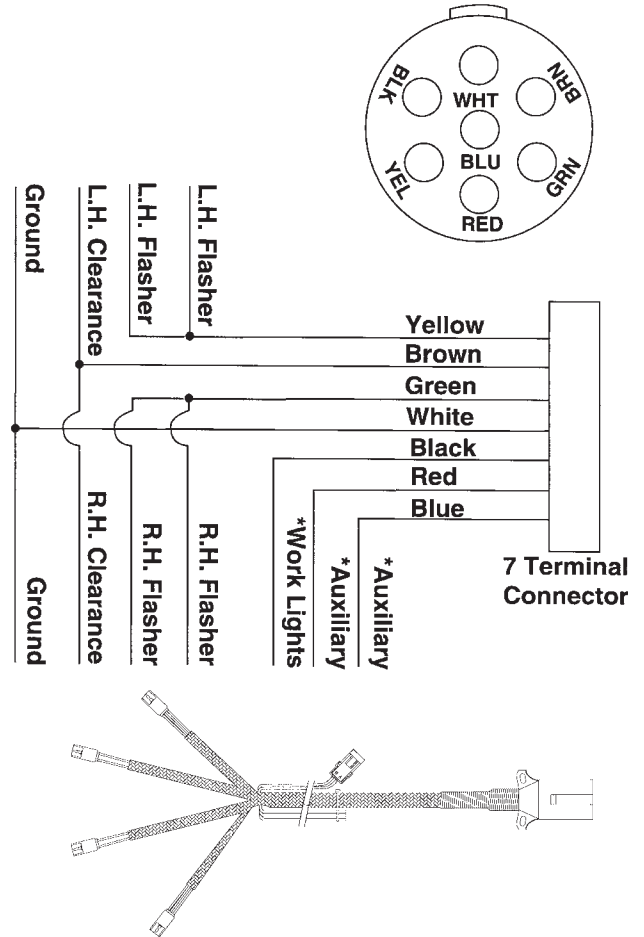

* Optional customer-supplied auxiliary lights and wires may be wired into existing plug terminals.

The light package supplied on the Model 3600 Twin-Line® Planter meets ASAE Standards. For the correct wiring harness to be wired into the lights on your tractor, check with the tractor manufacturer.

69922-35



MAINTENANCE

ELECTRICAL CONTROL CONSOLE SCHEMATIC

IMPORTANT: Before doing any electrical work, disconnect the control console from the tractor battery. Keep wiring harnesses away from high temperature areas or sharp edges. DO NOT route the wiring harnesses along battery cables. Use tie straps to keep wire harness away from moving parts on tractor and planter. Be sure ground connections to the tractor frame are clean to provide good electrical contact.

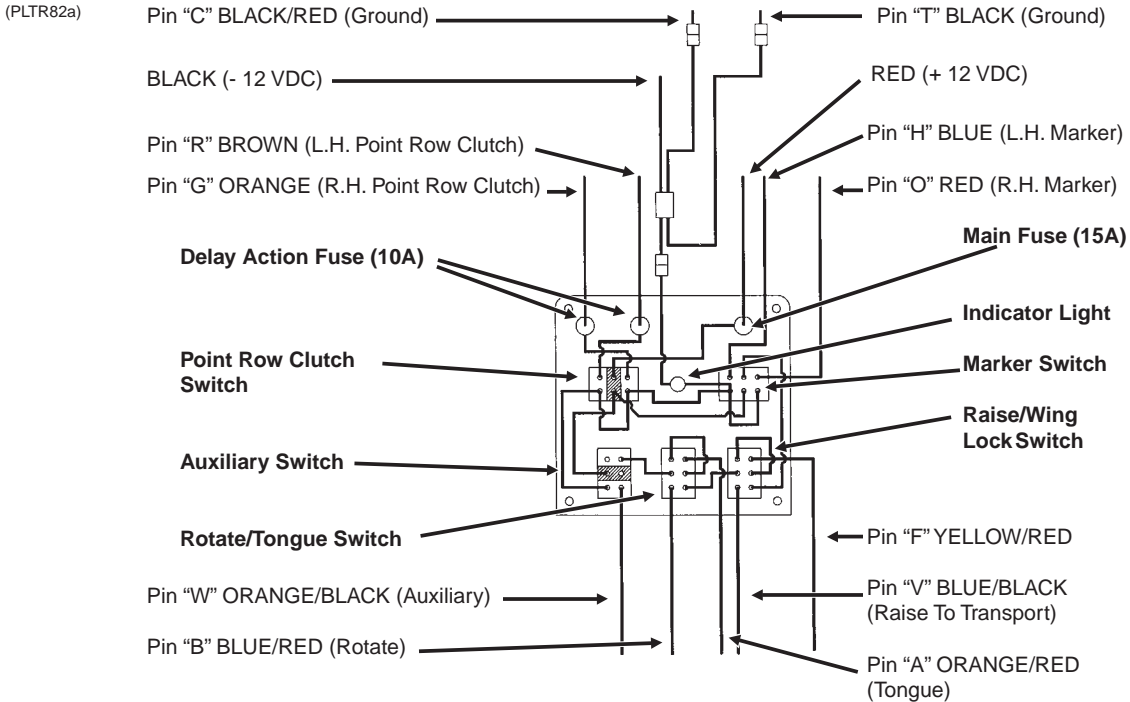

(INS238)

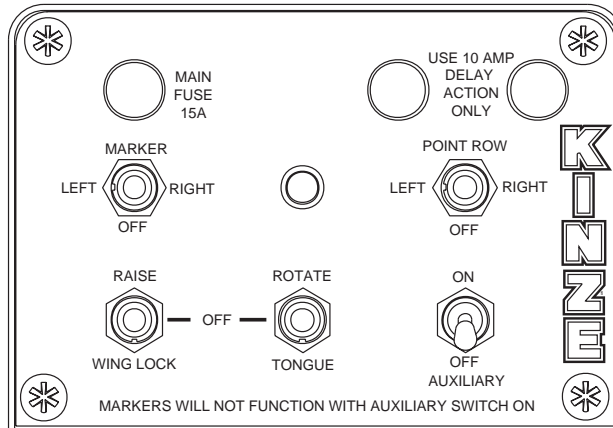

NOTE:

1. Operating marker or point row switch in either direction lights panel light.
2. Point row clutch switch operates independently of the rest of the control box.
3. Power to the marker switch is fed through the auxiliary switch and the two transport function switches. Operating any of the switches in the lower row disables the marker function and turns off the panel light. (If the point row clutch switch is in the "off" position.)

MAINTENANCE

ELECTRICAL WIRING HARNESS SCHEMATIC (On Tractor)

(ELC10c/ELC13)

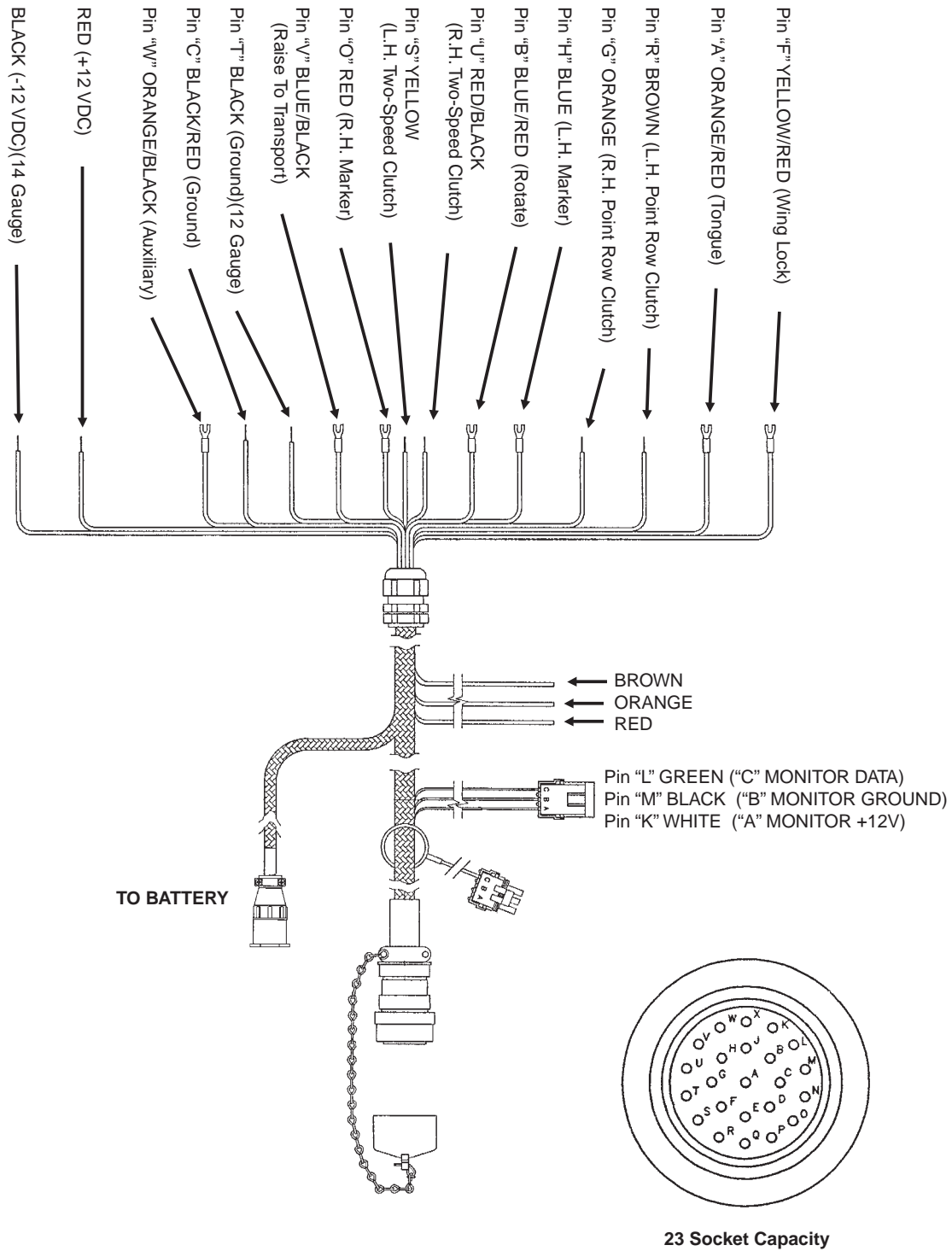

MAINTENANCE

ELECTRICAL WIRING HARNESS SCHEMATIC (On Planter)

(ELC13/ELC12b/TWL71d)

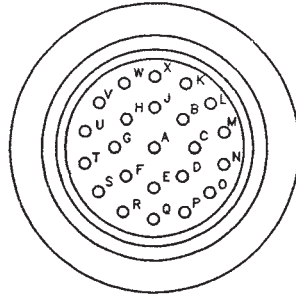

23 Pin Capacity

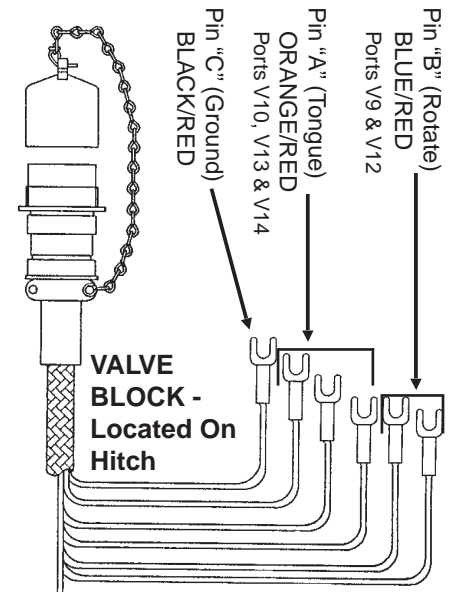

VALVE BLOCK - Located On Rear Center Frame

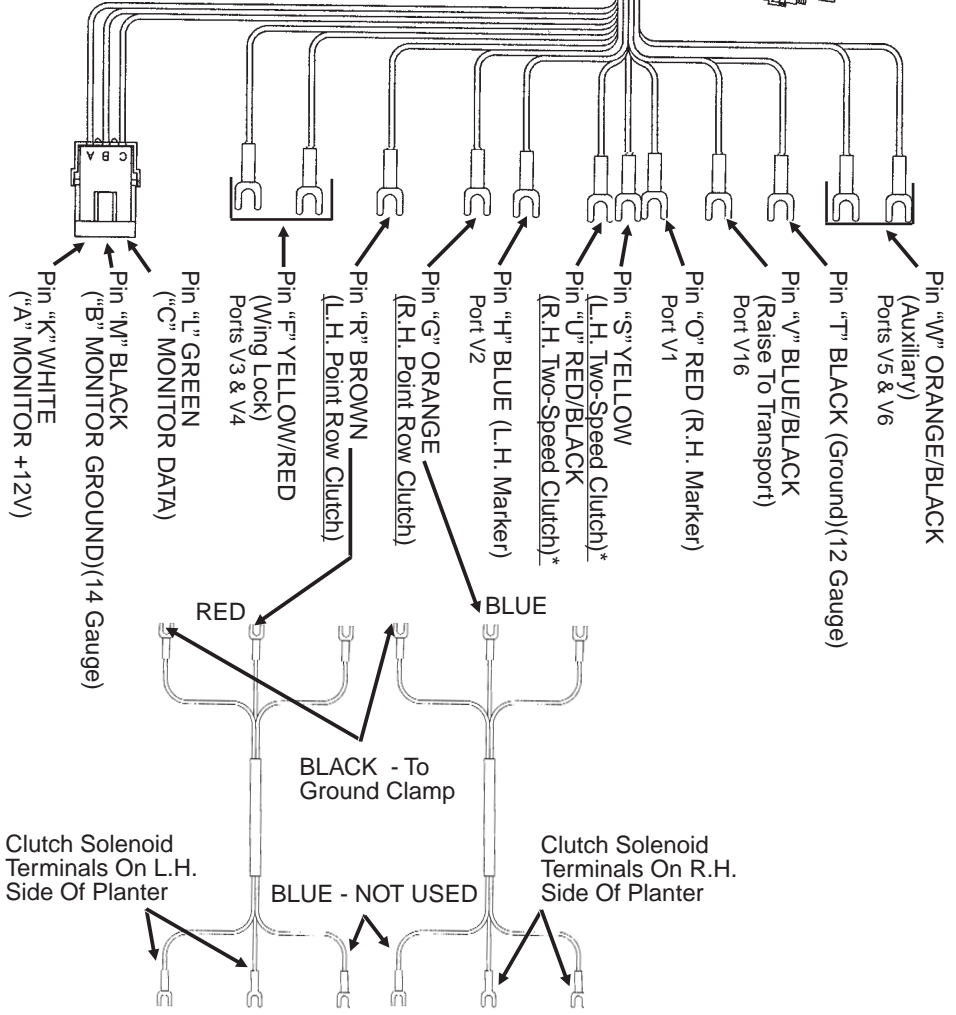

MAINTENANCE

(A7012a)

VALVE BLOCK - Located On Hitch

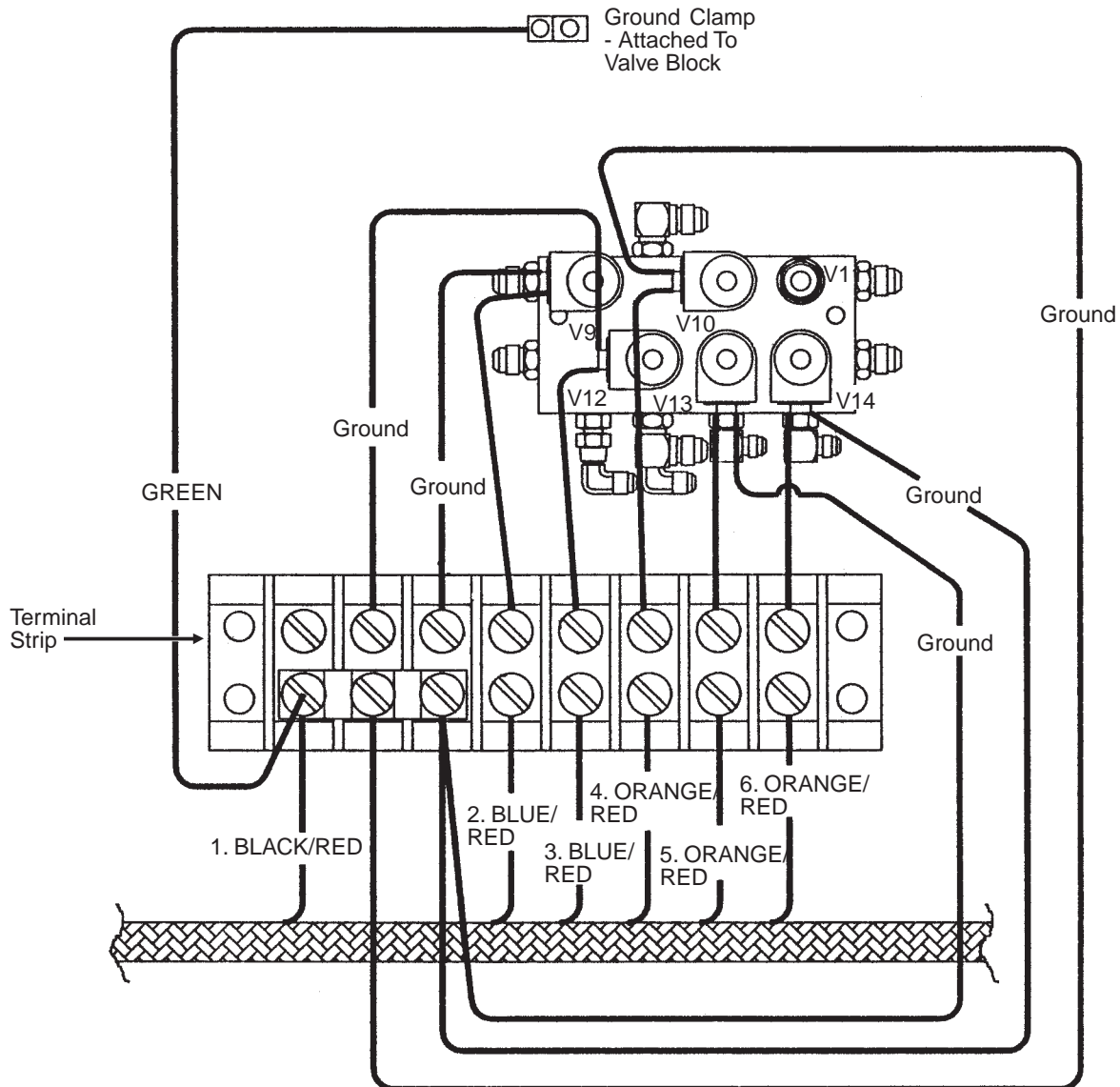

1. BLACK/RED - Pin "C" (Ground)
2. BLUE/RED - Pin "B" (Rotate) - Port V9
3. BLUE/RED - Pin "B" (Rotate) - Port V12
4. ORANGE/RED - Pin "A" (Tongue) - Port V10
5. ORANGE/RED - Pin "A" (Tongue) - Port V13
6. ORANGE/RED - Pin "A" (Tongue) - Port V14

MAINTENANCE

(A7102a)

VALVE BLOCK - Located On R.H. Rear Center Frame

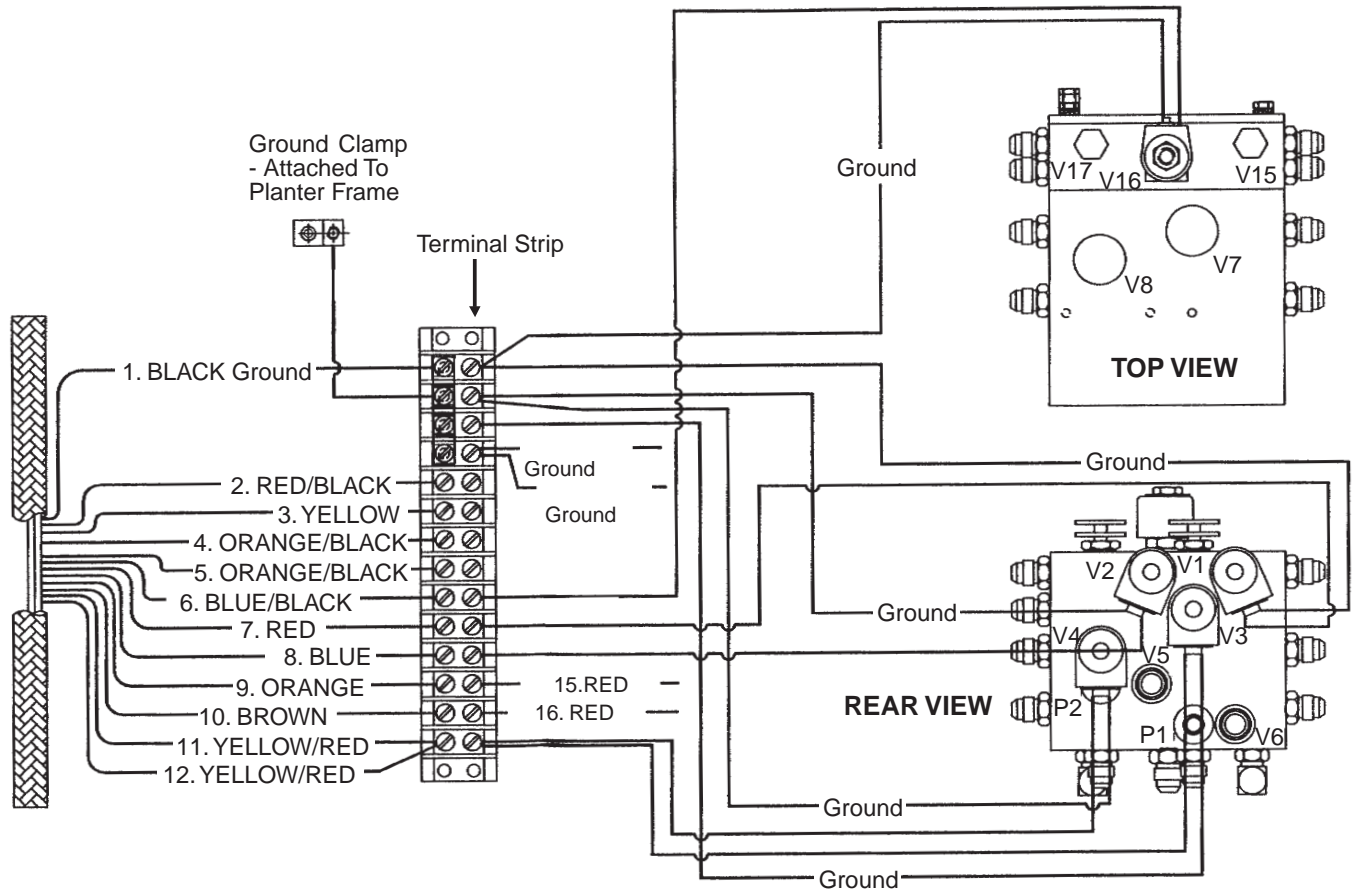

1. BLACK - Pin "T" (Ground)
2. RED/BLACK - Pin "U" (R.H. Two-Speed Clutch)*
3. YELLOW - Pin "S" (Le.H. Two-Speed Clutch)*
4. ORANGE/BLACK - Pin "W" (Auxiliary) - Ports V5 & V6
5. ORANGE/BLACK - Pin "W" (Auxiliary) - Ports V5 & V6
6. BLUE/BLACK - Pin "V" (Raise To Transport) - Port V16
7. RED - Pin "O" (R.H. Marker) - Port V1
8. BLUE - Pin "H" (L.H. Marker) - Port V2
9. ORANGE - Pin "G" (R.H. Point Row Clutch)
10. BROWN - Pin "R" (L.H. Point Row Clutch)
11. YELLOW/RED - Pin "F" (Wing Lock) - Ports V3 & V4
12. YELLOW/RED - Pin "F" (Wing Lock) - Ports V3 & V4
13. BLACK - (R.H. Point Row Ground)
14. BLACK - (L.H. Point Row Ground)
15. RED - (R.H. Point Row)
16. RED - (L.H. Point Row)

MAINTENANCE

HYDRAULIC SYSTEM SCHEMATIC

(TWL143/TWL325/TWL111)

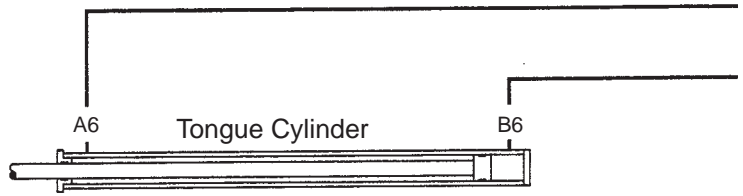

3/8" Hose AA (Pressure)



1/2" Hose BB (Return)

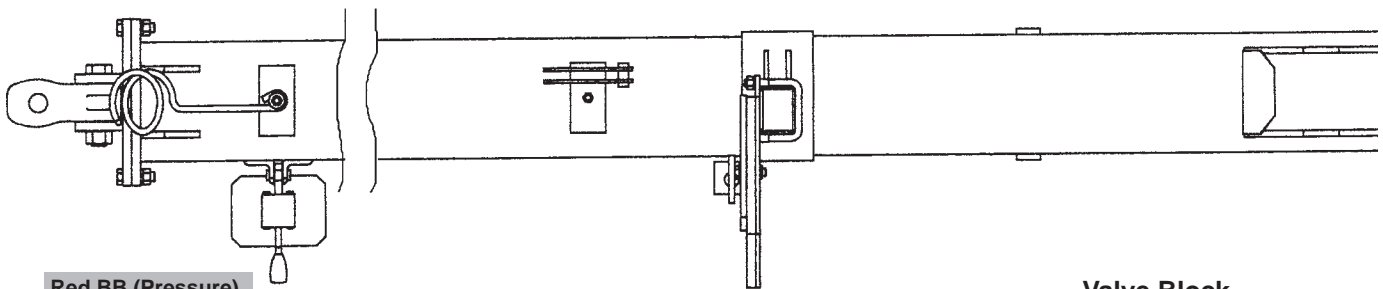

Red BB (Pressure)



Blue BB (Pressure)



Blue AA (Return)



Red AA (Return)



Valve Block
- Located On
Hitch

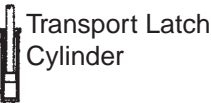
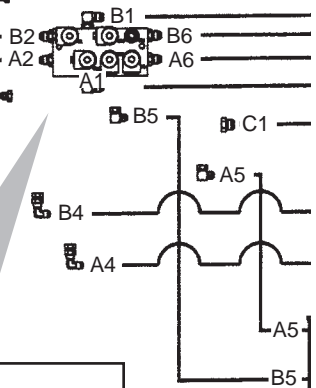

Tongue Lock
Cylinder

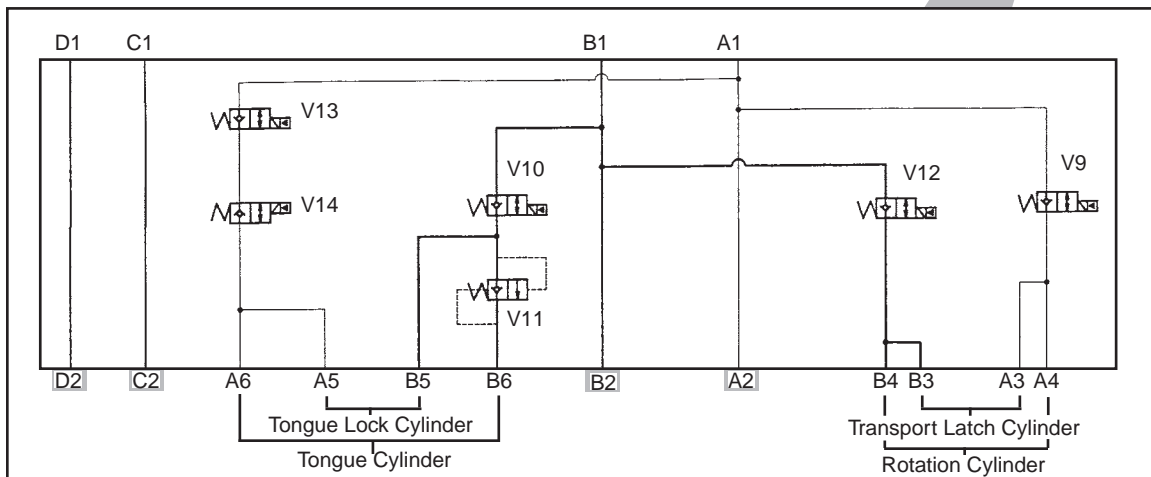

MAINTENANCE

(TWL108/TWL115)

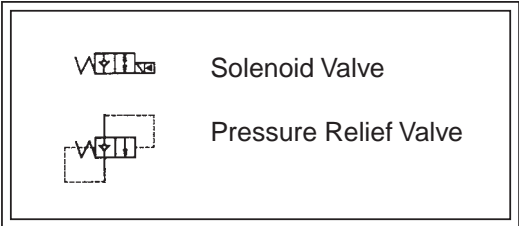
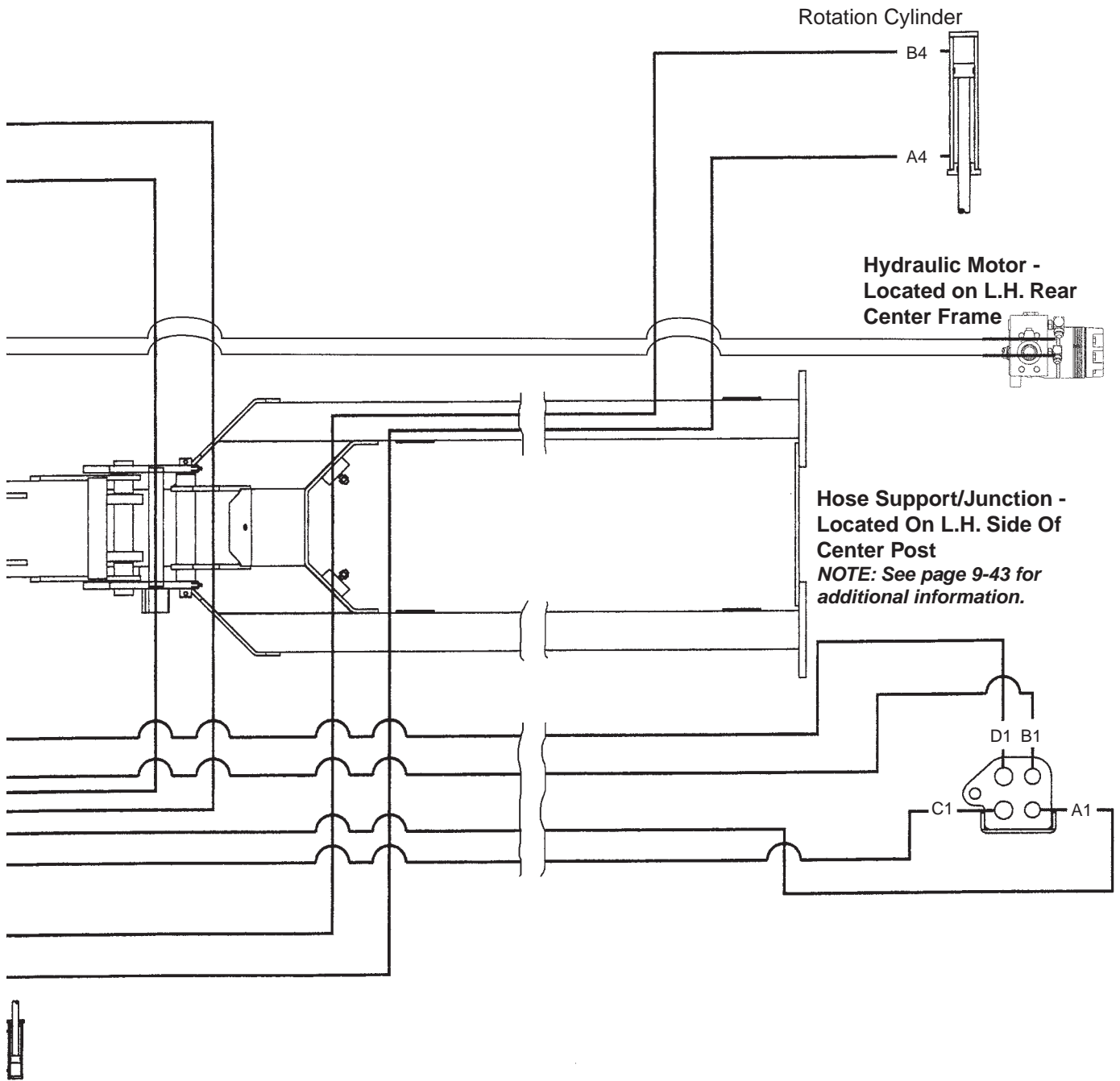

MAINTENANCE

HYDRAULIC SYSTEM SCHEMATIC (Continued)

(TWL105c/TWL113/TWL114)

16 Row Shown (Two Wing Lift Cylinders Per Wing)

12 Row (One Wing Lift Cylinder Per Wing)

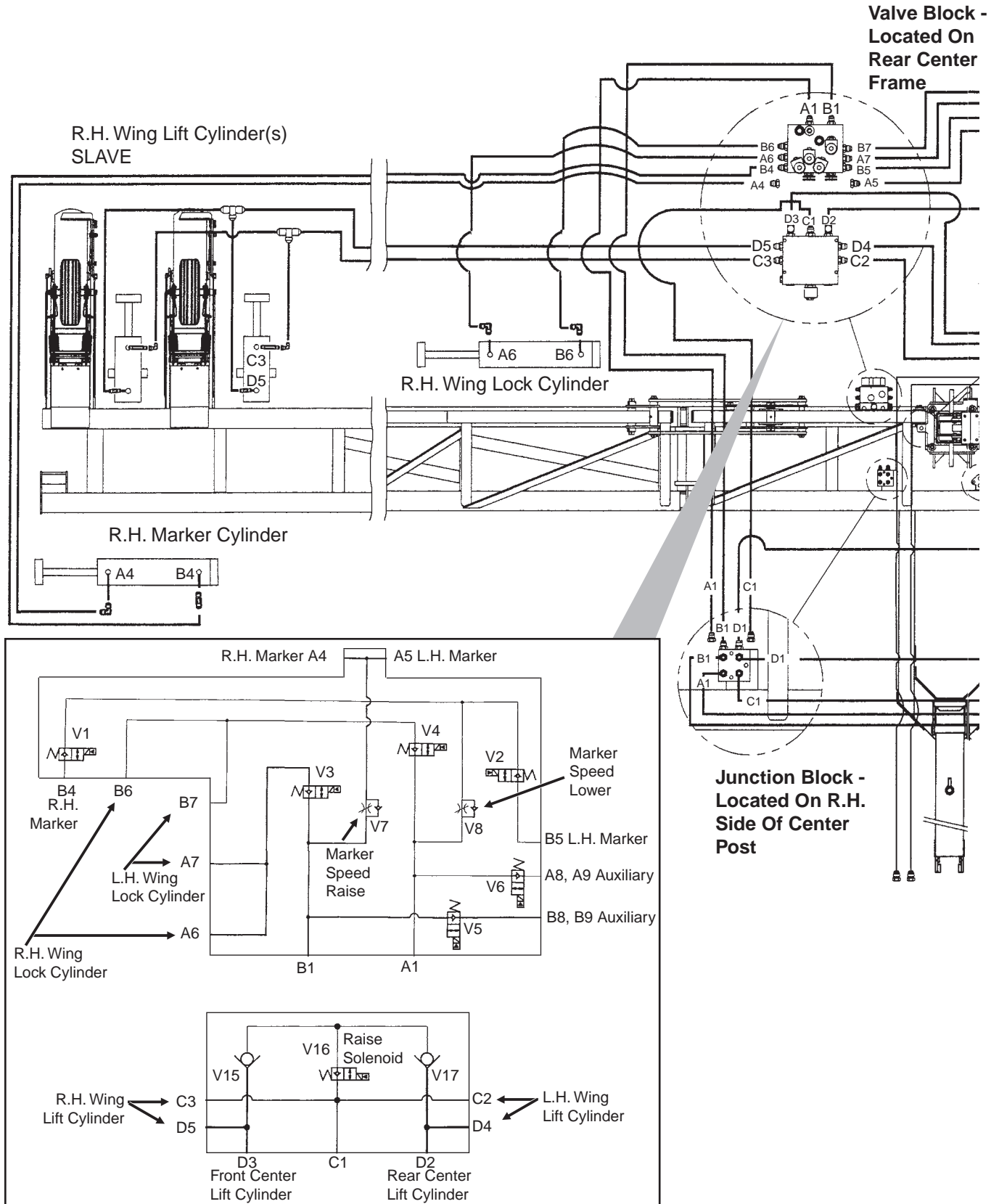

MAINTENANCE

(TWL106/TWL114)

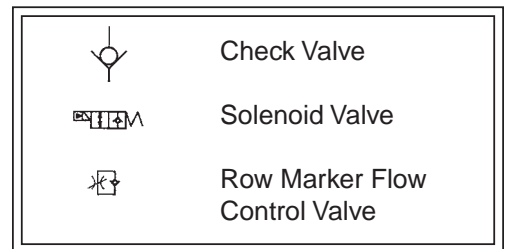
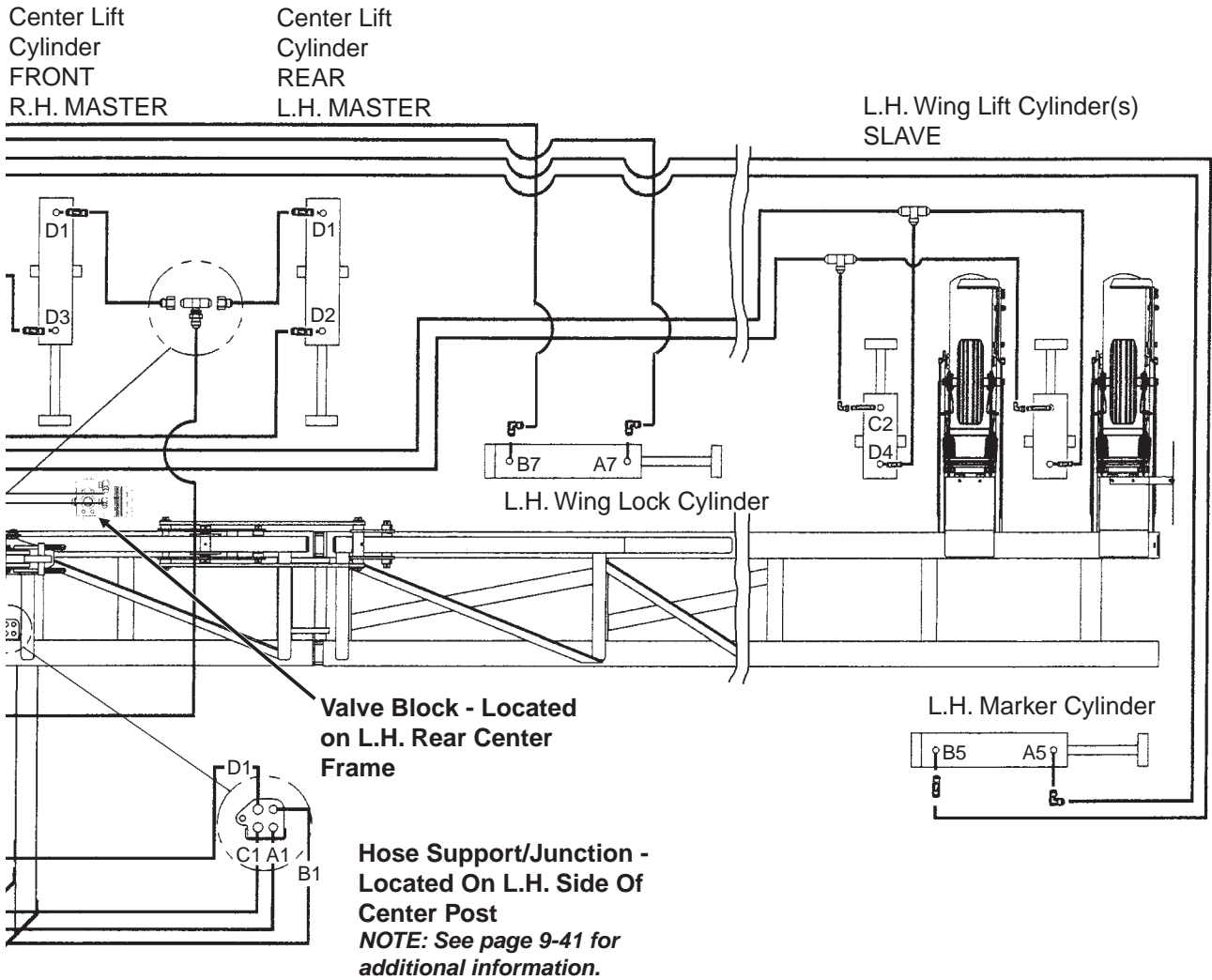

MAINTENANCE

HYDRAULIC SCHEMATIC - VACUUM FAN MOTOR SYSTEM

(PT79)

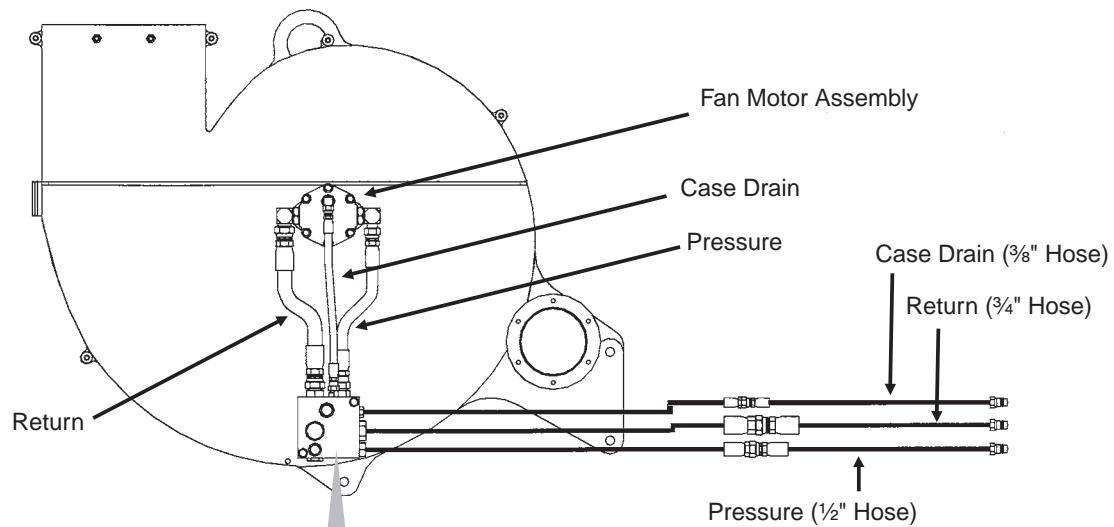

A11068bb

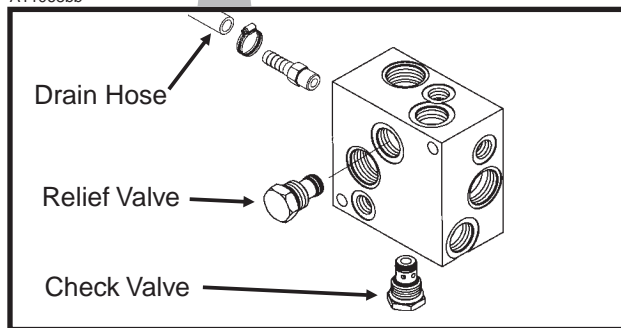

Vacuum Fan Motor Valve
Block Assembly
(See Machine Operation
Section)

IMPORTANT: Connect hydraulic motor case drain to a case drain return line with zero pressure on the tractor. Failure to connect to a return with zero pressure will cause damage to the hydraulic motor. **DO NOT** connect hydraulic motor case drain to SCV outlet. Contact tractor manufacturer for specific details on "zero pressure return".

MAINTENANCE

HYDRAULIC SCHEMATIC - OPTIONAL PTO PUMP DRIVE AND OIL COOLER SYSTEM

(TWL290c/PLTR177a)

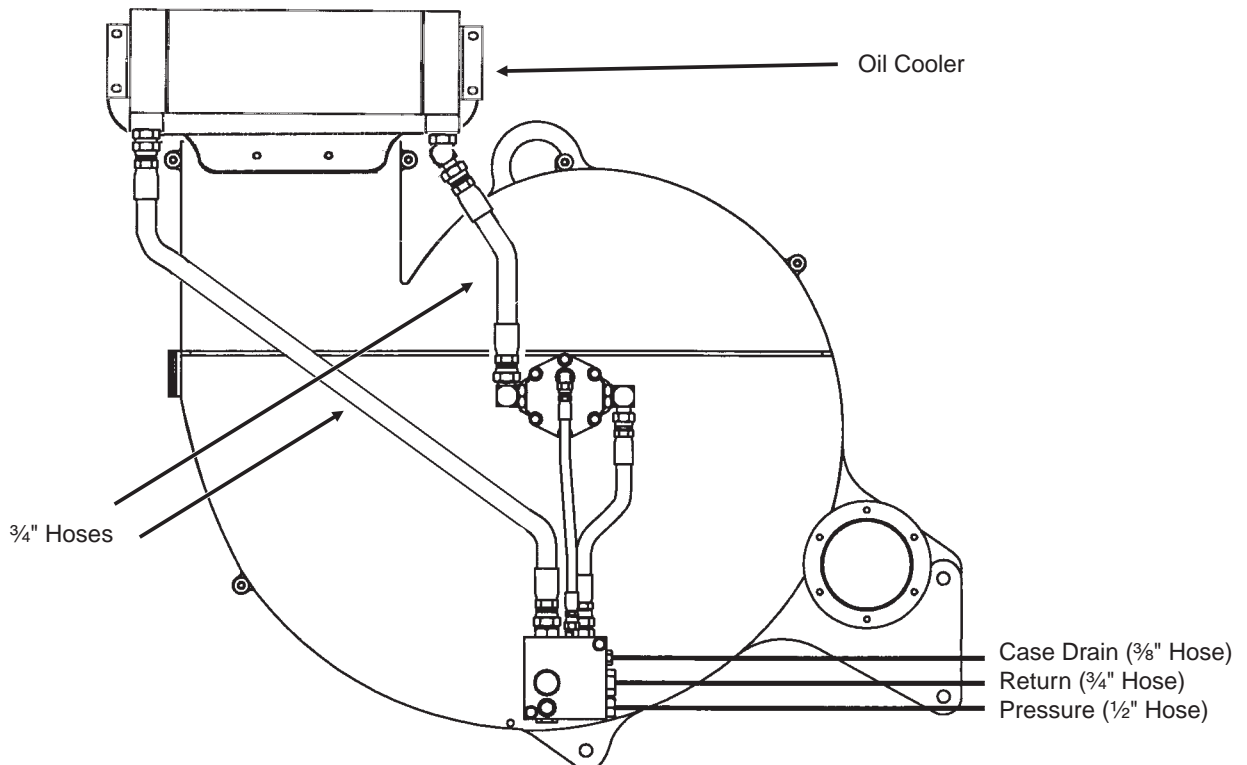
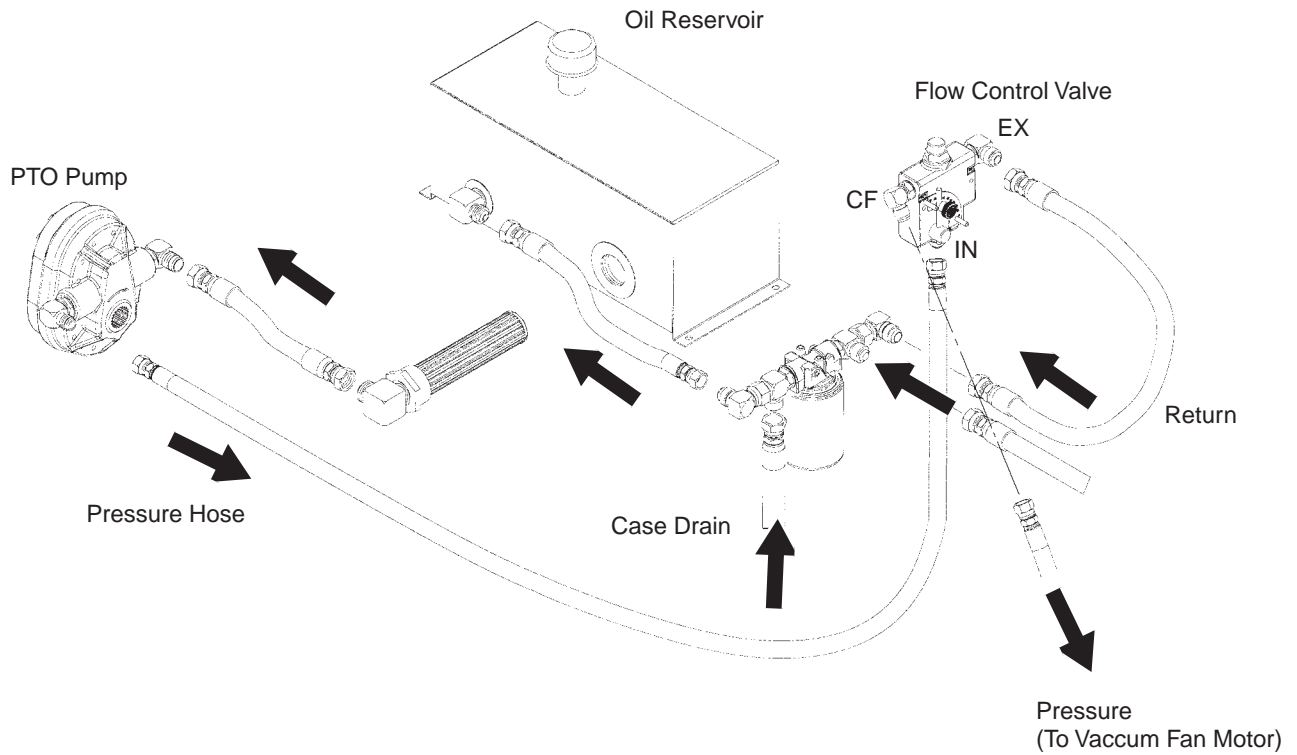

MAINTENANCE

Airline Schematic

(PNE40)

16 Row Shown

Front

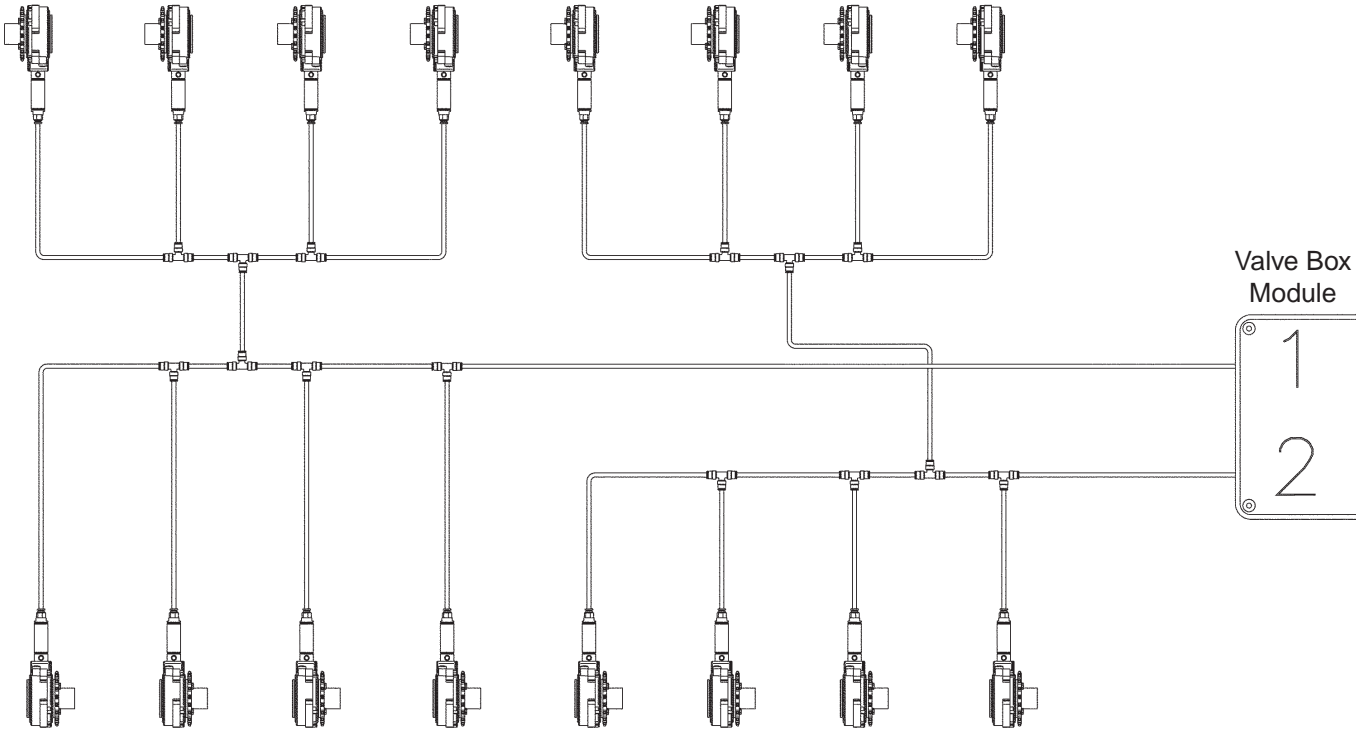

MAINTENANCE

Front

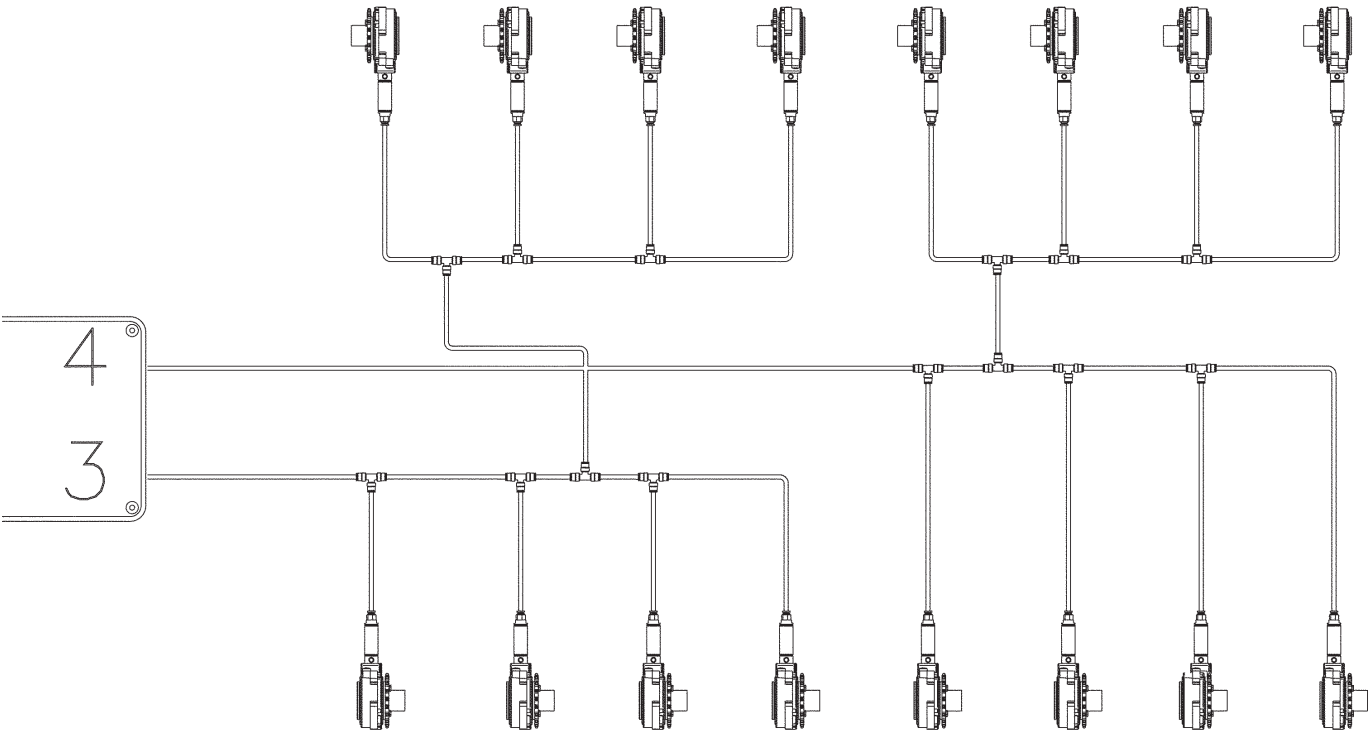

MAINTENANCE

PARTS LIST INDEX

ROW UNIT	
15" Seed Opener Disc Blade/Bearing Assembly And Scrapers	P11
Coulter Mounted Residue Wheels	P28
Covering Discs/Single Press Wheel	P14
Drag Closing Attachment.....	P17
Frame Mounted Coulter W/Residue Wheels.....	P30
Gauge Wheels	P12
Hopper Support And Meter Drive	P18
Parallel Arms, Mounting Support Plate And Quick Adjustable Down Force Springs Option	P10
Parallel Arms, Mounting Support Plate And Pneumatic Down Pressure Packaget.....	P4
Pneumatic Down Pressure Control Box, Sending Unit And Harnesses	P6
Pneumatic Down Pressure Air Compressor, Dual Solenoid Assembly, Tubing And Fittings.....	P8
Row Unit Mounted Disc Furrower	P24
Row Unit Mounted No Till Coulter	P23
Row Unit Mounted Residue Wheel	P26
Seed Hopper And Lid	P19
Seed Meter	P20
Shank Assembly, Seed Tube And Depth Adjustment	P2
Spring Tooth Incorporator	P22
"V" Closing Wheels	P16
EDGEVAC® SYSTEM	
Digital Vacuum Gauge, Analog Vacuum Gauge And Vacuum Fan Assembly	P34
Manifolds And Distribution Hoses	P40
Optional Flow Control Needle Valve Kit	P38
PTO Pump Drive And Oil Cooler Option.....	P42
Vacuum Fan Hydraulic Components	P36
Vacuum Fan Hydraulic Motor Assembly	P38
Vacuum Fan Motor Valve Block Assembly (Located Below Vacuum Fan Motor Assembly)	P39
BASE MACHINE	
2-Point Hitch Option	P46
Axle Assembly	P60
Center Frame.....	P52
Center Pivot	P58
Cylinders.....	P72
Electrical Components.....	P92
Ground Drive Wheel	P66
Hose Take-Up	P50
Hydraulic Drive	P54
Hydraulic Hoses And Fittings.....	P86
Inner Hitch	P48
Outer Hitch.....	P44
Row Marker Assemblies	P68
Row Marker Spindle/Hub/Blade.....	P67
Safety Chain	P44
Transport Wheels/Rock Guards.....	P62
Valve Box Module	P90
Valve And Junction Blocks.....	P78
Valves (Solenoid, Flow Control, Pressure Relief, Check, Proportional).....	P84
Wing Frame	P56
Wing Wheel Module.....	P64
ELECTRONIC SEED MONITOR	
KINZE Vision® Display	P94
Planter Monitor Module (PMM).....	P96
INTERPLANT® SYSTEM	
Interplant® Push Row Unit	P32
Interplant® Push Row Unit Drive.....	P98
FERTILIZER	
Fertilizer Openers, Mounts And Attachments	P100
Liquid Fertilizer	P112
Rear Trailer Hitch	P122
Decals, Paint And Miscellaneous.....	P124
Numerical Index.....	P127

SHANK ASSEMBLY, SEED TUBE AND DEPTH ADJUSTMENT

(D17014/RU166/A10142a/D16245)

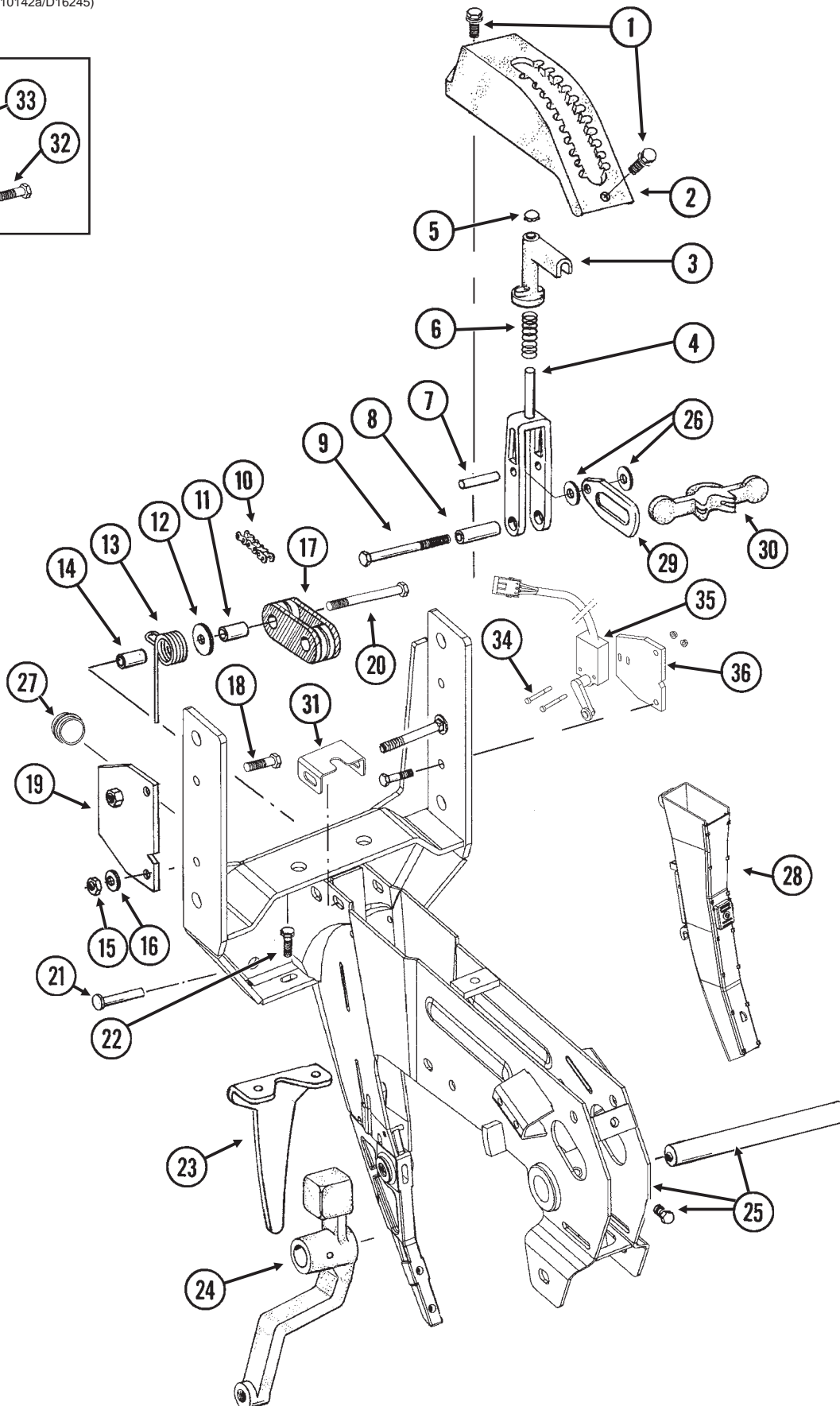
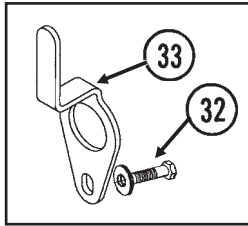

SHANK ASSEMBLY, SEED TUBE AND DEPTH ADJUSTMENT

ITEM	PART NO.	QTY. (Per Row)	DESCRIPTION
1.	G11015	2	Hex Washer Head Cap Screw, 3/8"-16 x 1 1/4"
2.	GB0274	1	Cover, Depth Adjustment
3.	GB0266	1	Handle, Depth Adjustment
4.	GB0267	1	Lever, Depth Adjustment
5.	GD3612	1	Cap Plug
6.	GD10993	1	Spring
7.	GD13361	1	Pin, 3/8" x 1 2/3"
8.	GD11259	1	Sleeve, 3/8" I.D. x 5/8" O.D. x 1 25/32" Long
9.	G11008	1	Hex Head Cap Screw, 3/8"-24 x 2 1/2", Grade 8
	G11007	1	Lock Nut, 3/8"-24, Grade C
10.	G3303-108	1	Chain, No. 41, 108 Pitch Including Connector Link
	G3303-16	1	Chain, No. 41, 16 Pitch Including Connector Link (Used W/Row Unit Extension Brackets)
	GR0196	1	Connector Link, No. 41
11.	GD1026	1	Sleeve, 1 3/16" Long
12.	G10201	1	Special Washer, 3/8" x 1 1/2" O.D.
13.	GD1065	1	Idler Spring
14.	GD7318	1	Sleeve, 1" Long
15.	G10108	1	Lock Nut, 3/8"-16
16.	G10210	1	Washer, 3/8" USS
17.	GD11962	1	Idler
18.	G10003	3	Hex Head Cap Screw, 3/8"-16 x 1 1/2"
	G10108	3	Lock Nut, 3/8"-16
19.	GD10867	2	Stop
20.	G10326	1	Hex Head Cap Screw, 3/8"-16 x 3 3/4"
21.	G10551	1	Clevis Pin, 1/4" x 2 1/2"
	G10669	1	Hair Pin Clip, No. 22
22.	G10312	2	Carriage Bolt, 5/16"-18 x 3/4"
	G10620	2	Serrated Flange Nut, 5/16"-18
23.	GD1033	1	Shield
24.		-	Wheel Arm, See "Gauge Wheels", Pages P12 And P13
25.	GA10157	1	Shank W/Gauge Wheel Pivot Spindle And Set Screw
	GD11001	-	Spindle
	G10438	-	Hex Head Cap Screw, 1/2"-13 x 3/4"
26.	G10207	2	Washer, 7/8" O.D. x 1 13/32" I.D. x .134" (If Applicable)
27.	GD11845	1	Dust Cap
28.			See "Planter Monitor Module (PMM)", Pages P96 And P97
29.	GB0285	1	Collar, Depth Adjustment
30.	GB0265	1	Pivot Link, Depth Adjustment
31.	GD16245	-	Sun Shade (Rubber)
32.	G10047	1	Hex Head Cap Screw, 3/8"-16 x 1 3/4"
	G10203	2-3	Washer, 3/8" SAE
	G10108	1	Lock Nut, 3/8"-16
33.	GD17014	1	Hose Guide
34.	G11298	2	Hex Slotted Head Cap Screw, #10-32 x 1"
	G11284	2	Serrated Flange Nut, #10-32
35.	GA13580	1	Limit Switch W/Cable
36.	GD19317	1	Implement Switch Bracket
A.	GA13593	-	Implement Switch Assembly, (Items 34-36)

PARALLEL ARMS, MOUNTING SUPPORT PLATE AND PNEUMATIC DOWN PRESSURE PACKAGE

(RU157b/RU159/RU157aa/A12405)

Pull Row Unit Shown

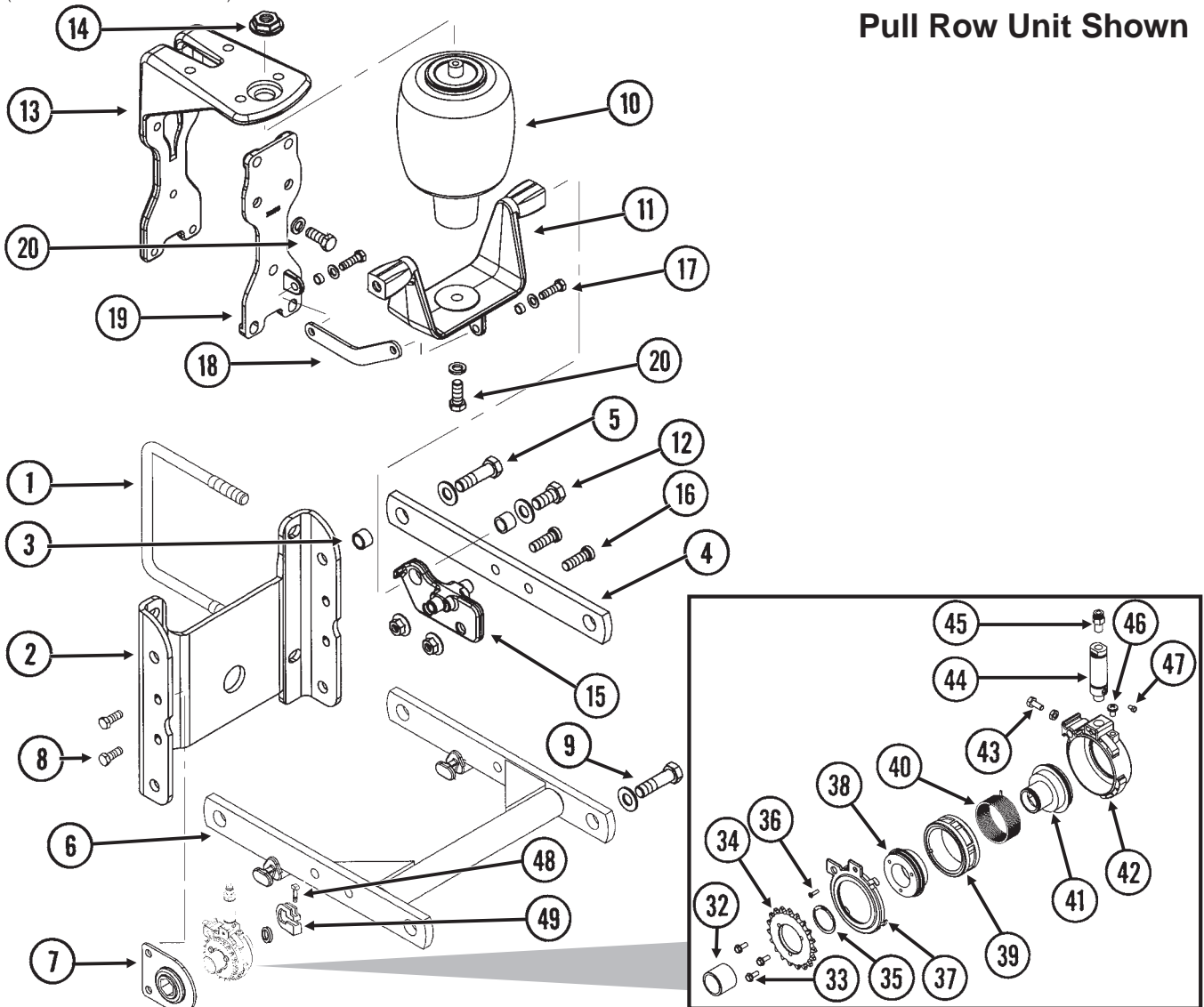

Push Row Unit Shown

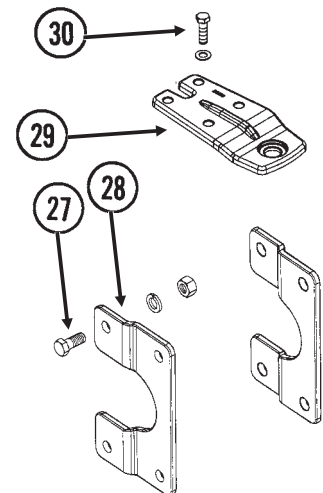
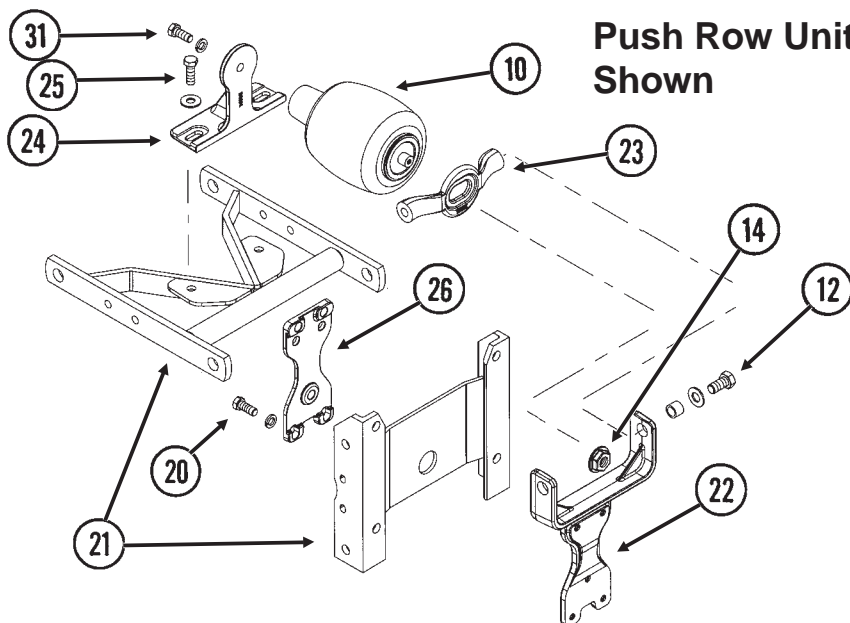

PARALLEL ARMS, MOUNTING SUPPORT PLATE AND PNEUMATIC DOWN PRESSURE PACKAGE

ITEM	PART NO.	QTY. (Per Row)	DESCRIPTION
1.	GD1113	2	U-Bolt, 5" x 7" x 5/8"-11
	G10230	4	Lock Washer, 5/8"
	G10104	4	Hex Nut, 5/8"-11
2.	GD10036	1	Mounting Support Plate
3.	GB0218	4	Bushing, 2 1/32" I.D. x 7/8" O.D. x 1 9/32" Long
4.	GD11422	2	Upper Parallel Arm
5.	G10732	4	Hex Head Cap Screw, 5/8"-18 x 2"
	GD7805	4	Special Washer, 5/8", Hardened
	G10412	4	Lock Nut, 5/8"-18
6.	GA5651	1	Lower Parallel Arm
7.	GA1720	1	Bearing/Sprocket, 7/8" Hex Bore
8.	G10001	2	Hex Head Cap Screw, 3/8"-16 x 1"
	G10229	2	Lock Washer, 3/8"
	G10101	2	Hex Nut, 3/8"-16
9.		-	See "Hopper Support And Meter Drive", Page P18
10.	GA11982	1	Air Spring Assembly
11.	GB0394	1	Saddle
12.	G11018	2	Hex Head Cap Screw, 5/8"-18 x 1 1/4"
	GD7805	2	Special Washer, 5/8", Hardened
	GD3180-30	2	Sleeve, 7/8" O.D. x 5/8" I.D. x 2 1/32"
13.	GB0396	1	Head Mount
14.	GB0397	1	Shoulder Nut, 3/4"-16
15.	GB0395	2	Bracket
16.	G11220	4	Hex Socket Cap Screw, 1/2"-13 x 1 1/2"
	G10071	4	Serrated Flange Nut, 1/2"-13
17.	G10004	2	Hex Head Cap Screw, 3/8"-16 x 1 1/4"
	G10203	2	Washer, 3/8" SAE
	GD11963-04	2	Spacer, 1/4"
	G10108	2	Lock Nut, 3/8"-16
18.	GD17794	1	Link
19.	GB0393	1	Plate
20.	G10037	7	Hex Head Cap Screw, 1/2"-13 x 1 1/4"
	G10206	2	Washer, 1/2" SAE (Lower Two Holes Only)
	G10228	7	Lock Washer, 1/2"
21.		-	See "Interplant Push Row Unit", Pages P32 And P33
22.	GB0390	1	Yoke Mount
23.	GB0392	1	Yoke
24.	GB0391	1	Mount
25.	G10017	2	Hex Head Cap Screw, 1/2"-13 x 1 1/2"
	G10216	2	Washer, 1/2" USS
	G10228	2	Lock Washer, 1/2"
	G10102	2	Hex Nut, 1/2"-11
26.	GB0389	1	Plate
27.	G10007	4	Hex Head Cap Screw, 5/8"-11 x 1 1/2"
	G10230	4	Lock Washer, 5/8"
	G10104	4	Hex Nut, 5/8"-11
28.	GB0366	2	Extension Bracket
29.	GB0398	1	Extension
30.	G10039	4	Hex Head Cap Screw, 1/2"-13 x 1 3/4"
	G10206	4	Washer, 1/2" SAE
	G10111	4	Lock Nut, 1/2"-13
31.	G10037	1	Hex Head Cap Screw, 1/2"-13 x 1 1/4"
	G10228	1	Lock Washer, 1/2"
32.	GD18891	1	Spacer, 1 1/4" O.D. x 1"
33.	G10020	1	Hex Head Cap Screw, 1/4"-20 x 5/8"
34.	GR1812	1	Sprocket, 19 Tooth
35.	G11295	1	Retaining Ring
36.	G11243	1	Slotted Flat Head Machine Screw, No. 8-32 x 1/2", Stainless Steel
37.	GR1894	1	Air Housing Cover
38.	GR1815	1	Sprocket Hub
39.	GR1818	1	Ratchet Gear
40.	GR1813	1	Clutch Spring
41.	GR1830	1	Hex Bushing
42.	GR1895	1	Air Clutch Housing
43.	G10023	3	Hex Head Cap Screw, 1/4"-20 x 3/4"
	G10103	3	Hex Nut, 1/4"-20
44.	GR1896	1	Air Cylinder
45.	GR1819	1	Push Connect, 1/8" NPT Male x 1/4"
46.	G11296	1	Pan Head Machine Screw, 1/4"-20 x 3/4" x 3/4"
47.	GR1898	1	Filter
48.	G10130	-	Square Head Machine Bolt, 5/16"-18 x 1 3/4"
	G10923	-	Flange Nut, 5/16"-18, No Serration
49.	GD11045	-	Lock Clamp
A.	G6325X	-	U-Bolt Package For 5" x 7" Toolbar, Includes: (2) GD1113, (4) G10230, (4) G10104
B.	GA12405	-	Air Clutch Assembly, (Items 32-48)
C.	G1K465	-	Pull Row Unit Assist Springs Package, Includes: (2) G10438, (2) G10216 And (2) GD8249
D.	G1K466	-	Push Row Unit Assist Springs Package, Includes: (2) GB0186, (2) GD14217 And (2) GD8249

PNEUMATIC DOWN PRESSURE CONTROL BOX, SENDING UNIT AND HARNESSES

(PNE30b/MTR27a/ELC27b/MTR45/MTR27/PNE30c)

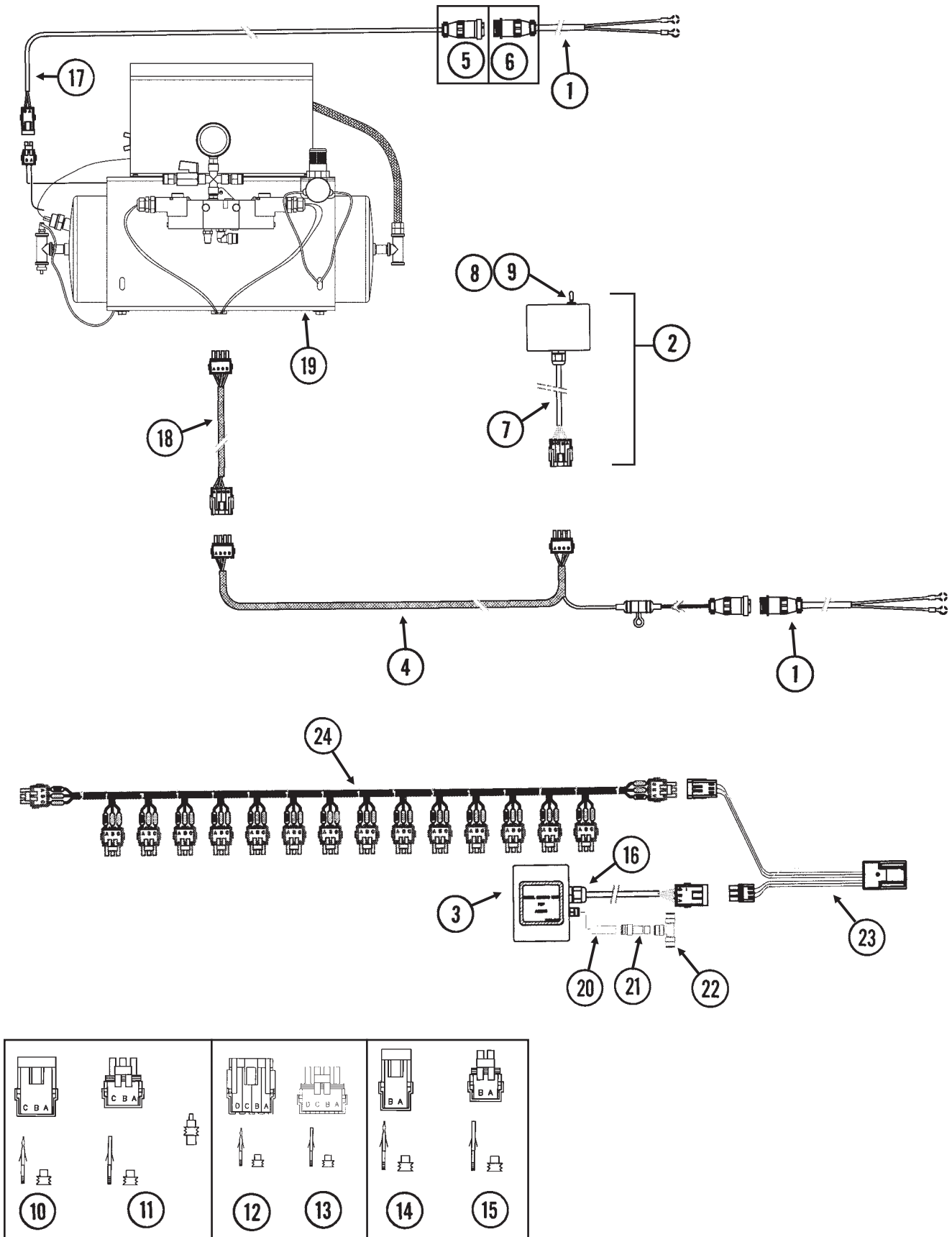

PNEUMATIC DOWN PRESSURE CONTROL BOX, SENDING UNIT AND HARNESSSES

ITEM	PART NO.	QTY.	DESCRIPTION
1.	GA7856	2	Power Lead Adapter
2.	GA12813	1	Control Box Assembly
3.	GA12815	1	Sending Unit
4.	GA12814	1	Wiring Harness W/Fuse Holder And Fuse, 206"
	GD14258	-	Fuse Holder
	GD14660	-	Fuse, 2 Amp Delay Action
5.	G1K268	-	Console Cable Connector Kit, Includes: (1) 3-Pin Connector, (1) Cable Clamp, (1) Lock Ring, (3) Female Terminal Pins
6.	G1K267	-	Console Cable Connector Kit, Includes: (1) 3-Pin Connector, (1) Cable Clamp, (3) Male Terminal Pins
7.	GA9964	1	Strain Relief
8.	GR1363	1	Hex Face Nut, 1 ⁵ / ₃₂ "-32
	GR1364	1	Internal Tooth Lock Washer, 1 ⁵ / ₃₂ "
9.	GA6978	1	Switch, 3 Position Toggle, Momentary On-Off-Momentary On
10.	G1K248	-	3-Pin Female Connector Kit (Black), Includes: (3) 3-Pin Female Housings, (9) Pin Contacts, (9) Seals
11.	G1K252	-	3-Pin Male Connector Kit (Black), Includes: (3) 3-Pin Male Housings, (9) Socket Contacts, (9) Seals
12.	GA8328	-	4-Pin Female Connector Kit, Includes: (1) 4-Pin Female Housing, (4) Pin Contacts, (4) Seals
13.	GA8329	-	4-Pin Male Connector Kit, Includes: (1) 4-Pin Male Housing, (4) Socket Contacts, (4) Seals
14.	G1K321	-	2-Pin Female Connector Kit (Black), Includes: (3) 2-Pin Female Housings, (6) Pin Contacts, (6) Seals
15.	G1K320	-	2-Pin Male Connector Kit (Black), Includes: (3) 2-Pin Male Housings, (6) Socket Contacts, (6) Seals
16.	GA9964	2	Strain Relief
17.	GA12684	1	Wiring Harness W/Fuse Holder And Fuse, 60'
	GD14258	-	Fuse Holder
	GD18275	-	Fuse, 20 Amp
18.	GA12858	1	Wiring Harness, 60'
19.			See "Pneumatic Down Pressure Air Compressor, Dual Solenoid Assembly, Tubing And Fittings", Pages P8 And P9
20.	GD17151-06	1	Nylon Tubing, 1/4" O.D. x 1 1/2'
21.	GD18796	1	Reducer, 3/8" To 1/4"
22.	GD18010	1	Tee, 3/8" Tube Union
23.	GA12812	1	Hall Effect Adapter
24.			See "KINZE Vision Display", Pages P94 And P95

PNEUMATIC DOWN PRESSURE AIR COMPRESSOR, DUAL SOLENOID ASSEMBLY, TUBING AND FITTINGS

(PNE06/PNE02/PNE05/A13169/PNE09/PNE08)

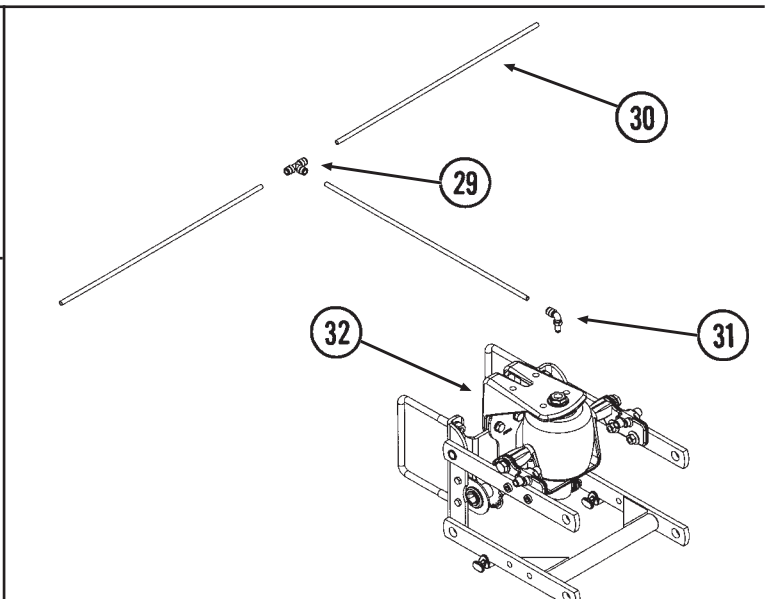
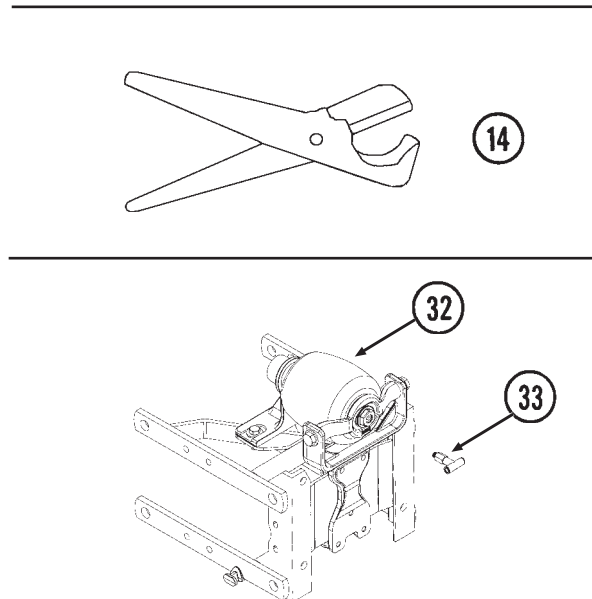
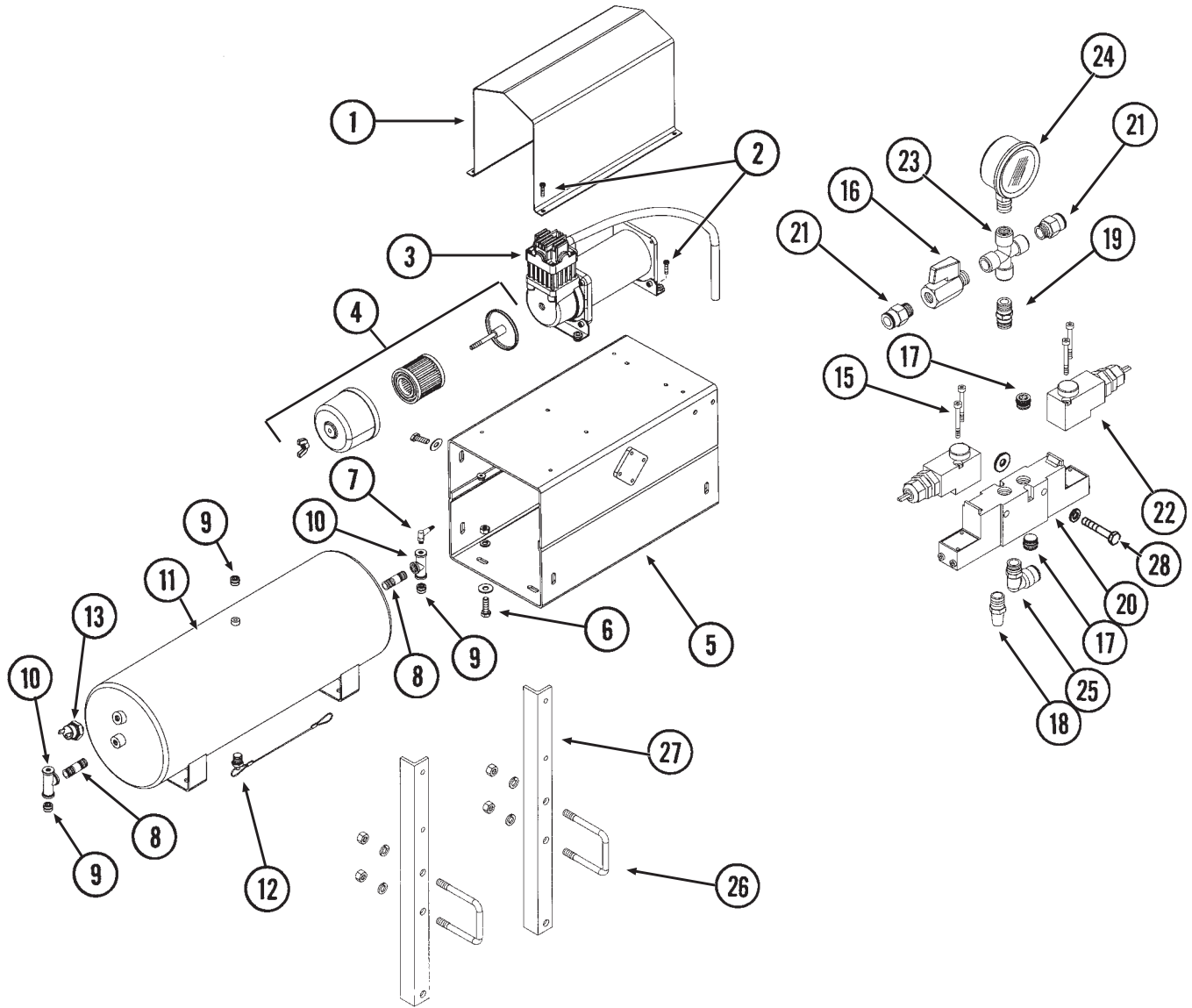

PNEUMATIC DOWN PRESSURE AIR COMPRESSOR, DUAL SOLENOID ASSEMBLY, TUBING AND FITTINGS

ITEM	PART NO.	QTY.	DESCRIPTION
1.	GD18112	1	Cover
2.	G11066	8	Phillips Pan Head Machine Screw, No. 10-24 x 3/4", Stainless Steel
	G10992	8	Serrated Flange Nut, No. 10-24
3.	GA12102	1	Air Compressor
4.	GA12404	1	Filter Assembly
	GR1809	-	Filter
5.	GA12358	1	Mount
6.	G10019	8	Hex Head Cap Screw, 5/16"-18 x 1"
	G10219	8	Washer, 5/16" USS
	G10232	8	Lock Washer, 5/16"
	G10106	8	Hex Nut, 5/16"-18
7.	GA13512	1	Valve Stem, 1/4" NPT
8.	GD19238	2	Nipple, 1/4" NPT
9.	GD17156	3	Plug, 1/4" NPT
10.	GD19237	2	Tee, 1/4" NPT
11.	GA11988	1	Tank, 3 Gallon
12.	GA11991	1	Drain, 1/4" NPT
13.	GR1778	1	Pressure Switch
14.	GA13169	1	Tube Cutter W/Blade
	GR1843	-	Blade
15.	G11247	4	Slotted Pan Head Machine Screw, M4-0.7 x 8
16.	GA11992	1	Shutoff Valve, 1/4" NPT
17.	GD17156	2	Plug, 1/4" NPT
18.	GA11997	1	Breather, 1/4" NPT
19.	GD17154	1	Connector, 1/4" Male
20.	GA11993	1	Block
21.	GD17141	3	Connector, 1/4" Male
22.	GA11994	2	Solenoid
23.	GD18078	1	Female Cross, 1/4" NPT
24.	GA12104	1	Pressure Gauge, 1/4" NPT
25.	GD17143	1	Swivel Elbow, 1/4" NPT x 3/8"
26.	GD4743	2	U-Bolt, 3" x 3" x 1/2"-13
	G10228	4	Lock Washer, 1/2"
	G10102	4	Hex Nut, 1/2"-13
27.	GD18119	2	Bracket
28.	G10040	2	Hex Head Cap Screw, 1/4"-20 x 1 3/4"
	G10227	2	Lock Washer, 1/4"
	G10209	2	Washer, 1/4" USS
29.	GD18010	-	Tee, 3/8" Tube Union
30.	GD17150-03	-	Nylon Tubing, 3/8" O.D. x 64', 12 Row Pull Row Units
	GD17150-04	-	Nylon Tubing, 3/8" O.D. x 86', 16 Row Pull Row Units
	GD17150-08	-	Nylon Tubing, 3/8" O.D. x 60', 11 Row Push Row Units
	GD17150-09	-	Nylon Tubing, 3/8" O.D. x 82', 15 Row Push Row Units
	GD17150-12	-	Nylon Tubing, 3/8" O.D. x 5', Even-Row Push Row Unit
31.	GD18011	-	Elbow, 3/8" x 1/8" NPT Extended
32.		-	See "Parallel Arms, Mounting Support Plate And Pneumatic Down Pressure Package", Pages P4 And P5
33.	GD18274	-	Tee, 3/8" x 1/8" NPT Extended, Push Row Unit
A.	GA12626	-	Air Compressor Assembly (Items 1-14)
B.	GA11995	-	Dual Solenoid Assembly (Items 15-25)

PARALLEL ARMS, MOUNTING SUPPORT PLATE AND QUICK ADJUSTABLE DOWN FORCE SPRINGS OPTION

RUB021/RUB022(RU78ff/B0366)

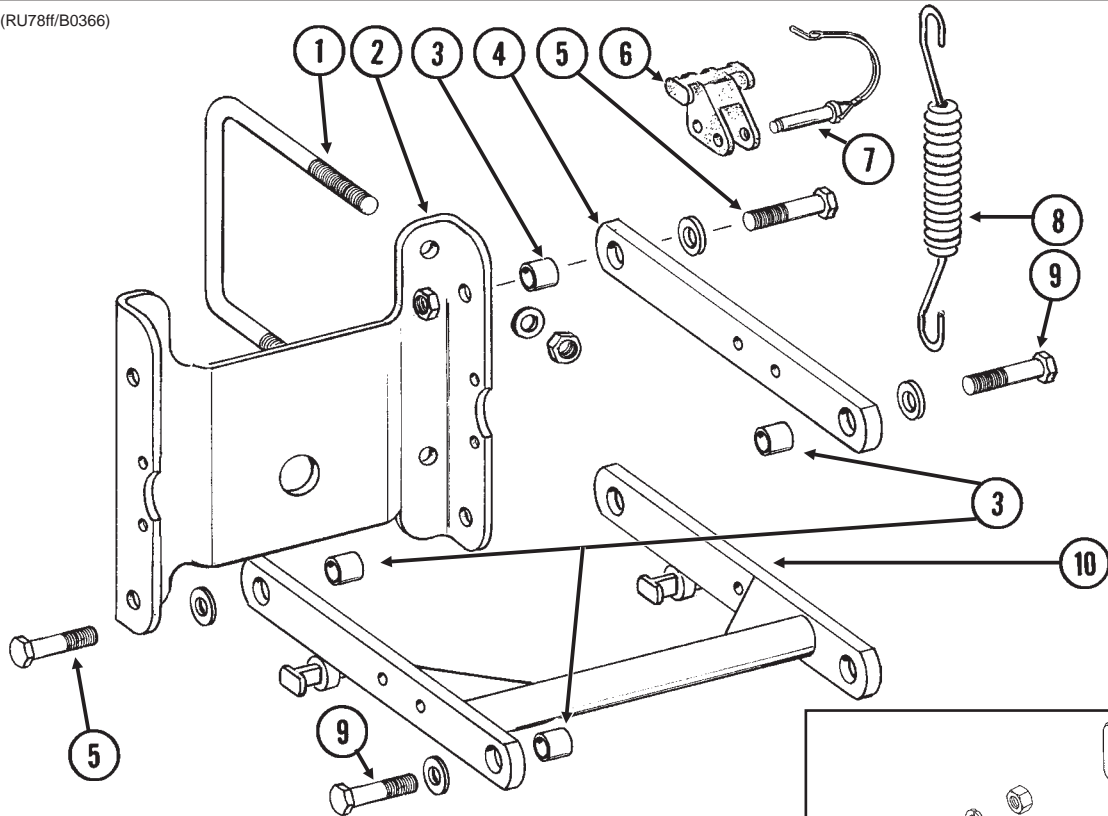

ITEM	PART NO.	QTY. (Per Row)	DESCRIPTION
1.	GD1113 G10230 G10104	2 4 4	U-Bolt, 5" x 7" x 5/8"-11 Lock Washer, 5/8" Hex Nut, 5/8"-11
2.	GD10036	1	Mounting Support Plate
3.	GB0218	4	Bushing, 2 1/32" I.D. x 7/8" O.D. x 1 9/32" Long
4.	GD11422	2	Upper Parallel Arm
5.	G10732 GD7805 G10412	4 4 4	Hex Head Cap Screw, 5/8"-18 x 2" Special Washer, 5/8", Hardened Lock Nut, 5/8"-18
6.	GB0186	2	Spring Anchor
7.	GD14217	2	Tab Lock Pin, 7/16" x 1 1/2"
8.	GD8249	2-4	Spring
9.		-	See "Hopper Support And Meter Drive", Page P18
10.	GA5651	1	Lower Parallel Arm
11.	GB0366	2	Extension Bracket
12.	G10007 G10230 G10104	4 4 4	Hex Head Cap Screw, 5/8"-11 x 1 1/2" Lock Washer, 5/8" Hex Nut, 5/8"-11
A.	G6325X	-	U-Bolt Package For 5" x 7" Toolbar, Includes: (2) GD1113, (4) G10230, (4) G10104

15" SEED OPENER DISC BLADE/BEARING ASSEMBLY AND SCRAPERS

(RU139)

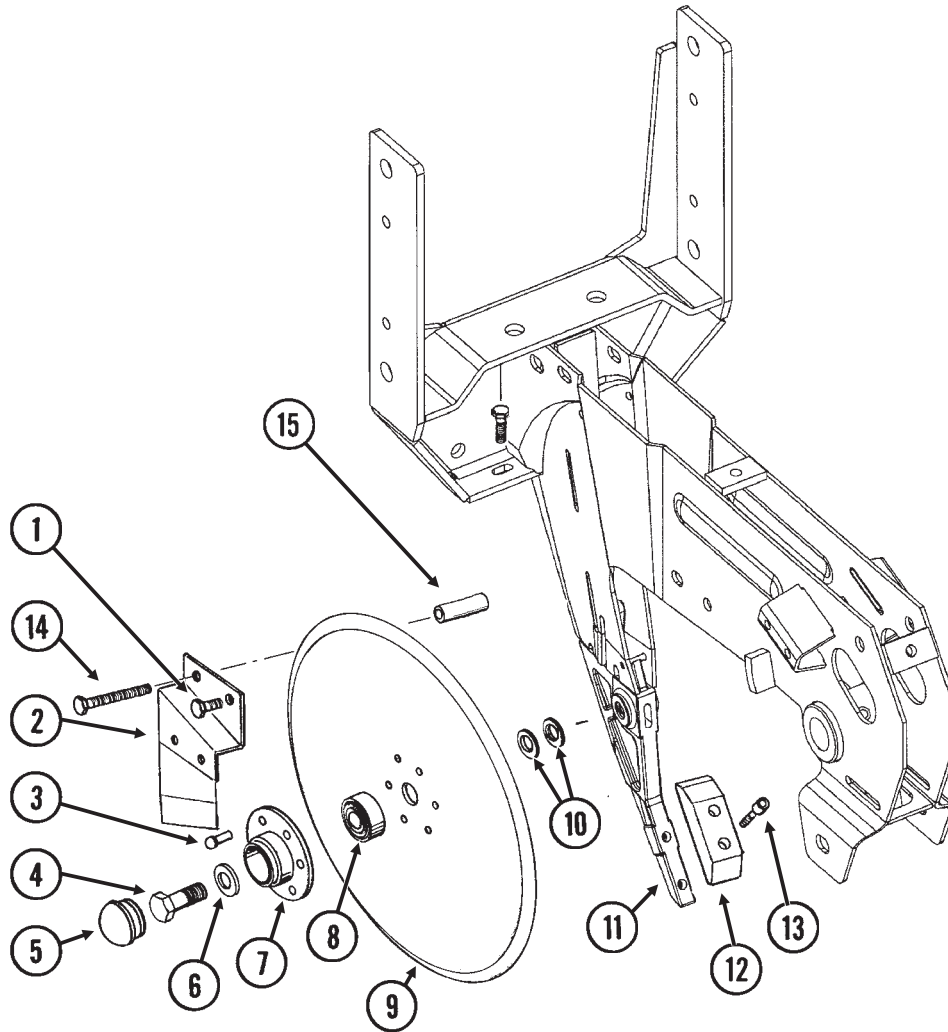

ITEM	PART NO.	QTY. (Per Row)	DESCRIPTION
1.	G10328	2	Hex Head Cap Screw, 3/8"-16 x 5/8"
	G10622	2	Serrated Flange Nut, 3/8"-16
2.	GA2012R	1	Disc Scraper, R.H.
	GA2012L	-	Disc Scraper, L.H. (Shown)
3.	G10427	12	Rivet, 1/4" x 1/2"
4.	GD11017	1	Special Hex Head Cap Screw, 5/8"-11 x 1 1/2", L.H. Threads
	G10007	1	Hex Head Cap Screw, 5/8"-11 x 1 1/2"
5.	GD11845	2	Dust Cap
6.	G10204	2	Special Machine Bushing, 5/8" x 1" O.D.
7.	GD10473	2	Bearing Housing
8.	GA2014	2	Bearing
9.	GD11306	2	Disc Blade, 3.5 mm x 15"
10.	G10213	-	Machine Bushing, 5/8" (.030" Thick)(As Required)
11.		-	See "Shank Assembly", Pages P2 And P3
12.	GB0301	1	Seed Tube Guard/Inner Scraper
13.	G10912	2	Hex Socket Head Cap Screw, 5/16"-18 x 1", Grade 8
14.	G10325	1	Hex Head Cap Screw, 3/8"-16 x 2 3/4"
	G10622	1	Serrated Flange Nut, 3/8"-16
15.	GD11259	1	Sleeve, 3/8" I.D. x 5/8" O.D. x 1 25/32" Long
A.	GA8324	-	Disc Blade/Bearing Assembly, Less Dust Cap (Items 3 And 7-9)

GAUGE WHEELS

(RU140)

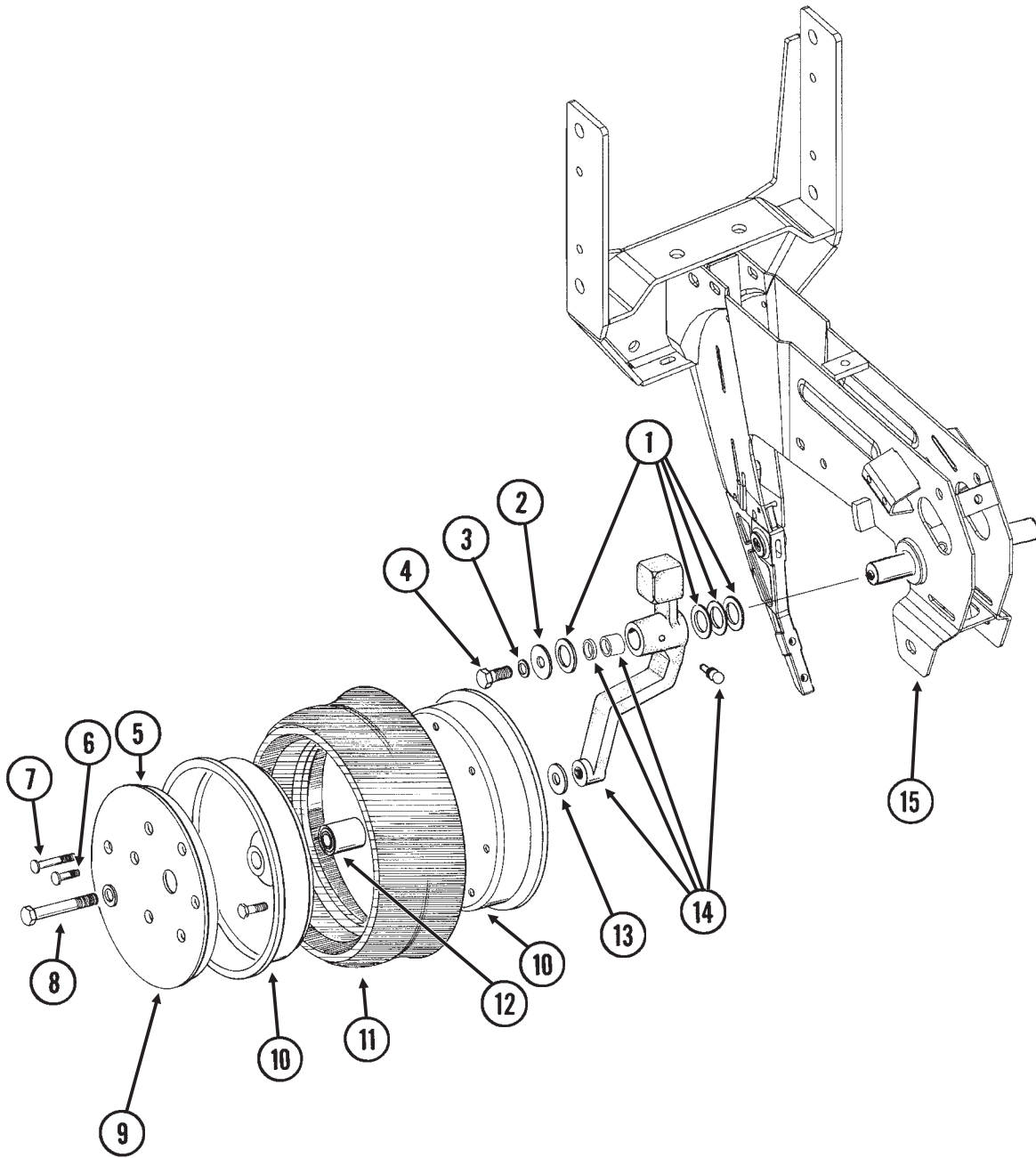

GAUGE WHEELS

ITEM	PART NO.	QTY. (Per Row)	DESCRIPTION
1.	G10940	-	Machine Bushing, 1" (.048" Thick)
2.	G10216	2	Washer, 1/2" USS
3.	G10228	2	Lock Washer, 1/2"
4.	G10014	1	Hex Head Cap Screw, 1/2"-13 x 1"
5.	GD11453	2	Cover
6.	G10338	12	Carriage Bolt, 5/16"-18 x 1 1/4"
	G10620	12	Serrated Flange Nut, 5/16"-18
7.	G10924	8	Carriage Bolt, 5/16"-18 x 1 3/4"
	G10620	8	Serrated Flange Nut, 5/16"-18
8.	G10010	2	Hex Head Cap Screw, 5/8"-11 x 3"
	G10230	2	Lock Washer, 5/8"
9.	G10018	14	Hex Head Cap Screw, 5/16"-18 x 5/8"
	G10109	14	Lock Nut, 5/16"-18, Grade 8
10.	GD11423	4	Half Wheel
11.	GD1086	2	Tire
12.	GA6171	2	Bearing
13.	G10204	2	Special Machine Bushing, 5/8" x 1" O.D.
14.	GA7975	1	Wheel Arm W/Grease Fitting, Bushings And Seals, L.H. (Shown)
	GA7976	1	Wheel Arm W/Grease Fitting, Bushings And Seals, R.H.
	G10640	1	Grease Fitting, 1/4"-28 (Per Arm)
	GB0276	2	Bushing, 1" I.D. x 1 1/4" O.D. x 1" Long (Per Arm)
	GD10991	2	Seal (Per Arm)
15.		-	See "Shank Assembly", Pages P2 And P3
A.	GA7949	-	Gauge Wheel Complete (Items 5-7 And 9-12)
B.	G1K296	-	Gauge Wheel Arm Bushing And Seal Driver Kit, Includes: (1) Seal Driver, (1) Bushing Driver, (1) Instruction

COVERING DISCS/SINGLE PRESS WHEEL

RUA054/RUB026(RU94d)

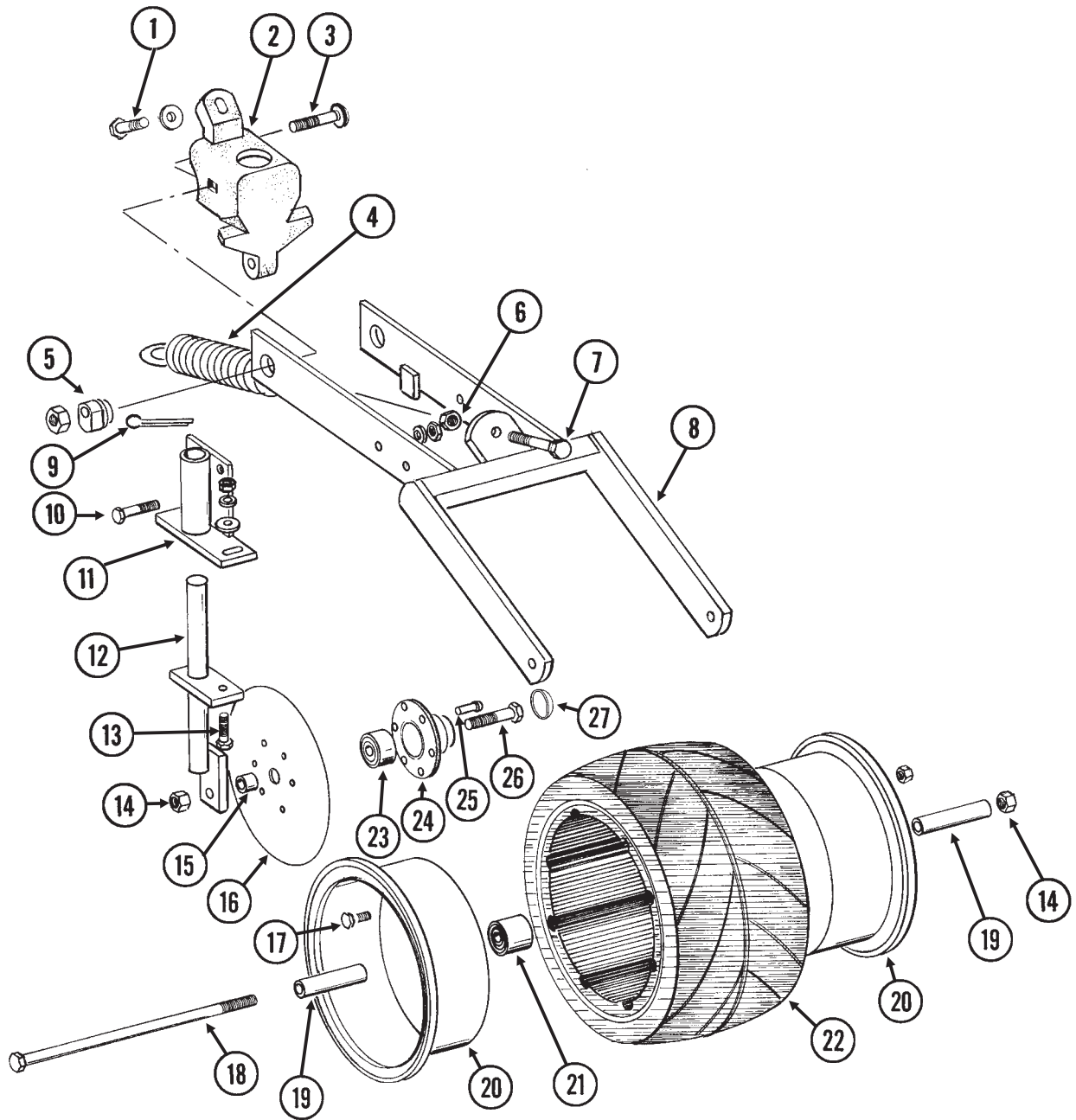

COVERING DISCS/SINGLE PRESS WHEEL

ITEM	PART NO.	QTY. (Per Row)	DESCRIPTION
1.	G10001	1	Hex Head Cap Screw, 3/8"-16 x 1"
	G10210	1	Washer, 3/8" USS
2.	GB0268	1	Wheel Arm Stop
3.	G10801	2	Carriage Bolt, 1/2"-13 x 2 1/4"
	G10315	-	Carriage Bolt, 1/2"-13 x 2 1/2" (Used W/Straight Drop In-Furrow Granular Chemical Bracket)
	G10102	2	Hex Nut, 1/2"-13
4.	GA2054	1	Spring
5.	GB0239	2	Eccentric Bushing
6.	G10102	1	Hex Nut, 1/2"-13
7.	G10015	1	Adjusting Bolt, 1/2"-13 x 5"
8.	GA6619	1	Mounting Arm
9.	G10463	2	Cotter Pin, 1/4" x 1 1/2"
10.	G10171	4	Hex Head Cap Screw, 5/16"-18 x 1 1/4"
	G10232	4	Lock Washer, 5/16"
	G10106	4	Hex Nut, 5/16"-18
11.	GA6620	2	Bracket
12.	GA6618	2	Mount
13.	G10303	2	Carriage Bolt, 5/16"-18 x 1"
	G10219	2	Washer, 5/16" USS
	G10232	2	Lock Washer, 5/16"
	G10106	2	Hex Nut, 5/16"-18
14.	G10107	3	Lock Nut, 5/8"-11
15.	GD1109	2	Bushing, 4 1/64" I.D. x 7/8" O.D. x 1/4" Long
16.	GD9290	2	Disc Blade, 8"
17.	G10018	7	Hex Head Cap Screw, 5/16"-18 x 5/8"
	G10109	7	Lock Nut, 5/16"-18, Grade 8
18.	G10152	1	Hex Head Cap Screw, 5/8"-11 x 9"
19.	GD3180-12	2	Sleeve, 5/8" I.D. x 7/8" O.D. x 2 7/8" Long
20.	GD9562	2	Half Wheel
21.	GA6171	1	Bearing
22.	GD9305	1	Tire
23.	GA2014	2	Bearing
24.	GD10473	2	Bearing Housing
25.	G10427	12	Rivet, 1/4" x 1/2"
26.	G10006	2	Hex Head Cap Screw, 5/8"-11 x 2 1/4"
27.	GD11845	2	Dust Cap
A.	GA6733	-	Single Press Wheel Complete W/Bearing (Items 17 And 20-22)
B.	GA6801	-	Covering Disc Blade Complete W/Bearing (Items 16 And 23-25)

"V" CLOSING WHEELS

(RU83i/RU83n)

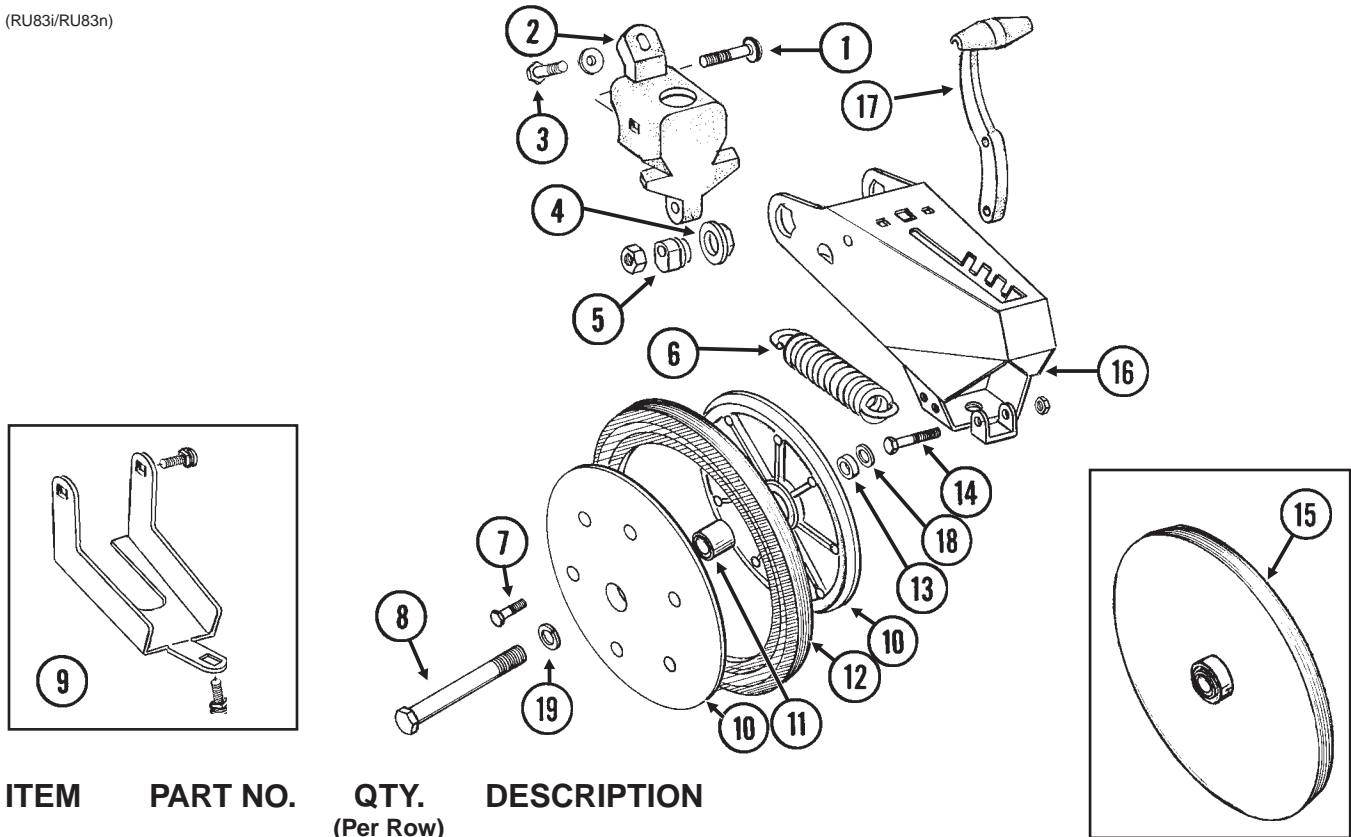

ITEM	PART NO.	QTY. (Per Row)	DESCRIPTION
1.	G10801	2	Carriage Bolt, 1/2"-13 x 2 1/4"
	G10111	2	Lock Nut, 1/2"-13
2.	GB0268	1	Wheel Arm Stop
3.	G10001	1	Hex Head Cap Screw, 3/8"-16 x 1"
	G10210	1	Washer, 3/8" USS
4.	GB0282	2	Stepped Bushing
5.	GB0239	2	Eccentric Bushing
6.	GD8460	1	Spring
7.	G10064	6	Hex Head Cap Screw, 1/4"-20 x 1"
8.	G10013	2	Hex Head Cap Screw, 5/8"-11 x 3 1/2"
	G10107	2	Lock Nut, 5/8"-11
9.	G1K345	-	Closing Wheel Shield Kit W/Hardware And Instruction
	G10308	2	Carriage Bolt, 3/8"-16 x 3/4"
	G10599	1	Carriage Bolt, 3/8"-16 x 1 1/4"
	G10210	1	Washer, 3/8" USS
	G10229	3	Lock Washer, 3/8"
	G10101	3	Hex Nut, 3/8"-16
10.	GD9120	4	Nylon Half Wheel
11.	GA6171	2	Bearing
12.	GD1085	2	Rubber Tire, 1" x 12"
13.	GD1109	2	Bushing, 4 1/64" I.D. x 7/8" O.D. x 1/4" Long
14.	G10133	1	Hex Head Cap Screw, 5/16"-18 x 1 1/2"
	G10109	1	Lock Nut, 5/16"-18, Grade 8
15.	GA6597	-	Cast Iron Closing Wheel W/Bearing
	GA6171	-	Bearing
16.	GA8322	1	Arm
17.	GB0254	1	Lever
18.	GD7805	2	Special Washer, 5/8", Hardened
19.	G10230	2	Lock Washer, 5/8"
A.	GA6434	-	Rubber Closing Wheel Complete W/Bearing (Items 7 And 10-12)

DRAG CLOSING ATTACHMENT

RUB050(RU90c)

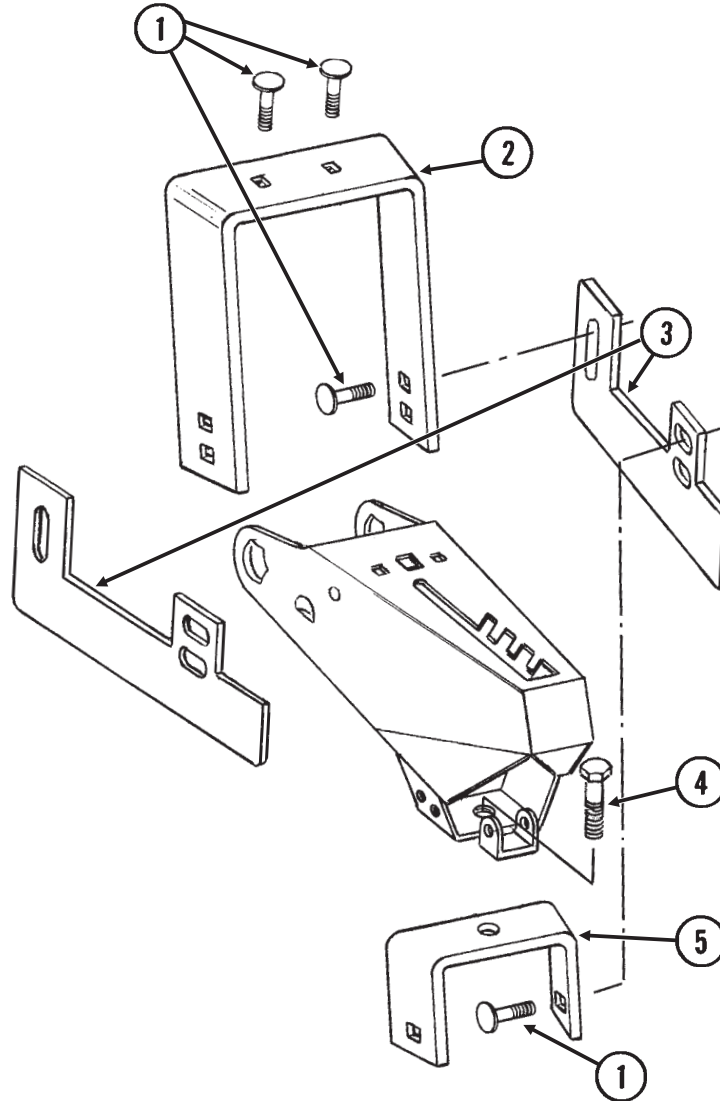

ITEM	PART NO.	QTY. (Per Row)	DESCRIPTION
1.	G10599	6	Carriage Bolt, 3/8"-16 x 1 1/4"
	G10210	6	Washer, 3/8" USS
	G10229	6	Lock Washer, 3/8"
	G10101	6	Hex Nut, 3/8"-16
2.	GD11508	1	Front Bracket
3.	GD11313	2	Blade
4.	G10007	1	Hex Head Cap Screw, 5/8"-11 x 1 1/2"
	G10230	1	Lock Washer, 5/8"
	G10104	1	Hex Nut, 5/8"-11
5.	GD11509	1	Rear Bracket
A.	G7566X	-	Drag Closing Attachment Complete (Items 1-5)

HOPPER SUPPORT AND METER DRIVE

(METR72)

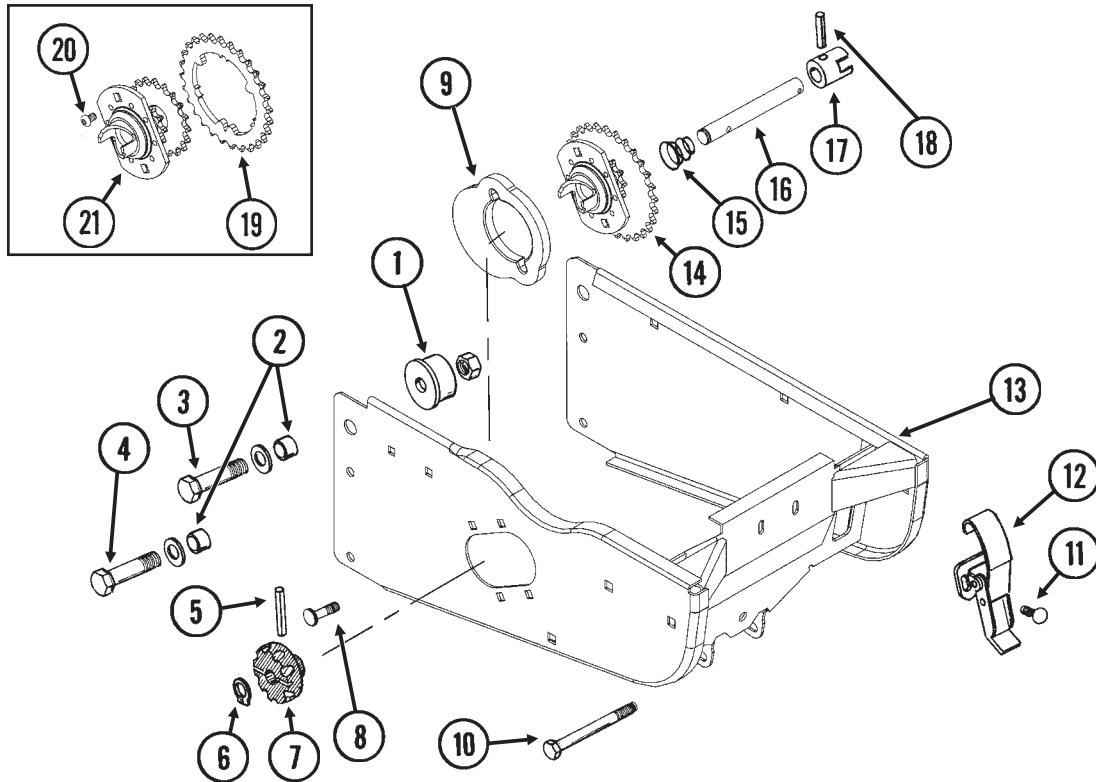

ITEM	PART NO.	QTY. (Per Row)	DESCRIPTION
1.	GB0314	2	Hopper Mount
2.	GB0218	4	Bushing, 2 ¹ / ₃₂ " I.D. x 7/8" O.D. x 1 ⁹ / ₃₂ " Long
3.	G10752	2	Hex Head Cap Screw, 5/8"-18 x 2 1/4"
	GD7805	2	Special Washer, 5/8", Hardened
	G10412	2	Lock Nut, 5/8"-18
4.	G10751	2	Hex Head Cap Screw, 5/8"-18 x 1 3/4"
	GD7805	2	Special Washer, 5/8", Hardened
	G10412	2	Lock Nut, 5/8"-18
5.	G10602	1	Spring Pin, 1/4" x 1 1/2"
6.	G10567	1	External Retaining Ring, 5/8"
7.	GD11239	1	Knob
8.	G10338	2	Carriage Bolt, 5/16"-18 x 1 1/4"
	G10620	2	Serrated Flange Nut, 5/16"-18
9.	GB0331	1	Clutch Adapter Plate
10.	G10061	1	Hex Head Cap Screw, 3/8"-16 x 3 1/2"
	G10210	2	Washer, 3/8" USS
	G10108	1	Lock Nut, 3/8"-16
11.	G10309	2	Carriage Bolt, 1/4"-20 x 5/8", Grade 2
	G10621	2	Serrated Flange Nut, 1/4"-20
12.	GA2007	1	Hopper Hold Down Latch
13.	GA10155	1	Hopper Support
14.	GA12143	1	Double Sprocket And Bearing, Drive Clutch, 11/28 Tooth
15.	GD11413	1	Spring
16.	GD15747	1	Shaft
17.	GB0278	1	Coupler
18.	G10546	1	Spring Pin, 3/16" x 1 1/4"
19.	GD17192	1	Bolt-On Sprocket, 28 Tooth
20.	G11222	3	Hex Socket Button Head Cap Screw, 5/16"-18 x 1/2", Stainless Steel
	G10620	3	Serrated Flange Nut, 5/16"-18
21.	GA10137	1	Double Sprocket And Bearing, Drive Clutch, 11/19 Tooth
A.	GA12144	-	Meter Drive Assembly, 11/28 Tooth (Items 5-7 And 14-18)

SEED HOPPER AND LID

(METR12)

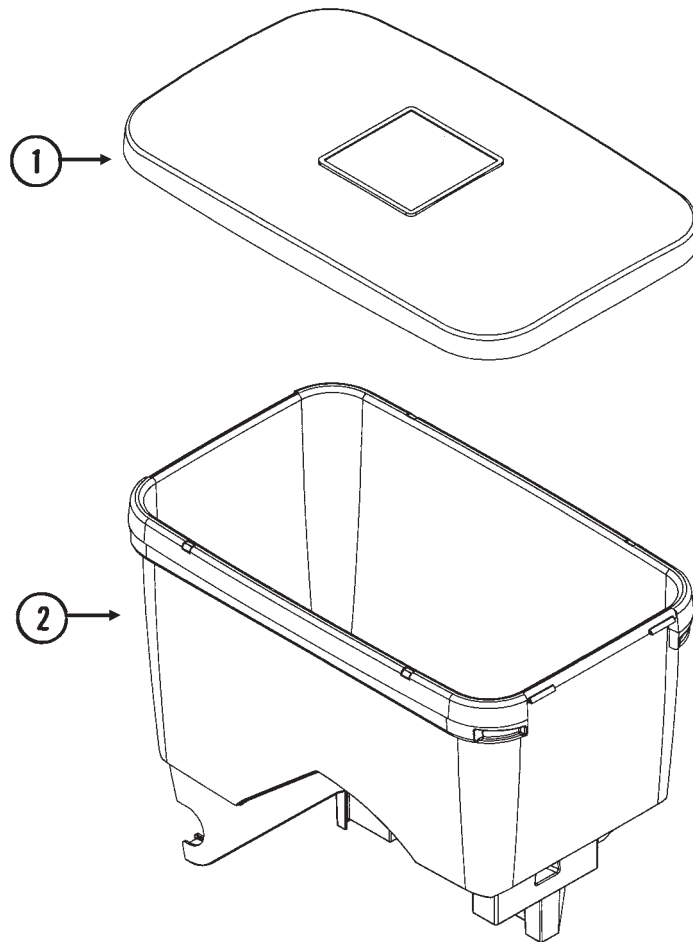



ITEM	PART NO.	QTY.	DESCRIPTION
1.	GD11279	1	Lid
2.	GA10634	1	Seed Hopper

SEED METER

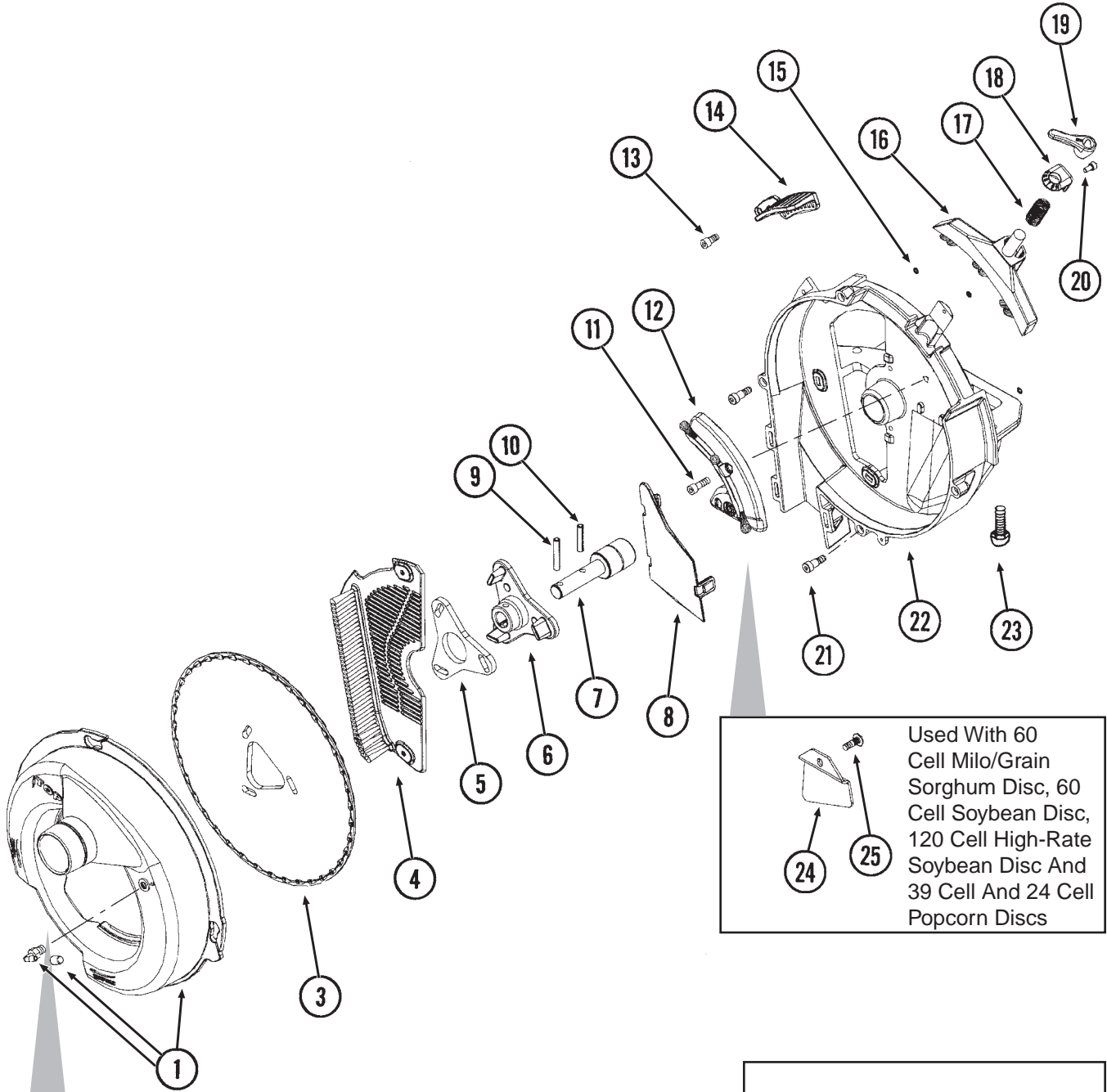
(METR69/METR65/A12133)



Used With 60 Cell Milo/Grain Sorghum Disc, 60 Cell Soybean Disc, 120 Cell High-Rate Soybean Disc And 39 Cell And 24 Cell Popcorn Discs

	<p>2 Used With 60 Cell Milo/Grain Sorghum Disc</p>
	<p>27 Used With 20 Cell Hill-Drop Acid-Delinted Cotton Discs; 54 Cell Acid-Delinted Cotton/ Small Dry Edible Bean Disc; And Small Cotton/Sunflower Disc</p>

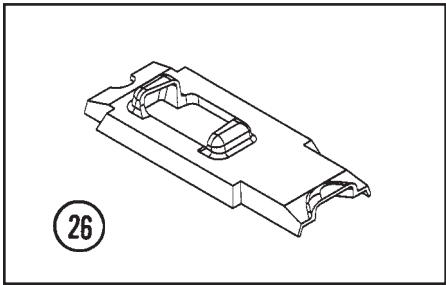

SEED METER

ITEM	PART NO.	QTY.	DESCRIPTION
1.	GA11911	1	Vacuum Cover W/Elbow And Cap
	GD17099	-	3/16" Hose Barb Elbow
	GD17152	-	Cap
2.	GA12133	1	Cleanout Brush (Used With 60 Cell Milo/Grain Sorghum Disc)
3.	GD17049	-	Seed Disc, Corn/Popcorn, 39 Cell, Light Blue Color-Coded
	GD17048	-	Seed Disc, Low-Rate Corn/Popcorn, 24 Cell, Light Green Color-Coded
	GD14467	-	Seed Disc, Soybean, 60 Cell, Black Color-Coded
	GD14468	-	Seed Disc, High-Rate Soybean, 120 Cell, Dark Blue Color-Coded
	GD17050	-	Seed Disc, Milo/Grain Sorghum, 60 Cell, Yellow Color-Coded
	GD17187	-	Seed Disc, Hill-Drop Cotton, Acid-Delinted, 3 Seeds Per Cell, 20 Cell, Brown Color-Coded
	GD18095	-	Seed Disc, Small Hill-Drop Cotton, Acid-Delinted, 20 Cell (3 Seeds Per Cell), Grey Color-Coded
	GD17186	-	Seed Disc, Cotton, Acid-Delinted/Small Dry Edible Bean, 54 Cell, Dark Green Color-Coded
	GD18098	-	Seed Disc, Small Cotton/Sunflower, 54 Cell, White Color-Coded
	GD14477	-	Seed Disc, Large Dry Edible Bean, 54 Cell, Tan Color-Coded
4.	GD17028	1	Wall Brush/Vent
5.	GD17021	1	Foam Spacer
6.	GB0328	1	Mount
7.	GA5698	1	Bearing
8.	GD14541	1	Discharge Cover
9.	G10602	1	Spring Pin, 1/4" x 1 1/2"
10.	G10603	1	Spring Pin, 1/4" x 1 1/4"
11.	G11213	1	Hex Socket Head Cap Screw, 1/4"-20 x 3/4"
12.	GA11935	1	Crowder Brush
13.	G10260	1	Hex Socket Head Cap Screw, 1/4"-20 x 1/2"
14.	GD17047	1	Air Inlet Screen
15.	GD17162	3	Push Nut, 1/8" I.D.
16.	GA10755	1	Singulator Brush
17.	GD14592	1	Spring
18.	GB0358	1	Cap
19.	GD15663	1	Brush Adjustment Lever
20.	G11173	1	Hex Socket Head Cap Screw, No. 10-24 x 3/8", Stainless Steel
21.	G11172	4	Hex Socket Head Shoulder Screw, 1/4"-20 x 3/8", Stainless Steel
22.	GB0319	1	Housing
23.	G11009	2	Locking Thumbscrew, 5/16"-18 x 3/4"
24.	GD17104	1	Seed Baffle (Used With 60 Cell Milo/Grain Sorghum Disc, 60 Cell Soybean Disc, 120 Cell High-Rate Soybean Disc And 39 Cell And 24 Cell Popcorn Discs)
25.	G11210	1	Rib Neck Bolt, 1/4"-20 x 3/4"
	G10323	1	Hex Flange Nut, 1/4"-20, No Serrations
26.	GD15700	1	Shank Cover, EdgeVac® Meter
27.	GA12154	-	Cleanout Brush W/Ball-Type Ejector (Used With 20 Cell Hill-Drop Acid-Delinted Cotton Discs And 54 Cell Acid-Delinted Cotton/Small Dry Edible Bean And Small Cotton/Sunflower Discs)

SPRING TOOTH INCORPORATOR

RUA055(RU95)

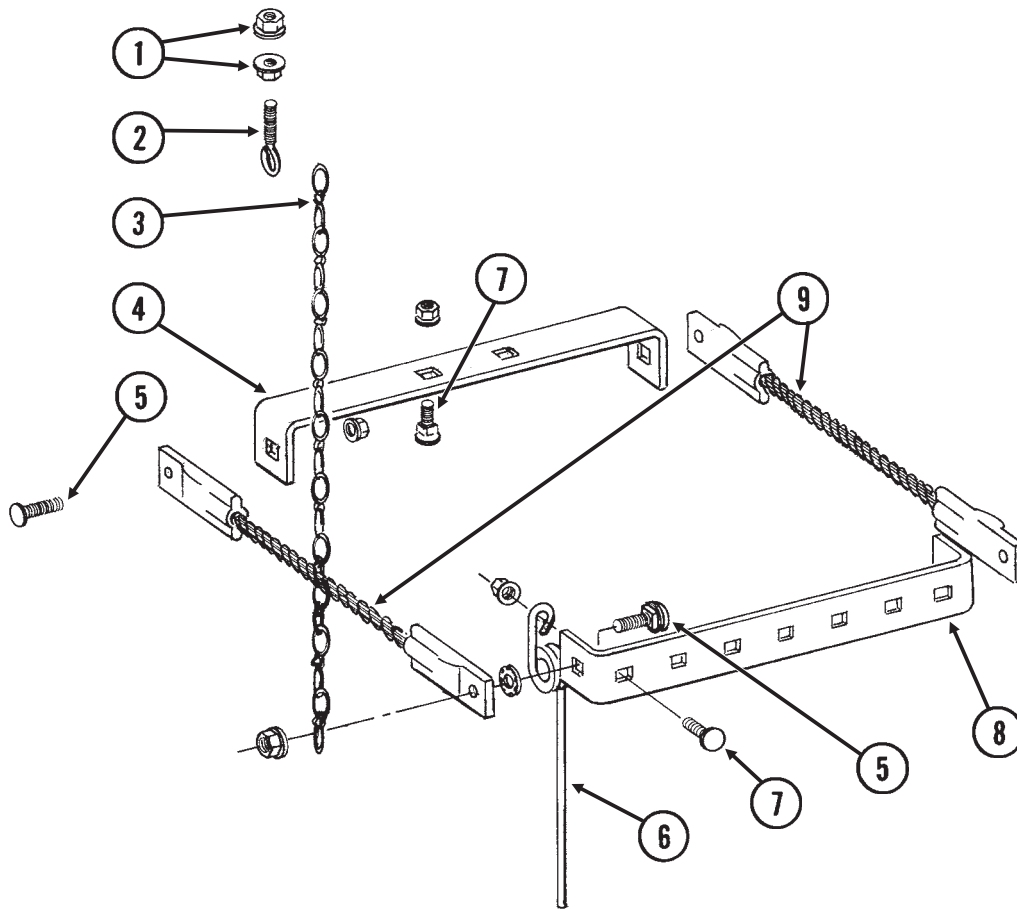

ITEM	PART NO.	QTY. (Per Row)	DESCRIPTION
1.	G10621	4	Serrated Flange Nut, 1/4"-20
2.	GD2460	2	Eyebolt, 1/4"-20
3.	G3305-01	4	Twin Loop Chain, 9 Links
4.	GD1143	1	Front Bracket
5.	G10305	4	Carriage Bolt, 3/8"-16 x 1"
	G10529	4	External Tooth Lock Washer, 3/8"
	G10622	4	Serrated Flange Nut, 3/8"-16
6.	GD1145	7	Spring Tooth
7.	G10308	9	Carriage Bolt, 3/8"-16 x 3/4"
	G10622	9	Serrated Flange Nut, 3/8"-16
8.	GD1144	1	Rear Bracket
9.	GA2094	2	Cable Assembly

ROW UNIT MOUNTED NO TILL COULTER

(D14398/RU102c/RU152)

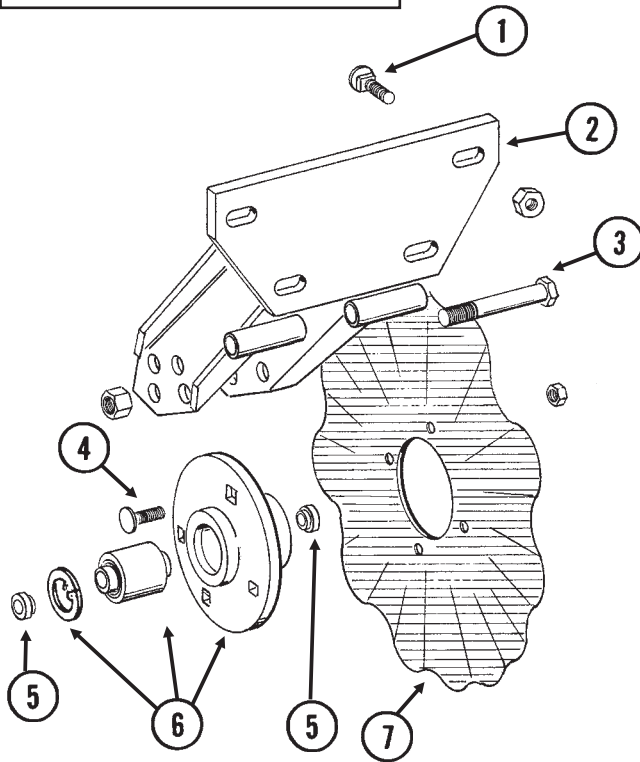
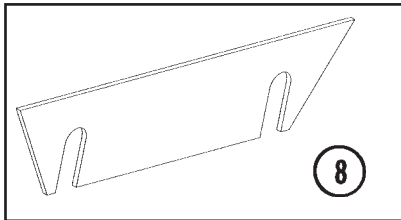

STYLE A

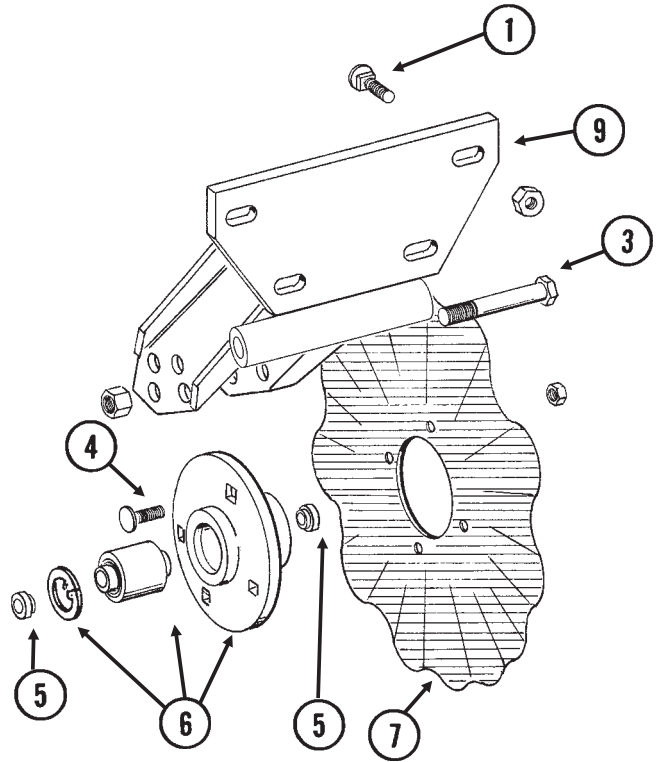

STYLE B

ITEM	PART NO.	QTY. (Per Row)	DESCRIPTION
1.	G10574	4	Carriage Bolt, 1/2"-13 x 1 1/4"
	G10111	4	Lock Nut, 1/2"-13
2.	GA5625	1	Arm (Style A)
3.	G10036	1	Hex Head Cap Screw, 5/8"-11 x 4"
	G10107	1	Lock Nut, 5/8"-11
4.	G10574	4	Carriage Bolt, 1/2"-13 x 1 1/4"
	G10111	4	Lock Nut, 1/2"-13
5.	GD11677	2	Adapter
6.	GA8641	1	Hub W/Bearing And Retaining Ring
	GA8603	-	Bearing, Double Row
	GD11652	-	Retaining Ring, 2 7/16"
7.	GD7803	-	Disc Blade, Fluted, 1", 8 Flutes (Shown)
	GD7804	-	Disc Blade, Bubbled, 1"
	GD9254	-	Disc Blade, Fluted, 3/4", 13 Flutes
	GD14398	-	Spacer
8.	GD14398	-	Spacer
9.	GA11520	1	Arm (Style B)

ROW UNIT MOUNTED DISC FURROWER

RUA059/RUA058(RU99/RU98g)

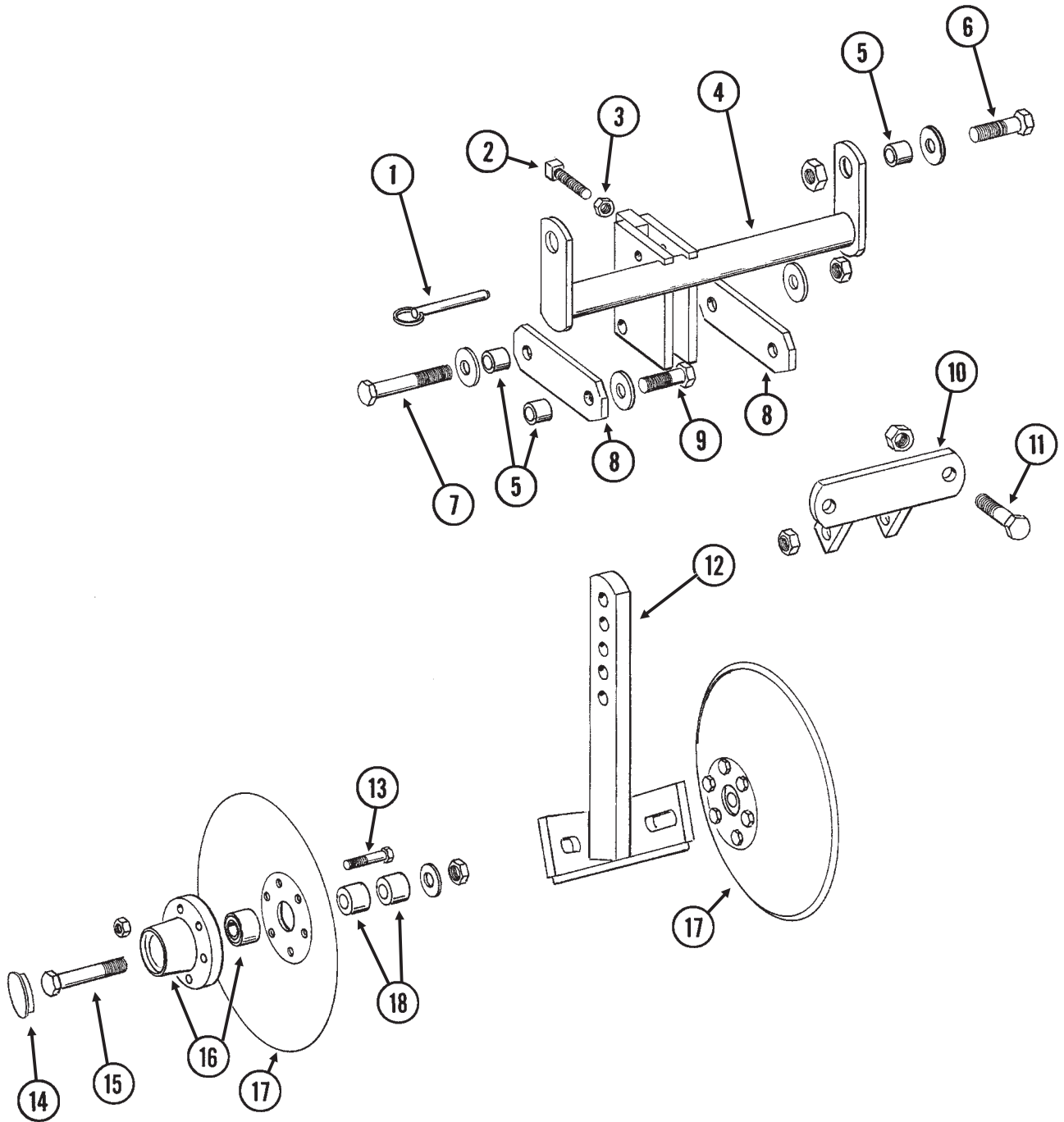

ROW UNIT MOUNTED DISC FURROWER

ITEM	PART NO.	QTY. (Per Row)	DESCRIPTION
1.	G10536	1	Detent Pin, 1/2" x 2 1/2" Grip
2.	G10597	1	Square Head Set Screw, 5/8"-11 x 2 1/4"
3.	G10503	1	Hex Jam Nut, 5/8"-11, Grade 2
4.	GA5719	1	Mounting Bracket
5.	GD7889	6	Bushing, 1" O.D. x 9/16" I.D. x 7/16" Long
6.	G10039	2	Hex Head Cap Screw, 1/2"-13 x 1 3/4"
	GD14674	2	Special Washer, 1/2", Hardened
	G10111	2	Lock Nut, 1/2"-13
7.	G10585	1	Hex Head Cap Screw, 1/2"-13 x 3 1/4"
	G10216	2	Washer, 1/2" USS
	G10111	1	Lock Nut, 1/2"-13
8.	GD7890	2	Link
9.	G10017	2	Hex Head Cap Screw, 1/2"-13 x 1 1/2"
	G10216	2	Washer, 1/2" USS
	G10111	2	Lock Nut, 1/2"-13
10.	GA5715	1	Anchor
11.	G10017	2	Hex Head Cap Screw, 1/2"-13 x 1 1/2"
	G10111	2	Lock Nut, 1/2"-13
12.	GA5718	1	Support Arm
13.	G10572	6	Truss Head Slotted Machine Screw, 5/16"-18 x 7/8"
	G10106	6	Hex Nut, 5/16"-18
14.	GD1132	2	Dust Cap
15.	G10318	2	Hex Head Cap Screw, 5/8"-11 x 4 1/2"
	GD7805	2	Special Washer, 5/8", Hardened
	G10107	2	Lock Nut, 5/8"-11
16.	GA5654	2	Hub W/Bearings
	GA2014	-	Bearing
17.	GD7823	-	Disc Blade, Solid, 12" (Shown)
	GD8307	-	Disc Blade, Notched, 12"
18.	GD7817-01	2	Spacer, 1 1/16" I.D. x 3/4" Long
	GD7817-04	2	Spacer, 1 1/16" I.D. x 1/2" Long

ROW UNIT MOUNTED RESIDUE WHEEL

(RU103dd/RU103d)

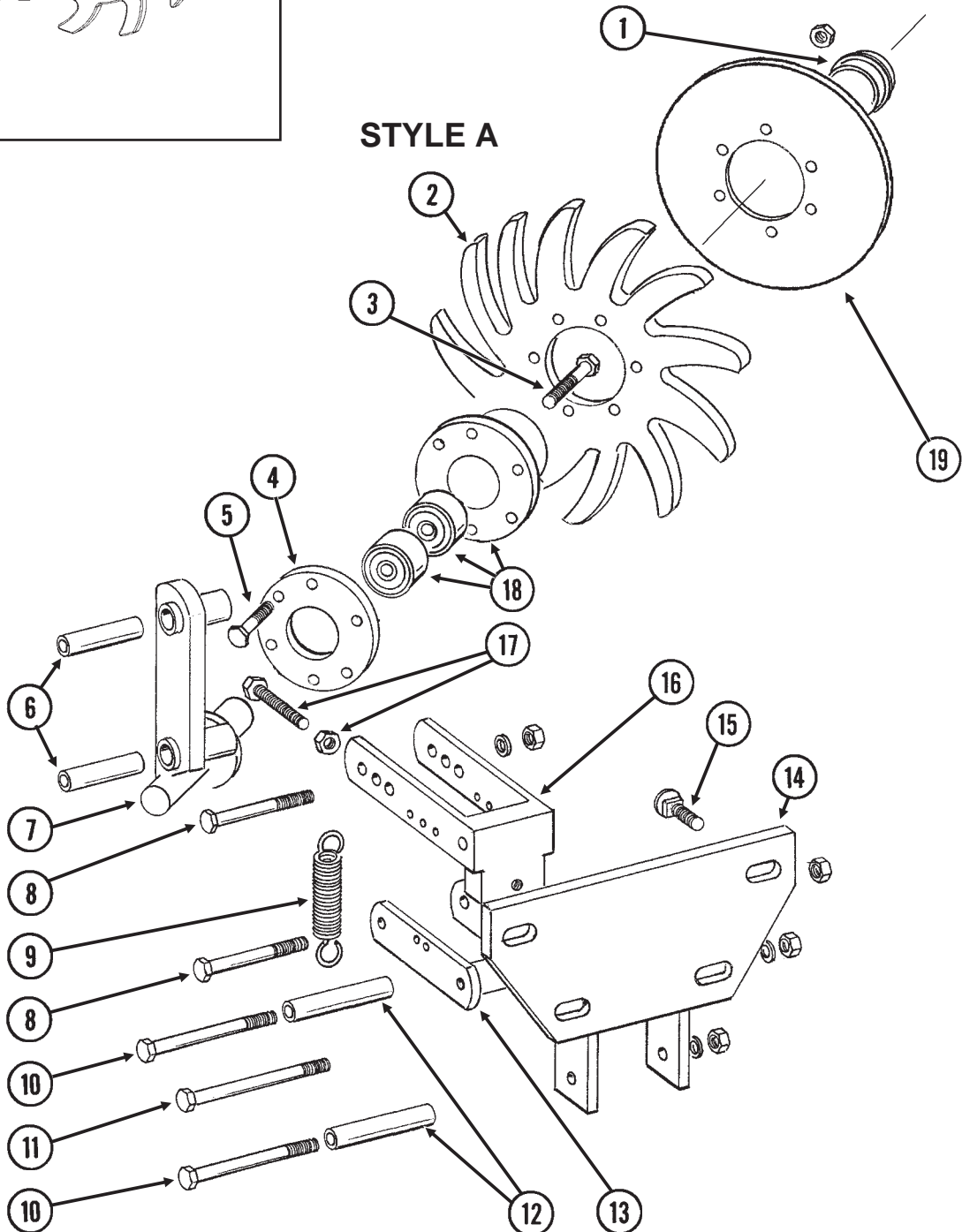
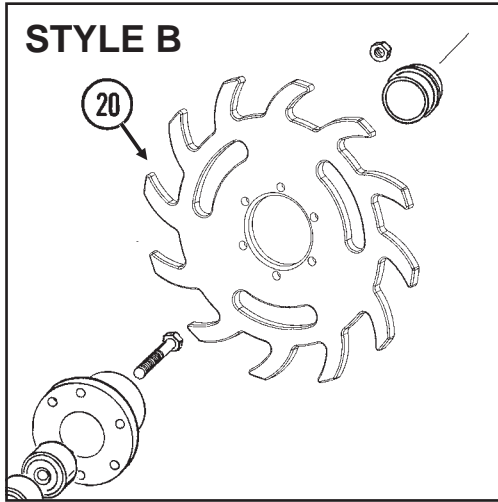

ROW UNIT MOUNTED RESIDUE WHEEL

ITEM	PART NO.	QTY. (Per Row)	DESCRIPTION
1.	GD1132	1	Dust Cap
2.	GD10552	1	Wheel, 12 Tine, 3/8" x 12"
3.	G10006	1	Hex Head Cap Screw, 5/8"-11 x 2 1/4"
4.	GD9724	1	Backing Plate
5.	G10133	6	Hex Head Cap Screw, 5/16"-18 x 1 1/2"
	G10109	6	Lock Nut, 5/16"-18, Grade 8
6.	GD9720	2	Spacer, 1/2" x 2 3/16" Long
7.	GA6838	1	Wheel Mount
8.	G10033	2	Hex Head Cap Screw, 1/2"-13 x 3 1/2"
	G10228	2	Lock Washer, 1/2"
	G10102	2	Hex Nut, 1/2"-13
9.	GD5857	2	Spring
10.	G10045	2	Hex Head Cap Screw, 1/2"-13 x 4 1/2"
	G10228	2	Lock Washer, 1/2"
	G10102	2	Hex Nut, 1/2"-13
11.	G10348	1	Hex Head Cap Screw, 1/2"-13 x 5" (Lockup Bolt)
	G10111	1	Lock Nut, 1/2"-13
12.	GD9715	2	Spacer, 1/2" x 3" Long
13.	GA6834	1	Lower Link
14.	GA6832	1	Mount
15.	G10574	4	Carriage Bolt, 1/2"-13 x 1 1/4"
	G10111	4	Lock Nut, 1/2"-13
16.	GA6833	1	Upper Link
17.	G10371	1	Hex Head Cap Screw, 1/2"-13 x 3", Full Thread
	G10501	1	Hex Jam Nut, 1/2"-13, Grade 2
18.	GA5654	1	Hub W/Bearings
	GA2014	-	Bearing
19.	GD12534	-	Cover
20.	GB0387	1	Wheel, 12 Tine, 3/8" x 12"
A.	GA7446	-	Wheel Assembly, 12 Tine, R.H. (Items 2, 4, 5 And 18)
B.	GA12236	-	Wheel Assembly, 12 Tine, R.H. (Items 4, 5, 18 And 20)

COULTER MOUNTED RESIDUE WHEELS

(RU104uuu/RU153)

STYLE A - Used With Style A Row Unit Mounted No Till Coulter

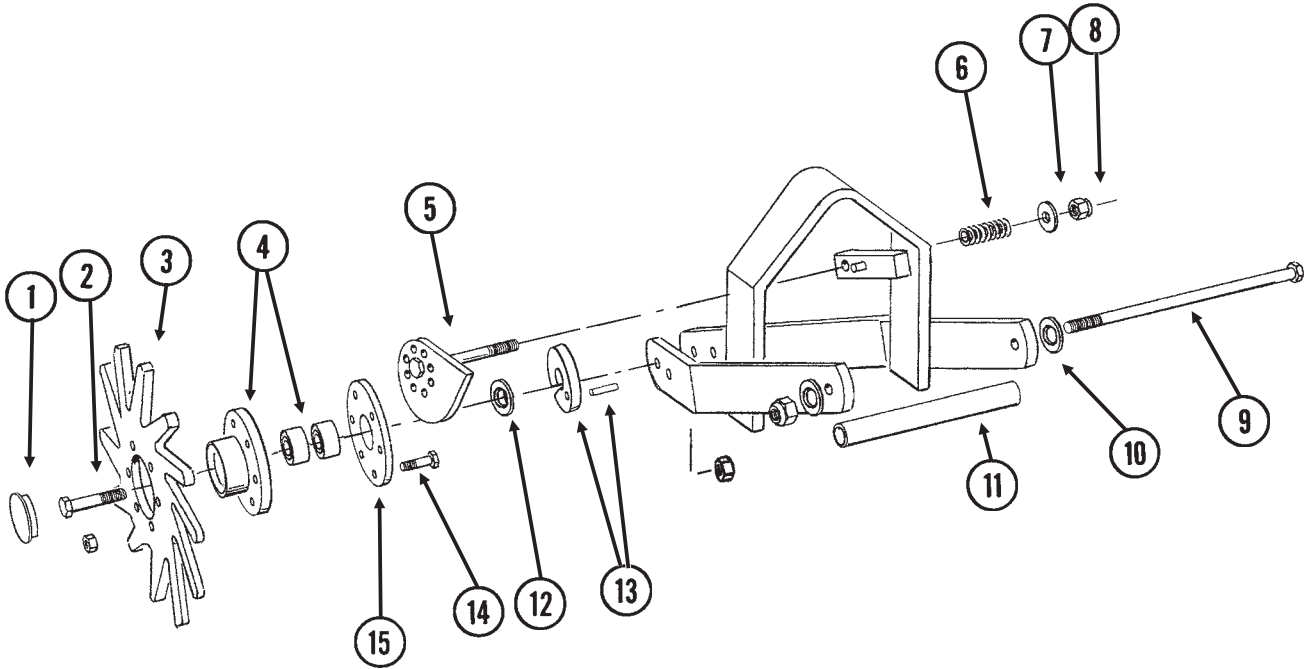

STYLE B - Used With Style B Row Unit Mounted No Till Coulter

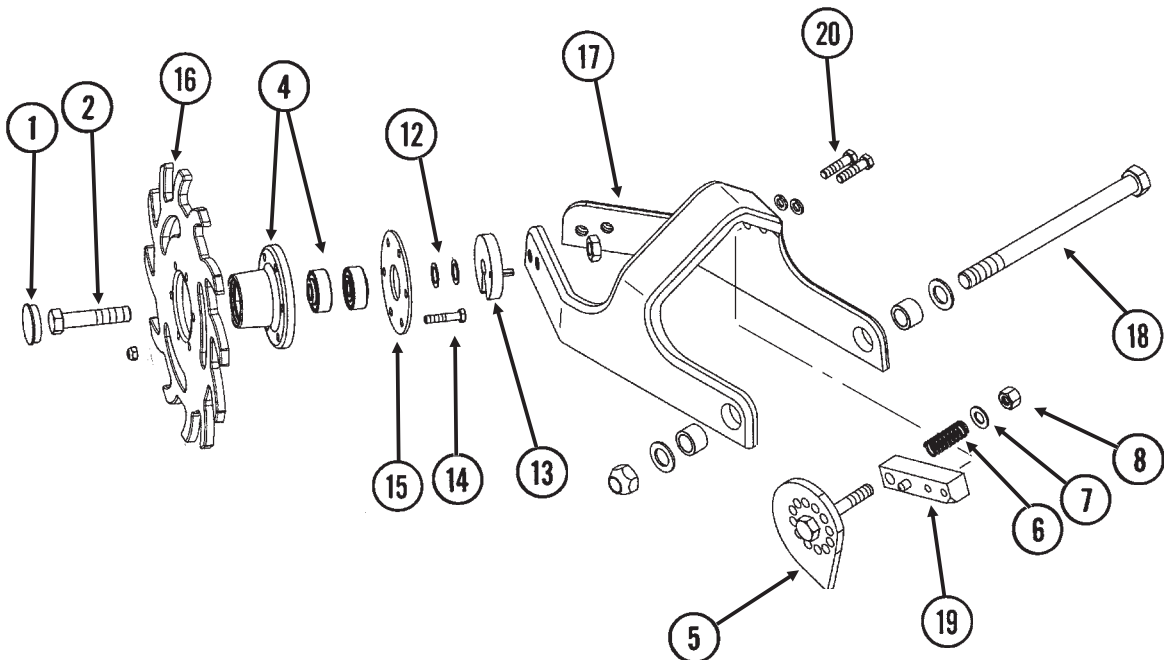

COULTER MOUNTED RESIDUE WHEELS

ITEM	PART NO.	QTY. (Per Row)	DESCRIPTION
1.	GD1132	2	Dust Cap
2.	G10010	2	Hex Head Cap Screw, 5/8"-11 x 3"
	G10503	2	Hex Jam Nut, 5/8"-11, Grade 2
3.	GD10552	2	Wheel, 12 Tine, 3/8" x 12"
4.	GA5654	2	Hub W/Bearings
	GA2014	-	Bearing
5.	GA7412	1	Cam
6.	GD10519	1	Spring
7.	G10206	1	Washer, 1/2" SAE
8.	G10974	1	Lock Nut W/Nylon Insert, 1/2"-13
9.	G11098	1	Hex Head Cap Screw, 1/2"-13 x 9 1/2", Grade 8
	GD14674	2	Special Washer, 1/2", Hardened
	G10974	1	Lock Nut W/Nylon Insert, 1/2"-13
10.	GA7271	1	Mount
11.	GD10526	1	Sleeve, 7 1/2"
12.	G10213	2-4	Machine Bushing, 5/8" (.030" Thick)
13.	GA8760	2	Weed Guard W/Spring Pin
	G10765	-	Spring Pin, 1/4" x 1"
14.	G10133	12	Hex Head Cap Screw, 5/16"-18 x 1 1/2"
	G10109	12	Lock Nut, 5/16"-18, Grade 8
15.	GD9724	2	Backing Plate
16.	GB0387	2	Wheel, 12 Tine, 3/8" x 12"
17.	GB0401	1	Mount
18.	G11236	1	Hex Head Cap Screw, 3/4"-10 x 10 1/2"
	GB0383	2	Bushing, 1 1/8" O.D. x 25/32" I.D. x 3/4" Long
	G10194	2	Washer, 3/4" SAE
	G11228	1	Lock Nut, 3/4"-10
19.	GA12256	1	Locking Pin
20.	G10003	2	Hex Head Cap Screw, 3/8"-16 x 1 1/2"
	G10229	2	Lock Washer, 3/8"
A.	GA7446	-	Wheel Assembly, 12 Tine, R.H. (Items 3, 4, 14 And 15) (Shown)
	GA7445	-	Wheel Assembly, 12 Tine, L.H. (Items 3, 4, 14 And 15)
B.	GA12236	-	Wheel Assembly, 12 Tine, R.H. (Items 4, 14, 15 And 16) (Shown)
	GA12235	-	Wheel Assembly, 12 Tine, L.H. (Items 4, 14, 15 And 16)
C.	G1K467	-	Residue Wheel Mount Kit (Items 17-20)

FRAME MOUNTED COULTER W/RESIDUE WHEELS

(RU135c/RU135g/RU153b/RU135hh)

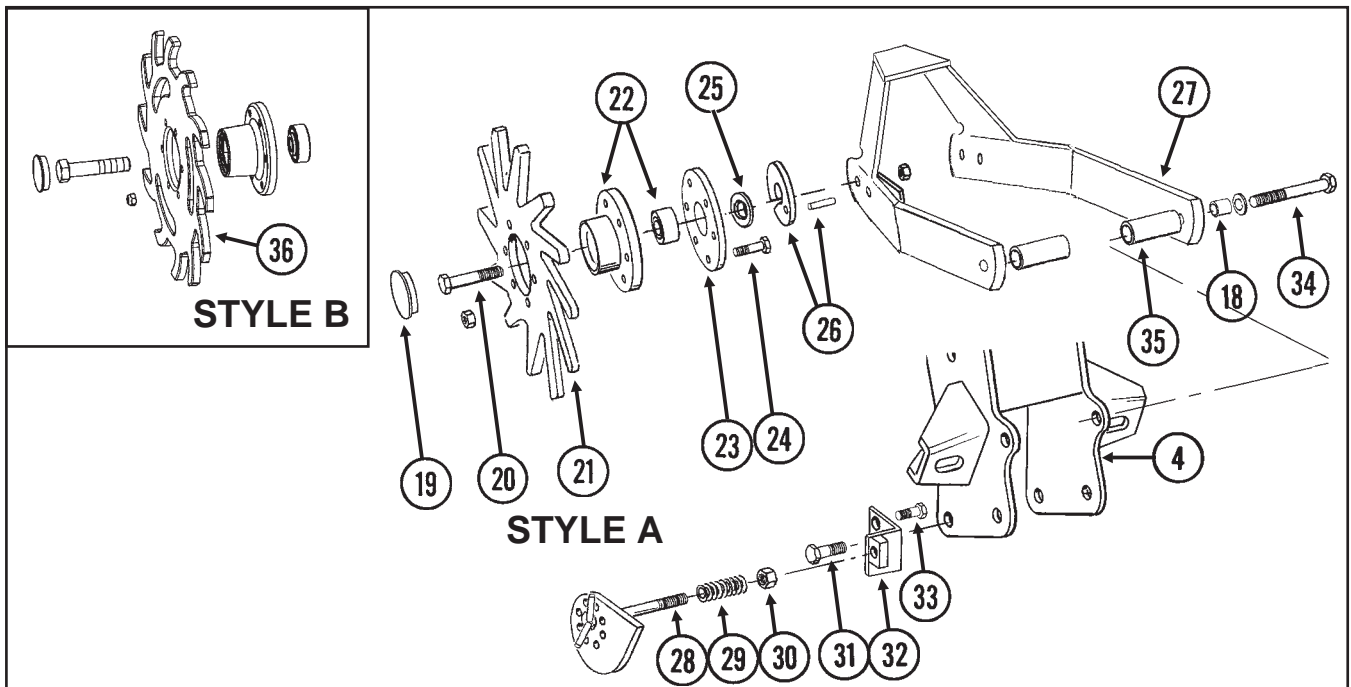
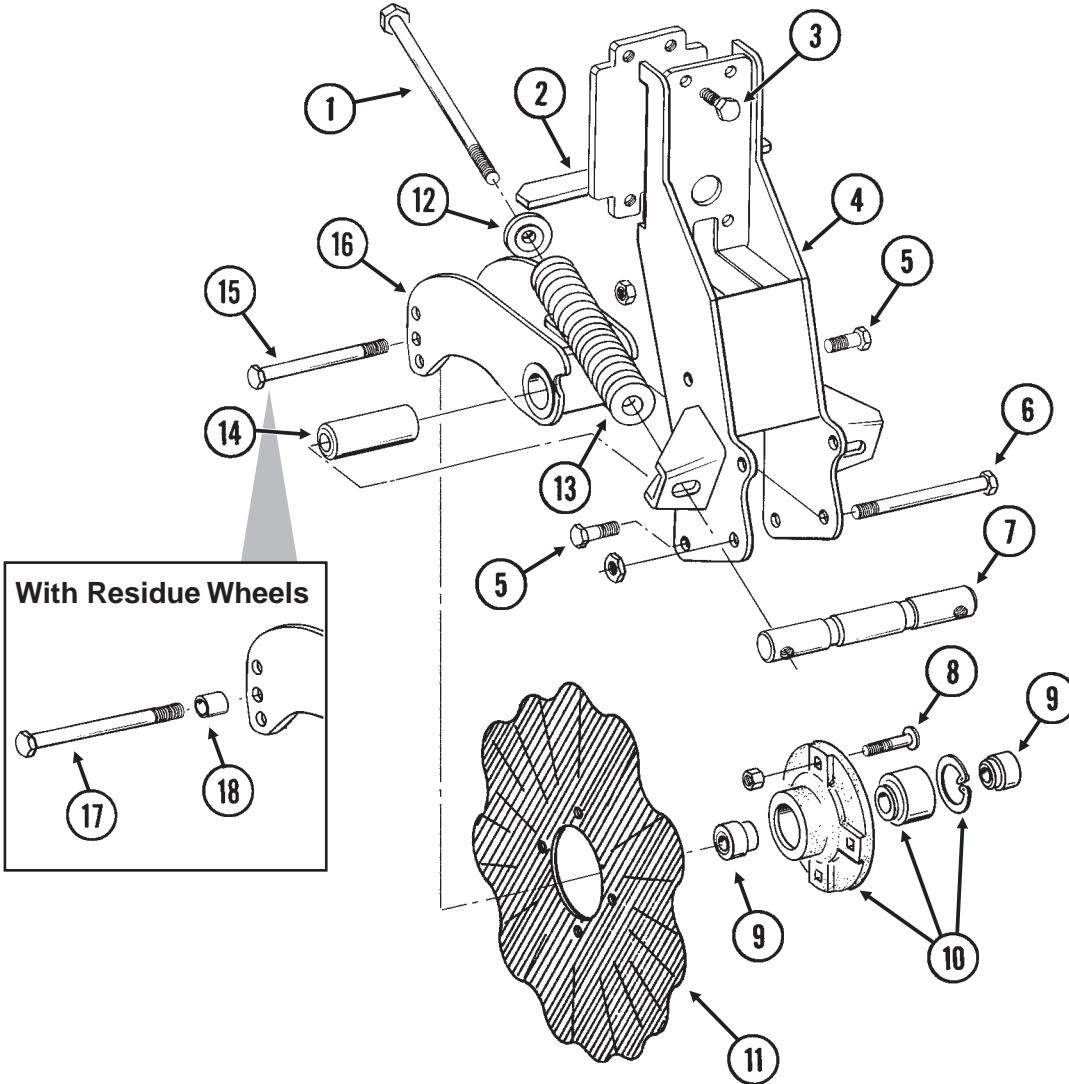

FRAME MOUNTED COULTER W/RESIDUE WHEELS

ITEM	PART NO.	QTY. (Per Row)	DESCRIPTION
1.	G11010	2	Hex Head Cap Screw, 3/4"-10 x 12"
2.	GA9844	1	Plate W/Angle
3.	G10039	4	Hex Head Cap Screw, 1/2"-13 x 1 3/4"
4.	GA9131	1	Coulter Frame
5.	G10007	4	Hex Head Cap Screw, 5/8"-11 x 1 1/2"
	G10107	4	Lock Nut, 5/8"-11
6.	G10400	1	Hex Head Cap Screw, 3/4"-10 x 6 1/2"
	G10112	1	Lock Nut, 3/4"-10
7.	GD12826	1	Spring Anchor Bar
8.	G10574	4	Carriage Bolt, 1/2"-13 x 1 1/4"
	G10111	4	Lock Nut, 1/2"-13
9.	GD12827	2	Adapter
10.	GA8641	1	Hub W/Bearing And Retaining Ring
	GA8603	1	Bearing, Double Row
	GD11652	1	Retaining Ring, 2 7/16"
11.	GD7803	1	Disc Blade, Fluted, 1", 8 Flutes (Shown)
	GD7804	-	Disc Blade, Bubbled, 1"
	GD9254	-	Disc Blade, Fluted, 3/4", 13 Flutes
12.	GB0213	2	Spring Seat
13.	GD12817	2	Compression Spring
14.	GD12829	1	Sleeve
15.	G10046	1	Hex Head Cap Screw, 5/8"-11 x 5"
	G10107	1	Lock Nut, 5/8"-11
16.	GA9845	1	Coulter Arm W/Grease Fitting
	G10643	-	Grease Fitting, 45°, 1/4"-28
17.	G10011	1	Hex Head Cap Screw, 5/8"-11 x 5 1/2"
	G10107	1	Lock Nut, 5/8"-11
18.	GB0218	3	Bushing, 2 1/32" I.D. x 7/8" O.D. x 1 9/32" Long
19.	GD1132	2	Dust Cap
20.	G10010	2	Hex Head Cap Screw, 5/8"-11 x 3"
	G10503	2	Hex Jam Nut, 5/8"-11, Grade 2
21.	GD10552	2	Wheel, 12 Tine, 3/8" x 12"
22.	GA5654	2	Hub W/Bearings
	GA2014	-	Bearing
23.	GD9724	2	Backing Plate
24.	G10133	12	Hex Head Cap Screw, 5/16"-18 x 1 1/2"
	G10109	12	Lock Nut, 5/16"-18, Grade 8
25.	G10213	2	Machine Bushing, 5/8" (.030" Thick)
26.	GA9862	2	Weed Guard W/Spring Pin
	G10765	-	Spring Pin, 1/4" x 1"
27.	GA9865	1	Mount
28.	GA9861	1	Cam
29.	GD10519	1	Spring
30.	G10974	1	Lock Nut W/Nylon Insert, 1/2"-13
31.	G10005	1	Hex Head Cap Screw, 5/8"-11 x 1 3/4"
	G10107	4	Lock Nut, 5/8"-11
32.	GA9864	1	Support
33.	G10014	1	Hex Head Cap Screw, 1/2"-13 x 1"
	G10102	1	Hex Nut, 1/2"-13
34.	G10011	2	Hex Head Cap Screw, 5/8"-11 x 5 1/2"
	G10205	2	Washer, 5/8" SAE
	G10730	2	Lock Nut W/Nylon Insert, 5/8"-11
35.	GD14170	2	Sleeve, 3"
36.	GB0386	2	Wheel, 12 Tine, 3/8" x 12"
A.	GA7446	-	Wheel Assembly, 12 Tine, R.H. (Items 21-24) (Shown)
	GA7445	-	Wheel Assembly, 12 Tine, L.H. (Items 21-24)
B.	GA12236	-	Wheel Assembly, 12 Tine, R.H. (Items 22, 23, 24 And 36) (Shown)
	GA12235	-	Wheel Assembly, 12 Tine, L.H. (Items 22, 23, 24 And 36)

INTERPLANT® PUSH ROW UNIT

(RU156c/RU141h)

NOTE: Push row units use the same seed tube, row unit depth adjustment components, quick adjustable down force springs, 15" opener disc blades, gauge wheels, closing wheels, meter drive and seed hopper as the pull row unit. See those pages for common parts.

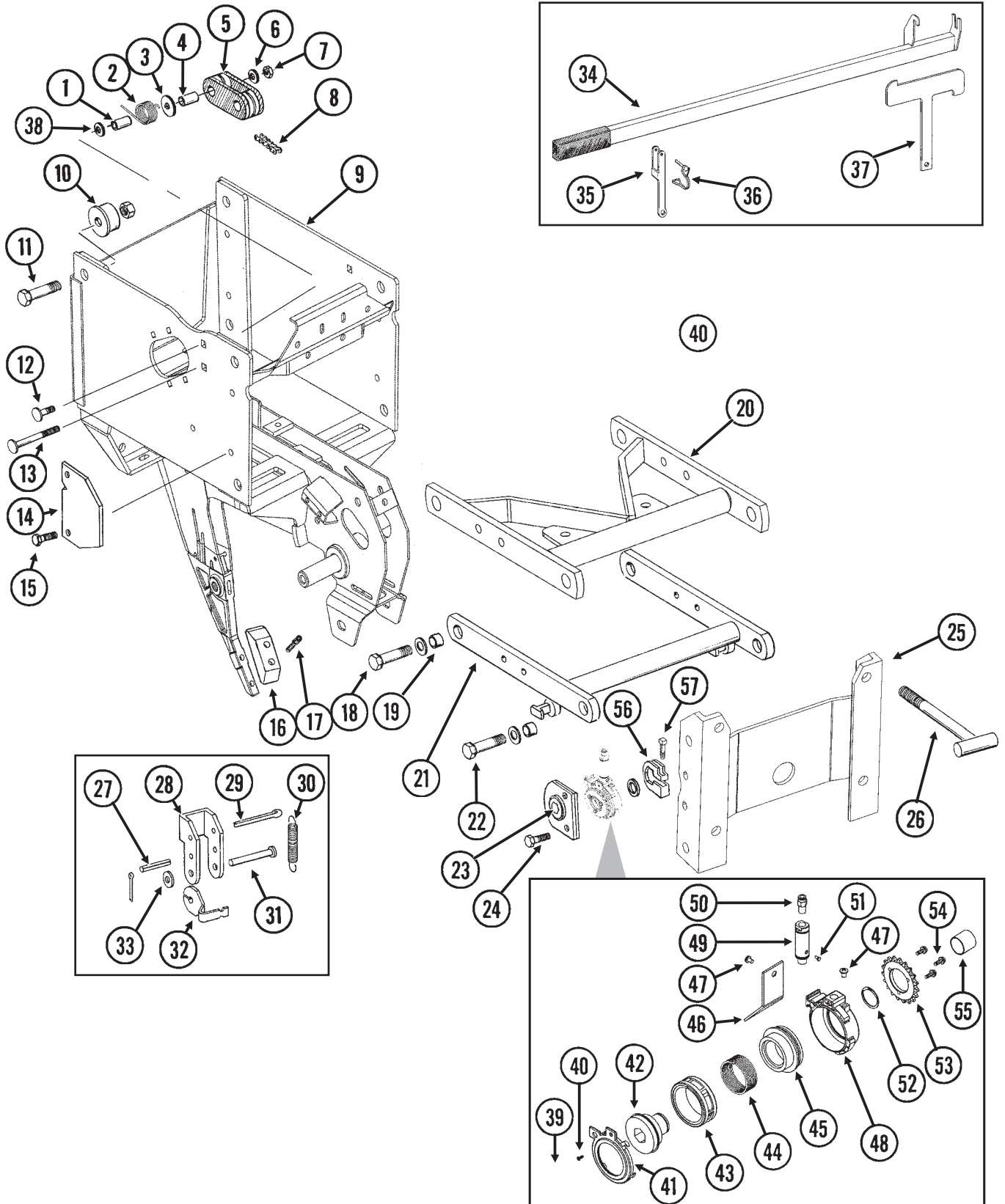

INTERPLANT® PUSH ROW UNIT

ITEM	PART NO.	QTY. (Per Row)	DESCRIPTION
1.	GD1026	1	Sleeve, 1 3/16" Long
2.	GD11218	1	Spring
3.	G10201	1	Special Washer, 3/8" x 1 1/2" O.D.
4.	GD8893-01	1	Sleeve, 1 3/8" Long
5.	GD11962	1	Idler
6.	G10210	1	Washer, 3/8" USS
7.	G10108	1	Lock Nut, 3/8"-16
8.	G3303-96	1	Chain, No. 41, 96 Pitch Including Connector Link
	GR0196	1	Connector Link, No. 41
9.	GA10161	-	Push Row Unit Shank
10.	GB0314	2	Hopper Mount
11.	G10751	2	Hex Head Cap Screw, 5/8"-18 x 1 3/4"
	G10412	2	Lock Nut, 5/8"-18
12.	G10599	1	Carriage Bolt, 3/8"-16 x 1 1/4"
	G10101	1	Hex Nut, 3/8"-16
	G10108	1	Lock Nut, 3/8"-16
13.	G10307	1	Carriage Bolt, 3/8"-16 x 3 1/2"
14.	GD10867	2	Stop
15.	G10004	4	Hex Head Cap Screw, 3/8"-16 x 1 1/4"
	G10108	4	Lock Nut, 3/8"-16
16.	GB0301	1	Seed Tube Guard/Inner Scraper
17.	G10912	2	Hex Socket Head Cap Screw, 5/16"-18 x 1", Grade 8
18.	G10751	4	Hex Head Cap Screw, 5/8"-18 x 1 3/4"
	GD7805	4	Special Washer, 5/8", Hardened
	G10412	4	Lock Nut, 5/8"-18
19.	GB0218	8	Bushing, 2 1/32" I.D. x 7/8" O.D. x 1 9/32" Long
20.	GA11969	1	Upper Arm
21.	GA5787	1	Lower Arm
22.	G10732	4	Hex Head Cap Screw, 5/8"-18 x 2"
	GD7805	4	Special Washer, 5/8", Hardened
	G10412	4	Lock Nut, 5/8"-18
23.	GA2180	-	Hanger Bearing, 7/8" Hex Bore
24.	G10004	2	Hex Head Cap Screw, 3/8"-16 x 1 1/4"
	G10229	2	Lock Washer, 3/8"
	G10101	2	Hex Nut, 3/8"-16
25.	GA11971	1	Mounting Plate
26.	GA9105	-	T-Bolt, 5/8"-11 x 6"
	G10230	-	Lock Washer, 5/8"
	G10104	-	Hex Nut, 5/8"-11
27.	G10718	2	Spring Pin, 5/16" x 1 1/8"
28.	GD11264	2	Lockup
29.	G10463	2	Cotter Pin, 1/4" x 1 1/2"
30.	GD11447	2	Spring
31.	G10284	2	Clevis Pin, 1/2" x 1 1/2"
	G10456	2	Cotter Pin, 1/8" x 3/4"
32.	GD11263	2	Spring Tab
33.	G10216	2	Washer, 1/2" USS
34.	GA8651	1	Lift Lever W/Boot
	GD11649	-	Boot
35.	GD18073	1	Bracket (Lift Lever)
36.	GD9695	1	Wire Lock Pin, 1/4" x 1 3/4"
37.	GD18074	1	Mount
38.	G10203	1	Washer, 3/8" SAE
39.	GR1900	1	Lock Collar
40.	G11243	1	Slotted Flat Head Machine Screw, No. 8-32 x 1/2", Stainless Steel
41.	GR1894	1	Air Housing Cover
42.	GR1830	1	Hex Bushing
43.	GR1818	1	Ratchet Gear
44.	GR1813	1	Clutch Spring
45.	GR1829	1	Sprocket Hub
46.	GR1899	1	Anti-Rotation
47.	G11296	2	Pan Head Machine Screw, 1/4"-20 x 3/4" x 3/4"
48.	GR1895	1	Air Clutch Housing
49.	GR1896	1	Air Cylinder
50.	GR1819	1	Push Connect, 1/8" NPT Male x 1/4"
51.	GR1898	1	Filter
52.	G11295	1	Retaining Ring
53.	GR1831	1	Sprocket, 19 Tooth
54.	G11239	3	Hex Head Cap Screw, 10-32 x 1/2"
55.	GD18891	1	Spacer, 1 1/4" O.D. x 1"
56.	GD11045	-	Lock Clamp
57.	G10130	-	Square Head Machine Bolt, 5/16"-18 x 1 3/4"
	G10923	-	Flange Nut, 5/16"-18, No Serration
A.	GA12630	-	Air Clutch Assembly, (Items 39-55)

DIGITAL VACUUM GAUGE, ANALOG VACUUM GAUGE AND VACUUM FAN ASSEMBLY

(A11154/A11156/GR1736/A10765/A11158/A11699/A7856/A11155/A8329/METR68)

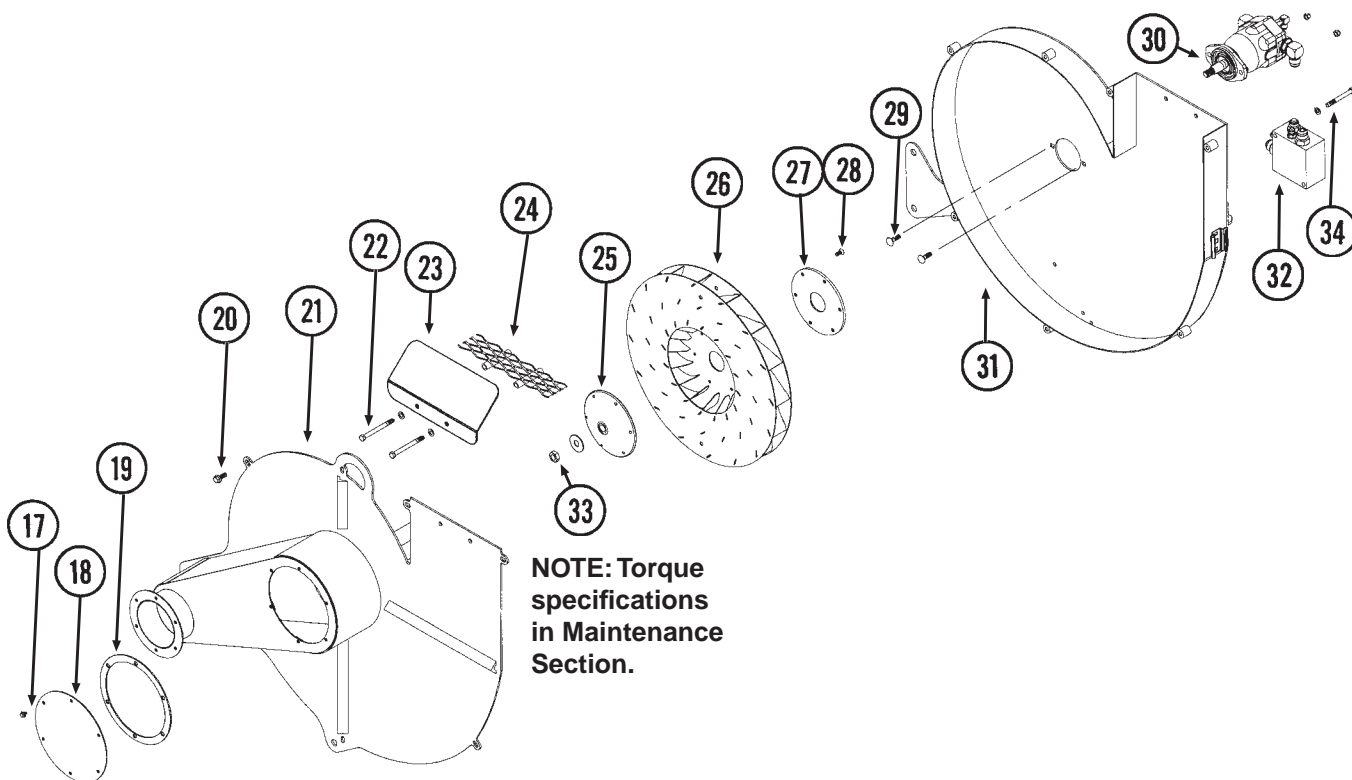
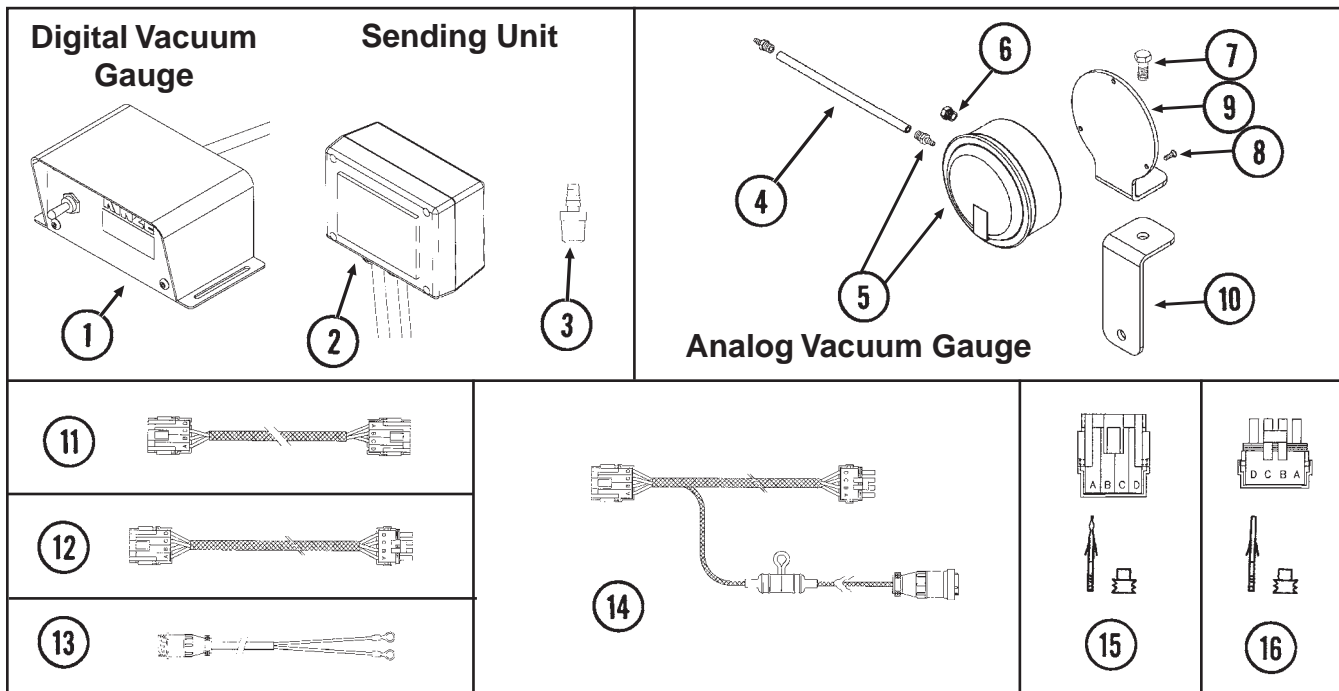

DIGITAL VACUUM GAUGE, ANALOG VACUUM GAUGE AND VACUUM FAN ASSEMBLY

ITEM	PART NO.	QTY.	DESCRIPTION
1.	GA11154	1	Digital Vacuum Gauge W/4-Pin Connector
2.	GA11156	1	Sending Unit W/1/4" Tubing And Harness W/4-Pin Male Connector
	GD16324-01	-	Clear Plastic Tubing, 1/4" x 45"
	GA9964	-	Strain Relief
3.	GR1736	1	Hose Barb, 1/8" NPT To 1/8" Barb
4.	GD15849-02	1	Clear Plastic Tubing, 5/16" O.D. x 120"
5.	GA10765	1	Analog Vacuum Gauge W/Hose Barb
	GR1777	-	Hose Barb, 1/8" Male NPT To 3/16" Barb
6.	GA10799	1	Breather, 1/8" Male NPT
7.	G10001	1	Hex Head Cap Screw, 3/8"-16 x 1"
	G10108	1	Lock Nut, 3/8"-16
8.	G11215	3	Hex Socket Head Cap Screw, No. 6-32 x 3/8", Grade 8
9.	GD15804	1	Mount
10.	GD15803	1	Support
11.	GA11159	1	Harness, 550", 12 Row 30"
	GA11160	-	Harness, 670", 16 Row 30"
12.	GA11699	-	Extension Harness, 180"
13.	GA7856	-	Power Lead Adapter
14.	GA11155	1	Harness W/Fuse Holder And Fuse, 132"
	GD14258	-	Fuse Holder
	GD14660	-	Fuse, 2 Amp Delay Action
	G1K268	-	Console Cable Connector Kit, Includes: (1) 3-Pin Connector, (1) Cable Clamp, (1) Lock Ring, (3) Female Terminal Pins
15.	GA8328	-	4-Pin Connector W/Female Housing, 4 Seals And 4 Pin Contacts
16.	GA8329	-	4-Pin Connector W/Male Housing, 4 Seals And 4 Socket Contacts
17.	G11166	6	Whiz Lock Bolt, 1/4"-20 x 3/4"
18.	GD16233	1	Manifold
19.	GD16241	1	Gasket
20.	G11124	7	Whiz Lock Bolt, 3/8"-18 x 1"
21.	GA11086	1	Cover
22.	G10063	2	Hex Head Cap Screw, 3/8"-16 x 4"
	G10203	2	Washer, 3/8" SAE
	G10108	2	Lock Nut, 3/8"-16
23.	GD15863	1	Discharge Deflector
24.	GA11987	2	Screen
25.	GD15790	1	Hub
26.	GA10635	1	Impeller
27.	GD15789	1	Backing Plate
28.	G11133	6	Hex Socket Head Cap Screw, 5/16"-18 x 3/4", Grade 8
29.	G10599	2	Carriage Bolt, 3/8"-16 x 1 1/4"
	G10229	2	Lock Washer, 3/8"
	G10101	2	Hex Nut, 3/8"-16
30.		-	See "Vacuum Fan Hydraulic Motor Assembly", Page P38
31.	GA11085	1	Shroud
32.		-	See "Vacuum Fan Motor Valve Block Assembly (Located Below Vacuum Fan Assembly)", Page P39
33.	G10205	1	Washer, 5/8" SAE
	G10499	1	Hex Jam Nut, 5/8"-18, Grade 2
34.	G10809	2	Hex Head Cap Screw, 3/8"-16 x 3 1/4"
	G10229	2	Lock Washer, 3/8"
A.	GA11087	-	Vacuum Fan Assembly (Items 17-34 On This Page And Items 1-3, 8 And 9 On Pages P36 And P37)

VACUUM FAN HYDRAULIC COMPONENTS

(PLTR176)

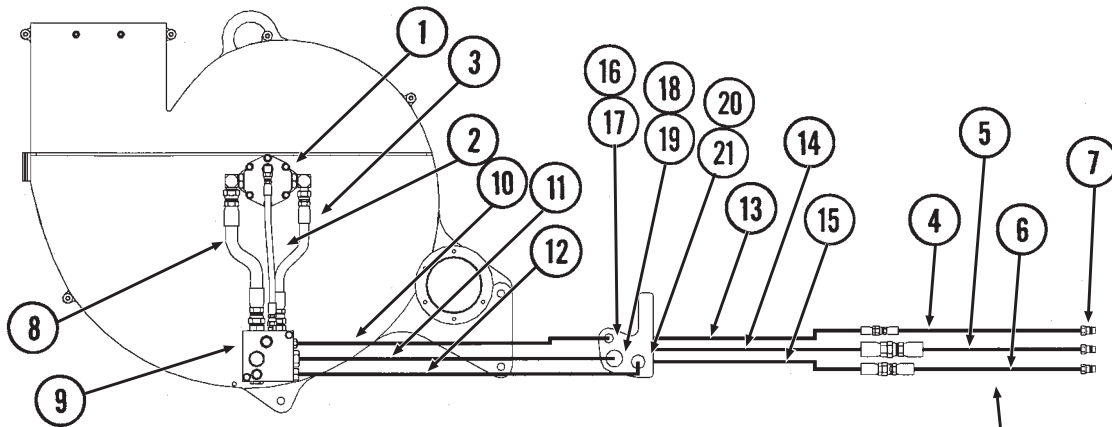

See "PTO Pump Drive And Oil Cooler Option", pages P42 and P43, if equipped with that option.

VACUUM FAN HYDRAULIC COMPONENTS

ITEM	PART NO.	QTY.	DESCRIPTION
1.		-	See "Vacuum Fan Hydraulic Motor Assembly", Page P38
2.	*A12015	1	Hose Assembly, $\frac{3}{8}$ " x 17"
3.	*A8261	1	Hose Assembly, $\frac{1}{2}$ " x 13 $\frac{1}{2}$ "
	*A12023	-	Hose Assembly, $\frac{3}{8}$ " x 218", 12 Row 30"
	*A12022	-	Hose Assembly, $\frac{3}{8}$ " x 268", 16 Row 30"
5.	*A3357	-	Hose Assembly, $\frac{3}{4}$ " x 218", 12 Row 30"
	*A3358	-	Hose Assembly, $\frac{3}{4}$ " x 268", 16 Row 30"
6.	*A8265	-	Hose Assembly, $\frac{1}{2}$ " x 218", 12 Row 30"
	*A8266	-	Hose Assembly, $\frac{1}{2}$ " x 268", 16 Row 30"
7.	GD4086	3	ISO Coupler
8.	*A3352	1	Hose Assembly, $\frac{3}{4}$ " x 13 $\frac{1}{2}$ "
9.		-	See "Vacuum Fan Motor Valve Block Assembly (Located Below Vacuum Fan Motor Assembly)", Page P39
10.	*A12017	1	Hose Assembly, $\frac{3}{8}$ " x 120"
11.	*A3354	1	Hose Assembly, $\frac{3}{4}$ " x 120"
12.	*A1467	1	Hose Assembly, $\frac{1}{2}$ " x 120"
13.	*A12024	1	Hose Assembly, $\frac{3}{8}$ " x 100", 12 Row 30"
	*A12021	-	Hose Assembly, $\frac{3}{8}$ " x 110", 16 Row 30"
14.	*A3355	1	Hose Assembly, $\frac{3}{4}$ " x 100", 12 Row 30"
	*A3356	-	Hose Assembly, $\frac{3}{4}$ " x 110", 16 Row 30"
15.	*A8253	1	Hose Assembly, $\frac{1}{2}$ " x 100", 12 Row 30"
	*A8263	-	Hose Assembly, $\frac{1}{2}$ " x 110", 16 Row 30"
16.	G306-06	1	Lock Nut, $\frac{9}{16}$ "-18
17.	G2700-06-06	1	Bulkhead Tube Union, $\frac{9}{16}$ "-18 Male JIC
18.	G306-12	1	Lock Nut, 1 $\frac{1}{16}$ "-12
19.	G2700-12	1	Bulkhead Tube Union, 1 $\frac{1}{16}$ "-12 Male JIC
20.	G306-10	1	Lock Nut, $\frac{7}{8}$ "-14
21.	G2700-10	1	Bulkhead Tube Union, $\frac{7}{8}$ "-14 Male JIC

* Hydraulic hose is not stocked by KINZE® Repair Parts, but can be made available on a special order basis. Call for quote.

VACUUM FAN HYDRAULIC MOTOR ASSEMBLY

(METR21a)

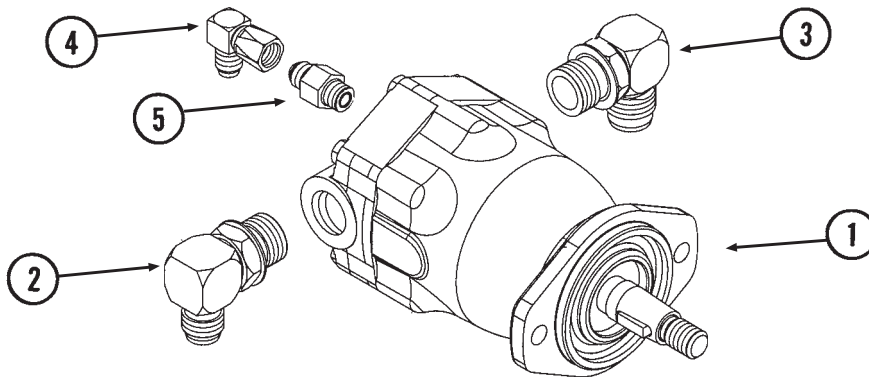

ITEM	PART NO.	QTY.	DESCRIPTION
1.	GA10149 GR1734	1 -	Hydraulic Motor Seal Kit
2.	G6801-10-12 GR1467	1 -	Elbow W/O-Ring, 90°, 7/8"-14 Male JIC To 1 1/16"-12 O-Ring O-Ring
3.	G6801-12 GR1467	1 -	Elbow W/O-Ring, 90°, 1 1/16"-12 Male JIC To O-Ring O-Ring
4.	G6500-06	1	Swivel Elbow, 90°, 9/16"-18 Male JIC To Female
5.	G6400-06 GR1045	1 -	Connector W/O-Ring, 9/16"-18 Male JIC To O-Ring O-Ring

OPTIONAL FLOW CONTROL NEEDLE VALVE KIT

(A11650)

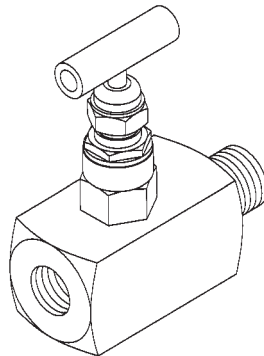

ITEM	PART NO.	QTY.	DESCRIPTION
1.	G1K426	-	Needle Valve Kit W/Instructions

VACUUM FAN MOTOR VALVE BLOCK ASSEMBLY (Located Below Vacuum Fan Motor Assembly)

(A11068d)

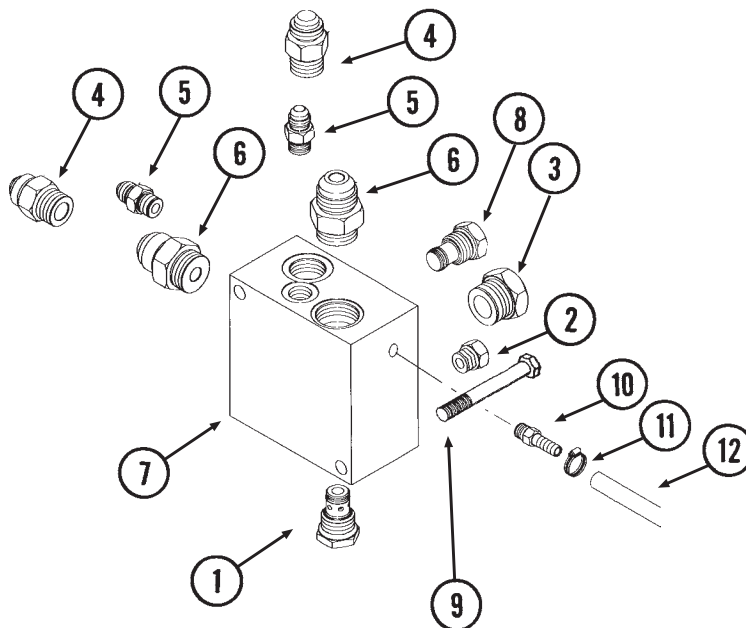

ITEM	PART NO.	QTY.	DESCRIPTION
1.	GA4293	1	Check Valve
2.	G6408-06	1	Plug W/O-Ring, 1/16"-18 O-Ring
	GR1045	-	O-Ring
3.	G6408-12	1	Plug W/O-Ring, 1 1/16"-12 O-Ring
	GR1467	-	O-Ring
4.	G6400-10	2	Connector W/O-Ring, 7/8"-14 Male JIC To O-Ring
	GR1466	-	O-Ring
5.	G6400-06	2	Connector W/O-Ring, 9/16"-18 Male JIC To O-Ring
	GR1045	-	O-Ring
6.	G6400-12	2	Connector W/O-Ring, 1 1/16"-12 Male JIC To O-Ring
	GR1467	-	O-Ring
7.	GD16188	1	Valve Block
8.	GA11934	1	Relief Valve Cartridge
9.	G10809	2	Hex Head Cap Screw, 3/8"-16 x 3 1/4"
	G10229	2	Lock Washer, 3/8"
10.	GD11700	1	Adapter, 1/4" NPT To 3/8" Barb
11.	G10681	1	Hose Clamp, No. 6
12.	GD6279-05	1	Clear Plastic Tubing, 9/16" O.D. x 60"

MANIFOLDS AND DISTRIBUTION HOSES

(PLTR175a)

12 Row 30" Shown

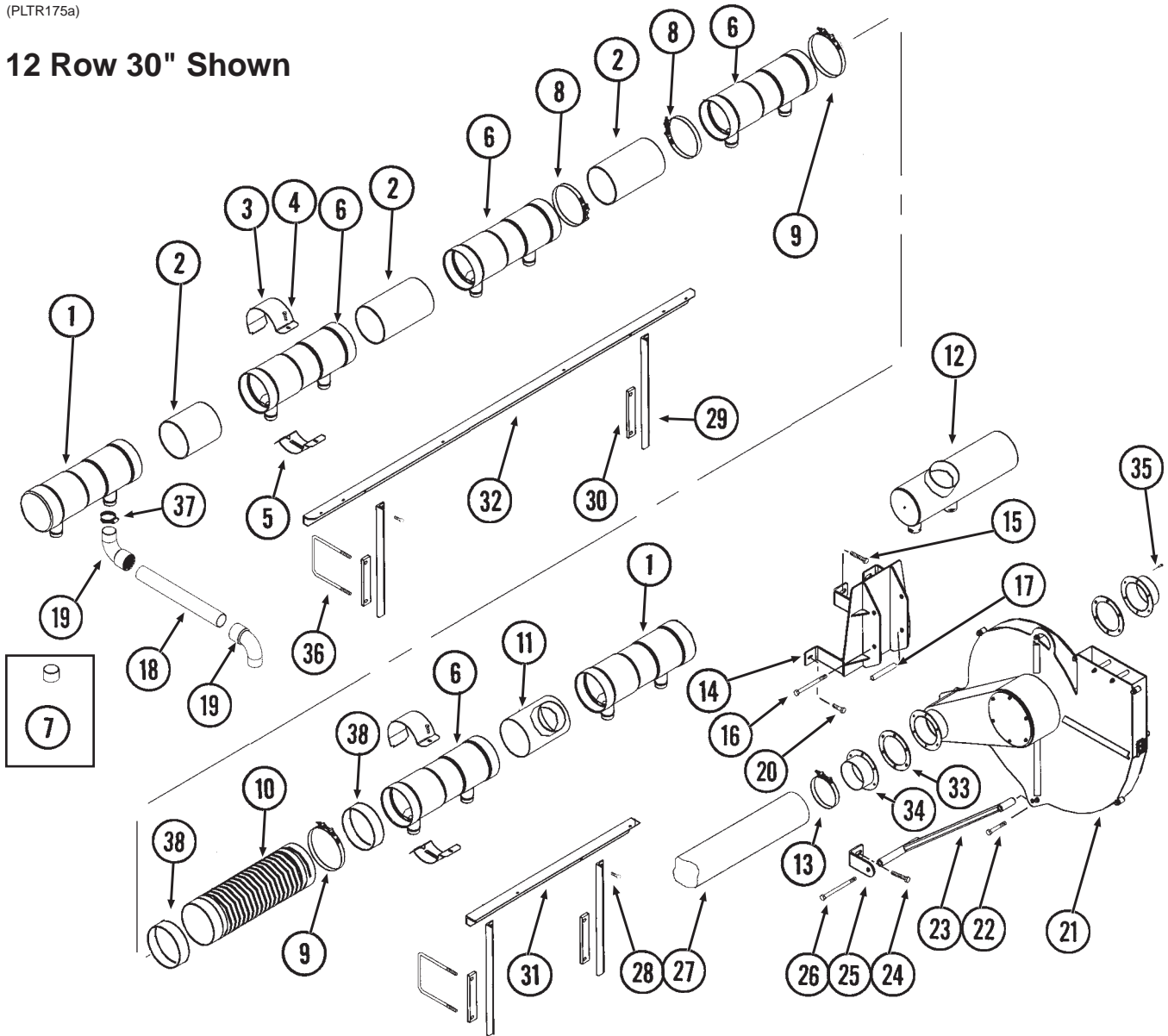

ITEM	PART NO.	QTY.	DESCRIPTION
1.	GD15850	3	Manifold, 21" (Open One End)
2.	GD15856-04	2	Pipe, 6" x 6", 12 Row 30"
	GD15856-03	4	Pipe, 6" x 11", 12 Row 30"
	GD15856-03	10	Pipe, 6" x 11", 16 Row 30"
3.	GD15854	7-15	Clamp
4.	G10312	7-15	Carriage Bolt, 5/16"-18 x 3/4"
	G10620	7-15	Serrated Flange Nut, 5/16"-18
5.	GA11164	7-15	Mount
6.	GD15799	4-12	Manifold, 21" (Open Both Ends)
7.	G11147	-	Cap, 2"
8.	G11145	7-23	T-Bolt Clamp, 7"
9.	G11194	4	T-Bolt Clamp, 7 1/4"
10.	GD16317-01	2	Hose, 7" x 21"
11.	GA12249	1	Manifold, 21 3/4"

MANIFOLDS AND DISTRIBUTION HOSES

ITEM	PART NO.	QTY.	DESCRIPTION
12.	GA11166	1	Manifold, 21 15/16"
13.	G11188	4	T-Bolt Clamp, 5 1/4"
14.	GA11119	1	Fan Mount
15.	G10543	2	Hex Head Cap Screw, 3/4"-10 x 3", Full Thread
	G10218	2	Washer, 3/4" USS
	G10105	2	Hex Nut, 3/4"-10
16.	G10830	2	Hex Head Cap Screw, 5/8"-11 x 7 1/2"
	G10230	2	Lock Washer, 5/8"
	G10104	2	Hex Nut, 5/8"-11
17.	GD3180-27	2	Sleeve, 5/8" I.D. x 7/8" O.D. x 5 3/4"
	GD3777-10	2	Sleeve, 1 3/4" x 3 1/8"
	GD3777-11	2	Sleeve, 1 3/4" x 2 1/2"
18.	GD15792-13	-	Hose, 2" x 50" (Pull Row Unit And Even-Row Push Row Unit)
	GD15792-05	-	Hose, 2" x 38" (Push Row Unit)
	GD15792-12	-	Hose, 2" x 44" (Push Row Unit)
	GD15792-06	-	Hose, 2" x 42" (Push Row Unit)
19.	GD14626	16-32	Elbow, 90°, 2"
20.	G10003	2	Hex Head Cap Screw, 3/8"-16 x 1 1/2"
	G10210	3	Washer, 3/8" USS
	G10229	2	Lock Washer, 3/8"
	G10101	2	Hex Nut, 3/8"-16
21.		-	See "Digital Vacuum Gauge, Analog Vacuum Gauge And Vacuum Fan Assembly", Pages P34 And P35
22.	G10318	1	Hex Head Cap Screw, 5/8"-11 x 4 1/2"
	G10230	2	Lock Washer, 5/8"
	G10104	2	Hex Nut, 5/8"-11
23.	GA11152	1	Fan Strut
24.	G10543	2	Hex Head Cap Screw, 3/4"-10 x 3", Full Thread
	G10105	2	Hex Nut, 3/4"-10
25.	GD16295	2	Support
26.	G10953	1	Hex Head Cap Screw, 5/8"-11 x 10"
	G10218	2	Washer, 3/4" USS
	G10230	1	Lock Washer, 5/8"
	G10104	1	Hex Nut, 5/8"-11
27.	GD15867-02	2	Hose, 5" x 48"
28.	G10019	24-36	Hex Head Cap Screw, 5/16"-18 x 1"
	G10232	24-36	Lock Washer, 5/16"
	G10106	24-36	Hex Nut, 5/16"-18
29.	GD16315	8-10	Support, 21 1/2"
30.	GD16316	8-10	Spacer, 1 1/2" x 9"
31.	GD16307	1	Manifold Rail, 37 1/2", L.H. Main Frame
	GD16306	1	Manifold Rail, 36 1/2", R.H. Main Frame
32.	GD16305	2	Manifold Rail, 87 1/2", L.H. And R.H. Wing, 12 Row 30"
	GD16319	2	Manifold Rail, 142 1/2", L.H. And R.H. Wing, 16 Row 30"
33.	GD16251	2	Gasket
34.	GA11153	2	Outlet, 5"
35.	G10023	12	Hex Head Cap Screw, 1/4"-20 x 3/4"
	G10110	12	Lock Nut, 1/4"-20, Grade B
36.	GD11721	8-10	U-Bolt, 5" x 7" x 1/2"-13
	G10228	16-20	Lock Washer, 1/2"
	G10102	16-20	Hex Nut, 1/2"-13
37.	G10676	-	Hose Clamp, No. 36, Stainless Stell
38.	GD16194-01	-	Tube, 6 5/8" x 2"

PTO PUMP DRIVE AND OIL COOLER OPTION

(TWL302a/D16644/TWL1j/TWL303/PLTR177a)

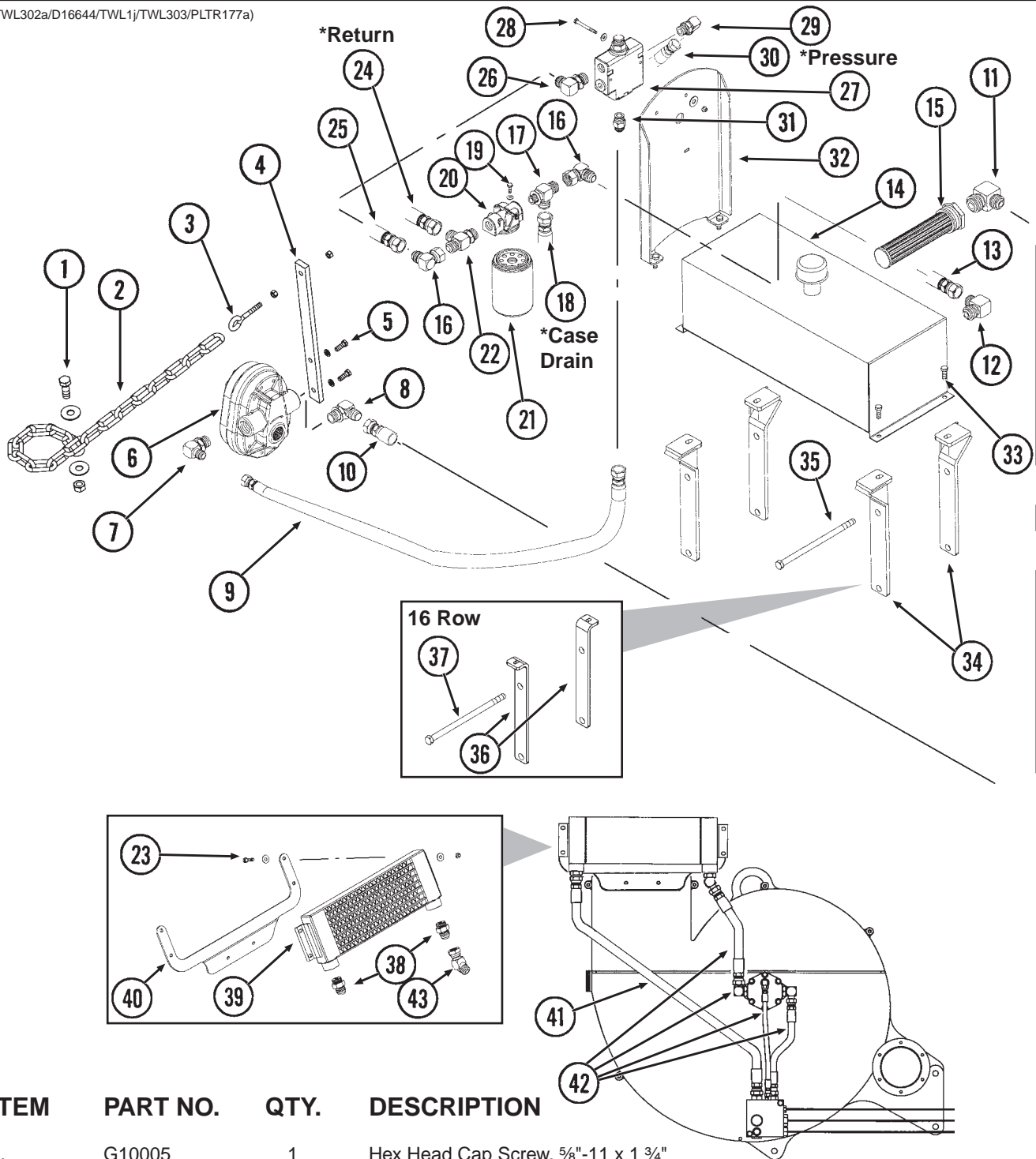

ITEM	PART NO.	QTY.	DESCRIPTION
------	----------	------	-------------

1.	G10005	1	Hex Head Cap Screw, 5/8"-11 x 1 3/4"
	G10217	2	Washer, 5/8" USS
	G10107	1	Lock Nut, 5/8"-11
2.	G3302-09	1	Coil Chain, No. 9/0, 17 Links
3.	GD16035	1	Eyebolt, 3/8"-16 x 4"
	G10101	2	Hex Nut, 3/8"-16
4.	GD16036	1	Anti-Rotation Bracket
5.	G10001	2	Hex Head Cap Screw, 3/8"-16 x 1"
	G10229	2	Lock Washer, 3/8"
6.	GA10919	1	PTO Pump
7.	G6801-10-12	1	Elbow W/O-Ring, 90°, 7/8"-14 Male JIC To 1 1/16"-12 O-Ring
	GR1467	-	O-Ring
8.	G6801-16	1	Elbow W/O-Ring, 90°, 1 5/16"-12 Female JIC To O-Ring
	GR1786	-	O-Ring

PTO PUMP DRIVE AND OIL COOLER OPTION

ITEM	PART NO.	QTY.	DESCRIPTION
9.	*A1464	1	Hose Assembly, 1/2" x 72"
10.	*A6201	1	Hose Assembly, 1" x 72"
11.	G2501-16-20	1	Elbow, 90°, 1 5/16"-12 Male JIC To 1 1/4" NPT
12.	G2501-12-16	1	Elbow, 90°, 1 1/16"-12 Male JIC To 1" NPT
13.	*A3371	1	Hose Assembly, 3/4" x 25"
14.	GA12802	1	Reservoir W/Breather, 10 Gallon
	GR1834	-	Breather
15.	GD16040	1	Strainer
16.	G6500-12	2	Swivel Elbow, 90°, 1 1/16"-12 Male JIC To Female
17.	G6804-12-12-08	1	Adjustable Tee W/O-Ring, 1 1/16"-12 Male JIC To 1 1/16"-12 Male O-Ring To 3/4"-16
	GR1467	-	O-Ring
18.	*A3282	-	Hose Assembly, 3/8" x 158", 12 Row 30"
	*A3283	-	Hose Assembly, 3/8" x 108", 16 Row 30"
19.	G10023	2	Hex Head Cap Screw, 1/4"-20 x 3/4"
	G10227	2	Lock Washer, 1/4"
20.	GD16038	1	Filter Head
21.	GD16037	1	Oil Filter, 10 Micron
22.	G6804-12	1	Adjustable Tee W/O-Ring, 1 1/16"-12 Male JIC To O-Ring
	GR1467	-	O-Ring
23.	G10171	4	Hex Head Cap Screw, 5/16"-18 x 1 1/4"
	G10219	8	Washer, 5/16" USS
	G10109	4	Lock Nut, 5/16"-18, Grade 8
24.	*A3675	-	Hose Assembly, 3/4" x 158", 12 Row 30"
	*A3340	-	Hose Assembly, 3/4" x 108", 16 Row 30"
25.	*A3351	1	Hose Assembly, 3/4" x 20"
26.	G6801-12-10	1	Elbow W/O-Ring, 90°, 1 1/16"-12 Male JIC To 7/8"-14 O-Ring
	GR1466	-	O-Ring
27.	GA10918	1	Flow Control Valve
28.	G10403	2	Hex Head Cap Screw, 1/4"-20 x 2 1/2"
	G10209	4	Washer, 1/4" USS
	G10110	2	Lock Nut, 1/4"-20, Grade 8
29.	G6801-10	1	Elbow W/O-Ring, 90°, 7/8"-14 Male JIC To O-Ring
	GR1466	-	O-Ring
30.	*A8283	-	Hose Assembly, 1/2" x 158", 12 Row 30"
	*A8250	-	Hose Assembly, 1/2" x 108", 16 Row 30"
31.	G6400-10	1	Connector W/O-Ring, 7/8"-14 Male JIC To O-Ring
	GR1466	-	O-Ring
32.	GA11523	1	Mounting Bracket
33.	G10001	2	Hex Head Cap Screw, 3/8"-16 x 1"
	G10210	4	Washer, 3/8" USS
	G10108	4	Lock Nut, 3/8"-16
34.	GA11544	4	Bracket, 12", 12 Row 30"
35.	G10148	4	Hex Head Cap Screw, 1/2"-13 x 9 1/2"
	G10228	4	Lock Washer, 1/2"
	G10102	4	Hex Nut, 1/2"-13
36.	GD16644	4	Bracket, 14 1/2", 16 Row 30"
37.	G11158	4	Hex Head Cap Screw, 1/2"-13 x 11 1/2"
	G10228	4	Lock Washer, 1/2"
	G10102	4	Hex Nut, 1/2"-13
38.	G6400-12	2	Connector W/O-Ring, 1 1/16"-12 Male JIC To O-Ring
	GR1467	-	O-Ring
39.	GA10917	1	Oil Cooler
40.	GD16608	1	Bracket
41.	*A3369	1	Hose Assembly, 3/4" x 40"
42.		-	See "Vacuum Fan Hydraulic Components", Pages P36 And P37
43.	G6502-12	1	Swivel Elbow, 45°, 1 1/16"-12 Male JIC To Female

* Hydraulic hose is not stocked by KINZE® Repair Parts, but can be made available on a special order basis. Call for quote.

OUTER HITCH/SAFETY CHAIN

PHA038/PHA025(TWL1h/WGN47a/B0292)

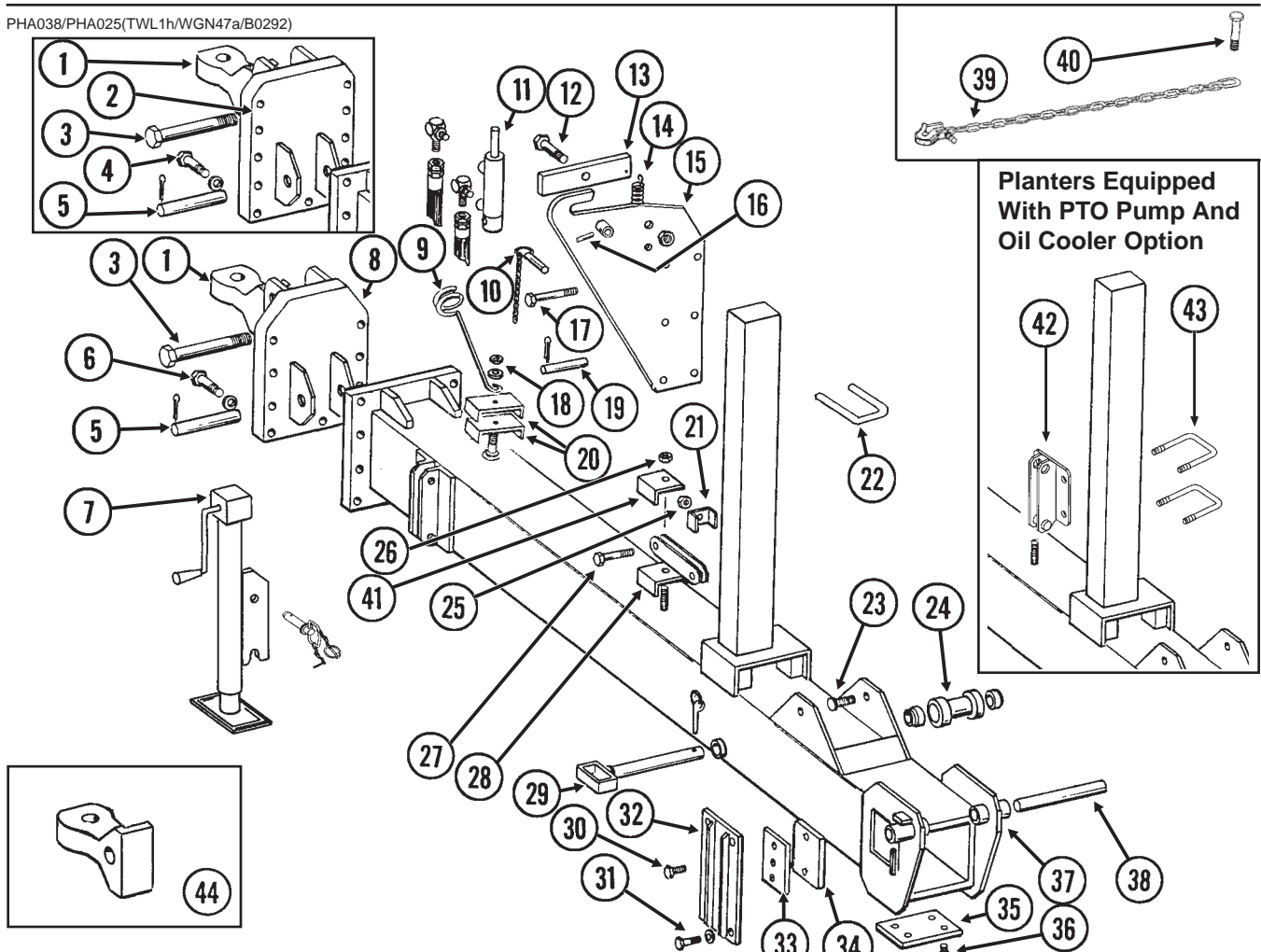

ITEM	PART NO.	QTY.	DESCRIPTION
1.	GB0237	1	Clevis, Single (1 3/4" Hole)
2.	GA9837	-	Hitch Mount, 16 Row 30"
3.	G10169	1	Hex Head Cap Screw, 1 1/4"-7 x 6"
	G10157	1	Lock Nut, 1 1/4"-7
4.	G10802	11	Hex Head Cap Screw, 3/4"-10 x 2 3/4"
	G10231	11	Lock Washer, 3/4"
	G10105	11	Hex Nut, 3/4"-10
5.	GD5173	1	Pin, 1 1/4" x 5 1/8"
	G10462	2	Cotter Pin, 3/16" x 2"
6.	G10009	9	Hex Head Cap Screw, 5/8"-11 x 2 1/2"
	G10230	9	Lock Washer, 5/8"
	G10104	9	Hex Nut, 5/8"-11
7.	GA4994	1	Jack Assembly Complete
	GA4995	-	Detent Pin Assembly
	GR0517	-	Pin
	GR0516	-	Crank Assembly
	GR0515	-	Bevel Gear Set, Includes: (2) Bevel Gears, (1) Gear Pin, (1) Groove Pin
8.	GA9836	1	Hitch Mount, 12 Row 30"
9.	GD8260	1	Hose Holder
10.	GA7022	1	Detent Pin W/Chain (Transport Latch Locking Pin)
11.			See "Transport Latch Cylinder", Page P74
12.	G10006	1	Hex Head Cap Screw, 5/8"-11 x 2 1/4"
	GB0218	1	Bushing, 2 1/32" I.D. x 7/8" O.D. x 1 9/32" Long
	GD7805	1	Special Washer, 5/8", Hardened
	G10107	1	Lock Nut, 5/8"-11
13.	GA7016	1	Catch Bar
14.	GD5857	1	Spring
15.	GA7433	1	Transport Latch
16.	G10765	-	Spring Pin, 1/4" x 1"
17.	G10062	1	Hex Head Cap Screw, 3/8"-16 x 3"
	GD2971-09	1	Sleeve, 2" Long
	G10108	1	Lock Nut, 3/8"-16
18.	GB0292	-	Hitch Clevis, Single (2" Hole)

OUTER HITCH/SAFETY CHAIN

ITEM	PART NO.	QTY.	DESCRIPTION
18.	G10216	1	Washer, 1/2" USS
	G10217	1	Washer, 5/8" USS
	G10111	1	Lock Nut, 1/2"-13
19.	GD7137	1	Pin, 3/4" x 3 3/8"
	G10457	2	Cotter Pin, 5/32" x 1 1/2"
20.	GD8188	-	Hose Clamp, 7/8" x 3" x 5 3/8"
	GD8189	-	Rubber Pad
21.	GD5892	2	Hose Clamp, 5/8" x 1 1/2" x 1 1/2"
22.	GD9953	3	U-Bolt, 3" x 4" x 5/8"-11
	G10205	1	Washer, 5/8" SAE
	G10230	6	Lock Washer, 5/8"
	G10104	6	Hex Nut, 5/8"-11
23.			See "Hose Take-Up", Pages P50 And P51
24.	GA4418	1	Roller W/Bronze Bushings, 12 Row 30"
	GA4842	-	Roller W/Bronze Bushings, 16 Row 30"
	GD6556	1	Bronze Bushing
25.	G10108	1	Lock Nut, 3/8"-16
26.	G10111	1	Lock Nut, 1/2"-13
27.	G10026	1	Hex Head Cap Screw, 3/4"-10 x 2"
	G10112	1	Lock Nut, 3/4"-10
28.	GA5842	1	Bracket, Jack Mount
	GD8189	-	Rubber Pad
29.	GA4402	1	Safety Pin, 12 3/4", 12 Row 30"
	GA4845	-	Safety Pin, 14 3/4", 16 Row 30"
	GD2558	-	Lynch Pin, 1/4"
	GD2557	-	Lynch Pin, 7/16"
30.	G10014	4	Hex Head Cap Screw, 1/2"-13 x 1"
	G10228	4	Lock Washer, 1/2"
31.	G10017	8	Hex Head Cap Screw, 1/2"-13 x 1 1/2", 12 Row 30"
	G10016	10	Hex Head Cap Screw, 1/2"-13 x 2", 16 Row 30"
	G10228	8-10	Lock Washer, 1/2"
	G10102	8-10	Hex Nut, 1/2"-13
32.	GA7029	2	Wear Mount, 12 Row 30"
	GA7084	-	Wear Mount, L.H., 16 Row 30"
	GA7085	-	Wear Mount, R.H., 16 Row 30"
	GA7083	-	Wear Pad Retainer, 16 Row 30"
33.	GD5154	-	Shim, 4" x 4" (As Required), All Sizes
	GD3501	-	Shim, 4" x 6" (As Required), 16 Row 30"
34.	GD9959	-	Wear Pad, Nylatron, 4" x 4" (As Required), All Sizes
	GD9960	-	Wear Pad, Nylatron, 4" x 6" (As Required), 16 Row 30"
35.	GD7519	3	Shim, 16 Gauge (16 Row 30" Only)
	GD7518	1	Shim, 3/8" (16 Row 30" Only)
36.	G10014	4	Hex Head Cap Screw, 1/2"-13 x 1"
	G10228	4	Lock Washer, 1/2"
	G10216	4	Washer, 1/2" USS
37.	A7010	-	Outer Hitch, "Y", 97", 12 Row 30" (Non-Stock Item)
	A7088	-	Outer Hitch, "Y", 127 1/2", 16 Row 30" (Non-Stock Item)
38.	GD5804	1	Pin, 1 1/4" x 12", 12 Row 30"
	GD7251	1	Pin, 1 1/4" x 14", 16 Row 30"
	G10610	2	Spring Pin, 3/8" x 2"
39.	GA7533	1	Safety Chain, 1/2"
	G1K412	-	Safety Chain Repair Kit, Includes (1) Hook, (1) Flat Washer, (1) Latch Pin, (1) Safety Latch And (1) Retaining Ring
40.	G11058	1	Hex Head Cap Screw, 1 1/4"-7 x 3"
	GD10646	1	Special Washer
	G10226	1	Washer, 1 1/4" SAE
	G10157	1	Lock Nut, 1 1/4"-7
41.	GD14121	1	Hose Clamp, 7/8" x 3 1/2"
42.	GA11528	1	Bracket
43.	GD16642	2	U-Bolt, 3" x 4" x 1/2"-13
	G10228	4	Lock Washer, 1/2"
	G10102	4	Hex Nut, 1/2"-13
44.	GB0292	-	Hitch Clevis, Single (2" Hole)

2-POINT HITCH OPTION

(A12406)

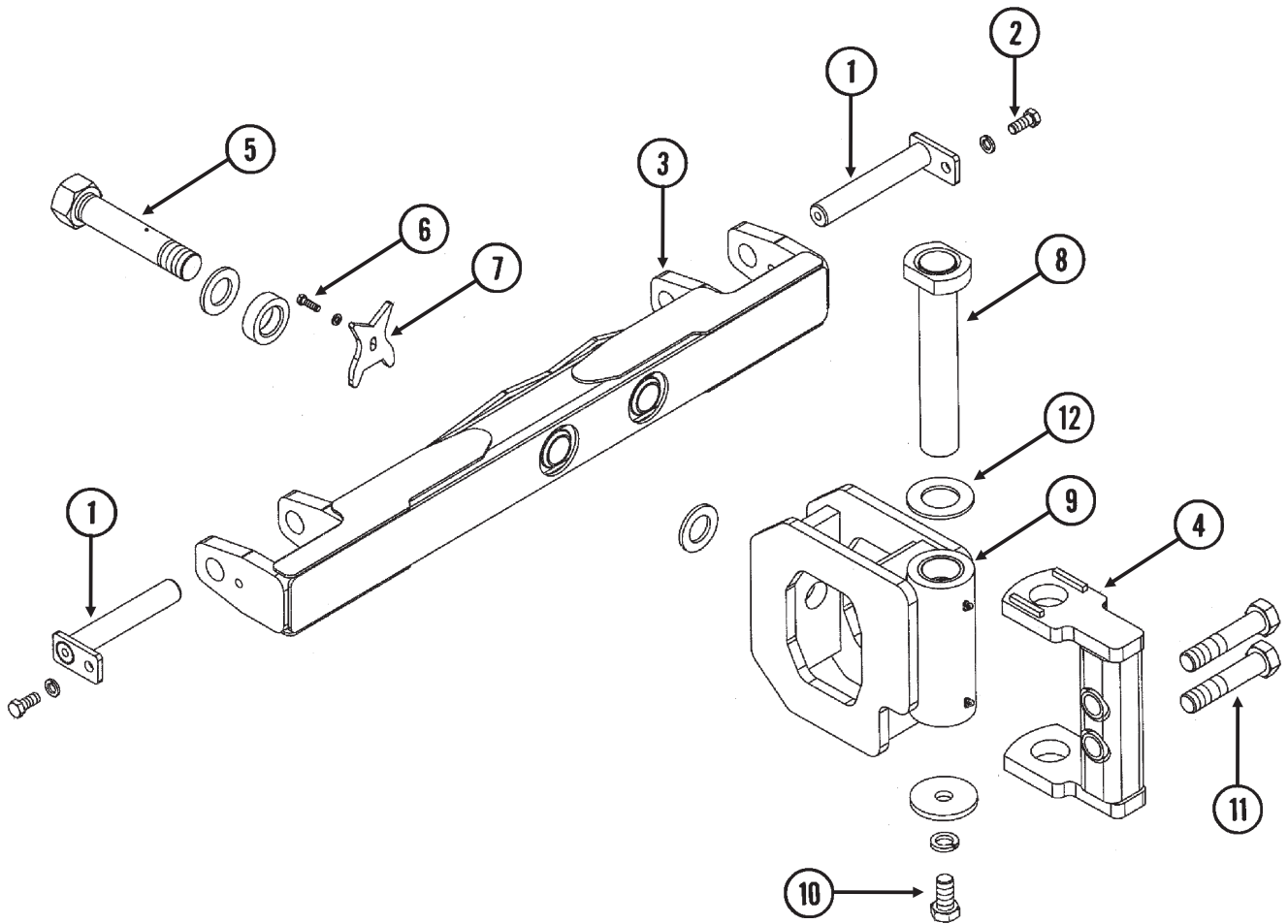

2-POINT HITCH OPTION

ITEM	PART NO.	QTY.	DESCRIPTION
1.	GA11079	2	Hammer Strap, Category 3N And 3
2.	G10007	2	Hex Head Cap Screw, 5/8"-11 x 1 1/2"
	G10230	2	Lock Washer, 5/8"
3.	GA12164	1	Hitch Bar
4.	GA12165	1	Pivot Mount
5.	GA11082	1	Pivot Bolt W/Grease Fitting, 1 3/4" x 10 3/8" (Total Length)
	G10640	-	Grease Fitting, 1/4"-28
	GD16303	2	Washer, 3" O.D. x 1 25/32" x 1/4" Thick
	GD16226	1	Sleeve, 3" O.D. x 1 25/32" x 29/32" Thick
6.	G10005	1	Hex Head Cap Screw, 5/8"-11 x 1 1/4"
	G10217	1	Washer, 5/8" USS
7.	GD15100	1	Pivot Lock
8.	GA12163	1	Pin, 13 3/8"
9.	GA11083	1	Hitch Pivot W/Bushings And Grease Fittings
	GD14562	2	Hardened Bushing, 2 3/4" O.D. x 2 1/4" I.D. x 3"
	G10779	2	Grease Fitting, 90°, 1/4"-28
10.	G11223	1	Hex Head Cap Screw, 1"-8 x 2"
	G10118	1	Lock Washer, 1"
	GD17245	1	Washer, 4" O.D. x 1 1/32" I.D. x 3/8"
11.	G10169	2	Hex Head Cap Screw, 1 1/4"-7 x 6"
	G10157	2	Lock Nut, 1 1/4"-7
12.	GD15725	1	Washer, 4" O.D. x 2 1/4" I.D. x 1/4"

INNER HITCH

PHA035/PHA037(TWL2i)

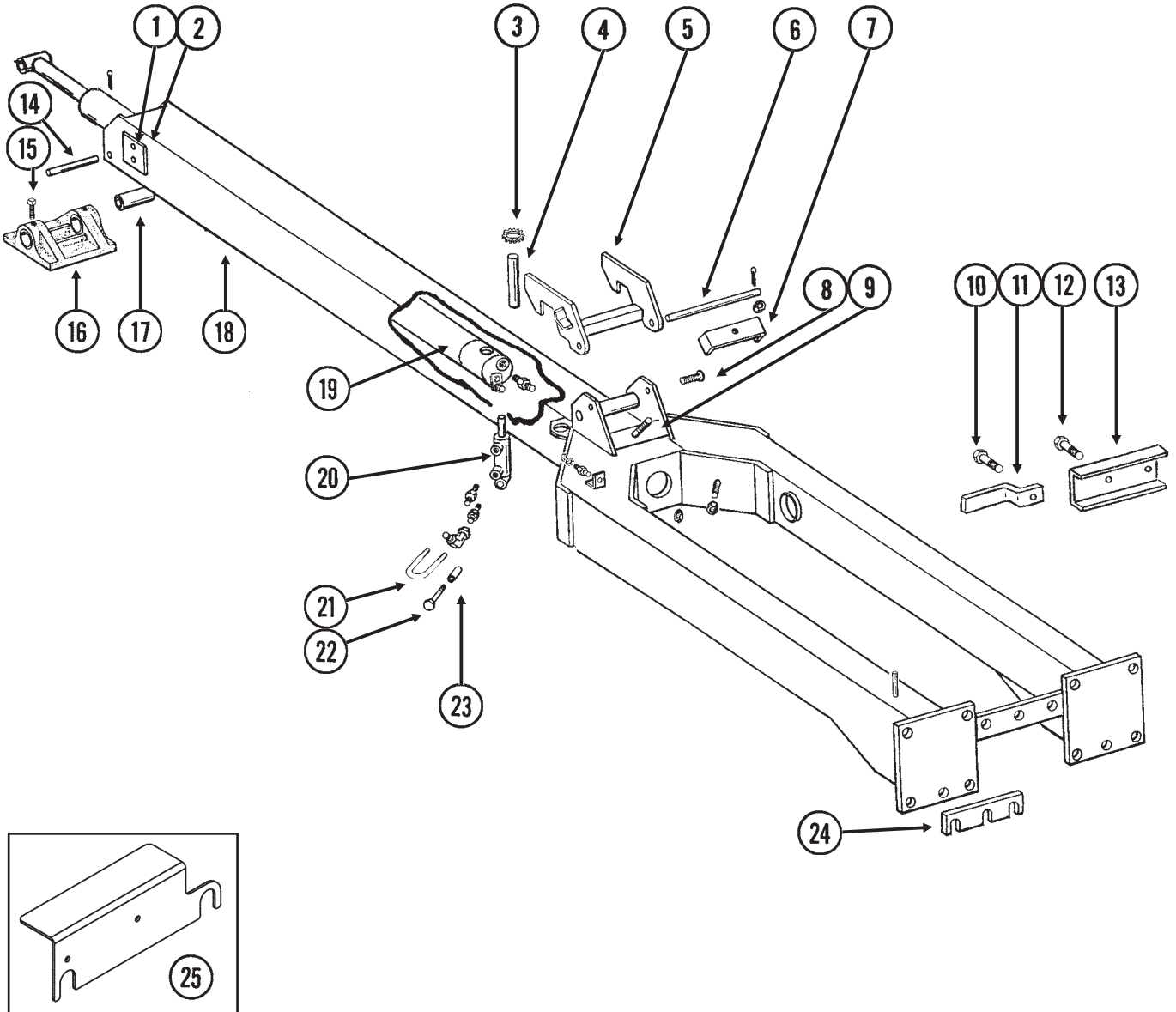

INNER HITCH

ITEM	PART NO.	QTY.	DESCRIPTION
1.	G10014	4	Hex Head Cap Screw, 1/2"-13 x 1", 12 Row 30"
	G10017	4	Hex Head Cap Screw, 1/2"-13 x 1 1/2", 16 Row 30"
	G10228	4	Lock Washer, 1/2", 16 Row 30"
2.	GD9959	2	Wear Pad, Nylatron, 4" x 4"
	GD5154	4-6	Shim, 4" x 4"
3.	G10894	-	External Washer
4.	GD3537-17	1	Shaft, 1 1/4" x 6 3/8", 12 Row 30"
	GD3537-18	-	Shaft, 1 1/4" x 7 3/8", 16 Row 30"
5.	GA7423	1	Tongue Hook W/Grease Fittings, 12 Row 30"
	GA7424	-	Tongue Hook W/Grease Fittings, 16 Row 30"
	G10641	-	Grease Fitting, 1/8" NPT
6.	GD5804	1	Pin, 1 1/4" x 12", 12 Row 30"
	GD7883	-	Pin, 1 1/4" x 14 1/2", 16 Row 30"
	G10468	2	Cotter Pin, 3/8" x 2"
7.	GD8188	-	Hose Clamp, 7/8" x 3" x 5 3/8"
	GD8189	-	Rubber Pad
8.			See "Hose Take-Up", Pages P50 And P51
9.	G11169	1	Hex Head Cap Screw, 1/2"-13 x 3 1/2"
	G10111	1	Lock Nut, 1/2"-13
10.	G10004	1	Hex Head Cap Screw, 3/8"-16 x 1 1/4"
	G10229	1	Lock Washer, 3/8"
	G10101	1	Hex Nut, 3/8"-16
11.	GD10650	1	Hose Clamp
12.	G10003	1	Hex Head Cap Screw, 3/8"-16 x 1 1/2"
	G10210	1	Washer, 3/8" USS
	G10108	1	Lock Nut, 3/8"-16
13.	GD10664	1	Shield (If Applicable)
14.	GD5173	1	Pin, 1 1/4" x 5 1/8"
	G10462	1	Cotter Pin, 3/16" x 2"
15.	G10131	1	Square Head Set Screw, 5/16"-18 x 3/4"
16.	GB0246	1	Shoe
17.	GD3537-11	1	Shaft, 1 1/4" x 7", 12 Row 30"
	GD3537-12	-	Shaft, 1 1/4" x 8", 16 Row 30"
18.	A7429	-	Inner Hitch, 169 3/8", 12 Row 30" (Shown) (Non-Stock Item)
	A7426	-	Inner Hitch, 205 3/8", 16 Row 30" (Non-Stock Item)
19.		-	See "Tongue Cylinder", Pages P74-76
20.		-	See "Tongue Lock Cylinder", Page P74
21.	GD10530	1	U-Bolt, 2 1/8" x 1 7/8" x 3/8"-16
	G10229	2	Lock Washer, 3/8"
	G10101	2	Hex Nut, 3/8"-16
22.	G10585	1	Hex Head Cap Screw, 1/2"-13 x 3 1/4"
	G10216	1	Washer, 1/2" USS
	G10228	1	Lock Washer, 1/2"
	G10102	1	Hex Nut, 1/2"-13
23.	GD10538-01	1	Sleeve
24.	GD13543	1	Shim, 2 1/2" x 10", 7 Gauge
	GD13544	1	Shim, 2 1/2" x 10", 10 Gauge
	GD13545	1	Shim, 2 1/2" x 10", 12 Gauge
25.	GD18116	1	Rotation Bracket

HOSE TAKE-UP

(TWL137e/TWL137d)

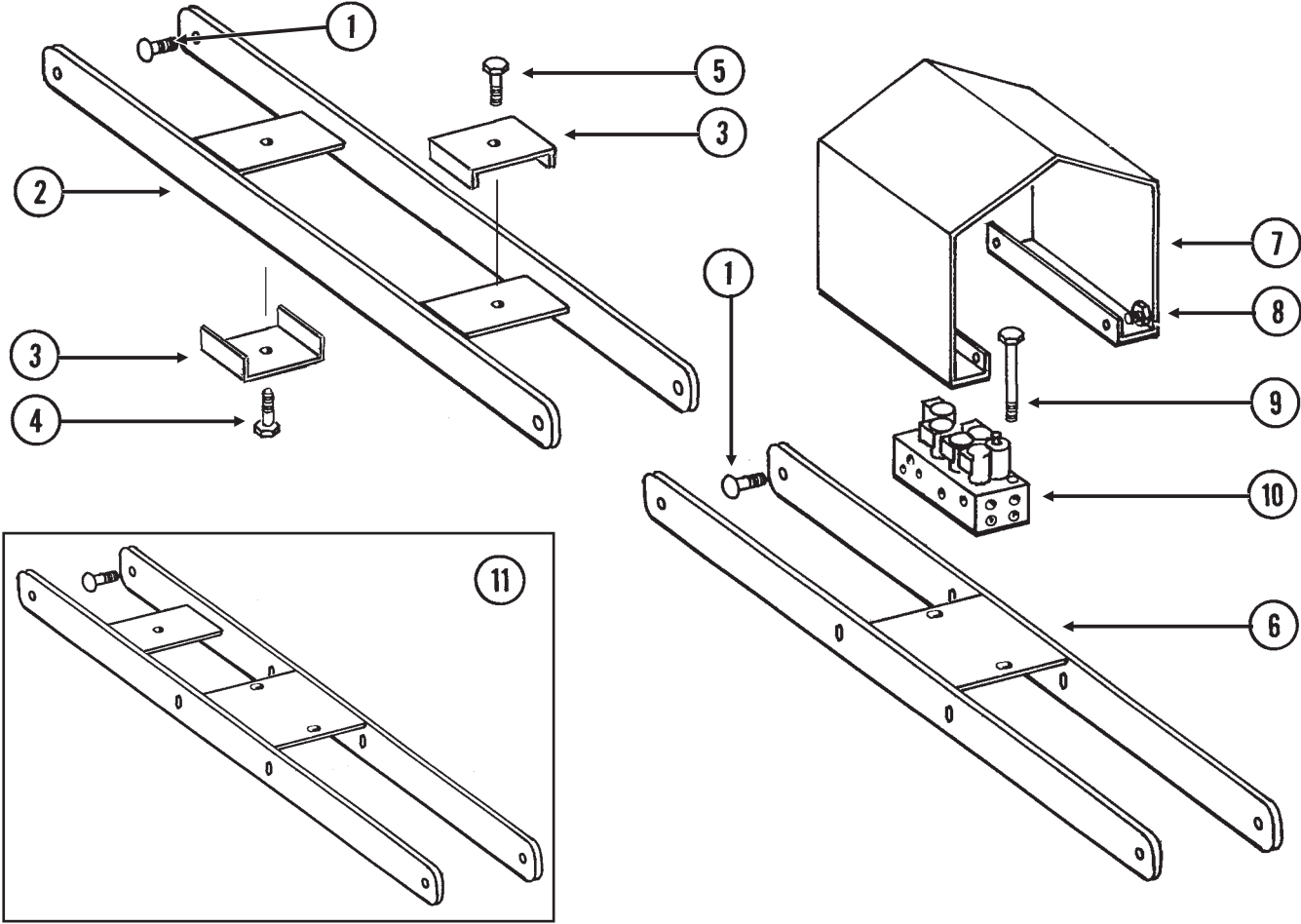

HOSE TAKE-UP

ITEM	PART NO.	QTY.	DESCRIPTION
1.	G10689	6	Carriage Bolt, 5/8"-11 x 2"
	GB0218	6	Bushing, 2 1/32" I.D. x 7/8" O.D. x 1 9/32" Long
	GD7805	6	Special Washer, 5/8", Hardened
	G10107	6	Lock Nut, 5/8"-11
2.	GA7013	-	Take-Up, 44 1/4", 12 Row
	GA7049	-	Take-Up, 56 1/4", 16 Row
3.	GD8188	2	Hose Clamp, 7/8" x 3" x 5 3/8"
	GD8189	2	Rubber Pad
4.	G10581	1-2	Hex Head Cap Screw, 1/2"-13 x 2 1/4"
	G10053	-	Hex Head Cap Screw, 1/2"-13 x 2 1/2"
	G10111	1	Lock Nut, 1/2"-13
5.	G10581	1	Hex Head Cap Screw, 1/2"-13 x 2 1/4"
	G10111	1	Lock Nut, 1/2"-13
6.	GA7021	-	Take-Up, 44 1/4", 12 Row
7.	GD9952	1	Cover
8.	G10004	4	Hex Head Cap Screw, 3/8"-16 x 1 1/4"
	G10229	4	Lock Washer, 3/8"
	G10203	8	Washer, 3/8" SAE
	G10101	4	Hex Nut, 3/8"-16
9.	G10172	2	Hex Head Cap Screw, 3/8"-16 x 5"
	G10210	2	Washer, 3/8" USS
	G10108	2	Lock Nut, 3/8"-16
10.			See "Valve Block - Located On Hitch", Pages P80 And P81
11.	GA7050	-	Take-Up, 56 1/4", 16 Row

CENTER FRAME

PFA070/VVB034(TWL138b)

12 ROW 30" SHOWN

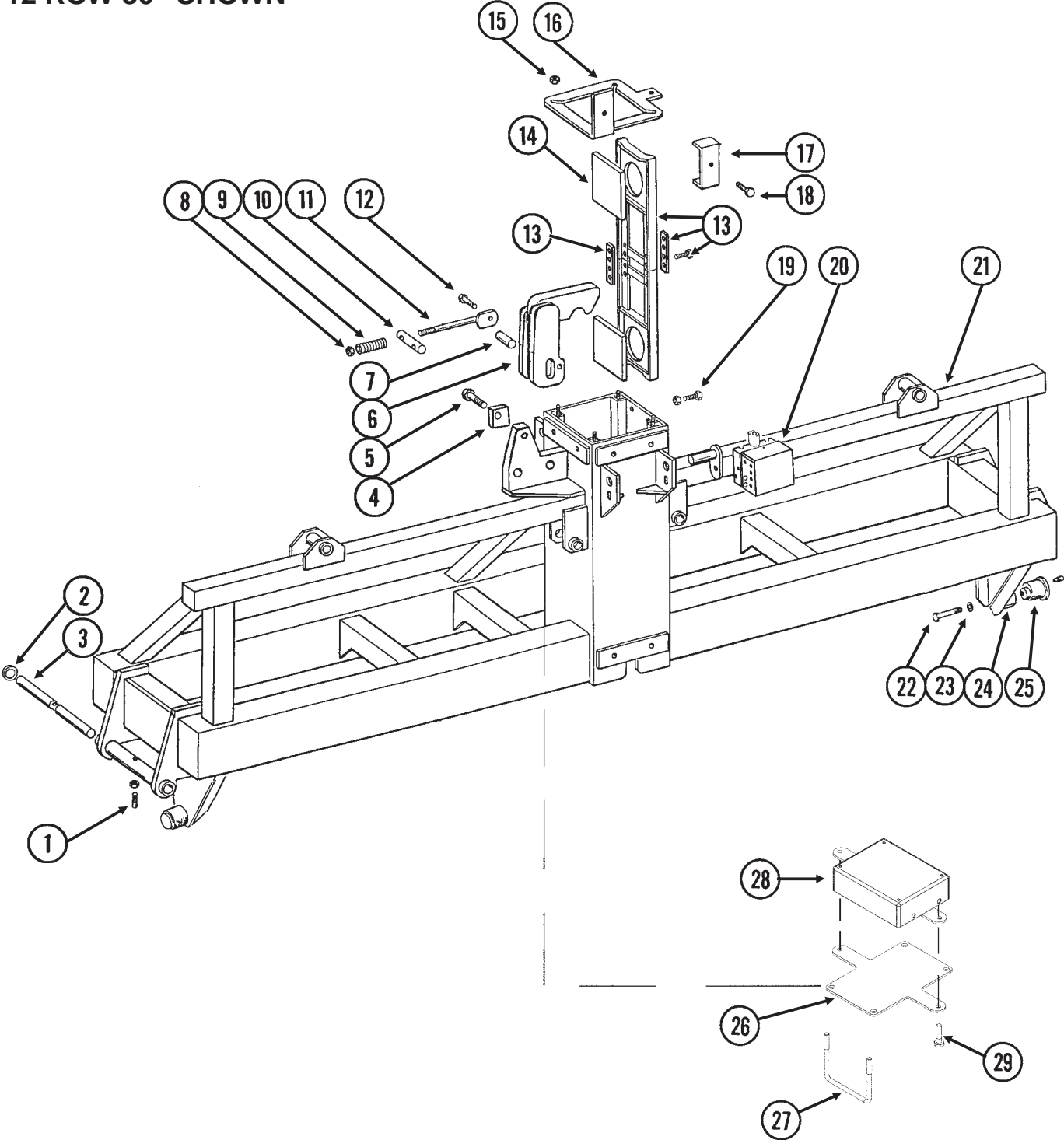

CENTER FRAME

ITEM	PART NO.	QTY.	DESCRIPTION
1.	G10102	1	Hex Nut, 1/2"-13
	G10828	1	Hex Socket Set Screw, 1/2"-13 x 1 1/4"
2.	G10404	-	Machine Bushing, 3 1/8" x 2 1/8" x 3/16" (As Required)
	G10234	-	Machine Bushing, 2 1/8", 10 Gauge (As Required)
	G10336	-	Machine Bushing, 2 1/8", 14 Gauge (As Required)
3.	GD10531	1	Hinge Pin, 2 1/8" x 25 3/4"
4.	GD10492	2	Adjustment Block
5.	G10085	-	Hex Head Cap Screw, 3/4"-10 x 3 3/4"
	G10218	-	Washer, 3/4" USS
	G10112	-	Lock Nut, 3/4"-10
6.	GA7390	-	Safety Hook
7.	GD9898	1	Pin, 1 1/4" x 2 15/16"
8.	G10205	2	Washer, 5/8" SAE
	G10107	2	Lock Nut, 5/8"-11
9.	GD10006	2	Spring
10.	GD9870	1	Pin, 1 1/4" x 6"
11.	GA6943	2	Spring Rod
12.	G10037	2	Hex Head Cap Screw, 1/2"-13 x 1 1/4"
	G10206	2	Washer, 1/2" SAE
	G10228	2	Lock Washer, 1/2"
	GD7904-02	2	Sleeve, 1/2" x 1/2" Long
13.	GA7579	4	Pad Holder W/Bars
	GD10706	-	Bar, 1 1/4" x 6" x 1/4" Thick
	GD10707	-	Bar, 1 1/4" x 6" (3/8" Thick)
	G10001	-	Hex Head Cap Screw, 3/8"-16 x 1"
14.	GD10053	8	Wear Pad, 7" x 7", 1/2" Thick
15.	GD7805	4	Special Washer, 5/8", Hardened
	G10104	4	Hex Nut, 5/8"-11
16.	GD9968	1	Cap
17.	GD8188	1	Hose Clamp, 7/8" x 3" x 5 3/8"
	GD8189	1	Rubber Pad
18.	G10053	1	Hex Head Cap Screw, 1/2"-13 x 2 1/2"
	G10228	1	Lock Washer, 1/2"
	G10102	1	Hex Nut, 1/2"-13
19.	G10543	16	Hex Head Cap Screw, 3/4"-10 x 3", Full Thread
	G10105	16	Hex Nut, 3/4"-10
20.		-	See "Valve Blocks - Located On R.H. Rear Center Frame", Page P79
21.	A7393	-	Frame W/Cam Follower Mounts, 136" (Non-Stock Item)
	GA6929	-	Cam Follower Mount, L.H.
	GA6928	-	Cam Follower Mount, R.H.
22.	G10025	2	Hex Head Cap Screw, 3/4"-10 x 1 1/2"
23.	GB0409	2	Spring Washer
24.	GD10532	2	Sleeve
25.	GA6497	2	Cam Follower W/Grease Fitting
	G10640	-	Grease Fitting, 1/4"-28
26.	GD18344	1	Valve Box Mount
27.	GD18329	2	U-Bolt, 5/16"-18
	G10106	2	Hex Nut, 5/16"-18
	G10232	2	Lock Washer, 5/16"
28.			See "Valve Box Module", Pages P90 and P91
29.	G10064	2	Hex Head Cap Screw, 1/4"-20 x 1"
	G10227	2	Lock Washer, 1/4"
	GD7363-01	2	Sleeve, 1/2" Long
	G10103	2	Hex Nut, 1/4"-20

HYDRAULIC DRIVE

(VI56)

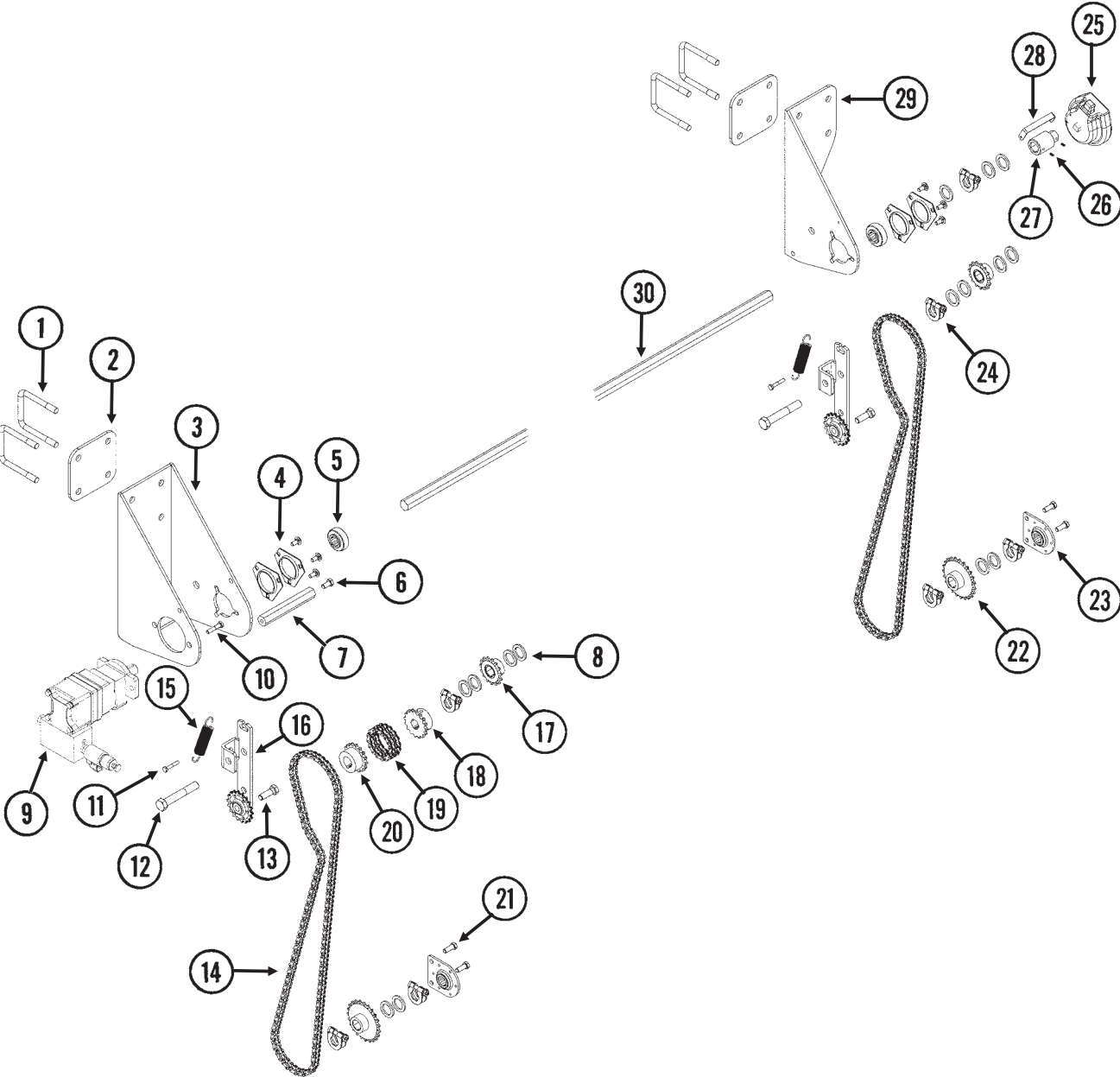

HYDRAULIC DRIVE

ITEM	PART NO.	QTY.	DESCRIPTION
1.	GD4743	4	U-Bolt, 3" x 3" x 1/2"-13
2.	GD18114	2	Spacer
3.	GA12569	1	Motor Bracket
4.	G3400-01	4	Flangette
5.	G2100-03	2	Bearing, 7/8" Hex Bore, Spherical
6.	G10002	1	Hex Head Cap Screw, 3/8"-16 x 3/4"
7.	GD18326	1	Hex Spacer
8.	G10233	15	Machine Bushing, 1", 10 Gauge
9.			See "Valve Block - Located On L.H. Rear Center Frame", Pages P82 And P83
10.	G10133	3	Hex Head Cap Screw, 5/16"-18 x 1 1/2"
11.	G10021	2	Hex Head Cap Screw, 1/4"-20 x 1 1/2"
12.	G10036	2	Hex Head Cap Screw, 5/8"-11 x 4"
13.	G10017	2	Hex Head Cap Screw, 1/2"-13 x 1 1/2"
14.	G3310-84	2	Chain, No. 40, 84 Pitch Including Connector Link
	GR0912	-	Connector Link, No. 40
15.	GD5857	2	Spring
16.	GA9553	2	Idler W/Sprocket And Hardware
	GA7154	-	Sprocket W/Bearing, 18 Tooth
	G10017	-	Hex Head Cap Screw, 1/2"-13 x 1 1/2"
	G10128	-	Machine Bushing, 1/2", 14 Gauge
	G10501	-	Hex Jam Nut, 1/2"-13, Grade 2
	GD13422	-	Idler Arm
17.	GA5105	2	Sprocket, 15 Tooth
18.	GD16490	2	Coupler, 1" I.D.
19.	G3317-16	1	Chain, Double No. 40, 16 Pitches
	GR1790	-	Connector Link, Double No. 40
20.	GD16489	1	Coupler, 7/8" Hex
21.	G10001	4	Hex Head Cap Screw, 3/8"-16 x 1"
22.	GA5108	2	Sprocket, 23 Tooth
23.	GA2180	2	Hanger Bearing, 7/8" Hex Bore
24.	GA11331	2	Hex Lock Clamp Assembly
25.	GA12565	1	Encoder Module
26.	G11242	1	Hex Socket Set Screw, 1/4"-20 x 3/8"
27.	GA12661	7	Hex Adapter Encoder
28.	GD18115	1	Encoder Bracket
29.	GD18014	1	Carrier Bracket
30.	GD0914-54.75	1	Hex Shaft, 7/8" x 54 3/4" (No Holes)

WING FRAME

(TWL180a/TWL139i)

**WITH INTERPLANT®
PACKAGE OPTIONS**

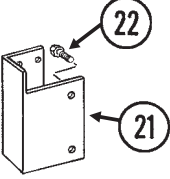

**NOTE: Installed On
Even-Row Push
Row Unit**

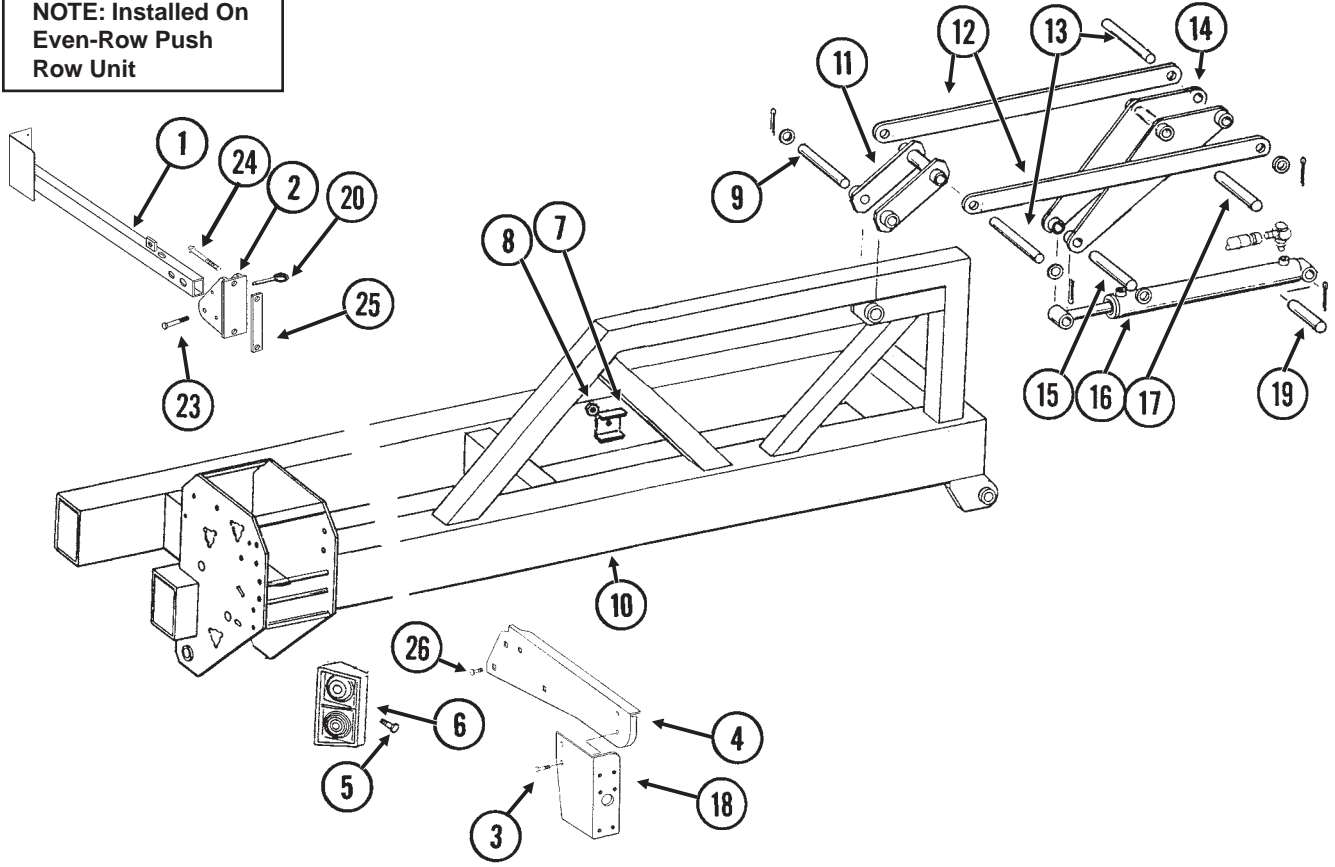

WING FRAME

ITEM	PART NO.	QTY.	DESCRIPTION
1.	GA9840	1	Light Bracket
2.	GB0309	1	Light Mount Bracket
3.	G10064	2	Hex Head Cap Screw, 1/4"-20 x 1"
	G10227	2	Lock Washer, 1/4"
	G10103	2	Hex Nut, 1/4"-20
4.	GD15950	1	Light Mount Extension
5.	G10064	8	Hex Head Cap Screw, 1/4"-20 x 1"
	G10110	8	Lock Nut, 1/4"-20, Grade B
6.		-	See "Electrical Components", Pages P92 And P93
7.	GD5875	-	Hose Clamp, 9/16" x 2 1/2" x 2"
8.	G10108	-	Lock Nut, 3/8"-16
9.	GD9963	1	Pin, 1 1/4" x 9"
	G10460	2	Cotter Pin, 1/4" x 2"
10.	A6904	-	Wing, R.H., 119 1/4", 12 Row (Non-Stock Item)
	A6905	-	Wing, L.H., 119 1/4", 12 Row (Non-Stock Item)
	A6892	-	Wing, R.H., 179 1/4", 16 Row (Two Wheel Towers Per Wing) (Non-Stock Item)
	A6893	-	Wing, L.H., 179 1/4", 16 Row (Two Wheel Towers Per Wing) (Non-Stock Item)
11.	GA7018	1	Link
12.	GD9956	2	Strap, 41"
13.	GD9964	2	Pin, 1 1/4" x 10 1/2"
	G10159	4	Machine Bushing, 1 1/4", 10 Gauge
	G10460	4	Cotter Pin, 1/4" x 2"
14.	GA7019	1	Toggle Link
15.	GD4108	1	Pin, 1 1/4" x 7"
	G10159	2	Machine Bushing, 1 1/4", 10 Gauge
	G10460	2	Cotter Pin, 1/4" x 2"
16.		-	See "Wing Lock Cylinder", Page P77
17.	GD9955	1	Pin 1 1/4" x 7"
	G10606	2	Spring Pin, 1/4" x 2"
18.	GD12724	1	Bracket
19.	GD6136	2	Pin, 1 1/4" x 5"
	G10460	4	Cotter Pin, 1/4" x 2"
20.	G10874	1	Detent Pin, 1/2" x 3 1/2" Grip
21.	GD12703	1	Push Row Unit Light Bracket
22.	G10001	2	Hex Head Cap Screw, 3/8"-16 x 1"
	G10229	2	Lock Washer, 3/8"
	G10101	2	Hex Nut, 3/8"-16
23.	G10033	1	Hex Head Cap Screw, 1/2"-13 x 3 1/2"
	G10206	4	Washer, 1/2" SAE
	G10111	1	Lock Nut, 1/2"-13
24.	G10439	2	Hex Head Cap Screw, 5/8"-11 x 7"
	G10230	2	Lock Washer, 5/8"
	G10104	2	Hex Nut, 5/8"-11
25.	GD1908	1	Mounting Bracket
26.	G10312	2	Carriage Bolt, 5/16"-18 x 3/4"
	G10620	2	Serrated Flange Nut, 5/16"-18
A.	G7698X	-	Push Row Unit Mounted Light Bracket Package (Items 21 And 22 On This Page And 42" Harness Extension, Item 5 On Pages P92 And P93)

CENTER PIVOT

PFA067/PFA068(TWL7c)

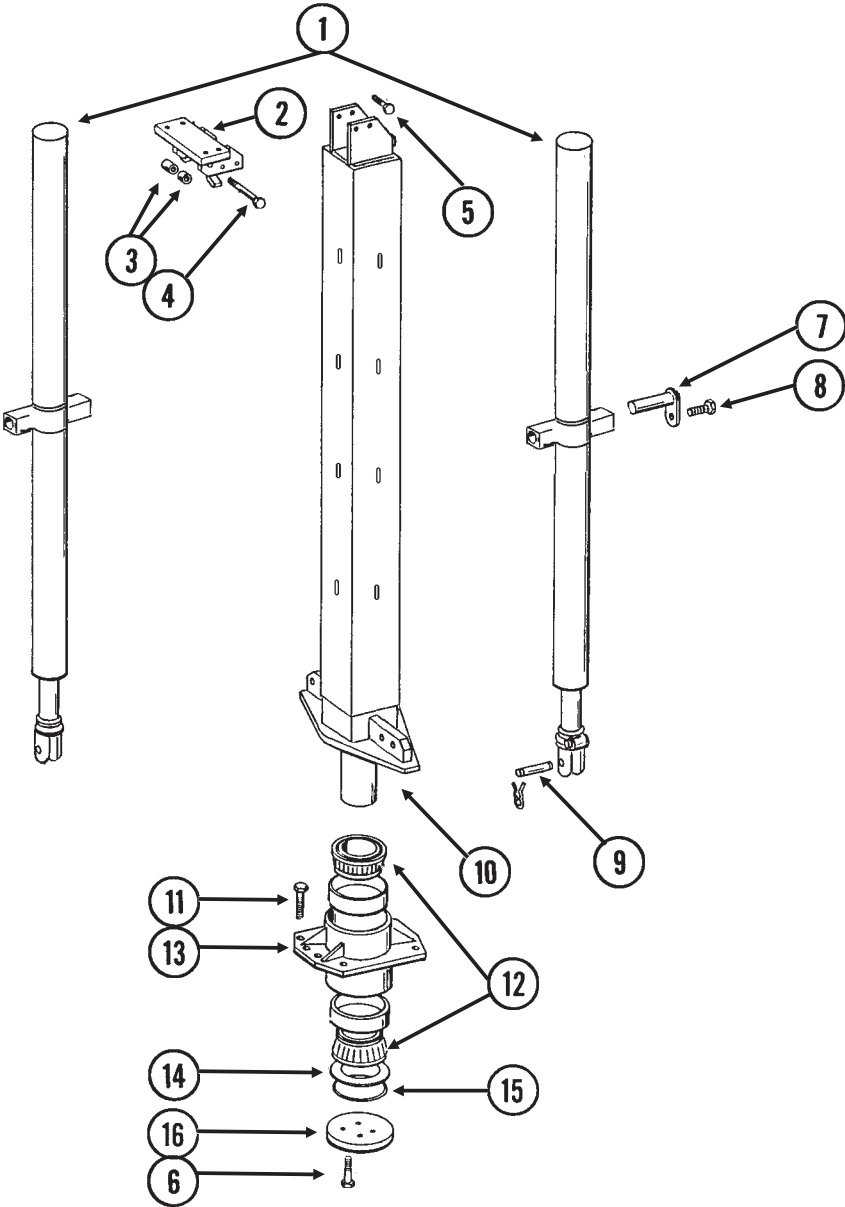

CENTER PIVOT

ITEM	PART NO.	QTY.	DESCRIPTION
1.		-	See "Center Lift Cylinder", Page P72
2.	GA6964	1	Hook Strap
3.	GD10447	1	Sleeve, 3 5/8"
	GD10446	1	Sleeve, 3 13/16"
4.	G10011	1	Hex Head Cap Screw, 5/8"-11 x 5 1/2"
	G10107	1	Lock Nut, 5/8"-11
5.	G10689	4	Carriage Bolt, 5/8"-11 x 2"
	G10107	4	Lock Nut, 5/8"-11
6.	G10027	4	Hex Head Cap Screw, 3/4"-10 x 2 1/2"
	GD2169	1	Special Washer, 25/32" I.D. x 1 1/4" O.D., Hardened
7.	GA5121	4	Pin, 2 1/8"
8.	G10017	4	Hex Head Cap Screw, 1/2"-13 x 1 1/2"
	G10216	4	Washer, 1/2" USS
	G10228	4	Lock Washer, 1/2"
	G10102	4	Hex Nut, 1/2"-13
9.	GR0375	2	Pin, 1" x 3 1/2"
	GR0193	4	Hair Pin Clip
10.	GA7540	1	Center Post
11.	G10441	8	Hex Head Cap Screw, 7/8"-9 x 3", Grade 8
	GD10063	8	Hardened Washer, 7/8"
	G11053	8	Hex Nut, 7/8"-9, Grade 8
12.	GA7096	2	Cone
13.	GA7067	1	Bearing Housing W/Cups, Less Grease Fitting
	GD10011	2	Cup
	G10779	1	Grease Fitting, 90°, 1/4"-28
14.	GD10012	-	Shim, .005" Thick (As Required)
	GD10013	-	Shim, .020" Thick (As Required)
	GD10014	-	Shim, .007" Thick (As Required)
15.	GD9130	1	O-Ring
16.	GD9636	1	Bearing Cap

AXLE ASSEMBLY

HTA043/HTA044/PFA071/PHA033/PHA034/PFA073(TWL140cc)

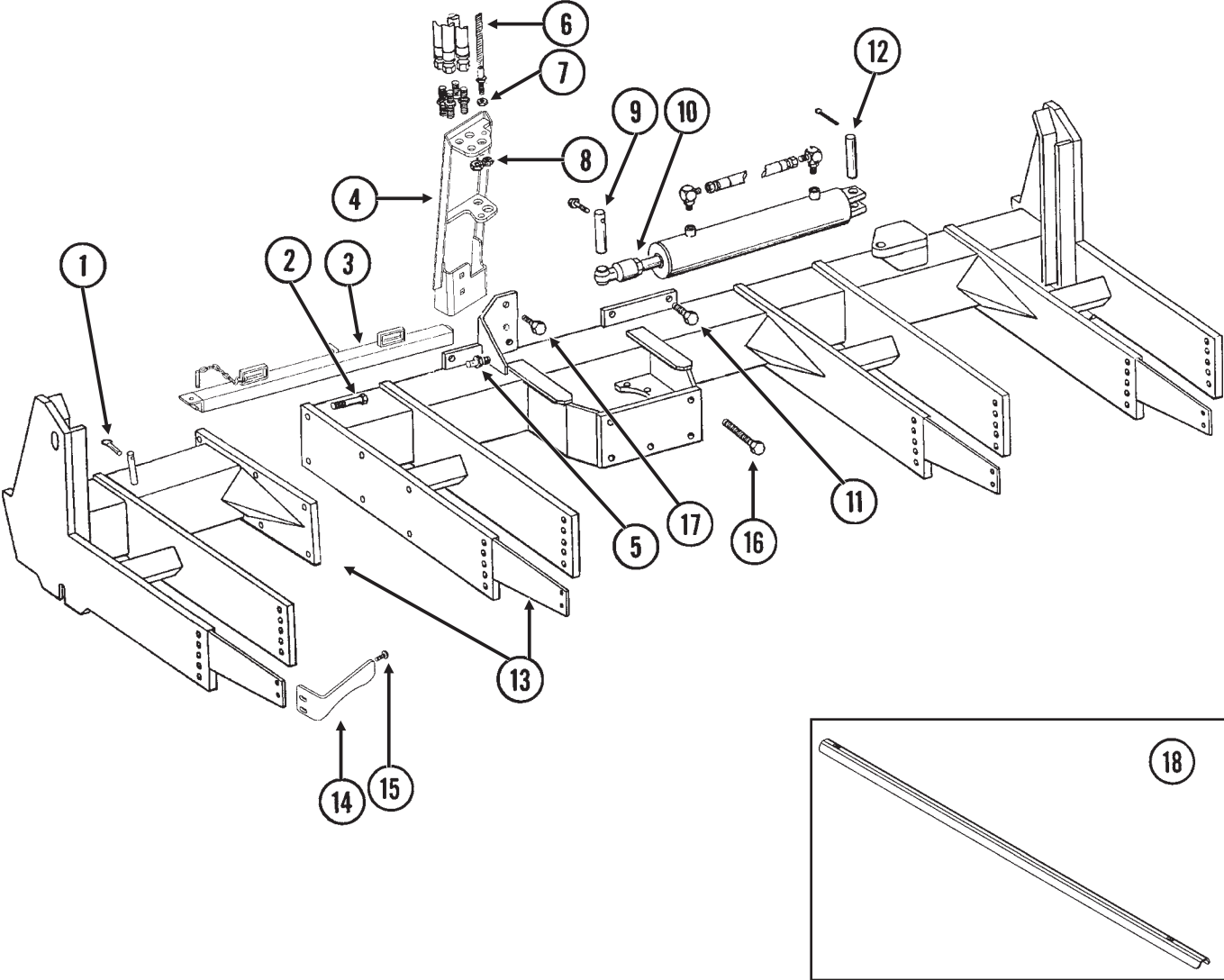

AXLE ASSEMBLY

ITEM	PART NO.	QTY.	DESCRIPTION
1.	GD2558	1	Lynch Pin, 1/4"
2.	G10802	6	Hex Head Cap Screw, 3/4"-10 x 2 3/4"
	G10028	-	Hex Head Cap Screw, 3/4"-10 x 3"
	G10231	6	Lock Washer, 3/4"
	G10105	6	Hex Nut, 3/4"-10
3.	GA7098	1	Manual Safety Lockup W/Detent Pin
	GA7022	1	Detent Pin W/Chain
4.	GA11200	1	Bulkhead Mount
5.	GD8276	1	Pin
	G10237	1	Lock Washer, 7/16"
	G10100	1	Hex Nut, 7/16"-14
6.	GA6608	-	Cable Assembly
7.	G10228	2	Lock Washer, 1/2"
	G10102	2	Hex Nut, 1/2"-13
8.	G306-08	2	Lock Nut, 3/4"-16
	G306-10	2	Lock Nut, 7/8"-14
9.	GD10092	1	Pin, 1 1/4" x 5 1/4"
	G10226	4	Washer, 1 1/4" SAE
	G10049	1	Hex Head Cap Screw, 3/8"-16 x 2 1/2"
	G10108	1	Lock Nut, 3/8"-16
10.		-	See "Rotation Cylinder", Page P72
11.	G10437	4	Hex Head Cap Screw, 3/4"-8 x 2 1/2", Grade 8
	GD2169	4	Special Washer, 25/32" I.D. x 1 1/4" O.D., Hardened
	G10436	4	Hex Nut, 3/4"-10
12.	GD10064	1	Pin, 1 1/4" x 5 1/4"
	G10460	2	Cotter Pin, 1/4" x 2"
13.	GA8062	-	Axle W/Stub Axle
	GA9883	-	Stub Axle, Narrow Row
14.	GD12543	-	Scraper
15.	G10636	-	Carriage Bolt, 1/2"-13 x 1 1/2"
	G10216	-	Washer, 1/2" USS
	G10228	-	Lock Washer, 1/2"
	G10102	-	Hex Nut, 1/2"-13
16.	G10808	6	Hex Head Cap Screw, 1"-8 x 10", Grade 8
	GD10231	6	Special Washer, 1 1/16" I.D. x 2" O.D.
	G10647	6	Hex Nut, 1"-8, Grade 8
17.	G10636	-	Carriage Bolt, 1/2"-13 x 1 1/2"
	G10228	-	Lock Washer, 1/2"
	G10102	-	Hex Nut, 1/2"-13
18.	GD18645	1	Cable Guard

TRANSPORT WHEELS/ROCK GUARDS

HTA032/HTA040/HTA043/HTA004(TWL141c)

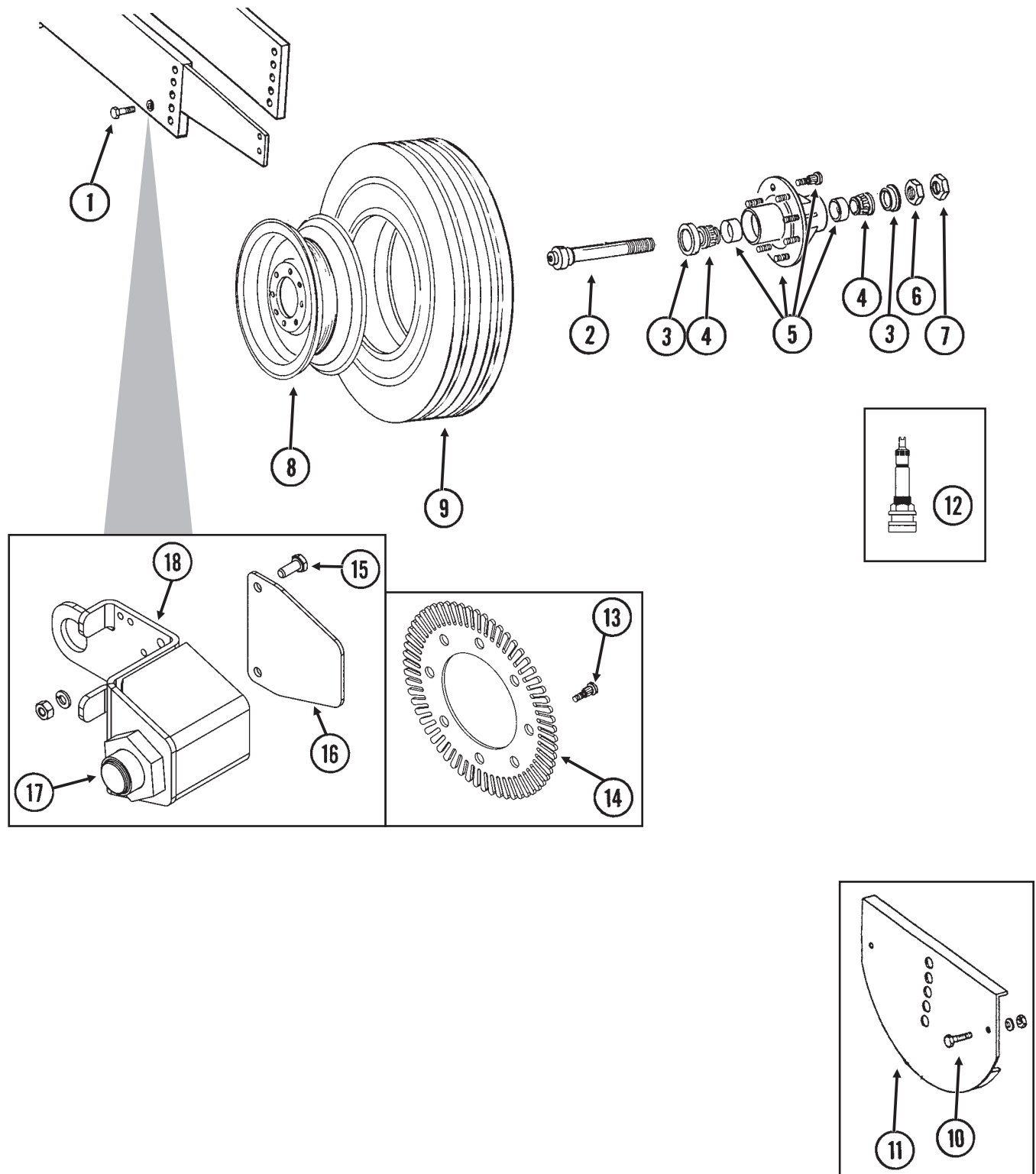

TRANSPORT WHEELS/ROCK GUARDS

ITEM	PART NO.	QTY. (Per Assy.)	DESCRIPTION
1.	G10448	2	Hex Head Cap Screw, 7/8"-9 x 2 1/2", Grade 8
	G10330	2	Lock Washer, 7/8"
2.	GA4727	1	Spindle W/Retaining Ring, 1 3/4"
	G10913	-	External Retaining Ring, 2 1/2"
3.	GA4722	2	Seal
4.	GA4723	2	Bearing
5.	GA4729	1	Hub W/Cups, Bolts, Nuts And Grease Fitting, 8 Bolt, 1 3/4" Bore
	G10640	-	Grease Fitting, 1/4"-28
	GD7079	-	Cup
	GR0528	-	Stud, 5/8"-12 x 2 1/4", Grade 8
6.	GD7089	1	Special Nut, 1 3/4"-12 UNF
7.	GD7864	1	Special Hex Nut, 1 3/4"-12 UNF
8.	GA9544	-	Rim, 5.5" x 22.5", All Sizes
9.	GD13409	-	Tire, 255-70R 22.5" W/O Center Rib, Tubeless (Specify Brand*)
10.	G10037	-	Hex Head Cap Screw, 1/2"-13 x 1 1/4"
	G10228	-	Lock Washer, 1/2"
	G10102	-	Hex Nut, 1/2"-13
11.	GA5716	-	Rock Guard (Optional)
12.	GA7434	-	Valve Stem
13.	GD18676	4	Lug Bolt, 5/8"-18 x 2 3/4"
14.	GD18643	1	Jump Start Wheel
15.	G10020	2	Hex Head Cap Screw, 1/4"-20 x 5/8"
	G10227	2	Lock Washer, 1/4"
	G10103	2	Hex Nut, 1/4"-20
16.	GD18646	1	Sensor Bracket Cover
17.	GA13204	1	Hall Effect Sensor
18.	GA13227	1	Sensor Bracket
A.	GA9545	-	Tire And Rim Assembly (Items 8, 9 And 12) (Specify Brand*)
B.	GA13214	-	Sensor Bracket Assembly (Items 15 - 18)

* Specific brand requests will be supplied only as available from current KINZE® Repair Parts stock. If a specific brand requested is not in stock, the brand available will be supplied.

WING WHEEL MODULE

(TWL110a)

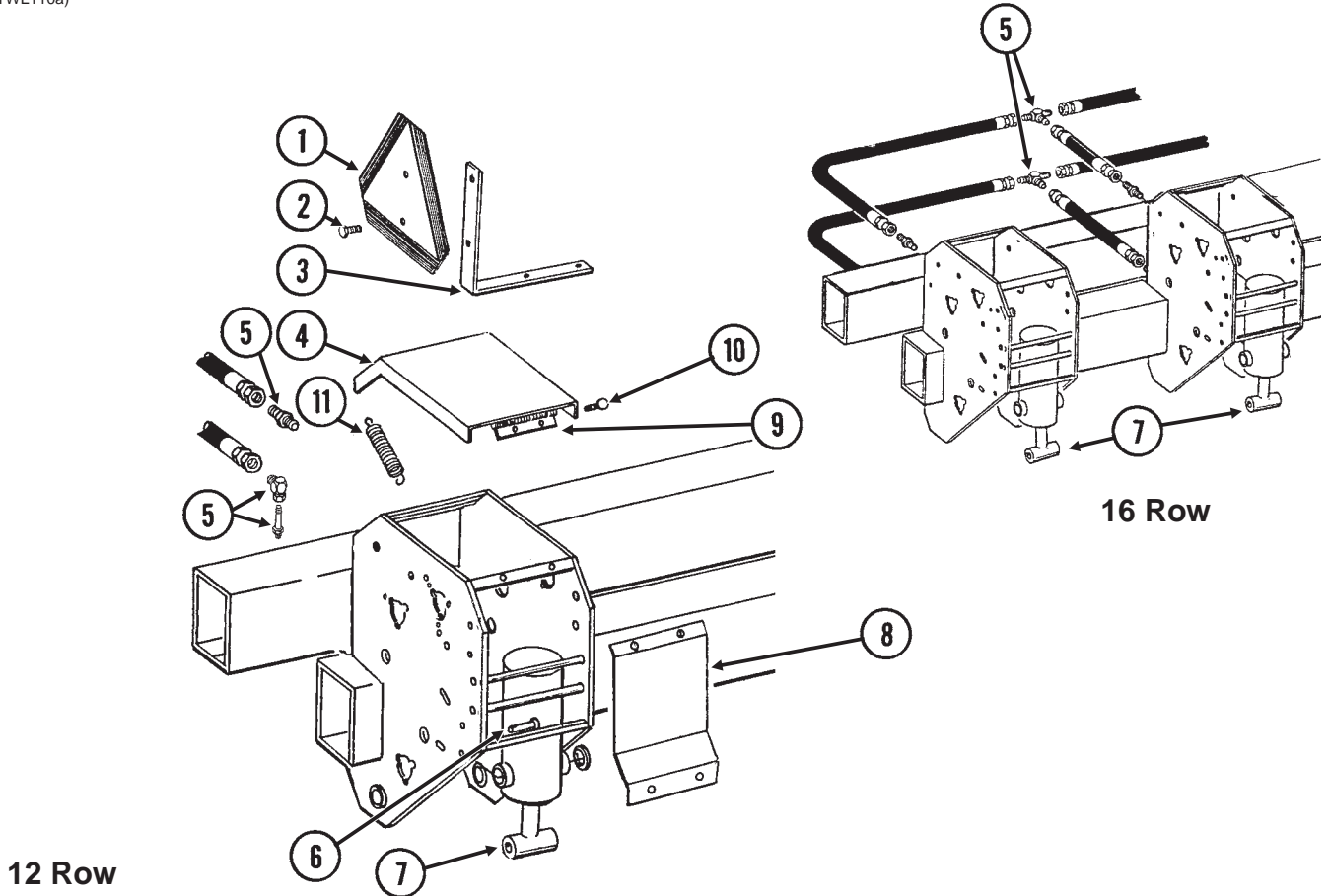

WING WHEEL MODULE

ITEM	PART NO.	QTY. (Per Assy.)	DESCRIPTION
1.	GD2199	1	SMV Sign
2.	G10022	2	Hex Head Cap Screw, 1/4"-20 x 1/2"
	G10227	2	Lock Washer, 1/4"
	G10103	2	Hex Nut, 1/4"-20
3.	GD9969	1	Bracket
4.	GD10298	1	Cover
5.		-	See "Hydraulic Hoses And Fittings On Planter Frame", Pages P88 And P89
6.	G10870	1	Clevis Pin, 3/8" x 1"
	G10860	1	Retaining Ring, 3/8"
7.		-	See "Wing Lift Cylinder", Page P73
8.	GD6895	1	Shield
9.	GD5789	1	Hinge, Female
	GD5790	1	Hinge W/Pins, Male
10.	G10064	6	Hex Head Cap Screw, 1/4"-20 x 1"
	G10209	4	Washer, 1/4" USS
	G10227	6	Lock Washer, 1/4"
	G10103	6	Hex Nut, 1/4"-20
11.	GD5857	1	Spring

GROUND DRIVE WHEEL

PTD057(TWL142c)

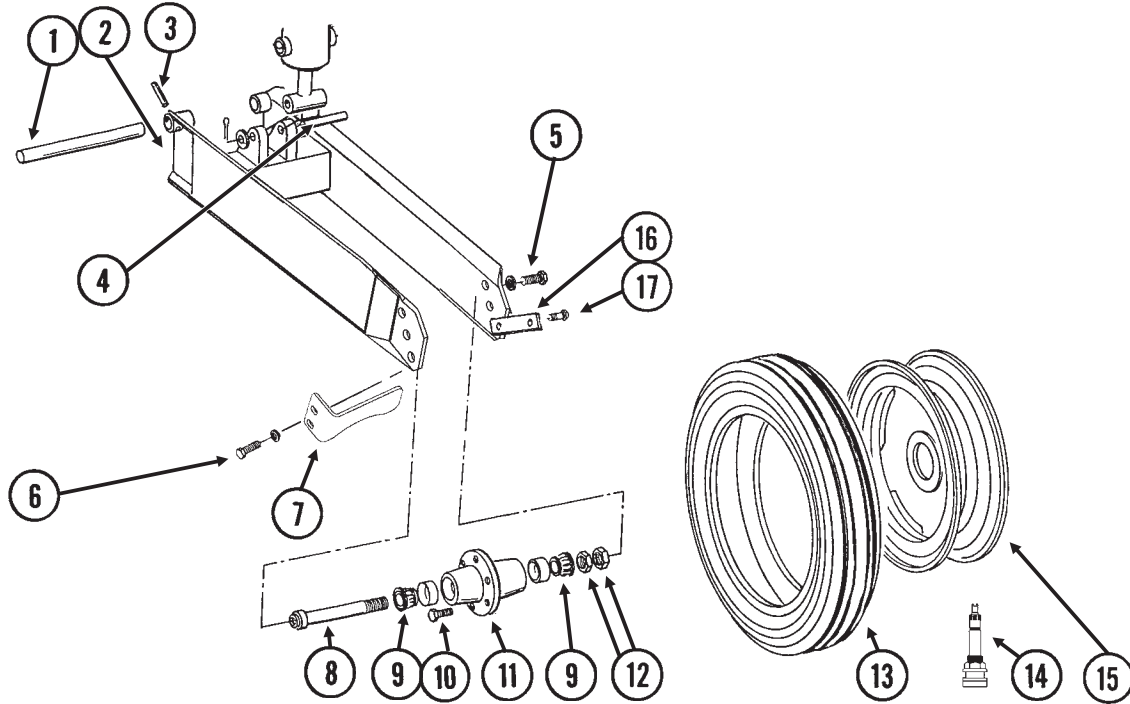

ITEM	PART NO.	QTY. (Per Assy.)	DESCRIPTION
1.	GD11695	-	Pin, 1 1/4" x 13 1/4"
2.	GA8677	1	Wheel Module
3.	G10610	-	Spring Pin, 3/8" x 2"
4.	GD5841	1	Pin, 1 1/4" x 5 5/8"
	G10226	2	Washer, 1 1/4" SAE
	G10460	2	Cotter Pin, 1/4" x 2"
5.	G10026	2	Hex Head Cap Screw, 3/4"-10 x 2"
	G10231	2	Lock Washer, 3/4"
6.	G10026	2	Hex Head Cap Screw, 3/4"-10 x 2"
	G10231	2	Lock Washer, 3/4"
	G10105	2	Hex Nut, 3/4"-10
7.	GA13335	1	Scraper
8.	GA4376	1	Spindle W/Round External Retaining Ring, 10"
	GD11490	-	Round External Retaining Ring
9.	GA0895	2	Bearing
10.	GR0270	6	Lug Bolt, 9/16"-18
11.	GA2148	1	Hub W/Cups, 6 Bolt
	GR0434	-	Cup
12.	G11081	2	Hex Jam Nut, 1 1/2"-12, Grade 2
13.	GD13401	1	Tire, 7.50" x 20", 8 Ply, Tubeless W/O Center Rib (Specify Brand*)
14.	GA7434	-	Valve Stem
15.	GA2908	1	Rim, 5.5" x 20"
16.	GD10144	1	Bar Clamp
17.	G10017	2	Hex Head Cap Screw, 1/2"-13 x 1 1/2"
	G10228	2	Lock Washer, 1/2"
	G10102	2	Hex Nut, 1/2"-13
A.	GA7997	-	Tire And Rim Assembly (Specify Brand*)(Items 13-15)
B.	GA4377	-	Hub And Spindle Assembly (Items 8, 9, 11 And 12)

* Specific brand requests will be supplied only as available from current KINZE® Repair Parts stock. If a specific brand requested is not in stock, the brand available will be supplied.

ROW MARKER SPINDLE/HUB/BLADE

MKR020(MKR4)

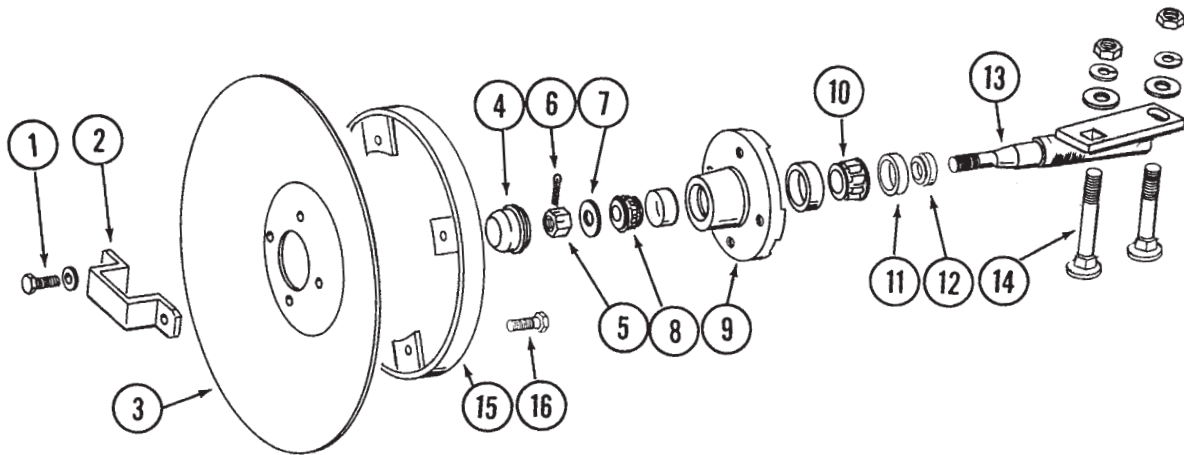

ITEM	PART NO.	QTY.	DESCRIPTION
		(Per Assy.)	
1.	G10722	4	Hex Head Cap Screw, 1/2"-20 x 1"
	G10228	4	Lock Washer, 1/2"
2.	GD2597	1	Retainer
3.	GD0746	1	Disc Blade, Solid, 16" (Shown)
	GD10283	-	Disc Blade, Notched, 16" (Optional)
4.	GD0840	1	Dust Cap
5.	G10725	1	Slotted Hex Nut, 5/8"-18
6.	G10544	1	Cotter Pin, 5/32" x 1"
7.	G10724	1	Washer, 5/8" SAE
8.	GA0257	1	Bearing
9.	GA0167	1	Hub W/Cups, 4 Bolt
	GR0151	-	Outer Cup
	GR0150	-	Inner Cup
10.	GA0245	1	Bearing
11.	GA0243	1	Grease Seal
12.	GA0899	1	Rubber Seal
13.	GA1676	1	Spindle, R.H.
	GA1677	-	Spindle, L.H. (Shown)
14.	G10844	2	Carriage Bolt, 1/2"-13 x 3 1/2"
	G10168	2	Machine Bushing, 1/2", 7 Gauge
	G10228	2	Lock Washer, 1/2"
	G10102	2	Hex Nut, 1/2"-13
15.	GA5853	1	Depth Band
16.	G10019	4	Hex Head Cap Screw, 5/16"-18 x 1"
	G10109	4	Lock Nut, 5/16"-18, Grade 8
A.	GA1679	-	Hub And Spindle Assembly, L.H. (Items 1, 2 And 4-13)
	GA1678	-	Hub And Spindle Assembly, R.H. (Items 1, 2 And 4-13)

ROW MARKER ASSEMBLY, 12 ROW 30"

(MKR14)

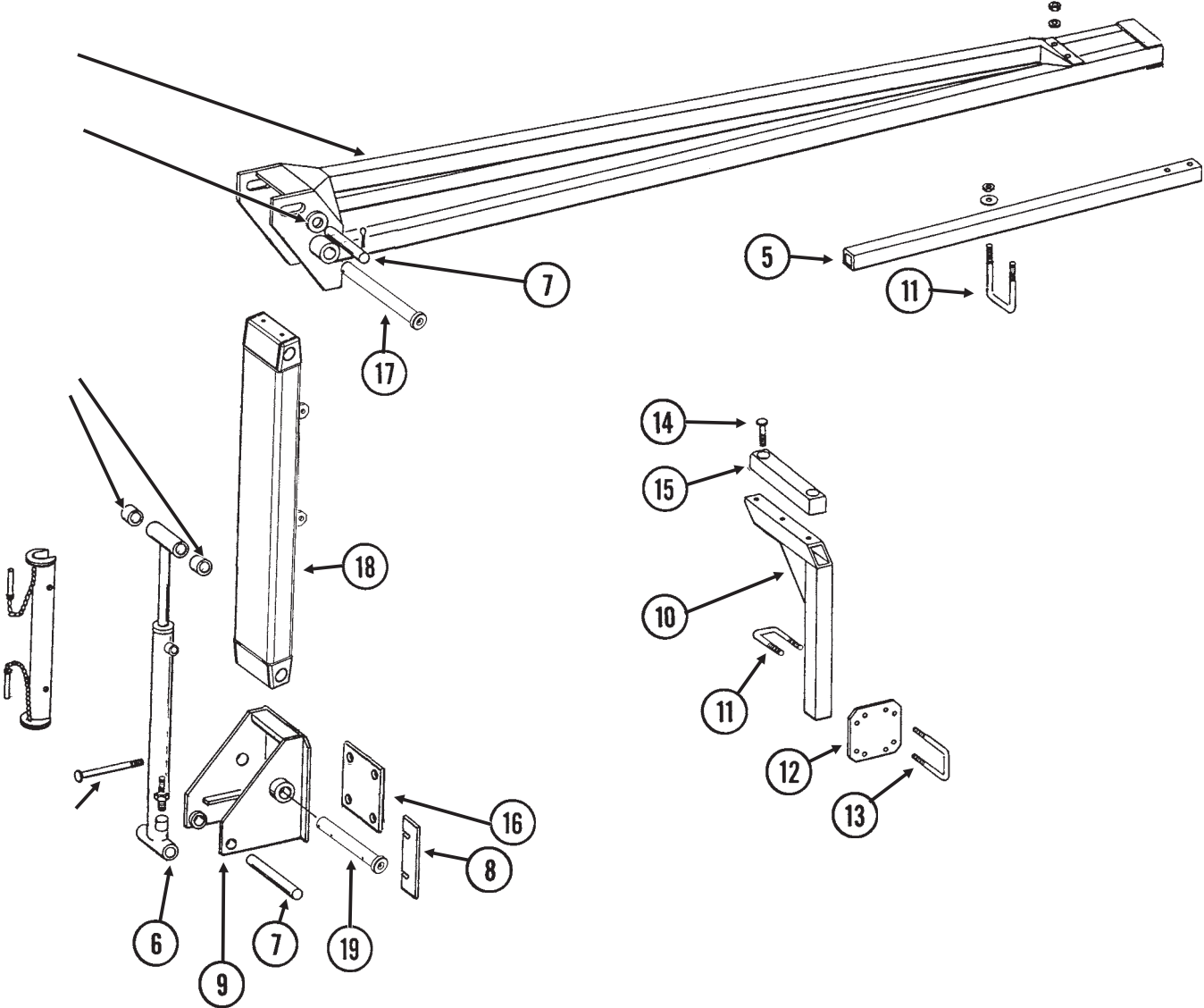

ROW MARKER ASSEMBLY, 12 ROW 30"

ITEM	PART NO.	QTY.	DESCRIPTION
		(Per Assy.)	
1.	GA4353	1	Arm W/Grease Fittings, Second Stage, 110"
	G10641	-	Grease Fitting, 1/8" NPT
2.	GD0752-41	4	Sleeve, 1"
3.	GA8170	1	Safety Lockup W/Detent Pins, 19 3/8"
	G10536	-	Detent Pin, 1/2" x 2 1/2" Grip
4.	G10011	4	Hex Head Cap Screw, 5/8"-11 x 5 1/2" (If Applicable)
	G10046	-	Hex Head Cap Screw, 5/8"-11 x 5" (If Applicable)
	G10008	-	Hex Head Cap Screw, 5/8"-11 x 2" (If Applicable)
	GD7805	8	Special Washer, 5/8", Hardened
	G10205	-	Washer, 5/8" SAE
	G10230	4	Lock Washer, 5/8"
	G10104	4	Hex Nut, 5/8"-11
5.	GD0453-07	1	Extension Tube, 45"
	GD0453-04	-	Extension Tube, 60", (L.H. Even-Row Marker) (If Applicable)
6.		-	See "Row Marker (Cushion) Cylinder", Page P77
7.	GD2161	2	Pin, 1 1/4" x 8 1/4"
	G10460	4	Cotter Pin, 1/4" x 2"
8.	GD10792	-	Shim, 2 1/2" x 7 1/4", 16 Gauge (As Required)
9.	GA5130	1	Mount
10.	GA7042	1	Stand, 20"
11.	GD2721	3	U-Bolt, 2" x 2" x 1/2"-13
	G10228	6	Lock Washer, 1/2"
	G10102	6	Hex Nut, 1/2"-13
12.	GD9981	1	Bar
13.	GD4743	2	U-Bolt, 3" x 3" x 1/2"-13
	G10216	4	Washer, 1/2" USS
	G10228	4	Lock Washer, 1/2"
	G10102	4	Hex Nut, 1/2"-13
14.	G10017	2	Hex Head Cap Screw, 1/2"-13 x 1 1/2"
	G10206	2	Washer, 1/2" SAE
	G10111	2	Lock Nut, 1/2"-13
15.	GA9088	-	Molded Stop, 12 1/4" Long
16.	GD13360	2	Plate, 6" x 6"
17.	GA11766	-	Pin W/Grease Fitting, 1 1/4" x 11 13/16"
	G10640	-	Grease Fitting, 1/4"-28
	GD16999	-	Marker Pin
18.	GA11590	-	Arm, First Stage
19.	GA11767	-	Pin W/Grease Fitting, 1 1/4" x 9 1/2"
	G10640	-	Grease Fitting, 1/4"-28
	GD16999	-	Marker Pin

ROW MARKER ASSEMBLY, 16 ROW 30"

(MKR15k)

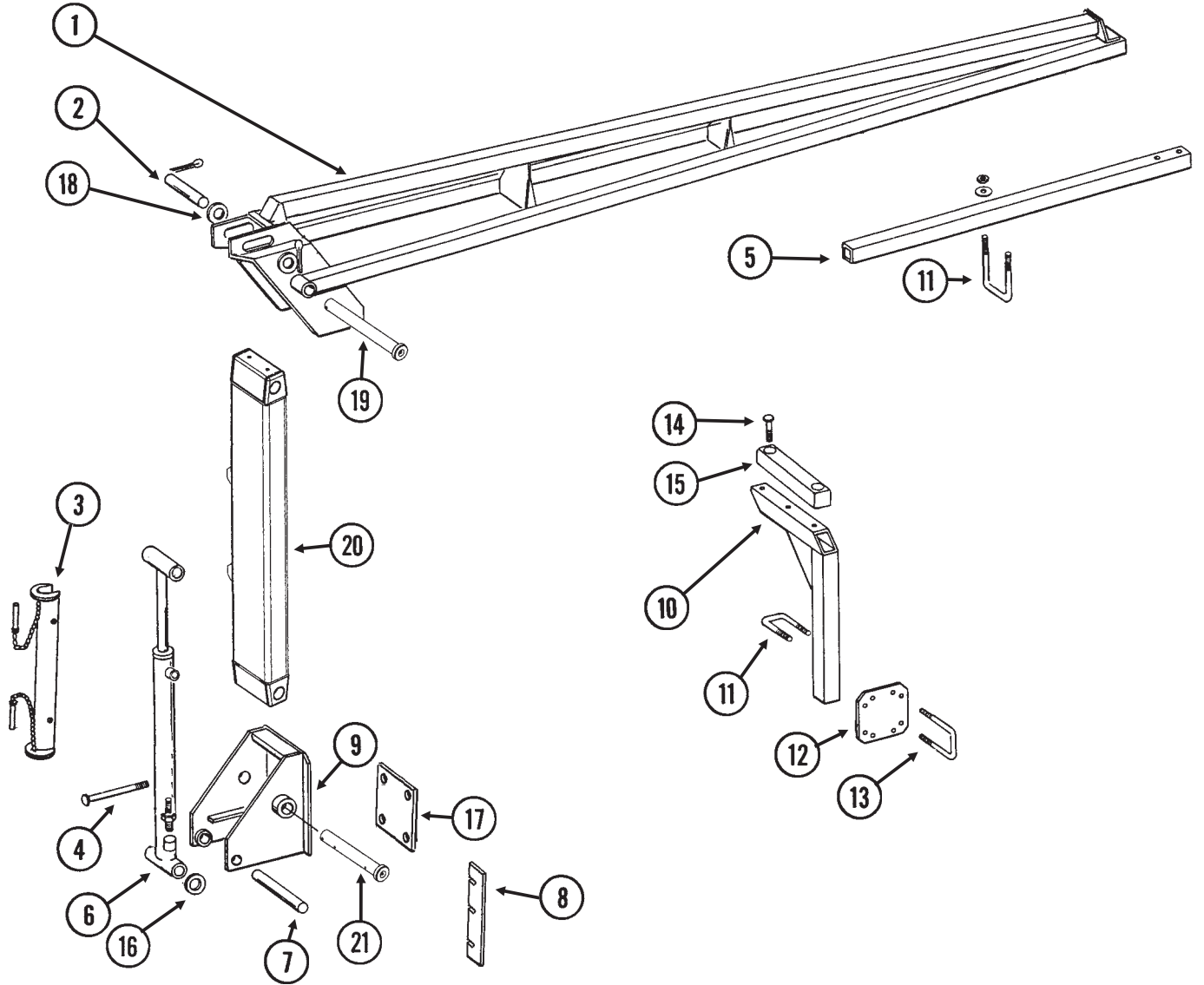

ROW MARKER ASSEMBLY, 16 ROW 30"

ITEM	PART NO.	QTY.	DESCRIPTION
		(Per Assy.)	
1.	GA7118	-	Arm, Second Stage, 172 1/4"
2.	GD1701	1	Pin, 1 1/4" x 6 1/2"
	G10460	2	Cotter Pin, 1/4" x 2"
3.	GA8170	1	Safety Lockup W/Detent Pins, 19 3/8"
	G10536	-	Detent Pin, 1/2" x 2 1/2" Grip
4.	G10012	-	Hex Head Cap Screw, 5/8"-11 x 6 1/2" (If Applicable)
	G10009	-	Hex Head Cap Screw, 5/8"-11 x 2 1/2" (If Applicable)
	GD7805	8	Special Washer, 5/8", Hardened
	G10230	6	Lock Washer, 5/8"
	G10104	6	Hex Nut, 5/8"-11
5.	GD0453-09	1	Extension Tube, 75, (L.H. Even-Row Marker) (If Applicable)
	GD0453-03	-	Extension Tube, 50"
6.		-	See "Row Marker (Cushion) Cylinder", Page P77
7.	GD0652	1	Pin, 1 1/4" x 9 1/2"
	G10460	2	Cotter Pin, 1/4" x 2"
8.	GD10793	-	Shim, 2 1/2" x 12 1/2", 16 Gauge (As Required) (Shown)
	GD11791	-	Shim, 2 1/2" x 8 1/4", 16 Gauge (As Required)
9.	GA4877	1	Mount
10.	GA7043	1	Stand, 30"
11.	GD2721	3	U-Bolt, 2" x 2" x 1/2"-13
	G10228	6	Lock Washer, 1/2"
	G10102	6	Hex Nut, 1/2"-13
12.	GD9981	1	Bar
13.	GD4743	2	U-Bolt, 3" x 3" x 1/2"-13
	G10216	4	Washer, 1/2" USS
	G10228	4	Lock Washer, 1/2"
	G10102	4	Hex Nut, 1/2"-13
14.	G10017	2	Hex Head Cap Screw, 1/2"-13 x 1 1/2"
	G10206	2	Washer, 1/2" SAE
	G10111	2	Lock Nut, 1/2"-13
15.	GA9088	-	Molded Stop, 12 1/4" Long
16.	G10979	4	Special Washer, 1 1/4" (As Required)
17.	GD13359	2	Plate, 7" x 7"
18.	G10226	2	Washer, 1 1/4" SAE
	G10322	2	Machine Bushing, 1 1/4", 18 Gauge
19.	GA11768	-	Pin W/Grease Fitting, 1 1/4" x 13"
	G10640	-	Grease Fitting, 1/4"-28
	GD17001	-	Marker Pin
20.	GA11569	-	Arm, First Stage, L.H. (Shown)
	GA11568	-	Arm, First Stage, R.H.
21.	GA11769	-	Pin W/Grease Fitting, 1 1/4" x 11 1/2"
	G10640	-	Grease Fitting, 1/4"-28
	GD17003	-	Marker Pin

ROTATION CYLINDER, ALL SIZES

(CYL11i)

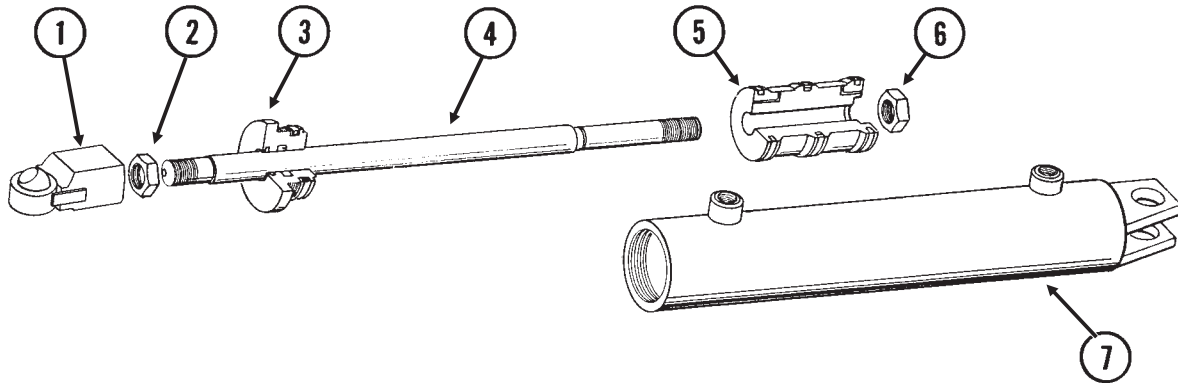

ITEM	PART NO.	QTY.	DESCRIPTION
1.	GA7221	1	Threaded Ball Joint End
2.	G10509	1	Hex Jam Nut, 1 1/4"-12, Grade 2
3.	GD11988	1	Gland
4.	GD11991	1	Rod
5.	GD11992	1	Piston
6.	G10972	1	Lock Nut, 1 1/4"-12
7.	A7220	1	Barrel (Non-Stock Item)
A.	GA8904	-	Cylinder Complete, 4" x 16" <i>(Part Number Stamped On Barrel)</i>
B.	GR1524	-	Seal Kit, Includes: (2) O-Rings, (1) U-Cup, (1) Wiper, (1) Seal, (2) Cast Iron Rings, (1) BU Ring, (1) Expander

CENTER LIFT CYLINDER, ALL SIZES

(CYL39c)

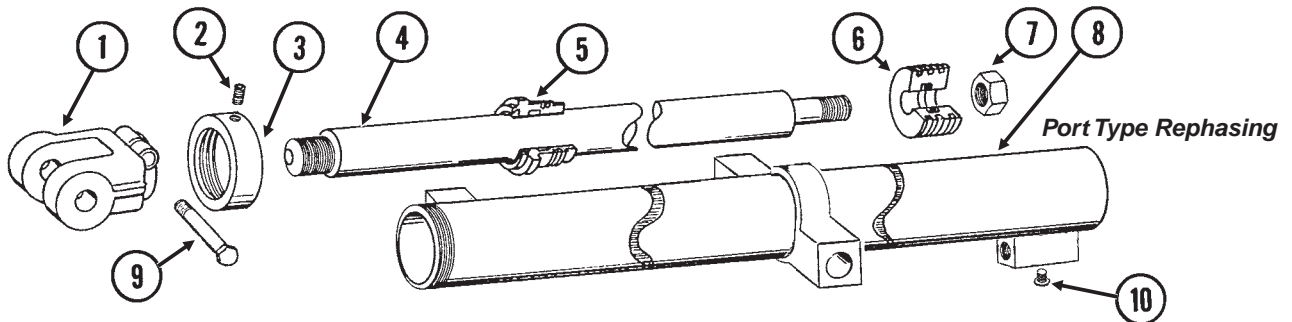

ITEM	PART NO.	QTY.	DESCRIPTION
1.	GD11951	1	Clevis
2.	G10907	1	Set Screw, 1/4"-20 x 1/4"
3.	GD11193	1	Cap
4.	GD10936	1	Rod
5.	GD10211	1	Gland
6.	GD11253	1	Piston
7.	G10958	1	Lock Nut, 1"-14
8.	GA8149	1	Barrel
9.	G10939	1	Hex Head Cap Screw, 3/8"-16 x 2 1/4"
	G10108	1	Lock Nut, 3/8"-16
10.	G6408-H04-O	1	Hex Socket Head Plug W/O-Ring, 7/16"-20 O-Ring
	GR1465	1	O-Ring
A.	GA8908	-	Cylinder Complete, 3" x 48" <i>(Part Number Stamped On Barrel)</i>
B.	GR1428	-	Seal Kit, Includes: (2) O-Rings, (2) BU Rings, (1) Wiper, (1) U-Cup, (1) Piston Seal, (2) Cast Iron Rings, (1) Expander

WING LIFT CYLINDER, 12 ROW

CYL031/CYL011(CYL45d)

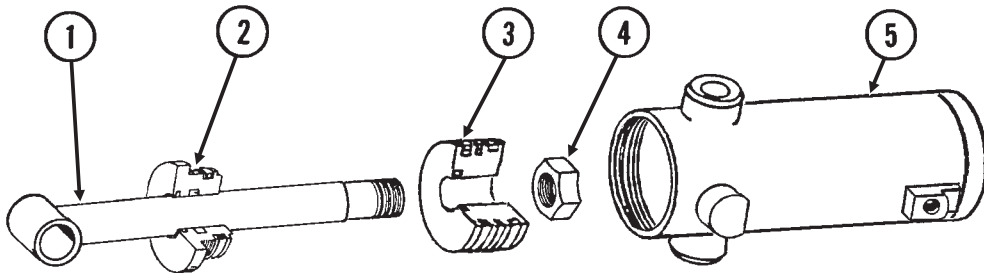

*Port Type
Rephasing*

ITEM	PART NO.	QTY	DESCRIPTION
1.	GA8320	1	Rod Assembly W/Grease Fitting
	G10640	-	Grease Fitting, 1/4"-28
2.	GD11995	1	Gland
3.	GD11994	1	Piston
4.	G10958	1	Lock Nut, 1"-14
5.	A8797	1	Barrel (Non-Stock Item)
A.	GA8909	-	Cylinder Complete, 4 1/4" x 6" (<i>Part Number Stamped On Barrel</i>)
B.	GR1523	-	Seal Kit, Includes: (1) Wiper, (2) O-Rings, (1) BU Ring, (1) U-Cup, (1) Seal, (2) Cast Iron Rings, (1) Expander

WING LIFT CYLINDER, 16 ROW

CYL031/CYL011(CYL41c)

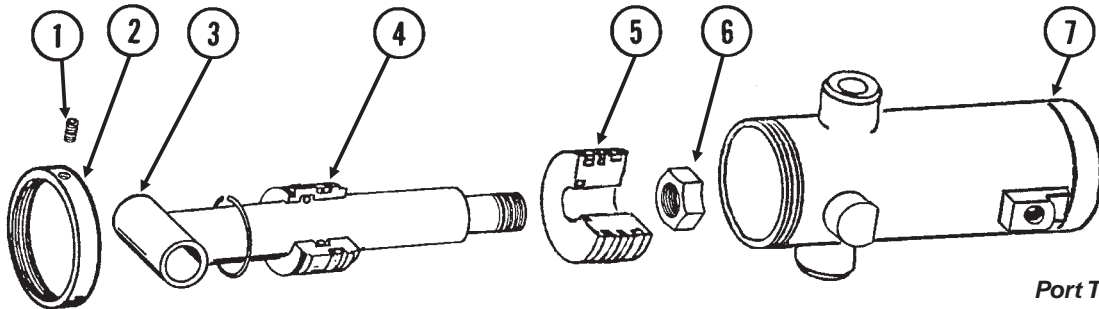

*Port Type
Rephasing*

ITEM	PART NO.	QTY	DESCRIPTION
1.	G10907	1	Set Screw, 1/4"-20 x 1/4"
2.	GD11193	1	Cap
3.	GA8157	1	Rod Assembly W/Grease Fitting
	G10449	-	Grease Fitting, 3/16", Drive-In
4.	GD11194	1	Gland
5.	GD11253	1	Piston
6.	G10958	1	Lock Nut, 1"-14
7.	A8873	1	Barrel (Non-Stock Item)
A.	GA8874	-	Cylinder Complete, 3" x 6" (<i>Part Number Stamped On Barrel</i>)
B.	GR1417	-	Seal Kit, Includes: (2) O-Rings, (2) BU Rings, (1) Expander, (1) Wiper, (1) U-Cup, (1) Piston Seal, (2) Cast Iron Rings

TRANSPORT LATCH CYLINDER, ALL SIZES

CYL035/CYL050(CYL9c)

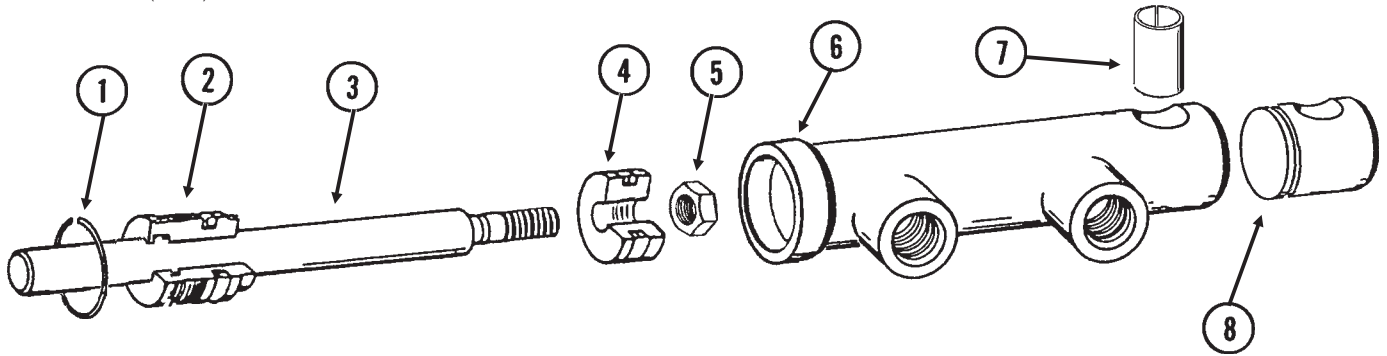

ITEM	PART NO.	QTY.	DESCRIPTION
1.	G10770	1	Internal Retaining Ring, 1 1/16"
2.	GD13170	1	Gland
3.	GD13425	1	Rod
4.	GD13172	1	Piston
5.	G11016	1	Lock Nut, 1/2"-20
6.	D13426	1	Barrel (Non-Stock Item)
7.	GD13400	1	Tension Bushing, 1" x 2" Long
8.	GD13173	1	End Cap
A.	GA9559	-	Cylinder Complete, 1 1/2" x 2 1/2" (Part Number Stamped On Barrel)
B.	GR1598	-	Seal Kit, Includes: (3) O-Rings, (2) BU Rings, (1) Wiper, (1) T-Seal, (1) Bronze Bushing, (1) Seal, (1) U-Cup

TONGUE LOCK CYLINDER, ALL SIZES

CYL035(CYL9d)

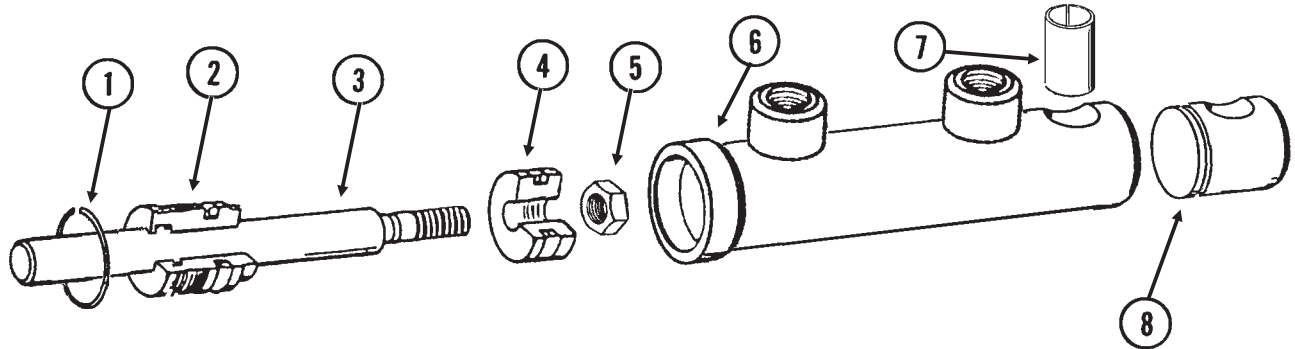

ITEM	PART NO.	QTY.	DESCRIPTION
1.	G10770	1	Internal Retaining Ring, 1 1/16"
2.	GD13170	1	Gland
3.	GD13171	1	Rod
4.	GD13172	1	Piston
5.	G11016	1	Lock Nut, 1/2"-20
6.	D13169	1	Barrel (Non-Stock Item)
7.	GD13400	1	Tension Bushing, 1" x 2" Long
8.	GD13173	1	End Cap
A.	GA9205	-	Cylinder Complete, 1 1/2" x 2 1/2" (Part Number Stamped On Barrel)
B.	GR1598	-	Seal Kit, Includes: (3) O-Rings, (2) BU Rings, (1) Wiper, (1) T-Seal, (1) Bronze Bushing, (1) Seal, (1) U-Cup

TONGUE CYLINDER, 12 ROW 30"

(CYL12f)

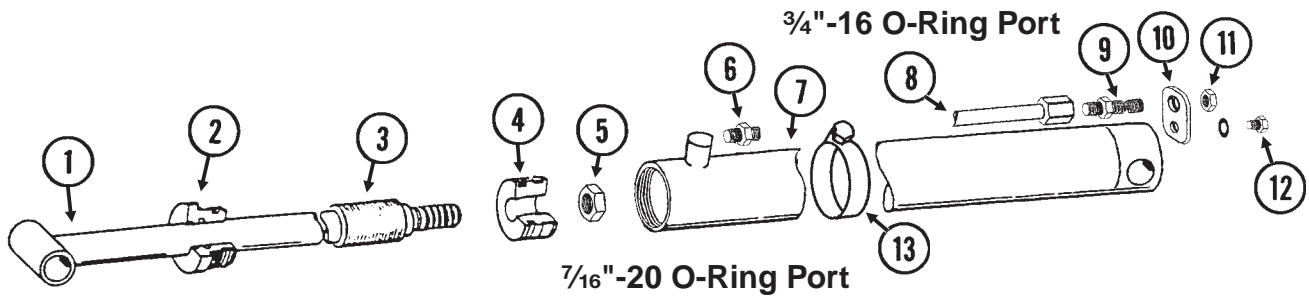

ITEM	PART NO.	QTY.	DESCRIPTION
1.	GA8893	1	Rod Assembly
2.	GD11984	1	Gland
3.	GD7147	1	Spacer
4.	GD11970	1	Piston
5.	G10972	1	Lock Nut, 1 1/4"-12
6.	G6400-08-04	1	Connector W/O-Ring, 3/4"-16 Male JIC To 7/16"-20 O-Ring
	GR1465	-	O-Ring
7.	GA8858	1	Barrel
8.	GA8978	1	Steel Hydraulic Line, 68 11/16"
9.	G2700-08	1	Bulkhead Tube Union, 3/4"-16 Male JIC
10.	GD12597	1	Bracket
11.	G306-08	1	Lock Nut, 3/4"-16
12.	G10328	1	Hex Head Cap Screw, 3/8"-16 x 5/8"
	G10229	1	Lock Washer, 3/8"
13.	G10990	1	Hose Clamp, No. 52
A.	GA8857	-	Cylinder Complete, 3" x 60" (<i>Part Number Stamped On Barrel</i>)
B.	GR1519	-	Seal Kit, Includes: (2) O-Rings, (1) BU Ring, (1) Wear Ring, (1) Wiper, (1) U-Cup, (1) T-Seal

TONGUE CYLINDER, 16 ROW 30"

CYL036(CYL12f)

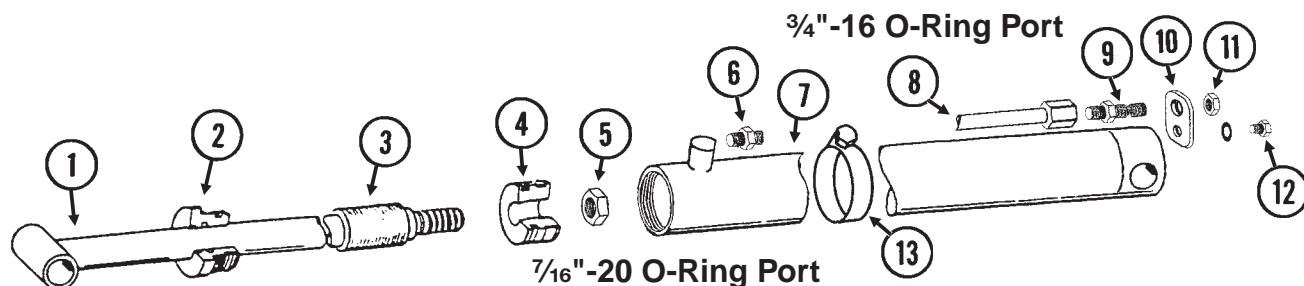

ITEM	PART NO.	QTY.	DESCRIPTION
1.	GA8859	1	Rod Assembly
2.	GD11984	1	Gland
3.	GD7147	1	Spacer
4.	GD11970	1	Piston
5.	G10972	1	Lock Nut, 1 1/4"-12
6.	G6400-08-04	1	Connector W/O-Ring, 3/4"-16 Male JIC To 7/16"-20 O-Ring
	GR1465	-	O-Ring
7.	GA8861	1	Barrel
8.	GA8979	1	Steel Hydraulic Line, 92 11/16"
9.	G2700-08	1	Bulkhead Tube Union, 3/4"-16 Male JIC
10.	GD12597	1	Bracket
11.	G306-08	1	Lock Nut, 3/4"-16
12.	G10328	1	Hex Head Cap Screw, 3/8"-16 x 5/8"
	G10229	1	Lock Washer, 3/8"
13.	G10990	1	Hose Clamp, No. 52
A.	GA8862	-	Cylinder Complete, 3" x 84" (<i>Part Number Stamped On Barrel</i>)
B.	GR1519	-	Seal Kit, Includes: (2) O-Rings, (1) BU Ring, (1) Wear Ring, (1) Wiper, (1) U-Cup, (1) T-Seal

WING LOCK CYLINDER, ALL SIZES

CYL032(CYL3f)

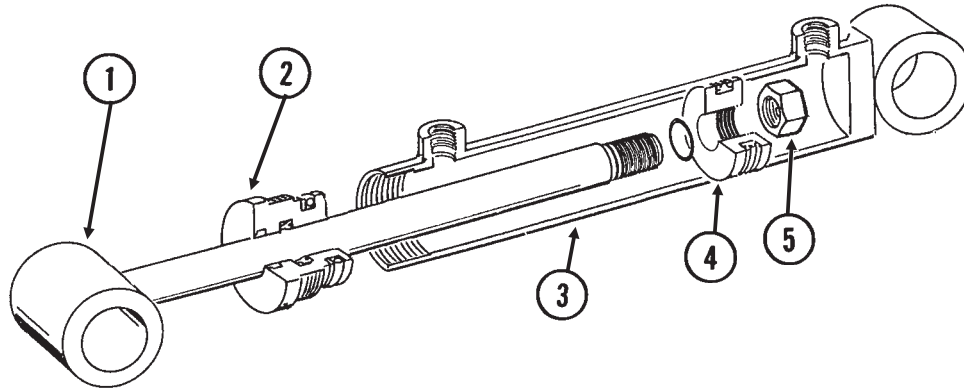

ITEM	PART NO.	QTY.	DESCRIPTION
1.	GA8898	1	Rod Assembly
2.	GD11985	1	Gland
3.	A8822	1	Barrel (Non-Stock Item)
4.	GD11986	1	Piston
5.	G10969	1	Lock Nut, 7/8"-14
A.	GA8899	-	Cylinder Complete, 2 1/2" x 20 1/16" <i>(Part Number Stamped On Barrel)</i>
B.	GR1522	-	Seal Kit, Includes: (1) T-Seal, (2) O-Rings, (1) BU Ring, (1) U-Cup, (1) Wiper

ROW MARKER (Cushion) CYLINDER, ALL SIZES

(CYL3d)

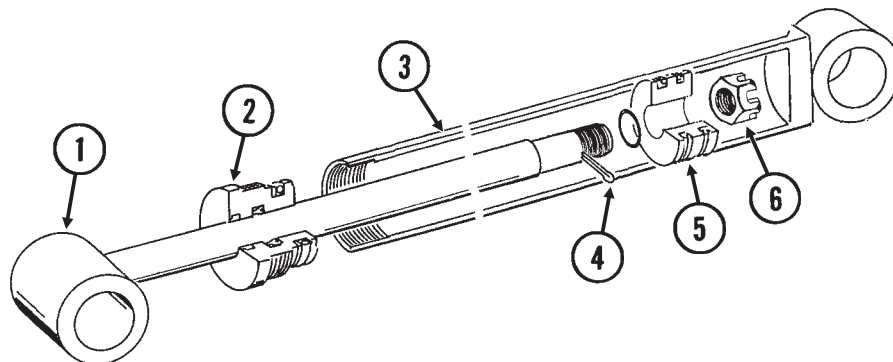

ITEM	PART NO.	QTY.	DESCRIPTION
1.	GA8871	1	Rod Assembly
2.	GD10207	1	Gland
3.	A7524	1	Barrel (Non-Stock Item)
4.	G10827	1	Cotter Pin, 1/8" x 1 3/4"
5.	GD11983	1	Piston
6.	G10962	1	Slotted Hex Nut, 7/8"-14
A.	GA8895	-	Cylinder Complete, 2 1/2" x 20 1/16" <i>(Part Number Stamped On Barrel)</i>
B.	GR1521	-	Seal Kit, Includes: (1) T-Seal, (2) O-Rings, (1) BU Ring, (1) Cast Iron Ring, (1) Wiper, (1) U-Cup

JUNCTION BLOCK - LOCATED ON R.H. SIDE OF CENTER PIVOT

VVB036(TWL24k)

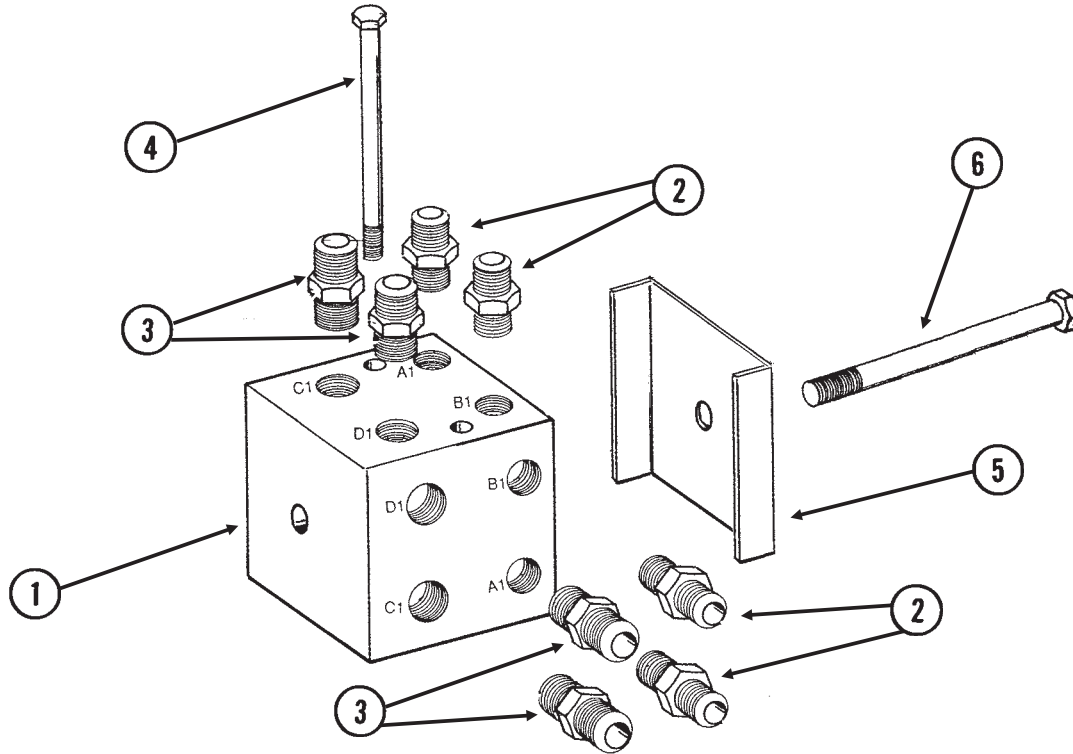

ITEM	PART NO.	QTY.	DESCRIPTION
1.	GD9971	1	Manifold Block
2.	G6400-08	4	Connector W/O-Ring, 3/4"-16 Male JIC To O-Ring
	GR1037	-	O-Ring
3.	G6400-10-08	4	Connector W/O-Ring, 7/8"-14 Male JIC To 3/4"-16 O-Ring
	GR1037	-	O-Ring
4.	G10172	2	Hex Head Cap Screw, 3/8"-16 x 5"
	G10229	2	Lock Washer, 3/8"
	G10101	2	Hex Nut, 3/8"-16
5.	GD0740	1	Hose Clamp, 3/4" x 4" x 3 1/2"
6.	G10871	1	Hex Head Cap Screw, 1/2"-13 x 6"
	G10228	1	Lock Washer, 1/2"
	G10102	1	Hex Nut, 1/2"-13

VALVE BLOCKS - LOCATED ON R.H. REAR CENTER FRAME

VVB034(TWL25e)

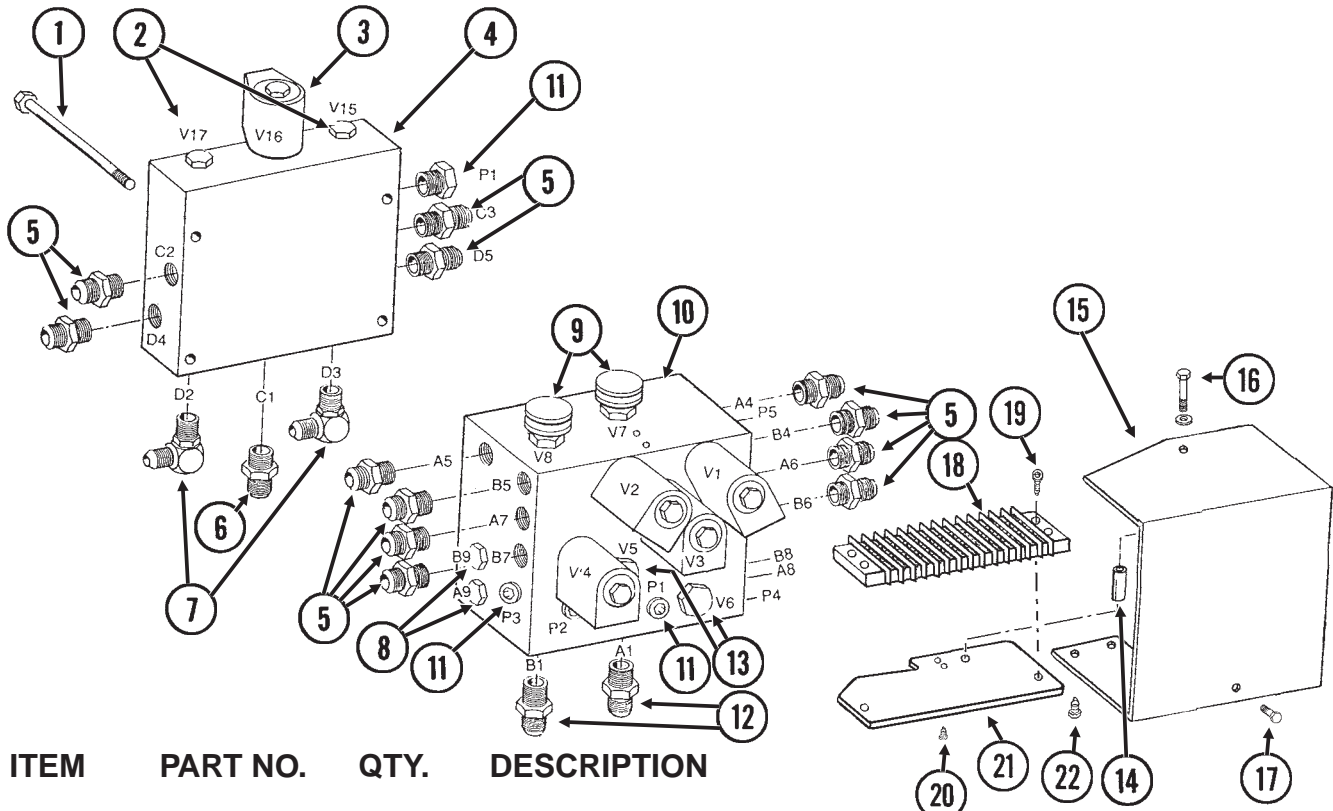

ITEM	PART NO.	QTY.	DESCRIPTION
1.	G10583	4	Hex Head Cap Screw, 5/16"-18 x 2 3/4"
	G10232	4	Lock Washer, 5/16"
2.		2	See "Check Valve", Page P85
3.		5	See "Solenoid Valve", Page P84
4.	GD9977	1	Block
5.	G6400-08	12	Connector W/O-Ring, 3/4"-16 Male JIC To O-Ring
	GR1037	-	O-Ring
6.	G6400-10	1	Connector W/O-Ring, 7/8"-14 Male JIC To O-Ring
	GR1466	-	O-Ring
7.	G6801-08-10	2	Elbow W/O-Ring, 90°, 3/4"-16 Male JIC To 7/8"-14 O-Ring
	GR1466	-	O-Ring
8.	G6408-08	4	Plug W/O-Ring, 3/4"-16 O-Ring
	GR1037	-	O-Ring
9.		2	See "Flow Control Valve", Page P84
10.	GD9533	1	Block
11.	G6408-H06-O	6	Hex Socket Head Plug W/O-Ring, 9/16"-18 O-Ring
	GR1045	-	O-Ring
12.	G6400-08-10	2	Connector W/O-Ring, 3/4"-16 Male JIC To 7/8"-14 O-Ring
	GR1466	-	O-Ring
13.	G6408-10	2	Plug W/O-Ring, 7/8"-14 O-Ring
	GR1466	-	O-Ring
14.	GD8066-02	1	Sleeve, 1" Long
15.	GD13146	1	Cover
16.	G10133	1	Hex Head Cap Screw, 5/16"-18 x 1 1/2"
	G10232	1	Lock Washer, 5/16"
17.	G10054	1	Hex Head Cap Screw, 5/16"-18 x 1/2"
	G10232	1	Lock Washer, 5/16"
	G10106	1	Hex Nut, 5/16"-18
18.	GA9097	1	Terminal Strip W/Screws, No. 6, 14 Terminal
	GR1635	-	Screw, No. 6-32 x 1/4"
19.	G11067	2	Phillips Pan Head Machine Screw, No. 8-32 x 3/4", Stainless Steel
20.	G11066	2	Phillips Pan Head Machine Screw, No. 10-24 x 3/4", Stainless Steel
21.	GA9095	1	Terminal Strip Mount
22.	G10977	2	Phillips Pan Head Machine Screw, No. 10-24 x 1/2", Stainless Steel

VALVE BLOCK - LOCATED ON HITCH

VVB035(TWL26f)

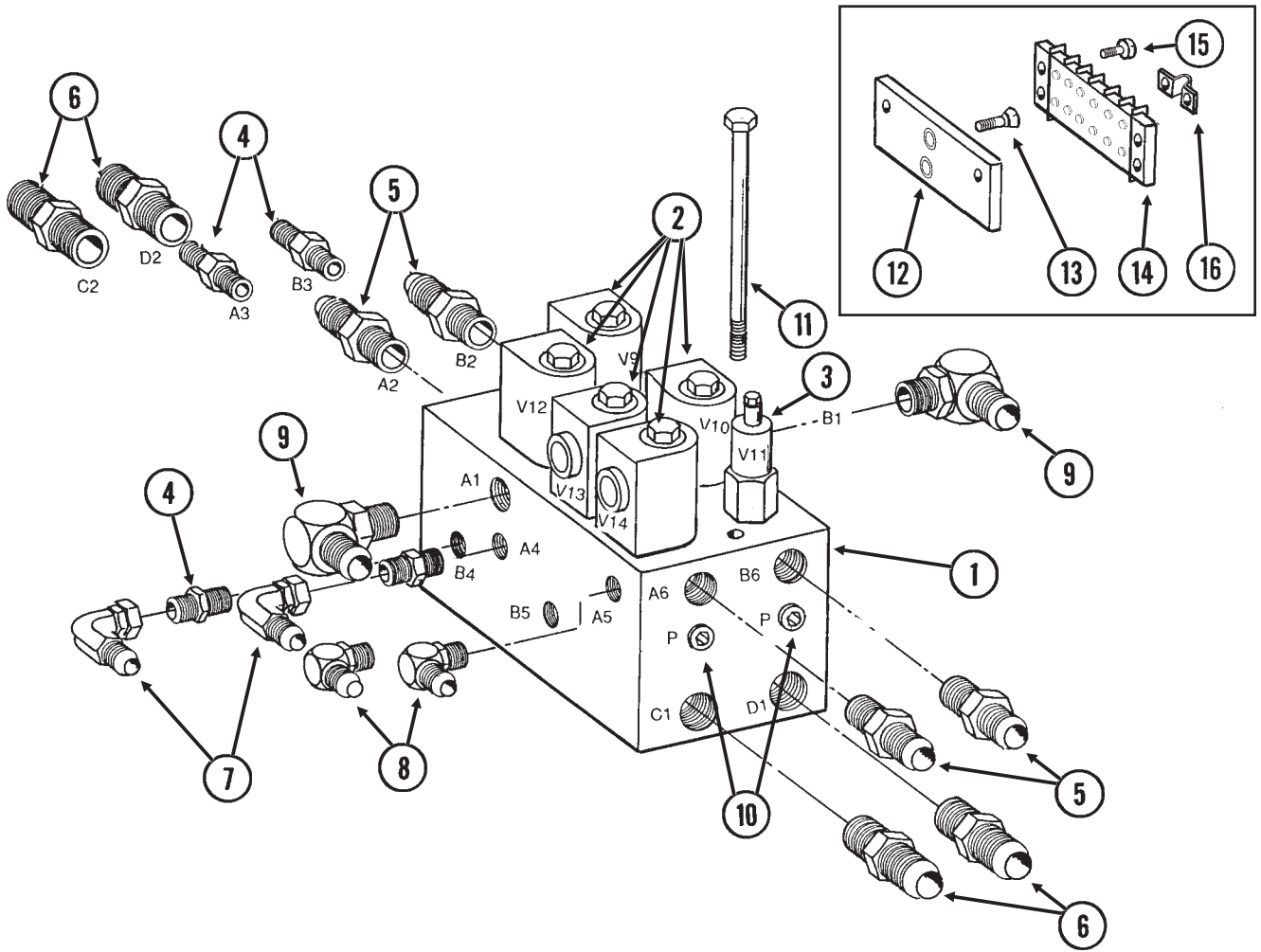

VALVE BLOCK - LOCATED ON HITCH

ITEM	PART NO.	QTY.	DESCRIPTION
1.	GD9905	1	Block
2.		-	See "Solenoid Valve", Page P84
3.		-	See "Pressure Relief Valve", Page P84
4.	G6400-06	4	Connector W/O-Ring, 9/16"-18 Male JIC To O-Ring
	GR1045	-	O-Ring
5.	G6400-08	4	Connector W/O-Ring, 3/4"-16 Male JIC To O-Ring
	GR1037	-	O-Ring
6.	G6400-10	4	Connector W/O-Ring, 7/8"-14 Male JIC To O-Ring
	GR1466	-	O-Ring
7.	G6500-06	2	Swivel Elbow, 90°, 9/16"-18 Male JIC To Female
8.	G6801-06	2	Elbow W/O-Ring, 90°, 9/16"-18 Male JIC To O-Ring
	GR1045	-	O-Ring
9.	G6801-08	2	Elbow W/O-Ring, 90°, 3/4"-16 Male JIC To O-Ring
	GR1037	-	O-Ring
10.	G6408-H06-O	2	Hex Socket Head Plug W/O-Ring, 9/16"-18 O-Ring
	GR1045	-	O-Ring
11.		-	See "Hose Take-Up", Pages P50 And P51
12.	GD12818	-	Terminal Strip Mount
13.	G11068	2	Phillips Flat Head Machine Screw, No. 10-24 x 5/8", Stainless Steel
14.	GA9098	-	Terminal Strip W/Screws, No. 6, 8 Terminal
	GR1635	-	Screw, No. 6-32 x 1/4"
15.	G11065	2	Phillips Pan Head Machine Screw, No. 8-32 x 5/8", Stainless Steel
16.		-	See "Electrical Components", Pages P92 And P93

VALVE BLOCK - LOCATED ON L.H. REAR CENTER FRAME

(PNE39a)

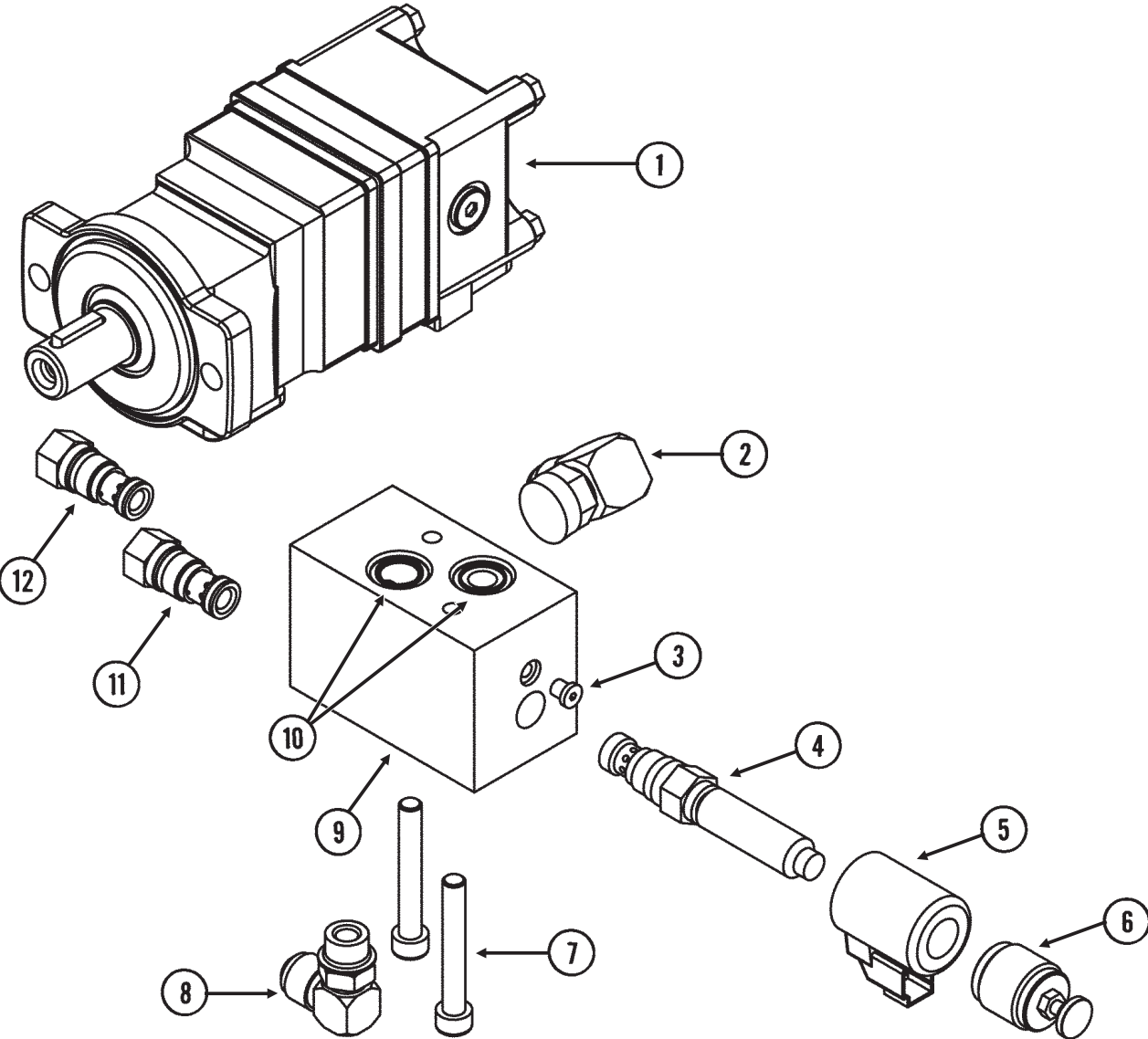

VALVE BLOCK - LOCATED ON L.H. REAR CENTER FRAME

ITEM	PART NO.	QTY.	DESCRIPTION
1.	GA13220	1	Hydraulic Motor
2.	G6801-12-10	1	Elbow W/O-Ring, 90°. 1 1/16"-12 Male JIC To 7/8"-14 O-Ring
	GR1466	-	O-Ring
3.	G6408-H02-0	1	O-Ring Plug
4.	GA13221	1	Proportional Valve
5.	GA13222	1	Coil
6.	GR1847	1	Manual Override
7.	G11258	2	Hex Socket Head Cap Screw, M10-1.5 x 2.75"
8.	G6801-10-08	1	Elbow W/O-Ring, 90°, 7/8"-14 Male JIC To 3/4"-16 O-Ring
	GR1037	-	O-Ring
9.	GD18672	1	Valve Block
10.	GD12070	2	O-Ring
11.	GA13223	1	Check Valve
12.	GA13224	1	Pressure Comp. Valve

SOLENOID VALVE

VVB019(TWL27c/TWL18/PLTR75c/A9481)

ITEM	PART NO.	QTY.	DESCRIPTION
1.	GR0761	1	Special Hex Nut, 1/2"-20
2.	G1K274	1	Coil Kit W/Contacts, Housings And Fork Terminals
	GD9529	2	Housing, Black
	GD9530	2	Contact
	G10996	2	Fork Terminal
3.	GR0763	1	Cartridge
A.	G1K275	-	Solenoid Valve Kit W/Solenoid Valve, Contacts, Housings And Fork Terminals
	GD9529	2	Housing, Black
	GD9530	2	Contact
	G10996	2	Fork Terminal
B.	GR0764	-	Seal Kit, Includes: (2) O-Rings, (1) BU Ring

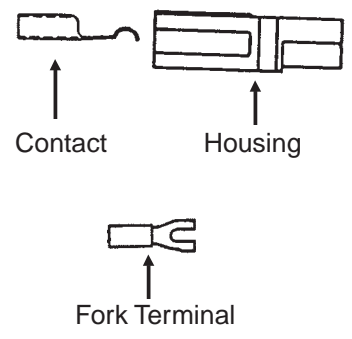
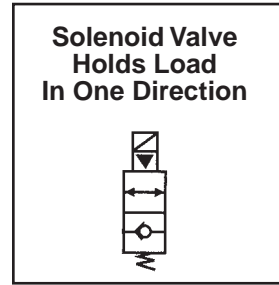
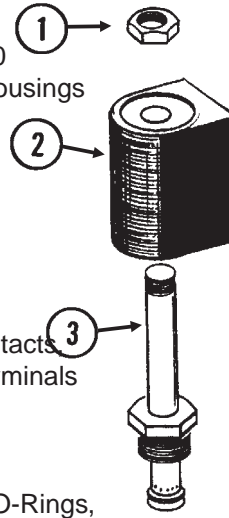

FLOW CONTROL VALVE

VVB020(TWL28)

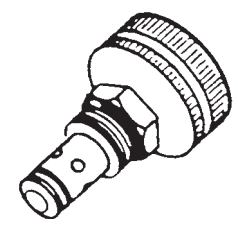

ITEM	PART NO.	QTY.	DESCRIPTION
A.	GA3413	-	Flow Control Valve
B.	GR0764	-	Seal Kit, Includes: (2) O-Rings, (1) BU Ring

PRESSURE RELIEF VALVE

VVB020(TWL29)

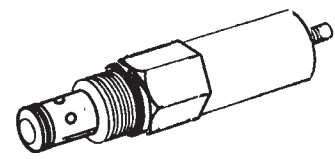

ITEM	PART NO.	QTY.	DESCRIPTION
A.	GA3407	-	Pressure Relief Valve, 1000 PSI
B.	GR0764	-	Seal Kit, Includes: (2) O-Rings, (1) BU Ring

PROPORTIONAL VALVE

(TWL322)

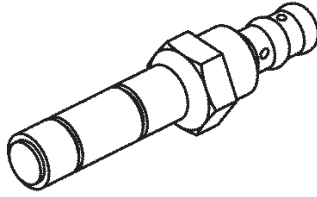

ITEM	PART NO.	QTY.	DESCRIPTION
A.	GA13078	-	Proportional Valve
B.	GR0764	-	Seal Kit, Includes: (2) O-Rings, (1) BU Ring

CHECK VALVE

VVB020(TWL30)

ITEM	PART NO.	QTY.	DESCRIPTION
A.	GA4293	-	Check Valve
B.	GR0764	-	Seal Kit, Includes: (2) O-Rings, (1) BU Ring

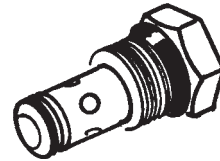

HYDRAULIC HOSES AND FITTINGS ON HITCH

(TWL107d/TWL107b)

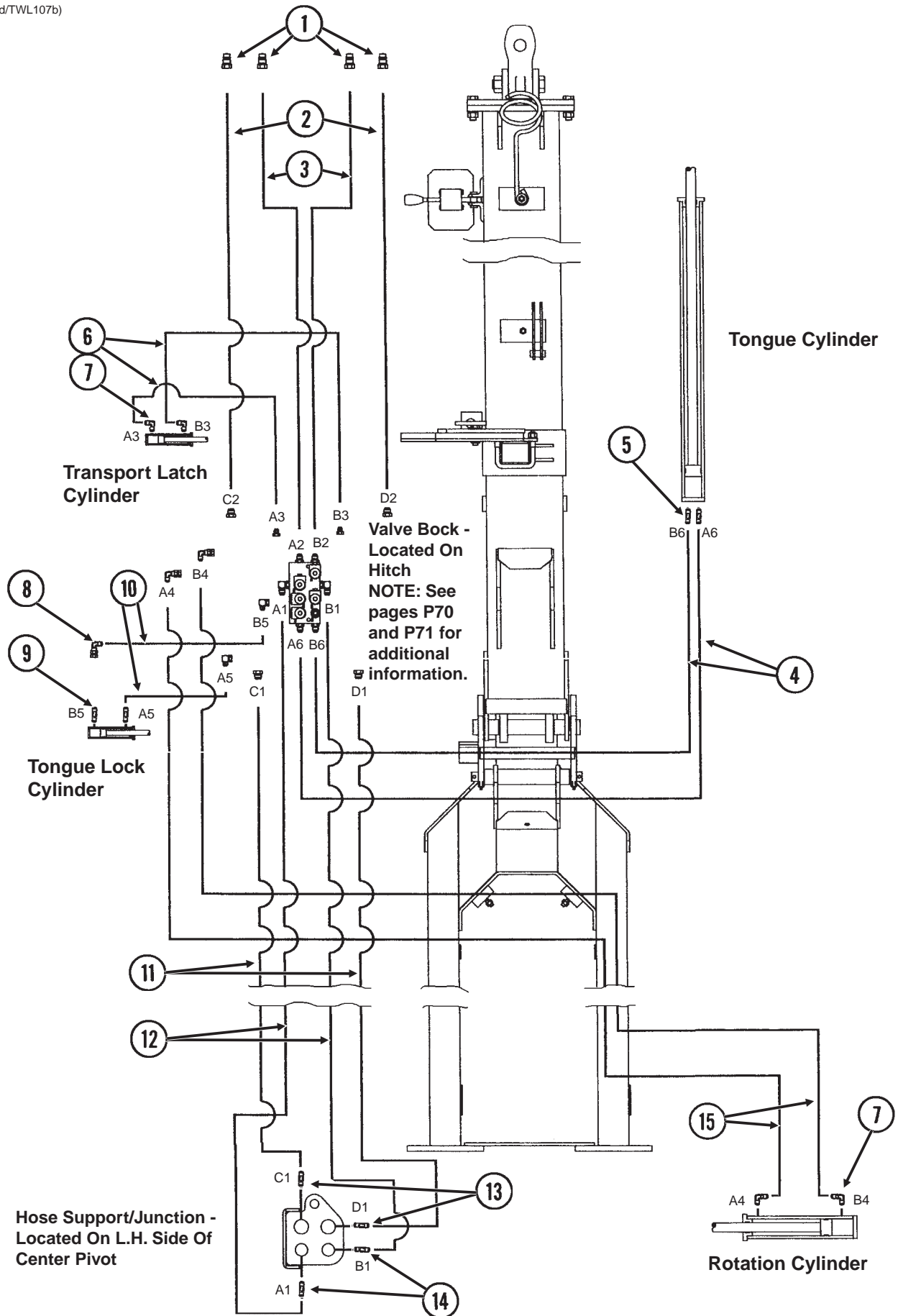

HYDRAULIC HOSES AND FITTINGS ON HITCH

ITEM	PART NO.	QTY.	DESCRIPTION
1.	GD4086	4	ISO Coupler
2.	*A1489	2	Hose Assembly, 1/2" x 191", 12 Row
	*A1491	2	Hose Assembly, 1/2" x 246", 16 Row
3.	*A3133	2	Hose Assembly, 3/8" x 191", 12 Row
	*A3183	2	Hose Assembly, 3/8" x 246", 16 Row
4.	*A3156	2	Hose Assembly, 3/8" x 68", 12 Row
	*A3118	2	Hose Assembly, 3/8" x 80", 16 Row
5.	G6400-08	1	Connector W/O-Ring, 3/4"-16 Male JIC To O-Ring
	GR1037	-	O-Ring
6.	*A7603	2	Hose Assembly, 1/4" x 112", 12 Row
	*A1129	2	Hose Assembly, 1/4" x 168", 16 Row
7.	G6801-06-08	4	Elbow W/O-Ring, 90°, 9/16"-18 Male JIC To 3/4"-16 O-Ring
	GR1037	-	O-Ring
8.	G6502-06	1	Swivel Elbow, 45°, 9/16"-18 Male JIC To Female
9.	G6400-06-08	2	Connector W/O-Ring, 9/16"-18 Male JIC To 3/4"-16 O-Ring
	GR1037	-	O-Ring
10.	*A1139	2	Hose Assembly, 1/4" x 40"
11.	*A1467	2	Hose Assembly, 1/2" x 120", 12 Row
	*A1478	2	Hose Assembly, 1/2" x 128", 16 Row
12.	*A1011	2	Hose Assembly, 3/8" x 125", 12 Row
	*A1041	2	Hose Assembly, 3/8" x 130", 16 Row
13.	G2700-10	2	Bulkhead Tube Union, 7/8"-14 Male JIC
14.	G2700-08	2	Bulkhead Tube Union, 3/4"-16 Male JIC
15.	*A1106	2	Hose Assembly, 1/4" x 130", 12 Row
	*A1116	2	Hose Assembly, 1/4" x 136", 16 Row

* Hydraulic hose is not stocked by KINZE® Repair Parts, but can be made available on a special order basis. Call for quote.

HYDRAULIC HOSES AND FITTINGS ON PLANTER FRAME

(TWL105b)

16 Row Shown (Two Wing Lift Cylinders Per Wing)
 12 Row (One Wing Lift Cylinder Per Wing)

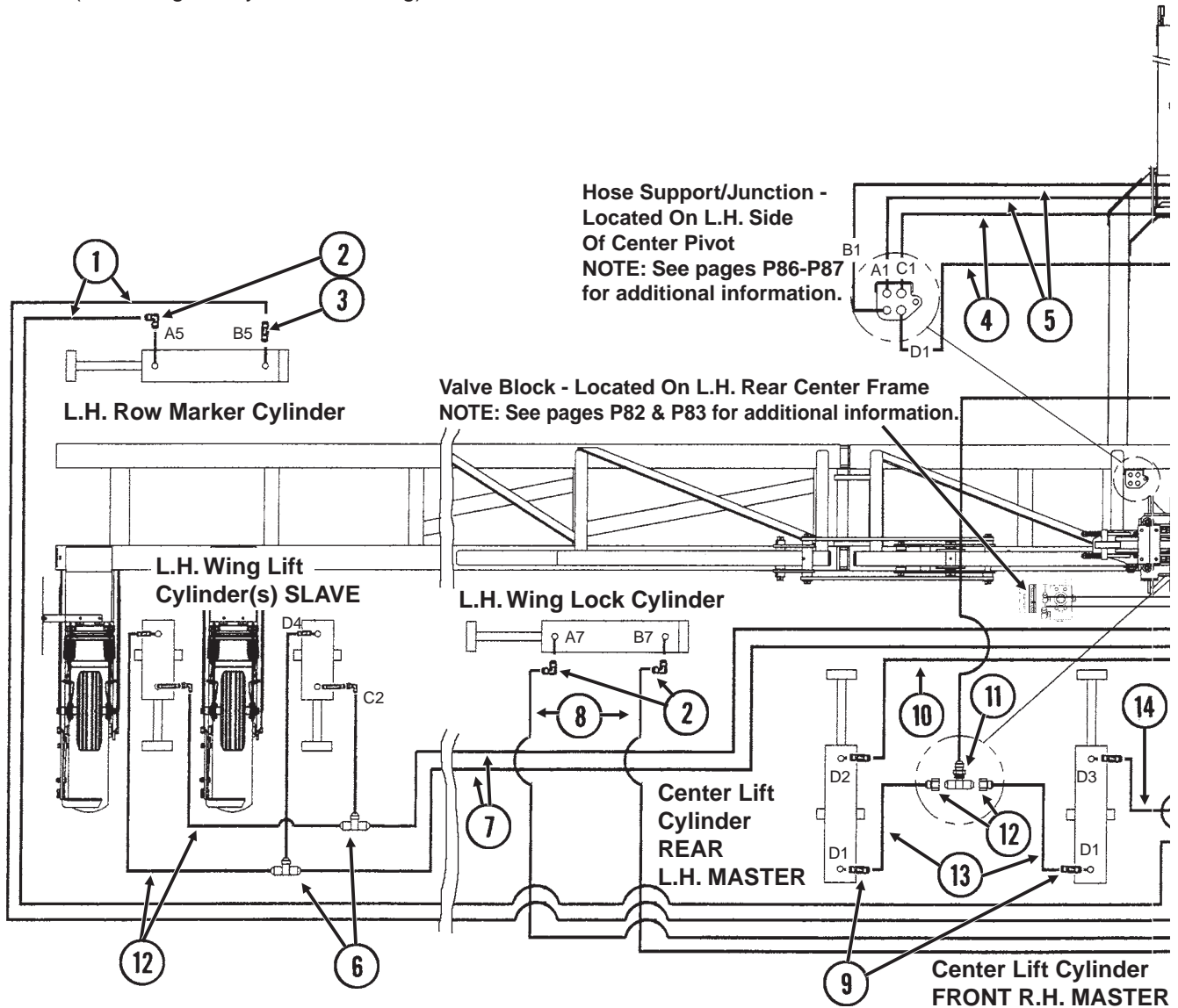

ITEM	PART NO.	QTY.	DESCRIPTION
1.	*A12042	2	Hose Assembly, 3/8" x 228", 12 Row
	*A1097	2	Hose Assembly, 3/8" x 288", 16 Row
2.	G6801-08	6	Elbow W/O-Ring, 90°, 3/4"-16 Male JIC To O-Ring
	GR1037	-	O-Ring
3.	G6400-08-04	2	Connector W/O-Ring, 3/4"-16 Male JIC To 7/16"-20 O-Ring
	GR1465	-	O-Ring
4.	*A8267	2	Hose Assembly, 1/2" x 58"
5.	*A3127	2	Hose Assembly, 3/8" x 58"
6.	G2603-08	4	Tee, 3/4"-16 Male JIC, 16 Row
7.	*A1033	2	Hose Assembly, 3/8" x 250", 12 Row
	*A1034	2	Hose Assembly, 3/8" x 272", 16 Row
8.	*A1055	2	Hose Assembly, 3/8" x 66"
9.	G6400-08	8	Connector W/O-Ring, 3/4"-16 Male JIC To O-Ring
	GR1037	-	O-Ring
10.	*A3128	1	Hose Assembly, 3/8" x 52"
11.	G2703-08-08-10	1	Bulkhead Tee 7/8"-14 Male JIC To 3/4"-16 JIC
12.	*A1018	4	Hose Assembly, 3/8" x 40"
13.	*A1076	2	Hose Assembly, 3/8" x 30"

HYDRAULIC HOSES AND FITTINGS ON PLANTER FRAME

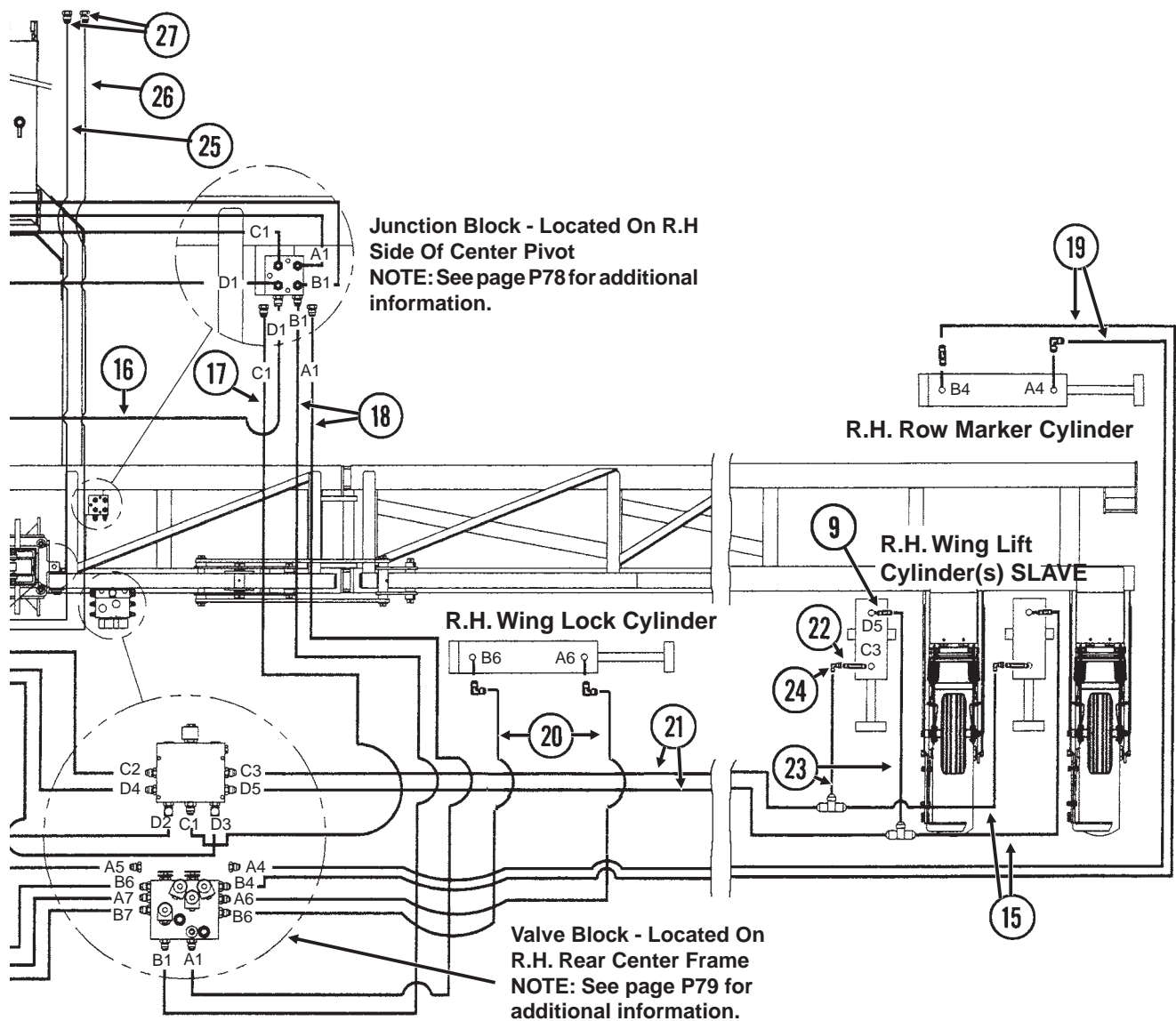

ITEM	PART NO.	QTY.	DESCRIPTION
14.	*A3131	1	Hose Assembly, 3/8" x 42"
15.	*A1028	4	Hose Assembly, 3/8" x 186", 12 Row
16.	*A1404	1	Hose Assembly, 1/2" x 41"
17.	*A1424	1	Hose Assembly, 1/2" x 30"
18.	*A1076	2	Hose Assembly, 3/8" x 30"
19.	*A1027	2	Hose Assembly, 3/8" x 182", 12 Row
	*A1097	2	Hose Assembly, 3/8" x 288", 16 Row
20.	*A1076	2	Hose Assembly, 3/8" x 30"
21.	*A1057	2	Hose Assembly, 3/8" x 216", 16 Row
22.	G6400-L-08	-	Long Connector W/O-Ring, 3/4"-16 Male JIC To O-Ring
	GR1037	-	O-Ring
23.	*A3122	4	Hose Assembly, 3/8" x 10 1/2", 16 Row 30"
24.	G6500-08	-	Swivel Elbow, 90°, 3/4"-16 Male JIC To Female
25.	GA12901	1	Hose Assembly, 3/4" x 510"
26.	GA8286	1	Hose Assembly, 1/2" x 510"
27.	GD4086	2	ISO Coupler

* Hydraulic hose is not stocked by KINZE® Repair Parts, but can be made available on a special order basis. Call for quote.

VALVE BOX MODULE

(A12554)

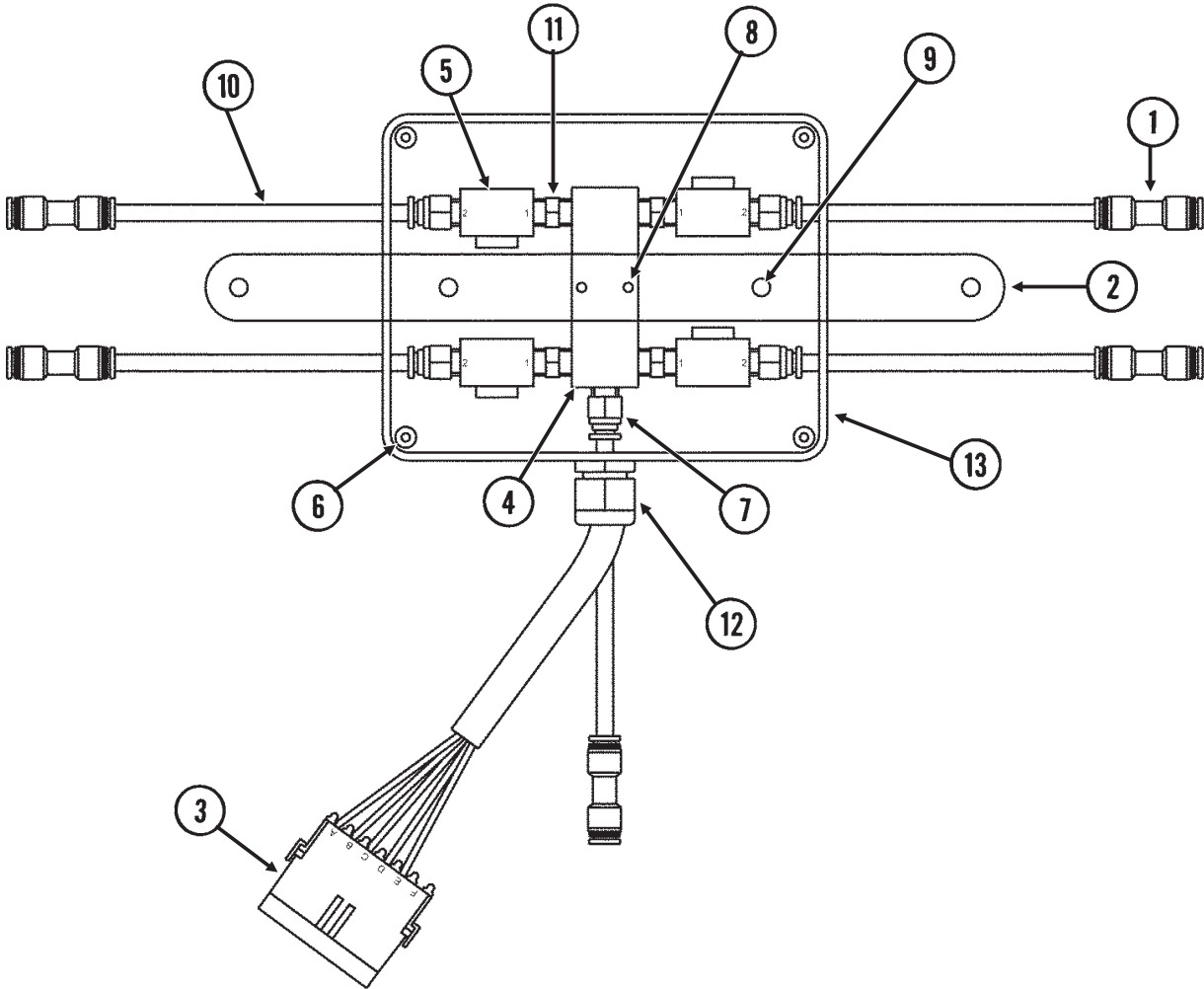

VALVE BOX MODULE

ITEM	PART NO.	QTY.	DESCRIPTION
1.	GD18395	5	Straight Union, 1/4"
2.	GD18389	1	Strap
3.	GA12861	1	Valve Box Harness
4.	GA12865	1	Manifold
5.	GA12866	4	Valve
6.	G11243	4	Slotted Flat Head Machine Screw, No. 8-32 x 1/2"
7.	GD18085	5	Male Connector, 1/4"
8.	G11244	2	Phillips Flat Head Machine Screw, No. 10-24 x 1 1/2"
	G10395	2	Hex Nut, No. 10-24
9.	G10022	2	Hex Head Cap Screw, 1/4"-20 x 1/2"
	G10110	2	Lock Nut, 1/4"-20, Grade B
10.	GD17151-05	5	Nylon Tube, 1/4" O.D. x 5" Long
11.	GD18398	5	Hex Nipple, 1/8" Pipe
12.	GA9963	1	Strain Relief
13.	GD18437	1	Valve Box Cover
A.	GA12554	-	Valve Box Module Assembly, (Items 1-13)

ELECTRICAL COMPONENTS

(TWL19a/TWL18/ELC14/ELC3a/ELC5c/MTR27a/ELC39/TWL26a/ELC8/A9481/ELC12b/MTR27/A9689b/A10924ELC4/FF27b/FF27c/ELC38/A9201a/A9202a/TWL20g/ELC34/ELC35/ELC10c)

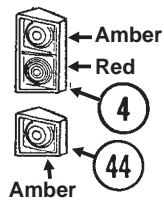
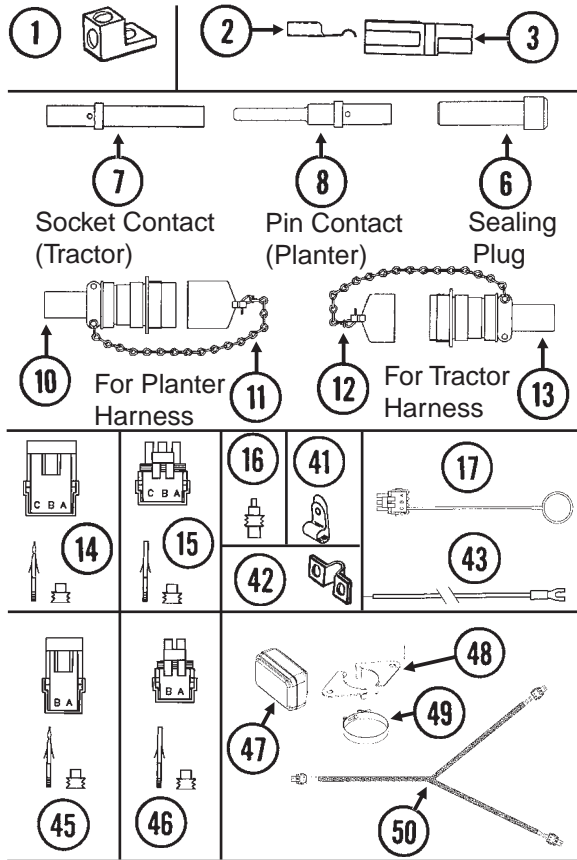

See "Wing Frame", pages P56 and P57 for light brackets.

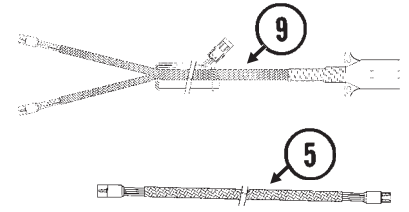

See "Digital Vacuum Gauge, Analog Vacuum Gauge And Vacuum Fan Assembly" Pages P34 and P35 for vacuum gauge electrical components.

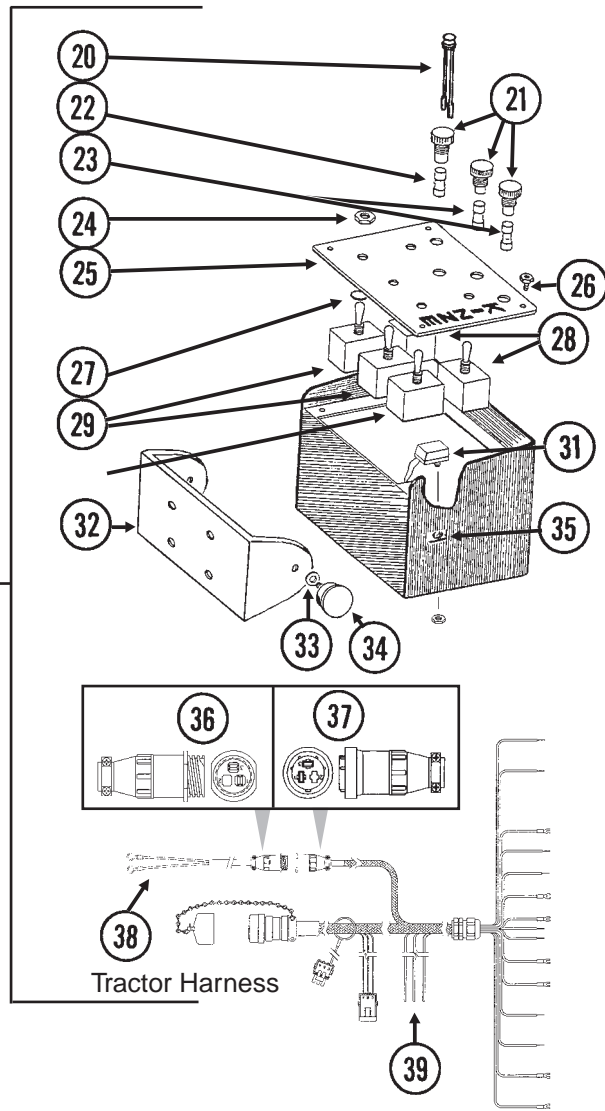
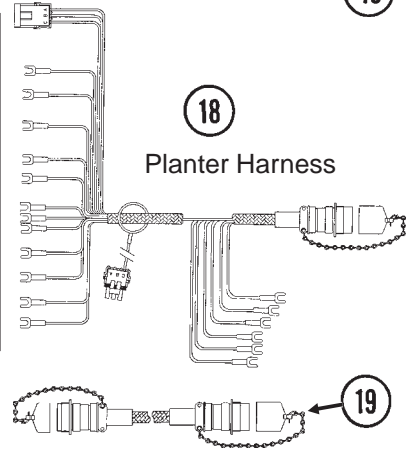

ITEM	PART NO.	QTY.	DESCRIPTION
1.	GA3584	-	Ground Clamp
2.	GD9530	-	Contact
3.	GD9529	-	Housing, Black
	GD12726	-	Housing, Red
4.	GA6699	1	Double Light Assembly (Shown)
	GA6700	1	Double Light Assembly
	GR1203	-	Red Lens
	GR1204	-	Amber Lens
	GR1205	-	Cover
	GR1206	-	Rubber Grommet (4)
	GR1207	-	Lamp Unit
	GR1208	-	Bulb
5.	GA9096	-	Harness Extension, 42"
6.	GD8739	-	Sealing Plug, No. 12

ELECTRICAL COMPONENTS

ITEM	PART NO.	QTY.	DESCRIPTION
7.	GD8740	-	Socket Contact, No. 14
8.	GD8741	-	Pin Contact, No. 14
9.	GA9202	-	Wiring Harness W/7 Terminal Female Connector, 786" (2 Light Connections), 12 Row
	GA9204	-	Wiring Harness W/7 Terminal Female Connector, 882" (2 Light Connections), 16 Row
	GA5385	-	7 Terminal Female Connector
10.	GA6109	1	Connector W/Cable Clamp, 23 Pin Capacity
11.	GA7862	-	Dust Cap W/Chain
12.	GA7863	-	Dust Cap W/Chain
13.	GA6108	1	Connector W/Cable Clamp, 23 Socket Capacity
14.	G1K248	-	3-Pin Female Connector Kit (Black), Includes: (3) 3-Pin Female Housings, (9) Pin Contacts, (9) Seals
15.	G1K252	-	3-Pin Male Connector Kit (Black), Includes: (3) 3-Pin Male Housings, (9) Socket Contacts, (9) Seals
16.	GD11089	-	Sealing Plug
17.	GA8047	-	Dust Plug (Black)
18.	GA9112	1	Wiring Harness W/Dust Cap, 516", 12 Row
	GA9113	-	Wiring Harness W/Dust Cap, 636", 16 Row
19.	GA7399	-	Harness Extension W/Dust Caps, 180"
20.	GA7077	1-4	Indicator Light
21.	GA2612	3-5	Fuse Holder W/Spade, 1 ³³ / ₅₀ "
22.	GD2829	1-2	Fuse, 15 Amp, Type AGC
23.	GD10243	2-6	Fuse, MDL 10 Amp Delay Action
24.	GR1363	5	Hex Face Nut, ¹⁵ / ₃₂ "-32
	GR1364	5	Internal Tooth Lock Washer, ¹⁵ / ₃₂ "
25.	GA8734	1	Cover Plate (Shown)
26.	GR1292	4	Pan Head Screw, No. 8-32 x 1/2"
27.	GD3860	-	O-Ring (If Applicable)
28.	GA2528	2	Switch, 3 Position Toggle, On-Off-On
29.	GA6978	2	Switch, 3 Position Toggle, Momentary On-Off-Momentary On
30.	GA6977	1-2	Switch, 2 Position Toggle, On-Off
31.	GA8731	1	Switch, Push Button W/Transformer
32.	GD9896	1	Mounting Bracket
33.	G10211	4	Washer, 1/4" SAE
34.	GA6975	2	Knob
35.	GR1290	2	Cage Nut, 1/4"-20
36.	G1K267	-	Console Cable Connector Kit, Includes: (1) 3-Pin Connector, (1) Cable Clamp, (3) Male Terminal Pins
37.	G1K268	-	Console Cable Connector Kit, Includes: (1) 3-Pin Connector, (1) Cable Clamp, (1) Lock Ring, (3) Female Terminal Pins
38.	GA7856	1	Power Lead Adapter
39.	GA8729	1	Wiring Harness W/Dust Cap And Power Cable
40.	G7633X	-	Backlit Control Console Assembly W/Mounting Brackets, Short Harness W/Dust Cap And Power Cable
41.	GD6291	-	Insulated Clamp, ³ / ₈ "
	GD13348	-	Insulated Clamp, ¹¹ / ₁₆ "
42.	GD13310	-	Jumper, ⁷ / ₁₆ "
43.	GA9481	-	Jumper Wire W/Fork Terminal, 13"
	G10996	-	Fork Terminal
44.	GA6701	1	Single Amber Light Assembly
	GR1204	-	Amber Lens
	GR1206	-	Rubber Grommet (2)
	GR1207	-	Lamp Unit
	GR1208	-	Bulb
45.	G1K321	-	2-Pin Female Connector Kit (Black), Includes: (3) 2-Pin Female Housings, (6) Pin Contacts, (6) Seals
46.	G1K320	-	2-Pin Male Connector Kit (Black), Includes: (3) 2-Pin Male Housings, (6) Socket Contacts, (6) Seals
47.	GA9689	2	Work Light Assembly
48.	GD16046	2	Bracket, 4 1/4" x 4"
49.	G11159	1-2	T-Bolt Clamp, 3 1/2" Stainless Steel
50.	GA10924	1	Wiring Harness, 348"

KINZE VISION® DISPLAY

(VI50/VI18/VI21/A12553/GR1838/GR1839/A12852/A12853)

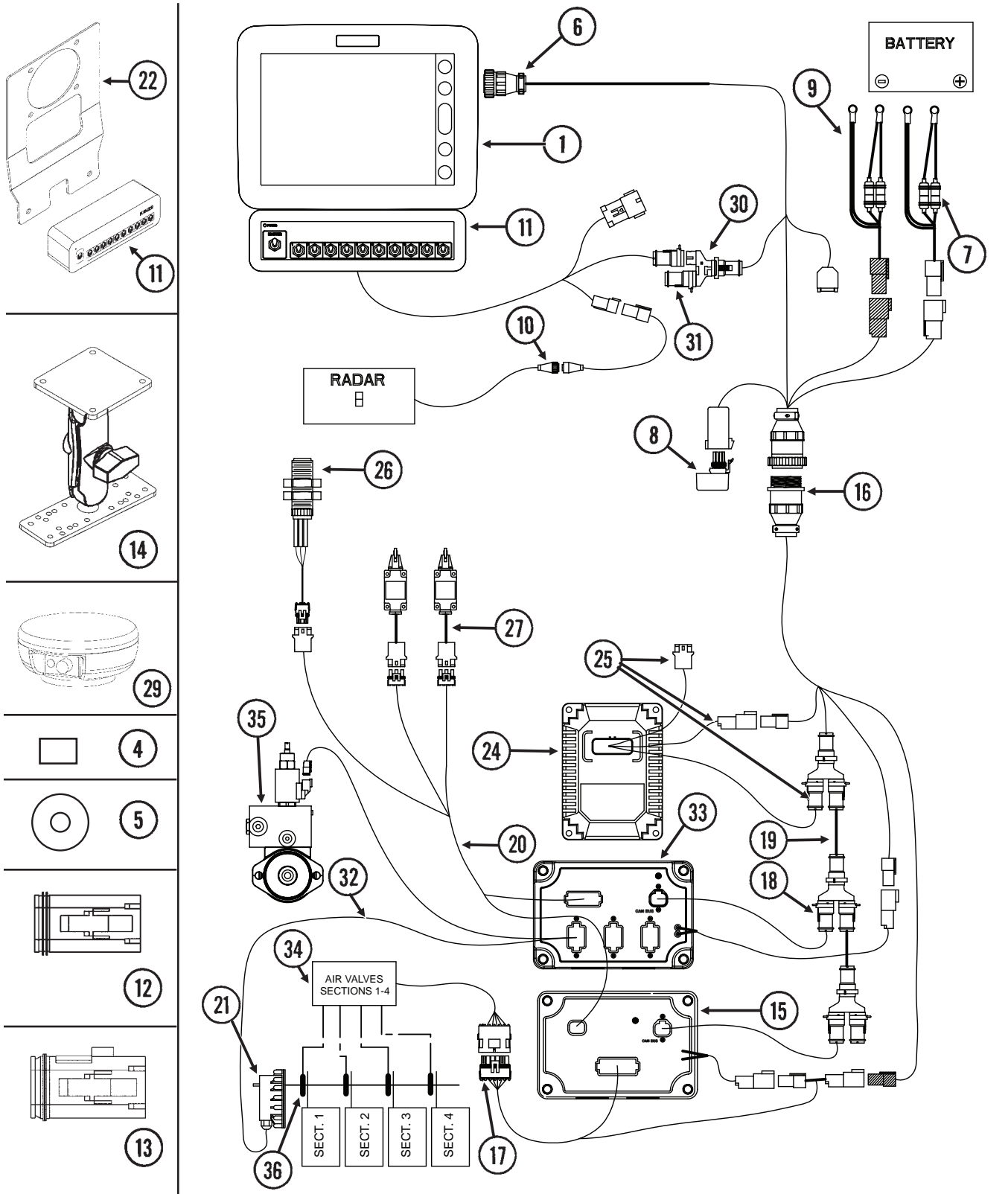

28

3

2

KINZE VISION® DISPLAY

ITEM	PART NO.	QTY.	DESCRIPTION
1.	*GA12536	1	Vision Display
2.	GA12852	1	Power Supply
3.	GA12853	1	Null Modem Cable
4.	GR1835	1	Flash Card
5.	GR1836	1	SMS CD
6.	GA12551	1	Display Cable
7.	GA12562	1	Power Cable
8.	GA12540	1	Power Control Relay
9.	GA12598	1	Seed Rate Power Cable
10.	GA12596	1	Radar Adapter Cable
11.	*GA12539	1	Switch Box Module
12.	GR1838	1	Dust Plug
13.	GR1839	1	Dust Plug
14.	GA12868	1	Mounting Bracket Assembly
	GD18407	1	Ram Base
	GD18408	1	Ram Vesa Base
15.	GA12537	1	Clutch Control Module
16.	GA12555	1	Implement Cable (12 Row)
	GA12655	-	Implement Cable (16 Row)
17.	GA12556	1	Seed Command Cable
18.	GA12558	1	Can Stub Cable, 8"
19.	GA12559	1	Can Extension, 5"
20.	GA12560	1	Implement Switch Extension Cable
21.	GA12565	1	Encoder Module
22.	GR1837	1	Switch Box Bracket
24.		-	See "Planter Monitor Module (PMM)", Pages P88 And P89
25.		-	See "Planter Monitor Module (PMM)", Pages P88 And P89
26.	GA13204	1	Hall Effect Sensor
27.	GA12561	2	Implement Switch Cable
28.	GA12553	1	GPS Cable
29.	GA12552	1	GPS Antenna
30.	GD18176	-	Y-Splice Connector
31.	GD18177	-	Terminator
32.	GA12568	1	Seed Rate Cable
33.	GA12564	1	Seed Rate Module
34.		-	See "Center Frame", Pages P44 And P45
35.		-	See "Valve Block - Located On L.H. Rear Center Frame", Pages P74 And P75
36.		-	See "Parallel Arms, Mounting Support Plate And Quick Adjustable Down Force Springs Option", Pages P10 And P11 And "Interplant Push Row Unit", Pages P34 And P35

PLANTER MONITOR MODULE (PMM)

(MTR60/MTR63/PMM01/MTR65/MTR61/MTR64/MTR62/PMM02)

Shaft Rotation Sensor

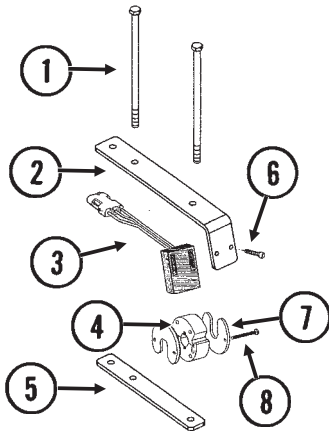

Magnetic Distance Sensor (MDS)

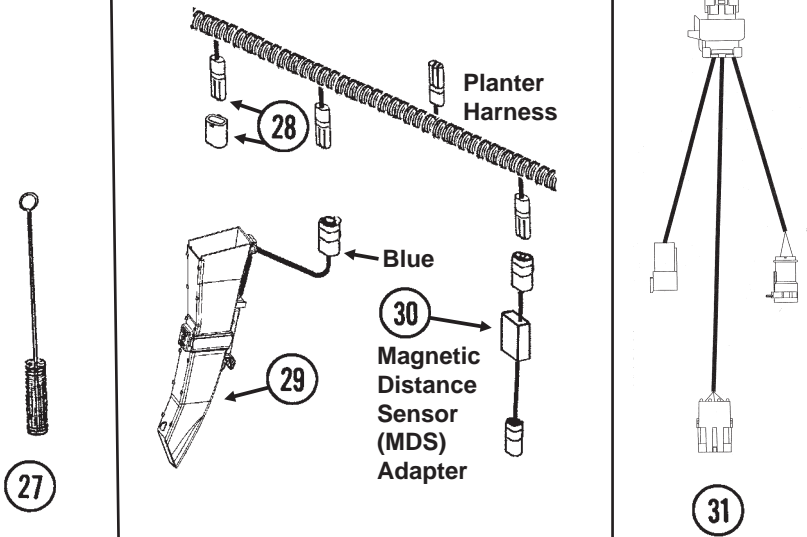
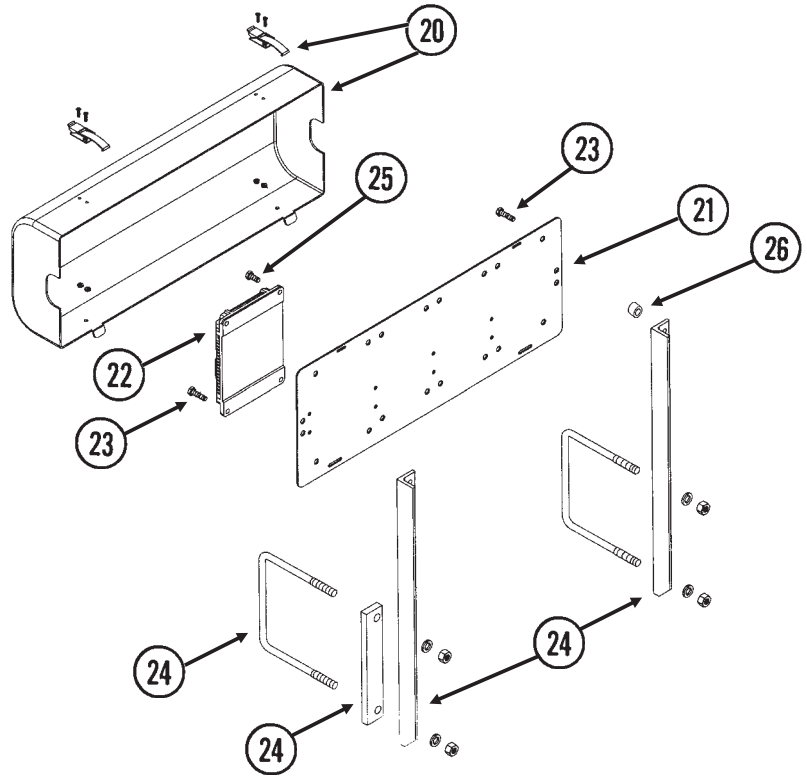
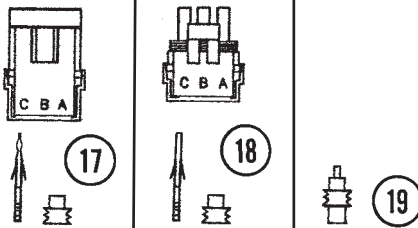
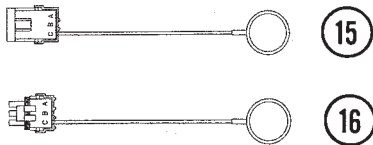
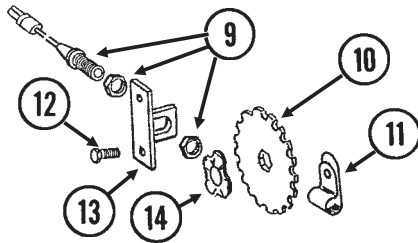

NOTE: See KINZE Vision® Planter Control System Display Operator Manual (M0214) and associated cab harness components.

ITEM	PART NO.	QTY.	DESCRIPTION
1.	G10686	4	Hex Head Cap Screw, 3/8"-16 x 8"
	G10229	4	Lock Washer, 3/8"
	G10101	4	Hex Nut, 3/8"-16
2.	GD18118	2	Shaft Sensor Mount
3.	GR1415	1	Rotation Sensor
4.	GR1414	1	Actuator
5.	GD18168	2	Mount

PLANTER MONITOR MODULE (PMM)

ITEM	PART NO.	QTY.	DESCRIPTION
6.	G10757	2	Pan Head Screw, No. 10-32 x 1 1/4"
	G10243	2	Washer, No. 10 SAE
	G10758	2	Hex Nut, No. 10-32
7.	GD11474	2	Cover
8.	G10927	2	Pan Head Machine Screw, No. 8-32 x 1 1/4", Stainless Steel
	G10931	2	Lock Washer, No. 8, Internal/External, Stainless Steel
	G10928	2	Hex Nut, No. 8-32, Stainless Steel
9.	GA5600	1	Magnetic Distance Sensor
10.	GD8751	-	Magnetic Distance Sensor Pulse Wheel
11.	GD6291	-	Insulated Clamp, 3/8"
12.	G10001	2	Hex Head Cap Screw, 3/8"-16 x 1"
	G10229	2	Lock Washer, 3/8"
	G10101	2	Hex Nut, 3/8"-16
13.	GD8770	1	Bracket
14.	GD8771	1	Spring Wave Washer
15.	GA8046	-	Dust Plug (Black)
	GA9978	-	Dust Plug (Blue)
16.	GA8047	-	Dust Plug (Black)
	GA9979	-	Dust Plug (Blue)
17.	G1K248	-	3-Pin Female Connector Kit (Black), Includes: (3) 3-Pin Female Housings, (9) Pin Contacts, (9) Seals
	G1K362	-	3-Pin Female Connector Kit (Blue), Includes: (3) 3-Pin Female Housings, (9) Pin Contacts, (9) Seals
18.	G1K252	-	3-Pin Male Connector Kit (Black), Includes: (3) 3-Pin Male Housings, (9) Socket Contacts, (9) Seals
	G1K363	-	3-Pin Male Connector Kit (Blue), Includes: (3) 3-Pin Male Housings, (9) Socket Contacts, (9) Seals
19.	GD11089	-	Sealing Plug
20.	GA12563	1	Module Cover Assembly W/Lock Clamps
	GA12641	-	Lock Clamp
	G11065	-	Phillips Pan Head Machine Screw, No. 8-32 x 5/8", Stainless Steel
	G11202	-	Lock Nut W/Nylon Insert, No. 8-32, Stainless Steel
21.	GD18013	1	Bracket
22.	GA12538	1	Planter Monitor Module
23.	G10031	4	Hex Head Cap Screw, 5/16"-18 x 1 3/4"
	G10232	4	Lock Washer, 5/16"
	G10106	4	Hex Nut, 5/16"-18
24.			See "Manifolds And Distribution Hoses", Pages P40 And P41
25.	G10043	2	Hex Head Cap Screw, 5/16"-18 x 3/4"
	G10232	2	Lock Washer, 5/16"
	G10106	2	Hex Nut, 5/16"-18
26.	GD2971-17	4	Sleeve, 7/8" Long
27.	GR0594	-	Brush
28.	GA7851	-	Planter Harness W/Dust Caps, 12 Row (16 Connectors)
	GA7852	-	Planter Harness W/Dust Caps, 16 Row (20 Connectors)
	GD11993	-	Dust Cap
29.	GA12650	-	Seed Tube W/Computerized Sensor, EdgeVac®
	GR1737	-	Sensor Only, EdgeVac®
	GA12636	-	Seed Tube (With Holes For Sensor Installation), EdgeVac®
30.	GA7859	1	Magnetic Distance Sensor Adapter (Analog To Digital)
31.	GA12557	1	Planter Monitor Module Cable
A.	GA6147	-	Magnetic Distance Sensor And Mounting Package (Items 9-14)

INTERPLANT® PUSH ROW UNIT DRIVE

(RU134/TWL516)

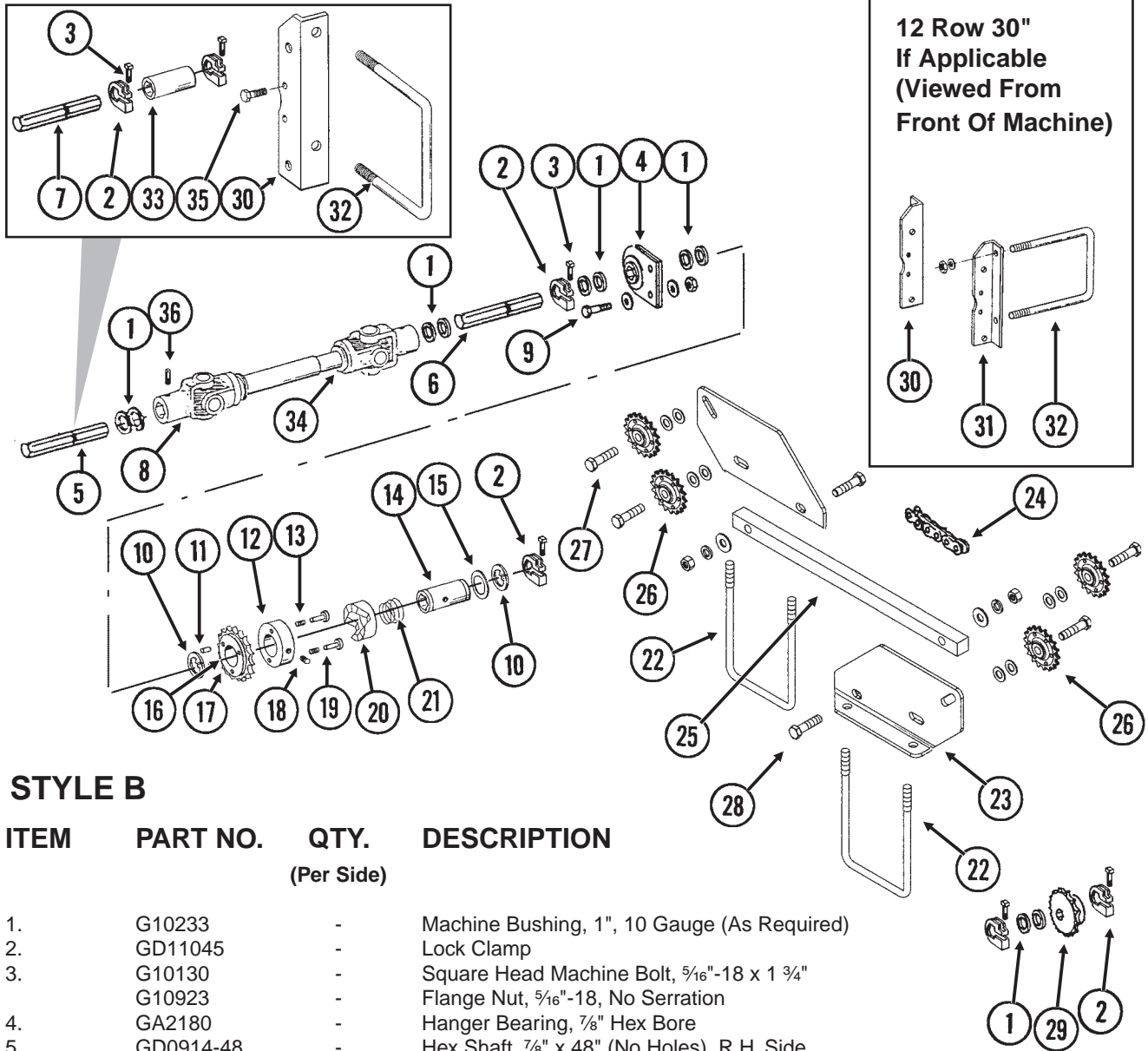

STYLE B

ITEM	PART NO.	QTY.	DESCRIPTION
		(Per Side)	
1.	G10233	-	Machine Bushing, 1", 10 Gauge (As Required)
2.	GD11045	-	Lock Clamp
3.	G10130	-	Square Head Machine Bolt, 5/16"-18 x 1 3/4"
	G10923	-	Flange Nut, 5/16"-18, No Serration
4.	GA2180	-	Hanger Bearing, 7/8" Hex Bore
5.	GD0914-48	-	Hex Shaft, 7/8" x 48" (No Holes), R.H. Side
	GD0914-66	-	Hex Shaft, 7/8" x 66" (No Holes), L.H. Side
6.	GD0914-90	-	Hex Shaft, 7/8" x 90" (No Holes), Both Sides, 12 Row 30"
	GD0914-124	-	Hex Shaft, 7/8" x 124" (No Holes), R.H. Side, 16 Row 30"
	GD0914-138	-	Hex Shaft, 7/8" x 138" (No Holes), L.H. Side, 16 Row 30"
7.	GD0914-24	-	Hex Shaft, 7/8" x 24" (No Holes), 12 Row 30" W/Even-Row Push Row Unit
	GD0914-33	-	Hex Shaft, 7/8" x 33" (No Holes), 16 Row 30" W/Even-Row Push Row Unit
8.	GA7052	-	U-Joint W/Grease Fitting, Female, 10 1/4" Long
	GR1557	-	Grease Fitting, 45°, Metric
	GR1297	-	Inboard Yoke And Outer Profile (10 1/4" U-Joint)
	GR1298	-	Inboard Yoke And Outer Profile (18 1/8" U-Joint)
	GR1294	-	Cross And Bearing Kit
	GR1293	-	Yoke, 7/8" Hex

INTERPLANT® PUSH ROW UNIT DRIVE

ITEM	PART NO.	QTY. (Per Side)	DESCRIPTION
9.	G10004	-	Hex Head Cap Screw, 3/8"-16 x 1 1/4"
	G10210	-	Washer, 3/8" USS
	G10229	-	Lock Washer, 3/8"
	G10101	-	Hex Nut, 3/8"-16
10.	G10496	2	External Inverted Snap Ring, 1 1/2"
11.	G10968	1	Spring Pin, 5/32" x 7/16"
12.	GR1405	1	Lock Collar
13.	GR1413	1	Spring
14.	GR1407	1	Drive Shaft
15.	GR1411	1	Shim
16.	GR1406	1	Bushing
17.	GR1412	1	Sprocket, 19 Tooth
18.	G10535	1	Hex Socket Set Screw, 3/8"-16 x 3/4"
19.	GR1410	1	Pin
20.	GR1409	1	Knurled Collar
21.	GR1408	1	Compression Spring
22.	GD8306	2	U-Bolt, 7" x 5" x 1/2"-13
	G10228	4	Lock Washer, 1/2"
	G10102	4	Hex Nut, 1/2"-13
23.	GD18094	2	Plate (Shown)
	GD18066	-	Plate
24.	G3310-226	1	Chain, No. 40, 226 Pitch Including Connector Link
	GR0912	-	Connector Link, No. 40
25.	GD18067	1	Brace
26.	GA7154	4	Sprocket W/Bearing, 18 Tooth
27.	G10016	4	Hex Head Cap Screw, 1/2"-13 x 2"
	G10206	8	Washer, 1/2" SAE
	G10228	4	Lock Washer, 1/2"
	G10102	4	Hex Nut, 1/2"-13
28.	G10016	2	Hex Head Cap Screw, 1/2"-13 x 2"
	G10216	2	Washer, 1/2" USS
	G10228	2	Lock Washer, 1/2"
	G10102	2	Hex Nut, 1/2"-13
29.	GA5107	2	Sprocket, 19 Tooth
30.	GD11972	-	Support Angle, R.H.
31.	GD11973	-	Support Angle, L.H.
32.	GD1113	-	U-Bolt, 5" x 7" x 5/8"-11
	G10230	-	Lock Washer, 5/8"
	G10104	-	Hex Nut, 5/8"-11
33.	GD1719	-	Coupler, 4"
34.	GA7051	1	U-Joint W/Grease Fitting, Male, 12 1/4" Long
	GR1557	-	Grease Fitting, 45°, Metric
	GR1296	-	Inner Profile
	GR1295	-	Inboard Yoke
	GR1301	-	Spring Pin, 8 mm x 50 mm
	GR1294	-	Cross And Bearing Kit
35.	GR1293	-	Yoke, 7/8" Hex
	G10752	-	Hex Head Cap Screw, 5/8"-18 x 2 1/4"
	GD7805	-	Special Washer, 5/8", Hardened
36.	G10412	-	Lock Nut, 5/8"-18
	G10688	-	Square Head Set Screw, 3/8"-16 x 5/8"
A.	GA8092	-	Clutch Sprocket Assembly, 19 Tooth (Items 10-21)
B.	G1K269	-	Lock Clamp Kit (Items 2 And 3)
C.	G1K331	-	Clutch Sprocket Kit (Items 11, 16 And 17)

DOUBLE DISC FERTILIZER OPENER AND MOUNT

FOC007(PT25e/TWL34a/FRTZ208)

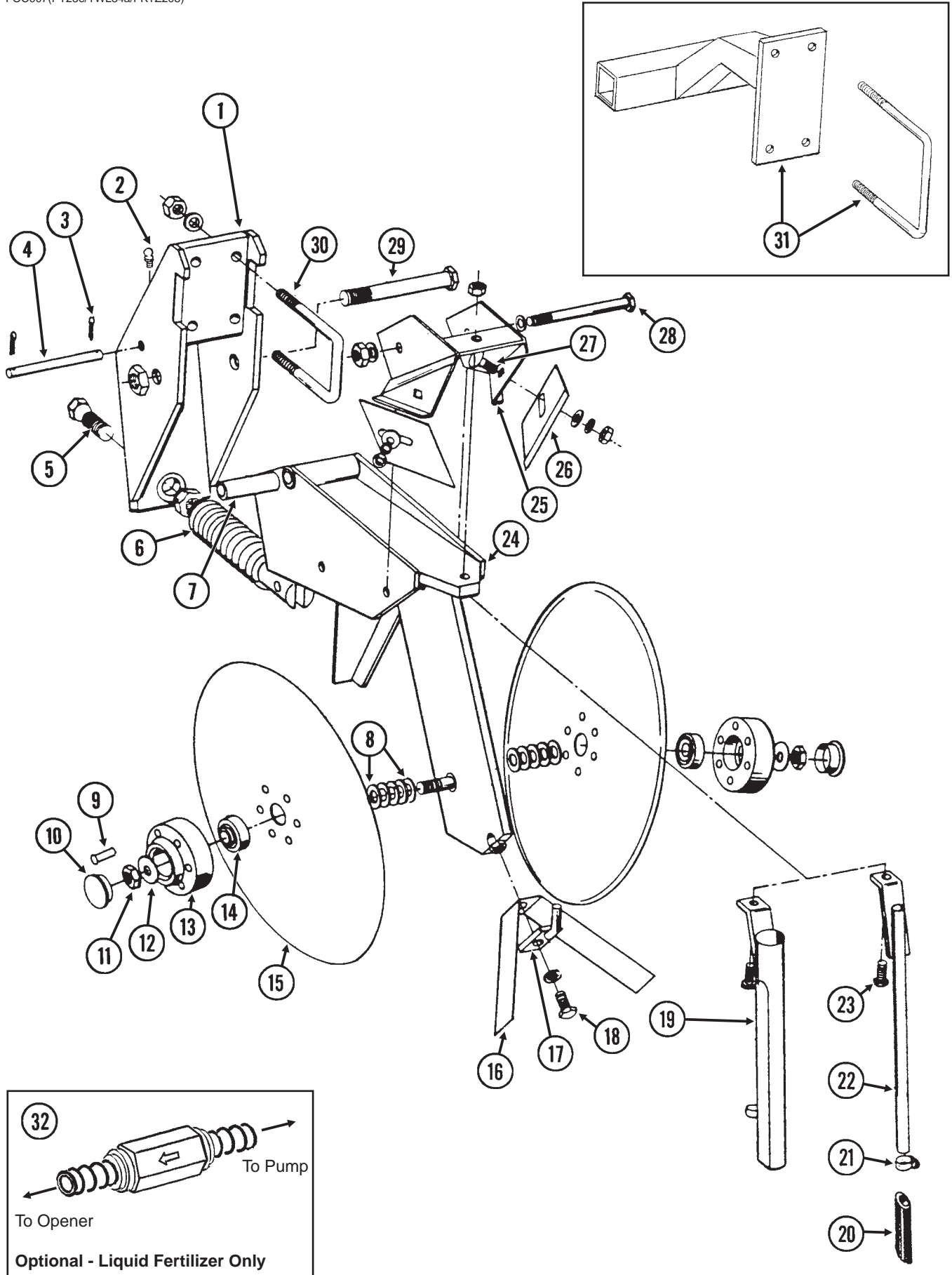

DOUBLE DISC FERTILIZER OPENER AND MOUNT

ITEM	PART NO.	QTY.	DESCRIPTION
		(Per Assy.)	
1.	GA8483	1	Bracket
2.	G10938	1	Grease Fitting, 1/4"-28, Taper Thread
3.	G10451	2	Cotter Pin, 1/8" x 1"
4.	GD1657	1	Lockup Pin
5.	GD0962	1	Hex Head Adjusting Bolt, 5/8"-18 x 3 1/4"
	G10499	1	Hex Jam Nut, 5/8"-18, Grade 2
6.	GA0328	1	Spring
7.	GD0487	1	Bushing, 4 1/64" I.D. x 3 1/2" Long
8.	G10213	-	Machine Bushing, 5/8" (.030" Thick)
9.	G10542	12	Rivet, 1/4" x 1 5/16"
10.	GD1132	2	Dust Cap
11.	G10503	1	Hex Jam Nut, 5/8"-11, Grade 2
	G10504	1	Hex Jam Nut, 5/8"-11, L.H. Threads, Grade 2
12.	G10204	2	Special Machine Bushing, 5/8" x 1" O.D.
13.	GB0134	2	Hub
14.	GA2014	2	Bearing
15.	GD11306	2	Disc Blade, 3.5 mm x 15"
16.	GD2589	1	Inner Scraper
17.	GA0312	1	Mount
18.	G10019	1	Hex Head Cap Screw, 5/16"-18 x 1"
	G10232	1	Lock Washer, 5/16"
19.	GA1369	-	Drop Tube, Dry Fertilizer
20.	GD11705	-	Extension
21.	G10681	-	Hose Clamp, No. 6
22.	GA8685	-	Drop Tube, Liquid Fertilizer
23.	G10133	1	Hex Head Cap Screw, 5/16"-18 x 1 1/2"
	G10221	1	Washer, 5/16" SAE
	G10109	1	Lock Nut, 5/16"-18, Grade 8
24.	GA9195	1	Shank
25.	GA0810	1	Scraper Mount
26.	GD1673	2	Scraper
27.	G10305	2	Carriage Bolt, 3/8"-16 x 1"
	G10210	2	Washer, 3/8" USS
	G10229	2	Lock Washer, 3/8"
	G10101	2	Hex Nut, 3/8"-16
28.	G10045	1	Hex Head Cap Screw, 1/2"-13 x 4 1/2"
	G10111	1	Lock Nut, 1/2"-13
29.	G10046	1	Hex Head Cap Screw, 5/8"-11 x 5"
	G10107	1	Lock Nut, 5/8"-11
30.	GD1138	2	U-Bolt, 2 1/2" x 2 1/2" x 1/2"-13
	G10228	4	Lock Washer, 1/2"
	G10102	4	Hex Nut, 1/2"-13
31.	GA7135	1	Mount W/U-Bolts (One Per Opener)
	GD1113	2	U-Bolt, 5" x 7" x 5/8"-11
	G10230	4	Lock Washer, 5/8"
	G10104	4	Hex Nut, 5/8"-11
32.	GA8983	-	Check Valve, Low Rate
A.	GA8845	-	Disc Blade And Bearing Assembly (Items 9 And 13-15)

HD SINGLE DISC FERTILIZER OPENER (Soil Press Wheel)

(TWL35d/TWL35b)

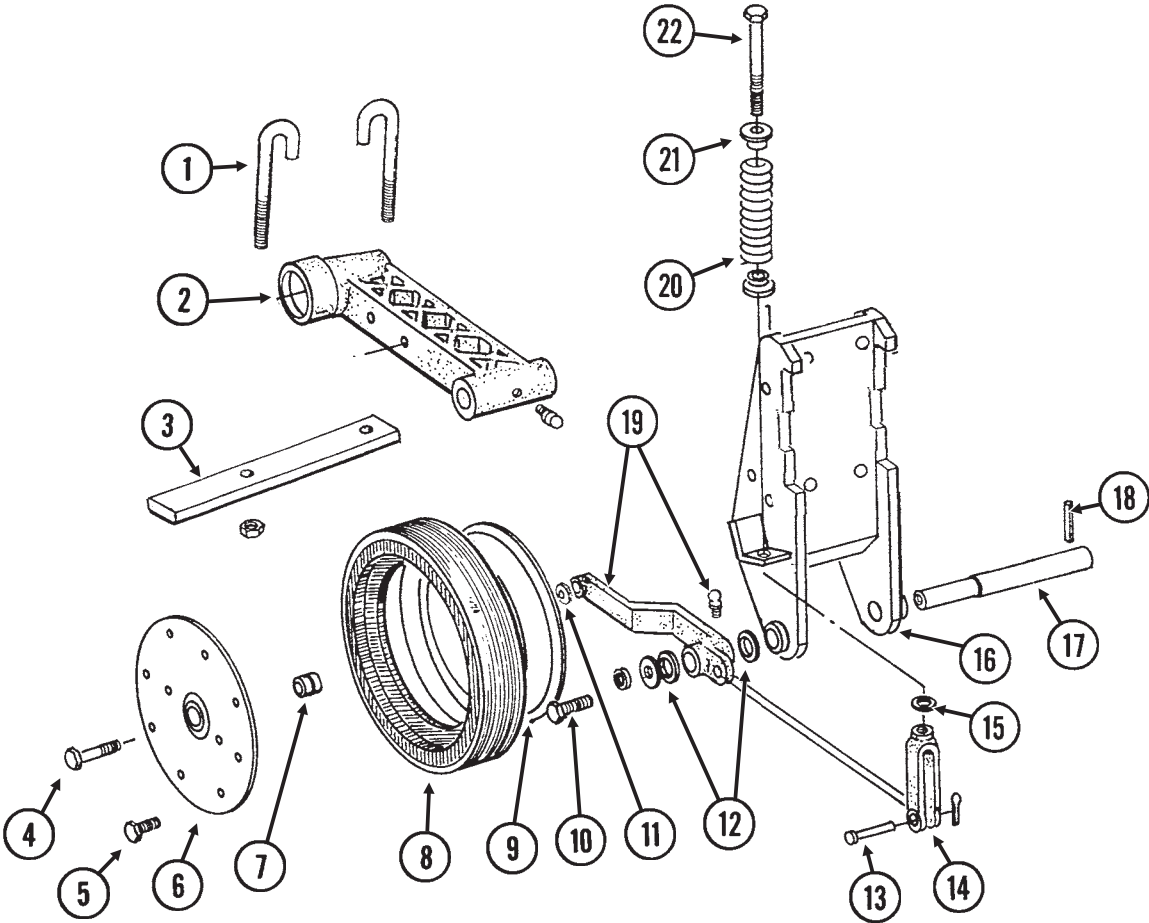

HD SINGLE DISC FERTILIZER OPENER (Soil Press Wheel)

ITEM	PART NO.	QTY.	DESCRIPTION
		(Per Assy.)	
1.	GD9705	2	J-Bolt, 1/2"-13
	G10228	2	Lock Washer, 1/2"
	G10102	2	Hex Nut, 1/2"-13
2.		-	See "HD Single Disc Fertilizer Opener (Drop Tube)", Pages P104 And P105
3.	GD9706	1	Lockup Bar
4.	G10010	1	Hex Head Cap Screw, 5/8"-11 x 3"
5.	G10961	11	Flanged Whiz Lock Screw, 5/16"-18 x 5/8", No Serration
	G10620	11	Serrated Flange Nut, 5/16"-18
6.	GD11954	1	Half Wheel Cover, Nylon
7.	GA6171	1	Bearing
8.	GD11953	1	Offset Tire
9.	GD11423	1	Half Wheel
10.	G10438	1	Hex Head Cap Screw, 1/2"-13 x 3/4"
	G10228	1	Lock Washer, 1/2"
	G10216	1	Washer, 1/2" USS
11.	G10230	1	Lock Washer, 5/8"
12.	G10526	10	Machine Bushing, 1" (.048" Thick)
13.	G10560	1	Clevis Pin, 1/2" x 1 3/4"
	G10456	1	Cotter Pin, 1/8" x 3/4"
14.	GD8218	1	Yoke
15.	G10205	1	Washer, 5/8" SAE
16.		-	See "HD Single Disc Fertilizer Opener (Drop Tube)", Pages P104 And P105
17.	GD7911	1	Pivot Pin
18.	G10610	1	Spring Pin, 3/8" x 2"
19.	GA8306	-	Wheel Arm W/Grease Fitting, R.H.
	GA8305	1	Wheel Arm W/Grease Fitting, L.H. (Shown)
	G10640	1	Grease Fitting, 1/4"-28
20.	GD8308	1	Spring
21.	GB0212	2	Spring Washer
22.	GD9709	1	Special Bolt
A.	G1K215	-	Lockup Kit (Items 1 And 3)
B.	GA8877	-	Gauge Wheel Complete (Items 5-9)

HD SINGLE DISC FERTILIZER OPENER (Drop Tube)

(PT27e/FRTZ208)

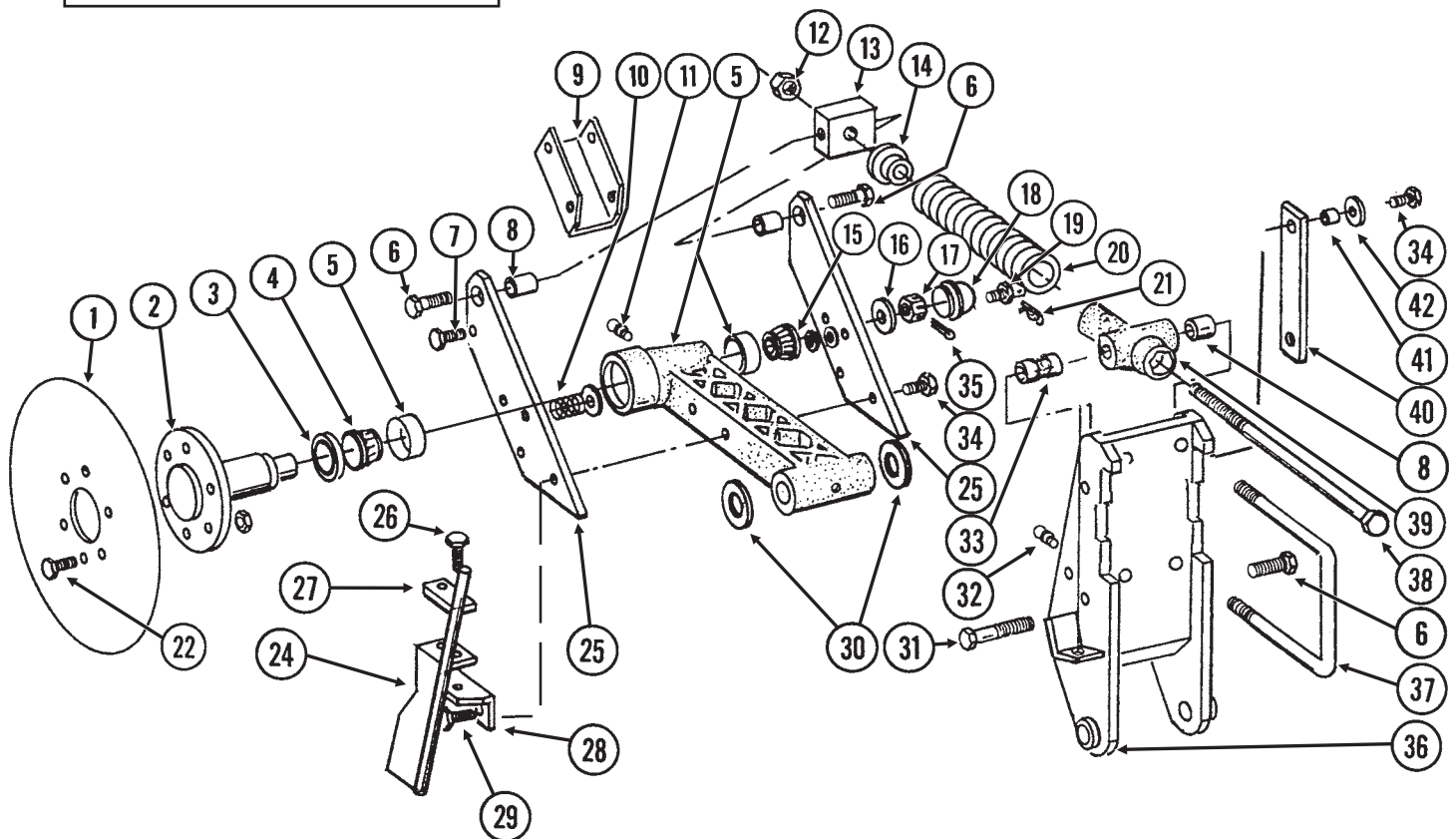
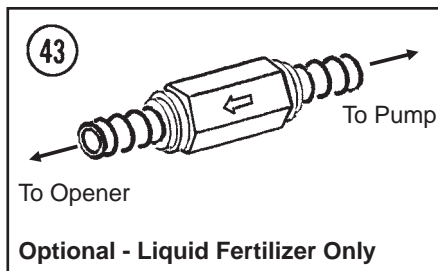

ITEM	PART NO.	QTY.	DESCRIPTION
		(Per Assy.)	
1.	GD7900	1	Disc Blade, 18"
	GD8247	-	Disc Blade, 20" (Optional)
2.	GB0205	1	Spindle
3.	GA4286	1	Seal
4.	GA4287	1	Bearing
5.	GA5887	1	Arm W/Cups And Washers
	GD6553	-	Inner Cup
	GR0188	-	Outer Cup
	G10205	3	Washer, 5/8" SAE

HD SINGLE DISC FERTILIZER OPENER (Drop Tube)

ITEM	PART NO.	QTY.	DESCRIPTION
		(Per Assy.)	
6.	G10007	3	Hex Head Cap Screw, 5/8"-11 x 1 1/2"
7.	G10001	2	Hex Head Cap Screw, 3/8"-16 x 1"
	G10108	2	Lock Nut, 3/8"-16
8.	GB0218	3	Bushing, 2 1/32" I.D. x 7/8" O.D. x 1 9/32" Long
9.	GD8238	1	Channel
10.	GD7962	2	Spring
11.	G10641	2	Grease Fitting, 1/8" NPT
12.	G10105	3	Hex Nut, 3/4"-10
13.	GD7908	1	Tap Block
14.	GB0213	1	Spring Seat
15.	GA0237	1	Bearing
16.	G10220	1	Machine Bushing, 1 1/16", 10 Gauge
17.	G10507	1	Slotted Nut, 1"-14
18.	GD1104	1	Dust Cap
19.	GD8276	1	Pin
	G10237	1	Lock Washer, 7/16"
	G10100	1	Hex Nut, 7/16"-14
20.	GD10273	1	Compression Spring
21.	G10592	1	Hair Pin Clip, No. 11
22.	G10594	6	Bolt, 1/2"-13 x 1 1/2"
	G10111	6	Lock Nut, 1/2"-13
23.	G10049	2	Hex Head Cap Screw, 3/8"-16 x 2 1/2"
	G10210	2	Washer, 3/8" USS
	G10108	2	Lock Nut, 3/8"-16
24.	GA8689	1	Drop Tube, L.H., Liquid Fertilizer (Shown)
	GA8688	-	Drop Tube, R.H., Liquid Fertilizer
25.	GD8224	2	Bar
26.	G10004	2	Hex Head Cap Screw, 3/8"-16 x 1 1/4"
	G10229	2	Lock Washer, 3/8"
27.	GD10487	1	Clamp
28.	GD10304	-	Angle, R.H.
	GD10303	1	Angle, L.H. (Shown)
29.	G10016	2	Hex Head Cap Screw, 1/2"-13 x 2"
	G10111	2	Lock Nut, 1/2"-13
30.	G10322	-	Machine Bushing, 1 1/4", 18 Gauge (As Required)
31.	G10862	1	Hex Head Cap Screw, 5/8"-11 x 3 1/4"
	G10205	2	Washer, 5/8" SAE
	G10230	1	Lock Washer, 5/8"
32.	G10640	1	Grease Fitting, 1/4"-28
33.	GD10242	1	Bushing, 2 1/4"
34.	G10039	5	Hex Head Cap Screw, 1/2"-13 x 1 3/4"
	G10111	5	Lock Nut, 1/2"-13
35.	G10459	1	Cotter Pin, 3/16" x 1 1/2"
36.	GA7240	-	Opener Mount, R.H.
	GA7239	1	Opener Mount, L.H. (Shown)
37.	GD1113	2	U-Bolt, 5" x 7" x 5/8"-11
	G10230	4	Lock Washer, 5/8"
	G10104	4	Hex Nut, 5/8"-11
38.	GD7907	1	Special Bolt
39.	GB0206	1	Rod Guide
40.	GD8239	1	Storage Strap
41.	GD7904-02	1	Sleeve, 1/2" x 1/2" Long
42.	G10216	3	Washer, 1/2" USS
43.	GA8983	-	Check Valve, Low Rate

NOTCHED SINGLE DISC FERTILIZER OPENER

(FRTZ208/B0405/TWL34e/TWL34g/FRTZ268/A12108)

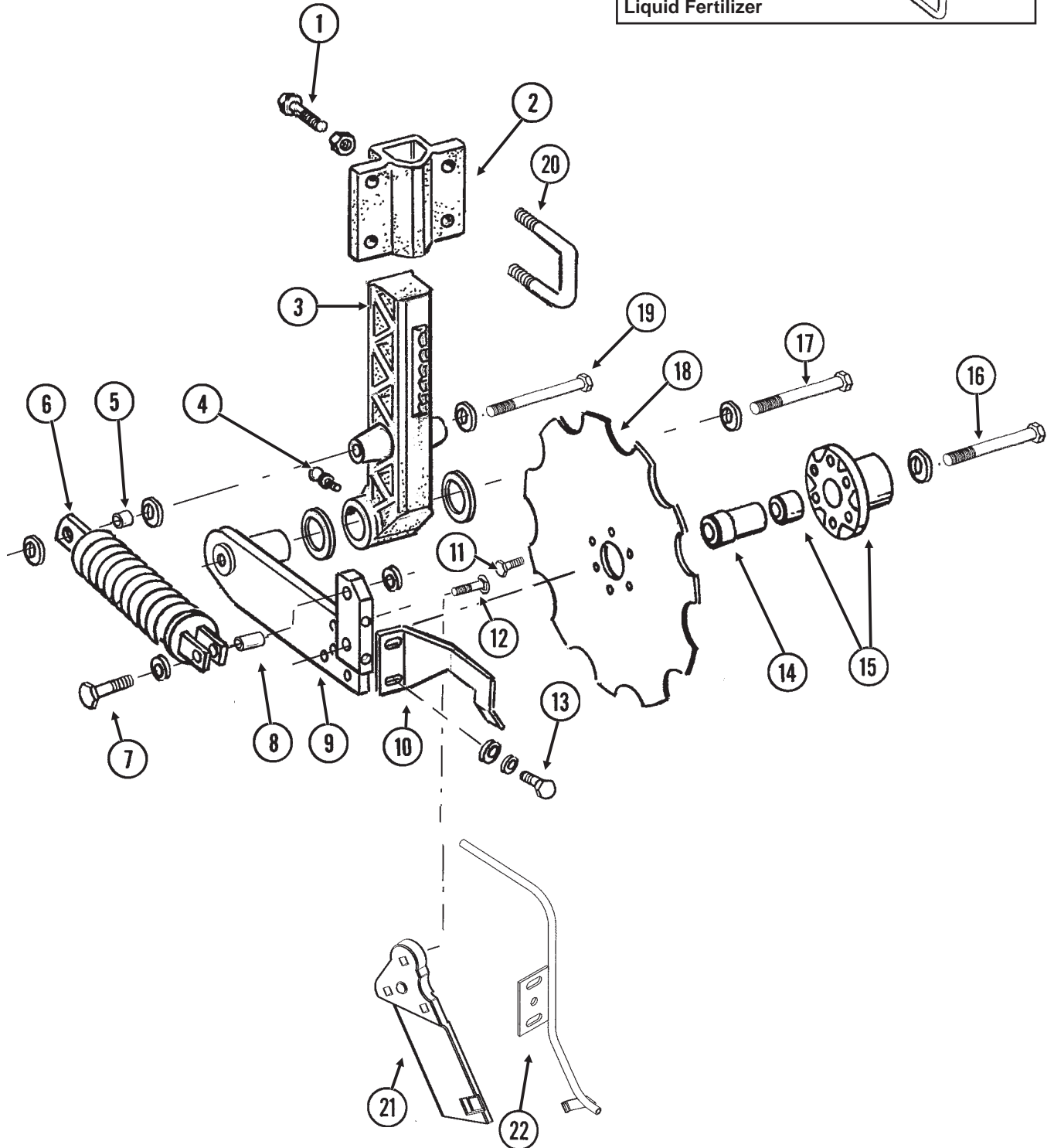
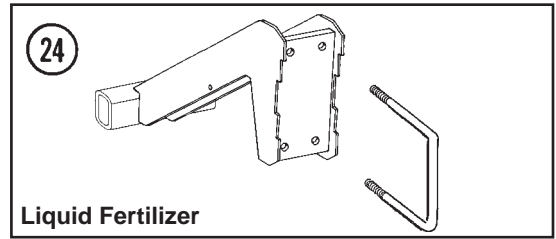
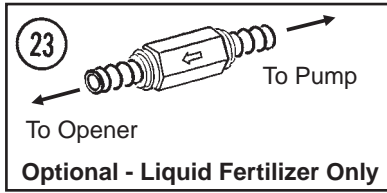

NOTCHED SINGLE DISC FERTILIZER OPENER

ITEM	PART NO.	QTY.	DESCRIPTION
		(Per Assy.)	
1.	G10017	3	Hex Head Cap Screw, 1/2"-13 x 1 1/2"
	G10102	3	Hex Nut, 1/2"-13
2.	GB0405	1	Mount, L.H. (Shown)
	GB0400	-	Mount, R.H.
3.	GB0296	1	Arm, 13 1/2"
4.	G10640	1	Grease Fitting, 1/4"-28
5.	GD12685	1	Bushing, 3/4" O.D. x 1/2" Long
6.	GA6966	1	Compression Spring Assembly
7.	G10047	1	Hex Head Cap Screw, 3/8"-16 x 1 3/4"
	G10210	2	Washer, 3/8" USS
	G10108	1	Lock Nut, 3/8"-16
8.	GD1026	1	Sleeve, 1 3/16" Long
9.	GA9433	1	Pivot Arm, L.H. (Shown)
	GA9434	-	Pivot Arm, R.H.
10.	GD11557	1	Scraper, L.H. (Shown)
	GD11558	-	Scraper, R.H.
11.	G10002	6	Hex Head Cap Screw, 3/8"-16 x 3/4"
12.	G10306	3	Carriage Bolt, 3/8"-16 x 2"
	G10108	3	Lock Nut, 3/8"-16
13.	G10991	2	Hex Head Cap Screw, 5/16"-18 x 7/8"
	G10232	2	Lock Washer, 5/16"
	G10219	2	Washer, 5/16" USS
14.	GD12679	1	Stepped Spacer, 3" Long
15.	GA9437	1	Hub W/Bearing
	GA8603	-	Double Row Bearing
16.	G10011	1	Hex Head Cap Screw, 5/8"-11 x 5 1/2"
	GD12677	1	Washer, 1 1/2" O.D., 7 Gauge, Hardened
	G10107	1	Lock Nut, 5/8"-11
17.	G10046	1	Hex Head Cap Screw, 5/8"-11 x 5"
	G10217	1	Washer, 5/8" USS
	G10450	2	Machine Bushing, 1 1/2", 18 Gauge (As Required)
	G10107	1	Lock Nut, 5/8"-11
18.	GD12676	1	Disc Blade, Notched, 16 3/4"
19.	G10871	1	Hex Head Cap Screw, 1/2"-13 x 6"
	G10206	3	Washer, 1/2" SAE
	G10111	1	Lock Nut, 1/2"-13
20.	GD13287	2	U-Bolt, 1 1/2" x 2 1/2" x 1/2"-13
	G10228	4	Lock Washer, 1/2"
	G10102	4	Hex Nut, 1/2"-13
21.	GB0323	1	Knife, L.H. (Shown)
	GB0322	-	Knife, R.H.
22.	GA12108	1	Drop Tube, Liquid Fertilizer (Shown)
	GA12109	-	Drop Tube, Liquid Fertilizer
23.	GA8983	-	Check Valve, Low Rate
24.	GA9565	1	Mount W/U-Bolts, Liquid Fertilizer
	GD1113	2	U-Bolt, 5" x 7" x 5/8"-11
	G10230	4	Lock Washer, 5/8"
	G10104	4	Hex Nut, 5/8"-11

RESIDUE WHEEL ATTACHMENT FOR NOTCHED SINGLE DISC FERTILIZER OPENER

DFC024(FRTZ165)

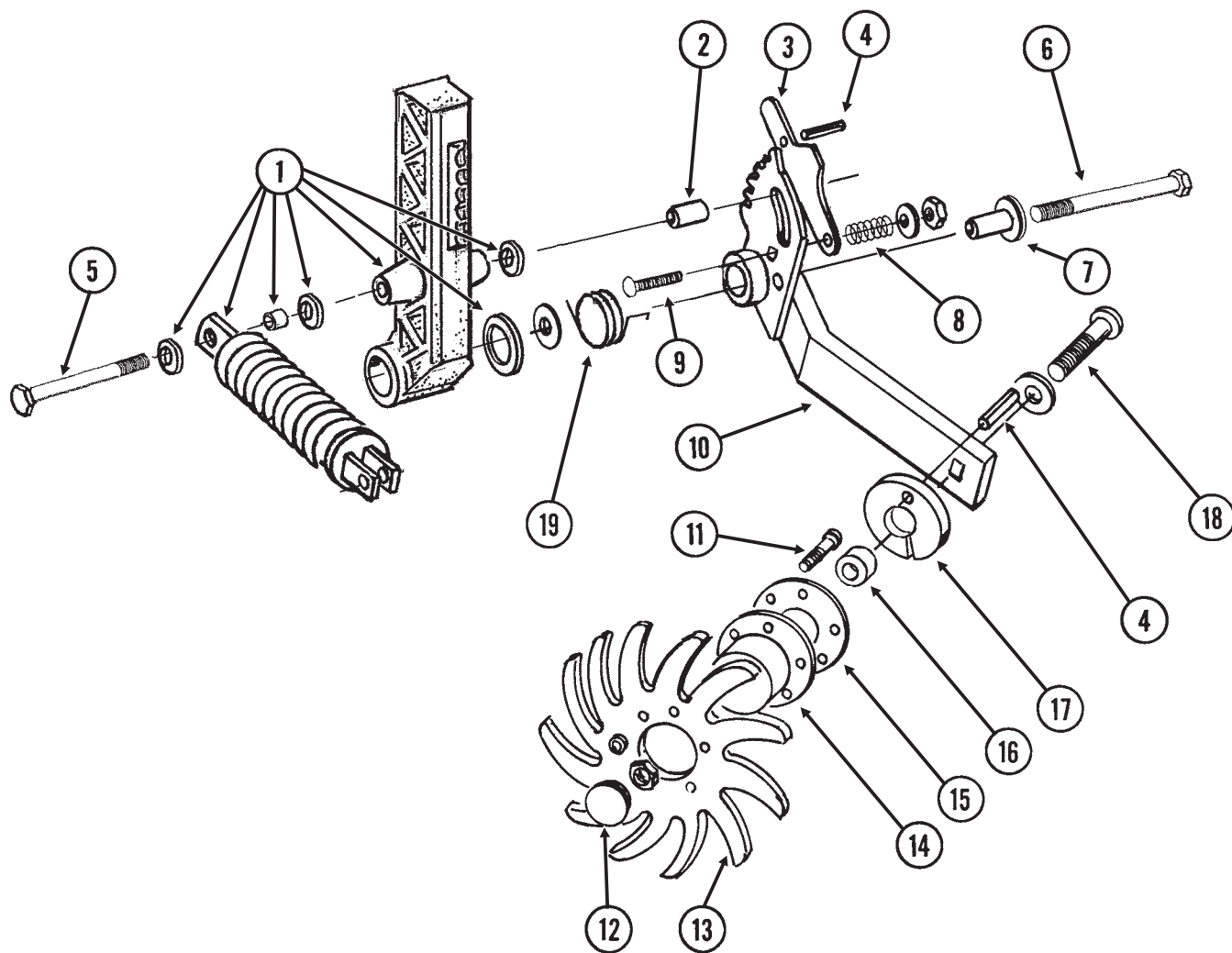

RESIDUE WHEEL ATTACHMENT FOR NOTCHED SINGLE DISC FERTILIZER OPENER

ITEM	PART NO.	QTY. (Per Assy.)	DESCRIPTION
1.		-	See "Notched Single Disc Fertilizer Opener", Pages P106 And P107
2.	GD12684	1	Bushing, 1 1/3" Long
3.	GD11178	1	Adjustment Lever
4.	G10603	2	Spring Pin, 1/4" x 1 1/4"
5.	G11034	1	Hex Head Cap Screw, 1/2"-13 x 7"
	G10111	1	Lock Nut, 1/2"-13
6.	G10830	1	Hex Head Cap Screw, 5/8"-11 x 7 1/2"
	GD7805	1	Special Washer, 5/8", Hardened
	G10107	1	Lock Nut, 5/8"-11
7.	GD11836	1	Sleeve, 2 1/8" Long
8.	GD7962	1	Spring
9.	G10306	1	Carriage Bolt, 3/8"-16 x 2"
	G10203	1	Washer, 3/8" SAE
	G10108	1	Lock Nut, 3/8"-16
10.	GA7999	1	Mount W/Grease Fitting, L.H. (Shown)
	GA7998	-	Mount W/Grease Fitting, R.H.
	G10640	-	Grease Fitting, 1/4"-28
11.	G10133	6	Hex Head Cap Screw, 5/16"-18 x 1 1/2"
	G10109	6	Lock Nut, 5/16"-18, Grade 8
12.	GD1132	2	Dust Cap
13.	GD10552	2	Wheel, 12 Tine, 3/8" x 12"
14.	GA5654	1	Hub W/Bearings
	GA2014	-	Bearing
15.	GD9724	1	Backing Plate
16.	GD7817-04	1	Spacer, 1 1/16" I.D. x 1/2" Long
17.	GD11188	1	Spacer
18.	G10908	1	Carriage Bolt, 5/8"-11 x 3"
	G10503	1	Hex Jam Nut, 5/8"-11, Grade 2
19.	GD11265	1	Spring, L.H. (Shown)
	GD11266	-	Spring, R.H.
A.	GA7445	-	Wheel Assembly, 12 Tine, L.H. (Items 11 And 13-15)(Shown)
	GA7446	-	Wheel Assembly, 12 Tine, R.H. (Items 11 And 13-15)

DEPTH/GAUGE WHEEL ATTACHMENT FOR NOTCHED SINGLE DISC FERTILIZER OPENER

(FRTZ256)

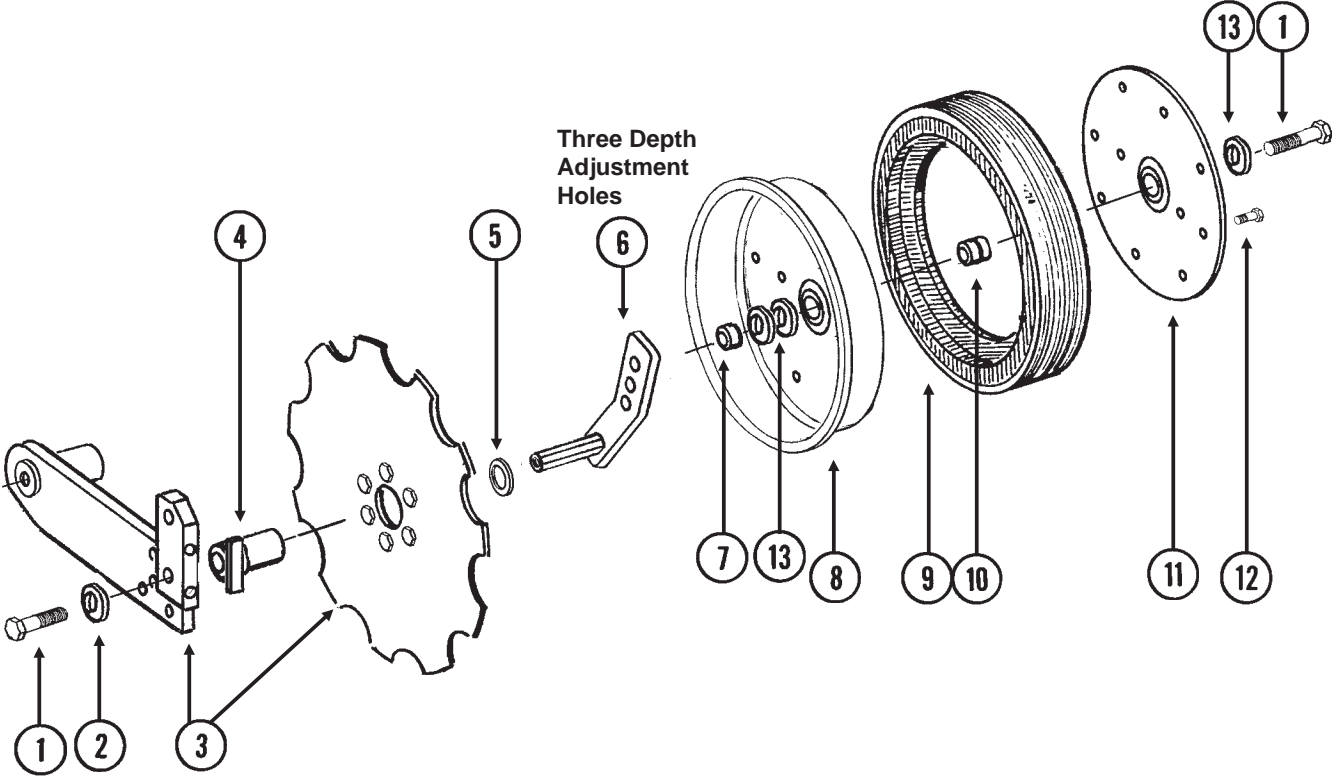

DEPTH/GAUGE WHEEL ATTACHMENT FOR NOTCHED SINGLE DISC FERTILIZER OPENER

ITEM	PART NO.	QTY.	DESCRIPTION
		(Per Assy.)	
1.	G10010	2	Hex Head Cap Screw, 5/8"-11 x 3"
2.	GD7805	1	Special Washer, 5/8", Hardened
3.		-	See "Notched Single Disc Fertilizer Opener", Pages P106 And P107
4.	GA9472	1	Blade Mount
5.	G10233	1	Machine Bushing, 1", 10 Gauge
6.	GA10037	1	Wheel Mount, L.H. (Shown)
	GA10036	1	Wheel Mount, R.H.
7.	GD13309	1	Spacer
8.	GD11423	1	Half Wheel
9.	GD11953	1	Offset Tire
10.	GA6171	1	Bearing
11.	GD11954	1	Half Wheel Cover, Nylon
12.	G10961	11	Flanged Whiz Lock Screw, 5/16"-18 x 3/4", No Serration
	G10620	11	Serrated Flange Nut, 5/16"-18
13.	G10204	-	Special Machine Bushing, 5/8" x 1" O.D. (As Required)
A.	GA8877	-	Gauge Wheel Complete (Items 8-12)

LIQUID FERTILIZER TANKS, SADDLES, SADDLE MOUNTS AND HOSES

LFC021/LFC023/LFC030/LFC012(FRTZ201g)

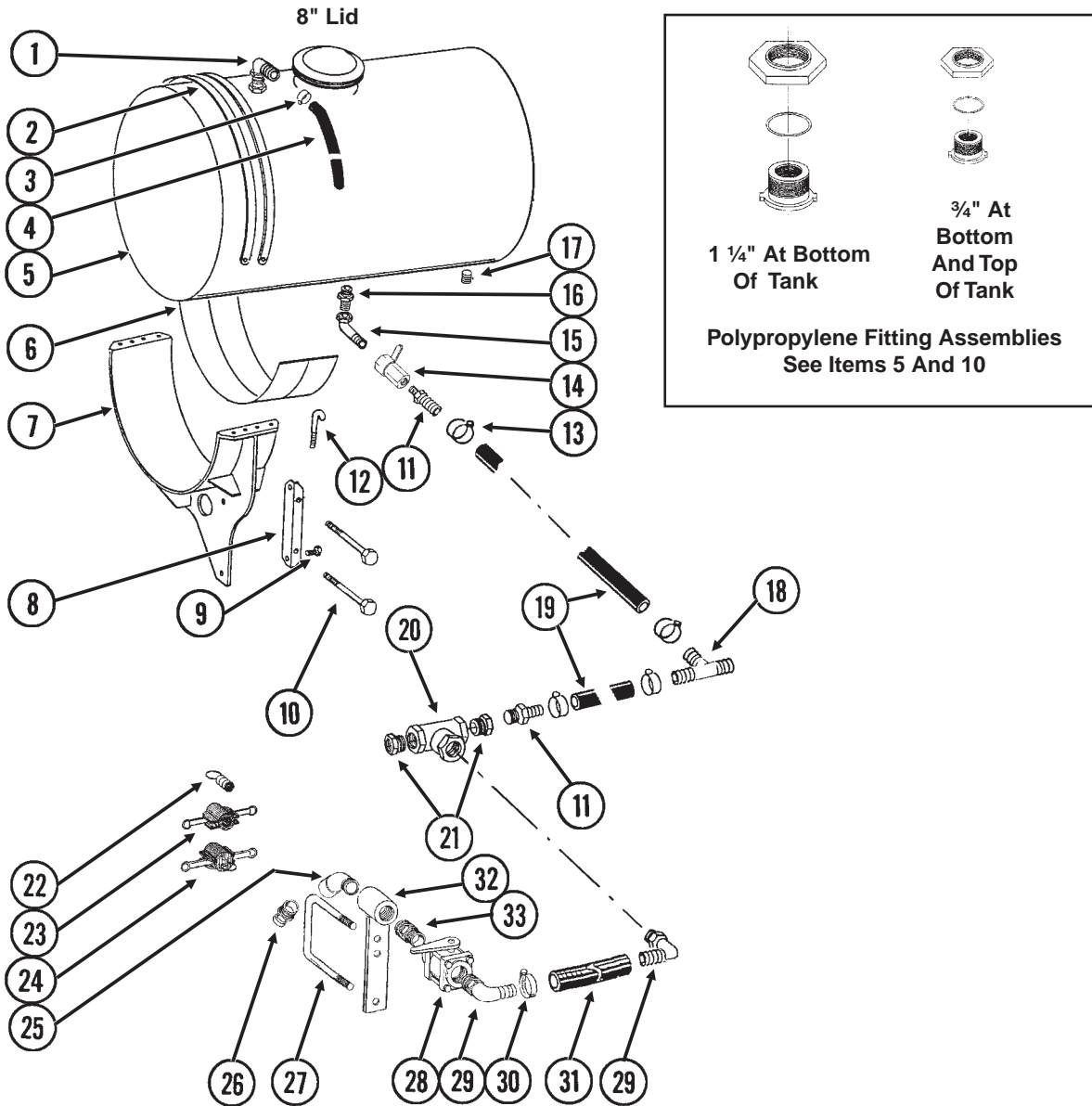

ITEM	PART NO.	QTY.	DESCRIPTION
1.	G10917	2	Elbow, 90°, 3/4" NPT To Barb
2.	GD1520	-	Band, 30" (4 Per Tank)
3.	G10278	2	Hose Clamp, No. 16
4.	G4205-11	-	Hose, 3/4" x 72" (One Per Tank)
5.	GA9905	4	Tank W/Lid And Fittings, 30" x 150 Gallon,
	GR1678	-	Lid W/Vent, 8" (Top Of Tank)
	GR0513	-	3/4" Polypropylene Fitting Assembly (Overflow Fitting, Nut, Bushing And O-Ring) (Top And Bottom Of Tank)
	GR1397	-	Overflow Fitting
	GR0508	-	1 1/4" Polypropylene Fitting Assembly (Nut, Bushing And O-Ring) (Bottom Of Tank)

LIQUID FERTILIZER TANKS, SADDLES, SADDLE MOUNTS AND HOSES

ITEM	PART NO.	QTY.	DESCRIPTION
6.	GD1862	-	Pad, 8" x 14' (For Two 30" Tanks)
7.	GA7133	-	Tank Mount (2 Per Tank)
8.	GD10110	-	Mounting Angle (2 Per Tank)
9.	G10007	-	Hex Head Cap Screw, 5/8"-11 x 1 1/2"
	G10230	-	Lock Washer, 5/8"
	G10104	-	Hex Nut, 5/8"-11
10.	G10342	-	Hex Head Cap Screw, 3/4"-10 x 8"
	G10218	-	Washer, 3/4" USS
	G10231	-	Lock Washer, 3/4"
	G10105	-	Hex Nut, 3/4"-10
11.	G10626	-	Adapter, 1 1/4" NPT To Barb
12.	GD1337	-	J-Bolt, 5/16"-18 (8 Per Tank)
	G11182	-	Lock Nut W/Nylon Insert, 5/16"-18, Grade 8 (8 Per Tank)
13.	G10674	-	Hose Clamp, No. 24
14.	GA4976	-	Shutoff Valve, 1 1/4" NPT
	GR1015	-	Body O-Ring
	GR1016	-	Stem O-Ring
	GR1017	-	Teflon Seat
	GR1018	-	Ball
	GR1019	-	Handle
15.	G10887	-	Elbow, 90°, 1 1/4" Male NPT To Female
16.	G10619	-	Close Nipple, 1 1/4" NPT
17.	G10096	-	Pipe Plug, 3/4" NPT
18.	G10633	-	Tee, 1 1/4" Barb
19.	G4200-03	1	Hose, 1 1/4" x 32', 12 Row
	G4200-06	-	Hose, 1 1/4" x 40', 16 Row
20.	G10888	-	Tee, 2" Female NPT
21.	G10616	-	Reducing Bushing, 2" Male NPT To 1 1/4" Female
22.	GD10777	-	Dust Plug, 2" Male Cam Lock
23.	GD3622	-	Adapter, 2" Female NPT To Cam Lock
24.	GD3951	-	Dust Cap, 2" Cam Lock
25.	G10889	-	Elbow, 45°, 2" Male NPT To Female
26.	GD3623	-	Adapter, 2" Male NPT To Cam Lock
27.	GD1113	-	U-Bolt, 5" x 7" x 5/8"-11
	G10230	-	Lock Washer, 5/8"
	G10104	-	Hex Nut, 5/8"-11
28.	GA2660	-	Shutoff Valve, 2" NPT
29.	G10630	-	Elbow, 90°, 2" NPT To Barb
30.	G10676	-	Hose Clamp, No. 36, Stainless Steel
31.	G4201-02	-	Hose, 2" x 12', 8 Row
	G4201-03	-	Hose, 2" x 18', 12/16 Row
32.	GA7845	-	Quick Fill Mount, 2"
33.	G10623	-	Close Nipple, 2" NPT

LIQUID FERTILIZER PISTON PUMP MOUNT AND GROUND DRIVE WHEEL

(TWL317b)

48 Tooth Drive Sprocket And 18 Tooth Driven Sprocket

Model NGP-7055

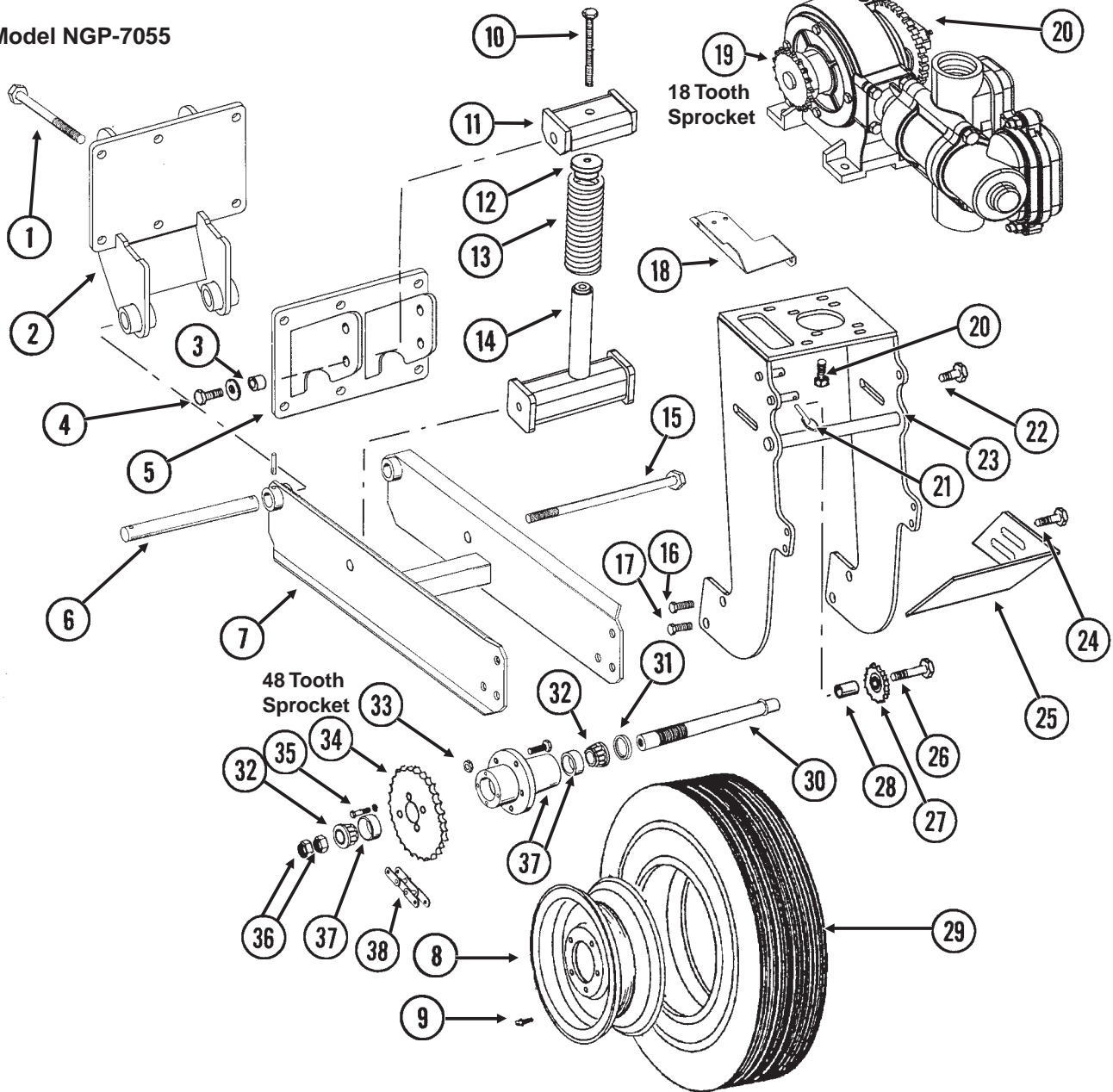

ITEM	PART NO.	QTY.	DESCRIPTION
1.	G10830	6	Hex Head Cap Screw, 5/8"-11 x 7 1/2"
	G10230	6	Lock Washer, 5/8"
	G10104	6	Hex Nut, 5/8"-11
2.	GA10624	1	Wheel Arm Mount
3.	GB0218	2	Bushing, 2 1/32" I.D. x 7/8" O.D. x 1 9/32" Long
4.	G10005	2	Hex Head Cap Screw, 5/8"-11 x 1 3/4"
	GD7805	2	Special Washer, 5/8", Hardened
	G10107	2	Lock Nut, 5/8"-11
5.	GA10622	1	Spring Mount
6.	GD2681	1	Pin, 1 1/4" x 13 1/2"
	G10460	2	Cotter Pin, 1/4" x 2"

LIQUID FERTILIZER PISTON PUMP MOUNT AND GROUND DRIVE WHEEL

ITEM	PART NO.	QTY.	DESCRIPTION
7.	GA10621	1	Arm W/Grease Fittings
	G10641	2	Grease Fitting, 1/8" NPT
8.	GA0241	1	Wheel, 5" x 15"
9.	GD1166	1	Valve Stem
10.	G10012	1	Hex Head Cap Screw, 5/8"-11 x 6 1/2"
	GD7805	1	Special Washer, 5/8", Hardened
11.	GA10908	1	Spring Mount
12.	GB0196	1	Washer
13.	GD7831	1	Compression Spring
14.	GA10907	1	Spring Guide
15.	G11122	1	Hex Head Cap Screw, 5/8"-11 x 12"
	G10107	1	Lock Nut, 5/8"-11
16.	G10026	2	Hex Head Cap Screw, 3/4"-10 x 2"
	G10231	2	Lock Washer, 3/4"
17.	G11042	2	Hex Head Cap Screw, 3/4"-10 x 1 3/4"
	G10231	2	Lock Washer, 3/4"
	G10105	2	Hex Nut, 3/4"-10
18.	GD13744	1	Hose Holder
19.	GR1146	1	Sprocket, 18 Tooth
20.		-	See "Liquid Fertilizer Piston Pump", Pages P118 And P119
21.	GD2558	1	Lynch Pin, 1/4"
22.	G10007	2	Hex Head Cap Screw, 5/8"-11 x 1 1/2"
	G10217	2	Washer, 5/8" USS
	G10230	2	Lock Washer, 5/8"
	G10104	2	Hex Nut, 5/8"-11
23.	GA10894	1	Pump Mount
24.	G10017	2	Hex Head Cap Screw, 1/2"-13 x 1 1/2"
	G10216	2	Washer, 1/2" USS
	G10228	2	Lock Washer, 1/2"
	G10102	2	Hex Nut, 1/2"-13
25.	GD13328	1	Scraper
26.	G10013	1	Hex Head Cap Screw, 5/8"-11 x 3 1/2"
	G10205	1	Washer, 5/8" SAE
	G10230	1	Lock Washer, 5/8"
	G10104	1	Hex Nut, 5/8"-11
27.	GA0262	1	Idler Sprocket W/Bearing, 15 Tooth
28.	GD7817-05	1	Spacer, 1 1/16" I.D. x 1 1/4" Long
29.	GD0844	1	Tire, 7.60" x 15", 8 Ply (Specify Brand*)
30.	GA2559	1	Spindle
31.	GA0252	2	Seal
32.	GA0251	2	Bearing
33.	GR0267	5	Lug Nut, 1/2"-20
34.	G2500-84	1	Sprocket, 48 Tooth
35.	G10019	4	Hex Head Cap Screw, 5/16"-18 x 1"
	G10232	4	Lock Washer, 5/16"
36.	GD0831	2	Shoulder Nut, 1 1/4"-12 UNF-2A
37.	GA0547	1	Hub W/Cups And Studs, 5 Bolt
	GR0190	2	Cup
	GR0204	5	Stud
38.	G3200-63	-	Chain, No. 2050, 63 Pitch Including Connector And Offset Link, Used With NGP-7075 Piston Pump
	GR0195	-	Connector Link, No. 2050
	GR0200	-	Offset Link, No. 2050

* Specific brand requests will be supplied only as available from current KINZE® Repair Parts stock. If a specific brand requested is not in stock, the brand available will be supplied. Different brand tires may have different diameters. Change in tire brand may affect rates. Field checks are recommended after any change in tires.

LIQUID FERTILIZER FLOW DIVIDER MOUNT AND HOSES

(FRTZ280/FRTZ298)

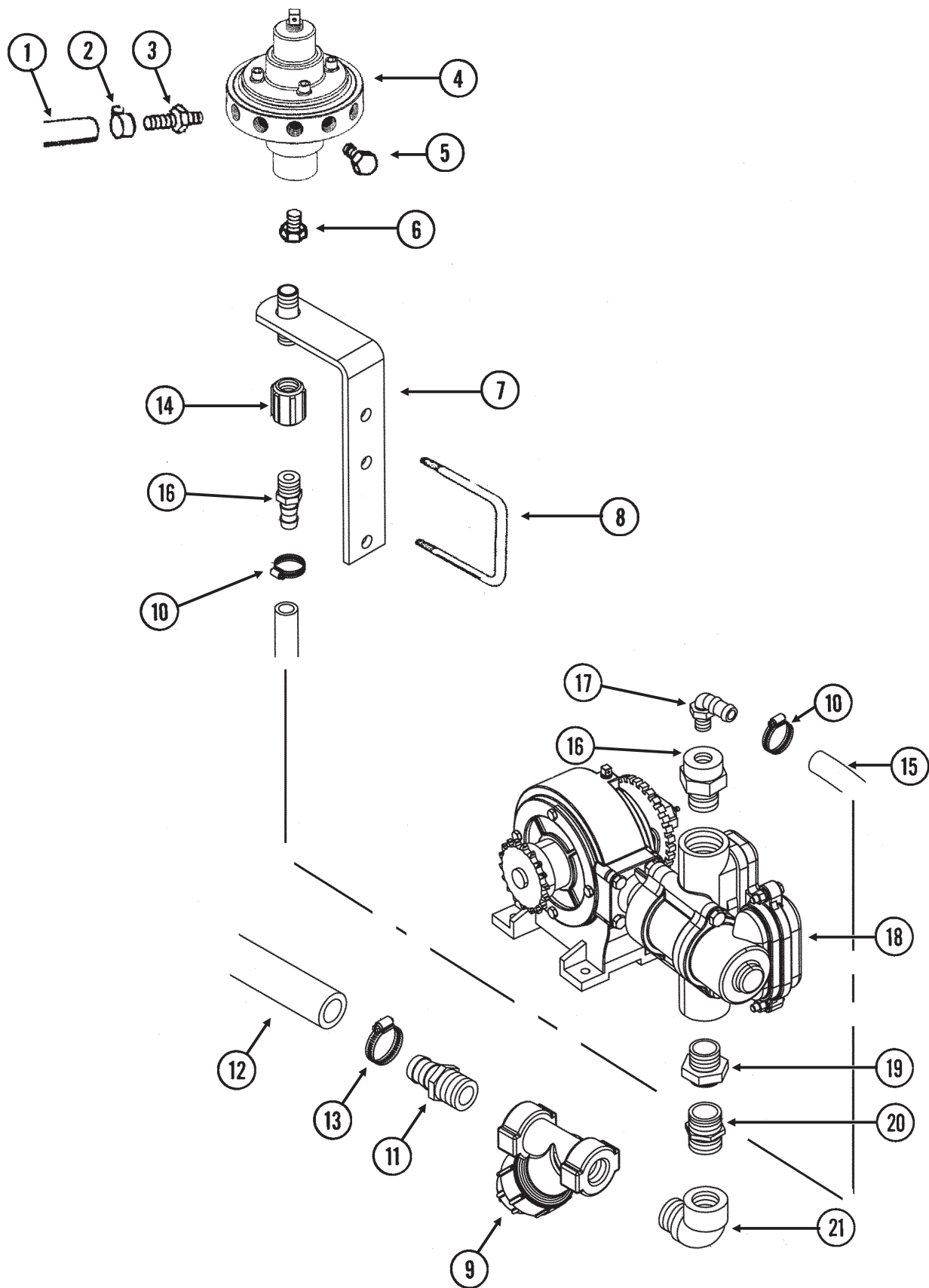

LIQUID FERTILIZER FLOW DIVIDER MOUNT AND HOSES

ITEM	PART NO.	QTY.	DESCRIPTION
1.	G4301-06	1	Hose, 3/8" x 160', 12 Row
	G4301-05	1-2	Hose, 3/8" x 120', 16 Row
2.	G10681	-	Hose Clamp, No. 6
3.	GD11700	-	Adapter, 1/4" NPT To 3/8" Barb
4.		-	See "Liquid Fertilizer Piston Pump Flow Divider", Pages P120 And P121
5.	G10292	-	Pipe Plug, 1/4" NPT
6.	G10995	1	Reducing Bushing, 1" Male NPT To 3/4" Female, Stainless Steel (If Applicable)
7.	GA6527	1	Mount, 3/4" NPT
8.	GD1113	1	U-Bolt, 5" x 7" x 5/8"-11
	G10230	2	Lock Washer, 5/8"
	G10104	2	Hex Nut, 5/8"-11
9.	GA3893	1	Strainer Complete
	GR0880	-	Screen, No. 40 Mesh
	GR0881	-	Gasket
	GR0882	-	Y-Body
	GR0883	-	End Cap
10.	G10278	-	Hose Clamp, No. 16
11.	G10626	2	Adapter, 1 1/4" NPT To Barb
12.		-	See "Liquid Fertilizer Tanks, Saddles, Saddle Mounts And Hoses", Pages P112 And P113
13.	G10674	2	Hose Clamp, No. 24
14.	G11083	1	Coupler, 3/4" Female NPT
15.	G4205-10	-	Hose, 3/4" x 200"
16.	G11237	1	Reducing Bushing, 1 1/2" Male NPT To 3/4" Female
17.	G10917	1	Elbow, 90°, 3/4" NPT To Barb
18.		-	See "Liquid Fertilizer Piston Pump", Pages P118 And P119
19.	G10615	1	Reducing Bushing, 1 1/2" Male NPT To 1 1/4" Female
20.	G10619	1	Close Nipple, 1 1/4" NPT
21.	G10887	1	Elbow, 90°, 1 1/4" Male NPT To Female

LIQUID FERTILIZER PISTON PUMP Uses 18 Tooth Sprocket

(A12335a/GR1808)

Model NGP-7055

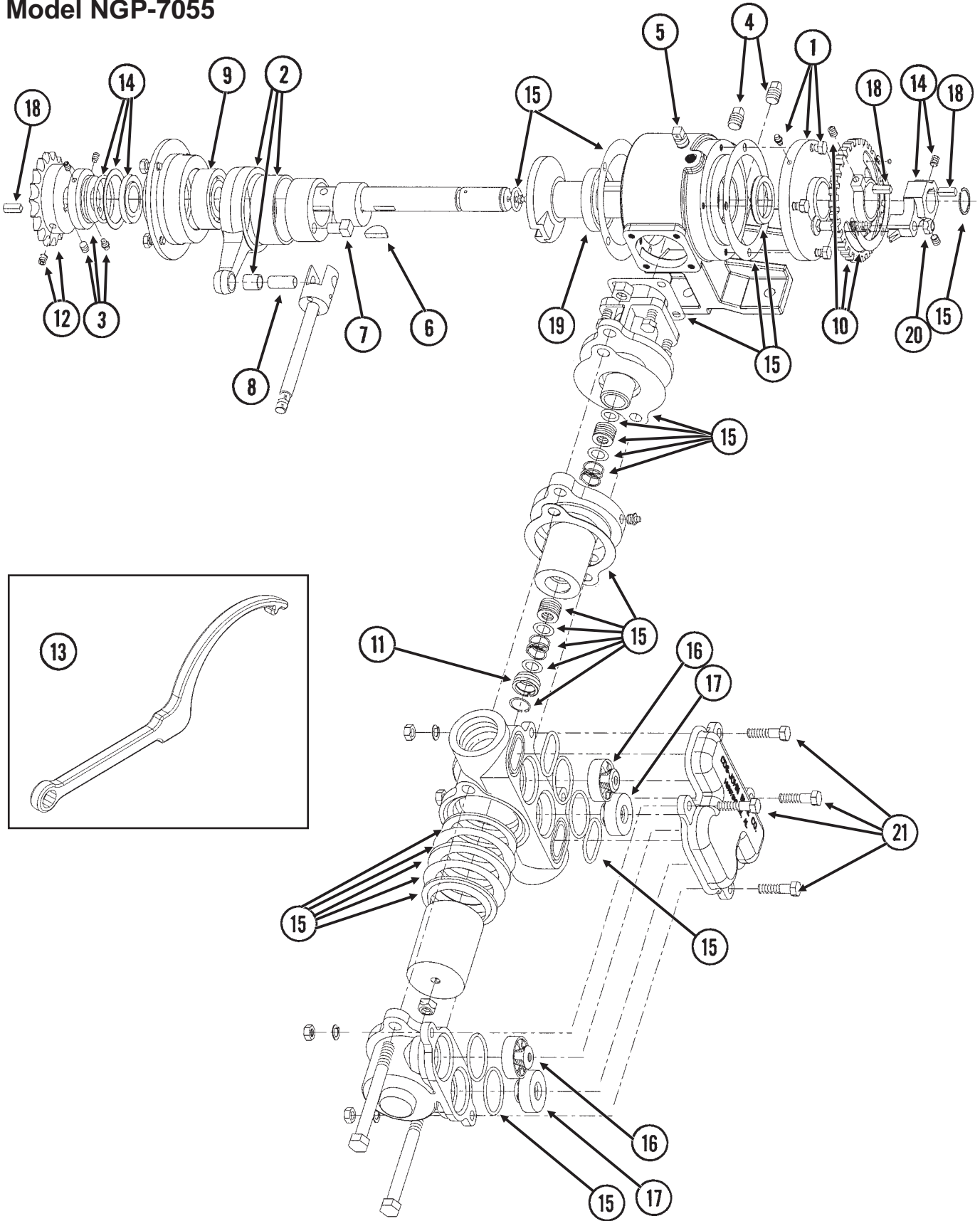

LIQUID FERTILIZER PISTON PUMP

Uses 18 Tooth Sprocket

ITEM	PART NO.	QTY.	DESCRIPTION
1.	GR1804	1	Flange Cover Assembly
	G10991	4	Hex Head Cap Screw, 5/16"-18 x 7/8"
2.	GR1803	1	Connecting Rod Assembly
3.	GR1801	1	Spacer Assembly
	G10693	3	Hex Socket Head Set Screw, 5/16"-18 x 3/8"
4.	GR1123	2	Plug
5.	GR1543	1	Vent Plug
6.	GR1112	1	Woodruff Key
7.	GR1120	1	Eccentric Pin
8.	GR1124	1	Pin
9.	GR1104	1	Bearing
10.	GR1805	1	Setting Hub Assembly
11.	GR1134	1	Stuffing Box Insert
12.	GR1146	1	Sprocket, 18 Tooth
13.	GR1808	1	Adjustment Wrench
14.	GR1806	1	Setting Pointer Assembly
15.	GR1796	1	Repair Kit, Includes: (6) Gaskets, (9) O-Rings, (4) Washers, (1) Retaining Ring, (2) Oil Seals, (1) Snap Ring, (1) Thrust Washer, (1) Rod Bushing, (2) Flange Plunger Packings, (2) Packing Springs, (2) Rod Vee Packing Sets
16.	GR1800	2	Discharge Valve Assembly
17.	GR1798	2	Suction Valve Assembly
18.	GR1118	3	Setting Arm Key
19.	GR1116	1	Bearing
20.	G10306	1	Carriage Bolt, 3/8"-16 x 2"
	G10108	1	Lock Nut, 3/8"-16
21.	G10003	4	Hex Head Cap Screw, 3/8"-16 x 1 1/2"
	G10210	4	Washer, 3/8" USS
	G10229	4	Lock Washer, 3/8"
	G10101	4	Hex Nut, 3/8"-16
A.	GA12335	-	Piston Pump Complete W/18 Tooth Sprocket (Model NGP-7055)

LIQUID FERTILIZER PISTON PUMP FLOW DIVIDER

(FRTZ159/PT40a/FRTZ202c)

Model FD-1200 Flow Divider, 12 Outlet

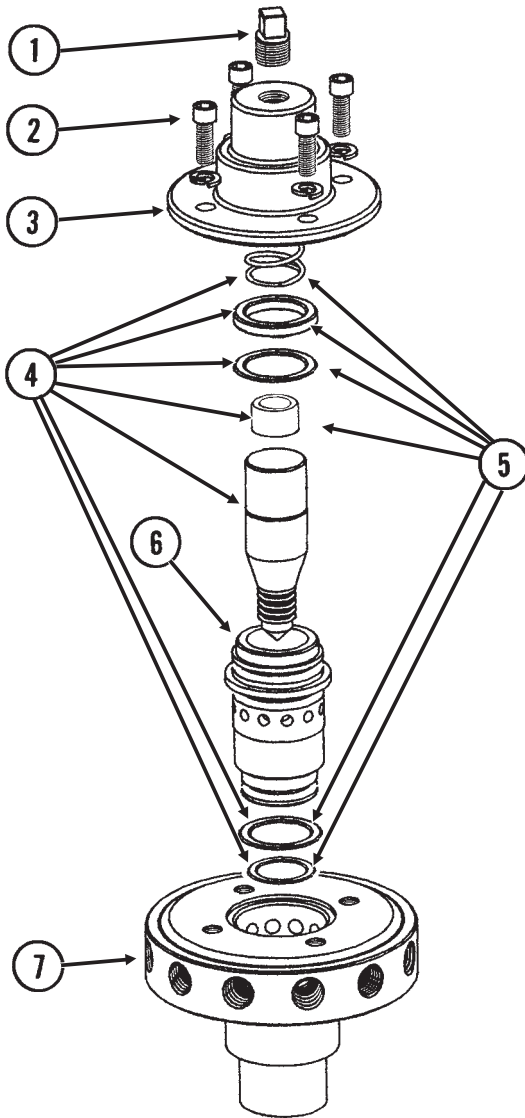

3/4" NPT

Model FD-2000 Flow Divider, 20 Outlet

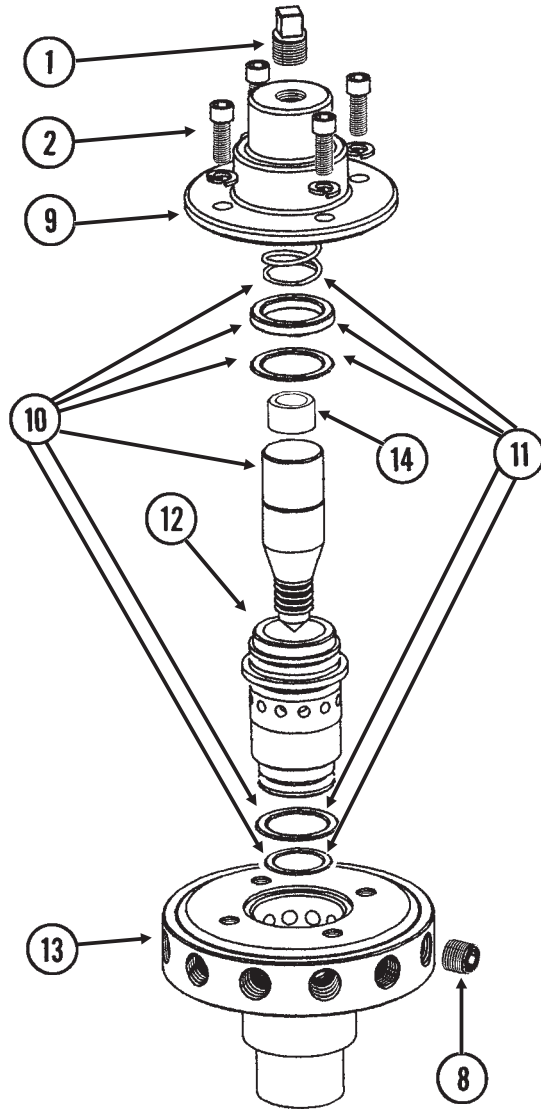

1" NPT

LIQUID FERTILIZER PISTON PUMP FLOW DIVIDER

ITEM	PART NO.	QTY.	DESCRIPTION
1.	GR1543	1	Vent Plug
2.	GR1542	4	Hex Socket Head Screw, 1/4"-20 x 3/4"
	GR1541	4	Lock Washer, 1/4", Stainless Steel
3.	GR1540	1	Cap
4.	GR1544	1	Needle Assembly W/Seal Kit (Item 22)
5.	GR1545	1	Seal Kit, Includes: (3) O-Rings, (1) Seal, (1) Spring, (1) Stainless Steel Sleeve
6.	GR1535	1	Sleeve
7.	GR1533	1	Body (12 Outlets)
8.	G10350	4	Hex Socket Head Plug, 1/4" NPT, Stainless Steel
9.	GR1566	1	Cap
10.	GR1567	1	Needle Assembly W/Seal Kit (Item 22)
11.	GR1568	1	Seal Kit, Includes: (3) O-Rings, (1) Seal, (1) Spring
12.	GR1561	1	Sleeve
13.	GR1559	1	Body (20 Outlets)
14.	GR1574	1	Sleeve, 1" O.D. x 1/2" Long, Stainless Steel
A.	GA8931	1	Liquid Fertilizer Piston Pump Flow Divider Complete, 12 Outlet (Model FD-1200) (Items 1-7) (12 Row Sizes)
B.	GA9407	1	Liquid Fertilizer Piston Pump Flow Divider Complete, 20 Outlet (Model FD-2000) (Items 1, 2 And 8-14) (16 Row Size)

REAR TRAILER HITCH

PHA032/LFC003(TWL47a)

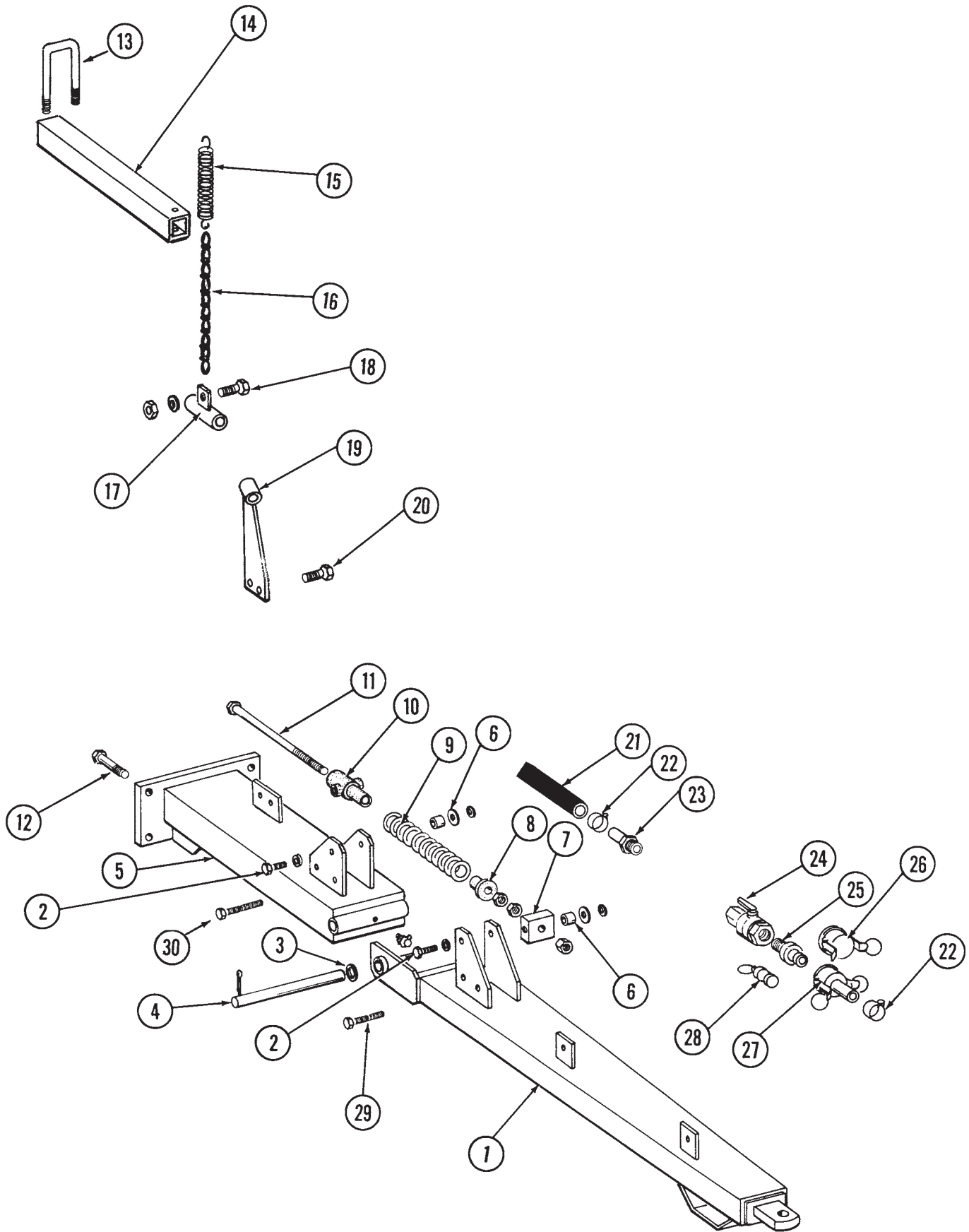

REAR TRAILER HITCH

ITEM	PART NO.	QTY.	DESCRIPTION
1.	GA6961	1	Hitch
2.	G10007	4	Hex Head Cap Screw, 5/8"-11 x 1 1/2"
	GD7805	4	Special Washer, 5/8", Hardened
	G10230	4	Lock Washer, 5/8"
3.	G10226	2	Washer, 1 1/4" SAE
4.	GD3547	1	Pin, 1 1/4" x 12 3/4"
	G10460	2	Cotter Pin, 1/4" x 2"
5.	GA6960	1	Hitch
6.	GB0218	4	Bushing, 2 1/32" I.D. x 7/8" O.D. x 1 9/32" Long
7.	GD7908	1	Tap Block
8.	GB0213	1	Spring Seat
9.	GD2115	1	Spring
10.	GB0206	1	Rod Guide
11.	GD7907	1	Special Bolt
	G10105	3	Hex Nut, 3/4"-10
12.	G10826	5	Hex Head Cap Screw, 1"-8 x 2 1/2"
	G10396	5	Lock Nut, 1"-8
13.	GD2721	2	U-Bolt, 2" x 2" x 1/2"-13
	G10228	4	Lock Washer, 1/2"
	G10102	4	Hex Nut, 1/2"-13
14.	GD10196	-	Hanger Tube
15.	GD0829	-	Spring
16.	G3305-03	-	Twin Loop Chain, 15 Links
17.	GA7209	-	Hose Support
18.	G10064	1	Hex Head Cap Screw, 1/4"-20 x 1"
	G10209	2	Washer, 1/4" USS
	G10110	1	Lock Nut, 1/4"-20, Grade B
19.	GA7208	-	Hose Support
20.	G10004	2	Hex Head Cap Screw, 3/8"-16 x 1 1/4"
	G10108	2	Lock Nut, 3/8"-16
21.	G4200-01	1	Hose, 1 1/4" x 22'
22.	G10672	6	Hose Clamp, No. 28
23.	G10626	1	Adapter, 1 1/4" NPT To Barb
24.	GA4976	1	Shutoff Valve, 1 1/4" NPT
	GR1015	-	Body O-Ring
	GR1016	-	Stem O-Ring
	GR1017	-	Teflon Seat
	GR1018	-	Ball
	GR1019	-	Handle
25.	GD1514	1	Adapter, 1 1/4" Male NPT To Cam Lock
26.	GD1515	1	Dust Cap, 1 1/4" Cam Lock
27.	GD1516	1	Adapter, 1 1/4" Barb To Female Cam Lock
28.	GD1517	1	Dust Plug, 1 1/4" Male Cam Lock
29.	G10172	1	Hex Head Cap Screw, 3/8"-16 x 5"
	G10229	1	Lock Washer, 3/8"
	G10101	1	Hex Nut, 3/8"-16
30.	G10756	1	Hex Head Cap Screw, 3/8"-16 x 6"
	G10229	1	Lock Washer, 3/8"
	G10101	1	Hex Nut, 3/8"-16

DECALS, PAINT AND MISCELLANEOUS

WARNING

ALWAYS USE SAFETY PINS IN TRANSPORT POSITION

7100-2

1



2



3

WARNING

AGRICULTURAL CHEMICALS CAN BE DANGEROUS. IMPROPER SELECTION OR USE CAN SERIOUSLY INJURE PERSONS, ANIMALS, PLANTS, SOIL OR OTHER PROPERTY. **BE SAFE.** SELECT THE RIGHT CHEMICAL FOR THE JOB. HANDLE WITH CARE. FOLLOW THE INSTRUCTIONS ON THE CONTAINER LABEL AND OF THE EQUIPMENT MANUFACTURER.

7100-115

4



5

DANGER

SERIOUS INJURY OR DEATH CAN RESULT FROM CONTACT WITH ELECTRICAL LINES. USE CARE TO AVOID CONTACT WITH ELECTRIC LINES WHEN MOVING OR OPERATING THIS MACHINE.

7100-117

6

ATTENTION

Connect directly to **BATTERY** whenever possible

Connect black lead to negative terminal

Connect to 12 Volts Only

7100-123

7

USE 1 TABLESPOON POWDERED GRAPHITE WITH EACH HOPPER FILL OF SEED. SEED TREATMENT, FOREIGN MATERIAL, DIRT, OR SEED CHAFF MAY CAUSE GRADUAL REDUCTION OF SEED POPULATION. REFER TO MANUAL FOR MAINTENANCE AND CARE.

7100-153

8

Twin-Line

7100-177

9

ROTATION

7100-192

10

WARNING

ALWAYS USE SAFETY STAND IN TRANSPORT POSITION

7100-200

11

MARKER SPEED CONTROL

SEE MANUAL FOR PROPER ADJUSTMENT

LOWER RAISE

7100-201

12

Interplant.

7100-202

13

ANALOG SENDING UNIT

PDP

A12646

7100-338

14

DANGER

DO NOT REMOVE THIS ASSEMBLY AFTER PLANTER IS ASSEMBLED FOR USE. REMOVAL OF THIS WHEEL AND AXLE ASSEMBLY CAN CAUSE THE MACHINE TO BECOME UNSTABLE AND TIP OVER CAUSING DAMAGE OR SERIOUS INJURY.

7100-215

15

NOTE

It is the responsibility of the user to read and understand the Operator's Manual in regards to safety, operation, lubrication and maintenance before operation of this equipment.

AN OPERATOR & PARTS MANUAL IS AVAILABLE FOR THIS MACHINE.

To obtain a manual, furnish model number and serial number and contact your KINZE Dealer or KINZE Manufacturing, Inc., P.O. Box 806 Williamsburg, IA 52361-0806 USA

16

WARNING

MAXIMUM INFLATION PRESSURE

75 PSI

7100-219

17

TORQUE 5/8" SPINDLE BOLTS TO 120 FT/LBS. CHECK PERIODICALLY AND RE-TORQUE AS NEEDED.

7100-231

18

KINZE 3600V

19



20

DECALS, PAINT AND MISCELLANEOUS

ROTATE KNURLED COLLAR
ON WRAP SPRING TIGHTENER
TO RELEASE SPRING
TENSION

7100-295

21

CAUTION

SET DOWN PRESSURE SPRINGS TO MINIMUM. LOWER
PLANTER TO GROUND AND EMPTY SEED HOPPERS.
REQUIRES 90 LB MIN TO LIFT.

7100-249

22

WARNING

TO AVOID INJURY --
STAND CLEAR--KEEP OTHERS
AWAY WHEN RAISING OR LOWERING
MARKERS. BEFORE TRANSPORTING
PLANTER FULLY EXTEND HYDRAULIC
CYLINDERS AND INSTALL LOCKING
PINS WHERE PROVIDED.

7100-42

23

WARNING

1. Read and understand the Operator's Manual.
2. Stop the tractor engine before leaving the operator's platform.
3. Keep riders off the machine.
4. Make certain everyone is clear of the machine before starting the tractor engine and operating.
5. Keep all shields in place.
6. Never lubricate, adjust, unclog or service the machine with tractor engine running.
7. Wait for all movement to stop before servicing.
8. Keep hands, feet and clothing away from moving parts.
9. Use flashing warning lights when operating on highways except when prohibited by law.

7100-46

24

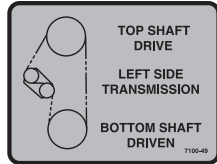

25

WARNING

USE SAFETY
CHAINS PROVIDED.
TOW ONLY WITH
FARM TRACTOR.

7100-302

26

CAUTION

REAR OF PLANTER SWINGS
WIDE IN TURNS. ALWAYS
ALLOW SUFFICIENT ROOM
TO CLEAR OBSTACLES
WHEN TURNING.

7100-63

27

WARNING

NEVER WALK UNDER OR WORK
ON PLANTER WHEN IT IS
RAISED WITHOUT SUPPORTING
THE FRAMES WITH
ADDITIONAL SUPPORTS.

7100-68

28

CAUTION

AVOID UNEVEN LOADING
OF HOPPERS, ESPECIALLY
DURING TRANSPORT

7100-75

29

WARNING

TO AVOID INJURY
ALWAYS USE HYDRAULIC CYLINDER
SAFETY LOCKOUT CHANNELS WHEN
TRANSPORTING PLANTER ON THE
ROAD. AFTER USE RETURN TO
STORAGE LOCATION.

7100-83

30

WARNING

THIS MACHINE HAS BEEN DESIGNED
AND BUILT WITH YOUR SAFETY IN
MIND. DO NOT MAKE ANY
ALTERATIONS OR CHANGES TO THIS
MACHINE. ANY ALTERATION TO THE
DESIGN OR CONSTRUCTION MAY
CREATE SAFETY HAZARDS.

7100-90

32

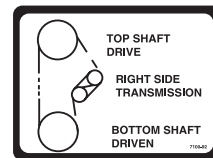

33

A A

34

ANALOG SENDING UNIT

E-V

A11156

7100-339

31



35



36



37



38



39

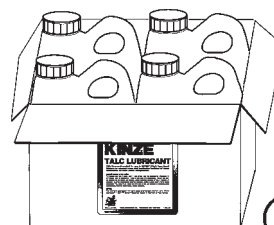

40



43



41

42

WARNING

STAY CLEAR
OF DISCHARGE
WHILE FAN
IS RUNNING

7100-301

44

IMPORTANT

-FAN MOTOR CASE DRAIN-
ALWAYS CONNECT THE FAN MOTOR CASE
DRAIN HOSE TO THE TRACTOR ZERO
PRESSURE RETURN. DO NOT CONNECT TO
THE TRACTOR SCV OR MOTOR RETURN
PORTS AS FAN FAILURE WILL OCCUR.

7100-329

45

DECALS, PAINT AND MISCELLANEOUS

ITEM	PART NO.	QTY.	DESCRIPTION
1.	G7100-02	3	Decal, Warning
2.	G7100-110	-	Decal, Grease Weekly
3.	G7100-111	-	Decal, Oil Daily
4.	G7100-115	-	Decal, Warning (1 Per Granular Chemical Hopper)
5.	G7100-116	-	Decal, Grease Daily
6.	G7100-117	1	Decal, Danger
7.	G7100-123	1	Decal, Attention
8.	G7100-153	-	Decal, Information (1 Per Seed Meter)
9.	G7100-177	1	Decal, Twin-Line®, ¾" x 3"
10.	G7100-192	-	Decal, Point Row Clutch Rotation
11.	G7100-200	-	Decal, Warning
12.	G7100-201	1	Decal, Information
13.	G7100-208	-	Decal, Interplant®
14.	G7100-338	-	Decal, Sending Unit
15.	G7100-215	1	Decal, Danger
16.	G7100-217	-	Decal, Note
17.	G7100-219	-	Decal, Warning
18.	G7100-234	-	Decal, Bolt Torque
19.	G7100-333	2	Decal, KINZE® 3600V
20.	G7100-247	-	Decal, Logo, 4 ⅜" x 4 ½" (2 Per Row Unit)
	G7100-252	-	Decal, Logo, 3 ½" x 3 ⅝" (Hopper Panel Extension)
21.	G7100-295	-	Decal, Spring Tension Release
22.	G7100-249	-	Decal, Caution
23.	G7100-42	4	Decal, Warning
24.	G7100-46	1	Decal, Warning
25.	G7100-49	1	Decal, Left Side Transmission
26.	G7100-302	1	Decal, Warning
27.	G7100-63	2	Decal, Caution
28.	G7100-68	3	Decal, Warning
29.	G7100-75	4	Decal, Caution
30.	G7100-83	2	Decal, Warning (1 Per Marker Lockup)
31.	G7100-339	-	Decal, Sending Unit
32.	G7100-90	1	Decal, Warning
33.	G7100-92	1	Decal, Right Side Transmission
34.	GD10057-01	-	Hose Identification Sleeve, Red AA
	GD10057-02	-	Hose Identification Sleeve, Red BB
	GD10057-03	-	Hose Identification Sleeve, Blue AA
	GD10057-04	-	Hose Identification Sleeve, Blue BB
35.	GM0213	-	Operator & Parts Manual, Model 3600V (EdgeVac® Seed Metering)
36.	GD1512	-	Tie Strap, 7 ½"
	GD2117	-	Tie Strap, 14 ½"
	GD1162	-	Tie Strap, 28"
	GD2984	-	Tie Strap, 34"
37.	GD2199	1	SMV Sign
38.	GR0146MPP	-	Powdered Graphite, Twenty-Four 1 Pound Containers
39.	GR0155MPP	-	Blue Paint, Twelve Aerosol Cans
40.	GR1570MPP	-	Talc Lubricant, Four 8 Pound Containers
	GR1828	-	Talc Lubricant, 30 Pound Containers
41.	G7100-261	-	Reflective Decal, Red, 1 ¾" x 9", Die-Cut (If Applicable)
	G7100-262	-	Reflective Decal, Amber, 1 ¾" x 9", Die-Cut (If Applicable)
	G7100-263	-	Reflective Decal, Orange, 1 ¾" x 9", Die-Cut (If Applicable)
42.	G7100-258	-	Reflective Decal, Red, 1 ½" x 9", Rectangular (If Applicable)
	G7100-259	-	Reflective Decal, Amber, 1 ½" x 9", Rectangular (If Applicable)
	G7100-260	-	Reflective Decal, Orange, 1 ½" x 9", Rectangular (If Applicable)
43.	G7100-311	2	Decal, EdgeVac®
44.	G7100-301	2	Decal, Warning
45.	G7100-329	-	Tag, Fan Motor Case Drain

NUMERICAL INDEX

Part No.	Page	Part No.	Page	Part No.	Page
A1011	P87	A8263	P37	G10026	P45, P66, P115
A1018	P88	A8265	P37	G10027	P59
A1027	P89	A8266	P37	G10028	P61
A1028	P89	A8267	P88	G10031	P97
A1033	P88	A8283	P43	G10033	P27, P57
A1034	P88	A6892	P57	G10036	P23, P55
A1041	P87	A6893	P57	G10037	P5, P53, P63
A1055	P88	A6904	P57	G10039	P5, P25, P31, P105
A1057	P89	A6905	P57	G10040	P9
A1076	P88, P89, P89	A7010	P45	G10043	P97
A1097	P88, P89	A7088	P45	G10045	P27, P101
A1106	P87	A7220	P72	G10046	P31, P69, P101, P107
A1116	P87	A7393	P53	G10047	P3, P107
A1129	P87	A7426	P49	G10049	P61, P105
A1139	P87	A7429	P49	G10053	P51, P53
A12015	P37	A7524	P77	G10054	P79
A12017	P37	A8797	P73	G10061	P18
A12021	P37	A8822	P77	G10062	P44
A12022	P37	A8873	P73	G10063	P35
A12023	P37	D13169	P74	G10064	P16, P53, P57, P65, P123
A12024	P37	D13426	P74	G10071	P5
A12042	P88	G10001	P5, P15, P16, P35, P42, P43, P53, P55, P57, P97, P105	G10085	P53
A1404	P89	G10002	P55, P107	G10096	P113
A1424	P89	G10003	P3, P29, P41, P49, P119	G10100	P61, P105
A1464	P43	G10004	P5, P33, P49, P51, P99, P105, P123	G10101	P5, P16, P17, P33, P35, P41, P42, P49, P51, P57, P78, P96, P97, P99, P101, P119, P123
A1467	P37, P87	G10005	P31, P42, P47, P114	G10102	P5, P9, P15, P27, P31, P41, P43, P45, P49, P53, P59, P61, P63, P66, P67, P69, P71, P78, P99, P101, P103, P107, P115, P123
A1478	P87	G10006	P15, P27, P44	G10103	P5, P53, P57, P63, P65
A1489	P87	G10007	P5, P10, P11, P17, P31, P47, P105, P113, P115, P123	G10104	P5, P10, P17, P33, P41, P44, P45, P53, P57, P69, P71, P99, P101, P105, P107, P113, P114, P115, P117
A1491	P87	G10008	P69	G10105	P41, P44, P53, P61, P66, P105, P113, P115, P123
A3118	P87	G10009	P44, P71	G10106	P9, P15, P25, P41, P53, P79, P97
A3122	P89	G10010	P13, P29, P31, P103, P111	G10107	P15, P16, P23, P25, P31, P42, P44, P51, P53, P59, P101, P107, P114, P115
A3127	P88	G10011	P31, P59, P69, P107		
A3128	P88	G10012	P71, P115		
A3131	P89	G10013	P16, P115		
A3133	P87	G10014	P13, P31, P45, P49		
A3156	P87	G10015	P15		
A3183	P87	G10016	P45, P99, P105		
A3282	P43	G10017	P5, P25, P45, P49, P55, P59, P66, P69, P71, P107, P115		
A3283	P43	G10018	P13, P15		
A3340	P43	G10019	P9, P41, P67, P101, P115		
A3351	P43	G10020	P5, P63		
A3352	P37	G10021	P55		
A3354	P37	G10022	P65, P91		
A3355	P37	G10023	P5, P41, P43		
A3356	P37	G10025	P53		
A3357	P37				
A3358	P37				
A3369	P43				
A3371	P43				
A3675	P43				
A6201	P43				
A7603	P87				
A8250	P43				
A8253	P37				
A8261	P37				

NUMERICAL INDEX

Part No.	Page	Part No.	Page	Part No.	Page
G10108.....	P3, P5, P18, P33, P35, P43, P44, P45, P49, P51, P57, P61, P72, P105, P107, P109, P119, P123	G10219.....	P9, P15, P43, P107	G10338.....	P13, P18
G10109.....	P13, P15, P16, P27, P29, P31, P43, P67, P101, P109	G10220.....	P105	G10342.....	P113
G10110.....	P41, P43, P57, P91, P123	G10221.....	P101	G10348.....	P27
G10111.....	P5, P16, P23, P25, P27, P31, P45, P49, P51, P57, P69, P71, P101, P105, P107, P109	G10226.....	P45, P61, P66, P71, P123	G10350.....	P121
G10112.....	P31, P45, P53	G10227.....	P9, P43, P53, P57, P63, P65	G10371.....	P27
G10118.....	P47	G10228.....	P5, P9, P13, P27, P41, P43, P45, P49, P53, P59, P61, P63, P66, P67, P69, P71, P78, P99, P101, P103, P107, P115, P123	G10395.....	P91
G10128.....	P55	G10229.....	P5, P16, P17, P29, P33, P35, P39, P41, P42, P49, P51, P57, P75, P76, P78, P96, P97, P99, P101, P105, P119, P123	G10396.....	P123
G10130.....	P5, P33, P98	G10230.....	P5, P10, P13, P16, P17, P33, P41, P44, P45, P47, P57, P69, P71, P99, P101, P103, P105, P107, P113, P114, P115, P117, P123	G10400.....	P31
G10131.....	P49	G10231.....	P44, P61, P66, P113, P115	G10403.....	P43
G10133.....	P16, P27, P29, P31, P55, P79, P101, P109	G10232.....	P9, P15, P41, P53, P79, P97, P101, P107, P115	G10404.....	P53
G10148.....	P43	G10233.....	P55, P98, P111	G10412.....	P5, P10, P18, P33, P99
G10152.....	P15	G10234.....	P53	G10427.....	P11, P15
G10157.....	P44, P45, P47	G10237.....	P61, P105	G10436.....	P61
G10159.....	P57	G10243.....	P97	G10437.....	P61
G10168.....	P67	G10260.....	P21	G10438.....	P3, P103
G10169.....	P44, P47	G10278.....	P112, P117	G10439.....	P57
G10171.....	P15, P43	G10284.....	P33	G10441.....	P59
G10172.....	P51, P78, P123	G10292.....	P117	G10448.....	P63
G10194.....	P29	G10303.....	P15	G10449.....	P73
G10201.....	P3, P33	G10305.....	P22, P101	G10450.....	P107
G10203.....	P3, P5, P33, P35, P51, P109	G10306.....	P107, P109, P119	G10451.....	P101
G10204.....	P11, P13, P101, P111	G10307.....	P33	G10456.....	P33, P103
G10205.....	P31, P35, P45, P53, P69, P103, P104, P105, P115	G10308.....	P16, P22	G10457.....	P45
G10206.....	P5, P29, P53, P57, P69, P71, P99, P107	G10309.....	P18	G10459.....	P105
G10207.....	P3	G10312.....	P3, P40, P57	G10460.....	P57, P61, P66, P69, P71, P114, P123
G10209.....	P9, P43, P65, P123	G10315.....	P15	G10462.....	P44, P49
G10210.....	P3, P15, P16, P17, P18, P33, P41, P43, P49, P51, P99, P101, P105, P107, P119	G10318.....	P25, P41	G10463.....	P15, P33
G10211.....	P93	G10322.....	P71, P105	G10468.....	P49
G10213.....	P11, P29, P31, P101	G10323.....	P21	G10496.....	P99
G10216.....	P5, P13, P25, P33, P45, P49, P59, P61, P69, P71, P99, P103, P105, P115	G10325.....	P11	G10499.....	P35, P101
G10217.....	P42, P45, P47, P107, P115	G10326.....	P3	G10501.....	P27, P55
G10218.....	P41, P53, P113	G10328.....	P11, P75, P76	G10503.....	P25, P29, P31, P101, P109
		G10330.....	P63	G10504.....	P101
		G10336.....	P53	G10507.....	P105
				G10509.....	P72
				G10526.....	P103
				G10529.....	P22
				G10535.....	P99
				G10536.....	P25, P69, P71
				G10542.....	P101
				G10543.....	P41, P53
				G10544.....	P67
				G10546.....	P18
				G10551.....	P3
				G10560.....	P103
				G10567.....	P18
				G10572.....	P25
				G10574.....	P23, P27, P31
				G10581.....	P51
				G10583.....	P79
				G10585.....	P25, P49
				G10592.....	P105
				G10594.....	P105

NUMERICAL INDEX

Part No.	Page	Part No.	Page	Part No.	Page
G10597	P25	G10860	P65	G11122	P115
G10599	P16, P17, P33, P35	G10862	P105	G11124	P35
G10602	P18, P21	G10870	P65	G11133	P35
G10603	P21, P109	G10871	P78, P107	G11145	P40
G10606	P57	G10874	P57	G11147	P40
G10610	P45, P66, P103	G10887	P113, P117	G11158	P43
G10615	P117	G10888	P113	G11159	P93
G10616	P113	G10889	P113	G11166	P35
G10619	P113, P117	G10894	P49	G11169	P49
G10620	P3, P13, P18, P40, P57, P103, P111	G10907	P72, P73	G11172	P21
G10621	P18, P22	G10908	P109	G11173	P21
G10622	P11, P22	G10912	P11, P33	G11182	P113
G10623	P113	G10913	P63	G11188	P41
G10626	P113, P117, P123	G10917	P112, P117	G11194	P40
G10630	P113	G10923	P5, P33, P98	G11202	P97
G10633	P113	G10924	P13	G11210	P21
G10636	P61	G10927	P97	G11213	P21
G10640	P13, P47, P53, P63, P69, P71, P73, P103, P105, P107, P109	G10928	P97	G11215	P35
G10641	P49, P69, P105, P115	G10931	P97	G11220	P5
G10643	P31	G10938	P101	G11222	P18
G10647	P61	G10939	P72	G11223	P47
G10669	P3	G10940	P13	G11228	P29
G10672	P123	G10953	P41	G11236	P29
G10674	P113, P117	G10958	P72, P73	G11237	P117
G10676	P41, P113	G10961	P103, P111	G11239	P33
G10681	P39, P101, P117	G10962	P77	G11242	P55
G10686	P96	G10968	P99	G11243	P5, P33, P91
G10688	P99	G10969	P77	G11244	P91
G10689	P51, P59	G10972	P72, P75, P76	G11247	P9
G10693	P119	G10974	P29, P31	G11258	P83
G10718	P33	G10977	P79	G11295	P5, P33
G10722	P67	G10979	P71	G11296	P5, P33
G10724	P67	G10990	P75, P76	G1K215	P103
G10725	P67	G10991	P107, P119	G1K248	P7, P93, P97
G10732	P5, P10, P33	G10992	P9	G1K252	P7, P93, P97
G10751	P18, P33	G10995	P117	G1K267	P7, P93
G10752	P18, P99	G10996	P84, P93	G1K268	P7, P35, P93
G10756	P123	G11007	P3	G1K269	P99
G10757	P97	G11008	P3	G1K274	P84
G10758	P97	G11009	P21	G1K275	P84
G10765	P29, P31, P44	G11010	P31	G1K296	P13
G10770	P74	G11015	P3	G1K320	P7, P93
G10779	P47, P59	G11016	P74	G1K321	P7, P93
G10801	P15, P16	G11018	P5	G1K331	P99
G10802	P44, P61	G11034	P109	G1K345	P16
G10808	P61	G11042	P115	G1K362	P97
G10809	P35, P39	G11053	P59	G1K363	P97
G10826	P123	G11058	P45	G1K412	P45
G10827	P77	G11065	P81, P97	G1K426	P38
G10828	P53	G11066	P9, P79	G1K465	P5
G10830	P41, P109, P114	G11067	P79	G1K466	P5
G10844	P67	G11068	P81	G1K467	P29
		G11081	P66	G2100-03	P55
		G11083	P117	G2500-84	P115
		G11098	P29	G2501-12-16	P43

NUMERICAL INDEX

Part No.	Page	Part No.	Page	Part No.	Page
G2501-16-20	P43	G6801-06-08	P87	G7633X	P93
G2603-08	P88	G6801-08	P81, P88	G7698X	P57
G2700-06-06	P37	G6801-08-10	P79	GA0167	P67
G2700-08	P75, P76, P87	G6801-10	P43	GA0237	P105
G2700-10	P37, P87	G6801-10-08	P83	GA0241	P115
G2700-12	P37	G6801-10-12	P38, P42	GA0243	P67
G2703-08-08-10	P88	G6801-12	P38	GA0245	P67
G306-06	P37	G6801-12-10	P43, P83	GA0251	P115
G306-08	P61, P75, P76	G6801-16	P42	GA0252	P115
G306-10	P37, P61	G6804-12	P43	GA0257	P67
G306-12	P37	G6804-12-12-08	P43	GA0262	P115
G3200-63	P115	G7100-02	P126	GA0312	P101
G3302-09	P42	G7100-110	P126	GA0328	P101
G3303-108	P3	G7100-111	P126	GA0547	P115
G3303-16	P3	G7100-115	P126	GA0810	P101
G3303-96	P33	G7100-116	P126	GA0895	P66
G3305-01	P22	G7100-117	P126	GA0899	P67
G3305-03	P123	G7100-123	P126	GA10036	P111
G3310-226	P99	G7100-153	P126	GA10037	P111
G3310-84	P55	G7100-177	P126	GA10137	P18
G3317-16	P55	G7100-192	P126	GA10149	P38
G3400-01	P55	G7100-200	P126	GA10155	P18
G4200-01	P123	G7100-201	P126	GA10157	P3
G4200-03	P113	G7100-208	P126	GA10161	P33
G4200-06	P113	G7100-215	P126	GA10621	P115
G4201-02	P113	G7100-217	P126	GA10622	P114
G4201-03	P113	G7100-219	P126	GA10624	P114
G4205-10	P117	G7100-234	P126	GA10634	P19
G4205-11	P112	G7100-247	P126	GA10635	P35
G4301-05	P117	G7100-249	P126	GA10755	P21
G4301-06	P117	G7100-252	P126	GA10765	P35
G6325X	P5, P10	G7100-258	P126	GA10799	P35
G6400-06	P38, P39, P81	G7100-259	P126	GA10894	P115
G6400-06-08	P87	G7100-260	P126	GA10907	P115
G6400-08	P78, P79, P81, P87, P88	G7100-261	P126	GA10908	P115
G6400-08-04	P75, P76, P88	G7100-262	P126	GA10917	P43
G6400-08-10	P79	G7100-263	P126	GA10918	P43
G6400-10	P39, P43, P79, P81	G7100-295	P126	GA10919	P42
G6400-10-08	P78	G7100-301	P126	GA10924	P93
G6400-12	P39, P43	G7100-302	P126	GA11079	P47
G6400-L-08	P89	G7100-311	P126	GA11082	P47
G6408-06	P39	G7100-329	P126	GA11083	P47
G6408-08	P79	G7100-333	P126	GA11085	P35
G6408-10	P79	G7100-338	P126	GA11086	P35
G6408-12	P39	G7100-339	P126	GA11087	P35
G6408-H02-0	P83	G7100-42	P126	GA11119	P41
G6408-H04-O	P72	G7100-46	P126	GA11152	P41
G6408-H06-O	P79, P81	G7100-49	P126	GA11153	P41
G6500-06	P38, P81	G7100-63	P126	GA11154	P35
G6500-08	P89	G7100-68	P126	GA11155	P35
G6500-12	P43	G7100-75	P126	GA11156	P35
G6502-06	P87	G7100-83	P126	GA11159	P35
G6502-12	P43	G7100-90	P126	GA11160	P35
G6801-06	P81	G7100-92	P126	GA11164	P40
		G7566X	P17	GA11166	P41

NUMERICAL INDEX

Part No.	Page	Part No.	Page	Part No.	Page
GA11200	P61	GA12554	P91	GA2007	P18
GA11331	P55	GA12555	P95	GA2012L	P11
GA11520	P23	GA12556	P95	GA2012R	P11
GA11523	P43	GA12557	P97	GA2014	P11, P15, P25, P27, P29, P31, P101, P109
GA11528	P45	GA12558	P95	GA2054	P15
GA11544	P43	GA12559	P95	GA2094	P22
GA11568	P71	GA12560	P95	GA2148	P66
GA11569	P71	GA12561	P95	GA2180	P33, P55, P98
GA11590	P69	GA12562	P95	GA2528	P93
GA11699	P35	GA12563	P97	GA2559	P115
GA11766	P69	GA12564	P95	GA2612	P93
GA11767	P69	GA12565	P55, P95	GA2660	P113
GA11768	P71	GA12568	P95	GA2908	P66
GA11769	P71	GA12569	P55	GA3407	P84
GA11911	P21	GA12596	P95	GA3413	P84
GA11934	P39	GA12598	P95	GA3584	P92
GA11935	P21	GA12626	P9	GA3893	P117
GA11969	P33	GA12630	P33	GA4286	P104
GA11971	P33	GA12636	P97	GA4287	P104
GA11982	P5	GA12641	P97	GA4293	P39, P85
GA11987	P35	GA12650	P97	GA4353	P69
GA11988	P9	GA12655	P95	GA4376	P66
GA11991	P9	GA12661	P55	GA4377	P66
GA11992	P9	GA12684	P7	GA4402	P45
GA11993	P9	GA12802	P43	GA4418	P45
GA11994	P9	GA12812	P7	GA4722	P63
GA11995	P9	GA12813	P7	GA4723	P63
GA11997	P9	GA12814	P7	GA4727	P63
GA12102	P9	GA12815	P7	GA4729	P63
GA12104	P9	GA12852	P95	GA4842	P45
GA12108	P107	GA12853	P95	GA4845	P45
GA12109	P107	GA12858	P7	GA4877	P71
GA12133	P21	GA12861	P91	GA4976	P113, P123
GA12143	P18	GA12865	P91	GA4994	P44
GA12144	P18	GA12866	P91	GA4995	P44
GA12154	P21	GA12868	P95	GA5105	P55
GA12163	P47	GA12901	P89	GA5107	P99
GA12164	P47	GA13078	P85	GA5108	P55
GA12165	P47	GA13169	P9	GA5121	P59
GA12235	P29, P31	GA13204	P63, P95	GA5130	P69
GA12236	P27, P29, P31	GA13214	P63	GA5385	P93
GA12249	P40	GA13220	P83	GA5600	P97
GA12256	P29	GA13221	P83	GA5625	P23
GA12335	P119	GA13222	P83	GA5651	P5, P10
GA12358	P9	GA13223	P83	GA5654	P25, P27, P29, P31, P109
GA12404	P9	GA13224	P83	GA5698	P21
GA12405	P5	GA13227	P63	GA5715	P25
GA12536	P95	GA13335	P66	GA5716	P63
GA12539	P95	GA13512	P9	GA5718	P25
GA12537	P95	GA1369	P101	GA5719	P25
GA12538	P97	GA1676	P67	GA5787	P33
GA12540	P95	GA1677	P67	GA5842	P45
GA12551	P95	GA1678	P67		
GA12552	P95	GA1679	P67		
GA12553	P95	GA1720	P5		

NUMERICAL INDEX

Part No.	Page	Part No.	Page	Part No.	Page
GA5853	P67	GA7133	P113	GA8688	P105
GA5887	P104	GA7135	P101	GA8689	P105
GA6108	P93	GA7154	P55, P99	GA8729	P93
GA6109	P93	GA7208	P123	GA8731	P93
GA6147	P97	GA7209	P123	GA8734	P93
GA6171	P13, P15, P16, P103, P111	GA7221	P72	GA8760	P29
GA6434	P16	GA7239	P105	GA8845	P101
GA6497	P53	GA7240	P105	GA8857	P75
GA6527	P117	GA7271	P29	GA8858	P75
GA6597	P16	GA7390	P53	GA8859	P76
GA6608	P61	GA7399	P93	GA8861	P76
GA6618	P15	GA7412	P29	GA8862	P76
GA6619	P15	GA7423	P49	GA8871	P77
GA6620	P15	GA7424	P49	GA8874	P73
GA6699	P92	GA7433	P44	GA8877	P103, P111
GA6700	P92	GA7434	P63, P66	GA8893	P75
GA6701	P93	GA7445	P29, P31, P109	GA8895	P77
GA6733	P15	GA7446	P27, P29, P31, P109	GA8898	P77
GA6801	P15	GA7533	P45	GA8899	P77
GA6832	P27	GA7540	P59	GA8904	P72
GA6833	P27	GA7579	P53	GA8908	P72
GA6834	P27	GA7845	P113	GA8909	P73
GA6838	P27	GA7851	P97	GA8931	P121
GA6928	P53	GA7852	P97	GA8978	P75
GA6929	P53	GA7856	P7, P35, P93	GA8979	P76
GA6943	P53	GA7859	P97	GA8983	P101, P105, P107
GA6960	P123	GA7862	P93	GA9088	P69, P71
GA6961	P123	GA7863	P93	GA9095	P79
GA6964	P59	GA7949	P13	GA9096	P92
GA6966	P107	GA7975	P13	GA9097	P79
GA6975	P93	GA7976	P13	GA9098	P81
GA6977	P93	GA7997	P66	GA9105	P33
GA6978	P7, P93	GA7998	P109	GA9112	P93
GA7013	P51	GA7999	P109	GA9113	P93
GA7016	P44	GA8046	P97	GA9131	P31
GA7018	P57	GA8047	P93, P97	GA9195	P101
GA7019	P57	GA8062	P61	GA9202	P93
GA7021	P51	GA8092	P99	GA9204	P93
GA7022	P44, P61	GA8149	P72	GA9205	P74
GA7029	P45	GA8157	P73	GA9407	P121
GA7042	P69	GA8170	P69, P71	GA9433	P107
GA7043	P71	GA8286	P89	GA9434	P107
GA7049	P51	GA8305	P103	GA9437	P107
GA7050	P51	GA8306	P103	GA9472	P111
GA7051	P99	GA8320	P73	GA9481	P93
GA7052	P98	GA8322	P16	GA9544	P63
GA7067	P59	GA8324	P11	GA9545	P63
GA7077	P93	GA8328	P7, P35	GA9553	P55
GA7083	P45	GA8329	P7, P35	GA9559	P74
GA7084	P45	GA8483	P101	GA9565	P107
GA7085	P45	GA8603	P23, P31, P107	GA9689	P93
GA7096	P59	GA8641	P23, P31	GA9836	P44
GA7098	P61	GA8651	P33	GA9837	P44
GA7118	P71	GA8677	P66	GA9840	P57
		GA8685	P101	GA9844	P31

NUMERICAL INDEX

Part No.	Page	Part No.	Page	Part No.	Page
GA9845	P31	GB0395	P5	GD10298	P65
GA9861	P31	GB0396	P5	GD10303	P105
GA9862	P31	GB0397	P5	GD10304	P105
GA9864	P31	GB0398	P5	GD1033	P3
GA9865	P31	GB0400	P107	GD10446	P59
GA9883	P61	GB0401	P29	GD10447	P59
GA9905	P112	GB0405	P107	GD10473	P11, P15
GA9963	P91	GB0409	P53	GD10487	P105
GA9964	P7, P35	GD0453-03	P71	GD10492	P53
GA9978	P97	GD0453-04	P69	GD10519	P29, P31
GA9979	P97	GD0453-07	P69	GD10526	P29
GB0134	P101	GD0453-09	P71	GD10530	P49
GB0186	P10	GD0487	P101	GD10531	P53
GB0196	P115	GD0652	P71	GD10532	P53
GB0205	P104	GD0740	P78	GD10538-01	P49
GB0206	P105, P123	GD0746	P67	GD10552	P27, P29, P31, P109
GB0212	P103	GD0752-41	P69	GD10646	P45
GB0213	P105, P123	GD0829	P123	GD1065	P3
GB0218	P5, P10, P18, P31, P33, P44, P51, P105, P114, P123	GD0831	P115	GD10650	P49
GB0237	P44	GD0840	P67	GD10664	P49
GB0239	P15, P16	GD0844	P115	GD10706	P53
GB0246	P49	GD0914-124	P98	GD10707	P53
GB0254	P16	GD0914-138	P98	GD10777	P113
GB0265	P3	GD0914-24	P98	GD10792	P69
GB0266	P3	GD0914-33	P98	GD10793	P71
GB0267	P3	GD0914-48	P98	GD1085	P16
GB0268	P15, P16	GD0914-54.75	P55	GD1086	P13
GB0274	P3	GD0914-66	P98	GD10867	P3, P33
GB0276	P13	GD0914-90	P98	GD10936	P72
GB0278	P18	GD0962	P101	GD10991	P13
GB0282	P16	GD10006	P53	GD10993	P3
GB0285	P3	GD10011	P59	GD11001	P3
GB0292	P44, P45	GD10012	P59	GD11017	P11
GB0296	P107	GD10013	P59	GD1104	P105
GB0301	P11, P33	GD10014	P59	GD11045	P5, P33, P98
GB0309	P57	GD10036	P5, P10	GD11089	P93, P97
GB0314	P18, P33	GD10053	P53	GD1109	P15, P16
GB0319	P21	GD10057-01	P126	GD1113	P5, P10, P99, P101, P105, P107, P113, P117
GB0322	P107	GD10057-02	P126	GD11178	P109
GB0323	P107	GD10057-03	P126	GD11188	P109
GB0328	P21	GD10057-04	P126	GD11193	P72, P73
GB0331	P18	GD10063	P59	GD11194	P73
GB0358	P21	GD10064	P61	GD11218	P33
GB0366	P5, P10	GD10092	P61	GD11239	P18
GB0383	P29	GD10110	P113	GD11253	P72, P73
GB0386	P31	GD10144	P66	GD11259	P3, P11
GB0387	P27, P29	GD10196	P123	GD11263	P33
GB0389	P5	GD10207	P77	GD11264	P33
GB0390	P5	GD10211	P72	GD11265	P109
GB0391	P5	GD10231	P61	GD11266	P109
GB0392	P5	GD10242	P105	GD11279	P19
GB0393	P5	GD10243	P93	GD11306	P11, P101
GB0394	P5	GD1026	P3, P33, P107	GD11313	P17
		GD10273	P105		
		GD10283	P67		

NUMERICAL INDEX

Part No.	Page	Part No.	Page	Part No.	Page
GD1132	P25, P27, P29, P31, P101, P109	GD12685	P107	GD15700	P21
GD1138	P101	GD12703	P57	GD15725	P47
GD11413	P18	GD12724	P57	GD15747	P18
GD11422	P5, P10, P13, P103, P111	GD12726	P92	GD15789	P35
GD1143	P22	GD12817	P31	GD15790	P35
GD1144	P22	GD12818	P81	GD15792-05	P41
GD11447	P33	GD12826	P31	GD15792-06	P41
GD1145	P22	GD12827	P31	GD15792-12	P41
GD11453	P13	GD12829	P31	GD15792-13	P41
GD11474	P97	GD13146	P79	GD15799	P40
GD11490	P66	GD13170	P74	GD15803	P35
GD11508	P17	GD13171	P74	GD15804	P35
GD11509	P17	GD13172	P74	GD15849-02	P35
GD11557	P107	GD13173	P74	GD15850	P40
GD11558	P107	GD13287	P107	GD15854	P40
GD1162	P126	GD13309	P111	GD15856-03	P40
GD11649	P33	GD13310	P93	GD15863	P35
GD11652	P23, P31	GD13328	P115	GD15867-02	P41
GD1166	P115	GD13348	P93	GD15950	P57
GD11677	P23	GD13359	P71	GD16035	P42
GD11695	P66	GD13360	P69	GD16036	P42
GD11700	P39, P117	GD13361	P3	GD16037	P43
GD11705	P101	GD1337	P113	GD16038	P43
GD11721	P41	GD13400	P74	GD16040	P43
GD11791	P71	GD13401	P66	GD16046	P93
GD11836	P109	GD13409	P63	GD16188	P39
GD11845	P3, P11, P15	GD13422	P55	GD16194-01	P41
GD11951	P72	GD13425	P74	GD16226	P47
GD11953	P103, P111	GD13543	P49	GD16233	P35
GD11954	P103, P111	GD13544	P49	GD16241	P35
GD11962	P3, P33	GD13545	P49	GD16245	P3
GD11963-04	P5	GD13744	P115	GD16251	P41
GD11970	P75, P76	GD14121	P45	GD16295	P41
GD11972	P99	GD14170	P31	GD16303	P47
GD11973	P99	GD14217	P10	GD16305	P41
GD11983	P77	GD14258	P7	GD16306	P41
GD11984	P75, P76	GD14258	P35	GD16307	P41
GD11985	P77	GD14398	P23	GD16315	P41
GD11986	P77	GD14467	P21	GD16316	P41
GD11988	P72	GD14468	P21	GD16317-01	P40
GD11991	P72	GD14477	P21	GD16319	P41
GD11992	P72	GD14541	P21	GD16324-01	P35
GD11993	P97	GD14562	P47	GD16489	P55
GD11994	P73	GD14592	P21	GD16490	P55
GD11995	P73	GD14626	P41	GD1657	P101
GD12070	P83	GD14660	P7, P35	GD16608	P43
GD12534	P27	GD14674	P25, P29	GD16642	P45
GD12543	P61	GD15100	P47	GD16644	P43
GD12597	P75, P76	GD1512	P126	GD1673	P101
GD12676	P107	GD1514	P123	GD16999	P69
GD12677	P107	GD1515	P123	GD17001	P71
GD12679	P107	GD1516	P123	GD17003	P71
GD12684	P109	GD1517	P123	GD1701	P71
		GD1520	P112	GD17014	P3
		GD15663	P21	GD17021	P21

NUMERICAL INDEX

Part No.	Page	Part No.	Page	Part No.	Page
GD17028	P21	GD18398	P91	GD5841	P66
GD17047	P21	GD18407	P95	GD5857	P27, P44, P55, P65
GD17048	P21	GD18408	P95	GD5875	P57
GD17049	P21	GD18437	P91	GD5892	P45
GD17050	P21	GD1862	P113	GD6136	P57
GD17099	P21	GD18643	P63	GD6279-05	P39
GD17104	P21	GD18645	P61	GD6291	P93, P97
GD17141	P9	GD18646	P63	GD6553	P104
GD17143	P9	GD18672	P83	GD6556	P45
GD17150-03	P9	GD18676	P63	GD6895	P65
GD17150-04	P9	GD18796	P7	GD7079	P63
GD17150-08	P9	GD18891	P5, P33	GD7089	P63
GD17150-09	P9	GD1908	P57	GD7137	P45
GD17150-12	P9	GD19237	P9	GD7147	P75, P76
GD17151-05	P91	GD19238	P9	GD7251	P45
GD17151-06	P7	GD2115	P123	GD7318	P3
GD17152	P21	GD2117	P126	GD7363-01	P53
GD17154	P9	GD2161	P69	GD7518	P45
GD17156	P9	GD2169	P59, P61	GD7519	P45
GD17162	P21	GD2199	P65, P126	GD7803	P23, P31
GD17186	P21	GD2460	P22	GD7804	P23, P31
GD17187	P21	GD2557	P45	GD7805	P5, P10, P16, P18, P25, P33, P44, P51, P53, P69, P71, P99, P109, P111, P114, P115, P123
GD1719	P99	GD2558	P45, P61, P115	GD7817-01	P25
GD17192	P18	GD2589	P101	GD7817-04	P25, P109
GD17245	P47	GD2597	P67	GD7817-05	P115
GD17794	P5	GD2681	P114	GD7823	P25
GD18010	P7, P9	GD2721	P69, P71, P123	GD7831	P115
GD18011	P9	GD2829	P93	GD7864	P63
GD18013	P97	GD2971-09	P44	GD7883	P49
GD18014	P55	GD2971-17	P97	GD7889	P25
GD18066	P99	GD2984	P126	GD7890	P25
GD18067	P99	GD3180-12	P15	GD7900	P104
GD18073	P33	GD3180-27	P41	GD7904-02	P53, P105
GD18074	P33	GD3180-30	P5	GD7907	P105, P123
GD18078	P9	GD3501	P45	GD7908	P105, P123
GD18085	P91	GD3537-11	P49	GD7911	P103
GD18094	P99	GD3537-12	P49	GD7962	P105, P109
GD18095	P21	GD3537-17	P49	GD8066-02	P79
GD18098	P21	GD3537-18	P49	GD8188	P45, P49, P51, P53
GD18112	P9	GD3547	P123	GD8189	P45, P49, P51, P53
GD18114	P55	GD3612	P3	GD8218	P103
GD18115	P55	GD3622	P113	GD8224	P105
GD18116	P49	GD3623	P113	GD8238	P105
GD18118	P96	GD3777-10	P41	GD8239	P105
GD18119	P9	GD3777-11	P41	GD8247	P104
GD18168	P96	GD3860	P93	GD8249	P10
GD18176	P95	GD3951	P113	GD8260	P44
GD18177	P95	GD4086	P37, P87, P89	GD8276	P61, P105
GD18274	P9	GD4108	P57	GD8306	P99
GD18275	P7	GD4743	P9, P55, P69, P71	GD8307	P25
GD18326	P55	GD5154	P45, P49	GD8308	P103
GD18329	P53	GD5173	P44, P49		
GD18344	P53	GD5789	P65		
GD18389	P91	GD5790	P65		
GD18395	P91	GD5804	P45, P49		

NUMERICAL INDEX

Part No.	Page	Part No.	Page	Part No.	Page
GD8460	P16	GR0270	P66	GR1406	P99
GD8739	P92	GR0375	P59	GR1407	P99
GD8740	P93	GR0434	P66	GR1408	P99
GD8741	P93	GR0508	P112	GR1409	P99
GD8751	P97	GR0513	P112	GR1410	P99
GD8770	P97	GR0515	P44	GR1411	P99
GD8771	P97	GR0516	P44	GR1412	P99
GD8893-01	P33	GR0517	P44	GR1413	P99
GD9120	P16	GR0528	P63	GR1414	P96
GD9130	P59	GR0594	P97	GR1415	P96
GD9254	P23, P31	GR0761	P84	GR1417	P73
GD9290	P15	GR0763	P84	GR1428	P72
GD9305	P15	GR0764	P84, P85	GR1465	P72, P75, P76, P88
GD9529	P84, P92	GR0880	P117	GR1466	P39, P43, P79, P81, P83
GD9530	P84, P92	GR0881	P117	GR1467	P38, P39, P42, P43
GD9533	P79	GR0882	P117	GR1519	P75, P76
GD9562	P15	GR0883	P117	GR1521	P77
GD9636	P59	GR0912	P99, P55	GR1522	P77
GD9695	P33	GR1015	P113, P123	GR1523	P73
GD9705	P103	GR1016	P113, P123	GR1524	P72
GD9706	P103	GR1017	P113, P123	GR1533	P121
GD9709	P103	GR1018	P113, P123	GR1535	P121
GD9715	P27	GR1019	P113, P123	GR1540	P121
GD9720	P27	GR1037	P78, P79, P81, P87, P88, P89	GR1541	P121
GD9724	P27, P29, P31, P109	GR1037	P83	GR1542	P121
GD9870	P53	GR1045	P38, P39, P79, P81	GR1543	P119, P121
GD9896	P93	GR1104	P119	GR1544	P121
GD9898	P53	GR1112	P119	GR1545	P121
GD9905	P81	GR1116	P119	GR1557	P98, P99
GD9952	P51	GR1118	P119	GR1559	P121
GD9953	P45	GR1120	P119	GR1561	P121
GD9955	P57	GR1123	P119	GR1566	P121
GD9956	P57	GR1124	P119	GR1567	P121
GD9959	P45, P49	GR1134	P119	GR1568	P121
GD9960	P45	GR1146	P115, P119	GR1570MPP	P126
GD9963	P57	GR1203	P92	GR1574	P121
GD9964	P57	GR1204	P92, P93	GR1598	P74
GD9968	P53	GR1205	P92	GR1635	P79, P81
GD9969	P65	GR1206	P92, P93	GR1678	P112
GD9971	P78	GR1207	P92, P93	GR1734	P38
GD9977	P79	GR1208	P92, P93	GR1736	P35
GD9981	P69, P71	GR1290	P93	GR1737	P97
GM0213	P126	GR1292	P93	GR1777	P35
GR0146MPP	P126	GR1293	P98, P99	GR1778	P9
GR0150	P67	GR1294	P98, P99	GR1786	P42
GR0151	P67	GR1295	P99	GR1790	P55
GR0155MPP	P126	GR1296	P99	GR1796	P119
GR0188	P104	GR1297	P98	GR1798	P119
GR0190	P115	GR1298	P98	GR1800	P119
GR0193	P59	GR1301	P99	GR1801	P119
GR0195	P115	GR1363	P7, P93	GR1803	P119
GR0196	P3, P33	GR1364	P7, P93	GR1804	P119
GR0200	P115	GR1397	P112	GR1805	P119
GR0204	P115	GR1405	P99	GR1806	P119
GR0267	P115				

NUMERICAL INDEX

Part No.	Page	Part No.	Page	Part No.	Page
GR1808	P119				
GR1809	P9				
GR1812	P5				
GR1813	P5, P33				
GR1815	P5				
GR1818	P5, P33				
GR1819	P5, P33				
GR1828	P126				
GR1829	P33				
GR1830	P5, P33				
GR1831	P33				
GR1834	P43				
GR1835	P95				
GR1836	P95				
GR1837	P95				
GR1838	P95				
GR1839	P95				
GR1843	P9				
GR1847	P83				
GR1894	P5, P33				
GR1895	P5, P33				
GR1896	P5, P33				
GR1898	P5, P33				
GR1899	P33				
GR1900	P33				

NUMERICAL INDEX

Part No.	Page	Part No.	Page	Part No.	Page