

# MODEL 3650 TWIN-LINE® PLANTER OPERATOR & PARTS MANUAL

**M0175**

**2/02**

This manual is applicable to: Model: 3650 Twin-Line® Planters  
Serial Number: Prior To 655105

Record the model number and serial number of your planter along with date purchased:

Model Number \_\_\_\_\_ 3650 \_\_\_\_\_

Serial Number \_\_\_\_\_

Date Purchased \_\_\_\_\_

## **SERIAL NUMBER**

The serial number plate is located on the planter frame to be readily available. It is suggested that the serial number and purchase date also be recorded above.

The serial number provides important information about your planter and may be required to obtain the correct replacement part. Always provide the model number and serial number to your KINZE® Dealer when ordering parts or anytime correspondence is made with KINZE Manufacturing, Inc.

D101602202





# PREDELIVERY/DELIVERY CHECKLIST

## TO THE DEALER

Predelivery service includes assembly, lubrication, adjustment and test. This service helps to ensure that the planter will be delivered to the customer ready for field use.

## PREDELIVERY CHECKLIST

After the planter has been completely assembled, use the following checklist and inspect the planter. Check off each item as it is found satisfactory or after proper adjustment is made.

- Recheck to be sure row units and optional attachments are properly spaced and assembled.
- Be sure shipping stand has been removed.
- Be sure all grease fittings are in place and lubricated.
- Check planter and make sure all working parts are moving freely, bolts are tight and cotter pins are spread.
- Check all drive chains for proper tension and alignment.
- Check for oil leaks and proper hydraulic operation.
- Check to be sure hydraulic hoses are routed correctly to prevent damage to hoses.
- Inflate tires to specified PSI air pressure. Tighten wheel bolts to specified torque.
- Check to be sure all safety decals are correctly located and legible. Replace if damaged.
- Check to be sure all reflective decals are correctly located and visible when the planter is in transport position.
- Check to be sure SMV sign is in place.
- Check to be sure safety/warning lights are installed correctly and working properly.
- Paint all parts scratched in shipment or assembly.
- Be sure all safety lockups are on the planter and correctly located.
- Check seed meters on test stand to ensure proper performance.

***This planter has been thoroughly checked and to the best of my knowledge is ready for delivery to the customer.***

---

(Signature Of Set-Up Person/Dealer Name/Date)

## OWNER REGISTER

Name \_\_\_\_\_ Delivery Date \_\_\_\_\_  
Street Address \_\_\_\_\_ Model No. \_\_\_\_\_ Serial No. \_\_\_\_\_  
City, State/Province \_\_\_\_\_ Dealer Name \_\_\_\_\_  
ZIP/Postal Code \_\_\_\_\_ Dealer No. \_\_\_\_\_

## DELIVERY CHECKLIST

At the time the planter is delivered, the following checklist is to be used as a reminder of very important information which should be conveyed to the customer. Check off each item as it is fully explained to the customer.

- Advise the customer that the life expectancy of this or any other machine is dependent on regular lubrication as directed in the Operator & Parts Manual.
- Tell the customer about all applicable safety precautions.
- Along with the customer, check to be sure the reflective decals and SMV sign are clearly visible with the planter in transport position and attached to the tractor. Check to be sure safety/warning lights are in working condition. Tell the customer to check federal, state/provincial and local regulations before towing or transporting on a road or highway.
- Give the Operator & Parts Manual to the customer and explain all operating adjustments.
- Read warranty to customer.
- Complete Warranty And Delivery Report form.

***To the best of my knowledge this machine has been delivered ready for field use and customer has been fully informed as to proper care and operation.***

---

(Signature Of Delivery Person/Dealer Name/Date)

## AFTER DELIVERY CHECKLIST

The following is a list of items we suggest to check during the first season of use of the equipment.

- Check with the customer as to the performance of the planter.
- Review with the customer the importance of proper maintenance and adherence with all safety precautions.
- Check for parts that may need to be adjusted or replaced.
- Check to be sure all safety decals, reflective decals and SMV sign are correctly located and legible. Replace if damaged or missing.
- Check to be sure safety/warning lights are working properly.

---

(Signature Of Follow-Up Person/Dealer Name/Date)

**RETURN THIS COMPLETED FORM TO KINZE® IMMEDIATELY, along with Warranty And Delivery Report.  
Retain photocopy of this form at dealership for After Delivery Check.**

*Tear Along Perforation*

# TABLE OF CONTENTS

---

<b>TO THE OWNER</b> .....	1-1
<b>WARRANTY</b> .....	1-2
<b>INTRODUCTION</b> .....	2-1
<b>SPECIFICATIONS</b> .....	3-1
<b>SAFETY PRECAUTIONS</b> .....	4-1
<b>SAFETY WARNING SIGNS</b> .....	5-1
<b>MACHINE OPERATION</b>	
Auxiliary Hydraulic Option .....	6-72
Checking Granular Chemical Application Rate .....	6-86
Checking Seed Population .....	6-85
Contact Drive Wheel Spring Adjustment .....	6-3
Electronic Seed Monitor System	
KPM I .....	6-15
KPM II .....	6-21
KPM II Stack-Mode .....	6-43
Even-Row Push Row Unit Option .....	6-73
Fertilizer Openers And Attachments .....	6-75
Field Operation .....	6-9
Field Test .....	6-84
Field To Transport Sequence .....	6-9
General Planting Rate Information .....	6-87
Half Rate (2 To 1) Drive .....	6-4
Hydraulic/Electric Operation .....	6-5
Initial Preparation Of The Planter .....	6-1
Leveling The Planter .....	6-2
Liquid Fertilizer Attachment .....	6-80
Manual Safety Lockup .....	6-82
Marker Length Adjustment .....	6-13
Marker Operation .....	6-12
Marker Safety Lockup .....	6-82
Marker Speed Adjustment .....	6-13
Metric Conversion Table .....	6-84
Planting And Application Rate Charts .....	6-88
Planting Speed .....	6-84
Point Row Clutch .....	6-70
Rear Trailer Hitch .....	6-81
Ridge Planting .....	6-4
Rock Guards .....	6-66
Shear Protection .....	6-5
Standard Rate Drive .....	6-4
Tire Pressure .....	6-3
Tongue Safety Pin .....	6-83
Tractor Preparation And Hookup .....	6-1
Tractor Requirements .....	6-1
Transmission Adjustment .....	6-4
Transport Latch Locking Pin .....	6-83
Transport To Field Sequence .....	6-6
Transporting The Planter .....	6-84
Two-Speed Point Row Clutch .....	6-71
<b>BULK FILL SYSTEM OPERATION</b>	
Auger Speed Adjustment .....	7-4
Bulk Seed Hopper Covers .....	7-8
Bulk Seed Hopper Monitor .....	7-5
Capacities .....	7-1
Cleanout .....	7-8
Filling .....	7-6
Hydraulic System .....	7-3
Introduction .....	7-1
Lower Auger Cover .....	7-8
Mini-Hopper Latch .....	7-3
Operation .....	7-7
Overflow .....	7-2
Seed Distribution Manifold .....	7-2
Seed Lubrication .....	7-6
<b>ROW UNIT OPERATION</b>	
Brush-Type Seed Meter .....	8-4
Closing Wheel Shield .....	8-2
Coulter Mounted Residue Wheels .....	8-18
Finger Pickup Seed Meter .....	8-3
Frame Mounted Coulters And Attachments .....	8-11
Granular Chemical Banding Options .....	8-19
Granular Chemical Hopper And Drive .....	8-18
Interplant® Push Row Unit Clutch Sprocket .....	8-21

# TABLE OF CONTENTS

---

<b>ROW UNIT OPERATION (Continued)</b>	
Interplant® Push Row Unit Lockups .....	8-20
Planting Depth .....	8-1
Quick Adjustable Down Force Springs .....	8-9
Row Unit Chain Routing .....	8-8
Row Unit Mounted Disc Frower .....	8-15
Row Unit Mounted No Till Coulter .....	8-17
Row Unit Mounted Residue Wheel .....	8-16
Seed Meter Cleanout .....	8-6
Seed Meter Drive Adjustment .....	8-7
Seed Meter Drive Release .....	8-7
“V” Closing Wheel Adjustment (Rubber And Cast Iron) .....	8-1
<b>LUBRICATION</b>	
Bushings .....	9-3
Center Post .....	9-5
Drive Chains .....	9-1
Grease Fittings .....	9-6
Interplant® Push Row Unit Lockups .....	9-5
Liquid Fertilizer Piston Pump Crankcase Oil Level .....	9-6
Lubrication Symbols .....	9-1
Point Row Clutch .....	9-6
Sealed Bearings .....	9-1
U-Joint Slides .....	9-5
Wheel Bearings .....	9-5
<b>MAINTENANCE</b>	
15" Seed Opener Disc Blade/Bearing Assembly .....	10-10
Brush-Type Seed Meter Maintenance .....	10-5
Brush-Type Seed Meter Troubleshooting .....	10-7
Bulk Seed Hopper Auger Removal .....	10-16
Bulk Seed Hopper Monitor System Wiring Schematic .....	10-40
Chain Tension Adjustment .....	10-1
Closing Wheel Troubleshooting .....	10-8
Coulter Mounted Residue Wheels .....	10-15
Electrical Control Console Schematic .....	10-35
Electrical Control Console Schematic (W/Optional Two-Speed Point Row Clutches) .....	10-41
Electrical Wiring Diagram For Light Package .....	10-34
Electrical Wiring Harness Schematic (On Tractor) .....	10-36
Electrical Wiring Harness Schematic (On Planter) .....	10-37
Finger Pickup Seed Meter Cleaning .....	10-3
Finger Pickup Seed Meter Inspection/Adjustment .....	10-2
Finger Pickup Seed Meter Troubleshooting .....	10-4
Frame Mounted Coulters And Attachments .....	10-11
Gauge Wheel Adjustment .....	10-8
Gauge Wheel Arm Bushing And/Or Seal Replacement .....	10-9
Gauge Wheel Arm Pivot Spindle Replacement .....	10-9
Granular Chemical Attachment .....	10-15
Hydraulic System Schematic .....	10-42
KPM I/KPM II/KPM II Stack-Mode Electronic Seed Monitor Troubleshooting .....	10-18
Lift Circuit Troubleshooting .....	10-24
Marker Bearing Lubrication Or Replacement .....	10-30
Marker Operation Troubleshooting .....	10-29
Marker Transport Stand Adjustment .....	10-30
Mounting Bolts And Hardware .....	10-1
Piston Pump Storage .....	10-33
Piston Pump Troubleshooting .....	10-33
Point Row Clutch Inspection .....	10-19
Point Row Clutch Troubleshooting .....	10-20
Preparation For Storage .....	10-34
Rotation Cylinder Circuit Troubleshooting .....	10-27
Row Unit Mounted Disc Frower .....	10-13
Row Unit Mounted No Till Coulter .....	10-14
Row Unit Mounted Residue Wheel .....	10-14
Seed Tube Guard/Inner Scraper .....	10-11
Solenoid Valve Troubleshooting .....	10-23
Tongue Cylinder Circuit Troubleshooting .....	10-26
Torque Values Chart .....	10-1
Two-Speed Point Row Clutch .....	10-21
Valves (Check, Flow Control, Pressure Relief, Solenoid) .....	10-21
Wear Pad Replacement And Adjustment .....	10-31
Wheel Bearing Lubrication Or Replacement .....	10-31
Wing Lock Cylinder Circuit Troubleshooting .....	10-28
<b>PARTS LIST INDEX</b> .....	P1
<b>PARTS SECTION NUMERICAL INDEX</b> .....	a

# TO THE OWNER

---

KINZE Manufacturing, Inc. would like to thank you for your patronage. We appreciate your confidence in KINZE® farm machinery. Your KINZE® planter has been carefully designed and sturdily built to provide dependable operation in return for your investment.

**This manual has been prepared to aid you in the operation and maintenance of the planter. It should be considered a permanent part of the machine and remain with the machine when you sell it.**

It is the responsibility of the user to read and understand the Operator & Parts Manual in regards to safety, operation, lubrication and maintenance before operation of this equipment. It is the user's responsibility to inspect and service the machine routinely as directed in the Operator & Parts Manual. We have attempted to cover all areas of safety, operation, lubrication and maintenance; however, there may be times when special care must be taken to fit your conditions.

Throughout this manual the symbol  and/or the words **NOTE, IMPORTANT, CAUTION, WARNING or DANGER** are used to call your attention to important information. The definition of each of these terms follows:

**NOTE:** Indicates a special point of information or addresses a machine adjustment.

**IMPORTANT:** Indicates information which, if not heeded, could result in damage to the machine.



**CAUTION:** Indicates a potentially hazardous situation which, if not avoided, may result in minor or moderate personal injury.



**WARNING:** Indicates a potentially hazardous situation which, if not avoided, could result in death or serious personal injury.



**DANGER:** Indicates an imminently hazardous situation which, if not avoided, will result in death or serious personal injury.



**WARNING:** Some photos in this manual may show safety covers, shields or lockups removed for visual clarity. **NEVER OPERATE** the machine without all safety covers, shields and lockups in place.

**NOTE:** Some photos in this manual may have been taken of prototype machines. Production machines may vary in appearance.

**NOTE:** Some photos and illustrations in this manual show optional attachments installed. Contact your KINZE® Dealer for purchase of optional attachments.

# WARRANTY

---

The KINZE® Limited Warranty for your new machine is stated on the back of the retail purchaser's copy of the Warranty And Delivery Report form. Additional copies of the Limited Warranty can be obtained through your KINZE® Dealer.

Warranty, within the warranty period, is provided as part of KINZE's support program for registered KINZE® products which have been operated and maintained as described in this manual. Evidence of equipment abuse or modification beyond original factory specifications will void the warranty. Normal maintenance, service and repair is not covered by KINZE® warranty.

To register your KINZE® product for warranty, a Warranty And Delivery Report form must be completed by the KINZE® Dealer and signed by the retail purchaser, with copies to the Dealer, to the retail purchaser and to KINZE Manufacturing, Inc. Registration must be completed and sent to KINZE Manufacturing, Inc. within 30 days of delivery of the KINZE® product to the retail purchaser. KINZE Manufacturing, Inc. reserves the right to refuse warranty on serial numbered products which have not been properly registered.

If service or replacement of failed parts which are covered by the Limited Warranty are required, it is the user's responsibility to deliver the machine along with the retail purchaser's copy of the Warranty And Delivery Report to the KINZE® Dealer for service. KINZE® warranty does not include cost of travel time, mileage, hauling or labor. Any prior arrangement made between the Dealer and the retail purchaser in which the Dealer agrees to absorb all or part of this expense should be considered a courtesy to the retail purchaser.

*KINZE® warranty does not include cost of travel time, mileage, hauling or labor.*



# INTRODUCTION

---

The Model 3650 Twin-Line<sup>®</sup> Planter is available in 30" row spacing configurations. Optional Interplant<sup>®</sup> Packages and Liquid Fertilizer Attachments are available for use on the Model 3650 planter.

## GENERAL INFORMATION

The information used in this manual was current at the time of printing. However, due to KINZE's continual attempt to improve its product, production changes may cause your machine to appear slightly different in detail. KINZE Manufacturing, Inc. reserves the right to change specifications or design without notice and without incurring obligation to install the same on machines previously manufactured.

Right hand (R.H.) and left hand (L.H.), as used throughout this manual, are determined by facing in the direction the machine will travel when in use, unless otherwise stated.

D021102248a

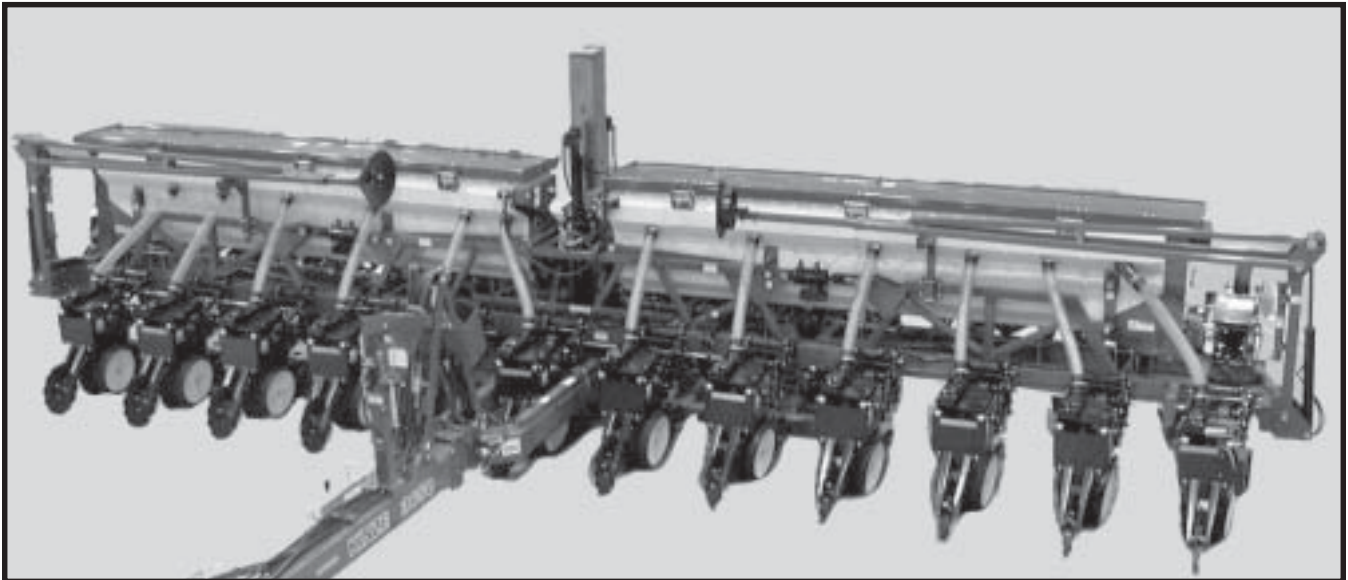

**Model 3650 12 Row 30" Shown With Interplant<sup>®</sup> Package And Even-Row Push Row Unit Options**

# INTRODUCTION

---

# SPECIFICATIONS

---

**TYPE** - Pull Type (Hydraulically rotates endwise to transport)

**PLANTING UNIT TYPES** - Push and Pull Row Units

<b>ROW SPACING</b>	<b>Standard</b>	<b>Interplant® Package</b>
	12 Row Narrow - 30" Rows	23/24 - 15" Rows
	16 Row Narrow - 30" Rows	31/32 - 15" Rows

**DRIVE SYSTEM** - Spring-loaded contact drive system  
- 7.50" x 20" rib implement wing tire - two on 12 row, four on 16 row  
- 4.80" x 8" contact drive tire - two on 12 row, four on 16 row  
- No. 40 chain and spring-loaded idlers  
- Point row clutches standard  
- 7/8" hex drill and drive shafts and end mounted seed transmissions

**TRANSPORT TIRES** - Equipped with four 255-70R 22.5" radial load range H tubeless rib implement tires  
- Adjustable height wheels for ridge planting

**TYPE LIFT** - Master/slave hydraulics  
- 12 row - 2 center lift (master) cylinders, 1 cylinder (slave) per wing wheel module (2 cylinders)  
- 16 row - 2 center lift (master) cylinders, 2 cylinders (slave) per wing wheel module (4 cylinders)

**MARKERS** - Independently controlled. Two-fold low profile with depth band on marker blade

## **MACHINE OPTIONS**

- Electronic Seed Monitors
  - KPM I
  - KPM II With Magnetic Distance Sensor Or Radar Distance Sensor
  - KPM II Stack-Mode With Magnetic Distance Sensor Or Radar Distance Sensor
- Two-Speed Point Row Clutch Package - Allows half width planting and reduced rate planting (Available through KINZE® Repair Parts)
- Interplant® Package Options
- Even-Row Push Row Unit Package
- Liquid Fertilizer With Piston Pump And Fertilizer Opener Options
- Liquid Fertilizer Low Rate Check Valve Option
- Rear Trailer Hitch
- Half Rate (2 To 1) Drive Reduction Package
- Rock Guard Package For Transport Wheel Arm

## **ROW UNIT OPTIONS/ATTACHMENTS**

- Finger Pickup Or Brush-Type Seed Meters
- Closing Wheel Options
  - Rubber "V" Closing Wheels
  - Cast Iron "V" Closing Wheels
- Granular Chemical Application
- Hopper Panel Extension Package
- Row Unit Mounted Coulter
- Row Unit Mounted Disc Furrowers
- Row Unit Mounted Residue Wheel
- Coulter Mounted Residue Wheels
- Frame Mounted Coulter - STYLE A & STYLE B
- Disc Furrowers For STYLE A Frame Mounted Coulter
- Residue Wheel Attachment For STYLE B Frame Mounted Coulter

# SPECIFICATIONS

## Dimensions/Operating

PLANTER SIZE	12 Row 30"	16 Row 30"
WIDTH	31' 2"	41' 2"
LENGTH	22' 3"	25' 3"

## Dimensions/Transport

PLANTER SIZE	12 Row 30"	16 Row 30"
WIDTH Standard or push units	11' 2"	11' 2"
WIDTH Push unit with no till coulters	11' 4"	11' 4"
Push unit with no till coulters and coulters mounted residue wheels	11' 8"	11' 8"
LENGTH*	37' 2"	47' 2"
HEIGHT	10' 8"	11' 0"

NOTE: L.H. transport wheel and axle stub assembly is removable for truck transport of base machine at 8' 6".

PLANTER SIZE	12 Row 30"	16 Row 30"
WEIGHT (Estimated)**	15,518 lbs.	18,678 lbs.

\* Add 1' 6" to length in transport position when equipped with the even-row push row unit.

\*\* Base Machine weights include planter frame, row markers, drive components, tires and wheels, hydraulic cylinders, KINZE® bulk fill seed distribution system, row units (closing wheel arms less closing wheels) and point row clutches.

# SAFETY PRECAUTIONS

Safe and careful operation of the tractor and planter at all times will contribute significantly to the prevention of accidents.

Since a large portion of farm accidents occur as a result of fatigue or carelessness, safety practices should be of utmost concern. Read and understand the instructions provided in this manual and on the warning signs. Review these instructions frequently! Listed below are other safety suggestions that should become common practice.

 **Never allow the planter to be operated by anyone who is unfamiliar with the operation of all functions of the unit. All operators should read and thoroughly understand the instructions given in this manual prior to moving the unit.**

 **Never permit any persons other than the operator to ride on the tractor.**

 **Never ride on the planter or allow others to do so.**

 **Always make sure there are no persons near the planter when marker assemblies are in operation or when rotating the planter.**

 **Always keep hands, feet and clothing away from moving parts. Do not wear loose-fitting clothing which may catch in moving parts.**

 **Always wear protective clothing, substantial shoes and suitable hearing and eye sight protectors applicable for the situation.**

 **Do not allow anyone to stand between the tongue or hitch and the towing vehicle when backing up to the planter.**

 **Be aware of bystanders, particularly children! Always look around to make sure it is safe to start the engine of the towing vehicle or move the planter. This is particularly important with higher noise levels and quiet cabs, as you may not hear people shouting.**

 **Use a tractor equipped with a roll-over-protective-system and fasten your seat belt prior to starting the engine.**

 **Before operating the planter for the first time and periodically thereafter, check to be sure the lug nuts on the transport wheels are tight. This is especially important if the planter is to be transported for a long distance.**

 **Never work under the planter while in raised position without using manual safety lockup.**

 **Install safety lockup devices on markers prior to transporting the planter or working around the unit.**

D021102203

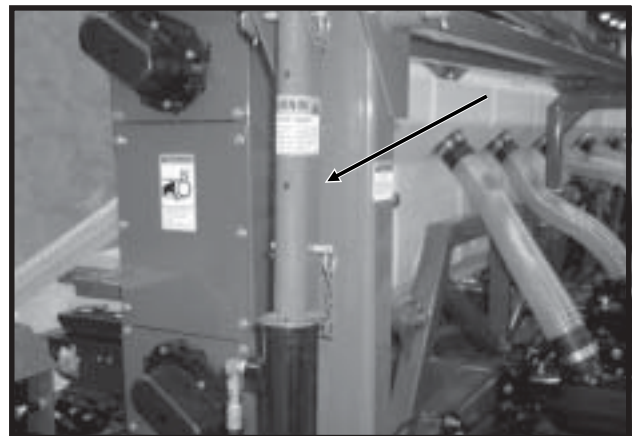

 **Watch for obstructions such as wires, tree limbs, etc., when folding markers.**

 **Care must be taken when operating row markers around overhead power lines.**

 **On machines where the outer transport wheel on the left side of the planter is bolt-on to allow legal width truck shipment, always install outer transport wheel assembly prior to unloading. DO NOT REMOVE THIS ASSEMBLY AFTER PLANTER IS ASSEMBLED FOR USE. DO NOT fold planter or tow planter while the outer transport wheel is removed. Tipping may occur because of narrow wheel base.**

 **The seed and fertilizer metering systems of this planter are designed to be driven by ground tires. Hydraulic motors power the bulk seed auger system. The use of additional hydraulic, electric or PTO drives may create serious safety hazards to you and others nearby. Always follow all appropriate safety standards and practices to protect you and others near this planter from injury.**

# SAFETY PRECAUTIONS

 Always install tongue safety pin, manual safety lockup and transport latch locking pin before transporting planter.

D032901115



Tongue Safety Pin

D032901117



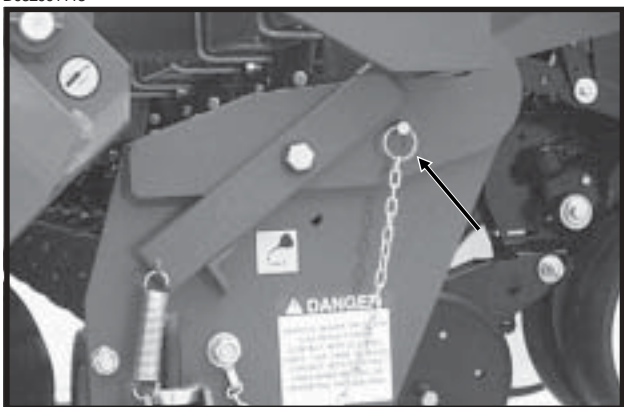

Manual Safety Lockup

D032901113





Transport Latch Locking Pin

 This machine has been designed and built with your safety in mind. Do not make any alterations or changes to this machine. Any alteration to the design or construction may create safety hazards.

 If the planter is going to be transported on a public highway, a safety chain should be obtained and installed. Always follow federal, state/provincial and local regulations regarding a safety chain when towing farm equipment on a public highway. Only a safety chain (not an elastic or nylon/plastic tow strap) should be used to retain the connection between the towing and towed machines in the event of separation of the primary attaching system.

 Check to be sure all safety/warning lights are working before transporting the machine on public roads.

 Avoid transporting loaded planter whenever possible. When it is necessary to transport the planter with the hoppers or tanks loaded, the added weight should be distributed evenly on the planter frame before rotating the planter.

 Limit towing speed to 15 MPH. Tow only with farm tractor of a minimum 90 HP.

 Always make sure safety/warning lights, reflective decals and SMV sign are in place and visible prior to transporting the machine on public roads. In this regard, check federal, state/provincial and local regulations.

 Allow for unit length when making turns.

 Always drive at a safe speed relative to local conditions and ensure your speed is low enough for an emergency stop to be safe and secure. Keep speed to a minimum.

 Reduce speed prior to turns to avoid the risk of overturning.

# SAFETY PRECAUTIONS

---



Always keep the tractor in gear to provide engine braking when going downhill. Do not coast.



Avoid sudden uphill turns on steep slopes.



Be a safe and courteous driver. Always yield to oncoming traffic in all situations, including narrow bridges, intersections, etc.



Rim and tire servicing can be dangerous. Explosive separation of a tire and rim parts can cause serious injury or death.



Agricultural chemicals used with this unit can be dangerous. Improper selection or use can seriously injure persons, animals, plants, soil and other property. **BE SAFE:** Select the right chemical for the job. Handle it with care. Follow the instructions of the chemical manufacturer.



Store the planter in an area away from human activity. **DO NOT** permit children to play on or around the stored unit.



Make sure the parked machine is on a hard, level surface. Wheel chocks may be needed to prevent unit from rolling.

# SAFETY PRECAUTIONS

---



# SAFETY WARNING SIGNS

The “WARNING” signs illustrated on these pages are placed on the machine to warn of hazards. The warnings found on these signs are for your personal safety and the safety of those around you. **OBSERVE THESE WARNINGS!**

- **Keep these signs clean so they can be readily observed. Wash with soap and water or cleaning solution as required.**
- **Replace “WARNING” signs should they become damaged, painted over or if they are missing.**
- **Check reflective decals and SMV sign periodically. Replace if they show loss of any of their reflective property.**
- **When replacing decals, clean the machine surface thoroughly using soap and water or cleaning solution to remove all dirt and grease.**

**NOTE: Style and locations of reflective decals and safety/warning lights conform to ANSI/ASAE S279.10 OCT 98.**

D032901114

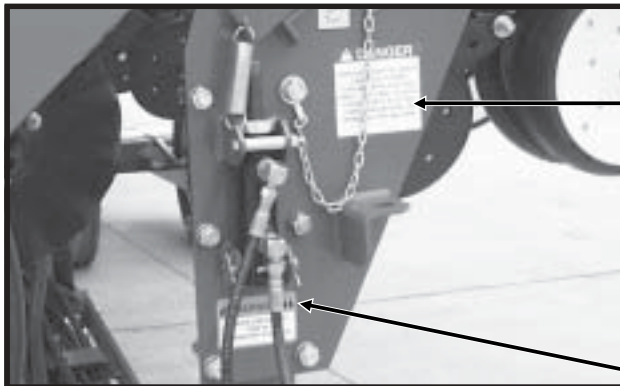

Part No. G7100-117 (Qty. 1)



Part No. G7100-02 (Qty. 1)

D101602202

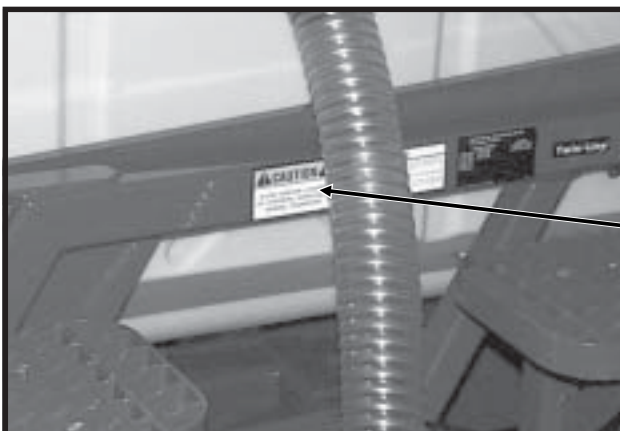

Part No. G7100-75  
(Qty. 4 - Front & Back/Left & Right)

# SAFETY WARNING SIGNS



Part No. G7100-172  
(Qty. 2 - One On Outer End  
Of Each Bulk Seed Hopper)



Part No. G7100-83  
(Qty. 1 Per Marker)



Part No. G7100-42  
(Qty. 2 Per Marker)

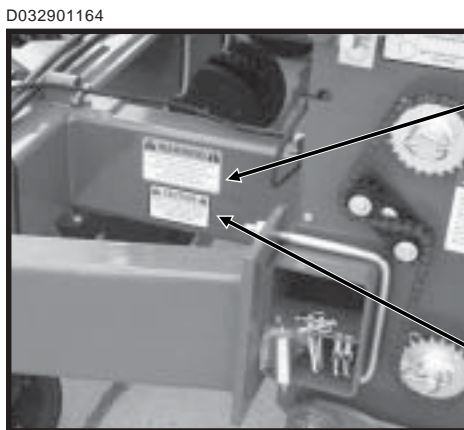
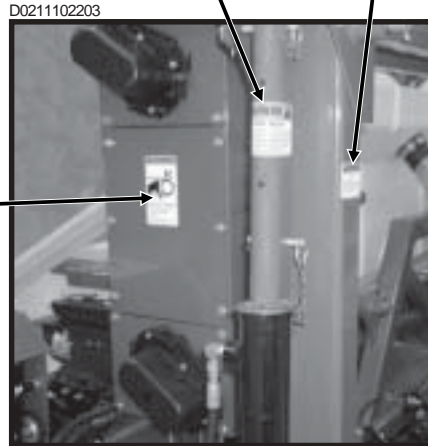

Shown With Marker Mount Included With  
Optional Even-Row Push Row Unit Package

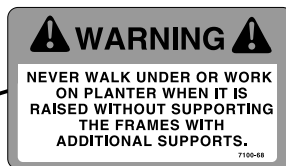

Part No. G7100-68  
(Qty. 2 - One On Each  
End Of Planter)



Part No. G7100-63  
(Qty. 2 - One On Each  
End Of Planter)

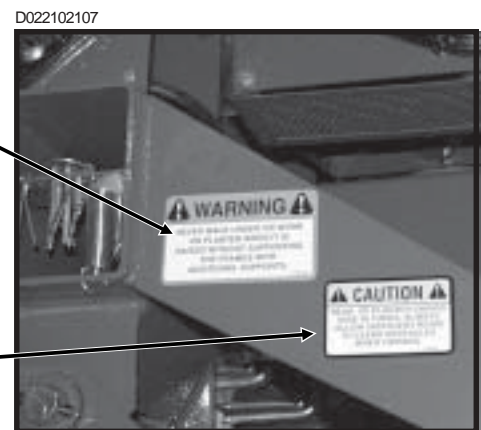

# SAFETY WARNING SIGNS

D032301138



Part No. G7100-68  
(Qty. 2 - R.H. Side Of Planter - Front/Back)

D032301138

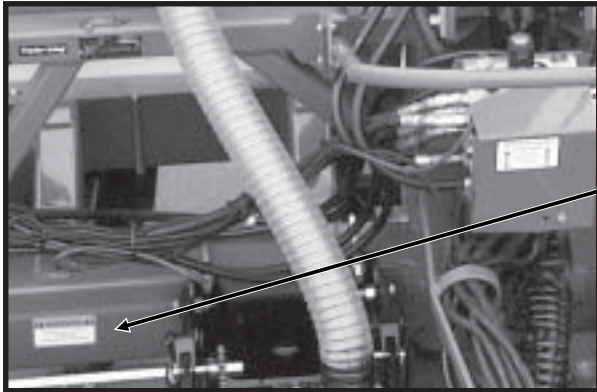

Part No. G7100-200  
(Qty. 2 - L.H. Side Of Planter - Front/Back)

D032901123

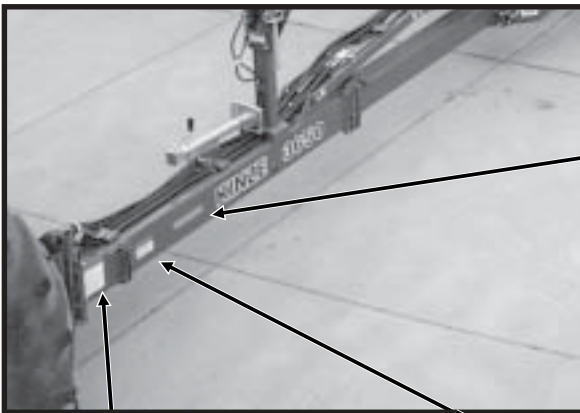

Part No. G7100-259 Amber Reflective Decal  
(Qty. 1)



Part No. G7100-46 (Qty. 1)



Part No. G7100-90 (Qty. 1)

# SAFETY WARNING SIGNS

D032901107

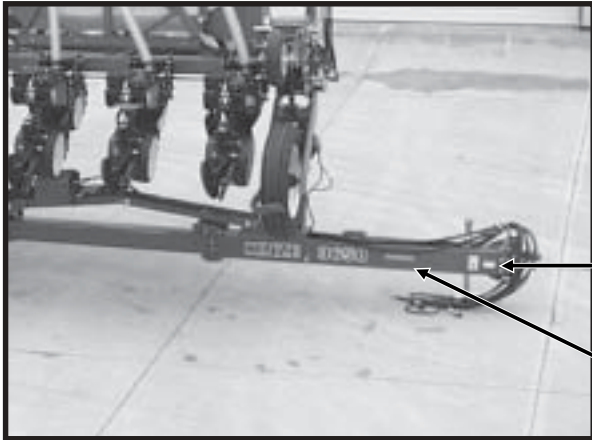

Part No. G7100-56 (Qty. 1)



Part No. G7100-259 Amber Reflective Decal (Qty. 1)

D021102206

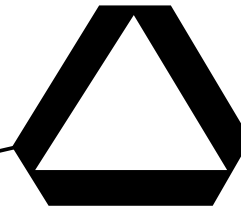
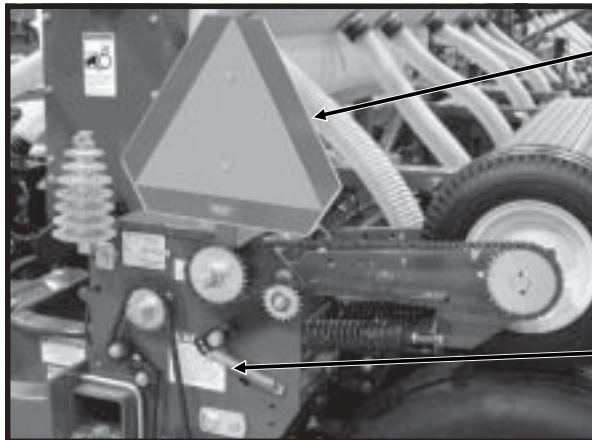

Part No. GD2199 (Qty. 1)



Part No. G7100-89 (Qty. 2 - Located On Wheel Modules On Both Ends Of Planter)

D021102204

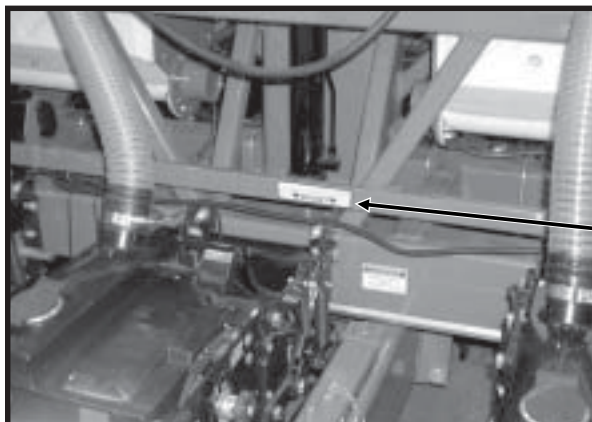

Part No. G7100-249 (With Optional Interplant® Package) (Qty. 1 - Located On Interplant® Lift Lever)

# SAFETY WARNING SIGNS

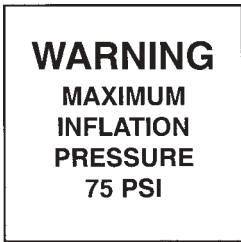

Part No. G7100-275 (Qty. 1 Per 255-70R 22.5 Transport Wheel Tire)



Part No. G7100-219 (Qty. 1 Per 255-70R 22.5 Transport Wheel Tire)

D032901106b

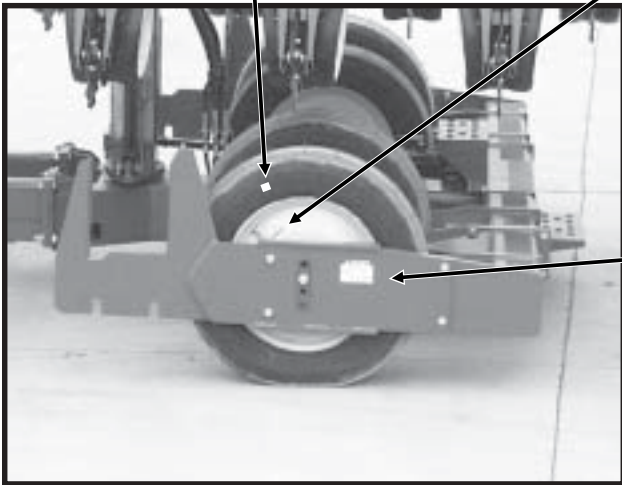

Part No. G7100-215 (Qty. 1 - Located On Outside End Of Stub Axle)

D021102210a

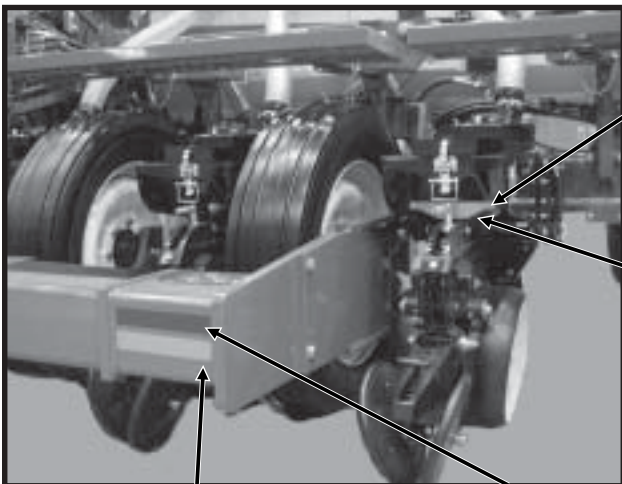

Part No. G7100-262 Amber Reflective Decal (Qty. 6 On 12 Row And 8 On 16 Row - Located On Every Other Row Unit Beginning On The First Row On The L.H. End Of The Planter - Rear-Facing In Planting Position/Side-Facing In Transport Position)



Part No. G7100-259 Amber Reflective Decal (Qty. 6 On 12 Row And 8 On 16 Row - Located On Every Other Row Unit Beginning On The First Row On The L.H. End Of The Planter - Rear-Facing In Planting Position/Side-Facing In Transport Position) **(With Optional Granular Chemical)**



Part No. G7100-260 Orange Reflective Decal (Qty. 2 - One Located On R.H. And L.H. Rear Sides Of Axle)



Part No. G7100-258 Red Reflective Decal (Qty. 2 - One Located On R.H. And L.H. Rear Sides Of Axle)

# SAFETY WARNING SIGNS

Part No. G7100-259 Amber Reflective Decal (Qty. 7 On 12 Row 30" And Qty. 9 On 16 Row 30" - Located On The Front Side Of The Front Toolbar And Marker Mounts - Forward-Facing In Planting Position/Side-Facing In Transport Position)

(TWL226)

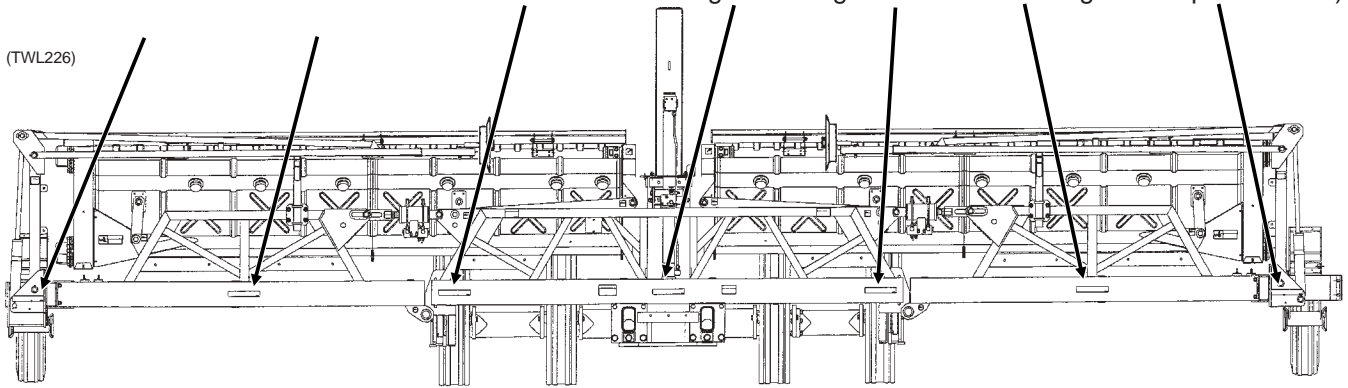

(TWL174b)

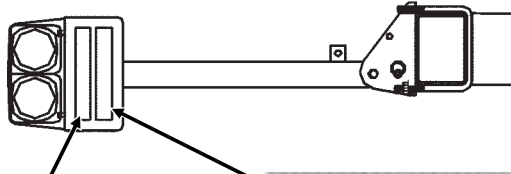

Part No. G7100-258 Red Reflective Decal (Qty. 1 - Located On The Front Light Bracket On The L.H. Wing Of The Planter - Rear-Facing In Transport Position)

Part No. G7100-260 Orange Reflective Decal (Qty. 1 - Located On The Front Light Bracket On The L.H. Wing Of The Planter - Rear-Facing In Transport Position)

D021102104b

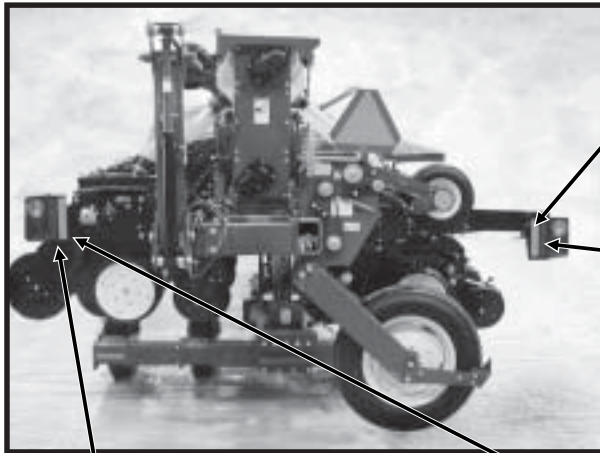

Part No. G7100-260 Orange Reflective Decal (Qty. 1 - Located On The Rear Light Bracket On The L.H. Wing Of The Planter - Rear-Facing In Transport Position)

Part No. G7100-258 Red Reflective Decal (Qty. 1 - Located On The Rear Light Bracket On The L.H. Wing Of The Planter - Rear-Facing In Transport Position)

Part No. G7100-258 Red Reflective Decal **(With Optional Interplant® Package)** (Qty. 1 - Located On Light Bracket On The L.H. Wing Of The Planter - Rear-Facing In Transport Position)

Part No. G7100-260 Orange Reflective Decal **(With Optional Interplant® Package)** (Qty. 1 - Located On Light Bracket On The L.H. Wing Of The Planter - Rear-Facing In Transport Position)

# SAFETY WARNING SIGNS

D101602212

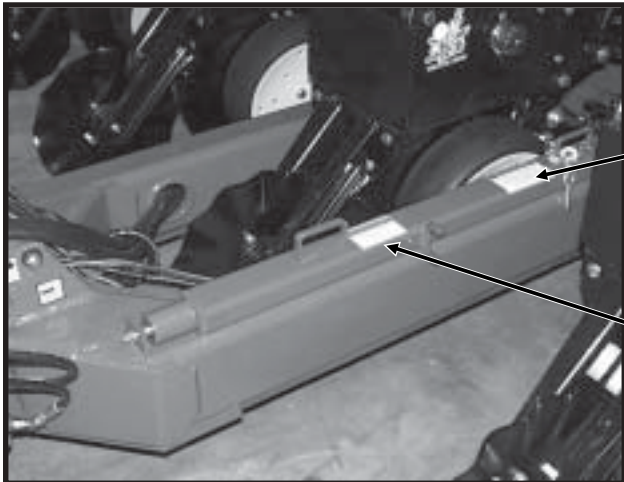

Part No. G7100-68  
(Qty. 1 - On Manual Safety Lockup)



Part No. G7100-200  
(Qty. 1 - On Manual Safety Lockup)

D101602206

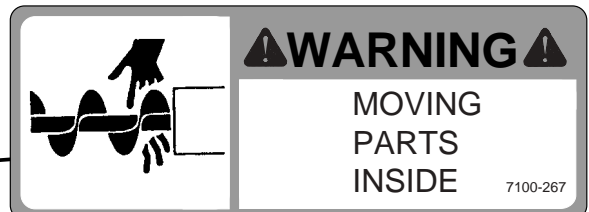
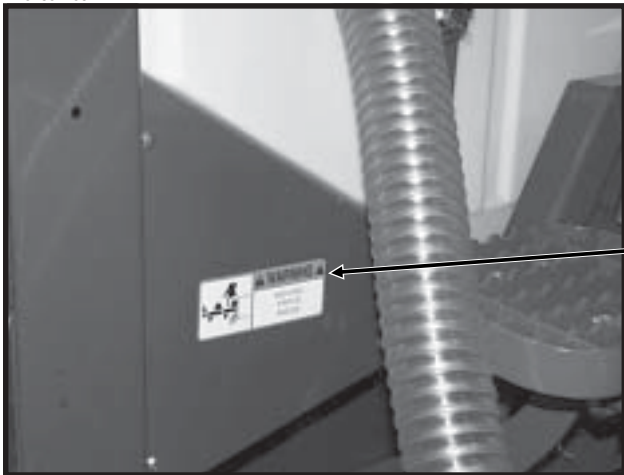

Part No. G7100-267 (Qty. 4 - On Front And Rear Lower Outer End Of Each Bulk Seed Hopper )

D021102209

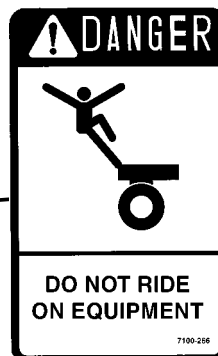
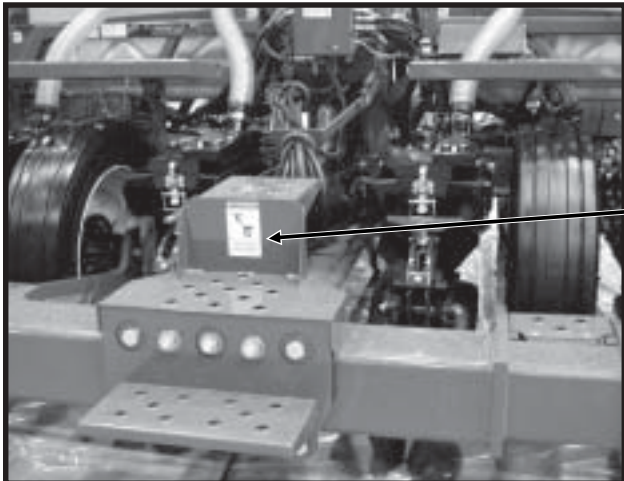

Part No. G7100-266 (Qty. 1)

# SAFETY WARNING SIGNS

D021102216



Part No. G7100-266  
(Qty. 2 - One on Each Bulk Seed Hopper Lid)



Part No. G7100-75 (Qty. 2 - One On Each Bulk Seed Hopper Lid)

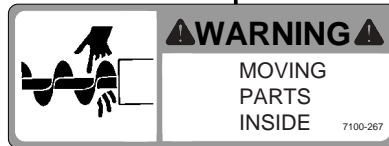

Part No. G7100-267 (Qty. 2 - One On Each Bulk Seed Hopper Lid)

D021102213

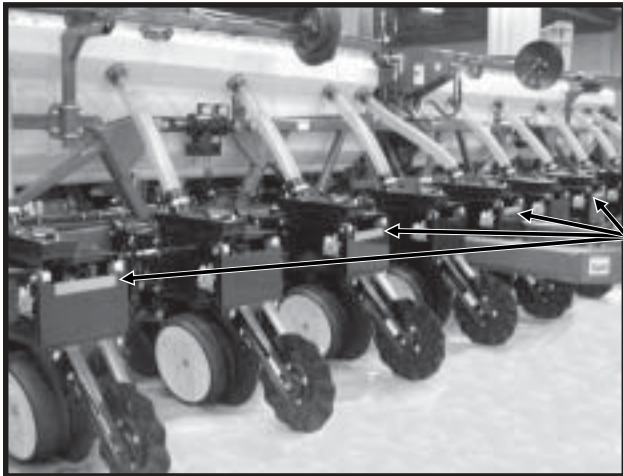

Part No. G7100-259 Amber Reflective Decal (With Optional Interplant® Package And/Or Even-Row Push Row Unit Package)  
(Qty. 5 On 12 Row And 7 On 16 Row - Located On The Front Of Every Other Interplant® Push Row Unit Beginning On The Second Row In On The L.H. Side Of The Planter - Plus One On Even-Row Push Row Unit If Equipped With That Option - Side-Facing In Transport Position)

06039901

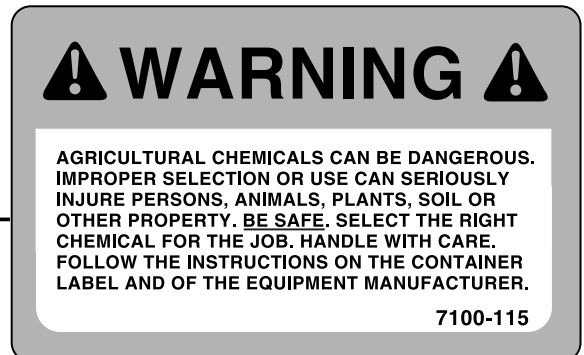

Part No. G7100-115 (With Optional Granular Chemical) (1 Per Row Unit - Located On Underside Of Optional Granular Chemical Hopper Lid)



# MACHINE OPERATION

The following information is general in nature and was written to aid the operator in preparation of the tractor and planter for use, and to provide general operating procedures. The operator's experience, familiarity with the machine and the following information should combine for efficient planter operation and good working habits.

**IMPORTANT: Always raise the planter out of the ground when making sharp turns or backing up.**

## INITIAL PREPARATION OF THE PLANTER

Lubricate the planter and row units per the lubrication information in this manual. Make sure all tires have been properly inflated. Check all drive chains for proper tension, alignment and lubrication.



**DANGER: The outer transport wheel on the left side of the machine is shipped not bolted on to allow narrower width truck shipment. DO NOT REMOVE THIS ASSEMBLY AFTER PLANTER IS ASSEMBLED FOR USE. DO NOT fold planter or tow planter while the outer transport wheel is removed. Tipping may occur because of narrow wheel base.**

## TRACTOR REQUIREMENTS

Consult your dealer for information on horsepower requirements and tractor compatibility. Requirements will vary with planter options, tillage and terrain. Three dual remote hydraulic outlets (SCV) are required on all sizes. A 12 volt DC electrical system is required on all sizes.

## TRACTOR PREPARATION AND HOOKUP

D092702101

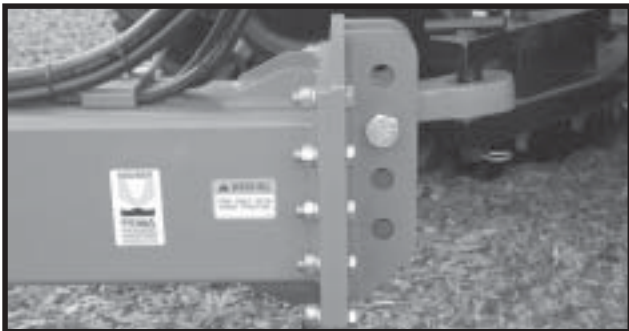

1. Adjust tractor drawbar to 13-17 inches above the ground. Adjust the drawbar so the hitch pin hole is directly below the center line of the PTO shaft. Make sure the drawbar is in a stationary position. See page 6-14 when using the even-row push row unit option.
2. Install control console on tractor in a convenient location within reach of the operator and close to the hydraulic controls. Mount control console securely and route power cord to the power source.

The control console operates on 12 volt DC only. If two 12 volt batteries are connected in series, ALWAYS make power connection on battery which is grounded to tractor chassis.

If two 6 volt batteries are connected in series, make sure power connection provides 12 volt DC across the positive terminal on one battery and negative terminal of the second battery.

3. Back tractor to planter and connect with 1 1/4" - 1 1/2" diameter hitch pin. If the tractor is not equipped with a hitch pin locking device, make sure hitch pin is secured with a locking pin or cotter pin.
4. Connect hydraulic hoses to tractor ports in a sequence which is both familiar and comfortable to the operator.

The hydraulic hoses are color coded as follows:  
Red AA - Lift Functions (Return)  
Red BB - Lift Functions (Pressure)  
Blue AA - Marker And Fold/Unfold Functions (Return)  
Blue BB - Marker And Fold/Unfold Functions (Pressure)  
Black AA - Bulk Fill System Functions (Return)  
Black BB - Bulk Fill System Functions (Pressure)

**NOTE: If the tractor has a motor return hookup, its use will allow the bulk fill system to work with reduced back pressure and reduced heat generation, but is not necessary for the proper operation of the system.**



**DANGER: Before applying pressure to the hydraulic system, make sure all connections are tight and hoses and fittings have not been damaged. Hydraulic fluid escaping under pressure can have sufficient force to penetrate skin, causing injury or infection.**

**IMPORTANT: Always wipe hose ends to remove any dirt before connecting couplers to tractor ports.**

5. Connect cable on planter to control console cable on tractor. Connect ASAE Standards 7 terminal connector for warning lights on planter to ASAE Standards receptacle on tractor. If your tractor is not equipped with an ASAE Standards receptacle, check with your tractor manufacturer for availability. Check to be sure warning lights on planter are working in conjunction with warning lights on tractor.
6. Raise jack stand and remount horizontally on storage bracket.
7. Lower planter to the planting position and check to be sure the hitch is level. If hitch slopes up or down, disconnect planter and adjust hitch clevis up or down as necessary.

**NOTE: If using an auxiliary attaching system to retain the connection between the planter and tractor hitch, be sure the auxiliary attaching system is of sufficient strength and length and correctly attached. An auxiliary attaching system (safety chain) is available from KINZE® through your KINZE® Dealer. Attach safety chain using an unused clevis mounting hole on planter hitch.**

# MACHINE OPERATION

## LEVELING THE PLANTER

For proper operation of the planter and row units, it is important that the planter frame and row unit parallel arms be approximately level. The toolbar should operate at a 20"-22" height, measured to the bottom of the toolbar.

D092702101



Four holes in the hitch bracket allow the clevis to be raised or lowered. In addition, the clevis may be turned over for a finer adjustment between mounting holes. When installing the clevis mounting bolt, make sure the lock nut is tightened to proper torque setting.

D032901180a

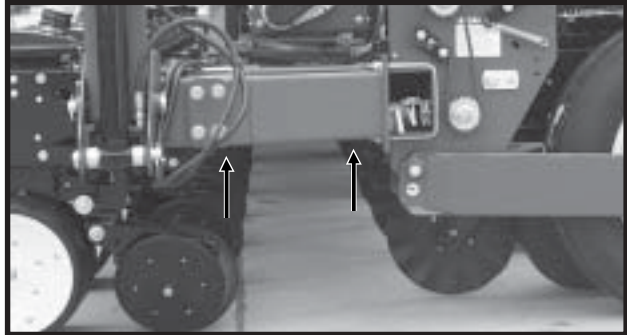

With the planter lowered to proper operating height, check to be sure the frame is level fore and aft. Recheck once planter is in the field.

It is important for the planter to operate level laterally. Tire pressure must be maintained at pressures specified. See "Tire Pressure".

Field and actual planting conditions will dictate which of the transport wheel settings to use to ensure row unit parallel arms are approximately parallel with the ground. It may also be necessary to lower the ground drive wheels to ensure level lateral toolbar operation if the transport wheels are set in one of the two lower sets of holes.

**NOTE: To allow adequate drive force after lowering the ground drive wheels, it may be necessary to lower the contact drive wheel arms to the lower sets of holes in the wheel modules and lower the down pressure springs to the lower mounting rods on the wheel modules.**

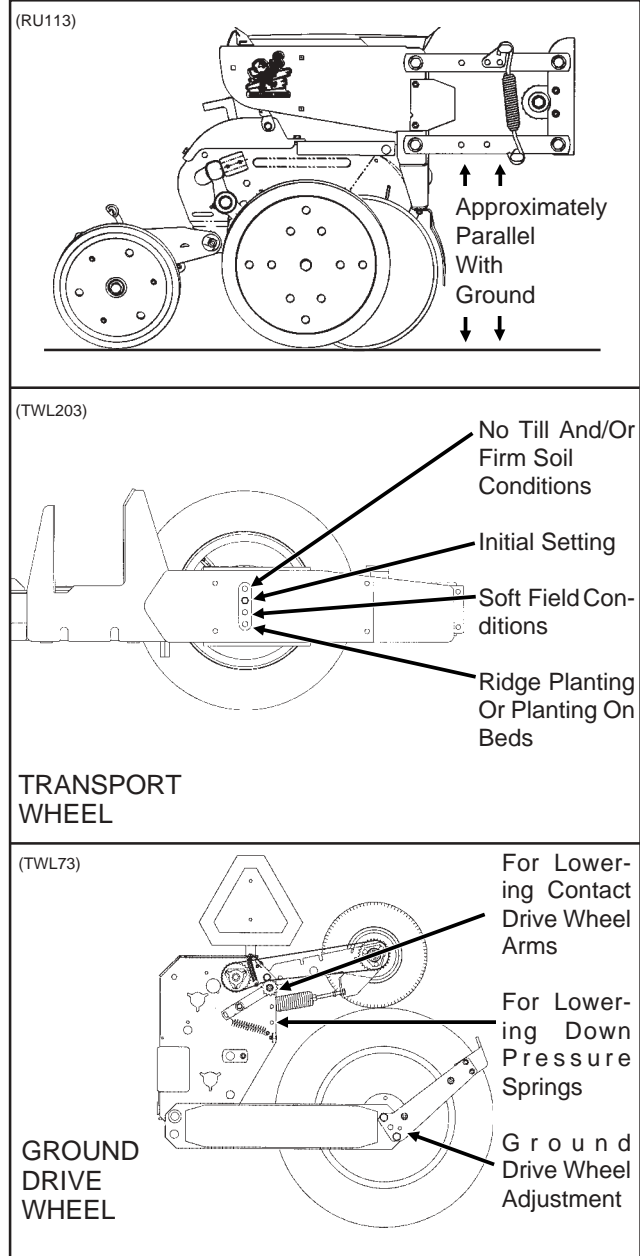

When the planter has been fully loaded with seed, granular chemicals, etc.; a field check should be made to be sure the wings are level with the center frame. If the wings are not level with the center frame, the drive wheels and/or transport wheels can be raised or lowered in the wheel arms to increase or decrease planter toolbar height. Hitch height should be raised accordingly to ensure level operation.

**NOTE: As the lift cylinders are port rephasing type, it is necessary for the cylinders to fully retract in order to rephase. Cylinder stops can not be used.**

# MACHINE OPERATION

**NOTE:** On planters equipped with push row units and no till coulters, the uplift from the down pressure springs may cause the wings to rise slightly in planting position. The problem is compounded if static pressure gets trapped in the planter's hydraulic lift system causing the wing cylinders to extend slightly. Operating the tractor's hydraulic system in the float position or moving the tractor's hydraulic lever to the float position briefly, to relieve the pressure, will help to maintain the proper toolbar height.

## CONTACT DRIVE WHEEL SPRING ADJUSTMENT

D011402101

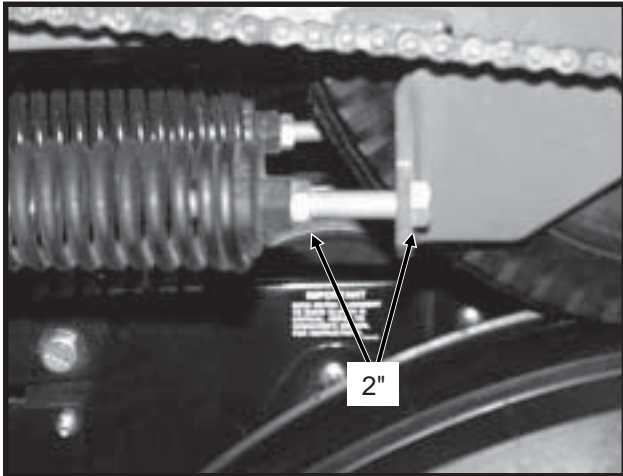

There are two down pressure springs on each contact drive wheel. The down pressure is factory preset and should need no further adjustment.

The spring tension is set leaving 2" between the spring plug and the bolt head.

## TIRE PRESSURE

D021102104c

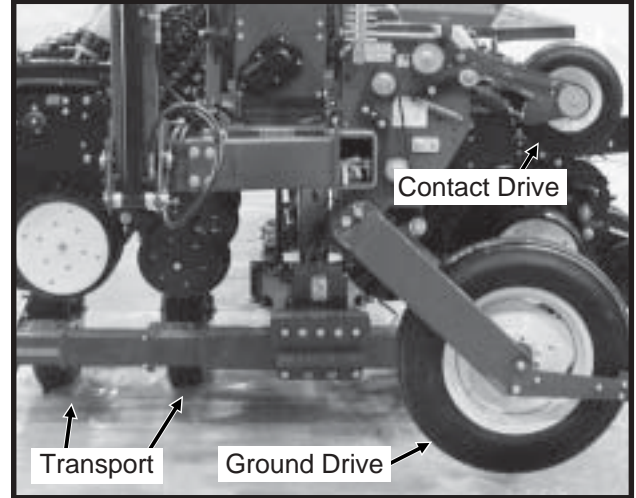

Tire pressure should be checked regularly and maintained as follows:

- 255-70R 22.5", Transport (Center Section) . . . 75 PSI
- 7.50" x 20", Ground Drive (Wings) . . . . .40 PSI
- 4.80" x 8", Contact Drive . . . . .50 PSI

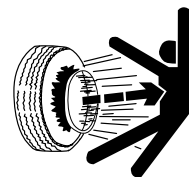

**! DANGER:** Rim and tire servicing can be dangerous. Explosive separation of tire and rim parts can cause serious injury or death.

Do not attempt to mount a tire unless you have the proper equipment and experience to perform the job. This should only be done by persons properly trained and equipped to do the job.

Always maintain the correct tire pressure. Do not inflate the tires above the recommended pressure.

When inflating tires, use a clip-on air chuck and extension hose long enough to allow you to stand to one side and NOT in front of or over the tire assembly. Use a safety cage to enclose the tire and rim assembly when inflating.

Inspect tires and wheels daily. Do not operate with low pressure, cuts, bubbles, damaged rims or missing lug bolts and nuts.

# MACHINE OPERATION

## TRANSMISSION ADJUSTMENT

Planting population rate changes are made at each end of the planter. The planter is designed to allow simple, rapid changes in sprockets to obtain the desired planting population. By removing the lynch pins on the hexagon shafts, sprockets can be interchanged with those from the sprocket storage rod bolted to the wheel module on each side of the planter.

Chain tension is controlled by a spring-loaded dual-sprocket idler. The idler assembly is adjusted with a ratchet arm. This arm has a release position to remove spring tension for replacing sprockets. The amount of spring tension on the chain is controlled by the ratchet arm.

A decal positioned on the transmission module provides proper chain routing. The planting rate charts found at the back of this section will aid you in selecting the correct sprocket combinations.

D021102104c

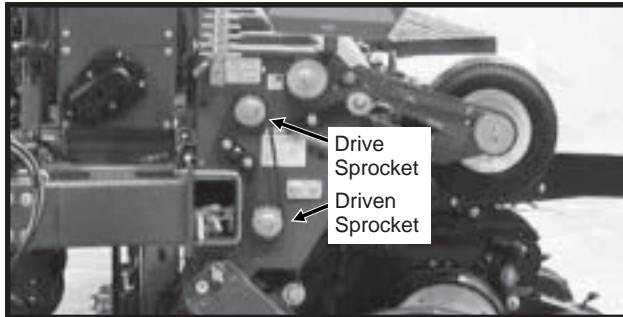

12 Row Machine Shown

## STANDARD RATE DRIVE

D021102104c



12 Row Machine Shown

Seed planting rate charts are based on the standard rate drive. The standard rate drive uses a 30 tooth sprocket on each contact wheel. Using the 15 tooth reduced rate sprocket in place of the 30 tooth sprocket will reduce the planting and application rates by approximately 50%. See "Half Rate (2 To 1) Drive".

## HALF RATE (2 TO 1) DRIVE

D070699113a

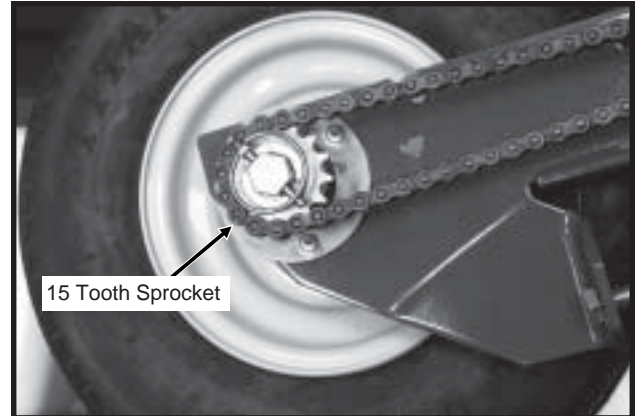

Half rate (2 to 1) drive is recommended only when desired population falls below that shown on planting rate charts. Replace the 30 tooth sprocket on each contact wheel with a 15 tooth sprocket. This will reduce the planter transmission speed and reduce planting and application rates by approximately 50%.

**NOTE: After each sprocket combination adjustment, make a field check to be sure you are planting at the desired rate.**

## RIDGE PLANTING

When ridge planting, the drive wheels and transport wheels can be lowered 2" or 4" to the lower mounting holes in the wheel arms to increase the planter toolbar height. The contact drive tire must also be lowered to the lower set of holes in the wheel module and the down pressure springs hooked on the lower rod. Hitch height should be raised accordingly to ensure level operation.

(TWL67a)

**Wheel Shown Mounted In Standard Location - Lower 2" Or 4" To Lower Mounting Holes When Ridge Planting**

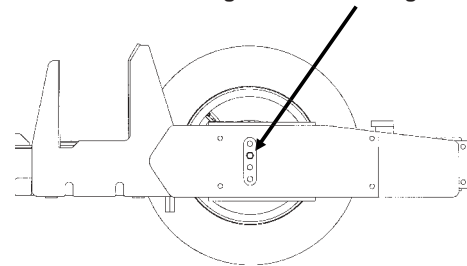

**NOTE: The toolbar should operate at a 20"-22" height measured from the bottom of the toolbar to the planting surface.**

# MACHINE OPERATION

## SHEAR PROTECTION

The planter driveline and row unit components are protected from damage by shear pins.

If excessive load should cause a pin to shear, it is important to determine where binding has occurred before replacing the pin. Replace shear pins with same size and type.

Additional shear pins can be found in the storage area located inside the rear planter frame.

To prevent future binding or breakage of components, check driveline alignment and follow prescribed lubrication schedules.

**NOTE: Drill shaft/transmission coupler alignment is critical.**

50981-10

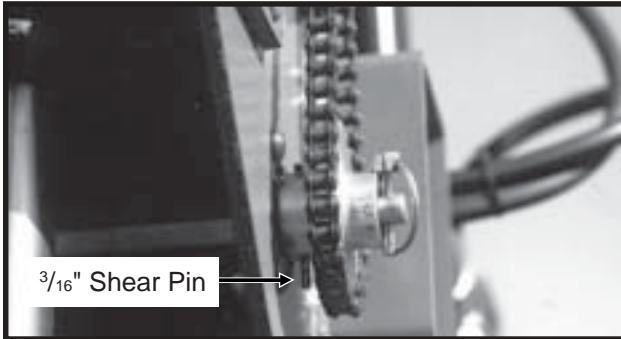

**Transmission Shaft**

## HYDRAULIC/ELECTRIC OPERATION

76746-24

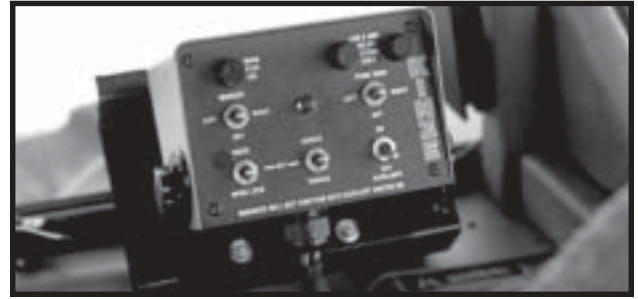

Switches on the control console located on the tractor are used to raise the planter to transport position, operate the rotate and tongue extension functions, lock and release the planter wings, and raise and lower the row markers.

**! DANGER: Care must be taken when operating row markers around overhead power lines.**

**NOTE: The back lit console is equipped with a switch on the back of the console which should be used to turn off the light during extended periods of non-use.**

All 3650 planters are equipped to operate from three dual remote hydraulic outlets. One set of hydraulic outlets, in conjunction with a switch on the control console, are used to operate the raise to transport function. The second set, in conjunction with the switches on the control console, are used to operate the markers and fold/unfold functions. The third set is for operation of the bulk fill system hydraulic motors.

The marker and point row selector switches are an ON-OFF-ON type.

If the planter is equipped with the optional Two-Speed Point Row Clutch Package, the point row switch and reduced rate switch operate independently of the rest of the control console. Power to the marker switch is fed through the auxiliary switch and the two transport function switches. Operating any of the switches in the lower row disables the marker function and turns off the indicator light for the markers.

A7435(TWL81)

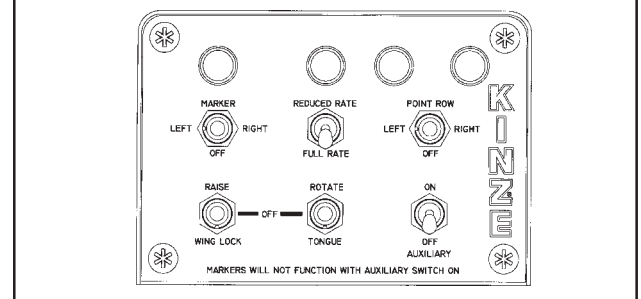

# MACHINE OPERATION

The raise/wing lock and rotate/tongue (fold function) switches are MOMENTARY ON-OFF-MOMENTARY ON type and must be held in position while operating the tractor hydraulic lever. Activating a fold function switch disables the marker circuit.



**WARNING: To ensure the safety of the operator and others nearby, the marker selector switch should be placed in its OFF (center) position when not in use. An indicator light on the control box panel is ON whenever the marker circuits or point row clutch circuits are energized.**

The auxiliary switch is an ON-OFF type switch which is used in conjunction with the hydraulic marker/folding functions control lever to operate optional attachments. All 3650 planters are shipped with the auxiliary switch installed in the control console. The auxiliary switch must be in the OFF position to enable other functions.

**NOTE: Activating the auxiliary switch disables all other control console switches except the point row clutch switch.**

**NOTE: The lift cylinders are (port type) rephasing cylinders. It is necessary for all of the lift cylinders to fully retract before they will rephase in the lowered position. Cylinder stops can not be used.**



**WARNING: Never work under the planter while in raised position without installing safety lockups.**



**WARNING: Make sure all hydraulic hoses are properly connected before operating the planter. Never connect or disconnect hydraulic hoses without first stopping the tractor engine and moving the hydraulic operating levers in both directions to relieve any pressure in the system.**

## TRANSPORT TO FIELD SEQUENCE

Position the planter in a relatively flat open area. Try to avoid an area with furrows, etc.

### SUMMARIZED TRANSPORT TO FIELD SEQUENCE

- Remove tongue safety pin.
- Remove transport latch locking pin.
- Remove manual safety lockup.
- Rotate planter to planting position.
- Lower planter to the ground.
- Release wing lock cylinders.
- Rephase planter lift cylinders.
- Raise planter to raised field position and retract tongue.
- Remove marker lockups.

**NOTE: Read the following information for more detailed instructions.**

D021102234b

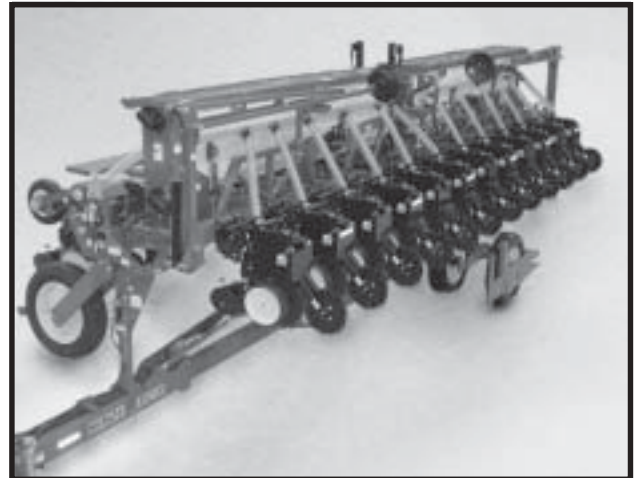

1. With the tongue fully extended and the planter in the raised transport position, remove the tongue safety pin and store it in the storage position.

D032901115



# MACHINE OPERATION

D032901120



2. Remove the transport latch locking pin from the locked transport position and place it in the storage location.

D032901113

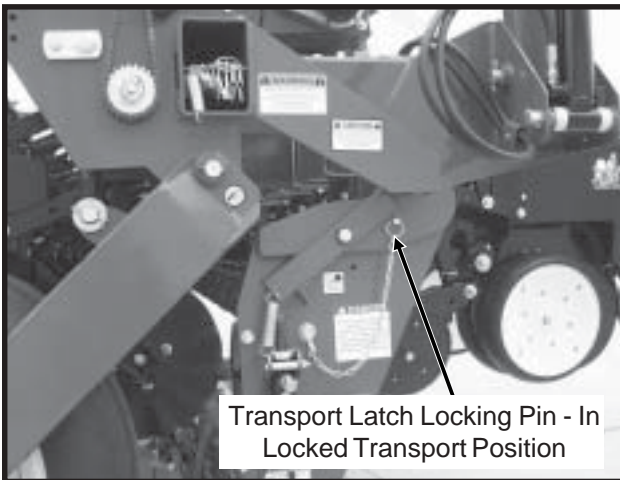

D032901114

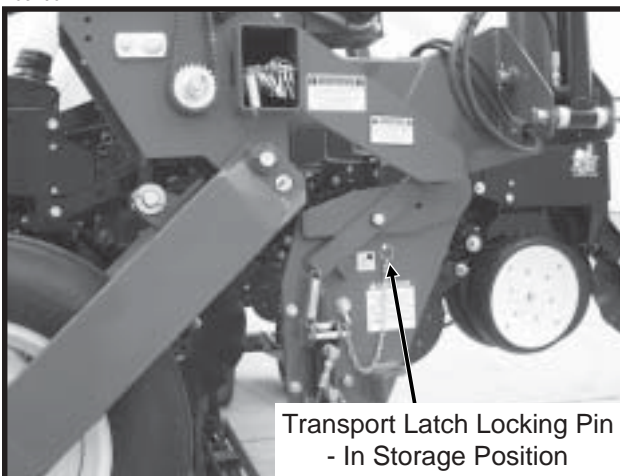

3. Remove the manual safety lockup from under the front center lift cylinder and place it in the storage location on the left side of the planter hitch.

D032901117

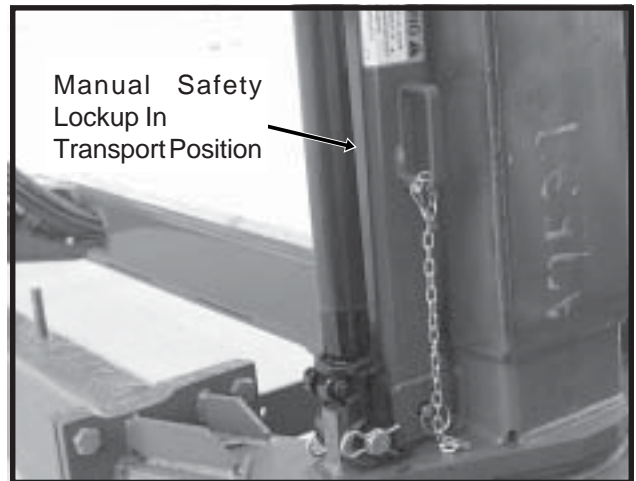

D101602212

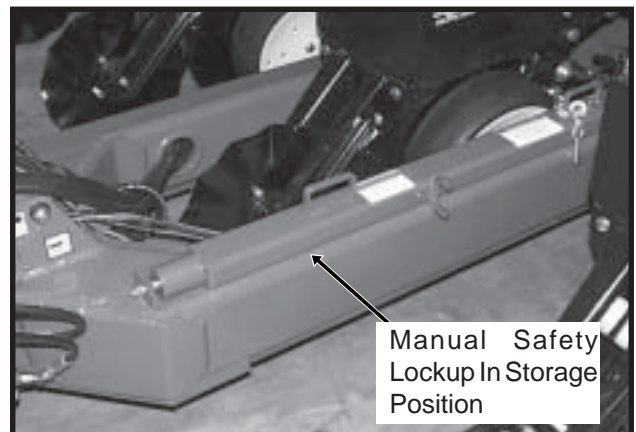

4. Hold the control console switch labeled "ROTATE/TONGUE" in "rotate" and operate the hydraulic lever to unfold the planter. The transport latch will automatically release.

76746-24

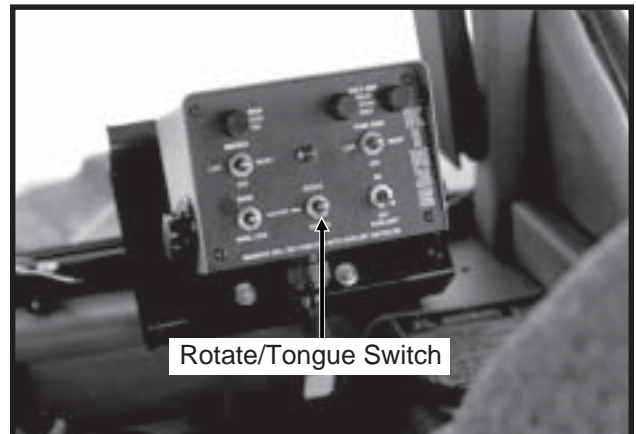

# MACHINE OPERATION

D021102236b



**Rotate Planter**

5. Slowly lower the planter to the ground.

D021102239b

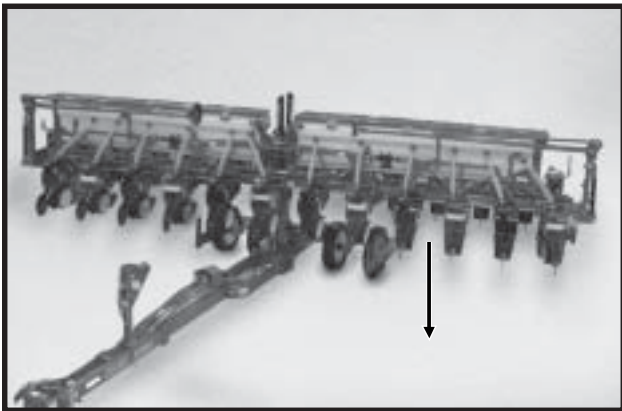

**Lower Planter**

6. Hold the control console switch labeled “RAISE/WING LOCK” in “wing lock” position and operate the hydraulic lever to extend the wing lock cylinders.

D021102257

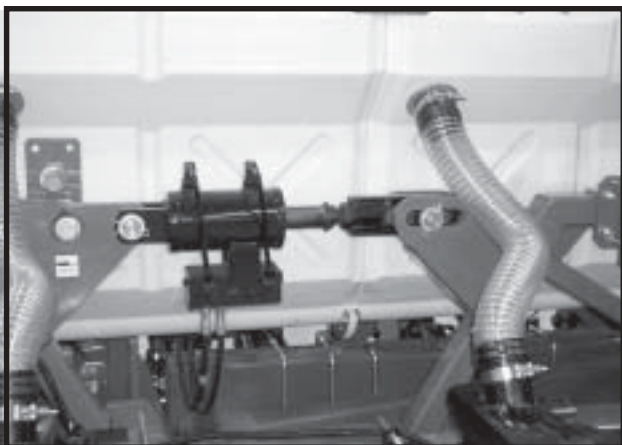

**Wing Lock Cylinder With Counter Balance Valve**

7. Hold the hydraulic lever (to lower planter) to rephase the planter lift cylinders. The length of time it takes to rephase the system may vary due to tractor hydraulic flow and/or oil temperature. Normally 5 to 20 seconds is adequate to rephase the system.
8. Raise the planter to the raised field position. Hold the control console switch labeled “ROTATE/TONGUE” in “tongue” and operate the hydraulic lever to retract the tongue.

D021102246b

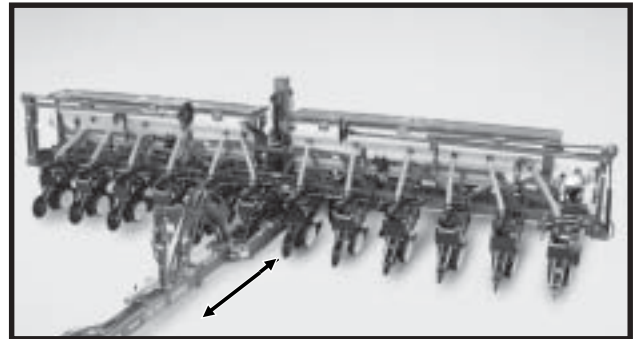

**Retract Tongue**

9. Remove and store marker lockups.

D032901130





# MACHINE OPERATION

## FIELD OPERATION

There are two raised positions on the planter. One is the “raised field position” which is when the planter wing cylinders are fully extended and the center lift cylinders are at mid-stroke. Because the solenoid, located on the top side of the valve blocks on the rear R.H. side of the center frame, is not energized, the wing cylinders cannot bypass oil preventing the planter from raising any higher. In the “raised field position” the row units are approximately 14 inches off the ground. This position is used in making turns or passing over waterways during field operation. The second raised position is the “raised transport position”.

D021102248a

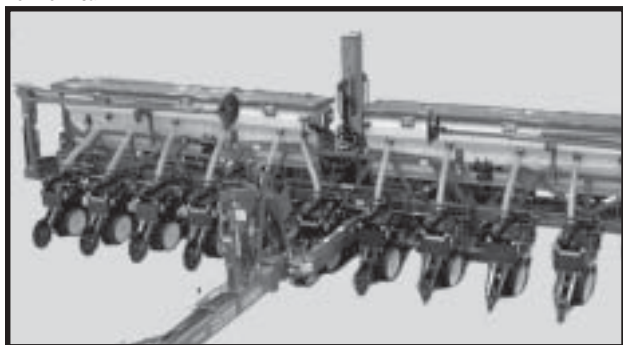

**Raised Field Position**

D032901145

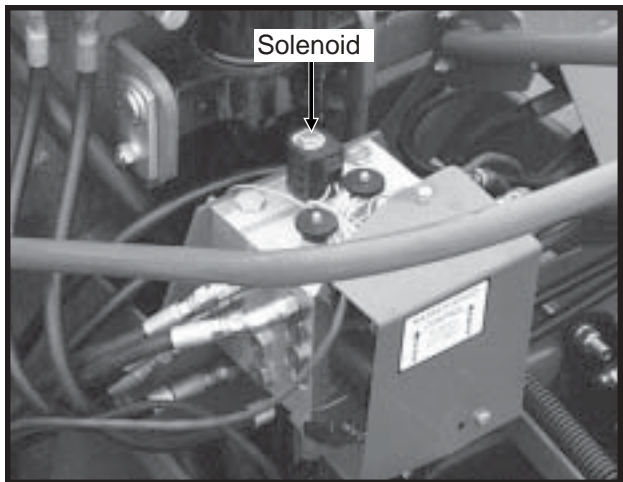

**Raise Solenoid**

See “Marker Operation” for field operation of row markers.

## FIELD TO TRANSPORT SEQUENCE

Position the planter in a relatively flat area. Try to avoid an area with furrows, etc.

### SUMMARIZED FIELD TO TRANSPORT SEQUENCE

- Install marker lockups.
- Raise planter to raised field position.
- Extend tongue.
- Retract wing lock cylinders.
- Raise planter to raised transport position.
- Rotate planter to transport position.
- Install tongue safety pin.
- Install transport latch locking pin.
- Install manual safety lockup.

NOTE: Read the following information for more detailed instructions.

1. Install marker lockups.

D021102203

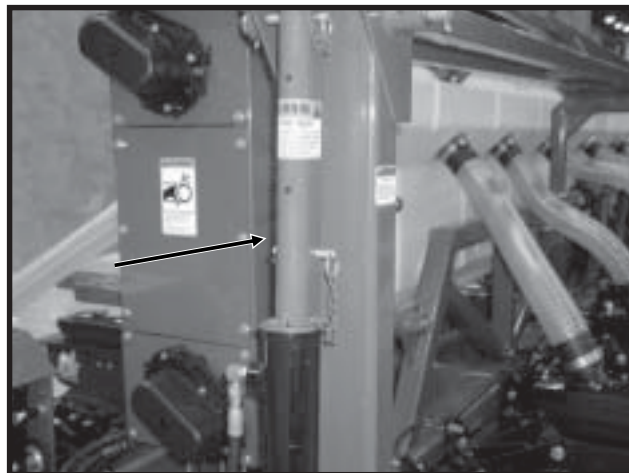

2. Using the hydraulic lever, raise the planter to the raised field position as shown below.

D021102248a

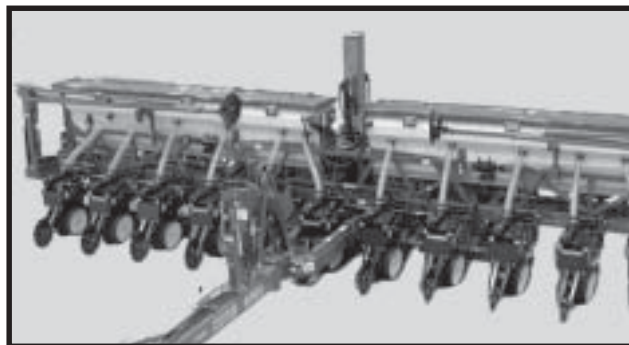

**Raised Field Position**

# MACHINE OPERATION

3. Hold the control console switch labeled “ROTATE/ TONGUE” in “**tongue**” and operate the hydraulic lever until the tongue is fully extended. Tongue lock latch will automatically release.

D021102246B

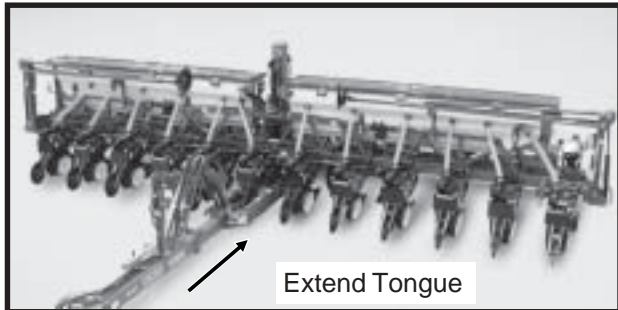

D032901126

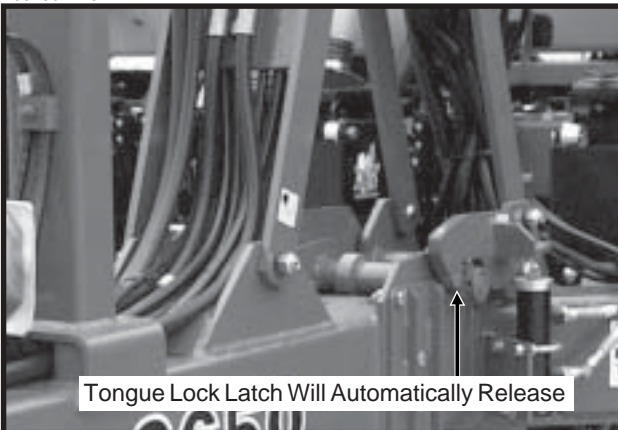

4. Hold the control console switch labeled “RAISE/ WING LOCK” in “**wing lock**” and operate the hydraulic lever until the wing lock cylinders are fully retracted.

76746-24

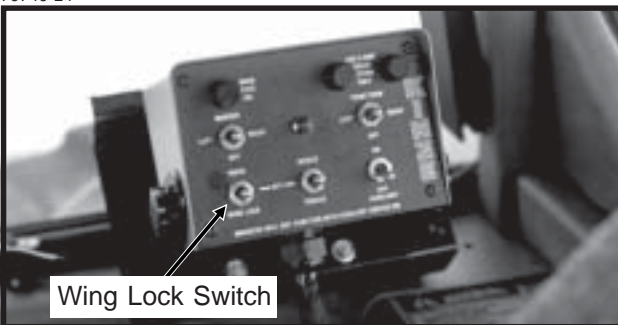

D021102215

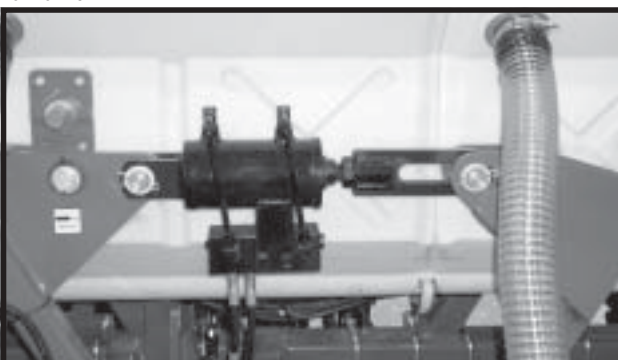

5. Hold the control console switch labeled “RAISE/ WING LOCK” in “**raise**” and operate the hydraulic lever until the two center lift cylinders are fully extended and the planter is fully raised.

D021102239B

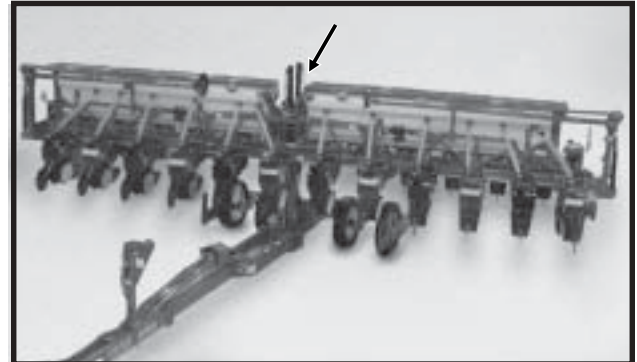

6. Hold the control console switch labeled “ROTATE/ TONGUE” in “**rotate**” and operate the hydraulic lever to rotate the planter until the transport latch is engaged.

D032901114

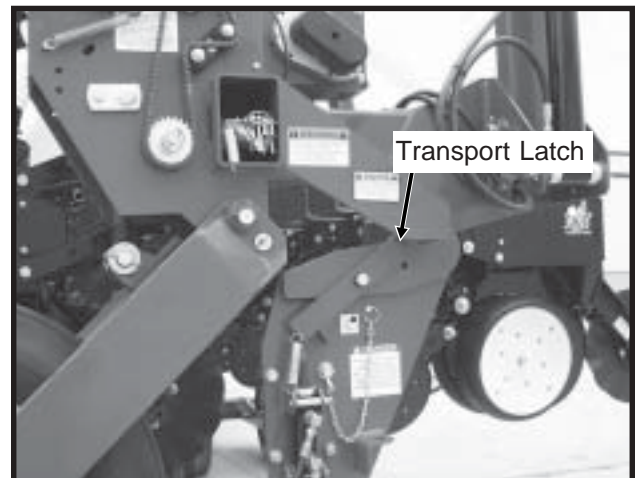

7. Install tongue safety pin.

D032301129



# MACHINE OPERATION

---

8. Install transport latch locking pin.

D032901113

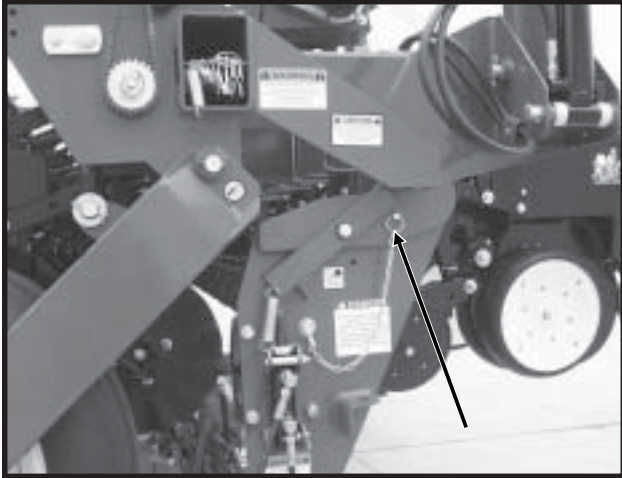

9. Remove manual safety lockup from its storage location on the left side of the planter hitch and position it behind the front center lift cylinder.

D101602212

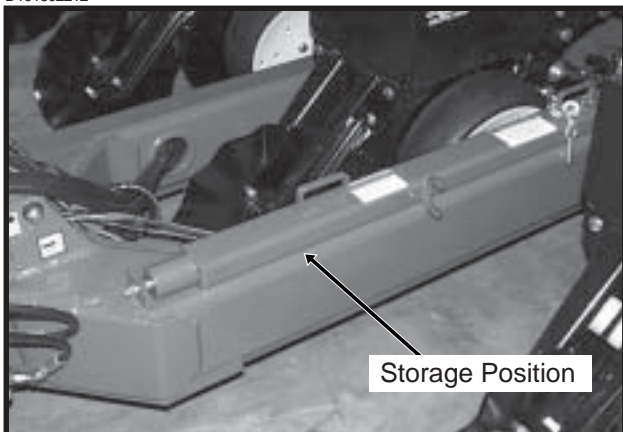

D032901117

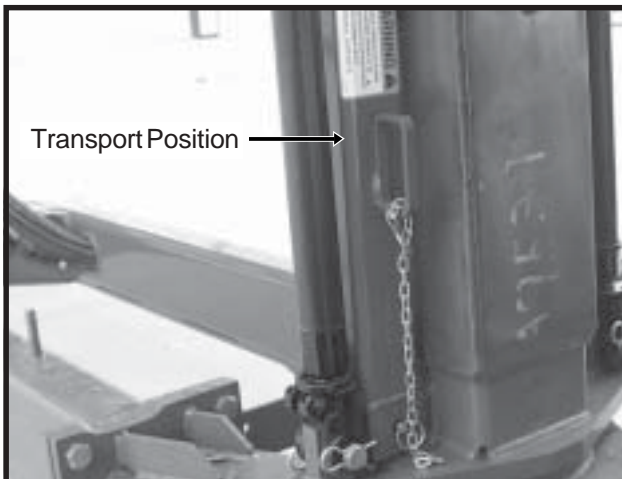

**DANGER:** Always install the manual safety lockup prior to working under the planter or while transporting the planter.

# MACHINE OPERATION

## MARKER OPERATION

D032901147

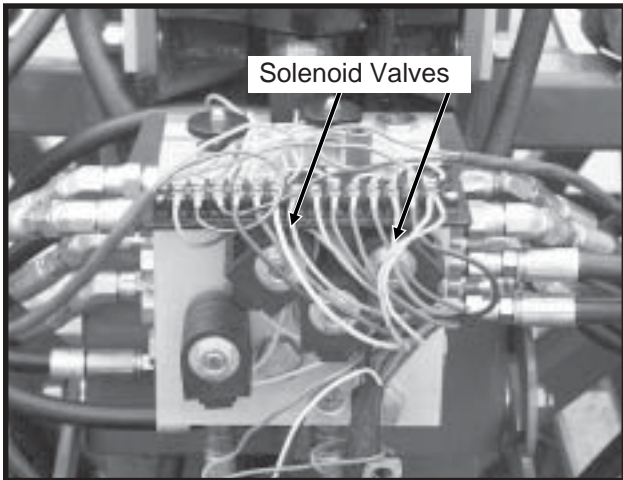

Shown With Cover Removed

D032901145

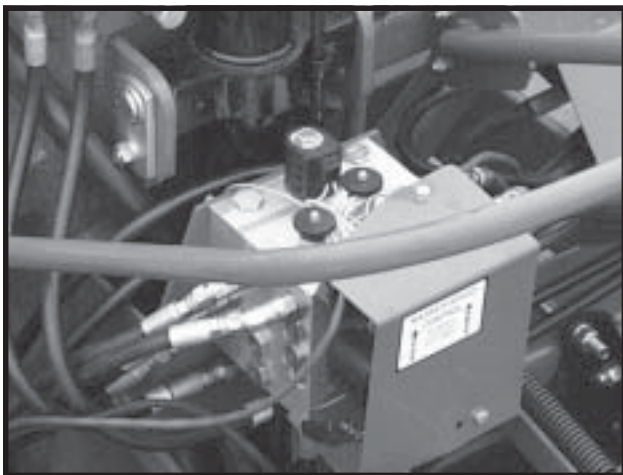

Shown With Cover Installed

76746-24

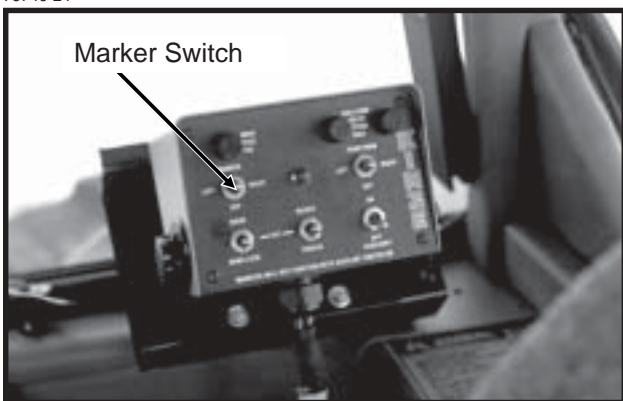

Three Position Selector Switch On Control Console

Two solenoid valves, located on the valve block on the rear R.H. side of the center frame, along with a three position selector switch on the control console permits the operator to lower or raise the desired marker.

See "Marker Speed Adjustment."

1. On the control console, select which marker you want lowered.
2. Operate hydraulic control lever to lower marker.
3. If opposite marker is to be used next, change control switch to other side.
4. At end of field, using hydraulic control lever, raise the down marker.
5. After making the turn, using the hydraulic lever, lower the pre-selected marker.
6. Continue to follow this procedure.

**NOTE: Both markers can be lowered by operating the switch in each position and operating the hydraulic lever twice. The markers will raise simultaneously with the hydraulic lever in the raise position.**

**IMPORTANT: Switch should be left in OFF position when planter is not in use. If left in ON position, it will drain the tractor battery.**

If the electrical system fails to operate properly:

- Check fuse.
- Check wiring connections.
- Check control switch.
- Check solenoid. SOLENOID HOUSING WILL BE MAGNETIZED WHEN ENERGIZED.



**DANGER: Care must be taken when operating row markers around overhead power lines.**

# MACHINE OPERATION

## MARKER SPEED ADJUSTMENT

The marker hydraulic system includes two flow control valves. One flow control valve controls the lowering speed of both markers and one controls the raising speed of both markers. To adjust marker speed, loosen the jam nut and turn the control(s) clockwise, or IN, to slow the travel speed and counterclockwise, or OUT, to increase the travel speed. The flow control(s) determines the amount of oil flow restriction through the valves, therefore determining travel speed of the markers. Tighten jam nut after adjustments are complete.

D032901145

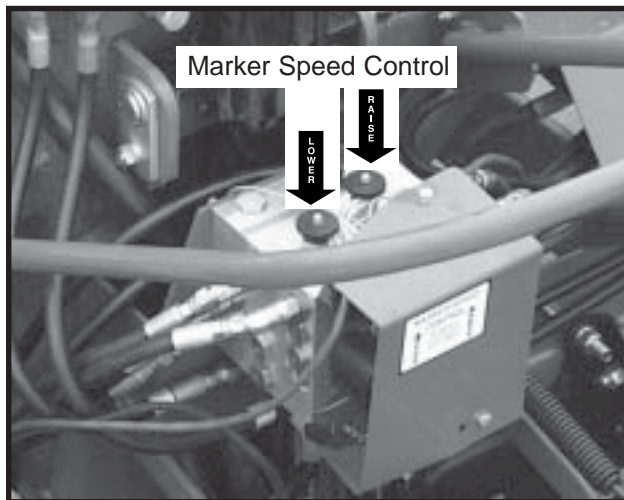

**IMPORTANT:** The flow controls should be properly adjusted before the marker assembly is first put into use. Excessive travel speed of the markers can damage the marker assembly.

**NOTE:** When oil is cold, hydraulics operate slowly. Make sure all adjustments are made with warm oil.

**NOTE:** On a tractor where the oil flow can not be controlled, the rate of flow of oil from the tractor may be greater than the rate at which the marker cylinder can accept the oil. The tractor hydraulic control lever will have to be held until the cylinder reaches the end of its stroke. This occurs most often on tractors with an open center hydraulic system.

On tractors equipped with flow control valves, marker speed adjustment should be made with the tractor flow controls in maximum position. After marker speed is set, the tractor flow controls can be adjusted to allow the hydraulic lever to stay in detent during the marker raise or lower cycle.

 **DANGER:** Care must be taken when operating markers around overhead power lines.

## MARKER LENGTH ADJUSTMENT

To determine the correct length at which to set the marker assemblies, multiply the number of rows by the average row spacing in inches. This provides the total planting width. Adjust the marker extension so the distance from the marker blade to the center line of the planter is equal to the total planting width previously obtained. Both the planter and marker assembly should be lowered to the ground when measurements are being taken. The measurement should be taken from the point where the blade contacts the ground. Adjust right and left marker assemblies equally and securely tighten clamping bolts. An example of marker length adjustment follows:

Number of rows	x	Row spacing (Inches)	=	Dimension between planter center line and marker blade.
----------------	---	----------------------	---	---

12 Rows x 30" Spacing = 360" Marker Dimension
---

60569-53

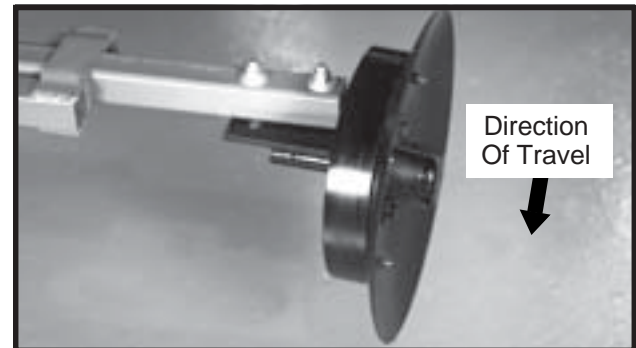

**Marker Blade Shown With Depth Band.**

The marker blade is installed so the concave side of the blade is outward to throw dirt away from the grease seals. The spindle assembly is slotted so the hub and blade can be angled to throw more or less dirt. To adjust the hub and spindle, loosen the 1/2" hardware and move the assembly as required. Tighten bolts to the specified torque.

**IMPORTANT:** A marker blade assembly that is set at a sharper angle than necessary will add unnecessary stress to the complete marker assembly and shorten the life of bearings and blades. Set the blade angle only as needed to leave a clear mark.

A field test is recommended to ensure the markers are properly adjusted. After the field test is made, make any minor adjustments as necessary.

A notched marker blade is available from KINZE® Repair Parts for use in more severe no till conditions.

(Continued On Following Page)

# MACHINE OPERATION

When using the even-row push row unit option, adjust marker extensions as shown below.

(TWL220aa)

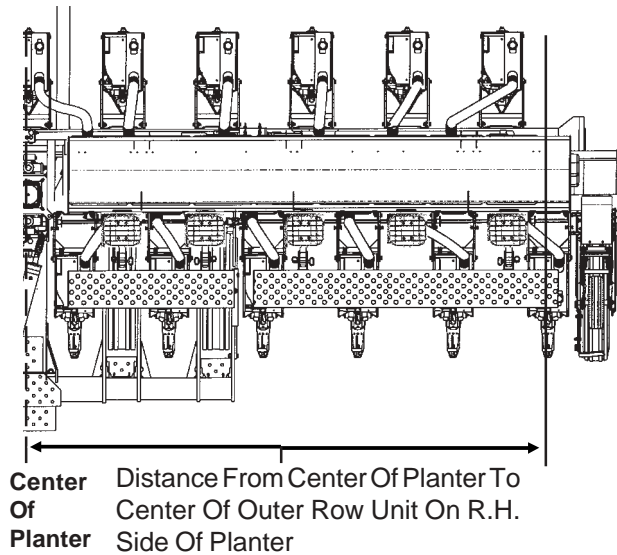
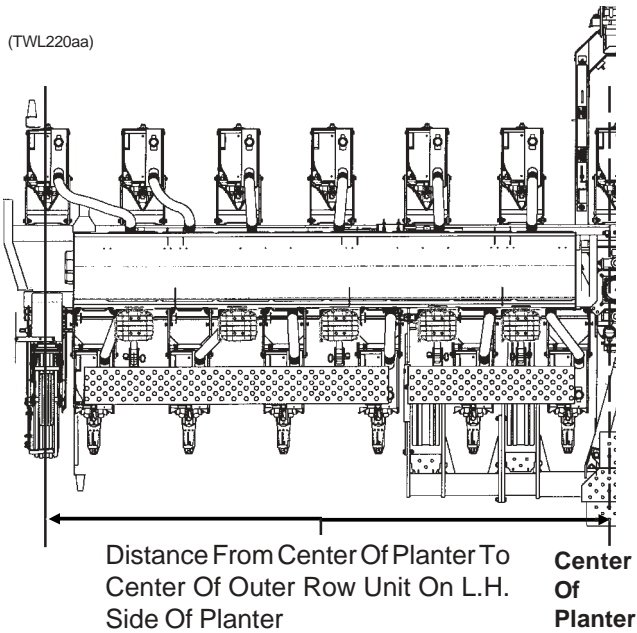

Center Of Planter To Center Of Outer Row Unit	x	2	+	15"	=	Dimension Between Planter Center Line And Marker Blade
				Row Spacing		

12 Row 30" With 12 Interplant® Push Row Units  
 (L.H. Marker 180" x 2 + 15" = 375")  
 (R.H. Marker 165" x 2 + 15" = 345")

16 Row 30" With 16 Interplant® Push Row Units  
 (L.H. Marker 240" x 2 + 15" = 495")  
 (R.H. Marker 225" x 2 + 15" = 465")

**NOTE:** If tractor hitch is offset 7 1/2" to the right of the center line of the tractor, add 7 1/2" to the marker dimension on the R.H. side of the planter and subtract 7 1/2" from the marker dimension on the L.H. side of the planter.

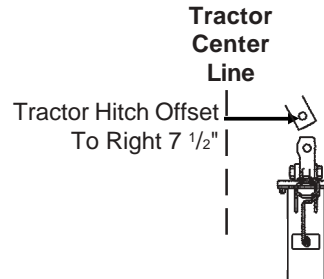

**NOTE:** Readjust markers when planting 30" rows.

## KPM I ELECTRONIC SEED MONITOR

(MTR28)

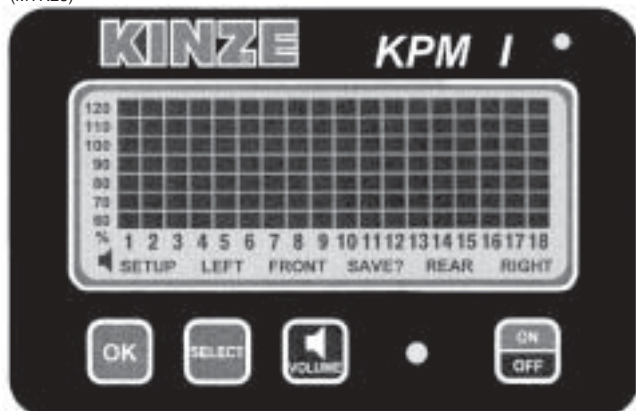

The electronic seed monitor system consists of a console, which is mounted on the tractor; seed tubes with computerized sensors, one of which is installed in each planter row unit; a primary harness\*, which connects the console to the planter harness; and a planter harness (junction Y-harness and/or harness extension where applicable), to which the individual seed tube sensors connect.

Seed flow for up to 36 rows, in two 18 row sections (left/right or rear/front), may be monitored with one monitor. For less complicated applications (18 rows or less), all rows may be programmed in one section and the other section left disabled.

The monitor system is powered by the tractor battery (requires 12 volts DC). The console receives information from each of the sensors and translates this information.

The single backlit Liquid Crystal Display (LCD) shows the active section, the number of monitored rows per section, the relative seed rate for each row (using a bar graph display) and scrolls various alarm and warning messages when an alarm condition exists. A continuous audible alarm will sound upon system malfunction or underflow conditions for any monitored row. Alarms must be acknowledged by the user. Various warnings may sound the alarm or flash one or more icons.

The monitor will power down if no activity is detected within one hour. No activity means there has been no new seed flow and no operator push key input. (If Applicable)

**\* NOTE: The primary harness, on all 3000 Series Planters, is hard-wired into the safety/warning light harness or control console harness included as standard equipment with the planter.**

Monitor Key Functions .....	6-15
LCD Functions .....	6-15
Changing The Audible Alarm Volume .....	6-16
Warnings And Alarms .....	6-16
Replacing A Faulty Sensor .....	6-17
Field Operation .....	6-18
Connecting Seed Tubes .....	6-18

### MONITOR KEY FUNCTIONS

Each key press is acknowledged by the monitor with a short beep.

#### OK

- Ends and saves the new setup during installation.
- Acknowledges and silences alarms in the operation mode.

#### SELECT

- Selects the application mode (rear/front or left/right) at the beginning of installation setup.
- Selects the active section(s) (rear, rear/front, left, right or left/right) in the normal mode.
- Has no affect on a system configured to monitor only one section.

#### VOLUME

- Pressing the key will turn the beeper on.
- Holding the key for periods of 2 seconds increases the volume until it reaches the maximum, at which time it rolls over to the minimum level.

#### ON/OFF

- Powers the unit on and off.

### LCD FUNCTIONS

The monitor collects data on the planting rates from all active rows and calculates an average. This average will determine the 100% mark. Seed rate for each row is then compared to the average value and the result is displayed on the bar graph.

The information regarding each section is displayed alternately every 5 seconds. While operating a system with two sections programmed, one or both sections may be selected any time. When only one section is selected, the monitor calculates the average based on the remaining active rows from that section.

**STEP 1** Press SELECT key once to show one section. The flashing icon shows the section that is not selected. The selected section is continuously displayed on the LCD.

**EXAMPLE:** The system is setup to display rear/front sections. Press SELECT key. The FRONT icon will be flashing and the REAR section will be displayed on the bar graph. After 1 minute the front row icon will stop flashing. The monitor will stay in this REAR only display through power down and power up. Each time the monitor is turned on while in REAR only mode, the FRONT icon will flash for 1 minute. Also if seed flow is sensed in the FRONT section while planting, the FRONT icon will resume flashing.

**STEP 2** Press SELECT key again to activate both sections.

**EXAMPLE:** Press SELECT key a second time. The information regarding each section will display alternately every 5 seconds.

For simple applications, where only one section is programmed, the display will automatically lock on that section. Pressing SELECT key will have no affect.

**NOTE:** When alternating between two sections, the display will lock on the section containing the first recognized alarm until the alarm is acknowledged by pressing the OK key or the alarm condition is removed.

## CHANGING THE AUDIBLE ALARM VOLUME

**STEP 1** Press and hold down the VOLUME key.

**STEP 2** The SETUP and VOLUME icons will turn on and the beeper will sound continuously. The intensity of the sound will change every 2 seconds. After the maximum volume is reached, the next change will set the volume to minimum and will continue to get louder every 2 seconds. When the desired volume is reached, release the key.

## WARNINGS AND ALARMS

- 1. System Alarms** - A system alarm is activated when the monitor detects a faulty sensor or one of several other communication faults.

The corresponding row number starts flashing and the beeper sounds. All segments on the corresponding bar graph are turned off. Pushing the OK key to acknowledge the alarm will turn the beeper off. The row number will continue to flash until the alarm condition is removed. If the monitor detects a faulty sensor and there is no planting activity present, the monitor will scroll "CHECK CONNECTION".

Another type of system alarm occurs when the monitor detects a data communication bus error. The three possible data communication bus errors are:

LCD Display	Error Condition
SYS HI	The data communication lead (green) has been shorted to the power lead (white).
SYS LO	The data communication lead (green) has been shorted to the ground lead (black).
SYS EC	An internal error has been detected.

- 2. Under Flow Alarms** - If the seed rate for one or more rows is less than 55% of the calculated average, the corresponding 60% segment will stay on, the corresponding row number starts flashing and the alarm sounds. Pushing the OK key to acknowledge the alarm will turn the alarm off. The 60% segment of the bar graph remains on and the row number continues to flash until the alarm condition is corrected.

**NOTE:** All alarms present within a short time before planting stops, are frozen on the screen and the text LOW or FAIL will display on the LCD. If the under flow is between 0% and 10%, this warrants a "FAIL" condition. If the under flow is between 10% and 55%, a "LOW" condition is generated. If multiple rows have an under flow condition, "FAIL" will display if any one or more rows is between 0% and 10%. This allows the user to identify and fix the problem rows.



**NOTE: This warning will not trigger unless a minimum time of continuous planting has passed.**

**NOTE: If all the rows show a seed rate of zero, the condition will not generate an alarm. It will be assumed the planter has stopped. The row numbers and the bottom 60% segment will remain on for all selected rows.**

3. **Multiple Alarms** - If more than one alarm condition occurs at the same time, pushing the OK key will acknowledge all alarms that are currently displayed. For example, if one row on the front and one row on the rear are alarming, pushing the OK key will only acknowledge one of them. However, if there are two alarms on the front, both alarms would be acknowledged with one push of the OK key.
4. **Section Not Selected Warning** - If the monitor was programmed for two sections and only one is currently selected for display (by pressing the SELECT key), the icon of the disabled section will flash for a period of 1 minute, then turn off at each power up. If seed flow is sensed in the disabled section, the icon for that section (front, left or right) will begin to flash.
5. **Seed Planting Stopped Warning** - When the monitor detects no seed flow on all rows, the monitor will emit 3 short beeps to alert the user. This warning will occur each time the planter is stopped, each time the planter is raised at the end of a row or if the mechanical drive fails while planting.

**NOTE: This warning will not trigger unless a minimum time of continuous planting has passed.**

6. **Seed Counting Sensor In Calibration Warning** - All seed counting sensors run a self-calibration sequence on power up. While in calibration the bottom segment of each corresponding bar graph will flash if the monitor detects movement or planting activity. If the monitor does not detect this, the message "WAIT CALIBRATION" will be scrolled.

7. **Seed Counting Sensor Too Dirty Warning** - After the seed counting sensors end their internal self-calibration, the monitor may detect one or more sensors are either too dirty or blocked. If the monitor detects planting or movement, the corresponding bar graph remains flashing. The monitor will display "CLEAN SENSORS" on the LCD if no movement or planting is detected, prompting the user to clean the tubes. If the tubes are dirty, they will still show seed flow with less accuracy. If the tubes are blocked the user will get an alarm as soon as planting starts. The corresponding bar graph will remain flashing until the problem is corrected and the monitor is powered down and then powered back up.
8. **Low Battery Warning** - The monitor is constantly monitoring its input voltage to quickly detect low power conditions. If the monitor detects that the input voltage has dropped below 10.5V, it will display "LOW POWER" on the LCD, provided that the monitor does not detect planting.

**NOTE: After the alarms have been acknowledged and if the alarm condition is still present, the LCD will continue to display the alarm condition.**

## REPLACING A FAULTY SENSOR

To replace a faulty sensor; (a) turn the monitor off, (b) disconnect the faulty sensor, (c) turn the monitor back on and (d) plug in the replacement sensor. The monitor will chirp twice to acknowledge the new sensor was learned and saved.

To replace more than one faulty sensor, proceed as stated above beginning with the lowest numbered row in the rear or left section and continue to replace sensors in increasing order. Then move on to the front or right section and continue in ascending row number order.

**NOTE: If the monitor is not turned off and then on, the replacement sensor(s) will be ignored until the next power on, at which point they will be randomly learned by the monitor.**

## FIELD OPERATION

(MTR28e/MTR28c/MTR28d/MTR28b)

Press the ON/OFF key to turn the monitor on and off.



Information regarding each section is displayed alternately every 5 seconds.

### REAR/FRONT CONFIGURATION

- Press the SELECT key once to show REAR section only.
- Press the SELECT key a second time to return to each section being displayed alternately every 5 seconds.
- Press the SELECT key a third time to show REAR section only again.



### LEFT/RIGHT CONFIGURATION

- Press the SELECT key once to show LEFT section only.
- Press the SELECT key a second time to show RIGHT section only.
- Press the SELECT key a third time to return to each section being displayed alternately every 5 seconds.



**NOTE: SELECT key has no function when only a single section is being used.**

Press the VOLUME key to increase or decrease volume. See “Changing The Audible Alarm Volume”.



Press the OK key to silence alarms. See “Warnings And Alarms”.



## CONNECTING SEED TUBES

**STEP 1** All the seed tubes w/sensors must be disconnected from the harness and the monitor must be off.

**STEP 2** Press the ON key. The monitor automatically enters the setup procedure. If the monitor was accidentally powered on with no sensors attached, the user can turn the monitor off at this point and the previous configuration is not lost.

**STEP 3** Press the SELECT key. Each time you press the SELECT key the mode will toggle between rear/front and left/right. The selected display will be solid and the configuration not currently selected will be flashing. By default the monitor starts in rear/front mode.

01229910

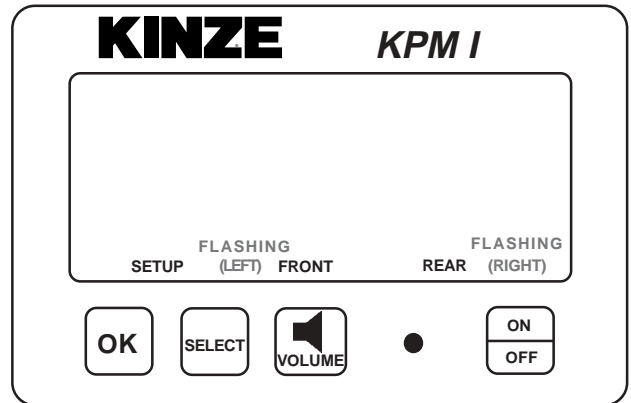

01229911

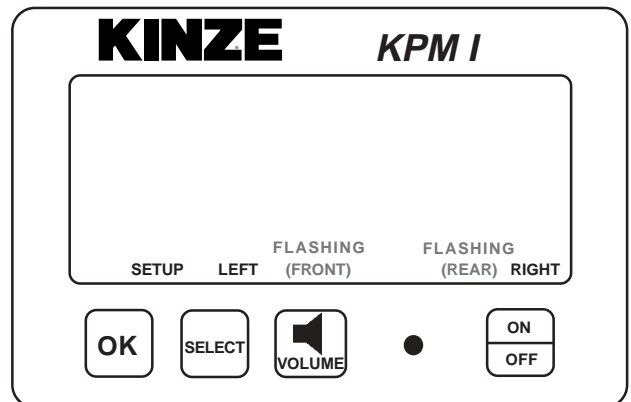

**NOTE: Model 3650 planters will use the rear configuration only. When Interplant® Package rows are in use, select the rear/front configurations. When all rows can be viewed on a single display (rear), pressing the select key has no function.**

**STEP 4** Press and hold the OK key to confirm the selection and continue holding until the row numbers appear on the display. During confirmation, the display will alternate between “NEW” and “SYS” to alert the user that the previous configuration will be lost. With the rear/front mode selected, the monitor automatically starts with the rear section. The REAR icon shows solid and the FRONT icon starts to flash. With the left/right mode selected, the monitor automatically starts with the left section. The LEFT icon shows solid and the RIGHT icon starts to flash.

01229912

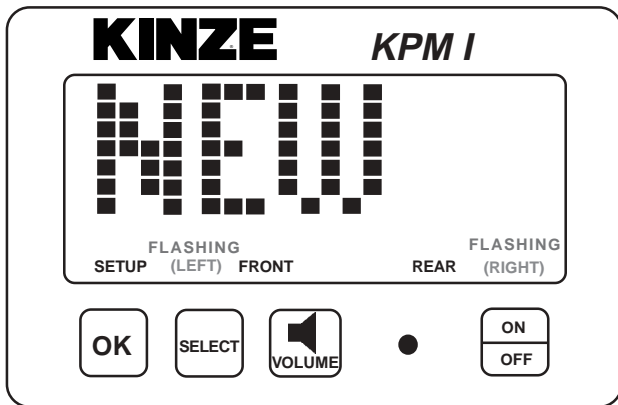

**STEP 5** Plug each seed tube w/sensor into the harness in a predetermined order. Row 1 first, row 2 second and so on up to 18 rows. When a sensor is plugged in, the corresponding row number on the LCD display will stay solid, the monitor will chirp twice and the LED (Light Emitting Diode) on the seed tube sensor will turn on for approximately 30 seconds to show connection is made. NOTE: Unless there is a faulty sensor, the installer should just have to connect the sensors in the proper order without checking the monitor is acknowledging each sensor.

01229915

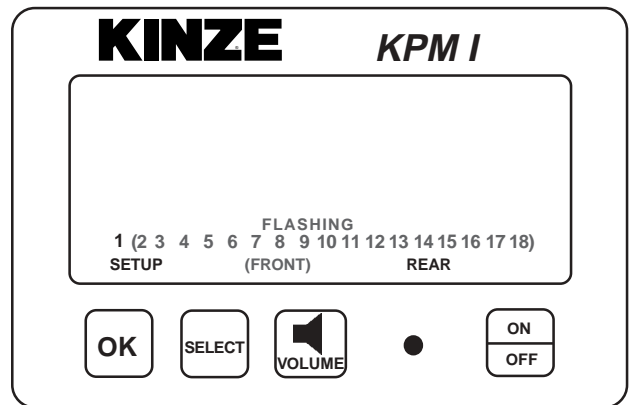

01229912a

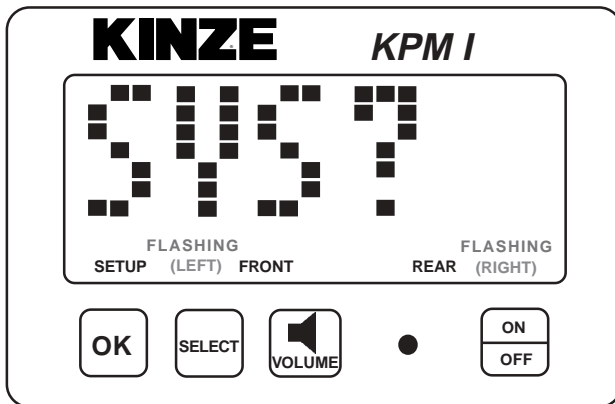

**STEP 6** When all the seed tubes w/sensors for the current section are installed, check to be sure the monitor displays solid numbers for the number of sensors connected.

01229916

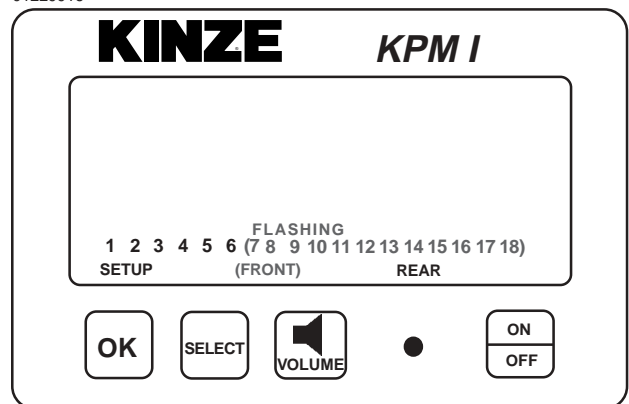

**STEP 7** If this condition is satisfied, press and hold the OK key to save the setup for the current section. The SAVE? icon will show followed by continuous short beeps indicating the monitor is preparing to save. The installer has 5 seconds to decide if he wants to save the current configuration. During this time the short beeps will sound. To complete the save, hold the OK key pressed until the word "DONE" shows on the screen followed by a long beep and the SAVE? icon turns off. When the OK key is released the monitor will continue with the second section installation.

01229917

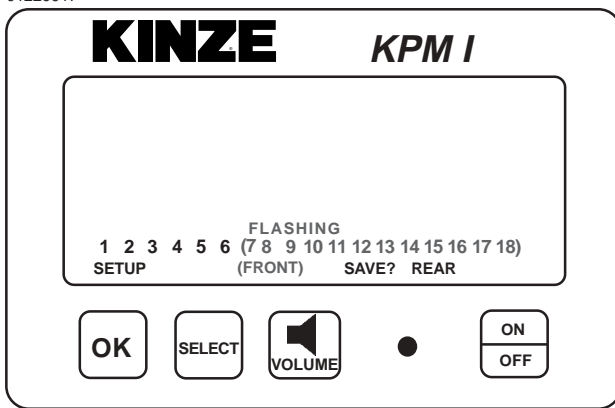

01229918

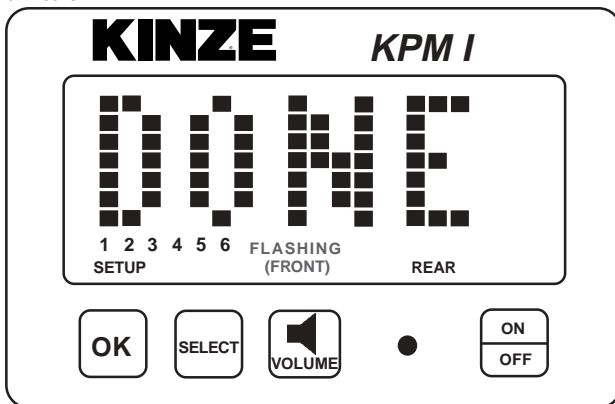

**STEP 8** Follow STEPS 5 through 7 to install the second section. If no seed tubes are installed on the second section, press and hold the OK key until the word "DONE" shows on the screen followed by a long beep and the SAVE? icon turns off.

01229919

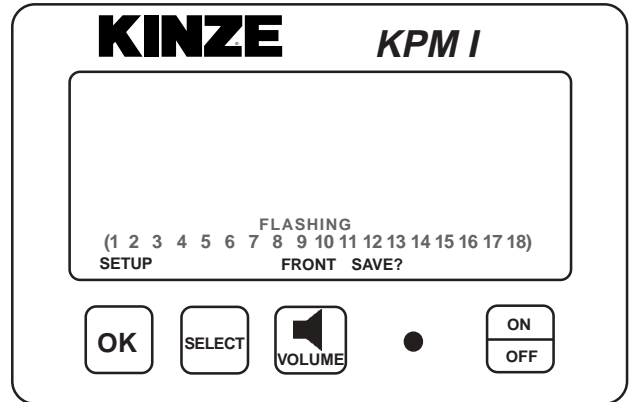

01229920

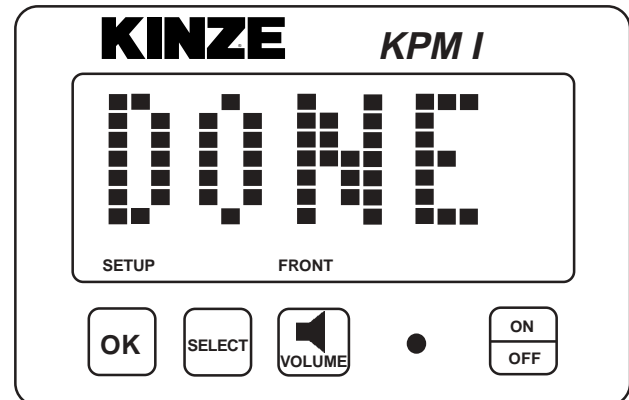

**NOTE:** Individual seed tubes may be unplugged for special situations. An alarm will sound which can be silenced by touching the OK key. The monitor will recognize each seed tube when reconnected.

## KPM II ELECTRONIC SEED MONITOR

(MTR29)

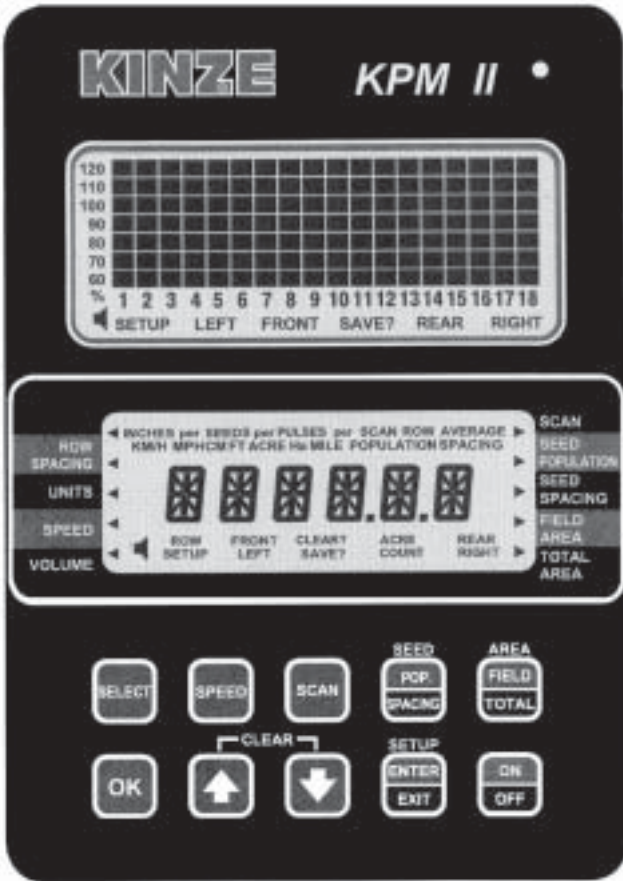

The electronic seed monitor system consists of a console, which is mounted on the tractor; seed tubes with computerized sensors, one of which is installed in each planter row unit; a primary harness\*, which connects the console to the planter harness; and a planter harness (junction Y-harness and/or harness extensions where applicable) to which the individual seed tube sensors and rotation sensors connect. The monitor works with a magnetic (pickup) distance sensor or radar distance sensor.

\* **NOTE:** The primary harness, on all 3000 Series Planters, is hard-wired into the safety/warning light harness or control console harness included as standard equipment with the planter.

Seed flow for up to 36 rows, in two 18 row sections (left/right or rear/front), may be monitored with one monitor. For less complicated applications (18 rows or less), all rows may be programmed in one section and the other left disabled.

The monitor system is powered by the tractor battery (requires 12 volts DC). The console receives information from each of the sensors and translates this information.

The console has two backlit Liquid Crystal Displays (LCD). The upper display shows the active section, the number of monitored rows per section, the relative seed rate for each row (using a bar graph display) and scrolls various alarm and warning messages when an alarm condition exists. A continuous audible alarm will sound upon system malfunction or underflow conditions for any monitored row. Alarms must be acknowledged by the user. Various warnings may sound the alarm or flash one or more icons. The lower display is used to display alphanumeric data such as row spacing, units (Metric or English), speed, volume, seed population, seed spacing, field area, total area and distance sensor pulses per mile/kilometer.

The monitor will power down if no activity is detected within one hour. No activity means there has been no new seed flow and no operator push key input. (If Applicable)

Monitor Key Functions .....	6-22
Upper LCD Functions .....	6-23
Lower LCD Functions .....	6-24
<b>Programming</b>	
Changing The Audible Alarm Volume .....	6-26
Units (Metric Or English) .....	6-27
Row Spacing .....	6-27
Speed .....	6-29
Clearing Total Area .....	6-30
Area Counter/Speedometer Mode .....	6-31
Warnings And Alarms .....	6-31
Replacing A Faulty Sensor .....	6-32
Field Operation .....	6-32
Clearing Field Area .....	6-33
Connecting Seed Tubes, Radar/Magnetic Distance Sensors And/Or Shaft Rotation Sensors .....	6-34
Row-By-Row Alarm Level Setting .....	6-42

## MONITOR KEY FUNCTIONS

Push keys allow the user to select or change the operating mode, the active displays or the current configuration. Depending on the operating mode or the current display selected, some keys are valid while some are not. Each key press if valid is acknowledged by a short beep and an action is taken. If the key press has no action associated, the key press is considered invalid and the user will not get any feedback.

### SELECT

- Selects the application mode (rear/front or left/right) at the beginning of installation in the setup mode.
- Selects the active section(s) (rear, rear/front, left, right or left/right) in the normal mode.
- Has no affect on a system configured to monitor only one section.
- While programming the monitor, the key will select the digit to change.

### SPEED

- Immediately displays the current ground speed.

### SCAN

- If the current average population or average spacing is displayed, this key sequentially displays the seed population/spacing on each row.
- If the display shows functions other than average seed population or spacing, pressing SCAN will sequentially display speed, average seed population and average seed spacing.
- Pressing a second time freezes the display on the current row.
- Pressing a third time restarts the sequential display.

### SEED POPULATION/SEED SPACING

- Immediately displays the average seed POPULATION and the average seed SPACING of all active rows.
- Each press alternates between seed spacing and seed population.

### AREA FIELD/AREA TOTAL

- Immediately displays the field and total area planted since the field/total area was last cleared.
- Each press alternates between field area and total area.

### OK

- Ends and saves the new setup during installation.
- Acknowledges and silences alarms in the operation mode.

### UP ARROW AND DOWN ARROW

- Scrolls sequentially through the display options on the lower LCD display.
- Freezes on the current row in the scan mode.
- Scrolls sequentially through the rows when the population scan is frozen.
- Used to enter programmable values in the programming mode.
- The Up and Down Arrow keys can be pressed at the same time to start the CLEAR function.

### SETUP ENTER/SETUP EXIT

- Enters and exits the programming mode.

### ON/OFF

- Powers the unit on and off.

## UPPER LCD FUNCTIONS

(MTR29H)

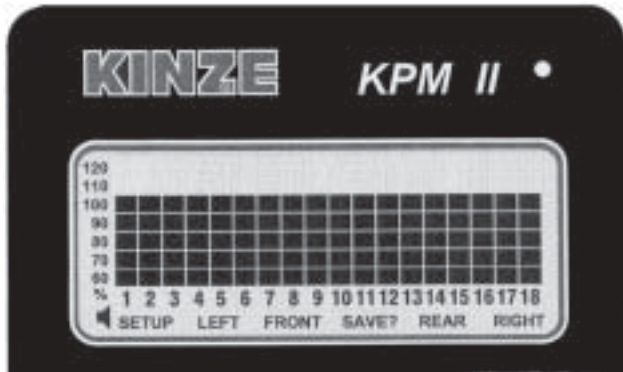

The monitor collects data on the planting rates from all active rows and calculates an average. This average will determine the 100% mark. Seed rate for each row is then compared to the average value and the result is displayed on the bar graph.

The information regarding each section is displayed alternately every 5 seconds. While operating a system with two sections programmed, one or both sections may be selected any time. When only one section is selected, the monitor calculates the average based on the remaining active rows from that section.

**STEP 1** Press SELECT key once to show one section. The flashing icon shows the section that is not selected. The selected section icon is continuously displayed on the LCD.

**EXAMPLE:** The system is setup to display rear/front sections. Press SELECT key. The FRONT icon will be flashing and the REAR section will be displayed on the bar graph. After 1 minute the front row icon will stop flashing. The monitor will stay in this REAR only display through power down and power up. Each time the monitor is turned on while in REAR only mode, the FRONT icon will flash for 1 minute. Also if seed flow is sensed in the FRONT section while planting, the FRONT icon will resume flashing.

When the front section is disabled, the row spacing will automatically double to maintain the proper implement width in the monitor. A 23 row 15" configuration changes to a 12 row 30" configuration with a touch of the SELECT key.

**STEP 2** Press SELECT key again to activate both sections.

**EXAMPLE:** Press SELECT key a second time. The information regarding each section will display alternately every 5 seconds.

For simple applications, where only one section is programmed, the display will automatically lock on that section. Pressing the SELECT key will have no affect.

**NOTE:** When alternating between two sections, the display will lock on the section containing the first recognized alarm until the alarm is acknowledged by pressing the OK key or the alarm condition is removed.

## LOWER LCD FUNCTIONS

(MTR29g)



- The UP and DOWN arrow keys will sequentially change what is being displayed on the lower LCD. Pressing the UP or DOWN arrow keys will move the arrow head icon (on the left and right hand side of the display) to another item. For example, if the arrow icon is pointing to SPEED, ground speed will be displayed on the LCD. Pressing the UP arrow key will move the icon to UNITS. The display will change to display all the icons used to represent the current (English or Metric) measurement system.
- The shortcut keys SPEED, SEED POPULATION/SPACING and AREA FIELD/TOTAL allow direct access to their respective displays. For example, no matter what is currently being displayed on the lower LCD, pressing the SPEED key will change the display to the current speed. Pressing the SEED POPULATION/SPACING or AREA FIELD/TOTAL keys will alternate between the two functions assigned to that key.
- Pressing the SCAN key while displaying seed spacing or population will cause a sequential display of each individual row. Pressing the SCAN key a second time will freeze the display on the currently displayed row. The UP or DOWN arrow keys can be used to change the currently displayed row. Pressing the SCAN key will restart the automatic advancing of the scan function.
- Pressing the SCAN key while displaying speed will cause a sequential display of speed, average planter population and average seed spacing. Pressing the SCAN key a second time will freeze the display on the currently displayed reading.

### ROW SPACING

Press the arrow keys to ROW SPACING to display the current spacing between rows in inches or centimeters. The ROW SPACING icons turn on, displaying a 3 digit, one decimal place format. In the acre counter mode, this function displays the implement width in feet or meters, using a 3 digit, no decimal places format.

### UNITS

Press the arrow keys to UNITS to display all the icons from the currently selected English or Metric measurement system. For the English system, the icons are: INCH, MPH, FT, ACRE and MILE. For the Metric system, the icons are: M, KM/H and Ha.

### SPEED

Press the SPEED key to display the current speed in MPH or KM/H, using a 3 digit, one decimal place format.

### VOLUME

Press the arrow keys to VOLUME to display the presently selected audible alarm volume. The SPEAKER icon turns on.

### SCAN

Press the SCAN key to display the seed spacing or seed population (see below) of each individual row. (1)Pressing the SCAN key while displaying any other function will cause the monitor to sequentially display speed, average seed population and average seed spacing. (2)Pressing the SCAN key a second time will freeze the display. (3)Pressing the SCAN key a third time restarts the sequential display. The UP and DOWN arrow keys can be used to change the current display.



## SEED POPULATION/SEED SPACING

Each SEED POP/SPACING key press alternates between seed population and seed spacing.

Seed population displays the average number of seeds or the row average number of seeds per acre or seeds per hectare for all the active rows. The average is displayed using a 6 digits, no decimal places format. The AVERAGE POPULATION icon will turn on. When in the scan mode, the scan arrow and SCAN ROW POPULATION will appear. The ROW number icon and the current row will be displayed on the left and the population will be displayed on the right in 1000's using 3 digits, one decimal place (e.g. 32.9 means 32,900). When in scan freeze mode, the scan arrow and ROW POPULATION will turn on (scan arrow may be flashing). The UP and DOWN keys may be used to lock on the desired row.

Seed spacing displays the average distance or the row average distance between seeds for all active rows in inches per seed or centimeters per seed, using a 3 digit, one decimal place format. When the average is displayed the AVERAGE SPACING icons are turned on. When in the scan mode, the scan arrow and SCAN ROW SPACING icons will appear. The ROW number icon and the current row will be displayed on the left and the spacing will be displayed on the right. The display will sequence to the next row every 5 seconds. When in scan freeze mode, the scan arrow and SPACING will turn on (scan arrow may be flashing). The UP and DOWN keys may be used to lock on the desired row.

## FIELD AREA/TOTAL AREA

Each AREA FIELD/TOTAL key press alternates between field area and total area.

Field area displays the total number of acres or hectares, using a 6 digit, one decimal place format.

**NOTE: When FIELD AREA is selected, the UP or DOWN key must be held in slightly longer than normal so the monitor will not mistake this action with a CLEAR, which consists of the UP and DOWN arrow keys pressed simultaneously. A beep will sound when the function activates.**

Total area displays the total number of acres or hectares, using a 6 digit, one decimal place format. The total area counter updates every time the field area counter increments. Clearing the total area counter will also clear the field area counter.

When the monitor is programmed as a rear only or rear/front configuration and shaft rotation sensors are installed, pressing the up arrow to move beyond row spacing lights an arrow on an unlabeled area above ROW SPACING. This is the automatically set division line between the L.H. shaft sensor and the R.H. shaft sensor. The display shows the first row on the rear section and the front section assigned to the R.H. shaft rotation sensor.

**EXAMPLE: On a 12 row 30" planter with Interplant® Package, the display would appear as follows:**

092597-21



THIS DISPLAY IS NOT ACCESSIBLE ON LEFT/RIGHT CONFIGURATIONS OR SYSTEMS WITHOUT SHAFT ROTATION SENSORS.

## PROGRAMMING - Changing The Audible Alarm Volume

**STEP 1** To enter the programming mode, press and hold the SETUP key. The monitor will emit several short beeps, followed by a long beep. On the lower LCD, the SETUP icon turns on and the arrow head icon will flash, indicating that the user can select an item to program.

**NOTE: The monitor must be in a programmable function (row spacing, units, speed, volume or area) to enter setup. The monitor will not enter setup in seed population or seed spacing.**

**STEP 2** Press the UP or DOWN arrow keys to move the flashing arrow to VOLUME. As the arrow icon moves, the lower LCD will display the current setting of the item selected.

**STEP 3** Press the OK key and the flashing arrow becomes solid and the beeper will sound.

**NOTE: The lower LCD will display the current volume and the SPEAKER icon is turned on. Settings are from 0 to 9.**

- Use the UP or DOWN arrow keys to change the setting. With every UP arrow key push, the beeper will increment by one step between the minimum and the maximum. If the maximum level (9) is reached the volume rolls over to the minimum level (0).
- Pressing the DOWN arrow key lowers the volume until the minimum level (0) is reached, at which point the volume rolls over to the maximum level (9).

**STEP 4** To exit without saving, press and release the OK key. The monitor will restore the lower LCD to show the setting of the item, and the arrow icon will flash, allowing the user to select another item to program.

To exit and save, press and hold the OK key. The monitor will emit several short beeps and SAVE? icon is turned on. After a short time a long beep is heard, and the lower LCD will display the word "DONE". Release the OK key. If the OK key is released BEFORE the word "DONE" is displayed, the changes WILL NOT BE SAVED. The word "DONE" MUST be displayed in order for the save to have occurred.

**NOTE: The programming mode may be exited at any time, by pressing the SETUP key. Pressing this key will return the monitor to its normal operation. All items changed and saved will come into affect immediately. Any items changed, but not saved will revert to the original programmed value.**

## PROGRAMMING - Units (Metric Or English)

**STEP 1** To enter the programming mode, press and hold the SETUP key. The monitor will emit several short beeps, followed by a long beep. On the lower LCD, the SETUP icon turns on and the arrow head icon will flash, indicating that the user can select an item to program.

**NOTE: The monitor must be in a programmable function (row spacing, units, speed, volume or area) to enter setup. The monitor will not enter setup in seed population or seed spacing.**

**STEP 2** Press the UP or DOWN arrow keys to move the flashing arrow to UNITS. As the arrow icon moves, the lower LCD will display the current setting of the item selected.

**STEP 3** Press the OK key and the flashing arrow becomes solid and the beeper will sound.

**NOTE: The lower LCD will alternately display all Metric icons or all English icons, indicating the Metric or English mode respectively.**

- Use the UP or DOWN arrow keys to change the setting.

**STEP 4** To exit without saving, press and release the OK key. The monitor will restore the lower LCD to show the setting of the item, and the arrow icon will flash, allowing the user to select another item to program.

To exit and save, press and hold the OK key. The monitor will emit several short beeps and SAVE? icon is turned on. After a short time a long beep is heard, and the lower LCD will display the word "DONE". Release the OK key. If the OK key is released BEFORE the word "DONE" is displayed, the changes WILL NOT BE SAVED. The word "DONE" MUST be displayed in order for the save to have occurred.

**NOTE: The programming mode may be exited at any time, by pressing the SETUP key. Pressing this key will return the monitor to its normal operation. All items changed and saved will come into affect immediately. Any items changed, but not saved will revert to the original programmed value.**

## PROGRAMMING - Row Spacing

**STEP 1** Prior to entering the programming mode, the application mode (rear/front or left/right) must be active. If the monitor is programmed in a rear/front configuration, both sections will be active (alternating every 5 seconds). You can then set the row spacing to the Interplant® row spacing.

EXAMPLE: On a 12 row 30" with Interplant® Package set the row spacing to 15.0 with front active.

When the monitor is in normal field operation mode, disabling the front section will automatically change the row spacing to 30".

**STEP 2** To enter the programming mode, press and hold the SETUP key. The monitor will emit several short beeps, followed by a long beep. On the lower LCD, the SETUP icon turns on and the arrow head icon will flash, indicating that the user can select an item to program.

**NOTE: The monitor must be in a programmable function (row spacing, units, speed, volume or area) to enter setup. The monitor will not enter setup in seed population or seed spacing.**

**STEP 3** Press the UP or DOWN arrow keys to move the flashing arrow to ROW SPACING. As the arrow icon moves, the lower LCD will display the current setting of the item selected.

**STEP 4** Press the OK key and the flashing arrow becomes solid and the beeper will sound.

**NOTE: The lower LCD will display the current row spacing (in inches or centimeters) and ROW SPACING icon is turned on.**

- The least significant digit of the displayed value will be blinking.
- This value can be changed by pressing either the UP or DOWN arrow keys.
- Once this digit is correct, press the MODE SELECT key and the blinking digit will move to the next significant digit, where the process can be repeated.

**NOTE:** The monitor limits the entry of row spacing to a minimum of 10.0 inches (25.4 cm) and to a maximum of 99.9 inches (253.7 cm). If the monitor is configured to a rear/front configuration, the limits change to a minimum of 5.0 inches (12.7 cm) and a maximum of 49.9 inches (126.8 cm).

**STEP 5** To exit without saving, press and release the OK key. The monitor will restore the lower LCD to show the setting of the item and the arrow icon will flash, allowing the user to select another item to program.

To exit and save, press and hold the OK key. The monitor will emit several short beeps and SAVE? icon is turned on. After a short time a long beep is heard, and the lower LCD will display the word "DONE". Release the OK key. If the OK key is released BEFORE the word "DONE" is displayed, the changes WILL NOT BE SAVED. The word "DONE" MUST be displayed in order for the save to have occurred.

To exit setup mode, press the SETUP key.

**NOTE:** The programming mode may be exited at any time, by pressing the SETUP key. Pressing this key will return the monitor to its normal operation. All items changed and saved will come into affect immediately. Any items changed, but not saved will revert to the original programmed value.

## PROGRAMMING - Speed

**STEP 1** To enter the programming mode, press and hold the SETUP key. The monitor will emit several short beeps, followed by a long beep. On the lower LCD, the SETUP icon turns on and the arrow head icon will flash, indicating that the user can select an item to program.

**NOTE: The monitor must be in a programmable function (row spacing, units, speed, volume or area) to enter setup. The monitor will not enter setup in seed population or seed spacing.**

**STEP 2** Press the UP or DOWN arrow keys to move the flashing arrow to SPEED. As the arrow icon moves, the lower LCD will display the current setting of the item selected.

**STEP 3** Press the OK key and the flashing arrow becomes solid and the beeper will sound.

The speed constant is used to record how many pulses are generated per mile (or kilometer) from the ground speed sensor. The lower LCD will display the current pulses per mile (or kilometer), using a 6 digit, no decimal place format. The PULSES per MILE (or PULSES per KM) icons are turned on.

**NOTE: It is highly recommended that a field calibration be done to establish the PPM (Pulses Per Mile) number on a new machine installation. Several factors can affect this value such as wheel slip on the magnetic distance sensor, mounting angle and height on the radar distance sensor, etc. IT IS NOT UNCOMMON FOR THE MPH ON THE MONITOR TO VARY SLIGHTLY FROM THE TRACTOR SPEEDOMETER. *Adjusting the PPM in the monitor to make the MPH or Km/h readings agree can cause serious errors in acre/hectare and population counts.* Do field checks to verify populations and seed spacings.**

**NOTE: On new system installations, the monitor will default to 500 PPM. This will have to be changed to obtain accurate readings from the monitor.**

- In field conditions, measure 330 feet ( $\frac{1}{16}$  mile) or 100 meters, depending on the unit of measurement selected.

- Pull the tractor up to the starting line.

- Press the UP and DOWN arrow keys at the same time and hold them down until the CLEAR? icon is displayed and the monitor beeps several times. When the data is actually cleared, the monitor will emit a long beep and the number of pulses is cleared.

- Drive the tractor for 330 feet ( $\frac{1}{16}$  mile) or 100 meters and stop.

- The monitor will count the number of pulses and display them.

**STEP 4** To exit without saving, press and release the OK key. The monitor will restore the lower LCD to show the setting of the item, and the arrow icon will flash, allowing the user to select another item to program.

To exit and save, press and hold the OK key. The monitor will emit several short beeps and SAVE? icon is turned on. After a short time a long beep is heard, and the lower LCD will display the word "DONE". Release the OK key. If the OK key is released BEFORE the word "DONE" is displayed, the changes WILL NOT BE SAVED. The word "DONE" MUST be displayed in order for the save to have occurred.

**NOTE: The programming mode may be exited at any time, by pressing the SETUP key. Pressing this key will return the monitor to its normal operation. All items changed and saved will come into affect immediately. Any items changed, but not saved will revert to the original programmed value.**

NOTE: If a discrepancy occurs and digits must be changed, follow STEPS 1 and 2 to enter the programming mode and proceed as follows:

- Press the OK key and the flashing arrow becomes solid. The least significant digit of the displayed value will be blinking.
- This value can be changed by pressing either the UP or DOWN arrow keys.
- Once this digit is correct, press the SELECT key and the blinking digit will move to the next significant digit, where the process can be repeated.

The monitor limits the entry of pulses per mile or kilometer to a minimum of 500 PPM (310 PPKM), and to a maximum of 500,000 PPM (310,686 PPKM).

KEY Action	Flashing Digit	Display Value
Press The UP Key	Right Most Digit	2031, 2032, 2033
Press The SELECT Key	Second Digit From Right	2033
Press The DOWN Key	Second Digit From Right	2023, 2013, 2003, 2093, 2083
Press The SELECT Key Twice	Left Most Digit	2083
Press The DOWN Key	Left Most Digit	1083, 0500 (Min. Value), 9500, 8500

## PROGRAMMING - Clearing Total Area

**NOTE: Clearing the total area counter will also clear the field area counter.**

**STEP 1** To enter the programming mode, press and hold the SETUP key. The monitor will emit several short beeps followed by a long beep. On the lower LCD, the SETUP icon turns on and the arrow head icon will flash, indicating that the user can select an item to program.

**NOTE: The monitor must be in a programmable function (row spacing, units, speed, volume or area) to enter setup. The monitor will not enter setup in seed population or seed spacing.**

**STEP 2** Press the UP or DOWN arrow keys to move the flashing arrow to TOTAL AREA. As the arrow icon moves, the lower LCD will display the current setting of the item selected.

**STEP 3** Press the OK key and the flashing arrow becomes solid and the beeper will sound.

- The lower LCD will display the total area and the ACRE (or Ha) icon turns on.
- With the flashing arrow on TOTAL AREA, press the OK key.

• To reset the counter, press the UP and DOWN arrow keys at the same time and hold them down for a short period of time to clear the data. The CLEAR? icon will be displayed and the monitor will beep several times. When the data is actually cleared, the monitor will emit a long beep, and the total area is reset to zeros. After the long beep, the previous recorded total area is not retrievable. Once cleared, the user **may not** choose to exit programming mode without saving as described in STEP 4.

**STEP 4** To exit and save, press and hold the OK key. The monitor will emit several short beeps and SAVE? icon is turned on. After a short time a long beep is heard, and the lower LCD will display the word "DONE". Release the OK key. If the OK key is released BEFORE the word "DONE" is displayed, the changes WILL NOT BE SAVED. The word "DONE" MUST be displayed in order for the save to have occurred.

**NOTE: The programming mode may be exited at any time, by pressing the SETUP key. Pressing this key will return the monitor to its normal operation. All items changed and saved will come into affect immediately. Any items changed, but not saved will revert to the original programmed value.**

## AREA COUNTER/SPEEDOMETER MODE

If the monitor is installed with only a radar distance sensor (no seed tubes attached), the monitor becomes a speedometer. If (a) the monitor is connected to a radar distance sensor, (b) the signal cable from the back of the console is connected to a sensing switch (Part No. G1K249 Acre Counter Switch Kit) instead of the seed tubes and (c) the implement width in feet (or meters) is programmed into the monitor, the monitor will function as an acre counter.

The seed spacing and seed population functions are not available in this mode. If the monitor is powered down, the seed tubes connected and the monitor powered up, the monitor will again show seed population and seed spacing in inches or centimeters. Row spacing reverts back to its programmed setting.

## WARNINGS AND ALARMS

- 1. System Alarms** - A system alarm is activated when the monitor detects a faulty sensor or one of several other communication faults.

The corresponding row number starts flashing and the beeper sounds. All segments on the corresponding bar graph are turned off. Pushing the OK key to acknowledge the alarm will turn the beeper off. The row number will continue to flash until the alarm condition is removed. If the monitor detects a faulty sensor and there is no planting activity present, the monitor will scroll "CHECK CONNECTION".

If the distance sensor is detected as faulty, the monitor will display either "PICKUP" or "RADAR", depending on the type of sensor installed, and the audible alarm will sound. The user can push the OK key to acknowledge the alarm. When the distance sensor is faulty, the monitor will change to a bar graph only mode where the rows are still displayed relative to each other. No area related information (speed, field area, total area, seed spacing or seed population) will be accumulated or displayed.

If a rotation shaft sensor is faulty, "LSHAFT", "RSHAFT" or "SHAFTS" will display.

Another type of system alarm occurs when the monitor detects a data communication bus error.

The three possible data communication bus errors are:

LCD Display	Error Condition
SYS HI	The data communication lead (green) has been shorted to the power lead (white).
SYS LO	The data communication lead (green) has been shorted to the ground lead (black).
SYS EC	An internal error has been detected.

- 2. Under Flow Alarms** - If the seed rate for one or more rows is less than 55% of the calculated average, the corresponding 60% segment will stay on, the corresponding row number starts flashing and the alarm sounds. Pushing the OK key to acknowledge the alarm will turn the alarm off. The 60% segment of the bar graph remains on and the row number continues to flash until the alarm condition is corrected.

**NOTE: All alarms present within a short time before planting stops are frozen on the screen and the text LOW or FAIL will display on the LCD. If the under flow is between 0% and 10%, this warrants a "FAIL" condition. If the under flow is between 10% and 55%, a "LOW" condition is generated. If multiple rows have an under flow condition, "FAIL" will display if any one or more rows is between 0% and 10%. This allows the user to identify and fix the problem rows.**

**NOTE: This warning will not trigger unless a minimum time of continuous planting has passed.**

**NOTE: If all the rows show a seed rate of zero, the condition will not generate an alarm. It will be assumed the planter has stopped. The row numbers and the bottom 60% segment will remain on for all selected rows.**

- 3. Multiple Alarms** - If more than one alarm condition occurs at the same time, pushing the OK key will acknowledge all alarms that are currently displayed. For example, if one row on the front and one row on the rear are alarming, pushing the OK key will only acknowledge one of them. However, if there are two alarms on the front, both alarms would be acknowledged with one push of the OK key.

4. **Section Not Selected Warning** - If the monitor was programmed for two sections and only one is currently selected for display (by pressing the SELECT key), the icon of the disabled section will flash for a period of 1 minute, then turn off at each power up. If seed flow is sensed in the disabled section, the icon for that section (front, left or right) will begin to flash.
5. **Seed Planting Stopped Warning** - When the monitor detects no seed flow on all rows, the monitor will emit 3 short beeps to alert the user. This warning will occur each time the planter is stopped, each time the planter is raised at the end of a row or if the mechanical drive fails while planting.

**NOTE: This warning will not trigger unless a minimum time of continuous planting has passed.**

6. **Seed Counting Sensor In Calibration Warning** - All seed counting sensors run a self-calibration sequence on power up. While in calibration the bottom segment of each corresponding bar graph will flash if the monitor detects movement or planting activity. If the monitor does not detect this, the message "WAIT CALIBRATION" will be scrolled.
7. **Seed Counting Sensor Too Dirty Warning** - After the seed counting sensors end their internal self-calibration, the monitor may detect one or more sensors are either too dirty or blocked. If the monitor detects planting or movement, the corresponding bar graph remains flashing. The monitor will display "CLEAN SENSORS" on the top LCD if no movement or planting is detected, prompting the user to clean the tubes. If the tubes are dirty, they will still show seed flow with less accuracy. If the tubes are blocked the user will get an alarm as soon as planting starts. The corresponding bar graph will remain flashing until the problem is corrected and the monitor is powered down and then powered back up.
8. **Low Battery Warning** - The monitor is constantly monitoring its input voltage to quickly detect low power conditions. If the monitor detects that the input voltage has dropped below 11.0V, it will display "LO SYS" on the lower LCD, provided that the monitor does not detect speed or planting.

**NOTE: After the alarms have been acknowledged and if the alarm condition is still present, the LCD will continue to display the alarm condition.**

## REPLACING A FAULTY SENSOR

To replace a faulty sensor; (a) turn the monitor off, (b) disconnect the faulty sensor, (c) turn the monitor back on and (d) plug in the replacement sensor. The monitor will chirp twice to acknowledge the new sensor was learned and saved.

To replace more than one faulty sensor, proceed as stated above beginning with the lowest numbered row in the rear/left section and continue to replace sensors in ascending order. Then move on to the front/right section and continue in ascending order.

If the monitor detects a faulty distance sensor, the lower LCD will immediately move to the speed display, show the word "PICKUP" or "RADAR" depending on the distance sensor installed, and the alarm will sound.

**NOTE: If the monitor is not turned off and then on, the replacement sensor(s) will be ignored until the next power on, at which point the sensors will be randomly learned by the monitor.**

## FIELD OPERATION

Press the ON/OFF key to turn the monitor on and off.



(MTR28e)

Information regarding each section is displayed alternately every 5 seconds.

### REAR/FRONT CONFIGURATION

- Press the SELECT key once to show REAR section only. (Monitor sets correct row spacing.)
- Press the SELECT key a second time to return to each section being displayed alternately every 5 seconds. (Monitor sets correct row spacing.)
- Press the SELECT key a third time to show REAR section only again.



(MTR28c)

### LEFT/RIGHT CONFIGURATION (If Applicable)

- Press the SELECT key once to show LEFT section only.
- Press the SELECT key a second time to show RIGHT section only.
- Press the SELECT key a third time to return to each section being displayed alternately every 5 seconds.



(MTR28c)

**NOTE: SELECT key has no function when only a single section is being used.**

At power up, the lower LCD will show speed (MPH or Km/h).



(MTR29g/MTR29b/MTR29a/MTR29c/MTR29f/MTR29c/MTR29f)

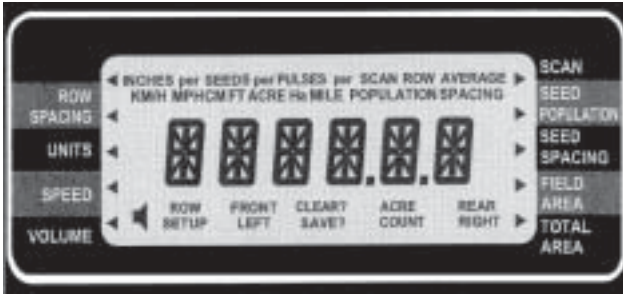

Press the UP or DOWN arrow keys to move the flashing arrow on the lower LCD to change what is displayed on the lower LCD.



Press the shortcut keys SPEED, SEED POPULATION/SEED SPACING or AREA FIELD/TOTAL for direct access to these displays.



(MTR29c/MTR29d/MTR29b/MTR29c)

Press the SEED POPULATION/SEED SPACING or AREA FIELD/TOTAL keys to alternate between the two functions assigned to that key.



Press the SEED POPULATION/SEED SPACING key to choose average seed spacing/population per acre.



Press the SCAN key to display individual rows starting at row 1.



Press the SCAN key again to lock on current row.

Press the SCAN key again to resume scrolling.

Use the UP or DOWN arrow keys to move to a particular row.



Press the SEED POPULATION/SEED SPACING key to go back to planter average.



## CLEARING FIELD AREA

(MTR29n/MTR28b)

To reset the counter, press the UP or DOWN arrow keys to move the arrow in the lower display to FIELD AREA.



Press the UP and DOWN arrow keys at the same time and hold them down for a short period of time to clear the data. The CLEAR? icon will be displayed and the monitor will beep several times. When the data is actually cleared, the monitor will emit a long beep, and the field area is reset to zero. After the long beep, the previous field area recorded is not retrievable.



**NOTE: Clearing the field area counter will not clear the total area counter. See "Programming-Clearing Total Area" for clearing total area.**

Press the OK key to silence alarms. See "Warnings And Alarms".



## CONNECTING SEED TUBES, RADAR/MAGNETIC DISTANCE SENSORS AND/OR SHAFT ROTATION SENSORS

**STEP 1** All the seed tubes w/sensors (including the radar, magnetic distance and shaft rotation sensors) must be unplugged from the harness and/or console and the monitor must be off.

**NOTE:** If the monitor detects a radar sensor but no seed tubes at power up, it will automatically go into AREA COUNT mode. See “Area Counter/Speedometer Mode”.

**NOTE:** Disconnect magnetic distance sensor between MDS adapter and planter harness. DO NOT disconnect between MDS and MDS adapter.

01189909

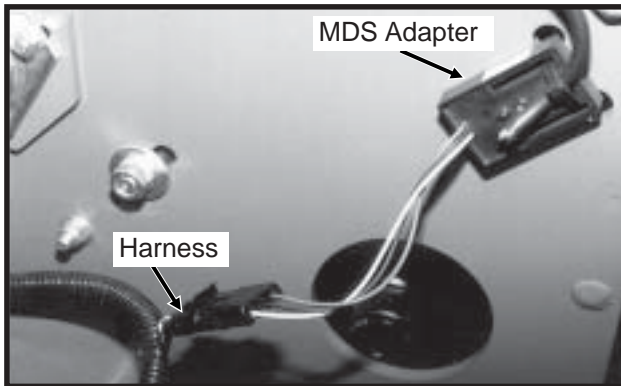

01189910

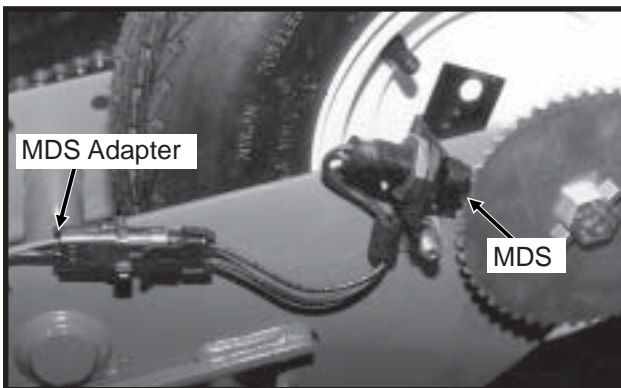

**STEP 2** Press the ON key. The monitor automatically enters the setup procedure.

**STEP 3** The monitor automatically defaults to front/rear. Press the SELECT key. Each time you press the SELECT key the mode will toggle between rear/front and left/right. The selected display will be solid and the configuration not currently selected will be flashing. By default the monitor starts in the rear/front mode.

01139923

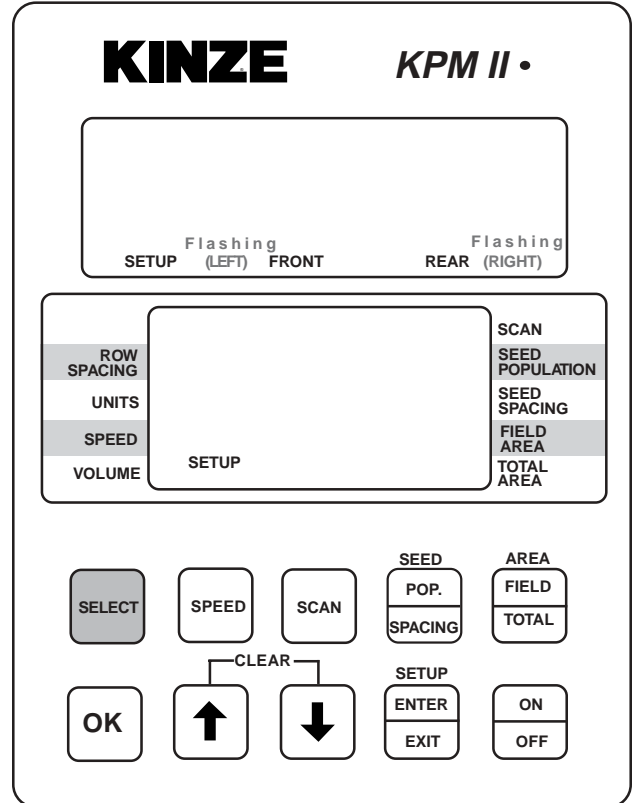

01139924

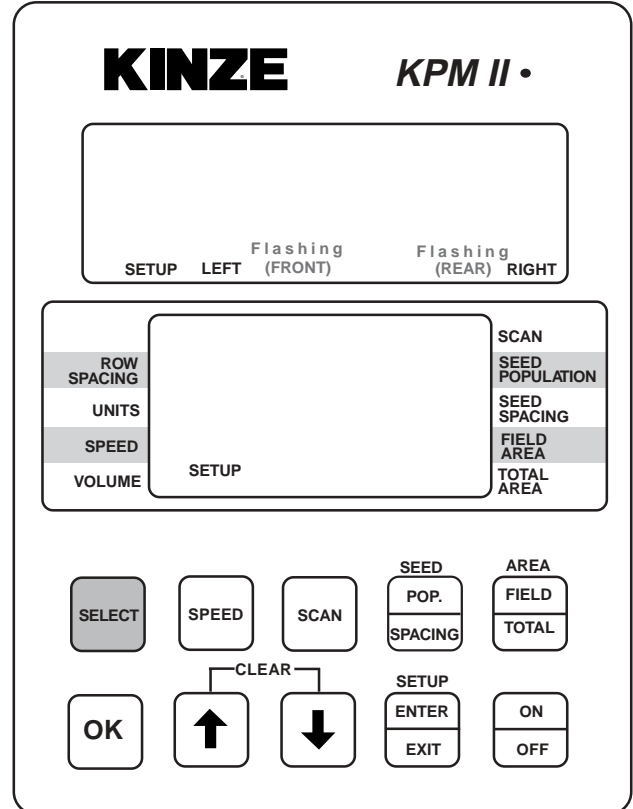

**NOTE:** Model 3650 planters select the rear configuration only. When Interplant® Package rows are in use, select the rear/front configuration.

**STEP 4** Press and hold the OK key to confirm selection. The upper display will alternate between “NEW” and “SYS?”.

The alarm will sound four short beeps followed by one long beep. At this point your selection has been saved and row numbers will appear flashing on the upper display.

01139922

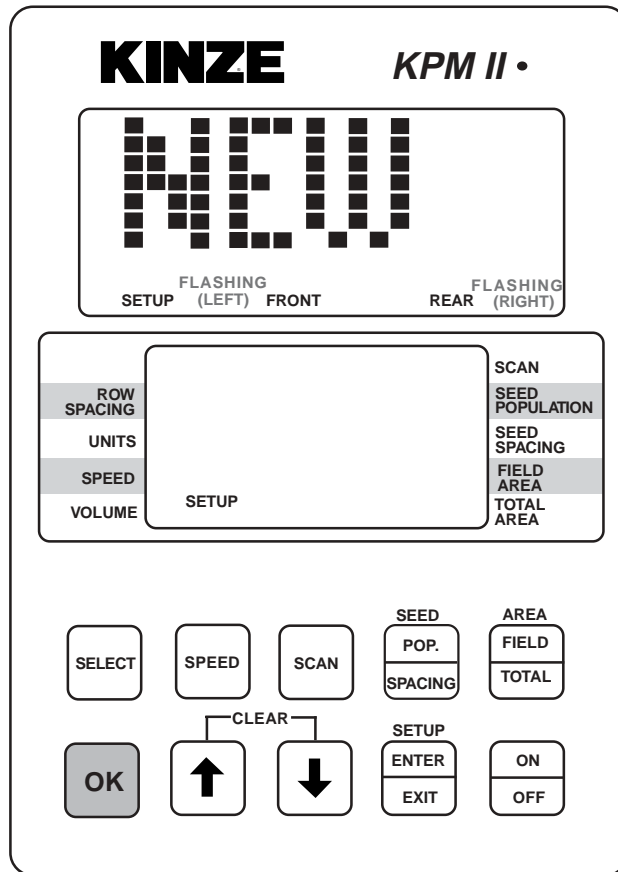

01139922

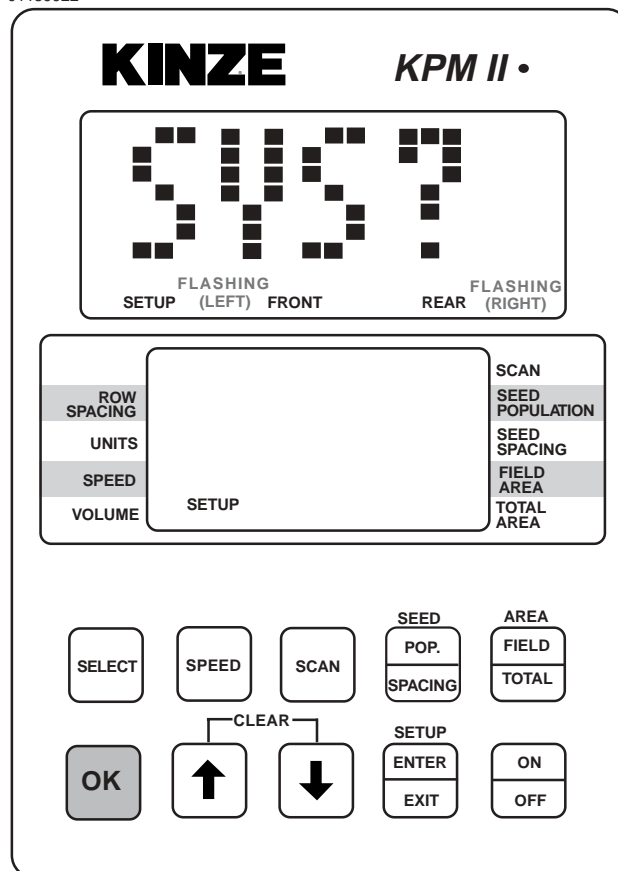

**STEP 5** Determine which row you want as number one and plug the seed tube w/sensor into the harness.

Continue plugging in sensors along with shaft rotation sensors if so equipped. Row 1 first, row 2 second and so on up to 18 rows. When a sensor is plugged in, the corresponding row number on the upper LCD display will stay solid, the monitor will chirp twice and a red LED (Light Emitting Diode) on the seed tube sensor will turn on for approximately 30 seconds to show connection is made.

D04219901

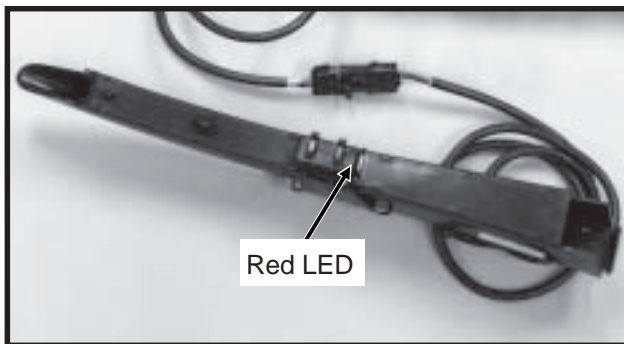

01139921

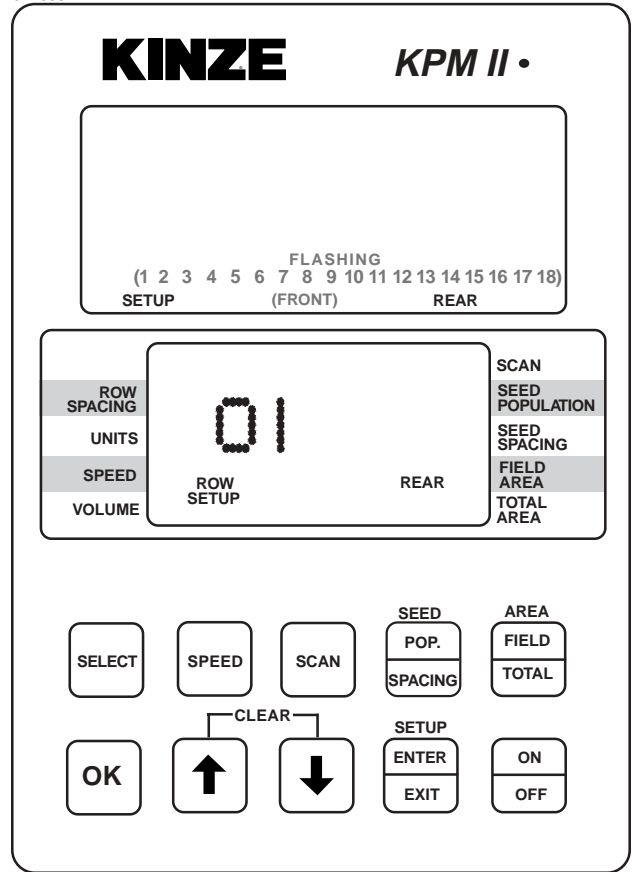

01139911

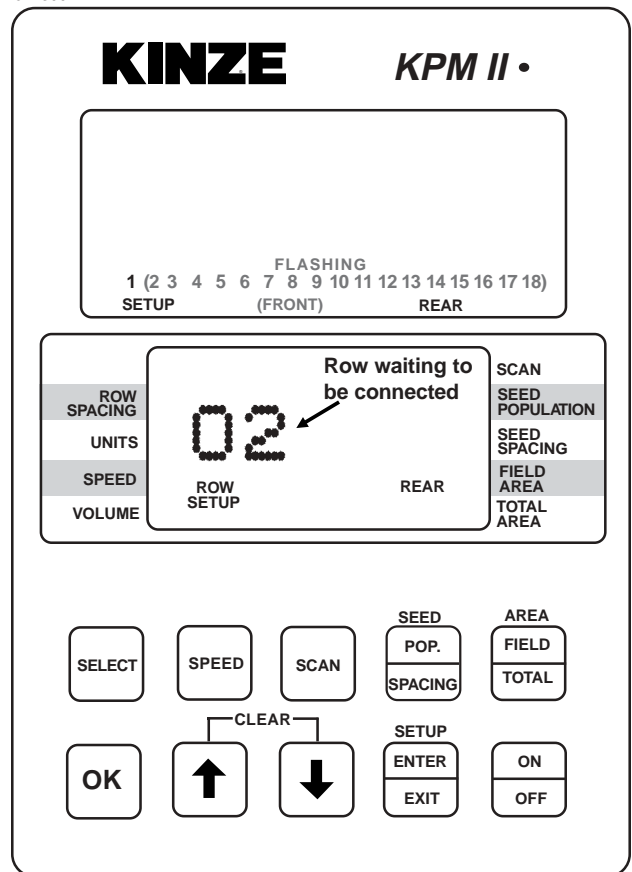

**STEP 6** If the monitor system includes shaft rotation sensors, these can be installed at any time as the seed tubes are connected. The first shaft rotation sensor installed will be assigned to the rows on the L.H. half of the planter and the second shaft rotation sensor connected will be assigned to the rows on the R.H. half of the planter.

01189906

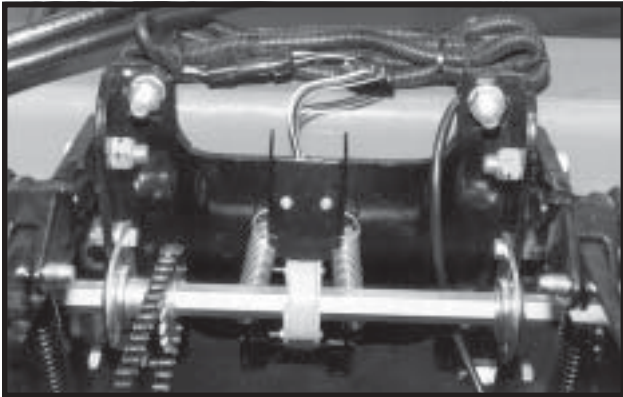

“LSHAFT” will display on the lower LCD when the first shaft rotation sensor is installed. “RSHAFT” will display when the second shaft rotation sensor is installed.

01139919

**KINZE**
**KPM II •**

FLASHING

1 (2 3 4 5 6 7 8 9 10 11 12 13 14 15 16 17 18)

SETUP (FRONT) REAR

ROW SPACING
UNITS
SPEED
VOLUME

LSHAFT

SCAN
SEED POPULATION
SEED SPACING
FIELD AREA
TOTAL AREA

SELECT	SPEED	SCAN	SEED POP. SPACING	AREA FIELD TOTAL
OK	↑	↓	SETUP ENTER EXIT	ON OFF

CLEAR

01139916

**KINZE**
**KPM II •**

FLASHING

1 2 3 4 5 6 7 8 9 10 11 12 (13 14 15 16 17 18)

SETUP (FRONT) REAR

ROW SPACING
UNITS
SPEED
VOLUME

RSHAFT

SCAN
SEED POPULATION
SEED SPACING
FIELD AREA
TOTAL AREA

SELECT	SPEED	SCAN	SEED POP. SPACING	AREA FIELD TOTAL
OK	↑	↓	SETUP ENTER EXIT	ON OFF

CLEAR

**STEP 7** When all the seed tubes for the current section (Rear/Front or Left/Right) are installed, check to be sure the monitor displays solid numbers for the number of seed tubes connected. Press and hold the OK key to save the setup for the current section. The SAVE? icon will display followed by continuous short beeps indicating the monitor is preparing to save. The installer has 5 seconds to decide to save the current configuration. During this time, four short beeps will sound followed by a long beep and the SAVE? icon will turn off and the word "DONE" shows on the screen. The monitor will continue to the second section installation (If Applicable).

01139914

01139913

**STEP 8** Follow STEPS 5 through 7 to install the second section. If no seed tubes are installed on the second section, press and hold the OK key. The word "DONE" will appear on upper display. The alarm will sound four short beeps followed by one long beep and the SAVE? icon turns off. The monitor has exited the setup mode. When you release the OK key the upper display will scroll "WAITING CALIBRATION". The lower display will show "GNDSPD" and the alarm will sound continually until the distance sensor is connected. See STEP 9.

01139912

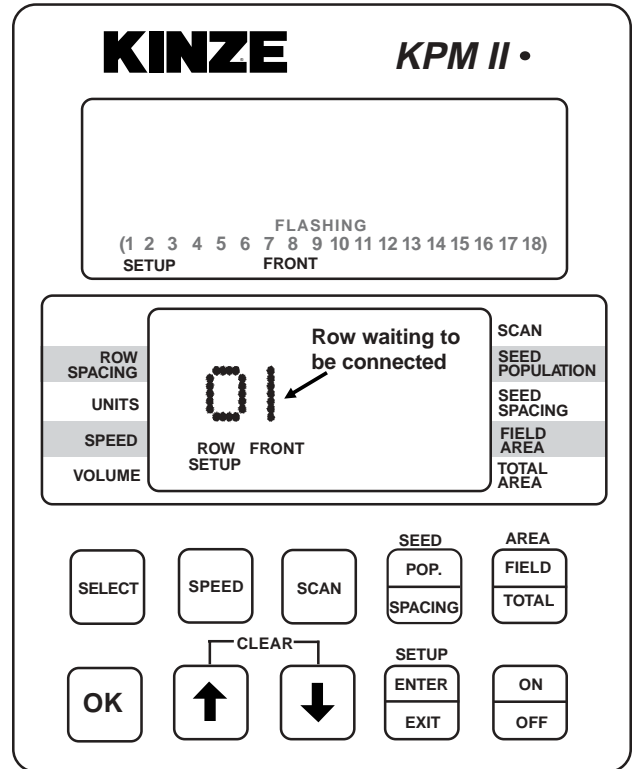

01139920

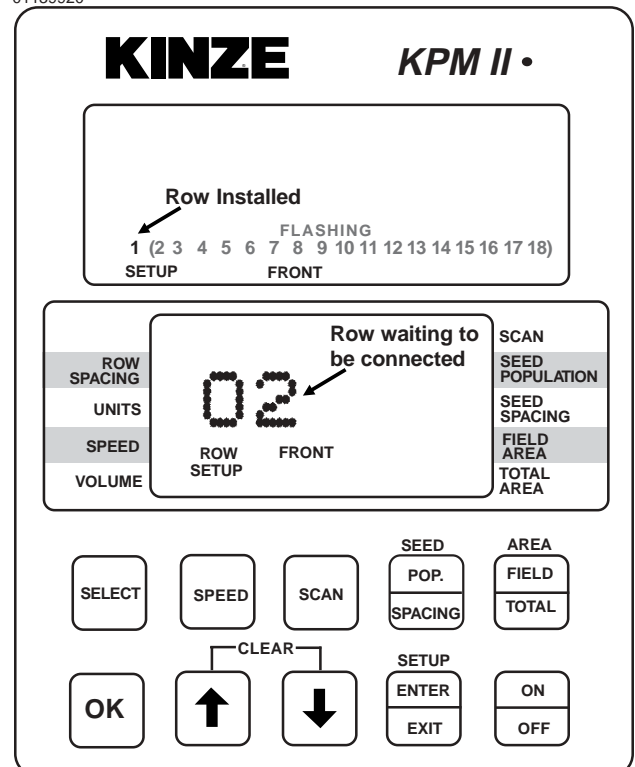

## STEP 8 (Continued)

01139910

**KINZE**
**KPM II •**

**Rows Installed**

1 2 3 4 5 6 7 8 9 10 11 (12 13 14 15 16 17 18)

FLASHING

SETUP FRONT SAVE?

ROW SPACING
UNITS
SPEED
VOLUME

Row waiting to be connected

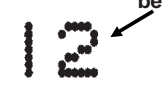

ROW SETUP FRONT SAVE?

SCAN
SEED POPULATION
SEED SPACING
FIELD AREA
TOTAL AREA

SELECT

SPEED

SCAN

SEED  
POP.  
SPACING

AREA  
FIELD  
TOTAL

OK

↑  
CLEAR

↓

SETUP  
ENTER  
EXIT

ON  
OFF

01139910a

**KINZE**
**KPM II •**

**DONE**

1 2 3 4 5 6 7 8 9 10 11 (12 13 14 15 16 17 18)

FLASHING

SETUP FRONT

ROW SPACING
UNITS
SPEED
VOLUME

FRONT

SETUP

SCAN
SEED POPULATION
SEED SPACING
FIELD AREA
TOTAL AREA

SELECT

SPEED

SCAN

SEED  
POP.  
SPACING

AREA  
FIELD  
TOTAL

OK

↑  
CLEAR

↓

SETUP  
ENTER  
EXIT

ON  
OFF



**STEP 9** With the lower display showing “GNDSPD”, connect the distance sensor. The monitor will display “PICKUP” if a magnetic distance sensor is connected or “RADAR” if a radar distance sensor is installed. Only one distance sensor can be connected at a time.

**NOTE:** To connect the radar distance sensor, install the 10" monitor/radar adapter between the console and radar distance sensor to adapt the monitor system to various tractor radar systems.

**NOTE:** To reprogram the system to monitor more or less rows (up to the maximum of 18 per section, 36 total), all sensors must be unplugged, followed by the complete setup procedure.

**NOTE:** Individual seed tubes may be unplugged for special situations. An alarm will sound which can be silenced by touching the OK key. The monitor will recognize the seed tube(s) when reconnected.

10250115

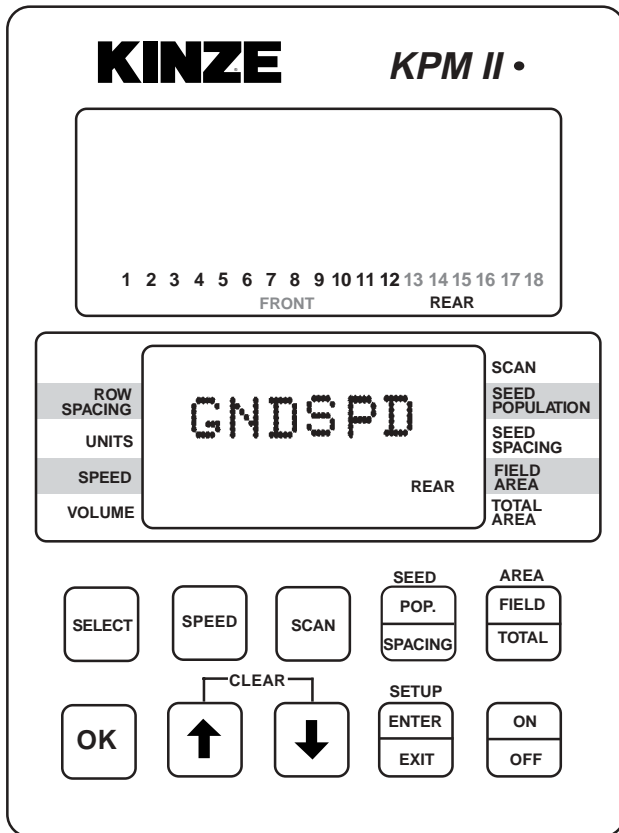

01139909

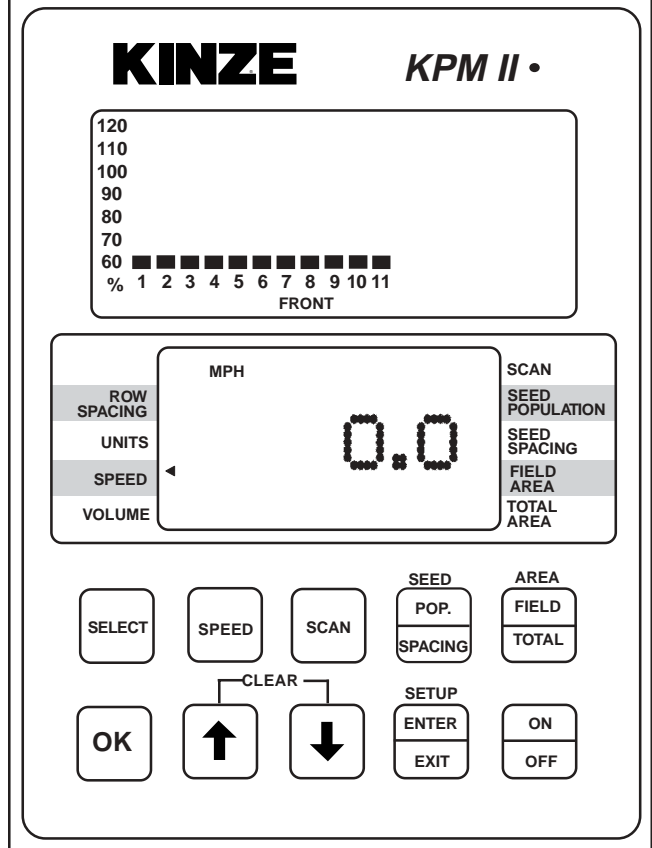

**ROW-BY-ROW ALARM LEVEL SETTING**  
*(Requires Version V0.06 or higher Software - KPM II Monitors Only)*

This feature allows the audio alarm to be disabled on selected rows in applications such as planting seed corn.

**NOTE: The seed monitor should be programmed to monitor all planter rows prior to performing these steps.**

**STEP 1** Enter the programming mode by pressing and holding the SETUP key. The monitor will emit several short beeps, followed by a long beep. On the lower LCD, the SETUP icon will turn on and the arrow head icon will flash, indicating the user can select an item to program.

**NOTE: The monitor must be in a programmable function (row spacing, unit, speed, volume or area) to enter setup. The monitor will not enter setup in seed population or seed spacing.**

**STEP 2** Press the UP or DOWN arrow keys to move the flashing arrow to SEED POPULATION. As the arrow icon moves, the lower LCD will display the current setting of each item selected.

**STEP 3** Press the OK key. Row number starts flashing.

**STEP 4** Arrow UP or DOWN to desired row.

**STEP 5** Press SELECT key. "AVG" starts flashing.

**STEP 6** Arrow UP or DOWN to choose one of the following options.

- HIGH - For Early Alarm (70%)
- AVG - For Standard Alarm Setting (55%)
- LOW - For Failed Alarm Only (25%)
- OFF - To Disable Row Alarm

**STEP 7** Press and hold the OK key to save alarm setting. There will be four short beeps, one long beep and the word "DONE" will appear when the save is completed.

**STEP 8** Repeat STEPS 3 through 7 for each row on which you wish to adjust the alarm setting.

**STEP 9** When finished, press the SETUP key to exit setup mode.

**NOTE: The programming mode may be exited at any time by pressing the SETUP key. Pressing this key will return the monitor to its normal operation. All items changed and saved will come into effect immediately. Any items changed, but not saved will revert to the original programmed value.**

**NOTE: Repeat STEPS 3 through 7 to change seed monitor back to the original settings when special row-by-row alarm level settings are no longer required.**

**NOTE:**  
**See "Programming - Row Spacing" for programming applicable row spacing.**

**See "KPM I/KPM II/KPM II Stack-Mode Electronic Seed Monitor Troubleshooting" in the Maintenance Section.**

04130116

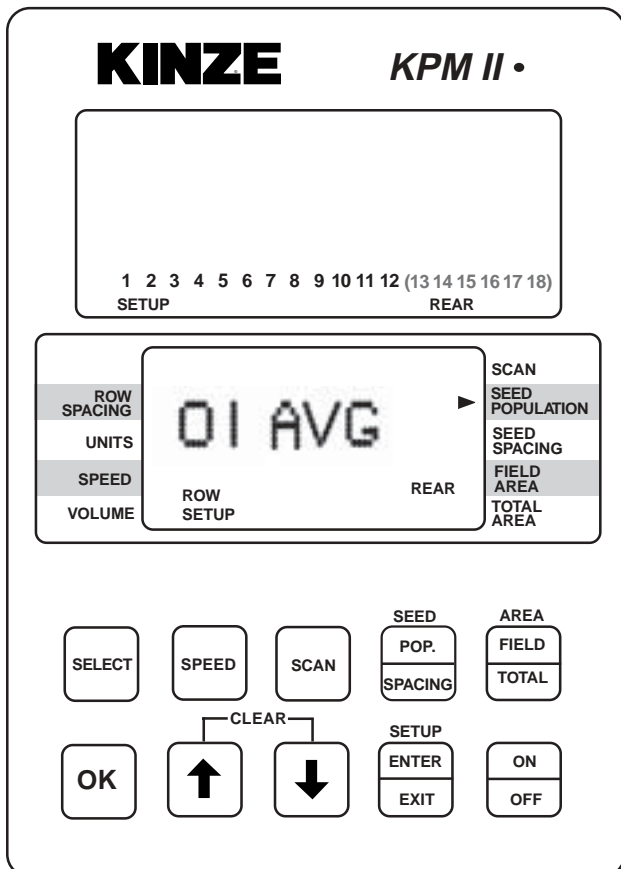

## KPM II STACK-MODE ELECTRONIC SEED MONITOR

(MTR41d)

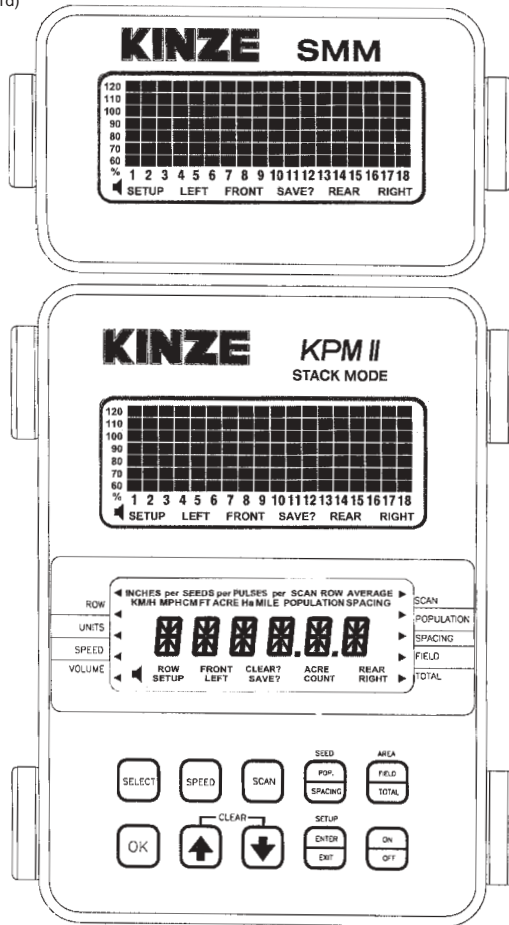

The KPM II Stack-Mode electronic seed monitor system consists of (a) a KPM II Stack-Mode console, which is mounted on the tractor; (b) seed tubes with sensors, one of which is installed in each planter row unit; (c) a magnetic distance sensor, which is installed on the planter; or a radar distance sensor, which is installed on the tractor; (d) shaft rotation sensors, which are installed on the planter drill shafts; and (e) a planter harness (junction Y-harness and/or extension harness where applicable), to which the individual seed tube sensors connect. The primary harness, which connects the monitor console to the planter harness, is hard-wired into the safety/warning light harness or control console harness included as standard equipment with the planter.

Software design of the KPM II Stack-Mode console allows the use of an add-on SMM console for simultaneous viewing of the seed flow bar graphs for standard (up to 36 rows) and/or Interplant® System rows (up to 36 rows). A total of 72 rows may be displayed in multiple sections (rear/front, left/right or four sections). The SMM console must be used to allow proper operation of the four section feature.

The SMM console is included with the Interplant® Stack-Mode Monitor Package for Model 3650 planters.

The monitor system is powered by the tractor battery (requires 12 volts DC). The console receives information from each of the sensors and translates this information.

The KPM II Stack-Mode console has two backlit Liquid Crystal Displays (LCD). The upper display shows the active section, the number of monitored rows per section, the relative seed rate for each row (using a bar graph display) and scrolls various alarm and warning messages when an alarm condition exists. A continuous audible alarm will sound upon system malfunction or underflow conditions for any monitored row. Alarms must be acknowledged by the user. Various warnings may sound the alarm or flash one or more icons. The lower display is used to display alphanumeric data such as row spacing, units (Metric or English), speed, volume, seed population, seed spacing, field area, total area and distance sensor pulses per mile/kilometer.

The SMM console has one backlit Liquid Crystal Display (LCD) which functions the same as the upper display on the KPM II Stack-Mode console except it does not scroll alarm and warning messages. The SMM console must be programmed into the system before printed text will display on the SMM console's LCD.

The monitor system will power down if no activity is detected within one hour. No activity means there has been no new seed flow and no operator push key input.

<b>Monitor Key Functions</b> .....	<b>6-44</b>
<b>Upper LCD Functions</b> .....	<b>6-45</b>
<b>Lower LCD Functions</b> .....	<b>6-46</b>
<b>Programming</b>	
<b>Changing The Audible Alarm Volume</b> .....	<b>6-48</b>
<b>Units (Metric Or English)</b> .....	<b>6-49</b>
<b>Row Spacing</b> .....	<b>6-49</b>
<b>Speed</b> .....	<b>6-51</b>
<b>Clearing Total Area</b> .....	<b>6-52</b>
<b>Area Counter/Speedometer Mode</b> .....	<b>6-53</b>
<b>Warnings And Alarms</b> .....	<b>6-53</b>
<b>Replacing A Faulty Sensor</b> .....	<b>6-54</b>
<b>Field Operation</b> .....	<b>6-55</b>
<b>Clearing Field Area</b> .....	<b>6-56</b>
<b>Connecting Seed Tubes, Radar/Magnetic Distance Sensors, SMM Console And/OR Shaft Rotation Sensors</b> .....	<b>6-57</b>
<b>Row-By-Row Alarm Level Setting</b> .....	<b>6-68</b>

## MONITOR KEY FUNCTIONS

Push keys allow the user to select or change the operating mode, the active displays or the current configuration. Depending on the operating mode or the current display selected, some keys are valid while some are not. Each key press if valid is acknowledged by a short beep and an action is taken. If the key press has no action associated, the key press is considered invalid and the user will not get any feedback.

### SELECT

- Selects the application mode (rear/front, left/right or four sections up to a maximum of 72 rows) at the beginning of installation in the setup mode.
- Selects the active section(s) (rear, rear/front, left, right or left/right) in the normal mode.
- Has no affect on a system configured to monitor only one section.
- While programming the monitor, the key will select the digit to change.

### SPEED

- Immediately displays the current ground speed.

### SCAN

- If the current average population or average spacing is displayed, this key sequentially displays the seed population/spacing on each row.
- If the display shows functions other than average seed population or spacing, pressing SCAN will sequentially display speed, average seed population and average seed spacing.
- Pressing a second time freezes the display on the current row.
- Pressing a third time restarts the sequential display.

### SEED POPULATION/SEED SPACING

- Immediately displays the average seed POPULATION and the average seed SPACING of all active rows.
- Each press alternates between seed spacing and seed population.

### AREA FIELD/AREA TOTAL

- Immediately displays the field and total area planted since the field/total area was last cleared.
- Each press alternates between field area and total area.

### OK

- Ends and saves the new setup during installation.
- Acknowledges and silences alarms in the operation mode.

### UP ARROW AND DOWN ARROW

- Scrolls sequentially through the display options on the lower LCD display.
- Freezes on the current row in the scan mode.
- Scrolls sequentially through the rows when the population scan is frozen.
- Used to enter programmable values in the programming mode.
- The Up and Down Arrow keys can be pressed at the same time to start the CLEAR function.

### SETUP ENTER/SETUP EXIT

- Enters and exits the programming mode.

### ON/OFF

- Powers the unit on and off.

# MACHINE OPERATION

# KPM II STACK-MODE

## UPPER LCD FUNCTIONS

(MTR29h)

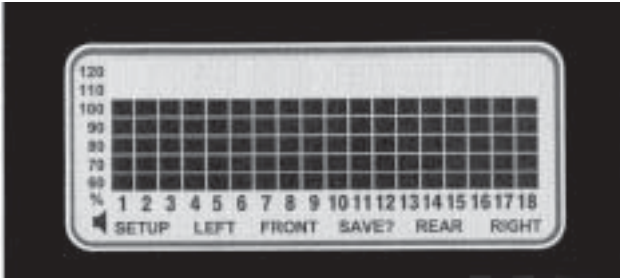

The monitor collects data on the planting rates from all active rows and calculates an average. This average will determine the 100% mark. Seed rate for each row is then compared to the average value and the result is displayed on the bar graph.

With only the stack-mode console programmed into the system, the information regarding each section is displayed alternately every 5 seconds. While operating a system with two sections programmed, one or both sections may be selected any time. When only one section is selected, the monitor calculates the average based on the remaining active rows from that section.

With the SMM console programmed into the system, two sections are viewed at the same time. If the system configuration is for four sections, the display will alternate every 5 seconds between a pair of sections. The select key will lock the display on rear sections. The SMM console shows RIGHT in the left/right configuration, FRONT in the front/rear configuration and front right/rear right in four sections configuration. The KPM II Stack-Mode console shows LEFT in the left/right configuration, REAR in the front/rear configuration and front left/rear left in four sections configuration.

**STEP 1** Press SELECT key once to show one section. The flashing icon shows the section that is not selected. The selected section icon is continuously displayed on the LCD.

**EXAMPLE:** The system is setup to display rear section on KPM II Stack-Mode console and front section on SMM console. Press SELECT key. The FRONT icon will be flashing and the REAR section will be displayed on the bar graph. The SMM console is only backlit. After 1 minute the front row icon will stop flashing. The monitor will stay in this REAR only display through power down and power up. Each time the monitor is turned on while in REAR only mode, the FRONT icon will flash for 1 minute.

If seed flow is sensed in the FRONT section while planting, the FRONT icon will resume flashing.

When the front section is disabled, the row spacing will automatically double to maintain the proper implement width in the monitor. A 23 row 15" configuration changes to a 12 row 30" configuration with a touch of the SELECT key.

**STEP 2** Press SELECT key again to activate both sections.

For simple applications, where only one section is programmed, the display will automatically lock on that section. Pressing the SELECT key will have no affect.

**NOTE:** When alternating between two sections, the display will lock on the section containing the first recognized alarm until the alarm is acknowledged by pressing the OK key or the alarm condition is removed.

## LOWER LCD FUNCTIONS

(MTR29g)



- The UP and DOWN arrow keys will sequentially change what is being displayed on the lower LCD. Pressing the UP or DOWN arrow keys will move the arrow head icon (on the left and right hand side of the display) to another item. For example, if the arrow icon is pointing to SPEED, ground speed will be displayed on the LCD. Pressing the UP arrow key will move the icon to UNITS. The display will change to display all the icons used to represent the current (English or Metric) measurement system.
- The shortcut keys SPEED, SEED POPULATION/SPACING and AREA FIELD/TOTAL allow direct access to their respective displays. For example, no matter what is currently being displayed on the lower LCD, pressing the SPEED key will change the display to the current speed. Pressing the SEED POPULATION/SPACING or AREA FIELD/TOTAL keys will alternate between the two functions assigned to that key.
- Pressing the SCAN key while displaying seed spacing or population will cause a sequential display of each individual row. Pressing the SCAN key a second time will freeze the display on the currently displayed row. The UP or DOWN arrow keys can be used to change the currently displayed row. Pressing the SCAN key will restart the automatic advancing of the scan function.
- Pressing the SCAN key while displaying speed will cause a sequential display of speed, average planter population and average seed spacing. Pressing the SCAN key a second time will freeze the display on the currently displayed reading.

## ROW SPACING

Press the arrow keys to ROW SPACING to display the current spacing between rows in inches or centimeters. The ROW SPACING icons turn on, displaying a 3 digit, one decimal place format. In the acre counter mode, this function displays the implement width in feet or meters, using a 3 digit, no decimal places format.

## UNITS

Press the arrow keys to UNITS to display all the icons from the currently selected English or Metric measurement system. For the English system, the icons are: INCH, MPH, FT, ACRE and MILE. For the Metric system, the icons are: M, KM/H and Ha.

## SPEED

Press the SPEED key to display the current speed in MPH or KM/H, using a 3 digit, one decimal place format.

## VOLUME

Press the arrow keys to VOLUME to display the presently selected audible alarm volume. The SPEAKER icon turns on.

## SCAN

Press the SCAN key to display the seed spacing or seed population (see steps 1-3 below) of each individual row. (1)Pressing the SCAN key while displaying any other function will cause the monitor to sequentially display speed, average seed population and average seed spacing. (2)Pressing the SCAN key a second time will freeze the display. (3)Pressing the SCAN key a third time restarts the sequential display. The UP and DOWN arrow keys can be used to change the current display.

# MACHINE OPERATION

# KPM II STACK-MODE

## SEED POPULATION/SEED SPACING

Each SEED POP/SPACING key press alternates between seed population and seed spacing.

Seed population displays the average number of seeds or the row average number of seeds per acre or seeds per hectare for all the active rows. The average is displayed using a 6 digits, no decimal places format. The AVERAGE POPULATION icon will turn on. When in the scan mode, the scan arrow and SCAN ROW POPULATION will appear. The ROW number icon and the current row will be displayed on the left and the population will be displayed on the right in 1000's using 3 digits, one decimal place (e.g. 32.9 means 32,900). When in scan freeze mode, the scan arrow and ROW POPULATION will turn on (scan arrow may be flashing). The UP and DOWN keys may be used to lock on the desired row.

Seed spacing displays the average distance or the row average distance between seeds for all active rows in inches per seed or centimeters per seed, using a 3 digit, one decimal place format. When the average is displayed the AVERAGE SPACING icons are turned on. When in the scan mode, the scan arrow and SCAN ROW SPACING icons will appear. The ROW number icon and the current row will be displayed on the left and the spacing will be displayed on the right. The display will sequence to the next row every 5 seconds. When in scan freeze mode, the scan arrow and SPACING will turn on (scan arrow may be flashing). The UP and DOWN keys may be used to lock on the desired row.

## FIELD AREA/TOTAL AREA

Each AREA FIELD/TOTAL key press alternates between field area and total area.

Field area displays the total number of acres or hectares, using a 6 digit, one decimal place format.

**NOTE: When FIELD AREA is selected, the UP or DOWN key must be held in slightly longer than normal so the monitor will not mistake this action with a CLEAR, which consists of the UP and DOWN arrow keys pressed simultaneously. A beep will sound when the function activates.**

Total area displays the total number of acres or hectares, using a 6 digit, one decimal place format. The total area counter updates every time the field area counter increments. Clearing the total area counter will also clear the field area counter.

When the monitor is programmed as a rear only or rear/front configuration and shaft rotation sensors are installed, pressing the up arrow to move beyond row spacing lights an arrow on an unlabeled area above ROW SPACING. This is the automatically set division line between the L.H. shaft sensor and the R.H. shaft sensor. The display shows the first row on the rear section and the front section assigned to the R.H. shaft rotation sensor.

**EXAMPLE: On a 12 row 30" planter with Interplant® Package, the display would appear as follows:**

092597-21



THIS DISPLAY IS NOT ACCESSIBLE ON LEFT/RIGHT CONFIGURATIONS OR SYSTEMS WITHOUT SHAFT ROTATION SENSORS.

## PROGRAMMING - Changing The Audible Alarm Volume

**STEP 1** To enter the programming mode, press and hold the SETUP key. The monitor will emit several short beeps, followed by a long beep. On the lower LCD, the SETUP icon turns on and the arrow head icon will flash, indicating that the user can select an item to program.

**NOTE: The monitor must be in a programmable function (row spacing, units, speed, volume or area) to enter setup. The monitor will not enter setup in seed population or seed spacing.**

**STEP 2** Press the UP or DOWN arrow keys to move the flashing arrow to VOLUME. As the arrow icon moves, the lower LCD will display the current setting of the item selected.

**STEP 3** Press the OK key and the flashing arrow becomes solid and the beeper will sound.

**NOTE: The lower LCD will display the current volume and the SPEAKER icon is turned on. Settings are from 0 to 9.**

- Use the UP or DOWN arrow keys to change the setting. With every UP arrow key push, the beeper will increment by one step between the minimum and the maximum. If the maximum level (9) is reached the volume rolls over to the minimum level (0).
- Pressing the DOWN arrow key lowers the volume until the minimum level (0) is reached, at which point the volume rolls over to the maximum level (9).

**STEP 4** To exit without saving, press and release the OK key. The monitor will restore the lower LCD to show the setting of the item, and the arrow icon will flash, allowing the user to select another item to program.

To exit and save, press and hold the OK key. The monitor will emit several short beeps and SAVE? icon is turned on. After a short time a long beep is heard, and the lower LCD will display the word "DONE". Release the OK key. If the OK key is released BEFORE the word "DONE" is displayed, the changes WILL NOT BE SAVED. The word "DONE" MUST be displayed in order for the save to have occurred.

**NOTE: The programming mode may be exited at any time, by pressing the SETUP key. Pressing this key will return the monitor to its normal operation. All items changed and saved will come into affect immediately. Any items changed, but not saved will revert to the original programmed value.**



# MACHINE OPERATION

# KPM II STACK-MODE

## PROGRAMMING - Units (Metric Or English)

**STEP 1** To enter the programming mode, press and hold the SETUP key. The monitor will emit several short beeps, followed by a long beep. On the lower LCD, the SETUP icon turns on and the arrow head icon will flash, indicating that the user can select an item to program.

**NOTE: The monitor must be in a programmable function (row spacing, units, speed, volume or area) to enter setup. The monitor will not enter setup in seed population or seed spacing.**

**STEP 2** Press the UP or DOWN arrow keys to move the flashing arrow to UNITS. As the arrow icon moves, the lower LCD will display the current setting of the item selected.

**STEP 3** Press the OK key and the flashing arrow becomes solid and the beeper will sound.

**NOTE: The lower LCD will alternately display all Metric icons or all English icons, indicating the Metric or English mode respectively.**

- Use the UP or DOWN arrow keys to change the setting.

**STEP 4** To exit without saving, press and release the OK key. The monitor will restore the lower LCD to show the setting of the item, and the arrow icon will flash, allowing the user to select another item to program.

To exit and save, press and hold the OK key. The monitor will emit several short beeps and SAVE? icon is turned on. After a short time a long beep is heard, and the lower LCD will display the word "DONE". Release the OK key. If the OK key is released BEFORE the word "DONE" is displayed, the changes WILL NOT BE SAVED. The word "DONE" MUST be displayed in order for the save to have occurred.

**NOTE: The programming mode may be exited at any time, by pressing the SETUP key. Pressing this key will return the monitor to its normal operation. All items changed and saved will come into affect immediately. Any items changed, but not saved will revert to the original programmed value.**

## PROGRAMMING - Row Spacing

**STEP 1** Prior to entering the programming mode, the application mode (rear/front, left/right or four sections) must be active. If the monitor is programmed in a rear/front configuration, both sections will be active (alternating every 5 seconds if the SMM console is not used). You can then set the row spacing to the Interplant® row spacing.

EXAMPLE: On a 12 row 30" with Interplant® Package set the row spacing to 15.0 with front active.

When the monitor is in normal field operation mode, disabling the front section will automatically change the row spacing to 30".

**STEP 2** To enter the programming mode, press and hold the SETUP key. The monitor will emit several short beeps, followed by a long beep. On the lower LCD, the SETUP icon turns on and the arrow head icon will flash, indicating that the user can select an item to program.

**NOTE: The monitor must be in a programmable function (row spacing, units, speed, volume or area) to enter setup. The monitor will not enter setup in seed population or seed spacing.**

**STEP 3** Press the UP or DOWN arrow keys to move the flashing arrow to ROW SPACING. As the arrow icon moves, the lower LCD will display the current setting of the item selected.

**STEP 4** Press the OK key and the flashing arrow becomes solid and the beeper will sound.

**NOTE: The lower LCD will display the current row spacing (in inches or centimeters) and ROW SPACING icon is turned on.**

- The least significant digit of the displayed value will be blinking.
- This value can be changed by pressing either the UP or DOWN arrow keys.
- Once this digit is correct, press the MODE SELECT key and the blinking digit will move to the next significant digit, where the process can be repeated.

**NOTE:** The monitor limits the entry of row spacing to a minimum of 10.0 inches (25.4 cm) and to a maximum of 99.9 inches (253.7 cm). If the monitor is configured to a rear/front configuration, the limits change to a minimum of 5.0 inches (12.7 cm) and a maximum of 49.9 inches (126.8 cm).

**STEP 5** To exit without saving, press and release the OK key. The monitor will restore the lower LCD to show the setting of the item and the arrow icon will flash, allowing the user to select another item to program.

To exit and save, press and hold the OK key. The monitor will emit several short beeps and SAVE? icon is turned on. After a short time a long beep is heard, and the lower LCD will display the word "DONE". Release the OK key. If the OK key is released BEFORE the word "DONE" is displayed, the changes WILL NOT BE SAVED. The word "DONE" MUST be displayed in order for the save to have occurred.

To exit setup mode, press the SETUP key.

**NOTE:** The programming mode may be exited at any time, by pressing the SETUP key. Pressing this key will return the monitor to its normal operation. All items changed and saved will come into affect immediately. Any items changed, but not saved will revert to the original programmed value.

## PROGRAMMING - Speed

**STEP 1** To enter the programming mode, press and hold the SETUP key. The monitor will emit several short beeps, followed by a long beep. On the lower LCD, the SETUP icon turns on and the arrow head icon will flash, indicating that the user can select an item to program.

**NOTE: The monitor must be in a programmable function (row spacing, units, speed, volume or area) to enter setup. The monitor will not enter setup in seed population or seed spacing.**

**STEP 2** Press the UP or DOWN arrow keys to move the flashing arrow to SPEED. As the arrow icon moves, the lower LCD will display the current setting of the item selected.

**STEP 3** Press the OK key and the flashing arrow becomes solid and the beeper will sound. The least significant digit of the displayed value will be blinking.

The speed constant is used to record how many pulses are generated per mile (or kilometer) from the ground speed sensor. The lower LCD will display the current pulses per mile (or kilometer), using a 6 digit, no decimal place format. The PULSES per MILE (or PULSES per KM) icons are turned on.

**NOTE: It is highly recommended that a field calibration be done to establish the PPM (Pulses Per Mile) number on a new machine installation. Several factors can affect this value such as wheel slip on the magnetic distance sensor, mounting angle and height on the radar distance sensor, etc. IT IS NOT UNCOMMON FOR THE MPH ON THE MONITOR TO VARY SLIGHTLY FROM THE TRACTOR SPEEDOMETER. Adjusting the PPM in the monitor to make the MPH or Km/h readings agree can cause serious errors in acre/hectare and population counts. Do field checks to verify populations and seed spacings.**

**NOTE: On new system installations, the monitor will default to 500 PPM. This will have to be changed to obtain accurate readings from the monitor.**

- In field conditions, measure 330 feet ( $\frac{1}{16}$  mile) or 100 meters, depending on the unit of measurement selected.

- Pull the tractor up to the starting line.

- Press the UP and DOWN arrow keys at the same time and hold them down until the CLEAR? icon is displayed and the monitor beeps several times. When the data is actually cleared, the monitor will emit a long beep and the number of pulses is cleared.

**NOTE: If the PPM number starts to count pulses with the tractor not moving, check the radar for vibration or other kinds of interference.**

- Drive the tractor for 330 feet ( $\frac{1}{16}$  mile) or 100 meters and stop.

- The monitor will count the number of pulses and display them.

**STEP 4** To exit without saving, press and release the OK key. The monitor will restore the lower LCD to show the setting of the item, and the arrow icon will flash, allowing the user to select another item to program.

To exit and save, press and hold the OK key. The monitor will emit several short beeps and SAVE? icon is turned on. After a short time a long beep is heard, and the lower LCD will display the word "DONE". Release the OK key. If the OK key is released BEFORE the word "DONE" is displayed, the changes WILL NOT BE SAVED. The word "DONE" MUST be displayed in order for the save to have occurred.

**NOTE: The programming mode may be exited at any time, by pressing the SETUP key. Pressing this key will return the monitor to its normal operation. All items changed and saved will come into affect immediately. Any items changed, but not saved will revert to the original programmed value.**

NOTE: If a discrepancy occurs and digits must be changed, follow STEPS 1 and 2 to enter the programming mode and proceed as follows:

- Press the OK key and the flashing arrow becomes solid. The least significant digit of the displayed value will be blinking.
- This value can be changed by pressing either the UP or DOWN arrow keys.
- Once this digit is correct, press the SELECT key and the blinking digit will move to the next significant digit, where the process can be repeated.

The monitor limits the entry of pulses per mile or kilometer to a minimum of 500 PPM (310 PPKM), and to a maximum of 500,000 PPM (310,686 PPKM).

KEY Action	Flashing Digit	Display Value
Press The UP Key	Right Most Digit	2031, 2032, 2033
Press The SELECT Key	Second Digit From Right	2033
Press The DOWN Key	Second Digit From Right	2023, 2013, 2003, 2093, 2083
Press The SELECT Key Twice	Left Most Digit	2083
Press The DOWN Key	Left Most Digit	1083, 0500 (Min. Value), 9500, 8500

## PROGRAMMING - Clearing Total Area

**NOTE: Clearing the total area counter will also clear the field area counter.**

**STEP 1** To enter the programming mode, press and hold the SETUP key. The monitor will emit several short beeps followed by a long beep. On the lower LCD, the SETUP icon turns on and the arrow head icon will flash, indicating that the user can select an item to program.

**NOTE: The monitor must be in a programmable function (row spacing, units, speed, volume or area) to enter setup. The monitor will not enter setup in seed population or seed spacing.**

**STEP 2** Press the UP or DOWN arrow keys to move the flashing arrow to TOTAL AREA. As the arrow icon moves, the lower LCD will display the current setting of the item selected.

**STEP 3** Press the OK key and the flashing arrow becomes solid and the beeper will sound.

- The lower LCD will display the total area and the ACRE (or Ha) icon turns on.
- With the flashing arrow on TOTAL AREA, press the OK key.

• To reset the counter, press the UP and DOWN arrow keys at the same time and hold them down for a short period of time to clear the data. The CLEAR? icon will be displayed and the monitor will beep several times. When the data is actually cleared, the monitor will emit a long beep, and the total area is reset to zeros. After the long beep, the previous recorded total area is not retrievable. Once cleared, the user **may not** choose to exit programming mode without saving as described in STEP 4.

**STEP 4** To exit and save, press and hold the OK key. The monitor will emit several short beeps and SAVE? icon is turned on. After a short time a long beep is heard, and the lower LCD will display the word "DONE". Release the OK key. If the OK key is released BEFORE the word "DONE" is displayed, the changes WILL NOT BE SAVED. The word "DONE" MUST be displayed in order for the save to have occurred.

**NOTE: The programming mode may be exited at any time, by pressing the SETUP key. Pressing this key will return the monitor to its normal operation. All items changed and saved will come into affect immediately. Any items changed, but not saved will revert to the original programmed value.**

## AREA COUNTER/SPEEDOMETER MODE

If the monitor is installed with only a radar distance sensor (no seed tubes attached), the monitor becomes a speedometer. If (a) the monitor is connected to a radar distance sensor, (b) the signal cable from the back of the console is connected to a sensing switch (Part No. G1K249 Acre Counter Switch Kit) instead of the seed tubes and (c) the implement width in feet (or meters) is programmed into the monitor, the monitor will function as an acre counter.

The seed spacing and seed population functions are not available in this mode. If the monitor is powered down, the seed tubes connected and the monitor powered up, the monitor will again show seed population and seed spacing in inches or centimeters. Row spacing reverts back to its programmed setting.

## WARNINGS AND ALARMS

- 1. System Alarms** - A system alarm is activated when the monitor detects a faulty sensor or one of several other communication faults.

The corresponding row number starts flashing and the beeper sounds. All segments on the corresponding bar graph are turned off. Pushing the OK key to acknowledge the alarm will turn the beeper off. The row number will continue to flash until the alarm condition is removed. If the monitor detects a faulty sensor and there is no planting activity present, the monitor will scroll "CHECK CONNECTION".

If the distance sensor is detected as faulty, the monitor will display either "PICKUP" or "RADAR", depending on the type of sensor installed, and the audible alarm will sound. The user can push the OK key to acknowledge the alarm. When the distance sensor is faulty, the monitor will change to a bar graph only mode where the rows are still displayed relative to each other. No area related information (speed, field area, total area, seed spacing or seed population) will be accumulated or displayed.

If a rotation shaft sensor is faulty, "LSHAFT", "RSHAFT" or "SHAFTS" will display.

Another type of system alarm occurs when the monitor detects a data communication bus error.

The four possible data communication bus errors are:

LCD Display	Error Condition
SYS HI	The data communication lead (green) has been shorted to the power lead (white).
SYS LO	The data communication lead (green) has been shorted to the ground lead (black).
SYS EC	An internal error has been detected.
COP	Cycled power ON/OFF to quickly.

- 2. Under Flow Alarms** - If the seed rate for one or more rows is less than 55% of the calculated average, the corresponding 60% segment will stay on, the corresponding row number starts flashing and the alarm sounds. Pushing the OK key to acknowledge the alarm will turn the alarm off. The 60% segment of the bar graph remains on and the row number continues to flash until the alarm condition is corrected.

**NOTE: All alarms present within a short time before planting stops are frozen on the screen and the text LOW or FAIL will display on the LCD. If the under flow is between 0% and 10%, this warrants a "FAIL" condition. If the under flow is between 10% and 55%, a "LOW" condition is generated. If multiple rows have an under flow condition, "FAIL" will display if any one or more rows is between 0% and 10%. This allows the user to identify and fix the problem rows.**

**NOTE: This warning will not trigger unless a minimum time of continuous planting has passed.**

**NOTE: If all the rows show a seed rate of zero, the condition will not generate an alarm. It will be assumed the planter has stopped. The row numbers and the bottom 60% segment will remain on for all selected rows.**

- 3. Multiple Alarms** - If more than one alarm condition occurs at the same time, pushing the OK key will acknowledge all alarms that are currently displayed. For example, if one row on the front and one row on the rear are alarming, pushing the OK key will only acknowledge one of them. However, if there are two alarms on the front, both alarms would be acknowledged with one push of the OK key.

4. **Section Not Selected Warning** - If the monitor was programmed for two sections and only one is currently selected for display (by pressing the SELECT key), the icon of the disabled section will flash for a period of 1 minute, then turn off at each power up. If seed flow is sensed in the disabled section, the icon for that section (front, left or right) will begin to flash.
5. **Seed Planting Stopped Warning** - When the monitor detects no seed flow on all rows, the monitor will emit 3 short beeps to alert the user. This warning will occur each time the planter is stopped, each time the planter is raised at the end of a row or if the mechanical drive fails while planting.

**NOTE: This warning will not trigger unless a minimum time of continuous planting has passed.**

6. **Seed Counting Sensor In Calibration Warning** - All seed counting sensors run a self-calibration sequence on power up. While in calibration the bottom segment of each corresponding bar graph will flash if the monitor detects movement or planting activity. If the monitor does not detect this, the message "WAIT CALIBRATION" will be scrolled.
7. **Seed Counting Sensor Too Dirty Warning** - After the seed counting sensors end their internal self-calibration, the monitor may detect one or more sensors are either too dirty or blocked. If the monitor detects planting or movement, the corresponding bar graph remains flashing. The monitor will display "CLEAN SENSORS" on the top LCD if no movement or planting is detected, prompting the user to clean the tubes. If the tubes are dirty, they will still show seed flow with less accuracy. If the tubes are blocked the user will get an alarm as soon as planting starts. The corresponding bar graph will remain flashing until the problem is corrected and the monitor is powered down and then powered back up.
8. **Low Battery Warning** - The monitor is constantly monitoring its input voltage to quickly detect low power conditions. If the monitor detects that the input voltage has dropped below 11.0V, it will display "LO SYS" on the lower LCD on the KPM II Stack-Mode console, provided that the monitor does not detect speed or planting.

**NOTE: After the alarms have been acknowledged and if the alarm condition is still present, the LCD will continue to display the alarm condition.**

## REPLACING A FAULTY SENSOR

**NOTE: Stack-mode sensors are identified by a blue 3-pin connector. Replace stack-mode seed sensors with like components only.**

To replace a faulty sensor; (a) turn the monitor off, (b) disconnect the faulty sensor, (c) turn the monitor back on and (d) plug in the replacement sensor. The monitor will chirp twice to acknowledge the new sensor was learned and saved.

To replace more than one faulty sensor, proceed as stated above for front/rear or left/right configurations beginning with the lowest numbered row in the rear/left section and continue to replace sensors in ascending order. Then move on to the front/right section and continue in ascending order. For four section configurations, begin with rear/left and continue to rear/right, then front/left and ending with front/right.

If the monitor detects a faulty distance sensor, the lower LCD will immediately move to the speed display, show the word "PICKUP" or "RADAR" depending on the distance sensor installed, and the alarm will sound.

**NOTE: If the monitor is not turned off and then on, the replacement sensor(s) will be ignored until the next power on, at which point the sensors will be randomly learned by the monitor.**

# MACHINE OPERATION

# KPM II STACK-MODE

## FIELD OPERATION

Press the ON/OFF key to turn the monitor on and off.



(MTR28e)

Information regarding each section is displayed alternately every 5 seconds.

### REAR/FRONT CONFIGURATION (Without SMM Console Installed)

- Press the SELECT key once to show REAR section only. (Monitor sets correct row spacing.)
- Press the SELECT key a second time to return to each section being displayed alternately every 5 seconds on KPM II Stack-Mode console. (Monitor sets correct row spacing.)
- Press the SELECT key a third time to show REAR section only again.



(MTR28c)

### REAR/FRONT CONFIGURATION (With SMM Console Installed)

- Press the SELECT key once to show REAR section only on KPM II Stack-Mode console. (Monitor sets correct row spacing.)
- Press the SELECT key a second time to show FRONT section on SMM console and REAR section on KPM II Stack-Mode console. (Monitor sets correct row spacing.)
- Press the SELECT key a third time to show REAR section only again.



(MTR28c)

### FOUR SECTION CONFIGURATION (With SMM Console Installed)

- Press the SELECT key once to show REAR/LEFT on KPM II Stack-Mode console and REAR/RIGHT sections on SMM console. (Monitor sets correct row spacing.)
- Press the SELECT key a second time to return to all four sections, right front and rear on SMM console and left front and rear on KPM II Stack-Mode console. (Monitor sets correct row spacing.)
- Press the SELECT key a third time to show REAR/LEFT on KPM II Stack-Mode console and REAR/RIGHT sections on SMM console again.



(MTR28c)

**NOTE: SELECT key has no function when only a single section is being used.**

At power up, the lower LCD will show speed (MPH or Km/h).

(MTR29g/MTR29b/MTR29a/MTR29c/MTR29f/MTR29c/MTR29f)

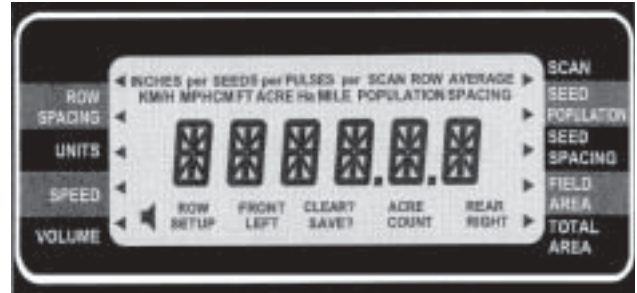

Press the UP or DOWN arrow keys to move the flashing arrow on the lower LCD to change what is displayed on the lower LCD.



Press the shortcut keys SPEED, SEED POPULATION/SEED SPACING or AREA FIELD/TOTAL for direct access to these displays.



(MTR29c/MTR29d/MTR29b/MTR29c)

Press the SEED POPULATION/SEED SPACING or AREA FIELD/TOTAL keys to alternate between the two functions assigned to that key.



Press the SEED POPULATION/SEED SPACING key to choose average seed spacing/population per acre.



Press the SCAN key to display individual rows starting at row 1.



Press the SCAN key again to lock on current row.

Press the SCAN key again to resume scrolling.

Use the UP or DOWN arrow keys to move to a particular row.



Press the SEED POPULATION/SEED SPACING key to go back to planter average.



## CLEARING FIELD AREA

(MTR29n/MTR28b)

To reset the counter, press the UP or DOWN arrow keys to move the arrow in the lower display to FIELD AREA.



Press the UP and DOWN arrow keys at the same time and hold them down for a short period of time to clear the data. The CLEAR? icon will be displayed and the monitor will beep several times. When the data is actually cleared, the monitor will emit a long beep, and the field area is reset to zero. After the long beep, the previous field area recorded is not retrievable.



**NOTE: Clearing the field area counter will not clear the total area counter. See “Programming-Clearing Total Area” for clearing total area.**

Press the OK key to silence alarms. See “Warnings And Alarms”.





# MACHINE OPERATION

# KPM II STACK-MODE

CONNECTING SEED TUBES, RADAR/MAGNETIC DISTANCE SENSORS, SMM CONSOLE AND/OR SHAFT ROTATION SENSORS

**STEP 1** All the seed tubes w/sensors (including the radar, magnetic distance, SMM console and shaft rotation sensors) must be unplugged from the harness and/or console and the monitor must be off.

**NOTE:** If the monitor detects a radar sensor but no seed tubes at power up, it will automatically go into AREA COUNT mode. See "Area Counter/Speedometer Mode".

**NOTE:** Disconnect magnetic distance sensor between MDS adapter and planter harness. DO NOT disconnect between MDS and MDS adapter.

01189909

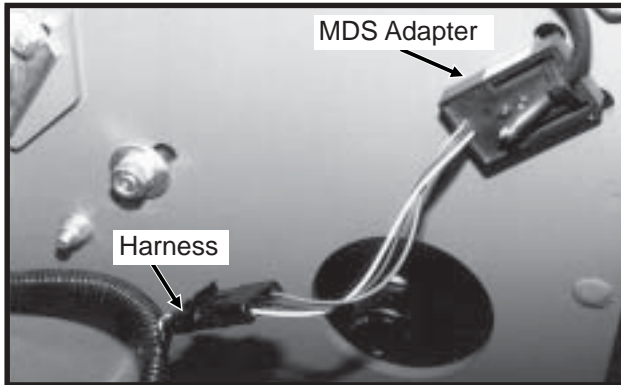

01189910

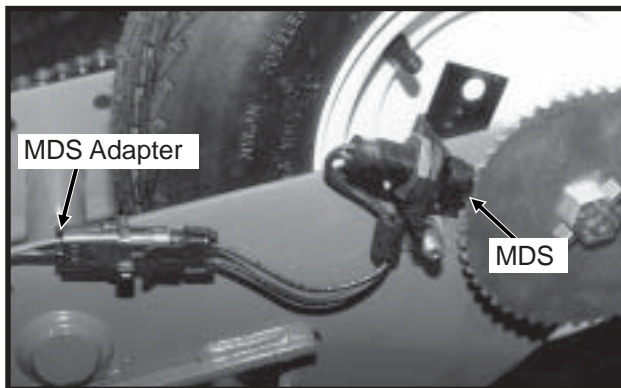

**STEP 2** Press the ON key. The monitor automatically enters the setup procedure. Monitor will scroll "NO SENSOR" on top LCD of KPM II stack-mode console.

**STEP 3** The monitor automatically defaults to front/rear. Press the SELECT key once for left/right and twice for four sections (front right/front left/rear right/rear left). The selected display will be solid and the configuration not currently selected will be flashing.

12060201

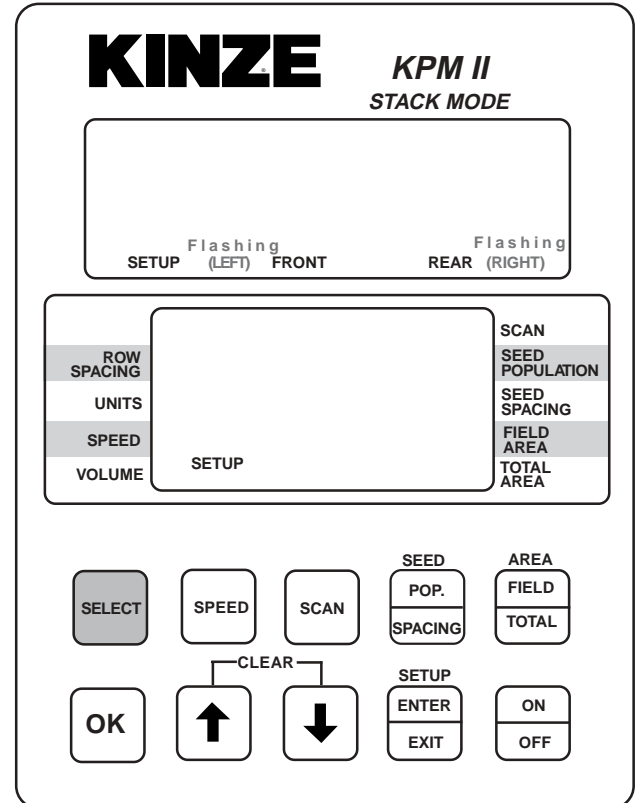

12060202

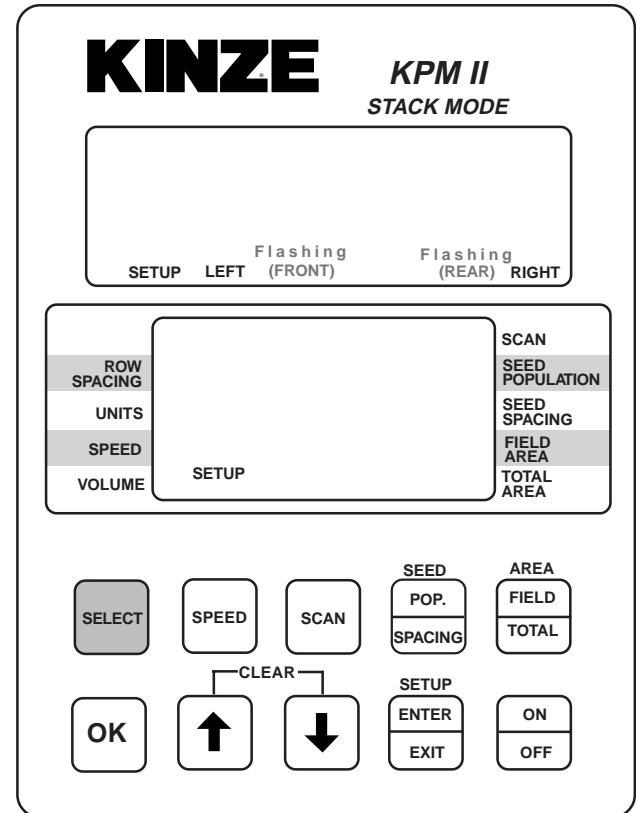

**NOTE:** Model 3650 planters select the rear configuration only. When Interplant® Package rows are in use, select the rear/front configuration.

# MACHINE OPERATION

# KPM II STACK-MODE

**STEP 4** Press and hold the OK key to confirm selection. The upper display will alternate between “NEW” and “SYS?”.

The alarm will sound four short beeps followed by one long beep. At this point your selection has been saved and row numbers will appear flashing on the upper display.

**NOTE:** Shown using rear/front configuration. The KPM II Stack-Mode console shows LEFT in the left/right configuration, REAR in the front/rear configuration and front left/rear left in the four sections configuration.

12060203

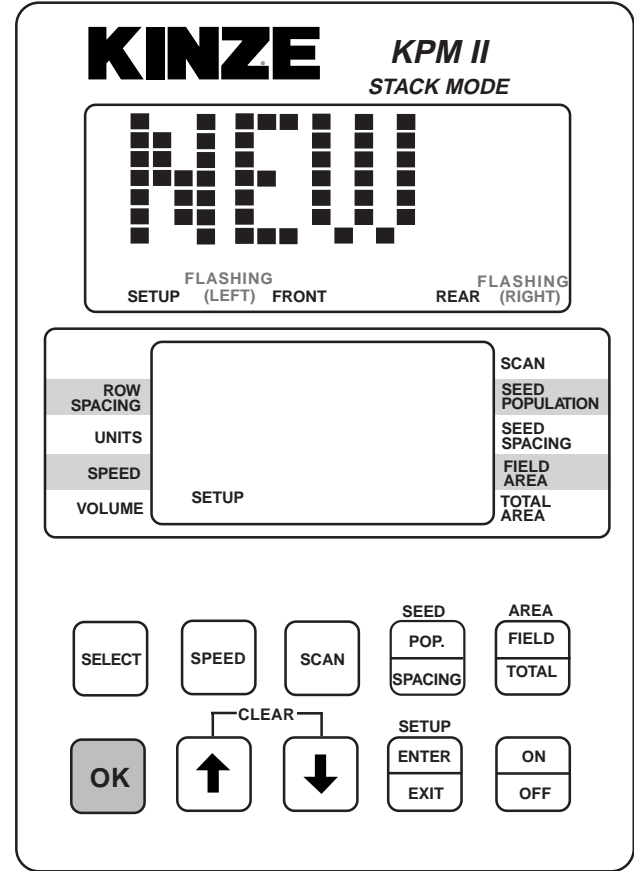

12020604

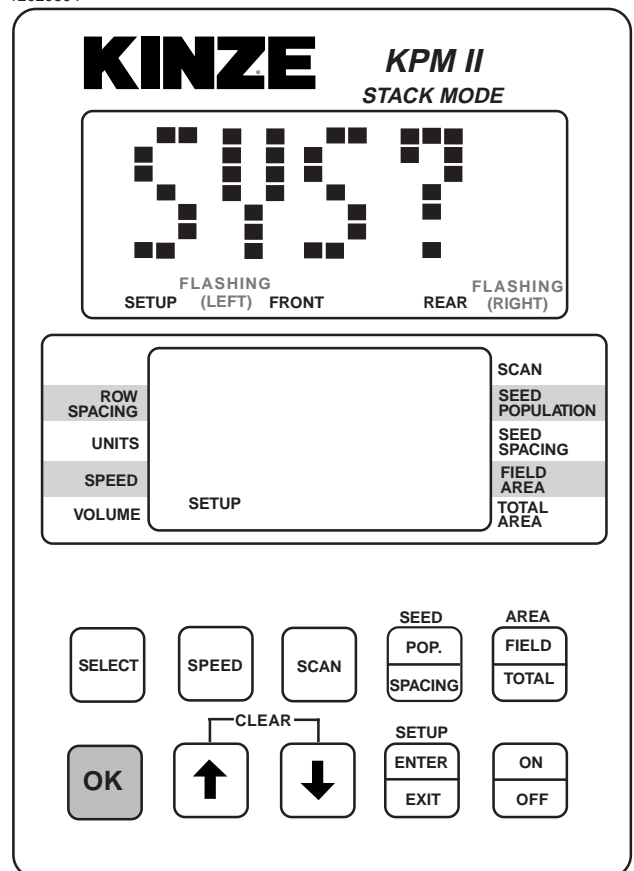

# MACHINE OPERATION

# KPM II STACK-MODE

**STEP 5** Determine which row you want as number one and plug the seed tube w/sensor into the harness.

Continue plugging in sensors along with shaft rotation sensors if so equipped. Row 1 first, row 2 second and so on up to 18 rows. When a sensor is plugged in, the corresponding row number on the upper LCD display will stay solid, the monitor will chirp twice and a red LED (Light Emitting Diode) on the seed tube sensor will turn on for approximately 30 seconds to show connection is made.

D120602101

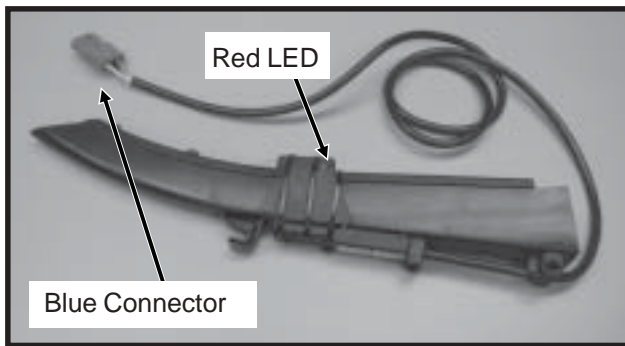

**NOTE:** Shown using rear/front configuration. The KPM II Stack-Mode console shows LEFT in the left/right configuration, REAR in the front/rear configuration and front left/rear left in the four sections configuration.

12060205

**KINZE KPM II STACK MODE**

FLASHING  
 (1 2 3 4 5 6 7 8 9 10 11 12 13 14 15 16 17 18)  
 SETUP (FRONT) REAR

ROW SPACING	01	SCAN
UNITS		SEED POPULATION
SPEED	ROW SETUP	SEED SPACING
VOLUME	REAR	FIELD AREA
		TOTAL AREA

SELECT

SPEED

SCAN

SEED POP. SPACING

AREA FIELD TOTAL

OK

CLEAR  
 ↑  
 ↓

SETUP ENTER EXIT  
 ON OFF

12020206

**KINZE KPM II STACK MODE**

FLASHING  
 1 (2 3 4 5 6 7 8 9 10 11 12 13 14 15 16 17 18)  
 SETUP (FRONT) REAR

ROW SPACING	02	SCAN
UNITS		SEED POPULATION
SPEED	ROW SETUP	SEED SPACING
VOLUME	REAR	FIELD AREA
		TOTAL AREA

SELECT

SPEED

SCAN

SEED POP. SPACING

AREA FIELD TOTAL

OK

CLEAR  
 ↑  
 ↓

SETUP ENTER EXIT  
 ON OFF

# MACHINE OPERATION

# KPM II STACK-MODE

**STEP 6** If the monitor system includes shaft rotation sensors, these can be installed at any time as the seed tubes are connected. The first shaft rotation sensor installed will be assigned to the rows on the L.H. half of the planter and the second shaft rotation sensor connected will be assigned to the rows on the R.H. half of the planter.

01189906

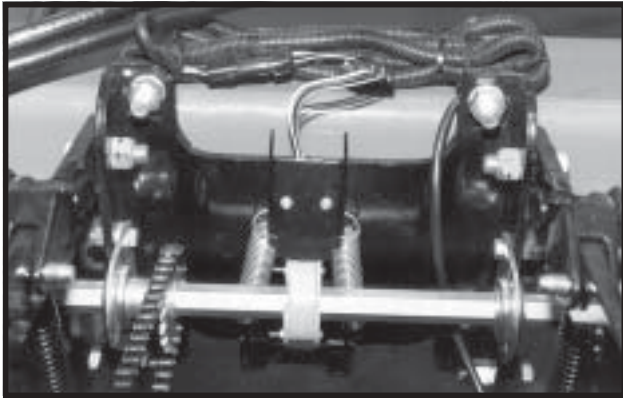

“LSHAFT” will display on the lower LCD when the first shaft rotation sensor is installed. “RSHAFT” will display when the second shaft rotation sensor is installed.

**NOTE:** Shown using rear/front configuration. The KPM II Stack-Mode console shows LEFT in the left/right configuration, REAR in the front/rear configuration and front left/rear left in the four sections configuration.

12060207

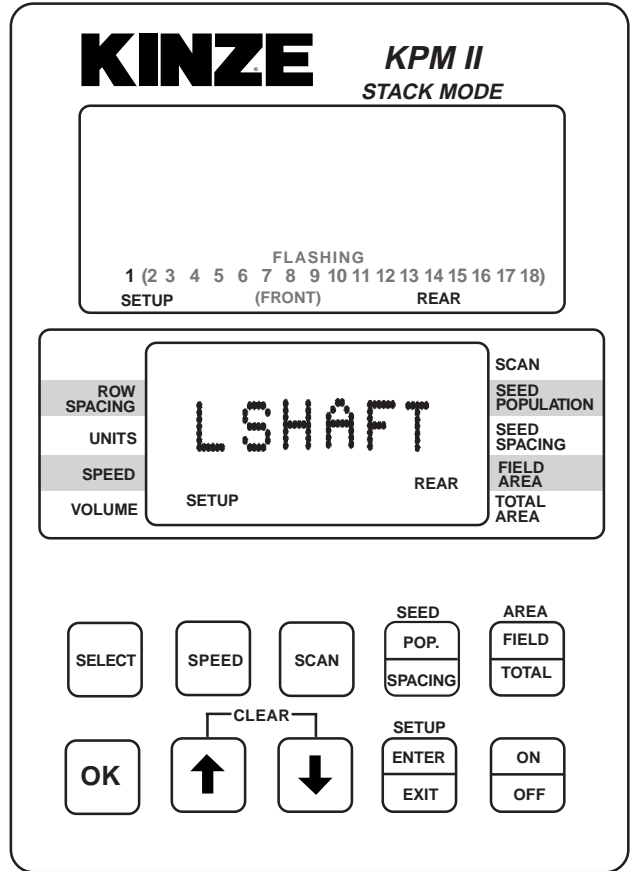

12060208

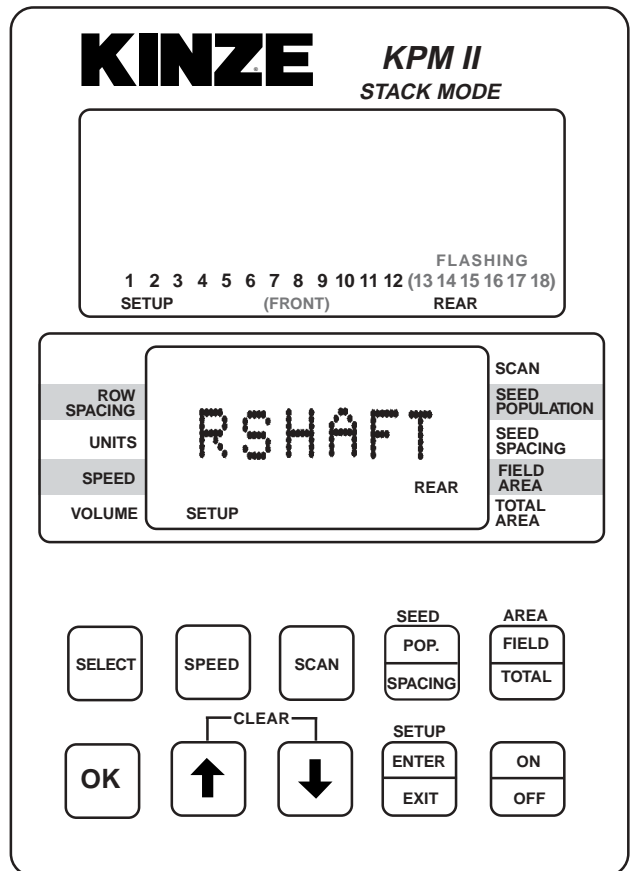

# MACHINE OPERATION

# KPM II STACK-MODE

**STEP 7** Connect SMM console into junction Y-harness which was installed between KPM II Stack-Mode console and the primary harness. SMM console will show a lighted screen and the KPM II Stack-Mode console will show KPM on the lower LCD.

12060211

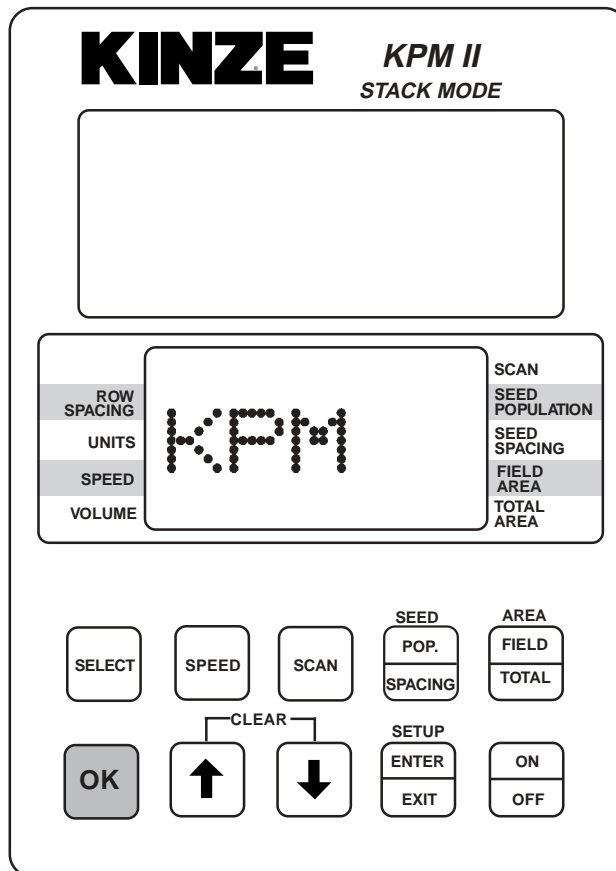

# MACHINE OPERATION

# KPM II STACK-MODE

**STEP 8** When all the seed tubes for the current section (rear/front, left/right or four section) are installed, check to be sure the upper LCD on the KPM II Stack-Mode console displays solid numbers for the number of seed tubes connected. Press and hold the OK key to save the setup for the current section. The SAVE? icon will display followed by continuous short beeps indicating the monitor is preparing to save. The installer has 5 seconds to decide to save the current configuration. During this time, four short beeps will sound followed by a long beep and the SAVE? icon will turn off and the word "DONE" shows on the screen. The monitor will continue to the second section installation (If Applicable).

**NOTE:** Shown using rear/front configuration. The KPM II Stack-Mode console shows LEFT in the left/right configuration, REAR in the front/rear configuration and front left/rear left in the four sections configuration. The SMM console shows RIGHT in the left/right configuration, FRONT in the front/rear configuration and front right/rear right in four sections configuration.

12060209

The diagram illustrates the KPM II Stack-Mode console interface. It is divided into three main sections:

- Top Section (SMM Screen):** Displays the brand name "KINZE" and the mode "SMM". Below this is a large empty rectangular area for the LCD display.
- Middle Section (KPM II Stack Mode Screen):** Displays "KINZE" and "KPM II STACK MODE". Below the display area, there is a row of numbers 1 through 18. Above numbers 13-18 is the word "FLASHING". Below numbers 1-12 is the word "SETUP". Below numbers 13-18 is the word "REAR". Below number 13 is the word "SAVE?".
- Bottom Section (Control Panel):** Contains several buttons:
  - A vertical column of buttons on the left: "ROW SPACING", "UNITS", "SPEED", and "VOLUME".
  - A central area with a large "13" and the text "Row waiting to be connected" with an arrow pointing to the number. Below this are "ROW SETUP" and "SAVE?".
  - A vertical column of buttons on the right: "SCAN", "SEED POPULATION", "SEED SPACING", "FIELD AREA", and "TOTAL AREA".
  - A bottom row of buttons: "SELECT", "SPEED", "SCAN", "SEED POP. SPACING", "AREA FIELD TOTAL", "OK", "CLEAR" (with up and down arrows), "SETUP ENTER EXIT", and "ON OFF".

## STEP 8 (Continued)

12060210

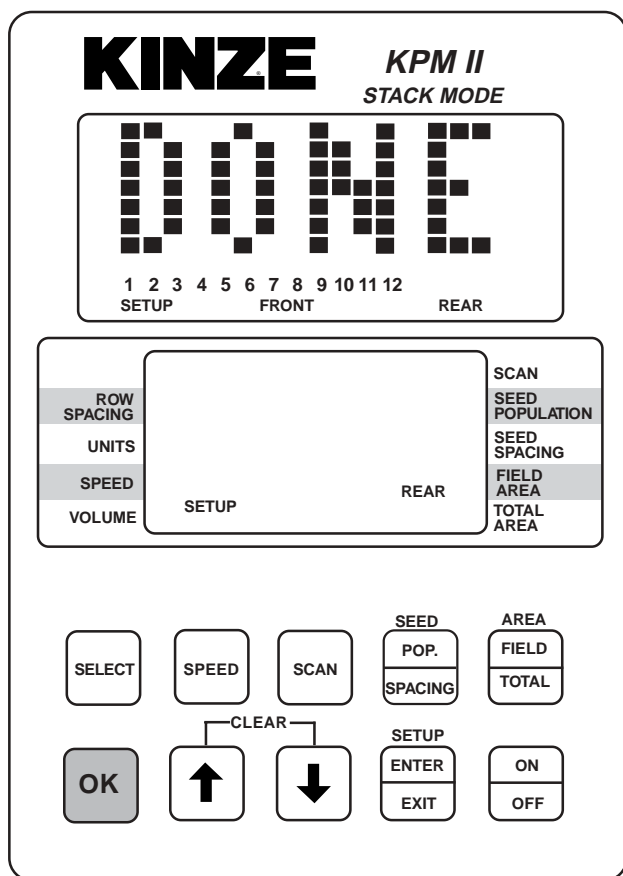

12060212

**STEP 9** Follow STEPS 5, 6 and 8 to install the second section. If no seed tubes are installed on the second section, press and hold the OK key. The word "DONE" will appear on upper display. The alarm will sound four short beeps followed by one long beep and the SAVE? icon turns off. The monitor has exited the setup mode. When you release the OK key the upper display will scroll "WAITING CALIBRATION". The lower display will show "GNDSPD" and the alarm will sound continually until the distance sensor is connected. See STEP 10.

**NOTE:** The SMM console shows nothing except its backlite screen until the entire system is saved.

**NOTE:** Shown using rear/front configuration. The KPM II Stack-Mode console shows LEFT in the left/right configuration, REAR in the front/rear configuration and front left/rear left in the four sections configuration. The SMM console shows RIGHT in the left/right configuration, FRONT in the front/rear configuration and front right/rear right in four sections configuration.

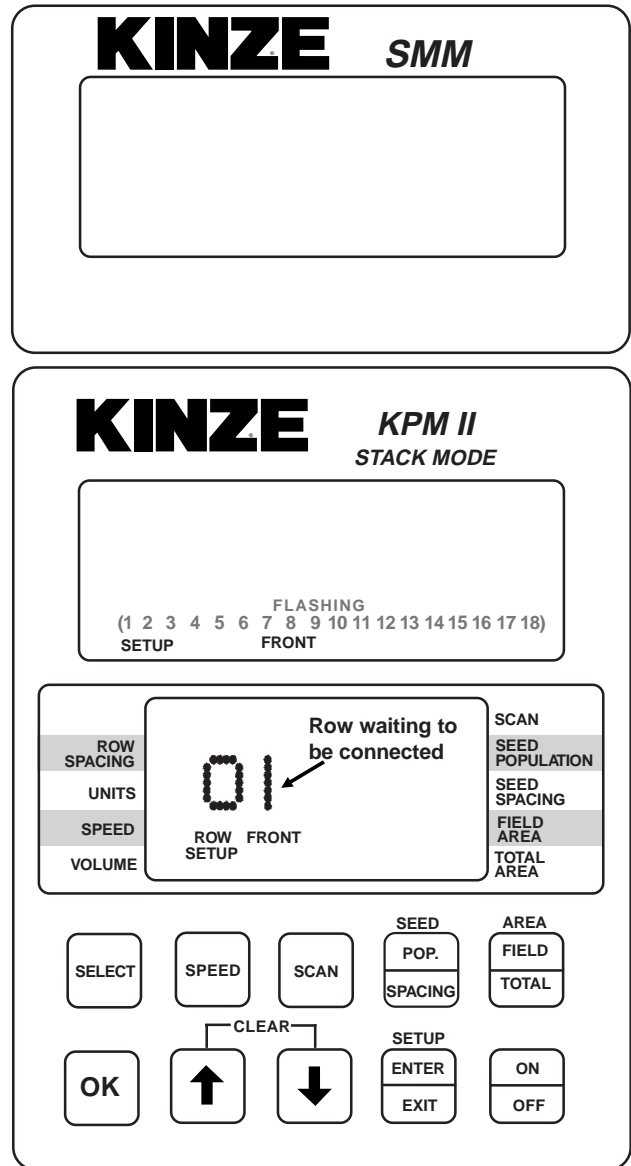



# MACHINE OPERATION

# KPM II STACK-MODE

## STEP 9 (Continued)

12060213



12060214

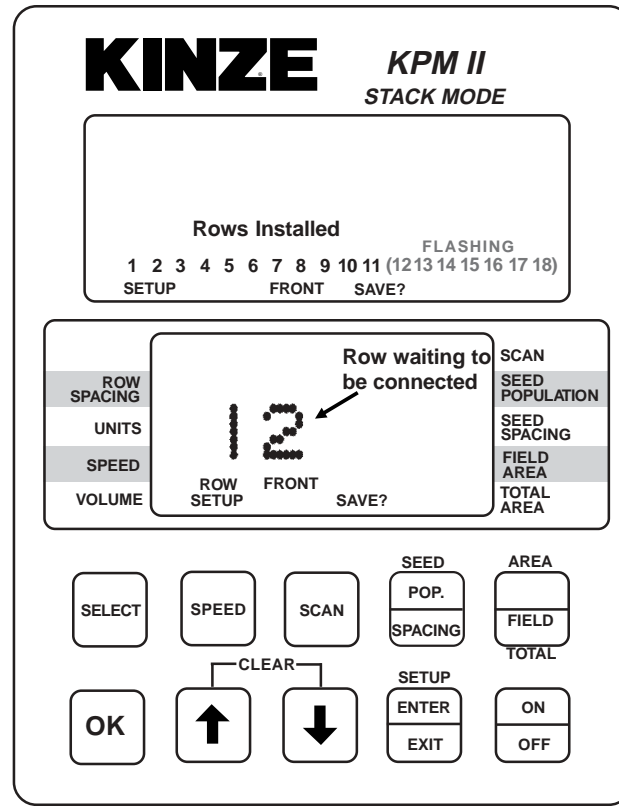
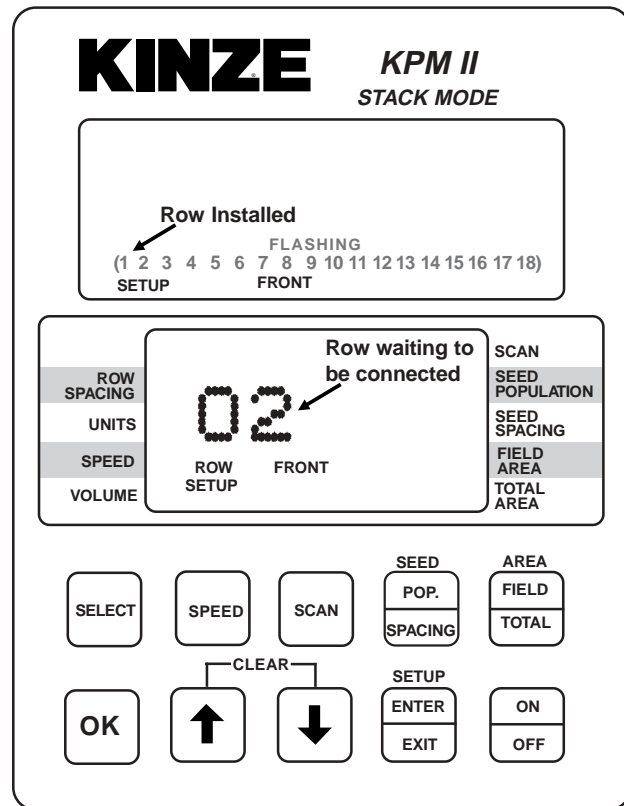

# MACHINE OPERATION

# KPM II STACK-MODE

## STEP 9 (Continued)

12060215

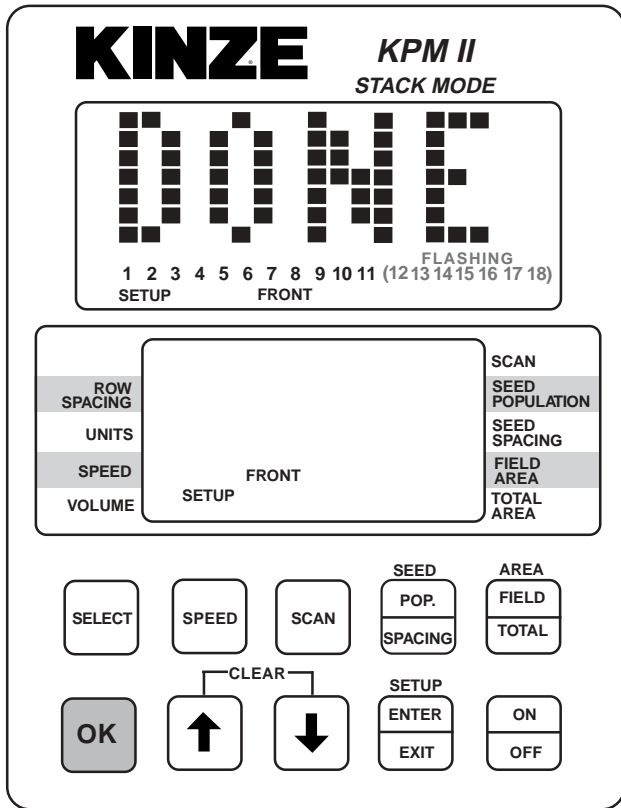
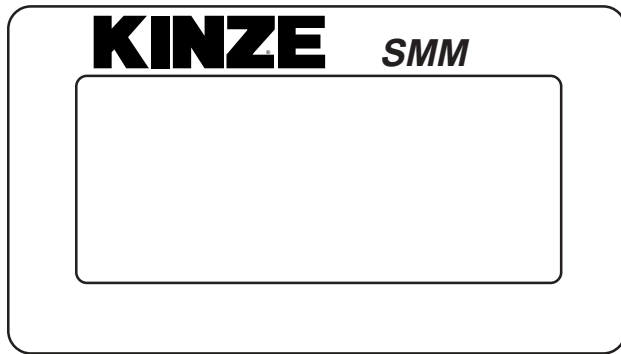

**STEP 10** With the lower display showing "GNDSPD", connect the distance sensor. The monitor will display "PICKUP" if a magnetic distance sensor is connected or "RADAR" if a radar distance sensor is installed. Only one distance sensor can be connected at a time.

**NOTE: Shown using rear/front configuration.** The KPM II Stack-Mode console shows LEFT in the left/right configuration, REAR in the front/rear configuration and front left/rear left in the four sections configuration. The SMM console shows RIGHT in the left/right configuration, FRONT in the front/rear configuration and front right/rear right in four sections configuration.

**NOTE: To connect the radar distance sensor, install the 10" monitor/radar adapter between the console and radar distance sensor to adapt the monitor system to various tractor radar systems.**

# MACHINE OPERATION

# KPM II STACK-MODE

## STEP 10 (Continued)

12060216

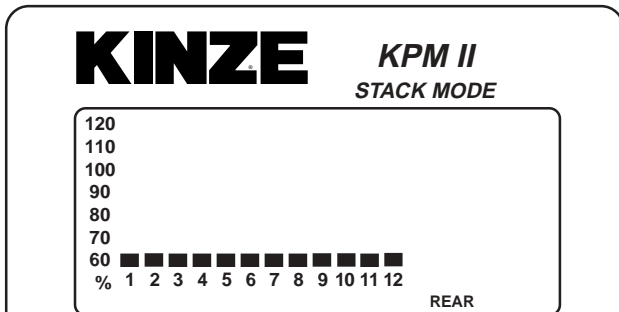
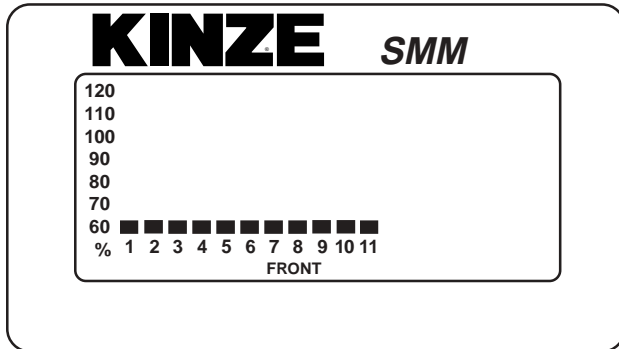

ROW SPACING	GNDSPD	SCAN
UNITS		SEED POPULATION
SPEED		SEED SPACING
VOLUME		FIELD AREA

REAR

SELECT	SPEED	SCAN	SEED POP. SPACING	AREA FIELD TOTAL
OK	CLEAR		SETUP ENTER EXIT	ON OFF
	↑	↓		

**NOTE:** To reprogram the system to monitor more or less rows (up to the maximum of 18 per section, 72 total on four section configuration), all sensors must be unplugged, followed by the complete setup procedure.

**NOTE:** Individual seed tubes may be unplugged for special situations. An alarm will sound which can be silenced by touching the OK key. The monitor will recognize the seed tube(s) when reconnected.

12060217

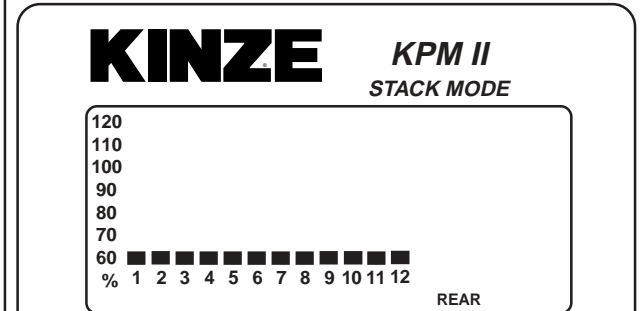
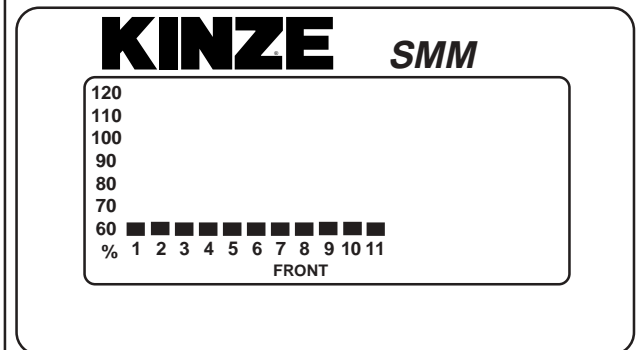

ROW SPACING	MPH	SCAN
UNITS		SEED POPULATION
SPEED		SEED SPACING
VOLUME		FIELD AREA

0.0

SELECT	SPEED	SCAN	SEED POP. SPACING	AREA FIELD TOTAL
OK	CLEAR		SETUP ENTER EXIT	ON OFF
	↑	↓		

# MACHINE OPERATION

# KPM II STACK-MODE

**ROW-BY-ROW ALARM LEVEL SETTING**  
*(Requires Version V2.05 or higher Software -  
 KPM II/KPM II Stack-Mode Monitors Only)*

This feature allows the audio alarm to be disabled on selected rows in applications such as planting seed corn.

**NOTE:** The seed monitor should be programmed to monitor all planter rows prior to performing these steps.

**NOTE:** Shown using rear/front configuration. The KPM II Stack-Mode console shows LEFT in the left/right configuration, REAR in the front/rear configuration and front left/rear left in the four sections configuration. The SMM console shows RIGHT in the left/right configuration, FRONT in the front/rear configuration and front right/rear right in four sections configuration.

**STEP 1** Enter the programming mode by pressing and holding the SETUP key. The monitor will emit several short beeps, followed by a long beep. On the lower LCD, the SETUP icon will turn on and the arrow head icon will flash, indicating the user can select an item to program.

**NOTE:** The monitor must be in a programmable function (row spacing, unit, speed, volume or area) to enter setup. The monitor will not enter setup in seed population or seed spacing.

**STEP 2** Press the UP or DOWN arrow keys to move the flashing arrow to SEED POPULATION. As the arrow icon moves, the lower LCD will display the current setting of each item selected.

12060218

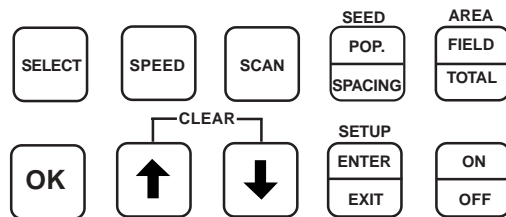
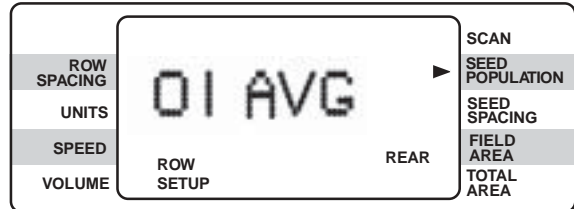
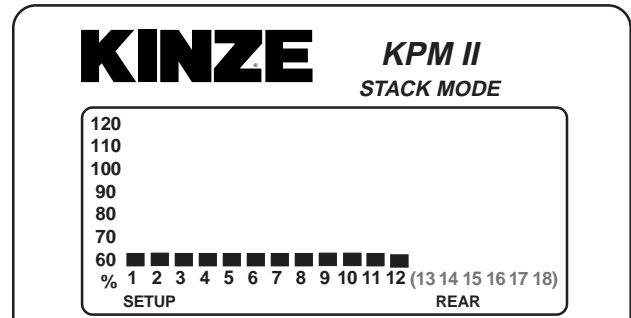
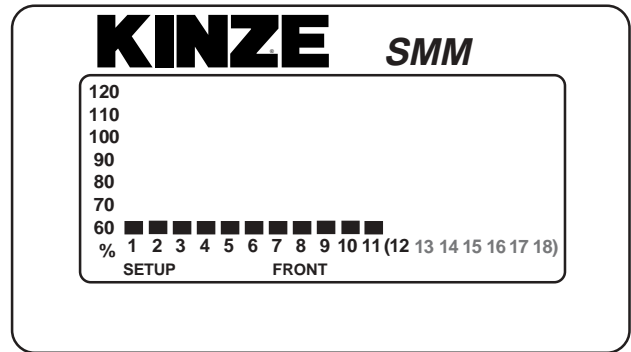

**STEP 3** Press the OK key. Row number starts flashing.

**STEP 4** Arrow UP or DOWN to desired row.

**STEP 5** Press SELECT key. "AVG" starts flashing.

**STEP 6** Arrow UP or DOWN to choose one of the following options.

HIGH - For Early Alarm (70%)  
AVG - For Standard Alarm Setting (55%)  
LOW - For Failed Alarm Only (25%)  
OFF - To Disable Row Alarm

**STEP 7** Press and hold the OK key to save alarm setting. There will be four short beeps, one long beep and the word "DONE" will appear when the save is completed.

**STEP 8** Repeat STEPS 3 through 7 for each row on which you wish to adjust the alarm setting.

**STEP 9** When finished, press the SETUP key to exit setup mode.

**NOTE: The programming mode may be exited at any time by pressing the SETUP key. Pressing this key will return the monitor to its normal operation. All items changed and saved will come into effect immediately. Any items changed, but not saved will revert to the original programmed value.**

**NOTE: Repeat STEPS 3 through 7 to change seed monitor back to the original settings when special row-by-row alarm level settings are no longer required.**

**NOTE:**

**See "Programming - Row Spacing" for programming applicable row spacing.**

**See "KPM I/KPM II/KPM II Stack-Mode Electronic Seed Monitor Troubleshooting" in the Maintenance Section.**

# MACHINE OPERATION

## POINT ROW CLUTCH

D032901166

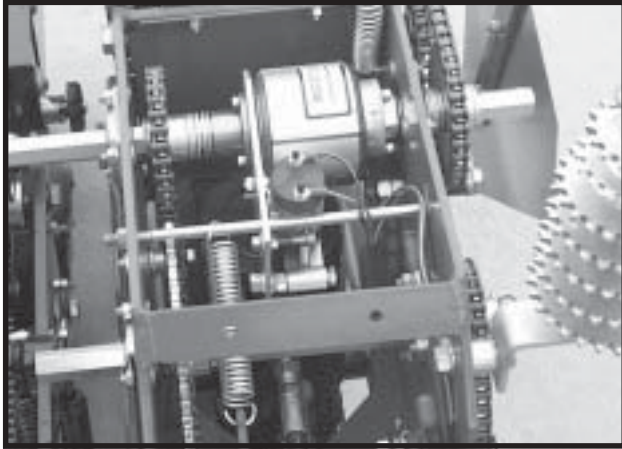

12 Row Machine Shown

With the use of electric-activated clutches, which disengage the drive, either half of the planter may be shut off for finishing up fields or for long point row situations.

76746-24

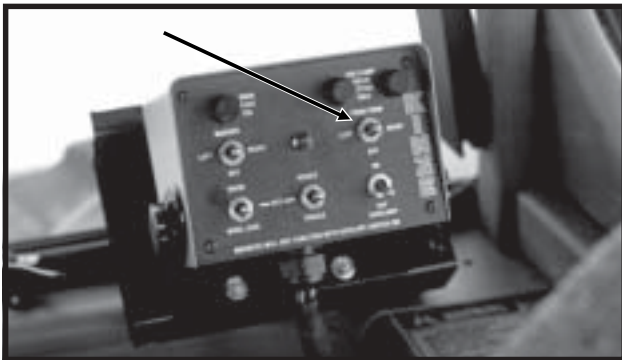

The selector switch for the clutches is located on the planter control console.

**NOTE: Switch should be left in OFF position when planter is not in use. If left in ON position, it will drain the tractor battery.**

**NOTE: Since the liquid fertilizer piston pump has its own drive wheel, liquid fertilizer application will not be affected by use of the point row clutch.**

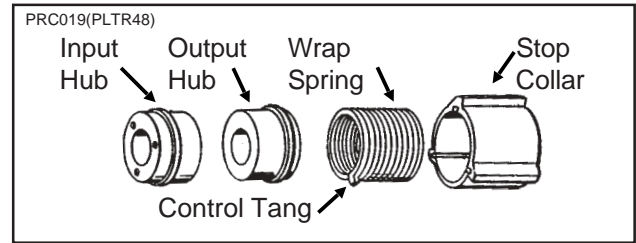

The point row clutch consists of a wrap spring riding on an input hub and an output hub. During operation the wrap spring is wrapped tightly over the hubs connecting them in a positive engagement. The greater the force of rotation the tighter the grip of the spring on the hubs.

Rotation in the opposite direction or stopping the spring from rotating prevents the transmission of torque from the input hub to the output hub, stopping the planter drive.

The input end of the spring is bent outward and is referred to as the control tang. The control tang fits into a slot in the stop collar that is located between the input and output hubs and over the wrap spring. If the stop collar is allowed to rotate with the input hub, the clutch is engaged. If the stop collar is stopped from rotating, the control tang connected to it is forced back and the spring opens. This allows the input hub to continue rotating without transmitting torque to the output hub; therefore, stopping the planter drive.

The stop collar is controlled by the use of an electric solenoid and an actuator arm. When the selector switch on the tractor control console is in the OFF position the solenoid coil is NOT ENERGIZED and the actuator arm will not contact the stop on the stop collar allowing it to rotate with the hubs and drive the planter.

When the operational switch is in the "DISENGAGE" (right or left) position the solenoid coil is ENERGIZED and the plunger in the solenoid coil retracts, allowing the actuator arm to contact the stop on the stop collar, disengaging the wrap spring and stopping the planter drive.

# MACHINE OPERATION

## TWO-SPEED POINT ROW CLUTCH

81826-8

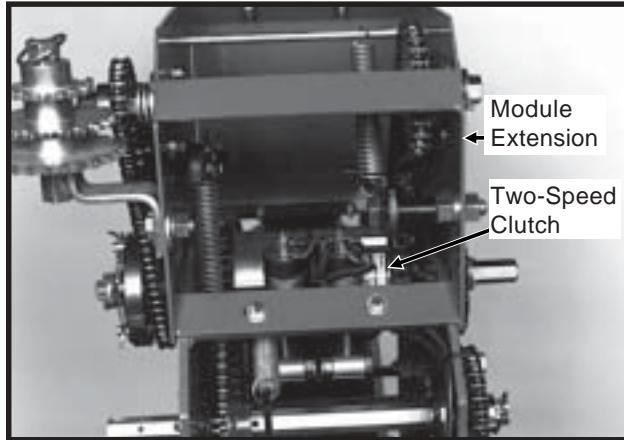

The Two-Speed Point Row Clutch Package is designed to allow on-the-go population rate adjustment as well as the capability to shut off either half of the planter for finishing up fields or for long point row situations.

The point row clutches are controlled by the point row clutch switch on the control console. The point row switch is used to shut off either the left or right half of the planter. Activating the reduced rate switch engages one solenoid on each clutch assembly and "in operation" reduces the planting rate for the entire planter.

**NOTE: Point row switch should be left in OFF position and rate switch should be left in FULL RATE position when planter is not in use. If left in ON and/or REDUCED RATE positions, it will drain the tractor battery.**

A7435(TWL81)

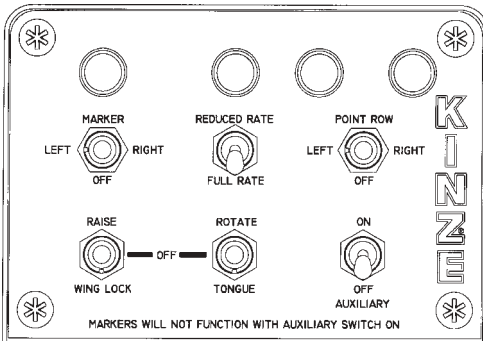

The ratio of population reduction is determined by the sprocket ratio between the drive and driven sprockets on the wheel module extension. A rate reduction decal like the one shown below is located on the wheel module extension.

(7100-214)D032901165

DRIVE	DRIVEN	% REDUCTION IN POPULATION
13	30	50
17	30	43
23*	30	23
24	30	20
25*	30	17
26*	30	13
27	30	10

\* Use sprockets off seed drive transmission

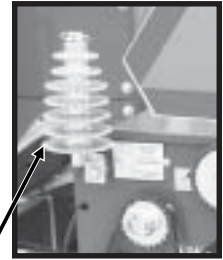

Full rate transmission shown. Two-speed clutch wheel module extension not installed.

(TWL80)

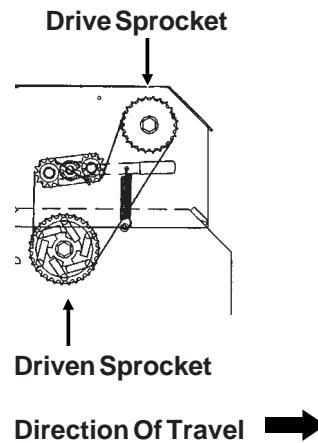

## ROCK GUARDS

(TWL198b)

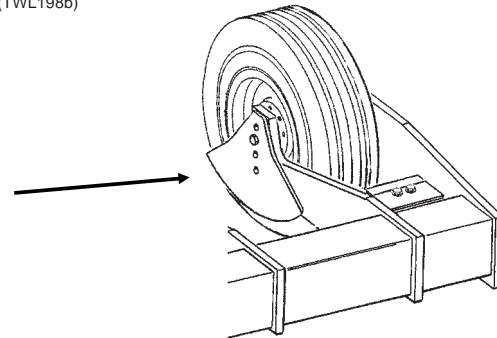

Optional transport wheel rock guards are designed for use on both sides of the inner two transport wheels and the inside of the outer two transport wheels when the planter is used in rocky conditions. Rock guards will help prevent rocks from being picked up by the wheels, which can cause damage to the row units.

# MACHINE OPERATION

## AUXILIARY HYDRAULIC OPTION

A customer-supplied auxiliary hydraulic option may be added to provide 10 GPM of oil flow at the rear of the planter. This option may be used for powering fertilizer or seed fill attachments, etc. Two customer-supplied solenoid valve kits (G1K275) are required to activate the auxiliary hydraulic option using the auxiliary switch on the control console.

D032901147

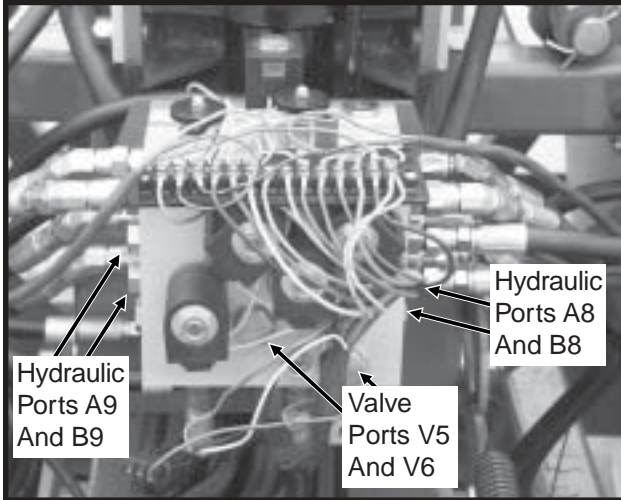

Valve Block Located On Rear Center Frame  
(Shown With Cover Removed)

76746-24

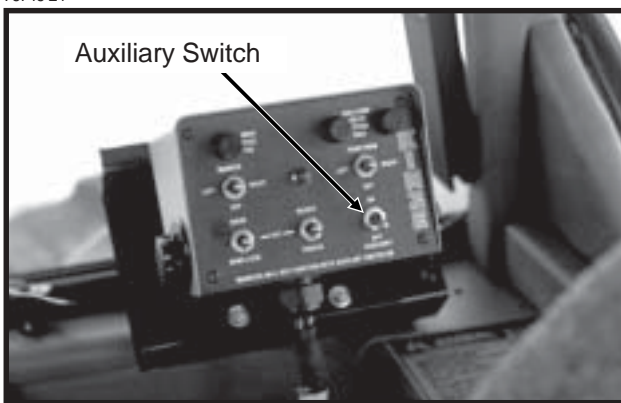

**NOTE:** Be sure markers are in transport position and all pressure is removed from the hydraulic system.

Remove the cover from the valve block, located on the rear center frame of the planter. Remove plugs from ports V5 and V6 and install the solenoid valve assemblies following the installation instruction supplied with each kit. Power to the solenoid assemblies should be connected to the orange/black wires located in the wiring harness connection to the L.H. side of the valve block.

Remove plugs from  $\frac{3}{4}$ "-16 o-ring ports A8 and B8 on R.H. side of valve block or ports A9 and B9 on L.H. side of valve block. Connect customer-supplied hydraulic hoses.

Refer to "Hydraulic System Schematics" and "Electrical Wiring Schematics" in the Maintenance Section of this manual for additional information.



**DANGER:** Before applying pressure to the hydraulic system, make sure all connections are tight and hoses and fittings have not been damaged. Hydraulic fluid escaping under pressure can have sufficient force to penetrate skin, causing injury or infection.

Before operating the auxiliary system be sure the marker switch on the control console is in the OFF position. Move the auxiliary switch on the control console to ON position. Operate hydraulic control lever (marker/folding functions) to engage auxiliary system.

**NOTE:** Auxiliary switch left in ON position disables all other control console switches.



# MACHINE OPERATION

## EVEN-ROW PUSH ROW UNIT OPTION

The even-row push row unit may be installed on the L.H. end of the forward toolbar to increase planting width.

If markers are set for 30" rows, the R.H. marker extension will need to be moved in 15" when using the even-row push row unit. The L.H. marker extension will need to be moved out 15". See "Marker Adjustment" for additional information.

To plant two 15" rows between last year's 30" rows and avoid tire damage from stalks by driving off the row, shift the planter off-center as shown in the illustration on the following page.

**NOTE: If tractor hitch is offset 7 1/2" to the right of the center line of the tractor, add 7 1/2" to the marker dimension on the R.H. side of the planter and subtract 7 1/2" from the marker dimension on the L.H. side of the planter.**

See "Seed Distribution Manifold" in Bulk Fill System Operation for closing off seed flow to the even-row push row unit.

(Continued On Following Page)

D021102248a

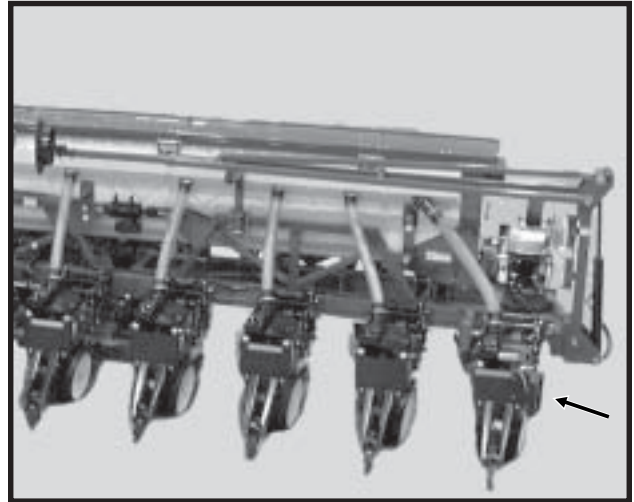

# MACHINE OPERATION

TWL220i

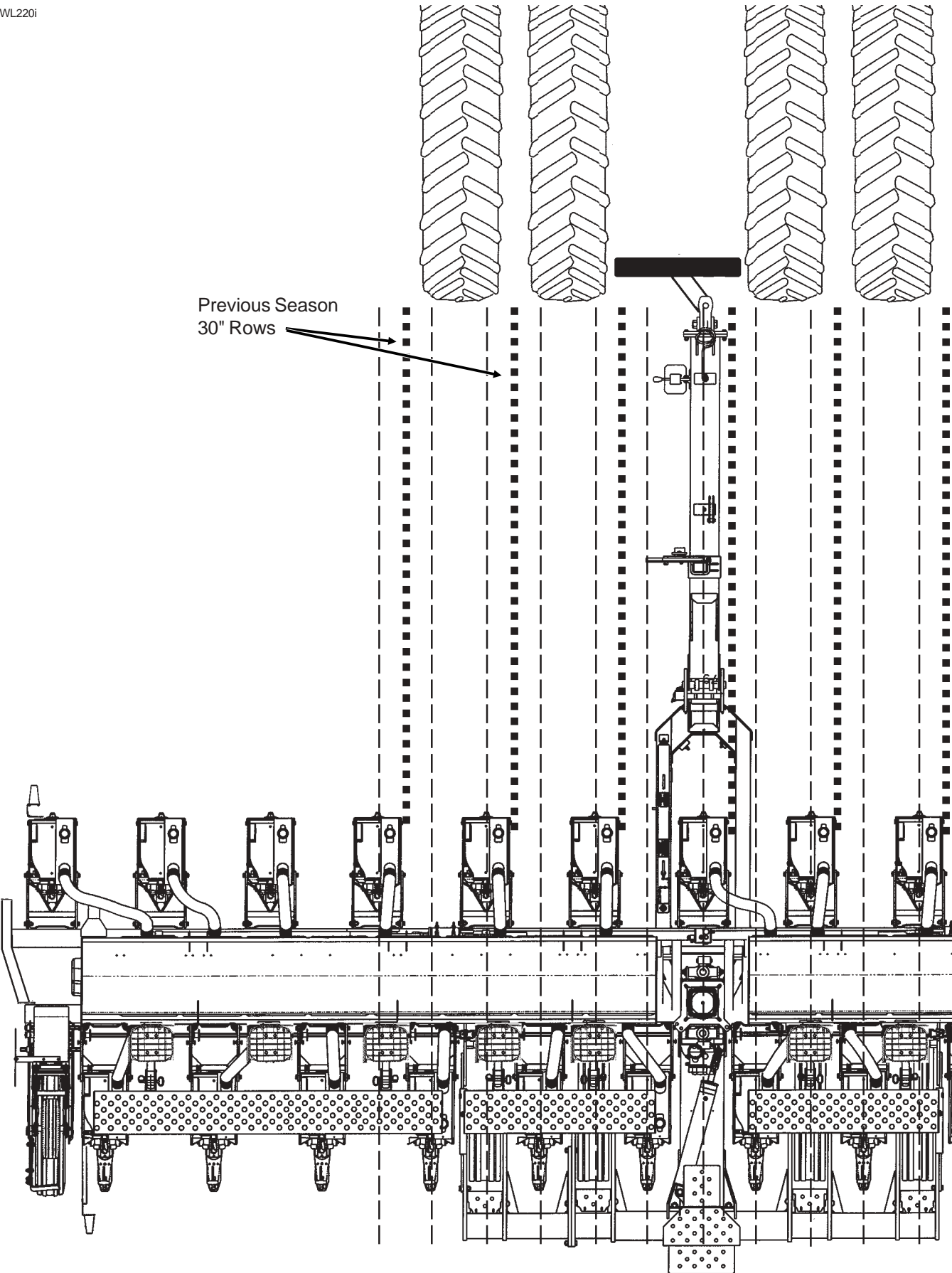

# MACHINE OPERATION

## DOUBLE DISC FERTILIZER OPENER

The double disc fertilizer openers should be positioned during assembly **to place fertilizer no closer than 2" to either side of the row**. If the planter frame is level and at proper 20" operating height, fertilizer depth will be approximately 4". Soil conditions can affect depth slightly.

The down pressure spring is factory preset at 250 lbs. down pressure but may be adjusted for various soil conditions. To adjust spring tension, loosen the jam nut with a  $15/16$ " wrench and use a 1" wrench to turn the adjustment bolt clockwise to increase tension or counterclockwise to decrease tension. Securely tighten the jam nut upon completion of tension adjustment. Do not attempt to set opener depth with spring pressure. The opener is designed to operate against a depth stop and spring up when encountering a foreign object or hard ground.

**IMPORTANT: Do not operate the double disc openers at full down pressure tension when planting in rocky ground. Chipping of the disc blades will occur.**

A gap of  $1/32$ " to  $1/16$ " should be maintained between the opener blades at the closest point. Blade adjustment is made by moving inside spacer washers to the outer side of the blade. After making this adjustment, check to be sure bearing assembly rivets are not contacting the shank.

D06259919

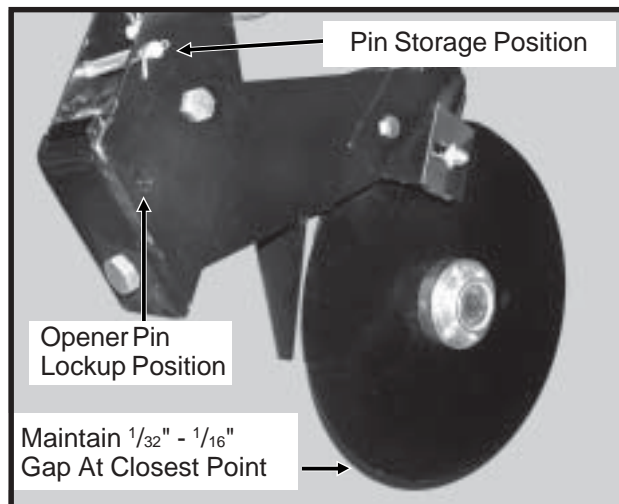

The outer scrapers on each disc blade may also be adjusted to make up for wear that may occur. Make sure the scrapers are adjusted to allow only slight contact with the blades.

The opener assembly is designed to be locked in a raised position when the fertilizer attachment is not in use or during storage. To lock the opener up, first raise the planter and place blocks under the openers. Then lower the planter until the hole in the pivot section aligns with the hole in the mounting bracket. Remove the lockup pin from the storage position in the mounting bracket and install it through the lockup hole and secure with cotter pins.



**WARNING: Always install all cylinder lockup devices before working under the unit.**

# MACHINE OPERATION

## NOTCHED SINGLE DISC FERTILIZER OPENER

The notched single disc fertilizer opener is designed for use in minimum and no till planting situations. Placement of fertilizer with the 16 <sup>3</sup>/<sub>4</sub>" diameter notched single disc fertilizer opener is recommended at 2 <sup>1</sup>/<sub>2</sub>" - 3" from the row. The opener is designed to hold the blade at a set-angle so the knife and drop tube run in the shadow of the blade. **Never locate the opener to place fertilizer closer than 2".**



**WARNING: Spring under pressure. DO NOT disassemble.**

(FRTZ210g/B0297)

**Depth Adjustment Cap Screws - Recommended Maximum Operating Depth 4" (Middle Bolt Holds Blade Angle But Must Be Loosened To Adjust Depth And Tightened First To Set Blade Angle)**

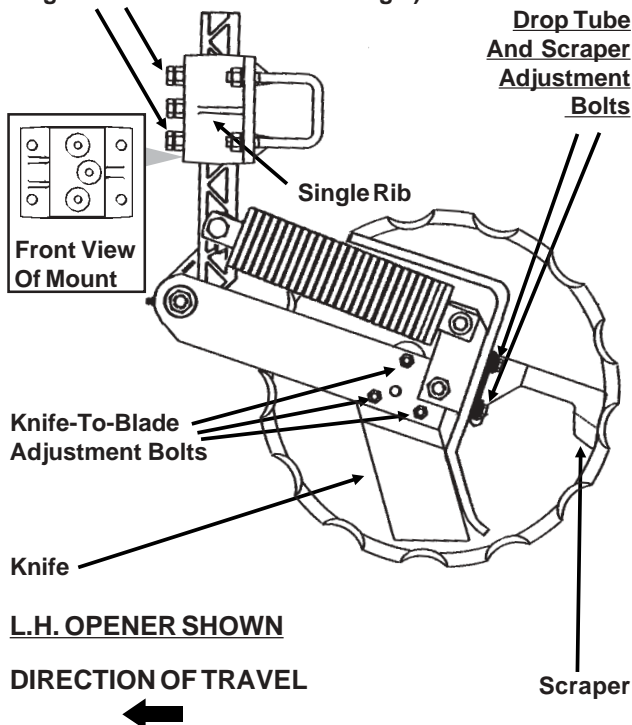

**L.H. OPENER SHOWN**

**DIRECTION OF TRAVEL**

**Adjust knife-to-blade** contact on each fertilizer opener so blade will turn by hand with slight resistance, but will not coast or freewheel. In dry, loose soil the knife adjustment is critical. If adjustment is not maintained, soil or residue may wedge between knife and blade, resulting in the blade not turning. If the knife is adjusted too tight, the blade will not turn causing the blade to push soil and residue. Knife **adjustment is made using the three <sup>3</sup>/<sub>8</sub>" mounting carriage bolts** and pivot pad on the knife. Because of blade runout, rotate blade one full revolution after adjustment. Readjust knife to the blade's tight spot as needed. **Never strike the knife with a heavy object or damage may occur.**

Using the slotted mounting holes in the drop tube mount, **adjust fertilizer drop tube** so it is protected from soil contact and wear behind the knife. The liquid drop tube should be adjusted <sup>1</sup>/<sub>4</sub>" - <sup>3</sup>/<sub>8</sub>" from the opener blade while keeping it behind the knife. **Adjust scraper** to just touch the opener blade. As the mounting hardware is tightened, the scraper is drawn tighter to the blade. After adjustment, rotate opener blade to be sure blade will turn by hand with slight resistance, but will not coast or freewheel.

**Adjust blade depth** on each row using the cap screws and jam nuts located on the opener mount. The blade can be adjusted to allow a maximum 4" blade depth. Check fertilizer hose clearance (If Applicable) after adjusting opener depth. Torque cap screws and jam nuts to 57 ft. lbs.

**NOTE: The blade runs through the ground at an angle relative to the direction of travel. For this reason and to ensure proper operation, the cast mount should be oriented so the single rib is on the same side of the blade as the drop tube.**

**NOTE: Recommended maximum operating depth is 4". To adjust depth: (a) Loosen depth adjustment cap screws. (b) Adjust depth. (c) Tighten middle cap screw to hold blade angle. (d) Tighten upper and lower cap screws.**

# MACHINE OPERATION

## RESIDUE WHEEL ATTACHMENT FOR NOTCHED SINGLE DISC FERTILIZER OPENER

D052201104

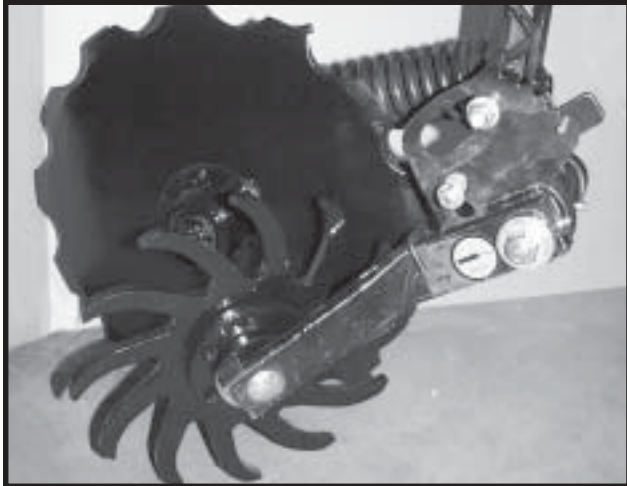

The residue wheel attachment for the notched single disc fertilizer opener is designed for applications where row unit mounted residue wheel attachments cannot be installed. The residue wheel is attached to the notched single disc fertilizer opener using  $\frac{5}{8}$ " x  $7\frac{1}{2}$ " and  $\frac{1}{2}$ " x  $6\frac{1}{2}$ " hardware.

Maximum depth is set by lifting the residue wheel and moving the adjustment lever down to increase depth or up to decrease depth in 1" increments (in relation to blade depth setting). Adjust all rows the same. Down force on the residue wheel is maintained by a torsion spring and is not adjustable.

Due to space restrictions, the residue wheel attachment for the notched single disc fertilizer opener is not applicable to Model 3650 planters equipped with Interplant® push row units and notched single disc fertilizer openers.

## DEPTH/GAUGE WHEEL ATTACHMENT FOR NOTCHED SINGLE DISC FERTILIZER OPENER

D061101202a

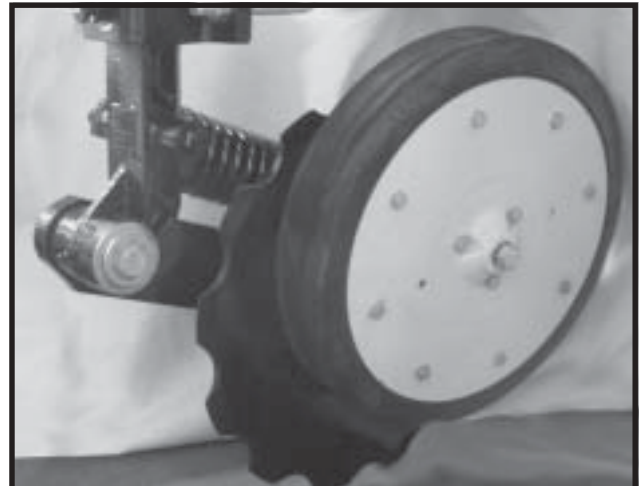

The depth/gauge wheel attachment for the notched single disc fertilizer opener is designed for use in situations where additional gauging is required to maintain desired fertilizer opener depth. The depth/gauge wheel is attached to the notched single disc fertilizer opener using a mounting block fastened to the pivot arm using  $\frac{5}{8}$ " hardware through the disc blade bearing.

Depth adjustment is made by using the 5 adjustment holes in the depth/gauge wheel mounting block. Moving the depth/gauge wheel increases/decreases depth in  $\frac{1}{2}$ " increments in relation to the blade depth setting made at the vertical mounting post.

Due to space restrictions, the depth/gauge wheel attachment for the notched single disc fertilizer opener is not applicable to Model 3650 planters equipped with Interplant® push row units and notched single disc fertilizer openers.

# MACHINE OPERATION

## HD SINGLE DISC FERTILIZER OPENER

D062601103

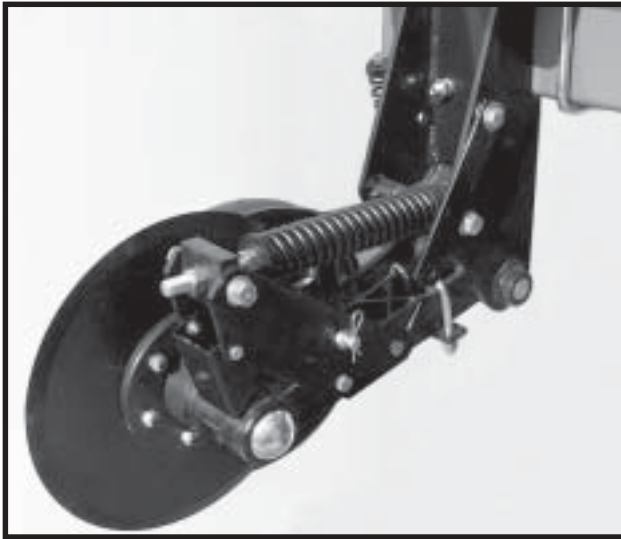

Placement of fertilizer with the HD single disc fertilizer opener is recommended at 3 1/2" - 4" from the row. **Never locate the opener to place fertilizer closer than 2".**

If planter frame is level and at 20" operating height, maximum blade depth for placement of fertilizer is approximately 5". Soil conditions can affect depth slightly.

**To adjust blade depth**, raise the planter to remove weight from the fertilizer opener. Loosen inside adjustment nut (A) with 1 1/8" wrench. Turn outside nut (B) clockwise to decrease blade depth or counterclockwise to increase blade depth. One full turn of the blade depth adjustment nut changes blade depth 3/8". Tighten inside nut tight against block (C). Adjust all fertilizer openers to the same depth.

L0114(PLTR3)

(Overhead View)

### DIRECTION OF TRAVEL

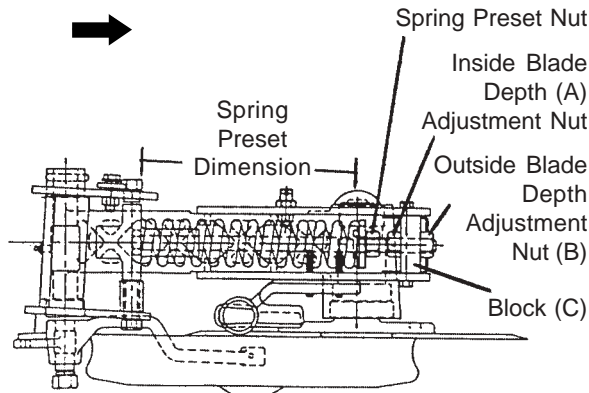

R.H. Configuration Shown

Fertilizer opener down pressure can be adjusted from 250 lbs. to 640 lbs. **To make down pressure adjustments**, raise planter to remove weight from the fertilizer opener and turn spring preset nut clockwise to increase down pressure and counterclockwise to decrease down pressure. Adjust all rows to a similar setting. Minimal spring pressure for acceptable operation is recommended. See chart for spring length setting specifications.

SPRING PRESET DIMENSION	DOWN PRESSURE (LBS.)
11"	250
10 3/4"	320
<b>*10 1/2"</b>	<b>370</b>
10 1/4"	450
10"	520
9 3/4"	580
9 1/2"	640

\* Suggested initial setting.

**NOTE: DO NOT adjust spring preset dimension to less than 9 1/2".**

**NOTE: Excessive down pressure can cause up-lift on the planter frame and affect performance of the machine. When lowered to planting position, planter frame should be at a height of approximately 20". In loose ground conditions, excessive down pressure can cause openers to run too deep and push dirt ahead of opener and may stop soil press wheel and/or opener blade from turning.**



**WARNING: Always install all lockup devices before working under the machine.**

**IMPORTANT: Do not operate HD single disc openers at full down pressure tension when planting in rocky ground. Chipping or breakage of the blades will occur.**

# MACHINE OPERATION

**Maintain liquid fertilizer drop tube/scraper adjustment** as shown below.

(INS16a)

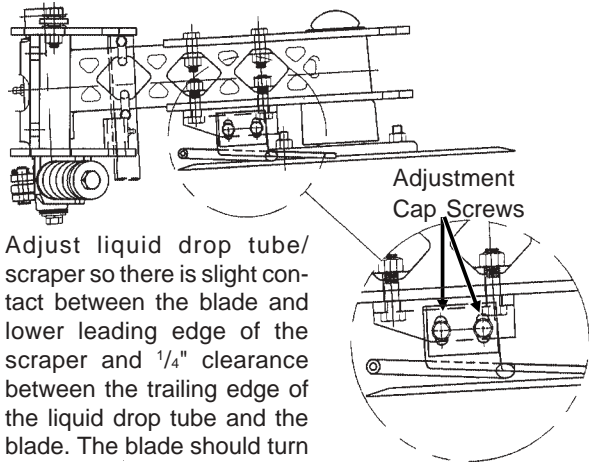

Adjust liquid drop tube/scraper so there is slight contact between the blade and lower leading edge of the scraper and 1/4" clearance between the trailing edge of the liquid drop tube and the blade. The blade should turn with minimum amount of drag.

Additional press wheel down pressure may be desirable in heavy moist soils. **To increase press wheel spring pressure** turn press wheel spring adjustment bolt clockwise.

D121202101

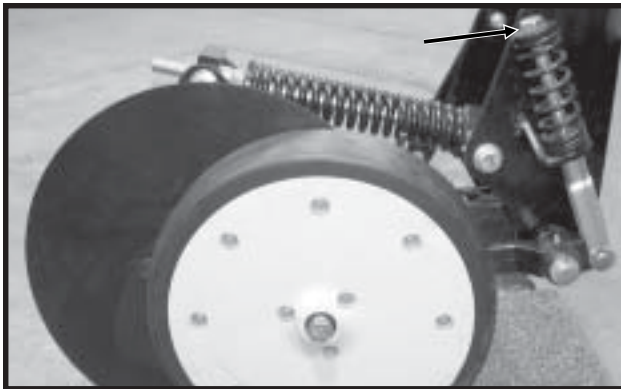

**NOTE:** The soil press wheel is not intended to be used for gauging fertilizer opener operating depth.

The HD single disc fertilizer opener is designed to be locked in a raised position when the fertilizer attachment is not in use or during storage.

To lock the HD single disc fertilizer opener in the raised position, proceed as follows:

**STEP 1** With the planter in the planting position, remove outside blade depth adjustment nut. ("B" in illustration on previous page.)

**STEP 2** Raise planter until adjustment bolt clears adjustment block.

**STEP 3** Raise spring to clear blade assembly and at the same time raise blade assembly until storage strap can be positioned onto lockup pin and install hair pin clip.

**STEP 4** Re-install depth adjustment nut and tighten.

D062601102

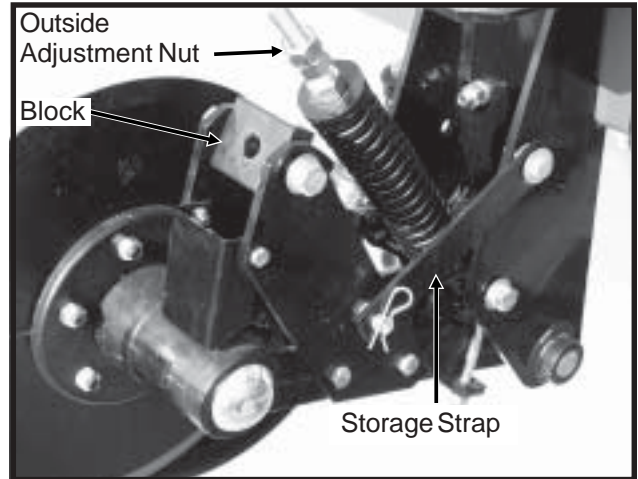

**NOTE:** The HD single disc fertilizer opener is equipped with a lockup bar that automatically raises and locks the soil press wheel when the blade assembly is raised.

FOC016(PLTR5b)

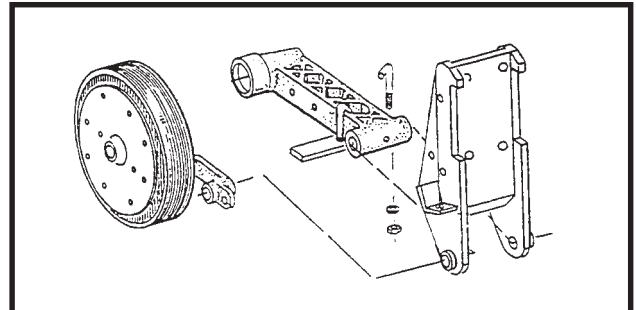

# MACHINE OPERATION

## LIQUID FERTILIZER ATTACHMENT

D041002215

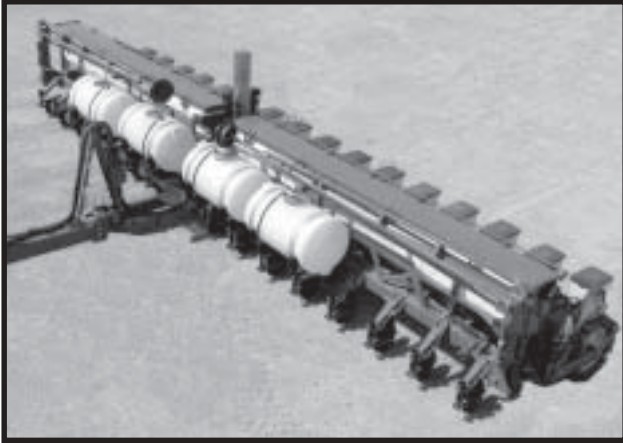

**NOTE:** An optional low rate check valve is available for installation in-line between the liquid fertilizer piston pump and the liquid fertilizer openers to ensure equal distribution of product at low rates. The check valve also eliminates the need for an anti-siphon loop if the valve is installed as close as possible to the fertilizer opener drop tube.

(FRTZ208)

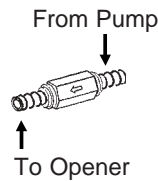

### PISTON PUMP

If the machine is equipped with the piston pump option, the rate of liquid fertilizer application is determined by the piston pump settings.

The delivery rate chart found at the end of this section provides an approximate application rate only. Actual delivery will vary with temperature and the particular fertilizer being used.

To adjust delivery rate, loosen the  $\frac{3}{8}$ " lock nut that secures the arm with the pointer and rotate the scale flange until the pointer is over the desired scale setting. The adjustment wrench will facilitate rotation of the scale flange. Tighten the  $\frac{3}{8}$ " lock nut being careful not to over tighten.

(PLTR9)

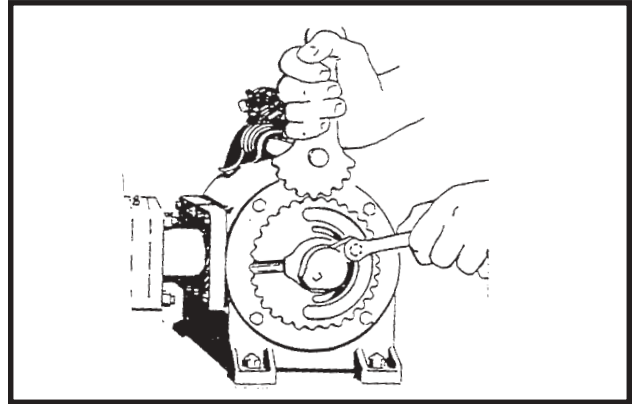

The operator and instruction manual shipped with the pump and flow divider should be kept and stored with this manual for future reference.

**NOTE:** Periodically check flow to all rows. If one or more lines are plugged, set rate will be delivered to remaining rows.

### CLEANING

The tanks and all hoses are made of sturdy plastic and rubber to resist corrosion. However, the tanks, hoses and metering pump should be thoroughly cleaned with water at the end of the planting season or prior to an extended period of non-use. Do not allow fertilizer to crystalize due to cold temperature or evaporation.

The strainer, located between the piston pump and ball valve (On machines equipped with the piston pump.), should be taken apart and cleaned daily. Remove the end cap to clean the screen.

(INS220)

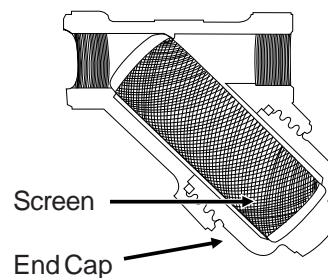

See "Piston Pump Storage" (If Applicable) in the Maintenance Section of this manual.



# MACHINE OPERATION

## REAR TRAILER HITCH

The Rear Trailer Hitch is used to tow a 3 or 4 wheel wagon behind the planter. Any hoses routed to the rear trailer hitch should follow hydraulic hose routings on the planter to allow the planter to be raised and rotated to and from the transport position without stretching the hoses.

**IMPORTANT:** The rear trailer hitch is designed for use with piston pump only. Maximum allowable hitch weight is 200 lbs. Gross towing weight should not exceed 6000 lbs. or the equivalent of a loaded 500 gallon tank and running gear.

**NOTE:** Periodically check feed hose for kinks to prevent restricted delivery rate.

(TWL231a)

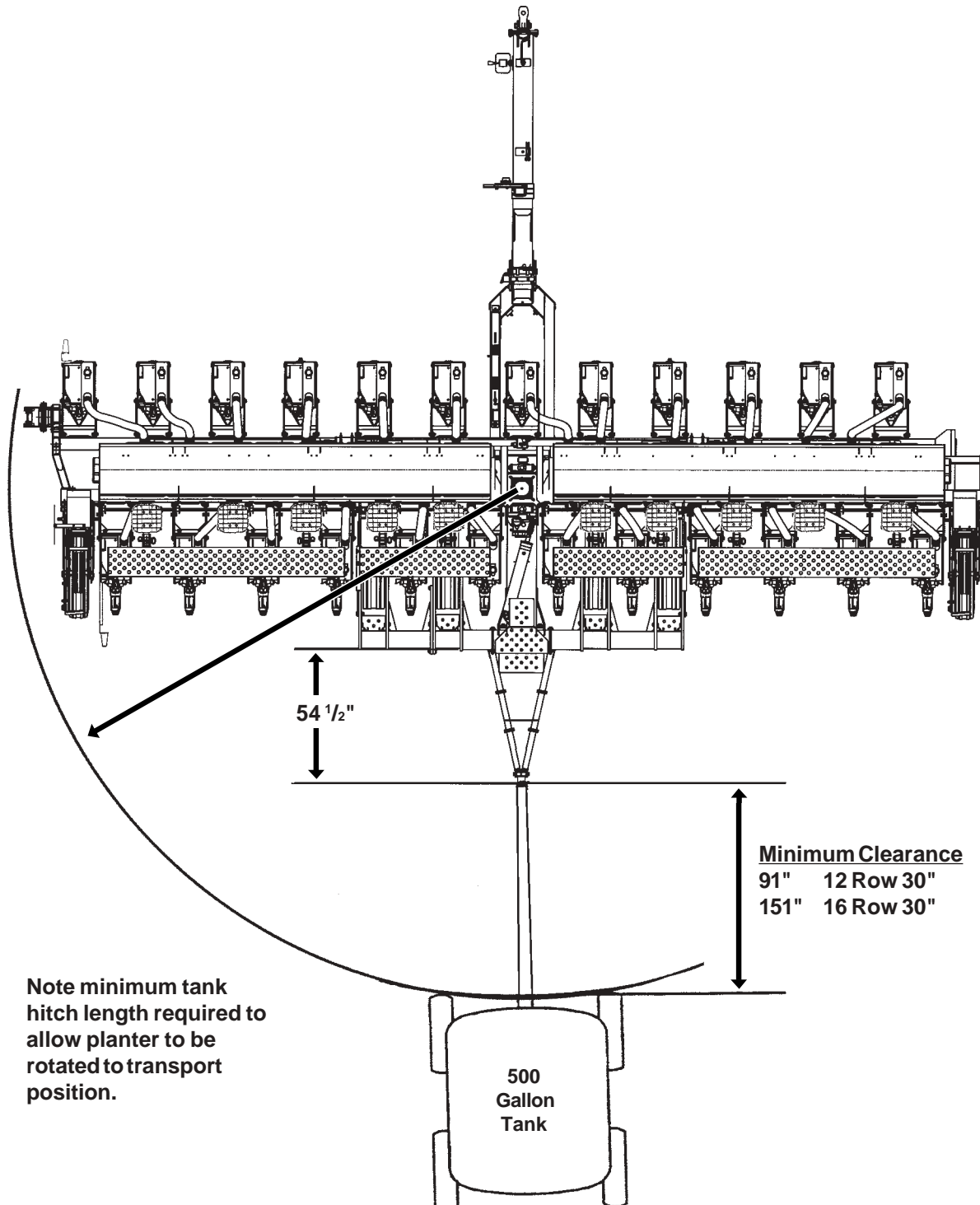

# MACHINE OPERATION

## MARKER SAFETY LOCKUP

Install safety lockups over marker cylinder rods when transporting the planter or working around the planter. When lockups are not in use, store in the storage position provided on the first stage marker arm.

 **WARNING: To avoid serious injury, keep others away when raising or lowering markers.**

D021102203

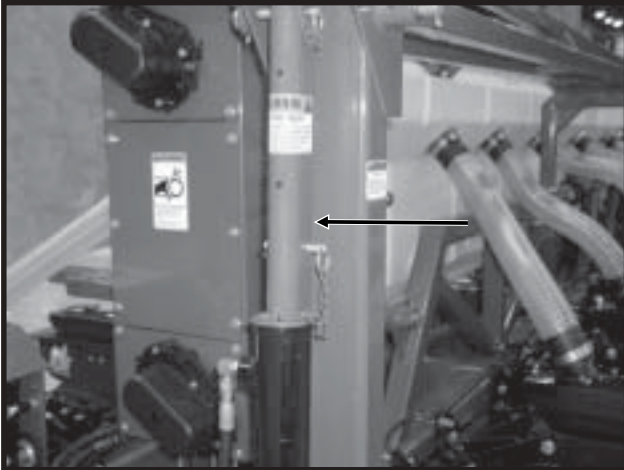

Marker Safety Lockup In Locked Position

D032901130

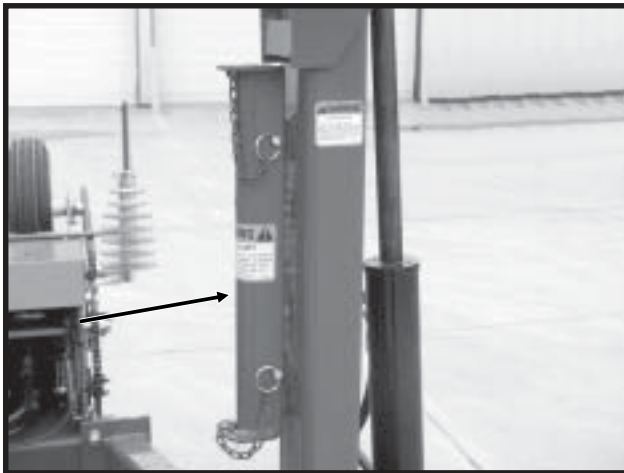

Marker Safety Lockup In Storage Position

## MANUAL SAFETY LOCKUP

Never allow anyone to work around or under the planter without first securing the manual safety lockup in the locked position. When transporting the planter use the manual safety lockup for added safety.

D032901117

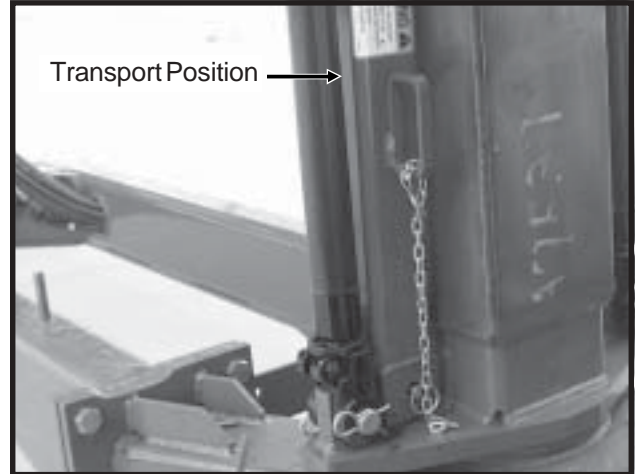

Manual Safety Lockup In Locked Position

D101602212

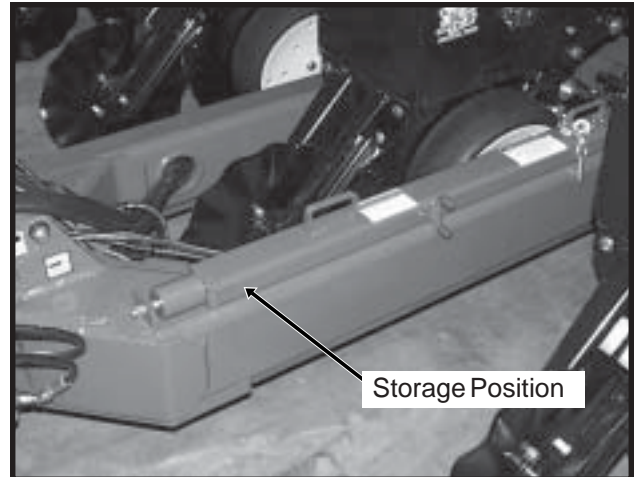

Manual Safety Lockup In Storage Position

For field operation remove the manual safety lockup and store on the L.H. side of the planter hitch.

# MACHINE OPERATION

## TONGUE SAFETY PIN

The tongue safety pin when installed will prevent the tongue cylinder from retracting should hydraulic failure occur or a sudden stop be made when transporting the planter. Never transport the planter without installing the tongue safety pin.

D032901115



**Tongue Safety Pin Installed For Transport**

D032901120

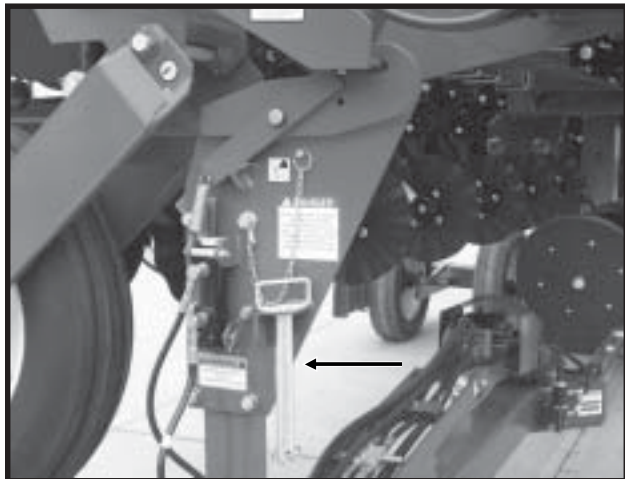

**Tongue Safety Pin Stored For Field Operation**

For field operation remove the tongue safety pin and store in the bracket provided on the transport latch post on the tongue of the planter.

## TRANSPORT LATCH LOCKING PIN

The transport latch locking pin when installed will prevent the latch bar from disengaging and allowing the planter frame to swing away. Never transport the planter without installing the transport latch locking pin.

D032901113

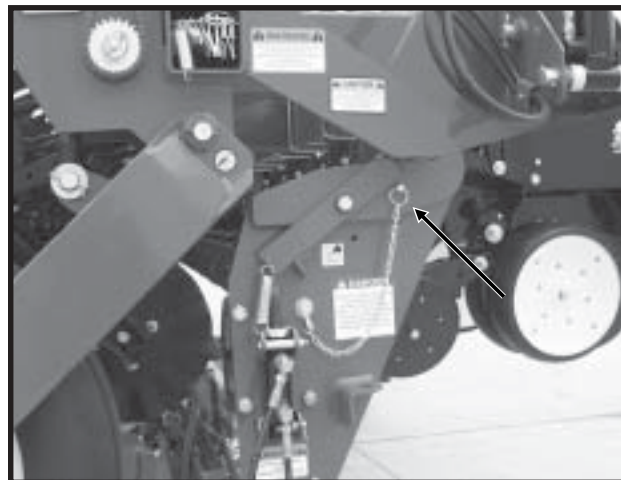

**Transport Latch Locking Pin Installed For Transport**

D032901120

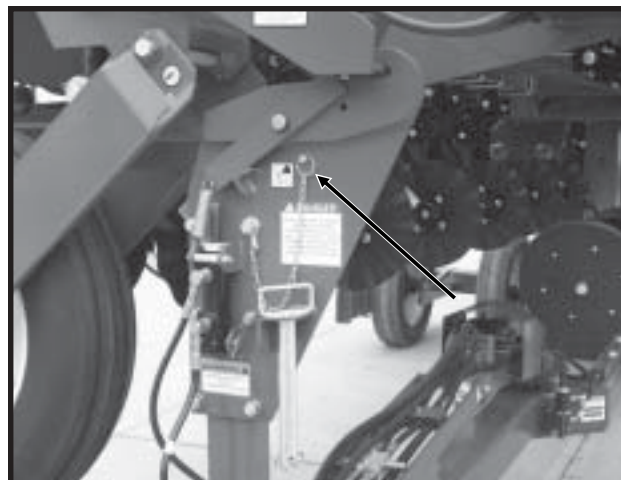

**Transport Latch Locking Pin Stored For Field Operation**

For field operation remove the transport latch locking pin and store in the location provided on the latch post.

# MACHINE OPERATION

## TRANSPORTING THE PLANTER



**WARNING:** Always make sure safety/warning lights, reflective decals and SMV sign are in place and visible prior to transporting the machine on public roads. In this regard, check federal, state/provincial and local regulations.

**IMPORTANT:** Avoid transporting planter with bulk hoppers loaded whenever possible. When it is necessary to transport the planter with the bulk hoppers loaded, the added weight should be distributed evenly on the planter frame before rotating the planter.



**WARNING:** Install all safety lockups and safety lock pins before transporting the planter.

## METRIC CONVERSION TABLE

Multiply	By	To Get
Inches (in.)	x 2.54	= centimeters (cm)
Inches (in.)	x 25.4	= millimeters (mm)
Feet (ft.)	x 30.48	= centimeters (cm)
Acres	x 0.405	= hectares (ha)
Miles per hour (mph)	x 1.609	= kilometers per hour (Km/h)
Pounds (lbs.)	x 0.453	= kilograms (kg)
Bushels (bu.)	x 35.238	= liters (l)
Gallons (gal.)	x 3.785	= liters (l)
Pounds per square inch (psi)	x 6.894	= kilopascals (kPa) (100 kPa = 1 bar)
Inch pounds (in. lbs.)	x 0.113	= newtons-meters (N•m)
Foot pounds (ft. lbs.)	x 1.356	= newtons-meters (N•m)
Centimeters (cm)	x .394	= inches (in.)
Millimeters (mm)	x .0394	= inches (in.)
Centimeters (cm)	x .0328	= feet (ft.)
Hectares (ha)	x 2.469	= acres
Kilometers per hour (Km/h)	x 0.621	= miles per hour (mph)
Kilograms (kg)	x 2.208	= pounds (lbs.)
Liters (l)	x 0.028	= bushels (bu.)
Liters (l)	x 0.264	= gallons (gal.)
Kilopascals (kPa) (100 kPa = 1 bar)	x 0.145	= pounds per square inch (psi)
Newtons-meters (N•m)	x 8.85	= inch pounds (in. lbs.)
Newtons-meters (N•m)	x 0.738	= foot pounds (ft. lbs.)

## PLANTING SPEED

Planters are designed to operate within a speed range of 2 to 8 MPH. See “Planting And Application Rate Charts”. Variations in ground speed will produce variations in rates. Finger pickup seed meter populations will tend to be disproportionately higher at high ground speeds.

**NOTE:** Due to a multitude of variables, seed spacing can be adversely affected at speeds above 5.5 MPH.

## FIELD TEST

With any change of field and/or planting conditions, seed size or planter adjustment, we recommend a field test be made to ensure proper seed placement and operation of row units. See “Rate Charts”, “Checking Seed Population” and “Checking Granular Chemical Application Rate” at end of this section.

- Check the planter for fore to aft and lateral level operation. See “Leveling The Planter” and “Leveling The Planter Wings”.
- Check **all** row units to be certain they are running level. When planting, the row unit parallel arms should be approximately parallel to the ground.
- Check row markers for proper operation and adjustment. See “Marker Length Adjustment”, “Marker Speed Adjustment” and “Marker Operation”.
- Check for proper application rates and placement of granular chemicals on **all** rows. See “Checking Granular Chemical Application Rate”.
- Check for desired depth placement and seed population on **all** rows. See “Checking Seed Population”.
- Check for proper application rates of fertilizer on **all** rows. See proper “Fertilizer Application Rate Chart”.

After the planter has been field tested, reinspect the machine.

- Hoses and fittings
- Bolts and nuts
- Cotter pins and spring pins
- Drive chain alignment

# MACHINE OPERATION

## CHECKING SEED POPULATION

1. Tie up one or more sets of closing wheels by running a light chain or rubber tarp strap between the hopper support panel and closing wheels. It may be necessary to decrease closing wheel arm spring tension.

L0069(RU113b)

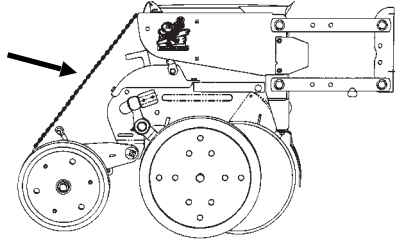

2. Plant a short distance and check to see if seed is visible in the seed trench. Adjust planting depth to a shallower setting if seed is not visible and recheck.

04059914a

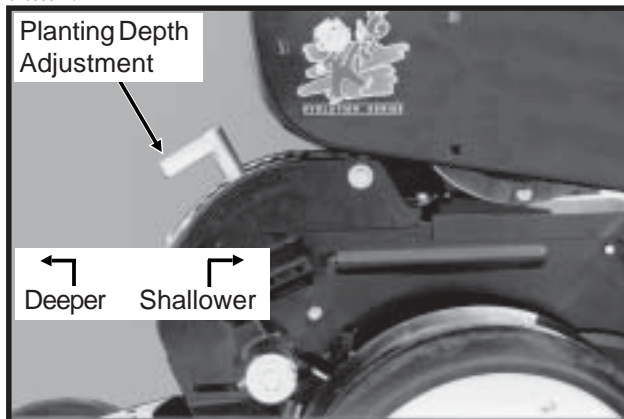

3. Measure  $\frac{1}{1000}$  of an acre. See chart for correct distance for row width being planted. For example, if planting 30" rows  $\frac{1}{1000}$  of an acre would be 17' 5".

LENGTH OF ROW IN FEET AND INCHES		
Fraction Of Acre	Row Width	
	15"	30"
$\frac{1}{1000}$	34' 10"	17' 5"

**NOTE: When planting with closing wheels raised and planting depth set shallow, seeds may bounce or roll affecting seed spacing accuracy.**

- Count seeds in measured distance.
- Multiply the number of seeds placed in  $\frac{1}{1000}$  of an acre by 1000. This will give you total population.

EXAMPLE: With 30" row spacing 17' 5" equals  $\frac{1}{1000}$  acre.

26 Seeds Counted	x	1000	=	26,000 Seeds Per Acre
---------------------	---	------	---	-----------------------

Seed count can be affected by drive ratio between drive wheel and seed meter, tire pressure and/or seed meter malfunction.

If seed check shows the average distance between seeds in inches is significantly different than the seed rate chart indicates, first check drive ratio between drive wheel and seed meter. Check drive wheel air pressure, check for incorrect sprocket(s) in driveline and check drive and driven sprockets in transmission for proper selection.

Second, check for seed meter malfunction. For example, if spacing between kernels of corn at the transmission setting being used is 8" and a gap of 16" is observed, a finger has lost its seed and not functioned properly. If two seeds are found within a short distance of each other, the finger has metered two seeds instead of one.

See "Finger Pickup Seed Meter Troubleshooting" and/or "Brush-Type Seed Meter Troubleshooting" in the Maintenance Section of this manual.

### Determining Pounds Per Acre (Brush-Type Seed Meter)

To determine pounds per acre:

Seeds Per Acre On Chart	÷	Seeds Per Pound From Seed Tag On Bag	=	Pounds Per Acre
-------------------------------	---	---	---	-----------------------

To determine bushels per acre:

Pounds Per Acre	÷	Unit Weight Of Seed	=	Bushels Per Acre
--------------------	---	------------------------	---	---------------------

The unit weight of:

- 1 Bushel Soybeans = 60 Pounds
- 1 Bushel Milo/Grain Sorghum = 56 Pounds
- 1 Bushel Cotton = 32 Pounds

If seeds per pound information is not available the following is an average:

- 2,600 seeds per pound for medium size soybeans
- 15,000 seeds per pound for medium size milo/  
grain sorghum
- 4,500 seeds per pound for medium size cotton

If seed check shows planting rate is significantly different than seed rate chart shows or if a particular meter is not planting accurately, see "Brush-Type Seed Meter Maintenance" and "Brush-Type Seed Meter Troubleshooting".

# MACHINE OPERATION

## CHECKING GRANULAR CHEMICAL APPLICATION RATE

Many things can affect the rate of delivery of granular chemicals such as temperature, humidity, speed, ground conditions, flowability of different material or any obstruction in the meter.



**WARNING: Agricultural chemicals can be dangerous if not selected and handled with care. Always read and follow directions supplied by the chemical manufacturer.**

A field check is important to determine correct application rates.

D05149901

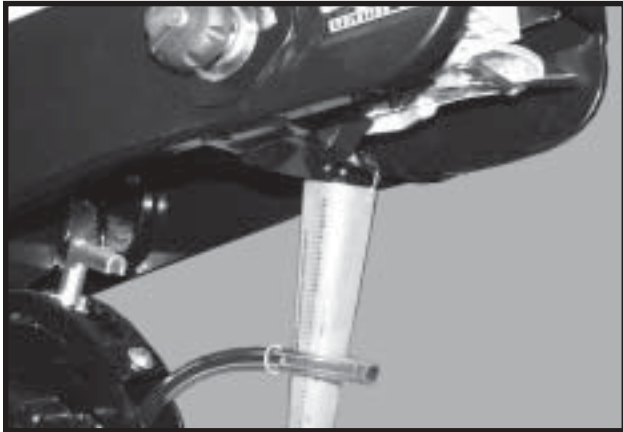

To check, fill insecticide and/or herbicide hoppers. Attach a calibrated vial to each granular chemical meter. Lower the planter and proceed as follows.

**NOTE: It is not necessary for seed meter clutch to be engaged during test. Disengage clutch to avoid dropping seed.**

Drive 1320 feet at planting speed. Weigh the chemical in ounces that was caught in one vial. Multiply that amount by the factor shown to determine pounds per acre.

POUNDS PER ACRE FACTOR FOR GIVEN ROW WIDTH	
Row Width	Factor
30"	0.83

EXAMPLE: You are planting 30" rows. You have planted for 1320 feet at the desired planting speed. You caught 12.0 ounces of chemical in one vial. 12.0 ounces times 0.83 equals 9.96 pounds per acre.

**NOTE: It is important to check calibration of all rows.**

### Metering Gate

Use the metering gate setting for distributing insecticide or herbicide as a starting point. The charts are based on a 5 miles per hour planting speed. For speeds faster than 5 miles per hour a higher gate setting should be used. For speeds slower than 5 miles per hour a lower gate setting should be used.

# MACHINE OPERATION

## GENERAL PLANTING RATE INFORMATION

These planting rate charts are applicable to KINZE® Model 3650 Twin-Line® Planters. See "Tire Pressure" for recommended tire pressures.

**IMPORTANT: The sprocket combinations listed in these charts are best for average conditions. Changes in sprocket combinations may be required to obtain desired planting population. TO PREVENT PLANTING MISCALCULATIONS, MAKE FIELD CHECKS TO BE SURE YOU ARE PLANTING AT THE DESIRED RATE.**

The size and shape of seed may affect the planting rate.

### Finger Pickup Corn Meter

Larger grades will generally plant more accurately at the high end of the ground speed range than smaller grades. Higher than optimum speeds may result in population rate increase or higher incidence of doubles, particularly with small seed. Medium round corn seed is most desirable for planting accuracy at optimum speed.

### Finger Pickup Oil Sunflower Meter

Larger grades will generally plant more accurately at the high end of the ground speed range than smaller grades. Higher than optimum speeds may result in population rate increase or higher incidence of doubles, particularly with small seed. No. 3 and/or No. 4 size oil sunflower seeds are recommended for use in the finger pickup seed meter equipped with oil sunflower fingers. No. 1 and/or No. 2 size confectionary sunflower seeds are recommended for use in the finger pickup seed meter equipped with corn fingers.

**NOTE: Seed additives, added to the seed in the hopper, may adversely affect performance of the finger pickup seed meter and accelerate wear. See "Finger Pickup Seed Meter" in the Row Unit Operation section.**

### Brush-Type Seed Meter (Soybean, Milo/Grain Sorghum, Acid-Delinted Cotton)

Rate charts are given in seeds per acre as well as seed spacing in inches rounded to the nearest tenth of an inch. Because of the large range in seed size, pounds per acre is not a suggested method of selecting transmission settings. When using smaller size seeds it may appear the pounds per acre is below what was expected and vice versa on large seed. To determine pounds per acre, use the formula given in "Determining Pounds Per Acre (Brush-Type Seed Meter)" in the "Checking Seed Population" section of this manual.

**NOTE: Due to a multitude of variables, seed spacing can be adversely affected at speeds above 5.5 MPH.**

Seed population per acre with 15" rows will be double the rate for 30" rows. See pages 6-88 and 6-89.

In some cases when planting 15" row soybeans or other crops, a **Half Rate (2 To 1) Drive Reduction Package** may be required to obtain the desired population and seed spacing.

**NOTE: Use of the Half Rate (2 To 1) Drive Reduction Package will reduce the planter transmission speed. The seeding rate will be approximately 50% of the chart reading when using the Half Rate (2 To 1) Drive Reduction Package. Planting speed can affect actual seeding rate. Make a field check and adjust setting in the transmissions as needed to obtain the desired seed drop.**

D021102206

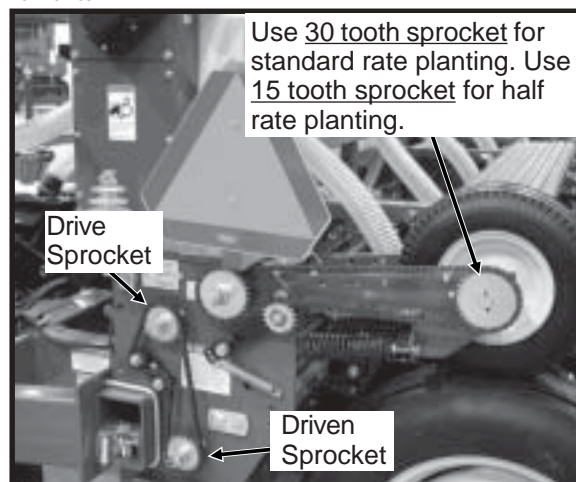

# MACHINE OPERATION

Z202

## PLANTING RATES FOR FINGER PICKUP SEED METERS (STANDARD DRIVE)

### APPROXIMATE SEEDS/ACRE FOR 30" ROW WIDTH

30" Rows	Transmission Sprockets		Recommended Speed Range (MPH)	Average Seed Spacing In Inches
	Drive	Driven		
16,186	17	28	4 to 6	12.9
16,785	17	27	4 to 6	12.5
17,431	17	26	4 to 6	12.0
18,090	19	28	4 to 6	11.6
18,128	17	25	4 to 6	11.5
18,760	19	27	4 to 6	11.1
18,883	17	24	4 to 6	11.1
19,481	19	26	4 to 6	10.7
19,704	17	23	4 to 6	10.6
20,261	19	25	4 to 6	10.3
21,104	19	24	4 to 6	9.9
21,898	23	28	4 to 6	9.5
22,022	19	23	4 to 6	9.5
22,709	23	27	4 to 6	9.2
22,850	24	28	4 to 6	9.2
23,583	23	26	4 to 6	8.9
23,697	24	27	4 to 6	8.8
23,802	25	28	4 to 6	8.8
23,853	17	19	4 to 6	8.8
24,526	23	25	4 to 6	8.5
24,608	24	26	4 to 6	8.5
24,684	25	27	4 to 6	8.5
24,755	26	28	4 to 6	8.4
25,548	23	24	4 to 6	8.2
25,592	24	25	4 to 6	8.2
25,633	25	26	4 to 6	8.2
25,671	26	27	4 to 6	8.1
25,707	27	28	4 to 6	8.1
26,659	23	23	4 to 6	7.8
27,646	28	27	4 to 6	7.6
27,684	27	26	4 to 6	7.6
27,770	25	24	4 to 6	7.5
27,818	24	23	4 to 6	7.5
28,709	28	26	4 to 6	7.3
28,791	27	25	4 to 6	7.3
28,977	25	23	4 to 6	7.2
29,795	19	17	4 to 6	7.0
29,858	28	25	4 to 6	7.0
29,991	27	24	4 to 6	7.0
30,136	26	23	4 to 6	7.0
31,102	28	24	3 to 6	6.7
31,295	27	23	3 to 6	6.7
32,271	23	19	3 to 5.5	6.5
32,454	28	23	3 to 5.5	6.5
33,674	24	19	3 to 5.5	6.2
35,077	25	19	3 to 5	6.0
36,068	23	17	3 to 5	5.8
36,480	26	19	3 to 5	5.7
37,636	24	17	3 to 5	5.6
37,883	27	19	3 to 5	5.5
39,204	25	17	3 to 4.5	5.3
39,287	28	19	3 to 4.5	5.3
40,772	26	17	3 to 4.5	5.1
42,340	27	17	3 to 4.5	4.9
43,908	28	17	3 to 4.5	4.8

**NOTE: See "General Planting Rate Information" and "Checking Seed Population" pages for additional information. Always check seed population in the field to ensure planting rates are correct.**



# MACHINE OPERATION

Z214/RH

## PLANTING RATES FOR BRUSH-TYPE SEED METERS (STANDARD DRIVE)

### APPROXIMATE SEEDS/ACRE FOR 30" ROW WIDTH

Transmission Sprockets		60 Cell Soybean Or High-Rate Milo/ Grain Sorghum	Average Seed Spacing In Inches	48 Cell Specialty Soybean Or High-Rate Acid-Delinted Cotton	Average Seed Spacing In Inches	Speed Range (MPH)
Drive	Driven	30" Rows		30" Rows		
17	28	80,928	2.6	64,742	3.2	2 to 8
17	27	83,926	2.5	67,141	3.1	2 to 8
17	26	87,154	2.4	69,723	3.0	2 to 8
19	28	90,449	2.3	72,359	2.9	2 to 8
19	27	93,799	2.2	75,039	2.8	2 to 8
17	24	94,416	2.2	75,533	2.8	2 to 8
17	23	98,521	2.1	78,817	2.7	2 to 8
19	25	101,303	2.1	81,042	2.6	2 to 8
19	24	105,524	2.0	84,419	2.5	2 to 8
23	28	109,491	1.9	87,593	2.4	2 to 8
19	23	110,112	1.9	88,090	2.4	2 to 8
24	28	114,252	1.8	91,402	2.3	2 to 8
24	27	118,483	1.8	94,786	2.2	2 to 8
17	19	119,263	1.8	95,410	2.2	2 to 8
24	26	123,040	1.7	98,432	2.1	2 to 8
26	28	123,773	1.7	99,018	2.1	2 to 8
24	25	127,962	1.6	102,370	2.0	2 to 8
26	27	128,357	1.6	102,686	2.0	2 to 8
23	23	133,294	1.6	106,635	2.0	2 to 8
27	26	138,420	1.5	110,736	1.9	2 to 8
24	23	139,089	1.5	111,271	1.9	2 to 8
25	23	144,884	1.4	115,907	1.8	2 to 8
19	17	148,975	1.4	119,180	1.8	2 to 8
27	24	149,955	1.4	119,964	1.7	2 to 8
28	24	155,509	1.3	124,407	1.7	2 to 8
23	19	161,355	1.3	129,084	1.6	2 to 8
28	23	162,270	1.3	129,816	1.6	2 to 8
24	19	168,371	1.2	134,696	1.6	2 to 8
25	19	175,386	1.2	140,309	1.5	2 to 8
23	17	180,338	1.2	144,270	1.5	2 to 8
26	19	182,402	1.1	145,922	1.4	2 to 7
27	19	189,417	1.1	151,534	1.4	2 to 7
28	19	196,433	1.1	157,146	1.3	2 to 7
26	17	203,861	1.0	163,089	1.3	2 to 7
27	17	211,702	0.9	169,362	1.2	2 to 7
28	17	219,542	0.9	175,634	1.2	2 to 7

**NOTE:** See "General Planting Rate Information" and "Checking Seed Population" pages for additional information.

**NOTE:** When using the Half Rate (2 To 1) Drive Reduction Package, rates will be approximately 50% of given numbers.

**NOTE:** Always check seed population in the field to ensure planting rates are correct.

# MACHINE OPERATION

Z214/RH

## PLANTING RATES FOR BRUSH-TYPE SEED METERS (STANDARD DRIVE)

### APPROXIMATE SEEDS/ACRE FOR 15" ROW WIDTH

Transmission Sprockets		60 Cell Soybean Or High-Rate Milo/ Grain Sorghum	Average Seed Spacing In Inches	48 Cell Specialty Soybean Or High-Rate Acid-Delinted Cotton	Average Seed Spacing In Inches	Speed Range (MPH)
Drive	Driven	15" Rows		15" Rows		
17	28	161,856	2.6	129,484	3.2	2 to 8
17	27	167,852	2.5	134,282	3.1	2 to 8
17	26	174,308	2.4	139,446	3.0	2 to 8
19	28	180,898	2.3	144,718	2.9	2 to 8
19	27	187,598	2.2	150,078	2.8	2 to 8
17	24	188,832	2.2	151,066	2.8	2 to 8
17	23	197,042	2.1	157,634	2.7	2 to 8
19	25	202,606	2.1	162,084	2.6	2 to 8
19	24	211,048	2.0	168,838	2.5	2 to 8
23	28	218,982	1.9	175,186	2.4	2 to 8
19	23	220,224	1.9	176,180	2.4	2 to 8
24	28	228,504	1.8	182,804	2.3	2 to 8
24	27	236,966	1.8	189,572	2.2	2 to 8
17	19	238,526	1.8	190,820	2.2	2 to 8
24	26	246,080	1.7	196,864	2.1	2 to 8
26	28	247,546	1.7	198,036	2.1	2 to 8
24	25	255,924	1.6	204,740	2.0	2 to 8
26	27	256,714	1.6	205,372	2.0	2 to 8
23	23	266,588	1.6	213,270	2.0	2 to 8
27	26	276,840	1.5	221,472	1.9	2 to 8
24	23	278,178	1.5	222,542	1.9	2 to 8
25	23	289,768	1.4	231,814	1.8	2 to 8
19	17	297,950	1.4	238,360	1.8	2 to 8
27	24	299,910	1.4	239,928	1.7	2 to 8
28	24	311,018	1.3	248,814	1.7	2 to 8
23	19	322,710	1.3	258,168	1.6	2 to 8
28	23	324,540	1.3	259,632	1.6	2 to 8
24	19	336,742	1.2	269,392	1.6	2 to 8
25	19	350,772	1.2	280,618	1.5	2 to 8
23	17	360,676	1.2	288,540	1.5	2 to 8
26	19	364,804	1.1	291,844	1.4	2 to 7
27	19	378,834	1.1	303,068	1.4	2 to 7
28	19	392,866	1.1	314,292	1.3	2 to 7
26	17	407,722	1.0	326,178	1.3	2 to 7
27	17	423,404	0.9	338,724	1.2	2 to 7
28	17	439,084	0.9	351,268	1.2	2 to 7

**NOTE:** See “General Planting Rate Information” and “Checking Seed Population” pages for additional information.

**NOTE:** When using the Half Rate (2 To 1) Drive Reduction Package, rates will be approximately 50% of given numbers.

**NOTE:** Always check seed population in the field to ensure planting rates are correct.

# MACHINE OPERATION

Z214/RH

## PLANTING RATES FOR BRUSH-TYPE SEED METERS (STANDARD DRIVE)

### APPROXIMATE SEEDS/ACRE FOR 30" ROW WIDTH

Transmission Sprockets		36 Cell Acid-Delinted Large Cotton	Average Seed Spacing In Inches	30 Cell Milo/Grain Sorghum Or Acid-Delinted Cotton	Average Seed Spacing In Inches	Speed Range (MPH)
Drive	Driven	30" Rows		30" Rows		
17	28	48,557	4.3	40,464	5.2	2 to 8
17	27	50,356	4.2	41,963	5.0	2 to 8
17	26	52,292	4.0	43,577	4.8	2 to 8
19	28	54,269	3.9	45,225	4.6	2 to 8
19	27	56,279	3.7	46,900	4.5	2 to 8
17	24	56,650	3.7	47,208	4.4	2 to 8
17	23	59,113	3.5	49,261	4.2	2 to 8
19	25	60,782	3.4	50,652	4.1	2 to 8
19	24	63,314	3.3	52,762	4.0	2 to 8
23	28	65,695	3.2	54,746	3.8	2 to 8
19	23	66,067	3.2	55,056	3.8	2 to 8
24	28	68,551	3.0	57,126	3.7	2 to 8
24	27	71,090	2.9	59,242	3.5	2 to 8
17	19	71,558	2.9	59,631	3.5	2 to 8
24	26	73,824	2.8	61,520	3.4	2 to 8
26	28	74,264	2.8	61,886	3.4	2 to 8
24	25	76,772	2.7	63,981	3.3	2 to 8
26	27	77,014	2.7	64,178	3.3	2 to 8
23	23	79,976	2.6	66,647	3.1	2 to 8
27	26	83,052	2.5	69,210	3.0	2 to 8
24	23	83,453	2.5	69,544	3.0	2 to 8
25	23	86,930	2.4	72,442	2.9	2 to 8
19	17	89,385	2.3	74,488	2.8	2 to 8
27	24	89,973	2.3	74,978	2.8	2 to 8
28	24	93,305	2.2	77,755	2.7	2 to 8
23	19	96,813	2.2	80,678	2.6	2 to 8
28	23	97,362	2.1	81,135	2.6	2 to 8
24	19	101,023	2.1	84,185	2.5	2 to 8
25	19	105,232	2.0	87,693	2.4	2 to 8
23	17	108,233	1.9	90,169	2.3	2 to 8
26	19	109,441	1.9	91,201	2.3	2 to 7
27	19	113,650	1.8	94,709	2.2	2 to 7
28	19	117,860	1.8	98,216	2.1	2 to 7
26	17	122,317	1.7	101,930	2.1	2 to 7
27	17	127,021	1.6	105,851	2.0	2 to 7
28	17	131,725	1.6	109,771	1.9	2 to 7

**NOTE:** See “General Planting Rate Information” and “Checking Seed Population” pages for additional information.

**NOTE:** When using the Half Rate (2 To 1) Drive Reduction Package, rates will be approximately 50% of given numbers.

**NOTE:** Always check seed population in the field to ensure planting rates are correct.

# MACHINE OPERATION

Z202

## PLANTING RATES FOR BRUSH-TYPE SEED METERS (STANDARD DRIVE) APPROXIMATE HILLS/ACRE FOR 30" ROW WIDTH

Due to variations in cotton seed size, meters equipped with the 12 cell acid-delinted hill-drop cotton discs will plant from 3 to 6 seeds per cell. Select proper disc for seed size range to be planted.

*To determine planter transmission setting,* determine desired hill spacing and select the transmission ratio closest to the hill spacing in inches on the chart. To decrease population increase spacing. To increase population decrease spacing.

*To determine population per acre,* determine average seeds per hill and hills per acre by doing a field check. Measure  $\frac{1}{1000}$  of an acre ( $\frac{1}{1000}$  acre = Length of row 17' 5" for 30" row width). Multiply average seeds per hill by hills per acre.  
EXAMPLE: 4 seeds per hill x (13 hills x 1000) = 52,000

Transmission Sprockets		NUMBER OF HILLS PER ACRE 12 Cell Hill-Drop Cotton, Acid-Delinted 30" Rows	Average Hill Spacing In Inches	Speed Range (MPH)
Drive	Drive			
17	28	16,186	12.9	2 to 8
17	27	16,785	12.5	2 to 8
17	26	17,431	12.0	2 to 8
19	28	18,090	11.6	2 to 8
19	27	18,760	11.1	2 to 8
17	24	18,883	11.1	2 to 8
17	23	19,704	10.6	2 to 8
19	25	20,261	10.3	2 to 8
19	24	21,105	9.9	2 to 8
23	28	21,898	9.5	2 to 8
19	23	22,022	9.5	2 to 8
24	28	22,850	9.2	2 to 8
24	27	23,697	8.8	2 to 8
17	19	23,853	8.8	2 to 8
24	26	24,608	8.5	2 to 8
26	28	24,755	8.4	2 to 8
24	25	25,592	8.2	2 to 8
26	27	25,671	8.1	2 to 8
23	23	26,659	7.8	2 to 8
27	26	27,684	7.6	2 to 8
24	23	27,818	7.5	2 to 8
25	23	28,977	7.2	2 to 8
19	17	29,795	7.0	2 to 8
27	24	29,991	7.0	2 to 8
28	24	31,102	6.7	2 to 8
23	19	32,271	6.5	2 to 8
28	23	32,454	6.5	2 to 8
24	19	33,674	6.2	2 to 8
25	19	35,077	6.0	2 to 8
23	17	36,068	5.8	2 to 8
26	19	36,480	5.7	2 to 7
27	19	37,883	5.5	2 to 7
28	19	39,287	5.3	2 to 7
26	17	40,772	5.1	2 to 7
27	17	42,340	4.9	2 to 7
28	17	43,908	4.8	2 to 7

NOTE: See "General Planting Rate Information" and "Checking Seed Population" pages for additional information.

NOTE: When using the Half Rate (2 To 1) Drive Reduction Package, rates will be approximately 50% of given numbers.

NOTE: Always check seed population in the field to ensure planting rates are correct.

# MACHINE OPERATION

## DRY INSECTICIDE APPLICATION RATES APPROXIMATE POUNDS/ACRE AT 5 MPH FOR 30" ROW WIDTH

Meter Setting	30" Rows
<b>CLAY GRANULES</b>	
10	4.9
11	5.4
12	6.1
13	6.9
14	7.7
15	8.5
16	9.6
17	10.7
18	11.4
19	13.1
20	14.2
21	15.5
22	16.4
23	17.2
24	18.8
25	20.9
26	23.0
27	24.1
28	25.4
29	27.8
30	29.6
<b>SAND GRANULES</b>	
5	2.9
6	4.9
7	5.3
8	6.3
9	7.8
10	8.9
11	10.2
12	11.2
13	12.6
14	14.1
15	15.5
16	17.5
17	19.4
18	21.8
19	24.3
20	25.7
21	27.6
22	29.6
23	32.0
24	34.4
25	36.9

**NOTE:** The above chart represents average values and should be used only as a starting point. The granular chemical flows through the given meter opening at a nearly uniform rate regardless of roller speed. Your actual rate will vary depending upon the insecticide you are using, your planting speed and your plant population. Planting speed/ground speed has the greatest effect on application rate.

Your actual rate must be checked in the field with the actual insecticide that you are using and at the speed and population at which you will be planting. See "Checking Granular Chemical Application Rate" page for additional information.



**WARNING:** Agricultural chemicals can be dangerous if not selected and handled with care. Always read and follow directions supplied by the chemical manufacturer.

# MACHINE OPERATION

---

## DRY HERBICIDE APPLICATION RATES

APPROXIMATE POUNDS/ACRE AT 5 MPH FOR 30" ROW WIDTH

### CLAY GRANULES

Meter Setting	30" Rows
10	4.7
11	5.2
12	5.8
13	6.5
14	7.3
15	8.2
16	9.0
17	9.9
18	10.7
19	11.6
20	12.6
21	13.6
22	14.6
23	15.7
24	17.0
25	18.1
26	19.4
27	20.9
28	22.6
29	24.3
30	26.7

**NOTE:** The above chart represents average values and should be used only as a starting point. The granular chemical flows through the given meter opening at a nearly uniform rate regardless of roller speed. Your actual rate will vary depending upon the herbicide you are using, your planting speed and your plant population. Planting speed/ground speed has the greatest effect on application rate.

Your actual rate must be checked in the field with the actual herbicide that you are using and at the speed and population at which you will be planting. See "Checking Granular Chemical Application Rate" page for additional information.



**WARNING:** Agricultural chemicals can be dangerous if not selected and handled with care. Always read and follow directions supplied by the chemical manufacturer.

# MACHINE OPERATION

---

## LIQUID FERTILIZER PISTON PUMP APPLICATION RATES GALLONS PER ACRE

Applies To Model LM-4405 Pump With 18 Tooth Sprocket

Pump Setting	1	2	3	4	5	6	7	8	9	10
12 Row 30"	3.7	7.4	11.1	14.8	18.5	22.1	25.8	29.5	33.2	36.9
16 Row 30"	2.8	5.5	8.3	11.1	13.9	16.6	19.4	22.2	24.9	27.7

Above chart is for planters equipped with 7.60" x 15" drive wheel, based on 91" forward travel per wheel revolution, 48 tooth drive sprocket and 18 tooth driven sprocket on metering pump. Chart is based on average wheel slippage and liquid viscosities.

Measure and weigh one gallon of actual fertilizer solution to determine exact application rate. This chart was calculated based on a solution weighing ten pounds per gallon.

**NOTE:** Fertilizer application rates can vary from the above chart. To prevent application miscalculations, make field checks to be sure you are applying fertilizer to all rows at the desired rate.

**NOTE:** Flow to all rows should be checked periodically. If one or more lines are plugged, the desired rate will be delivered to the remaining rows keeping total application rate at desired rate.

To check the exact number of gallons your fertilizer attachment will actually deliver on a 30" row spacing, proceed as follows:

Remove the hose from one of the fertilizer openers and insert it into a collection container which has been secured to the planter frame. Engage the fertilizer attachment and drive forward for 174'. Measure the fluid ounces caught in the container and multiply that amount by 100. Divide that amount by 128. The result will be the gallons of fertilizer delivered per acre when planting in 30" rows. Rinse the collection container and repeat test on other rows if necessary.

# MACHINE OPERATION

---



# BULK FILL SYSTEM OPERATION

## INTRODUCTION

The bulk fill system consists of two bulk seed hopper assemblies with drop hoses to direct seed to row unit mini-hoppers. Each bulk seed hopper feeds half of the planter. The mini-hoppers replace the standard 1.9 bushel seed hoppers. The row units and seed meters are the same as used on other KINZE® planters.

D121702109

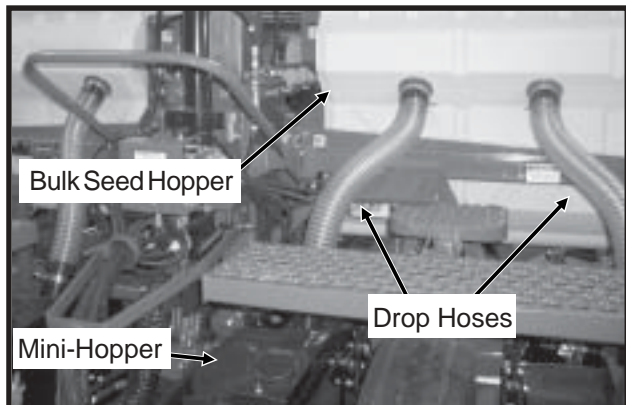

The bulk fill system is designed to evenly distribute seed to each row to assure all seed meters maintain a ready supply of seed. Seed placed in the bulk seed hopper is elevated by a stair step-design system of bristle-tipped augers to the distribution manifold located at the top of the bulk seed hopper. Drop collars attached to the distribution manifold direct seed through a drop hose to a mini-hopper on each row unit. At initial fill, as one mini-hopper and drop hose is filled to capacity the auger inside the distribution manifold carries seed on to the next row until all active row outlets are filled to capacity.

D021102218

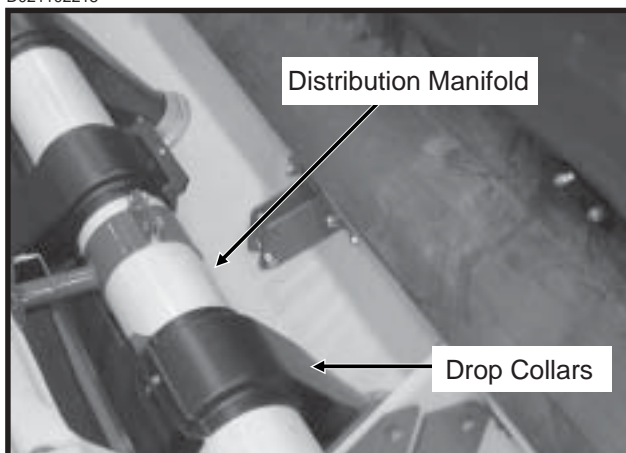

**NOTE:** After all row outlets are filled to capacity, seed will continue to be evenly distributed to all rows until the bulk seed hopper is empty. When the bulk seed hopper is empty or the auger system is shut off, all drop hoses will “plant out” equally and all rows should run out of seed at approximately the same time.

## CAPACITIES

System hopper capacity is approximately 55 bushels for the 12 row 30" planter and 85 bushels for the 16 row 30" planter.

Each drop hose/mini-hopper combination has a capacity of 16 pounds of seed. Example: At 16 pounds per row, a 50 pound bag of soybeans will fill 3 rows. It will take 5 to 6 bags (3 per bulk seed hopper) of seed to charge all rows on a 16 row planter or 11 to 12 bags (6 per bulk seed hopper) to charge all rows on an Inter-plant® Package equipped 16 row planter (31 or 32 rows).

The capacity of the mini-hopper and seed meter only is 8.75 pounds (approximately 5 quarts) of seed. When planting seed variety plots, it may be desirable to fill mini-hoppers using the access hole provided on each mini-hopper.

# BULK FILL SYSTEM OPERATION

## SEED DISTRIBUTION MANIFOLD

A handle and lock pin located inside each bulk seed hopper allows the seed distribution manifold to be rotated to direct seed to front and rear rows or to rear rows only. When the handle is pointing to the rear, seed flows to the rear rows only as the manifold is rotated to close off seed from the forward pointing drop collars. When the handle is pointing toward the front, seed flows to the front and rear rows equally as all outlets are enabled.

D021102218

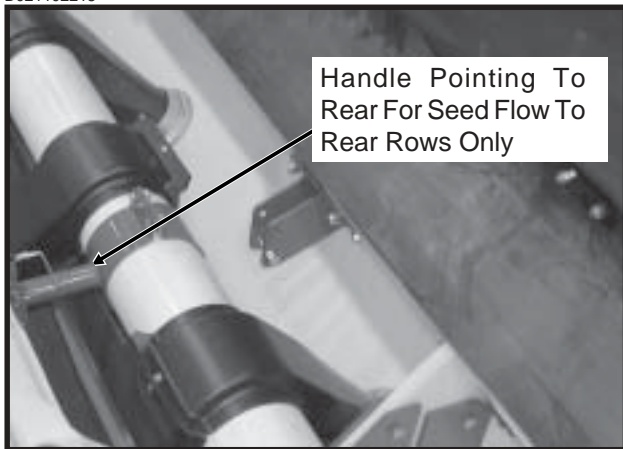

## OVERFLOW

An overflow is provided so seed not used to charge drop hoses/mini-hoppers, can return to the seed reservoir to be picked up by the horizontal floor auger and recirculated through the system.

D021102222

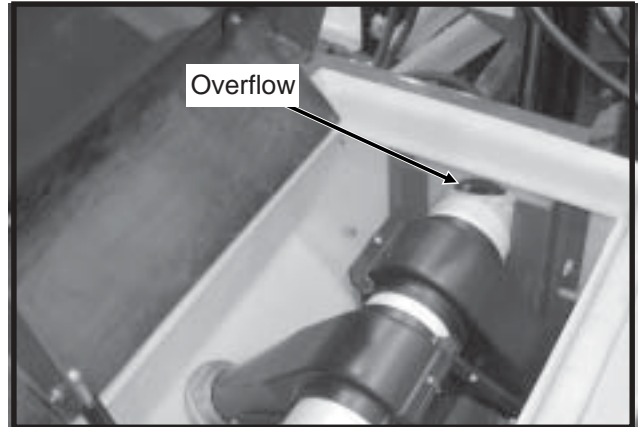

**NOTE: On machines equipped with the Even-Row Push Row Unit Package, detach the 8" drop tube inside the bulk seed hopper and rotate the cover plate on the distribution manifold 180° to close off seed flow to the even-row push row unit. Install 3" cap supplied with Even-Row Push Row Unit Package to the drop tube on the inside of the bulk seed hopper using hose clamp.**

D031302113A

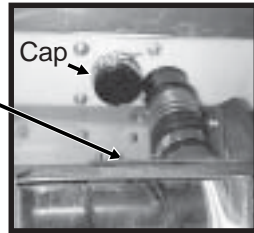

# BULK FILL SYSTEM OPERATION

## MINI-HOPPER LATCH

Due to the pull exerted by the drop hose on the mini-hopper as the row unit moves up and down, a pin is provided to secure the mini-hopper latch.

D041801101

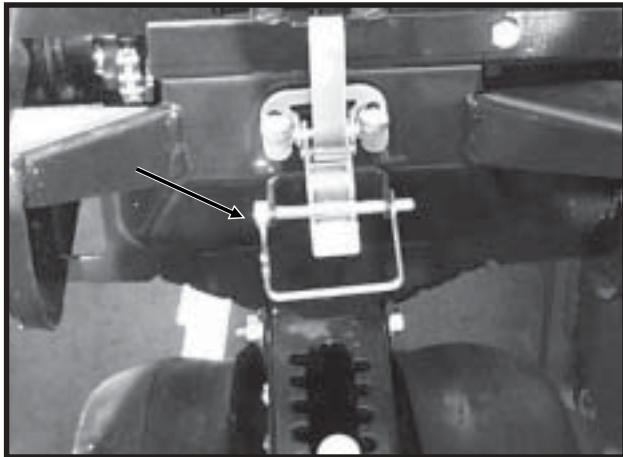

## HYDRAULIC SYSTEM

D121802120

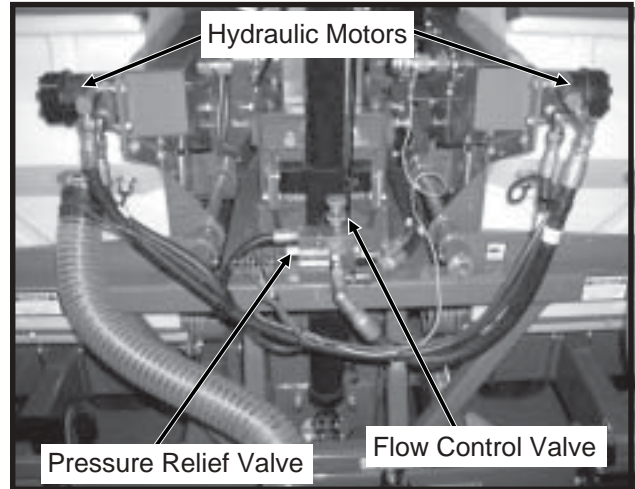

**Shown With Terminal Strip Cover Removed**

The hydraulic system includes two centrally-mounted hydraulic motors plumbed in series, a pressure relief valve, a check valve and an adjustable flow control valve. The flow control allows auger speed to be varied to meet seed demand.

The hydraulic system operates from one selective control valve. A separate (third) remote SCV is required on the tractor, in addition to the two remotes required to operate the lift, row marker and rotate functions.

If the tractor has a motor return circuit, its use will allow the system to work with reduced back pressure and reduced heat generation, but is not required for the proper operation of the system.

If the tractor has cab mounted flow controls, open the needle type flow control on the planter and use the flow control valve on the tractor to adjust auger speed. Adjust accordingly. See "Auger Speed Adjustment" and the tractor's operators manual.

The hydraulic motor circuit will use 1.5 to 4.0 gallons per minute (GPM) at 700 PSI to operate a fully loaded bulk fill system.

An in-line check valve in the return line prevents reverse operation of the auger system.

**IMPORTANT: The proper auger speed when planting is critical. Excess auger speed will cause more seed than necessary to be drawn into the system which may cause wear on mechanical components and potential damage to the seed.**

# BULK FILL SYSTEM OPERATION

## AUGER SPEED ADJUSTMENT

Auger speed should be adjusted to deliver seed to the row units at a rate equal to the planting rate. This keeps all the drop hoses, mini-hoppers and seed meters filled equally but will not cause seed to be recirculated through the system excessively.

D121802120

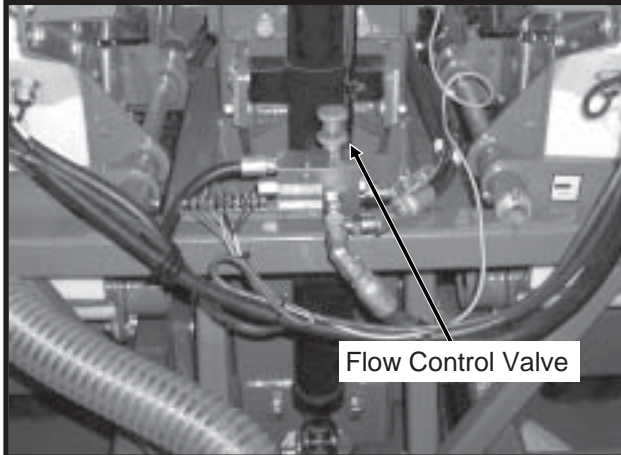

Shown With Terminal Strip Cover Removed

To adjust auger speed, loosen the jam nut and turn the control clockwise, or IN, to decrease auger speed and counterclockwise, or OUT, to increase the auger speed. The auger speed can also be adjusted from the tractor. Adjust flow control on the planter for full flow and control auger speed using the tractor's flow control.

**IMPORTANT: The proper auger speed when planting is critical. Excess auger speed will cause more seed than necessary to be drawn into the system which may cause wear on mechanical components or increase the potential for damage to the seed.**

When set correctly, the system will keep all hoppers and hoses full with minimum overflow out of the top auger. The fine tuning of the auger speeds can be accomplished by slowing the auger speed until the system is starved, indicated by a center row running low on seed. Adjust auger RPM upward to keep up with planting rate.

It is suggested that the top distribution manifold auger speed be set at 20 to 25 RPM for planting seeds such as corn and 80 to 100 RPM for planting seeds such as soybeans. These speeds are approximate depending on row size of planter, and planting speed and population.

A rotation indicator is provided on the upper inboard end of each bulk seed hopper that allows the operator to monitor shaft rotation.

D121802120

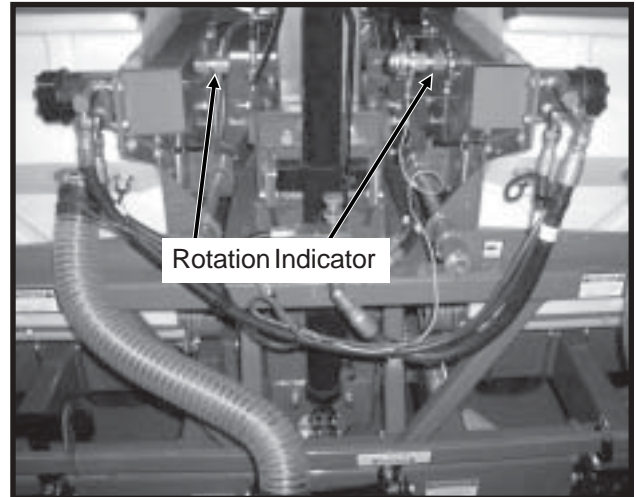

# BULK FILL SYSTEM OPERATION

## BULK SEED HOPPER MONITOR

D013103110



The bulk seed hopper monitor system consists of a console, which is mounted on the tractor; a speed sensor, which is located over the rotation indicator on the L.H. bulk seed hopper; and two seed flow sensor assemblies. One sensor is installed in each bulk seed hopper in the inner-most pull row unit drop funnel.

The bulk seed hopper monitor system is powered by the tractor battery (requires 12 volts DC). If connected to the convenience outlet provided on the tractor, the bulk seed hopper monitor system powers down when the tractor is powered down. If the system is wired directly to the tractor battery, use the push button switch on the console to turn the system off.

D121802102

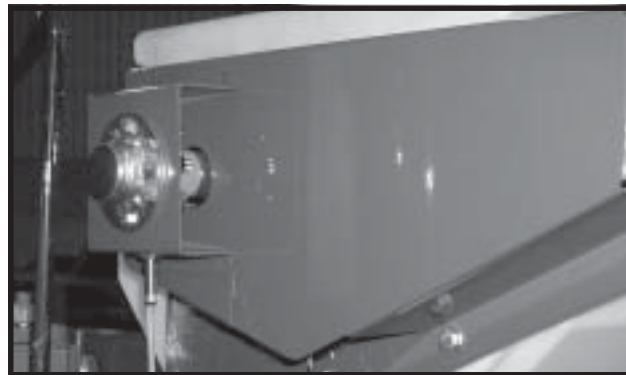

The console displays auger RPM to assist in fine tuning and monitoring the auger speed.

A warning light, incorporating a 100 second delay, turns on when no seed flow is sensed in either drop funnel in which the sensors are installed.

D121802116

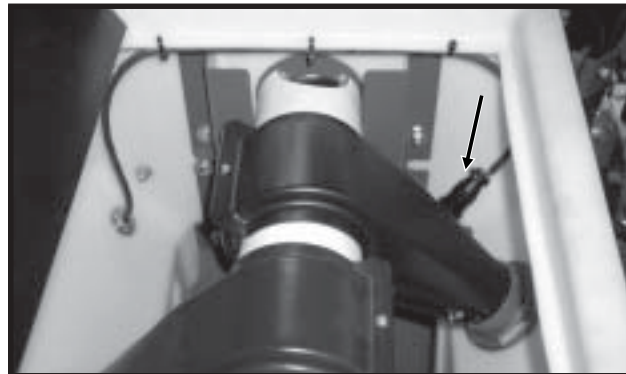

See "Auger Speed Adjustment" for additional information.

# BULK FILL SYSTEM OPERATION

## FILLING

Use clean seed and make certain there are no foreign objects in the hopper. Always close hopper lids during field operation to prevent the accumulation of dust or dirt in the seed meters which will cause premature wear.

When filling an empty planter, it is recommended that the auger system be operated so the drop hoses will fill as the seed is put into the bulk seed hoppers. (Be sure all shields and covers are in place before operating system.) Open the flow control valve so the top (distribution manifold) auger turns at approximately 60 to 75 RPM. Fill the bulk seed hoppers with the desired amount of seed. When all drop hoses are filled, shut off the system and return the flow control to its planting operation setting. See "Auger Speed Adjustment".

D121802120

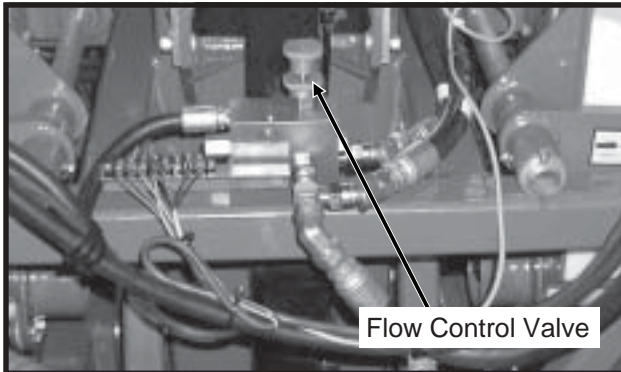

**Shown With Terminal Strip Cover Removed**

When all drop hoses are filled, seed can be placed in any location in the bulk seed hopper and it will be distributed evenly to all rows.

When starting a new system, switching to a different type of seed (i.e. corn to soybeans) or using an unfamiliar type of seed treatment, it is very important to test the operation of the system with a small amount of seed before completely filling the bulk seed hoppers.

D021102222

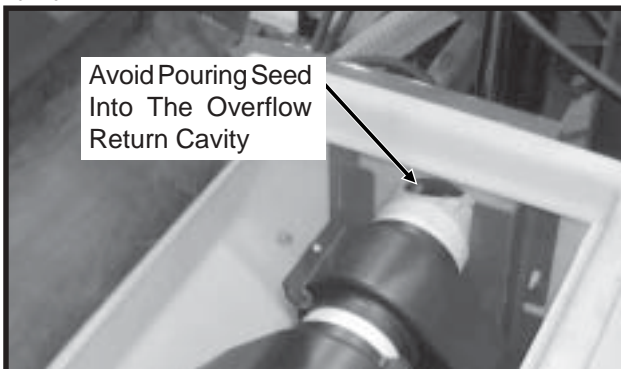

**NOTE: When filling the bulk seed hoppers, avoid pouring seed into the overflow return cavity.**

## SEED LUBRICATION

The use of powdered graphite is recommended. In addition to the benefits graphite provides the seed meters, graphite will also aid seed flow through the bulk fill auger system. If seed treatments or inoculants that add moisture to the seed are used, talc is recommended along with the graphite. Be sure to test unfamiliar combinations before completely filling the system. Apply any seed treatments, graphite and/or talc alternately in layers with the seed while filling the bulk seed hopper. The auger lift system will mix the seed, seed treatments, graphite and/or talc, so pre-mixing may not be as critical as with planters equipped with individual seed hoppers.

As new seed is added to the bulk seed hopper, and seed from a previous fill is still present, some mixing will occur. Generally the seed in the bulk seed hopper closest to the inboard end of the hopper will be planted first before the seed is circulated through the auger lift system. Be certain this seed is treated as it would not have had a chance to mix with the seed treatments, graphite and/or talc.

82354-1e



See "Finger Pickup Seed Meter" and "Brush-Type Seed Meter" in the Row Unit Operation section for additional information.

# BULK FILL SYSTEM OPERATION

---

## OPERATION

After seed is distributed to all rows, adjust the speed of the auger hydraulic motors as necessary to maintain an adequate supply of seed without excessive seed movement. See "Row Unit Operation" section for operation of seed meters and various row unit optional equipment.

Seed will be delivered equally to all rows until the bulk seed hopper supplying those rows is empty. When the bulk seed hopper is empty, the drop hoses and mini-hoppers will each contain approximately 16 pounds of seed. This information can be used to determine the area that can be planted as the system empties.

EXAMPLE: Planting population is 32,000 seeds/acre. You are planting corn that weighs 50 pounds per 80,000 kernels. 16 pounds of seed in drop hoses/mini-hoppers will equal approximately 25,600 seeds. This will be enough seed to plant 0.8 acres per row (9.6 acres with a 12 row 30" planter or 12.8 acres with a 16 row 30" planter).

See "Checking Seed Population" in Machine Operation section for additional information.

The planting range can be tested by filling the entire system, turning off the auger drive and planting until the hoses/mini-hoppers are empty. Trial runs like this will give you a good idea as to how much seed to place in the bulk seed hoppers at the end of the planting season or when planning to switch varieties of seed, etc.

Many factors affect the seed demand rate including planter operating speed, population rate, number of rows, length of rows and size of seed. The suggested method when starting the season is to fill the system and then observe the seed level in the drop hoses during planting passes. Increase or decrease the auger speed as necessary to maintain a constant supply of seed to the meters.

The system is designed to run continuously and will not plug if allowed to operate without planting. If left running continuously for an extended period of time (15-20 minutes) with no planting activity, the overflow cavity on the inboard end of the bulk seed hopper will fill with seed and seed will begin to boil out to the top of the overflow. This excess seed will fall back into the main part of the bulk seed hopper. No damage to the auger system will occur.

**NOTE: If the system is operated for an excessive period without planting activity, and depending on how much seed is in the bulk seed hopper around the overflow return, seed falling back into the main bulk seed hopper could eventually collect under the lid, push the lid upward and overflow onto the ground.**

**NOTE: Avoid allowing the system to run continuously when no seed is being planted as seed will recirculate through the auger system multiple times and seed damage may occur.**

# BULK FILL SYSTEM OPERATION

## CLEANOUT

Periodically empty the bulk seed hoppers completely to remove any foreign objects and to ensure proper seed meter operation.

When changing seed varieties or switching crops, a small amount of seed and fines will remain in the lower trough area of the bulk seed hoppers. To clean, remove the screen in the lower auger transfer area at the outer end of each bulk seed hopper. Starting at the center of the planter, hydraulically operate the auger system while using compressed air or a leaf blower to move remaining seed/fines toward the discharge hole.



**WARNING:** Always keep hands, feet and clothing away from moving parts. Do not wear loose-fitting clothing which may catch in moving parts.

D051402110

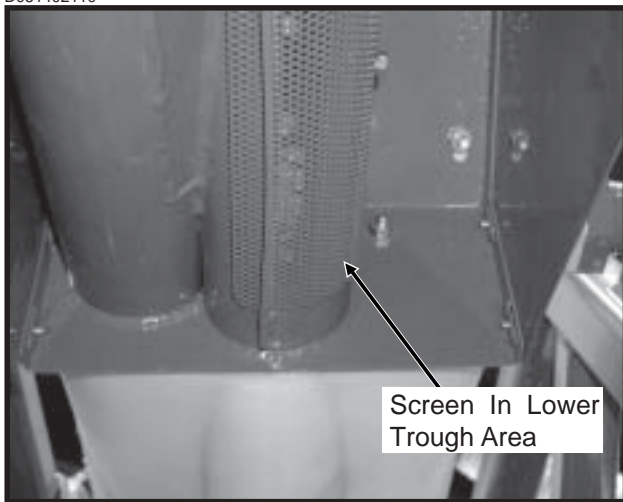

A small amount of seed may be left in the mini-hoppers. Empty these by removing the mini-hoppers and mini-hopper lids and dumping or by vacuuming the remaining seed out.

D21102226

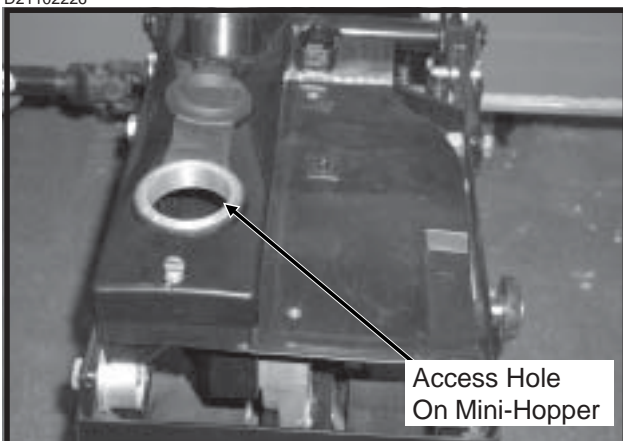

## LOWER AUGER COVER

D051402115

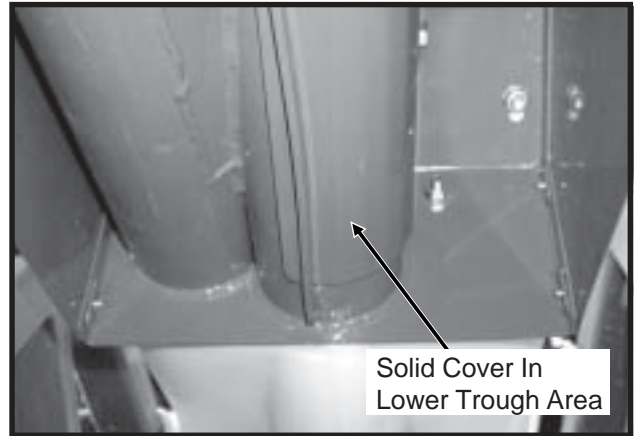

Two covers are provided for the lower auger trough. A mesh screen is used for most larger seeds, including corn and soybeans. A solid cover, to replace the screen, is supplied with the planter for use when planting very small seeds.

## BULK SEED HOPPER COVERS

D021102229a



**NOTE:** The bulk seed hoppers are not water tight. Store the planter inside when possible. Fitted covers are available from KINZE® Repair Parts for use if the planter must be stored outside. Secure covers using grommets in covers and customer-supplied tie-down straps as needed.



# ROW UNIT OPERATION

## PLANTING DEPTH

Planting depth is maintained by the row unit gauge wheels. To increase or decrease the planting depth, first raise the planter to remove weight from the wheels. Then push down on the depth adjustment handle and reposition it forward to decrease depth or rearward to increase planting depth. Adjust all units to the same setting initially. Then lower the planter and check operation and planting depth of all row units. It may be necessary to readjust some rows to obtain uniform operation. Available depth adjustment range is approximately  $\frac{1}{2}$ " to 3  $\frac{1}{2}$ ".



**WARNING:** Never work under the planter while in raised position without using safety lockups.

04059914a

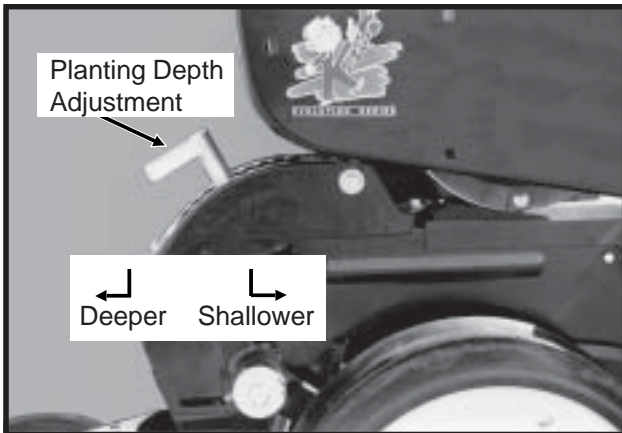

## "V" CLOSING WHEEL ADJUSTMENT (Rubber And Cast Iron)



**WARNING:** Raise planter and install safety lockups before making closing wheel adjustments.

After adjusting planting depth, check the operation of the "V" closing wheels. The "V" closing wheels should have enough down pressure to close the seed trench and ensure good soil to seed contact. To increase spring pressure on the closing wheels, move the 5-position quick adjustable down force lever located on the top of the closing wheel arm to the rear. Moving the lever forward decreases spring tension.

Adjust all row units to a similar setting.

LF212299-15

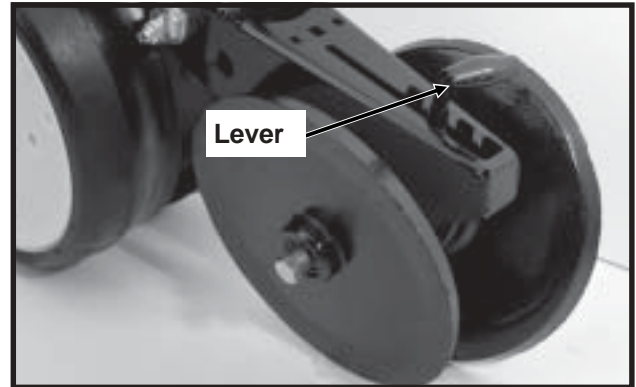

Light soil usually requires less down force at average depth (approximately 2") while heavy soil requires increased down force.

Eccentric bushings in the wheel arm stop allow for lateral adjustment of the "V" closing wheel assembly. Using a  $\frac{3}{4}$ " wrench, loosen the hardware which attaches the closing wheel arm to the wheel arm stop. Using another  $\frac{3}{4}$ " wrench turn the eccentric bushings until the **closing wheels are aligned with the seed trench**. Tighten hardware.

LF2122299-15

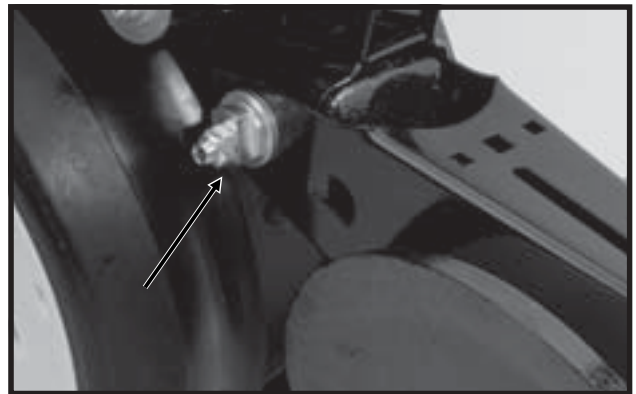

The closing wheels can be installed in two locations either "offset" (to improve residue flow) or "directly" opposite. If set "directly" opposite, the forward installation holes should be used.

(RU83d)

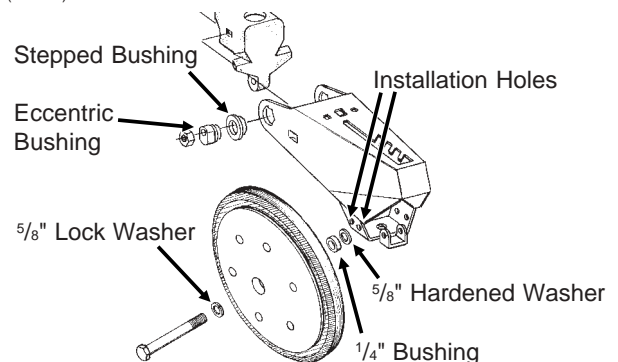

# ROW UNIT OPERATION

---

## CLOSING WHEEL SHIELD (Rubber And Cast Iron “V” Closing Wheels)

D11090208a

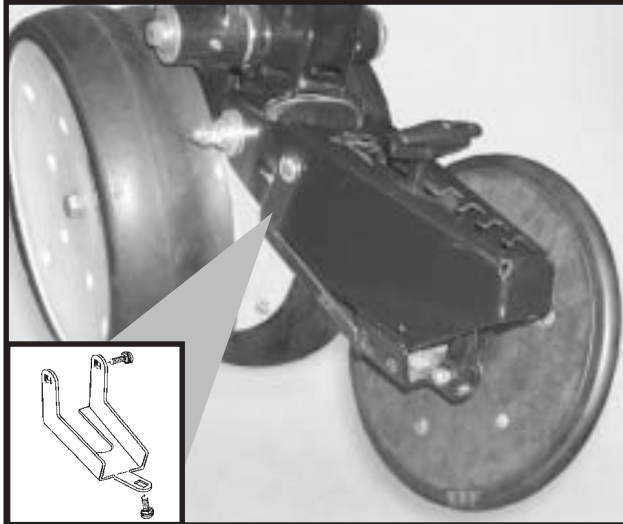

**Shown With Closing Wheel Removed For Visual Clarity**

The optional closing wheel shield is designed to be installed onto the underside of the closing wheel arm to help prevent root balls and stalks from plugging the closing wheels.

# ROW UNIT OPERATION

## FINGER PICKUP SEED METER

Refer to the planting rate chart for recommended seed drive transmission sprocket combinations.

D05030001

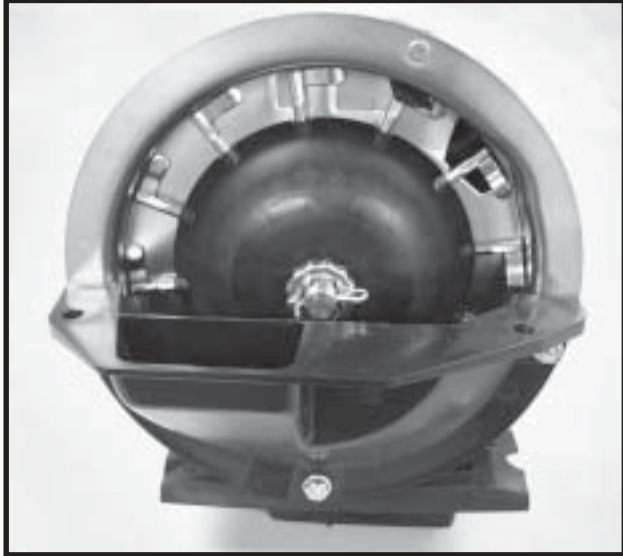

Shown With Corn Fingers Installed

The following seed fingers are available for use with the finger pickup seed meter:

(PLTR91/PLTR92/PLTR91a)

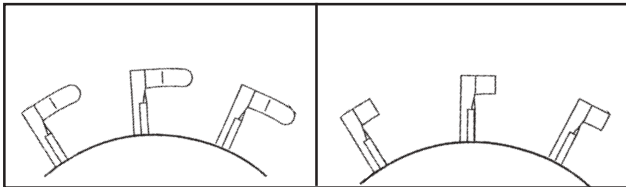

Corn Fingers

Oil Sunflower Fingers

No. 3 and/or No. 4 size oil sunflower seeds are recommended for use in the finger pickup seed meter equipped with oil sunflower fingers.

No. 1 and/or No. 2 size confectionary sunflower seeds are recommended for use in the finger pickup seed meter equipped with corn fingers.

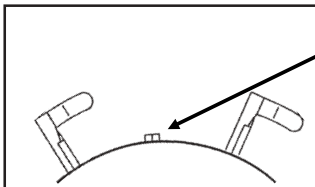

Half Rate Blank Finger

Blank fingers are used to replace alternate fingers in the finger wheel to reduce the planting rate by half while allowing the finger wheel to maintain a minimum of 40 RPM when planting low rates.

**NOTE: Always check seed population in the field to ensure planting rates are correct.**

**NOTE: To ensure efficient operation of the finger pickup seed meter and extend the life of its components, powdered graphite should be mixed with the seed twice daily. Mix  $\frac{1}{3}$  cup per bulk hopper for 12 row machines or  $\frac{1}{2}$  cup per bulk hopper for 16 row machines. Even distribution of the graphite with the seed is critical with newer seed coatings to provide lubrication for the finger pickup mechanism. Graphite application frequency may need to be increased if using additional seed additives.**

**NOTE: See "Seed Lubrication" in Bulk Fill System Operation section for additional information.**

82354-1e



**NOTE: Follow manufacturer's recommendations when applying and mixing other seed treatments.**

See "General Planting Rate Information", "Finger Pickup Seed Meter Troubleshooting" and "Finger Pickup Seed Meter Inspection/Adjustment" for additional information.

# ROW UNIT OPERATION

## BRUSH-TYPE SEED METER

LF212299-13a



Shown Without Seed Disc Installed

60607-40a(PLTR13)

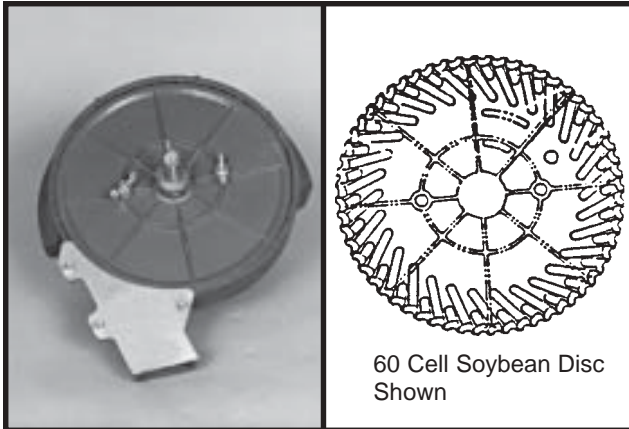

60 Cell Soybean Disc Shown

The following seed discs are available for use with the brush-type seed meter:

**Soybean:** 60 cells to meter seed sizes from 2200 to 4000 seeds per pound (Black color-coded).

(PLTR14)

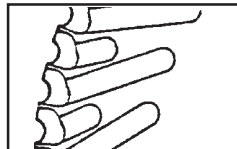

**Specialty soybean:** 48 cells to meter seed sizes from 1400 to 2200 seeds per pound (Dark blue color-coded).

(PLTR15)

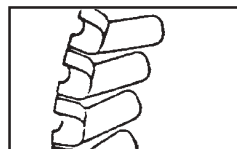

**Small milo/grain sorghum:** 30 cells to meter seed sizes from 14,000 to 20,000 seeds per pound (Red color-coded).

(PLTR16)

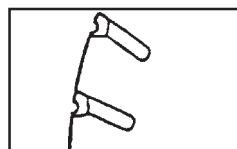

**Large milo/grain sorghum:**

30 cells to meter seed sizes from 10,000 to 16,000 seeds per pound (Light blue color-coded).

(PLTR17)

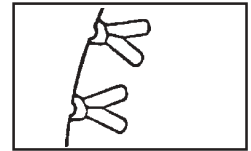

**High-rate small milo/grain sorghum:**

60 cells to meter seed sizes from 12,000 to 18,000 seeds per pound (Red color-coded). (PLTR18)

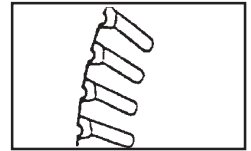

**High-rate large milo/grain sorghum:**

60 cells to meter seed sizes from 10,000 to 14,000 seeds per pound (Yellow color-coded). (PLTR19)

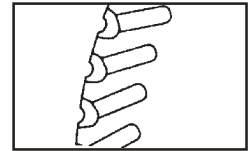

**Cotton, acid-delinted:** 30 cells to meter seed sizes from 4200 to 5200 seeds per pound (White color-coded).

(PLTR20)

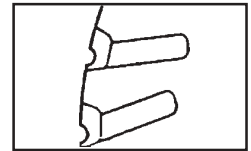

**Large cotton, acid-delinted:**

36 cells to meter seed sizes from 3800 to 4400 seeds per pound (Tan color-coded).

(PLTR21)

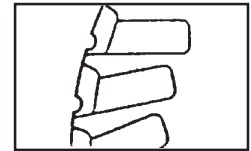

**High-rate cotton, acid-delinted:**

48 cells to meter seed sizes from 4200 to 5200 seeds per pound (Light green color-coded).

(PLTR22)

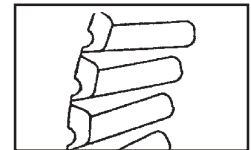

**Hill-drop cotton, acid-delinted:** 12 cells, 3 to 6 seeds/cell, to meter seed sizes from 4000 to 5200 seeds per pound (Brown color-coded). (PLTR23)

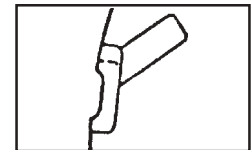

**Small hill-drop cotton, acid-delinted:** 12 cells, 3 to 6 seeds/cell, to meter seed sizes from 5000 to 6200 seeds per pound (Dark green color-coded).

(PLTR23)

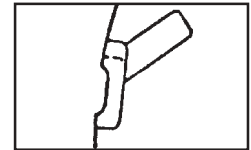

(RU14c)

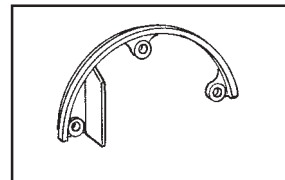

Use GD11122 upper brush retainer when using soybean and cotton discs.

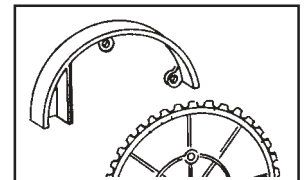

Use GD8237 upper brush retainer when using milo/grain sorghum discs.

# ROW UNIT OPERATION

When installing the seed disc onto the meter hub, turn the disc counterclockwise while tightening the two wing nuts that retain the disc. The seed disc should have only slight resistance when rotated counterclockwise after wing nuts are tight.

The brush-type seed meter attaches to the mini-hopper in the same manner as the finger pickup seed meter. Secure to bottom of mini-hopper with two  $\frac{5}{16}$ " thumbscrews. Tighten thumbscrews slightly with pliers. **DO NOT OVER TIGHTEN.**

Erratic seed spacing may result from misalignment between the drive coupler and seed meter input shaft. Misalignment may cause momentary stoppage of seed disc. Check alignment after initial installation. If adjustment is required, refer to "Meter Drive Adjustment" for correct procedure.

Refer to the planting rate charts in this manual for recommended seed drive transmission sprocket combinations.

**IMPORTANT: Use powdered graphite or talc with each fill of seed. Additional graphite or talc may be required to retard buildup of seed treatments on meter components. Frequency of monitor seed tube cleaning may be affected due to use of additional graphite or talc.**

82354-1e



Powdered graphite should be added with the seed each time the bulk seed hopper is filled. Use 1 cup per hopper fill for 12 row machines and 1  $\frac{1}{2}$  cup per hopper fill for 16 row machines. Graphite should be added in layers as the bulk seed hoppers are filled. The use of powdered graphite will prolong the life of the brush-type seed meter components, reduce buildup of seed treatment on components in the meter and improve seed spacing.

**Talc seed lubricant** may be used in lieu of or in addition to graphite to reduce seed treatment buildup on bulk fill auger system components, seed discs and meter components and will improve meter performance. Coat seed discs and brushes with talc before installing meters. Fill each bulk hopper  $\frac{1}{2}$  full of seed, add 4  $\frac{1}{4}$  cups of talc for 12 row planters or 6  $\frac{1}{2}$  cups of talc for 16 row planters and mix thoroughly. Finish filling bulk hopper, add another 4  $\frac{1}{4}$  cups of talc for 12 row planters or 6  $\frac{1}{2}$  cups of talc for 16 row planters. Adjust rate of talc use as needed so all seeds are coated, while avoiding a buildup of talc in the bottom of the hopper. Humid conditions and/or small sized seeds with extra seed treatment may require additional talc to prevent seed treatment buildup on auger bristles, seed discs and/or meter brushes.

**NOTE: Some liquid seed treatments or inoculants may create buildup on seed discs or brushes. Check frequently for proper population and/or seed delivery when using any liquid seed treatment.**

All seed treatment should be thoroughly mixed with the seed per the manufacturers' recommendations. Seed treatment dumped on top of the seed after the hopper is filled, and not mixed properly will cause bridging of the seed in the meter, reducing population or stopping the meter from planting. Additional graphite or talc may be required to retard buildup of seed treatments on meter components.

**NOTE: See "Seed Lubrication" in Bulk Fill System Operation section for additional information.**

**NOTE: Foreign material, such as hulls, stems, etc., may affect seed delivery. Clean seed is required to ensure accurate seed metering from the brush-type seed meter. Seed discs should be removed daily to check for buildup of foreign material, such as hulls, in the seed meter or the brushes.**

# ROW UNIT OPERATION

## SEED METER CLEANOUT

To maintain genetic purity, thorough seed meter cleanout is important.

To clean the seed meter, remove the thumbscrews on top of the mini-hopper lid and remove the mini-hopper lid.

D051402103



D051402103

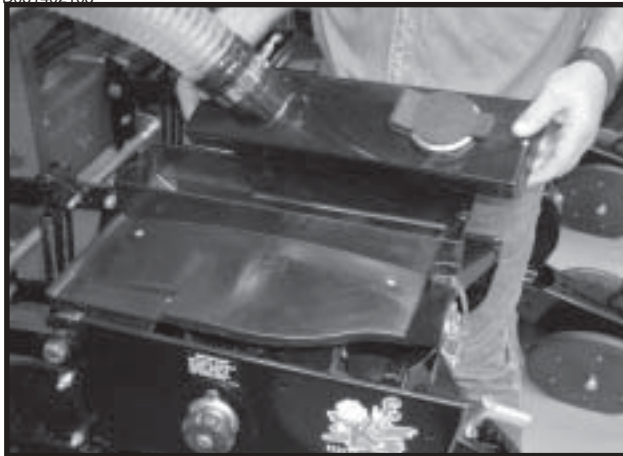

Disengage the seed drive and remove the seed mini-hopper and meter.

Dump the seed from the right rear corner of the mini-hopper into a container.

D05170201

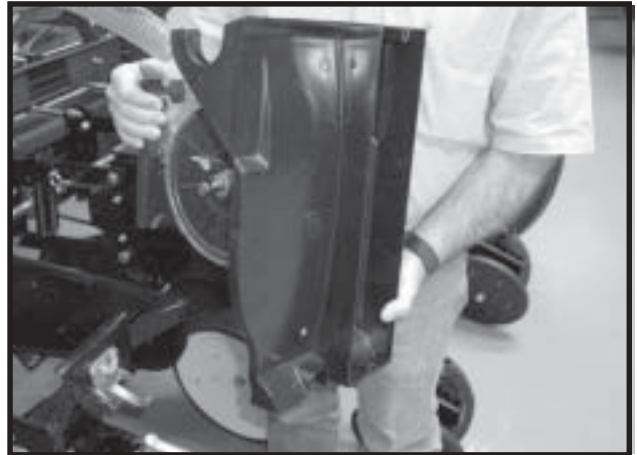

Remove seed disc by loosening wing nuts. Empty the meter. Thoroughly inspect brushes to ensure all seed is removed. Replace seed disc and install wing nuts.

# ROW UNIT OPERATION

## SEED METER DRIVE RELEASE

The seed meter drive is equipped with a clutch release mechanism that allows the drive to be disengaged from the seed metering unit for removal of the mini-hopper. Disconnecting the drive allows the operator to check granular chemical application rates without dropping seed. It also allows one or more of the rows to be disconnected when finishing fields.

D04199906

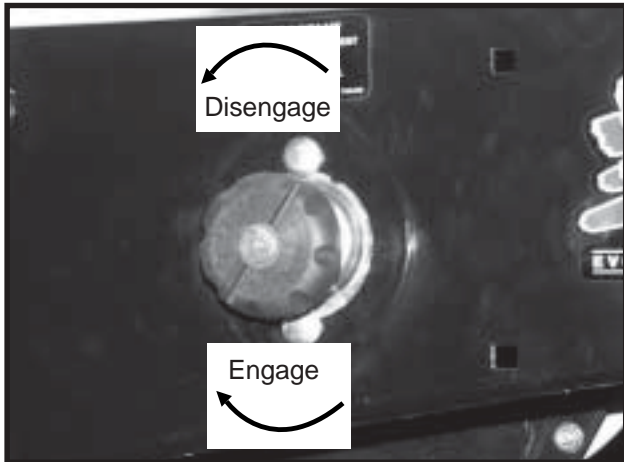

To disengage the drive, turn the knob  $\frac{1}{4}$  turn counter-clockwise. To engage the drive, turn the knob  $\frac{1}{4}$  turn clockwise.

## SEED METER DRIVE ADJUSTMENT

**NOTE: The seed meter drive coupler must be properly aligned with the meter input shaft.**

Improper alignment between the drive coupler and input shaft of the meter can cause the meter housing to flex as the meter rotates. This continual flexing of the meter housing can cause damage to the housing. Any time the hopper support panel is removed or replaced, vertical and horizontal alignment should be checked.

Erratic seed spacing may result from misalignment between the drive coupler and seed meter input shaft. Misalignment may cause momentary stoppage of brush-type meter seed disc. Check alignment after initial installation.

Although the meter drive has a self-aligning feature, the slotted mounting hole in the hopper support panel and clutch plate allow for alignment adjustment between the drive coupler and meter shaft. If the drive clutch is centered in the hole in the hopper support panel the drive should be in alignment.

D04209903

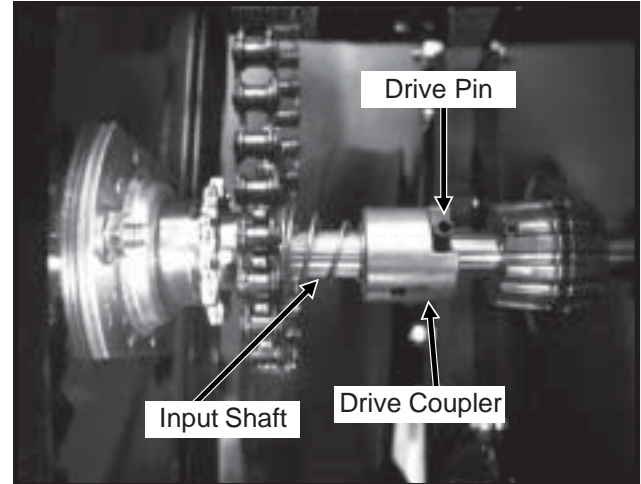

### To check alignment:

- Engage drive coupler over pin on meter shaft.
- Drive shaft on clutch should be centered in sprocket bore.
- If adjustment is needed, proceed as follows.

### To adjust drive clutch:

- Slightly loosen both  $\frac{5}{16}$ " carriage bolts.
- Move clutch assembly to correct any misalignment.
- Tighten both  $\frac{5}{16}$ " carriage bolts.

**NOTE: Removing chain idler tension will allow easier clutch alignment adjustments.**

D04199906

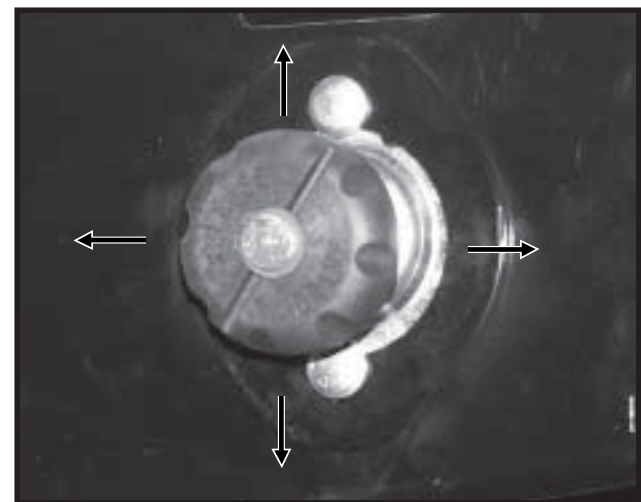

# ROW UNIT OPERATION

## ROW UNIT CHAIN ROUTING

For proper operation and to minimize wear, the row unit drive chains must be properly tensioned and aligned.

Inspect and replace weak, worn or broken springs and/or idlers and idler bushings.

**NOTE: When idler shows signs of wear, it can be reversed for prolonged use.**

D041801102(RU80g)

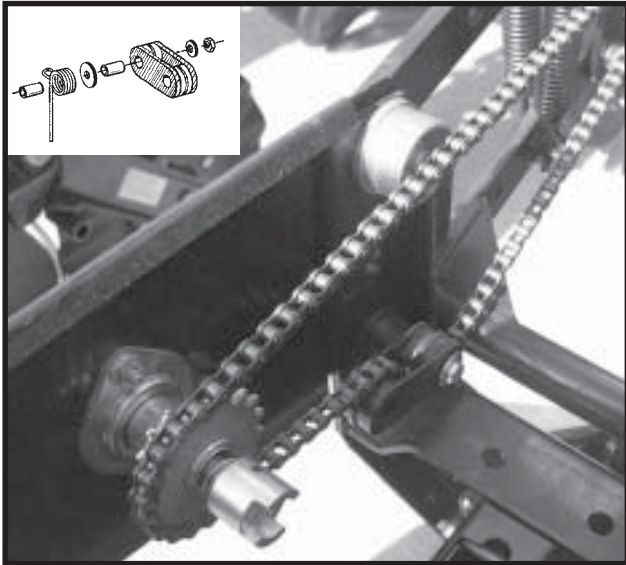

**Pull Row Unit Meter Drive**

D04209901a(RU80g)

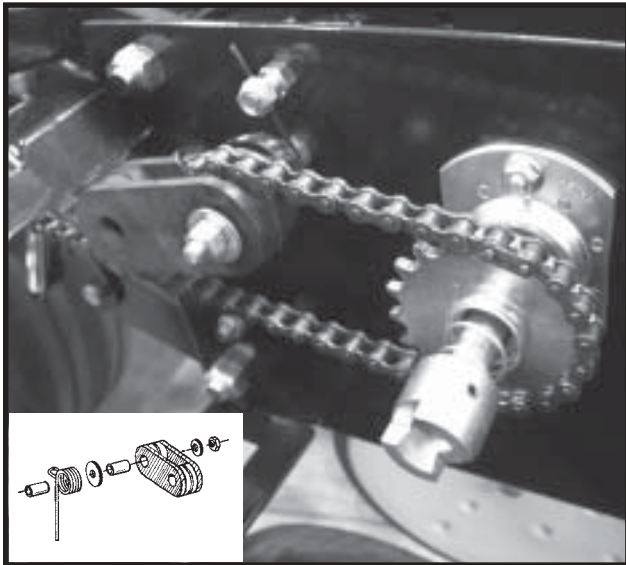

**Push Row Unit Meter Drive**

D05139901b(RU92l)

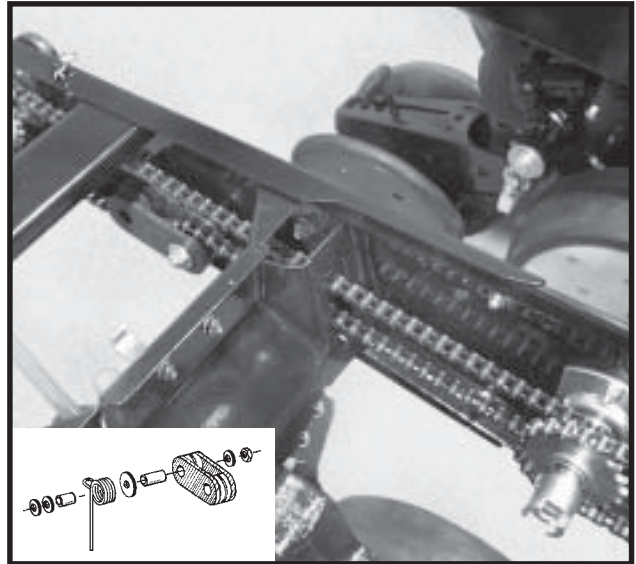

**Row Unit Granular Chemical Drive**

**NOTE: Make sure connector link is installed with closed end oriented properly as shown below.**

(PLTR24)



**Direction Of Chain Travel** →



# ROW UNIT OPERATION

## QUICK ADJUSTABLE DOWN FORCE SPRINGS

Quick adjustable down force springs are designed to increase penetration in hard soil and keep the row unit from bouncing in rough field conditions.

Two springs per row, one on the L.H. parallel arms and one on the R.H. parallel arms, are used unless equipped with row unit mounted no till coulters. Four springs per row are used with row unit mounted no till coulters.

LF212199-3a

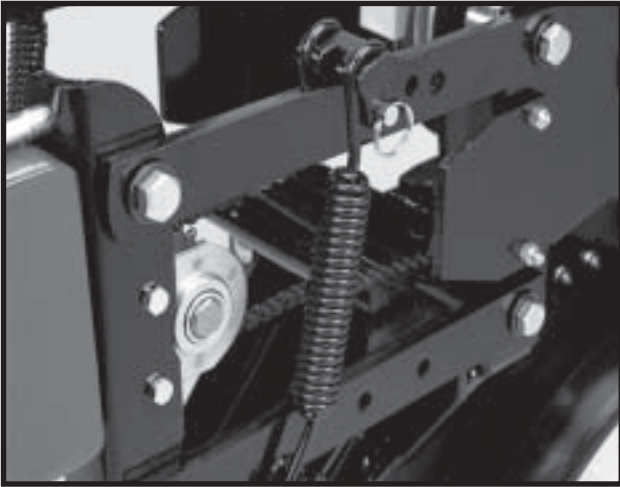

**Two Springs Per Row (Dual)**

LF212199-3

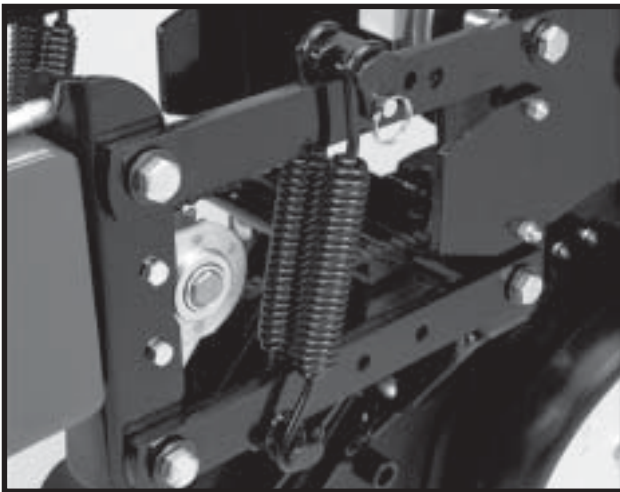

**Four Springs Per Row (Quad)  
(Used Only In Conjunction With Row Unit  
Mounted No Till Coulters)**

There are four positions for spring tension adjustment. Position 1 allows for minimum down pressure and position 4 for maximum down pressure.

L0096(PLTR27e)

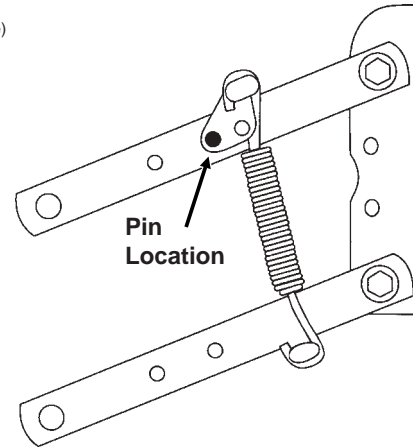

**Position 1 (Minimum)**

(PLTR28e)

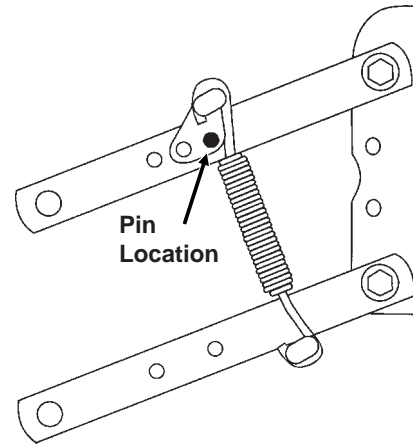

**Position 2**

(PLTR29e)

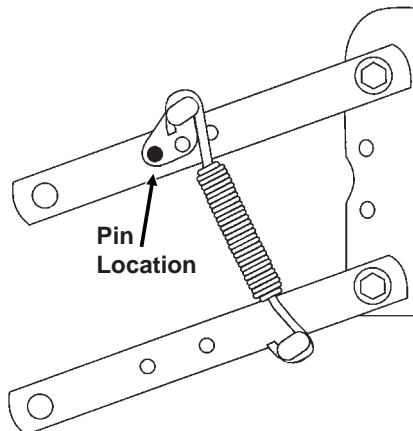

**Position 3**

(Continued On Following Page)

# ROW UNIT OPERATION

---

(PLTR30e)

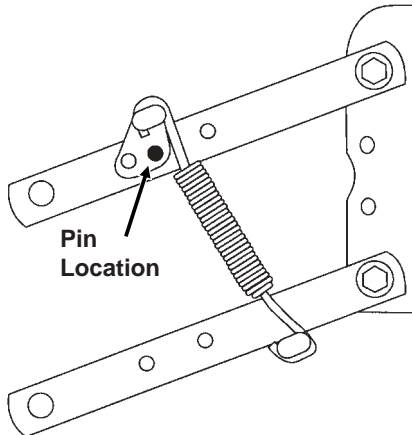

## Position 4 (Maximum)

To adjust spring tension, raise planter and remove spring mount pin at top of spring. Slide mount to desired position and install pin.

**NOTE:** It is necessary for the operator to adjust springs according to field conditions. If springs are adjusted for too much down pressure for field conditions, it is possible for the row units to lift the planter to the extent that the drive wheels do not make sufficient contact. Too much down pressure in soft field conditions can cause the row unit to run too deep.



**WARNING:** Always install safety lockups or lower machine to the ground before working under or around the machine.

**NOTE:** Springs must always be installed with open side of spring hooks toward mini-hoppers to prevent binding on spring mount adjustment pins.

# ROW UNIT OPERATION

## FRAME MOUNTED COULTER - STYLE A

LF212299-20

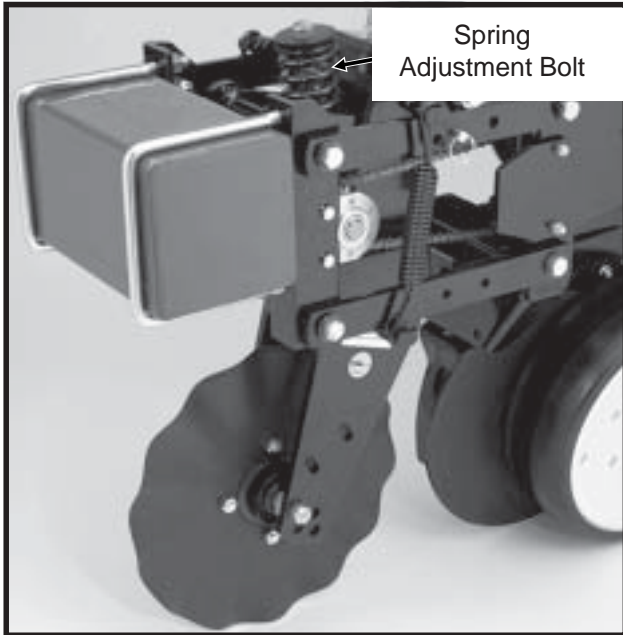

Frame mounted coulters with 1" bubbled, 1" fluted (8 flutes) or 3/4" fluted (13 flutes) blades may be used on pull row units only. (Not compatible with push row units.)

The frame mounted coulter is designed to allow required spring down pressure on the coulter for maximum penetration while exerting less shock load on the row unit.

The frame mounted coulter can be used with or without the depth control bar installed. In most applications, especially in rocky planting conditions, the depth control bar **should not be used**. Use of the depth control bar transfers down force from the coulter to the row unit making less down force available to the coulter blade.

## DEPTH ADJUSTMENT (Without Depth Control Bar Installed)

56314-14a

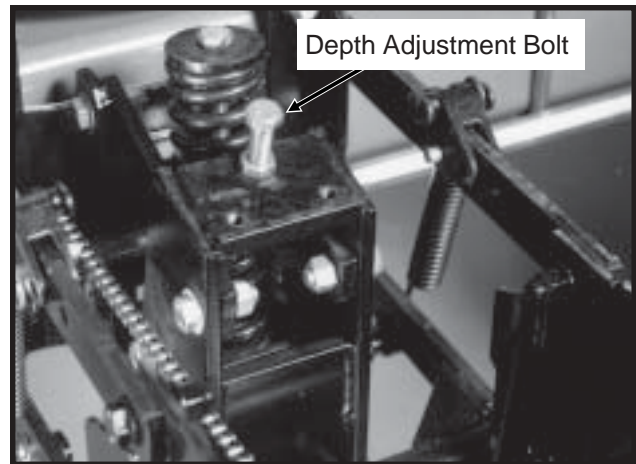

When the depth control bar is not used, operating depth of the coulter blade is determined by adjusting the depth adjustment bolt and positioning of the blade assembly in the fork mount. The depth adjustment bolt will stop downward travel of the coulter arm assembly. One turn of the adjusting bolt will change depth setting approximately 1/4". Initial setting of the depth adjustment bolt should be with approximately 1 3/8" of thread showing. With this setting and the toolbar height at 20", the coulter depth will be approximately 2" with coulter mounting spindle in top hole. Turn the adjustment bolt clockwise to decrease operating depth. Turn the depth adjustment bolt counterclockwise to increase operating depth.

LF212299-20

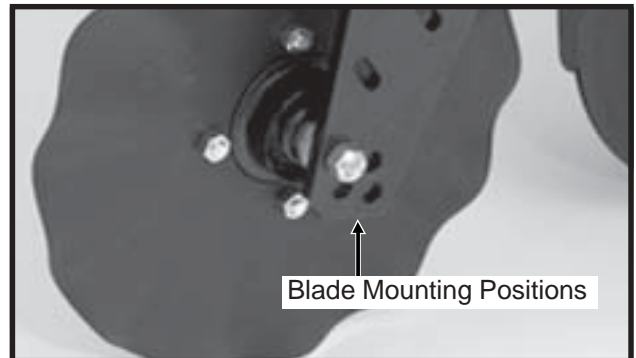

# ROW UNIT OPERATION

## DEPTH ADJUSTMENT

(With Depth Control Bar Installed)

LF212199-4

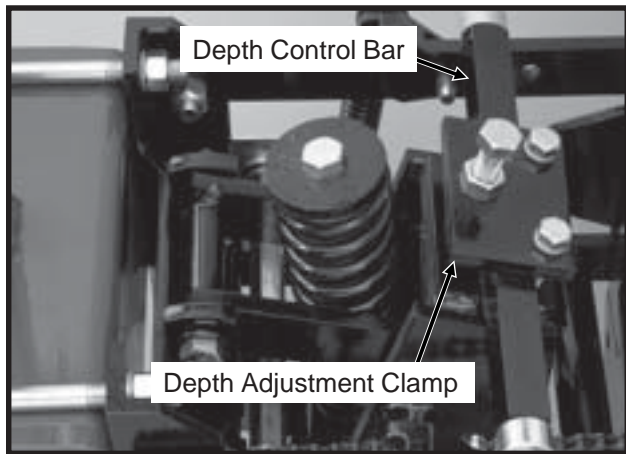

In certain applications it is desirable to use the depth control bar. In uneven terrain, use of the depth control bar allows greater depth control. The up and down movement of the row unit allows the coulter to move up and down at a rate of approximately  $\frac{1}{2}$  that of the row unit, maintaining a more uniform operating depth. When using the disc furrower attachment, the depth control bar should always be used, as operating depth of the coulter is critical for the disc furrowers to operate with minimal gouging.

When using the depth control bar, down force springs must be located in the forward position and the depth adjustment bolt used only to attach the depth adjustment clamp to the coulter assembly. Operating depth of the coulter blade is adjusted by positioning the blade assembly in the fork mount. Four blade mounting adjustment positions are available at  $\frac{1}{2}$ " increments. Initial position of the blade assembly should be in the top hole. This position will locate the coulter blade approximately  $\frac{1}{4}$ " deeper than the row unit opener blade. In heavy residue it may be desirable to position the blade assembly in the second position to insure that the residue is cut and not forced down into the seed zone. Additional holes are used to compensate for coulter blade wear.

LF212299-20

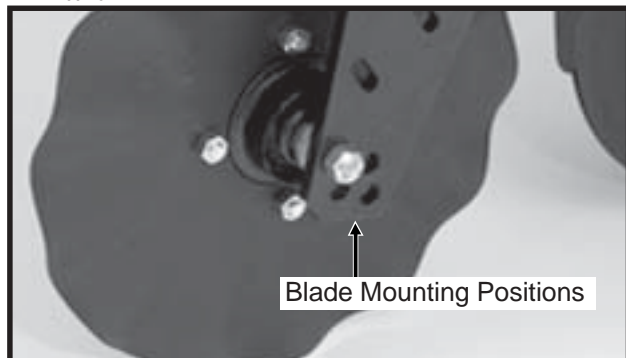

## SPRING ADJUSTMENT

**Down force adjustment is made by** tightening or loosening the spring adjustment bolt. With the planter in the raised position, turn the bolt clockwise to increase down force or counterclockwise to decrease down force. Set all rows equally.

Compressed Spring Length (Including Washer)	Pounds Down Pressure With Blade $\frac{1}{2}$ " Above Maximum Down Position	Pounds Down Pressure With Blade 4" Above Maximum Down Position
13 $\frac{5}{16}$ "	90	230
12 $\frac{5}{16}$ "	190	330
Suggested initial setting.		
11 $\frac{5}{16}$ "	300	430

A5649rev.(PLTR44)

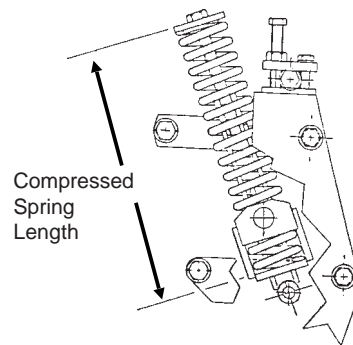

**IMPORTANT: Excessive down force may cause increased wear on components.**

## COULTER BLADE ADJUSTMENT

The coulter blade can be aligned with the row unit disc opener by moving the spacer washers from one side of the coulter blade hub to the other.

56314-12

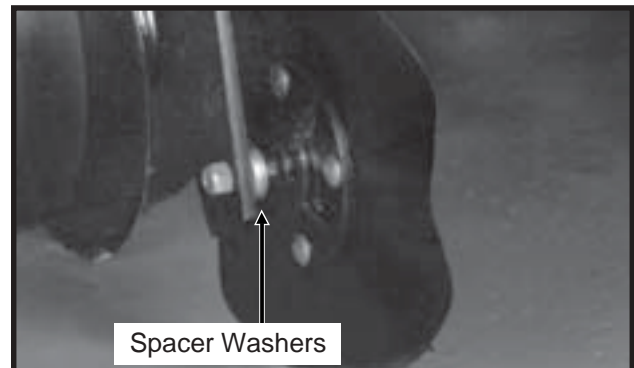

Field adjustment should be made as needed. Operating height of the planter frame will affect operating depth of the frame mounted coulter.

**NOTE: Torque  $\frac{5}{8}$ " spindle bolts to 120 ft. lbs.**

# ROW UNIT OPERATION

## FRAME MOUNTED COULTER - STYLE B

LF083002101

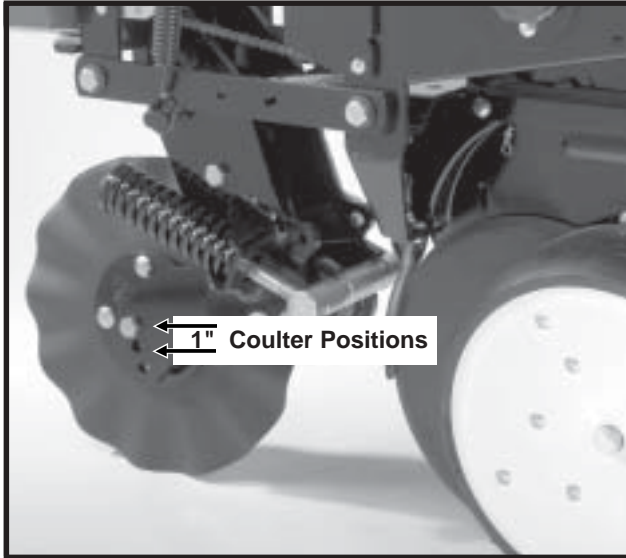

Frame mounted coulters with 1" bubbled, 1" fluted (8 flutes) or 3/4" fluted (13 flutes) blades may be used on pull row units only. (Not compatible with push row units.)

The frame mounted coulters is designed to apply necessary spring down pressure on the coulters for maximum penetration while exerting less shock load on the row unit.

The initial location of the coulters blade is in the top hole. The blade can be relocated to one of the lower two holes (1" increments) as wear occurs or if deeper operation of the blade is desired.

LF083002101

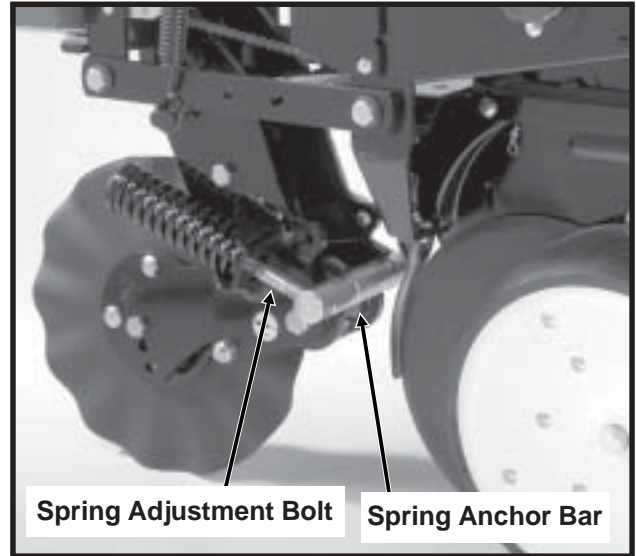

### DOWN PRESSURE ADJUSTMENT

Down force adjustment is made by tightening or loosening the two spring adjustment bolts. With the planter in raised position, turn the bolts clockwise to increase down pressure or counterclockwise to decrease down force. Set both springs the same.

Down force on the blade is shown below in lbs.

End Of Spring Adjustment Bolt Flush With Spring Anchor Bar (Shown Above)	End Of Spring Adjustment Bolt Extended 1/2" Through Spring Anchor Bar	All Threads Used (Maximum)
275 lbs.	400 lbs.	500 lbs.

**NOTE: Avoid setting down pressure higher than is required for consistent soil penetration. Excessive pressure will increase the chances of damage to coulters components when the coulters strikes an obstacle.**

# ROW UNIT OPERATION

## DISC FURROWER

(For Use With Style A Frame Mounted Coulter)

The disc furrower for use with the frame mounted coulter may be equipped with either 12" solid blades or 12" notched blades.

Disc furrowers are used to clear crop residue, dirt clods and dry soil from in front of the row units for a clean and smooth seed bed. Notched blades are used for heavier residue conditions. The notched blades cut crop residue and move it aside to prevent plugging or pushing.

56314-19

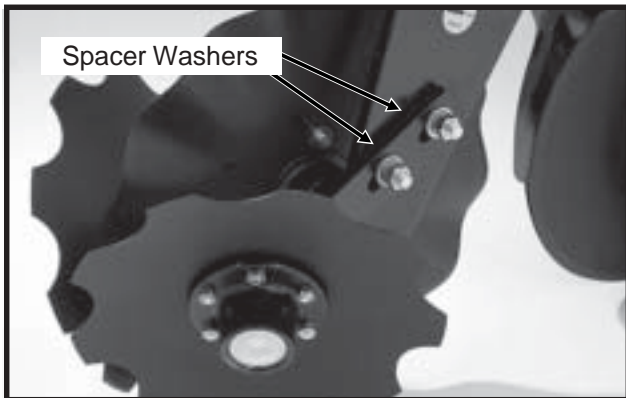

Blades can be adjusted so front edges meet by adding spacer washers between the disc furrower arm and frame mounted coulter fork mount.

Slotted holes in the frame mounted coulter fork mount and in the disc furrower arm allow for vertical and horizontal adjustment. Blades can be adjusted so the front edges meet or one blade can be moved to the rear and the other to the front of the slot so the cutting edge of one blade overlaps the edge of the other blade.

56314-17a

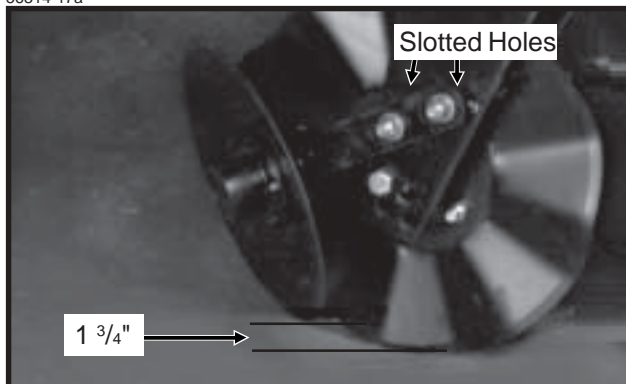

Initial setting for each disc furrower blade is 1 3/4" shallower than the coulter blade. Further adjustment may be desired for various applications.

**NOTE: The depth control bar should always be used when the frame mounted coulter is equipped with disc furrowers.**

## RESIDUE WHEELS

(For Use With Style B Frame Mounted Coulter)

The residue wheels for use with the frame mounted coulter may be used on pull row units only.

LF083002102



The residue wheels are attached to the frame mounted coulter with two cap screws and sleeves allowing the unit to free-float. A 2-position spindle bolt mounting allows the tined wheels to be mounted interlocked or staggered. Depth adjustment is made using a spring-loaded cam and pin with 11 positions in 1/4" increments. A high point on the cam allows the wheels to be locked up so they do not contact the ground. A weed guard, located on the inboard side of each wheel, aids in the prevention of weed wrap which can cause premature bearing failure.

(RU135d)

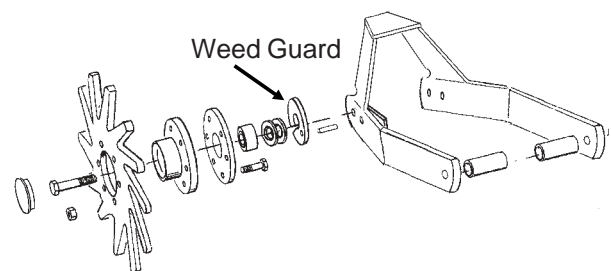

**NOTE: Opening in weed guard must point down.**

# ROW UNIT OPERATION

## ROW UNIT MOUNTED DISC FURROWER

The row unit mounted disc furrower is for use on pull row units only (not compatible with Interplant® push row units). The disc furrower may be equipped with either 12" solid blades or 12" notched blades.

Disc furrowers are used to clear crop residue, dirt clods and dry soil from in front of the row units for a clean and smooth seed bed. Notched blades are used for heavier residue conditions. The notched blades cut crop residue and move it aside to prevent plugging or pushing.

LF212299-22

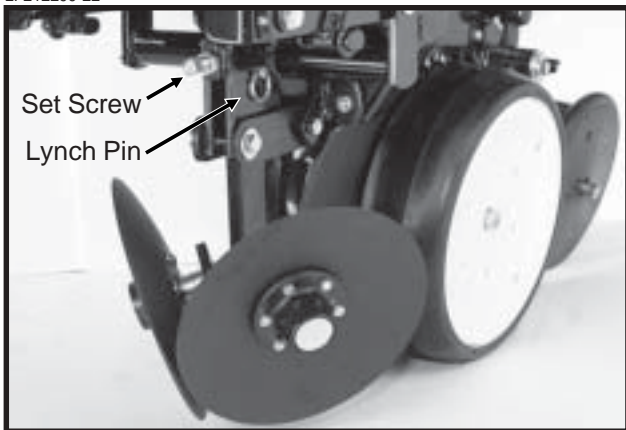

Vertical adjustment in  $\frac{1}{3}$ " increments is possible by removing the lynch pin which secures the vertical support arm and moving the support arm up or down as required. Re-install lynch pin. Finer adjustment can be attained by removing the lynch pin and using the  $\frac{5}{8}$ " x  $2 \frac{1}{4}$ " set screw to clamp the support arm in the required position.

(RU98e)

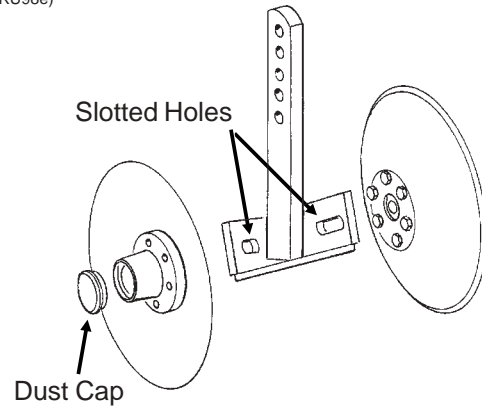

Slotted holes in the support arm where the blades are mounted allow fore and aft adjustment of the disc blades. Blades can be adjusted so the front edges meet or one blade can be moved to the rear and the other to the front of the slot so the cutting edge of one blade overlaps the edge of the other blade. The dust cap must be removed to make these adjustments.

# ROW UNIT OPERATION

## ROW UNIT MOUNTED RESIDUE WHEEL

The row unit mounted residue wheel may be used on pull row units and push row units.

D101701113

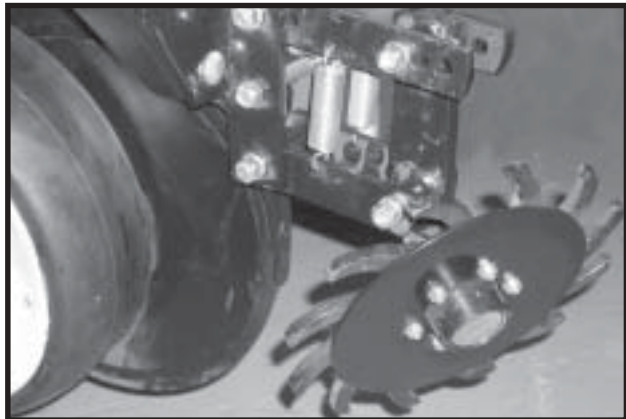

Two adjustable springs on the parallel links on each residue wheel allow for down force adjustment. Position 1 as shown at right provides minimum down pressure and position 3 maximum down pressure.

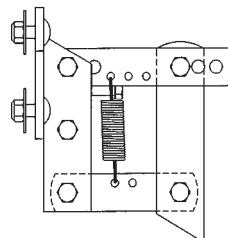

**Position 1** (*Minimum*)(PLTR31a)

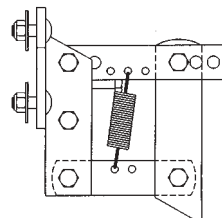

**Position 2** (PLTR32a)

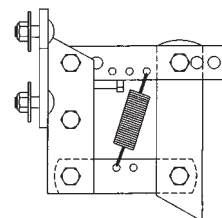

**Position 3** (*Maximum*)(PLTR33a)

For additional uplift or float, position springs as shown below.

(PLTR34a)

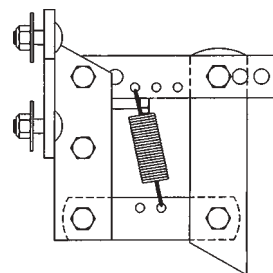

To adjust down force springs, raise the row unit out of the ground and reposition springs as shown for the desired down pressure.



# ROW UNIT OPERATION

D101701112

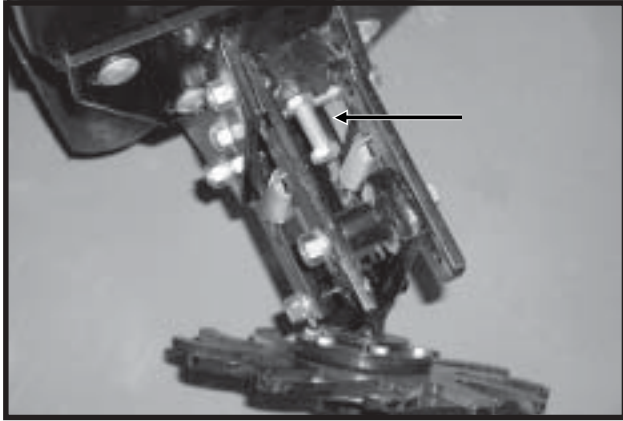

A full threaded bolt and jam nut located on the upper link allows maximum depth to be set for loose soil conditions. Initial setting should be 1 3/4" above the depth of the row unit double disc opener.

Three holes in the upper link allow for wheel angle adjustment. With the wheel mount in the most vertical position, using the rear hole in the upper link, the residue wheel is most aggressive. Moving the wheel mount to one of the forward holes reduces the aggressiveness of the wheel for use in mulch till applications where the soil is loose.

D101701202

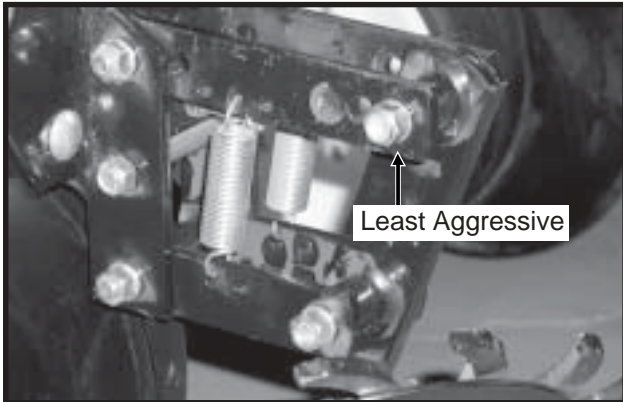

To lock the residue wheel up out of the ground, remove the 1/2" x 5" lockup bolt, raise the residue wheel and install bolt.

D011701203

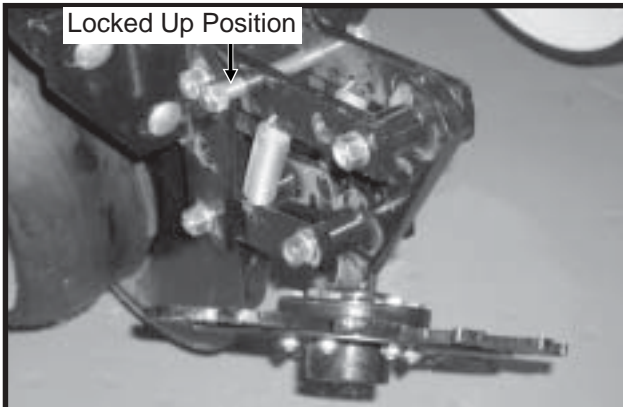

## ROW UNIT MOUNTED NO TILL COULTER

LF212299-19a

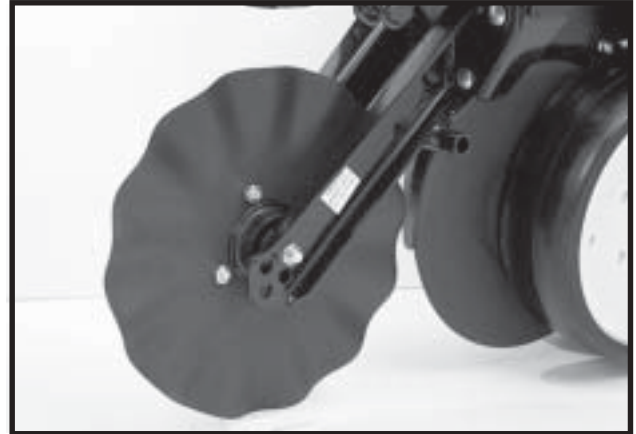

Row unit mounted no till coulters with 1" bubbled, 1" fluted (8 flutes) or 3/4" fluted (13 flutes) blades may be used on pull row units and push row units. (3/4" fluted shown)

Four quick adjustable down force springs are required per row when using row unit mounted no till coulters. See "Quick Adjustable Down Force Springs".

For proper operation, the coulters blade should be aligned in relation to the row unit double disc openers. The coulters assembly can be adjusted by loosening the four attaching bolts, moving coulters arm to align and tightening the four attaching bolts.

The coulters blade can be adjusted to one of four 1/2" incremental settings in the forked arm. Initial location of the coulters is in the top hole. As the coulters blade wears, the blade should be adjusted downward to one of the three lower settings to maintain the coulters blade at or slightly below the opener discs. In very hard soil conditions such as compacted wheel tracks, opener penetration and cutting of surface residue may be improved by adjusting the coulters to operate below the depth of the double disc opener blades.

Operating depth can be checked by setting the planter down on a level concrete floor and checking the relationship between the coulters blade and row unit opener blade. Make sure the planter is level and coulters is square with the planter frame and aligned with the row unit disc opener.

**NOTE: Torque 5/8" spindle bolts to 120 ft. lbs.**

# ROW UNIT OPERATION

## COULTER MOUNTED RESIDUE WHEELS

LF212299-23



Coulters mounted residue wheels are designed for use on pull row units and push row units.

The coulters mounted residue wheels are attached to the row unit mounted no till coulters with one cap screw and sleeve allowing the unit to free-float. A 2-position spindle bolt mounting allows the tined wheels to be mounted interlocked or staggered. Depth adjustment is made using a spring-loaded cam and pin with 11 positions in  $\frac{1}{4}$ " increments. A high point on the cam allows the wheels to be locked up so they do not contact the ground. A weed guard, located on the inboard side of each wheel, aids in the prevention of weed wrap which can cause premature bearing failure.

(RU104n)

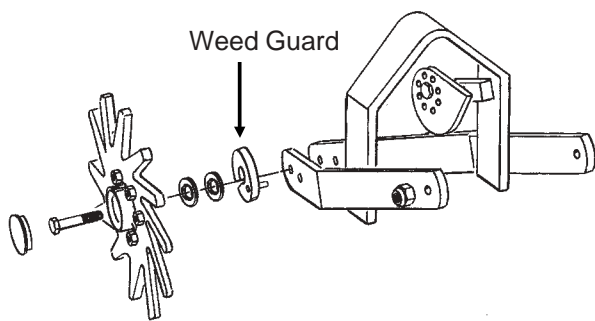

**NOTE:** Opening in weed guard must point down.

## GRANULAR CHEMICAL HOPPER AND DRIVE

LF212299-6



The granular chemical hopper has a 1.4 cubic feet capacity.

Be sure no foreign objects get into the hopper when it is being filled. Replace the hopper lids after filling the hoppers to prevent the accumulation of dirt and moisture.

The metering gate located on the bottom of the hopper regulates the application rate. See "Dry Insecticide And Dry Herbicide Application Rate Charts" in this manual. Calibrate using the chemical manufacturers' instructions.



**WARNING:** Agricultural chemicals can be dangerous. Improper selection or use can seriously injure persons, animals, plants, soil or other property. **BE SAFE:** Select the right chemical for the job. Handle it with care. Follow the instructions on the container label.

The granular chemical clutch drive coupler and meter shaft can be disengaged and engaged by turning the throwout knob located at the rear of the hopper support panel. To engage the drive, turn the knob  $\frac{1}{4}$  turn clockwise. To disengage the drive, turn the knob  $\frac{1}{4}$  turn counterclockwise. Slotted holes in the hopper support panel and clutch housing allow for alignment adjustment between the clutch drive coupler and meter shaft.

LF212299-4

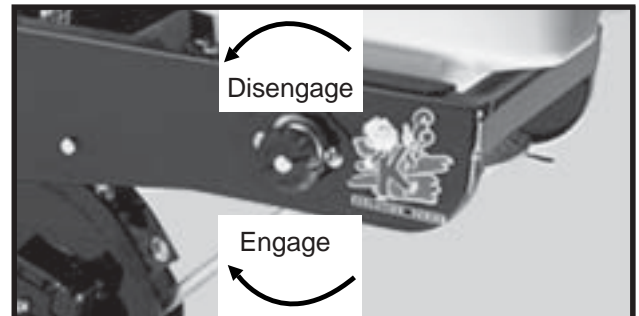

# ROW UNIT OPERATION

---

## GRANULAR CHEMICAL BANDING OPTIONS

Granular chemical banding options allow 4 1/2" slope-compensating banding or straight drop in-furrow placement.

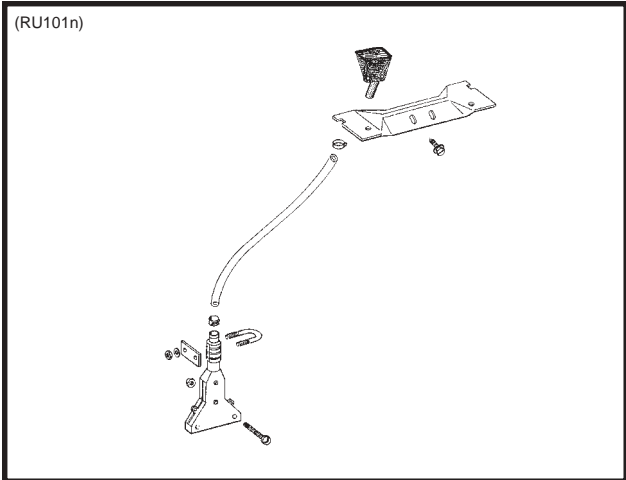

**4 1/2" Slope-Compensating Bander**

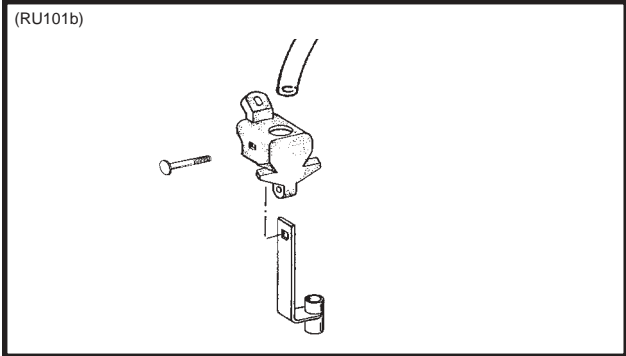

**Straight Drop In-Furrow Placement**

# ROW UNIT OPERATION

## INTERPLANT® PUSH ROW UNIT LOCK-UPS

Push row unit lockups are designed to allow the push row units to be locked in the raised position.



**WARNING:** Always install all safety lock-ups or lower planter to the ground before working under or around the machine.

D06099904



**Push Row Unit Locked In Raised Position**

D06099906

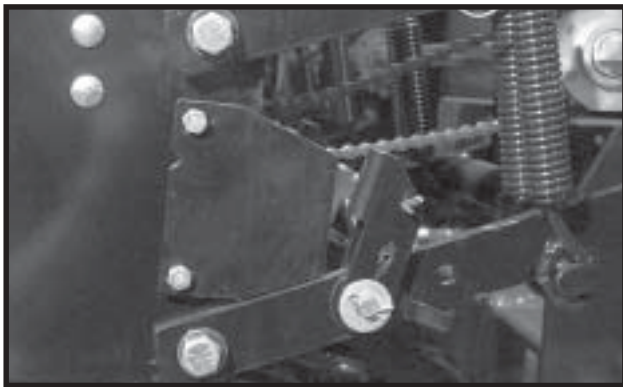

**Lockup Released For Field Operation**

D051502103



**Lift Lever Positioned To Lift Push Row Unit**

### To lock in raised position:

1. Set row unit down pressure springs to minimum setting.
2. Lower the planter to the planting position.
3. On each push row unit lockup, flip the spring tab forward.

D060499108

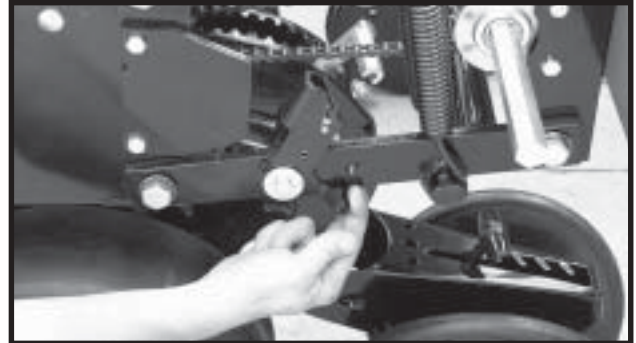

4. Using the lift lever, raise the push row unit to allow the spring loaded lockups to snap into locked position under the row unit stops.
5. Repeat Steps 3 and 4 on remaining push row units.

### To release lockups:

1. Lower the planter to the planting position.
2. On each push row unit lockup, flip the spring tab rearward.

D060499107

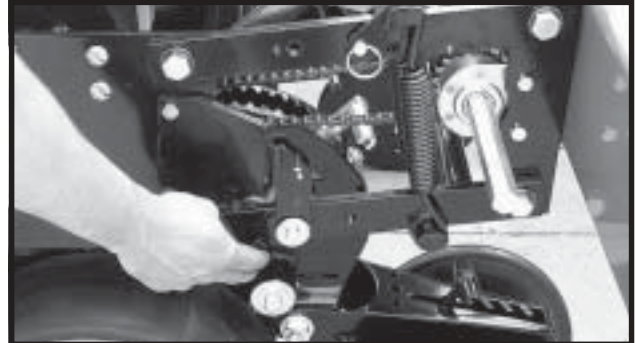

3. Using the lift lever, raise the push row unit to allow the spring loaded lockups to snap out of locked position. Lower row unit to the ground.
4. Repeat Step 3 on remaining push row units.

D021102204

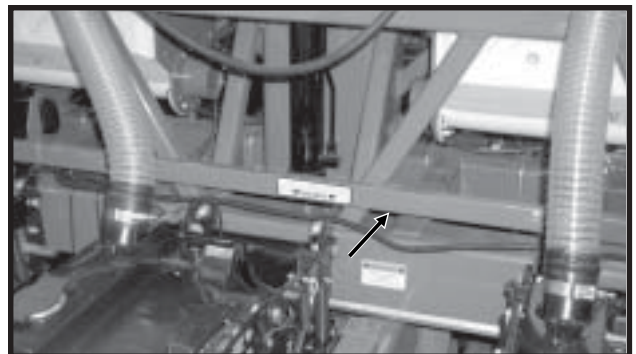

**Lift Lever In Storage Location**

# ROW UNIT OPERATION

---

## INTERPLANT® PUSH ROW UNIT CLUTCH SPROCKETS

D032901171

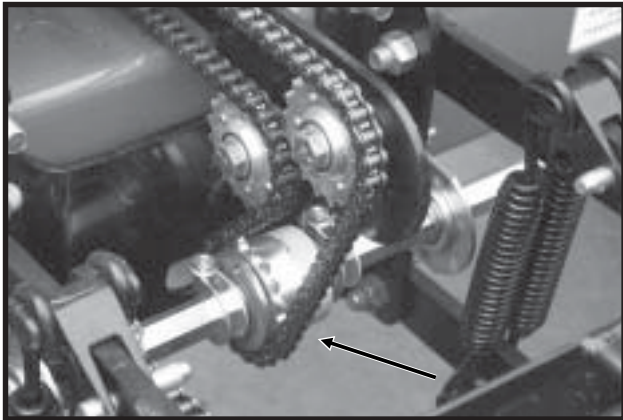

The push row unit clutch sprockets are designed to allow the push row unit drill shafts to be disengaged when only the pull row units are being used.

To disengage the push row unit drill shaft using the clutch sprocket, rotate the knurled collar on the clutch sprocket  $\frac{1}{4}$  turn. Then using a  $\frac{7}{8}$ " wrench on the drill shaft, rock the drill shaft slightly to take pressure off of the spring loaded pins in the clutch to allow the pins to "pop" out, disengaging the drive. To engage the drive, rotate the knurled collar  $\frac{1}{4}$  turn and turn the drill shaft with a  $\frac{7}{8}$ " wrench until the drive pins engage the drive sprocket.



**WARNING: Always install all safety lock-ups or lower planter to the ground before working under or around the machine.**

# ROW UNIT OPERATION

---

# LUBRICATION

The following pages show the locations of all lubrication points. Proper lubrication of all moving parts will help ensure efficient operation of your KINZE® planter and prolong the life of friction producing parts.



**WARNING: Always install safety lockups or lower to the ground before working under the machine.**

## LUBRICATION SYMBOLS

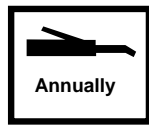
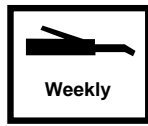

Lubricate at frequency indicated with an SAE multipurpose type grease.



Lubricate at frequency indicated with a high quality SAE 10 weight oil or a quality spray lubricant.

## SEALED BEARINGS

LF212199-3

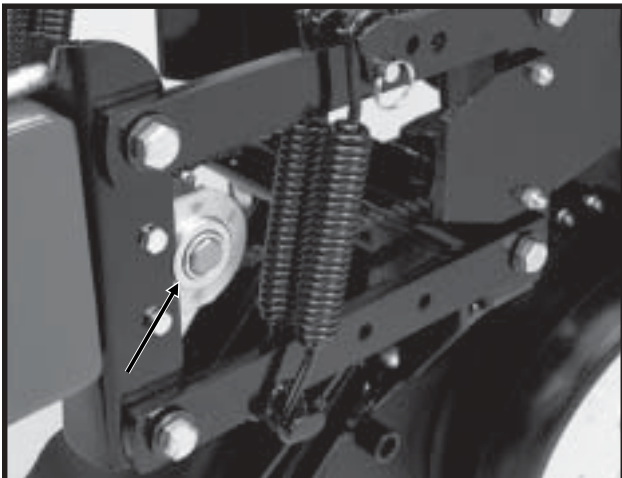

A number of sealed bearings are used on your KINZE® planter to provide trouble free operation. These are located in such areas as the drive shaft, row units and transmission bearings. Sealed bearings are lubricated for life. Due to the seals, relubrication is not practical.

## DRIVE CHAINS

All transmission and drive chains should be lubricated daily with a high quality chain lubricant. Extreme operating conditions such as dirt, temperature or speed may require more frequent lubrication. If a chain becomes stiff, it should be removed, soaked and washed in solvent to loosen and remove dirt from the joints. Then soak the chain in oil so the lubricant can penetrate between the rollers and bushings.

D041801102

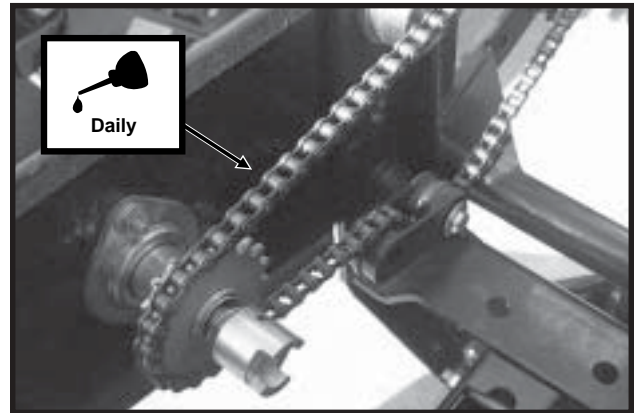

**Pull Row Unit Drive Chains**

D05139901b

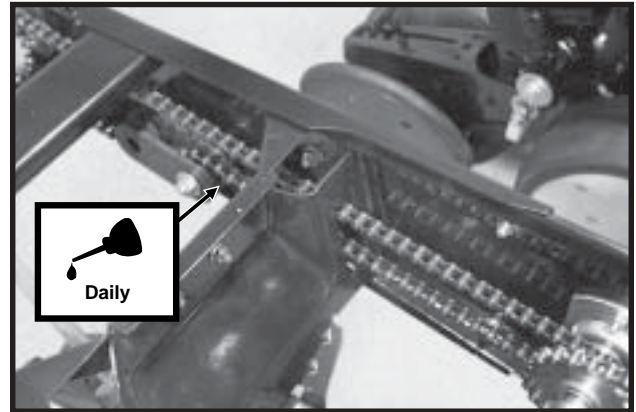

**Row Unit Granular Chemical Drive Chains**

D04209901a

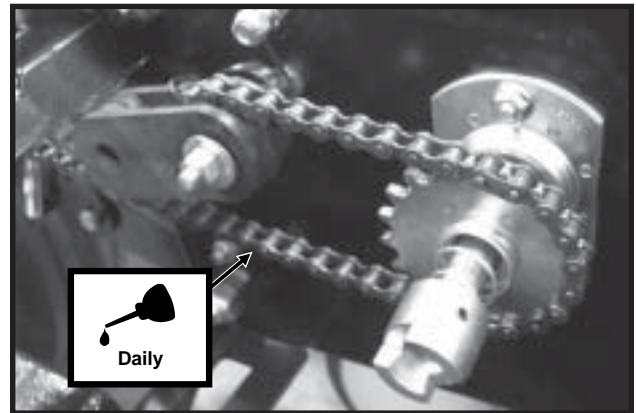

**Push Row Unit Drive Chains**

# LUBRICATION

D032901153(PLTR52a)

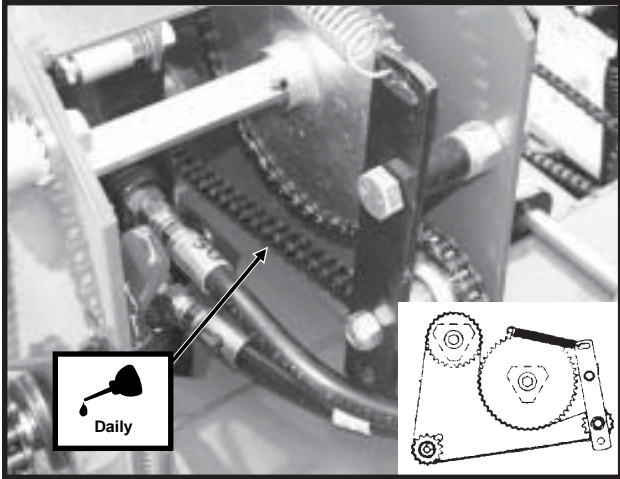

**Inner Wheel Module Drive Chains**

D032901150

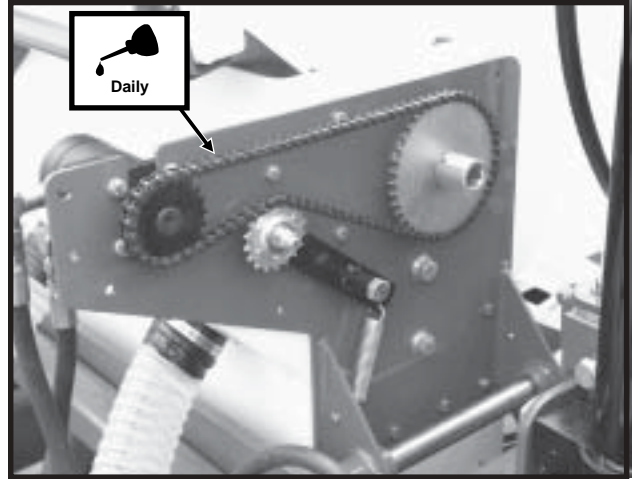

**Bulk Fill System Hydraulic Motor Chains**  
(Shown With Cover Removed - NOTE: Slot in rear of cover allows chain to be oiled without removing cover.)

D021102206

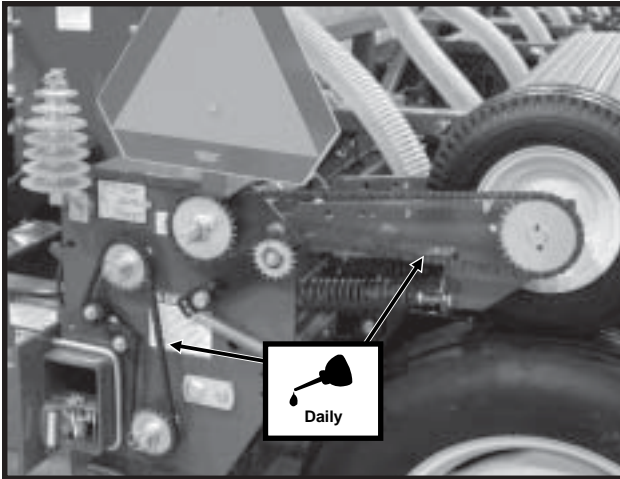

**Contact Wheel Drive Chains**  
**Planter Transmission Drive Chains**

D013003108

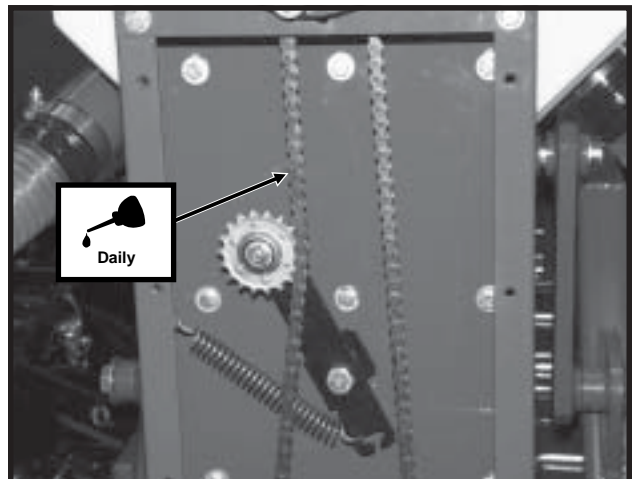

**Bulk Fill System Gearbox Chains**  
(Shown With Center Cover Removed - NOTE: Chain can be oiled through top mesh cover without removing cover.)

D032901148

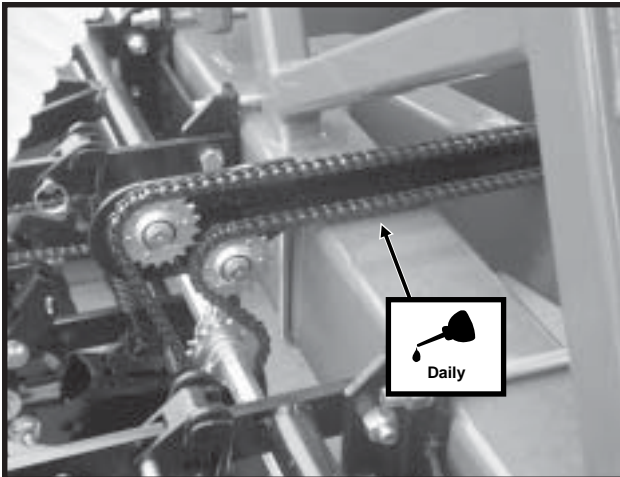

**Interplant® Drive Chains**

D030502110

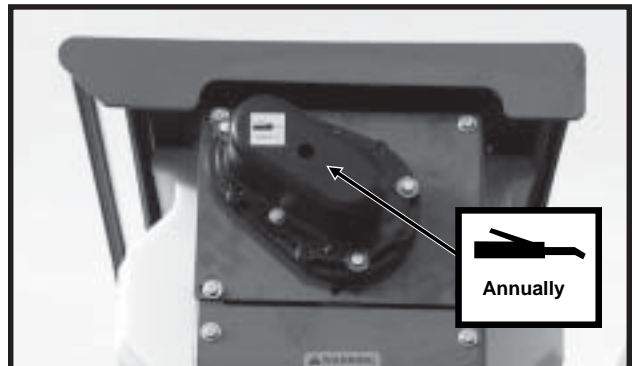

**Gearbox Drive Chains (5-10 Pumps For Each Gearbox)**



# LUBRICATION

## BUSHINGS

Lubricate bushings at the frequency indicated.

Using a torque wrench, check each bolt for proper torque. If bolt is loose, it should be removed and the bushing inspected for cracks and wear. Replace bushing if necessary **Only hardened flat washers should be used. Replace damaged flat washers with proper part. Torque bolts to 130 ft. lbs.**

LF212299-22

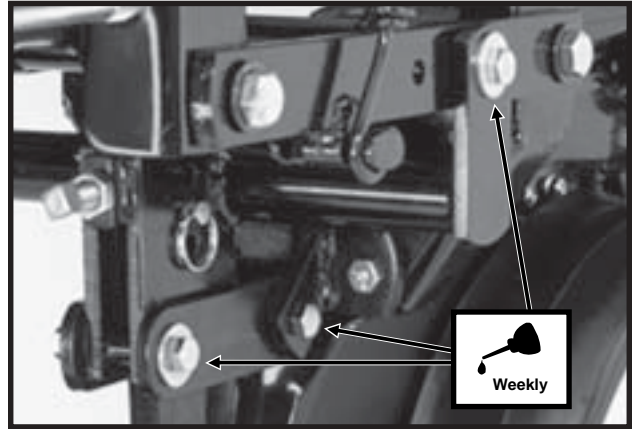

Row Unit Mounted Disc Furrower Parallel Linkage (6 Per Row)

LF212199-3

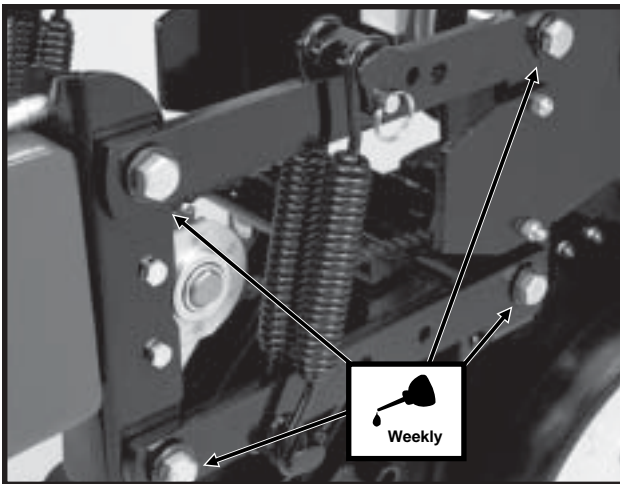

Pull Row Unit And/Or Push Row Unit Parallel Linkage (8 Per Row)

LF212199-2

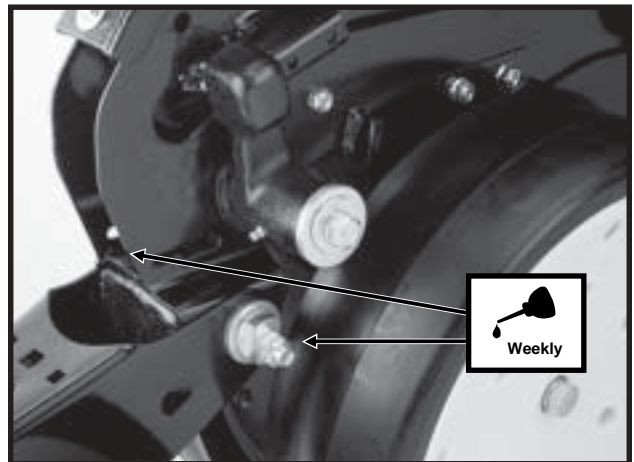

Row Unit "V" Closing Wheel Eccentric Bushings (2 Per Row)

D061899-1

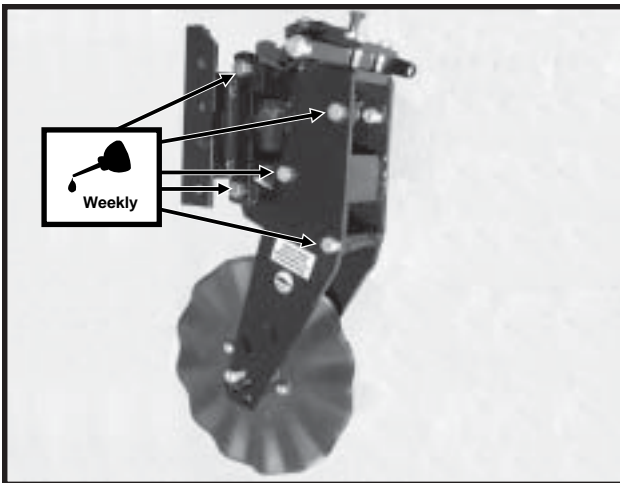

Frame Mounted Coulter Parallel Linkage - STYLE A (10 Per Row)

*Shown not installed on row unit for visual clarity.*

# LUBRICATION

D032901126

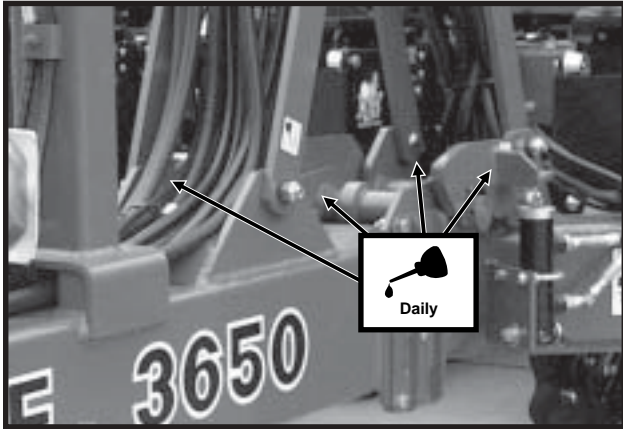

Hose Take-Up (6 Locations)

**IMPORTANT: CENTER POST AND POLY WEAR PADS REQUIRE NO LUBRICATION. ANY OIL OR GREASE WILL ATTRACT DIRT AND ACCELERATE WEAR ON THE CENTER POST AND ON THE POLY WEAR PADS.**

D032901120

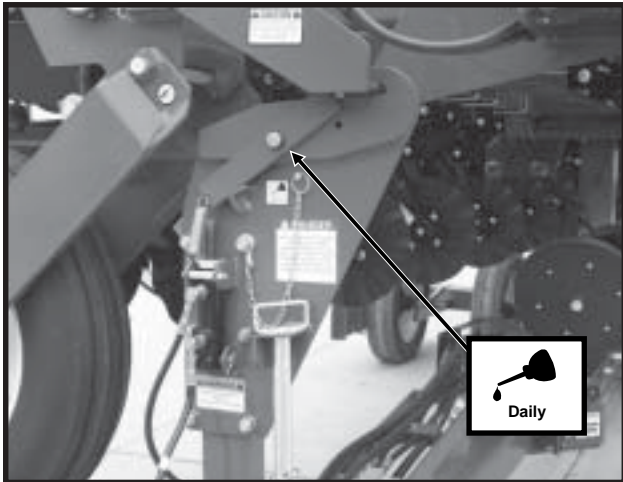

Transport Latch (1 Location)

D021102206

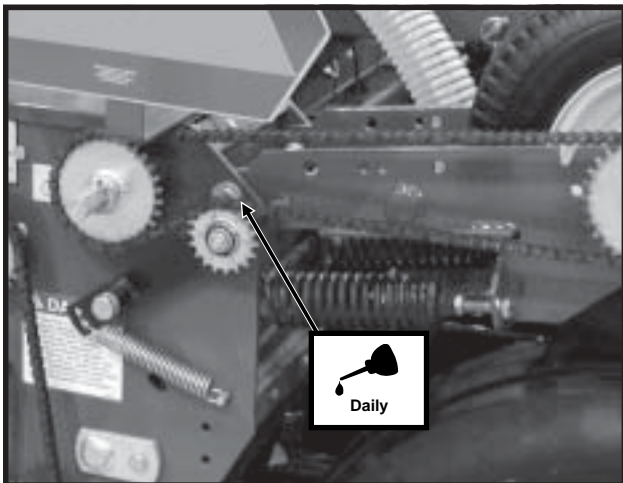

Contact Drive Wheel Arm (2 Per Wheel Assembly)

# LUBRICATION

## INTERPLANT® PUSH ROW UNIT LOCKUPS

D06099906

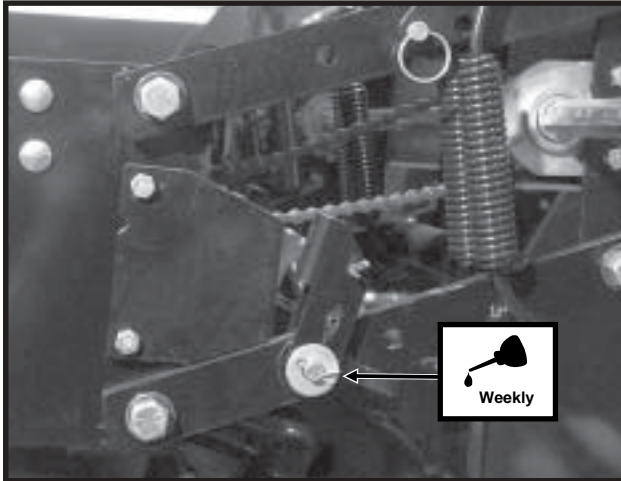

2 Per Row

## CENTER POST

D032901117

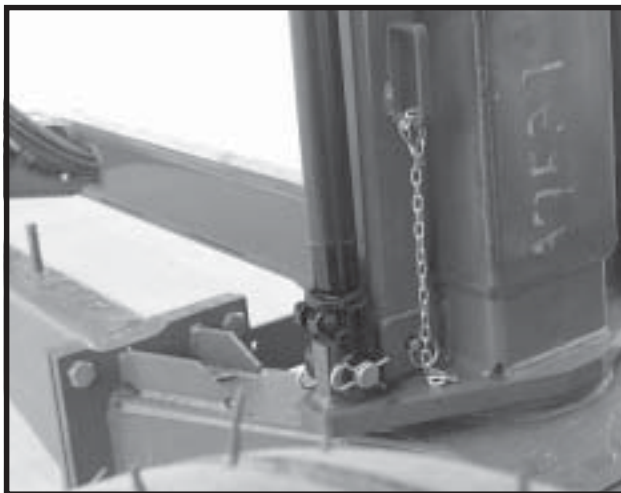

The center post is clad with stainless steel. To prolong service life keep stainless steel surface clean and free of any lubrication.

**IMPORTANT: CENTER POST AND POLY WEAR PADS REQUIRE NO LUBRICATION. ANY OIL OR GREASE WILL ATTRACT DIRT AND ACCELERATE WEAR ON THE CENTER POST AND ON THE POLY WEAR PADS.**

See "Wear Pad Replacement/Adjustment" for additional information.

## U-JOINT SLIDES

Lubricate all U-joint slides daily with a high quality SAE 10 weight oil or a quality spray lubricant.

D040301107

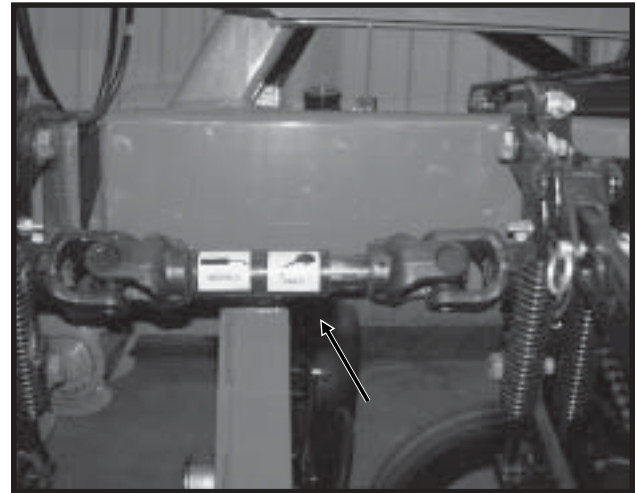

## WHEEL BEARINGS

The transport wheel hubs are equipped with grease fittings. Pump grease into the hub until grease comes out around the seals. See "Grease Fittings" for lubrication frequency.

All wheel bearings should be repacked annually and checked for wear. This applies to all drive wheels, transport wheels and marker hubs.

To check for wear, lift the wheel off the ground. Check for endplay in the bearings by moving the tire in and out. Rotate the tire to check for roughness in the bearings. If bearings sound rough, the hub should be removed and the bearings inspected and replaced if necessary. See "Wheel Bearing Lubrication Or Replacement".

To repack wheel hubs, follow the procedure outlined for wheel bearing replacement with the exception that bearings and bearing cups are reused.

# LUBRICATION

## POINT ROW CLUTCH

D032901166

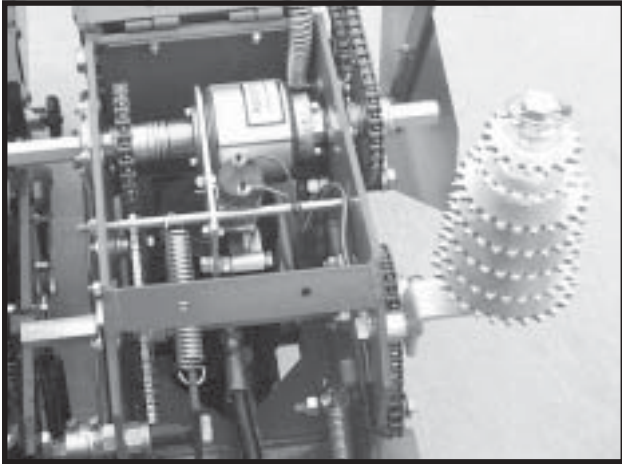

The point row clutches are permanently lubricated and sealed and require no periodic maintenance. **DO NOT LUBRICATE. KEEP CLUTCHES CLEAN.**

## LIQUID FERTILIZER PISTON PUMP CRANKCASE OIL LEVEL

12229799

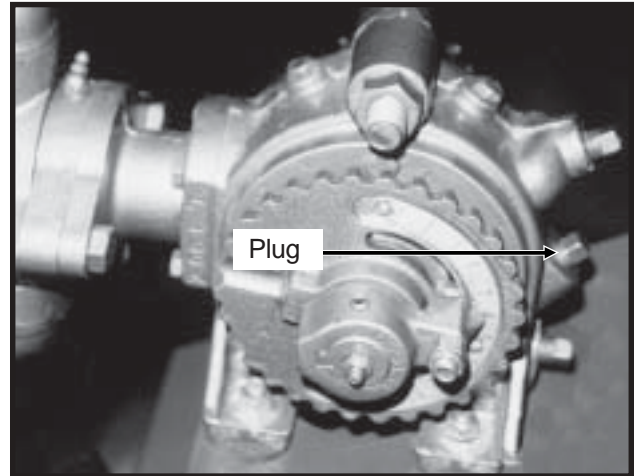

Check crankcase oil daily and maintain at plug level. Fill as needed with EP 90 weight gear oil. Total oil capacity is approximately  $\frac{3}{4}$  pint.

Refer to operator and instruction manual supplied with the pump and flow divider for additional information.

## GREASE FITTINGS

Those parts equipped with grease fittings should be lubricated at the frequency indicated with an SAE multipurpose type grease. Be sure to clean the fitting thoroughly before using grease gun. The frequency of lubrication recommended is based on normal operating conditions. Severe or unusual conditions may require more frequent attention.



**WARNING:** Always install safety lockups or lower to the ground before working under or around the machine.

**NOTE:** Numbers on photo below correspond to photos on following pages showing lubrication frequencies.

D021102248a

12 Row 30" With Interplant® Package And Even-Row Push Row Unit Package Shown

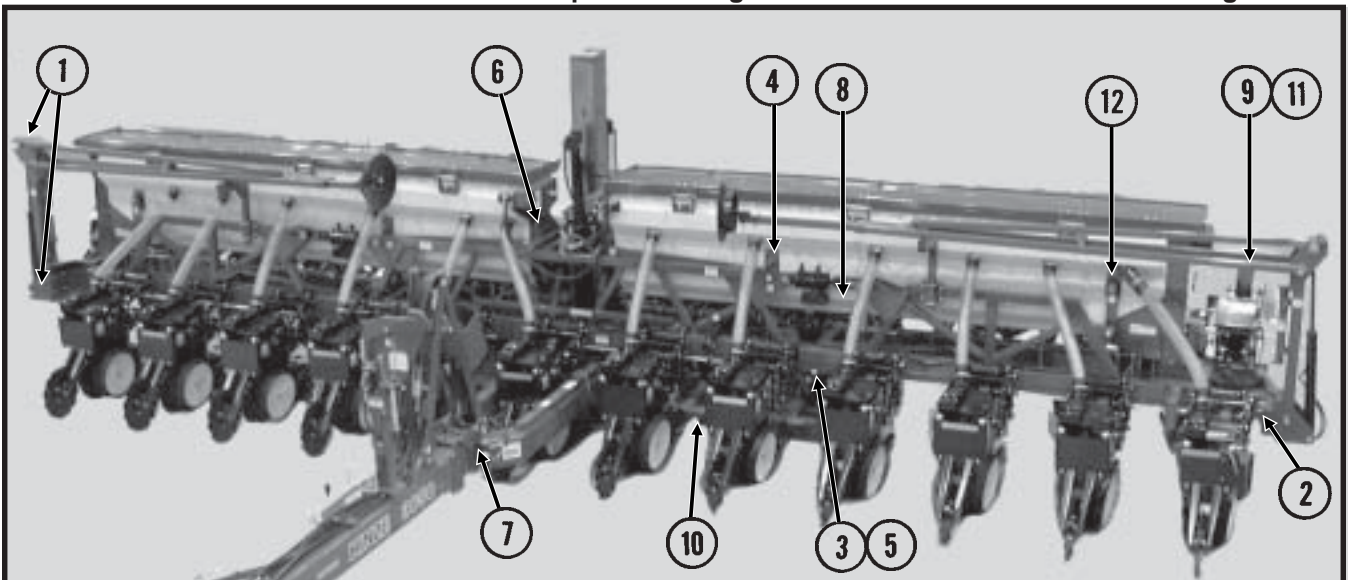

# LUBRICATION

D021102245b

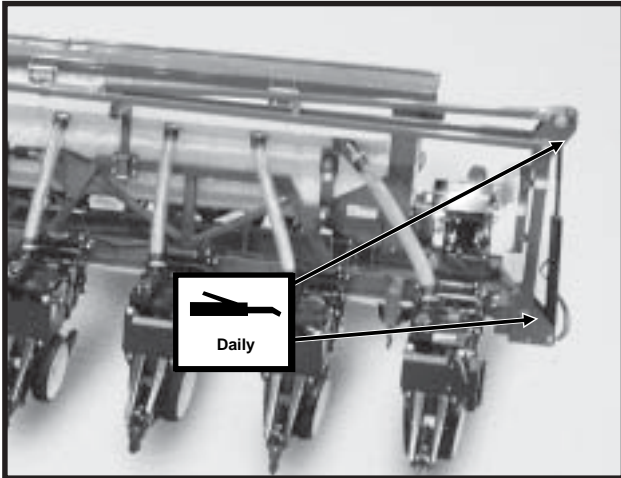

1. Marker Assemblies - 4 Zerks Per Assembly On 12 Row 30". 2 Zerks Per Assembly On 16 Row 30".

D032901181

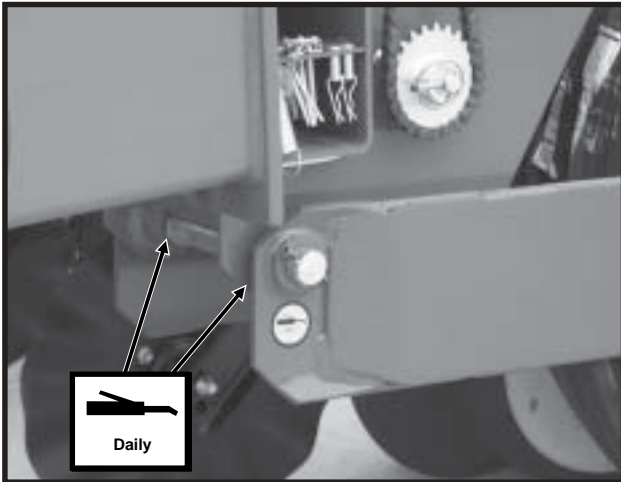

2. Wing Wheel Pivot - 2 Zerks Per Wheel Module

D030502105

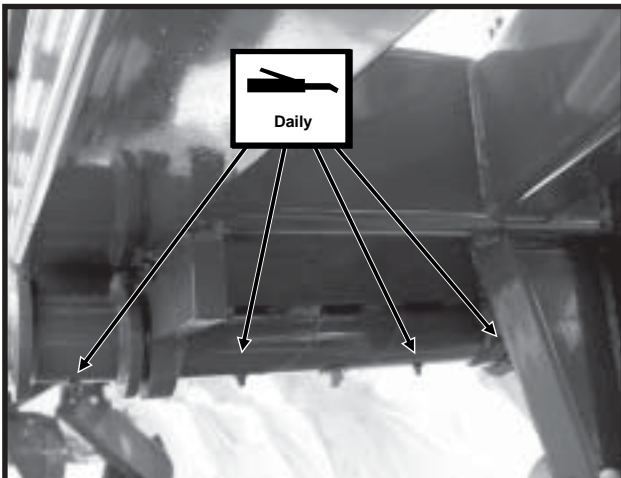

3. Wing Hinges - 4 Zerks Per Wing

D021102215

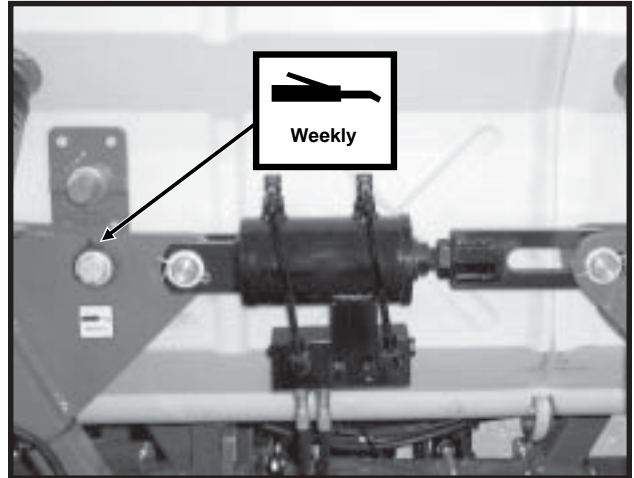

4. Link Pivot - 2 Zerks Per Wing

D030502101

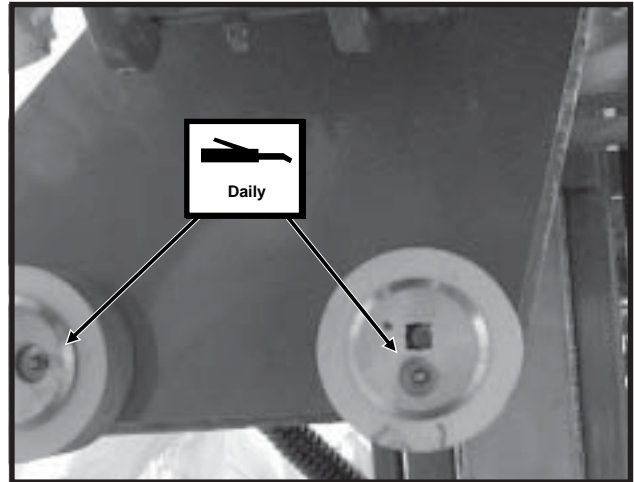

5. Cam Follower - 1 Zerk Per Follower

D121802120

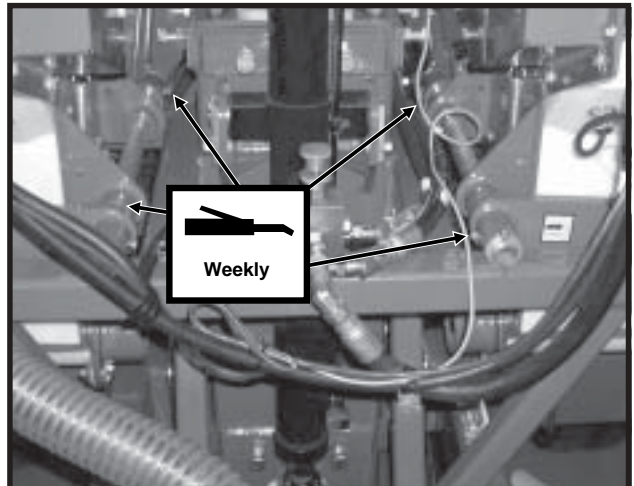

6. Inside Bulk Seed Hopper Pivot - 2 Zerks Per Pivot

# LUBRICATION

D040301105

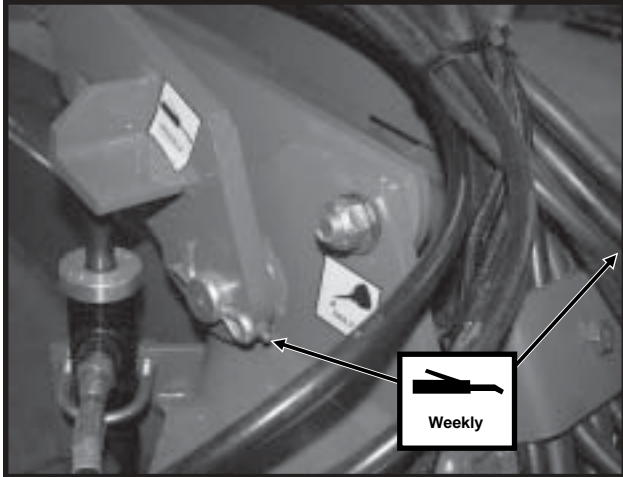

7. Tongue Hook - 2 Zerks

D040301107

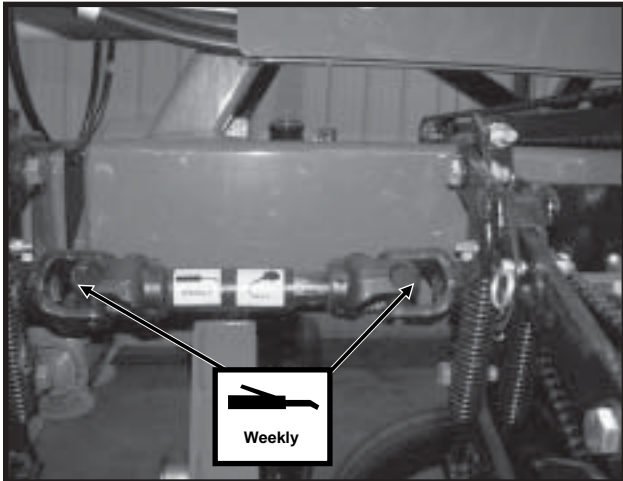

8. U-Joints - 2 Zerks Per Hinge Area

D04200001

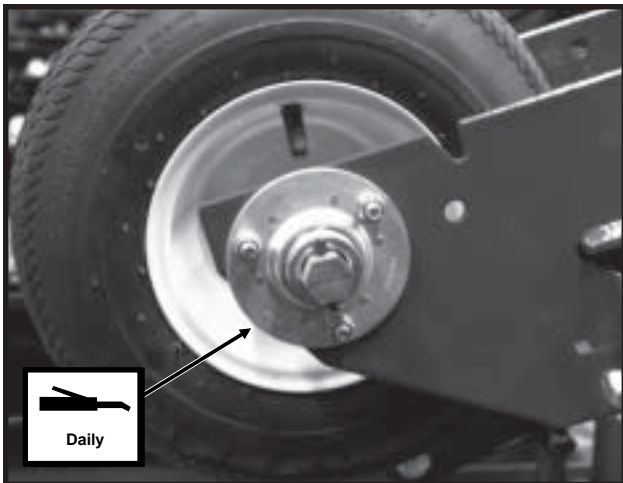

9. (If Applicable) Contact Wheel Arm Bearing - 2 Zerks Per Arm Assembly (**Rotate tire while filling with grease.**)

D040301106

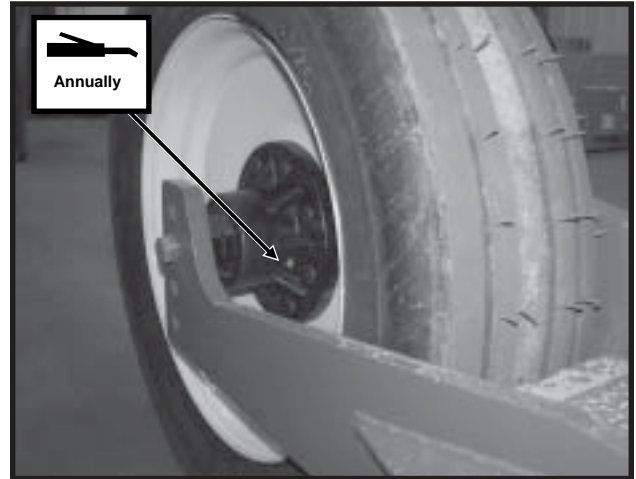

10. Transport Wheel Bearings - 1 Zerk Per Hub

05199819a

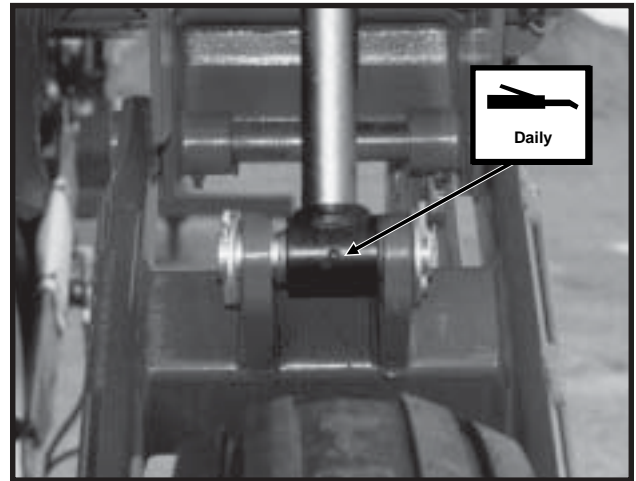

11. Wing Lift Cylinders - 1 Zerk Per Cylinder

D030502107

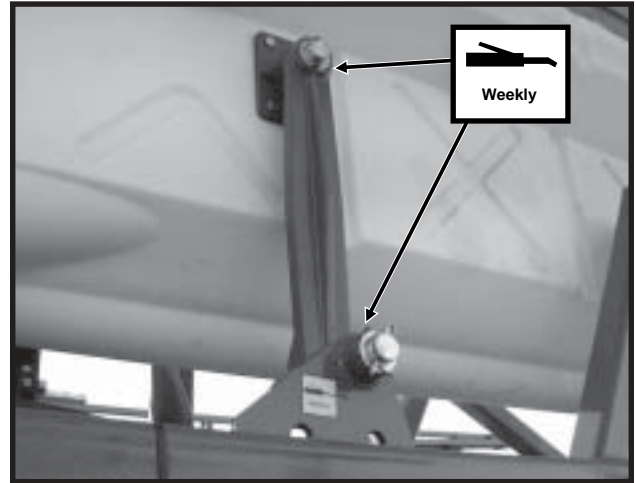

12. Outside Bulk Seed Hopper Link - 2 Zerks Per Link

# LUBRICATION

## Row Unit

LF212199-2

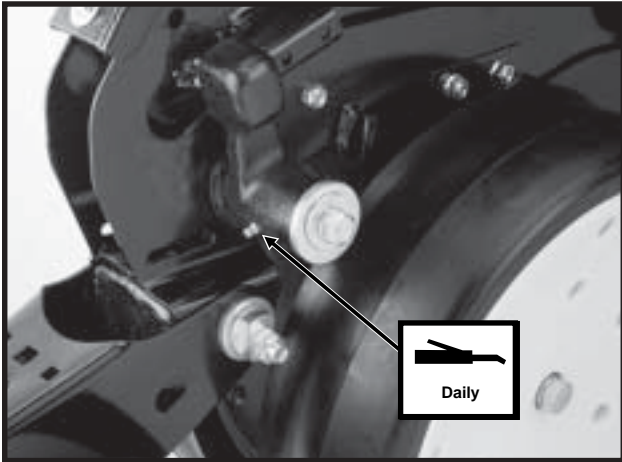

Gauge Wheel Arms - 1 Zerk Per Arm  
**(Seals in gauge wheel arm are installed with lip facing out to allow grease to purge dirt away from seal. Pump grease into arm until fresh grease appears between washers and arm.)**

LF212299-19

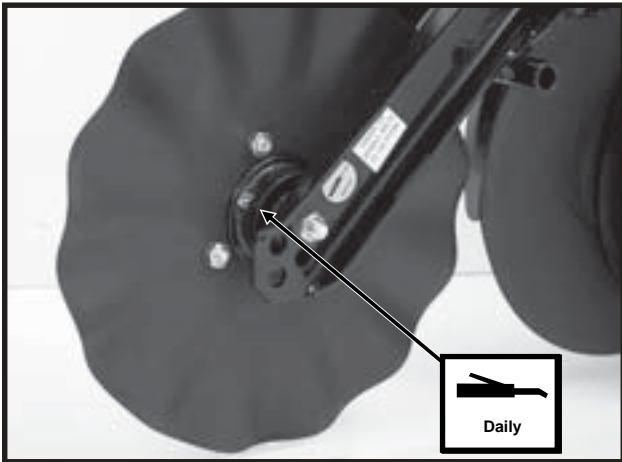

(If Applicable) Row Unit Mounted No Till Coupler Hubs - 1 Zerk Per Hub  
**(Pump grease into hub until grease comes out around the seals. Spin hub while filling with grease.)**

56673-6

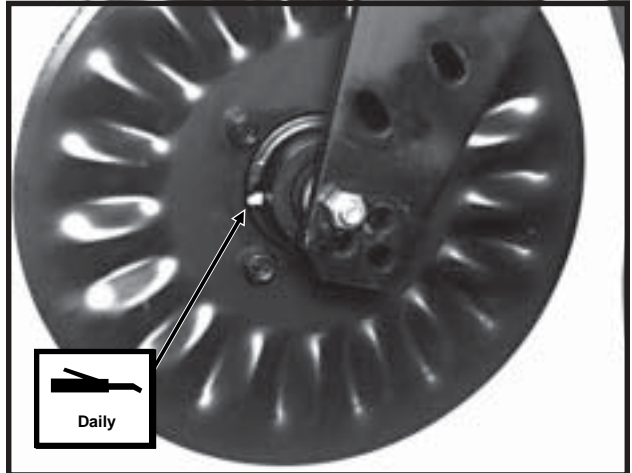

(If Applicable) Frame Mounted Coupler Hubs - STYLE A - 1 Zerk Per Hub  
**(Pump grease into hub until grease comes out around the seals. Spin hub while filling with grease.)**

LF083002101

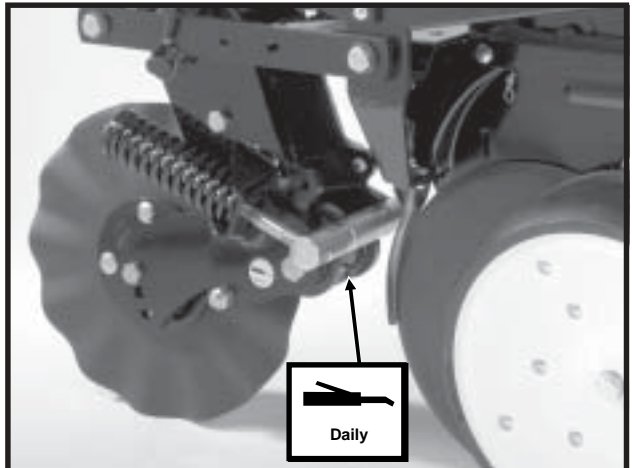

(If Applicable) Frame Mounted Coupler - STYLE B - 1 Zerk Per Arm

# LUBRICATION

## Fertilizer Openers

D060801304

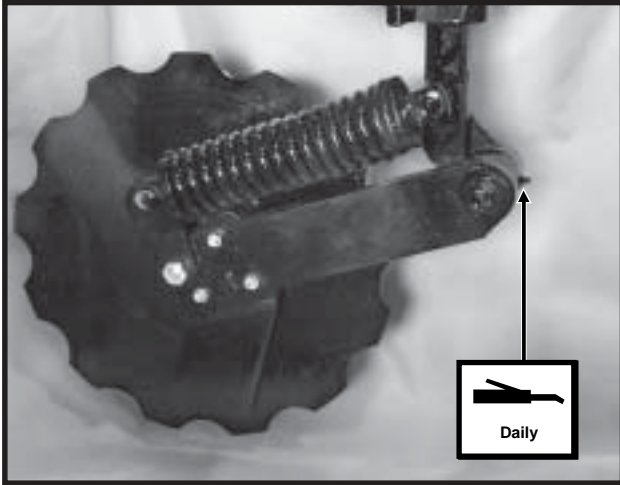

Notched Single Disc Fertilizer Opener - 1 Zerk

D052201104

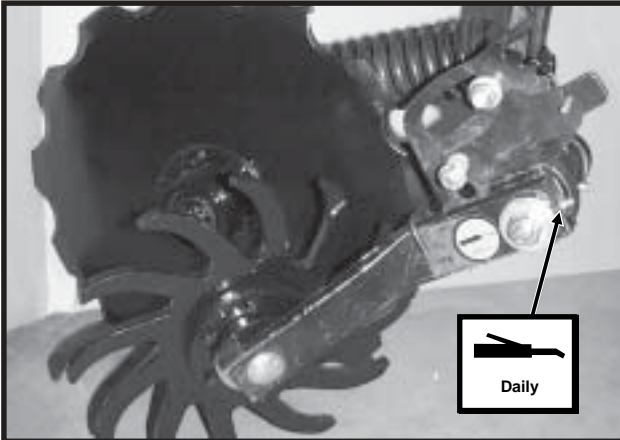

(If Applicable) Residue Wheel Attachment For Use With Notched Single Disc Fertilizer Opener - 1 Zerk

D06259919

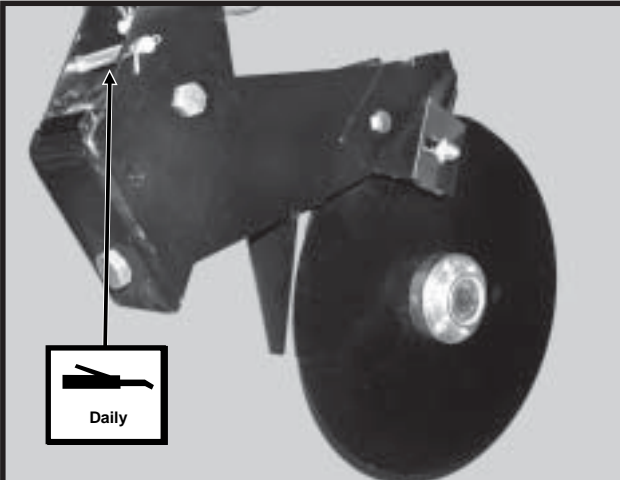

Double Disc Fertilizer Opener - 1 Zerk

D060801304

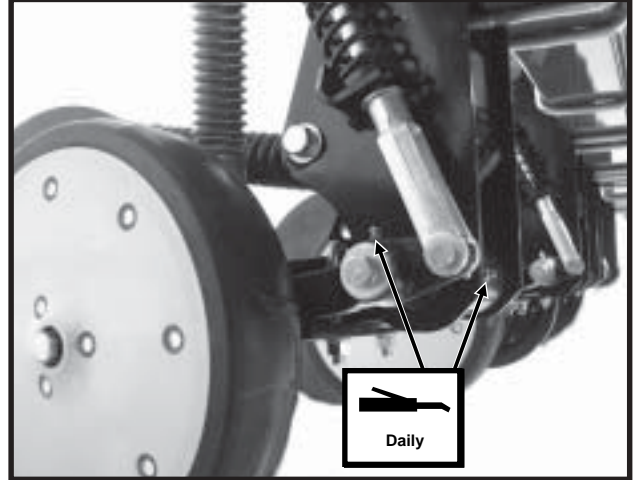

HD Single Disc Fertilizer Opener - 2 Zerks  
(Located On Wheel Arm And Opener Mount)

D060801303

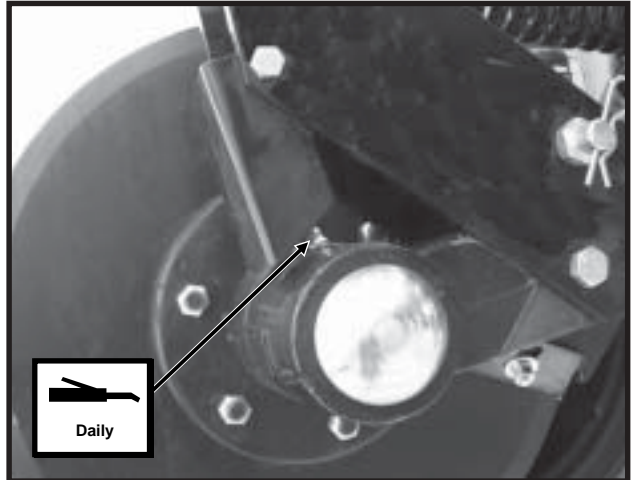

HD Single Disc Fertilizer Opener - 1 Zerk  
(Located On Disc Opener Spindle Hub)

## Liquid Fertilizer Attachment

12229799

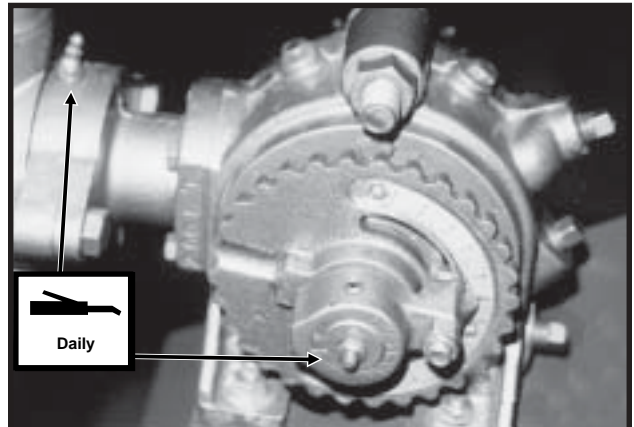

Piston Pump - 2 Zerks (Fill zerk on outboard stuffing box until lubricant seeps out of drain hole in bottom.)



# MAINTENANCE

## MOUNTING BOLTS AND HARDWARE

Before operating the planter for the first time, check to be sure all hardware is tight. Check all hardware again after approximately the first 50 hours of operation and at the beginning of each planting season thereafter.

All hardware used on the KINZE® planter are Grade 5 (high strength) unless otherwise noted. Cap screws are marked with three radial lines on the head. If hardware must be replaced, be sure to replace it with hardware of equal size, strength and thread type. Refer to the torque values chart when tightening hardware.

**Row unit parallel linkage bushing bolts - 130 Ft. Lbs. (See "Bushings" in the Lubrication Section of this manual.)**

**IMPORTANT:** Over tightening hardware can cause as much damage as under tightening. Tightening hardware beyond the recommended range can reduce its shock load capacity.



**WARNING:** Before operating the planter for the first time and periodically thereafter, check to be sure the lug nuts on the transport wheels are tight. This is especially important if the planter is to be transported for a long distance.

**Center Section Transport Tire Lug Nuts - 125 Ft. Lbs.  
Wing Ground Drive Tire Lug Bolts - 90 Ft. Lbs.  
5/8" No Till Coultter Spindle Bolts - 120 Ft. Lbs.**

### TORQUE VALUES CHART - PLATED HARDWARE

Bolt Diameter	Grade 2		Grade 5		Grade 8	
	Coarse	Fine	Coarse	Fine	Coarse	Fine
1/4"	50 In. Lbs.	56 In. Lbs.	76 In. Lbs.	87 In. Lbs.	9 Ft. Lbs.	10 Ft. Lbs.
5/16"	8 Ft. Lbs.	9 Ft. Lbs.	13 Ft. Lbs.	14 Ft. Lbs.	18 Ft. Lbs.	20 Ft. Lbs.
3/8"	15 Ft. Lbs.	17 Ft. Lbs.	23 Ft. Lbs.	26 Ft. Lbs.	33 Ft. Lbs.	37 Ft. Lbs.
7/16"	25 Ft. Lbs.	27 Ft. Lbs.	37 Ft. Lbs.	41 Ft. Lbs.	52 Ft. Lbs.	58 Ft. Lbs.
1/2"	35 Ft. Lbs.	40 Ft. Lbs.	57 Ft. Lbs.	64 Ft. Lbs.	80 Ft. Lbs.	90 Ft. Lbs.
9/16"	50 Ft. Lbs.	60 Ft. Lbs.	80 Ft. Lbs.	90 Ft. Lbs.	115 Ft. Lbs.	130 Ft. Lbs.
5/8"	70 Ft. Lbs.	80 Ft. Lbs.	110 Ft. Lbs.	125 Ft. Lbs.	160 Ft. Lbs.	180 Ft. Lbs.
3/4"	130 Ft. Lbs.	145 Ft. Lbs.	200 Ft. Lbs.	220 Ft. Lbs.	280 Ft. Lbs.	315 Ft. Lbs.
7/8"	125 Ft. Lbs.	140 Ft. Lbs.	320 Ft. Lbs.	350 Ft. Lbs.	450 Ft. Lbs.	500 Ft. Lbs.
1"	190 Ft. Lbs.	205 Ft. Lbs.	480 Ft. Lbs.	530 Ft. Lbs.	675 Ft. Lbs.	750 Ft. Lbs.
1 1/8"	265 Ft. Lbs.	300 Ft. Lbs.	600 Ft. Lbs.	670 Ft. Lbs.	960 Ft. Lbs.	1075 Ft. Lbs.
1 1/4"	375 Ft. Lbs.	415 Ft. Lbs.	840 Ft. Lbs.	930 Ft. Lbs.	1360 Ft. Lbs.	1500 Ft. Lbs.
1 3/8"	490 Ft. Lbs.	560 Ft. Lbs.	1100 Ft. Lbs.	1250 Ft. Lbs.	1780 Ft. Lbs.	2030 Ft. Lbs.
1 1/2"	650 Ft. Lbs.	730 Ft. Lbs.	1450 Ft. Lbs.	1650 Ft. Lbs.	2307 Ft. Lbs.	2670 Ft. Lbs.

**NOTE:** Unplated hardware and bolts with lock nuts should be torqued approximately 1/3 higher than the above values. Bolts lubricated prior to installation should be torqued to 70% of value shown in chart.



**GRADE 2**  
No Marks



**GRADE 5**  
3 Marks



**GRADE 8**  
6 Marks

## CHAIN TENSION ADJUSTMENT

The drive chains have spring loaded idlers and therefore are self-adjusting. The only adjustment needed is to shorten the chain if wear stretches the chain and reduces spring tension. The pivot point of these idlers should be checked periodically to ensure they rotate freely.

Additional chain links can be found in the storage box located inside the planter frame.

(MT18a)

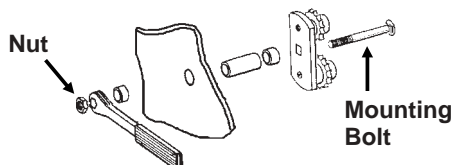

D021102206

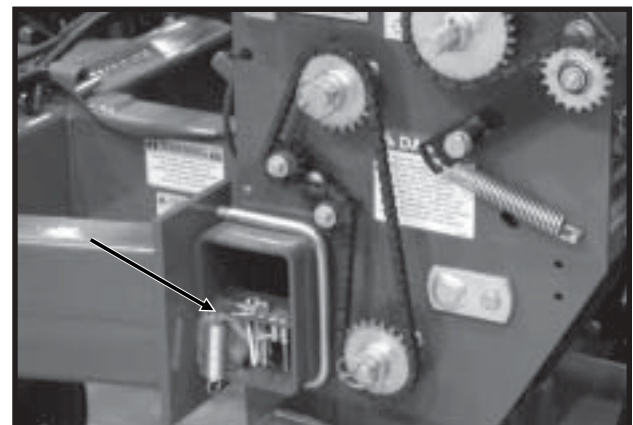

**NOTE:** The nut on the mounting bolt (on applicable idler assemblies) must be kept tight or chain tension will not be maintained and adjustment wrench will not function properly.

# MAINTENANCE

## FINGER PICKUP SEED METER INSPECTION/ADJUSTMENT

To inspect or service the finger pickup seed meter, remove the meter from the mini-hopper by removing the two thumbscrews which secure the mechanism to the hopper. Remove the baffle from the meter assembly by removing three cap screws. This will permit access to the finger pickup.

D052102103

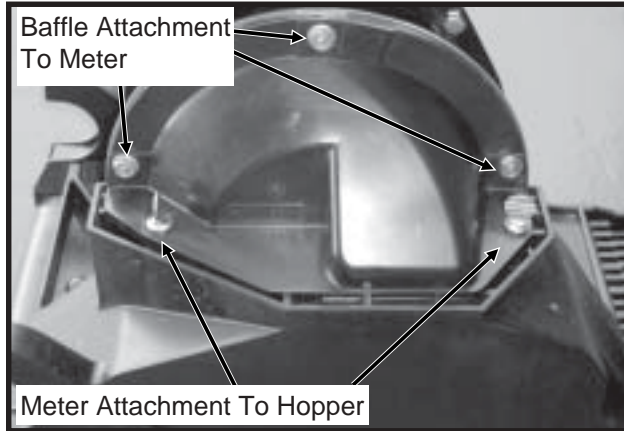

Rotate the seed meter drive by hand to ensure that the springs are holding the tabs of the fingers against the carrier plate where indicated in the photo and that the fingers are being raised in the correct area.

D05030002a

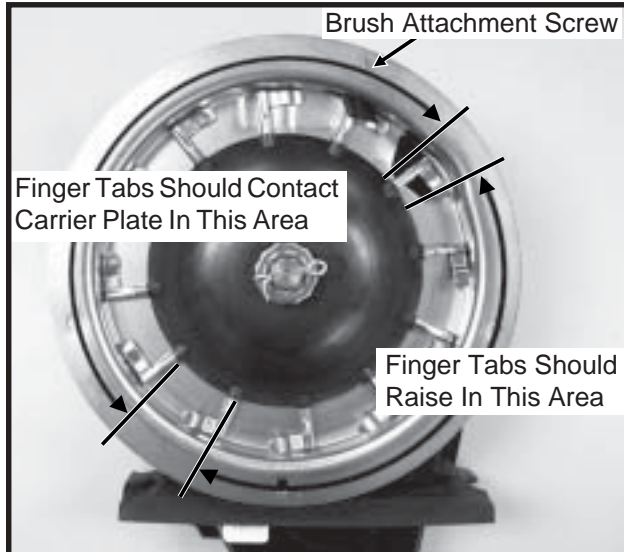

A build-up of debris or chaff may prevent proper finger operation and will require disassembly and cleaning of the finger pickup meter as follows:

1. Remove cotter pin, cover nut and adjusting nut and wave washer (If Applicable) from drive shaft.
2. Carefully lift finger holder, along with fingers and cam, off of the shaft. Clean.

60620-3b

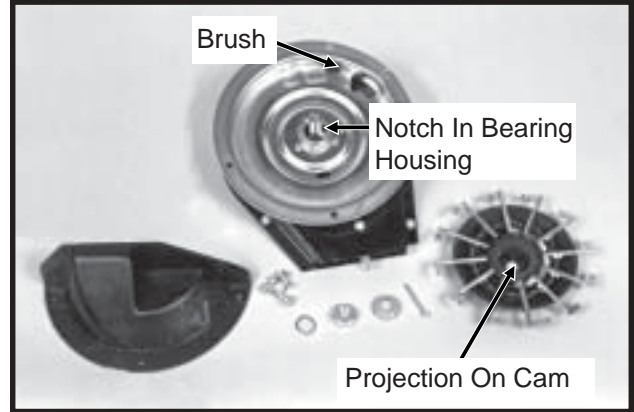

3. Check brush for wear and replace if necessary or following every 100 acres per row of operation.

EXAMPLE: Approximately 1200 acres of corn or sunflowers on a 12 row machine or 1600 acres on an 16 row machine.

**NOTE: It is not necessary to remove finger holder to replace brush.**

4. To replace fingers or springs, remove springs from fingers and remove finger from holder by lifting it out of the friction fit slot. Under average conditions, life expectancy of these parts should be 600-900 acres per row of operation.
5. After cleaning and/or replacing defective parts, reassemble the meter in the reverse order. When replacing fingers, make sure the open end of the spring loop is toward the inside of the finger holder.

60620-22

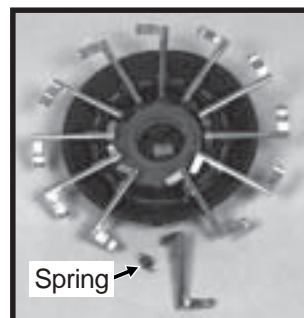

**Corn Finger Assembly**  
(Position Spring Opening Toward Holder)

D07299902



**Oil Sunflower Finger Assembly**

6. Make sure fingers are installed in holder so that holder will be positioned flush with the carrier plate when assembled. A projection on the cam is designed to align with a mating notch in the bearing housing to ensure proper operation when assembled.

# MAINTENANCE

50725-4

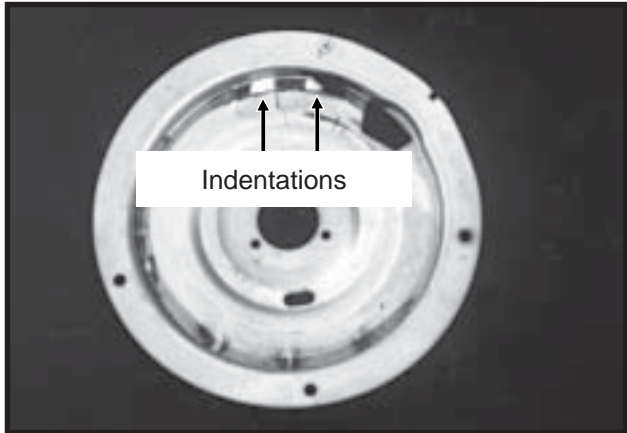

**Photo Shows Worn Carrier Plate**

- Before installing the finger holder on the carrier plate, check the indentations on the carrier plate for wear. Excessive wear of the carrier plate at the indentations will cause over planting especially when using small sizes of seed.

Inspect the carrier plate annually. Under average conditions, the life expectancy of the carrier plate should be 250-300 acres per row of operation.

- With finger holder flush against the carrier, install wave washer and adjusting nut. Tighten adjusting nut to fully compress wave washer. Then back off nut  $\frac{1}{2}$  to 2 flats ( $\frac{1}{12}$  to  $\frac{1}{3}$  turn) to obtain rolling torque of 22 to 25 inch pounds.

D07299903/D07309912

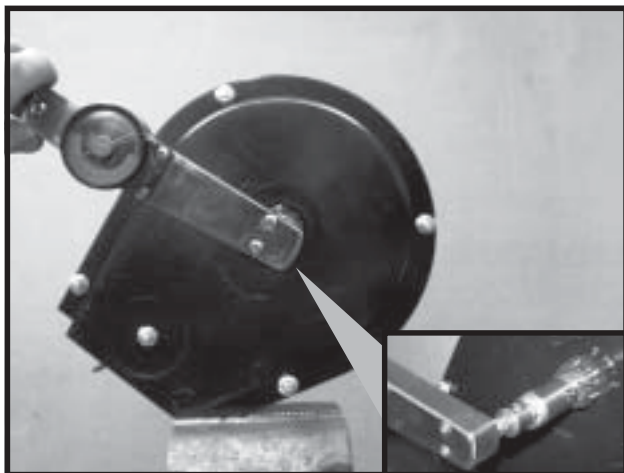

- Turn finger holder by hand to make sure it is positioned firmly against the carrier plate, but is not over tightened and can be rotated with moderate force.
- Install cover nut and cotter pin and reinstall baffle.

**NOTE: Check tightness of adjusting nut on each unit after first day of use and periodically thereafter.**

To inspect or replace the seed belt, remove the four cap screws around the edge of the housing cover and the nut from the belt idler mounting bolt.

60620-13a/60887-97

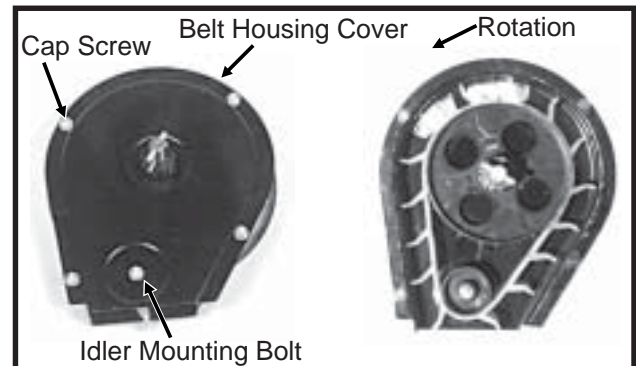

If the belt is being replaced, make sure it is installed to correctly orient the paddles as shown. A diagram molded into the drive sprocket also illustrates the correct orientation.

Reinstall the housing cover. DO NOT TIGHTEN hardware at this time. Wedge a screwdriver between the sprocket hub and housing cover as shown below. Pry cover down until it is centered on the belt housing and tighten hardware. Check idler alignment by rotating meter drive shaft. The seed belt should "run" centered on the idler or with only slight contact with the belt housing or cover.

**IMPORTANT: Do not over tighten hardware.**

D06200030



## FINGER PICKUP SEED METER CLEANING

- Disassemble meter.
- Blow out any foreign material present in the meter mechanism.
- Wash in mild soap and water. DO NOT USE GASOLINE, KEROSENE OR ANY OTHER PETROLEUM BASED PRODUCT.
- Dry thoroughly.
- Coat lightly with a rust inhibitor.
- Reassemble and store in a dry place.

# MAINTENANCE

## FINGER PICKUP SEED METER TROUBLESHOOTING

PROBLEM	POSSIBLE CAUSE	SOLUTION
One row not planting seed.	Drive release not engaged.	Engage drive release mechanism.
	Foreign material in mini-hopper or drop hose.	Clean hopper, drop hose and finger carrier mechanism.
	Row unit drive chain off of sprocket or broken.	Check drive chain.
Drive release does not engage properly.	Drive release shaft is not aligned properly with meter drive shaft.	Align drive mechanism. See "Seed Meter Drive Adjustment".
Unit is skipping.	<b>Foreign material or obstruction in meter.</b>	<b>Clean and inspect.</b>
	<b>Finger holder improperly adjusted.</b>	<b>Adjust to specifications. (22 to 25 in. lbs. rolling torque)</b>
	<b>Broken fingers.</b>	<b>Replace fingers and/or springs as required.</b>
	Planting too slowly.	Increase planting speed to within recommended range.
Planting too many doubles.	Planting too fast.	Stay within recommended speed range.
	<b>Loose finger holder.</b>	<b>Adjust to specifications. (22 to 25 in. lbs. rolling torque)</b>
	<b>Worn brush in carrier plate.</b>	<b>Inspect and replace if necessary.</b>
Overplanting.	<b>Worn carrier plate.</b> <b>Seed hopper additive being used.</b>	<b>Inspect and replace if necessary.</b> <b>Reduce or eliminate additive or increase graphite.</b>
Underplanting.	<b>Seed belt installed backwards.</b>	<b>Remove and install correctly.</b>
	<b>Weak or broken springs.</b>	<b>Replace.</b>
	<b>Spring not properly installed.</b>	<b>Remove finger holder and correct.</b>
	<b>Seed belt catching or dragging.</b>	<b>Replace belt.</b>
	<b>Brush dislodging seed.</b>	<b>Replace brush.</b>
Irregular or incorrect seed spacing.	Driving too fast.	Check chart for correct speed.
	Wrong tire pressure.	Inflate tires to correct air pressure.
	Drive wheels slipping.	Reduce down pressure on row unit down force springs.
	Wrong sprockets.	Check seed rate charts for correct sprocket combinations.
Seed spacing not as indicated in charts.	Wrong tire pressure.	Inflate tires to correct air pressure.
	Inconsistent seed size.	Do field check and adjust sprockets accordingly.
	Wrong sprockets.	Check chart for correct sprocket combination.
	Charts are approximate.	Slight variations due to wear in meter components and tire slippage due to field conditions may produce seed spacing variations.
	Stiff or worn drive chains.	Replace chains.
Scattering of seeds.	Planting too fast.	Reduce planting speed.
	Seed tube improperly installed.	Check seed tube installation.
	Seed tube worn or damaged.	Replace seed tube.
Seed tubes and/or openers plugging.	Allowing planter to roll backward when lowering.	Lower planter only when tractor is moving forward.
Inconsistent seed depth.	Rough seed bed.	Adjust down pressure springs. Reduce planting speed.
	Partially plugged seed tube.	Inspect and clean.
	Seed tube improperly installed.	Install properly.

# MAINTENANCE

## BRUSH-TYPE SEED METER MAINTENANCE

60607-10a

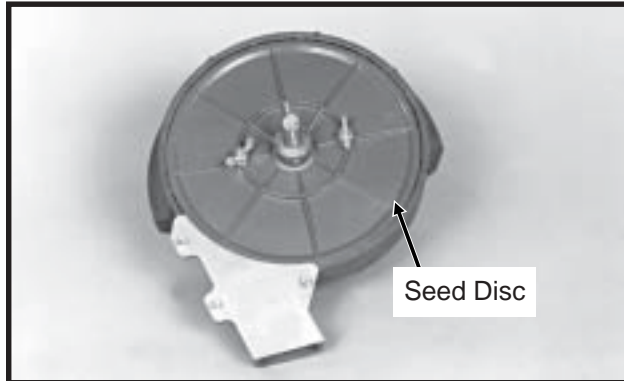

D04239911

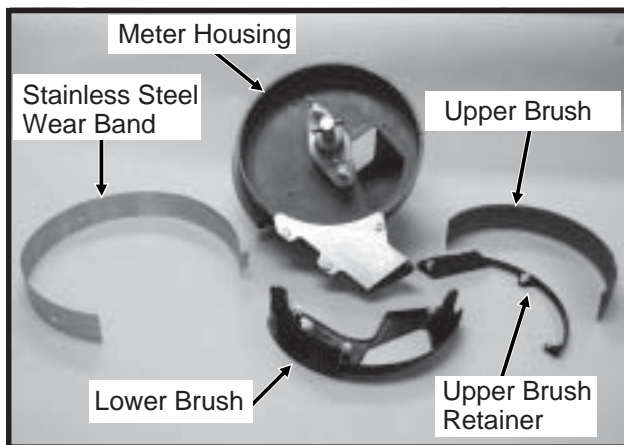

Only clean, high quality seed should be used for maximum meter accuracy. Damaged or cracked seed, hulls or foreign materials may become lodged in the upper brush and greatly reduce meter accuracy. It is suggested that the seed disc be removed daily, inspected and cleaned. Check for buildup of foreign material on the seed disc, particularly in the seed loading slots. Clean the disc by washing it with soap and water. Check for cracked seed, hulls, etc. lodged between the brush retainer and stainless steel wear band which can greatly reduce the accuracy of the meter because the upper brush will not be able to retain the seed in the seed disc pocket. Clean the brush areas of the meter housing thoroughly.

D04239912a

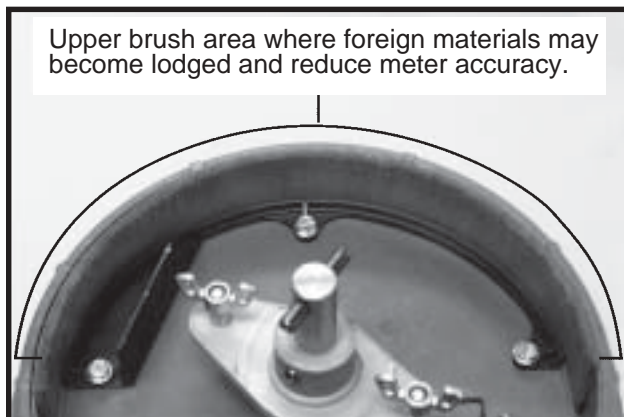

**IMPORTANT:** Close bulk seed hopper lids after hoppers are filled to prevent accumulation of dust or dirt in the seed meter which will cause premature wear.

Cleaning brush-type seed meter for storage:

1. Remove meter from mini-hopper by removing the two thumbscrews which secure the meter to the mini-hopper.
2. Remove seed disc and wash with soap and water and dry thoroughly.
3. Remove upper brush by removing the three hex head screws from the brush retainer and removing brush retainer and upper brush.
4. Remove the three hex head screws from the lower brush and remove lower brush and stainless steel wear band.
5. Wash all parts and meter housing with soap and water and dry thoroughly.
6. Inspect all parts for wear and replace worn parts.
7. Reassemble meter except for seed disc. **Meter should be stored in a rodent-free space with seed disc removed.**

### Seed Disc Wear

HD112690(PLTR40b)

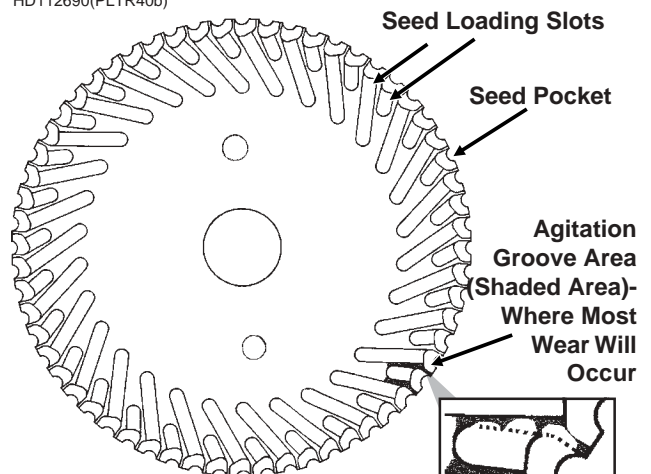

Most wear on the seed disc will be found in the agitation groove area (area between the seed loading slots). Wear will affect planting accuracy at high RPM. To measure for wear, lay a straight edge across the surface of the disc and measure the gap between the disc (at the agitation groove area) and the straight edge. If the agitation groove areas are worn in excess of .030" and accuracy starts to drop off at higher meter RPM, the seed disc should be replaced.

Estimated life expectancy of the seed disc under normal operating conditions should be approximately 200 acres per row. Severe operating conditions such as dust, lack of lubrication or abrasive seed coating could reduce life expectancy of the seed disc to under 100 acres per row.

# MAINTENANCE

## Upper Brush

LF212299-13a

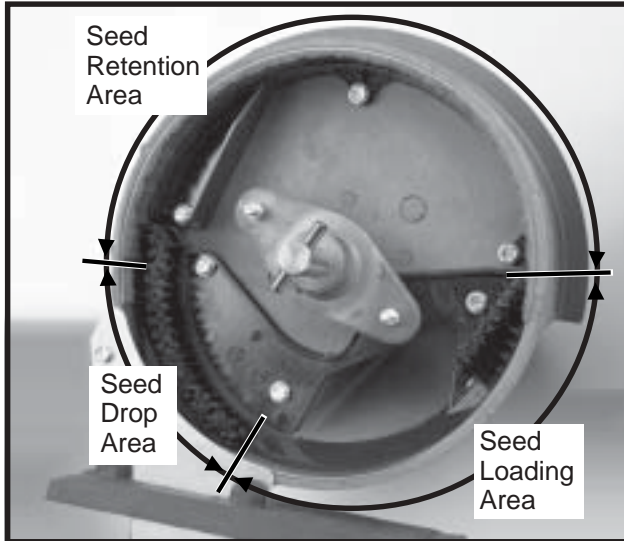

The upper brush holds seed in the seed disc pocket in the seed retention area.

The brush must apply enough pressure against the seed in the seed disc pocket as the disc rotates through the seed retention area to prevent the seed from dropping out of the disc pocket. A damaged spot, excessive wear on the brush or foreign material lodged in the brush may greatly reduce meter performance.

The upper brush should be replaced at approximately 120-400 acres per row of use or sooner if damage or excessive wear is found.

### Installation Of Upper Brush

Position upper brush into inner perimeter of seed retention area. Make sure the base of the brush is tight against the bottom of the meter housing. Install brush retainer and three hex head screws. Tighten center screw first, left screw second and right screw last.

**NOTE: Use GD11122 upper brush retainer when using soybean and cotton discs. Use GD8237 upper brush retainer when using milo/grain sorghum discs. GD11122 brush retainer shown.**

LF212299-13a

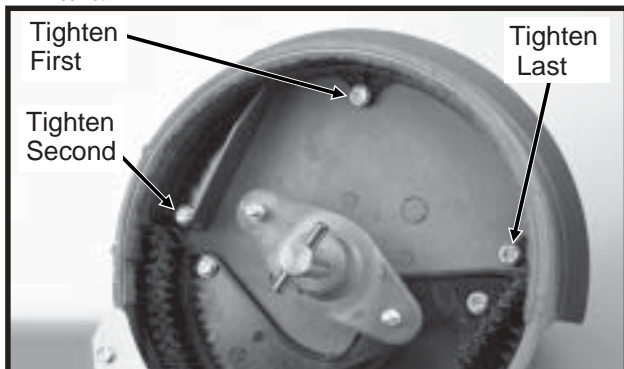

## Stainless Steel Wear Band

D04239917a

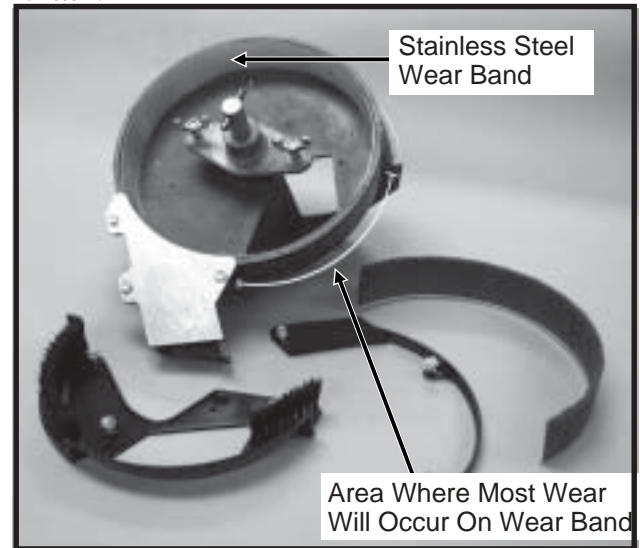

The purpose of the stainless steel wear band is to protect the meter housing from wear. The band is .030" thick and should be replaced when approximately .020" of wear is found in the primary area of wear. If the wear band is allowed to wear through or if the meter is used without the wear band in place, damage to the meter housing may occur.

Estimated life expectancy of the stainless steel wear band is 240-800 acres per row.

## Lower Brush

D04239911

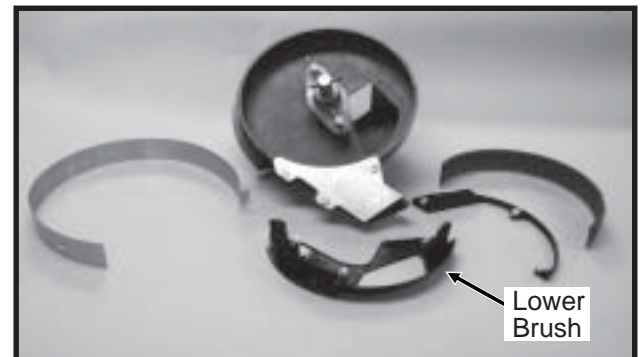

The lower brush has several functions. One function is to move seed down the seed loading slots to the seed pockets. The second function is to isolate seed in the reservoir from entering the seed tube and a third is to clean the seed loading slots.

Estimated life expectancy of the lower brush is 240-800 acres per row. The lower brush should be replaced if the bristles are deformed or missing or if there are cracks in the brush retainer.

# MAINTENANCE

## BRUSH-TYPE SEED METER TROUBLESHOOTING

PROBLEM	POSSIBLE CAUSE	SOLUTION
Low count.	Meter RPM too high.	Reduce planting speed.
	Misalignment between drive clutch and meter.	See "Seed Meter Drive Adjustment".
	Seed sensor not picking up all seeds dropped.	Clean seed tube. Switch meter to different row. If problem stays with same row, replace sensor.
	Lack of lubrication causing seeds not to release from disc properly.	Use graphite or talc as recommended.
	Seed size too large for seed disc being used.	Switch to smaller seed or appropriate seed disc. See "Brush-Type Seed Meter" for proper seed disc for size of seed being used.
	Seed treatment buildup in meter.	Reduce amount of treatment used and/or thoroughly mix treatment with seed. Add talc.
Low count at low RPM and higher count at higher RPM.	Foreign material lodged in upper brush.	Remove seed disc and remove foreign material from between brush retainer and bristles. Clean thoroughly.
	Worn upper brush.	Replace. See "Maintenance".
Low count at higher RPM and normal count at low RPM.	Seed disc worn in the agitation groove area.	Replace disc. See "Maintenance".
High count.	Seed size too small for seed disc.	Switch to larger seed or appropriate seed disc.
	Incorrect seed rate transmission setting.	Reset transmission. Refer to proper rate chart in "Machine Operation" section of manual.
	Upper brush too wide (fanned out) for small seed size.	Replace upper brush.
High count. (Milo/Grain Sorghum)	Incorrect brush retainer being used.	Make sure GD8237 brush retainer is installed to keep upper brush from fanning out.
Upper brush laid back.	Seed treatment buildup on brush.	Remove brush. Wash with soap and water. Dry thoroughly before reinstalling. See "Maintenance".
	Buildup of foreign material at base of brush.	Remove brush retainer and brush. Clean thoroughly. Reinstall.

# MAINTENANCE

## CLOSING WHEEL TROUBLESHOOTING

PROBLEM	POSSIBLE CAUSE	SOLUTION
Closing wheel(s) leave severe imprint in soil.	Too much closing wheel down pressure.	Adjust closing wheel pressure.
Closing wheel(s) not firming soil around seed.	Insufficient closing wheel down pressure.	Adjust closing wheel pressure. Severe no till conditions may require use of cast iron closing wheels.
"V" closing wheel running on top of seed furrow.	Improper centering.	Align. See "V Closing Wheel Adjustment".

## GAUGE WHEEL ADJUSTMENT

To prevent an accumulation of dirt or trash, gauge wheels should lightly contact the opener blades. Gauge wheels and opener blades should turn with only slight resistance.

To adjust clearance between gauge wheels and opener blades, add or remove machine bushings between the shank and gauge wheel arm. Store remaining machine bushings between gauge wheel arm and flat washer on outer side of gauge wheel arm.

**NOTE:** It may be desirable to space gauge wheel further from blade when operating in sticky soils.

LF212199-2

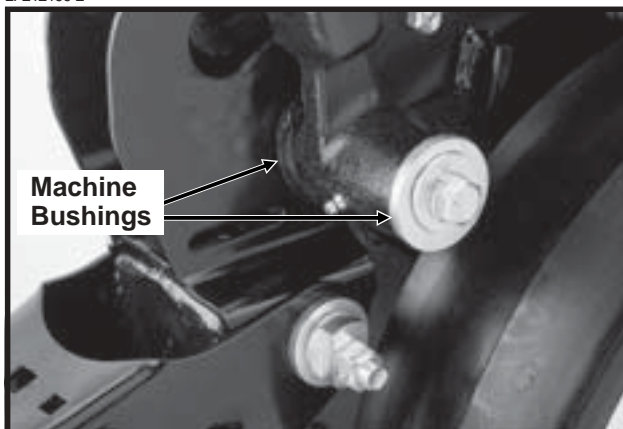

(RU113)

**Machine Bushings - Minimum 2 Between Arm And Shank/ Minimum 1 Between Arm And Bolt Head**

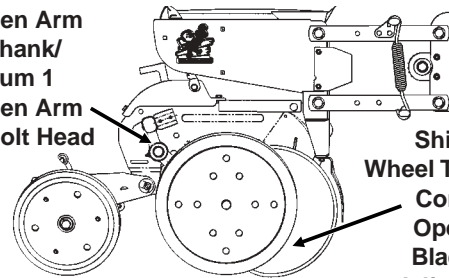

**Shim Gauge Wheel To Lightly Contact The Opener Disc Blade-Check Adjustment In Field Position**



# MAINTENANCE

## GAUGE WHEEL ARM BUSHING AND/OR SEAL REPLACEMENT

(RU113)

Gauge Wheel Arm Bushings/Seals

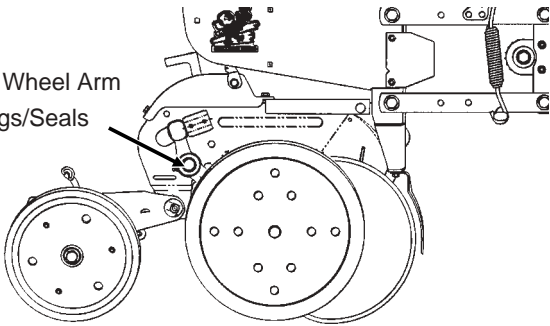

**NOTE: A Gauge Wheel Arm Bushing And Seal Driver Kit (G1K296), for use in bushing and seal replacement, is available through your KINZE® Dealer.**

**To replace gauge wheel arm assembly bushing(s) and/or seal(s):**

1. Remove gauge wheel from arm.
2. Remove the gauge wheel arm assembly from the shank assembly.
3. Remove seal and bushing and discard. Clean and dry inner bore.

(A7975/RU122)

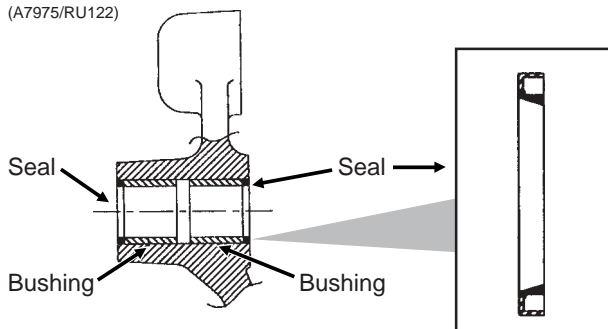

4. Drive/press replacement bushing inside bore of arm to a depth of .125" below flush.
5. Coat wiping edge of seal with grease.
6. Drive/press seal into place with lip to the outside as shown above.

**NOTE: Use extra care to protect the sealing lip during installation. Apply uniform pressure to assemble the seal into the bore of the arm. Never apply a direct hammer blow to the seal surface.**

7. Inspect gauge wheel pivot spindle.
8. Reinstall gauge wheel arm assembly and gauge wheel.

**NOTE: Special machine bushing between gauge wheel arm and gauge wheel.**

9. Shim for proper gauge wheel tire/disc blade clearance.
10. Lubricate with an SAE multipurpose type grease.

## GAUGE WHEEL ARM PIVOT SPINDLE REPLACEMENT

(RU113)

Gauge Wheel Pivot Spindle

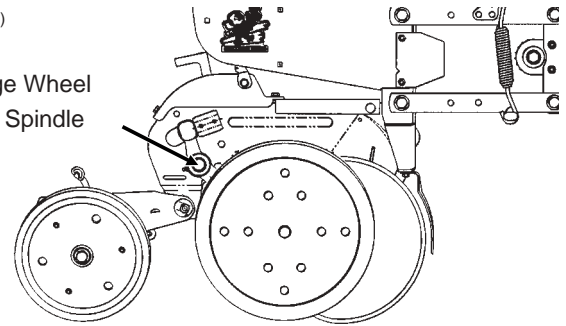

**To replace gauge wheel pivot spindle:**

1. Remove the gauge wheel and arm assemblies from the shank assembly.
2. Remove 1/2" x 3/4" cap screw that locks the pivot spindle in place and remove the spindle.

D06189902

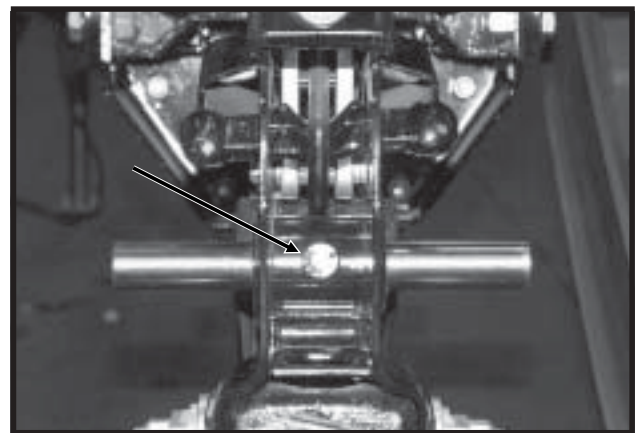

3. Install the replacement spindle and position as shown below. Exact centering is critical.

(A7966)

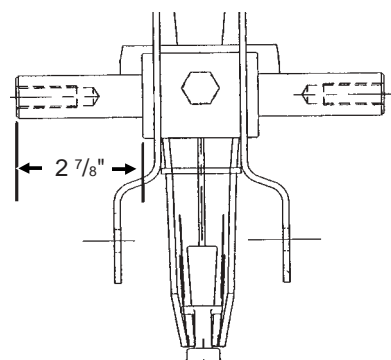

4. Install 1/2" x 3/4" cap screw and torque to lock pivot spindle in place.
5. Install gauge wheel and arm assemblies. Shim for proper gauge wheel tire/disc blade clearance.

# MAINTENANCE

## 15" SEED OPENER DISC BLADE/ BEARING ASSEMBLY

Approximately 1"-1 1/2" of blade-to-blade contact should be maintained to properly open and form the seed trench. As the blade diameter decreases, due to wear, it will be necessary to relocate machine bushings from inside to outside to maintain approximately 1"-1 1/2" of contact.

**NOTE: If proper blade-to-blade contact cannot be maintained after relocating machine bushings or if blade diameter wears below 14 1/2", the blade should be replaced.**

**IMPORTANT: Excessive blade contact may result in premature disc opener bearing/hub failures and excessive wear on seed tube guard/inner scraper. When properly adjusted, if one blade is held in fixed position, the opposite blade should be able to be rotated with minimal force. (Less than 5 pounds force at outer edge of blade.)**

(RU113)

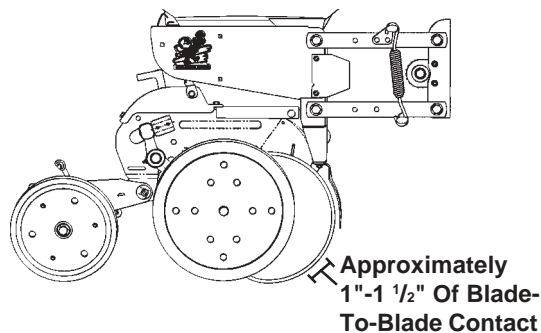

### To replace disc blade/bearing assembly:

1. Remove gauge wheel.
2. Remove scraper.
3. Remove bearing dust cap.
4. Remove cap screw, washer and disc blade/bearing assembly. The machine bushings between the shank and disc blade are used to maintain the approximate 1"-1 1/2" of blade-to-blade contact.

**IMPORTANT: Left hand side of opener uses a left hand threaded cap screw. DO NOT OVER TIGHTEN. Damage to shank threads will require replacement of row unit shank assembly.**

5. Install machine bushing(s), new disc blade/bearing assembly, washer and cap screw. Torque 5/8"-11 Grade 5 cap screw to value shown in "Torque Values Chart".

**NOTE: Replace disc blade only with disc blade of equal thickness.**

6. Replace bearing dust cap.
7. Install scraper.
8. Install gauge wheel.

It may be necessary to replace only the bearing if there is excessive endplay or if the bearing sounds or feels rough when the disc blade is rotated.

### To replace bearing:

1. Remove gauge wheel, scraper, bearing cap, cap screw, washer and disc blade/bearing assembly.
2. Remove 1/4" rivets from bearing housing to expose bearing.
3. After installing new bearing, install three evenly spaced 1/4" cap screws into three of the six holes in the bearing housing to hold the bearing and bearing housing in place. Install rivets in the other three holes. Remove 1/4" cap screws and install rivets in those three holes.
4. Reinstall disc blade/bearing assembly, washer and cap screw. Torque 5/8"-11 cap screw to value shown in "Torque Values Chart" at the beginning of this section.
5. Replace bearing dust cap.
6. Install scraper and gauge wheel.

# MAINTENANCE

## SEED TUBE GUARD/INNER SCRAPER

The seed tube guard protects the seed tube and acts as the inner scraper for the seed opener disc blades.

Remove the seed tube and check for wear. Excessive wear on the seed tube indicates a worn seed tube guard. Replace the seed tube guard if it measures  $\frac{5}{8}$ " or less at the lower end. A new seed tube guard measures approximately  $\frac{7}{8}$ ".

LF212199-12

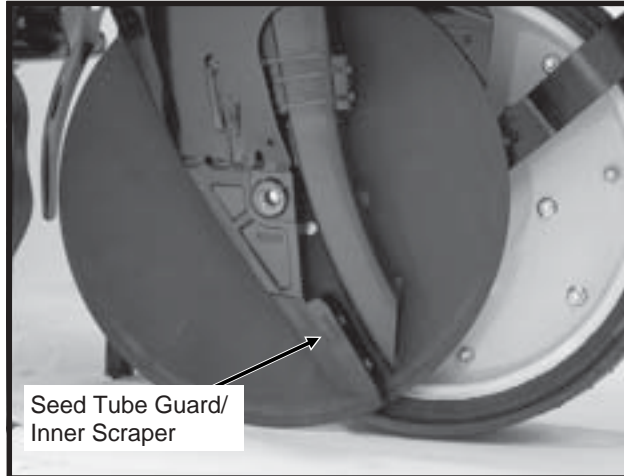

Shown With Gauge Wheel And Seed Opener Disc Blade Removed For Visual Clarity

**IMPORTANT: No till planting or planting in hard ground conditions, especially when the planter is not equipped with no till coulters, and/or excessive blade-to-blade contact will increase seed tube guard wear and necessitate more frequent inspection and/or replacement.**

To replace the seed tube guard, remove the seed tube and the two hex socket head cap screws which attach the seed tube guard. Hold the replacement seed tube guard centered between the seed opener disc blades. Install, but DO NOT tighten, the hex socket head cap screws. Using a clamp or vise-grip, squeeze the opener blades together in front of the seed tube guard. Tighten the seed tube guard retaining screws. Remove the clamps. The distance between the seed tube guard and opener blades should be equal on both sides. Reinstall seed tube.

**IMPORTANT: Over tightening the hex socket head cap screws may damage the threads in the shank and require replacement of the shank. A seed tube guard that is worn excessively may allow the blades to wear into the row unit shank, also requiring replacement of the shank.**

## FRAME MOUNTED COULTER - STYLE A

LF212299-20

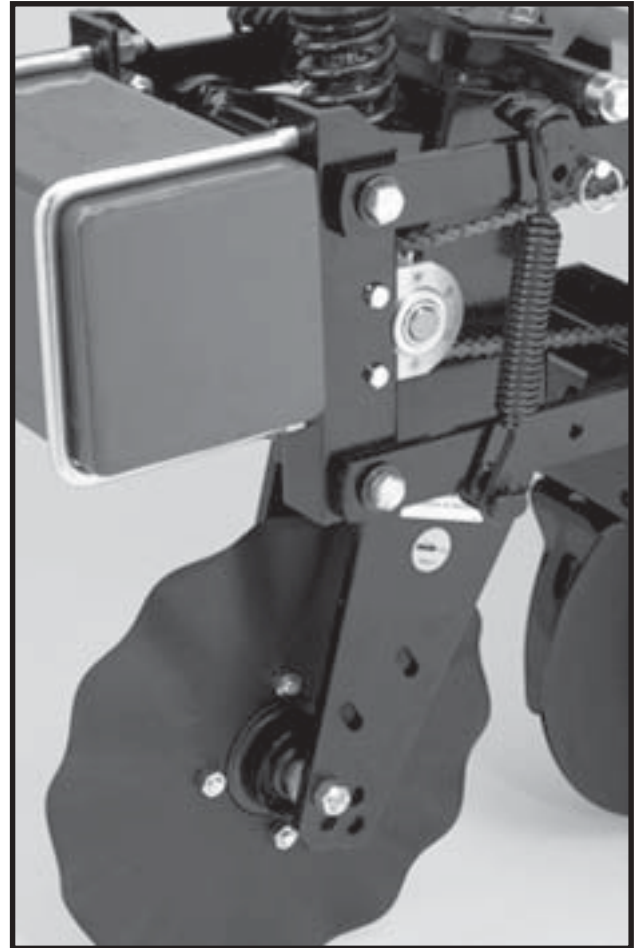

If properly maintained and lubricated (If Applicable) the bearings in the frame mounted coulters hub may never need to be replaced. Lubricate (If Applicable) at frequency indicated in the Lubrication Section of this manual. Check periodically to be sure nuts and hardware are tightened to proper torque specification. Be sure the coulters are positioned square with the planter frame and aligned in front of row unit disc opener.

**NOTE: Torque  $\frac{5}{8}$ " spindle bolts to 120 ft. lbs.**

See "Frame Mounted Coulters" in Row Unit Operation Section of this manual for depth and spring adjustment.

When the 16" diameter coulters blade (1" fluted, 1" bubbled or  $\frac{3}{4}$ " fluted) is worn to 14  $\frac{1}{2}$ " (maximum allowable wear), it should be replaced.

(If Applicable) Timely lubrication at the frequency indicated in the Lubrication Section of this manual is necessary to purge moisture and dirt from bearing and seal. This will also lubricate the seal. Add grease until it comes out around the seal.

# MAINTENANCE

## FRAME MOUNTED COULTER - STYLE B

LF083002101

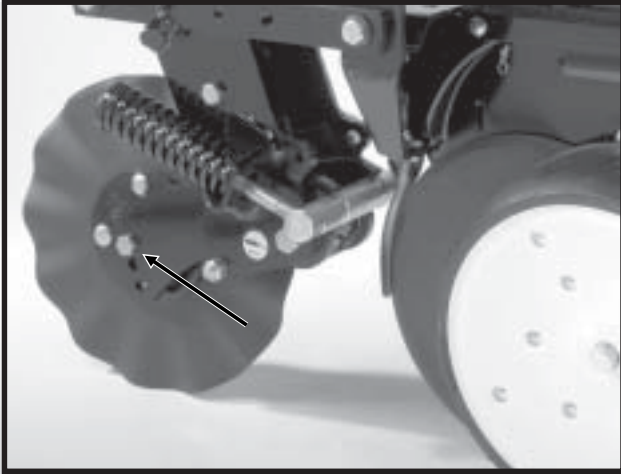

**NOTE: Torque  $\frac{5}{8}$ " spindle bolts to 120 ft. lbs.**

See "Frame Mounted Coultter - Style B" in Row Unit Operation Section of this manual for depth and spring adjustment.

When the 16" diameter coultter blade (1" fluted, 1" bubbled or  $\frac{3}{4}$ " fluted) is worn to 14  $\frac{1}{2}$ " (maximum allowable wear), it should be replaced.

## DISC FURROWER (For Use With Style A Frame Mounted Coultter)

LF212299-21

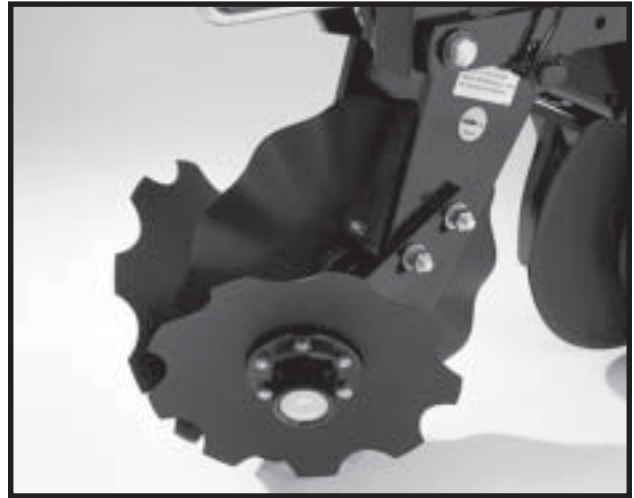

The blade hubs are equipped with sealed bearings. If bearings sound or feel rough when the blade is rotated, replace the bearings.

When the 12" diameter blades (solid or notched) are worn to 11", they should be replaced.

# MAINTENANCE

## RESIDUE WHEELS (For Use With Style B Frame Mounted Coulter)

LF083002102

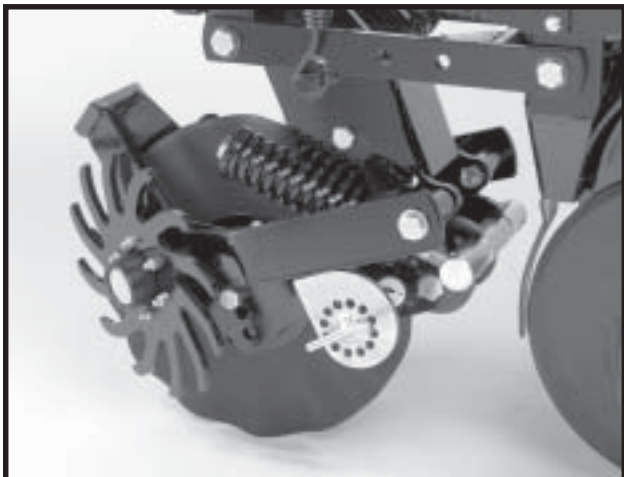

The wheel hub is equipped with sealed bearings. If bearings sound or feel rough when the wheel is rotated, replace the bearings.

## ROW UNIT MOUNTED DISC FURROWER

LF212299-22



Lubricate the bushings in the support arm and mounting bracket at the frequency indicated in the Lubrication Section of this manual. Using a torque wrench, check each bolt for proper torque. If the bolt is loose, it should be removed and the bushing inspected for cracks and wear. Replace bushings as necessary. **Only hardened flat washers should be used. Replace damaged flat washers with proper part. Torque bolts to 130 ft. lbs.**

The blade hubs are equipped with sealed bearings. If bearings sound or feel rough when the blade is rotated, replace the bearings.

When the 12" diameter blades (solid or notched) are worn to 11", they should be replaced.

# MAINTENANCE

## ROW UNIT MOUNTED RESIDUE WHEEL

D101701113



The wheel hub is equipped with sealed bearings. If bearings sound or feel rough when the wheel is rotated, replace the bearings.

## ROW UNIT MOUNTED NO TILL COULTER

LF212299-19a

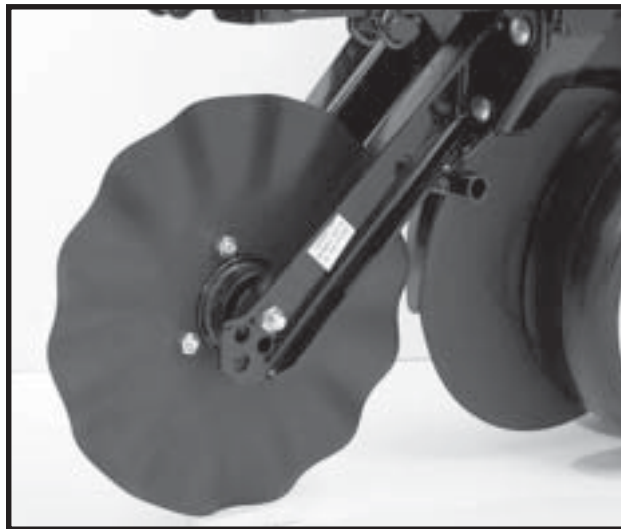

Lubricate (If Applicable) at frequency indicated in the Lubrication Section of this manual. Check periodically to be sure nuts and hardware are tightened to proper torque specification.

**NOTE: Torque  $\frac{5}{8}$ " spindle bolts to 120 ft. lbs.**

Be sure the coulters are positioned square with the row unit and aligned in front of row unit disc opener.

The coulters blade can be adjusted to one of four settings. Initially the blade is set in the highest position. As the blade wears it can be adjusted to one of the three lower settings. See "Row Unit Mounted No Till Coulters" in Row Unit Operation Section of this manual.

When the 16" diameter coulters blade is worn to 14  $\frac{1}{2}$ " (maximum allowable wear), it should be replaced.

(If Applicable) Timely lubrication at the frequency indicated in the Lubrication Section of this manual is necessary to purge moisture and dirt from bearings and seals. This will also lubricate the seals. Add grease until it comes out around the seals. Spin hub while filling with grease.

# MAINTENANCE

## COULTER MOUNTED RESIDUE WHEELS

LF212299-23

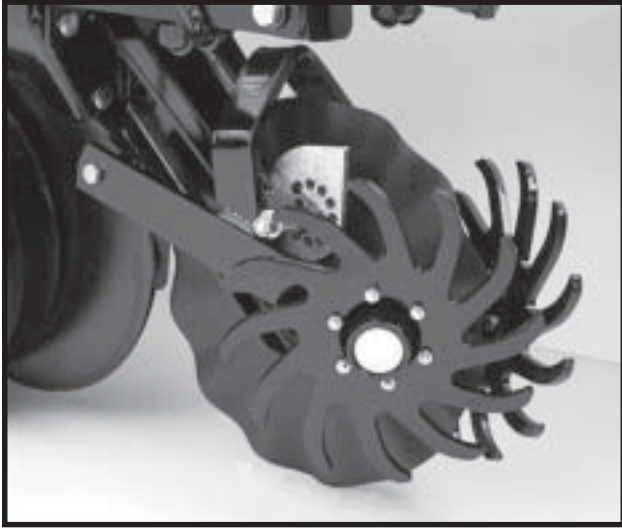

The wheel hubs are equipped with sealed bearings. If bearings sound or feel rough when the wheel is rotated, replace the bearings.

## GRANULAR CHEMICAL ATTACHMENT

Prior to storage of the planter, disengage the granular chemical drive by rotating the throwout knob  $\frac{1}{4}$  turn counterclockwise. Remove the drive chain and empty and clean all granular chemical hoppers. Clean the drive chains and coat them with a rust preventive spray or submerge chains in oil. Inspect and replace any worn or broken parts.

Install hoppers and chains. Check chain alignment.

LF212299-4

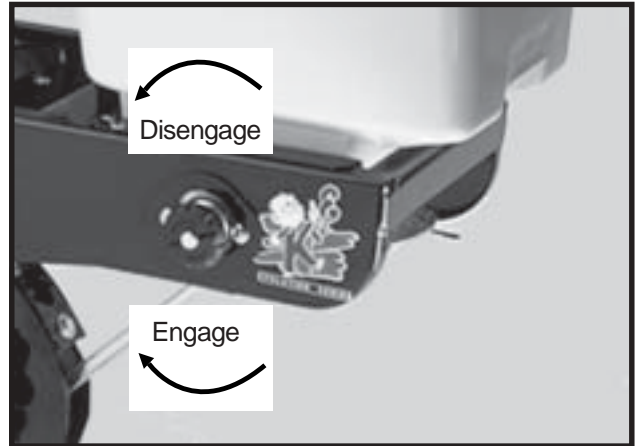

# MAINTENANCE

## BULK SEED HOPPER AUGER REMOVAL

Augers are removed through the outer ends of the bulk seed hoppers.

To remove bulk seed hopper auger(s):

- Remove top mesh cover.
- Remove center cover plate.
- Release drive chain tension and remove chain.
- Remove plastic gearbox cover(s) from gearbox(es).
- Remove 1/4" spring pins on outer ends of hex shafts.
- Remove top and/or bottom cover plates with gearbox(es) attached.
- Remove spring pins, sprocket(s), shield, gasket and plug(s). (If Replacing Components)
- Pull auger(s).

D021102203

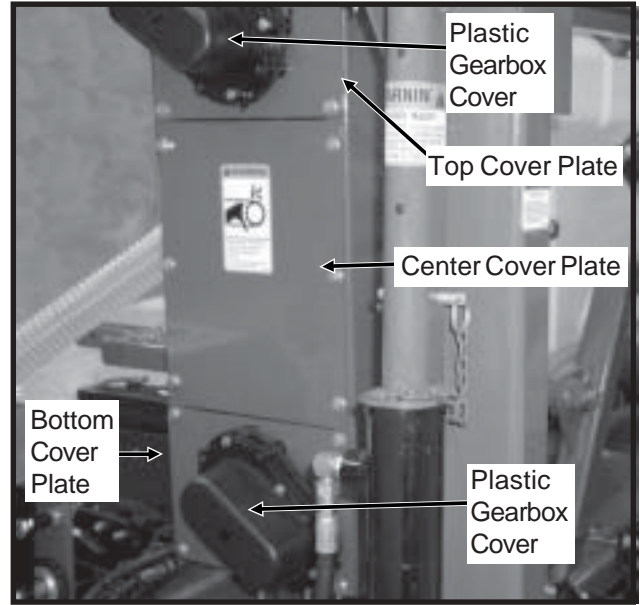

R.H. Side Of Planter

(TWL222/TWL227)

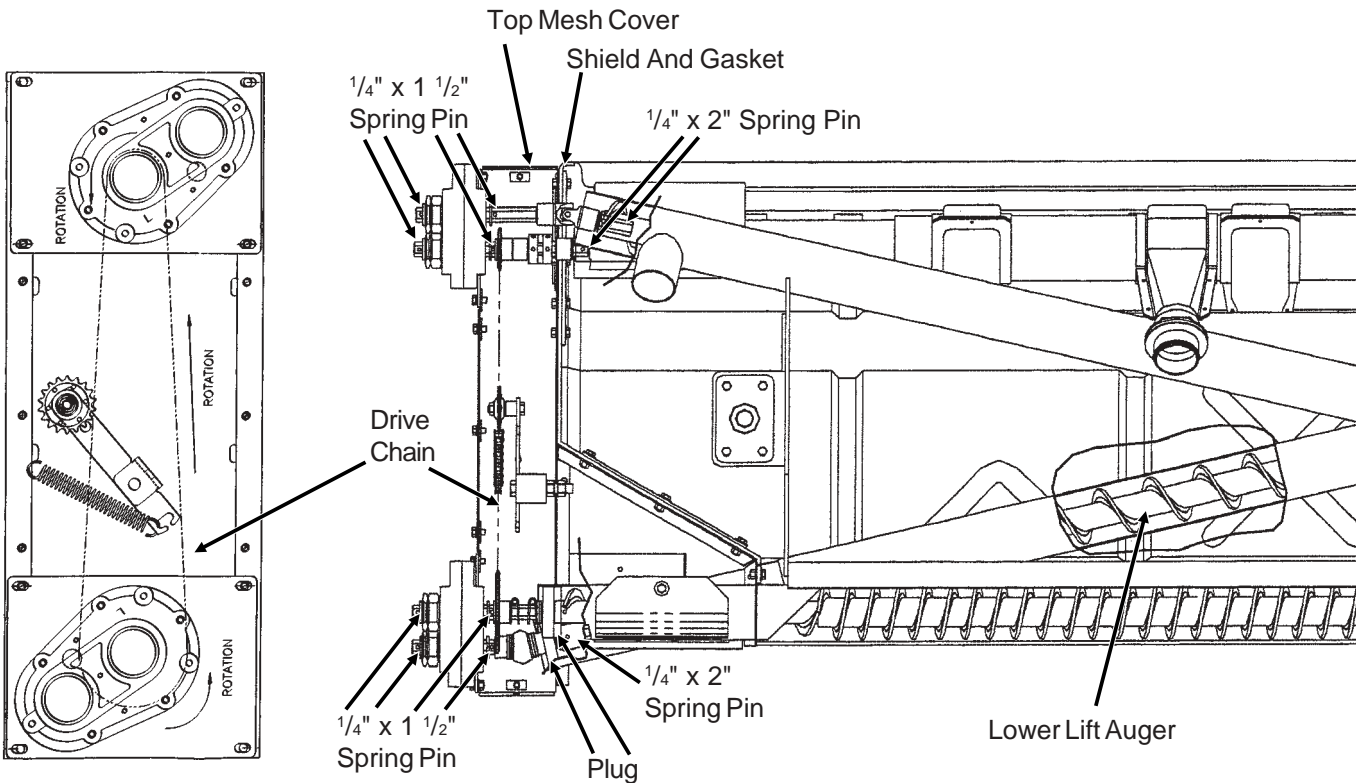

Viewed From L.H. Side Of Planter



# MAINTENANCE

---

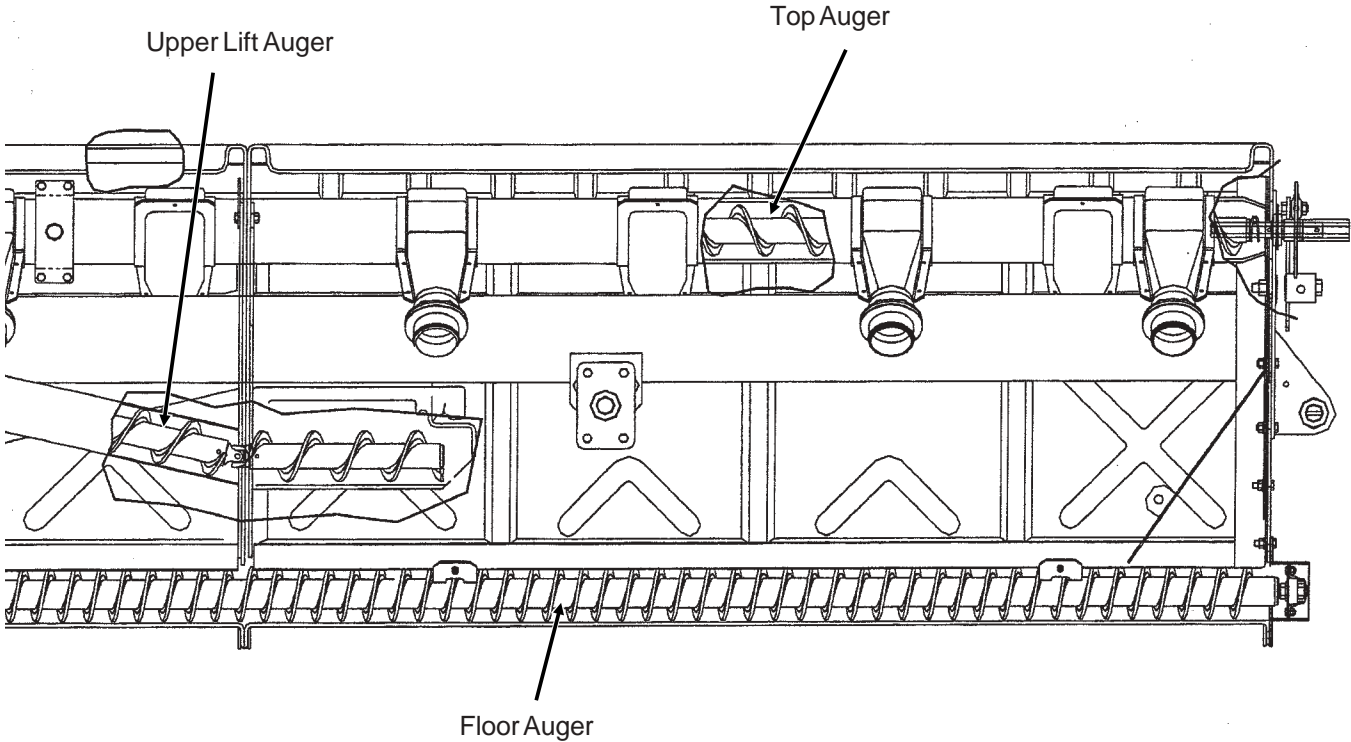

# MAINTENANCE

## KPM I/KPM II/KPM II STACK-MODE ELECTRONIC SEED MONITOR TROUBLESHOOTING

PROBLEM	POSSIBLE CAUSE	SOLUTION
Single sensor communication alarm comes on (alarm on with no bar graph and a flashing row number on a single row).	Faulty seed tube sensor.	Replace sensor.
	Break in the harness just before the seed tube sensor.	Inspect for break in harness and repair. If break can't be found, replace harness section.
	Dirty or corroded connector.	Clean connector.
Sensor communication alarms come on for all sensors (alarm on with no bar graphs and flashing row numbers on all rows).	Faulty monitor.	Replace monitor.
	Break in the harness just after the monitor.	Inspect for break in harness and repair. If break can't be found, replace harness section.
	Dirty or corroded connector.	Clean connector.
Sensor communication alarms come on for some sensors (alarm on with no bar graphs and flashing row numbers on all rows).	Break in the harness.	Inspect for break in harness and repair. If break can't be found, replace harness section corresponding with the alarming sensors.
	Dirty or corroded connector.	Clean connector.
Faulty monitor values (such as speed, area, etc.) being displayed. (KPM II And KPM II Stack-Mode Only)	Incorrect monitor settings.	Change settings to properly correspond to the system.
	Faulty radar/magnetic distance sensor.	Replace sensor.
	Improperly mounted radar sensor.	Properly mount sensor.
Underplanting or no planting alarm on a single sensor when planting (alarm on with a single bar graph segment on and a flashing row number on a single row).	Seed tube sensor is blocked.	Clean sensor.
	Faulty seed tube sensor.	Replace sensor.
Seed tube sensor dirty or blocked warning comes on (after calibration, bar graph keeps flashing for a single row).	Seed tube sensor is dirty.	Clean sensor.
	Faulty seed tube sensor.	Replace sensor.
LED on the seed tube sensor will not come on.	Faulty seed tube sensor.	Replace sensor.
	Dirty or corroded connector.	Clean connector.
	Break in the harness just before the sensor.	Repair harness.
Erroneous MPH readings at idle. (Radar Distance Sensor Only)	Radar sensor not located in a stable location.	Relocate to a more stable location.

# MAINTENANCE

## POINT ROW CLUTCH INSPECTION

The point row clutch is permanently lubricated and sealed and requires no periodic maintenance.

D032901166

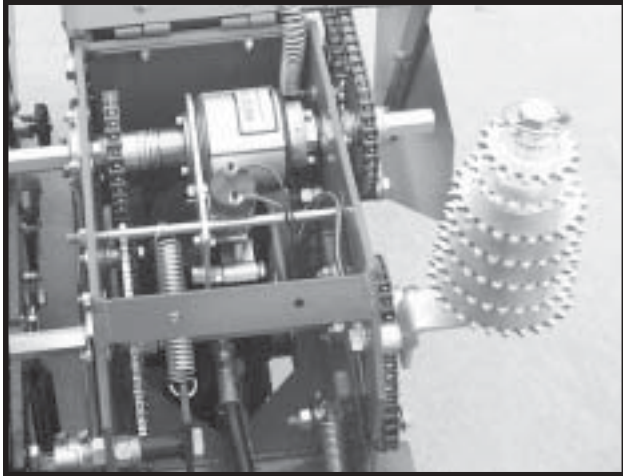

The right hand clutch operates clockwise and the left hand clutch operates counterclockwise. Therefore, some of the parts of the clutch such as the wrap spring differ from one side of the planter to the other. Be sure to use the correct repair part if a clutch must be repaired.

**NOTE: The point row clutch input shaft on the R.H. side of the machine will have an "L" stamped on it and the shaft on the L.H. side of the machine will have an "R" stamped on it.**

If the clutch or clutches fail to operate, first determine if the problem is electrical or mechanical. Place the operational switch in the RIGHT or LEFT position. When the switch is in the RIGHT or LEFT position and the fuse on the rear of the control console is in working condition, the red indicator light on the control console should be lighted. If light does not come on, check the fuses on the front of the control console. See "Point Row Clutch Troubleshooting" chart. If fuses are not blown, check the clutch and wiring harness for power with a test light or volt meter. If the solenoid is operating properly, the plunger on the solenoid will retract causing a clicking sound. The plunger will also be magnetized which can be checked by touching the plunger with a metal object.

**NOTE: Always replace fuse with proper size and type when replacing fuse. Use MDL 10 amp slow blow fuse on front of control console.**

PRC019(PLTR53)

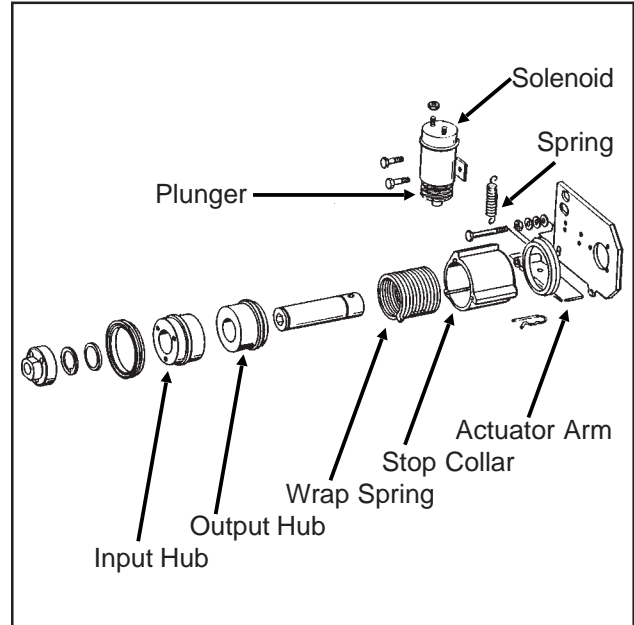

(PLTR54)

### ACTUATOR ARM ADJUSTMENT

**NOTE: Gap between actuator arm and stop on stop collar should be  $1/8"$  ( $\pm 1/32"$ ) when the solenoid is NOT engaged.**

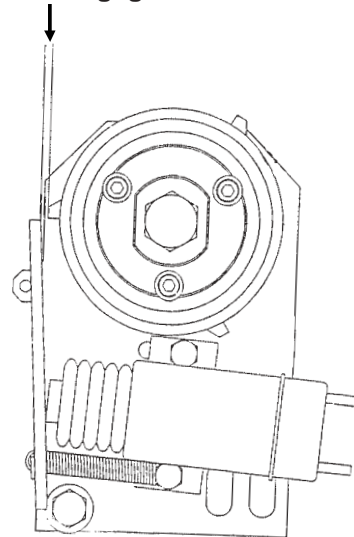

**NOTE: To adjust gap between actuator arm and stop, loosen nut on mounting pin and move pin in slot until there is  $1/8"$  ( $\pm 1/32"$ ) gap between arm and stop on stop collar. Retighten nut.**

# MAINTENANCE

## POINT ROW CLUTCH TROUBLESHOOTING

PROBLEM	POSSIBLE CAUSE	SOLUTION
Neither clutch will disengage.	Main fuse blown in control console.	Replace defective fuse.
	Poor terminal connection in wiring harness.	Repair or replace.
	Wiring damage in wiring harness.	Repair or replace.
	Low voltage at coil. (12 volts required)	Check battery connections.
One side of planter will not re-engage.	Shear pin in seed drive transmission sheared.	Replace with one of equal size and grade.
One clutch will not engage.	Fuses blown.	Replace defective fuses.
	Actuator arm and plunger stuck in disengaged position.	Remove, free up and reinstall.
	Actuator arm out of adjustment.	Adjust actuator arm mounting pin in slot so that actuator arm clears stop on stop collar by approximately 1/8" when clutch is rotated.
	Wrap spring broken or stretched.	Disassemble clutch and replace spring.
	Foreign substance such as oil or grease on the input or output hubs.	Disassemble clutch. Clean hubs and spring and reassemble.
	Something touching the stop collar.	Check to ensure collar is free to turn with clutch.
	Clutch assembled incorrectly.	Check clutch and diagram for correct assembly.
Clutch slipping.	Wrap spring stretched.	"Lock" clutch output shaft from turning. Place torque wrench on input shaft and rotate in direction of drive. After input shaft has rotated a short distance the wrap spring should tighten onto the input hub. If slippage occurs at less than 100 ft. lbs. replace spring. If spring still slips after installing new spring, replace input hub.
Planter will not re-engage while planter is moving forward.	Spring in actuator arm not strong enough to push arm away from stop collar when operational switch is turned to the ON position.	Remove spring from inside solenoid and stretch spring slightly or replace. Reinstall spring. If that fails, file the stop on the stop collar slightly so that the stop is not as aggressive.
Frequent solenoid burnout.	Fuses too large.	Replace fuses on front panel with 10 amp slow blow fuses.
Frequent fuse burnout.	Low voltage (12 volts required).	Check power source voltage for partially discharged battery, etc.
	Damage to wiring harness.	Locate damage and repair or replace harness.
Clutch or clutches will not disengage.	Input and output shafts out of alignment.	Align input and output shafts to prevent drag.
	Input or output shaft is pushed in too far creating a coupler.	Reposition input and output shafts.

# MAINTENANCE

## TWO-SPEED POINT ROW CLUTCH

The two-speed point row clutch is similar in design and operation to the standard point row clutch except for the two-speed function. If a two-speed clutch or clutches fail to operate properly, refer to “Point Row Clutch Inspection” and “Point Row Clutch Troubleshooting” for additional information.

**NOTE: If the “Reduced Rate/Full Rate” functions fail to engage or disengage, see troubleshooting chart for possible cause.**

(TWL75)

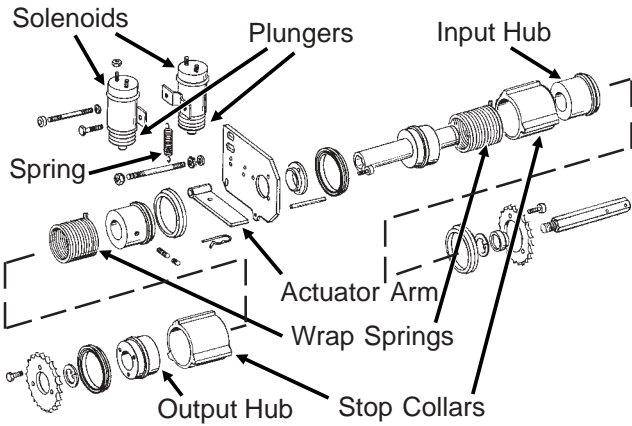

## RELIEF VALVE (Located On Hitch )

All 12 Row - 16 Row If Applicable

(TWL148/TWL171)

STYLE A



STYLE B

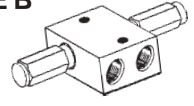

The relief valve pressure is preset and is not adjustable.

## PILOT OPERATED CHECK VALVE INSPECTION (Located In Valve Block On R.H. Side Of Center Pivot)

(TWL30b)

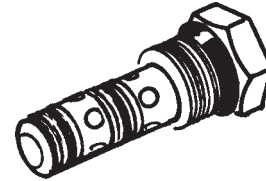

The pilot operated check valve prevents the wing lock cylinders from retracting without applied hydraulic pressure. The wing lock cylinders become the wing flex upper stop during field operation. If the valve fails to function properly, remove the valve from the valve block and check for foreign material or check to see if the o-ring is leaking internally. Replace if found to be defective.

# MAINTENANCE

---

## CHECK VALVE (Located In Valve Block On Rear Center Frame)

(TWL30)

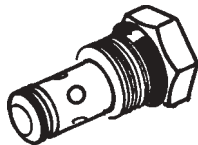

The check valves, located in the valve block on the rear side of the center post, trap oil flow in the planter's lift system to keep the toolbar level during field operation. Consult your KINZE® Dealer for service.

## FLOW CONTROL VALVE INSPECTION (Located In Valve Block On Rear Center Frame)

VVB020(TWL28)

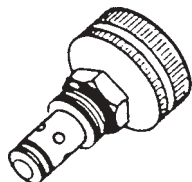

The flow control valves should be adjusted for row marker raise and lower speed as part of the assembly procedure or upon initial operation. If the valve fails to function properly or requires frequent adjustment, it should be removed for inspection. Check for foreign material and contamination on both the valve and the seating area of the valve body. Replace any components found to be defective.

## PRESSURE RELIEF VALVE INSPECTION (Located In Valve Block On Hitch)

VVB020(TWL29)

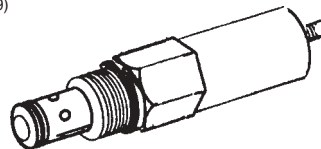

If the pressure relief valve fails to release the tongue lock or function properly, remove the valve from the valve block and check for foreign material or check to see if the o-ring is leaking internally. Replace if found to be defective.

## FLOW CONTROL VALVE INSPECTION (Located In Valve Block On Front Center Frame)

(TWL28a)

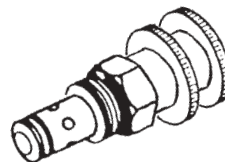

The flow control valve allows auger speed to be varied to meet seed demand. If the valve fails to function properly or requires frequent adjustment, it should be removed for inspection. Check for foreign material and contamination on both the valve and the seating area of the valve body. Replace any components found to be defective.

# MAINTENANCE

## PRESSURE RELIEF VALVE INSPECTION (Located In Valve Block On Front Center Frame)

(TWL24c)

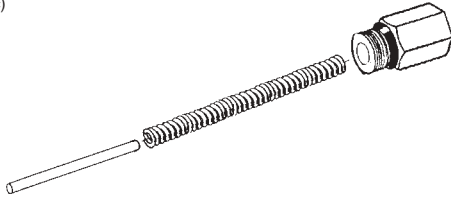

The pressure relief valve limits the applied pressure to the hydraulic auger drive motors to prevent mechanical damage to the motors. If the valve fails to function properly, it should be removed for inspection. Check for foreign material and contamination on both the valve and the seating area of the valve body. Replace any components found to be defective.

## CHECK VALVE INSPECTION (Located In Valve Block On Front Center Frame)

(TWL24b)



The check valve operates as an in-line check in the return line to prevent reverse operation of the auger system. If the valve fails to function properly, it should be removed for inspection. Check for foreign material or check to see if the o-ring is leaking internally. Replace if found to be defective.

## SOLENOID VALVE INSPECTION

VVB019(PLTR55)

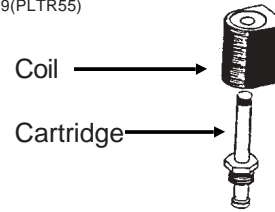

The solenoid valve consists of a chambered body containing a cartridge valve which is activated by an electrical coil.

If the solenoid or solenoids fail to operate, first determine if the problem is electrical or hydraulic. If the valve is working properly, a click will be heard when the solenoid coil is energized. This will be the valve stem opening up. If no sound is heard, check the solenoid coil by touching the top of the coil housing with a metallic object such as a pliers or screwdriver. If the coil is working properly, the coil housing will be strongly magnetized when energized. If the voltage to the coil is low, the coil will be weakly magnetized when energized and no click will be heard.

## SOLENOID VALVE TROUBLESHOOTING

PROBLEM	POSSIBLE CAUSE	SOLUTION
None of the solenoids will operate.	Low voltage.	Must be connected to 12 volt DC only. Negative ground.
	Blown fuse.	Replace fuse in control console on tractor with AGC-15 amp only.
	Battery connection.	Clean and tighten.
	Wiring harness damaged.	Repair or replace.
One solenoid valve will not operate.	Bad switch.	Replace on control panel.
	Cut wire in harness.	Locate and repair.
	Bad coil.	Replace.
	Poor connection at coil.	Check.
Valve operating when not energized.	Valve stem stuck open.	Replace cartridge.
	O-ring leaking.	Install new o-ring kit.
	Foreign material under poppet.	Remove cartridge and clean.

# MAINTENANCE

## LIFT CIRCUIT TROUBLESHOOTING

PROBLEM	POSSIBLE CAUSE	SOLUTION
Right wing raises faster than left wing. The right wing may even raise completely before the center frame and left wing start to raise. If the planter is loaded, the center frame and left wing may not be able to raise at all.	Master cylinder, located on front side of center post, leaking internally. NOTE: Make sure the lift system is completely rephased.	Repair or replace master cylinder.
Left wing raises faster than right wing. The left wing may even raise completely before the center frame and right wing start to raise. If the planter is loaded, the center frame and right wing may not be able to raise at all.	Master cylinder, located on rear side of center post, leaking internally. NOTE: Make sure the lift system is completely rephased.	Repair or replace master cylinder.
Center frame will raise, but wings do not.	Planter hydraulic circuit out of phase. Usually occurs when the planter is lowered from transport position.	Hold hydraulic lever in lowering position to give the hydraulic circuit more time to rephase.
Center frame will continue to raise after the wing cylinders have reached full stroke when going to raised field position.	Solenoid valve in port V16 leaking.	Replace solenoid valve cartridge.
Planter will raise to raise field position, but will not raise to transport position.	Solenoid valve coil in port V16 is not energized.	Be sure control console switch is in "raise" position to energize solenoid coil in port V16. Check control console fuse by moving auxiliary switch to ON position. If red light comes on the fuse is OK. Return auxiliary to OFF position. Check for poor wire connection or damaged wire and repair. Solenoid valve coil is defective. All solenoid valves used on the planter are the same. Switch the solenoid coil with one you know is working. If this cures the problem, replace defective coil.
	Solenoid valve cartridge in port V16 is stuck closed.	All solenoid valves used on the planter are the same. Switch the solenoid cartridge with one you know is working. If this cures the problem, replace defective cartridge.
Left wing lowering slower than center frame and right wing. If hydraulic lever is held in lowering position, the left wing cylinder will attempt to extend.	Check valve in port V17 leaking internally.	Remove check valve in port V17 and inspect for foreign material in valve and remove if possible. Replace check valve. If above fails, switch check valve in port V17 with check valve in port V15. If problem moves or switches to right wing, replace defective check valve.

(Continued On Following Page)



# MAINTENANCE

## LIFT CIRCUIT TROUBLESHOOTING (Continued)

PROBLEM	POSSIBLE CAUSE	SOLUTION
Right wing lowering slower than center frame and left wing. If hydraulic lever is held in lowering position, the right wing cylinder will attempt to extend.	Check valve in port V15 leaking internally.	Remove check valve in port V15 and inspect for foreign material in valve and remove if possible. Replace check valve. If above fails, switch check valve in port V15 with check valve in port V17. If problem moves or switches to right wing, replace defective check valve.
Planter will not raise.	Tractor may have hydraulic problem.	Repair tractor hydraulics.
	Planter may be overloaded with hopper extensions and/or extra fertilizer tanks, coulters or non-KINZE® approved attachments.	Remove weight.
	Center pivot wear pads may be adjusted too tight and are now binding on the post.	Adjust pads.
	Check relief valve pressure should be 2500 PSI (±50).	Replace defective cartridge.
Planter will not rephase.	Piston seal expanded into barrel rephasing grooves. (Only cylinders with rephasing groove in barrel.)	Consult your KINZE® Dealer.
	All cylinders not completely retracted. Caused by mechanical interference on or between planter frame and wheel lift module.	Remove interference.
	One or more cylinders are completely retracted but not bypassing oil and not allowing remaining cylinders to retract.	Move tractor hydraulic lever to the raise position briefly and down again. Slow down the lowering of the planter from the raised transport position to the planting position. This will slow the flow of oil that passes by the rephasing groove in the wing cylinders.
Planter will not lower or lowers too slow.	Lift cylinder counter balance valve pilot pressure set too high.	Adjust pilot pressure on valve.  Turn screw clockwise to reduce setting and release load. Complete adjustment range is 3 turns.

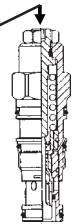

# MAINTENANCE

## TONGUE CYLINDER CIRCUIT TROUBLESHOOTING

PROBLEM	POSSIBLE CAUSE	SOLUTION
Tongue cylinder will not extend, but will retract.	No power to solenoid valve coil in port V10 and/or V14. Both must be energized.	Check wiring between control console and solenoid coils looking for damaged wires and poor connections.
	Solenoid valve coil defective.	Switch coil from port V13 with V10. If tongue still will not extend, switch coil from V14 with V13. It will not be necessary to remove any of the wire connections to the solenoid. All three of these solenoids are normally energized when the tongue switch is energized. Replace defective coil.
	Solenoid valve cartridges in port V10 and/or V14 stuck closed.	Switch cartridge from port V10 with cartridge in port V13. If tongue cylinder retracts, replace defective cartridge from port V10. If problem continues, switch cartridge from port V14 with cartridge in port V13. Replace defective cartridge.
Tongue cylinder will not extend but tongue lock cylinder extends.	Pressure relief valve in port V11 stuck closed or pressure setting too high. (Valve is factory set to open at 1000 PSI.)	Replace or adjust pressure relief valve. To adjust, loosen lock nut and turn counterclockwise to decrease pressure.
Tongue hook does not release before the tongue starts to extend.	Solenoid valve cartridge in port V11 stuck open or pressure setting too low. (Valve is factory set to open at 1000 PSI.)	Replace or adjust pressure relief valve. To adjust, loosen lock nut and turn clockwise to increase pressure.
Tongue cylinder will not retract, but will extend.	Solenoid valve coil in port V13 defective.	Switch coil from port V13 with coil from port V14. If coil from port V13 is bad, the tongue will extend but not retract. Replace defective coil.
	Solenoid valve cartridge in port V13 stuck closed.	Switch cartridge from port V13 with cartridge from port V14. If cartridge is bad, the tongue will extend but not retract. Replace defective cartridge.
Tongue extends with the switch off.	Solenoid valve cartridge in port V10 and V14 stuck open.	Replace solenoid valve cartridge.
Tongue retracts with the switch off.	Solenoid valve cartridge in port V13 stuck open.	Replace solenoid valve cartridge.

# MAINTENANCE

## ROTATION CYLINDER CIRCUIT TROUBLESHOOTING

PROBLEM	POSSIBLE CAUSE	SOLUTION
Cylinder does not extend, but will retract.	Solenoid valve coil in port V12 defective.	Switch coil from port V12 with coil in port V9. If cylinder extends but will not retract, replace defective coil from port V12.
	Solenoid valve cartridge in port V12 is stuck closed.	Switch cartridge from port V12 with cartridge in port V9. If cylinder extends but will not retract, replace defective cartridge from port V12.
Cylinder does not retract, but will extend.	Solenoid valve coil in port V9 defective.	Switch coil from port V9 with coil in port V12. If cylinder extends but will not retract, replace defective coil from port V9.
	Solenoid valve cartridge in port V9 is stuck closed.	Switch cartridge from port V9 with cartridge in port V12. If cylinder extends but will not retract, replace defective cartridge from port V9.

# MAINTENANCE

## WING LOCK CYLINDER CIRCUIT TROUBLESHOOTING

PROBLEM	POSSIBLE CAUSE	SOLUTION
Cylinders will not extend or retract.	No power to the solenoid valve coils.	Auxiliary switch may be in the ON position. Must be in OFF position. Check fuse at control console. Replace fuse with 15 amp type AGC if blown. Check for poor wire connection or damaged wire. Repair as required.
Cylinders will not extend.	Solenoid valve coil in port V4 not energized.	Check for power to coil. Check coil ground wire. If OK, switch coil from port V3 with coil from port V4. If cylinders extend but will not retract, replace defective coil.
	Solenoid valve cartridge in port V4 stuck closed.	Switch cartridge in port V3 with cartridge in port V4. If cylinders extend but will not retract, replace defective cartridge.
	Pilot pressure on counter balance valve port S1 set too high.	*Adjust pilot pressure on valve.  Turn screw clockwise to reduce setting and release load. Complete adjustment range is 3 turns.
Cylinders will not retract.	Solenoid valve coil in port V3 not energized.	Check for power to coil. Check coil ground wire. If OK, switch coil from port V4 with coil from port V3. If cylinders retract but will not extend, replace defective coil.
	Solenoid valve cartridge in port V3 stuck closed.	Switch cartridge in port V4 with cartridge in port V3. If cylinders retract but will not extend, replace defective cartridge.
	Pilot operated check valve in port D10 stuck closed.	Replace pilot operated check valve.
Cylinders retract with the switch off.	Solenoid valve cartridge in port V3 stuck open.	Replace solenoid valve cartridge.
Cylinders extend with the switch off.	Solenoid valve cartridge in port V4 stuck open.	Replace solenoid valve cartridge.
Cylinder leaks down. Will not hold weight of wing in transport.	Counter balance valve leaking or stuck open.	*Switch valves with another cylinder. If this resolves the problem, replace defective valve. If it does not, check for internal leak in cylinder.

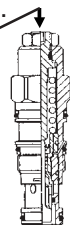

\*Adjustment or replacement to wing cylinder counter balance valves should be made with the planter lowered to planting position, tractor off and system hydraulic pressure relieved.

# MAINTENANCE

## MARKER OPERATION TROUBLESHOOTING

PROBLEM	POSSIBLE CAUSE	SOLUTION
Right marker lowering slower than left marker.	Solenoid valve cartridge in port V1 not opening completely.	Switch cartridge with one in port V2. If problem follows cartridge, replace cartridge.
	Hose pinched or collapsed.	Inspect hose routing. Replace or repair hoses as required.
Left marker lowering slower than right marker.	Solenoid valve cartridge in port V2 not opening completely.	Switch cartridge with one in port V1. If problem follows cartridge, replace cartridge.
	Hose pinched or collapsed.	Inspect hose routing. Replace or repair hoses as required.
Both markers lowering.	Solenoid valve cartridge stuck open. If marker switch is in the left marker position, the right cartridge (V1) is defective. If the marker switch is in the right marker position, the left cartridge (V2) is defective.	Replace solenoid valve cartridge.
Neither marker will lower.	Blown fuse.	Check red light on control console. It should be on if switch is on. If light is not on, switch to opposite marker position. If light comes on, switch may be defective. Replace switch. Otherwise replace fuse.
	Coils at V1 and V2 not energized.	Poor ground on wire, bad wire connection or damaged wire. Repair as required.
	Marker flow control valve closed too far.	See Operation Section for adjustment.
Neither marker will raise.	Marker flow control valve closed too far.	See Operation Section for adjustment.
Right marker will not lower.	Solenoid coil in port V1 not energized.	Check switch on control console. Replace if defective. Check coil ground wire. Check for poor connection or damaged wire.
	Solenoid cartridge in port V1 stuck closed.	Switch cartridge with one on the planter you know is operating properly. If right marker lowers, replace defective cartridge.
Left marker will not lower.	Solenoid coil in port V2 not energized.	Check switch on control console. Replace if defective. Check coil ground wire. Check for poor connection or damaged wire.
	Solenoid cartridge in port V2 stuck closed.	Switch cartridge with one on the planter you know is operating properly. If left marker lowers, replace defective cartridge.
Markers traveling too fast and damaging rubber stop on transport stands and/or damaging pivot at rod end of marker cylinders.	Marker transport stand not adjusted correctly to allow marker cushion cylinders to operate as designed.	See "Marker Transport Stand Adjustment".
	Marker flow control valve out of adjustment.	See Operation Section for adjustment.

# MAINTENANCE

## MARKER TRANSPORT STAND ADJUSTMENT

It is critical that the marker transport stands are adjusted correctly to allow the marker cushion cylinders to function properly.

To adjust the transport stands:

1. Fold markers to transport position.
2. Loosen mounting hardware to allow transport stands to drop down or remove transport stands.
3. With tractor engine shut off, release hydraulic pressure on marker cylinders.
4. Locate transport stands so marker arm rests lightly on transport stand. When the transport stands are correctly adjusted the pin at the rod end of the cylinder should be loose enough to rotate and move back and forth in the mounting slot.
5. Torque mounting hardware.

(TWL200a)

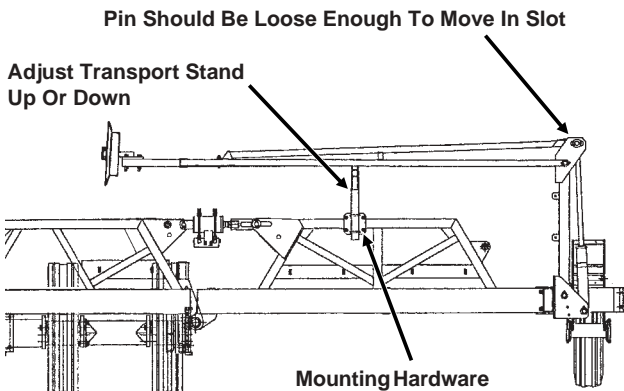

## MARKER BEARING LUBRICATION OR REPLACEMENT

1. Remove marker blade.
2. Remove dust cap from hub.
3. Remove cotter pin, nut and washer.
4. Slide hub from spindle.
5. Remove bearings and cups and discard if bearings are being replaced. Clean hub and dry. Remove bearings only and not cups if repacking.
6. Press in new bearing cups with thickest edge facing in. (Bearing replacement procedure only.)
7. Pack bearings with heavy duty wheel bearing grease thoroughly forcing grease between roller cone and bearing cage. Also fill the space between the bearing cups in the hub with grease.
8. Install rubber seal into grease seal. Place inner bearing in place and press in new rubber seal/grease seal.
9. Clean spindle and install hub.
10. Install outer bearing, washer and slotted hex nut. Tighten slotted hex nut while rotating hub until there is some drag. This assures that all bearing surfaces are in contact. Back off slotted nut to nearest locking slot and install cotter pin.
11. Fill dust caps approximately  $\frac{3}{4}$  full of wheel bearing grease and install on hub.
12. Install blade and dust cap retainer on hub and tighten evenly and securely.

(PLTR45/PLTR99/PLTR98/PLTR102)

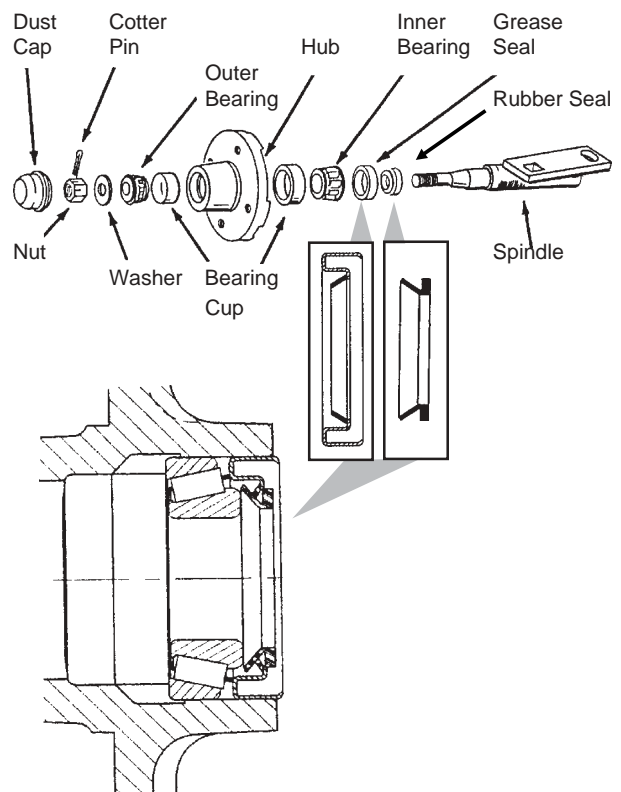

# MAINTENANCE

## WHEEL BEARING LUBRICATION OR REPLACEMENT

**NOTE: Each transport wheel hub is equipped with a grease fitting for lubrication. The below procedure is used only for bearing replacement.**

1. Raise tire clear of ground and remove wheel.
2. Remove double jam nuts and slide hub from spindle.
3. Remove bearings, seals (Where Applicable) and cups and discard if bearings are being replaced. Clean hub and dry. Remove bearings only and not cups if repacking.
4. Press in new bearing cups with thickest edge facing in. (Bearing replacement procedure only.)
5. Pack bearings with heavy duty wheel bearing grease thoroughly forcing grease between roller cone and bearing cage. Also fill the space between the bearing cups in the hub with grease.
6. Place inner bearing and seal (Where Applicable) in place.
7. Clean spindle and install hub.
8. Install outer bearing, seal (Where Applicable) and stepped nut. Tighten jam nut while rotating hub until there is some drag. This assures that all bearing surfaces are in contact. Back off jam nut  $\frac{1}{4}$  turn or until there is only slight drag when rotating the hub. Install second jam nut to lock against first.
9. Install wheel on hub and tighten evenly and securely. Torque wheel bolts to specified torque.

(EF35e)

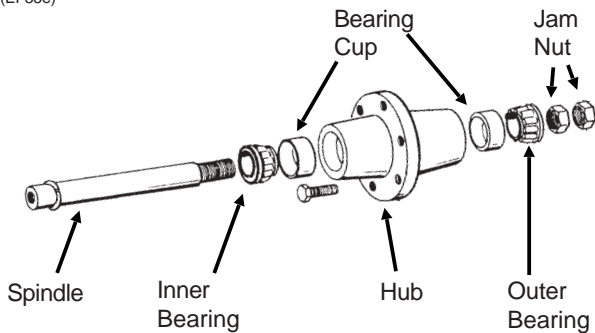

HTA029(PLTR56)

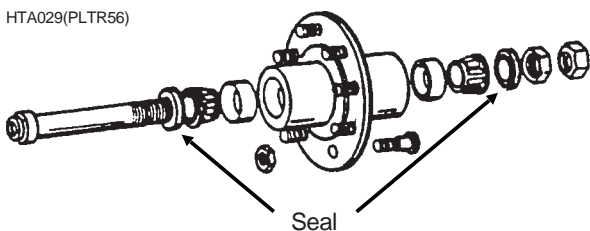

## WEAR PAD REPLACEMENT AND ADJUSTMENT

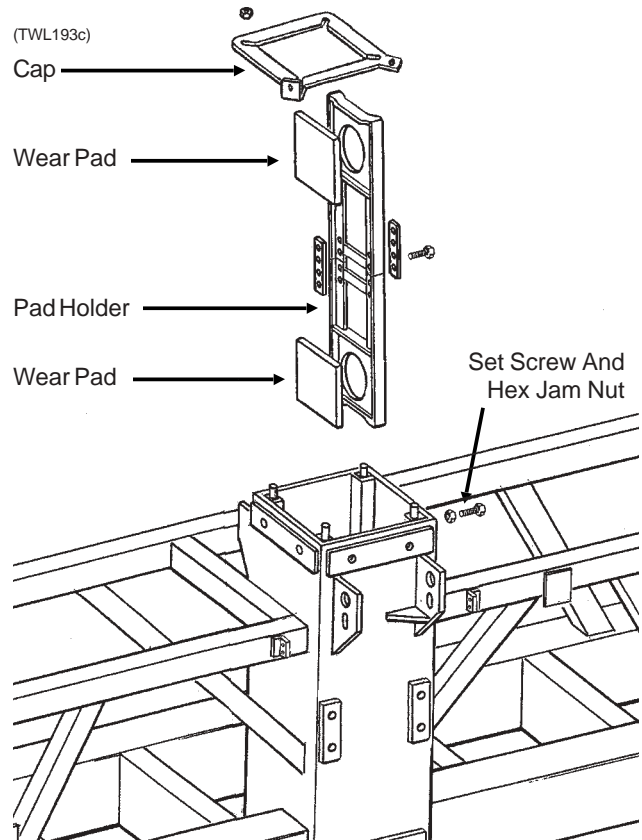

The center section of the planter consists of a steel tubular frame equipped with four wear pad assemblies which travel up and down against a stainless steel clad center post. Each wear pad assembly consists of a pad holder and two wear pads. The wear pads are held in place by the pad holder and adjusted and locked in adjustment by  $\frac{3}{4}$ " set screws and hex jam nuts.

Check pad adjustment and wear annually. Replace any broken or missing adjustment set screws.



**WARNING: Always install all safety lockups and safety lock pins before working under the unit.**

To check adjustment and wear, park the planter on a level surface. Raise the planter to the raised field position. Visually check the four upper adjustable wear pads. Each wear pad should lightly contact the stainless steel clad center post. The maximum allowable gap between the plastic wear pad and the stainless steel post, when checked using a thickness gauge, should be no more than .060". Raise the planter to the raised transport position, install all safety lockups and visually check the four lower adjustable wear pads. Maximum allowable gap on the lower pads is .060" also.

# MAINTENANCE

(TWL109b)

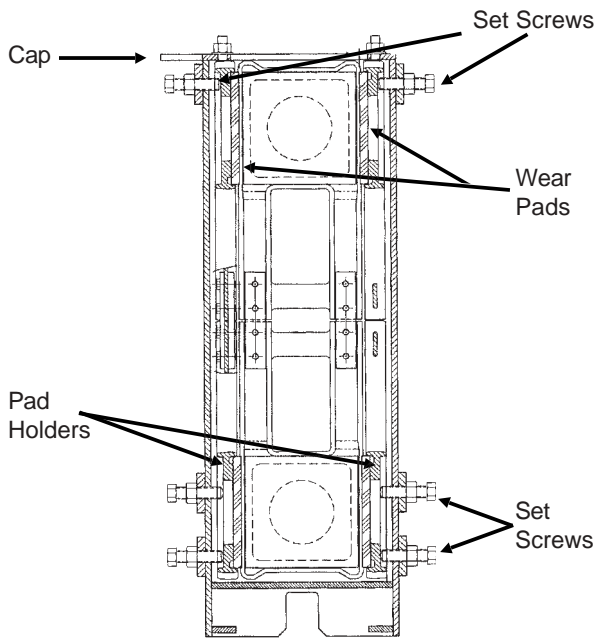

If adjustment is necessary proceed as follows: (a) Lower the planter to field operation position. It may be necessary to the loosen cap mounting nuts to allow wear pad adjustment. (b) Loosen the necessary hex jam nuts. (c) Tighten set screws until the wear pad lightly contacts the stainless steel clad center post. **DO NOT OVER TIGHTEN.** (d) Tighten hex jam nuts. (e) Recheck clearance. If clearance is not to specifications, repeat adjustment steps. (f) Torque hex jam nuts to 130 ft. lbs. Tighten cap mounting bolts if applicable.

**NOTE: If exposed wear pad is worn to less than 1/8" as shown below, replace the wear pad.**

(TWL149a)

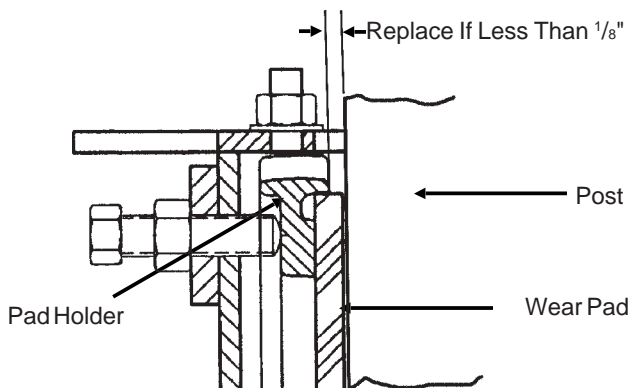

If replacement is necessary proceed as follows: (a) Lower the planter to field operation position. (b) Remove the four 5/8" nuts and remove the cap from the top of the center post. It will be necessary to remove the hose clamp first. (c) Remove the sixteen 3/4" hex jam nuts and set screws, which lock the wear pads in place, and slide the four wear pad holders with wear pads out of the top of the center post. (d) Place a minimal amount of heavy grease in pad holder prior to installing pad to hold pad in place during installation. (e) Reinstall the wear pad assembly. (f) Apply an anti-seize lubricant to set screw threads. Hand tighten set screw until the wear pad lightly contacts the stainless steel clad center post.

**IMPORTANT: DO NOT OVER TIGHTEN WEAR PADS. OVER TIGHTENING WILL CAUSE PREMATURE WEAR.**

(g) Install and torque hex jam nuts to 130 ft. lbs. (h) Position the center post cap over the studs and torque the nuts evenly alternating between studs. Tighten the nuts until the cap is distorted as shown in the photo below.

10249620a

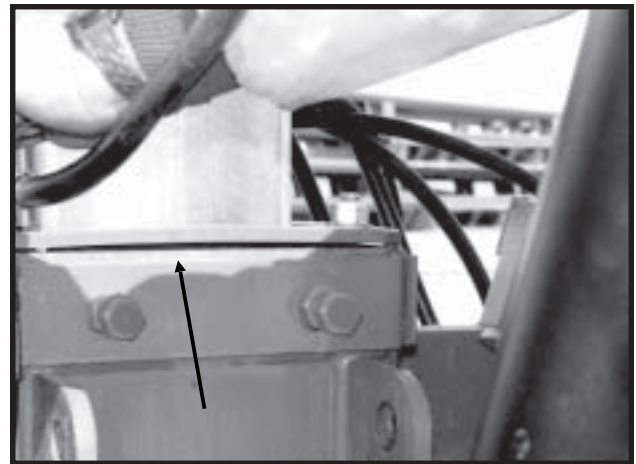



# MAINTENANCE

## PISTON PUMP STORAGE

**IMPORTANT: KEEP AIR OUT OF PUMP! This is the only way to prevent corrosion. Even for short periods of storage, the entrance of air into the pump, will cause RAPID AND SEVERE CORROSION.**

### Overnight Storage

SUSPENSION FERTILIZER must be flushed from the pump for ANY storage period.

### Winter Storage

1. Flush pump thoroughly with 5 to 10 gallons of fresh water and circulate until all corrosive salts are dissolved in the pump.
2. With the pump set on 10, draw in a mixture of half diesel fuel and half 10 weight oil until the discharge is clean. Then plug inlet and outlet.

12229799

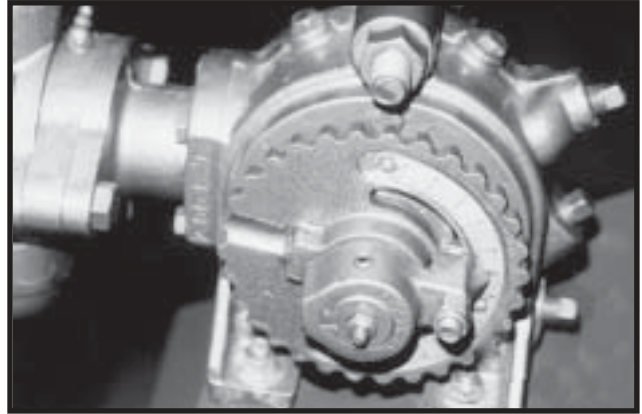

## PISTON PUMP TROUBLESHOOTING

PROBLEM	POSSIBLE CAUSE	SOLUTION
Pump hard or impossible to prime.	Valves fouled or in wrong place.	Inspect and clean valves.
	Air leak in suction line.	Repair leak.
	Pump set too low.	Adjust pump setting.
	Packing washers worn out.	Replace.
Low metering.	Valves fouled or in wrong place.	Inspect and clean valves.
	Air leak in suction line.	Repair leak.
	Pump set too low.	Adjust pump setting.
	Broken valve spring.	Replace spring.
Over meters.	Broken discharge valve spring.	Replace spring.
	Trash under valves.	Inspect and clean valves.
	Improper rate setting.	Adjust pump setting.
Leaks through when stopped.	Broken discharge valve spring.	Replace spring.
	Trash under valves.	Inspect and clean valves.
Fertilizer solution leaking under stuffing box.	Packing washers worn out.	Replace.
Pump using excessive oil.	Oil seals or o-ring worn and leaking.	Replace.
Pump operates noisily.	Crankcase components worn excessively.	Inspect and replace if necessary.

# MAINTENANCE

## PREPARATION FOR STORAGE

Store the planter in a dry sheltered area if possible.

Remove all trash that may be wrapped on sprockets or shafts and remove dirt that can draw and hold moisture.

Clean all drive chains and coat with a rust preventative spray, or remove chains and submerge in oil.

Lubricate planter and row units at all lubrication points.

If possible, remove weight from all tires particularly if the unit is stored outdoors, in which case it is best to remove wheels and tires for storage in a cool, dry area.

Inspect the planter for parts that are in need of replacement and order during the "off" season.

Make sure bulk seed hoppers and all mini-hoppers and granular chemical hoppers are empty and clean.

Clean seed meters and store in a rodent-free, dry area.

Remove seed discs from brush-type seed meters, clean and store meters with discs removed.

Grease exposed areas of cylinder rods before storing planter.

Disassemble, clean and grease all U-joint slides.

Grease or paint disc openers/blades and marker blades to prevent rust.

Flush liquid fertilizer metering pump with clean water. See "Piston Pump Storage".

## ELECTRICAL WIRING DIAGRAM FOR LIGHT PACKAGE

(WGN66a)

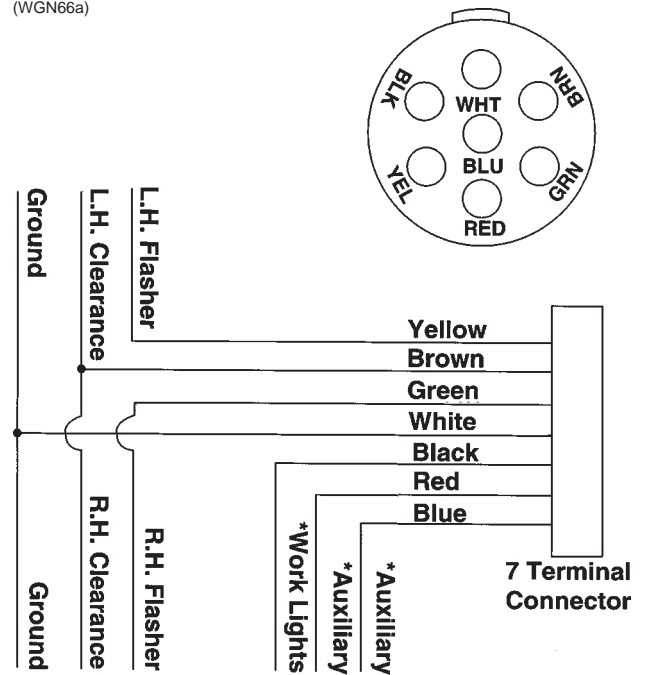

\* Optional customer-supplied auxiliary lights and wires may be wired into existing plug terminals.

Light package supplied on the Model 3650 Twin-Line® Planter meets ASAE Standards. For the correct wiring harness to be wired into the lights on your tractor, check with the tractor manufacturer.

69922-35

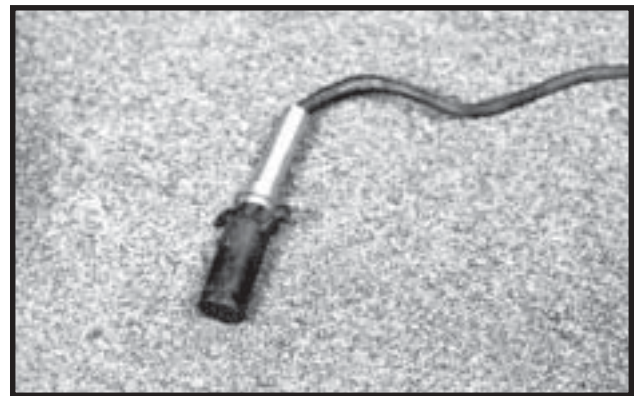

# MAINTENANCE

## ELECTRICAL CONTROL CONSOLE SCHEMATIC

**IMPORTANT:** Before doing any electrical work, disconnect the control console from the tractor battery. Keep wiring harnesses away from high temperature areas or sharp edges. DO NOT route the wiring harnesses along battery cables. Use tie straps to keep wire harness away from moving parts on tractor and planter. Be sure ground connections to the tractor frame are clean to provide good electrical contact.

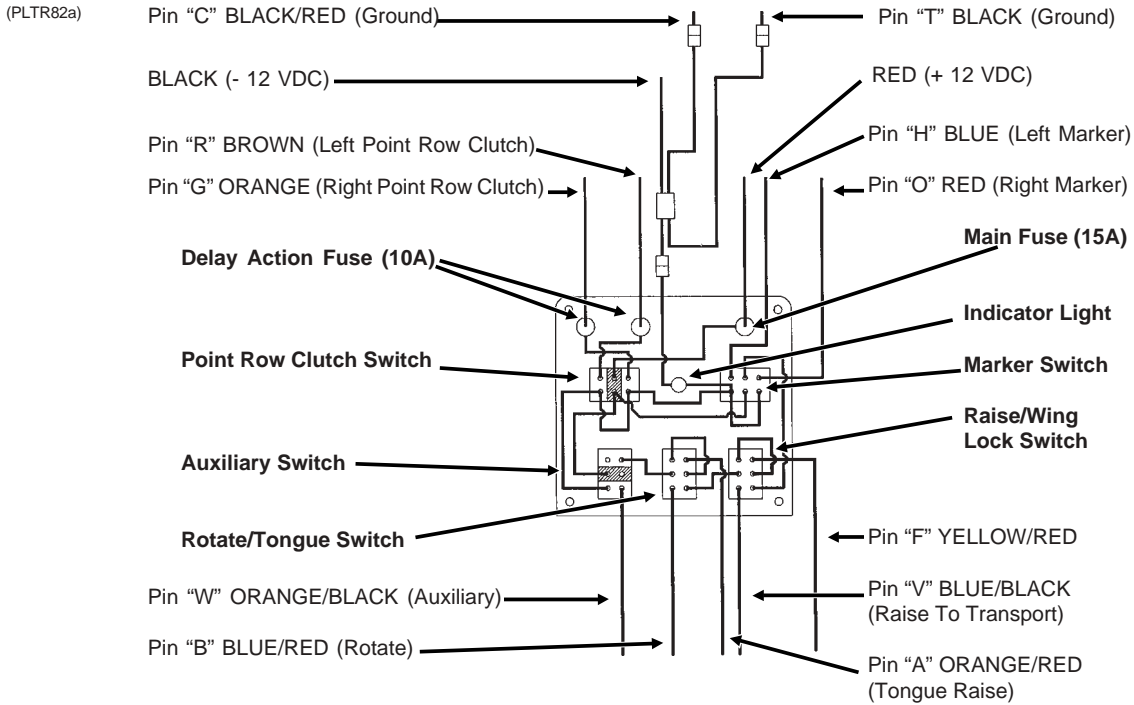

(INS238)

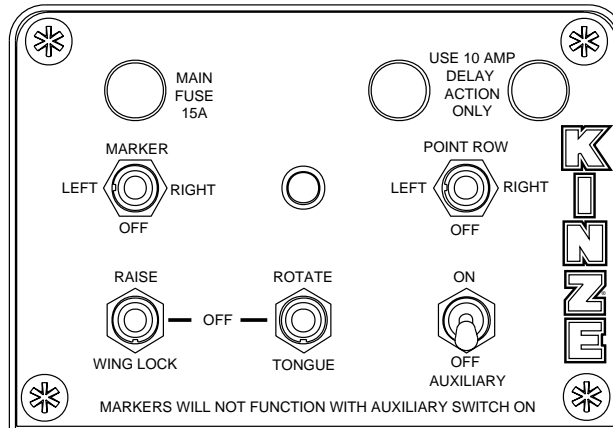

### NOTE:

1. Operating marker or point row switch in either direction lights panel light.
2. Point row clutch switch operates independently of the rest of the control box.
3. Power to the marker switch is fed through the auxiliary switch and the two transport function switches. Operating any of the switches in the lower row disables the marker function and turns off the panel light. (If the point row clutch switch is in the "off" position.)

See page 10-41 for electrical control console schematic and wiring harness to two-speed point row clutch solenoids for planter equipped with the optional Two-Speed Point Row Clutch Package.

# MAINTENANCE

## ELECTRICAL WIRING HARNESS SCHEMATIC (On Tractor)

(ELC10&ELC13)

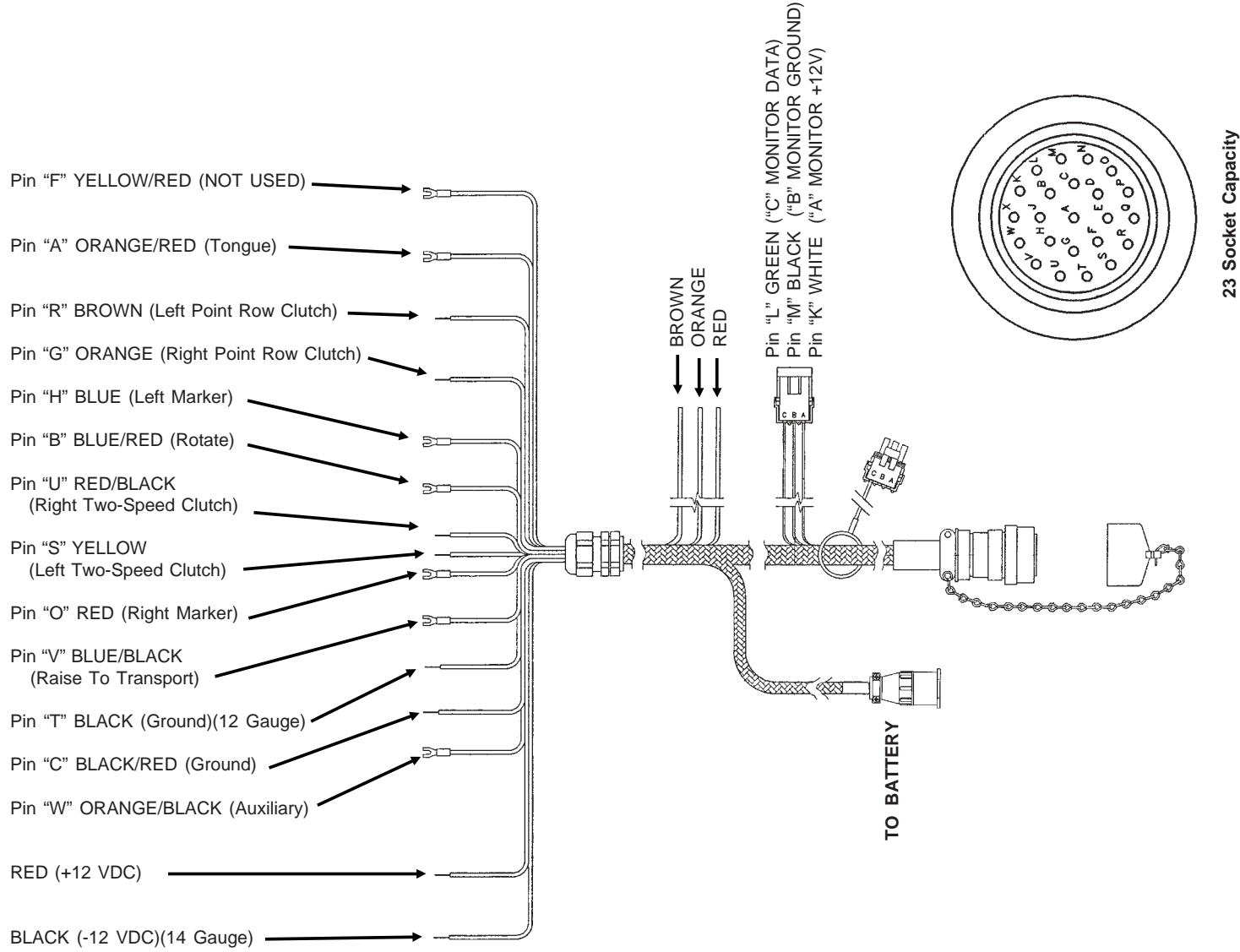

# MAINTENANCE

## ELECTRICAL WIRING HARNESS SCHEMATIC (On Planter)

(ELC13/ELC12b/TWVL71b)

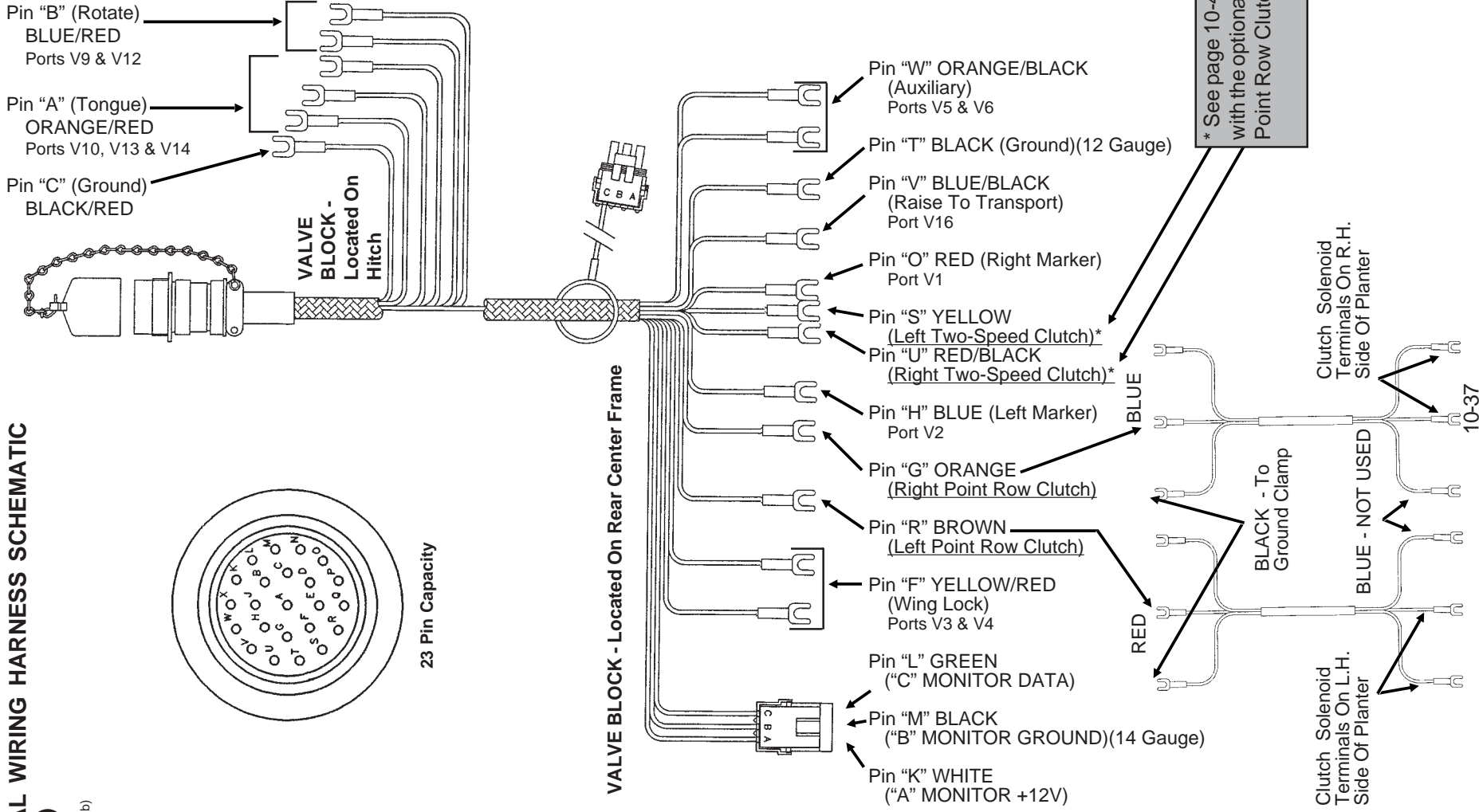

# MAINTENANCE

(A7012a)

## VALVE BLOCK - Located On Hitch

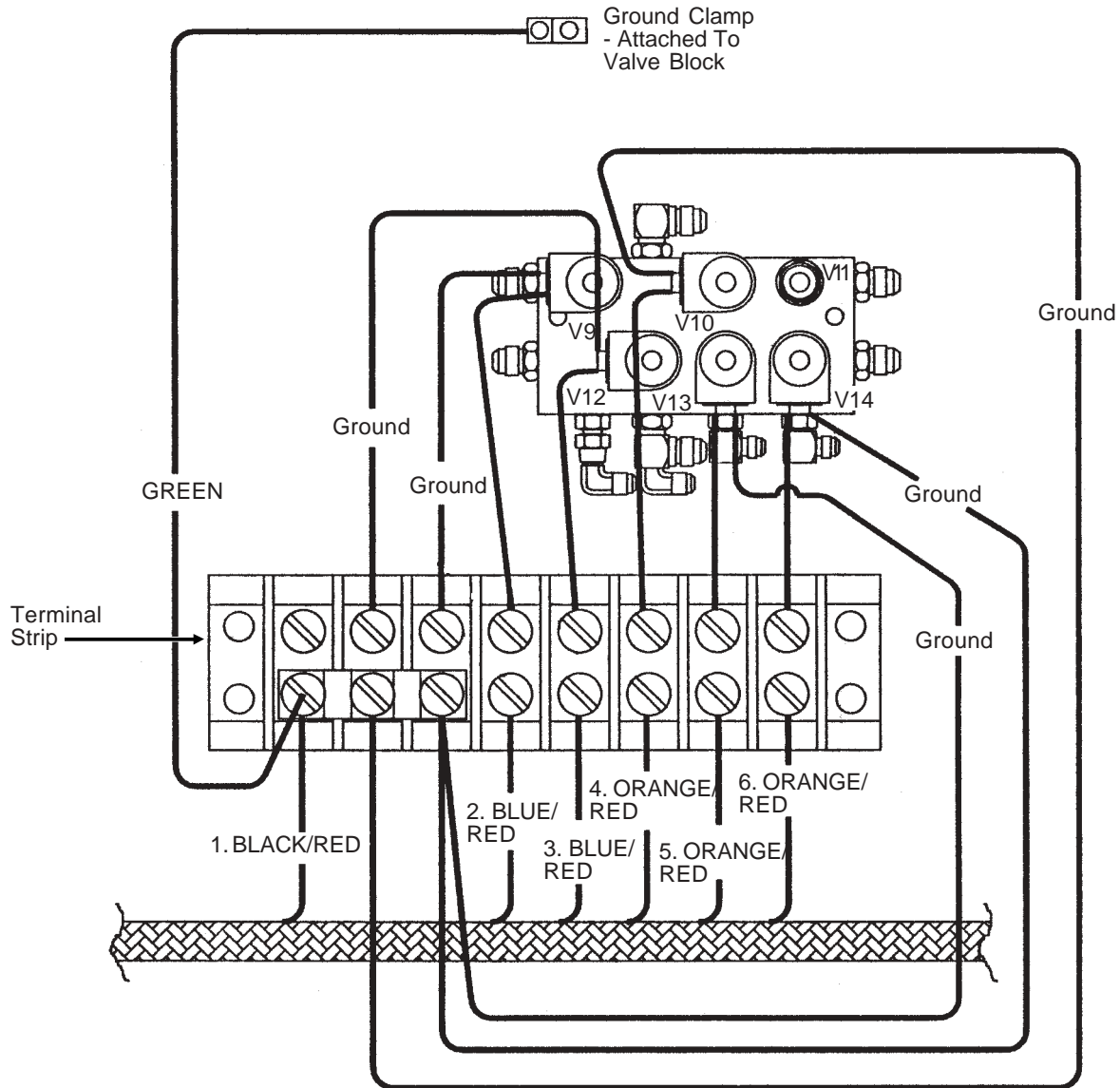

1. BLACK/RED - Pin "C" (Ground)
2. BLUE/RED - Pin "B" (Rotate) - Port V9
3. BLUE/RED - Pin "B" (Rotate) - Port V12
4. ORANGE/RED - Pin "A" (Tongue) - Port V10
5. ORANGE/RED - Pin "A" (Tongue) - Port V13
6. ORANGE/RED - Pin "A" (Tongue) - Port V14

# MAINTENANCE

(A7102a)

## VALVE BLOCK - Located On Rear Center Frame

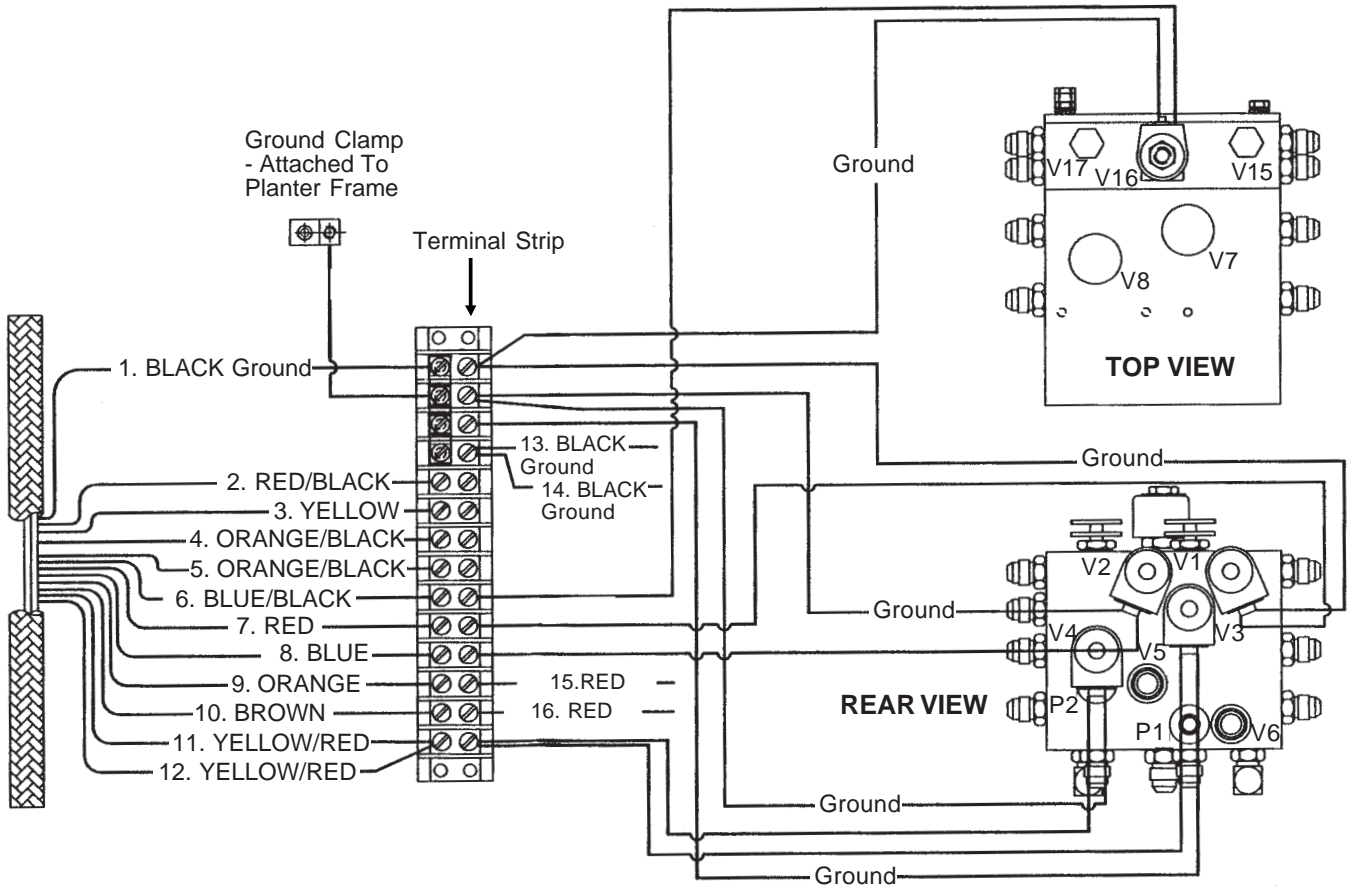

1. BLACK - Pin "T" (Ground)
2. RED/BLACK - Pin "U" (Right Two-Speed Clutch)\*
3. YELLOW - Pin "S" (Left Two-Speed Clutch)\*
4. ORANGE/BLACK - Pin "W" (Auxiliary) - Ports V5 & V6
5. ORANGE/BLACK - Pin "W" (Auxiliary) - Ports V5 & V6
6. BLUE/BLACK - Pin "V" (Raise To Transport) - Port V16
7. RED - Pin "O" (Right Marker) - Port V1
8. BLUE - Pin "H" (Left Marker) - Port V2
9. ORANGE - Pin "G" (Right Point Row Clutch)
10. BROWN - Pin "R" (Left Point Row Clutch)
11. YELLOW/RED - Pin "F" (Wing Lock) - Ports V3 & V4
12. YELLOW/RED - Pin "F" (Wing Lock) - Ports V3 & V4
13. BLACK - (R.H. Point Row Ground)
14. BLACK - (L.H. Point Row Ground)
15. RED - (R.H. Point Row)
16. RED - (L.H. Point Row)

\* See page 10-41 if equipped with the optional Two-Speed Point Row Clutch Package.

# MAINTENANCE

## BULK SEED HOPPER MONITOR SYSTEM WIRING SCHEMATIC

(A9098b)

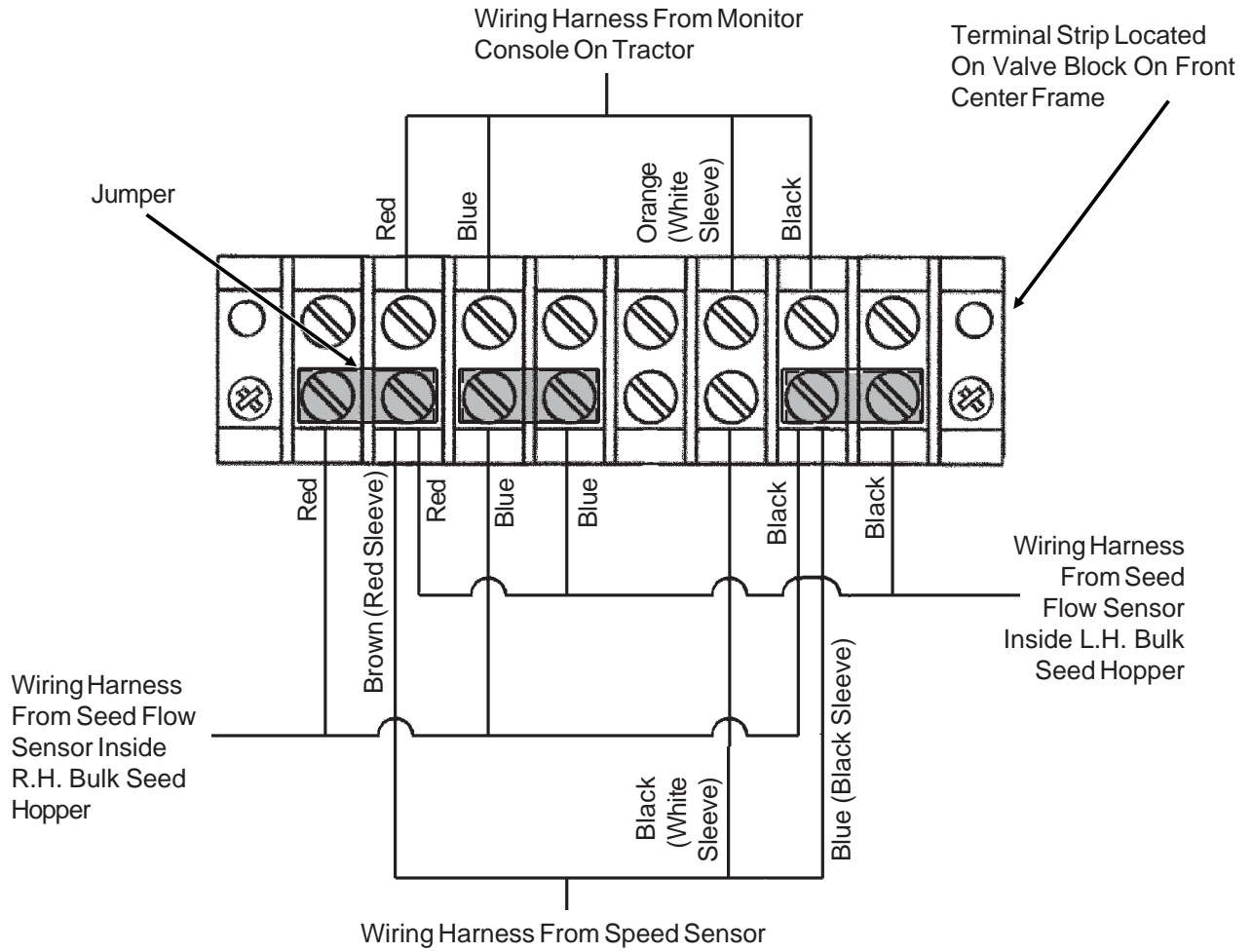



# MAINTENANCE

## ELECTRICAL CONTROL CONSOLE SCHEMATIC (With Optional Two-Speed Point Row Clutches) AND WIRING HARNESS AT TWO-SPEED POINT ROW CLUTCH SOLENOIDS

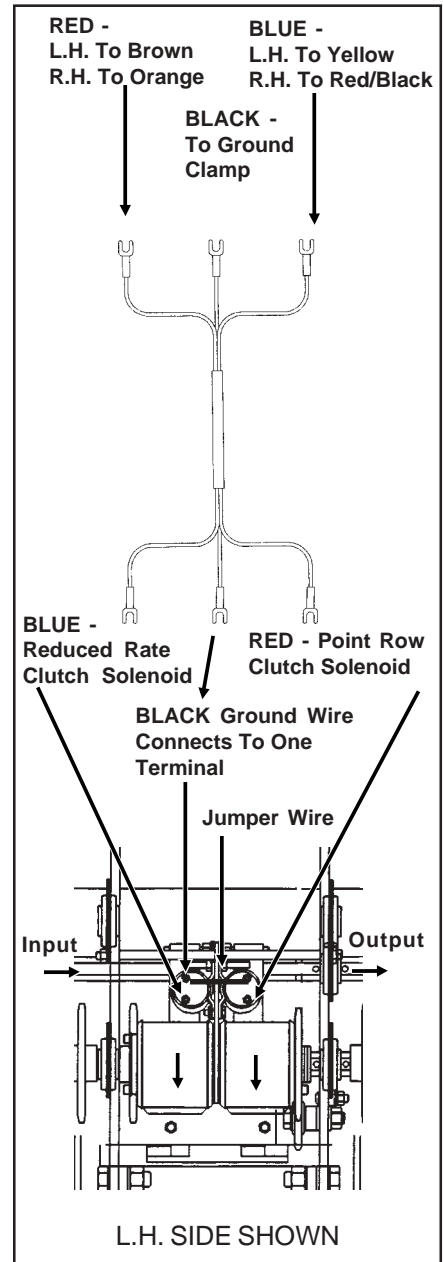
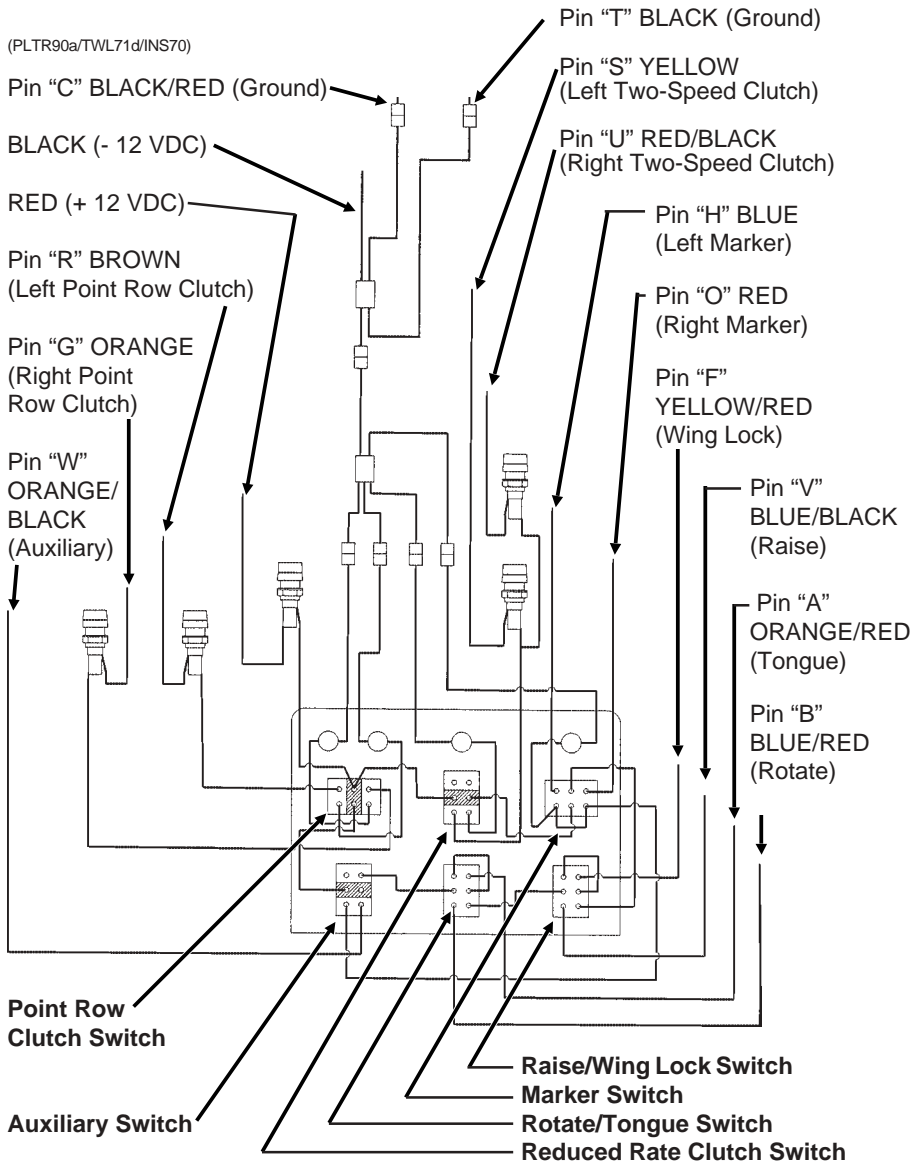

(INS260)

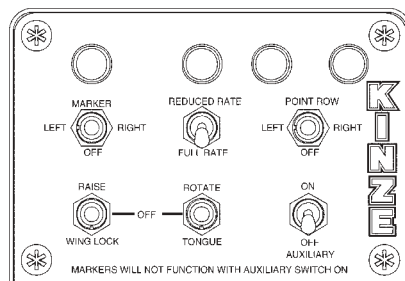

### NOTE:

1. Point row and reduced rate clutch switches operate independently of the rest of the control console.
2. Power to the marker switch is fed through the auxiliary switch and the two transport function switches. Operating any of the switches in the lower row disables the marker function and turns off the panel light for the markers.

**NOTE:** Before doing any electrical work, disconnect the control console from the tractor battery. Keep wiring harnesses away from high temperature areas or sharp edges. **DONOT** route the wiring harnesses along battery cables. Use tie straps to keep wire harness away from moving parts on tractor and planter. Be sure ground connections to the tractor frame are clean to provide good electrical contact.

# MAINTENANCE

## HYDRAULIC SYSTEM SCHEMATIC

(TWL206a)

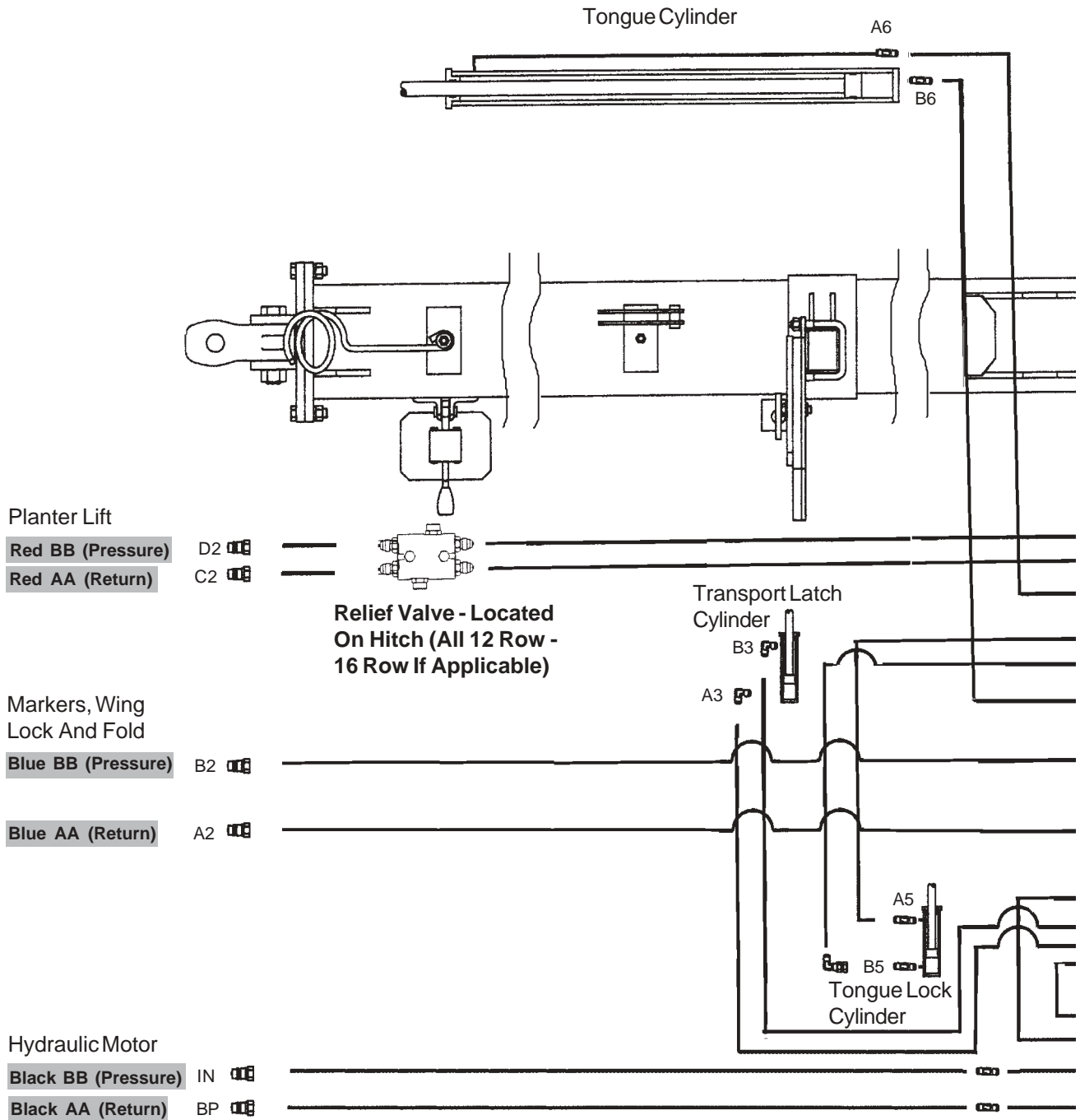

# MAINTENANCE

(TWL115)

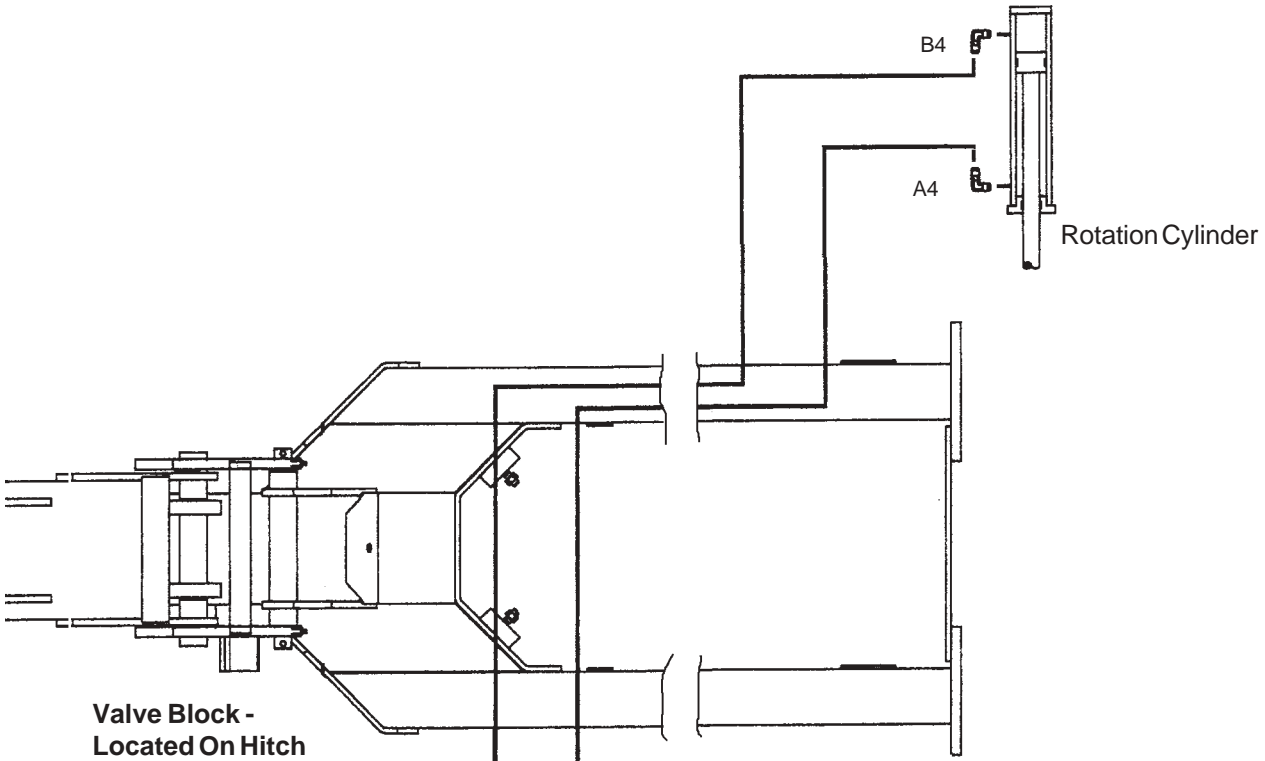
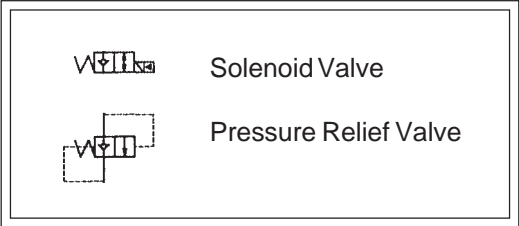

**Valve Block - Located On Hitch**

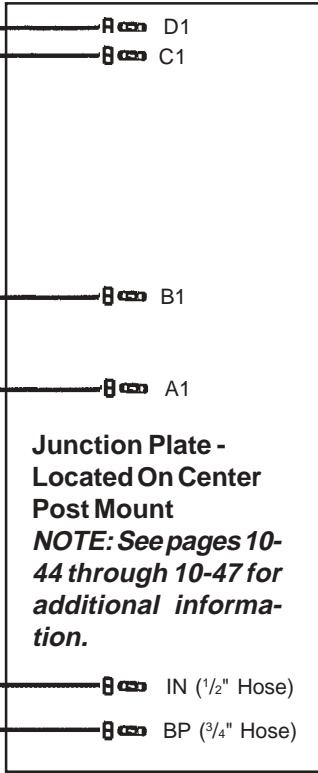
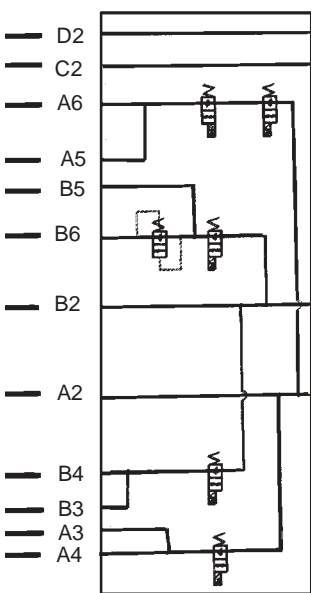

# MAINTENANCE

## HYDRAULIC SYSTEM SCHEMATIC (Continued)

12 Row 30" (One Wing Lift Cylinder Per Wing)

16 Row 30" Shown (Two Wing Lift Cylinders Per Wing)

(TWL207c)

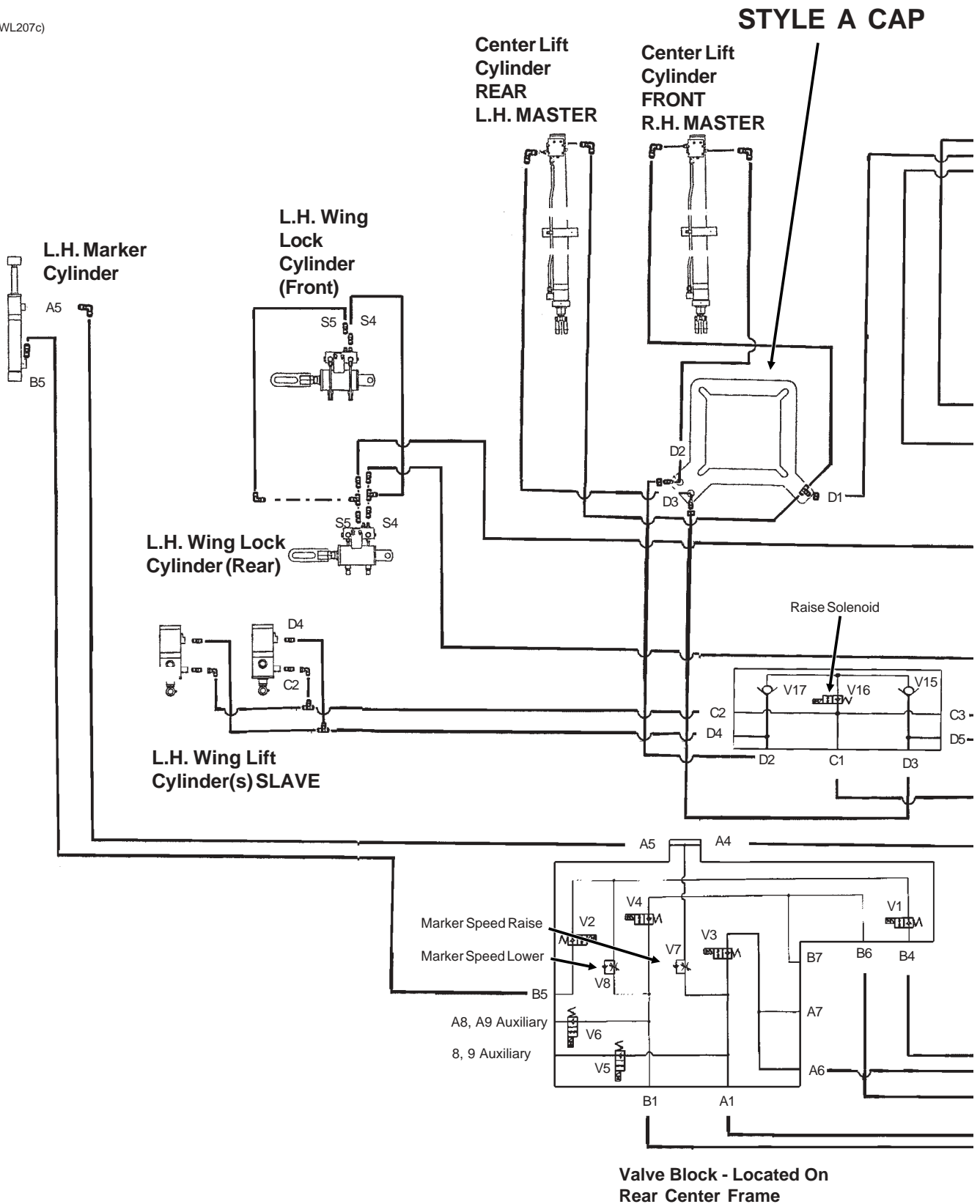

# MAINTENANCE

**Junction Plate -  
Located On Center  
Post Mount**  
*NOTE: See pages 10-  
42 and 10-43 for  
additional information.*

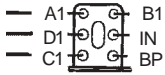

**Hydraulic  
Motor - Left  
Side Of  
Planter**

**Hydraulic  
Motor - Right  
Side Of  
Planter**

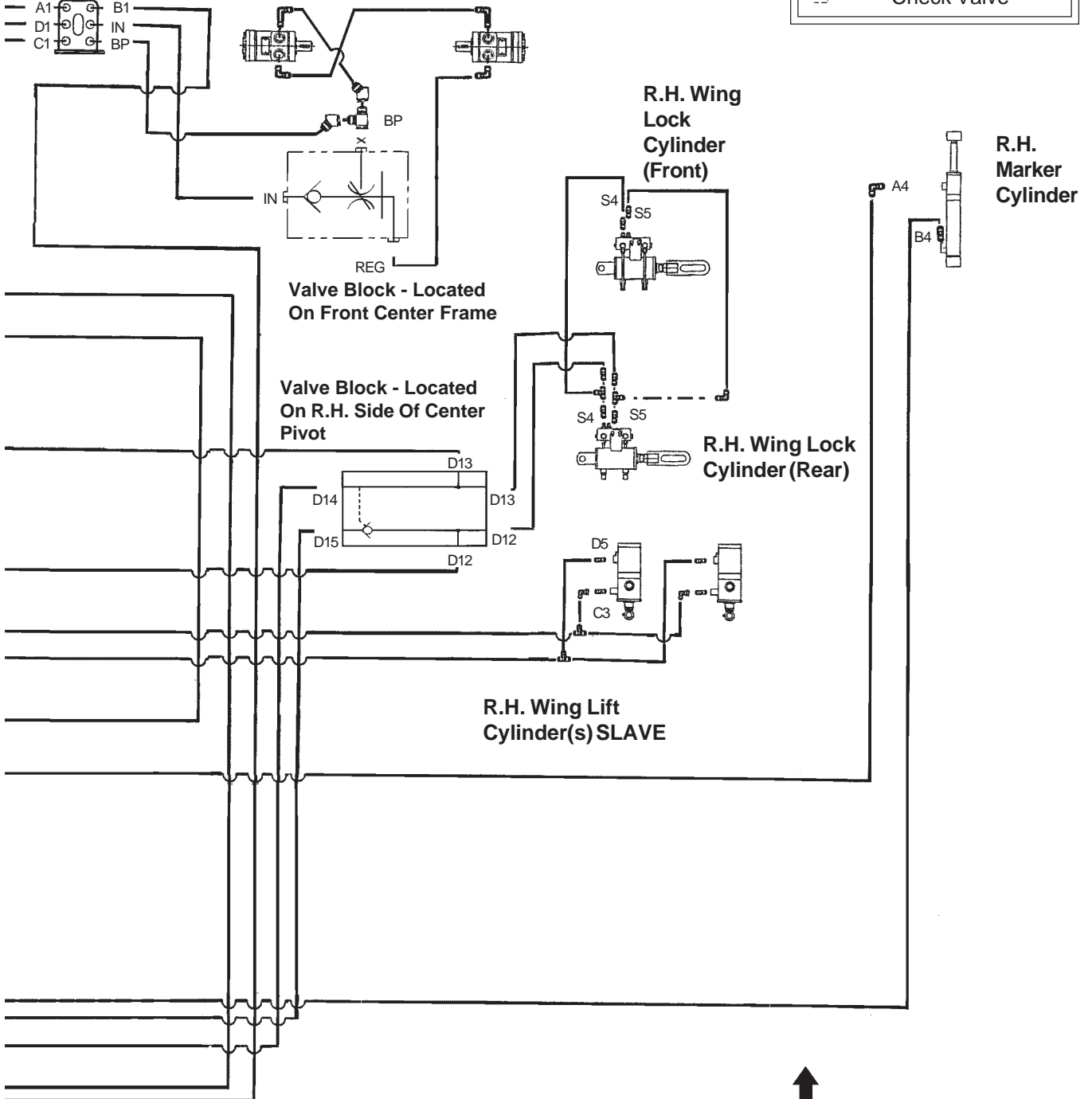
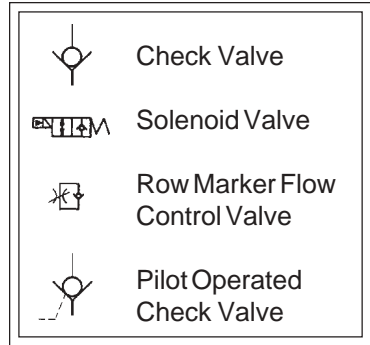

**↑  
DIRECTION  
OF TRAVEL**

# MAINTENANCE

## HYDRAULIC SYSTEM SCHEMATIC (Continued)

12 Row 30" (One Wing Lift Cylinder Per Wing)

16 Row 30" Shown (Two Wing Lift Cylinders Per Wing)

(TWL207d)

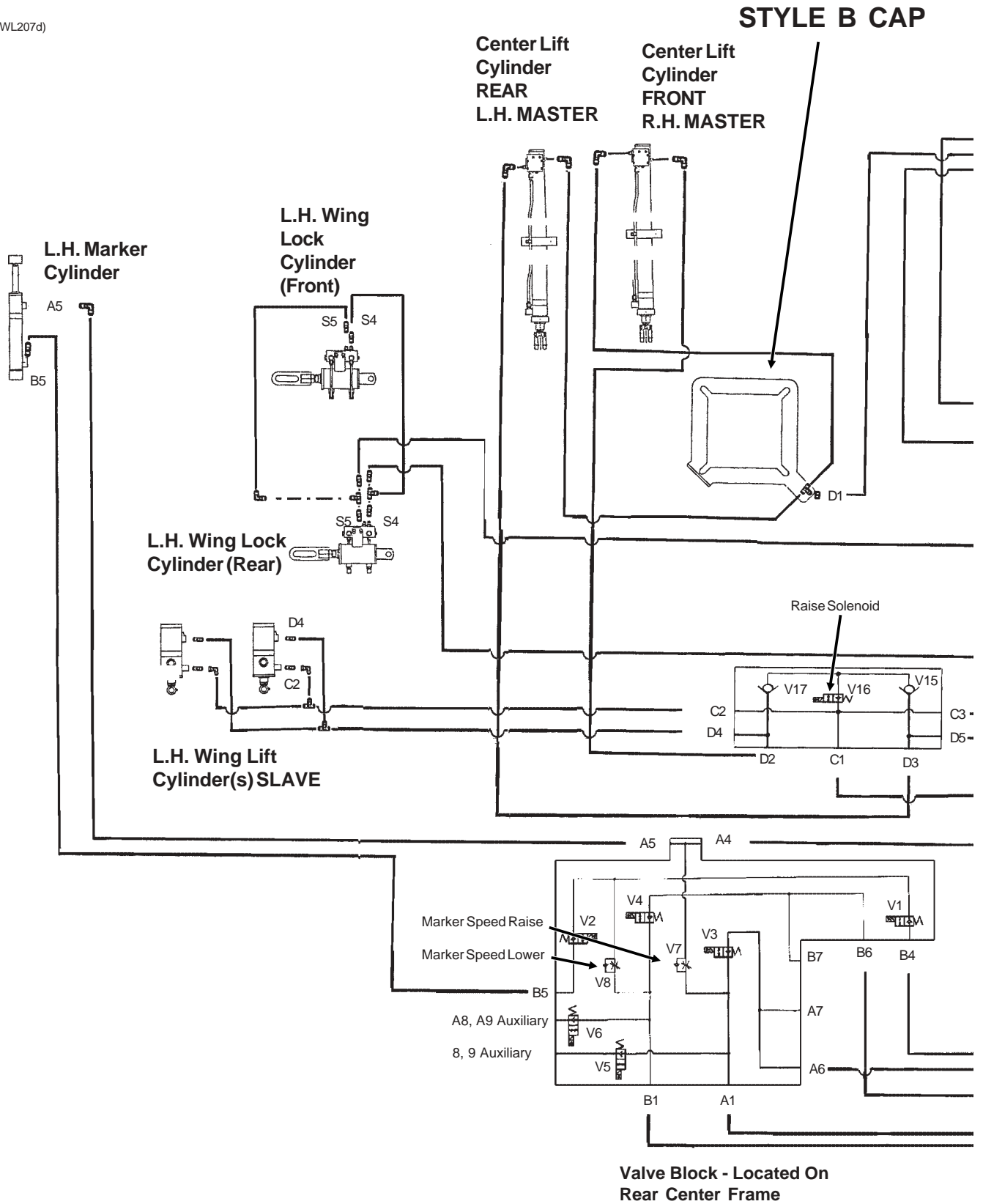

# MAINTENANCE

**Junction Plate - Located On Center Post Mount**  
**NOTE: See pages 10-42 and 10-43 for additional information.**

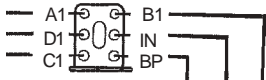

**Hydraulic Motor - Left Side Of Planter**

**Hydraulic Motor - Right Side Of Planter**

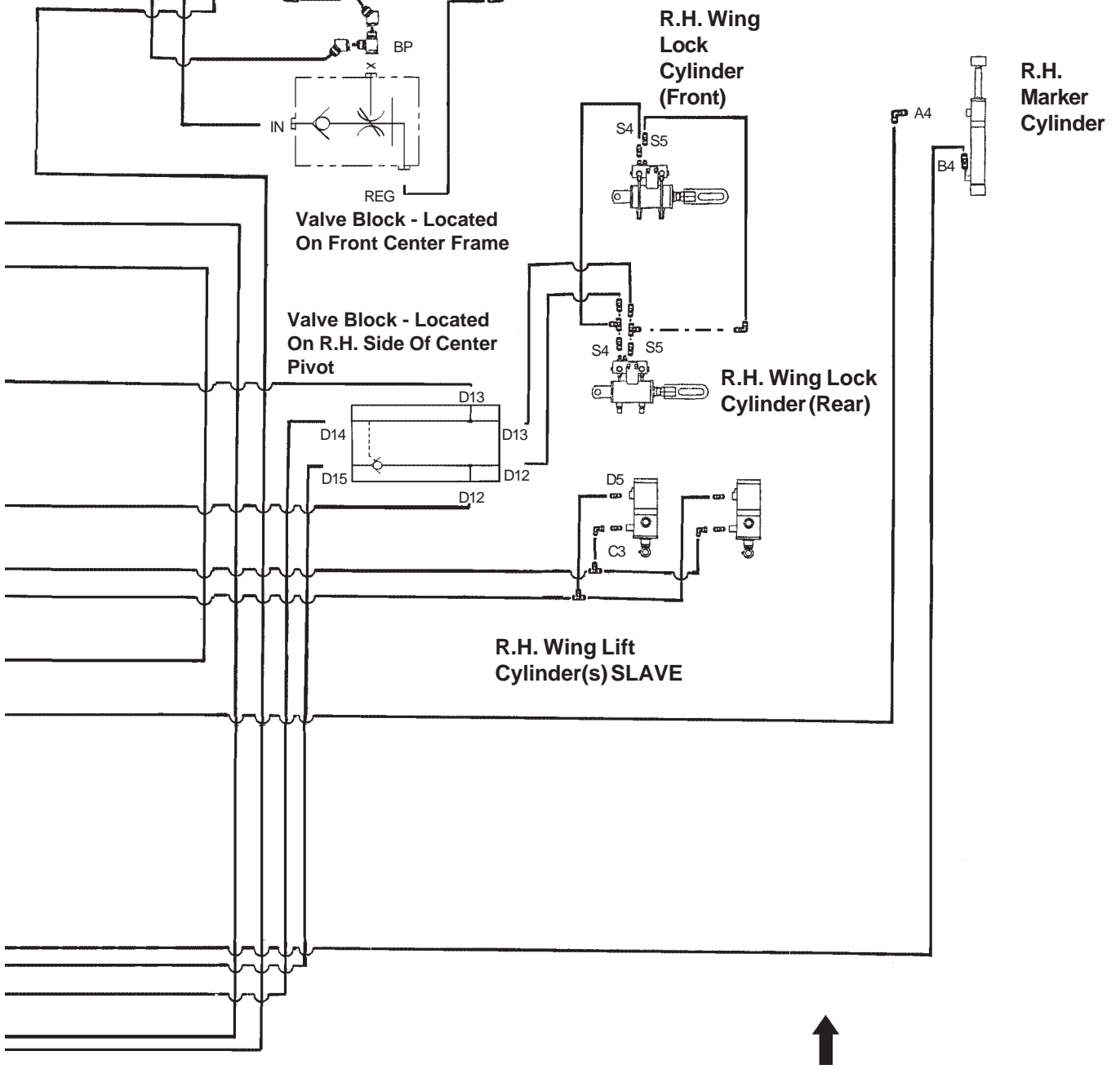
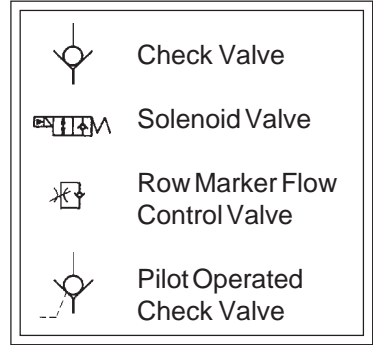

**↑**  
**DIRECTION OF TRAVEL**

# MAINTENANCE

---



# PARTS LIST INDEX

---

## ROW UNIT

15" Seed Opener Disc Blade/Bearing Assembly And Scrapers .....	P5
Brush-Type Seed Meter .....	P23
Coulter Mounted Residue Wheels .....	P34
Finger Pickup Seed Meter .....	P22
Frame Mounted Coulters And Attachments .....	P36
Gauge Wheels .....	P6
Granular Chemical Banding Options .....	P27
Granular Chemical Hopper And Hopper Panel Extension .....	P24
Granular Chemical Meter And Meter Drive .....	P26
Hopper Support And Meter Drive .....	P9
Interplant® Push Row Unit .....	P40
Mini-Hopper And Drop Hoses .....	P10
Parallel Arms, Mounting Support Plate And Quick Adjustable Down Force Springs .....	P4
Row Unit Mounted Disc Furrower .....	P30
Row Unit Mounted No Till Coulter .....	P28
Row Unit Mounted Residue Wheel .....	P32
Shank Assembly, Seed Tube And Depth Adjustment .....	P2
"V" Closing Wheels .....	P8

## BASE MACHINE

Axle Assembly .....	P54
Center Frame .....	P48
Center Pivot .....	P52
Contact Drive Wheel And Drive Shaft(s) .....	P58
Cylinders .....	P77
Electrical Components .....	P102
Ground Drive Wheel .....	P61
Hose Take-Up .....	P46
Hydraulic Hoses And Fittings .....	P96
Inner Hitch .....	P44
Inner Module Drive .....	P64
Marker Assemblies .....	P72
Marker Spindle/Hub/Blade .....	P76
Outer Hitch .....	P42
Point Row Clutch .....	P66
Safety Chain .....	P42
Transport Wheels/Rock Guards .....	P56
Transmission And Row Unit Drill Shafts .....	P62
Two-Speed Point Row Clutch .....	P68
Two-Speed Point Row Clutch Wheel Module Extension .....	P70
Valve Blocks .....	P88
Valves (Solenoid, Flow Control, Pressure Relief, Check) .....	P93
Wing Frame .....	P50

## BULK FILL SYSTEM

Bulk Seed Hopper Gearbox Drive .....	P12
Bulk Seed Hopper And Hydraulic Motor Drive .....	P14
Bulk Seed Hopper Auger Assembly .....	P20
Bulk Seed Hopper Auger Manifold Assembly .....	P18
Bulk Seed Hopper Catwalk .....	P11
Bulk Seed Hopper Lid .....	P16
Bulk Seed Hopper Monitor .....	P108

## ELECTRONIC SEED MONITOR

KPM I/KPM II Electronic Seed Monitor .....	P104
KPM II Stack-Mode Electronic Seed Monitor .....	P106

## INTERPLANT® SYSTEM

Interplant® Push Row Unit .....	P40
Interplant® Push Row Unit Drive .....	P110

## FERTILIZER

Openers, Mounts And Attachments .....	P112
Liquid Fertilizer .....	P122
Rear Trailer Hitch .....	P134

Decals, Paint And Miscellaneous .....	P136
---------------------------------------	------

Numerical Index .....	a
-----------------------	---

# SHANK ASSEMBLY, SEED TUBE AND DEPTH ADJUSTMENT

RUB023/RUB024RUB022(RU80i)

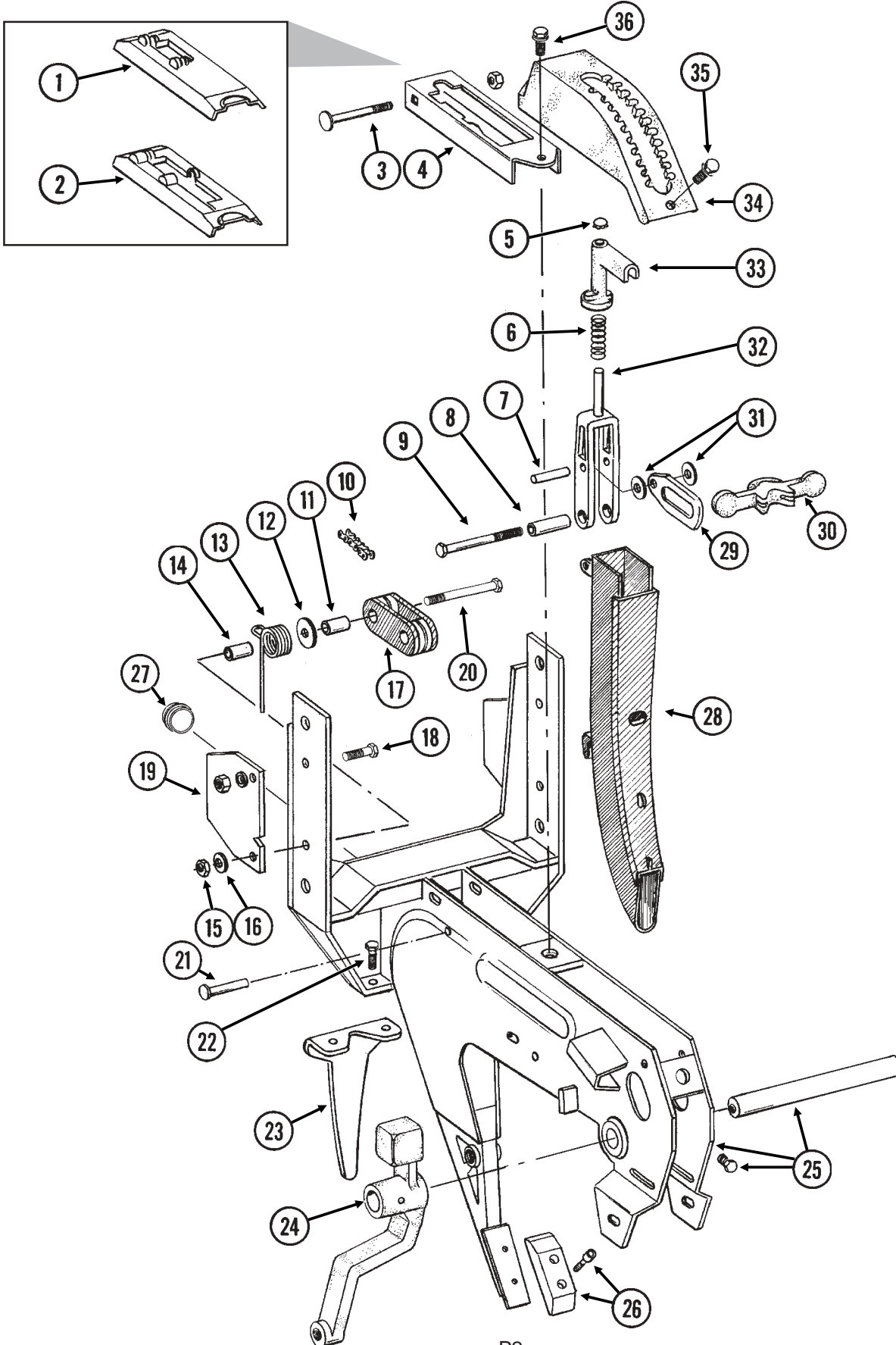

# SHANK ASSEMBLY, SEED TUBE AND DEPTH ADJUSTMENT

ITEM	PART NO.	QTY. (Per Row)	DESCRIPTION
1.		-	Shank Cover, See "Brush-Type Seed Meter", Page P23
2.		-	Shank Cover, See "Finger Pickup Seed Meter", Page P22
3.	G10304	1	Carriage Bolt, $\frac{3}{8}$ "-16 x 3"
	G10108	1	Lock Nut, $\frac{3}{8}$ "-16
4.	GD10986	1	Cover
5.	GD3612	1	Cap Plug
6.	GD10993	1	Spring
7.	GD13361	1	Pin, $\frac{3}{8}$ " x $1\frac{2}{3}$ "
8.	GD11259	1	Sleeve, $\frac{3}{8}$ " I.D. x $\frac{5}{8}$ " O.D. x $1\frac{25}{32}$ " Long
9.	G11008	1	Hex Head Cap Screw, $\frac{3}{8}$ "-24 x $2\frac{1}{2}$ ", Grade 8
	G11007	1	Lock Nut, $\frac{3}{8}$ "-24, Grade C
10.	G3303-98	1	Chain, No. 41, 98 Pitch Including Connector Link
	GR0196	1	Connector Link, No. 41
11.	GD1026	1	Sleeve, $1\frac{3}{16}$ " Long
12.	G10201	1	Special Washer, $\frac{3}{8}$ " x $1\frac{1}{2}$ " O.D.
13.	GD1065	1	Idler Spring
14.	GD7318	1	Sleeve, 1" Long
15.	G10108	1	Lock Nut, $\frac{3}{8}$ "-16
16.	G10210	1	Washer, $\frac{3}{8}$ " USS
17.	GD11962	1	Idler
18.	G10003	3	Hex Head Cap Screw, $\frac{3}{8}$ "-16 x $1\frac{1}{2}$ "
	G10108	3	Lock Nut, $\frac{3}{8}$ "-16
19.	GD10867	2	Stop
20.	G10326	1	Hex Head Cap Screw, $\frac{3}{8}$ "-16 x $3\frac{3}{4}$ "
21.	G10551	1	Clevis Pin, $\frac{1}{4}$ " x $2\frac{1}{2}$ "
	G10669	1	Hair Pin Clip, No. 22
22.	G10312	2	Carriage Bolt, $\frac{5}{16}$ "-18 x $\frac{3}{4}$ "
	G10620	2	Flange Nut, $\frac{5}{16}$ "-18
23.	GD1033	1	Shield
24.		-	See "Gauge Wheels", Pages P6 And P7
25.	GA7965	1	Shank W/Gauge Wheel Pivot Spindle And Set Screw
	GD11001	-	Spindle
	G10438	-	Hex Head Cap Screw, $\frac{1}{2}$ "-13 x $\frac{3}{4}$ "
26.		-	See "15" Seed Opener Disc Blade/Bearing Assembly And Scrapers", Page P5
27.	GD11845	1	Dust Cap
28.	GD1130	-	Seed Tube (No Monitor) See "KPM I/KPM II Electronic Seed Monitor" Or "KPM II Stack-Mode Electronic Seed Monitor" For Seed Tube With Sensor, Pages P104-P107
29.	GB0285	1	Collar, Depth Adjustment
30.	GB0265	1	Pivot Link, Depth Adjustment
31.	G10207	2	Washer, $\frac{7}{8}$ " O.D. x $\frac{13}{32}$ " I.D. x .134" (If Applicable)
32.	GB0267	1	Lever, Depth Adjustment
33.	GB0266	1	Handle, Depth Adjustment
34.	GB0274	1	Cover, Depth Adjustment
35.	G10985	1	Hex Washer Head Cap Screw, $\frac{3}{8}$ "-16 x 1"
36.	G11015	1	Hex Washer Head Cap Screw, $\frac{3}{8}$ "-16 x $1\frac{1}{4}$ "

# PARALLEL ARMS, MOUNTING SUPPORT PLATE AND QUICK ADJUSTABLE DOWN FORCE SPRINGS

RUB021/RUB022(RU78e/RU79a)

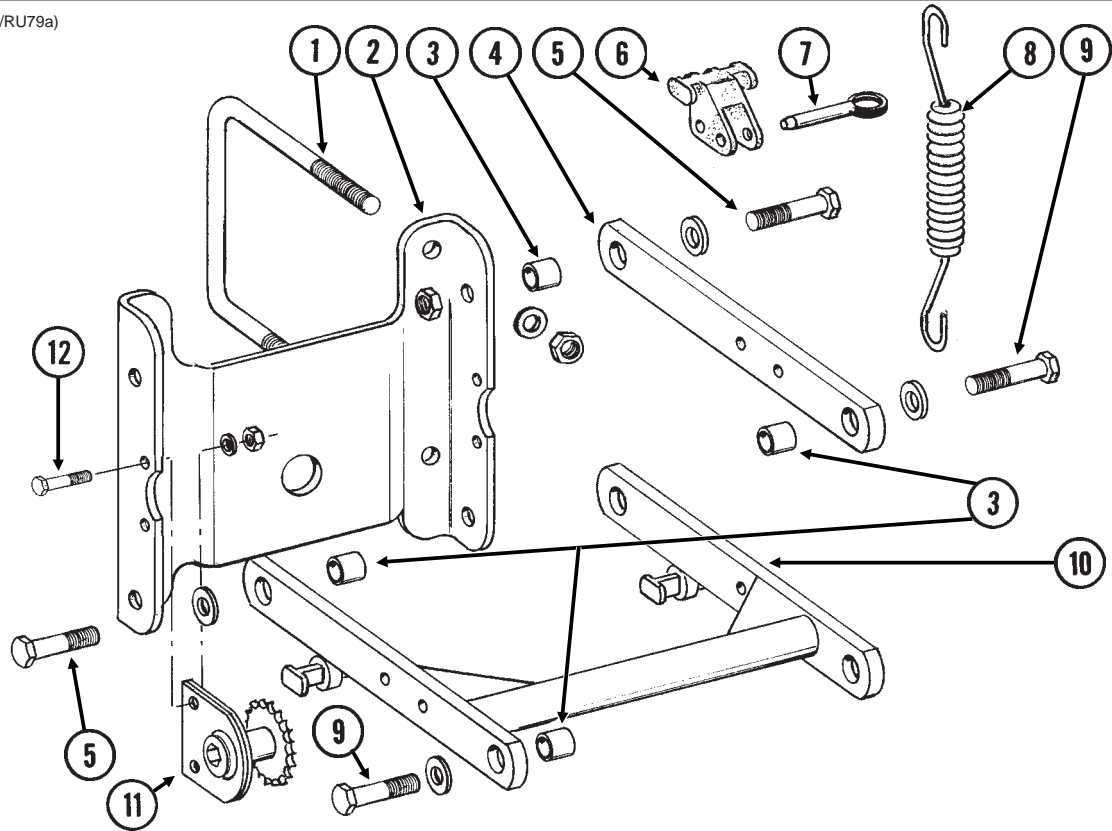

ITEM	PART NO.	QTY. (Per Row)	DESCRIPTION
1.	GD1113	-	U-Bolt, 5" x 7" x 5/8"-11
	G10230	4	Lock Washer, 5/8"
	G10104	4	Hex Nut, 5/8"-11
2.	GD10036	1	Mounting Support Plate
3.	GB0218	4	Bushing, 21/32" I.D. x 7/8" O.D. x 19/32" Long
4.	GD11422	2	Upper Parallel Arm
5.	G10732	4	Hex Head Cap Screw, 5/8"-18 x 2"
	GD7805	4	Special Washer, 5/8", Hardened
	G10412	4	Lock Nut, 5/8"-18
6.	GB0186	2	Spring Anchor
7.	G10545	2	Detent Pin, 1/2" x 1 1/3" Grip
8.	GD8249	2-4	Spring
9.		-	See "Hopper Support And Meter Drive", Page P9
10.	GA5651	1	Lower Parallel Arm
11.	GA1720	1	Bearing/Sprocket, 7/8" Hex Bore
12.	G10001	2	Hex Head Cap Screw, 3/8"-16 x 1"
	G10229	2	Lock Washer, 3/8"
	G10101	2	Hex Nut, 3/8"-16
A.	G6325X	-	U-Bolt Package For 5" x 7" Toolbar, Includes: (2) GD1113, (4) G10230, (4) G10104

# 15" SEED OPENER DISC BLADE/BEARING ASSEMBLY AND SCRAPERS

RUB023/RUB025(RU82e)

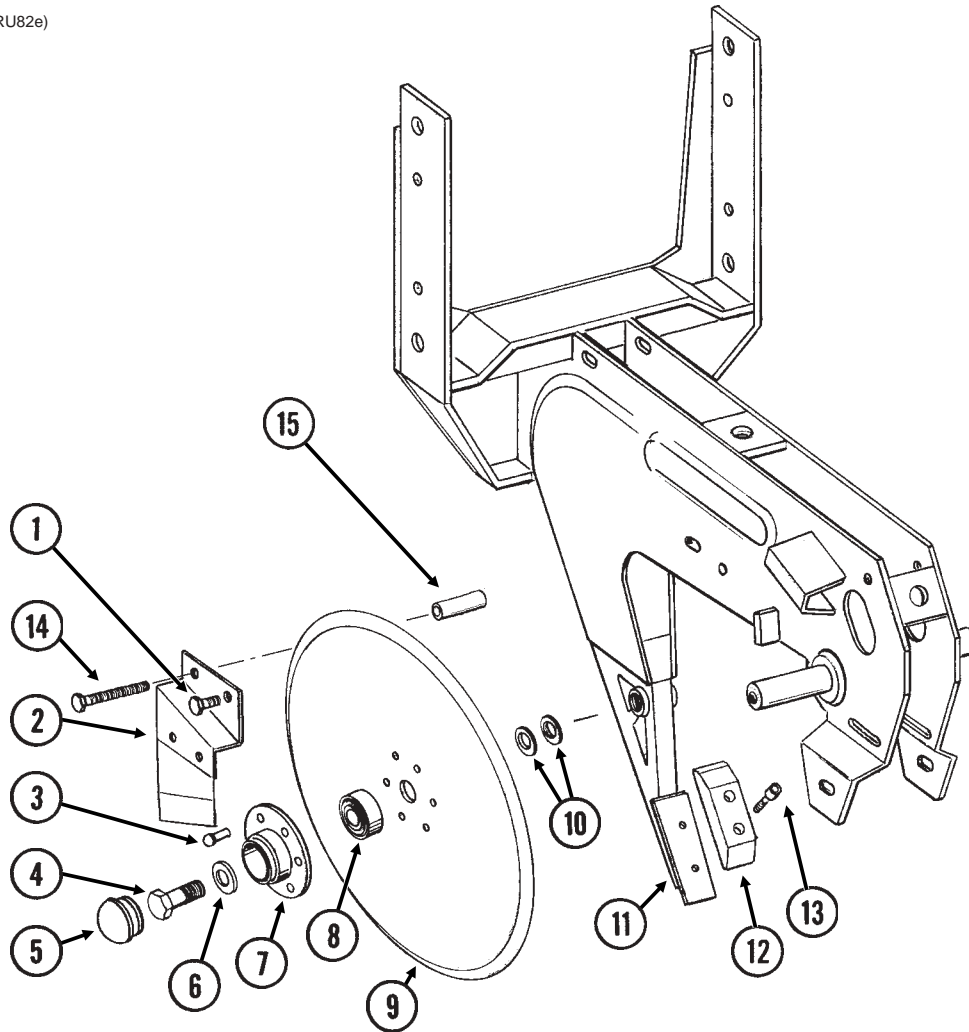

ITEM	PART NO.	QTY. (Per Row)	DESCRIPTION
1.	G10328	2	Hex Head Cap Screw, $\frac{3}{8}$ "-16 x $\frac{5}{8}$ "
	G10622	2	Flange Nut, $\frac{3}{8}$ "-16
2.	GA2012R	1	Disc Scraper, R.H.
	GA2012L	-	Disc Scraper, L.H. (Shown)
3.	G10427	12	Rivet, $\frac{1}{4}$ " x $\frac{1}{2}$ "
4.	GD11017	1	Special Hex Head Cap Screw, $\frac{5}{8}$ "-11 x 1 $\frac{1}{2}$ ", L.H. Thread
	G10007	1	Hex Head Cap Screw, $\frac{5}{8}$ "-11 x 1 $\frac{1}{2}$ "
5.	GD11845	2	Dust Cap
6.	G10204	2	Special Machine Bushing, $\frac{5}{8}$ " x 1" O.D.
7.	GD10473	2	Bearing Housing
8.	GA2014	2	Bearing
9.	GD11306	2	Disc Blade, 3.5mm x 15"
10.	G10213	-	Machine Bushing, $\frac{5}{8}$ " (.030" Thick)(As Required)
11.		-	See "Shank Assembly", Pages P2 And P3
12.	GB0301	1	Seed Tube Guard/Inner Scraper
13.	G10912	2	Hex Socket Head Cap Screw, $\frac{5}{16}$ "-18 x 1", Grade 8
14.	G10325	1	Hex Head Cap Screw, $\frac{3}{8}$ "-16 x 2 $\frac{3}{4}$ "
	G10622	1	Flange Nut, $\frac{3}{8}$ "-16
15.	GD11259	1	Sleeve, $\frac{3}{8}$ " I.D. x $\frac{5}{8}$ " O.D. x 1 $\frac{25}{32}$ " Long
A.	GA8324	-	Disc Blade And Bearing Assembly Less Bearing Cap (Items 3 And 7-9)

# GAUGE WHEELS

RUB027/RUB023(RU84a/RU84b)

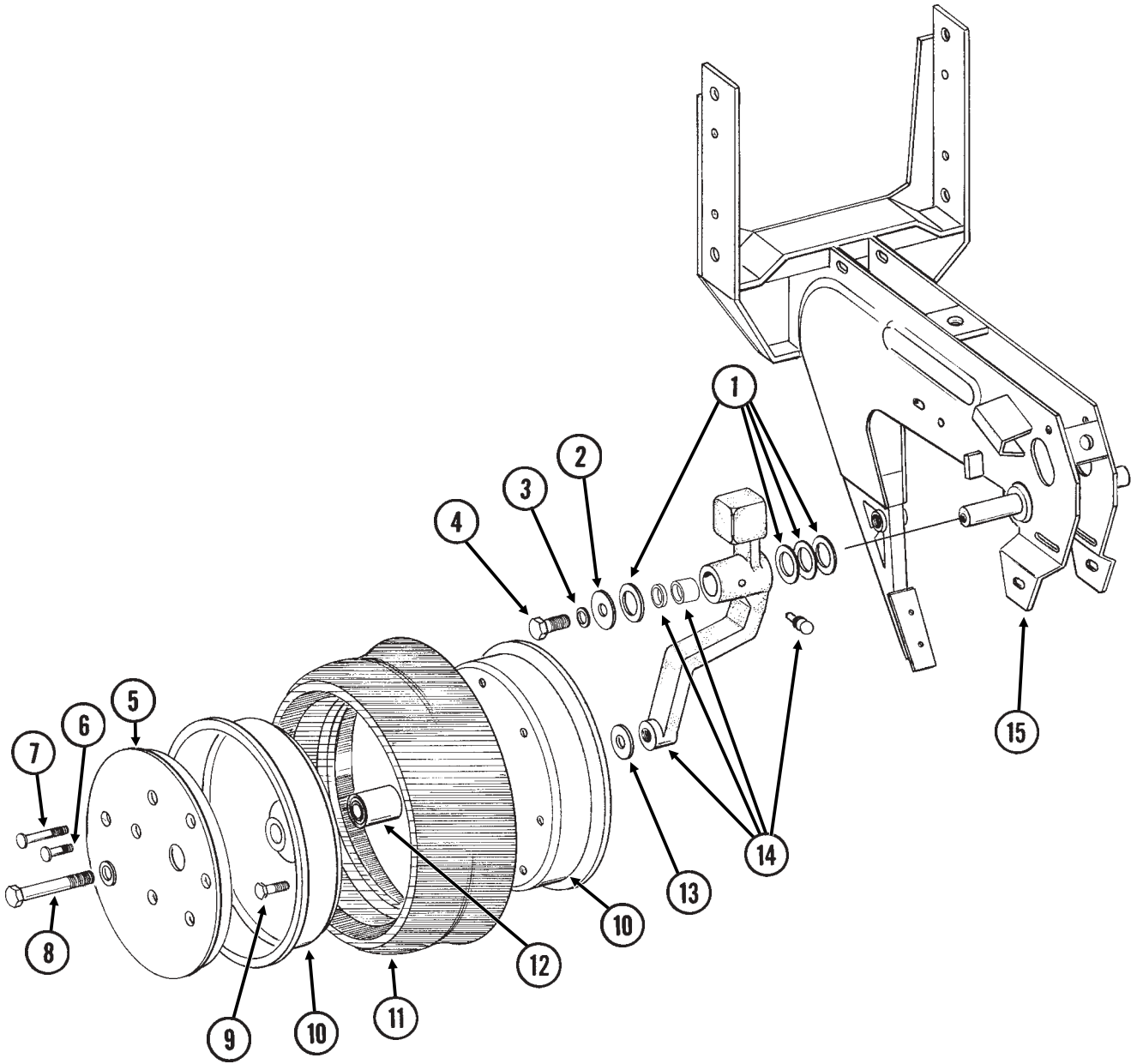

# GAUGE WHEELS

ITEM	PART NO.	QTY. (Per Row)	DESCRIPTION
1.	G10940	-	Machine Bushing, 1" (.048" Thick)
2.	G10216	2	Washer, 1/2" USS
3.	G10228	2	Lock Washer, 1/2"
4.	G10014	1	Hex Head Cap Screw, 1/2"-13 x 1"
5.	GD11453	2	Cover
6.	G10338	12	Carriage Bolt, 5/16"-18 x 1 1/4"
	G10620	12	Flange Nut, 5/16"-18
7.	G10924	8	Carriage Bolt, 5/16"-18 x 1 3/4"
	G10620	8	Flange Nut, 5/16"-18
8.	G10010	2	Hex Head Cap Screw, 5/8"-11 x 3"
	G10230	2	Lock Washer, 5/8"
9.	G10018	14	Hex Head Cap Screw, 5/16"-18 x 5/8"
	G10109	14	Lock Nut, 5/16"-18
10.	GD11423	4	Half Wheel
11.	GD1086	2	Tire
12.	GA6171	2	Bearing
13.	G10204	2	Special Machine Bushing, 5/8" x 1" O.D.
14.	GA7975	1	Wheel Arm W/Grease Fitting, Bushings And Seals, L.H. (Shown)
	GA7976	1	Wheel Arm W/Grease Fitting, Bushings And Seals, R.H.
	G10640	1	Grease Fitting, 1/4"-28 (Per Arm)
	GB0276	2	Bushing, 1" I.D. x 1 1/4" O.D. x 1" Long (Per Arm)
	GD10991	2	Seal (Per Arm)
15.		-	See "Shank Assembly, Seed Tube And Depth Adjustment", Pages P2 And P3
A.	GA7949	-	Gauge Wheel Complete (Items 5-7 And 9-12)

# "V" CLOSING WHEELS

RUB026(RU83e)

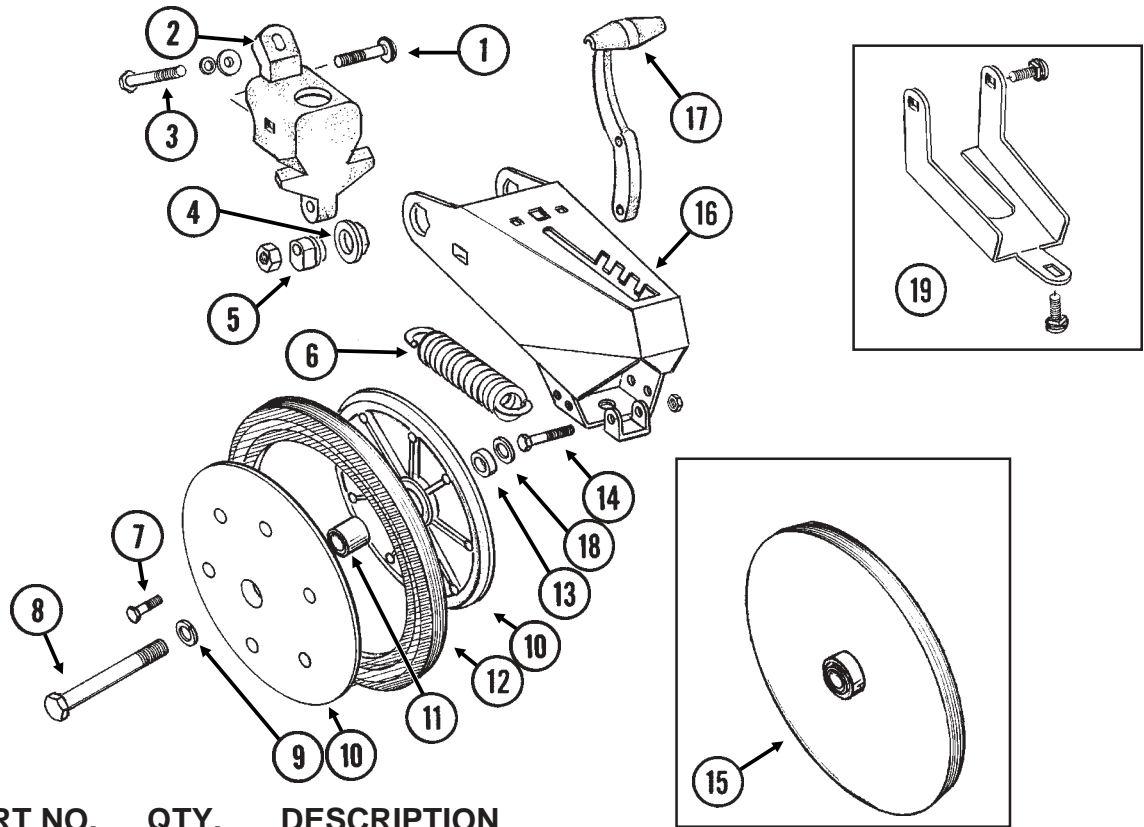

ITEM	PART NO.	QTY. (Per Row)	DESCRIPTION
1.	G10801 G10315	2 -	Carriage Bolt, 1/2"-13 x 2 1/4" Carriage Bolt, 1/2"-13 x 2 1/2" (Used W/Straight Drop In-Furrow Granular Chemical Bracket)
2.	G10111	2	Lock Nut, 1/2"-13
3.	GB0268 G10003 G10229 G10210	1 1 1 2	Wheel Arm Stop Hex Head Cap Screw, 3/8"-16 x 1 1/2" Lock Washer, 3/8" Washer, 3/8" USS
4.	GB0282	2	Stepped Bushing
5.	GB0239	2	Eccentric Bushing
6.	GD8460	1	Spring
7.	G10064	6	Hex Head Cap Screw, 1/4"-20 x 1"
8.	G10013 G10107	2 2	Hex Head Cap Screw, 5/8"-11 x 3 1/2" Lock Nut, 5/8"-11
9.	G10230	2	Lock Washer, 5/8"
10.	GD9120	4	Nylon Half Wheel
11.	GA6171	2	Bearing
12.	GD1085	2	Rubber Tire, 1" x 12"
13.	GD1109	2	Bushing, 41/64" I.D. x 7/8" O.D. x 1/4" Long
14.	G10133 G10109	1 1	Hex Head Cap Screw, 5/16"-18 x 1 1/2" Lock Nut, 5/16"-18
15.	GA6597 GA6171	- -	Cast Iron Closing Wheel W/Bearing Bearing
16.	GA8322	1	Arm
17.	GB0254	1	Lever
18.	GD7805	2	Special Washer, 5/8", Hardened
19.	G1K345 G10308 G10210 G10229 G10101	- 3 1 3 3	Closing Wheel Shield Kit W/Hardware And Instruction Carriage Bolt, 3/8"-16 x 3/4" Washer, 3/8" USS Lock Washer, 3/8" Hex Nut, 3/8"-16
A.	GA6434	-	Rubber Closing Wheel Complete W/Bearing (Items 7 And 10-12)



# HOPPER SUPPORT AND METER DRIVE

RUB028/RUB029(RU86i)

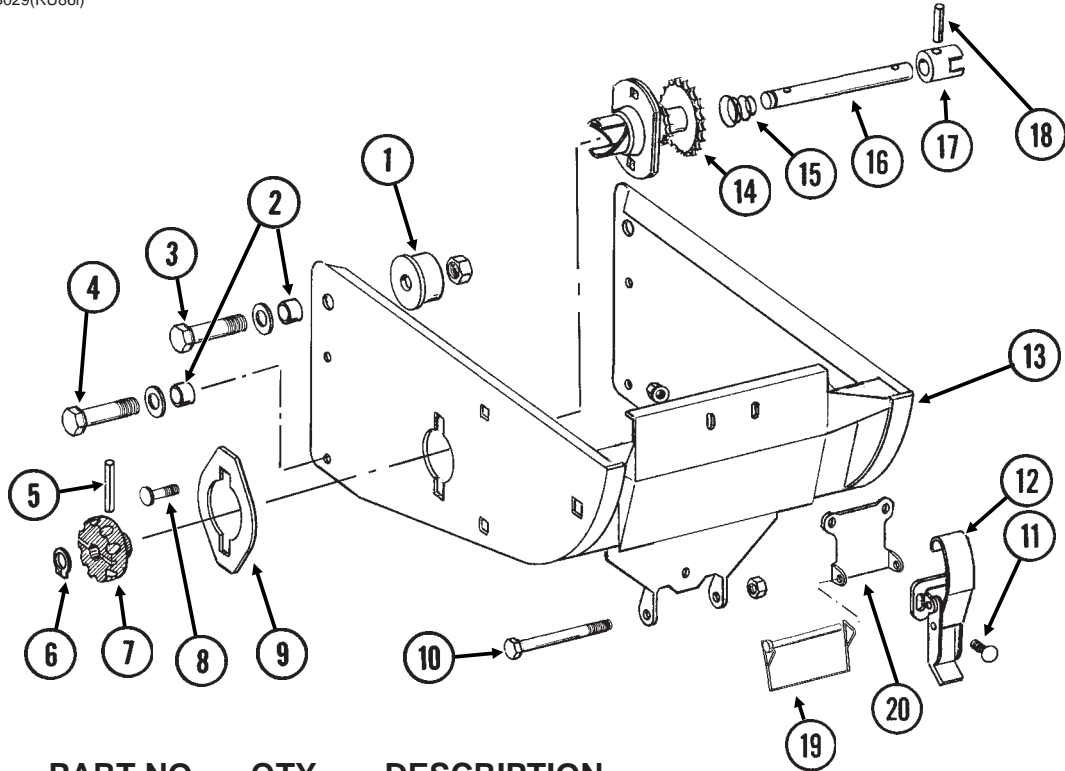

ITEM	PART NO.	QTY. (Per Row)	DESCRIPTION
1.	GB0314	2	Hopper Mount
2.	GB0218	4	Bushing, $2\frac{1}{32}$ " I.D. x $\frac{7}{8}$ " O.D. x $\frac{19}{32}$ " Long
3.	G10752	2	Hex Head Cap Screw, $\frac{5}{8}$ "-18 x $2\frac{1}{4}$ "
	GD7805	2	Special Washer, $\frac{5}{8}$ ", Hardened
	G10412	2	Lock Nut, $\frac{5}{8}$ "-18
4.	G10751	2	Hex Head Cap Screw, $\frac{5}{8}$ "-18 x $1\frac{3}{4}$ "
	GD7805	2	Special Washer, $\frac{5}{8}$ ", Hardened
	G10412	2	Lock Nut, $\frac{5}{8}$ "-18
5.	G10602	1	Spring Pin, $\frac{1}{4}$ " x $1\frac{1}{2}$ "
6.	G10567	1	External Retaining Ring, $\frac{5}{8}$ "
7.	GD11239	1	Knob
8.	G10338	2	Carriage Bolt, $\frac{5}{16}$ "-18 x $1\frac{1}{4}$ "
	G10620	2	Flange Nut, $\frac{5}{16}$ "-18
9.	GD11305	1	Plate
10.	G10061	1	Hex Head Cap Screw, $\frac{3}{8}$ "-16 x $3\frac{1}{2}$ "
	G10210	2	Washer, $\frac{3}{8}$ " USS
	G10108	1	Lock Nut, $\frac{3}{8}$ "-16
11.	G10309	2	Carriage Bolt, $\frac{1}{4}$ "-20 x $\frac{5}{8}$ ", Grade 2
	G10621	2	Flange Nut, $\frac{1}{4}$ "-20
12.	GA2007	1	Hopper Hold Down Latch
13.	GA8304	1	Hopper Support
14.	GA9538	1	Double Sprocket And Bearing, Drive Clutch, 11/19 Tooth
15.	GD11413	1	Spring
16.	GD10958	1	Shaft
17.	GB0278	1	Coupler
18.	G10546	1	Spring Pin, $\frac{3}{16}$ " x $1\frac{1}{4}$ "
19.	GD10705	1	Locking Clip Pin, $\frac{1}{4}$ " x $2\frac{1}{2}$ "
20.	GD13110	1	Retainer
A.	GA9539	-	Meter Drive Assembly Complete (Items 5-7 And 14-18)

# MINI-HOPPER AND DROP HOSES

RUB031(TWL189c)

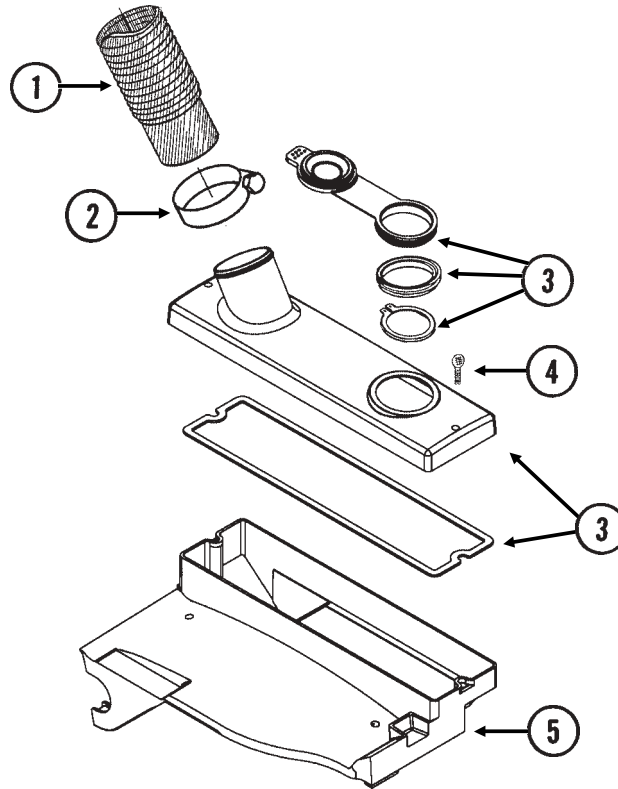

ITEM	PART NO.	QTY. (Per Row)	DESCRIPTION
1.	GD12797-01	1	Drop Hose, 3 1/4" x 34"
	GD12797-02	-	Drop Hose, 3 1/4" x 30"
	GD12797-03	-	Drop Hose, 3 1/4" x 8"
2.	G10999	2	T-Bolt Hose Clamp, 3 1/4"
3.	GA9623	1	Lid W/Gasket, Snap Ring, View Port Support And View Cap
	GD13530	-	Gasket
	G11037	-	External Retaining Ring, 2 7/8" (If Applicable)
	GD13645	-	View Port Support (If Applicable)
	GD13412	-	View Cap
4.	G11033	2	Thumbscrew, 5/16"-18 x 1"
	GD12132	2	Seal
5.	GA9547	1	Mini-Hopper

# BULK SEED HOPPER CATWALK

(TWL189d)

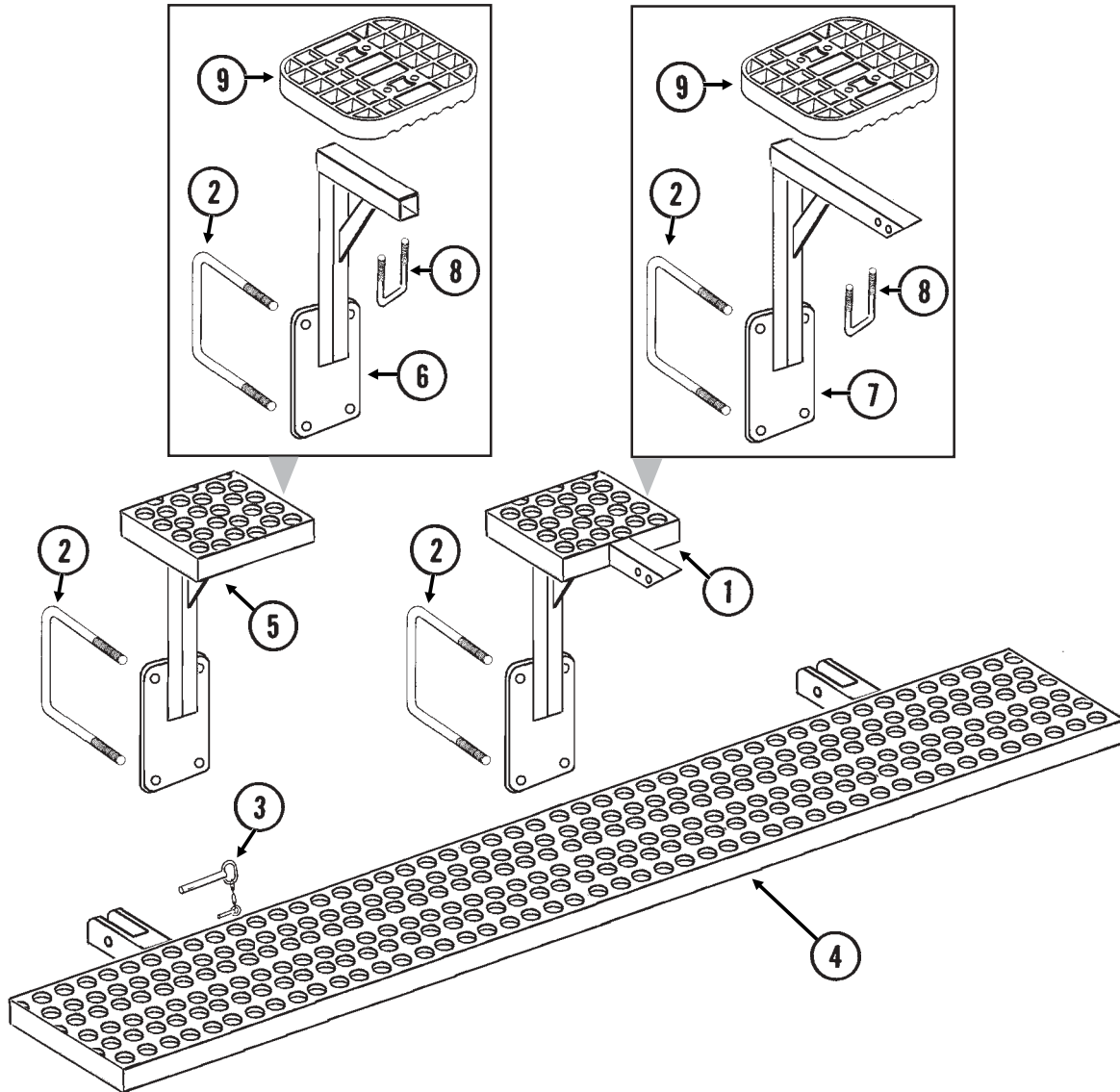

ITEM	PART NO.	QTY.	DESCRIPTION
1.	GA9681	8-12	Support Step
2.	GD1113	20-24	U-Bolt, 5" x 7" x 5/8"-11
	G10230	40-48	Lock Washer, 5/8"
	G10104	40-48	Hex Nut, 5/8"-11
3.	GA6189	8-12	Hitch Pin
4.	GA9682	1	Catwalk, 53", R.H., 12 Row 30" And 16 Row 30"
	GA9683	1	Catwalk, 53", L.H., 12 Row 30" And 16 Row 30"
	GA9684	2	Catwalk, 96", Center, 12 Row 30"
	GA9685	4	Catwalk, 61", Center, 16 Row 30"
5.	GA9686	2	Support Step, 12 Row 30" Only
6.	GA9868	2	Step Support, 12 Row 30" Only
7.	GA9867	8-12	Step Support
8.	GD2721	20-24	U-Bolt, 2" x 2" x 1/2"-13
	G10206	40-48	Washer, 1/2" SAE
	G10111	40-48	Lock Nut, 1/2"-13
9.	GB0315	10-12	Step

# BULK SEED HOPPER GEARBOX DRIVE

(TWL213b/TWL190g)

## L.H. Side Of Planter - 12 Row Shown

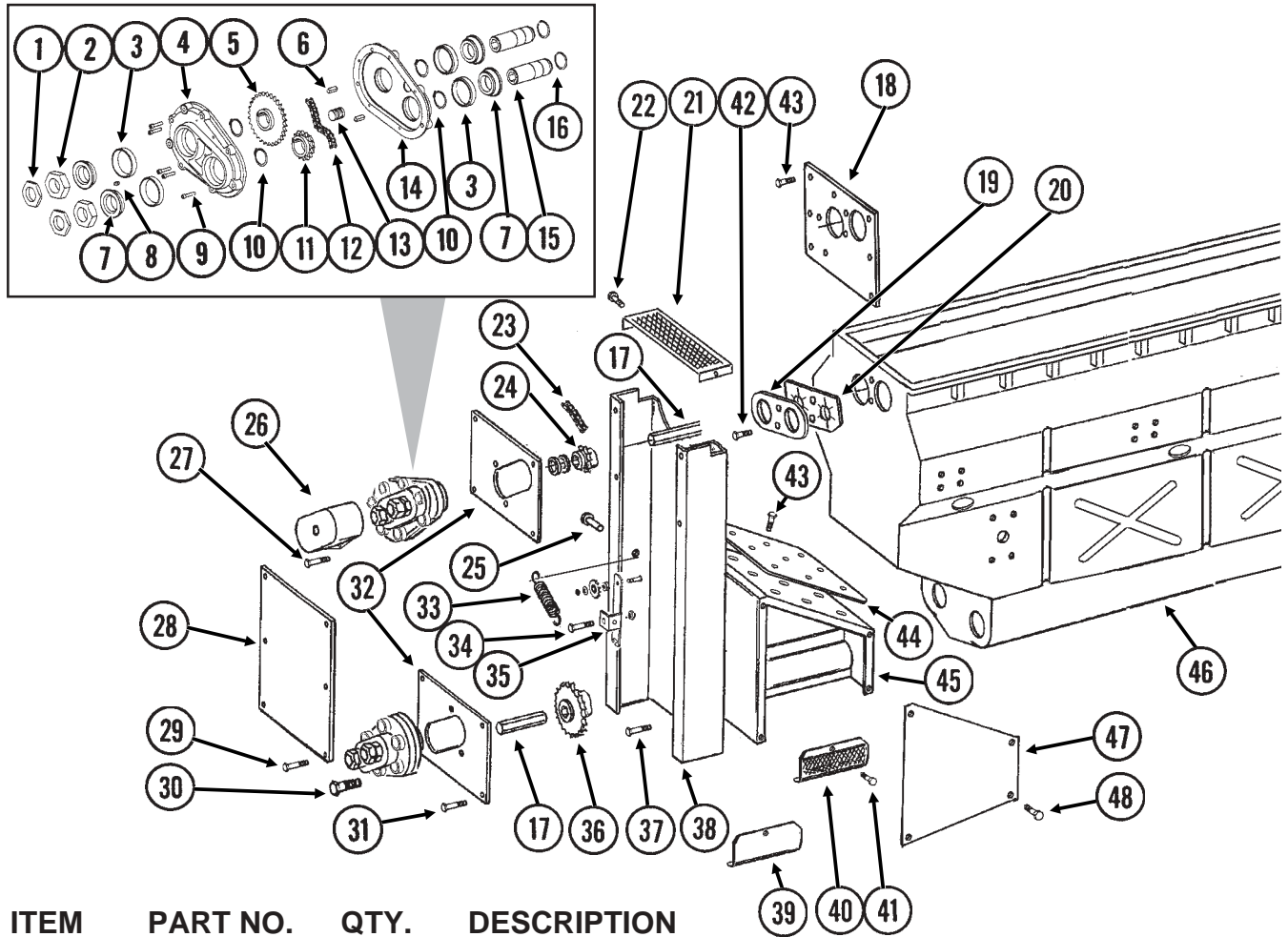

ITEM	PART NO.	QTY. (Per Hopper)	DESCRIPTION
1.	GD13396	4	Jam Nut, 1 1/2"-12 (3/8" Thick)
2.	G10087	4	Hex Jam Nut, 1 1/2"-12, Grade 2
3.	GR0434	8	Cup
4.	GD13186	1	Outer Housing, L.H. (Shown)
	GD13533	1	Outer Housing, R.H.
5.	GD12698	2	Sprocket, 30 Tooth
6.	GD13226-01	4	Key, 5/16" Square x 1"
7.	GA0895	8	Bearing
8.	G10640	2	Grease Fitting, 1/4"-28
9.	G11022	10	Hex Socket Head Cap Screw, 1/4"-28 x 1 1/4"
10.	G10283	8	External Retaining Ring, 1 1/2"
11.	GD12696	2	Sprocket, 16 Tooth
12.	GA9574	2	Chain, No. 40
13.	GD13225	2	Chain Idler
14.	GD13185	1	Inner Housing, L.H. (Shown)
	GD13534	1	Inner Housing, R.H.
15.	GD13194	4	Hub
16.	GD11490	4	Round External Retaining Ring
17.		-	See "Bulk Seed Hopper Auger Assembly", Pages P20 And P21
18.	GD14112	1	Plate, 13 1/2" x 12"
19.	GD14107	1	Shield, 4 1/2" x 8 7/16"
20.	GD14094	1	Rubber Gasket

# BULK SEED HOPPER GEARBOX DRIVE

ITEM	PART NO.	QTY. (Per Hopper)	DESCRIPTION
21.	GA9182	2	Mesh Cover
22.	G10001	4	Hex Head Cap Screw, $\frac{3}{8}$ "-16 x 1"
	G10210	4	Washer, $\frac{3}{8}$ " USS
23.	G3310-126	1	Chain, No. 40, 126 Pitch Including Connector Link
	GR0912	-	Connector Link, No. 40
24.	GA5106	1	Sprocket, 17 Tooth
25.	G10870	1	Clevis Pin, $\frac{3}{8}$ " x 1"
	G10860	1	Retaining Ring, $\frac{3}{8}$ "
26.	G11035	4	Hex Head Cap Screw, $\frac{1}{4}$ "-28 x $\frac{1}{2}$ "
	G10211	4	Washer, $\frac{1}{4}$ " SAE
27.	GD12791	2	Plastic Cover
28.	GD13128	1	Cover Plate
29.	G10001	6	Hex Head Cap Screw, $\frac{3}{8}$ "-16 x 1"
	G10210	6	Washer, $\frac{3}{8}$ " USS
30.	G10060	6	Hex Head Cap Screw, $\frac{5}{16}$ "-18 x 2 $\frac{1}{2}$ "
	G10219	6	Washer, $\frac{5}{16}$ " USS
	G10109	6	Lock Nut, $\frac{5}{16}$ "-18
31.	G10002	8	Hex Head Cap Screw, $\frac{3}{8}$ "-16 x $\frac{3}{4}$ "
	G11017	4	Flange Nut, $\frac{3}{8}$ "-16
32.	GD13129	2	Cover Plate
33.	GD5857	1	Spring
34.	G10743	1	Hex Head Cap Screw, $\frac{5}{8}$ "-11 x 3 $\frac{3}{4}$ "
	G10104	1	Hex Nut, $\frac{5}{8}$ "-11
	G10107	1	Lock Nut, $\frac{5}{8}$ "-11
35.	GA9624	1	Idler W/Sprocket And Hardware
	GA7154	-	Sprocket W/Bearing, 18 Tooth
	G10581	-	Hex Head Cap Screw, $\frac{1}{2}$ "-13 x 2 $\frac{1}{4}$ "
	GD10356	-	Bushing, $\frac{3}{4}$ " Long
	G10128	-	Machine Bushing, $\frac{1}{2}$ ", 14 Gauge
	G10501	-	Hex Jam Nut, $\frac{1}{2}$ "-13, Grade 2
36.	GA5202	1	Sprocket, 34 Tooth
37.	G10002	13	Hex Head Cap Screw, $\frac{3}{8}$ "-16 x $\frac{3}{4}$ "
	G10210	13	Washer, $\frac{3}{8}$ " USS
	G11017	13	Flange Nut, $\frac{3}{8}$ "-16
38.	GA9176	1	Auger Drive Housing
39.	GD13134	-	Lower Auger Cover
40.	GD13246	1	Lower Auger Screen
41.	G10001	1	Hex Head Cap Screw, $\frac{3}{8}$ "-16 x 1"
	G10210	1	Washer, $\frac{3}{8}$ " USS
42.	G10001	2	Hex Head Cap Screw, $\frac{3}{8}$ "-16 x 1"
	G11017	2	Flange Nut, $\frac{3}{8}$ "-16
43.	G10001	17	Hex Head Cap Screw, $\frac{3}{8}$ "-16 x 1"
	G10210	17	Washer, $\frac{3}{8}$ " USS
	G11017	17	Flange Nut, $\frac{3}{8}$ "-16
44.	GD14111	1	Plate, 13" x 11 $\frac{1}{2}$ "
45.	GA9172	-	Auger Housing, R.H.
	GA9173	-	Auger Housing, L.H.
46.		-	See "Bulk Seed Hopper And Hydraulic Motor Drive", Pages P14 And P15
47.	GD13149	2	Cover
48.	G10020	8	Hex Head Cap Screw, $\frac{1}{4}$ "-20 x $\frac{5}{8}$ "
	G10227	8	Lock Washer, $\frac{1}{4}$ "
A.	GA9603	2	Chain Case Assembly, L.H. (Items 1-16) (Shown)
	GA9602	2	Chain Case Assembly, R.H. (Items 1-16)

# BULK SEED HOPPER AND HYDRAULIC MOTOR DRIVE

RUB032/RUB033(TWL190i/TWL190c/TWL190h)

## R.H. Side Of Planter - 12 Row Shown

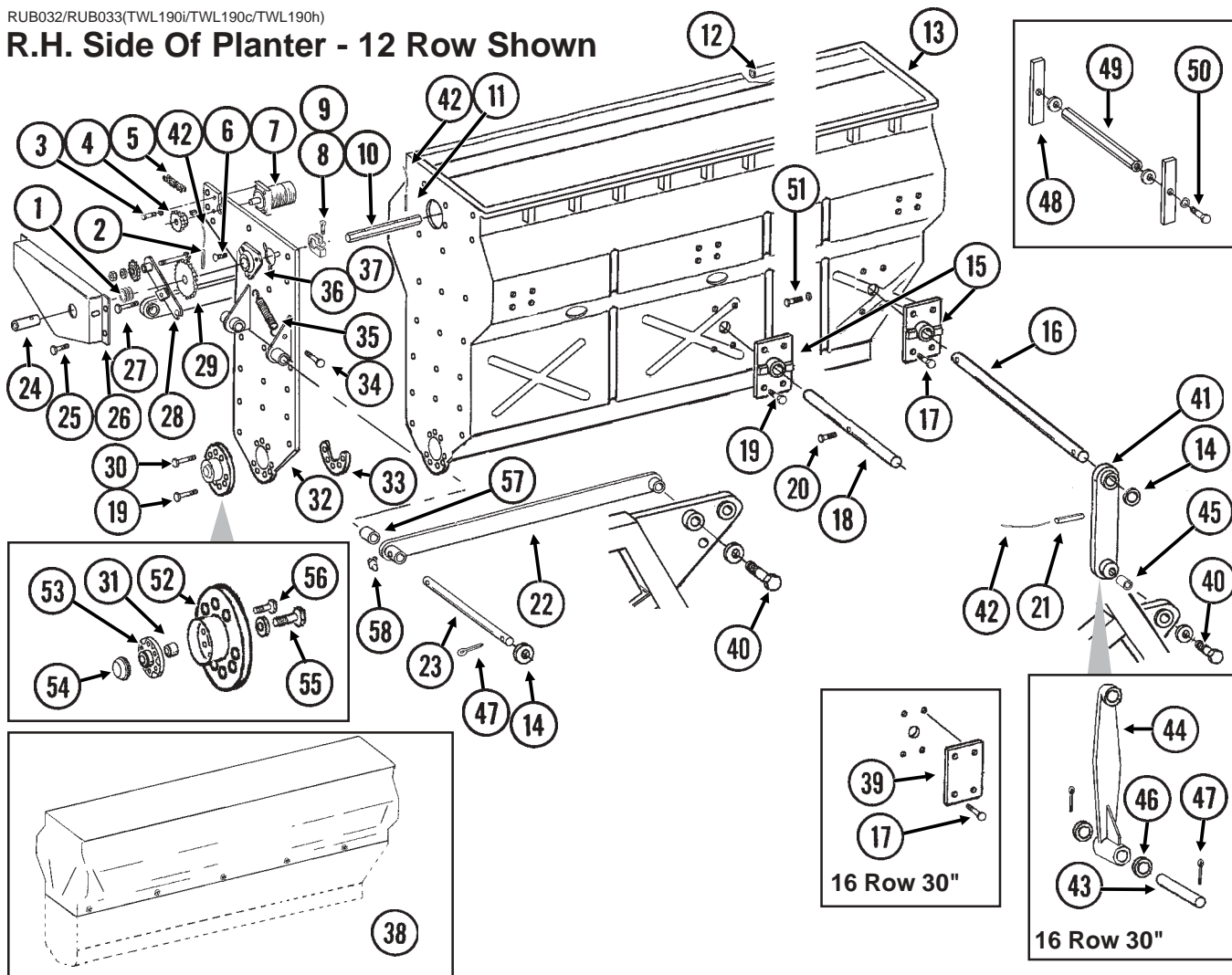

ITEM	PART NO.	QTY.	DESCRIPTION
		(Per Hopper)	
1.	G10233	3	Machine Bushing, 1", 10 Gauge
2.	G10602	1	Spring Pin, 1/4" x 1 1/2"
3.	G10001	4	Hex Head Cap Screw, 3/8"-16 x 1"
	G10229	4	Lock Washer, 3/8"
4.	GA9625	1	Sprocket, 20 Tooth
5.	G3310-88	1	Chain, No. 40, 88 Pitch Including Connector Link
	GR0912	-	Connector Link, No. 40
6.	G10312	3	Carriage Bolt, 5/16"-18 x 3/4"
	G10923	3	Flange Nut, 5/16"-18, No Serration
7.	GA9395	1	Hydraulic Motor
	GR1558	-	Seal Kit (Eaton), Includes: (6) Seals, (1) BU Ring, (3) O-Rings, (7) Seal Washers
	GR1637	-	Seal Kit (TCI), Includes: (2) Seals, (1) Ring, (4) O-Rings
8.	GD11045	1	Lock Clamp
9.	G10130	1	Square Head Machine Bolt, 5/16"-18 x 1 3/4"
	G10923	1	Flange Nut, 5/16"-18, No Serration
10.	GD13460	1	Hex Shaft, 7/8" x 7 3/4" (2 Holes)
11.	G10606	2	Spring Pin, 1/4" x 2"
12.	GD13575-01	2	Tube, 1" O.D. x 144", 12 Row 30"
	GD13575-02	2	Tube, 1" O.D. x 216", 16 Row 30"
13.	GD13432	1	Inner Tank, R.H., 12 Row 30" And 16 Row 30"
	G1K356	1	Outer Tank Kit, R.H., 12 Row 30" And 16 Row 30"
	GD13433	1	Inner Tank, L.H., 12 Row 30" And 16 Row 30"
	G1K355	1	Outer Tank Kit, L.H., 12 Row 30" And 16 Row 30"
	GD13434	1	Center Tank, R.H. And L.H., 16 Row 30"
14.	G10979	4	Special Washer, 1 1/4"
15.	-	-	See "Bulk Seed Hopper Auger Manifold Assembly", Pages P18 And P19
16.	GD13144	1	Pin, 1 1/4" x 20 1/2"

# BULK SEED HOPPER AND HYDRAULIC MOTOR DRIVE

ITEM	PART NO.	QTY. (Per Hopper)	DESCRIPTION
17.	G10004	8-16	Hex Head Cap Screw, 3/8"-16 x 1 1/4"
	G11017	8-16	Flange Nut, 3/8"-16
18.	GD13142	1	Pin, 1 1/4" x 20"
19.	G10003	8	Hex Head Cap Screw, 3/8"-16 x 1 1/2"
	G11017	8	Flange Nut, 3/8"-16
20.	G10049	1	Hex Head Cap Screw, 3/8"-16 x 2 1/2"
	G10108	1	Lock Nut, 3/8"-16
21.	G10600	2	Spring Pin, 5/16" x 2 1/2"
22.	GA9160	2	Link, 52"
23.	GD13143	1	Pin, 1 1/4" x 26"
24.	GD13554	1	Coupler, 3 1/4"
25.	G10001	6	Hex Head Cap Screw, 3/8"-16 x 1"
	G10210	6	Washer, 3/8" USS
	G11017	6	Flange Nut, 3/8"-16
26.	GD13122	1	Cover, R.H.
	GD13123	-	Cover, L.H.
27.	G10036	1	Hex Head Cap Screw, 5/8"-11 x 4"
	G10104	1	Hex Nut, 5/8"-11
	G10107	1	Lock Nut, 5/8"-11
28.	GA9554	1	Idler W/Sprocket And Hardware
	GA7154	-	Sprocket W/Bearing, 18 Tooth
	G10017	-	Hex Head Cap Screw, 1/2"-13 x 1 1/2"
	G10128	-	Machine Bushing, 1/2", 14 Gauge
	G10501	-	Hex Jam Nut, 1/2"-13, Grade 2
29.	GA7180	1	Sprocket, 40 Tooth
30.	G10001	23	Hex Head Cap Screw, 3/8"-16 x 1"
	G10210	10	Washer, 3/8" USS
	G11017	23	Flange Nut, 3/8"-16
31.	GA2014	1	Bearing
32.	GA9157	1	Tank Mount, L.H.
	GA9158	-	Tank Mount, R.H.
33.	GD13555	3	Tie Plate
34.	G10870	1	Clevis Pin, 3/8" x 1"
	G10860	1	Retaining Ring, 3/8"
35.	GD5857	1	Spring
36.	G3400-01	1	Flangette
37.	G2100-03	2	Bearing, 7/8" Hex Bore, Spherical
38.	G1K338	1	Hopper Cover Kit, 12 Row 30", Includes: (1) L.H. Bulk Seed Hopper Cover, (1) R.H. Bulk Seed Hopper Cover
	G1K339	1	Hopper Cover Kit, 16 Row 30", Includes: (1) L.H. Bulk Seed Hopper Cover, (1) R.H. Bulk Seed Hopper Cover
39.	GD13147	-	Plate, 4" x 6"
40.	G10417	4	Hex Head Cap Screw, 7/8"-9 x 4 1/2"
	G10659	4	Washer, 7/8" USS
41.	GA9162	2	Link, 13", 12 Row 30"
42.	GD13524-01	-	Lock Wire, 10", Stainless Steel
43.	GD13597	2	Pin, 1 1/4" x 8 5/8"
44.	GB0308	2	Link, 18", 16 Row 30"
45.	GD2734-13	2	Sleeve, 1 1/4" O.D. x 3 1/8" Long
46.	G10159	4	Machine Bushing, 1 1/4", 10 Gauge
47.	G10460	4	Cotter Pin, 1/4" x 2"
48.	GD14056	4	Bar, 1" x 8"
49.	GD14057	2	Hex Shaft, 7/8" x 12"
50.	G10016	4	Hex Head Cap Screw, 1/2"-13 x 2"
	G10228	4	Lock Washer, 1/2"
	G10216	4	Washer, 1/2" USS
51.	G10001	4	Hex Head Cap Screw, 3/8"-16 x 1"
	G10101	4	Hex Nut, 3/8"-16
52.	GA9848	1	End Cap
53.	GD10473	1	Bearing Housing
54.	GD11845	1	Dust Cap
55.	G10007	1	Hex Head Cap Screw, 5/8"-11 x 1 1/2"
	G10205	1	Washer, 5/8" SAE
	G10107	1	Lock Nut, 5/8"-11
56.	G10020	6	Hex Head Cap Screw, 1/4"-20 x 5/8"
	G10110	6	Lock Nut, 1/4"-20
57.	GD0752-41	2	Sleeve, 1"
58.	G10779	2	Grease Fitting, 90°, 1/4"-28
A.	GA9859	-	Bearing Cap Assembly (Items 31 And 52-56)

# BULK SEED HOPPER LID

(TWL190)

## L.H. Side Of Planter - 12 Row Shown

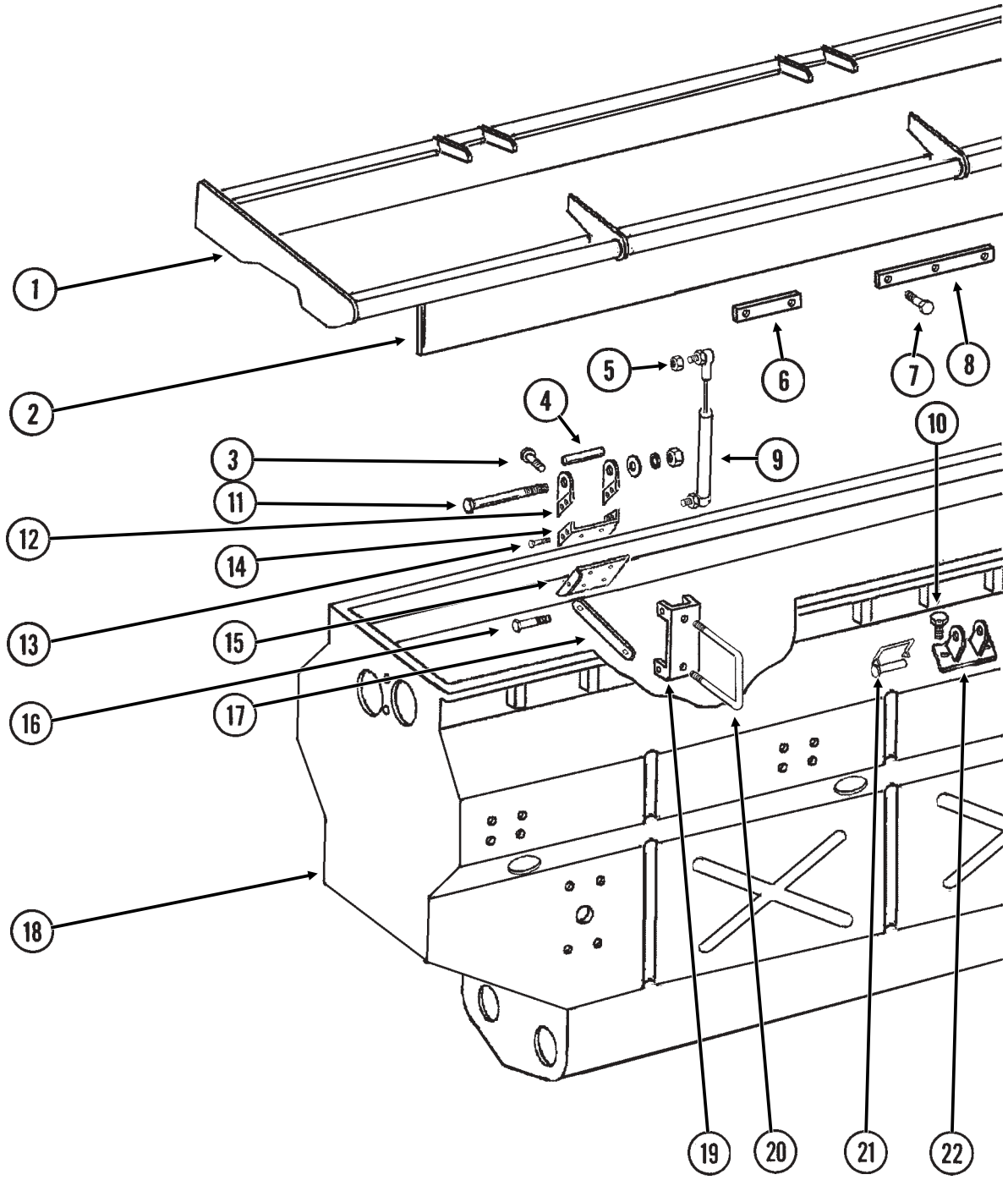



# BULK SEED HOPPER LID

ITEM	PART NO.	QTY.	DESCRIPTION
		(Per Hopper)	
1.	GA9890	1	Tank Lid, R.H., 12 Row 30"
	GA9891	1	Tank Lid, L.H., 12 Row 30"
	GA9892	-	Tank Lid, R.H., 16 Row 30"
	GA9893	-	Tank Lid, L.H., 16 Row 30"
2.	GD13217	1	Splash Guard Strip, 12 Row 30"
	GD13218	-	Splash Guard Strip, 16 Row 30"
3.	G10001	8	Hex Head Cap Screw, $\frac{3}{8}$ "-16 x 1"
	G11017	8	Flange Nut, $\frac{3}{8}$ "-16
4.	GD7904-05	-	Sleeve, 5 $\frac{3}{8}$ " Long
5.	G10109	4	Lock Nut, $\frac{5}{16}$ "-18
6.	GD13470	7-	Retainer, 1" x 3"
7.	G10312	20	Carriage Bolt, $\frac{5}{16}$ "-18 x $\frac{3}{4}$ "
	G10303	4	Carriage Bolt, $\frac{5}{16}$ "-18 x 1"
	G10109	24	Lock Nut, $\frac{5}{16}$ "-18
8.	GD12847	2-	Retainer, 1" x 18"
9.	GA9404	2	Gas Spring, 134 Pounds
10.	G10305	2	Carriage Bolt, $\frac{3}{8}$ "-16 x 1"
	G11017	2	Flange Nut, $\frac{3}{8}$ "-16
11.	G10829	3-4	Hex Head Cap Screw, $\frac{1}{2}$ "-13 x 6 $\frac{1}{2}$ "
	G10216	6-8	Washer, $\frac{1}{2}$ " USS
	G10111	3-4	Lock Nut, $\frac{1}{2}$ "-13
12.	GD13595	6-8	Hinge Tab
13.	G10043	12-16	Hex Head Cap Screw, $\frac{5}{16}$ "-18 x $\frac{3}{4}$ "
	G10219	24-32	Washer, $\frac{5}{16}$ " USS
	G10109	12-16	Lock Nut, $\frac{5}{16}$ "-18
14.	GD13190	3-4	Hinge Plate
15.	GD13151	-	Bracket
16.	G10019	4	Hex Head Cap Screw, $\frac{5}{16}$ "-18 x 1"
	G10219	4	Washer, $\frac{5}{16}$ " USS
	G10923	4	Flange Nut, $\frac{5}{16}$ "-18, No Serration
17.	GD13152	-	Brace
18.		-	See "Bulk Seed Hopper And Hydraulic Motor Drive" , Pages P14 And P15
19.	GD13198	2	Spring Anchor
20.	GD13491	2	U-Bolt, 2" x 6" x $\frac{3}{8}$ "-16
	G10901	4	Lock Nut, $\frac{3}{8}$ "-16
21.	GD10705	1	Locking Clip Pin, $\frac{1}{4}$ " x 2 $\frac{1}{2}$ "
22.	GA9588	1	Latch

# BULK SEED HOPPER AUGER MANIFOLD ASSEMBLY

RUB034(TWL192c)

L.H. Side Of Planter Shown

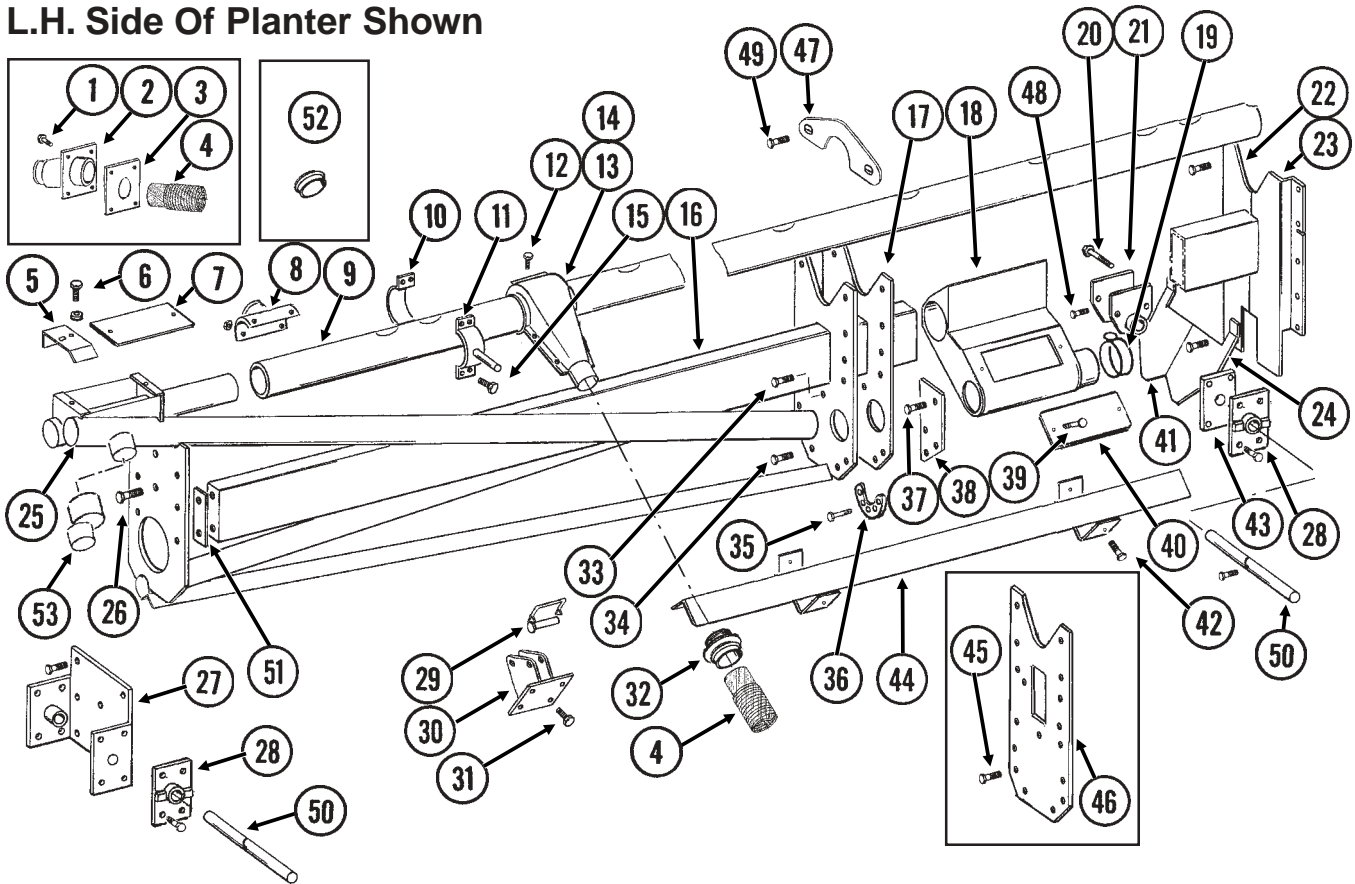

ITEM	PART NO.	QTY.	DESCRIPTION
		(Per Hopper)	
1.	G10019	4	Hex Head Cap Screw, $\frac{5}{16}$ "-18 x 1"
	G10923	4	Flange Nut, $\frac{5}{16}$ "-18, No Serration
2.	GA9199	1	Drop Tube (Even-Row Push Row Unit Only)
3.	GD13790	1	Backing Plate (Even-Row Push Row Unit)
4.		-	See "Mini-Hopper And Drop Hoses", Page P10
5.	GD13163	1	Shield
6.	G10020	2	Hex Head Cap Screw, $\frac{1}{4}$ "-20 x $\frac{5}{8}$ "
	G10227	1	Lock Washer, $\frac{1}{4}$ "
	G10209	2	Washer, $\frac{1}{4}$ " USS
7.	GD13136	1	Cover
8.	GA9589	1	Cover Plate
9.	GD13205	1	Distribution Manifold, 126", L.H., 12 Row 30"
	GD13206	-	Distribution Manifold, 126", R.H., 12 Row 30"
	GD13207	-	Distribution Manifold, 197", L.H., 16 Row 30"
	GD13208	-	Distribution Manifold, 197", R.H., 16 Row 30"
10.	GD13183	1	Clamp
11.	GA9159	1	Handle
12.	G11020	1	Phillips Pan Head Machine Screw, No. 10-24
13.	GD11968	-	Funnel, Top
14.	GA9621	-	Funnel, Bottom
15.	G10043	4	Hex Head Cap Screw, $\frac{5}{16}$ "-18 x $\frac{3}{4}$ "
	G10109	4	Lock Nut, $\frac{5}{16}$ "-18
16.	GA9174	1	Support Tube, 133 $\frac{3}{4}$ ", 12 Row 30"
	GA9181	-	Support Tube, 204 $\frac{1}{4}$ ", 16 Row 30"
17.	GD13211	-	Tie Plate

# BULK SEED HOPPER AUGER MANIFOLD ASSEMBLY

ITEM	PART NO.	QTY. (Per Hopper)	DESCRIPTION
18.	GD13351	1	Transfer Housing, L.H. (Shown)
	GD13382	-	Transfer Housing, R.H.
19.	G11036	1	Hose Clamp, Style 4
20.	G10033	2	Hex Head Cap Screw, 1/2"-13 x 3 1/2"
	G10216	2	Washer, 1/2" USS
	G10111	2	Lock Nut, 1/2"-13
21.	GA9175	2	Support
22.	GD13126	1	Baffle, R.H.
23.	GD13127	1	Baffle, L.H.
24.	GD13125	-	Baffle, L.H.
25.	GA9170	1	Auger Housing Assembly, R.H.
	GA9171	-	Auger Housing Assembly, L.H.
26.	G10007	2	Hex Head Cap Screw, 5/8"-11 x 1 1/2"
	G10217	2	Washer, 5/8" USS
	G10230	2	Lock Washer, 5/8"
27.	GD13148	1	Auger Mount Plate
28.	GB0307	-	Plate
29.	GD10705	2	Locking Clip Pin, 1/4" x 2 1/2"
30.	GA9196	2	Latch
31.	G10001	8	Hex Head Cap Screw, 3/8"-16 x 1"
	G10210	8	Washer, 3/8" USS
	G11017	8	Flange Nut, 3/8"-16
32.	GB0312	12-16	Nipple
	GB0313	12-16	Nut, 3 1/4"-12
33.	G10003	2	Hex Head Cap Screw, 3/8"-16 x 1 1/2"
	G10210	2	Washer, 3/8" USS
34.	G10003	12	Hex Head Cap Screw, 3/8"-16 x 1 1/2"
	G11017	12	Flange Nut, 3/8"-16
35.	G10003	5-10	Hex Head Cap Screw, 3/8"-16 x 1 1/2"
	G10108	5-10	Lock Nut, 3/8"-16
36.	GD13555	2-4	Tie Plate
37.	G10003	16	Hex Head Cap Screw, 3/8"-16 x 1 1/2"
	G11017	16	Flange Nut, 3/8"-16
38.	GD13120	4	Tie Bar
39.	G10018	2	Hex Head Cap Screw, 5/16"-18 x 5/8"
	G10232	2	Lock Washer, 5/16"
40.	GD13464	2	Cover
41.	GD13124	-	Baffle Plate, R.H.
42.	G10001	4	Hex Head Cap Screw, 3/8"-16 x 1"
	G10210	4	Washer, 3/8" USS
	G11017	4	Flange Nut, 3/8"-16
43.	GD13227	2	Plate, 4" x 6"
44.	GD13138	1-2	Tunnel Cover
45.	G10003	15	Hex Head Cap Screw, 3/8"-16 x 1 1/2"
	G11017	15	Flange Nut, 3/8"-16
46.	GD13571	2	Tie Plate, 16 Row 30"
47.	GD14058	1-2	Bracket
48.	G10049	1	Hex Head Cap Screw, 3/8"-16 x 2 1/2"
	G10108	1	Lock Nut, 3/8"-16
49.	G10003	2	Hex Head Cap Screw, 3/8"-16 x 1 1/2"
	G11017	2	Flange Nut, 3/8"-16
50.		-	See "Bulk Seed Hopper And Hydraulic Motor Drive", Pages P14 And P15
51.	GD13576	-	Shim, 10 Gauge x 1 3/8" x 5 3/8"
	GD13577	-	Shim, 1/4" x 1 3/8" x 5 3/8"
52.	G11000	-	Cap, 3"
53.	GA9667	1	Spout Extension

# BULK SEED HOPPER AUGER ASSEMBLY

(TWL228)

L.H. Side Of Planter Shown

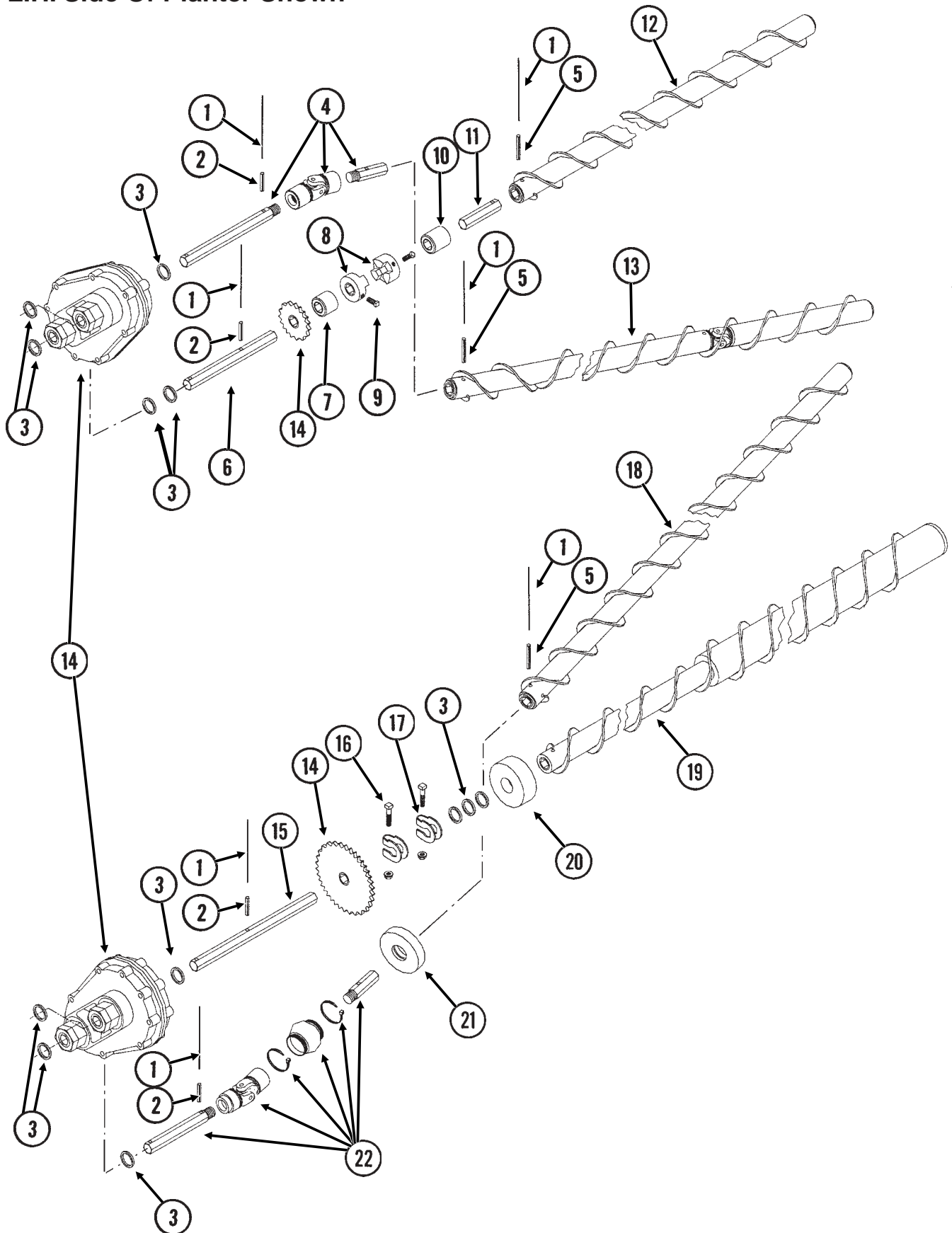

# BULK SEED HOPPER AUGER ASSEMBLY

ITEM	PART NO.	QTY.	DESCRIPTION
		(Per Hopper)	
1.	GD13524-01	11	Lock Wire, 10", Stainless Steel
2.	G10602	8	Spring Pin, 1/4" x 1 1/2"
3.	G10233	12	Machine Bushing, 1", 10 Gauge
4.	GA9823	1	Shaft Assembly W/U-Joint, 15 3/16", L.H.
	GA9824	-	Shaft Assembly W/U-Joint, 15 3/16", R.H.
	GA9169	-	U-Joint, L.H. Threads
	GA9168	-	U-Joint, R.H. Threads
5.	G10606	3	Spring Pin, 1/4" x 2"
6.	GD13204	1	Shaft, 7/8" x 8 5/8" (2 Holes)
7.	GD3660-17	1	Sleeve, 1 1/8"
8.	GB0287	2	Coupler
9.	G10131	2	Square Head Set Screw, 5/16"-18 x 3/4"
10.	GD3660-16	1	Sleeve, 1 1/2"
11.	GD13203	1	Shaft, 7/8" x 3 1/2" (1 Hole)
12.	GA9191	1	Top Auger, L.H., 147 1/2", 12 Row 30"
	GA9192	-	Top Auger, R.H., 147 1/2", 12 Row 30"
	GA9193	-	Top Auger, L.H., 217 1/2", 16 Row 30"
	GA9194	-	Top Auger, R.H., 217 1/2", 16 Row 30"
13.	GA9189	1	Upper Lift Auger Assembly W/U-Joint And Hardware, 91 5/8", L.H.
	GA9190	-	Upper Lift Auger Assembly W/U-Joint And Hardware, 91 5/8", R.H.
	GA9177	-	U-Joint
	G10606	-	Spring Pin, 1/4" x 2"
14.		-	See "Bulk Seed Hopper Gearbox Drive", Pages P12 And P13
15.	GD14067	1	Shaft, 7/8" x 12" (2 Holes)
16.	G10130	2	Square Head Machine Bolt, 5/16"-18 x 1 3/4"
	G10923	2	Flange Nut, 5/16"-18, No Serration
17.	GD11045	2	Lock Clamp
18.	GA9183	1	Lower Lift Auger, 83 1/2", L.H.
	GA9184	-	Lower Lift Auger, 83 1/2", R.H.
19.	GA9387	1	Floor Auger, L.H., 150 1/4", 12 Row 30"
	GA9388	-	Floor Auger, R.H., 150 1/4", 12 Row 30"
	GA9389	-	Floor Auger, L.H., 220 3/4", 16 Row 30"
	GA9390	-	Floor Auger, R.H., 220 3/4", 16 Row 30"
20.	GD14108	1	Plug W/Stepped Hole, 1 1/4" x 3 1/2"
21.	GD13168	1	Plug W/Stepped Hole, 3/4" x 3 1/2"
22.	GA9825	1	Shaft Assembly W/U-Joint, Boot And Tie Cables, 12 1/2", L.H.
	GA9826	-	Shaft Assembly W/U-Joint, Boot And Tie Cables, 12 1/2", R.H.
	GA9179	-	U-Joint, L.H. Threads (Stepped End)
	GA9180	-	U-Joint, R.H. Threads (Stepped End)
	GD13542	-	Boot
	GD1512	-	Tie Strap, 7 1/2"

# FINGER PICKUP SEED METER

RUA015/RUA056/RUA057(RU131/RU13d)

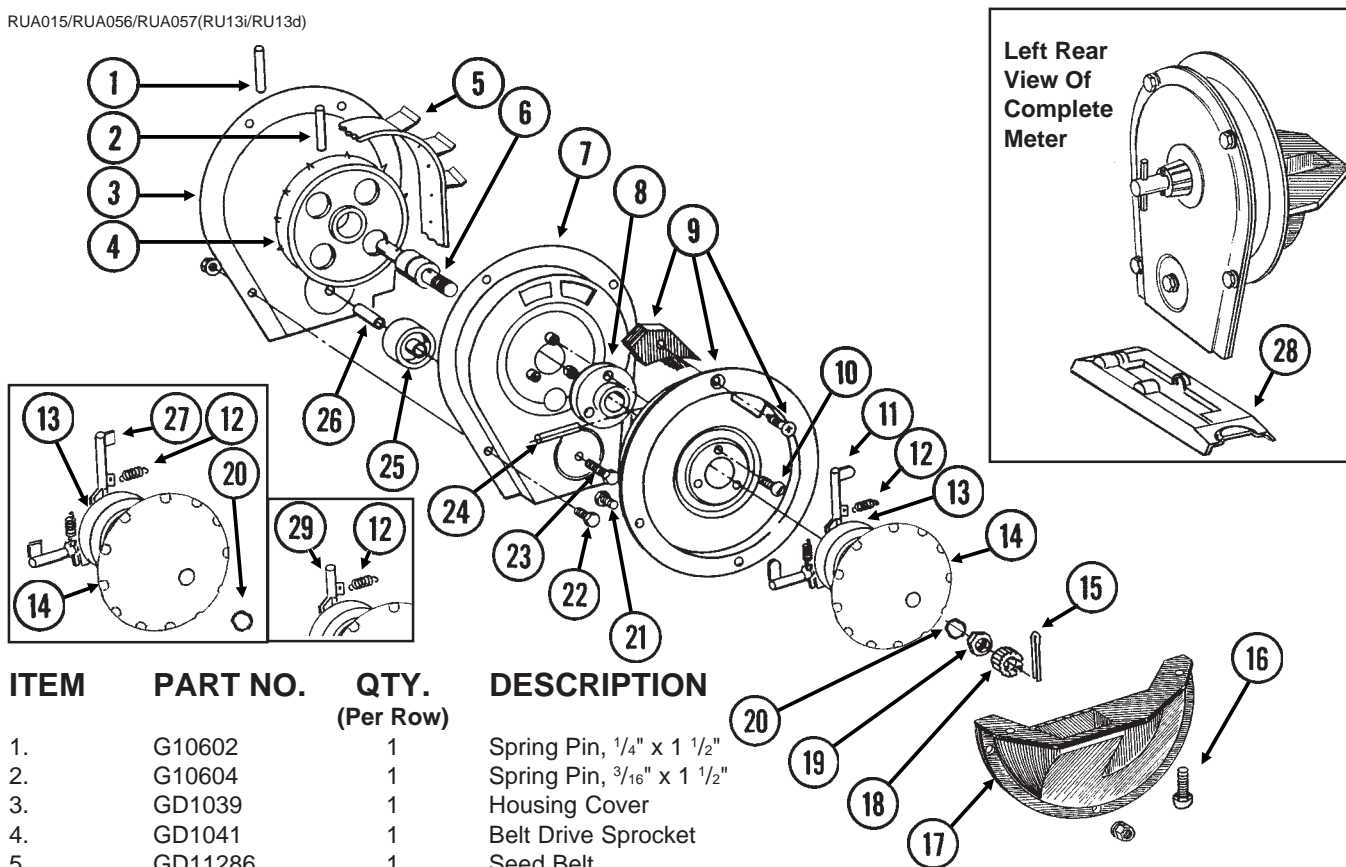

ITEM	PART NO.	QTY. (Per Row)	DESCRIPTION
1.	G10602	1	Spring Pin, 1/4" x 1 1/2"
2.	G10604	1	Spring Pin, 3/16" x 1 1/2"
3.	GD1039	1	Housing Cover
4.	GD1041	1	Belt Drive Sprocket
5.	GD11286	1	Seed Belt
6.	GA2019	1	Bearing
7.	GA2018	1	Conveyor Housing
8.	GB0110	1	Bearing Housing
9.	GR0664	1	Carrier Plate W/Brush And Screw
	GA2020	-	Brush
	G10690	-	Rolling Thread Screw, No. 10 x 3/4"
10.	G10401	3	Slotted Hex Washer Head Screw, No. 10-32 x 5/8"
11.	GD10733	12	Finger, Corn
12.	GD6501	12	Spring
13.	GB0111	1	Cam
14.	GD11528	1	Finger Holder
15.	G10470	1	Cotter Pin, 5/32" x 1"
16.	G11009	2	Locking Thumbscrew, 5/16"-18 x 3/4"
17.	GD11311	1	Seed Baffle
18.	GD1083	1	Cover Nut
19.	G10500	1	Jam Nut, 5/8"-18 UNF
20.	GA8343	1	Wave Washer, 5/8" (Triple Wave)
21.	G10020	3	Hex Head Cap Screw, 1/4"-20 x 5/8"
	G10323	3	Hex Flange Nut, 1/4"-20
22.	G10022	4	Hex Head Cap Screw, 1/4"-20 x 1/2"
	G10621	4	Flange Nut, 1/4"-20
23.	G10021	1	Hex Head Cap Screw, 1/4"-20 x 1 1/2"
	G10621	1	Flange Nut, 1/4"-20
24.	G10603	1	Spring Pin, 1/4" x 1 1/4"
25.	GD1042	1	Idler
26.	GB0120	1	Bushing, 17/64" I.D. x 1 1/32" Long
27.	GD10226	12	Finger, Oil Sunflower
28.	GD11373	1	Shank Cover, Finger Pickup Seed Meter
29.	GD11787	-	Half Rate Blank Finger

- A. GR1487 - Finger Assembly, Corn (Items 11-14 And 20)
- B. GR1327 - Finger Assembly, Oil Sunflower (Items 12-14, 20 And 27)

# BRUSH-TYPE SEED METER

RUA037/RUA056/RUA057(RU14e)

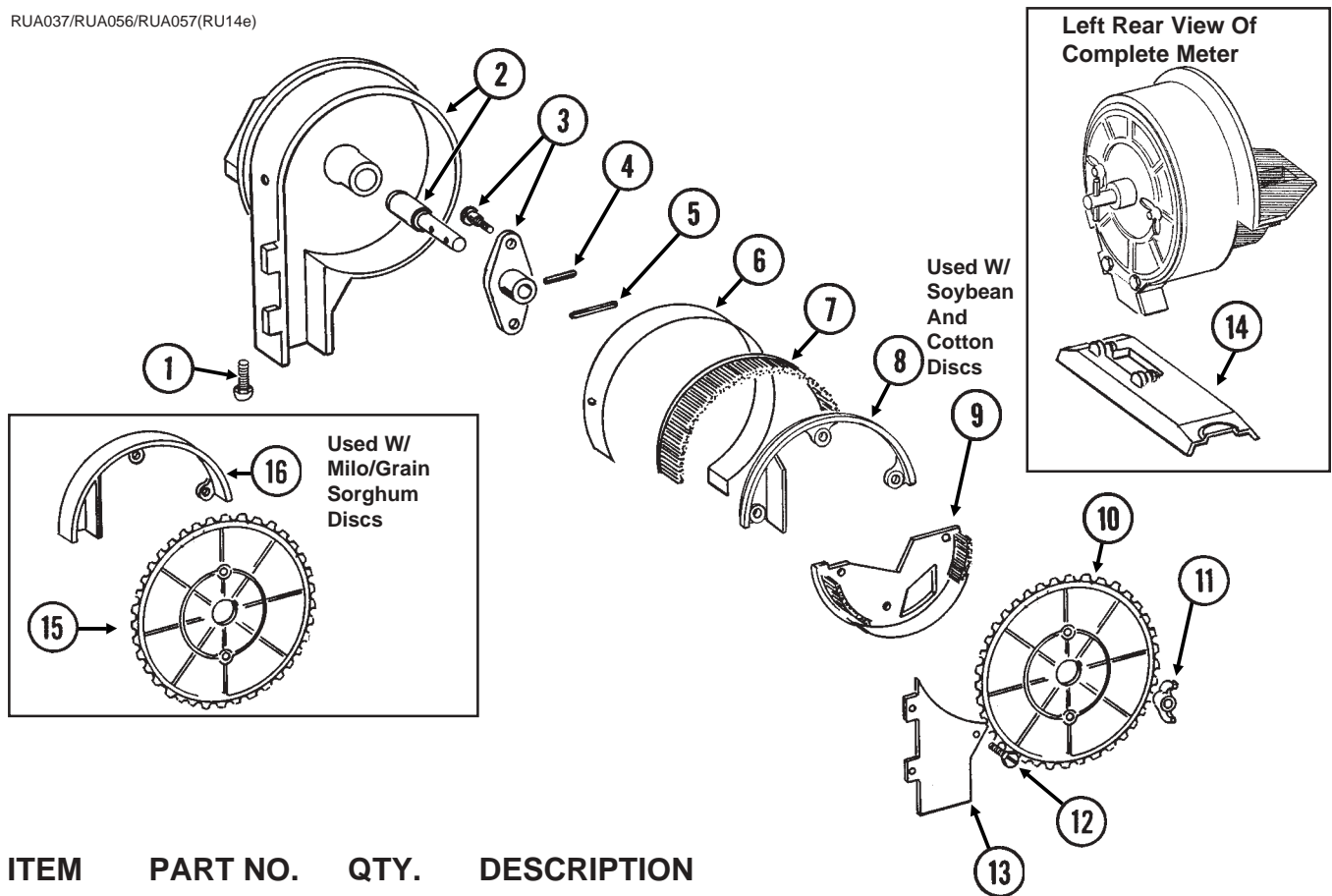

ITEM	PART NO.	QTY. (Per Row)	DESCRIPTION
1.	G11009	2	Locking Thumbscrew, $\frac{5}{16}$ "-18 x $\frac{3}{4}$ "
2.	GA6027	1	Housing W/Bearing
	GA5698	-	Bearing
3.	GA6038	1	Hub W/Shoulder Bolts
	GD1755	-	Shoulder Bolt, $\frac{1}{4}$ "-20 (2 Used)
4.	G10603	1	Spring Pin, $\frac{1}{4}$ " x $1\frac{1}{4}$ "
5.	G10602	1	Spring Pin, $\frac{1}{4}$ " x $1\frac{1}{2}$ "
6.	GD8778	1	Wear Strip
7.	GA5699	1	Upper Brush
8.	GD11122	1	Upper Brush Retainer (Used W/Soybean And Cotton Discs)
9.	GA5834	1	Lower Brush
10.	GA5794	-	Seed Disc, Soybean, 60 Cell, Black Color-Coded
	GA6184	-	Seed Disc, Specialty Soybean, 48 Cell, Dark Blue Color-Coded
	GA5796	-	Seed Disc, Cotton, Acid-Delinted, 30 Cell, White Color-Coded
	GA6168	-	Seed Disc, Large Cotton, Acid-Delinted, 36 Cell, Tan Color-Coded
	GA6478	-	Seed Disc, High-Rate Cotton, Acid-Delinted, 48 Cell, Light Green Color-Coded
	GA6182	-	Seed Disc, Hill-Drop Cotton, Acid-Delinted, 12 Cell, Brown Color-Coded
	GA7255	-	Seed Disc, Small Hill-Drop Cotton, Acid-Delinted, 12 Cell, Dark Green Color-Coded
11.	G10531	2	Nylon Insert Wing Nut, $\frac{1}{4}$ "-20
12.	G10584	9	Slotted Tap Screw, No. 10-24 x $\frac{1}{2}$ "
	G10634	-	Slotted Tap Screw, No. 10-24 x $\frac{5}{8}$ " (Use As Required)
13.	GD7878	1	Cover
14.	GD11374	1	Shank Cover, Brush-Type Seed Meter
15.	GA5982	-	Seed Disc, Small Milo/Grain Sorghum, 30 Cell, Red Color-Coded
	GA6187	-	Seed Disc, Large Milo/Grain Sorghum, 30 Cell, Light Blue Color-Coded
	GA5795	-	Seed Disc, High-Rate Small Milo/Grain Sorghum, 60 Cell, Red Color-Coded
	GA6633	-	Seed Disc, High-Rate Large Milo/Grain Sorghum, 60 Cell, Yellow Color-Coded
16.	GD8237	-	Upper Brush Retainer (Used W/Milo/Grain Sorghum Discs)

# GRANULAR CHEMICAL HOPPER AND HOPPER PANEL EXTENSION

RUA052/RUA053/RUB028(RU92k)

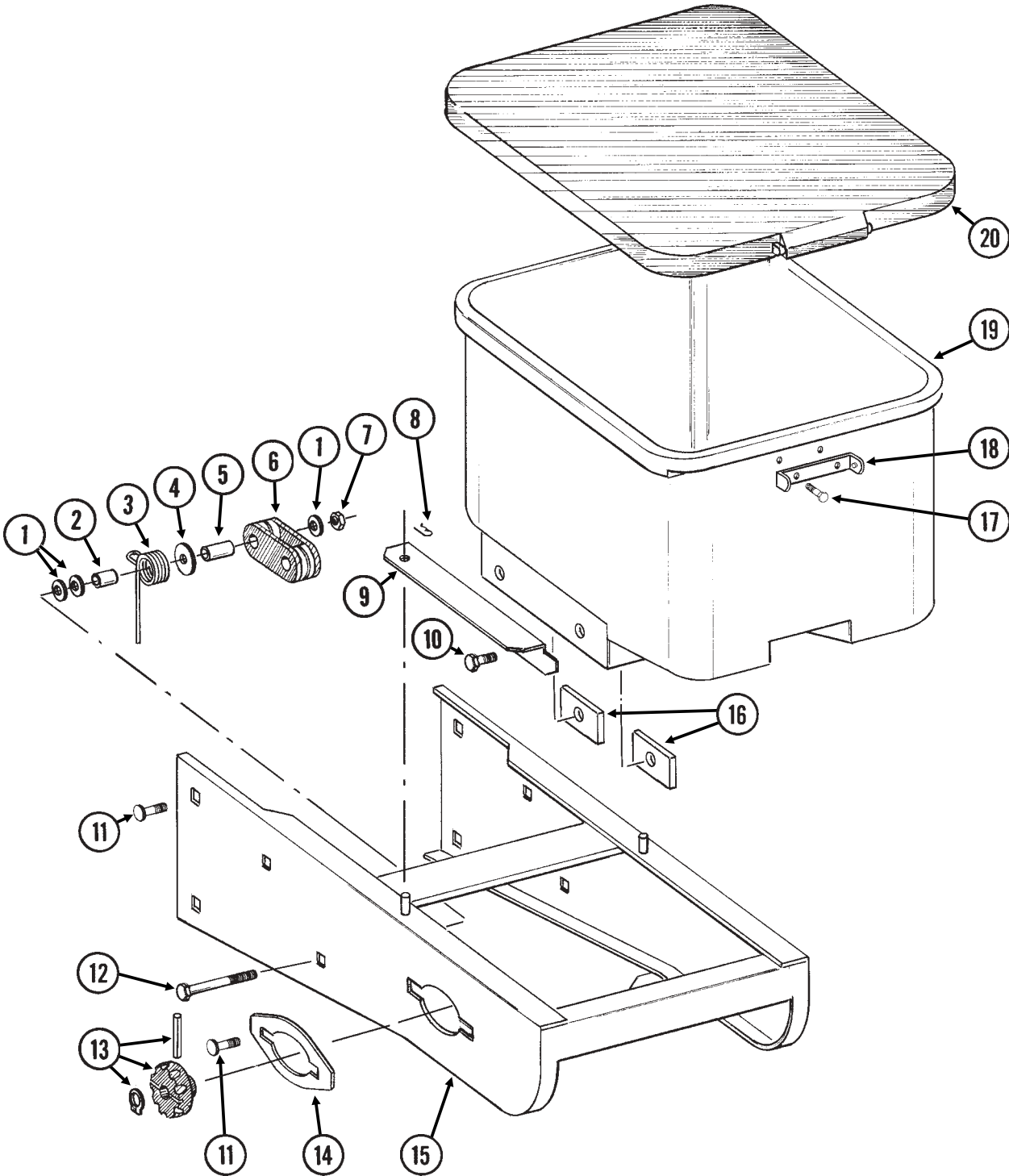



# GRANULAR CHEMICAL HOPPER AND HOPPER PANEL EXTENSION

---

ITEM	PART NO.	QTY. (Per Row)	DESCRIPTION
1.	G10210	3	Washer, $\frac{3}{8}$ " USS
2.	GD2971-10	1	Sleeve, $\frac{9}{16}$ " Long
3.	GD11219	1	Spring
4.	G10201	1	Special Washer, $\frac{3}{8}$ " x 1 $\frac{1}{2}$ " O.D.
5.	GD1026	1	Sleeve, 1 $\frac{3}{16}$ " Long
6.	GD11962	1	Idler
7.	G10108	1	Lock Nut, $\frac{3}{8}$ "-16
8.	G10670	2	Hair Pin Clip, No. 3
9.	GD1059L	1	Support, L.H. (Shown)
	GD1059R	1	Support, R.H.
10.	G10002	4	Hex Head Cap Screw, $\frac{3}{8}$ "-16 x $\frac{3}{4}$ "
	G10229	4	Lock Washer, $\frac{3}{8}$ "
11.	G10312	8	Carriage Bolt, $\frac{5}{16}$ "-18 x $\frac{3}{4}$ "
	G10620	8	Flange Nut, $\frac{5}{16}$ "-18
12.	G10325	1	Hex Head Cap Screw, $\frac{3}{8}$ "-16 x 2 $\frac{3}{4}$ "
13.		-	See "Granular Chemical Meter And Meter Drive", Page P26
14.	GD11305	1	Plate
15.	A8422	1	Hopper Panel Extension <b>(Non-Stock Item)</b> <b>(Sub Wholegoods Order Code 700-01080)</b>
16.	GD11424	4	Block
17.	G10023	2	Hex Head Cap Screw, $\frac{1}{4}$ "-20 x $\frac{3}{4}$ "
	G10621	2	Flange Nut, $\frac{1}{4}$ "-20
18.	GD1060	1	Hinge
19.	GA8371	1	Hopper
20.	GA4444	1	Lid

# GRANULAR CHEMICAL METER AND METER DRIVE

RUA051/RUB028(RU91a)

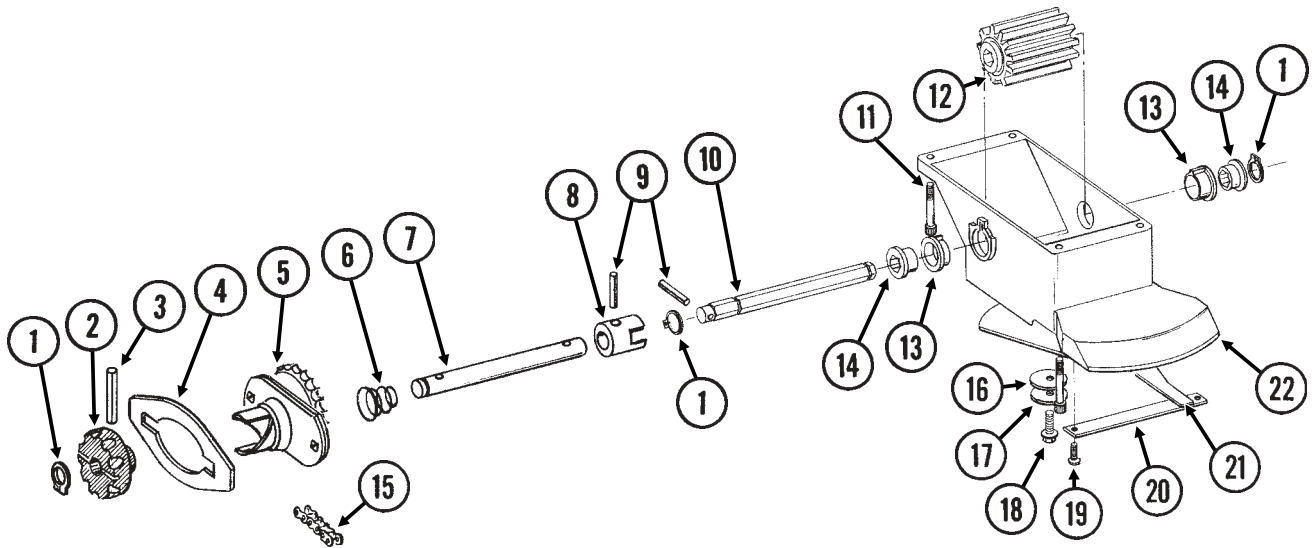

ITEM	PART NO.	QTY. (Per Row)	DESCRIPTION
1.	G10567	3	External Retaining Ring, $\frac{5}{8}$ "
2.	GD11239	1	Knob
3.	G10602	1	Spring Pin, $\frac{1}{4}$ " x 1 $\frac{1}{2}$ "
4.	-	-	See "Granular Chemical Hopper And Hopper Panel Extension", Pages P24 And P25
5.	GA8364	1	Sprocket And Bearing, Drive Clutch, 24 Tooth
6.	GD11413	1	Spring
7.	GD11240	1	Shaft
8.	GB0278	1	Coupler
9.	G10546	2	Spring Pin, $\frac{3}{16}$ " x 1 $\frac{1}{4}$ "
10.	GD11297	1	Shaft
11.	G10921	4	Hex Socket Head Cap Screw, No. 10-24 x $\frac{7}{8}$ "
	G10257	4	Lock Washer, No. 10
12.	GD7148	1	Feed Roller, Hex Bore
13.	GB0115	2	Bearing
14.	GD7258	2	Hex Bushing
15.	G3303-114	1	Chain, No. 41, 114 Pitch Including Connector Link
	GR0196	1	Connector Link, No. 41
16.	G10660	1	Wave Washer, $\frac{1}{2}$ "
17.	G10209	1	Washer, $\frac{1}{4}$ " USS
18.	G10570	1	Slotted Hex Self-Tapping Screw, $\frac{1}{4}$ "-20 x $\frac{3}{4}$ "
19.	G10521	2	Slotted Pan Head Self-Tapping Screw, No. 10 x $\frac{3}{8}$ "
20.	GD1061	1	Support Strap
21.	GD1063	1	Metering Gate
22.	GB0116	1	Granular Housing
A.	GA8326	-	Granular Chemical Meter Complete (Items 1, 9, 10, 12-14 And 16-22)

# GRANULAR CHEMICAL BANDING OPTIONS

RUA061/RUA073(RU101n)

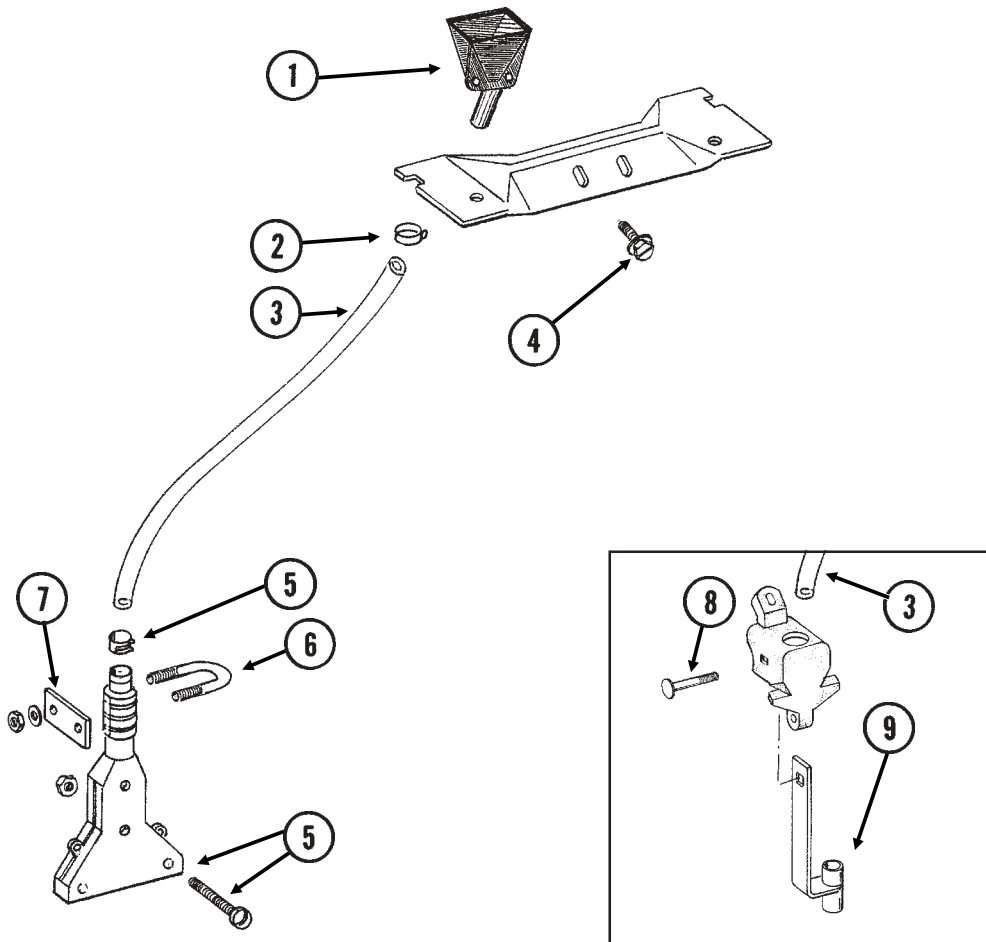

ITEM	PART NO.	QTY.	DESCRIPTION
1.	GD2423	1	Funnel
2.	G10673	1	Hose Clamp, No. 8
3.	GD2947	1	Hose, 7/16" x 28"
4.	G10523	2	Slotted Pan Head Self-Tapping Screw, No. 10 x 1/2"
5.	GA6907	1	Slope-Compensating Bander W/Hardware (4 1/2" Band Width)
	G10864	1	Uni-Clamp
	G10757	2	Pan Head Screw, No. 10-32 x 1 1/4"
	G10758	2	Hex Nut, No. 10-32
6.	GD10963	1	U-Bolt, 1 1/2" x 1 5/16" x 1/4"-20
	G10209	2	Washer, 1/4" USS
	G10110	2	Lock Nut, 1/4"-20
7.	GD10984	1	Spacer
8.	G10315	1	Carriage Bolt, 1/2"-13 x 2 1/2" (Replaces Existing 1/2" x 2 1/4" Hardware)
9.	GA6741	1	Bracket (Straight Drop In-Furrow)

# ROW UNIT MOUNTED NO TILL COULTER

RUA061(RU102/RU102c)

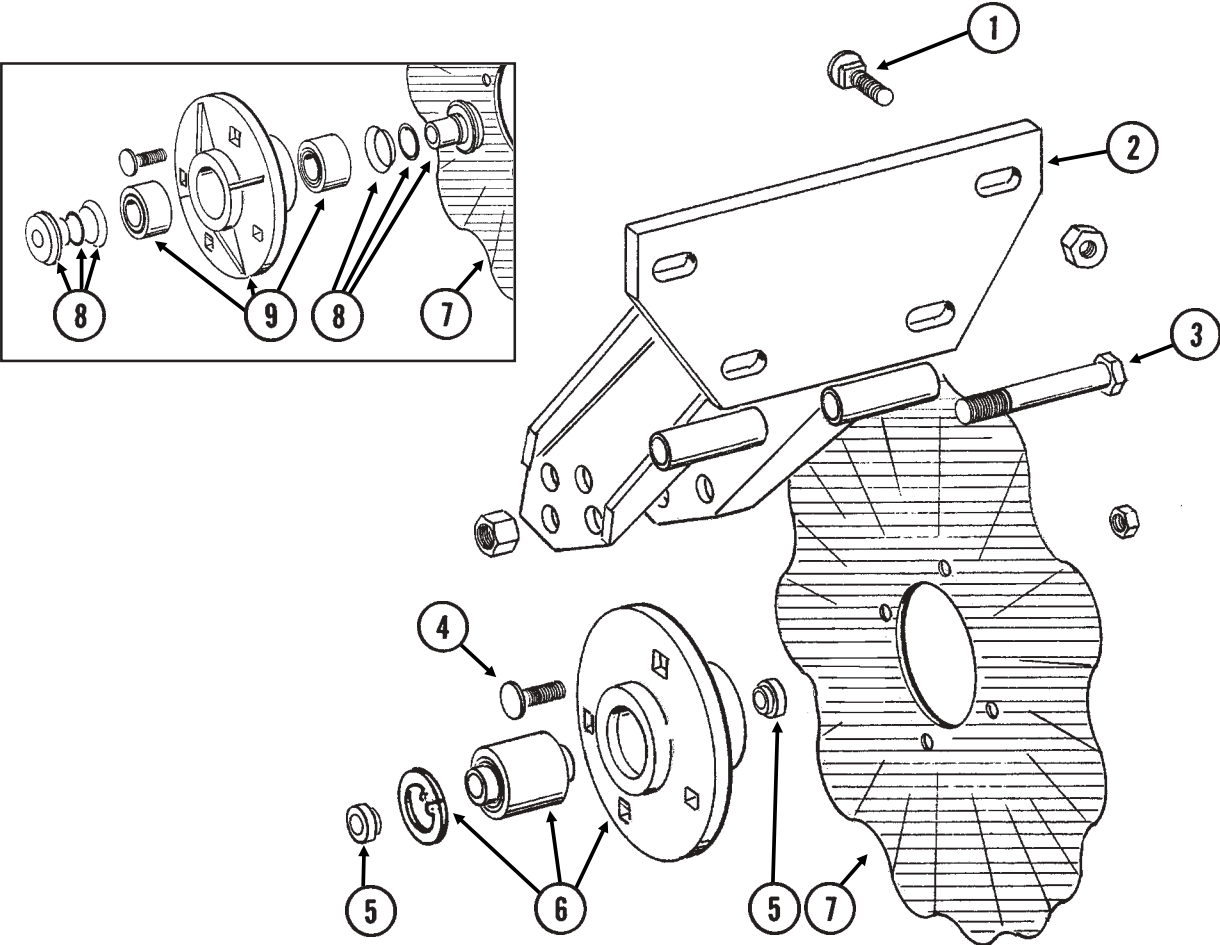

# ROW UNIT MOUNTED NO TILL COULTER

---

ITEM	PART NO.	QTY. (Per Row)	DESCRIPTION
1.	G10574	4	Carriage Bolt, 1/2"-13 x 1 1/4"
	G10111	4	Lock Nut, 1/2"-13
2.	GA5625	1	Arm
3.	G10036	1	Hex Head Cap Screw, 5/8"-11 x 4"
	G10107	1	Lock Nut, 5/8"-11
4.	G10574	4	Carriage Bolt, 1/2"-13 x 1 1/4"
	G10111	4	Lock Nut, 1/2"-13
5.	GD11677	2	Adapter
6.	GA8641	1	Hub W/Bearing And Retaining Ring
	GA8603	-	Double Row Bearing
	GD11652	-	Retaining Ring, 2 7/16"
7.	GD7803	-	Disc Blade, Fluted, 1", 8 Flutes (Shown)
	GD7804	-	Disc Blade, Bubbled, 1"
	GD9254	-	Disc Blade, Fluted, 3/4", 13 Flutes
8.	GB0227	2	Adapter W/O-Ring And Spring Washer
	GD8844	2	O-Ring
	GD8843	2	Spring Washer
9.	GA5640	1	Hub W/Bearings And Grease Fitting ( <b>Sub G1K289</b> )
	GA5622	-	Bearing (2 Used Per Hub)
	G10640	-	Grease Fitting, 1/4"-28

# ROW UNIT MOUNTED DISC FURROWER

RUA059/RUA058(RU99/RU98g)

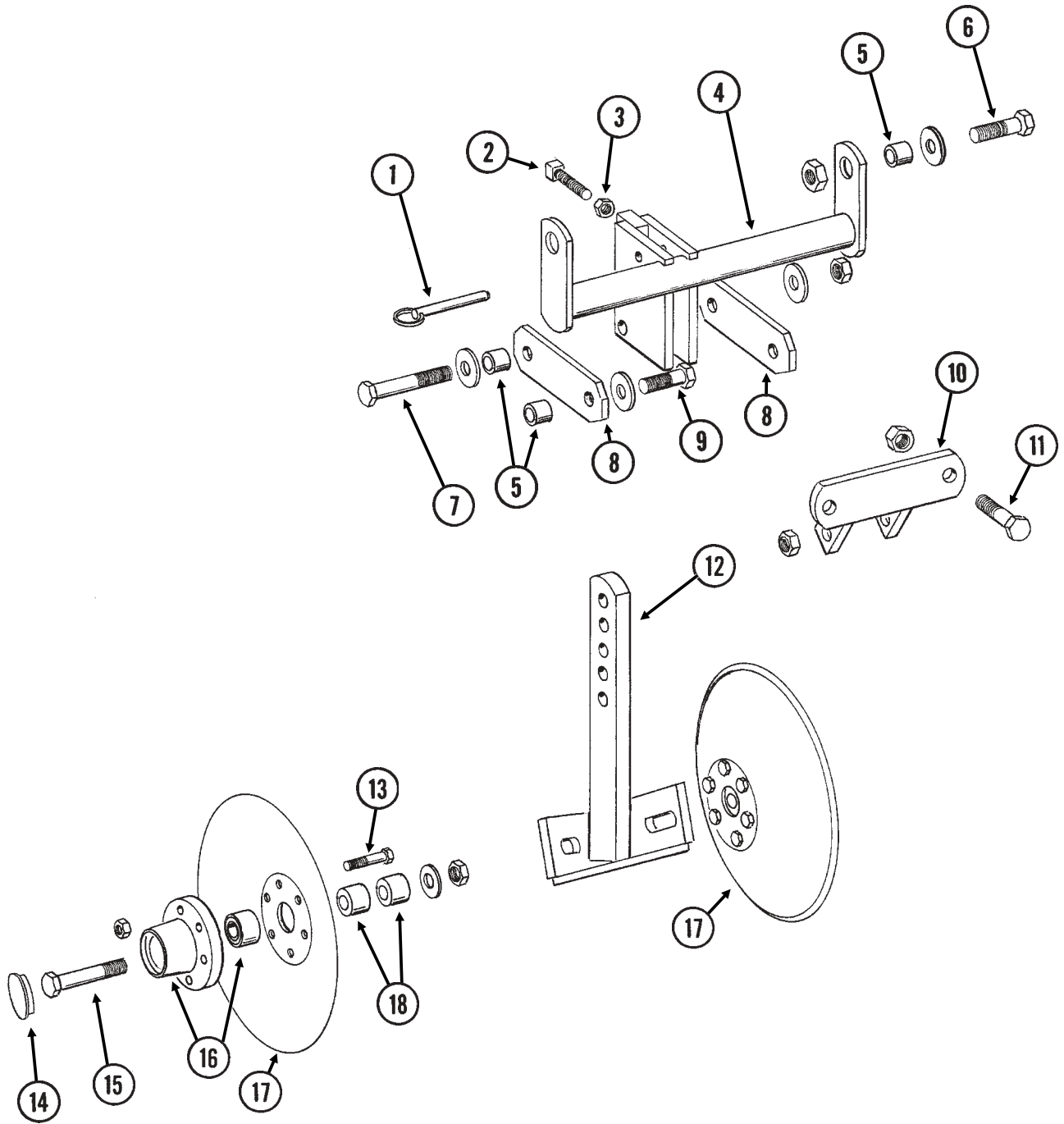

# ROW UNIT MOUNTED DISC FURROWER

---

ITEM	PART NO.	QTY. (Per Row)	DESCRIPTION
1.	G10536	1	Detent Pin, 1/2" x 2 1/2" Grip
2.	G10597	1	Square Head Set Screw, 5/8"-11 x 2 1/4"
3.	G10503	1	Hex Jam Nut, 5/8"-11, Grade 2
4.	GA5719	1	Mounting Bracket
5.	GD7889	6	Bushing
6.	G10039	2	Hex Head Cap Screw, 1/2"-13 x 1 3/4"
	G10216	2	Washer, 1/2" USS
	G10111	2	Lock Nut, 1/2"-13
7.	G10585	1	Hex Head Cap Screw, 1/2"-13 x 3 1/4"
	G10216	2	Washer, 1/2" USS
	G10111	1	Lock Nut, 1/2"-13
8.	GD7890	2	Link
9.	G10017	2	Hex Head Cap Screw, 1/2"-13 x 1 1/2"
	G10216	2	Washer, 1/2" USS
	G10111	2	Lock Nut, 1/2"-13
10.	GA5715	1	Anchor
11.	G10017	2	Hex Head Cap Screw, 1/2"-13 x 1 1/2"
	G10111	2	Lock Nut, 1/2"-13
12.	GA5718	1	Support Arm
13.	G10572	6	Truss Head Slotted Machine Screw, 5/16"-18 x 7/8"
	G10106	6	Hex Nut, 5/16"-18
14.	GD1132	2	Dust Cap
15.	G10318	2	Hex Head Cap Screw, 5/8"-11 x 4 1/2"
	GD7805	2	Special Washer, 5/8", Hardened
	G10107	2	Lock Nut, 5/8"-11
16.	GA5654	2	Hub W/Bearings
	GA2014	-	Bearing
17.	GD7823	-	Disc Blade, Solid, 12" (Shown)
	GD8307	-	Disc Blade, Notched, 12"
18.	GD7817-01	2	Spacer, 11/16" I.D. x 3/4" Long
	GD7817-04	2	Spacer, 11/16" I.D. x 1/2" Long

# ROW UNIT MOUNTED RESIDUE WHEEL

(RU103d)

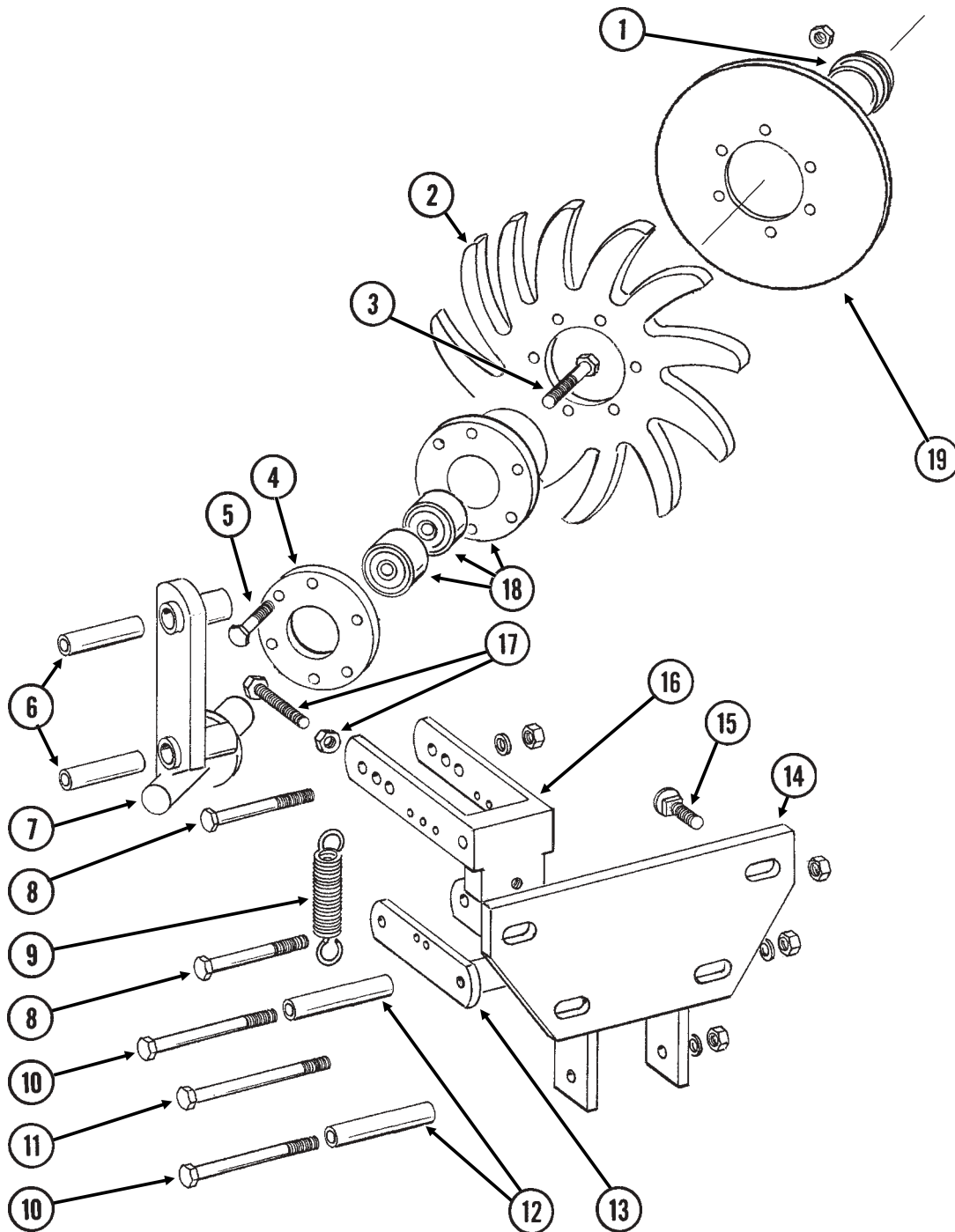



# ROW UNIT MOUNTED RESIDUE WHEEL

ITEM	PART NO.	QTY. (Per Row)	DESCRIPTION
1.	GD1132	1	Dust Cap
2.	GD10552	1	Wheel, 12 Tine, $\frac{3}{8}$ " x 12"
3.	G10006	1	Hex Head Cap Screw, $\frac{5}{8}$ "-11 x 2 $\frac{1}{4}$ "
4.	GD9724	1	Backing Plate
5.	G10133	6	Hex Head Cap Screw, $\frac{5}{16}$ "-18 x 1 $\frac{1}{2}$ "
	G10109	6	Lock Nut, $\frac{5}{16}$ "-18
6.	GD9720	2	Spacer, $\frac{1}{2}$ " x 2 $\frac{3}{16}$ " Long
7.	GA6838	1	Wheel Mount
8.	G10033	2	Hex Head Cap Screw, $\frac{1}{2}$ "-13 x 3 $\frac{1}{2}$ "
	G10228	2	Lock Washer, $\frac{1}{2}$ "
	G10102	2	Hex Nut, $\frac{1}{2}$ "-13
9.	GD5857	2	Spring
10.	G10045	2	Hex Head Cap Screw, $\frac{1}{2}$ "-13 x 4 $\frac{1}{2}$ "
	G10228	2	Lock Washer, $\frac{1}{2}$ "
	G10102	2	Hex Nut, $\frac{1}{2}$ "-13
11.	G10348	1	Hex Head Cap Screw, $\frac{1}{2}$ "-13 x 5" (Lockup Bolt)
	G10111	1	Lock Nut, $\frac{1}{2}$ "-13
12.	GD9715	2	Spacer, $\frac{1}{2}$ " x 3" Long
13.	GA6834	1	Lower Link
14.	GA6832	1	Mount
15.	G10574	4	Carriage Bolt, $\frac{1}{2}$ "-13 x 1 $\frac{1}{4}$ "
	G10111	4	Lock Nut, $\frac{1}{2}$ "-13
16.	GA6833	1	Upper Link
17.	G10371	1	Hex Head Cap Screw, $\frac{1}{2}$ "-13 x 3", Full Thread
	G10501	1	Hex Jam Nut, $\frac{1}{2}$ "-13, Grade 2
18.	GA5654	1	Hub W/Bearings
	GA2014	-	Bearing
19.	GD12534	-	Cover
A.	GA7446	-	Wheel Assembly, 12 Tine (Items 2, 4, 5 And 18)

# COULTER MOUNTED RESIDUE WHEELS

RUA063(RU104p)

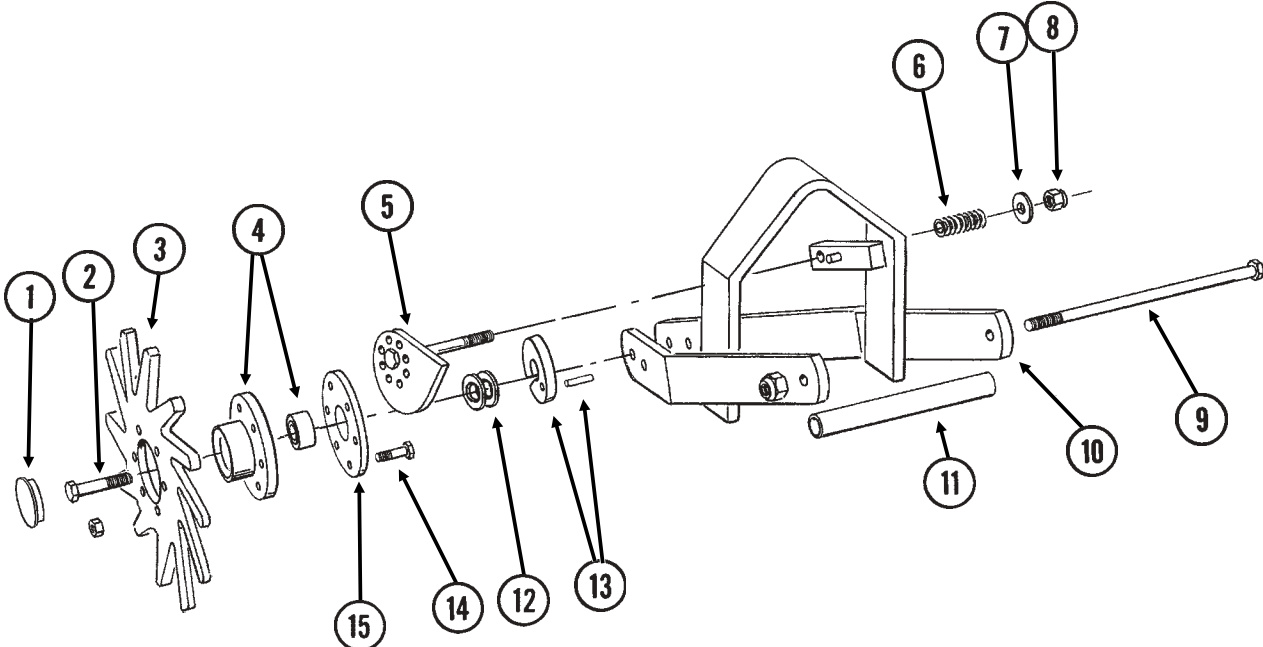

# COULTER MOUNTED RESIDUE WHEELS

---

ITEM	PART NO.	QTY. (Per Row)	DESCRIPTION
1.	GD1132	2	Dust Cap
2.	G10009	2	Hex Head Cap Screw, $\frac{5}{8}$ "-11 x 2 $\frac{1}{2}$ "
3.	GD10552	2	Wheel, 12 Tine, $\frac{3}{8}$ " x 12"
4.	GA5654	2	Hub W/Bearings
	GA2014	-	Bearing
5.	GA7412	1	Cam
6.	GD10519	1	Spring
7.	G10206	1	Washer, $\frac{1}{2}$ " SAE
8.	G10974	1	Lock Nut W/Nylon Insert, $\frac{1}{2}$ "-13
9.	G10148	1	Hex Head Cap Screw, $\frac{1}{2}$ "-13 x 9 $\frac{1}{2}$ "
	G10974	1	Lock Nut W/Nylon Insert, $\frac{1}{2}$ "-13
10.	GA7271	1	Mount
11.	GD10526	1	Sleeve, 7 $\frac{1}{2}$ "
12.	G10213	4	Machine Bushing, $\frac{5}{8}$ " (.030" Thick)
13.	GA8760	2	Weed Guard W/Spring Pin
	G10765	-	Spring Pin, $\frac{1}{4}$ " x 1"
14.	G10133	12	Hex Head Cap Screw, $\frac{5}{16}$ "-18 x 1 $\frac{1}{2}$ "
	G10109	12	Lock Nut, $\frac{5}{16}$ "-18
15.	GD9724	2	Backing Plate
A.	GA7446	-	Wheel Assembly, 12 Tine, R.H. (Items 3, 4, 14 And 15) (Shown)
	GA7445	-	Wheel Assembly, 12 Tine, L.H. (Items 3, 4, 14 And 15)

# FRAME MOUNTED COULTER W/DISC FURROWER

RUA058/RUA064/RUA070/RUA071/RUA072/RUA068(RU107f/RU107b)

STYLE A

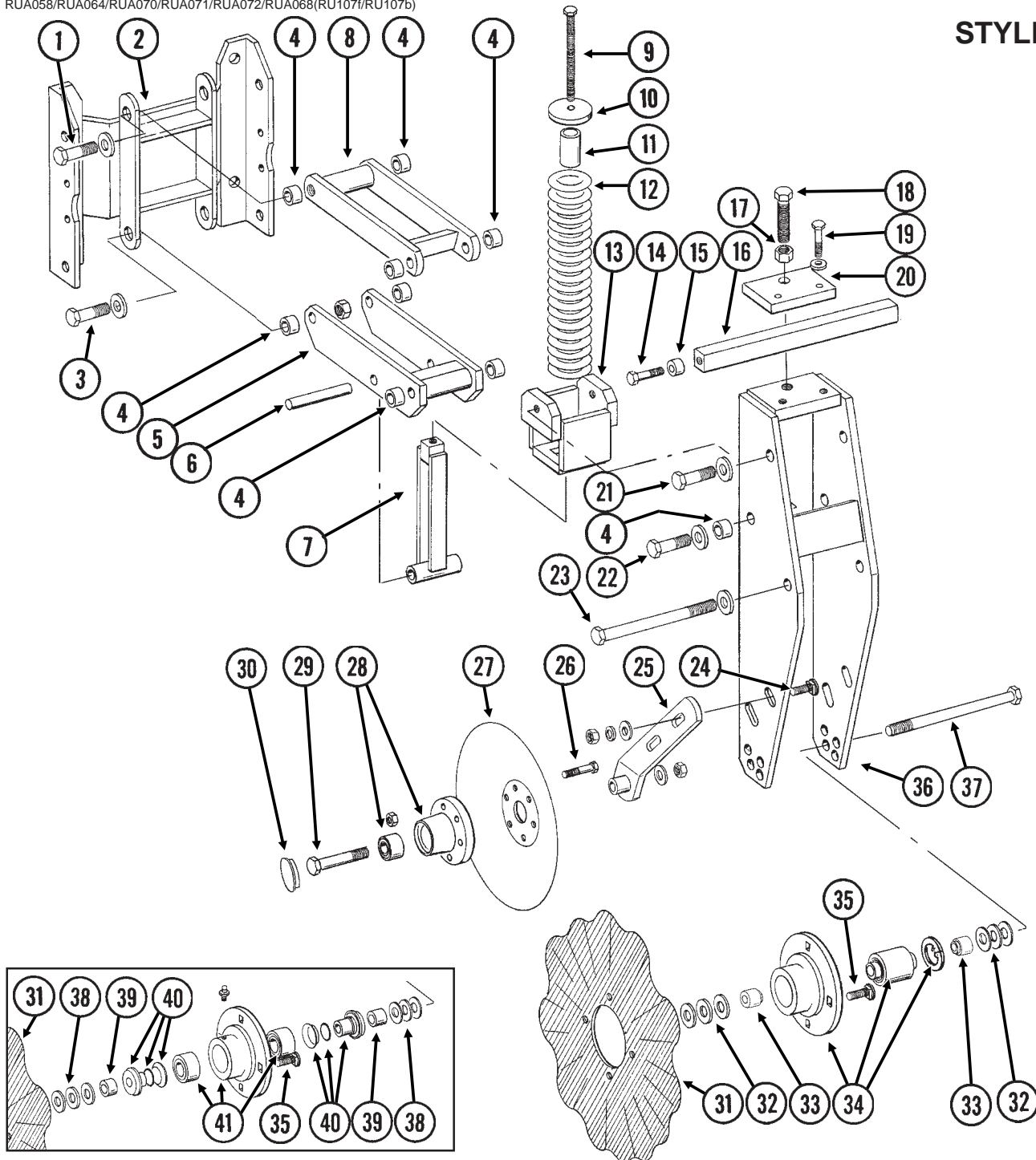

ITEM PART NO. QTY. DESCRIPTION  
(Per Row)

1.	G10008	2	Hex Head Cap Screw, 5/8"-11 x 2"
	GD7805	2	Special Washer, 5/8", Hardened
2.	GA5798	1	Support Plate
3.	G10008	2	Hex Head Cap Screw, 5/8"-11 x 2"
	GD7805	2	Special Washer, 5/8", Hardened
	G10107	2	Lock Nut, 5/8"-11
4.	GB0218	10	Bushing, 21/32" I.D. x 7/8" O.D. x 19/32" Long
5.	GA5631	1	Lower Parallel Link
6.	GD7815	1	Pin, 5/8" x 4 1/4"
7.	GA5635	1	Spring Guide

# FRAME MOUNTED COULTER W/DISC FURROWER

ITEM	PART NO.	QTY. (Per Row)	DESCRIPTION
8.	GA5630	1	Upper Parallel Link
9.	G10573	1	Hex Head Cap Screw, 5/8"-11 x 5 1/2", Full Thread
10.	GB0196	1	Washer
11.	GD7817-09	1	Spacer, 11/16" I.D. x 1 3/4" Long
12.	GD7831	1	Compression Spring
13.	GA5637	1	Spring Socket
14.	GD7818	2	Special Bolt
15.	GD7817-01	2	Spacer, 11/16" I.D. x 3/4" Long
16.	GD7816	1	Depth Control Bar
17.	G10104	1	Hex Nut, 5/8"-11
18.	G10582	1	Hex Head Cap Screw, 5/8"-11 x 4", Full Thread
19.	G10581	2	Hex Head Cap Screw, 1/2"-13 x 2 1/4"
	G10228	2	Lock Washer, 1/2"
20.	GD7811	1	Depth Adjustment Clamp
21.	G10008	2	Hex Head Cap Screw, 5/8"-11 x 2"
	GD7805	2	Special Washer, 5/8", Hardened
	GD1109	-	Bushing, 41/64" I.D. x 7/8" O.D. x 1/4" Long (As Required)
	G10107	1	Lock Nut, 5/8"-11
22.	G10055	2	Hex Head Cap Screw, 5/8"-11 x 1 1/4"
	GD7805	2	Special Washer, 5/8", Hardened
23.	G10012	1	Hex Head Cap Screw, 5/8"-11 x 6 1/2"
	GD7805	2	Special Washer, 5/8", Hardened
	GD1109	-	Bushing, 41/64" I.D. x 7/8" O.D. x 1/4" Long (As Required)
	G10107	1	Lock Nut, 5/8"-11
24.	G10747	4	Carriage Bolt, 1/2"-13 x 2"
	G10206	-	Washer, 1/2" SAE (As Required)
	G10228	4	Lock Washer, 1/2"
	G10102	4	Hex Nut, 1/2"-13
25.	GA5636	2	Arm
26.	G10572	12	Truss Head Slotted Machine Screw, 5/16"-18 x 7/8"
	G10106	12	Hex Nut, 5/16"-18
27.	GD7823	2	Disc Blade, Solid, 12" (Shown)
	GD8307	-	Disc Blade, Notched, 12"
28.	GA5654	2	Hub W/Bearings
	GA2014	4	Bearing
29.	G10036	2	Hex Head Cap Screw, 5/8"-11 x 4"
	G10107	2	Lock Nut, 5/8"-11
30.	GD1132	2	Dust Cap
31.	GD7803	1	Disc Blade, Fluted, 1", 8 Flutes (Shown)
	GD7804	-	Disc Blade, Bubbled, 1"
	GD9254	-	Disc Blade, Fluted, 3/4", 13 Flutes
32.	G10213	-	Machine Bushing, 5/8" (.030" Thick) (As Required)
	G10918	-	Machine Bushing, 5/8", 14 Gauge (As Required)
33.	GD11698	2	Adapter
34.	GA8641	1	Hub W/Bearing And Retaining Ring
	GA8603	-	Double Row Bearing
	GD11652	-	Retaining Ring, 2 7/16"
35.	G10574	4	Carriage Bolt, 1/2"-13 x 1 1/4"
	G10111	4	Lock Nut, 1/2"-13
36.	GA5643	1	Fork Mount
37.	G10068	1	Hex Head Cap Screw, 5/8"-11 x 6"
	G10107	1	Lock Nut, 5/8"-11
38.	G10217	-	Washer, 5/8" USS (As Required)
39.	GD7817-04	2	Spacer, 11/16" I.D. x 1/2" Long
40.	GB0227	2	Adapter W/O-Ring And Spring Washer
	GD8844	-	O-Ring
	GD8843	-	Spring Washer
41.	GA5640	1	Hub W/Bearings And Grease Fitting (Sub G1K290)
	GA5622	-	Bearing (2 Used Per Hub)
	G10640	-	Grease Fitting, 1/4"-28

# FRAME MOUNTED COULTER

(RU135c/RU135g/RU135h)

## STYLE B

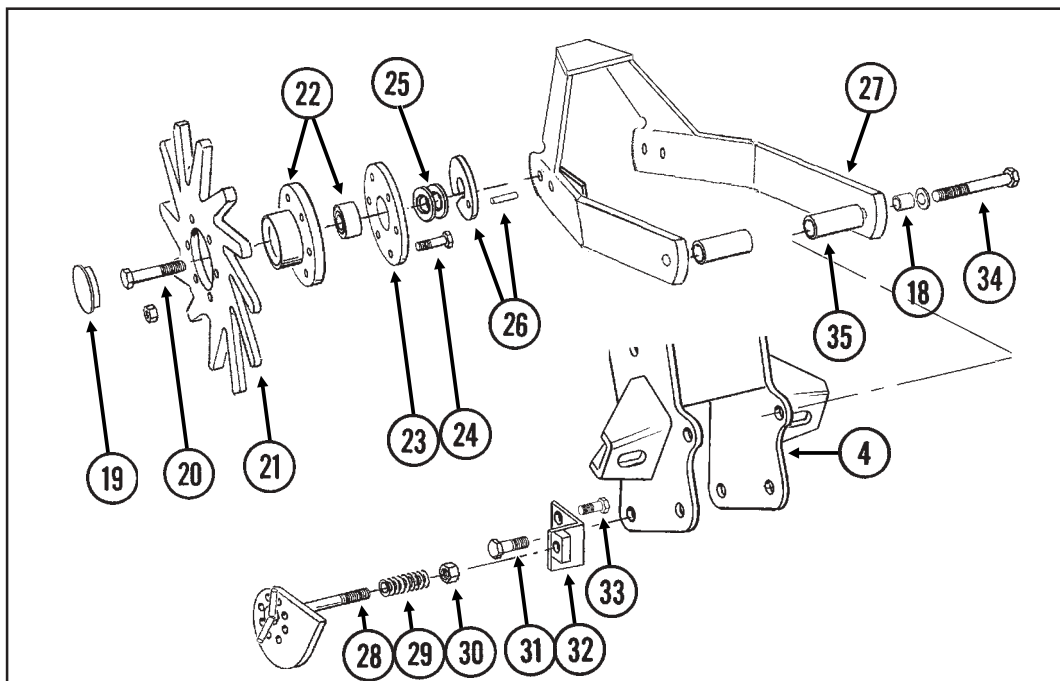
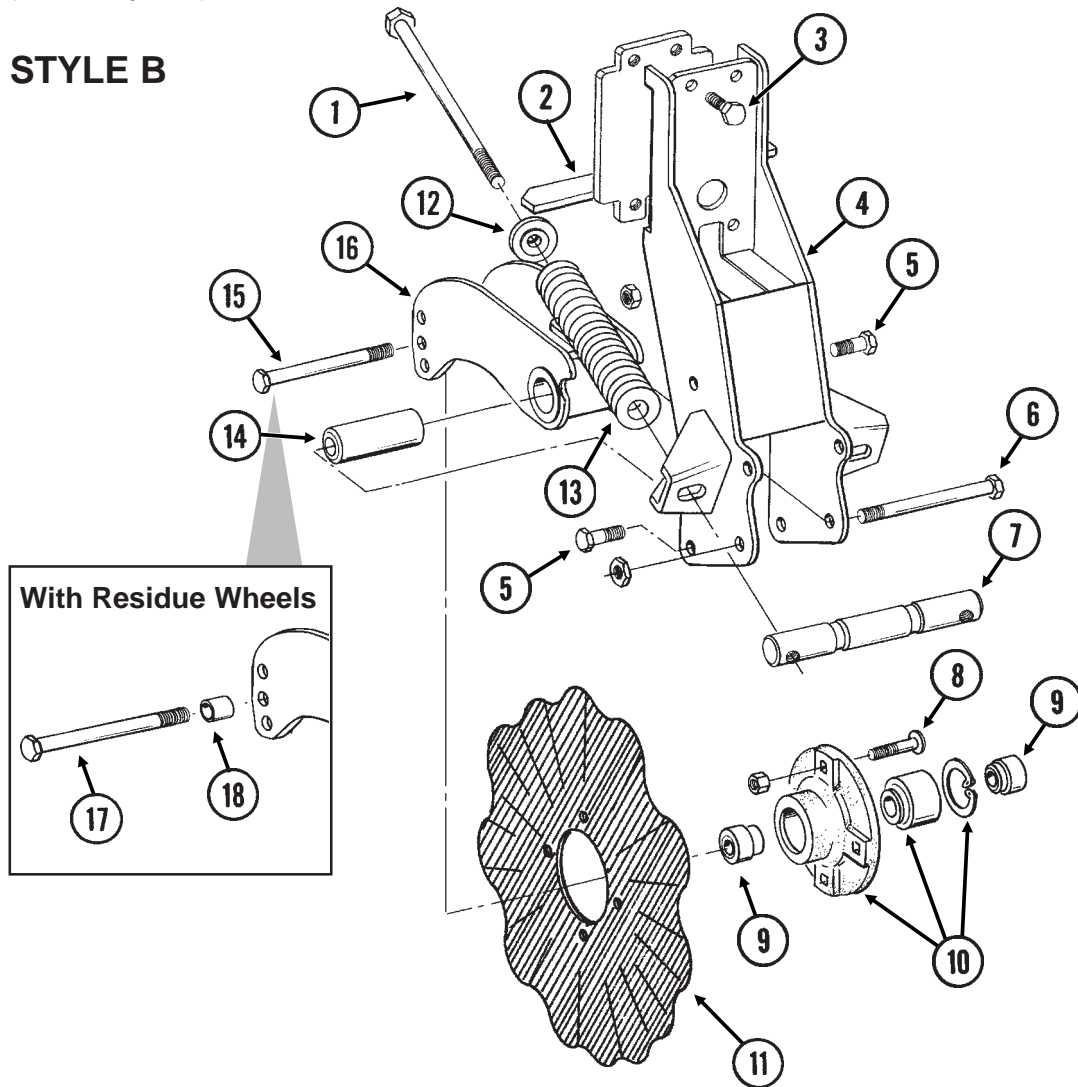

# FRAME MOUNTED COULTER

ITEM	PART NO.	QTY. (Per Row)	DESCRIPTION
1.	G11010	2	Hex Head Cap Screw, 3/4"-10 x 12"
2.	GA9844	1	Plate W/Angle
3.	G10039	4	Hex Head Cap Screw, 1/2"-13 x 1 3/4"
4.	GA9131	1	Coulter Frame
5.	G10007	4	Hex Head Cap Screw, 5/8"-11 x 1 1/2"
	G10107	4	Lock Nut, 5/8"-11
6.	G10400	1	Hex Head Cap Screw, 3/4"-10 x 6 1/2"
	G10112	1	Lock Nut, 3/4"-10
7.	GD12826	1	Spring Anchor Bar
8.	G10574	4	Carriage Bolt, 1/2"-13 x 1 1/4"
	G10111	4	Lock Nut, 1/2"-13
9.	GD12827	2	Adapter
10.	GA8641	1	Hub W/Bearing And Retaining Ring
	GA8603	1	Double Row Bearing
	GD11652	1	Retaining Ring, 2 7/16"
11.	GD7803	1	Disc Blade, Fluted, 1", 8 Flutes (Shown)
	GD7804	-	Disc Blade, Bubbled, 1"
	GD9254	-	Disc Blade, Fluted, 3/4", 13 Flutes
12.	GB0213	2	Spring Seat
13.	GD12817	2	Compression Spring
14.	GD12829	1	Sleeve
15.	G10046	1	Hex Head Cap Screw, 5/8"-11 x 5"
	G10107	1	Lock Nut, 5/8"-11
16.	GA9845	1	Coulter Arm W/Grease Fitting
	G10643	-	Grease Fitting, 45°, 1/4"-28
17.	G10011	1	Hex Head Cap Screw, 5/8"-11 x 5 1/2"
	G10107	1	Lock Nut, 5/8"-11
18.	GB0218	3	Bushing, 2 1/32" I.D. x 7/8" O.D. x 19/32" Long
19.	GD1132	2	Dust Cap
20.	G10009	2	Hex Head Cap Screw, 5/8"-11 x 2 1/2"
21.	GD10552	2	Wheel, 12 Tine, 3/8" x 12"
22.	GA5654	2	Hub W/Bearings
	GA2014	-	Bearing
23.	GD9724	2	Backing Plate
24.	G10133	12	Hex Head Cap Screw, 5/16"-18 x 1 1/2"
	G10109	12	Lock Nut, 5/16"-18
25.	G10213	4	Machine Bushing, 5/8" (.030" Thick)
26.	GA9862	2	Weed Guard W/Spring Pin
	G10765	-	Spring Pin, 1/4" x 1"
27.	GA9865	1	Mount
28.	GA9861	1	Cam
29.	GD10519	1	Spring
30.	G10974	1	Lock Nut W/Nylon Insert, 1/2"-13
31.	G10005	1	Hex Head Cap Screw, 5/8"-11 x 1 3/4"
	G10107	4	Lock Nut, 5/8"-11
32.	GA9864	1	Support
33.	G10014	1	Hex Head Cap Screw, 1/2"-13 x 1"
	G10102	1	Hex Nut, 1/2"-13
34.	G10011	2	Hex Head Cap Screw, 5/8"-11 x 5 1/2"
	G10205	2	Washer, 5/8" SAE
	G10730	2	Nylon Insert Lock Nut, 5/8"-11
35.	GD14170	2	Sleeve, 3"
A.	GA7446	-	Wheel Assembly, 12 Tine, R.H. (Items 21-24) (Shown)
	GA7445	-	Wheel Assembly, 12 Tine, L.H. (Items 21-24)

# INTERPLANT® PUSH ROW UNIT

RPU011/RPU012/RPU013(RU89r/RU86k/RU121/RU89q)

**NOTE:** Push row units use the same seed tube, row unit depth adjustment components, quick adjustable down force springs, 15" opener disc blades, gauge wheels, closing wheels, meter drive and mini-hopper as the pull row unit. See those pages for common parts.

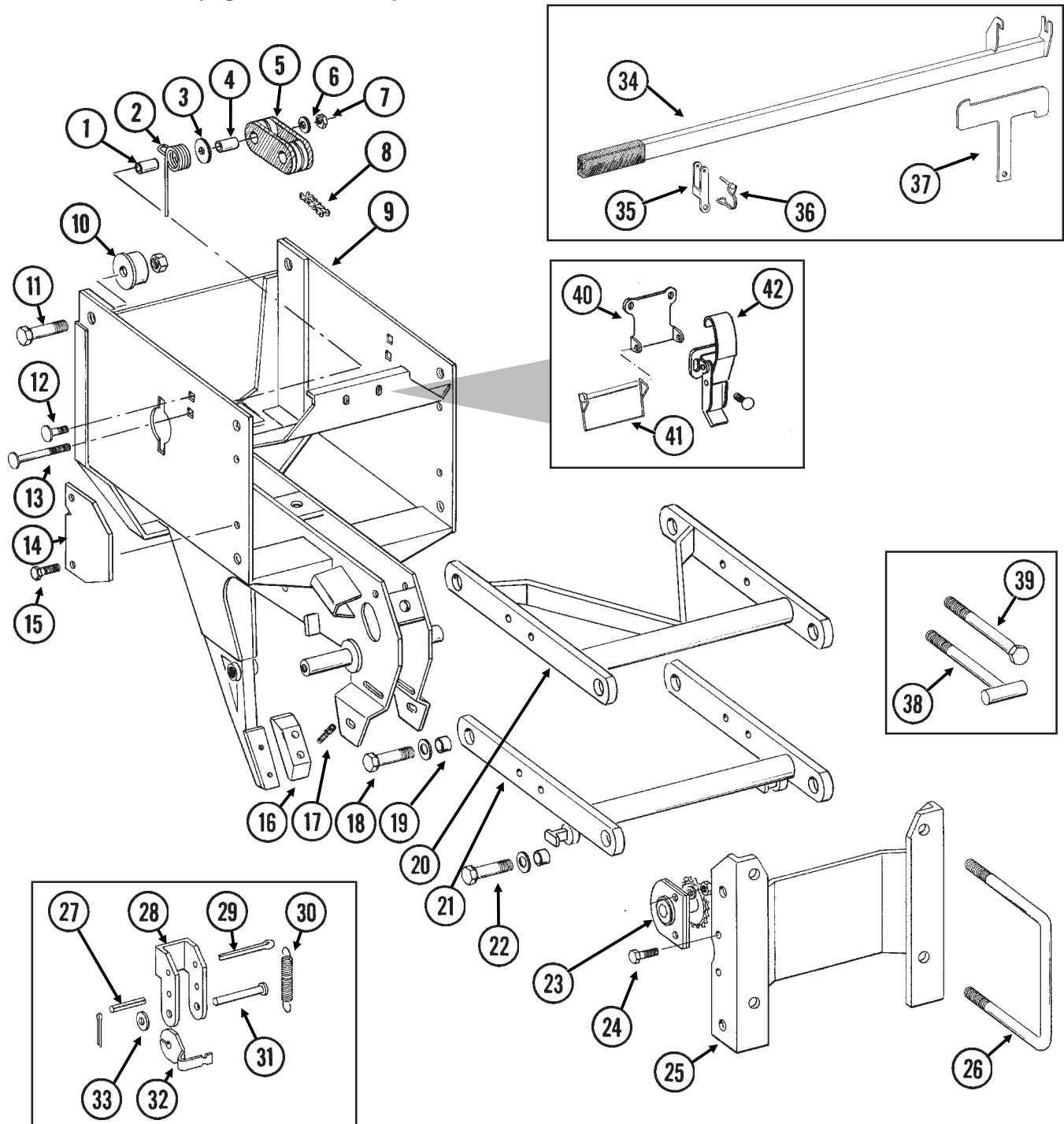

ITEM	PART NO.	QTY. (Per Row)	DESCRIPTION
1.	GD8893-01	1	Sleeve, 1 3/8" Long
2.	GD11218	1	Spring
3.	G10201	1	Special Washer, 3/8" x 1 1/2" O.D.
4.	GD1026	1	Sleeve, 1 3/16" Long



# INTERPLANT® PUSH ROW UNIT

ITEM	PART NO.	QTY. (Per Row)	DESCRIPTION
5.	GD11962	1	Idler
6.	G10210	1	Washer, 3/8" USS
7.	G10108	1	Lock Nut, 3/8"-16
8.	G3303-96	1	Chain, No. 41, 96 Pitch Including Connector Link
	GR0196	1	Connector Link, No. 41
9.	GA8037	-	Push Row Unit Shank
10.	GB0314	2	Hopper Mount
11.	G10751	2	Hex Head Cap Screw, 5/8"-18 x 1 3/4"
	G10412	2	Lock Nut, 5/8"-18
12.	G10599	1	Carriage Bolt, 3/8"-16 x 1 1/4"
	G10101	1	Hex Nut, 3/8"-16
	G10108	1	Lock Nut, 3/8"-16
13.	G10307	1	Carriage Bolt, 3/8"-16 x 3 1/2"
14.	GD10867	2	Stop
15.	G10004	4	Hex Head Cap Screw, 3/8"-16 x 1 1/4"
	G10108	4	Lock Nut, 3/8"-16
16.	GB0301	1	Seed Tube Guard/Inner Scraper
17.	G10912	2	Hex Socket Head Cap Screw, 5/16"-18 x 1", Grade 8
18.	G10751	4	Hex Head Cap Screw, 5/8"-18 x 1 3/4"
	GD7805	4	Special Washer, 5/8", Hardened
	G10412	4	Lock Nut, 5/8"-18
19.	GB0218	8	Bushing, 2 1/32" I.D. x 7/8" O.D. x 19/32" Long
20.	GA8930	-	Upper Arm
21.	GA5787	1	Lower Arm
22.	G10732	4	Hex Head Cap Screw, 5/8"-18 x 2"
	GD7805	4	Special Washer, 5/8", Hardened
	G10412	4	Lock Nut, 5/8"-18
23.	GA1720	1	Bearing/Sprocket, 7/8" Hex Bore
24.	G10004	2	Hex Head Cap Screw, 3/8"-16 x 1 1/4"
	G10229	2	Lock Washer, 3/8"
	G10101	2	Hex Nut, 3/8"-16
25.	GA5786	1	Mounting Plate
26.	GD1113	2	U-Bolt, 5" x 7" x 5/8"-11
	G10230	4	Lock Washer, 5/8"
	G10104	4	Hex Nut, 5/8"-11
27.	G10718	2	Spring Pin, 5/16" x 1 1/8"
28.	GD11264	2	Lockup
29.	G10463	2	Cotter Pin, 1/4" x 1 1/2"
30.	GD11447	2	Spring
31.	G10284	2	Clevis Pin, 1/2" x 1 1/2"
	G10456	2	Cotter Pin, 1/8" x 3/4"
32.	GD11263	2	Spring Tab
33.	G10216	2	Washer, 1/2" USS
34.	GA8651	1	Lift Lever W/Boot
	GD11649	-	Boot
35.	GD11659	1	Bracket
36.	GD9695	1	Wire Lock Pin, 1/4" x 1 3/4"
37.	GD11752	1	Mount
38.	GA9105	-	T-Bolt, 5/8"-11 x 6"
	G10230	-	Lock Washer, 5/8"
	G10104	-	Hex Nut, 5/8"-11
39.	G10830	-	Hex Head Cap Screw, 5/8"-11 x 7 1/2"
	G10230	-	Lock Washer, 5/8"
	G10104	-	Hex Nut, 5/8"-11
40.	GD13110	-	Retainer
41.	GD10705	-	Locking Clip Pin, 1/4" x 2 1/2"
42.	GA2007	-	Hopper Hold Down Latch

# OUTER HITCH/SAFETY CHAIN

PHA038/PHA025(TWL1e/WGN47a)

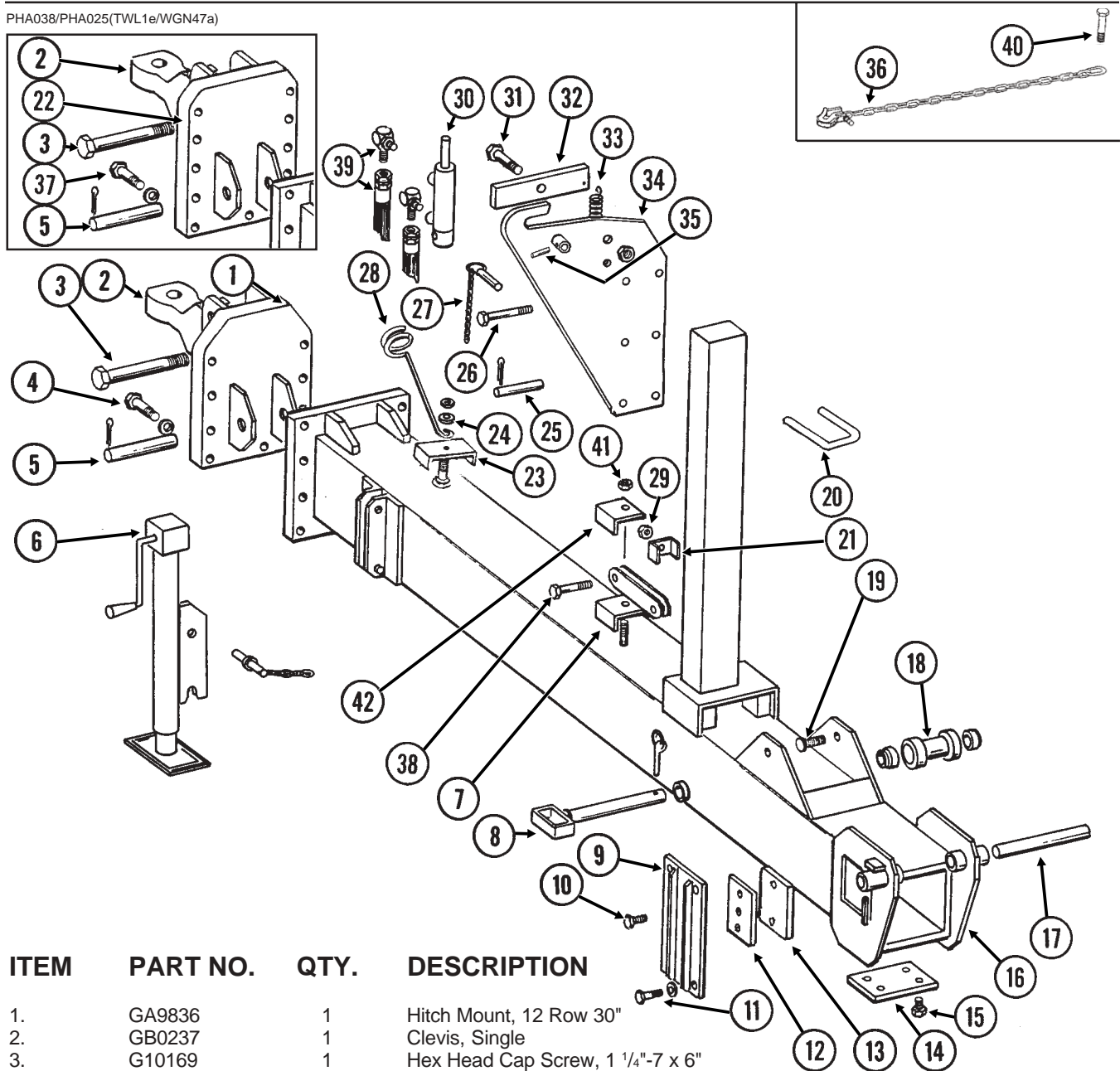

ITEM	PART NO.	QTY.	DESCRIPTION
1.	GA9836	1	Hitch Mount, 12 Row 30"
2.	GB0237	1	Clevis, Single
3.	G10169	1	Hex Head Cap Screw, 1 1/4"-7 x 6"
	G10157	1	Lock Nut, 1 1/4"-7
4.	G10009	9	Hex Head Cap Screw, 5/8"-11 x 2 1/2"
	G10230	9	Lock Washer, 5/8"
	G10104	9	Hex Nut, 5/8"-11
5.	GD5173	1	Pin, 1 1/4" x 5 1/8"
	G10462	2	Cotter Pin, 3/16" x 2"
6.	GA4994	1	Jack Assembly Complete
	GA4995	-	Detent Pin Assembly
	GR0517	-	Pin
	GR0516	-	Crank Assembly
	GR0515	-	Bevel Gear
7.	GA5842	1	Bracket, Jack Mount
	GD8189	-	Rubber Pad
8.	GA4402	1	Safety Pin, 12 3/4", 12 Row 30"
	GA4845	-	Safety Pin, 14 3/4", 16 Row 30"
	GD2558	-	Lynch Pin, 1/4"
	GD2557	-	Lynch Pin, 7/16"
9.	GA7029	2	Wear Mount, 12 Row 30"
	GA7084	-	Wear Mount, L.H., 16 Row 30"
	GA7085	-	Wear Mount, R.H., 16 Row 30"
	GA7083	-	Wear Pad Retainer, 16 Row 30"

# OUTER HITCH/SAFETY CHAIN

ITEM	PART NO.	QTY.	DESCRIPTION
10.	G10016	8	Hex Head Cap Screw, 1/2"-13 x 2"
	G10216	8	Washer, 1/2" USS
11.	G10017	8	Hex Head Cap Screw, 1/2"-13 x 1 1/2", 12 Row 30"
	G10016	10	Hex Head Cap Screw, 1/2"-13 x 2", 16 Row 30"
	G10228	8-10	Lock Washer, 1/2"
	G10102	8-10	Hex Nut, 1/2"-13
12.	GD5154	-	Shim, 4" x 4" (As Required), All Sizes
	GD3501	-	Shim, 4" x 6" (As Required), 16 Row 30"
13.	GD9959	-	Wear Pad, Nylatron, 4" x 4" (As Required), All Sizes
	GD9960	-	Wear Pad, Nylatron, 4" x 6" (As Required), 16 Row 30"
14.	GD7519	3	Shim, 16 Gauge (16 Row 30" Only)
	GD7518	1	Shim, 3/8" (16 Row 30" Only)
15.	G10014	4	Hex Head Cap Screw, 1/2"-13 x 1"
	G10228	4	Lock Washer, 1/2"
	G10216	4	Washer, 1/2" USS
16.	A7010	-	Outer Hitch, "Y", 97", 12 Row 30" <b>(Non-Stock Item)</b>
	A7088	-	Outer Hitch, "Y", 127 1/2", 16 Row 30" <b>(Non-Stock Item)</b>
17.	GD5804	1	Pin, 1 1/4" x 12", 12 Row 30"
	GD7251	1	Pin, 14", 16 Row 30"
	G10610	2	Spring Pin, 3/8" x 2"
18.	GA4418	1	Roller W/Bronze Bushings, 12 Row 30"
	GA4842	-	Roller W/Bronze Bushings, 16 Row 30"
	GD6556	1	Bronze Bushing
19.			See "Hose Take-Up", Pages P46 And P47
20.	GD9953	3	U-Bolt, 3" x 4" x 5/8"-11
	G10205	1	Washer, 5/8" SAE
	G10230	6	Lock Washer, 5/8"
	G10104	6	Hex Nut, 5/8"-11
21.	GD5892	2	Hose Clamp, 5/8" x 1 1/2" x 1 1/2"
22.	GA9837	-	Hitch Mount, 16 Row 30"
23.	GD8188	-	Clamp, 3" x 5 3/8"
	GD8189	-	Rubber Pad
24.	G10216	1	Washer, 1/2" USS
	G10111	1	Lock Nut, 1/2"-13
25.	GD7137	1	Pin, 3/4" x 3 3/8"
	G10457	2	Cotter Pin, 5/32" x 1 1/2"
26.	G10809	1	Hex Head Cap Screw, 3/8"-16 x 3 1/4"
	GD2971-09	1	Sleeve, 2" Long
	G10108	1	Lock Nut, 3/8"-16
27.	GA7022	1	Detent Pin W/Chain (Transport Latch Locking Pin)
28.	GD8260	1	Hose Holder
29.	G10108	1	Lock Nut, 3/8"-16
30.			See "Transport Latch Cylinder", Page P83
31.	G10006	1	Hex Head Cap Screw, 5/8"-11 x 2 1/4"
	GB0218	1	Bushing, 21/32" I.D. x 7/8" O.D. x 19/32" Long
	GD7805	1	Special Washer, 5/8", Hardened
	G10107	1	Lock Nut, 5/8"-11
32.	GA7016	1	Catch Bar
33.	GD5857	1	Spring
34.	GA7433	1	Transport Latch
35.	G10765	-	Spring Pin, 1/4" x 1"
36.	GA7533	1	Safety Chain, 1/2"
37.	G10802	11	Hex Head Cap Screw, 3/4"-10 x 2 3/4"
	G10231	11	Lock Washer, 3/4"
	G10105	11	Hex Nut, 3/4"-10
38.	G10026	1	Hex Head Cap Screw, 3/4"-10 x 2"
	G10112	1	Lock Nut, 3/4"-10
39.		-	See "Hydraulic Hoses And Fittings On Hitch", Pages P96 And P97
40.	G11058	1	Hex Head Cap Screw, 1 1/4"-7 x 3"
	GD10646	1	Special Washer
	G10226	1	Washer, 1 1/4" SAE
	G10157	1	Lock Nut, 1 1/4"-7
41.	G10111	1	Lock Nut, 1/2"-13
42.	GD14121	1	Hose Clamp

# INNER HITCH, "Y"

PHA035/PHA037(TWL2e)

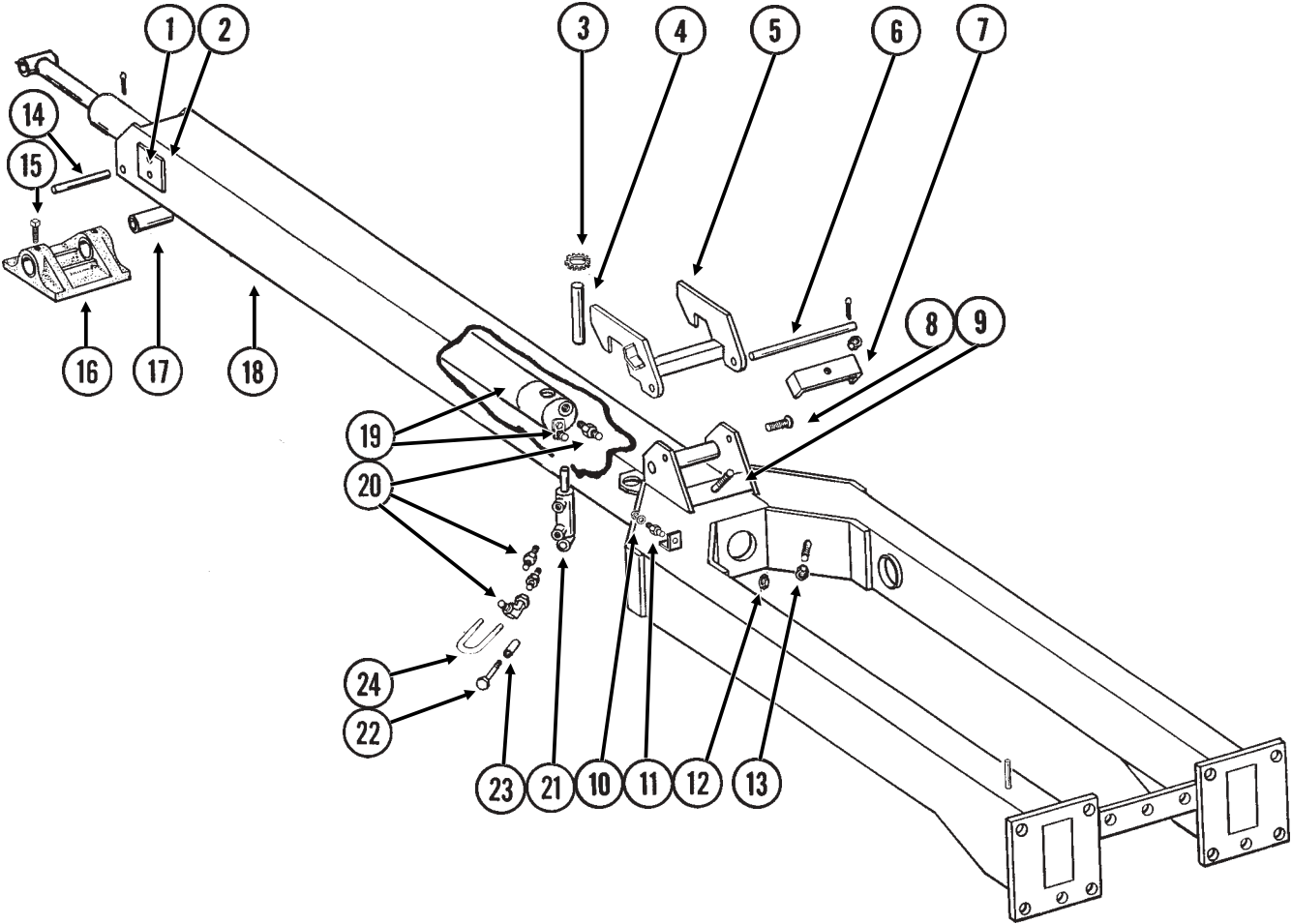

# INNER HITCH, "Y"

ITEM	PART NO.	QTY.	DESCRIPTION
1.	G10017	4	Hex Head Cap Screw, 1/2"-13 x 1 1/2", 16 Row 30"
	G10014	-	Hex Head Cap Screw, 1/2"-13 x 1", 12 Row 30"
	G10228	4-6	Lock Washer, 1/2"
2.	GD9959	2	Wear Pad, Nylatron, 4" x 4"
	GD5154	4	Shim, 4" x 4"
3.	G10894	-	External Washer
4.	GD3537-17	1	Shaft, 1 1/4" x 6 3/8", 12 Row 30"
	GD3537-18	-	Shaft, 1 1/4" x 7 3/8", 16 Row 30"
5.	GA7423	1	Tongue Hook W/Grease Fittings, 12 Row 30"
	GA7424	-	Tongue Hook W/Grease Fittings, 16 Row 30"
	G10641	-	Grease Fitting, 1/8" NPT
6.	GD5804	1	Pin, 1 1/4" x 12", 12 Row 30"
	GD7883	-	Pin, 1 1/4" x 14 1/2", 16 Row 30"
	G10468	2	Cotter Pin, 3/8" x 2"
7.	GD8188	-	Clamp, 3" x 5 3/8"
	GD8189	-	Rubber Pad
8.			See "Hose Take-Up", Pages P46 And P47
9.	G10581	1	Hex Head Cap Screw, 1/2"-13 x 2 1/4"
	G10111	1	Lock Nut, 1/2"-13
10.	G10237	1	Lock Washer, 7/16"
	G10100	1	Hex Nut, 7/16"-14
11.	GD8276	1	Pin
12.	G10108	1	Lock Nut, 3/8"-16
13.	G10111	1	Lock Nut, 1/2"-13
14.	GD5173	1	Pin, 1 1/4" x 5 1/8"
	G10462	1	Cotter Pin, 3/16" x 2"
15.	G10131	1	Square Head Set Screw, 5/16"-18 x 3/4"
16.	GB0246	1	Shoe
17.	GD3537-11	1	Shaft, 1 1/4" x 7", 12 Row 30"
	GD3537-12	-	Shaft, 1 1/4" x 8", 16 Row 30"
18.	A9146	-	Inner Hitch, 169 3/8", 12 Row 30" (Shown) <b>(Non-Stock Item)</b>
	A9151	-	Inner Hitch, 205 3/8", 16 Row 30" <b>(Non-Stock Item)</b>
19.		-	See "Tongue Cylinder", Pages P85 And P86
20.		-	See "Hydraulic Hoses And Fittings On Hitch", Pages P96 And P97
21.		-	See "Tongue Lock Cylinder", Page P84
22.	G10585	1	Hex Head Cap Screw, 1/2"-13 x 3 1/4"
	G10216	1	Washer, 1/2" USS
	G10228	1	Lock Washer, 1/2"
	G10102	1	Hex Nut, 1/2"-13
23.	GD10538-01	1	Sleeve
24.	GD10530	1	U-Bolt, 2 1/8" x 1 7/8" x 3/8"-16
	G10229	2	Lock Washer, 3/8"
	G10101	2	Hex Nut, 3/8"-16

# HOSE TAKE-UP

PHA039(TWL137/TWL171)

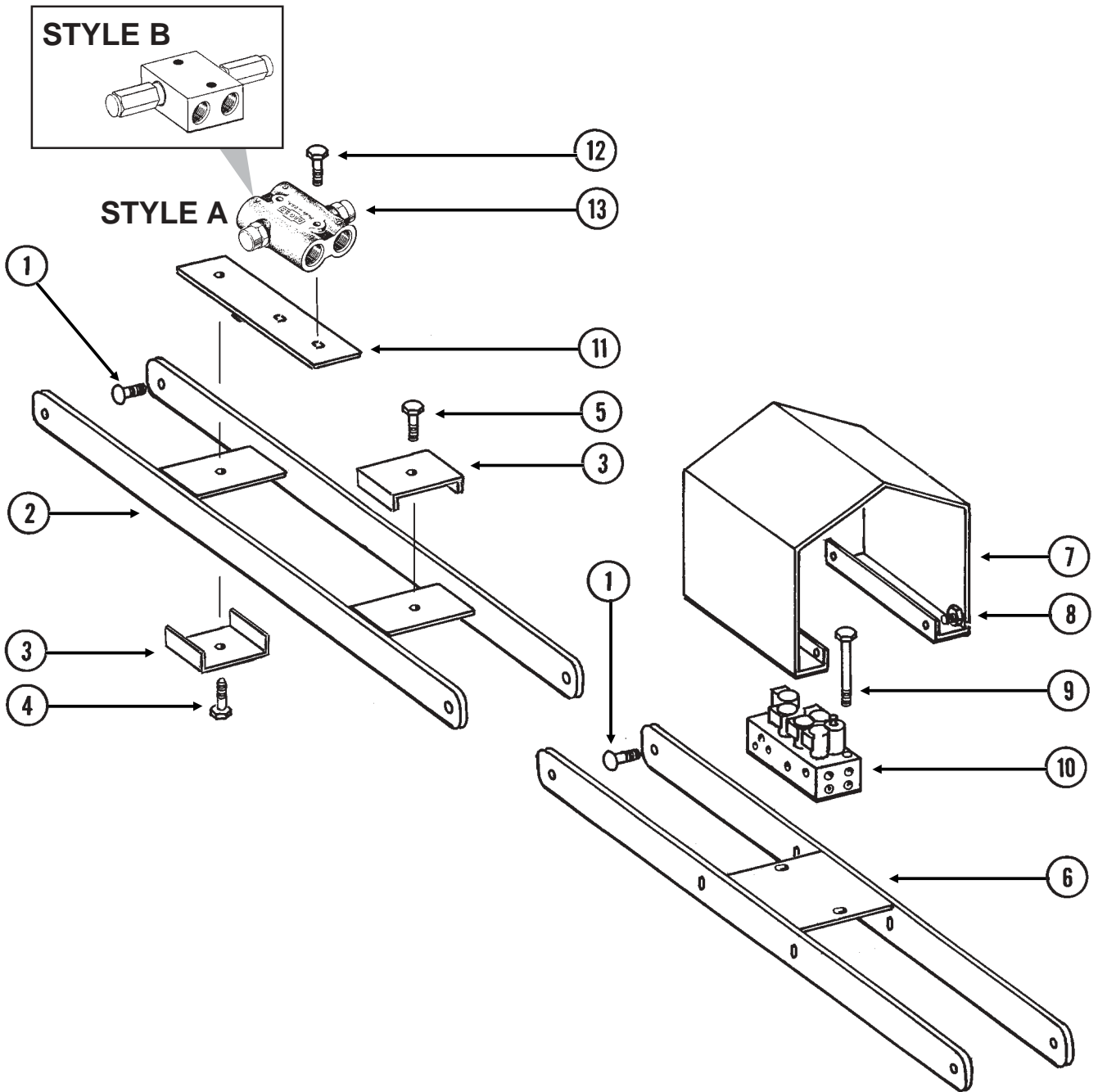

# HOSE TAKE-UP

---

ITEM	PART NO.	QTY.	DESCRIPTION
1.	G10689	6	Carriage Bolt, $\frac{5}{8}$ "-11 x 2"
	GB0218	6	Bushing, $\frac{21}{32}$ " I.D. x $\frac{7}{8}$ " O.D. x $\frac{19}{32}$ " Long
	GD7805	6	Special Washer, $\frac{5}{8}$ ", Hardened
	G10107	6	Lock Nut, $\frac{5}{8}$ "-11
2.	GA7013	-	Take-Up, 44 $\frac{1}{4}$ ", 12 Row 30" (Shown)
	GA7049	-	Take-Up, 56 $\frac{1}{4}$ ", 16 Row 30"
3.	GD8188	2	Clamp, 3" x 5 $\frac{3}{8}$ "
	GD8189	2	Rubber Pad
4.	G10581	1	Hex Head Cap Screw, $\frac{1}{2}$ "-13 x 2 $\frac{1}{4}$ "
	G10053	-	Hex Head Cap Screw, $\frac{1}{2}$ "-13 x 2 $\frac{1}{2}$ "
	G10111	1	Lock Nut, $\frac{1}{2}$ "-13
5.	G10581	1	Hex Head Cap Screw, $\frac{1}{2}$ "-13 x 2 $\frac{1}{4}$ "
	G10111	1	Lock Nut, $\frac{1}{2}$ "-13
6.	GA7021	-	Take-Up, 44 $\frac{1}{4}$ ", 12 Row 30" (Shown)
	GA7050	-	Take-Up, 56 $\frac{1}{4}$ ", 16 Row 30"
7.	GD9952	1	Cover
8.	G10004	4	Hex Head Cap Screw, $\frac{3}{8}$ "-16 x 1 $\frac{1}{4}$ "
	G10229	4	Lock Washer, $\frac{3}{8}$ "
	G10203	8	Washer, $\frac{3}{8}$ " SAE
	G10101	4	Hex Nut, $\frac{3}{8}$ "-16
9.	G10172	2	Hex Head Cap Screw, $\frac{3}{8}$ "-16 x 5"
	G10210	2	Washer, $\frac{3}{8}$ " USS
	G10108	2	Lock Nut, $\frac{3}{8}$ "-16
10.			See "Valve Block - Located On Hitch", Page P92
11.	GA8131	1	Mount, All 12 Row 30", 16 Row 30" If Applicable
12.	G10902	2	Carriage Bolt, $\frac{5}{16}$ "-18 x 2 $\frac{1}{2}$ "
	G10232	2	Lock Washer, $\frac{5}{16}$ "
	G10106	2	Hex Nut, $\frac{5}{16}$ "-18
13.			See "Relief Valve - Located On Hitch", All 12 Row 30", 16 Row 30" (If Applicable), Page P95

# CENTER FRAME

PFA085/PHS051(TWL193b)

## 12 ROW 30" SHOWN

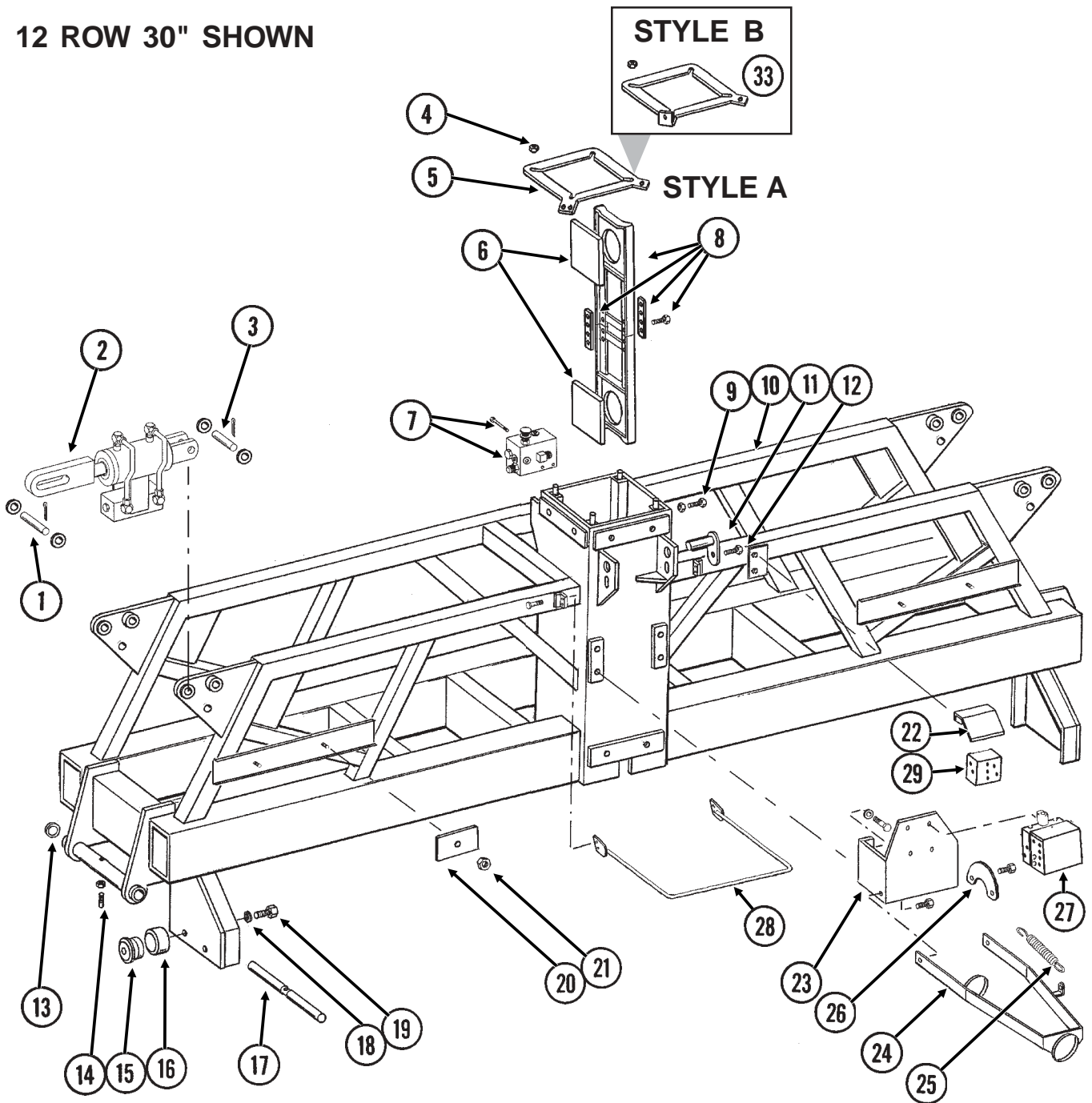



# CENTER FRAME

ITEM	PART NO.	QTY.	DESCRIPTION
1.		-	See "Wing Frame", Pages P50 And P51
2.		-	See "Wing Lock Cylinders", Pages P81 And P82
3.	GD0535	2	Pin, 1 1/4" x 4 1/2"
	G10159	4	Machine Bushing, 1 1/4", 10 Gauge
	G10460	4	Cotter Pin, 1/4" x 2"
4.	GD7805	4	Special Washer, 5/8", Hardened
	G10104	4	Hex Nut, 5/8"-11
5.	GD12819	1	Cap
6.	GD10053	8	Wear Pad, 7" Square
7.		-	See "Valve Block - Located On Front Center Frame", Page P88
8.	GA7579	4	Pad Holder W/Bars
	GD10706	-	Bar, 1 1/4" x 6" (1/4" Thick)
	GD10707	-	Bar, 1 1/4" x 6" (3/8" Thick)
	G10001	-	Hex Head Cap Screw, 3/8"-16 x 1"
9.	G10543	16	Hex Head Adjusting Bolt, 3/4"-10 x 3"
	G10105	16	Hex Nut, 3/4"-10
10.	A9001	-	Frame, 136", 12 Row 30" And 16 Row 30" <b>(Non-Stock Item)</b>
11.	GA5121	4	Pin
12.	G10017	4	Hex Head Cap Screw, 1/2"-13 x 1 1/2"
	G10216	4	Washer, 1/2" USS
	G10228	4	Lock Washer, 1/2"
13.	G10404	-	Machine Bushing, 3 1/8" x 2 1/8" x 3/16" (As Required)
	G10234	-	Machine Bushing, 2 1/8", 10 Gauge (As Required)
	G10336	-	Machine Bushing, 2 1/8", 14 Gauge (As Required)
14.	G10102	1	Hex Nut, 1/2"-13
	G10828	1	Hex Socket Set Screw, 1/2"-13 x 1 1/4"
15.	GA6497	4	Cam Follower W/Grease Fitting
	G10640	-	Grease Fitting, 1/4"-28
16.	GD14066	4	Sleeve
17.	GD10531	1	Hinge Pin, 2 1/8" x 25 3/4"
18.	GD9052	2	Special Washer, 3/4" I.D. x 2" O.D., Hardened
19.	G10025	2	Hex Head Cap Screw, 3/4"-10 x 1 1/2"
20.	GD13154	4	Hose Clamp, 4 3/4" x 9"
21.	G10108	4	Lock Nut, 3/8"-16
22.	GD14102	1	Cover
23.	GD12774	1	Mount
24.	GA9142	1	Hose Holder
25.	GD8249	1	Spring
	GD7904-02	2	Sleeve, 1/2" x 1/2" Long
26.	GD13107	1	Spring Pivot
27.		-	See "Valve Blocks - Located On Rear Center Frame", Pages P90 And P91
28.	GA9556	1	Handle
29.		-	See "Valve Block - Located On R.H. Side Of Center Pivot", Page P89
30.	GD14093	1	Cap

# WING FRAME

PFA086(TWL211/TW:187c/TWL180a/TWL194f/TWL194e/TWL188/TWL39b)

## 12 ROW 30" SHOWN

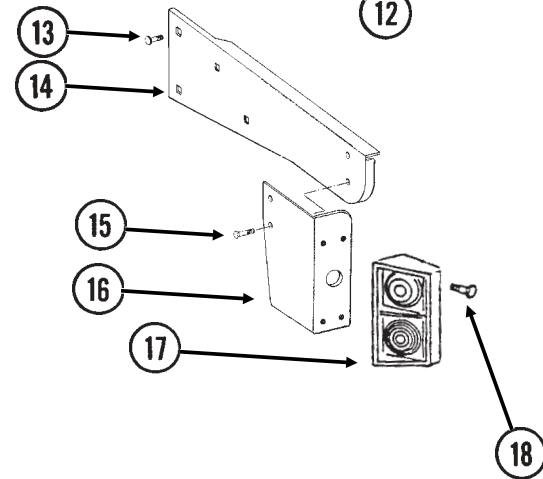
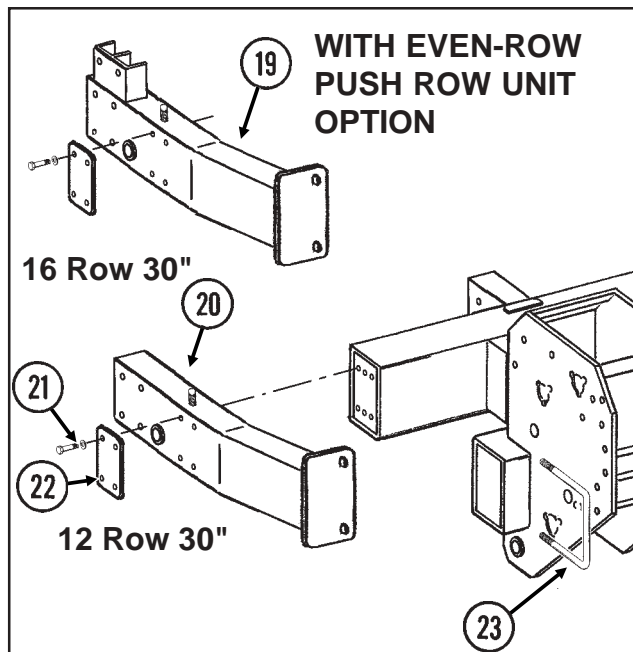
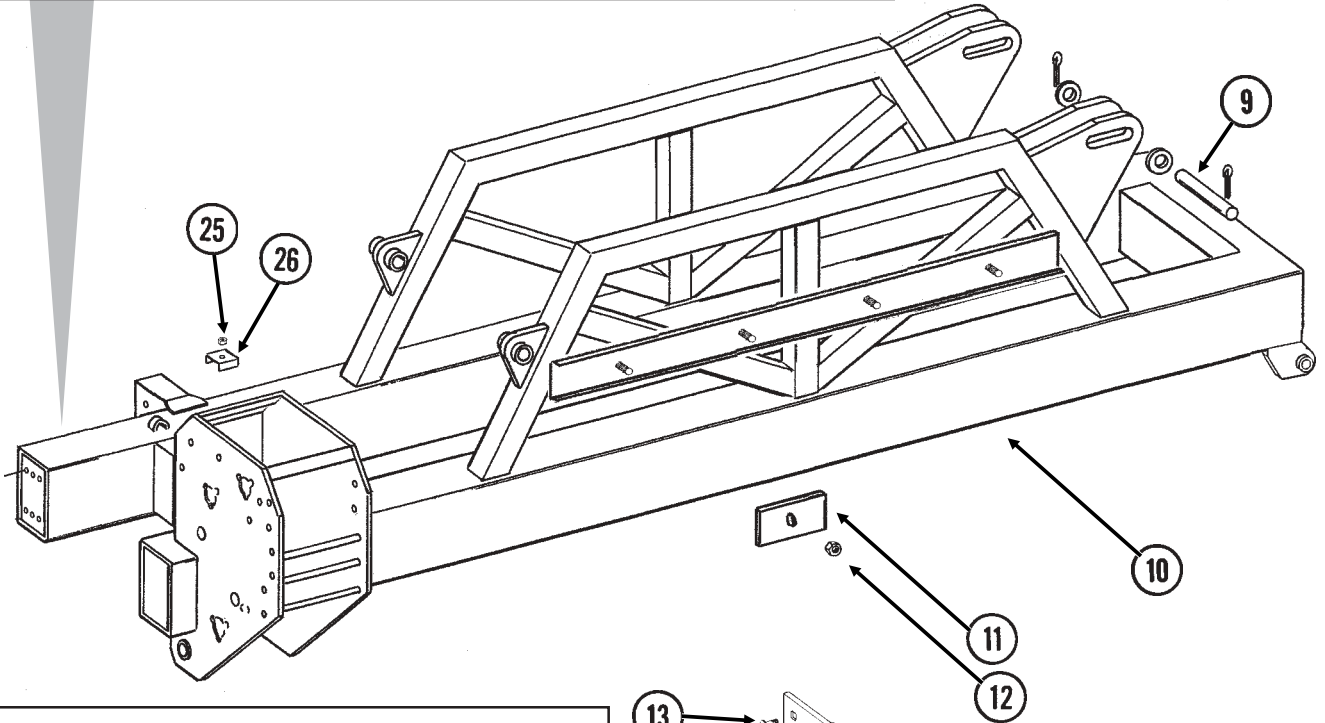
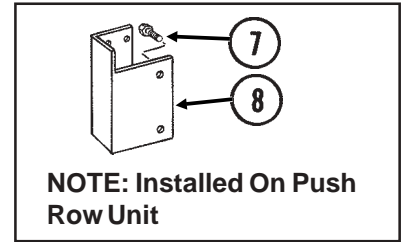
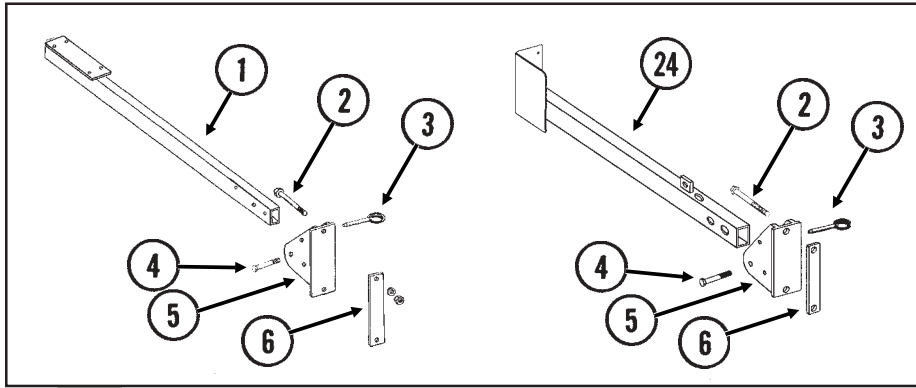

# WING FRAME

ITEM	PART NO.	QTY.	DESCRIPTION
1.	GA9549	1	Light Bracket
2.	G10439	2	Hex Head Cap Screw, $\frac{5}{8}$ "-11 x 7"
	G10230	2	Lock Washer, $\frac{5}{8}$ "
	G10104	2	Hex Nut, $\frac{5}{8}$ "-11
3.	G10874	1	Detent Pin, $\frac{1}{2}$ " x 3 $\frac{1}{2}$ " Grip
4.	G10038	1	Hex Head Cap Screw, $\frac{1}{2}$ "-13 x 3"
	G10111	1	Lock Nut, $\frac{1}{2}$ "-13
5.	GB0309	1	Light Mount Bracket
6.	GD1908	1	Mounting Bracket
7.	G10001	2	Hex Head Cap Screw, $\frac{3}{8}$ "-16 x 1"
	G10229	2	Lock Washer, $\frac{3}{8}$ "
	G10101	2	Hex Nut, $\frac{3}{8}$ "-16
8.	GD12703	1	Push Row Unit Light Bracket
9.	GD0826	4	Pin, 1 $\frac{1}{4}$ " x 5 $\frac{1}{2}$ "
	GD0752-47	8	Sleeve, $\frac{1}{2}$ "
	G10159	8	Machine Bushing, 1 $\frac{1}{4}$ ", 10 Gauge
	G10460	8	Cotter Pin, $\frac{1}{4}$ " x 2"
10.	A9070	-	Wing, R.H., 120", 12 Row 30" <b>(Non-Stock Item)</b>
	A9069	-	Wing, L.H., 124", 12 Row 30" <b>(Non-Stock Item)</b>
	A9072	-	Wing, R.H., 180", 16 Row 30" <b>(Non-Stock Item)</b>
	A9073	-	Wing, L.H., 184", 16 Row 30" <b>(Non-Stock Item)</b>
11.	GD13153	8-10	Hose Clamp, 3 $\frac{1}{4}$ " x 9"
12.	G10108	8-10	Lock Nut, $\frac{3}{8}$ "-16
13.	G10312	2	Carriage Bolt, $\frac{5}{16}$ "-18 x $\frac{3}{4}$ "
	G10620	2	Flange Nut, $\frac{5}{16}$ "-18
14.	GD12754	1	Light Mount Extension
15.	G10064	2	Hex Head Cap Screw, $\frac{1}{4}$ "-20 x 1"
	G10227	2	Lock Washer, $\frac{1}{4}$ "
	G10103	2	Hex Nut, $\frac{1}{4}$ "-20
16.	GD12724	1	Bracket
17.			See "Electrical Components", Pages P102 And P103
18.	G10064	8	Hex Head Cap Screw, $\frac{1}{4}$ "-20 x 1"
	G10110	8	Lock Nut, $\frac{1}{4}$ "-20
19.	GA9903	1	Marker Mount, 16 Row 30"
20.	GA9902	1	Marker Mount, 12 Row 30"
21.	G10050	4	Hex Head Cap Screw, $\frac{3}{4}$ "-10 x 5"
	G10231	4	Lock Washer, $\frac{3}{4}$ "
22.	GD14163	1	Plate
23.	GD1113	1	U-Bolt, 5" x 7" x $\frac{5}{8}$ "-11
	G10230	2	Lock Washer, $\frac{5}{8}$ "
	G10104	2	Hex Nut, $\frac{5}{8}$ "-11
24.	GA9840	1	Light Bracket
25.	G10108	5	Lock Nut, $\frac{3}{8}$ "-16
26.	GD5875	5	Hose Clamp, $\frac{9}{16}$ " x 2 $\frac{1}{2}$ " x 2"
A.	G7698X	-	Push Row Unit Mounted Light Bracket Package (Items 7 And 8 On This Page And $\frac{3}{8}$ " Insulated Clamp, Item 41 On Pages P102 And P103)

# CENTER PIVOT

PFA087(TWL196a)

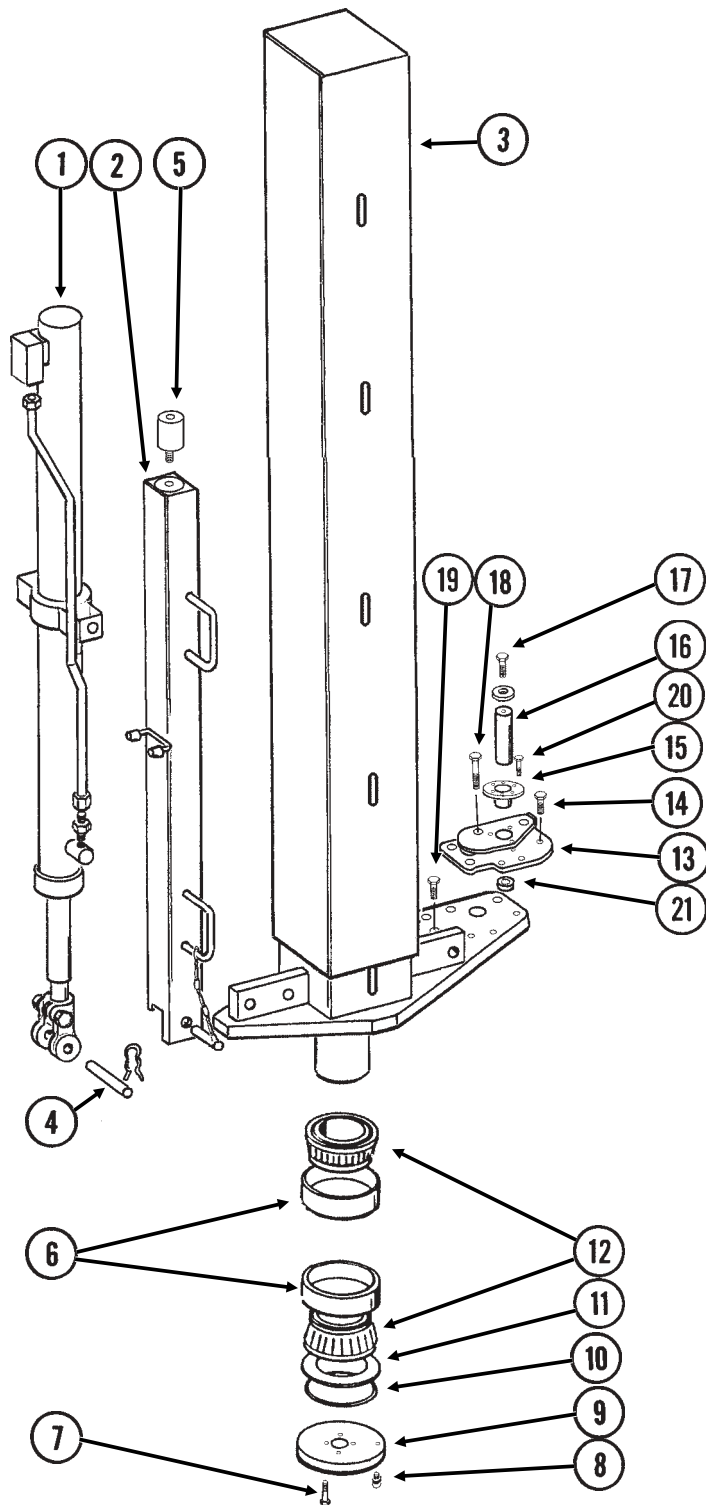

# CENTER PIVOT

ITEM	PART NO.	QTY.	DESCRIPTION
1.		-	See "Center Lift Cylinder", Pages P78 And P79
2.	GA9915	1	Manual Safety Lockup W/Detent Pin
	GA7022	-	Detent Pin W/Chain
3.	GA9089	1	Center Post
4.	GR0375	2	Pin, 1" x 3 1/2"
	GR0193	4	Hair Pin Clip
5.	GD14192	1	Lockup Extension
6.	GD10011	2	Cup
7.	G10027	4	Hex Head Cap Screw, 3/4"-10 x 2 1/2"
	GD2169	4	Special Washer, 25/32" I.D. x 1 1/4" O.D., Hardened
8.	G10640	1	Grease Fitting, 1/4"-28
9.	GD13338	1	Bearing Cap
10.	GD13350	1	O-Ring Seal
11.	GD10012	10	Shim, .005" Thick (As Required)
	GD10013	10	Shim, .020" Thick (As Required)
	GD10014	10	Shim, .007" Thick (As Required)
12.	GA7096	2	Cone
13.	GA9618	1	Taper Lock Mount
14.	G11018	3	Hex Head Cap Screw, 5/8"-18 x 1 1/4"
	GD7805	2	Special Washer, 5/8", Hardened
15.	GD13519	1	Taper Lock Collar
16.	GD13520	1	Taper Lock Pin
17.	G10443	1	Hex Head Cap Screw, 5/8"-11 x 1"
	G10205	1	Washer, 5/8" SAE
18.	G11019	2	Hex Head Cap Screw, 5/8"-18 x 5"
	GD7805	2	Special Washer, 5/8", Hardened
19.	G10751	2	Hex Head Cap Screw, 5/8"-18 x 1 3/4"
	GD7805	2	Special Washer, 5/8", Hardened
20.	G10004	3	Hex Head Cap Screw, 3/8"-16 x 1 1/4"
21.	GD13525	1	Tension Bushing, 1 1/2" O.D. x 1 1/4" I.D. x 5/8" Long

# AXLE ASSEMBLY

PHA055/PHA056(TWL198d)

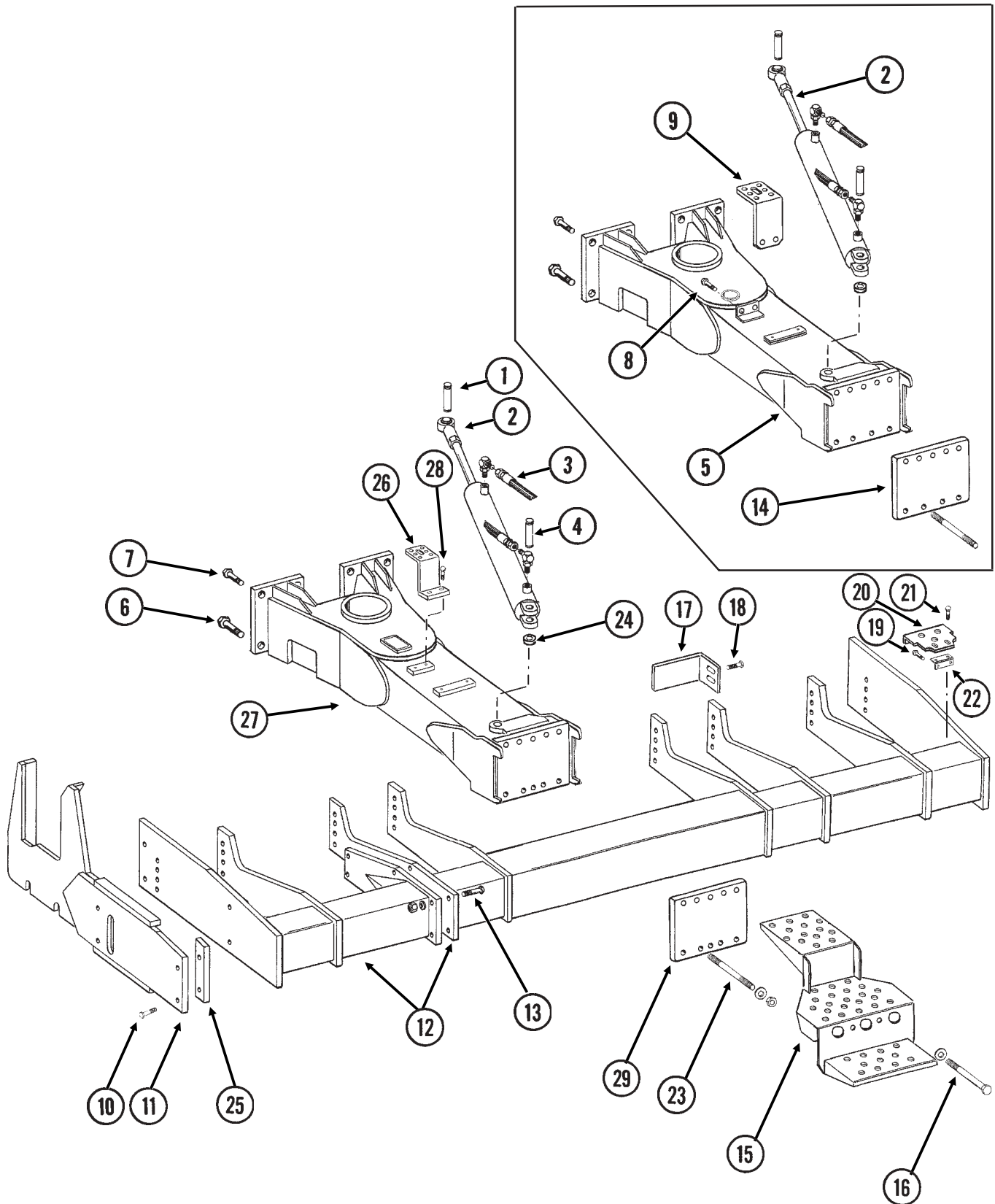

# AXLE ASSEMBLY

ITEM	PART NO.	QTY.	DESCRIPTION
1.		-	See "Center Pivot", Pages P52 And P53
2.		-	See "Rotation Cylinder", Page P77
3.		-	See "Hydraulic Hoses And Fittings On Hitch", Pages P96 And P97
4.	GD10064	1	Pin, 1 1/4" x 5 1/4"
	G10460	2	Cotter Pin, 1/4" x 2"
5.	GA9491	1	Center Post Mount
6.	G10479	6	Hex Head Cap Screw, 1"-14 x 3"
	GD10231	6	Special Washer, 1 1/16" I.D. x 2" O.D.
	G10155	6	Hex Nut, 1"-14
7.	G10097	4	Hex Head Cap Screw, 3/4"-16 x 2 1/2"
	GD2169	4	Special Washer, 25/32" I.D. x 1 1/4" O.D., Hardened
	G10098	4	Hex Nut, 3/4"-16
8.	G10017	2	Hex Head Cap Screw, 1/2"-13 x 1 1/2"
	G10228	2	Lock Washer, 1/2"
	G10102	2	Hex Nut, 1/2"-13
9.	GD13337	1	Bulkhead Plate
10.	G10028	8	Hex Head Cap Screw, 3/4"-10 x 3"
	G10231	8	Lock Washer, 3/4"
	G10105	8	Hex Nut, 3/4"-10
11.	GA9093	1	Roller Guide, L.H. (Shown)
	GA9094	-	Roller Guide, R.H.
12.	A8995	-	Axle W/Stub <b>(Non-Stock Item)</b>
13.	G11039	7	Hex Head Cap Screw, 3/4"-16 x 3 1/4", Grade 8
	GD2169	7	Special Washer, 25/32" I.D. x 1 1/4" O.D., Hardened
	G10098	7	Hex Nut, 3/4"-16
14.	GD13332	1	Plate
15.	GA9488	1	Steps
16.	G11013	7-9	Hex Head Cap Screw, 1"-14 x 11 1/2"
	GD10231	7-9	Special Washer, 1 1/16" I.D. x 2" O.D.
	G10155	7-9	Hex Nut, 1"-14
17.	GD13328	4	Scraper
18.	G10039	8	Hex Head Cap Screw, 1/2"-13 x 1 3/4"
	G10228	8	Lock Washer, 1/2"
19.	G10019	8	Hex Head Cap Screw, 5/16"-18 x 1"
	G10232	8	Lock Washer, 5/16"
20.	GD13331	4	Hinged Step
21.	G10338	8	Carriage Bolt, 5/16"-18 x 1 1/4"
	G10232	8	Lock Washer, 5/16"
	G10106	8	Hex Nut, 5/16"-18
22.	GD13329	4	Hinge
23.	GD13568	3-2	Stud, 1"-14 x 12"
	GD10231	6-4	Special Washer, 1 1/16" I.D. x 2" O.D.
	G10155	3-2	Hex Nut, 1"-14
24.	GD11751	1	Steel Bushing, 1" Wide
25.	GD14091	-	Shim, 1 1/4" x 9 3/8", 14 Gauge
	GD14092	-	Shim, 1 1/4" x 9 3/8", 10 Gauge
26.	GD14073	1	Bulkhead Plate
27.	GA9849	1	Center Post Mount
28.	G10014	2	Hex Head Cap Screw, 1/2"-13 x 1"
	G10228	2	Lock Washer, 1/2"
29.	GD14077	1	Plate

# TRANSPORT WHEELS/ROCK GUARDS

(TWL198a)

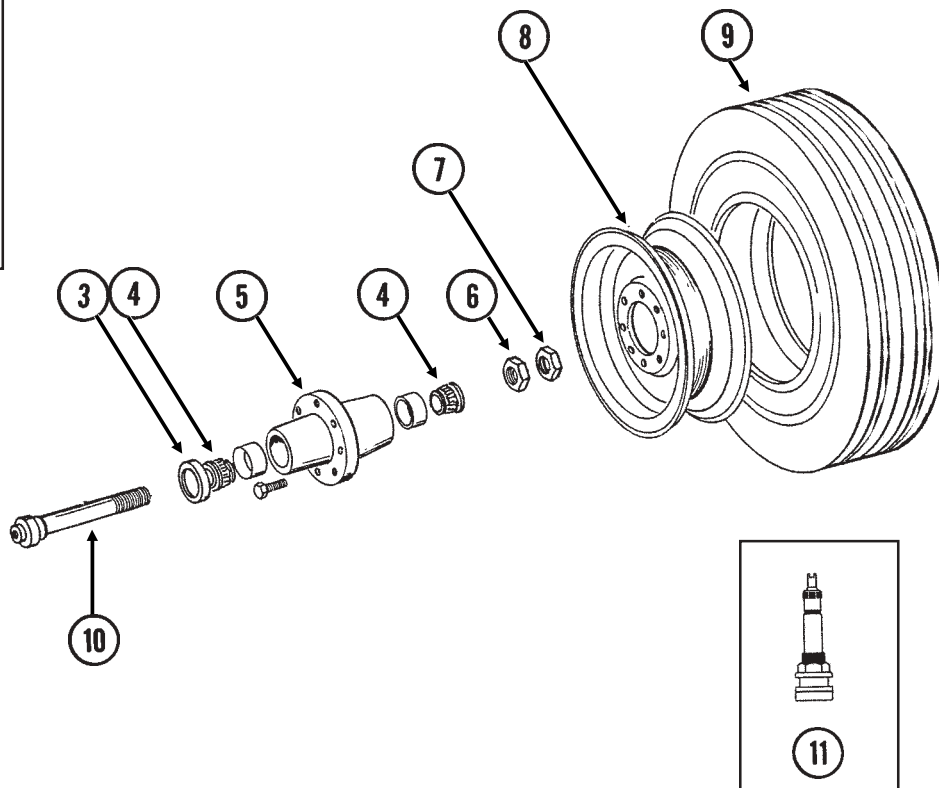
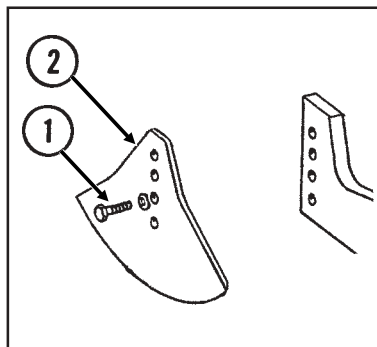



# TRANSPORT WHEELS/ROCK GUARDS

ITEM	PART NO.	QTY. (Per Assy.)	DESCRIPTION
1.	G10448	2	Hex Head Cap Screw, 7/8"-9 x 2 1/2", Grade 8
	G10330	2	Lock Washer, 7/8"
2.	GA9198	-	Rock Guard (Optional)
3.	GA4722	2	Seal
4.	GA4723	2	Bearing
5.	GA4729	1	Hub W/Cups, Bolts, Nuts And Grease Fitting, 8 Bolt, 1 3/4" Bore
	G10640	-	Grease Fitting, 1/4"-28
	GD7079	-	Cup
	GR0528	-	Lug Bolt, 5/8"-18 x 2 1/4"
	GR0531	-	Nut, 5/8"-18 UNF
6.	GD7089	1	Special Nut, 1 3/4"-12 UNF
7.	GD7864	1	Special Hex Nut, 1 3/4"-12 UNF
8.	GA9544	-	Rim, 5.5" x 22.5"
9.	GD13409	-	Tire, 255-70R 22.5" W/O Center Rib (Specify Brand*)
10.	GA4727	1	Spindle W/Retaining Ring, 1 3/4"
	G10913	-	External Retaining Ring, 2 1/2"
11.	GA7434	-	Valve Stem
A.	GA9545	-	Tire And Rim Assembly (Items 8, 9 And 11) (Specify Brand*)

\* Specific brand requests will be supplied only as available from current KINZE® stock. If a specific brand requested is not in stock, the brand available will be supplied.

# CONTACT DRIVE WHEEL AND DRIVE SHAFT(S)

PTD057/PFA046/PTD075/PLA033(TWL11m)

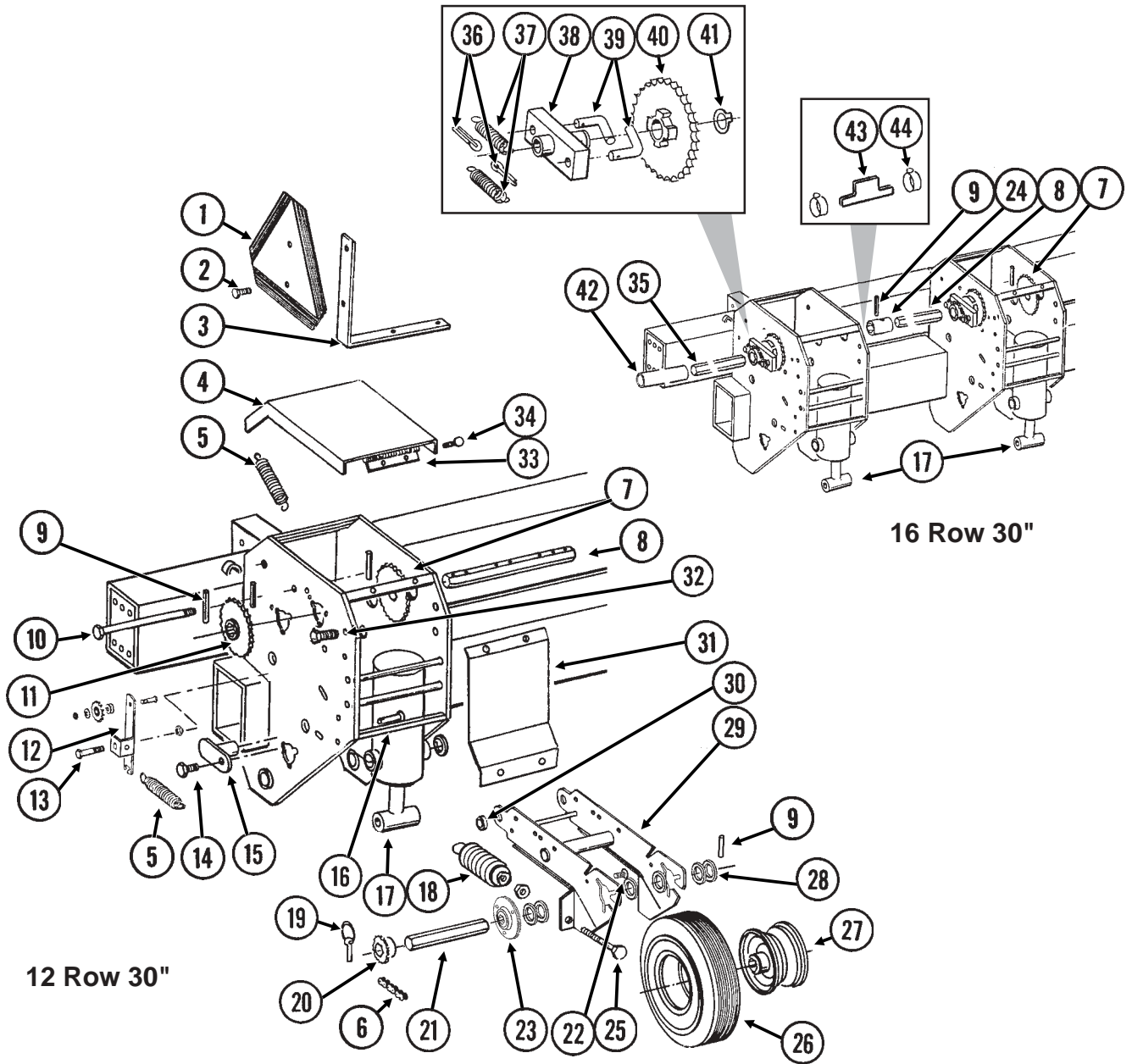

# CONTACT DRIVE WHEEL AND DRIVE SHAFT(S)

ITEM	PART NO.	QTY. (Per Assy.)	DESCRIPTION
1.	GD2199	1	SMV Sign
2.	G10022	2	Hex Head Cap Screw, 1/4"-20 x 1/2"
	G10227	2	Lock Washer, 1/4"
	G10103	2	Hex Nut, 1/4"-20
3.	GD9969	1	Bracket
4.	GD10298	1	Cover
5.	GD5857	2	Spring
6.	G3310-110	1	Chain, No. 40, 110 Pitch Including Connector Link, Half Rate (2 To 1) Drive
	G3310-118	-	Chain, No. 40, 118 Pitch Including Connector Link
	GR0912	-	Connector Link, No. 40
7.		-	See "Inner Module Drive", Pages P64 And P65
8.		-	See "Point Row Clutch", Pages P66 And P67
9.	G10602	4	Spring Pin, 1/4" x 1 1/2"
10.	G10595	-	Hex Head Cap Screw, 3/8"-16 x 10" (Used To Secure Point Row Clutch)
	G10108	-	Lock Nut, 3/8"-16
11.	GA5114	1	Sprocket, 30 Tooth
12.	GA9553	1	Idler W/Sprocket And Hardware, L.H.
	GA9554	1	Idler W/Sprocket And Hardware, R.H. (Shown)
	GA7154	-	Sprocket W/Bearing, 18 Tooth
	G10017	-	Hex Head Cap Screw, 1/2"-13 x 1 1/2"
	G10128	-	Machine Bushing, 1/2", 14 Gauge
	G10501	-	Hex Jam Nut, 1/2"-13, Grade 2
13.	G10036	1	Hex Head Cap Screw, 5/8"-11 x 4"
	G10918	3	Machine Bushing, 5/8", 14 Gauge
	G10104	1	Hex Nut, 5/8"-11
	G10107	1	Lock Nut, 5/8"-11
14.	G10017	2	Hex Head Cap Screw, 1/2"-13 x 1 1/2"
	G10216	2	Washer, 1/2" USS
	G10228	2	Lock Washer, 1/2"
	G10102	2	Hex Nut, 1/2"-13
15.	GA5121	2	Pin
16.	G10870	2	Clevis Pin, 3/8" x 1"
	G10860	2	Retaining Ring, 3/8"
17.		-	See "Wing Lift Cylinder", Page P80
18.	GA2068	2	Spring W/Plug
19.	GD2558	1	Lynch Pin, 1/4"
20.	GA5114	1	Sprocket, 30 Tooth
	GA5105	-	Sprocket, 15 Tooth, Half Rate (2 To 1) Drive
21.	GD6775	1	Hex Shaft, 7/8" x 11 3/4" (2 Holes)
22.	G10303	6	Carriage Bolt, 5/16"-18 x 1"
	G10232	6	Lock Washer, 5/16"
	G10106	6	Hex Nut, 5/16"-18
23.	GA9846	-	Flanged Bearing, 7/8" Hex Bore
24.	GD5212	1	Coupler, 1 3/4", 16 Row 30" Only
25.	G10890	2	Hex Head Adjusting Bolt, 1/2"-13 x 4", Grade 2
	G10501	2	Hex Jam Nut, 1/2"-13, Grade 2
26.	GD4700	1	Tire, 4.80" x 8", 4 Ply, Rib Implement (Specify Brand*)
	GD4701	-	Valve Stem
27.	GA3553	1	Rim, 3.75" x 8"
28.	G10233	-	Machine Bushing, 1", 10 Gauge

(Continued)

# CONTACT DRIVE WHEEL AND DRIVE SHAFT(S)

ITEM	PART NO.	QTY. (Per Assy.)	DESCRIPTION
(Continued)			
29.	GA7372	1	Wheel Arm
30.	GB0218	2	Bushing, 2 <sup>1</sup> / <sub>32</sub> " I.D. x 7 <sup>7</sup> / <sub>8</sub> " O.D. x 1 <sup>9</sup> / <sub>32</sub> " Long
31.	GD6895	1	Shield
32.	G10005	2	Hex Head Cap Screw, 5 <sup>5</sup> / <sub>8</sub> "-11 x 1 3 <sup>3</sup> / <sub>4</sub> "
	G10235	4	Machine Bushing, 7 <sup>7</sup> / <sub>8</sub> ", 14 Gauge
	GD7805	2	Special Washer, 5 <sup>5</sup> / <sub>8</sub> ", Hardened
	G10205	2	Washer, 5 <sup>5</sup> / <sub>8</sub> " SAE
	G10107	2	Lock Nut, 5 <sup>5</sup> / <sub>8</sub> "-11
33.	GD5789	1	Hinge, Female
	GD5790	1	Hinge W/Pins, Male
34.	G10064	6	Hex Head Cap Screw, 1 <sup>1</sup> / <sub>4</sub> "-20 x 1"
	G10209	4	Washer, 1 <sup>1</sup> / <sub>4</sub> " USS
	G10227	6	Lock Washer, 1 <sup>1</sup> / <sub>4</sub> "
	G10103	6	Hex Nut, 1 <sup>1</sup> / <sub>4</sub> "-20
35.	GD10099	-	Hex Shaft, 7 <sup>7</sup> / <sub>8</sub> " x 29 5 <sup>5</sup> / <sub>8</sub> "
36.	G10464	2	Cotter Pin, 3 <sup>3</sup> / <sub>16</sub> " x 1"
37.	GD1256	2	Spring
38.	GA0378	1	Block And Hub Assembly
39.	GD1255	2	L-Pin
40.	GA5165	1	Sprocket, 30 Tooth
41.	G10430	1	External Retaining Ring, 1 1 <sup>1</sup> / <sub>4</sub> "
42.	GD13652	1	Pipe, 1" x 23 1 <sup>1</sup> / <sub>4</sub> "
43.	GD14115	1	Catch
44.	G10278	2	Hose Clamp, No. 16
A.	GA3552	-	Tire And Rim Assembly (Items 26 And 27) (Specify Brand*)
B.	GA9843	-	Ratchet/Sprocket Assembly (L.H. Side Of Planter) (Items 36-41)
	GA5164	-	Ratchet/Sprocket Assembly (R.H. Side Of Planter)
C.	G1K324	-	Contact Wheel Arm Replacement Kit (Items 9, 21, 22, 23, 25, 28 And 29)

\* Specific brand requests will be supplied only as available from current KINZE® stock. If a specific brand requested is not in stock, the brand available will be supplied. Different brand tires may have different diameters. Change in tire brand could result in rate changes. To maintain consistent planting rates throughout all rows, it is recommended that all contact tires be of the same brand and be equally inflated.

# GROUND DRIVE WHEEL

PTD057(TWL142b)

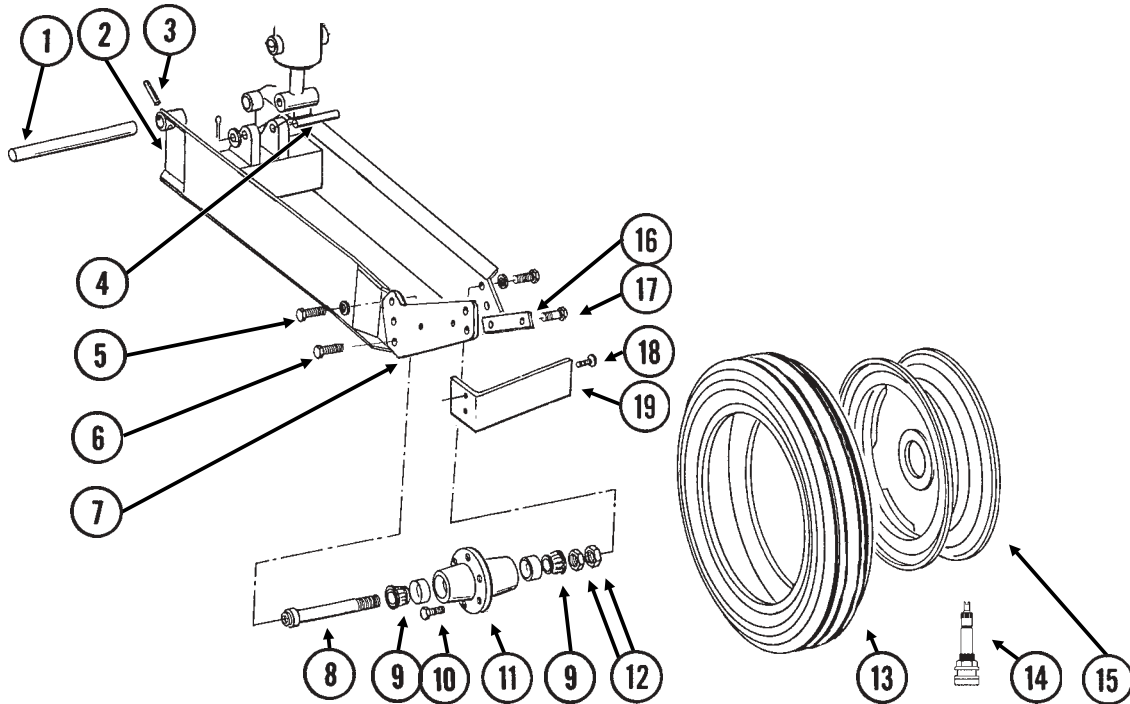

ITEM	PART NO.	QTY. (Per Assy.)	DESCRIPTION
1.	GD11695	-	Pin, 1 1/4" x 13 1/4"
2.	GA8677	1	Wheel Module
3.	G10610	-	Spring Pin, 3/8" x 2"
4.	GD5841	1	Pin, 1 1/4" x 5 5/8"
	G10226	2	Washer, 1 1/4" SAE
	G10460	2	Cotter Pin, 1/4" x 2"
5.	G10026	2	Hex Head Cap Screw, 3/4"-10 x 2"
	G10231	2	Lock Washer, 3/4"
6.	G10026	2	Hex Head Cap Screw, 3/4"-10 x 2"
	G10231	2	Lock Washer, 3/4"
	G10105	2	Hex Nut, 3/4"-10
7.	GD10128	1	Scraper Arm
8.	GA4376	1	Spindle W/Round External Retaining Ring, 10"
	GD11490	-	Round External Retaining Ring
9.	GA0895	2	Bearing
10.	GR0270	6	Lug Bolt, 9/16"-18
11.	GA2148	1	Hub W/Cups, 6 Bolt
	GR0434	-	Cup
12.	G10087	2	Hex Jam Nut, 1 1/2"-12, Grade 2
13.	GD10795	1	Tire, 7.50" x 20", 6 Ply, Tubeless W/O Center Rib (Specify Brand*) <b>(Sub GD13401)</b>
14.	GA7434	-	Valve Stem
15.	GA2908	1	Rim, 5.5" x 20"
16.	GD10144	1	Bar Clamp
17.	G10039	2	Hex Head Cap Screw, 1/2"-13 x 1 3/4"
	G10228	2	Lock Washer, 1/2"
	G10102	2	Hex Nut, 1/2"-13
18.	G10636	2	Carriage Bolt, 1/2"-13 x 1 1/2"
	G10216	2	Washer, 1/2" USS
	G10228	2	Lock Washer, 1/2"
	G10102	2	Hex Nut, 1/2"-13
19.	GD12543	1	Scraper
A.	GA7997	-	Tire And Rim Assembly (Specify Brand*)(Items 13-15)

\* Specific brand requests will be supplied only as available from current KINZE® stock. If a specific brand requested is not in stock, the brand available will be supplied.

# TRANSMISSION AND ROW UNIT DRILL SHAFTS

PTD056/PTD065/PTD076/PTD079(TWL14e)

## 12 Row 30" Shown

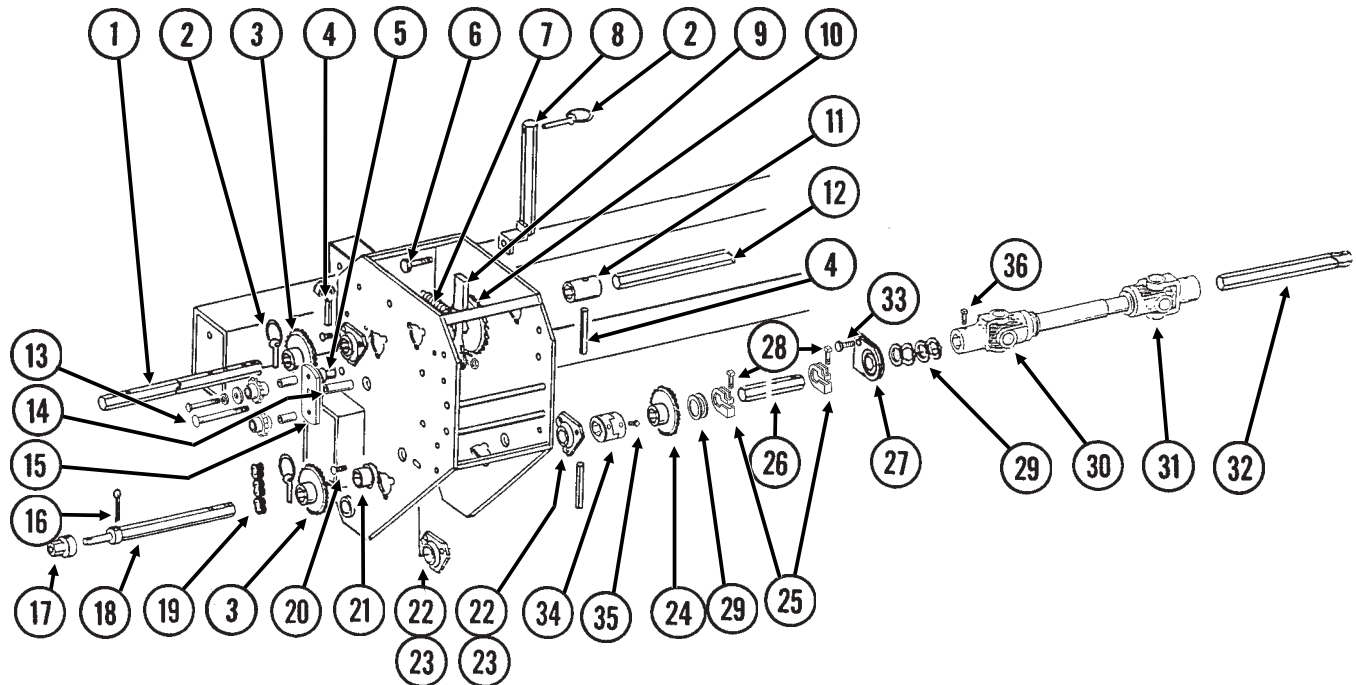

ITEM	PART NO.	QTY. (Per Side)	DESCRIPTION
1.	GD6780	1	Shaft, 7/8" x 15"
2.	GD2558	3	Lynch Pin, 1/4"
3.	GA5106	1	Sprocket, 17 Tooth
	GA5107	1	Sprocket, 19 Tooth
	GA5108	2	Sprocket, 23 Tooth
	GA5109	1	Sprocket, 24 Tooth
	GA5110	1	Sprocket, 25 Tooth
	GA5111	1	Sprocket, 26 Tooth
	GA5112	1	Sprocket, 27 Tooth
	GA5113	1	Sprocket, 28 Tooth
4.	G10602	-	Spring Pin, 1/4" x 1 1/2"
5.	G10870	1	Clevis Pin, 3/8" x 1"
	G10860	1	Retaining Ring, 3/8"
6.	G10016	1	Hex Head Cap Screw, 1/2"-13 x 2"
	GD10356	1	Bushing, 3/4" Long (If Applicable)
	G10228	1	Lock Washer, 1/2"
	G10527	2	Lock Washer, 1/2", Internal/External
	G10102	1	Hex Nut, 1/2"-13
7.	GD5857	1	Spring
8.	GA4630	1	Sprocket Storage Rod
9.	GA4235	1	Ratchet Arm W/Protective Closure
	G10445	-	Protective Closure
10.		-	See "Inner Module Drive", Pages P64 And P65
11.	GD5212	1	Coupler, 1 3/4", 16 Row 30" Only
12.	GD10100	1	Hex Shaft, 7/8" x 31 3/8", 16 Row 30" Only
13.	G10314	1	Carriage Bolt, 1/2"-13 x 3"
	G10111	1	Lock Nut, 1/2"-13
14.	GD3180-05	1	Sleeve, 5/8" I.D. x 7/8" O.D. x 1 3/16" Long

# TRANSMISSION AND ROW UNIT DRILL SHAFTS

ITEM	PART NO.	QTY. (Per Side)	DESCRIPTION
15.	GA7336	1	Idler W/Bolt-On Sprockets
	GD7426	-	Sprocket, 12 Tooth
	GD1026	-	Sleeve, 1 <sup>3</sup> / <sub>16</sub> " Long
	G10210	-	Washer, <sup>3</sup> / <sub>8</sub> " USS
	G10229	-	Lock Washer, <sup>3</sup> / <sub>8</sub> "
	G10047	-	Hex Head Cap Screw, <sup>3</sup> / <sub>8</sub> "-16 x 1 <sup>3</sup> / <sub>4</sub> "
16.	G10462	-	Cotter Pin, <sup>3</sup> / <sub>16</sub> " x 2"
17.	GD7127	1	Shear Coupler
18.	GD7612	1	Shaft, <sup>7</sup> / <sub>8</sub> " x 13 <sup>1</sup> / <sub>2</sub> "
19.	G3310-80	1	Chain, No. 40, 80 Pitch Including Connector Link
	GR0912	-	Connector Link, No. 40
20.	G10303	-	Carriage Bolt, <sup>5</sup> / <sub>16</sub> "-18 x 1"
	G10232	-	Lock Washer, <sup>5</sup> / <sub>16</sub> "
	G10106	-	Hex Nut, <sup>5</sup> / <sub>16</sub> "-18
21.	GA5548	1	Special Bearing
22.	G3400-01	-	Flangette
23.	G2100-03	-	Bearing, <sup>7</sup> / <sub>8</sub> " Hex Bore, Spherical
24.	GA5107	1	Sprocket, 19 Tooth, Interplant® Drive
25.	GD11045	-	Lock Clamp
26.	GD0914-106.5	2	Hex Shaft, <sup>7</sup> / <sub>8</sub> " x 106 <sup>1</sup> / <sub>2</sub> " (No Holes), Wing, 12 Row 30"
	GD0914-166.75	-	Hex Shaft, <sup>7</sup> / <sub>8</sub> " x 166 <sup>3</sup> / <sub>4</sub> " (No Holes), Wing, 16 Row 30"
27.	GA2180	-	Hanger Bearing, <sup>7</sup> / <sub>8</sub> " Hex Bore
28.	G10130	-	Square Head Machine Bolt, <sup>5</sup> / <sub>16</sub> "-18 x 1 <sup>3</sup> / <sub>4</sub> "
	G10923	-	Flange Nut, <sup>5</sup> / <sub>16</sub> "-18, No Serration
29.	G10233	-	Machine Bushing, 1", 10 Gauge
30.	GA7052	-	U-Joint W/Grease Fitting, Female, 10 <sup>1</sup> / <sub>4</sub> " Long
	GR1557	-	Grease Fitting, 45°, Metric
	GR1297	-	Inboard Yoke And Outer Profile
	GR1294	-	Cross And Bearing Kit
	GR1293	-	Yoke, <sup>7</sup> / <sub>8</sub> " Hex
31.	GA7051	-	U-Joint W/Grease Fitting, Male, 12 <sup>1</sup> / <sub>4</sub> " Long
	GR1557	-	Grease Fitting, 45°, Metric
	GR1296	-	Inner Profile
	GR1295	-	Inboard Yoke
	GR1301	-	Spring Pin, 8mm x 50mm
	GR1294	-	Cross And Bearing Kit
	GR1293	-	Yoke, <sup>7</sup> / <sub>8</sub> " Hex
32.	GD0914-45	1	Hex Shaft, <sup>7</sup> / <sub>8</sub> " x 45", R.H. Main Frame (No Holes)
	GD0914-35	-	Hex Shaft, <sup>7</sup> / <sub>8</sub> " x 35", L.H. Main Frame (No Holes)
33.	G10004	2	Hex Head Cap Screw, <sup>3</sup> / <sub>8</sub> "-16 x 1 <sup>1</sup> / <sub>4</sub> "
	G10229	2	Lock Washer, <sup>3</sup> / <sub>8</sub> "
	G10101	-	Hex Nut, <sup>3</sup> / <sub>8</sub> "-16
34.	GB0287	2	Coupler
35.	G10131	4	Square Head Set Screw, <sup>5</sup> / <sub>16</sub> "-18 x <sup>3</sup> / <sub>4</sub> "
36.	G10688	-	Square Head Set Screw, <sup>3</sup> / <sub>8</sub> "-16 x <sup>5</sup> / <sub>8</sub> "
A.	G1K269	-	Lock Clamp Kit (Items 25 And 28)

# INNER MODULE DRIVE

PTD058/PFA046/PTD077(TWL16b)

12 Row 30" Shown  
(Located In Inside Module On 16 Row 30")

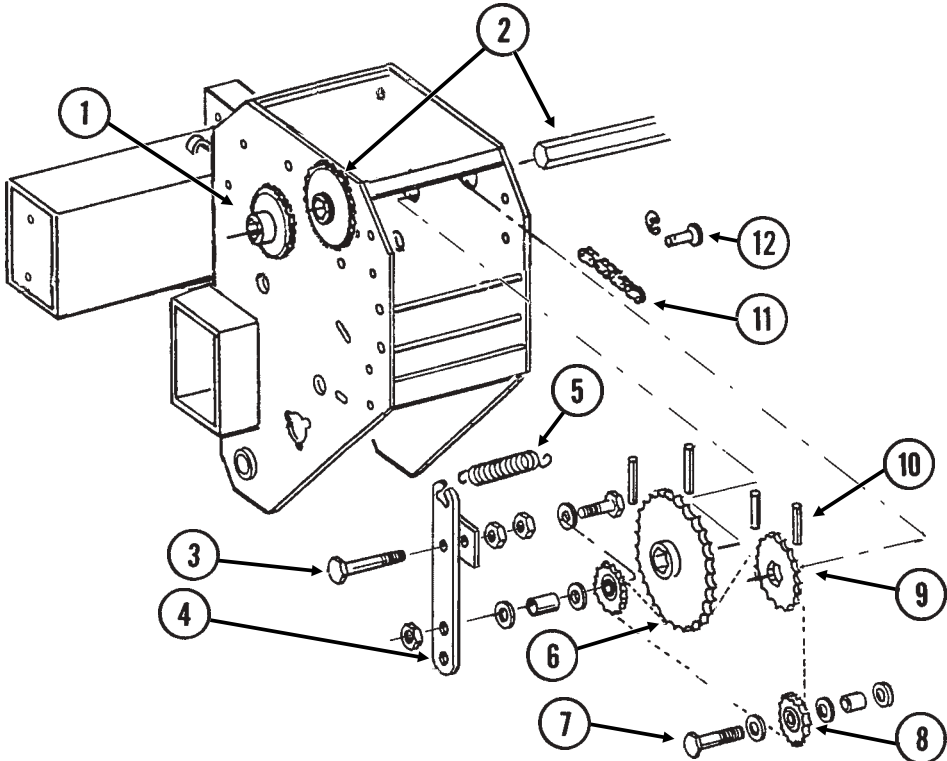



# INNER MODULE DRIVE

ITEM	PART NO.	QTY.	DESCRIPTION
		(Per Module)	
1.		-	See "Transmission And Row Unit Drill Shafts", Pages P62 And P63
2.		-	See "Contact Drive Wheel And Drive Shaft(s)", Pages P58-P60
3.	G10743	1	Hex Head Cap Screw, $\frac{5}{8}$ "-11 x $3\frac{3}{4}$ "
	G10104	1	Hex Nut, $\frac{5}{8}$ "-11
	G10107	1	Lock Nut, $\frac{5}{8}$ "-11
4.	GA9557	1	Idler W/Sprocket And Hardware, L.H.
	GA9558	-	Idler W/Sprocket And Hardware, R.H. (Shown)
	GA7154	-	Sprocket W/Bearing, 18 Tooth
	G10038	-	Hex Head Cap Screw, $\frac{1}{2}$ "-13 x 3"
	GD10007	-	Spacer, 1 $\frac{1}{8}$ "
	G10206	-	Washer, $\frac{1}{2}$ " SAE
	G10111	-	Lock Nut, $\frac{1}{2}$ "-13
5.	GD5857	1	Spring
6.	GA5194	1	Sprocket, 50 Tooth
7.	G10581	1	Hex Head Cap Screw, $\frac{1}{2}$ "-13 x 2 $\frac{1}{4}$ "
	GD7889	1	Bushing
	G10168	2	Machine Bushing, $\frac{1}{2}$ ", 7 Gauge
	G10205	2	Washer, $\frac{5}{8}$ " SAE
	G10111	1	Lock Nut, $\frac{1}{2}$ "-13
8.	GA7154	1	Sprocket W/Bearing, 18 Tooth
9.	GA5113	1	Sprocket, 28 Tooth
10.	G10602	-	Spring Pin, $\frac{1}{4}$ " x 1 $\frac{1}{2}$ "
11.	G3310-100	1	Chain, No. 40, 100 Pitch Including Connector Link
	GR0912	-	Connector Link, No. 40
12.	G10870	1	Clevis Pin, $\frac{3}{8}$ " x 1"
	G10860	1	Retaining Ring, $\frac{3}{8}$ "

# POINT ROW CLUTCH

PRC019(TWL144a/TWL71d)

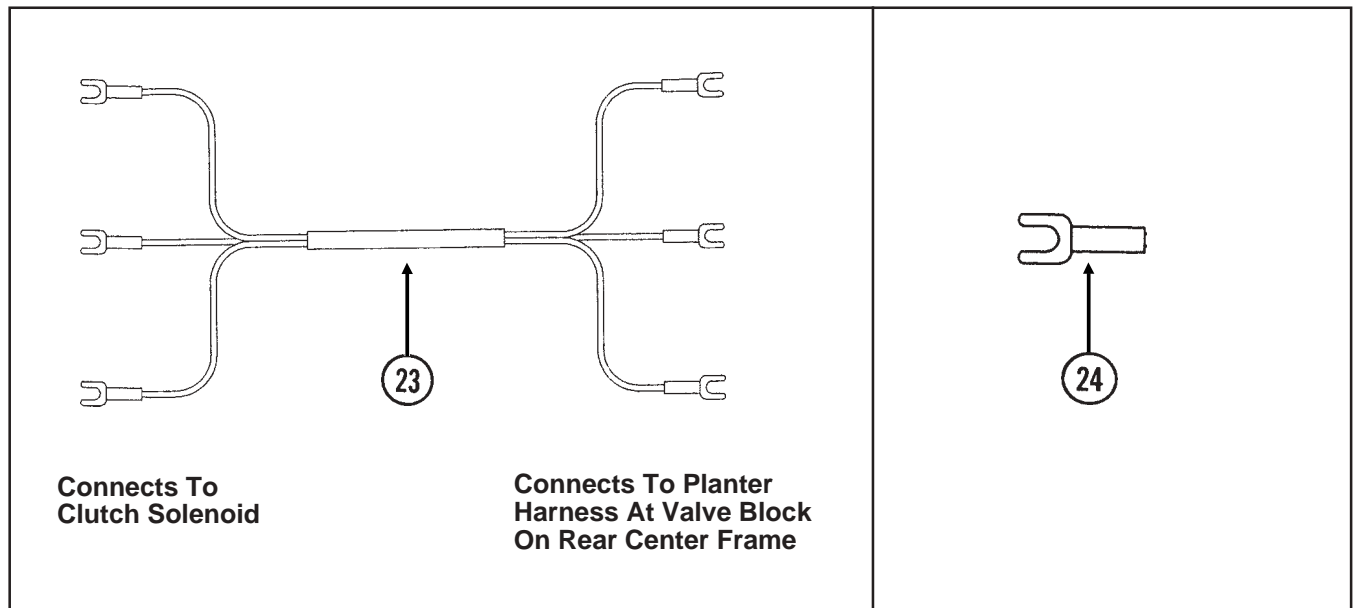
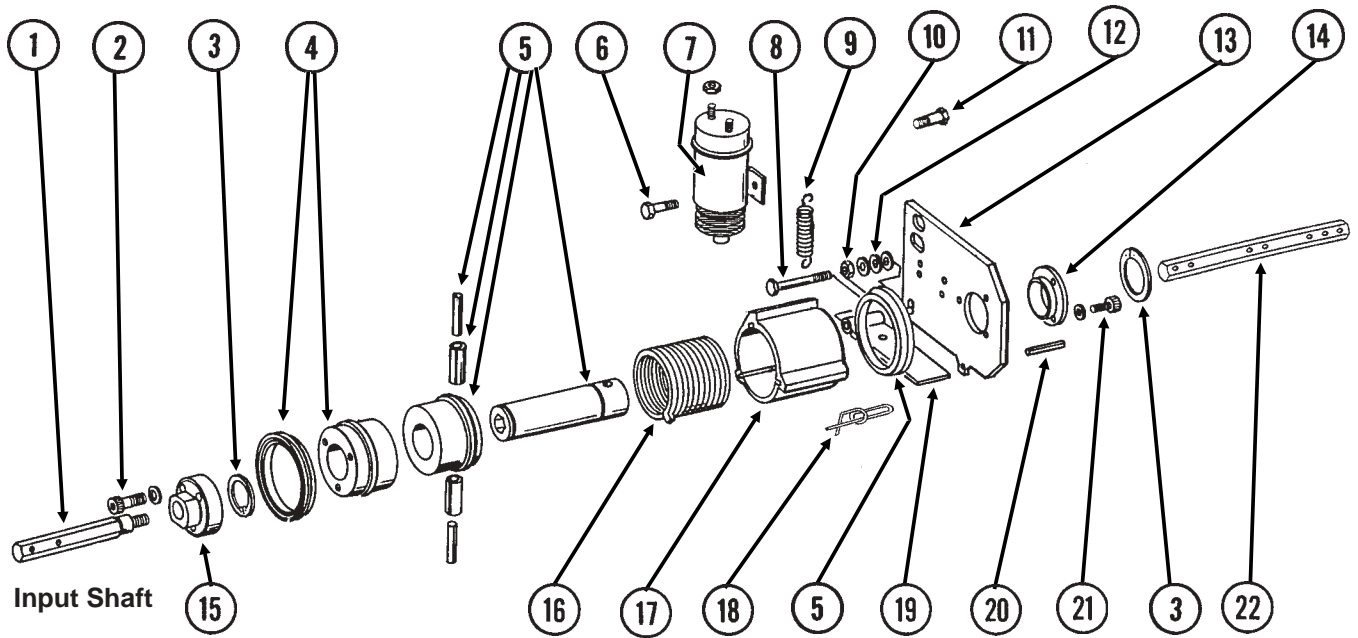

# POINT ROW CLUTCH

ITEM	PART NO.	QTY. (Per Assy.)	DESCRIPTION
1.	GD10069	1	Input Shaft, L.H. Thread (R.H. Side Of Machine)
	GD10068	-	Input Shaft, R.H. Thread (L.H. Side Of Machine)
2.	G10374	3	Hex Socket Head Screw, 1/4"-20 x 1"
	G10227	3	Lock Washer, 1/4"
3.	G10496	2	External Inverted Snap Ring, 1 1/2"
4.	GA9568	1	Input Hub W/Seal
	GD10120	-	Seal
5.	GA7137	1	Hub/Sleeve Assembly W/Seal And Spring Pins
	GD10120	-	Seal
	G10765	-	Spring Pin, 1/4" x 1"
	G10804	-	Spring Pin, 5/32" x 7/8"
6.	G10023	1	Hex Head Cap Screw, 1/4"-20 x 3/4"
	G10227	1	Lock Washer, 1/4"
	G10103	1	Hex Nut, 1/4"-20
7.	GA8393	1	Solenoid Complete
	GR1306	1	Snap Ring
	GR1303	1	Spring
	GR1304	1	Boot
	GR1305	1	Plunger
8.	G10049	1	Hex Head Cap Screw, 3/8"-16 x 2 1/2"
	G10229	2	Lock Washer, 3/8"
	G10497	1	Hex Jam Nut, 3/8"-16
9.	GD10123	1	Spring
10.	G10101	1	Hex Nut, 3/8"-16
11.	G10900	1	Socket Head Cap Screw, 1/4"-20 x 1 3/4"
	G10227	1	Lock Washer, 1/4"
	G10103	2	Hex Nut, 1/4"-20
12.	G10203	1	Washer, 3/8" SAE
13.	GD10103	1	Mounting Plate
14.	GD9667	1	Bushing
15.	GD10071	1	Coupler W/L.H. Threads (R.H. Side Of Machine)
	GD10070	1	Coupler W/R.H. Threads (L.H. Side Of Machine)
16.	GD9672	1	Spring, R.H. (R.H. Side Of Machine)
	GD9671	-	Spring, L.H. (L.H. Side Of Machine)
17.	GD10102	1	Stop Collar
18.	GD11120	1	Rue Ring Cotter, 5/16"
19.	GD10510	1	Actuator Arm
20.	G10859	1	Spring Pin, 3/16" x 2 1/4"
21.	G10253	3	Socket Head Screw, No. 10-32 x 1/2"
	G10257	3	Lock Washer, No. 10
22.	GD10543	-	Hex Shaft, 7/8" x 13"
23.	GA9479	1	Wiring Harness, 228", R.H. Side, 12 Row 30"
	GA9480	-	Wiring Harness, 264", L.H. Side, 12 Row 30"
	GA9483	-	Wiring Harness, 252", R.H. Side, 16 Row 30"
	GA9482	-	Wiring Harness, 300", L.H. Side, 16 Row 30"
24.	G10996	-	Fork Terminal
A.	GA7110	-	Point Row Clutch Assembly, R.H. (R.H. Side Of Machine) (Items 1-21)
	GA7111	-	Point Row Clutch Assembly, L.H. (L.H. Side Of Machine) (Items 1-21)

# TWO-SPEED POINT ROW CLUTCH

PRC023(TWL145/A7274/TWL71d/TWL18)

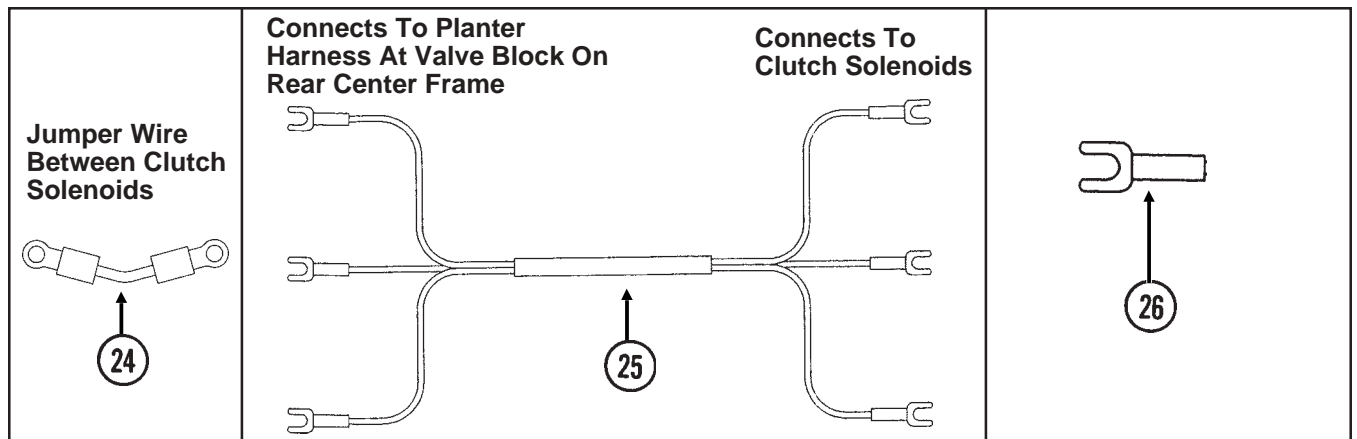
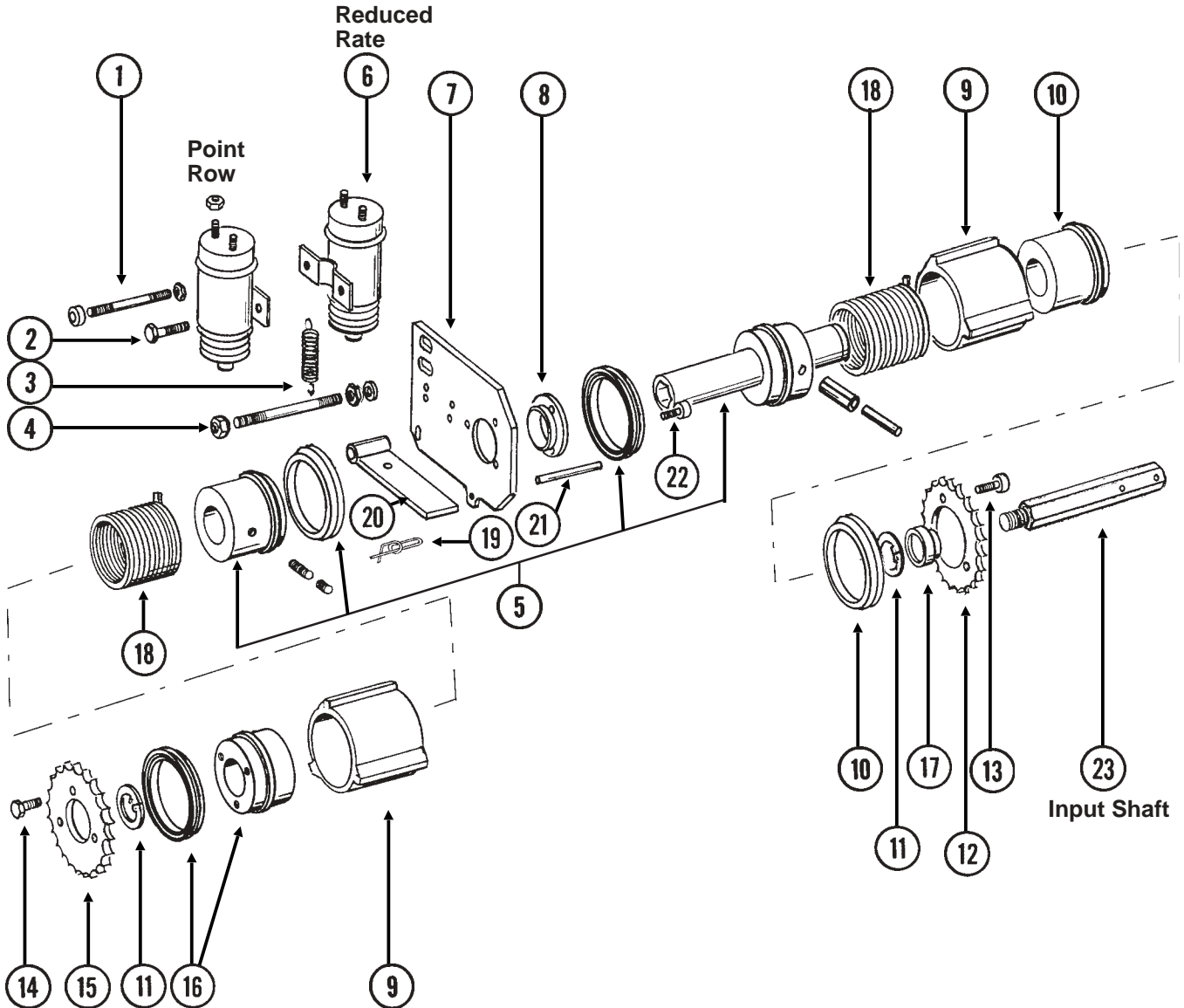

# TWO-SPEED POINT ROW CLUTCH

ITEM	PART NO.	QTY. (Per Assy.)	DESCRIPTION
1.	GD10635	1	Threaded Rod, 1/4"-20 x 3 1/2"
	G10103	2	Hex Nut, 1/4"-20
	G10227	2	Lock Washer, 1/4"
	GD10282	2	Allen Nut, 1/4"-20
2.	G10023	1	Hex Head Cap Screw, 1/4"-20 x 3/4"
	G10227	1	Lock Washer, 1/4"
	G10103	1	Hex Nut, 1/4"-20
3.	GD10123	2	Spring
4.	GD10636	1	Threaded Rod, 3/8"-16 x 4 1/4"
	G10108	2	Lock Nut, 3/8"-16
	G10229	2	Lock Washer, 3/8"
	G10101	2	Hex Nut, 3/8"-16
5.	GA7463	1	Hub/Sleeve Assembly W/Seals, Sleeve, Pins And Screws
	GD10120	-	Seal
	GD10584	-	Sleeve
	G10873	-	Hex Socket Set Screw, 5/16"-18 x 3/4"
	G10872	-	Hex Socket Set Screw, 5/16"-18 x 1/4"
	G10804	-	Spring Pin, 5/32" x 7/8"
	G10765	-	Spring Pin, 1/4" x 1"
	6.	GA8393	2
GR1306	-	Snap Ring	
GR1303	-	Spring	
GR1304	-	Boot	
GR1305	-	Plunger	
7.	GD10103	1	Mounting Plate
8.	GD10586	1	Bushing
9.	GD10585	2	Stop Collar
10.	GA9571	1	Hub W/Seal
	GD10120	-	Seal
11.	G10496	2	External Inverted Snap Ring, 1 1/2"
12.	GD10578	1	Input Sprocket, 28 Tooth
13.	G10374	3	Hex Socket Head Screw, 1/4"-20 x 1"
	GD10588	3	Key
14.	G10023	3	Hex Head Cap Screw, 1/4"-20 x 3/4"
	G10227	3	Lock Washer, 1/4"
15.	GD10579	1	Output Sprocket, 28 Tooth
16.	GA9572	1	Hub W/Seal
	GD10120	-	Seal
17.	GD10638	1	Coupler W/R.H. Threads
	GD10587	-	Coupler W/L.H. Threads
18.	GD9672	2	Spring, R.H. (R.H. Side Of Machine)
	GD9671	-	Spring, L.H. (L.H. Side Of Machine)
19.	GD11120	2	Rue Ring Cotter, 5/16"
20.	GD10510	2	Actuator Arm
21.	G10859	1	Spring Pin, 3/16" x 2 1/4"
22.	G10876	3	Hex Socket Head Screw, No. 10-32 x 1/4"
23.	GD10069	1	Input Shaft, L.H. Thread (R.H. Side Of Machine)
	GD10068	-	Input Shaft, R.H. Thread (L.H. Side Of Machine)
24.	GA7274	1	Jumper Wire (Between Solenoids)
25.	GA9479	1	Wiring Harness, 228", R.H. Side, 12 Row 30"
	GA9480	-	Wiring Harness, 264", L.H. Side, 12 Row 30"
	GA9483	-	Wiring Harness, 252", R.H. Side, 16 Row 30"
	GA9482	-	Wiring Harness, 300", L.H. Side, 16 Row 30"
26.	G10996	-	Fork Terminal

# TWO-SPEED POINT ROW CLUTCH WHEEL MODULE EXTENSION

PRC022/PRC019/PTD078/PTD079(TWL77c/TWL84b/TWL79a/TWL80)

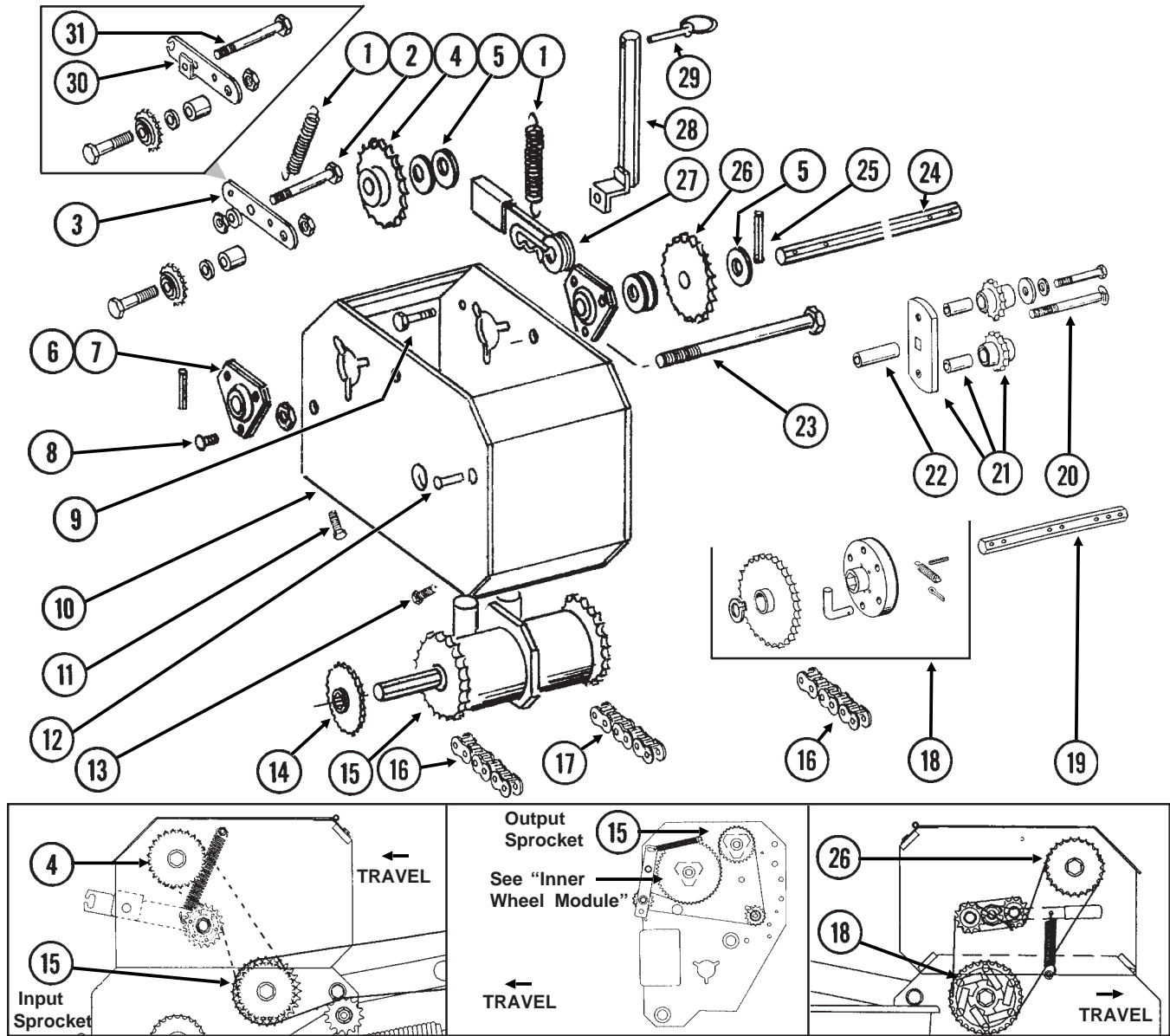

ITEM	PART NO.	QTY.	DESCRIPTION
		(Per Assy.)	
1.	GD5857	2	Spring
2.	G10013	1	Hex Head Cap Screw, 5/8"-11 x 3 1/2"
	G10204	2	Special Machine Bushing, 5/8" x 1" O.D.
	G10107	1	Lock Nut, 5/8"-11
	G10104	1	Hex Nut, 5/8"-11
3.	GA7307	1	Idler W/Sprocket And Hardware
	GA7154	-	Sprocket W/Bearing, 18 Tooth
	G10053	-	Hex Head Cap Screw, 1/2"-13 x 2 1/2"
	GD10356	-	Bushing, 3/4" Long
	G10206	-	Washer, 1/2" SAE
	G10111	-	Lock Nut, 1/2"-13
4.	GA5113	1	Sprocket, 28 Tooth
5.	G10233	-	Machine Bushing, 1", 10 Gauge
6.	G3400-01	-	Flangette
7.	G2100-03	-	Bearing, 7/8" Hex Bore, Spherical
8.	G10312	6	Carriage Bolt, 5/16"-18 x 3/4"
	G10232	6	Lock Washer, 5/16"
	G10106	6	Hex Nut, 5/16"-18

# TWO-SPEED POINT ROW CLUTCH WHEEL MODULE EXTENSION

ITEM	PART NO.	QTY. (Per Assy.)	DESCRIPTION
9.	G10037	1	Hex Head Cap Screw, 1/2"-13 x 1 1/4"
	G10216	1	Washer, 1/2" USS
	G10228	1	Lock Washer, 1/2"
	G10102	1	Hex Nut, 1/2"-13
10.	GA7306	1	Extension Bracket
11.	G10857	2	Hex Head Cap Screw, 1/4"-20 x 1 1/4"
	G10209	2	Washer, 1/4" USS
	G10227	2	Lock Washer, 1/4"
	G10103	2	Hex Nut, 1/4"-20
12.	G10408	1	Clevis Pin, 5/16" x 3/4"
	G10409	1	Retaining Ring, 5/16"
13.	G10064	2	Hex Head Cap Screw, 1/4"-20 x 1"
	G10209	2	Washer, 1/4" USS
	G10227	2	Lock Washer, 1/4"
	G10103	2	Hex Nut, 1/4"-20
14.		-	See "Contact Drive Wheel And Drive Shaft(s)", Pages P58-P60
15.		-	See "Two-Speed Point Row Clutch", Pages P68 And P69
16.	G3310-74	2	Chain, No. 40, 74 Pitch Including Connector Link
	GR0912	-	Connector Link, No. 40
17.	G3310-100	1	Chain, No. 40, 100 Pitch Including Connector Link
	GR0912	-	Connector Link, No. 40
18.	GA7320	1	Overrunning Sprocket Assembly, R.H.
	GA7321	-	Overrunning Sprocket Assembly, L.H.
	G10430	1	External Retaining Ring, 1 1/4"
	GD1255	6	L-Pin
	G10546	6	Spring Pin, 3/16" x 1 1/4"
	G10470	6	Cotter Pin, 5/32" x 1"
	GD10366	6	Spring
	GA7317	1	Block
	GA7319	1	Sprocket W/Bushing, 30 Tooth
	19.	GD10543	1
20.	G10863	1	Carriage Bolt, 1/2"-13 x 2 3/4"
	G10111	1	Lock Nut, 1/2"-13
21.	GA7336	1	Idler W/Bolt-On Sprockets
	GD7426	-	Sprocket, 12 Tooth
	GD1026	-	Sleeve, 1 3/16" Long
	G10210	-	Washer, 3/8" USS
	G10229	-	Lock Washer, 3/8"
	G10047	-	Hex Head Cap Screw, 3/8"-16 x 1 3/4"
	22.	GD3180-18	1
23.	G10595	1	Hex Head Cap Screw, 3/8"-16 x 10"
	G10108	1	Lock Nut, 3/8"-16
24.	GD10355	1	Shaft, 7/8" x 13 3/4"
25.	G10602	3	Spring Pin, 1/4" x 1 1/2"
26.	GA5109	1	Sprocket, 24 Tooth
	GA5105	1	Sprocket, 15 Tooth
	GA5106	1	Sprocket, 17 Tooth
	GA5112	1	Sprocket, 27 Tooth
	GA5108	-	Sprocket, 23 Tooth (From Transmission)
	GA5110	-	Sprocket, 25 Tooth (From Transmission)
	GA5111	-	Sprocket, 26 Tooth (From Transmission)
	27.	GA4235	1
28.	GA7313	1	Sprocket Storage Rod
29.	GD2558	2	Lynch Pin, 1/4"
	G10445	-	Protective Closure
30.	GA9918	1	Idler Assembly W/Sprocket And Hardware
	GD10356	-	Bushing, 3/4" Long
	G10128	-	Machine Bushing, 1/2", 14 Gauge
	G10501	-	Hex Jam Nut, 1/2"-13, Grade 2
	G10053	-	Hex Head Cap Screw, 1/2"-1 x 2 1/2"
	GA7154	-	Sprocket W/Bearing, 18 Tooth
	31.	G10743	1
	G10107	1	Lock Nut, 5/8"-11
	G10104	1	Hex Nut, 5/8"-11

# MARKER ASSEMBLY

12 ROW 30"

MKR019/MKR027(MKR14e)

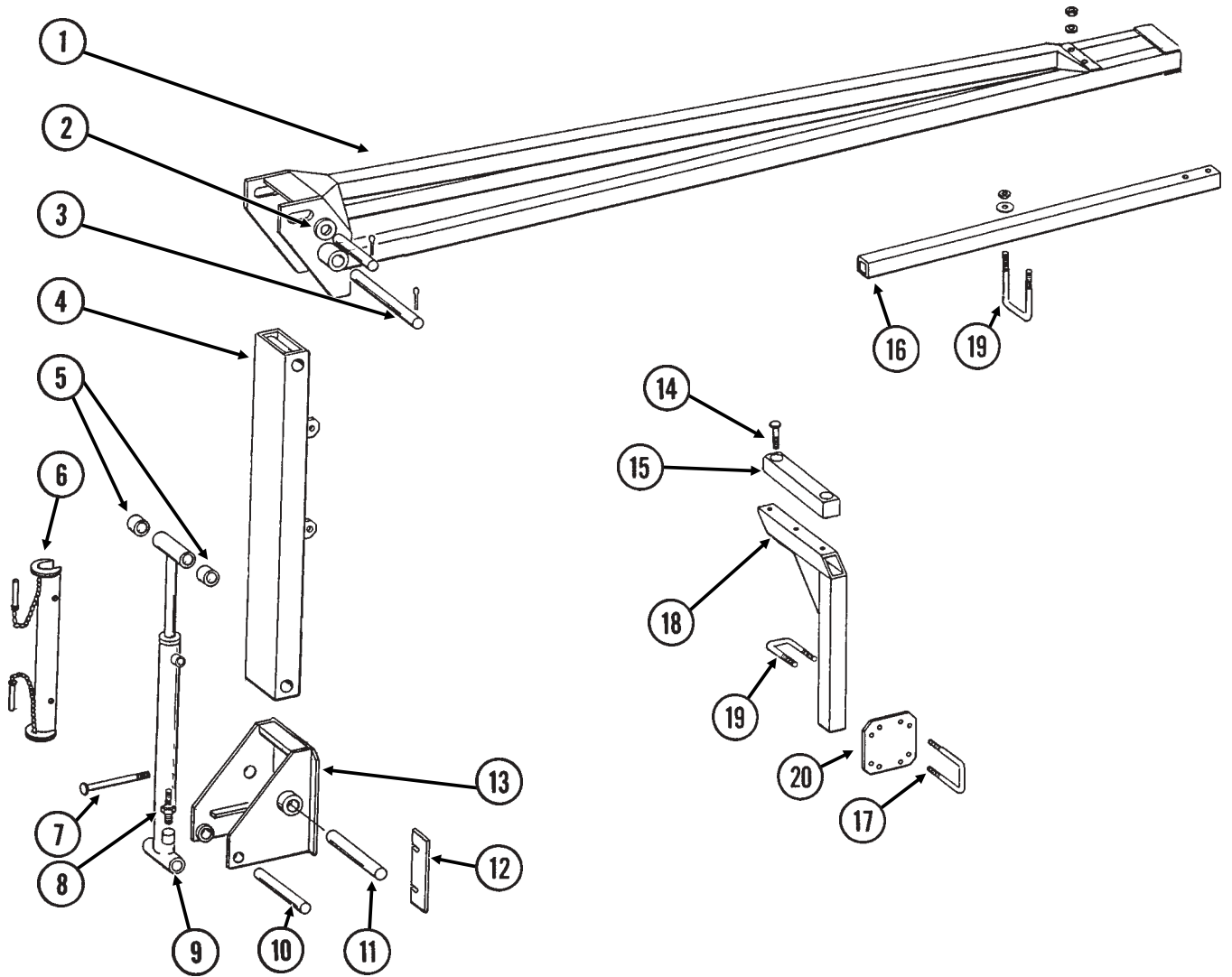



# MARKER ASSEMBLY

# 12 ROW 30"

ITEM	PART NO.	QTY.	DESCRIPTION
		(Per Assy.)	
1.	GA4353	1	Arm W/Grease Fittings, Second Stage, 110"
	G10641	-	Grease Fitting, 1/8" NPT
2.	G10226	2	Washer, 1 1/4" SAE
3.	GD3214	1	Pin, 1 1/4" x 12 1/4"
	G10460	2	Cotter Pin, 1/4" x 2"
4.	GA4611	1	Arm W/Grease Fittings, First Stage
	G10641	-	Grease Fitting, 1/8" NPT
5.	GD0752-41	4	Sleeve, 1"
6.	GA8170	1	Safety Lockup W/Detent Pins, 19 3/8"
	G10536	-	Detent Pin, 1/2" x 2 1/2" Grip
7.	G10046	4	Hex Head Cap Screw, 5/8"-11 x 5"
	G10205	8	Washer, 5/8" SAE
	G10230	4	Lock Washer, 5/8"
	G10104	4	Hex Nut, 5/8"-11
8.		-	See "Hydraulic Hoses And Fittings On Planter Frame", Pages P98-P101
9.		-	See "Marker Cylinder", Page P87
10.	GD2161	2	Pin, 1 1/4" x 8 1/4"
	G10460	4	Cotter Pin, 1/4" x 2"
11.	GD0652	1	Pin, 1 1/4" x 9 1/2"
	G10460	2	Cotter Pin, 1/4" x 2"
12.	GD10792	-	Shim (As Required)
13.	GA5130	1	Mount
14.	G10017	2	Hex Head Cap Screw, 1/2"-13 x 1 1/2"
	G10228	2	Lock Washer, 1/2"
	G10102	2	Hex Nut, 1/2"-13
15.	GA9088	1	Molded Stop, 12 1/4" Long
16.	GD0453-07	1	Extension Tube, 45"
17.	GD4743	2	U-Bolt, 3" x 3" x 1/2"-13
	G10228	4	Lock Washer, 1/2"
	G10102	4	Hex Nut, 1/2"-13
18.	GA7042	1	Stand, 20"
19.	GD2721	1	U-Bolt, 2" x 2" x 1/2"-13
	G10228	2	Lock Washer, 1/2"
	G10102	2	Hex Nut, 1/2"-13
20.	GD9981	1	Bar

# MARKER ASSEMBLY

16 ROW 30"

MKR019/MKR023MKR027(MKR15d)

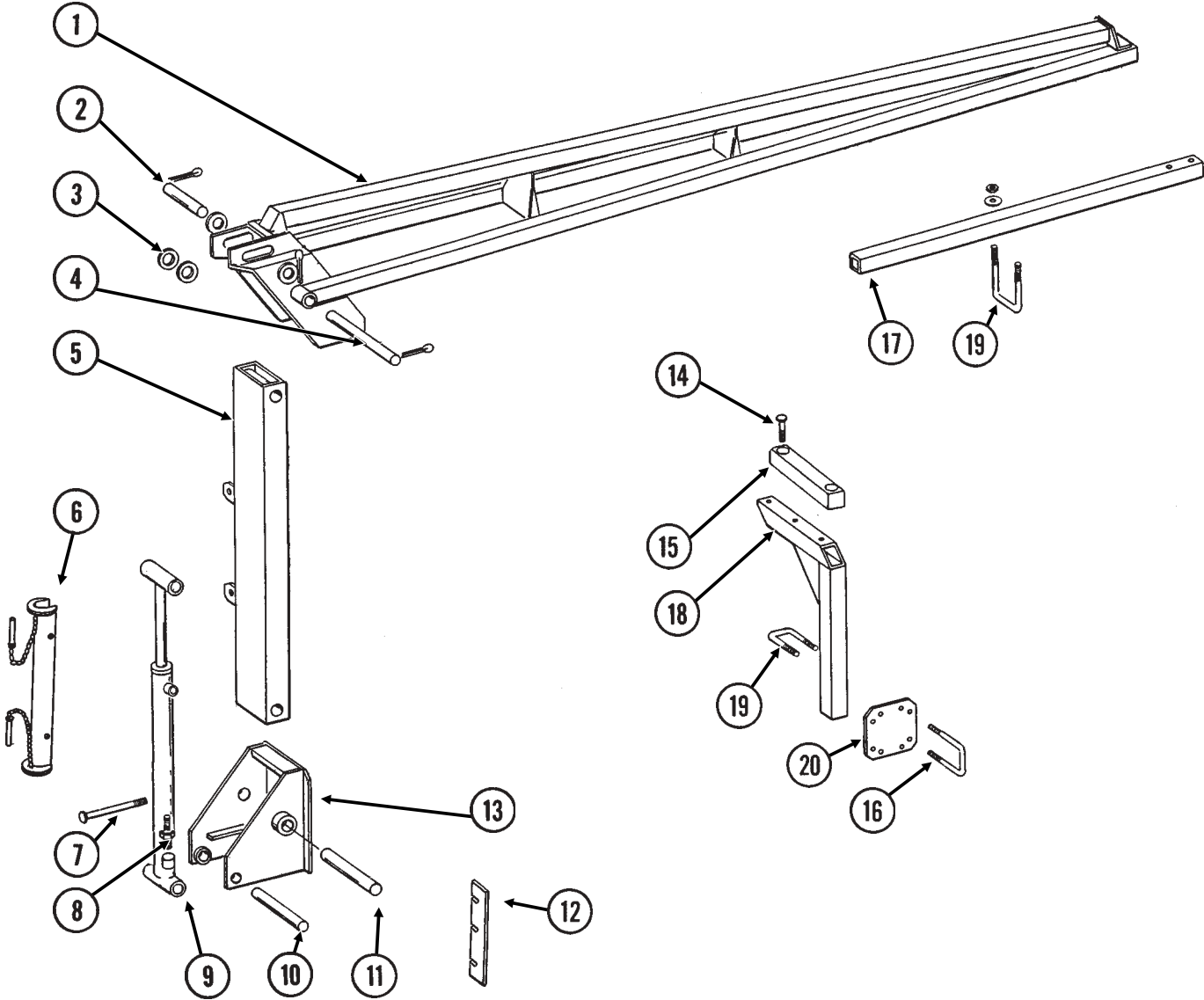

# MARKER ASSEMBLY

# 16 ROW 30"

ITEM	PART NO.	QTY.	DESCRIPTION
		(Per Assy.)	
1.	GA7118	1	Arm, Second Stage, 172 1/4"
2.	GD1701	1	Pin, 1 1/4" x 6 1/2"
	G10460	2	Cotter Pin, 1/4" x 2"
3.	G10979	4	Special Washer, 1 1/4"
4.	GD0737	1	Pin, 1 1/4" x 13 1/4"
	G10460	2	Cotter Pin, 1/4" x 2"
5.	GA4878	1	Arm W/Grease Fittings, First Stage, R.H.
	GA4983	-	Arm W/Grease Fittings, First Stage, L.H.
	G10641	-	Grease Fitting, 1/8" NPT
6.	GA8170	1	Safety Lockup W/Detent Pins, 19 3/8"
	G10536	-	Detent Pin, 1/2" x 2 1/2" Grip
7.	G10068	-	Hex Head Cap Screw, 5/8"-11 x 6"
	G10205	6	Washer, 5/8" SAE
	G10230	6	Lock Washer, 5/8"
	G10104	6	Hex Nut, 5/8"-11
8.		-	See "Hydraulic Hoses And Fittings On Planter Frame", Pages P98-P101
9.		-	See "Marker Cylinder", Page P87
10.	GD0652	1	Pin, 1 1/4" x 9 1/2"
	G10460	2	Cotter Pin, 1/4" x 2"
11.	GD7209	1	Pin, 1 1/4" x 11 1/2"
	G10049	1	Hex Head Cap Screw, 3/8"-16 x 2 1/2"
	G10108	1	Lock Nut, 3/8"-16
12.	GD10793	-	Shim (As Required) (Shown)
	GD11791	-	Shim (As Required)
13.	GA4877	1	Mount
14.	G10017	2	Hex Head Cap Screw, 1/2"-13 x 1 1/2"
	G10228	2	Lock Washer, 1/2"
	G10102	2	Hex Nut, 1/2"-13
15.	GA9088	1	Molded Stop, 12 1/4" Long
16.	GD4743	2	U-Bolt, 3" x 3" x 1/2"-13
	G10228	4	Lock Washer, 1/2"
	G10102	4	Hex Nut, 1/2"-13
17.	GD0453-03	1	Extension Tube, 50"
18.	GA7043	1	Stand, 30"
19.	GD2721	3	U-Bolt, 2" x 2" x 1/2"-13
	G10228	6	Lock Washer, 1/2"
	G10102	6	Hex Nut, 1/2"-13
20.	GD9981	1	Bar

# MARKER SPINDLE/HUB/BLADE

MKR020(MKR4)

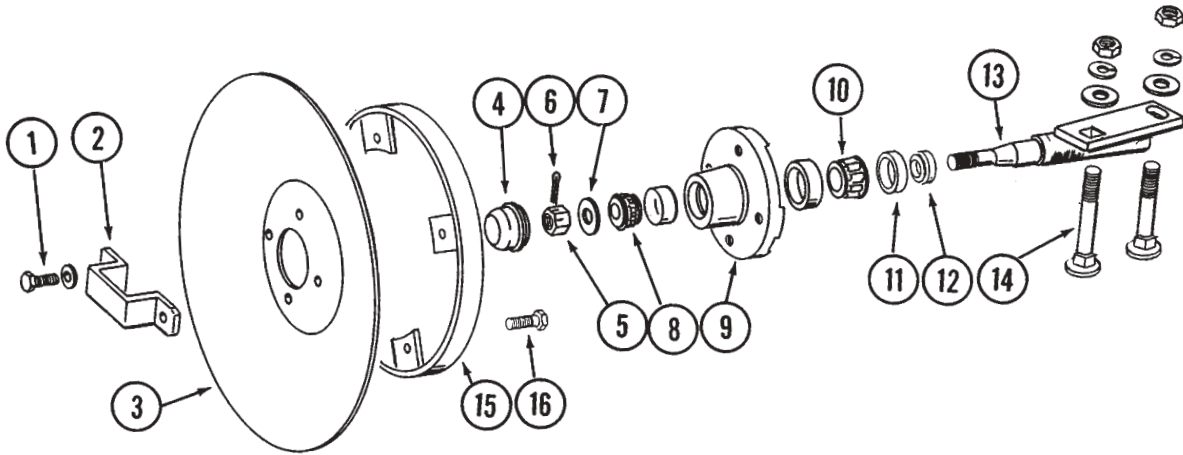

ITEM	PART NO.	QTY.	DESCRIPTION
		(Per Assy.)	
1.	G10722	4	Hex Head Cap Screw, 1/2"-20 x 1"
	G10228	4	Lock Washer, 1/2"
2.	GD2597	1	Retainer
3.	GD0746	1	Disc Blade, Solid, 16" (Shown)
	GD10283	-	Disc Blade, Notched, 16" (Optional)
4.	GD0840	1	Dust Cap
5.	G10725	1	Slotted Hex Nut, 5/8"-18
6.	G10544	1	Cotter Pin, 5/32" x 1"
7.	G10724	1	Washer, 5/8" SAE
8.	GA0257	1	Bearing
9.	GA0167	1	Hub W/Cups
	GR0151	-	Outer Cup
	GR0150	-	Inner Cup
10.	GA0245	1	Bearing
11.	GA0243	1	Grease Seal
12.	GA0899	1	Rubber Seal
13.	GA1676	1	Spindle, R.H.
	GA1677	-	Spindle, L.H. (Shown)
14.	G10844	2	Carriage Bolt, 1/2"-13 x 3 1/2"
	G10168	2	Machine Bushing, 1/2", 7 Gauge
	G10228	2	Lock Washer, 1/2"
	G10102	2	Hex Nut, 1/2"-13
15.	GA5853	1	Depth Band
16.	G10019	4	Hex Head Cap Screw, 5/16"-18 x 1"
	G10109	4	Lock Nut, 5/16"-18
A.	GA1679	-	Hub And Spindle Assembly, L.H. (Items 1, 2 And 4-13)
	GA1678	-	Hub And Spindle Assembly, R.H. (Items 1, 2 And 4-13)

# ROTATION CYLINDER, ALL SIZES

(CYL11d)

3/4" -16 O-Ring Ports

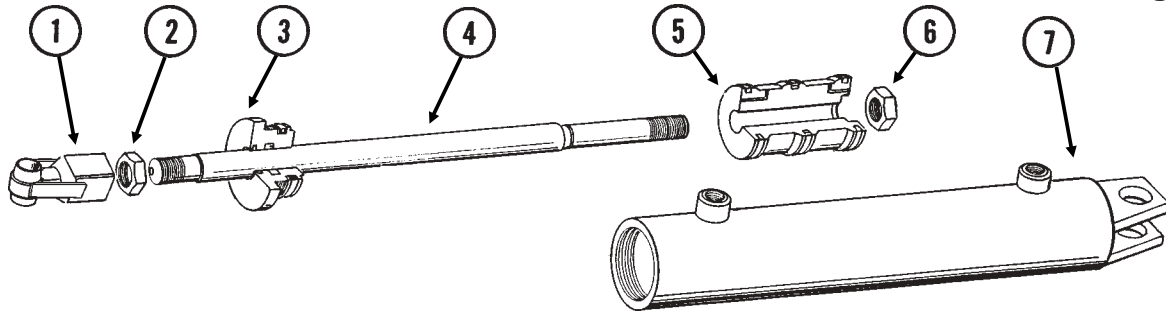

ITEM	PART NO.	QTY.	DESCRIPTION
1.	GA9688	1	Clevis ( <b>Sub GD14059 And GA7221</b> )
2.	G10509	1	Hex Jam Nut, 1 1/4"-12, Grade 2
3.	GD11988	1	Gland
4.	GD12667	1	Rod ( <b>Sub GD14059 And GA7221</b> )
5.	GD11992	1	Piston
6.	G10972	1	Lock Nut, 1 1/4"-12
7.	A9018	1	Barrel ( <b>Non-Stock Item</b> )
A.	GA9019	-	Cylinder Complete, 4" x 20" ( <i>Part Number Stamped On Barrel</i> )
B.	GR1524	-	Seal Kit, Includes: (2) O-Rings, (1) U-Cup, (1) Wiper, (1) Seal, (2) Cast Iron Rings, (1) BU Ring, (1) Expander

# ROTATION CYLINDER, ALL SIZES

(CYL11d)

3/4" -16 O-Ring Ports

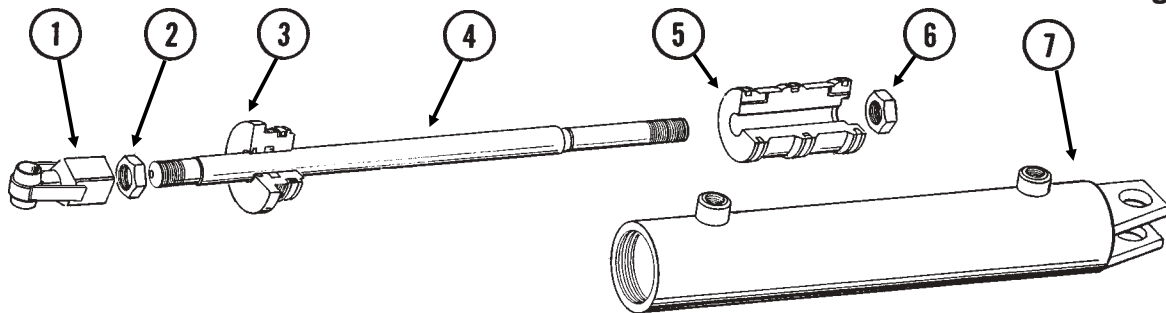

ITEM	PART NO.	QTY.	DESCRIPTION
1.	GA7221	1	Clevis
2.	G10509	1	Hex Jam Nut, 1 1/4"-12, Grade 2
3.	GD11988	1	Gland
4.	GD14059	1	Rod
5.	GD11992	1	Piston
6.	G10972	1	Lock Nut, 1 1/4"-12
7.	A9018	1	Barrel ( <b>Non-Stock Item</b> )
A.	GA9842	-	Cylinder Complete, 4" x 20" ( <i>Part Number Stamped On Barrel</i> )
B.	GR1524	-	Seal Kit, Includes: (2) O-Rings, (1) U-Cup, (1) Wiper, (1) Seal, (2) Cast Iron Rings, (1) BU Ring, (1) Expander

# CENTER LIFT CYLINDER, 12 ROW 30"

(CYL54c)

## Port Type Rephasing

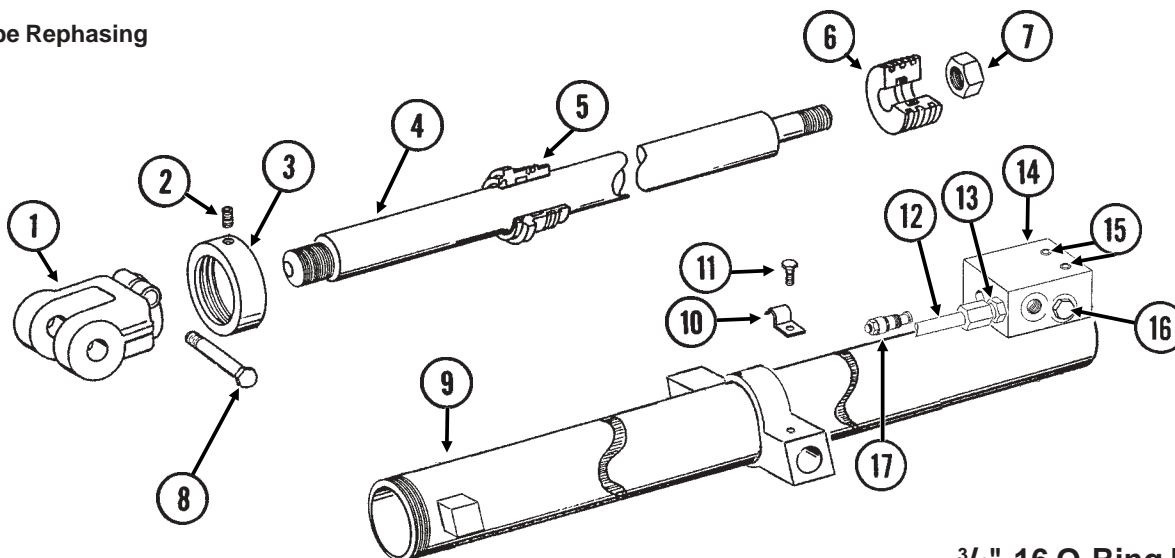

**3/4"-16 O-Ring Ports**

ITEM	PART NO.	QTY.	DESCRIPTION
1.	GD11951	1	Clevis
2.	G10907	1	Set Screw, 1/4"-20 x 1/4"
3.	GD11193	1	Cap
4.	GD10936	1	Rod
5.	GD10211	1	Gland
6.	GD11253	1	Piston
7.	G10958	1	Lock Nut, 1"-14
8.	G10939	1	Hex Head Cap Screw, 3/8"-16 x 2 1/4"
	G10108	1	Lock Nut, 3/8"-16
9.	GA9009	1	Barrel
10.	GD12657	1	Half Clip
11.	G10022	1	Hex Head Cap Screw, 1/4"-20 x 1/2"
	G10227	1	Lock Washer, 1/4"
12.	GA9011	1	Steel Hydraulic Line, 43 5/16"
13.	G6400-08	-	Connector W/O-Ring, 3/4"-16 Male JIC To O-Ring
	GR1037	0	O-Ring
14.	GD11579	1	Block
15.	G10932	2	Hex Socket Head Cap Screw, 5/16"-18 x 2", Grade 8
16.	G6408-08	-	Plug W/O-Ring, 3/4"-16 O-Ring
	GR1037	-	O-Ring
17.	GA8882	1	Counter Balance Valve
A.	GA9010	-	Cylinder Complete, 3" x 48" (Part Number Stamped On Barrel)
B.	GR1550	-	Seal Kit (For Cylinder And Counter Balance Valve), Includes: (1) Wiper, (1) U-Cup, (7) O-Rings, (4) BU Rings, (1) Seal, (1) Expander, (2) Cast Iron Rings

# CENTER LIFT CYLINDER, 16 ROW 30"

(CYL54c)

## Port Type Rephasing

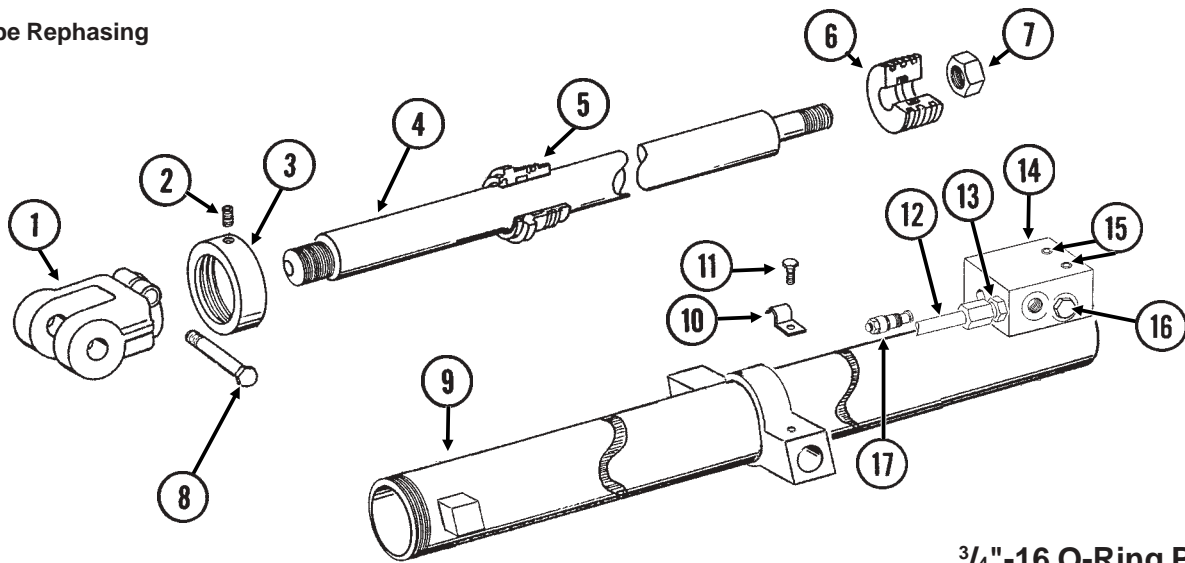

3/4"-16 O-Ring Ports

ITEM	PART NO.	QTY.	DESCRIPTION
1.	GD11951	1	Clevis
2.	G10907	1	Set Screw, 1/4"-20 x 1/4"
3.	GD13303	1	Cap
4.	GD13306	1	Rod
5.	GD13307	1	Gland
6.	GD13304	1	Piston
7.	G10958	1	Lock Nut, 1"-14
8.	G10939	1	Hex Head Cap Screw, 3/8"-16 x 2 1/4"
	G10108	1	Lock Nut, 3/8"-16
9.	GA9470	1	Barrel
10.	GD12657	1	Half Clip
11.	G10022	1	Hex Head Cap Screw, 1/4"-20 x 1/2"
	G10227	1	Lock Washer, 1/4"
12.	GA9011	1	Steel Hydraulic Line, 43 5/16"
13.	G6400-08	-	Connector W/O-Ring, 3/4"-16 Male JIC To O-Ring
	GR1037	0	O-Ring
14.	GD11579	1	Block
15.	G10932	2	Hex Socket Head Cap Screw, 5/16"-18 x 2", Grade 8
16.	G6408-08	-	Plug W/O-Ring, 3/4"-16 O-Ring
	GR1037	-	O-Ring
17.	GA8882	1	Counter Balance Valve
A.	GA9471	-	Cylinder Complete, 3 1/4" x 48" ( <i>Part Number Stamped On Barrel</i> )
B.	GR1572	-	Seal Kit (For Cylinder And Counter Balance Valve), Includes: (1) Wiper, (1) U-Cup, (7) O-Rings, (4) BU Rings, (1) Seal, (1) Expander, (2) Cast Iron Rings

# WING LIFT CYLINDER, 12 ROW 30"

CYL031/CYL011(CYL45d)

Port Type Rephasing

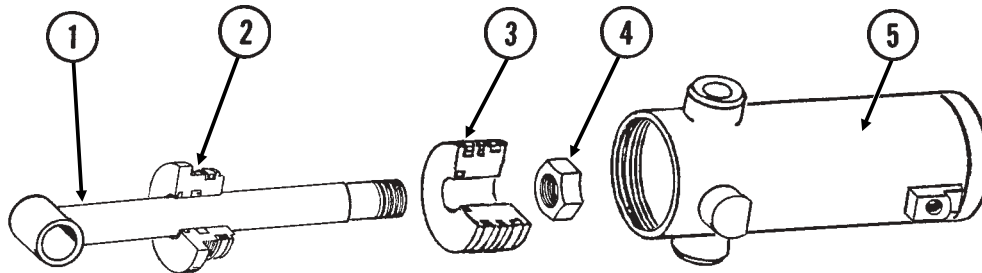

Port Type Rephasing

<sup>3</sup>/<sub>4</sub>"-16 O-Ring Ports

ITEM	PART NO.	QTY	DESCRIPTION
1.	GA8320	1	Rod Assembly W/Grease Fitting
	G10640	-	Grease Fitting, 1/4"-28
2.	GD11995	1	Gland
3.	GD11994	1	Piston
4.	G10958	1	Lock Nut, 1"-14
5.	A8797	1	Barrel <b>(Non-Stock Item)</b>
A.	GA8909	-	Cylinder Complete, 4 1/4" x 6" <i>(Part Number Stamped On Barrel)</i>
B.	GR1523	-	Seal Kit, Includes: (1) Wiper, (2) O-Rings, (1) BU Ring, (1) U-Cup, (2) Seals, (1) Piston Ring

# WING LIFT CYLINDER, 16 ROW 30"

CYL031/CYL011(CYL41c)

Port Type Rephasing

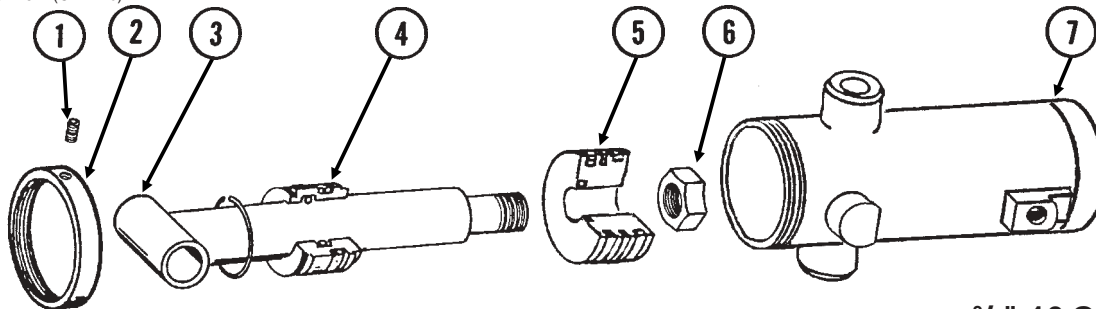

Port Type Rephasing

<sup>3</sup>/<sub>4</sub>"-16 O-Ring Ports

ITEM	PART NO.	QTY.	DESCRIPTION
1.	G10907	1	Set Screw, 1/4"-20 x 1/4"
2.	GD13303	1	Cap
3.	GA8157	1	Rod Assembly W/Grease Fitting
	G10449	-	Grease Fitting, 3/16", Drive-In
4.	GD13302	1	Gland
5.	GD13304	1	Piston
6.	G10958	1	Lock Nut, 1"-14
7.	A9467	1	Barrel <b>(Non-Stock Item)</b>
A.	GA9468	-	Cylinder Complete, 3 1/4" x 6" <i>(Part Number Stamped On Barrel)</i>
B.	GR1573	-	Seal Kit, Includes: (1) Expander, (2) O-Rings, (1) BU Ring, (1) Wiper, (1) U-Cup, (1) Piston Seal, (2) Cast Iron Rings



# WING LOCK CYLINDER, R.H. FRONT AND L.H. REAR

(CYL2d)

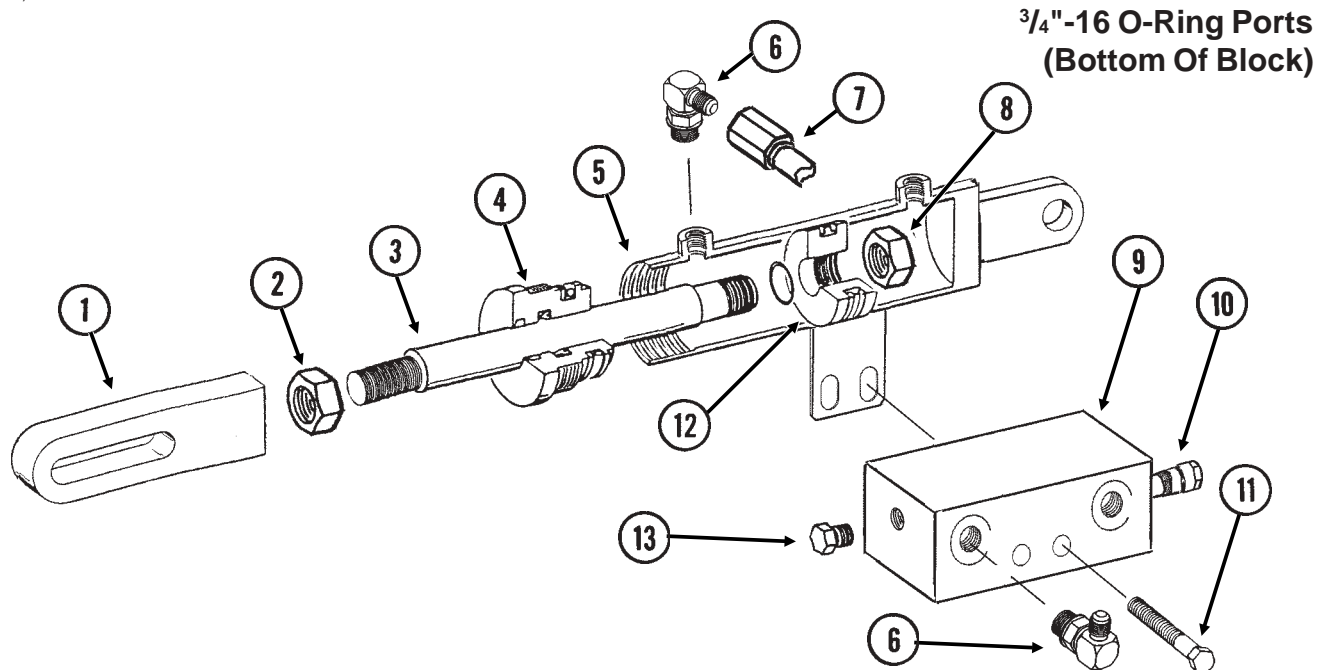

ITEM	PART NO.	QTY.	DESCRIPTION
1.	GA9013	1	Clevis
2.	G10509	1	Hex Jam Nut, 1 1/4"-12, Grade 2
3.	GD12658	1	Rod
4.	GD12659	1	Gland
5.	A9015	1	Barrel <b>(Non-Stock Item)</b>
6.	G6801-06-08	4	Elbow W/O-Ring, 90°, 9/16"-18 Male JIC To 3/4"-16 O-Ring
	GR1037	-	O-Ring
7.	GA9012	2	Steel Hydraulic Line, 7 9/16"
8.	G10972	1	Lock Nut, 1 1/4"-12
9.	GD12665	1	Block
10.	GA8882	1	Counter Balance Valve
11.	G10753	2	Hex Head Cap Screw, 3/8"-16 x 4 1/2"
	G10203	4	Washer, 3/8" SAE
	G10229	2	Lock Washer, 3/8"
	G10101	2	Hex Nut, 3/8"-16
12.	GD12660	1	Piston
13.	G6408-08	3	Plug W/O-Ring, 3/4"-16 O-Ring
	GR1037	-	O-Ring
A.	GA9016	-	Cylinder Complete, 4" x 3 1/2" <i>(Part Number Stamped On Barrel)</i>
B.	GR1551	-	Seal Kit (For Cylinder And Counter Balance Valve), Includes: (1) Wiper, (5) O-Rings, (4) BU Rings, (1) U-Cup, (1) T-Seal

# WING LOCK CYLINDER, L.H. FRONT AND R.H. REAR

(CYL2e)

**3/4"-16 O-Ring Ports  
(Bottom Of Block)**

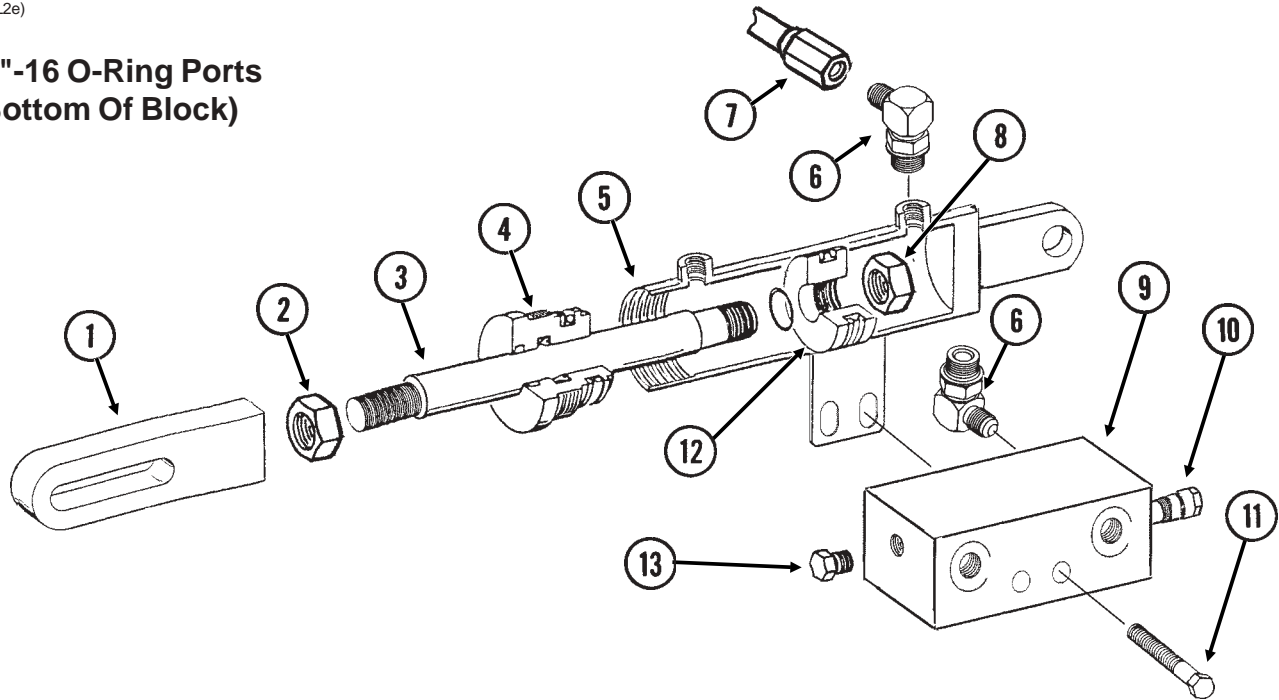

ITEM	PART NO.	QTY.	DESCRIPTION
1.	GA9013	1	Clevis
2.	G10509	1	Hex Jam Nut, 1 1/4"-12, Grade 2
3.	GD12658	1	Rod
4.	GD12659	1	Gland
5.	A9015	1	Barrel <b>(Non-Stock Item)</b>
6.	G6801-06-08	4	Elbow W/O-Ring, 90°, 9/16"-18 Male JIC To 3/4"-16 O-Ring
	GR1037	-	O-Ring
7.	GA9012	2	Steel Hydraulic Line, 7 9/16"
8.	G10972	1	Lock Nut, 1 1/4"-12
9.	GD12665	1	Block
10.	GA8882	1	Counter Balance Valve
11.	G10753	2	Hex Head Cap Screw, 3/8"-16 x 4 1/2"
	G10203	4	Washer, 3/8" SAE
	G10229	2	Lock Washer, 3/8"
	G10101	2	Hex Nut, 3/8"-16
12.	GD12660	1	Piston
13.	G6408-08	3	Plug W/O-Ring, 3/4"-16 O-Ring
	GR1037	-	O-Ring
A.	GA9134	-	Cylinder Complete, 4" x 3 1/2" <i>(Part Number Stamped On Barrel)</i>
B.	GR1551	-	Seal Kit (For Cylinder And Counter Balance Valve), Includes: (1) Wiper, (5) O-Rings, (4) BU Rings, (1) U-Cup, (1) T-Seal

# TRANSPORT LATCH CYLINDER, ALL SIZES

CYL035/CYL050(CYL9b)

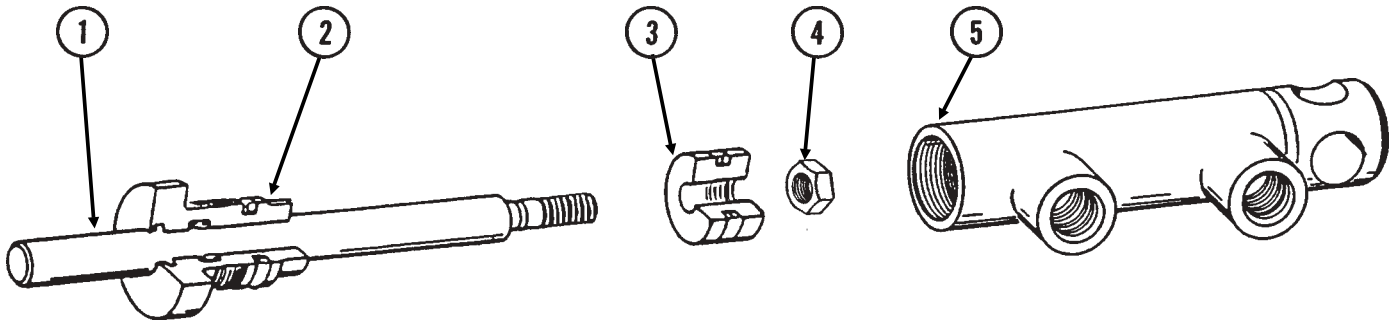

ITEM	PART NO.	QTY.	DESCRIPTION
1.	GD7124	1	Rod
2.	GD7122	1	Gland
3.	GD7120	1	Piston
4.	GR0999	1	Lock Nut, 1/2"-20
5.	A6020	1	Barrel <b>(Non-Stock Item)</b>
A.	GA4309	-	Cylinder Complete, 1 1/2" x 2 1/2" <i>(Part Number Stamped On Barrel)</i>
B.	GR1001	-	Seal Kit, Includes: (2) O-Rings, (1) U-Cup, (1) Wiper, (1) T-Seal

# TRANSPORT LATCH CYLINDER, ALL SIZES

CYL035/CYL050(CYL9c)

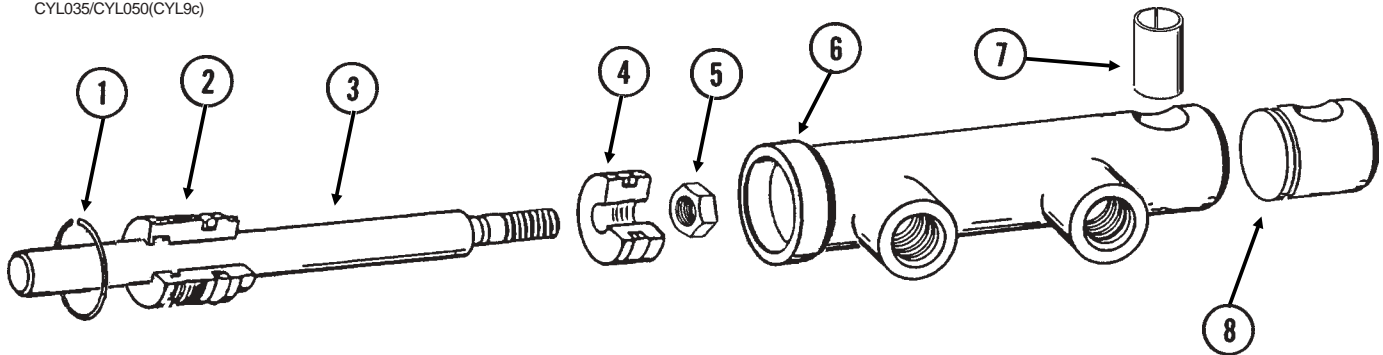

ITEM	PART NO.	QTY.	DESCRIPTION
1.	G10770	1	Internal Retaining Ring, 1 11/16"
2.	GD13170	1	Gland
3.	GD13425	1	Rod
4.	GD13172	1	Piston
5.	G11016	1	Lock Nut, 1/2"-20
6.	D13426	1	Barrel <b>(Non-Stock Item)</b>
7.	GD13400	1	Tension Bushing, 1" x 2"
8.	GD13173	1	EndCap
A.	GA9559	-	Cylinder Complete, 1 1/2" x 2 1/2" <i>(Part Number Stamped On Barrel)</i>
B.	GR1598	-	Seal Kit, Includes: (4) O-Rings, (2) BU Rings, (1) Wiper, (1) T-Seal, (1) Bronze Bushing

# TONGUE LOCK CYLINDER, ALL SIZES

CYL035(CYL9b)

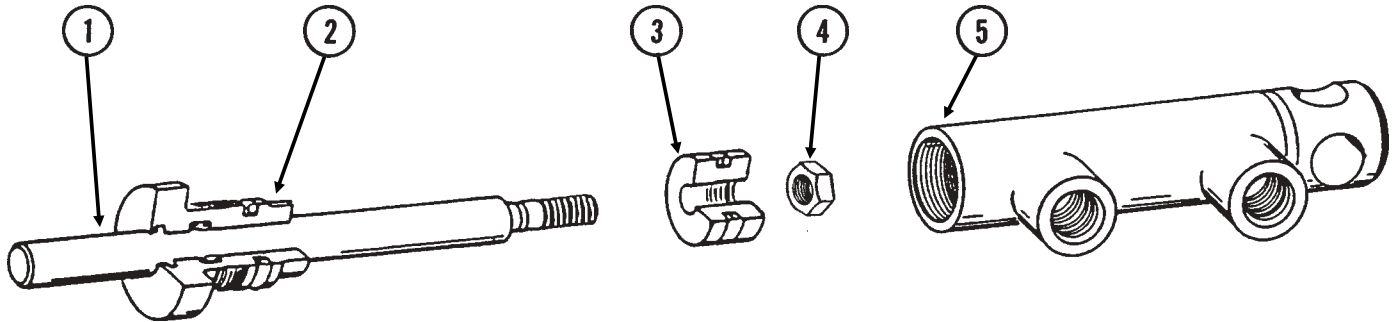

ITEM	PART NO.	QTY.	DESCRIPTION
1.	GD7123	1	Rod
2.	GD7122	1	Gland
3.	GD7120	1	Piston
4.	GR0999	1	Lock Nut, 1/2"-20
5.	A6020	1	Barrel <b>(Non-Stock Item)</b>
A.	GA4310	-	Cylinder Complete, 1 1/2" x 2 1/2" <i>(Part Number Stamped On Barrel)</i>
B.	GR1001	-	Seal Kit, Includes: (2) O-Rings, (1) U-Cup, (1) Wiper, (1) T-Seal

# TONGUE LOCK CYLINDER, ALL SIZES

CYL035(CYL9d)

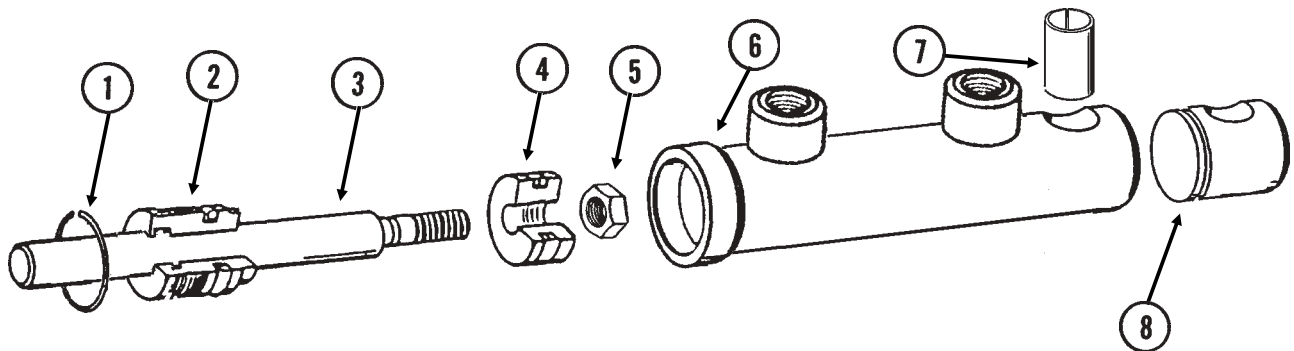

ITEM	PART NO.	QTY.	DESCRIPTION
1.	G10770	1	Internal Retaining Ring, 1 11/16"
2.	GD13170	1	Gland
3.	GD13171	1	Rod
4.	GD13172	1	Piston
5.	G11016	1	Lock Nut, 1/2"-20
6.	D13169	1	Barrel <b>(Non-Stock Item)</b>
7.	GD13400	1	Tension Bushing, 1" x 2"
8.	GD13173	1	End Cap
A.	GA9205	-	Cylinder Complete, 1 1/2" x 2 1/2" <i>(Part Number Stamped On Barrel)</i>
B.	GR1598	-	Seal Kit, Includes: (4) O-Rings, (2) BU Rings, (1) Wiper, (1) T-Seal, (1) Bronze Bushing

# TONGUE CYLINDER, 12 ROW 30"

(CYL12)

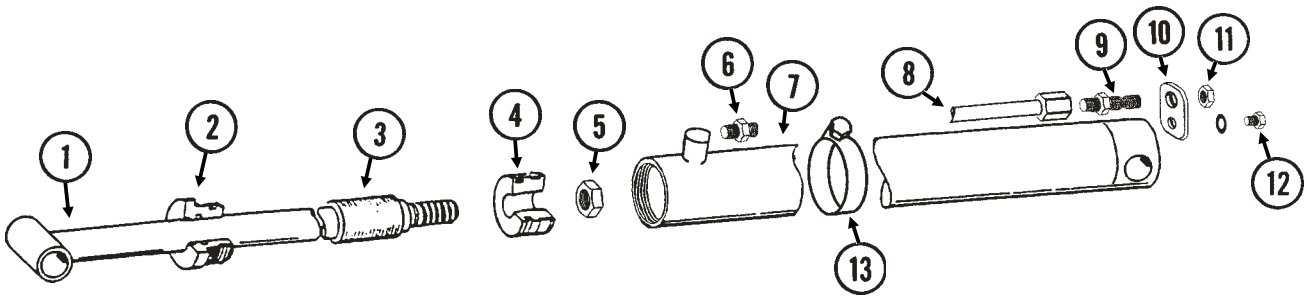

**$\frac{3}{4}$ "-16 O-Ring Port  
And  $\frac{3}{4}$ "-16 JIC Port**

ITEM	PART NO.	QTY.	DESCRIPTION
1.	GA8893	1	Rod Assembly
2.	GD11984	1	Gland
3.	GD7147	1	Spacer
4.	GD11970	1	Piston
5.	G10972	1	Lock Nut, 1 $\frac{1}{4}$ "-12
6.	G6400-08-04	1	Connector W/O-Ring, $\frac{3}{4}$ "-16 Male JIC To $\frac{7}{16}$ "-20 O-Ring
	GR1465	-	O-Ring
7.	GA8858	1	Barrel
8.	GA8978	1	Steel Hydraulic Line, 68 $\frac{11}{16}$ "
9.	G2700-08	1	Bulkhead Tube Union, $\frac{3}{4}$ "-16 Male JIC
10.	GD12597	1	Bracket
11.	G306-08	1	Lock Nut, $\frac{3}{4}$ "-16
12.	G10328	1	Hex Head Cap Screw, $\frac{3}{8}$ "-16 x $\frac{5}{8}$ "
	G10229	1	Lock Washer, $\frac{3}{8}$ "
13.	G10990	1	Hose Clamp, No. 52
A.	GA8857	-	Cylinder Complete, 3" x 60" ( <i>Part Number Stamped On Barrel</i> )
B.	GR1519	-	Seal Kit, Includes: (2) O-Rings, (1) BU Ring, (1) Wear Ring, (1) Wiper, (1) U-Cup, (1) T-Seal W/BU Rings

# TONGUE CYLINDER, 16 ROW 30"

CYL036(CYL12f)

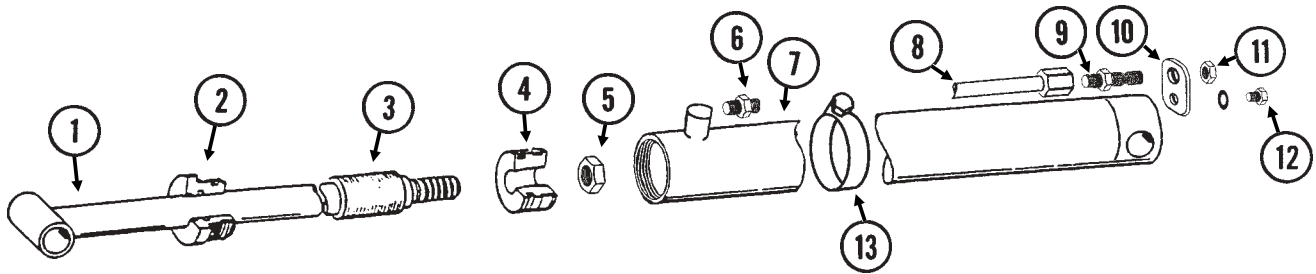

**3/4"-16 O-Ring Port  
And 3/4"-16 JIC Port**

ITEM	PART NO.	QTY.	DESCRIPTION
1.	GA8859	1	Rod Assembly
2.	GD11984	1	Gland
3.	GD7147	1	Spacer
4.	GD11970	1	Piston
5.	G10972	1	Lock Nut, 1 1/4"-12
6.	G6400-08-04	1	Connector W/O-Ring, 3/4"-16 Male JIC To 7/16"-20 O-Ring
	GR1465	-	O-Ring
7.	GA8861	1	Barrel
8.	GA8979	1	Steel Hydraulic Line, 92 11/16"
9.	G2700-08	1	Bulkhead Tube Union, 3/4"-16 Male JIC
10.	GD12597	1	Bracket
11.	G306-08	1	Lock Nut, 3/4"-16
12.	G10328	1	Hex Head Cap Screw, 3/8"-16 x 5/8"
	G10229	1	Lock Washer, 3/8"
13.	G10990	1	Hose Clamp, No. 52
A.	GA8862	-	Cylinder Complete, 3" x 84" (Part Number Stamped On Barrel)
B.	GR1519	-	Seal Kit, Includes: (2) O-Rings, (1) BU Ring, (1) Wear Ring, (1) Wiper, (1) U-Cup, (1) T-Seal W/BU Rings

# MARKER (Cushion) CYLINDER

(CYL3d)

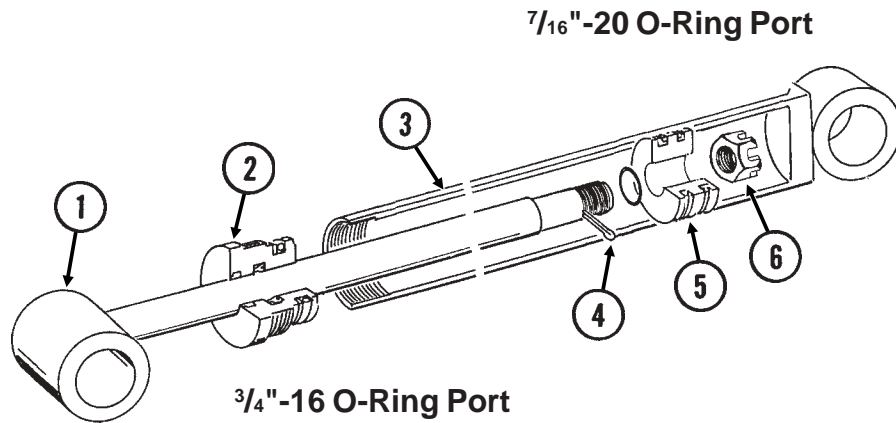

ITEM	PART NO.	QTY.	DESCRIPTION
1.	GA8871	1	Rod Assembly
2.	GD10207	1	Gland
3.	A7524	1	Barrel <b>(Non-Stock Item)</b>
4.	G10827	1	Cotter Pin, 1/8" x 1 3/4"
5.	GD11983	1	Piston
6.	G10962	1	Slotted Hex Nut, 7/8"-14
A.	GA8895	-	Cylinder Complete, 2 1/2" x 20 1/16" <i>(Part Number Stamped On Barrel)</i>
B.	GR1521	-	Seal Kit, Includes: (1) T-Seal, (2) O-Rings, (1) BU Ring, (1) Cast Iron Ring, (1) Wiper, (1) Lip Seal

# VALVE BLOCK - LOCATED ON FRONT CENTER FRAME

VVB036(TWL24d)

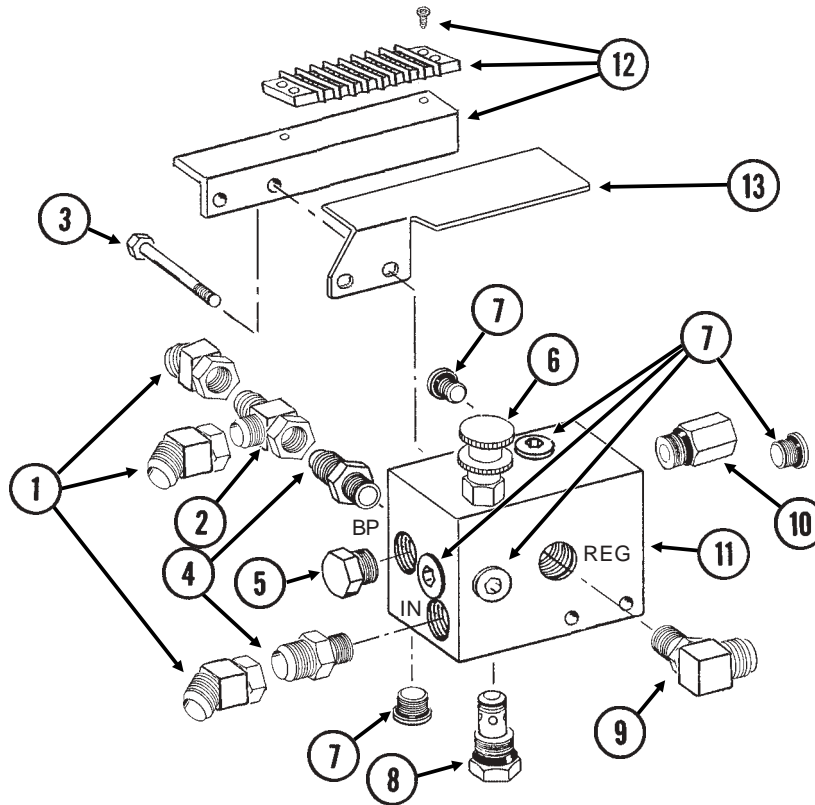

ITEM	PART NO.	QTY.	DESCRIPTION
1.	G6502-10	3	Swivel Elbow, 45°, 7/8"-14 Male JIC To Female
2.	G6602-10	1	Swivel Tee, 7/8"-14 JIC
3.	G10325	2	Hex Head Cap Screw, 3/8"-16 x 2 3/4"
	G10108	2	Lock Nut, 3/8"-16
4.	G6400-10-08	2	Connector W/O-Ring, 7/8"-14 Male JIC To 3/4"-16 O-Ring
	GR1037	-	O-Ring
5.	GR1603	1	Plug W/Stop Pin
6.		-	See "Flow Control Valve", Page P93
7.	GR1607	6	Socket Plug
8.		-	See "Check Valve", Page P93
9.	G6801-10-08	1	Elbow W/O-Ring, 90°, 7/8"-14 Male JIC To 3/4"-16 O-Ring
	GR1037	-	O-Ring
10.		-	See "Pressure Relief Valve", Page P93
11.		-	Block <b>(Non-Stock Item)</b>
12.		-	See "Bulk Seed Hopper Monitor", Pages P108 And P109
13.	GD14390	-	Cover
A.	GR1609	-	Seal Kit, Includes: (12) O-Rings, (2) BU Rings



# VALVE BLOCK - LOCATED ON R.H. SIDE OF CENTER PIVOT

VVB036(TWL208)

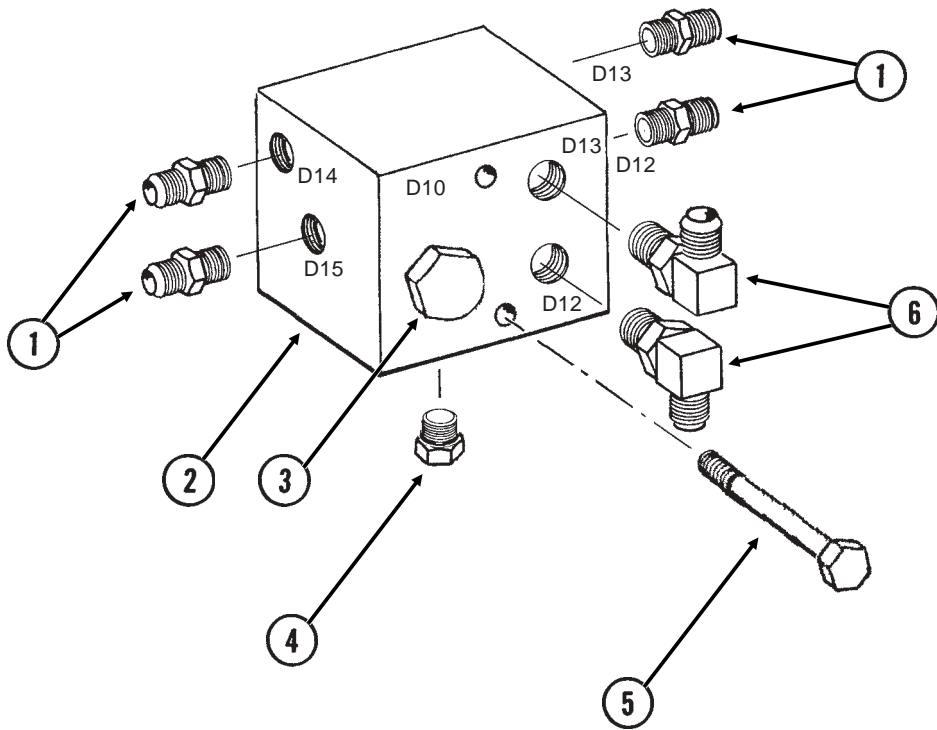

ITEM	PART NO.	QTY.	DESCRIPTION
1.	G6400-08 GR1037	4 -	Connector W/O-Ring, $\frac{3}{4}$ "-16 Male JIC To O-Ring O-Ring
2.	GD12758	1	Block
3.		-	See "Pilot Operated Check Valve", Page P95
4.	G6408-08 GR1037	1 -	Plug W/O-Ring, $\frac{3}{4}$ "-16 O-Ring O-Ring
5.	G10062 G10108	2 2	Hex Head Cap Screw, $\frac{3}{8}$ "-16 x 3" Lock Nut, $\frac{3}{8}$ "-16
6.	G6801-08 GR1037	2 -	Elbow W/O-Ring, 90°, $\frac{3}{4}$ "-16 Male JIC To O-Ring O-Ring

# VALVE BLOCKS - LOCATED ON REAR CENTER FRAME

VVB034(TWL25b)

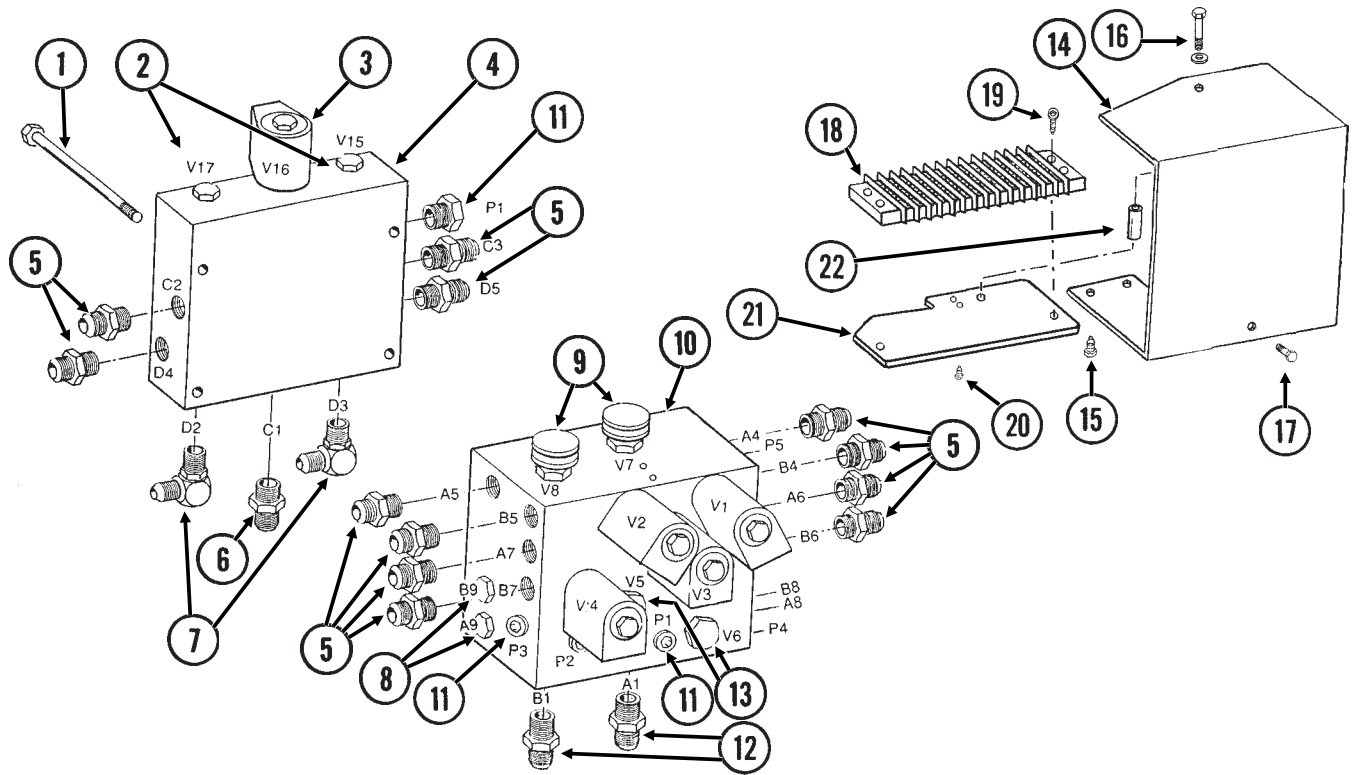

# VALVE BLOCKS - LOCATED ON REAR CENTER FRAME

ITEM	PART NO.	QTY.	DESCRIPTION
1.	G10583	4	Hex Head Cap Screw, $\frac{5}{16}$ "-18 x 2 $\frac{3}{4}$ "
	G10232	4	Lock Washer, $\frac{5}{16}$ "
2.		2	See "Check Valve", Page P95
3.		5	See "Solenoid Valve", Page P94
4.	GD9977	1	Block
5.	G6400-08	12	Connector W/O-Ring, $\frac{3}{4}$ "-16 Male JIC To O-Ring
	GR1037	-	O-Ring
6.	G6400-10	1	Connector W/O-Ring, $\frac{7}{8}$ "-14 Male JIC To O-Ring
	GR1466	-	O-Ring
7.	G6801-08-10	2	Elbow W/O-Ring, 90°, $\frac{3}{4}$ "-16 Male JIC To $\frac{7}{8}$ "-14 O-Ring
	GR1466	-	O-Ring
8.	G6408-08	4	Plug W/O-Ring, $\frac{3}{4}$ "-16 O-Ring
	GR1037	-	O-Ring
9.		2	See "Flow Control Valve", Page P94
10.	GD9533	1	Block
11.	G6408-H06-O	6	Hex Socket Head Plug W/O-Ring, $\frac{9}{16}$ "-18 O-Ring
	GR1045	-	O-Ring
12.	G6400-08-10	2	Connector W/O-Ring, $\frac{3}{4}$ "-16 Male JIC To $\frac{7}{8}$ "-14 O-Ring
	GR1466	-	O-Ring
13.	G6408-10	2	Plug W/O-Ring, $\frac{7}{8}$ "-14 O-Ring
	GR1466	-	O-Ring
14.	GD13146	1	Cover
15.	G10977	2	Phillips Pan Head Machine Screw, No. 10-24 x $\frac{1}{2}$ ", Stainless Steel
16.	G10133	1	Hex Head Cap Screw, $\frac{5}{16}$ "-18 x 1 $\frac{1}{2}$ "
	G10232	1	Lock Washer, $\frac{5}{16}$ "
17.	G10054	1	Hex Head Cap Screw, $\frac{5}{16}$ "-18 x $\frac{1}{2}$ "
	G10232	1	Lock Washer, $\frac{5}{16}$ "
	G10106	1	Hex Nut, $\frac{5}{16}$ "-18
18.	GA9097	1	Terminal Strip W/Screws, No. 6, 14 Terminal
	GR1635	-	Screw, No. 6-32 x $\frac{1}{4}$ "
19.	G11002	2	Slotted Pan Head Machine Screw, No. 8-32 x $\frac{3}{4}$ ", Stainless Steel
20.	G11004	2	Slotted Pan Head Machine Screw, No. 10-24 x $\frac{3}{4}$ ", Stainless Steel
21.	GA9095	1	Terminal Strip Mount
22.	GD8066-02	1	Sleeve, 1" Long

# VALVE BLOCK - LOCATED ON HITCH

VVB035(TWL26f)

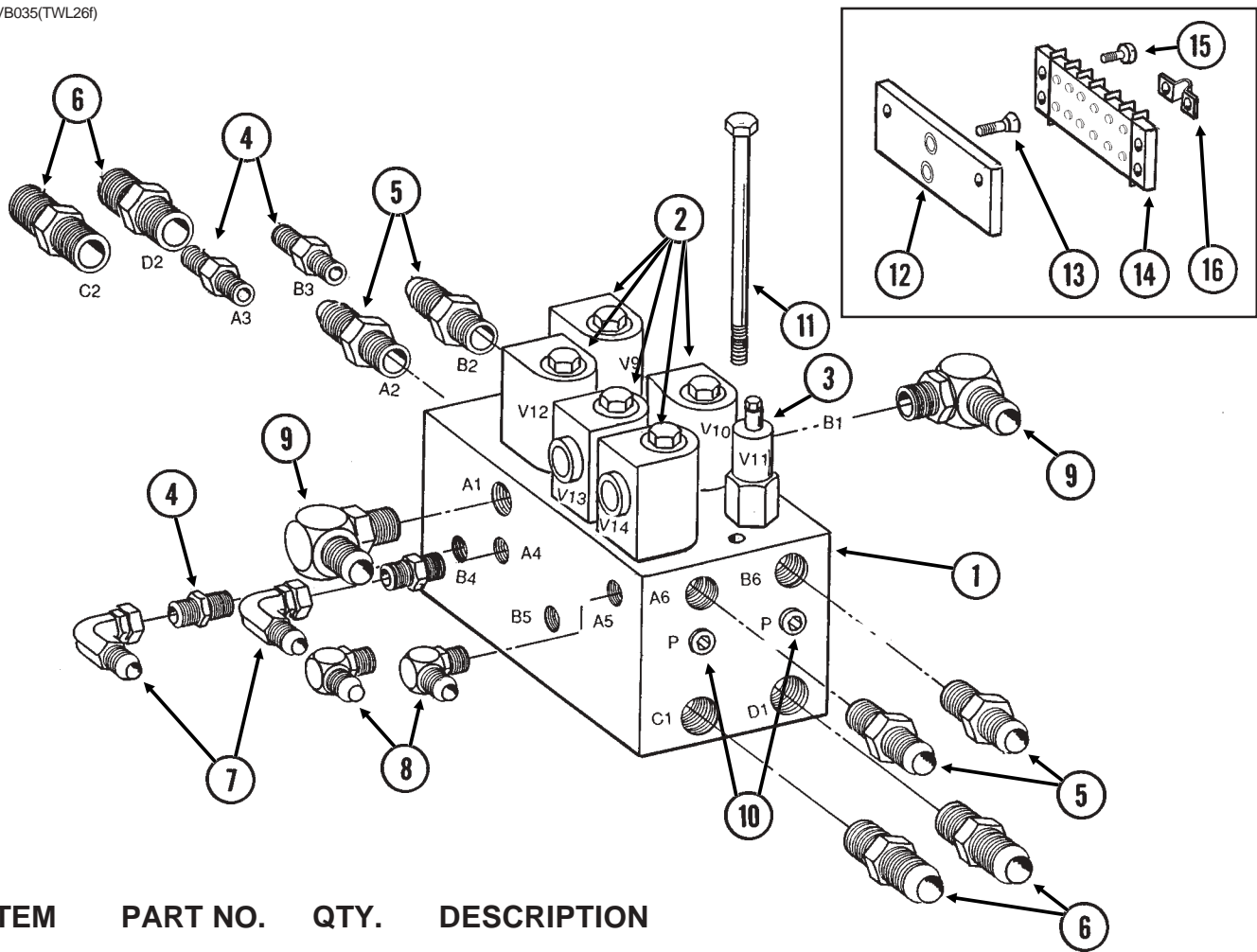

ITEM	PART NO.	QTY.	DESCRIPTION
1.	GD9905	1	Block
2.	-	-	See "Solenoid Valve", Page P94
3.	-	-	See "Pressure Relief Valve", Page P94
4.	G6400-06 GR1045	4 -	Connector W/O-Ring, 9/16"-18 Male JIC To O-Ring O-Ring
5.	G6400-08 GR1037	4 -	Connector W/O-Ring, 3/4"-16 Male JIC To O-Ring O-Ring
6.	G6400-10 GR1466	4 -	Connector W/O-Ring, 7/8"-14 Male JIC To O-Ring O-Ring
7.	G6500-06	2	Swivel Elbow, 90°, 9/16"-18 Male JIC To Female
8.	G6801-06 GR1045	2 -	Elbow W/O-Ring, 90°, 9/16"-18 Male JIC To O-Ring O-Ring
9.	G6801-08 GR1037	2 -	Elbow W/O-Ring, 90°, 3/4"-16 Male JIC To O-Ring O-Ring
10.	G6408-H06-O GR1045	2 -	Hex Socket Head Plug W/O-Ring, 9/16"-18 O-Ring O-Ring
11.	-	-	See "Hose Take-Up", Pages P46 And P47
12.	GD12818	-	Terminal Strip Mount
13.	G11001	2	Slotted Flat Head Machine Screw, No. 10-24 x 5/8", Stainless Steel
14.	GA9098 GR1635	- -	Terminal Strip W/Screws, No. 6, 8 Terminal Screw, No. 6-32 x 1/4"
15.	G11002	2	Slotted Pan Head Machine Screw, No. 8-32 x 3/4", Stainless Steel
16.	-	-	See "Electrical Components", Pages P102 And P103

## FLOW CONTROL VALVE (Located In Valve Block On Front Center Frame)

(TWL28a)

ITEM	PART NO.	QTY.	DESCRIPTION
A.	GR1601	-	Flow Control Valve
B.	GR1610	-	Seal Kit, Includes: (2) O-Rings, (1) BU Ring

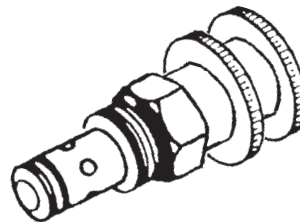

## PRESSURE RELIEF VALVE (Located In Valve Block On Front Center Frame)

(TWL24c)

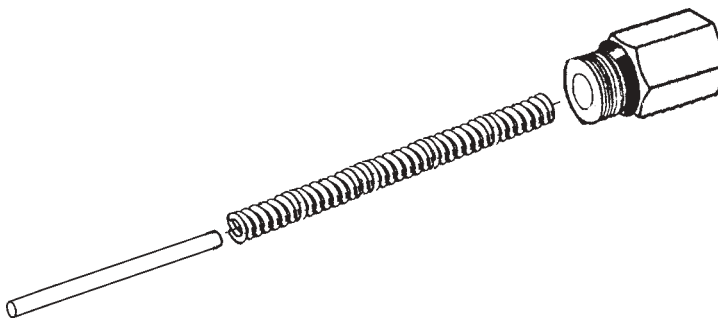

ITEM	PART NO.	QTY.	DESCRIPTION
1.	GR1604	1	Cap
2.	GR1605	1	Compression Spring
3.	GR1606	1	Spring Guide
4.	GR1608	2	O-Ring

## CHECK VALVE (Located In Valve Block On Front Center Frame)

(TWL24b)

ITEM	PART NO.	QTY.	DESCRIPTION
A.	GR1602	-	Check Cartridge
B.	GR1610	-	Seal Kit, Includes: (2) O-Rings, (1) BU Ring

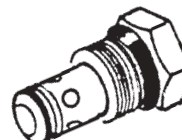

# SOLENOID VALVE

VVB019(TWL27c/TWL18/PLTR75c/A9481)

ITEM	PART NO.	QTY.	DESCRIPTION
1.	GR0761	1	Special Hex Nut, 1/2"-20
2.	G1K274	1	Coil Kit W/Contacts, Housings And Fork Terminals
	GD9529	2	Housing, Black
	GD9530	2	Contact
	G10996	2	Fork Terminal
3.	GR0763	1	Cartridge
A.	G1K275	-	Solenoid Valve Kit W/Contacts, Housings And Fork Terminals
	GD9529	2	Housing, Black
	GD9530	2	Contact
	G10996	2	Fork Terminal
B.	GR0764	-	Seal Kit, Includes: (2) O-Rings, (1) BU Ring

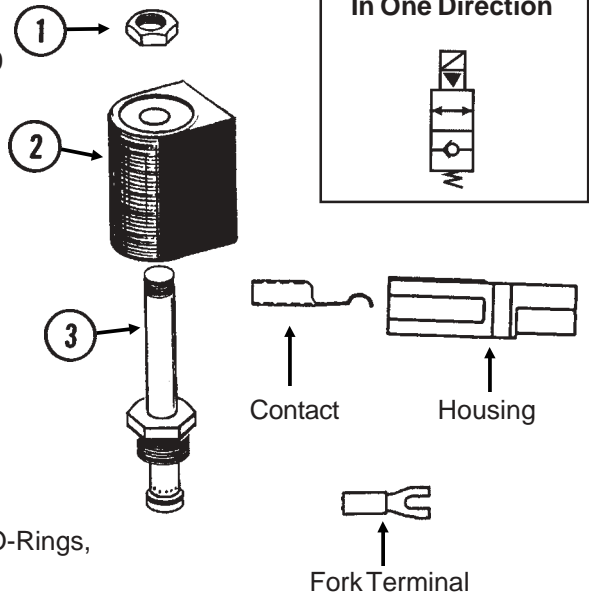

# FLOW CONTROL VALVE (Located In Valve Block On Rear Center Frame)

VVB020(TWL28)

ITEM	PART NO.	QTY.	DESCRIPTION
A.	GA3413	-	Flow Control Valve
B.	GR0764	-	Seal Kit, Includes: (2) O-Rings, (1) BU Ring

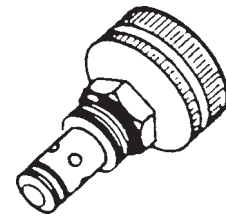

# PRESSURE RELIEF VALVE (Located In Valve Block On Hitch)

VVB020(TWL29)

ITEM	PART NO.	QTY.	DESCRIPTION
A.	GA3407	-	Pressure Relief Valve, 1000 PSI
B.	GR0764	-	Seal Kit, Includes: (2) O-Rings, (1) BU Ring

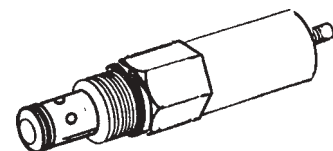

# RELIEF VALVE (Located On Hitch)

(TWL147/TWL171)

All 12 Row 30", 16 Row 30" (If Applicable)

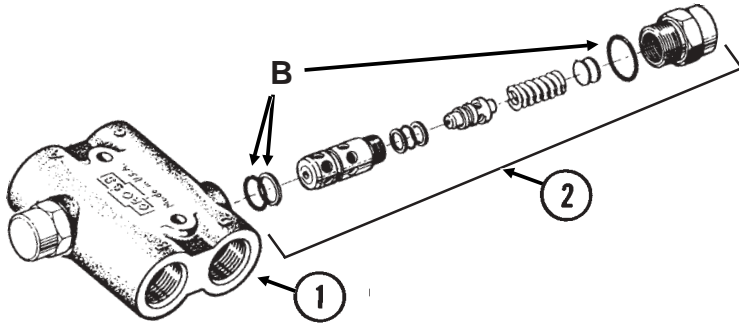

**STYLE A**

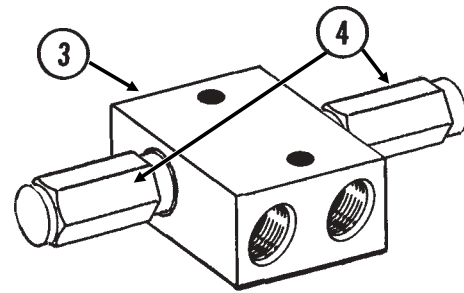

**STYLE B**

ITEM	PART NO.	QTY.	DESCRIPTION
1.	GR1402	1	Body
2.	GR1403	2	Cartridge
3.	GR1513	1	Body
4.	GR1514	2	Cartridge
A.	GA8129A	-	Relief Valve Complete (Items 1 And 2)
B.	GR1404	-	Seal Kit For Style A, Includes: (2) O-Rings, (1) BU Ring
C.	GA8129B	-	Relief Valve Complete (Items 3 And 4)
D.	GR1515	-	Seal Kit For Style B, Includes: (2) O-Rings, (1) BU Ring

# CHECK VALVE (Located In Valve Block On Rear Center Frame)

VVB020(TWL30)

ITEM	PART NO.	QTY.	DESCRIPTION
A.	GA4293	-	Check Valve
B.	GR0764	-	Seal Kit, Includes: (2) O-Rings, (1) BU Ring

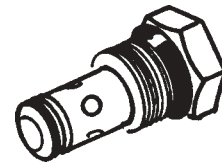

# PILOT OPERATED CHECK VALVE (Located In Valve Block On R.H. Side Of Front Center Frame)

VVB020(TWL30b)

ITEM	PART NO.	QTY.	DESCRIPTION
A.	GA9126	-	Pilot Operated Check Valve
B.	GR1627	-	Seal Kit, Includes: (3) O-Rings, (4) BU Rings

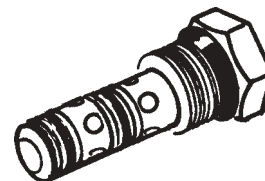

# HYDRAULIC HOSES AND FITTINGS ON HITCH

(TWL206/TWL206b)

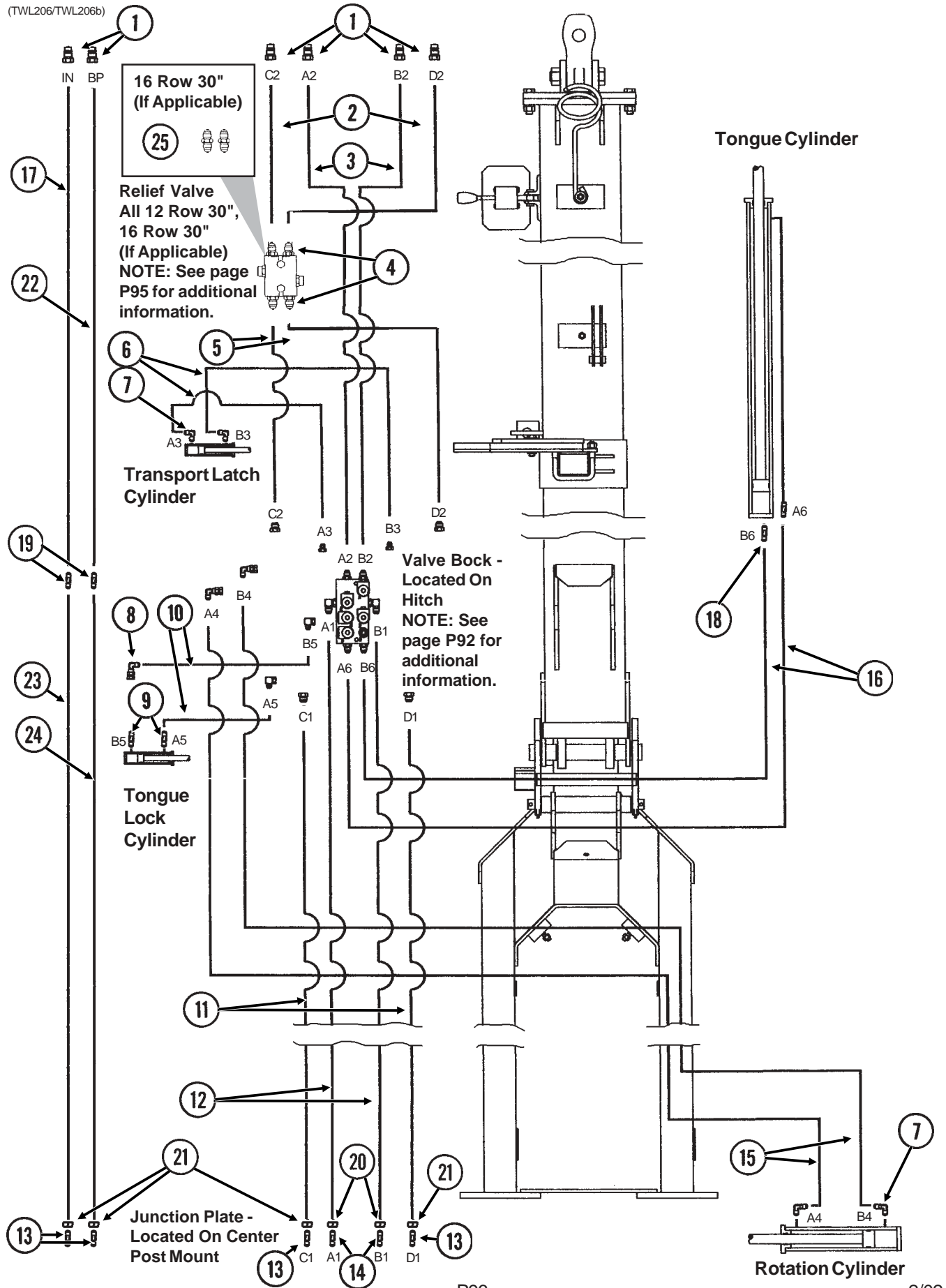



# HYDRAULIC HOSES AND FITTINGS ON HITCH

ITEM	PART NO.	QTY.	DESCRIPTION
1.	GD4086	6	ISO Coupler
2.	*A8206	2	Hose Assembly, 1/2" x 147", 12 Row 30"
	*A8200	2	Hose Assembly, 1/2" x 178", 16 Row 30"
3.	*A3133	2	Hose Assembly, 3/8" x 191", 12 Row 30"
	*A3183	2	Hose Assembly, 3/8" x 246", 16 Row 30"
4.	G6400-10	4	Connector W/O-Ring, 7/8"-14 Male JIC To O-Ring
	GR1466	-	O-Ring
5.	*A8203	2	Hose Assembly, 1/2" x 43", 12 Row 30"
	*A1463	2	Hose Assembly, 1/2" x 68", 16 Row 30"
6.	*A7603	2	Hose Assembly, 1/4" x 112", 12 Row 30"
	*A1129	2	Hose Assembly, 1/4" x 168", 16 Row 30"
7.	G6801-06-08	4	Elbow W/O-Ring, 90°, 9/16"-18 Male JIC To 3/4"-16 O-Ring
	GR1037	-	O-Ring
8.	G6502-06	1	Swivel Elbow, 45°, 9/16"-18 Male JIC To Female
9.	G6400-06-08	2	Connector W/O-Ring, 9/16"-18 Male JIC To 3/4"-16 O-Ring
	GR1037	-	O-Ring
10.	*A1139	2	Hose Assembly, 1/4" x 40", 12 Row 30" And 16 Row 30"
11.	*A8217	2	Hose Assembly, 1/2" x 133", 12 Row 30"
	*A8218	2	Hose Assembly, 1/2" x 139", 16 Row 30"
12.	*A3137	2	Hose Assembly, 3/8" x 140", 12 Row 30"
	*A3115	2	Hose Assembly, 3/8" x 146", 16 Row 30"
13.	G2700-10	4	Bulkhead Tube Union, 7/8"-14 Male JIC
14.	G2700-08	2	Bulkhead Tube Union, 3/4"-16 Male JIC
15.	*A1106	2	Hose Assembly, 1/4" x 130", 12 Row 30"
	*A1116	2	Hose Assembly, 1/4" x 136", 16 Row 30"
16.	*A3156	2	Hose Assembly, 3/8" x 68", 12 Row 30"
	*A3118	2	Hose Assembly, 3/8" x 80", 16 Row 30"
17.	*A1477	1	Hose Assembly, 1/2" x 198", 12 Row 30"
	*A1444	1	Hose Assembly, 1/2" x 250", 16 Row 30"
18.	G6400-08	1	Connector W/O-Ring, 3/4"-16 Male JIC To O-Ring
	GR1037	-	O-Ring
19.	G2403-10	2	Union, 7/8"-14 Male JIC
20.	G306-08	2	Lock Nut, 3/4"-16
21.	G306-10	4	Lock Nut, 7/8"-14
22.	*A3331	1	Hose Assembly, 3/4" x 198", 12 Row 30"
	*A3332	1	Hose Assembly, 3/4" x 250", 16 Row 30"
23.	*A8216	1	Hose Assembly, 1/2" x 144"
24.	*A3333	1	Hose Assembly, 3/4" x 144"
25.	G2403-10	2	Union, 7/8"-14 Male JIC

\* Hydraulic hose is not stocked by KINZE® Repair Parts, but can be made available on a special order basis. Call for quote.

# HYDRAULIC HOSES AND FITTINGS ON PLANTER FRAME

(TWL207b)

16 Row 30" Shown (Two Wing Lift Cylinders Per Wing)  
 12 Row 30" (One Wing Lift Cylinder Per Wing)

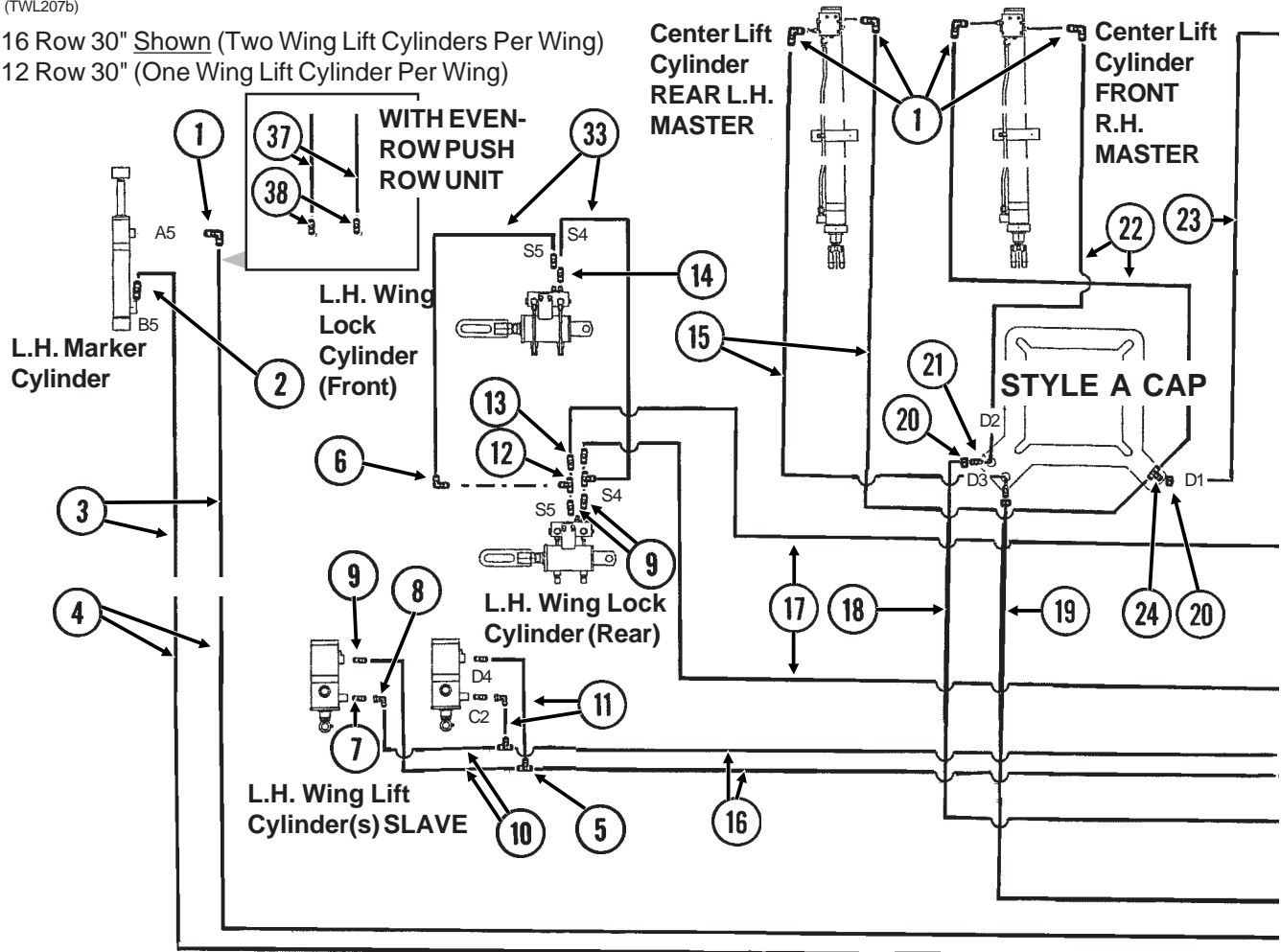

ITEM	PART NO.	QTY.	DESCRIPTION
1.	G6801-08 GR1037	6 -	Elbow W/O-Ring, 90°, 3/4"-16 Male JIC To O-Ring O-Ring
2.	G6400-08-04 GR1465	2 -	Connector W/O-Ring, 3/4"-16 Male JIC To 7/16"-20 O-Ring O-Ring
3.	*A3220 *A3219	4 -	Hose Assembly, 3/8" x 82", 12 Row 30" Hose Assembly, 3/8" x 104", 16 Row 30"
4.	*A3101 *A3161	4 -	Hose Assembly, 3/8" x 168", 12 Row 30" Hose Assembly, 3/8" x 210", 16 Row 30"
5.	G2603-08	4	Tee, 3/4"-16 Male JIC
6.	G6502-08	9	Swivel Elbow, 45°, 3/4"-16 Male JIC To Female
7.	G6400-L-08 GR1037	2-4 -	Long Connector W/O-Ring, 3/4"-16 Male JIC To O-Ring O-Ring
8.	G6500-08	2-4	Swivel Elbow, 90°, 3/4"-16 Male JIC To Female
9.	G6400-08 GR1037	6-8 -	Connector W/O-Ring, 3/4"-16 Male JIC To O-Ring O-Ring
10.	*A1018	4	Hose Assembly, 3/8" x 40"
11.	*A3218	4	Hose Assembly, 3/8" x 8"
12.	G6602-08	4	Swivel Tee, 3/4"-16 JIC
13.	G2406-08-06	4	Reducer, 3/4"-16 Female JIC To 9/16"-18 Male JIC
14.	G6400-06-08 GR1037	4 -	Connector W/O-Ring, 9/16"-18 Male JIC To 3/4"-16 O-Ring O-Ring
15.	*A3153	2	Hose Assembly, 3/8" x 22"
16.	*A1054 *A3163	4 -	Hose Assembly, 3/8" x 204", 12 Row 30" Hose Assembly, 3/8" x 225", 16 Row 30"
17.	*A1008	1	Hose Assembly, 3/8" x 110"
18.	*A1079	1	Hose Assembly, 3/8" x 24"
19.	*A1086	1	Hose Assembly, 3/8" x 28"

# HYDRAULIC HOSES AND FITTINGS ON PLANTER FRAME

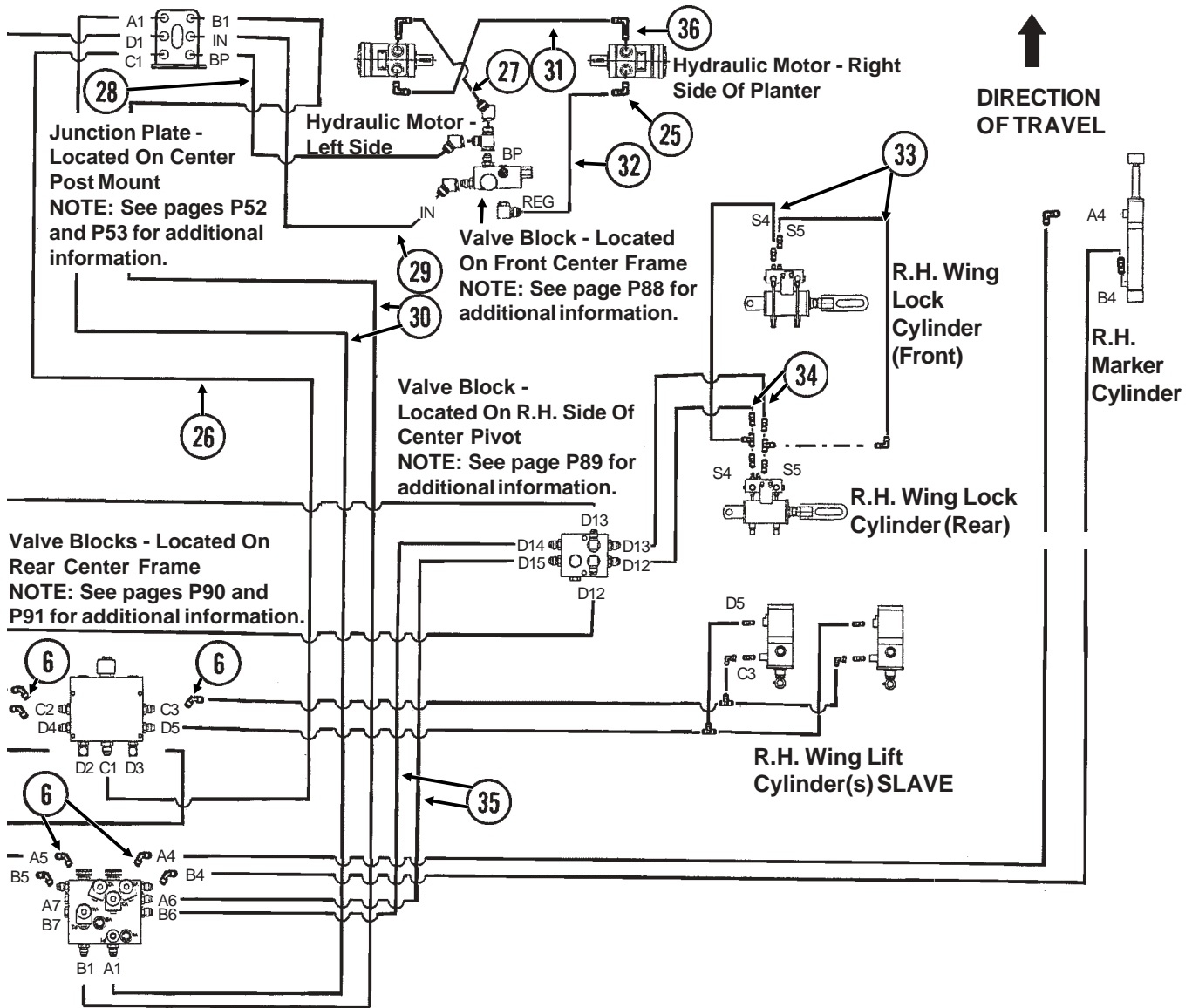

ITEM	PART NO.	QTY.	DESCRIPTION
20.	G306-08	3	Lock Nut, 3/4"-16
21.	G2700-08	2	Bulkhead Tube Union, 3/4"-16 Male JIC
22.	*A1076	2	Hose Assembly, 3/8" x 30"
23.	*A8215	1	Hose Assembly, 1/2" x 87"
24.	G2704-08	1	Bulkhead Tee, 3/4"-16 JIC
25.	G6801-10	2	Elbow W/O-Ring, 90°, 7/8"-14 Male JIC To O-Ring
	GR1466	-	O-Ring
26.	*A1464	1	Hose Assembly, 1/2" x 72"
27.	*A3329	1	Hose Assembly, 3/4" x 29"
28.	*A3330	1	Hose Assembly, 3/4" x 107"
29.	*A8214	1	Hose Assembly, 1/2" x 107"
30.	*A1053	2	Hose Assembly, 3/8" x 72"
31.	*A1457	1	Hose Assembly, 1/2" x 51"
32.	*A1424	1	Hose Assembly, 1/2" x 30"
33.	*A1189	4	Hose Assembly, 1/4" x 36"
34.	*A3152	2	Hose Assembly, 3/8" x 62"
35.	*A1098	2	Hose Assembly, 3/8" x 26"
36.	G6801-L-10	2	Long Elbow W/O-Ring, 90°, 7/8"-14 Male JIC To O-Ring
	GR1466	-	O-Ring
37.	*A1073	2	Hose Assembly, 3/8" x 18"
38.	G2403-08	2	Union, 3/4"-16 Male JIC

\* Hydraulic hose is not stocked by KINZE® Repair Parts, but can be made available on a special order basis. Call for quote.

# HYDRAULIC HOSES AND FITTINGS ON PLANTER FRAME

(TWL207a)

16 Row 30" Shown (Two Wing Lift Cylinders Per Wing)  
 12 Row 30" (One Wing Lift Cylinder Per Wing)

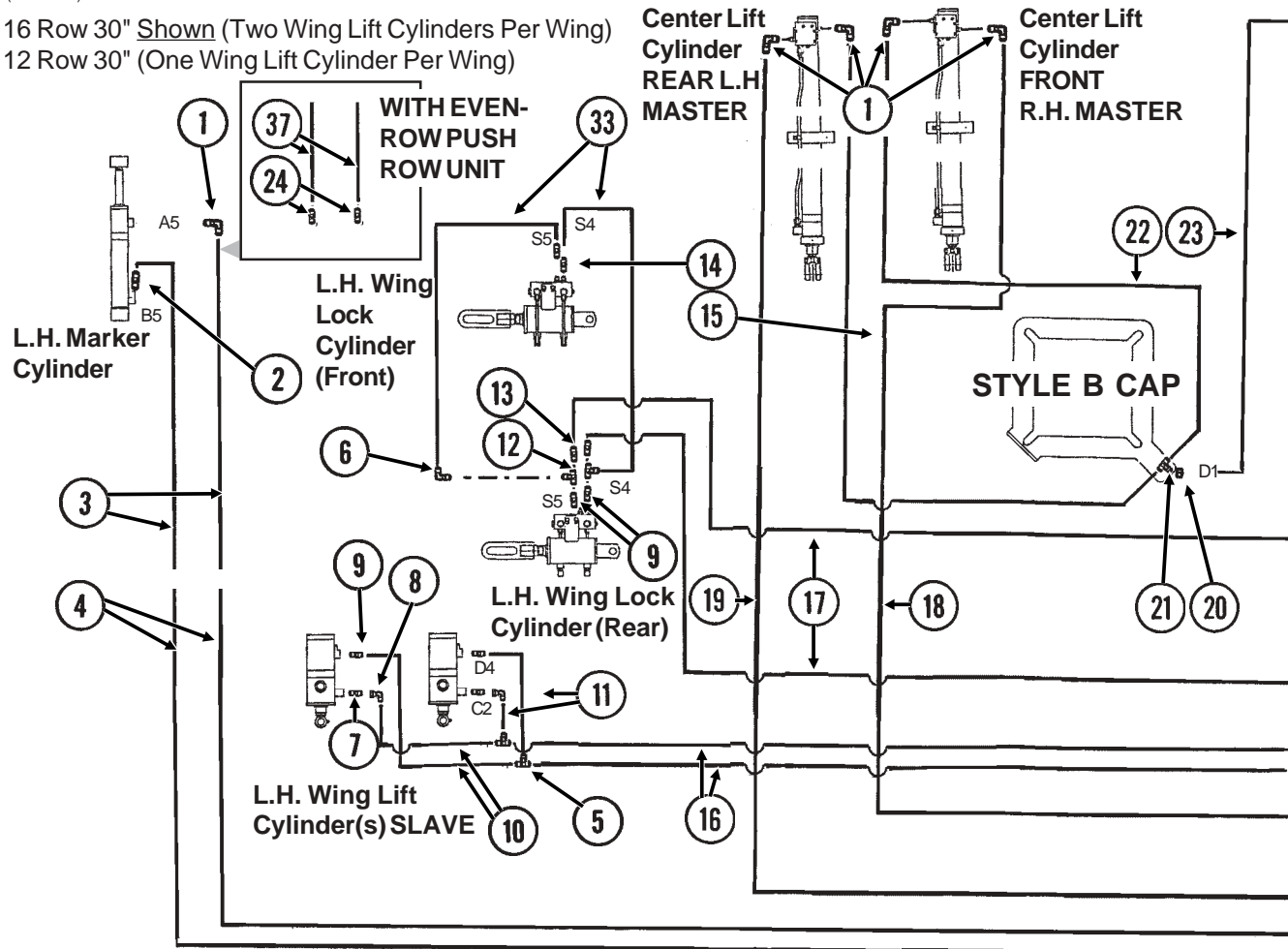

ITEM	PART NO.	QTY.	DESCRIPTION
1.	G6801-08 GR1037	6 -	Elbow W/O-Ring, 90°, 3/4"-16 Male JIC To O-Ring
2.	G6400-08-04 GR1465	2 -	Connector W/O-Ring, 3/4"-16 Male JIC To 7/16"-20 O-Ring
3.	*A3220	4	Hose Assembly, 3/8" x 82", 12 Row 30"
4.	*A3219 *A3101	- 4	Hose Assembly, 3/8" x 104", 16 Row 30" Hose Assembly, 3/8" x 168", 12 Row 30"
5.	*A3161	-	Hose Assembly, 3/8" x 210", 16 Row 30"
6.	G2603-08	4	Tee, 3/4"-16 Male JIC
7.	G6502-08 G6400-L-08 GR1037	9 2-4 -	Swivel Elbow, 45°, 3/4"-16 Male JIC To Female Long Connector W/O-Ring, 3/4"-16 Male JIC To O-Ring O-Ring
8.	G6500-08	2-4	Swivel Elbow, 90°, 3/4"-16 Male JIC To Female
9.	G6400-08 GR1037	6-8 -	Connector W/O-Ring, 3/4"-16 Male JIC To O-Ring O-Ring
10.	*A1018	4	Hose Assembly, 3/8" x 40"
11.	*A3218	4	Hose Assembly, 3/8" x 8"
12.	G6602-08	4	Swivel Tee, 3/4"-16 JIC
13.	G2406-08-06	4	Reducer, 3/4"-16 Female JIC To 9/16"-18 Male JIC
14.	G6400-06-08 GR1037	4 -	Connector W/O-Ring, 9/16"-18 Male JIC To 3/4"-16 O-Ring O-Ring
15.	*A3153	1	Hose Assembly, 3/8" x 22"
16.	*A1054 *A3163	4 -	Hose Assembly, 3/8" x 204", 12 Row 30" Hose Assembly, 3/8" x 225", 16 Row 30"
17.	*A1008	2	Hose Assembly, 3/8" x 110"
18.	*A1021	1	Hose Assembly, 3/8" x 56"
19.	*A3128	1	Hose Assembly, 3/8" x 52"

# HYDRAULIC HOSES AND FITTINGS ON PLANTER FRAME

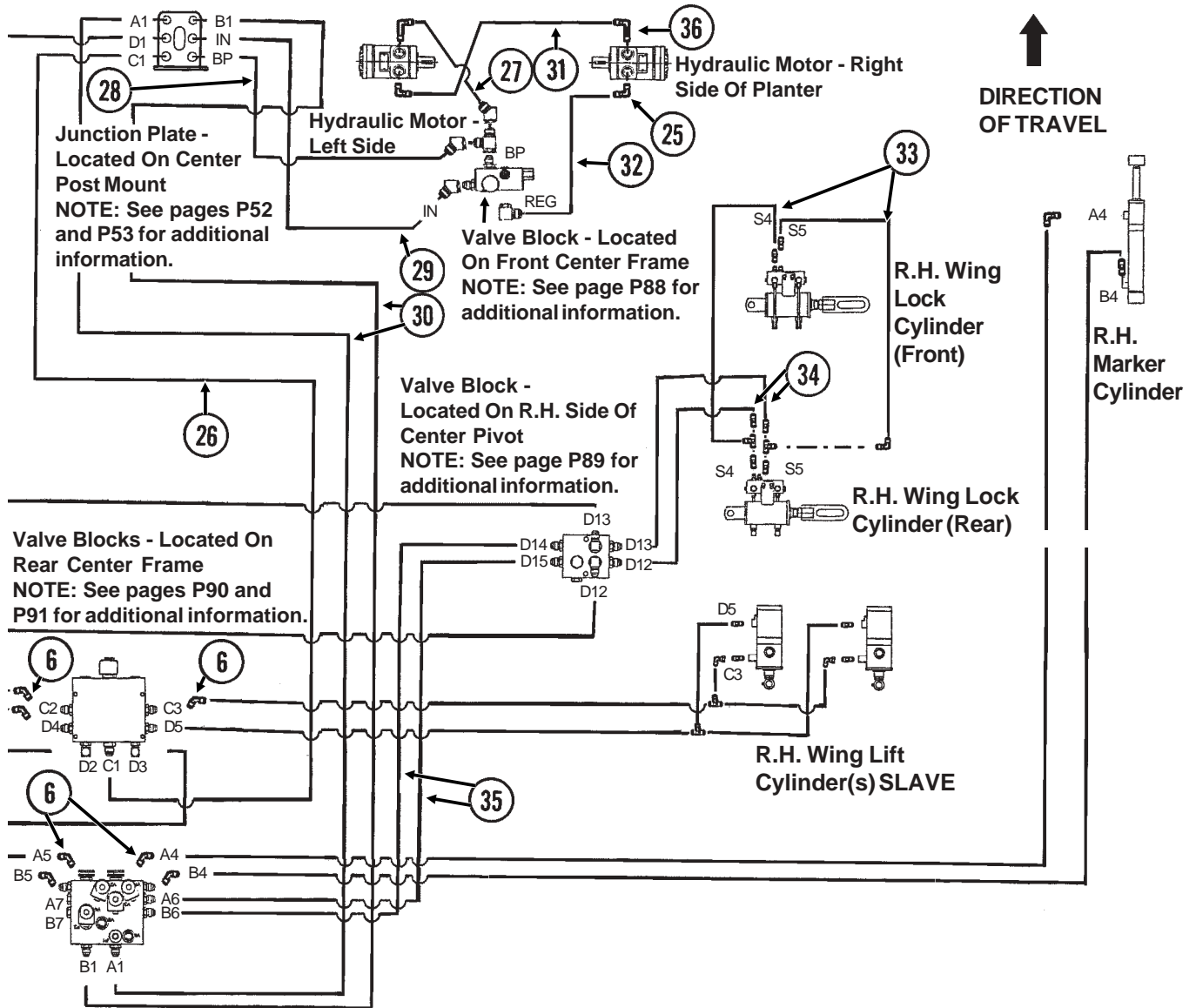

ITEM	PART NO.	QTY.	DESCRIPTION
20.	G306-08	3	Lock Nut, 3/4"-16
21.	G2700-08	2	Bulkhead Tube Union, 3/4"-16 Male JIC
22.	*A1076	1	Hose Assembly, 3/8" x 30"
23.	*A8215	1	Hose Assembly, 1/2" x 87"
24.	G2403-08	2	Union, 3/4"-16 Male JIC
25.	G6801-10	2	Elbow W/O-Ring, 90°, 7/8"-14 Male JIC To O-Ring
	GR1466	-	O-Ring
26.	*A1464	1	Hose Assembly, 1/2" x 72"
27.	*A3329	1	Hose Assembly, 3/4" x 29"
28.	*A3330	1	Hose Assembly, 3/4" x 107"
29.	*A8214	1	Hose Assembly, 1/2" x 107"
30.	*A1053	2	Hose Assembly, 3/8" x 72"
31.	*A1457	1	Hose Assembly, 1/2" x 51"
32.	*A1424	1	Hose Assembly, 1/2" x 30"
33.	*A1189	4	Hose Assembly, 1/4" x 36"
34.	*A3152	2	Hose Assembly, 3/8" x 62"
35.	*A1098	2	Hose Assembly, 3/8" x 26"
36.	G6801-L-10	2	Long Elbow W/O-Ring, 90°, 7/8"-14 Male JIC To O-Ring
	GR1466	-	O-Ring
37.	*A1073	2	Hose Assembly, 3/8" x 18"

\* Hydraulic hose is not stocked by KINZE® Repair Parts, but can be made available on a special order basis. Call for quote.

# ELECTRICAL COMPONENTS

(TWL19a/TWL18/ELC14/ELC3a/ELC5c/MTR27a/ELC8/TWL26e/A9481/ELC4/TWL23/PT50/ELC39/TWL20/ELC34/ELC35/ELC10c

**NOTE:** See "Wing Frame", pages P50 and P51, for light brackets.

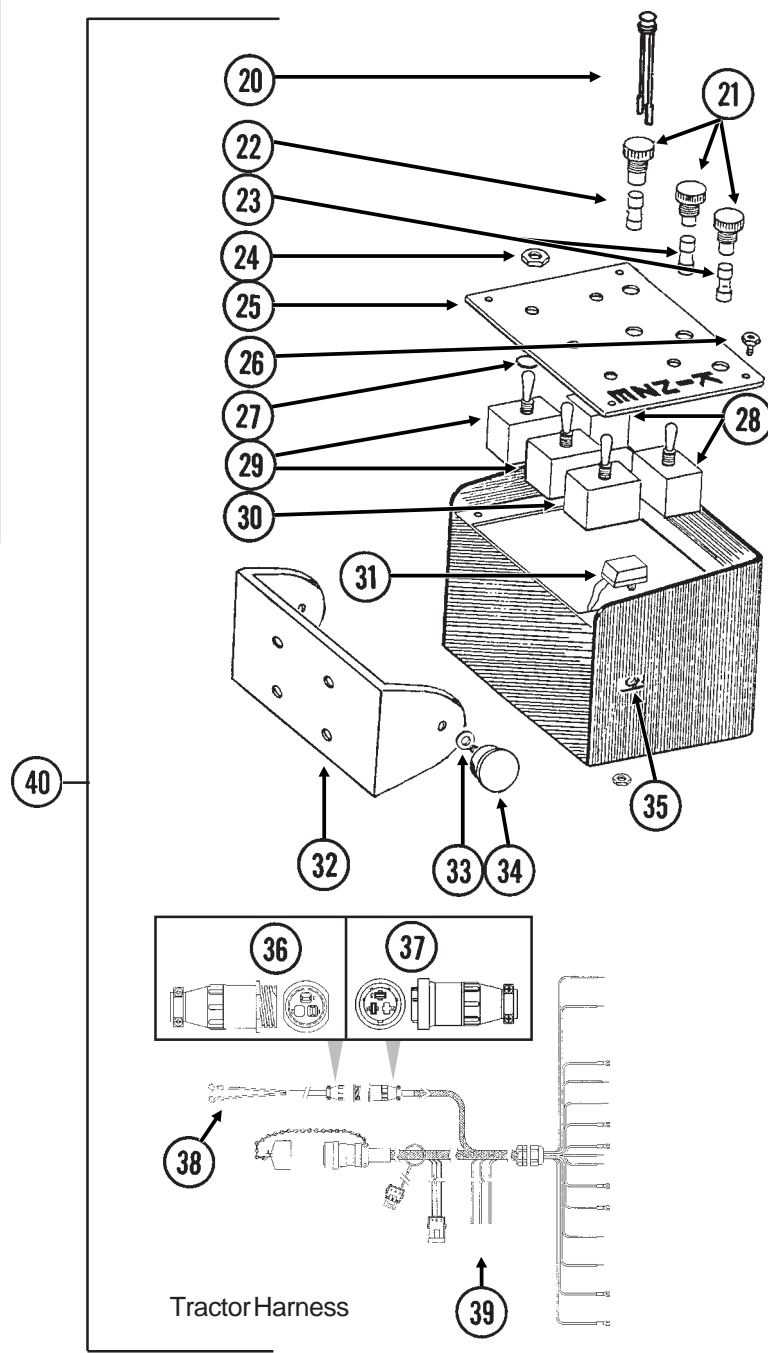
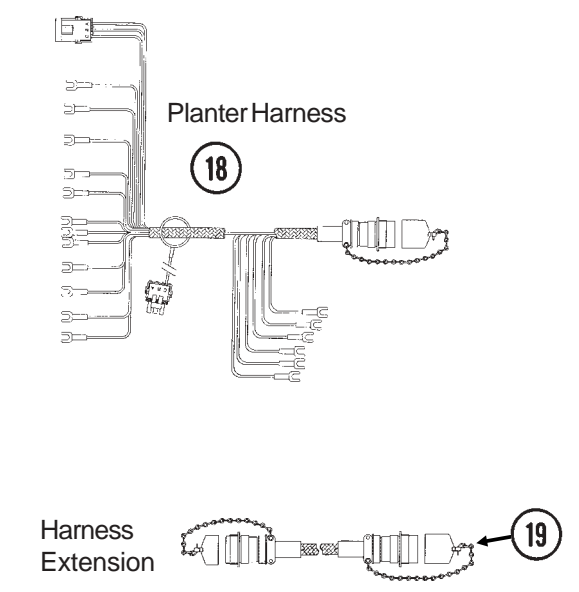
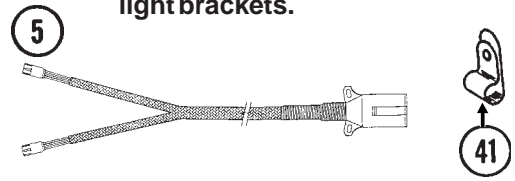
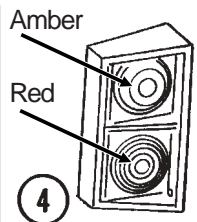
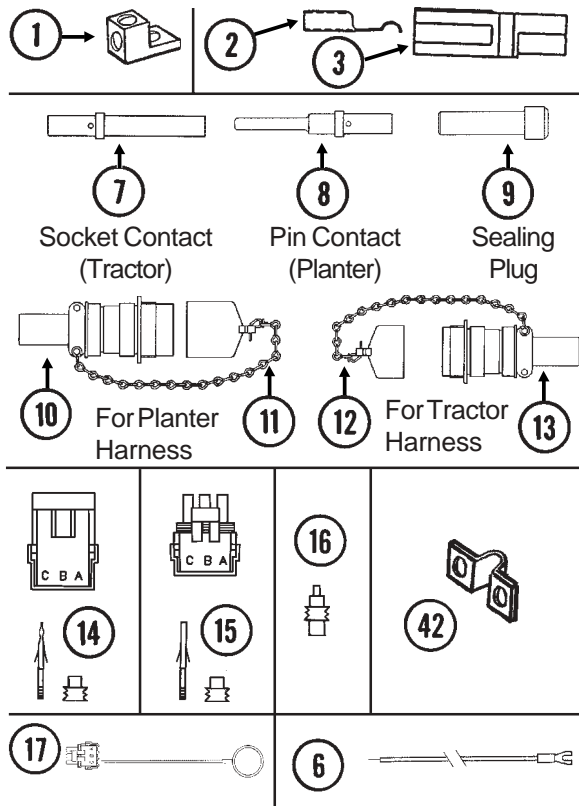

ITEM	PART NO.	QTY.	DESCRIPTION
1.	GA3584	-	Ground Clamp
2.	GD9530	-	Contact
3.	GD9529	-	Housing, Black
	GD12726	-	Housing, Red

# ELECTRICAL COMPONENTS

ITEM	PART NO.	QTY.	DESCRIPTION
4.	GA6699	1	Double Light Assembly (Shown)
	GA6700	1	Double Light Assembly
	GR1203	-	Red Lens
	GR1204	-	Amber Lens
	GR1205	-	Cover
	GR1206	-	Rubber Grommet (4)
	GR1207	-	Lamp Unit
	GR1208	-	Bulb
5.	GA9202	-	Wiring Harness W/7 Terminal Female Connector, 786" (2 Light Connections), 12 Row 30"
	GA9204	-	Wiring Harness W/7 Terminal Female Connector, 882" (2 Light Connections), 16 Row 30"
	GA5385	-	7 Terminal Female Connector
6.	GA9481	-	Jumper Wire W/Fork Terminal, 13"
	G10996	-	Fork Terminal
7.	GD8740	-	Socket Contact, No. 14
8.	GD8741	-	Pin Contact, No. 14
9.	GD8739	-	Sealing Plug, No. 12
10.	GA6109	1	Connector W/Cable Clamp, 23 Pin Capacity
11.	GA7862	-	Dust Cap W/Chain
12.	GA7863	-	Dust Cap W/Chain
13.	GA6108	1	Connector W/Cable Clamp, 23 Socket Capacity
14.	G1K248	-	3-Pin Female Connector Kit, Includes: (3) 3-Pin Female Housings, (9) Pin Contacts, (9) Seals
15.	G1K252	-	3-Pin Male Connector Kit, Includes: (3) 3-Pin Male Housings, (9) Socket Contacts, (9) Seals
16.	GD11089	-	Sealing Plug
17.	GA8047	-	Dust Plug
18.	GA9112	1	Wiring Harness W/Dust Cap, 516", 12 Row 30"
	GA9113	-	Wiring Harness W/Dust Cap, 636", 16 Row 30"
19.	GA7399	-	Harness Extension W/Dust Caps, 15'
20.	GA7077	1-4	Indicator Light
21.	GA2612	3-5	Fuse Holder W/Spade, 1 <sup>33</sup> / <sub>50</sub> "
	GR1628	-	Fuse Holder W/Spade, 1 <sup>39</sup> / <sub>50</sub> "
22.	GD2829	1-2	Fuse, 15 Amp, Type AGC
23.	GD10243	2-6	Fuse, MOL 10 Amp Delay Action
24.	GR1363	5	Hex Face Nut, <sup>15</sup> / <sub>32</sub> "-32
	GR1364	5	Internal Tooth Lock Washer, <sup>15</sup> / <sub>32</sub> "
25.	GA8734	1	Cover Plate (Shown)
	GA8735	-	Cover Plate, Planters Equipped With Two-Speed Point Row Clutch
26.	GR1292	4	Pan Head Screw, No. 8-32 x 1/2"
27.	GD3860	-	O-Ring (If Applicable)
28.	GA2528	2	Switch, 3 Position Toggle, On-Off-On
29.	GA6978	2	Switch, 3 Position Toggle, Momentary On-Off- Momentary On
30.	GA6977	1-2	Switch, 2 Position Toggle, On-Off
31.	GA8731	1	Switch, Push Button W/Transformer
32.	GD9896	1	Mounting Bracket
33.	G10211	4	Washer, 1/4" SAE
34.	GA6975	2	Knob
35.	GR1290	2	Cage Nut, 1/4"-20
36.	G1K267	-	Power Lead Adapter Connector Kit, Includes: (1) 3-Pin Connector, (1) Cable Clamp, (3) Male Terminal Pins
37.	G1K268	-	Console Cable Connector Kit, Includes: (1) 3-Pin Connector, (1) Cable Clamp, (1) Lock Ring, (3) Female Terminal Pins
38.	GA7856	1	Power Lead Adapter
39.	GA8729	1	Wiring Harness W/Dust Cap And Power Cable
40.	G7633X	-	Backlit Control Console Assembly W/Mounting Brackets, Short Harness W/Dust Cap And Power Cable
	G7639X	-	Backlit Control Console Assembly W/Mounting Brackets, Short Harness W/Dust Cap And Power Cable, Planters Equipped With Two-Speed Point Row Clutch
41.	GD6291	-	Insulated Clamp, <sup>3</sup> / <sub>8</sub> "
	GD13348	-	Insulated Clamp, <sup>11</sup> / <sub>16</sub> "
42.	GD13310	-	Jumper

**NOTE: See "Point Row Clutch" or "Two-Speed Point Row Clutch" for R.H. and L.H. Wiring Harness for the point row clutches. See "KPM I/KPM II/KPM II Stack-Mode Electronic Seed Monitor" for those components.**

# KPM I/KPM II ELECTRONIC SEED MONITOR

(MTR42a/MTR27zz)

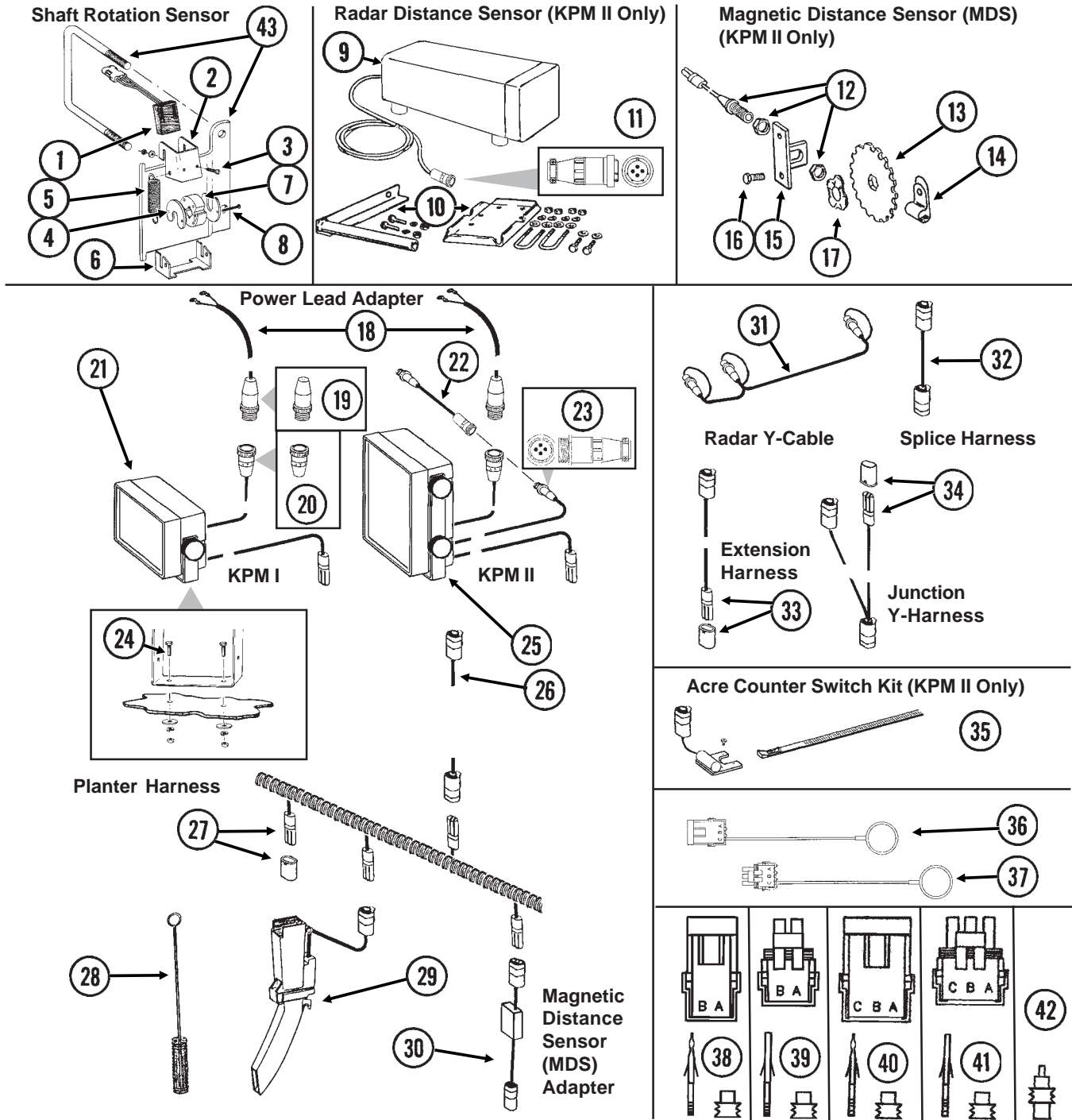

ITEM	PART NO.	QTY.	DESCRIPTION
1.	GR1415	1	Rotation Sensor
2.	GD11169	1	Mount
3.	G10757	2	Pan Head Screw, No. 10-32 x 1 1/4"
	G10243	2	Washer, No. 10 SAE
	G10758	2	Hex Nut, No. 10-32
4.	GD11474	2	Cover
5.	GD5857	2	Spring
6.	GD11170	1	Spring Mount
7.	GR1414	1	Actuator
8.	G10927	2	Pan Head Machine Screw, No. 8-32 x 1 1/4", Stainless Steel
	G10931	2	Lock Washer, No. 8, Internal/External, Stainless Steel
	G10928	2	Hex Nut, No. 8-32, Stainless Steel



# KPM I/KPM II ELECTRONIC SEED MONITOR

ITEM	PART NO.	QTY.	DESCRIPTION
9.	GA7858	-	Radar Distance Sensor W/20' Cable
10.	GA8026	-	Radar Sensor Pipe/Mounting Bracket Package
11.	G1K323	-	4-Pin Connector Kit W/Female Housing, 4 Pins And Cable Clamp
12.	GA5600	1	Magnetic Distance Sensor
13.	GD8751	-	Magnetic Distance Sensor Pulse Wheel
14.	GD6291	-	Insulated Clamp, 3/8"
15.	GD8770	1	Bracket
16.	G10004	2	Hex Head Cap Screw, 3/8"-16 x 1 1/4"
	G10229	2	Lock Washer, 3/8"
	G10101	2	Hex Nut, 3/8"-16
17.	GD8771	1	Spring Wave Washer
18.	GA7856	1	Power Lead Adapter
19.	G1K267	-	Power Lead Adapter Connector Kit, Includes: (1) Cable Clamp, (1) 3-Pin Connector, (3) Male Terminal Pins
20.	G1K268	-	Console Cable Connector Kit, Includes: (1) Cable Clamp, (1) 3-Pin Connector, (1) Lock Ring, (3) Female Terminal Pins
21.	GA8680	1	KPM I Backlit Console W/Mounting Bracket, Power Lead Adapter (Item 18), Brush (Item 28) And Dust Plug (Item 36)
	GR1390	-	Mounting Bracket, KPM I
	GR1392	-	Console Mounting Bracket Hardware Package (Includes 2 Knobs And 1/4" Hardware)
22.	GA9144	-	Monitor/Radar Adapter, 10"
23.	G1K322	-	4-Pin Connector Kit W/Male Housing, 4 Female Socket Contacts And Cable Clamp
24.	G10022	2	Hex Head Cap Screw, 1/4"-20 x 1/2"
	G10211	2	Washer, 1/4" SAE
	G10227	2	Lock Washer, 1/4"
	G10103	2	Hex Nut, 1/4"-20
25.	GA9393	-	KPM II Backlit Console W/Mounting Bracket, Power Lead Adapter (Item 18), Brush (Item 28), Dust Plug (Item 36) And Monitor/Radar Adapter, 10" (Item 22)
	GR1391	-	Mounting Bracket, KPM II
	GR1393	-	Console Mounting Bracket Hardware Package (Includes 4 Knobs And 1/4" Hardware)
26.		-	Included In Tractor/Planter Wiring Harnesses, See Items 18 And 39, Pages P102 And P103
27.	GA7851	-	Planter Harness W/Dust Caps, 12 Row (16 Connectors)
	GA7852	-	Planter Harness W/Dust Caps, 16 Row (20 Connectors)
	GD11993	-	Dust Cap
28.	GR0594	-	Brush
29.	GA8495	-	Seed Tube W/Computerized Sensor
	GR1395	-	Sensor Only
	GR1461	-	Seed Tube (With Holes For Computerized Sensor Installation)
	GD2117	-	Tie Strap, 14 1/2"
30.	GA7859	1	Magnetic Distance Sensor Adapter (Analog To Digital)
31.	GR0586	1	Radar Y-Cable (Used To Connect Radar Distance Sensor For Multiple Functions)
32.	GA7857	-	Splice Harness, 1'
33.	GA7854	-	Extension Harness W/Dust Cap, 15'
	GA7855	-	Extension Harness W/Dust Cap, 30'
	GD11993	-	Dust Cap
34.	GA7853	-	Junction Y-Harness W/Dust Cap
	GD11993	-	Dust Cap
35.	G1K249	-	Acre Counter Switch Kit (Used W/KPM II Console Only)
36.	GA8046	-	Dust Plug (Black)
37.	GA8047	-	Dust Plug (Black)
38.	G1K321	-	2-Pin Female Connector Kit (Black), Includes: (3) 2-Pin Female Housings, (6) Pin Contacts, (6) Seals
39.	G1K320	-	2-Pin Male Connector Kit (Black), Includes: (3) 2-Pin Male Housings, (6) Socket Contacts, (6) Seals
40.	G1K248	-	3-Pin Female Connector Kit (Black), Includes: (3) 3-Pin Female Housings, (9) Pin Contacts, (9) Seals
41.	G1K252	-	3-Pin Male Connector Kit (Black), Includes: (3) 3-Pin Male Housings, (9) Socket Contacts, (9) Seals
42.	GD11089	-	Sealing Plug
43.	G1K364	-	Rotation Sensor Mount Kit, Includes: (2) Mounts, (2) GD1113 5" x 7" U-Bolts, (4) 10230 Lock Washers, (4) G10104 Hex Nuts, (1) Instruction
A.	GA6147	-	Magnetic Distance Sensor And Mounting Package (Items 12-17)

# KPM II STACK-MODE ELECTRONIC SEED MONITOR

(MTR43)

## Shaft Rotation Sensor

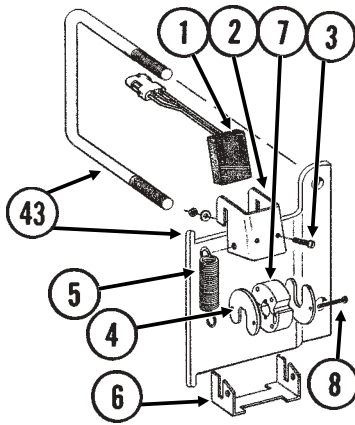

## Radar Distance Sensor

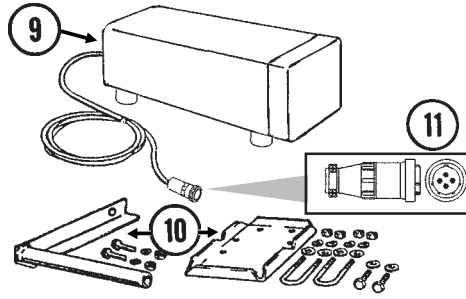

## Magnetic Distance Sensor (MDS)

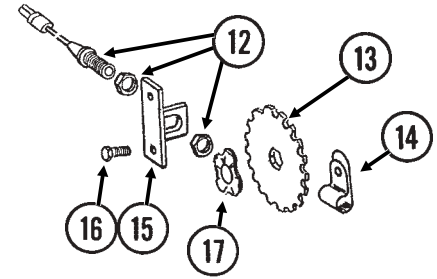

## Power Lead Adapter

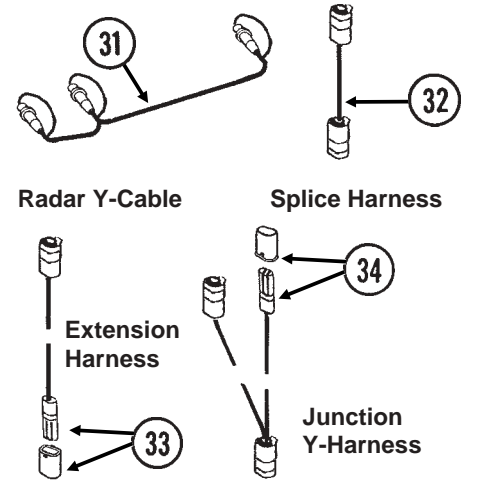
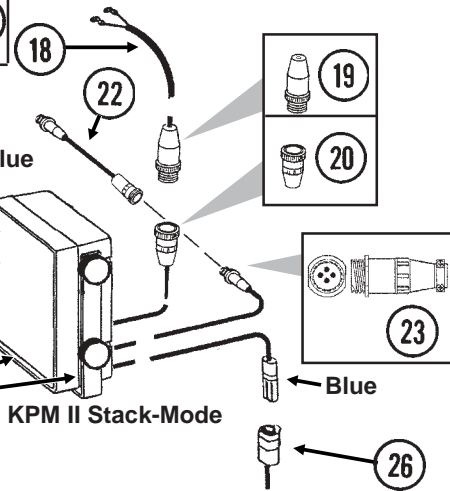

## SMM

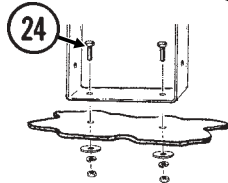
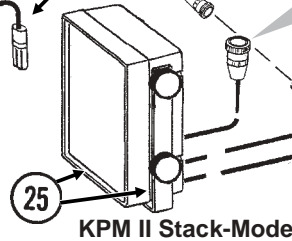
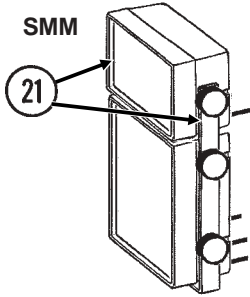

## Planter Harness

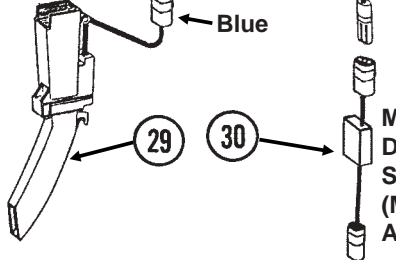
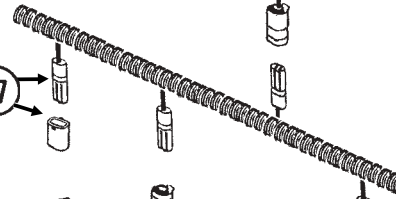
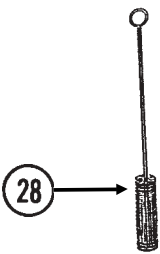

## Magnetic Distance Sensor (MDS) Adapter

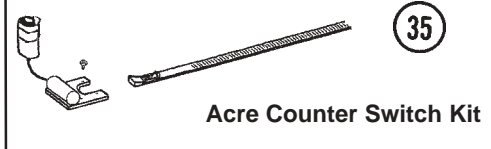

## Acre Counter Switch Kit

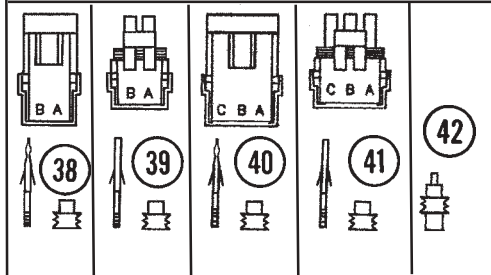
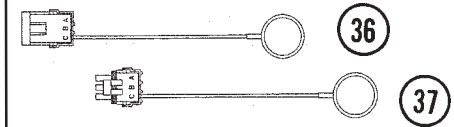

ITEM	PART NO.	QTY.	DESCRIPTION
1.	GR1415	1	Rotation Sensor
2.	GD11169	1	Mount
3.	G10757	2	Pan Head Screw, No. 10-32 x 1 1/4"
	G10243	2	Washer, No. 10 SAE
	G10758	2	Hex Nut, No. 10-32
4.	GD11474	2	Cover
5.	GD5857	2	Spring
6.	GD11170	1	Spring Mount
7.	GR1414	1	Actuator
8.	G10927	2	Pan Head Machine Screw, No. 8-32 x 1 1/4", Stainless Steel
	G10931	2	Lock Washer, No. 8, Internal/External, Stainless Steel
	G10928	2	Hex Nut, No. 8-32, Stainless Steel
9.	GA7858	-	Radar Distance Sensor W/20' Cable
10.	GA8026	-	Radar Sensor Pipe/Mounting Bracket Package

# KPM II STACK-MODE ELECTRONIC SEED MONITOR

ITEM	PART NO.	QTY.	DESCRIPTION
11.	G1K323	-	4-Pin Connector Kit W/Female Housing, 4 Pins And Cable Clamp
12.	GA5600	1	Magnetic Distance Sensor
13.	GD8751	-	Magnetic Distance Sensor Pulse Wheel
14.	GD6291	-	Insulated Clamp, 3/8"
15.	GD8770	1	Bracket
16.	G10004	2	Hex Head Cap Screw, 3/8"-16 x 1 1/4"
	G10229	2	Lock Washer, 3/8"
	G10101	2	Hex Nut, 3/8"-16
17.	GD8771	1	Spring Wave Washer
18.	GA7856	1	Power Lead Adapter
19.	G1K267	-	Power Lead Adapter Connector Kit, Includes: (1) Cable Clamp, (1) 3-Pin Connector, (3) Male Terminal Pins
20.	G1K268	-	Console Cable Connector Kit, Includes: (1) Cable Clamp, (1) 3-Pin Connector, (1) Lock Ring, (3) Female Terminal Pins
21.	GA9857	1	SMM Backlit Console W/Mounting Bracket And Dust Plug (Item 36)
	GR1631	-	Mounting Bracket, KPM II Stack-Mode And SMM Consoles
	GR1632	-	Console Mounting Bracket Hardware Package (Includes 2 Knobs And 1/4" Hardware)
22.	GA9144	-	Monitor/Radar Adapter, 10"
23.	G1K322	-	4-Pin Connector Kit W/Male Housing, 4 Female Socket Contacts And Cable Clamp
24.	G10022	2	Hex Head Cap Screw, 1/4"-20 x 1/2"
	G10211	2	Washer, 1/4" SAE
	G10227	2	Lock Washer, 1/4"
	G10103	2	Hex Nut, 1/4"-20
25.	GA9858	-	KPM II Stack-Mode Backlit Console W/Mounting Bracket, Power Lead Adapter (Item 18), Brush (Item 28), Dust Plug (Item 36) And Monitor/Radar Adapter, 10" (Item 22)
	GR1391	-	Mounting Bracket, KPM II
	GR1393	-	Console Mounting Bracket Hardware Package (Includes 4 Knobs And 1/4" Hardware)
26.		-	Included In Tractor/Planter Wiring Harnesses, See Items 18 And 39, Pages P102 And P103
27.	GA7851	-	Planter Harness W/Dust Caps, 12 Row (16 Connectors)
	GA8052	-	Planter Harness W/Dust Caps, 16 Row (20 Connectors)
	GD11993	-	Dust Cap
28.	GR0594	-	Brush
29.	GA9847	-	Seed Tube W/Computerized Sensor (KPM II Stack-Mode)
	GR1629	-	Sensor Only (KPM II Stack-Mode)
	GR1461	-	Seed Tube (With Holes For Computerized Sensor Installation)
	GD2117	-	Tie Strap, 14 1/2"
30.	GA7859	1	Magnetic Distance Sensor Adapter (Analog To Digital)
31.	GR0586	1	Radar Y-Cable (Used To Connect Radar Distance Sensor For Multiple Functions)
32.	GA7857	-	Splice Harness, 1'
33.	GA7854	-	Extension Harness W/Dust Cap, 15'
	GA7855	-	Extension Harness W/Dust Cap, 30'
	GD11993	-	Dust Cap
34.	GA7853	-	Junction Y-Harness W/Dust Cap
	GD11993	-	Dust Cap
35.	G1K249	-	Acre Counter Switch Kit
36.	GA8046	-	Dust Plug (Black)
	GA9978	-	Dust Plug (Blue)
37.	GA8047	-	Dust Plug (Black)
	GA9979	-	Dust Plug (Blue)
38.	G1K321	-	2-Pin Female Connector Kit (Black), Includes: (3) 2-Pin Female Housings, (6) Pin Contacts, (6) Seals
39.	G1K320	-	2-Pin Male Connector Kit (Black), Includes: (3) 2-Pin Male Housings, (6) Socket Contacts, (6) Seals
40.	G1K248	-	3-Pin Female Connector Kit (Black), Includes: (3) 3-Pin Female Housings, (9) Pin Contacts, (9) Seals
	G1K362	-	3-Pin Female Connector Kit (Blue), Includes: (3) 3-Pin Female Housings, (9) Pin Contacts, (9) Seals
41.	G1K252	-	3-Pin Male Connector Kit (Black), Includes: (3) 3-Pin Male Housings, (9) Socket Contacts, (9) Seals
	G1K363	-	3-Pin Male Connector Kit (Blue), Includes: (3) 3-Pin Male Housings, (9) Socket Contacts, (9) Seals
42.	GD11089	-	Sealing Plug
43.	G1K364	-	Rotation Sensor Mount Kit, Includes: (2) Mounts, (2) GD1113 5" x 7" U-Bolts, (4) G10230 Lock Washers, (4) G10104 Hex Nuts, (1) Instruction
A.	GA6147	-	Magnetic Distance Sensor And Mounting Package (Items 12-17)

# BULK SEED HOPPER MONITOR

(TWL229/A9957/A9955/TWL230/TWL24e/TWL26e/A9481/ELC35/ELC34/MTR27h/A7856/A9951/A9952/A9953b/TWL24f)

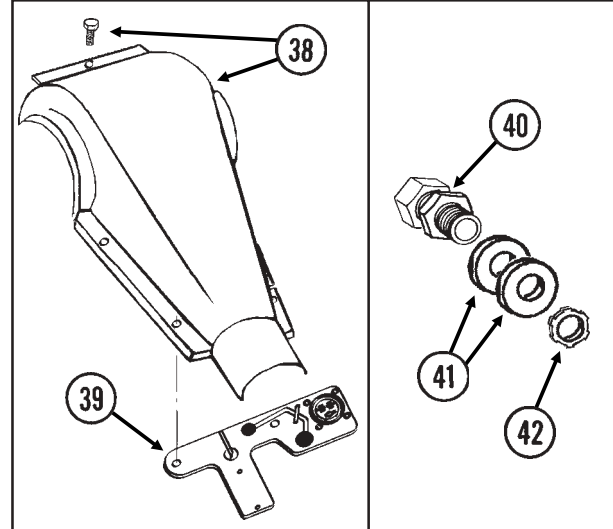
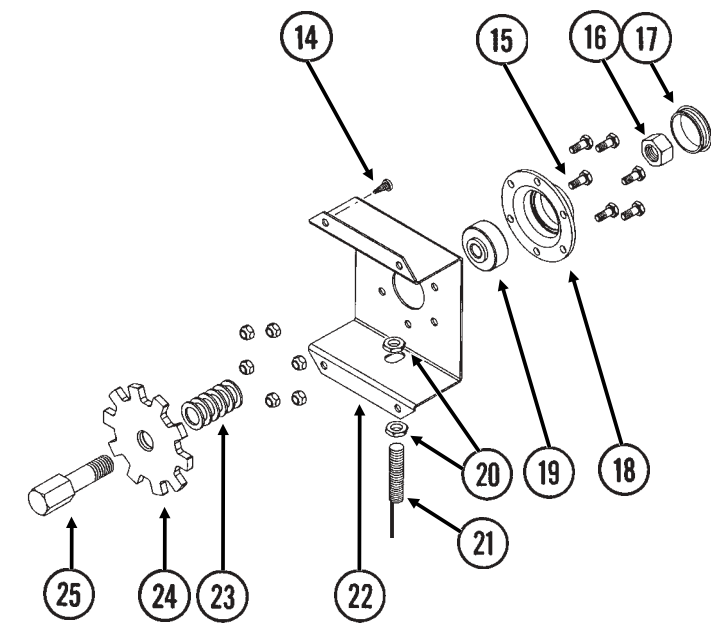
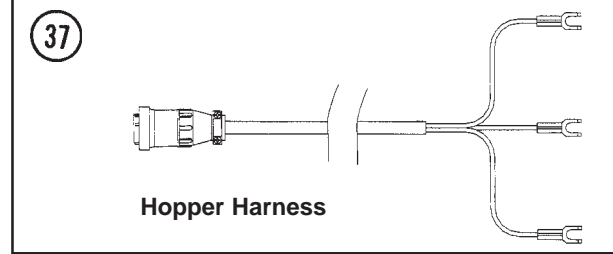
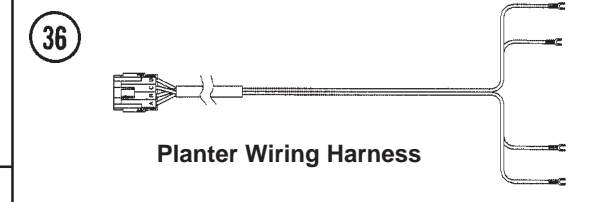
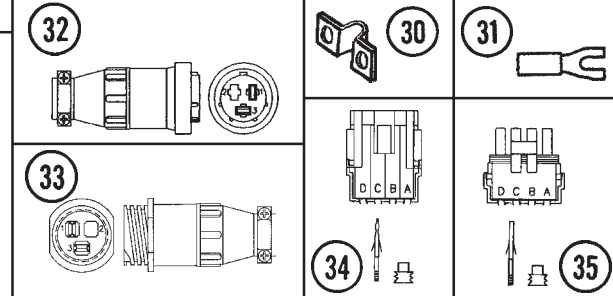
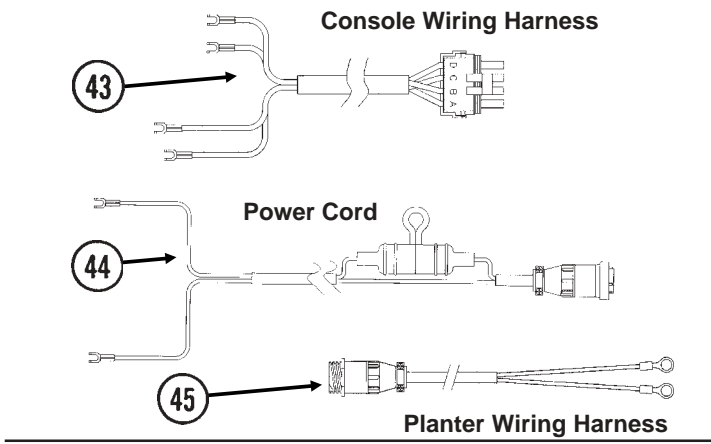
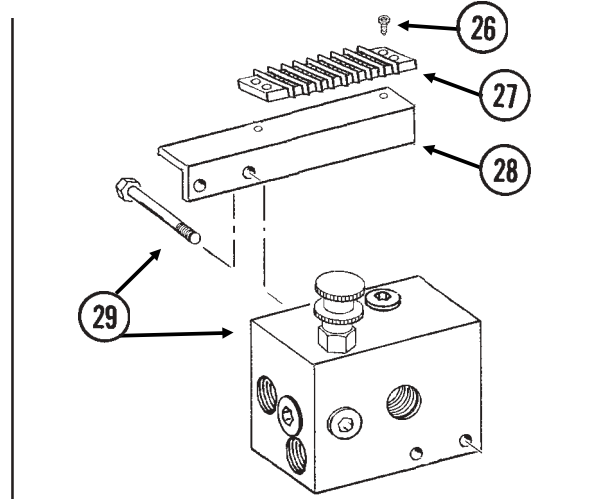
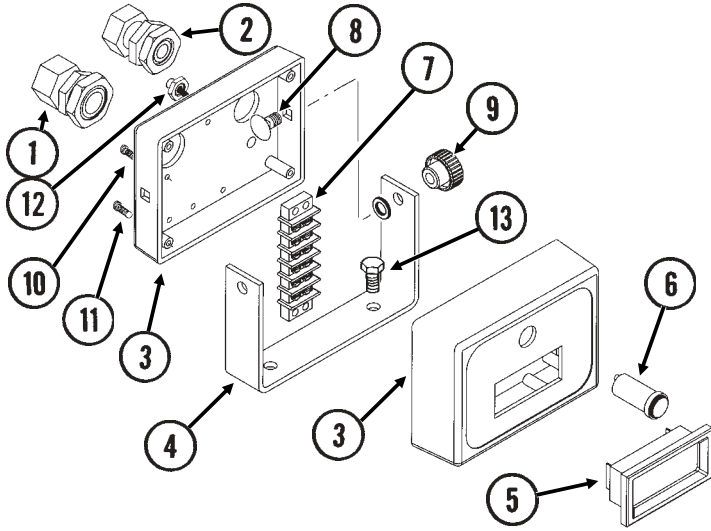

# BULK SEED HOPPER MONITOR

ITEM	PART NO.	QTY.	DESCRIPTION
1.	GA9963	1	Strain Relief W/1 1/16" Lock Nut And 15/16" Hex Nut
2.	GA9964	1	Strain Relief W/15/16" Lock Nut And 7/8" Hex Nut
3.	GA9962	1	Console Box
4.	GD14259	1	Bracket
5.	GA9965	1	Tachometer Meter
6.	GA9959	1	Red Light Assembly
7.	GA9960	1	Terminal Strip W/Screws, No. 5, 6 Terminal
	GR1635	-	Screw, No. 6 x 1/4"
8.	G11059	2	Carriage Bolt, 1/4"-20 x 1/2", Grade 2
	GD14261	2	Nylon Washer
9.	GA9958	2	Knob
10.	G11069	5	Flat Head Slotted Machine Screw, No. 4-40 x 3/8"
11.	G11070	4	Pan Head Machine Screw, No. 4 x 3/8"
12.	GA10021	1	Switch, Push Button
13.	G10022	2	Hex Head Cap Screw, 1/4"-20 x 1/2"
	G10211	2	Washer, 1/4" SAE
	G10227	2	Lock Washer, 1/4"
	G10103	2	Hex Nut, 1/4"-20
14.	G11062	4	Sheet Metal Screw, 1/4"-14 x 1/2"
15.	G10020	6	Hex Head Cap Screw, 1/4"-20 x 5/8", Grade B
	G10110	6	Lock Nut, 1/4"-20, Grade B
16.	G10104	1	Hex Nut, 5/8"-11
17.	GD11845	1	Hub Cap
18.	GD10473	1	Bearing Housing
19.	GA2014	1	Bearing
20.	GD14257	2	Nut, M12 x 1"
21.	GA9954	1	Speed Sensor Assembly
22.	GD14254	1	Bracket
23.	G10918	6	Machine Bushing, 5/8", 14 Gauge
24.	GD14255	1	Sensor Wheel
25.	GD14256	1	Speed Sensor Shaft
26.	G11002	2	Slotted Pan Head Machine Screw, No. 8-32 x 3/4", Stainless Steel
	G10251	2	Hex Nut, No. 8-32
27.	GA9098	1	Terminal Strip W/Screws, No. 6, 8 Terminal
	GR1635	-	Screws, No. 6 x 1/4"
28.	GD14266	1	Bracket
29.		-	See "Valve Block - Located On Front Center Frame", Page P88
30.	GD13310	3	Jumper
31.	G10996	-	Fork Terminal
32.	G1K268	-	Console Cable Connector Kit, Includes: (1) 3-Pin Connector, (1) Cable Clamp, (1) Lock Ring, (3) Female Terminal Pins
33.	G1K267	-	Power Cable Connector Kit, Includes: (1) 3-Pin Connector, (1) Cable Clamp, (3) Male Terminal Pins
34.	GA8328	-	4-Pin Female Connector W/Female Housing, 4 Pin Contacts And 4 Seals
35.	GA8329	-	4-Pin Male Connector W/Male Housing, 4 Socket Contacts And 4 Seals
36.	GA9951	1	Wiring Harness, 564"
37.	GA9952	2	Hopper Harness, 84"
38.		-	See "Bulk Seed Hopper Auger Manifold Assembly", Pages P19 And P19
39.	GA9953	2	Seed Flow Sensor Assembly
40.	GD14270	2	Power Cable Connector
41.	G10235	4	Machine Bushing, 7/8", 14 Gauge
42.	GD4163	2	Lock Nut, 1/2" Conduit
43.	GA9957	1	Wiring Harness, 156"
44.	GA9955	1	Power Cord W/Fuse Holder And Fuse
	GD14258	-	Fuse Holder
	GD14269	-	Fuse, 1 Amp, Type AGC
45.	GA7856	1	Power Lead Adapter
A.	GA9961	-	Monitor Console Assembly (Items 1-12 And 43 And 44)

# INTERPLANT® PUSH ROW UNIT DRIVE

(TWL33d)

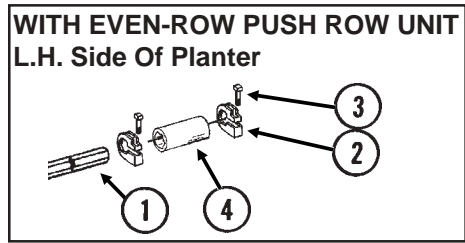

**R.H. Side Shown**

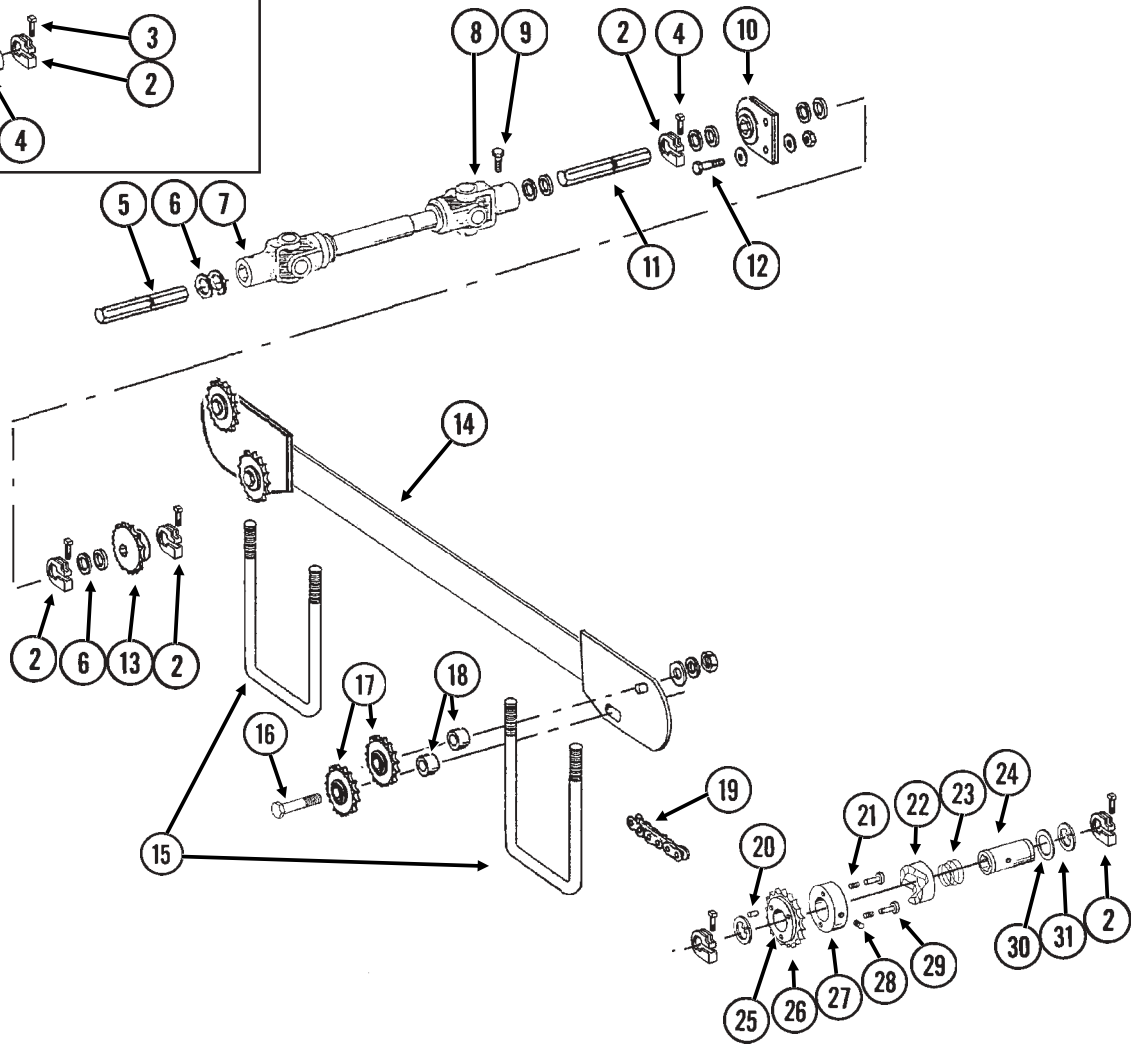

ITEM	PART NO.	QTY.	DESCRIPTION
		(Per Side)	
1.	GD0914-30	1	Hex Shaft, 7/8" x 30" (No Holes), W/Even-Row Push Row Unit
2.	GD11045	-	Lock Clamp

# INTERPLANT® PUSH ROW UNIT DRIVE

ITEM	PART NO.	QTY. (Per Side)	DESCRIPTION
3.	G10130	-	Square Head Machine Bolt, $\frac{5}{16}$ "-18 x 1 $\frac{3}{4}$ "
	G10923	-	Flange Nut, $\frac{5}{16}$ "-18, No Serration
4.	GD1719	1	Coupler, 4"
5.	GD0914-48	1	Hex Shaft, $\frac{7}{8}$ " x 48" (No Holes), R.H. Side
	GD0914-66	-	Hex Shaft, $\frac{7}{8}$ " x 66" (No Holes), L.H. Side
6.	G10233	-	Machine Bushing, 1", 10 Gauge (As Required)
7.	GA7052	1	U-Joint W/Grease Fitting, Female, 10 $\frac{1}{4}$ " Long
	GR1557	-	Grease Fitting, 45°, Metric
	GR1297	-	Inboard Yoke And Outer Profile
	GR1294	-	Cross And Bearing Kit
	GR1293	-	Yoke, $\frac{7}{8}$ " Hex
8.	GA7051	1	U-Joint W/Grease Fitting, Male, 12 $\frac{1}{4}$ " Long
	GR1557	-	Grease Fitting, 45°, Metric
	GR1296	-	Inner Profile
	GR1295	-	Inboard Yoke
	GR1301	-	Spring Pin, 8mm x 50mm
	GR1294	-	Cross And Bearing Kit
	GR1293	-	Yoke, $\frac{7}{8}$ " Hex
9.	G10688	2	Square Head Set Screw, $\frac{3}{8}$ "-16 x $\frac{5}{8}$ "
10.	GA2180	-	Hanger Bearing, $\frac{7}{8}$ " Hex Bore
11.	GD0914-66	1	Hex Shaft, $\frac{7}{8}$ " x 66" (No Holes), R.H. Side, 12 Row 30"
	GD0914-76	-	Hex Shaft, $\frac{7}{8}$ " x 76" (No Holes), L.H. Side, 12 Row 30"
	GD0914-124	-	Hex Shaft, $\frac{7}{8}$ " x 124" (No Holes), R.H. Side, 16 Row 30"
	GD0914-138	-	Hex Shaft, $\frac{7}{8}$ " x 138" (No Holes), L.H. Side, 16 Row 30"
12.	G10004	-	Hex Head Cap Screw, $\frac{3}{8}$ "-16 x 1 $\frac{1}{4}$ "
	G10210	-	Washer, $\frac{3}{8}$ " USS
	G10229	-	Lock Washer, $\frac{3}{8}$ "
	G10101	-	Hex Nut, $\frac{3}{8}$ "-16
13.	GA5107	1	Sprocket, 19 Tooth
14.	GA9138	1	Mount
15.	GD8306	2	U-Bolt, 7" x 5" x $\frac{1}{2}$ "-13
	G10228	4	Lock Washer, $\frac{1}{2}$ "
	G10102	4	Hex Nut, $\frac{1}{2}$ "-13
16.	G10581	4	Hex Head Cap Screw, $\frac{1}{2}$ "-13 x 2 $\frac{1}{4}$ "
	G10206	4	Washer, $\frac{1}{2}$ " SAE
	G10228	4	Lock Washer, $\frac{1}{2}$ "
	G10102	4	Hex Nut, $\frac{1}{2}$ "-13
17.	GA7154	4	Sprocket W/Bearing, 18 Tooth
18.	GD9229	4	Spacer, 1 $\frac{1}{4}$ " O.D. x $\frac{1}{2}$ " Long
19.	G3310-222	1	Chain, No. 40, 222 Pitch Including Connector Link
	GR0912	-	Connector Link, No. 40
20.	G10968	1	Spring Pin, $\frac{5}{32}$ " x $\frac{7}{16}$ "
21.	GR1413	1	Spring
22.	GR1409	1	Knurled Collar
23.	GR1408	1	Compression Spring
24.	GR1407	1	Drive Shaft
25.	GR1406	1	Bushing
26.	GR1412	1	Sprocket, 19 Tooth
27.	GR1405	1	Lock Collar
28.	G10535	1	Hex Socket Set Screw, $\frac{3}{8}$ "-16 x $\frac{3}{4}$ "
29.	GR1410	1	Pin
30.	GR1411	1	Shim
31.	G10496	2	External Inverted Snap Ring, 1 $\frac{1}{2}$ "
A.	GA8092	-	Clutch Sprocket Assembly, 19 Tooth (Items 20-31)
B.	G1K269	-	Lock Clamp Kit (Items 2 And 3)

# DOUBLE DISC FERTILIZER OPENER AND MOUNT

FOC007(PT25e/TWL34a/FRTZ208)

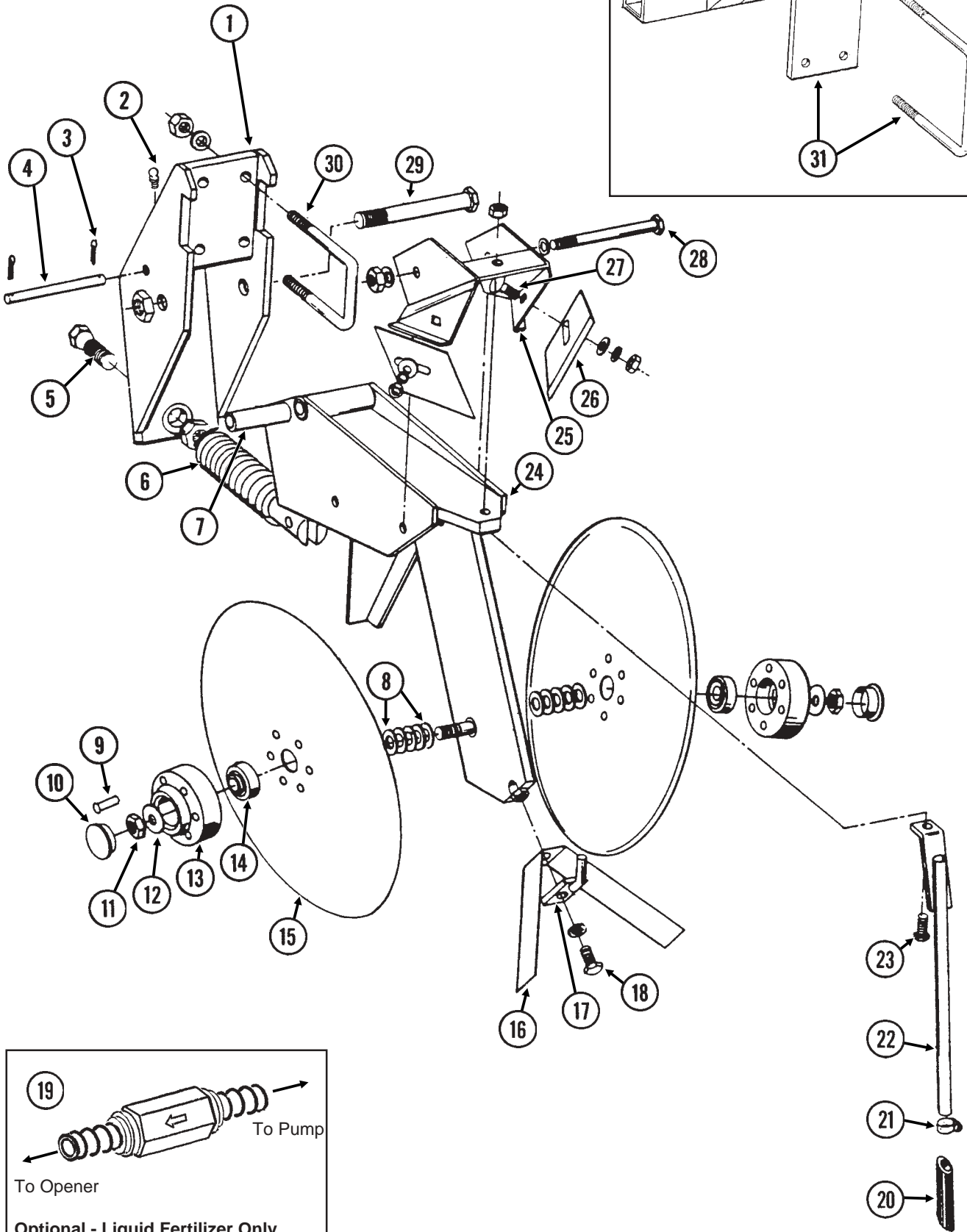



# DOUBLE DISC FERTILIZER OPENER AND MOUNT

ITEM	PART NO.	QTY.	DESCRIPTION
		(Per Assy.)	
1.	GA8483	1	Bracket
2.	G10938	1	Grease Fitting, 1/4"-28, Taper Thread
3.	G10451	2	Cotter Pin, 1/8" x 1"
4.	GD1657	1	Lockup Pin
5.	GD0962	1	Hex Head Adjusting Bolt, 5/8"-18 x 3 1/4"
	G10499	1	Hex Jam Nut, 5/8"-18, Grade 2
6.	GA0328	1	Spring
7.	GD0487	1	Bushing, 41/64" I.D. x 3 1/2" Long
8.	G10213	-	Machine Bushing, 5/8" (.030" Thick)
9.	G10542	12	Rivet, 1/4" x 1 5/16"
10.	GD1132	2	Dust Cap
11.	G10503	1	Hex Jam Nut, 5/8"-11, Grade 2
	G10504	1	Hex Jam Nut, 5/8"-11, L.H. Thread, Grade 2
12.	G10204	2	Special Machine Bushing, 5/8" x 1" O.D.
13.	GB0134	2	Hub
14.	GA2014	2	Bearing
15.	GD11306	2	Disc Blade, 3.5mm x 15"
16.	GD2589	1	Inner Scraper
17.	GA0312	1	Mount
18.	G10019	1	Hex Head Cap Screw, 5/16"-18 x 1"
	G10232	1	Lock Washer, 5/16"
19.	GA8983	-	Check Valve, Low Rate
20.	GD11705	-	Extension
21.	G10681	-	Hose Clamp, No. 6
22.	GA8685	-	Drop Tube, Liquid Fertilizer
23.	G10133	1	Hex Head Cap Screw, 5/16"-18 x 1 1/2"
	G10221	1	Washer, 5/16" SAE
	G10109	1	Lock Nut, 5/16"-18
24.	GA9195	1	Shank
25.	GA0810	1	Scraper Mount
26.	GD1673	2	Scraper
27.	G10305	2	Carriage Bolt, 3/8"-16 x 1"
	G10210	2	Washer, 3/8" USS
	G10229	2	Lock Washer, 3/8"
	G10101	2	Hex Nut, 3/8"-16
28.	G10045	1	Hex Head Cap Screw, 1/2"-13 x 4 1/2"
	G10111	1	Lock Nut, 1/2"-13
29.	G10046	1	Hex Head Cap Screw, 5/8"-11 x 5"
	G10107	1	Lock Nut, 5/8"-11
30.	GD1138	2	U-Bolt, 2 1/2" x 2 1/2" x 1/2"-13
	G10228	4	Lock Washer, 1/2"
	G10102	4	Hex Nut, 1/2"-13
31.	GA7135	1	Mount W/U-Bolts
	GD1113	2	U-Bolt, 5" x 7" x 5/8"-11
	G10230	4	Lock Washer, 5/8"
	G10104	4	Hex Nut, 5/8"-11
A.	GA8845	-	Disc Blade And Bearing Assembly (Items 9 And 13-15)

# HD SINGLE DISC FERTILIZER OPENER (Soil Press Wheel)

(TWL35b)

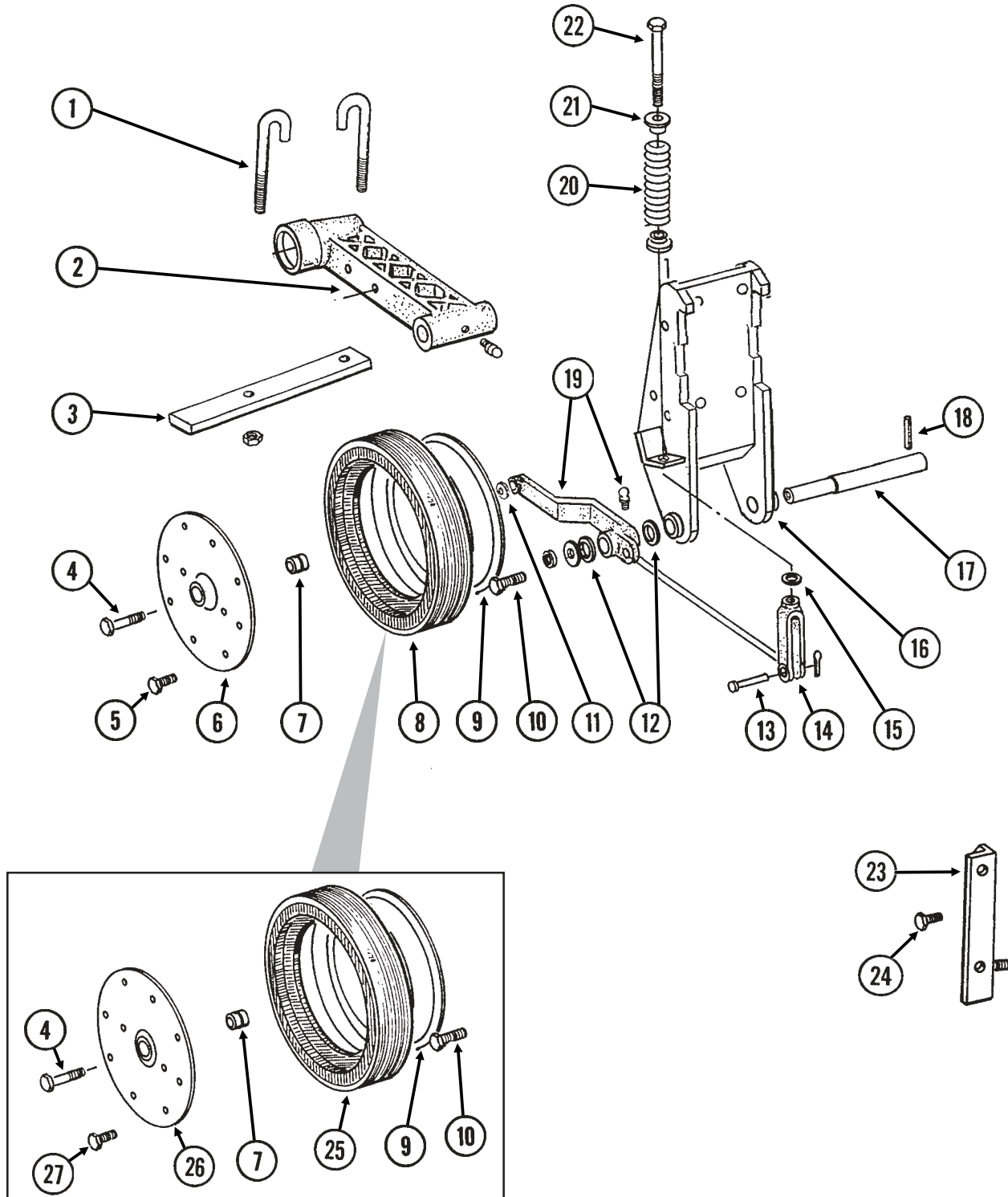

# HD SINGLE DISC FERTILIZER OPENER (Soil Press Wheel)

ITEM	PART NO.	QTY.	DESCRIPTION
		(Per Assy.)	
1.	GD9705	2	J-Bolt, 1/2"-13
	G10228	2	Lock Washer, 1/2"
	G10102	2	Hex Nut, 1/2"-13
2.		-	See "HD Single Disc Fertilizer Opener (Blade And Drop Tube)", Pages P116 And P117
3.	GD9706	1	Lockup Bar
4.	G10010	1	Hex Head Cap Screw, 5/8"-11 x 3"
5.	G10018	11	Hex Head Cap Screw, 5/16"-18 x 5/8"
	G10109	11	Lock Nut, 5/16"-18
6.	GD4888	1	Half Wheel Cover, Metal
7.	GA6171	1	Bearing
8.	GD4850	1	Offset Tire
9.	GD11423	1	Half Wheel
10.	G10438	1	Hex Head Cap Screw, 1/2"-13 x 3/4"
	G10228	1	Lock Washer, 1/2"
	G10216	1	Washer, 1/2" USS
11.	G10230	1	Lock Washer, 5/8"
12.	G10526	10	Machine Bushing, 1" (.048" Thick)
13.	G10560	1	Clevis Pin, 1/2" x 1 3/4"
	G10456	1	Cotter Pin, 1/8" x 3/4"
14.	GD8218	1	Yoke
15.	G10205	1	Washer, 5/8" SAE
16.		-	See "HD Single Disc Fertilizer Opener (Blade And Drop Tube)", Pages P116 And P117
17.	GD7911	1	Pivot Pin
18.	G10610	1	Spring Pin, 3/8" x 2"
19.	GA8306	-	Wheel Arm W/Grease Fitting, R.H.
	GA8305	1	Wheel Arm W/Grease Fitting, L.H. (Shown)
	G10640	1	Grease Fitting, 1/4"-28
20.	GD8308	1	Spring
21.	GB0212	2	Washer
22.	GD9709	1	Special Bolt
23.	GA6345	-	Mounting Angle, L.H. (As Required) (Shown)
	GA6344	-	Mounting Angle, R.H. (As Required)
24.	G10005	-	Hex Head Cap Screw, 5/8"-11 x 1 3/4"
	G10230	-	Lock Washer, 5/8"
	G10104	-	Hex Nut, 5/8"-11
25.	GD11953	1	Offset Tire
26.	GD11954	1	Half Wheel Cover, Nylon
27.	G10961	11	Flanged Whiz-Lock Screw, 5/16"-18 x 3/4", No Serration
	G10620	11	Flange Nut, 5/16"-18
A.	G1K215	-	Lockup Kit (Items 1 And 3)
B.	GA8877	-	Wheel Assembly (Items 7, 9 And 25-27)

# HD SINGLE DISC FERTILIZER OPENER (Blade And Drop Tube)

FOC016/FOC007/FOC019(PT27c/FRTZ208)

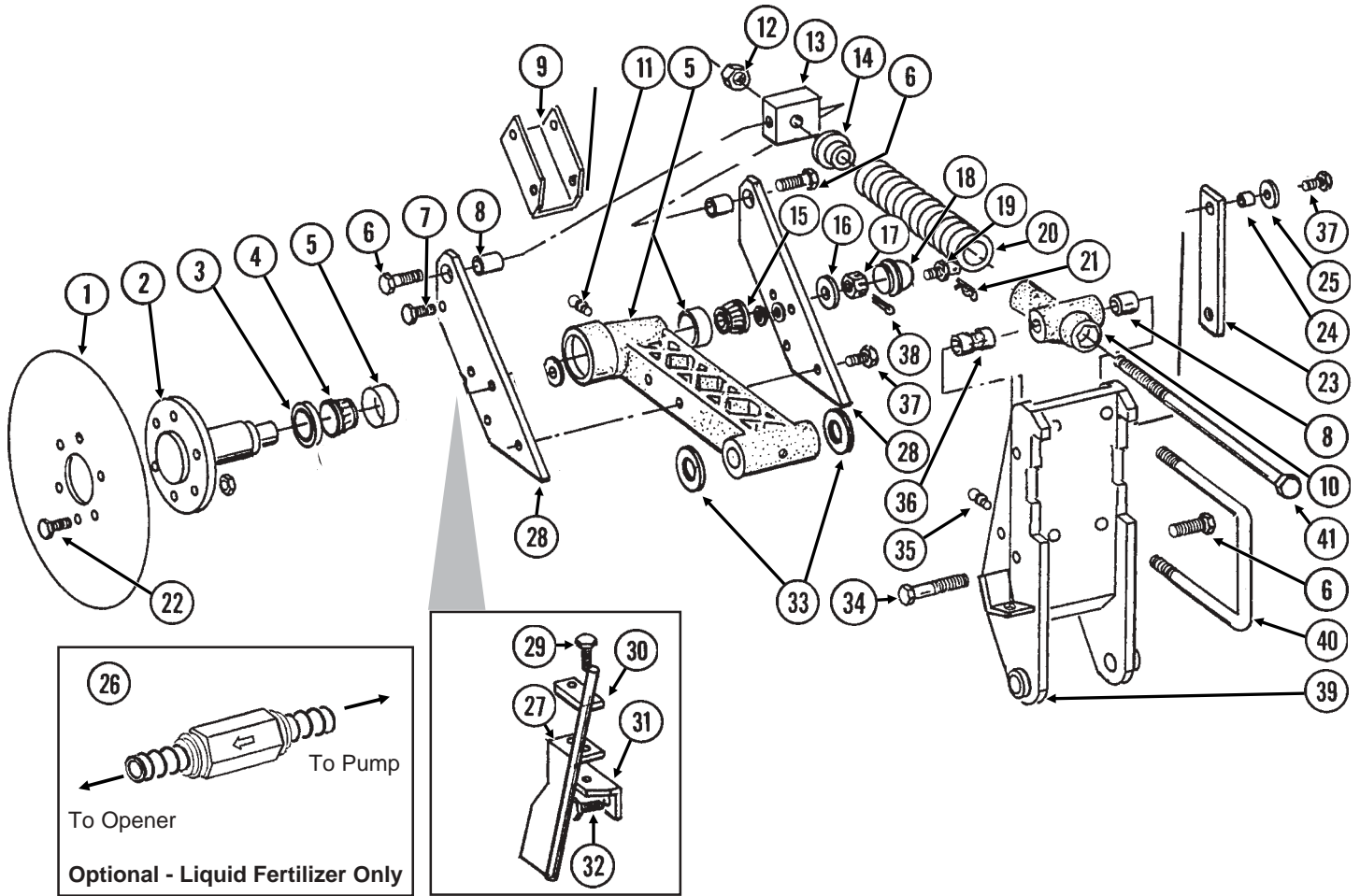

**ITEM PART NO. QTY. DESCRIPTION**  
(Per Assy.)

1.	GD7900	1	Disc Blade, 18"
2.	GB0205	1	Spindle
3.	GA4286	1	Seal
4.	GA4287	1	Bearing
5.	GA5887	1	Arm W/Cups And Washers
	GD6553	-	Cup
	GR0188	-	Cup
	G10205	3	Washer, 5/8" SAE
6.	G10007	3	Hex Head Cap Screw, 5/8"-11 x 1 1/2"
7.	G10001	2	Hex Head Cap Screw, 3/8"-16 x 1"
	G10108	2	Lock Nut, 3/8"-16
8.	GB0218	3	Bushing, 21/32" I.D. x 7/8" O.D. x 19/32" Long
9.	GD8238	1	Channel
10.	GB0206	1	Rod Guide
11.	G10641	2	Grease Fitting, 1/8" NPT
12.	G10105	3	Hex Nut, 3/4"-10
13.	GD7908	1	Tap Block
14.	GB0213	1	Spring Seat
15.	GA0237	1	Bearing
16.	G10220	1	Machine Bushing, 1 1/16", 10 Gauge
17.	G10507	1	Slotted Nut, 1"-14
18.	GD1104	1	Dust Cap

# HD SINGLE DISC FERTILIZER OPENER (Blade And Drop Tube)

ITEM	PART NO.	QTY.	DESCRIPTION
		(Per Assy.)	
19.	GD8276	1	Pin
	G10237	1	Lock Washer, $\frac{7}{16}$ "
	G10100	1	Hex Nut, $\frac{7}{16}$ "-14
20.	GD10273	1	Compression Spring
21.	G10592	1	Hair Pin Clip, No. 11
22.	G10594	6	Bolt, $\frac{1}{2}$ "-13 x $1\frac{1}{2}$ "
	G10111	6	Lock Nut, $\frac{1}{2}$ "-13
23.	GD8239	1	Storage Strap
24.	GD7904-02	1	Sleeve, $\frac{1}{2}$ " x $\frac{1}{2}$ " Long
25.	G10216	3	Washer, $\frac{1}{2}$ " USS
26.	GA8983	-	Check Valve, Low Rate
27.	GA8689	1	Drop Tube, L.H., Liquid Fertilizer (Shown)
	GA8688	-	Drop Tube, R.H., Liquid Fertilizer
28.	GD8224	2	Bar
29.	G10004	2	Hex Head Cap Screw, $\frac{3}{8}$ "-16 x $1\frac{1}{4}$ "
	G10229	2	Lock Washer, $\frac{3}{8}$ "
30.	GD10487	1	Clamp
31.	GD10304	-	Angle, R.H.
	GD10303	1	Angle, L.H. (Shown)
32.	G10016	2	Hex Head Cap Screw, $\frac{1}{2}$ "-13 x 2"
	G10111	2	Lock Nut, $\frac{1}{2}$ "-13
33.	G10322	-	Machine Bushing, $1\frac{1}{4}$ ", 18 Gauge (As Required)
34.	G10862	1	Hex Head Cap Screw, $\frac{5}{8}$ "-11 x $3\frac{1}{4}$ "
	G10205	2	Washer, $\frac{5}{8}$ " SAE
	G10230	1	Lock Washer, $\frac{5}{8}$ "
35.	G10640	1	Grease Fitting, $\frac{1}{4}$ "-28
36.	GD10242	1	Bushing, $2\frac{1}{4}$ "
37.	G10039	5	Hex Head Cap Screw, $\frac{1}{2}$ "-13 x $1\frac{3}{4}$ "
	G10111	5	Lock Nut, $\frac{1}{2}$ "-13
38.	G10459	1	Cotter Pin, $\frac{3}{16}$ " x $1\frac{1}{2}$ "
39.	GA7240	-	Opener Mount, R.H.
	GA7239	1	Opener Mount, L.H. (Shown)
40.	GD1113	2	U-Bolt, 5" x 7" x $\frac{5}{8}$ "-11
	G10230	4	Lock Washer, $\frac{5}{8}$ "
	G10104	4	Hex Nut, $\frac{5}{8}$ "-11
41.	GD7907	1	Special Bolt

# NOTCHED SINGLE DISC FERTILIZER OPENER

FOC018(TWL34h/FRTZ209j/FRTZ208)

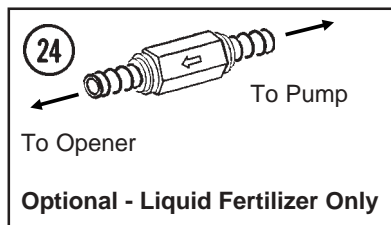
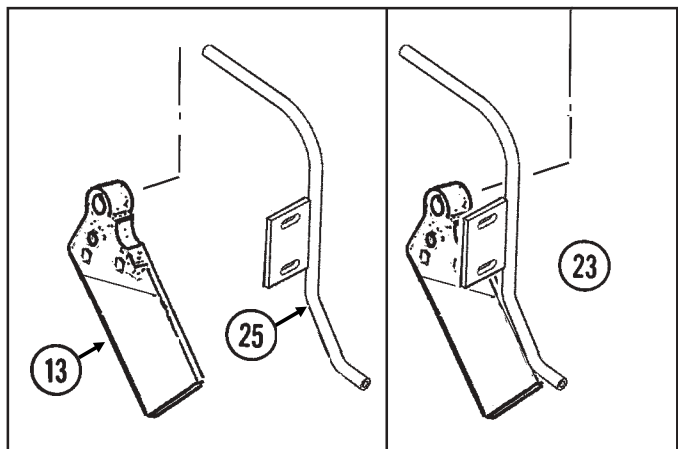
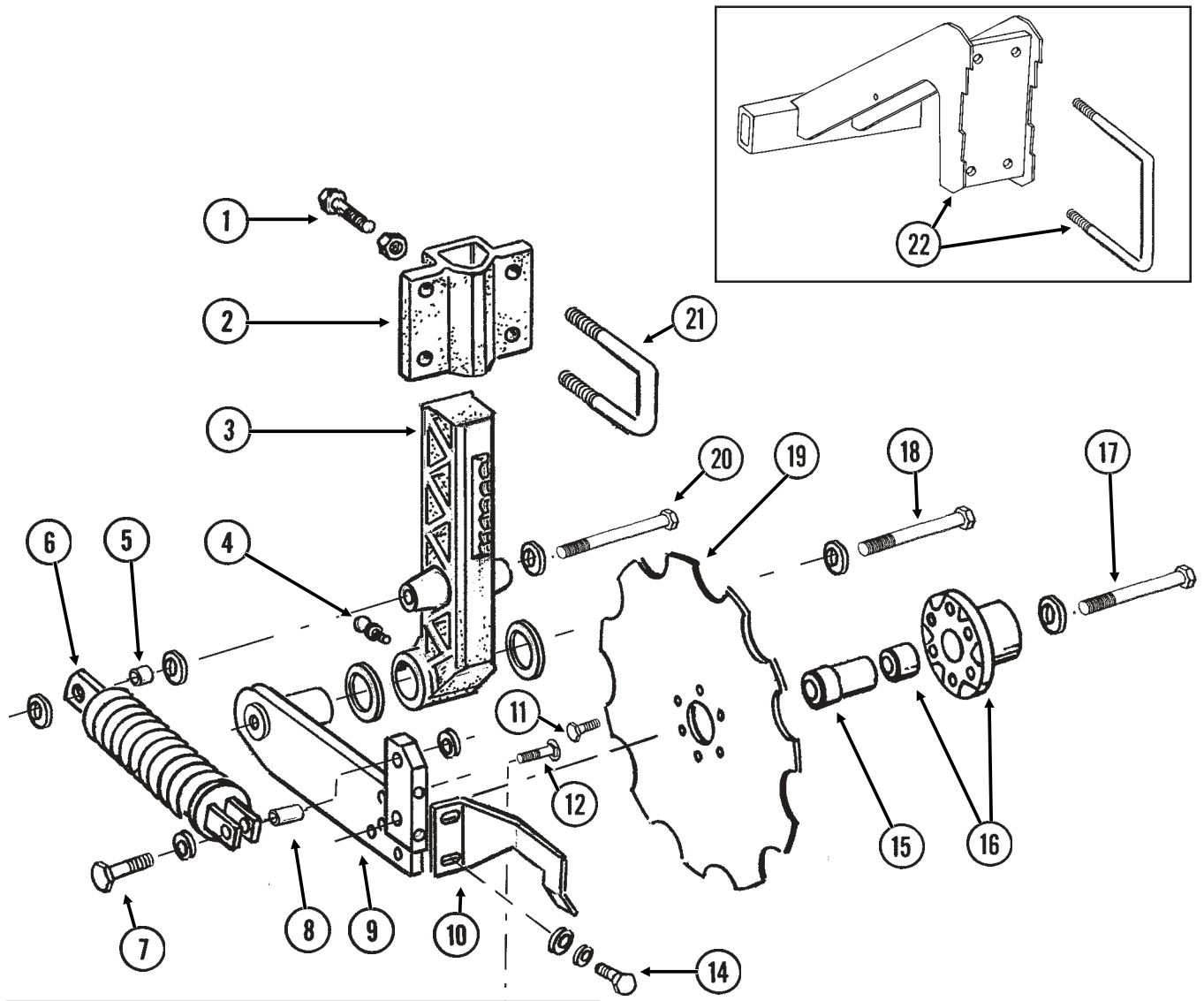

# NOTCHED SINGLE DISC FERTILIZER OPENER

ITEM	PART NO.	QTY.	DESCRIPTION
		(Per Assy.)	
1.	G10017	3	Hex Head Cap Screw, 1/2"-13 x 1 1/2"
	G10102	3	Hex Nut, 1/2"-13
2.	GB0297	1	Mount
3.	GB0296	1	Arm, 13 1/2"
4.	G10640	1	Grease Fitting, 1/4"-28
5.	GD12685	1	Bushing, 3/4" O.D. x 1/2" Long
6.	GA6966	1	Compression Spring Assembly
7.	G10047	1	Hex Head Cap Screw, 3/8"-16 x 1 3/4"
	G10210	2	Washer, 3/8" USS
	G10108	1	Lock Nut, 3/8"-16
8.	GD1026	1	Sleeve, 1 3/16" Long
9.	GA9433	1	Pivot Arm, L.H. (Shown)
	GA9434	-	Pivot Arm, R.H.
10.	GD11557	1	Scraper, L.H. (Shown)
	GD11558	-	Scraper, R.H.
11.	G10002	6	Hex Head Cap Screw, 3/8"-16 x 3/4"
12.	G10306	3	Carriage Bolt, 3/8"-16 x 2"
	G10108	3	Lock Nut, 3/8"-16
13.	GB0249	1	Knife, L.H. (Shown)
	GB0248	-	Knife, R.H.
14.	G10991	2	Hex Head Cap Screw, 5/16"-18 x 7/8"
	G10232	2	Lock Washer, 5/16"
	G10219	6	Washer, 5/16" USS
15.	GD12679	1	Stepped Spacer, 3" Long
16.	GA9437	1	Hub W/Bearing
	GA8603	-	Double Row Bearing
17.	G10011	1	Hex Head Cap Screw, 5/8"-11 x 5 1/2"
	GD12677	1	Washer, 1 1/2" O.D., 7 Gauge, Hardened
	G10107	1	Lock Nut, 5/8"-11
18.	G10046	1	Hex Head Cap Screw, 5/8"-11 x 5"
	G10217	1	Washer, 5/8" USS
	G10450	2	Machine Bushing, 1 1/2", 18 Gauge (As Required)
	G10107	1	Lock Nut, 5/8"-11
19.	GD12676	1	Disc Blade, Notched, 16 3/4"
20.	G10871	1	Hex Head Cap Screw, 1/2"-13 x 6"
	G10206	3	Washer, 1/2" SAE
	G10111	1	Lock Nut, 1/2"-13
21.	GD13287	2	U-Bolt, 1 1/2" x 2 1/2" x 1/2"-13
	G10228	4	Lock Washer, 1/2"
	G10102	4	Hex Nut, 1/2"-13
22.	GA9565	1	Mount W/U-Bolts
	GD1113	2	U-Bolt, 5" x 7" x 5/8"-11
	G10230	4	Lock Washer, 5/8"
	G10104	4	Hex Nut, 5/8"-11
23.	GA9461	1	Knife/Drop Tube, L.H., Liquid Fertilizer (Shown)
			<b>(Sub GA8399 And GB0249)</b>
	GA9462	1	Knife/Drop Tube, R.H., Liquid Fertilizer
			<b>(Sub GA8398 And GB0248)</b>
24.	GA8983	-	Check Valve, Low Rate
25.	GA8399	-	Drop Tube, L.H., Liquid Fertilizer (Shown)
	GA8398	1	Drop Tube, R.H., Liquid Fertilizer

# RESIDUE WHEEL ATTACHMENT FOR NOTCHED SINGLE DISC FERTILIZER OPENER

DFC024(FRTZ165I)

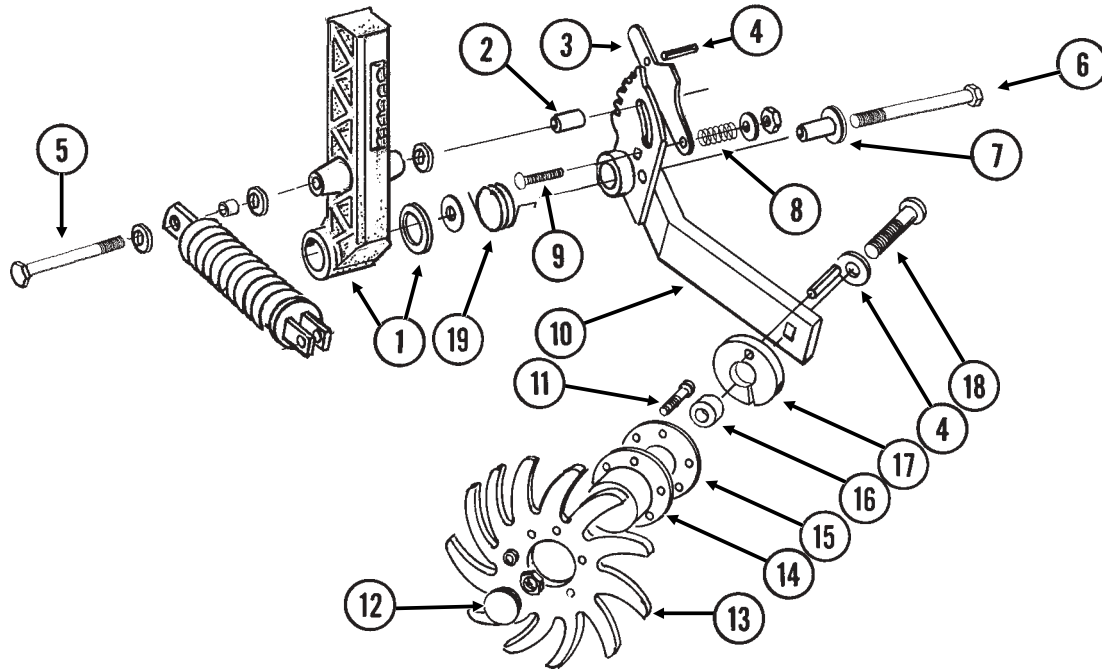

ITEM	PART NO.	QTY.	DESCRIPTION
		(Per Assy.)	
1.		-	See "Notched Single Disc Fertilizer Opener", Pages P118 And P119
2.	GD12684	1	Bushing, 1 1/3" Long
3.	GD11178	1	Adjustment Lever
4.	G10603	2	Spring Pin, 1/4" x 1 1/4"
5.	G11034	1	Hex Head Cap Screw, 1/2"-13 x 7"
	G10111	1	Lock Nut, 1/2"-13
6.	G10830	1	Hex Head Cap Screw, 5/8"-11 x 7 1/2"
	GD7805	1	Special Washer, 5/8", Hardened
	G10107	1	Lock Nut, 5/8"-11
7.	GD11836	1	Sleeve, 2 1/8" Long
8.	GD7962	1	Spring
9.	G10306	1	Carriage Bolt, 3/8"-16 x 2"
	G10203	1	Washer, 3/8" SAE
	G10108	1	Lock Nut, 3/8"-16
10.	GA7999	1	Mount W/Grease Fitting, L.H. (Shown)
	GA7998	-	Mount W/Grease Fitting, R.H.
	G10640	-	Grease Fitting, 1/4"-28
11.	G10133	6	Hex Head Cap Screw, 5/16"-18 x 1 1/2"
	G10109	6	Lock Nut, 5/16"-18
12.	GD1132	2	Dust Cap
13.	GD10552	2	Wheel, 12 Tine, 3/8" x 12"
14.	GA5654	1	Hub W/Bearings
	GA2014	-	Bearing
15.	GD9724	1	Backing Plate
16.	GD7817-04	1	Spacer, 11/16" I.D. x 1/2" Long
17.	GD11188	1	Spacer
18.	G10908	1	Carriage Bolt, 5/8"-11 x 3"
	G10503	1	Hex Jam Nut, 5/8"-11, Grade 2
19.	GD11265	1	Spring, L.H. (Shown)
	GD11266	-	Spring, R.H.
A.	GA7445	-	Wheel Assembly, 12 Tine, L.H. (Items 11 And 13-15)(Shown)
	GA7446	-	Wheel Assembly, 12 Tine, R.H. (Items 11 And 13-15)



# DEPTH/GAUGE WHEEL ATTACHMENT FOR NOTCHED SINGLE DISC FERTILIZER OPENER

(FRTZ209d)

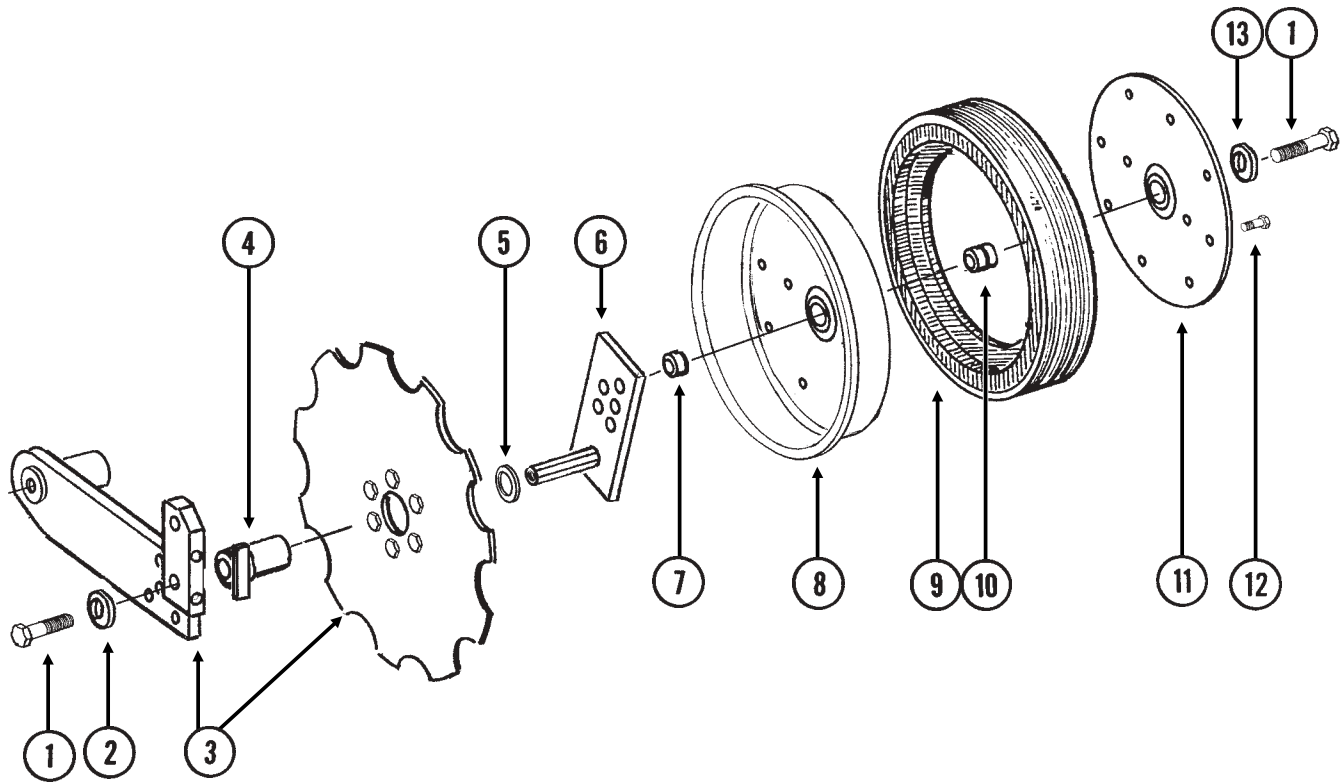

ITEM	PART NO.	QTY.	DESCRIPTION
(Per Assy.)			
1.	G10010	2	Hex Head Cap Screw, $\frac{5}{8}$ "-11 x 3"
2.	GD7805	1	Special Washer, $\frac{5}{8}$ ", Hardened
3.		-	See "Notched Single Disc Fertilizer Opener", Pages P118 And P119
4.	GA9472	1	Blade Mount
5.	G10233	1	Machine Bushing, 1", 10 Gauge
6.	GA9473	1	Wheel Mount
7.	GD13309	1	Spacer
8.	GD11423	1	Half Wheel
9.	GD11953	1	Offset Tire
10.	GA6171	1	Bearing
11.	GD11954	1	Half Wheel Cover, Nylon
12.	G10961	11	Flanged Whiz-Lock Screw, $\frac{5}{16}$ "-18 x $\frac{3}{4}$ ", No Serration
	G10620	11	Flange Nut, $\frac{5}{16}$ "-18
13.	G10204	1	Special Machine Bushing, $\frac{5}{8}$ " x 1" O.D.
A.	GA8877	-	Wheel Assembly (Items 8-12)

# LIQUID FERTILIZER TANKS, SADDLES, SADDLE MOUNTS AND HOSES

LFC021/LFC023/LFC030/LFC012(FRTZ201a)

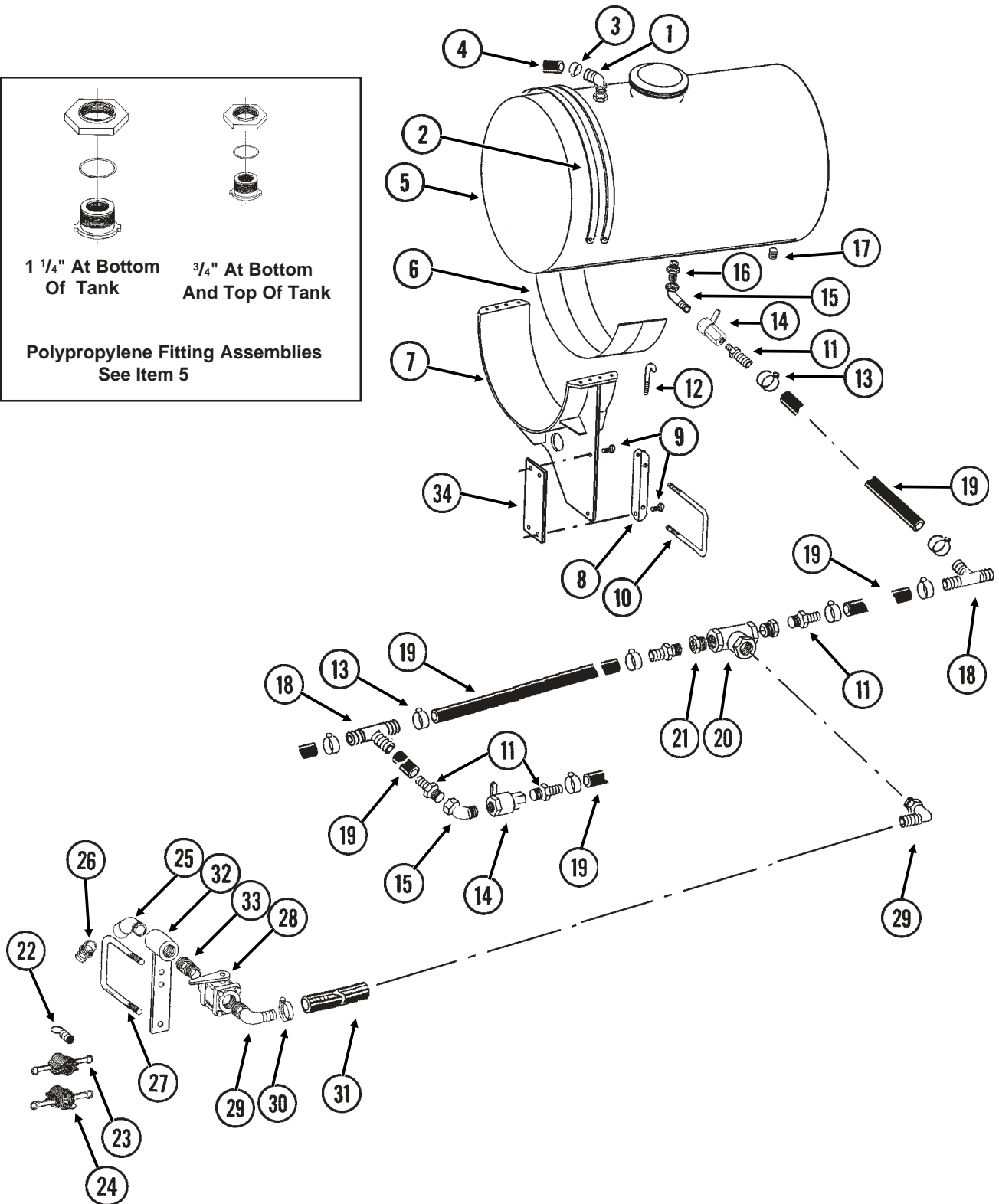
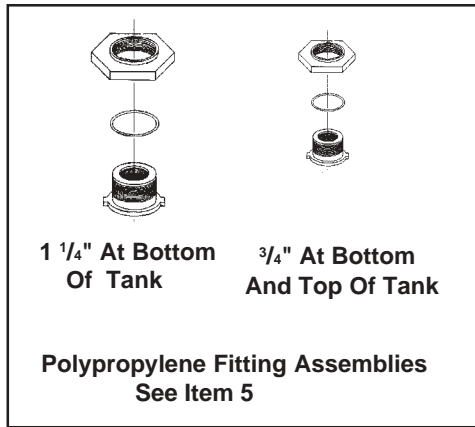

# LIQUID FERTILIZER TANKS, SADDLES, SADDLE MOUNTS AND HOSES

---

ITEM	PART NO.	QTY.	DESCRIPTION
1.	G10917	4	Elbow, 90°, 3/4" NPT To Barb
2.	GD1520	16	Band, 30" (4 Per Tank)
3.	G10278	4	Hose Clamp, No. 16
4.	G4205-11	-	Hose, 3/4" x 72" (One Per Tank)
5.	GD1812	4	Tank W/Lid And Fittings, 30" x 150 Gallon
	GR1005	-	Fillwell, 10", Threaded (Top Of Tank)
	GR1006	-	Lid, 10", Threaded (Top Of Tank)
	GR0513	-	3/4" Polypropylene Fitting Assembly (Nut, Bushing And O-Ring)
	GR0508	-	1 1/4" Polypropylene Fitting Assembly (Nut, Bushing And O-Ring)
6.	GD1862	2	Pad, 8" x 14"
7.	GA9671	8	Tank Mount (2 Per Tank)
8.	GD10110	8	Mounting Angle (2 Per Tank)
9.	G10007	24	Hex Head Cap Screw, 5/8"-11 x 1 1/2"
	G10230	24	Lock Washer, 5/8"
	G10104	24	Hex Nut, 5/8"-11
10.	GD1747	8	U-Bolt, 5" x 7" x 3/4"-10
	G10231	16	Lock Washer, 3/4"
	G10105	16	Hex Nut, 3/4"-10
11.	G10626	10	Adapter, 1 1/4" NPT To Barb
12.	GD1337	32	J-Bolt, 5/16"-18 (8 Per Tank)
	G10109	32	Lock Nut, 5/16"-18 (8 Per Tank)
13.	G10674	24	Hose Clamp, No. 24
14.	GA4976	5	Shutoff Valve, 1 1/4" NPT
	GR1015	-	Body O-Ring
	GR1016	-	Stem O-Ring
	GR1017	-	Teflon Seat
	GR1018	-	Ball
	GR1019	-	Handle
15.	G10887	5	Elbow, 90°, 1 1/4" Male NPT To Female
16.	G10619	4	Close Nipple, 1 1/4" NPT
17.	G10096	4	Pipe Plug, 3/4" NPT
18.	G10633	3	Tee, 1 1/4" Barb
19.	G4200-03	1	Hose, 1 1/4" x 32', 12 Row 30"
	G4200-06	-	Hose, 1 1/4" x 40', 16 Row 30"
20.	G10888	1	Tee, 2" Female NPT
21.	G10616	2	Reducing Bushing, 2" Male NPT To 1 1/4" Female
22.	GD10777	1	Dust Plug, 2" Male Cam Lock
23.	GD3622	1	Adapter, 2" Female NPT To Cam Lock
24.	GD3951	1	Dust Cap, 2" Cam Lock
25.	G10889	1	Elbow, 45°, 2" Male NPT To Female
26.	GD3623	1	Adapter, 2" Male NPT To Cam Lock
27.	GD1113	1	U-Bolt, 5" x 7" x 5/8"-11
	G10230	2	Lock Washer, 5/8"
	G10104	2	Hex Nut, 5/8"-11
28.	GA2660	1	Shutoff Valve, 2" NPT
29.	G10630	2	Elbow, 90°, 2" NPT To Barb
30.	G10676	2	Hose Clamp, No. 36
31.	G4201-03	1	Hose, 2" x 18'
32.	GA7845	1	Quick Fill Mount, 2"
33.	G10623	1	Close Nipple, 2" NPT
34.	GD13648	4	Plate, 4" x 10 1/2" (Outboard Tanks Only)

# LIQUID FERTILIZER PISTON PUMP MOUNT/DRIVE

(TWL219c)

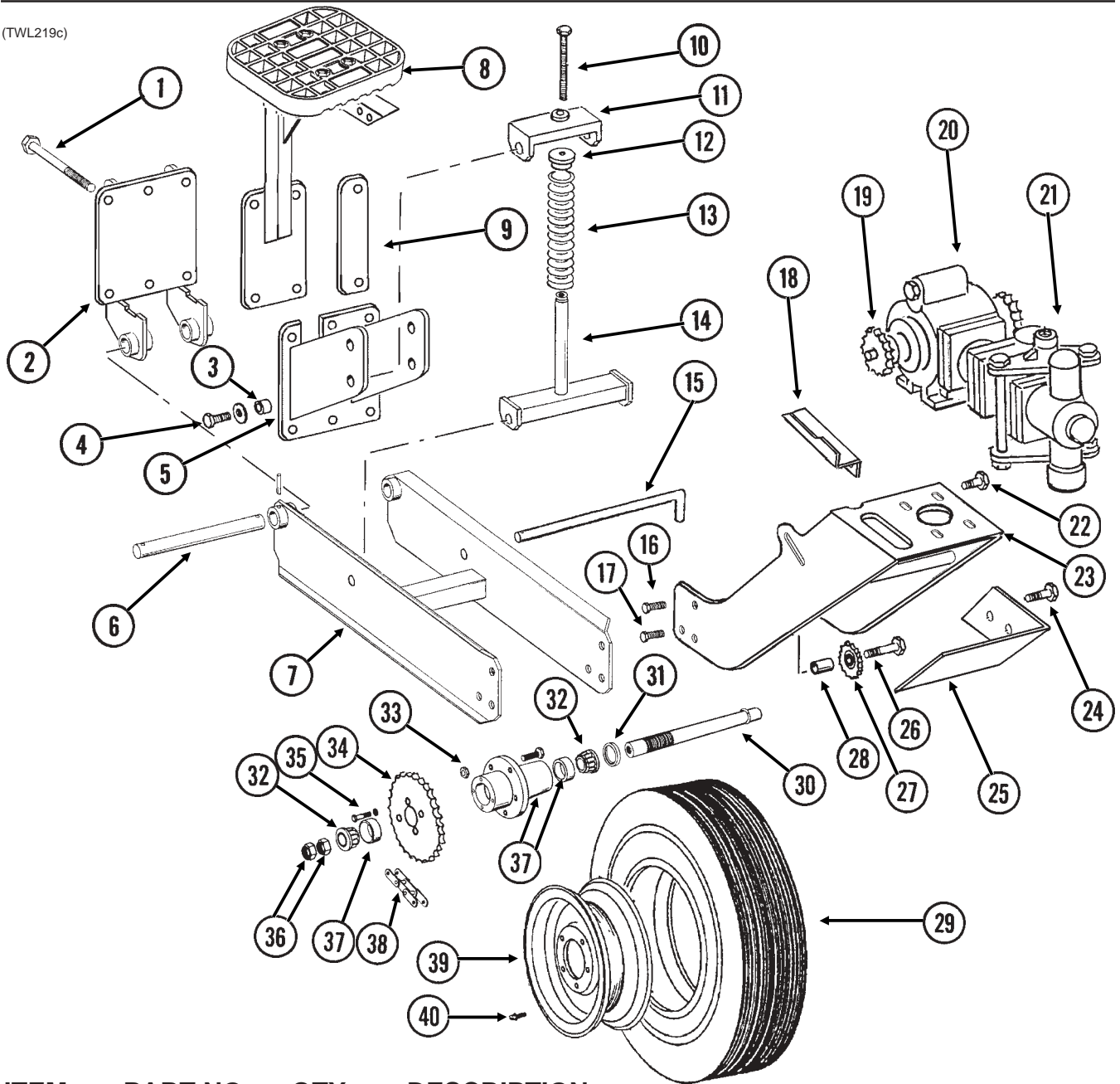

ITEM	PART NO.	QTY.	DESCRIPTION
1.	G10830	6	Hex Head Cap Screw, 5/8"-11 x 7 1/2"
	G10230	6	Lock Washer, 5/8"
	G10104	6	Hex Nut, 5/8"-11
2.	GA9711	1	Wheel Arm Mount
3.	GB0218	2	Bushing, 21/32" I.D. x 7/8" O.D. x 19/32" Long
4.	G10005	2	Hex Head Cap Screw, 5/8"-11 x 1 3/4"
	GD7805	2	Special Washer, 5/8", Hardened
	G10107	2	Lock Nut, 5/8"-11
5.	GA9712	1	Spring Mount
6.	GD2681	1	Pin, 1 1/4" x 13 1/2"
	G10460	2	Cotter Pin, 1/4" x 2"
7.	GA6307	1	Arm W/Grease Fittings
	G10641	2	Grease Fitting, 1/8" NPT
8.	-	-	See "Bulk Seed Hopper Catwalk", Page P11
9.	GD13766	1	Spacer Plate

# LIQUID FERTILIZER PISTON PUMP MOUNT/DRIVE

ITEM	PART NO.	QTY.	DESCRIPTION
10.	G10012	1	Hex Head Cap Screw, $\frac{5}{8}$ "-11 x 6 $\frac{1}{2}$ "
	GD7805	1	Special Washer, $\frac{5}{8}$ ", Hardened
11.	GA6308	1	Spring Mount
12.	GB0196	1	Washer
13.	GD7831	1	Compression Spring
14.	GA6309	1	Spring Guide
15.	GD8917	1	L-Pin, 12 $\frac{3}{8}$ "
	GD2558	1	Lynch Pin, $\frac{1}{4}$ "
16.	G10026	2	Hex Head Cap Screw, $\frac{3}{4}$ "-10 x 2"
	G10231	2	Lock Washer, $\frac{3}{4}$ "
17.	G11042	2	Hex Head Cap Screw, $\frac{3}{4}$ "-10 x 1 $\frac{3}{4}$ "
	G10231	2	Lock Washer, $\frac{3}{4}$ "
	G10105	2	Hex Nut, $\frac{3}{4}$ "-10
18.	GD13744	1	Hose Holder
19.	GR1146	1	Sprocket, 18 Tooth
20.		-	See "Liquid Fertilizer Piston Pump (Crankcase Assembly)", Pages P129 And P130
	GR0200	1	Offset Link, No. 2050
21.		-	See "Liquid Fertilizer Piston Pump (Cylinder Assembly)", Pages P129 And P130
22.	G10007	2	Hex Head Cap Screw, $\frac{5}{8}$ "-11 x 1 $\frac{1}{2}$ "
	G10217	2	Washer, $\frac{5}{8}$ " USS
	G10230	2	Lock Washer, $\frac{5}{8}$ "
	G10104	2	Hex Nut, $\frac{5}{8}$ "-11
23.	GA9709	1	Pump Mount
24.	G10017	2	Hex Head Cap Screw, $\frac{1}{2}$ "-13 x 1 $\frac{1}{2}$ "
	G10216	2	Washer, $\frac{1}{2}$ " USS
	G10228	2	Lock Washer, $\frac{1}{2}$ "
	G10102	2	Hex Nut, $\frac{1}{2}$ "-13
25.	GD13328	1	Scraper
26.	G10013	1	Hex Head Cap Screw, $\frac{5}{8}$ "-11 x 3 $\frac{1}{2}$ "
	G10205	1	Washer, $\frac{5}{8}$ " SAE
	G10230	1	Lock Washer, $\frac{5}{8}$ "
	G10104	1	Hex Nut, $\frac{5}{8}$ "-11
27.	GA0262	1	Idler Sprocket W/Bearing, 15 Tooth
28.	GD7817-05	1	Spacer, $\frac{11}{16}$ " I.D. x 1 $\frac{1}{4}$ " Long
29.	GD0844	1	Tire, 7.60" x 15", 8 Ply (Specify Brand*)
30.	GA2559	1	Spindle
31.	GA0252	2	Seal
32.	GA0251	2	Bearing
33.	GR0267	5	Lug Nut, $\frac{1}{2}$ "-20
34.	G2500-84	1	Sprocket, 48 Tooth
35.	G10019	4	Hex Head Cap Screw, $\frac{5}{16}$ "-18 x 1"
	G10232	4	Lock Washer, $\frac{5}{16}$ "
36.	GD0831	2	Shoulder Nut, 1 $\frac{1}{4}$ "-12 UNF-2A
37.	GA0547	1	Hub W/Cups And Studs, 5 Bolt
	GR0190	2	Cup
	GR0204	5	Stud
38.	G3200-59	1	Chain, No. 2050, 59 Pitch Including Connector Link And Offset Link
	GR0195	1	Connector Link, No. 2050
39.	GA0241	1	Wheel, 5" x 15"
40.	GD1166	1	Valve Stem

\* Specific brand requests will be supplied only as available from current KINZE® stock. If a specific brand requested is not in stock, the brand available will be supplied. Different brand tires may have different diameters. Change in tire brand could result in rate changes.

# LIQUID FERTILIZER FLOW DIVIDER MOUNT AND HOSES

(FRTZ215a)

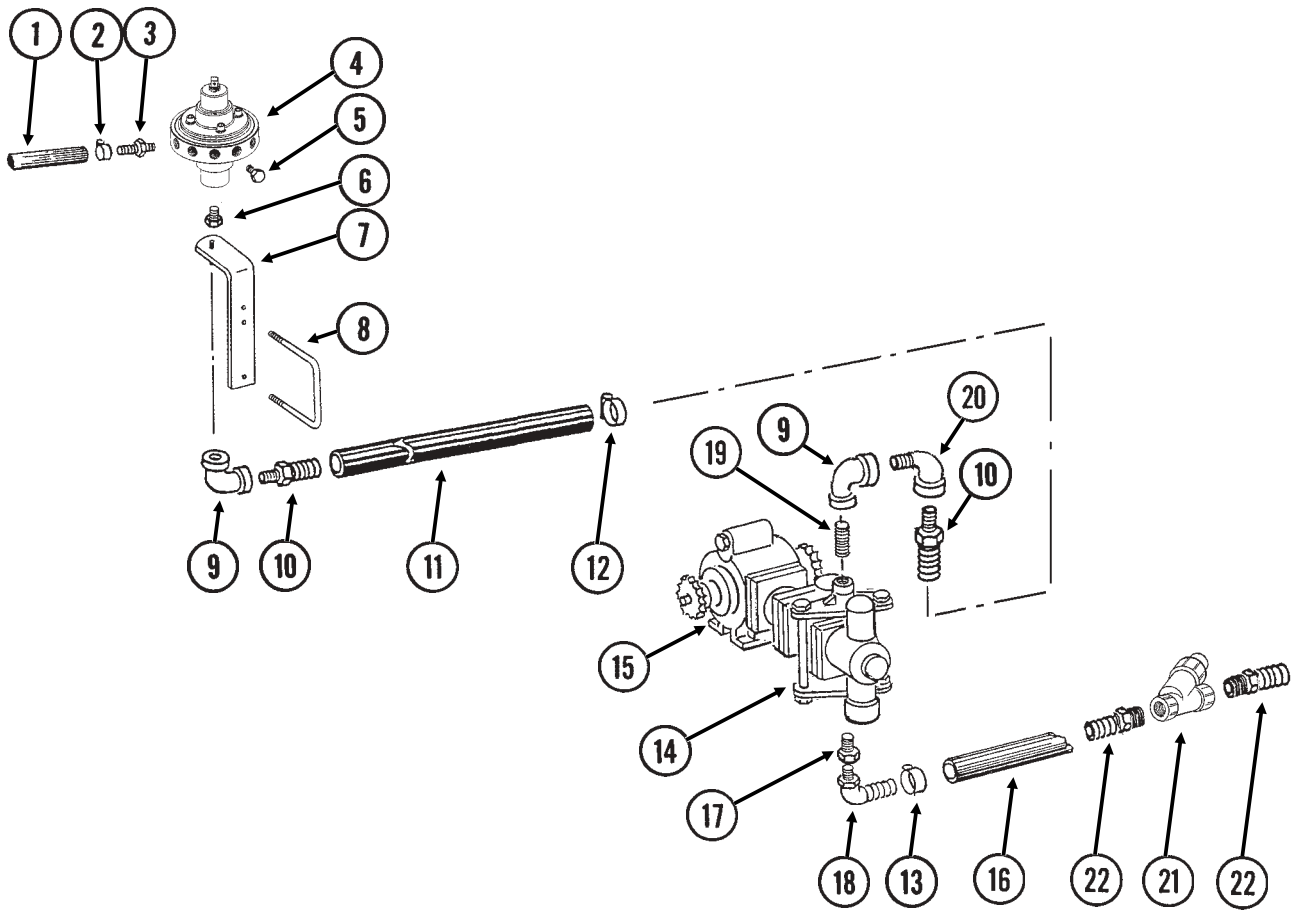

# LIQUID FERTILIZER FLOW DIVIDER MOUNT AND HOSES

ITEM	PART NO.	QTY.	DESCRIPTION
1.	G4301-06	1	Hose, 3/8" x 160', 12 Row 30"
	G4301-05	2	Hose, 3/8" x 120', 16 Row 30"
2.	G10681	24-32	Hose Clamp, No. 6
3.	GD11700	12-16	Adapter, 1/4" NPT To 3/8" Barb
4.		-	See "Liquid Fertilizer Piston Pump Flow Divider", Pages P132 And P133
5.	G10292	-	Pipe Plug, 1/4" NPT
6.	G10995	1	Reducing Bushing, 1" Male NPT To 3/4" Female, Stainless Steel, 16 Row 30"
7.	GA6527	1	Support, 3/4" NPT
8.	GD1113	1	U-Bolt, 5" x 7" x 5/8"-11
	G10230	2	Lock Washer, 5/8"
	G10104	2	Hex Nut, 5/8"-11
9.	G10733	2	Elbow, 90°, 3/4" Female NPT
10.	G10734	2	Adapter, 3/4" NPT To Barb
11.	G4205-08	-	Hose, 3/4" x 150"
12.	G10278	2	Hose Clamp, No. 16
13.	G10674	2	Hose Clamp, No. 24
14.		-	See "Liquid Fertilizer Piston Pump (Cylinder Assembly)", Pages P130 And P131
15.		-	See "Liquid Fertilizer Piston Pump (Crankcase Assembly)", Pages P128 And P129
16.		-	Hose, 1 1/4", See "Liquid Fertilizer Tanks, Saddles, Saddle Mounts And Hoses", Pages P122 And P123
17.	G10615	1	Reducing Bushing, 1 1/2" Male NPT To 1 1/4" Female
18.	G10629	1	Elbow, 90°, 1 1/4" NPT To Barb
19.	G10389	1	Pipe Nipple, 3/4" NPT x 1 1/2" Long
20.	G10735	1	Elbow, 90°, 3/4" Male NPT To Female
21.	GA3893	1	Strainer Complete
	GR0880	-	Screen, No. 40 Mesh
	GR0881	-	Gasket
	GR0882	-	Y-Body
	GR0883	-	End Cap
22.	G10626	2	Adapter, 1 1/4" NPT To Barb

# LIQUID FERTILIZER PISTON PUMP (Crankcase Assembly)

John Blue® Model L-4405

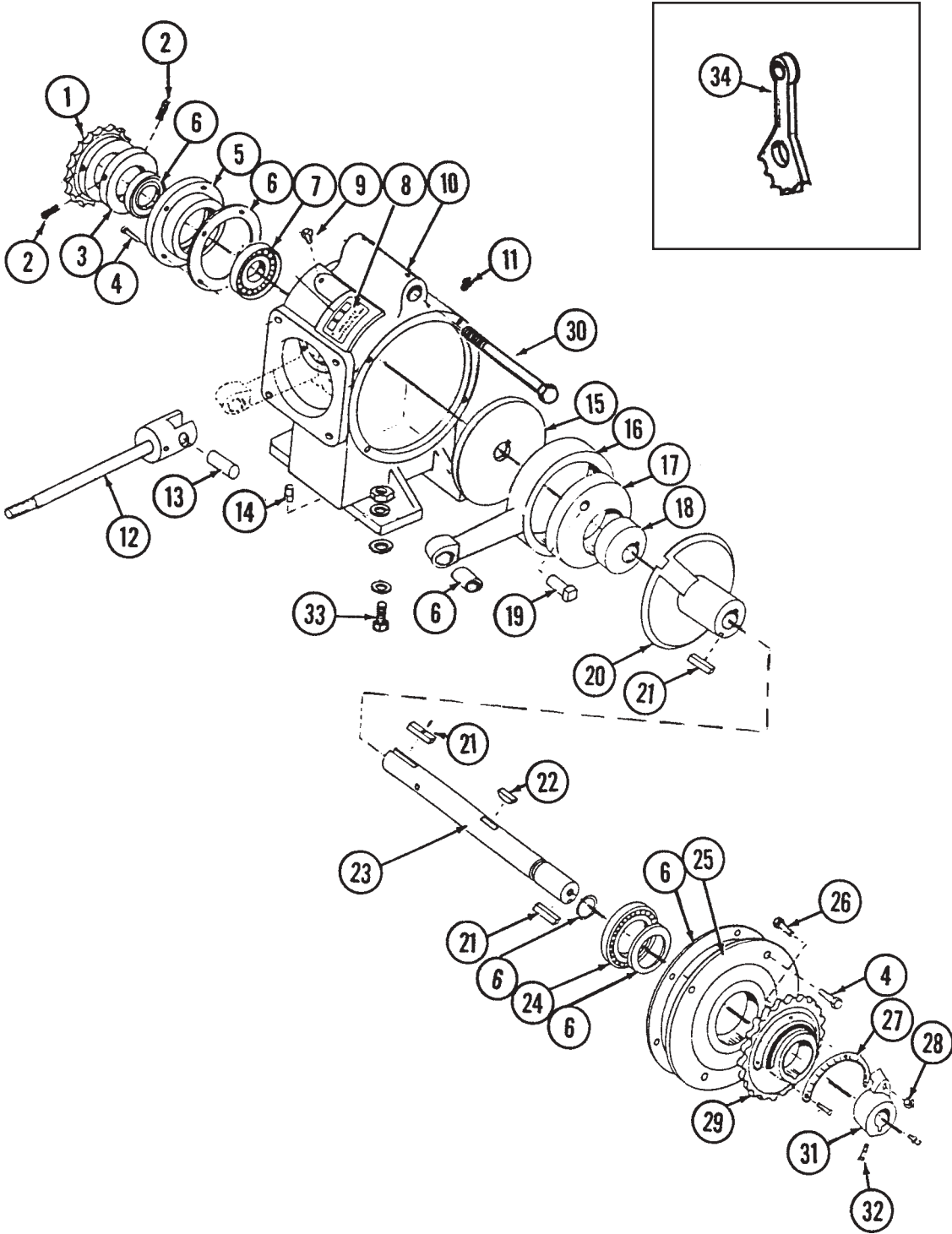



# LIQUID FERTILIZER PISTON PUMP (Crankcase Assembly)

ITEM	PART NO.	QTY.	DESCRIPTION
1.		-	See "Liquid Fertilizer Piston Pump Mount/Drive", Pages P124 And P125
2.	G10688	2	Square Head Set Screw, $\frac{3}{8}$ "-16 x $\frac{5}{8}$ "
3.	GR1147	1	Spacer
4.	G10019	4	Hex Head Cap Screw, $\frac{5}{16}$ "-18 x 1"
5.	GR1102	1	Housing
6.	GR1173	-	Repair Kit, Includes Item 5 On "Liquid Fertilizer Piston Pump (Cylinder Assembly)", Pages P130 And P131
7.	GR1104	1	Bearing
8.	GR1105	1	Name Plate
9.	G10054	2	Hex Head Cap Screw, $\frac{5}{16}$ "-18 x $\frac{1}{2}$ "
10.	GR1106	1	Crankcase
11.	GR1107	1	Vent Plug
12.		-	See "Liquid Fertilizer Piston Pump (Cylinder Assembly)", Pages P130 And P131
13.		-	See "Liquid Fertilizer Piston Pump (Cylinder Assembly)", Pages P130 And P131
14.	GR1123	3	Plug
15.	GR1108	1	Disc
16.	GR1109	1	Connecting Rod
17.	GR1110	1	Large Eccentric
18.	GR1111	1	Small Eccentric
19.	GR1120	1	Eccentric Pin
20.	GR1119	1	Sleeve
21.	GR1118	3	Setting Arm Key
22.	GR1112	1	Woodruff Key
23.	GR1148	1	Crankshaft
24.	GR1116	1	Bearing
25.	GR1166	1	Cover Plate
26.	GR1167	1	Square Head Bolt, $\frac{3}{8}$ "-16 x 1 $\frac{3}{4}$ "
27.	GR1168	1	Scale
28.	G10108	1	Lock Nut, $\frac{3}{8}$ "-16
29.	GR1114	1	Flange
30.	G10318	1	Hex Head Cap Screw, $\frac{5}{8}$ "-11 x 4 $\frac{1}{2}$ "
	G10104	1	Hex Nut, $\frac{5}{8}$ "-11
31.	GR1165	1	Arm
32.	G10693	4	Hex Socket Head Set Screw, $\frac{5}{16}$ "-18 x $\frac{3}{8}$ "
33.	G10003	4	Hex Head Cap Screw, $\frac{3}{8}$ "-16 x 1 $\frac{1}{2}$ "
	GR1122	4	Mounting Pad
	G10210	8	Washer, $\frac{3}{8}$ " USS
	G10229	4	Lock Washer, $\frac{3}{8}$ "
	G10101	4	Hex Nut, $\frac{3}{8}$ "-16
34.	GR1100	1	Adjustment Wrench
A.	GA6154	1	Piston Pump Complete Less 23 Tooth Sprocket (L-4405), Includes Crankcase (Items 2-34 On This Page) And Cylinder (Items 1-22 On Pages P130 And P131) Assemblies

# LIQUID FERTILIZER PISTON PUMP (Cylinder Assembly)

John Blue® Model L-4405

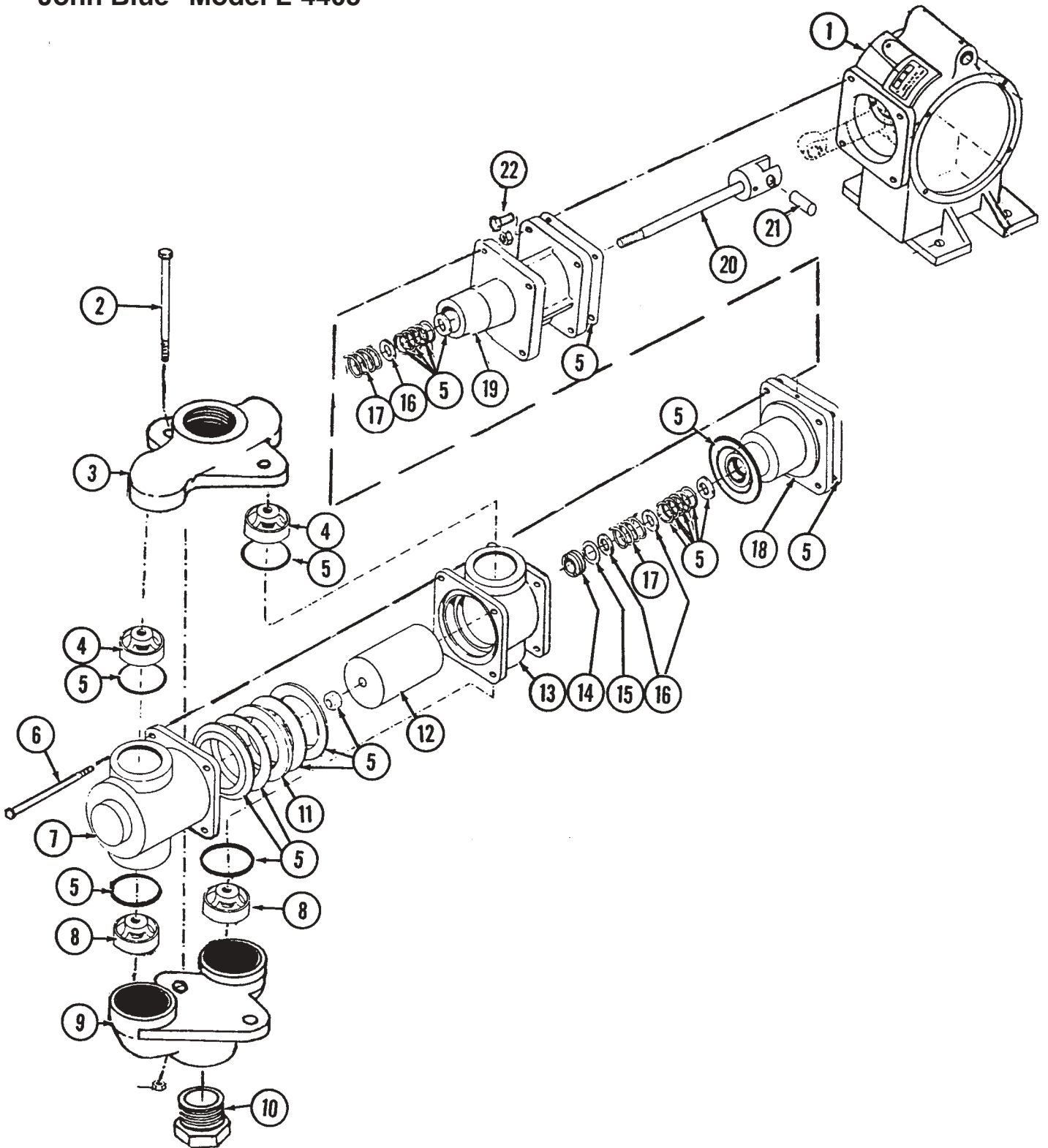

# LIQUID FERTILIZER PISTON PUMP (Cylinder Assembly)

---

ITEM	PART NO.	QTY.	DESCRIPTION
1.		-	See "Liquid Fertilizer Piston Pump (Crankcase Assembly)", Pages P128 And P129
2.	G10686	2	Hex Head Cap Screw, $\frac{3}{8}$ "-16 x 8"
	G10101	2	Hex Nut, $\frac{3}{8}$ "-16
3.	GR1145	1	Discharge Manifold
4.	GR1144	2	Discharge Valve
5.	GR1173	-	Repair Kit, Includes Item 6 On "Liquid Fertilizer Piston Pump (Crankcase Assembly)", Pages P128 And P129
6.	G10687	4	Hex Head Cap Screw, $\frac{3}{8}$ "-16 x 5 $\frac{1}{2}$ "
	G10101	4	Hex Nut, $\frac{3}{8}$ "-16
7.	GR1143	1	Outboard Cylinder
8.	GR1142	2	Suction Valve
9.	GR1140	1	Suction Manifold
10.		-	See "Liquid Fertilizer Piston Pump Mount/Drive", Pages P124 And P125
11.	GR1137	1	Flange Packing Washer
12.	GR1136	1	Plunger
13.	GR1135	1	Inboard Cylinder
14.	GR1134	1	Stuffing Box Insert
15.	GR1133	1	Retaining Ring
16.	GR1129	3	Washer
17.	GR1130	2	Packing Spring
18.	GR1132	1	Outboard Stuffing Box
19.	GR1127	1	Crosshead Guide
20.	GR1125	1	Piston Rod
21.	GR1124	1	Pin
22.	G10019	4	Hex Head Cap Screw, $\frac{5}{16}$ "-18 x 1"

# LIQUID FERTILIZER PISTON PUMP FLOW DIVIDER

(FRTZ202a/FRTZ202c/FRTX202d)

### 12 Row 30" Model FD-1200 Flow Divider

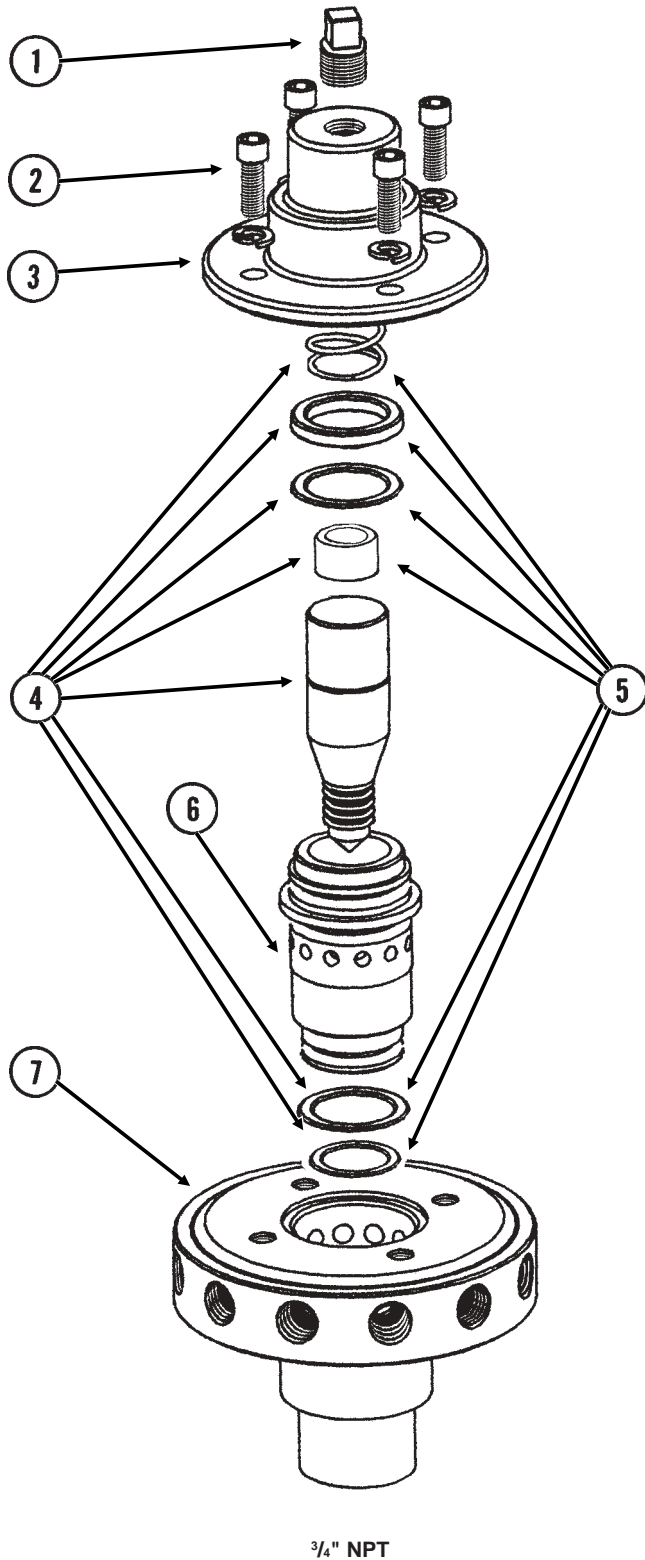

### 16 Row 30" Model FD-2000 Flow Divider

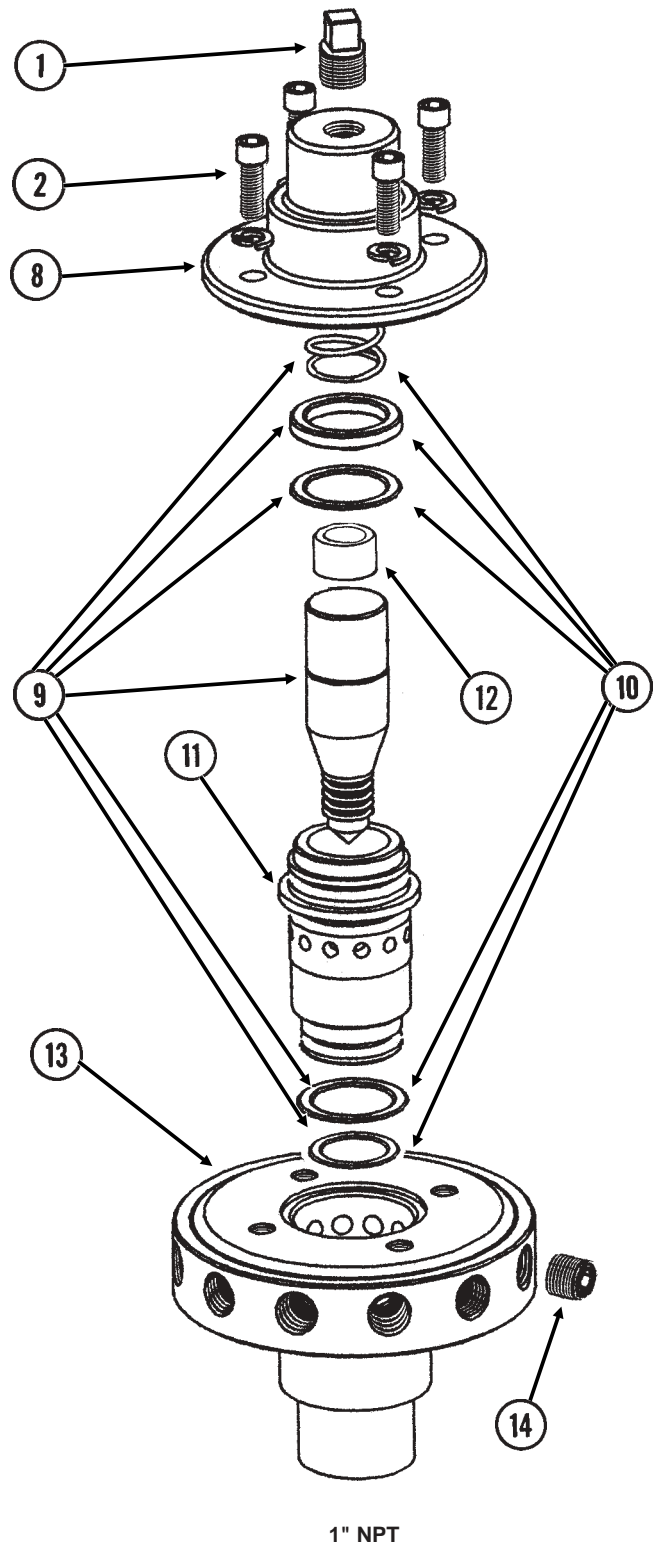

# LIQUID FERTILIZER PISTON PUMP FLOW DIVIDER

---

ITEM	PART NO.	QTY.	DESCRIPTION
1.	GR1543	1	Plug
2.	GR1542	4	Hex Socket Head Screw, 1/4"-20 x 3/4", Stainless Steel
	GR1541	4	Lock Washer, 1/4", Stainless Steel
3.	GR1540	1	Cap
4.	GR1544	1	Needle Assembly W/Seal Kit (Item 11)
5.	GR1545	1	Seal Kit, Includes: (3) O-Rings, (1) Seal, (1) Spring, (1) Stainless Steel Sleeve
6.	GR1535	1	Sleeve
7.	GR1533	1	Body
8.	GR1566	1	Cap
9.	GR1567	1	Needle Assembly W/Seal Kit (Item 11)
10.	GR1568	1	Seal Kit, Includes: (3) O-Rings, (1) Seal, (1) Spring
11.	GR1561	1	Sleeve
12.	GR1574	1	Sleeve, 1" O.D. x 1/2" Long, Stainless Steel
13.	GR1559	1	Body
14.	G10350	4	Hex Socket Head Plug, 1/4" NPT, Stainless Steel
A.	GA8931	1	Liquid Fertilizer Piston Pump Flow Divider Complete, 12 Outlet (Model FD-1200)
B.	GA9407	1	Liquid Fertilizer Piston Pump Flow Divider Complete, 20 Outlet (Model FD-2000)

# REAR TRAILER HITCH

(A9895)

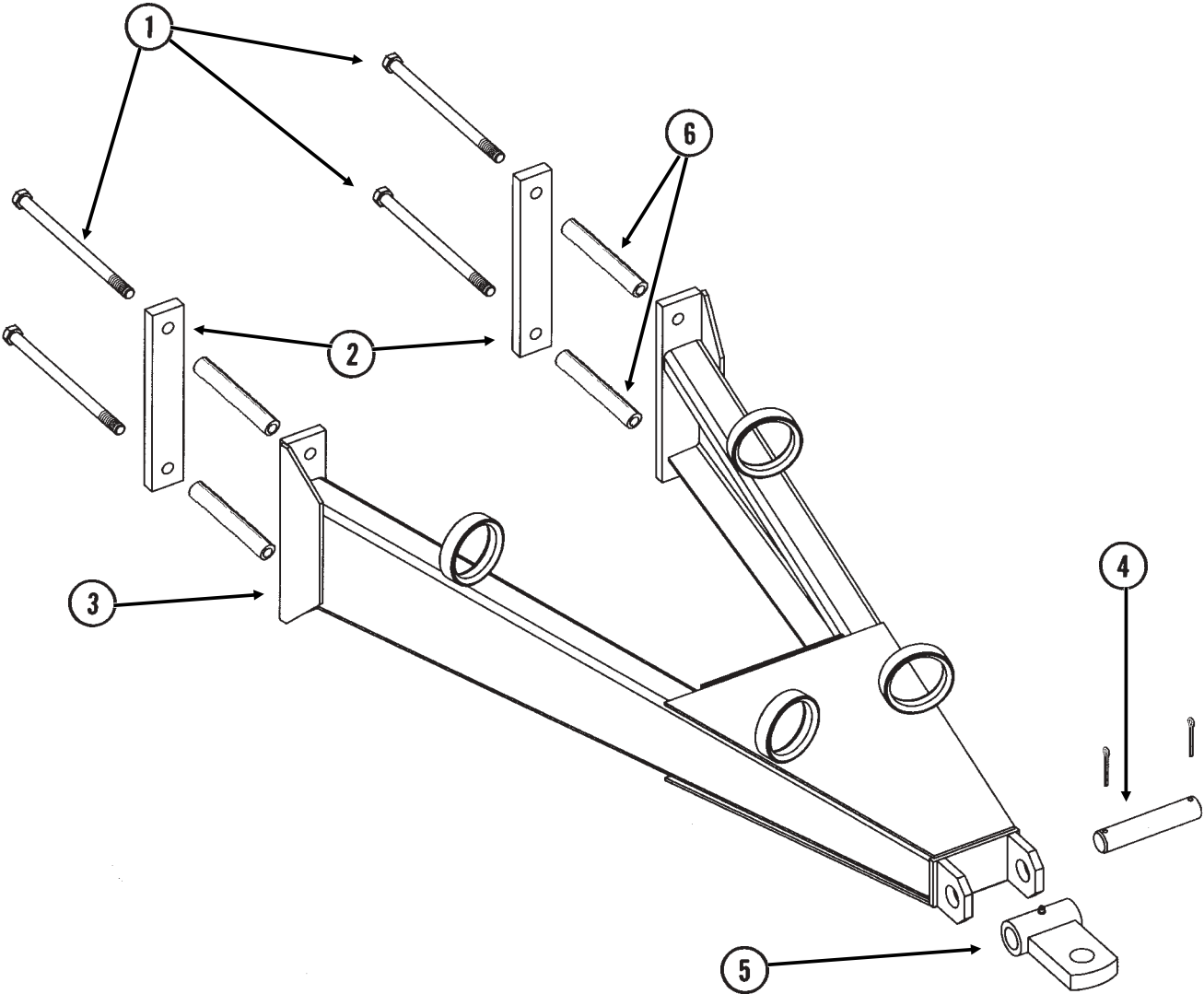

# REAR TRAILER HITCH

---

ITEM	PART NO.	QTY.	DESCRIPTION
1.	G11063	4	Hex Head Cap Screw, $\frac{5}{8}$ "-11 x 10 $\frac{1}{2}$ "
	G10230	4	Lock Washer, $\frac{5}{8}$ "
	G10104	4	Hex Nut, $\frac{5}{8}$ "-11
2.	GD14150	2	Clamp, 2" x 11 $\frac{3}{4}$ "
3.	GA9896	1	Hitch
4.	GD8839	1	Pin, 1 $\frac{1}{4}$ " x 6 $\frac{1}{4}$ "
	G10460	2	Cotter Pin, $\frac{1}{4}$ " x 2"
5.	GA6177	1	Clevis W/Grease Fitting
	G10640	-	Grease Fitting, $\frac{1}{4}$ "-28
6.	GD7817-14	4	Spacer, $\frac{11}{16}$ " I.D. x 7 $\frac{7}{8}$ " Long (If Applicable)

# DECALS, PAINT AND MISCELLANEOUS

**WARNING**

ALWAYS USE SAFETY PINS IN TRANSPORT POSITION

7100-2

1



2



4



3



5

**WARNING**

AGRICULTURAL CHEMICALS CAN BE DANGEROUS. IMPROPER SELECTION OR USE CAN SERIOUSLY INJURE PERSONS, ANIMALS, PLANTS, SOIL OR OTHER PROPERTY. BE SAFE. SELECT THE RIGHT CHEMICAL FOR THE JOB. HANDLE WITH CARE. FOLLOW THE INSTRUCTIONS ON THE CONTAINER LABEL AND OF THE EQUIPMENT MANUFACTURER.

7100-115

6

**DANGER**

SERIOUS INJURY OR DEATH CAN RESULT FROM CONTACT WITH ELECTRICAL LINES. USE CARE TO AVOID CONTACT WITH ELECTRIC LINES WHEN MOVING OR OPERATING THIS MACHINE.

7100-117

7

**WARNING**

DISCONNECT HYDRAULIC LINES FROM TRACTOR BEFORE REMOVING COVER.

SEE OPERATOR'S MANUAL FOR SERVICE INSTRUCTIONS.

7100-172

8

USE 1 TABLESPOON POWDERED GRAPHITE WITH EACH HOPPER FILL OF SEED. SEED TREATMENT, FOREIGN MATERIAL, DIRT, OR SEED CHAFF MAY CAUSE GRADUAL REDUCTION OF SEED POPULATION. REFER TO MANUAL FOR MAINTENANCE AND CARE.

7100-153

9

**Twin-Line**

7100-177

10

**WARNING**

ALWAYS USE SAFETY STAND IN TRANSPORT POSITION

7100-200

11

**ROTATION**

7100-192

12

**MARKER SPEED CONTROL**

LOWER RAISE

SEE MANUAL FOR PROPER ADJUSTMENT

7100-201

13

**Interplant**

14

TRANSMISSION RATE REDUCTION

DRIVE	DRIVEN	% REDUCTION & REPLICATION
18	38	50
17	38	45
22"	38	33
24	38	30
28"	38	17
28"	38	15
27	38	10

\* Use sprockets off seed drive transmission

7100-214

15

**DANGER**

DO NOT REMOVE THIS ASSEMBLY AFTER PLANTER IS ASSEMBLED FOR USE. REMOVAL OF THIS WHEEL AND AXLE ASSEMBLY CAN CAUSE THE MACHINE TO BECOME UNSTABLE AND TIP OVER CAUSING DAMAGE OR SERIOUS INJURY.

7100-215

16

**NOTE**

It is the responsibility of the user to read and understand the Operator's Manual in regards to safety, operation, lubrication and maintenance before operation of this equipment.

AN OPERATOR & PARTS MANUAL IS AVAILABLE FOR THIS MACHINE.

To obtain a manual, furnish model number and serial number and contact your KINZE Dealer or KINZE Manufacturing, Inc., P.O. Box 806 Williamsburg, IA 52361-0806 USA

17

**WARNING**

MAXIMUM INFLATION PRESSURE 75 PSI

7100-211

18

**WARNING**

MAXIMUM INFLATION PRESSURE 75 PSI

19

TORQUE 5/8" SPINDLE BOLTS TO 120 FT/LBS. CHECK PERIODICALLY AND RE-TORQUE AS NEEDED.

7100-234

20



21

**KINZE 3650**

22

**IMPORTANT**

SEED METER ALIGNMENT TO DRIVE CLUTCH IS CRITICAL. REFER TO OPERATOR'S MANUAL FOR INSTRUCTIONS.

7100-248

24

**WARNING**

TO AVOID INJURY -- STAND CLEAR--KEEP OTHERS AWAY WHEN RAISING OR LOWERING MARKERS. BEFORE TRANSPORTING PLANTER FULLY EXTEND HYDRAULIC CYLINDERS AND INSTALL LOCKING PINS WHERE PROVIDED.

7100-42

25

**CAUTION**

SET DOWN PRESSURE SPRINGS TO MINIMUM. LOWER PLANTER TO GROUND AND EMPTY SEED HOPPERS. REQUIRES 90 LB MIN TO LIFT.

7100-249

23

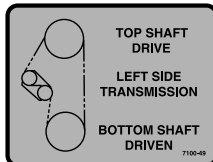

26

**WARNING**

TOW ONLY WITH FARM TRACTOR

7100-56

27

**WARNING**

1. Read and understand the Operator's Manual.
2. Stop the tractor engine before leaving the operator's platform.
3. Keep riders off the machine.
4. Make certain everyone is clear of the machine before starting the tractor engine and operating.
5. Keep all shields in place.
6. Never lubricate, adjust, unclog or service the machine with tractor engine running.
7. Wait for all movement to stop before servicing.
8. Keep hands, feet and clothing away from moving parts.
9. Use flashing warning lights when operating on highways except when prohibited by law.

7100-46

28

**CAUTION**

REAR OF PLANTER SWINGS WIDE IN TURNS. ALWAYS ALLOW SUFFICIENT ROOM TO CLEAR OBSTACLES WHEN TURNING.

7100-63

29



# DECALS, PAINT AND MISCELLANEOUS

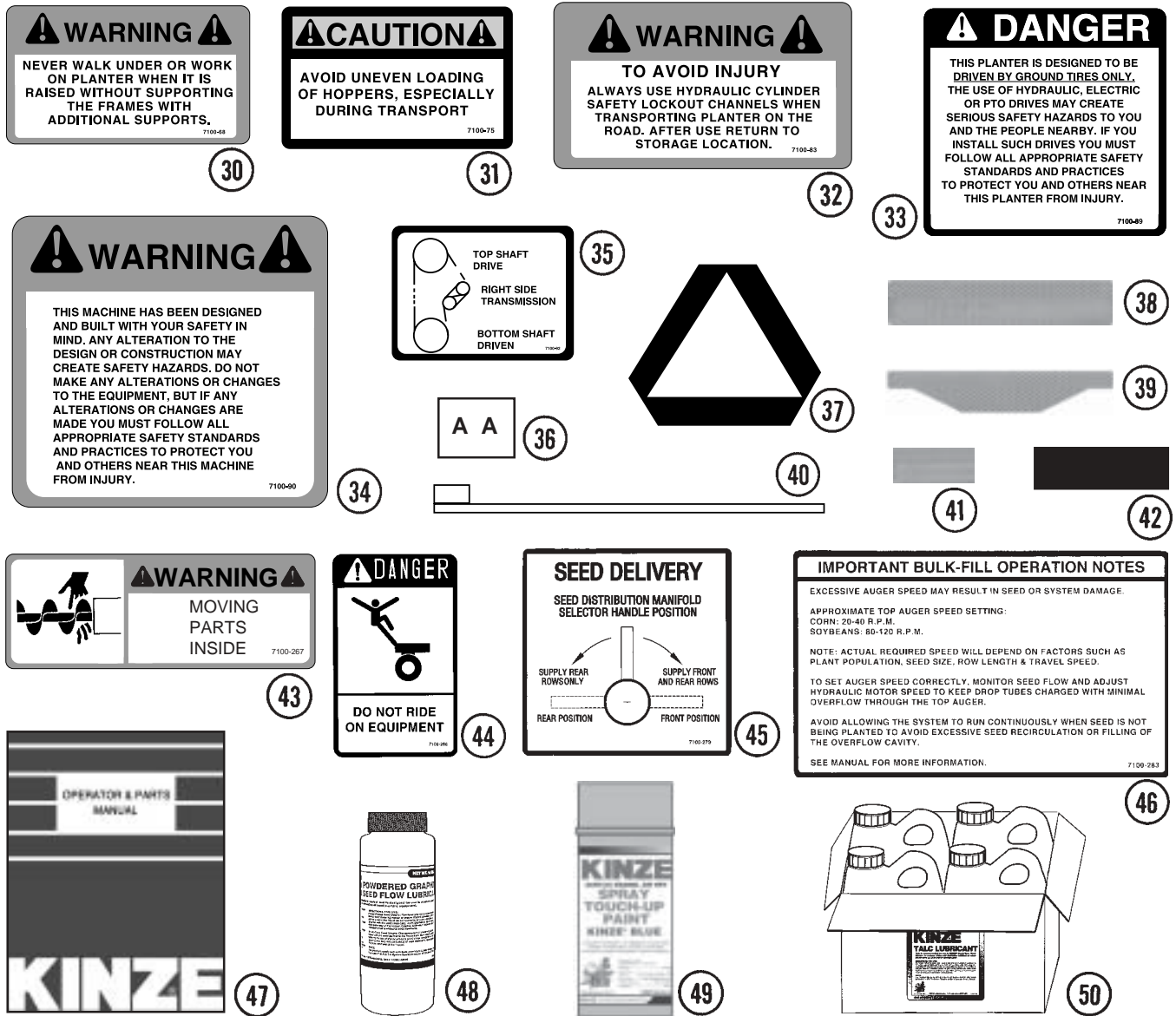

ITEM	PART NO.	QTY.	DESCRIPTION
1.	G7100-02	3	Decal, Warning
2.	G7100-110	-	Decal, Grease Weekly
3.	G7100-111	-	Decal, Oil Daily
4.	G7100-116	-	Decal, Grease Daily
5.	G7100-277	-	Decal, Grease Annually
6.	G7100-115	-	Decal, Warning (1 Per Granular Chemical Hopper)
7.	G7100-117	1	Decal, Danger
8.	G7100-172	-	Decal, Warning
9.	G7100-153	-	Decal, Information (1 Per Brush-Type Seed Meter)
10.	G7100-177	1	Decal, Twin-Line®, 3/4" x 3"
11.	G7100-200	-	Decal, Warning
12.	G7100-192	-	Decal, Point Row Clutch Rotation
13.	G7100-201	1	Decal, Information
14.	G7100-208	-	Decal, Interplant®
15.	G7100-214	-	Decal, Two-Speed Point Row Clutch Rate Reduction
16.	G7100-215	1	Decal, Danger
17.	G7100-217	-	Decal, Note

# DECALS, PAINT AND MISCELLANEOUS

ITEM	PART NO.	QTY.	DESCRIPTION
18.	G7100-219	-	Decal, Warning
19.	G7100-275	-	Decal, Warning
20.	G7100-234	-	Decal, Bolt Torque
21.	G7100-247	-	Decal, Logo, 4 3/8" x 4 1/2" (2 Per Row Unit)
	G7100-252	-	Decal, Logo, 3 1/2" x 3 5/8" (Hopper Panel Extension)
22.	G7100-264	2	Decal, 3650
23.	G7100-249	-	Decal, Caution
24.	G7100-248	-	Decal, Meter Alignment (1 Per Row Unit)
25.	G7100-42	4	Decal, Warning
26.	G7100-49	1	Decal, Left Side Transmission
27.	G7100-56	1	Decal, Warning
28.	G7100-46	1	Decal, Warning
29.	G7100-63	2	Decal, Caution
30.	G7100-68	3	Decal, Warning
31.	G7100-75	4	Decal, Caution
32.	G7100-83	2	Decal, Warning (1 Per Marker Lockup)
33.	G7100-89	2	Decal, Danger
34.	G7100-90	1	Decal, Warning
35.	G7100-92	1	Decal, Right Side Transmission
36.	GD10057-01	-	Hose Identification Sleeve, Red AA
	GD10057-02	-	Hose Identification Sleeve, Red BB
	GD10057-03	-	Hose Identification Sleeve, Blue AA
	GD10057-04	-	Hose Identification Sleeve, Blue BB
	GD10057-05	-	Hose Identification Sleeve, Black AA
	GD10057-06	-	Hose Identification Sleeve, Black BB
37.	GD2199	1	SMV Sign
38.	G7100-258	-	Reflective Decal, Red, 1 1/2" x 9", Rectangular (If Applicable)
	G7100-259	-	Reflective Decal, Amber, 1 1/2" x 9", Rectangular (If Applicable)
	G7100-260	-	Reflective Decal, Orange, 1 1/2" x 9", Rectangular (If Applicable)
39.	G7100-261	-	Reflective Decal, Red, 1 3/4" x 9", Die-Cut (If Applicable)
	G7100-262	-	Reflective Decal, Amber, 1 3/4" x 9", Die-Cut (If Applicable)
	G7100-263	-	Reflective Decal, Orange, 1 3/4" x 9", Die-Cut (If Applicable)
40.	GD1512	-	Tie Strap, 7 1/2"
	GD2117	-	Tie Strap, 14 1/2"
	GD1162	-	Tie Strap, 28"
	GD2984	-	Tie Strap, 34"
41.	G7100-276	-	Reflective Decal, Orange, 1" x 2 1/4", Rectangular
42.	GD13706-01	-	Antislip Tape, 4" x 9"
	GD13706-02	-	Antislip Tape, 4" x 12"
	GD13706-03	-	Antislip Tape, 4" x 16"
43.	G7100-267	-	Decal, Warning
44.	G7100-266	-	Decal, Danger
45.	G7100-279	-	Decal, Seed Delivery (Located On Underside Of Hopper Lid)
46.	G7100-283	-	Decal, Important (Located On Underside Of Hopper Lid)
47.	GM0175	-	Operator & Parts Manual, Model 3650
48.	GR0146	-	Powdered Graphite, 1 Pound Container
	GR0146MPP	-	Powdered Graphite, Twenty-Four 1 Pound Containers
49.	GR0155	-	Blue Paint, Aerosol Can (Shown)
	GR0155MPP	-	Blue Paint, Twelve Aerosol Cans
50.	GR1570MPP	-	Talc Lubricant, Four 8 Pound Containers

# NUMERICAL INDEX

Part No.	Page	Part No.	Page	Part No.	Page
A1008	P98, P100	A8995	P55	G10043	P17, P18
A1018	P98, P100	A9001	P49	G10045	P33, P113
A1021	P100	A9015	P81, P82	G10046	P39, P73, P113, P119
A1053	P99, P101	A9018	P77	G10047	P63, P71, P119
A1054	P98, P100	A9069	P51	G10049	P15, P19, P67, P75
A1073	P99, P101	A9070	P51	G10050	P51
A1076	P99, P101	A9072	P51	G10053	P47, P70, P71
A1079	P98	A9073	P51	G10054	P91, P129
A1086	P98	A9146	P45	G10055	P37
A1098	P99, P101	A9151	P45	G10060	P13
A1106	P97	A9467	P80	G10061	P9
A1116	P97	D13169	P84	G10062	P89
A1129	P97	D13426	P83	G10064	P8, P51, P60, P71
A1139	P97	G10001	P4, P13, P14, P15, P17, P19, P49, P51, P116	G10068	P37, P75
A1189	P99, P101	G10002	P13, P25, P119	G10087	P12, P61
A1424	P99, P101	G10003	P3, P8, P15, P19, P129	G10096	P123
A1444	P97	G10004	P15, P41, P47, P53, P63, P105, P107, P111, P117	G10097	P55
A1457	P99, P101	G10005	P39, P60, P115, P124	G10098	P55
A1463	P97	G10006	P33, P43	G10100	P45, P117
A1464	P99, P101	G10007	P5, P15, P19, P39, P116, P123, P125	G10101	P4, P8, P15, P41, P45, P47, P51, P63, P67, P69, P81, P82, P105, P107, P111, P113, P129, P131
A1477	P97	G10008	P36, P37	G10102	P33, P37, P39, P43, P45, P49, P55, P59, P61, P62, P71, P73, P75, P76, P111, P113, P115, P119, P125
A3101	P98, P100	G10009	P35, P39, P42	G10103	P51, P59, P60, P67, P69, P71, P105, P107, P109
A3115	P97	G10010	P7, P115, P121	G10104	P4, P11, P13, P15, P37, P41, P42, P43, P49, P51, P59, P65, P70, P71, P73, P75, P109, P113, P115, P117, P127, P129, P135
A3118	P97	G10011	P39, P119	G10105	P43, P49, P55, P61, P116, P123, P125
A3128	P100	G10012	P37, P125	G10106	P31, P37, P47, P55, P59, P63, P70, P91
A3133	P97	G10013	P8, P70, P125	G10107	P8, P13, P15, P29, P31, P36, P37, P39, P43, P47, P59, P60, P65, P70, P71, P113, P119, P120, P124
A3137	P97	G10014	P7, P39, P43, P45, P55	G10108	P3, P9, P15, P19, P25, P41, P43, P45, P47, P49, P51, P59, P69, P71, P75, P78, P79, P88, P89, P116, P119, P120, P129
A3152	P99, P101	G10016	P15, P43, P62, P117		
A3153	P98, P100	G10017	P15, P31, P43, P45, P49, P55, P59 P73, P75, P119, P125		
A3156	P97	G10018	P7, P19, P115		
A3161	P98, P100	G10019	P17, P18, P55, P76, P113, P125, P129, P131		
A3163	P98, P100	G10020	P13, P15, P18, P22, P109		
A3183	P97	G10021	P22		
A3218	P98, P100	G10022	P22, P59, P78, P79, P105, P107, P109		
A3219	P98, P100	G10023	P25, P67, P69		
A3220	P98, P100	G10025	P49		
A3329	P99, P101	G10026	P43, P61, P125		
A3330	P99, P101	G10027	P53		
A3331	P97	G10028	P55		
A3332	P97	G10033	P19, P33		
A3333	P97	G10036	P15, P29, P37, P59		
A6020	P83, P84	G10037	P71		
A7010	P43	G10038	P51, P65		
A7088	P43	G10039	P31, P39, P55, P61, P117		
A7524	P87				
A7603	P97				
A8200	P97				
A8203	P97				
A8206	P97				
A8214	P99, P101				
A8215	P99, P101				
A8216	P97				
A8217	P97				
A8218	P97				
A8422	P25				
A8797	P80				

# NUMERICAL INDEX

Part No.	Page	Part No.	Page	Part No.	Page
G10109	.... P7, P8, P13, P17, P18, ..... P33, P35, P39, P76, ..... P113, P115, P120, ..... P123	G10227	..... P13, P18, P51, P59, ..... P60, P67, P69, P71, ..... P78, P79, P105, ..... P107, P109	G10328	..... P5, P85, P86
G10110	..... P15, P27, P51, P109	G10228	..... P7, P15, P33, P37, ..... P43, P45, P49, P55, ..... P59, P61, P62, P71, ..... P73, P75, P76, P111, ..... P113, P115, P119, ..... P125	G10330	..... P57
G10111	..... P8, P11, P17, P19, ..... P29, P31, P33, P37, ..... P39, P43, P45, P47, ..... P51, P62, P65, P70, ..... P71, P113, P117, ..... P119, P120	G10229	..... P4, P8, P14, P25, ..... P41, P45, P47, P51, ..... P63, P67, P69, P71, ..... P81, P82, P85, P86, ..... P105, P107, P111, ..... P113, P117, P129	G10336	..... P49
G10112	..... P39, P43	G10230	..... P4, P7, P8, P11, ..... P19, P41, P42, P43, ..... P51, P73, P75, P113, ..... P115, P117, P119, ..... P123, P124, P125, ..... P127, P135	G10338	..... P7, P9, P55
G10128	..... P13, P15, P59, P71	G10231	..... P43, P51, P55, P61, ..... P123, P125	G10348	..... P33
G10130	..... P14, P21, P63, P111	G10232	..... P19, P47, P55, P59, ..... P63, P70, P91, P113, ..... P119, P125	G10350	..... P133
G10131	..... P21, P45, P63	G10233	..... P14, P21, P59, P63, ..... P70, P111, P121	G10371	..... P33
G10133	..... P8, P33, P35, P39, ..... P91, P113, P120	G10234	..... P49	G10374	..... P67, P69
G10148	..... P35	G10235	..... P60, P109	G10389	..... P127
G10155	..... P55	G10237	..... P45, P117	G10400	..... P39
G10157	..... P42, P43	G10243	..... P104, P106	G10401	..... P22
G10159	..... P15, P49, P51	G10251	..... P109	G10404	..... P49
G10168	..... P65, P76	G10253	..... P67	G10408	..... P71
G10169	..... P42	G10257	..... P26, P67	G10409	..... P71
G10172	..... P47	G10278	..... P60, P123, P127	G10412	..... P4, P9, P41
G10201	..... P3, P25, P40	G10283	..... P12	G10417	..... P15
G10203	..... P47, P67, P81, ..... P82, P120	G10284	..... P41	G10427	..... P5
G10204	..... P5, P7, P70, ..... P113, P121	G10292	..... P127	G10430	..... P60, P71
G10205	..... P15, P39, P43, P53, ..... P60, P65, P73, P75, ..... P115, P116, P117, ..... P125	G10303	..... P17, P59, P63	G10438	..... P3, P115
G10206	..... P11, P35, P37, P65, ..... P70, P111, P119	G10304	..... P3	G10439	..... P51
G10207	..... P3	G10305	..... P17, P113	G10443	..... P53
G10209	..... P18, P26, P27, ..... P60, P71	G10306	..... P119, P120	G10445	..... P62, P71
G10210	..... P3, P8, P9, P13, ..... P15, P19, P25, P41, ..... P47, P63, P71, P111, ..... P113, P119, P129	G10307	..... P41	G10448	..... P57
G10211	..... P13, P103, P105, ..... P107, P109	G10308	..... P8	G10449	..... P80
G10213	..... P5, P35, P37, ..... P39, P113	G10309	..... P9	G10450	..... P119
G10216	..... P7, P15, P17, P19, ..... P31, P41, P43, P45, ..... P49, P59, P61, P71, ..... P115, P117, P125	G10312	..... P3, P14, P17, ..... P25, P51, P70	G10451	..... P113
G10217	..... P19, P37, P119, ..... P125	G10314	..... P62	G10456	..... P41, P115
G10219	..... P13, P17, P119	G10315	..... P8, P27	G10457	..... P43
G10220	..... P116	G10318	..... P31, P129	G10459	..... P117
G10221	..... P113	G10322	..... P117	G10460	..... P15, P49, P51, P55, ..... P61, P73, P75, ..... P124, P135
G10226	..... P43, P61, P73	G10323	..... P22	G10462	..... P42, P45, P63
		G10325	..... P5, P25, P88	G10463	..... P41
		G10326	..... P3	G10464	..... P60
				G10468	..... P45
				G10470	..... P22, P71
				G10479	..... P55
				G10496	..... P67, P69, P111
				G10497	..... P67
				G10499	..... P113
				G10500	..... P22
				G10501	..... P13, P15, P33, ..... P59, P71
				G10503	..... P31, P113, P120
				G10504	..... P113
				G10507	..... P116
				G10509	..... P77, P81, P82
				G10521	..... P26
				G10523	..... P27
				G10526	..... P115
				G10527	..... P62
				G10531	..... P23
				G10535	..... P111
				G10536	..... P31, P73, P75
				G10542	..... P113

# NUMERICAL INDEX

Part No.	Page	Part No.	Page	Part No.	Page
G10543	P49	G10674	P123, P127	G10894	P45
G10544	P76	G10676	P123	G10900	P67
G10545	P4	G10681	P113, P127	G10901	P17
G10546	P9, P26, P71	G10686	P131	G10902	P47
G10551	P3	G10687	P131	G10907	P78, P79, P80
G10560	P115	G10688	P63, P111, P129	G10908	P120
G10567	P9, P26	G10689	P47	G10912	P5, P41
G10570	P26	G10690	P22	G10913	P57
G10572	P31, P37	G10693	P129	G10917	P123
G10573	P37	G10718	P41	G10918	P37, P59, P109
G10574	P29, P33, P37, P39	G10722	P76	G10921	P26
G10581	P13, P37, P45, P47, P47, P65, P111	G10724	P76	G10923	P14, P17, P18, P21, P63, P111
G10582	P37	G10725	P76	G10924	P7
G10583	P91	G10730	P39	G10927	P104, P106
G10584	P23	G10732	P4, P41	G10928	P104, P106
G10585	P31, P45	G10733	P127	G10931	P104, P106
G10592	P117	G10734	P127	G10932	P78, P79
G10594	P117	G10735	P127	G10938	P113
G10595	P59, P71	G10743	P13, P65, P71	G10939	P78, P79
G10597	P31	G10747	P37	G10940	P7
G10599	P41	G10751	P9, P41, P53	G10958	P78, P79, P80
G10600	P15	G10752	P9	G10961	P115, P121
G10602	P9, P14, P21, P22, P23, P26, P59, P62, P65, P71	G10753	P81, P82	G10962	P87
G10603	P22, P23, P120	G10755	P27, P104, P106	G10968	P111
G10604	P22	G10757	P27, P104, P106	G10972	P77, P81, P82, P85, P86
G10606	P14, P21	G10758	P27, P104, P106	G10974	P35, P39
G10610	P43, P61, P115	G10765	P35, P39, P43, P67, P69	G10977	P91
G10615	P127	G10770	P83, P84	G10979	P14, P75
G10616	P123	G10779	P15	G10985	P3
G10619	P123	G10801	P8	G10990	P85, P86
G10620	P3, P7, P9, P25, P51, P115, P121	G10802	P43	G10991	P119
G10621	P9, P22, P25	G10804	P67, P69	G10995	P127
G10622	P5	G10809	P43	G10996	P67, P69, P94, P103, P109
G10623	P123	G10827	P87	G10999	P10
G10626	P123, P127	G10828	P49	G11000	P19
G10629	P127	G10829	P17	G11001	P92
G10630	P123	G10830	P41, P120, P124	G11002	P91, P92, P109
G10633	P123	G10844	P76	G11004	P91
G10634	P23	G10857	P71	G11007	P3
G10636	P61	G10859	P67, P69	G11008	P3
G10640	P7, P12, P29, P37, P49, P53, P57, P80, P115, P117, P119, P120, P135	G10860	P13, P15, P59, P62, P65	G11009	P22, P23
G10641	P45, P73, P75, P116, P124	G10862	P117	G11010	P39
G10643	P39	G10863	P71	G11013	P55
G10659	P15	G10864	P27	G11015	P3
G10660	P26	G10870	P13, P15, P59, P62, P65	G11016	P83, P84
G10669	P3	G10871	P119	G11017	P13, P15, P17, P19
G10670	P25	G10872	P69	G11018	P53
G10673	P27	G10873	P69	G11019	P53
		G10874	P51	G11020	P18
		G10876	P69	G11022	P12
		G10887	P123	G11033	P10
		G10888	P123	G11034	P120
		G10889	P123	G11035	P13
		G10890	P59		

# NUMERICAL INDEX

Part No.	Page	Part No.	Page	Part No.	Page
G11036	P19	G3310-74	P71	G7100-219	P138
G11037	P10	G3310-80	P63	G7100-234	P138
G11039	P55	G3310-88	P14	G7100-247	P138
G11042	P125	G3400-01	P15, P63, P70	G7100-248	P138
G11058	P43	G4200-03	P123	G7100-249	P138
G11059	P109	G4200-06	P123	G7100-252	P138
G11062	P109	G4201-03	P123	G7100-258	P138
G11063	P13	G4205-08	P127	G7100-259	P138
G11069	P109	G4205-11	P123	G7100-260	P138
G11070	P109	G4301-05	P127	G7100-261	P138
G1K215	P115	G4301-06	P127	G7100-262	P138
G1K248	P103, P105, P107	G6325X	P4	G7100-263	P138
G1K249	P105 P107	G6400-06	P92	G7100-264	P138
G1K252	P103, P105, P107	G6400-06-08	P97, P98, P100	G7100-266	P138
G1K267	P103, P105, P107, P109	G6400-08	P78, P79, P89, P91, P92, P97, P98, P100	G7100-267	P138
G1K268	P103, P105, P107, P109	G6400-08-04	P85, P86, P98, P100	G7100-275	P138
G1K269	P63, P111	G6400-08-10	P91	G7100-276	P138
G1K274	P94	G6400-10	P91, P92, P97	G7100-277	P137
G1K275	P94	G6400-10-08	P88	G7100-279	P138
G1K320	P105, P107	G6400-L-08	P98, P100	G7100-283	P138
G1K321	P105, P107	G6408-08	P78, P79, P81, P82, P89, P91	G7100-42	P138
G1K322	P105, P107	G6408-10	P91	G7100-46	P138
G1K323	P105, P107	G6408-H06-O	P91, P92	G7100-49	P138
G1K324	P60	G6500-06	P92	G7100-56	P138
G1K338	P15	G6500-08	P98, P100	G7100-63	P138
G1K339	P15	G6502-06	P97	G7100-68	P138
G1K345	P8	G6502-08	P98, P100	G7100-75	P138
G1K355	P14	G6502-10	P88	G7100-83	P138
G1K356	P14	G6602-08	P98, P100	G7100-89	P138
G1K362	P107	G6602-10	P88	G7100-90	P138
G1K363	P107	G6801-06	P92	G7100-92	P138
G1K364	P105, P107	G6801-06-08	P81, P82, P97	G7633X	P103
G2100-03	P15, P63, P70	G6801-08	P89, P92, P98, P100	G7639X	P103
G2403-08	P99, P101	G6801-08-10	P91	G7698X	P51
G2403-10	P97	G6801-10	P99, P101	GA0167	P76
G2406-08-06	P98, P100	G6801-10-08	P88	GA0237	P116
G2500-84	P125	G6801-L-10	P9, P101	GA0241	P125
G2603-08	P98, P100	G7100-02	P137	GA0243	P76
G2700-08	P85, P86, P97, P99, P101	G7100-110	P137	GA0245	P76
G2700-10	P97	G7100-111	P137	GA0251	P125
G2704-08	P99	G7100-115	P137	GA0252	P125
G306-08	P85, P86, P97, P99, P101	G7100-116	P137	GA0257	P76
G306-10	P97	G7100-117	P137	GA0262	P125
G3200-59	P125	G7100-153	P137	GA0312	P113
G3303-11	P26	G7100-172	P137	GA0328	P113
G3303-96	P41	G7100-177	P137	GA0378	P60
G3303-98	P3	G7100-192	P137	GA0547	P125
G3310-100	P65, P71	G7100-200	P137	GA0810	P113
G3310-110	P59	G7100-201	P137	GA0895	P12, P61
G3310-118	P59	G7100-208	P137	GA0899	P76
G3310-126	P13	G7100-214	P137	GA10021	P109
G3310-222	P111	G7100-215	P137	GA1676	P76
		G7100-217	P137	GA1677	P76
				GA1678	P76
				GA1679	P76
				GA1720	P4, P41

# NUMERICAL INDEX

Part No.	Page	Part No.	Page	Part No.	Page
GA2007	P9, P41	GA5113	P62, P65, P70	GA6345	P115
GA2012L	P5	GA5114	P59	GA6434	P8
GA2012R	P5	GA5121	P49, P59	GA6478	P23
GA2014	P5, P15, P31, P33, P35, P37, P39, P109, P113, P120	GA5130	P73	GA6497	P49
GA2018	P22	GA5164	P60	GA6527	P127
GA2019	P22	GA5165	P60	GA6597	P8
GA2020	P22	GA5194	P65	GA6633	P23
GA2068	P59	GA5202	P13	GA6699	P103
GA2148	P61	GA5385	P103	GA6700	P103
GA2180	P63, P111	GA5548	P63	GA6741	P27
GA2528	P103	GA5600	P105, P107	GA6832	P33
GA2559	P125	GA5622	P29, P37	GA6833	P33
GA2612	P103	GA5625	P29	GA6834	P33
GA2660	P123	GA5630	P37	GA6838	P33
GA2908	P61	GA5631	P36	GA6907	P27
GA3407	P94	GA5635	P36	GA6966	P119
GA3413	P94	GA5636	P37	GA6975	P103
GA3552	P60	GA5637	P37	GA6977	P103
GA3553	P59	GA5640	P29, P37	GA6978	P103
GA3584	P102	GA5643	P37	GA7013	P47
GA3893	P127	GA5651	P4	GA7016	P43
GA4235	P62, P71	GA5654	P31, P33, P35 P37, P39, P120	GA7021	P47
GA4286	P116	GA5698	P23	GA7022	P43, P53
GA4287	P116	GA5699	P23	GA7029	P42
GA4293	P95	GA5715	P31	GA7042	P73
GA4309	P83	GA5718	P31	GA7043	P75
GA4310	P84	GA5719	P31	GA7049	P47
GA4353	P73	GA5786	P41	GA7050	P47
GA4376	P61	GA5787	P41	GA7051	P63, P111
GA4402	P42	GA5794	P23	GA7052	P63
GA4418	P43	GA5795	P23	GA7052	P111
GA4444	P25	GA5796	P23	GA7077	P103
GA4611	P73	GA5798	P36	GA7083	P42
GA4630	P62	GA5834	P23	GA7084	P42
GA4722	P57	GA5842	P42	GA7085	P42
GA4723	P57	GA5853	P76	GA7096	P53
GA4727	P57	GA5887	P116	GA7110	P67
GA4729	P57	GA5982	P23	GA7111	P67
GA4842	P43	GA6027	P23	GA7118	P75
GA4845	P42	GA6038	P23	GA7135	P113
GA4877	P75	GA6108	P103	GA7137	P67
GA4878	P75	GA6109	P103	GA7154	P13, P15, P59, P65, P70, P71, P111
GA4976	P123	GA6147	P105, P107	GA7180	P15
GA4983	P75	GA6154	P129	GA7221	P77
GA4994	P42	GA6168	P23	GA7239	P117
GA4995	P42	GA6171	P7, P8, P115, P121	GA7240	P117
GA5105	P59, P71	GA6177	P135	GA7255	P23
GA5106	P13, P62, P71	GA6182	P23	GA7271	P35
GA5107	P62, P63, P111	GA6184	P23	GA7274	P69
GA5108	P62, P71	GA6187	P23	GA7306	P71
GA5109	P62, P71	GA6189	P11	GA7307	P70
GA5110	P62, P71	GA6307	P124	GA7313	P71
GA5111	P62, P71	GA6308	P125	GA7317	P71
GA5112	P62, P71	GA6309	P125	GA7319	P71
		GA6344	P115	GA7320	P71

# NUMERICAL INDEX

Part No.	Page	Part No.	Page	Part No.	Page
GA7321	P71	GA8371	P25	GA9138	P111
GA7336	P63, P71	GA8393	P67, P69	GA9142	P49
GA7372	P60	GA8398	P119	GA9144	P105, P107
GA7399	P103	GA8399	P119	GA9157	P15
GA7412	P35	GA8483	P113	GA9158	P15
GA7423	P45	GA8495	P105	GA9159	P18
GA7424	P45	GA8603	P29, P37, P39, P119	GA9160	P15
GA7433	P43	GA8641	P29, P37, P39	GA9162	P15
GA7434	P57, P61	GA8651	P41	GA9168	P21
GA7445	P35, P39, P120	GA8677	P61	GA9169	P21
GA7446	P33, P35, P39, P120	GA8680	P105	GA9170	P19
GA7463	P69	GA8685	P113	GA9171	P19
GA7533	P43	GA8688	P117	GA9172	P13
GA7579	P49	GA8689	P117	GA9173	P13
GA7845	P123	GA8729	P103	GA9174	P18
GA7851	P105, P107	GA8731	P103	GA9175	P19
GA7852	P105	GA8734	P103	GA9176	P13
GA7853	P105, P107	GA8735	P103	GA9177	P21
GA7854	P105, P107	GA8760	P35	GA9179	P21
GA7855	P105, P107	GA8845	P113	GA9180	P21
GA7856	P103, P105, P107, P109	GA8857	P85	GA9181	P18
GA7857	P105, P107	GA8858	P85	GA9182	P13
GA7858	P105, P106	GA8859	P86	GA9183	P21
GA7859	P105, P107	GA8861	P86	GA9184	P21
GA7862	P103	GA8862	P86	GA9189	P21
GA7863	P103	GA8871	P87	GA9190	P21
GA7949	P7	GA8877	P115, P121	GA9191	P21
GA7965	P3	GA8882	P78, P79, P81, P82	GA9192	P21
GA7975	P7	GA8893	P85	GA9193	P21
GA7976	P7	GA8895	P87	GA9194	P21
GA7997	P61	GA8909	P80	GA9195	P113
GA7998	P120	GA8930	P41	GA9196	P19
GA7999	P120	GA8931	P133	GA9198	P57
GA8026	P105, P106	GA8978	P85	GA9199	P18
GA8037	P41	GA8979	P86	GA9202	P103
GA8046	P105, P107	GA8983	P113, P117, P119	GA9204	P103
GA8047	P103, P105, P107	GA9009	P78	GA9205	P84
GA8052	P107	GA9010	P78	GA9387	P21
GA8092	P111	GA9011	P78, P79	GA9388	P21
GA8129A	P95	GA9012	P81, P82	GA9389	P21
GA8129B	P95	GA9013	P81, P82	GA9390	P21
GA8131	P47	GA9016	P81	GA9393	P105
GA8157	P80	GA9019	P77	GA9395	P14
GA8170	P73, P75	GA9088	P73, P75	GA9404	P17
GA8304	P9	GA9089	P53	GA9407	P133
GA8305	P115	GA9093	P55	GA9433	P119
GA8306	P115	GA9094	P55	GA9434	P119
GA8320	P80	GA9095	P91	GA9437	P119
GA8322	P8	GA9097	P91	GA9461	P119
GA8324	P5	GA9098	P92, P109	GA9462	P119
GA8326	P26	GA9105	P41	GA9468	P80
GA8328	P109	GA9112	P103	GA9470	P79
GA8329	P109	GA9113	P103	GA9471	P79
GA8343	P22	GA9126	P95	GA9472	P121
GA8364	P26	GA9131	P39	GA9473	P121
		GA9134	P82	GA9479	P67, P69



# NUMERICAL INDEX

Part No.	Page	Part No.	Page	Part No.	Page
GA9480	P67, P69	GA9847	P107	GB0248	P119
GA9481	P103	GA9848	P15	GB0249	P119
GA9482	P67, P69	GA9849	P55	GB0254	P8
GA9483	P67, P69	GA9857	P107	GB0265	P3
GA9488	P55	GA9858	P107	GB0266	P3
GA9491	P55	GA9859	P15	GB0267	P3
GA9538	P9	GA9861	P39	GB0268	P8
GA9539	P9	GA9862	P39	GB0274	P3
GA9544	P57	GA9864	P39	GB0276	P7
GA9545	P57	GA9865	P39	GB0278	P9, P26
GA9547	P10	GA9867	P11	GB0282	P8
GA9549	P51	GA9868	P11	GB0285	P3
GA9553	P59	GA9890	P17	GB0287	P21, P63
GA9554	P15, P59	GA9891	P17	GB0296	P119
GA9556	P49	GA9892	P17	GB0297	P119
GA9557	P65	GA9893	P17	GB0301	P5, P41
GA9558	P65	GA9896	P135	GB0307	P19
GA9559	P83	GA9902	P51	GB0308	P15
GA9565	P119	GA9903	P51	GB0309	P51
GA9568	P67	GA9915	P53	GB0312	P19
GA9571	P69	GA9918	P71	GB0313	P19
GA9572	P69	GA9951	P109	GB0314	P9, P41
GA9574	P12	GA9952	P109	GB0315	P11
GA9588	P17	GA9953	P109	GD0453-03	P75
GA9589	P18	GA9954	P109	GD0453-07	P73
GA9602	P13	GA9955	P109	GD0487	P113
GA9603	P13	GA9957	P109	GD0535	P49
GA9618	P53	GA9958	P109	GD0652	P73, P75
GA9621	P18	GA9959	P109	GD0737	P75
GA9623	P10	GA9960	P109	GD0746	P76
GA9624	P13	GA9961	P109	GD0752-41	P15, P73
GA9625	P14	GA9962	P109	GD0752-47	P51
GA9667	P19	GA9963	P109	GD0826	P51
GA9671	P123	GA9964	P109	GD0831	P125
GA9681	P11	GA9965	P109	GD0840	P76
GA9682	P11	GA9978	P107	GD0844	P125
GA9683	P11	GA9979	P107	GD0914-106.5	P63
GA9684	P11	GB0110	P22	GD0914-124	P111
GA9685	P11	GB0111	P22	GD0914-138	P111
GA9686	P11	GB0115	P26	GD0914-166.75	P63
GA9688	P77	GB0116	P26	GD0914-30	P110
GA9709	P125	GB0120	P22	GD0914-35	P63
GA9711	P124	GB0134	P113	GD0914-45	P63
GA9712	P124	GB0186	P4	GD0914-48	P111
GA9823	P21	GB0196	P37, P125	GD0914-66	P111
GA9824	P21	GB0205	P116	GD0914-76	P111
GA9825	P21	GB0206	P116	GD0962	P113
GA9826	P21	GB0212	P115	GD10007	P65
GA9836	P42	GB0213	P39, P116	GD10011	P53
GA9837	P43	GB0218	P4, P9, P36, P39, P41, P43, P47, P60, P116, P124	GD10012	P53
GA9840	P51			GD10013	P53
GA9842	P77			GD10014	P53
GA9843	P60	GB0227	P29, P37	GD10036	P4
GA9844	P39	GB0237	P42	GD10053	P49
GA9845	P39	GB0239	P8	GD10057-01	P138
GA9846	P59	GB0246	P45	GD10057-02	P138

# NUMERICAL INDEX

Part No.	Page	Part No.	Page	Part No.	Page
GD10057-03	P138	GD1059L	P25	GD11297	P26
GD10057-04	P138	GD1059R	P25	GD1130	P3
GD10057-05	P138	GD1060	P25	GD11305	P9, P25
GD10057-06	P138	GD1061	P26	GD11306	P5, P113
GD10064	P55	GD1063	P26	GD11311	P22
GD10068	P67, P69	GD10635	P69	GD1132	P31, P33, P35, P37, P39, P113, P120
GD10069	P67, P69	GD10636	P69	GD11373	P22
GD10070	P67	GD10638	P69	GD11374	P23
GD10071	P67	GD10646	P43	GD1138	P113
GD10099	P60	GD1065	P3	GD11413	P9, P26
GD10100	P62	GD10705	P9, P17, P19, P41	GD11422	P4
GD10102	P67	GD10706	P49	GD11423	P7, P115, P121
GD10103	P67, P69	GD10707	P49	GD11424	P25
GD10110	P123	GD10733	P22	GD11447	P41
GD10120	P67, P69	GD10777	P123	GD11453	P7
GD10123	P67, P69	GD10792	P73	GD11474	P104, P106
GD10128	P61	GD10793	P75	GD11490	P12, P61
GD10144	P61	GD10795	P61	GD11528	P22
GD10207	P87	GD1083	P22	GD11557	P119
GD10211	P78	GD1085	P8	GD11558	P119
GD10226	P22	GD1086	P7	GD11579	P78, P79
GD10231	P55	GD10867	P3, P41	GD1162	P138
GD10242	P117	GD10936	P78	GD11649	P41
GD10243	P103	GD10958	P9	GD11652	P29, P37, P39
GD1026	P3, P25, P40, P63, P71, P119	GD10963	P27	GD11659	P41
GD10273	P117	GD10984	P27	GD1166	P125
GD10282	P69	GD10986	P3	GD11677	P29
GD10283	P76	GD10991	P7	GD11695	P61
GD10298	P59	GD10993	P3	GD11698	P37
GD10303	P117	GD11001	P3	GD11700	P127
GD10304	P117	GD11017	P5	GD11705	P113
GD1033	P3	GD1104	P116	GD11751	P55
GD10355	P71	GD11045	P14, P21, P63, P110	GD11752	P41
GD10356	P13, P62, P70, P71	GD11089	P103, P105, P107	GD11787	P22
GD10366	P71	GD1109	P8, P37	GD11791	P75
GD1039	P22	GD11120	P67, P69	GD11836	P120
GD1041	P22	GD11122	P23	GD11845	P3, P5, P15, P109
GD1042	P22	GD1113	P4, P11, P41, P51, P113, P117, P119, P123, P127	GD11951	P78, P79
GD10473	P5, P15, P109	GD11169	P104, P106	GD11953	P115, P121
GD10487	P117	GD11170	P104, P106	GD11954	P115, P121
GD10510	P67, P69	GD11178	P120	GD11962	P3, P25, P41
GD10519	P35, P39	GD11188	P120	GD11968	P18
GD10526	P35	GD11193	P78	GD11970	P85, P86
GD10530	P45	GD11218	P40	GD11983	P87
GD10531	P49	GD11219	P25	GD11984	P85, P86
GD10538-01	P45	GD11239	P9, P26	GD11988	P77
GD10543	P67, P71	GD11240	P26	GD11992	P77
GD10552	P33, P35, P39, P120	GD11253	P78	GD11993	P105, P107
GD10578	P69	GD11259	P3, P5	GD11994	P80
GD10579	P69	GD11263	P41	GD11995	P80
GD10584	P69	GD11264	P41	GD12132	P10
GD10585	P69	GD11265	P120	GD12534	P33
GD10586	P69	GD11266	P120	GD12543	P61
GD10587	P69	GD11286	P22	GD1255	P60, P71
GD10588	P69			GD1256	P60

# NUMERICAL INDEX

Part No.	Page	Part No.	Page	Part No.	Page
GD12597	P85, P86, P78, P79	GD13168	P21	GD13519	P53
GD12658	P81, P82	GD13170	P83, P84	GD13520	P53
GD12659	P81, P82	GD13171	P84	GD13524-01	P15, P21
GD12660	P81, P82	GD13172	P83, P84	GD13525	P53
GD12665	P81, P82	GD13173	P83, P84	GD13530	P10
GD12667	P77	GD13183	P18	GD13533	P12
GD12676	P119	GD13185	P12	GD13534	P12
GD12677	P119	GD13186	P12	GD13542	P21
GD12679	P119	GD13190	P17	GD13554	P15
GD12684	P120	GD13194	P12	GD13555	P15, P19
GD12685	P119	GD13198	P17	GD13568	P55
GD12696	P12	GD13203	P21	GD13571	P19
GD12698	P12	GD13204	P21	GD13575-01	P14
GD12703	P51	GD13205	P18	GD13575-02	P14
GD12724	P51	GD13206	P18	GD13576	P19
GD12726	P102	GD13207	P18	GD13577	P19
GD12754	P51	GD13208	P18	GD13595	P17
GD12758	P89	GD13211	P18	GD13597	P15
GD12774	P49	GD13217	P17	GD13645	P10
GD12791	P13	GD13218	P17	GD13648	P123
GD12797-01	P10	GD13225	P12	GD13652	P60
GD12797-02	P10	GD13226-01	P12	GD13706-01	P138
GD12797-03	P10	GD13227	P19	GD13706-02	P138
GD12817	P39	GD13246	P13	GD13706-03	P138
GD12818	P92	GD13287	P119	GD13744	P125
GD12819	P49	GD13302	P80	GD13766	P124
GD12826	P39	GD13303	P79, P80	GD13790	P18
GD12827	P39	GD13304	P79, P80	GD14056	P15
GD12829	P39	GD13306	P79	GD14057	P15
GD12847	P17	GD13307	P79	GD14058	P19
GD13107	P49	GD13309	P121	GD14059	P77
GD13110	P9, P41	GD13310	P103, P109	GD14066	P49
GD13120	P19	GD13328	P55, P125	GD14067	P21
GD13122	P15	GD13329	P55	GD14073	P55
GD13123	P15	GD13331	P55	GD14077	P55
GD13124	P19	GD13332	P55	GD14091	P55
GD13125	P19	GD13337	P55	GD14092	P55
GD13126	P19	GD13338	P53	GD14093	P49
GD13127	P19	GD13348	P103	GD14094	P12
GD13128	P13	GD13350	P53	GD14102	P49
GD13129	P13	GD13351	P19	GD14107	P12
GD13134	P13	GD13361	P3	GD14108	P21
GD13136	P18	GD1337	P123	GD14111	P13
GD13138	P19	GD13382	P19	GD14112	P12
GD13142	P15	GD13396	P12	GD14115	P60
GD13143	P15	GD13400	P83, P84	GD14121	P43
GD13144	P14	GD13409	P57	GD14150	P135
GD13146	P91	GD13412	P10	GD14163	P51
GD13147	P15	GD13425	P83	GD14170	P39
GD13148	P19	GD13432	P14	GD14192	P53
GD13149	P13	GD13433	P14	GD14254	P109
GD13151	P17	GD13434	P14	GD14255	P109
GD13152	P17	GD13460	P14	GD14256	P109
GD13153	P51	GD13464	P19	GD14257	P109
GD13154	P49	GD13470	P17	GD14258	P109
GD13163	P18	GD13491	P17	GD14259	P109

# NUMERICAL INDEX

Part No.	Page	Part No.	Page	Part No.	Page
GD14261	P109	GD4743	P75	GD7823	P31, P37
GD14266	P109	GD4850	P115	GD7831	P37, P125
GD14269	P109	GD4888	P115	GD7864	P57
GD14270	P109	GD5154	P43, P45	GD7878	P23
GD14390	P88	GD5173	P42, P45	GD7883	P45
GD1512	P21	GD5212	P59, P62	GD7889	P31, P65
GD1512	P138	GD5789	P60	GD7890	P31
GD1520	P123	GD5790	P60	GD7900	P116
GD1657	P113	GD5804	P43, P45	GD7904-02	P49, P117
GD1673	P113	GD5841	P61	GD7904-05	P17
GD1701	P75	GD5857	P13, P15, P33, P43, P59, P62, P65, P70, P104, P106	GD7907	P117
GD1719	P111			GD7908	P116
GD1747	P123			GD7911	P115
GD1755	P23	GD5875	P51	GD7962	P120
GD1812	P123	GD5892	P43	GD8066-02	P91
GD1862	P123	GD6291	P103, P105, P107	GD8188	P43, P45, P47
GD1908	P51	GD6501	P22	GD8189	P42, P43, P45, P47
GD2117	P105, P107, P138	GD6553	P116	GD8218	P115
GD2161	P73	GD6556	P43	GD8224	P117
GD2169	P53, P55	GD6775	P59	GD8237	P23
GD2199	P59, P138	GD6780	P62	GD8238	P116
GD2423	P27	GD6895	P60	GD8239	P117
GD2557	P42	GD7079	P57	GD8249	P4, P49
GD2558	P42, P59, P62, P71, P125	GD7089	P57	GD8260	P43
GD2589	P113	GD7120	P83, P84	GD8276	P45, P117
GD2597	P76	GD7122	P83, P84	GD8306	P111
GD2681	P124	GD7123	P84	GD8307	P31, P37
GD2721	P11, P73, P75	GD7124	P83	GD8308	P115
GD2734-13	P15	GD7127	P63	GD8460	P8
GD2829	P103	GD7137	P43	GD8739	P103
GD2947	P27	GD7147	P85, P86	GD8740	P103
GD2971-09	P43	GD7148	P26	GD8741	P103
GD2971-10	P25	GD7209	P75	GD8751	P105, P107
GD2984	P138	GD7251	P43	GD8770	P105, P107
GD3180-05	P62	GD7258	P26	GD8771	P105, P107
GD3180-18	P71	GD7318	P3	GD8778	P23
GD3214	P73	GD7426	P63, P71	GD8839	P135
GD3501	P43	GD7518	P43	GD8843	P29, P37
GD3537-11	P45	GD7519	P43	GD8844	P29, P37
GD3537-12	P45	GD7612	P63	GD8893-01	P40
GD3537-17	P45	GD7803	P29, P37, P39	GD8917	P125
GD3537-18	P45	GD7804	P29, P37, P39	GD9052	P49
GD3612	P3	GD7805	P4, P8, P9, P31, P36, P37, P41, P43, P47, P49, P53, P60, P120, P121, P124, P125	GD9120	P8
GD3622	P123			GD9229	P111
GD3623	P123	GD7811	P37	GD9254	P29, P37, P39
GD3660-16	P21	GD7815	P36	GD9529	P94, P102
GD3660-17	P21	GD7816	P37	GD9530	P94, P102
GD3860	P103	GD7817-01	P31, P37	GD9533	P91
GD3951	P123	GD7817-04	P31, P37, P120	GD9667	P67
GD4086	P97	GD7817-05	P125	GD9671	P67, P69
GD4163	P109	GD7817-09	P37	GD9672	P67, P69
GD4700	P59	GD7817-14	P135	GD9695	P41
GD4701	P59	GD7818	P37	GD9705	P115
GD4743	P73			GD9706	P115
				GD9709	P115

# NUMERICAL INDEX

Part No.	Page	Part No.	Page	Part No.	Page
GD9715	P33	GR1018	P123	GR1293	P63, P111
GD9720	P33	GR1019	P123	GR1294	P63, P111
GD9724	P33, P35, P39, P120	GR1037	P78, P79, P81, P82, P88, P89, P91, P92, P97, P98, P100	GR1295	P63, P111
GD9896	P103			GR1296	P63, P111
GD9905	P92	GR1045	P91, P92	GR1297	P63, P111
GD9952	P47	GR1100	P129	GR1301	P63, P111
GD9953	P43	GR1102	P129	GR1303	P67, P69
GD9959	P43, P45	GR1104	P129	GR1304	P67, P69
GD9960	P43	GR1105	P129	GR1305	P67, P69
GD9969	P59	GR1106	P129	GR1306	P67, P69
GD9977	P91	GR1107	P129	GR1327	P22
GD9981	P73, P75	GR1108	P129	GR1363	P103
GM0175	P138	GR1109	P129	GR1364	P103
GR0146	P138	GR1110	P129	GR1390	P105
GR0146MPP	P138	GR1111	P129	GR1391	P105, P107
GR0150	P76	GR1112	P129	GR1392	P105
GR0151	P76	GR1114	P129	GR1393	P105, P107
GR0155	P138	GR1116	P129	GR1395	P105
GR0155MPP	P138	GR1118	P129	GR1402	P95
GR0188	P116	GR1119	P129	GR1403	P95
GR0190	P125	GR1120	P129	GR1404	P95
GR0193	P53	GR1122	P129	GR1405	P111
GR0195	P125	GR1123	P129	GR1406	P111
GR0196	P3, P26, P41	GR1124	P131	GR1407	P111
GR0200	P125	GR1125	P131	GR1408	P111
GR0204	P125	GR1127	P131	GR1409	P111
GR0267	P125	GR1129	P131	GR1410	P111
GR0270	P61	GR1130	P131	GR1411	P111
GR0375	P53	GR1132	P131	GR1412	P111
GR0434	P12, P61	GR1133	P131	GR1413	P111
GR0508	P123	GR1134	P131	GR1414	P104, P106
GR0513	P123	GR1135	P131	GR1415	P104, P106
GR0515	P42	GR1136	P131	GR1461	P105, P107
GR0516	P42	GR1137	P131	GR1465	P85, P86, P98, P100
GR0517	P42	GR1140	P131	GR1466	P91, P92, P97, P99, P101
GR0528	P57	GR1142	P131	GR1487	P22
GR0531	P57	GR1143	P131	GR1513	P95
GR0586	P105, P107	GR1144	P131	GR1514	P95
GR0594	P105, P107	GR1145	P131	GR1515	P95
GR0664	P22	GR1146	P125	GR1519	P85, P86
GR0761	P94	GR1147	P129	GR1521	P87
GR0763	P94	GR1148	P129	GR1523	P80
GR0764	P94, P95	GR1165	P129	GR1524	P77
GR0880	P127	GR1166	P129	GR1533	P133
GR0881	P127	GR1167	P129	GR1535	P133
GR0882	P127	GR1168	P129	GR1540	P133
GR0883	P127	GR1173	P129, P131	GR1541	P133
GR0912	P13, P14, P59, P63, P65, P71, P71, P111	GR1203	P103	GR1542	P133
GR0999	P83, P84	GR1204	P103	GR1543	P133
GR1001	P83, P84	GR1205	P103	GR1544	P133
GR1005	P123	GR1206	P103	GR1545	P133
GR1006	P123	GR1207	P103	GR1550	P78
GR1015	P123	GR1208	P103	GR1551	P81, P82
GR1016	P123	GR1290	P103	GR1557	P63, P111
GR1017	P123	GR1292	P103	GR1558	P14

# NUMERICAL INDEX

Part No.	Page	Part No.	Page	Part No.	Page
GR1559 .....	P133				
GR1561 .....	P133				
GR1566 .....	P133				
GR1567 .....	P133				
GR1568 .....	P133				
GR1570MPP .....	P138				
GR1572 .....	P79				
GR1573 .....	P80				
GR1574 .....	P133				
GR1598 .....	P83, P84				
GR1601 .....	P93				
GR1602 .....	P93				
GR1603 .....	P88				
GR1604 .....	P93				
GR1605 .....	P93				
GR1606 .....	P93				
GR1607 .....	P88				
GR1608 .....	P93				
GR1609 .....	P88				
GR1610 .....	P93				
GR1627 .....	P95				
GR1628 .....	P103				
GR1629 .....	P107				
GR1631 .....	P107				
GR1632 .....	P107				
GR1635 .....	P91, P92, P109				
GR1637 .....	P14				