

MODEL 3700 FRONT FOLD PLANTER OPERATOR MANUAL

M0233-01

Rev. 7/14

This manual is applicable to: Model 3700 Forward Folding Planters
2010 to 2014 Production

Record the model number and serial number of your planter along with date purchased:
3700

Model Number _____

Serial Number _____

Date Purchased _____

Monitor Serial Number _____
Measured Pulses Per Mile/Km (Radar Distance Sensor) _____
Measured Pulses Per Mile/ Km (Magnetic Distance Sensor) _____

SERIAL NUMBER

The serial number plate is located on the planter frame as shown below. The serial number provides important information about your planter and is needed to obtain correct replacement parts. Always provide model number and serial number to your Kinze Dealer when ordering parts or when contacting Kinze Manufacturing, Inc.

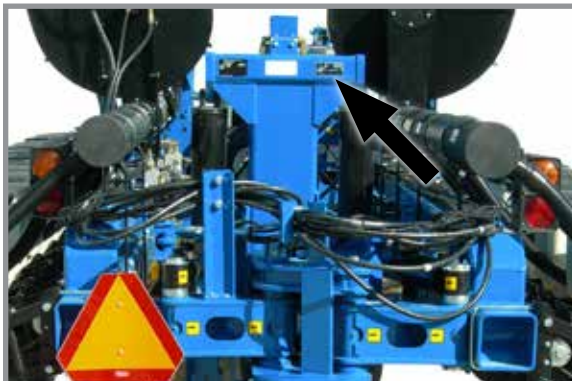

Serial number plate location - prior to 2013



**Serial number plate location -
2013 production and on**

This page intentionally left blank.

OVERVIEW

To The Owner	1-1
Warranty	1-2
General Information	1-2
Specifications	1-3
General Safety Rules	1-5
Safety Signs And Decals	1-6
Safety Precautions	1-6

MACHINE OPERATION

Planter Lift Safety Lockup	2-1
Row Marker Safety Lockup	2-1
Hitch Parallel Linkage Lockup	2-2
2-Speed Jack Assembly	2-2
Initial Planter Preparation	2-3
Tractor Requirements	2-4
EdgeVac Tractor Mounted PTO Pump and Planter Mounted Hydraulics	2-4
Tractor Preparation and Hookup	2-5
Transporting Planter	2-7
Level Planter	2-8
Contact Wheel Spring Adjustment	2-8
Contact Wheel Drive Sprockets	2-9
Seed Rate Transmission Adjustment	2-9
Wrap Spring Wrench Operation	2-10
Shear Protection	2-10
Sliding Hitch Linkage	2-11
Hydraulic/Electric Operation	2-12
Hydraulic Drive	2-13
Ag Leader Electric Clutches	2-13
Row Unit Air Clutches	2-13
Hall Effect Sensor	2-13
Transport to Field Sequence	2-14
Field Operation	2-17
Field to Transport Sequence	2-18
Row Marker Operation	2-22
Row Marker Speed Adjustment	2-23
Row Marker Chain Adjustment	2-23
Row Marker Length And Disc Blade Adjustment	2-24
EdgeVac System	2-25
Vacuum Fan Valve Block Assembly	2-25
Analog Vacuum or Pressure Gauge	2-25
Air Seed Delivery (ASD) System	2-26
ASD Entrainer Access	2-26
ASD Tanks - Clean Out	2-27
ASD Scale Package Option	2-27
Kinze Cobalt System	2-30

Ag Leader Integra Display	2-30
Planter Monitor Module (PMM)	2-30
Kinze ISOBUS Option	2-30
Point Row Clutches	2-31
Two-Speed Point Row Clutches	2-32
Piston Pump	2-33
Check Valves	2-34
Low-Rate (Pop-Up) Liquid Fertilizer System	2-34
Rear Trailer Hitch (24 Row 30" Only)	2-34
Field Test	2-35
Field Check Seed Population	2-35
Determining Pounds Per Acre (Brush-Type Meter)	2-36
Determining Bushels Per Acre	2-36
Field Check Granular Chemical Application	2-37

ROW UNIT OPERATION

Planting Depth	3-1
"V" Closing Wheel Adjustment (Rubber or Cast Iron)	3-1
Closing Wheel Shield (Rubber or Cast Iron "V" Closing Wheels)	3-1
Drag Closing Attachment	3-2
Covering Discs/Single Press Wheel Adjustment	3-2
Seed Hoppers	3-3
Seed Meter Drive Release	3-3
Row Unit Extension Brackets	3-3
Row Unit Chain Routing	3-4
Quick Adjustable Down Force Springs Option (Standard or Heavy Duty)	3-5
Pneumatic Down Pressure	3-6
Brush-Type Seed Meter	3-8
Finger Pickup Seed Meter	3-9
EdgeVac Seed Meters	3-10
Seed Meter Cleanout	3-13
Additives	3-14
Frame Mounted Coulter (Pull Row)	3-15
Residue Wheels (Frame Mounted Coulter)	3-15
Row Unit Mounted Disc Furrower (Pull Row)	3-16
Row Unit Mounted Residue Wheel	3-17
Row Unit Mounted No Till Coulter	3-18
Coulter Mounted Residue Wheels	3-18
Granular Chemical Hopper and Drive	3-19
Spring Tooth Incorporator	3-19
Granular Chemical Banding Options	3-20
Granular Chemical Bander Shield	3-20

RATE CHARTS 4-1

LUBRICATION AND MAINTENANCE

Lubrication 5-1

Lubrication Symbols 5-1

Sealed Bearings 5-1

Air Clutch Lubrication. 5-1

Wheel Bearings 5-1

Drive Chains 5-2

Bushings 5-4

Sliding Hitch Linkage 5-4

PTO Shaft Coupling 5-5

Wrap Spring Wrench Assembly 5-5

Liquid Fertilizer Piston Pump Crankcase Oil Level 5-5

Grease Fittings 5-6

Mounting Bolts and Hardware 5-10

Tire Pressure 5-12

Finger Pickup Seed Meter Inspection/Adjustment 5-13

Cleaning Finger Pickup Seed Meter For Storage 5-15

Brush-Type Seed Meter Maintenance 5-16

Cleaning Brush-Type Seed Meter For Storage 5-17

Vacuum Manifold Maintenance 5-17

EdgeVac Seed Meter Maintenance 5-18

EdgeVac Seed Meter Cleanout 5-18

Gauge Wheel Adjustment 5-19

Gauge Wheel Arm Pivot Spindle Replacement 5-19

Gauge Wheel Arm Bushing/Seal Replacement. 5-20

15" Seed Opener Disc Blade/Bearing Assembly 5-21

Seed Tube Guard/Inner Scraper 5-22

Frame Mounted Coulter 5-22

Residue Wheels (For Use With Frame Mounted Coulter) 5-22

Row Unit Mounted Disc Furrower 5-23

Row Unit Mounted No Till Coulter 5-23

Coulter or Row Unit Mounted Residue Wheels 5-23

Granular Chemical Attachment 5-24

Spring Tooth Incorporator 5-24

Wrap Spring Wrench Cleaning and repair 5-24

Single and Two-Speed Point Row Clutch Maintenance 5-25

Planter Mounted Pump Drive and Oil Cooler. 5-27

Digital Vacuum Gauge Adjustment 5-27

Check Valve 5-28

Dentent Lever Valve 5-28

Flow Control Valves 5-28

Pressure Relief Valves 5-28

Relief Valve Cartridge 5-28

Solenoid Valve 5-29

Stroke Limiter Valve 5-29

Chain Tension Adjustment 5-29

Stroke Limiter (Height Stop) Valve Adjustment 5-30

Detent Lever (Lowering Control) Valve Adjustment 5-31

Row Marker Bearing Lubrication or Replacement 5-32

Air Clutch Cleaning 5-33

Lift/Ground Drive Wheel Bearing Repack or Replacement 5-34

Transport Wheel Bearing Replacement 5-35

Fertilizer Check Valve Cleaning and Repair. 5-36

Piston Pump Storage 5-36

Low-Rate Liquid Fertilizer System 5-36

Preparation for Storage 5-37

Electrical Wiring Diagram for Light Package 5-39

Electrical Control Console Schematic 5-40

Electrical Wiring Harness Schematic (on tractor) 5-41

Electrical Wiring Harness Schematic (on planter) 5-42

Valve Block - Located on Hitch 5-43

Valve Blocks - Located on Tower and R.H. Wing 5-44

Control Console Schematic (Optional Two-Speed Point Row Clutches) 5-45

Electrical Wiring Harness Schematic (Vacuum Fan Control) 5-46

Hydraulic schematic (ASD System) 5-47

Hydraulic Schematic (Vacuum Fan System) 24 Row 30" 5-48

Hydraulic Schematic (Vacuum Fan System) 24 Row 20"/22" 5-50

Hydraulic System Schematic (24 Row 20"/22"/30") 5-52

Hydraulic System Schematic (36 Row 20") 5-54

Hydraulic Valve Block Locations 5-56

Hydraulic Valve Block Functions 5-57

Air Clutch Airline Schematic 5-58

ISOBUS Implement Cable 5-60

ISOBUS CAN Jumper Cable 5-60

Product Control Module Cable 5-61

Implement Switch Extension Cable 5-62

Section Adapter Cable - 24 Row 5-63

Section Adapter Cable - 36 Row 5-63

Clutch Cable - 24 Row 5-64

Clutch Cable - 36 Row 5-65

TROUBLESHOOTING

Air Clutch 6-1

Air Seed Delivery (ASD) 6-1

Closing Wheel 6-1

Lift Circuit 6-2

Piston Pump 6-3

PTO Pump Drive and Oil Cooler Option 6-5

Row Marker Operation 6-5

Seed Meter (Brush-Type) 6-6

Seed Meter (EdgeVac) 6-7

Seed Meter (Finger Pickup) 6-9

Solenoid Valve 6-10

Stroke Limiter Valve 6-10

Kinze Manufacturing, Inc. thanks you for your patronage. We appreciate your confidence in Kinze farm machinery. Your Kinze planter has been carefully designed to provide dependable operation in return for your investment.

This manual has been prepared to aid you in the operation and maintenance of the planter. It should be considered a permanent part of the machine and remain with the machine when you sell it.

It is the responsibility of the user to read and understand the Operator Manual in regards to safety, operation, lubrication and maintenance before operation of this equipment. It is the user's responsibility to inspect and service the machine routinely as directed in the Operator Manual. We have attempted to cover all areas of safety, operation, lubrication and maintenance; however, there may be times when special care must be taken to fit your conditions.

Throughout this manual the symbol  and the words **DANGER**, **WARNING**, and **CAUTION** are used to call attention to safety information that if not followed, will or could result in death or injury. **NOTICE** and **NOTE** are used to call your attention to important information. The definition of each of these terms follows:



DANGER Indicates a hazardous situation which, if not avoided, will result in death or serious injury.



WARNING Indicates a hazardous situation which, if not avoided, could result in death or serious injury.



CAUTION, used with the safety alert symbol, indicates a hazardous situation which, if not avoided, could result in minor or moderate injury.

NOTICE is used to address practices not related to personal injury.

NOTE: Special point of information or machine adjustment instructions.



WARNING

Improperly operating or working on this equipment could result in death or serious injury. Read and follow all instructions in Operator Manual before operating or working on this equipment.



WARNING

Some photos in this manual may show safety covers, shields, or lockup devices removed for visual clarity. **NEVER OPERATE OR WORK ON** machine without all safety covers, shields, and lockup devices in place as required.

NOTE: Photos in this manual may be of prototype machines. Production machines may vary in appearance.

NOTE: Some photos and illustrations in this manual show optional attachments installed. Contact your Kinze Dealer for purchase of optional attachments.

WARRANTY

The Kinze Limited Warranty for your new machine is stated on the retail purchaser's copy of the Warranty And Delivery Receipt form. Additional copies of the Limited Warranty can be obtained through your Kinze Dealer.

Warranty, within the warranty period, is provided as part of Kinze's support program for registered Kinze products which have been operated and maintained as described in this manual. Evidence of equipment abuse or modification beyond original factory specifications will void the warranty. Normal maintenance, service and repair is not covered by Kinze warranty.

To register your Kinze product for warranty, a Warranty And Delivery Receipt form must be completed by the Kinze Dealer and signed by the retail purchaser, with copies to the Dealer, and to the retail purchaser. Registration must be completed and submitted to Kinze Manufacturing, Inc. within 5 business days of delivery of the Kinze product to the retail purchaser. Kinze Manufacturing, Inc. reserves the right to refuse warranty on serial numbered products which have not been properly registered.

If service or replacement of failed parts which are covered by the Limited Warranty are required, it is the user's responsibility to deliver the machine along with the retail purchaser's copy of the Warranty And Delivery Receipt to the Kinze Dealer for service. Kinze warranty does not include cost of travel time, mileage, hauling or labor. Any prior arrangement made between the Dealer and the retail purchaser in which the Dealer agrees to absorb all or part of this expense should be considered a courtesy to the retail purchaser.

Kinze warranty does not include cost of travel time, mileage, hauling, or labor.

GENERAL INFORMATION

The Model 3700 Front Folding Planter is available in multiple sizes and row configurations with EdgeVac or mechanical meters, conventional hoppers or Air Seed Delivery system (ASD), liquid fertilizer, and various other options. Contact your Kinze Dealer for additional details.



Model 3700 24 Row ASD Planter

Information used in these instructions was current at time of printing. However, due to Kinze's ongoing product improvement, production changes may cause your machine to appear slightly different in detail. Kinze Manufacturing, Inc. reserves the right to change specifications or design without notice and without incurring obligation to install the same on machines previously manufactured.

Right hand (R.H.) and left hand (L.H.), as used throughout this manual, are determined by facing direction machine travels in use unless otherwise stated.

Specifications

Specification	Conventional Hoppers		
	24R 20	24R 22	24R N 30
Number of Rows	24R 20	24R 22	24R N 30
Row Spacing	20"	22"	30"
Weight Empty (Mechanical)	18,300 lb	18,800 lb	20,348 lb
Weight Empty (EdgeVac)	20,000 lb	20,200 lb	24,190
Transport Height	10'-9"	10'-9"	11'-7"
Planting Length	27'-4"	27'-4"	30'-11"
Transport Length	32'-0"	32'-0"	36'-11"
Planting Width	43' 11"	43' 11"	62'-9"
Transport Width (14'-0" with granular chemical option)	13'-0"	13'-0"	13'-0"
Seed Capacity	1.90 bu. / hopper (Mechanical); 1.75 bu. / hopper (EdgeVac)		
Transport Tire Size	(4) 36 x 16-17.5 rib duplex 14-ply tubeless		
Transport Tire Pressure	75 psi		
Wing/Lift Tires	(4 - 24R, 6 - 36R) 7.5" x 20", 8-ply, Tubeless Rib Implement		
Field Tire Pressure	40 psi		
Contact Drive Tires	(4) 4.80 x 8"		
Piston Pump Drive Tires (Optional)	(2) 7.60" x 15"		
Field Lift	Four Master/Two Slave Hydraulics		
Row Markers	Independently controlled, three stage, low profile equipped disk blade depth bands.		

Specifications

Specification	Air Seed Delivery (ASD)			
	24R 20	24R 22	24R N 30	36R N 20
Number of Rows	24R 20	24R 22	24R N 30	36R N 20
Row Spacing	20"	22"	30"	20"
Weight Empty (Mechanical)	19,700 lb	19,900 lb	25,241 lb	26,872 lb
Weight Empty (EdgeVac)	21,100 lb	21,300	---	---
Transport Height	13'-0"	13'-0"	13'-0"	13'-0"
Planting Length	27'-4"	27'-4"	30'-11"	30'-11"
Transport Length	32'-0"	32'-0"	36'-11"	40'-2"
Planting Width	43'-11"	47'-11"	62' 9"	63' 9"
Transport Width (14'-0" with granular chemical option)	13'-8"	13'-8"	13'-8"	13'-8"
Seed Capacity	110 bu.			
ASD Fill Dimensions (planting position)	8' 7"			
Transport Tire Size	(4) 36 x 16-17.5 rib duplex 14-ply tubeless			
Transport Tire Pressure	75 psi			
Wing/Lift Tires	(4 - 24R, 6 - 36R) 7.5" x 20", 8-ply, Tubeless Rib Implement			
Field Tire Pressure	40 psi			
Contact Drive Tires	(4) 4.80 x 8"			
Piston Pump Drive Tires (Optional)	(2) 7.60" x 15"			
Field Lift	Four Master/Two Slave Hydraulics			
Row Markers	Independently controlled, three stage, low profile equipped disk blade depth bands.			

Tractor Hydraulic Requirements

Configuration	Requirements		Description
<i>Base machine with mechanical meters</i>	2 SCV	15 gpm	#1 SCV: planter lift
			#2 SCV: markers / fold (with 12v control console)
<i>Base machine with mechanical meters Air seed delivery (ASD) system</i>	3 SCV	25 gpm	#1 SCV: planter lift
			#2 SCV: markers / fold (with 12v control console)
			#3 SCV: ASD system
<i>Base machine with EdgeVac meters Tractor mounted PTO hydraulic pump</i>	2 SCV	15 gpm	#1 SCV: planter lift
			#2 SCV: markers / fold (with 12v control console)

NOTE: Tractor-mounted PTO hydraulic pump supplies oil flow for EdgeVac hydraulic circuit.

1. Read and understand instructions provided in this manual and warning labels. Review these instructions frequently!
2. This machine is designed and built with your safety in mind. Do not make any alterations or changes to this machine. Any alteration to design or construction may create safety hazards.
3. A large portion of farm accidents happen from fatigue or carelessness. Safe and careful operation of tractor and planter will help prevent accidents.
4. Never allow planter to be operated by anyone unfamiliar with operation of all functions of the unit. Operators must read and thoroughly understand all instructions given in this manual before operating or working on equipment.
5. Be aware of bystanders, particularly children! Always look around to make sure it is safe to start tow vehicle engine or move planter. This is particularly important with higher noise levels and quiet cabs, as you may not hear people shouting.
6. Make sure planter weight does not exceed towing capacity of tractor, or bridge and road limits. This is critical to maintain safe control and prevent death or injury, or property and equipment damage.
7. Never ride or allow others to ride on planter.
8. Store planter in an area away from human activity. DO NOT permit children to play on or around the stored unit.
9. Keep hands, feet, and clothing away from moving parts. Do not wear loose-fitting clothing which may catch in moving parts.
10. Always wear protective clothing, shoes, gloves, and hearing and eye protection applicable for the situation.
11. Do not allow anyone to stand between tongue or hitch and towing vehicle when backing up to planter.
13. Prevent electrocution, other injuries, or property and equipment damage. Watch for obstructions such as wires, tree limbs, etc. when operating machine. Be aware of clearances during turns and when folding/unfolding planter.
14. Reinstall all guards removed for maintenance activities. Never leave guards off during operation.
15. Use of aftermarket hydraulic, electric, or PTO drives may create serious safety hazards to you and people nearby. If you install such drives, follow all appropriate safety standards and practices to protect you and others near this planter from injury.
16. Follow all federal, state/provincial and local regulations when towing farm equipment on a public highway. Use safety chain (not an elastic or nylon/plastic tow strap) to retain connection between towing and towed machines in the event of primary attaching system separation.
17. Make sure all safety/warning lights, SMV sign, and reflective decals are in place and working properly before transporting the machine on public roads.
18. Limit towing speed to 15 MPH. Tow only with farm tractor of a minimum 90 HP. Allow for unit length when making turns.
19. Reduce speed prior to turns to avoid the risk of overturning. Always drive at a safe speed relative to local conditions and ensure your speed is slow enough for a safe emergency stop.
20. Chemical application is often an integral part of planting. Follow label instructions for proper chemical mixing, handling and container disposal methods.
21. Be familiar with safety procedures for immediate first aid should you accidentally contact chemical substances.
22. Use the proper protective clothing and safety equipment when handling chemicals.
23. Chemicals are supplied with Material Safety Data Sheets (MSDS) that provide full information about the chemical, its effects on exposure, and first aid needs in the event of an emergency. Keep your MSDS file up-to-date and available for first responders in case of emergency.
24. When servicing ground engaging components such as opening disks and firming points, use special care to avoid points and edges worn sharp during use.
25. Use professional help if you are unfamiliar with working on hydraulic systems. Pressurized hydraulic fluid can penetrate body tissue and result in death, serious infection, or other injuries.

Following are some common hazard warnings associated with this equipment. Pay close attention to all safety, operating, and maintenance information in this manual and decals applied to your equipment.

 **DANGER!**

Contacting or coming close to power lines or other high energy sources will cause death or serious injury. Keep away from power lines or high energy sources at all times.

 **WARNING**

Improperly operating or working on this equipment could result in death or serious injury. Read and follow all instructions in Operator Manual before operating or working on this equipment.

 **WARNING**

Falling equipment can cause death or serious injury. Install all lockup devices or lower planter to ground before working on equipment.

 **WARNING**

Explosive separation of rim and tire parts can cause death or serious injury. Overinflation, rim and tire servicing, improper use of rims and tires, or worn or improperly maintained tires could result in a tire explosion.

SAFETY SIGNS AND DECALS

 **WARNING**

All safety/warning lights, reflective decals, and SMV sign must be in place and visible before transporting machine on public roads or death, serious injury, and damage to property and equipment may result. Check federal, state/provincial, and local regulations before transporting equipment on public roads.

Safety signs and decals are placed on the machine to warn of hazards and provide important operating and maintenance instructions. Information on these signs are for your personal safety and the safety of those around you. FOLLOW ALL SAFETY INSTRUCTIONS!

- Keep signs clean so they can be easily seen. Wash with soap and water or cleaning solution as required.
- Replace safety signs if damaged, painted over, or missing.
- Check reflective decals and SMV sign periodically. Replace if they show any loss of reflective properties.
- Clean machine surface thoroughly with soap and water or cleaning solution to remove all dirt and grease when replacing decals.

NOTE: Safety sign and decal locations are shown in the Parts Manual for this machine.

NOTE: Style and locations of SMV sign, reflective decals, and safety/warning lights conform to ANSI/ASABE S279.14 JUL 2008 and ANSI/ASABE S276.6 JAN 2005.

PLANTER LIFT SAFETY LOCKUP

WARNING

Uncontrolled machine movement can crush or cause loss of control resulting in death, serious injury, or damage to property and equipment. Install all safety lockup devices before working under or transporting this equipment.

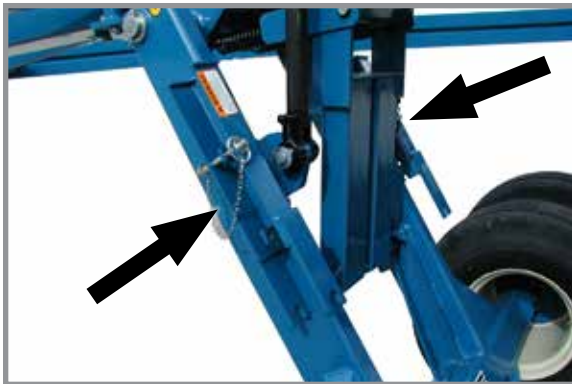

Safety lockup in storage position

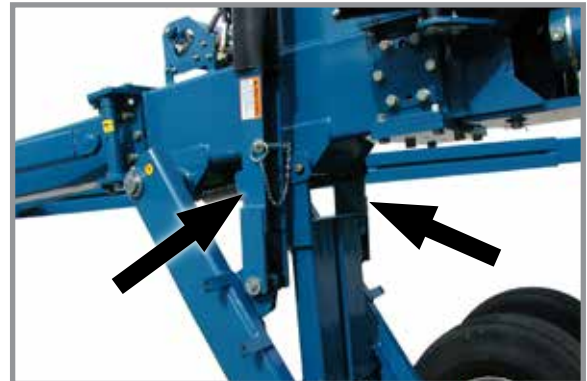

Safety lockup in transport/maintenance position

Planter lift safety lockup is installed between lift cylinder and wheel lift arm. It is held in place by a pin and lynch pin. Remove safety lockup and store on hose take-up for field operation.

ROW MARKER SAFETY LOCKUP

WARNING

Row marker can lower at any time and could cause death or serious injury. Stay away from row markers! Install safety lockup device when not in use.

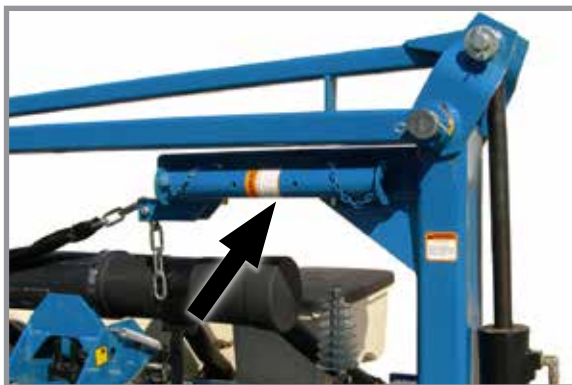

Row marker safety lockup stored

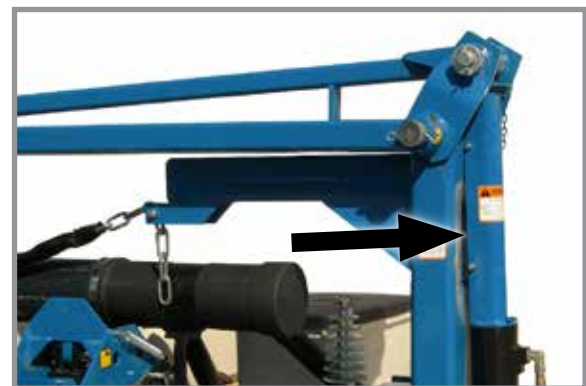

Row marker safety lockup installed

Always install row marker lockups when working on, storing, or transporting planter. Hold in place with two clevis pins.

⚠ WARNING

Planter hitch may raise uncontrollably during folding/unfolding and can cause death, serious injury, or damage property and equipment. **DO NOT** fold or unfold planter without planter attached to a tractor. **DO NOT** unhitch planter from tractor unless fully folded for transport or fully unfolded with planting units lowered to ground.

⚠ WARNING

Uncontrolled movement of equipment can cause loss of control and could result in death, serious injury, or damage to property and equipment. Install all safety pins before transporting equipment.

HITCH PARALLEL LINKAGE LOCKUP

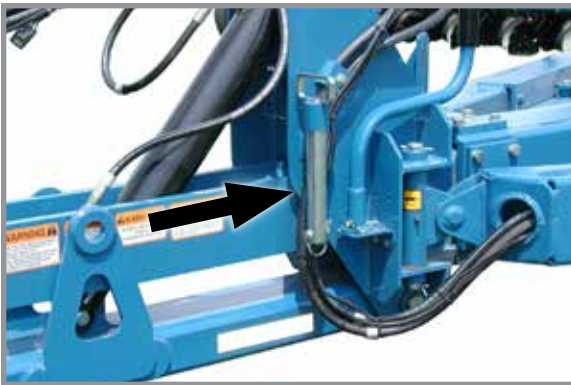

Hitch parallel linkage pin stored

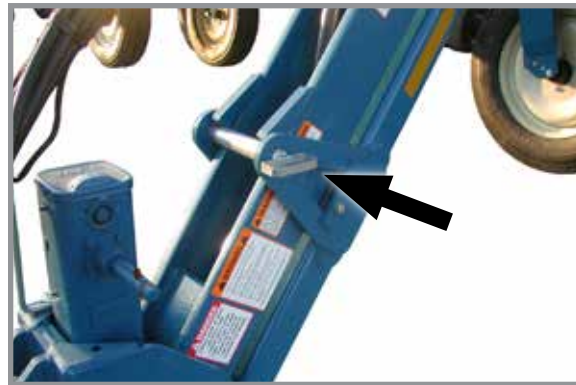

Hitch parallel linkage pin installed

A hitch parallel linkage lock pin locks hitch parallel linkage in raised (transport) position.

2-SPEED JACK ASSEMBLY

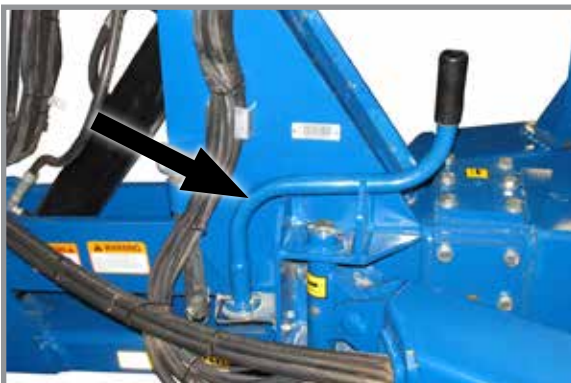

Jack handle stored

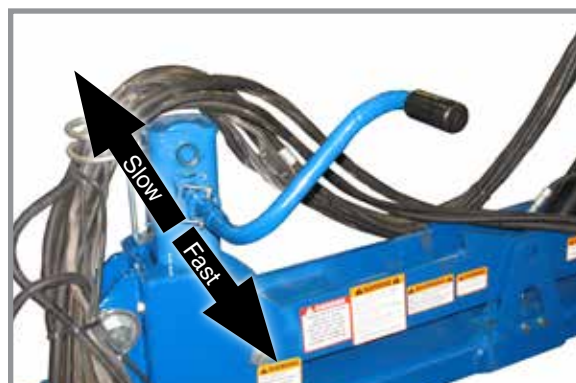

Jack handle installed

Store jack on L.H. side of hitch. Secure in place with spring pin. Install jack on hitch post and secure in place with spring pin. Pull out on handle for high speed or push in on handle for low speed operation.

WARNING

Improperly operating or working on this equipment could result in death or serious injury. Read and follow all instructions in Operator Manual before operating or working on this equipment.

INITIAL PLANTER PREPARATION

Following information is general in nature to aid in preparation of tractor and planter for use, and to provide general operating procedures. Operator experience, familiarity with the machine, and the following information should combine for efficient planter operation and good working habits.

WARNING

Explosive separation of rim and tire can cause death or serious injury. Overinflation, rim and tire servicing, improper use of rims and tires, worn, or improperly maintained tires could result in a tire explosion.

WARNING

Wheel separation can cause loss of control resulting in death, serious injury, or damage to property and equipment. Check lug nuts on transport wheels are tight before operating planter for first time and periodically after.

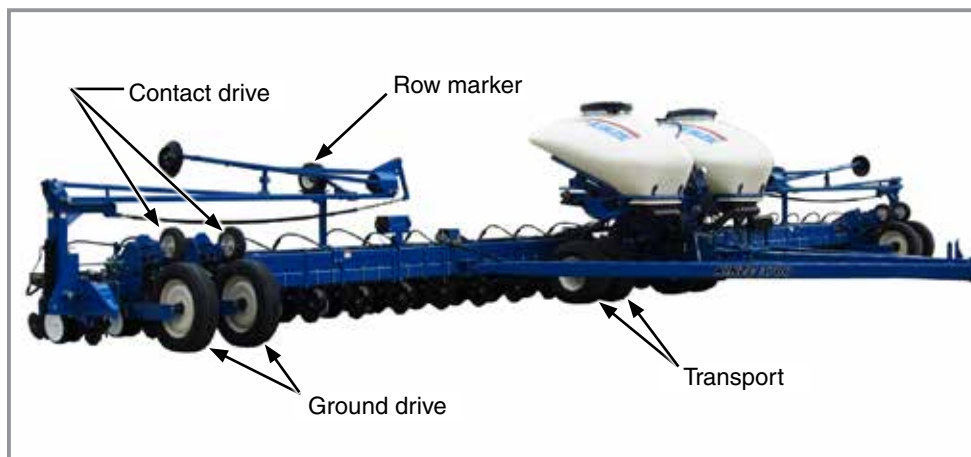

Tire locations (L.H. mirrors R.H. shown)

1. Torque transport wheel $\frac{3}{4}$ " - 16 lug nuts to 200 ft-lb (244 N-m).
2. Inflate tires to the following specifications:
 - Ground drive (wings) - 225 x 70R 22.5 - 75 psi (517.1 kPa)
 - Transport - 36" x 16" x 17.5" - 75 psi (517.1 kPa)
 - Contact drive - 4.80" x 8" - 50 psi (344.7 kPa)
 - Row marker - 16" x 6.5" x 8" - 14 psi (96.5 kPa)
 - Liquid fertilizer piston pump (Not shown) - 4.10" x 6" - 50 psi (344.7 kPa)
3. Lubricate planter and row units per lubrication information in this manual.
4. Check all drive chains for proper tension, alignment, and lubrication.

TRACTOR REQUIREMENTS

! WARNING

Loss of control of equipment during transport can result in death, serious injury, or damage to property and equipment. Tractor gross weight must be greater than planter gross weight with attachments and options.

Consult your dealer for information on horsepower requirements and tractor compatibility. Requirements vary with planter options, tillage, and terrain.

Two dual remote hydraulic outlets (SCV) are required on all sizes of conventional planters equipped with row markers.

Four dual remote hydraulic outlets (SCV) are required on all sizes of ASD planters equipped with row markers. A 12 volt DC electrical system is required on all sizes.

EDGEVAC TRACTOR MOUNTED PTO PUMP AND PLANTER MOUNTED HYDRAULICS



Two-section PTO hydraulic pump



8 gal (30.3 L) reservoir

Edgevac equipped planters require a 1 3/4"-20 spline 1000 RPM PTO to operate PTO-driven two section hydraulic pump capable of supplying 15 gpm (56.8 Lpm) to two hydraulic motors/vacuum fans.

EdgeVac Seed Metering System operates from an 8 gal (30.3 L) capacity oil reservoir.

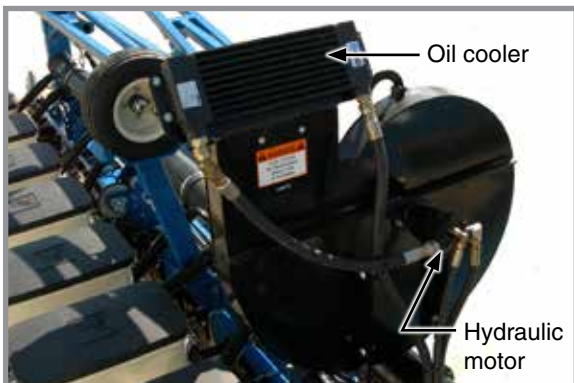

Vacuum fan assembly with oil cooler

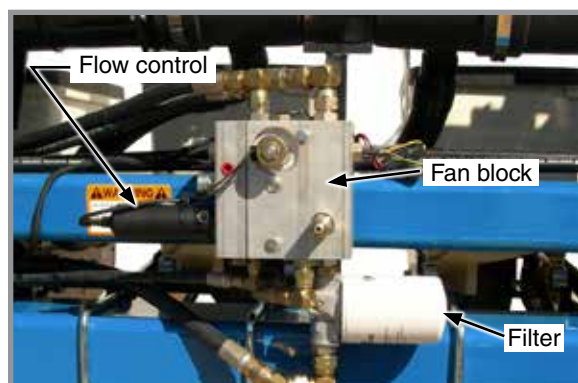

Vacuum fan block and filter

Other dual fan system components include two oil coolers, two replaceable cartridge-type filters, two motorized flow controls, pressure compensating valves, solenoid valves, and relief valves.

TRACTOR PREPARATION AND HOOKUP



Planter control console



Digital vacuum gauge control console

1. Install planter control console (all) and digital vacuum gauge (EdgeVac only) control consoles on tractor in convenient locations within operator reach and close to hydraulic controls. Mount control consoles securely and route power cables to power source. A power lead adapter may be required. See Lubrication and Maintenance section for wiring schematics.

NOTE: Control console operates on 12 volt DC only. If two 6 volt batteries are connected in series, make sure power connection provides 12 volt DC across positive terminal on one battery and negative terminal of second battery. ALWAYS make power connection on battery grounded to tractor chassis.

2. Adjust tractor drawbar 13-17 inches above ground with hitch pin hole directly below PTO shaft center line. Make sure drawbar is in a stationary position.

WARNING

Planter hitch may raise uncontrollably during folding/unfolding and can cause death, serious injury, or damage property and equipment. DO NOT fold or unfold planter without planter attached to a tractor. DO NOT unhitch planter from tractor unless fully folded for transport or fully unfolded with planting units lowered to ground.

3. Back tractor to planter and connect with minimum 1¼" diameter hitch pin. Make sure hitch pin is secured with a locking pin or cotter pin. If tractor is not equipped with a hitch pin locking device.

NOTE: DO NOT install safety chain using clevis mounting hardware. Safety chain MUST be installed separately.

4. Safety chain must be used to keep planter and tractor connected in case of a hitch pin/drawbar failure. Attach safety chain at an unused clevis mounting hole on the planter hitch. Torque hardware to 840 ft-lb (1138.8 N-m).



Tractor and safety chain hookup

 **WARNING**

Pressurized hydraulic fluid can penetrate body tissue and result in death, serious infection, or other injuries. Fluid injected under skin must be **IMMEDIATELY** removed by a surgeon familiar with this type of injury. Make sure connections are tight and hoses and fittings are not damaged before applying system pressure. Leaks can be invisible. Keep away from suspected leaks. Relieve pressure before connecting or disconnecting tractor, searching for leaks, or performing any system maintenance.

NOTICE

Wipe hose ends to remove any dirt before connecting couplers to tractor ports or contamination may cause equipment failure.

NOTICE

Connect hydraulic motor case drain to a case drain return line with zero PSI on tractor. Failure to connect to a return with zero PSI will cause hydraulic motor shaft seal damage. **DO NOT** connect hydraulic motor case drain to a SCV outlet or motor return circuit connection. Contact tractor manufacturer for specific details on “zero pressure return”.

NOTICE

Always connect hydraulic motor return hose to tractor motor return port. Do not connect to tractor SCV unless through a motor spool or hydraulic motor failure can occur. If a motor return port is not available on the tractor, the SCV controlling the ASD system **MUST** be in the float position before planter is moved in planting or field raised position when ASD system is not in use.

5. Connect hydraulic hoses to tractor ports in a sequence familiar and comfortable to the operator.

Color and Label	Machine Function	Hose Size	Hose Function
Red AA	Field Lift	1/2"	Pressure
Red BB		1/2"	Return
Blue AA	Planter Fold & Row Marker	3/8"	Return
Blue BB		3/8"	Pressure
Green RR	EdgeVac Vacuum Fan	3/4"	Return
Green PP		1/2"	Pressure
Orange CD		3/8"	Case Drain
Yellow RR	ASD System Pressure Fan	3/4"	Return
Yellow PP		1/2"	Pressure
Orange CD		3/8"	Case Drain

NOTICE

Clean and grease PTO shaft coupling with high-pressure industrial coupling grease (Chevron® coupling grease or equivalent) meeting AGMA CG-1 and CG-2 Standards each time driveshaft is installed or premature wear and equipment failure can occur.

NOTE: A tractor model-specific PTO mount kit is required and available from GnL Engineering (319-227-7222 or gnengineering.net) and Rowe Manufacturing (800-544-4123 or rowemfg.com).

6. (If applicable) Install PTO pump onto tractor PTO shaft. Make sure shaft rotation matches direction indicated on pump housing.
7. Connect ASABE Standards 7 terminal connector for safety/warning lights on planter to ASABE Standards receptacle on tractor. If your tractor is not equipped with an ASABE Standards receptacle, check with your tractor manufacturer for availability. Check warning lights on planter work in conjunction with warning lights on tractor.

NOTE: A 12 volt battery connection is required to power the vacuum fan digital gauge. Connect “red” wire to positive (+) battery terminal and “black” wire to negative (-) battery terminal.

Completely raise parking jack to prevent damage to jack assembly and equipment when moving planter.

TRANSPORTING PLANTER **WARNING**

Uncontrolled movement of equipment can cause loss of control and could result in death, serious injury, or damage to property and equipment. Install all safety pins before transporting equipment.

 **WARNING**

Uncontrolled machine movement can crush or cause loss of control resulting in death, serious injury, or damage to property and equipment. Install all safety lockup devices before working under or transporting this equipment.

 **WARNING**

Transporting planter with hoppers over half full or unevenly loaded can cause loss of control and could result in death, serious injury, or damage to property and equipment. Properly load planter when transporting. Be aware of extra transport weight, and road conditions and limits.

Make sure safety/warning lights, reflective decals, and SMV sign are in place and visible before transporting machine on public roads. It is your responsibility to check and comply with all federal, state/provincial, and local regulations.

Be aware of road and bridge weight limits. Allow for additional weight of added options and any additional material or substances that have been added to the machine.

LEVEL PLANTER

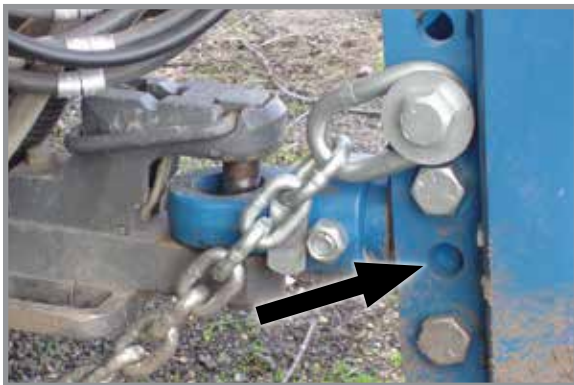

Clevis adjustment holes

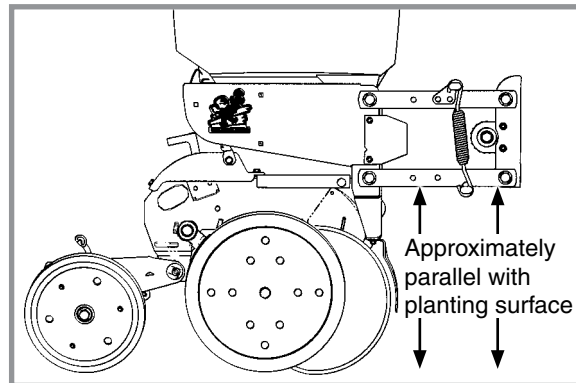

Level row units

Toolbar should operate at 20"-22" height from planting surface. Tire pressures must be maintained at pressures specified for planter to operate level laterally. Check toolbar and row unit parallel arms are level front to back with planter lowered to proper operating height.

Five holes in the hitch bracket allow clevis to be raised or lowered. Clevis may be turned over for a finer adjustment between mounting holes. Torque hardware to 840 ft-lb (1138.8 N-m).

Field and actual planting conditions determine which wheel settings to use to ensure row unit parallel arms are approximately parallel with planting surface. If planting in extremely soft soil conditions it may be necessary to move ground drive tires to lower sets of mounting holes. To allow adequate drive force after lowering the ground drive tires, it may be necessary to lower contact drive arms to lower set of holes in wheel module and relocate down pressure springs to lower mounting rod on wheel module.

If planter center is higher or lower than wings after rephasing, contact your Kinze Dealer for valve adjustment or maintenance.

CONTACT WHEEL SPRING ADJUSTMENT

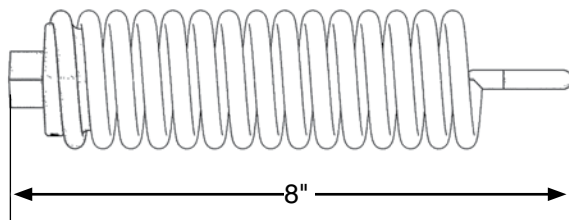

Spring length measurement (Factory setting)



Contact drive springs

There are two down pressure springs on each contact drive wheel. Spring tension is factory set to approximately 200 lb (90.7 kg) of down force at tire contact point and should require no further adjustment.

NOTE: Measurement must be taken in planting position with proper tire pressure.

CONTACT WHEEL DRIVE SPROCKETS

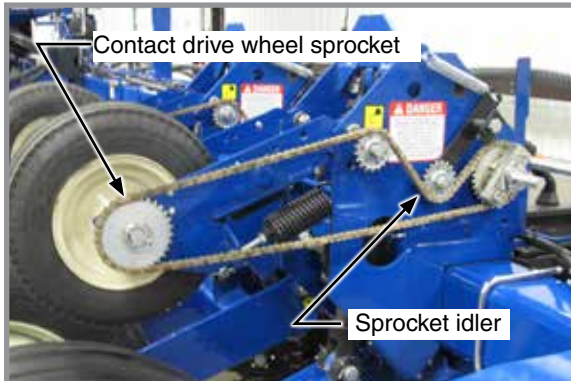

Contact wheel drive



Optional half-rate drive sprocket

Contact wheel drive works the same for mechanical or EdgeVac planters except for sprocket size. Chain tension is controlled by a spring-loaded sprocket idler. Planting rate charts in "Rate Chart" section help you select correct sprockets.

NOTE: Make a field test after each sprocket combination change to be sure you are planting at desired rate.

22 tooth, 28 tooth or 44 tooth sprockets at each contact drive wheel can be exchanged with sprockets on storage rod bolted to wheel module on each side of planter chains. 22 tooth sprockets require 148 pitch No. 40 chains. 28 tooth sprockets require 150 pitch chains. 44 tooth sprockets require use 158 pitch chains.

NOTE: 22, 28 and 44 tooth drive sprockets do NOT apply to all rate charts. Check chart titles to make sure proper rate chart is selected.

NOTE: 54 cell sunflower disc uses 15 tooth drive sprocket at contact wheels and 28 tooth drive sprocket at wheel module reverser plates with 19 tooth sprocket. 15 tooth sprockets require 144 pitch No. 40 chains. Applicable sprockets, chains and instructions supplied in G1K469 Sunflower Rate Reduction Kit.

Seed planting rate charts are based on standard rate drive. Standard rate drive uses a 30 tooth sprocket and No. 40 118 pitch chain on each contact wheel. Optional half-rate (2 to 1) drive is recommended only when population falls below planting rate charts. Replace 30 tooth sprocket on each contact wheel with a 15 tooth sprocket and shorter No. 40 110 pitch chain. This reduces planter transmission speed and planting and application rates by approximately 50%.

SEED RATE TRANSMISSION ADJUSTMENT

Planting population rate changes are made using seed rate transmissions at end of each planter wing. Seed rate transmissions allow simple, rapid changes of sprockets by removing lynch pins on hexagon shafts and changing sprockets with those from the sprocket storage rod bolted to transmissions.

Chain tension is controlled by a spring-loaded dual sprocket idler. Idler assembly is adjusted with a easy-release idler arm with a release position to adjust spring tension for planting or remove spring tension for replacing sprockets. See "Wrap Spring Wrench Operation".

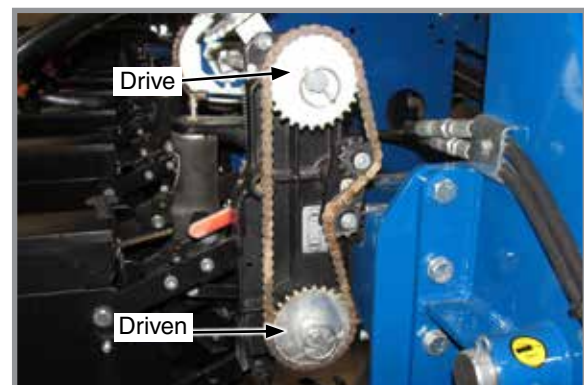

Seed rate transmission

A decal on the transmission (behind chain idler) shows proper chain routing. "Rate Charts" section of this manual will help you select correct sprocket combinations.

WRAP SPRING WRENCH OPERATION

Chain idlers are equipped with wrap spring wrenches. L.H. rotation wrap spring wrenches have a blue release collar and R.H. rotation wrap spring wrenches have a grey or black release collar.

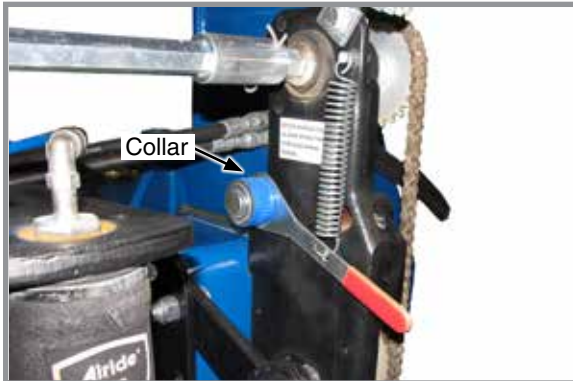

Wrap spring wrench (L.H. rotation shown)



Chain idler tensioning

Rotate collar on wrap spring wrench and pull handle to release chain tension.

Rotate chain idler into chain and pull handle to tension idler spring.

SHEAR PROTECTION

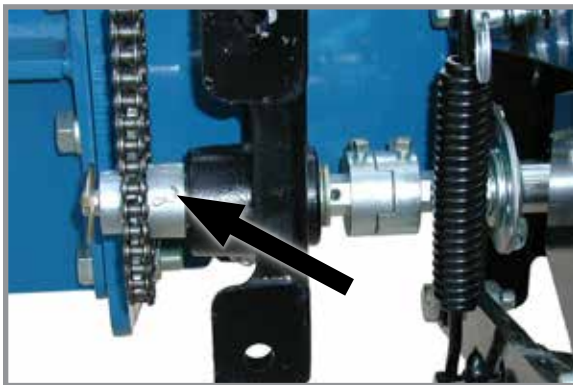

Transmission shaft shear pin



Spare shear pin storage

Planter driveline and seed and granular chemical drivelines are protected from damage by shear pins.

NOTICE

Misalignment of drill shaft/transmission coupler alignment will cause equipment damage.

Determine where binding has occurred if excessive load causes a pin to shear before replacing pin. Replace shear pins with same size and type.

Additional shear pins are in the storage area located at end of each planter wing on inboard side of transport hook.

SLIDING HITCH LINKAGE



Axle link slide (L.H. shown)

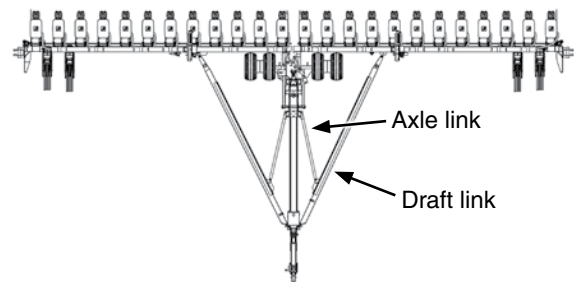

24 Row 30" and 36 Row 20" planters are equipped with sliding axle links which connect R.H. and L.H. draft links to transport axle. Axle links move in a slide on inner side of each draft link when planter folds or unfolds. When axle links reach end of slides, main transport axle is telescoped forward into transport position or rearward into field position.

NOTICE

DO NOT GREASE axle link slides or excess dirt accumulation may cause equipment failure. Inspect daily to ensure free movement of axle links in slides. Keep axle link slides clean. Use only powdered graphite if lubrication is desired.

Stops at either end of slides are designed to allow dirt to escape in normal operating conditions. Under extremely dusty conditions it may be necessary to clean slides.

DIGITAL VACUUM GAUGE

Digital vacuum gauge control console is equipped with a power toggle switch, run/stop (fans) toggle switch, and two fan speed control toggle switches for the vacuum fans.

Power switch applies power to control console. Run/stop toggle switch turns both fans on when power switch is ON. Fan speed control switches adjust each fan (left or right).



Digital vacuum gauge control console

PTO PUMP INITIAL STARTUP

1. Fill reservoir with SAE 10W-20 multigrade wide temperature range transmission hydraulic fluid or equivalent.
2. Start system. Allow to run with tractor at idle and fans turned off for 1-2 minutes.
3. Allow to run with tractor at idle and fans at full speed for 1-2 minutes.
4. Check fluid level in reservoir and fill as required.

NOTE: Fluid level in each tank should be within 1"-2" from top of the tank after pump has run and hydraulic hoses are primed to allow fluid to expand when heated.

5. Bring tractor to PTO speed and adjust flow control to desired vacuum level using switches on vacuum fan control console.

HYDRAULIC/ELECTRIC OPERATION

Control console switches and tractor's hydraulic system are used to raise planter to transport position, operate rotate and tongue extension functions, lock and release planter wings, and raise and lower row markers.

NOTE: Turn console backlighting OFF during extended periods of non-use using push button switch on back of console.



Single point row clutch control box



Two-speed point row clutch control box

Two dual remote hydraulic outlets (SCV) are required on all sizes of conventional planters equipped with row markers. Three dual remote hydraulic outlets (SCV) are required on all sizes of ASD planters equipped with row markers. One set of outlets is used to operate lift function, one set is used to operate markers, tongue and fold/unfold functions and the third set is used to operate ASD functions (If Applicable).

Marker and point row selector switches are an ON-OFF-ON type. If planter is equipped with optional Two-Speed Point Row Clutch Package, point row switch and reduced rate switch operate independently from rest of control console.

Power to marker switch is fed through auxiliary switch and two transport function switches. Operating any lower row switch disables markers and turns off marker indicator light.

Raise/wing lock and rotate/tongue (fold function) switches are MOMENTARY ON-OFF-MOMENTARY ON type and must be held in position while operating tractor hydraulic SCV control. Activating a fold function switch disables marker circuit.

WARNING

Marker selector switch must be OFF (center position) when not in use to prevent accidental extension which could result in death or serious injury, or damage to property and equipment. An indicator light on control box panel is ON whenever marker circuits or point row clutch circuits are energized.

Auxiliary switch is not used. Keep switch OFF at all times.

NOTE: Activating auxiliary switch disables all other control console switches except point row clutch switch.

HYDRAULIC DRIVE

When stopping in the middle of a field, drive runs a split second after tractor and planter come to a complete stop. Shut master switch OFF before coming to a complete stop to avoid bunching of seeds.

To avoid skips starting from a complete stop, lift planter and back-up 4-6 feet, put planter in ground, and accelerate slowly to continue planting.

AG LEADER ELECTRIC CLUTCHES

Electric clutches along with GPS can stop seed flow by turning off seed meters (and planter sections) based on field mapping and previously planted areas.

ROW UNIT AIR CLUTCHES

Set Air clutch system pressure to 50 psi.



Air clutch pressure setting

HALL EFFECT SENSOR

Set Hall Effect sensor within 1/8" of pick-up disc.

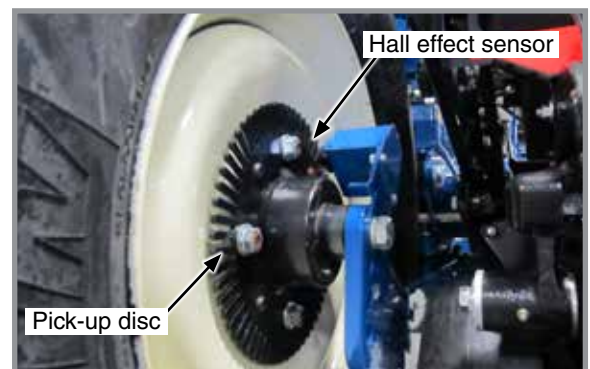

Hall effect sensor and pick-up disc

TRANSPORT TO FIELD SEQUENCE

Position planter in a relatively flat open area without furrows, etc.

SUMMARIZED TRANSPORT TO FIELD SEQUENCE

1. Remove hitch parallel linkage lock pin or lockup.
2. Lower hitch parallel linkage to release wing hooks.

NOTICE

Unfolding planter without using tractor to assist may cause equipment damage especially in soft conditions or when loaded with seed or fertilizer. Use tractor to reduce stress on frame, drive, and transport components.

3. Place tractor in reverse and hold in clutch. Start unfolding planter and slowly back up tractor as planter unfolds.
4. Raise planter to remove weight from center (slave) lift cylinder lockups and remove lockups.
5. Lower planter.
6. Remove row marker lockups.
7. Lower catwalk ladder (36 row 20" ASD only)

NOTE: Read following information for detailed instructions.

WARNING

Planter hitch may raise uncontrollably during folding/unfolding and can cause death, serious injury, or damage property and equipment. DO NOT fold or unfold planter without planter attached to a tractor. DO NOT unhitch planter from tractor unless fully folded for transport or fully unfolded with planting units lowered to ground.

NOTICE

DO NOT LOWER planter frame onto transport axle in folded transport position or transport tires and row units will be damaged.



Hitch parallel linkage pin installed

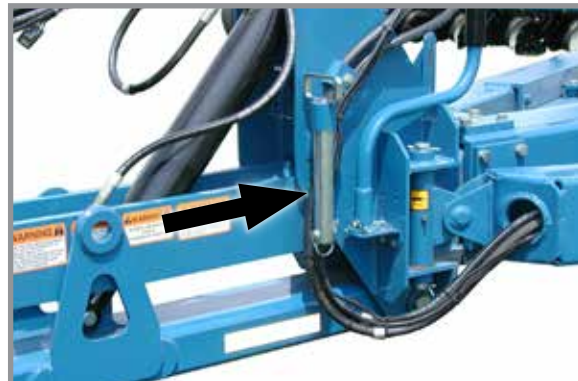

Hitch parallel linkage pin stored

1. Fully extend hitch parallel linkage cylinder located on hitch. Remove hitch parallel linkage lock pin from hitch parallel linkage or cylinder lockup from cylinder rod. Store in location provided.

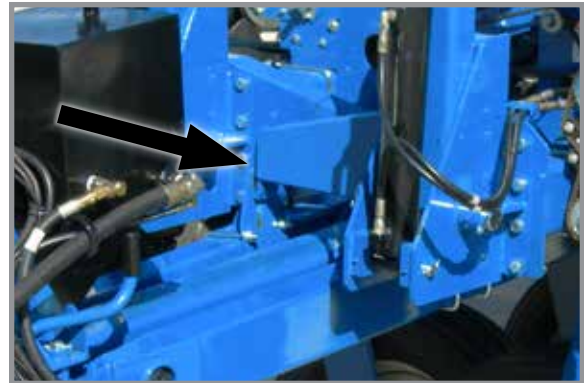
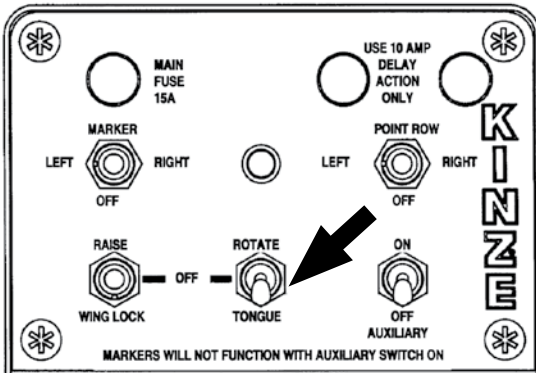

Hitch release from wing hook

2. Hold "ROTATE/TONGUE" switch in "TONGUE" position while operating proper tractor hydraulic control to completely retract hitch parallel linkage cylinder and lower hitch until wing wheels are on ground and hitch has released from hooks on ends of wings.

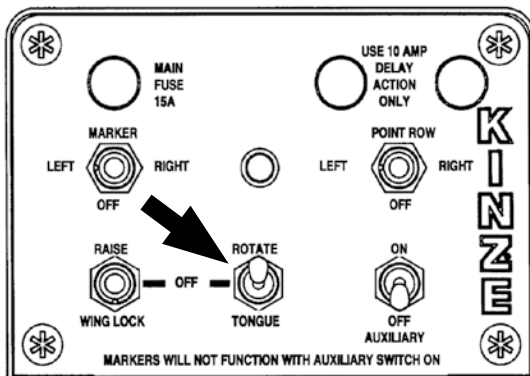

Planter unfolding

NOTICE

Unfolding planter without using tractor to assist may cause equipment damage especially in soft conditions or when loaded with seed or fertilizer. Use tractor to reduce stress on frame, drive, and transport components.

3. Hold control console ROTATE/TONGUE switch in **ROTATE** and operate hydraulic control to unfold planter. Tongue begins to retract and wings (supported by wing wheels) begin to unfold. Place tractor transmission in a low reverse gear and slowly back up as planter unfolds. Center axle tires should remain stationary and wing tires should roll in a continuous arc with minimal side loading on tires or their mounting structures. Hold switch in "ROTATE" position until tongue cylinder is fully retracted.

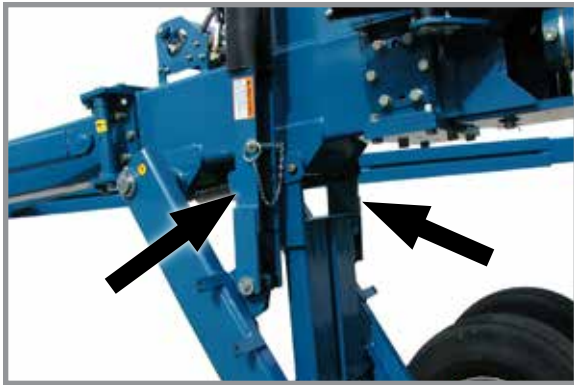

Safety lockups in transport position

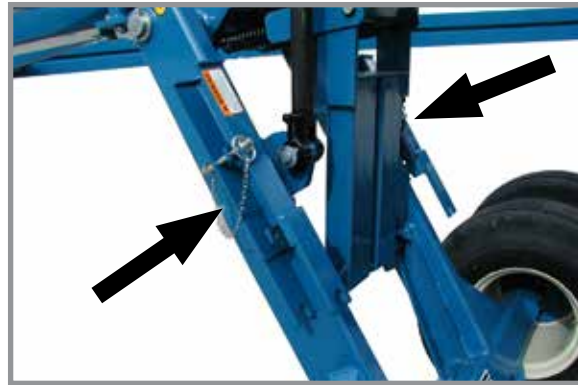

Safety lockups in storage position

NOTE: Automatic safety lock will release when planter is raised to remove weight from center lift cylinder lockups. Raising planter too high will reset the mechanism. If this happens, lower machine until hydraulic system stalls against the automatic safety, raise machine slightly to release automatic safety lock and then lower planter.

4. Raise planter to remove weight from center lift (slave) cylinder safety lockups. Remove pins and safety lockups and place in storage location.
5. Lower machine to ground. Center drops until toolbar is level and then entire planter lowers evenly. Hold tractor's hydraulic lever 5 to 10 seconds to rephase system when all lift cylinders are fully retracted.



Lowering planter

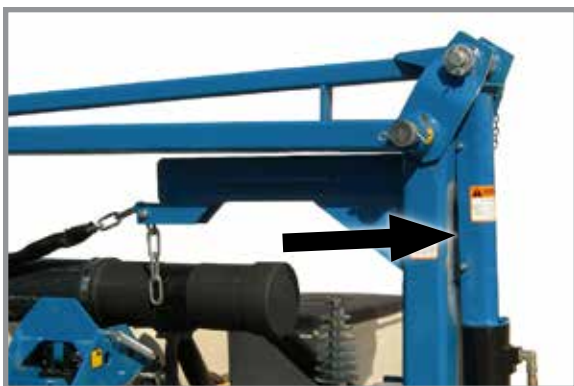

Row marker safety lockup installed

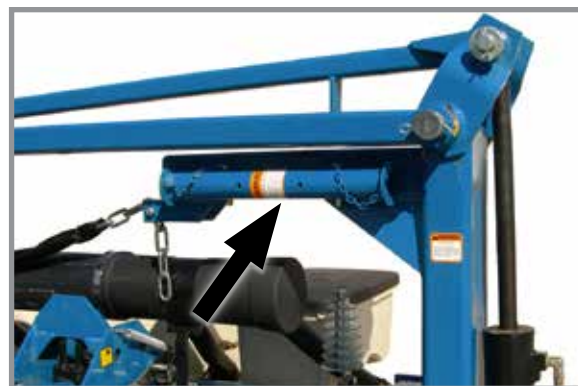

Row marker safety lockup stored

6. Remove and store marker lockups.



Catwalk and ladder folded



Catwalk and ladder unfolded

7. (36 Row 20" only) Pull on catwalk release lever and swing catwalk extension out until it locks into position. Lift and swing over ladder.

FIELD OPERATION

Planters are designed to operate within a speed range of 2 - 8 mph (3 - 13 kph). Higher ground speeds can cause more variation in seed spacing. Speeds above 5.5 mph (8.8 kph) are typically not recommended.

NOTICE: Always raise planter out of ground when making sharp turns or backing up.

Normal field planting operation requires use of tractor's hydraulic control to raise and lower planter frame when making field turn arounds. Place hydraulic lever in float position during normal field operation.

NOTICE: Operate row markers in float position to prevent damage to row markers.

Operate row markers with control console switch for that marker in ON (LEFT or RIGHT) position and tractor's hydraulic control. After markers are lowered to ground, move hydraulic control to operate markers in float position. Marker speed is controlled with flow control valves located in planter hitch valve block. One valve controls raise speed and other valve controls lower speed of both markers. See "Row Marker Speed Adjustment" and "Row Marker Operation".

FIELD TO TRANSPORT SEQUENCE

Position planter in a relatively flat open area without furrows, etc.

SUMMARIZED FIELD TO TRANSPORT SEQUENCE

1. Raise and stow catwalk ladder (36 Row 20" ASD only).
2. Install marker lockups.
3. Raise planter to fully extend master/slave cylinders.
4. Install center (slave) lift cylinder lockups.
5. Lower planter onto center lift cylinder lockups.

NOTICE

Folding planter without using tractor to assist may cause equipment damage especially in soft conditions or when loaded with seed or fertilizer. Use tractor to reduce stress on frame, drive, and transport components.

6. Place tractor in low forward gear and hold in clutch. Start folding planter and move tractor slowly forward as planter folds to keep wing wheel side pressure to a minimum.
7. Raise hitch parallel linkage to engage wing hooks.
8. Install hitch parallel linkage lock pin or lockup bracket.
9. Lower hitch parallel linkage cylinder.

NOTE: Read following information for detailed instructions.

WARNING

Planter hitch may raise uncontrollably during folding/unfolding and can cause death, serious injury, or damage property and equipment. DO NOT fold or unfold planter without planter attached to a tractor. DO NOT unhitch planter from tractor unless fully folded for transport or fully unfolded with planting units lowered to ground.



Catwalk and ladder unfolded

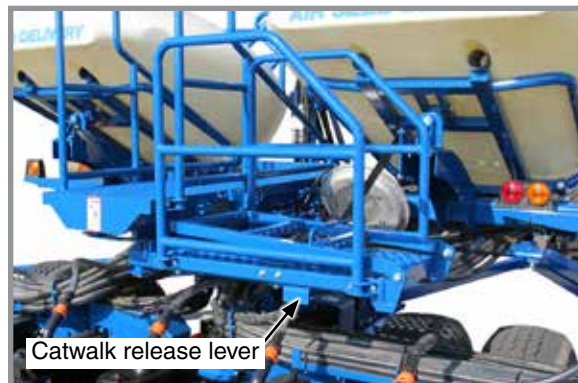

Catwalk and ladder folded

1. (36 Row 20" only) Lift and swing over ladder onto top of catwalk extension. Pull on catwalk release lever and swing extension to right until it locks into position.

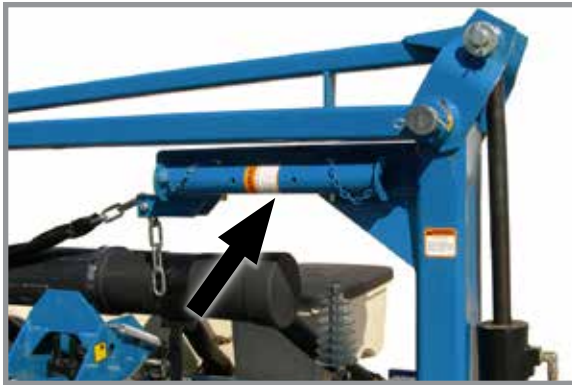

Row marker safety lockup stored

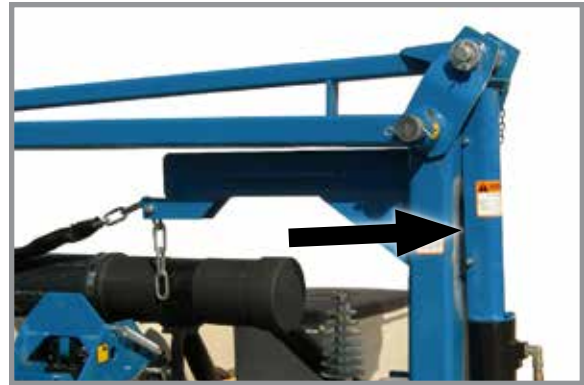

Row marker safety lockup installed

2. Install cylinder lockups on marker cylinders to prevent markers from unfolding when not in use or planter is in transport position.

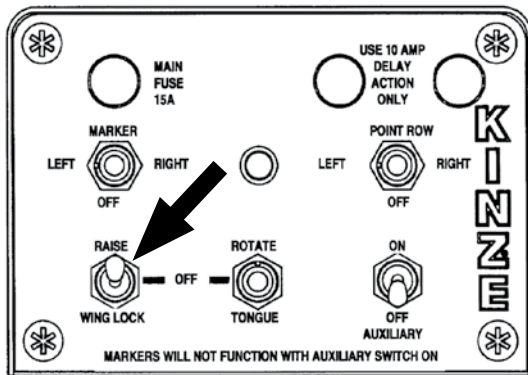

Raising planter

3. Hold RAISE/WING LOCK switch on control console in **RAISE** while operating proper tractor hydraulic control to raise planter. Planter frame should raise level until lift (master) cylinders at ends of wings are fully extended. Center lift (slave) cylinders will continue to extend (at a somewhat slower rate) until they are fully extended.

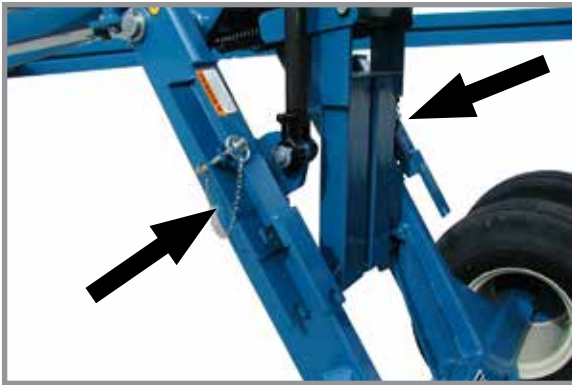

Safety lockups in storage position

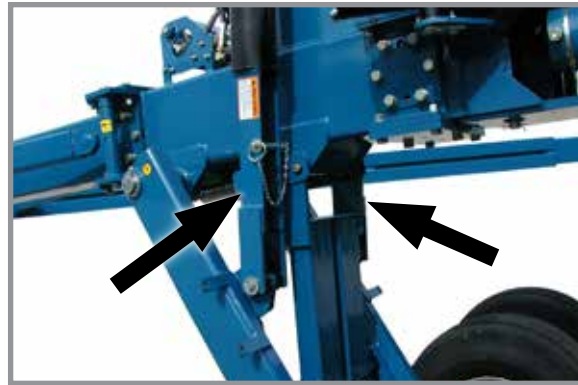

Safety lockups in transport position

NOTICE

DO NOT fold planter into transport position without lift cylinder lockups installed or uncontrolled planter settling can damage equipment.

4. Install center (slave) lift cylinder lockups. Install pin assembly to lock each in place.
5. Lower planter onto center lift (slave) cylinder lockups.

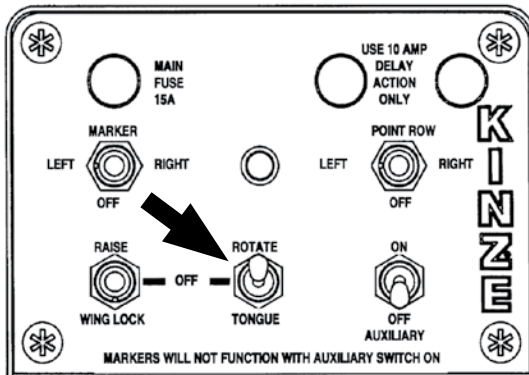

Planter folding

6. Hold **ROTATE/TONGUE** switch in **ROTATE** and operate hydraulic control to fold planter. Slowly idle tractor forward as you fold planter, allowing center axle tires to remain stationary and wing tires to roll in a continuous arc with minimal side loading on tires or their mounting structure. Hooks on wing ends should pass over planter hitch and contact stops on draft links.

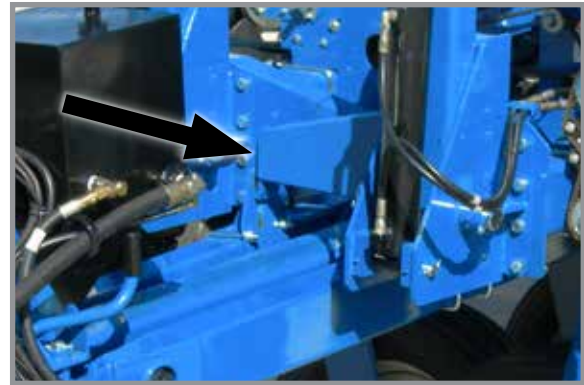
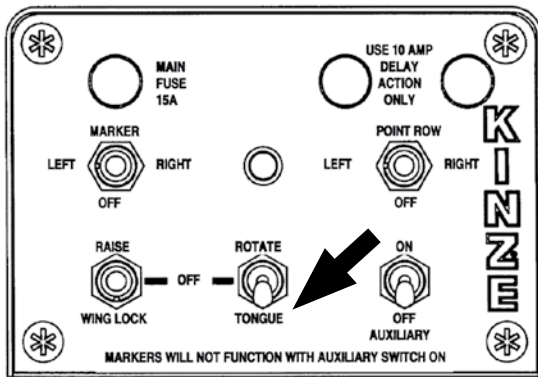

Wing end hook

NOTICE

DO NOT LOWER planter frame onto transport axle in folded transport position or transport tires and row units will be damaged.

7. Raise hitch parallel linkage to completely engage wing hooks and completely lift wing wheels off ground.

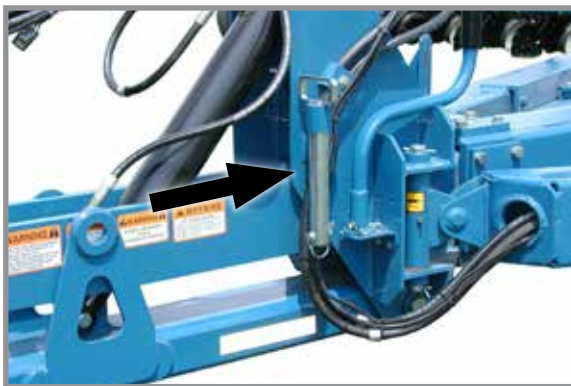

Hitch parallel linkage pin stored



Hitch parallel linkage pin installed

8. Install parallel linkage lock pin.
9. Lower parallel link cylinder onto lock pin.

ROW MARKER OPERATION



DANGER!

Contacting or coming close to power lines or other high energy sources will cause death or serious injury. Keep away from power lines or high energy sources at all times.



Marker switch

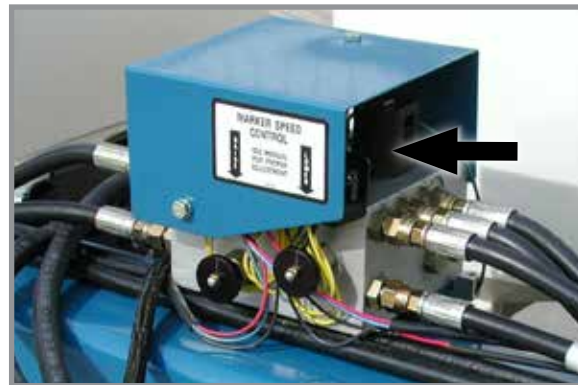

Row marker solenoid valves

Two solenoid valves on valve block at rear R.H. side of center frame, and a three position selector switch on control console permit operator to lower or raise desired row marker.

NOTICE

Marker position switch must be OFF when planter is not in use or tractor battery will drain.

NOTE: See row marker adjustments on following pages.

1. Select which row marker to lower on control console.
2. Operate hydraulic control to lower row marker.
3. Move control switch to other side to operate opposite row marker.
4. Raise row marker at end of field using hydraulic control.
5. After turn, using the hydraulic control, lower the pre-selected row marker.
6. Continue to follow this procedure.

NOTE: Both row markers can be lowered by operating switch in each position and hydraulic control twice. Row markers raise simultaneously with hydraulic control in raise position.

If electrical system does not operate properly:

- Check fuse.
- Check wiring connections.
- Check control switch.
- Check solenoid. SOLENOID HOUSING IS MAGNETIZED WHEN ENERGIZED.

ROW MARKER SPEED ADJUSTMENT

NOTICE

**Excessive row marker travel speed can damage row markers.
Adjust flow controls before row markers are first used.**

Marker hydraulic system includes two flow control valves. One flow control valve sets lowering speed and one sets raising speed of both markers. Flow controls determine amount of oil flow restriction through valves, varying marker travel speed.

Loosen jam nut and turn control clockwise, or IN to slow travel speed. Turn counterclockwise, or OUT to increase travel speed. Tighten jam nut after adjustments are complete.

NOTE: Tractors with flow control valves. Make row marker speed adjustment with tractor flow controls in maximum position. After row marker speed is set, adjust tractor flow controls to allow hydraulic control to stay in detent during marker raise or lower cycle.

NOTE: Hydraulics operate slowly when oil is cold. Make all adjustments with oil warm.

NOTE: On a tractor where oil flow cannot be controlled, tractor flow rate may be greater than rate marker cylinder can accept. Hold tractor hydraulic control lever until cylinder reaches end of its stroke. This occurs most often on tractors with an open center hydraulic system.

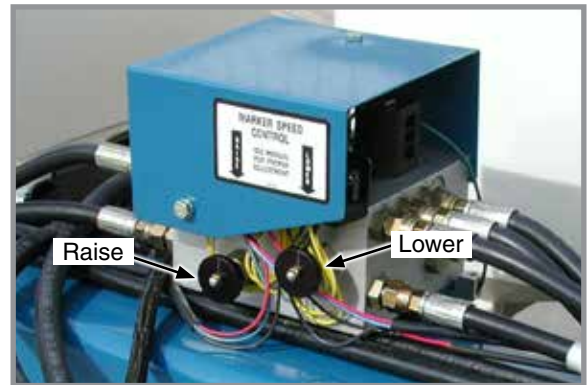

Row marker speed control adjustment

ROW MARKER CHAIN ADJUSTMENT

WARNING

**Uncontrolled marker movement can cause death or serious injury.
set marker switch OFF and shut off tractor prior to adjustment.**

NOTE: Operate two-fold or three-fold row markers with the tractor's hydraulic valve in float position.

Chain adjustment is critical. Adjust chain with second stage of marker in vertical position and first stage in horizontal position.

Chain must be adjusted so third stage of marker is pulled out as soon as second stage begins outward travel. Chain stretches with use and needs routine adjustment. It may be necessary to twist chain for a finer adjustment.

Marker chain is PROPERLY ADJUSTED if marker blade pushes dirt 12" or less as marker completes fold into field operating position. Chain should have some slack when marker is in field operating position.

Marker chain is TOO LOOSE and should be adjusted if marker blade pushes dirt more than 12" as it completes the fold into field operating position.

Marker chain is TOO TIGHT if it will not allow marker blade to follow ground contour and chain is tight when marker is in field operating position.

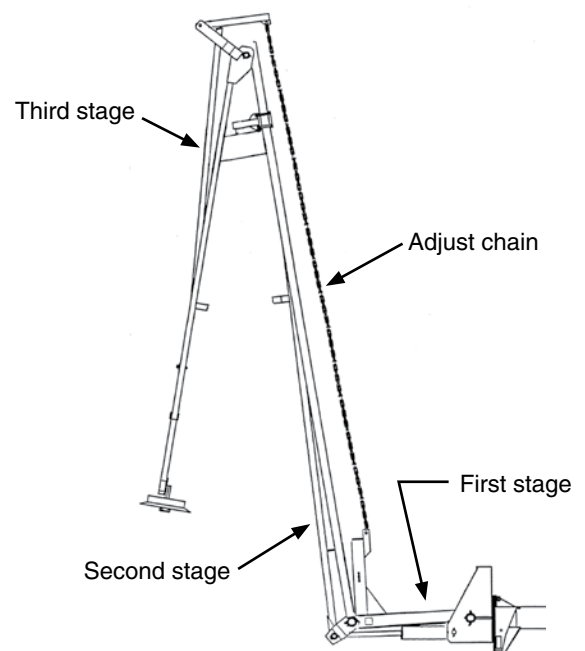

ROW MARKER LENGTH AND DISC BLADE ADJUSTMENT

1. Multiply number of rows by the average row spacing in inches to determine total planting width.

Row Marker Lengths	
24 Row 20"	480" (1,219.2 cm)
24 Row 22"	528" (1,341.12 cm)
24 Row 30"	720" (1,828.8 cm)
36 Row 20"	720" (1,828.8 cm)

2. Lower planter and row marker assembly to ground.
3. Measure from planter center line to a point where blade contacts ground.
4. Adjust row marker extension so distance from marker disc blade to center line of planter is equal to total planting width. Adjust right and left row marker assemblies equally and securely tighten clamping bolts.

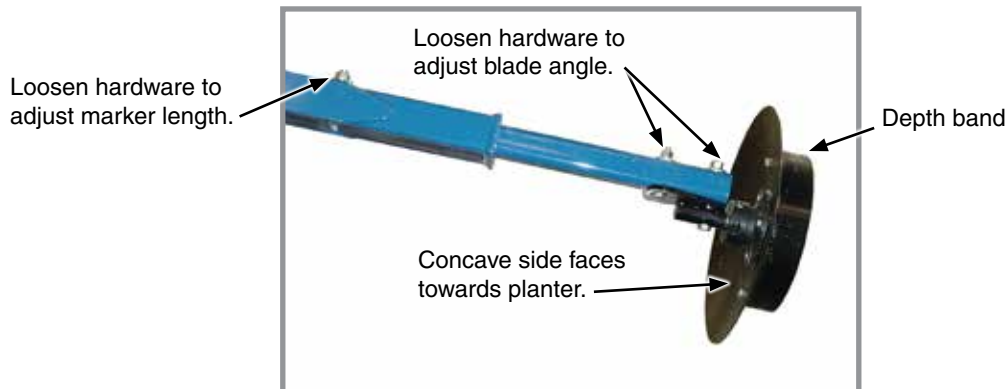

Row marker disc blade angle adjustment

NOTICE

Setting marker disc blade assembly at a sharper angle than needed adds stress to row marker assembly and shortens bearing and blade life. Set blade angle only as needed to leave a clear mark.

Marker disc blade is installed with concave side facing inward. Spindle assembly is slotted so hub and blade can be angled to throw more or less dirt.

5. Loosen hardware and move assembly as required.
6. Tighten bolts to specified torque.
7. Do a field test to ensure markers are properly adjusted.

NOTE: A notched marker blade is available from Kinze through your Kinze Dealer for use in more severe no till conditions.

EDGEVAC SYSTEM

Kinze EdgeVac seed metering system includes seed meters, seed discs, and an air system consisting of a hydraulic driven vacuum fan which draws air through manifolds, hoses, and seed meters on each row unit.

WARNING

Moving fan blades can cause amputation or severe injury. Never operate vacuum fan with cover removed.

VACUUM FAN VALVE BLOCK ASSEMBLY

A pressure relief valve prevents build up of oil pressure over 35 PSI in case drain line when vacuum fan motor is operating. This valve vent oils outside through a drain hole in aluminum valve block. This can occur whenever case drain is improperly connected or pressure in motor circuit builds.

Valve block contains a check valve that prevents vacuum fan from operating in wrong direction if pressure is applied to return side of motor and allows fan to coast to a stop when tractor hydraulic control is returned to neutral position.

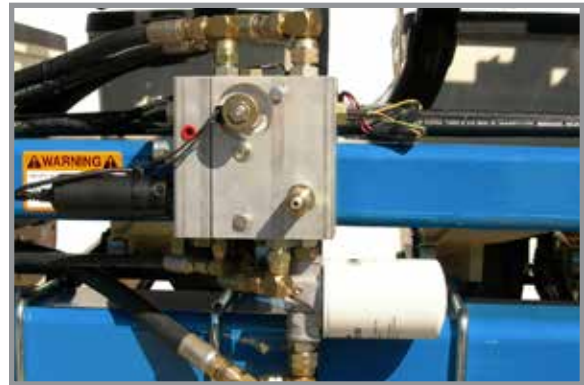

Vacuum fan valve block

See “Hydraulic Schematic (Vacuum Fan System)” in Lubrication and Maintenance section.

NOTE: Fan turns at a reduced speed if reverse pressure is applied.

ANALOG VACUUM OR PRESSURE GAUGE

Analog vacuum or pressure gauge connects directly to EdgeVac (vacuum) or ASD (pressure) manifold and is teed into digital sending units.

Only adjustment is to “zero” needle with no vacuum or pressure present. If there is a significant difference between gauge and a reading taken at meters, a different manifold location should be found to connect hose to gauge and digital sending unit.



Analog gauge

NOTE: Analog gauges are identical EXCEPT for plug and hose barb locations in side of gauge housing. DO NOT connect EdgeVac or ASD hose to wrong gauge. Check plug and hose barb installation if readout is erratic or appears inaccurate.

AIR SEED DELIVERY (ASD) SYSTEM

CAUTION

Seed flying out of disconnected delivery tube at high velocity can cause injury. Do not disconnect delivery tubes when system is operating.

NOTICE

Foreign materials can plug system. Make sure seed is clean and free of debris when filling ASD hoppers.

NOTICE

Do not turn on system with tractor engine at full speed or system damage may occur.

NOTICE

Do not operate ASD system above maximum system operating pressure of 20 inches of water or seed bridging may occur.

1. **Before filling hoppers refer to “Row Unit Operation” for additives information.** Fill hoppers with seed, latch lids, and secure with pin.
2. Start air seed delivery system with tractor engine at idle.
3. Increase engine speed to full and set initial system pressure using flow control valve.
4. Allow system to warm up and adjust pressure if necessary.

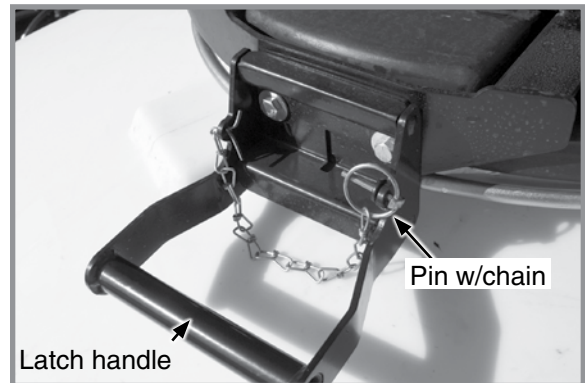

ASD tank lid latch

Recommended pressures:

- Corn – 12 inches of water
- Soybeans – 10 inches of water
- Actual pressure needed is affected by seed size, shape, and coating.

ASD ENTRAINER ACCESS

1. Shut down ASD system.
2. Loosen wing nut and turn retainer holding shutoff door in its storage location.
3. Remove rubber plug closest to area in entrainer needing attention.
4. Insert shutoff door into open slot and push into entrainer at a slight upward angle.
5. When work is complete, remove shutoff door, return door to storage location, and plug open slot.

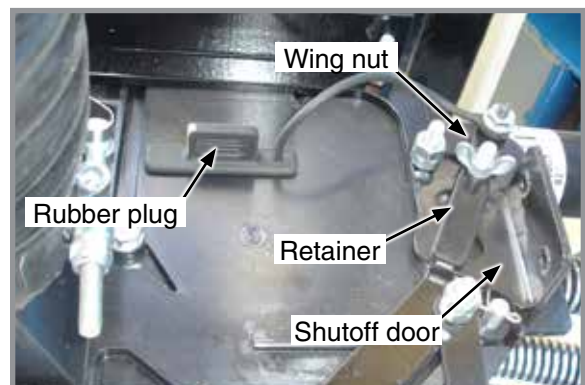

ASD entrainer (end view)

ASD TANKS - CLEAN OUT



Cleanout chute storage location

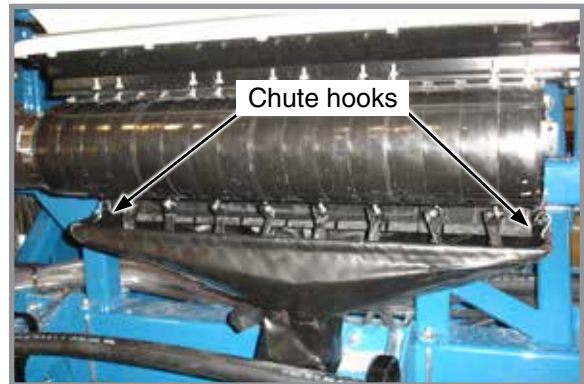

Cleanout chute installed

1. Remove ASD tank cleanout chute from storage location under L.H. ASD tank.
2. Position tube of chute under entrainer and attach hooks on each end of entrainment assembly.
3. Open cleanout doors and empty tank.
4. Close all cleanout doors and return cleanout chute to storage location.

ASD SCALE PACKAGE OPTION

NOTICE

High-pressure water can damage display. Remove display before power washing planter.

NOTICE

Remove and store display at end of planting season. Damage from sun and weather exposure may result.

- Provides seed weight or estimated acres remaining for each ASD hopper.
- Displays total (gross) seed weight or estimated acres remaining for both hoppers combined.
- Warns operator when seed goes below a pre-defined level (when using a Kinze Vision display).

Operation of ASD Scale Package display is controlled by buttons located on its face:

- Two screen-defined selection buttons.
- Backlight ON/OFF button.
- UP/DOWN arrow buttons.
- Screen position is changed by loosening thumb screw on mount at back of monitor and repositioning screen.

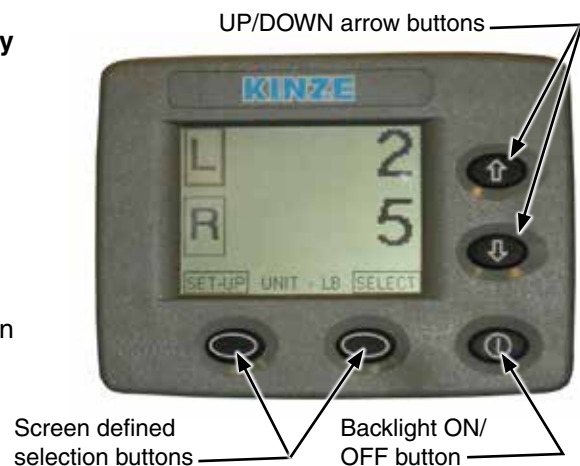

SETUP ASD SCALE PACKAGE DISPLAY

1. Press SET-UP button.



2. First setup screen displays and ALARM LEVEL box is highlighted.
3. Press SELECT button.
4. Press UP or DOWN arrows to change alarm weight level. Select BACK to save changes.
5. Press UP or DOWN arrows to highlight WEIGHT/ACRE MODE box. Press SELECT button.
6. Press UP or DOWN arrow buttons to toggle between weight or acre mode. This selection affects if values are displayed as pounds or estimated acres of seed remaining. Press BACK to save changes.
7. Press DOWN arrow to select second set-up screen.



NOTE: CALIBRATION# and SETUP# are automatic and do not need to be changed.

8. Select CONTRAST or BACKLIGHT. Use UP or DOWN arrow buttons to change levels. Press BACK to save changes.
9. Select BACK to return to main screen.



MONITOR SEED LEVELS

1. Main screen displays information for left and right hoppers.
2. Select L or R for individual hopper status information.
3. Select BACK to return to main screen.
4. Press down arrow once or twice for GROSS screen to appear.
This provides combined status information for both hoppers.
5. Press down arrow again to return to main screen.



ENTER SEED INFORMATION

1. Highlight and select either L (left) or R (right) for the appropriate input screen.
2. At input screen, L or R side is indicated at left side of screen and seed weight or acres remaining is on right side.



3. Press arrow keys to select desired box; press SELECT to darken and use arrow keys to change.

NOTE: Seed information entered must be accurate for remaining estimated acres to calculate correctly.

- SEEDS/ACRE is population rate.
- SEEDS/LB value comes from seed specifications.
- ZERO is selected to zero hopper that is selected.

4. Select BACK to return to main screen.



KINZE COBALT SYSTEM

The Cobalt electronic seed monitor system consists of a tractor-mounted console, seed tubes with computerized sensors installed in each planter row unit, a primary harness connecting console to planter harness, and a planter harness (junction Y-harness and/or harness extension where applicable), connected to each seed tube sensor.

Cobalt monitor is built to withstand harsh environments associated with today’s agricultural industry. The weathertight enclosure seals out dirt and moisture encountered during normal operating conditions

This system is compatible with all Kinze planters, and can be transferred between multiple vehicles to maximize return on investment.

The Cobalt system allows manual control of air clutches and variable population control when planter is equipped with these options. It is not GPS compatible.

NOTE: See Kinze Cobalt Operator Manual for installation and programming.



Kinze Cobalt display

AG LEADER INTEGRA DISPLAY

Integra is a full-featured hub of any precision farming operation. A large, full-color 12.1" HD touchscreen display is easy to read and offers powerful, year-round precision farming tools. Mapping, planter and application control, yield monitoring, real-time data logging, and more – are all controlled from the cab using the Integra display.

Four video camera inputs provide operators a better view of equipment operation and safety by allowing them to view live video on the display.

NOTE: See Integra Operator Manual for installation and programming.



Ag Leader Integra display

PLANTER MONITOR MODULE (PMM)

PMM Magnetic Distance Sensor Package includes a planter-mounted module enclosure with cover and mounting hardware, seed tubes w/sensors, planter harness, planter monitor cable, shaft rotation sensors and magnetic distance sensor components.

Ag Leader Integra display and associated cab harnesses are also required.

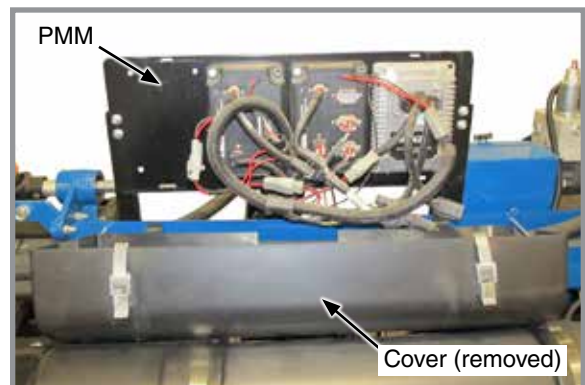

Planter Monitor Module (PMM)

KINZE ISOBUS OPTION

Kinze ISOBUS option consists of a planter monitor module (PMM), and planter control module (PCM). Kinze planters will communicate directly with most ISO compatible monitors.

POINT ROW CLUTCHES

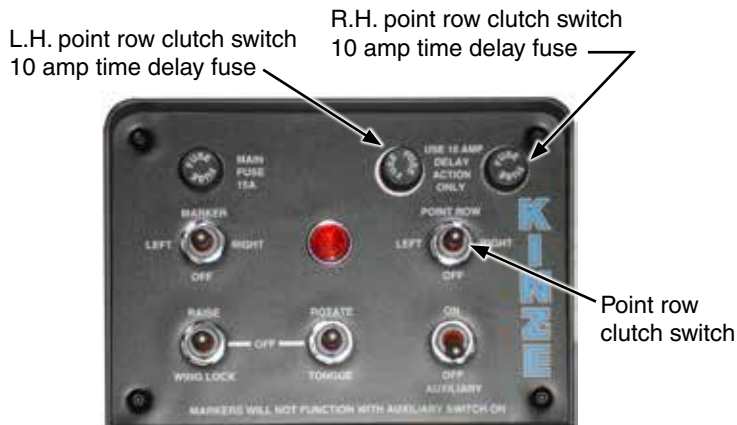

Single point row clutch control box



Point row clutch

Electric-activated clutches disengage drive on either half of planter for finishing up fields or for long point row situations. Clutch selector switch is located on tractor control box.

NOTICE

Switch must be OFF when planter is not in use or tractor battery will be drained.

NOTE: Liquid fertilizer piston pump has its own drive wheel and is not affected by point row clutch.

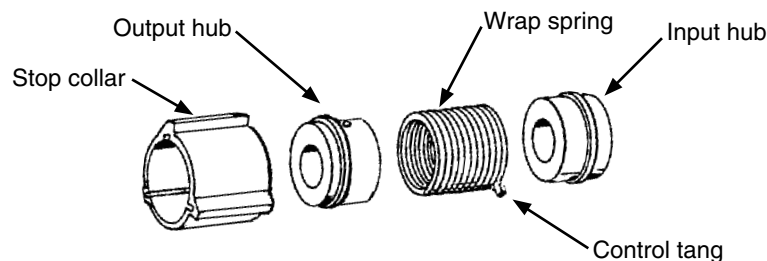

Clutch consists of a wrap spring riding on an input and output hub. Wrap spring is wrapped tightly over hubs during operation locking them together. Higher speeds create a tighter grip of spring on hubs.

Input end of spring is bent outward and is called the control tang. Control tang fits into a slot in stop collar located between input and output hubs over wrap spring. If stop collar is allowed to rotate with input hub, clutch is engaged. If stop collar is stopped from rotating, control tang connected to it is forced back and spring opens. This allows input hub to continue rotating without transmitting torque to output hub, stopping planter drive.

Stop collar is controlled by an electric solenoid and an actuator arm. When selector switch on tractor control box is OFF, solenoid coil is NOT ENERGIZED and actuator arm will not contact stop on stop collar, allowing it to rotate with hubs and drive planter.

When operational switch is in "DISENGAGE" (right or left) solenoid coil IS ENERGIZED and plunger in solenoid coil pulls actuator arm against stop on stop collar, disengaging wrap spring and stopping planter drive.

TWO-SPEED POINT ROW CLUTCHES

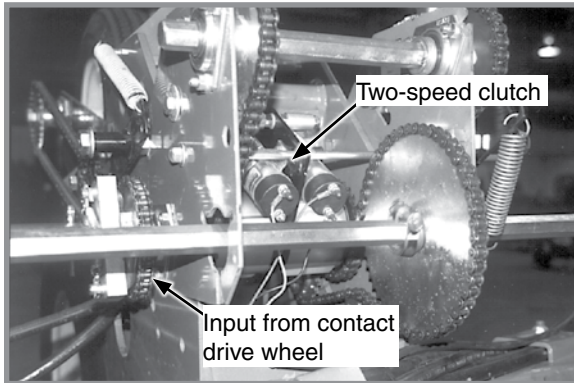

Two-speed point row clutch

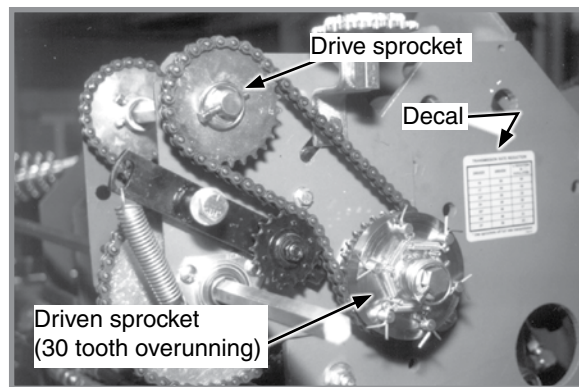

Two-speed point row clutch driven sprockets

Optional Two-Speed Point Row Clutch Package allows on-the-go population rate adjustment and capability to shut off either half of planter for finishing up fields or for long point row situations.

Population reduction ratio is determined by sprocket ratio between wheel module extension drive and driven sprockets. A rate reduction decal is located on wheel module extension.

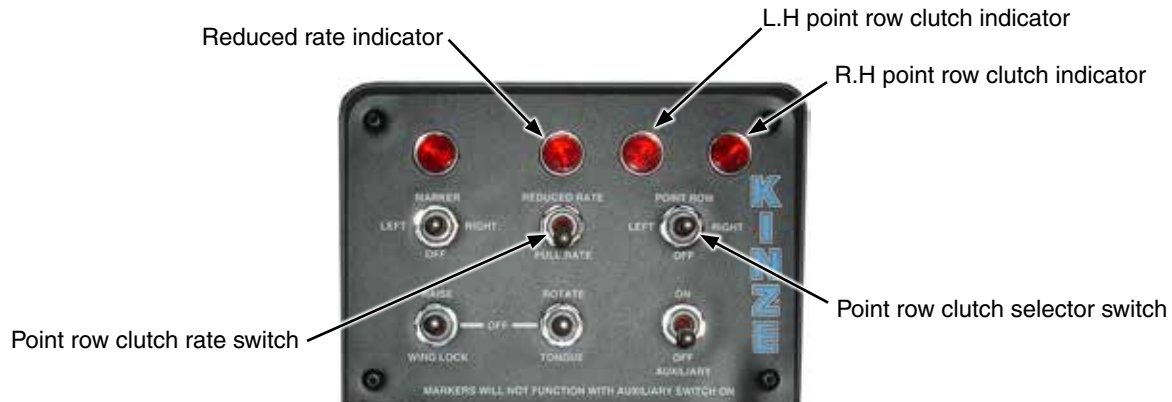

Two-speed point row clutch control box

Point row clutches are controlled by control console point row clutch switches. The point row switch shuts off left or right half of planter. Activating reduced rate switch engages one solenoid on each clutch assembly and reduces planting rate for entire planter.

NOTICE

Point row switch must be OFF and rate switch left in FULL RATE when planter is not in use or tractor battery will be drained.

NOTE: Liquid fertilizer piston pump has its own drive wheel and is not affected by point row clutch.

PISTON PUMP

NOTE: Keep manuals shipped with pump and flow divider with this manual.

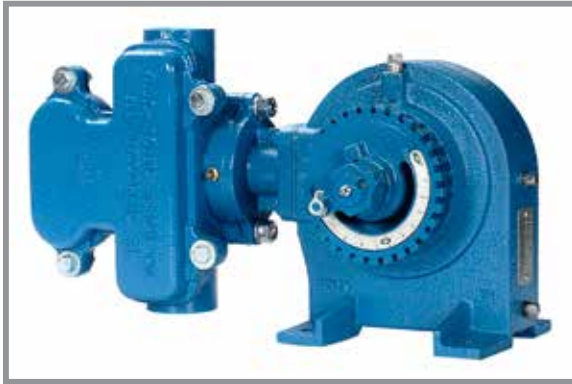

Piston pump

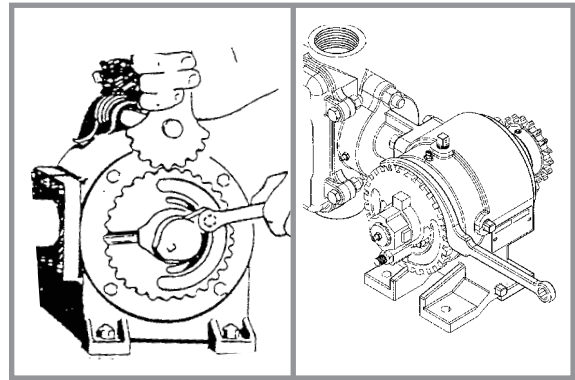

Adjusting delivery rate

NOTE: Delivery rate chart in Rate Chart section of this manual provides approximate application rate only. Delivery varies with temperature and fertilizer.

Loosen $\frac{3}{8}$ " lock nut that secures arm with pointer and rotate scale flange with adjustment wrench until pointer is over desired scale setting. Tighten $\frac{3}{8}$ " lock nut. **DO NOT OVERTIGHTEN.**

NOTE: Periodically check flow to all rows. Set rate is delivered to remaining rows if one or more lines are plugged.

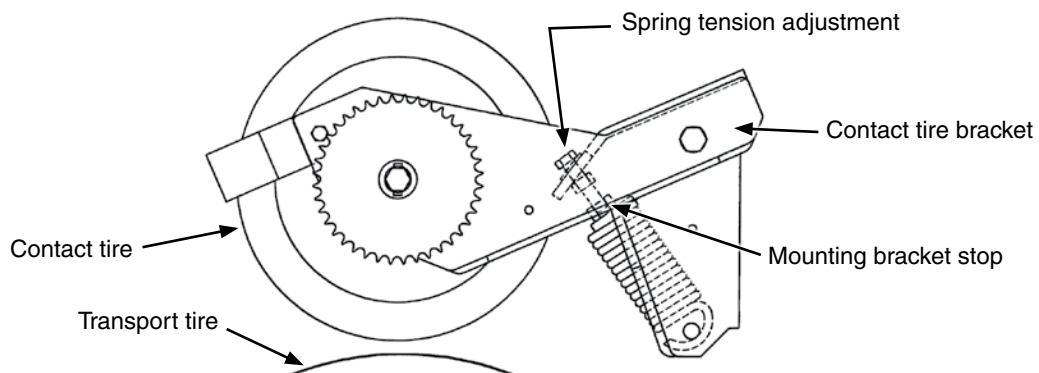

Set piston pump drive spring tension so there is no slack in springs when contact tire bracket is resting on mounting bracket stop. Contact tire and transport tire should not be touching.

CLEANING

Clean tanks, hoses, and metering pump thoroughly with water at end of planting season or prior to an extended period of non-use. Do not allow fertilizer to crystallize from cold temperature or evaporation.

On machines equipped with piston pump, take apart and clean strainer located between piston pump and ball valve daily. Remove the end cap to clean the screen. See Piston Pump Storage in Maintenance Section of this manual.

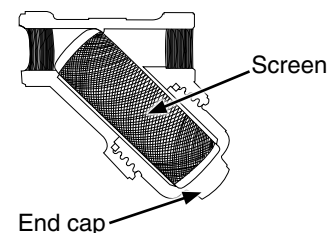

CHECK VALVES



Old style non-reparable check valve



New style reparable check valve

Optional low rate check valves are available for in-line installation between liquid fertilizer piston pump and openers to ensure equal distribution of product at low rates. Check valves eliminate anti-siphon loops.

LOW-RATE (POP-UP) LIQUID FERTILIZER SYSTEM

Check flow out of each row frequently to ensure orifices have not been plugged.

If fluid is allowed to sit in the lines overnight and the temperature drops below 32 degrees fahrenheit it is recommended that the orifices be removed and the lines be flushed before continuing operations. Many fertilizers can salt out in temperatures under 32 degrees fahrenheit and clog orifices.

REAR TRAILER HITCH (24 ROW 30" ONLY)



Trailer hitch



Hitch position during lift

Rear trailer hitch is used to tow a 3 or 4 wheel wagon behind planter. Hitch height during field operation and transport is 15". Hitch height will raise to approximately 42" when planter is lifted.

NOTICE

Rear trailer hitch is designed for use with piston pump only. Maximum allowable hitch weight is 200 lb (90.71 kg). Do not exceed 6,000 lb (2,721.55 kg) gross towing weight or the equivalent of a loaded 500 gal (1,892.7 L) tank and running gear or equipment can be damaged.

NOTE: Periodically check feed hose for kinks to prevent restricted delivery rate.

Adjust rear trailer hitch length by loosening the 5/8" set screws at rear of outer tube, removing 1" x 8 1/2" bolt at center of hitch, and sliding hitch in or out to one of 4 sets of adjustment holes. Reinstall and tighten hardware.

FIELD TEST

Perform a field test with any change of field and/or planting conditions, seed size or planter adjustment to ensure proper seed placement and operation of row units.

- Check planter for front to rear and lateral level operation. See "Level Planter".
- Check **all** row units to be certain they are running level. Row unit parallel arms should be approximately parallel to the ground when planting.
- Check row markers for proper operation and adjustment. See "Row Marker Speed Adjustment", "Row Marker Chain Adjustment", and "Row Marker Length and Disc Blade Adjustment".
- Check for proper application rates and placement of granular chemicals on **all** rows. See "Field Check Granular Chemical Application".
- Check for desired depth placement and seed population on **all** rows. See "Field Check Seed Population".
- Check for proper application rates of fertilizer on **all** rows. See "Fertilizer Application Rate Chart".

Reinspect machine after field testing.

- Hoses And Fittings
- Bolts And Nuts
- Cotter Pins And Spring Pins
- Drive Chain Alignment

FIELD CHECK SEED POPULATION

1. Tie up one or more sets of closing wheels by running a chain or rubber tarp strap between the hopper support panel and closing wheels. It may be necessary to decrease closing wheel arm spring tension.

Chain, rubber tarp strap, or similar.

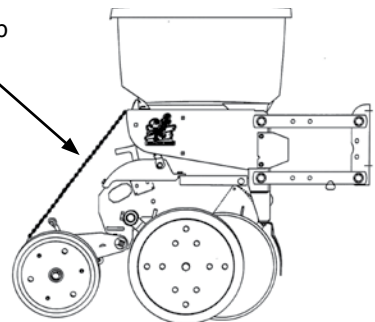

2. Plant a short distance and check to see if seed is visible in the seed trench. Adjust planting depth to a shallower setting if seed is not visible and recheck.

Planting depth adjustment handle

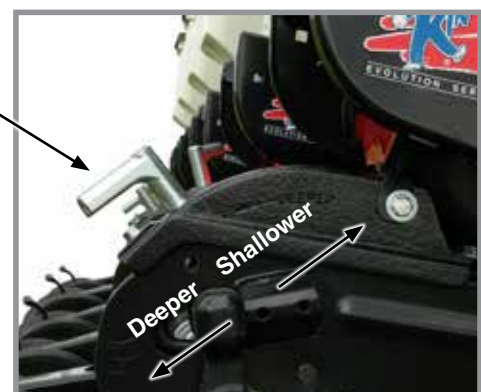

Planting depth adjustment

3. Measure $\frac{1}{1000}$ of an acre. See chart for correct distance for row width being planted. For example, if planting 30" rows $\frac{1}{1000}$ of an acre would be 17' 5".

$\frac{1}{1000}$ Acre Seed Population Count Row Width/Distance			
Row Width	20"	22"	30"
Distance	26'2" (797.56 cm)	23'9" (723.9 cm)	17'5" (581.66)

NOTE: Seeds may bounce or roll when planting with closing wheels raised and planting depth set shallow affecting seed spacing accuracy.

4. Count seeds in measured distance.
5. Multiply number of seeds placed in $\frac{1}{1000}$ of an acre by 1000. This gives total population.

EXAMPLE: 30" row spacing 17' 5" equals $\frac{1}{1000}$ acre.
 26 seeds counted x 1000 = 26,000 seeds per acre

Seed count can be affected by drive wheel and seed meter drive ratio, tire pressure, and/or seed meter malfunction.

1. If seed check shows average distance between seeds in inches is significantly different than seed rate chart indicates, first check drive ratio between drive wheel and seed meter. Check drive wheel air pressure, check for incorrect sprocket(s) in driveline and check drive and driven sprockets on transmission(s) for proper selection.
2. Check for seed meter malfunction. For example, if spacing between kernels of corn at the transmission setting being used is 8" and a gap of 16" is observed, a finger has lost its seed and not functioned properly. If two seeds are found within a short distance of each other, finger has metered two seeds instead of one.
3. See "Seed Meter (Finger Pickup) Troubleshooting" or "Seed Meter (Brush-Type) Troubleshooting" in Troubleshooting Section of this manual.

DETERMINING POUNDS PER ACRE (BRUSH-TYPE METER)

Seeds per acre ÷ Seeds per pound (from label) = Pounds per acre

If seeds per pound information is not available use the following averages:

- 2,600 seeds per pound for medium size soybeans
- 15,000 seeds per pound for medium size milo/grain sorghum
- 4,500 seeds per pound for medium size cotton

DETERMINING BUSHELS PER ACRE

Pounds per acre ÷ Seed unit weight = Bushels per acre

Average Unit Weight of:

- 1 Bushel Soybeans = 60 Pounds
- 1 Bushel Milo/Grain Sorghum = 56 Pounds
- 1 Bushel Cotton = 32 Pounds

If seed population check shows planting rate is significantly different than seed rate chart shows or if a particular meter is not planting accurately, see "Brush-Type Seed Meter Maintenance" and "Seed Meter (Brush-Type) Troubleshooting".

FIELD CHECK GRANULAR CHEMICAL APPLICATION

Temperature, humidity, speed, ground conditions, flowability of different material, or meter obstructions can affect granular chemical rate of delivery.

WARNING

Agricultural chemicals can cause death or serious injury to persons, animals, and plants or seriously damage soil, equipment, or property. Read and follow all chemical and equipment manufacturers labels and instructions.

Perform a field check to determine application rates.

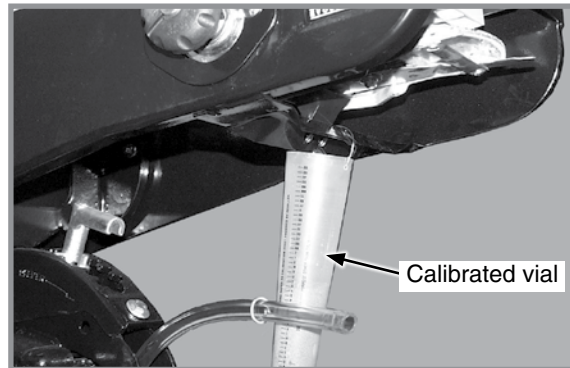

Granular chemical field check

1. Fill insecticide and/or herbicide hoppers.
2. Attach a calibrated vial to each granular chemical meter.

NOTE: Disengage clutch to avoid dropping seed during test.

3. Lower planter and drive 1320 feet at planting speed.
4. Weigh chemical in ounces caught in one vial.
5. Multiply that amount by factor shown to determine pounds per acre.

Pounds Per Acre	
Row Width	Factor
20"	1.25
22"	1.13
30"	.83

EXAMPLE: You are planting 30" rows. You have planted for 1320 feet at desired planting speed. You caught 12.0 ounces of chemical in one vial. 12.0 ounces times 0.83 equals 9.96 pounds per acre.

NOTE: Check calibration of all rows.

METERING GATE

Use metering gate setting as a starting point for distributing insecticide or herbicide. Charts are based on 5 mph (8 kph) planting speed. Use a higher gate setting for speeds faster than 5 mph (8 kph) and a lower setting for speeds slower than 5 mph (8 kph).

This page intentionally left blank.

PLANTING DEPTH

Planting depth is maintained by adjustable row unit gauge wheels. Depth adjustment range is approximately ½" to 3½".

1. Raise planter to remove weight from wheels.
2. Push down on depth adjustment handle and reposition it forward to decrease or rearward to increase planting depth. Initially adjust all units to the same setting.
3. Lower planter and check operation and planting depth of all row units. Readjust individual rows as needed for uniform operation.

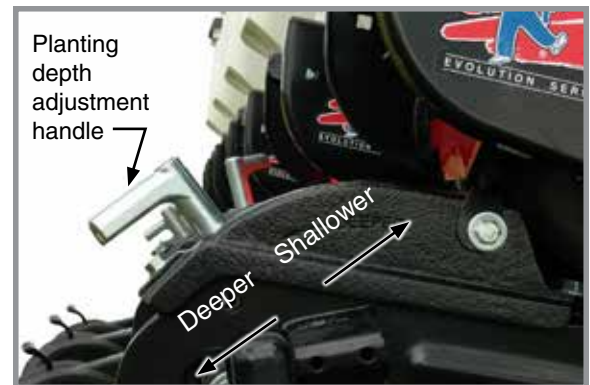

Planting depth adjustment

“V” CLOSING WHEEL ADJUSTMENT (RUBBER OR CAST IRON)

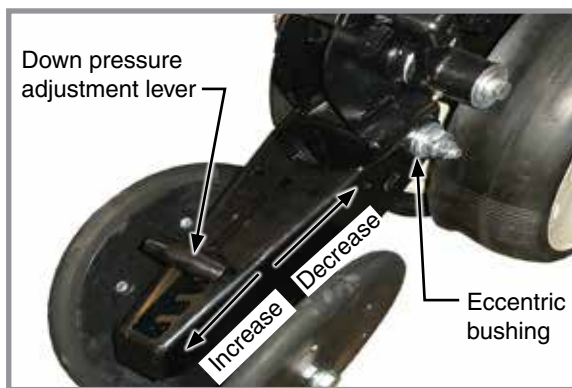

“V” Closing wheel adjustments

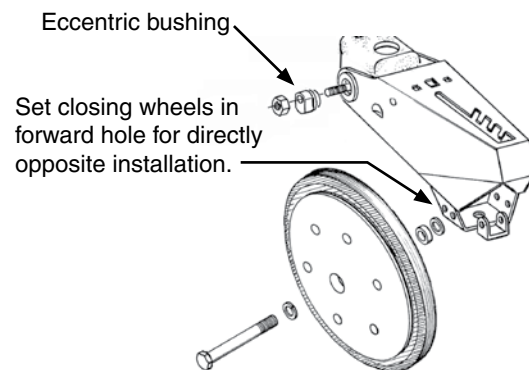

“V” closing wheels should have enough down pressure to close the seed trench and ensure good soil to seed contact. Move 5-position quick adjustable down force lever on the top of closing wheel arm to the rear to increase closing wheel spring pressure. Move lever forward to decrease pressure. Adjust all row units to a similar setting. Light soil usually requires less down force at average depth (approximately 2") while heavy soil requires increased down force.

Eccentric bushings in the wheel arm stop allow for lateral adjustment of the “V” closing wheel assembly. Use a ¾" wrench to loosen hardware attaching closing wheel arm to wheel arm stop. Use another ¾" wrench to turn eccentric bushings until **closing wheels are aligned with seed trench**. Tighten hardware.

Closing wheels can be installed “offset” (to improve residue flow) or “directly” opposite. Use forward installation holes if set “directly” opposite.

CLOSING WHEEL SHIELD (RUBBER OR CAST IRON “V” CLOSING WHEELS)

Optional closing wheel shield is installed on underside of closing wheel arm to help prevent root balls and stalks from clogging closing wheels.

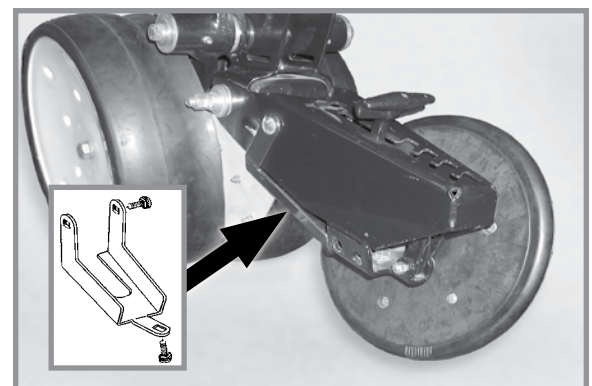

Closing wheel shield (Closing wheel removed)

DRAG CLOSING ATTACHMENT

Drag closing attachment pulls loose soil over seed trench.

NOTE: Use of a seed firming wheel or other seed firming device is recommended with drag closing attachment.

Front and rear adjustment is made using slotted holes in blades. Adjust all rows the same. Wheel arm stop eccentric bushings provide lateral adjustment. Use a 3/4" wrench to loosen closing wheel arm to wheel arm stop hardware. Use another 3/4" wrench to turn eccentric bushings until drag closing attachment is aligned with seed trench. Tighten hardware.

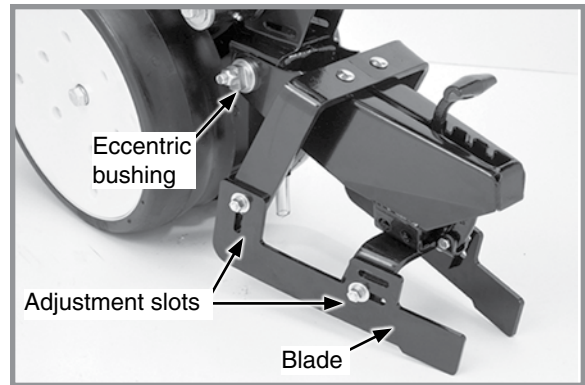

Drag closing attachment

COVERING DISCS/SINGLE PRESS WHEEL ADJUSTMENT

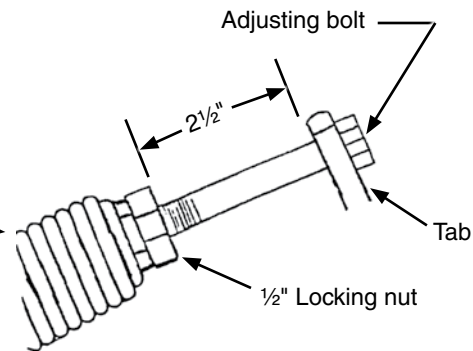
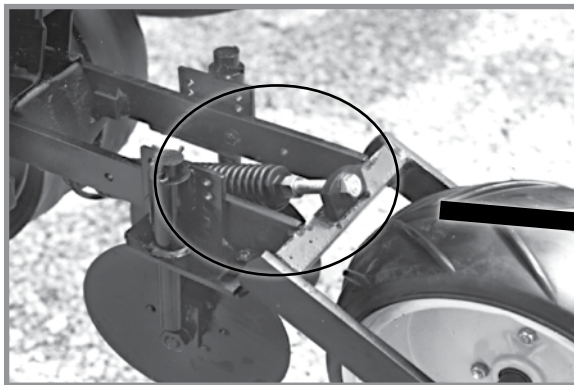

Press wheel down force adjustment

Check operation of covering discs/single press wheels after adjusting planting depth. Initial press wheel down force spring setting is 2 1/2" between mounting arm tab and locking nut. Loosen 1/2" locking nut and turn adjusting bolt in to increase down force or out to decrease down force. Tighten locking nut against spring plug. Adjust all row units to a similar setting.

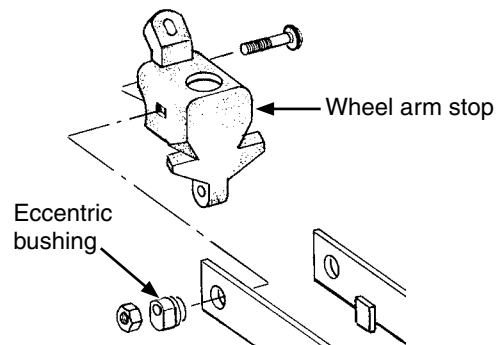
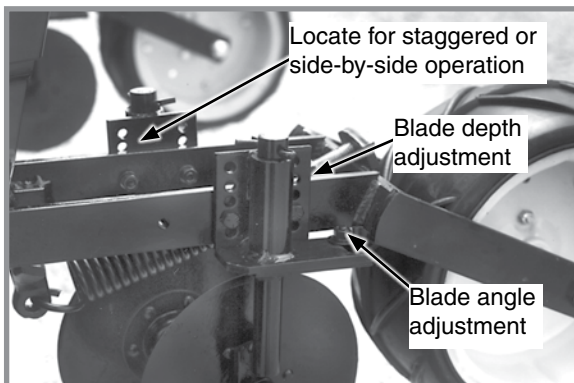

Covering disc adjustments

Eccentric bushings in the wheel arm stop allow for lateral adjustment of covering discs/single press wheel assembly. Use a 3/4" wrench to loosen hardware attaching closing wheel arm to wheel arm stop. Use another 3/4" wrench to turn eccentric bushings until covering discs/single press wheel assembly is aligned with seed trench. Tighten hardware. Two sets of holes in mounting arm locate covering discs for staggered or side-by-side operation. Five sets of holes in each disc bracket allow 1/2" incremental blade depth adjustment. Slotted holes in disc mount and bracket allow for 0° - 15° blade angle adjustment. Adjust covering discs on all row units to similar settings.

SEED HOPPERS

Mechanical seed hopper has a capacity of 1.9 bushels.

EdgeVac seed hopper has a capacity of 1.75 bushels.

Use clean seed and make certain there are no foreign objects inside when filling seed hopper. **Replace hopper lids after hoppers are filled to prevent accumulation of dust or dirt in seed meter which can cause premature wear.** See "Finger Pickup Seed Meter", "Brush-Type Seed Meter", or EdgeVac Seed Meter".

Periodically empty hoppers completely to remove any foreign objects and to ensure proper seed meter operation.

Disengage meter drive and hopper latch and lift hopper off hopper support. See "Seed Meter Drive Release".

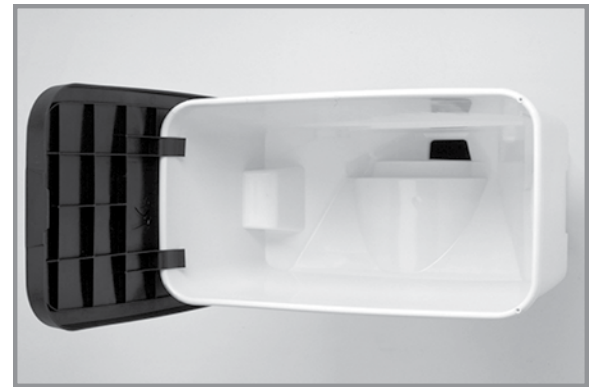

Mechanical seed hopper

SEED METER DRIVE RELEASE

A clutch release mechanism disengages seed meter drive from seed meter to remove seed hopper or prevent meter from operating. Releasing drive allows operator to check granular chemical application rates without dropping seed. It also allows one or more rows to be disconnected when finishing fields.

Turn knob ¼ turn counterclockwise to release or ¼ turn clockwise to engage drive.



Seed meter drive release

ROW UNIT EXTENSION BRACKETS

Row unit extension brackets extend row units rearward 4" to provide clearance for coulter mounted residue wheels and HD single disc fertilizer openers.

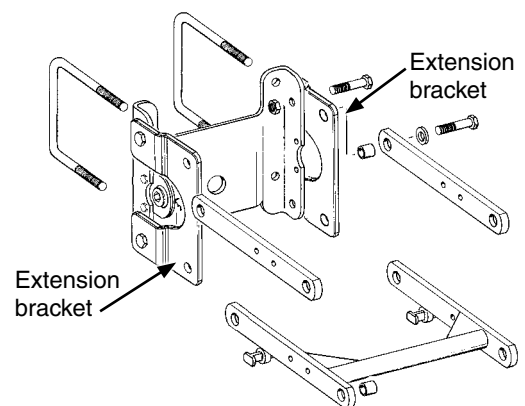

Row unit extension brackets

ROW UNIT CHAIN ROUTING

Row unit drive chains must be properly tensioned and aligned for proper operation and to minimize wear.

Inspect and replace weak, worn or broken springs, idlers, and idler bushings.

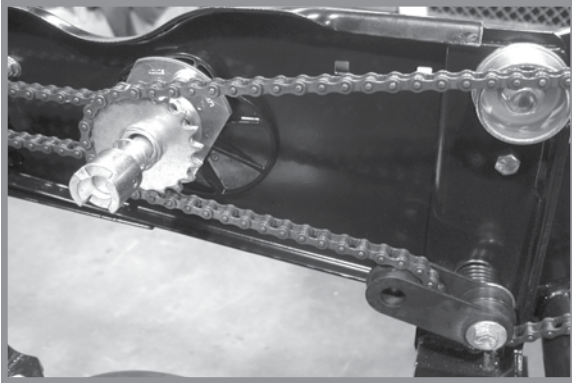

Mechanical pull row unit meter drive

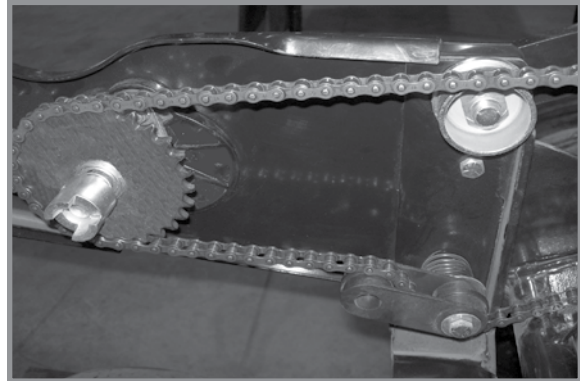

EdgeVac pull row unit meter drive



Row unit granular chemical drive

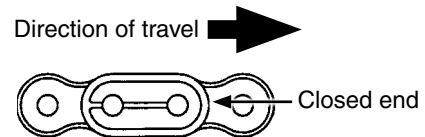

NOTE: Install connector link with closed end facing direction of travel.

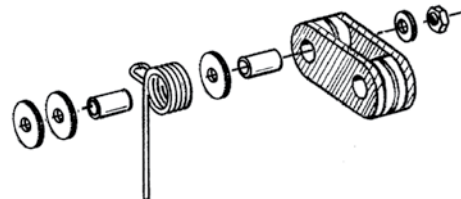

NOTE: Reverse idler when worn on one side for extended use.

QUICK ADJUSTABLE DOWN FORCE SPRINGS OPTION (STANDARD OR HEAVY DUTY)

Standard and heavy duty quick adjustable down force springs are available in increase penetration in hard soil and keep row unit from bouncing in rough field conditions. Two springs per row, one on each side parallel arms, are used unless equipped with row unit mounted no till coulters. Row unit mounted no till coulters require four springs per row.

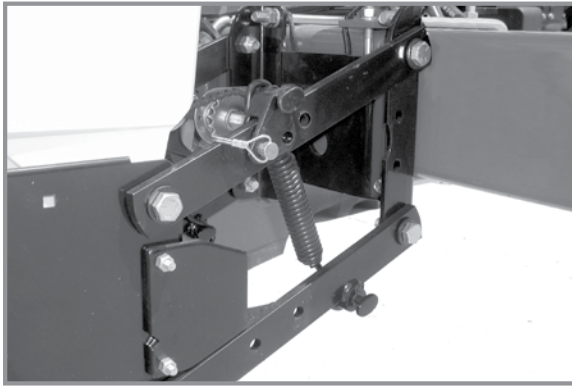

Two springs per row (Dual)

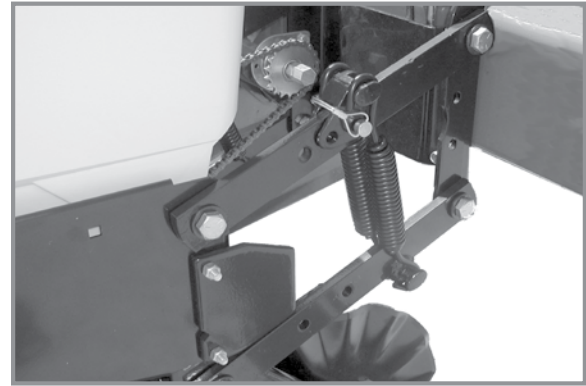

Four springs per row (Quad)

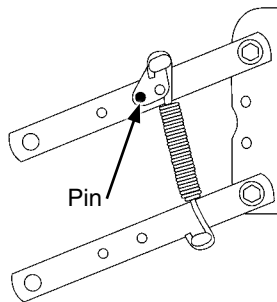

Position 1 (Least)

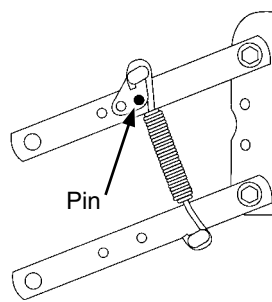

Position 2

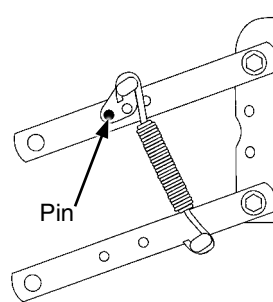

Position 3

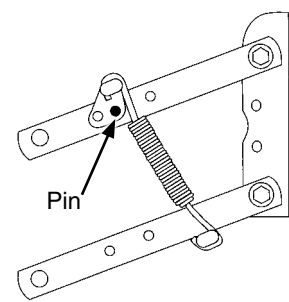

Position 4 (Most)

There are four positions to set down pressure spring tension.

Standard and Heavy Duty Spring Down Force Pressure*				
Position	2 Springs		4 Springs	
	Standard D8249	Heavy Duty D21337	Standard D8249	Heavy Duty D21337
1	41lb (18.6 kg)	43 lb (19.5 kg)	74 lb (33.6 kg)	80 lb (36.3 kg)
2	73 lb (33.1 kg)	86 lb (39.0 kg)	120 lb (54.4 kg)	144 lb (65.3 kg)
3	136 lb (61.7 kg)	167 lb (75.7 kg)	255 lb (115.7 kg)	307 lb (139.3 kg)
4	207 lb (93.9 kg)	249 lb (113.0 kg)	369 lb (167.4 kg)	470 lb (213.2 kg)

*Pressure does not include weight of row unit, seed, or options.

NOTICE

Springs must be installed with open side of spring hooks toward seed hoppers to prevent binding on spring mount adjustment pins.

1. Raise planter and remove spring mount pin at top of spring.
2. Slide mount to desired position and install pin.

NOTE: Adjust springs for field conditions. Too much down pressure in hard field conditions can cause row units to lift planter and keep drive wheels from making contact. Too much down pressure in soft field conditions can cause row unit to run too deep.

PNEUMATIC DOWN PRESSURE

Row unit down pressure can be adjusted on-the-go as field conditions change. A cab-mounted control box adjusts pressure (Older models may have a digital readout). Two planter-mounted 12 VDC air compressors with 3 gallon capacity air tank supplies air for the down pressure system.



Pull row unit air spring

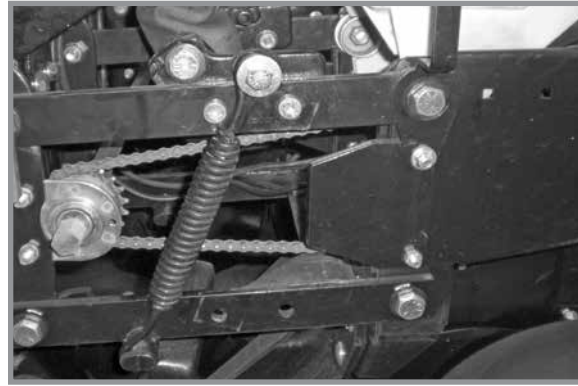

Pull row unit assist springs

Packages include upper and lower air spring mounting castings for pull row units, 150 psi rated air springs, $\frac{3}{8}$ " O.D. nylon hoses, dual solenoid air valve and stainless steel, 160 psi, 2" liquid-filled gauge and planter wiring harness.

Pneumatic down pressure row unit extension brackets are required in some applications.

NOTE: Assist springs are available through your Kinze dealer if additional down pressure is needed. One spring is installed on outer side of parallel arms on each side of row unit.

FIELD OPERATION

NOTE: Adjust down pressure with planter lowered and row openers in ground for most accurate adjustment. Pressure can be adjusted from tractor using control console, or at planter using manual control valves on compressor assembly.



Control console

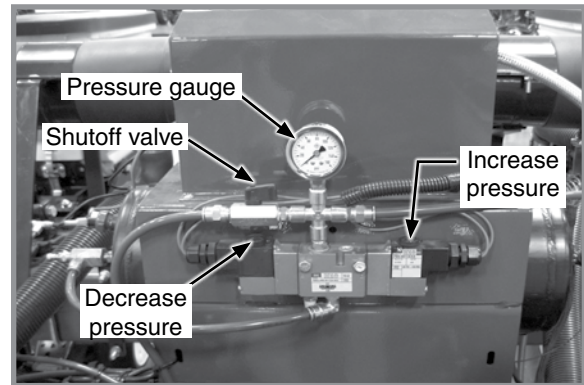

Air compressor assembly controls

ADJUST DOWN PRESSURE FROM CAB











Push toggle switch left to increase or right to decrease pressure.

ADJUST DOWN PRESSURE AT PLANTER

Push and hold decrease or increase button on compressor assembly to decrease or increase pressure.

NOTE: Value on the air pressure gauge is NOT down pressure force. Multiply air pressure (psi) by four (4) to calculate down pressure.

BRUSH-TYPE SEED METER

	Crop	Disc Color-Code (Disc Part No.)	Upper Brush Retainer	Cells	Seed Size Range	*Lubricant
	Soybean	Black (GA5794)	GD11122	60	2200 to 4000 seeds/lb.	Graphite Talc
	Specialty Soybean	Dark Blue (GA6184)	GD11122	48	1400 to 2200 seeds/lb.	Graphite Talc
	Small Milo/Grain Sorghum	Red (GA5982)	GD8237	30	14,000 to 20,000 seeds/lb.	Talc
	Large Milo Grain Sorghum	Light Blue (GA6187)	GD8237	30	10,000 to 16,000 seeds/lb.	Talc
	High-Rate Small Milo/Grain Sorghum	Red (GA5795)	GD8237	60	12,000 to 18,000 seeds/lb.	Talc
	High-Rate Large Milo/Grain Sorghum	Yellow (GA6633)	GD8237	60	10,000 to 14,000 seeds/lb.	Talc
	Cotton, Acid-Delinted	White (GA5796)	GD11122	30	4200 to 5200 seeds/lb.	Talc
	Large Cotton, Acid Delinted	Tan (GA6168)	GD11122	36	3800 to 4400 seeds/lb.	Talc
	High-Rate Cotton, Acid-Delinted	Light Green (GA6478)	GD11122	48	4200 to 5200 seeds/lb.	Talc
	Hill-Drop Cotton, Acid-Delinted	Brown (GA6182)	GD11122	12 (3 to 6 seeds/ cell)	4000 to 5200 seeds/lb.	Talc
	Small Hill-Drop Cotton, Acid-Delinted	Dark Green (GA7255)	GD11122	12 (3 to 6 seeds/ cell)	5000 to 6200 seeds/lb.	Talc

*For More information on application rate see Additives section.

	<p>Use GD11122 upper brush retainer when using cotton and soybean discs.</p>		<p>Use GD8237 upper brush retainer when using milo/grain sorghum discs.</p>
---	---	---	--

Turn seed disc counterclockwise when installing on meter hub while tightening two wing nuts that retain disc. Seed disc should have slight resistance when rotated counterclockwise after wing nuts are tight.

Brush-type seed meter attaches to seed hopper same as finger pickup seed meter. Secure to bottom of seed hopper with two 5/16" thumbscrews. Tighten thumbscrews slightly with pliers. **DO NOT OVER TIGHTEN.**

Misalignment between drive coupler and seed meter input shaft may cause erratic seed spacing from momentary stoppage of seed disc. Check alignment and adjust as needed.

Refer to planting rate charts in this manual for recommended seed drive transmission sprocket combinations.



Shown without seed disc installed



NOTICE

Replace hopper lids after hoppers are filled to prevent accumulation of dust or dirt in seed meter which will cause premature wear.

NOTE: Clean seed is required to ensure accurate seed metering from brush-type seed meters. Remove seed discs daily and check seed meter or brushes for buildup of foreign material, such as hulls, stems, etc.

FINGER PICKUP SEED METER

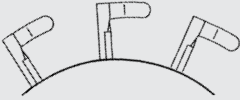
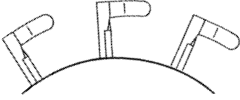
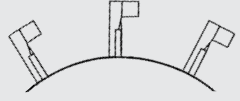









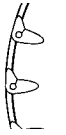

Crop	Fingers	*Lubricant
Corn	 Part No.: GR1848 - Finger Assembly, Corn	Graphite Talc
No. 1 and/or No. 2 size Confectionery Sunflower Seeds	 Part No.: GR1848 - Finger Assembly, Corn	Talc
No. 3 and/or No. 4 size Oil Sunflower Seeds	 Part No.: GR1897 - Finger Assembly, Oil	Talc
Blank fingers replace alternate fingers to reduce planting rate by half while allowing the finger wheel to maintain a minimum of 40 RPM when planting low rates.	 Part No.: GD11787 - Half Rate Blank Finger	Graphite Talc

*For More information on application rate see Additives section.

NOTE: Always field check seed population to verify planting rates.

NOTE: Refer to planting rate charts in this manual for recommended seed drive transmission sprocket combinations.

EDGEVAC SEED METERS

	Crop	Disc Color-Code (Disc Part No.)	Cells	Seed Size Range	Singulator Brush Setting	Vacuum Setting (H2O)	*Lubricant	See Notes
	Corn	Light Blue (GD17049)	39	35-70 lbs./80k	5-7	18-20	Graphite Talc	4, 5
	Popcorn			2210-4200 seeds/lb.	9	18	Graphite Talc	1, 4, 5
	Low-Rate Corn	Light Green (GD17048)	24	35-70 lbs./80k	5-7	18-20	Graphite Talc	4, 5
	Low-Rate Popcorn			2210-4200 seeds/lb.	9	18	Graphite Talc	1, 4, 5
	Soybean	Black (GD14467)	60	2200-4000 seeds/lb.	5	10	Graphite Talc	1
	Soybean, High-Rate	Dark Blue (GD14468)	120	2200-4000 seeds/lb.	5	10	Graphite Talc	-
	Milo/Grain Sorghum	Yellow (GD17050)	60	10,000 - 20,000 seeds/lb.	3-6	20	Talc	1, 2
	Hill-Drop Cotton, Acid-Delinted	Brown (GD17187)	20 (3 seeds/ cell)	3800-4400 seeds/lb.	8	23	Talc	3
	Small Hill-Drop Cotton, Acid- Delinted	Grey (GD18095)	20 (3 seeds/ cell)	4200-4400 seeds/lb.	-	-	Talc	3
	Cotton, Acid- Delinted	Dark Green (GD17186)	54	3800-5200 seeds/lb.	8	20	Talc	3
	Dry Edible Bean, Small			1200-2500 seeds/lb.	6	18	Graphite Talc	3, 5
	Dry Edible Bean, Large	Tan (GD14477)	54	800-1200 seeds/lb.	5	18	Graphite Talc	5
	Small Cotton/ Sunflower	White (GD18098)	54	4200-5200 seeds/lb.	5	30	Talc	3
	Sugar Beets	Dark Orange (GD24805)	80	All	5-6	15-18	Graphite	1

***For More information on application rate see Additives section.**

Install selected seed disc. Position vacuum cover on meter by aligning keyhole slots over bolt heads. Push cover on meter and turn counter clockwise to lock in place.

NOTES:

1. Requires use of seed meter baffle.
2. Requires use of cleanout brush.
3. Requires use of cleanout brush w/ball-type ejector.
4. Flat seeds may require higher vacuum level.
5. Larger seeds may require lower singulator brush setting. Smaller seeds may require higher setting.

NOTE: See “EdgeVac General Planting Rate Information” and “Check Seed Population” pages for more information. Always field check seed population to ensure planting rates are correct.

NOTE: Singulator brush settings are marked from 1 thru 11. Lower singulator brush settings are least aggressive. Higher singulator brush settings are most aggressive.

NOTE: Mixing seed sizes and shapes affects meter performance. Use consistent seed size and shape.

NOTE: Use 1 tablespoon powdered graphite with each hopper fill of seed. Seed treatment, foreign material, dirt or seed chaff may cause gradual reduction of seed disc fill (population). See “Additives” pages for more information.

NOTE: Excessive seed treatment, humidity, and light-weight seed can affect meter performance. Use ½ cup of talc with each hopper fill of seed and mix thoroughly to coat all seeds and adjust rates as needed. Use of talc aids seed flow into meter, singulation, and disc seed drop.

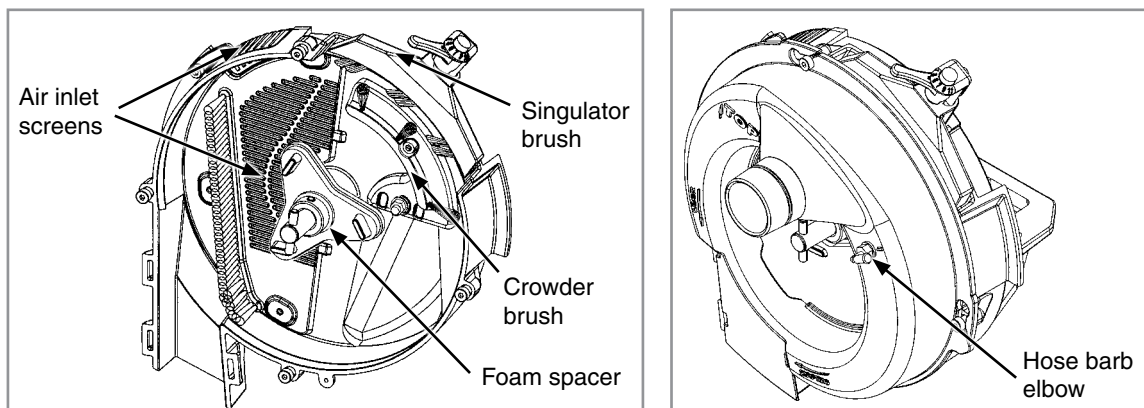

NOTE: Foreign material in seed disc orifices, such as seed chips, hulls, stems, etc., may affect seed delivery. Clean seed ensures accurate seed metering from vacuum seed meter. Remove Seed discs daily to check for buildup of foreign material in seed disc orifices.

Crowder brush aids in singulation of small flat seeds by crowding seeds to outer perimeter of seed disc and orienting seeds to allow singulator brush to be more effective.

Air inlet screens allow air to enter system and aids in keeping field residue or other foreign material out of meter.

Foam spacer gently preloads seed disc against vacuum cover when no vacuum is present.

3/16" hose barb elbow on seed meter vacuum cover allows measurement of vacuum level at each meter. A customer-supplied vacuum gauge is required.

See “EdgeVac Seed Meter Maintenance” and “Preparation For Storage” in Lubrication and Maintenance section for more information.

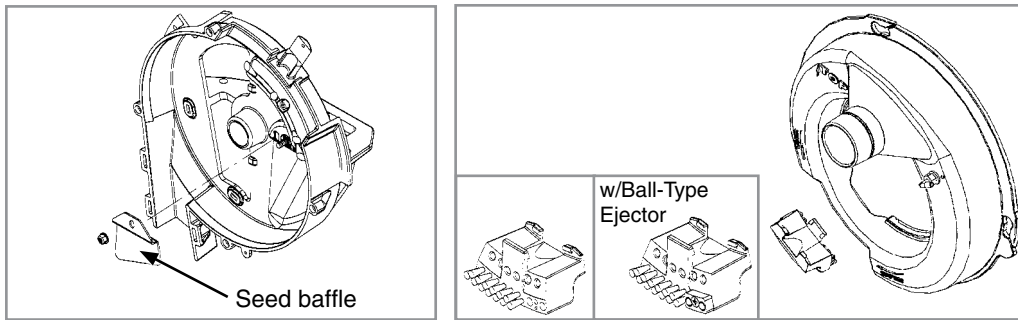

NOTE: Damaged seed or seed containing foreign material will cause plugging of seed disc orifices and require more frequent seed meter cleanout to prevent underplanting.

SEED BAFFLE

Seed baffle prevents excessive seed in meter from restricting air flow through seed. Used with 60 Cell Milo/Grain Sorghum Disc, 60 Cell Soybean Disc, 120 Cell High-Rate Soybean Disc, 39 Cell and 24 Cell Popcorn Discs, and 80 Cell Sugar Beet Disc.

CLEANOUT BRUSH

Cleanout brush removes foreign material and seed remnants to help prevent plugging of seed disc orifices. Used with 60 Cell Milo/Grain Sorghum Disc.

CLEANOUT BRUSH W/BALL-TYPE EJECTOR

Cleanout brush w/ball-type ejector ejects seed remnants from seed disc orifices. Used with 20 Cell Hill-Drop Cotton, Acid-Delinted (3 Seeds Per Cell) Discs; 54 Cell Acid-Delinted Cotton/Small Dry Edible Bean; and Small Cotton/Sunflower Discs.

NOTICE

Replace hopper or tank lids after filling to prevent accumulation of dust or dirt in seed meter resulting in premature wear.

NOTE: Seed size, seed shape, seed treatments, travel speed, and planting rate affect meter performance.

1. Select seed disc (and seed meter baffle, cleanout brush and/or cleanout brush w/ball-type ejector if applicable) to match crop and population.

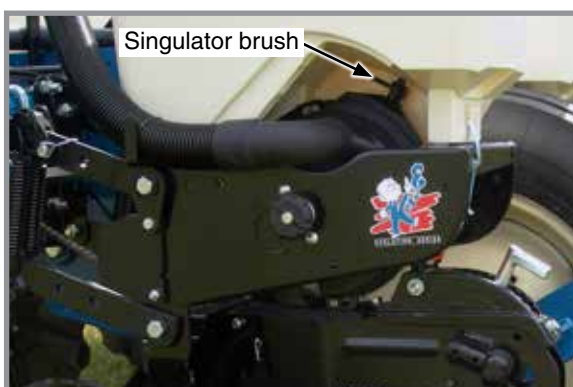

Singulator brush adjustment location

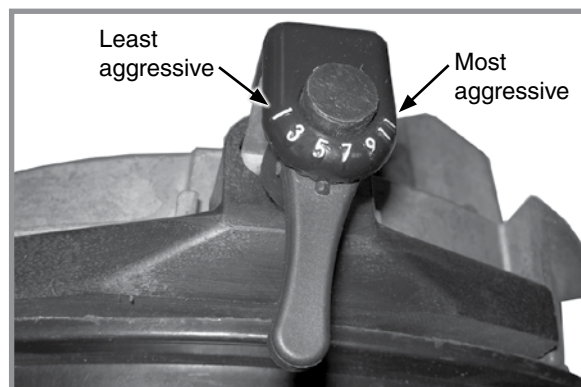

Singulator brush adjustment lever

2. Adjust singulator brush to initial setting. Seed size, seed shape, seed treatments, travel speed and planting rate all affect meter performance.
3. With vacuum fan running, lower planter to planting position and drive forward a short distance to load seed into seed disc cells.

- Adjust vacuum level to initial setting according to tables on page.

NOTE: Vacuum reading will be much lower when seed disc cells are empty. Load all seed cells before setting vacuum level.

NOTE: Operate vacuum fan 3-5 minutes to bring oil up to normal operating temperature prior to making final vacuum level adjustment.

- Perform optional seed disc fill check.



Remove vacuum cover and seed disc

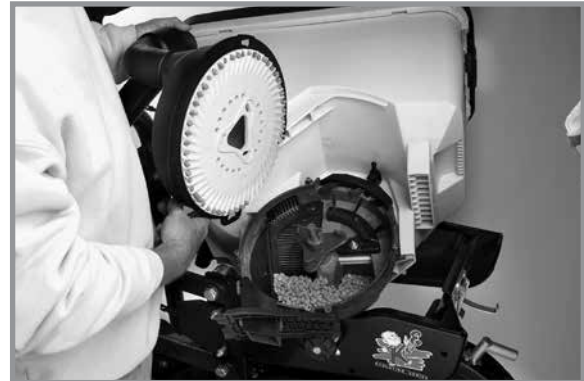

Check seed fill

With vacuum hose connected and vacuum fan operating, remove vacuum cover and seed disc as an assembly. Inspect seed discs for proper seed fill.

See “Seed Metering System (EdgeVac) Troubleshooting” in Troubleshooting section.

SEED METER CLEANOUT

NOTE: Use of damaged seed or seed containing foreign material will cause plugging of seed cell orifices and require more frequent seed meter cleanout to prevent underplanting.

Thorough seed meter cleanout is important to maintain genetic purity.

- Disengage seed drive and remove seed hopper and meter.
- Dump seed from right rear corner of hopper into a container.
- (Mechanical) Disassemble seed disc by removing wing nuts.
(EdgeVac) Lay hopper on its right side. Rotate seed meter vacuum cover clockwise to align keyhole slots with bolt heads. Lift off cover. Remove seed disc.
- Empty Meter.
- Thoroughly inspect brushes in meter to ensure all seed is removed.
- Replace seed disc. (Mechanical) Install wing nuts. (EdgeVac) Install Vacuum cover.

ADDITIVES

The use of graphite is recommended to promote seed flow, provide lubrication for the seed meter and to help dissipate static charge buildup. Among the available dry seed lubricants graphite is the most effective and easiest to use and it requires no mechanical agitation

CONVENTIONAL HOPPERS

Mix one tablespoon of **powdered graphite** with seed each time hoppers are filled. Regular graphite use prolongs life of the seed meter components, improves seed spacing, and may reduce buildup of seed treatments.

NOTE: DO NOT apply graphite only in center of hopper. It will filter too quickly through the seed and not distribute as evenly as desired.

Apply graphite around outer perimeter of hopper.

ASD HOPPERS

Mix 1 pound bottle of powdered graphite each time the bulk seed hopper is filled. Graphite should be added in layers as the bulk seed hoppers are filled. Regular graphite use prolongs life of the seed meter components, improves seed spacing, and may reduce buildup of seed treatments.



Adding graphite to conventional hopper



Adding graphite ASD hopper

NOTE: Additional graphite may be required to retard buildup of seed treatments on meter components. More frequent cleaning of monitor seed tubes may be necessary due to use of additional graphite.

Talc seed lubricant may be used as a drying agent in addition to graphite lubrication. The drying agent may improve seed release and/or **to retard buildup of seed treatments on meter components.**

1. Fill hopper $\frac{1}{2}$ full of seed, add $\frac{1}{4}$ cup (conventional); 2 pounds (ASD) of talc and **mix thoroughly**.
2. Finish filling hopper, add another $\frac{1}{4}$ cup (conventional); 2 pounds (ASD) of talc and **mix thoroughly**.
3. Adjust rate of talc use as needed so all seeds are coated, while avoiding a buildup of talc in bottom of hopper.

Humid conditions and/or small sized seeds with extra seed treatment may require additional talc to maintain meter performance.

NOTE: Liquid seed treatments or inoculants may create buildup on the seed disc or brushes. Check frequently for proper population and/or seed delivery when using any liquid seed treatment.

Completely mix all treatments with seed following manufacturers' recommendations. Seed treatment dumped on top of seed after hopper is filled may not mix properly and cause seed bridging, reducing population or stopping meter from planting.

Lubricant Application Rate	
Graphite	
Conventional Hoppers	1 Tbs./Hopper Fill
ASD Hoppers	1 Pound Bottle/Hopper
Talc	
Conventional Hoppers	$\frac{1}{4}$ C.*
ASD Hoppers	4 Pounds/Hopper*
*Double amount of talc for sunflowers.	

FRAME MOUNTED COULTER (PULL ROW)

Frame mounted coulters with 1" bubbled, 1" fluted (8 flutes) or ¾" fluted (13 flutes) blades are used on pull row units only.

Springs provide down pressure on coulters for maximum penetration while exerting less shock load on row unit.

Initial coulters blade location is in top hole. Relocate blade to one of lower two holes (1" increments) as wear occurs or for deeper blade operation.

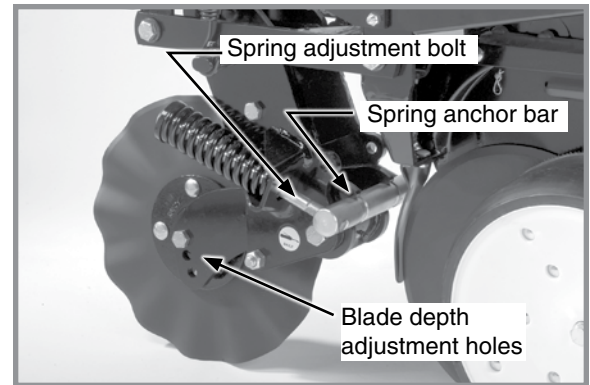

Frame mounted coulter adjustment

DOWN PRESSURE ADJUSTMENT

NOTICE

Excessive down pressure can damage coulters components when coulters strike an obstacle. Do not set down pressure higher than needed for consistent soil penetration.

Raise planter. Turn spring adjustment bolts clockwise to increase or counterclockwise to decrease down pressure. Set both springs to specification shown in following table:

Frame Mounted Coulter Spring Downpressure Settings		
End flush with spring anchor bar	Extended ½" through spring anchor bar	All threads used
275 lb (124.7 kg)	400 lb (181.4 kg)	500 lb (226.8 kg)

RESIDUE WHEELS (FRAME MOUNTED COULTER)

NOTICE

Tined wheel forward mounting positions cannot be used on four rows behind axle due to inadequate clearance.

Residue wheels attach to frame mounted coulters with two cap screws and sleeves allowing the unit to free-float. A 2-position spindle bolt mounting positions wheels interlocked or staggered. Depth adjustment is made with a spring-loaded cam and pin with 11 positions in ¼" increments. A high point on the cam allows wheels to be locked up.

A weed guard on the inboard side of each wheel helps prevent weed wrap which can cause premature bearing failure.

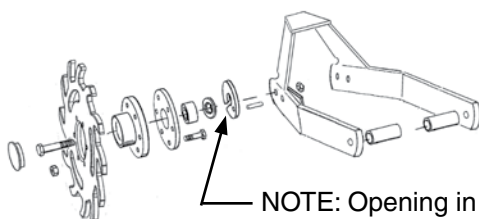

NOTE: Opening in weed guard must face down.

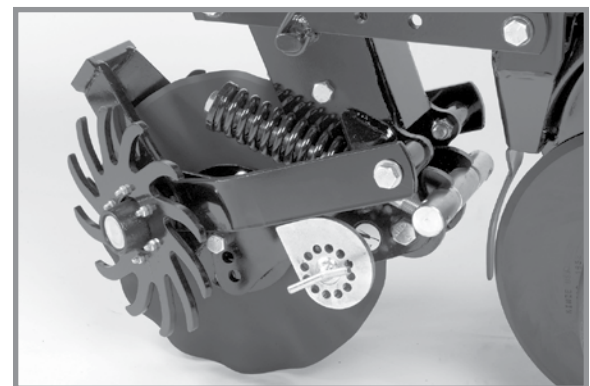

Frame mounted coulter residue wheel

ROW UNIT MOUNTED DISC FURROWER (PULL ROW)

Disc furrowers are used to clear crop residue, dirt clods, and dry soil from in front of row units for a clean and smooth seed bed. The disc furrower may be equipped with 12" solid blades or 12" notched blades. Notched blades are for heavier residue conditions and cut crop residue and move it aside to prevent plugging or pushing.

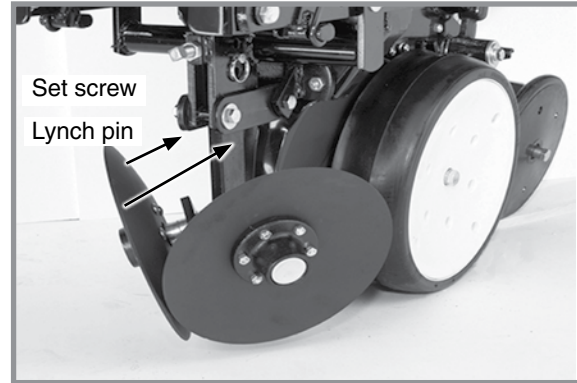
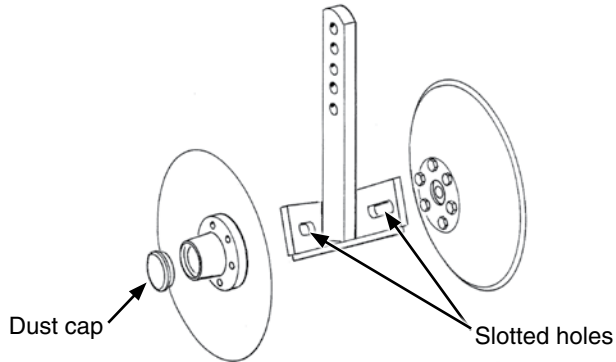

Disc furrower adjustment

Vertical adjustment can be made in $\frac{1}{8}$ " increments. Remove lynch pin in vertical support arm and move arm up or down. Reinstall lynch pin. Finer adjustment can be made by removing lynch pin and using $\frac{5}{8}$ " x $2\frac{1}{4}$ " set screw to clamp support arm in position. Slotted holes in support arm allow front to rear disc blade adjustment. Blades can be adjusted so front edges meet or cutting edge of one blade overlaps edge of other blade.

NOTE: Dust cap must be removed to make adjustments.

ROW UNIT MOUNTED RESIDUE WHEEL

Row unit mounted residue wheels are used on pull and push row units.

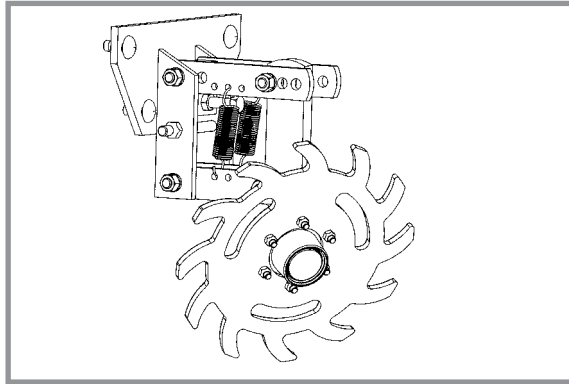

Row Unit Mounted Residue Wheel

Two adjustable springs on each residue wheel parallel links provide down force adjustment. Position 1 provides minimum down pressure and position 3 maximum down pressure.

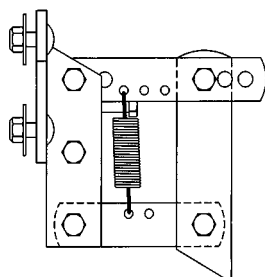

Position 1 (Least)

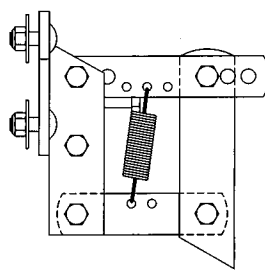

Position 2

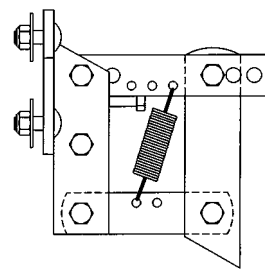

Position 3 (Most)

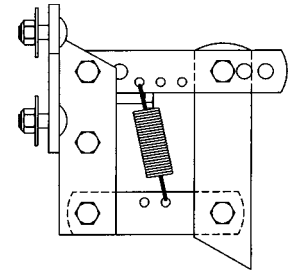

Additional uplift or float

Raise row unit and reposition springs to adjust down pressure.

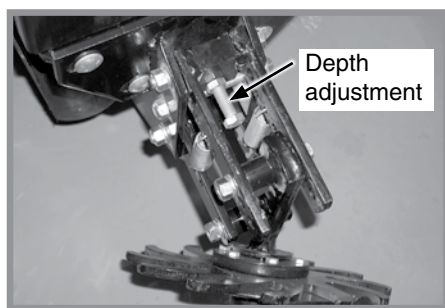

Wheel depth adjustment

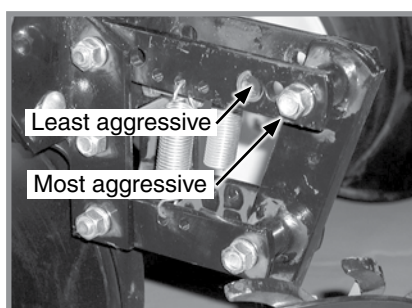

Wheel angle adjustment

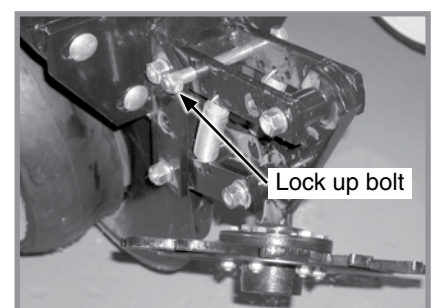

Wheel lock up

A full threaded bolt and jam nut located on the upper link sets maximum depth for loose soil conditions. Initial setting is 1 $\frac{3}{4}$ " above row unit double disc opener depth.

Three holes in upper link adjust wheel angle. With wheel mount in most vertical position, using the rear hole in the upper link, the residue wheel is most aggressive. Moving wheel mount to a forward hole reduces aggressiveness of residue wheel for use in mulch till applications where soil is loose.

To lock residue wheel up, remove 1/2" x 5" lockup bolt, raise residue wheel and install bolt.

ROW UNIT MOUNTED NO TILL COULTER

Row unit mounted no till coulters with 1" bubbled, 1" fluted (8 flutes) or ¾" fluted (13 flutes) blades may be used on pull row units and push row units (¾" fluted shown). Four quick adjustable down force springs are required per row when using row unit mounted no till coulters. See "Quick Adjustable Down Force Springs Options".

Align coulters to row unit double disc openers. Adjust by loosening four attaching bolts, moving coulters, and tightening four attaching bolts. Coulters can be adjusted to one of four ½" incremental settings in the forked arm. Initial location is the top hole.

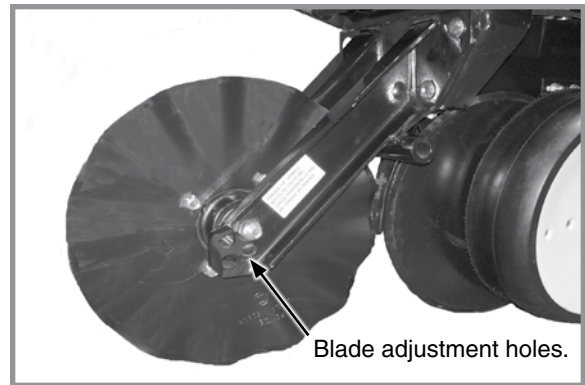

Row Unit Mounted No Till Coulters

Move blade as it wears to one of the three lower holes to maintain coulters at or slightly above opener discs as needed. Adjust coulters below depth of double disc opener blades in very hard soil conditions such as compacted wheel tracks to improve opener penetration and cutting of surface residue.

Check operating depth by setting planter down on a level concrete floor and checking relationship between coulters and row unit opener blade. Make sure planter is level and coulters are square with planter frame and aligned with row unit disc opener.

NOTE: Torque 5/8" spindle hardware to 120 ft-lb (162.7 N-m).

COULTER MOUNTED RESIDUE WHEELS

Coulters mounted residue wheels are designed for use on pull row units and push row units. Row unit extension brackets are required on the four center pull row units if the planter is equipped with coulters mounted residue wheels.

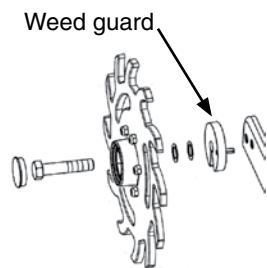

NOTE: Opening in weed guard must face down.



Coulters mounted residue wheels

Residue wheels attach to row unit mounted coulters with two cap screws and sleeves allowing unit to free-float. A 2-position spindle bolt mounting positions wheels interlocked or staggered. Depth adjustment is made with a spring-loaded cam and pin with 11 positions in ¼" increments. A high point on the cam allows wheels to be locked up.

A weed guard on the inboard side of each wheel helps prevent weed wrap which can cause premature bearing failure.

GRANULAR CHEMICAL HOPPER AND DRIVE

WARNING

Agricultural chemicals can cause death or serious injury to persons, animals, and plants or seriously damage soil, equipment, or property. Read and follow all chemical and equipment manufacturers labels and instructions.

The granular chemical hopper has a 1.4 cubic feet capacity.

Make sure no foreign objects get into hopper when it is being filled. Replace hopper lids after filling to prevent accumulation of dirt and moisture.

A metering gate on bottom of hopper regulates the application rate. See "Dry Insecticide and Dry Herbicide Application Rate Charts" in this manual. Calibrate using chemical manufacturers' instructions.



Granular chemical hopper

Granular chemical clutch drive coupler and meter shaft can be disengaged and engaged by turning throwout knob at rear of hopper support panel.

Rotate knob $\frac{1}{4}$ turn counterclockwise to disengage and $\frac{1}{4}$ turn clockwise to engage.

Slotted holes in hopper support panel and clutch housing allow for alignment adjustment between clutch drive coupler and meter shaft.

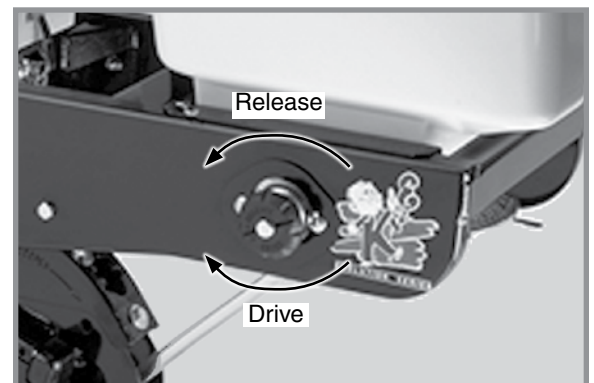

Granular chemical drive release

SPRING TOOTH INCORPORATOR

Spring tooth incorporator smooths soil behind row unit and incorporates granular chemicals.

Adjust two mounting chains on each spring tooth incorporator so there is approximately $\frac{1}{8}$ " slack in chain when unit is lowered to planting position.

NOTE: Spring tooth incorporator is not compatible with covering discs/single press wheel option.

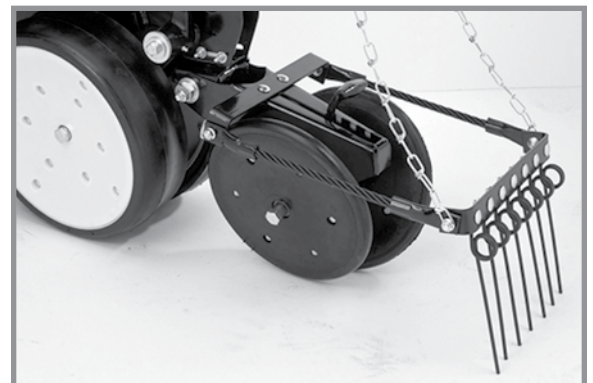

Spring tooth incorporator

GRANULAR CHEMICAL BANDING OPTIONS

Granular chemical banding options allow 4½" slope-compensating banding, straight drop in-furrow placement or 14" rear banding.

NOTE: Granular chemical rear bander is not compatible with covering discs/single press wheel option.

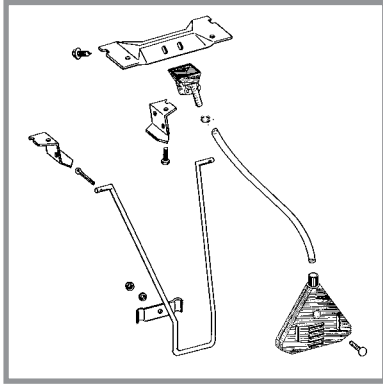

14" rear banding

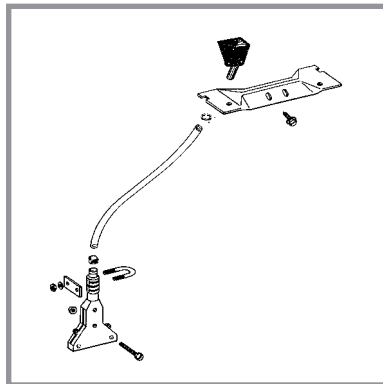

4½" slope-compensating bander

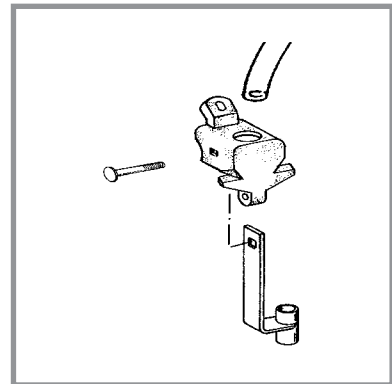

Straight drop in-furrow placement

GRANULAR CHEMICAL BANDER SHIELD

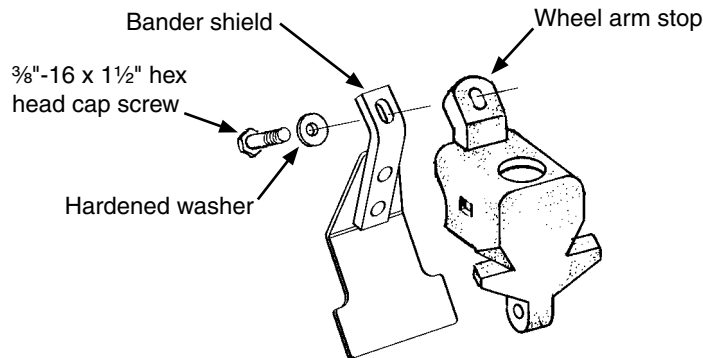

Optional granular chemical bander shield is installed on underside of wheel arm stop to shield crop residue from lodging in granular chemical bander.

GENERAL PLANTING RATE INFORMATION

These planting rate charts apply to KINZE Model 3700 planters.

NOTICE

Sprocket combinations in these charts are for average conditions. Changes in sprocket combinations may be required for desired planting population. ALWAYS MAKE FIELD CHECKS TO BE SURE YOU ARE PLANTING AT DESIRED RATE.

NOTICE

Seed additives added in the hopper may affect finger pickup seed meter performance and accelerate wear.

NOTE: Seed size and shape may affect planting rate.

NOTE: Not all row spacings listed apply to all size planters.

NOTE: Speeds above 5.5 MPH (8.8 KPH) can adversely affect seed spacing.

MECHANICAL

Finger Pickup Corn Meter

Larger grades generally plant more accurately at the high end of the ground speed range than smaller grades. Higher than optimum speeds may result in population rate increase or higher incidence of doubles, particularly with small seed. Medium round corn seed is most desirable for planting accuracy at optimum speed.

Finger Pickup Oil Sunflower Meter

Larger grades generally plant more accurately at the high end of the ground speed range than smaller grades. Higher than optimum speeds may result in population rate increase or higher incidence of doubles, particularly with small seed. No. 3 and/or No. 4 size oil sunflower seeds are recommended for use in finger pickup seed meters equipped with oil sunflower fingers. No. 1 and/or No. 2 size confectionery sunflower seeds are recommended for use in finger pickup seed meters equipped with corn fingers.

Brush-Type Seed Meter (Soybean, Milo/Grain Sorghum, Acid-Delinted Cotton)

Rate charts are given in seeds per acre as well as seed spacing in inches rounded to nearest tenth of an inch. Because of large range in seed size, pounds per acre is not a suggested method of selecting transmission settings. Smaller size seed pounds per acre may be below what was expected and large seed pounds per acre may appear above expectations. To determine pounds per acre, use formula given in "Determining Pounds Per Acre (Brush-Type Seed Meter)" in "Check Seed Population" in Machine Operation section of this manual.

NOTE: Planting speed can affect actual seeding rate. Make a field check and adjust transmission setting to obtain desired seed drop.

NOTE: Seed population per acre with 15" rows double rate for 30" rows, as well as 18" rows versus 36" rows and 19" rows versus 38" rows, at listed sprocket combination. See following pages.

NOTE: Half Rate (2 to 1) Drive Reduction Package may be required to obtain desired population and seed spacing when planting 15" row soybeans or other crops. Half Rate Drive with brush-type seed meters reduces planter transmission speed. Seeding rate will be approximately 50% of chart reading when using Half Rate (2 To 1) Drive Reduction Package.

**EXAMPLE: 30" row spacing using 60 cell seed discs in brush-type seed meters.
 $80,928 \div 2 = 40,464$ Population (2.6" Seed Spacing x 2 = 5.2" Seed Spacing)**

EDGEVAC

NOTE: 22, 28 and 44 tooth drive sprockets are NOT applicable to all rate charts. Check chart titles to ensure proper rate chart is selected. 22 tooth sprockets require use of 148 pitch No. 40 chains, 28 tooth sprockets require use of 150 pitch No. 40 chains and 44 tooth sprockets require use of 158 pitch No. 40 chains.

NOTE: When using 54 cell sunflower disc, use 15 tooth drive sprocket at contact wheels and replace 28 tooth drive sprocket at wheel module reverser plates with 19 tooth sprocket. 15 tooth sprockets require use of 144 pitch No. 40 chains. Applicable sprockets, chains, and instructions supplied in G1K469 Sunflower Rate Reduction Kit.

**PLANTING RATES FOR FINGER PICKUP SEED METERS (STANDARD DRIVE)
APPROXIMATE SEEDS/ACRE FOR VARIOUS ROW WIDTHS**

20" Rows	22" Rows	30" Rows	Transmission Sprockets		Recommended Speed Range (MPH)	Average Seed Spacing In Inches
			Drive	Driven		
24,279	22,013	16,186	17	28	4 to 6	12.9
25,178	22,828	16,785	17	27	4 to 6	12.5
26,147	23,706	17,431	17	26	4 to 6	12.0
27,135	24,602	18,090	19	28	4 to 6	11.6
27,192	24,654	18,128	17	25	4 to 6	11.5
28,140	25,514	18,760	19	27	4 to 6	11.1
28,325	25,681	18,883	17	24	4 to 6	11.1
29,222	26,494	19,481	19	26	4 to 6	10.7
29,556	26,797	19,704	17	23	4 to 6	10.6
30,392	27,555	20,261	19	25	4 to 6	10.3
31,656	28,701	21,104	19	24	4 to 6	9.9
32,847	29,781	21,898	23	28	4 to 6	9.5
33,033	29,950	22,022	19	23	4 to 6	9.5
34,064	30,884	22,709	23	27	4 to 6	9.2
34,275	31,076	22,850	24	28	4 to 6	9.2
35,375	32,073	23,583	23	26	4 to 6	8.9
35,546	32,228	23,697	24	27	4 to 6	8.8
35,703	32,371	23,802	25	28	4 to 6	8.8
35,780	32,440	23,853	17	19	4 to 6	8.8
36,789	33,355	24,526	23	25	4 to 6	8.5
36,912	33,467	24,608	24	26	4 to 6	8.5
37,026	33,570	24,684	25	27	4 to 6	8.5
37,133	33,667	24,755	26	28	4 to 6	8.4
38,322	34,745	25,548	23	24	4 to 6	8.2
38,388	34,805	25,592	24	25	4 to 6	8.2
38,450	34,861	25,633	25	26	4 to 6	8.2
38,507	34,913	25,671	26	27	4 to 6	8.1
38,561	34,962	25,707	27	28	4 to 6	8.1
39,989	36,256	26,659	23	23	4 to 6	7.8
41,469	37,599	27,646	28	27	4 to 6	7.6
41,526	37,650	27,684	27	26	4 to 6	7.6
41,655	37,767	27,770	25	24	4 to 6	7.5
41,727	37,832	27,818	24	23	4 to 6	7.5
43,064	39,044	28,709	28	26	4 to 6	7.3
43,187	39,156	28,791	27	25	4 to 6	7.3
43,466	39,409	28,977	25	23	4 to 6	7.2
44,693	40,521	29,795	19	17	4 to 6	7.0
44,787	40,607	29,858	28	25	4 to 6	7.0
44,987	40,788	29,991	27	24	4 to 6	7.0
45,204	40,985	30,136	26	23	4 to 6	7.0
46,653	42,299	31,102	28	24	3 to 6	6.7
46,943	42,561	31,295	27	23	3 to 6	6.7
48,407	43,889	32,271	23	19	3 to 5.5	6.5
48,681	44,137	32,454	28	23	3 to 5.5	6.5
50,511	45,797	33,674	24	19	3 to 5.5	6.2
52,616	47,705	35,077	25	19	3 to 5	6.0
54,102	49,052	36,068	23	17	3 to 5	5.8
54,720	49,613	36,480	26	19	3 to 5	5.7
56,454	51,185	37,636	24	17	3 to 5	5.6
56,825	51,521	37,883	27	19	3 to 5	5.5
58,806	53,317	39,204	25	17	3 to 4.5	5.3
58,931	53,430	39,287	28	19	3 to 4.5	5.3
61,158	55,450	40,772	26	17	3 to 4.5	5.1
63,510	57,582	42,340	27	17	3 to 4.5	4.9
65,862	59,715	43,908	28	17	3 to 4.5	4.8

NOTE: See "General Planting Rate Information" and "Check Seed Population" pages for more information. Always field check seed population to verify planting rates.

**PLANTING RATES FOR BRUSH-TYPE SEED METERS (STANDARD DRIVE)
APPROXIMATE SEEDS/ACRE FOR VARIOUS ROW WIDTHS**

Transmission Sprockets		60 Cell Soybean Or High-Rate Milo/Grain Sorghum			Average Seed Spacing In Inches	48 Cell Specialty Soybean Or High-Rate Acid-Delinted Cotton			Average Seed Spacing In Inches	Speed Range (MPH)
Drive	Driven	20" Rows	22" Rows	30" Rows		20" Rows	22" Rows	30" Rows		
17	28	121,392	110,062	80,928	2.6	97,113	88,049	64,742	3.2	2 to 8
17	27	125,889	114,139	83,926	2.5	100,712	91,312	67,141	3.1	2 to 8
17	26	130,731	118,529	87,154	2.4	104,712	94,823	69,723	3.0	2 to 8
19	28	135,674	123,011	90,449	2.3	108,539	98,408	72,359	2.9	2 to 8
19	27	140,699	127,567	93,799	2.2	112,559	102,053	75,039	2.8	2 to 8
17	24	141,624	128,406	94,416	2.2	113,300	102,725	75,533	2.8	2 to 8
17	23	147,782	133,989	98,521	2.1	118,226	107,191	78,817	2.7	2 to 8
19	25	151,955	137,772	101,303	2.1	121,563	110,217	81,042	2.6	2 to 8
19	24	158,286	143,513	105,524	2.0	126,629	114,810	84,419	2.5	2 to 8
23	28	164,237	148,908	109,491	1.9	131,390	119,126	87,593	2.4	2 to 8
19	23	165,168	149,752	110,112	1.9	132,135	119,802	88,090	2.4	2 to 8
24	28	171,379	155,383	114,252	1.8	137,103	124,307	91,402	2.3	2 to 8
24	27	177,725	161,137	118,483	1.8	142,179	128,909	94,786	2.2	2 to 8
17	19	178,895	162,198	119,263	1.8	143,115	129,758	95,410	2.2	2 to 8
24	26	184,560	167,334	123,040	1.7	147,648	133,868	98,432	2.1	2 to 8
26	28	185,660	168,331	123,773	1.7	148,527	134,664	99,018	2.1	2 to 8
24	25	191,943	174,028	127,962	1.6	153,555	139,223	102,370	2.0	2 to 8
26	27	192,536	174,566	128,357	1.6	154,029	139,653	102,686	2.0	2 to 8
23	23	199,941	181,280	133,294	1.6	159,953	145,024	106,635	2.0	2 to 8
27	26	207,630	188,251	138,420	1.5	166,104	150,601	110,736	1.9	2 to 8
24	23	208,634	189,161	139,089	1.5	166,907	151,329	111,271	1.9	2 to 8
25	23	217,326	197,042	144,884	1.4	173,861	157,634	115,907	1.8	2 to 8
19	17	223,463	202,606	148,975	1.4	178,770	162,085	119,180	1.8	2 to 8
27	24	224,933	203,939	149,955	1.4	179,946	163,151	119,964	1.7	2 to 8
28	24	233,264	211,492	155,509	1.3	186,661	169,194	124,407	1.7	2 to 8
23	19	242,033	219,443	161,355	1.3	193,626	175,554	129,084	1.6	2 to 8
28	23	243,405	220,687	162,270	1.3	194,724	176,550	129,816	1.6	2 to 8
24	19	252,557	228,985	168,371	1.2	202,044	183,187	134,696	1.6	2 to 8
25	19	263,079	238,525	175,386	1.2	210,464	190,820	140,309	1.5	2 to 8
23	17	270,507	245,260	180,338	1.2	216,405	196,207	144,270	1.5	2 to 8
26	19	273,603	248,067	182,402	1.1	218,883	198,454	145,922	1.4	2 to 7
27	19	284,126	257,607	189,417	1.1	227,301	206,086	151,534	1.4	2 to 7
28	19	294,650	267,149	196,433	1.1	235,719	213,719	157,146	1.3	2 to 7
26	17	305,792	277,251	203,861	1.0	244,634	221,801	163,089	1.3	2 to 7
27	17	317,553	289,915	211,702	0.9	245,043	230,332	169,362	1.2	2 to 7
28	17	329,313	298,577	219,542	0.9	263,451	238,862	175,634	1.2	2 to 7

NOTE: See "General Planting Rate Information" and "Check Seed Population" pages for additional information.

NOTE: When using Half Rate (2 To 1) Drive Reduction Package, rates are approximately 50% of given numbers.

NOTE: Always field check seed population to ensure planting rates are correct.

**PLANTING RATES FOR BRUSH-TYPE SEED METERS (STANDARD DRIVE)
APPROXIMATE SEEDS/ACRE FOR VARIOUS ROW WIDTHS**

Transmission Sprockets		36 Cell Acid-Delinted Large Cotton			Average Seed Spacing In Inches	30 Cell Milo/Grain Sorghum Or Acid-Delinted Cotton			Average Seed Spacing In Inches	Speed Range (MPH)
Drive	Driven	20" Rows	22" Rows	30" Rows		20" Rows	22" Rows	30" Rows		
17	28	72,836	66,038	48,557	4.3	60,696	55,031	40,464	5.2	2 to 8
17	27	75,534	68,484	50,356	4.2	62,945	57,070	41,963	5.0	2 to 8
17	26	78,438	71,117	52,292	4.0	65,366	59,265	43,577	4.8	2 to 8
19	28	81,404	73,806	54,269	3.9	67,838	61,506	45,225	4.6	2 to 8
19	27	84,419	76,539	56,279	3.7	70,350	63,784	46,900	4.5	2 to 8
17	24	84,975	77,044	56,650	3.7	70,812	64,203	47,208	4.4	2 to 8
17	23	88,670	80,394	59,113	3.5	73,892	66,995	49,261	4.2	2 to 8
19	25	91,173	82,664	60,782	3.4	75,978	68,887	50,652	4.1	2 to 8
19	24	94,971	86,107	63,314	3.3	79,143	71,756	52,762	4.0	2 to 8
23	28	98,543	89,345	65,695	3.2	82,119	74,455	54,746	3.8	2 to 8
19	23	99,101	89,851	66,067	3.2	82,584	74,876	55,056	3.8	2 to 8
24	28	102,827	93,229	68,551	3.0	85,689	77,691	57,126	3.7	2 to 8
24	27	106,635	96,682	71,090	2.9	88,863	80,569	59,242	3.5	2 to 8
17	19	107,337	97,319	71,558	2.9	89,447	81,098	59,631	3.5	2 to 8
24	26	110,736	100,401	73,824	2.8	92,280	83,667	61,520	3.4	2 to 8
26	28	111,396	100,999	74,264	2.8	92,829	84,165	61,886	3.4	2 to 8
24	25	115,158	104,410	76,772	2.7	95,972	87,014	63,981	3.3	2 to 8
26	27	115,521	104,739	77,014	2.7	96,267	87,282	64,178	3.3	2 to 8
23	23	119,964	108,767	79,976	2.6	99,971	90,640	66,647	3.1	2 to 8
27	26	124,578	112,951	83,052	2.5	103,815	94,126	69,210	3.0	2 to 8
24	23	125,180	113,496	83,453	2.5	104,316	94,580	69,544	3.0	2 to 8
25	23	130,395	118,225	86,930	2.4	108,663	98,521	72,442	2.9	2 to 8
19	17	134,078	121,564	89,385	2.3	111,732	101,304	74,488	2.8	2 to 8
27	24	134,960	122,363	89,973	2.3	112,467	101,970	74,978	2.8	2 to 8
28	24	139,958	126,895	93,305	2.2	116,633	105,747	77,755	2.7	2 to 8
23	19	145,220	131,666	96,813	2.2	121,017	109,722	80,678	2.6	2 to 8
28	23	146,043	132,412	97,362	2.1	121,703	110,344	81,135	2.6	2 to 8
24	19	151,535	137,391	101,023	2.1	126,278	114,492	84,185	2.5	2 to 8
25	19	157,848	143,116	105,232	2.0	131,540	119,262	87,693	2.4	2 to 8
23	17	162,350	147,197	108,233	1.9	135,254	122,630	90,169	2.3	2 to 8
26	19	164,162	148,840	109,441	1.9	136,802	124,033	91,201	2.3	2 to 7
27	19	170,475	154,564	113,650	1.8	142,064	128,804	94,709	2.2	2 to 7
28	19	176,790	160,290	117,860	1.8	147,324	133,574	98,216	2.1	2 to 7
26	17	183,476	166,351	122,317	1.7	152,895	138,625	101,930	2.1	2 to 7
27	17	190,532	172,749	127,021	1.6	158,777	143,957	105,851	2.0	2 to 7
28	17	197,588	179,146	131,725	1.6	164,657	149,289	109,771	1.9	2 to 7

NOTE: See "General Planting Rate Information" and "Check Seed Population" pages for additional information.

NOTE: When using Half Rate (2 To 1) Drive Reduction Package, rates are approximately 50% of given numbers.

NOTE: Always field check seed population to ensure planting rates are correct.

**PLANTING RATES FOR BRUSH-TYPE SEED METERS (STANDARD DRIVE)
APPROXIMATE HILLS/ACRE FOR VARIOUS ROW WIDTHS**

Due to variations in cotton seed size, meters equipped with the 12 cell acid-delinted hill-drop cotton discs will plant from 3 to 6 seeds per cell. Select proper disc for seed size range to be planted.

To determine planter transmission setting, determine desired hill spacing and select the transmission ratio closest to the hill spacing in inches on the chart. To decrease population increase spacing. To increase population decrease spacing.

To determine population per acre, determine average seeds per hill and hills per acre by doing a field check. Measure $\frac{1}{1000}$ of an acre ($\frac{1}{1000}$ acre = Length of row 17' 5" for 30" row width, 23' 9" for 22" row width and 26' 2" for 20" row width). Multiply average seeds per hill by hills per acre. **EXAMPLE:** 4 seeds per hill x (13 hills x 1000) = 52,000

Transmission Sprockets		NUMBER OF HILLS PER ACRE 12 Cell Hill-Drop Cotton, Acid-Delinted			Average Hill Spacing In Inches	Speed Range (MPH)
Drive	Drive	20" Rows	22" Rows	30" Rows		
17	28	24,279	22,013	16,186	12.9	2 to 8
17	27	25,178	22,828	16,785	12.5	2 to 8
17	26	26,147	23,706	17,431	12.0	2 to 8
19	28	27,135	24,602	18,090	11.6	2 to 8
19	27	28,140	25,514	18,760	11.1	2 to 8
17	24	28,325	25,681	18,883	11.1	2 to 8
17	23	29,556	26,797	19,704	10.6	2 to 8
19	25	30,392	27,555	20,261	10.3	2 to 8
19	24	31,658	28,703	21,105	9.9	2 to 8
23	28	32,847	29,781	21,898	9.5	2 to 8
19	23	33,033	29,950	22,022	9.5	2 to 8
24	28	34,275	31,076	22,850	9.2	2 to 8
24	27	35,546	32,228	23,697	8.8	2 to 8
17	19	35,780	32,440	23,853	8.8	2 to 8
24	26	36,912	33,467	24,608	8.5	2 to 8
26	28	37,133	33,667	24,755	8.4	2 to 8
24	25	38,388	34,805	25,592	8.2	2 to 8
26	27	38,507	34,913	25,671	8.1	2 to 8
23	23	39,989	36,256	26,659	7.8	2 to 8
27	26	41,526	37,650	27,684	7.6	2 to 8
24	23	41,727	37,832	27,818	7.5	2 to 8
25	23	43,466	39,409	28,977	7.2	2 to 8
19	17	44,693	40,521	29,795	7.0	2 to 8
27	24	44,987	40,788	29,991	7.0	2 to 8
28	24	46,653	42,299	31,102	6.7	2 to 8
23	19	48,407	43,889	32,271	6.5	2 to 8
28	23	48,681	44,137	32,454	6.5	2 to 8
24	19	50,511	45,797	33,674	6.2	2 to 8
25	19	52,616	47,705	35,077	6.0	2 to 8
23	17	54,102	49,052	36,068	5.8	2 to 8
26	19	54,720	49,613	36,480	5.7	2 to 7
27	19	56,825	51,521	37,883	5.5	2 to 7
28	19	58,931	53,430	39,287	5.3	2 to 7
26	17	61,158	55,450	40,772	5.1	2 to 7
27	17	63,510	57,582	42,340	4.9	2 to 7
28	17	65,862	59,715	43,908	4.8	2 to 7

NOTE: See "General Planting Rate Information" and "Check Seed Population" pages for additional information.

NOTE: When using Half Rate (2 To 1) Drive Reduction Package, rates are approximately 50% of given numbers.

NOTE: Always field check seed population to ensure planting rates are correct.

**EDGEVAC PLANTING RATES FOR CORN / POPCORN 39 CELL DISC
22 TOOTH CONTACT WHEEL DRIVE SPROCKET
APPROXIMATE SEEDS / ACRE FOR VARIOUS ROW WIDTHS**

20" Rows	22" Rows	30" Rows	Transmission Sprockets		Recomm. Speed Range (MPH)	Average Seed Spacing In Inches
			Drive	Driven		
34,813	31,648	23,209	15	28	4 to 6	9.0
36,102	32,820	24,068	15	27	4 to 6	8.7
37,491	34,083	24,994	15	26	4 to 6	8.4
38,991	35,446	25,994	15	25	4 to 6	8.0
39,455	35,868	26,303	17	28	4 to 6	7.9
40,615	36,923	27,077	15	24	4 to 6	7.7
40,916	37,196	27,277	17	27	4 to 6	7.7
42,381	38,528	28,254	15	23	4 to 6	7.4
42,490	38,627	28,326	17	26	4 to 6	7.4
44,096	40,088	29,398	19	28	4 to 6	7.1
44,189	40,172	29,460	17	25	4 to 6	7.1
45,730	41,572	30,486	19	27	4 to 6	6.9
46,031	41,846	30,687	17	24	4 to 6	6.8
47,489	43,171	31,659	19	26	4 to 6	6.6
48,032	43,665	32,021	17	23	4 to 6	6.5
49,388	44,898	32,925	19	25	4 to 6	6.4
51,303	46,639	34,202	15	19	4 to 6	6.1
51,446	46,769	34,297	19	24	4 to 6	6.1
53,380	48,527	35,587	23	28	4 to 6	5.9
53,683	48,802	35,788	19	23	4 to 6	5.8
55,357	50,325	36,905	23	27	4 to 6	5.7
55,701	50,637	37,134	24	28	4 to 6	5.6
57,339	52,126	38,226	15	17	4 to 6	5.5
57,764	52,513	38,509	24	27	4 to 6	5.4
58,144	52,858	38,763	17	19	4 to 6	5.4
59,786	54,350	39,857	23	25	4 to 6	5.2
60,343	54,857	40,228	26	28	4 to 6	5.2
62,277	56,615	41,518	23	24	4 to 6	5.0
62,385	56,714	41,590	24	25	4 to 6	5.0
62,663	56,967	41,776	27	28	4 to 6	5.0
64,984	59,077	43,323	23	23	4 to 6	4.8
67,391	61,265	44,927	28	27	4 to 6	4.7
67,484	61,349	44,989	27	26	4 to 6	4.6
67,810	61,645	45,206	24	23	4 to 6	4.6
69,983	63,621	46,655	28	26	4 to 6	4.5
70,183	63,803	46,789	27	25	4 to 6	4.5
70,635	64,214	47,090	25	23	4 to 6	4.4
72,629	66,027	48,420	19	17	4 to 6	4.3
73,107	66,461	48,738	27	24	4 to 6	4.3
73,460	66,782	48,974	26	23	4 to 6	4.3
75,815	68,923	50,543	28	24	4 to 6	4.1
76,286	69,351	50,857	27	23	4 to 6	4.1
78,665	71,514	52,443	23	19	4 to 6	4.0
79,111	71,919	52,741	28	23	4 to 6	4.0
82,085	74,623	54,724	24	19	4 to 6	3.8
85,506	77,732	57,004	25	19	4 to 6	3.7
87,920	79,927	58,613	23	17	4 to 6	3.6
88,926	80,842	59,284	26	19	4 to 6	3.5
91,743	83,402	61,162	24	17	4 to 6	3.4
92,346	83,951	61,564	27	19	4 to 6	3.4
95,565	86,877	63,710	25	17	4 to 6	3.3
95,766	87,060	63,844	28	19	4 to 6	3.3
99,388	90,352	66,258	26	17	4 to 6	3.2
99,643	90,584	66,428	23	15	4 to 6	3.1
103,210	93,828	68,807	27	17	4 to 6	3.0

NOTE: See "General Planting Rate Information" and "Check Seed Population" pages for more information. Always field check seed population to verify planting rates.

**EDGEVAC PLANTING RATES FOR CORN / POPCORN 39 CELL DISC
28 TOOTH CONTACT WHEEL DRIVE SPROCKET
APPROXIMATE SEEDS / ACRE FOR VARIOUS ROW WIDTHS**

20" Rows	22" Rows	30" Rows	Transmission Sprockets		Recomm. Speed Range (MPH)	Average Seed Spacing In Inches
			Drive	Driven		
44,307	40,280	29,538	15	28	4 to 6	7.1
45,948	41,771	30,632	15	27	4 to 6	6.8
47,716	43,378	31,810	15	26	4 to 6	6.6
49,624	45,113	33,083	15	25	4 to 6	6.3
50,215	45,650	33,477	17	28	4 to 6	6.2
51,692	46,993	34,461	15	24	4 to 6	6.1
52,075	47,341	34,717	17	27	4 to 6	6.0
53,940	49,036	35,960	15	23	4 to 6	5.8
54,078	49,162	36,052	17	26	4 to 6	5.8
56,123	51,021	37,415	19	28	4 to 6	5.6
56,241	51,128	37,494	17	25	4 to 6	5.6
58,201	52,910	38,801	19	27	4 to 6	5.4
58,584	53,258	39,056	17	24	4 to 6	5.4
60,440	54,945	40,293	19	26	4 to 6	5.2
61,131	55,574	40,754	17	23	4 to 6	5.1
62,858	57,143	41,905	19	25	4 to 6	5.0
65,295	59,359	43,530	15	19	4 to 6	4.8
65,477	59,524	43,651	19	24	4 to 6	4.8
67,938	61,762	45,292	23	28	4 to 6	4.6
68,323	62,112	45,549	19	23	4 to 6	4.6
70,454	64,049	46,970	23	27	4 to 6	4.5
70,892	64,447	47,261	24	28	4 to 6	4.4
72,977	66,343	48,651	15	17	4 to 6	4.3
73,518	66,834	49,012	24	27	4 to 6	4.3
74,001	67,274	49,334	17	19	4 to 6	4.2
76,091	69,173	50,727	23	25	4 to 6	4.1
76,800	69,818	51,200	26	28	4 to 6	4.1
79,261	72,056	52,841	23	24	4 to 6	4.0
79,399	72,181	52,933	24	25	4 to 6	4.0
79,753	72,503	53,169	27	28	4 to 6	3.9
82,707	75,188	55,138	23	23	4 to 6	3.8
85,770	77,973	57,180	28	27	4 to 6	3.7
85,888	78,080	57,259	27	26	4 to 6	3.7
86,303	78,457	57,535	24	23	4 to 6	3.6
89,069	80,972	59,380	28	26	4 to 6	3.5
89,324	81,203	59,549	27	25	4 to 6	3.5
89,899	81,727	59,933	25	23	4 to 6	3.5
92,438	84,034	61,625	19	17	4 to 6	3.4
93,046	84,587	62,030	27	24	4 to 6	3.4
93,495	84,996	62,330	26	23	4 to 6	3.4
96,492	87,720	64,328	28	24	4 to 6	3.3
97,091	88,265	64,727	27	23	4 to 6	3.2
100,119	91,018	66,746	23	19	4 to 6	3.1
100,687	91,534	67,125	28	23	4 to 6	3.1
104,472	94,975	69,648	24	19	4 to 6	3.0
108,825	98,932	72,550	25	19	4 to 6	2.9
111,898	101,726	74,599	23	17	4 to 6	2.8
113,178	102,889	75,452	26	19	4 to 6	2.8
116,763	106,148	77,842	24	17	4 to 6	2.7
117,531	106,847	78,354	27	19	4 to 6	2.7
121,628	110,571	81,086	25	17	4 to 6	2.6
121,884	110,804	81,256	28	19	4 to 6	2.6
126,493	114,994	84,329	26	17	4 to 6	2.5
126,818	115,289	84,545	23	15	4 to 6	2.5
131,359	119,417	87,572	27	17	4 to 6	2.4

NOTE: See "General Planting Rate Information" and "Check Seed Population" pages for more information. Always field check seed population to verify planting rates.

**EDGEVAC PLANTING RATES FOR LOW-RATE CORN / POPCORN 24 CELL DISC
22 TOOTH CONTACT WHEEL DRIVE SPROCKET
APPROXIMATE SEEDS / ACRE FOR VARIOUS ROW WIDTHS**

20" Rows	22" Rows	30" Rows	Transmission Sprockets		Recomm. Speed Range (MPH)	Average Seed Spacing In Inches
			Drive	Driven		
21,423	19,476	14,282	15	28	4 to 6	14.6
22,217	20,197	14,811	15	27	4 to 6	14.1
23,071	20,974	15,381	15	26	4 to 6	13.6
23,994	21,813	15,996	15	25	4 to 6	13.1
24,280	22,073	16,187	17	28	4 to 6	12.9
24,994	22,722	16,663	15	24	4 to 6	12.5
25,179	22,890	16,786	17	27	4 to 6	12.5
26,081	23,710	17,387	15	23	4 to 6	12.0
26,148	23,770	17,432	17	26	4 to 6	12.0
27,136	24,669	18,091	19	28	4 to 6	11.6
27,193	24,721	18,129	17	25	4 to 6	11.5
28,141	25,583	18,761	19	27	4 to 6	11.1
28,326	25,751	18,884	17	24	4 to 6	11.1
29,224	26,567	19,482	19	26	4 to 6	10.7
29,558	26,871	19,705	17	23	4 to 6	10.6
30,393	27,630	20,262	19	25	4 to 6	10.3
31,571	28,701	21,048	15	19	4 to 6	9.9
31,659	28,781	21,106	19	24	4 to 6	9.9
32,849	29,863	21,899	23	28	4 to 6	9.5
33,035	30,032	22,024	19	23	4 to 6	9.5
34,066	30,969	22,711	23	27	4 to 6	9.2
34,277	31,161	22,852	24	28	4 to 6	9.1
35,286	32,078	23,524	15	17	4 to 6	8.9
35,547	32,315	23,698	24	27	4 to 6	8.8
35,781	32,528	23,854	17	19	4 to 6	8.8
36,791	33,446	24,527	23	25	4 to 6	8.5
37,134	33,758	24,756	26	28	4 to 6	8.4
38,324	34,840	25,549	23	24	4 to 6	8.2
38,391	34,901	25,594	24	25	4 to 6	8.2
38,562	35,056	25,708	27	28	4 to 6	8.1
39,990	36,355	26,660	23	23	4 to 6	7.8
41,471	37,701	27,648	28	27	4 to 6	7.6
41,528	37,753	27,686	27	26	4 to 6	7.6
41,729	37,935	27,819	24	23	4 to 6	7.5
43,067	39,151	28,711	28	26	4 to 6	7.3
43,190	39,263	28,793	27	25	4 to 6	7.3
43,468	39,516	28,978	25	23	4 to 6	7.2
44,695	40,632	29,797	19	17	4 to 6	7.0
44,989	40,899	29,993	27	24	4 to 6	7.0
45,206	41,097	30,138	26	23	4 to 6	6.9
46,655	42,414	31,104	28	24	4 to 6	6.7
46,945	42,677	31,297	27	23	4 to 6	6.7
48,409	44,008	32,273	23	19	4 to 6	6.5
48,684	44,258	32,456	28	23	4 to 6	6.4
50,514	45,922	33,676	24	19	4 to 6	6.2
52,619	47,835	35,079	25	19	4 to 6	6.0
54,105	49,186	36,070	23	17	4 to 6	5.8
54,724	49,749	36,482	26	19	4 to 6	5.7
56,457	51,324	37,638	24	17	4 to 6	5.6
56,828	51,662	37,886	27	19	4 to 6	5.5
58,809	53,463	39,206	25	17	4 to 6	5.3
58,933	53,576	39,289	28	19	4 to 6	5.3
61,162	55,602	40,774	26	17	4 to 6	5.1
61,318	55,744	40,879	23	15	4 to 6	5.1
63,514	57,740	42,343	27	17	4 to 6	4.9

NOTE: See "General Planting Rate Information" and "Check Seed Population" pages for more information. Always field check seed population to verify planting rates.

**EDGEVAC PLANTING RATES FOR LOW-RATE CORN / POPCORN 24 CELL DISC
28 TOOTH CONTACT WHEEL DRIVE SPROCKET
APPROXIMATE HILLS / ACRE FOR VARIOUS ROW WIDTHS**

20" Rows	22" Rows	30" Rows	Transmission Sprockets		Recomm. Speed Range (MPH)	Average Seed Spacing In Inches
			Drive	Driven		
27,134	24,667	18,089	15	28	4 to 6	11.6
28,139	25,581	18,759	15	27	4 to 6	11.1
29,221	26,565	19,481	15	26	4 to 6	10.7
30,390	27,627	20,260	15	25	4 to 6	10.3
30,752	27,956	20,501	17	28	4 to 6	10.2
31,656	28,778	21,104	15	24	4 to 6	9.9
31,891	28,992	21,261	17	27	4 to 6	9.8
33,033	30,030	22,022	15	23	4 to 6	9.5
33,117	30,107	22,078	17	26	4 to 6	9.5
34,370	31,245	22,913	19	28	4 to 6	9.1
34,442	31,311	22,961	17	25	4 to 6	9.1
35,643	32,402	23,762	19	27	4 to 6	8.8
35,877	32,616	23,918	17	24	4 to 6	8.7
37,013	33,649	24,676	19	26	4 to 6	8.5
37,437	34,034	24,958	17	23	4 to 6	8.4
38,494	34,995	25,663	19	25	4 to 6	8.1
39,987	36,352	26,658	15	19	4 to 6	7.8
40,098	36,453	26,732	19	24	4 to 6	7.8
41,605	37,823	27,737	23	28	4 to 6	7.5
41,841	38,038	27,894	19	23	4 to 6	7.5
43,146	39,224	28,764	23	27	4 to 6	7.3
43,414	39,468	28,943	24	28	4 to 6	7.2
44,691	40,628	29,794	15	17	4 to 6	7.0
45,022	40,929	30,015	24	27	4 to 6	7.0
45,318	41,199	30,212	17	19	4 to 6	6.9
46,598	42,362	31,065	23	25	4 to 6	6.7
47,032	42,757	31,355	26	28	4 to 6	6.7
48,540	44,127	32,360	23	24	4 to 6	6.5
48,624	44,204	32,416	24	25	4 to 6	6.5
48,841	44,401	32,561	27	28	4 to 6	6.4
50,650	46,045	33,767	23	23	4 to 6	6.2
52,526	47,751	35,017	28	27	4 to 6	6.0
52,598	47,816	35,065	27	26	4 to 6	6.0
52,852	48,047	35,235	24	23	4 to 6	5.9
54,546	49,587	36,364	28	26	4 to 6	5.7
54,702	49,729	36,468	27	25	4 to 6	5.7
55,054	50,049	36,703	25	23	4 to 6	5.7
56,609	51,463	37,739	19	17	4 to 6	5.5
56,981	51,801	37,988	27	24	4 to 6	5.5
57,257	52,051	38,171	26	23	4 to 6	5.5
59,092	53,720	39,394	28	24	4 to 6	5.3
59,459	54,053	39,639	27	23	4 to 6	5.3
61,313	55,739	40,875	23	19	4 to 6	5.1
61,661	56,055	41,107	28	23	4 to 6	5.1
63,979	58,163	42,653	24	19	4 to 6	4.9
66,645	60,586	44,430	25	19	4 to 6	4.7
68,527	62,297	45,684	23	17	4 to 6	4.6
69,311	63,010	46,207	26	19	4 to 6	4.5
71,506	65,005	47,671	24	17	4 to 6	4.4
71,976	65,433	47,984	27	19	4 to 6	4.4
74,485	67,714	49,657	25	17	4 to 6	4.2
74,642	67,856	49,761	28	19	4 to 6	4.2
77,465	70,422	51,643	26	17	4 to 6	4.0
77,663	70,603	51,776	23	15	4 to 6	4.0
80,444	73,131	53,629	27	17	4 to 6	3.9

NOTE: See "General Planting Rate Information" and "Check Seed Population" pages for more information. Always field check seed population to verify planting rates.

**EDGEVAC PLANTING RATES FOR SOYBEAN AND MILO / GRAIN SORGHUM 60 CELL DISCS
22 TOOTH CONTACT WHEEL DRIVE SPROCKET
APPROXIMATE SEEDS / ACRE FOR VARIOUS ROW WIDTHS**

20" Rows	22" Rows	30" Rows	Transmission Sprockets		Recomm. Speed Range (MPH)	Average Seed Spacing In Inches
			Drive	Driven		
53,558	48,690	35,706	15	28	4 to 6	5.9
55,542	50,493	37,028	15	27	4 to 6	5.6
57,678	52,435	38,452	15	26	4 to 6	5.4
59,985	54,532	39,990	15	25	4 to 6	5.2
60,700	55,181	40,466	17	28	4 to 6	5.2
62,485	56,804	41,657	15	24	4 to 6	5.0
62,948	57,225	41,965	17	27	4 to 6	5.0
65,202	59,274	43,468	15	23	4 to 6	4.8
65,369	59,426	43,579	17	26	4 to 6	4.8
67,841	61,673	45,227	19	28	4 to 6	4.6
67,984	61,803	45,322	17	25	4 to 6	4.6
70,353	63,958	46,902	19	27	4 to 6	4.5
70,816	64,378	47,211	17	24	4 to 6	4.4
73,059	66,417	48,706	19	26	4 to 6	4.3
73,895	67,177	49,263	17	23	4 to 6	4.2
75,982	69,074	50,654	19	25	4 to 6	4.1
78,928	71,753	52,619	15	19	4 to 6	4.0
79,148	71,952	52,765	19	24	4 to 6	4.0
82,123	74,657	54,749	23	28	4 to 6	3.8
82,589	75,081	55,059	19	23	4 to 6	3.8
85,165	77,422	56,776	23	27	4 to 6	3.7
85,694	77,903	57,129	24	28	4 to 6	3.7
88,214	80,194	58,809	15	17	4 to 6	3.6
88,867	80,789	59,245	24	27	4 to 6	3.5
89,452	81,320	59,635	17	19	4 to 6	3.5
91,978	83,616	61,318	23	25	4 to 6	3.4
92,835	84,395	61,890	26	28	4 to 6	3.4
95,810	87,100	63,873	23	24	4 to 6	3.3
95,977	87,252	63,985	24	25	4 to 6	3.3
96,405	87,641	64,270	27	28	4 to 6	3.3
99,976	90,887	66,651	23	23	4 to 6	3.1
103,679	94,253	69,119	28	27	4 to 6	3.0
103,821	94,383	69,214	27	26	4 to 6	3.0
104,323	94,839	69,548	24	23	4 to 6	3.0
107,666	97,878	71,778	28	26	4 to 6	2.9
107,974	98,158	71,983	27	25	4 to 6	2.9
108,669	98,790	72,446	25	23	4 to 6	2.9
111,738	101,580	74,492	19	17	4 to 6	2.8
112,473	102,248	74,982	27	24	4 to 6	2.8
113,016	102,742	75,344	26	23	4 to 6	2.8
116,638	106,035	77,759	28	24	4 to 6	2.7
117,363	106,694	78,242	27	23	4 to 6	2.7
121,023	110,021	80,682	23	19	4 to 6	2.6
121,710	110,645	81,140	28	23	4 to 6	2.6
126,285	114,805	84,190	24	19	4 to 6	2.5
131,547	119,588	87,698	25	19	4 to 6	2.4
135,261	122,965	90,174	23	17	4 to 6	2.3
136,809	124,372	91,206	26	19	4 to 6	2.3
141,142	128,311	94,095	24	17	4 to 6	2.2
142,071	129,155	94,714	27	19	4 to 6	2.2
147,023	133,657	98,015	25	17	4 to 6	2.1
147,333	133,939	98,222	28	19	4 to 6	2.1
152,904	139,004	101,936	26	17	4 to 6	2.1
153,296	139,360	102,197	23	15	4 to 6	2.0
158,785	144,350	105,857	27	17	4 to 6	2.0

NOTE: See "General Planting Rate Information" and "Check Seed Population" pages for more information. Always field check seed population to verify planting rates.

**EDGEVAC PLANTING RATES FOR SOYBEAN AND MILO / GRAIN SORGHUM 60 CELL DISCS
28 TOOTH CONTACT WHEEL DRIVE SPROCKET
APPROXIMATE SEEDS / ACRE FOR VARIOUS ROW WIDTHS**

20" Rows	22" Rows	30" Rows	Transmission Sprockets		Recomm. Speed Range (MPH)	Average Seed Spacing In Inches
			Drive	Driven		
68,165	61,968	45,444	15	28	4 to 6	4.6
70,690	64,264	47,127	15	27	4 to 6	4.4
73,409	66,735	48,939	15	26	4 to 6	4.3
76,345	69,405	50,897	15	25	4 to 6	4.1
77,254	70,231	51,503	17	28	4 to 6	4.1
79,526	72,297	53,017	15	24	4 to 6	3.9
80,115	72,832	53,410	17	27	4 to 6	3.9
82,984	75,440	55,323	15	23	4 to 6	3.8
83,197	75,633	55,464	17	26	4 to 6	3.8
86,343	78,493	57,562	19	28	4 to 6	3.6
86,525	78,659	57,683	17	25	4 to 6	3.6
89,541	81,401	59,694	19	27	4 to 6	3.5
90,130	81,936	60,086	17	24	4 to 6	3.5
92,984	84,531	61,990	19	26	4 to 6	3.4
94,048	85,499	62,699	17	23	4 to 6	3.3
96,704	87,913	64,469	19	25	4 to 6	3.2
100,454	91,322	66,969	15	19	4 to 6	3.1
100,733	91,576	67,155	19	24	4 to 6	3.1
104,520	95,018	69,680	23	28	4 to 6	3.0
105,113	95,557	70,075	19	23	4 to 6	3.0
108,391	98,538	72,261	23	27	4 to 6	2.9
109,065	99,150	72,710	24	28	4 to 6	2.9
112,272	102,066	74,848	15	17	4 to 6	2.8
113,104	102,822	75,403	24	27	4 to 6	2.8
113,848	103,498	75,899	17	19	4 to 6	2.8
117,063	106,421	78,042	23	25	4 to 6	2.7
118,153	107,412	78,769	26	28	4 to 6	2.7
121,940	110,855	81,293	23	24	4 to 6	2.6
122,152	111,048	81,435	24	25	4 to 6	2.6
122,698	111,543	81,798	27	28	4 to 6	2.6
127,242	115,674	84,828	23	23	4 to 6	2.5
131,955	119,959	87,970	28	27	4 to 6	2.4
132,136	120,124	88,091	27	26	4 to 6	2.4
132,774	120,704	88,516	24	23	4 to 6	2.4
137,030	124,573	91,353	28	26	4 to 6	2.3
137,421	124,928	91,614	27	25	4 to 6	2.3
138,306	125,733	92,204	25	23	4 to 6	2.3
142,212	129,283	94,808	19	17	4 to 6	2.2
143,147	130,134	95,431	27	24	4 to 6	2.2
143,839	130,762	95,892	26	23	4 to 6	2.2
148,449	134,954	98,966	28	24	4 to 6	2.1
149,371	135,792	99,581	27	23	4 to 6	2.1
154,030	140,027	102,686	23	19	4 to 6	2.0
154,903	140,821	103,269	28	23	4 to 6	2.0
160,727	146,115	107,151	24	19	4 to 6	2.0
167,424	152,203	111,616	25	19	4 to 6	1.9
172,151	156,501	114,767	23	17	4 to 6	1.8
174,121	158,291	116,080	26	19	4 to 6	1.8
179,636	163,305	119,757	24	17	4 to 6	1.7
180,817	164,380	120,545	27	19	4 to 6	1.7
187,120	170,110	124,747	25	17	4 to 6	1.7
187,514	170,468	125,010	28	19	4 to 6	1.7
194,605	176,914	129,737	26	17	4 to 6	1.6
195,104	177,368	130,070	23	15	4 to 6	1.6
202,090	183,718	134,727	27	17	4 to 6	1.6

NOTE: See "General Planting Rate Information" and "Check Seed Population" pages for more information. Always field check seed population to verify planting rates.

**EDGEVAC PLANTING RATES FOR SOYBEAN 60 CELL DISC
44 TOOTH CONTACT WHEEL DRIVE SPROCKET
APPROXIMATE SEEDS / ACRE FOR VARIOUS ROW WIDTHS**

20" Rows	22" Rows	30" Rows	Transmission Sprockets		Recomm. Speed Range (MPH)	Average Seed Spacing In Inches
			Drive	Driven		
107,110	97,372	71,406	15	28	4 to 6	2.9
111,077	100,979	74,051	15	27	4 to 6	2.8
115,349	104,863	76,899	15	26	4 to 6	2.7
119,963	109,057	79,975	15	25	4 to 6	2.6
121,391	110,355	80,927	17	28	4 to 6	2.6
124,961	113,601	83,308	15	24	4 to 6	2.5
125,887	114,443	83,925	17	27	4 to 6	2.5
130,394	118,540	86,930	15	23	4 to 6	2.4
130,729	118,844	87,153	17	26	4 to 6	2.4
135,672	123,338	90,448	19	28	4 to 6	2.3
135,958	123,598	90,639	17	25	4 to 6	2.3
140,697	127,907	93,798	19	27	4 to 6	2.2
141,623	128,748	94,415	17	24	4 to 6	2.2
146,109	132,826	97,406	19	26	4 to 6	2.1
147,780	134,346	98,520	17	23	4 to 6	2.1
151,953	138,139	101,302	19	25	4 to 6	2.1
157,846	143,496	105,231	15	19	4 to 6	2.0
158,284	143,895	105,523	19	24	4 to 6	2.0
164,235	149,304	109,490	23	28	4 to 6	1.9
165,166	150,151	110,111	19	23	4 to 6	1.9
170,318	154,834	113,545	23	27	4 to 6	1.8
171,376	155,796	114,250	24	28	4 to 6	1.8
176,416	160,378	117,611	15	17	4 to 6	1.8
177,723	161,566	118,482	24	27	4 to 6	1.8
178,892	162,629	119,261	17	19	4 to 6	1.8
183,943	167,221	122,629	23	25	4 to 6	1.7
185,657	168,779	123,771	26	28	4 to 6	1.7
191,607	174,189	127,738	23	24	4 to 6	1.6
191,941	174,491	127,960	24	25	4 to 6	1.6
192,797	175,270	128,532	27	28	4 to 6	1.6
199,938	181,762	133,292	23	23	4 to 6	1.6
207,343	188,494	138,229	28	27	4 to 6	1.5
207,628	188,753	138,419	27	26	4 to 6	1.5
208,631	189,665	139,087	24	23	4 to 6	1.5
215,318	195,744	143,545	28	26	4 to 6	1.5
215,933	196,303	143,955	27	25	4 to 6	1.5
217,324	197,567	144,883	25	23	4 to 6	1.4
223,460	203,146	148,973	19	17	4 to 6	1.4
224,930	204,482	149,954	27	24	4 to 6	1.4
226,017	205,470	150,678	26	23	4 to 6	1.4
233,261	212,056	155,507	28	24	4 to 6	1.3
234,710	213,373	156,473	27	23	4 to 6	1.3
242,030	220,028	161,354	23	19	4 to 6	1.3
243,403	221,275	162,269	28	23	4 to 6	1.3
	229,594	168,369	24	19	4 to 6	1.2
	239,160	175,384	25	19	4 to 6	1.2
	245,913	180,336	23	17	4 to 6	1.2
	248,727	182,400	26	19	4 to 6	1.1
NOTE: Planting rates over 250,000 seeds/acre are not recommended with subject seed disc and/or drive ratio.		188,177	24	17	4 to 6	1.1
		189,415	27	19	4 to 6	1.1
		196,018	25	17	4 to 6	1.1
		196,430	28	19	4 to 6	1.1
		203,858	26	17	4 to 6	1.0
		204,381	23	15	4 to 6	1.0
		211,699	27	17	4 to 6	1.0

NOTE: See "General Planting Rate Information" and "Check Seed Population" pages for more information. Always field check seed population to verify planting rates.

**EDGEVAC PLANTING RATES FOR HIGH-RATE SOYBEAN 120 CELL DISC
22 TOOTH CONTACT WHEEL DRIVE SPROCKET
APPROXIMATE SEEDS / ACRE FOR VARIOUS ROW WIDTHS**

20" Rows	22" Rows	30" Rows	Transmission Sprockets		Recomm. Speed Range (MPH)	Average Seed Spacing In Inches
			Drive	Driven		
107,117	97,379	71,411	15	28	4 to 6	2.9
111,084	100,986	74,056	15	27	4 to 6	2.8
115,357	104,870	76,904	15	26	4 to 6	2.7
119,971	109,065	79,981	15	25	4 to 6	2.6
121,399	110,363	80,933	17	28	4 to 6	2.6
124,970	113,609	83,313	15	24	4 to 6	2.5
125,895	114,450	83,930	17	27	4 to 6	2.5
130,403	118,548	86,935	15	23	4 to 6	2.4
130,738	118,852	87,158	17	26	4 to 6	2.4
135,681	123,347	90,454	19	28	4 to 6	2.3
135,967	123,606	90,645	17	25	4 to 6	2.3
140,707	127,915	93,804	19	27	4 to 6	2.2
141,632	128,757	94,422	17	24	4 to 6	2.2
146,118	132,835	97,412	19	26	4 to 6	2.1
147,790	134,355	98,527	17	23	4 to 6	2.1
151,963	138,148	101,309	19	25	4 to 6	2.1
157,857	143,506	105,238	15	19	4 to 6	2.0
158,295	143,905	105,530	19	24	4 to 6	2.0
164,246	149,315	109,497	23	28	4 to 6	1.9
165,177	150,161	110,118	19	23	4 to 6	1.9
170,329	154,845	113,553	23	27	4 to 6	1.8
171,387	155,806	114,258	24	28	4 to 6	1.8
176,428	160,389	117,619	15	17	4 to 6	1.8
177,735	161,577	118,490	24	27	4 to 6	1.8
178,904	162,640	119,269	17	19	4 to 6	1.8
183,955	167,232	122,637	23	25	4 to 6	1.7
185,669	168,790	123,780	26	28	4 to 6	1.7
191,620	174,200	127,747	23	24	4 to 6	1.6
191,954	174,503	127,969	24	25	4 to 6	1.6
192,810	175,282	128,540	27	28	4 to 6	1.6
199,952	181,774	133,301	23	23	4 to 6	1.6
207,357	188,507	138,238	28	27	4 to 6	1.5
207,642	188,766	138,428	27	26	4 to 6	1.5
208,645	189,677	139,097	24	23	4 to 6	1.5
215,333	195,757	143,555	28	26	4 to 6	1.5
215,948	196,316	143,965	27	25	4 to 6	1.5
217,339	197,581	144,892	25	23	4 to 6	1.4
223,475	203,159	148,984	19	17	4 to 6	1.4
224,946	204,496	149,964	27	24	4 to 6	1.4
226,032	205,484	150,688	26	23	4 to 6	1.4
233,277	212,070	155,518	28	24	4 to 6	1.3
234,726	213,387	156,484	27	23	4 to 6	1.3
242,047	220,042	161,364	23	19	4 to 6	1.3
243,419	221,290	162,280	28	23	4 to 6	1.3
	229,610	168,380	24	19	4 to 6	1.2
	239,177	175,396	25	19	4 to 6	1.2
	245,930	180,349	23	17	4 to 6	1.2
	248,744	182,412	26	19	4 to 6	1.1
NOTE: Planting rates over 250,000 seeds/acre are not recommended with subject seed disc and/or drive ratio.		188,190	24	17	4 to 6	1.1
		189,428	27	19	4 to 6	1.1
		196,031	25	17	4 to 6	1.1
		196,444	28	19	4 to 6	1.1
		203,872	26	17	4 to 6	1.0
		204,395	23	15	4 to 6	1.0
		211,713	27	17	4 to 6	1.0

NOTE: See "General Planting Rate Information" and "Check Seed Population" pages for more information. Always field check seed population to verify planting rates.

**EDGEVAC PLANTING RATES FOR HIGH-RATE SOYBEAN 120 CELL DISC
28 TOOTH CONTACT WHEEL DRIVE SPROCKET
APPROXIMATE SEEDS / ACRE FOR VARIOUS ROW WIDTHS**

20" Rows	22" Rows	30" Rows	Transmission Sprockets		Recomm. Speed Range (MPH)	Average Seed Spacing In Inches
			Drive	Driven		
136,331	123,937	90,887	15	28	4 to 6	2.3
141,380	128,527	94,253	15	27	4 to 6	2.2
146,818	133,471	97,878	15	26	4 to 6	2.1
152,690	138,809	101,794	15	25	4 to 6	2.1
154,508	140,462	103,005	17	28	4 to 6	2.0
159,052	144,593	106,035	15	24	4 to 6	2.0
160,231	145,664	106,820	17	27	4 to 6	2.0
165,968	150,880	110,645	15	23	4 to 6	1.9
166,393	151,267	110,929	17	26	4 to 6	1.9
172,685	156,987	115,124	19	28	4 to 6	1.8
173,049	157,317	115,366	17	25	4 to 6	1.8
179,081	162,801	119,387	19	27	4 to 6	1.8
180,259	163,872	120,173	17	24	4 to 6	1.7
185,969	169,063	123,979	19	26	4 to 6	1.7
188,097	170,997	125,398	17	23	4 to 6	1.7
193,408	175,825	128,938	19	25	4 to 6	1.6
200,908	182,644	133,939	15	19	4 to 6	1.6
201,466	183,151	134,311	19	24	4 to 6	1.6
209,040	190,037	139,360	23	28	4 to 6	1.5
210,226	191,114	140,151	19	23	4 to 6	1.5
216,783	197,075	144,522	23	27	4 to 6	1.4
218,129	198,299	145,419	24	28	4 to 6	1.4
224,545	204,131	149,696	15	17	4 to 6	1.4
226,208	205,644	150,805	24	27	4 to 6	1.4
227,696	206,996	151,797	17	19	4 to 6	1.4
234,125	212,841	156,083	23	25	4 to 6	1.3
236,306	214,824	157,538	26	28	4 to 6	1.3
243,880	221,709	162,587	23	24	4 to 6	1.3
244,305	222,095	162,870	24	25	4 to 6	1.3
245,395	223,087	163,597	27	28	4 to 6	1.3
	231,349	169,656	23	23	4 to 6	1.2
	239,917	175,939	28	27	4 to 6	1.2
	240,247	176,181	27	26	4 to 6	1.2
	241,408	177,032	24	23	4 to 6	1.2
	249,145	182,706	28	26	4 to 6	1.1
	249,857	183,228	27	25	4 to 6	1.1
		184,409	25	23	4 to 6	1.1
		189,615	19	17	4 to 6	1.1
		190,863	27	24	4 to 6	1.1
		191,785	26	23	4 to 6	1.1
		197,932	28	24	4 to 6	1.1
		199,161	27	23	4 to 6	1.0
		205,373	23	19	4 to 6	1.0
		206,538	28	23	4 to 6	1.0
		214,302	24	19	4 to 6	1.0
		223,231	25	19	4 to 6	0.9
		229,534	23	17	4 to 6	0.9
		232,161	26	19	4 to 6	0.9
		239,514	24	17	4 to 6	0.9
		241,090	27	19	4 to 6	0.9
		249,494	25	17	4 to 6	0.8
			28	19	4 to 6	0.8
			26	17	4 to 6	0.8
			23	15	4 to 6	0.8
			27	17	4 to 6	0.8

NOTE: See "General Planting Rate Information" and "Check Seed Population" pages for more information. Always field check seed population to verify planting rates.

**EDGEVAC PLANTING RATES FOR HILL-DROP COTTON (3 SEEDS PER CELL), 20 CELL DISC
22 TOOTH CONTACT WHEEL DRIVE SPROCKET
APPROXIMATE HILLS / ACRE FOR VARIOUS ROW WIDTHS**

20" Rows	22" Rows	30" Rows	Transmission Sprockets		Recomm. Speed Range (MPH)	Average Seed Spacing In Inches
			Drive	Driven		
17,853	16,230	11,902	15	28	4 to 6	17.6
18,514	16,831	12,343	15	27	4 to 6	16.9
19,226	17,478	12,817	15	26	4 to 6	16.3
19,995	18,177	13,330	15	25	4 to 6	15.7
20,233	18,394	13,489	17	28	4 to 6	15.5
20,828	18,935	13,886	15	24	4 to 6	15.1
20,983	19,075	13,988	17	27	4 to 6	14.9
21,734	19,758	14,489	15	23	4 to 6	14.4
21,790	19,809	14,526	17	26	4 to 6	14.4
22,614	20,558	15,076	19	28	4 to 6	13.9
22,661	20,601	15,107	17	25	4 to 6	13.8
23,451	21,319	15,634	19	27	4 to 6	13.4
23,605	21,459	15,737	17	24	4 to 6	13.3
24,353	22,139	16,235	19	26	4 to 6	12.9
24,632	22,392	16,421	17	23	4 to 6	12.7
25,327	23,025	16,885	19	25	4 to 6	12.4
26,309	23,918	17,540	15	19	4 to 6	11.9
26,383	23,984	17,588	19	24	4 to 6	11.9
27,374	24,886	18,250	23	28	4 to 6	11.5
27,530	25,027	18,353	19	23	4 to 6	11.4
28,388	25,807	18,925	23	27	4 to 6	11.0
28,565	25,968	19,043	24	28	4 to 6	11.0
29,405	26,731	19,603	15	17	4 to 6	10.7
29,480	26,800	19,653	23	26	4 to 6	10.6
29,622	26,930	19,748	24	27	4 to 6	10.6
29,755	27,050	19,836	25	28	4 to 6	10.5
29,817	27,107	19,878	17	19	4 to 6	10.5
30,659	27,872	20,439	23	25	4 to 6	10.2
30,762	27,965	20,508	24	26	4 to 6	10.2
30,857	28,052	20,571	25	27	4 to 6	10.2
30,945	28,132	20,630	26	28	4 to 6	10.1
31,937	29,033	21,291	23	24	4 to 6	9.8
31,992	29,084	21,328	24	25	4 to 6	9.8
32,044	29,130	21,362	25	26	4 to 6	9.8
32,091	29,174	21,394	26	27	4 to 6	9.8
32,135	29,214	21,423	27	28	4 to 6	9.8
33,325	30,296	22,217	23	23	4 to 6	9.4
34,560	31,418	23,040	28	27	4 to 6	9.1
34,607	31,461	23,071	27	26	4 to 6	9.1
34,714	31,558	23,143	25	24	4 to 6	9.0
34,774	31,613	23,183	24	23	4 to 6	9.0
35,889	32,626	23,926	28	26	4 to 6	8.7
35,991	32,719	23,994	27	25	4 to 6	8.7
36,223	32,930	24,149	25	23	4 to 6	8.7
37,246	33,860	24,831	19	17	4 to 6	8.4
37,324	33,931	24,883	28	25	4 to 6	8.4
37,491	34,083	24,994	27	24	4 to 6	8.4
37,672	34,247	25,115	26	23	4 to 6	8.3
38,879	35,345	25,920	28	24	4 to 6	8.1
39,121	35,565	26,081	27	23	4 to 6	8.0
40,341	36,674	26,894	23	19	4 to 6	7.8
40,570	36,882	27,047	28	23	4 to 6	7.7
42,095	38,268	28,063	24	19	4 to 6	7.5
43,849	39,863	29,233	25	19	4 to 6	7.2
45,087	40,988	30,058	23	17	5 to 6	7.0

NOTE: See "General Planting Rate Information" and "Check Seed Population" pages for more information. Always field check seed population to verify planting rates.

**EDGEVAC PLANTING RATES FOR HILL-DROP COTTON (3 SEEDS PER CELL), 20 CELL DISC
28 TOOTH CONTACT WHEEL DRIVE SPROCKET
APPROXIMATE HILLS / ACRE FOR VARIOUS ROW WIDTHS**

20" Rows	22" Rows	30" Rows	Transmission Sprockets		Recomm. Speed Range (MPH)	Average Seed Spacing In Inches
			Drive	Driven		
22,722	20,656	15,148	15	28	4 to 6	13.8
23,563	21,421	15,709	15	27	4 to 6	13.3
24,470	22,245	16,313	15	26	4 to 6	12.8
25,448	23,135	16,966	15	25	4 to 6	12.3
25,751	23,410	17,168	17	28	4 to 6	12.2
26,509	24,099	17,672	15	24	4 to 6	11.8
26,705	24,277	17,803	17	27	4 to 6	11.7
27,661	25,147	18,441	15	23	4 to 6	11.3
27,732	25,211	18,488	17	26	4 to 6	11.3
28,781	26,164	19,187	19	28	4 to 6	10.9
28,842	26,220	19,228	17	25	4 to 6	10.9
29,847	27,134	19,898	19	27	4 to 6	10.5
30,043	27,312	20,029	17	24	4 to 6	10.4
30,995	28,177	20,663	19	26	4 to 6	10.1
31,349	28,500	20,900	17	23	4 to 6	10.0
32,235	29,304	21,490	19	25	4 to 6	9.7
33,485	30,441	22,323	15	19	4 to 6	9.4
33,578	30,525	22,385	19	24	4 to 6	9.3
34,840	31,673	23,227	23	28	4 to 6	9.0
35,038	31,852	23,358	19	23	4 to 6	9.0
36,130	32,846	24,087	23	27	4 to 6	8.7
36,355	33,050	24,237	24	28	4 to 6	8.6
37,424	34,022	24,949	15	17	4 to 6	8.4
37,520	34,109	25,013	23	26	4 to 6	8.4
37,701	34,274	25,134	24	27	4 to 6	8.3
37,870	34,427	25,246	25	28	4 to 6	8.3
37,949	34,499	25,300	17	19	4 to 6	8.3
39,021	35,474	26,014	23	25	4 to 6	8.0
39,151	35,592	26,101	24	26	4 to 6	8.0
39,272	35,702	26,181	25	27	4 to 6	8.0
39,384	35,804	26,256	26	28	4 to 6	8.0
40,647	36,952	27,098	23	24	4 to 6	7.7
40,717	37,016	27,145	24	25	4 to 6	7.7
40,783	37,075	27,188	25	26	4 to 6	7.7
40,843	37,130	27,229	26	27	4 to 6	7.7
40,899	37,181	27,266	27	28	4 to 6	7.7
42,414	38,558	28,276	23	23	4 to 6	7.4
43,985	39,986	29,323	28	27	4 to 6	7.1
44,045	40,041	29,364	27	26	4 to 6	7.1
44,181	40,165	29,454	25	24	4 to 6	7.1
44,258	40,235	29,505	24	23	4 to 6	7.1
45,677	41,524	30,451	28	26	4 to 6	6.9
45,807	41,643	30,538	27	25	4 to 6	6.8
46,102	41,911	30,735	25	23	4 to 6	6.8
47,404	43,094	31,603	19	17	4 to 6	6.6
47,504	43,185	31,669	28	25	4 to 6	6.6
47,716	43,378	31,810	27	24	4 to 6	6.6
47,946	43,587	31,964	26	23	4 to 6	6.5
49,483	44,985	32,989	28	24	4 to 6	6.3
49,790	45,264	33,194	27	23	4 to 6	6.3
51,343	46,676	34,229	23	19	4 to 6	6.1
51,634	46,940	34,423	28	23	4 to 6	6.1
53,576	48,705	35,717	24	19	4 to 6	5.9
55,808	50,734	37,205	25	19	4 to 6	5.6
57,384	52,167	38,256	23	17	5 to 6	5.5

NOTE: See "General Planting Rate Information" and "Check Seed Population" pages for more information. Always field check seed population to verify planting rates.

**EDGEVAC PLANTING RATES FOR COTTON / SMALL DRY EDIBLE BEAN/SUNFLOWER, 54 CELL DISC
22 TOOTH CONTACT WHEEL DRIVE SPROCKET
APPROXIMATE SEEDS / ACRE FOR VARIOUS ROW WIDTHS**

20" Rows	22" Rows	30" Rows	Transmission Sprockets		Recomm. Speed	Average Seed Spacing
			Drive	Driven	Range (MPH)	In Inches
48,203	43,821	32,135	15	28	4 to 6	6.5
49,988	45,444	33,325	15	27	4 to 6	6.3
51,911	47,191	34,607	15	26	4 to 6	6.0
53,987	49,079	35,991	15	25	4 to 6	5.8
54,630	49,663	36,420	17	28	4 to 6	5.7
56,236	51,124	37,491	15	24	4 to 6	5.6
56,653	51,503	37,769	17	27	4 to 6	5.5
58,681	53,347	39,121	15	23	4 to 6	5.3
58,832	53,484	39,221	17	26	4 to 6	5.3
61,057	55,506	40,704	19	28	4 to 6	5.1
61,185	55,623	40,790	17	25	4 to 6	5.1
63,318	57,562	42,212	19	27	4 to 6	5.0
63,735	57,941	42,490	17	24	4 to 6	4.9
65,753	59,776	43,836	19	26	4 to 6	4.8
66,506	60,460	44,337	17	23	4 to 6	4.7
68,383	62,167	45,589	19	25	4 to 6	4.6
71,035	64,578	47,357	15	19	4 to 6	4.4
71,233	64,757	47,489	19	24	4 to 6	4.4
73,911	67,192	49,274	23	28	4 to 6	4.2
74,330	67,573	49,553	19	23	4 to 6	4.2
76,648	69,680	51,099	23	27	4 to 6	4.1
77,124	70,113	51,416	24	28	4 to 6	4.1
79,393	72,175	52,928	15	17	4 to 6	4.0
79,981	72,710	53,320	24	27	4 to 6	3.9
80,507	73,188	53,671	17	19	4 to 6	3.9
82,780	75,255	55,187	23	25	4 to 6	3.8
83,551	75,956	55,701	26	28	4 to 6	3.8
86,229	78,390	57,486	23	24	4 to 6	3.6
86,379	78,526	57,586	24	25	4 to 6	3.6
86,765	78,877	57,843	27	28	4 to 6	3.6
89,978	81,798	59,985	23	23	4 to 6	3.5
93,311	84,828	62,207	28	27	4 to 6	3.4
93,439	84,944	62,293	27	26	4 to 6	3.4
93,890	85,355	62,594	24	23	4 to 6	3.3
96,900	88,091	64,600	28	26	4 to 6	3.2
97,176	88,342	64,784	27	25	4 to 6	3.2
97,802	88,911	65,202	25	23	4 to 6	3.2
100,564	91,422	67,043	19	17	4 to 6	3.1
101,226	92,023	67,484	27	24	4 to 6	3.1
101,715	92,468	67,810	26	23	4 to 6	3.1
104,975	95,431	69,983	28	24	4 to 6	3.0
105,627	96,024	70,418	27	23	4 to 6	3.0
108,921	99,019	72,614	23	19	4 to 6	2.9
109,539	99,581	73,026	28	23	4 to 6	2.9
113,657	103,324	75,771	24	19	4 to 6	2.8
118,392	107,629	78,928	25	19	4 to 6	2.6
121,735	110,668	81,157	23	17	4 to 6	2.6
123,128	111,935	82,085	26	19	4 to 6	2.5
127,028	115,480	84,685	24	17	4 to 6	2.5
127,864	116,240	85,243	27	19	4 to 6	2.5
132,321	120,292	88,214	25	17	4 to 6	2.4
132,599	120,545	88,400	28	19	4 to 6	2.4
137,614	125,103	91,743	26	17	4 to 6	2.3
137,967	125,424	91,978	23	15	4 to 6	2.3
142,907	129,915	95,271	27	17	4 to 6	2.2

NOTE: See "General Planting Rate Information" and "Check Seed Population" pages for more information. Always field check seed population to verify planting rates.

**EDGEVAC PLANTING RATES FOR COTTON / SMALL DRY EDIBLE BEAN / SUNFLOWER, 54 CELL DISC
28 TOOTH CONTACT WHEEL DRIVE SPROCKET
APPROXIMATE SEEDS / ACRE FOR VARIOUS ROW WIDTHS**

20" Rows	22" Rows	30" Rows	Transmission Sprockets Drive Driven		Recomm. Speed Range (MPH)	Average Seed Spacing In Inches
61,349	55,772	40,899	15	28	4 to 6	5.1
63,621	57,837	42,414	15	27	4 to 6	4.9
66,068	60,062	44,045	15	26	4 to 6	4.7
68,711	62,464	45,807	15	25	4 to 6	4.6
69,529	63,208	46,352	17	28	4 to 6	4.5
71,574	65,067	47,716	15	24	4 to 6	4.4
72,104	65,549	48,069	17	27	4 to 6	4.3
74,685	67,896	49,790	15	23	4 to 6	4.2
74,877	68,070	49,918	17	26	4 to 6	4.2
77,708	70,644	51,806	19	28	4 to 6	4.0
77,872	70,793	51,915	17	25	4 to 6	4.0
80,587	73,261	53,724	19	27	4 to 6	3.9
81,117	73,742	54,078	17	24	4 to 6	3.9
83,686	76,078	55,791	19	26	4 to 6	3.7
84,644	76,949	56,429	17	23	4 to 6	3.7
87,033	79,121	58,022	19	25	4 to 6	3.6
90,409	82,190	60,272	15	19	4 to 6	3.5
90,660	82,418	60,440	19	24	4 to 6	3.5
94,068	85,516	62,712	23	28	4 to 6	3.3
94,602	86,001	63,068	19	23	4 to 6	3.3
97,552	88,684	65,035	23	27	4 to 6	3.2
98,158	89,235	65,439	24	28	4 to 6	3.2
101,045	91,859	67,363	15	17	4 to 6	3.1
101,794	92,540	67,862	24	27	4 to 6	3.1
102,463	93,148	68,309	17	19	4 to 6	3.1
105,356	95,778	70,238	23	25	4 to 6	3.0
106,338	96,671	70,892	26	28	4 to 6	2.9
109,746	99,769	73,164	23	24	4 to 6	2.9
109,937	99,943	73,291	24	25	4 to 6	2.9
110,428	100,389	73,619	27	28	4 to 6	2.8
114,518	104,107	76,345	23	23	4 to 6	2.7
118,759	107,963	79,173	28	27	4 to 6	2.6
118,922	108,111	79,282	27	26	4 to 6	2.6
119,497	108,633	79,665	24	23	4 to 6	2.6
123,327	112,115	82,218	28	26	4 to 6	2.5
123,679	112,436	82,453	27	25	4 to 6	2.5
124,476	113,160	82,984	25	23	4 to 6	2.5
127,990	116,355	85,327	19	17	4 to 6	2.5
128,832	117,120	85,888	27	24	4 to 6	2.4
129,455	117,686	86,303	26	23	4 to 6	2.4
133,604	121,458	89,069	28	24	4 to 6	2.3
134,434	122,213	89,623	27	23	4 to 6	2.3
138,627	126,024	92,418	23	19	4 to 6	2.3
139,413	126,739	92,942	28	23	4 to 6	2.2
144,654	131,504	96,436	24	19	4 to 6	2.2
150,681	136,983	100,454	25	19	4 to 6	2.1
154,936	140,851	103,291	23	17	4 to 6	2.0
156,708	142,462	104,472	26	19	4 to 6	2.0
161,672	146,975	107,781	24	17	4 to 6	1.9
162,736	147,942	108,490	27	19	4 to 6	1.9
168,408	153,099	112,272	25	17	4 to 6	1.9
168,763	153,421	112,509	28	19	4 to 6	1.9
175,145	159,223	116,763	26	17	4 to 6	1.8
175,594	159,631	117,063	23	15	4 to 6	1.8
181,881	165,346	121,254	27	17	4 to 6	1.7

NOTE: See "General Planting Rate Information" and "Check Seed Population" pages for more information. Always field check seed population to verify planting rates.

**EDGEVAC PLANTING RATES FOR SUNFLOWER, 54 CELL DISC
15 TOOTH CONTACT WHEEL DRIVE SPROCKET / 19 TOOTH REVERSER DRIVE SPROCKET
APPROXIMATE SEEDS / ACRE FOR VARIOUS ROW WIDTHS**

20" Rows	22" Rows	30" Rows	Transmission Sprockets		Recomm. Speed Range (MPH)	Average Seed Spacing In Inches
			Drive	Driven		
22,281	20,256	14,854	15	28	4 to 6	14.1
23,106	21,006	15,404	15	27	4 to 6	13.6
23,995	21,814	15,997	15	26	4 to 6	13.1
24,955	22,686	16,637	15	25	4 to 6	12.6
25,252	22,956	16,835	17	28	4 to 6	12.4
25,995	23,632	17,330	15	24	4 to 6	12.1
26,187	23,807	17,458	17	27	4 to 6	12.0
27,125	24,659	18,083	15	23	4 to 6	11.6
27,194	24,722	18,130	17	26	4 to 6	11.5
28,223	25,657	18,815	19	28	4 to 6	11.1
28,282	25,711	18,855	17	25	4 to 6	11.1
29,268	26,607	19,512	19	27	4 to 6	10.7
29,461	26,782	19,640	17	24	4 to 6	10.6
30,394	27,631	20,262	19	26	4 to 6	10.3
30,742	27,947	20,494	17	23	4 to 6	10.2
31,609	28,736	21,073	19	25	4 to 6	9.9
32,835	29,850	21,890	15	19	4 to 6	9.6
32,927	29,933	21,951	19	24	4 to 6	9.5
34,164	31,059	22,776	23	28	4 to 6	9.2
34,358	31,235	22,905	19	23	4 to 6	9.1
35,430	32,209	23,620	23	27	4 to 6	8.9
35,650	32,409	23,767	24	28	4 to 6	8.8
36,698	33,362	24,466	15	17	4 to 6	8.5
36,970	33,609	24,647	24	27	4 to 6	8.5
37,213	33,830	24,809	17	19	4 to 6	8.4
39,858	36,235	26,572	23	24	4 to 6	7.9
38,621	35,110	25,747	26	28	4 to 6	8.1
39,858	36,235	26,572	23	24	4 to 6	7.9
39,928	36,298	26,619	24	25	4 to 6	7.9
40,106	36,460	26,737	27	28	4 to 6	7.8
41,591	37,810	27,728	23	23	4 to 6	7.5
43,132	39,211	28,755	28	27	4 to 6	7.3
43,191	39,265	28,794	27	26	4 to 6	7.3
43,400	39,454	28,933	24	23	4 to 6	7.2
44,791	40,719	29,861	28	26	4 to 6	7.0
44,919	40,835	29,946	27	25	4 to 6	7.0
45,208	41,098	30,139	25	23	4 to 6	6.9
46,485	42,259	30,990	19	17	4 to 6	6.7
46,790	42,537	31,194	27	24	4 to 6	6.7
47,016	42,742	31,344	26	23	4 to 6	6.7
48,523	44,112	32,349	28	24	4 to 6	6.5
48,825	44,386	32,550	27	23	4 to 6	6.4
50,348	45,770	33,565	23	19	4 to 6	6.2
50,633	46,030	33,755	28	23	4 to 6	6.2
52,537	47,761	35,024	24	19	4 to 6	6.0
54,726	49,751	36,484	25	19	4 to 6	5.7
56,271	51,155	37,514	23	17	4 to 6	5.6
56,915	51,741	37,943	26	19	4 to 6	5.5
58,717	53,379	39,145	24	17	4 to 6	5.3
59,104	53,731	39,402	27	19	4 to 6	5.3
61,164	55,604	40,776	25	17	4 to 6	5.1
61,293	55,721	40,862	28	19	4 to 6	5.1
63,610	57,828	42,407	26	17	4 to 6	4.9
63,774	57,976	42,516	23	15	4 to 6	4.9
66,057	60,052	44,038	27	17	4 to 6	4.7

NOTE: See "General Planting Rate Information" and "Check Seed Population" pages for more information. Always field check seed population to verify planting rates.

**EDGEVAC PLANTING RATES FOR LARGE DRY EDIBLE BEAN, 54 CELL DISC
22 TOOTH CONTACT WHEEL DRIVE SPROCKET
APPROXIMATE SEEDS / ACRE FOR VARIOUS ROW WIDTHS**

20" Rows	22" Rows	30" Rows	Transmission Sprockets Drive Driven		Recomm. Speed Range (MPH)	Average Seed Spacing In Inches
48,203	43,821	32,135	15	28	4 to 6	6.5
49,988	45,444	33,325	15	27	4 to 6	6.3
51,911	47,191	34,607	15	26	4 to 6	6.0
53,987	49,079	35,991	15	25	4 to 6	5.8
54,630	49,663	36,420	17	28	4 to 6	5.7
56,236	51,124	37,491	15	24	4 to 6	5.6
56,653	51,503	37,769	17	27	4 to 6	5.5
58,681	53,347	39,121	15	23	4 to 6	5.3
58,832	53,484	39,221	17	26	4 to 6	5.3
61,057	55,506	40,704	19	28	4 to 6	5.1
61,185	55,623	40,790	17	25	4 to 6	5.1
63,318	57,562	42,212	19	27	4 to 6	5.0
63,735	57,941	42,490	17	24	4 to 6	4.9
65,753	59,776	43,836	19	26	4 to 6	4.8
66,506	60,460	44,337	17	23	4 to 6	4.7
68,383	62,167	45,589	19	25	4 to 6	4.6
71,035	64,578	47,357	15	19	4 to 6	4.4
71,233	64,757	47,489	19	24	4 to 6	4.4
73,911	67,192	49,274	23	28	4 to 6	4.2
74,330	67,573	49,553	19	23	4 to 6	4.2
76,648	69,680	51,099	23	27	4 to 6	4.1
77,124	70,113	51,416	24	28	4 to 6	4.1
79,393	72,175	52,928	15	17	4 to 6	4.0
79,981	72,710	53,320	24	27	4 to 6	3.9
80,507	73,188	53,671	17	19	4 to 6	3.9
82,780	75,255	55,187	23	25	4 to 6	3.8
83,551	75,956	55,701	26	28	4 to 6	3.8
86,229	78,390	57,486	23	24	4 to 6	3.6
86,379	78,526	57,586	24	25	4 to 6	3.6
86,765	78,877	57,843	27	28	4 to 6	3.6
89,978	81,798	59,985	23	23	4 to 6	3.5
93,311	84,828	62,207	28	27	4 to 6	3.4
93,439	84,944	62,293	27	26	4 to 6	3.4
93,890	85,355	62,594	24	23	4 to 6	3.3
96,900	88,091	64,600	28	26	4 to 6	3.2
97,176	88,342	64,784	27	25	4 to 6	3.2
97,802	88,911	65,202	25	23	4 to 6	3.2
100,564	91,422	67,043	19	17	4 to 6	3.1
101,226	92,023	67,484	27	24	4 to 6	3.1
101,715	92,468	67,810	26	23	4 to 6	3.1
104,975	95,431	69,983	28	24	4 to 6	3.0
105,627	96,024	70,418	27	23	4 to 6	3.0
108,921	99,019	72,614	23	19	4 to 6	2.9
109,539	99,581	73,026	28	23	4 to 6	2.9
113,657	103,324	75,771	24	19	4 to 6	2.8
118,392	107,629	78,928	25	19	4 to 6	2.6
121,735	110,668	81,157	23	17	4 to 6	2.6
123,128	111,935	82,085	26	19	4 to 6	2.5
127,028	115,480	84,685	24	17	4 to 6	2.5
127,864	116,240	85,243	27	19	4 to 6	2.5
132,321	120,292	88,214	25	17	4 to 6	2.4
132,599	120,545	88,400	28	19	4 to 6	2.4
137,614	125,103	91,743	26	17	4 to 6	2.3
137,967	125,424	91,978	23	15	4 to 6	2.3
142,907	129,915	95,271	27	17	4 to 6	2.2

NOTE: See "General Planting Rate Information" and "Check Seed Population" pages for more information. Always field check seed population to verify planting rates.

**EDGEVAC PLANTING RATES FOR LARGE DRY EDIBLE BEAN 54 CELL DISC
28 TOOTH CONTACT WHEEL DRIVE SPROCKET
APPROXIMATE SEEDS / ACRE FOR VARIOUS ROW WIDTHS**

20" Rows	22" Rows	30" Rows	Transmission Sprockets Drive Driven		Recomm. Speed Range (MPH)	Average Seed Spacing In Inches
61,349	55,772	40,899	15	28	4 to 6	5.1
63,621	57,837	42,414	15	27	4 to 6	4.9
66,068	60,062	44,045	15	26	4 to 6	4.7
68,711	62,464	45,807	15	25	4 to 6	4.6
69,529	63,208	46,352	17	28	4 to 6	4.5
71,574	65,067	47,716	15	24	4 to 6	4.4
72,104	65,549	48,069	17	27	4 to 6	4.3
74,685	67,896	49,790	15	23	4 to 6	4.2
74,877	68,070	49,918	17	26	4 to 6	4.2
77,708	70,644	51,806	19	28	4 to 6	4.0
77,872	70,793	51,915	17	25	4 to 6	4.0
80,587	73,261	53,724	19	27	4 to 6	3.9
81,117	73,742	54,078	17	24	4 to 6	3.9
83,686	76,078	55,791	19	26	4 to 6	3.7
84,644	76,949	56,429	17	23	4 to 6	3.7
87,033	79,121	58,022	19	25	4 to 6	3.6
90,409	82,190	60,272	15	19	4 to 6	3.5
90,660	82,418	60,440	19	24	4 to 6	3.5
94,068	85,516	62,712	23	28	4 to 6	3.3
94,602	86,001	63,068	19	23	4 to 6	3.3
97,552	88,684	65,035	23	27	4 to 6	3.2
98,158	89,235	65,439	24	28	4 to 6	3.2
101,045	91,859	67,363	15	17	4 to 6	3.1
101,794	92,540	67,862	24	27	4 to 6	3.1
102,463	93,148	68,309	17	19	4 to 6	3.1
105,356	95,778	70,238	23	25	4 to 6	3.0
106,338	96,671	70,892	26	28	4 to 6	2.9
109,746	99,769	73,164	23	24	4 to 6	2.9
109,937	99,943	73,291	24	25	4 to 6	2.9
110,428	100,389	73,619	27	28	4 to 6	2.8
114,518	104,107	76,345	23	23	4 to 6	2.7
118,759	107,963	79,173	28	27	4 to 6	2.6
118,922	108,111	79,282	27	26	4 to 6	2.6
119,497	108,633	79,665	24	23	4 to 6	2.6
123,327	112,115	82,218	28	26	4 to 6	2.5
123,679	112,436	82,453	27	25	4 to 6	2.5
124,476	113,160	82,984	25	23	4 to 6	2.5
127,990	116,355	85,327	19	17	4 to 6	2.5
128,832	117,120	85,888	27	24	4 to 6	2.4
129,455	117,686	86,303	26	23	4 to 6	2.4
133,604	121,458	89,069	28	24	4 to 6	2.3
134,434	122,213	89,623	27	23	4 to 6	2.3
138,627	126,024	92,418	23	19	4 to 6	2.3
139,413	126,739	92,942	28	23	4 to 6	2.2
144,654	131,504	96,436	24	19	4 to 6	2.2
150,681	136,983	100,454	25	19	4 to 6	2.1
154,936	140,851	103,291	23	17	4 to 6	2.0
156,708	142,462	104,472	26	19	4 to 6	2.0
161,672	146,975	107,781	24	17	4 to 6	1.9
162,736	147,942	108,490	27	19	4 to 6	1.9
168,408	153,099	112,272	25	17	4 to 6	1.9
168,763	153,421	112,509	28	19	4 to 6	1.9
175,145	159,223	116,763	26	17	4 to 6	1.8
175,594	159,631	117,063	23	15	4 to 6	1.8
181,881	165,346	121,254	27	17	4 to 6	1.7

NOTE: See "General Planting Rate Information" and "Check Seed Population" pages for more information. Always field check seed population to verify planting rates.

**PLANTING RATES FOR (EDGEVAC) SUGAR BEETS 80 CELL DISC
22 TOOTH CONTACT WHEEL DRIVE SPROCKET**

APPROXIMATE SEEDS/ACRE FOR VARIOUS ROW WIDTHS

20" Rows	22" Rows	30" Rows	Transmission Sprockets		Recomm. Speed Range (MPH)	Average Seed Spacing In Inches (20" and 22" Rows)	Average Seed Spacing In Inches (30" Rows)
			Drive	Driven			
71,412	64,920	47,608	15	28	4 to 6	3.2	4.4
74,055	67,323	49,370	15	27	4 to 6	3.1	4.2
76,905	69,913	51,270	15	26	4 to 6	3.0	4.1
79,982	72,710	53,321	15	25	4 to 6	2.9	3.9
80,932	73,575	53,955	17	28	4 to 6	2.8	3.9
83,314	75,740	55,543	15	24	4 to 6	2.8	3.8
83,929	76,299	55,953	17	27	4 to 6	2.8	3.8
86,935	79,032	57,957	15	23	4 to 6	2.6	3.6
87,157	79,234	58,105	17	26	4 to 6	2.6	3.6
90,455	82,232	60,304	19	28	4 to 6	2.5	3.5
90,646	82,406	60,431	17	25	4 to 6	2.5	3.5
93,803	85,276	62,535	19	27	4 to 6	2.5	3.4
94,422	85,838	62,948	17	24	4 to 6	2.4	3.3
97,412	88,557	64,942	19	26	4 to 6	2.4	3.2
98,526	89,569	65,684	17	23	4 to 6	2.3	3.2
101,308	92,098	67,538	19	25	4 to 6	2.3	3.1
105,237	95,670	70,158	15	19	4 to 6	2.2	3.0
105,529	95,936	70,353	19	24	4 to 6	2.2	3.0
109,498	99,544	72,999	23	28	4 to 6	2.1	2.9
110,117	100,106	73,411	19	23	4 to 6	2.1	2.8
113,554	103,231	75,703	23	27	4 to 6	2.0	2.8
114,258	103,871	76,172	24	28	4 to 6	2.0	2.7
117,618	106,926	78,412	15	17	4 to 6	2.0	2.7
118,489	107,717	78,993	24	27	4 to 6	1.9	2.6
119,271	108,428	79,514	17	19	4 to 6	1.9	2.6
122,637	111,488	81,758	23	25	4 to 6	1.9	2.5
123,778	112,526	82,519	26	28	4 to 6	1.9	2.5
127,748	116,134	85,165	23	24	4 to 6	1.8	2.4
127,969	116,336	85,313	24	25	4 to 6	1.8	2.4
128,542	116,856	85,694	27	28	4 to 6	1.8	2.4
133,302	121,183	88,868	23	23	4 to 6	1.7	2.3
138,237	125,670	92,158	28	27	4 to 6	1.7	2.3
138,428	125,843	92,285	27	26	4 to 6	1.6	2.2
139,095	126,450	92,730	24	23	4 to 6	1.6	2.2
143,554	130,503	95,703	28	26	4 to 6	1.6	2.2
143,966	130,878	95,977	27	25	4 to 6	1.6	2.2
144,892	131,720	96,595	25	23	4 to 6	1.6	2.1
148,985	135,441	99,323	19	17	4 to 6	1.5	2.1
149,963	136,330	99,975	27	24	4 to 6	1.5	2.1
150,689	136,990	100,459	26	23	4 to 6	1.5	2.1
155,517	141,379	103,678	28	24	4 to 6	1.5	2.0
156,483	142,257	104,322	27	23	4 to 6	1.5	2.0
161,363	146,694	107,575	23	19	4 to 6	1.4	2.0
162,280	147,527	108,187	28	23	4 to 6	1.4	2.0
168,382	153,074	112,254	24	19	4 to 6	1.4	1.9
175,397	159,452	116,931	25	19	4 to 6	1.3	1.8
180,348	163,952	120,232	23	17	4 to 6	1.3	1.8
182,412	165,829	121,608	26	19	4 to 6	1.3	1.7
188,191	171,083	125,461	24	17	4 to 6	1.2	1.7
189,428	172,207	126,285	27	19	4 to 6	1.2	1.7
196,031	178,210	130,687	25	17	4 to 6	1.2	1.6
196,443	178,585	130,962	28	19	4 to 6	1.2	1.6
203,871	185,337	135,914	26	17	4 to 6	1.1	1.6
204,394	185,813	136,263	23	15	4 to 6	1.1	1.5
211,714	192,467	141,143	27	17	4 to 6	1.1	1.5

NOTE: See "General Planting Rate Information" and "Check Seed Population" pages for more information. Always field check seed population to verify planting rates.

**PLANTING RATES FOR (EDGEVAC) SUGAR BEETS 80 CELL DISC
15 TOOTH CONTACT WHEEL DRIVE SPROCKET/19 TOOTH REVERSER DRIVEN SPROCKETS
APPROXIMATE SEEDS/ACRE FOR VARIOUS ROW WIDTHS**

20" Rows	22" Rows	30" Rows	Transmission Sprockets		Recomm. Speed Range (MPH)	Average Seed Spacing In Inches (20" and 22" Rows)	Average Seed Spacing In Inches (30" Rows)
			Drive	Driven			
33,009	30,008	22,006	15	28	4 to 6	7.0	9.5
34,231	31,119	22,821	15	27	4 to 6	6.7	9.2
35,548	32,316	23,699	15	26	4 to 6	6.5	8.9
36,970	33,609	24,647	15	25	4 to 6	6.2	8.4
37,410	34,009	24,940	17	28	4 to 6	6.1	8.3
38,511	35,010	25,674	15	24	4 to 6	6.0	8.1
38,795	35,268	25,863	17	27	4 to 6	6.0	8.1
40,185	36,531	26,790	15	23	4 to 6	5.7	7.8
40,287	36,625	26,858	17	26	4 to 6	5.7	7.8
41,812	38,011	27,874	19	28	4 to 6	5.5	7.5
41,900	38,091	27,933	17	25	4 to 6	5.5	7.5
43,359	39,417	28,906	19	27	4 to 6	5.3	7.3
43,645	39,677	29,097	17	24	4 to 6	5.3	7.2
45,027	40,934	30,018	19	26	4 to 6	5.1	7.0
45,542	41,402	30,362	17	23	4 to 6	5.0	6.9
46,828	42,571	31,219	19	25	4 to 6	4.9	6.7
48,644	44,222	32,429	15	19	4 to 6	4.7	6.4
48,779	44,345	32,520	19	24	4 to 6	4.7	6.4
50,614	46,013	33,743	23	28	4 to 6	4.6	6.2
50,900	46,273	33,933	19	23	4 to 6	4.5	6.1
52,489	47,717	34,992	23	27	4 to 6	4.4	6.0
52,814	48,013	35,210	24	28	4 to 6	4.3	5.9
54,367	49,425	36,245	15	17	4 to 6	4.3	5.8
54,770	49,791	36,513	24	27	4 to 6	4.2	5.7
55,131	50,119	36,754	17	19	4 to 6	4.2	5.7
56,687	51,534	37,791	23	25	4 to 6	4.0	5.5
57,215	52,013	38,143	26	28	4 to 6	4.0	5.5
59,050	53,681	39,366	23	24	4 to 6	3.9	5.3
59,152	53,774	39,435	24	25	4 to 6	3.9	5.3
59,416	54,015	39,611	27	28	4 to 6	3.9	5.3
61,617	56,015	41,078	23	23	4 to 6	3.7	5.1
63,898	58,089	42,599	28	27	4 to 6	3.6	5.0
63,986	58,169	42,657	27	26	4 to 6	3.6	4.9
64,295	58,450	42,863	24	23	4 to 6	3.6	4.9
66,356	60,323	44,237	28	26	4 to 6	3.5	4.7
66,546	60,497	44,364	27	25	4 to 6	3.5	4.7
66,974	60,886	44,650	25	23	4 to 6	3.4	4.6
68,866	62,605	45,911	19	17	4 to 6	3.3	4.5
69,318	63,017	46,212	27	24	4 to 6	3.3	4.5
69,654	63,322	46,436	26	23	4 to 6	3.3	4.5
71,885	65,350	47,924	28	24	4 to 6	3.2	4.3
72,332	65,756	48,221	27	23	4 to 6	3.2	4.3
74,588	67,807	49,725	23	19	4 to 6	3.1	4.2
75,012	68,192	50,008	28	23	4 to 6	3.1	4.2
77,832	70,756	51,888	24	19	4 to 6	2.9	4.0
81,075	73,704	54,050	25	19	4 to 6	2.9	3.9
83,363	75,785	55,575	23	17	4 to 6	2.8	3.8
84,317	76,652	56,212	26	19	4 to 6	2.7	3.7
86,988	79,080	57,992	24	17	4 to 6	2.6	3.6
87,560	79,600	58,373	27	19	4 to 6	2.6	3.6
90,612	82,375	60,408	25	17	4 to 6	2.6	3.5
90,803	82,548	60,535	28	19	4 to 6	2.6	3.5
94,236	85,669	62,824	26	17	4 to 6	2.5	3.4
94,478	85,889	62,985	23	15	4 to 6	2.4	3.3
97,862	88,965	65,241	27	17	4 to 6	2.3	3.2

NOTE: See "General Planting Rate Information" and "Check Seed Population" pages for more information. Always field check seed population to verify planting rates.

**LIQUID FERTILIZER PISTON PUMP APPLICATION RATES
GALLONS PER ACRE**

**Model NGP-6055 Pumps With 18 Tooth Contact Wheel Drive Sprocket
(Planter equipped with two piston pumps.)**

Pump Setting	2	3	4	5	6	7	8	9	10
24 Row 30"	9.2	13.6	18.2	22.8	27.4	32.0	36.6	41.2	45.6

**Model NGP-7055 Pumps With 18 Tooth Sprocket and Ground Drive
(Planter equipped with two piston pumps.)**

Pump Setting	2	3	4	5	6	7	8	9	10
24 Row 30"	7.4	11.1	14.8	18.5	22.1	25.8	29.5	33.2	36.9

Charts are for planters equipped with contact drive. Check tires for correct operating pressure.

Charts calculated based on a solution weighing ten pounds per gallon.

NOTE: Fertilizer application rates can vary from weights calculated in above chart. Make field checks to be sure you are applying fertilizer at desired rate.

To check the exact number of gallons your fertilizer attachment will actually deliver on a 30" row spacing:

1. Remove hose from one fertilizer opener and insert it into a collection container secured planter frame.
2. Engage fertilizer attachment and drive forward for 174'.
3. Measure fluid ounces caught in container and multiply by 100. Divide that amount by 128. Result is gallons fertilizer delivered per acre when planting in 30" rows. To convert this delivery rate for other row widths, multiply by the following conversion factors:

20" x 1.50 22" x 1.36 38" x 0.79

4. Rinse collection container and repeat test on other rows if necessary.

HIGH-RATE LIQUID FERTILIZER PISTON PUMP APPLICATION RATES GALLONS PER ACRE**Model NGP-6055 Piston Pump (Using Flow Dividers)
With 18 Tooth Sprocket (Planter Equipped With Two Piston Pumps)**

Below charts for planters equipped with 37" drive wheel and 15" contact wheel, based on 47.125" forward travel per contact wheel revolution, 48 tooth drive sprocket, and 18 tooth driven sprocket on metering pump. Chart is based on average wheel slippage and liquid viscosities.

Chart calculated based on a solution weighing ten pounds per gallon.

NOTE: Fertilizer application rates can vary from weights calculated in chart. Make field checks to be sure you are applying fertilizer at desired rate.

NOTE: Periodically check flow rates to all rows. Set flow rate is still delivered to remaining rows even if lines are plugged.

24 Row 20"	
Pump Setting	Gal./Acre
10	31.0
9.75	30.3
9.5	29.5
9.25	28.7
9	27.9
8.75	27.1
8.5	26.4
8.25	25.6
8	24.8
7.75	24.0
7.5	23.3
7.25	22.5
7	21.7
6.75	20.9
6.5	20.2
6.25	19.4
6	18.6
5.75	17.8
5.5	17.1
5.25	16.3
5	15.5
4.75	14.7
4.5	14.0
4.25	13.2
4	12.4
3.75	11.6
3.5	10.9
3.25	10.1
3	9.3
2.75	8.5
2.5	7.7
2.25	7.0
2	6.2

24 Row 22"	
Pump Setting	Gal./Acre
10	28.2
9.75	27.5
9.5	26.8
9.25	26.1
9	25.4
8.75	24.7
8.5	24.0
8.25	23.3
8	22.6
7.75	21.9
7.5	21.2
7.25	20.4
7	19.7
6.75	19.0
6.5	18.3
6.25	17.6
6	16.9
5.75	16.2
5.5	15.5
5.25	14.8
5	14.1
4.75	13.4
4.5	12.7
4.25	12.0
4	11.3
3.75	10.6
3.5	9.9
3.25	9.2
3	8.5
2.75	7.8
2.5	7.0
2.25	6.3
2	5.6

To check exact number of gallons your fertilizer attachment will actually deliver on a 20" or 22" row spacing:

1. Remove hose from one fertilizer opener and insert it into a collection container secured planter frame.
2. Engage fertilizer attachment and drive forward for 170'.
3. Measure fluid ounces caught in container and multiply by 24. Divide that amount by the row spacing in inches. Result is gallons of fertilizer delivered per acre.
4. Rinse collection container and repeat test on other rows if necessary.

**LOW-RATE (POP-UP) LIQUID FERTILIZER PISTON PUMP
APPLICATION RATES GALLONS PER ACRE**

**Model NGP-6055 Piston Pump (Using Orifices)
With 18 Tooth Sprocket (Planter Equipped With One Piston Pump)**

Below charts for planters equipped with 37" drive wheel and 15" contact wheel, based on 47.125" forward travel per contact wheel revolution, 23 tooth drive sprocket, and 18 tooth driven sprocket on metering pump. Chart is based on average wheel slippage and liquid viscosities.

Chart calculated based on a solution weighing ten pounds per gallon.

NOTE: Fertilizer application rates can vary from weights calculated in chart. Make field checks to be sure you are applying fertilizer at desired rate.

NOTE: Periodically check flow rates to all rows. Set flow rate is still delivered to remaining rows even if lines are plugged.

24 Row 20"	
Pump Setting	Gal./Acre
6.5	10.1
6.3	9.7
6.0	9.3
5.8	8.9
5.5	8.5
5.3	8.1
5	7.8
4.75	7.4
4.5	7.0
4.25	6.6
4	6.2
3.75	5.8
3.5	5.4
3.25	5.0
3	4.7
2.75	4.3
2.5	3.9
2.25	3.5
2	3.1

24 Row 22"	
Pump Setting	Gal./Acre
6.5	9.2
6.25	8.8
6	8.5
5.75	8.1
5.5	7.8
5.25	7.4
5	7.0
4.75	6.7
4.5	6.3
4.25	6.0
4	5.6
3.75	5.3
3.5	4.9
3.25	4.6
3	4.2
2.75	3.9
2.5	3.5
2.25	3.2
2	2.8

Orifice Sizing Chart		
Speed	Orifice Size	P/N
2-4 mph	0.02	GA17118
4-8mph	0.025	GA17119

To check exact number of gallons your fertilizer attachment will actually deliver on a 20" or 22" row spacing:

1. Remove hose from one fertilizer opener and insert it into a collection container secured planter frame.
2. Engage fertilizer attachment and drive forward for 170'.
3. Measure fluid ounces caught in container and multiply by 24. Divide that amount by the row spacing in inches. Result is gallons of fertilizer delivered per acre.
4. Rinse collection container and repeat test on other rows if necessary.

DRY INSECTICIDE APPLICATION RATES
APPROXIMATE POUNDS/ACRE AT 5 MPH (8 KPH)

Meter Setting	20" Rows	22" Rows	30" Rows
CLAY GRANULES			
10	7.4	6.7	4.9
11	8.1	7.3	5.4
12	9.2	8.3	6.1
13	10.4	9.4	6.9
14	11.6	10.5	7.7
15	12.8	11.6	8.5
16	14.4	13.1	9.6
17	16.1	14.6	10.7
18	17.1	15.5	11.4
19	19.7	17.8	13.1
20	21.3	19.3	14.2
21	23.3	21.1	15.5
22	24.6	22.3	16.4
23	25.8	23.4	17.2
24	28.2	25.6	18.8
25	31.4	28.4	20.9
26	34.5	31.3	23.0
27	36.2	32.8	24.1
28	38.1	34.5	25.4
29	41.7	37.8	27.8
30	44.4	40.3	29.6
SAND GRANULES			
5	4.4	3.9	2.9
6	7.4	6.7	4.9
7	8.0	7.2	5.3
8	9.5	8.6	6.3
9	11.7	10.6	7.8
10	13.4	12.1	8.9
11	15.3	13.9	10.2
12	16.8	15.2	11.2
13	18.9	17.1	12.6
14	21.2	19.2	14.1
15	23.3	21.1	15.5
16	26.3	23.8	17.5
17	29.1	26.4	19.4
18	32.7	29.7	21.8
19	36.5	33.1	24.3
20	38.6	35.0	25.7
21	41.4	37.5	27.6
22	44.4	40.3	29.6
23	48.0	43.5	32.0
24	51.6	46.8	34.4
25	55.4	50.2	36.9

NOTE: Chart represents average values and should be used only as a starting point. Granular chemical flows through meter opening at a nearly uniform rate regardless of roller speed. Your actual rate will vary depending on insecticide, planting speed, and plant population. Planting speed/ground speed has the greatest effect on application rate.

Field check your actual rate with insecticide you are using at speed and population you will be planting. See "Checking Granular Chemical Application Rate" in Machine Operation section for more information..

DRY HERBICIDE APPLICATION RATES
APPROXIMATE POUNDS/ACRE AT 5 MPH (8 KPH)

CLAY GRANULES

Meter Setting	20" Rows	22" Rows	30" Rows
10	7.1	6.4	4.7
11	7.8	7.1	5.2
12	8.7	7.9	5.8
13	9.8	8.8	6.5
14	11.0	9.9	7.3
15	12.3	11.2	8.2
16	13.5	12.2	9.0
17	14.9	13.5	9.9
18	16.1	14.6	10.7
19	17.4	15.8	11.6
20	18.9	17.1	12.6
21	20.4	18.5	13.6
22	21.9	19.9	14.6
23	23.6	21.4	15.7
24	25.5	23.1	17.0
25	27.2	24.6	18.1
26	29.1	26.4	19.4
27	31.4	28.4	20.9
28	33.9	30.7	22.6
29	36.5	33.1	24.3
30	40.1	36.3	26.7

NOTE: Chart represents average values and should be used only as a starting point. Granular chemical flows through given meter opening at a nearly uniform rate regardless of roller speed. Your actual rate will vary depending on specific herbicide, planting speed, and plant population. Planting speed/ground speed has the greatest effect on application rate.

Field check your actual rate with herbicide you are using at speed and population you will be planting. See "Checking Granular Chemical Application Rate" in Machine Operation section for more information.

LUBRICATION

Following pages show locations of all lubrication points. Proper lubrication of moving parts helps ensure efficient operation of your Kinze planter and prolongs the life of friction producing parts.

LUBRICATION SYMBOLS

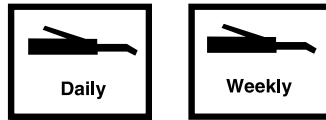

Lubricate at frequency indicated with SAE multipurpose grease.



Lubricate at frequency indicated with high quality SAE 10 weight oil or spray lubricant.

SEALED BEARINGS

Sealed bearings are used on your Kinze planter to provide trouble free operation.

These are located on drive shafts, row units, and transmission bearings. Sealed bearings are lubricated for life and are not serviceable.

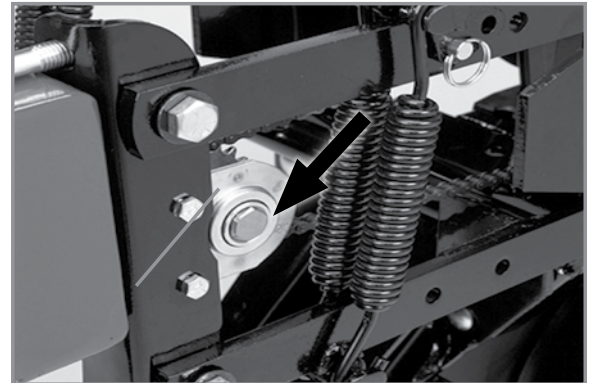

Sealed bearing (Typical)

AIR CLUTCH LUBRICATION

Lubricate air clutches every 75-100 hours.

Remove Phillips head screw and spray a 1-2 second burst of silicone spray into each clutch. Reinstall screw.

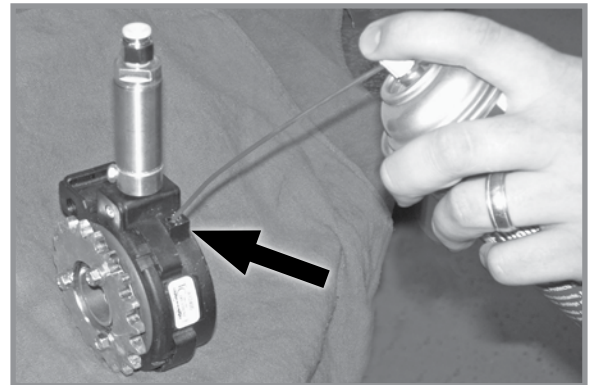

Air clutch lubrication

WHEEL BEARINGS

All drive, transport, and marker hub wheel bearings should be repacked annually and checked for wear.

1. Raise wheel off ground.
2. Check for bearing endplay by moving wheel side to side.
3. Rotate wheel to check for bearing roughness. If bearings sound rough, remove hub and inspect bearings.

NOTE: To repack wheel hubs, follow procedure outlined for wheel bearing replacement in this section except bearings and bearing cups are reused.

DRIVE CHAINS

Lubricate all transmission and drive chains daily with a high quality chain lubricant. Extreme operating conditions such as dirt, temperature, or speed may require more frequent lubrication.

If a chain becomes stiff, it should be removed, soaked, and washed in solvent to loosen and remove dirt from joints. Soak chain in oil so lubricant can penetrate between rollers and bushings.

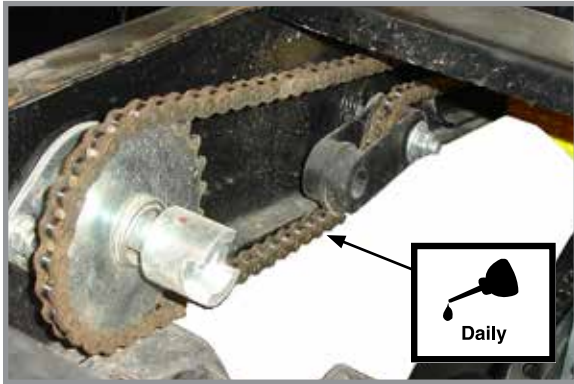

Row unit granular chemical drive chains

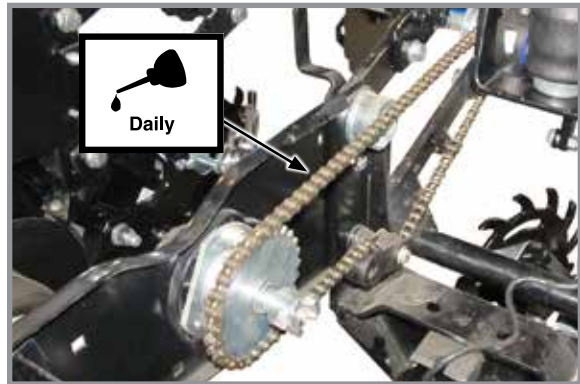

Row unit drive chains

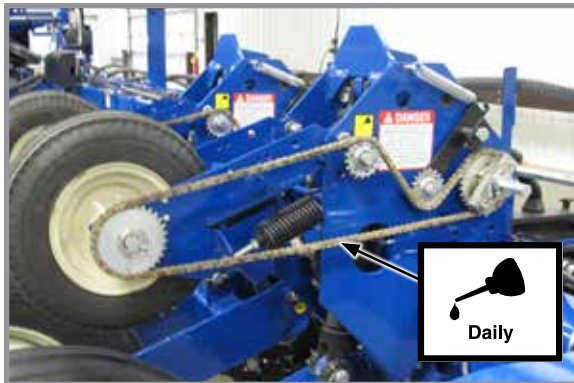

Contact wheel drive chains

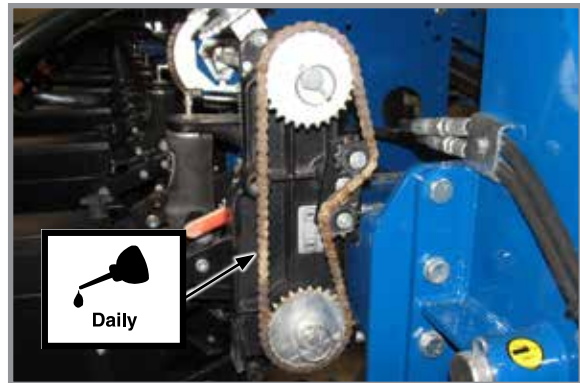

Transmission chains

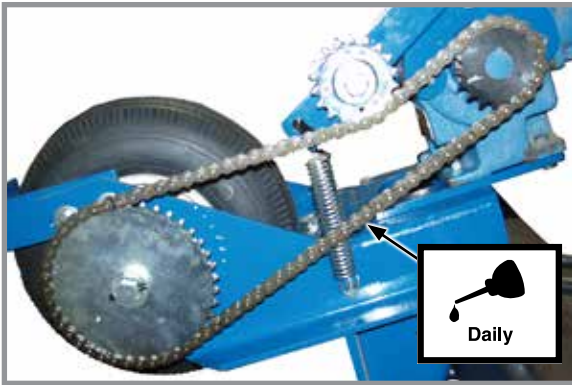

Optional piston pump drive chain

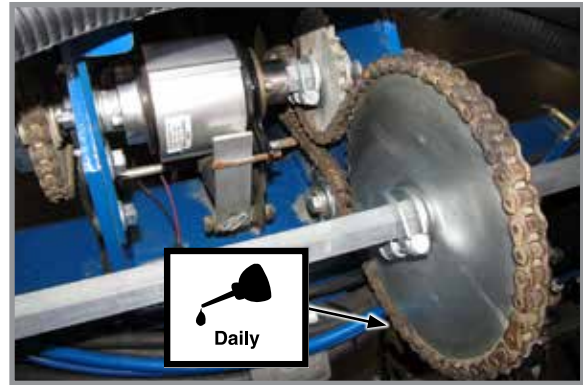

Inner module (point row clutch) drive chains

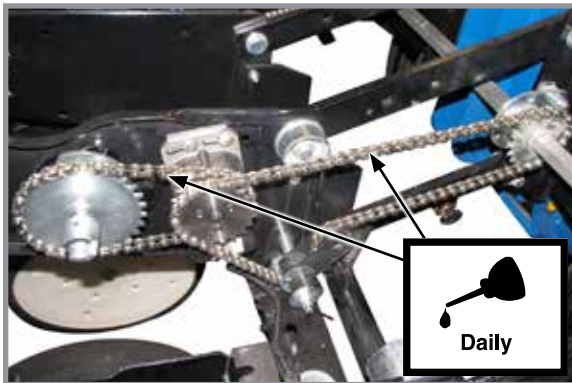

Row Unit Electric Clutches

BUSHINGS

Lubricate bushings at frequency indicated.

Check each bolt for proper torque. If bolt is loose, removed it and inspect bushing for cracks and wear. Replace bushing if necessary. Use **only hardened flat washers**. Replace damaged flat washers with proper part. Torque hardware to 130 ft-lb (176.2 N-m).

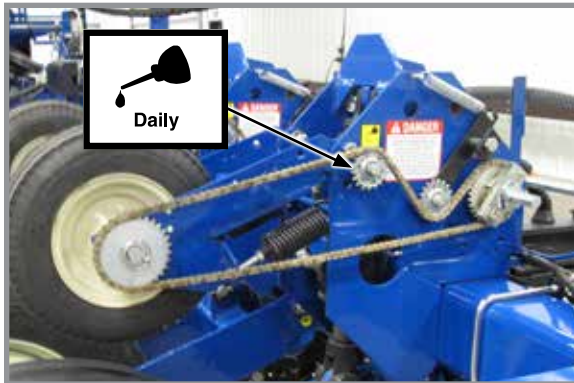

Contact wheel arm (2 per assembly)

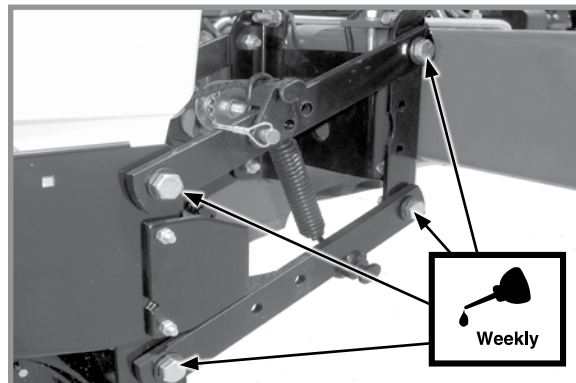

Row unit parallel linkages (8 per row)

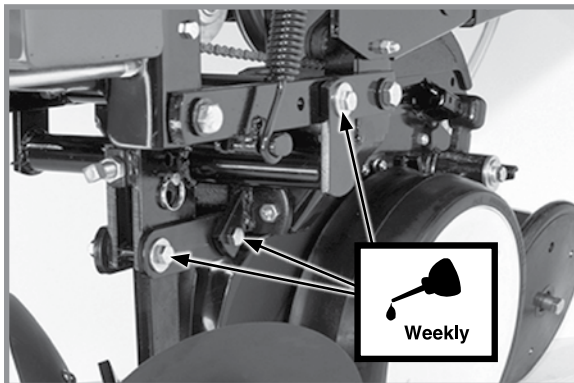

Row unit mounted disc furrower parallel linkages (6 per row)

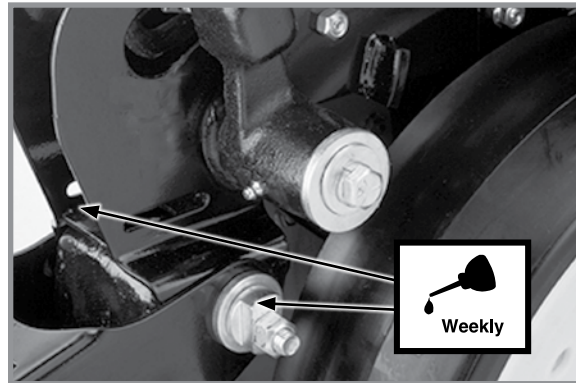

Row unit "v" closing wheel, covering discs/ single press wheel and/or drag closing wheel eccentric bushings (2 per row)

SLIDING HITCH LINKAGE

Inspect linkage daily to ensure free movement of axle links in slides.

Keep axle link slides clean. DO NOT GREASE the axle link slides. Powdered graphite may be used if lubrication is desired.

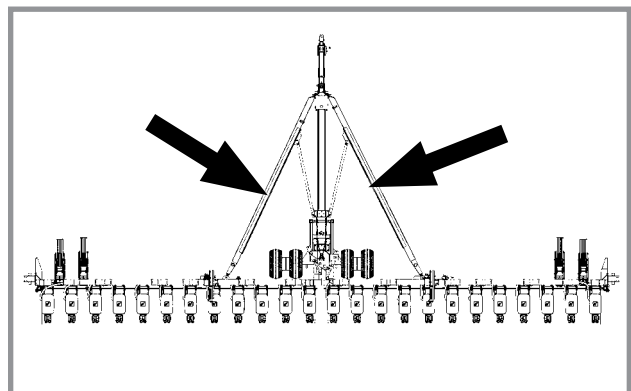

PTO SHAFT COUPLING

Clean and grease PTO shaft coupling each time pump is installed.

Apply coating of high-speed industrial coupling grease, such as Chevron® Coupling Grease meeting AGMA CG-1 and CG-2 Standards to extend shaft spline life.



PTO pump installed

WRAP SPRING WRENCH ASSEMBLY

Wrap spring wrench components may require occasional lubrication to operate correctly using a high quality spray lubricant.

Operate wrap spring wrench when lubricating so lubricant can be absorbed into wrap spring area.

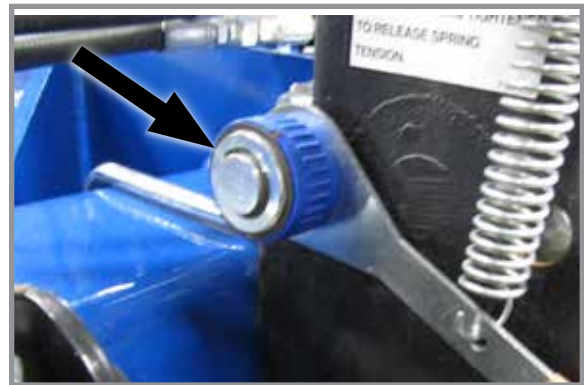

Wrap spring wrench lubrication

LIQUID FERTILIZER PISTON PUMP CRANKCASE OIL LEVEL

Check crankcase oil daily and maintain at oil level check plug. Fill as needed with EP 90 weight gear oil. Total oil capacity is approximately ¾ pint.

Refer to operator and instruction manual supplied with pump and flow divider for more information.

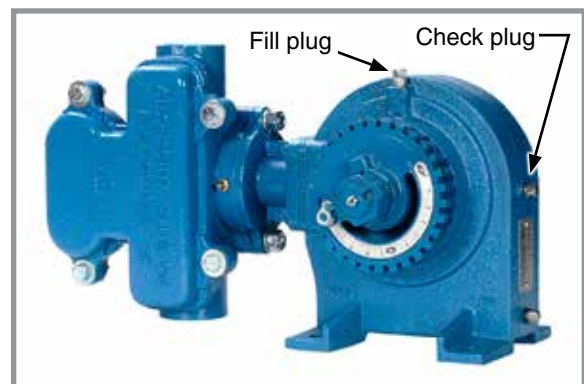

Piston pump oil fill and check plug locations

GREASE FITTINGS

! WARNING

Uncontrolled machine movement can crush or cause loss of control resulting in death, serious injury, or damage to property and equipment. Install all safety lockup devices before working under or transporting this equipment.

Parts equipped with grease fittings should be lubricated at frequency indicated with an SAE multipurpose grease. Clean fitting thoroughly before using grease gun. Frequency of lubrication recommended is based on normal operating conditions. Severe or unusual conditions may require more frequent attention.

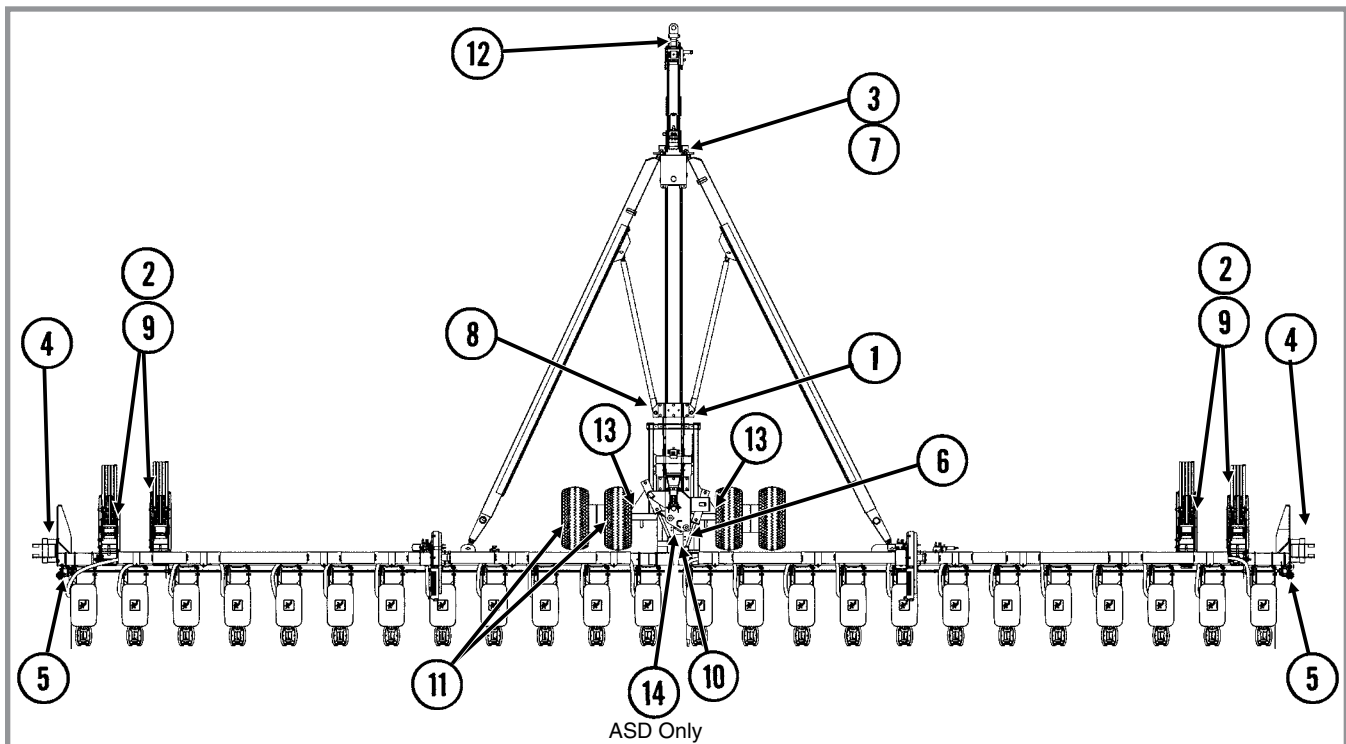

NOTE: Numbers on illustration above correspond to photos on following pages showing lubrication frequencies.

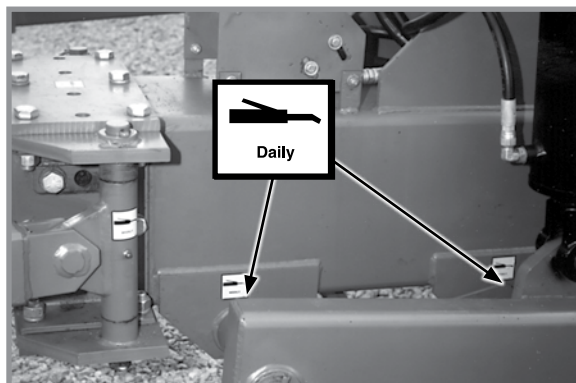

1. Axle and automatic safety lock pivots (7)

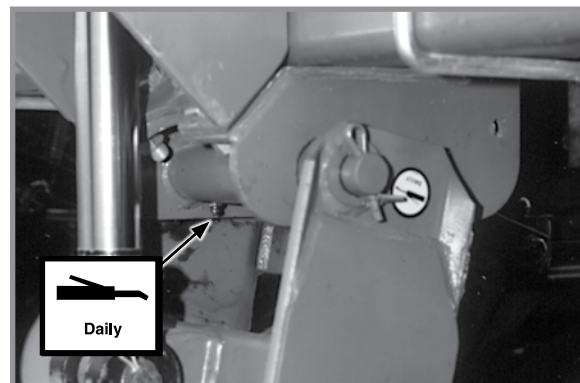

2. Ground drive wheel pivot (2 per wheel module)

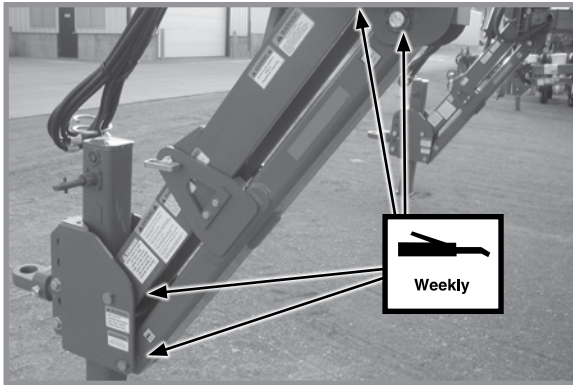

3. Upper and lower hitch linkage (2 per link)

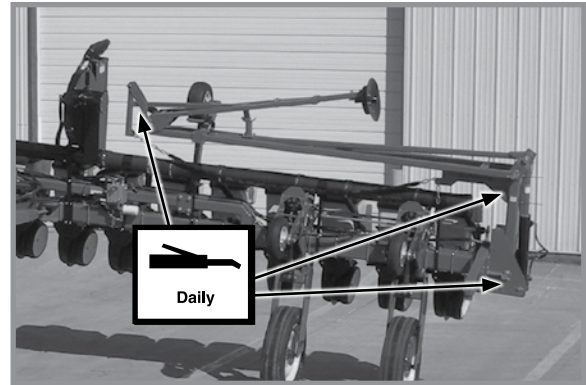

4. Row Marker Assemblies (11 per side)
(General locations shown)

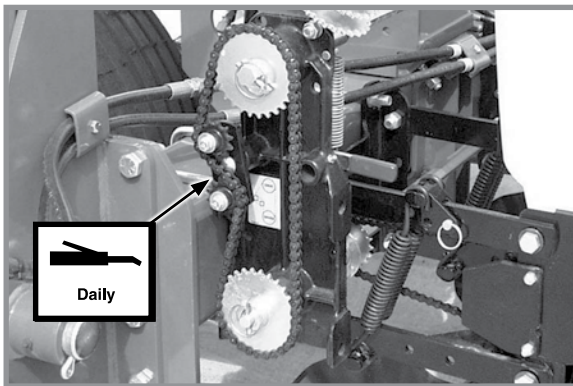

5. Seed rate transmission assembly idler pivot
(1 per assembly)

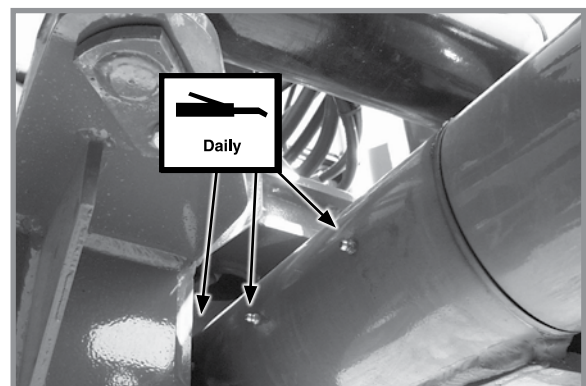

6. Wing pivot knuckle
(3 per knuckle on horizontal shaft)

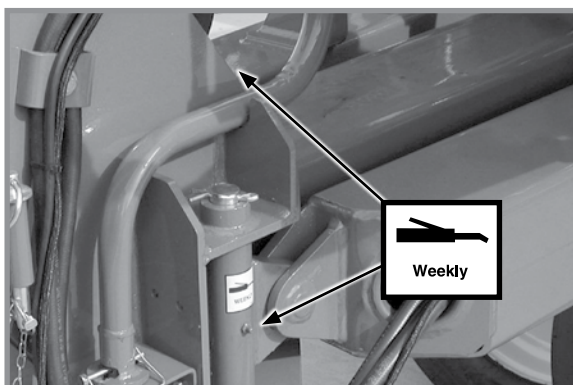

7. Link assemblies (1 per assembly)
Front wear pads (4)

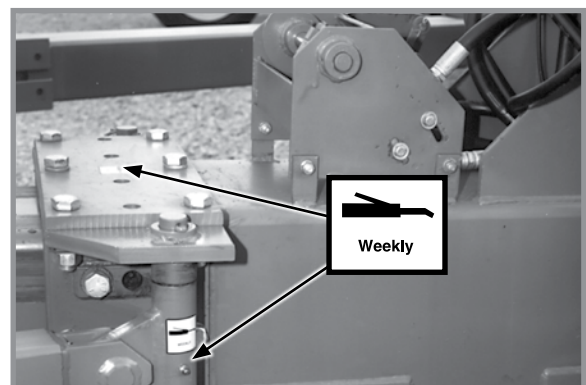

8. Axle link assemblies (1 per assembly)
Rear wear pads (2 sets - 16)

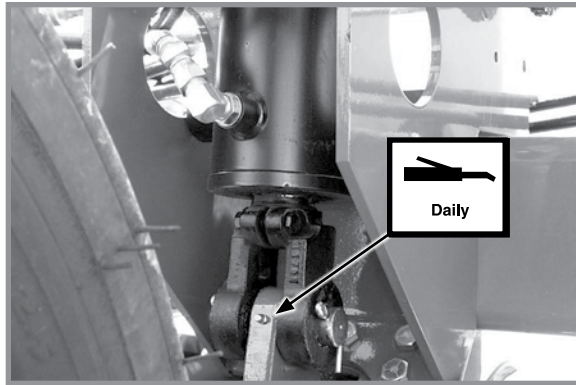

9. Wheel module lift cylinder mount (1 per wheel module)

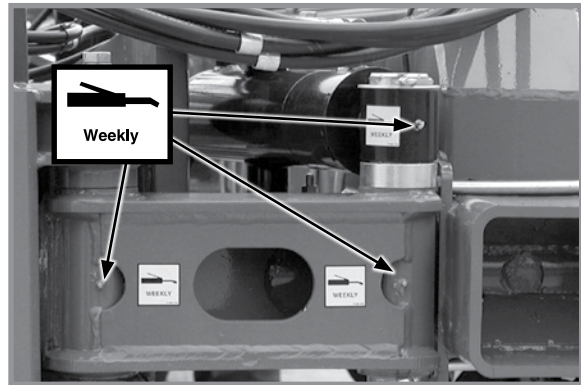

10. Wing pivot knuckle - 1 per knuckle on shaft
Helper cylinders (1 per cylinder)

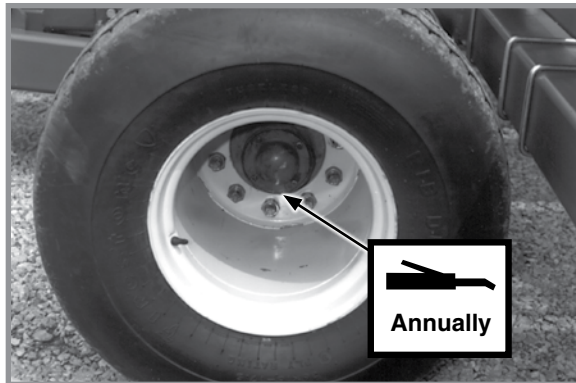

11. Transport wheel bearing (1 per wheel hub)

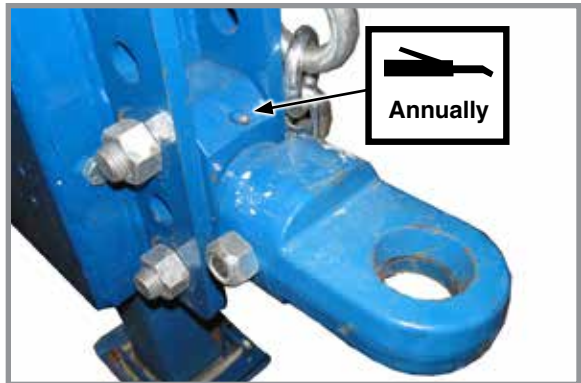

12. Swivel block (1)

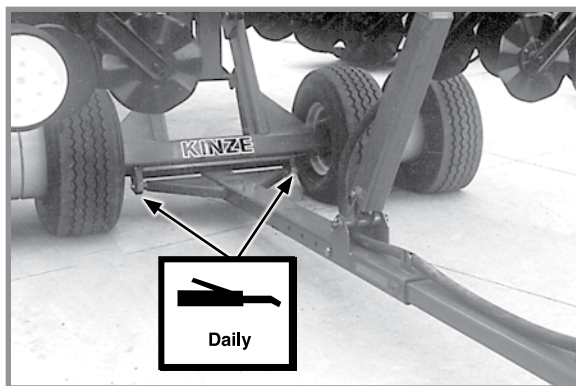

13. Rear trailer hitch pivot (2)

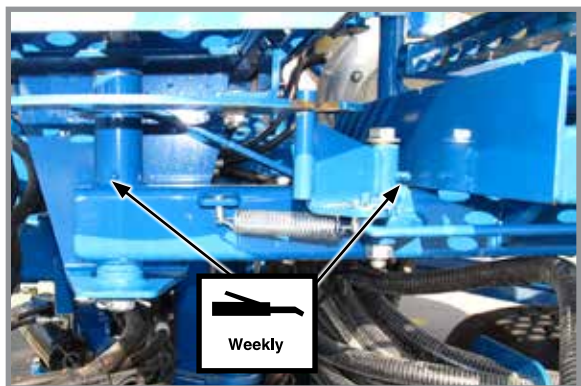

14. 36 Row ASD catwalk extension pivots (2)

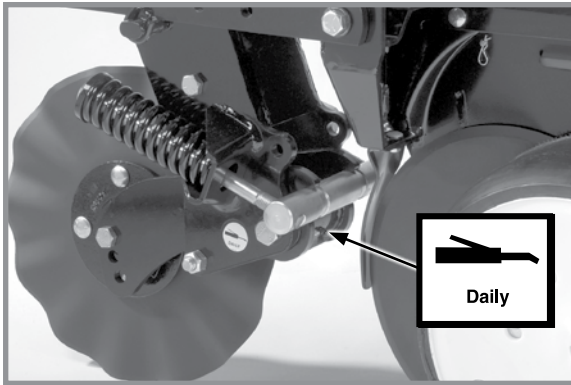

Frame Mounted Coulter (1 per arm)



Notched single disc opener (1 per arm)

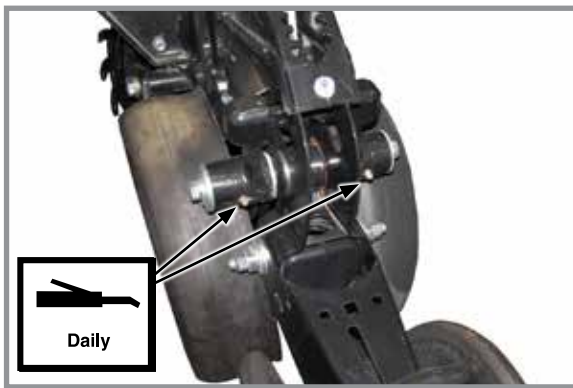

Gauge wheel arms (2)

Seals in gauge wheel arm are installed with lip facing out to allow grease to purge dirt away from seal. Pump grease into arm until fresh grease appears between washers and arm.

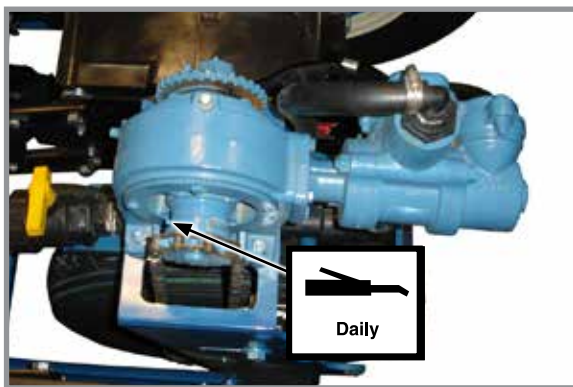

Piston pump L.H. side (1)

Fill until grease seeps out of bottom drain hole.

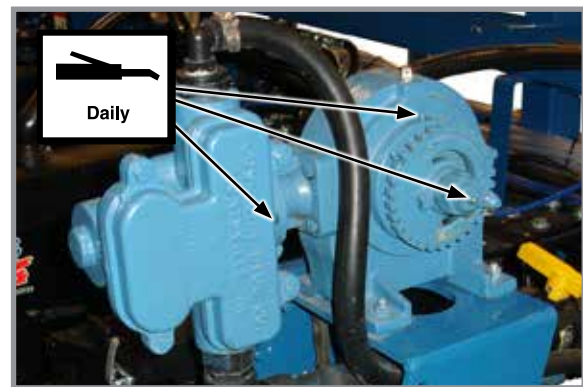

Piston pump R.H. side (3)

MOUNTING BOLTS AND HARDWARE

Before operating planter for the first time, check all hardware is tight. Check all hardware again after first 50 hours of operation and beginning of each planting season.

All hardware used on the Kinze planter is Grade 5 (high strength) unless otherwise noted. Grade 5 cap screws are marked with three radial lines on the head. Hardware must be replaced with equal size, strength, and thread type.

⚠ WARNING

Loose transport wheel lug nuts can result in wheel separation from planter and can result in death, serious injury, and damage to property and equipment. Check transport wheel lug nut torque before operating planter for the first time and periodically thereafter.

NOTICE

Over-tightening hardware can reduce its shock load capacity and cause equipment failure.



GRADE 2
No Marks



GRADE 5
3 Marks



GRADE 8
6 Marks

TORQUE VALUES CHART - PLATED HARDWARE

Diameter	Grade 2		Grade 5		Grade 8	
	Coarse	Fine	Coarse	Fine	Coarse	Fine
1/4"	50 in-lb	56 in-lb	76 in-lb	87 in-lb	9 ft-lb	10 ft-lb
5/16"	8 ft-lb	9 ft-lb	13 ft-lb	14 ft-lb	18 ft-lb	20 ft-lb
3/8"	15 ft-lb	17 ft-lb	23 ft-lb	26 ft-lb	33 ft-lb	37 ft-lb
7/16"	25 ft-lb	27 ft-lb	37 ft-lb	41 ft-lb	52 ft-lb	58 ft-lb
1/2"	35 ft-lb	40 ft-lb	57 ft-lb	64 ft-lb	80 ft-lb	90 ft-lb
9/16"	50 ft-lb	60 ft-lb	80 ft-lb	90 ft-lb	115 ft-lb	130 ft-lb
5/8"	70 ft-lb	80 ft-lb	110 ft-lb	125 ft-lb	160 ft-lb	180 ft-lb
3/4"	130 ft-lb	145 ft-lb	200 ft-lb	220 ft-lb	280 ft-lb	315 ft-lb
7/8"	125 ft-lb	140 ft-lb	320 ft-lb	350 ft-lb	450 ft-lb	500 ft-lb
1"	190 ft-lb	205 ft-lb	480 ft-lb	530 ft-lb	675 ft-lb	750 ft-lb
1 1/8"	265 ft-lb	300 ft-lb	600 ft-lb	670 ft-lb	960 ft-lb	1075 ft-lb
1 1/4"	375 ft-lb	415 ft-lb	840 ft-lb	930 ft-lb	1360 ft-lb	1500 ft-lb
1 3/8"	490 ft-lb	560 ft-lb	1100 ft-lb	1250 ft-lb	1780 ft-lb	2030 ft-lb
1 1/2"	650 ft-lb	730 ft-lb	1450 ft-lb	1650 ft-lb	2307 ft-lb	2670 ft-lb

NOTE: Torque unplated hardware and bolts with lock nuts approximately 1/3 higher than above values. Torque bolts lubricated prior to installation to 70% of value shown in chart.

TORQUE VALUES- Pneumatic Down Pressure

Diameter	Torque Value
1/8" NPT	120 in-lb Maximum
1/2"-13	180 in-lb Maximum
3/4"-16	180 in-lb Maximum

NOTE: Use these torque values with pneumatic down pressure components.

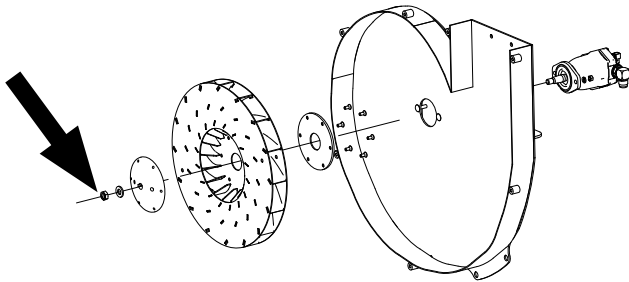

NOTE: Torque EdgeVac fan impeller assembly to motor shaft 5/8"-18 hex jam nut 50 ft-lb (67.8 N-m).

Cylinder Rod Piston Retaining Nut Torque Chart

	Non-Nylock Nut	Nylock Nut
1/2"-20	55-70 ft-lb (75-95 N-m)	45-55 ft-lb (61-75 N-m)
3/4"-16	115-125 ft-lb (156-169 N-m)	100-115 ft-lb (136-156 N-m)
7/8"-14	150-180 ft-lb (203-244 N-m)	130-150 ft-lb (176-203 N-m)
1"-14	275-330 ft-lb (373-447 N-m)	250-275 ft-lb (339-373 ft-lb)
1 1/8"-12	300-375 ft-lb (407-508 N-m)	275-300 ft-lb (373-407 N-m)
1 1/4"-12	300-375 ft-lb (407-508 N-m)	275-300 ft-lb (373-407 N-m)

SPECIAL TORQUE VALUES & INSTRUCTIONS

Row unit parallel linkage bushing hardware	130 ft-lb (176 Nm)
5/8" No till coultter spindle hardware	120 ft-lb (162 Nm)
Transport Tire Inner Budd Nuts**	315 ft-lb (427 Nm)
Transport Tire Outer Budd Nuts**	1075 ft-lb (1458 Nm)

****NOTE: Loosen outer budd nut first, then loosen inner budd nut.**

TIRE PRESSURE

! WARNING

Explosive separation of rim and tire can cause death or serious injury. Overinflation, rim and tire servicing, improper use of rims and tires, worn, or improperly maintained tires could result in a tire explosion.

- Maintain proper tire pressure. Inflating a tire above or below the recommended pressure can cause tire damage.
- Mount tires only by properly trained personnel using proper equipment.
- Replace tires with cuts or bubbles. Replace damaged rims. Replace missing lug bolts and nuts.
- Do not weld or heat wheel assembly. Heating increases tire pressure.

TRANSPORT TIRES

! WARNING

Over-inflation of tires can result in explosive separation of rim and tire and cause death or serious injury. Different size rims are designed for different tire pressures. Inflate to correct pressure for specific rim size.

Do not exceed following maximum pressures:

- Rims stamped with “224”: 75 psi (517.1 kPa) maximum pressure.
- Rims stamped with “276”: 100 psi (689.4 kPa) maximum pressure.

INFLATION SPECIFICATIONS

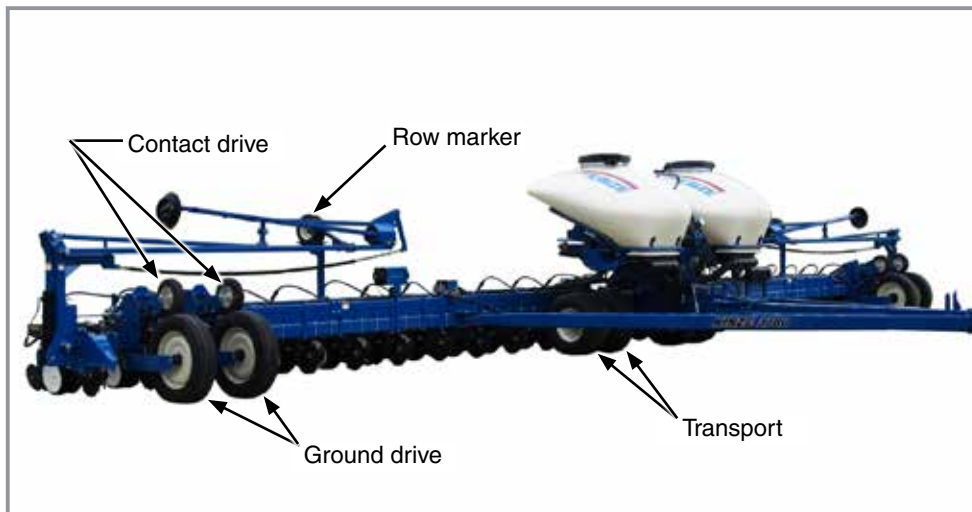

Tire locations (L.H. mirrors R.H. shown)

Ground drive (wings) 255-70R 22.5	75 psi (517.1 kPa)
Transport - 36" x 16" x 17.5"	75 psi (517.1 kPa)
Contact drive - 4.80" x 8"	50 psi (344.7 kPa)
Row marker - 16" x 6.5" x 8"	14 psi (96.5 kPa)
Liquid fertilizer piston pump (Not shown) 4.10" x 6"	50 psi (344.7 kPa)

FINGER PICKUP SEED METER INSPECTION/ADJUSTMENT

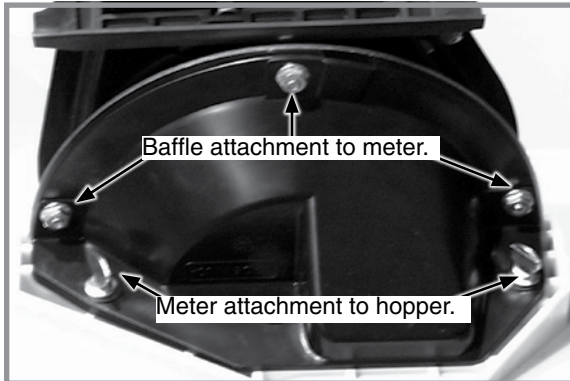

Removing meter and baffle

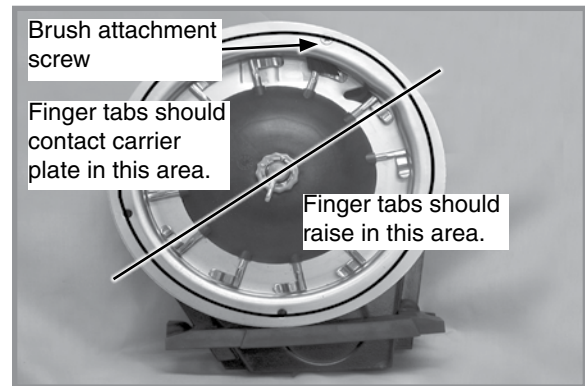

Proper finger operation

1. Remove two thumbscrews and meter from seed hopper and remove three cap screws and baffle from meter assembly.
2. Rotate seed meter drive by hand to ensure springs are holding tabs of fingers against carrier plate and fingers raise in correct area as shown in above photo.

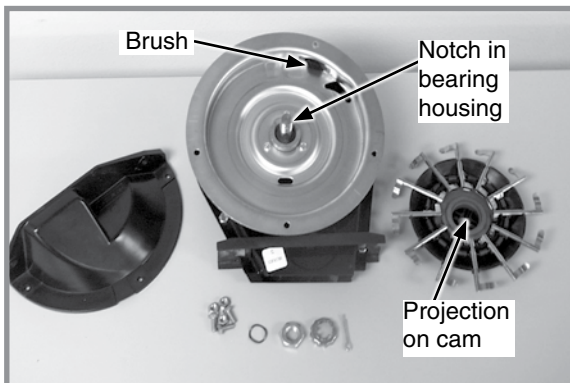

Finger pickup meter parts

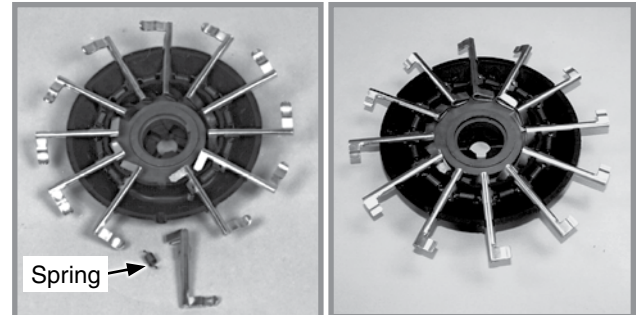

Corn Finger Assembly
(Position Spring Opening
Toward Holder)

**Oil Sunflower Finger
Assembly**

Buildup of debris or chaff may prevent proper finger operation and requires disassembly and cleaning of finger pickup meter.

1. Remove cotter pin, cover nut and adjusting nut and wave washer (If applicable) from drive shaft.
2. Carefully lift finger holder with fingers and cam off shaft and clean.
3. Check brush for wear and replace if necessary or after every 100 acres per row of operation (Approximately 800 acres of corn or sunflowers on a 8 row machine or 1200 acres on an 12 row machine).

NOTE: It is not necessary to remove finger holder to replace brush.

4. Remove springs from fingers and remove finger from holder by lifting it out of friction fit slot. Life expectancy of these parts is about 600-900 acres per row of operation under average conditions.
5. Reassemble meter in reverse order after cleaning and replacing defective parts. Make sure open end of spring loop is toward inside of finger holder when replacing fingers.
6. Install fingers in holder so holder is flush with carrier plate when assembled. A cam projection aligns with a mating notch in bearing housing to ensure proper operation when assembled.
7. Check indentations on carrier plate for wear before installing finger holder on carrier plate. Excessive wear of carrier plate at indentations will cause over planting especially with small sizes of seed. Inspect carrier plate annually. Life expectancy should be 250-300 acres per row of operation under average conditions.
8. Install wave washer and adjusting nut with finger holder flush against carrier. Tighten adjusting nut to fully compress wave washer. Back off nut $\frac{1}{2}$ to 2 flats to obtain rolling torque of 22 to 25 inch pounds.
9. Turn finger holder by hand to make sure it is firmly against carrier plate, but can be rotated with moderate force.
10. Install cover nut and cotter pin. Reinstall baffle.

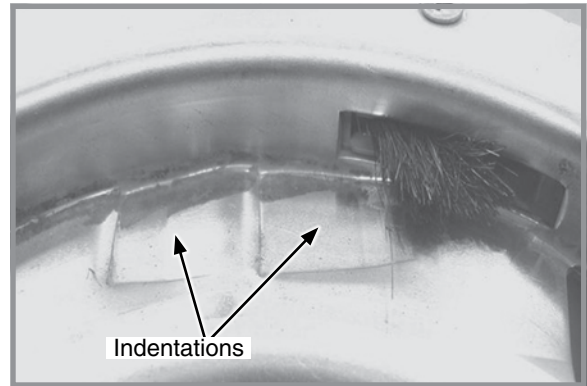

Worn carrier plate

NOTE: Check adjusting nut tightness on each unit after first day of use and periodically thereafter.

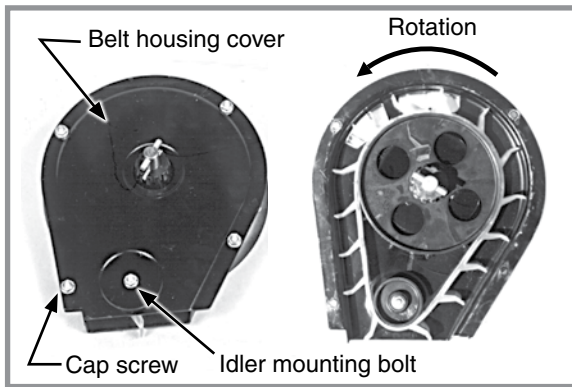
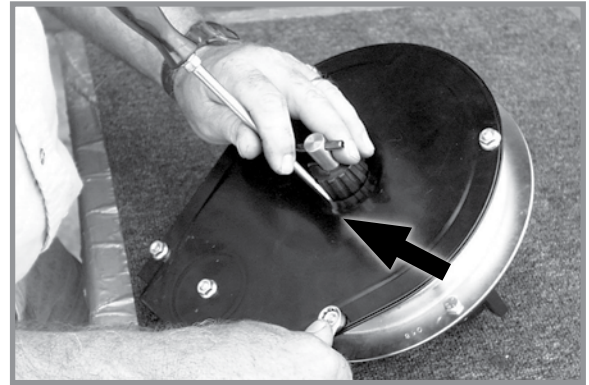
**Belt idler****Centering belt housing cover**

Remove four cap screws around edge of housing cover and nut from belt idler mounting bolt. Paddles must be correctly oriented as shown above if belt is replaced. A diagram molded into drive sprocket shows correct orientation.

NOTICE

Do not over-tighten hardware or components may be damaged.

Reinstall housing cover. **DO NOT TIGHTEN** hardware. Wedge a screwdriver between sprocket hub and housing cover as shown above. Pry cover down until centered on belt housing and tighten hardware. Rotate meter drive shaft and check idler alignment. Seed belt should "run" centered on idler or with only slight contact with belt housing or cover.

CLEANING FINGER PICKUP SEED METER FOR STORAGE

1. Disassemble meter and blow out any foreign material.
2. Wash **ONLY** in mild soap and water. Do not use gasoline, kerosene, or any other petroleum based product. Dry thoroughly.
3. Coat lightly with a rust inhibitor.
4. Rotate finger assembly so finger does not touch brush.
5. Reassemble and store in a dry, rodent-free location.

BRUSH-TYPE SEED METER MAINTENANCE

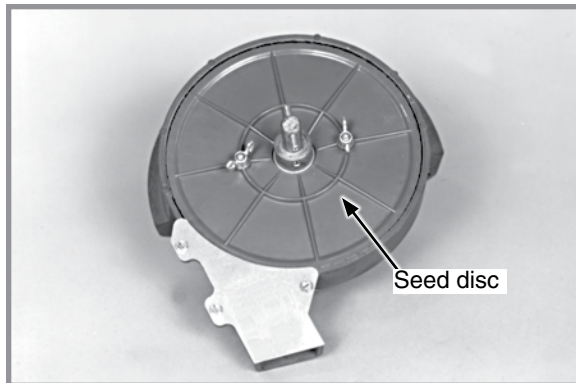

Brush-type seed meter seed disc installed

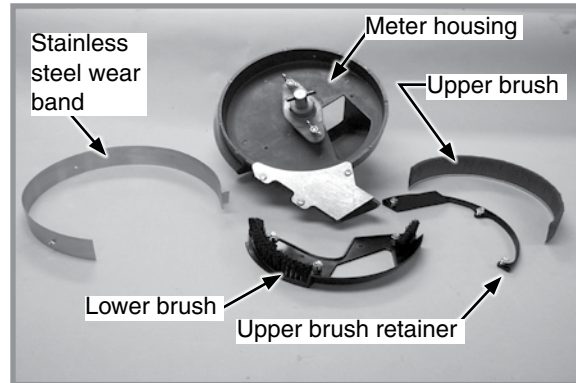

Brush-type seed meter parts

Use clean, high quality seed. Damaged or cracked seed, hulls, or foreign materials can become lodged in upper brush and greatly reduce meter accuracy. Remove seed disc daily and check for buildup of foreign material on seed disc, particularly in seed loading slots. Clean disc by washing it with soap and water. Check for cracked seed, hulls, etc. lodged between brush retainer and stainless steel wear band which can greatly reduce accuracy of the meter because upper brush will not be able to retain seed in seed disc pocket. Thoroughly clean brush areas of meter housing.

SEED DISC WEAR

Most seed disc wear is found in the agitation groove area (area between seed loading slots). Wear affects planting accuracy at high RPM. Lay a straight edge across disc surface at agitation groove area and measure gap between disc and straight edge. If agitation groove areas are worn in excess of .030" and accuracy starts to drop off at higher meter RPM, replace seed disc. Estimated seed disc life expectancy under normal operating conditions is approximately 200 acres per row. Severe operating conditions such as dust, lack of lubrication or abrasive seed coating could reduce seed disc life expectancy to under 100 acres per row.

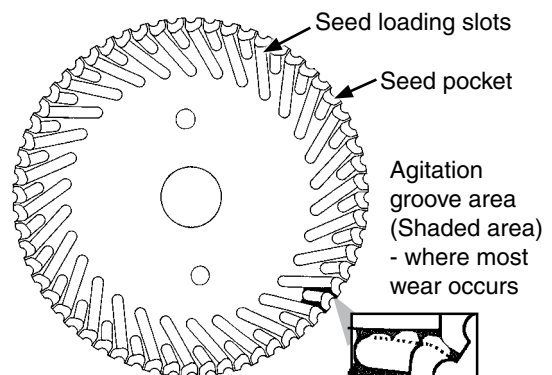

STAINLESS STEEL WEAR BAND

NOTICE

If wear band wears through or if meter is used without wear band in place, meter housing may be damaged.

Stainless steel wear band protects meter housing from wear and is .030" thick. Replace wear band when there is approximately .020" of wear in primary wear area. Estimated life expectancy of stainless steel wear band is 240-800 acres per row.

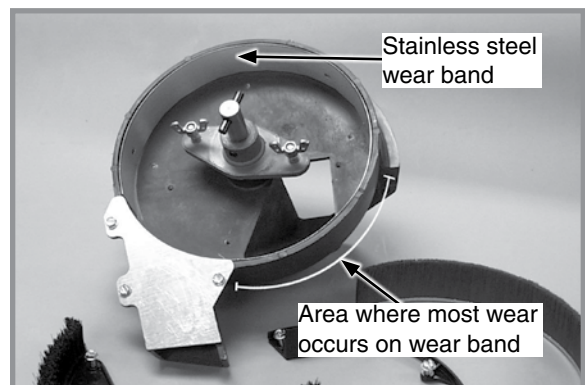

Stainless steel wear band

UPPER BRUSH

Upper brush holds seed in seed disc pocket in seed retention area. Brush must apply enough pressure against seed in seed disc pocket as disc rotates through seed retention area to prevent seed from dropping out of disc pocket. A damaged spot, excessive brush wear, or foreign material lodged in brush may greatly reduce meter performance.

Replace upper brush at 120-400 acres per row of use or sooner if damage or excessive wear is found. Position upper brush into inner perimeter of seed retention area. Make sure base of brush is tight against bottom of meter housing. Install brush retainer and three hex head screws. Tighten screws in sequence shown in photo at right.

NOTE: Use GD11122 upper brush retainer for soybean and cotton discs. Use GD8237 upper brush retainer for milo/grain sorghum discs.

LOWER BRUSH

Lower brush moves seed down seed loading slots to seed pockets, isolates seed in reservoir from entering seed tube, and cleans seed loading slots. Estimated lower brush life expectancy is 240-800 acres per row. Replace lower brush if bristles are deformed or missing, or if there are cracks in brush retainer.

CLEANING BRUSH-TYPE SEED METER FOR STORAGE

1. Remove meter from seed hopper by removing two thumbscrews securing meter to hopper.
2. Remove seed disc and wash with soap and water and dry thoroughly.
3. Remove three hex head screws from brush retainer. Remove brush retainer and upper brush.
4. Remove three hex head screws from lower brush. Remove lower brush and stainless steel wear band.
5. Wash all parts and meter housing with soap and water and dry thoroughly.
6. Inspect all parts and replace worn parts.
7. Reassemble meter except for seed disc. Store meter in a dry, rodent-free space with seed disc removed.

VACUUM MANIFOLD MAINTENANCE

Dust accumulates in manifolds and hoses during normal operation. Clean manifolds annually. Abnormally dusty planting conditions may require more frequent cleaning.

1. Remove vacuum hose from each seed meter.
2. Operate vacuum fan at full hydraulic flow from tractor for two minutes to clear manifolds, hoses, and fittings of dust and debris.
3. Shut down fan and replace hoses

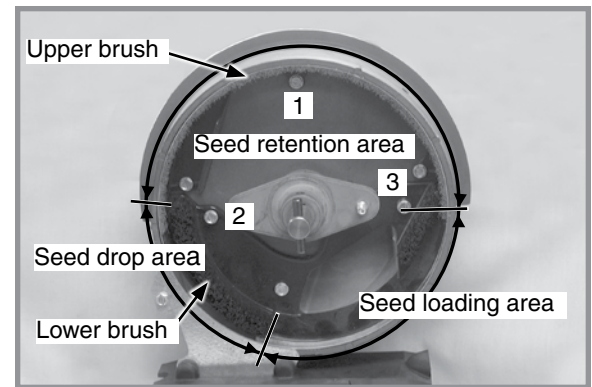

Upper brush installation

EDGEVAC SEED METER MAINTENANCE

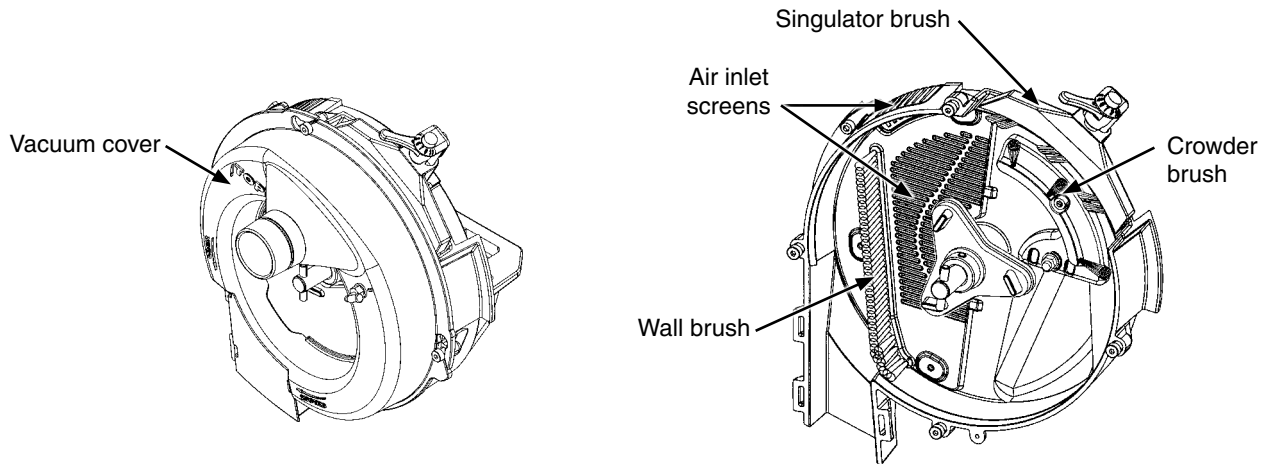

Before each planting season inspect seed discs, singulator brush, crowder brush, wall brush, and air inlet screens and clean or replace as needed.

Use clean, high quality seed for maximum meter accuracy. Damaged or cracked seed, hulls, and foreign material may become lodged in seed disc orifices and greatly reduce meter accuracy.

Inspect and clean seed discs daily checking for any buildup of foreign material and blocked orifices. If seed disc orifices are plugged frequently with seed remnants, cleanout brush or cleanout brush with ball-type ejector (if applicable) may need to be replaced. Clean seed disc by washing it with soap and water. Dry thoroughly.

Inspect singulator brush for wear after every 200 acres per row of operation. If adjustment of singulator brush does not affect meter performance or if brushes appear frayed, singulator brush may need to be replaced.

Replace seed disc or vacuum cover if abnormally high vacuum is required or if consistent operation can not be achieved.

See "Preparation For Storage" for additional EdgeVac Seed Metering System maintenance.

NOTE: Remove seed discs from meters for annual storage and store them vertically on a dowel or pipe.

EDGEVAC SEED METER CLEANOUT

Thorough seed meter cleanout is important to maintain genetic purity.

1. Disengage seed drive and remove seed hopper and meter. Lay hopper on its right side.
2. Rotate vacuum cover clockwise to align key hole slots with bolt heads. Lift off cover.
3. Remove seed disc.
4. Empty meter and hopper by allowing seed to run out of meter.
5. Inspect brushes in meter to ensure all seed is removed.
6. Replace seed disc and install vacuum cover.

NOTE: Use of damaged seed or seed containing foreign material will cause plugging of seed cell orifices and require more frequent seed meter cleanout to prevent underplanting.

GAUGE WHEEL ADJUSTMENT

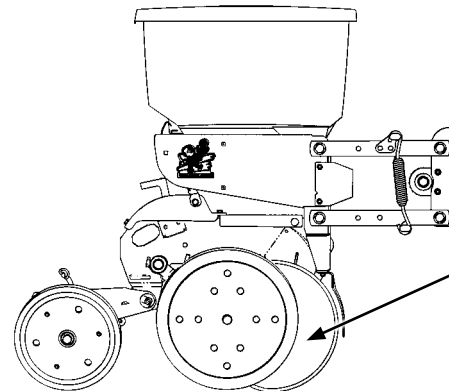
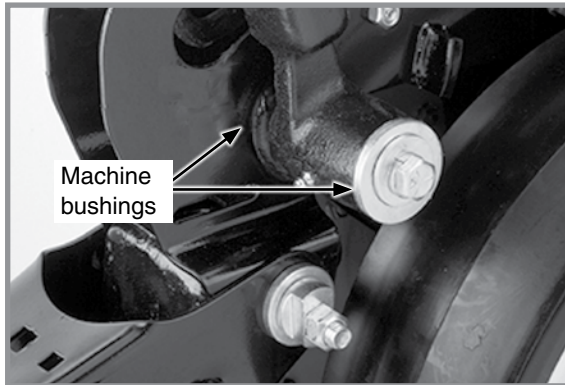

Gauge wheel adjustment

Gauge wheels should lightly contact opener blades to prevent accumulation of dirt or trash. Gauge wheels and opener blades should turn with only slight resistance.

Add or remove machine bushings between shank and gauge wheel arm to adjust clearance between gauge wheels and opener blades. Store remaining machine bushings between gauge wheel arm and flat washer on outer side of gauge wheel arm.

NOTE: It may be desirable to space gauge wheel further from blade when operating in sticky soils.

GAUGE WHEEL ARM PIVOT SPINDLE REPLACEMENT

1. Remove gauge wheel and arm assemblies from shank assembly.
2. Remove $\frac{1}{2}$ " x $\frac{3}{4}$ " cap screw that locks pivot spindle in place and remove spindle.
3. Install replacement spindle and position as shown. Exact centering is critical.
4. Install $\frac{1}{2}$ " x $\frac{3}{4}$ " cap screw and torque to lock pivot spindle in place.
5. Install gauge wheel and arm assemblies. Shim for proper gauge wheel tire/disc blade clearance.

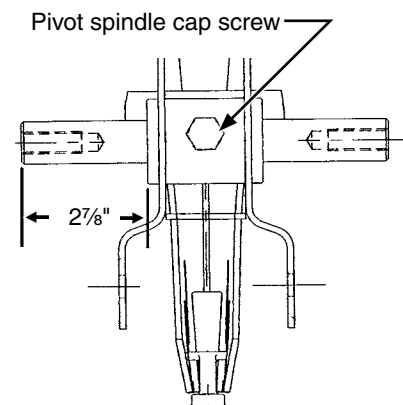

GAUGE WHEEL ARM BUSHING/SEAL REPLACEMENT

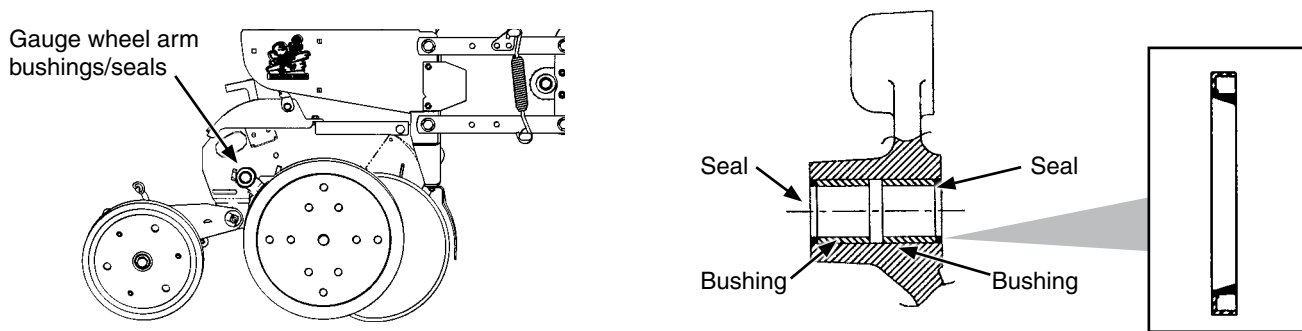

NOTE: Gauge Wheel Arm Bushing and Seal Driver Kit (G1K296) is available through your Kinze Dealer.

1. Remove gauge wheel from arm.
2. Remove gauge wheel arm from shank assembly.
3. Remove seal and bushing and discard. Clean and dry inner bore.
4. Drive/press replacement bushing inside bore of arm to a depth of .125" below flush.
5. Coat wiping edge of seal with grease.
6. Drive/press seal into place with lip to outside.

NOTE: Use extra care to protect the sealing lip during installation. Apply uniform pressure to assemble the seal into the bore of the arm. Never apply a direct hammer blow to the seal surface.

7. Inspect gauge wheel pivot spindle.
8. Reinstall gauge wheel arm assembly and gauge wheel.

NOTE: Use special machine bushing between gauge wheel arm and gauge wheel.

9. Shim for proper gauge wheel tire/disc blade clearance.
10. Lubricate with an SAE multipurpose grease.

15" SEED OPENER DISC BLADE/BEARING ASSEMBLY

NOTICE

Excessive blade contact may result in premature disc opener bearing/hub failures and excessive wear on seed tube guard/inner scraper. When properly adjusted, if one blade is held in fixed position, opposite blade should rotate with less than 5 pounds force at outer edge of blade.

Maintain approximately $1" \pm \frac{1}{2}"$ of blade-to-blade contact to properly open and form seed trench. As blade diameter decreases due to wear, it is necessary to relocate machine bushings from inside to outside to maintain $1" \pm \frac{1}{2}"$ of contact.

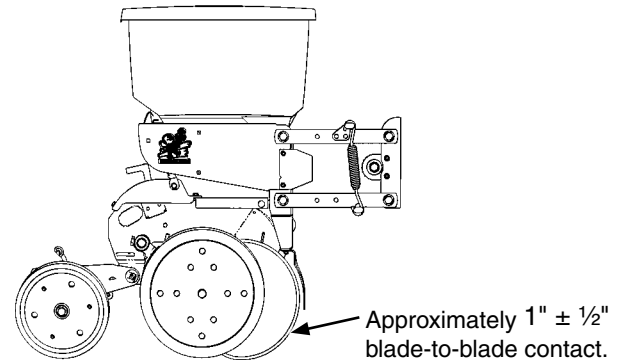

NOTE: Proper blade clearance is critical. Blades should have $1" \pm \frac{1}{2}"$ contact in this area. When blades are turned by hand in opposite directions against each other, there should be only light resistance to turning. Re-adjust blade scraper if necessary to center it between the blades.

NOTE: Replace blades if proper blade-to-blade contact cannot be maintained after relocating machine bushings or if blade diameter wears below $14\frac{1}{2}"$.

REPLACE DISC BLADE/BEARING ASSEMBLY

NOTE: Only bearing may need to be replaced if there is excessive endplay or if bearing sounds or feels rough when disc blade is rotated.

1. Remove gauge wheel, scraper, and bearing dust cap.
2. Remove cap screw, washer and disc blade/bearing assembly. Machine bushings between shank and disc blade are used to maintain approximate $1" \pm \frac{1}{2}"$ of blade-to-blade contact.

NOTICE

Left hand side of opener uses a left hand threaded cap screw. DO NOT OVER TIGHTEN. Damage to shank threads require replacement of row unit shank assembly.

3. Install machine bushing(s), new disc blade bearing assembly, washer and cap screw. Torque $\frac{5}{8}"$ -11 Grade 5 cap screw to 110 ft-lb (149.14 N-m).

NOTE: Replace disc blades only with disc blades of equal thickness.

4. Install bearing dust cap, scraper, and gauge wheel.

REPLACE BEARING ONLY

1. Remove gauge wheel, scraper, bearing cap, cap screw, washer and disc blade/bearing assembly.
2. Remove $\frac{1}{4}"$ rivets from bearing housing to expose bearing.
3. Installing new bearing. install three evenly spaced $\frac{1}{4}"$ cap screws into three of six holes in bearing housing to hold bearing and bearing housing in place. Install rivets in other three holes. Remove $\frac{1}{4}"$ cap screws and install rivets in those three holes.
4. Reinstall disc blade/bearing assembly, washer and cap screw. Torque $\frac{5}{8}"$ -11 cap screw to 110 ft-lb (149.14 N-m).
5. Install bearing dust cap, scraper, and gauge wheel.

SEED TUBE GUARD/INNER SCRAPER

Seed tube guard protects seed tube and acts as inner scraper for seed opener disc blades.

Remove seed tube and check for wear. Excessive wear on seed tube indicates a worn seed tube guard. Replace seed tube guard if it measures $\frac{5}{8}$ " or less at lower end. A new seed tube guard measures approximately $\frac{7}{8}$ ".

NOTE: No till planting or planting in hard ground conditions, especially when planter is not equipped with no till coulters, and/or excessive blade-to-blade contact increases seed tube guard wear and requires more frequent inspection and/or replacement.

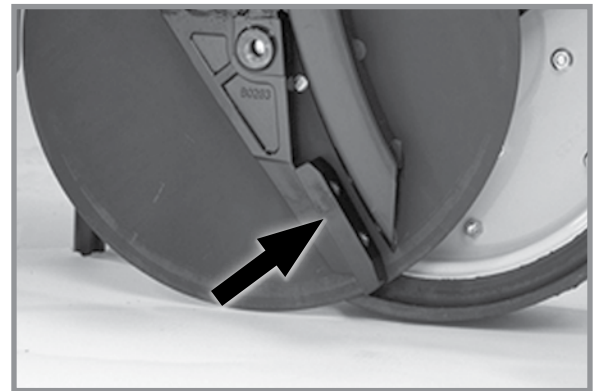

Seed tube guard/inner scraper
(Gauge wheel/seed opener disc blade removed)

NOTICE

Over tightening hex socket head cap screws may damage shank threads and require replacement of shank. An excessively worn seed tube guard may allow blades to wear into row unit shank, also requiring replacement of shank.

Remove seed tube and two hex socket head cap screws that attach seed tube guard. Hold replacement seed tube guard centered between seed opener disc blades. Install hex socket head cap screws. **DO NOT TIGHTEN.** Using a clamp or vise-grip, squeeze opener blades together in front of seed tube guard. Tighten seed tube guard retaining screws. Remove clamps. Distance between seed tube guard and opener blades should be equal on both sides. Reinstall seed tube.

FRAME MOUNTED COULTER

NOTE: Torque $\frac{5}{8}$ " spindle hardware to 120 ft-lb (162.7 N-m)

See "Frame Mounted Coulters" in Row Unit Operation section of this manual for depth and spring adjustment.

Replace 16" diameter coulters blade (1" fluted, 1" bubbled or $\frac{3}{4}$ " fluted) when worn to 14 $\frac{1}{2}$ " (maximum allowable wear).

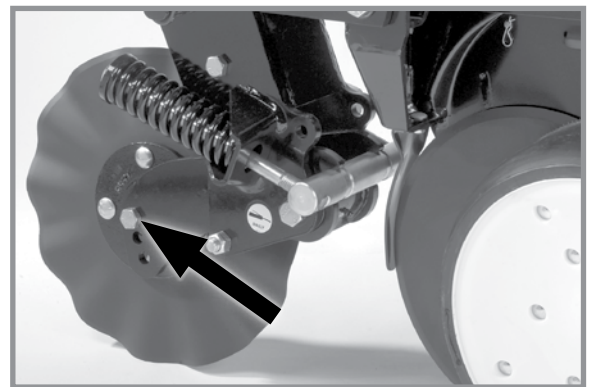

Frame mounted coulters spindle

RESIDUE WHEELS (FOR USE WITH FRAME MOUNTED COULTER)

Wheel hub is equipped with sealed bearings. Replace bearings if a bearing sounds or feels rough when wheel is rotated.

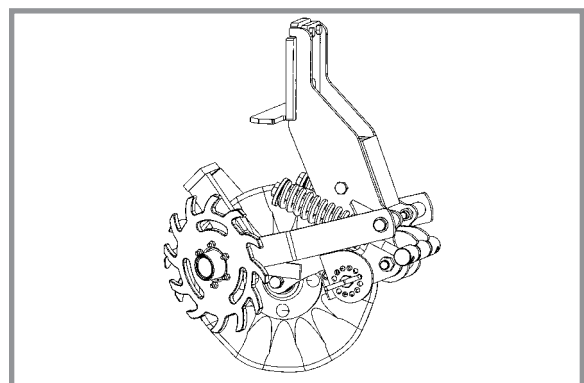

Frame mounted coulters residue wheels

ROW UNIT MOUNTED DISC FURROWER

Lubricate bushings in support arm mounting bracket at frequency indicated in Lubrication of this section. Check each bolt for proper torque. If bolt is loose, it should be removed and bushing inspected for cracks and wear. Replace bushings as necessary.

NOTE: Use only hardened flat washers. Replace damaged flat washers with proper part. Torque bolts to 130 ft-lb (176.2 N-m).

Blade hubs are equipped with sealed bearings. Replace bearings if a bearing sounds or feels rough when wheel is rotated.

Replace solid or notched 12" diameter blades when worn to 11".

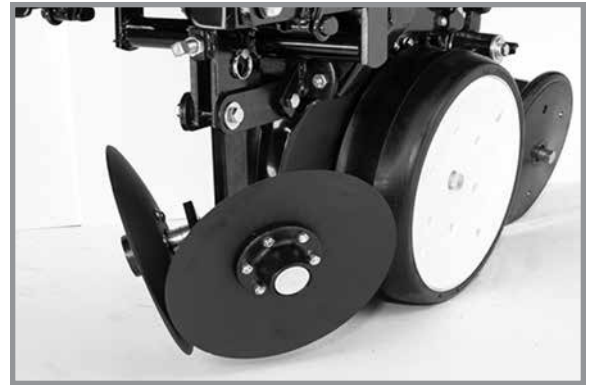

Row unit mounted disc furrower

ROW UNIT MOUNTED NO TILL COULTER

Check nuts and hardware periodically for proper torque. Be sure coulters are positioned square with row unit and aligned in front of row unit disc opener.

NOTE: Torque 5/8" spindle hardware to 120 ft-lb (162 N-m).

Coulter blade can be adjusted to one of four settings. Initially blade is set in highest position. As blade wears it can be adjusted to one of three lower settings. See "Row Unit Mounted No Till Coulter" in Row Unit Operation section of this manual.

Replace 16" diameter coulters when worn to 14½".



Row unit mounted no till coulters

COULTER OR ROW UNIT MOUNTED RESIDUE WHEELS



Coulter mounted residue wheels

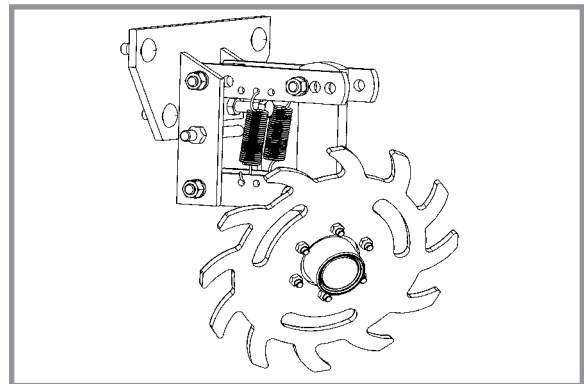

Row unit mounted residue wheels

Wheel hubs are equipped with sealed bearings. If a bearing sounds or feels rough when wheel is rotated, replace them.

GRANULAR CHEMICAL ATTACHMENT

Before storing planter, disengage granular chemical drive by rotating throwout knob $\frac{1}{4}$ turn counterclockwise. Remove drive chain and empty and clean all granular chemical hoppers. Clean drive chains and coat them with a rust preventive spray or submerge chains in oil. Inspect and replace worn or broken parts.

Install hoppers and chains. Check chain alignment.

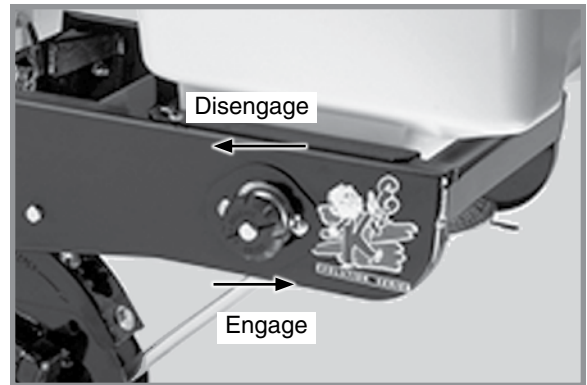

Granular chemical throwout knob

SPRING TOOTH INCORPORATOR

Before storing planter, inspect each spring tooth incorporator and replace worn or broken parts. Check for loose hardware and tighten as needed.

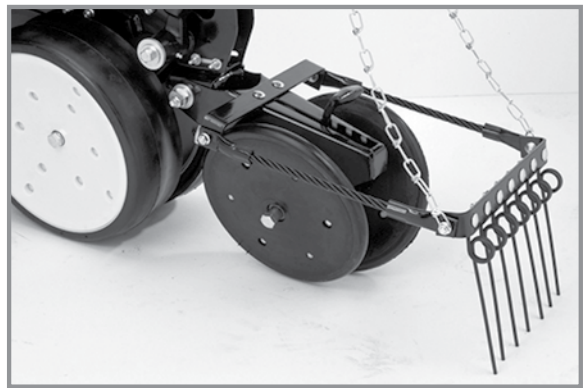

Spring tooth incorporator

WRAP SPRING WRENCH CLEANING AND REPAIR

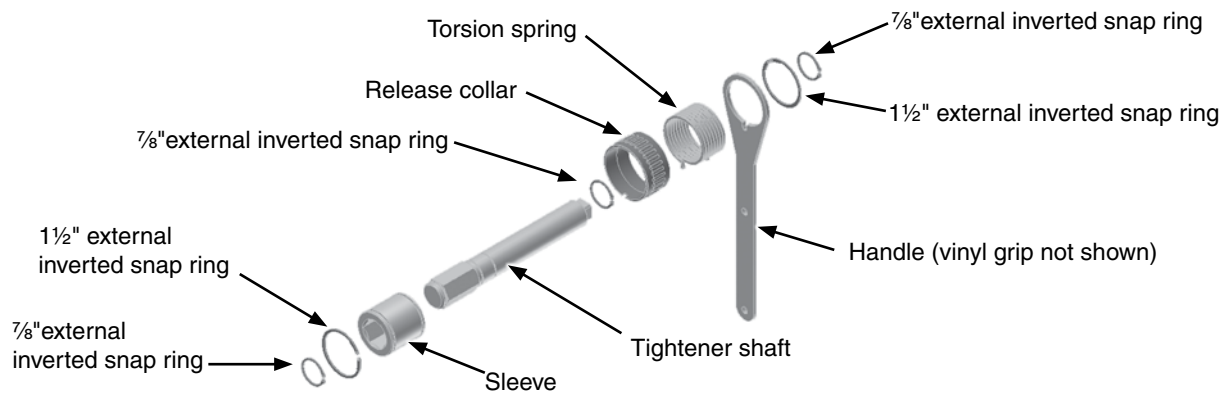

1. Remove $\frac{1}{4}$ "-20 x $\frac{1}{2}$ " cap screw securing idler with sprockets to wrench tightener shaft and remove wrap spring wrench from planter.
2. Remove split rings and disassemble as shown above. Soak metal parts in solvent and thoroughly clean.

NOTE: L.H. and R.H. release collars and torsion springs are different. Order correct parts for each assembly.

3. Replace damaged parts. Lubricate parts with high quality silicon lubricant and reassemble.
4. Reinstall wrap spring wrench on planter.

SINGLE AND TWO-SPEED POINT ROW CLUTCH MAINTENANCE

Point row clutch is permanently lubricated and sealed and requires no periodic maintenance. Two-speed point row clutch is similar in design and operation to standard point row clutch except for two-speed function.

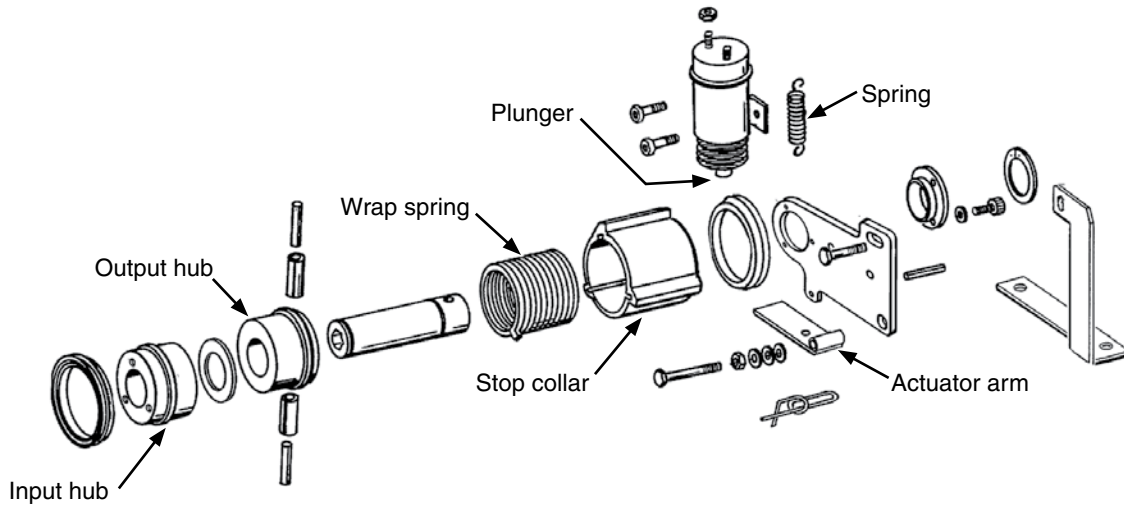

Single point row clutch main parts

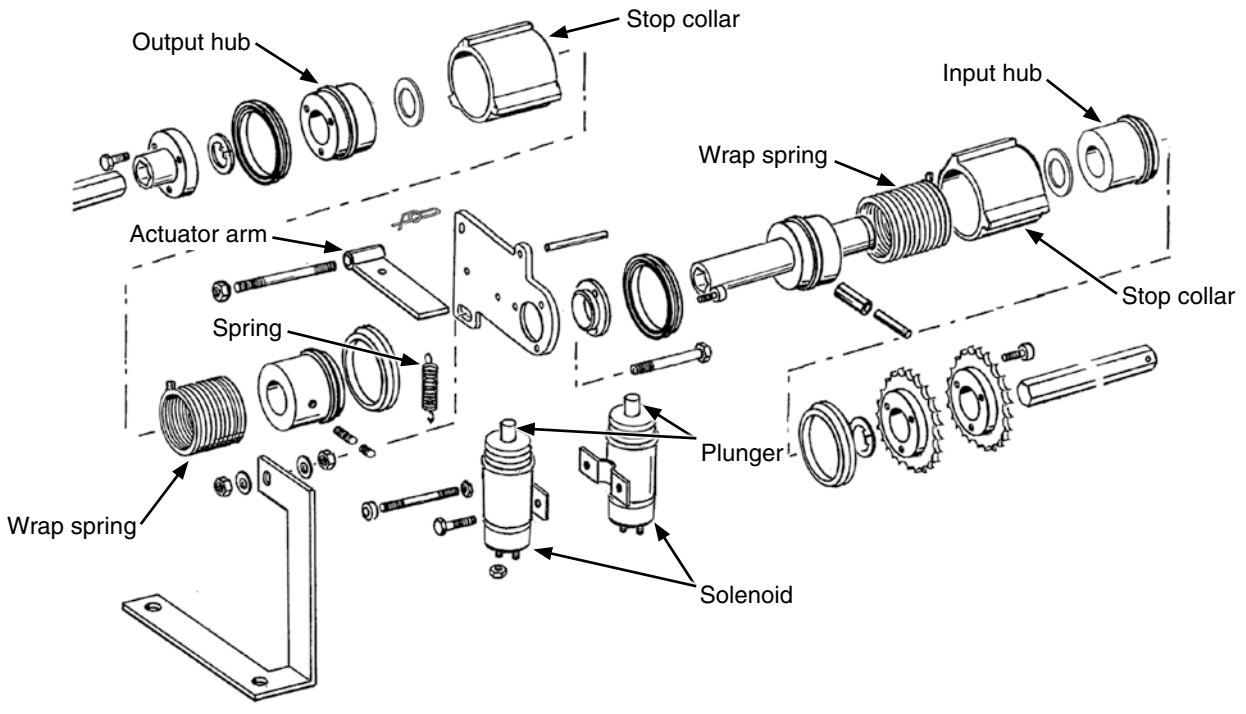

Two-speed point row clutch main parts

TESTING AND FUSE REPLACEMENT

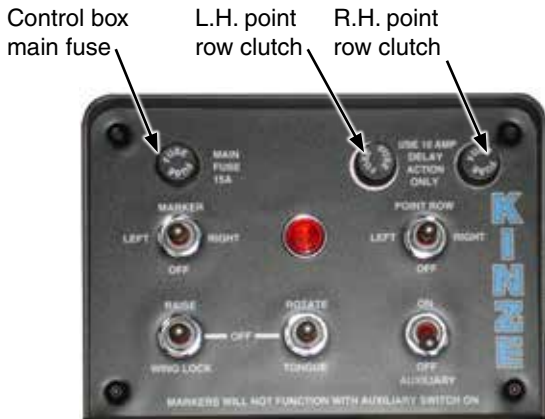

Single speed point row clutch control box (Front View)

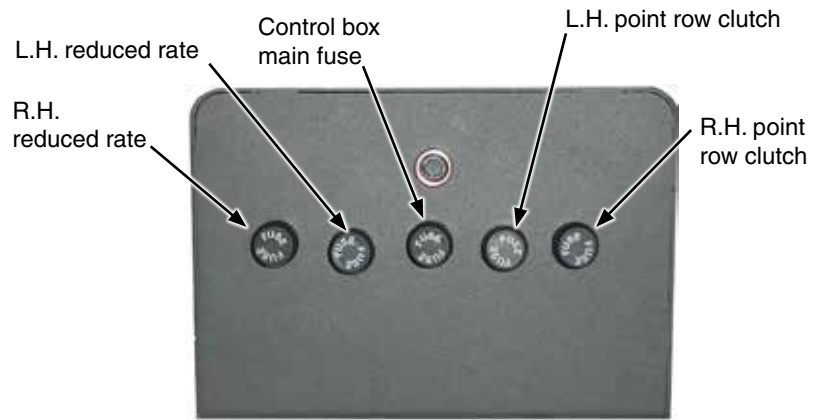

Two-speed point row clutch control box (Rear view)

NOTE: Replace all point row fuses with MDL 10 amp slow blow fuses.

If the clutch or clutches fail to operate, first determine if problem is electrical or mechanical.

Place operation switch in RIGHT or LEFT position. Solenoid plunger will retract causing a clicking sound if it is operating properly. Touch plunger with a metal object to check if it is electrically magnetized. Check clutch and wiring harness for power with a test light or volt meter.

NOTE: R.H. clutch operates clockwise and L.H. clutch operates counterclockwise. Clutch parts such as the wrap spring are side specific. Use correct repair part if a clutch must be repaired.

Also see "Point Row Clutch Troubleshooting" in Troubleshooting section.

ACTUATOR ARM ADJUSTMENT

Gap between actuator arm and stop on stop collar should be $\frac{1}{8}$ " ($\pm\frac{1}{32}$ ") when solenoid is NOT engaged.

Loosen nut on mounting pin and move pin in slot until there is a $\frac{1}{8}$ " ($\pm\frac{1}{32}$ ") gap between arm and stop on stop collar. Retighten nut.

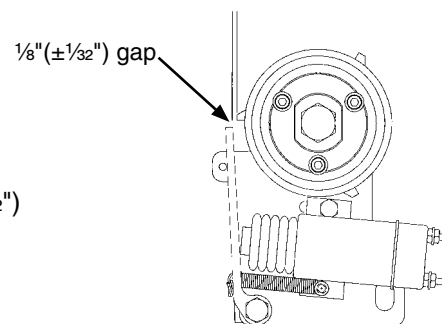

PLANTER MOUNTED PUMP DRIVE AND OIL COOLER



Oil filter location



Oil cooler location

NOTICE

Clean and grease PTO shaft coupling with high-pressure industrial coupling grease (Chevron® coupling grease or equivalent) meeting AGMA CG-1 and CG-2 Standards each time driveshaft is installed or premature wear and equipment failure can occur.

NOTE: Periodically check and clean oil coolers.

1. Replace 10-micron spin-on filters on each wing annually.
2. Fill system with SAE 10W-20 multigrade wide temperature range transmission hydraulic fluid. Reservoir capacity is approximately 10 gal (37.8L).
3. Start system and run with tractor at idle and fans turned off for 1-2 minutes. Switch fans to full speed and run with tractor at idle for 1-2 minutes.
4. Check reservoir fluid level and fill as required. Hydraulic fluid level should be within 1"-2" from top of reservoir after pump has run and hydraulic hoses have been primed to allow fluid to expand when heated.

DIGITAL VACUUM GAUGE ADJUSTMENT

Digital vacuum gauge is factory calibrated. However, vacuum varies throughout manifold system and it may be necessary to adjust digital readout to match actual vacuum at meter.

Load seed discs with seed and compare digital vacuum gauge readouts to reading taken from analog gauges or a hand held gauge at several meters along length of planter. Elbow connections located on covers of seed meters allow testing of meter vacuum levels without removing vacuum hoses.



EdgeVac digital vacuum gauge

If there is more than 1" or 2" (H₂O) difference, adjust digital gauge by inserting a small flat bladed screwdriver into opening on back of digital gauge housing and turning potentiometer until digital gauge displays vacuum present at meter. Compare readings at 10" and 20" of vacuum.

CHECK VALVE

A check valve is located in each vacuum fan motor block assembly and operates as a return line check to prevent vacuum fan motor reverse operation. Check valves are also located in valve block on left wing and trap oil flow in planter's lift system to keep toolbar level during field operation. Another check valve is located in junction block on left wing of planter on 24 Row 30" and 36 Row 20" sizes. Remove and inspect valve. If it does not operate properly. Check for foreign material and if O-ring is leaking internally. Replace if defective.

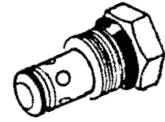

DENTENT LEVER VALVE

Detent lever valve, located near tower assembly on R.H. side of machine, blocks oil flow from master cylinders until slave cylinders are at same height as master cylinders when planter is being lowered from transport into field position. Contact your Kinze Dealer for service.

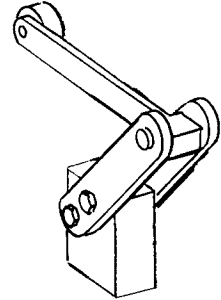

FLOW CONTROL VALVES

Two flow control valves are located in valve block on right wing of planter. Flow control valves should be adjusted for row marker raise and lower speed as part of assembly procedure or upon initial operation. If valve fails to function properly or requires frequent adjustment, it should be removed for inspection. Check for foreign material and contamination on valve and seating areas of valve body. Replace defective components.

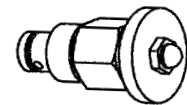

PRESSURE RELIEF VALVES

Pressure relief valve in valve block on left wing of planter functions during lowering out of raised transport sequence. Valve is factory set and should require no additional adjustment. Pressure relief valve located in valve block on tongue functions during tongue extend cycle. This pressure relief valve ensures latch cylinder extends and releases prior to tongue extending. Valve is factory set and should require no additional adjustment. Contact your Kinze Dealer for service.

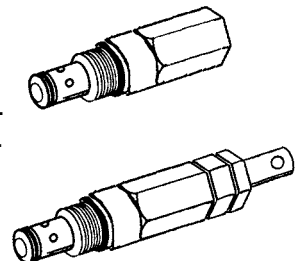

NOTICE

Connect hydraulic motor case drain to a case drain return line with zero pressure on tractor or hydraulic motor will be damaged. DO NOT connect hydraulic motor case drain to SCV outlet. Contact tractor manufacturer for specific details on "zero pressure return".

RELIEF VALVE CARTRIDGE

Pressure relief valve located in vacuum fan motor block assembly helps prevent damage to vacuum fan motor by limiting pressure in the motor case drain line. It is set to open at 35 PSI. If valve fails to function properly, it should be removed for inspection. Check for foreign material and contamination on valve and the seating area of valve body. Replace if defective.



SOLENOID VALVE

Solenoid valve consists of a chambered body with an electric coil actuated cartridge valve.

If solenoid or solenoids fail to operate, first determine if problem is electrical or hydraulic. If valve is working properly, a click will be heard when solenoid coil is energized and valve stem opens. If no sound is heard, check solenoid coil by touching top of coil housing with a metallic object such as a pliers or screwdriver. If coil is working properly, coil housing will be strongly magnetized when energized. If voltage to coil is low it will be weakly magnetized when energized and no click will be heard.

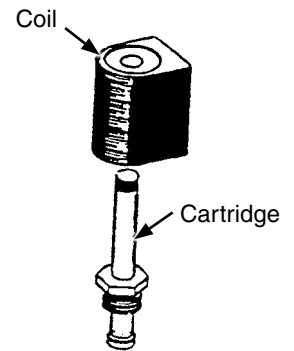

STROKE LIMITER VALVE

Stroke limiter valve, located near tower assembly on L.H. side of machine, limits height planter will raise during turn around when planter is in field operation. Contact your Kinze Dealer for service.

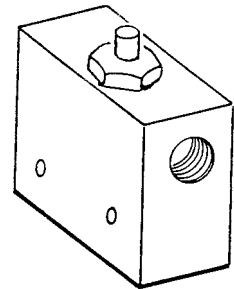

CHAIN TENSION ADJUSTMENT

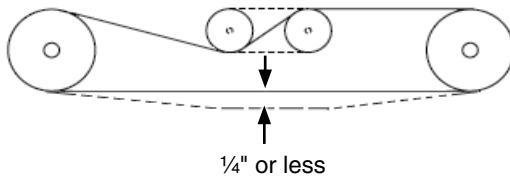

Chain link storage location (each wing)

Most drive chains have a spring loaded idler and are self-adjusting. The only adjustment needed is to shorten chain if wear stretches chain and reduces spring tension. Check idler pivot point periodically to ensure they rotate freely.

On chains with slotted idlers for adjustment, adjust so chain has 1/4" or less sag at longest span. See "Wrap Spring Wrench Assembly" for additional information.

Additional chain links can be found in the storage area located at end of planter frame on inboard side of transport hook.

STROKE LIMITER (HEIGHT STOP) VALVE ADJUSTMENT

Field turn around height of toolbar should measure 39"-41" from ground if stroke limiter valve is correctly adjusted.

1. Lower planter to ground and hold hydraulic lever for 15-20 seconds to rephase system.

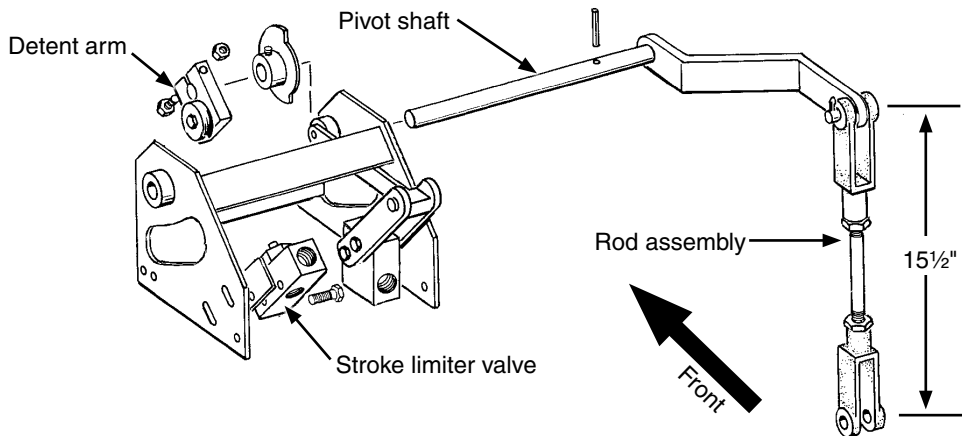

2. Check rod assembly adjustment bolt is set at $15\frac{3}{4}$ " pin to pin when planter is fully lowered. Adjust as needed.

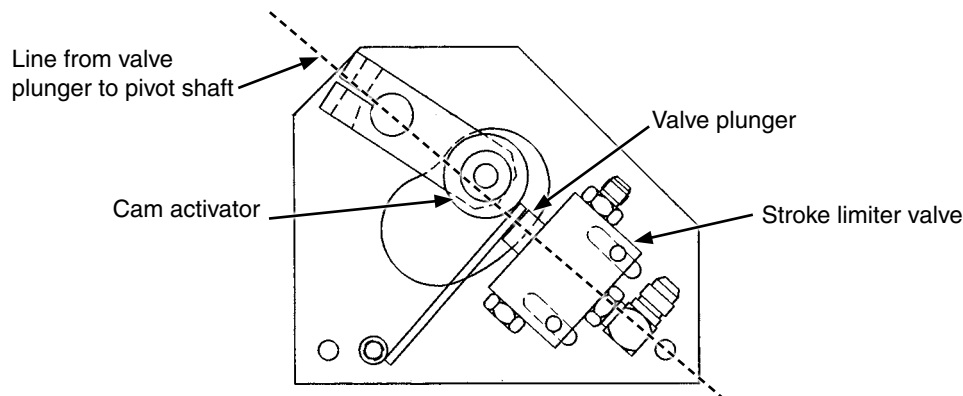

3. Check stroke limiter (height stop) valve plunger is depressed and pointing in a straight line to center of pivot shaft on cam activator.
4. Loosen detent arm (height stop assembly) clamping bolt and rotate detent arm over depressed stroke limiter valve plunger. Valve plunger should be fully depressed when detent arm is rotated over plunger arm, but must not bind. If binding occurs, move valve assembly away from detent arm while keeping valve plunger aligned with pivot shaft. Slide stroke limiter valve up or down in slotted mounting holes as needed to adjust. Tighten stroke limiter valve mounting bolts and recheck adjustment. Be sure detent arm is positioned as shown and tighten detent arm clamping bolt.
5. Raise planter until stroke limiter valve (height stop assembly) halts lift cylinder. Toolbar should measure 39"-41" from ground. If adjustment is needed, loosen detent arm clamping bolt and rotate detent arm counterclockwise to reduce and clockwise to increase lift height. Tighten clamping bolt and mark a line on detent arm and cam activator shaft for easier alignment later.

NOTE: When lowering from transport position, planter toolbar should level out to a height of 39"-41" from ground at field turn around. If it doesn't, rephase and/or remove air from the hydraulic lines and recheck toolbar height. Repeat above adjustments as needed.

DETENT LEVER (LOWERING CONTROL) VALVE ADJUSTMENT

Center of planter should drop until toolbar is level and then entire planter should lower evenly when lowering planter for field operation from transport position if detent lever valve is correctly adjusted.

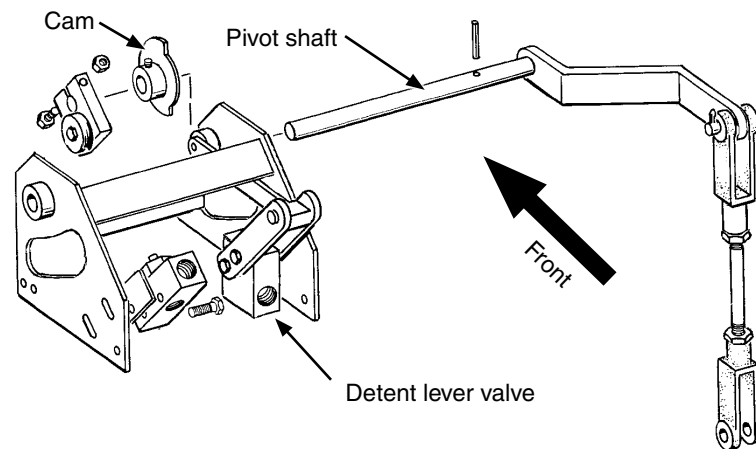

1. Raise planter to field turn around position and check toolbar height is 39"-41". Adjust following procedure for stroke limiter valve adjustment. Stroke limiter (height stop) valve must be correctly adjusted prior to adjusting detent lever (lowering control) valve.

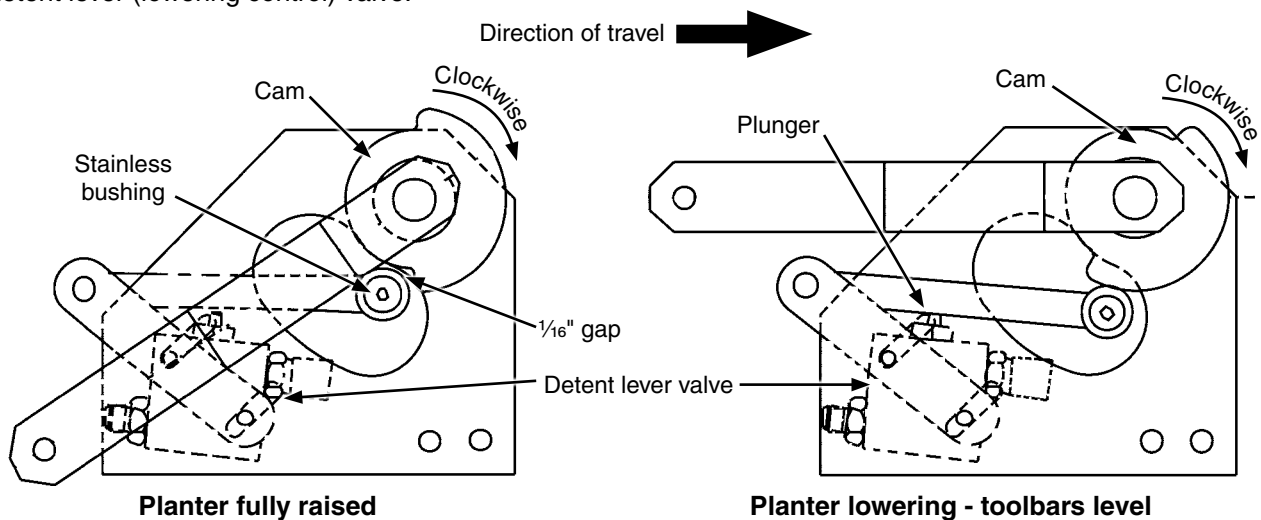

2. Raise planter to fully raised position. With cam positioned as shown, adjust detent lever (lowering control) valve in its mounting slots so there is $\frac{1}{16}$ " gap between stainless bushing and cam. Lower edge of cam must be above pivot point of stainless bushing.

NOTE: While lowering planter, center cylinders should begin to retract while wing cylinders stay extended. When toolbar becomes level, large radius of cam should cause arm to depress plunger on detent lever valve allowing wing cylinders to start retracting.

3. Lower planter. If center of planter drops lower than wings, loosen set screws and rotate cam clockwise. If wing cylinder begins to retract too early and wings drop lower than center of planter, rotate cam counterclockwise. Adjust cam with planter in raised position.
4. After final adjustment, remove one set screw and drill a depression in cam activator shaft with a $\frac{1}{4}$ " drill bit. Reinstall set screw and repeat with second set screw. This prevents cam from slipping on pivot shaft.

ROW MARKER BEARING LUBRICATION OR REPLACEMENT

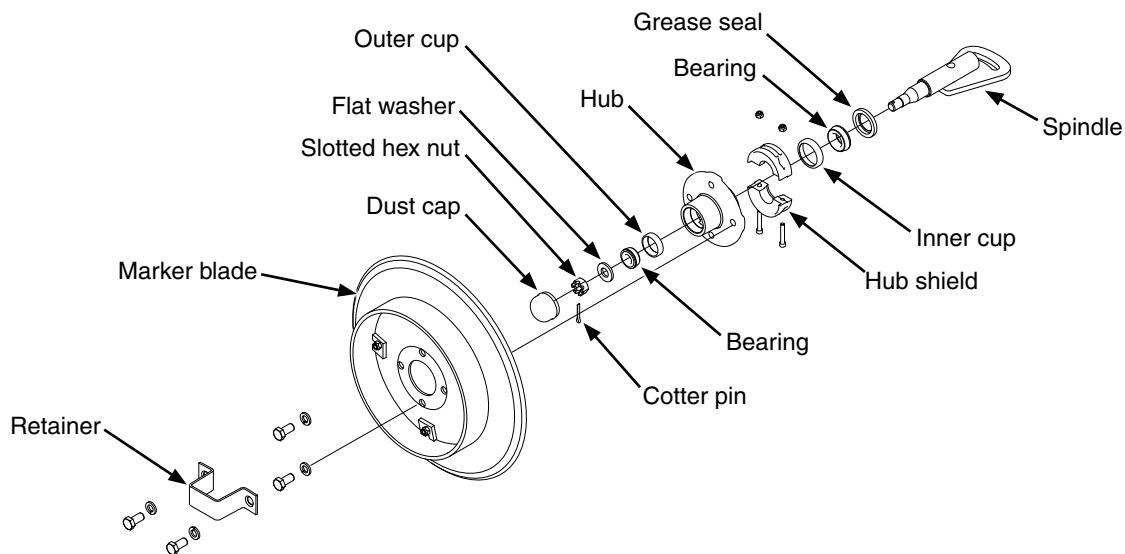

1. Remove retainer and marker blade.
2. Remove dust cap from hub.
2. Remove hub shield. Note direction of installation.
3. Remove cotter pin, slotted hex nut, and washer.
4. Slide hub from spindle.
5. Remove bearings and cups and discard if bearings are being replaced. Clean hub and dry. Remove bearings only and not cups if repacking.
6. Press in new bearing cups with thickest edge facing in. (Bearing replacement procedure only.)
7. Pack bearings with heavy duty wheel bearing grease thoroughly forcing grease between roller cone and bearing cage. Fill the space between the bearing cups in the hub with grease.
8. Install rubber seal into grease seal. Place inner bearing in place and press in new rubber seal/grease seal.
9. Clean spindle and install hub.
10. Install outer bearing, washer and slotted hex nut. Tighten slotted hex nut while rotating hub until there is some drag. This ensures all bearing surfaces are in contact. Back off slotted nut to nearest locking slot and install cotter pin.
11. Fill dust caps approximately $\frac{3}{4}$ full of wheel bearing grease and install on hub.
12. Install hub shield.
13. Install marker blade and retainer on hub. Tighten hardware evenly.

AIR CLUTCH CLEANING

(Yearly at end of planting season)

NOTE: If system is equipped with Pneumatic Down Pressure, air clutches must be removed from planter for cleaning. If system is not equipped with Pneumatic Down Pressure, air clutches can be disassembled and cleaned on planter.

At each row unit:

1. Remove meter assembly.
2. Press down collar on air fitting and remove air hose.
3. Loosen tension from chain and remove from air clutch sprocket.
4. Loosen lock clamp and slide clamp, washer, and air clutch away from chain.
5. Use a $\frac{5}{16}$ " wrench and remove sprocket from air clutch assembly.
6. Remove small Phillips-head screw from side of air clutch housing and remove housing cover.

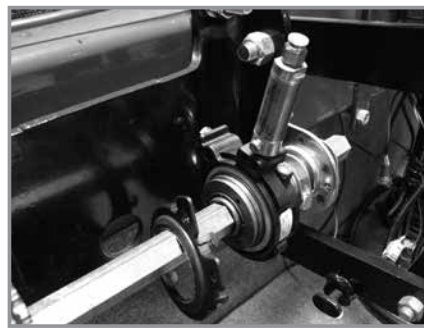
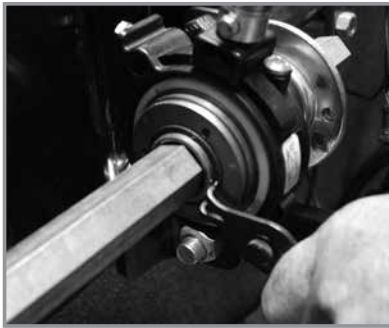

7. Expand retaining ring and remove from assembly.
8. Remove and separate sprocket hub, ratchet gear, clutch spring, and hex bushing from air clutch housing.
9. Remove debris and dirt from clutch components. Clean parts with brake cleaner or equivalent cleaner.
10. Make sure parts are completely dry. Lubricate sprocket hub, ratchet gear, clutch spring, and hex bushing with silicone spray.
11. Reverse procedure to assemble air clutch assembly.
12. Place one drop of pneumatic or light-duty hydraulic oil in air cylinder fitting before attaching air line.
13. Install meter assembly.

! WARNING

Uncontrolled machine movement can crush or cause loss of control resulting in death, serious injury, or damage to property and equipment. Install all safety lockup devices before working under or transporting this equipment.

LIFT/GROUND DRIVE WHEEL BEARING REPACK OR REPLACEMENT

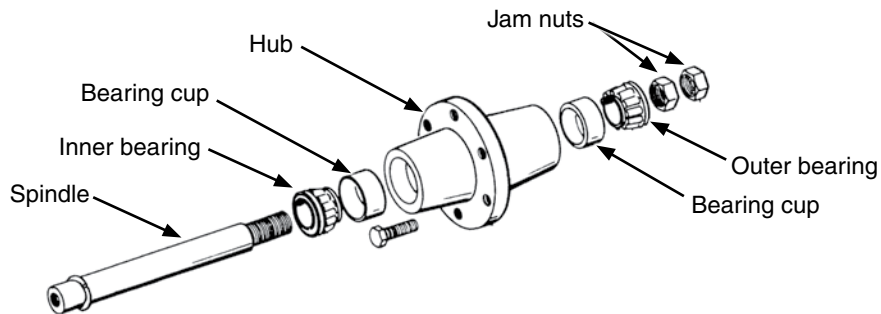

1. Raise tire clear of ground and remove wheel.
2. Remove double jam nuts and slide hub from spindle.
3. Remove bearings and cups and discard if bearings are being replaced. Clean hub and dry. Remove bearings only and not cups if repacking.
4. Press in new bearing cups with thickest edge facing in. (Bearing replacement procedure only.)
5. Pack bearings with heavy duty wheel bearing grease thoroughly forcing grease between roller cone and bearing cage. Fill space between bearing cups and hub with grease.
6. Place inner bearing in place.
7. Clean spindle and install hub.
8. Install outer bearing and jam nut. Tighten jam nut while rotating hub until there is some drag. This ensures all bearing surfaces are in contact. Back off jam nut ¼ turn or until there is only slight drag when rotating hub. Install second jam nut to lock against first.
9. Install wheel on hub. Tighten hardware evenly.

⚠ WARNING

Uncontrolled machine movement can crush or cause loss of control resulting in death, serious injury, or damage to property and equipment. Install all safety lockup devices before working under or transporting this equipment.

TRANSPORT WHEEL BEARING REPLACEMENT

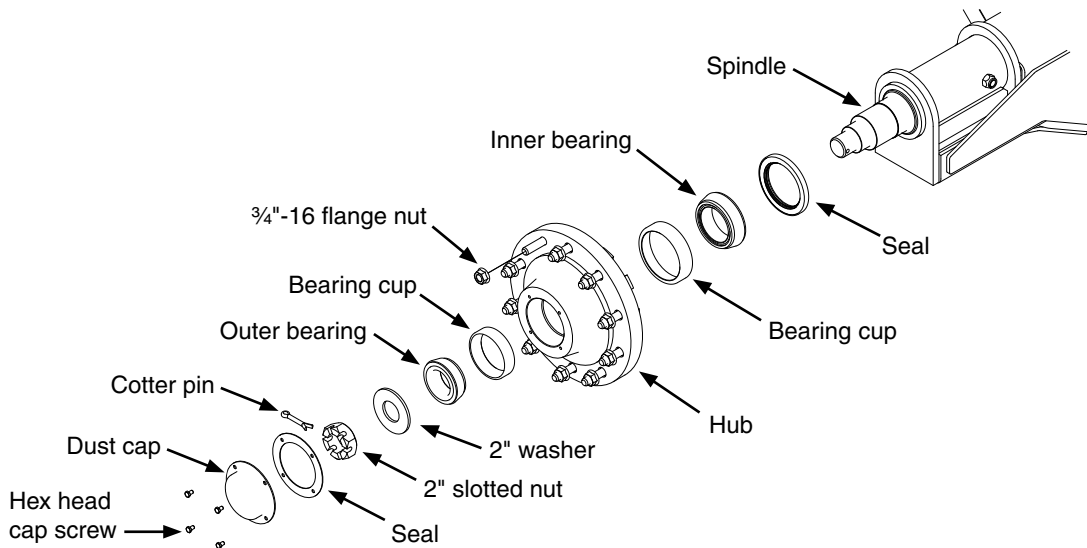

1. Raise tires clear of ground and support with jack stand. Remove wheels.
2. Remove dust cap attachment hardware and cap from wheel hub.
3. Remove cotter pin, slotted nut, and 2" washer.
4. Slide hub from axle spindle. Use a hub puller if necessary.
5. Remove bearings and cups from hub and discard. Thoroughly clean and dry wheel hub.
6. Press in new bearing cups with thickest edges facing in.
7. Pack bearing with heavy-duty wheel bearing grease. Thoroughly force grease between roller cone and bearing cage. Fill space between bearing cups and hub with grease.
8. Place inner bearing in hub and press in new grease seal with lip pointing towards bearing.
9. Clean axle spindle and install hub.
10. Install outer bearing, 2" washer, and slotted nut. Tighten slotted nut while rotating hub until there is some drag. This ensures all bearing surfaces are in contact. Back off slotted nut to nearest locking slot and install cotter pin. Check bearing endplay.
11. Fill dust cap half full of wheel bearing grease and install on hub with four hex head cap screws.
12. Install wheels and remove jack stand. Torque $\frac{3}{4}$ " flange nuts to 280 ft-lb (379.6 N-m).

FERTILIZER CHECK VALVE CLEANING AND REPAIR

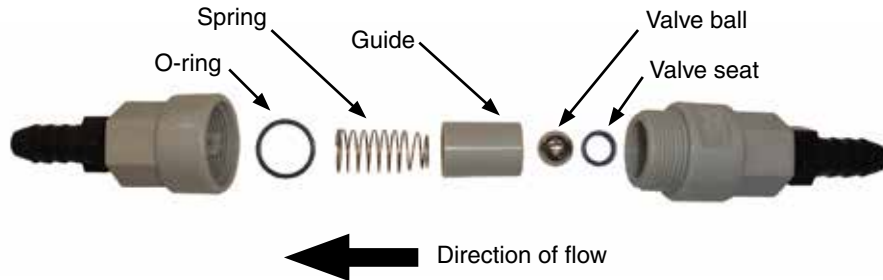

1. Unscrew valve body and separate halves. Note direction and location of parts.
2. Clean and inspect parts. Flush with clean water. Replace damaged parts.
3. Reassemble exactly as shown. O-ring and valve seat must be firmly in place inside each half of valve body.

PISTON PUMP STORAGE

NOTICE

**Entrance of air into pump will cause rapid and severe corrosion.
KEEP AIR OUT OF PUMP!**

NOTE: SUSPENSION FERTILIZER must be flushed from pump for ANY storage period.

1. Flush pump with 5 to 10 gallons of fresh water and circulate until all corrosive salts are dissolved in pump.
2. Set pump on 10. Draw in a mixture of half diesel fuel and 10 weight oil until discharge is clean. Plug inlet and outlet.

LOW-RATE LIQUID FERTILIZER SYSTEM

Clean strainers daily.

Flush all lines with water for 30 to 60 seconds then drain water before storage.

PREPARATION FOR STORAGE

Store planter in a dry sheltered area if possible.

Remove all trash wrapped on sprockets or shafts and remove dirt that can draw and hold moisture.

Clean all drive chains and coat with a rust preventative spray, or remove chains and submerge in oil.

Lubricate planter and row units at all lubrication points.

Inspect planter for parts that in need of replacement and order during “off” season.

Make sure all seed and granular chemical hoppers are empty and clean.

Remove seed discs from seed meters, clean and store meters in a rodent-free, dry area with discs removed. Store seed discs vertically on a dowel or pipe.

Remove vacuum hose from each seed meter. Operate vacuum fan at full hydraulic flow from tractor for two minutes to clear manifolds, hoses and fittings of dust and debris.

Clean breather on analog vacuum and pressure gauges.

Disassemble, clean and grease all U-joint slides.

Grease or paint disc openers/blades and row marker disc blades to prevent rust.

Flush liquid fertilizer tanks, hoses and metering pump with clean water. See “Piston Pump Storage” if applicable.

Empty dry fertilizer hoppers. Clean hoppers. Disassemble and clean metering augers. Reassemble, coating all metal parts with rust preventative.

ASD System:

- Clean out ASD hopper, entrainment assembly, and delivery hoses.
- Disconnect delivery hoses from entrainer ports. Install small orange caps onto ports. Attach hoses to caps.
- Disconnect delivery hoses from air dissipator at each row unit. Install large orange caps. Attach hoses to caps.
- Check all bolts and fasteners used to assemble and attach entrainment device are tight (if applicable).
- Loosen knobs on entrainer cleanout doors to remove pressure from door gaskets.
- Inspect all seed delivery hoses and replace any that are worn, cut, or cracked.

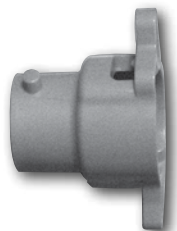

Entrainer cap

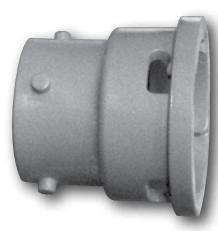

Air dissipator cap

This page intentionally left blank.

ELECTRICAL WIRING DIAGRAM FOR LIGHT PACKAGE

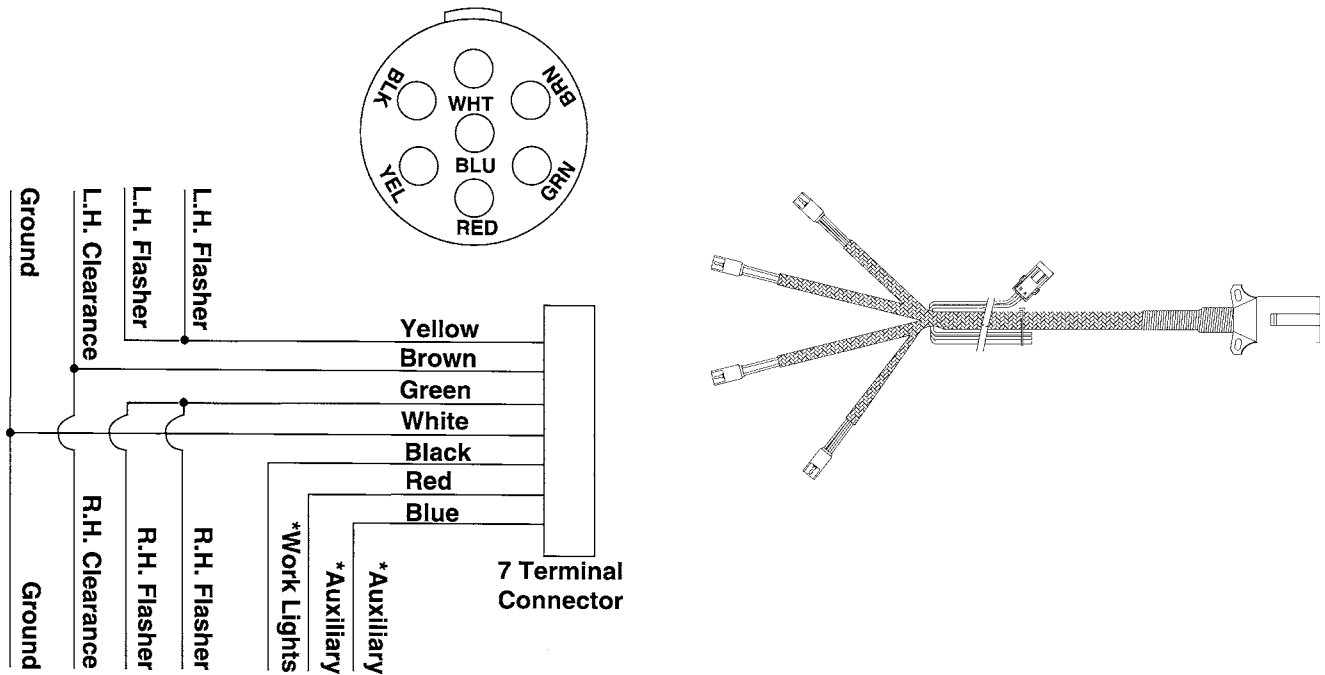

Light packages supplied on Model 3700 Front Folding Planters meet ASABE Standards. Check with tractor manufacturer for correct wiring harness to be wired into lights on your tractor, .

***Optional customer-supplied auxiliary lights and wires may be wired into existing plug terminals.**

ELECTRICAL CONTROL CONSOLE SCHEMATIC

NOTICE

Disconnect control console from tractor battery before doing any electrical work or shorting will damage equipment. Keep wiring harnesses away from high temperature areas or sharp edges. **DO NOT** route wiring harnesses along battery cables. Use cable ties to keep wire harness away from moving parts on tractor and planter. Ground connections to tractor frame must be clean to provide good electrical contact.

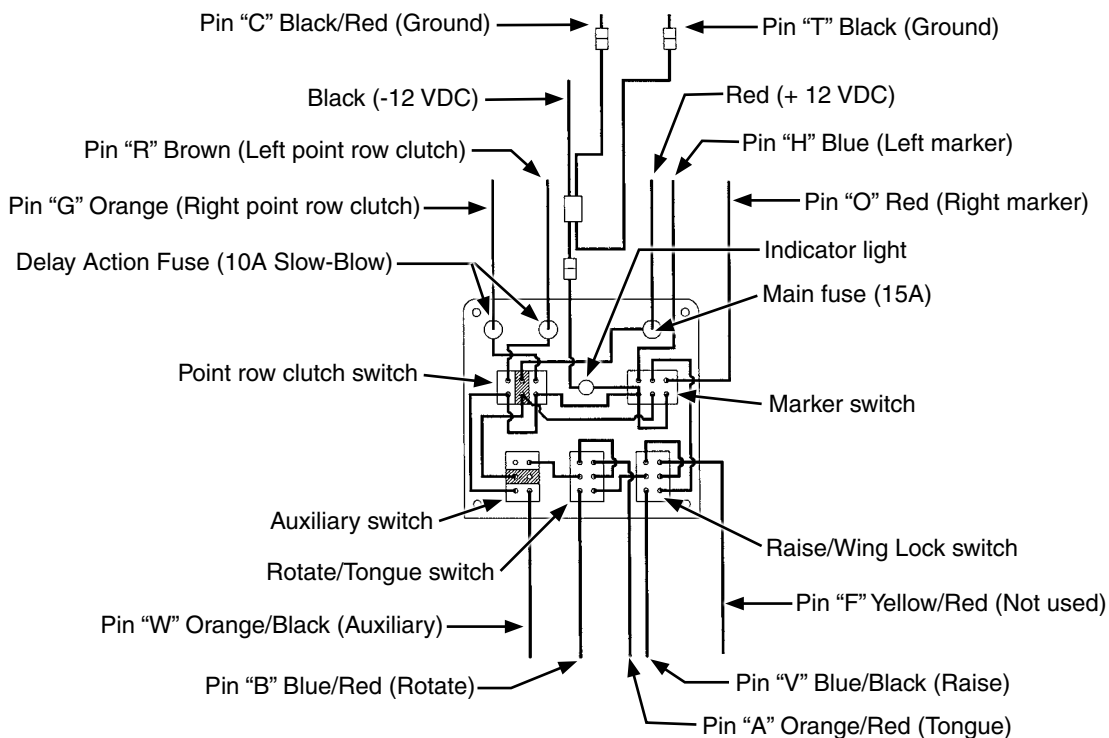
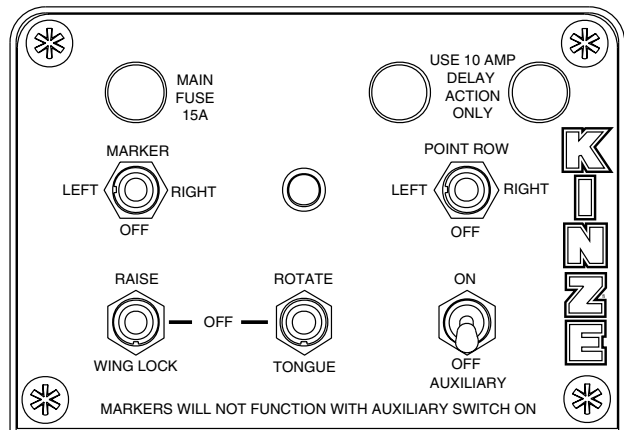

NOTE:

1. Operating row marker or point row switch in either direction lights panel light.
2. Point row clutch switch operates independently from rest of control box.
3. Power to row marker switch is fed through auxiliary switch and two transport function switches. Operating any switch in lower row disables row marker function and turns off panel light. (If point row clutch switch is "OFF".)
4. See page 6-41 for two-speed point row clutch electrical control console and wiring harness schematics.

ELECTRICAL WIRING HARNESS SCHEMATIC (ON TRACTOR)

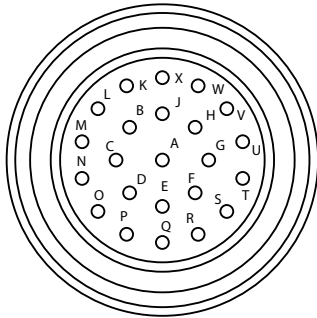

Pin No.	Wire Color	Function	Wire Ga.
A	Orange/Red	Tongue Raise	14
B	Blue/Red	Fold	14
C	Black/Red	Ground	14
D	White	Monitor B 12V	14
E	Green	Monitor B DATA	14
F	Yellow/Red	Wing Lock	14
G	Orange	Point Row - Right	12
H	Blue	Marker - Left	14
J	Black	Monitor B Ground	14
K	White	Monitor A 12V	14
L	Green	Monitor A Data	14
M	Black	Monitor A Ground	14
N	---	---	---
O	Red	Marker - Right	14
P	---	---	---
Q	---	---	---
R	Brown	Point Row - Left	12
S	Yellow	Reduced Rate - Left	12
T	Black	Ground	12
U	Red/Black	Reduced Rate - Right	12
V	Blue/Black	Raise to Transport	14
W	Orange/Black	Auxiliary	14
X	---	---	---

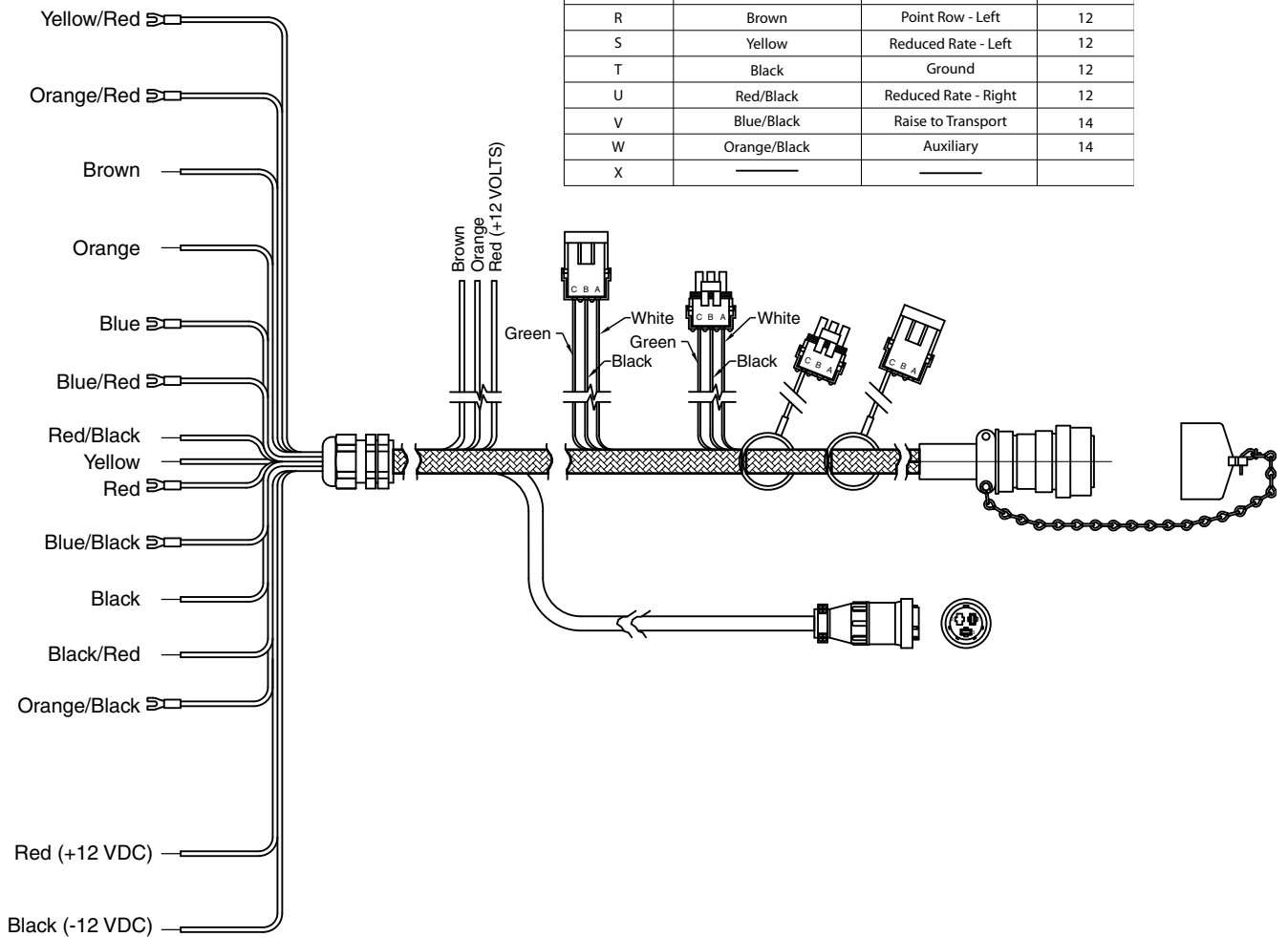

ELECTRICAL WIRING HARNESS SCHEMATIC (ON PLANTER)

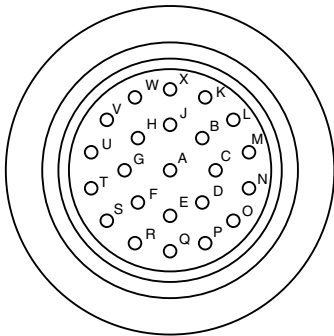

Pin No.	Wire Color	Function	Wire Ga.
A	Orange/Red	Tongue Raise	14
B	Blue/Red	Fold	14
C	Black/Red	Ground	14
D	White	Monitor B 12V	14
E	Green	Monitor B Data	14
F	Yellow/Red	Not Used	14
G	Orange	PT. Row - Right	12
H	Blue	Marker - Left	14
J	Black	Monitor B Ground	14
K	White	Monitor A 12V	14
L	Green	Monitor A Data	14
M	Black	Monitor A Ground	14
N	---	---	---
O	Red	Marker - Right	14
P	---	---	---
Q	---	---	---
R	Brown	PT. Row - Left	12
S	Yellow	Reduced Rate - Left	12
T	Black	Ground	12
U	Red/Black	Reduced Rate - Right	12
V	Blue/Black	Raise to Transport	14
W	Orange/Black	Auxiliary	14
X	---	---	---

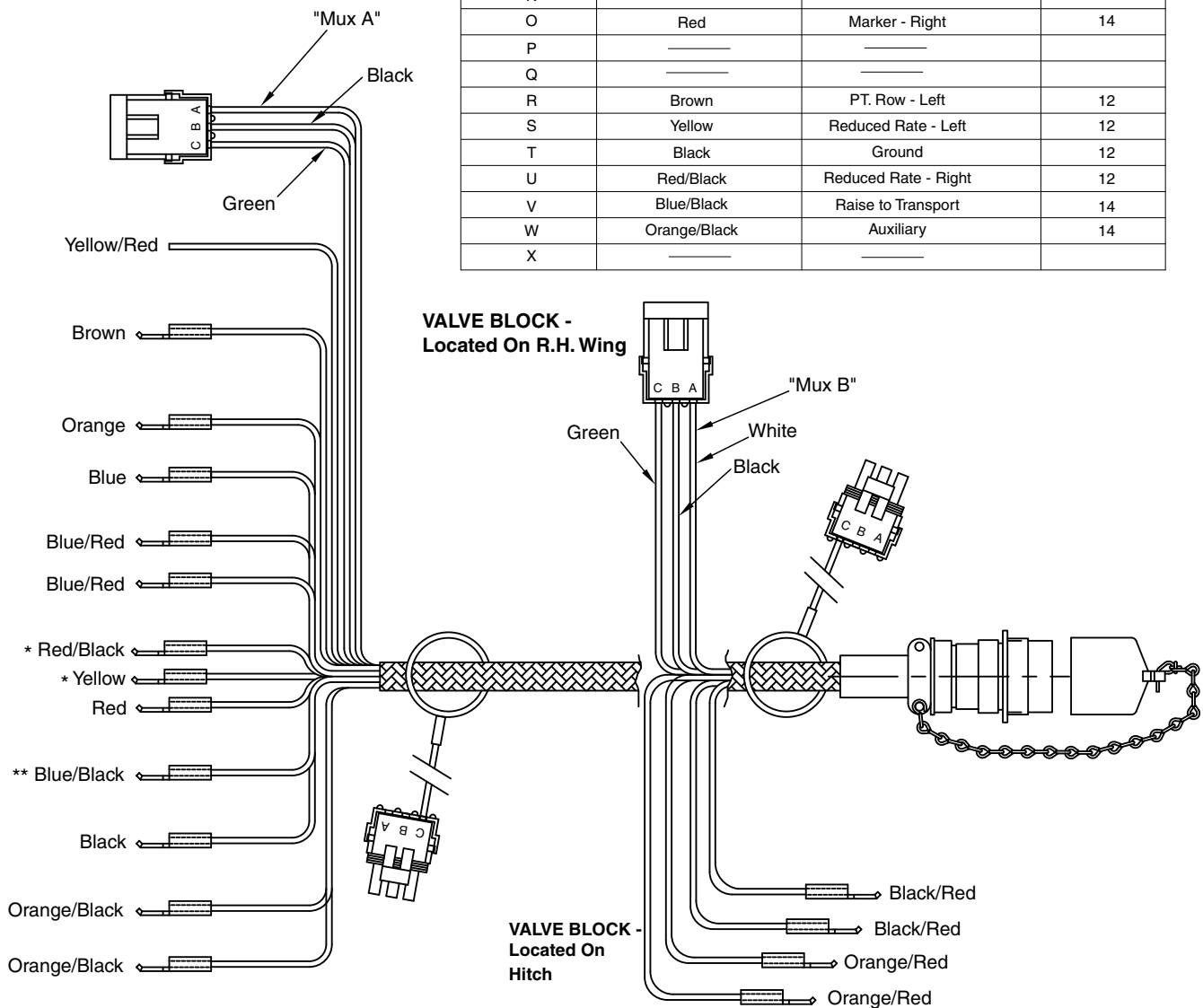

** NOTE: Harness To Port V14 On Valve Block Located On Tower

* See page 6-41 if equipped with optional Two-Speed Point Row Clutch Package.

VALVE BLOCK - LOCATED ON HITCH

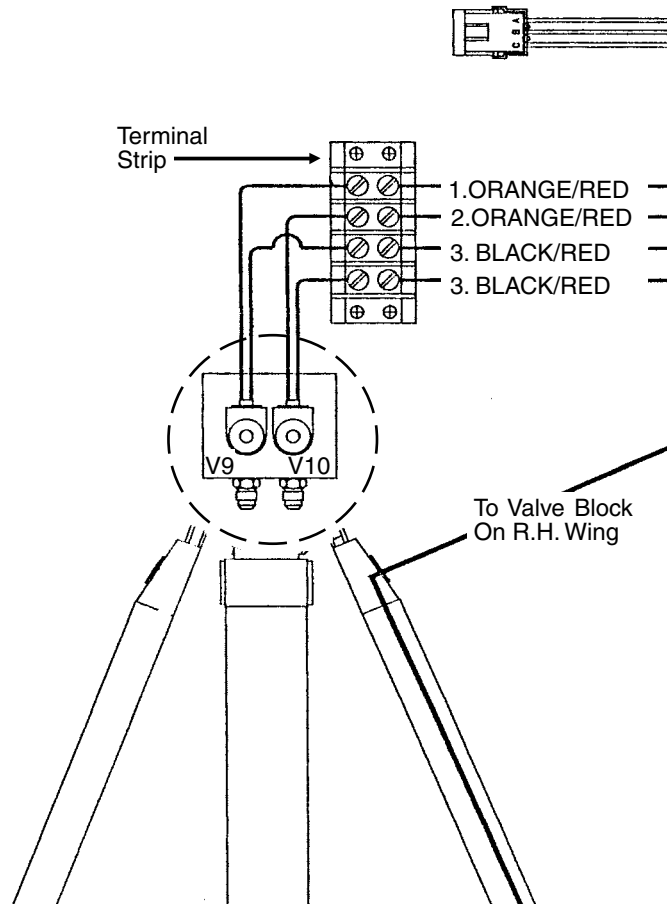

- 1. ORANGE/RED - Pin "A" (Tongue Retract/Extend) - Port V9
- 2. ORANGE/RED - Pin "A" (Tongue Retract/Extend) - Port V10
- 3. BLACK/RED - Pin "C" (Ground)

VALVE BLOCKS - LOCATED ON TOWER AND R.H. WING

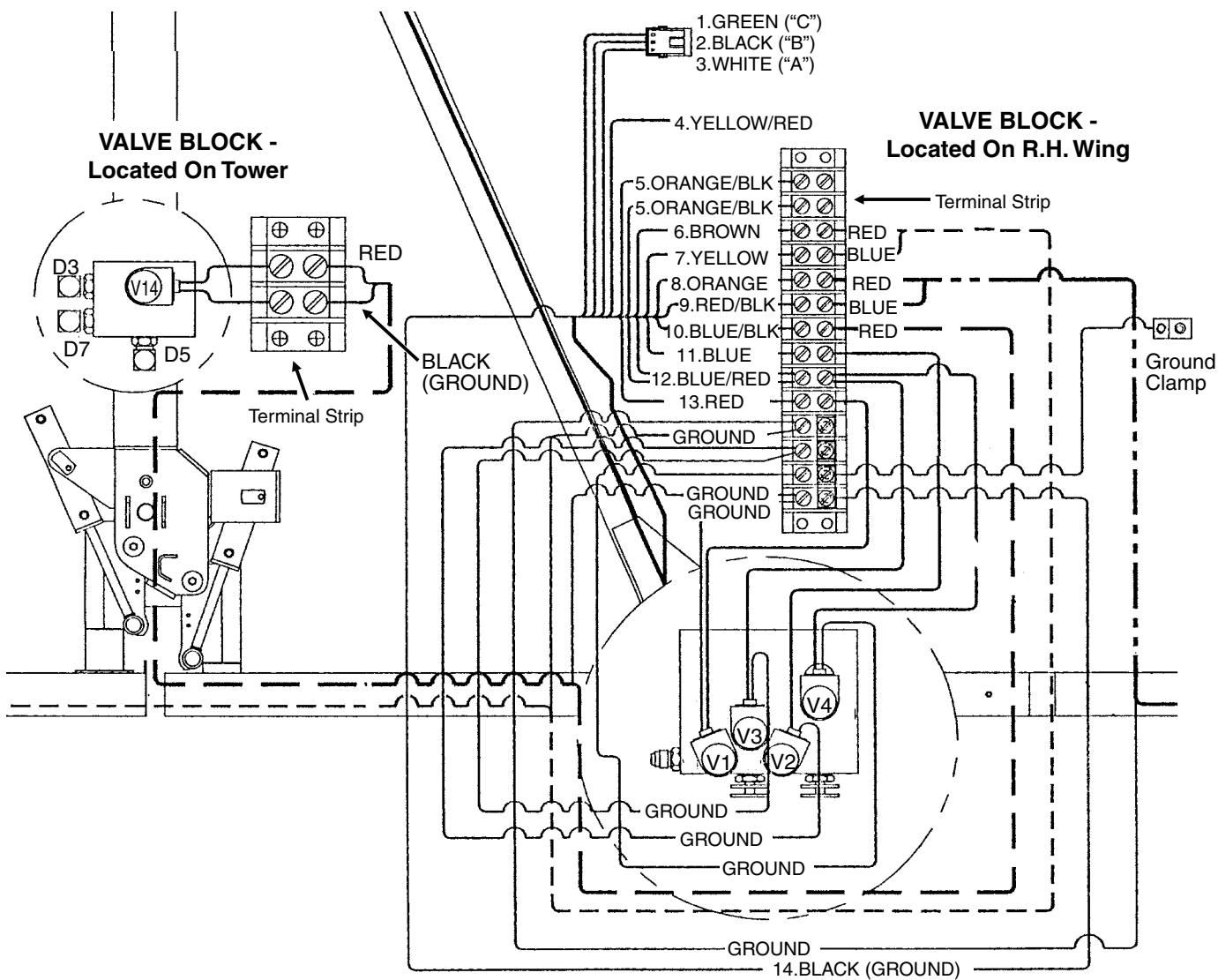

1. GREEN - Pin "L" ("C" MONITOR DATA)
2. BLACK - Pin "M" ("B" MONITOR GROUND)
3. WHITE - Pin "K" ("A" MONITOR +12V)
4. YELLOW/RED - Pin "F" (NOT USED)
5. ORANGE/BLACK - Pin "W" (Auxiliary)
6. BROWN - Pin "R" (L.H. Point Row Clutch)
7. YELLOW - Pin "S" (L.H. Two-Speed Clutch)*
8. ORANGE - Pin "G" (R.H. Point Row Clutch)
9. RED/BLACK - Pin "U" (R.H. Two-Speed Clutch)*
10. BLUE/BLACK - Pin "V" (Raise)
11. BLUE - Pin "H" (L.H. Marker) - Port V2
12. BLUE/RED - Pin "B" (Rotate) - Ports V3 And V4
13. RED - Pin "O" (R.H. Marker) - Port V1
14. BLACK - Pin "T" (Ground)

* See page 6-41 if equipped with optional Two-Speed Point Row Clutch Package.

CONTROL CONSOLE SCHEMATIC (OPTIONAL TWO-SPEED POINT ROW CLUTCHES)

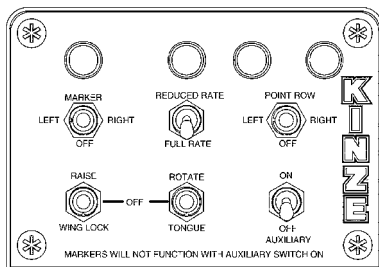
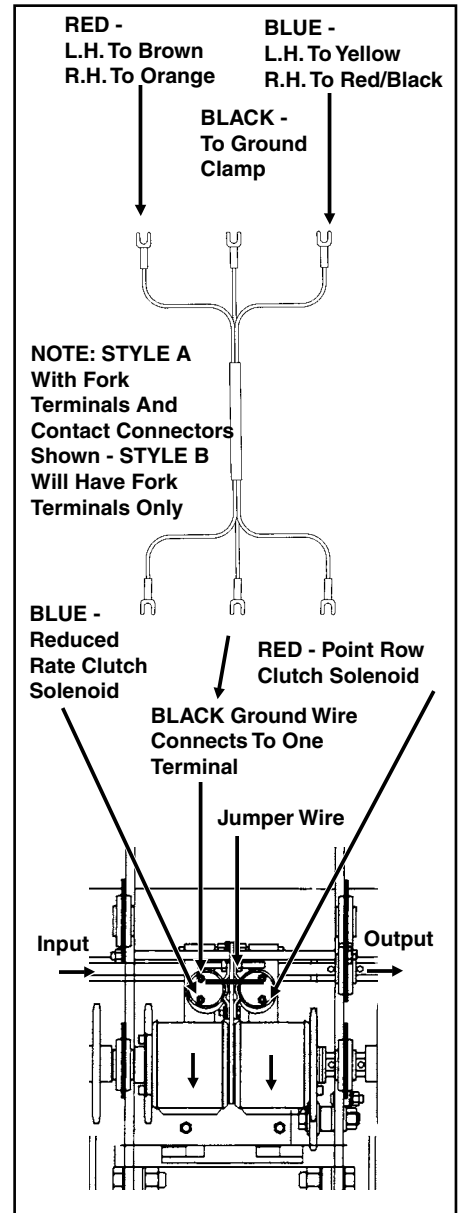
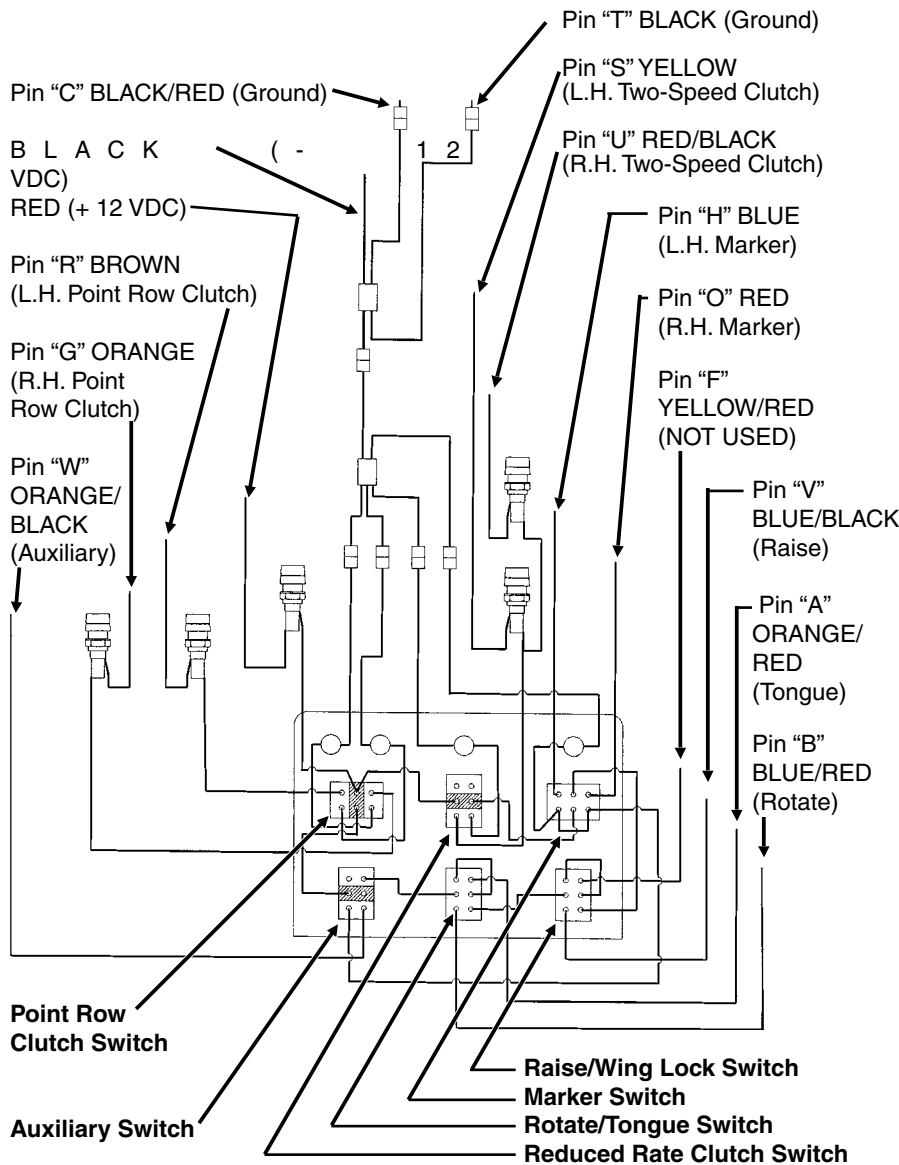

NOTE:

1. Point row and reduced rate clutch switches operate independently from rest of control console.
2. Power to marker switch is fed through auxiliary switch and two transport function switches. Operating any switch in lower row disables marker function and turns off panel light for markers.

NOTICE
 Disconnect control console from tractor battery before doing any electrical work or shorting will damage equipment. Keep wiring harnesses away from high temperature areas or sharp edges. **DO NOT** route wiring harnesses along battery cables. Use cable ties to keep wire harness away from moving parts on tractor and planter. Ground connections to tractor frame must be clean to provide good electrical contact.

ELECTRICAL WIRING HARNESS SCHEMATIC (VACUUM FAN CONTROL)

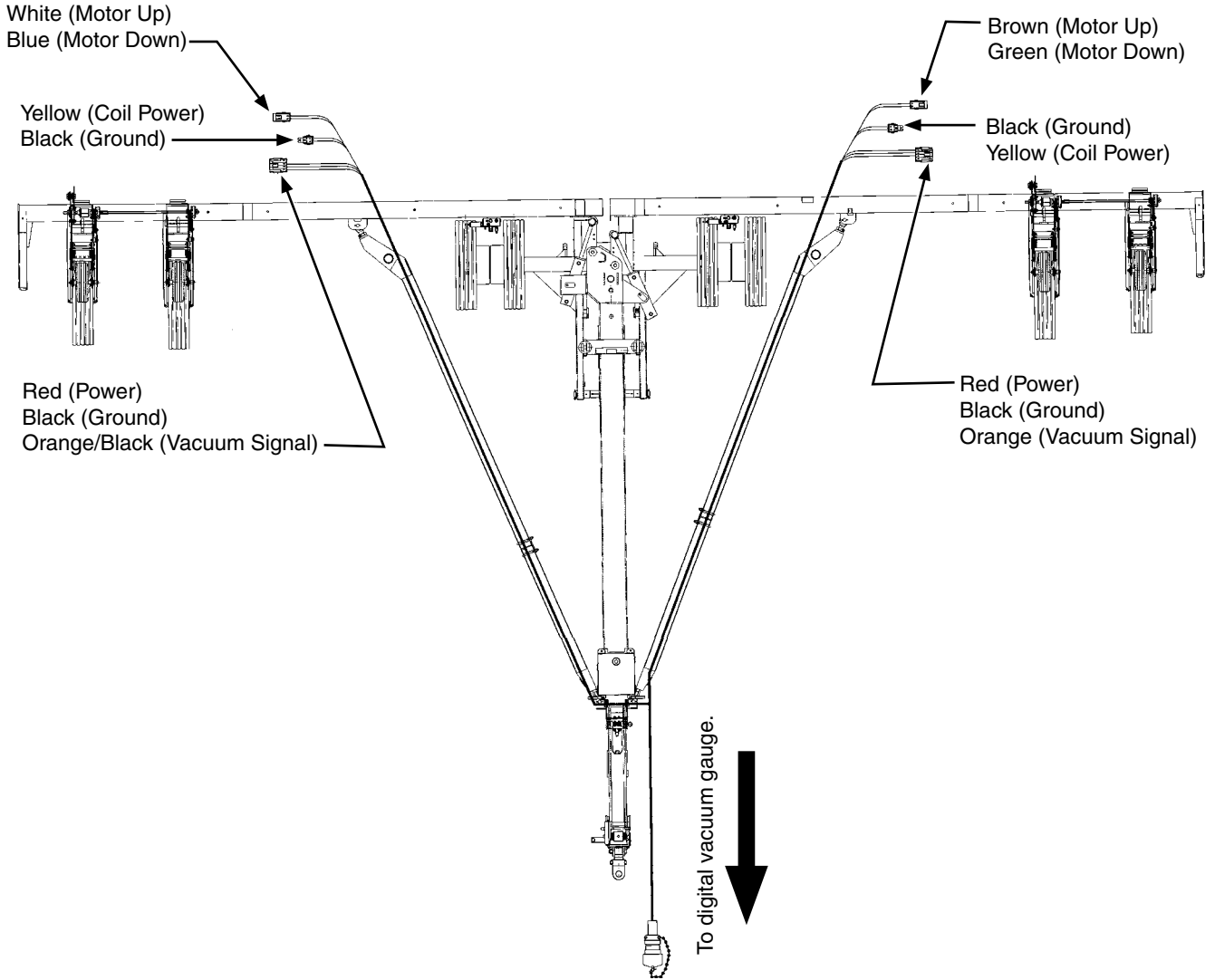

HYDRAULIC SCHEMATIC (ASD SYSTEM)

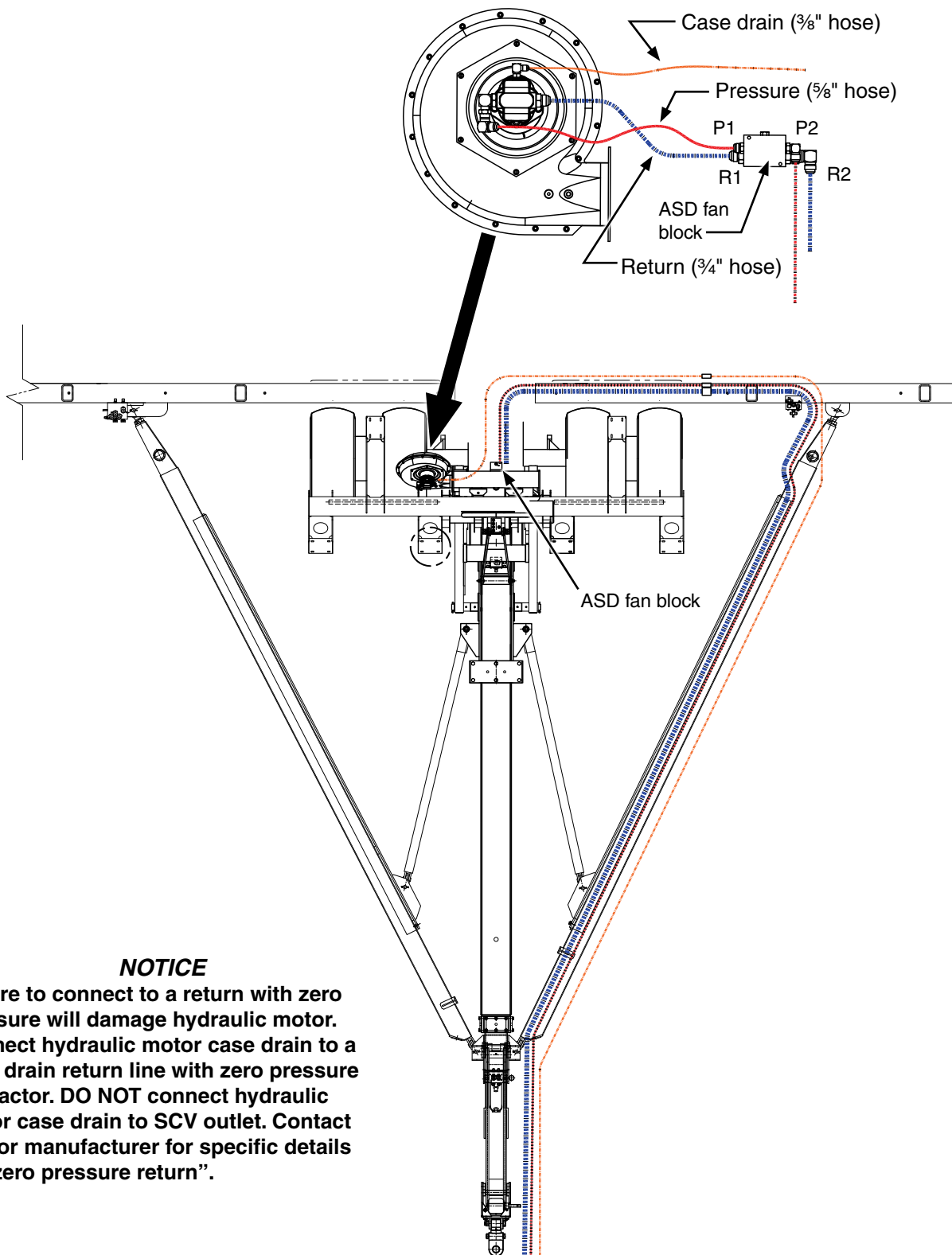

HYDRAULIC SCHEMATIC (VACUUM FAN SYSTEM) 24 ROW 30"

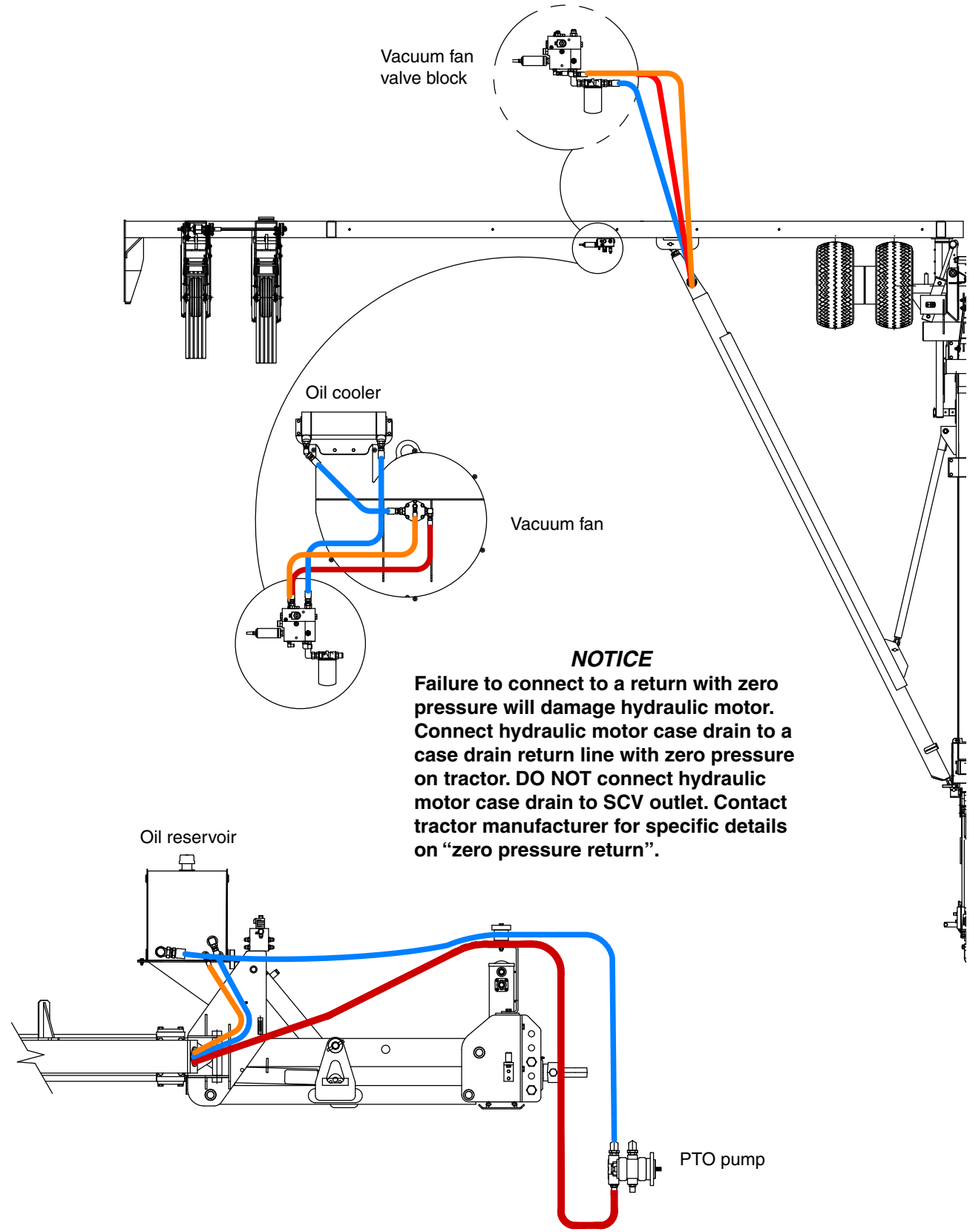

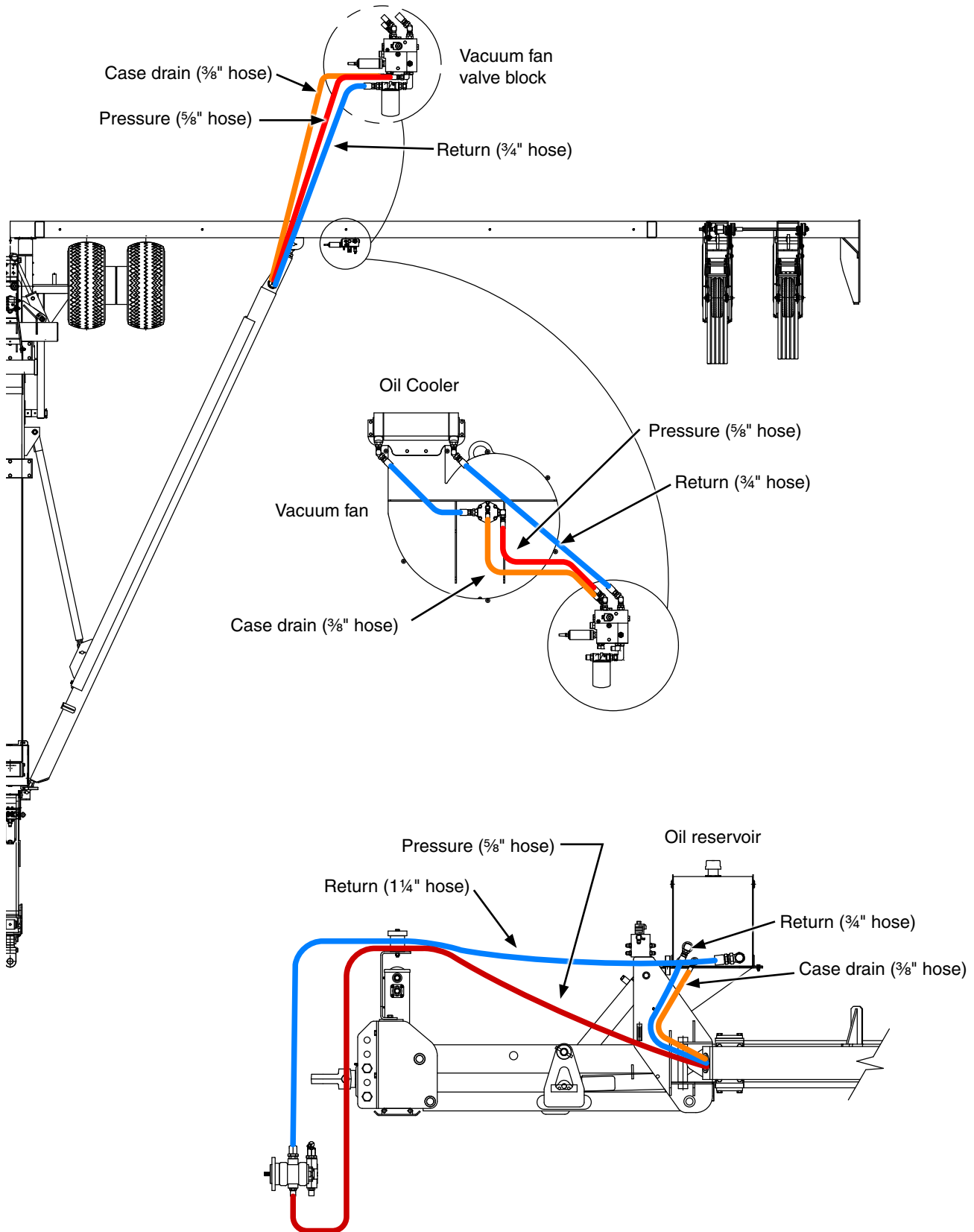

HYDRAULIC SCHEMATIC (VACUUM FAN SYSTEM) 24 ROW 20"/22"

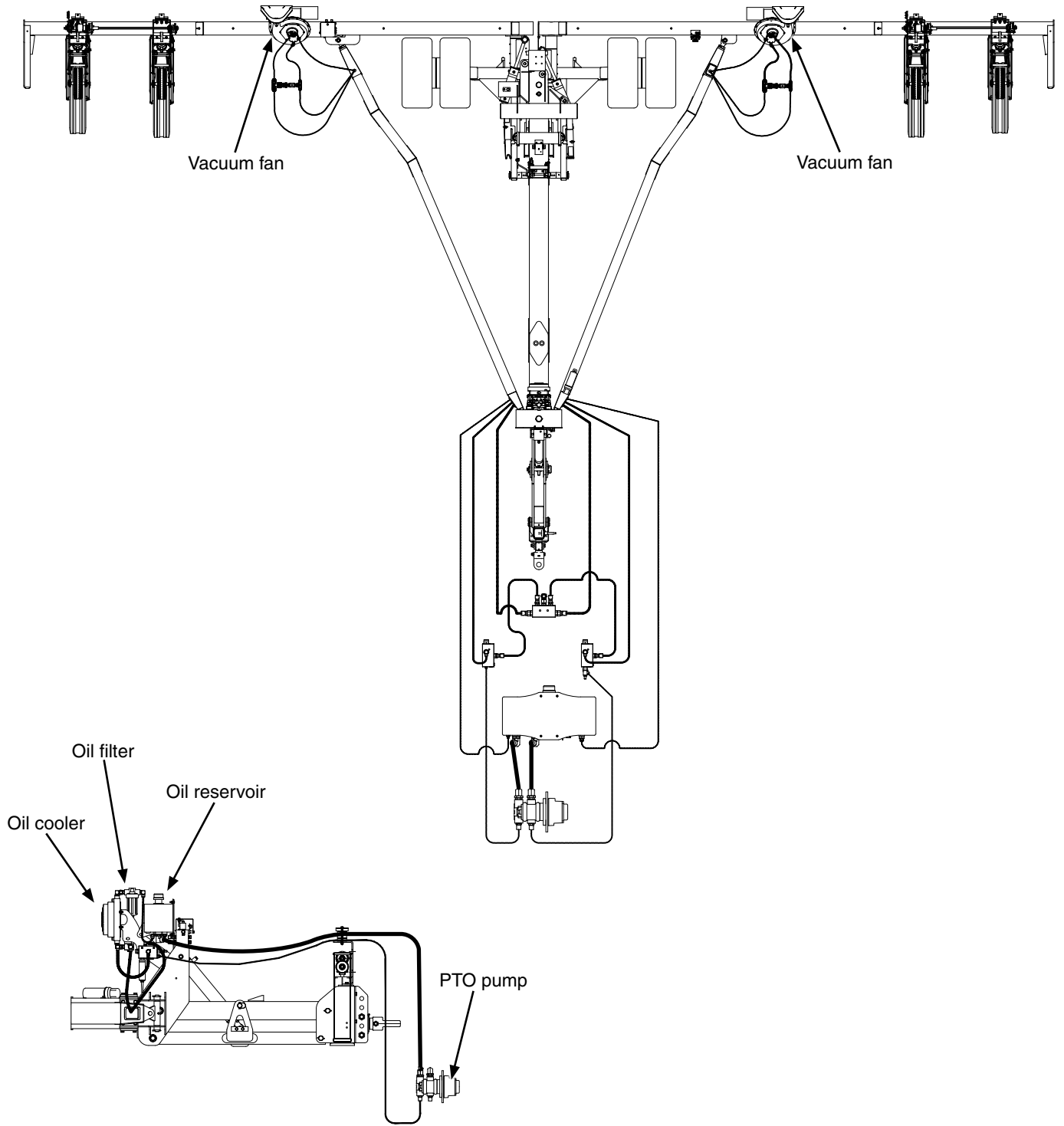

This page intentionally left blank.

HYDRAULIC SYSTEM SCHEMATIC (24 ROW 20"/22"/30")

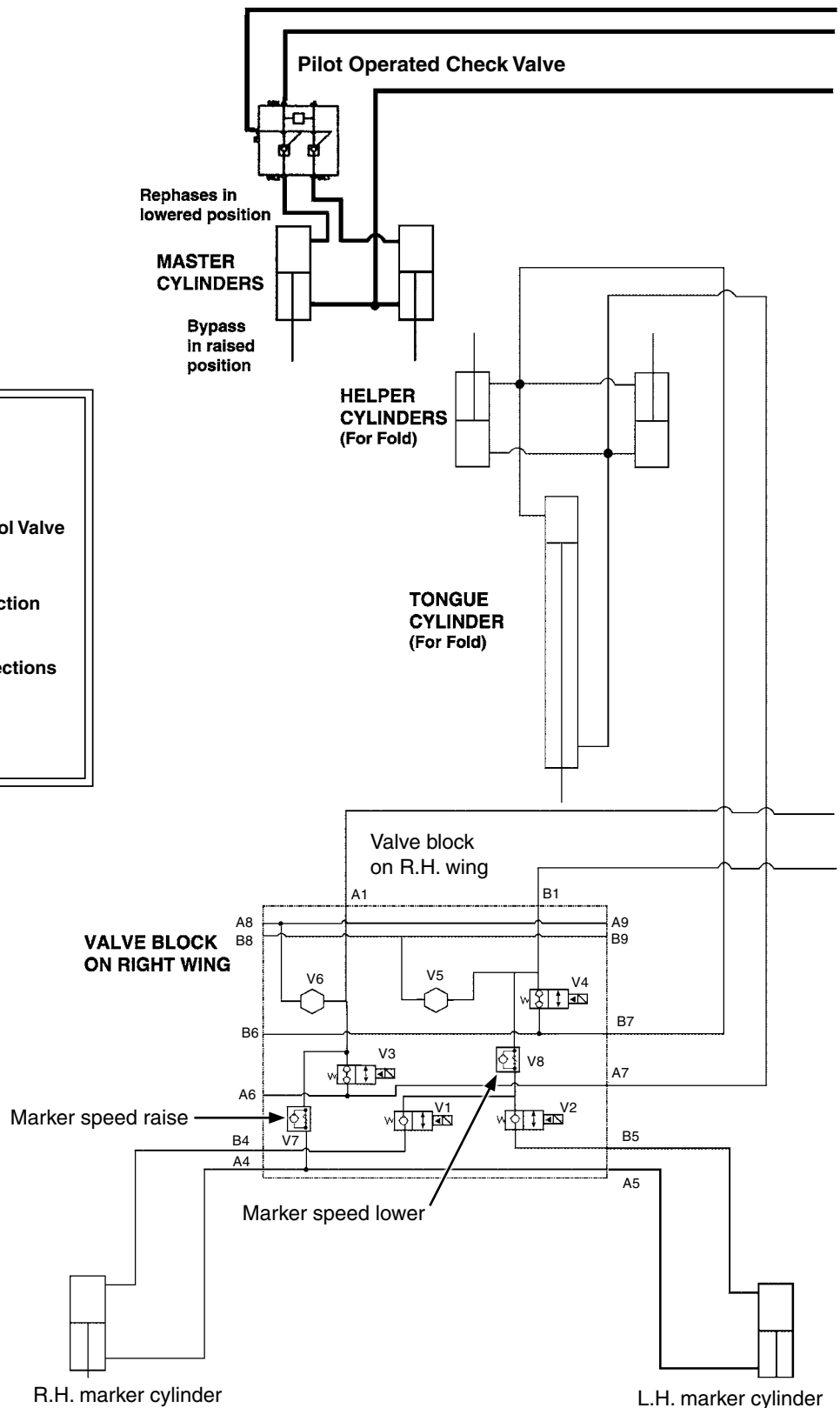
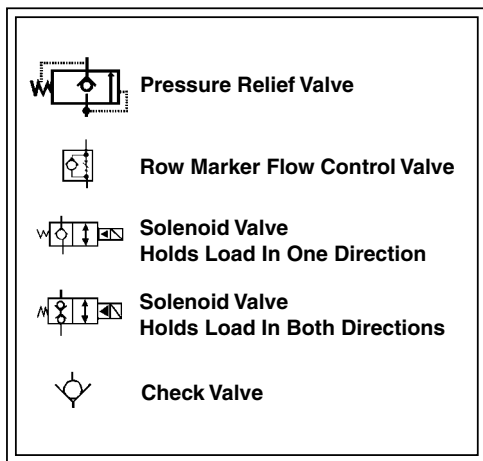

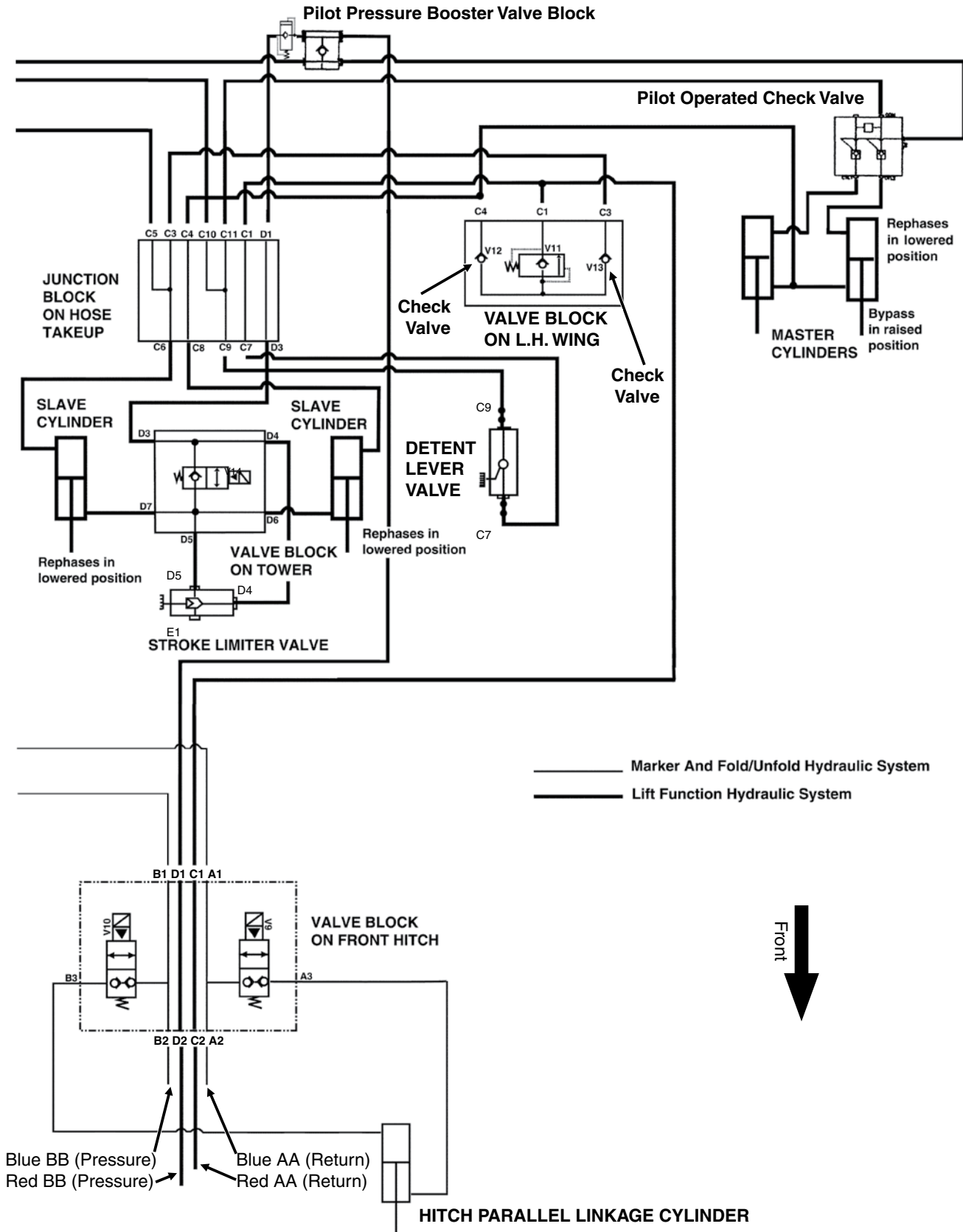

HYDRAULIC SYSTEM SCHEMATIC (36 ROW 20")

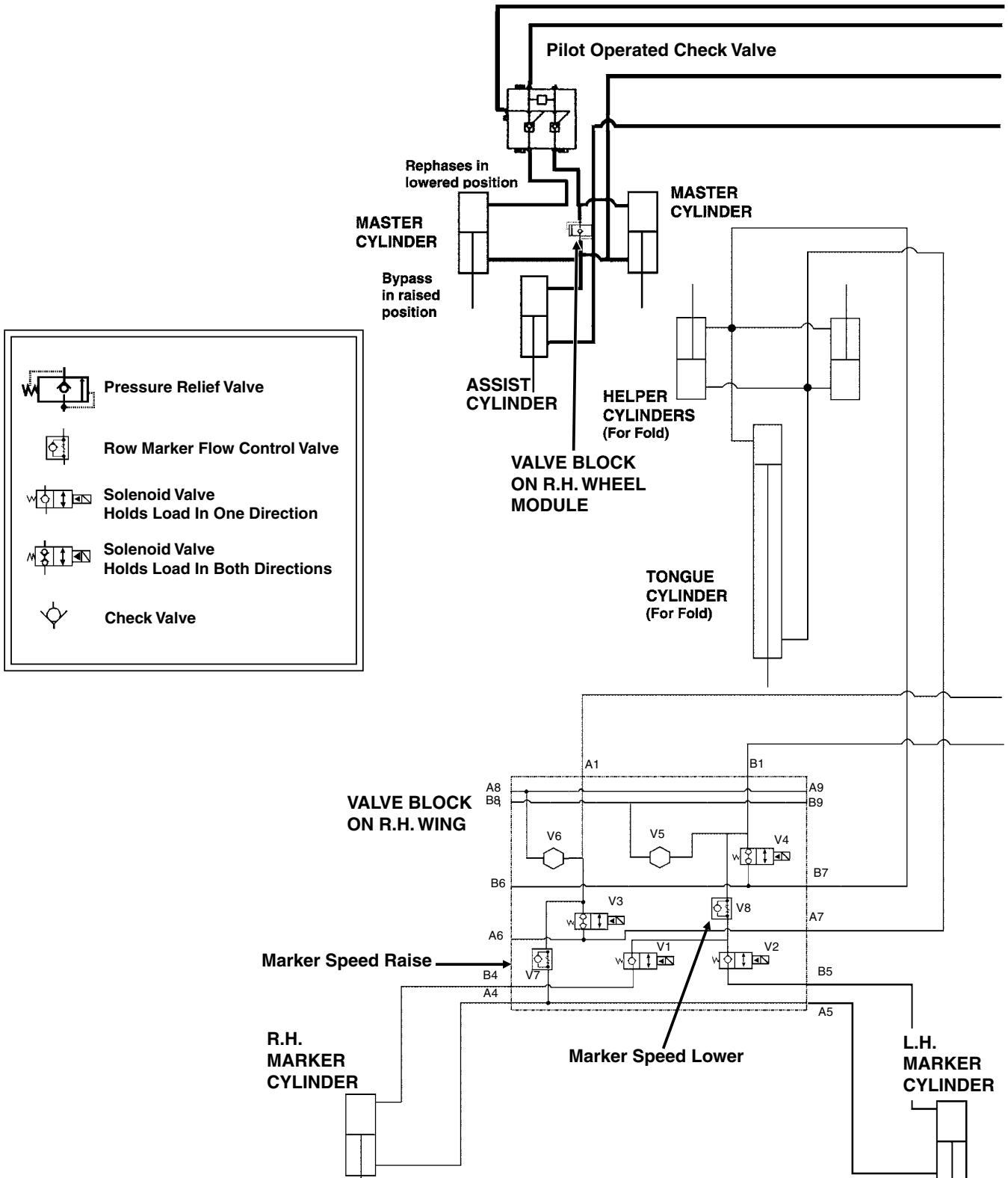

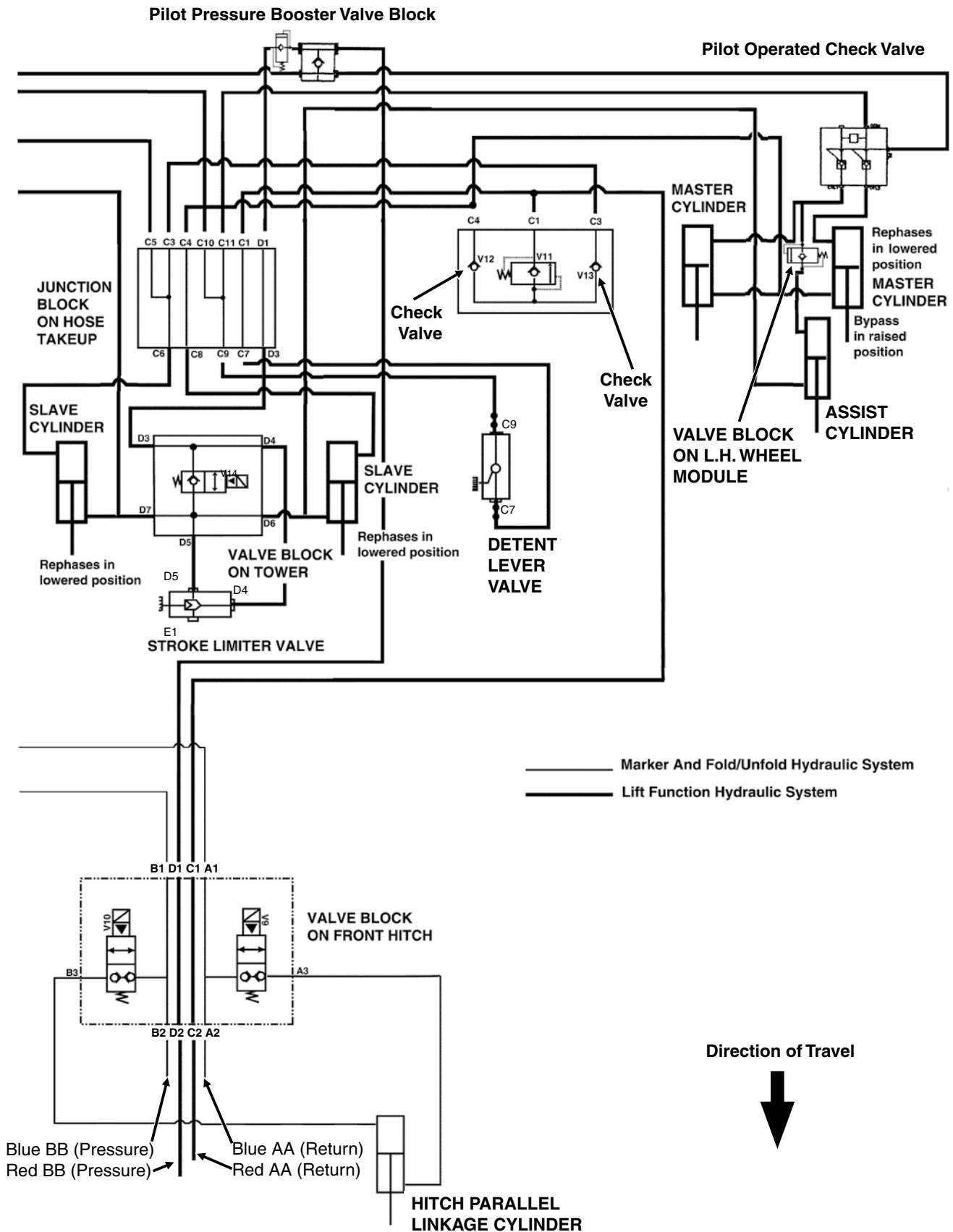

HYDRAULIC VALVE BLOCK LOCATIONS

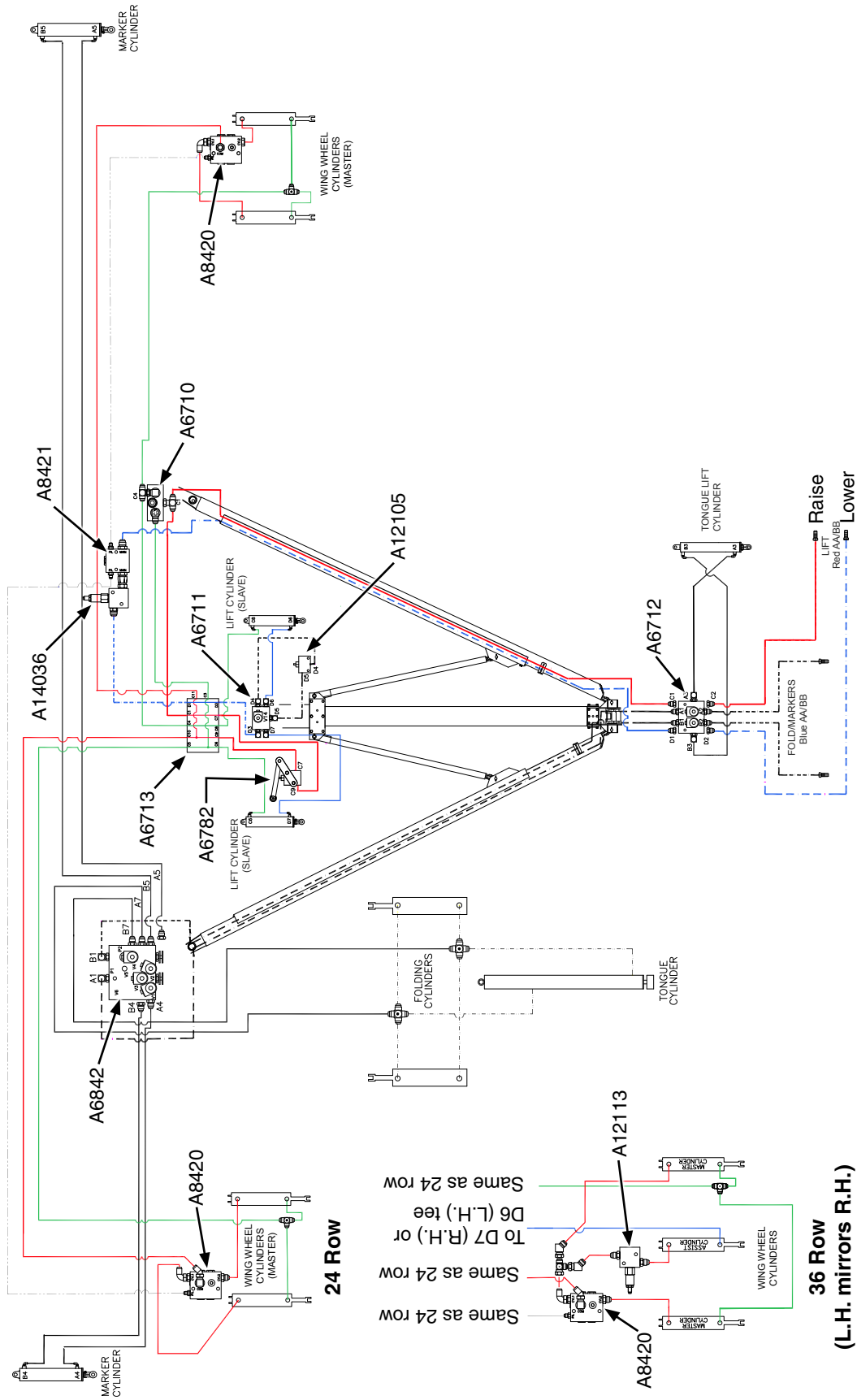

HYDRAULIC VALVE BLOCK FUNCTIONS

Valve Assembly	Name	Function
A6710	Valve block on L.H. wing	1500 psi relief valve. Allows lower from transport.
A6711	Valve block on tower	Oil enters D3 and flows past V14 to rod end of slave cylinders when lowering planter. Oil from rod side of slave cylinders goes in D6 and D7 when raising planter. V14 is closed so oil goes out D5 to height stop plunger and comes back in on D4 to tractor. Oil flows directly to tractor when V14 is energized and allows planter to raise to transport height.
A6712	Valve block on front hitch	Controls tongue lift cylinder and routes hydraulic hoses to left and right side drag links.
A6713	Junction block on hose take-up	Planter lift circuit junction block. Routes hydraulic flow to all planter lift related valves.
A6782	Detent Lever Valve	Blocks oil from exiting wing cylinders when lowering until center of planter reaches a predetermined height (level toolbars) and then is mechanically opened.
A6842	Valve block on R.H. wing	Controls markers and marker speed. Routes hydraulic flow to tongue and fold cylinders.
A8420	Pilot Operated Check Valve	Traps oil in butt ends of wing cylinders until pilot pressure from A8421 opens check valves and allows cylinders to retract.
A8421	Valve block on L.H. wing	Opens pilot operated check valves in A8420 when lowering.
A12105	Stroke Limiter Valve	Shuts off hydraulic flow to set field turn height.
A12113	Valve block on L.H. and R.H. wheel module (36 row 20 only)	Blocks flow from port 2 to 1 until pressure exceeds valve set pressure (1000 psi). Allows free reverse flow from 1 to 2 if pressure at 1 is at least 10 psi greater than pressure at 2.
A14036	Pilot Pressure Booster Valve Block	Located on inboard side of A8421 to create 1000 psi pressure on pilot lines to ensure wing wheels lower together.

AIR CLUTCH AIRLINE SCHEMATIC

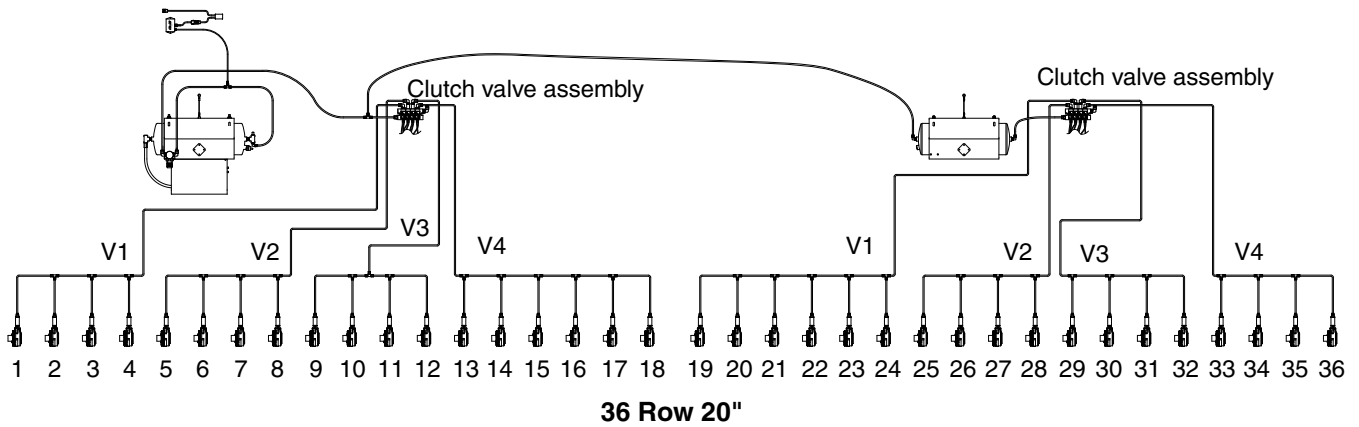
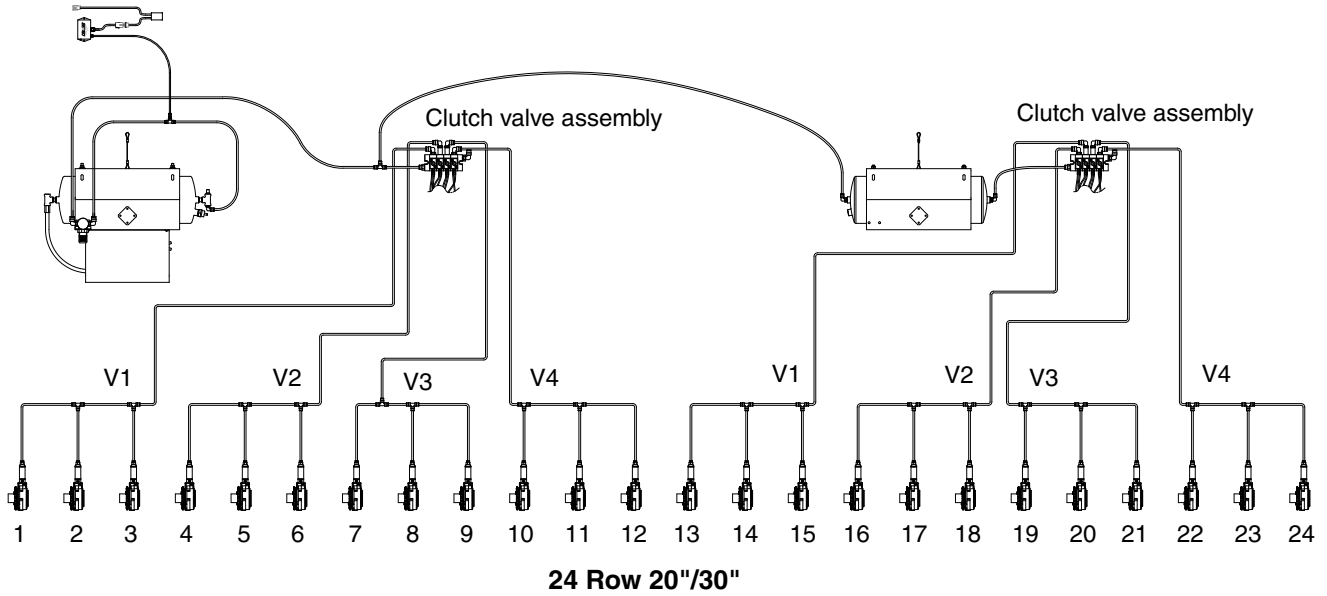

ELECTRIC CLUTCH SCHEMATIC

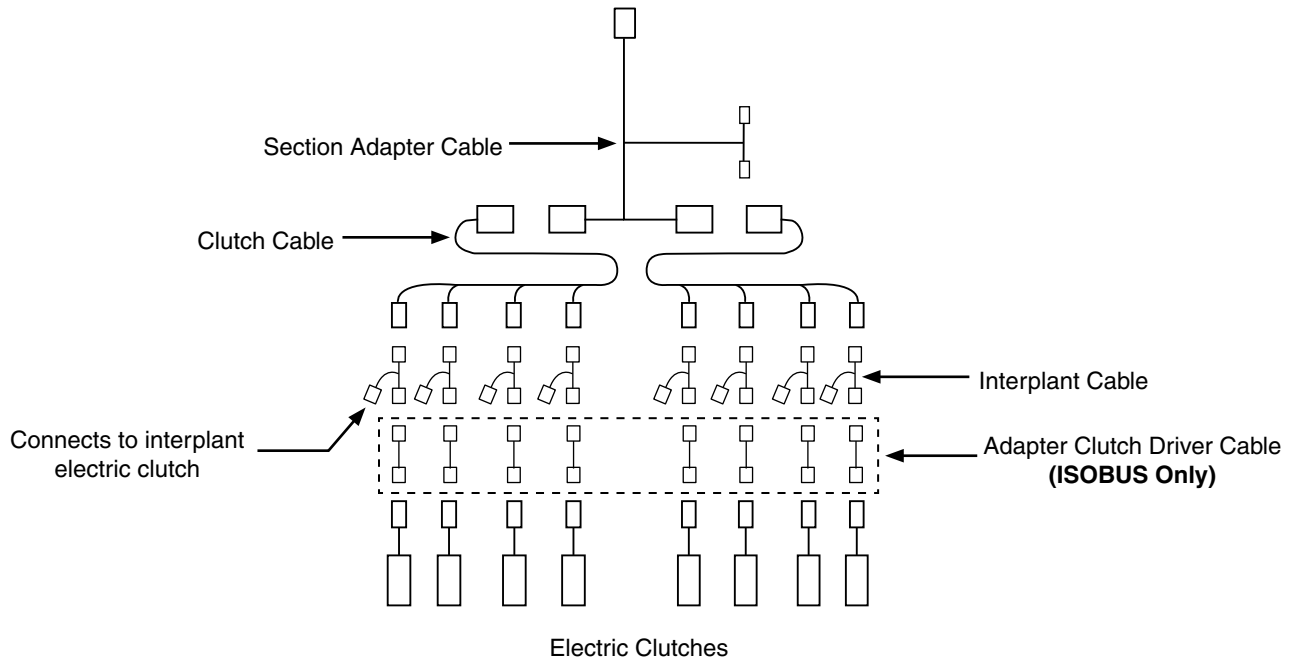

ISOBUS CABLE RATE CONTROL

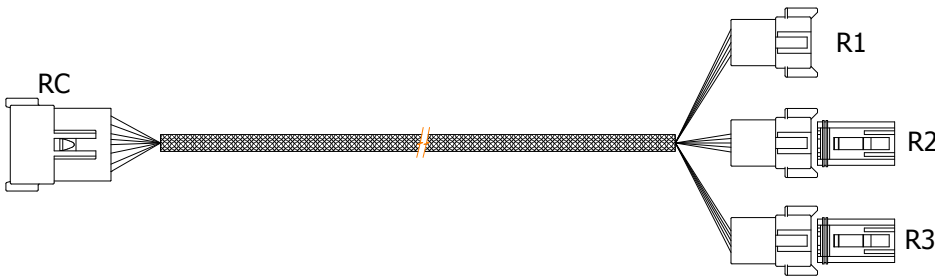

Signal	RC	Wire/Color	R1	R2	R3
Load Power	1	Red	1	1	1
Load Ground	2	Black	4	4	4
PWM 1 Power	3	Red/Green	-	-	-
PWM 1 Ground	47	Black/Green	-	-	-
PWM 2 Power	52	Red/Yellow	-	-	-
PWM 2 Ground	67	Black/Yellow	-	-	-
PWM 3 Power	72	Red/Blue	-	-	-
PWM 3 Ground	87	Black/Blue	-	-	-
Meter Speed 1	93	Green	-	-	-
Meter Speed 2	10	Green	-	3	-
Meter Speed 3	11	Green/Red	-	-	3

ISOBUS IMPLEMENT CABLE

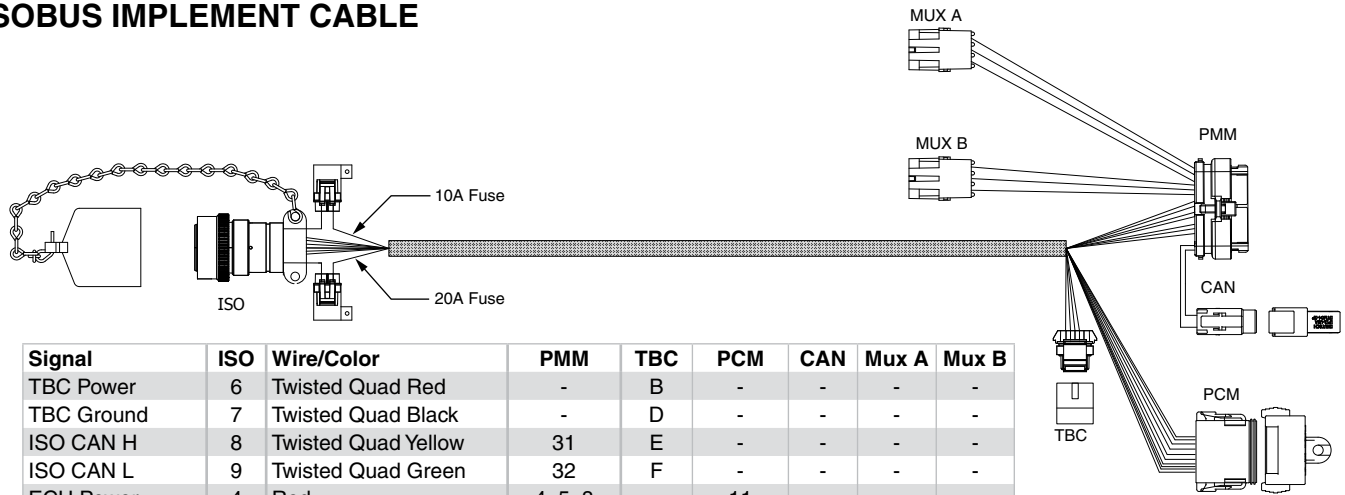

Signal	ISO	Wire/Color	PMM	TBC	PCM	CAN	Mux A	Mux B
TBC Power	6	Twisted Quad Red	-	B	-	-	-	-
TBC Ground	7	Twisted Quad Black	-	D	-	-	-	-
ISO CAN H	8	Twisted Quad Yellow	31	E	-	-	-	-
ISO CAN L	9	Twisted Quad Green	32	F	-	-	-	-
ECU Power	4	Red	4, 5, 8	-	11	-	-	-
ECU Ground	2	Black	14, 15	-	12	-	-	-
LOAD Power	3	Red	-	-	1, 2, 3, 4	-	-	-
LOAD Ground	1	Black	-	-	5, 6, 7, 8	-	-	-
MUX A Power	-	Jacketed 3-Cond White	12	-	-	-	A	-
MUX A Ground	-	Jacketed 3-Cond Black	3	-	-	-	B	-
MUX A Signal	-	Jacketed 3-Cond Green	28	-	-	-	C	-
PROP CAN H	-	Twisted Pair Yellow	34	-	-	1	-	-
PROP CAN L	-	Twisted Pair Green	35	-	-	2	-	-
MUX B Power	-	Jacketed 3-Cond White	23	-	-	-	-	A
MUX B Ground	-	Jacketed 3-Cond Black	26	-	-	-	-	B
MUX B Signal	-	Jacketed 3-Cond Green	7	-	-	-	-	C

ISOBUS CAN JUMPER CABLE

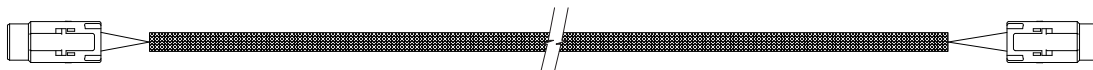

SIGNAL	CAN	WIRE/COLOR
CAN H	1	Twisted Pair Yellow
CAN L	2	Twisted Pair Green

PRODUCT CONTROL MODULE CABLE

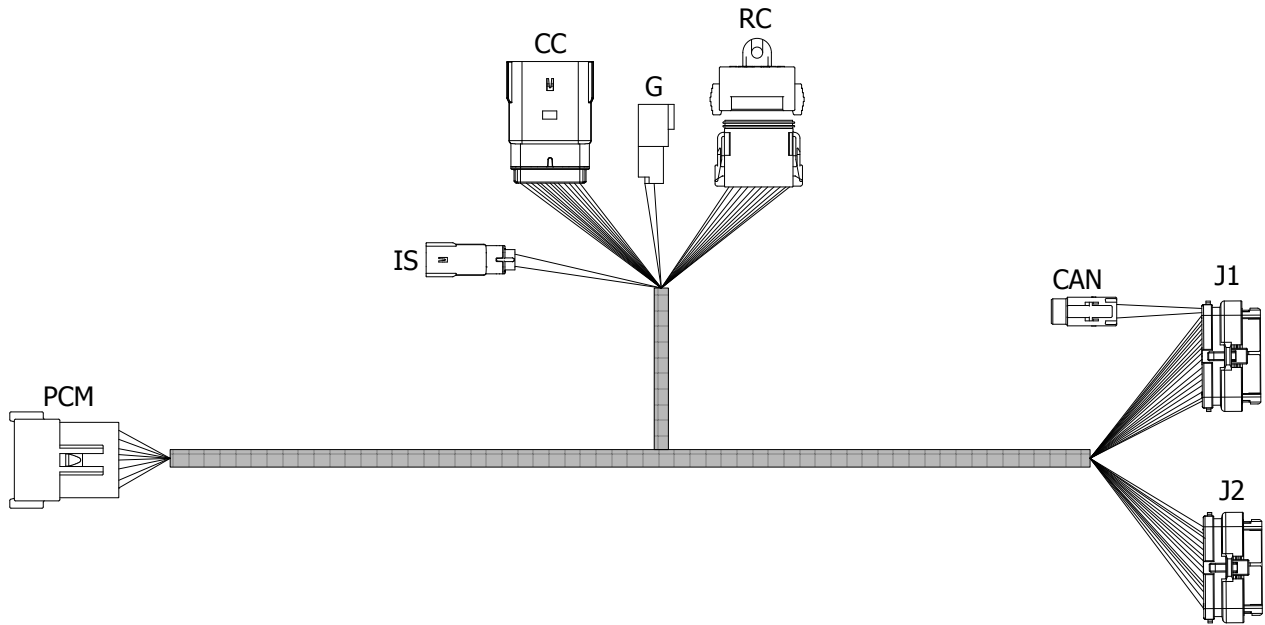

Signal	PCM	Wire/Color	J1	J2	CAN	RC	CC	IS	G
Load Power	1	Red	2	-	-	-	-	-	-
Load Power	2	Red	3	-	-	1	-	-	-
Load Power	3	Red	4	-	-	-	-	1	-
Load Power	4	Red	5	-	-	-	-	-	-
Load Ground	5	Black	-	-	-	-	-	-	1, 2
Load Ground	6	Black	14, 15	-	-	-	-	-	-
Load Ground	7	Black	16	-	-	2	-	-	-
Load Ground	8	Black	17	-	-	-	-	-	-
ECU Power	11	White/Red	11	-	-	-	-	-	-
CAN H	-	Twisted Pair Yellow	34	-	1	-	-	-	-
CAN L	-	Twisted Pair Green	33	-	2	-	-	-	-
Switch In	-	Red/Green	10	-	-	-	-	2	-
Section 1	-	White	24	-	-	-	1	-	-
Section 2	-	Green	25	-	-	-	2	-	-
Section 3	-	Orange	26	-	-	-	3	-	-
Section 4	-	Blue	27	-	-	-	4	-	-
Section 5	-	Brown	-	11	-	-	5	-	-
Section 6	-	Yellow	-	10	-	-	6	-	-
Section 7	-	Violet	-	9	-	-	7	-	-
Section 8	-	Gray	-	8	-	-	8	-	-
Section 9	-	Pink	-	7	-	-	9	-	-
Section 10	-	Tan	-	6	-	-	10	-	-
Section 11	-	Red/Green	-	5	-	-	11	-	-
Section 12	-	Black/Red	-	4	-	-	12	-	-
PWM 1 Power	-	Red/White	-	23	-	3	-	-	-
PWM 1 Ground	-	Black/White	35	-	-	4	-	-	-
PWM 2 Power	-	Red/Yellow	-	12	-	5	-	-	-
PWM 2 Ground	-	Black/Yellow	12	-	-	6	-	-	-
PWM 3 Power	-	Red/Blue	1	-	-	7	-	-	-
PWM 3 Ground	-	Black/Blue	-	24	-	8	-	-	-
Meter Speed 1	-	Green	30	-	-	9	-	-	-
Meter Speed 2	-	Green/White	29	-	-	10	-	-	-
Meter Speed 3	-	Green/Red	-	33	-	11	-	-	-

IMPLEMENT SWITCH EXTENSION CABLE

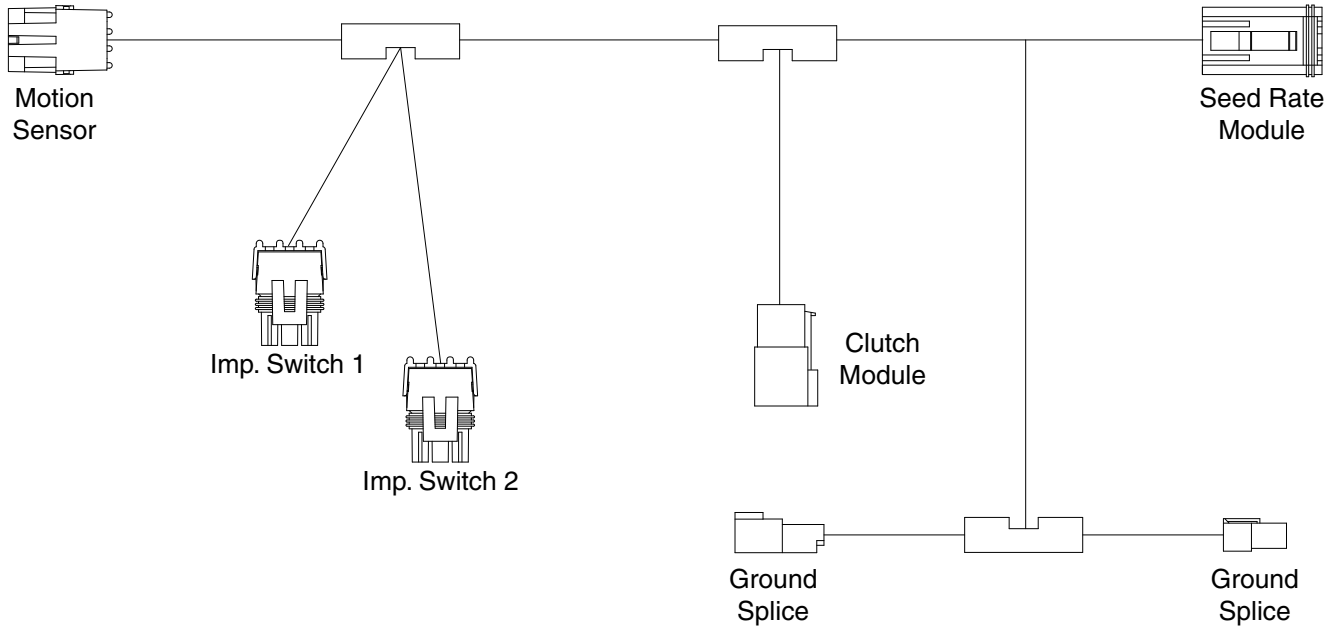

Signal	Imp. Switch 1 WP Tower 1	Imp. Switch 2 WP Tower 2	Motion Sensor WP Shroud	Color	Clutch Module Molex Recept	Seed Rate Module Deutsch Plug	Ground Splice 1	Ground Splice 2	Gauge
12V+ Power	A	A	-	Brown	1	12	-	-	16
Switch Signal	B	B	-	Green	2	10	-	-	16
Motion Signal	-	-	C	White	-	11	-	-	16
Ground	-	-	B	Black	-	6	-	-	16
12V+ Power	-	-	A	Red	-	1	-	-	16
Ground	C (Blue 16 AWG)	C (Blue 16 AWG)	-	Black	-	-	2	2	12
12V+ Power	-	-	-	Red	-	-	1	1	12

SECTION ADAPTER CABLE - 24 ROW

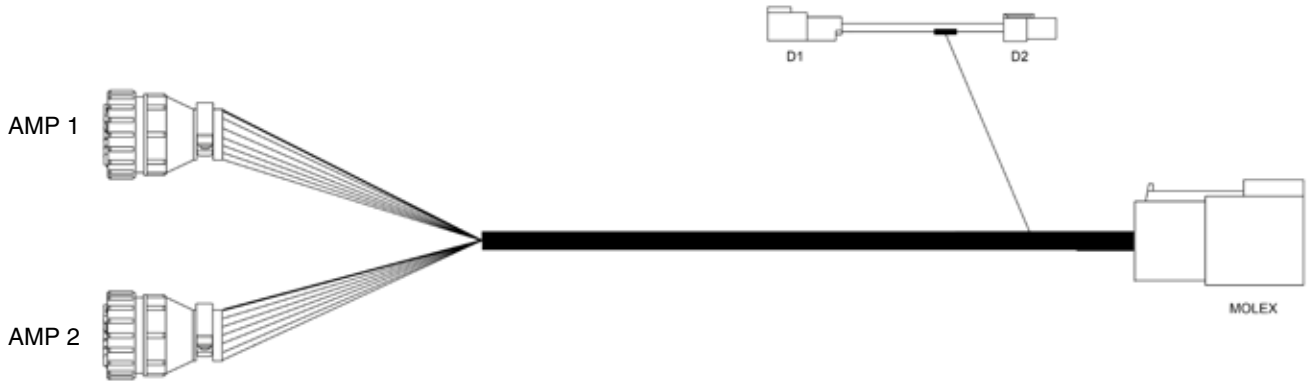

Signal	Color	AMP 1 (Left)	AMP 2 (Right)	Molex	D1	D2
High Current Power	Red	1 (16 Gauge)	1 (16 Gauge)	-	1 (12 Gauge)	1 (12 Gauge)
Ground	Black	-	-	-	2	2
Row 1, 2	Black	2, 3	-	1	-	-
Row 3, 4	Brown	4, 5	-	2	-	-
Row 5, 6	Orange	6, 7	-	3	-	-
Row 7, 8	Pink	8, 9	-	4	-	-
Row 9, 10	Green	10, 11	-	5	-	-
Row 11, 12	Yellow	12, 13	-	6	-	-
Row 13, 14	Blue	-	12, 13	7	-	-
Row 15, 16	Violet	-	10, 11	8	-	-
Row 17, 18	Red	-	8, 9	9	-	-
Row 19, 20	Tan	-	6, 7	10	-	-
Row 21, 22	Gray	-	4, 5	11	-	-
Row 23, 24	White	-	2, 3	12	-	-

SECTION ADAPTER CABLE - 36 ROW

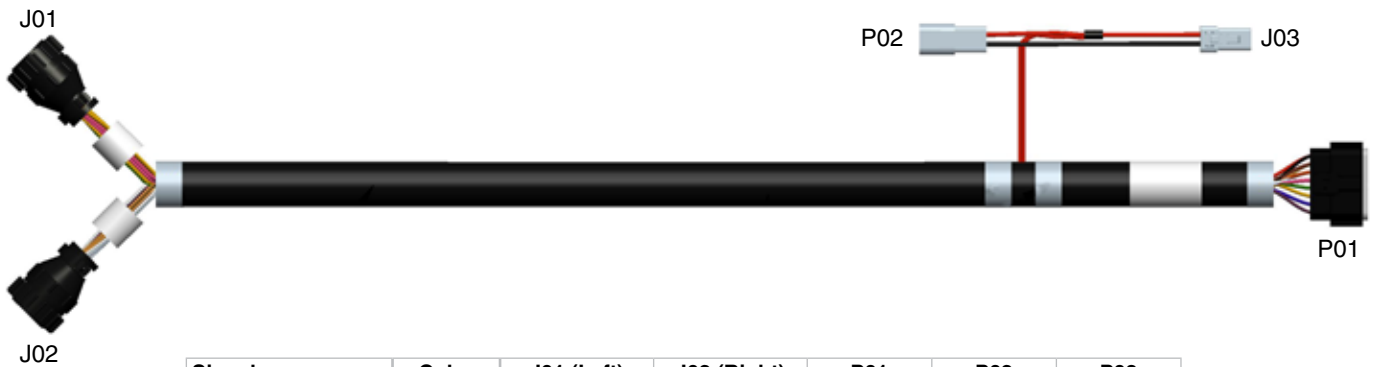

Signal	Color	J01 (Left)	J02 (Right)	P01	P02	P03
Power	Red	1	1	-	1	1
Ground	Black	-	-	-	2	2
Row 1, 2, 3	Black	2, 3, 4	-	1	-	-
Row 4, 5, 6	Brown	5, 6, 7	-	2	-	-
Row 7, 8, 9	Orange	8, 9, 10	-	3	-	-
Row 10, 11, 12	Pink	11, 12, 13	-	4	-	-
Row 13, 14, 15	Green	14, 15, 16	-	5	-	-
Row 16, 17, 18	Yellow	17, 18, 19	-	6	-	-
Row 19, 20, 21	Blue	-	17, 18, 19	7	-	-
Row 22, 23, 24	Violet	-	14, 15, 16	8	-	-
Row 25, 26, 27	Red	-	11, 12, 13	9	-	-
Row 28, 29, 30	Tan	-	8, 9, 10	10	-	-
Row 31, 32, 33	Gray	-	5, 6, 7	11	-	-
Row 34, 35, 36	White	-	2, 3, 4	12	-	-

CLUTCH CABLE - 24 ROW

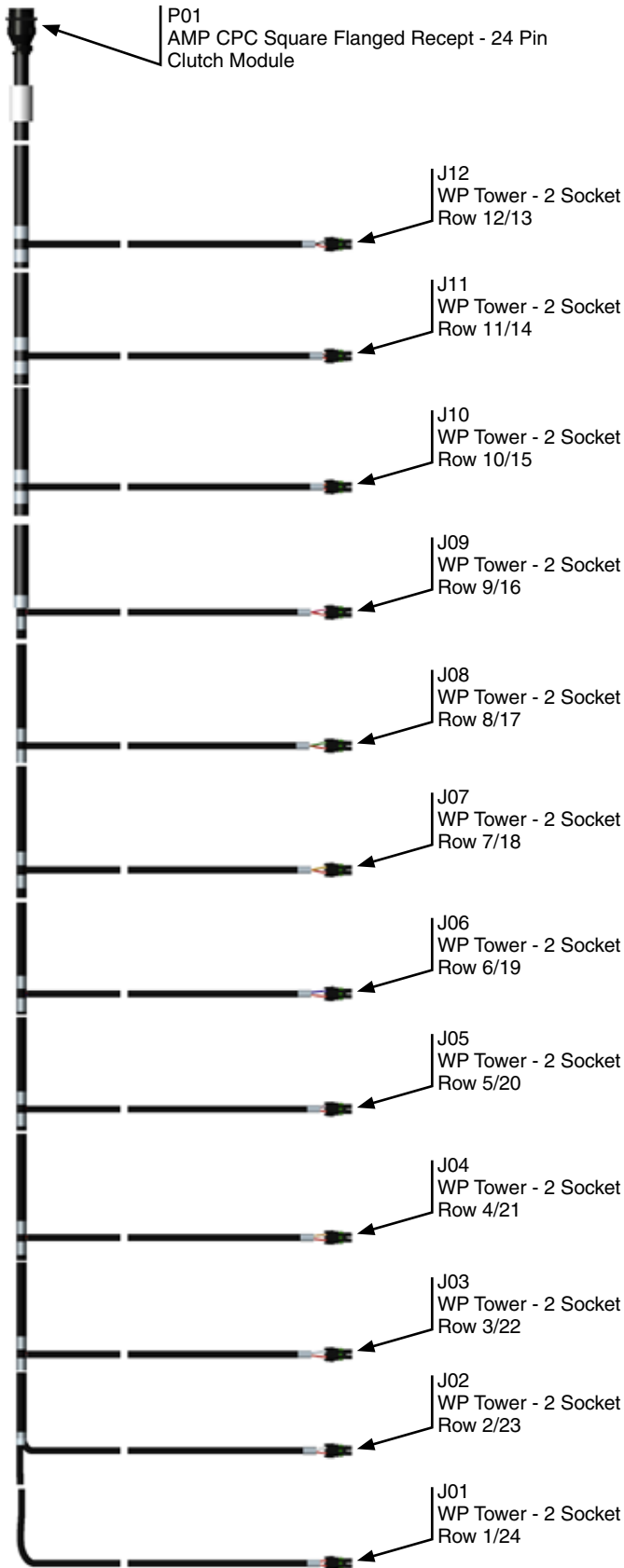

Signal	Clutch Cable	Row 1/24	Row 2/23	Row 3/22	Row 4/21	Row 5/20	Row 6/19	Row 7/18	Row 8/17	Row 9/16	Row 10/15	Row 11/14	Row 12/13
Power	1	A	A	A	A	A	A	A	A	A	A	A	A
Row 1/24	2	B											
Row 2/23	3		B										
Row 3/22	4			B									
Row 4/21	5				B								
Row 5/20	6					B							
Row 6/19	7						B						
Row 7/18	8							B					
Row 8/17	9								B				
Row 9/16	10									B			
Row 10/15	11										B		
Row 11/14	12											B	
Row 12/13	13												B

CLUTCH CABLE - 36 ROW

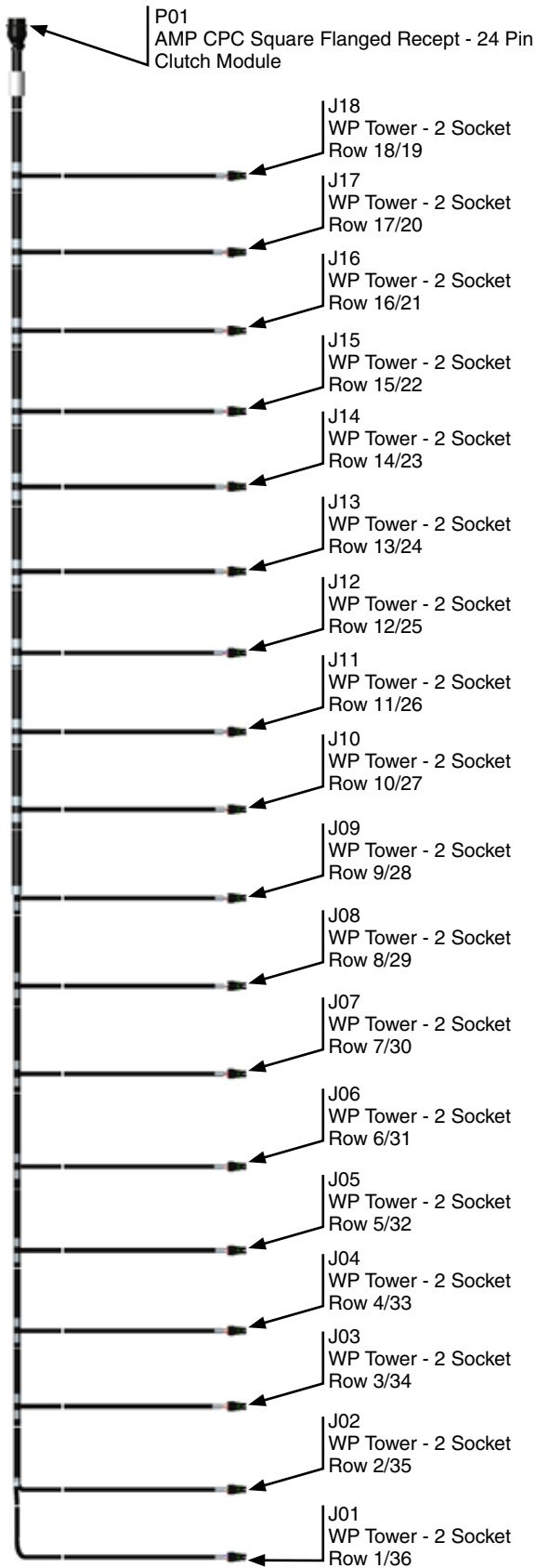

Signal	Clutch Cable	Row 1/36	Row 2/35	Row 3/34	Row 4/33	Row 5/32	Row 6/31	Row 7/30	Row 8/29	Row 9/28	Row 10/27	Row 11/26	Row 12/25	Row 13/24	Row 14/23	Row 15/22	Row 16/21	Row 17/20	Row 18/19
Power	1	A		A	A	A	A	A	A	A	A	A	A	A	A	A	A	A	A
Row 1/36	2	B																	
Row 2/35	3		B																
Row 3/34	4			B															
Row 4/33	5				B														
Row 5/32	6					B													
Row 6/31	7						B												
Row 7/30	8							B											
Row 8/29	9								B										
Row 9/28	10									B									
Row 10/27	11										B								
Row 11/26	12											B							
Row 12/25	13												B						
Row 13/24	14													B					
Row 14/23	15														B				
Row 15/22	16															B			
Row 16/21	17																B		
Row 17/20	18																	B	
Row 18/19	19																		B

This page intentionally left blank.

AIR CLUTCH

PROBLEM	POSSIBLE CAUSE	SOLUTION
Clutches slip (effected row does not plant or skips).	Plunger in cylinder seized.	Remove air line and lubricated with pneumatic or light duty hydraulic oil.
	Worn Clutch.	Replace worn items.
	Dirt/debris buildup inside clutch.	Disassemble clean as needed. Reassemble.

AIR SEED DELIVERY (ASD)

PROBLEM	POSSIBLE CAUSE	SOLUTION
Seed does not travel through delivery tubes.	System pressure set too low.	Increase system pressure.
Seed stops flowing to row unit during planting.	Seed surging.	Shut down air seed delivery system and restart system from idle; seed should start flowing.
	Debris in system.	Insert shutoff door, open cleanout door. remove plug.
Seed does not move from entrainer at startup after exposure to water.	Seed swelled in entrainer.	Insert shutoff door, open cleanout door. remove swelled seed.

CLOSING WHEEL

PROBLEM	POSSIBLE CAUSE	SOLUTION
Closing wheel(s) leave severe imprint in soil.	Too much closing wheel down pressure.	Adjust closing wheel pressure.
Closing wheel(s) not firming soil around seed.	Not enough closing wheel down pressure.	Adjust closing wheel pressure. Severe no till conditions may require use of cast iron closing wheels.
"V" closing wheel running on top of seed furrow.	Improper centering.	Align. See "V Closing Wheel Adjustment".
Single closing wheel not directly over seed.	Improper centering.	Align. See "Covering Discs/Single Press Wheel Adjustment".

KPM III ELECTRONIC SEED MONITOR

PROBLEM	POSSIBLE CAUSE	SOLUTION
Single sensor communication alarm comes on.	Faulty seed tube sensor.	Replace sensor.
	Break in the harness just before the seed tube sensor.	Inspect for break in harness and repair. If break can't be found, replace harness section.
	Dirty or corroded connector.	Clean connector.
Sensor communication alarms come on for all sensors.	Faulty monitor.	Repair/Replace monitor.
	Break in the harness just after the monitor.	Inspect for break in harness and repair. If break can't be found, replace harness section.
	Dirty or corroded connector.	Clean connector.
Sensor communication alarms come on for some sensors.	Break in the harness.	Inspect for break in harness and repair. If break can't be found, replace harness section corresponding with alarming sensors.
	Dirty or corroded connector.	Clean connector.
Faulty monitor values (such as speed, area, etc.) being displayed.	Incorrect monitor settings.	Change settings to properly correspond to the system.
	Faulty radar/magnetic distance sensor.	Replace sensor.
	Improperly mounted radar sensor.	Properly mount sensor.
Underplanting or no planting alarm on a single sensor when planting (alarm on with a single bargraph segment on and a flashing row number on a single row.	Seed tube sensor is blocked.	Clean sensor.
	Faulty seed tube sensor.	Replace sensor.
	Meter not planting or underplanting.	Repair/replace meter.
	Chain broken or off sprocket.	Repair as necessary.
Seed tube sensor dirty or blocked warning comes on.	Seed tube sensor is dirty.	Clean sensor.
	Faulty seed tube sensor.	Replace sensor.
LED on seed tube sensor will not come on.	Faulty seed tube sensor.	Replace sensor.
	Dirty or corroded connector.	Clean connector.
	Break in the harness just before the sensor.	Repair harness.
Erroneous MPH readings at idle. (Radar Distance Sensor Only)	Radar sensor not located in a stable location.	Relocate to a more stable location.

LIFT CIRCUIT

PROBLEM	POSSIBLE CAUSE	SOLUTION
Field turn around toolbar height is not 39"-41".	Stroke limiter valve is out of adjustment.	Consult your Kinze Dealer for service.
Planter not leveling out when lowering from transport.	Detent lever valve out of adjustment.	Consult your Kinze Dealer for service.
Planter settles.	Lift cylinder leaking.	Repair or replace cylinder.

PISTON PUMP

PROBLEM	POSSIBLE CAUSE	SOLUTION
Pump hard or impossible to prime.	Valves fouled or in wrong place.	Inspect and clean valves.
	Air leak in suction line.	Repair leak.
	Pump set too low.	Adjust pump setting.
	Packing washers worn out.	Replace.
Low metering.	Valves fouled or in wrong place.	Inspect and clean valves.
	Air leak in suction line.	Repair leak.
	Pump set too low.	Adjust pump setting.
	Broken valve spring.	Replace spring.
Over meters.	Broken discharge valve spring.	Replace spring.
	Trash under valves.	Inspect and clean valves.
	Improper rate setting.	Adjust pump setting.
Leaks through when stopped.	Broken discharge valve spring.	Replace spring.
	Trash under valves.	Inspect and clean valves.
Fertilizer solution leaking under stuffing box.	Packing washers worn out.	Replace.
Pump using excessive oil.	Oil seals or O-ring worn and leaking.	Replace.
Pump operates noisily.	Crankcase components worn excessively.	Inspect and replace if necessary.

POINT ROW CLUTCH

PROBLEM	POSSIBLE CAUSE	SOLUTION
No clutches disengage.	Main fuse blown in control console.	Replace defective fuse.
	Poor terminal connection in wiring harness.	Repair or replace.
	Wiring damage in wiring harness.	Repair or replace.
	Low voltage at coil. (12 volts required)	Check battery connections.
One section of planter will not re-engage.	Shear pin at seed drive transmission(s) sheared.	Replace pin with one of equal size and grade.
One clutch will not engage.	Fuses blown.	Replace defective fuses.
	Actuator arm and plunger stuck in disengaged position.	Remove, free up, and reinstall.
	Actuator arm out of adjustment.	Adjust actuator arm mounting pin in slot so that actuator arm clears stop on stop collar by approximately " when clutch is rotated.
	Wrap spring broken or stretched.	Disassemble clutch and replace spring.
	Something touching the stop collar.	Check to ensure collar is free to turn with clutch.
	Clutch assembled incorrectly.	Check clutch and diagram for correct assembly.
Clutch slipping.	Wrap spring stretched.	"Lock" clutch output shaft from turning. Place torque wrench on input shaft and rotate in direction of drive. After input shaft has rotated a short distance the wrap spring should tighten onto the input hub. If slippage occurs at less than 100 ft. lbs. replace spring. If spring still slips after installing new spring, replace input hub.
Planter section does not re-engage while planter is moving forward.	Spring in actuator arm not strong enough to push arm operational switch is turned to the ON position.	Remove spring from inside solenoid and stretch spring slightly or replace. Reinstall spring. If that fails, file the away from stop collar when stop on the stop collar slightly so that the stop is not as aggressive.
Frequent solenoid burnout.	Fuses too large.	Replace fuses on front panel with 10 amp slow blow fuses.
Frequent fuse burnout.	Low voltage (12 volts required).	Check power source voltage for partially discharged battery, etc.
	Damage to wiring harness.	Repair or replace harness.
Clutch or clutches will not disengage.	Input and output shafts out of alignment.	Align input and output shafts to prevent drag.
	Input or output shaft is pushed in too far creating a coupler.	Reposition input and output shafts.

PTO PUMP DRIVE AND OIL COOLER OPTION

PROBLEM	POSSIBLE CAUSE	SOLUTION
Pump is squealing.	Lack of oil to pump.	Check for plugged suction strainer. Check oil level.
Oil temperature high.	Low oil level.	Check oil level and add as required.
Desired fan speed cannot be achieved.	Low oil level.	Check oil level and add as required.
	Plugged filter.	Check and change as required.
Vacuum level not displayed.	Digital vacuum gauge console power OFF.	Turn ON.
	Cable not plugged in.	Check connection.
	Digital vacuum gauge console has no power.	Check fuse.

ROW MARKER OPERATION

PROBLEM	POSSIBLE CAUSE	SOLUTION
Right marker lowering slower than left marker.	Solenoid valve cartridge in port V1 not opening completely.	Switch with cartridge in port V2. If problem repeats, replace cartridge.
	Hose pinched or collapsed.	Inspect hose routing. Replace or repair hoses as required.
Left marker lowering slower than right marker.	Solenoid valve cartridge in port V2 not opening completely.	Switch with cartridge in port V1. If problem repeats, replace cartridge.
	Hose pinched or collapsed.	Inspect hose routing. Replace or repair hoses as required.
Both markers lowering.	Solenoid valve cartridge stuck open. If left marker switch is selected, right cartridge (V1) is defective. If right marker switch is selected, left cartridge (V2) is defective.	Replace solenoid valve cartridge.
Neither marker lowers.	Blown fuse.	Check red light on control console. It should be on if switch is on. If light is not on, switch to opposite marker position. If light comes on, switch may be defective. Replace switch. Otherwise replace fuse.
	Coils at V1 and V2 not energized.	Poor ground on wire, bad wire connection or damaged wire. Repair as required.
	Marker flow control valve closed too far.	See "Row Marker Speed Adjustment".
Neither marker will raise.	Marker flow control valve closed too far.	See "Row Marker Speed Adjustment".
Right marker will not lower.	Solenoid coil in port V1 not energized.	Check switch on control console. Replace if defective. Check coil ground wire. Check for poor connection or damaged wire.
	Solenoid cartridge in port V1 stuck closed.	Switch cartridge with one on the planter you know is operating properly. If right marker lowers, replace defective cartridge.
Left marker will not lower.	Solenoid coil in port V2 not energized.	Check switch on control console. Replace if defective. Check coil ground wire. Check for poor connection or damaged wire.
	Solenoid cartridge in port V2 stuck closed.	Switch cartridge with one on the planter you know is operating properly. If left marker lowers, replace defective cartridge.
Markers traveling too fast and damaging rubber stop on transport stands and/or damaging pivot at rod end of marker cylinders.	Marker transport stand not adjusted correctly to allow marker cushion cylinders to operate as designed.	See "Row Marker Transport Stand Adjustment".
	Adjust row marker flow control valve.	See "Row Marker Speed Adjustment".

SEED METER (BRUSH-TYPE)

PROBLEM	POSSIBLE CAUSE	SOLUTION
Low count.	Meter RPM too high.	Reduce planting speed.
	Seed sensor not picking up all seeds dropped.	Clean seed tube. Switch meter to different row. If problem stays in same row, replace sensor.
	Lack of lubrication causing seeds not to release from disc properly.	Use graphite or talc as recommended.
	Seed size too large for seed disc being used.	Switch to smaller seed or appropriate seed disc. See "Brush-Type Seed Meter" for proper seed disc for size of seed being used.
	Seed treatment buildup in meter.	Reduce treatment amount used. Thoroughly mix treatment with seed. Add talc.
Low count at low RPM and higher count at higher RPM.	Foreign material lodged in upper brush.	Remove seed disc and remove foreign material from between brush retainer and bristles. Clean thoroughly.
	Worn upper brush.	Replace. See "Brush-Type Seed Meter Maintenance".
Low count at higher RPM and normal count at low RPM.	Seed disc worn in agitation groove area.	Replace disc. Replace. See "Brush-Type Seed Meter Maintenance".
High count.	Seed size too small for seed disc.	Switch to larger or appropriate seed disc.
	Incorrect seed rate transmission setting.	Reset transmission. Refer to rate charts.
	Upper brush too wide (fanned out) for small seed size.	Replace upper brush.
High count. (Milo/Grain Sorghum)	Incorrect brush retainer being used.	Make sure GD8237 brush retainer is used to keep upper brush from fanning out.
Upper brush laid back.	Seed treatment buildup on brush.	Remove brush. Wash with soap and water. Dry thoroughly before reinstalling.
	Foreign material buildup at base of brush.	Remove brush retainer and brush. Clean thoroughly. Reinstall.

SEED METER (EDGEVAC)

PROBLEM	POSSIBLE CAUSE	SOLUTION
Low seed count.	Meter RPM too high.	Reduce planting rate or planting speed.
	Singulator brush setting too aggressive.	Adjust singulator brush.
	Vacuum level too low.	Increase fan speed.
	Seed sensor not picking up all seeds dropped.	Clean seed tube. Move meter to different row.
	Seeds sticking to seed disc.	Use graphite or talc to aid release.
	Seed treatment buildup in seed disc recesses.	Reduce amount of treatment used and or mix thoroughly. Add talc.
	Seed size too large for disc used.	Use appropriate disc for seed size.
	Wrong transmission setting.	Change transmission to desired rate.
	Wrong seed disc.	Use appropriate disc for seed type and size.
	Drive wheel slippage.	Compensate by adjusting transmission sprockets.
	Low tire pressure.	Adjust tire pressure to correct level.
	Failed/worn drive components.	Inspect and replace parts as required.
	Plugged orifices in seed disc.	Inspect and clean disc. Check cleanout brush. (If Applicable)
	Loss of vacuum at meter.	Check for foreign material between vacuum cover and disc. Inspect parts for wear/damage. Clean or replace as required.
	Seed bridging in hopper.	Add graphite to improve seed flow.
	Faulty vacuum gauge reading.	Repair/replace gauge.
	Dirt in vacuum manifold.	Check vacuum manifold for dirt and clean.
	Seed baffle (If applicable) not allowing seed flow due to bridging of seed.	Mix talc thoroughly to coat all seeds. Remove seed baffle. See Row Unit Operation section.
	60 cell soybean disc not filling properly due to excessive RPM.	Replace with 120 cell soybean disc.
	Seed disc worn.	Replace.
Vacuum cover worn.	Replace.	
Not planting seed.	Seed hoppers empty.	Fill seed hopper.
	Seed tube plugged/damaged.	Clean or replace tube.
	Meter drive damaged.	Repair/replace drive components.
	Low/no vacuum.	Inspect vacuum system and repair as necessary.
	Singulator brush setting too aggressive.	Adjust singulator brush.
	Faulty vacuum gauge.	Repair/replace vacuum gauge.
	Seed bridging in hopper.	Add graphite to improve seed flow.
	Loss of vacuum at meter.	Check for foreign material between vacuum cover and disc. Inspect parts for wear/ damage. Clean and/or replace as required.
	Wrong seed disc.	Use appropriate disc for seed type and size.
	Meter drive clutch not engaged.	Engage drive clutch.
	Fan not running.	Start fan.
	Dirt in vacuum manifold.	Check vacuum manifold for dirt and clean.

Continued on next page.

SEED METER (EDGEVAC) - Continued

PROBLEM	POSSIBLE CAUSE	SOLUTION
Not planting seed. (Continued)	Seed baffle (If Applicable) not allowing seed flow due to bridging of seed.	Mix talc thoroughly to coat all seeds. Remove seed baffle. Row Unit Operation section.
	60 cell soybean disc not filling properly due to excessive RPM.	Replace with 120 cell soybean disc.
High seed count.	Wrong transmission setting.	Change transmission to desired rate.
	High vacuum.	Adjust vacuum level to appropriate level.
	Wrong seed disc.	Replace seed disc.
	Singulator brush setting not aggressive enough.	Adjust singulator brush.
	Worn singulator brush.	Inspect brush and replace as required.
	Seed leaking past wall brush.	Inspect wall brush condition and installation. Replace as necessary.
	Faulty vacuum gauge.	Check gauge line for dirt/obstruction. Repair/replace vacuum gauge.
Poor seed spacing.	Obstruction in seed tube.	Clean seed tube.
	Dirty/damaged seed disc.	Inspect seed disc for damage, foreign material in orifices or seed treatment buildup in recesses. Clean or replace.
	Wrong vacuum setting.	Adjust vacuum to appropriate level.
	Excess foreign material in seed.	Inspect and clean meter and seed discs. Use clean, undamaged seed.
	Incorrect singulator brush setting.	Adjust singulator brush to appropriate setting.
	Inconsistent driveline.	Inspect drive components for rust, misalignment, worn or damaged parts. Replace/repair as required.
	Toolbar not level or wrong height.	Adjust hitch to level toolbar and row units.
	Planting too fast for conditions.	Reduce speed.
	Rough field conditions.	Reduce speed.
Irregular seed population.	Driving too fast.	Reduce speed.
	Drive wheels slipping.	Reduce speed. Decrease row unit down pressure spring settings.
Unable to achieve desired vacuum level.	Tractor hydraulic flow set too low.	Increase flow to fan motor.
	Incorrect hydraulic connections.	Check all hydraulic connections and hose routings.
	Damaged fan components.	Inspect motor and impeller for wear/damage and repair/replace as necessary.
	Vacuum hose pinched/kinked/blocked.	Inspect air lines for any damage or obstruction. Clean air lines and manifold by removing end cap from manifold and running fan at high speed.
	Vacuum hose loose/disconnected.	Inspect and reattach all air hoses.
	Tractor not producing required hydraulic flow/pressure.	Have tractor serviced by qualified technician.
	Dirt in vacuum gauge line.	Check gauge line for dirt/obstruction and clean.

SEED METER (FINGER PICKUP)

PROBLEM	POSSIBLE CAUSE	SOLUTION
One row not planting seed.	Drive release not engaged.	Engage drive release mechanism.
	Foreign material in hopper.	Clean hopper and finger carrier mechanism.
	Seed hopper empty.	Fill seed hopper.
	Row unit drive chain off of sprocket or broken.	Check drive chain.
Unit is skipping.	Foreign material or obstruction in meter.	Clean and inspect.
	Finger holder improperly adjusted.	Adjust to specifications. (22 to 25 in. lbs. rolling torque)
	Broken fingers.	Replace fingers and/or springs as required.
	Planting too slowly.	Increase planting speed to within recommended range.
Planting too many doubles.	Planting too fast.	Stay within recommended speed range.
	Loose finger holder.	Adjust to specifications. (22 to 25 in. lbs. rolling torque)
	Worn brush in carrier plate.	Inspect and replace if necessary.
Overplanting.	Worn carrier plate.	Inspect and replace if necessary.
	Seed hopper additive being used.	Reduce or eliminate additive or increase graphite.
Underplanting.	Seed belt installed backwards.	Remove and install correctly.
	Weak or broken springs.	Replace.
	Spring not properly installed.	Remove finger holder and correct.
	Seed belt catching or dragging.	Replace belt.
	Brush dislodging seed.	Replace brush.
Irregular or incorrect seed spacing.	Driving too fast.	Check chart for correct speed.
	Wrong tire pressure.	Inflate tires to correct air pressure.
	Drive wheels slipping.	Reduce down pressure on row unit down force springs.
	Wrong sprockets.	Check seed rate charts for correct sprocket combinations.
Seed spacing not as indicated in charts.	Wrong tire pressure.	Inflate tires to correct air pressure.
	Inconsistent seed size.	Perform field check and adjust sprockets.
	Wrong sprockets.	Check chart for correct sprocket combination.
	Charts are approximate.	Slight variations due to wear in meter components and tire slippage due to field conditions may produce seed spacing variations.
	Stiff or worn drive chains.	Replace chains.
Scattering of seeds.	Planting too fast.	Reduce planting speed.
	Seed tube improperly installed.	Check seed tube installation.
	Seed tube worn or damaged.	Replace seed tube.
Seed tubes and/or openers plugging.	Allowing planter to roll backward when lowering.	Lower planter only when tractor is moving forward.
Inconsistent seed depth.	Rough seed bed.	Adjust down pressure springs. Reduce planting speed.
	Partially plugged seed tube.	Inspect and clean.
	Seed tube improperly installed.	Install properly.

SOLENOID VALVE

PROBLEM	POSSIBLE CAUSE	SOLUTION
No solenoids operate.	Low voltage.	Must be connected to 12 volt DC only. Negative ground.
	Blown fuse.	Replace control console fuse with AGC-15 amp.
	Battery connection.	Clean and tighten.
	Wiring harness damaged.	Repair or replace.
One solenoid valve will not operate.	Bad switch.	Replace on control panel.
	Cut wire in harness.	Locate and repair.
	Bad coil.	Replace.
	Poor connection at coil.	Check.
Valve operating when not energized.	Valve stem stuck open.	Replace cartridge.
	O-ring leaking.	Install new O-ring kit.
	Foreign material under poppet.	Remove and clean cartridge.

STROKE LIMITER VALVE

PROBLEM	POSSIBLE CAUSE	SOLUTION
Planter will not raise.	Poppet not moving freely in adapter and mechanical stop has poppet pushed completely in with no air gap.	Remove adapter from valve block. Check movement of poppet in adapter. It should move freely. If not, remove poppet from adapter and clean seal area. Inspect poppet stem for damage.
Planter will not stop at the raised field position.	Mechanical stop arm not adjusted correctly.	Adjust mechanical stop arm.
External leak.	Worn or damaged O-rings.	Install seal kit.