

MODEL 3800 FRONT FOLD PLANTER OPERATOR'S MANUAL

M0235-01

Rev. 8/13

This manual is applicable to: Model 3800 Forward Folding Planters

Record the model number and serial number of your planter along with date purchased:

Model Number _____ 3800 _____

Serial Number _____

Date Purchased _____

Monitor Serial Number _____
Measured Pulses Per Mile/Km (Radar Distance Sensor) _____
Measured Pulses Per Mile/ Km (Magnetic Distance Sensor) _____

SERIAL NUMBER

The serial number plate is located on planter frame as shown below. The serial number provides important information about your planter and is needed to obtain correct replacement parts. Always provide model number and serial number to your Kinze Dealer when ordering parts or when contacting Kinze Manufacturing, Inc.

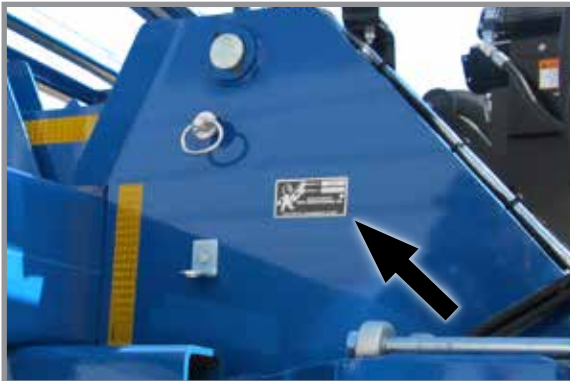

Serial plate location prior to 2013 production



Serial plate location 2013 production and on

This page intentionally blank.

TO THE DEALER

Predelivery service includes assembly, lubrication, adjustment and test. This service helps ensure planter is delivered to retail customer/end user ready for field use.

PREDELIVERY CHECKLIST

Use the following checklist after planter is completely assembled. Check off each item as it is found satisfactory or after proper adjustment is made.

- Center pivot base mounting and transport wheel spindle hex head cap screws torqued to 450 ft-lb (610.1 N-m).
- Row units properly spaced and optional attachments correctly assembled.
- Row marker assemblies installed and adjusted at each end of the planter.
- EdgeVac and ASD components properly installed (as applicable).
- All grease fittings in place and lubricated.
- All working parts move freely, bolts are tight, and cotter pins are spread.
- Check all drive chains for proper tension and alignment.
- Check for oil leaks and proper hydraulic operation.
- Hydraulic hoses correctly routed to prevent damage.
- Inflate tires to specified air pressure and torque wheel lug bolts and lug nuts as specified in the manual.
- All safety decals correctly located and legible. Replace if damaged.
- All reflective decals and SMV sign correctly located and visible when the planter is in transport position.
- Safety/warning lights correctly installed and working properly.
- Paint all parts scratched during shipment or assembly.
- All safety lockup devices on the planter and correctly located.
- Auxiliary safety chain properly installed and hardware torqued to specification.
- PTO shaft correctly sized for tractor used with planter. Oil reservoir filled to capacity and system inspected for leaks (if applicable).
- Control box properly installed in tractor. All cables correctly routed and secure.

Planter has been thoroughly checked and is ready for delivery to retail customer/end user.

(Signature Of Set-Up Person/Dealer Name/Date)

OWNER REGISTER

Name _____ Delivery Date _____

Street Address _____ Model No. 3800 Serial No. _____

City, State/Province _____ Dealer Name _____

ZIP/Postal Code _____ Dealer No. _____

DELIVERY CHECKLIST

Use the following checklist at time planter is delivered as a reminder of very important information which should be conveyed to retail customer/end user. Check off each item as it is fully explained.

- Check proper operation of vacuum fan, ASD fan, and PTO-driven pump with tractor used with planter.
- Life expectancy of this or any other machine is dependent on regular lubrication as directed in the Operator Manual.
- All applicable safety precautions.
- Along with retail customer/end user, check reflective decals and SMV sign are clearly visible with planter in transport position and attached to tractor. Check safety/warning lights are in working condition. Tell retail customer/end user to check federal, state/provincial, and local regulations before towing or transporting on a road or highway.
- Give Operator Manual, Parts Manual, and all Instruction Sheets to retail customer/end user and explain all operating adjustments.
- Read warranty to retail customer/end user.
- Complete Warranty and Delivery Report form.

To the best of my knowledge this machine has been delivered ready for field use and customer has been fully informed as to proper care and operation.

(Signature Of Delivery Person/Dealer Name/Date)

AFTER DELIVERY CHECKLIST

The following is a list of items we suggest to check during the first season of use of the equipment.

- Check planter performance with retail customer/end user.
- Check performance of EdgeVac or mechanical seed metering system with retail customer/end user.
- Review importance of proper maintenance and adherence to all safety precautions with retail customer/end user.
- Check for parts that may need to be adjusted or replaced.
- Check all safety decals, reflective decals, and SMV sign are correctly located as shown in the Parts Manual and that decals are legible. Replace if damaged or missing.
- Check safety/warning lights are working properly.

(Signature Of Follow-Up Person/Dealer Name/Date)

Retain a copy of this form for auditing purposes.

Tear Along Perforation



OVERVIEW

To The Owner	1-1
Warranty	1-2
General Information	1-2
Specifications	1-3
General Safety Rules	1-5
Safety Signs And Decals	1-6
Safety Precautions	1-6

MACHINE OPERATION

Wing Latch Hook Safety Pins	2-1
Transport Cylinder Safety Lockups	2-1
Row Marker Safety Lockup	2-2
Initial Planter Preparation	2-3
Tractor Requirements	2-4
Tractor Preparation and Hookup	2-5
Level Planter	2-11
Hydraulic Drive	2-12
Hydraulic Drive U-Joint Shaft Assemblies	2-12
Row Unit Air Clutches	2-12
Ag Leader Electric Clutches	2-12
Hall Effect Sensor	2-12
Row Marker Operation	2-13
Row Marker Speed Adjustment	2-14
Row Marker Length Adjustments	2-14
Transport to Field Sequence	2-15
Field Operation	2-17
Field to Transport Sequence	2-18
Analog Vacuum or Pressure Gauge	2-21
EdgeVac System	2-21
Vacuum Fan Motor Valve Block Assembly	2-21
Air Seed Delivery (ASD) System	2-22
ASD Entrainer Access	2-22
ASD Tanks - Clean Out	2-23
ASD Scale Package Option	2-23
Kinze Cobalt System	2-26
Ag Leader Integra Display	2-26
Planter Monitor Module (PMM)	2-26
Kinze ISOBUS Option	2-26
Field Test	2-27
Field Check Seed Population	2-27
Determining Pounds Per Acre (Brush-Type Meter)	2-28
Determining Bushels Per Acre	2-28
Field Check Granular Chemical Application	2-29

ROW UNIT OPERATION

Planting Depth	3-1
"V" Closing Wheel Adjustment (Rubber or Cast Iron)	3-1
Closing Wheel Shield (Rubber or Cast Iron "V" Closing Wheels)	3-1
Drag Closing Attachment	3-2
Covering Discs/Single Press Wheel Adjustment	3-2
Seed Hoppers	3-3
Seed Meter Drive Release	3-3
Row Unit Extension Brackets	3-3
Row Unit Chain Routing	3-4
Quick Adjustable Down Force Springs Option (Standard or Heavy Duty)	3-5
Pneumatic Down Pressure	3-6
General Planting Rate Information	3-9
Brush-Type Seed Meter	3-10
Finger Pickup Seed Meter	3-11
EdgeVac Seed Meters	3-12
Seed Meter Cleanout	3-15
Additives	3-16
Frame Mounted Coulter (Pull Row)	3-17
Residue Wheels (Frame Mounted Coulter)	3-17
Row Unit Mounted Disc Furrower (Pull Row)	3-18
Row Unit Mounted Residue Wheel	3-19
Row Unit Mounted No Till Coulter	3-20
Coulter Mounted Residue Wheels	3-20
Granular Chemical Hopper and Drive	3-21
Spring Tooth Incorporator	3-21
Granular Chemical Banding Options	3-22
Granular Chemical Bander Shield	3-22
Dry Insecticide Application Rates Approximate Pounds/Acre at 5 MPH	3-23
Dry Herbicide Application Rates Approximate Pounds/Acre at 5 MPH for 30" Row Width	3-24
Clay Granules	3-24

FERTILIZER

Notched Single Disc Opener	4-1
Residue Wheel Attachment for Notched Single Disc Fertilizer Opener	4-2
Depth/Gauge Wheel Attachment for Notched Single Disc Fertilizer Opener	4-2
Liquid Fertilizer Attachment	4-4
Rear Trailer Hitch	4-6
Liquid Fertilizer Piston Pump Application Rates	4-7

LUBRICATION AND MAINTENANCE

Lubrication 5-1

Lubrication Symbols 5-1

Sealed Bearings 5-1

Air Clutch Lubrication 5-1

Wheel Bearings 5-1

Drive Chains 5-2

Bushings 5-3

PTO Shaft Assembly 5-4

U-Joint Slides 5-4

Liquid Fertilizer Piston Pump 5-4

Crankcase Oil Level 5-4

Grease Fittings 5-5

Mounting Bolts and Hardware 5-9

Tire Pressure 5-10

Finger Pickup Seed Meter Inspection/Adjustment 5-11

Cleaning Finger Pickup Seed Meter For Storage 5-12

Brush-Type Seed Meter Maintenance 5-13

Cleaning Brush-Type Seed Meter For Storage 5-14

Vacuum Manifold Maintenance 5-14

EdgeVac Seed Meter Maintenance 5-15

EdgeVac Seed Meter Cleanout 5-15

Drag Closing Attachment 5-16

Gauge Wheel Adjustment 5-16

Gauge Wheel Arm Bushing/Seal Replacement 5-17

Gauge Wheel Arm Pivot Spindle Replacement 5-17

15" Seed Opener Disc Blade/Bearing Assembly 5-18

Seed Tube Guard/Inner Scraper 5-19

Frame Mounted Coulter 5-19

Residue Wheels (For Use With Frame Mounted Coulter) 5-19

Row Unit Mounted Disc Furrower 5-20

Row Unit Mounted No Till Coulter 5-20

Coulter Mounted Residue Wheels 5-20

Row Unit Mounted Residue Wheel 5-21

Granular Chemical Attachment 5-21

Spring Tooth Incorporator 5-21

Planter Mounted Pump Drive and Oil Cooler 5-22

Digital Vacuum Gauge Adjustment 5-22

Check Valve (Vacuum Fan) 5-23

Counter Balance Valve (Center of Rear H-Frame) 5-23

Flow Control Valve 5-23

Pressure Reducing Valve (Center of Rear H-Frame) 5-23

Relief Valve Cartridge 5-23

Solenoid Valve 5-23

Row Marker Bearing Lubrication or Replacement 5-24

Air Clutch Cleaning 5-25

Lift/Ground Drive Wheel Bearing
 Repack or Replacement 5-26

Transport Wheel Bearing Replacement 5-27

Fertilizer Check Valve Cleaning and Repair 5-28

Piston Pump Storage 5-28

Preparation for Storage 5-29

Electrical Light Harness Schematics 5-30

Electrical Control Console Schematic
 (Planter Functions) 5-32

Electrical Wiring Harness Schematic (On Tractor) 5-33

Electrical Wiring Harnesses Schematic (On Planter) 5-34

Vacuum Fan Gauges Electrical
 Wiring Harness Schematic 5-36

Vacuum Fan System Hydraulic Schematic 5-37

Hydraulic System Schematic 5-38

Valve Block Schematics 5-40

ASD System Hydraulic schematic 5-41

Hydraulic Drive System Schematic 5-42

Air Clutch Airline Schematic 5-42

Electric Clutch Schematic 5-43

ISOBUS Implement Cable 5-44

ISOBUS CAN Jumper Cable 5-44

Product Control Module Cable 5-45

Implement Switch Extension Cable 5-46

Section Adapter Cable - 24 Row 5-47

Clutch Cable - 24 Row (R.H. Shown) 5-48

TROUBLESHOOTING

Air Clutch 6-1

Air Seed Delivery (ASD) 6-1

Closing Wheel 6-1

Lift/Fold Circuit Troubleshooting 6-1

Piston Pump 6-2

PTO Pumps and Oil Coolers 6-2

Row Marker Circuit Troubleshooting 6-3

Seed Meter (Brush-Type) 6-4

Seed Meter (EdgeVac) 6-5

Seed Meter (Finger Pickup) 6-7

Solenoid Valve 6-8

Kinze Manufacturing, Inc. thanks you for your patronage. We appreciate your confidence in Kinze farm machinery. Your Kinze planter has been carefully designed to provide dependable operation in return for your investment.

This manual has been prepared to aid you in the operation and maintenance of the planter. It should be considered a permanent part of the machine and remain with the machine when you sell it.

It is the responsibility of the user to read and understand the Operator Manual in regards to safety, operation, lubrication and maintenance before operation of this equipment. It is the user's responsibility to inspect and service the machine routinely as directed in the Operator Manual. We have attempted to cover all areas of safety, operation, lubrication and maintenance; however, there may be times when special care must be taken to fit your conditions.

Throughout this manual the symbol  and the words **DANGER**, **WARNING**, and **CAUTION** are used to call attention to safety information that if not followed, will or could result in death or injury. **NOTICE** and **NOTE** are used to call your attention to important information. The definition of each of these terms follows:



DANGER Indicates a hazardous situation which, if not avoided, will result in death or serious injury.



WARNING Indicates a hazardous situation which, if not avoided, could result in death or serious injury.



CAUTION, used with the safety alert symbol, indicates a hazardous situation which, if not avoided, could result in minor or moderate injury.

NOTICE is used to address practices not related to personal injury.

NOTE: Special point of information or machine adjustment instructions.



WARNING

Improperly operating or working on this equipment could result in death or serious injury. Read and follow all instructions in Operator Manual before operating or working on this equipment.



WARNING

Some photos in this manual may show safety covers, shields, or lockup devices removed for visual clarity. **NEVER OPERATE OR WORK ON** machine without all safety covers, shields, and lockup devices in place as required.

NOTE: Photos in this manual may be of prototype machines. Production machines may vary in appearance.

NOTE: Some photos and illustrations in this manual show optional attachments installed. Contact your Kinze Dealer for purchase of optional attachments.

WARRANTY

The Kinze Limited Warranty for your new machine is stated on the retail purchaser's copy of the Warranty And Delivery Receipt form. Additional copies of the Limited Warranty can be obtained through your Kinze Dealer.

Warranty, within the warranty period, is provided as part of Kinze's support program for registered Kinze products which have been operated and maintained as described in this manual. Evidence of equipment abuse or modification beyond original factory specifications will void the warranty. Normal maintenance, service and repair is not covered by Kinze warranty.

To register your Kinze product for warranty, a Warranty And Delivery Receipt form must be completed by the Kinze Dealer and signed by the retail purchaser, with copies to the Dealer, and to the retail purchaser. Registration must be completed and submitted to Kinze Manufacturing, Inc. within 5 business days of delivery of the Kinze product to the retail purchaser. Kinze Manufacturing, Inc. reserves the right to refuse warranty on serial numbered products which have not been properly registered.

If service or replacement of failed parts which are covered by the Limited Warranty are required, it is the user's responsibility to deliver the machine along with the retail purchaser's copy of the Warranty And Delivery Receipt to the Kinze Dealer for service. Kinze warranty does not include cost of travel time, mileage, hauling or labor. Any prior arrangement made between the Dealer and the retail purchaser in which the Dealer agrees to absorb all or part of this expense should be considered a courtesy to the retail purchaser.

Kinze warranty does not include cost of travel time, mileage, hauling, or labor.

GENERAL INFORMATION

The Model 3800 Forward Folding Planter is available with EdgeVac or mechanical meters, conventional hoppers or Air Seed Delivery system (ASD), Interplant, liquid fertilizer, and various other options. Contact your Kinze Dealer for available options and configurations.



Model 3800 24 Row ASD Planter

Information used in these instructions was current at time of printing. However, due to Kinze's ongoing product improvement, production changes may cause your machine to appear slightly different in detail. Kinze Manufacturing, Inc. reserves the right to change specifications or design without notice and without incurring obligation to install the same on machines previously manufactured.

Right hand (R.H.) and left hand (L.H.), as used throughout this manual, are determined by facing direction machine travels in use unless otherwise stated.

Specification	Conventional Hoppers	Air Seed Delivery (ASD)
Number of Rows	24R N 30	24R N 30
Weight Empty (Mechanical)	25,500 lb (11,567 kg)	27,050 lb (12,670 kg)
Weight Empty (EdgeVac)	28,040 lb (12,719 kg)	29,590 lb (13,422 kg)
Transport Height	10' 5" (3.18M)	13' 5" (4.1M)
Fill Height (Planting Position)		8' 5" (2.6M)
Planting Length	25' 9" (7.9M)	27' 0" (8.3M)
Transport Length	41' 3" (12.6M)	42' 6" (13.0M)
Planting Width	63' 1" (19.3M)	63' 1" (19.3M)
Transport Width (Standard)	14' 1" (4.3M)	14' 1" (4.3M)
Transport Width (Granular Chemical)	15' 9" (4.8M)	15' 9" (4.8M)
Seed Capacity	1.90 bu. (Mechanical / Hopper) 1.75 bu. (EdgeVac / Hopper)	Two 55 bu. Tanks
Transport Tire Size	Two 445-50R R22.5 radial load range L. 120 psi (827.3 kPa)	
Center Section (Field) Tire Size	Four 41 x 11R 22.5 radial load range H. 75 psi (517.1 kPa)	
Wing (Field) Tire Size	Six 7.50" x 20" 8 ply tubeless rib implement tires (three per side). 40 psi (275.7 kPa)	
Marker Arm Tire	Two 20.5 x 8.0-10 tires (one per side). 35 psi (241.3 kPa)	
Drive System	Dual motor, 2-section hydraulic drive with #40 chain. Standard single row air clutches in eight sections.	
Hydraulic Lift System (Field Operation)	Four Master, four slave, two assist rephasing cylinders.	
Row Markers	Independently controlled, three stage, w/16" solid disk blade depth bands. One marker gauge wheel w/20.5 x 8.0-10 tire per arm.	

3800 Mechanical

Configuration	Requirements		Description
<i>Base machine with mechanical meters Hydraulic seed rate control</i>	3 SCV	25 gpm	#1 SCV: planter lift
			#2 SCV: fold (with 12v control console)
			#3 SCV: hydraulic seed rate control
<i>Base machine with mechanical meters Hydraulic seed rate control Row markers</i>	4 SCV	30 gpm	#1 SCV: planter lift
			#2 SCV: fold (with 12v control console)
			#3 SCV: hydraulic seed rate control
			#4 SCV: markers

3800 EdgeVac

Configuration	Requirements		Description
<i>Base machine with EdgeVac meters Hydraulic seed rate control Planter mounted PTO hydraulic pump</i>	3 SCV	30 gpm	#1 SCV: planter lift
			#2 SCV: fold
			#3 SCV: hydraulic seed rate control
<i>Base machine with EdgeVac meters Hydraulic seed rate control Row markers Planter mounted PTO hydraulic pump (Supplies EdgeVac hydraulic circuit)</i>	4 SCV	30 gpm	#1 SCV: planter lift
			#2 SCV: fold
			#3 SCV: hydraulic seed rate control
			#4 SCV: markers

3800 ASD Mechanical

Configuration	Requirements		Description
<i>Base machine with mechanical meters Hydraulic seed rate control Air seed delivery (ASD) system</i>	4 SCV	35 gpm	#1 SCV: planter lift
			#2 SCV: fold
			#3 SCV: hydraulic seed rate control
			#4 SCV: air seed delivery system
<i>Base machine with mechanical meters Hydraulic seed rate control Air seed delivery (ASD) system Row markers</i>	5 SCV*	40 gpm	#1 SCV: planter lift
			#2 SCV: fold
			#3 SCV: hydraulic seed rate control
			#4 SCV: air seed delivery system
			#5 SCV: markers

3800 ASD EdgeVac

Configuration	Requirements		Description
<i>Base machine with EdgeVac meters Hydraulic seed rate control Air seed delivery (ASD) system Planter mounted PTO hydraulic pump</i>	4 SCV	40 gpm	#1 SCV: planter lift
			#2 SCV: fold
			#3 SCV: hydraulic seed rate control
			#4 SCV: air seed delivery system
<i>Base machine with EdgeVac meters Hydraulic seed rate control Air seed delivery (ASD) system Row markers Planter mounted PTO hydraulic pump. (Supplies EdgeVac hydraulic circuit)</i>	5 SCV*	45 gpm	#1 SCV: planter lift
			#2 SCV: fold
			#3 SCV: hydraulic seed rate control
			#4 SCV: air seed delivery system
			#5 SCV: markers

*SCV requirements can be reduced to **four** by ordering G1K495, Marker/Fold Circuit Selector Kit, from Kinze Repair Parts. This kit combines marker and fold functions for operation by one SCV control.

1. Read and understand instructions provided in this manual and warning labels. Review these instructions frequently!
2. This machine is designed and built with your safety in mind. Do not make any alterations or changes to this machine. Any alteration to design or construction may create safety hazards.
3. A large portion of farm accidents happen from fatigue or carelessness. Safe and careful operation of tractor and planter will help prevent accidents.
4. Never allow planter to be operated by anyone unfamiliar with operation of all functions of the unit. Operators must read and thoroughly understand all instructions given in this manual before operating or working on equipment.
5. Be aware of bystanders, particularly children! Always look around to make sure it is safe to start tow vehicle engine or move planter. This is particularly important with higher noise levels and quiet cabs, as you may not hear people shouting.
6. Make sure planter weight does not exceed towing capacity of tractor, or bridge and road limits. This is critical to maintain safe control and prevent death or injury, or property and equipment damage.
7. Never ride or allow others to ride on planter.
8. Store planter in an area away from human activity. NEVER permit children to play on or around the stored unit.
9. Keep hands, feet, and clothing away from moving parts. Do not wear loose-fitting clothing which may catch in moving parts.
10. Always wear protective clothing, shoes, gloves, and hearing and eye protection applicable for the situation.
11. Do not allow anyone to stand between tongue or hitch and towing vehicle when backing up to planter.
13. Prevent electrocution, other injuries, or property and equipment damage. Watch for obstructions such as wires, tree limbs, etc. when operating machine. Be aware of clearances during turns and when folding/unfolding planter.
14. Reinstall all guards removed for maintenance activities. Never leave guards off during operation.
15. Use of aftermarket hydraulic, electric, or PTO drives may create serious safety hazards to you and people nearby. If you install such drives, follow all appropriate safety standards and practices to protect you and others near this planter from injury.
16. Follow all federal, state/provincial and local regulations when towing farm equipment on a public highway. Use safety chain (not an elastic or nylon/plastic tow strap) to retain connection between towing and towed machines in the event of primary attaching system separation.
17. Make sure all safety/warning lights, SMV sign, and reflective decals are in place and working properly before transporting the machine on public roads.
18. Limit towing speed to 15 MPH. Tow only with farm tractor of a minimum 90 HP. Allow for unit length when making turns.
19. Reduce speed prior to turns to avoid the risk of overturning. Always drive at a safe speed relative to local conditions and ensure your speed is slow enough for a safe emergency stop.
20. Chemical application is often an integral part of planting. Follow label instructions for proper chemical mixing, handling and container disposal methods.
21. Be familiar with safety procedures for immediate first aid should you accidentally contact chemical substances.
22. Use proper protective clothing and safety equipment when handling chemicals.
23. Chemicals are supplied with Material Safety Data Sheets (MSDS) that provide full information about the chemical, its effects on exposure, and first aid needs in the event of an emergency. Keep your MSDS file up-to-date and available for first responders in case of emergency.
24. When servicing ground engaging components such as opening disks and firming points, use special care to avoid points and edges worn sharp during use.
25. Use professional help if you are unfamiliar with working on hydraulic systems. Pressurized hydraulic fluid can penetrate body tissue and result in death, serious infection, or other injuries.

Following are some common hazard warnings associated with this equipment. Pay close attention to all safety, operating, and maintenance information in this manual and decals applied to your equipment.

 **DANGER!**

Contacting or coming close to power lines or other high energy sources will cause death or serious injury. Keep away from power lines or high energy sources at all times.

 **WARNING**

Improperly operating or working on this equipment could result in death or serious injury. Read and follow all instructions in Operator Manual before operating or working on this equipment.

 **WARNING**

Falling equipment can cause death or serious injury. Install all lockup devices or lower planter to ground before working on equipment.

 **WARNING**

Explosive separation of rim and tire parts can cause death or serious injury. Overinflation, rim and tire servicing, improper use of rims and tires, or worn or improperly maintained tires could result in a tire explosion.

SAFETY SIGNS AND DECALS

 **WARNING**

All safety/warning lights, reflective decals, and SMV sign must be in place and visible before transporting machine on public roads or death, serious injury, and damage to property and equipment may result. Check federal, state/provincial, and local regulations before transporting equipment on public roads.

Safety signs and decals are placed on the machine to warn of hazards and provide important operating and maintenance instructions. Information on these signs are for your personal safety and the safety of those around you. FOLLOW ALL SAFETY INSTRUCTIONS!

- Keep signs clean so they can be easily seen. Wash with soap and water or cleaning solution as required.
- Replace safety signs if damaged, painted over, or missing.
- Check reflective decals and SMV sign periodically. Replace if they show any loss of reflective properties.
- Clean machine surface thoroughly with soap and water or cleaning solution to remove all dirt and grease when replacing decals.

NOTE: Safety sign and decal locations are shown in the Parts Manual for this machine.

NOTE: Style and locations of SMV sign, reflective decals, and safety/warning lights conform to ANSI/ASABE S279.14 JUL 2008 and ANSI/ASABE S276.6 JAN 2005.

WING LATCH HOOK SAFETY PINS

WARNING

Uncontrolled movement of equipment can cause loss of control and could result in death, serious injury, or damage to property and equipment. Install all safety pins before transporting equipment.



Wing latch hook safety pin in storage location



Wing latch hook safety pin installed

Wing latch hook safety pin prevents latch bar from disengaging and planter frame from swinging open. Never transport planter without installing wing latch hook safety pin and lynch pin. For field operation remove wing latch hook safety pin and store in storage location.

TRANSPORT CYLINDER SAFETY LOCKUPS

WARNING

Uncontrolled machine movement can crush or cause loss of control resulting in death, serious injury, or damage to property and equipment. Install all safety lockup devices before working under or transporting this equipment.

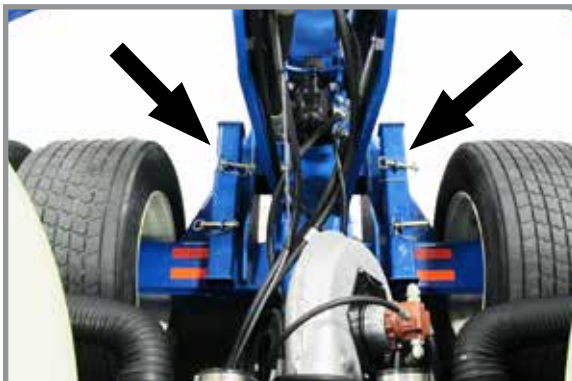

Transport cylinder safety lockup storage location

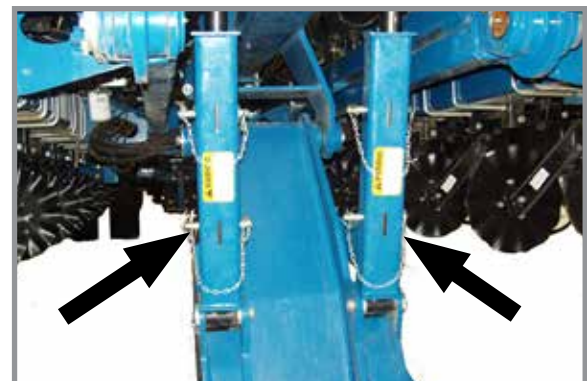

Transport cylinder safety lockups installed

Install transport cylinder safety lockups when transporting or working around planter. Store in position provided on transport axle assembly.

ROW MARKER SAFETY LOCKUP**⚠ WARNING**

Row marker can lower at any time and could cause death or serious injury. Stay away from row markers! Install safety lockup device when not in use.



Marker arm safety lockup storage location



Marker arm safety lockup installed

Install row marker safety lockups when transporting or working around planter. Store in position provided on marker arm assemblies. Hold in place with detent pins.

WARNING

Improperly operating or working on this equipment could result in death or serious injury. Read and follow all instructions in Operator Manual before operating or working on this equipment.

INITIAL PLANTER PREPARATION

Following information is general in nature to aid in preparation of tractor and planter for use, and to provide general operating procedures. Operator experience, familiarity with the machine, and the following information should combine for efficient planter operation and good working habits.

WARNING

Explosive separation of rim and tire can cause death or serious injury. Overinflation, rim and tire servicing, improper use of rims and tires, worn, or improperly maintained tires could result in a tire explosion.

WARNING

Wheel separation can cause loss of control resulting in death, serious injury, or damage to property and equipment. Check lug nuts on transport wheels are tight before operating planter for first time and periodically after.

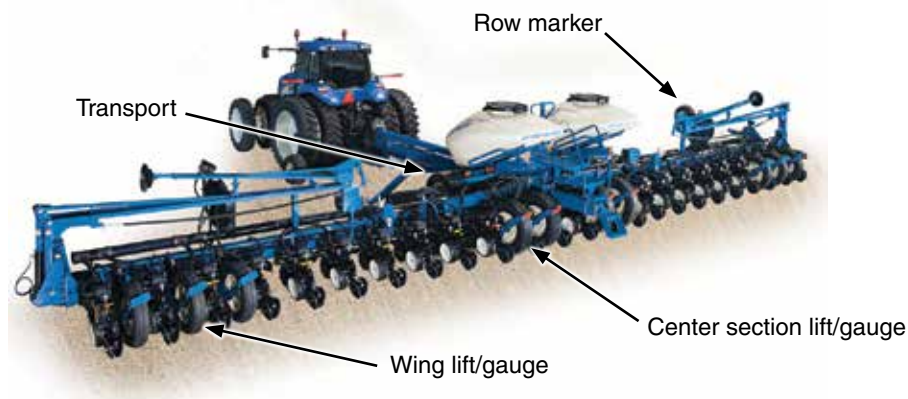

Tire locations

1. Torque transport wheel $\frac{3}{4}$ "- 16 lug nuts to 200 ft-lb (244 N-m).
2. Inflate tires to the following specifications:
 - Center section lift/gauge - 41 x 11R22.5" radial load range H ("224" rim) - 75 psi (517.1 kPa)
 - Center section lift/gauge - 41 x 11R22.5" radial load range H ("276" rim) - 75 psi (517.1 kPa)
 - Wing lift/gauge - 7.50" x 20" 8 ply custom rib implement - 40 psi (275.7 kPa)
 - Transport - 445-50R22.5 radial load range H - 120 psi (827.3 kPa)
 - Row marker - 20.5 x 8.0-10 - 35 psi (241.3 kPa)
 - Liquid fertilizer piston pump - 7.60" x 15" rib implement - 40 psi (275.7 kPa)
3. Lubricate planter and row units per lubrication information in this manual.
4. Check all drive chains for proper tension, alignment, and lubrication.

TRACTOR REQUIREMENTS

Consult your dealer for information on horsepower requirements and tractor compatibility. Requirements vary with planter options, tillage, and terrain.

Three dual remote hydraulic outlets (SCV) are required on all sizes of conventional planters equipped with row markers.

Four dual remote hydraulic outlets (SCV) are required on all sizes of ASD planters equipped with row markers. A 12 volt DC electrical system is required on all sizes.

WARNING

Loss of control of equipment during transport can result in death, serious injury, or damage to property and equipment. Tractor gross weight must be greater than planter gross weight with attachments and options. Tow with minimum 200 HP farm tractor.

A 1 $\frac{3}{4}$ "-20 spline 1000 RPM PTO is required to operate PTO-driven two section hydraulic pump capable of supplying 15 gpm (56.8 Lpm) to two hydraulic motors/vacuum fans.

Other dual fan system components include two oil coolers, two replaceable cartridge-type filters, two motorized flow controls, pressure compensating valves, solenoid valves, and relief valves.

EdgeVac Seed Metering System operates from an 8 gal. (30.3 L) capacity oil reservoir.

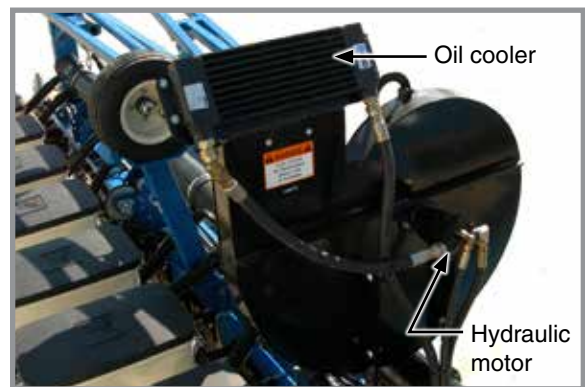

Vacuum fan assembly with oil cooler

A 12 volt battery connection is required to power the vacuum fan control console. Connect the "red" wire to the positive (+) battery terminal and the "black" wire to the negative (-) battery terminal.

NOTE: Tractor's 3 point hitch must have a minimum lift capacity of 10,000 lb (4536 kg) to raise hitch weight of machine, attachments, seed, and dry chemicals.

Tractor front end stability is necessary for safe, efficient operation. It may be necessary to add front ballast to your tractor for satisfactory field operation and transport stability. Refer to your tractor operator's manual for front ballast recommendations.

NOTE: Tractor drawbar may need to be removed to provide clearance for the planter.

TRACTOR PREPARATION AND HOOKUP

NOTICE

Operating tractor's 3 point hitch in DRAFT mode can cause hitch to move up and down causing unlevel operation of the planter. 3 point hitch must be operated in POSITION mode.

Correct adjustment and operation of the tractor's 3 point hitch is critical for peak planter performance.

NOTICE

Movement of tractor's 3 point hitch during field operation may cause poor planter performance and/or damage to the planter. Consult your tractor dealer if necessary.

Adjust tractor's 3 point hitch response sensitivity settings for correct reaction speed for raising/controlling planter hitch for fold and unfold functions.

1. Hitch planter to tractor with a Category 3N, Category 3, or Category 4 hitch.

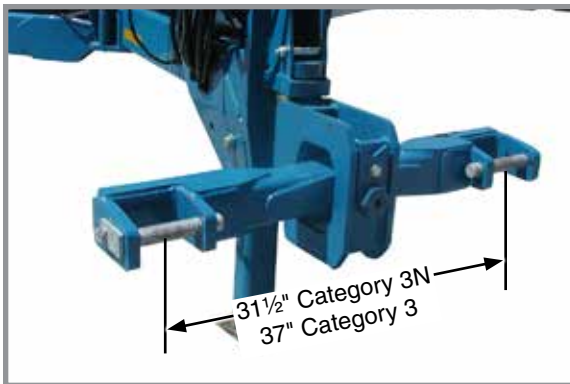

Category 3N or 3 hitch



Category 4 bushing

NOTE: A 3-point quick hitch adapter is required.

Category 4 hitch requires installation of two, 2" bushings (stored on front inner hitch), on two hitch pins.

2. Install planter control console and digital vacuum gauge control consoles on tractor in convenient locations within operator reach and close to hydraulic controls. Mount control consoles securely and route power cables to power source. A power lead adapter may be required. See Lubrication and Maintenance section for wiring schematics.

NOTE: Control consoles operate on 12 volt DC only. ALWAYS make power connection on battery grounded to tractor chassis when two 12 volt batteries are connected in series.



Planter control console



Digital vacuum gauge control console

PLANTER CONTROL CONSOLE

Tractor's hydraulic system and planter control console switches are used to raise planter to transport position, operate fold functions, and raise and lower row markers.

Model 3800 planters with conventional seed hoppers are equipped to operate from three dual remote hydraulic outlets (SCV), including one SCV for optional row markers.

! DANGER!

Contacting or coming close to power lines or other high energy sources will cause death or serious injury. Keep away from power lines or high energy sources at all times.

! WARNING

Being struck by a moving marker can cause death or serious injury. Markers can move unexpectedly when SCV controls are operated. Keep marker switch OFF when not in use.

NOTICE

Control console face is backlit with a power switch on back side. Turn off console when not in use or tractor battery will drain.

Marker switch is an ON-OFF-ON type. Point row is not used on planters with hydraulic drive. Keep switch OFF when not in use.

Transport axle and wing fold switches are MOMENTARY ON-OFF-MOMENTARY ON type and must be held in position while operating tractor hydraulic control. Activating a fold function switch disables marker circuit.

Auxiliary switch is not used. Keep switch OFF at all times.

NOTE: Activating auxiliary switch disables all control console switches.

DIGITAL VACUUM GAUGE

Digital vacuum gauge control console is equipped with a power toggle switch, run/stop (fans) toggle switch, and two fan speed control toggle switches for the vacuum fans.

Power switch applies power to control console. Run/stop toggle switch turns both fans on when power switch is ON. Fan speed control switches adjusts each fan (left or right).



Digital vacuum gauge control console

NOTICE

Power switch must be OFF when planter is not in use or tractor battery will be drained.

3. Set tractor rear wheel at 60" (double planter row) spacing. Dual tires should center on 120". Check tractor operator's manual for correct front and rear tire pressures. (If Applicable)
4. Adjust lower lift links on tractor so planter lifts level from side to side and raises high enough for planter transport clearance. Set tractor sway blocks to prevent side sway.

NOTICE

EdgeVac equipped planters tractor drawbar must be removed before attaching planter to tractor or equipment will be damaged.

5. Connect planter to tractor.
6. (If Applicable) Install PTO shaft assembly between tractor PTO output shaft and hydraulic pump gearbox on planter.

NOTICE

FAILURE TO FOLLOW THESE INSTRUCTIONS WILL RESULT IN SEVERE DAMAGE TO IMPLEMENT AND/OR TRACTOR. A tractor model-specific PTO shaft assembly is required. Procedure MUST be followed every time a different tractor is attached to determine if correct length PTO shaft assembly is being used.

NOTE: Tractor must be equipped with a 1 $\frac{3}{4}$ "-20 spline PTO and 3-point quick hitch adapter.

Following steps will calculate dimension Z shown in illustration at right to determine correct PTO shaft length.

- A. Make sure tractor and planter are on a level surface.
Raise or lower hitch until X and Y are equal.

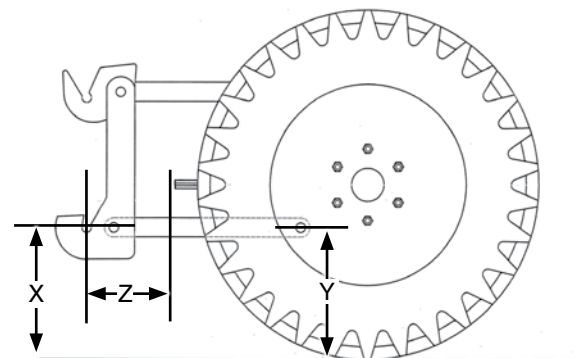

- B. Position rod across lower lift links. Measure precise distance between center of lower lift point and end of tractor's PTO shaft to obtain dimension Z. Use a square on PTO shaft to take an accurate measurement. Dimension Z must fall in a range for PTO assemblies listed below.

PTO Assembly Options (Select Using Dimension Z):

- 658-00688 - 24½" to 27"
- 658-00689 - 31½" to 34½" (*Measurement between 27" and 31½", shorten as needed.*)
- 658-00690 - Over 34½" (*Trim to fit as needed.*)

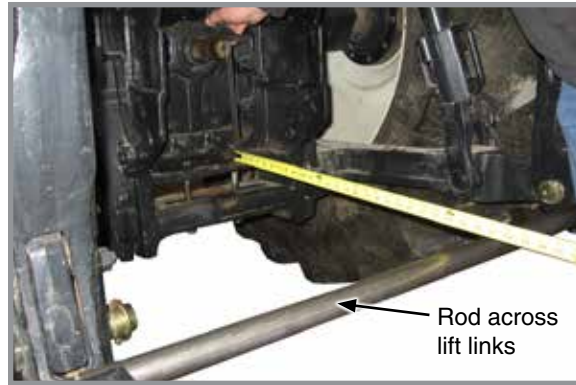

Determining PTO shaft length

PTO LENGTH ADJUSTMENT

NOTE: Trim all guard tubes and inner/outer sliding profiles equally. PTO 658-00690 go to next page.

Example: Dimension Z = 28". Use PTO 658-00689 and trim 3½" (31½" - 28" = 3½") off tractor and planter ends of PTO guards and tubes.

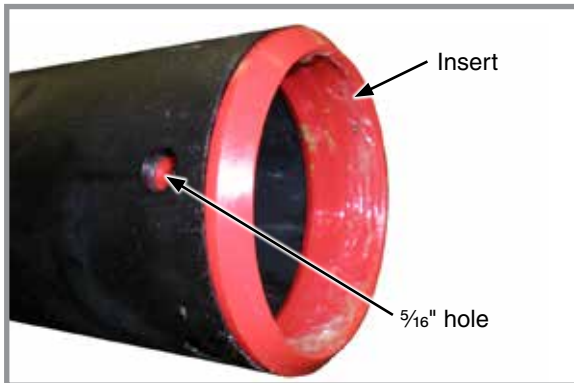

Remove insert from inner plastic guard tube before trimming. Use trimmed portion of tube as a template to locate and drill 5/16" holes for reinstallation.

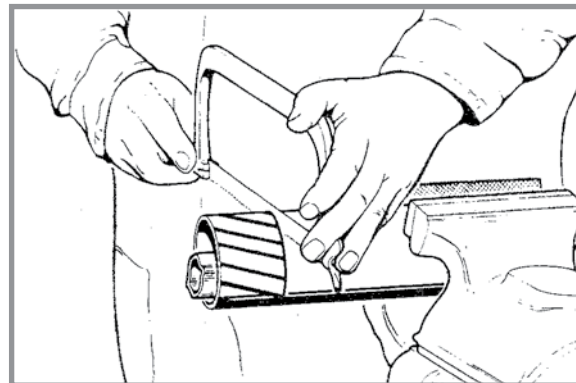

Shorten inner and outer plastic guard tubes by determined length.

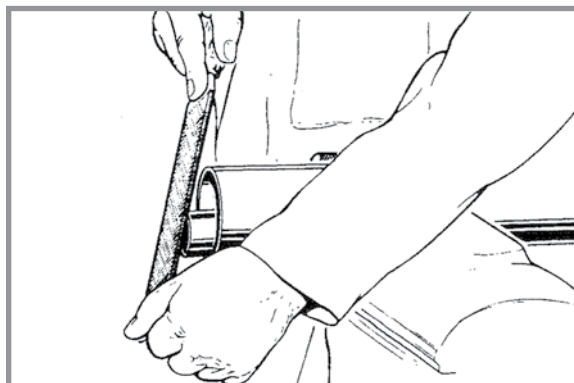

Use plastic tube as a template to shorten inner and outer metal sliding profiles to same length. This leaves inner profile to extend beyond guard tube as before.

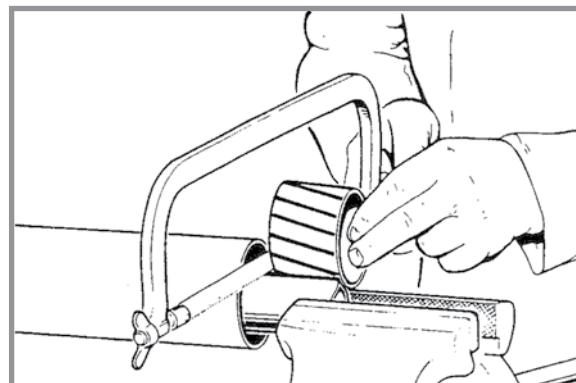

Round off all sharp edges and remove burrs. Grease sliding profiles. No other changes may be made to PTO assembly.

658-00690 PTO ASSEMBLY ONLY

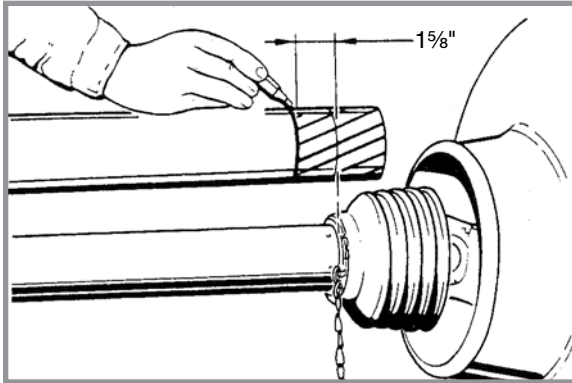

Fully raise 3-point arms and connect PTO to tractor and planter with sections disconnected. Hold PTO halves side-by-side as shown above. Mark location $1\frac{5}{8}$ " from where it would collide with PTO U-joint area. Trim following instructions on previous page.



658-00690 PTO shaft shown properly cut to length with plastic guard tubes in place.

NOTICE

Clean and grease PTO shaft coupling with high-pressure industrial coupling grease (Chevron coupling grease or equivalent) meeting AGMA CG-1 and CG-2 Standards each time driveshaft is installed or premature wear and equipment failure can occur.

PTO PUMP INITIAL STARTUP

1. Fill reservoir with SAE 10W-20 multigrade wide temperature range transmission hydraulic fluid or equivalent.
2. Start system. Allow to run with tractor at idle and fans turned off for 1-2 minutes.
3. Allow to run with tractor at idle and fans at full speed for 1-2 minutes.
4. Check fluid level in reservoir and fill as required.

NOTE: Fluid level in each tank should be within 1"-2" from top of the tank after pump has run and hydraulic hoses are primed to allow fluid to expand when heated.

5. Bring tractor to PTO speed and adjust flow control to desired vacuum level using switches on vacuum fan control console.

! WARNING

Pressurized hydraulic fluid can penetrate body tissue and result in death, serious infection, or other injuries. Fluid injected under skin must be IMMEDIATELY removed by a surgeon familiar with this type of injury. Make sure connections are tight and hoses and fittings are not damaged before applying system pressure. Leaks can be invisible. Keep away from suspected leaks. Relieve pressure before connecting or disconnecting tractor, searching for leaks, or performing any system maintenance.

NOTICE

Wipe hose ends to remove any dirt before connecting couplers to tractor ports or contamination may cause equipment failure.

7. Connect hydraulic hoses to tractor ports in a sequence familiar and comfortable to the operator. Move tractor control levers back and forth to relieve any pressure in the tractor hydraulic system before attaching hoses.

NOTICE

Connect hydraulic motor case drain to a case drain return line with zero PSI on tractor. Failure to connect to a return with zero PSI will cause hydraulic motor shaft seal damage. DO NOT connect hydraulic motor case drain to a SCV outlet or motor return circuit connection. Contact tractor manufacturer for specific details on “zero pressure return”.

NOTICE

Always connect hydraulic motor return hose to tractor motor return port. Do not connect to tractor SCV unless through a motor spool or hydraulic motor failure can occur. If a motor return port is not available on the tractor, the SCV controlling the ASD system MUST be in the float position before planter is moved in planting or field raised position when ASD system is not in use.

Color and Label	Machine Function	Hose Size	Hose Function
Red AA	Field Lift	1/2"	Return
Red BB		1/2"	Pressure
Blue AA	Planter Fold	3/8"	Return
Blue BB		3/8"	Pressure
Black AA	Row Marker	3/8"	Return
Black BB		3/8"	Pressure
Black RR	Seed Rate Hydraulic Drive	1/2"	Return
Black PP		3/8"	Pressure
Oil flow supplied by planter-mounted hydraulic pump	EdgeVac Vacuum Fan	3/4"	Return
		1/2"	Pressure
		3/8"	Case Drain
Yellow RR	ASD System Pressure Fan	3/4"	Return
Yellow PP		1/2"	Pressure
Orange CD		3/8"	Case Drain

NOTE: Hydraulic Drive System requires constant system pressure. If erratic behavior is observed it may be necessary to disable tractor load sense system. Refer to your tractor manual for instructions.

8. Connect cable on planter to planter control console cable on tractor. Connect cable on planter to vacuum fan control console (if applicable). Connect ASAE Standards 7 terminal connector for safety/warning lights on planter to ASAE Standards receptacle on tractor. Check safety/warning lights on planter are working in conjunction with warning lights on tractor.

NOTE: If your tractor is not equipped with an ASAE Standards receptacle, check with your tractor manufacturer for availability.

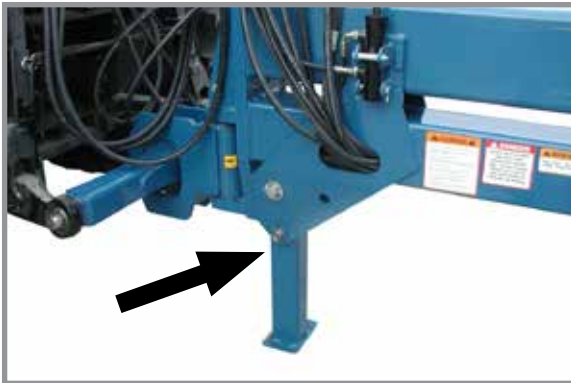

Jack stand pin in down and locked position

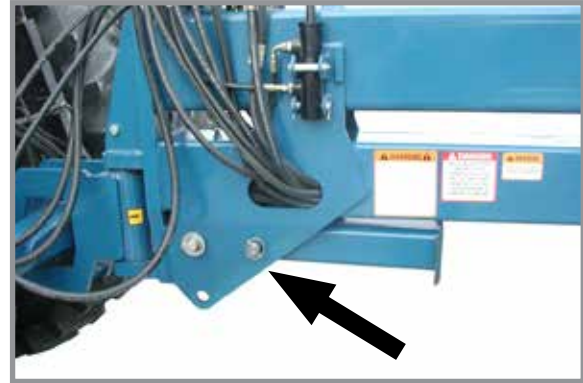

Jack stand pin in up and locked position

8. Raise planter slowly and watch for any interference. Remove pin from jack stand and swing jack stand to the horizontal position. Install pin in uplock position.

LEVEL PLANTER

Toolbar should operate at 20"-22" height from planting surface and toolbar heights must be adjusted equally. Check planter toolbars are level and at correct operating heights. Tire pressure must be maintained at pressures specified for planter to operate level laterally. Check toolbars and row unit parallel arms are level front to back with planter lowered to proper operating height.

Field and actual planting conditions dictate which wheel settings to use to ensure row unit parallel arms are approximately parallel with planting surface.

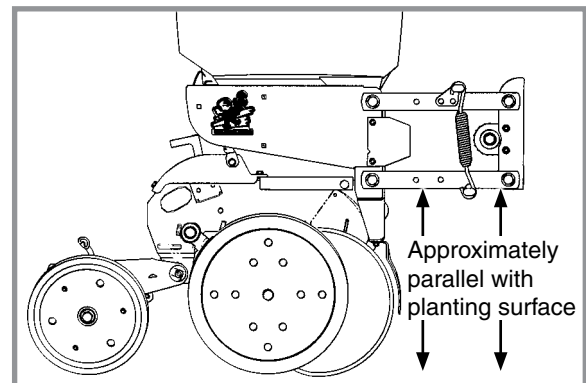

**Center section lift/gauge wheel
(Rock shaft axle) initial setting**



Wing lift/gauge wheel initial setting

Make a field check fully loaded with seed, granular chemicals, etc. Lift/gauge wheels can be raised or lowered in wheel arms to increase or decrease planter toolbar height. If wings are not level with center frame. Adjust hitch height to ensure level operation.

HYDRAULIC DRIVE

When stopping in the middle of a field, drive runs a split second after tractor and planter come to a complete stop. Shut master switch OFF before coming to a complete stop to avoid bunching of seeds. To avoid skips starting from a complete stop, lift planter and back-up 4-6 feet, put planter in ground, and accelerate slowly to continue planting.

HYDRAULIC DRIVE U-JOINT SHAFT ASSEMBLIES

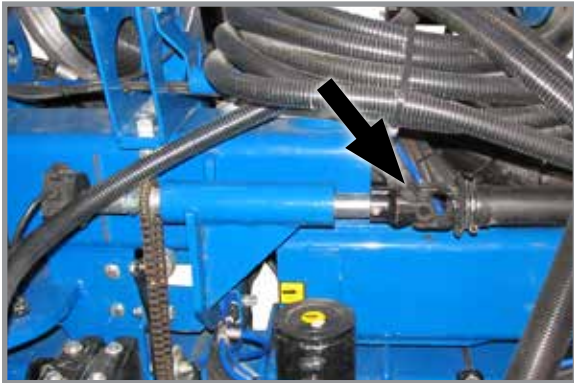

Center section hinge area U-joint (R.H.)



Wing U-joint (R.H.)

U-joint shaft assemblies for hydraulic drive system are used between planter center section and each wing assembly to allow for up and down wing movement.

ROW UNIT AIR CLUTCHES

Set Air clutch system pressure to 50 psi.



Air clutch pressure setting

AG LEADER ELECTRIC CLUTCHES

Electric clutches along with GPS can stop seed flow by turning off seed meters (and planter sections) based on field mapping and previously planted areas.

HALL EFFECT SENSOR

Set Hall Effect sensor within 1/8" of pick-up disc.

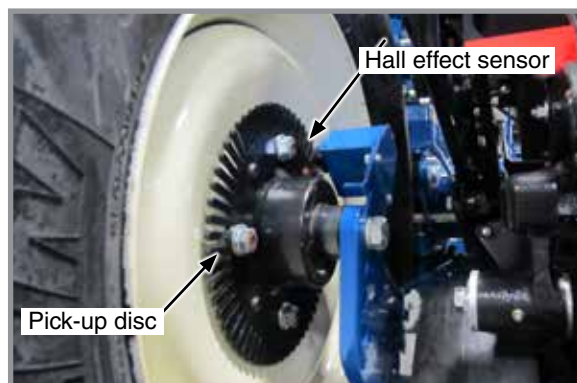

Hall effect sensor and pick-up disc

ROW MARKER OPERATION



DANGER!

Contacting or coming close to power lines or other high energy sources will cause death or serious injury. Keep away from power lines or high energy sources at all times.

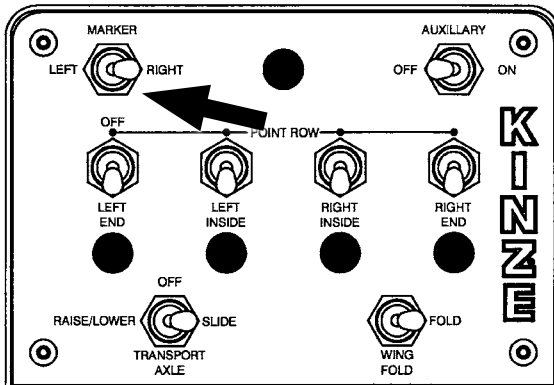

Row marker selector switch

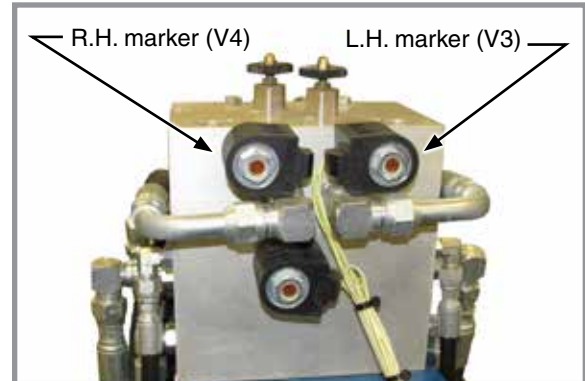

Row marker solenoid valves

Two solenoid valves on valve block at front of planter and a three position selector switch on control console lower or raise desired row marker.

NOTICE

Marker position switch must be OFF when planter is not in use or tractor battery will drain.

See "Row Marker Speed Adjustment".

1. Select which row marker to lower on control console.
2. Operate hydraulic control to lower row marker.
3. Move control switch to other side to operate opposite row marker.
4. Raise row marker at end of field using hydraulic control.
5. After turn, using the hydraulic control, lower the pre-selected row marker.
6. Continue to follow this procedure.

NOTE: On a tractor where oil flow cannot be controlled, tractor flow rate may be greater than rate marker cylinder can accept. Hold tractor hydraulic control lever until cylinder reaches end of its stroke. This occurs most often on tractors with an open center hydraulic system.

NOTE: Both row markers can be lowered by operating switch in each position and hydraulic control twice. Row markers raise simultaneously with hydraulic control in raise position.

If electrical system does not operate properly:

- Check fuse.
- Check wiring connections.
- Check control switch.
- Check solenoid. SOLENOID HOUSING IS MAGNETIZED WHEN ENERGIZED.

ROW MARKER SPEED ADJUSTMENT

NOTICE

Excessive row marker travel speed can damage row markers. Adjust flow controls before row markers are first used.

Loosen jam nut and turn control clockwise, or IN to slow travel speed. Turn counterclockwise, or OUT to increase travel speed. Tighten jam nut after adjustments are complete.

NOTE: Hydraulics operate slowly when oil is cold. Make all adjustments with oil warm.

NOTE: Adjust row marker speed with tractor flow controls (if equipped) in maximum position. After row marker speed is set, adjust tractor flow controls to allow hydraulic control to stay in detent during marker raise or lower cycle.

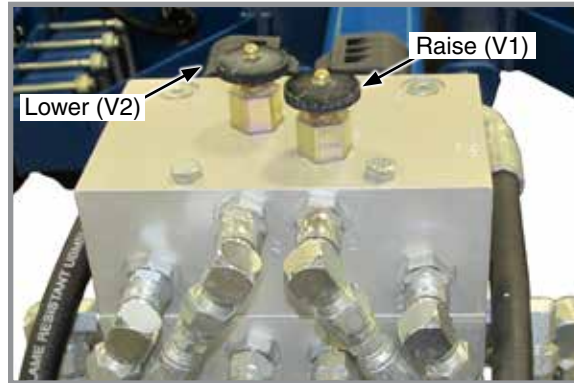

Row marker flow control valves

ROW MARKER LENGTH ADJUSTMENTS

1. Multiply number of rows by the average row spacing in inches to determine total planting width.

Row Marker Length	
24 Row 30"	720" (1,828.8 cm)

2. Lower planter and row marker assembly to ground.
3. Measure from planter center line to a point where blade contacts ground.
4. Adjust row marker extension so distance from marker disc blade to center line of planter is equal to total planting width. Adjust right and left row marker assemblies equally and securely tighten clamping bolts.

NOTICE

Setting marker disc blade assembly at a sharper angle than needed adds stress to row marker assembly and shortens bearing and blade life. Set blade angle only as needed to leave a clear mark.

Marker disc blade is installed with concave side facing inward. Spindle assembly is slotted so hub and blade can be angled to throw more or less dirt.

5. Loosen hardware and move assembly as required.
6. Tighten bolts to specified torque.
7. Do a field test to ensure markers are properly adjusted.

NOTE: A notched marker blade is available from Kinze through your Kinze Dealer for use in more severe no till conditions.

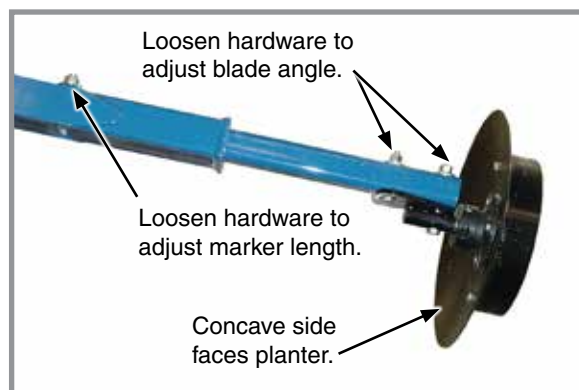

Row marker disc blade angle adjustment

TRANSPORT TO FIELD SEQUENCE

Position planter in a relatively flat open area without furrows, etc.

SUMMARIZED TRANSPORT TO FIELD SEQUENCE

1. Remove wing latch hook safety pin and hydraulic lockups from transport position and place in storage location.
2. Retract field tires and hold for 30 seconds to rephase cylinders.
3. Extend field tires to fully lowered position.
4. Lower transport tires until rear field tires are 3" - 5" off ground.
5. Partially lower 3-point hitch to release wing latch hooks.

NOTICE

Unfolding planter without using tractor to assist may cause equipment damage especially in soft conditions or when loaded with seed or fertilizer. Use tractor to reduce stress on frame, drive, and transport components.

6. Place tractor in reverse and hold in clutch. Start unfolding planter and slowly back up tractor as planter unfolds.
7. Fully raise transport tires.
8. Adjust 3-point hitch until planter hitch is level or slightly up.

NOTE: Read following information for detailed instructions.

1. Remove wing latch hook safety pin and lynch pin from transport position and place in storage location.

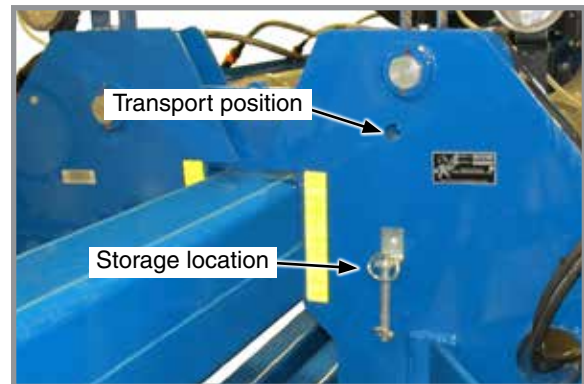

2. Operate field raise function hydraulic control to retract field tires. Hold for 30 seconds to rephase cylinders.
3. Operate field raise function hydraulic control to lower field tires.



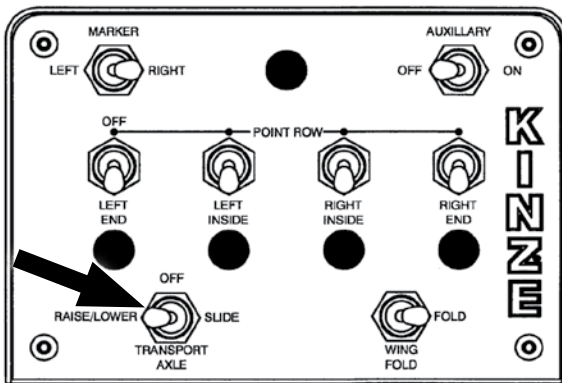

NOTICE

DO NOT retract transport cylinders completely or driveline and transport tires will be damaged. Keep weight of planter on field tires and transport axle tires on ground during folding.

4. Hold TRANSPORT AXLE switch in **RAISE/LOWER** and operate fold/unfold functions hydraulic control to lower transport axle until field tires are 3" - 5" off ground ground.

NOTICE

Lower 3 point hitch only until wing latch hooks release or damage will occur at rear of wing folding links. DO NOT lower hitch further.

5. Partially lower tractor 3 point hitch to release wing latch hooks.

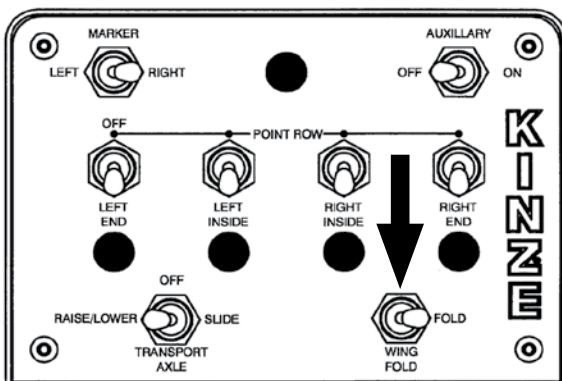
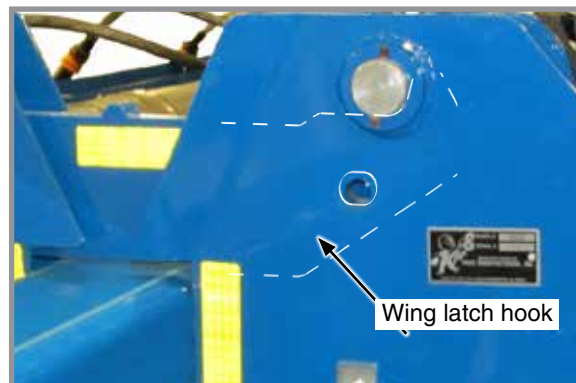

6. Hold control console WING FOLD switch in **FOLD** and operate fold/unfold functions hydraulic control to unfold planter. Tongue begins to retract and wings (supported by wing wheels) begin to unfold. Place tractor transmission in a low reverse gear and slowly back up as planter unfolds. Center axle tires should remain stationary and wing tires should roll in a continuous arc with minimal side loading on tires or their mounting structures.

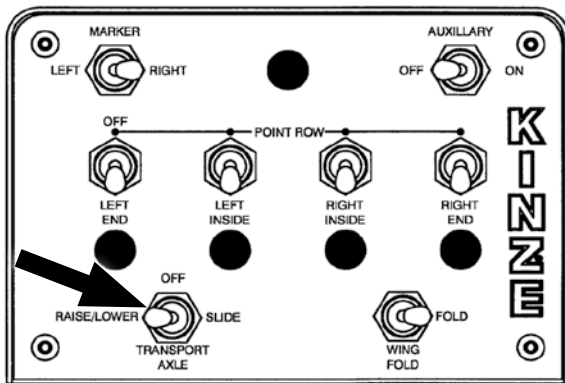

7. Hold TRANSPORT AXLE switch in **RAISE/LOWER** and operate fold/unfold functions hydraulic control to raise transport axle wheels to fully raised planting position.
8. Lower 3 point to level hitch position.



FIELD OPERATION

Planters are designed to operate within a speed range of 2 - 8 mph (3 - 13 kph). Higher ground speeds can cause more variation in seed spacing. Speeds above 5.5 mph (8.8 kph) are typically not recommended.

NOTICE: Always raise planter out of ground when making sharp turns or backing up.

Normal field planting operation requires use of tractor's hydraulic control to raise and lower planter frame when making field turn arounds.

NOTICE: Operate row markers in float position to prevent damage to row markers.

Operate row markers with control console switch for that marker in ON (LEFT or RIGHT) position and tractor's hydraulic control. After markers are lowered to ground, move hydraulic control to operate markers in float position. Marker speed is controlled with flow control valves located in planter hitch valve block. One valve controls raise speed and other valve controls lower speed of both markers. See "Row Marker Speed Adjustment" and "Row Marker Operation".

FIELD TO TRANSPORT SEQUENCE

Position planter in a relatively flat open area without furrows, etc.

SUMMARIZED FIELD TO TRANSPORT SEQUENCE

1. Raise planter to field turn around height.
2. Lower transport tires until rear field tires are 3" - 5" off ground.

NOTICE

Folding planter without using tractor to assist may cause equipment damage especially in soft conditions or when loaded with seed or fertilizer. Use tractor to reduce stress on frame, drive, and transport components.

NOTE: 3-point may have to be raised slightly to allow wings to completely fold to transport position.

3. Place tractor in low forward gear and hold in clutch. Start folding planter and move tractor slowly forward as planter folds to keep wing wheel side pressure to a minimum.
4. When planter is completely folded, fully raise tractor 3-point to lock wing latch hooks.
5. Fully lower transport tires.
6. Fully retract field tires.
7. Install wing latch safety pin and hydraulic lockups.

NOTE: Read following information for detailed instructions.

1. Operate field raise function hydraulic control to raise planter to raised field height.

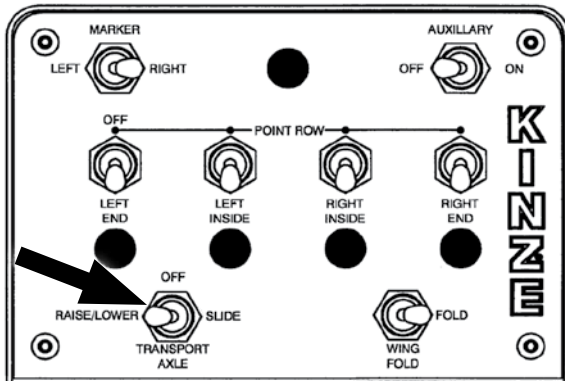

**NOTICE**

DO NOT carry full weight of planter on transport axle tires during folding or equipment can be damaged. Lower transport axle tires until weight begins to transfer onto transport axle tires.

- Hold control console switch labeled TRANSPORT AXLE in **RAISE/LOWER** and operate fold/unfold functions hydraulic control to lower transport axle wheels 3" - 5" from ground.

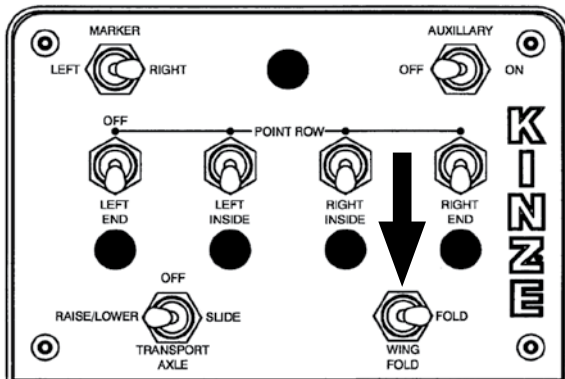

NOTE: Use tractor 3 point control to adjust hitch height so wing latch hooks pass over hitch and engage latch pins.

NOTE: In soft soil conditions wings may not fold completely into position against tongue. Retract wing wheels slightly to allow wings to fold into latching position.

- Hold WING FOLD switch in **FOLD** and operate hydraulic control fold/unfold functions to fold planter to transport position. **Slowly** idle tractor forward as you fold planter, allowing center axle tires to remain stationary and wing tires to roll in a continuous arc with minimal side loading on tires or their mounting structures.

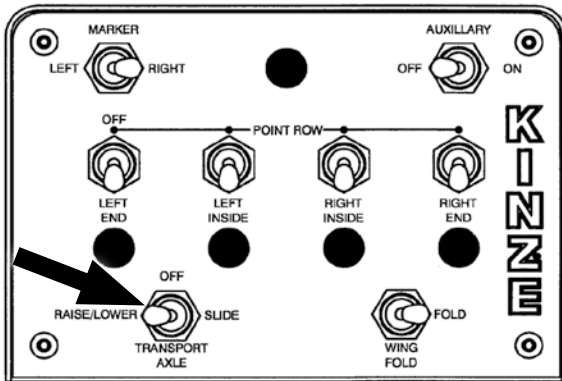

4. Raise front of planter with tractor 3 point hitch.

NOTE: Transport axle cylinder circuit is equipped with counter balance valves which hydraulically lock cylinders. Cylinders will not extend or retract until hydraulic pressure/flow is applied.

5. Hold control console switch labeled TRANSPORT AXLE in **RAISE/LOWER** and operate fold/unfold functions hydraulic control to fully lower the transport axle tires, raising rear of planter.
6. Operate field raise function hydraulic control to raise field tires/wheels.



7. Remove wing latch hook safety pin and lynch pin from storage location and install in transport position.

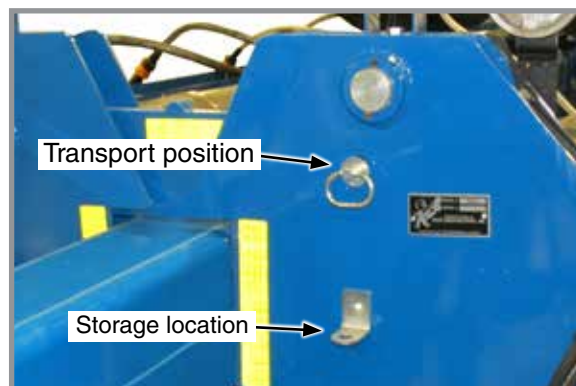

ANALOG VACUUM OR PRESSURE GAUGE



EdgeVac system vacuum gauge



ASD system pressure gauge

Analog vacuum or pressure gauges connect directly to EdgeVac or ASD manifolds. ASD pressure gauge is mounted at center of planter and Edgevac vacuum gauges are mounted at each end of planter.

The only gauge adjustment is to “zero” needle with no vacuum or pressure present.

NOTE: Analog gauges are identical EXCEPT for plug and hose barb locations in side of gauge housing. DO NOT connect EdgeVac or ASD hose to wrong gauge. Check plug and hose barb installation if readout is erratic or appears inaccurate.

EDGEVAC SYSTEM

Kinze EdgeVac seed metering system includes seed meters, seed discs, and an air system consisting of a hydraulic driven vacuum fan which draws air through manifolds, hoses, and seed meters on each row unit.

WARNING

Moving fan blades can cause amputation or severe injury. Never operate vacuum fan with cover removed.

VACUUM FAN MOTOR VALVE BLOCK ASSEMBLY

A pressure relief valve prevents build up of oil pressure over 35 PSI in case drain line when vacuum fan motor is operating and vents oil outside valve block. This can occur whenever case drain is improperly connected or pressure in motor circuit builds.

See “Vacuum Fan Motor System Hydraulic Diagram” in Lubrication and Maintenance section.

Valve block contains a check valve that prevents vacuum fan from operating in wrong direction if pressure is applied to return side of motor and allows fan to coast to a stop when tractor hydraulic control is returned to neutral position.



EdgeVac system fan block

NOTE: Fan turns at a reduced speed if reverse pressure is applied.

AIR SEED DELIVERY (ASD) SYSTEM

CAUTION

Seed flying out of disconnected delivery tube at high velocity can cause injury. Do not disconnect delivery tubes when system is operating.

NOTICE

Foreign materials can plug system. Make sure seed is clean and free of debris when filling ASD hoppers.

NOTICE

Do not turn on system with tractor engine at full speed or system damage may occur.

NOTICE

Do not operate ASD system above maximum system operating pressure of 20 inches of water or seed bridging may occur.

1. **Before filling hoppers refer to “Row Unit Operation” for additives information.** Fill hoppers with seed, latch lids, and secure with pin.
2. Start air seed delivery system with tractor engine at idle.
3. Increase engine speed to full and set initial system pressure using flow control valve.
4. Allow system to warm up and adjust pressure if necessary.

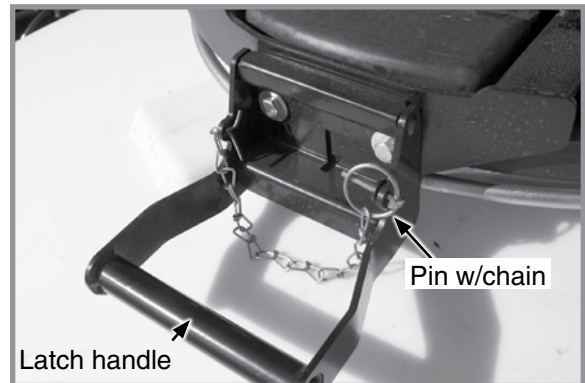

ASD tank lid latch

Recommended pressures:

- Corn – 12 inches of water
- Soybeans – 10 inches of water
- Actual pressure needed is affected by seed size, shape, and coating.

ASD ENTRAINER ACCESS

1. Shut down ASD system.
2. Loosen wing nut and turn retainer holding shutoff door in its storage location.
3. Remove rubber plug closest to area in entrainer needing attention.
4. Insert shutoff door into open slot and push into entrainer at a slight upward angle.
5. When work is complete, remove shutoff door, return door to storage location, and plug open slot.

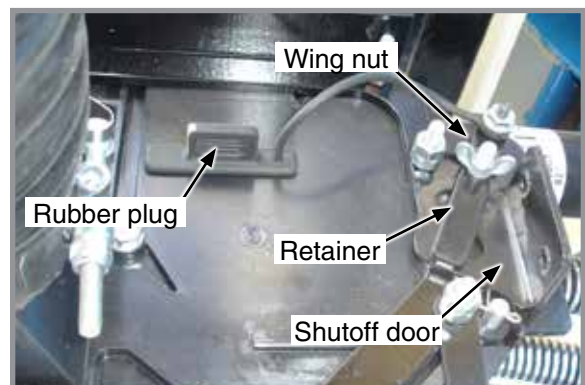

ASD entrainer (end view)

ASD TANKS - CLEAN OUT

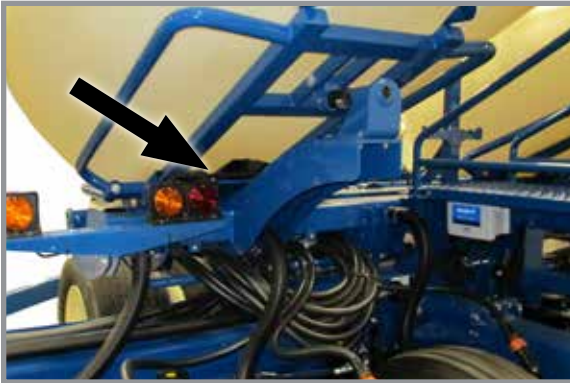

Cleanout chute storage location

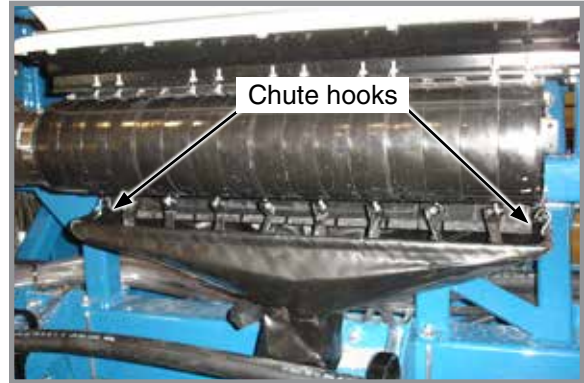

Cleanout chute installed

1. Remove ASD tank cleanout chute from storage location beneath catwalk.
2. Position tube of chute under entrainer and attach hooks on each end of entrainment assembly.
3. Open cleanout doors and empty tank.
4. Close all cleanout doors and return cleanout chute to storage location.

ASD SCALE PACKAGE OPTION

NOTICE

High-pressure water can damage display. Remove display before power washing planter.

NOTICE

Remove and store display at end of planting season. Damage from sun and weather exposure may result.

- Provides seed weight or estimated acres remaining for each ASD hopper.
- Displays total (gross) seed weight or estimated acres remaining for both hoppers combined.
- Warns operator when seed goes below a pre-defined level (when using a Kinze Vision display).

Operation of ASD Scale Package display is controlled by buttons located on its face:

- Two screen-defined selection buttons.
- Backlight ON/OFF button.
- UP/DOWN arrow buttons.
- Screen position is changed by loosening thumb screw on mount at back of monitor and repositioning screen.

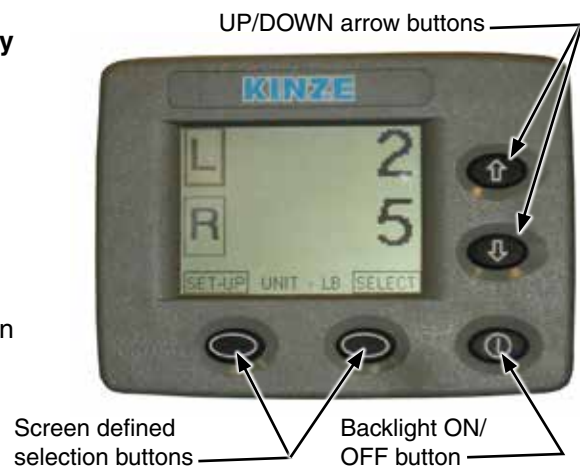

SETUP ASD SCALE PACKAGE DISPLAY

1. Press SET-UP button.



2. First setup screen displays and ALARM LEVEL box is highlighted.
3. Press SELECT button.
4. Press UP or DOWN arrows to change alarm weight level. Select BACK to save changes.
5. Press UP or DOWN arrows to highlight WEIGHT/ACRE MODE box. Press SELECT button.
6. Press UP or DOWN arrow buttons to toggle between weight or acre mode. This selection affects if values are displayed as pounds or estimated acres of seed remaining. Press BACK to save changes.



7. Press DOWN arrow to select second set-up screen.

NOTE: CALIBRATION# and SETUP# are automatic and do not need to be changed.

8. Select CONTRAST or BACKLIGHT. Use UP or DOWN arrow buttons to change levels. Press BACK to save changes.
9. Select BACK to return to main screen.



MONITOR SEED LEVELS

1. Main screen displays information for left and right hoppers.
2. Select L or R for individual hopper status information.
3. Select BACK to return to main screen.
4. Press down arrow once or twice for GROSS screen to appear. This provides combined status information for both hoppers.
5. Press down arrow again to return to main screen.



ENTER SEED INFORMATION

1. Highlight and select either L (left) or R (right) for the appropriate input screen.
2. At input screen, L or R side is indicated at left side of screen and seed weight or acres remaining is on right side.



3. Press arrow keys to select desired box; press SELECT to darken and use arrow keys to change.

NOTE: Seed information entered must be accurate for remaining estimated acres to calculate correctly.

- SEEDS/ACRE is population rate.
 - SEEDS/LB value comes from seed specifications.
 - ZERO is selected to zero hopper that is selected.
4. Select BACK to return to main screen.



KINZE COBALT SYSTEM

The Cobalt electronic seed monitor system consists of a tractor-mounted console, seed tubes with computerized sensors installed in each planter row unit, a primary harness connecting console to planter harness, and a planter harness (junction Y-harness and/or harness extension where applicable), connected to each seed tube sensor.

Cobalt monitor is built to withstand harsh environments associated with today's agricultural industry. The weathertight enclosure seals out dirt and moisture encountered during normal operating conditions.

This system is compatible with all Kinze planters, and can be transferred between multiple vehicles to maximize return on investment.

The Cobalt system allows manual control of air clutches and variable population control when planter is equipped with these options. It is not GPS compatible.

NOTE: See Kinze Cobalt Operator Manual for installation and programming.



Kinze Cobalt display

AG LEADER INTEGRA DISPLAY

Integra is a full-featured hub of any precision farming operation. A large, full-color 12.1" HD touchscreen display is easy to read and offers powerful, year-round precision farming tools. Mapping, planter and application control, yield monitoring, real-time data logging, and more – are all controlled from the cab using the Integra display.

Four video camera inputs provide operators a better view of equipment operation and safety by allowing them to view live video on the display.

NOTE: See Integra Operator Manual for installation and programming.



Ag Leader Integra display

PLANTER MONITOR MODULE (PMM)

PMM Magnetic Distance Sensor Package includes a planter-mounted module enclosure with cover and mounting hardware, seed tubes w/sensors, planter harness, planter monitor cable, shaft rotation sensors and magnetic distance sensor components.

Ag Leader Integra display and associated cab harnesses are also required.

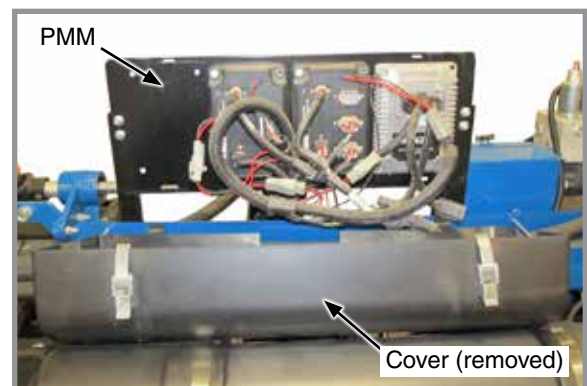

Planter Monitor Module (PMM)

KINZE ISOBUS OPTION

Kinze ISOBUS option consists of a planter monitor module (PMM), and planter control module (PCM). Kinze planters will communicate directly with most ISO compatible monitors. See ISOBUS Manual for more information.

FIELD TEST

Perform a field test with any change of field and/or planting conditions, seed size or planter adjustment to ensure proper seed placement and operation of row units.

- Check planter for front to rear and lateral level operation. See “Level Planter”.
- Check **all** row units to be certain they are running level. Row unit parallel arms should be approximately parallel to the ground when planting.
- Check row markers for proper operation and adjustment. See “Row Marker Adjustment” and “Row Marker Speed Adjustment”.
- Check for proper application rates and placement of granular chemicals on **all** rows. See “Field Check Granular Chemical Application”.
- Check for desired depth placement and seed population on **all** rows. See “Field Check Seed Population”.
- Check for proper application rates of fertilizer on **all** rows. See “Fertilizer Application Rate Chart”.

Reinspect machine after field testing.

- Hoses And Fittings
- Bolts And Nuts
- Cotter Pins And Spring Pins
- Drive Chain Alignment

FIELD CHECK SEED POPULATION

1. Tie up one or more sets of closing wheels by running a chain or rubber tarp strap between the hopper support panel and closing wheels. It may be necessary to decrease closing wheel arm spring tension.

Chain, rubber tarp strap, or similar.

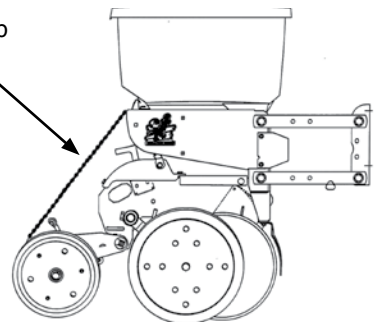

2. Plant a short distance and check to see if seed is visible in the seed trench. Adjust planting depth to a shallower setting if seed is not visible and recheck.

Planting depth adjustment handle

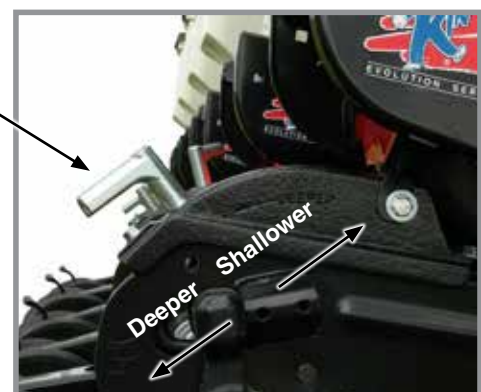

Planting depth adjustment

NOTE: Seeds may bounce or roll when planting with closing wheels raised and planting depth set shallow affecting seed spacing accuracy.

3. Count seeds in 17' 5" (30" rows = $\frac{1}{1000}$ of an acre) measured distance.
5. Multiply number of seeds placed in $\frac{1}{1000}$ of an acre by 1000. This gives total population.

30" row spacing = 17' 5" = $\frac{1}{1000}$ acre.

26 seeds counted x 1000 = 26,000 seeds per acre

NOTE: Seed count can be affected by seed meter drive ratio, tire pressure, and/or seed meter malfunction.

1. If seed check shows average distance between seeds in inches is significantly different than seed rate chart indicates, first check drive ratio between drive wheel and seed meter. Check drive wheel air pressure, check for incorrect sprocket(s) in driveline and check drive and driven sprockets on transmission(s) for proper selection.
2. Check for seed meter malfunction. For example, if spacing between kernels of corn at the transmission setting being used is 8" and a gap of 16" is observed, a finger has lost its seed and not functioned properly. If two seeds are found within a short distance of each other, finger has metered two seeds instead of one.
3. See "Seed Meter (Finger Pickup) Troubleshooting" or "Seed Meter (Brush-Type) Troubleshooting" in Troubleshooting Section of this manual.

DETERMINING POUNDS PER ACRE (BRUSH-TYPE METER)

Seeds per acre \div Seeds per pound (from label) = Pounds per acre

If seeds per pound information is not available use the following averages:

2,600 seeds per pound for medium size soybeans

15,000 seeds per pound for medium size milo/grain sorghum

4,500 seeds per pound for medium size cotton

DETERMINING BUSHELS PER ACRE

Pounds per acre \div Seed unit weight = Bushels per acre

Average Unit Weight of:

1 Bushel Soybeans = 60 Pounds

1 Bushel Milo/Grain Sorghum = 56 Pounds

1 Bushel Cotton = 32 Pounds

If seed population check shows planting rate is significantly different than seed rate chart shows or if a particular meter is not planting accurately, see "Brush-Type Seed Meter Maintenance" and "Seed Meter (Brush-Type) Troubleshooting".

FIELD CHECK GRANULAR CHEMICAL APPLICATION

Temperature, humidity, speed, ground conditions, flowability of different material, or meter obstructions can affect granular chemical rate of delivery.

WARNING

Agricultural chemicals can cause death or serious injury to persons, animals, and plants or seriously damage soil, equipment, or property. Read and follow all chemical and equipment manufacturers labels and instructions.

Perform a field check to determine application rates.

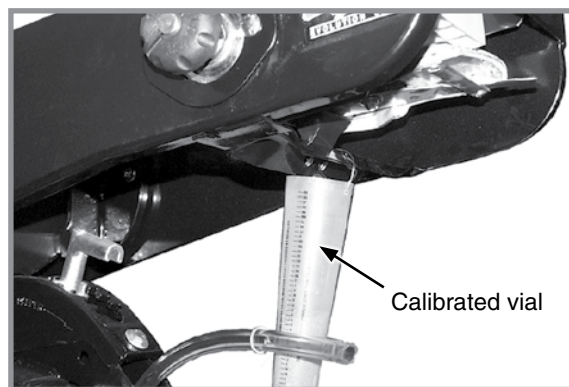

Granular chemical field check

1. Fill insecticide and/or herbicide hoppers.
2. Attach a calibrated vial to each granular chemical meter.

NOTE: Disengage clutch to avoid dropping seed during test.

3. Lower planter and drive 1320 feet at planting speed.
4. Weigh chemical in ounces caught in one vial.
5. Multiply that amount by .83 to determine pounds per acre.

EXAMPLE: You are planting 30" rows for 1320 feet at desired planting speed. You caught 12.0 ounces of chemical in one vial. 12.0 ounces times .83 equals 9.96 pounds per acre.

NOTE: Check calibration of all rows.

METERING GATE

Use metering gate setting as a starting point for distributing insecticide or herbicide. Charts are based on 5 mph (8 kph) planting speed. Use a higher gate setting for speeds faster than 5 mph (8 kph) and a lower setting for speeds slower than 5 mph (8 kph).

This page intentionally left blank.

PLANTING DEPTH

Planting depth is maintained by adjustable row unit gauge wheels. Depth adjustment range is approximately ½" to 3½".

1. Raise planter to remove weight from wheels.
2. Push down on depth adjustment handle and reposition it forward to decrease or rearward to increase planting depth. Initially adjust all units to the same setting.
3. Lower planter and check operation and planting depth of all row units. Readjust individual rows as needed for uniform operation.

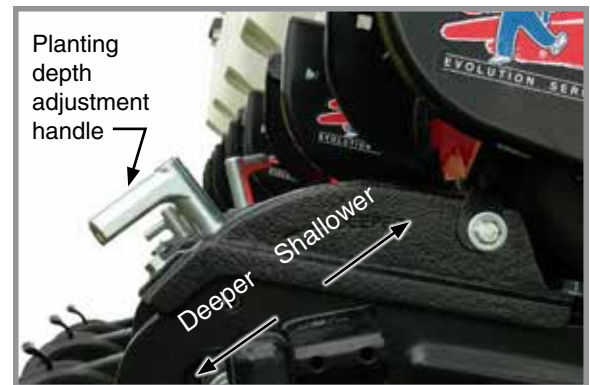

Planting depth adjustment

“V” CLOSING WHEEL ADJUSTMENT (RUBBER OR CAST IRON)

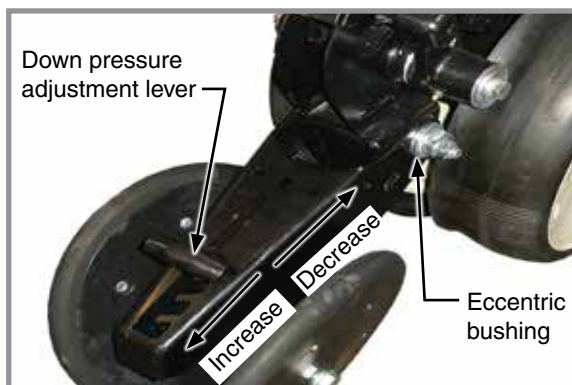

“V” Closing wheel adjustments

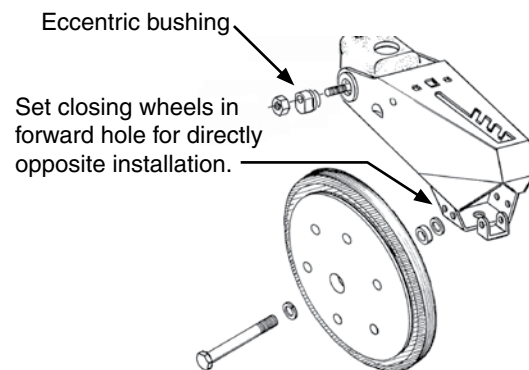

“V” closing wheels should have enough down pressure to close the seed trench and ensure good soil to seed contact. Move 5-position quick adjustable down force lever on the top of closing wheel arm to the rear to increase closing wheel spring pressure. Move lever forward to decrease pressure. Adjust all row units to a similar setting. Light soil usually requires less down force at average depth (approximately 2") while heavy soil requires increased down force.

Eccentric bushings in the wheel arm stop allow for lateral adjustment of the “V” closing wheel assembly. Use a ¾" wrench to loosen hardware attaching closing wheel arm to wheel arm stop. Use another ¾" wrench to turn eccentric bushings until **closing wheels are aligned with seed trench**. Tighten hardware.

Closing wheels can be installed “offset” (to improve residue flow) or “directly” opposite. Use forward installation holes if set “directly” opposite.

CLOSING WHEEL SHIELD (RUBBER OR CAST IRON “V” CLOSING WHEELS)

Optional closing wheel shield is installed on underside of closing wheel arm to help prevent root balls and stalks from clogging closing wheels.

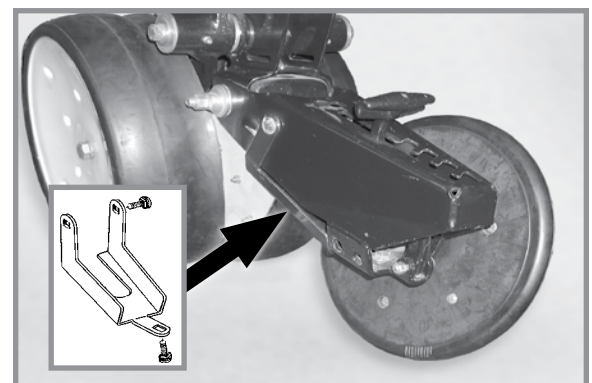

Closing wheel shield (Closing wheel removed)

DRAG CLOSING ATTACHMENT

Drag closing attachment pulls loose soil over seed trench.

NOTE: Use of a seed firming wheel or other seed firming device is recommended with drag closing attachment.

Front and rear adjustment is made using slotted holes in blades. Adjust all rows the same. Wheel arm stop eccentric bushings provide lateral adjustment. Use a 3/4" wrench to loosen closing wheel arm to wheel arm stop hardware. Use another 3/4" wrench to turn eccentric bushings until drag closing attachment is aligned with seed trench. Tighten hardware.

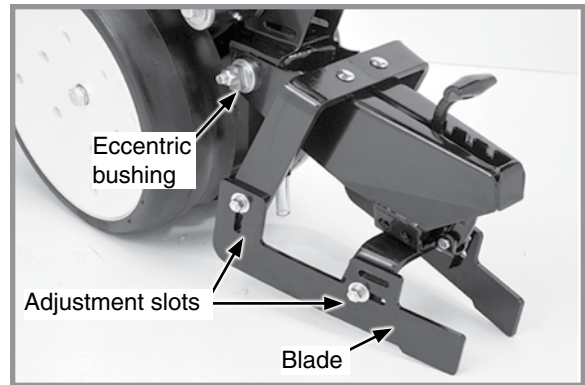

Drag closing attachment

COVERING DISCS/SINGLE PRESS WHEEL ADJUSTMENT

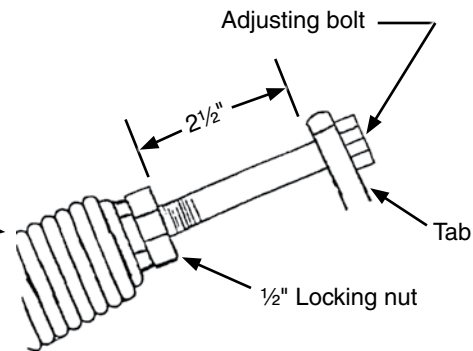
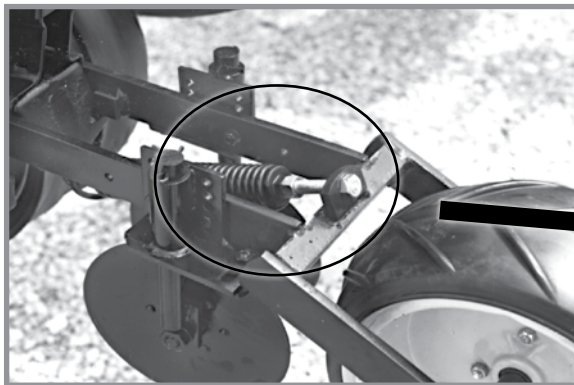

Press wheel down force adjustment

Check operation of covering discs/single press wheels after adjusting planting depth. Initial press wheel down force spring setting is 2 1/2" between mounting arm tab and locking nut. Loosen 1/2" locking nut and turn adjusting bolt in to increase down force or out to decrease down force. Tighten locking nut against spring plug. Adjust all row units to a similar setting.

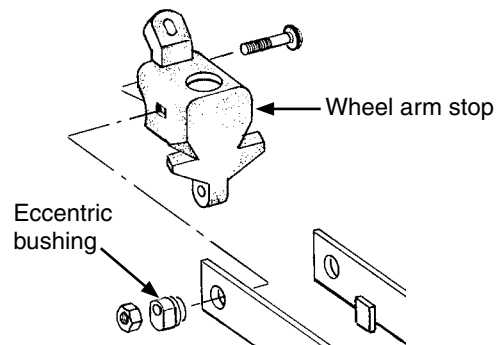
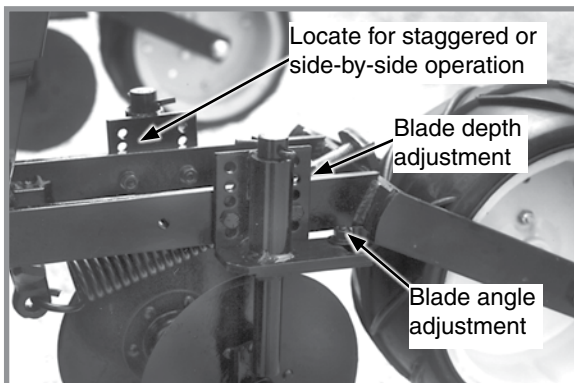

Covering disc adjustments

Eccentric bushings in the wheel arm stop allow for lateral adjustment of covering discs/single press wheel assembly. Use a 3/4" wrench to loosen hardware attaching closing wheel arm to wheel arm stop. Use another 3/4" wrench to turn eccentric bushings until covering discs/single press wheel assembly is aligned with seed trench. Tighten hardware. Two sets of holes in mounting arm locate covering discs for staggered or side-by-side operation. Five sets of holes in each disc bracket allow 1/2" incremental blade depth adjustment. Slotted holes in disc mount and bracket allow for 0° - 15° blade angle adjustment. Adjust covering discs on all row units to similar settings.

SEED HOPPERS

Mechanical seed hopper has a capacity of 1.9 bushels.

EdgeVac seed hopper has a capacity of 1.75 bushels.

Use clean seed and make certain there are no foreign objects inside when filling seed hopper. **Replace hopper lids after hoppers are filled to prevent accumulation of dust or dirt in seed meter which can cause premature wear.** See "Finger Pickup Seed Meter", "Brush-Type Seed Meter", or Edgevac Seed Meter".

Periodically empty hoppers completely to remove any foreign objects and to ensure proper seed meter operation.

Disengage meter drive and hopper latch and lift hopper off hopper support. See "Seed Meter Drive Release".

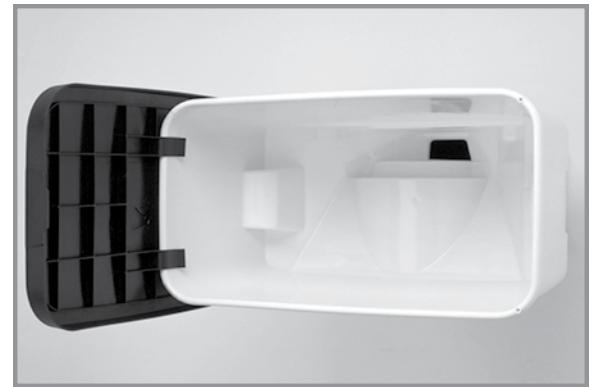

Mechanical seed hopper

SEED METER DRIVE RELEASE

A clutch release mechanism disengages seed meter drive from seed meter to remove seed hopper or prevent meter from operating. Releasing drive allows operator to check granular chemical application rates without dropping seed. It also allows one or more rows to be disconnected when finishing fields.

Turn knob ¼ turn counterclockwise to release or ¼ turn clockwise to engage drive.

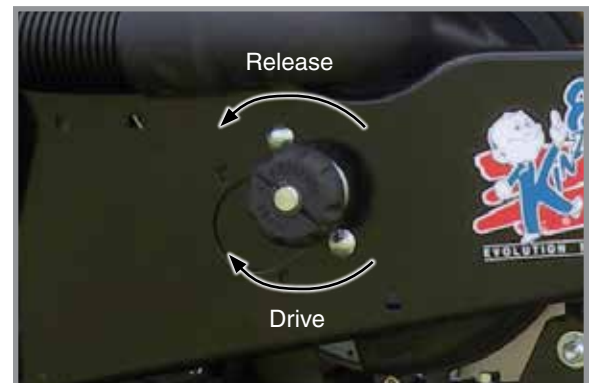

Seed meter drive release

ROW UNIT EXTENSION BRACKETS

Row unit extension brackets extend row units rearward 4" to provide clearance for coulter mounted residue wheels and HD single disc fertilizer openers.

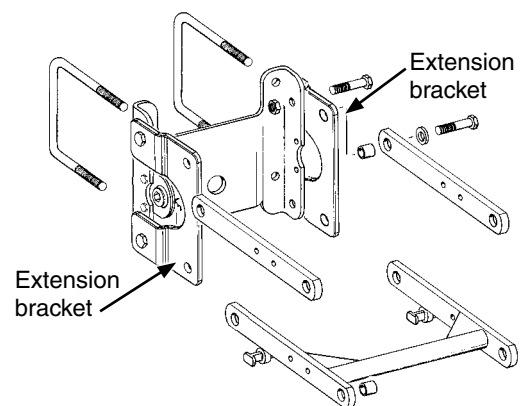

Row unit extension brackets

ROW UNIT CHAIN ROUTING

Row unit drive chains must be properly tensioned and aligned for proper operation and to minimize wear.

Inspect and replace weak, worn or broken springs, idlers, and idler bushings.

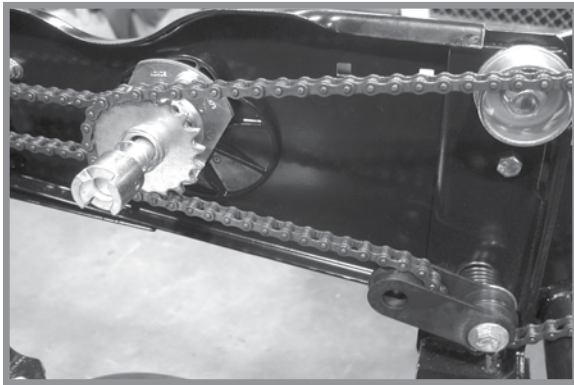

Mechanical pull row unit meter drive

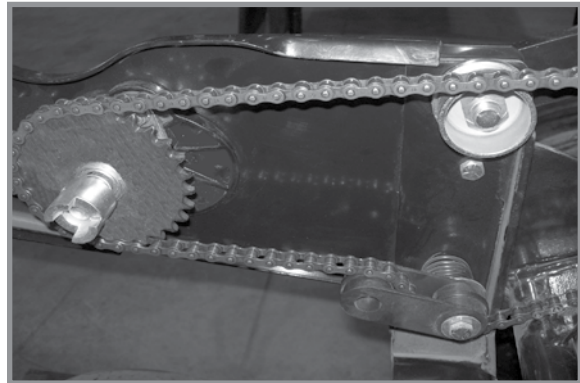

EdgeVac pull row unit meter drive



Row unit granular chemical drive

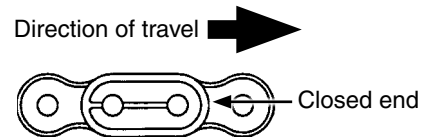

NOTE: Install connector link with closed end facing direction of travel.

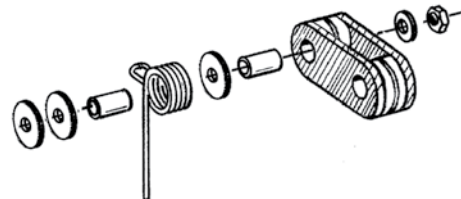

NOTE: Reverse idler when worn on one side for extended use.

QUICK ADJUSTABLE DOWN FORCE SPRINGS OPTION (STANDARD OR HEAVY DUTY)

Standard and heavy duty quick adjustable down force springs are available in increase penetration in hard soil and keep row unit from bouncing in rough field conditions. Two springs per row, one on each side parallel arms, are used unless equipped with row unit mounted no till coulters. Row unit mounted no till coulters require four springs per row.

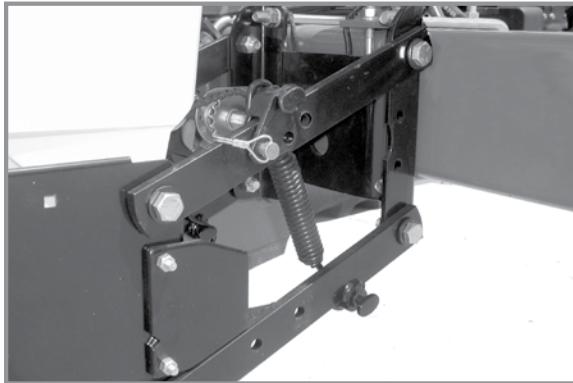

Two springs per row (Dual)

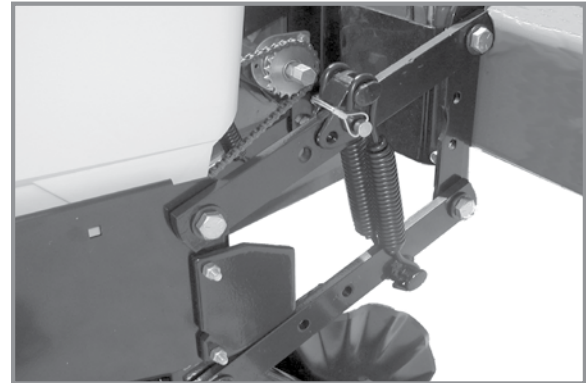

Four springs per row (Quad)

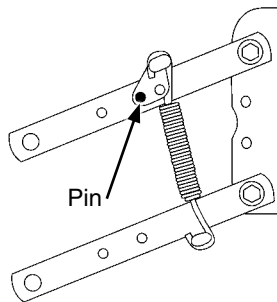

Position 1 (Least)

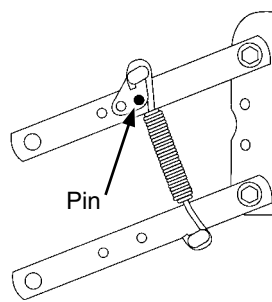

Position 2

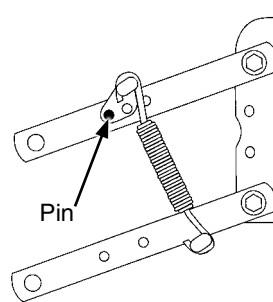

Position 3

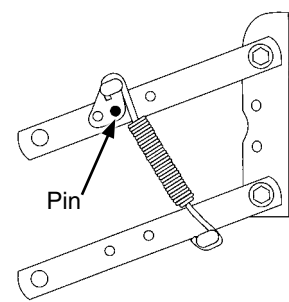

Position 4 (Most)

There are four positions to set down pressure spring tension.

Standard and Heavy Duty Spring Down Force Pressure*				
	2 Springs		4 Springs	
Position	Standard D8249	Heavy Duty D21337	Standard D8249	Heavy Duty D21337
1	41lb (18.6 kg)	43 lb (19.5 kg)	74 lb (33.6 kg)	80 lb (36.3 kg)
2	73 lb (33.1 kg)	86 lb (39.0 kg)	120 lb (54.4 kg)	144 lb (65.3 kg)
3	136 lb (61.7 kg)	167 lb (75.7 kg)	255 lb (115.7 kg)	307 lb (139.3 kg)
4	207 lb (93.9 kg)	249 lb (113.0 kg)	369 lb (167.4 kg)	470 lb (213.2 kg)

*Pressure does not include weight of row unit, seed, or options.

NOTICE

Springs must be installed with open side of spring hooks toward seed hoppers to prevent binding on spring mount adjustment pins.

1. Raise planter and remove spring mount pin at top of spring.
2. Slide mount to desired position and install pin.

NOTE: Adjust springs for field conditions. Too much down pressure in hard field conditions can cause row units to lift planter and keep drive wheels from making contact. Too much down pressure in soft field conditions can cause row unit to run too deep.

PNEUMATIC DOWN PRESSURE

Row unit down pressure can be adjusted on-the-go as field conditions change. A cab-mounted control box adjusts pressure (Older models may have a digital readout). Two planter-mounted 12 VDC air compressors with 3 gallon capacity air tank supplies air for the down pressure system.



Pull row unit air spring

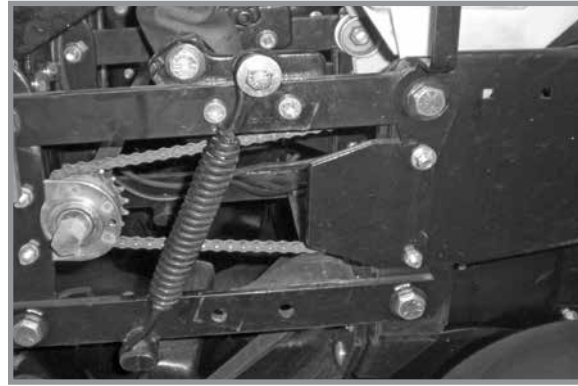

Pull row unit assist springs

Packages include upper and lower air spring mounting castings for pull row units, 150 psi rated air springs, $\frac{3}{8}$ " O.D. nylon hoses, dual solenoid air valve and stainless steel, 160 psi, 2" liquid-filled gauge and planter wiring harness.

Pneumatic down pressure row unit extension brackets are required in some applications.

NOTE: Assist springs are available through your Kinze dealer if additional down pressure is needed. One spring is installed on outer side of parallel arms on each side of row unit.

FIELD OPERATION

NOTE: Adjust down pressure with planter lowered and row openers in ground for most accurate adjustment. Pressure can be adjusted from tractor using control console, or at planter using manual control valves on compressor assembly.



Control console

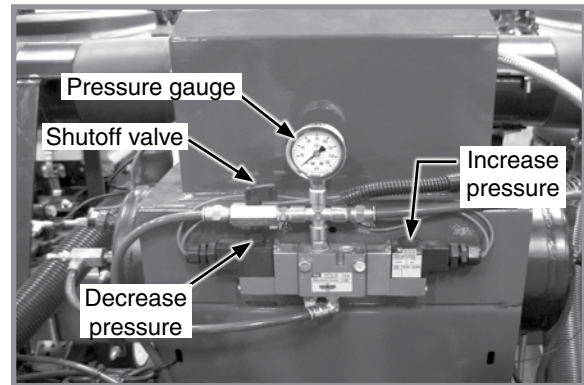

Air compressor assembly controls

ADJUST DOWN PRESSURE FROM CAB

Push toggle switch left to increase or right to decrease pressure.

ADJUST DOWN PRESSURE AT PLANTER

Push and hold decrease or increase button on compressor assembly to decrease or increase pressure.

NOTE: Value on the air pressure gauge is NOT down pressure force. Multiply air pressure (psi) by four (4) to calculate down pressure.

This page intentionally blank.

GENERAL PLANTING RATE INFORMATION***NOTICE***

Seed additives added in the hopper may affect finger pickup seed meter performance and accelerate wear.

NOTE: Seed size and shape may affect planting rate.

NOTE: Speeds above 5.5 MPH (8.8 KPH) can adversely affect seed spacing.

Finger Pickup Corn Meter

Larger grades generally plant more accurately at the high end of the ground speed range than smaller grades. Higher than optimum speeds may result in population rate increase or higher incidence of doubles, particularly with small seed. Medium round corn seed is most desirable for planting accuracy at optimum speed.











Finger Pickup Oil Sunflower Meter

Larger grades generally plant more accurately at the high end of the ground speed range than smaller grades. Higher than optimum speeds may result in population rate increase or higher incidence of doubles, particularly with small seed. No. 3 and/or No. 4 size oil sunflower seeds are recommended for use in finger pickup seed meters equipped with oil sunflower fingers. No. 1 and/or No. 2 size confectionery sunflower seeds are recommended for use in finger pickup seed meters equipped with corn fingers.

Brush-Type Seed Meter (Soybean, Milo/Grain Sorghum, Acid-Delinted Cotton)

Rate charts are given in seeds per acre as well as seed spacing in inches rounded to nearest tenth of an inch. Because of large range in seed size, pounds per acre is not a suggested method of selecting transmission settings. Smaller size seed pounds per acre may be below what was expected and large seed pounds per acre may appear above expectations. To determine pounds per acre, use formula given in "Determining Pounds Per Acre (Brush-Type Seed Meter)" in "Check Seed Population" in Machine Operation section of this manual.

BRUSH-TYPE SEED METER

	Crop	Disc Color-Code (Disc Part No.)	Upper Brush Retainer	Cells	Seed Size Range	*Lubricant
	Soybean	Black (GA5794)	GD11122	60	2200 to 4000 seeds/lb.	Graphite Talc
	Specialty Soybean	Dark Blue (GA6184)	GD11122	48	1400 to 2200 seeds/lb.	Graphite Talc
	Small Milo/Grain Sorghum	Red (GA5982)	GD8237	30	14,000 to 20,000 seeds/lb.	Talc
	Large Milo Grain Sorghum	Light Blue (GA6187)	GD8237	30	10,000 to 16,000 seeds/lb.	Talc
	High-Rate Small Milo/Grain Sorghum	Red (GA5795)	GD8237	60	12,000 to 18,000 seeds/lb.	Talc
	High-Rate Large Milo/Grain Sorghum	Yellow (GA6633)	GD8237	60	10,000 to 14,000 seeds/lb.	Talc
	Cotton, Acid-Delinted	White (GA5796)	GD11122	30	4200 to 5200 seeds/lb.	Talc
	Large Cotton, Acid Delinted	Tan (GA6168)	GD11122	36	3800 to 4400 seeds/lb.	Talc
	High-Rate Cotton, Acid-Delinted	Light Green (GA6478)	GD11122	48	4200 to 5200 seeds/lb.	Talc
	Hill-Drop Cotton, Acid-Delinted	Brown (GA6182)	GD11122	12 (3 to 6 seeds/ cell)	4000 to 5200 seeds/lb.	Talc
	Small Hill-Drop Cotton, Acid-Delinted	Dark Green (GA7255)	GD11122	12 (3 to 6 seeds/ cell)	5000 to 6200 seeds/lb.	Talc

*For More information on application rate see Additives section.

	<p>Use GD11122 upper brush retainer when using cotton and soybean discs.</p>		<p>Use GD8237 upper brush retainer when using milo/grain sorghum discs.</p>
---	--	---	---

Turn seed disc counterclockwise when installing on meter hub while tightening two wing nuts that retain disc. Seed disc should have slight resistance when rotated counterclockwise after wing nuts are tight.

Brush-type seed meter attaches to seed hopper same as finger pickup seed meter. Secure to bottom of seed hopper with two 5/16" thumbscrews. Tighten thumbscrews slightly with pliers. **DO NOT OVER TIGHTEN.**

Misalignment between drive coupler and seed meter input shaft may cause erratic seed spacing from momentary stoppage of seed disc. Check alignment and adjust as needed.

Refer to planting rate charts in this manual for recommended seed drive transmission sprocket combinations.



Shown without seed disc installed



NOTICE

Replace hopper lids after hoppers are filled to prevent accumulation of dust or dirt in seed meter which will cause premature wear.

NOTE: Clean seed is required to ensure accurate seed metering from brush-type seed meters. Remove seed discs daily and check seed meter or brushes for buildup of foreign material, such as hulls, stems, etc.

FINGER PICKUP SEED METER

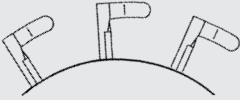
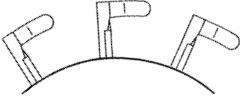
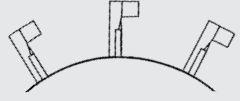









Crop	Fingers	*Lubricant
Corn	 Part No.: GR1848 - Finger Assembly, Corn	Graphite Talc
No. 1 and/or No. 2 size Confectionery Sunflower Seeds	 Part No.: GR1848 - Finger Assembly, Corn	Talc
No. 3 and/or No. 4 size Oil Sunflower Seeds	 Part No.: GR1897 - Finger Assembly, Oil	Talc
Blank fingers replace alternate fingers to reduce planting rate by half while allowing the finger wheel to maintain a minimum of 40 RPM when planting low rates.	 Part No.: GD11787 - Half Rate Blank Finger	Graphite Talc

*For More information on application rate see Additives section.

NOTE: Always field check seed population to verify planting rates.

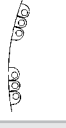
NOTE: Refer to planting rate charts in this manual for recommended seed drive transmission sprocket combinations.

EDGEVAC SEED METERS

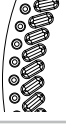
	Crop	Disc Color-Code (Disc Part No.)	Cells	Seed Size Range	Singulator Brush Setting	Vacuum Setting (H2O)	*Lubricant	See Notes
	Corn	Light Blue (GD17049)	39	35-70 lbs./80k	5-7	18-20	Graphite Talc	4, 5
	Popcorn			2210-4200 seeds/lb.	9	18	Graphite Talc	1, 4, 5
	Low-Rate Corn	Light Green (GD17048)	24	35-70 lbs./80k	5-7	18-20	Graphite Talc	4, 5
	Low-Rate Popcorn			2210-4200 seeds/lb.	9	18	Graphite Talc	1, 4, 5
	Soybean	Black (GD14467)	60	2200-4000 seeds/lb.	5	10	Graphite Talc	1
	Soybean, High-Rate	Dark Blue (GD14468)	120	2200-4000 seeds/lb.	5	10	Graphite Talc	-
	Milo/Grain Sorghum	Yellow (GD17050)	60	10,000 - 20,000 seeds/lb.	3-6	20	Talc	1, 2
	Hill-Drop Cotton, Acid-Delinted	Brown (GD17187)	20 (3 seeds/ cell)	3800-4400 seeds/lb.	8	23	Talc	3
	Small Hill-Drop Cotton, Acid- Delinted	Grey (GD18095)	20 (3 seeds/ cell)	4200-4400 seeds/lb.	-	-	Talc	3
	Cotton, Acid- Delinted	Dark Green (GD17186)	54	3800-5200 seeds/lb.	8	20	Talc	3
	Dry Edible Bean, Small			1200-2500 seeds/lb.	6	18	Graphite Talc	3, 5
	Dry Edible Bean, Large	Tan (GD14477)	54	800-1200 seeds/lb.	5	18	Graphite Talc	5
	Small Cotton/ Sunflower	White (GD18098)	54	4200-5200 seeds/lb.	5	30	Talc	3
	Sugar Beets	Dark Orange (GD24805)	80	All	5-6	15-18	Graphite	1

***For More information on application rate see Additives section.**

Install selected seed disc. Position vacuum cover on meter by aligning keyhole slots over bolt heads. Push cover on meter and turn counter clockwise to lock in place.

NOTES:

1. Requires use of seed meter baffle.
2. Requires use of cleanout brush.
3. Requires use of cleanout brush w/ball-type ejector.
4. Flat seeds may require higher vacuum level.
5. Larger seeds may require lower singulator brush setting. Smaller seeds may require higher setting.

NOTE: See “EdgeVac General Planting Rate Information” and “Check Seed Population” pages for more information. Always field check seed population to ensure planting rates are correct.

NOTE: Singulator brush settings are marked from 1 thru 11. Lower singulator brush settings are least aggressive. Higher singulator brush settings are most aggressive.

NOTE: Mixing seed sizes and shapes affects meter performance. Use consistent seed size and shape.

NOTE: Use 1 tablespoon powdered graphite with each hopper fill of seed. Seed treatment, foreign material, dirt or seed chaff may cause gradual reduction of seed disc fill (population). See “Additives” pages for more information.

NOTE: Excessive seed treatment, humidity, and light-weight seed can affect meter performance. Use ½ cup of talc with each hopper fill of seed and mix thoroughly to coat all seeds and adjust rates as needed. Use of talc aids seed flow into meter, singulation, and disc seed drop.

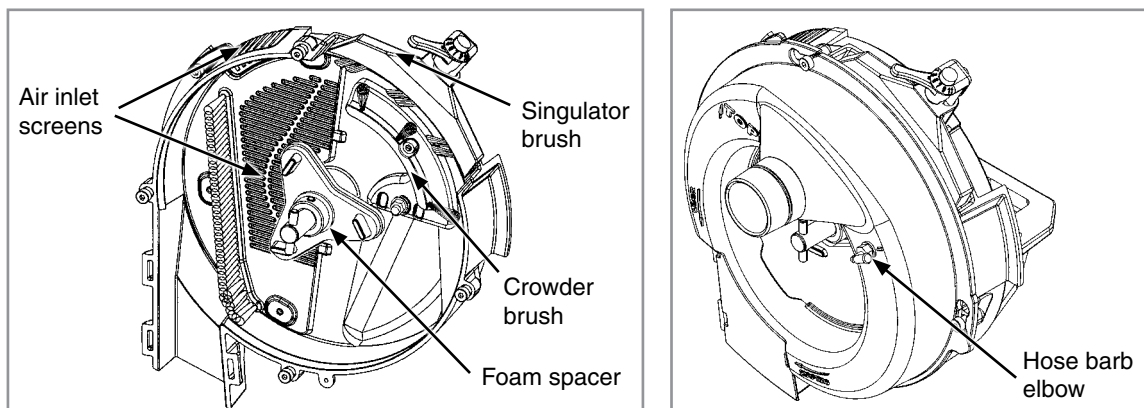

NOTE: Foreign material in seed disc orifices, such as seed chips, hulls, stems, etc., may affect seed delivery. Clean seed ensures accurate seed metering from vacuum seed meter. Remove Seed discs daily to check for buildup of foreign material in seed disc orifices.

Crowder brush aids in singulation of small flat seeds by crowding seeds to outer perimeter of seed disc and orienting seeds to allow singulator brush to be more effective.

Air inlet screens allow air to enter system and aids in keeping field residue or other foreign material out of meter.

Foam spacer gently preloads seed disc against vacuum cover when no vacuum is present.

3/16" hose barb elbow on seed meter vacuum cover allows measurement of vacuum level at each meter. A customer-supplied vacuum gauge is required.

See “EdgeVac Seed Meter Maintenance” and “Preparation For Storage” in Lubrication and Maintenance section for more information.

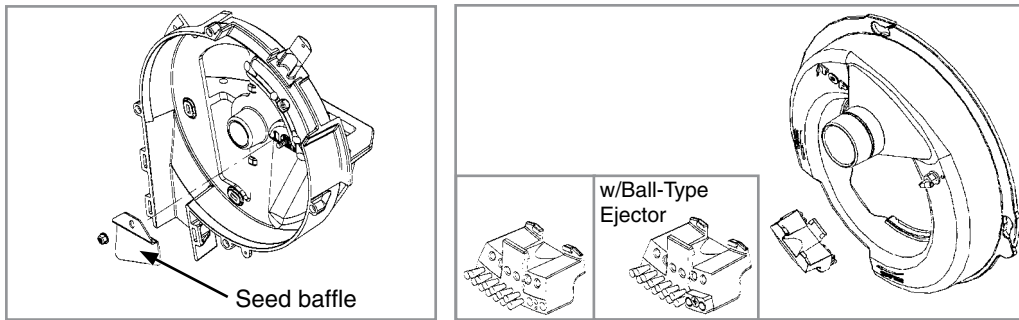

NOTE: Damaged seed or seed containing foreign material will cause plugging of seed disc orifices and require more frequent seed meter cleanout to prevent underplanting.

SEED BAFFLE

Seed baffle prevents excessive seed in meter from restricting air flow through seed. Used with 60 Cell Milo/Grain Sorghum Disc, 60 Cell Soybean Disc, 120 Cell High-Rate Soybean Disc and 39 Cell, 24 Cell Popcorn Discs, and 80 Cell Sugar Beet Disc.

CLEANOUT BRUSH

Cleanout brush removes foreign material and seed remnants to help prevent plugging of seed disc orifices. Used with 60 Cell Milo/Grain Sorghum Disc.

CLEANOUT BRUSH W/BALL-TYPE EJECTOR

Cleanout brush w/ball-type ejector ejects seed remnants from seed disc orifices. Used with 20 Cell Hill-Drop Cotton, Acid-Delinted (3 Seeds Per Cell) Discs; 54 Cell Acid-Delinted Cotton/Small Dry Edible Bean; and Small Cotton/Sunflower Discs.

NOTICE

Replace hopper or tank lids after filling to prevent accumulation of dust or dirt in seed meter resulting in premature wear.

NOTE: Seed size, seed shape, seed treatments, travel speed, and planting rate affect meter performance.

1. Select seed disc (and seed meter baffle, cleanout brush and/or cleanout brush w/ball-type ejector if applicable) to match crop and population.

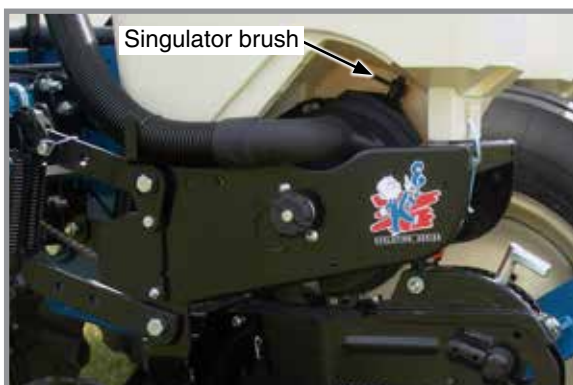

Singulator brush adjustment location

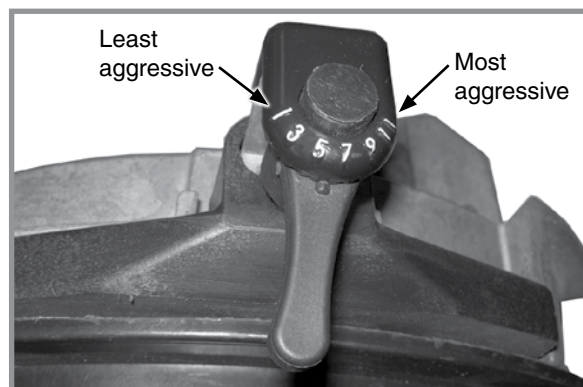

Singulator brush adjustment lever

2. Adjust singulator brush to initial setting. Seed size, seed shape, seed treatments, travel speed and planting rate all affect meter performance.
3. With vacuum fan running, lower planter to planting position and drive forward a short distance to load seed into seed disc cells.

- Adjust vacuum level to initial setting according to tables on page.

NOTE: Vacuum reading will be much lower when seed disc cells are empty. Load all seed cells before setting vacuum level.

NOTE: Operate vacuum fan 3-5 minutes to bring oil up to normal operating temperature prior to making final vacuum level adjustment.

- Perform optional seed disc fill check.



Remove vacuum cover and seed disc



Check seed fill

With vacuum hose connected and vacuum fan operating, remove vacuum cover and seed disc as an assembly. Inspect seed discs for proper seed fill.

See “Seed Metering System (EdgeVac) Troubleshooting” in Troubleshooting section.

SEED METER CLEANOUT

NOTE: Use of damaged seed or seed containing foreign material will cause plugging of seed cell orifices and require more frequent seed meter cleanout to prevent underplanting.

Thorough seed meter cleanout is important to maintain genetic purity.

- Disengage seed drive and remove seed hopper and meter.
- Dump seed from right rear corner of hopper into a container.
- (Mechanical) Disassemble seed disc by removing wing nuts.
(EdgeVac) Lay hopper on its right side. Rotate seed meter vacuum cover clockwise to align keyhole slots with bolt heads. Lift off cover. Remove seed disc.
- Empty Meter.
- Thoroughly inspect brushes in meter to ensure all seed is removed.
- Replace seed disc. (Mechanical) Install wing nuts. (EdgeVac) Install Vacuum cover.

ADDITIVES

The use of graphite is recommended to promote seed flow, provide lubrication for the seed meter and to help dissipate static charge buildup. Among the available dry seed lubricants graphite is the most effective and easiest to use and it requires no mechanical agitation

CONVENTIONAL HOPPERS

Mix one tablespoon of **powdered graphite** with seed each time hoppers are filled. Regular graphite use prolongs life of the seed meter components, improves seed spacing, and may reduce buildup of seed treatments.

NOTE: DO NOT apply graphite only in center of hopper. It will filter too quickly through the seed and not distribute as evenly as desired.

Apply graphite around outer perimeter of hopper.

ASD HOPPERS

Mix 1 pound bottle of powdered graphite each time the bulk seed hopper is filled. Graphite should be added in layers as the bulk seed hoppers are filled. Regular graphite use prolongs life of the seed meter components, improves seed spacing, and may reduce buildup of seed treatments.



Adding graphite to conventional hopper



Adding graphite ASD hopper

NOTE: Additional graphite may be required to retard buildup of seed treatments on meter components. More frequent cleaning of monitor seed tubes may be necessary due to use of additional graphite.

Talc seed lubricant may be used as a drying agent in addition to graphite lubrication. The drying agent may improve seed release and/or **to retard buildup of seed treatments on meter components.**

1. Fill hopper $\frac{1}{2}$ full of seed, add $\frac{1}{4}$ cup (conventional); 2 pounds (ASD) of talc and **mix thoroughly**.
2. Finish filling hopper, add another $\frac{1}{4}$ cup (conventional); 2 pounds (ASD) of talc and **mix thoroughly**.
3. Adjust rate of talc use as needed so all seeds are coated, while avoiding a buildup of talc in bottom of hopper.

Humid conditions and/or small sized seeds with extra seed treatment may require additional talc to maintain meter performance.

NOTE: Liquid seed treatments or inoculants may create buildup on the seed disc or brushes. Check frequently for proper population and/or seed delivery when using any liquid seed treatment.

Completely mix all treatments with seed following manufacturers' recommendations. Seed treatment dumped on top of seed after hopper is filled may not mix properly and cause seed bridging, reducing population or stopping meter from planting.

Lubricant Application Rate	
Graphite	
Conventional Hoppers	1 Tbs./Hopper Fill
ASD Hoppers	1 Pound Bottle/Hopper
Talc	
Conventional Hoppers	$\frac{1}{4}$ C.*
ASD Hoppers	4 Pounds/Hopper*
*Double amount of talc for sunflowers.	

FRAME MOUNTED COULTER (PULL ROW)

Frame mounted coulters with 1" bubbled, 1" fluted (8 flutes) or ¾" fluted (13 flutes) blades are used on pull row units only.

Springs provide down pressure on coulters for maximum penetration while exerting less shock load on row unit.

Initial coulters blade location is in top hole. Relocate blade to one of lower two holes (1" increments) as wear occurs or for deeper blade operation.

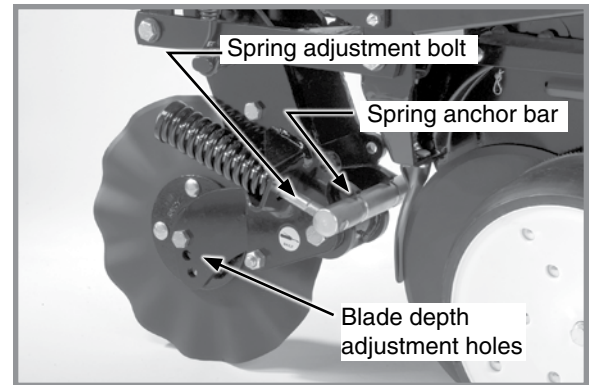

Frame mounted coulter adjustment

DOWN PRESSURE ADJUSTMENT

NOTICE

Excessive down pressure can damage coulters components when coulters strike an obstacle. Do not set down pressure higher than needed for consistent soil penetration.

Raise planter. Turn spring adjustment bolts clockwise to increase or counterclockwise to decrease down pressure. Set both springs to specification shown in following table:

Frame Mounted Coulter Spring Downpressure Settings		
End flush with spring anchor bar	Extended ½" through spring anchor bar	All threads used
275 lb (124.7 kg)	400 lb (181.4 kg)	500 lb (226.8 kg)

RESIDUE WHEELS (FRAME MOUNTED COULTER)

NOTICE

Tined wheel forward mounting positions cannot be used on four rows behind axle due to inadequate clearance.

Residue wheels attach to frame mounted coulters with two cap screws and sleeves allowing the unit to free-float. A 2-position spindle bolt mounting positions wheels interlocked or staggered. Depth adjustment is made with a spring-loaded cam and pin with 11 positions in ¼" increments. A high point on the cam allows wheels to be locked up.

A weed guard on the inboard side of each wheel helps prevent weed wrap which can cause premature bearing failure.

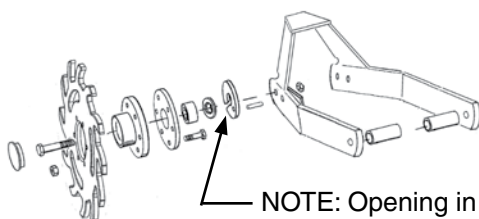

NOTE: Opening in weed guard must face down.

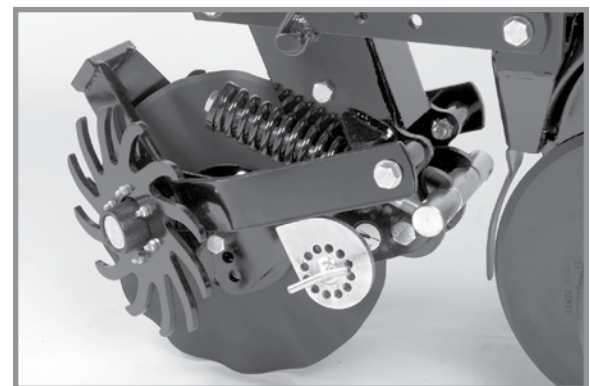

Frame mounted coulter residue wheel

ROW UNIT MOUNTED DISC FURROWER (PULL ROW)

Disc furrowers are used to clear crop residue, dirt clods, and dry soil from in front of row units for a clean and smooth seed bed. The disc furrower may be equipped with 12" solid blades or 12" notched blades. Notched blades are for heavier residue conditions and cut crop residue and move it aside to prevent plugging or pushing.

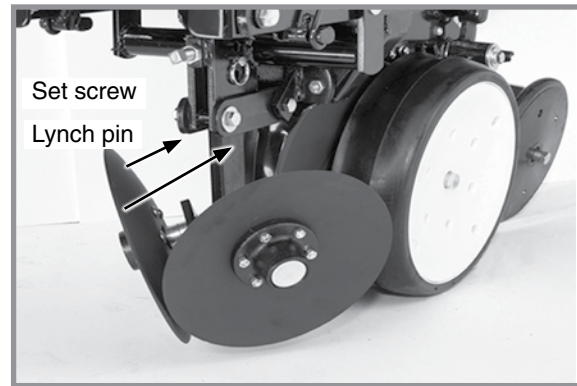
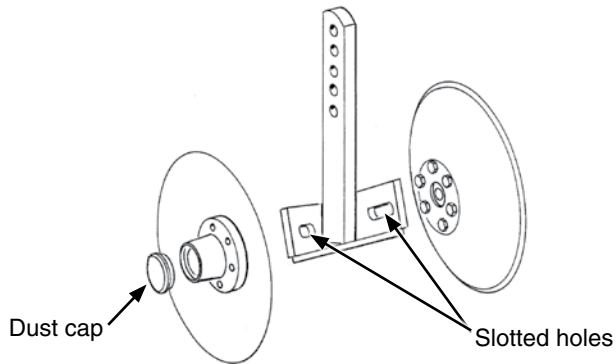

Disc furrower adjustment

Vertical adjustment can be made in $\frac{1}{8}$ " increments. Remove lynch pin in vertical support arm and move arm up or down. Reinstall lynch pin. Finer adjustment can be made by removing lynch pin and using $\frac{5}{8}$ " x $2\frac{1}{4}$ " set screw to clamp support arm in position. Slotted holes in support arm allow front to rear disc blade adjustment. Blades can be adjusted so front edges meet or cutting edge of one blade overlaps edge of other blade.

NOTE: Dust cap must be removed to make adjustments.

ROW UNIT MOUNTED RESIDUE WHEEL

Row unit mounted residue wheels are used on pull and push row units.

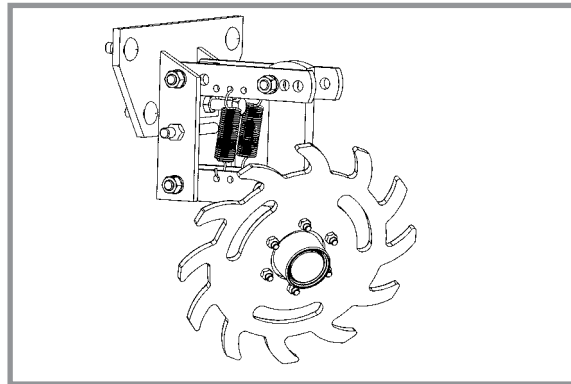

Row Unit Mounted Residue Wheel

Two adjustable springs on each residue wheel parallel links provide down force adjustment. Position 1 provides minimum down pressure and position 3 maximum down pressure.

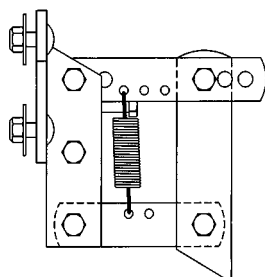

Position 1 (Least)

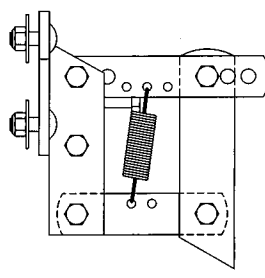

Position 2

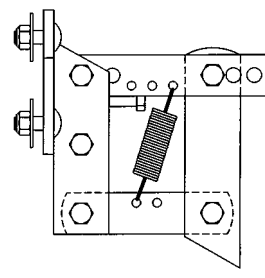

Position 3 (Most)

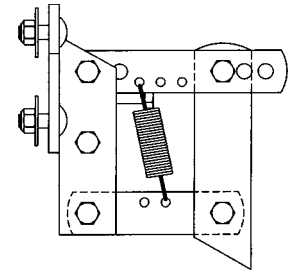

Additional uplift or float

Raise row unit and reposition springs to adjust down pressure.

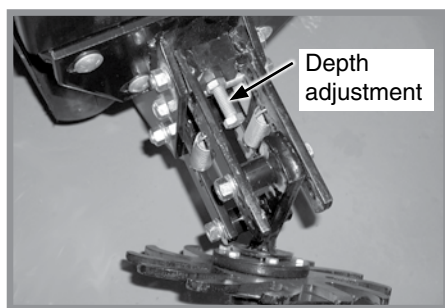

Wheel depth adjustment

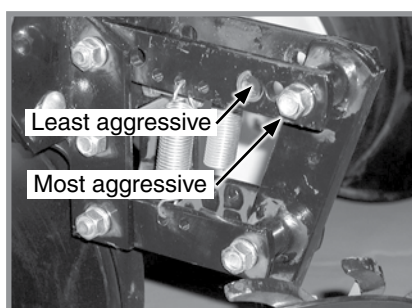

Wheel angle adjustment

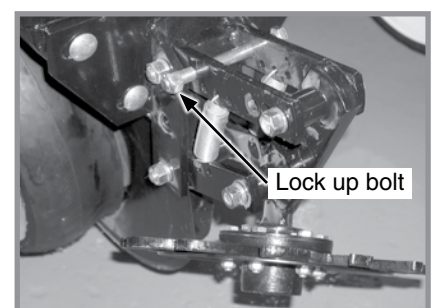

Wheel lock up

A full threaded bolt and jam nut located on the upper link sets maximum depth for loose soil conditions. Initial setting is 1 $\frac{3}{4}$ " above row unit double disc opener depth.

Three holes in upper link adjust wheel angle. With wheel mount in most vertical position, using the rear hole in the upper link, the residue wheel is most aggressive. Moving wheel mount to a forward hole reduces aggressiveness of residue wheel for use in mulch till applications where soil is loose.

To lock residue wheel up, remove 1/2" x 5" lockup bolt, raise residue wheel and install bolt.

ROW UNIT MOUNTED NO TILL COULTER

Row unit mounted no till coulters with 1" bubbled, 1" fluted (8 flutes) or ¾" fluted (13 flutes) blades may be used on pull row units and push row units (¾" fluted shown). Four quick adjustable down force springs are required per row when using row unit mounted no till coulters. See "Quick Adjustable Down Force Springs Options".

Align coulters to row unit double disc openers. Adjust by loosening four attaching bolts, moving coulters, and tightening four attaching bolts. Coulters can be adjusted to one of four ½" incremental settings in the forked arm. Initial location is the top hole.

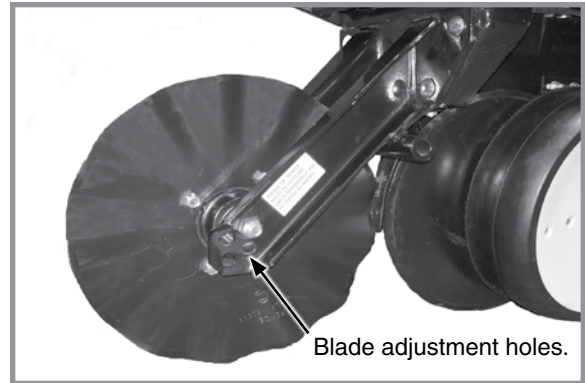

Row Unit Mounted No Till Coulters

Move blade as it wears to one of the three lower holes to maintain coulters at or slightly below opener discs. Adjust coulters below depth of double disc opener blades in very hard soil conditions such as compacted wheel tracks to improve opener penetration and cutting of surface residue.

Check operating depth by setting planter down on a level concrete floor and checking relationship between coulters and row unit opener blade. Make sure planter is level and coulters are square with planter frame and aligned with row unit disc opener.

NOTE: Torque 5/8" spindle hardware to 120 ft-lb (162.7 N-m).

COULTER MOUNTED RESIDUE WHEELS

Coulters mounted residue wheels are designed for use on pull row units and push row units. Row unit extension brackets are required on the four center pull row units if the planter is equipped with coulters mounted residue wheels.

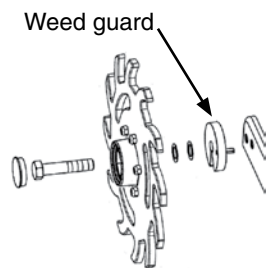

NOTE: Opening in weed guard must face down.



Coulters mounted residue wheels

Residue wheels attach to row unit mounted coulters with two cap screws and sleeves allowing unit to free-float. A 2-position spindle bolt mounting positions wheels interlocked or staggered. Depth adjustment is made with a spring-loaded cam and pin with 11 positions in ¼" increments. A high point on the cam allows wheels to be locked up.

A weed guard on the inboard side of each wheel helps prevent weed wrap which can cause premature bearing failure.

GRANULAR CHEMICAL HOPPER AND DRIVE

WARNING

Agricultural chemicals can cause death or serious injury to persons, animals, and plants or seriously damage soil, equipment, or property. Read and follow all chemical and equipment manufacturers labels and instructions.

The granular chemical hopper has a 1.4 cubic feet capacity.

Make sure no foreign objects get into hopper when it is being filled. Replace hopper lids after filling to prevent accumulation of dirt and moisture.

A metering gate on bottom of hopper regulates the application rate. See "Dry Insecticide and Dry Herbicide Application Rate Charts" in this manual. Calibrate using chemical manufacturers' instructions.



Granular chemical hopper

Granular chemical clutch drive coupler and meter shaft can be disengaged and engaged by turning throwout knob at rear of hopper support panel.

Rotate knob $\frac{1}{4}$ turn counterclockwise to disengage and $\frac{1}{4}$ turn clockwise to engage.

Slotted holes in hopper support panel and clutch housing allow for alignment adjustment between clutch drive coupler and meter shaft.

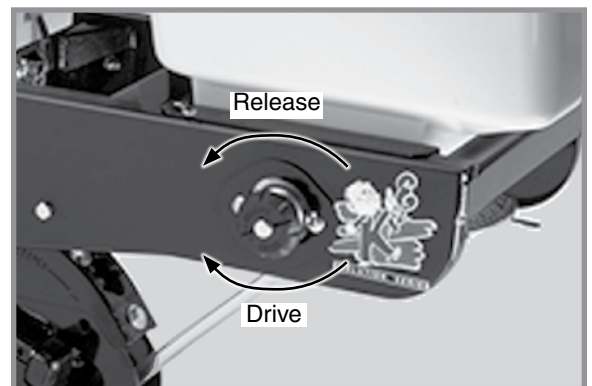

Granular chemical drive release

SPRING TOOTH INCORPORATOR

Spring tooth incorporator smooths soil behind row unit and incorporates granular chemicals.

Adjust two mounting chains on each spring tooth incorporator so there is approximately $\frac{1}{8}$ " slack in chain when unit is lowered to planting position.

NOTE: Spring tooth incorporator is not compatible with covering discs/single press wheel option.

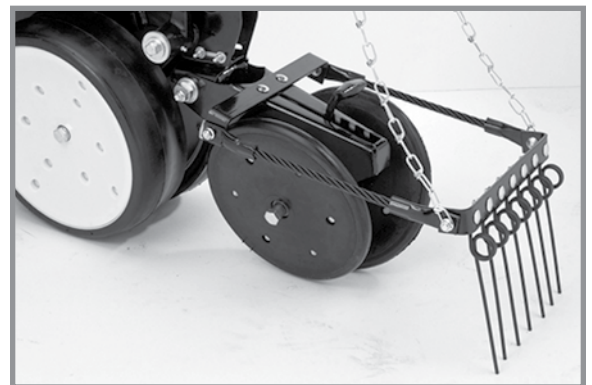

Spring tooth incorporator

GRANULAR CHEMICAL BANDING OPTIONS

Granular chemical banding options allow 4½" slope-compensating banding, straight drop in-furrow placement or 14" rear banding.

NOTE: Granular chemical rear bander is not compatible with covering discs/single press wheel option.

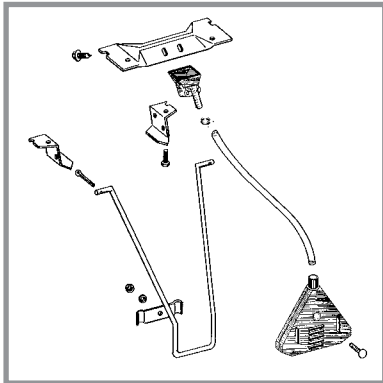

14" rear banding

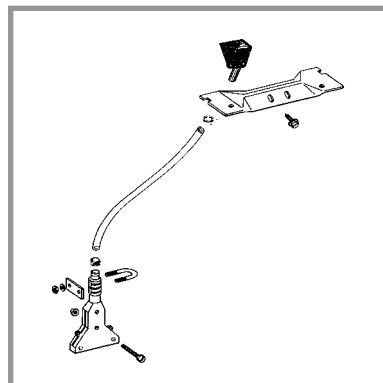

4½" slope-compensating bander

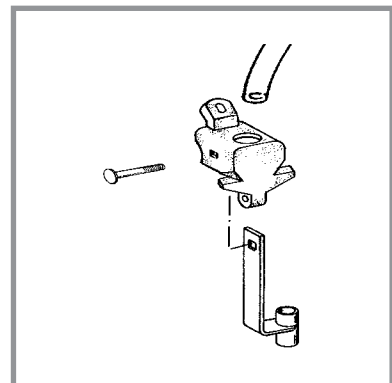

Straight drop in-furrow placement

GRANULAR CHEMICAL BANDER SHIELD

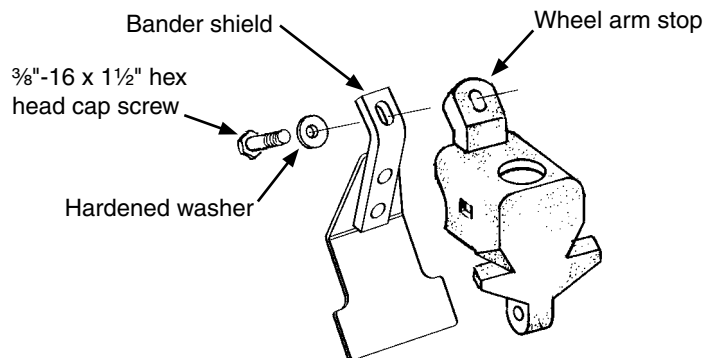

Optional granular chemical bander shield is installed on underside of wheel arm stop to shield crop residue from lodging in granular chemical bander.

DRY INSECTICIDE APPLICATION RATES APPROXIMATE POUNDS/ACRE AT 5 MPH

Meter Setting	30" Rows
CLAY GRANULES	
10	4.9
11	5.4
12	6.1
13	6.9
14	7.7
15	8.5
16	9.6
17	10.7
18	11.4
19	13.1
20	14.2
21	15.5
22	16.4
23	17.2
24	18.8
25	20.9
26	23.0
27	24.1
28	25.4
29	27.8
30	29.6
SAND GRANULES	
5	2.9
6	4.9
7	5.3
8	6.3
9	7.8
10	8.9
11	10.2
12	11.2
13	12.6
14	14.1
15	15.5
16	17.5
17	19.4
18	21.8
19	24.3
20	25.7
21	27.6
22	29.6
23	32.0
24	34.4
25	36.9

NOTE: Chart represents average values and should be used only as a starting point. Granular chemical flows through meter opening at a nearly uniform rate regardless of roller speed. Your actual rate will vary depending on insecticide, planting speed, and plant population. Planting speed/ground speed has the greatest effect on application rate.

Field check your actual rate with insecticide you are using at speed and population you will be planting. See "Checking Granular Chemical Application Rate" in Machine Operation section for more information.

DRY HERBICIDE APPLICATION RATES
APPROXIMATE POUNDS/ACRE AT 5 MPH FOR 30" ROW WIDTH
CLAY GRANULES

Meter Setting	30" Rows
10	4.7
11	5.2
12	5.8
13	6.5
14	7.3
15	8.2
16	9.0
17	9.9
18	10.7
19	11.6
20	12.6
21	13.6
22	14.6
23	15.7
24	17.0
25	18.1
26	19.4
27	20.9
28	22.6
29	24.3
30	26.7

NOTE: Chart represents average values and should be used only as a starting point. Granular chemical flows through meter opening at a nearly uniform rate regardless of roller speed. Your actual rate will vary depending on insecticide, planting speed, and plant population. Planting speed/ground speed has the greatest effect on application rate.

Field check your actual rate with insecticide you are using at speed and population you will be planting. See "Checking Granular Chemical Application Rate" in Machine Operation section for more information.

NOTCHED SINGLE DISC OPENER

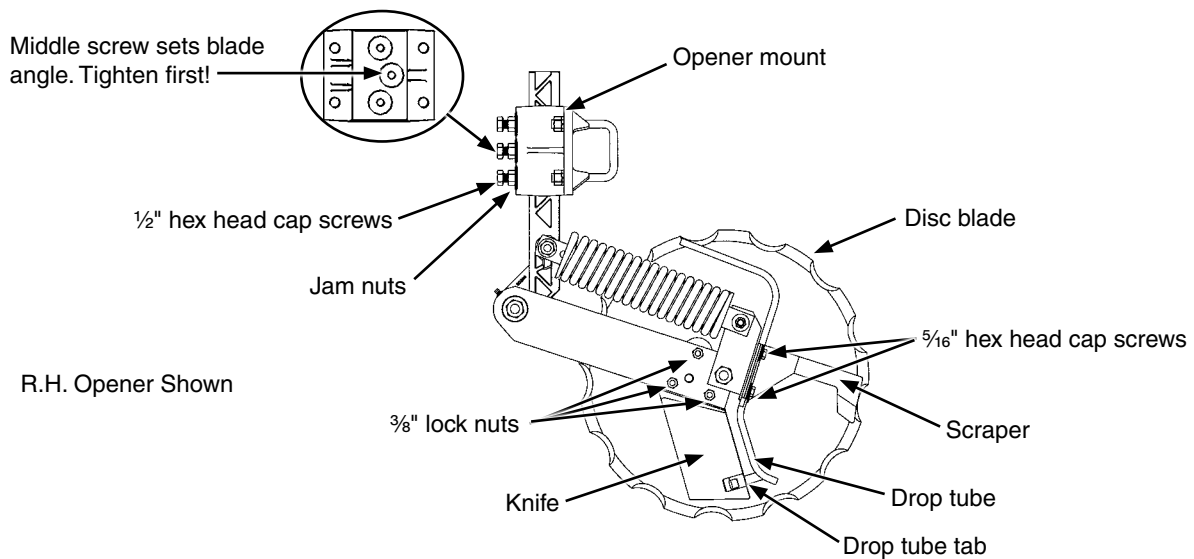

Notched single disc opener adjustments

CAUTION

Compressed spring may fly out of this assembly if attempting to disassemble and cause injury. Do not take apart this assembly.

Disc blades are sharp and can cut causing serious injury. Wear gloves when working on or turning disc blades by hand.

NOTICE

Never strike knife with heavy object. Damage to knife will occur.

If knife to disc blade clearance is too large, soil or residue can wedge between knife and blade, and blade will not turn.

1. Adjust knife to disc blade contact. Loosen or tighten 3/8" lock nuts to adjust knife's entire leading edge against disc blade. Turn blade and check for slight resistance without freewheeling. Readjust knife to blade's tight spot as needed.

NOTICE

Adjust liquid drop tube out of path of soil flow across knife. Drop tube and tab wear quickly if not correctly adjusted.

2. Adjust scraper and drop tube. Loosen two 5/16" hex head cap screws. Adjust scraper until just touching disc blade. Adjust drop tube until it is centered between knife and disc blade. Tighten screws. Turn blade and check for slight resistance without freewheeling. Repeat as needed. Insert flat bladed pry bar or screwdriver between knife and drop tube above drop tube tab. Carefully bend tube until 1/4" - 3/8" from disc blade.

NOTE: Maximum disc blade depth 4" (10.2 cm).

3. Adjust blade depth. Loosen three 1/2" hex head cap screws and jam nuts in opener mount. Adjust opener assembly up or down to desired blade depth. Tighten center hex head cap screw and jam nut first to set proper disc blade angle. Tighten remaining hex head cap screws and jam nuts. Torque hex head cap screws and jam nuts to 57 ft-lb (77.29 N-m). Check fertilizer hose clearance and adjust as necessary.

RESIDUE WHEEL ATTACHMENT FOR NOTCHED SINGLE DISC FERTILIZER OPENER



Notched single disc opener residue wheel attachment

Residue wheel attachment for notched single disc fertilizer opener is used where row unit mounted residue wheel attachments cannot be installed. Residue wheel is attached to notched single disc fertilizer opener with $\frac{5}{8}$ " x $7\frac{1}{2}$ " and $\frac{1}{2}$ " x $6\frac{1}{2}$ " hardware.

Maximum depth is set by lifting residue wheel and moving adjustment lever down to increase depth or up to decrease depth in 1" increments (in relation to blade depth setting). Adjust all rows the same. Residue wheel down force is maintained by a torsion spring and is not adjustable.

DEPTH/GAUGE WHEEL ATTACHMENT FOR NOTCHED SINGLE DISC FERTILIZER OPENER

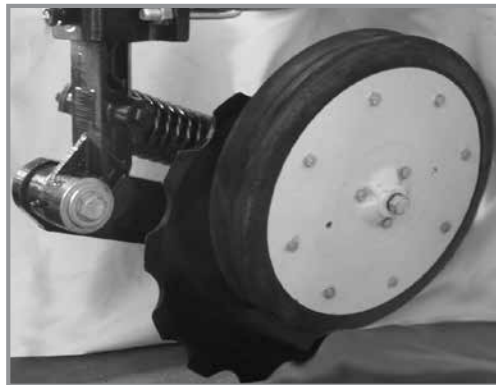

Notched single disc opener depth/gauge wheel

Depth/gauge wheel attachment for notched single disc fertilizer opener is used where additional gauging is required to maintain desired fertilizer opener depth. Depth/gauge wheel is attached to notched single disc fertilizer opener using a mounting block fastened to the pivot arm with $\frac{5}{8}$ " hardware through disc blade bearing.

Depth adjustment is made using 3 adjustment holes in depth/gauge wheel mounting block. Moving depth/gauge wheel increases/decreases depth in approximate 1" increments in relation to blade depth setting made at vertical mounting post.

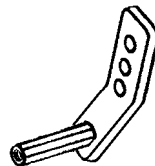

Adjust liquid drop tube/scrapper so there is slight contact between blade and scraper lower leading edge, and ¼" clearance between liquid drop tube trailing edge and blade. Blade should turn with minimum amount of drag.

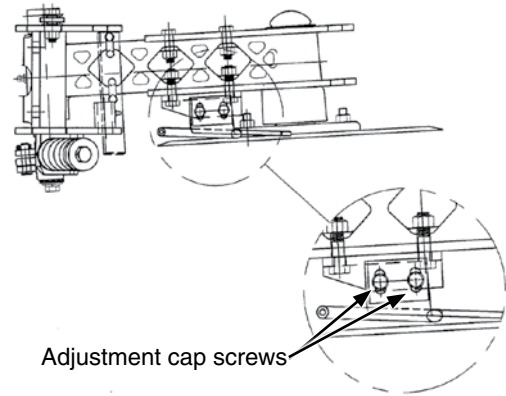

NOTE: Soil press wheel is not for gauging fertilizer opener operating depth.

Additional press wheel down pressure may be desirable in heavy moist soils. Turn press wheel spring adjustment bolt clockwise to increase down pressure.

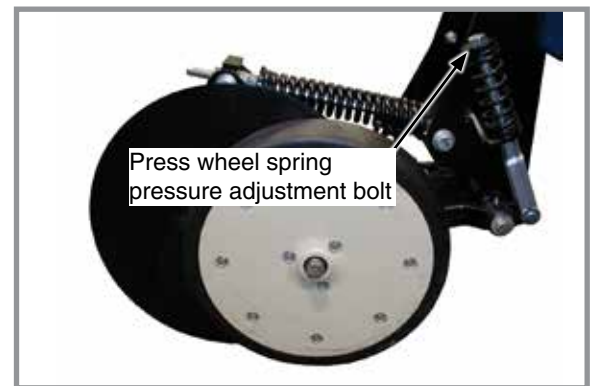

Press wheel down pressure adjustment

HD single disc fertilizer opener can be raised and locked up when fertilizer attachment is not used or during storage.

NOTE: A lockup bar automatically raises and locks soil press wheel when blade assembly is raised.

1. Place planter in planting position.
2. Remove outside blade depth adjustment.
3. Raise planter until adjustment bolt clears adjustment block.
4. Raise spring to clear blade assembly and raise blade assembly until storage strap can be positioned on lockup pin. Install hair pin clip.
5. Reinstall depth adjustment nut and tighten

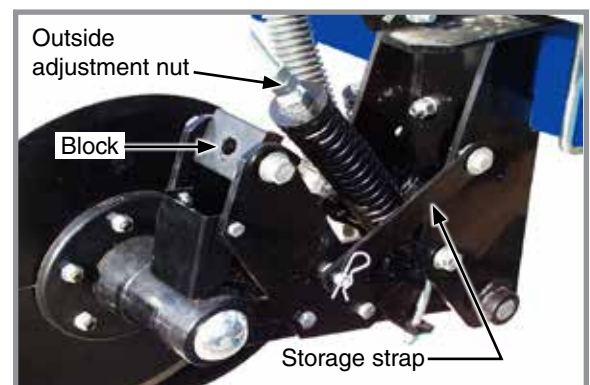

HD opener lockup

LIQUID FERTILIZER ATTACHMENT

WARNING

Agricultural chemicals can cause death or serious injury to persons, animals, and plants or seriously damage soil, equipment, or property. Read and follow all chemical and equipment manufacturers labels and instructions.

CAUTION

Overfilling tank can cause siphoning, tank collapse, personal injury, and damage to property and equipment. Do not overfill tank. Do not leave planter unattended when filling tank. Close fill valve and open tank lid if siphoning occurs. Follow all chemical manufacturers first aid, cleanup, and handling instructions.

NOTICE

Placing fertilizer too close to seeds or in excessive amounts can cause germination or seedling damage. Check with your fertilizer dealer or chemical manufacturer for correct amount and placement.



3800 ASD liquid fertilizer

CHECK VALVES



Old style non-reparable check valve



New style reparable check valve

Optional low rate check valves are available for in-line installation between liquid fertilizer squeeze or piston pump and openers to ensure equal distribution of product at low rates. Check valves eliminate anti-siphon loops.

PISTON PUMP

NOTE: Keep manuals shipped with pump and flow divider with this manual.

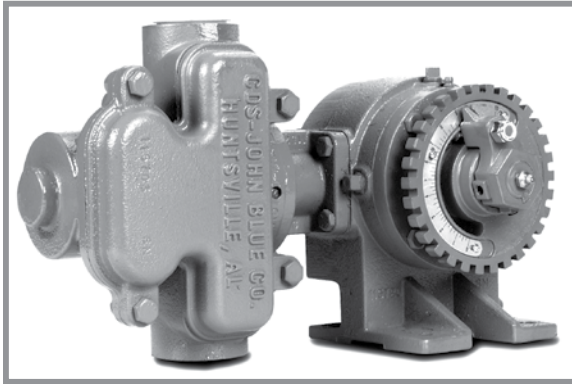

Piston pump

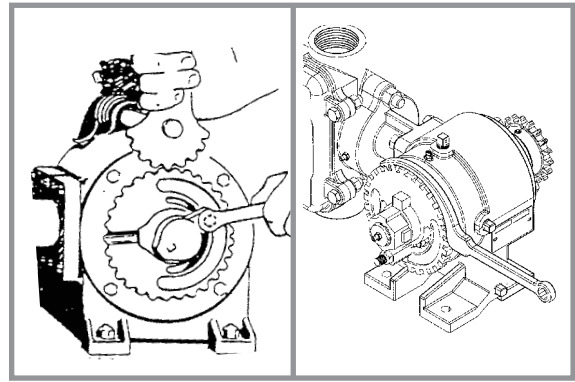

Adjusting delivery rate

NOTE: Delivery rate chart at back of this section provides approximate application rate only. Delivery varies with temperature and fertilizer.

Loosen $\frac{3}{8}$ " lock nut that secures arm with pointer and rotate scale flange with adjustment wrench until pointer is over desired scale setting. Tighten $\frac{3}{8}$ " lock nut. **DO NOT OVERTIGHTEN.**

NOTE: Periodically check flow to all rows. Set rate is still delivered to remaining rows if one or more lines are plugged.

PISTON PUMP GROUND DRIVE WHEEL SPRING ADJUSTMENT

Initial down pressure spring tension on piston pump ground drive wheel, is set leaving $12\frac{1}{4}$ " between the bottom of mounting plate and plug on top of spring. This dimension is taken with planter raised (tire not contacting the ground). Further adjustment can be made to fit conditions.

NOTE: Piston pump ground drive wheel assembly can be locked in raised position when not in use. Remove two cap screws that attach upper end of spring to spring mount. Reattach spring using upper holes in spring mount. Reverse procedure to reset for field use.

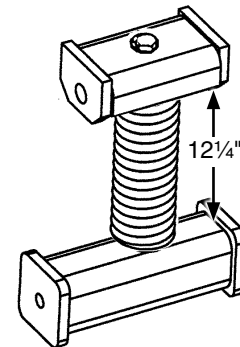

CLEANING

Clean tanks, hoses, and metering pump thoroughly with water at end of planting season or prior to an extended period of non-use. Do not allow fertilizer to crystallize from cold temperature or evaporation.

On machines equipped with piston pump, take apart and clean strainer located between piston pump and ball valve daily. Remove the end cap to clean the screen. See Piston Pump Storage in Maintenance Section of this manual.

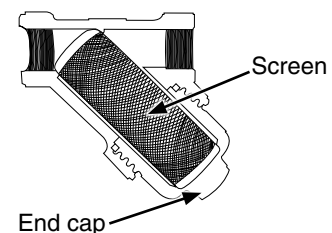

REAR TRAILER HITCH

Rear trailer hitch is used to tow a 3 or 4 wheel wagon behind planter. Hoses routed to rear trailer hitch should follow hydraulic hose routings on planter to allow planter to be raised, lowered, folded, or unfolded without stretching hoses.

NOTICE

Exceeding towing capacity can result in loss of control or equipment failure and cause death, serious injury, or damage to property and equipment. Maximum allowable hitch weight is 200 lb (90.7 kg). Gross towing weight should not exceed 16,000 lb (7,257.5 kg) or equivalent of a loaded 1,000 gal (3,785.4 L) tank and running gear.

NOTE: Connection points are provided on rear trailer hitch for connection of customer supplied transport safety chains.

NOTE: Periodically check feed hose for kinks to prevent restricted delivery rate.

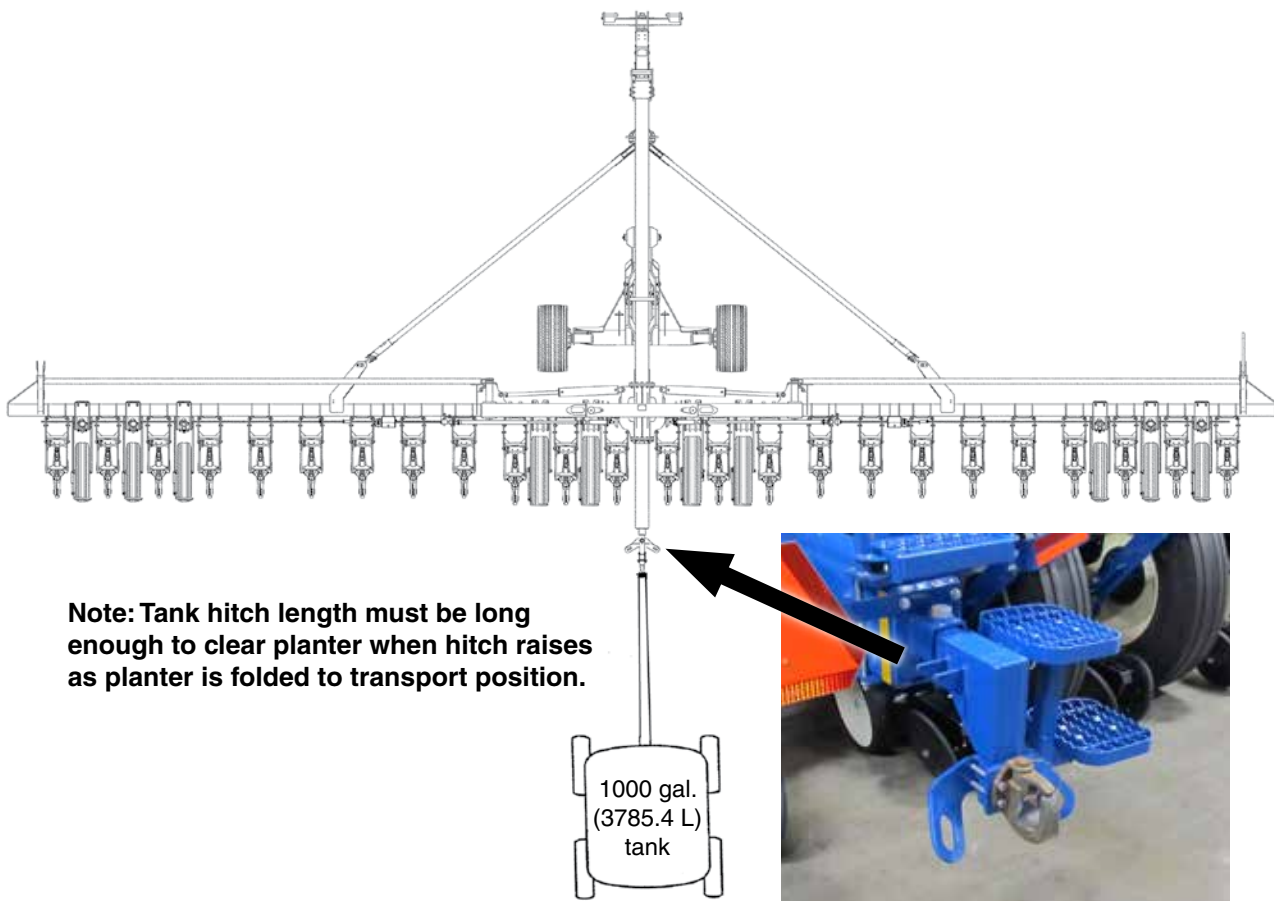

Note: Tank hitch length must be long enough to clear planter when hitch raises as planter is folded to transport position.

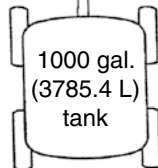

Rear trailer hitch (w/ASD steps)

**LIQUID FERTILIZER PISTON PUMP APPLICATION RATES
GALLONS PER ACRE**

**Model NGP-7055 Piston Pump
With 18 Tooth Sprocket (Planter Equipped With Two Piston Pumps)**

Pump Setting	2	3	4	5	6	7	8	9	10
24 Row 30"	7.4	11.1	14.8	18.5	22.1	25.8	29.5	33.2	36.9

Above chart is for planters equipped with 7.60" x 15" drive wheel, based on 91" forward travel per wheel revolution, 48 tooth drive sprocket, and 18 tooth driven sprocket on metering pump. Chart is based on average wheel slippage and liquid viscosities.

Chart calculated based on a solution weighing ten pounds per gallon.

NOTE: Fertilizer application rates can vary from weights calculated in above chart. Make field checks to be sure you are applying fertilizer at desired rate.

NOTE: Periodically check flow rates to all rows. Set flow rate is still delivered to remaining rows even if a lines are plugged.

To check exact number of gallons your fertilizer attachment will actually deliver on a 30" row spacing:

1. Remove hose from one fertilizer opener and insert it into a collection container secured planter frame.
2. Engage fertilizer attachment and drive forward for 174'.
3. Measure fluid ounces caught in container and multiply by 100. Divide that amount by 128. Result is gallons of fertilizer delivered per acre when planting in 30" rows.
4. Rinse collection container and repeat test on other rows if necessary.

This page intentionally left blank.

LUBRICATION

Following pages show locations of all lubrication points. Proper lubrication of moving parts helps ensure efficient operation of your Kinze planter and prolongs the life of friction producing parts.

LUBRICATION SYMBOLS

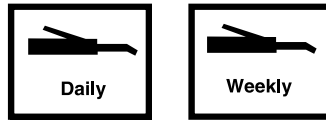

Lubricate at frequency indicated with SAE multipurpose grease.



Lubricate at frequency indicated with high quality SAE 10 weight oil or spray lubricant.

SEALED BEARINGS

Sealed bearings are used on your Kinze planter to provide trouble free operation.

These are located on drive shafts, row units, and transmission bearings. Sealed bearings are lubricated for life and are not serviceable.

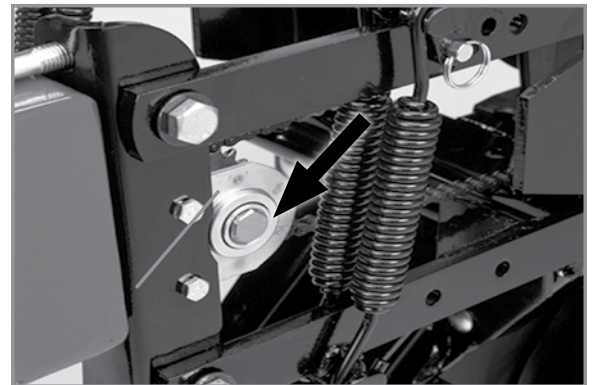

Sealed bearing (Typical)

AIR CLUTCH LUBRICATION

Lubricate air clutches every 75-100 hours.

Remove Phillips head screw and spray a 1-2 second burst of silicone spray into each clutch. Reinstall screw.

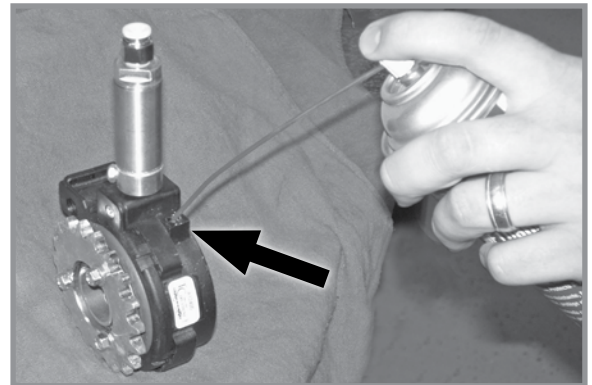

Air clutch lubrication

WHEEL BEARINGS

All drive, transport, and marker hub wheel bearings should be repacked annually and checked for wear.

1. Raise wheel off ground.
2. Check for bearing endplay by moving wheel side to side.
3. Rotate wheel to check for bearing roughness. If bearings sound rough, remove hub and inspect bearings.

NOTE: To repack wheel hubs, follow procedure outlined for wheel bearing replacement in this section except bearings and bearing cups are reused.

DRIVE CHAINS

Lubricate all transmission and drive chains daily with a high quality chain lubricant. Extreme operating conditions such as dirt, temperature, or speed may require more frequent lubrication. If a chain becomes stiff, it should be removed, soaked, and washed in solvent to loosen and remove dirt from joints. Soak chain in oil so lubricant can penetrate between rollers and bushings.

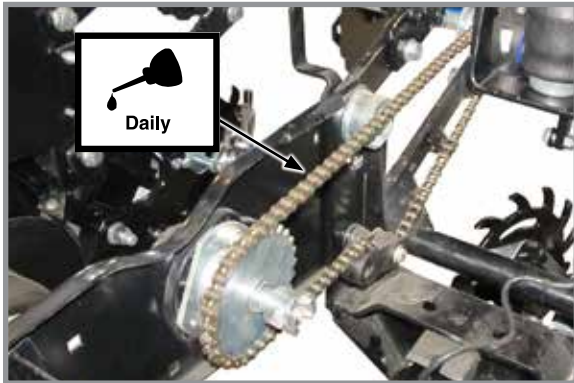

Row unit drive chains

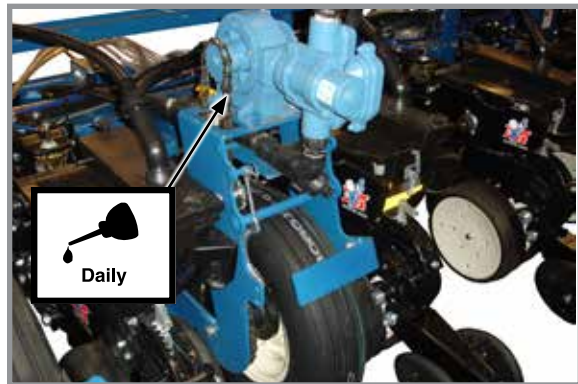

Piston pump ground drive chain

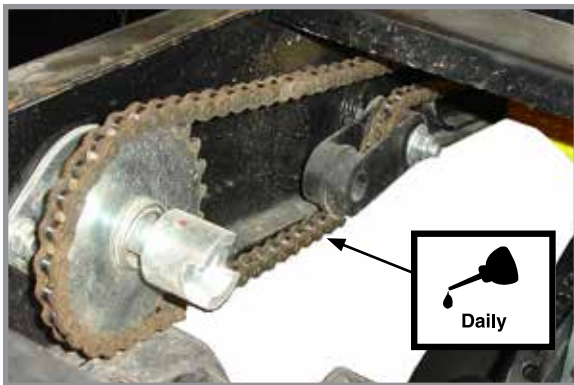

Row unit granular chemical drive chains

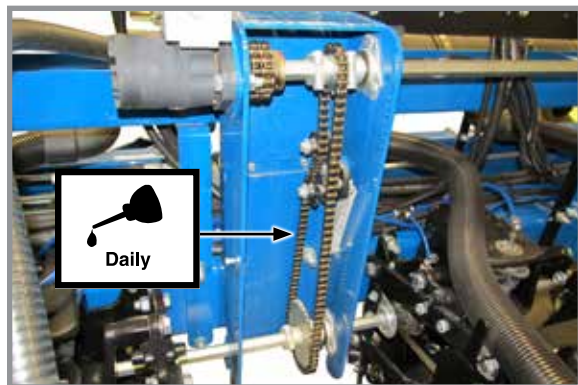

Hydraulic drive chains

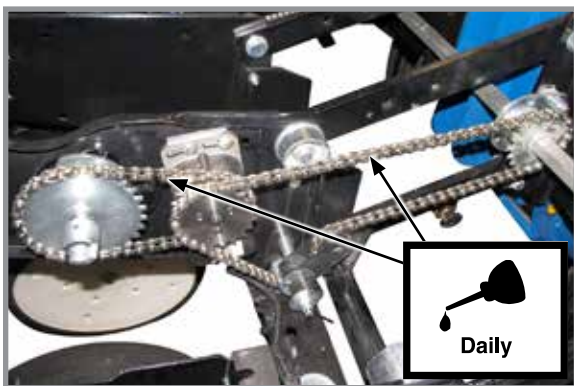

Row Unit Electric Clutches

BUSHINGS

Lubricate bushings at frequency indicated.

Check each bolt for proper torque. If bolt is loose, removed it and inspect bushing for cracks and wear. Replace bushing if necessary. Use **only hardened flat washers**. Replace damaged flat washers with proper part. Torque hardware to 130 ft-lb (176.2 N-m).

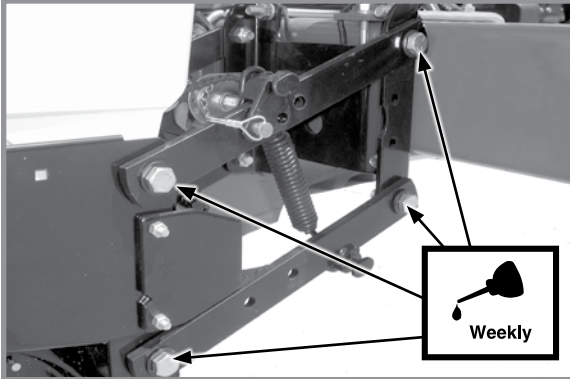

Row unit parallel linkages (8 per row)

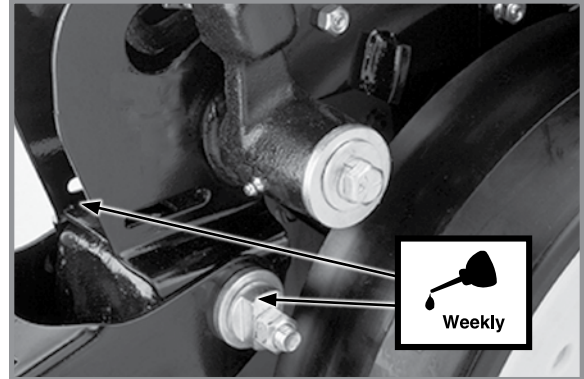

Row unit "v" closing wheel, covering discs/
single press wheel and/or drag closing wheel
eccentric bushings (2 per row)

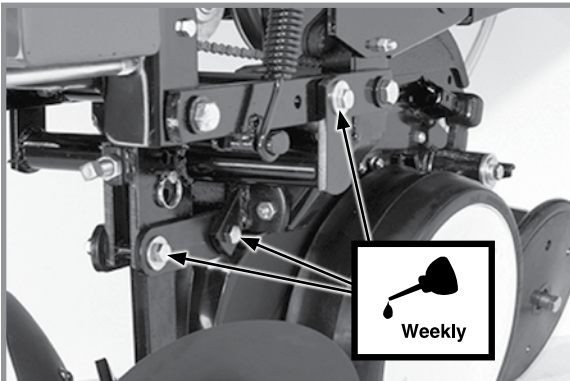

Row unit mounted disc furrower parallel
linkages (6 per row)

PTO SHAFT ASSEMBLY

WARNING

Contact with rotating PTO shafts can cause death or serious injury. Stay away from PTO shafts at all times unless clearly disconnected from power source.

NOTICE

Lubricate every 8 hours or equipment failure can occur.

- Lubricate ball, socket and inner cross kit with at least 15 pumps of grease, or until purged.
- Lubricate double yoke and all other areas with at least 10 pumps of grease, or until purged.
- PTO Drive Gearboxes - Fill with EP 80/90 Gear Lubricant. Fill plug is approximately 28 oz.

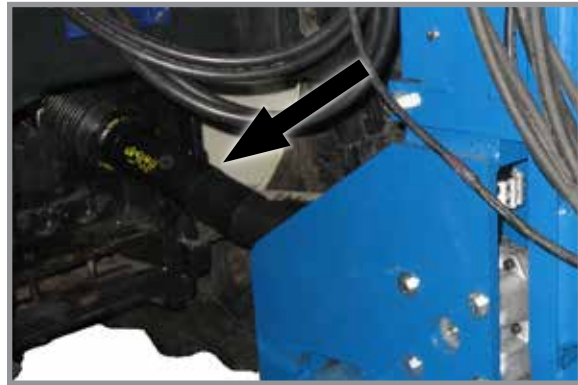

PTO shaft assembly

Visually inspect all wear surfaces inside double yoke to ensure presence of grease after lubricating.

NOTE: Clean and grease PTO shaft coupling each time pump is installed.

NOTE: Apply coating of high-speed industrial coupling grease, such as Chevron® Coupling Grease meeting AGMA CG-1 and CG-2 Standards to extend shaft spline life.

U-JOINT SLIDES

Lubricate all U-joint slides with a high quality lubricant.

NOTE: Apply coating of high-speed industrial coupling grease, such as Chevron® Coupling Grease meeting AGMA CG-1 and CG-2 Standards to extend shaft life.

LIQUID FERTILIZER PISTON PUMP CRANKCASE OIL LEVEL

Check crankcase oil daily and maintain at oil level check plug. Fill as needed with EP 90 weight gear oil. Total oil capacity is approximately ¾ pint.

Refer to operator and instruction manual supplied with pump and flow divider for more information.

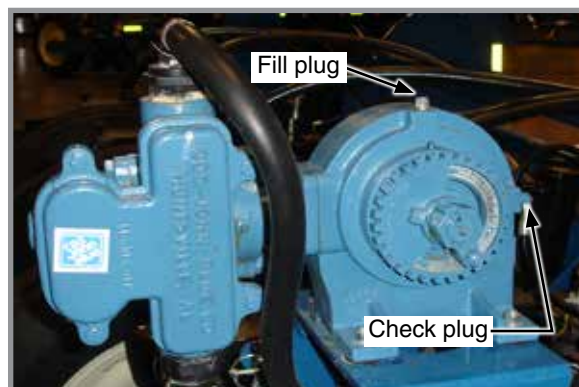

Piston pump oil fill and check plug locations

GREASE FITTINGS

⚠ WARNING

Uncontrolled machine movement can crush or cause loss of control resulting in death, serious injury, or damage to property and equipment. Install all safety lockup devices before working under or transporting this equipment.

Parts equipped with grease fittings should be lubricated at frequency indicated with an SAE multipurpose grease. Clean fitting thoroughly before using grease gun. Frequency of lubrication recommended is based on normal operating conditions. Severe or unusual conditions may require more frequent attention.

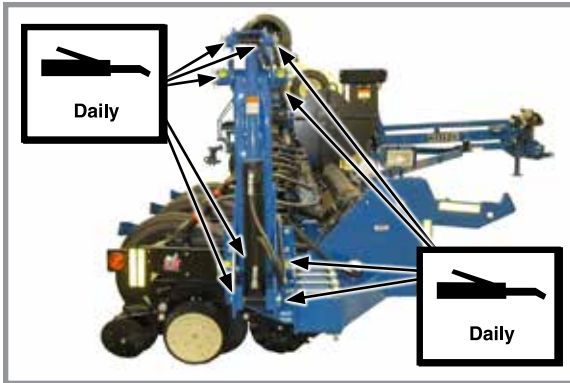

Marker arm assemblies (9 per end)

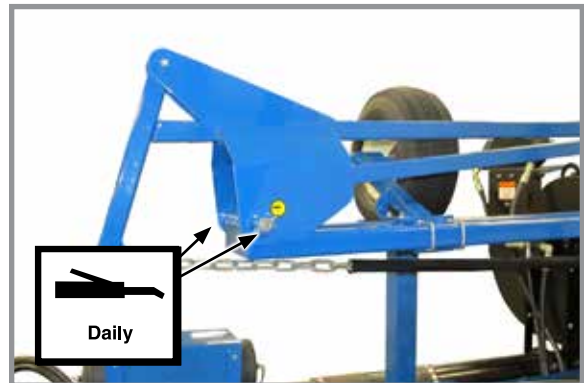

Marker arm assemblies (2 per hinge point)

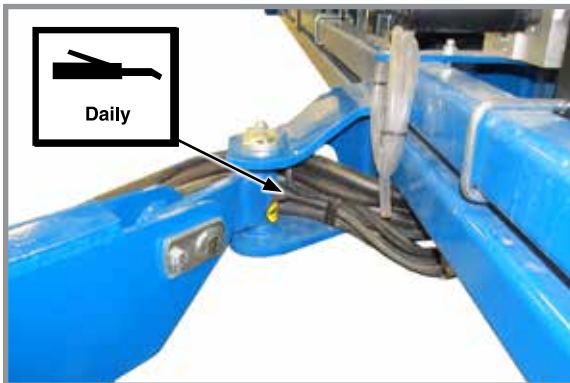

Wing linkage pivot (1 per wing)

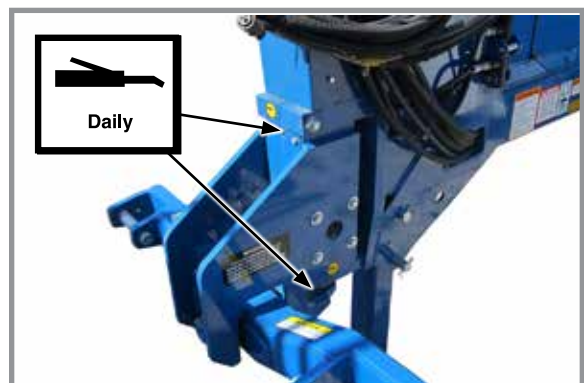

Hitch pivot (2)

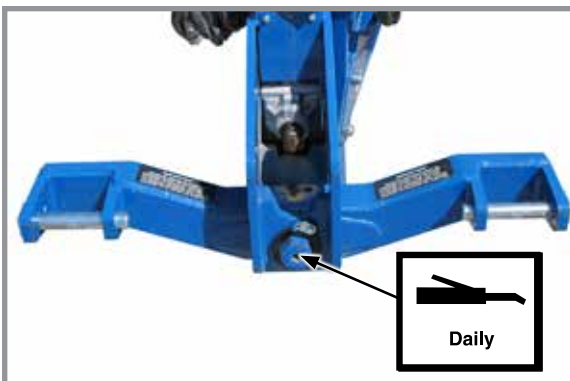

Hitch pivot pin (1)

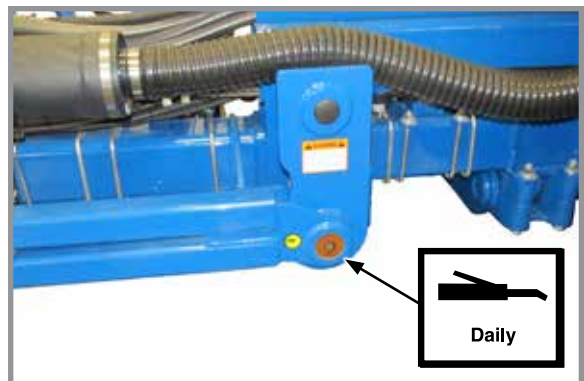

Outer front end of stub wing (1 per wing)



Outer back end of stub wing (2 per wing)

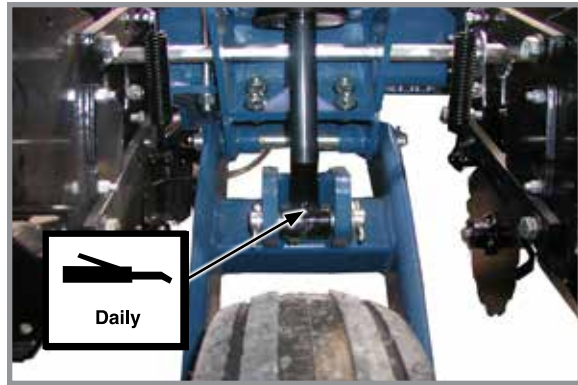

Wing lift cylinders (1 per cylinder)

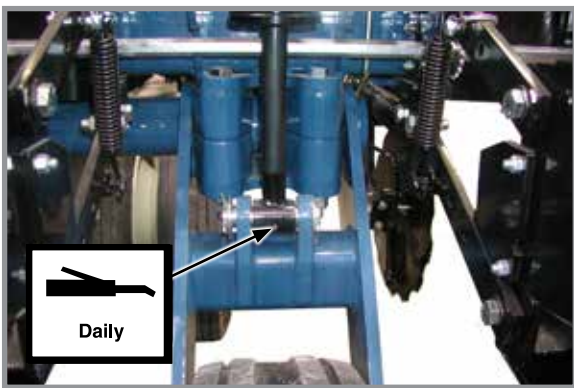

Center section lift cylinders (1 per cylinder)

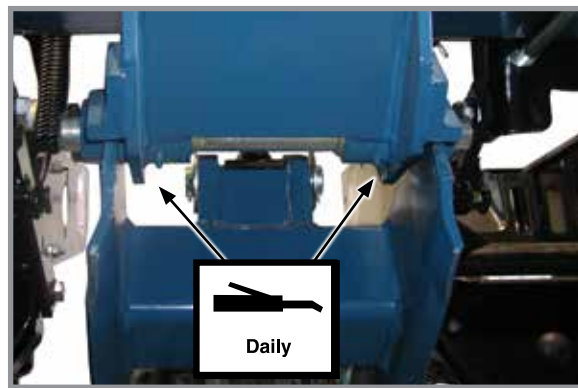

Wing wheel pivot (2 per wheel module)

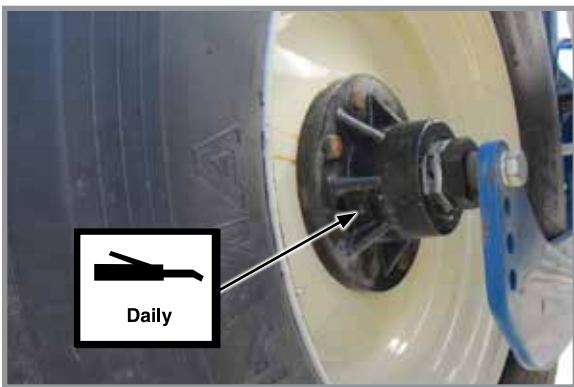

Rock shaft wheel hub (1 per hub)

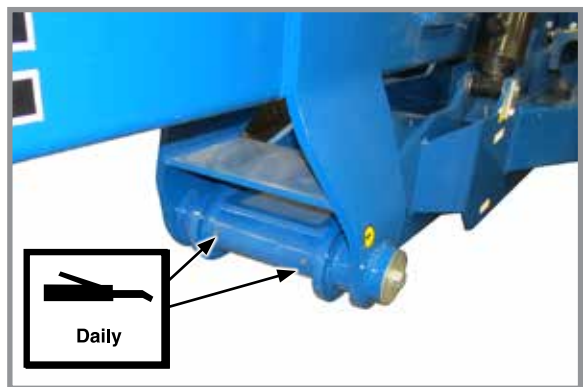

Transport axle pivot (2)

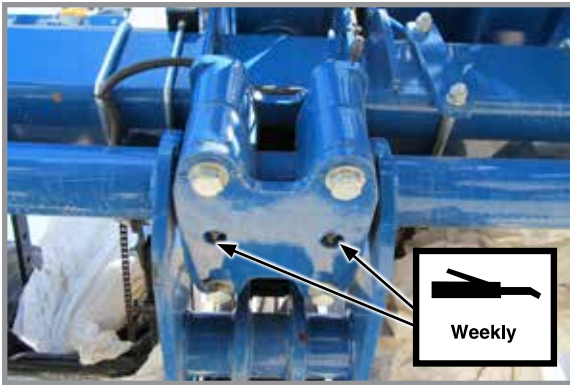

Center section lift axle pivot (2 per wheel)

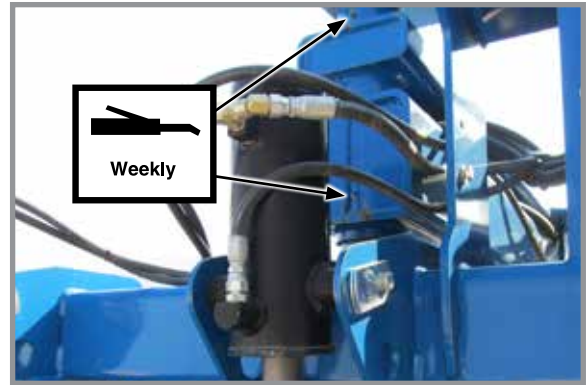

Inner end of stub wing (2 per wing)

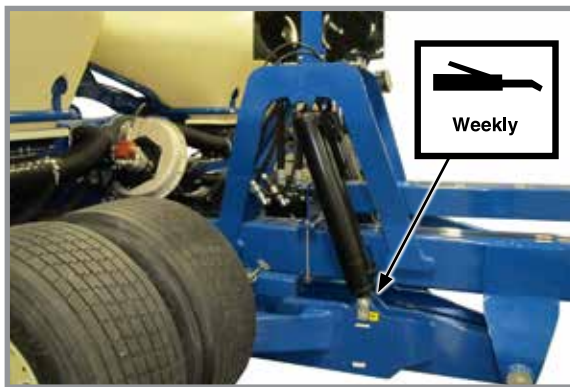

Transport axle lift cylinder (1 per side)

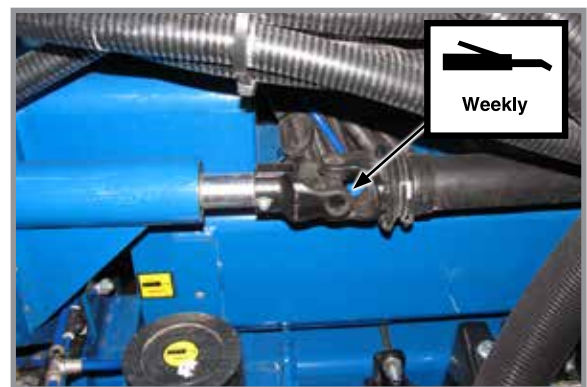

Inner drive shaft U-joint (1 per side)



Outer drive shaft U-joint (1 per side)



PTO shaft assembly (1)



Planter PTO shaft U-joints and pillow block (3)

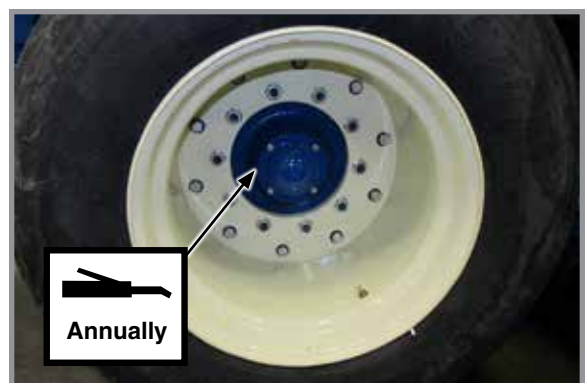

Transport wheel bearings (1 per hub)

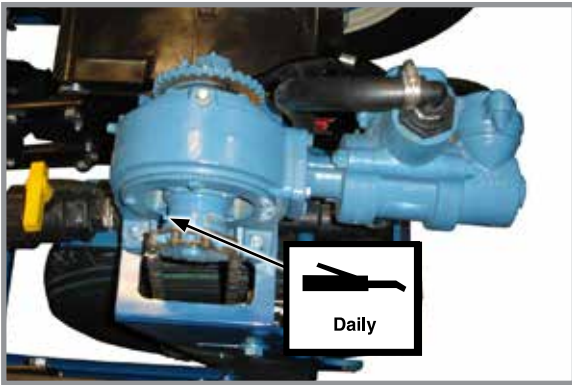

Piston pump L.H. side (1)

Fill until grease seeps out of bottom drain hole.

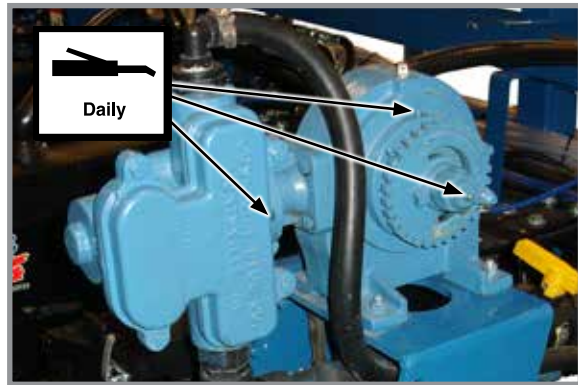

Piston pump R.H. side (3)

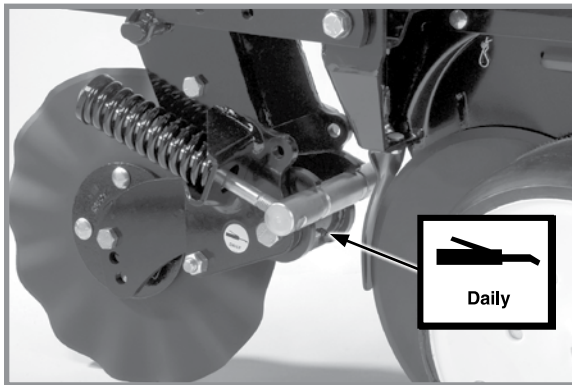

Frame Mounted Coulter - 1 Per Arm

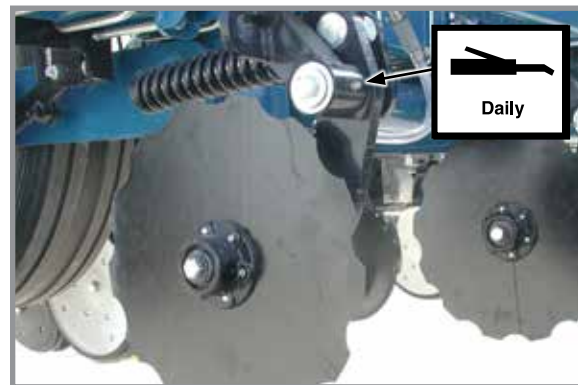

Notched single disc opener - 1 Per Arm

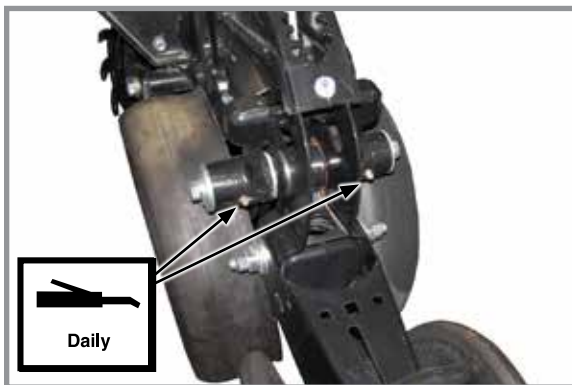

Gauge wheel arms (2)

Seals in gauge wheel arm are installed with lip facing out to allow grease to purge dirt away from seal. Pump grease into arm until fresh grease appears between washers and arm.

MOUNTING BOLTS AND HARDWARE

Before operating planter for the first time, check all hardware is tight. Check all hardware again after first 50 hours of operation and beginning of each planting season.

All hardware used on the Kinze planter is Grade 5 (high strength) unless otherwise noted. Grade 5 cap screws are marked with three radial lines on the head. Hardware must be replaced with equal size, strength, and thread type.

! WARNING

Loose transport wheel lug nuts can result in wheel separation from planter and can result in death, serious injury, and damage to property and equipment. Check transport wheel lug nut torque before operating planter for the first time and periodically thereafter.

NOTICE

Over-tightening hardware can reduce its shock load capacity and cause equipment failure.



GRADE 2
No Marks



GRADE 5
3 Marks



GRADE 8
6 Marks

TORQUE VALUES CHART - PLATED HARDWARE

Diameter	Grade 2		Grade 5		Grade 8	
	Coarse	Fine	Coarse	Fine	Coarse	Fine
1/4"	50 in-lb	56 in-lb	76 in-lb	87 in-lb	9 ft-lb	10 ft-lb
5/16"	8 ft-lb	9 ft-lb	13 ft-lb	14 ft-lb	18 ft-lb	20 ft-lb
3/8"	15 ft-lb	17 ft-lb	23 ft-lb	26 ft-lb	33 ft-lb	37 ft-lb
7/16"	25 ft-lb	27 ft-lb	37 ft-lb	41 ft-lb	52 ft-lb	58 ft-lb
1/2"	35 ft-lb	40 ft-lb	57 ft-lb	64 ft-lb	80 ft-lb	90 ft-lb
9/16"	50 ft-lb	60 ft-lb	80 ft-lb	90 ft-lb	115 ft-lb	130 ft-lb
5/8"	70 ft-lb	80 ft-lb	110 ft-lb	125 ft-lb	160 ft-lb	180 ft-lb
3/4"	130 ft-lb	145 ft-lb	200 ft-lb	220 ft-lb	280 ft-lb	315 ft-lb
7/8"	125 ft-lb	140 ft-lb	320 ft-lb	350 ft-lb	450 ft-lb	500 ft-lb
1"	190 ft-lb	205 ft-lb	480 ft-lb	530 ft-lb	675 ft-lb	750 ft-lb
1 1/8"	265 ft-lb	300 ft-lb	600 ft-lb	670 ft-lb	960 ft-lb	1075 ft-lb
1 1/4"	375 ft-lb	415 ft-lb	840 ft-lb	930 ft-lb	1360 ft-lb	1500 ft-lb
1 3/8"	490 ft-lb	560 ft-lb	1100 ft-lb	1250 ft-lb	1780 ft-lb	2030 ft-lb
1 1/2"	650 ft-lb	730 ft-lb	1450 ft-lb	1650 ft-lb	2307 ft-lb	2670 ft-lb

NOTE: Torque unplated hardware and bolts with lock nuts approximately 1/3 higher than above values. Torque bolts lubricated prior to installation to 70% of value shown in chart.

SPECIAL TORQUE VALUES

Transport Tire Flange Nuts	350 ft-lb (475 N-m)
Tranport Tire (W/Duals Cap Screws)	160 ft-lb (217 N-m)
Center Section Lift/Gauge Tire Lug Nuts	180 ft-lb (244 N-m)
Wing Lift/Gauge Tire Lug Bolts	90 ft-lb (122 N-m)
3 Point Hitch Adapter Pin and Pivot Bolt	550 ft-lb (746 N-m)

TORQUE VALUES- Pneumatic Down Pressure

Diameter	Torque Value
1/8" NPT	120 in-lb Maximum
1/2"-13	180 in-lb Maximum
3/4"-16	180 in-lb Maximum

NOTE: Use these torque values with pneumatic down pressure components.

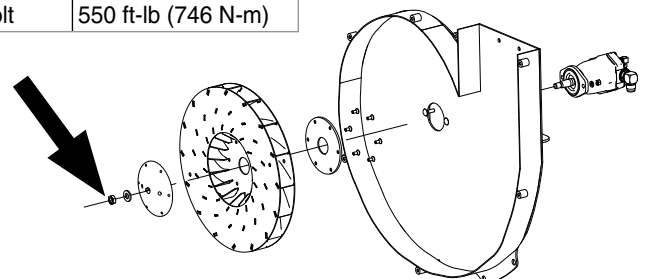

NOTE: Torque EdgeVac fan impeller assembly to motor shaft 5/8"-18 hex jam nut 50 ft-lb (67.8 N-m).

TIRE PRESSURE

WARNING

Explosive separation of rim and tire can cause death or serious injury. Overinflation, rim and tire servicing, improper use of rims and tires, worn, or improperly maintained tires could result in a tire explosion.

- Maintain proper tire pressure. Inflating a tire above or below the recommended pressure can cause tire damage.
- Mount tires only by properly trained personnel using proper equipment.
- Replace tires with cuts or bubbles. Replace damaged rims. Replace missing lug bolts and nuts.
- Do not weld or heat wheel assembly. Heating increases tire pressure.

TRANSPORT TIRES

WARNING

Over-inflation of tires can result in explosive separation of rim and tire and cause death or serious injury. Different size rims are designed for different tire pressures. Inflate to correct pressure for specific rim size.

Do not exceed following maximum pressures:

- Rims stamped with “224”: 75 psi (517.1 kPa) maximum pressure.
- Rims stamped with “276”: 100 psi (689.4 kPa) maximum pressure.

INFLATION SPECIFICATIONS

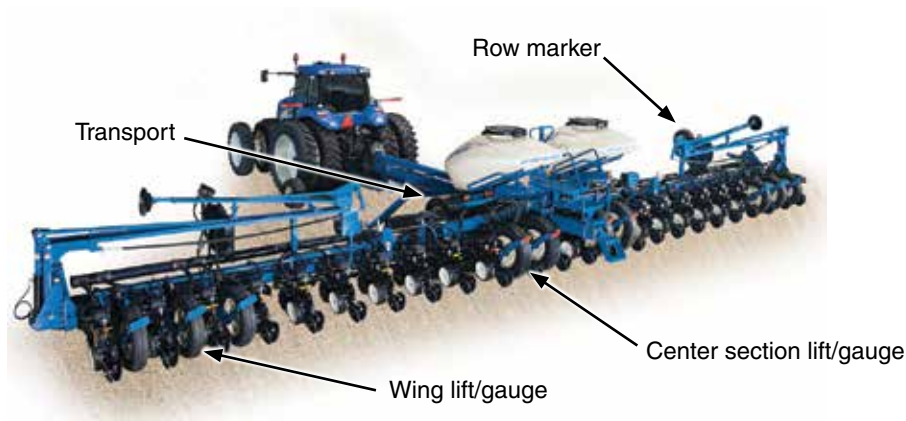

Tire locations

- Center section lift/gauge - 41 x 11R22.5" radial load range H (“224” rim) - 75 psi (517.1 kPa)
- Center section lift/gauge - 41 x 11R22.5" radial load range H (“276” rim) - 75 psi (517.1 kPa)
- Wing lift/gauge - 7.50" x 20" 8 ply custom rib implement - 40 psi (275.7 kPa)
- Transport - 445-50R22.5 radial load range H - 120 psi (827.3 kPa)
- Row marker - 20.5 x 8.0-10 - 35 psi (241.3 kPa)
- Liquid fertilizer piston pump - 7.60" x 15" rib implement - 40 psi (275.7 kPa)

FINGER PICKUP SEED METER INSPECTION/ADJUSTMENT

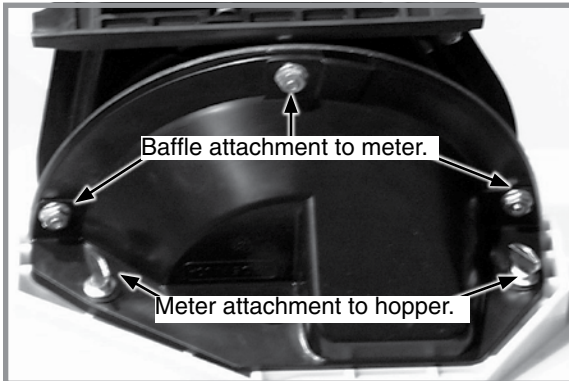

Removing meter and baffle

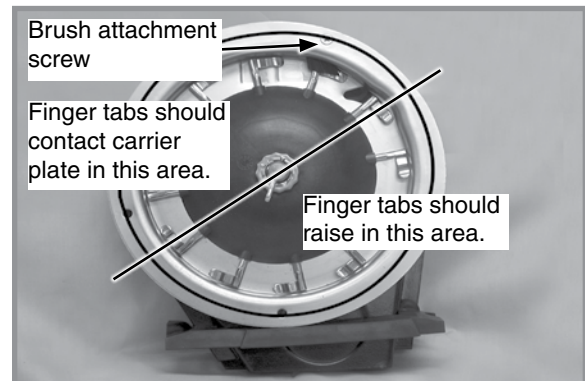

Proper finger operation

1. Remove two thumbscrews and meter from seed hopper and remove three cap screws and baffle from meter assembly.
2. Rotate seed meter drive by hand to ensure springs are holding tabs of fingers against carrier plate and fingers raise in correct area as shown in above photo.

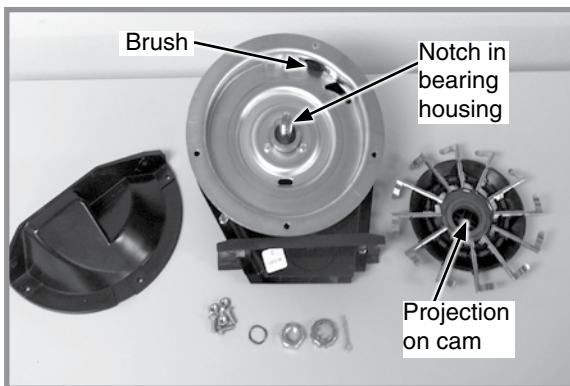

Finger pickup meter parts

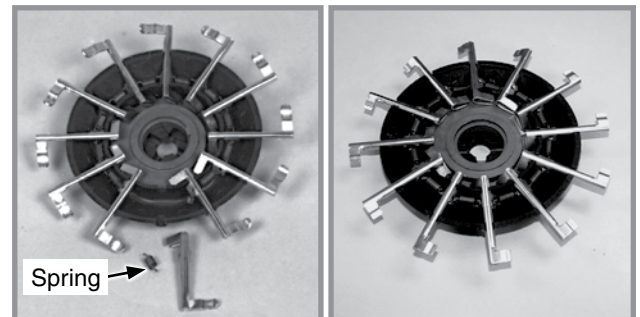

Corn Finger Assembly
(Position Spring Opening
Toward Holder)

**Oil Sunflower Finger
Assembly**

Buildup of debris or chaff may prevent proper finger operation and requires disassembly and cleaning of finger pickup meter.

1. Remove cotter pin, cover nut and adjusting nut and wave washer (If applicable) from drive shaft.
2. Carefully lift finger holder with fingers and cam off shaft and clean.
3. Check brush for wear and replace if necessary or after every 100 acres per row of operation (Approximately 800 acres of corn or sunflowers on a 8 row machine or 1200 acres on an 12 row machine).

NOTE: It is not necessary to remove finger holder to replace brush.

4. Remove springs from fingers and remove finger from holder by lifting it out of friction fit slot. Life expectancy of these parts is about 600-900 acres per row of operation under average conditions.
5. Reassemble meter in reverse order after cleaning and replacing defective parts. Make sure open end of spring loop is toward inside of finger holder when replacing fingers.
6. Install fingers in holder so holder is flush with carrier plate when assembled. A cam projection aligns with a mating notch in bearing housing to ensure proper operation when assembled.

7. Check indentations on carrier plate for wear before installing finger holder on carrier plate. Excessive wear of carrier plate at indentations will cause over planting especially with small sizes of seed. Inspect carrier plate annually. Life expectancy should be 250-300 acres per row of operation under average conditions.
8. Install wave washer and adjusting nut with finger holder flush against carrier. Tighten adjusting nut to fully compress wave washer. Back off nut $\frac{1}{2}$ to 2 flats to obtain rolling torque of 22 to 25 inch pounds.
9. Turn finger holder by hand to make sure it is firmly against carrier plate, but can be rotated with moderate force.
10. Install cover nut and cotter pin. Reinstall baffle.

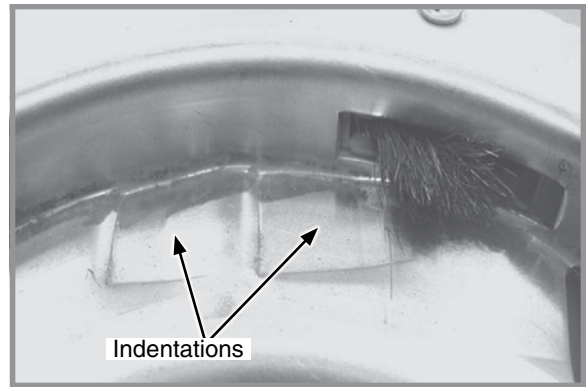
**Worn carrier plate**

NOTE: Check adjusting nut tightness on each unit after first day of use and periodically thereafter.

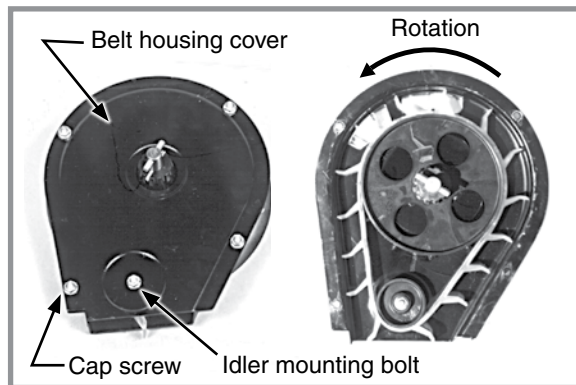
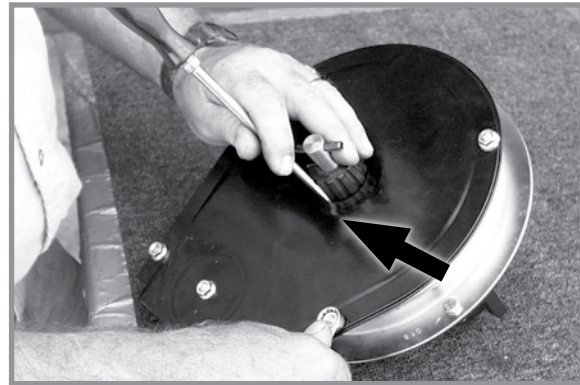
**Belt idler****Centering belt housing cover**

Remove four cap screws around edge of housing cover and nut from belt idler mounting bolt. Paddles must be correctly oriented as shown above. If belt is replaced. A diagram molded into drive sprocket shows correct orientation.

NOTICE

Do not over-tighten hardware or components may be damaged.

Reinstall housing cover. **DO NOT TIGHTEN** hardware. Wedge a screwdriver between sprocket hub and housing cover as shown above. Pry cover down until centered on belt housing and tighten hardware. Rotate meter drive shaft and check idler alignment. Seed belt should "run" centered on idler or with only slight contact with belt housing or cover.

CLEANING FINGER PICKUP SEED METER FOR STORAGE

1. Disassemble meter and blow out any foreign material.
2. Wash **ONLY** in mild soap and water. Do not use gasoline, kerosene, or any other petroleum based product. Dry thoroughly.
3. Coat lightly with a rust inhibitor.
4. Rotate finger assembly so finger does not touch brush.
5. Reassemble and store in a dry, rodent-free location.

BRUSH-TYPE SEED METER MAINTENANCE

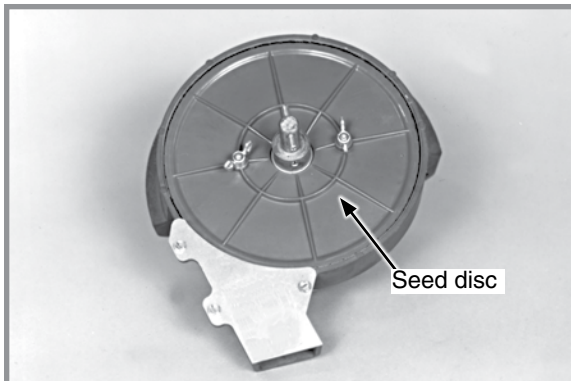

Brush-type seed meter seed disc installed

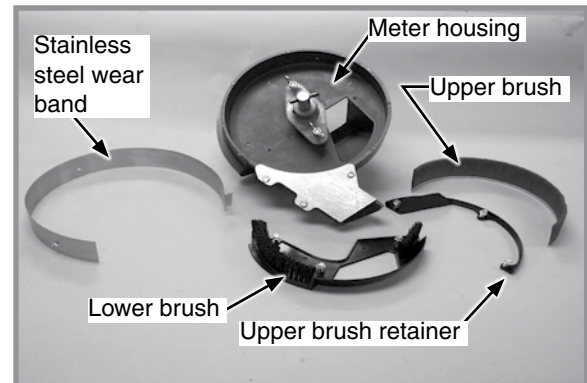

Brush-type seed meter parts

Use clean, high quality seed. Damaged or cracked seed, hulls, or foreign materials can become lodged in upper brush and greatly reduce meter accuracy. Remove seed disc daily and check for buildup of foreign material on seed disc, particularly in seed loading slots. Clean disc by washing it with soap and water. Check for cracked seed, hulls, etc. lodged between brush retainer and stainless steel wear band which can greatly reduce accuracy of the meter because upper brush will not be able to retain seed in seed disc pocket. Thoroughly clean brush areas of meter housing.

SEED DISC WEAR

Most seed disc wear is found in the agitation groove area (area between seed loading slots). Wear affects planting accuracy at high RPM. Lay a straight edge across disc surface at agitation groove area and measure gap between disc and straight edge. If agitation groove areas are worn in excess of .030" and accuracy starts to drop off at higher meter RPM, replace seed disc. Estimated seed disc life expectancy under normal operating conditions is approximately 200 acres per row. Severe operating conditions such as dust, lack of lubrication or abrasive seed coating could reduce seed disc life expectancy to under 100 acres per row.

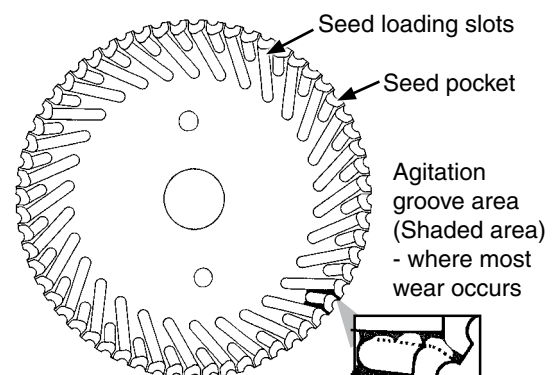

STAINLESS STEEL WEAR BAND

NOTICE

If wear band wears through or if meter is used without wear band in place, meter housing may be damaged.

Stainless steel wear band protects meter housing from wear and is .030" thick. Replace wear band when there is approximately .020" of wear in primary wear area. Estimated life expectancy of stainless steel wear band is 240-800 acres per row.

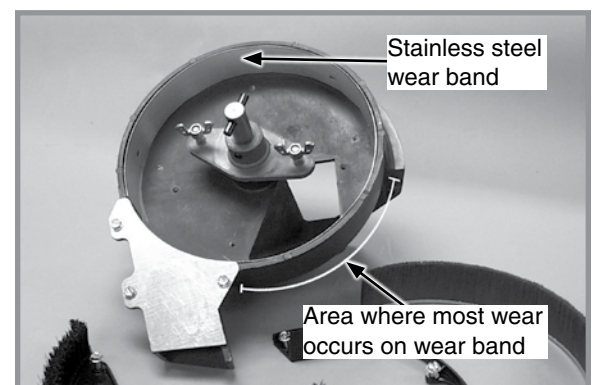

Stainless steel wear band

UPPER BRUSH

Upper brush holds seed in seed disc pocket in seed retention area. Brush must apply enough pressure against seed in seed disc pocket as disc rotates through seed retention area to prevent seed from dropping out of disc pocket. A damaged spot, excessive brush wear, or foreign material lodged in brush may greatly reduce meter performance.

Replace upper brush at 120-400 acres per row of use or sooner if damage or excessive wear is found. Position upper brush into inner perimeter of seed retention area. Make sure base of brush is tight against bottom of meter housing. Install brush retainer and three hex head screws. Tighten screws in sequence shown in photo at right.

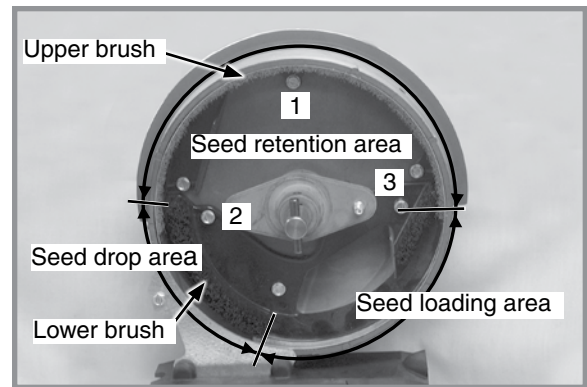

Upper brush installation

NOTE: Use GD11122 upper brush retainer for soybean and cotton discs. Use GD8237 upper brush retainer for milo/grain sorghum discs.

LOWER BRUSH

Lower brush moves seed down seed loading slots to seed pockets, isolates seed in reservoir from entering seed tube, and cleans seed loading slots. Estimated lower brush life expectancy is 240-800 acres per row. Replace lower brush if bristles are deformed or missing, or if there are cracks in brush retainer.

CLEANING BRUSH-TYPE SEED METER FOR STORAGE

1. Remove meter from seed hopper by removing two thumbscrews securing meter to hopper.
2. Remove seed disc and wash with soap and water and dry thoroughly.
3. Remove three hex head screws from brush retainer. Remove brush retainer and upper brush.
4. Remove three hex head screws from lower brush. Remove lower brush and stainless steel wear band.
5. Wash all parts and meter housing with soap and water and dry thoroughly.
6. Inspect all parts and replace worn parts.
7. Reassemble meter except for seed disc. Store meter in a dry, rodent-free space with seed disc removed.

VACUUM MANIFOLD MAINTENANCE

Dust accumulates in manifolds and hoses during normal operation. Clean manifolds annually. Abnormally dusty planting conditions may require more frequent cleaning.

1. Remove vacuum hose from each seed meter.
2. Operate vacuum fan at full hydraulic flow from tractor for two minutes to clear manifolds, hoses, and fittings of dust and debris.
3. Shut down fan and replace hoses

EDGEVAC SEED METER MAINTENANCE

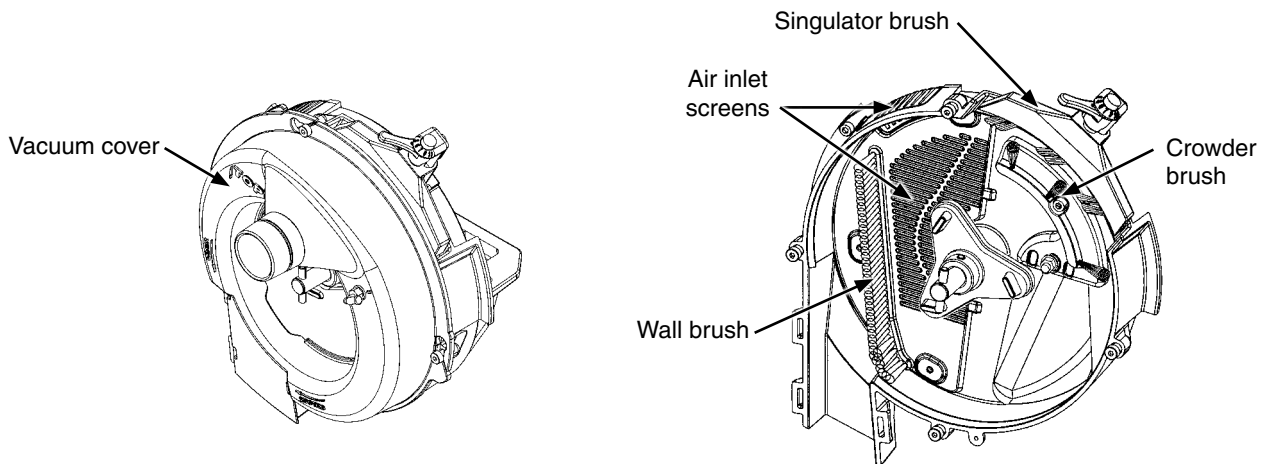

Before each planting season inspect seed discs, singulator brush, crowder brush, wall brush, and air inlet screens and clean or replace as needed.

Use clean, high quality seed for maximum meter accuracy. Damaged or cracked seed, hulls, and foreign material may become lodged in seed disc orifices and greatly reduce meter accuracy.

Inspect and clean seed discs daily checking for any buildup of foreign material and blocked orifices. If seed disc orifices are plugged frequently with seed remnants, cleanout brush or cleanout brush with ball-type ejector (if applicable) may need to be replaced. Clean seed disc by washing it with soap and water. Dry thoroughly.

Inspect singulator brush for wear after every 200 acres per row of operation. If adjustment of singulator brush does not affect meter performance or if brushes appear frayed, singulator brush may need to be replaced.

Replace seed disc or vacuum cover if abnormally high vacuum is required or if consistent operation can not be achieved.

See "Preparation For Storage" for additional EdgeVac Seed Metering System maintenance.

NOTE: Remove seed discs from meters for annual storage and store them vertically on a dowel or pipe.

EDGEVAC SEED METER CLEANOUT

Thorough seed meter cleanout is important to maintain genetic purity.

1. Disengage seed drive and remove seed hopper and meter. Lay hopper on its right side.
2. Rotate vacuum cover clockwise to align key hole slots with bolt heads. Lift off cover.
3. Remove seed disc.
4. Empty meter and hopper by allowing seed to run out of meter.
5. Inspect brushes in meter to ensure all seed is removed.
6. Replace seed disc and install vacuum cover.

NOTE: Use of damaged seed or seed containing foreign material will cause plugging of seed cell orifices and require more frequent seed meter cleanout to prevent underplanting.

DRAG CLOSING ATTACHMENT

Inspect each drag closing attachment and replace any worn or broken parts before storing planter. Check for loose hardware and tighten as needed.

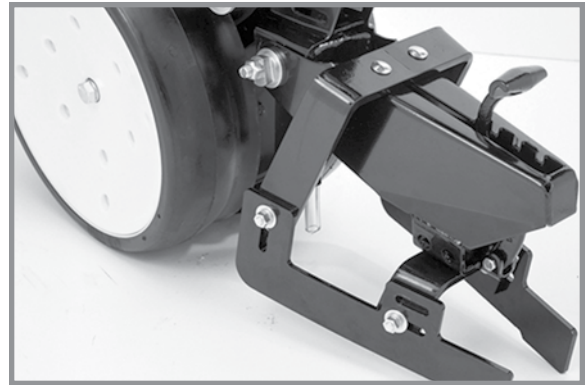

Drag Closing Attachment

GAUGE WHEEL ADJUSTMENT

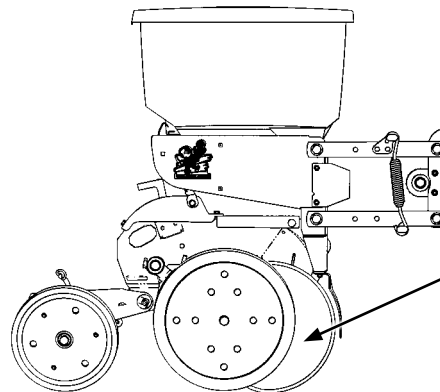
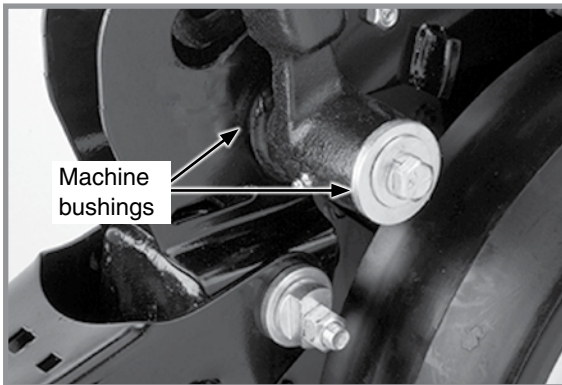

Gauge wheel adjustment

Gauge wheels should lightly contact opener blades to prevent accumulation of dirt or trash. Gauge wheels and opener blades should turn with only slight resistance.

Add or remove machine bushings between shank and gauge wheel arm to adjust clearance between gauge wheels and opener blades. Store remaining machine bushings between gauge wheel arm and flat washer on outer side of gauge wheel arm.

NOTE: It may be desirable to space gauge wheel further from blade when operating in sticky soils.

GAUGE WHEEL ARM BUSHING/SEAL REPLACEMENT

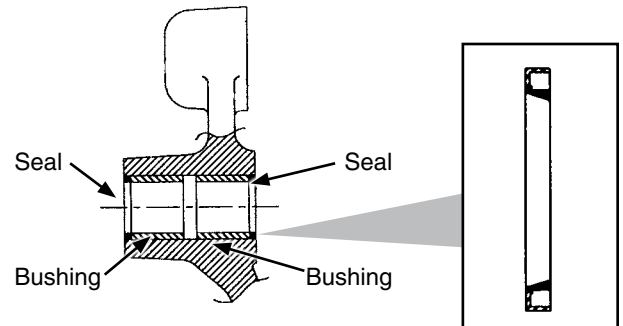
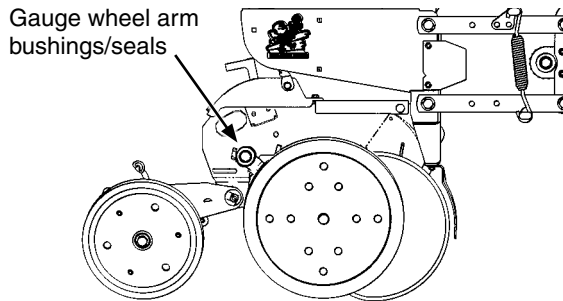

NOTE: Gauge Wheel Arm Bushing and Seal Driver Kit (G1K296) is available through your Kinze Dealer.

1. Remove gauge wheel from arm.
2. Remove gauge wheel arm from shank assembly.
3. Remove seal and bushing and discard. Clean and dry inner bore.
4. Drive/press replacement bushing inside bore of arm to a depth of .125" below flush.
5. Coat wiping edge of seal with grease.
6. Drive/press seal into place with lip to outside.

NOTE: Use extra care to protect the sealing lip during installation. Apply uniform pressure to assemble the seal into the bore of the arm. Never apply a direct hammer blow to the seal surface.

7. Inspect gauge wheel pivot spindle.
8. Reinstall gauge wheel arm assembly and gauge wheel.

NOTE: Use special machine bushing between gauge wheel arm and gauge wheel.

9. Shim for proper gauge wheel tire/disc blade clearance.
10. Lubricate with an SAE multipurpose grease.

GAUGE WHEEL ARM PIVOT SPINDLE REPLACEMENT

1. Remove gauge wheel and arm assemblies from shank assembly.
2. Remove $\frac{1}{2}$ " x $\frac{3}{4}$ " cap screw that locks pivot spindle in place and remove spindle.
3. Install replacement spindle and position as shown. Exact centering is critical.
4. Install $\frac{1}{2}$ " x $\frac{3}{4}$ " cap screw and torque to lock pivot spindle in place.
5. Install gauge wheel and arm assemblies. Shim for proper gauge wheel tire/disc blade clearance.

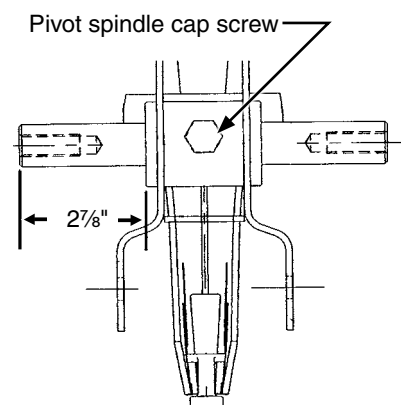

15" SEED OPENER DISC BLADE/BEARING ASSEMBLY

NOTICE

Excessive blade contact may result in premature disc opener bearing/hub failures and excessive wear on seed tube guard/inner scraper. When properly adjusted, if one blade is held in fixed position, opposite blade should rotate with less than 5 pounds force at outer edge of blade.

Maintain approximately $1" \pm \frac{1}{2}"$ of blade-to-blade contact to properly open and form seed trench. As blade diameter decreases due to wear, it is necessary to relocate machine bushings from inside to outside to maintain $1" \pm \frac{1}{2}"$ of contact.

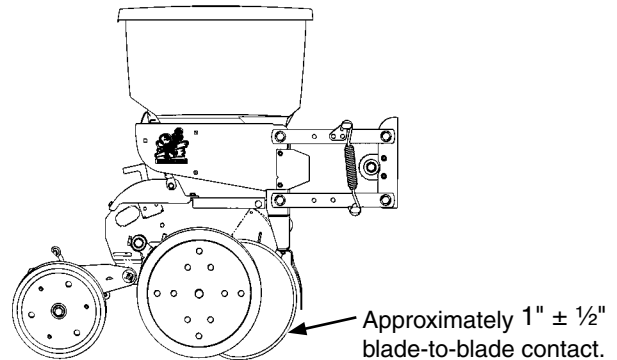

NOTE: Proper blade clearance is critical. Blades should have $1" \pm \frac{1}{2}"$ contact in this area. When blades are turned by hand in opposite directions against each other, there should be only light resistance to turning. Re-adjust blade scraper if necessary to center it between the blades.

NOTE: Replace blades if proper blade-to-blade contact cannot be maintained after relocating machine bushings or if blade diameter wears below $14\frac{1}{2}"$.

REPLACE DISC BLADE/BEARING ASSEMBLY

NOTE: Only bearing may need to be replaced if there is excessive endplay or if bearing sounds or feels rough when disc blade is rotated.

1. Remove gauge wheel, scraper, and bearing dust cap.
2. Remove cap screw, washer and disc blade/bearing assembly. Machine bushings between shank and disc blade are used to maintain approximate $1" \pm \frac{1}{2}"$ of blade-to-blade contact.

NOTICE

Left hand side of opener uses a left hand threaded cap screw. DO NOT OVER TIGHTEN. Damage to shank threads require replacement of row unit shank assembly.

3. Install machine bushing(s), new disc blade bearing assembly, washer and cap screw. Torque $\frac{5}{8}"$ -11 Grade 5 cap screw to 110 ft-lb (149.14 N-m).

NOTE: Replace disc blades only with disc blades of equal thickness.

4. Install bearing dust cap, scraper, and gauge wheel.

REPLACE BEARING ONLY

1. Remove gauge wheel, scraper, bearing cap, cap screw, washer and disc blade/bearing assembly.
2. Remove $\frac{1}{4}"$ rivets from bearing housing to expose bearing.
3. Installing new bearing. install three evenly spaced $\frac{1}{4}"$ cap screws into three of six holes in bearing housing to hold bearing and bearing housing in place. Install rivets in other three holes. Remove $\frac{1}{4}"$ cap screws and install rivets in those three holes.
4. Reinstall disc blade/bearing assembly, washer and cap screw. Torque $\frac{5}{8}"$ -11 cap screw to 110 ft-lb (149.14 N-m).
5. Install bearing dust cap, scraper, and gauge wheel.

SEED TUBE GUARD/INNER SCRAPER

Seed tube guard protects seed tube and acts as inner scraper for seed opener disc blades.

Remove seed tube and check for wear. Excessive wear on seed tube indicates a worn seed tube guard. Replace seed tube guard if it measures $\frac{5}{8}$ " or less at lower end. A new seed tube guard measures approximately $\frac{7}{8}$ ".

NOTE: No till planting or planting in hard ground conditions, especially when planter is not equipped with no till coulters, and/or excessive blade-to-blade contact increases seed tube guard wear and requires more frequent inspection and/or replacement.

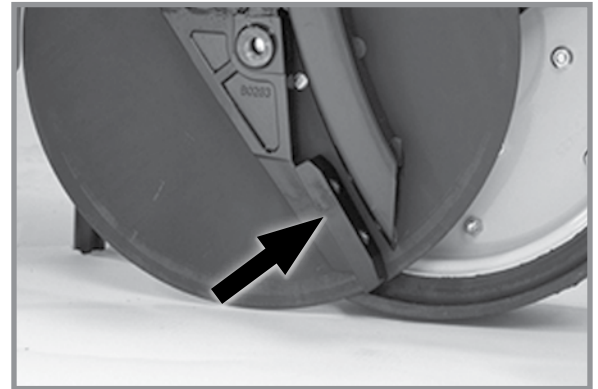

Seed tube guard/inner scraper
(Gauge wheel/seed opener disc blade removed)

NOTICE

Over tightening hex socket head cap screws may damage shank threads and require replacement of shank. An excessively worn seed tube guard may allow blades to wear into row unit shank, also requiring replacement of shank.

Remove seed tube and two hex socket head cap screws that attach seed tube guard. Hold replacement seed tube guard centered between seed opener disc blades. Install hex socket head cap screws. **DO NOT TIGHTEN.** Using a clamp or vise-grip, squeeze opener blades together in front of seed tube guard. Tighten seed tube guard retaining screws. Remove clamps. Distance between seed tube guard and opener blades should be equal on both sides. Reinstall seed tube.

FRAME MOUNTED COULTER

NOTE: Torque $\frac{5}{8}$ " spindle hardware to 120 ft-lb (162.7 N-m)

See "Frame Mounted Coulters" in Row Unit Operation section of this manual for depth and spring adjustment.

Replace 16" diameter coulters blade (1" fluted, 1" bubbled or $\frac{3}{4}$ " fluted) when worn to 14 $\frac{1}{2}$ " (maximum allowable wear).

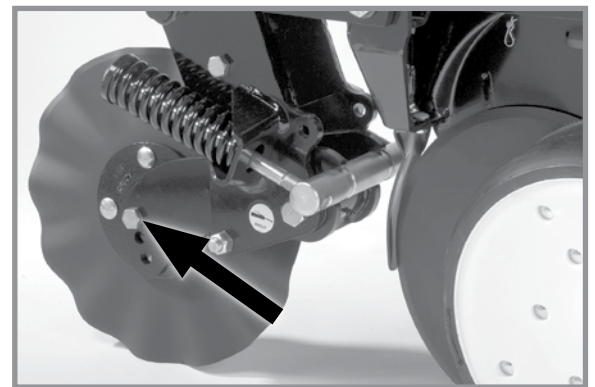

Frame mounted coulters spindle

RESIDUE WHEELS (FOR USE WITH FRAME MOUNTED COULTER)

Wheel hub is equipped with sealed bearings. Replace bearings if a bearing sounds or feels rough when wheel is rotated.

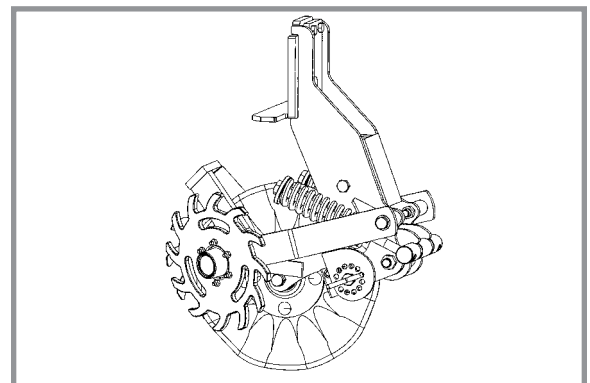

Frame mounted coulters residue wheels

ROW UNIT MOUNTED DISC FURROWER

Lubricate bushings in support arm mounting bracket at frequency indicated in Lubrication of this section. Check each bolt for proper torque. If bolt is loose, it should be removed and bushing inspected for cracks and wear. Replace bushings as necessary.

NOTE: Use only hardened flat washers. Replace damaged flat washers with proper part. Torque bolts to 130 ft-lb (176.2 N-m).

Blade hubs are equipped with sealed bearings. Replace bearings if a bearing sounds or feels rough when wheel is rotated.

Replace solid or notched 12" diameter blades when worn to 11".

ROW UNIT MOUNTED NO TILL COULTER

Check nuts and hardware periodically for proper torque. Be sure coulters are positioned square with row unit and aligned in front of row unit disc opener.

NOTE: Torque $\frac{5}{8}$ " spindle hardware to 120 ft-lb (162 N-m).

Coulters can be adjusted to one of four settings. Initially blade is set in highest position. As blade wears it can be adjusted to one of three lower settings. See "Row Unit Mounted No Till Coulters" in Row Unit Operation section of this manual.

Replace 16" diameter coulters when worn to 14½".

COULTER MOUNTED RESIDUE WHEELS

Wheel hubs are equipped with sealed bearings. If bearings sound or feel rough when wheel is rotated, replace them.

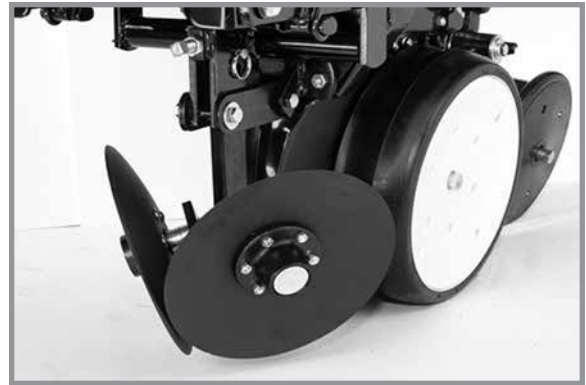

Row unit mounted disc furrower



Row unit mounted no till coulters



Coulters mounted residue wheels

ROW UNIT MOUNTED RESIDUE WHEEL

Wheel hub is equipped with sealed bearings. If a bearing sounds or feels rough when wheel is rotated, replace them.

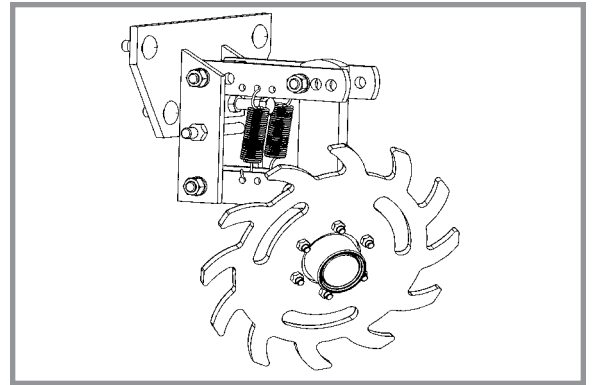

Row unit mounted residue wheels

GRANULAR CHEMICAL ATTACHMENT

Before storing planter, disengage granular chemical drive by rotating throwout knob ¼ turn counterclockwise. Remove drive chain and empty and clean all granular chemical hoppers. Clean drive chains and coat them with a rust preventive spray or submerge chains in oil. Inspect and replace worn or broken parts.

Install hoppers and chains. Check chain alignment.

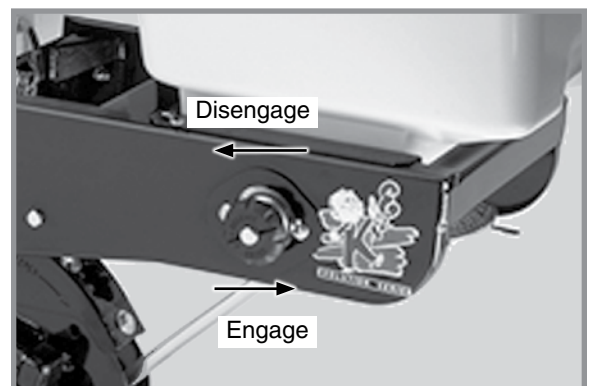

Granular chemical throwout knob

SPRING TOOTH INCORPORATOR

Before storing planter, inspect each spring tooth incorporator and replace worn or broken parts. Check for loose hardware and tighten as needed.

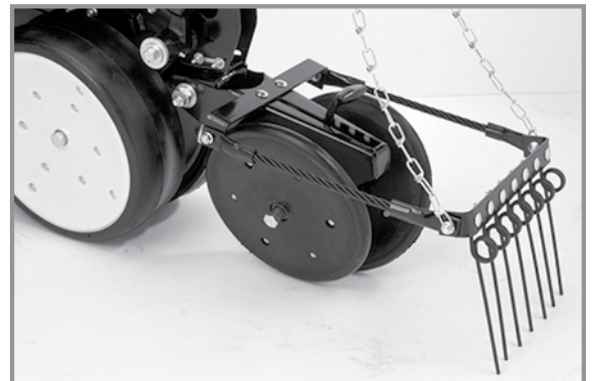

Spring tooth incorporator

PLANTER MOUNTED PUMP DRIVE AND OIL COOLER

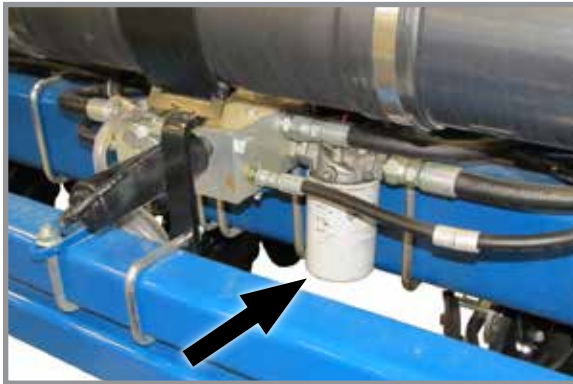

Oil filter location



Oil cooler location

NOTICE

Clean and grease PTO shaft coupling with high-pressure industrial coupling grease (Chevron® coupling grease or equivalent) meeting AGMA CG-1 and CG-2 Standards each time driveshaft is installed or premature wear and equipment failure can occur.

NOTE: Periodically check and clean oil coolers.

1. Replace 10-micron spin-on filters on each wing annually.
2. Fill system with SAE 10W-20 multigrade wide temperature range transmission hydraulic fluid. Reservoir capacity is approximately 10 gal (37.8L).
3. Start system and run with tractor at idle and fans turned off for 1-2 minutes. Switch fans to full speed and run with tractor at idle for 1-2 minutes.
4. Check reservoir fluid level and fill as required. Hydraulic fluid level should be within 1"-2" from top of reservoir after pump has run and hydraulic hoses have been primed to allow fluid to expand when heated.

DIGITAL VACUUM GAUGE ADJUSTMENT

Digital vacuum gauge is factory calibrated. However, vacuum varies throughout manifold system and it may be necessary to adjust digital readout to match actual vacuum at meter.

Load seed discs with seed and compare digital vacuum gauge readouts to reading taken from analog gauges or a hand held gauge at several meters along length of planter. Elbow connections located on covers of seed meters allow testing of meter vacuum levels without removing vacuum hoses.



EdgeVac digital vacuum gauge

If there is more than 1" or 2" (H₂O) difference, adjust digital gauge by inserting a small flat bladed screwdriver into opening on back of digital gauge housing and turning potentiometer until digital gauge displays vacuum present at meter. Compare readings at 10" and 20" of vacuum.

CHECK VALVE (VACUUM FAN)

Check valve located in valve block below vacuum fan motor assembly operates as a return line check to prevent vacuum fan motor reverse operation. Remove and inspect valve. If it does not operate properly. Check for foreign material and if O-ring is leaking internally. Replace if defective.

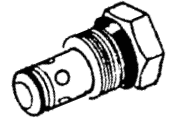

COUNTER BALANCE VALVE (Center of Rear H-Frame)

Counter balance valve is used for hydraulic load holding as a safety feature to prevent planter from being unintentionally lowered. Valve is factory set and should require no additional adjustments. Contact your Kinze Dealer for service.

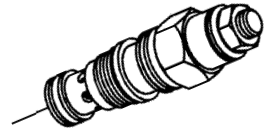

FLOW CONTROL VALVE

Flow control valves should be adjusted for row marker raise and lower speed as part of assembly procedure or upon initial operation. If valve fails to function properly or requires frequent adjustment, it should be removed for inspection. Check for foreign material and contamination on valve and seating areas of valve body. Replace defective components.

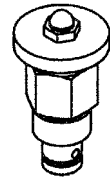

PRESSURE REDUCING VALVE (Center of Rear H-Frame)

Pressure reducing valve limits available hydraulic pressure to transport axle cylinder when cylinder is retracting. Contact your Kinze Dealer for service.

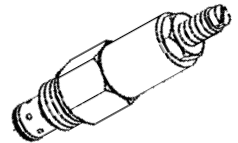

NOTICE

Connect hydraulic motor case drain to a case drain return line with zero pressure on tractor or hydraulic motor will be damaged. DO NOT connect hydraulic motor case drain to SCV outlet. Contact tractor manufacturer for specific details on “zero pressure return”.

RELIEF VALVE CARTRIDGE

Pressure relief valve located in valve block below vacuum fan motor assembly helps prevent damage to vacuum fan motor by limiting pressure in the motor case drain line. It is set to open at 35 PSI. If valve fails to function properly, it should be removed for inspection. Check for foreign material and contamination on valve and the seating area of valve body. Replace if defective.

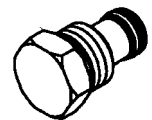

SOLENOID VALVE

Solenoid valve consists of a chambered body with an electric coil actuated cartridge valve.

If solenoid or solenoids fail to operate, first determine if problem is electrical or hydraulic. If valve is working properly, a click will be heard when solenoid coil is energized and valve stem opens. If no sound is heard, check solenoid coil by touching top of coil housing with a metallic object such as a pliers or screwdriver. If coil is working properly, coil housing will be strongly magnetized when energized. If voltage to coil is low it will be weakly magnetized when energized and no click will be heard.

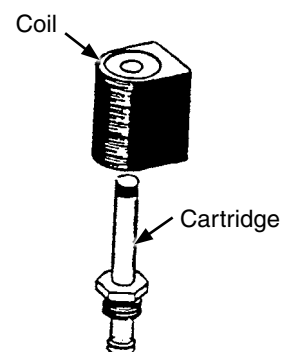

ROW MARKER BEARING LUBRICATION OR REPLACEMENT

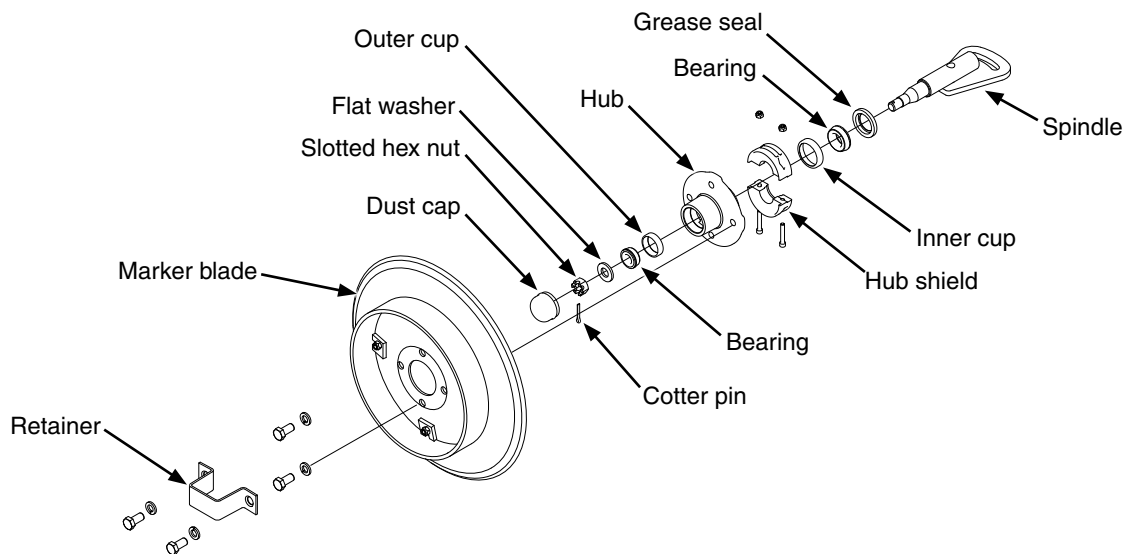

1. Remove retainer and marker blade.
2. Remove dust cap from hub.
2. Remove hub shield. Note direction of installation.
3. Remove cotter pin, slotted hex nut, and washer.
4. Slide hub from spindle.
5. Remove bearings and cups and discard if bearings are being replaced. Clean hub and dry. Remove bearings only and not cups if repacking.
6. Press in new bearing cups with thickest edge facing in. (Bearing replacement procedure only.)
7. Pack bearings with heavy duty wheel bearing grease thoroughly forcing grease between roller cone and bearing cage. Fill the space between the bearing cups in the hub with grease.
8. Install rubber seal into grease seal. Place inner bearing in place and press in new rubber seal/grease seal.
9. Clean spindle and install hub.
10. Install outer bearing, washer and slotted hex nut. Tighten slotted hex nut while rotating hub until there is some drag. This ensures all bearing surfaces are in contact. Back off slotted nut to nearest locking slot and install cotter pin.
11. Fill dust caps approximately $\frac{3}{4}$ full of wheel bearing grease and install on hub.
12. Install hub shield.
13. Install marker blade and retainer on hub. Tighten hardware evenly.

AIR CLUTCH CLEANING

(Yearly at end of planting season)

NOTE: If system is equipped with Pneumatic Down Pressure, air clutches must be removed from planter for cleaning. If system is not equipped with Pneumatic Down Pressure, air clutches can be disassembled and cleaned on planter.

At each row unit:

1. Remove meter assembly.
2. Press down collar on air fitting and remove air hose.
3. Loosen tension from chain and remove from air clutch sprocket.
4. Loosen lock clamp and slide clamp, washer, and air clutch away from chain.
5. Use a $\frac{5}{16}$ " wrench and remove sprocket from air clutch assembly.
6. Remove small Phillips-head screw from side of air clutch housing and remove housing cover.

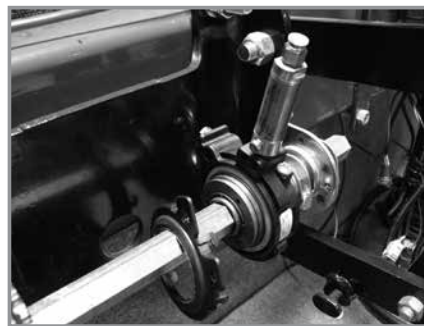
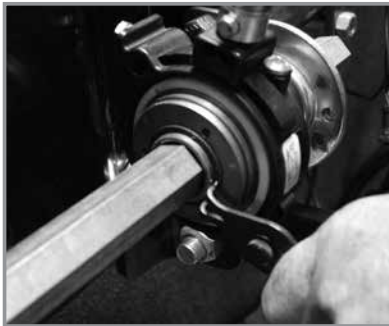

7. Expand retaining ring and remove from assembly.
8. Remove and separate sprocket hub, ratchet gear, clutch spring, and hex bushing from air clutch housing.
9. Remove debris and dirt from clutch components. Clean parts with brake cleaner or equivalent cleaner.
10. Make sure parts are completely dry. Lubricate sprocket hub, ratchet gear, clutch spring, and hex bushing with silicone spray.
11. Reverse procedure to assemble air clutch assembly.
12. Place one drop of pneumatic or light-duty hydraulic oil in air cylinder fitting before attaching air line.
13. Install meter assembly.

! WARNING

Uncontrolled machine movement can crush or cause loss of control resulting in death, serious injury, or damage to property and equipment. Install all safety lockup devices before working under or transporting this equipment.

LIFT/GROUND DRIVE WHEEL BEARING REPACK OR REPLACEMENT

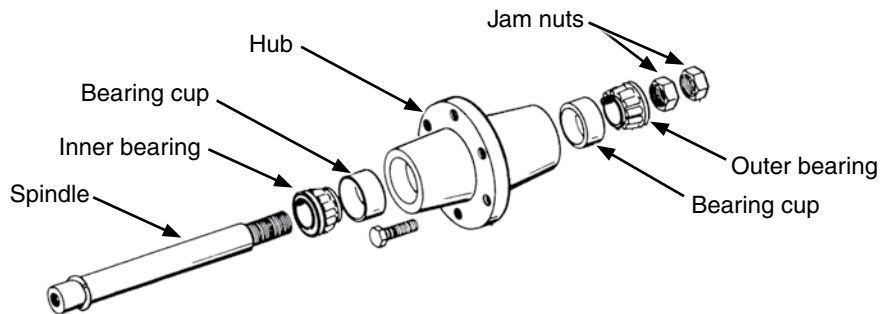

1. Raise tire clear of ground and remove wheel.
2. Remove double jam nuts and slide hub from spindle.
3. Remove bearings and cups and discard if bearings are being replaced. Clean hub and dry. Remove bearings only and not cups if repacking.
4. Press in new bearing cups with thickest edge facing in. (Bearing replacement procedure only.)
5. Pack bearings with heavy duty wheel bearing grease thoroughly forcing grease between roller cone and bearing cage. Fill space between bearing cups and hub with grease.
6. Place inner bearing in place.
7. Clean spindle and install hub.
8. Install outer bearing and jam nut. Tighten jam nut while rotating hub until there is some drag. This ensures all bearing surfaces are in contact. Back off jam nut ¼ turn or until there is only slight drag when rotating hub. Install second jam nut to lock against first.
9. Install wheel on hub. Tighten hardware evenly.

⚠ WARNING

Uncontrolled machine movement can crush or cause loss of control resulting in death, serious injury, or damage to property and equipment. Install all safety lockup devices before working under or transporting this equipment.

TRANSPORT WHEEL BEARING REPLACEMENT

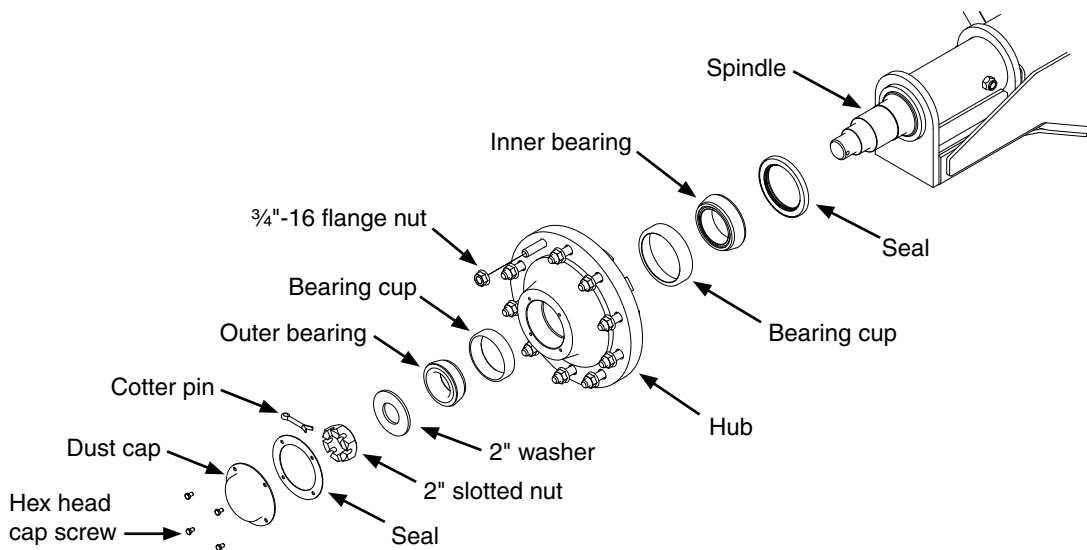

1. Raise tires clear of ground and support with jack stand. Remove wheels.
2. Remove dust cap attachment hardware and cap from wheel hub.
3. Remove cotter pin, slotted nut, and 2" washer.
4. Slide hub from axle spindle. Use a hub puller if necessary.
5. Remove bearings and cups from hub and discard. Thoroughly clean and dry wheel hub.
6. Press in new bearing cups with thickest edges facing in.
7. Pack bearing with heavy-duty wheel bearing grease. Thoroughly force grease between roller cone and bearing cage. Fill space between bearing cups and hub with grease.
8. Place inner bearing in hub and press in new grease seal with lip pointing towards bearing.
9. Clean axle spindle and install hub.
10. Install outer bearing, 2" washer, and slotted nut. Tighten slotted nut while rotating hub until there is some drag. This ensures all bearing surfaces are in contact. Back off slotted nut to nearest locking slot and install cotter pin. Check bearing endplay.
11. Fill dust cap half full of wheel bearing grease and install on hub with four hex head cap screws.
12. Install wheels and remove jack stand. Torque $\frac{3}{4}$ " flange nuts to 280 ft-lb (379.6 N-m).

FERTILIZER CHECK VALVE CLEANING AND REPAIR

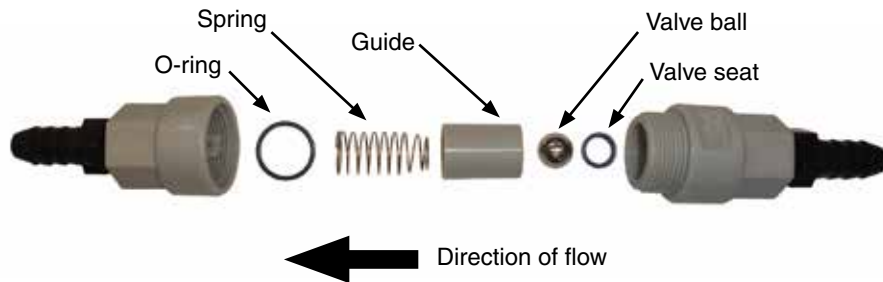

1. Unscrew valve body and separate halves. Note direction and location of parts.
2. Clean and inspect parts. Flush with clean water. Replace damaged parts.
3. Reassemble exactly as shown. O-ring and valve seat must be firmly in place inside each half of valve body.

PISTON PUMP STORAGE



Liquid fertilizer piston pump

NOTICE

Entrance of air into pump will cause rapid and severe corrosion.
KEEP AIR OUT OF PUMP!

NOTE: SUSPENSION FERTILIZER must be flushed from pump for ANY storage period.

1. Flush pump with 5 to 10 gallons of fresh water and circulate until all corrosive salts are dissolved in pump.
2. Set pump on 10. Draw in a mixture of half diesel fuel and 10 weight oil until discharge is clean. Plug inlet and outlet.

PREPARATION FOR STORAGE

Store planter in a dry sheltered area if possible.

Remove all trash wrapped on sprockets or shafts and remove dirt that can draw and hold moisture.

Clean all drive chains and coat with a rust preventative spray, or remove chains and submerge in oil.

Lubricate planter and row units at all lubrication points.

Inspect planter for parts that in need of replacement and order during “off” season.

Make sure all seed and granular chemical hoppers are empty and clean.

Remove seed discs from seed meters, clean and store meters in a rodent-free, dry area with discs removed. Store seed discs vertically on a dowel or pipe.

Remove vacuum hose from each seed meter. Operate vacuum fan at full hydraulic flow from tractor for two minutes to clear manifolds, hoses and fittings of dust and debris.

Clean breather on analog vacuum and pressure gauges.

Disassemble, clean and grease all U-joint slides.

Grease or paint disc openers/blades and row marker disc blades to prevent rust.

Flush liquid fertilizer tanks, hoses and metering pump with clean water. See “Piston Pump Storage” if applicable.

Empty dry fertilizer hoppers. Clean hoppers. Disassemble and clean metering augers. Reassemble, coating all metal parts with rust preventative.

ASD System:

- Clean out ASD hopper, entrainment assembly, and delivery hoses.
- Disconnect delivery hoses from entrainer ports. Install small orange caps onto ports. Attach hoses to caps.
- Disconnect delivery hoses from air dissipator at each row unit. Install large orange caps. Attach hoses to caps.
- Check all bolts and fasteners used to assemble and attach entrainment device are tight (if applicable).
- Loosen knobs on entrainer cleanout doors to remove pressure from door gaskets.
- Inspect all seed delivery hoses and replace any that are worn, cut, or cracked.

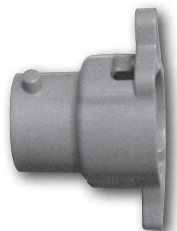

Entrainer cap

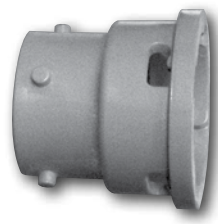

Air dissipator cap

ELECTRICAL LIGHT HARNESS SCHEMATICS

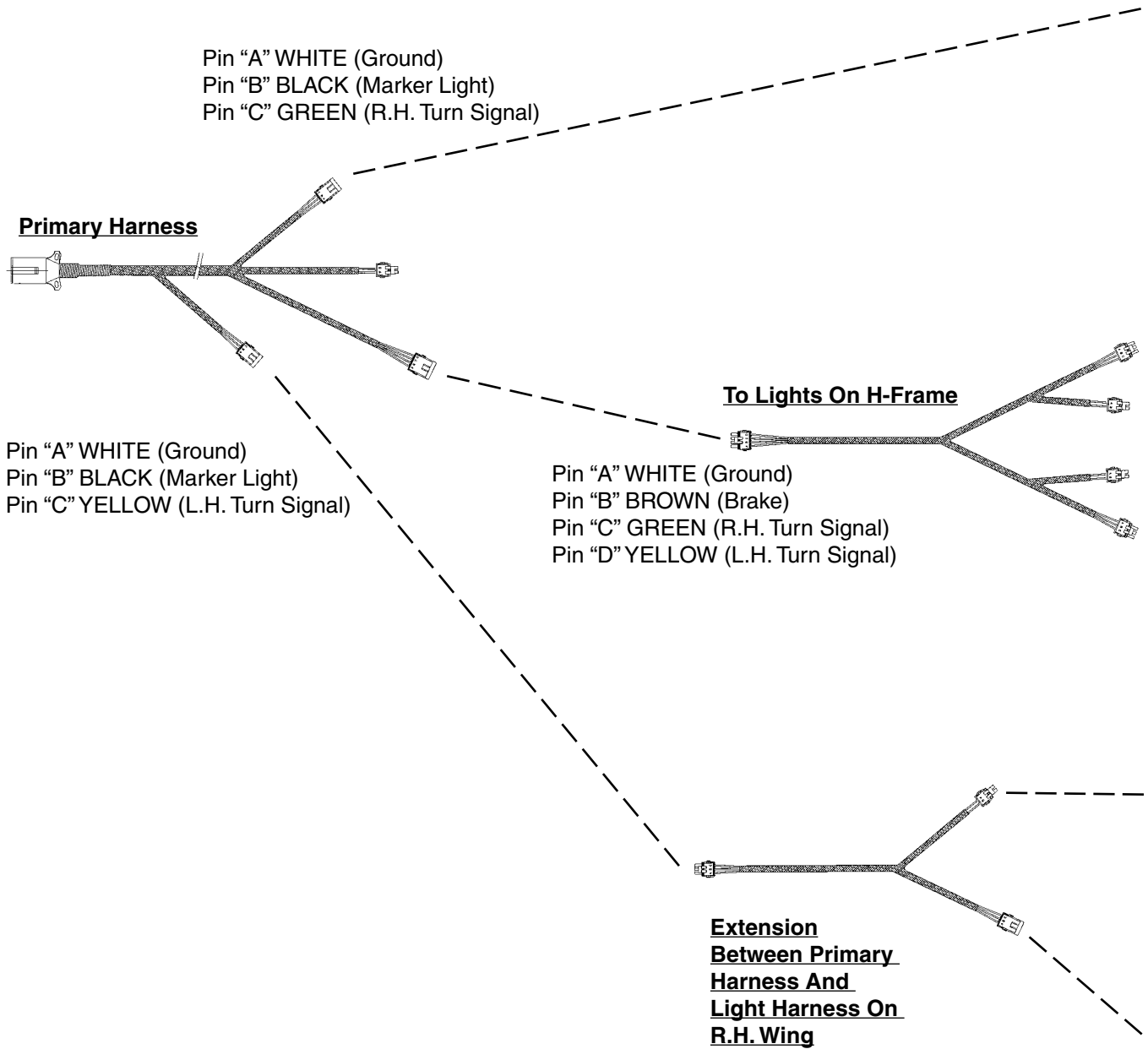

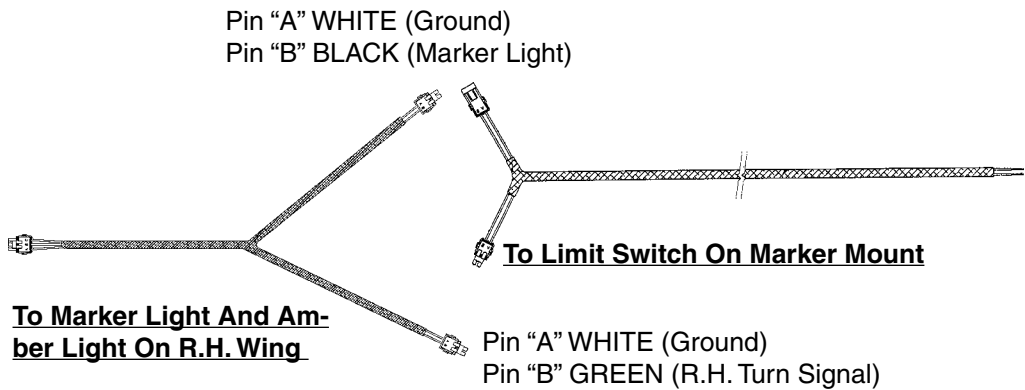

- Pin "A" WHITE (Ground)
- Pin "B" BROWN (Brake)
- Pin "C" GREEN (R.H. Turn Signal)
- Pin "A" WHITE (Ground)
- Pin "B" GREEN (R.H. Turn Signal)
- Pin "A" WHITE (Ground)
- Pin "B" YELLOW (L.H. Turn Signal)
- Pin "A" WHITE (Ground)
- Pin "B" BROWN (Brake)
- Pin "C" YELLOW (L.H. Turn Signal)

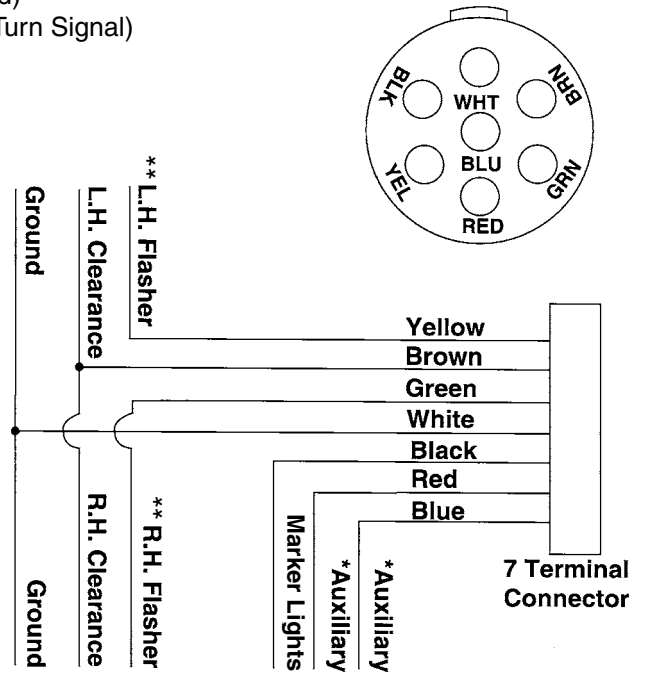

- * Optional customer-supplied auxiliary lights and wires may be wired into existing plug terminals.
- ** Rear and side flashers.

Light packages supplied on Model 3800 Forward Folding Planters meet ASABE Standards. For correct wiring harness to be wired into lights on your tractor, check with tractor manufacturer.

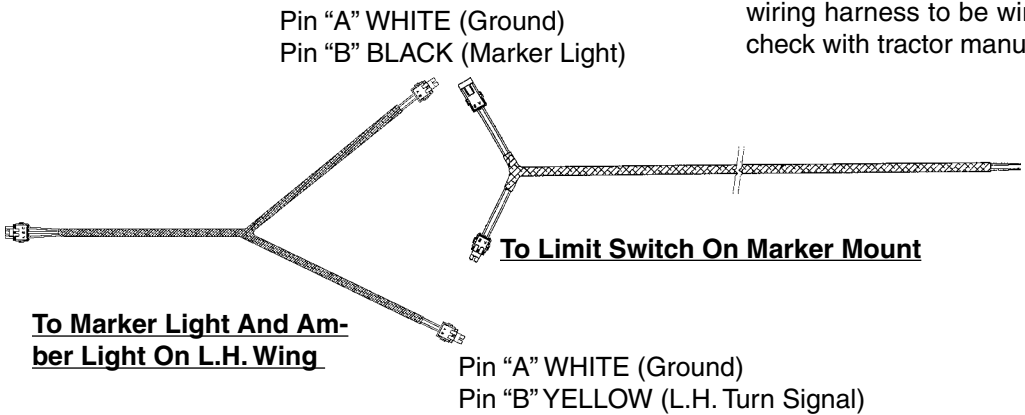

ELECTRICAL CONTROL CONSOLE SCHEMATIC (PLANTER FUNCTIONS)

NOTICE

Disconnect control console from tractor battery before doing any electrical work or shorting may damage equipment. Keep wiring harnesses away from high temperature areas or sharp edges. **DO NOT** route wiring harnesses along battery cables. Use cable ties to keep wire harnesses away from moving parts on tractor and planter. Be sure ground connections to tractor frame are clean to provide good electrical contact.

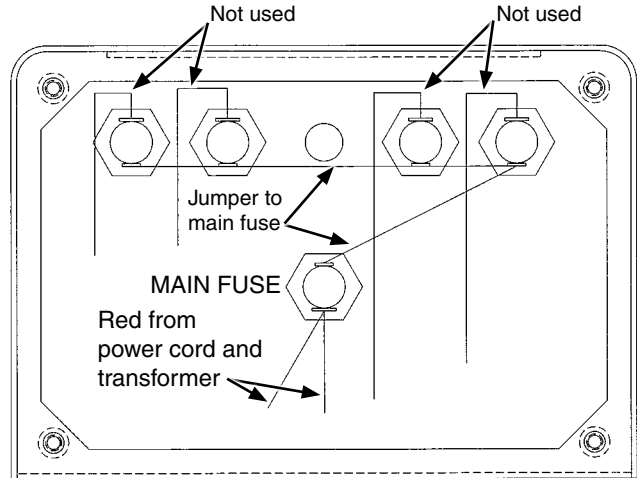
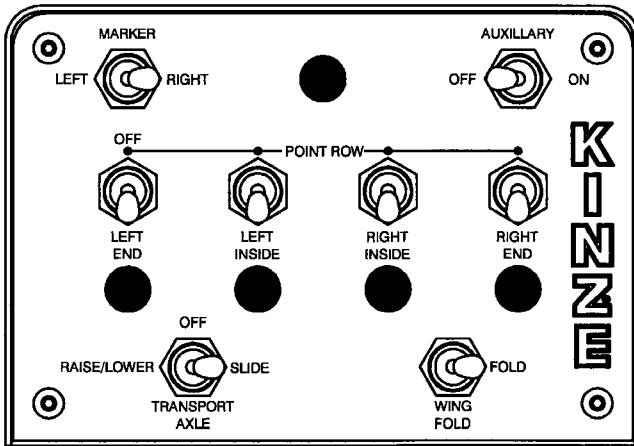

- A. 6" White Jumper
- B.-D., Q. 4" White Jumper (4)
- E. 4" Red Jumper
- F. 7" Orange Jumper
- G.-J. 3" White Jumper (4)
- K. 5" Black Jumper
- L.-P. 7" Purple Jumper (5)
- R. 4" White Jumper

- Pin "A" ORANGE/RED (Slide)
- Pin "R" BROWN (Not Used)
- Pin "G" ORANGE (Not Used)
- Pin "H" BLUE (L.H. Marker)
- Pin "B" BLUE/RED (Fold)
- Pin "U" RED/BLACK (Not Used)
- Pin "S" YELLOW (Not Used)
- Pin "O" RED (R.H. Marker)
- Pin "V" BLUE/BLACK (Raise To Transport)
- Pin "T" BLACK (Ground)(12 Gauge)
- Pin "C" BLACK/RED (Ground)
- Pin "W" ORANGE/BLACK (Auxiliary)
- * Not Used
- ** To Main Fuse

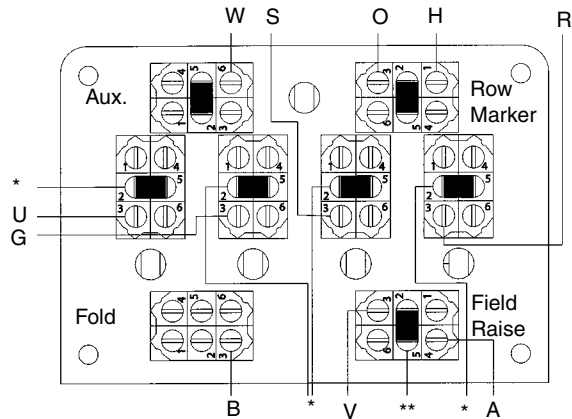
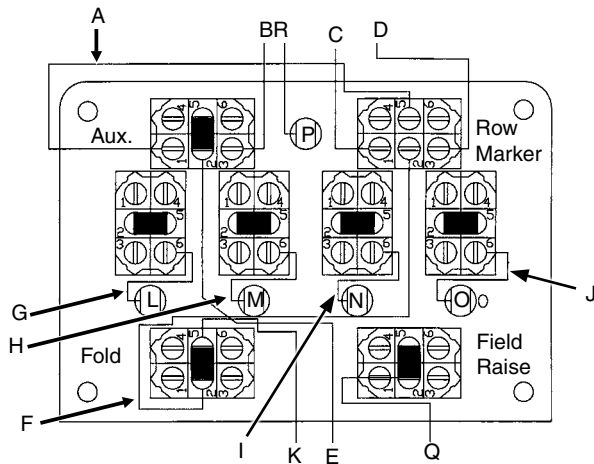

NOTE:

1. Operating marker switches in either direction lights panel light.
2. Power to marker switch is fed through auxiliary switch and two transport function switches. Operating any lower row switch disables marker function and turns off panel light.

ELECTRICAL WIRING HARNESS SCHEMATIC (ON TRACTOR)

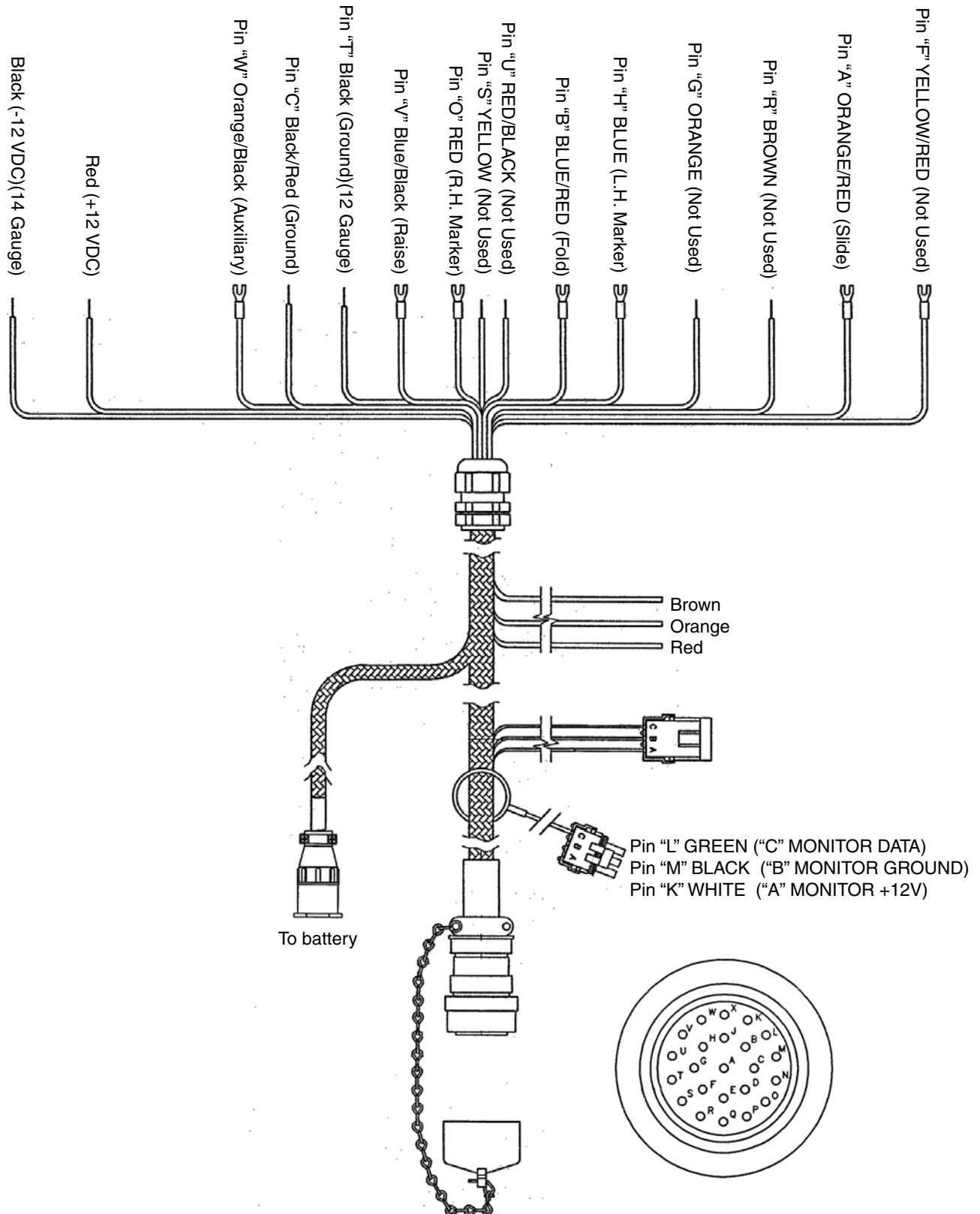

ELECTRICAL WIRING HARNESSES SCHEMATIC (ON PLANTER)

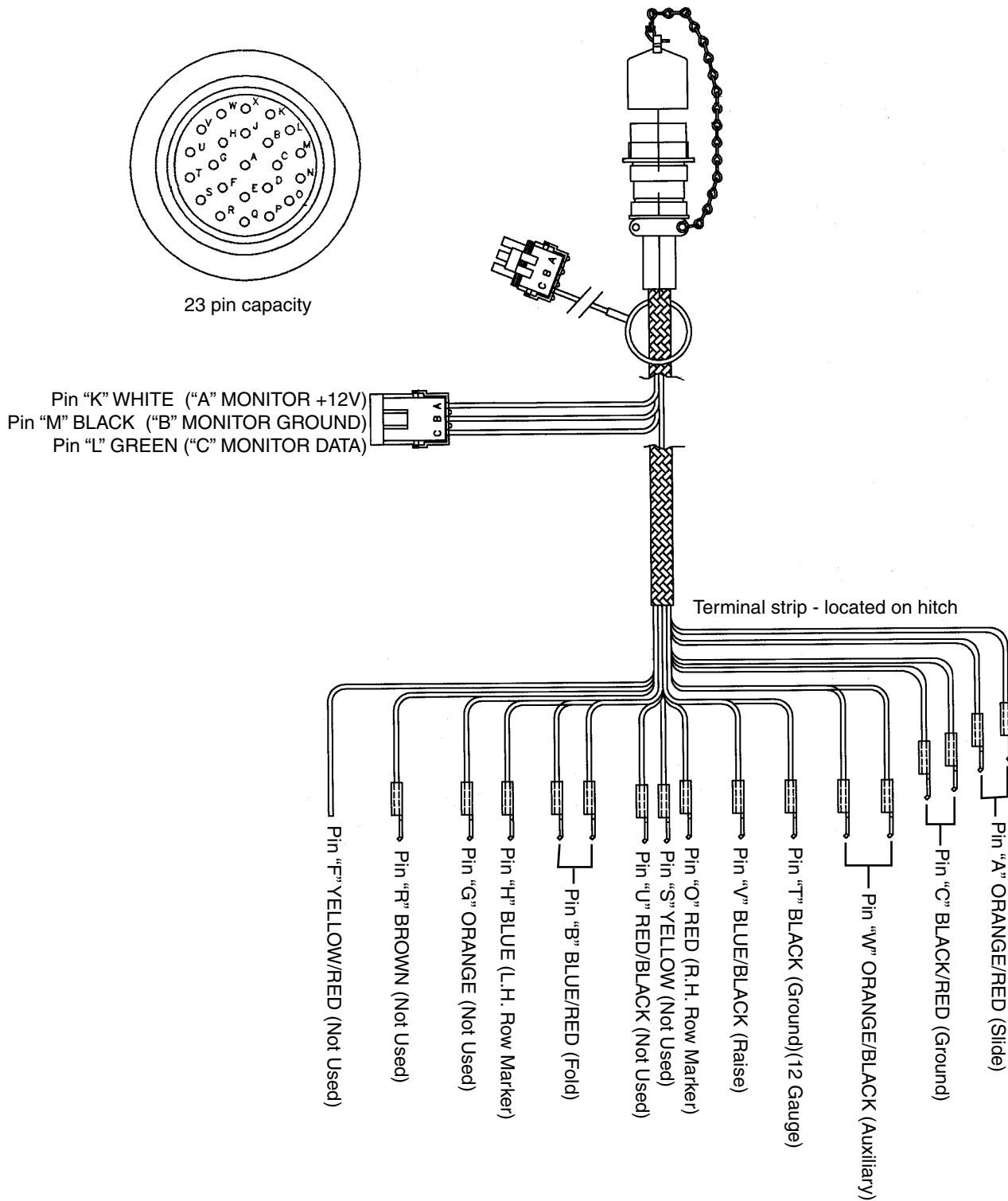

ELECTRICAL WIRING HARNESSES SCHEMATIC (On Planter) (Continued)

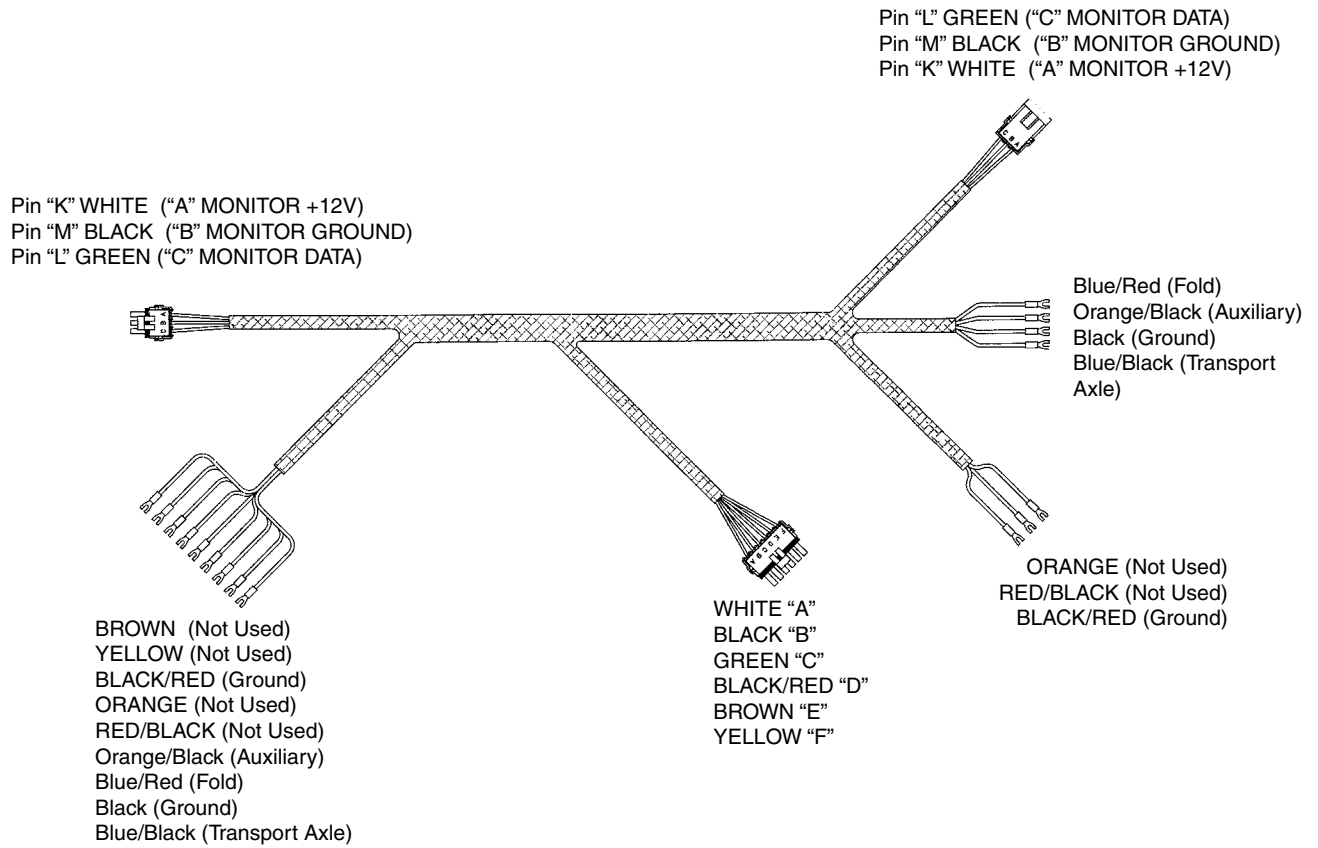

TERMINAL STRIP - Located On Hitch

VACUUM FAN GAUGES ELECTRICAL WIRING HARNESS SCHEMATIC

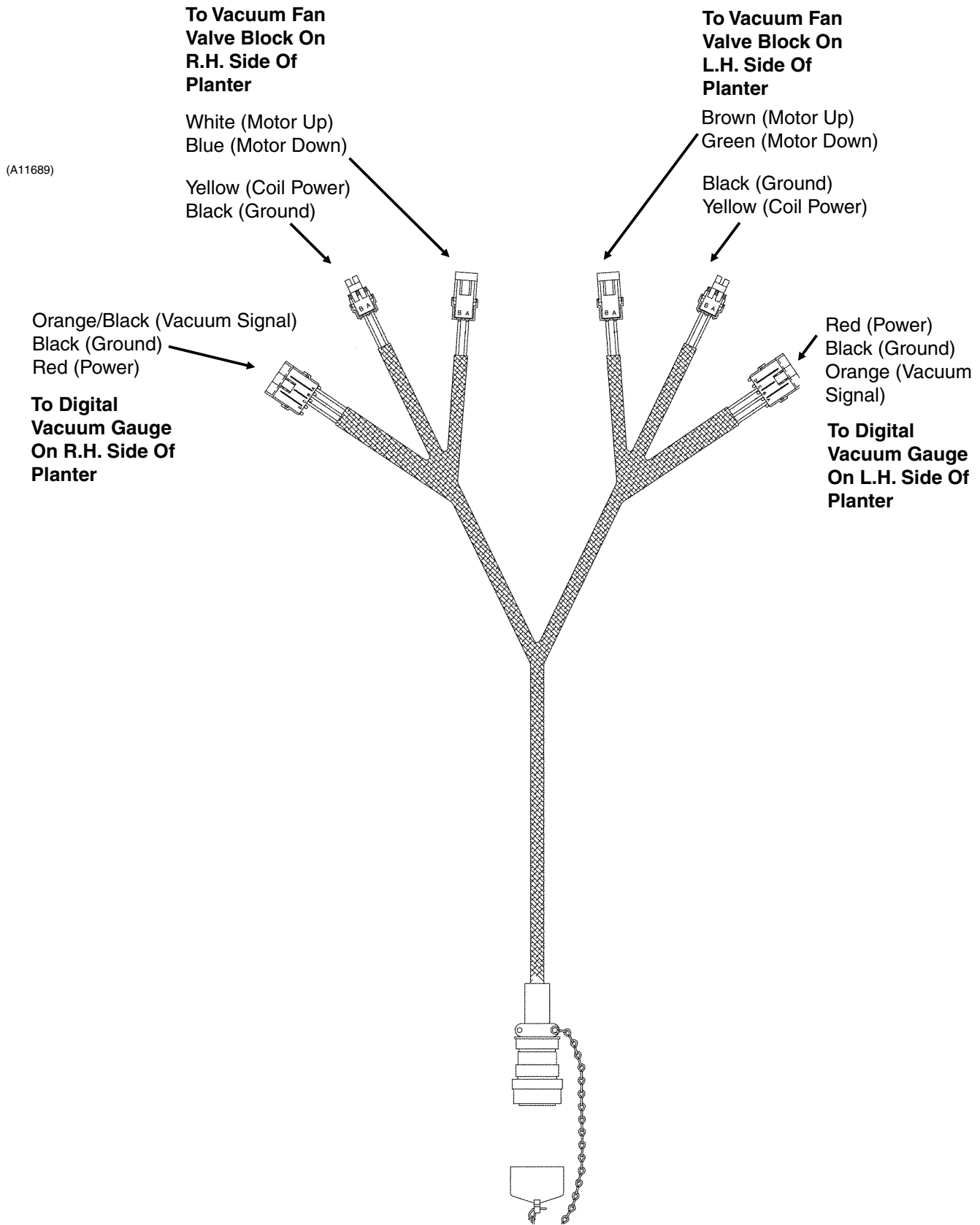

VACUUM FAN SYSTEM HYDRAULIC SCHEMATIC

NOTICE

Failure to connect to a return with zero pressure will damage hydraulic motor. Connect hydraulic motor case drain to a case drain return line with zero pressure on tractor. DO NOT connect hydraulic motor case drain to SCV outlet. Contact tractor manufacturer for specific details on "zero pressure return".

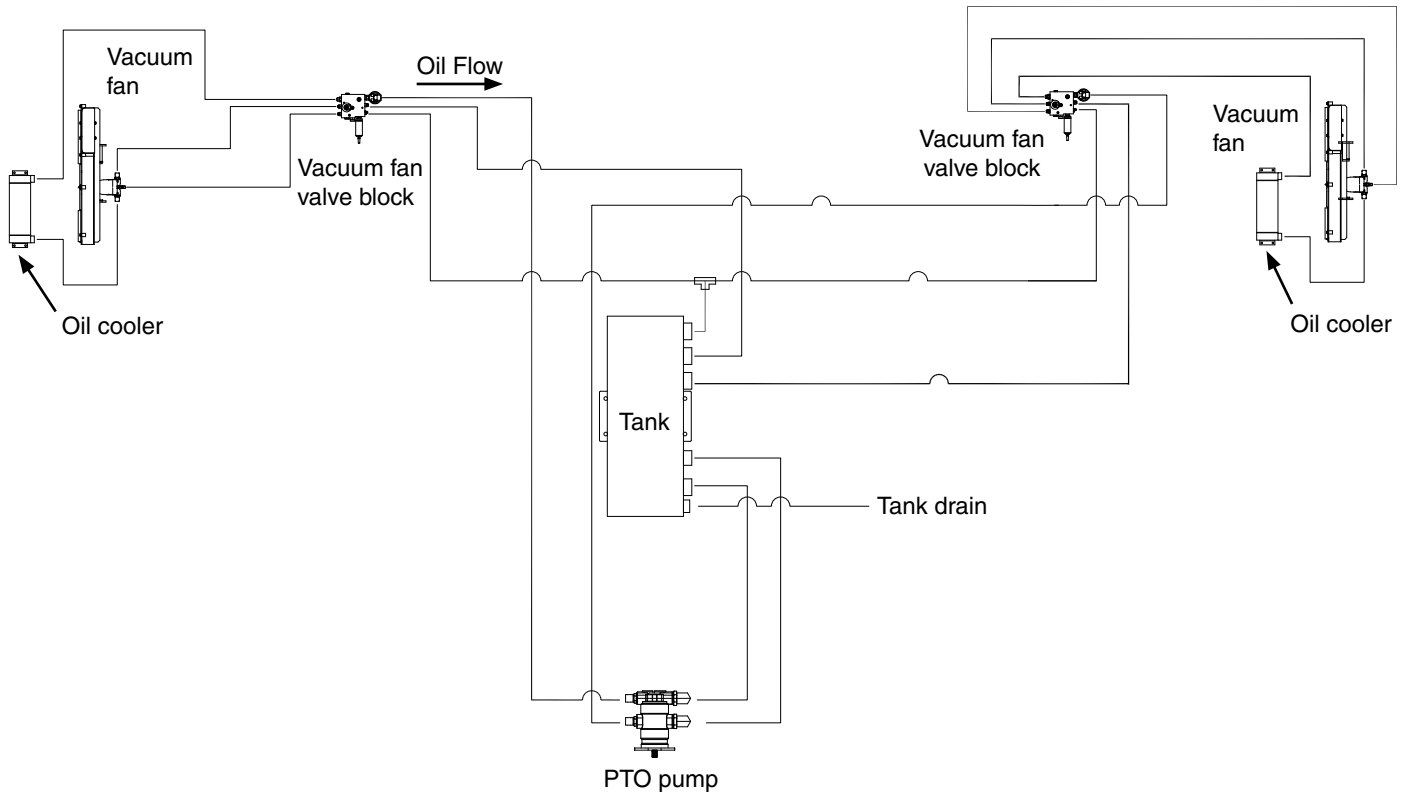

HYDRAULIC SYSTEM SCHEMATIC

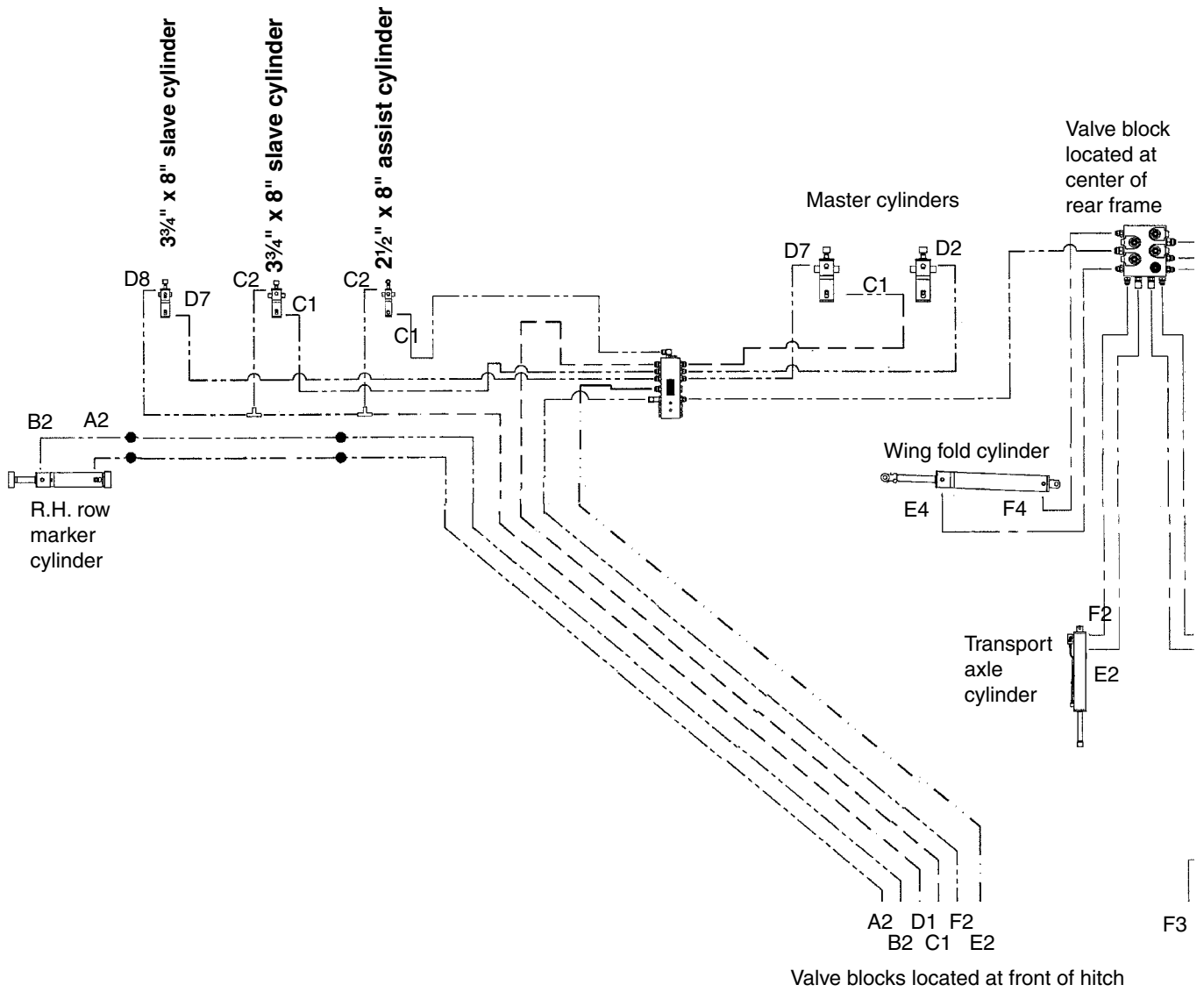

LIFT CIRCUIT (60')

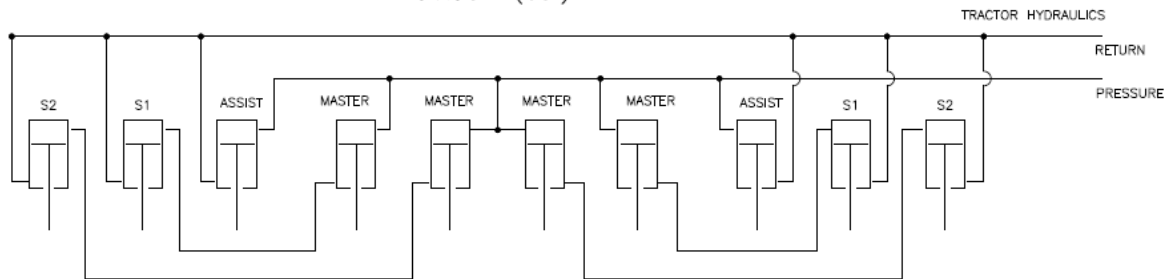

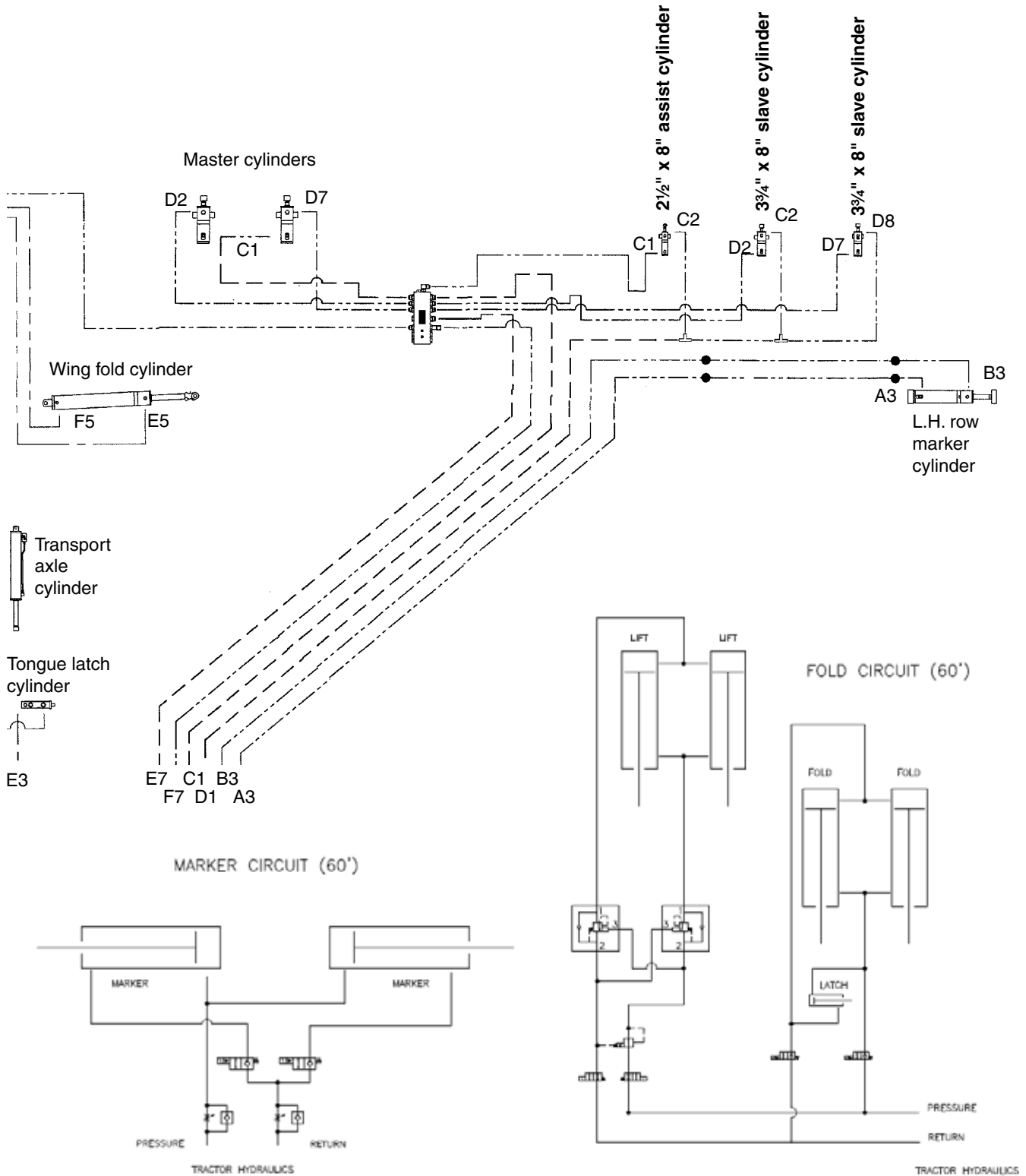

VALVE BLOCK SCHEMATICS

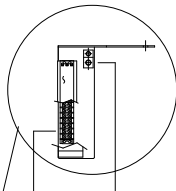
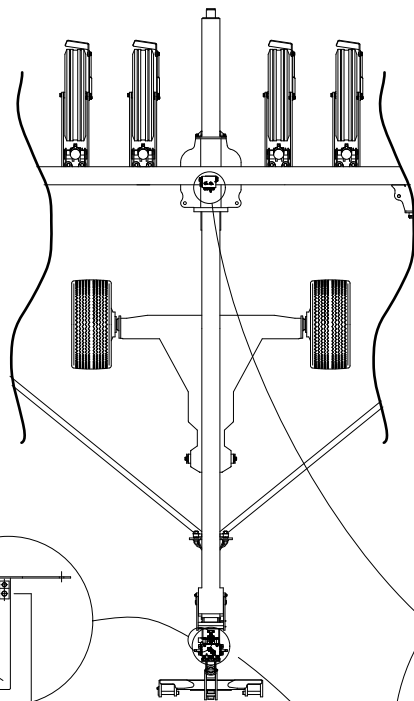

Terminal Strip on Valve Block on Front of Hitch

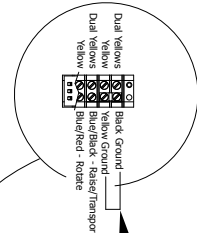

Jumper Wire (#14)

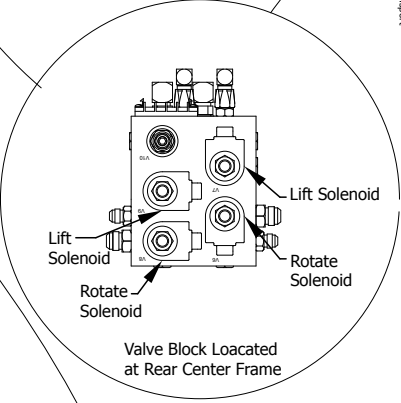

Valve Block Loacted at Rear Center Frame

Brown	Brown - Point Row Left End
Yellow	Yellow - Point Row Left Inside
Orange	Orange - Point Row Right Inside
Red/Black	Red/Black - Point Row Right End
Open	Blue - L.H. Marker
Open	Red - R.H. Marker
Blue/Red	Dual Blue/Reds - Fold/Rotate
Yellow	Orange/Red - Slide Cylinder
Open	Orange/Red - Slide Cylinder
Open	Black
Black	Black
Black/Red	Black/Red - Ground
Green	Black/Red - Ground
Orange/Black	Dual Orange/Blacks - Auxiliary
Blue/Black	Blue/Black - Raise to Transport

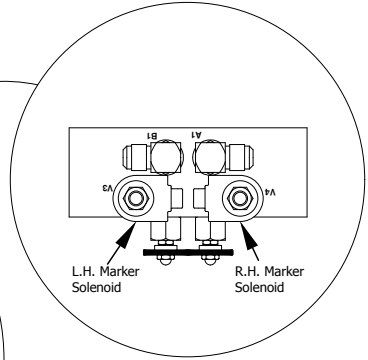

Valve Block Loacted at Front of Hitch

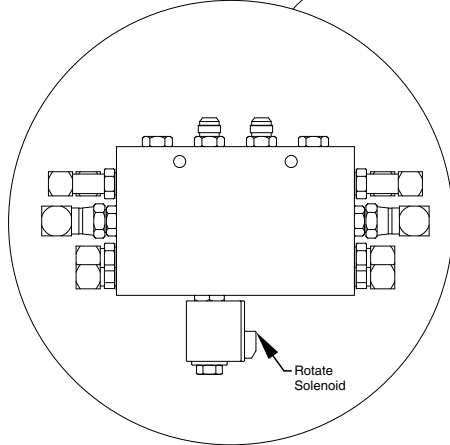

Rotate Solenoid

ASD SYSTEM HYDRAULIC SCHEMATIC

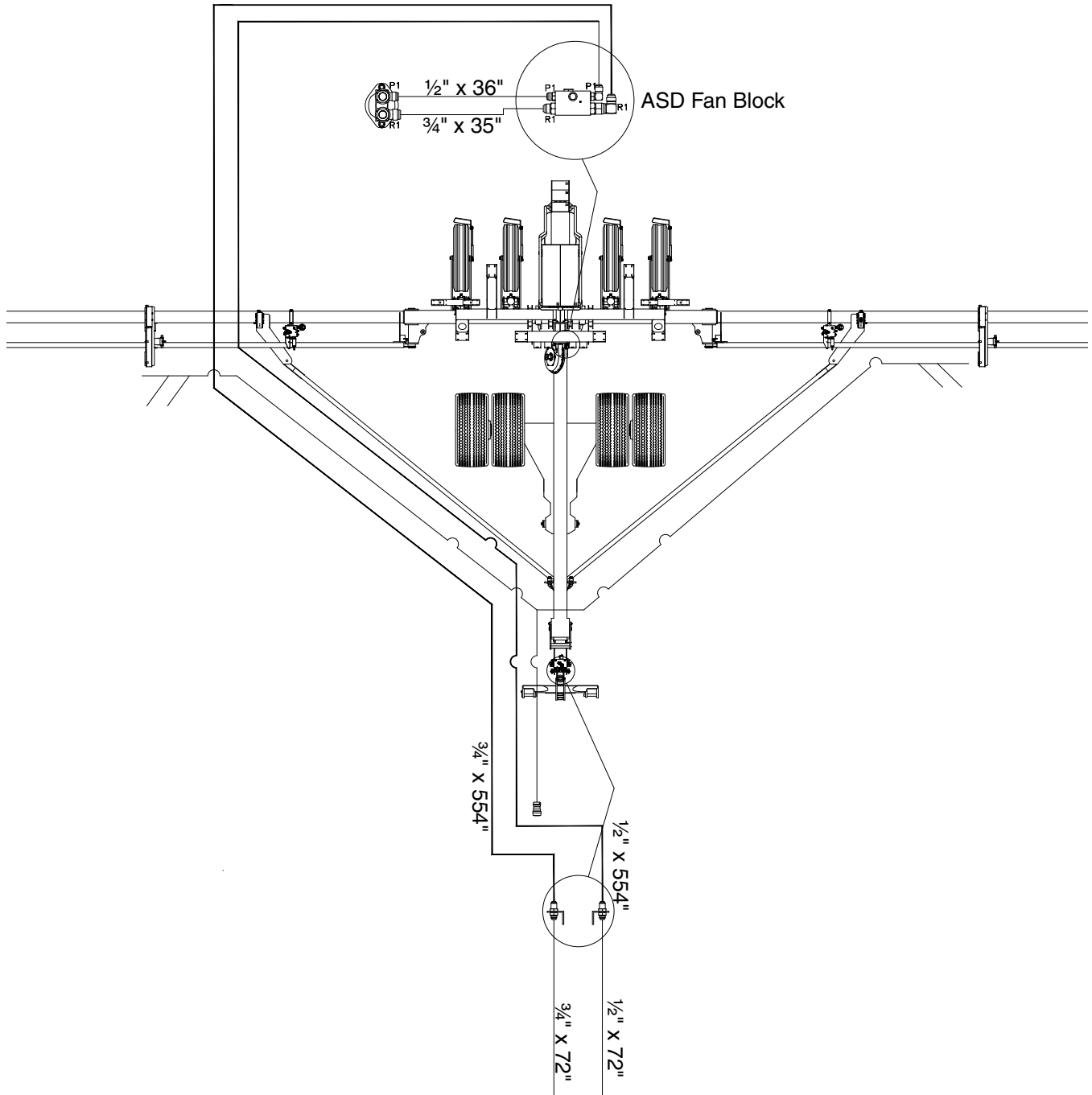

HYDRAULIC DRIVE SYSTEM SCHEMATIC

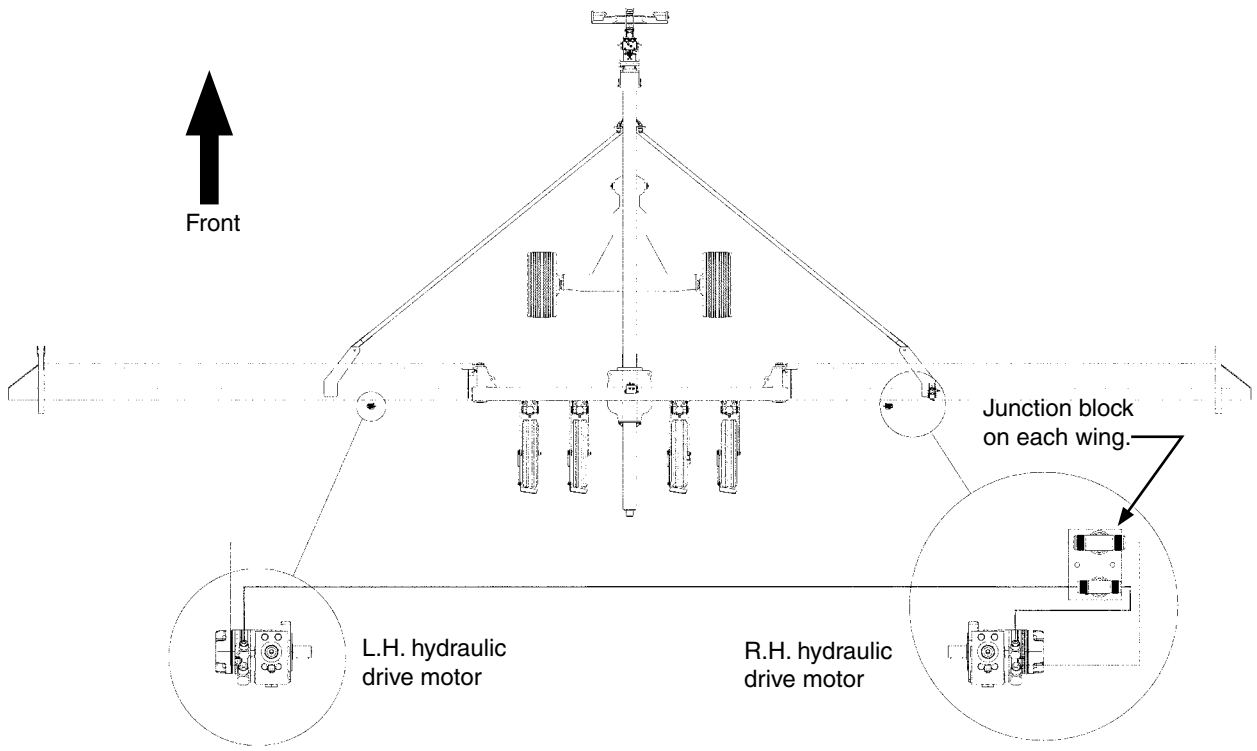

AIR CLUTCH AIRLINE SCHEMATIC

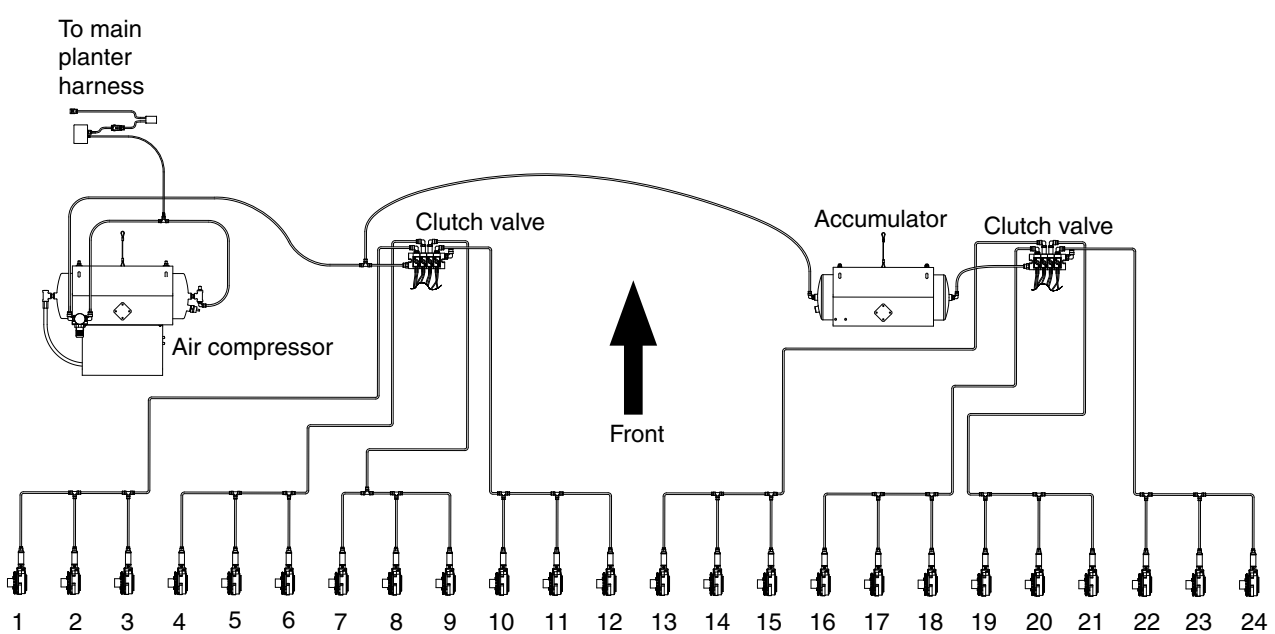

ELECTRIC CLUTCH SCHEMATIC

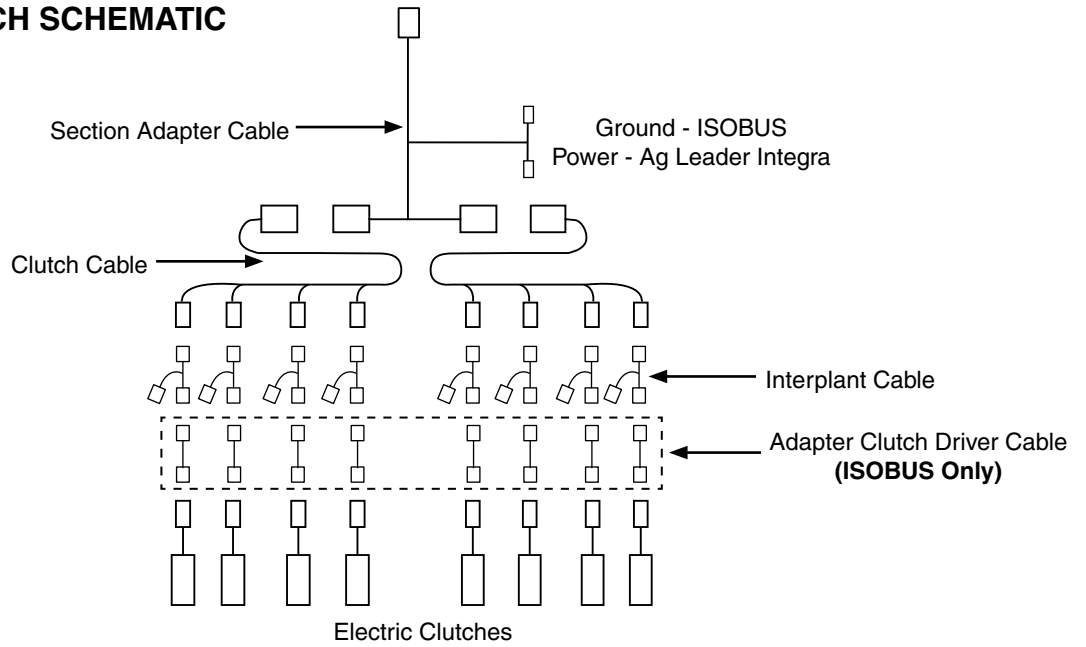

ISOBUS IMPLEMENT CABLE

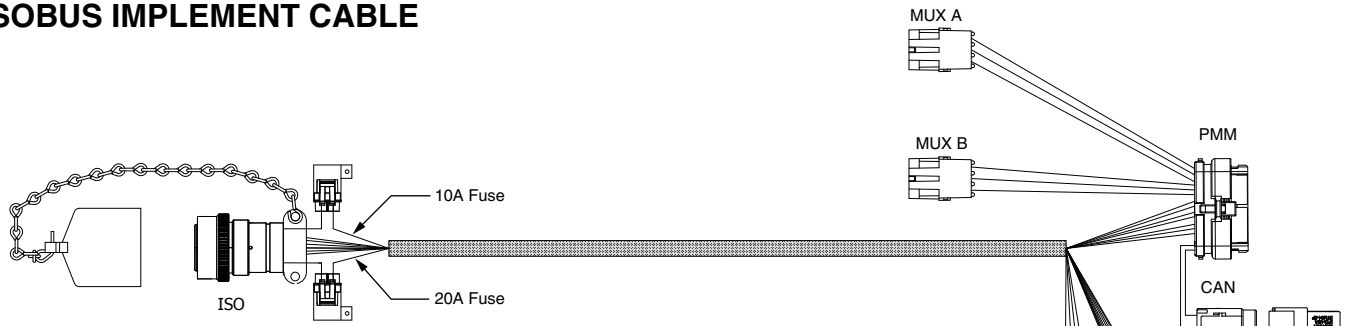

Signal	ISO	Wire/Color	PMM	TBC	PCM	CAN	Mux A	Mux B
TBC Power	6	Twisted Quad Red	-	B	-	-	-	-
TBC Ground	7	Twisted Quad Black	-	D	-	-	-	-
ISO CAN H	8	Twisted Quad Yellow	31	E	-	-	-	-
ISO CAN L	9	Twisted Quad Green	32	F	-	-	-	-
ECU Power	4	Red	4, 5, 8	-	11	-	-	-
ECU Ground	2	Black	14, 15	-	12	-	-	-
LOAD Power	3	Red	-	-	1, 2, 3, 4	-	-	-
LOAD Ground	1	Black	-	-	5, 6, 7, 8	-	-	-
MUX A Power	-	Jacketed 3-Cond White	12	-	-	-	A	-
MUX A Ground	-	Jacketed 3-Cond Black	3	-	-	-	B	-
MUX A Signal	-	Jacketed 3-Cond Green	28	-	-	-	C	-
PROP CAN H	-	Twisted Pair Yellow	34	-	-	1	-	-
PROP CAN L	-	Twisted Pair Green	35	-	-	2	-	-
MUX B Power	-	Jacketed 3-Cond White	23	-	-	-	-	A
MUX B Ground	-	Jacketed 3-Cond Black	26	-	-	-	-	B
MUX B Signal	-	Jacketed 3-Cond Green	7	-	-	-	-	C

ISOBUS CAN JUMPER CABLE

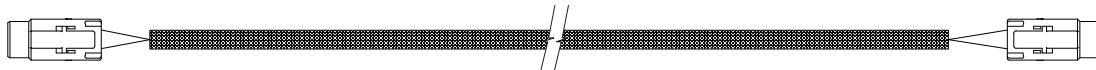

Signal	CAN	Wire/Color
CAN H	1	Twisted Pair Yellow
CAN L	2	Twisted Pair Green

PRODUCT CONTROL MODULE CABLE

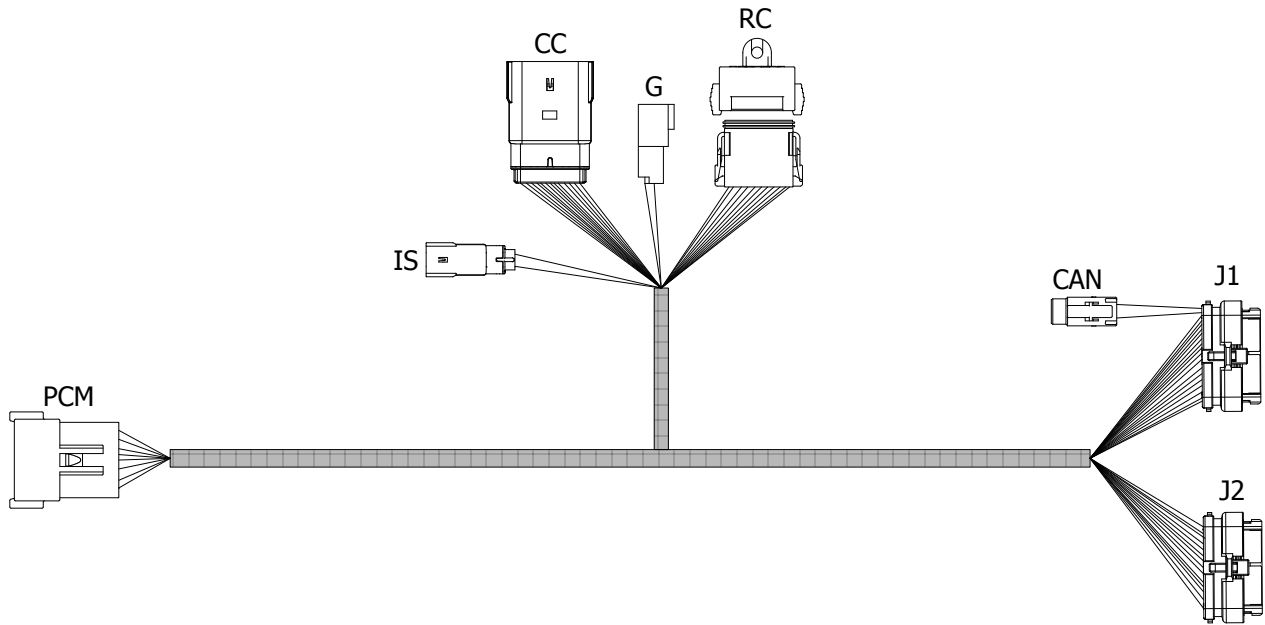

Signal	PCM	Wire/Color	J1	J2	CAN	RC	CC	IS	G
Load Power	1	Red	2	-	-	-	-	-	-
Load Power	2	Red	3	-	-	1	-	-	-
Load Power	3	Red	4	-	-	-	-	1	-
Load Power	4	Red	5	-	-	-	-	-	-
Load Ground	5	Black	-	-	-	-	-	-	1, 2
Load Ground	6	Black	14, 15	-	-	-	-	-	-
Load Ground	7	Black	16	-	-	2	-	-	-
Load Ground	8	Black	17	-	-	-	-	-	-
ECU Power	11	White/Red	11	-	-	-	-	-	-
CAN H	-	Twisted Pair Yellow	34	-	1	-	-	-	-
CAN L	-	Twisted Pair Green	33	-	2	-	-	-	-
Switch In	-	Red/Green	10	-	-	-	-	2	-
Section 1	-	White	24	-	-	-	1	-	-
Section 2	-	Green	25	-	-	-	2	-	-
Section 3	-	Orange	26	-	-	-	3	-	-
Section 4	-	Blue	27	-	-	-	4	-	-
Section 5	-	Brown	-	11	-	-	5	-	-
Section 6	-	Yellow	-	10	-	-	6	-	-
Section 7	-	Violet	-	9	-	-	7	-	-
Section 8	-	Gray	-	8	-	-	8	-	-
Section 9	-	Pink	-	7	-	-	9	-	-
Section 10	-	Tan	-	6	-	-	10	-	-
Section 11	-	Red/Green	-	5	-	-	11	-	-
Section 12	-	Black/Red	-	4	-	-	12	-	-
PWM 1 Power	-	Red/White	-	23	-	3	-	-	-
PWM 1 Ground	-	Black/White	35	-	-	4	-	-	-
PWM 2 Power	-	Red/Yellow	-	12	-	5	-	-	-
PWM 2 Ground	-	Black/Yellow	12	-	-	6	-	-	-
PWM 3 Power	-	Red/Blue	1	-	-	7	-	-	-
PWM 3 Ground	-	Black/Blue	-	24	-	8	-	-	-
Meter Speed 1	-	Green	30	-	-	9	-	-	-
Meter Speed 2	-	Green/White	29	-	-	10	-	-	-
Meter Speed 3	-	Green/Red	-	33	-	11	-	-	-

IMPLEMENT SWITCH EXTENSION CABLE

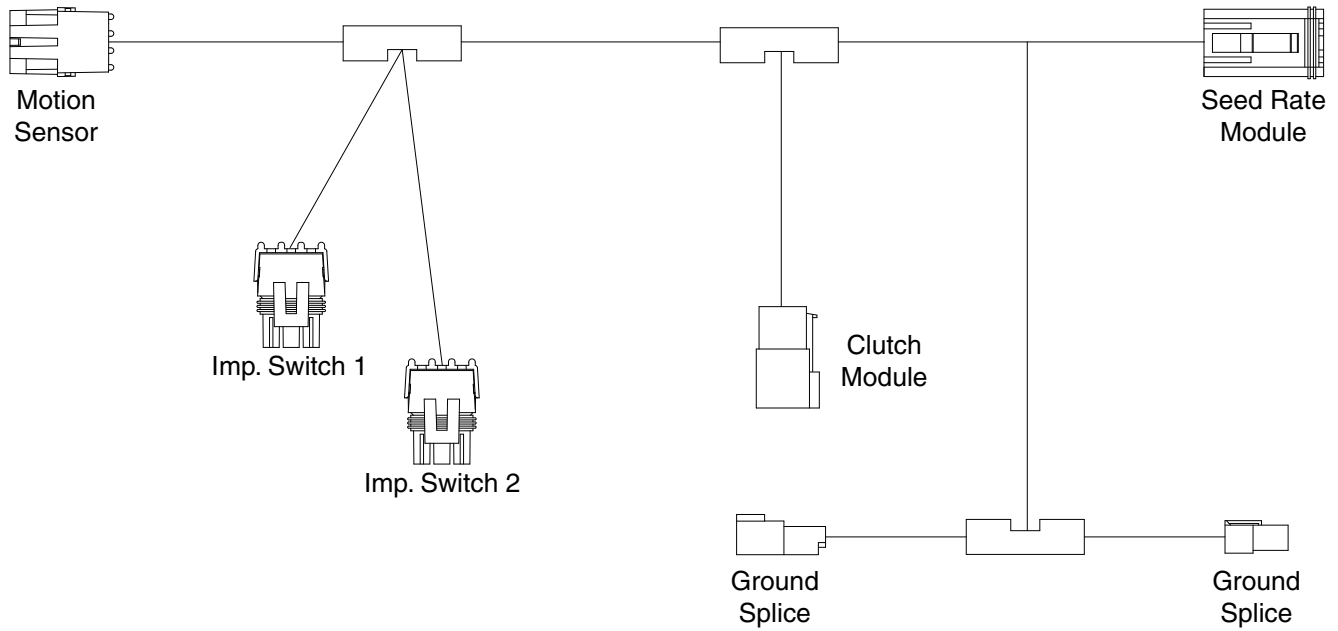

Signal	Imp. Switch 1 WP Tower 1	Imp. Switch 2 WP Tower 2	Motion Sensor WP Shroud	Color	Clutch Module Molex Recept	Seed Rate Module Deutsch Plug	Ground Splice 1	Ground Splice 2	Gauge
12V+ Power	A	A	-	Brown	1	12	-	-	16
Switch Signal	B	B	-	Green	2	10	-	-	16
Motion Signal	-	-	C	White	-	11	-	-	16
Ground	-	-	B	Black	-	6	-	-	16
12V+ Power	-	-	A	Red	-	1	-	-	16
Ground	C (Blue 16 AWG)	C (Blue 16 AWG)	-	Black	-	-	2	2	12
12V+ Power	-	-	-	Red	-	-	1	1	12

SECTION ADAPTER CABLE - 24 ROW

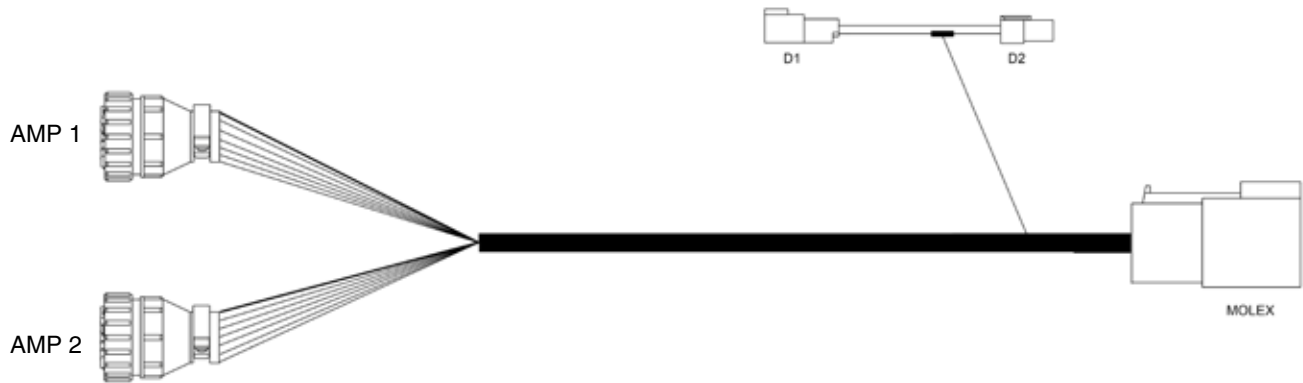

Signal	Color	AMP 1 (Left)	AMP 2 (Right)	Molex	D1	D2
High Current Power	Red	1 (16 Gauge)	1 (16 Gauge)	-	1 (12 Gauge)	1 (12 Gauge)
Ground	Black	-	-	-	2	2
Row 1, 2	Black	2, 3	-	1	-	-
Row 3, 4	Brown	4, 5	-	2	-	-
Row 5, 6	Orange	6, 7	-	3	-	-
Row 7, 8	Pink	8, 9	-	4	-	-
Row 9, 10	Green	10, 11	-	5	-	-
Row 11, 12	Yellow	12, 13	-	6	-	-
Row 13, 14	Blue	-	12, 13	7	-	-
Row 15, 16	Violet	-	10, 11	8	-	-
Row 17, 18	Red	-	8, 9	9	-	-
Row 19, 20	Tan	-	6, 7	10	-	-
Row 21, 22	Gray	-	4, 5	11	-	-
Row 23, 24	White	-	2, 3	12	-	-

CLUTCH CABLE - 24 ROW (R.H. SHOWN)

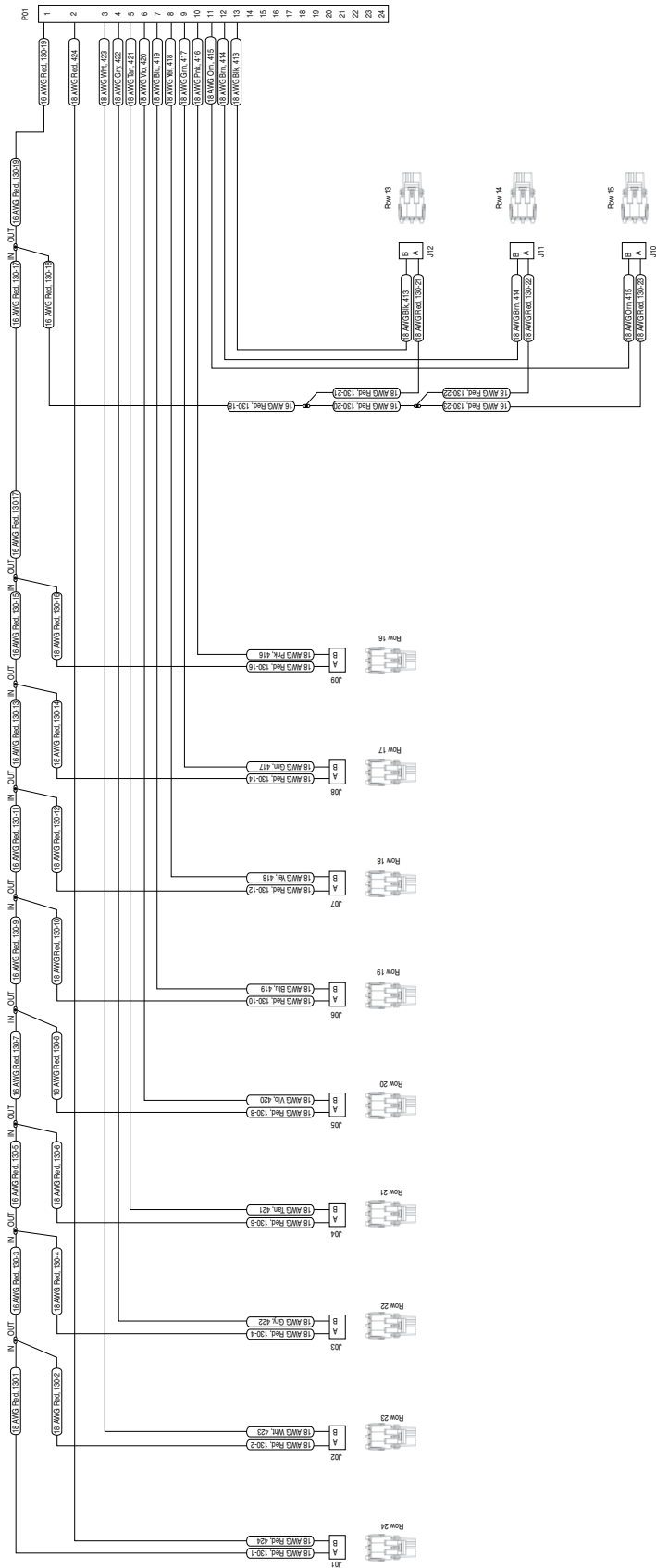

R.H. Clutch Cable

Signal	Clutch Cable	Row 13	Row 14	Row 15	Row 16	Row 17	Row 18	Row 19	Row 20	Row 21	Row 22	Row 23	Row 24
Power	1	A	A	A	A	A	A	A	A	A	A	A	A
	2												B
	3												
	4										B		
	5									B			
	6								B				
	7							B					
	8						B						
	9					B							
	10				B								
	11			B									
	12		B										
	13	B											

L.H. Clutch Cable

Signal	Clutch Cable	Row 1	Row 2	Row 3	Row 4	Row 5	Row 6	Row 7	Row 8	Row 9	Row 10	Row 11	Row 12
Power	1	A	A	A	A	A	A	A	A	A	A	A	A
	2	B											
	3		B										
	4			B									
	5				B								
	6					B							
	7						B						
	8							B					
	9								B				
	10									B			
	11										B		
	12											B	
	13												B

This page intentionally blank.

AIR CLUTCH

PROBLEM	POSSIBLE CAUSE	SOLUTION
Clutches slip (effected row does not plant or skips).	Plunger in cylinder seized.	Remove air line and lubricated with pneumatic or light duty hydraulic oil.
	Worn Clutch.	Replace worn items.
	Dirt/debris buildup inside clutch.	Disassemble and clean. Reassemble.

AIR SEED DELIVERY (ASD)

PROBLEM	POSSIBLE CAUSE	SOLUTION
Seed does not travel through delivery tubes.	System pressure set too low.	Increase system pressure.
Seed stops flowing to row unit during planting.	Seed surging.	Shut down air seed delivery system and restart system from idle; seed should start flowing.
	Debris in system.	Insert shutoff door, open cleanout door. Remove debris.
Seed does not move from entrainer at startup after exposure to water.	Seed swelled in entrainer.	Insert shutoff door, open cleanout door. Remove swelled seed.

CLOSING WHEEL

PROBLEM	POSSIBLE CAUSE	SOLUTION
Closing wheel(s) leave severe imprint in soil.	Too much closing wheel down pressure.	Adjust closing wheel pressure.
Closing wheel(s) not firming soil around seed.	Not enough closing wheel down pressure.	Adjust closing wheel pressure. Severe no till conditions may require use of cast iron closing wheels.
"V" closing wheel running on top of seed furrow.	Improper centering.	Align. See "V Closing Wheel Adjustment".
Single closing wheel not directly over seed.	Improper centering.	Align. See "Covering Discs/Single Press Wheel Adjustment".

LIFT/FOLD CIRCUIT TROUBLESHOOTING

PROBLEM	POSSIBLE CAUSE	TROUBLESHOOTING*	SOLUTION
Planter raising uneven.	Master cylinder leaking.	Raise planter slowly until master cylinder reaches mid stroke. If master cylinder is leaking corresponding slave cylinder will have greater rod length. If planter settles when hydraulic lever is released, check assist cylinders.	Perform leak test. Consult your Kinze Dealer for leak testing. Install seal kit.
	Slave cylinder leaking.	Fold planter to transport position. Retract field tires and observe which tire settles.	Perform leak test. Consult your Kinze Dealer for leak testing. Install seal kit.
Planter raising evenly, but settles when hydraulic lever released.	Assist cylinder leaking.	Fold planter to transport position. Retract assist cylinder and observe which tire settles.	Perform leak test. Consult your Kinze Dealer for leak testing. Install seal kit.

*Operate hydraulics slowly to accentuate problem.

PISTON PUMP

PROBLEM	POSSIBLE CAUSE	SOLUTION
Pump hard or impossible to prime.	Valves fouled or in wrong place.	Inspect and clean valves.
	Air leak in suction line.	Repair leak.
	Pump set too low.	Adjust pump setting.
	Packing washers worn out.	Replace.
Low metering.	Valves fouled or in wrong place.	Inspect and clean valves.
	Air leak in suction line.	Repair leak.
	Pump set too low.	Adjust pump setting.
	Broken valve spring.	Replace spring.
Over meters.	Broken discharge valve spring.	Replace spring.
	Trash under valves.	Inspect and clean valves.
	Improper rate setting.	Adjust pump setting.
Leaks through when stopped.	Broken discharge valve spring.	Replace spring.
	Trash under valves.	Inspect and clean valves.
Fertilizer solution leaking under stuffing box.	Packing washers worn out.	Replace.
Pump using excessive oil.	Oil seals or O-ring worn and leaking.	Replace.
Pump operates noisily.	Crankcase components worn excessively.	Inspect and replace if necessary.

PTO PUMPS AND OIL COOLERS

PROBLEM	POSSIBLE CAUSE	SOLUTION
Pump is squealing.	Lack of oil to pump.	Check for plugged suction strainer. Check oil level.
Oil temperature is high.	Low oil level.	Check oil level and add as required.
Desired fan speed cannot be achieved.	Low oil level.	Check oil level and add as required.
	Plugged filter.	Check and change as required.
Vacuum level not displayed.	Digital vacuum gauge console power OFF.	Turn ON.
	Cable not plugged in.	Check connection.
	No power to digital vacuum gauge console.	Check fuse.

ROW MARKER CIRCUIT TROUBLESHOOTING

PROBLEM	POSSIBLE CAUSE	SOLUTION
Right marker lowering slower than left marker.	Solenoid valve cartridge in port V3 not opening completely.	Switch cartridge with one in port V4. If problem follows cartridge, replace cartridge.
	Hose pinched or collapsed.	Inspect hose routing. Replace or repair hoses as required.
Left marker lowering slower than right marker.	Solenoid valve cartridge in port V4 not opening completely.	Switch cartridge with one in port V3. If problem follows cartridge, replace cartridge.
	Hose pinched or collapsed.	Inspect hose routing. Replace or repair hoses as required.
Both markers lowering.	Solenoid valve cartridge stuck open. If marker switch is in the left marker position, the right cartridge (V3) is defective. If the marker switch is in the right marker position, the left cartridge (V4) is defective.	Replace solenoid valve cartridge.
Neither marker will lower.	Blown fuse.	Check red light on control console. It should be on if switch is ON. If light is not on, switch to opposite marker position. If light comes on, switch may be defective. Replace switch. Otherwise replace fuse.
	Coils at V3 and V4 not energized.	Poor ground on wire, bad wire connection or damaged wire. Repair as required.
	Adjust marker flow control valve.	See "Machine Operation" for adjustment.
Neither marker will raise.	Adjust marker flow control valve.	See "Machine Operation" for adjustment.
Right marker will not lower.	Solenoid coil in port V3 not energized.	Check switch on control console. Replace if defective. Check coil ground wire. Check for poor connection or damaged wire.
	Solenoid cartridge in port V3 stuck closed.	Switch cartridge with one on planter you know is operating properly. If right marker lowers, replace defective cartridge.
Left marker will not lower.	Solenoid coil in port V4 not energized.	Check switch on control console. Replace if defective. Check coil ground wire. Check for poor connection or damaged wire.
	Solenoid cartridge in port V4 stuck closed.	Switch cartridge with one on planter you know is operating properly. If right marker lowers, replace defective cartridge.
Markers travel too fast and damage row marker stands and/or pivot at rod end of marker cylinders.	Adjust marker flow control valve.	See "Machine Operation" for adjustment.

SEED METER (BRUSH-TYPE)

PROBLEM	POSSIBLE CAUSE	SOLUTION
Low count.	Meter RPM too high.	Reduce planting speed.
	Seed sensor not picking up all seeds dropped.	Clean seed tube. Switch meter to different row. If problem stays in same row, replace sensor.
	Lack of lubrication causing seeds not to release from disc properly.	Use graphite or talc as recommended.
	Seed size too large for seed disc being used.	Switch to smaller seed or appropriate seed disc. See "Brush-Type Seed Meter" for proper seed disc for size of seed being used.
	Seed treatment buildup in meter.	Reduce treatment amount used. Thoroughly mix treatment with seed. Add talc.
Low count at low RPM and higher count at higher RPM.	Foreign material lodged in upper brush.	Remove seed disc and remove foreign material from between brush retainer and bristles. Clean thoroughly.
	Worn upper brush.	Replace. See "Brush-Type Seed Meter Maintenance".
Low count at higher RPM and normal count at low RPM.	Seed disc worn in agitation groove area.	Replace disc. Replace. See "Brush-Type Seed Meter Maintenance".
High count.	Seed size too small for seed disc.	Switch to larger or appropriate seed disc.
	Incorrect seed rate transmission setting.	Reset transmission. Refer to rate charts.
	Upper brush too wide (fanned out) for small seed size.	Replace upper brush.
High count. (Milo/Grain Sorghum)	Incorrect brush retainer being used.	Make sure GD8237 brush retainer is used to keep upper brush from fanning out.
Upper brush laid back.	Seed treatment buildup on brush.	Remove brush. Wash with soap and water. Dry thoroughly before reinstalling.
	Foreign material buildup at base of brush.	Remove brush retainer and brush. Clean thoroughly. Reinstall.

SEED METER (EDGEVAC)

PROBLEM	POSSIBLE CAUSE	SOLUTION
Low seed count.	Meter RPM too high.	Reduce planting rate or planting speed.
	Singulator brush setting too aggressive.	Adjust singulator brush.
	Vacuum level too low.	Increase fan speed.
	Seed sensor not picking up all seeds dropped.	Clean seed tube. Move meter to different row.
	Seeds sticking to seed disc.	Use graphite or talc to aid release.
	Seed treatment buildup in seed disc recesses.	Reduce amount of treatment used and or mix thoroughly. Add talc.
	Seed size too large for disc used.	Use appropriate disc for seed size.
	Wrong transmission setting.	Change transmission to desired rate.
	Wrong seed disc.	Use appropriate disc for seed type and size.
	Drive wheel slippage.	Compensate by adjusting transmission sprockets.
	Low tire pressure.	Adjust tire pressure to correct level.
	Failed/worn drive components.	Inspect and replace parts as required.
	Plugged orifices in seed disc.	Inspect and clean disc. Check cleanout brush. (If Applicable)
	Loss of vacuum at meter.	Check for foreign material between vacuum cover and disc. Inspect parts for wear/damage. Clean or replace as required.
	Seed bridging in hopper.	Add graphite to improve seed flow.
	Faulty vacuum gauge reading.	Repair/replace gauge.
	Dirt in vacuum manifold.	Check vacuum manifold for dirt and clean.
	Seed baffle (If applicable) not allowing seed flow due to bridging of seed.	Mix talc thoroughly to coat all seeds. Remove seed baffle. See Row Unit Operation section.
	60 cell soybean disc not filling properly due to excessive RPM.	Replace with 120 cell soybean disc.
	Seed disc worn.	Replace.
Vacuum cover worn.	Replace.	
Not planting seed.	Seed hoppers empty.	Fill seed hopper.
	Seed tube plugged/damaged.	Clean or replace tube.
	Meter drive damaged.	Repair/replace drive components.
	Low/no vacuum.	Inspect vacuum system and repair as necessary.
	Singulator brush setting too aggressive.	Adjust singulator brush.
	Faulty vacuum gauge.	Repair/replace vacuum gauge.
	Seed bridging in hopper.	Add graphite to improve seed flow.
	Loss of vacuum at meter.	Check for foreign material between vacuum cover and disc. Inspect parts for wear/ damage. Clean and/or replace as required.
	Wrong seed disc.	Use appropriate disc for seed type and size.
	Meter drive clutch not engaged.	Engage drive clutch.
	Fan not running.	Start fan.
	Dirt in vacuum manifold.	Check vacuum manifold for dirt and clean.

SEED METER (EDGEVAC) - Continued

PROBLEM	POSSIBLE CAUSE	SOLUTION
Not planting seed. (Continued)	Seed baffle (If Applicable) not allowing seed flow due to bridging of seed.	Mix talc thoroughly to coat all seeds. Remove seed baffle. Row Unit Operation section.
	60 cell soybean disc not filling properly due to excessive RPM.	Replace with 120 cell soybean disc.
High seed count.	Wrong transmission setting.	Change transmission to desired rate.
	High vacuum.	Adjust vacuum level to appropriate level.
	Wrong seed disc.	Replace seed disc.
	Singulator brush setting not aggressive enough.	Adjust singulator brush.
	Worn singulator brush.	Inspect brush and replace as required.
	Seed leaking past wall brush.	Inspect wall brush condition and installation. Replace as necessary.
	Faulty vacuum gauge.	Check gauge line for dirt/obstruction. Repair/replace vacuum gauge.
Poor seed spacing.	Obstruction in seed tube.	Clean seed tube.
	Dirty/damaged seed disc.	Inspect seed disc for damage, foreign material in orifices or seed treatment buildup in recesses. Clean or replace.
	Wrong vacuum setting.	Adjust vacuum to appropriate level.
	Excess foreign material in seed.	Inspect and clean meter and seed discs. Use clean, undamaged seed.
	Incorrect singulator brush setting.	Adjust singulator brush to appropriate setting.
	Inconsistent driveline.	Inspect drive components for rust, misalignment, worn or damaged parts. Replace/repair as required.
	Toolbar not level or wrong height.	Adjust hitch to level toolbar and row units.
	Planting too fast for conditions.	Reduce speed.
	Rough field conditions.	Reduce speed.
Irregular seed population.	Driving too fast.	Reduce speed.
	Drive wheels slipping.	Reduce speed. Decrease row unit down pressure spring settings.
Unable to achieve desired vacuum level.	Tractor hydraulic flow set too low.	Increase flow to fan motor.
	Incorrect hydraulic connections.	Check all hydraulic connections and hose routings.
	Damaged fan components.	Inspect motor and impeller for wear/damage and repair/replace as necessary.
	Vacuum hose pinched/kinked/blocked.	Inspect air lines for any damage or obstruction. Clean air lines and manifold by removing end cap from manifold and running fan at high speed.
	Vacuum hose loose/disconnected.	Inspect and reattach all air hoses.
	Tractor not producing required hydraulic flow/pressure.	Have tractor serviced by qualified technician.
	Dirt in vacuum gauge line.	Check gauge line for dirt/obstruction and clean.

Continued on next page.

SEED METER (FINGER PICKUP)

PROBLEM	POSSIBLE CAUSE	SOLUTION
One row not planting seed.	Drive release not engaged.	Engage drive release mechanism.
	Foreign material in hopper.	Clean hopper and finger carrier mechanism.
	Seed hopper empty.	Fill seed hopper.
	Row unit drive chain off of sprocket or broken.	Check drive chain.
Unit is skipping.	Foreign material or obstruction in meter.	Clean and inspect.
	Finger holder improperly adjusted.	Adjust to specifications. (22 to 25 in. lbs. rolling torque)
	Broken fingers.	Replace fingers and/or springs as required.
	Planting too slowly.	Increase planting speed to recommended speed range.
Planting too many doubles.	Planting too fast.	Stay within recommended speed range.
	Loose finger holder.	Adjust to specifications. (22 to 25 in. lbs. rolling torque)
	Worn brush in carrier plate.	Inspect and replace if necessary.
Overplanting.	Worn carrier plate.	Inspect and replace if necessary.
	Seed hopper additive being used.	Reduce or eliminate additive or increase graphite.
Underplanting.	Seed belt installed backwards.	Remove and install correctly.
	Weak or broken springs.	Replace.
	Spring not properly installed.	Remove finger holder and correct.
	Seed belt catching or dragging.	Replace belt.
	Brush dislodging seed.	Replace brush.
Irregular or incorrect seed spacing.	Driving too fast.	Check chart for correct speed.
	Wrong tire pressure.	Inflate tires to correct air pressure.
	Drive wheels slipping.	Reduce down pressure on row unit down force springs.
	Wrong sprockets.	Check seed rate charts for correct sprocket combinations.
Seed spacing not as indicated in charts.	Wrong tire pressure.	Inflate tires to correct air pressure.
	Inconsistent seed size.	Perform field check and adjust sprockets.
	Wrong sprockets.	Check chart for correct sprocket combination.
	Charts are approximate.	Slight variations due to wear in meter components and tire slippage due to field conditions may produce seed spacing variations.
	Stiff or worn drive chains.	Replace chains.
Scattering of seeds.	Planting too fast.	Reduce planting speed.
	Seed tube improperly installed.	Check seed tube installation.
	Seed tube worn or damaged.	Replace seed tube.
Seed tubes and/or openers plugging.	Allowing planter to roll backward when lowering.	Lower planter only when tractor is moving forward.
Inconsistent seed depth.	Rough seed bed.	Adjust down pressure springs. Reduce planting speed.
	Partially plugged seed tube.	Inspect and clean.
	Seed tube improperly installed.	Install properly.

SOLENOID VALVE

PROBLEM	POSSIBLE CAUSE	SOLUTION
No solenoids operate.	Low voltage.	Must be connected to 12 volt DC only. Negative ground.
	Blown fuse.	Replace control console fuse with AGC-15 amp.
	Battery connection.	Clean and tighten.
	Wiring harness damaged.	Repair or replace.
One solenoid valve will not operate.	Bad switch.	Replace on control panel.
	Cut wire in harness.	Locate and repair.
	Bad coil.	Replace.
	Poor connection at coil.	Check.
Valve operating when not energized.	Valve stem stuck open.	Replace cartridge.
	O-ring leaking.	Install new O-ring kit.
	Foreign material under poppet.	Remove and clean cartridge.