

**ECONO-FOLD® II PLANTER
PULL TYPE II PLANTER**

**OPERATOR & PARTS
MANUAL**

M0135

Rev. 4/90

This manual is applicable to: Econo-Fold® II
Model: EF
Serial Number : 20140 And On

Pull Type II
Model: PT
Serial Number: 11485 And On

Record the model number and serial number of your planter with date purchased:

Model Number _____

Serial Number _____

Date Purchased _____

PREDELIVERY/DELIVERY CHECK LIST

TO THE DEALER

Preelivery service includes assembly, lubrication, adjustment and test. This service assures that the planter will be delivered to the customer ready for field use.

PREDELIVERY CHECK LIST

After the planter has been completely assembled, use the following check list and inspect the planter. Check off each item as it is found satisfactory or after proper adjustment is made.

- Recheck to be sure row units and optional attachments are properly spaced and assembled.
- Be sure all grease fittings are in place and lubricated.
- Check planter and make sure all working parts are moving freely, bolts are tight and cotter pins are spread.
- Check for oil leaks, proper hydraulic operation and proper chain alignment.
- Inflate tires to specified PSI air pressure. Tighten wheel bolts to specified torque.
- Check to be sure all safety decals are correctly located and legible. Replace if damaged.
- Check to be sure the red reflectors and amber reflectors are correctly located and visible when the planter is in transport position.
- Check to be sure SMV sign is in place.
- Check to be sure flashing warning lights are installed correctly and working properly.
- Paint all parts scratched in shipment or assembly.
- Be sure all safety lockups are on the planter and correctly located.
- Be sure wing locks and drive wheel lockups on Econo-Fold models work properly.

This planter has been thoroughly checked and to the best of my knowledge is ready for delivery to the customer.

(Signature of Set-up Person/Date)

OWNER REGISTER

Name _____

Date Sold _____

Street Address _____

Model _____

City & State _____

Serial Number _____

DELIVERY CHECK LIST

At the time the planter is delivered, the following check list is a reminder of very important information which should be conveyed to the customer. Check off each item as it is fully explained to the customer.

- Advise the customer that the life expectancy of this or any other machine is dependent on regular lubrication as directed in the operator's manual.
- Tell the customer about all safety precautions.
- Along with the customer, check to be sure the red and amber reflectors and SMV sign are clearly visible with the planter in transport position and attached to the tractor. Check to be sure flashing warning lights are in working condition. Tell the customer to check federal, state and local regulations before towing or transporting on a road or highway.
- Give the operator's manual to the customer and explain all operating adjustments.
- Read warranty to customer.
- Complete Warranty And Delivery Report Form.

To the best of my knowledge this machine has been delivered ready for field use and customer has been fully informed as to proper care and operation.

(Signature of Delivery Person/Date)

AFTER DELIVERY CHECK LIST

The following is a list of items we suggest to check during the first season of use of the equipment.

- Check with the customer as to the performance of the planter.
- Review with the customer the importance of proper maintenance and safety precautions.
- Check for parts that may need to be adjusted or replaced.
- Check to be sure all safety decals, SMV sign and reflectors are correctly located and legible. Replace if damaged or missing.
- Check to be sure safety warning lights are working properly.

(Signature of Follow-up Person/Date)

**RETURN TO KINZE IMMEDIATELY, along with Warranty And Delivery Report.
Retain photocopy of this form at dealership for After Delivery Check.**

TABLE OF CONTENTS

TO THE OWNER.....	1-1
WARRANT.....	1-2
INTRODUCTION	
General Information.....	2-1
Serial Number.....	2-1
SAFETY PRECAUTIONS.....	3-1/3-2
SAFETY WARNING SIGNS	
Econo-Fold II	4-1 and 4-3
Pull Type II	4-2 and 4-3
OPERATION	
Initial Preparation Of The Planter.....	5-1
Tractor Preparation And Hookup.....	5-1
Leveling The Planter.....	5-1
Tire Pressure	5-1
Transmission Adjustment.....	5-2
Contact Drive Wheel Adjustment	5-2/5-3
Shear Pin Protection.....	5-3/5-4
Hydraulic Operation	5-4
Marker Speed Adjustment.....	5-5
Marker Adjustment.....	5-6
Transporting The Planter.....	5-7
Folding The Planter Wings (Econo-Fold Models)	5-7/5-9
Tractor Speed.....	5-9
Field Test.....	5-9
Point Row Wrap Spring Clutch (Econo-Fold Models)	5-10
Fertilizer Opener	5-10
Dry Fertilizer Attachment	5-11/5-14
Liquid Fertilizer Attachment	5-14/5-15
General Planting Rate Information.....	5-16
Checking Seed Population.....	5-16A/5-16B
Checking Granular Chemical Application Rate	5-16B
Planting And Application Rate Charts.....	5-17/5-27
LUBRICATION	
Sealed Bearings.....	6-1
Drive Chains.....	6-1
Wheel Bearings.....	6-1
Lubrication Locations	6-2/6-5

TABLE OF CONTENTS (Continued)

MAINTENANCE

Mounting Bolts And Hardware.....	7-1
Torque Values Chart.....	7-1
Chain Tension Adjustment.....	7-2/7-3
Chain Routing	
Drive Wheel Drive Chain	5-3
Reverser Plate Drive Chain	7-2
Standard Row Unit Transmission	5-2
Push Unit Transmission	5-2
Dry Fertilizer Transmission	7-2
Liquid Fertilizer Squeeze Pump Drive	7-2
Sequencing Valve Inspection.....	7-3
Marker Flow Control Valve Inspection	7-3
Marker Bearing Lubrication Or Replacement.....	7-4
Wheel Bearing Lubrication Or Replacement.....	7-4
Point Row Wrap Spring Clutch	
Inspection (Econo-Fold Models)	7-4A/7-4B
Preparation For Storage.....	7-5
PARTS LIST INDEX	P1
PARTS SECTION NUMERICAL INDEX	a

TO THE OWNER

Kinze Manufacturing, Inc. would like to thank you for your patronage. We appreciate your confidence in KINZE farm machinery. Your KINZE planter has been carefully designed and sturdily built to provide dependable operation in return for your investment.

This manual has been prepared to aid you in the operation and maintenance of the planter and should be considered a permanent part of the machine and should remain with the machine when you sell it.

It is the responsibility of the user to read and understand the Operator's Manual in regards to safety, operation, lubrication and maintenance before operation of this equipment. It is the user's responsibility to inspect and service the machine routinely as directed in the Operator's Manual. We have attempted to cover all areas of safety, operation, lubrication and maintenance; however, there may be times when special care must be taken to fit your conditions.

Throughout this manual the symbol  and the words, NOTE, CAUTION, WARNING and DANGER are used to call your attention to important safety information. The definition of each of these terms used follows:

NOTE: Indicates a special point of information.

CAUTION: Indicates that a failure to observe can cause damage to the machine or equipment.

 **WARNING:** Indicates that a failure to observe can cause damage to the machine or equipment and/or personal injury.

 **DANGER:** Indicates that a failure to observe can cause most serious damage to the machine or equipment and/or most serious personal injury.

 **WARNING:** Some photos in this manual may show safety covers, shields or lockups removed for visual clarity. **NEVER OPERATE** the machine without all safety covers, shields and lockups in place.

NOTE: Some photos in this manual may have been taken of prototype machines. Production machines may vary in appearance.

NOTE: Some photos and illustrations in this manual show optional attachments installed. Contact your KINZE Dealer for purchase of optional attachments.

This manual is applicable to: Econo-Fold II Planter
 Model Number EF, Serial Number 20140 and on

 Pull Type II Planter
 Model Number PT, Serial Number 11485 and on

Record the model number and serial number of your planter with date purchased:

Model Number _____

Serial Number _____

Date Purchased _____

WARRANTY

The KINZE Limited Warranty for your new machine is stated on the back of the retail purchaser's copy of the Warranty And Delivery Report form.

Warranty, within the warranty period, is provided as part of KINZE's support program for registered KINZE products which have been operated and maintained as described in this manual. Evidence of equipment abuse or modification beyond original factory specifications will void the warranty. Normal maintenance, service and repair is not covered by KINZE warranty.

To register your KINZE product for warranty, a Warranty And Delivery Report form must be completed by the KINZE Dealer and signed by the retail purchaser, with copies to the Dealer, to the retail purchaser and to KINZE. Registration must be completed and sent to KINZE within 30 days of delivery of the KINZE product to the retail purchaser. KINZE reserves the right to refuse warranty on serial numbered products which have not been properly registered.

Additional copies of the Limited Warranty can be obtained through your KINZE Dealer.

If service or replacement of failed parts which are covered by the Limited Warranty are required, it is the user's responsibility to deliver the machine along with the retail purchaser's copy of the Warranty And Delivery Report to the KINZE Dealer for service. Kinze warranty does not include cost of travel time, mileage, hauling or labor. Any prior arrangement made between the Dealer and the retail purchaser in which the Dealer agrees to absorb all or part of this expense should be considered a courtesy to the retail purchaser.

KINZE warranty does not include cost of travel time, mileage, hauling or labor.

INTRODUCTION

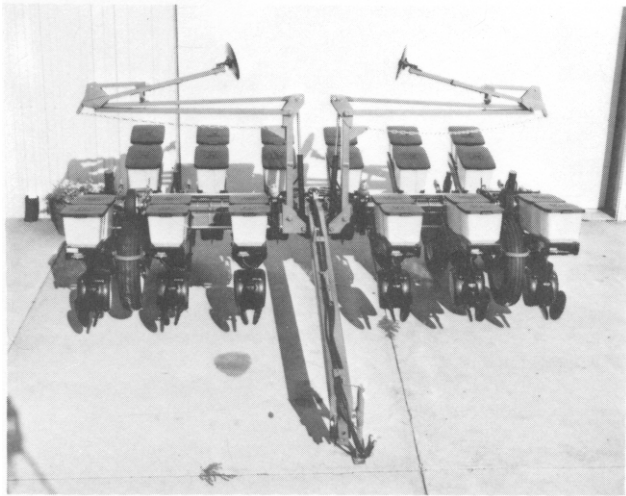

The Econo-Fold II planter is available with a choice of 8 row narrow or wide and 12 row narrow row spacings.

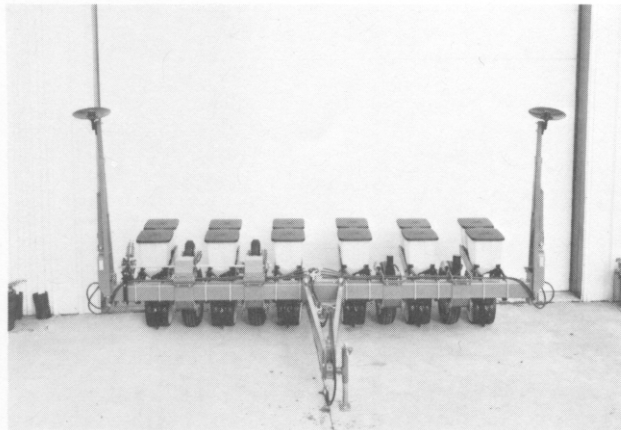

The Pull Type II planter is available with a choice of 2, 4, 6 and 8 row models with narrow or wide row spacings. A double frame package option, liquid or dry fertilizer application equipment, quick-fill auger for dry fertilizer and push row units are also available.

For information on installation of heavy duty coulters and row units refer to the Kinze Row Unit Manual.

GENERAL INFORMATION

The information and photos used in this manual were current at the time of printing. However, due to Kinze's continual attempt to improve its product, production changes may cause your machine to appear slightly different in detail. Kinze Manufacturing reserves the right to change specifications or design without notice and without incurring obligation to install the same on machines previously manufactured.

Right hand or left hand as used throughout this manual is determined by facing in the direction the machine will travel when in use, unless otherwise stated.

SERIAL NUMBER

The serial number provides important information about your planter and may be required to obtain the correct replacement part.

The serial number plate is located on the planter frame to be readily available. It is suggested that the serial number and purchase date also be recorded in the space provided on the inside front cover of this manual. Always provide the serial number and model number to your Kinze dealer when ordering parts or anytime correspondence is made with Kinze Manufacturing.

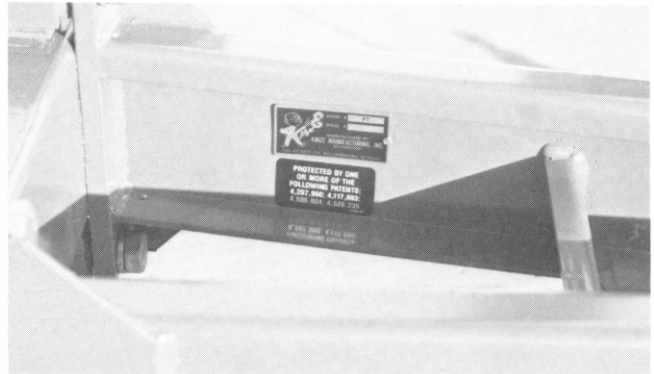

Pull Type II

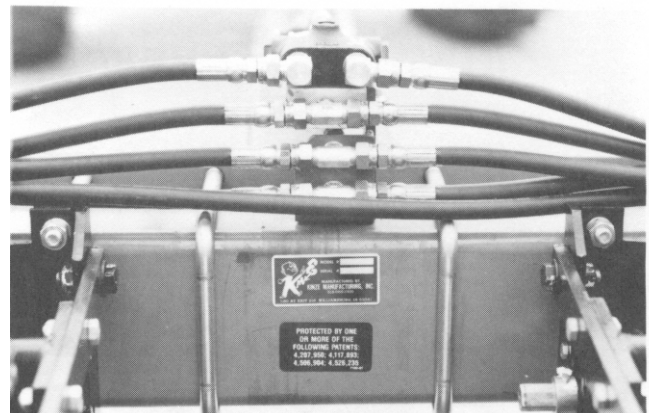

Econo-Fold II

SAFETY PRECAUTIONS

Safe and careful operation of the tractor and planter at all times will contribute significantly to the prevention of accidents. Since a large portion of farm accidents occur as a result of fatigue or carelessness, safety practices should be of the utmost concern. Read and understand the instructions provided in this manual as well as those provided in your Kinze Row Unit Manual. Listed below are a few other safety suggestions that should become common practice.

- Never permit any persons other than the operator to ride on the tractor.
- Never ride on the planter frame or allow others to do so.
- Make sure there are no persons near the planter when markers are in operation.
- Make necessary safety preparations prior to transporting the machine on public roads. This includes installing Slow Moving Vehicle (SMV) emblem and use of adequate lights or safety warnings after dark.
- Observe legal prohibitions and regulations when transporting this machine on public roads.
- Limit towing speeds to 15 MPH. Tow only with farm tractor of at least 50 H.P. size.
- Watch for obstructions such as wires, tree limbs, etc., when folding markers.

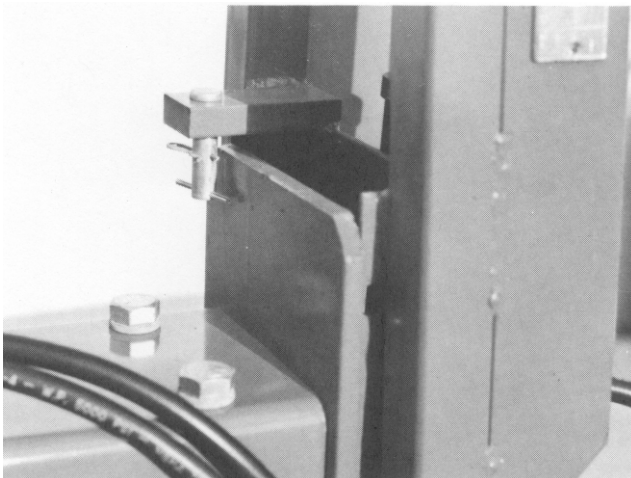

Conventional Marker Lockup

- Always install marker lockup/safety pins before transporting or parking any planter equipped with conventional markers.

- Lower the planter when not in use and cycle the hydraulic control lever to relieve pressure in cylinders and hoses.



Lift Cylinder Lockup Bracket

- Always install all cylinder lockup brackets before towing the planter or working under the unit.

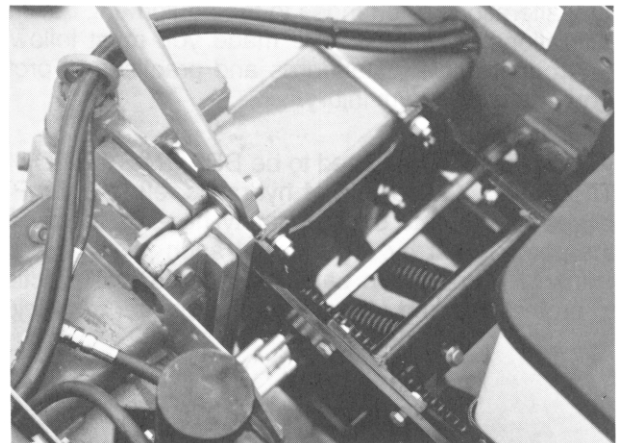

Wing Locking Bolt

- Always secure wing locking bolts before operating the planter. (Econo-Fold Models Only)
- Avoid standing between the wing and main frame when folding the planter. Wing may swing suddenly. (Econo-Fold Models Only)

SAFETY PRECAUTIONS



Wing Safety Latches and Pin

- Always make sure wings are secured with safety latches and pins before towing planter. (Econo-Fold Models Only)
- This machine has been designed and built with your safety in mind. Any alteration to the design or construction may create safety hazards. Do not make any alterations or changes to the equipment, but if any alterations or changes are made you must follow all appropriate safety standards and practices to protect you and others from injury.
- This planter is designed to be **DRIVEN BY GROUND TIRES ONLY**. The use of hydraulic, electric, or PTO drives may create serious safety hazards to you and the people near by. If you install such drives you must follow all appropriate safety standards and practices to protect you and others near this planter from injury.

SAFETY WARNING SIGNS

The “WARNING” signs illustrated on these pages are placed on the machine to warn of hazards. The warnings found on these signs are for your personal safety and those around you. **OBSERVE THESE WARNINGS!**

- Keep these signs clean so they can be readily observed. Wash with soap and water or cleaning solution as required.
- Replace “WARNING” signs should they become damaged, painted over or if they are missing.
- Check SMV sign periodically. Replace if it shows loss of any of its reflective property.
- When replacing decals, clean the machine surface thoroughly using soap and water or cleaning solution to remove all dirt and grease.

SAFETY WARNING SIGNS

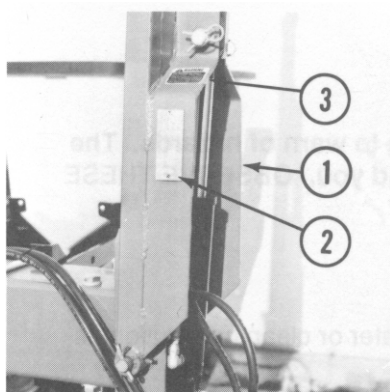

Pull Type Planter

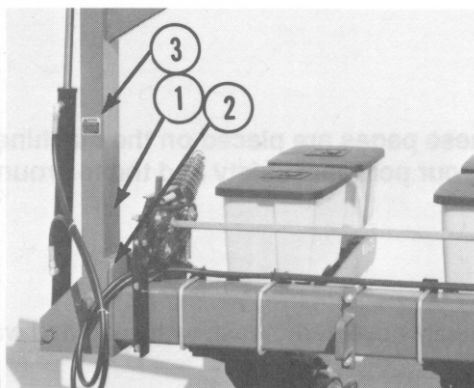

Econo-Fold Planter

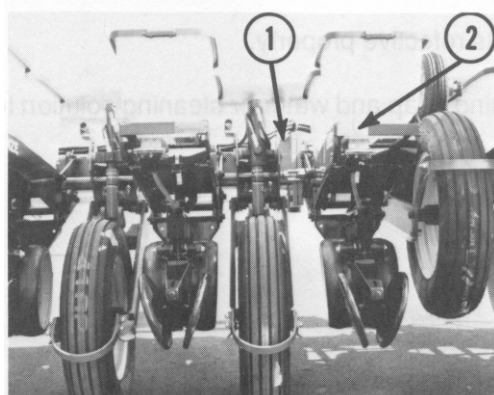
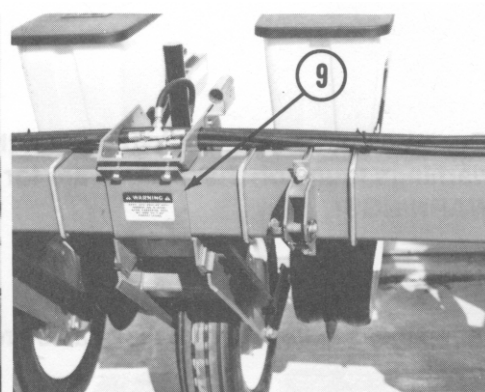

Econo-Fold Planter Only

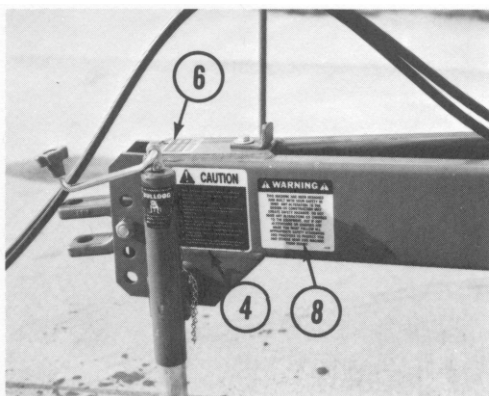
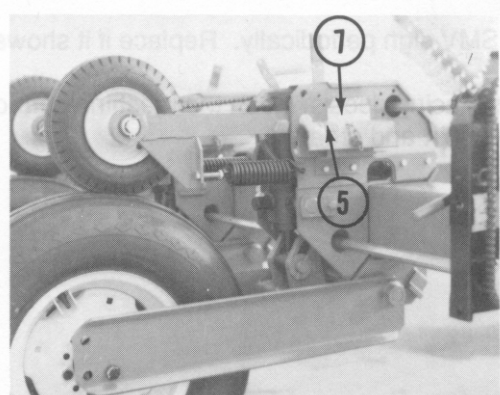

Pull Type Planter

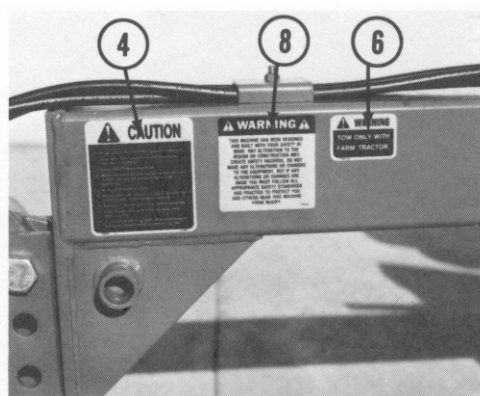

Econo-Fold Planter

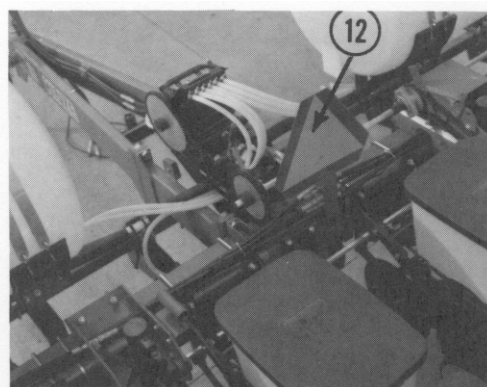
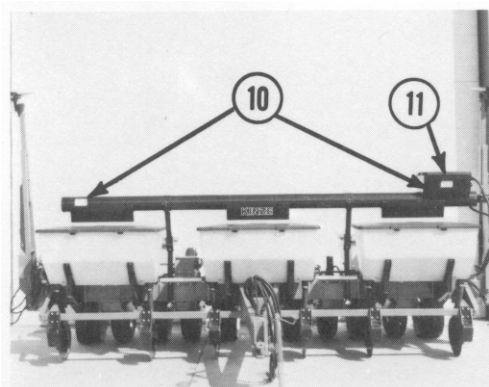

Pull Type Planter Shown

SAFETY WARNING SIGNS

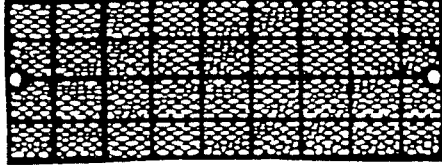

1. Part No. 7200-03 Red Reflector
Pull Type Qty. 2/Econo-Fold Qty. 4
2. Part No. 7200-04 Amber Reflector
Pull Type Qty. 2/Econo-Fold Qty. 4



3. Part No. 7100-42



4. Part No. 7100-46

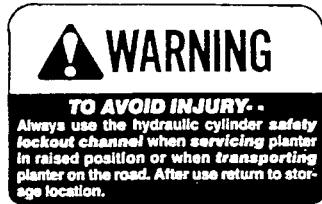

5. Part No. 7100-47



6. Part No. 7100-56



7. Part No. 7100-89



8. Part No. 7100-90



9. Part No. 7100-71
Econo-Fold Only

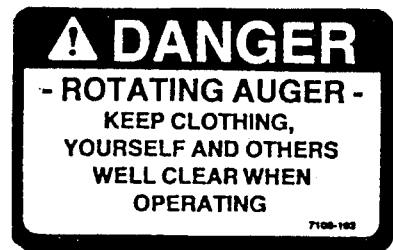

10. Part No. 7100-103
Dry Fertilizer Quick Fill

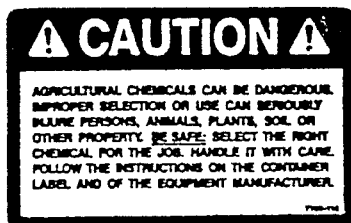

11. Part No. 7100-115
Located on under side of dry fertilizer quick fill hopper lid.

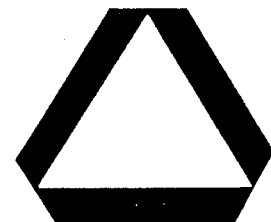

12. Part No. D2199
SMV Emblem

OPERATION

The following information is general in nature and was written to aid the operator in preparation of the tractor and planter for use, and to provide general operating procedures. The operator's experience, familiarity with the machine and the following information should combine for efficient planter operation and good working habits. The operator's manual for the row units used with your Kinze planter should also be readily available and consulted for planter operation.

INITIAL PREPARATION OF THE PLANTER

Lubricate the planter and row units per the lubrication information in this manual and the Row Unit Operator's Manual. Make sure all tires have been properly inflated. Check all drive chains for proper tension and lubrication.

TRACTOR PREPARATION AND HOOKUP

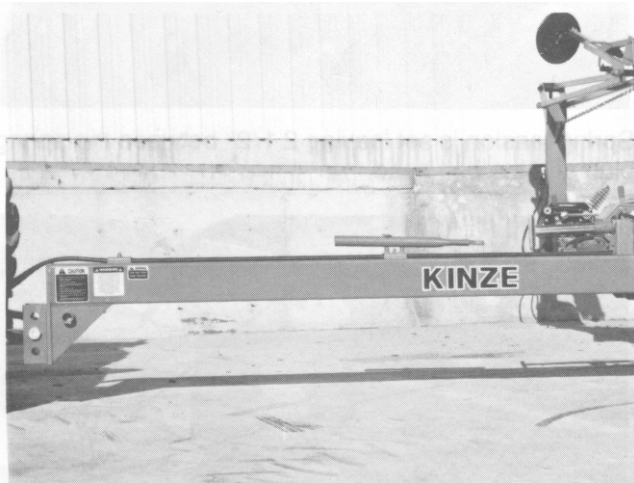

1. Adjust tractor drawbar so that it is 13 to 17 inches above the ground. Then adjust the drawbar so that the hitch pin hole is directly below the center line of the tractor PTO shaft. Make sure the drawbar is in a stationary position.
2. Back tractor to planter and connect with hitch pin. Make sure hitch pin is secured with locking pin or cotter pin.
3. Connect hydraulic hoses to tractor ports in a sequence which is both familiar and comfortable to the operator.

⚠ WARNING: Before applying pressure to the hydraulic system, make sure all connections are tight and that hoses and fittings have not been damaged. Hydraulic fluid escaping under pressure can have sufficient force to penetrate skin, causing injury or infection.

IMPORTANT: Always wipe hose ends to remove any dirt before connecting couplers to tractor ports.

4. Raise jack stand and remount horizontally on storage bracket.
5. Lower planter to the planting position and check fore and aft levelness. (See "Leveling The Planter.")

LEVELING THE PLANTER

For proper operation of the planter and row units, it is important that the unit operates level.

Unless the tractor drawbar is adjustable for height, the fore and aft level adjustment must be maintained by the position of the hitch clevis. Holes in the hitch bracket allow the clevis to be raised or lowered. When installing clevis mounting bolt, tighten hex nut to proper torque setting.

Always check fore and aft levelness with the planter lowered to the proper operating depth. If the planter is equipped with push units be sure the parallel arms on the push units and the standard units are operating at the same angle. When the push units are locked up and not being used, adjust the hitch slightly higher in the front to give the push units more ground clearance. If the planter is equipped with the optional double frame, the fore and aft levelness can be checked by measuring the height of both the front and back tool bars.

In order to maintain lateral levelness, it is important that tire pressure be maintained at pressures specified.

TIRE PRESSURE

Tire pressure should be checked regularly and maintained as follows:

Transport/Ground Drive 7.50 x 20	40 PSI
Transport/Ground Drive 7.60 x 15	40 PSI
Contact Drive 4.10 x 6	60 PSI

IMPORTANT: Tire pressure must be correctly maintained in all transport/ground drive tires to ensure levelness and proper operation of planter.

OPERATION

TRANSMISSION ADJUSTMENT

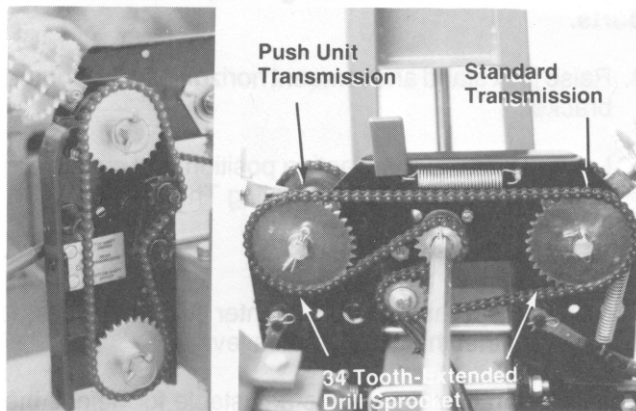

Planting population rate changes are made at the end mounted transmissions. There are two transmissions on Econo-Fold planters and one transmission on Pull Type planters.

The transmission is designed to allow simple, rapid changes in sprockets to obtain the desired planting population. By removing the lynch pins on the hexagon shafts, sprockets can be interchanged with those from the sprocket storage rod bolted to the transmission case.

Chain tension is controlled by a spring-loaded dual-sprocket idler. The idler assembly is adjusted with a ratchet arm located to the inside of the transmission. This arm has a release position to remove spring tension for replacing sprockets. The amount of spring tension on the chain can be controlled by the ratchet arm.

The planting rate charts found in the Operation Section of this manual will aid you in selecting the correct sprocket combinations.

NOTE: Replacing the 17 tooth drive sprocket, located on the inner side of the top transmission shaft, with the extended drill sprocket (34 tooth 2:1 ratio/50 tooth 3:1 ratio) will reduce the planter transmission speed and reduce planting rates by 1/2 or 1/3 depending on the sprocket used.

IMPORTANT: After each sprocket combination adjustment, make field check to be sure you are planting at the desired rate.

CONTACT DRIVE WHEEL ADJUSTMENTS

There are two down pressure springs on each contact drive wheel. The down pressure is factory preset and should need no further adjustment.

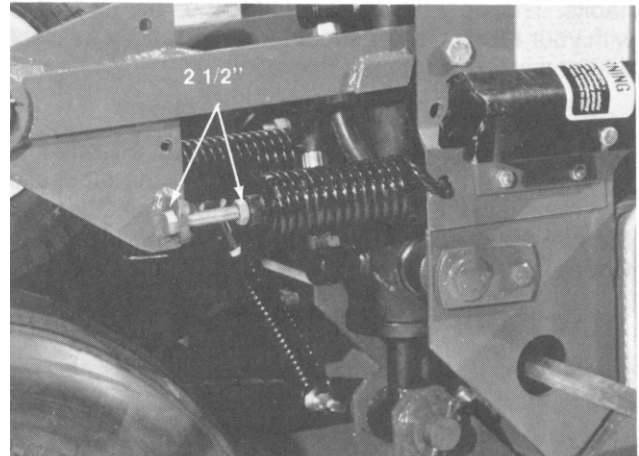

Spring tension is set leaving 2 1/2" between the spring plug and the bolt head.

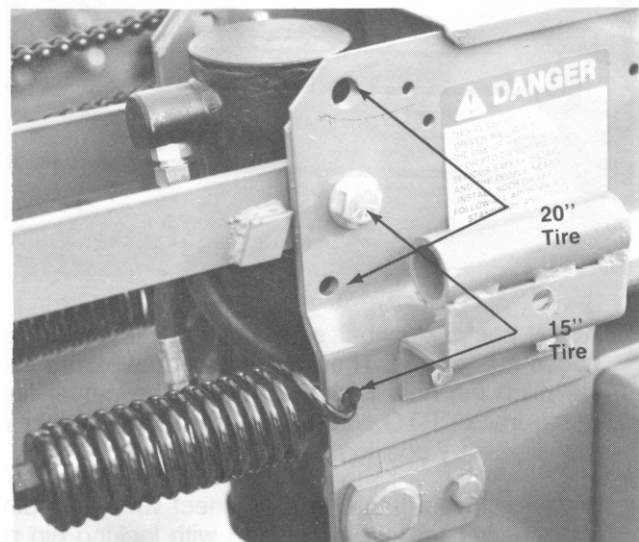

On planters equipped with 15" drive tires, the contact drive wheel arms and down pressure springs are attached to the wheel module mount using the lower set of mounting holes. On planters equipped with 20" drive tires, the contact drive wheel arms and down pressure springs are attached to the wheel module mount using the upper set of mounting holes.

15" tires are mounted using the lower forward holes in the ground drive-wheel arm. 20" tires are mounted using the upper holes in the ground drive-wheel arm.

For ridge planting to raise the bar height 3", mount the 20" tires in the lower rear holes in the ground drive-wheel arm. Mount the contact drive wheel arm and springs in the lower set of mounting holes in the wheel module mount and raise the hitch height.

OPERATION

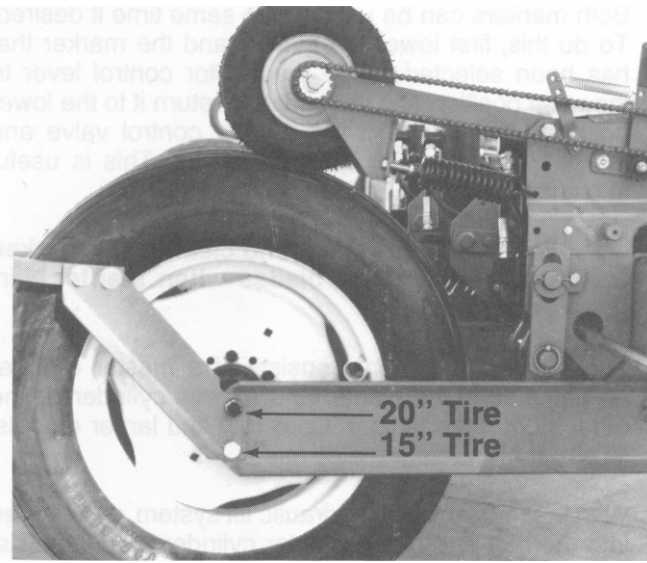

Due to the closer clearance between the wheel assembly and the drive tire when a planter is equipped with the 20" drive tire, a tire scraper should always be used. This will prevent a buildup of dirt/mud between the wheel arm assembly and the tire. Adjust the scraper so it does not contact the tire.

SHEAR PIN PROTECTION

The planter drive line is protected with a shear pin on each transmission and each drive wheel. If the seed meters on the row units fail to operate, check the shear pins.

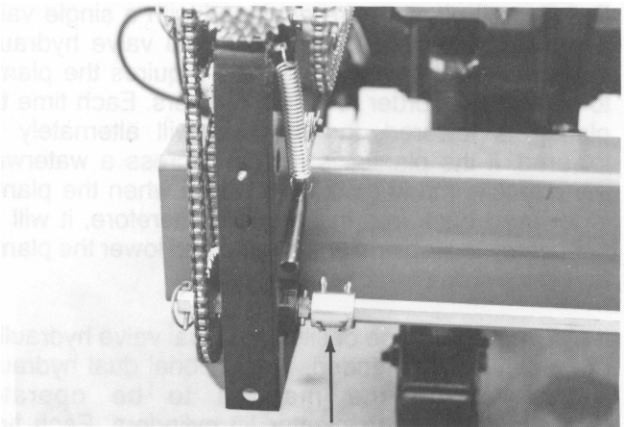
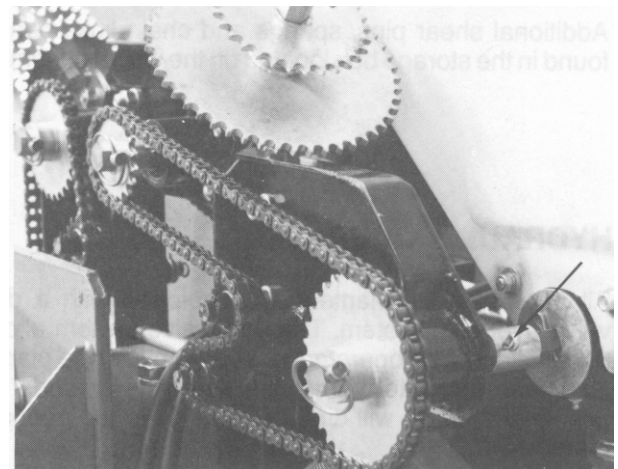
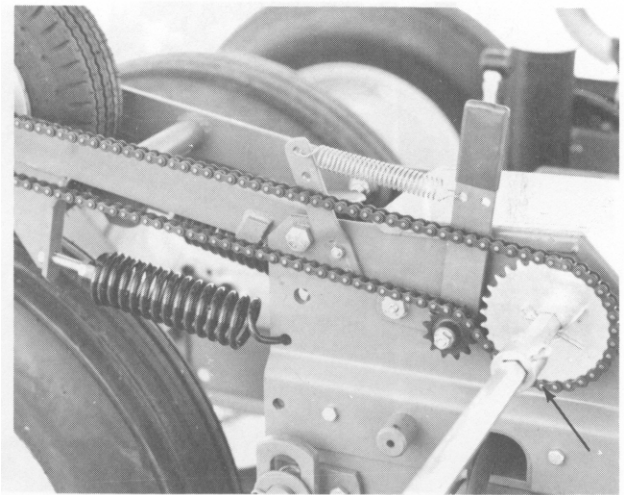
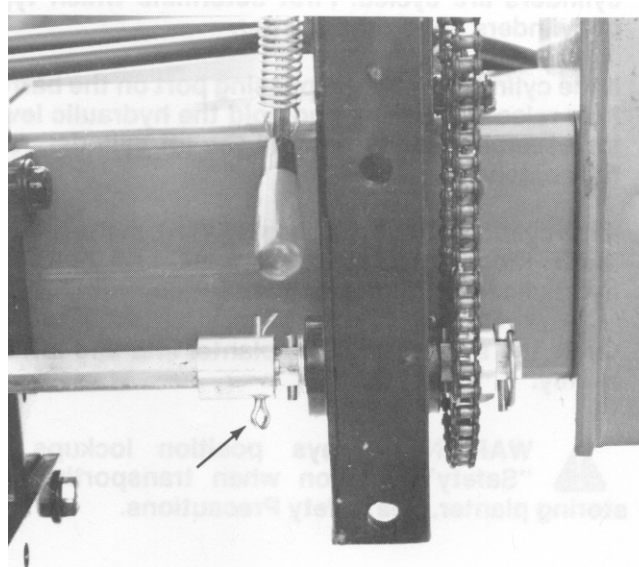

If excessive load should cause a pin to shear, it is important to determine where binding has occurred before replacing the pin. Turn the shaft by hand, checking for misalignment and for the possibility of seized parts. When the shaft can be turned by hand (with the aid of a wrench) replace the pin with one of identical size.

To prevent future binding or breakage of components, follow prescribed lubrication schedules.

OPERATION

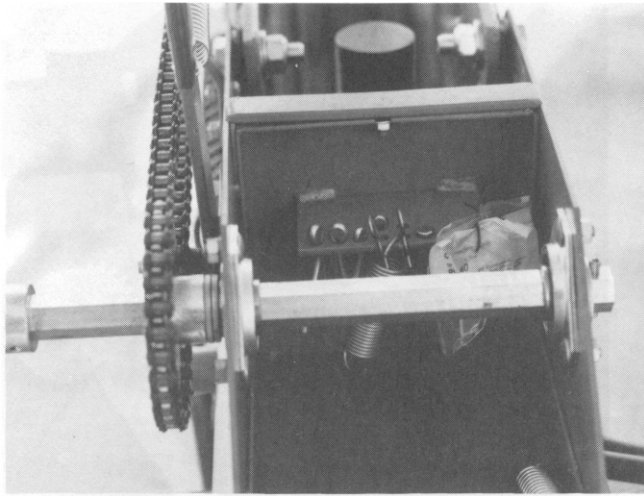

Additional shear pins, springs and chain links can be found in the storage box located on the wheel assembly.

HYDRAULIC OPERATION

All Econo-Fold II planters are equipped with a dual valve hydraulic system. The dual valve system allows the markers to be operated independently of the planter lift cylinders. Each time a marker is raised, the sequencing valve will direct flow to lower the opposite marker.

Pull Type II planters are equipped with a single valve hydraulic system or an optional dual valve hydraulic system. The single valve system requires the planter to be raised in order to lift the markers. Each time the planter is lowered, the markers will alternately be lowered. If the planter is raised to cross a waterway, the opposite marker will be lowered when the planter is lowered back into the ground. Therefore, it will be necessary to stop and again raise and lower the planter to restore correct marker operation.

If planting in this type of situation, dual valve hydraulics are highly recommended. The optional dual hydraulic system allows the markers to be operated independently of the planter lift cylinders. Each time a marker is raised, the sequencing valve will direct flow to lower the opposite marker.

Both markers can be used at the same time if desired. To do this, first lower the planter and the marker that has been selected. Move the tractor control lever to the raise position and immediately return it to the lower position. This will shift the marker control valve and the remaining marker will be lowered. This is useful in planting contours and terraces.

⚠ WARNING: Always stand clear of the marker assemblies and blades when planter is in operation.

The planter lift system consists of a master cylinder on one side of the planter and a slave cylinder on the other side of the planter. On 6 row and larger models, lift assist cylinders are also used.

With the master/slave hydraulic lift system, oil is forced into the butt end of the master cylinder (and lift assist cylinders on applicable models) when the hydraulic lever on the tractor is moved to the raise position. As the master cylinder is extended, oil from the rod end of the master cylinder is forced into the butt end of the slave cylinder. The displacement on the rod end of the master cylinder is equal to the displacement on the butt end of the slave cylinder. This causes the two cylinders to move at the same rate so that the planter will raise and lower evenly.

IMPORTANT: The planter lift cylinders may get out of phase and the planter will lift unevenly. On each master cylinder and each slave cylinder a port, located on the barrel on the rod end of the cylinder, or a valve, located in the piston in the cylinder, allows the lift system to be rephased with the cylinders are cycled. First determine which type of cylinders are on the planter.

If the cylinders have a rephasing port on the barrel, fully raise the planter and hold the hydraulic lever for several seconds until all the lift cylinders are fully extended.

If the cylinders have a rephasing valve in the piston, lower the planter to the ground and hold the hydraulic lever for 5 seconds.

Cycle the system until the planter lifts and lowers evenly.

⚠ WARNING: Always position lockups in "Safety" position when transporting or storing planter. See Safety Precautions.

OPERATION

MARKER SPEED ADJUSTMENT

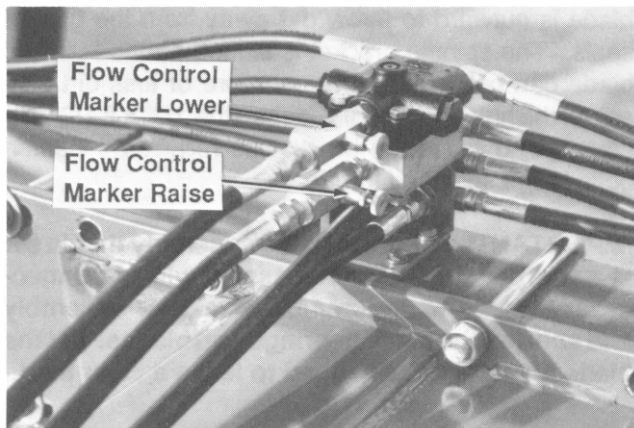

ECONO-FOLD II

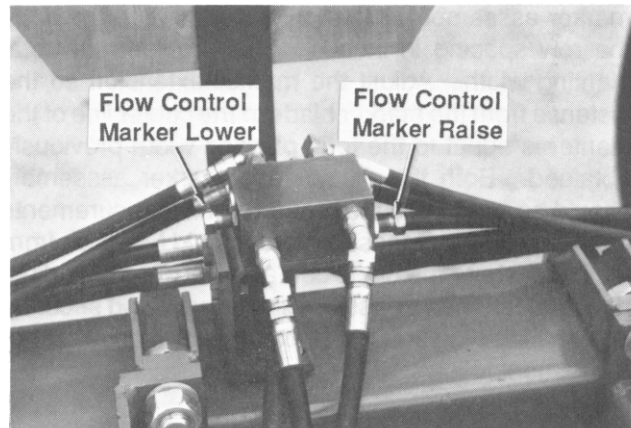

PULL TYPE II

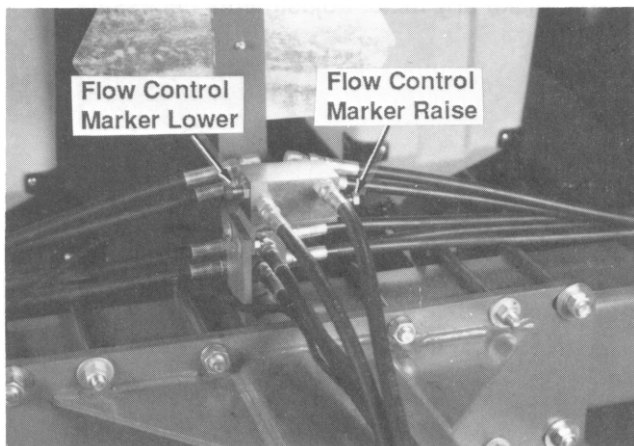

ECONO-FOLD II

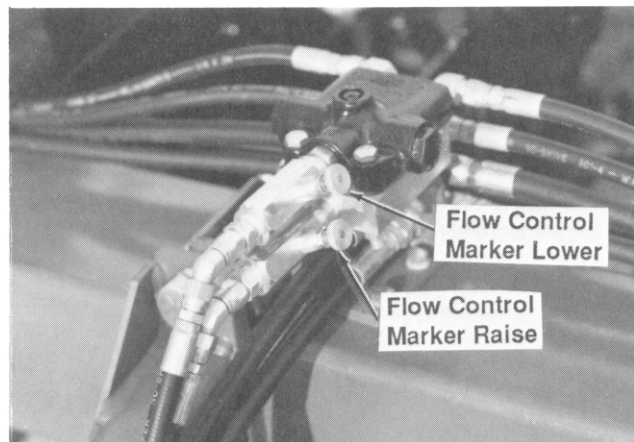

PULL TYPE II

The marker hydraulic system has two flow control valves. One flow control valve controls the lowering speed of both markers and one controls the raising speed of both markers. To adjust marker speed, loosen the jam nut and turn the control clockwise or "in" to slow the travel speed and counterclockwise or "out" to increase the travel speed. The adjusting bolt determines the amount of oil flow restriction through the valve, therefore determining travel speed of the markers.

⚠ DANGER: The flow controls should be properly adjusted before the marker assembly is first put into use. Excessive travel speed of the markers can be dangerous and/or damage the marker assembly.

NOTE: When oil is cold, hydraulics operate slowly. Make sure all adjustments are made with warm oil. Do not overtighten lock nut.

NOTE: On a tractor where the oil flow can not be controlled, the rate of flow of oil from the tractor may be greater than the rate at which the marker cylinder can accept it. The tractor hydraulic control lever will have to be held until the cylinder reaches the end of its stroke. This occurs most often on tractors with the open center hydraulic system.

On tractors with the closed center hydraulic system, the tractor's hydraulic flow control can be set so the tractor's detent will function properly.

OPERATION

MARKER ADJUSTMENT

To determine the correct length at which to set the marker assemblies, multiply the number of rows by the row spacing in inches. This provides the total planting width. Adjust the marker extension so the distance from the marker blade to the center line of the planter is equal to the total planting width previously obtained. Both the planter and marker assembly should be lowered to the ground when measurements are being taken. Measurement should be taken from the point where the blade contacts the ground. Adjust right and left marker assemblies equally and securely tighten clamping bolts. An example of marker length adjustment follows:

Number Of Rows	X	Row Spacing (Inches)	=	Dimension between planter center line and marker blade.
-------------------	---	-------------------------	---	--

8 X 30" = 240" Marker Dimension

The marker blade is installed so the concave side of the blade is outward to throw dirt away from the grease seals. The spindle bracket is slotted so the hub and blade can be angled to throw more or less dirt. To adjust the hub and spindle, loosen the 1/2" x 3 1/2" cap screws and move the bracket as required. Tighten bolts to the specified torque.

IMPORTANT: A marker blade assembly that is set at a sharper angle than necessary will add unnecessary stress to the complete marker assembly and shorten the life of bearings and blades. Set the blade angle only as needed to leave a clear mark.

We recommend a field test be made to ensure the markers are properly adjusted. After the field test is made, make any minor adjustments necessary.



OPERATION

TRANSPORTING THE PLANTER

⚠ WARNING: Always make necessary safety preparations prior to transporting the planter on public roads. This includes installing a Slow Moving Vehicle (SMV) emblem and use of adequate lights or safety warning.

Always install cylinder lockup bracket on lift cylinders and make sure wings are latched before towing planter.

FOLDING THE PLANTER WINGS (ECONO-FOLD MODELS)

NOTE: The 8 row 30 and 8 row wide planters are equipped with a triple folding marker in which the 3rd stage must be folded manually before the wings are folded for transport. The 12 row 30 planter is equipped with a triple folding marker in which chain tension automatically folds the third stage of the marker assembly.

⚠ DANGER: The 3rd stage of the 8 row Econo-Fold marker must be folded manually for transport or the markers will extend beyond the planter frame.

WARNING: Avoid standing between the wing and main frame when folding the planter. Wing may swing suddenly.

The Econo-Fold planter is equipped with hinged wings that fold manually to obtain a narrower width for transporting the planter.

NOTE: The 12 row planter is equipped with one drive wheel assembly on each wing which must be locked up prior to folding the planter wings. While the planter is in the lowered planting position, remove the lynch pin which secures the wheel lockup bar in the storage position. Swing the lockup bar down onto the wheel arm tab. Install lynch pin.

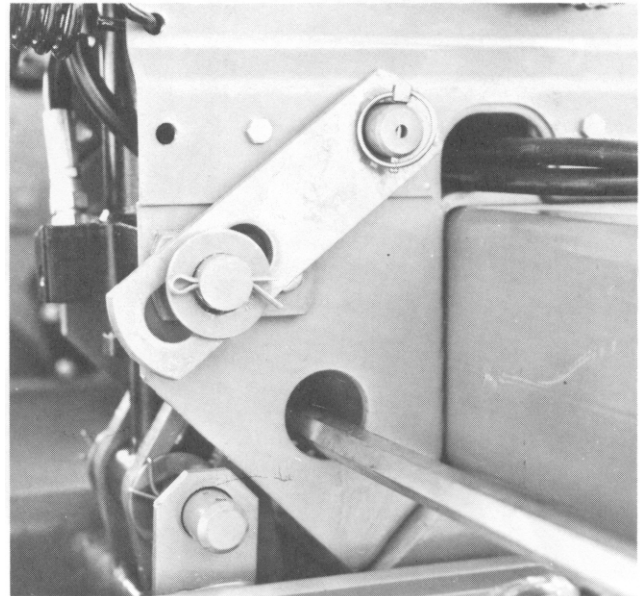

Storage Position

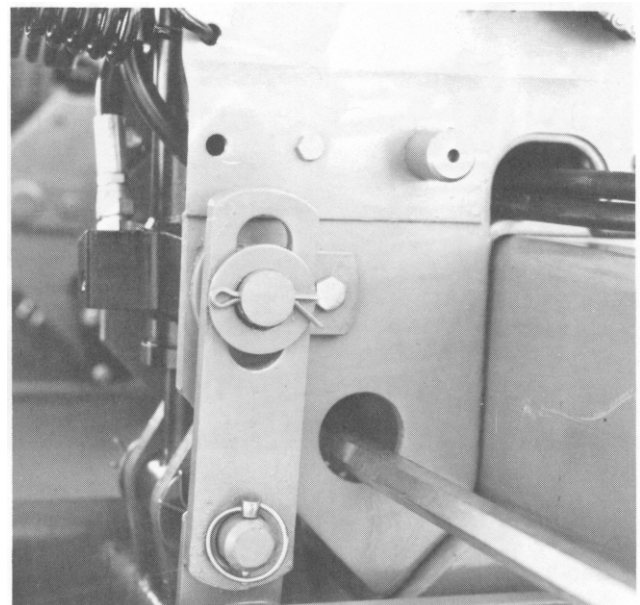

Locked Position

OPERATION

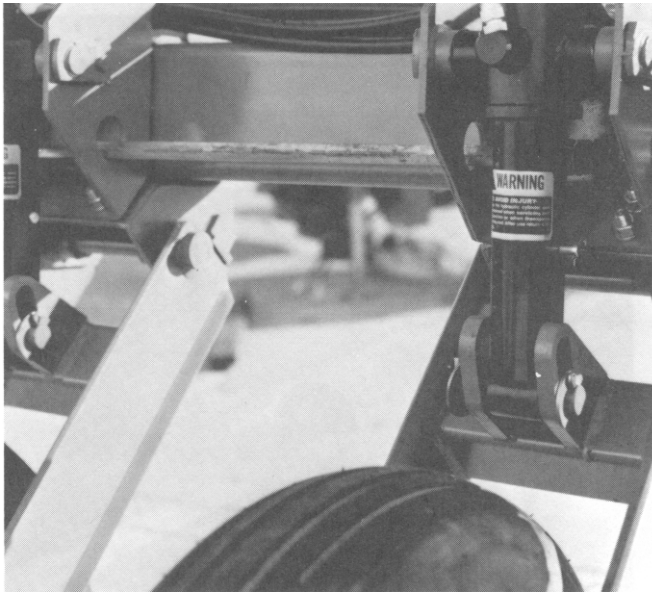

To fold the wing for transport, raise planter completely and install cylinder lockups.

NOTE: Remove the wing latch safety pin from the safety latch.

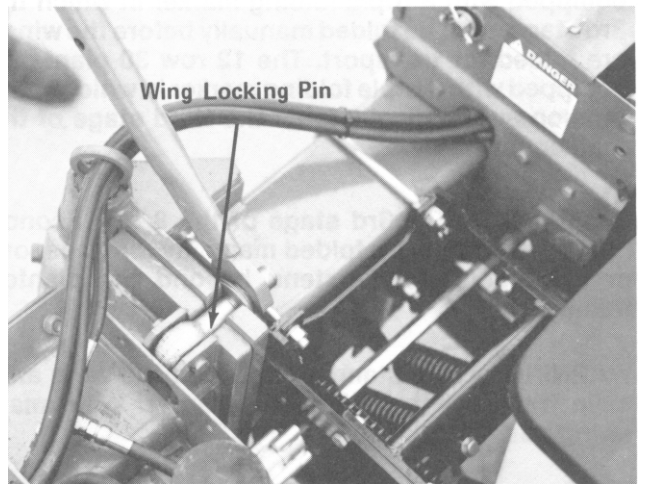
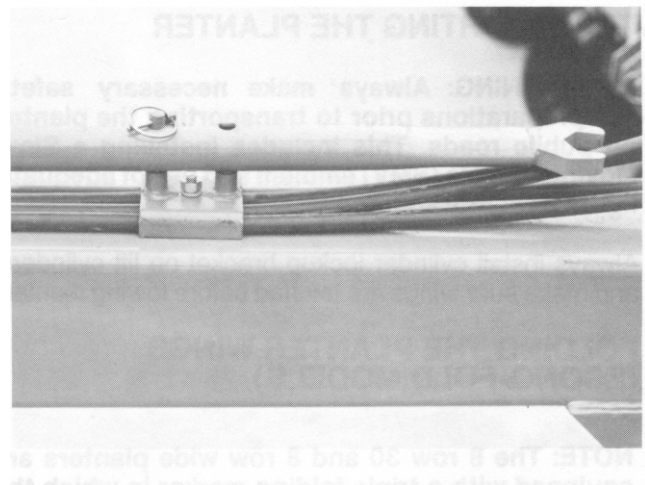

Using the special wrench which is stored on the hitch of the planter, loosen the 1 1/4" hex nut which secures the wing locking pin. Swing the wing locking pin over to release the wing of the planter. Swing the wing forward until the wing latches come together. Reinstall wing latch safety pin in safety latch. Secure with lynch pin.

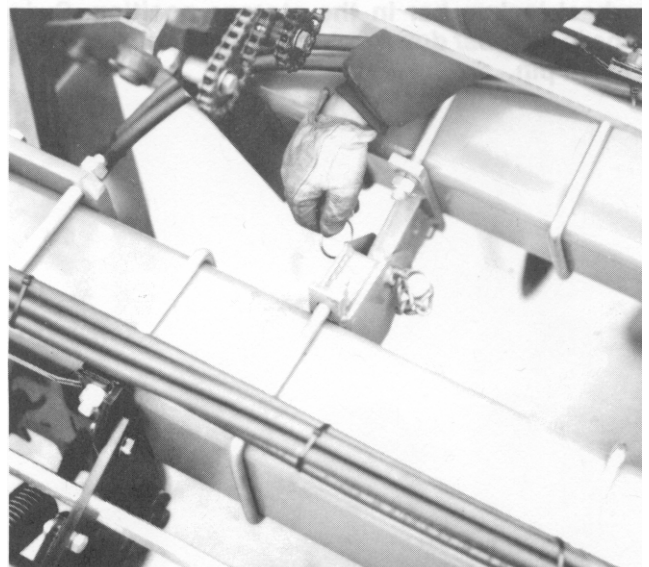
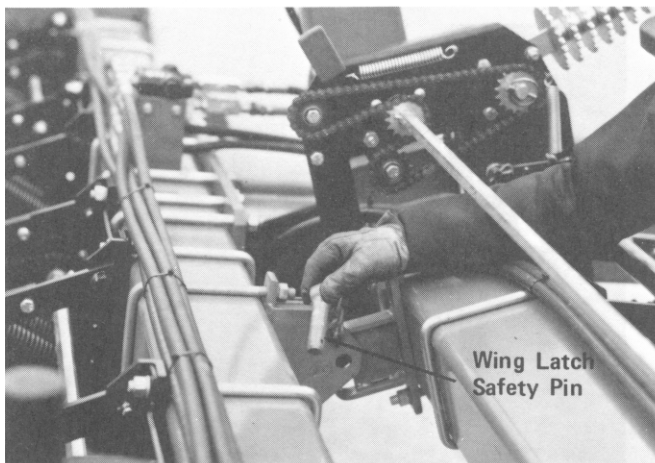

OPERATION

Fold other wing in the same manner.



To fold the wing into planting position, remove safety pin in wing latch and swing the wing into position. Put the wing lockup pin in its slot in the wing plate. Using the special wrench, tighten the 1 1/4" hex nut on the wing locking pin to secure the wing in planting position.

Fold other wing in the same manner.

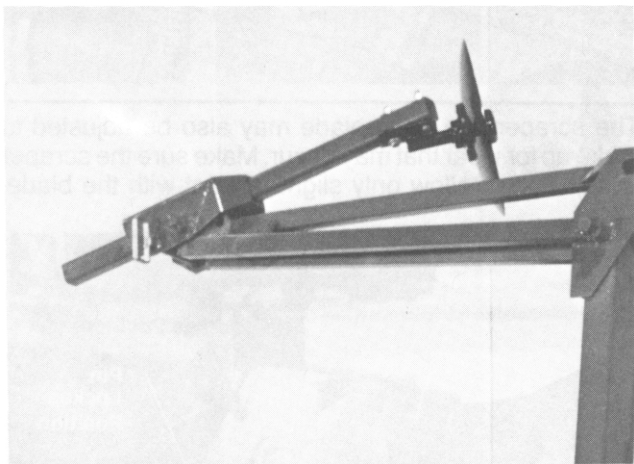

NOTE: The 3rd stage of the marker on 8 row 30 and 8 row wide planters must then be extended manually and secured in place using a stabilizer pin and lynch pin.

TRACTOR SPEED

Planters are designed to operate within a speed range of 2 to 8 M.P.H. Variations in ground speed will produce variations in rates. Corn meter populations will tend to be disproportionately higher at high ground speeds. While soybean and sorghum feed cup populations will tend to be disproportionately lower at high speed.

FIELD TEST

A field test of the planter should be made prior to initial operation and periodically thereafter to ensure proper planter operation.

- Check the planter for fore and aft and lateral level operation. See "Leveling The Planter".
- Check **all** row units to be certain they are running level. When planting, the row unit parallel arms should be parallel to the ground.
- Check row markers for proper operation and adjustment. See "Marker Adjustment", "Marker Speed Adjustment" and "Marker Operation".
- Check for proper application rates and placement of granular chemicals on **all** rows. See "Checking Chemical Application Rates".
- Check for desired depth placement and seed population on **all** rows. Consult your row unit manual and "Checking Seed Population".
- Check for proper application rates of fertilizer on **all** rows. See proper "Fertilizer Application Rate Chart".

After the planter has been field tested, reinspect the machine.

- Hoses And Fittings
- Bolts And Nuts
- Cotter Pins And Roll Pins
- Drive Chain Alignment And Tension

OPERATION

POINT ROW WRAP SPRING CLUTCH (OPTIONAL) Econo-Fold II

With the point row wrap spring clutch you have the capability to shut off either half of the planter for finishing up fields or for long point row situations.

The operational switches for the clutches are located on the tractor.

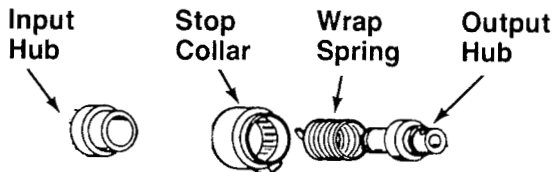

The wrap spring clutch consists of a wrap spring riding on an input hub and an output hub. During normal operation the wrap spring is wrapped tightly over the hubs connecting them in a positive engagement. The greater the force of rotation the tighter the grip of the spring on the hubs. Rotation in the opposite direction or stopping the spring from rotating prevents the transmission of torque from the input hub to the output hub thus stopping the planter drive.

The input end of the spring is bent outward and is referred to as the control tang. The control tang fits into a slot in the nylon stop collar that is located between the input and output hubs and over the wrap spring. If the stop collar is allowed to rotate with the input hub,

the clutch is engaged. If the stop collar is stopped from rotating the spring tang connected to it is forced back and the spring opens. This allows the input hub to continue rotating without transmitting torque to the output hub and therefore stopping the planter drive.

The stop collar is controlled by the use of an electric solenoid and an actuator arm. When the operational switch on the tractor is in the "ON" position the solenoid coil is not energized and the actuator arm will not contact the stop on the stop collar allowing it to rotate with the hubs and drive the planter.

When the operational switch is in the "OFF" position the solenoid coil is energized and the plunger in the solenoid coil pulls the actuator arm against the stop on the stop collar, disengaging the wrap spring and stopping the planter drive.

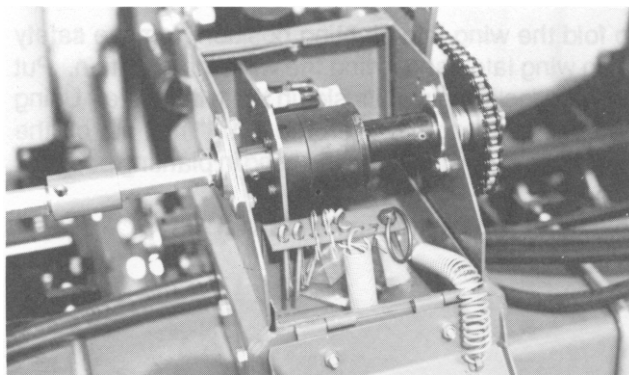

FERTILIZER OPENER

The double disc fertilizer openers should be positioned during assembly to place the fertilizer no closer than 2" to either side of the row and if planter frame is level, fertilizer depth will be approximately 4". Soil conditions can affect depth.

The down pressure springs are factory preset at 250 pounds down pressure but may be adjusted for various soil conditions. To adjust spring tension, loosen the jam nut with 15/16" wrench and use a 1" wrench to turn the adjustment bolt clockwise to increase tension or counterclockwise to decrease tension. Securely tighten the jam nut upon completion of tension adjustment. Do not attempt to set opener depth with spring pressure. The opener is designed to operate against depth stop and spring up when encountering a foreign object or hard ground.

CAUTION: Do not operate the double disc openers at full down pressure tension when planting in rocky ground. Chipping of the blades may occur.

The opener blades should have 1" of contact with each other. Blade adjustment can be made by moving inside spacer washers to the outer side of the blade. After making such an adjustment, check to be sure bearing assembly rivets are not hitting shank.

The scrapers on each blade may also be adjusted to make up for wear that may occur. Make sure the scraper is adjusted to allow only slight contact with the blade.

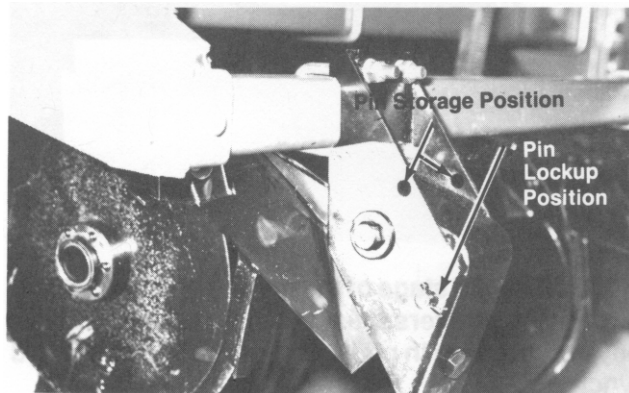

The opener assembly is designed to be locked in a raised position when the fertilizer attachment is not in use or during storage. To lock the opener, first raise the planter and place blocks under the openers. Then lower the planter until the hole in the pivot section aligns with the hole in the mounting bracket. Remove the lockup pin from the storage position in the mounting bracket and install it through the lockup hole and secure with cotter pins.

⚠ DANGER: Always install all cylinder lockup brackets before working under the unit.

OPERATION

DRY FERTILIZER ATTACHMENT Pull Type II

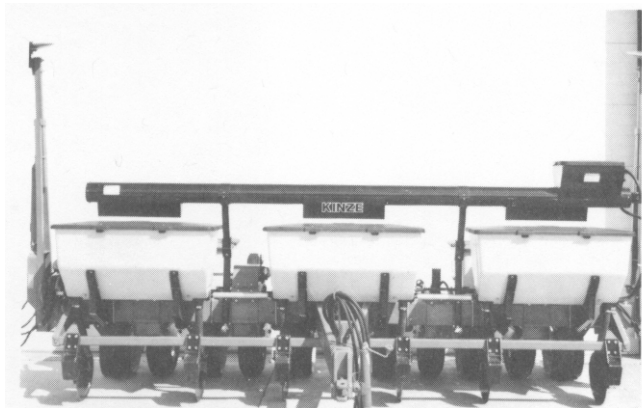

The rate of fertilizer application is determined by the type of auger assembly used in the hopper and by the drive/driven sprocket combination on the fertilizer drive.

In most situations the regular rate auger assembly is most desirable and has a wide range of application rates. The high rate auger assembly should be considered where a very high rate (usually over 250 lbs. per acre) of fertilizer is required. Uneven delivery of fertilizer will occur if the high rate auger assembly is used at too low a rate setting.

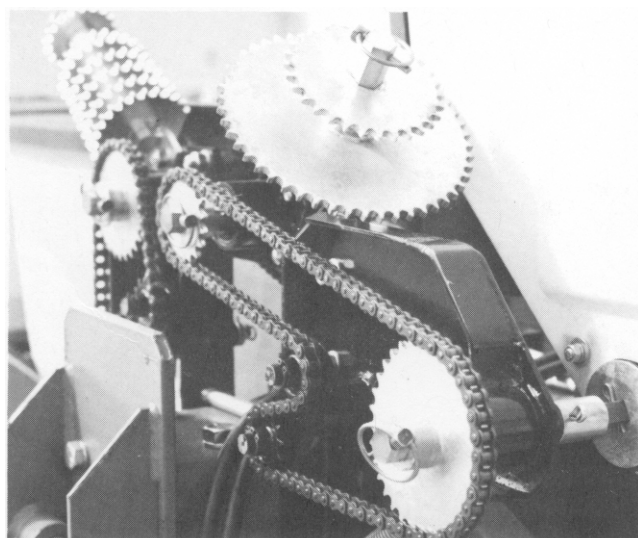

The fertilizer transmission is located on the right end of the planter directly ahead of the row unit transmission on all models. This transmission is designed to allow simple, rapid changes in sprockets to obtain the desired fertilizer application rates. By removing the pins on the

hexagon shafts, sprockets can be interchanged with those on the sprocket storage rod bolted to the transmission case. Chain tension is controlled by a spring loaded dual sprocket idler. This idler is adjusted with a ratchet arm located to the inside of the transmission. This arm has a release position to remove spring tension for replacing sprockets. The amount of spring tension on the chain can be controlled by the ratchet arm. The fertilizer application charts found at the end of this section will aid you in selecting the correct sprocket combinations.

IMPORTANT: After each sprocket combination adjustment, make a field check to be sure you are applying fertilizer at the desired rate.

The dry fertilizer attachment meters granules by volume rather than weight. For this reason, and given the variances in brands and fertilizer analysis, the weight metered during actual application may vary considerably. Use the chart for reference only. It is suggested that a container be used to catch and measure application (as explained following the application chart) to obtain a closer estimate.

Since most fertilizers easily absorb moisture, it is important that fertilizer be kept dry during use and storage. In addition to waste, deposits of fertilizer left in the hopper can cause metal corrosion. Hoppers should be emptied at the end of each days use.

IMPORTANT: Certain analysis of fertilizer if placed too close to the seed may cause germination or seedling damage especially if used in amounts in excess of fertilizer manufacturers recommendations. Check with your fertilizer dealer or manufacturer for the correct amount and placement.

⚠ WARNING: Agricultural chemicals can be dangerous if not selected and handled with care. Always read and follow directions supplied by the chemical manufacturer.

OPERATION

CLEANING

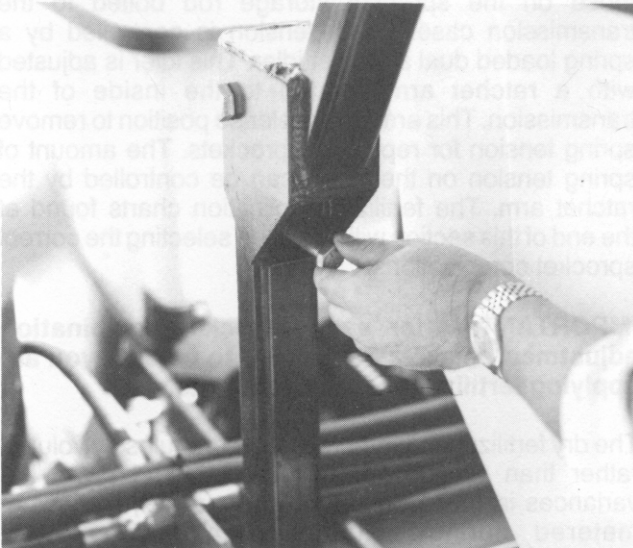

If the planter is equipped with the optional quick fill attachment, it will be necessary to first remove the two 1/2" bolts that secure the auger tube and rotate the auger tube back as shown.

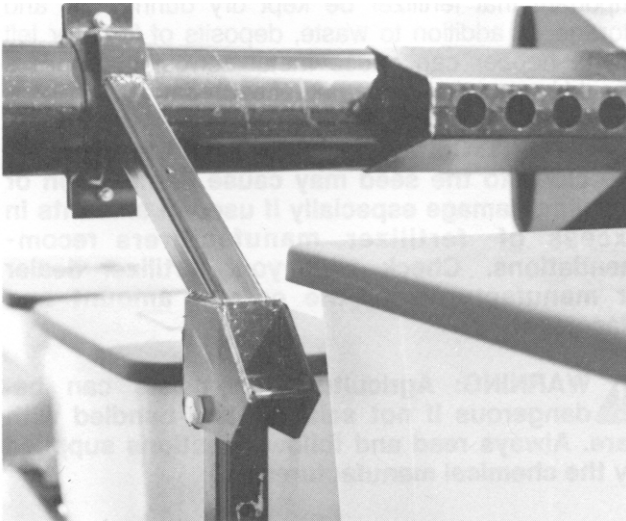

OPERATION



To disassemble auger assemblies, remove 1/4" cotter pin and large flat washer from one end of the shaft. Replace cotter pin to prevent the assembly from coming apart as it is removed. Pull auger assembly from opposite end of hopper. Again remove cotter pin from end of auger shaft and remove all auger components for cleaning. Coat all parts with rust preventative before reassembly.

To reassemble, slide auger assembly through the outlet housing back into the hopper. Secure in place by reinstalling the washer and cotter pin.

NOTE: The auger assemblies can be installed on the auger shaft in one of two different positions depending on where the two cotter pins are placed. The correct position is determined by the location of the hoppers. In some applications the auger shaft may need to extend further out of the hopper on one side in order to couple with the next hopper.

The dry fertilizer hoppers are designed to tip forward for dumping and ease of cleaning. To dump hoppers, first disconnect the drive shaft from the transmission or adjacent hopper. **LOOSEN HOSE CLAMPS AND REMOVE HOSES FROM EACH HOPPER.**

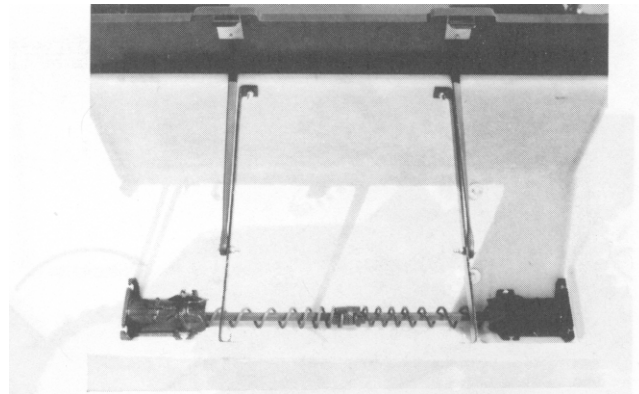

Check auger installation by rotating auger shaft in the "opposite" direction of planter travel to see that the spirals on the auger move toward the ends of the hopper. If not, remove auger assembly, turn 180° and reinstall.

Finally, remove the two cap screws from the hopper bracket at the rear of each hopper. Rotate hopper lids to the back side of the hopper and carefully tip hopper forward. After dumping contents, flush all loose fertilizer from the hopper and hoses.

At the end of the planting season, or when fertilizer attachment is not going to be used for a period of time, the hoppers should be disassembled, cleaned and coated with a rust preventative.

OPERATION

Be certain augers turn freely. If not, loosen the 5/16" carriage bolts in the outlet housings, rotate the auger several times and retighten the 5/16" carriage bolts. This should allow the housings to realign themselves with the auger.

Install auger baffles over the augers and secure in place with two hair pin clips in each hopper. Do not operate fertilizer attachment without auger baffles in place.

IMPORTANT: Frequent lubrication of auger bearings is critical to ensure that the augers will turn freely. Check lubrication section for frequency.

NOTE: MAKE SURE AUGER SPRING(S) CARRY FERTILIZER TO THE OUTER ENDS OF THE HOPPER WHEN ROTATED IN THE DIRECTION OF ROTATION THEY WILL TURN WHEN THE PLANTER IS OPERATING. FERTILIZER TRANSMISSION ROTATES IN OPPOSITE DIRECTION OF PLANTER TRAVEL.

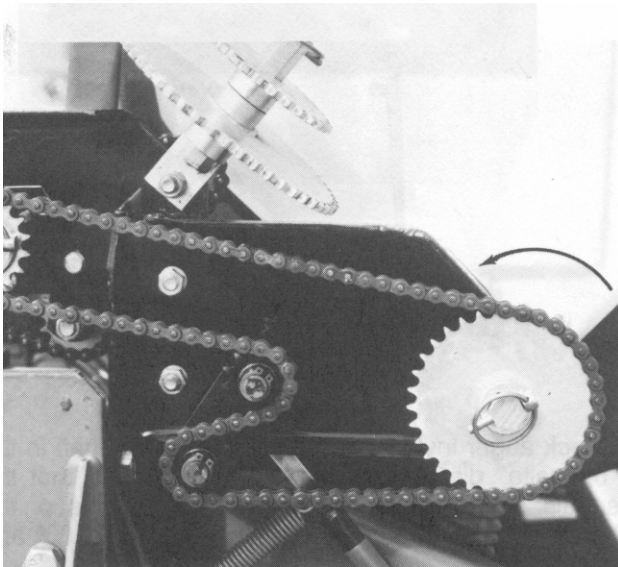

If the planter is equipped with a dry fertilizer quick fill attachment and the fertilizer attachment is not going to be used for a period of time, pull the auger from the quick fill tube and thoroughly clean the auger and tube and treat with a rust preventative.

LIQUID FERTILIZER ATTACHMENT Pull Type II

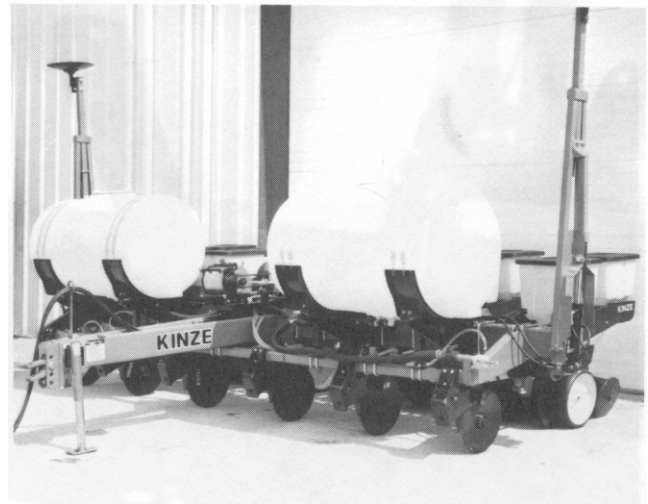

The rate of liquid fertilizer application is determined by the combination of sprockets on the squeeze pump driven and drive shafts. When changing sprocket combinations, make sure sprockets are in alignment, sprocket retaining collars are tight and chain tension is sufficiently restored.

The delivery rate chart found at the end of this section provides an approximate application rate only. Actual delivery will vary with temperature and the particular fertilizer being used.

IMPORTANT: Certain analysis of fertilizer if placed too close to the seed may cause germination or seedling damage especially if used in amounts in excess of fertilizer manufacturers recommendations. Check with your fertilizer dealer or manufacturer for the correct amount and placement.

⚠ WARNING: Agricultural chemicals can be dangerous if not selected and handled with care. Always read and follow directions supplied by the chemical manufacturer.

Shut-off valves provided at various locations, should be closed to shut off flow when the planter sets overnight or for extended periods of time. It is also important to close the tank valves whenever service on the pump or hoses is being performed. To prolong the life of the hoses in the squeeze pump, the discharge manifold must be repositioned to the rearward position to prevent hose distortion.

OPERATION

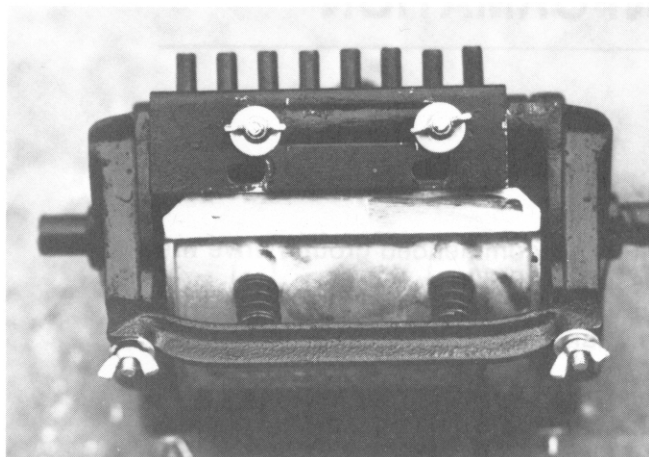

Discharge Manifold Rearward

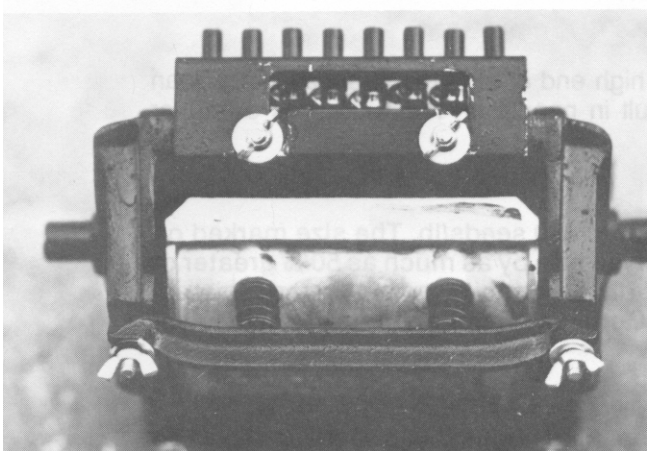

Discharge Manifold Forward

The discharge manifold must be in the forward position when the pump is in operation. To reposition the manifold, loosen the wing nuts and slide the manifold forward and sideways or rearward as required and retighten nuts.

CAUTION: Avoid excessive pressure when using the quick fill attachment. The rubber plugs installed in the manifold may be forced out under pressure.

If either of the end pump hoses should run off the back plate, loosen the hose clamp on the intake manifold and rotate the hose as follows.

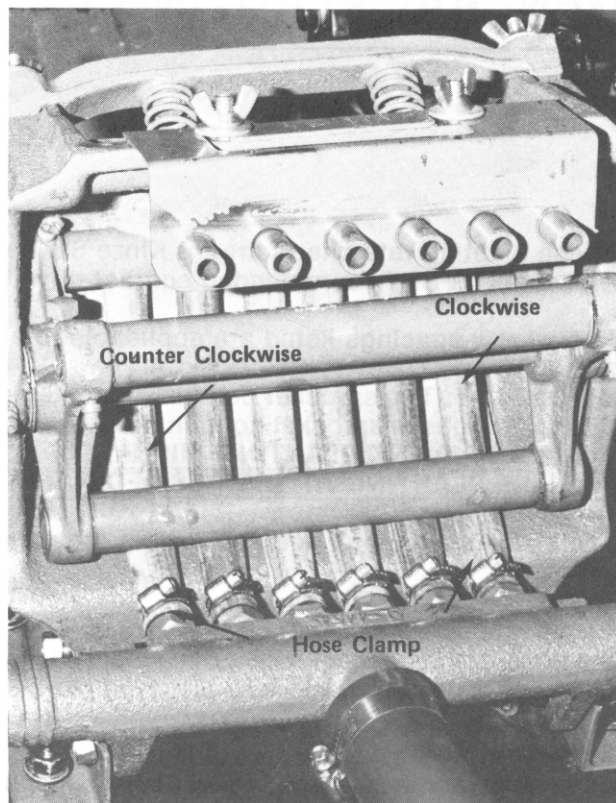

For the *right hand hose* (facing the pump from rear of planter) twist the hose 1/4 turn in the clockwise direction.

For the *left hand hose* (facing front of pump) twist the hose 1/4 turn in the counter-clockwise direction.

Retighten hose clamp.

Cleaning

The tanks and all hoses are made of sturdy plastic and rubber to resist corrosion. However, the tank should be rinsed with water after each season or extended period of non-use. Do not allow fertilizer to crystallize because of cold temperature or evaporation.

At the end of the planting season, thoroughly clean all parts with clean water and flush the tanks, hoses, and metering pump prior to storage.

GENERAL PLANTING RATE INFORMATION

These planting rate charts are for Kinze Series II planters. Recommended ground drive tire pressure 40 PSI. Recommended contact drive tire pressure 60 PSI.

Not all row spacings listed are applicable to all model planters.

IMPORTANT: The sprocket combinations listed in these charts are best for average conditions. Changes in sprocket combinations may be required to obtain desired planting population. **TO PREVENT PLANTING MISCALCULATIONS, MAKE FIELD CHECKS TO BE SURE YOU ARE PLANTING AT THE DESIRED RATE.**

The size and shape of seed will affect the planting rate:

Corn

Larger grades will generally plant more accurately at the high end of the ground speed range than the small grades. Higher than optimum speeds may result in population rate increases or higher incidence of doubles, particularly with small seed.

Soybeans

Soybeans vary in size from about 3500 seeds/lb. to about 1800 seeds/lb. The size marked on each bag is an average. Seeds within each bag may vary in size by as much as 50% greater or 50% smaller than the average. These charts are based on uniformly sized soybeans. Your actual planting rate will vary somewhat from the chart. Generally, larger beans will give lower rates and smaller beans will give higher rates.

Sorghum/Milo

Sorghum/milo seeds vary in size from about 12000 seeds/lb. to about 25000 seeds/lb. The size marked on each bag is an average. Seeds within each bag may vary in size by as much as 50% greater or 50% smaller than average.

Rates for 18 and 19 inch row spacing are two times 36 and 38 inch row spacing.

NOTE: Use of the extended drill sprocket package will reduce the planter transmission speed. The seeding rate will be approximately 1/2 of the chart reading when using the 2:1 sprocket package (34 tooth sprocket) or 1/3 of the chart reading when using the 3:1 sprocket package (50 tooth sprocket). Planting speed can affect actual seeding rate, so make a field check and adjust setting in the transmission as needed to obtain the desired seed drop.

OPERATION

CHECKING SEED POPULATION

1. Tie up one or more sets of closing wheels by running a light chain between the hopper support panel and closing wheels.

L0069

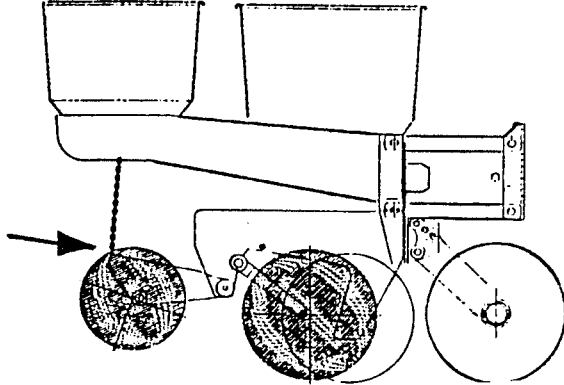

2. Plant a short distance and check to see if seed is visible in the seed trench. Adjust planting depth to a shallower setting if seed is not visible and recheck.

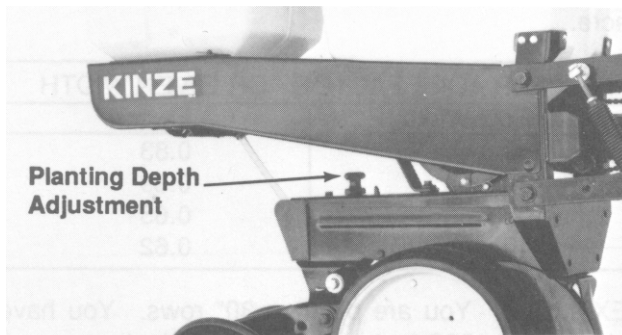

3. Measure 1/1000 of an acre. See chart for correct distance for row width spacing being planted. For example: If planting 30" rows, 1/1000 of an acre would be 17'5".

LENGTH OF ROW IN FEET AND INCHES				
Fraction Of Acre	Row Width			
	30"	36"	38"	40"
1/1000	17'5"	14'6"	13'10"	13' 1"

NOTE: When planting with closing wheels raised and planting depth set shallow, seeds may bounce or roll affecting seed spacing accuracy.

4. Multiply the number of seeds placed in the 1/1000 of an acre by 1000. This will give you total population.

EXAMPLE: With 30" row spacing 17'5" equals 1/1000 acre.

26 Seeds Counted	x	1000	=	26,000 Seeds Per Acre
---------------------	---	------	---	-----------------------

Corn Meter

Seed count can be affected by two things; drive ratio between drive wheel and corn meter, and/or corn meter malfunction.

If seed check shows the average distance between seeds in inches is significantly different than the seed rate chart indicates, first check drive ratio between drive wheel and corn meter. Check drive wheel pressure, check for incorrect sprocket(s) in drive line and check drive and driven sprockets in transmission for proper selection.

Second check for corn meter malfunction. FOR EXAMPLE, if spacing between kernels at the transmission setting being used is 8" and a gap of 16" is observed, a finger has lost its seed and not functioned properly. Seed population will be less than the desired amount. If two seeds are found within a few inches of each other, the finger has metered two seeds instead of one.

See "Plateless Corn Meter Trouble Shooting" in your Kinze Row Unit Manual.

Soybean Feed Cup Meter

1. Check seeds per pound on seed bag.

2. Use seed rate chart closest to seed count per pound listed on bag. Use small seeds chart for 2700 or more seeds per pound, medium seeds chart for 2200 to 2700 seeds per pound and large seeds chart for 2200 and less seeds per pound.

3. To determine seeds per foot:

Seeds Per Lb.	x	Desired Lbs. Per Acre	=	Seeds Per Acre
------------------	---	--------------------------	---	-------------------

Seeds Per Acre	+	Ft. Of Row Per Acre	=	Seeds Per Ft.
-------------------	---	------------------------	---	------------------

34,800 Ft. = 1 Acre/15" Rows	17,400 Ft. = 1 Acre/30" Rows
29,000 Ft. = 1 Acre/18" Rows	14,500 Ft. = 1 Acre/36" Rows
27,600 Ft. = 1 Acre/19" Rows	13,800 Ft. = 1 Acre/38" Rows
	13,100 Ft. = 1 Acre/40" Rows

OPERATION

4. To determine seeds per acre, count seeds in 1/1000 of an acre and multiply by 1000.

If seed check shows planting rate is significantly different than seed rate chart shows, see "Feed Cup Meter Trouble Shooting" in your Kinze Row Unit Manual.

Milo Feed Cup Meter

1. Check seeds per pound on seed bag.
2. Use seed rate chart for the medium or low rate milo meter being used and the desired pounds per acre. Use medium rate chart and medium rate milo meter for 4.3 lbs. per acre through 45.6 lbs. per acre. Use low rate chart and low rate milo meter for 1.3 lbs. per acre through 13.9 lbs. per acre.
3. To determine seeds per foot:

Seeds Per Lb.	x	Desired Lbs. Per Acre	=	Seeds Per Acre
------------------	---	--------------------------	---	-------------------

Seeds Per Acre	+	Ft. Of Row Per Acre	=	Seeds Per Ft.
-------------------	---	------------------------	---	------------------

34,800 Ft. = 1 Acre/15" Rows	17,400 Ft. = 1 Acre/30" Rows
29,000 Ft. = 1 Acre/18" Rows	14,500 Ft. = 1 Acre/36" Rows
27,600 Ft. = 1 Acre/19" Rows	13,800 Ft. = 1 Acre/38" Rows
	13,100 Ft. = 1 Acre/40" Rows

4. To determine seeds per acre, count seeds in 1/1000 of an acre and multiply by 1000.

5. To determine pounds per acre, multiply seeds per acre planted by seeds per pound as stated on seed bag.

If seed check shows planting rate is significantly different than seed chart shows, see "Feed Cup Meter Trouble Shooting" in your Kinze Row Unit Manual.

NOTE: The milo meter is a volume type meter and the rate chart is a starting point only and actual rate may vary because of seed size, planting speed, meter wear, etc.

CHECKING GRANULAR CHEMICAL APPLICATION RATE

Many things can affect the rate of delivery. Temperature, humidity, speed, ground conditions, flow-ability of different material or any obstruction in the metering.

A field check is important for correct application rates.

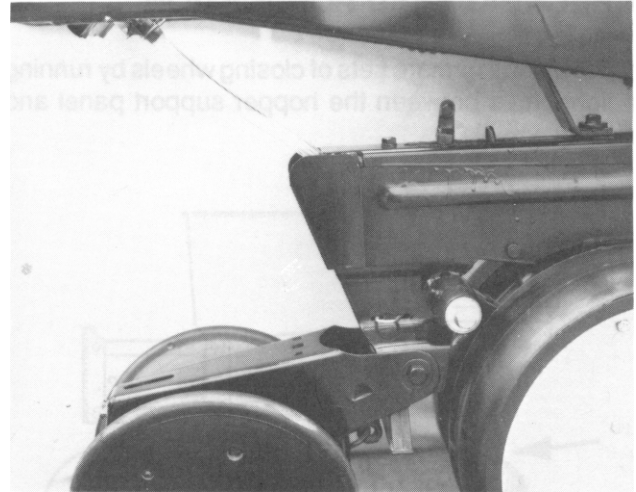

To check, fill insecticide and/or herbicide hoppers. Attach a cloth bag to each granular diffuser. Lower the planter and proceed as follows.

Drive 1320 feet at planting speed. Weigh the chemical in ounces that was caught in one bag. Multiply that amount by the factor shown to determine pounds per acre.

LBS. PER ACRE FACTOR FOR GIVEN WIDTH	
Row Width	Factor
30 Inch	0.83
36 Inch	0.69
38 Inch	0.65
40 Inch	0.62

EXAMPLE: You are planting 30" rows. You have planted for 1320 feet at the desired planting speed. You caught 12.0 ounces of chemical in one bag. 12.0 ounces times 0.83 equals 9.96 pounds per acre.

Metering Gate

Use the metering gate setting for distributing insecticide or herbicide as a starting point. The chart is based on a 5 miles per hour planting speed. For speeds faster than 5 miles per hour a higher gate setting should be used. For speeds slower than 5 miles per hour a lower gate setting should be used.



WARNING: Agricultural chemicals can be dangerous if not selected and handled with care. Always read and follow directions supplied by the chemical manufacturer.

OPERATION

PULL TYPE II/ECONO-FOLD II

PLANTING RATES FOR PLATELESS CORN METERS SEED POPULATIONS/ACRE FOR VARIOUS ROW WIDTHS

20 Inch	30 Inch	36 Inch	38 Inch	40 Inch	Transmission Sprockets		Recomm. Speed Range (MPH)	Average Seed Spacing In Inches
					Drive	Driven		
24,278	16,186	13,488	12,778	12,139	17	28	4 to 8	12.9
25,178	16,785	13,988	13,251	12,589	17	27	4 to 8	12.5
26,146	17,431	14,526	13,761	13,073	17	26	4 to 8	12.0
27,135	18,090	15,075	14,281	13,567	19	28	4 to 8	11.6
27,192	18,128	15,107	14,312	13,596	17	25	4 to 8	11.5
28,140	18,760	15,633	14,810	14,070	19	27	4 to 8	11.1
28,325	18,883	15,736	14,908	14,162	17	24	4 to 8	11.1
29,222	19,481	16,234	15,380	14,611	19	26	4 to 8	10.7
29,556	19,704	16,420	15,556	14,778	17	23	4 to 8	10.6
30,391	20,261	16,884	15,995	15,195	19	25	4 to 8	10.3
31,657	21,104	17,587	16,662	15,829	19	24	4 to 8	9.9
32,847	21,898	18,249	17,288	16,424	23	28	4 to 8	9.5
33,034	22,022	18,352	17,386	16,517	19	23	4 to 8	9.5
34,064	22,709	18,924	17,928	17,032	23	27	4 to 8	9.2
34,275	22,850	19,042	18,040	17,138	24	28	4 to 8	9.2
35,374	23,583	19,652	18,618	17,687	23	26	4 to 8	8.9
35,545	23,697	19,747	18,708	17,772	24	27	4 to 8	8.8
35,704	23,802	19,835	18,791	17,852	25	28	4 to 8	8.8
35,779	23,853	19,877	18,831	17,889	17	19	4 to 7.5	8.8
36,789	24,526	20,438	19,363	18,395	23	25	4 to 7.5	8.5
36,912	24,608	20,507	19,427	18,456	24	26	4 to 7.5	8.5
37,026	24,684	20,570	19,487	18,513	25	27	4 to 7.5	8.5
37,132	24,755	20,629	19,543	18,566	26	28	4 to 7.5	8.4
38,322	25,548	21,290	20,169	19,161	23	24	4 to 7.5	8.2
38,389	25,592	21,327	20,205	19,194	24	25	4 to 7.5	8.2
38,450	25,633	21,361	20,237	19,225	25	26	4 to 7.5	8.2
38,507	25,671	21,393	20,267	19,254	26	27	4 to 7.5	8.1
38,560	25,707	21,422	20,295	19,280	27	28	4 to 7.5	8.1
39,988	26,659	22,216	21,046	19,994	23	23	4 to 7	7.8
41,469	27,646	23,038	21,826	20,735	28	27	4 to 7	7.6
41,526	27,684	23,070	21,856	20,763	27	26	4 to 7	7.6
41,654	27,770	23,141	21,923	20,827	25	24	4 to 7	7.5
41,727	27,818	23,181	21,961	20,863	24	23	4 to 7	7.5
43,064	28,709	23,924	22,665	21,532	28	26	4 to 6.5	7.3
43,187	28,791	23,993	22,730	21,594	27	25	4 to 6.5	7.3
43,465	28,977	24,147	22,876	21,733	25	23	4 to 6.5	7.2
44,693	29,795	24,829	23,522	22,346	19	17	4 to 6.5	7.0
44,787	29,858	24,881	23,572	22,393	28	25	4 to 6.5	7.0
44,987	29,991	24,993	23,677	22,493	27	24	4 to 6.5	7.0
45,204	30,136	25,113	23,792	22,602	26	23	4 to 6.5	7.0
46,653	31,102	25,918	24,554	23,326	28	24	3 to 6	6.7
46,943	31,295	26,079	24,707	23,471	27	23	3 to 6	6.7
48,407	32,271	26,893	25,477	24,203	23	19	3 to 5.5	6.5
48,681	32,454	27,045	25,622	24,341	28	23	3 to 5.5	6.5
50,511	33,674	28,062	26,585	25,256	24	19	3 to 5.5	6.2
52,616	35,077	29,231	27,693	26,308	25	19	3 to 5	6.0
54,102	36,068	30,056	28,474	27,051	23	17	3 to 5	5.8
54,721	36,480	30,400	28,800	27,360	26	19	3 to 5	5.7
56,454	37,636	31,363	29,713	28,227	24	17	3 to 5	5.6
56,825	37,883	31,570	29,908	28,413	27	19	3 to 5	5.5
58,806	39,204	32,670	30,951	29,403	25	17	3 to 4.5	5.3
58,930	39,287	32,739	31,016	29,465	28	19	3 to 4.5	5.3
61,158	40,772	33,977	32,189	30,579	26	17	3 to 4.5	5.1
63,510	42,340	35,284	33,427	31,755	27	17	3 to 4.5	4.9
65,863	43,908	36,590	34,665	32,931	28	17	3 to 4.5	4.8

IMPORTANT: See "General Planting Rate Information" and "Checking Seed Population" pages for additional information. Always check seed population in the field to ensure planting rates are correct.

**PLANTING RATES FOR PLATELESS SOYBEAN METERS
APPROXIMATE POUNDS/ACRE FOR VARIOUS ROW WIDTH - MEDIUM SEEDS**

10 Inch	15 Inch	20 Inch	30 Inch	36 Inch	38 Inch	40 Inch	Transmission Sprockets		Recomm. Speed Range (MPH)
							Drive	Driven	
115	77	57	38	32	30	29	17	28	4 to 8
119	79	60	40	33	31	30	17	27	4 to 8
124	83	62	41	34	33	31	17	26	4 to 8
128	86	64	43	36	34	32	19	28	4 to 8
133	89	67	44	37	35	33	19	27	4 to 8
134	89	67	45	37	35	34	17	24	4 to 8
140	93	70	47	39	37	35	17	23	4 to 8
144	96	72	48	40	38	36	19	25	4 to 8
150	100	75	50	42	39	37	19	24	4 to 8
155	104	78	52	43	41	39	23	28	4 to 8
156	104	78	52	43	41	39	19	23	4 to 8
162	108	81	54	45	43	41	24	28	4 to 8
168	112	84	56	47	44	42	24	27	4 to 8
169	113	85	56	47	45	42	17	19	4 to 7.5
175	116	87	58	49	46	44	24	26	4 to 7.5
176	117	88	59	49	46	44	26	28	4 to 7.5
182	121	91	61	50	48	45	24	25	4 to 7.5
182	122	91	61	51	48	46	26	27	4 to 7.5
189	126	95	63	53	50	47	23	23	4 to 7
197	131	98	66	55	52	49	27	26	4 to 7
198	132	99	66	55	52	49	24	23	4 to 7
206	137	103	69	57	54	51	25	23	4 to 6.5
212	141	106	71	59	56	53	19	17	4 to 6.5
213	142	106	71	59	56	53	27	24	4 to 6.5
221	147	110	74	61	58	55	28	24	3 to 6
229	153	115	76	64	60	57	23	19	3 to 5.5
230	154	115	77	64	61	58	28	23	3 to 5.5
239	159	120	80	66	63	60	24	19	3 to 5.5
249	166	125	83	69	66	62	25	19	3 to 5
256	171	128	85	71	67	64	23	17	3 to 5
259	173	130	86	72	68	65	26	19	3 to 5
269	179	134	90	75	71	67	27	19	3 to 5
279	186	139	93	77	73	70	28	19	3 to 4.5
289	193	145	96	80	76	72	26	17	3 to 4.5
301	200	150	100	84	79	75	27	17	3 to 4.5
312	208	156	104	87	82	78	28	17	3 to 4.5

IMPORTANT: See "General Planting Rate Information" and "Checking Seed Population" pages for additional information.

NOTE: When using the 2 to 1 Drive Reduction Package, rates will be approximately 1/2 of given numbers.

IMPORTANT: Always check seed population in the field to ensure planting rates are correct.

**PLANTING RATES FOR PLATELESS SOYBEAN METERS
APPROXIMATE BEANS/ACRE FOR VARIOUS ROW WIDTHS - SMALL SEEDS**

10 Inch	15 Inch	20 Inch	30 Inch	36 Inch	38 Inch	40 Inch	Transmission Sprockets		Recomm. Speed Range (MPH)	Seed Spacing (Inches)	Seeds/ Foot
							Drive	Driven			
434,423	289,615	217,211	144,808	120,673	114,322	108,606	17	28	4 to 8	1.4	8
450,513	300,342	225,256	150,171	125,142	118,556	112,628	17	27	4 to 8	1.4	9
467,840	311,893	233,920	155,947	129,956	123,116	116,960	17	26	4 to 8	1.3	9
485,531	323,688	242,766	161,844	134,870	127,771	121,383	19	28	4 to 8	1.3	9
503,514	335,676	251,757	167,838	139,865	132,504	125,879	19	27	4 to 8	1.2	10
506,827	337,884	253,413	168,942	140,785	133,375	126,707	17	24	4 to 8	1.2	10
528,863	352,575	264,431	176,288	146,906	139,174	132,216	17	23	4 to 8	1.2	10
543,795	362,530	271,898	181,265	151,054	143,104	135,949	19	25	4 to 8	1.2	10
566,453	377,636	283,227	188,818	157,348	149,067	141,613	19	24	4 to 8	1.1	11
587,749	391,832	293,874	195,916	163,264	154,671	146,937	23	28	4 to 8	1.1	11
591,082	394,055	295,541	197,027	164,189	155,548	147,770	19	23	4 to 8	1.1	11
613,303	408,869	306,651	204,434	170,362	161,395	153,326	24	28	4 to 8	1.0	12
636,018	424,012	318,009	212,006	176,672	167,373	159,004	24	27	4 to 8	1.0	12
640,202	426,801	320,101	213,401	177,834	168,474	160,051	17	19	4 to 7.5	1.0	12
660,480	440,320	330,240	220,160	183,467	173,811	165,120	24	26	4 to 7.5	1.0	13
664,411	442,941	332,206	221,470	184,559	174,845	166,103	26	28	4 to 7.5	0.9	13
686,899	457,933	343,450	228,966	190,805	180,763	171,725	24	25	4 to 7.5	0.9	13
689,019	459,346	344,510	229,673	191,394	181,321	172,255	26	27	4 to 7.5	0.9	13
715,520	477,013	357,760	238,507	198,756	188,295	178,880	23	23	4 to 7	0.9	14
743,040	495,360	371,520	247,680	206,400	195,537	185,760	27	26	4 to 7	0.8	14
746,630	497,753	373,315	248,877	207,397	196,481	186,657	24	23	4 to 7	0.8	14
777,739	518,493	388,870	259,246	216,039	204,668	194,436	25	23	4 to 6.5	0.8	15
799,699	533,133	399,849	266,566	222,139	210,447	199,925	19	17	4 to 6.5	0.8	15
804,960	536,640	402,480	268,320	223,600	211,832	201,240	27	24	4 to 6.5	0.8	15
834,773	556,516	417,387	278,258	231,881	219,677	208,693	28	24	3 to 6	0.8	16
866,156	577,437	433,078	288,719	240,599	227,936	216,539	23	19	3 to 5.5	0.7	17
871,068	580,712	435,534	290,356	241,963	229,228	217,767	28	23	3 to 5.5	0.7	17
903,815	602,543	451,907	301,272	251,060	237,846	225,954	24	19	3 to 5.5	0.7	17
941,474	627,649	470,737	313,825	261,520	247,756	235,368	25	19	3 to 5	0.7	18
968,057	645,371	484,028	322,686	268,905	254,752	242,014	23	17	3 to 5	0.6	19
979,133	652,755	489,566	326,378	271,981	257,666	244,783	26	19	3 to 5	0.6	19
1,016,792	677,861	508,396	338,931	282,442	267,577	254,198	27	19	3 to 5	0.6	19
1,054,451	702,967	527,225	351,484	292,903	277,487	263,613	28	19	3 to 4.5	0.6	20
1,094,325	729,550	547,162	364,775	303,979	287,980	273,581	26	17	3 to 4.5	0.6	21
1,136,414	757,609	568,207	378,805	315,671	299,056	284,104	27	17	3 to 4.5	0.6	22
1,178,504	785,669	589,252	392,835	327,362	310,133	294,626	28	17	3 to 4.5	0.5	23

IMPORTANT: See "General Planting Rate Information" and "Checking Seed Population" pages for additional information.

NOTE: When using the 2 to 1 Drive Reduction Package, rates will be approximately 1/2 of given numbers.

IMPORTANT: Always check seed population in the field to ensure planting rates are correct.

**PLANTING RATES FOR PLATELESS SOYBEAN METERS
APPROXIMATE BEANS/ACRE FOR VARIOUS ROW WIDTHS - MEDIUM SEEDS**

10 Inch	15 Inch	20 Inch	30 Inch	36 Inch	38 Inch	40 Inch	Transmission Sprockets		Recomm. Speed Range (MPH)	Seed Spacing (Inches)	Seeds/ Foot
							Drive	Driven			
298,805	199,204	149,403	99,602	83,001	78,633	74,701	17	28	4 to 8	2.1	6
309,872	206,581	154,936	103,291	86,076	81,545	77,468	17	27	4 to 8	2.0	6
321,790	214,527	160,895	107,263	89,386	84,682	80,448	17	26	4 to 8	1.9	6
333,959	222,639	166,979	111,320	92,766	87,884	83,490	19	28	4 to 8	1.9	6
346,328	230,885	173,164	115,443	96,202	91,139	86,582	19	27	4 to 8	1.8	7
348,606	232,404	174,303	116,202	96,835	91,738	87,152	17	24	4 to 8	1.8	7
363,763	242,509	181,882	121,254	101,045	95,727	90,941	17	23	4 to 8	1.7	7
374,034	249,356	187,017	124,678	103,898	98,430	93,508	19	25	4 to 8	1.7	7
389,619	259,746	194,809	129,873	108,227	102,531	97,405	19	24	4 to 8	1.6	7
404,266	269,511	202,133	134,755	112,296	106,386	101,067	23	28	4 to 8	1.6	8
406,559	271,039	203,279	135,520	112,933	106,989	101,640	19	23	4 to 8	1.5	8
421,843	281,229	210,921	140,614	117,179	111,011	105,461	24	28	4 to 8	1.5	8
437,467	291,644	218,733	145,822	121,519	115,123	109,367	24	27	4 to 8	1.4	8
440,345	293,563	220,172	146,782	122,318	115,880	110,086	17	19	4 to 7.5	1.4	8
454,292	302,862	227,146	151,431	126,192	119,551	113,573	24	26	4 to 7.5	1.4	9
456,996	304,664	228,498	152,332	126,943	120,262	114,249	26	28	4 to 7.5	1.4	9
472,464	314,976	236,232	157,488	131,240	124,333	118,116	24	25	4 to 7.5	1.3	9
473,922	315,948	236,961	157,974	131,645	124,716	118,481	26	27	4 to 7.5	1.3	9
492,150	328,100	246,075	164,050	136,708	129,513	123,037	23	23	4 to 7	1.3	9
511,079	340,719	255,539	170,360	141,966	134,494	127,770	27	26	4 to 7	1.2	10
513,548	342,365	256,774	171,183	142,652	135,144	128,387	24	23	4 to 7	1.2	10
534,946	356,630	267,473	178,315	148,596	140,775	133,736	25	23	4 to 6.5	1.2	10
550,050	366,700	275,025	183,350	152,792	144,750	137,512	19	17	4 to 6.5	1.1	11
553,669	369,112	276,834	184,556	153,797	145,702	138,417	27	24	4 to 6.5	1.1	11
574,175	382,783	287,087	191,392	159,493	151,099	143,544	28	24	3 to 6	1.1	11
595,760	397,174	297,880	198,587	165,489	156,779	148,940	23	19	3 to 5.5	1.1	11
599,139	399,426	299,570	199,713	166,428	157,668	149,785	28	23	3 to 5.5	1.0	11
621,663	414,442	310,832	207,221	172,684	163,596	155,416	24	19	3 to 5.5	1.0	12
647,566	431,710	323,783	215,855	179,879	170,412	161,891	25	19	3 to 5	1.0	12
665,850	443,900	332,925	221,950	184,958	175,224	166,462	23	17	3 to 5	0.9	13
673,468	448,979	336,734	224,489	187,075	177,229	168,367	26	19	3 to 5	0.9	13
699,371	466,247	349,685	233,124	194,270	184,045	174,843	27	19	3 to 5	0.9	13
725,274	483,516	362,637	241,758	201,465	190,861	181,318	28	19	3 to 4.5	0.9	14
752,700	501,800	376,350	250,900	209,083	198,079	188,175	26	17	3 to 4.5	0.8	14
781,650	521,100	390,825	260,550	217,125	205,697	195,412	27	17	3 to 4.5	0.8	15
810,600	540,400	405,300	270,200	225,167	213,316	202,650	28	17	3 to 4.5	0.8	16

IMPORTANT: See "General Planting Rate Information" and "Checking Seed Population" pages for additional information.

NOTE: When using the 2 to 1 Drive Reduction Package, rates will be approximately 1/2 of given numbers.

IMPORTANT: Always check seed population in the field to ensure planting rates are correct.

**PLANTING RATES FOR PLATELESS SOYBEAN METERS
APPROXIMATE BEANS/ACRE FOR VARIOUS ROW WIDTHS - LARGE SEEDS**

10 Inch	15 Inch	20 Inch	30 Inch	36 Inch	38 Inch	40 Inch	Transmission Sprockets		Recomm. Speed Range (MPH)	Seed Spacing (Inches)	Seeds/ Foot
							Drive	Driven			
206,865	137,910	103,432	68,955	57,462	54,438	51,716	17	28	4 to 8	3.0	4
214,526	143,018	107,263	71,509	59,591	56,454	53,632	17	27	4 to 8	2.9	4
222,777	148,518	111,389	74,259	61,883	58,626	55,694	17	26	4 to 8	2.8	4
231,202	154,135	115,601	77,067	64,223	60,843	57,800	19	28	4 to 8	2.7	4
239,765	159,843	119,882	79,922	66,601	63,096	59,941	19	27	4 to 8	2.6	5
241,342	160,895	120,671	80,447	67,040	63,511	60,336	17	24	4 to 8	1.6	5
251,835	167,890	125,918	83,945	69,954	66,272	62,959	17	23	4 to 8	2.5	5
258,946	172,631	129,473	86,315	71,929	68,144	64,737	19	25	4 to 8	2.4	5
269,735	179,824	134,868	89,912	74,927	70,983	67,434	19	24	4 to 8	2.3	5
279,876	186,584	139,938	93,292	77,743	73,652	69,969	23	28	4 to 8	2.2	5
281,463	187,642	140,732	93,821	78,184	74,069	70,366	19	23	4 to 8	2.2	5
292,044	194,696	146,022	97,348	81,123	76,854	73,011	24	28	4 to 8	2.1	6
302,861	201,907	151,430	100,954	84,128	79,700	75,715	24	27	4 to 8	2.1	6
304,853	203,236	152,427	101,617	84,681	80,225	76,213	17	19	4 to 7.5	2.1	6
314,509	209,673	157,255	104,836	87,364	82,766	78,627	24	26	4 to 7.5	2.0	6
316,381	210,921	158,191	105,460	87,884	83,258	79,095	26	28	4 to 7.5	2.0	6
327,090	218,060	163,545	109,029	90,858	86,076	81,772	24	25	4 to 7.5	1.9	6
328,099	218,733	164,050	109,366	91,139	86,342	82,025	26	27	4 to 7.5	1.9	6
340,718	227,146	170,359	113,573	94,644	89,663	85,180	23	23	4 to 7	1.8	7
353,823	235,882	176,911	117,941	98,284	93,111	88,456	27	26	4 to 7	1.8	7
355,532	237,022	177,766	118,511	98,759	93,561	88,883	24	23	4 to 7	1.8	7
370,346	246,897	185,173	123,449	102,874	97,460	92,587	25	23	4 to 6.5	1.7	7
380,803	253,869	190,401	126,934	105,779	100,211	95,201	19	17	4 to 6.5	1.6	7
383,308	255,539	191,654	127,769	106,475	100,871	95,827	27	24	4 to 6.5	1.6	7
397,505	265,003	198,752	132,502	110,418	104,607	99,376	28	24	3 to 6	1.6	8
412,449	274,966	206,224	137,483	114,569	108,539	103,112	23	19	3 to 5.5	1.5	8
414,788	276,525	207,394	138,263	115,219	109,155	103,697	28	23	3 to 5.5	1.5	8
430,381	286,921	215,191	143,460	119,550	113,258	107,595	24	19	3 to 5.5	1.5	8
448,314	298,876	224,157	149,438	124,532	117,977	112,078	25	19	3 to 5	1.4	9
460,972	307,315	230,486	153,657	128,048	121,308	115,243	23	17	3 to 5	1.4	9
466,246	310,831	233,123	155,415	129,513	122,696	116,562	26	19	3 to 5	1.3	9
484,179	322,786	242,089	161,393	134,494	127,415	121,045	27	19	3 to 5	1.3	9
502,111	334,741	251,056	167,370	139,475	132,135	125,528	28	19	3 to 4.5	1.2	10
521,099	347,399	260,549	173,700	144,750	137,131	130,275	26	17	3 to 4.5	1.2	10
541,141	360,761	270,571	180,380	150,317	142,406	135,285	27	17	3 to 4.5	1.2	10
561,183	374,122	280,592	187,061	155,884	147,680	140,296	28	17	3 to 4.5	1.1	11

IMPORTANT: See "General Planting Rate Information" and "Checking Seed Population" pages for additional information.

NOTE: When using the 2 to 1 Drive Reduction Package, rates will be approximately 1/2 of given numbers.

IMPORTANT: Always check seed population in the field to ensure planting rates are correct.

OPERATION

PULL TYPE II/ECONO-FOLD II

PLANTING RATES FOR PLATELESS INTERMEDIATE RATE MILO METERS APPROXIMATE POUNDS/ACRE FOR VARIOUS ROW WIDTHS - MEDIUM SEEDS

10 Inch	15 Inch	20 Inch	30 Inch	36 Inch	38 Inch	40 Inch	Transmission Sprockets		Recomm. Speed Range (MPH)
							Drive	Driven	
18.2	12.1	9.1	6.1	5.1	4.8	4.5	17	28	4 to 8
18.9	12.6	9.4	6.3	5.2	5.0	4.7	17	27	4 to 8
19.6	13.1	9.8	6.5	5.4	5.2	4.9	17	26	4 to 8
20.3	13.6	10.2	6.8	5.6	5.4	5.1	19	28	4 to 8
21.1	14.1	10.5	7.0	5.9	5.6	5.3	19	27	4 to 8
21.2	14.2	10.6	7.1	5.9	5.6	5.3	17	24	4 to 8
22.2	14.8	11.1	7.4	6.2	5.8	5.5	17	23	4 to 8
22.8	15.2	11.4	7.6	6.3	6.0	5.7	19	25	4 to 8
23.7	15.8	11.9	7.9	6.6	6.2	5.9	19	24	4 to 8
24.6	16.4	12.3	8.2	6.8	6.5	6.2	23	28	4 to 8
24.8	16.5	12.4	8.3	6.9	6.5	6.2	19	23	4 to 8
25.7	17.1	12.8	8.6	7.1	6.8	6.4	24	28	4 to 8
26.6	17.8	13.3	8.9	7.4	7.0	6.7	24	27	4 to 8
26.8	17.9	13.4	8.9	7.4	7.1	6.7	17	19	4 to 7.5
27.7	18.4	13.8	9.2	7.7	7.3	6.9	24	26	4 to 7.5
27.8	18.6	13.9	9.3	7.7	7.3	7.0	26	28	4 to 7.5
28.8	19.2	14.4	9.6	8.0	7.6	7.2	24	25	4 to 7.5
28.9	19.2	14.4	9.6	8.0	7.6	7.2	26	27	4 to 7.5
30.0	20.0	15.0	10.0	8.3	7.9	7.5	23	23	4 to 7
31.1	20.8	15.6	10.4	8.6	8.2	7.8	27	26	4 to 7
31.3	20.9	15.6	10.4	8.7	8.2	7.8	24	23	4 to 7
32.6	21.7	16.3	10.9	9.0	8.6	8.1	25	23	4 to 6.5
33.5	22.3	16.7	11.2	9.3	8.8	8.4	19	17	4 to 6.5
33.7	22.5	16.9	11.2	9.4	8.9	8.4	27	24	4 to 6.5
35.0	23.3	17.5	11.7	9.7	9.2	8.7	28	24	3 to 6
36.3	24.2	18.1	12.1	10.1	9.5	9.1	23	19	3 to 5.5
36.5	24.3	18.2	12.2	10.1	9.6	9.1	28	23	3 to 5.5
37.9	25.2	18.9	12.6	10.5	10.0	9.5	24	19	3 to 5.5
39.4	26.3	19.7	13.2	11.0	10.4	9.9	25	19	3 to 5
40.6	27.0	20.3	13.5	11.3	10.7	10.1	23	17	3 to 5
41.0	27.3	20.5	13.7	11.4	10.8	10.3	26	19	3 to 5
42.6	28.4	21.3	14.2	11.8	11.2	10.6	27	19	3 to 5
44.2	29.4	22.1	14.7	12.3	11.6	11.0	28	19	3 to 4.5
45.8	30.6	22.9	15.3	12.7	12.1	11.5	26	17	3 to 4.5
47.6	31.7	23.8	15.9	13.2	12.5	11.9	27	17	3 to 4.5
49.4	32.9	24.7	16.5	13.7	13.0	12.3	28	17	3 to 4.5

IMPORTANT: See "General Planting Rate Information" and "Checking Seed Population" pages for additional information.

NOTE: When using the 2 to 1 Drive Reduction Package, rates will be approximately 1/2 of given numbers.

IMPORTANT: Always check seed population in the field to ensure planting rates are correct.

PLANTING RATES FOR PLATELESS LOW RATE MILO METERS APPROXIMATE POUNDS/ACRE FOR VARIOUS ROW WIDTHS - MEDIUM SEEDS

10 Inch	15 Inch	20 Inch	30 Inch	36 Inch	38 Inch	40 Inch	Transmission Sprockets		Recomm. Speed Range (MPH)
							Drive	Driven	
5.6	3.7	2.8	1.9	1.5	1.5	1.4	17	28	4 to 8
5.8	3.8	2.9	1.9	1.6	1.5	1.4	17	27	4 to 8
6.0	4.0	3.0	2.0	1.7	1.6	1.5	17	26	4 to 8
6.2	4.1	3.1	2.1	1.7	1.6	1.6	19	28	4 to 8
6.4	4.3	3.2	2.2	1.8	1.7	1.6	19	27	4 to 8
6.5	4.3	3.2	2.2	1.8	1.7	1.6	17	24	4 to 8
6.8	4.5	3.4	2.3	1.9	1.8	1.7	17	23	4 to 8
7.0	4.6	3.5	2.3	1.9	1.8	1.7	19	25	4 to 8
7.2	4.8	3.6	2.4	2.0	1.9	1.8	19	24	4 to 8
7.5	5.0	3.8	2.5	2.1	2.0	1.9	23	28	4 to 8
7.6	5.0	3.8	2.5	2.1	2.0	1.9	19	23	4 to 8
7.8	5.2	3.9	2.6	2.2	2.1	2.0	24	28	4 to 8
8.1	5.4	4.1	2.7	2.3	2.1	2.0	24	27	4 to 8
8.2	5.5	4.1	2.7	2.3	2.2	2.0	17	19	4 to 7.5
8.4	5.6	4.2	2.8	2.3	2.2	2.1	24	26	4 to 7.5
8.5	5.7	4.2	2.8	2.4	2.2	2.1	26	28	4 to 7.5
8.8	5.9	4.4	2.9	2.4	2.3	2.2	24	25	4 to 7.5
8.8	5.9	4.4	2.9	2.4	2.3	2.2	26	27	4 to 7.5
9.2	6.1	4.6	3.1	2.5	2.4	2.3	23	23	4 to 7
9.5	6.3	4.8	3.2	2.6	2.5	2.4	27	26	4 to 7
9.5	6.4	4.8	3.2	2.7	2.5	2.4	24	23	4 to 7
9.9	6.6	5.0	3.3	2.8	2.6	2.5	25	23	4 to 6.5
10.2	6.8	5.1	3.4	2.8	2.7	2.6	19	17	4 to 6.5
10.3	6.9	5.1	3.4	2.9	2.7	2.6	27	24	4 to 6.5
10.7	7.1	5.3	3.6	3.0	2.8	2.7	28	24	3 to 6
11.1	7.4	5.5	3.7	3.1	2.9	2.8	23	19	3 to 5.5
11.1	7.4	5.6	3.7	3.1	2.9	2.8	28	23	3 to 5.5
11.6	7.7	5.8	3.9	3.2	3.0	2.9	24	19	3 to 5.5
12.0	8.0	6.0	4.0	3.3	3.2	3.0	25	19	3 to 5
12.4	8.3	6.2	4.1	3.4	3.3	3.1	23	17	3 to 5
12.5	8.3	6.3	4.2	3.5	3.3	3.1	26	19	3 to 5
13.0	8.7	6.5	4.3	3.6	3.4	3.3	27	19	3 to 5
13.5	9.0	6.7	4.5	3.7	3.5	3.4	28	19	3 to 4.5
14.0	9.3	7.0	4.7	3.9	3.7	3.5	26	17	3 to 4.5
14.5	9.7	7.3	4.8	4.0	3.8	3.6	27	17	3 to 4.5
15.1	10.0	7.5	5.0	4.2	4.0	3.8	28	17	3 to 4.5

IMPORTANT: See "General Planting Rate Information" and "Checking Seed Population" pages for additional information.

NOTE: When using the 2 to 1 Drive Reduction Package, rates will be approximately 1/2 of given numbers.

IMPORTANT: Always check seed population in the field to ensure planting rates are correct.

OPERATION**PULL TYPE II/ECONO-FOLD II****DRY INSECTICIDE APPLICATION RATES****APPROXIMATE POUNDS/ACRE FOR DIFFERENT ROW WIDTHS - CLAY GRANULES**

METER SETTING	10 Inch	15 Inch	20 Inch	30 Inch	36 Inch	38 Inch	40 Inch
10	14.8	9.9	7.4	4.9	4.1	3.9	3.7
11	16.3	10.9	8.1	5.4	4.5	4.3	4.1
12	18.3	12.2	9.2	6.1	5.1	4.8	4.6
13	20.7	13.8	10.3	6.9	5.7	5.4	5.2
14	23.0	15.3	11.5	7.7	6.4	6.0	5.7
15	25.6	17.1	12.8	8.5	7.1	6.7	6.4
16	28.8	19.2	14.4	9.6	8.0	7.6	7.2
17	32.0	21.3	16.0	10.7	8.9	8.4	8.0
18	34.3	22.9	17.2	11.4	9.5	9.0	8.6
19	39.3	26.2	19.6	13.1	10.9	10.3	9.8
20	42.5	28.3	21.2	14.2	11.8	11.2	10.6
21	46.6	31.0	23.3	15.5	12.9	12.3	11.6
22	49.2	32.8	24.6	16.4	13.7	12.9	12.3
23	51.5	34.3	25.8	17.2	14.3	13.6	12.9
24	56.5	37.6	28.2	18.8	15.7	14.9	14.1
25	62.6	41.7	31.3	20.9	17.4	16.5	15.6
26	69.0	46.0	34.5	23.0	19.2	18.1	17.2
27	72.2	48.1	36.1	24.1	20.0	19.0	18.0
28	76.2	50.8	38.1	25.4	21.2	20.1	19.1
29	83.5	55.7	41.8	27.8	23.2	22.0	20.9
30	88.8	59.2	44.4	29.6	24.7	23.4	22.2

APPROXIMATE POUNDS/ACRE FOR DIFFERENT ROW WIDTHS - SAND GRANULES

5	8.7	5.8	4.4	2.9	2.4	2.3	2.2
6	14.6	9.7	7.3	4.9	4.0	3.8	3.6
7	16.0	10.7	8.0	5.3	4.4	4.2	4.0
8	18.9	12.6	9.5	6.3	5.3	5.0	4.7
9	23.3	15.5	11.6	7.8	6.5	6.1	5.8
10	26.8	17.8	13.4	8.9	7.4	7.0	6.7
11	30.6	20.4	15.3	10.2	8.5	8.0	7.6
12	33.5	22.3	16.7	11.2	9.3	8.8	8.4
13	37.8	25.2	18.9	12.6	10.5	10.0	9.5
14	42.2	28.1	21.2	14.1	11.7	11.1	10.5
15	46.6	31.0	23.3	15.5	12.9	12.3	11.6
16	52.4	34.9	26.2	17.5	14.6	13.8	13.1
17	58.2	38.8	29.1	19.4	16.2	15.3	14.6
18	65.5	43.7	32.7	21.8	18.2	17.2	16.4
19	72.8	48.5	36.4	24.3	20.2	19.1	18.2
20	77.1	51.4	38.6	25.7	21.4	20.3	19.3
21	82.9	55.3	41.5	27.6	23.0	21.8	20.7
22	88.8	59.2	44.4	29.6	24.7	23.4	22.2
23	96.0	64.0	48.0	32.0	26.7	25.3	24.0
24	103.3	68.9	51.7	34.4	28.7	27.2	25.8
25	110.6	73.7	55.3	36.9	30.7	29.1	27.6

IMPORTANT: The above chart represents average values and should be used only as a starting point. Your actual rate will vary depending upon the insecticide you are using, your planting speed, and your plant population.

Your actual rate must be checked in the field with the actual insecticide that you are using at the speed and population at which you will be planting.

DRY HERBICIDE APPLICATION RATES

APPROXIMATE POUNDS/ACRE FOR DIFFERENT ROW WIDTHS - CLAY GRANULES

Meter Setting	10 Inch	15 Inch	20 Inch	30 Inch	36 Inch	38 Inch	40 Inch
10	14.0	9.3	7.0	4.7	3.9	3.7	3.5
11	15.7	10.5	7.9	5.2	4.4	4.1	3.9
12	17.5	11.6	8.7	5.8	4.9	4.6	4.4
13	19.5	13.0	9.7	6.5	5.4	5.1	4.9
14	21.8	14.6	10.9	7.3	6.1	5.7	5.5
15	24.7	16.5	12.4	8.2	6.9	6.5	6.2
16	27.1	18.0	13.5	9.0	7.5	7.1	6.8
17	29.7	19.8	14.8	9.9	8.2	7.8	7.4
18	32.0	21.3	16.0	10.7	8.9	8.4	8.0
19	34.9	23.3	17.5	11.6	9.7	9.2	8.7
20	37.8	25.2	18.9	12.6	10.5	10.0	9.5
21	40.7	27.2	20.4	13.6	11.3	10.7	10.2
22	43.7	29.1	21.8	14.6	12.1	11.5	10.9
23	47.1	31.4	23.6	15.7	13.1	12.4	11.8
24	50.9	34.0	25.5	17.0	14.1	13.4	12.7
25	54.4	36.3	27.2	18.1	15.1	14.3	13.6
26	58.2	38.8	29.1	19.4	16.2	15.3	14.6
27	62.6	41.7	31.3	20.9	17.4	16.5	15.6
28	67.8	45.2	33.9	22.6	18.8	17.8	17.0
29	72.8	48.5	36.4	24.3	20.2	19.1	18.2
30	80.0	53.4	40.0	26.7	22.2	21.1	20.0

IMPORTANT: The above chart represents average values and should be used only as a starting point. Your actual rate will vary depending upon the herbicide you are using, your planting speed, and your plant population.

Your actual rate must be checked in the field with the actual herbicide that you are using and at the speed and population at which you will be planting.

Rates for 18 and 19 inch row spacing are two times 36 and 38 inch row spacing.

DRY FERTILIZER APPLICATION RATES

Approximate Rate In Pounds Per Acre
Regular Rate Augers

Drive Sprocket	Driven Sprocket	30 Inch Rows	36 Inch Rows	38 Inch Rows
15	**66	87	73	68
19	**66	106	89	83
15	50	127	107	99
19	50	158	135	124
15	33	180	150	140
19	33	227	191	177
30	50	245	205	192
33	50	270	227	202
15	19	322	270	252
30	33	360	303	280
* High Rate Augers				
15	33	270	225	210
19	33	341	287	266
30	50	368	308	288
33	50	405	341	303
15	19	483	405	378
30	33	540	455	420

- * Uneven delivery may result in attempting to use lower rates than indicated by the chart.
- ** Optional low rate sprocket.

Above chart for planters equipped with Kinze drive. Recommended ground drive tire pressure 40 PSI. Recommended contact drive tire pressure 60 PSI.

This chart was calculated with a bulk density of 65 pounds per cubic foot.

IMPORTANT: Fertilizer application rates can vary from the weights calculated in the above chart. To prevent application miscalculations, make field checks to be sure you are applying fertilizer at the desired rate.

To check the exact number of pounds your fertilizer attachment will actually deliver on a 40 inch row spacing, proceed as follows:

Remove one spout from one of the fertilizer hoppers and attach a container under the opening. Engage the fertilizer attachment and drive forward for 130 feet. Weigh the amount of fertilizer caught in the container and multiply that amount by 100. The result will be the pounds of fertilizer delivered per acre when planting in 40 inch rows. To convert this delivery rate for narrower rows, multiply by the following conversion factors.

- 30" Multiply by 1.33
- 36" Multiply by 1.11
- 38" Multiply by 1.05

LIQUID FERTILIZER APPLICATION RATES									
		Row Space Gal. Per Acre					Row Space Gal. Per Acre		
Drive	Driven	38	36	30	Drive	Driven	38	36	30
16	62	5.6	5.7	7.1	62	*60	22.4	22.7	28.4
16	*60	5.8	5.8	7.3	46	44	22.7	23.0	28.7
18	62	6.3	6.4	8.0	20	18	24.1	24.4	30.5
18	*60	6.5	6.6	8.2	18	16	24.4	24.7	30.9
16	52	6.7	6.7	8.4	52	46	24.5	24.8	31.0
20	62	7.0	7.1	8.9	*60	52	25.0	25.4	31.7
					52	44	25.6	25.9	32.4
18	52	7.5	7.6	9.5	62	52	25.8	26.2	32.7
16	46	7.5	7.6	9.5	20	16	27.1	27.4	34.3
16	44	7.9	8.0	10.5	*60	46	28.3	28.6	35.8
20	52	8.3	8.5	10.6	62	46	29.2	29.6	37.0
18	46	8.5	8.6	10.7	*60	44	29.6	29.9	37.4
18	44	8.9	9.0	11.2	62	44	30.5	31.0	38.7
20	46	9.4	9.5	11.9	44	30	31.8	32.2	40.3
20	44	9.9	10.0	12.5	30	20	32.5	33.0	41.2
30	62	10.5	10.6	13.3	46	30	33.2	33.7	42.1
30	*60	10.8	11.0	13.7	30	18	36.1	36.6	45.8
16	30	11.6	11.7	14.6	52	30	37.6	38.1	47.6
30	52	12.5	12.6	15.8	30	16	40.6	41.2	51.5
18	30	13.0	13.2	16.5	*60	30	43.4	43.9	54.9
30	46	14.1	14.3	17.9	62	30	44.8	45.4	56.7
20	30	14.5	14.6	18.3	44	20	47.7	48.3	60.4
30	44	14.8	15.0	18.7	46	20	49.9	50.5	63.1
44	62	15.4	15.6	19.5	44	18	53.0	53.7	67.1
44	*60	15.9	16.1	20.1	46	18	55.4	56.2	70.2
46	62	16.1	16.3	20.4	52	20	56.4	57.1	71.4
46	*60	16.6	16.8	21.0	44	16	59.6	60.0	75.5
16	20	17.3	17.6	22.0	46	16	62.3	63.1	78.9
52	62	18.2	18.4	23.0	52	18	62.6	63.4	79.3
44	52	18.3	18.6	23.2	*60	20	65.0	65.9	82.4
52	*60	18.8	19.0	23.8	62	20	67.2	68.1	85.1
46	52	19.2	19.4	24.3	52	16	70.4	71.4	89.2
16	18	19.3	19.5	24.4	*60	18	72.3	73.2	91.5
18	20	19.5	19.8	24.7	62	18	74.7	75.7	94.6
44	46	20.7	21.0	26.3	*60	16	81.3	82.4	103.0
*60	62	21.0	21.3	26.6	62	16	84.0	85.1	106.4

Above chart for planters equipped with Kinze drive. Recommended ground drive tire pressure 40 PSI. Recommended contact drive tire pressure 60 PSI.

This chart was calculated based on a solution weighing ten pounds per gallon.

IMPORTANT: Fertilizer application rates can vary from the above chart. To prevent application miscalculations, make field checks to be sure you are applying fertilizer at the desired rate.

LUBRICATION

The following pages show the locations of all lubrication points. Proper lubrication of all moving parts will help ensure efficient operation of your Kinze planter and prolong the life of friction producing parts. Those parts equipped with grease fittings should be lubricated at the frequency indicated with an SAE multipurpose type grease. Be sure to clean the fitting thoroughly before using grease gun. The frequency of lubrication recommended is based on normal operating conditions. Severe or unusual conditions may require more frequent attention.

Refer to the Kinze Row Unit Manual for lubrication of all row units.

SEALED BEARINGS

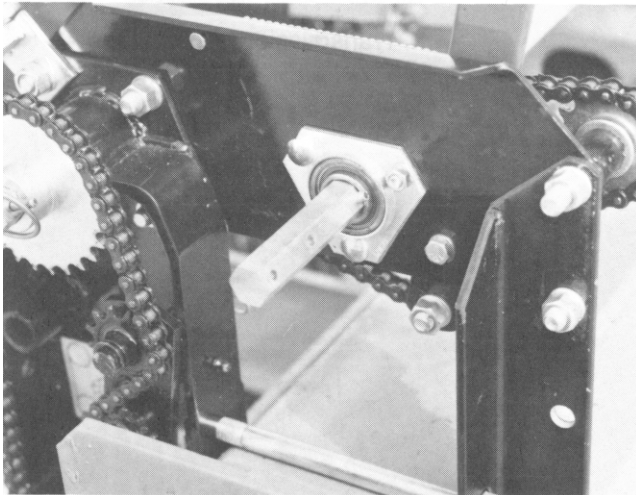

A number of sealed bearings are used on your Kinze planter to provide trouble free operation. These are located in such areas as the drive shaft, row units, and transmission bearings. Sealed bearings are lubricated for life, and due to the seals, relubrication is not practical.

DRIVE CHAINS

The transmission and drive chains should be lubricated approximately every 8-10 hours with a good quality spray lubricant. Extreme operating conditions such as dirt, temperature, or speed may require more frequent lubrication. If a chain becomes stiff, it should be removed, soaked and washed in solvent to loosen and remove dirt from the joints. Then soak the chain in oil so the lubricant can penetrate between the rollers and bushings.

WHEEL BEARINGS

Wheel bearings should be repacked with clean, heavy-duty axle grease approximately once a year or at the beginning of each planting season. This applies to all drive wheels, transport wheels and marker hubs. Transport wheels may require less frequent service depending upon amount of road travel. Follow the procedure outlined for wheel bearing replacement with the exception that bearings and bearing cups are reused.

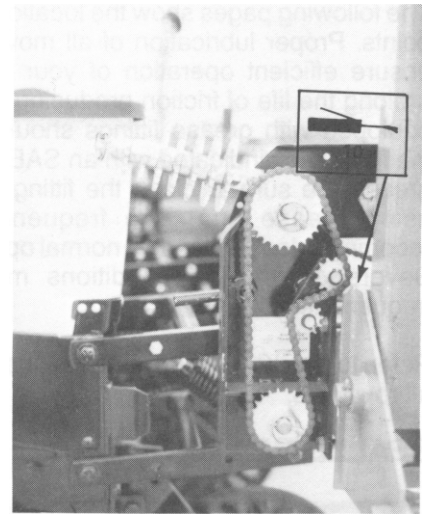
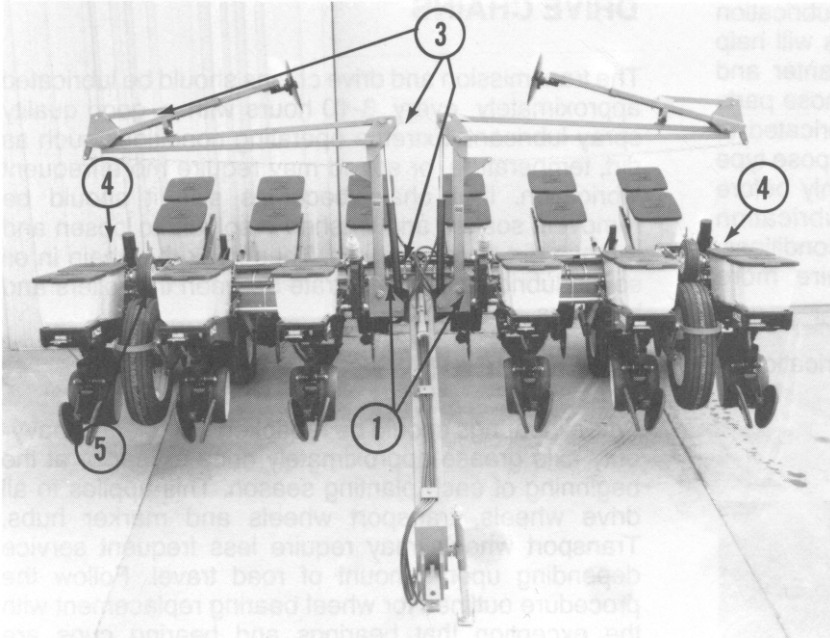

1. Transmission Assemblies -
1 Zerk Per Assembly (Idler)

12 Row Model

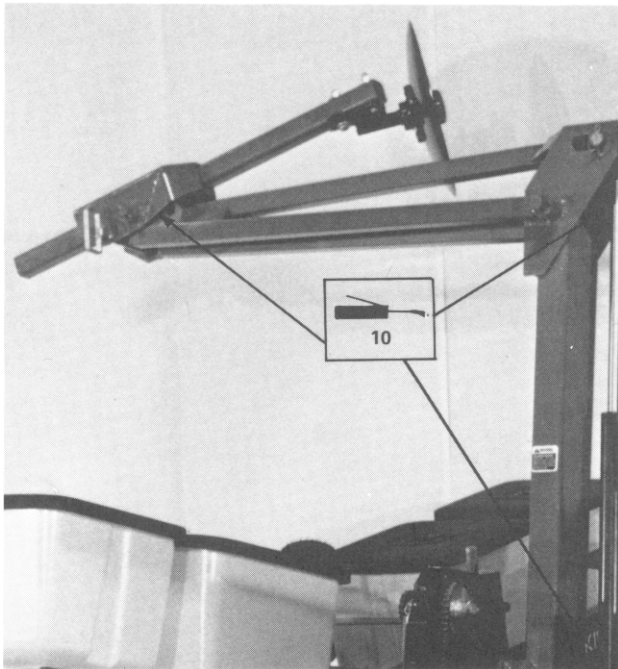

2. Marker Assemblies (8 Row Model)
3 Zerks Per Assembly

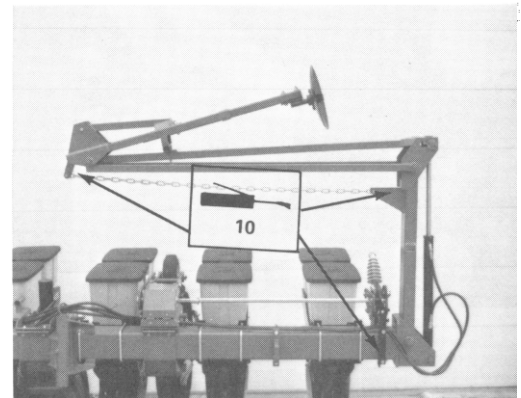

3. Marker Assemblies (12 Row Model)
3 Zerks Per Assembly

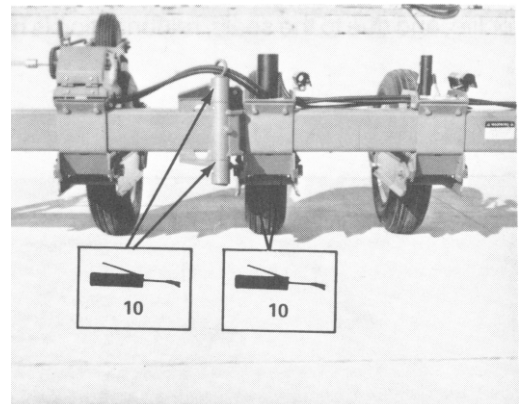

4. Hinge Assemblies - 2 Zerks Per Assembly
5. Wheel Modules - 2 Zerks Per Module



Frequency of lubrication in hours.

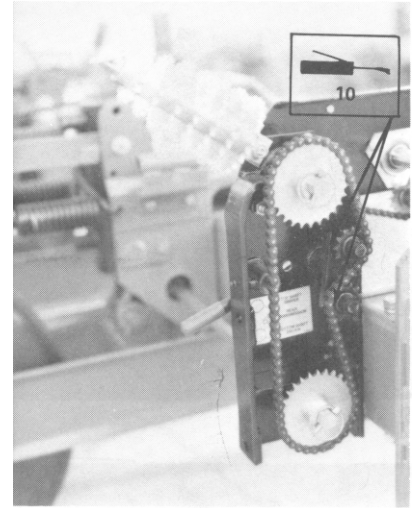
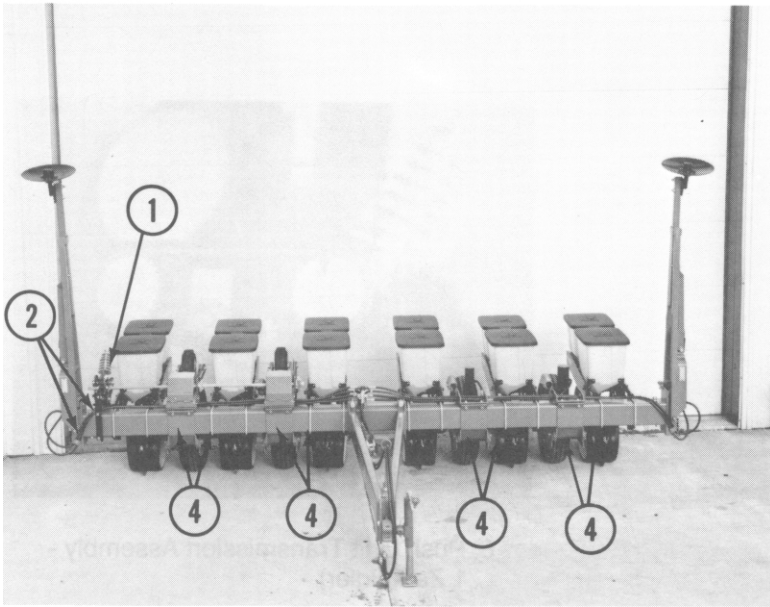

1. Transmission Assembly -
1 Zerk (Idler)

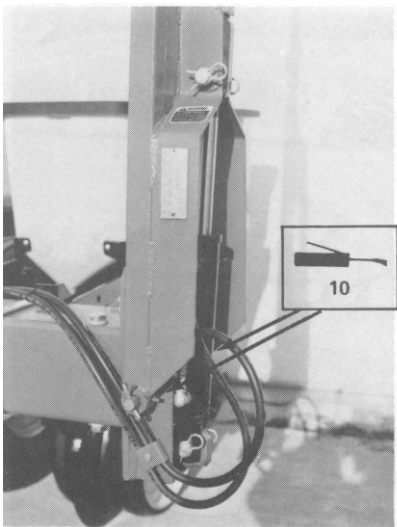

2. Conventional Marker Assemblies -
2 Zerks Per Assembly

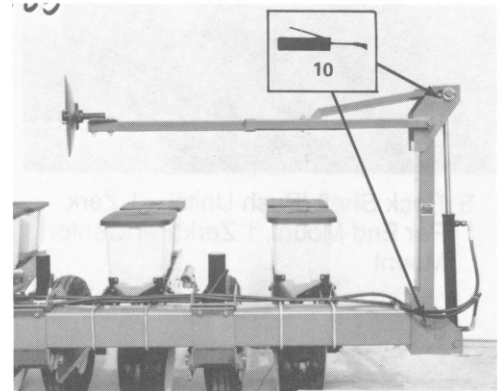

3. Low Profile Marker Assemblies -
2 Zerks Per Assembly

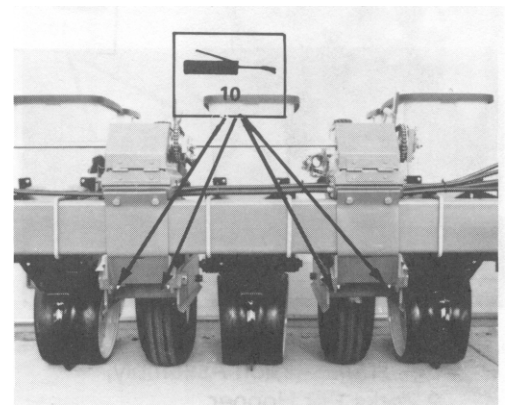

4. Lower Wheel Module Assemblies -
2 Zerks Per Module



Frequency of lubrication in hours.

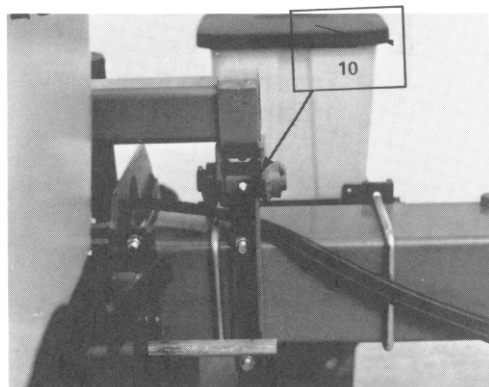
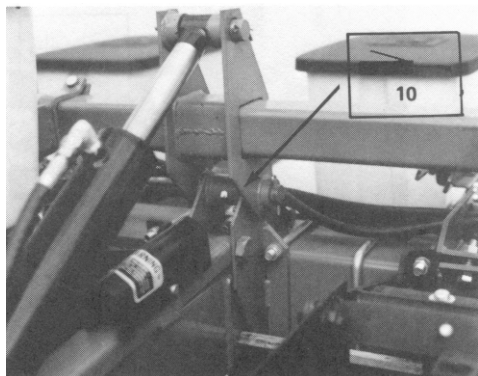

5. Rock Shaft (Push Units) - 1 Zerk Per End Mount, 1 Zerk Per Center Mount

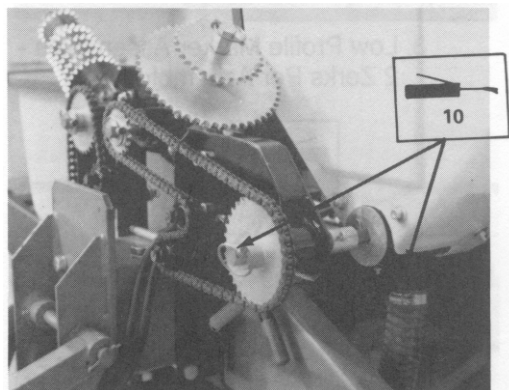

7. Dry Fertilizer Attachment - 1 Zerk Per Transmission Assembly, 2 Zerks Per Hopper

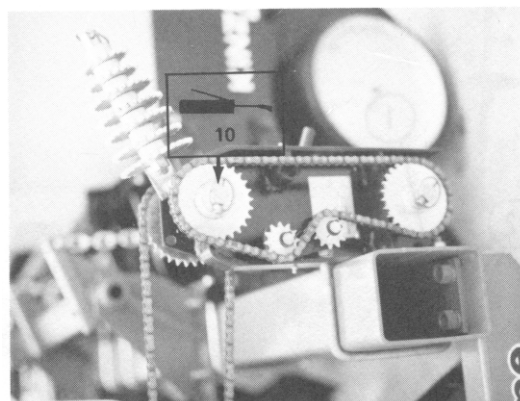

6. Push Unit Transmission Assembly - 1 Zerk (Idler)

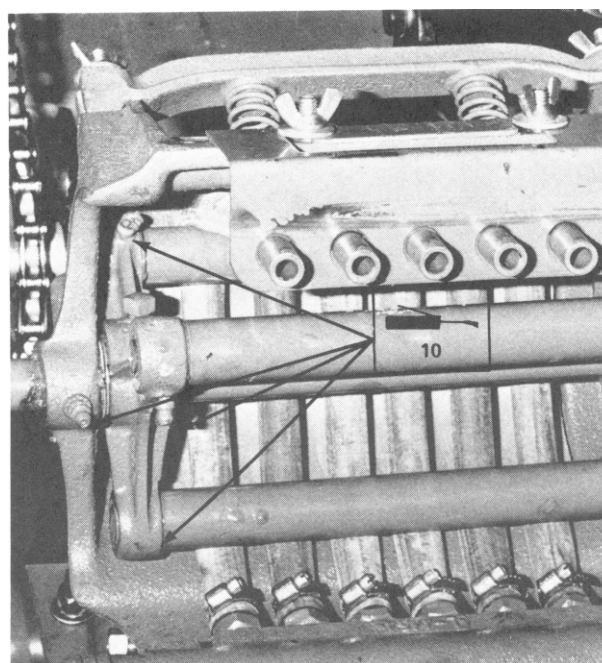

8. Liquid Fertilizer Attachment, Squeeze Pump - 8 Zerks Per Pump



Frequency of lubrication in hours.

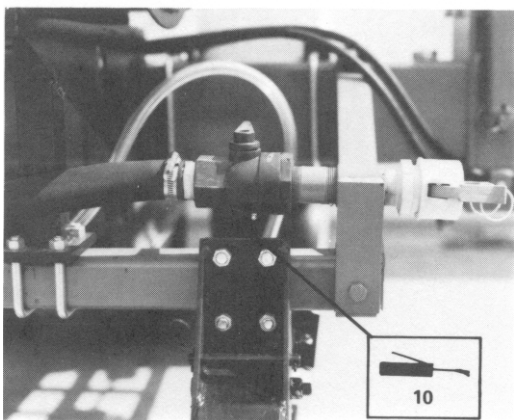

9. Liquid Fertilizer Attachment,
Shut Off Valves - 1 Zerk
Per Valve

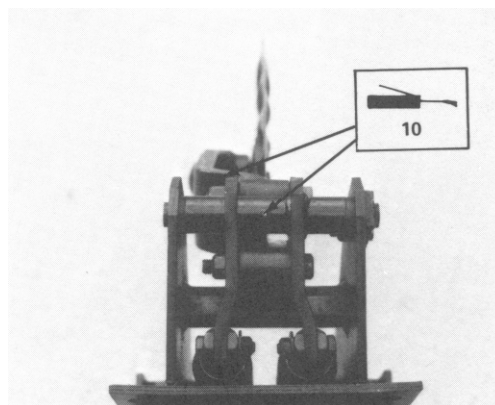

10. Frame Mounted Coulter -
1 Zerk Per Mount, 1 Zerk
Per Arm



Frequency of lubrication in hours.

MAINTENANCE

MOUNTING BOLTS AND HARDWARE



Before operating the planter for the first time, check to be sure all nuts and bolts are tight. Check all nuts and bolts again after approximately the first 50 hours of operation and at the beginning of each planting season thereafter.

All bolts used on the Kinze planter are Grade 5 (high strength) unless otherwise noted. Refer to the torque value chart when tightening bolts.

NOTE: Overtightening bolts can cause as much damage as undertightening. Tightening a bolt beyond the recommended range can reduce its shock load capacity.

⚠ WARNING: Before operating the planter for the first time and periodically thereafter, check to be sure the bolts on the transport wheels are tight. This is especially important if the planter is going to be transported for a long distance.

TORQUE VALUES CHART - PLATED HARDWARE

Bolt Dia.	Grade 2 		Grade 5 		Grade 8 	
	Course	Fine	Course	Fine	Course	Fine
1/4	50 In. Lbs.	56 In. Lbs.	76 In. Lbs.	87 In. Lbs.	9 Ft. Lbs.	10 Ft. Lbs.
5/16	8 Ft. Lbs.	9 Ft. Lbs.	13 Ft. Lbs.	14 Ft. Lbs.	18 Ft. Lbs.	20 Ft. Lbs.
3/8	15 Ft. Lbs.	17 Ft. Lbs.	23 Ft. Lbs.	26 Ft. Lbs.	33 Ft. Lbs.	37 Ft. Lbs.
7/16	25 Ft. Lbs.	27 Ft. Lbs.	37 Ft. Lbs.	41 Ft. Lbs.	52 Ft. Lbs.	58 Ft. Lbs.
1/2	35 Ft. Lbs.	40 Ft. Lbs.	57 Ft. Lbs.	64 Ft. Lbs.	80 Ft. Lbs.	90 Ft. Lbs.
9/16	50 Ft. Lbs.	60 Ft. Lbs.	80 Ft. Lbs.	90 Ft. Lbs.	115 Ft. Lbs.	130 Ft. Lbs.
5/8	70 Ft. Lbs.	80 Ft. Lbs.	110 Ft. Lbs.	125 Ft. Lbs.	160 Ft. Lbs.	180 Ft. Lbs.
3/4	130 Ft. Lbs.	145 Ft. Lbs.	200 Ft. Lbs.	220 Ft. Lbs.	280 Ft. Lbs.	315 Ft. Lbs.
7/8	125 Ft. Lbs.	140 Ft. Lbs.	320 Ft. Lbs.	350 Ft. Lbs.	450 Ft. Lbs.	500 Ft. Lbs.
1	190 Ft. Lbs.	205 Ft. Lbs.	480 Ft. Lbs.	530 Ft. Lbs.	675 Ft. Lbs.	750 Ft. Lbs.
1 1/8	265 Ft. Lbs.	300 Ft. Lbs.	600 Ft. Lbs.	670 Ft. Lbs.	960 Ft. Lbs.	1075 Ft. Lbs.
1 1/4	375 Ft. Lbs.	415 Ft. Lbs.	840 Ft. Lbs.	930 Ft. Lbs.	1360 Ft. Lbs.	1500 Ft. Lbs.
1 3/8	490 Ft. Lbs.	560 Ft. Lbs.	1100 Ft. Lbs.	1250 Ft. Lbs.	1780 Ft. Lbs.	2030 Ft. Lbs.
1 1/2	650 Ft. Lbs.	730 Ft. Lbs.	1450 Ft. Lbs.	1650 Ft. Lbs.	2307 Ft. Lbs.	2670 Ft. Lbs.

NOTE: Unplated bolts should be torqued approximately 1/3 higher than the above values. Bolts having lock nuts should be tightened to approximately 50% of amounts shown in chart. Bolts lubricated prior to installation should be torqued to 70% of value shown on chart.

MAINTENANCE

CHAIN TENSION ADJUSTMENT

Many of the drive chains are spring loaded and therefore self-adjusting. The only adjustment needed is to shorten the chain if wear stretches the chain and reduces spring tension. The pivot point of these idlers should be checked periodically to ensure they will rotate freely.

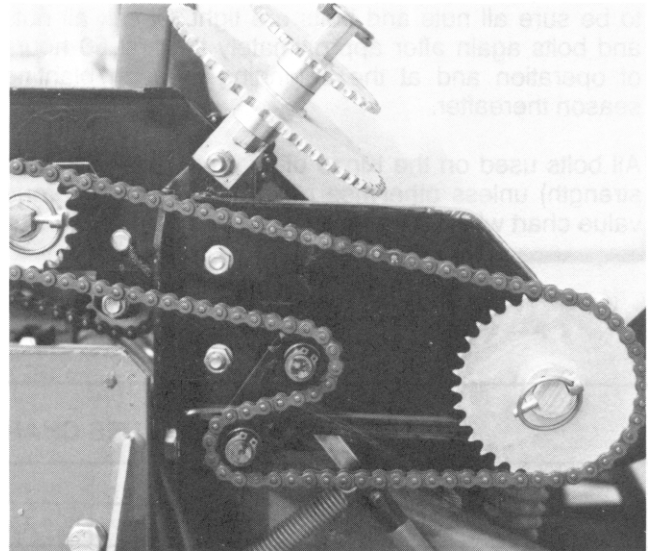
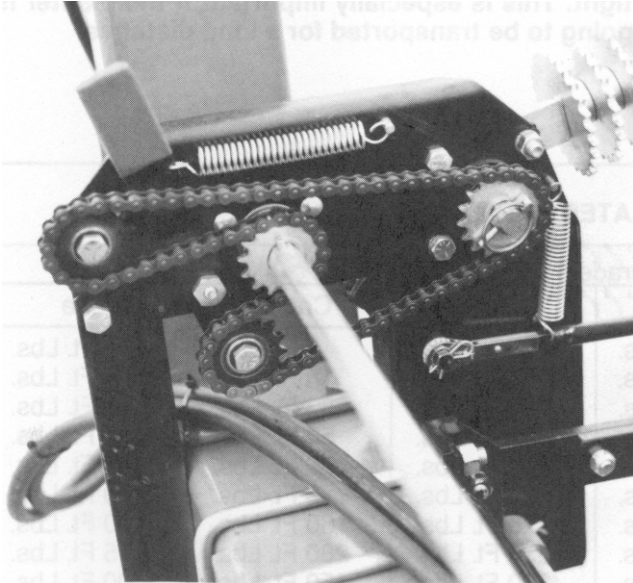

On planters equipped with markers that have chain linkage for folding the 3rd stage of the marker, the chain must be adjusted so the 3rd stage of the marker is pulled out as soon as the 2nd stage begins outward travel. The chain may stretch and need to be readjusted with usage. It may be necessary to twist the chain for a finer adjustment.

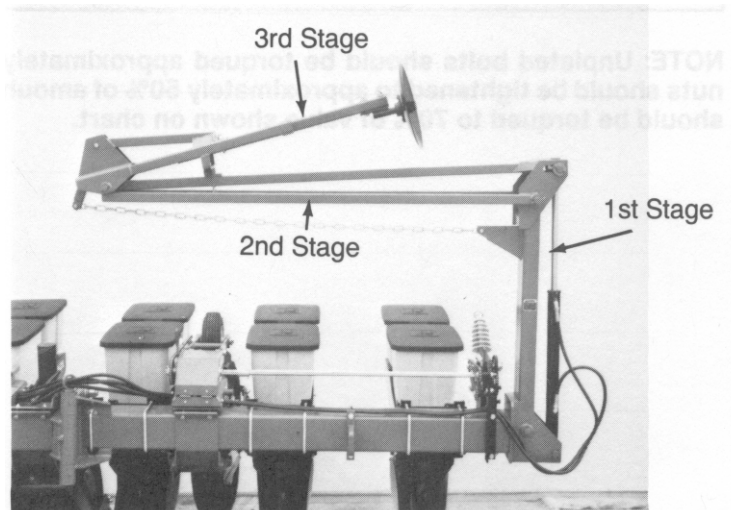
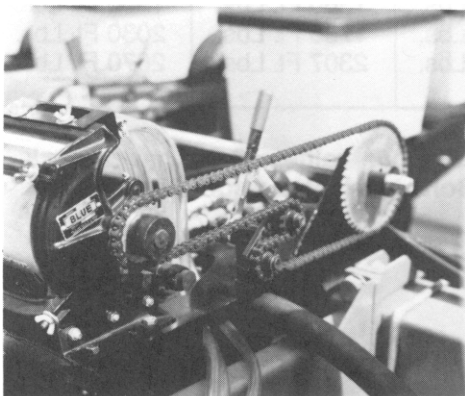

MAINTENANCE

Additional shear pins, springs and chain links can be found in the storage box located on the wheel assembly.

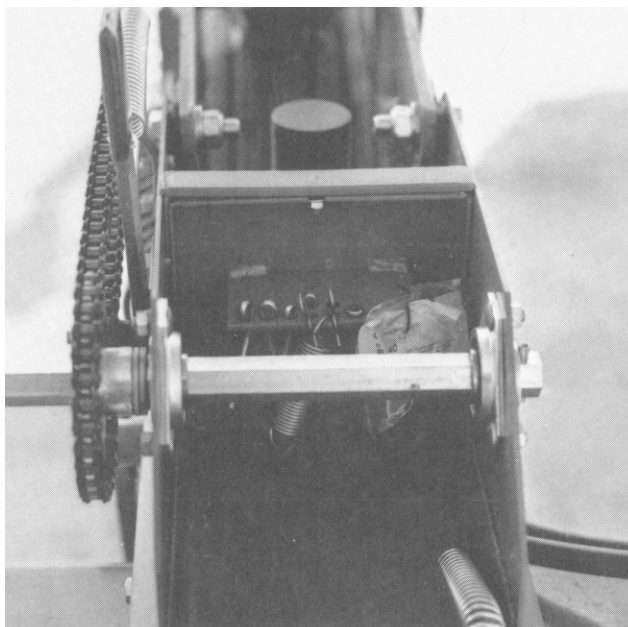

SEQUENCING VALVE INSPECTION

The sequencing valve consists of a chambered body containing a spool and a series of check valves to direct hydraulic flow. Should the valve malfunction, the components may be removed for inspection. The spool is accessible by removing either side plug and one check valve is accessible from the top of the valve body. It is necessary to disconnect the outlet hoses from the back of the valve to gain access to the remaining retainers and check valves. Inspect all parts for pitting, contamination or foreign material. Also check seating surfaces inside the valve. Replace any parts found to be defective.

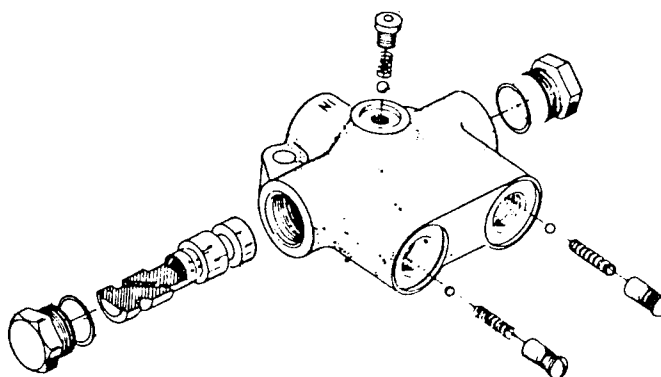

IMPORTANT: Make sure correct check ball and spring are installed in each check valve bore upon reassembly.

MARKER FLOW CONTROL VALVE INSPECTION

The flow control valves should be adjusted for raise and lower speed as part of the assembly procedure or upon initial operation. If the valve fails to function properly or requires frequent adjustment, the needle valve should be removed for inspection. Check for foreign material and contamination on both the valve and the seating area of the valve body. Replace any components found to be defective.

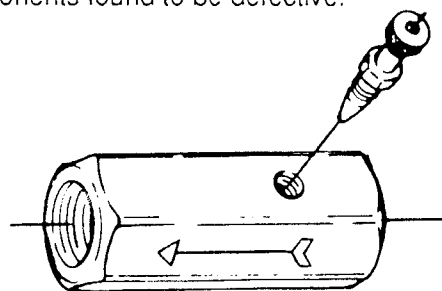

IMPORTANT: The flow control valves must be installed with the arrows pointed toward the tractor.

MAINTENANCE

VALVE BLOCK ASSEMBLY INSPECTION

(Marker Sequencing & Flow Control Valves)

The valve block assembly consists of the marker sequencing and flow control valves in one assembly.

The sequencing valve portion consists of a chambered body containing a spool and series of check valves to direct hydraulic flow. Should the valve malfunction, the components may be removed for inspection.

1. Remove valve block assembly from planter.
2. Remove detent assembly and port adapter assemblies from rear of valve block.
3. Remove plug from both sides of valve block and remove spool.
4. Inspect all parts for pitting, contamination or foreign material. Also check seating surfaces inside the valve. Replace any parts found to be defective.
5. Lubricate spool with a light oil and re-install. Check to be sure spool moves freely in valve body.

IMPORTANT: Make sure correct check ball(s) and spring are installed in each valve bore upon reassembly.

A flow control valve is located on each side of the block assembly. The flow control valves should be adjusted for raise and lower speed as part of the assembly procedure or upon initial operation. If the valve fails to function properly or requires frequent adjustment, the needle valve should be removed for inspection. Check for foreign material and contamination. Be sure needle moves freely in adjustment screw. Replace any components found to be defective.

Port Adapter, Spring, 7/16" Check Ball,
1/4" Steel Ball

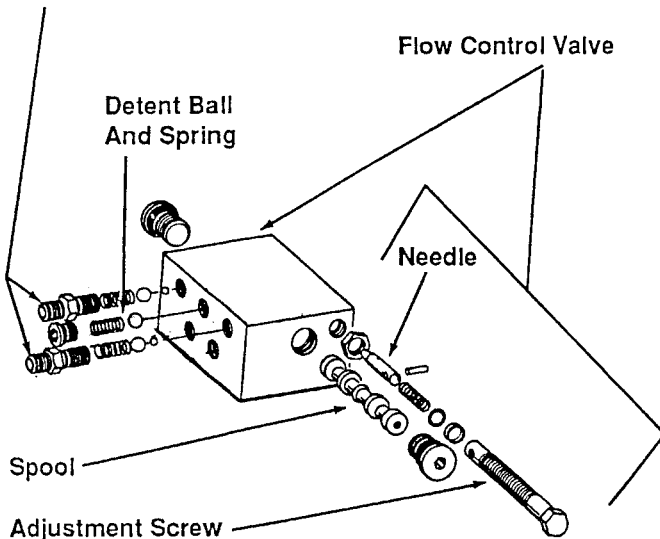

MAINTENANCE

MARKER OPERATION TROUBLE SHOOTING		
PROBLEM	POSSIBLE CAUSE	POSSIBLE SOLUTION
Both markers lowering and only one raising at a time.	Hoses from cylinders to valve connected backwards.	Check hosing diagram in manual and correct.
Same marker always operating.	Spool in sequencing valve not shifting.	Remove spool, inspect for foreign material, making sure all ports in spool are open. Clean and re-install.
Both markers lower and raise at same time.	Foreign material under check ball in sequencing valve. Check ball missing or installed incorrectly in sequencing valve.	Remove hose fitting, spring and balls and clean. May be desirable to remove spool and clean as well. Disassemble and correct. See illustration in Parts Section.
Marker (in raised position) settling down.	Damaged o-ring in marker cylinder or cracked piston. Spool in sequencing valve not shifting completely because detent ball or spring is missing. Spool in sequencing valve shifting back toward center position.	Disassemble cylinder and inspect for damage and repair. Check valve assembly and install parts as needed. Restrict flow of hydraulic oil from tractor to sequencing valve.
Neither marker will move.	Flow control closed too far.	Loosen locking nut and turn flow control adjustment bolt out or counterclockwise until desired speed is set.
Markers moving to fast.	Flow control open too far.	Loosen locking nut and turn flow control adjustment bolt in or clockwise until desired speed is set.
Sporadic marker operation speed. (Machines equipped with valve block assembly only.)	Needle sticking open in flow control valve.	Remove flow control, inspect and repair or replace.

MAINTENANCE

MARKER BEARING LUBRICATION OR REPLACEMENT

1. Remove marker blade.
2. Remove hub cap from hub.
3. Remove cotter pin, axle nut and washer.
4. Slide hub from spindle.
5. Remove bearings and cups and discard if bearings are being replaced. Clean hub and dry. Remove bearings only and not cups if repacking.
6. Press in new bearing cups with thickest edge facing in. (Bearing replacement procedure only.)
7. Pack bearings with heavy duty wheel bearing grease thoroughly forcing grease between roller cone and bearing cage. Also fill the space between the bearing cups in the hub with grease.
8. Place inner bearing in place and press in new rubber seal and grease seal.
9. Clean spindle and install hub.
10. Install outer bearing, washer or outer seal and slotted hex nut. Tighten slotted hex nut while rotating hub until there is some drag. This assures that all bearing surfaces are in contact. Back off slotted nut to nearest locking slot and install cotter pin.
11. Fill hub caps approximately 3/4 full of wheel bearing grease and install on hub.
12. Install blade on hub and tighten evenly and securely.

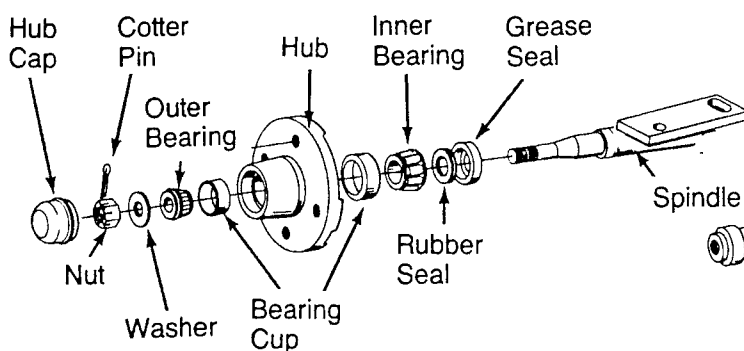

WHEEL BEARING LUBRICATION OR REPLACEMENT

1. Raise tire clear of ground and remove wheel.
2. Remove double jam nuts and slide hub from spindle.
3. Remove bearings and cups and discard if bearings are being replaced. Clean hub and dry. Remove bearings only and not cups if repacking.
4. Press in new bearing cups with thickest edge facing in. (Bearing replacement procedure only.)
5. Pack bearings with heavy duty wheel bearing grease thoroughly forcing grease between roller cone and bearing cage. Also fill the space between the bearing cups in the hub with grease.
6. Place inner bearing in place.
7. Clean axle and install hub.
8. Install outer bearing and jam nut. Tighten jam nut while rotating hub until there is some drag. This assures that all bearing surfaces are in contact. Back off jam nut 1/4 turn or until there is only slight drag when rotating the hub. Install second jam nut to lock against first.
9. Install wheel on hub and tighten evenly and securely.

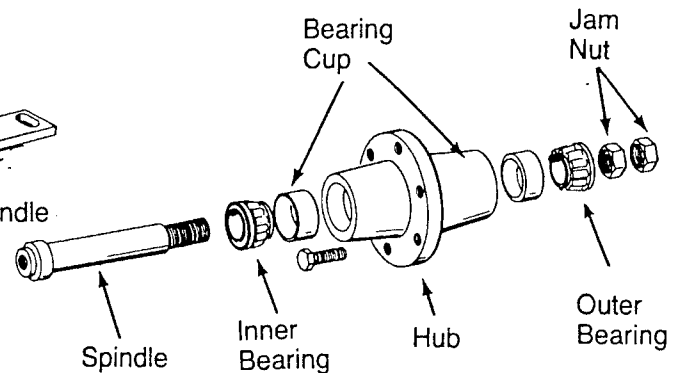

MAINTENANCE

POINT ROW WRAP SPRING CLUTCH INSPECTION (Optional Econo-Fold II)

The point row wrap spring clutch is permanently lubricated and requires no periodic maintenance. **Do no lubricate. Keep clutches clean. To clean, blow air through the clutch.**

The right hand clutch operates clockwise and the left hand clutch operates counterclockwise. Therefore, some of the parts of the clutch such as the wrap spring differ from one side of the planter to the other. Be sure to use the correct repair part for the clutch being repaired.

If the clutch or clutches fail to operate, first determine if the problem is electrical or mechanical. Place the operational switch in the "OFF" position. This should energize the solenoid coil. If the solenoid is operating properly, the plunger on the solenoid will retract causing a clicking sound. If the plunger does not retract,

check the coil for power either with a test light or by touching the plunger with a metal object. If the coil is working properly, the plunger will be magnetized. If the plunger is not magnetized, check the wiring harness at the coil terminals with a test light or volt meter. Power at this point would indicate that the coil is defective and must be replaced. Should there be not power at this point, check the wiring harness back to the tractor until the problem is located.

If power is getting to the solenoid coil and the plunger will not retract, place the operational switch in the "ON" position and check to see if the plunger can move in and out freely. If not, move the plunger in and out until it is freed up or replace the solenoid assembly. Corrosion or foreign material can cause the plunger to stick. A small amount of penetrating oil may free up the plunger. Caution should be taken to prevent oil from getting on the hubs or spring.

TROUBLE SHOOTING		
PROBLEM	POSSIBLE CAUSE	POSSIBLE SOLUTION
Neither clutch will disengage.	Fuse blown in control box. Poor terminal connection in wiring harness. Wiring damage in wiring harness. Low voltage at coil (12 volts required.)	Replace fuse. Repair or replace Repair or replace. Check battery connections.
One clutch will not disengage.	Shear pin at row unit transmission sheared. Electrical failure	Replace with one of equal size and grade. Check solenoid, wiring harness and coil terminals.
One clutch will not engage.	Actuator arm and plunger stuck in disengaged position. Actuator arm stop out of adjustment Wrap spring broken or stretched. The coils near the center of a stretched spring will be uneven with the rest of the coils. Foreign substance such as oil or grease on the input or output hubs. Something touching the stop collar. Clutch assembled incorrectly.	Remove, free up and reinstall. Adjust sleeve on actuator limit stop so that actuator arm clears stop on stop collar by approximately 1/16" when clutch is rotated. Disassemble clutch and replace spring. Disassemble clutch. Clean hubs and spring and reassemble. Check to ensure collar is free to turn with clutch. Check clutch and diagram for correct assembly.

MAINTENANCE

<p>Clutch slipping.</p>	<p>Foreign substance such as oil or grease on the input or output hubs causing the spring to slip on the hub.</p> <p>Wrap spring stretched.</p>	<p>Disassemble clutch and clean hubs and spring. Reassemble.</p> <p>Disassemble clutch and inspect spring for uneven coils near the center of the spring. Replace spring.</p>
<p>Clutch will not re-engage while planter is moving forward.</p>	<p>Spring in actuator arm not strong enough to push arm away from stop collar when operational switch is turned to the "ON" position.</p>	<p>Remove spring and stretch spring slightly. Reinstall spring. If that fails, file the stop on the stop collar slightly so that the stop is not as aggressive.</p>

NOTE: To identify parts see Point Row Wrap Spring Clutch Assembly pages in Parts Section of this manual.

MAINTENANCE

PREPARATION FOR STORAGE

Store the planter in a dry sheltered area if possible.

Remove all trash that may be wrapped on sprockets or shafts and remove dirt that can draw and hold moisture.

Clean all drive chains and coat with a rust preventative spray, or remove chains and submerge in oil.

Lubricate planter and row units at all lubrication points.

If possible, remove weight from all tires particularly if the unit is stored outdoors, in which case it is best to remove wheels and tires for storage in a cool dry area.

Inspect the planter and row units for parts that are in need of replacement and order during the "off" season.

Make sure all seed, herbicide and insecticide hoppers are empty and clean.

Clean seed meters and store in a dry area. (Refer to row unit manual for proper procedures)

Grease exposed areas of cylinder rods before storing planter.

If the planter is equipped with a liquid fertilizer attachment, open the shut off valve and flush water through the system.

If the planter is equipped with a dry fertilizer attachment, clean the fertilizer hoppers, openers and all rubber spouts.

If the planter is equipped with a dry fertilizer quick fill attachment, pull auger from tube and thoroughly clean auger and tube and treat with a rust preventative.

PARTS LIST INDEX

Econo-Fold Hitch Assembly	P2
Econo-Fold Frame Assembly	P3
Pull Type Hitch And Frame Assembly	P4/P5
Transport And Ground Drive Wheel Assembly	P6/P7
Contact Drive Wheel And Arm Assembly	P8/P9
Econo-Fold Wheel Lockup Assembly	P10
Tire Scraper Assembly	P10
Econo-Fold Wrap Spring Clutch Assembly, Style A	P10A
Econo-Fold Wrap Spring Clutch Assembly, Style B	P10B
Econo-Fold Drive Line	P11/P13
Pull Type Drive Line	P14/P16
Ratchet And Sprocket Assembly	P17
Magnetic Distance Sensor	P17
Transmission Assembly	P18/P19
Econo-Fold Marker Assembly	P20/P23
Pull Type Conventional Marker Assembly	P24/P25
Pull Type Low Profile Marker Assembly	P26/P27
Marker Hub Assembly	P28
Cylinders	P29/P32
Marker Sequencing/Flow Control Valve	P32A
Marker Sequencing Valve	P33
Marker Flow Control Valve	P33
Econo-Fold Hydraulic System	P34/P37
Pull Type Hydraulic System	P38/P45
Push Unit Drill Shaft And Transmission Assembly	P46/P49
Rock Shaft Assembly	P50/P51A
Twin Push Stabilizer Linkage	P51B
Frame Mounted Coulter Assembly	P52/P53
Fertilizer Opener	P54/P55
Fertilizer Opener Mounting Bar	P56/P57
Dry Fertilizer Transmission Assembly	P58/P59
Dry Fertilizer Hopper And Mounts	P60/P61
Dry Fertilizer Couplers	P62/P63
Dry Fertilizer Quick Fill Assembly	P64/P65
Squeeze Pump Mounting Bracket, Sprocket And Adapter Package, And Drive Line	P66/P68
Liquid Fertilizer Squeeze Pumps	P69/P71
Liquid Fertilizer Tanks, Saddles, Mounts, Hoses And Fittings	P72/P73
Decals, Reflectors And Tie Straps	P74/P75
Warning Lights And SMV	P76
Parts Section Numerical Index	a

ECONO-FOLD HITCH ASSEMBLY

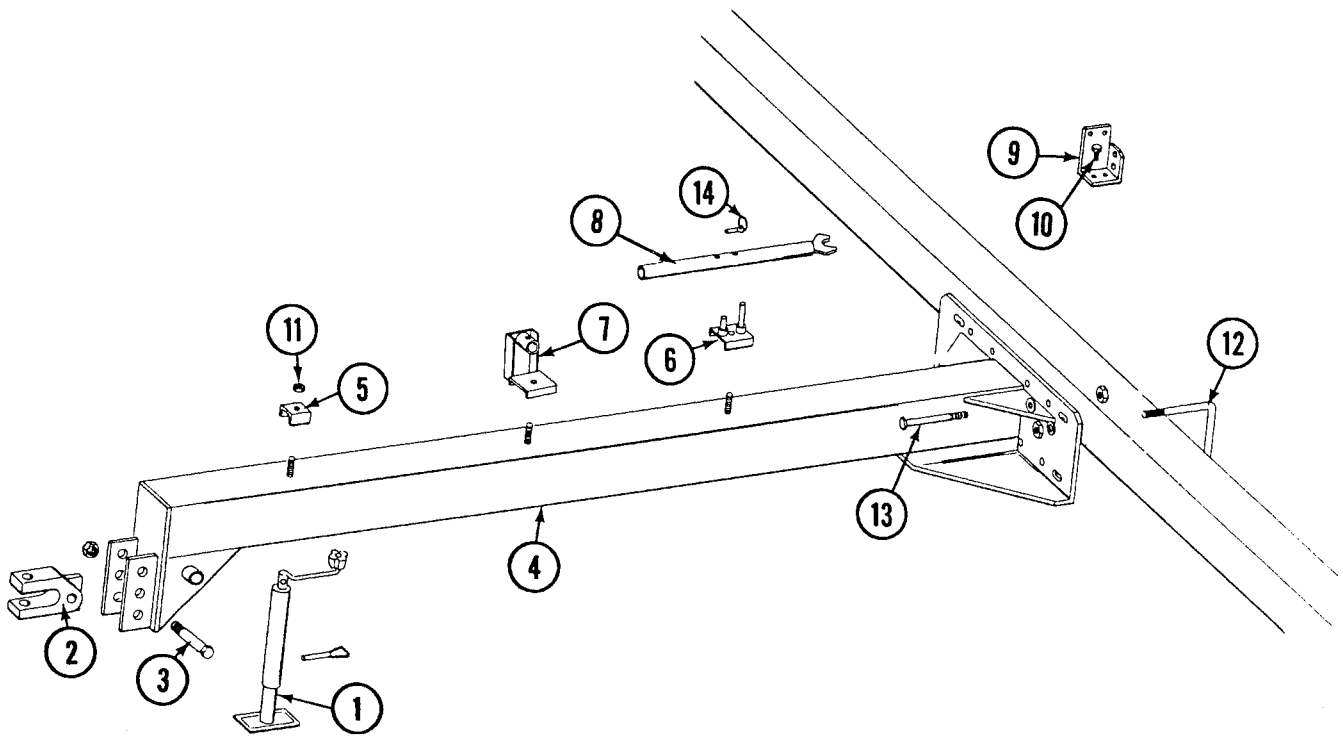

ITEM	PART NO.	DESCRIPTION
1.	4100-02	Jack Assembly
	R0255	Pin and Chain Repair Kit
2.	B0156	Clevis
3.	10169	HHCS, 1 1/4" - 7 x 6"
	10157	Lock Nut, 1 1/4" - 7
4.	A5126	Hitch, 133 3/8", 8 Row 30 and 12 Row 30
	A5127	Hitch, 151 3/8", 8 Row Wide
5.	D0740	Clamp
6.	A2452	Clamp, Hose and Wrench Storage
7.	A2451	Clamp, Hose and Jack Storage
8.	A2460	Wrench
9.	A5141	Angle, Valve Mount
10.	10001	HHCS, 3/8" - 16 x 1"
11.	10111	Lock Nut, 1/2" - 13
12.	D1748	U-Bolt, 7" x 7" x 3/4" - 10
	10218	Washer, 3/4" USS
	10231	Lock Washer, 3/4"
	10105	Hex Nut, 3/4" - 10
13.	10177	HHCS, 5/8" - 11 x 9 1/2"
	10190	Special Washer, 5/8"
	10107	Lock Nut, 5/8" - 11
14.	D2558	Lynch Pin, 1/4"

ECONO-FOLD FRAME ASSEMBLY

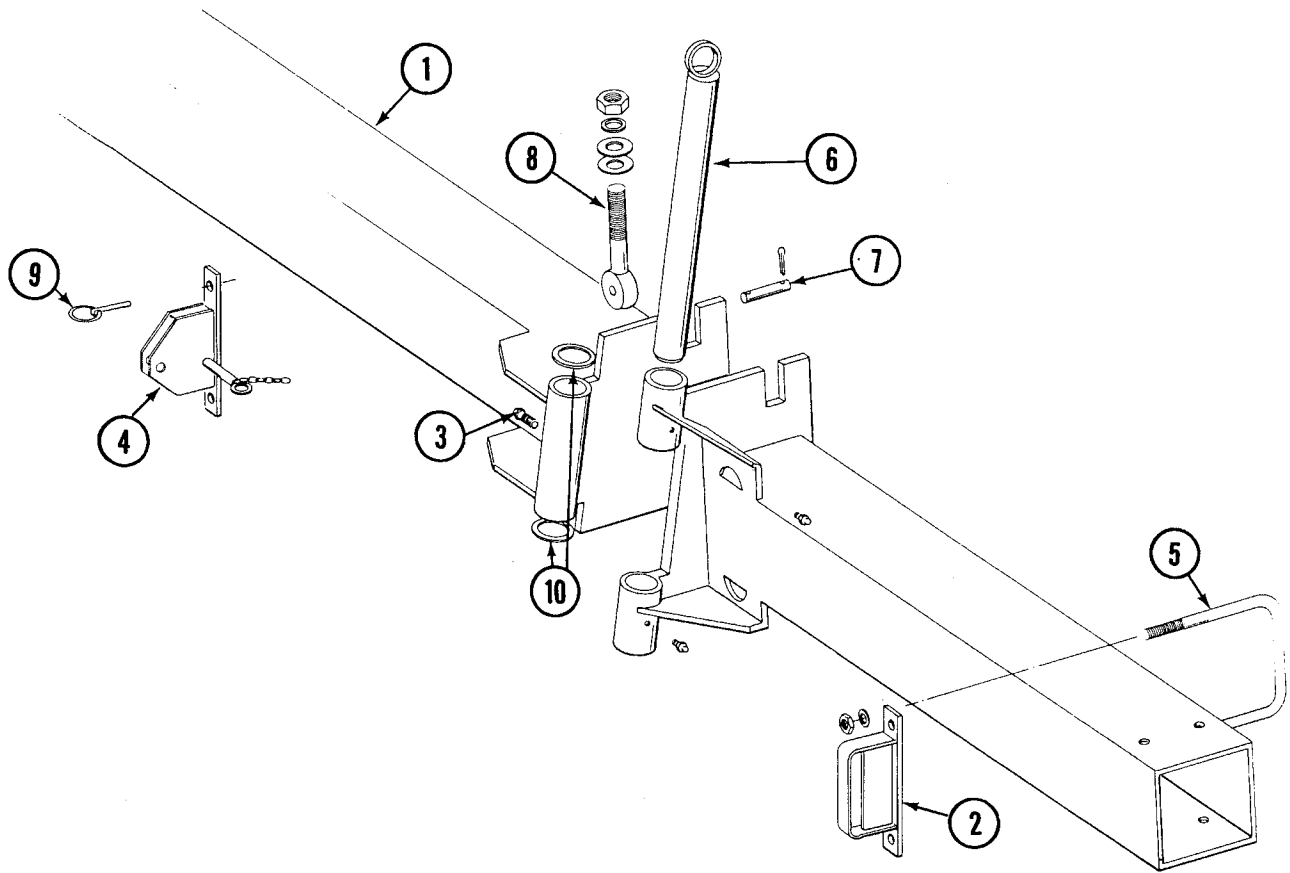

ITEM	PART NO.	DESCRIPTION
1.		Frame W/Grease Fittings, 237 1/2", 8 Row 30 Frame W/Grease Fittings, 294", 8 Row Wide Frame W/Grease Fittings, 357 1/2", 12 Row 30
	10641	Grease Fitting, 1/8" NPT
2.	A2698	Latch
3.	10007	HHCS, 5/8" - 11 x 1 1/2"
	10230	Lock Washer, 5/8"
4.	A2699	Latch W/Pin and Chain
	A2700	Pin and Chain
5.	D1114	U-Bolt, 7" x 7" x 5/8" - 11
	10230	Lock Washer, 5/8"
	10104	Hex Nut, 5/8" - 11
6.	A2493	Pin
7.	D3311	Pin, 7/8" x 3 1/8"
	10457	Cotter Pin, 5/32" x 1 1/2"
8.	D3373	Eye Bolt
	10139	Washer, 1 1/4" USS
	10236	Lock Washer, 1 1/4"
	10239	Hex Nut, 1 1/4" - 7
9.	D2558	Lynch Pin, 1/4"
10.	10404	Machinery Bushing

PULL TYPE HITCH AND FRAME ASSEMBLY

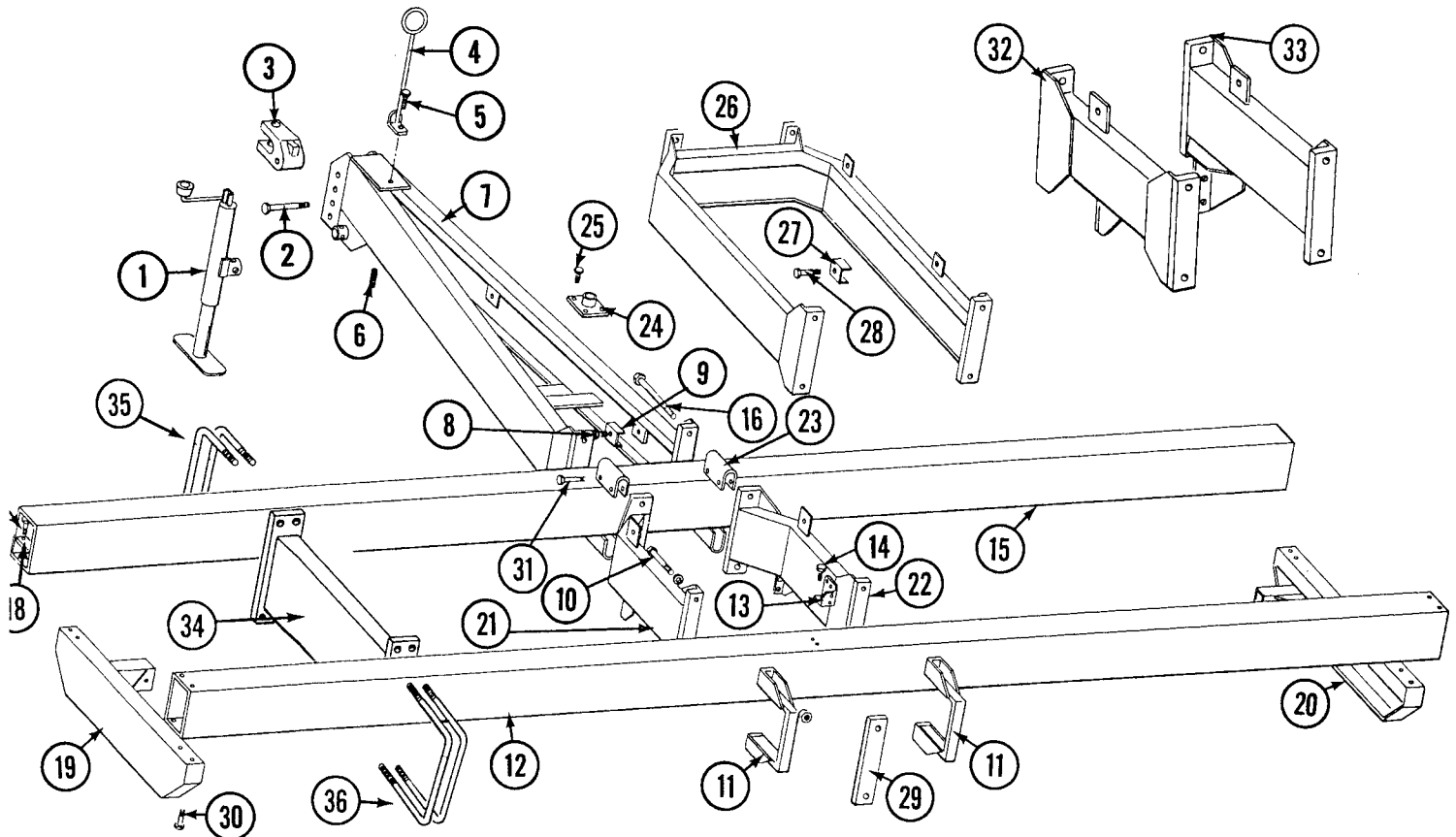

ITEM PART NO. DESCRIPTION

ITEM	PART NO.	DESCRIPTION
1.	4100-02	Jack Assembly
	R0255	Repair Kit (Chain and Pin)
2.	10417	HHCS, 7/8" - 9 x 4 1/2"
	10418	Lock Nut, 7/8" - 9
3.	B0180	Clevis
4.	A5167	Hose Holder
5.	10348	HHCS, 1/2" - 13 x 5"
	10216	Washer, 1/2" USS
	10228	Lock Washer, 1/2"
	10102	Hex Nut, 1/2" - 13
6.	D5888	Spring
7.	A5162	Hitch (Serial No. 11485 - 11732) (Shown)
	A4276	Hitch (Serial No. 11733 and on)
8.	10047	HHCS, 3/8" - 16 x 1 3/4"
	10108	Lock Nut, 3/8" - 16
9.	D5875	Hose Clamp
10.	10119	HHCS, 1" - 8 x 3"
	10118	Lock Washer, 1"
	10117	Hex Nut, 1" - 8
11.	A5169	Hitch Clamp
12.		Bar, 7" x 7" x 106", 2 Row 38
		Bar, 7" x 7" x 120", 4 Row 30
		Bar, 7" x 7" x 144", 4 Row 36 and 38
		Bar, 7" x 7" x 150", 4 Row 40
		Bar, 7" x 7" x 180", 6 Row 30
		Bar, 7" x 7" x 220", 6 Row 36 and 38
		Bar, 7" x 7" x 230", 6 Row 40
		Bar, 7" x 7" x 240", 8 Row 30
		Bar, 7" x 7" x 296", 8 Row 36 and 38
		Bar, 7" x 7" x 310", 8 Row 40

PULL TYPE HITCH AND FRAME ASSEMBLY

ITEM	PART NO.	DESCRIPTION
13.	A5141	Angle, Valve Mount
14.	10001	HHCS, 3/8" - 16 x 1"
15.		Double Frame Bar, 7" x 5" x 106", 2 Row 38
		Double Frame Bar, 7" x 5" x 120", 4 Row 30
		Double Frame Bar, 7" x 5" x 144", 4 Row 36 and 38
		Double Frame Bar, 7" x 5" x 150", 4 Row 40
		Double Frame Bar, 7" x 5" x 180", 6 Row 30
		Double Frame Bar, 7" x 5" x 220", 6 Row 36 and 38
		Double Frame Bar, 7" x 5" x 230", 6 Row 40
		Double Frame Bar, 7" x 5" x 240", 8 Row 30
		Double Frame Bar, 7" x 5" x 296", 8 Row 36 and 38
		Double Frame Bar, 7" x 5" x 310", 8 Row 40
16.	10402	HHCS, 1" - 8 x 8"
	10118	Lock Washer, 1"
	10117	Hex Nut, 1" - 8
17.	10026	HHCS, 3/4" - 10 x 2"
	10112	Lock Nut, 3/4" - 10
18.	D5930	Bar
19.	A5199	End Extension, L.H.
20.	A5198	End Extension, R.H.
21.	A5201	Center Extension, L.H., Offset, 24"
22.	A5200	Center Extension, R.H., Offset, 24"
23.	A5197	Spacer
24.	A5187	Bracket, Jack Mount
25.	10037	HHCS, 1/2" - 13 x 1 1/4"
	10228	Lock Washer, 1/2"
	10102	Hex Nut, 1/2" - 13
26.	A5265	Hitch Extension, Standard Push Unit (30" Rows), 38" x 26 1/2"
	A4259	Hitch Extension, Standard Push Unit (30" Rows), 46" x 26 1/2"
	A5449	Hitch Extension, Standard Push Unit (Wide Rows), 38" x 23 1/2"
	A4261	Hitch Extension, Standard Push Unit (Wide Rows), 46" x 23 1/2"
	A5266	Hitch Extension, Twin Push Unit, 48" x 26 1/2"
	A4260	Hitch Extension, Twin Push Unit, 56" x 26 1/2"
27.	D6027	Hose Clamp
28.	10003	HHCS, 3/8" - 16 x 1 1/2"
	10049	HHCS, 3/8" - 16 x 2 1/2"
	10108	Lock Nut, 3/8" - 16
29.	D6026	Shim, Used W/HD Down Pressure Springs When Row Unit Straddles Hitch Clamp
30.	10026	HHCS, 3/4" - 10 x 2", Single Frame Planter
	10027	HHCS, 3/4" - 10 x 2 1/2", With Double Frame Package
	10231	Lock Washer, 3/4"
	10105	Hex Nut, 3/4" - 10
31.	10061	HHCS, 3/8" - 16 x 3 1/2"
	10210	Flat Washer, 3/8" USS
	10108	Lock Nut, 3/8" - 16
32.	A5269	Hitch/Center Extension, L.H., Straight, 24"
33.	A5270	Hitch/Center Extension, R.H., Straight, 24"
34.	A4265	Straight Extension
35.	D1113	U-Bolt, 5" x 7" x 5/8" - 11
	10230	Lock Washer, 5/8"
	10104	Hex Nut, 5/8" - 11
36.	D1114	U-Bolt, 7" x 7" x 5/8" - 11
	10230	Lock Washer, 5/8"
	10104	Hex Nut, 5/8" - 11

TRANSPORT AND GROUND DRIVE WHEEL ASSEMBLY

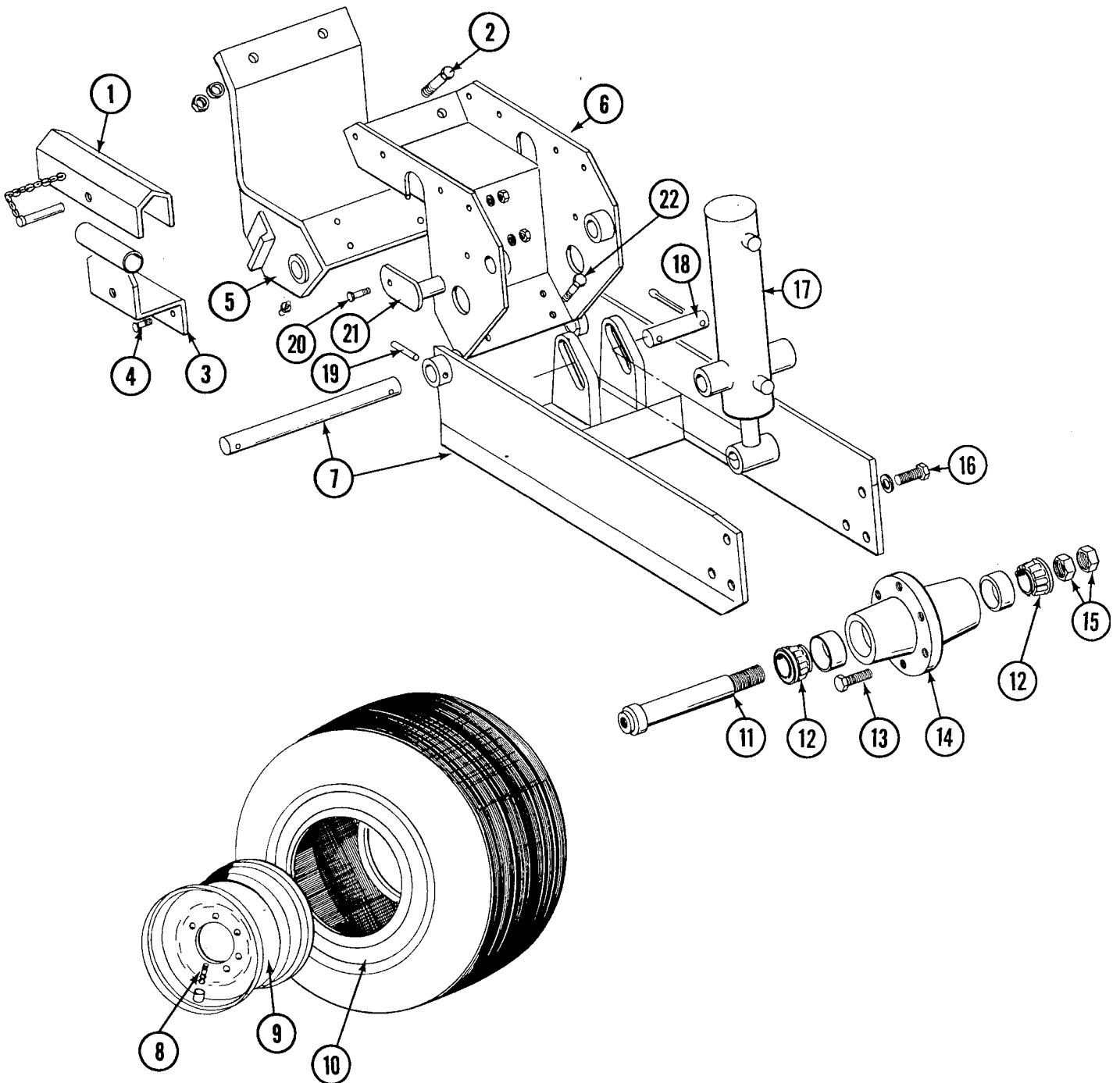

TRANSPORT AND GROUND DRIVE WHEEL ASSEMBLY

ITEM	PART NO.	DESCRIPTION
1.	A5221	Lockup W/Pin
	A4250	Lockup W/Pins (Not Shown)
2.	10009	HHCS, 5/8"-11 x 2 1/2"
	10230	Lock Washer, 5/8"
	10104	Hex Nut, 5/8"-11
3.	A5150	Mount
4.	10001	HHCS, 3/8"-16 x 1"
	10203	Washer, 3/8" SAE
	10229	Lock Washer, 3/8"
	10101	Hex Nut, 3/8"-16
5.	A5123	Clamp W/Grease Fittings
	10641	Grease Fitting, 1/8" NPT
6.	A5122	Wheel Tower Clamp
7.	A5125	Arm W/Pin, Standard (Shown)
	A5151	Arm W/Pin and Lockup Tab, L.H., 12 Row 30 Econo-Fold Only (See Econo-Fold 12 Row 30 Wheel Lockup)
	A5152	Arm W/Pin and Lockup Tab, R.H., 12 Row 30 Econo-Fold Only (See Econo-Fold 12 Row 30 Wheel Lockup)
	D5804	Pin, 1 1/4" x 12"
8.	D1166	Valve Stem
9.	A2142	Rim W/Valve Protector, 20 x 5/50F, Optional On Pull Type Planter, Standard On Econo-Fold Planter
	A5196	Rim W/Valve Protector, 15 x 5, Pull Type Planter
10.	D2648	Tire, 7.50 x 20, 6 Ply, Tubeless, Optional On Pull Type Planter, Standard On Econo-Fold Planter
	D6177	Tire, 7.50 x 20, Tube Type Less Tube, Optional On Pull Type Planter, Standard On Econo-Fold Planter
	D4167	Tube, 7.50 x 20
	D0844	Tire, 7.60 x 15, 4 Ply, Tubeless, Pull Type Planter Only
11.	A2558	Spindle
12.	A0895	Cone, Timken
	A5356	Cone, SKF
13.	R0270	Lug Bolt, 9/16"-12
14.	A2148	Hub W/Cups, (R0434), 6 Bolt
	A4231	Hub W/Cups, (R0957), 6 Bolt
	R0434	Cup, Timken
	R0957	Cup, SKF
15.	10087	Jam Nut, 1 1/2"-10
16.	10026	HHCS, 3/4"-10 x 2"
	10231	Lock Washer, 3/4"
17.		Cylinder (See Lift Cylinder)
18.	D5841	Pin, 1 1/4" x 5 5/8"
	10139	Washer, 1 1/4" USS (Not Shown)
	10460	Cotter Pin, 1/4" x 2"
19.	10610	Spring Pin, 3/8" x 2"
20.	10037	HHCS, 1/2"-13 x 1 1/4"
	10228	Lock Washer, 1/2"
	10102	Hex Nut, 1/2"-13
21.	A5121	Pin, Cylinder Mount
22.	10008	HHCS, 5/8"-11 x 2"
	10230	Lock Washer, 5/8"
	10104	Hex Nut, 5/8"-11
23.	10450	Machinery Bushing (Not Shown) Used only when A5356 bearing and R0957 cup are used.
A.	A5124	Wheel Module Subassembly, Includes: (2)10610, (1)A5123 and (1) A5125

CONTACT DRIVE WHEEL AND ARM ASSEMBLY

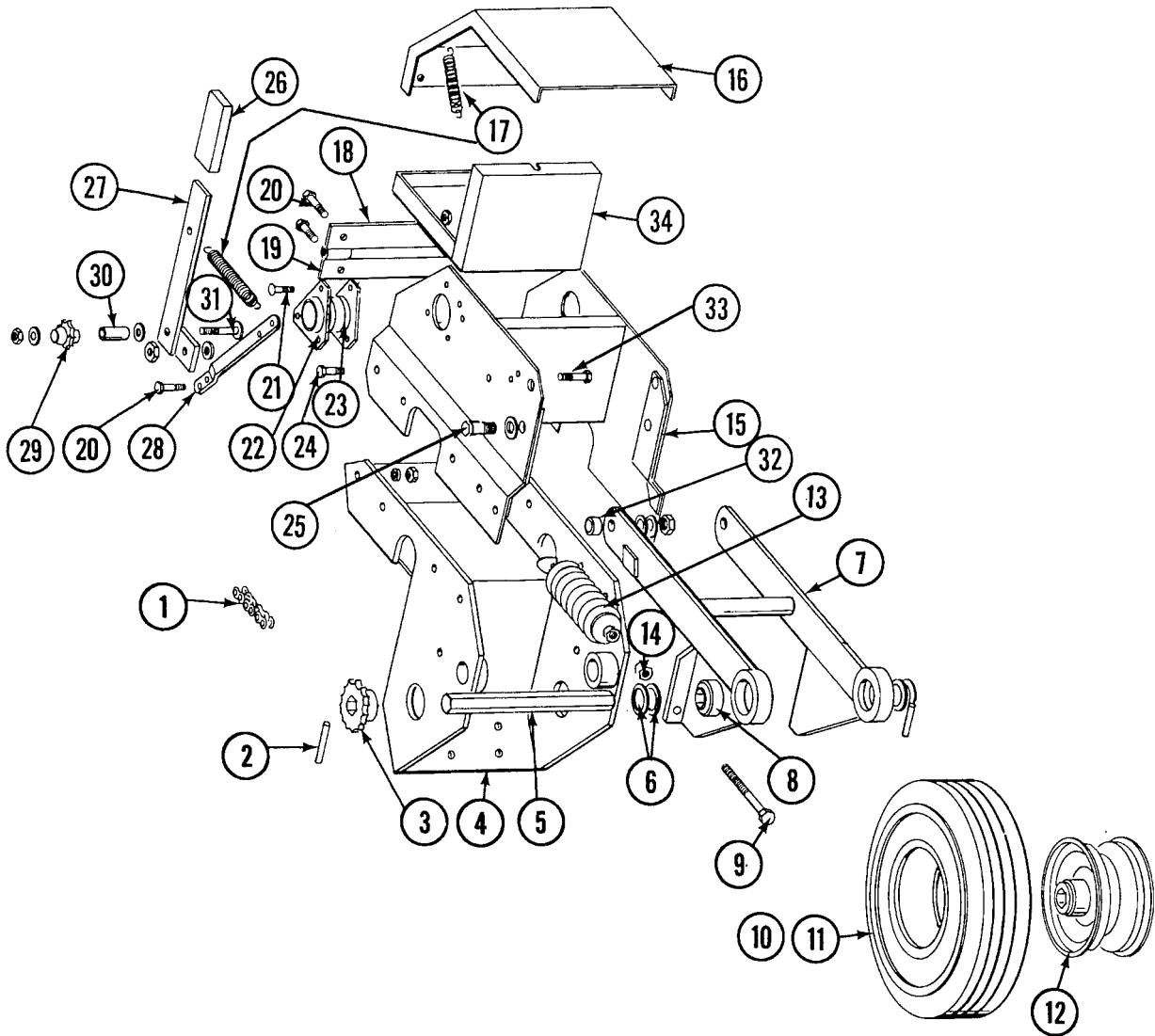

CONTACT DRIVE WHEEL AND ARM ASSEMBLY

ITEM	PART NO.	DESCRIPTION
1.	3310-132	Chain, No. 40, 132 Pitch Including Connector Link
	R0912	Connector Link, No. 40
2.	10602	Spring Pin, 1/4" x 1 1/2"
3.	A5105	Sprocket, 15 Tooth
4.		Wheel Tower Clamp (See Transport and Ground Drive Wheel)
5.	D5797	Shaft, 7/8" x 10"
6.	10233	Machinery Bushing, 1"
7.	A5117	Wheel Arm
8.	A5116	Bearing, 7/8 Hex Bore, Cylindrical
9.	10051	Hex Head Adjusting Bolt, 1/2" - 13 x 3", Grade 2
10.	D5753	Tire, 4.10 x 6
11.	D5752	Tube
12.	A5089	Rim
13.	A2068	Spring
14.	10501	Jam Nut, 1/2"
15.	A5118	Mount
16.	A5119	Cover
17.	D5857	Spring
18.	D5790	Hinge, Male
19.	D5789	Hinge, Female
20.	10064	HHCS, 1/4" - 20 x 1"
	10227	Lock Washer, 1/4"
	10103	Hex Nut, 1/4" - 20
21.	10312	Carriage Bolt, 5/16" - 18 x 3/4"
	10232	Lock Washer, 5/16"
	10106	Hex Nut, 5/16" - 18
22.	3400-01	Flangette
23.	2100-03	Bearing, 7/8 Hex Bore, Spherical
24.	10001	HHCS, 3/8" - 16 x 1"
	10229	Lock Washer, 3/8"
	10101	Hex Nut, 3/8" - 16
25.	10005	HHCS, 5/8" - 11 x 1 3/4"
	10235	Machinery Bushing
	10205	Washer, 5/8" SAE
	10107	Lock Nut, 5/8" - 11
26.	D5827	Cover
27.	A5157	Idler Arm, L.H.
	A5158	Idler Arm, R.H.
28.	D5860	Bar
29.	D5815	Idler Sprocket, 12 Tooth
30.	D1026	Sleeve
31.	10306	Carriage Bolt, 3/8" - 16 x 2"
	10210	Washer, 3/8" USS
	10108	Lock Nut, 3/8" - 16
32.	B0123	Bushing
33.	10001	HHCS, 3/8" - 16 x 1"
	10229	Lock Washer, 3/8"
	D5756	Special Nut, 3/8" - 16
34.	A5180	Tool Box Insert
A.	A5090	Tire and Rim Assembly, Includes: (1) D5753, (1) D5752, (1) A5089

ECONO-FOLD WHEEL LOCKUP ASSEMBLY TIRE SCRAPER ASSEMBLY

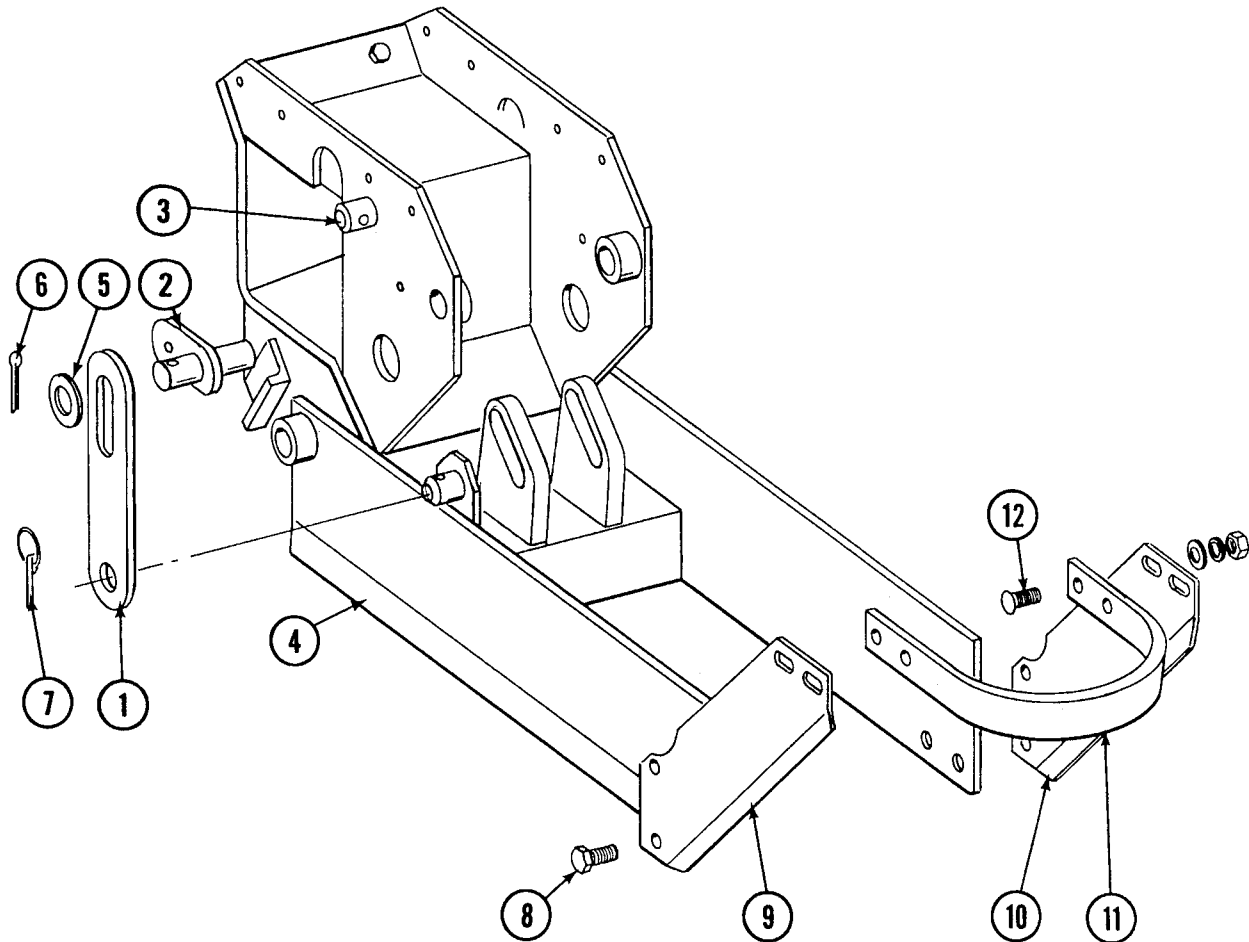

ITEM	PART NO.	DESCRIPTION
1.	D5853	Bar, Wheel Lockup , 12 Row 30
2.	A5148	Pin, Cylinder Mount , 12 Row 30
3.	D5850	Storage Pin
4.		Arm (See Transport and Ground Drive Wheel)
5.	10139	Washer, 1 1/4" USS
6.	10460	Cotter Pin, 1/4" x 2"
7.	D2558	Lynch Pin, 1/4"
8.	10025	HHCS, 3/4" - 10 x 1 1/2"
	10231	Lock Washer, 3/4"
	10105	Hex Nut, 3/4" - 10
9.	D5845	Scraper Mount, L.H.
10.	D5846	Scraper Mount, R.H.
11.	D5847	Scraper Bar (Used With 20" Tire)
12.	10313	Carriage Bolt, 1/2" - 13 x 1 1/2"
	10228	Lock Washer, 1/2"
	10216	Washer, 1/2" USS
	10102	Hex Nut, 1/2" - 13

ECONO-FOLD POINT ROW WRAP SPRING CLUTCH ASSEMBLY (OPTIONAL)

STYLE A

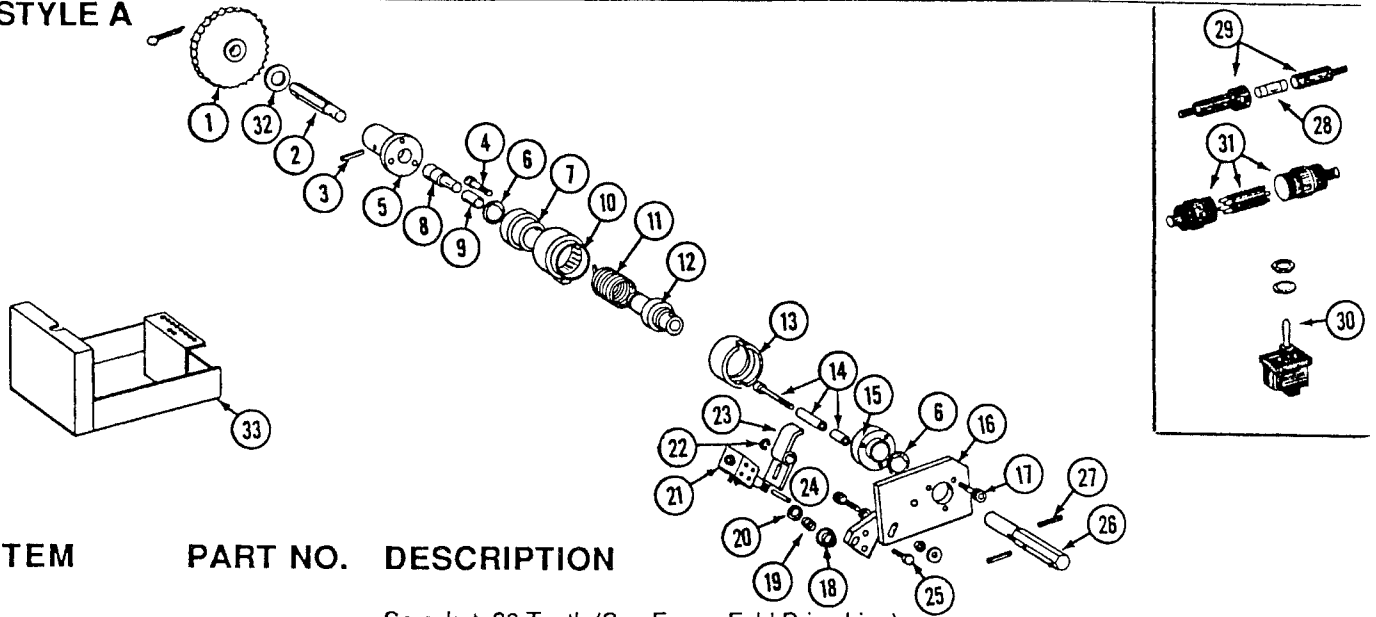

ITEM	PART NO.	DESCRIPTION
1.		Sprocket, 30 Tooth (See Econo-Fold Drive Line)
2.	D6559	Shaft(One End Turned Down), 4", Use W/A4305(Shown)
	D7134	Shaft(All Hex), 4", Use W/A4765
3.	10602	Spring Pin, 1/4" x 1 1/2", Use W/A4305 (Shown)
	10031	HHCS, 5/16"-18 x 1 3/4", Use W/A4765
	10109	Lock Nut, 5/16"-18, Use W/A4765
4.	10474	Socket Head Cap Screw, 5/16"-18 x 3/8"
5.	A4305	Drive Hub, Round Bore, Use W/D6559
	A4765	Drive Hub, Hex Bore, Use W/D7134
6.	R0478	Retaining Ring
7.	D6562	Input Hub
8.	A2022	Bearing
9.	D5329	Sleeve
10.	R0471	Stop Collar
11.	R0470	Wrap Spring, CW, 2"
	R0469	Wrap Spring, CCW, 2"
12.	R0462	Output Hub
13.	R0472	Dust Cover
14.	R0475	Actuator Limit Stop
15.	R0468	Plate Bearing
16.	D6566	Plate, R.H.
	D6565	Plate, L.H.
17.	10260	Socket Head Cap Screw, 1/4"-20 x 1/2"
18.	R0646	Boot
19.	R0474	Spring, Actuator Return
20.	R0647	Boot Sleeve
21.	R0466	Coil Assembly
22.	R0479	Retaining Ring
23.	R0465	Actuator Arm
24.	10259	Socket Head Cap Screw, #10-32 x 7/8"
	10257	Lock Washer, #10
	10243	Flat Washer, #10
25.	10261	Socket Button Head Screw, #10-32 x 3/8"
	10243	Flat Washer, #10
26.	D6558	Shaft, 8"
27.	10473	Roll Pin, 5/16" x 1 1/4"
28.	D2829	Fuse, AGC-15
29.	A1917	Fuse Holder
30.	A0533	Toggle Switch
31.	A1911	Trailer Connector, 4 Prong
32.	10345	Machinery Bushing (As Required)
33.	A4308	Tool Box Insert

ECONO-FOLD POINT ROW WRAP SPRING CLUTCH ASSEMBLY (OPTIONAL)

STYLE B

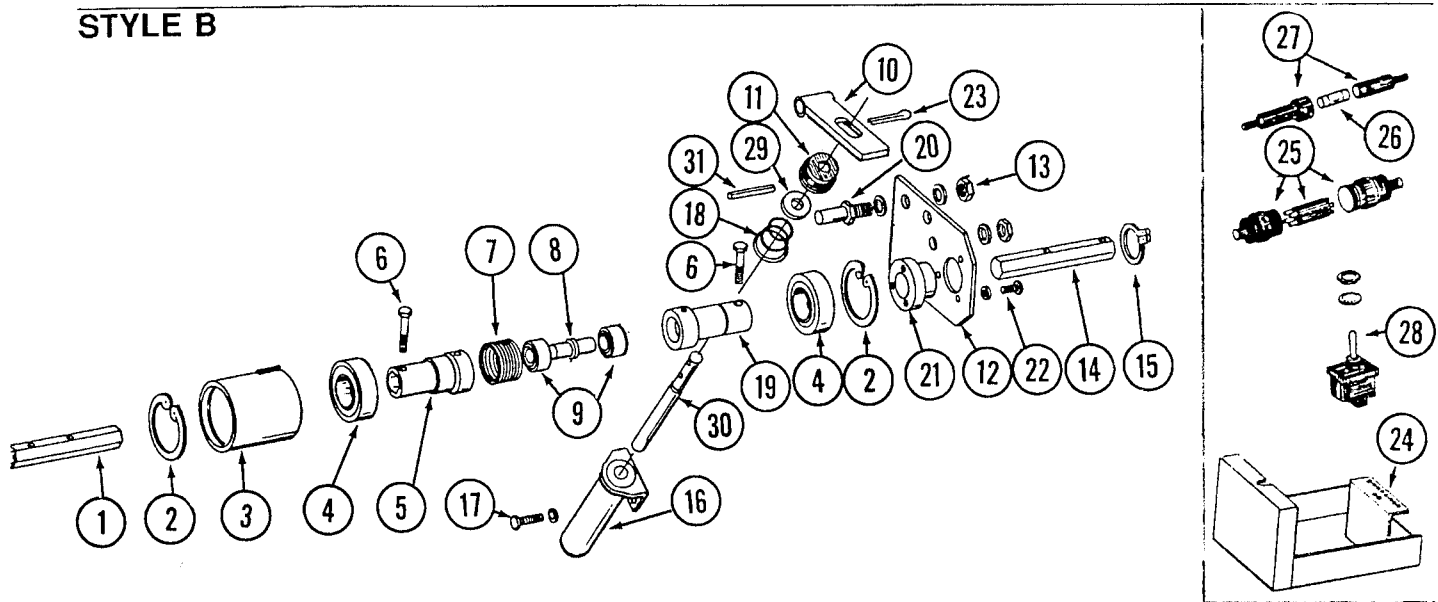

ITEM	PART NO.	DESCRIPTION
1.	D7339	Shaft, 8", 8 And 12 Row
2.	10136	Snap Ring, 3"
3.	A4924	Stop Collar, R.H.
	A4925	Stop Collar, L.H.
4.	A4921	Bearing
5.	D7872	Input Hub
6.	10041	Hex Head Cap Screw, 5/16"-18 x 2"
	10109	Lock Nut, 5/16"-18
7.	D7306	Wrap Spring, CW, 2"
	D7305	Wrap Spring, CCW, 2"
8.	D7319	Pilot Pin
9.	A4919	Bearing
10.	A5566	Actuator Arm
11.	R0646	Rubber Boot
12.	D7624	Plate
13.	10203	Washer, 3/8" SAE
	10229	Lock Washer, 3/8"
	10497	Hex Nut, 3/8"-16, Grade 2
14.	D7157	Shaft, 5 3/8"
	D7762	Shaft, 6 3/8" (Used with Magnetic Distance Sensor)
15.	10496	Snap Ring, External Inverted
16.	A5557	Solenoid
17.	10023	Hex Head Cap Screw, 1/4"-20 x 3/4"
	10227	Lock Washer, 1/4"
	10103	Hex Nut, 1/4"-20
18.	D1075	Spring
19.	D7873	Output Hub
20.	D7316	Mounting Pin
21.	D7314	Bushing
22.	10253	Hex Socket Head Screw, No. 10-32 x 1/2"
	10257	Lock Washer, No. 10
23.	10451	Cotter Pin, 1/8" x 1"
24.	A4308	Tool Box Insert
25.	A1911	Trailer Connector, 4 Prong
26.	D2829	Fuse, AGC-15
27.	A1917	Fuse Holder
28.	A0533	Toggle Switch
29.	10370	Machine Bushing
30.	D7623	Plunger
31.	10187	Slotted Spring Pin, 5/32" x 2"

ECONO-FOLD DRIVE LINE, 12 ROW 30

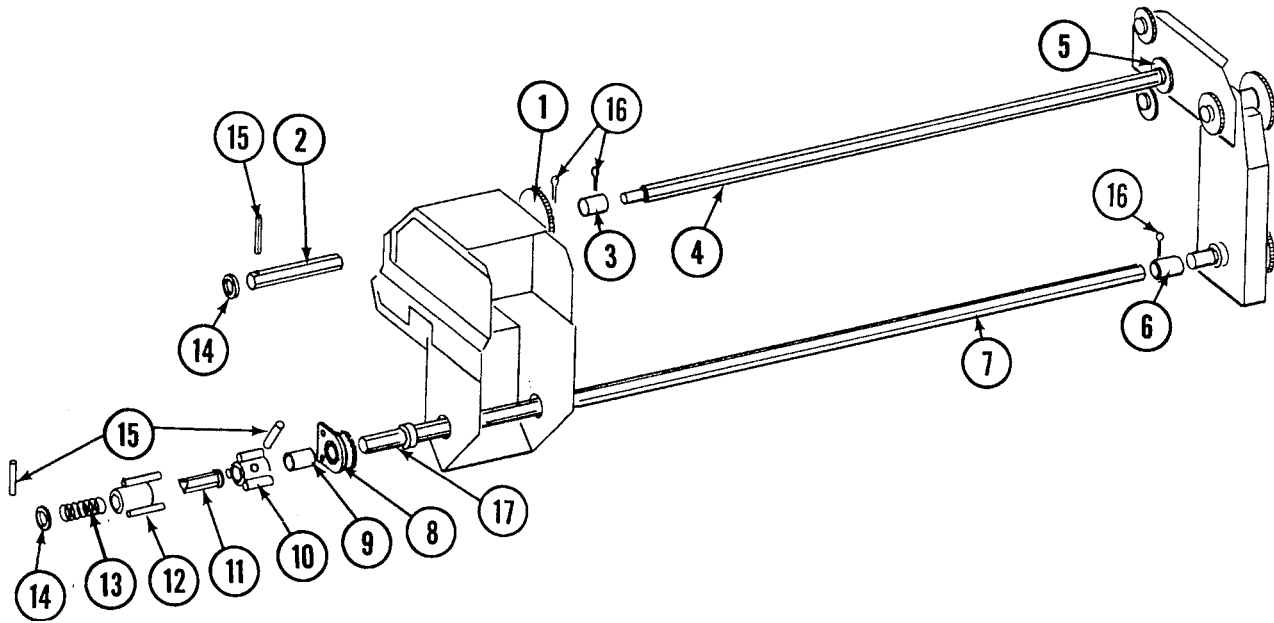

ITEM	PART NO.	DESCRIPTION
1.	A5114	Sprocket, 30 Tooth
2.	D5833	Drive Shaft, 13 1/2"
	D6622	Drive Shaft, 14 7/8", Used when drive is on inner side of wheel module.
3.	D5961	Coupler, 2 3/4"
4.	D5832	Drive Shaft, 46 1/2"
5.		Sprocket (See Transmission)
6.	D5212	Coupler
7.	D2548-75.75	Drill Shaft, Wing
8.	A2180	Hanger Bearing, 7/8 Hex
	A1720	Hanger Bearing/Sprocket, 7/8 Hex
9.	D1199-03	Spacer, 5/8"
10.	A2374	Coupler
11.	A2450	Drill Shaft, Main Frame, 90", R.H.
	A2449	Drill Shaft, Main Frame, 79", L.H.
12.	A2373	Coupler
13.	D2962	Spring
14.	10233	Machinery Bushing (As Required)
15.	10602	Spring Pin, 1/4" x 1 1/2"
16.	10460	Cotter Pin, 1/4" x 2"
17.	D0917	Lock Collar, 7/8 Hex, Les Set Screws
	10145	Set Screw, 5/16" - 18 x 1/2"

ECONO-FOLD DRIVE LINE, 8 ROW 30 AND WIDE

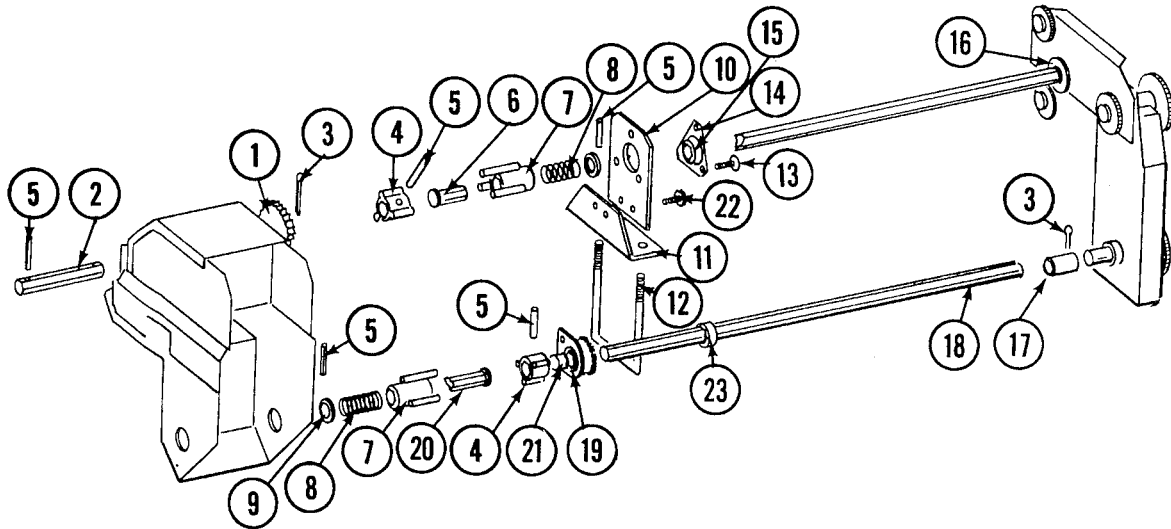

ITEM	PART NO.	DESCRIPTION
1.	A5114	Sprocket, 30 Tooth
2.	D5833	Drive Shaft, 13 1/2"
	D6622	Drive Shaft, 14 7/8", Used when drive is on inner side of wheel module.
3.	10460	Cotter Pin, 1/4" x 2"
4.	A2374	Coupler
5.	10602	Spring Pin, 1/4" x 1 1/2"
6.	A5138	Drive Shaft, 47 1/2", 8 Row 30
	A5139	Drive Shaft, 62", 8 Row Wide
7.	A2373	Coupler
8.	D2962	Spring
9.	10233	Machinery Bushing (As Required)
10.	D5828	Bearing Plate
11.	D5823	Bracket
12.	D1114	U-Bolt, 7" x 7" x 5/8" - 11
	10217	Washer, 5/8" USS
	10230	Lock Washer, 5/8"
	10104	Hex Nut, 5/8" - 11
13.	10303	Carriage Bolt, 5/16" - 18 x 1"
	10232	Lock Washer, 5/16"
	10106	Hex Nut, 5/16" - 18
14.	3400-01	Flangette
15.	2100-03	Bearing, 7/8 Hex Bore, Spherical
16.		Sprocket (see transmission)
17.	D5212	Coupler
18.	D2548-45.75	Drill Shaft, Wing, 8 Row 30
	D2548-59.75	Drill Shaft, Wing, 8 Row Wide
19.	A2180	Hanger Bearing, 7/8" Hex
	A1720	Hanger Bearing/Sprocket, 7/8" Hex
20.	A2446	Drill Shaft, Main Frame, 60", R.H., 8 Row 30
	A2445	Drill Shaft, Main Frame, 49", L.H., 8 Row 30
	A2448	Drill Shaft, Main Frame, 73", R.H., 8 Row Wide
	A2447	Drill Shaft, Main Frame, 63", L.H., 8 Row Wide

ECONO-FOLD DRIVE LINE, 8 ROW 30 AND WIDE

ITEM	PART NO.	DESCRIPTION
21.	D1199-03	Spacer, 5/8", 8 Row 30
	D1199-05	Spacer, 5", 8 Row wide
	D1199-06	Spacer, 1 1/4", 8 Row Wide
22.	10001	HHCS, 3/8" - 16 x 1"
	10203	Washer, 3/8" SAE
	10229	Lock Washer, 3/8"
	10101	Hex Nut, 3/8" - 16
23.	D0917	Lock Collar, 7/8 Hex, Less Set Screws
	10145	Set Screw, 5/16" - 18 x 1/2"

PULL TYPE DRIVE LINE, 2 ROW 38

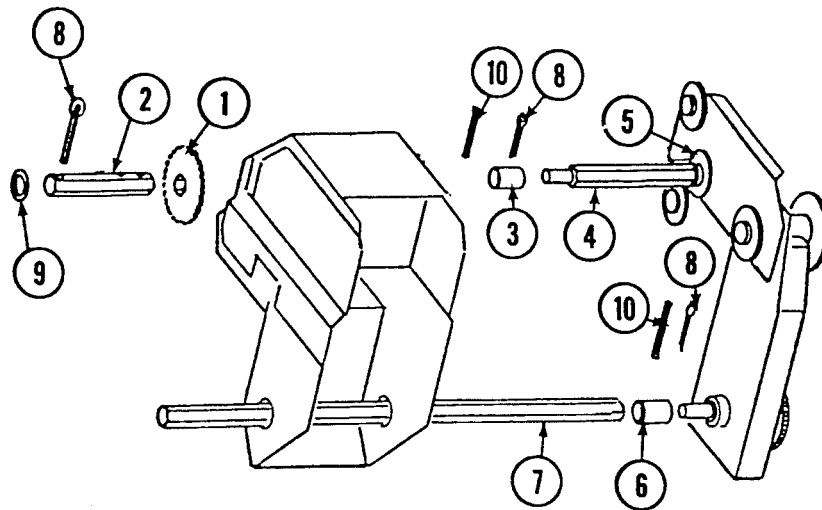

ITEM	PART NO.	DESCRIPTION
1.	A5114	Sprocket, 30 Tooth
2.	D6178	Drive Shaft, 11 3/4"
3.	D5961	Coupler, 2 3/4"
4.	D5885-04	Drive Shaft, 8"
5.		Sprocket (See Transmission)
6.	D5886	Coupler
7.	D5887-75	Drill Shaft
8.	10460	Cotter Pin, 1/4" x 2"
9.	10233	Machine Bushing (As Required)
10.	10602	Spring Pin, 1/4" x 1 1/2"

PULL TYPE DRIVE LINE, 4 ROW 30 AND WIDE

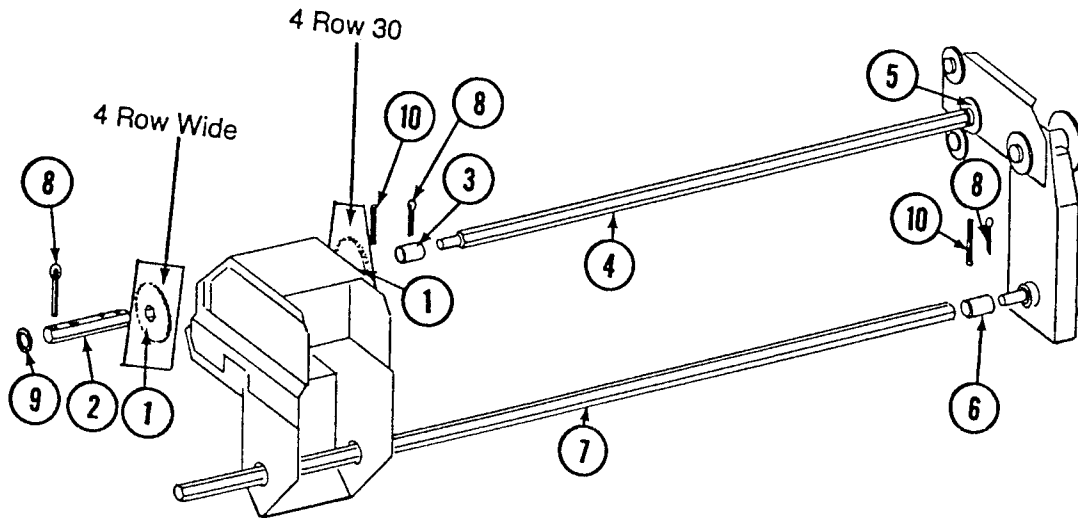

ITEM	PART NO.	DESCRIPTION
1.	A5114	Sprocket, 30 Tooth
2.	D7819	Drive Shaft, 15" (4 Holes), 4 Row 30
	D5958	Drive Shaft, 16" (4 Holes), 4 Row 36 and 38
	D6891	Drive Shaft, 15 1/2" (2 Holes), 4 Row 40
3.	D5961	Coupler, 2 3/4"
4.	D5885-02	Drive Shaft, 19", 4 Row 30
	D5885-03	Drive Shaft, 24", 4 Row 36, 38 and 40
5.		Sprocket (See Transmission)
6.	D5886	Coupler
7.	D5887-105	Drill Shaft, 4 Row 30
	D5887-128	Drill Shaft, 4 Row 36 and 38
	D5887-137	Drill Shaft, 4 Row 40
8.	10460	Cotter Pin, 1/4" x 2"
9.	10233	Machine Bushing (As Required)
10.	10602	Spring Pin, 1/4" x 1 1/2"

PULL TYPE DRIVE LINE

6 ROW 30 AND WIDE, 8 ROW 30 AND WIDE

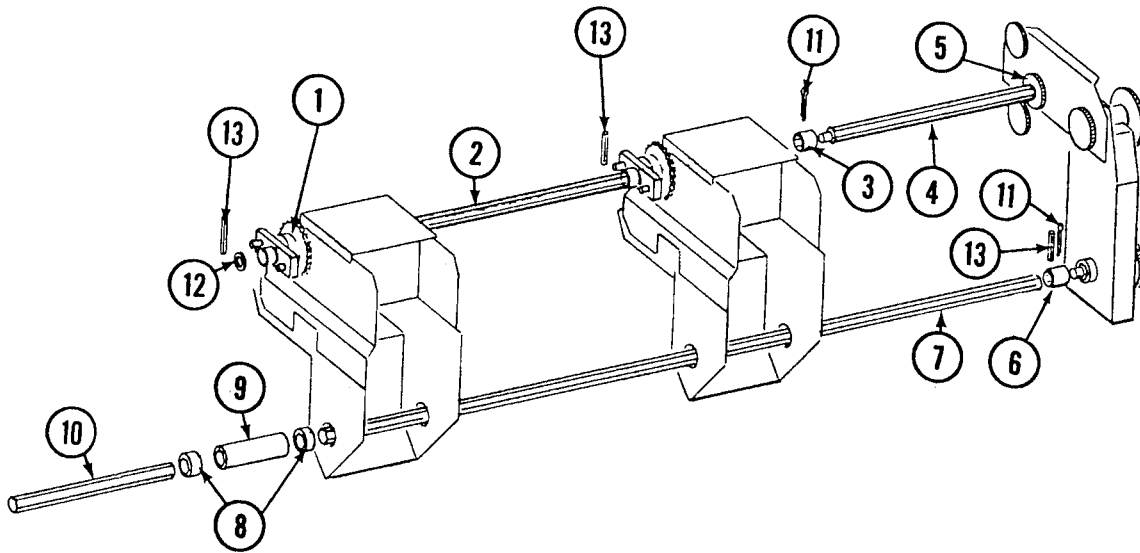

ITEM	PART NO.	DESCRIPTION
1.		Ratchet And Sprocket Assembly (See Ratchet and Sprocket)
2.	D5884-01	Drive Shaft, 36" (3 Holes), 6 Row 30 and 8 Row 30
	D5960	Drive Shaft, 50" (6 Holes), 6 Row 36 and 38
	D5959	Drive Shaft, 52" (6 Holes), 8 Row 36 and 38
3.	D5961	Coupler
4.	D5885-01	Drive Shaft, 30"
5.		Sprocket (See Transmission)
6.	D5886	Coupler
7.	D5887-165	Drill Shaft, 6 Row 30
	D5887-204	Drill Shaft, 6 Row 36 and 38
	D5887-225	Drill Shaft, 8 Row 30
	D5887-144	Drill Shaft, 8 Row 36 And 38
8.	D0917	Lock Collar, Less Set Screws
	10145	Set Screws, 5/16"-18 x 1/2"
9.	D1719	Coupler, 8 Row Wide Only
10.	D0914-137	Drill Shaft, 8 Row 36 And 38
11.	10460	Cotter Pin, 1/4" x 2"
12.	10233	Machine Bushing (As Required)
13.	10602	Spring Pin, 1/4" x 1 1/2"

RATCHET AND SPROCKET ASSEMBLY

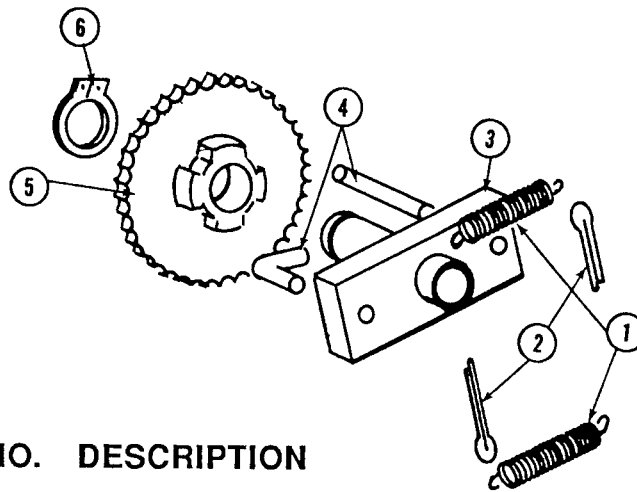

ITEM	PART NO.	DESCRIPTION
1.	D1256	Spring
2.	10464	Cotter Pin, 3/16" x 1"
3.	A0378	Block and Hub Assembly
4.	D1255	"L" Pin
5.	A5165	Hub/Sprocket Assembly, 30 Tooth
6.	10430	Ring
A.	A5164	Ratchet/Sprocket Assembly Complete

MAGNETIC DISTANCE SENSOR

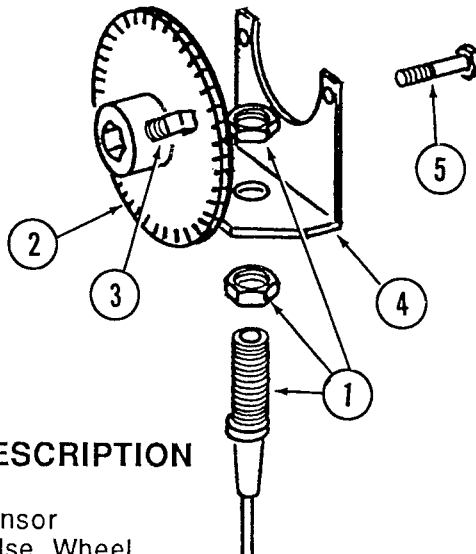

ITEM	PART NO.	DESCRIPTION
1.	A5600	Sensor
2.	A5549	Pulse Wheel
3.	10145	Set Screw, 5/16"-18 x 1/2"
4.	D7632	Bracket
5.	10043	HHCS, 5/16"-18 x 3/4"
	10232	Lock Washer, 5/16"
	10106	Hex Nut, 5/16"-18

TRANSMISSION ASSEMBLY

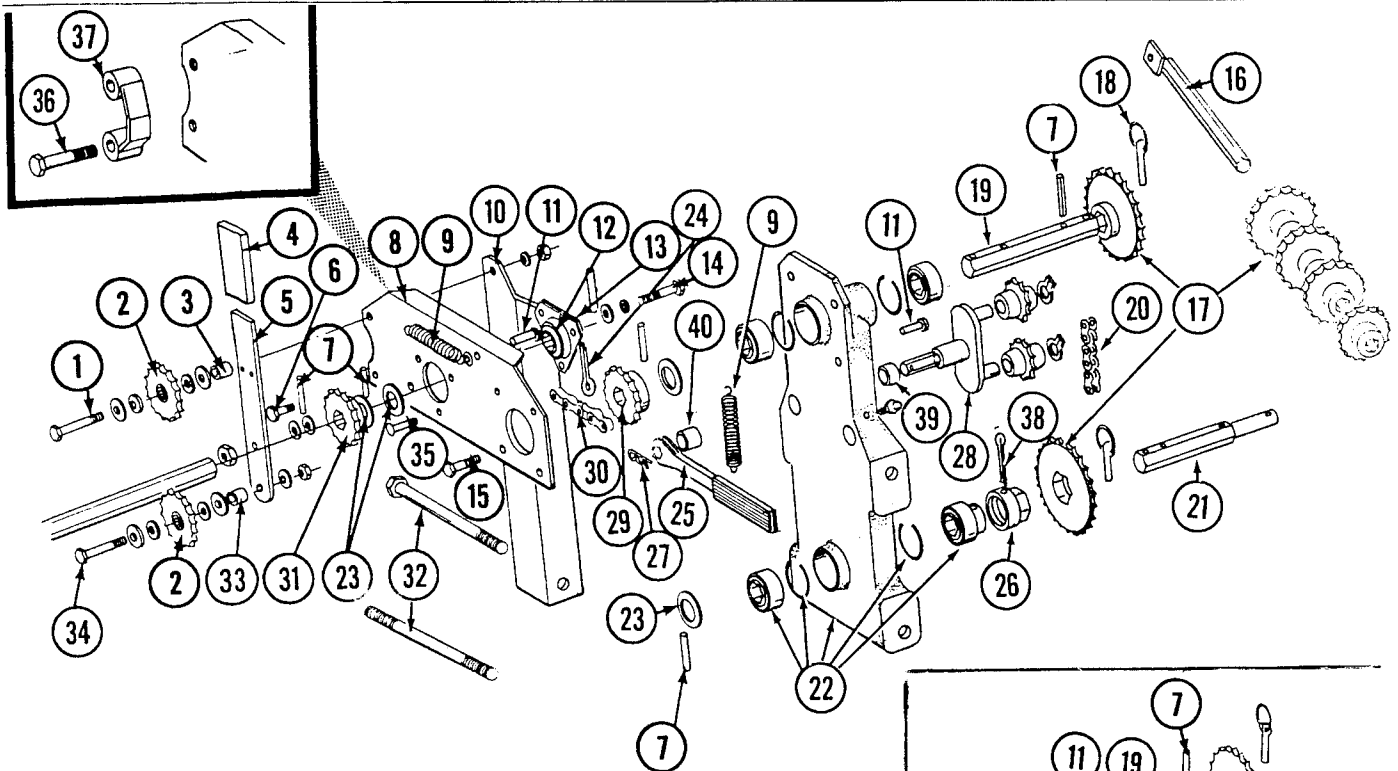

ITEM	PART NO.	DESCRIPTION
1.	10035	HHCS, 1/2"-13 x 4"
	10216	Washer, 1/2" USS (Large)
	10128	Machine Bushing, 1/2" (Small)
	10228	Lock Washer, 1/2"
	10102	Hex Nut, 1/2"-13
2.	A5103	Idler Sprocket W/Bearing, 15 Tooth
3.	D4887-04	Sleeve, 1 1/4"
4.	D5827	Cover
5.	D5829	Arm
6.	10039	HHCS, 1/2"-13 x 1 3/4"
	10228	Lock Washer, 1/2"
	10102	Hex Nut, 1/2"-13
7.	10602	Spring Pin, 1/4" x 1 1/2"
8.	D5824	Plate, R.H. (Shown)
	D5825	Plate, L.H.
9.	D5857	Spring
10.	D5830	Angle Support, R.H. (Shown)
	D5831	Angle Support, L.H.
11.	10478	Clevis Pin, 5/16" x 1"
	10409	Retaining Ring, 5/16"
12.	2100-03	Bearing, 7/8" Hex Bore, Spherical
13.	3400-01	Flangette
14.	10001	HHCS, 3/8"-16 x 1"
	10210	Washer, 3/8" USS
	10203	Washer, 3/8" SAE
	D5756	Special Nut, 3/8"-16
15.	10037	HHCS, 1/2"-13 x 1 1/4"
	10228	Lock Washer, 1/2"
	10102	Hex Nut, 1/2"-13
16.	A5146	Rod, Sprocket Storage
17.	A5106	Sprocket, 17 Tooth
	A5107	Sprocket, 19 Tooth
	A5108	Sprocket, 23 Tooth (Qty. 2)
	A5109	Sprocket, 24 Tooth
	A5110	Sprocket, 25 Tooth
	A5111	Sprocket, 26 Tooth
	A5112	Sprocket, 27 Tooth
	A5113	Sprocket, 28 Tooth

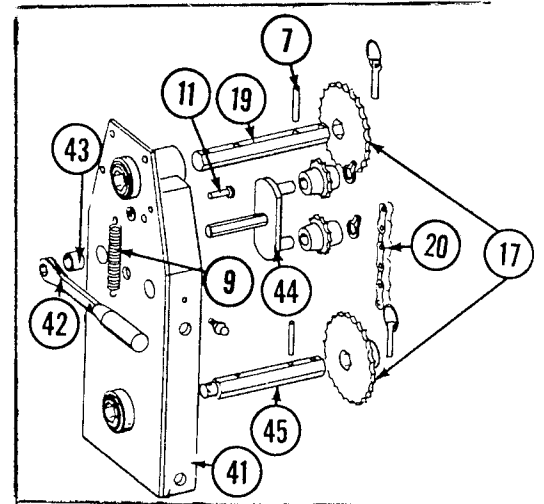

TRANSMISSION ASSEMBLY

ITEM	PART NO.	DESCRIPTION
18.	D2558	Lynch Pin, 1/4"
19.	D5835	Shaft, 7/8" x 7"
20.	3310-80	Chain, No. 40, 80 Pitch Including Connector Link
	R0912	Connector Link, No. 40
21.	D7822	Shaft, 7/8" x 7"
22.	A5629	Transmission Plate W/ Bearings, Grease Fittings and Retaining Rings
	A5116	Bearing, 7/8" Hex Bore, Cylindrical
	A5624	Special Bearing, 7/8" Hex Bore x 1.6"
	D6551	Ring
	10641	Grease Fitting, 1/8" NPT
23.	10233	Machine Bushing
24.	10460	Cotter Pin, 1/4" x 2"
25.	A4235	Ratchet Wrench W/Rectangular Protective Closure
	10445	Protective Closure (Rectangular)
26.	D7127	Shear Coupler
27.	10670	Hair Pin Clip, No. 3
28.	A5628	Idler W/Sprockets and Rings
	D7426	Sprocket
	10435	Ring
29.	A5106	Sprocket, 17 Tooth
	A5202	Sprocket, 34 Tooth (2:1 Drive Reduction)
	A5194	Sprocket, 50 Tooth (3:1 Drive Reduction)
30.	3310-89	Chain, No. 40, 89 Pitch Including Connector and Offset Link
	3310-08	Chain, No. 40, Used With 2:1 Drive Reduction Sprocket
	3310-40	Chain, No. 40, Used With 3:1 Drive Reduction Sprocket, Pull Type
	3310-16	Chain, No. 40, Used With 3:1 Drive Reduction Sprocket, Econo-Fold
	R0911	Offset Link, No. 40
	R0912	Connector Link, No. 40
31.	A5105	Sprocket, 15 Tooth
32.	10093	HHCS, 5/8"-11 x 8 1/2"
	D6793	Stud, 5/8"-11 x 9 1/2" (Threaded both ends)
	10230	Lock Washer, 5/8"
	10107	Hex Nut, 5/8"-11
33.	D4887-03	Sleeve, 3/4"
34.	10016	HHCS, 1/2"-13 x 2"
	10216	Washer, 1/2" USS (Large)
	10128	Machine Bushing, 1/2" (Small)
	10228	Lock Washer, 1/2"
	10102	Hex Nut, 1/2"-13
35.	10312	Carriage Bolt, 5/16"-18 x 3/4"
	10232	Lock Washer, 5/16"
	10106	Hex Nut, 5/16"-18
36.	10053	HHCS, 1/2"-13 x 2 1/2"
37.	A4470	Idler Mount, R.H.
	A4469	Idler Mount, L.H.
38.	10462	Cotter Pin, 3/16" x 2"
39.	D2734-01	Sleeve, 1/2"
40.	D6819	Idler Sleeve, 7/16"
41.	A5144	Transmission Plate W/Bearing and Grease Fittings
	A5116	Bearing, 7/8" Hex Bore, Cylindrical
	10640	Grease Fitting, 1/4"-28
	10641	Grease Fitting, 1/8" NPT
42.	A5365	Ratchet Arm With Protective Closure
	10410	Protective Closure (Round)
43.	D0935	Idler Sleeve, 9/16"
44.	A5136	Idler W/Sprockets and Rings
	D7426	Sprocket
	10435	Ring
45.	D5215	Shaft, 7/8" x 6 3/8"

ECONO-FOLD MARKER ASSEMBLY, 12 ROW 30

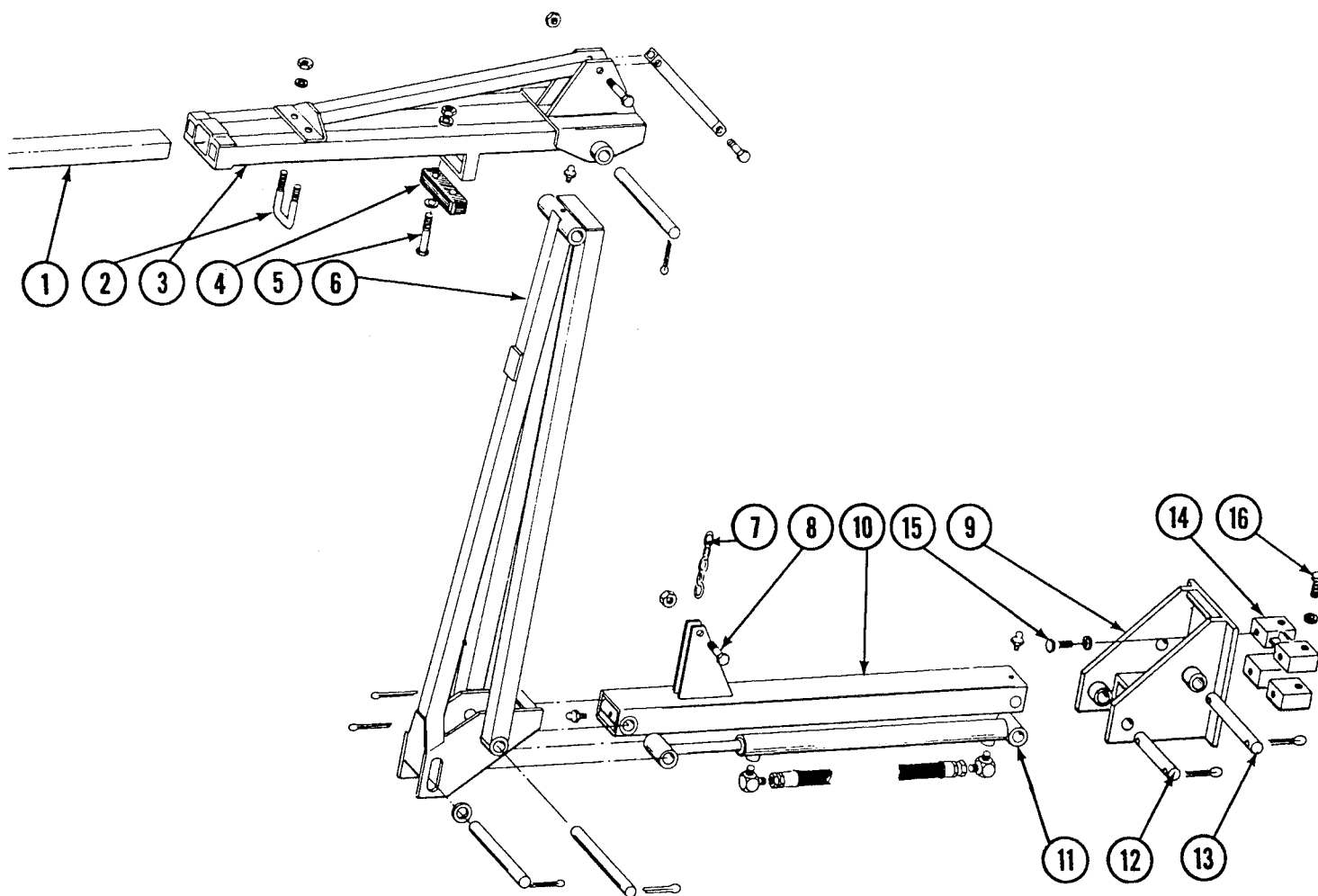

ECONO-FOLD MARKER ASSEMBLY, 12 ROW 30

ITEM	PART NO.	DESCRIPTION
1.	D0453-02	Extension Tube, 40"
2.	D2721	U-Bolt, 2" x 2" x 1/2" - 13
	10228	Lock Washer, 1/2"
	10102	Hex Nut, 1/2" - 13
3.	A2475	Arm W/Pin and Link Arm, Third Stage, 35"
	10038	HHCS, 1/2" - 13 x 3"
	10111	Lock Nut, 1/2" - 13
	A2145	Link Arm
	10016	HHCS, 1/2" - 13 x 2"
	D2697	Pin, 7/8" x 11"
	10463	Cotter Pin, 1/4" x 11"
4.	D2698	Rubber Stop
5.	10047	HHCS, 3/8" - 16 x 1 3/4"
	10210	Washer, 3/8" USS
	10229	Lock Washer, 3/8"
	10101	Hex Nut, 3/8" - 16
6.	A2476	Arm W/Pins, Washers, and Grease Fitting, Second Stage, 78"
	10226	Washer, 1 1/4" SAE
	D2161	Pin, 1 1/4" x 8 1/2"
	10460	Cotter Pin, 1/4" x 2"
	D3214	Pin, 1 1/4" x 12 1/4"
	10641	Grease Fitting, 1/8" NPT
7.	3302-04	Chain
8.	10039	HHCS, 1/2" - 13 x 1 3/4"
	10111	Lock Nut, 1/2" - 13
9.	A5130	Mount
10.	A2483	Arm W/Grease Fittings, First Stage, 44"
	10641	Grease Fitting, 1/8" NPT
11.		Cylinder (See Econo-Fold Marker Cylinder)
12.	D2161	Pin, 1 1/4" x 8 1/2"
	10460	Cotter Pin, 1/4" x 2"
13.	D0652	Pin, 1 1/4" x 9 1/2"
	10460	Cotter Pin, 1/4"
14.	B0177	Tap Block
15.	10008	HHCS, 5/8" - 11 x 2", Grade 2
	10230	Lock Washer, 5/8"
16.	10026	HHCS, 3/4" - 10 x 2"
	10231	Lock Washer, 3/4"

ECONO-FOLD MARKER ASSEMBLY, 8 ROW 30 AND WIDE

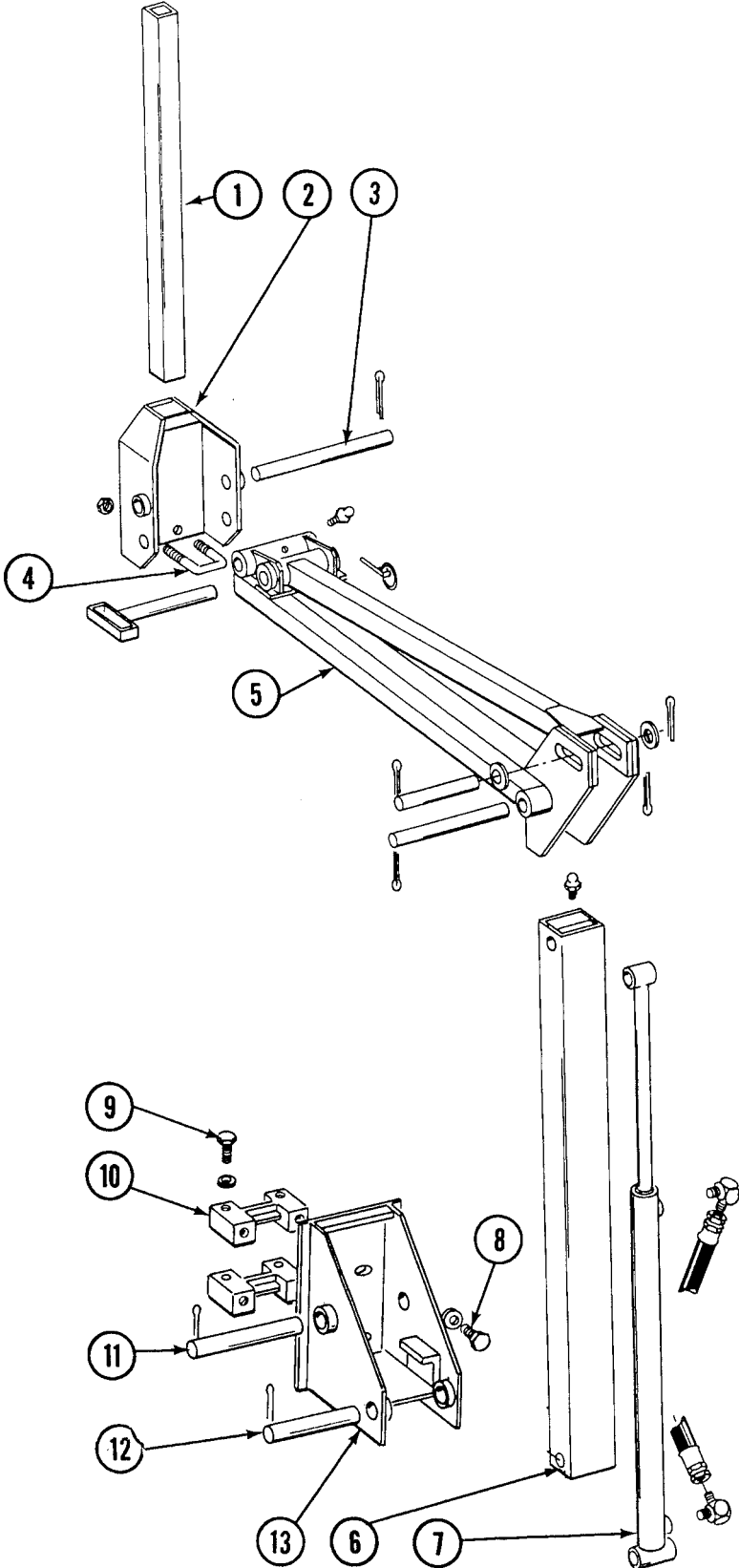

ECONO-FOLD MARKER ASSEMBLY, 8 ROW 30 AND WIDE

ITEM	PART NO.	DESCRIPTION	
1.	D0453-03	Extension Tube, 50", 8 Row 30	
	D0453-04	Extension Tube, 60", 8 Row Wide	
2.	A2492	Bracket	
3.	D2697	Pin, 7/8" x 11"	
	10463	Cotter Pin, 1/4" x 1 1/2"	
4.	D2721	U-Bolt, 2" x 2" x 1/2" - 13	
	10111	Lock Nut, 1/2" - 13	
5.	A2474	Arm W/Pins, Washers, and Grease Fitting, 43", 8 Row 30	
	A2479	Arm W/Pins, Washers, and Grease Fitting, 60", 8 Row Wide	
	10641	Grease Fitting, 1/8" NPT	
	D2558	Lynch Pin, 1/4"	
	A2498	Pin W/Handle	
	10460	Cotter Pin, 1/4" x 2"	
	D2161	Pin, 1 1/4" x 8 1/4"	
	D3214	Pin, 1 1/4" x 12 1/4"	
	10226	Washer, 1 1/4" SAE	
	6.	A2482	Link W/Grease Fittings, First Stage, 44"
		10641	Grease Fitting, 1/8" NPT
	7.		Cylinder (See Econo-Fold Marker Cylinder)
	8.	10008	HHCS, 5/8" - 11 x 2", Grade 2
10230		Lock Washer, 5/8"	
9.	10026	HHCS, 3/4" - 10 x 2"	
	10231	Lock Washer, 3/4"	
10.	B0177	Tap Block	
11.	D0652	Pin, 1 1/4" x 9 1/2"	
	10460	Cotter Pin, 1/4" x 2"	
12.	D2161	Pin, 1 1/4" x 8 1/4"	
	10460	Cotter Pin, 1/4" x 2"	
13.	A5130	Mount	

PULL TYPE CONVENTIONAL MARKER ASSEMBLY

4 ROW 30 AND WIDE, 6 ROW 30

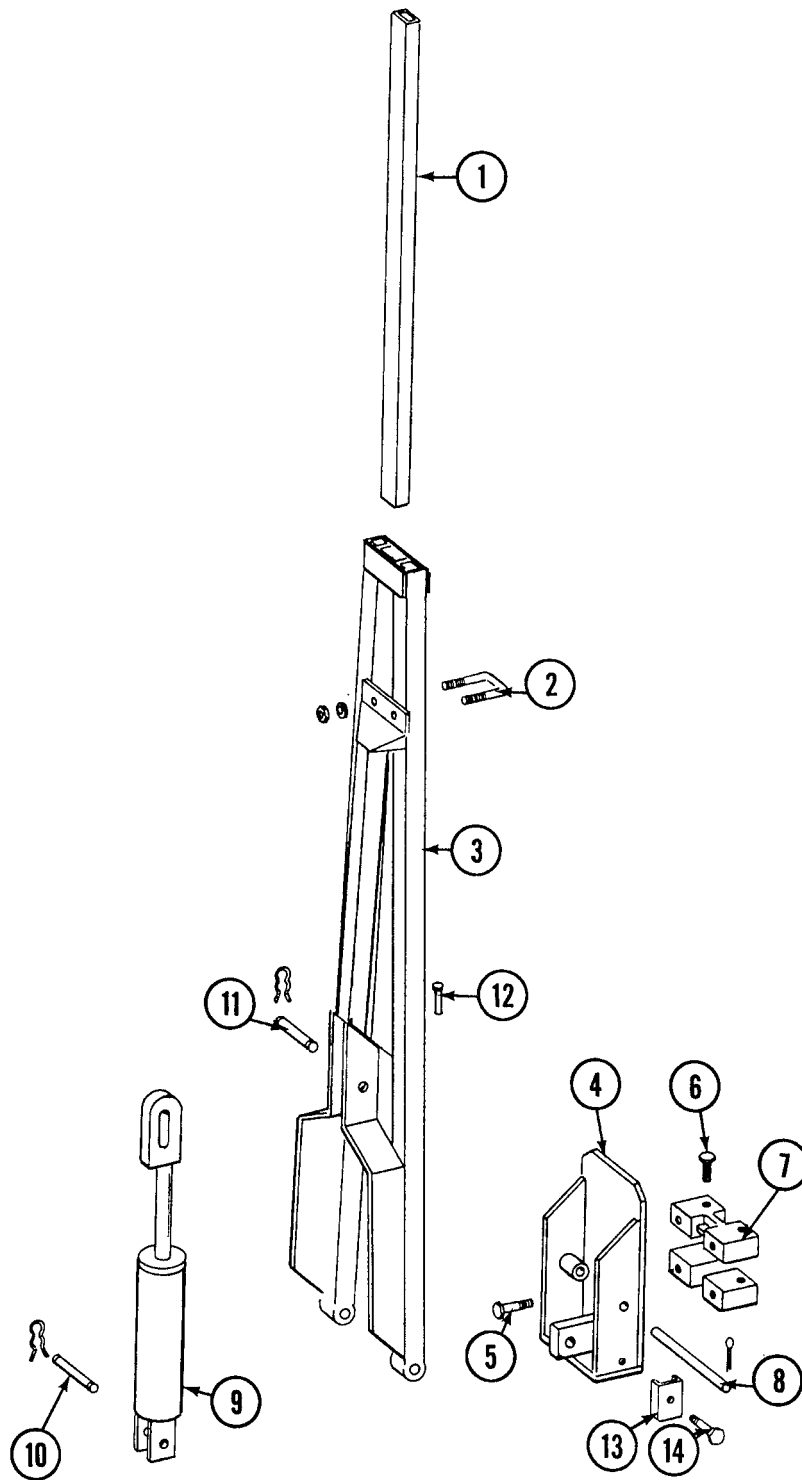

PULL TYPE CONVENTIONAL MARKER ASSEMBLY 4 ROW 30 AND WIDE, 6 ROW 30

ITEM	PART NO.	DESCRIPTION
1.	D0453-02	Extension Tube, 40", 4 Row 30, 6 Row 30
	D0453-07	Extension Tube, 45", 4 Row 36 and 38
	D0453-03	Extension Tube, 50", 4 Row 40
2.	D2721	U-Bolt, 2" x 2" x 1/2" - 13
	10228	Lock Washer, 1/2"
	10102	Hex Nut, 1/2" - 13
3.	A5175	Marker Arm, 31 1/2", 4 Row 30
	A5184	Marker Arm W/Grease Fittings, 44 1/2", 4 Row Wide
	A5183	Marker Arm W/Grease Fittings, 58 1/2", 6 Row 30
	10640	Grease Fitting, 1/4" 28
4.	A5177	Mount W/Grease Fittings, 4 Row 30
	A5178	Mount, 4 Row Wide and 6 Row 30
	10640	Grease Fitting, 1/4" - 28
5.	10008	HHCS, 5/8" - 11 x 2", Grade 2
	10230	Lock Washer, 5/8"
6.	10026	HHCS, 3/4" - 10 x 2"
	10027	HHCS, 3/4" - 10 x 2 1/2"
	10231	Lock Washer, 3/4"
7.	B0177	Tap Block
8.	D0438	Pin, 13 1/2"
	10460	Cotter Pin, 1/4" x 2"
9.		Cylinder (See Marker Cylinder)
10.	R0367	Pin, 2 7/8"
	R0193	Clip
11.	R0375	Pin, 3 1/2"
	R0193	Clip
12.	D0462	Pin, Lockup
	10670	Hair Pin Clip, No. 3
	10187	Spring Pin, 5/32" x 2"
	D5892	Hose Clamp
13.	10133	HHCS, 5/16" - 18 x 1 1/2"
	10232	Lock Washer, 5/16"
	10106	Hex Nut, 5/16" - 18

PULL TYPE LOW PROFILE MARKER ASSEMBLY 6 ROW WIDE, 8 ROW 30 AND WIDE

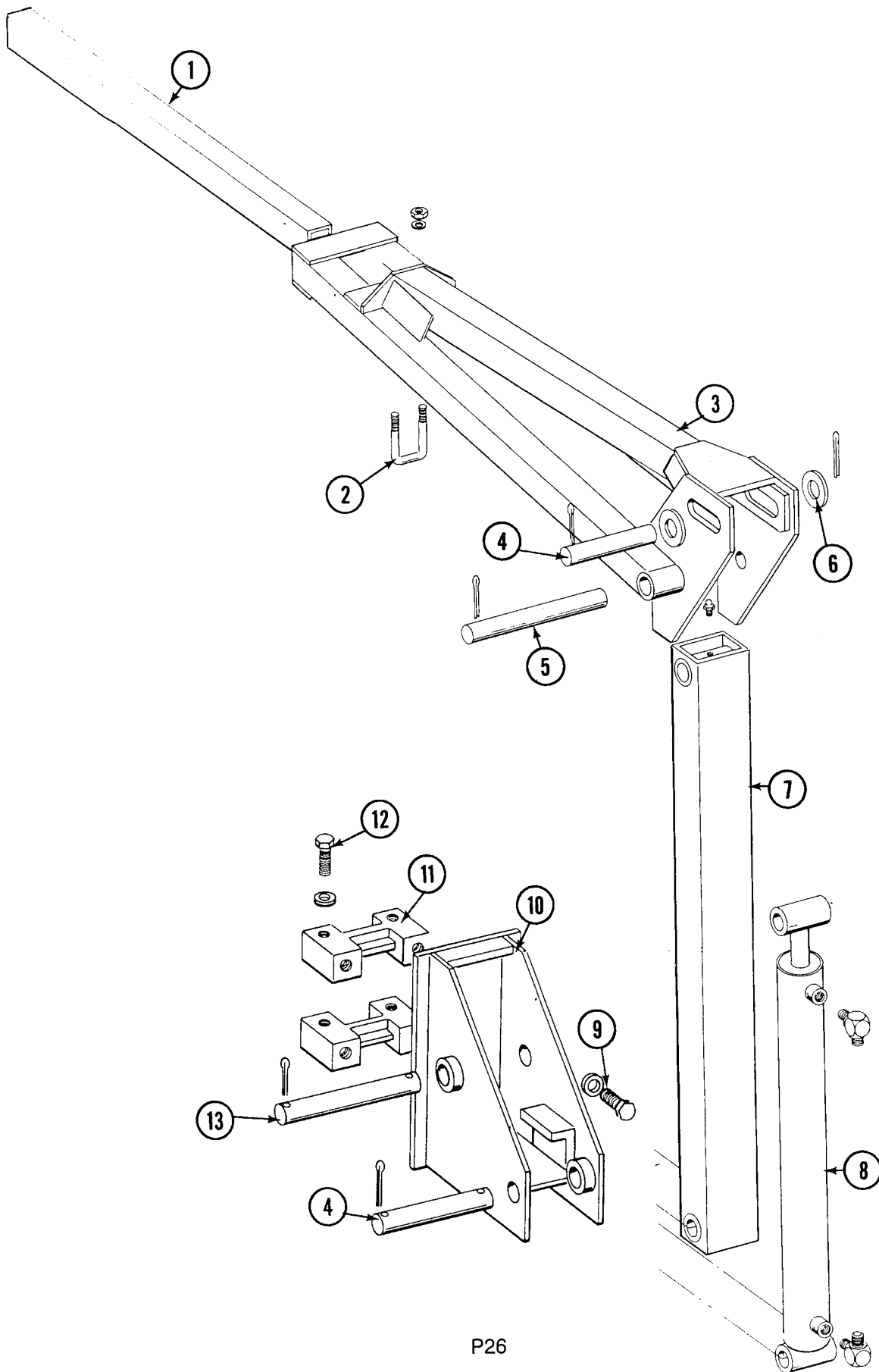

PULL TYPE LOW PROFILE MARKER ASSEMBLY 6 ROW WIDE, 8 ROW 30 AND WIDE

ITEM	PART NO.	DESCRIPTION
1.	D0453-03	Extension Tube, 50", 6 Row 36, 38, and 40 and 8 Row 30
	D0453-04	Extension Tube, 60", 8 Row 36 and 38
	D0453-08	Extension Tube, 65", 8 Row 40
2.	D2721	U-Bolt, 2" x 2" x 1/2" - 13
	10228	Lock Washer, 1/2"
	10102	Hex Nut, 1/2" - 13
3.	A5190	Arm, Second Stage, 35", 6 Row Wide
	A5188	Arm, Second Stage, 46", 8 Row 30
	A5192	Arm, Second Stage, 67", 8 Row Wide
4.	D2161	Pin, 1 1/4" x 8 1/4"
	10460	Cotter Pin, 1/4" x 2"
5.	D3214	Pin, 1 1/4" x 12 1/4"
	10460	Cotter Pin, 1/4" x 2"
6.	10226	Washer, 1 1/4" SAE
7.	A5173	Arm W/Grease Fittings, First Stage
	10641	Grease Fittings, 1/8"
8.		Cylinder (See Marker Cylinder)
9.	10008	HHCS, 5/8" - 11 x 2", Grade 2
	10230	Lock Washer, 5/8"
10.	A5130	Mount
11.	B0177	Tap Block
12.	10026	HHCS, 3/4" - 10 x 2"
	10027	HHCS, 3/4" - 10 x 2 1/2"
	10231	Lock Washer, 3/4"
13.	D0652	Pin, 1 1/4" x 9 1/2"
	10460	Cotter Pin, 1/4" x 2"

MARKER HUB ASSEMBLY

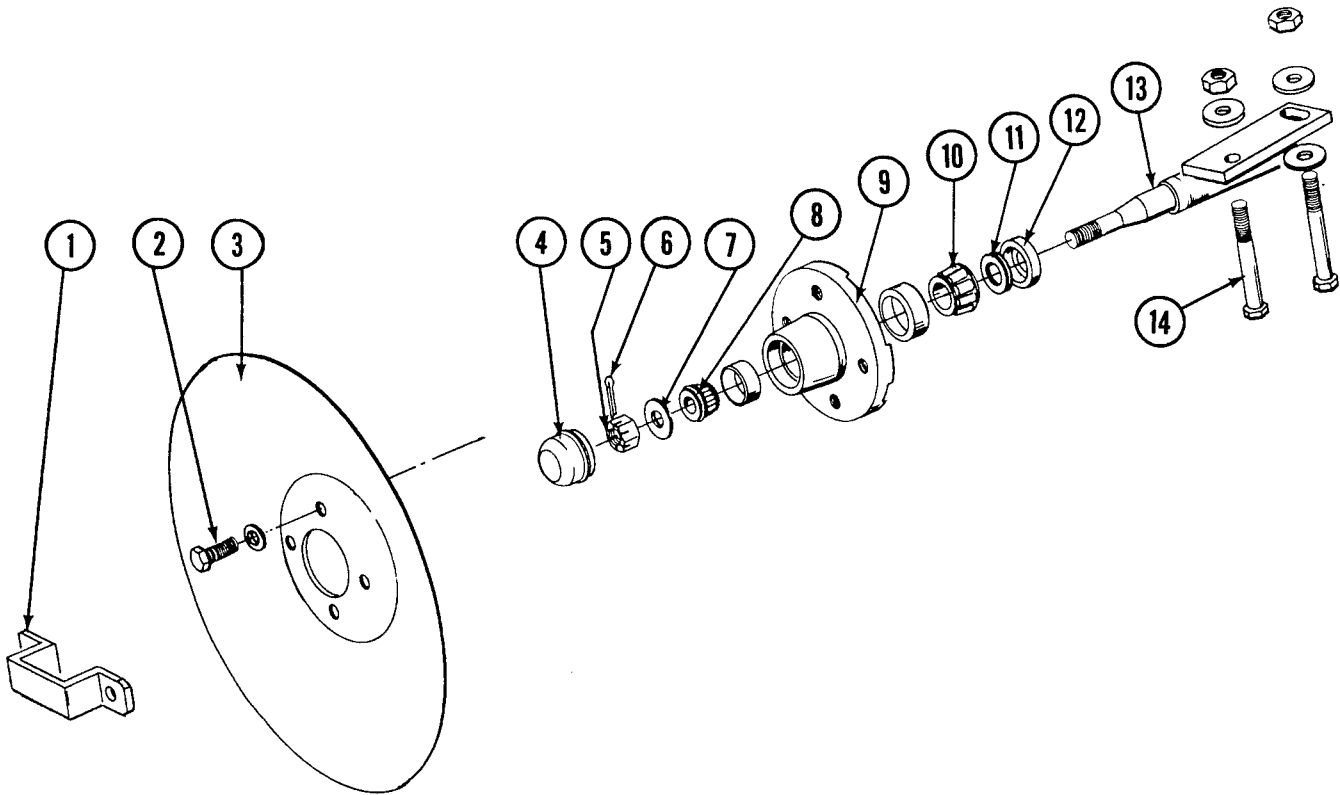

ITEM PART NO. DESCRIPTION

1.	D2597	Retainer
2.	10722	HHCS, 1/2" - 20 x 1"
	10228	Lock Washer, 1/2"
3.	D0746	Blade, 16"
4.	D0840	Cap
5.	10725	Hex Nut, Slotted, 5/8" - 18
6.	10470	Cotter Pin, 5/32" x 1"
7.	10724	Washer, 5/8"
8.	A0257	Bearing, Outer
9.	A0167	Hub W/Cups
	R0151	Cup, Outer
	R0150	Cup, Inner
10.	A0245	Bearing, Inner
11.	A0899	Seal, Rubber
12.	A0243	Seal, Grease
13.	A1677	Spindle, L.H., Less Hardware (Shown)
	A1676	Spindle, R.H., Less Hardware
14.	10033	HHCS, 1/2" - 13 x 3 1/2"
	10168	Machinery Bushing, 1/2", 7 Ga.
	10102	Hex Nut, 1/2" - 13
A.	A1679	Hub and Spindle Assembly, L.H., Includes: (1) A1676, (4) 10722, (4) 10228, (1) D0840, (1) 10725, (1) 10470, (1) 10724, (1) A0257, (1) A0167, (1) A0245, (1) A0899, (1) A0243
	A1678	Hub and Spindle Assembly, R.H., Includes: (1) A1677, (4) 10722, (4) 10228, (1) D0840, (1) 10725, (1) 10470, (1) 10724, (1) A0257, (1) A0167, (1) A0245, (1) A0899, (1) A0243

MASTER LIFT CYLINDER, ALL MODELS

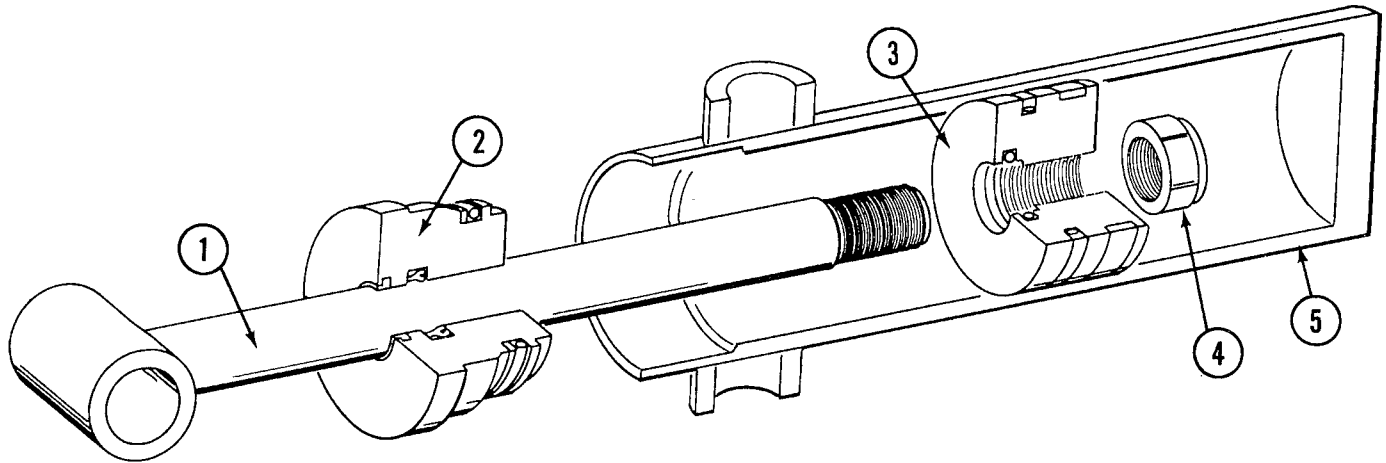

ITEM	PART NO.	DESCRIPTION
1.	A5452	Rod Assembly
2.	D5947	Gland
3.	D5948	Piston
4.	R0923	Special Jam Nut, 1" - 14
5.	A5451	Barrel
A.	A5091	Cylinder Complete, 3 1/2" x 8"
B.	R0931	Seal Kit, Includes: (1) Wear Ring, (2) O-Rings, (1) BU Ring, (1) U-Cup, (1) Wiper, (1) Chem Cast Seal W/Wear Ring

SLAVE LIFT CYLINDER, ALL MODELS

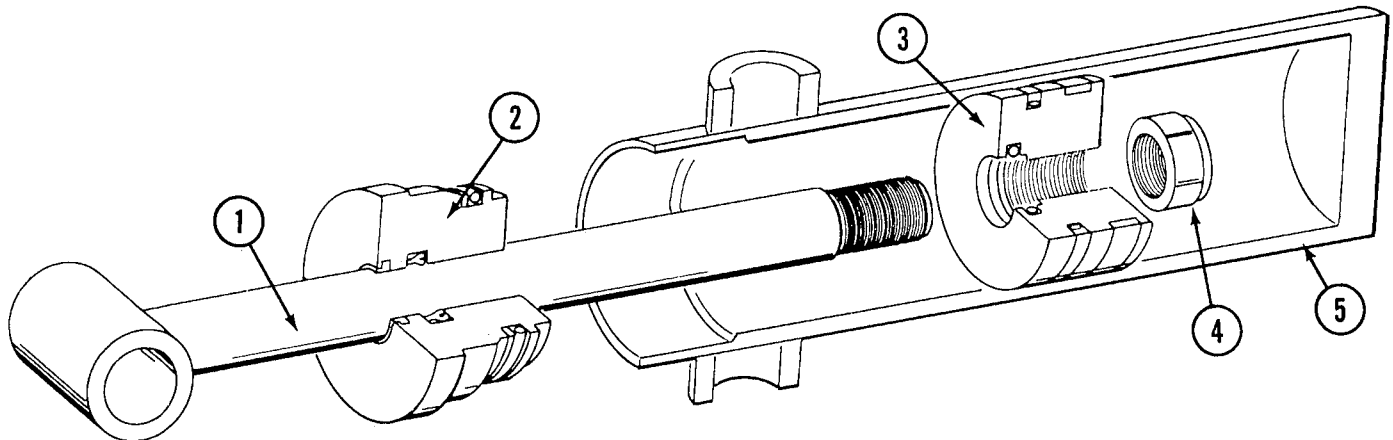

ITEM	PART NO.	DESCRIPTION
1.	A5249	Rod Assembly
2.	D5946	Gland
3.	D4896	Piston
4.	R0923	Special Jam Nut, 1" - 14
5.	A5250	Barrel
A.	A5092	Cylinder Complete, 3 1/4" x 8"
B.	R0922	Seal Kit, Includes: (2) O-Rings, (1) BU Ring, (1) Wear Ring, (1) Rod Wiper, (1) Polypak, (1) Piston Seal

LIFT ASSIST CYLINDER, ECONO-FOLD 8 ROW 30 AND WIDE PULL TYPE 6 ROW 30 AND WIDE AND 8 ROW 30 AND WIDE

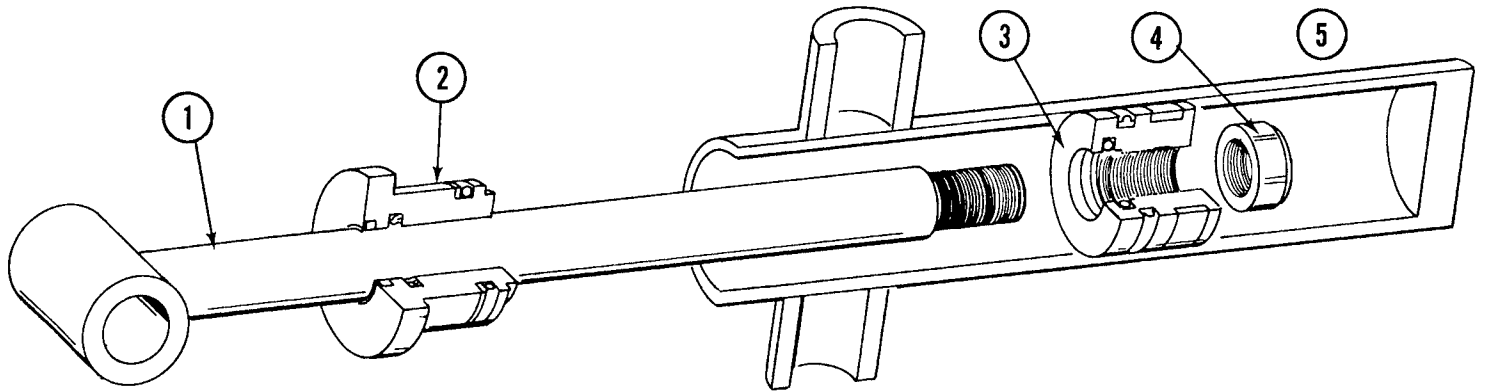

ITEM PART NO. DESCRIPTION

1.	A5452	Rod Assembly
2.	D5954	Gland
3.	D5956	Piston
4.	R0923	Special Jam Nut, 1" - 14
5.	A5455	Barrel
A.	A5093	Cylinder Complete, 2 1/2" x 8"
B.	R0930	Seal Kit, Includes: (1) Wear Ring, (1) T-Seal, (2) O-Rings, (1) BU Ring, (1) U-Cup, (1) Wiper

LIFT ASSIST CYLINDER, ECONO-FOLD 12 ROW 30

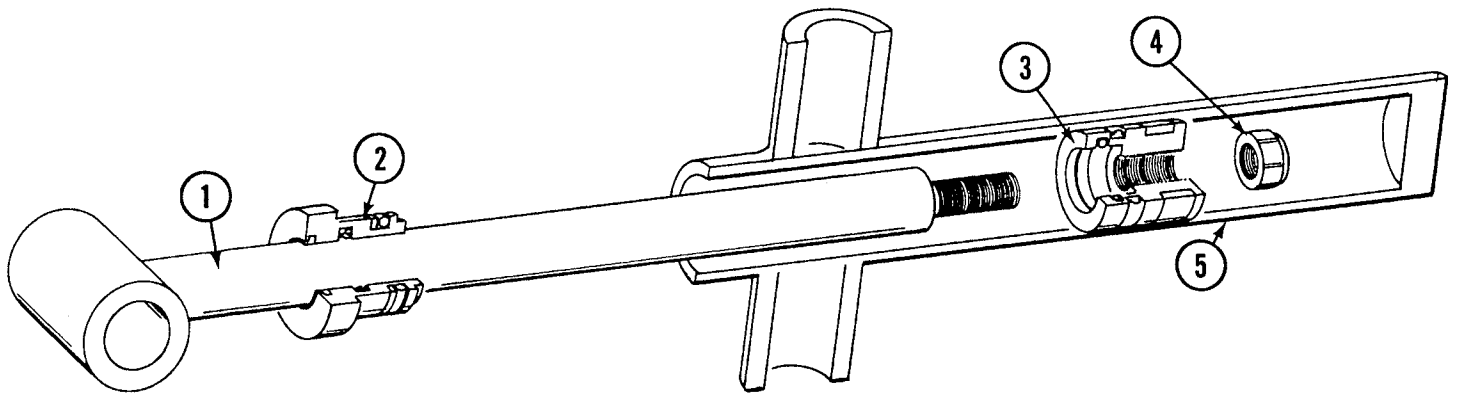

ITEM PART NO. DESCRIPTION

1.	A5457	Rod Assembly
2.	D6242	Gland
3.	D6250	Piston
4.	R0960	Jam Nut, 1/2" - 20
5.	A5456	Barrel
A.	A5094	Cylinder Complete, 1 3/4" x 8"
B.	R0958	Seal Kit, Includes: (1) Wear Ring, (1) T-Seal and BU Rings, (2) O-Rings, (1) BU Ring, (1) U-Cup, (1) Wiper

MASTER LIFT CYLINDER, ALL MODELS

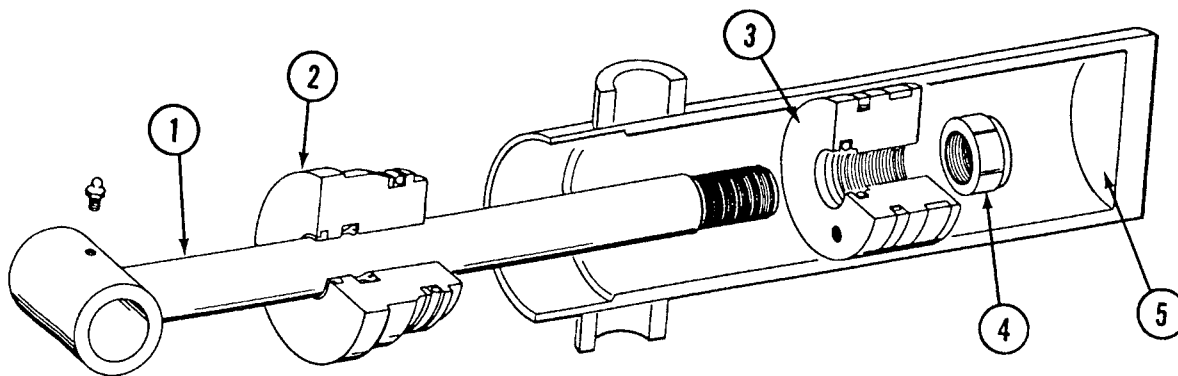

ITEM	PART NO.	DESCRIPTION
1.	A4320	Rod Assembly W/Grease Fitting
	10449	Grease Fitting
2.	D5947	Gland
3.	A4296	Piston W/Rephasing Valve
4.	R0983	Lock Nut, 1"-14
5.	A4295	Barrel
A.*	A4257	Cylinder Complete, 3 1/2" x 8"
B.	R0982	Seal Kit, Includes: (1)Wear Ring, (2)O-Rings, (1)BU Ring, (1)U-Cup, (1)Wiper, (1)Uniring

*Part number stamped on barrel.

SLAVE LIFT CYLINDER, ALL MODELS

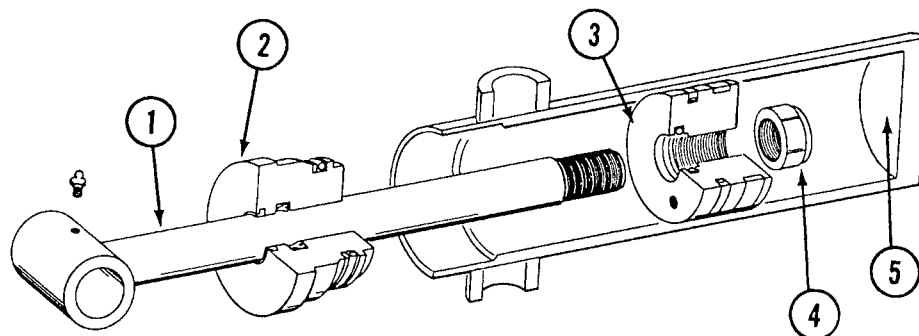

ITEM	PART NO.	DESCRIPTION
1.	A4320	Rod Assembly W/Grease Fitting
	10449	Grease Fitting
2.	D5946	Gland
3.	A4298	Piston W/Rephasing Valve
4.	R0983	Lock Nut, 1"-14
5.	A4297	Barrel
A.*	A4258	Cylinder Complete, 3 1/4" x 8"
B.	R0984	Seal Kit, Includes: (2)O-Ring, (1)BU Ring, (1)Wear Ring, (1)Rod Wiper, (1)Uniring, (1)U-Cup

*Part number stamped on barrel.

ROCK SHAFT LIFT CYLINDER - Frame Mounted Lift

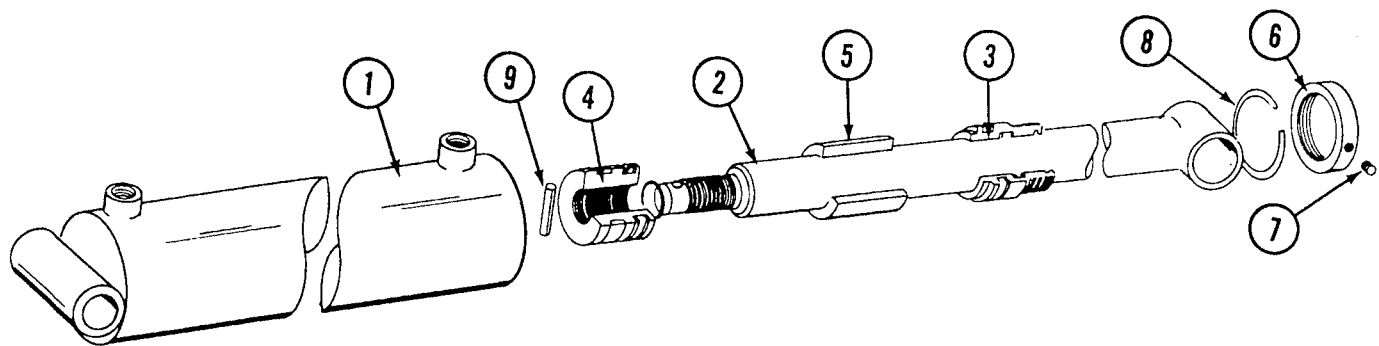

ITEM	PART NO.	DESCRIPTION
1.	R0519	Barrel
2.	R0518	Rod Assembly
3.	R0128	Gland
4.	R0129	Piston
5.	R0130	Stroke Collar
6.	R0131	Head Gland Nut
7.	10114	Set Screw, No. 10-32 x 1/4"
8.	R0132	Wire Ring
9.	10604	Roll Pin
A.	A0977	Cylinder Complete, 3" x 8" (1/2" NPT Ports)
B.	R0133	Seal Kit, Includes: (4)O-Rings, (4)BU Rings, (1)Rod Wiper, (1)Wear Ring

ROCK SHAFT LIFT CYLINDER - Frame Mounted Lift

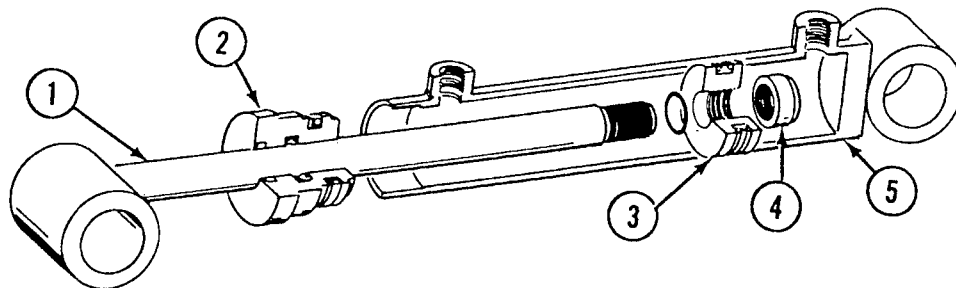

ITEM	PART NO.	DESCRIPTION
1.	A5563	Rod Assembly
2.	D6574	Gland
3.	D7629	Piston
4.	R1030	Lock Nut, 1 1/4"-12
5.	A5562	Barrel
A.	A5541	Cylinder Complete, 3" x 8" (3/4" O-Ring Ports)
B.	R1031	Seal Kit, Includes: (2)O-Rings, (1)BU Ring, (1)Rod Wiper, (1)Wear Ring, (1)Uniring, (1)U-Cup

PULL TYPE CONVENTIONAL MARKER CYLINDER 4 ROW 30 AND WIDE AND 6 ROW 30

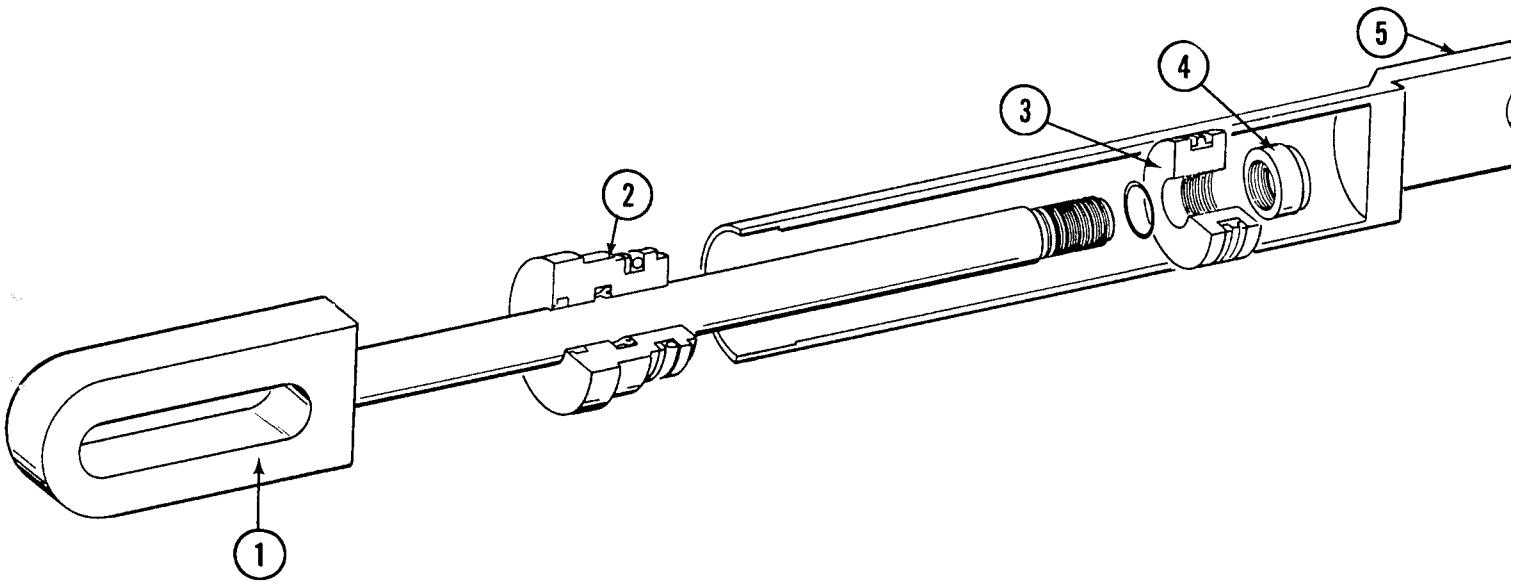

ITEM	PART NO.	DESCRIPTION
1.	A5453	Rod Assembly
2.	D5949	Gland
3.	D4632	Piston
4.	R0959	Lock Nut, 3/4" - 16
5.	A5454	Barrel
A.	A5095	Cylinder Complete, 2" x 8"
B.	R0927	Seal Kit, Includes: (1) T Seal, (2) O-Rings, (1) BU Ring, (1) U-Cup, (1) Wiper

PULL TYPE LOW PROFILE MARKER CYLINDER 6 ROW WIDE AND 8 ROW 30 AND WIDE

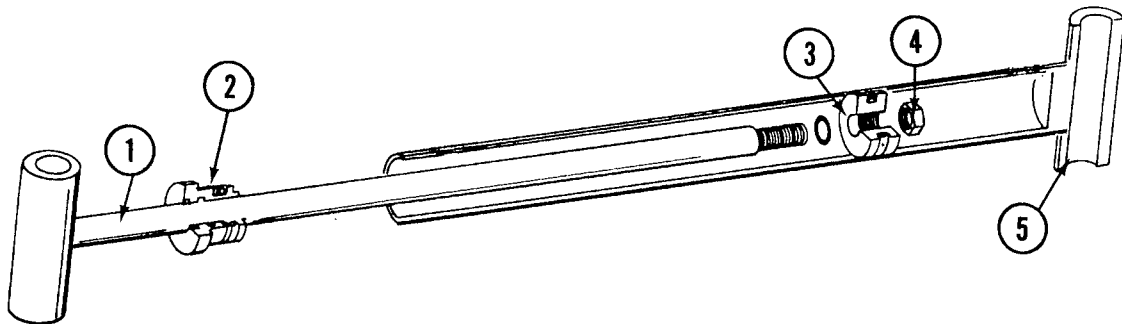

ITEM	PART NO.	DESCRIPTION
1.	A5459	Rod Assembly
2.	D5949	Gland
3.	D4632	Piston
4.	R0959	Lock Nut, 3/4" - 16
5.	A5460	Barrel
A.	A5097	Cylinder Complete, 2" x 20"
B.	R0927	Seal Kit, Includes: (1) T Seal, (2) O-Rings, (1) BU Ring, (1) U-Cup, (1) Wiper

ECONO-FOLD LOW PROFILE MARKER CYLINDER, ALL ECONO-FOLD MODELS

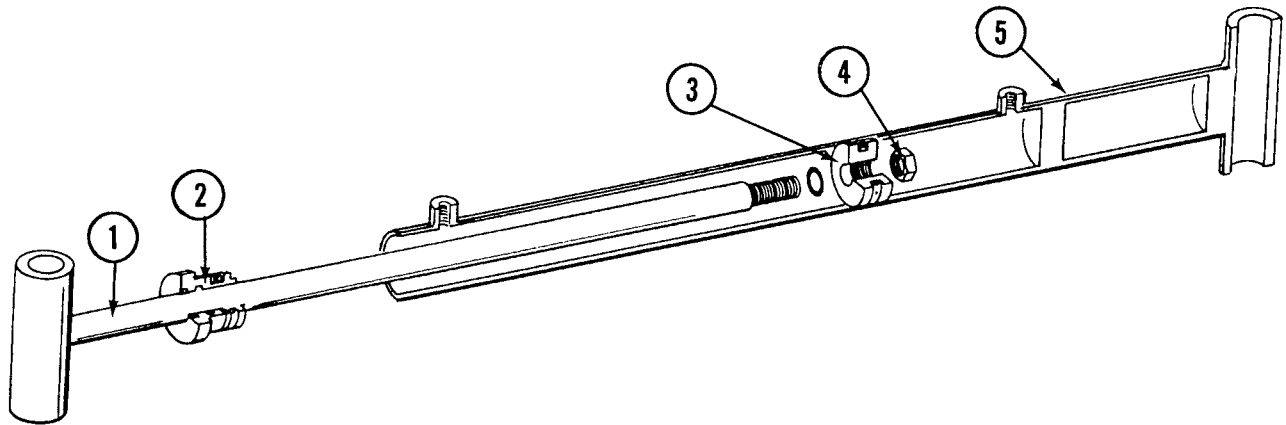

ITEM	PART NO.	DESCRIPTION
1.	A5459	Rod Assembly
2.	D5949	Gland
3.	D4632	Piston
4.	R0959	Lock Nut, 3/4" - 16
5.	A5458	Barrel
A.	A5096	Cylinder Complete, 2" x 20 1/16"
B.	R0927	Seal Kit, Includes: (1) T Seal, (2) O-Rings, (1) BU Ring, (1) U-Cup, (1) Wiper

ROCK SHAFT LIFT CYLINDER

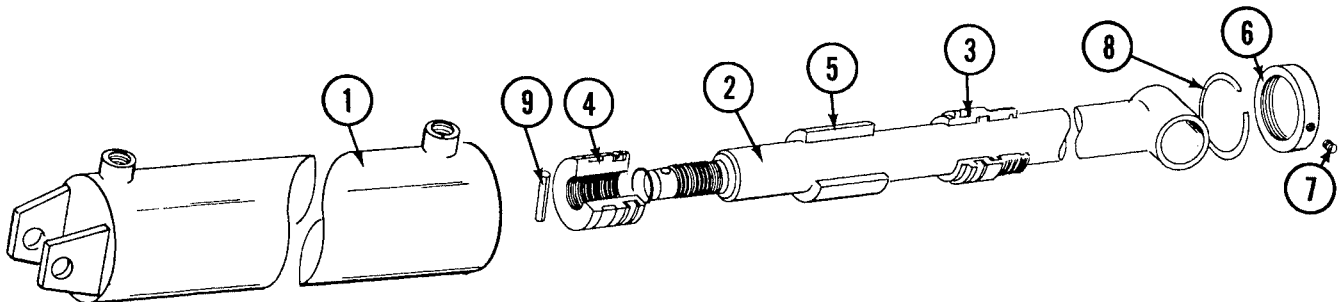

ITEM	PART NO.	DESCRIPTION
1.		Barrel
2.	R0518	Rod Assembly
3.	R0128	Gland
4.	R0129	Piston
5.	R0130	Stroke Collar
6.	R0131	Head Gland Nut
7.	10114	Set Screw, No. 10-32 x 1/4"
8.	R0132	Wire Ring
9.	10604	Roll Pin
A.	A5326	Cylinder Complete, 3" x 8"
B.	R0133	Seal Kit, Includes: (4) O-Rings, (4) BU Rings, (1) Rod Wiper, (1) Wear Ring

MARKER SEQUENCING/FLOW CONTROL VALVE

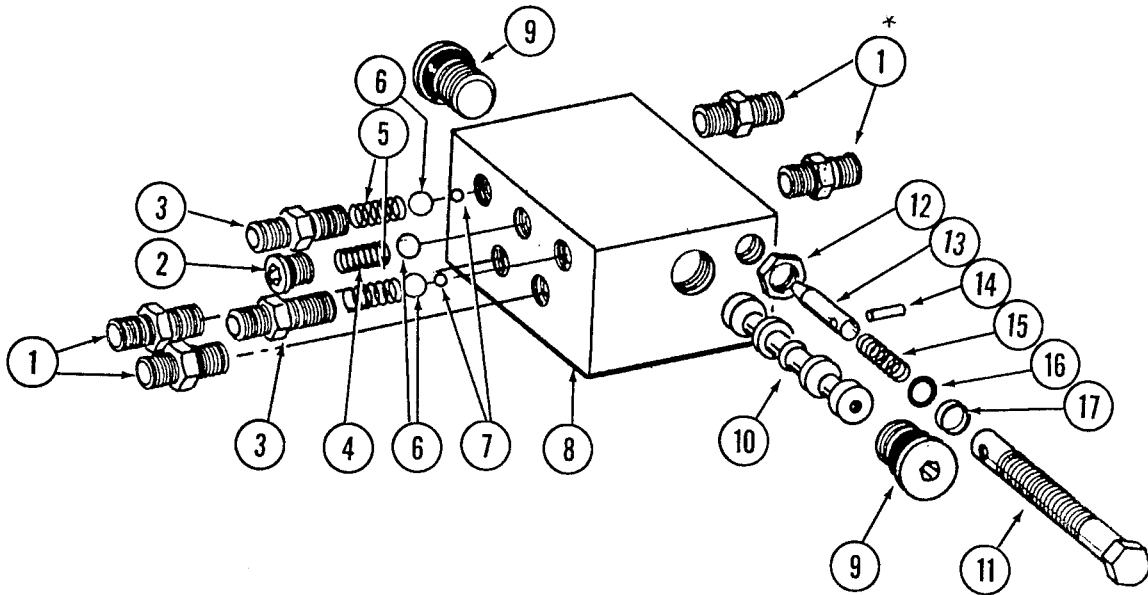

ITEM	PART NO.	DESCRIPTION
1.	6400-06	Connector, 9/16"-18 Male 37° JIC to 9/16"-18 O-Ring
	R1045	O-Ring
2.	R1034	Hex Socket O-Ring Plug
	R1035	O-Ring
3.	R1032	Port Adapter
	R1045	O-Ring
4.	R1033	Detent Spring
5.	R1036	Spring
6.	R1044	7/16" Check Ball
7.	R1043	1/4" Steel Ball
8.		Valve Body (None Stock Item)
9.	R1047	Hex Socket Plug
	R1037	O-Ring
10.		Spool (None Stock Item)
11.	R1042	Adjustment Screw
12.	R1048	Hex Jam Nut, 1/2"-20
13.	R1038	Needle
14.	R1039	Spring Pin
15.	R1046	Compression Spring
16.	R1040	O-Ring
17.	R1041	Teflon BU Ring
A.	A5552	Valve Assembly Complete (Items 1-17)
B.	A5572	Flow Control Portion Only (Items 11-17)

*Not used on models with 3/8" hoses.

MARKER SEQUENCING VALVE

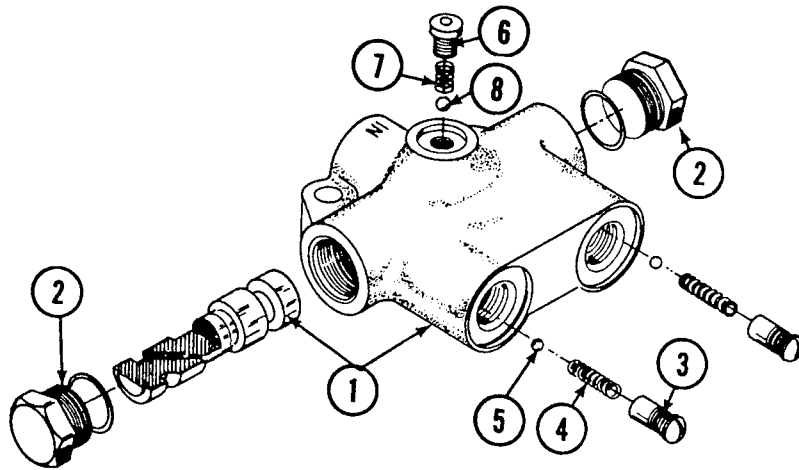

ITEM	PART NO.	DESCRIPTION
1.		Valve Body and Spool
2.	R0271	Plug Assembly, O-Ring Boss
3.	R0273	Retainer, Check Valve
4.	R0277	Spring, Check Valve
5.	R0275	Ball, Check 3/16" Diameter
6.	R0274	Plug Assembly, O-Ring Boss
7.	R0278	Spring
8.	R0276	Ball, 1/4" Diameter
A.	A0282	Sequencing Valve, Complete

MARKER FLOW CONTROL VALVE

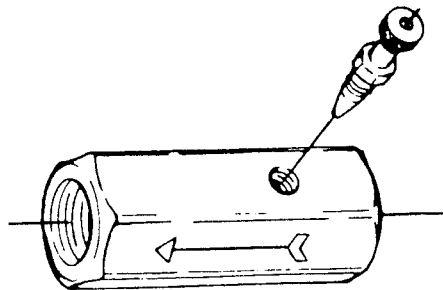

ITEM	PART NO.	DESCRIPTION
A.*	A0270A	Flow Control Valve Assembly
	R0103	Needle Valve Only
B.**	A0270B	Flow Control Valve Assembly
	R0642	Needle Valve Only
C.***	A0270C	Flow Control Valve Assembly
	R0767	Needle Valve Only

* To identify - Rego KLF375 stamped on valve body.

** To identify - Deltrol stamped on valve body.

*** To identify - Partrol stamped on valve body.

ECONO-FOLD HYDRAULIC SYSTEM, 8 ROW 30 AND WIDE

Dual Valve

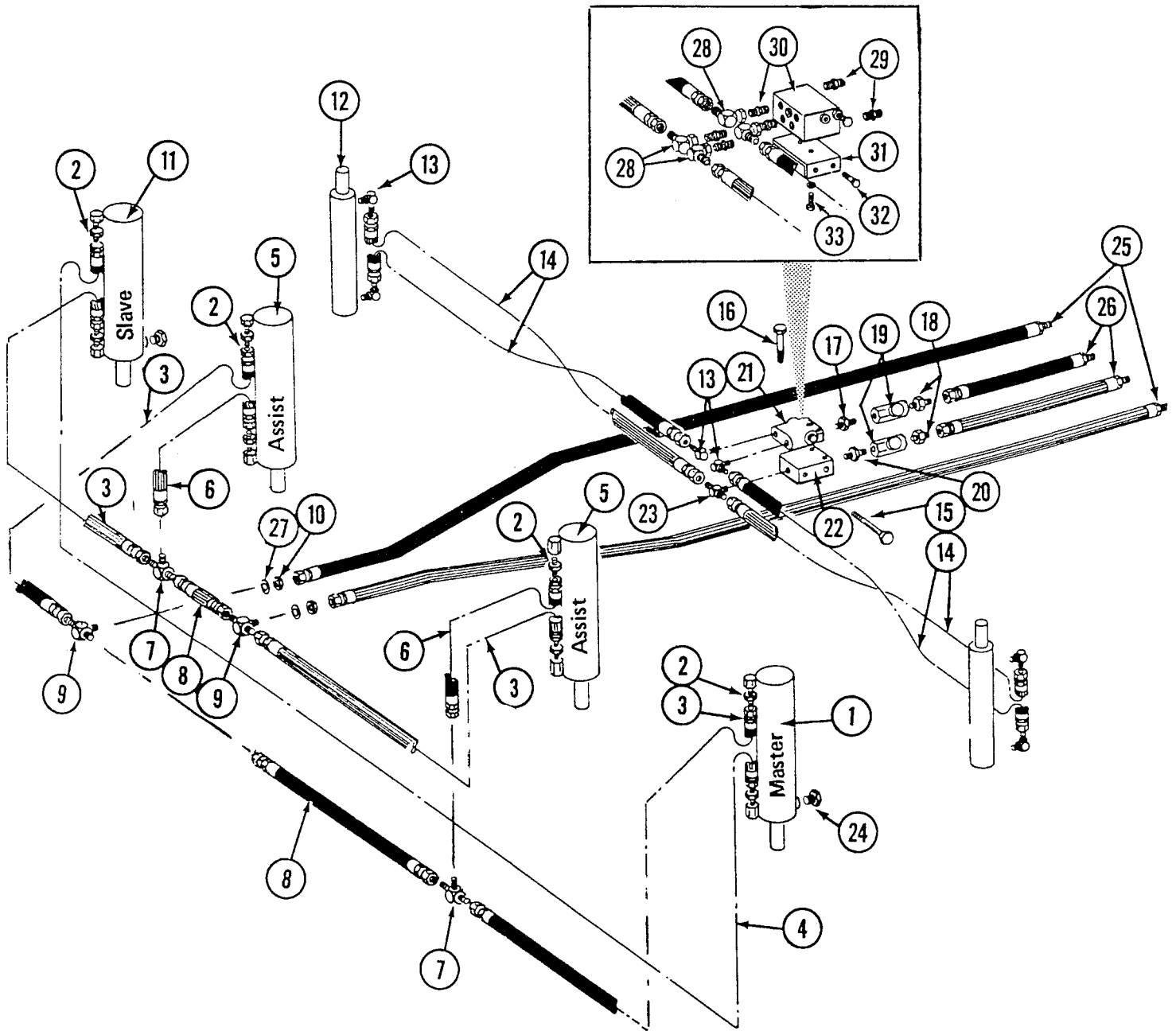

ECONO-FOLD HYDRAULIC SYSTEM, 8 ROW 30 AND WIDE

ITEM	PART NO.	DESCRIPTION
1.		Cylinder (See Master Lift Cylinder)
2.	6400-08	Connector, 3/4"-16 Male O-Ring to 37° JIC
3.	A3131	Hose Assembly, 3/8" x 42", 8 Row 30
	A1096	Hose Assembly, 3/8" x 50 1/2", 8 Row Wide
4.	A3115	Hose Assembly, 3/8" x 146", 8 Row 30
	A3105	Hose Assembly, 3/8" x 170", 8 Row Wide
5.		Cylinder (See Lift Assist Cylinder)
6.	A1000	Hose Assembly, 3/8" x 15", 8 Row 30 and Wide
7.	2603-08	Tee, 3/4"-16 Male 37° JIC
8.	A1086	Hose Assembly, 3/8" x 28", 8 Row 30
	A3119	Hose Assembly, 3/8" x 36", 8 Row Wide
9.	2703-08	Bulkhead Tee, 3/4"-16 Male 37° JIC
10.	306-08	Lock Nut, 3/4"-16
11.		Cylinder (See Slave Lift Cylinder)
12.		Cylinder (See Marker Cylinder)
13.	6801-08	Elbow, 3/4"-16 Male 37° JIC to 3/4"-16 O-Ring
14.	A3101	Hose Assembly, 3/8" x 168", 8 Row 30
	A1030	Hose Assembly, 3/8" x 192", 8 Row Wide
15.	10004	HHCS, 3/8"-16 x 1 1/4"
	10229	Lock Washer, 3/8"
16.	10325	HHCS, 3/8"-16 x 2 3/4"
	10229	Lock Washer, 3/8"
	10101	Hex Nut, 3/8"-16
17.	6401-08-06	Adapter, 3/4"-16 Male O-Ring to 3/8" NPT
18.	2404-08-06	Adapter, 3/4"-16 Male 37° JIC to 3/8" NPT
19.		Valve (See Marker Flow Control Valve)
20.	5404-06-06	Coupling, 3/8" Male NPT
21.		Valve (See Sequencing Valve)
22.	D5861	Block
23.	2601-08-06	Tee, 3/4"-16 Male 37° JIC to 3/8" NPT
24.	6408-10	Plug, 7/8"-14 Male O-Ring (Only on cylinder with rephasing port on barrel.)
25.	A3112	Hose Assembly, 3/8" x 180", 8 Row 30
	A3134	Hose Assembly, 3/8" x 198", 8 Row Wide
26.	A3130	Hose Assembly, 3/8" x 173", 8 Row 30
	A3133	Hose Assembly, 3/8" x 191", 8 Row Wide
27.	10215	Machine Bushing
28.	6500-08-06	Elbow, 3/4"-16 Male 37° JIC to 9/16"-18 Female 37° JIC
29.	6400-08-06	Adapter, 3/4"-16 Male 37° JIC to 9/16"-18 O-Ring
30.		Valve (See Marker Sequencing/Flow Control Valve)
31.	D7630	Mounting Angle
32.	10004	HHCS, 3/8"-16 X 1 1/4"
	10210	Washer, 3/8" USS
	10229	Lock Washer, 3/8"
	10101	Hex Nut, 3/8"-16
33.	10001	HHCS, 3/8"-16 x 1"
	10229	Lock Washer, 3/8"

ECONO-FOLD HYDRAULIC SYSTEM, 12 ROW 30

Dual Valve

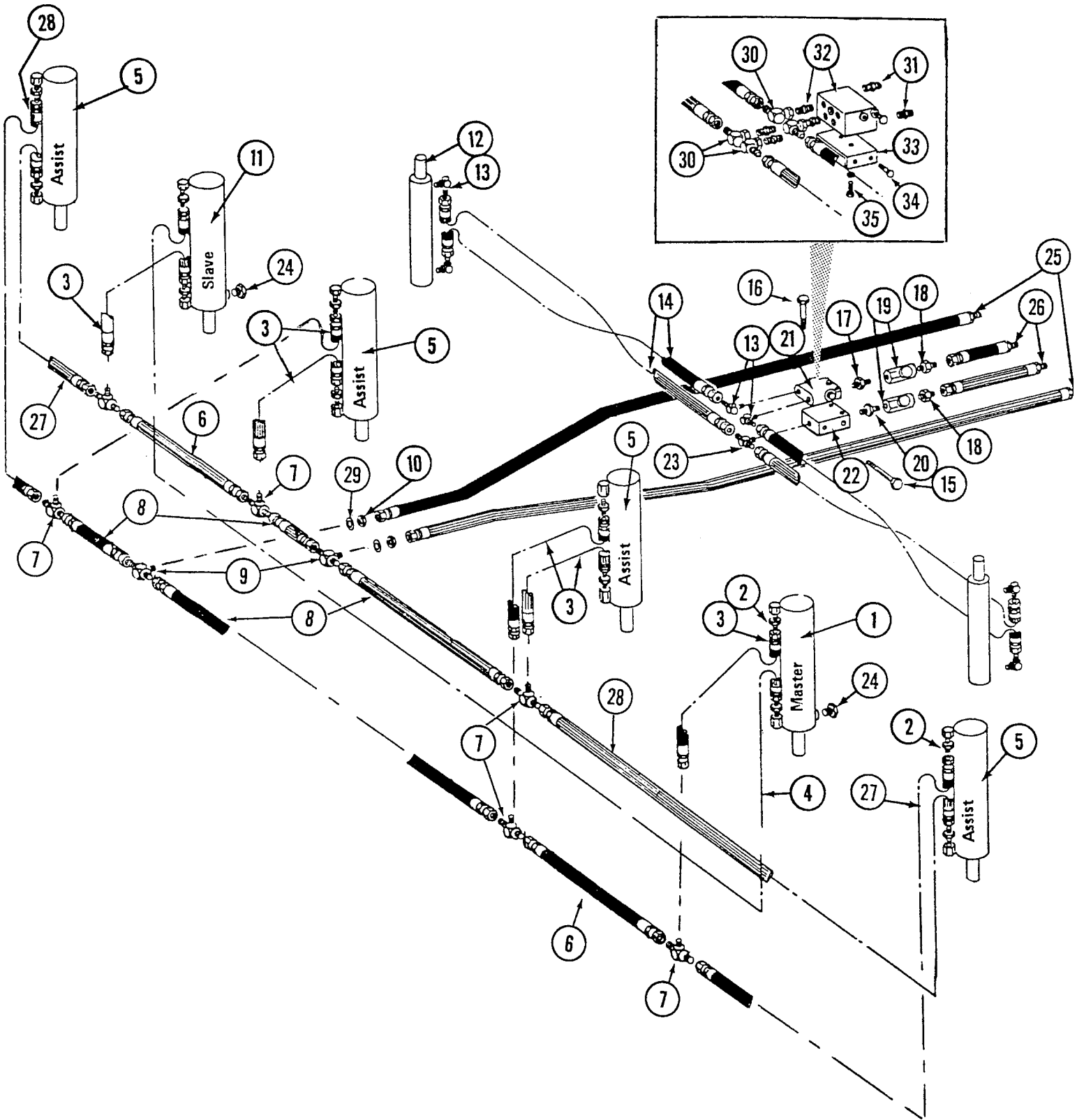

ECONO-FOLD HYDRAULIC SYSTEM, 12 ROW 30

ITEM	PART NO.	DESCRIPTION
1.		Cylinder (See Master Lift Cylinder)
2.	6400-08	Connector, 3/4"-16 Male O-Ring to 37° JIC
3.	A1000	Hose Assembly, 3/8" x 15"
4.	A1054	Hose Assembly, 3/8" x 204"
5.		Cylinder (See Lift Assist Cylinder)
6.	A1076	Hose Assembly, 3/8" x 30"
7.	2603-08	Tee, 3/4"-16 Male 37° JIC
8.	A3127	Hose Assembly, 3/8" x 58"
9.	2703-08	Bulkhead Tee, 3/4"-16 Male 37° JIC
10.	306-08	Lock Nut, 3/4"-16
11.		Cylinder (See Slave Lift Cylinder)
12.		Cylinder (See Marker Cylinder)
13.	6801-08	Elbow, 3/4"-16 Male 37° JIC to 3/4"-16 O-Ring
14.	A1089	Hose Assembly, 3/8" x 240"
15.	10004	HHCS, 3/8"-16 x 1 1/4"
	10229	Lock Washer, 3/8"
16.	10325	HHCS, 3/8"-16 x 2 3/4"
	10229	Lock Washer, 3/8"
	10101	Hex Nut, 3/8"-16
17.	6401-08-06	Adapter, 3/4"-16 Male O-Ring to 3/8" NPT
18.	2404-08-06	Adapter, 3/4"-16 Male 37° JIC to 3/8" NPT
19.		Valve (See Marker Flow Control Valve)
20.	5404-06-06	Coupling, 3/8" Male NPT
21.		Valve (See Sequencing Valve)
22.	D5861	Block
23.	2601-08-06	Tee, 3/4"-16 Male 37° JIC to 3/8" NPT
24.	6408-10	Plug, 7/8"-14 Male O-Ring (Only on cylinder with rephasing port on barrel.)
25.	A3112	Hose Assembly, 3/8" x 180"
26.	A3130	Hose Assembly, 3/8" x 173"
27.	A3128	Hose Assembly, 3/8" x 52"
28.	A3129	Hose Assembly, 3/8" x 79"
29.	10215	Machine Bushing
30.	6500-08-06	Elbow, 3/4"-16 Male 37° JIC to 9/16"-18 Female 37° JIC
31.	6400-08-06	Adapter, 3/4"-16 Male 37° JIC to 9/16"-18 O-Ring
32.		Valve (See Marker Sequencing/Flow Control Valve)
33.	D7630	Mounting Angle
34.	10004	HHCS, 3/8"-16 X 1 1/4"
	10210	Washer, 3/8" USS
	10229	Lock Washer, 3/8"
	10101	Hex Nut, 3/8"-16
35.	10001	HHCS, 3/8"-16 x 1"
	10229	Lock Washer, 3/8"

PULL TYPE HYDRAULIC SYSTEM, 4 ROW 30 AND WIDE CONVENTIONAL MARKER

Single Valve

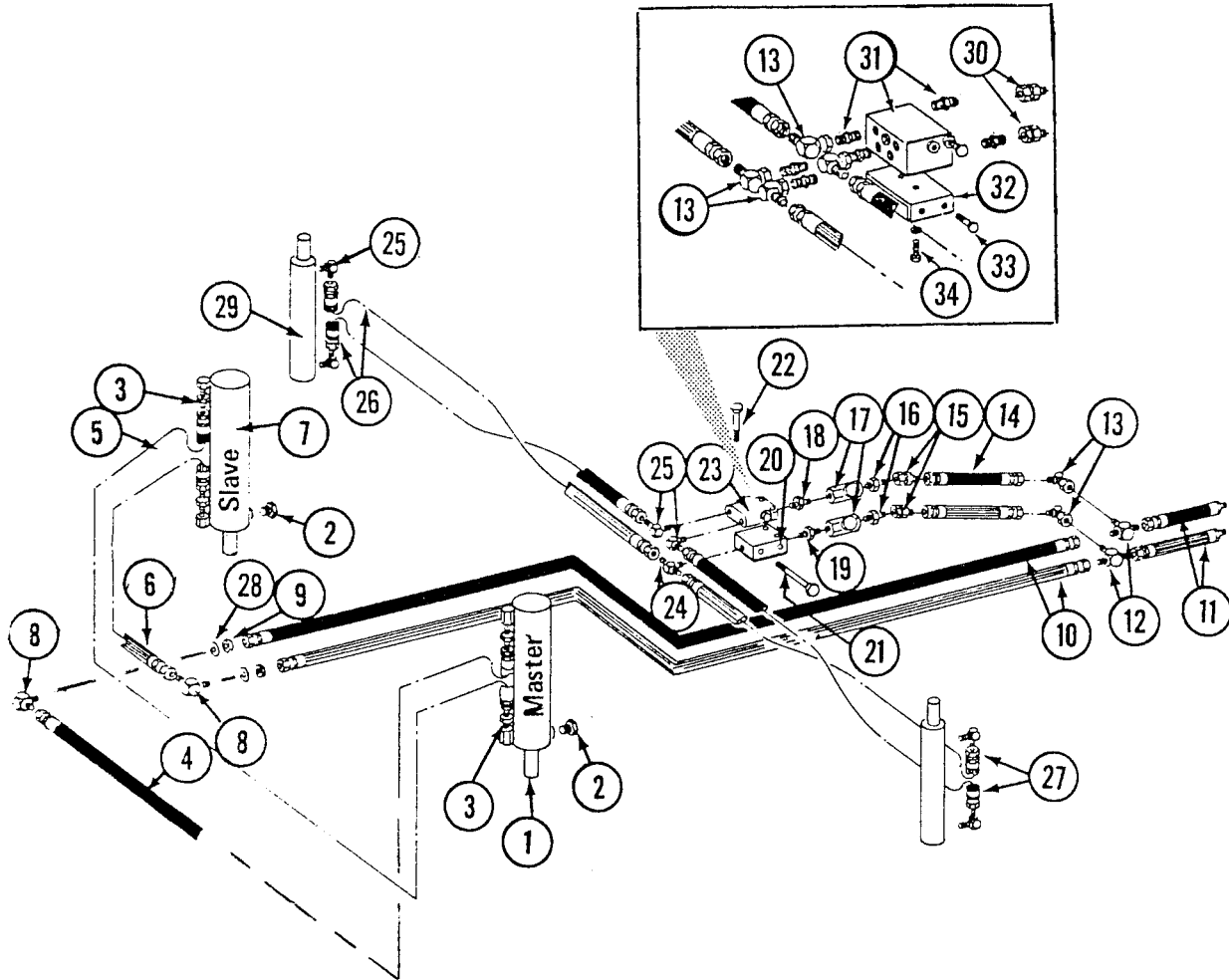

PULL TYPE HYDRAULIC SYSTEM, 4 ROW 30 AND WIDE CONVENTIONAL MARKER

ITEM	PART NO.	DESCRIPTION
1.		Cylinder (See Master Lift Cylinder)
2.	6408-10	Plug, 7/8"-14 Male O-Ring
3.	6400-08	Connector, 3/4"-16 Male O-Ring to 37° JIC
4.	A1018	Hose Assembly, 3/8" x 40", 4 Row 30
	A1020	Hose Assembly, 3/8" x 48", 4 Row 36/38
	A1096	Hose Assembly, 3/8" x 50 1/2", 4 Row 40
5.	A3113	Hose Assembly, 3/8" x 84", 4 Row 30
	A3136	Hose Assembly, 3/8" x 100", 4 Row 36/38
	A1092	Hose Assembly, 3/8" x 104", 4 Row 40"
6.	A1020	Hose Assembly, 3/8" x 48", 4 Row 30
	A1021	Hose Assembly, 3/8" x 56", 4 Row 36/38/40
7.		Cylinder (See Slave Lift Cylinder)
8.	2701-08	Elbow, 3/4"-16 Male 37° JIC
9.	306-08	Lock Nut, 3/4"-16
10.	A1076	Hose Assembly, 3/8" x 30"
11.	A3135	Hose Assembly, 3/8" x 100"
12.	2603-08-08-06	Tee, 3/4"-16 Male 37° JIC to 9/16"-18 37° JIC
13.	6500-06	Elbow, 9/16"-18 Male 37° JIC to Female 37° JIC
14.	A1169	Hose Assembly, 1/4" x 24"
	A1182	Hose Assembly, 1/4" x 30", With Double Frame Package
15.	6502-06	Elbow, 45°, 9/16"-18 Male 37° JIC to Female 37° JIC
	6500-06	Elbow, 90°, 9/16"-18 Male 37° JIC to Female 37° JIC, Used on Single Frame With Frame Mounted Rock Shaft Lift
16.	2404-06-06	Adapter, 9/16"-18 Male 37° JIC to 3/8" NPT
17.		Valve (See Marker Flow Control Valve)
18.	6401-08-06	Adapter, 3/4"-16 Male O-Ring to 3/8" NPT
19.	5404-06-06	Coupling, 3/8" Male NPT
20.	D5861	Block
21.	10004	HHCS, 3/8"-16 x 1 1/4"
	10229	Lock Washer, 3/8"
22.	10325	HHCS, 3/8"-16 x 2 3/4"
	10229	Lock Washer, 3/8"
	10101	Hex Nut, 3/8"-16
23.		Valve (See Sequencing Valve)
24.	2601-06-06	Tee, 9/16"-18 Male 37° JIC to 3/8" NPT
25.	6801-06-08	Elbow, 9/16"-18 Male 37° JIC to 3/4"-16 O-Ring
26.	A1170	Hose Assembly, 1/4" x 95", 4 Row 30
	A1171	Hose Assembly, 1/4" x 108", 4 Row 36/38
	A1103	Hose Assembly, 1/4" x 110", 4 Row 40
27.	A1102	Hose Assembly, 1/4" x 90", 4 Row 30
	A1150	Hose Assembly, 1/4" x 103", 4 Row 36/38
	A1172	Hose Assembly, 1/4" x 105", 4 Row 40
28.	10215	Machine Bushing
29.		Cylinder (See Marker Cylinder)
30.	6502-06	Elbow, 45°, 9/16"-18 Male 37° JIC to Female
31.		Valve (See Marker Sequencing/Flow Control Valve)
32.	D7630	Mounting Angle
33.	10004	HHCS, 3/8"-16 X 1 1/4"
	10210	Washer, 3/8" USS
	10229	Lock Washer, 3/8"
	10101	Hex Nut, 3/8"-16
34.	10001	HHCS, 3/8"-16 x 1"
	10229	Lock Washer, 3/8"

PULL TYPE HYDRAULICS, 4 ROW 30 AND WIDE OPTIONS AND ATTACHMENTS

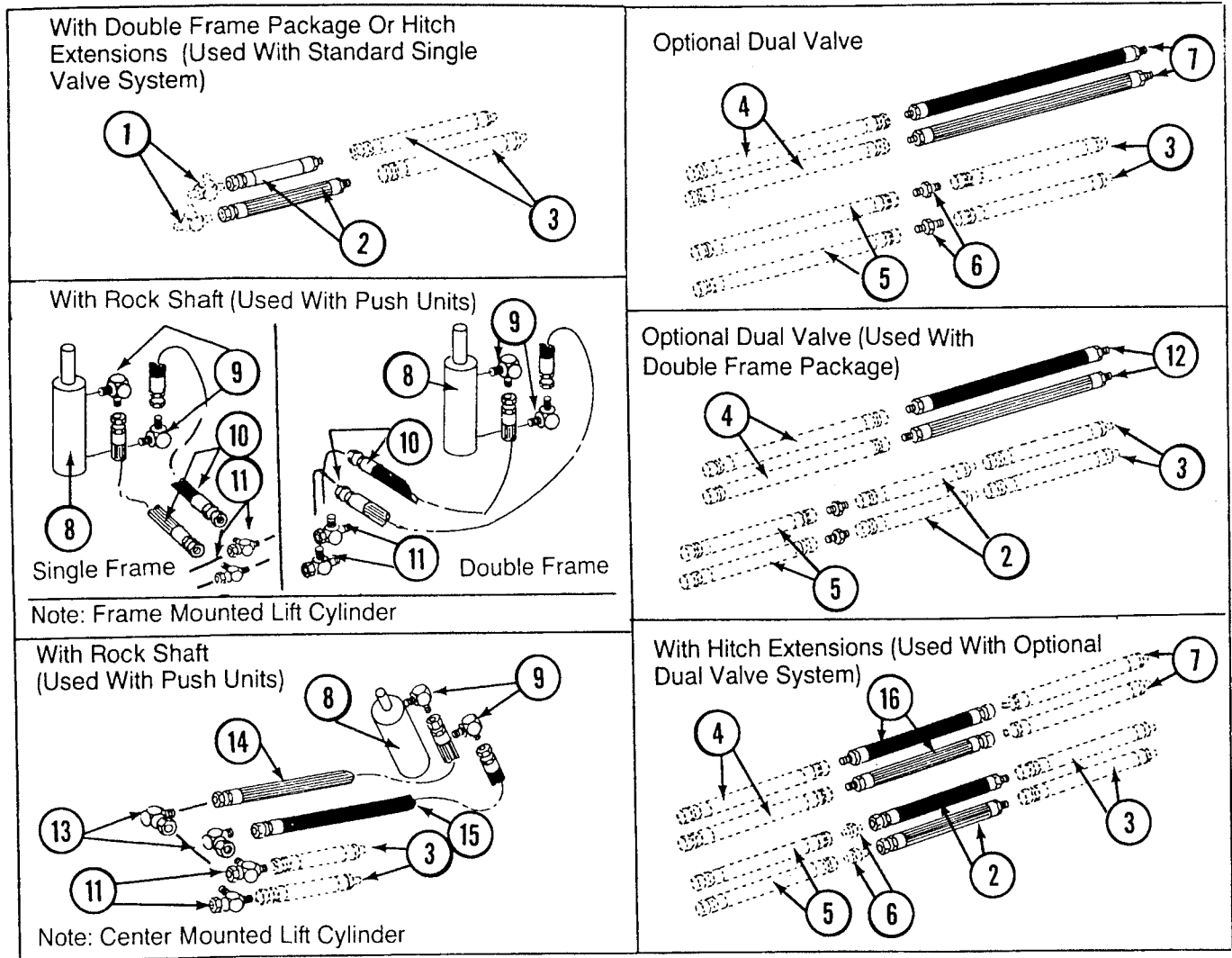

PULL TYPE HYDRAULICS, 4 ROW 30 AND WIDE OPTIONS AND ATTACHMENTS

ITEM	PART NO.	DESCRIPTION
1.		See Item 12 Page P38
2.	A3142	Hose Assembly, 3/8" x 30", With Double Frame Package
	A3149	Hose Assembly, 3/8" x 46", With Standard Push Unit Extension
	A3150	Hose Assembly, 3/8" x 56", With Twin Push Unit Extension
	A3147	Hose Assembly, 3/8" x 24", With Hitch Extensions
3.		See Item 11 Page P38
4.		See Item 14 Page P38
5.		See Item 10 Page P38
6.	2403-08	Union, 3/4"-16 Male 37° JIC
7.	A1173	Hose Assembly, 1/4" x 100"
8.		Cylinder (See Rock Shaft Lift Cylinder - Center Mounted Lift or Frame Mounted Lift)
9.	2501-08-08	Elbow, 3/4"-16 Male 37° JIC to 1/2" NPT
	6801-08	Elbow, 3/4"-16 Male 37° JIC to 3/4" O-Ring
10.	A1020	Hose Assembly, 3/8" x 48"
11.	6602-08	Tee, 3/4"-16 37° JIC
12.	A1174	Hose Assembly, 1/4" x 130"
13.	6500-08	Elbow, 3/8"-16 Male 37° JIC to Female 37° JIC
14.	A1021	Hose Assembly, 3/8" x 56"
15.	A1019	Hose Assembly, 3/8" x 44"
16.	A1178	Hose Assembly, 1/4" x 46", With Standard Push Unit Extension
	A1179	Hose Assembly, 1/4" x 56", With Twin Push Unit Extension
	A1177	Hose Assembly, 1/4" x 24", With Hitch Extensions

PULL TYPE HYDRAULIC SYSTEM, 6 ROW 30 CONVENTIONAL MARKER

Single Valve

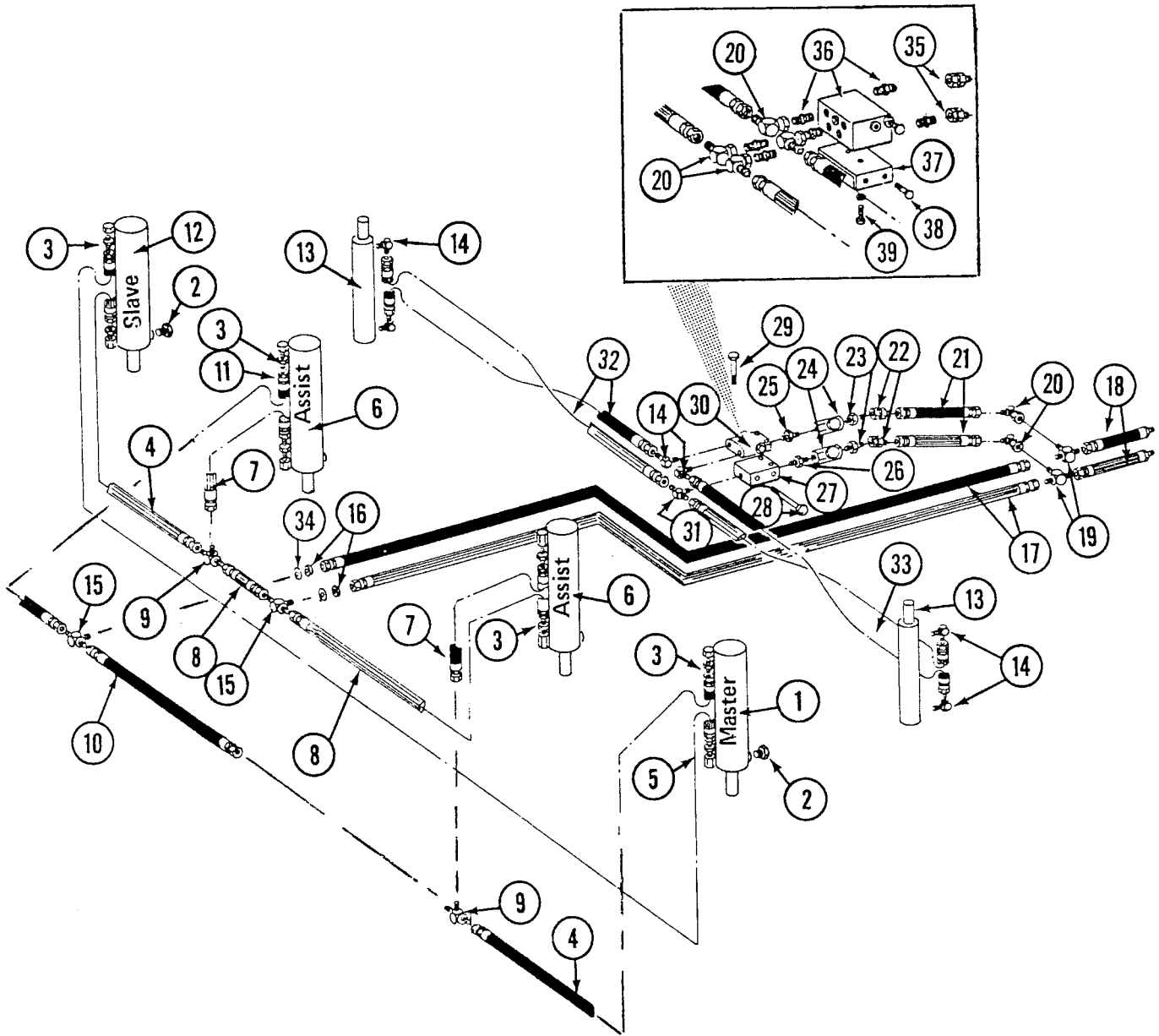

PULL TYPE HYDRAULIC SYSTEM, 6 ROW 30 CONVENTIONAL MARKER

ITEM	PART NO.	DESCRIPTION
1.		Cylinder (See Master Lift Cylinder)
2.	6408-10	Plug, 7/8"-14 Male R-Ring (Only On Cylinder With Rephasing Port On Barrel)
3.	6400-08	Connector, 3/4"-16 Male O-Ring to 37° JIC
4.	A1018	Hose Assembly, 3/8" x 40"
5.	A3115	Hose Assembly, 3/8" x 146"
6.		Cylinder (See Lift Assist Cylinder)
7.	A1000	Hose Assembly, 3/8" x 15"
8.	A3119	Hose Assembly, 3/8" x 36"
9.	2603-08	Tee, 3/4"-16 Male 37° JIC
10.	A1098	Hose Assembly, 3/8" x 26"
11.	A1019	Hose Assembly, 3/8" x 44"
12.		Cylinder (See Slave Lift Cylinder)
13.		Cylinder (See Marker Cylinder)
14.	6801-06-08	Elbow, 9/16"-18 Male 37° JIC to 3/4"-16 O-Ring
15.	2703-08	Bulkhead Tee, 3/4"-16 Male 37° JIC
16.	306-08	Lock Nut, 3/4"-16
17.	A1076	Hose Assembly, 3/8" x 30"
18.	A3135	Hose Assembly, 3/8" x 100"
19.	2603-08-08-06	Tee, 3/4"-16 Male 37° JIC to 9/16"-18 37° JIC
20.	6500-06	Elbow, 9/16"-18 Male 37° JIC to Female 37° JIC
21.	A1169	Hose Assembly, 1/4" x 24"
	A1182	Hose Assembly, 1/4" x 30", With Double Frame Package
22.	6502-06	Elbow, 45°, 9/16"-18 Male 37° JIC to Female 37° JIC
	6500-06	Elbow, 90°, 9/16"-18 Male 37° JIC to Female 37° JIC, Used on Single Frame Planters With Frame Mounted Rock Shaft Lift.
23.	2404-06-06	Adapter, 9/16"-18 Male 37° JIC to 3/8" NPT
24.		Valve (See Marker Flow Control Valve)
25.	6401-08-06	Adapter, 3/4"-16 Male O-Ring to 3/8" NPT
26.	5405-06-06	Coupling, 3/8" Male NPT
27.	D5861	Block
28.	10004	HHCS, 3/8"-16 x 1 1/4"
	10229	Lock Washer, 3/8"
29.	10325	HHCS, 3/8"-16 x 2 3/4"
	10229	Lock Washer, 3/8"
	10101	Hex Nut, 3/8"-16
30.		Valve (See Sequencing Valve)
31.	2601-06-06	Tee, 9/16"-18 Male 37° JIC to 3/8" NPT
32.	A1105	Hose Assembly, 1/4" x 125"
33.	A1168	Hose Assembly, 1/4" x 120"
34.	10215	Machine Bushing
35.	6502-06	Elbow, 45°, 9/16"-18 Male 37° JIC to Female
36.		Valve (See Marker Sequencing/Flow Control Valve)
37.	D7630	Mounting Angle
38.	10004	HHCS, 3/8"-16 X 1 1/4"
	10210	Washer, 3/8" USS
	10229	Lock Washer, 3/8"
	10101	Hex Nut, 3/8"-16
39.	10001	HHCS, 3/8"-16 x 1"
	10229	Lock Washer, 3/8"

PULL TYPE HYDRAULICS, 6 ROW 30 OPTIONS AND ATTACHMENTS

With Double Frame Package Or Hitch Extensions
(Used With Standard Single Valve System)

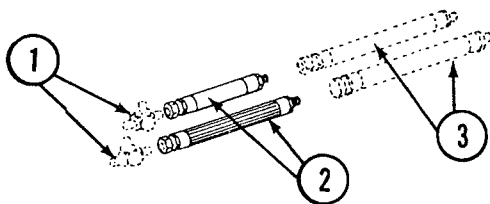

Optional Dual Valve

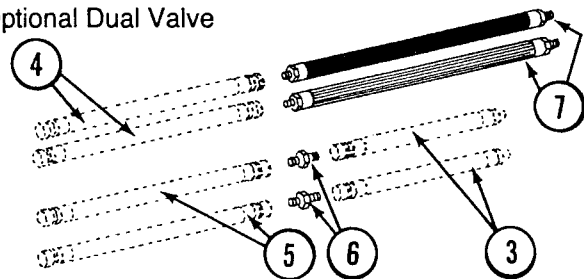

With Rock Shaft (Used With Push Units)

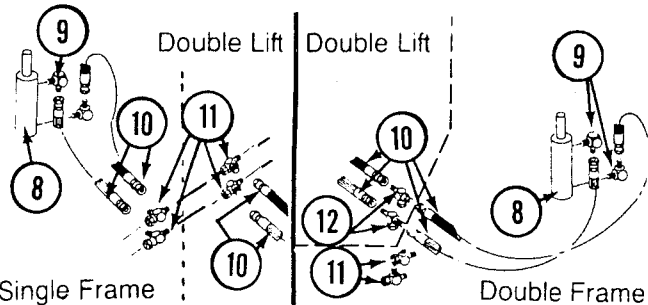

Single Frame Double Frame

Note: Frame Mounted Lift Cylinder(s)

Optional Dual Valve (Used With
Double Frame Package)

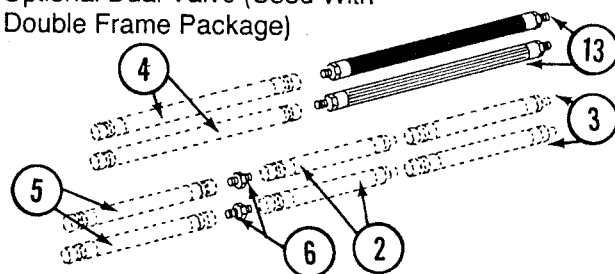

With Rock Shaft
(Used With Push Units)

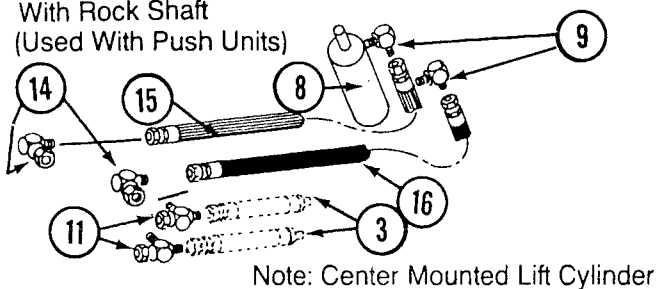

Note: Center Mounted Lift Cylinder

With Hitch Extensions (Used With
Optional Dual Valve System)

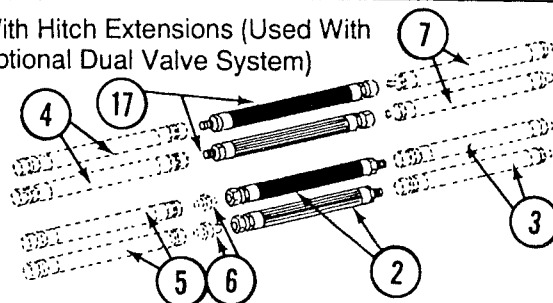

PULL TYPE HYDRAULICS, 6 ROW 30 OPTIONS AND ATTACHMENTS

ITEM	PART NO.	DESCRIPTION
1.		See Item 19 Page P41
2.	A3142	Hose Assembly, 3/8" x 30", With Double Frame Package
	A3149	Hose Assembly, 3/8" x 46", With Standard Push Unit Extension
	A3150	Hose Assembly, 3/8" x 56", With Twin Push Unit Extension
	A3147	Hose Assembly, 3/8" x 24", With Hitch Extensions
3.		See Item 18 Page P41
4.		See Item 21 Page P41
5.		See Item 17 Page P41
6.	2403-08	Union, 3/4"-16 Male 37° JIC
7.	A1173	Hose Assembly, 1/4" x 100"
8.		Cylinder (See Rock Shaft Lift Cylinder - Center Mounted Lift or Frame Mounted Lift)
9.	2501-08-08	Elbow, 3/4"-16 Male 37° JIC to 1/2" NPT
	6801-08	Elbow, 3/4"-16 Male 37° JIC to 3/4" O-Ring
10.	A3156	Hose Assembly, 3/8" x 68", With Twin Push
	A1020	Hose Assembly, 3/8" x 48", With Standard Push
11.	6602-08	Tee, 3/4"-16 37° JIC
12.	6600-08	Tee, Outlet 3/4"-16 37° JIC
13.	A1174	Hose Assembly, 1/4" x 130"
14.	6500-08	Elbow, 3/8"-16 Male 37° JIC to Female 37° JIC
15.	A1021	Hose Assembly, 3/8" x 56"
16.	A1019	Hose Assembly, 3/8" x 44"
17.	A1178	Hose Assembly, 1/4" x 46", With Standard Push Unit Extension
	A1179	Hose Assembly, 1/4" x 56", With Twin Push Unit Extension
	A1177	Hose Assembly, 1/4" x 24", With Hitch Extensions

PULL TYPE HYDRAULIC SYSTEM 6 ROW WIDE AND 8 ROW 30 AND WIDE LOW PROFILE MARKER

Single Valve

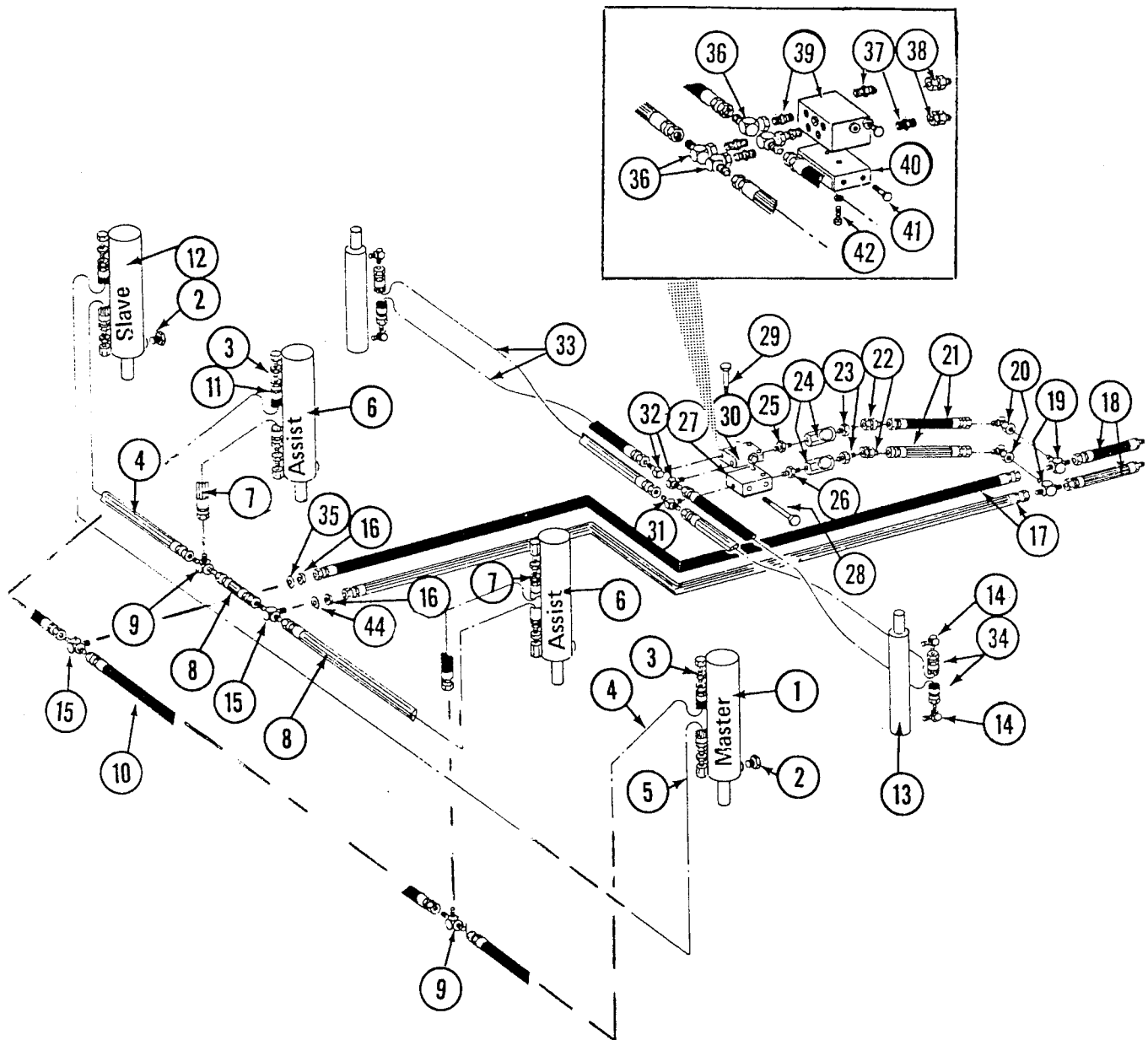

PULL TYPE HYDRAULIC SYSTEM

6 ROW WIDE AND 8 ROW 30 AND WIDE

LOW PROFILE MARKER

ITEM	PART NO.	DESCRIPTION
1.		Cylinder (See Master Lift Cylinder)
2.	6408-10	Plug, 7/8"-14 Male O-Ring (Only On Cylinder With Rephasing Port On Barrel)
3.	6400-08	Connector, 3/4"-16 Male O-Ring to 37° JIC
4.	A1020	Hose Assembly, 3/8" x 48", 6 Row 36/38 and 8 Row 36/38
	A1096	Hose Assembly, 3/8" x 50 1/2", 6 Row 40 and 8 Row 40
	A1018	Hose Assembly, 3/8" x 40", 8 Row 30
5.	A3132	Hose Assembly, 3/8" x 178", 6 Row 36/38
	A1028	Hose Assembly, 3/8" x 186", 6 Row 40
	A1054	Hose Assembly, 3/8" x 204", 8 Row 30
	A3139	Hose Assembly, 3/8" x 254", 8 Row 36/38
	A3141	Hose Assembly, 3/8" x 260", 8 Row 40
6.		Cylinder (See Lift Assist Cylinder)
7.	A1000	Hose Assembly, 3/8" x 15"
8.	A1019	Hose Assembly, 3/8" x 44", 6 Row 36/38
	A1020	Hose Assembly, 3/8" x 48", 6 Row 40
	A1055	Hose Assembly, 3/8" x 66", 8 Row 30
	A3138	Hose Assembly, 3/8" x 82", 8 Row 36/38
	A3113	Hose Assembly, 3/8" x 84", 8 Row 40
9.	2603-08	Tee, 3/4"-16 Male 37° JIC
10.	A1044	Hose Assembly, 3/8" x 34", 6 Row 36/38
	A3119	Hose Assembly, 3/8" x 36", 6 Row 40
	A1021	Hose Assembly, 3/8" x 56", 8 Row 30
	A1053	Hose Assembly, 3/8" x 72", 8 Row 36/38
	A1039	Hose Assembly, 3/8" x 76", 8 Row 40
11.	A3128	Hose Assembly, 3/8" x 52", 6 Row 36/38
	A1021	Hose Assembly, 3/8" x 56", 6 Row 40
	A1039	Hose Assembly, 3/8" x 76", 8 Row 30
	A1006	Hose Assembly, 3/8" x 90", 8 Row 36/38
	A3140	Hose Assembly, 3/8" x 94", 8 Row 40
12.		Cylinder (See Slave Lift Cylinder)
13.		Cylinder (See Marker Cylinder)
14.	6801-08	Elbow, 3/4"-16 Male 37° to 3/4"-16 O-Ring
	6400-08	Connector, 3/4"-16 Male O-Ring to 37° JIC
15.	2703-08	Bulkhead Tee, 3/4"-16 Male 37° JIC
16.	306-08	Lock Nut, 3/4"-16
17.	A1076	Hose Assembly, 3/8" x 30"
18.	A3135	Hose Assembly, 3/8" x 100"
19.	2603-08	Tee, 3/4"-16 Male 37° JIC
20.	6500-08	Elbow, 3/4"-16 Male 37° JIC to Female 37° JIC
21.	A1079	Hose Assembly, 3/8" x 24"
	A3142	Hose Assembly, 3/8" x 30", With Double Frame Package
22.	6502-08	Elbow, 45°, 3/4"-16 Male 37° JIC to Female 37° JIC
	6500-08	Elbow, 90°, 3/4"-16 Male 37° JIC to Female 37° JIC, Used On Single Frame Planters With Frame Mounted Rock Shaft Lift and Twin Push Units.
	2501-08-06	Elbow, 90°, 3/4"-16 Male 37° JIC to 3/8" NPT, Used On Single Frame Planters With Frame Mounted Rock Shaft Lift and Standard Push Units (Item 23 not used).
23.	2404-08-06	Adapter, 3/4"-16 Male 37° JIC to 3/8" NPT
24.		Valve (See Marker Flow Control Valve)
25.	6401-08-06	Adapter, 3/4"-16 Male O-Ring to 3/8" NPT
26.	5404-06-06	Coupling, 3/8" Male NPT
27.	D5861	Block

PULL TYPE HYDRAULIC SYSTEM 6 ROW WIDE AND 8 ROW 30 AND WIDE LOW PROFILE MARKER

ITEM	PART NO.	DESCRIPTION
28.	10004	HHCS, 3/8"-16 x 1 1/4"
	10229	Lock Washer, 3/8"
29.	10325	HHCS, 3/8"-16 x 2 3/4"
	10229	Lock Washer, 3/8"
	10101	Hex Nut, 3/8"-16
30.		Valve (See Sequencing Valve)
31.	2601-08-06	Tee, 3/4"-16 Male 37° JIC to 3/8" NPT
32.	6801-08	Elbow, 3/4"-16 Male 37° JIC to 3/4"-16 O-Ring
33.	A1013	Hose Assembly, 3/8" x 150", 6 Row 36/38
	A3114	Hose Assembly, 3/8" x 156", 6 Row 40 and 8 Row 30
	A1028	Hose Assembly, 3/8" x 186", 8 Row 36/38
	A1029	Hose Assembly, 3/8" x 190", 8 Row 40
34.	A3137	Hose Assembly, 3/8" x 140", 6 Row 36/38
	A3115	Hose Assembly, 3/8" x 146", 6 Row 40
	A1090	Hose Assembly, 3/8" x 162", 8 Row 30
	A3132	Hose Assembly, 3/8" x 178", 8 Row 36/38
	A1028	Hose Assembly, 3/8" x 186", 8 Row 40
35.	10215	Machine Bushing
36.	6500-08-06	Elbow, 3/4"-16 Male 37° JIC to 9/16"-18 Female 37° JIC
37.	6400-08-06	Adapter, 3/4"-16 Male 37° JIC to 9/16"-18 O-Ring
38.	6502-08	Elbow, 45°, 3/4"-16 Male 37° JIC to Female 37° JIC
39.		Valve (See Marker Sequencing/Flow Control Valve)
40.	D7630	Mounting Angle
41.	10004	HHCS, 3/8"-16 X 1 1/4"
	10210	Washer, 3/8" USS
	10229	Lock Washer, 3/8"
	10101	Hex Nut, 3/8"-16
42.	10001	HHCS, 3/8"-16 x 1"
	10229	Lock Washer, 3/8"

PULL TYPE HYDRAULICS, 6 ROW WIDE AND 8 ROW 30 AND WIDE OPTIONS AND ATTACHMENTS

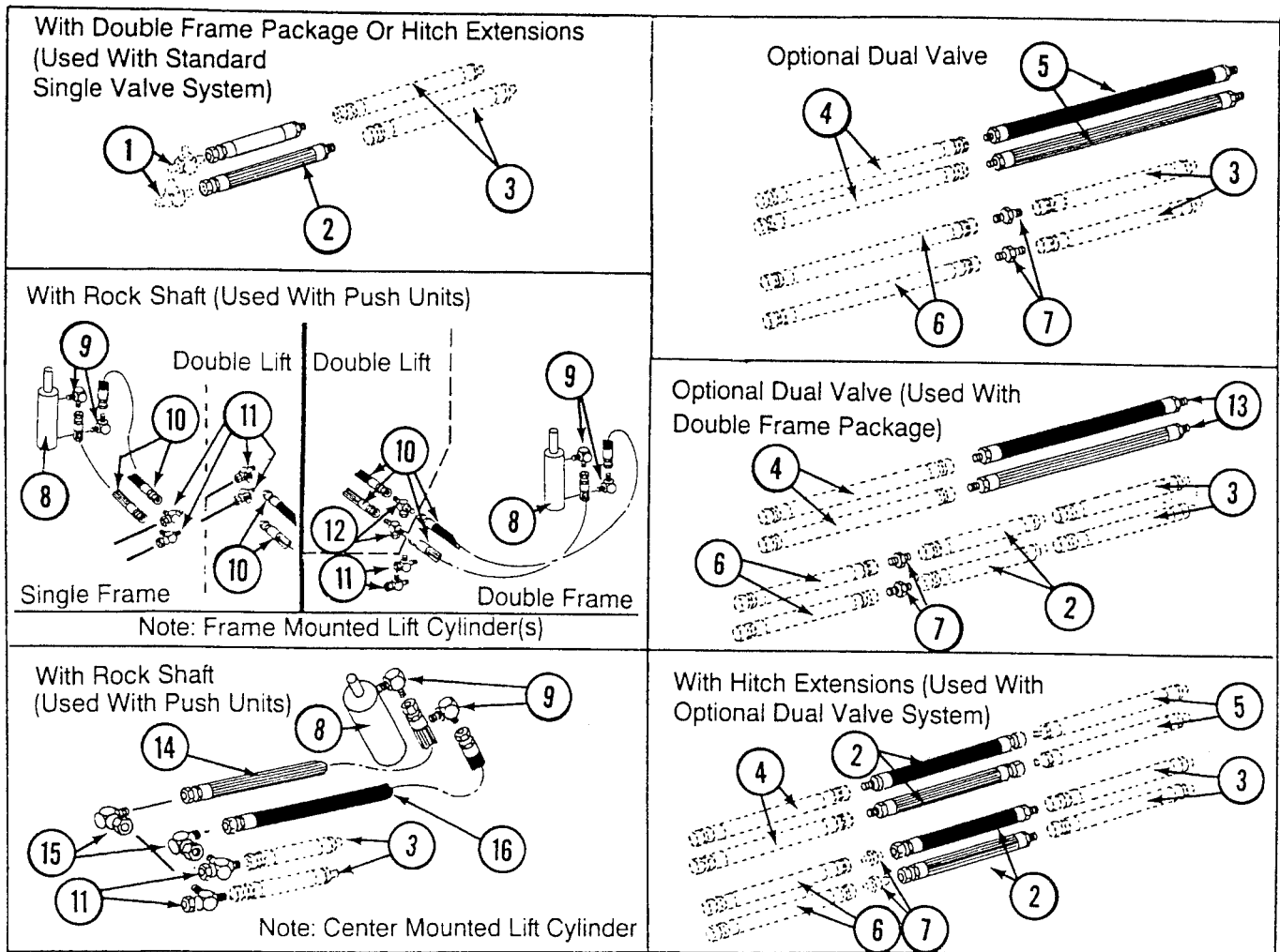

ITEM	PART NO.	DESCRIPTION
------	----------	-------------

1.		See Item 19 Page P42
2.	A3142	Hose Assembly, 3/8" x 30", With Double Frame Package
	A3149	Hose Assembly, 3/8" x 46", With Standard Push Unit Extension
	A3150	Hose Assembly, 3/8" x 56", With Twin Push Unit Extension
	A3147	Hose Assembly, 3/8" x 24", With Hitch Extensions
3.		See Item 18 Page 42
4.		See Item 21 Page 42
5.	A3148	Hose Assembly, 3/8" x 100"
6.		See Item 17 Page P42
7.	2403-08	Union, 3/4"-16 Male 37° JIC
8.		Cylinder (See Rock Shaft Lift Cylinder - Center Mounted Lift or Frame Mounted Lift)
9.	2501-08-08	Elbow, 3/4"-16 Male 37° JIC to 1/2" NPT
	6801-08	Elbow, 3/4"-16 JIC to 3/4" O-Ring
10.	A3156	Hose Assembly, 3/8" x 68", 8 Row 30/Wide With Standard Push and 8 Row 30 With Twin Push
	A1020	Hose Assembly, 3/8" x 48", 6 Row Wide With Standard Push
11.	6602-08	Tee, 3/4"-16 37° JIC
12.	6600-08	Tee, Outlet 3/4"-16 37° JIC
13.	A3144	Hose Assembly, 3/8" x 130"
14.	A1021	Hose Assembly, 3/8" x 56"
15.		See Item 20 Page P42
16.	A1019	Hose Assembly, 3/8" x 44"



PULL TYPE HYDRAULIC SYSTEM, 2 ROW

Single Valve

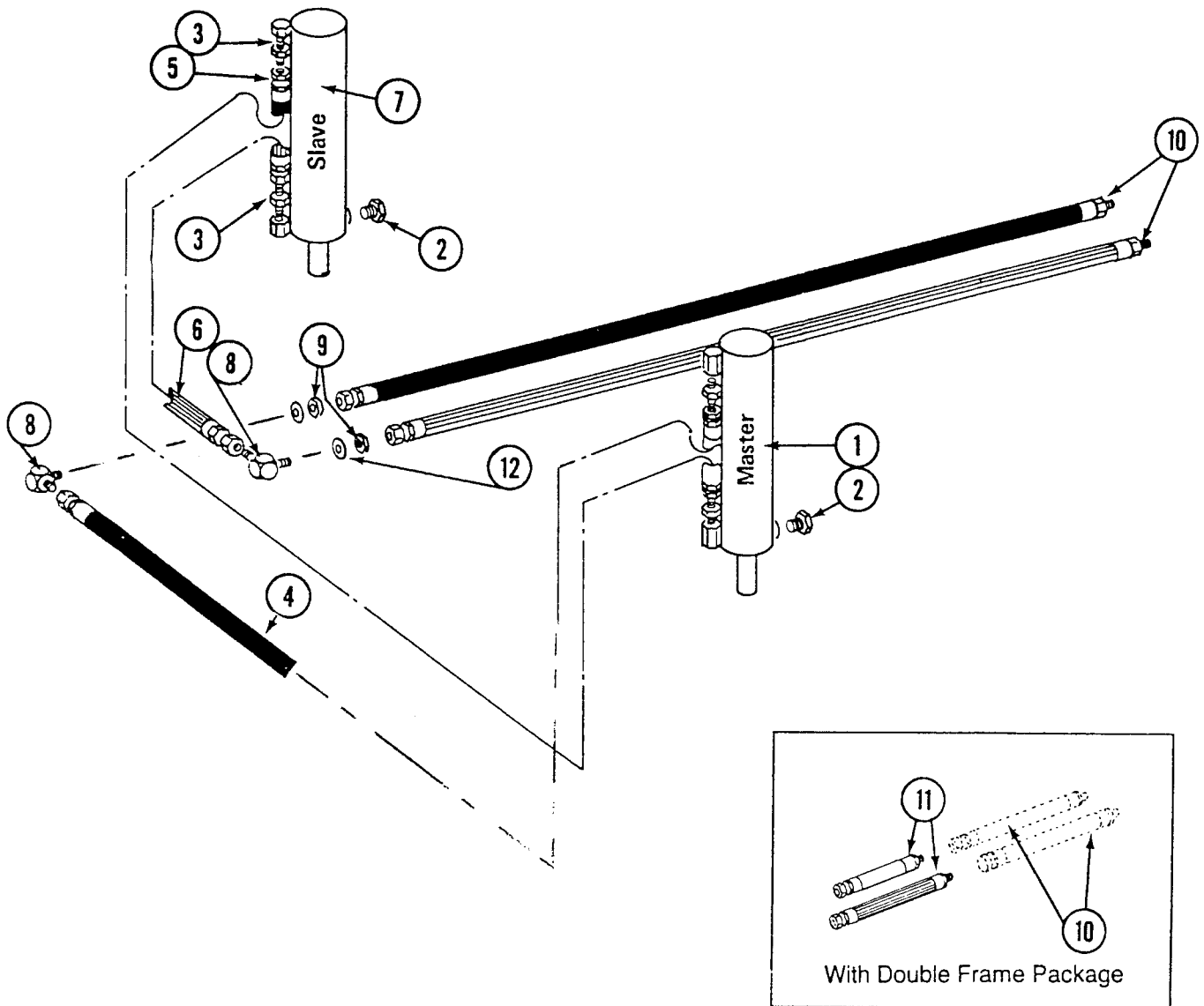

ITEM	PART NO.	DESCRIPTION
1.		Cylinder (See Master Lift Cylinder)
2.	6408-10	Plug, 7/8"-14 Male O-Ring (Only on cylinder with rephasing port on barrel)
3.	6400-08	Connector, 3/4"-16 Male O-Ring to 37° JIC
4.	A1020	Hose Assembly, 3/8" x 48"
5.	A3136	Hose Assembly, 3/8" x 100"
6.	A1021	Hose Assembly, 3/8" x 56"
7.		Cylinder (See Slave Lift Cylinder)
8.	2701-08	Elbow, 3/4"-16 Male 37° JIC
9.	306-08	Lock Nut, 3/4"-16
10.	A1001	Hose Assembly, 3/8" x 135"
11.	A3142	Hose Assembly, 3/8" x 30", With Double Frame Package
12.	10215	Machine Bushing

PULL TYPE PUSH UNIT DRILL SHAFT AND TRANSMISSION ASSEMBLY

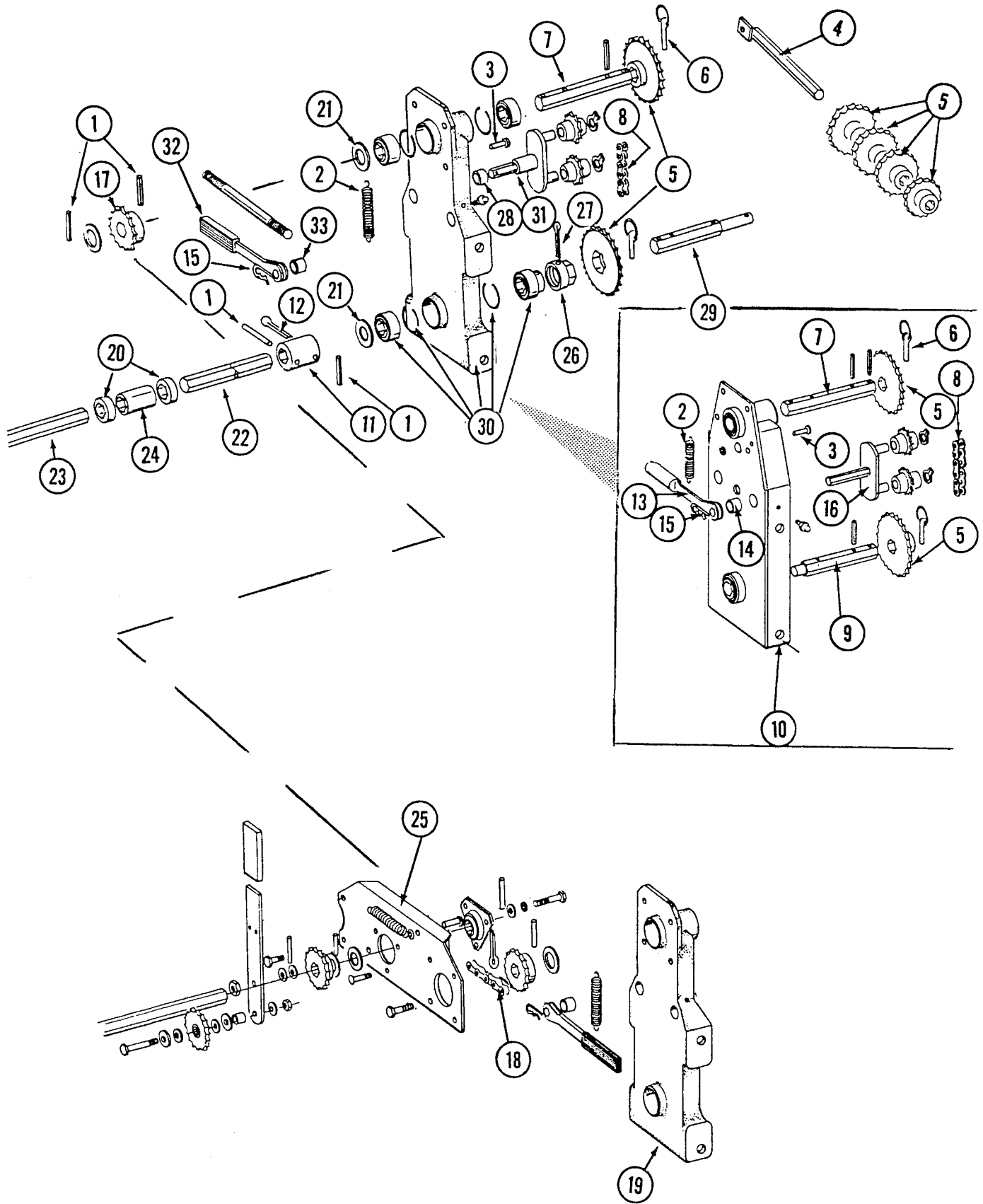

PULL TYPE PUSH UNIT DRILL SHAFT AND TRANSMISSION ASSEMBLY

ITEM	PART NO.	DESCRIPTION
1.	10602	Spring Pin, 1/4" x 1 1/2"
2.	D5857	Spring
3.	10478	Clevis Pin, 5/16" x 1"
	10409	Retaining Ring, 5/16"
4.	A5146	Rod, Sprocket Storage
5.	A5106	Sprocket, 17 Tooth
	A5107	Sprocket, 19 Tooth
	A5108	Sprocket, 23 Tooth (Qty. 2)
	A5109	Sprocket, 24 Tooth
	A5110	Sprocket, 25 Tooth
	A5111	Sprocket, 26 Tooth
	A5112	Sprocket, 27 Tooth
	A5113	Sprocket, 28 Tooth
6.	D2558	Lynch Pin, 1/4"
7.	D5835	Shaft, 7/8" x 7"
8.	3310-80	Chain, No. 40, 80 Pitch Including Connector Link
	R0912	Connector Link, No. 40
9.	D5215	Shaft, 7/8" x 6 3/8"
10.	A5144	Transmission Plate W/Bearings and Grease Fittings
	A5116	Bearing, 7/8" Hex Bore, Cylindrical
	10640	Grease Fitting, 1/4"-28
	10641	Grease Fitting, 1/8" NPT
11.	D5886	Coupler, 1 3/4"
12.	10460	Cotter Pin, 1/4" x 2"
13.	A5365	Ratchet Arm With Protective Closure
	10410	Protective Closure, Round
14.	D0935	Idler Sleeve, 9/16"
15.	10670	Hair Pin Clip, No. 3
16.	A5136	Idler W/Sprockets and Rings
	D7426	Sprocket
	10435	Ring
17.	A5202	Sprocket, 34 Tooth
18.	3310-26	Chain, No. 40, 26 Pitch Including Connector Link (To be added to 3310-89)
	R0912	Connector Link, No. 40
19.		Standard Row Unit Transmission (See Transmission)
20.	D0917	Lock Collar, Less Set Screws
	10145	Set Screws, 5/16"-18 x 1/2"
21.	10233	Machine Bushing
22.	D5887-95	Drill Shaft, 4 Row 30
	D5887-109	Drill Shaft, 4 Row Wide
	D5887-155	Drill Shaft, 6 Row 30
	D5887-185	Drill Shaft, 6 Row Wide
	D5887-215	Drill Shaft, 8 Row 30
	D5887-144	Drill Shaft, 8 Row Wide
23.	D0914-118	Drill Shaft, 8 Row Wide
24.	D1719	Coupler, 8 Row Wide
25.		Reverser Plate (See Transmission)
26.	D7127	Shear Coupler
27.	10462	Cotter Pin, 3/16" x 2"
28.	D2734-01	Sleeve, 1/2"
29.	D7822	Shaft, 7/8" x 7"
30.	A5629	Transmission Plate W/Bearings, Grease Fittings and Retaining Rings
	A5116	Bearing, 7/8" Hex Bore, Cylindrical
	A5624	Special Bearing, 7/8" Hex Bore x 1.6"
	D6551	Ring
	10641	Grease Fitting, 1/8" NPT
31.	A5628	Idler W/Sprockets and Rings
	D7426	Sprocket
	10435	Ring
32.	A4235	Ratchet Wrench W/Protective Closure
	10445	Protective Closure (Rectangular)
33.	D6819	Idler Sleeve, 7/16"

PULL TYPE PUSH UNIT DRILL SHAFT AND TRANSMISSION ASSEMBLY (WITH DOUBLE FRAME PACKAGE)

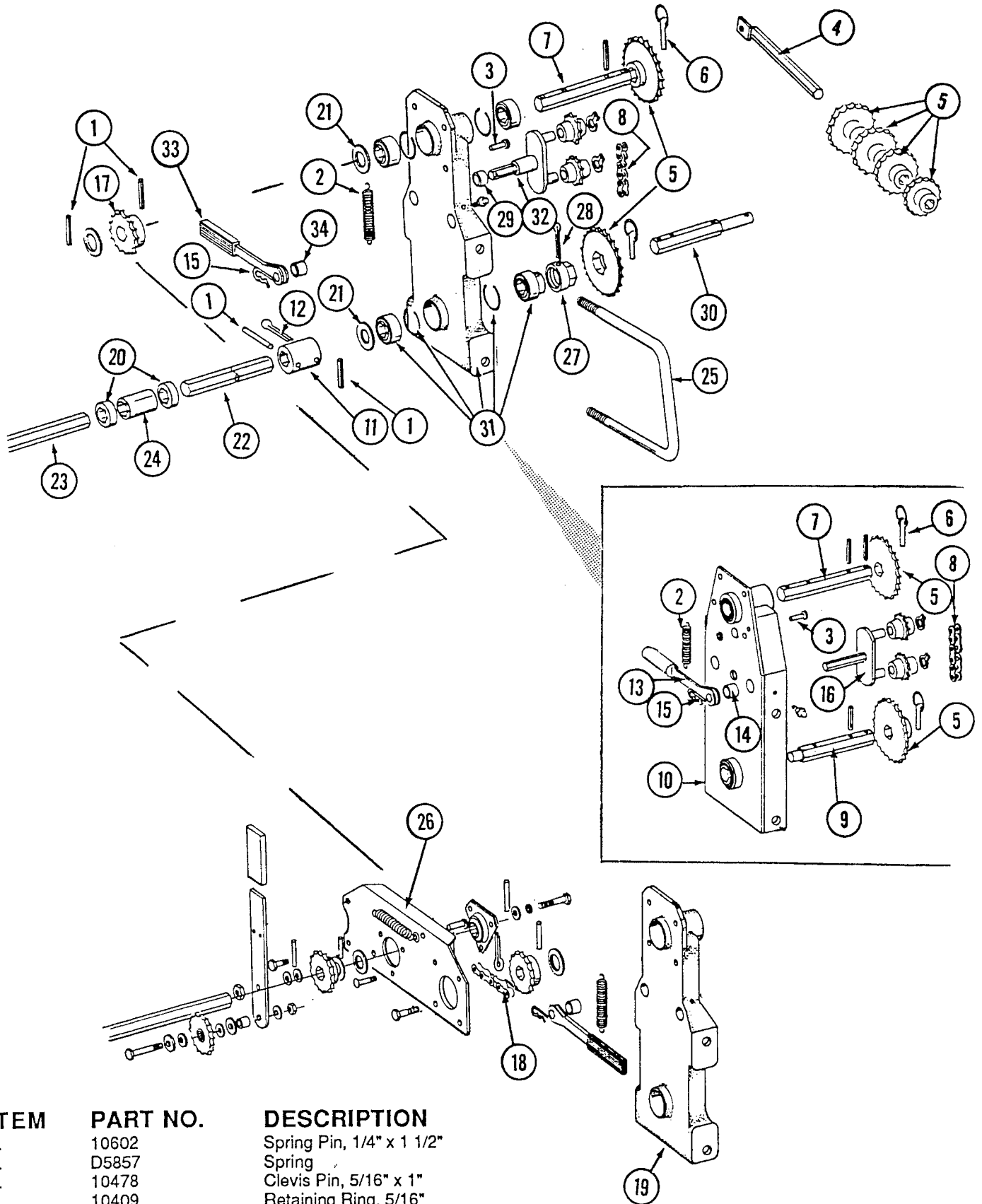

ITEM	PART NO.	DESCRIPTION
1.	10602	Spring Pin, 1/4" x 1 1/2"
2.	D5857	Spring
3.	10478	Clevis Pin, 5/16" x 1"
	10409	Retaining Ring, 5/16"
4.	A5146	Rod, Sprocket Storage

PULL TYPE PUSH UNIT DRILL SHAFT AND TRANSMISSION ASSEMBLY(WITH DOUBLE FRAME PACKAGE)

ITEM	PART NO.	DESCRIPTION
5.	A5106	Sprocket, 17 Tooth
	A5107	Sprocket, 19 Tooth
	A5108	Sprocket, 23 Tooth (Qty. 2)
	A5109	Sprocket, 24 Tooth
	A5110	Sprocket, 25 Tooth
	A5111	Sprocket, 26 Tooth
	A5112	Sprocket, 27 Tooth
	A5113	Sprocket, 28 Tooth
6.	D2558	Lynch Pin, 1/4"
7.	D5835	Shaft, 7/8" x 7"
8.	3310-80	Chain, No. 40, 80 Pitch Including Connector Link
	R0912	Connector Link, No. 40
9.	D5215	Shaft, 7/8" x 6 3/8"
10.	A5144	Transmission Plate W/Bearings and Grease Fittings
	A5116	Bearing, 7/8" Hex Bore, Cylindrical
	10640	Grease Fitting, 1/4"-28
	10641	Grease Fitting, 1/8" NPT
11.	D5886	Coupler, 1 3/4"
12.	10460	Cotter Pin, 1/4" x 2"
13.	A5365	Ratchet Arm With Protective Closure
	10410	Protective Closure, Round
14.	D0935	Idler Sleeve, 9/16"
15.	10670	Hair Pin Clip, No. 3
16.	A5136	Idler W/Sprockets and Rings
	D7426	Sprocket
	10435	Ring
17.	A5202	Sprocket, 34 Tooth
18.	3310-147	Chain, No. 40, 147 Pitch Including Connector and Offset Links (To be added to 3310-89)
	R0912	Connector Link, No. 40
	R0911	Offset Link, No. 40
19.		Standard Row Unit Transmission (See Transmission)
20.	D0917	Lock Collar, Less Set Screws
	10145	Set Screws, 5/16"-18 x 1/2"
21.	10233	Machine Bushing
22.	D5887-95	Drill Shaft, 4 Row 30
	D5887-109	Drill Shaft, 4 Row Wide
	D5887-155	Drill Shaft, 6 Row 30
	D5887-185	Drill Shaft, 6 Row Wide
	D5887-215	Drill Shaft, 8 Row 30
	D5887-144	Drill Shaft, 8 Row Wide
23.	D0914-118	Drill Shaft, 8 Row Wide
24.	D1719	Coupler, 8 Row Wide
25.	D1113	U-Bolt, 5" x 7" x 5/8"-11
	10230	Lock Washer, 5/8"
	10104	Hex Nut, 5/8"-11
26.		Reverser Plate (See Transmission)
27.	D7127	Shear Coupler
28.	10462	Cotter Pin, 3/16" x 2"
29.	D2734-01	Sleeve, 1/2"
30.	D7822	Shaft, 7/8" x 7"
31.	A5629	Transmission Plate W/Bearings, Grease Fittings and Retaining Rings
	A5116	Bearing, 7/8" Hex Bore, Cylindrical
	A5624	Special Bearing, 7/8" Hex Bore x 1.6"
	D6551	Ring
	10641	Grease Fitting, 1/8" NPT
32.	A5628	Idler W/Sprockets and Rings
	D7426	Sprocket
	10435	Ring
33.	A4235	Ratchet Wrench W/Protective Closure
	10445	Protective Closure (Rectangular)
34.	D6819	Idler Sleeve, 7/16"

ROCK SHAFT ASSEMBLY

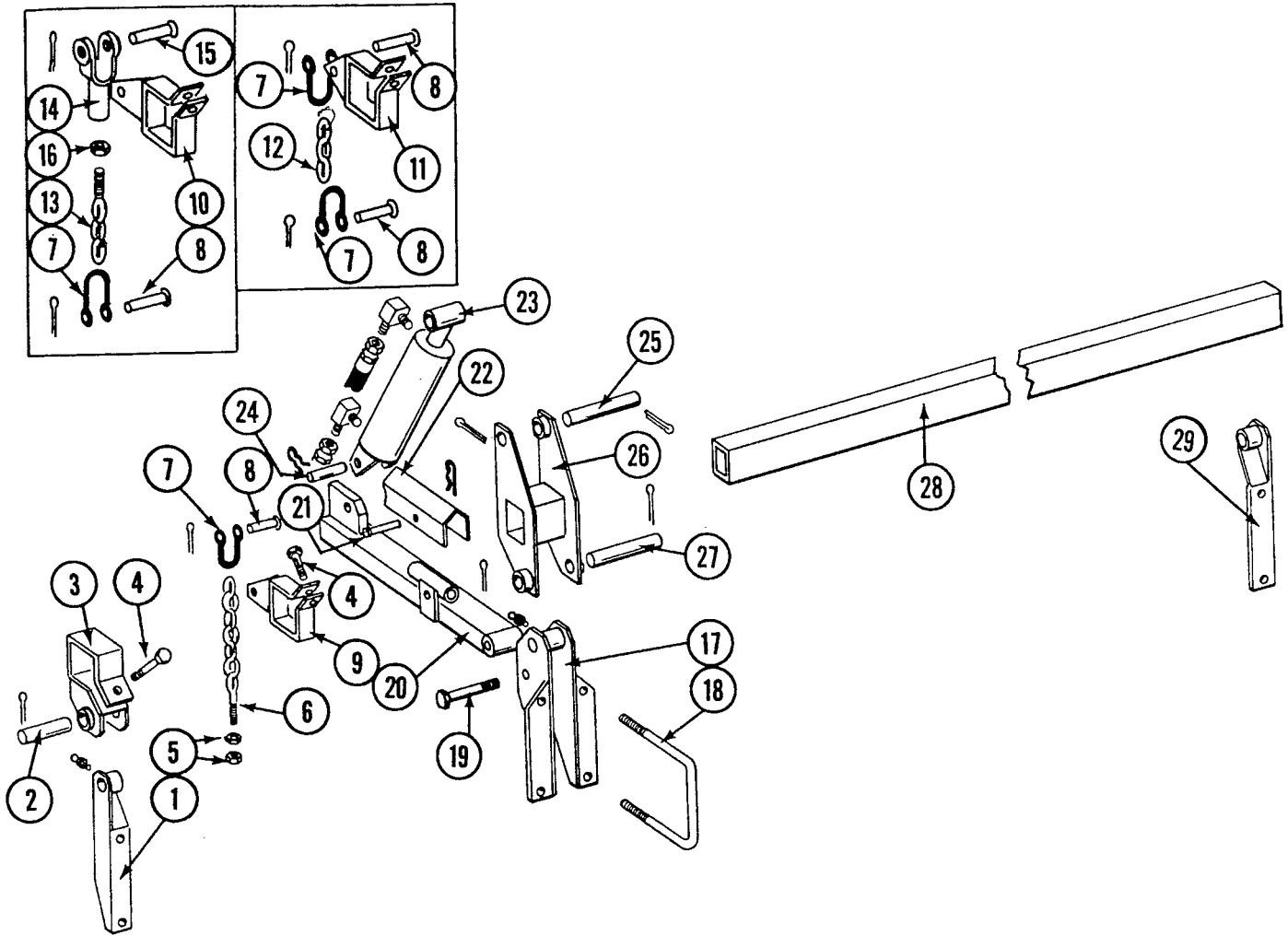

ITEM PART NO. DESCRIPTION

1.	A5313 10641	End Mount W/Grease Fitting, L.H. Grease Fitting, 1/8" NPT
2.	D6136 10460	Pin, 1 1/4" x 5" Cotter Pin, 1/4" x 2"
3.	A5315	End Mount Clamp
4.	10053 10228 10102	HHCS, 1/2" - 13 x 2 1/2" Lock Washer, 1/2" Hex Nut, 1/2" - 13
5.	10102	Hex Nut, 1/2" - 13
6.	A5319	Chain
7.	D2551	Clevis
8.	10166 10467	Clevis Pin, 3/8" x 1 1/2" Cotter Pin, 5/32" x 3/4"
9.	A5318	Unit Lift, Standard
10.	A5329	Unit Lift, Long, Twin Push
11.	A5328	Unit Lift, Short, Twin Push
12.	3306-03	Chain, Twin Push
13.	A5330	Chain, Twin Push
14.	D3517	Yoke Ends
15.	10284 10451	Clevis Pin, 1/2" x 1 1/2" Cotter Pin, 1/8" x 1"
16.	10289	Hex Nut, 1/2" - 20
17.	A5311 10641	Center Mount W/Grease Fitting Grease Fitting, 1/8" NPT

ROCK SHAFT ASSEMBLY-CENTER MOUNTED LIFT CYLINDER

ITEM	PART NO.	DESCRIPTION
18.	D1113	U-Bolt, 5" x 7" x 5/8" - 11
	D1114	U-Bolt, 7" x 7" x 5/8" - 11
	10152	HHCS, 5/8" - 11 x 9"
	10230	Lock Washer, 5/8"
	10104	Hex Nut, 5/8" - 11
19.	10263	HHCS, 1" - 8 x 5"
	10118	Lock Washer, 1"
	10117	Hex Nut, 1" - 8
20.	A5314	Cylinder Mount
21.	10561	Clevis Pin, 1/2" x 3"
	10670	Hair Pin Clip, No. 3
22.	A5316	Lockup
23.		Cylinder (See Rock Shaft Cylinder)
24.	R0375	Pin
	R0193	Hair Pin Clip
25.	D3550	Pin, 1 1/4" x 5 5/8"
	10460	Cotter Pin, 1/4" x 2"
26.	A5317	Cylinder Pivot Mount
27.	D4108	Shaft, 1 1/4" x 7"
	10460	Cotter Pin, 1/4" x 2"
28.	D3518-09	Tube, 3" x 3" x 90", 4 Row 30
	D3518-10	Tube, 3" x 3" x 114", 4 Row 36/38
	D3518-11	Tube, 3" x 3" x 150", 6 Row 30
	D3518-12	Tube, 3" x 3" x 190", 6 Row 36/38
	D3518-13	Tube, 3" x 3" x 210", 8 Row 30
	D3518-14	Tube, 3" x 3" x 266", 8 Row 36/38
29.	A5312	End Mount W/Grease Fitting, R.H.
	10641	Grease Fitting, 1/8" NPT

ROCK SHAFT ASSEMBLY - FRAME MOUNTED LIFT CYLINDER(S)

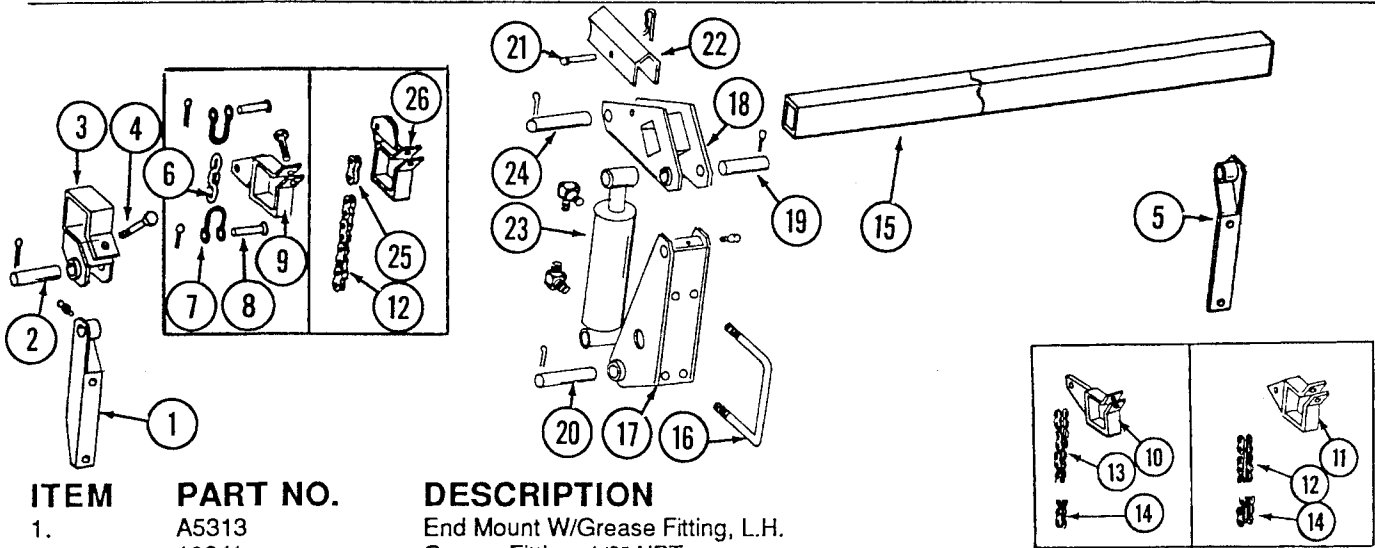

ITEM	PART NO.	DESCRIPTION
1.	A5313 10641	End Mount W/Grease Fitting, L.H. Grease Fitting, 1/8" NPT
2.	D6136	Pin, 1 1/4" x 5"
3.	A5315	End Mount Clamp
4.	10053 10228 10102	HHCS, 1/2"-13 x 2 1/2" Lock Washer, 1/2" Hex Nut, 1/2"-13
5.	A5312 10641	End Mount W/Grease Fitting, R.H. Grease Fitting, 1/8" NPT
6.	3306-03	Chain, Standard Push, 5/16" Coil Type
7.	D2551	Clevis
8.	10166 10467	Clevis Pin, 3/8" x 1 1/2" Cotter Pin, 5/32" x 3/4"
9.	A5318	Unit Lift, Standard, Used With 5/16" Coil Type Chain
10.	A4574	Unit Lift, Long, Twin Push
11.	A4575	Unit Lift, Short, Twin Push
12.	3313-08 R1000	Chain, Twin Push, No. 60 Roller, 8 Pitch Including Connector Link Connector Link, No. 60 Roller
13.	3313-10 R1000	Chain, Twin Push, No. 60 Roller, 10 Pitch Including Connector Link Connector Link, No. 60 Roller
14.	R1000	Connector Link, No. 60 Roller
15.	D3518-09 D3518-10 D3518-11 D3518-12 D3518-13 D3518-14	Tube, 3" x 3" x 90", 4 Row 30 Tube, 3" x 3" x 114", 4 Row 36/38 Tube, 3" x 3" x 150", 6 Row 30 Tube, 3" x 3" x 190", 6 Row 36/38 Tube, 3" x 3" x 210", 8 Row 30 Tube, 3" x 3" x 266", 8 Row 36/38
16.	D1113 D1114 10230 10104	U-Bolt, 5" x 7" x 5/8"-11 U-Bolt, 7" x 7" x 5/8"-11 Lock Washer, 5/8" Hex Nut, 5/8"-11
17.	A4570 10641	Cylinder Mount W/Grease Fitting Grease Fitting, 1/8" NPT
18.	A4569	Cylinder Pivot Mount
19.	D6869 10460	Shaft, 1 1/4" x 6 1/2" Cotter Pin, 1/4" x 2"
20.	D6870 10460	Pin, 1 1/4" x 6" Cotter Pin, 1/4" x 2"
21.	10561 10670	Clevis Pin, 1/2" x 3" Hair Pin Clip, No. 3
22.	A5316	Lockup
23.		Cylinder (See Rock Shaft Cylinder-Frame Mounted Lift)
24.	D3550 10460	Pin, 1 1/4" x 5 5/8" Cotter Pin, 1/4" x 2"
25.	R1022	Offset Link, No. 2060 Roller
26.	A5471	Unit Lift, Standard, Used With No. 2060 Roller Type Lift Chain

TWIN PUSH STABILIZER LINKAGE

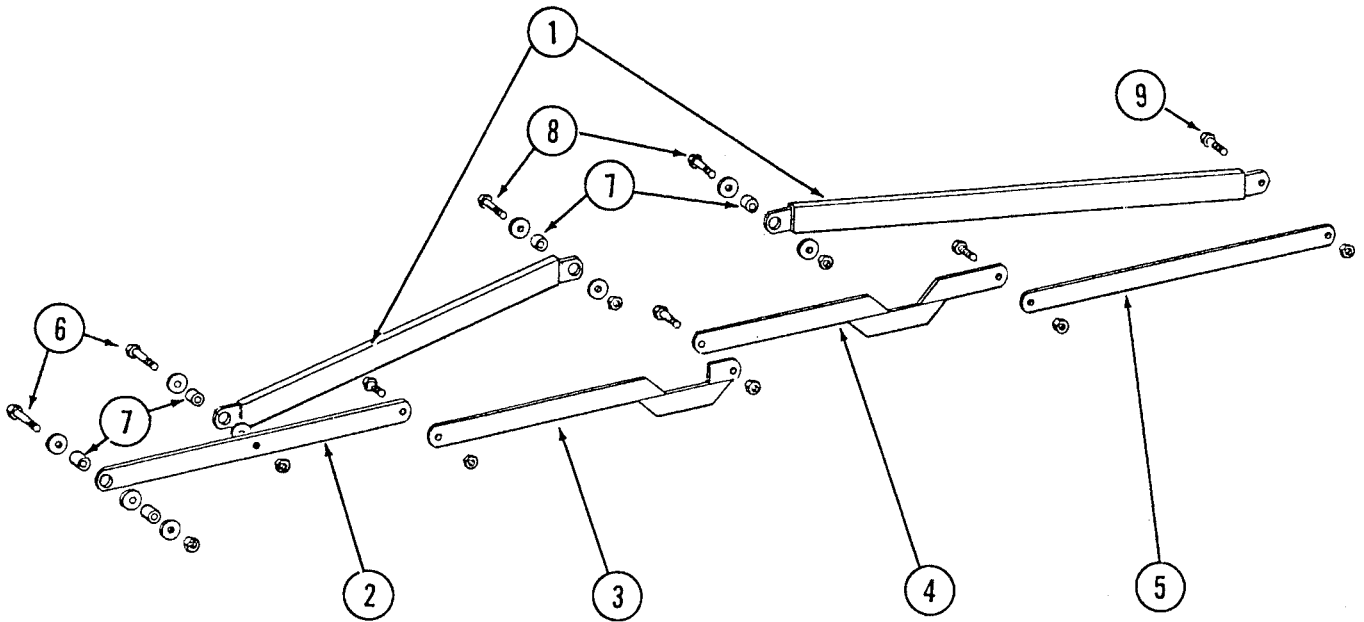

ITEM	PART NO.	DESCRIPTION
1.	A4964	Linkage Arm, 6/8 Row
2.	D7393	Arm, L.H., 6/8 Row
3.	A4965	Center Linkage Arm. L.H., 4/6/8 Row
4.	A4966	Center Linkage Arm, R.H., 4/6/8 Row
5.	D7394	Arm, R.H., 6/8 Row
6.	10010	HHCS, 5/8"-11 x 3"
	10217	Washer, 5/8" USS
	10107	Lock Nut, 5/8"-11
7.	B0123	Bushing
8.	10008	HHCS, 5/8"-11 x 2"
	10217	Washer, 5/8" USS
	10107	Lock Nut, 5/8"-11
9.	10010	HHCS, 5/8"-11 x 3"
	10036	HHCS, 5/8"-11 x 4"
	10217	Washer, 5/8" USS
	10107	Lock Nut, 5/8"-11

FRAME MOUNTED COULTER ASSEMBLY

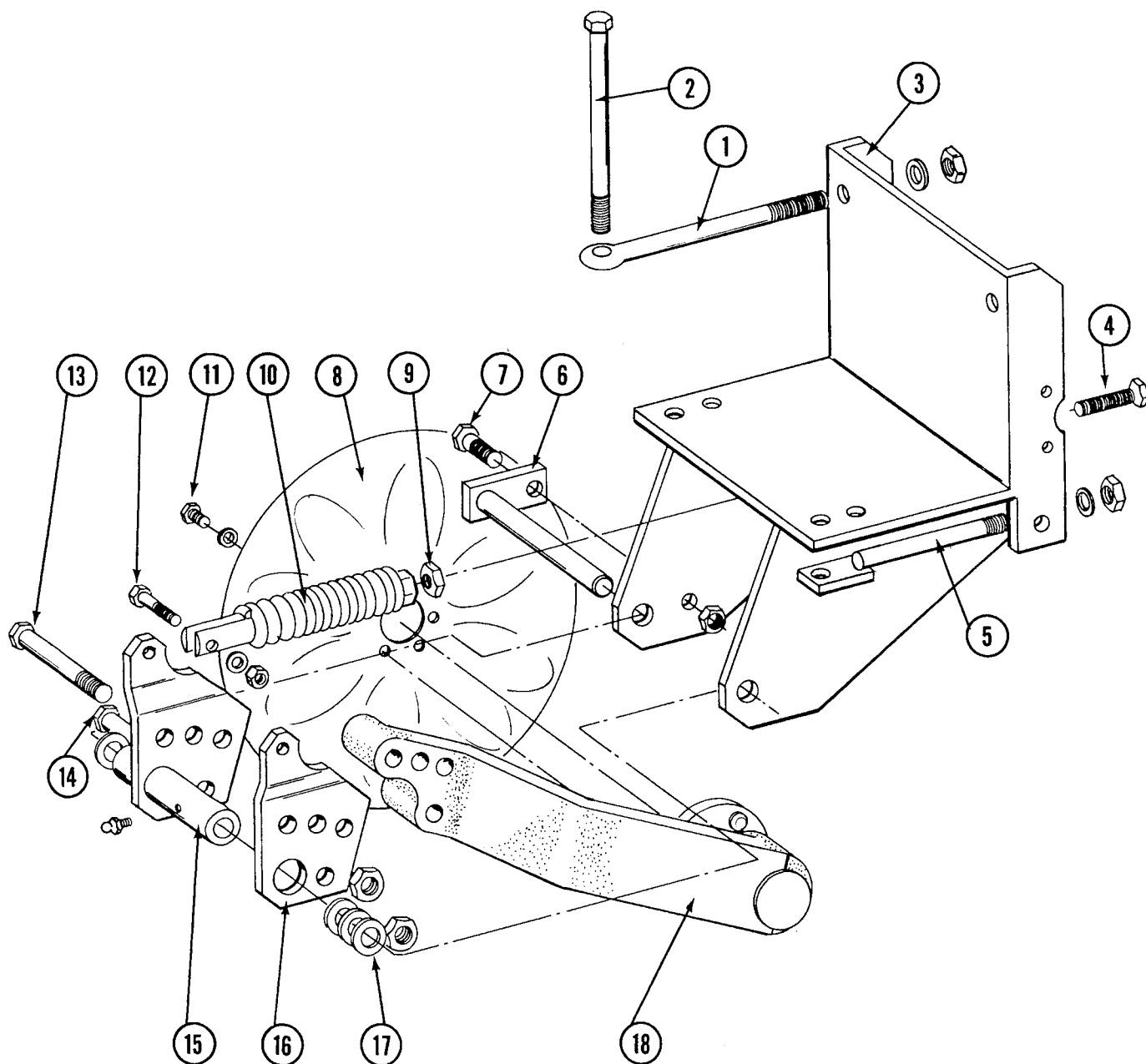

FRAME MOUNTED COULTER ASSEMBLY

ITEM	PART NO.	DESCRIPTION
1.	D0830	Eye Bolt, 3/4" - 10 x 9"
	10231	Lock Washer, 3/4"
	10105	Hex Nut, 3/4" - 10
2.	10030	HHCS, 3/4" - 10 x 9"
	10231	Lock Washer, 3/4"
	10105	Hex Nut, 3/4" - 10
3.	A1695	Mount
4.	D0962	Hex Head Adjusting Bolt, 5/8" -18
5.	A5285	Tie Bolt
	10228	Lock Washer, 1/2"
	10102	Hex Nut, 1/2" - 13
6.	A1689	Hammer Strap
7.	10017	HHCS, 1/2" - 13 x 1 1/2"
	10111	Lock Nut, 1/2" - 13
8.	D1105	Fluted Blade, 16"
	D1106	Ripple Blade, 16"
9.	10499	Jam Nut, 5/8" - 18
10.	A2356	Spring
11.	10002	HHCS, 3/8" - 16 x 3/4"
	10229	Lock Washer, 3/8"
12.	10016	HHCS, 1/2" - 13 x 2"
	10216	Washer, 1/2" USS
	10111	Lock Nut, 1/2" - 13
13.	10036	HHCS, 5/8" - 11
	10107	Lock Nut, 5/8" - 11
14.	10044	HHCS, 3/4" - 10 x 4"
	10112	Lock Nut, 3/4" -10
15.	A1692	Mount W/Grease Fitting
	10641	Grease Fitting, 1/8" NPT
16.	D2511	Plate
17.	10526	Machine Bushing
18.		Heavy Duty Coultter Arm Assembly, See Kinze Row Unit Manual

FERTILIZER OPENER

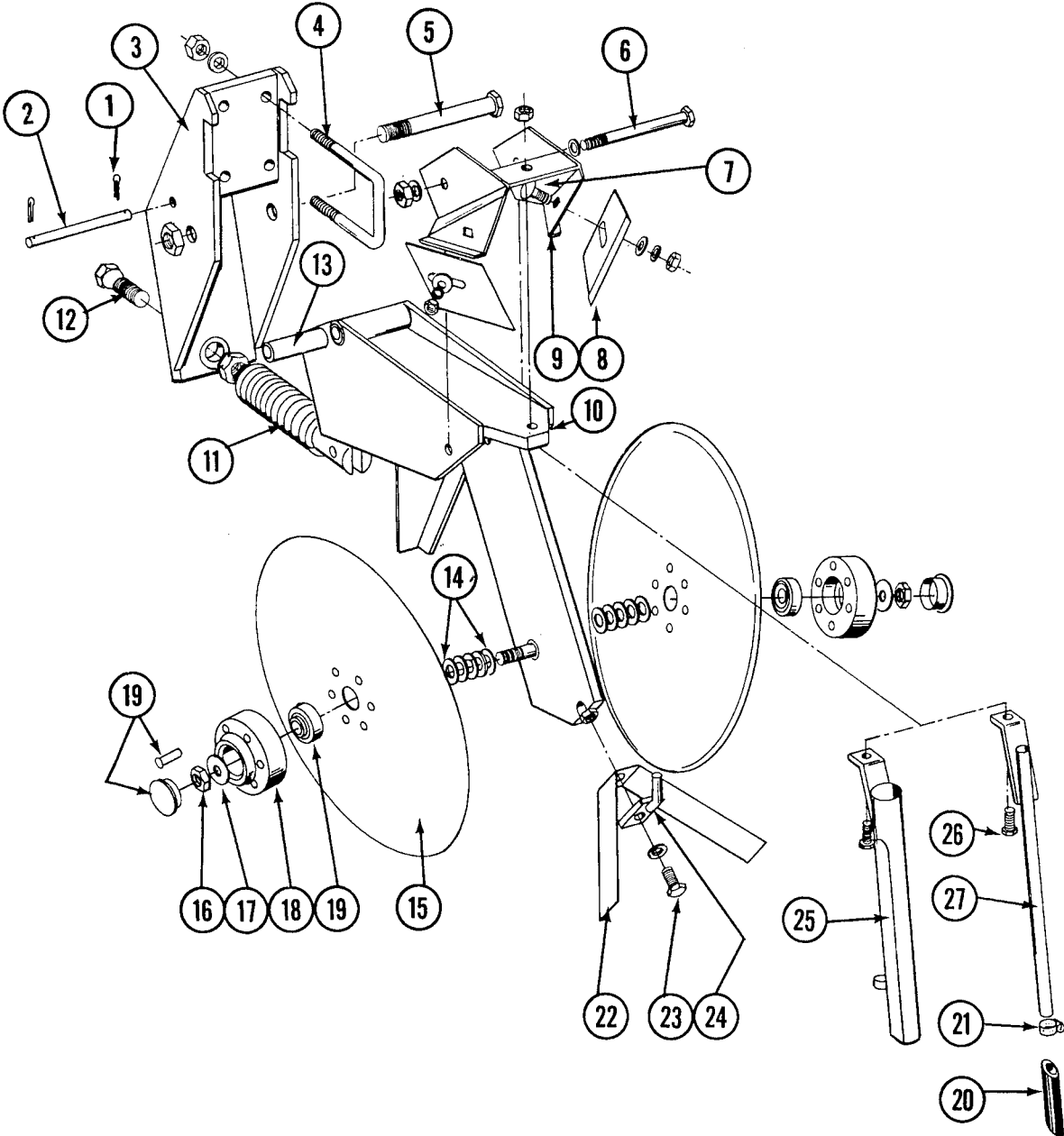

FERTILIZER OPENER

ITEM	PART NO.	DESCRIPTION
1.	10451	Cotter Pin, 1/8" x 1"
2.	D1657	Lockup Pin
3.	A0785	Bracket
4.	D1339	U-Bolt, 2 1/2" x 2 1/2" x 1/2" - 13
	10228	Lock Washer, 1/2"
	10102	Hex Nut, 1/2" - 13
5.	10046	HHCS, 5/8" - 11 x 5"
	10107	Lock Nut, 5/8" - 11
6.	10045	HHCS, 1/2" - 13 x 4 1/2"
	10216	Washer, 1/2" USS
	10111	Lock Nut, 1/2" - 13
7.	10305	Carriage Bolt, 3/8" - 16 x 1"
	10210	Washer, 3/8" USS
	10229	Lock Washer, 3/8"
	10101	Hex Nut, 3/8" - 16
8.	D1673	Scraper
9.	A0810	Mount
10.	A0308	Shank
11.	A0328	Spring
12.	D0962	Hex Head Adjusting Bolt, 5/8" - 18
	10499	Jam Nut, 5/8" - 18
13.	D0487	Bushing
14.	10213	Machine Bushing, 11/16"
15.	D1030	Blade, 15"
16.	10503	Jam Nut, R.H., 5/8" - 11
	10504	Jam Nut, L.H., 5/8" - 11
17.	10204	Machinery Bushing, 21/32"
18.	B0134	Hub
19.	1K139	Bearing W/Cap and Rivets
	D1132	Cap
	10651	Rivet, 1/4" x 1 3/8"
20.	D1797	Extension
21.	10681	Clamp, No. 6
22.	D2589	Scraper, Inner
23.	10019	HHCS, 5/16" - 18 x 1"
	10232	Lock Washer, 5/16"
24.	A0312	Mount
25.	A1369	Drop Tube, Dry Fertilizer
26.	10133	HHCS, 5/16" - 18 x 1 1/2"
	10109	Lock Nut, 5/16" - 18
27.	A0318	Drop Tube, Liquid Fertilizer
A.	A0320	Disk and Bearing Assembly, Includes: (6) 10651, (1) B0134, (1) Bearing, (1) D1030
B.	6156X	Double Disk Fertilizer Opener With U-Bolts, Less Drop Tubes

FERTILIZER OPENER MOUNTING BAR

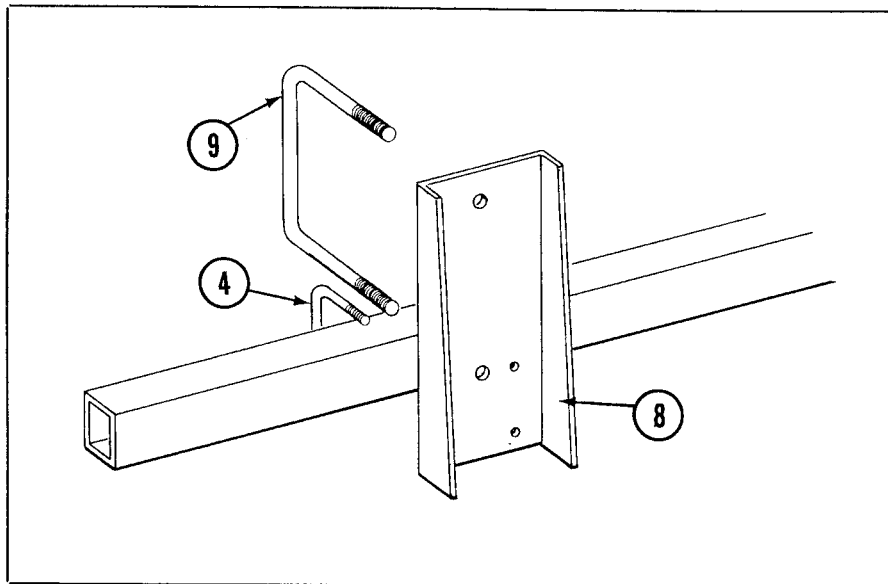
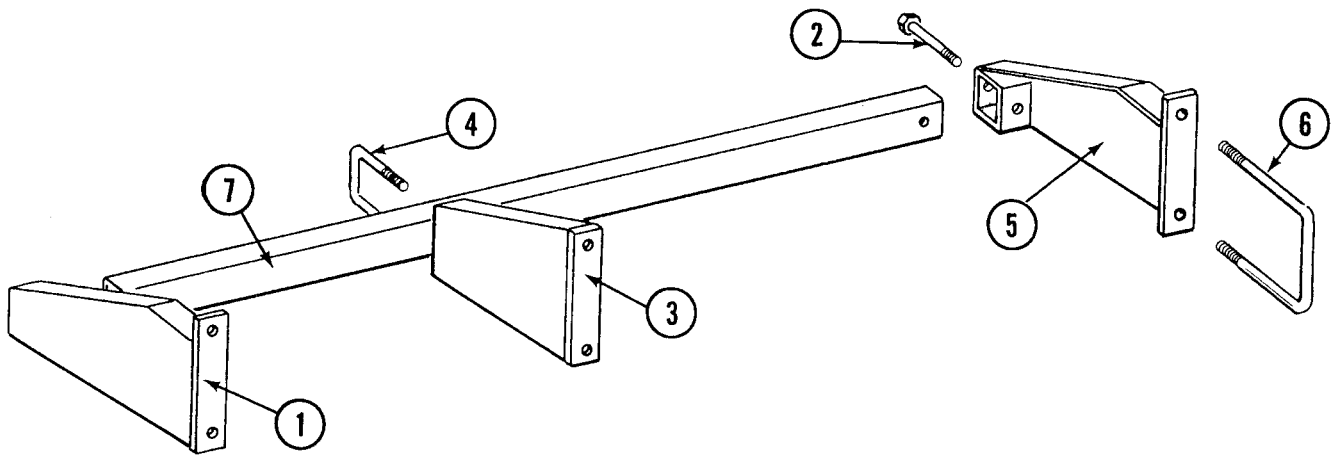

FERTILIZER OPENER MOUNTING BAR

ITEM	PART NO.	DESCRIPTION
1.	A5231	Support, L.H., Pull Type Only
2.	10035	HHCS, 1/2" - 13 x 4"
	10228	Lock Washer, 1/2"
	10102	Hex Nut, 1/2" - 13
3.	A5237	Support, L.H. (shown) 8 Row Only
	A5236	Support, R.H., 8 Row Only
4.	D1339	U-Bolt, 2 1/2" x 2 1/2" x 1/2" - 13
	10228	Lock Washer, 1/2"
	10102	Hex Nut, 1/2" - 13
5.	A5230	Support, R.H., Pull Type Only
6.	D1114	U-Bolt, 7" x 7" x 5/8" - 11
	10230	Lock Washer, 5/8"
	10104	Hex Nut, 5/8" - 11
7.	D1685-18	Bar, 91", 2 Row 38
	D1685-14	Bar, 105", 4 Row 30
	D0971-48	Bar, 45", 4 Row 30 Used W/Special Mounts (Qty. 2)
	D1685-15	Bar, 129", 4 Row Wide
	D1685-13	Bar, 165", 6 Row 30
	D0971-47	Bar, 75", 6 Row 30, Used W/Special Mounts (Qty. 2)
	D1685-12	Bar, 205", 6 Row Wide
	D1685-16	Bar, 225", 8 Row 30
	D1685-17	Bar, 281", 8 Row Wide
8.	D6208	Special Mount, Double Frame W/Frame Mounted Coulters
9.	D1747	U-Bolt, 3/4" - 10 x 5" x 7"
	10231	Lock Washer, 3/4"
	10105	Hex Nut, 3/4" - 10

DRY FERTILIZER TRANSMISSION ASSEMBLY

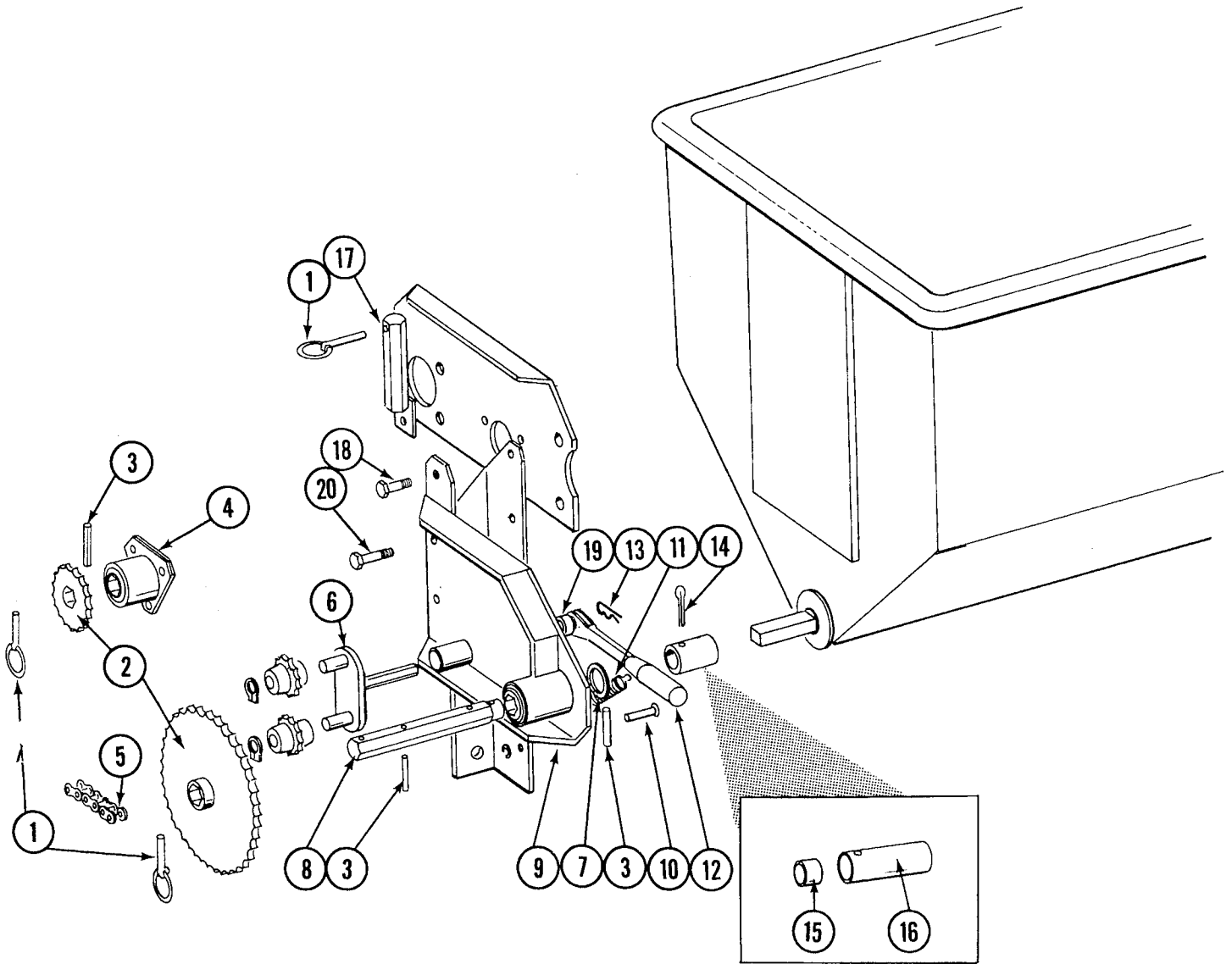

DRY FERTILIZER TRANSMISSION ASSEMBLY

ITEM	PART NO.	DESCRIPTION
1.	D2558	Lynch Pin, 1/4"
2.	A5368	Sprocket, 15 Tooth
	A5107	Sprocket, 19 Tooth
	A5114	Sprocket, 30 Tooth
	A5115	Sprocket, 33 Tooth
	A5194	Sprocket, 50 Tooth
	A5195	Sprocket, 66 Tooth, Optional Low Rate Sprocket
3.	10602	Spring Pin, 1/4" x 1 1/2"
4.	A5223	Spacer W/Bearing
	A5116	Bearing
5.	3310-106	Chain, No. 40, 106 Pitch Including Connector Link
	R0912	Connector Link, No. 40
6.	A5136	Idler W/Sprockets and Rings
	D5815	Sprocket
	10435	Ring
7.	10233	Machinery Bushing (As Required)
8.	D5215	Shaft
9.	A5226	Plate W/Bearing and Grease Fitting
	A5116	Bearing
	10640	Grease Fitting, 1/4" - 28
10.	10408	Clevis Pin, 5/16" x 3/4"
	10409	Retaining Ring, 5/16"
11.	D5857	Spring
12.	A5365	Ratchet Arm With Protective Closure
	10410	Protective Closure, Red
13.	10670	Hair Pin, No. 3
14.	10460	Cotter Pin, 1/4" x 2"
15.	D2769	Round Insert, 2 Row 38 Only
16.	A5278	Coupler, 26 1/8", 2 Row 38
	D5970	Coupler, 1 5/8", 4 Row 30, 6 Row 30 and 8 Row 30
	D5971	Coupler, 9 5/8", 8 Row 36/38
	D6029	Coupler, 8", 4 Row 36/38 and 6 Row 36/38
17.	A5229	Rod, Sprocket Storage
18.	10035	HHCS, 1/2" - 13 x 4"
	10228	Lock Washer, 1/2"
	10102	Hex Nut, 1/2" - 13
19.	D0935	Hex Sleeve
20.	10039	HHCS, 1/2" - 13 x 1 3/4"
	10228	Lock Washer, 1/2"
	10102	Hex Nut, 1/2" - 13

DRY FERTILIZER HOPPER AND MOUNTS

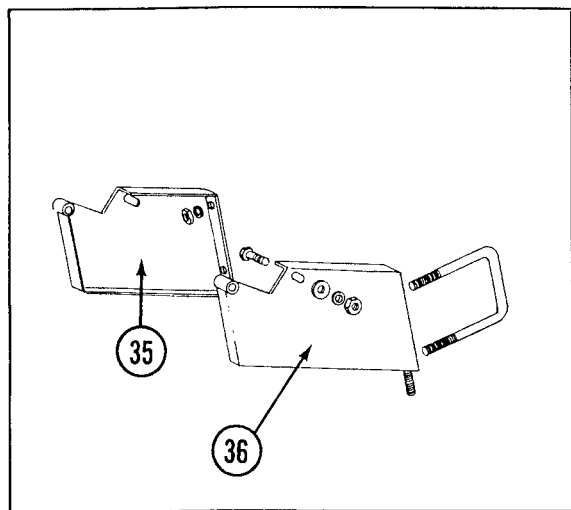
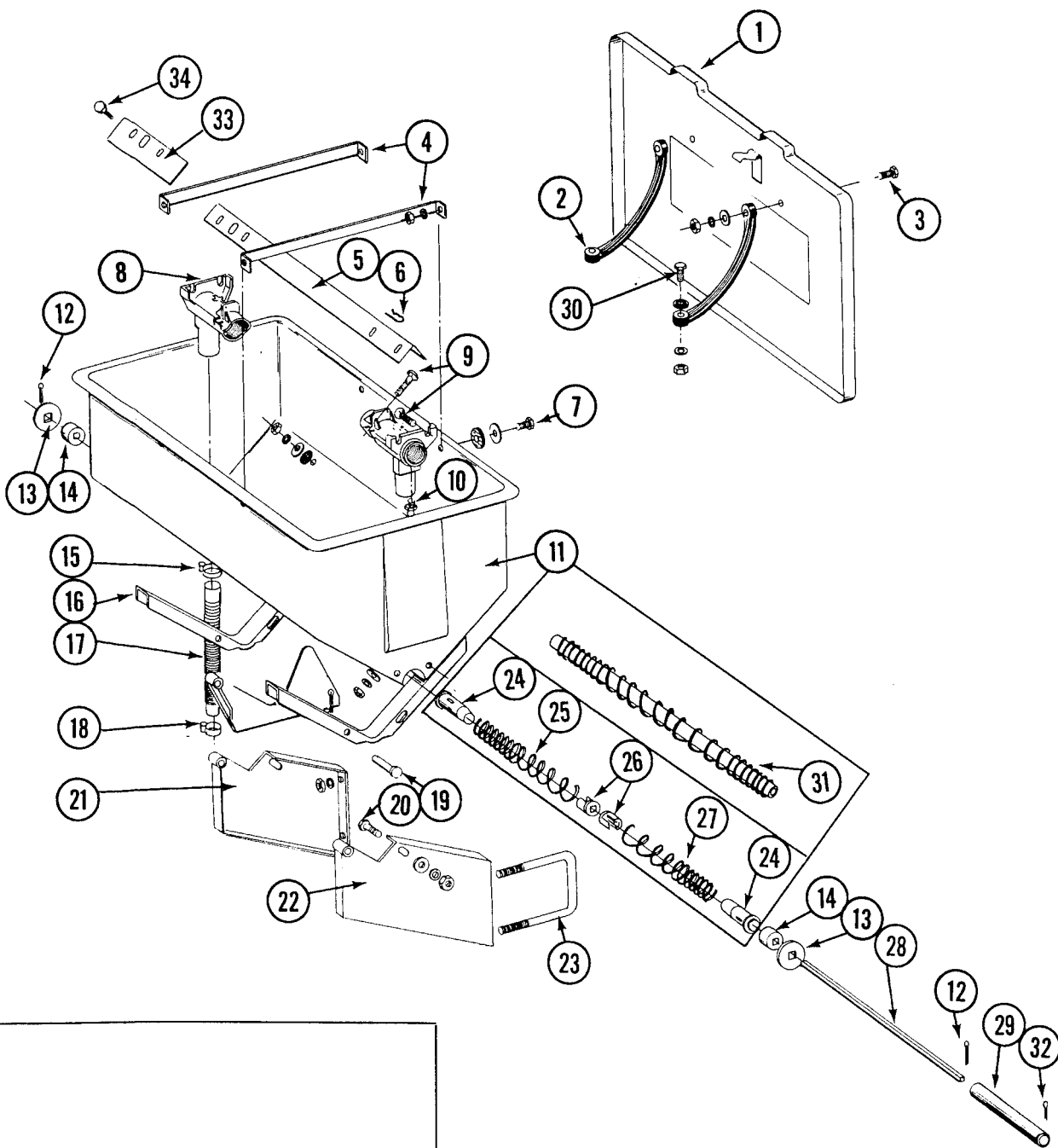

DRY FERTILIZER HOPPER AND MOUNTS

ITEM	PART NO.	DESCRIPTION
1.	A2101	Lid, Includes Clips and Pop Rivets
	D1380	Clip
	10655	Pop Rivet, 3/16" x 13/32"
2.	D1210	Strap, Rubber
3.	10171	HHCS, 5/16" - 18 x 1 1/4"
	10219	Washer, 5/16" USS
	10232	Lock Washer, 5/16"
	10106	Hex Nut, 5/16" - 18
4.	D1209	Strap, Reinforcing
5.	D1207	Baffle
6.	10670	Hair Pin Clip, No. 3
7.	10171	HHCS, 5/16" - 18 x 1 1/4"
	10201	Washer, Special
	D1213	Washer, Rubber
	10232	Lock Washer, 5/16"
	10106	Hex Nut, 5/16" - 18
8.	D1200	Housing, Outlet
9.	10303	Carriage Bolt, 5/16" - 18 x 1", Grade 2
	10219	Washer, 5/16" USS
	10232	Lock Washer, 5/16"
	10106	Hex Nut, 5/16" - 18
10.	10641	Grease Fitting, 1/8" NPT, 45°
11.	D1379	Hopper
12.	10464	Cotter Pin, 3/16" x 1"
13.	D1212	Washer, Special
14.	D1206	Bearing
15.	10676	Clamp, No. 36
16.	D1208	Saddle
17.	D3790	Tube, Rubber
18.	10672	Clamp, No. 28
19.	10561	Clevis Pin, 1/2" x 3"
	10451	Cotter Pin, 1/8" x 1"
20.	10037	HHCS, 1/2" - 13 x 1 1/4"
	10206	Washer, 1/2" SAE
	10228	Lock Washer, 1/2"
	10102	Hex Nut, 1/2" - 13
21.	A0864	Hopper Mount, R.H.
22.	A0863	Hopper Mount, L.H.
23.	D1114	U-Bolt, 7" x 7" x 5/8" - 11
	10230	Lock Washer, 5/8"
	10104	Hex Nut, 5/8" - 11
24.	D1202	Guide
25.	D1204	Spring, R.H., Regular Rate
26.	D1203	Plug
27.	D1205	Spring, L.H., Regular Rate
28.	D1201	Shaft
29.		Drive Coupler (See Dry Fertilizer Couplers)
30.	10133	HHCS, 5/16" - 18 x 1 1/2"
	10219	Washer, 5/16" USS
	10232	Lock Washer, 5/16"
	10106	Hex Nut, 5/16" - 18
31.	A5238	Auger Assembly, High Rate
32.	10462	Cotter Pin, 3/16" x 2"
33.	D4667	Extension Plate (Optional)
34.	10019	HHCS, 5/16" - 18 x 1"
	10219	Washer, 5/16" USS
	10232	Lock Washer, 5/16"
	10106	Hex Nut, 5/16" - 18
35.	A5274	Hopper Mount, Special R.H.
36.	A5275	Hopper Mount, Special L.H.

DRY FERTILIZER COUPLERS

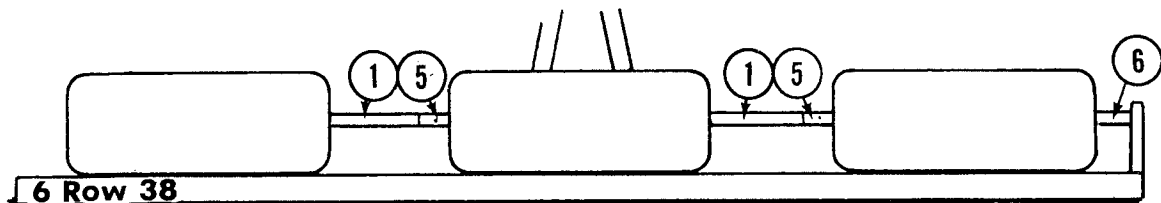
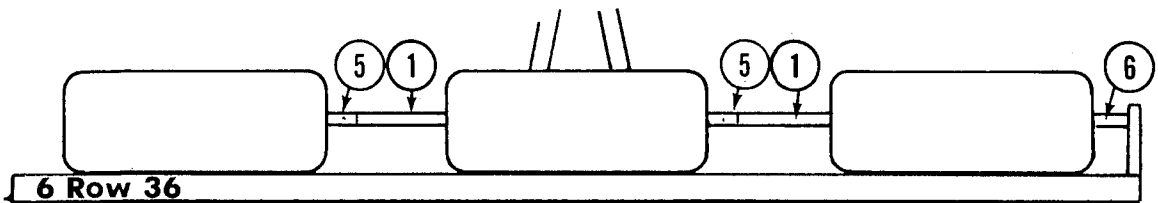
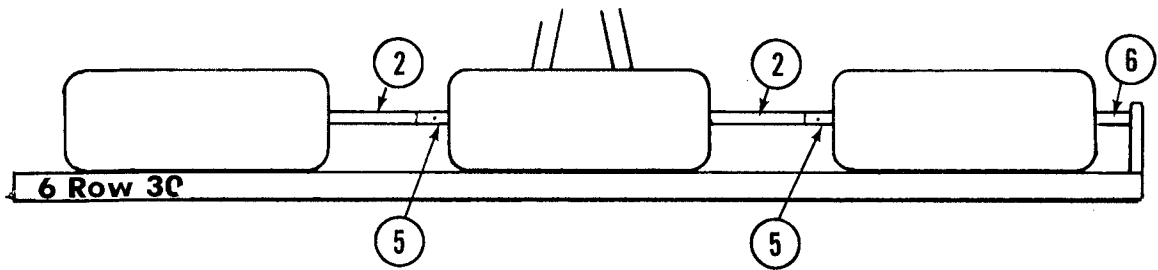
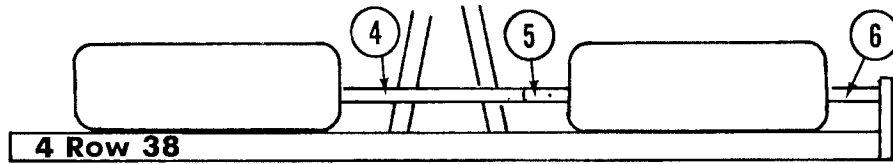
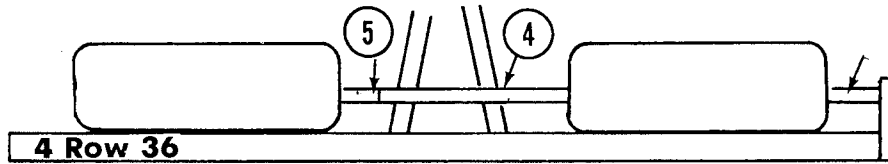
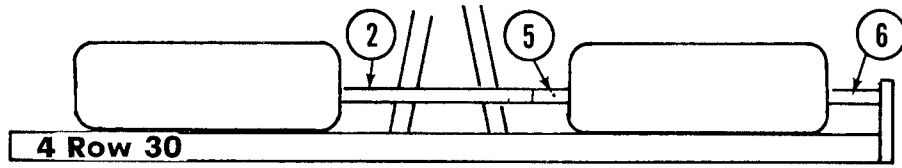

DRY FERTILIZER COUPLERS

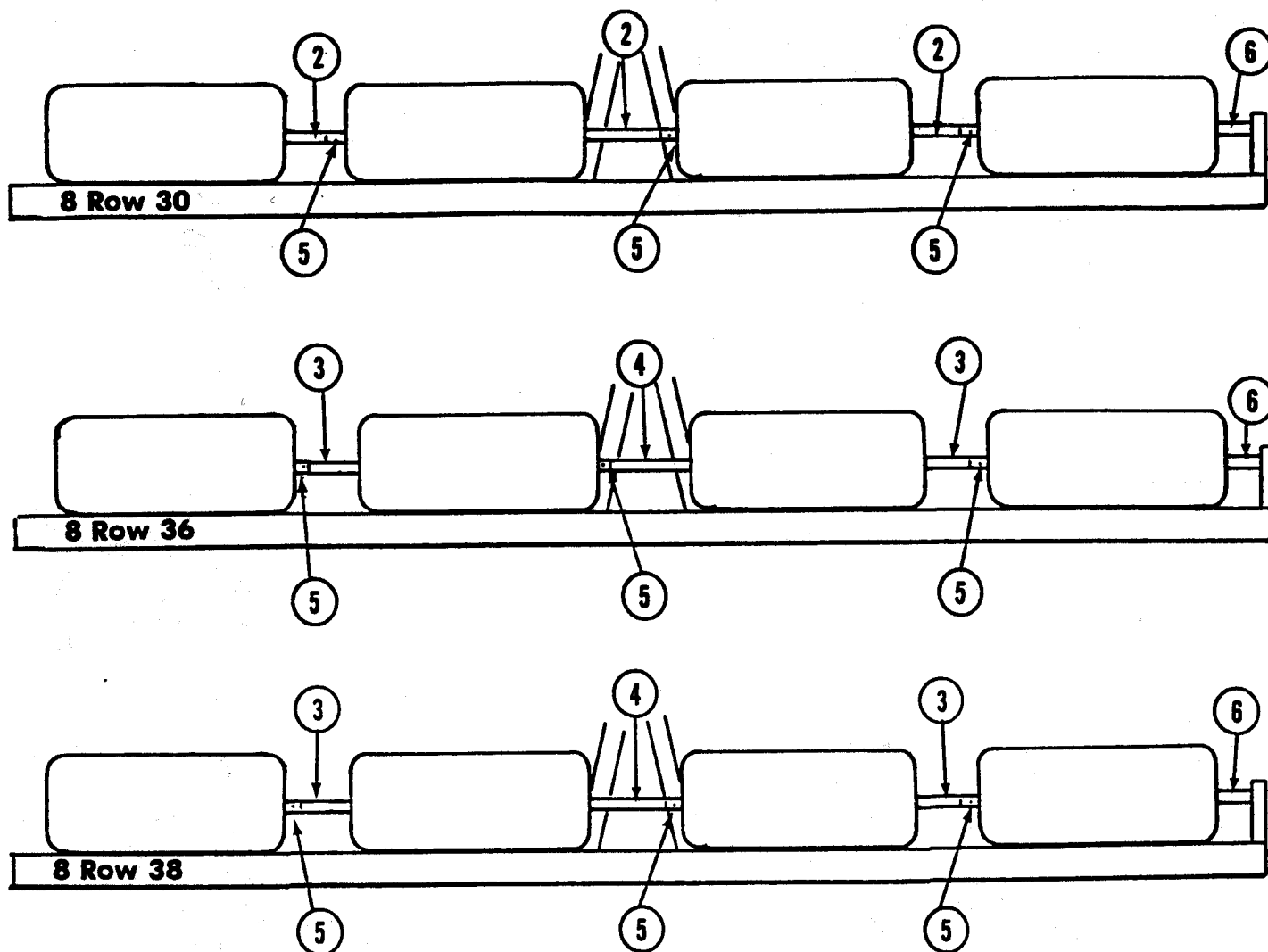

ITEM	PART NO.	DESCRIPTION
1.	A5279	Coupler, 29 1/8"
2.	A2309	Coupler, 16 1/8"
3.	A2315	Coupler, 30 5/8"
4.	A5278	Coupler, 26 1/8"
5.	D2768	Insert, Square
6.		Coupler (See Dry Fertilizer Transmission)

DRY FERTILIZER QUICK FILL ASSEMBLY

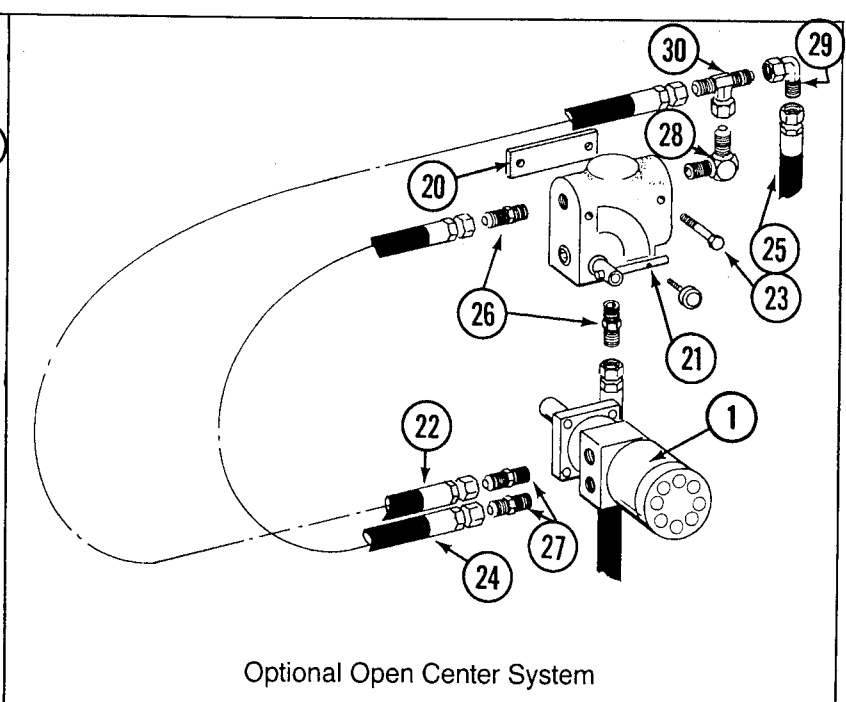
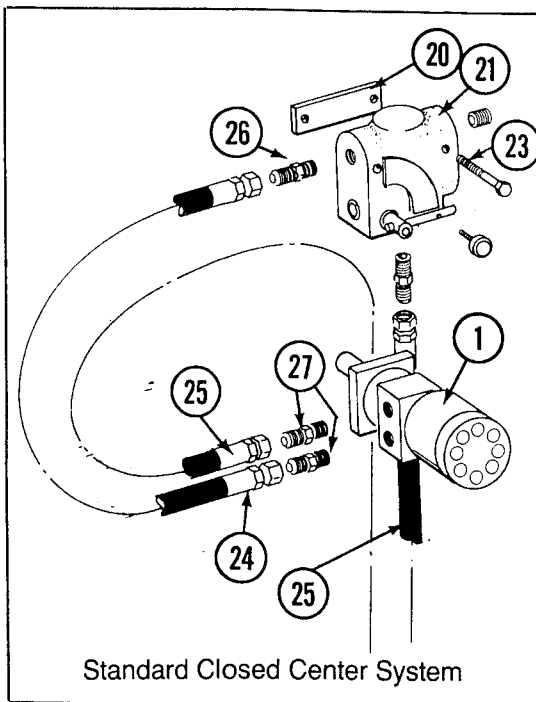
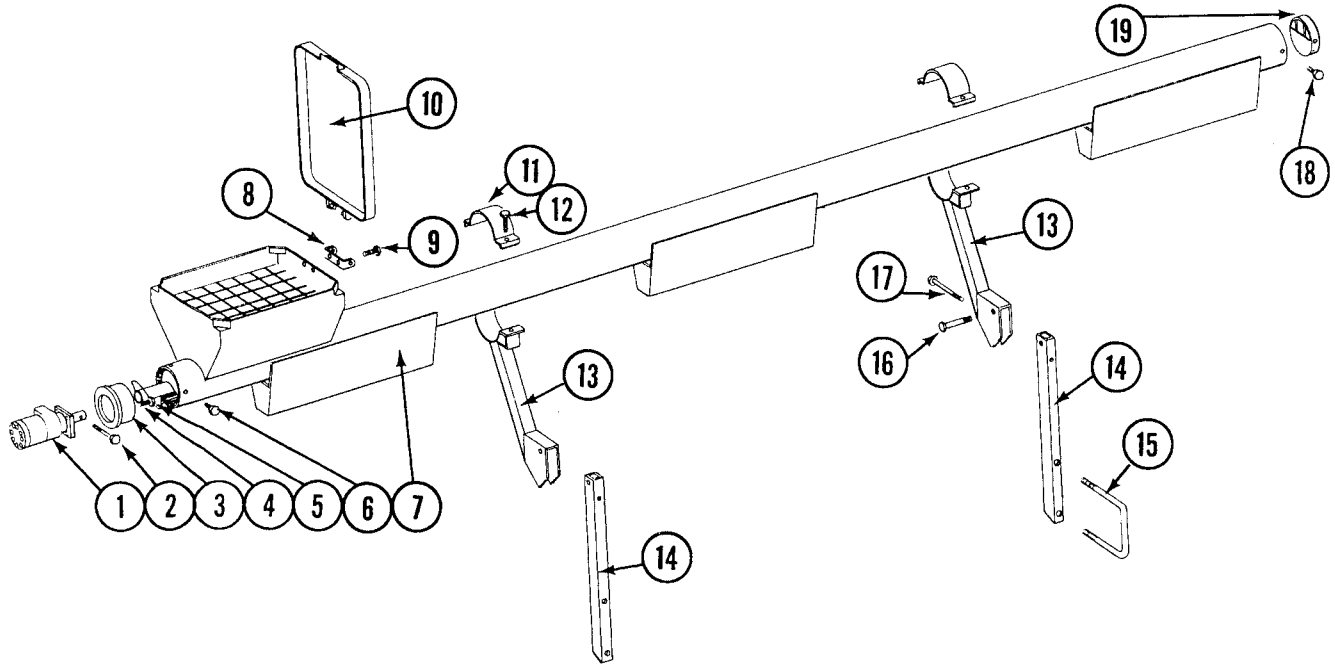

ITEM	PART NO.	DESCRIPTION
1.	A5163	Motor
2.	10041	HHCS, 5/16" - 18 x 2"
	10109	Lock Nut, 5/16" - 18
3.	B0174	Motor Mount
4.	10004	HHCS, 3/8" - 16 x 1 1/4"
	10229	Lock Washer, 3/8"
5.	A5395	Auger, 96", 4 Row 30
	A5396	Auger, 116", 4 Row Wide
	A5397	Auger, 153", 6 Row 30
	A5398	Auger, 180", 6 Row Wide
	A5399	Auger, 213", 8 Row 30
	A5400	Auger, 252", 8 Row Wide

DRY FERTILIZER QUICK FILL ASSEMBLY

ITEM	PART NO.	DESCRIPTION
6.	10023	HHCS, 1/4" - 20 x 3/4"
	10227	Lock Washer, 1/4"
7.	A5379	Auger Tube, 104", 4 Row 30
	A5380	Auger Tube, 122", 4 Row Wide
	A5381	Auger Tube, 160", 6 Row 30
	A5382	Auger Tube, 187", 6 Row Wide
	A5383	Auger Tube, 220", 8 Row 30
	A5384	Auger Tube, 261", 8 Row Wide
8.	D1060	Hinge
9.	10064	HHCS, 1/4" - 20 x 1"
	10227	Lock Washer, 1/4"
	10103	Hex Nut, 1/4" - 20
10.	D1524	Lid
11.	D6202	Clamp
12.	10003	HHCS, 3/8" - 16 x 1 1/2"
	10229	Lock Washer, 3/8"
	10101	Hex Nut, 3/8" - 16
13.	A5372	Mount
14.	D6201	Mounting Tube
15.	D1114	U-Bolt, 7" x 7" x 5/8" - 11
	10230	Lock Washer, 5/8"
	10104	Hex Nut, 5/8" - 11
16.	10013	HHCS, 5/8" - 11 x 3 1/2"
	10230	Lock Washer, 5/8"
	10104	Hex Nut, 5/8" - 11
17.	10038	HHCS, 1/2" - 13 x 3"
	10228	Lock Washer, 1/2"
	10102	Hex Nut, 1/2" - 13
18.	10023	HHCS, 1/4" - 20 x 3/4"
	10227	Lock Washer, 1/4"
	10103	Hex Nut, 1/4" - 20
19.	A5373	End Shield
20.	D6244	Spacer
21.	A5374	Flow Control Valve
22.	A1424	Hose Assembly, 1/2" x 30"
23.	10403	HHCS, 1/4" - 20 x 2 1/2"
	10227	Lock Washer, 1/4"
	10103	Hex Nut, 1/4" - 20
24.	A1450	Hose Assembly, 1/2" x 22"
25.	A1444	Hose Assembly, 1/2" x 225", 4 Row 30
	A1445	Hose Assembly, 1/2" x 235", 4 Row Wide
	A1446	Hose Assembly, 1/2" x 255", 6 Row 30
	A1447	Hose Assembly, 1/2" x 275", 6 Row Wide
	A1448	Hose Assembly, 1/2" x 285", 8 Row 30
	A1449	Hose Assembly, 1/2" x 315", 8 Row Wide
26.	2404-10-08	Adapter, 7/8" - 14 Male 37° JIC to 1/2" NPT
27.	6400-10	Connector, 7/8" - 14 Male 37° JIC to 7/8" - 14 O-Ring
28.	2501-10-08	Elbow, 7/8" - 14 Male 37° JIC to 1/2" NPT
29.	6500-10	Swivel Elbow, 7/8" - 14 Male 37° JIC to Female
30.	6600-10	Tee, 7/8" 14 Male/Female 37° JIC

SQUEEZE PUMP MOUNTING BRACKET, SPROCKET AND ADAPTER PACKAGE, AND DRIVE LINE

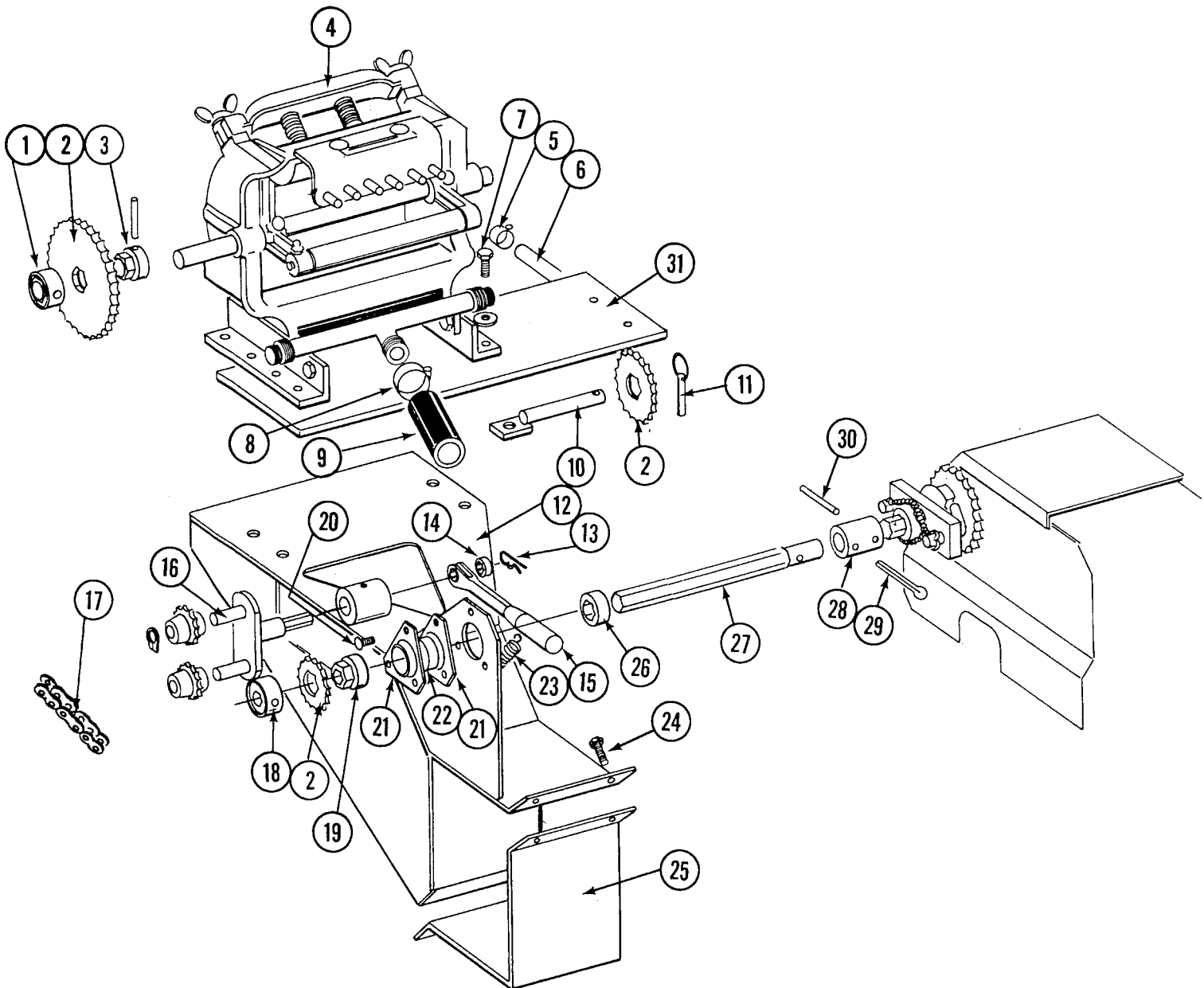

SQUEEZE PUMP MOUNTING BRACKET, SPROCKET AND ADAPTER PACKAGE, AND DRIVE LINE

ITEM	PART NO.	DESCRIPTION
1.	D1215	Lock Collar W/Set Screws
	10120	Set Screw, 3/8" - 16 x 1/2"
2.	2500-70	Sprocket, 16 Tooth
	2500-71	Sprocket, 18 Tooth
	2500-72	Sprocket, 20 Tooth
	2500-73	Sprocket, 30 Tooth
	2500-74	Sprocket, 44 Tooth
	2500-75	Sprocket, 46 Tooth
	2500-76	Sprocket, 52 Tooth
	2500-78	Sprocket, 62 Tooth
	2500-77	Sprocket, 60 Tooth (Optional)
3.	D1216	Adapter (Less Roll Pin) W/Set Screws
	10600	Roll Pin, 5/16" x 2 1/4"
	10120	Set Screw, 3/8" - 16 x 1/2"
4.		Squeeze Pump (See Liquid Fertilizer Squeeze Pump)
5.		Clamp (See Liquid Fertilizer Squeeze Pump)
6.		Hose (See Liquid Fertilizer Squeeze Pump)
7.	10421	HHCS, 7/16" - 14 x 1 1/4"
	10081	Flat Washer, USS, 7/16"
	10237	Lock Washer, 7/16"
	10100	Hex Nut, 7/16" - 14
8.		Clamp (See Liquid Fertilizer Tanks, Saddles, Mounts, Hoses and Fittings)
9.		Hose (See Liquid Fertilizer Tanks, Saddles, Mounts, Hoses and Fittings)
10.	A5251	Rod, Sprocket Storage
11.	D2558	Lynch Pin, 1/4"
12.	A5366	Mount
13.	10670	Hair Pin Clip, No. 3
14.	D0935	Sleeve
15.	A5365	Ratchet Arm W/Protective Closure
	10410	Protective Closure, Red
16.	A5136	Idler W/Sprockets and Rings
	D5815	Sprocket
	10435	Ring
17.	3310-155	Chain, No. 40, 155 Pitch Including Connector and Offset Link
	R0912	Connector Link, No. 40
	R0911	Offset Link, No. 40
18.	A2355	Lock Collar W/Set Screws
	10120	Set Screws, 3/8" - 16 x 1/2"
19.	A2354	Adapter W/Set Screws
	10120	Set Screws, 3/8" - 16 x 1/2"
20.	10303	Carriage Bolt, 5/16" - 18 x 1"
	10232	Lock Washer, 5/16"
	10106	Hex Nut, 5/16" - 18
21.	3400-01	Flangette
22.	2100-03	Bearing, 7/8 Hex Bore, Spherical
23.	D5857	Spring
24.	10017	HHCS, 1/2" - 13 x 1 1/2"
	10228	Lock Washer, 1/2"
	10102	Hex Nut, 1/2" - 13
25.	D6182	Saddle Clamp

SQUEEZE PUMP MOUNTING BRACKET, SPROCKET AND ADAPTER PACKAGE, AND DRIVE LINE

ITEM	PART NO.	DESCRIPTION
26.	D0917	Lock Collar, 7/8 Hex, Less Set Screws
	10145	Set Screw, 5/16" - 18 x 1/2"
27.	D5987	Shaft, 30", 4 Row 30 and 6 Row 30
	D5988	Shaft, 36", 4 Row Wide and 6 Row Wide
	D5989	Shaft, 60", 8 Row 30
	D5990	Shaft, 74", 8 Row Wide
28.	D3839	Coupler
29.	10460	Cotter Pin, 1/4" x 2"
30.	10602	Spring Pin, 1/4" x 1 1/2"
31.	D6165	Plate, 8 Row Only
A.	6801X	Sprocket and Adapter Package, Includes: (1) 10600, (1) 2500-70, (1) 2500-71, (1) 2500-72, (1) 2500-73, (1) 2500-74, (1) 2500-75, (1) 2500-76, (1) 2500-78, (1) A2354, (1) D1215, (1) D1216 (1) A2355

LIQUID FERTILIZER SQUEEZE PUMP

4 Row Models

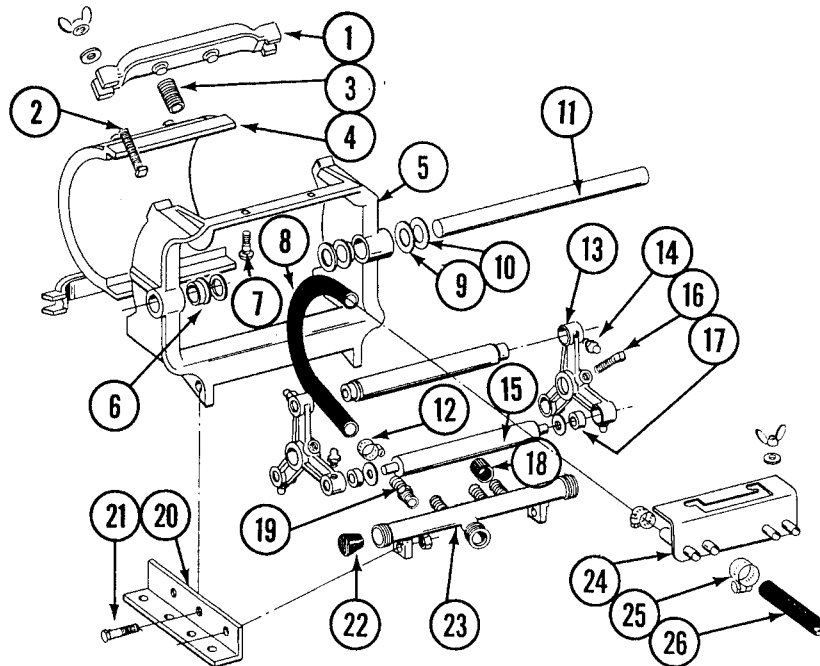

ITEM	PART NO.	DESCRIPTION
1.	R0216	Spring Anchor Bar
2.	10130	Sq. Head Machine Bolt, 5/16" - 18 x 1 3/4"
	10219	Washer, 5/16" USS
	10144	Wing Nut, 5/16" - 18
3.	R0214	Spring
4.	R0212	Plate
5.	R0208	Frame
6.	R0207	Bushing (Nylon)
7.	10303	Round Head Machine Bolt, 5/6" - 18 x 1"
	10219	Washer, 5/16" USS
	10144	Wing Nut, 5/16" - 18
8.	R0215	Metering Hose, 1/2" x 13"
9.	R0225	Shim, 1/32"
10.	R0226	Shim, 3/64"
11.	R0210	Shaft
12.	10681	Clamp, No. 6
13.	R0223	Roller Arm
14.	10640	Grease Fitting, 1/4" - 28
15.	R0209	Roller
16.	10131	Set Screw, 5/16" - 18 x 3/4"
17.	R0227	Bushing, Nylon
18.	R0211	Rubber Cap
19.	R0232	Hose Adapter
20.	R0213	Base Angle
21.	10004	HHCS, 3/8" - 16 x 1 1/4"
	10101	Hex Nut, 3/8" - 16
22.	R0217	Manifold Plug
23.	R0228	Intake Manifold
24.	R0224	Discharge Manifold
25.	10673	Clamp, No. 8
26.	4300-03	Hose, 1/2" x 30"

A. A0321 Squeeze Pump Complete, 4 Rows

LIQUID FERTILIZER SQUEEZE PUMP

6 Row Models

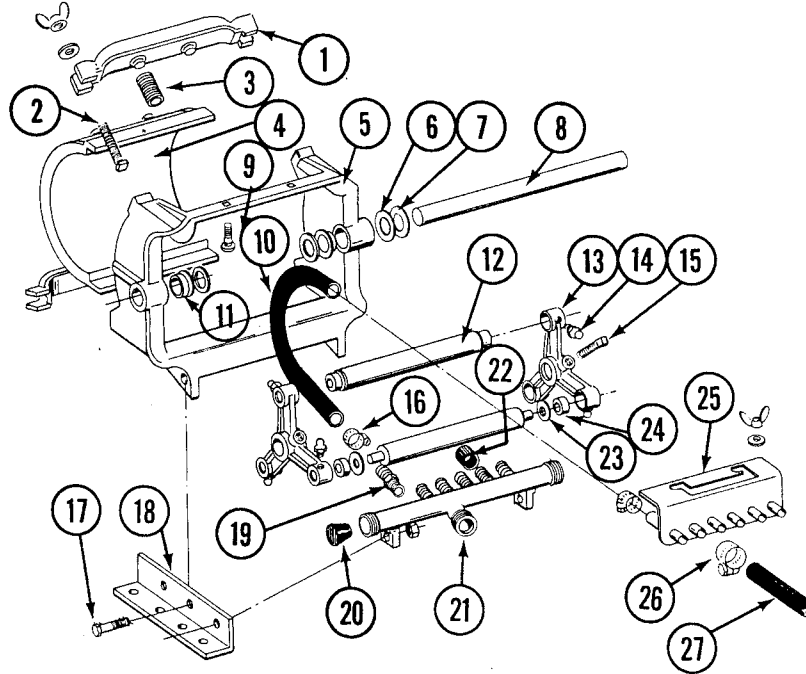

ITEM	PART NO.	DESCRIPTION
1.	R0216	Spring Anchor Bar
2.	10130	Square Head Machine Bolt, 5/16" - 18 x 1 3/4"
	10219	Washer, 5/16" USS
	10144	Wing Nut, 5/16" - 18
3.	R0214	Spring
4.	R0212	Plate
5.	R0208	Frame
6.	R0225	Shim, 1/32"
7.	R0226	Shim, 3/64"
8.	R0210	Shaft
9.	10303	Round Head Machine Bolt, 5/16" - 18 x 1"
	10219	Washer, 5/16" USS
	10144	Wing Nut, 5/16" - 18
10.	R0215	Metering Hose, 1/2" x 13"
11.	R0207	Bushing, Nylon
12.	R0233	Roller
13.	R0231	Roller Arm
14.	10640	Grease Fitting, 1/4" - 28
15.	10131	Set Screw, 5/16" - 18 x 3/4"
16.	10681	Clamp, No. 6
17.	10004	HHCS, 3/8" - 16 x 1 1/4"
	10101	Hex Nut, 3/8" - 16
18.	R0213	Base Angle
19.	R0232	Hose Adapter
20.	R0217	Manifold Plug
21.	R0228	Intake Manifold
22.	R0211	Rubber Cap
23.	R0229	Washer, Nylon
24.	R0230	Bearing, Roller
25.	R0224	Discharge Manifold
26.	10681	Clamp, No. 6
27.	4300-04	Hose, 1/2" x 50'

A. A0322 Squeeze Pump Complete, 6 Row
P70

LIQUID FERTILIZER SQUEEZE PUMP

8 Row Models

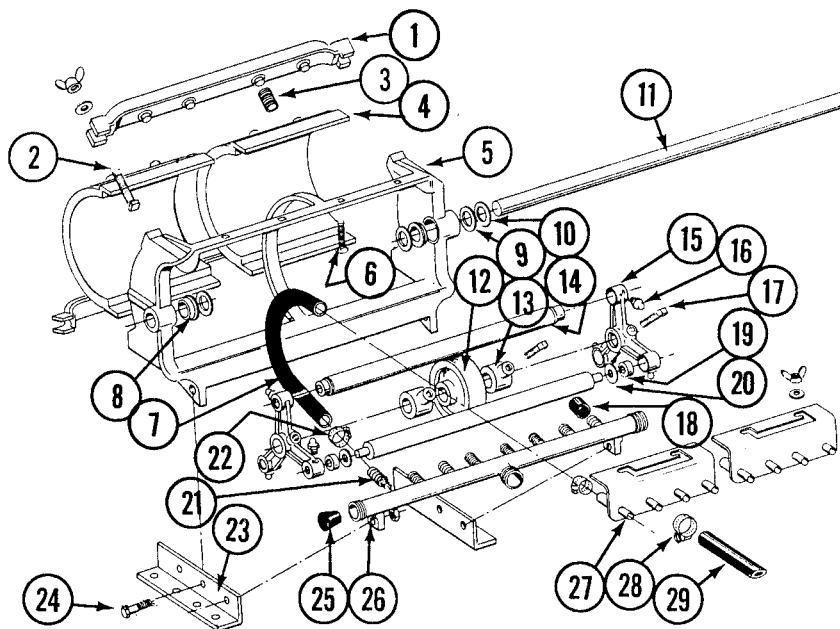

ITEM	PART NO.	DESCRIPTION
1.	R0221	Spring Anchor Bar
2.	10130	Square Head Machine Bolt, 5/16" - 18 x 1 3/4"
	10219	Flat Washer, 5/16"
	10144	Wing Nut, 5/16" - 18
3.	R0214	Spring
4.	R0212	Plate
5.	R0222	Frame
6.	10303	Round Head Machine Bolt, 18 x 1"
	10219	Washer, 5/16" USS
	10144	Wing Nut, 5/16" - 18
7.	R0215	Metering Hose, 1/2" x 13"
8.	R0207	Bushing, Nylon
9.	R0225	Shim, 1/32"
10.	R0226	Shim, 3/64"
11.	R0220	Shaft
12.	R0281	Back Up Roller
13.	R0282	Set Collar
14.	R0283	Roller
15.	R0231	Roller Arm
16.	10640	Grease Fitting, 1/4" - 28
17.	10131	Set Screw, 5/16" - 18 x 3/4"
18.	R0211	Rubber Cap
19.	R0230	Bearing
20.	R0229	Washer, Nylon
21.	R0232	Hose Adapter
22.	10681	Clamp, No. 6
23.	R0279	Base Angle, Left
	R0280	Base Angle, Right
24.	10004	HHCS, 3/8" - 16 x 1 1/4"
	10101	Hex Nut, 3/8" - 16
25.	R0217	Manifold Plug
26.	R0284	Intake Manifold
27.	R0236	Discharge Manifold
28.	10681	Clamp, No. 6
29.	4300-05	Hose, 1/2" x 100'
A.	A0323	Squeeze Pump Complete, 8 Rows

LIQUID FERTILIZER TANKS, SADDLES, MOUNTS, HOSES AND FITTINGS

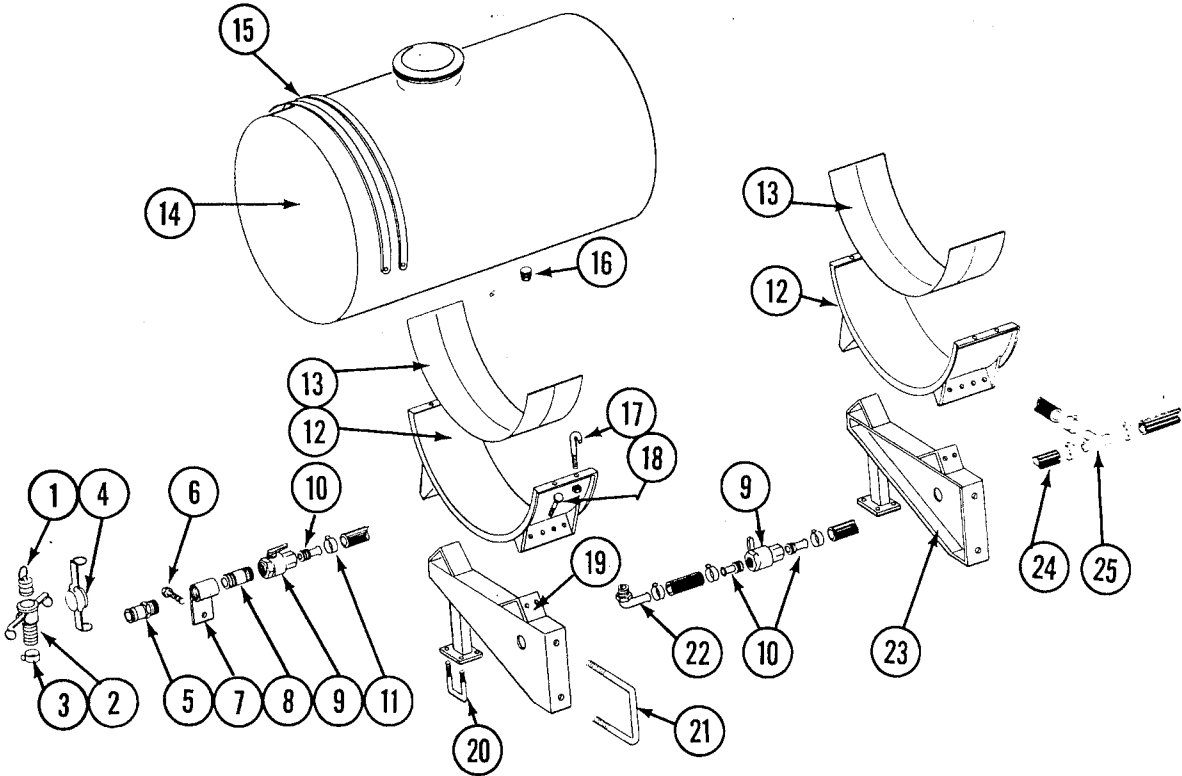

LIQUID FERTILIZER TANKS, SADDLES, MOUNTS, HOSES AND FITTINGS

ITEM	PART NO.	DESCRIPTION
1.	D1517	Dust Plug
2.	D1516	Adapter
3.	10672	Clamp, No. 28
4.	D1515	Dust Cap, 1 1/4"
5.	D1514	Adapter
6.		(See Fertilizer Opener Mounting Bar)
7.	A0918	Quick Fill Mount
8.	10270	Pipe Nipple, Nylon, 1 1/4" x 3"
9.	A0499	Nylon Ball Valve, 1 1/4"
	A4976	Ball Valve, Full Port(Repairable)
	R1015	Body O-Ring (Use With A4976)
	R1016	Stem O-Ring (Use With A4976)
	R1017	Teflon Seat (Use With A4976)
	R1018	Ball (Use With A4976)
	R1019	Handle (Use With A4976)
10.	10745	Adapter, 1 1/4" NPT to 1 1/4" Barb Fitting
11.	10674	Clamp, No. 24
12.	A5264	Saddle
13.	D1862	Pad, 8" x 14'
14.	A5258	Tank W/Lid and Fittings, 30" x 110 Gallon, 4 Row Models
	D1812	Tank W/Lid and Fittings, 30" x 150 Gallon, 6 and 8 Row Models
	R0508	1 1/4" Nylon Fitting
	R0509	Fillwell (Use With R0510)
	R1005	Fillwell, Threaded (Use With R1006)
	R0510	Lid, 10" (Use With R0509)
	R1006	Lid, 10", Thread (Use With R1005)
	R0513	3/8" Nylon Fitting
15.	D1520	Band, 30"
16.	10096	Plug, 3/4" Nylon
17.	D1337	J-Bolt, 5/16"
	10109	Lock Nut, 5/16"-18
18.	10003	HHCS, 3/8"-16 x 1 1/2"
	10210	Washer, 3/8" USS
	10229	Lock Washer, 3/8"
	10101	Hex Nut, 3/8"-16
19.	A5263	Saddle Mount (Shown)
	A5353	Saddle Mount, Special (Frame Mounted Coulters)
20.	D1339	U-Bolt, 1/2"-13 x 2 1/2" x 2 1/2"
	10228	Lock Washer, 1/2"
	10102	Hex Nut, 1/2"-13
21.	D1114	U-Bolt, 5/8"-11 x 7" x 7"
	10230	Lock Washer, 5/8"
	10104	Hex Nut, 5/8"-11
22.	10742	Elbow
23.	A5262	Saddle Mount (Shown)
	A5352	Saddle Mount, Special (Frame Mounted Coulters)
24.	4200-01	Hose, 1 1/4" x 22', 4 Row Models
	4200-02	Hose, 1 1/4" x 27', 6 Row Models
	4200-03	Hose, 1 1/4" x 32', 8 Row Models
25.	10750	Tee, 1 1/4" Nylon

DECALS, REFLECTORS AND TIE STRAPS

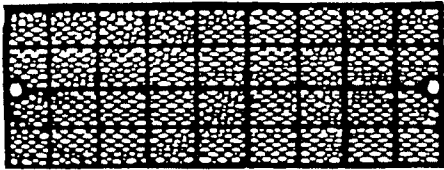
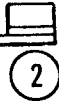

3

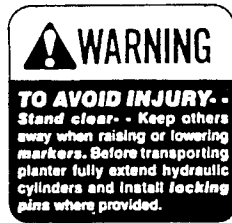

4



5

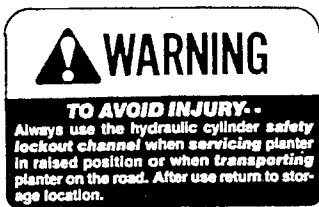

6



7



8



9

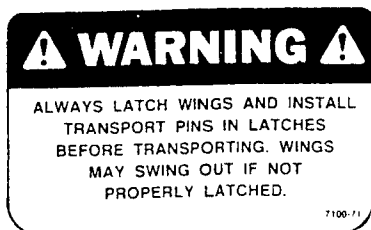

10



11



12

DECALS, REFLECTORS AND TIE STRAPS

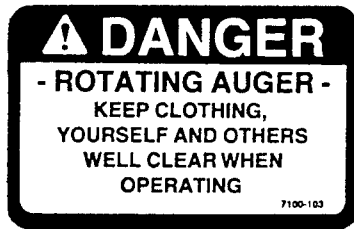

13

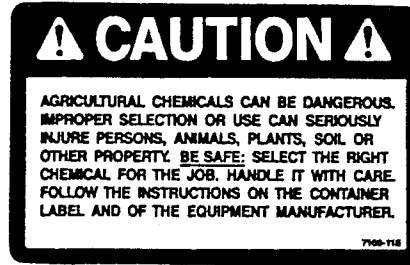

14

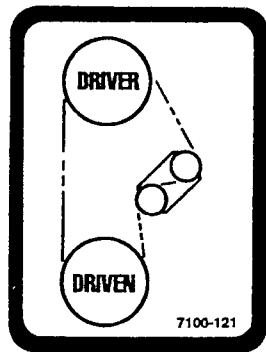

15

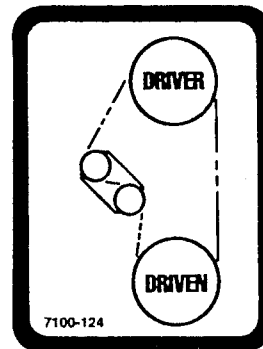

16

ITEM	PART NO.	DESCRIPTION
1.	R0155	Blue Paint, Aerosol (Not Shown)
	R0439	Blue Paint, Quart
	R0440	Blue Paint, Gallon
2.	D1162	Tie Strap, 28"
	D1512	Tie Strap, 6"
	D2117	Tie Strap, 14 1/2"
	D2984	Tie Strap, 33"
3.	7200-03	Reflector, Red
	7200-04	Reflector, Amber
4.	7100-42	Decal, Warning
5.	7100-46	Decal, Caution
6.	7100-47	Decal, Warning
7.	7100-23	Decal, KINZE, 2 1/4" x 10"
	7100-54	Decal, KINZE, 4 3/16" x 17 3/16"
	7100-104	Decal, KINZE, 3" x 12" (Shown)
8.	7100-56	Decal, Warning
9.	7100-60	Decal, Double Frame
10.	7100-71	Decal, Warning
11.	7100-89	Decal, Danger
12.	7100-90	Decal, Warning
13.	7100-103	Decal, Danger
14.	7100-115	Decal, Caution
15.	7100-121	Decal, Transmission
16.	7100-124	Decal, Transmission

WARNING LIGHTS AND SMV

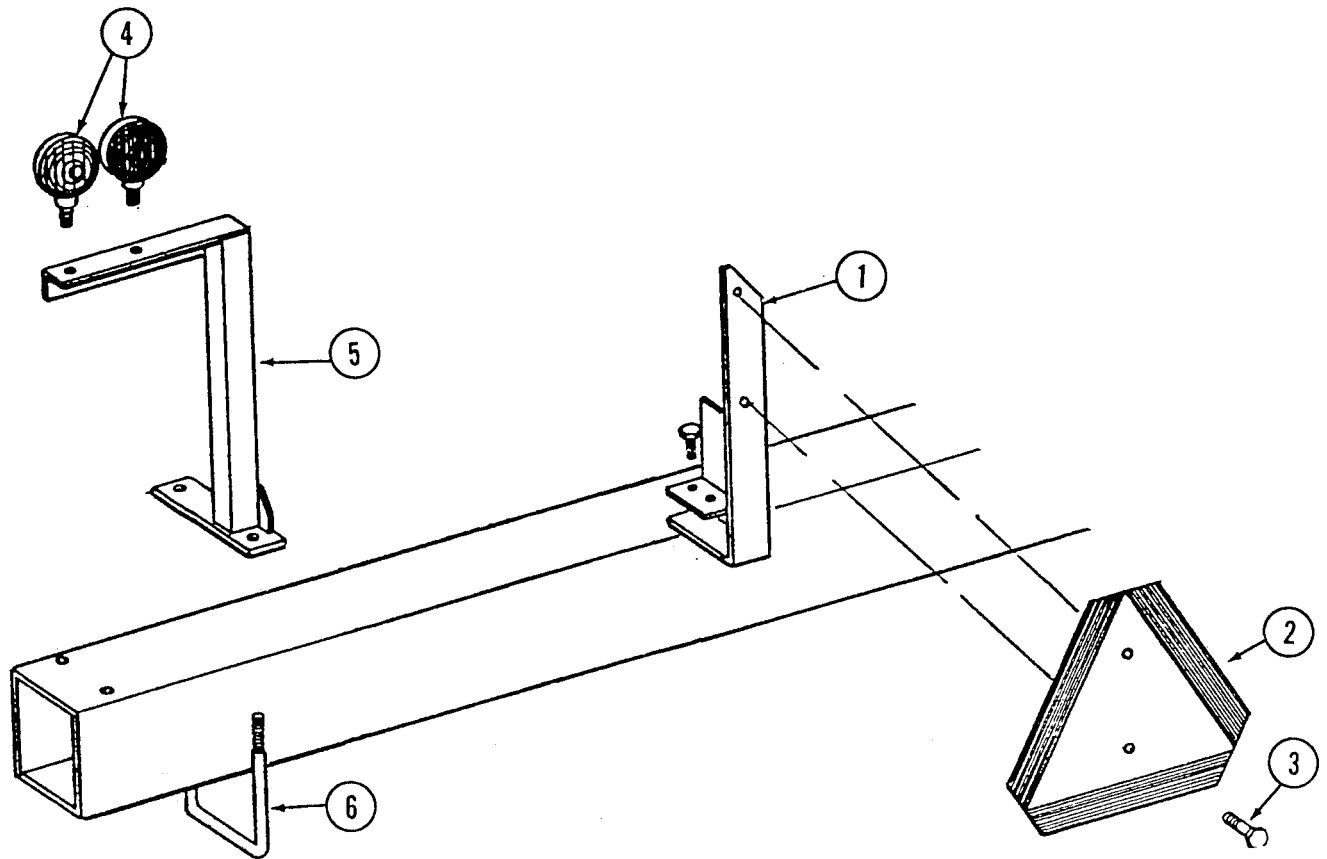

ITEM	PART NO.	DESCRIPTION
1.	D7152	Bracket
2.	D2199	SMV Emblem
3.	10023	HHCS, 1/4"-20 x 3/4"
	10110	Lock Nut, 1/4"-20
4.	A4122	Single Red Light Assembly Complete W/Female Terminal
	A4123	Double Amber Light Assembly Complete W/Male Terminal
	R0968	Bulb, No. 1156
	R0970	Red Lens
	R0969	Amber Lens
	10289	Hex Nut, 1/2"-20
	10266	Female Terminal
	10269	Male Terminal
5.	A4775	Bracket, L.H. (Shown)
	A4776	Bracket, R.H.
6.	D7145	U-Bolt, 7" x 7" x 1/2"-13
	10228	Lock Washer, 1/2"
	10102	Hex Nut, 1/2"-13

NUMERICAL INDEX

PART NO.	PAGE	PART NO.	PAGE	PART NO.	PAGE
1K139	P55	6500-08-06	P35, P37, P44	10043	P17
306-08	P35, P37, P39, P41, P43, P45	6500-08	P39B, P41B, P43	10044	P53
2100-03	P9, P12, P18, P67	6500-10	P65	10045	P55
2403-08	P39B, P41B, P44A	6502-06	P39, P41, P44	10046	P55
2404-06-06	P39, P41	6502-08	P43, P44	10047	P4, P21
2404-08-06	P35, P37, P43	6600-08	P41B, P44A	10049	P5
2404-10-08	P65	6600-10	P65	10051	P9
2500-70	P67	6602-08	P39B, P41B, P44A	10053	P19, P50, P51A
2500-71	P67	6801-06-08	P39, P41	10061	P5
2500-72	P67	6801-08	P35, P37, P41B, P43, P44, P44A	10064	P9, P65
2500-73	P67	6801X	P68	10081	P67
2500-74	P67	7100-23	P75	10087	P7
2500-75	P67	7100-42	P75	10093	P19
2500-76	P67	7100-46	P75	10096	P73
2500-77	P67	7100-47	P75	10100	P67
2500-78	P67	7100-54	P75	10101	P7, P9, P13, P21, P35, P37, P39, P41, P44, P55, P65, P69, P70, P71, P73
2501-08-06	P43	7100-56	P75	10102	P4, P5, P7, P10, P18, P19, P21, P25, P27, P28, P50, P51A, P53, P55, P57, P59, P61, P65, P67, P73, P76
2501-08-08	P39B, P41B, P44A	7100-60	P75	10103	P9, P10B, P65
2501-10-08	P65	7100-71	P75	10104	P3, P5, P7, P12, P49, P51, P51A, P57, P61, P65, P73
2601-06-06	P39, P41	7100-89	P75	10105	P2, P5, P10, P53, P57
2601-08-06	P35, P37, P44	7100-90	P75	10106	P9, P12, P17, P19, P25, P61, P67
2603-08-08-06	P39, P41	7100-103	P75	10107	P2, P9, P19, P51B, P53, P55
2603-08	P35, P37, P41, P43	7100-104	P75	10108	P4, P5, P9
2701-08	P39, P45	7100-115	P75	10109	P10A, P10B, P55, P64, P73
2703-08	P35, P37, P41, P43	7100-121	P75	10110	P76
3302-04	P21	7100-124	P75	10111	P2, P21, P23, P53, P55
3306-03	P50, P51A	7200-03	P75	10112	P5, P53
3310-08	P19	7200-04	P75	10114	P30B, P32
3310-16	P19	10001	P2, P5, P7, P9, P13, P18, P35, P37, P39, P41, P44	10117	P4, P5, P51
3310-26	P47	10002	P53	10118	P4, P5, P51
3310-40	P19	10003	P5, P65, P73	10119	P4
3310-80	P19, P47, P49	10004	P35, P37, P39, P41, P44, P64, P69, P70, P71	10120	P67
3310-89	P19	10005	P9	10128	P18, P19
3310-106	P59	10007	P3	10130	P69, P70, P71
3310-132	P9	10008	P7, P21, P23, P25, P27, P51B	10131	P69, P70, P71
3310-147	P49	10009	P7	10133	P25, P55, P61
3310-155	P67	10010	P51B	10136	P10B
3313-08	P51A	10013	P65	10139	P3, P7, P10
3313-10	P51A	10016	P19, P21, 53	10144	P69, P70, P71
3400-01	P9, P12, P18, P67	10017	P53, P67	10145	P11, P13, P16, P17, P47, P49, P68
4100-02	P2, P4	10019	P55, P61	10152	P51
4200-01	P73	10023	P10B, P65, P76	10157	P2
4200-02	P73	10025	P10	10166	P50, P51A
4200-03	P73	10026	P5, P7, P21, P23, P25, P27	10168	P28
4300-03	P69	10027	P5, P25, P27	10169	P2
4300-04	P70	10030	P53	10171	P61
4300-05	P71	10031	P10A	10177	P2
5404-06-06	P35, P37, P39, P43	10033	P28		
5405-06-06	P41	10035	P18, P57, P59		
6156X	P55	10036	P51B, P53		
6400-06	P32A	10037	P5, P7, P18, P61		
6400-08-06	P35, P37, P44	10038	P21, P65		
6400-08	P35, P37, P39, P41, P43, P45	10039	P18, P21, P59		
6400-10	P65	10041	P10B, P64		
6401-08-06	P35, P37, P39, P41, P43				
6408-10	P35, P37, P39, P41, P43, P45				
6500-06	P39, P41				

NUMERICAL INDEX

PART NO.	PAGE	PART NO.	PAGE	PART NO.	PAGE
10187	P10B, P25	10312	P9, P19	10670	P19, P25, P47, P49, P51, P51A, P59, P61, P67
10190	P2	10313	P10	10672	P61, P73
10201	P61	10325	P35, P37, P39, P41, P44	10673	P69
10203	P7, P10B, P13, P18	10345	P10A	10674	P73
10204	P55	10348	P4	10676	P61
10205	P9	10370	P10B	10681	P55, P69, P70, P71
10206	P61	10402	P5	10722	P28
10210	P5, P9, P18, P21, P35, P37, P39, P41, P44, P55, P73	10403	P65	10724	P28
10213	P55	10404	P3	10725	P28
10215	P395 P37, P39, P41, P44, P45	10408	P59	10742	P73
10216	P4, P10, P18, P19, P53, P55	10409	P18, P47, P48, P59	10745	P73
10217	P12, P51B	10410	P19, P47, P49, P59, P67	10750	P73
10218	P2	10417	P4	A0167	P28
10219	P61, P69, P70, P71	10418	P4	A0243	P28
10226	P21, P23, P27	10421	P67	A0245	P28
10227	P9, P10B, P65	10430	P17	A0257	P28
10228	P4, P5, P7, P10, P18, P19, P21, P25, P27, P28, P50, P51A, P53, P55, P57, P59, P61, P65, P67, P73, P76	10435	P19, P47, P49, P59, P67	A0270A	P33
10229	P7, P9, P10B, P13, P21, P35, P37, P39, P41, P44, P53, P55, P64, P65, P73	10445	P19, P47, P49	A0270B	P33
10230	P3, P5, P7, P12, P19, P21, P23, P25, P27, P49, P51, P51A, P57, P61, P65, P73	10449	P30A	A0270C	P33
10231	P2, P5, P7, P10, P21, P23, P25, P27, P53, P57	10450	P7	A0282	P33
10232	P9, P12, P17, P19, P25, P55, P61, P67	10451	P10B, P50, P55, P61	A0308	P55
10233	P9, P11, P12, P14, P15, P16, P19, P47, P49, P59	10457	P3	A0312	P55
10235	P9	10460	P7, P10, P11, P12, P14, P15, P16, P19, P21, P23, P25, P27, P47, P49, P50, P51, P51A, P59, P68	A0318	P55
10236	P3	10462	P19, P47, P49, P61	A0320	P55
10237	P67	10463	P21, P23	A0321	P69
10239	P3	10464	P17, P61	A0322	P70
10243	P10A	10467	P50, P51A	A0323	P71
10253	P10B	10470	P28	A0328	P55
10257	P10A, P10B	10473	P10A	A0378	P17
10259	P10A	10474	P10A	A0499	P73
10260	P10A	10478	P18, P47, P48	A0533	P10A, P10B
10261	P10A	10496	P10B	A0785	P55
10263	P51	10497	P10B	A0810	P55
10266	P76	10499	P53, P55	A0863	P61
10269	P76	10501	P9	A0864	P61
10270	P73	10503	P55	A0895	P7
10284	P50	10504	P55	A0899	P28
10289	P50, P76	10526	P53	A0918	P73
10303	P12, P61, P67, P69, P70, P71	10561	P51, P51A, P61	A0977	P30B
10305	P55	10600	P67	A1000	P35, P37, P41, P43
10306	P9	10602	P9, P10A, P11, P12, P14, P15, P16, P18, P47, P48, P59, P68	A1001	P45
		10604	P30B, P32	A1006	P43
		10610	P7	A1013	P44
		10640	P19, P25, P47, P49, P59, P69, P70, P71	A1016	P73
		10641	P3, P7, P19, P21, P23, P27, P47, P49, P50, P51, P51A, P53, P61	A1018	P39, P41, P43
		10651	P55	A1019	P39B, P41, P41B, P43, P44A
		10655	P61	A1020	P39, P39B, P41B, P43, P44A, P45
				A1021	P39, P39B, P41B, P43, P44A, P45
				A1028	P43, P44
				A1029	P44
				A1030	P35
				A1039	P43
				A1044	P43
				A1053	P43
				A1054	P37, P43
				A1055	P43

NUMERICAL INDEX

PART NO.	PAGE	PART NO.	PAGE	PART NO.	PAGE
A1076	P37, P39, P41, P43	A2450	P11	A4297	P30A
A1079	P43	A2451	P2	A4298	P30A
A1086	P35	A2452	P2	A4305	P10A
A1089	P37	A2460	P2	A4308	P10A, P10B
A1090	P44	A2474	P23	A4320	P30A
A1092	P39	A2475	P21	A4469	P19
A1096	P35, P39, P43	A2476	P21	A4470	P19
A1098	P41	A2479	P23	A4569	P51A
A1102	P39	A2482	P23	A4570	P51A
A1103	P39	A2483	P21	A4574	P51A
A1105	P41	A2492	P23	A4575	P51A
A1150	P39	A2493	P3	A4765	P10A
A1168	P41	A2498	P23	A4775	P76
A1169	P39, P41	A2558	P7	A4776	P76
A1170	P39	A2698	P3	A4919	P10B
A1171	P39	A2699	P3	A4921	P10B
A1172	P39	A2700	P3	A4924	P10B
A1173	P39B, P41B	A3101	P35	A4925	P10B
A1174	P39B, P41B	A3105	P35	A4964	P51B
A1177	P39B, P41B	A3112	P35, P37	A4965	P51B
A1178	P39B, P41B	A3113	P39, P43	A4966	P51B
A1179	P39B, P41B	A3114	P44	A4976	P73
A1182	P39, P41	A3115	P35, P41, P44	A5089	P9
A1369	P55	A3119	P35, P41, P43	A5090	P9
A1424	P65	A3127	P37	A5091	P29
A1444	P65	A3128	P37, P43	A5092	P29
A1445	P65	A3129	P37	A5093	P30
A1446	P65	A3130	P35, P37	A5094	P30
A1447	P65	A3131	P35	A5095	P31
A1448	P65	A3132	P43, P44	A5096	P32
A1449	P65	A3133	P35	A5097	P31
A1450	P65	A3134	P35	A5103	P18
A1676	P28	A3135	P39, P41, P43	A5105	P9, P19
A1677	P28	A3136	P39, P45	A5106	P18, P19, P47, P49
A1678	P28	A3137	P44	A5107	P18, P47, P49, P59
A1679	P28	A3138	P43	A5108	P18, P47, P49
A1689	P53	A3139	P43	A5109	P18, P47, P49
A1692	P53	A3140	P43	A5110	P18, P47, P49
A1695	P53	A3141	P43	A5111	P18, P47, P49
A1720	P11, P12	A3142	P39B, P41B, P43, P44A, P45	A5112	P18, P47, P49
A1911	P10A, P10B	A3144	P44A	A5113	P18, P47, P49
A1917	P10A, P10B	A3147	P39B, P41B, P44A	A5114	P11, P12, P14, P15, P59
A2022	P10A	A3148	P44A	A5115	P59
A2068	P9	A3149	P39B, P41B, P44A	A5116	P9, P19, P47, P49, P59
A2101	P61	A3150	P39B, P41B, P44A	A5117	P9
A2142	P7	A3156	P41B, P44A	A5118	P9
A2145	P21	A4122	P76	A5119	P9
A2148	P7	A4123	P76	A5121	P7
A2180	P11, P12	A4231	P7	A5122	P7
A2309	P63	A4235	P19, P47, P49	A5123	P7
A2315	P63	A4250	P7	A5124	P7
A2354	P67	A4257	P30A	A5125	P7
A2355	P67	A4258	P30A	A5126	P2
A2356	P53	A4259	P5	A5127	P2
A2373	P11, P12	A4260	P5	A5130	P21, P23, P27
A2374	P11, P12	A4261	P5	A5136	P19, P47, P49, P59, P67
A2445	P12	A4265	P5	A5138	P12
A2446	P12	A4276	P4	A5139	P12
A2447	P12	A4295	P30A		
A2448	P12	A4296	P30A		
A2449	P11				

NUMERICAL INDEX

PART NO.	PAGE	PART NO.	PAGE	PART NO.	PAGE
A5141	P2, P5	A5312	P51, P51A	B0174	P64
A5144	P19, P47, P49	A5313	P50, P51A	B0177	P21, P23, P25, P27
A5146	P18, P47, P48	A5314	P51	B0180	P4
A5148	P10	A5315	P50, P51A	D0438	P25
A5150	P7	A5316	P51, P51A	D0453-02	P21, P25
A5151	P7	A5317	P51	D0453-03	P23, P25, P27
A5152	P7	A5318	P50, P51A	D0453-04	P23, P27
A5157	P9	A5319	P50	D0453-07	P25
A5158	P9	A5326	P32	D0453-08	P27
A5162	P4	A5328	P50	D0462	P25
A5163	P64	A5329	P50	D0487	P55
A5164	P17	A5330	P50	D0652	P21, P23, P27
A5165	P17	A5352	P73	D0740	P2
A5167	P4	A5353	P73	D0746	P28
A5169	P4	A5356	P7	D0830	P53
A5173	P27	A5365	P19, P47, P49, P59, P67	D0840	P28
A5175	P25	A5366	P67	D0844	P7
A5177	P25	A5368	P59	D0914-118	P47, P49
A5178	P25	A5372	P65	D0914-137	P16
A5180	P9	A5373	P65	D0917	P11, P13, P16, P47, P49, P68
A5183	P25	A5374	P65	D0935	P19, P47, P49, P59, P67
A5184	P25	A5379	P65	D0962	P53, P55
A5187	P5	A5380	P65	D0971-47	P57
A5188	P27	A5381	P65	D0971-48	P57
A5190	P27	A5382	P65	D1026	P9
A5192	P27	A5383	P65	D1030	P55
A5194	P19, P59	A5384	P65	D1060	P65
A5195	P59	A5395	P64	D1075	P10B
A5196	P7	A5396	P64	D1105	P53
A5197	P5	A5397	P64	D1106	P53
A5198	P5	A5398	P64	D1113	P5, P49, P51, P51A
A5199	P5	A5399	P64	D1114	P3, P5, P12, P51, P51A, P57, P61, P65, P73
A5200	P5	A5400	P64	D1132	P55
A5201	P5	A5449	P5	D1162	P75
A5202	P19, P47, P49	A5451	P29	D1166	P7
A5221	P7	A5452	P29, P30	D1190-03	P11, P13
A5223	P59	A5453	P31	D1199-05	P13
A5226	P59	A5454	P31	D1199-06	P13
A5229	P59	A5455	P30	D1200	P61
A5230	P57	A5456	P30	D1201	P61
A5231	P57	A5457	P30	D1202	P61
A5236	P57	A5458	P32	D1203	P61
A5237	P57	A5459	P31, P32	D1204	P61
A5238	P61	A5460	P31	D1205	P61
A5249	P29	A5471	P51A	D1206	P61
A5250	P29	A5541	P30B	D1207	P61
A5251	P67	A5552	P32A	D1208	P61
A5258	P73	A5549	P17	D1209	P61
A5262	P73	A5557	P10B	D1210	P61
A5263	P73	A5562	P30B	D1212	P61
A5264	P73	A5563	P30B	D1213	P61
A5265	P5	A5566	P10B	D1215	P67
A5266	P5	A5572	P32A	D1216	P67
A5269	P5	A5600	P17	D1255	P17
A5270	P5	A5624	P19, P47, P49	D1256	P17
A5274	P61	A5628	P19, P47, P49	D1337	P73
A5275	P61	A5629	P19, P47, P49	D1339	P55, P57, P73
A5278	P59, P63	B0123	P9, P51B		
A5279	P63	B0134	P55		
A5285	P53	B0156	P2		
A5311	P50				

NUMERICAL INDEX

PART NO.	PAGE	PART NO.	PAGE	PART NO.	PAGE
D1379	P61	D4167	P7	D5888	P4
D1380	P61	D4632	P31, P32	D5892	P25
D1512	P75	D4667	P61	D5930	P5
D1514	P73	D4887-03	P19	D5946	P29, P30A
D1515	P73	D4887-04	P18	D5947	P29, P30A
D1516	P73	D4896	P29	D5948	P29
D1517	P73	D5212	P11, P12	D5949	P31, P32
D1520	P73	D5215	P19, P47, P49, P59	D5954	P30,
D1524	P65	D5329	P10A	D5956	P30
D1657	P55	D5629	P47	D5958	P15
D1673	P55	D5752	P9	D5959	P16
D1685-12	P57	D5753	P9	D5960	P16
D1685-13	P57	D5756	P9, P18	D5961	P11, P14, P15, P16
D1685-14	P57	D5789	P9	D5970	P59
D1685-15	P57	D5790	P9	D5971	P59
D1685-16	P57	D5797	P9	D5987	P68
D1685-17	P57	D5804	P7	D5988	P68
D1685-18	P57	D5815	P9, P59, P67	D5989	P68
D1719	P16, P47, P49	D5823	P12	D5990	P68
D1747	P57	D5824	P18	D6026	P5
D1748	P2	D5825	P18	D6027	P5
D1797	P55	D5827	P9, P18	D6029	P59
D1812	P73	D5828	P12	D6136	P50, P51A
D1862	P73	D5829	P18	D6165	P68
D2117	P75	D5830	P18	D6177	P7
D2161	P21, P23, P27	D5831	P18	D6178	P14
D2199	P76	D5832	P11	D6182	P67
D2511	P53	D5833	P11, P12	D6201	P65
D2548-45.75	P12	D5835	P19, P47, P49	D6202	P65
D2548-59.75	P12	D5841	P7	D6208	P57
D2548-75.75	P11	D5845	P10	D6242	P30
D2551	P50, P51A	D5846	P10	D6244	P65
D2558	P2, P3, P10, P19, P23, P47, P49, P59, P67	D5847	P10	D6250	P30
D2589	P55	D5850	P10	D6551	P19, P47, P49
D2597	P28	D5853	P10	D6558	P10A
D2648	P7	D5857	P9, P18, P47, P48, P59, P67	D6559	P10A
D2697	P21, P23	D5860	P9	D6562	P10A
D2698	P21	D5861	P35, P37, P39, P41, P43	D6565	P10A
D2721	P21, P23, P25, P27	D5875	P4	D6566	P10A
D2729	P59	D5884-01	P16	D6574	P30B
D2734-01	P19, P47, P49	D5885-01	P16	D6622	P11, P12
D2768	P63	D5885-02	P15	D6793	P19
D2829	P10A, P10B	D5885-03	P15	D6819	P19, P47, P49
D2962	P11, P12	D5885-04	P14	D6869	P51A
D2984	P75	D5886	P14, P15, P16, P47, P49	D6870	P51A
D3214	P21, P23, P27	D5887-75	P14	D6891	P15
D3311	P3	D5887-95	P47, P49	D7127	P19, P47, P49
D3373	P3	D5887-105	P15	D7134	P10A
D3517	P50	D5887-109	P47, P49	D7145	P76
D3518-09	P51, P51A	D5887-128	P15	D7152	P76
D3518-10	P51, P51A	D5887-137	P15	D7157	P10B
D3518-11	P51, P51A	D5887-144	P16, P47, P49	D7305	P10B
D3518-12	P51, P51A	D5887-155	P47, P49	D7306	P10B
D3518-13	P51, P51A	D5887-165	P16	D7314	P10B
D3518-14	P51, P51A	D5887-185	P47, P49	D7316	P10B
D3550	P51, P51A	D5887-204	P16	D7319	P10B
D3790	P61	D5887-215	P47, P49	D7339	P10B
D3839	P68	D5887-225	P16	D7393	P51B
D4108	P51			D7394	P51B
				D7426	P19, P47, P49
				D7623	P10B

NUMERICAL INDEX

PART NO.	PAGE	PART NO.	PAGE	PART NO.	PAGE
D7624	P10B	R0282	P71	R1034	P32A
D7629	P30B	R0283	P71	R1035	P32A
D7630	P35, P37, P39, P41, P44	R0284	P71	R1033	P32A
D7632	P17	R0367	P25	R1036	P32A
D7762	P10B	R0375	P25, P51	R1037	P32A
D7819	P15	R0434	P7	R1038	P32A
D7822	P19, P47, P49	R0439	P75	R1039	P32A
D7872	P10B	R0440	P75	R1040	P32A
D7873	P10B	R0462	P10A	R1041	P32A
R0103	P33	R0465	P10A	R1042	P32A
R0128	P30B, P32	R0466	P10A	R1043	P32A
R0129	P30B, P32	R0468	P10A	R1044	P32A
R0130	P30B, P32	R0469	P10A	R1045	P32A
R0131	P30B, P32	R0470	P10A	R1046	P32A
R0132	P30B, P32, P32A	R0471	P10A	R1047	P32A
R0133	P30B, P32	R0472	P10A	R1048	P32A
R0134	P32A	R0474	P10A		
R0135	P32A	R0475	P10A		
R0150	P28	R0478	P10A		
R0151	P28	R0479	P10A		
R0155	P75	R0508	P73		
R0193	P25, P51	R0509	P73		
R0207	P69, P70, P71	R0510	P73		
R0208	P69, P70	R0513	P73		
R0209	P69	R0518	P30B, P32		
R0210	P69, P70	R0519	P30B		
R0211	P69, P70, P71	R0642	P33		
R0212	P69, P70, P71	R0646	P10A, 10B		
R0213	P69, P70	R0647	P10A		
R0214	P69, P70, P71	R0767	P33		
R0215	P69, P70, P71	R0911	P19, P49, P67		
R0216	P69, P70	R0912	P9, P19, P47, P49, P59		
R0217	P69, P70, P71	R0912	P67		
R0220	P71	R0922	P29		
R0221	P71	R0923	P29, P30		
R0222	P71	R0927	P31, P32		
R0223	P69	R0930	P30		
R0224	P69, P70	R0931	P29		
R0225	P69, P70, P71	R0957	P7		
R0226	P69, P70, P71	R0958	P30		
R0227	P69	R0959	P31, P32		
R0228	P69, P70	R0960	P30		
R0229	P70, P71	R0968	P76		
R0230	P70, P71	R0969	P76		
R0231	P70, P71	R0970	P76		
R0232	P69, P70, P71	R0982	P30A		
R0233	P70	R0983	P30A		
R0236	P71	R0984	P30A		
R0255	P2, P4	R1000	P51A		
R0270	P7	R1005	P73		
R0271	P33	R1006	P73		
R0273	P33	R1015	P73		
R0274	P33	R1016	P73		
R0275	P33	R1017	P73		
R0276	P33	R1018	P73		
R0277	P33	R1019	P73		
R0278	P33	R1022	P51A		
R0279	P71	R1030	P30B		
R0280	P71	R1031	P30B		
R0281	P71	R1032	P32A		