

**PULL TYPE PLANTER (RIGID FRAME)**

**OPERATOR & PARTS  
MANUAL**

**M0106**

**This page left blank intentionally.**

# TO THE OWNER

---

We at Kinze Manufacturing wish to thank you for your patronage and appreciate your confidence in Kinze farm machinery. Your Kinze Planter Bar has been carefully designed and sturdily built to provide years of dependable operation in return for your investment.

This manual has been prepared to aid you in the assembly, operation, and maintenance of the planter bar. Refer to it when necessary to maintain the machine in efficient operating condition.

Throughout this manual the symbol  and the words **Caution** and **Warning** are used to call your attention to important safety information. The definition of each of these terms used, follows:

**NOTE:** Indicates a special point of information.

**CAUTION:** Indicates that a failure to observe can cause damage to the machine or equipment.

 **WARNING:** Indicates that a failure to observe can cause damage to equipment and/or personal injury.

This manual is applicable to:

Rigid Frame Pull Type Planter Bar-Model Number PT

Serial Number 10660 and on

Record the model number and serial number of your planter with date purchased below:

Date Purchased \_\_\_\_\_

Serial Number \_\_\_\_\_

Model Number \_\_\_\_\_

(

.

.

.

(

.

.

.

(

# TABLE OF CONTENTS

---

<b>New Machine Warranty</b> .....	1
<b>Introduction</b> .....	2
General Information .....	2
Serial Number .....	2
<b>Safety Precautions</b> .....	3
<b>Assembly</b> .....	4
Hardware .....	4
Torque Values .....	4
Assembly .....	4
Row Unit Assembly and Installation .....	6
Insecticide and Herbicide Attachment .....	8
Rear Mount Insecticide Spreader .....	10
Marker Assembly Installation .....	11
Conventional Marker Assembly .....	11
Double Folding Low Profile Marker Assembly .....	11
Marker Hydraulics .....	12
Optional Equipment .....	15
Regular Duty Down Pressure Springs .....	15
Heavy Duty Down Pressure Springs .....	15
Coulters .....	16
Dry Fertilizer Attachment .....	17
Liquid Fertilizer Attachment .....	22
<b>Lubrication</b> .....	24
Sealed Bearings .....	24
Corn Meter Lubrication .....	24
Chains .....	24
Wheel Bearings .....	24
<b>Operation</b> .....	26
Initial Preparation of the Planter Bar .....	26
Tractor Preparation and Hook-up .....	26
Leveling the Planter Bar .....	27
Transmission Adjustment .....	27
Tire Pressure .....	27
Hydraulic Marker Operation .....	28
Marker Adjustment .....	28
Tractor Speed .....	29
Planting Depth .....	29
Closing Wheel Pressure .....	29
Plateless Drive Release .....	29
Feed Cup Meters .....	30
Shear Pin Protection .....	30
Down Pressure Spring Adjustment .....	31
Double Disk Opener .....	31
Dry Fertilizer Attachment .....	32
Liquid Fertilizer Attachment .....	33
Planting Rate for Plateless Corn Meter .....	34
Planting Rate for Soybean Meters .....	35
Planting Rate for Plateless Regular Rate .....	36
Sorghum Meters .....	36
Planting Rate for Plateless Low Rate .....	37
Sorghum Meters .....	37
Dry Insecticide Application Rates .....	38
Dry Herbicide Application Rates .....	39
Dry Fertilizer Application Rates .....	40
Liquid Fertilizer Application Rates .....	41
Seed Meter Troubleshooting .....	42
<b>Maintenance</b> .....	45
Mounting Bolts and Hardware .....	45
Chain Tension Adjustment .....	45
Corn Meter Inspection/Cleaning .....	46
Sequencing Valve Inspection .....	47
Flow Control Valve Inspection .....	47
Wheel or Marker Bearing Lubrication or Replacement .....	48
Preparation for Storage .....	48
<b>Parts List</b> .....	51
<b>Numerical Index</b> .....	100

(

(  
:  
:  
:

(

:  
:  
:

(

# NEW MACHINE WARRANTY

---

No warranties express or implied are made or will be deemed to have been made by Kinze of the products sold under this Agreement except as follows:

Kinze warrants to the original purchaser for use that if any part of the product proves to be defective in material or workmanship within one year from date of original purchase, and is reported to Kinze within 10 days after such defect is discovered, Kinze will (at our option) either replace or repair said part. Return of the defective part to Kinze and submission of a completed warranty request must be accomplished within 30 days of the date that the replacement is made available.

This warranty does not apply to damage resulting from misuse, neglect, accident or improper installation or maintenance. A part will not be considered defective if it substantially fulfills performance specifications. Labor, shipping, field service, travel or administrative expenses incurred in connection with warranty replacements are not covered. Tires are not warranted by Kinze

Manufacturing, Inc. and such claims must be pursued through the tire manufacturer's warranty.

Kinze warrants all replacement parts for a period of 90 days from date of purchase by the customer. Parts warranty is subject to the same provisions, restrictions and exclusions as new machine warranty and carries the same return and reporting requirements.

The foregoing warranty is exclusive and in lieu of all other warranties or merchantability, fitness for purpose and of any other type, whether express or implied. Kinze neither assumes nor authorizes anyone to assume for it any other obligation or liability other than stated above, and will not be liable for consequential damages. Purchaser accepts these terms and warranty limitations unless the product is returned within the fifteen days for full refund of purchase price.

Kinze reserves the right to make changes or to add improvements at any time without notice or obligations.

**ATTENTION: Effective 12/1/87  
amendments were made to the  
KINZE New Machine Warranty.  
Refer to insert W12187.**

# INTRODUCTION

## General Information

The information and photos used in this manual were current at the time of printing. However, due to Kinze's continual attempt to improve its product, possible in-line production changes may cause your machine to appear slightly different in detail. Kinze Manufacturing reserves the right to change specifications or design without notice and without incurring obligation to install the same on machines previously manufactured.

Right hand or left hand as used throughout this manual is determined by facing in the direction the machine will travel when in use.

## Serial Number

The serial number provides important information about your planter bar and may be required to obtain the correct replacement part.

The serial number plate is located on the planter bar frame to be readily available. It is suggested that the serial number and purchased date also be recorded in the space provided on the inside front cover of this manual. Always provide the serial number and model number to your Kinze dealer when ordering parts or anytime correspondence is made with Kinze Manufacturing.

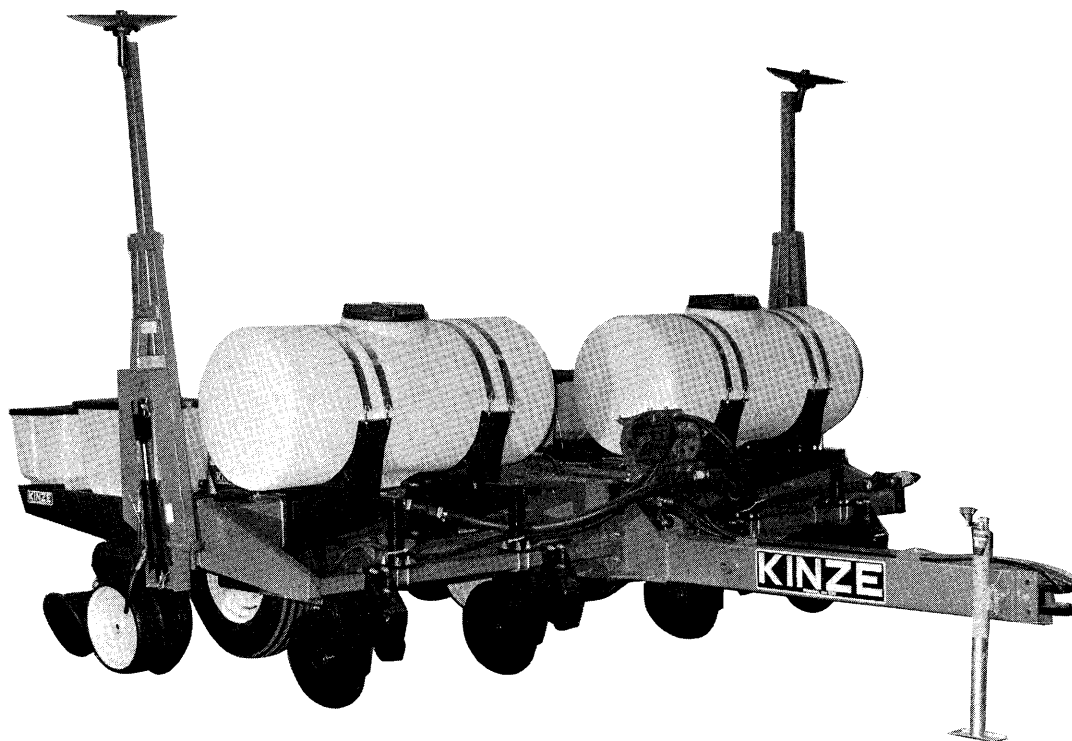

Available Models	Bar Length	Marker Assembly	Options Available
4 Row-30"	128"	Conventional	Fluted or Ripple Coulters Dry and Liquid Fertilizer Attachments Down Pressure Springs
4 Row-Wide	136"	Conventional	
6 Row-30"	169"	Conventional	
6 Row-Wide	214"	Low Profile-Double Folding	
8 Row-30"	229"	Low Profile-Double Folding	



# SAFETY PRECAUTIONS

---

Safe and careful operation of the tractor and planter bar at all times will contribute significantly to the prevention of accidents.

Since a large portion of farm accidents occur as a result of fatigue or carelessness, safety practices should be of utmost concern. Read and understand the instructions provided in this manual as well as those provided in your row unit operator's manual. Listed below are a few other safety suggestions that should become common practice.

Never permit any persons other than the operator to ride on the tractor.

Never ride on the planter bar frame or allow others to do so.

Limit towing speeds to 15 MPH.

Always make sure there are no persons near the planter bar when gauge marker assemblies are in operation.

Always lower the planter bar when not in use and cycle the hydraulic control lever to relieve pressure in cylinders and hoses.

Always make necessary safety preparations prior to transporting the machine on public roads. This includes installing Slow Moving Vehicle (SMV) emblem and use of adequate lights or safety warnings after dark.

Watch for obstructions such as wires, tree limbs, etc., when folding marker assemblies.

Always install marker lock up/safety pins before transporting or parking any planter bar equipped with conventional marker assemblies.

Always install lift cylinder lock up bracket before towing planter bar or working under the unit.



**Marker Assembly**

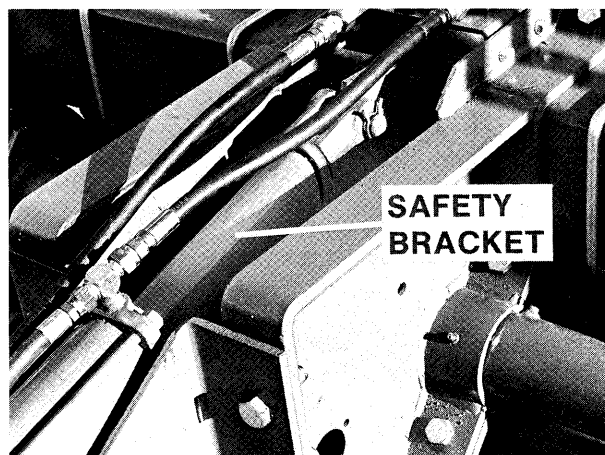

**Pull Type Planter Lift Cylinder**

# ASSEMBLY

The following instructions are provided for assembly of the Kinze pull type planter bar. Please read through the instructions prior to assembly. Become familiar with the procedures before actual set up will facilitate smoother assembly and possibly save time by eliminating backtracking. Although there may be procedures for assembly other than those shown, caution should be taken to avoid unnecessary risk to compensate for the extra time it takes to safely perform each step.



Prior to starting, inspect all components for possible damage incurred during shipment. Notify the freight or carrier agent immediately of any damage found. Any parts shortages should be noted and reported to Kinze Manufacturing, Inc. immediately.

Since the assembly instructions which follow are written for several sizes and configurations of units, they are divided into major components which are interchangeable. The interchangeability designed into each Kinze planter bar simplifies assembly as well as operation, service, and parts availability for any size and model unit.

## Hardware

All bolts furnished with the planter bar, unless otherwise noted, are SAE Grade 5. These high strength bolts are distinguished by these radial lines on the head. If bolts must be replaced, be sure to replace them with bolts of equal size and strength.

In many cases bolts have been pre-installed in the holes in which they go during assembly. It is suggested that bolts be left somewhat loose until parts have been assembled. This especially applies to bearing flanges, idler sprockets, etc. Then tighten all bolts to the torque value specified below unless otherwise noted.

TORQUE VALUES		
Bolt Diameter	Grade 5 Three Radial Dashes 	Grade 8 Six Radial Dashes 
	Foot-Pounds	Foot-Pounds
3/8"	30	— —
1/2"	75	— —
5/8"	150	— —
3/4"	270	— —
1"	— —	910

## Frame Assembly

1. Place the pre-assembled planter bar frame in an area which provides sufficient space for complete assembly. Keep in mind the access necessary in both height and width to remove the completed machine.
2. Unband the shipping bundle and inspect for damage. Remove markers, hitch and hydraulic package.
3. While supporting the frame with an overhead hoist or front end loader, remove the bolts which fasten the frame to the skid. Carefully lower the planter frame to a level position.

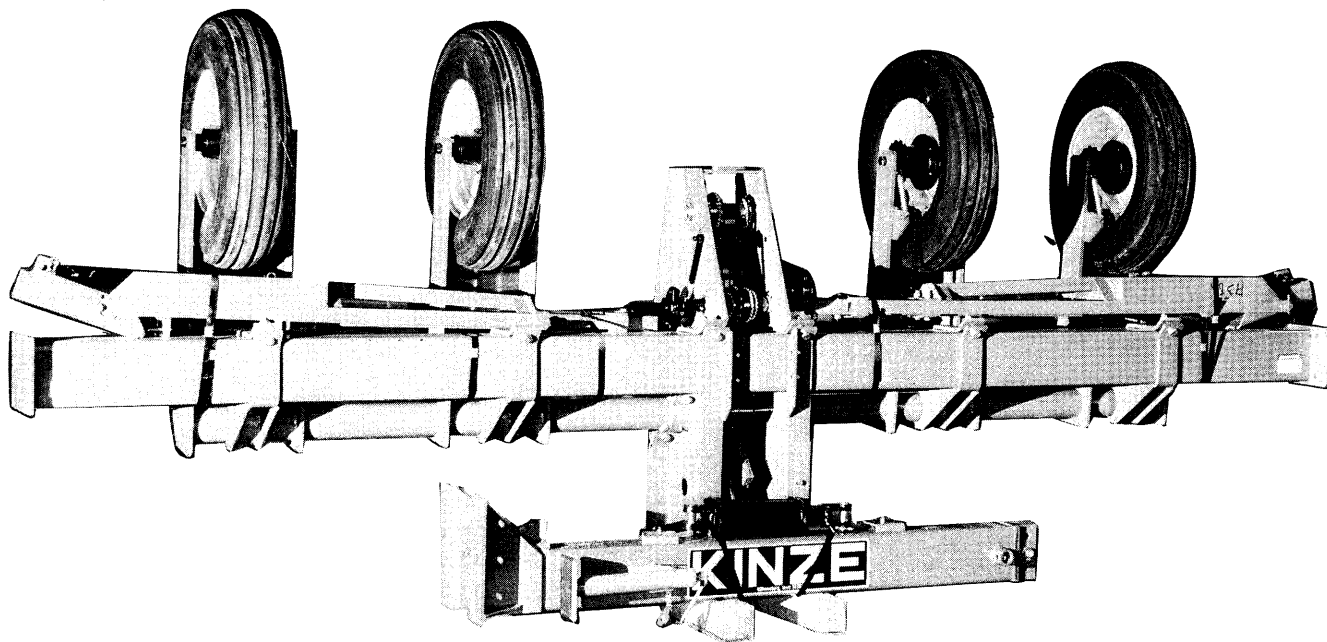

# ASSEMBLY

4. Bolt hitch assembly to planter frame with six  $\frac{3}{4}$ " x  $2\frac{1}{2}$ " cap screws, lock washers and hex nuts. Tighten mounting bolts securely.
5. Install jack stand on tongue assembly to support planter frame during final assembly.
6. Install two  $\frac{1}{2}$ " NPT x  $\frac{3}{4}$ "-16JIC elbow fittings in  $3\frac{1}{2}$ " x 8" hydraulic lift cylinder so that fittings are pointed toward the cylinder base.

**NOTE: If the planter bar is being plumbed for a single valve system, install two  $\frac{1}{2}$ " NPT x  $\frac{3}{4}$ "-16JIC tee fittings in cylinder ports instead of elbow fittings.**

7. Install cylinder as shown with shaft end pointing toward rear of planter bar. Secure in place with clevis pins and lock clips. The shorter of the two clevis pins is installed on the shaft end of the cylinder.
8. Attach  $\frac{3}{8}$ " hydraulic hoses to lift cylinder. The 117" hose connects to rear (shaft end) fitting and 105" hose connects to front (base end) fitting.

**NOTE: The 8 Row 30" model uses two lift cylinders connected by four  $\frac{3}{8}$ " x 60" hydraulic and two  $\frac{3}{4}$ "x16-JIC tube tees. For assembly of the lift and marker hydraulic system on these models, refer to the illustrations in the marker hydraulic section .**

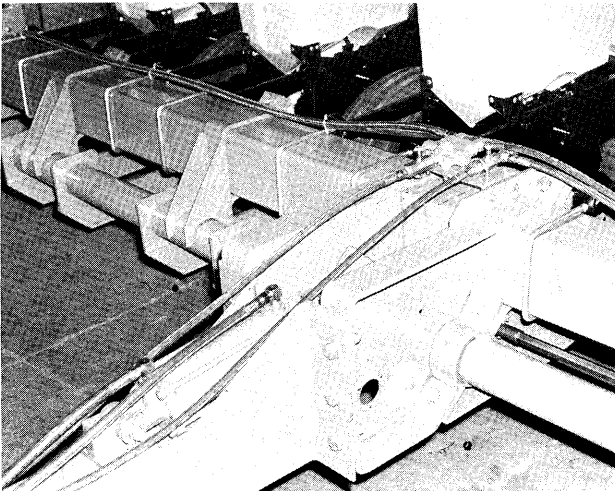
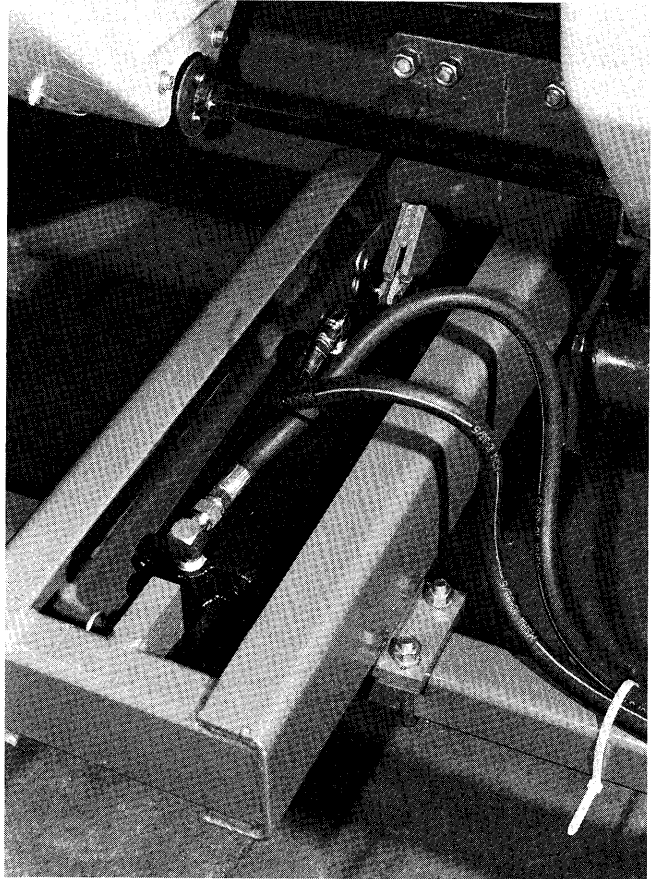

9. Install customer supplied coupler on tractor end of each hose. The couplers installed must be the SAE type to match the tractor being used.

# ASSEMBLY

## Row Unit Assembly and Installation

The frame on all of the Kinze planter bars is constructed of 7"x7" square tubing to accept most popular types of row units.

**NOTE: If planter units other than Kinze Precision Placement Units are being installed, it is suggested that the manual for the particular brand and model be consulted.**

1. Measure the full length of the planter bar and locate center.
2. Mark center of each row by measuring to each side of bar center. The two middle units will be located half the row width from the center. For example, when units are being installed for 30" rows, measure 15" to each side from the center of the bar and every 30" thereafter to the ends of the bar.
3. Mark a squared vertical line 4½" to each side of the row center. This will allow correct positioning and vertical alignment of each row unit as it is being installed.
4. Remove 5/8" x 1¾" hex head cap screw, with bushing and lock nut from shipping position on each support bracket.

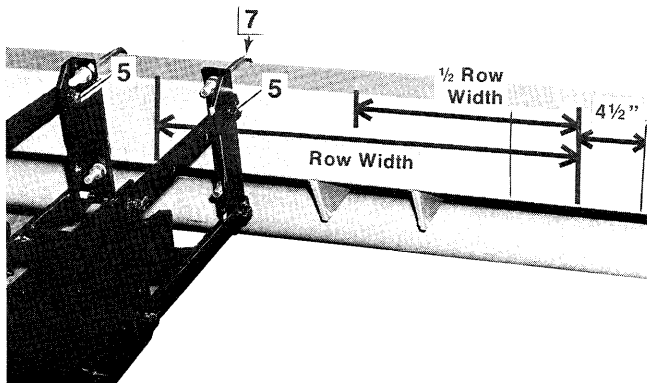

5. Swing right and left upper parallel arms to a position parallel with lower arms and attach to support brackets with bolts and bushings provided.
6. Position row unit on planter bar, aligning inside edge of support brackets with marks made earlier.
7. Attach row units using 5/8" U-bolts, lock washers, and hex nuts.

**IMPORTANT: If heavy duty down pressure springs are to be installed, the front support plate must be installed on the U-bolts directly behind the row unit support angles prior to installing lock washers and nuts.**

8. Remove plateless drive clutch and drive bearing and sprocket assembly from shipping position on rear of row unit. Both parts are wired to the row unit frame.

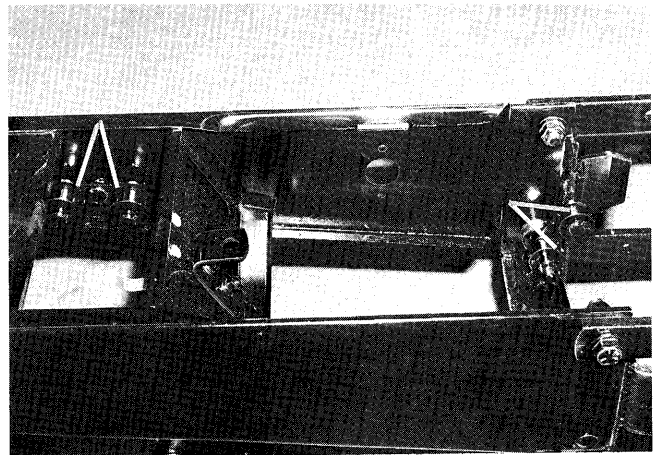

9. Attach drive bearing and sprocket to inside of left support bracket with 3/8" x 1" cap screws provided. Do not tighten at this time.
10. Turn all chain idler spools to break loose any paint that may restrict movement.
11. Remove bolts which extend into bearing support on plateless drive and reuse to attach drive to left side panel of hopper support.

# ASSEMBLY

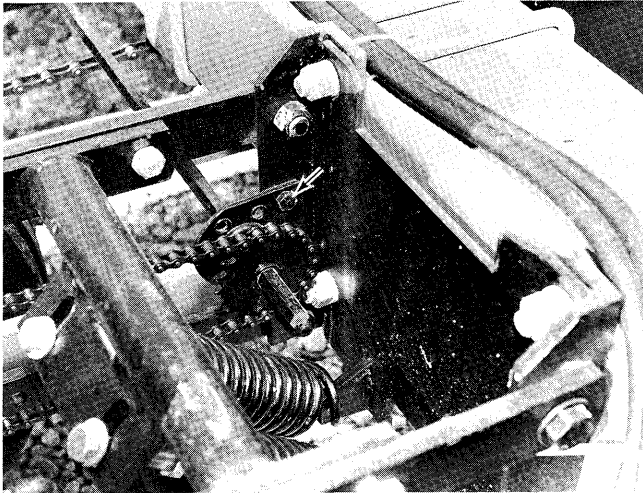

12. Slide drill shafts (hole end first) through the drive bearing/sprocket assemblies on each side of the transmission beginning with the outside row unit on each side.

9/16" Hex Drill Shaft		
Planter Size	PULL TYPE	
	Left	Right
4-30"	47"	37"
4-Wide	60"	48"
6-30"	77"	67"
6-Wide	98"	86"
8-30"	107"	98"

13. Remove cotter pin from drill shaft driver and remove driver from transmission coupler. Install driver onto end of drill shaft and slide driver and drill shaft into coupler. Align the hole in all three components and install 3/16" x 2" cotter pin.

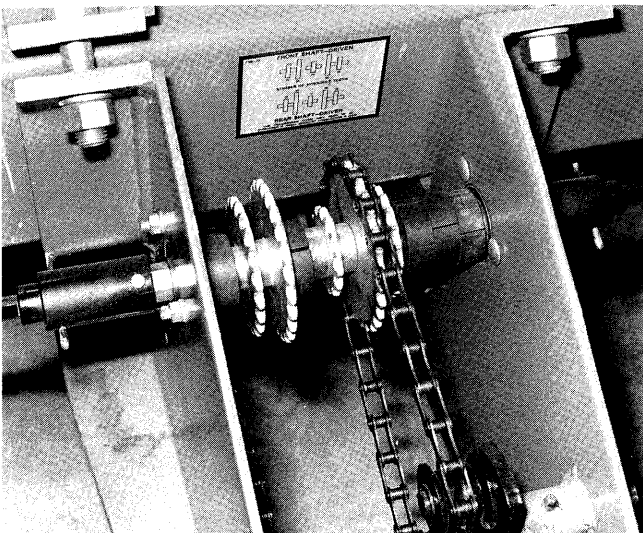

14. Tighten the attachment bolts on all bearing/sprocket assemblies after making sure they are in alignment.

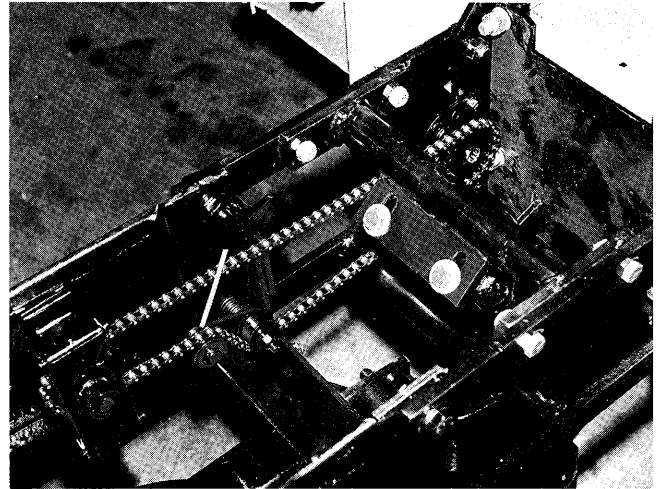

15. Install drive chains around row unit drive sprocket and plateless drive sprocket; then join with connecting link. Position drive chain over and under chain idlers as shown.

16. Route insecticide hopper drive chain around planter drive sprocket and connect with link.

17. Remove hold down latch clip from shipping position on inside of seed hopper and reattach to outside of hopper with 3/8" x 3/4" socket head cap screw, flat washer, lock washer, hex nut...and 1/4" x 3/4" carriage bolt, rubber washer, flat washer and self-locking flange nut.

18. Install seed tube in shank as shown. Position hook on the front of the tube over alignment pin in shank. Then pivot top of tube forward and secure with retainer pin and locking clip. Once the tube has been secured in position, tighten 3/8" nut on bolt at front of shank cover.

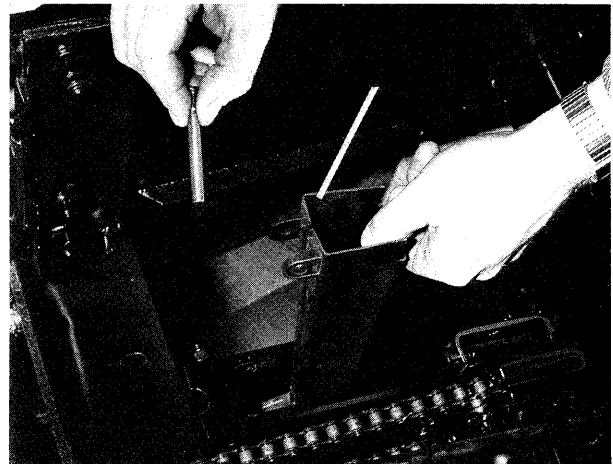

# ASSEMBLY

---

If electronic seed monitor tubes are being installed, refer to the accompanying instructions.

19. Install seed metering unit on hopper bottom with two 5/16" hex flange nuts.
20. Install seed hopper and latch in position. Adjust latch up or down as necessary for a secure fit.
21. Install red reflector on rear corner of hopper support on outside row unit of each side.

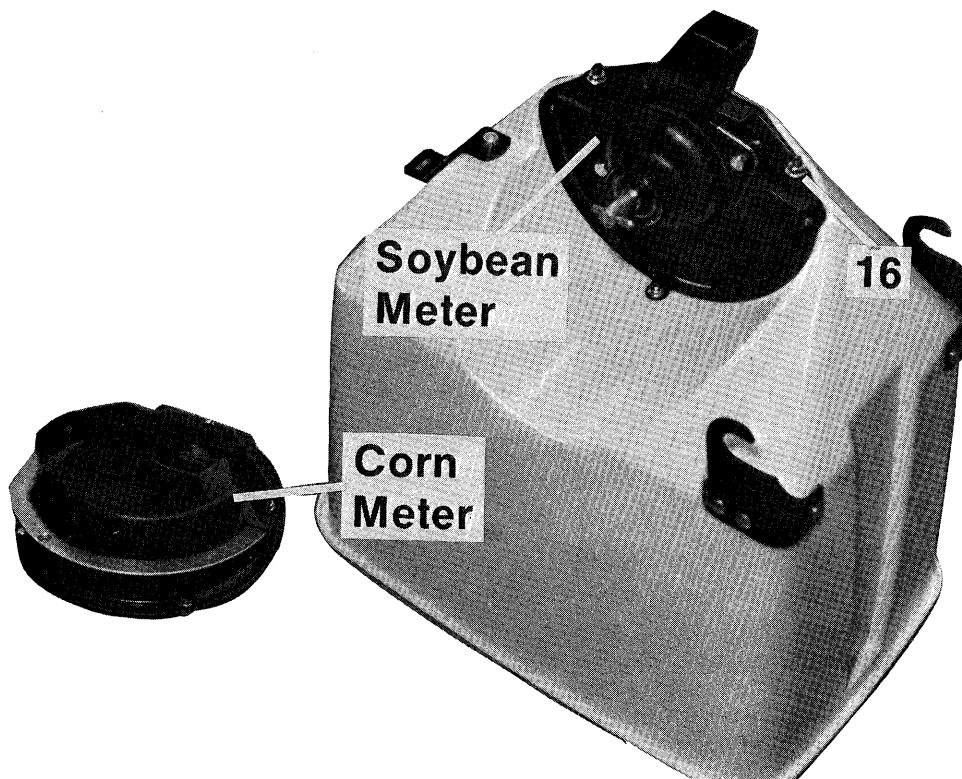

# ASSEMBLY

## INSECTICIDE AND HERBICIDE ATTACHMENT

1. Attach insecticide and/or herbicide funnel to hopper support with two No. 10x $\frac{1}{2}$ " self tapping screws. Install insecticide funnel facing forward and herbicide funnel facing rearward.
2. Attach plastic hose(s) to funnel(s) with spring clamp. Hose may be cut if necessary to eliminate bends and provide straight line granule delivery.

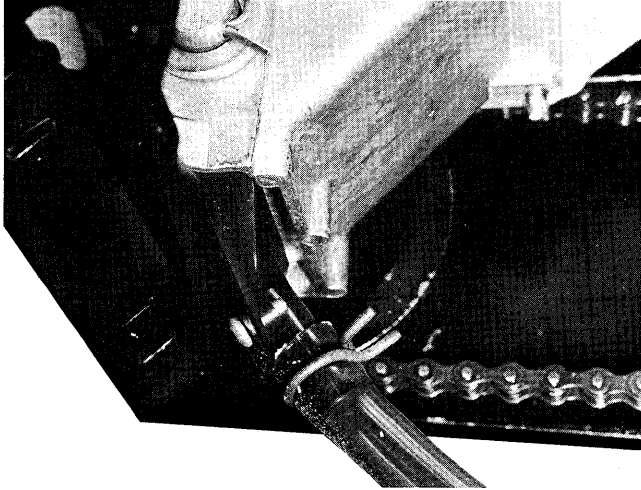

3. Insert adapter tube into insecticide bander and secure bander to shank as illustrated with spring locking clip.
4. Insert insecticide hose into tube and bander assembly. Shorten hose if necessary to eliminate all bends.

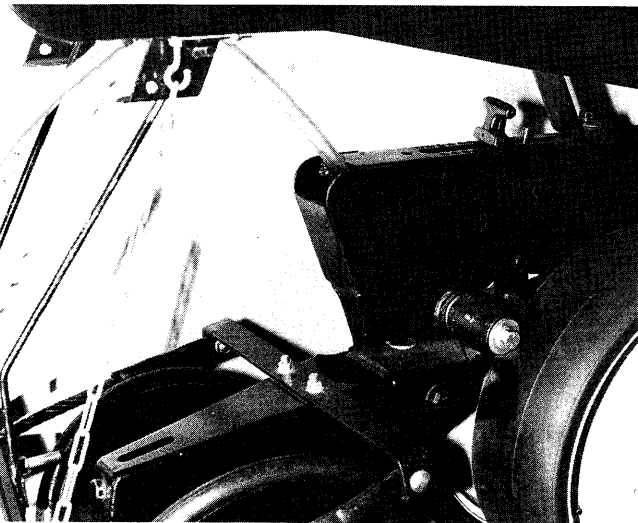

5. Attach herbicide bander hanger brackets to hopper support with four  $\frac{1}{4}$ "x $\frac{3}{4}$ " carriage bolts, lock washers and hex nuts.

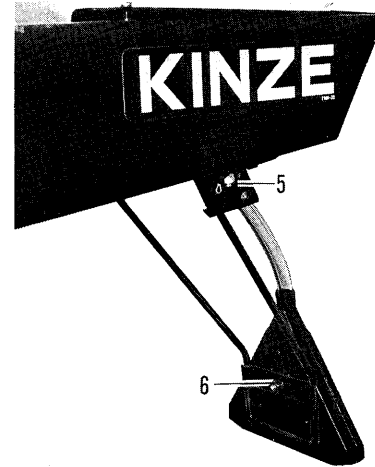

6. Install herbicide bander hanger in brackets and secure in place with cotter pins. Attach bander to hanger with strap,  $\frac{3}{8}$ "x2" carriage bolt, lock washer and hex nut. The bander may be adjusted for height on the hanger.

The insecticide/herbicide hopper is shipped for use as a single granular spreader. If the hopper is to be used with both insecticide and herbicide a second granular spreader and a hopper divider must be installed as follows:

7. Remove  $\frac{1}{4}$ " cap screws, flange nuts and cover plate from inside of hopper.

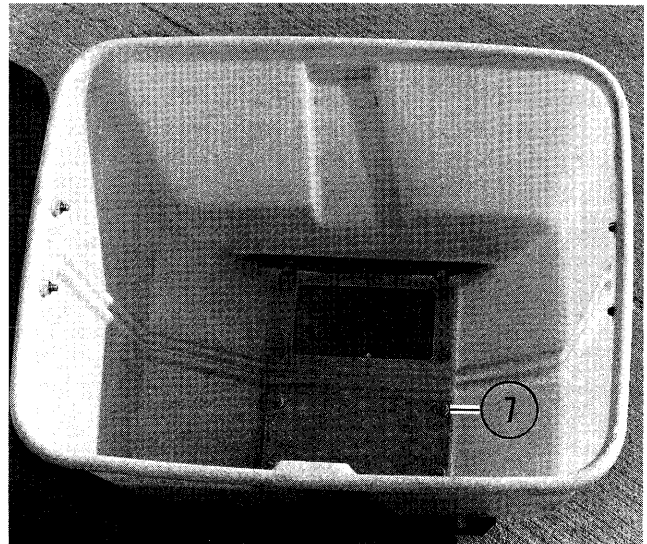

8. Remove cotter pin and washer(s) from roller shaft on existing granular housing.
9. Attach drive coupler to both granular housings with  $\frac{5}{32}$ "x  $1\frac{1}{2}$ " cotter pins.

# ASSEMBLY

10. Attach second granular housing to hopper with four  $\frac{1}{4}$ "x $\frac{3}{4}$ " self tapping screws. Do not install the two inboard screws at this time.
11. Remove right plug from front of hopper and remove  $\frac{1}{4}$ " nut and washer from right hinge screws.
12. Install hopper divider. Secure divider to front of hopper with  $\frac{1}{2}$ "x $\frac{3}{4}$ " cap screw, washer and nut. Rear of hopper is secured with existing hinge screw and hardware. Seal divider with silicone.

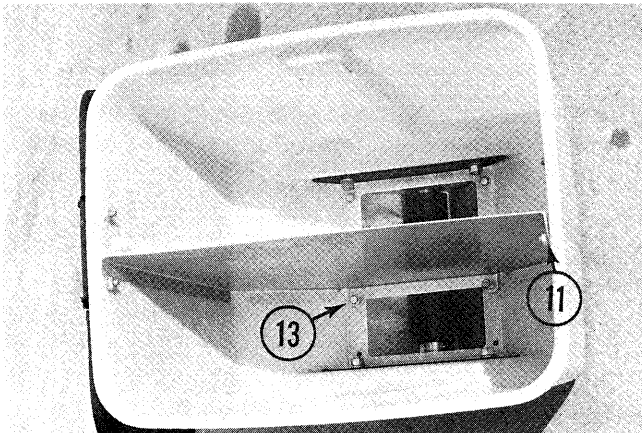

13. Install two remaining housing attachment screws through divider tabs and granular housing. Be certain roller shafts are in alignment and turn freely before tightening screws.
14. Route insecticide and/or herbicide drive chain around 11 tooth part of double sprocket seed hopper drive. Run both upper and lower halves of chain through slot in hopper support and around idlers as shown.

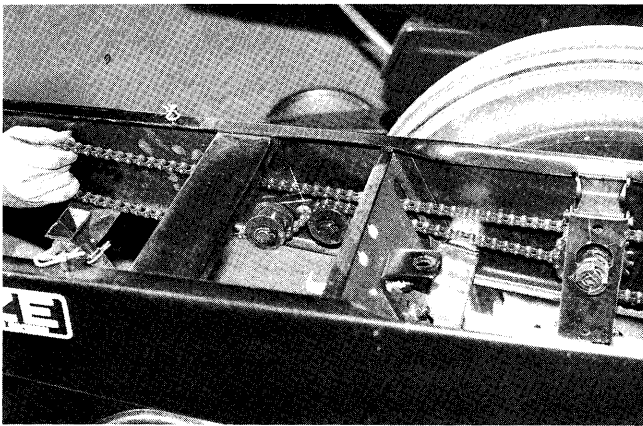

15. Position hopper on rear of support panel and install drive chain around sprocket. Then lower hopper until side brackets seat on support pins. Secure in place with spring locking pins.

16. If necessary, reposition spouts so they are directly beneath and snub against the granular housing openings.

## Rear Mount Insecticide Spreader

To attach the insecticide spreader to an existing herbicide diffuser, proceed as follows:

1. Attach welded bracket to herbicide diffuser with  $\frac{3}{8}$ "x $2\frac{1}{2}$ " carriage bolt provided.
2. Attach insecticide spreader to welded bracket as shown.

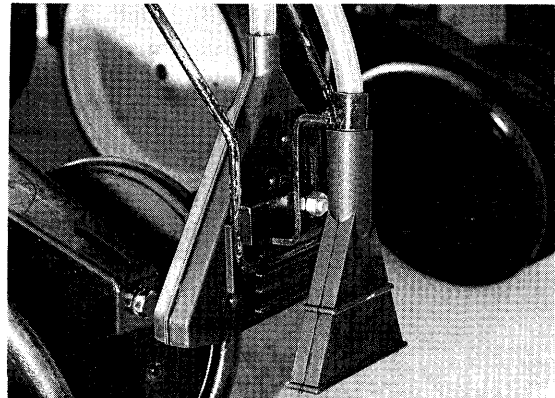

3. Removing tapping screw from hopper funnel and turn funnel 180 degrees so that insecticide exits out the rear of the planter unit.
4. Insert hose into welded bracket. Then attach other end of hose to funnel with hose clamp.

The insecticide spreader may also be rear mounted on units not equipped with the herbicide diffuser. Simply install the diffuser hanger as instructed for the herbicide package and attach welded bracket to hanger with clamp and  $\frac{3}{8}$ " x  $1\frac{1}{2}$ " carriage bolt provided. Make sure funnel projects to the rear of the row unit.

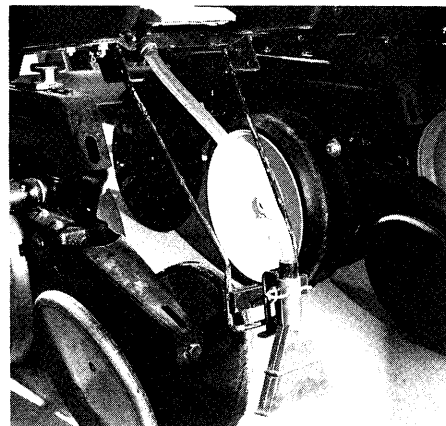



# ASSEMBLY

## MARKER ASSEMBLY INSTALLATION

Depending upon the size of the planter bar, the marker assemblies will be either a conventional or double folding low profile design. Refer to model configurations following "Introduction" for the type of marker used on each model.

### Conventional Marker Assembly

1. The conventional marker assemblies are pre-assembled with the exception of installing the marker disk and hydraulic components. The hub on each marker assembly is designed for either right or left hand installation. Make sure the marker is mounted on the correct side that the spindle and blade project forward. Attach bracket to mounting pad on end of planter bar with four  $\frac{1}{2}$ "x $1\frac{3}{4}$ " cap screws, lock washers and hex nuts.

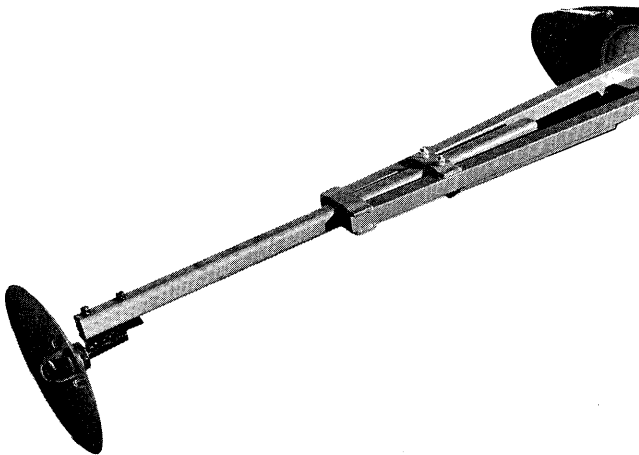

2. Using the bolts pre-installed in the hub, attach the 16" disk to throw dirt out away from the hub and grease seals. Be sure to alternate bolts while tightening to avoid distorting the disk's shape or breaking the marker hub. The spindle bracket has slotted mounting holes which allow the angle of the blade to be increased or decreased.
3. Final position of the extension must be set by the operator and is discussed in the operation section of this manual.
4. Refer to the "Marker Hydraulics section which follows for connection of the marker cylinders, hoses and additional hydraulic components.

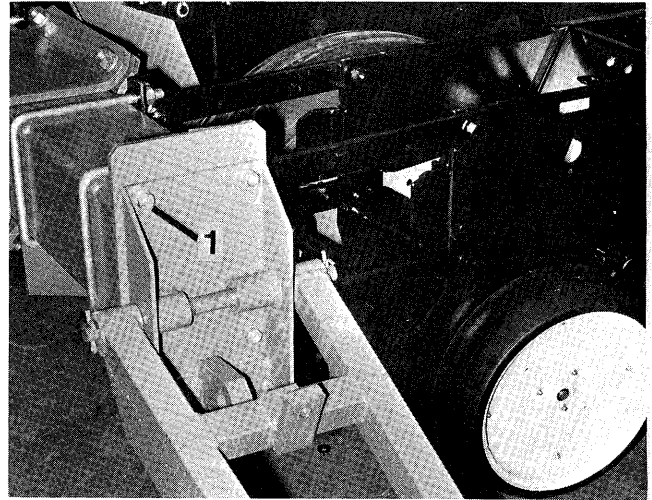

### Double Folding -Low Profile Marker Assembly

1. Install mounting bracket/first stage to mounting pad on end of planter bar with four  $\frac{1}{2}$ "x $1\frac{3}{4}$ " cap screws, lock washers and hex nuts. This assembly is interchangeable between the right and left sides.

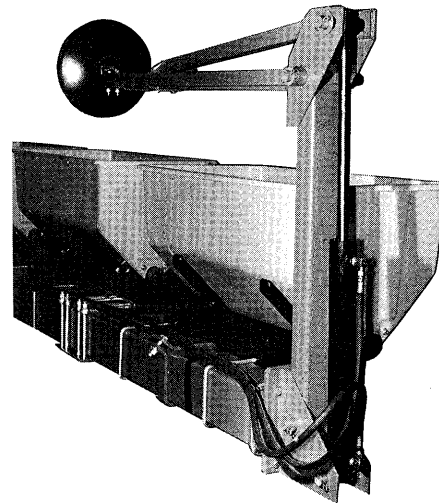

2. Attach pre-assembled second stage of marker with extension and hub to first stage with pivot pin and cotter pins.

**IMPORTANT:** The hub on each second stage is designed for either right or left hand installation. Make sure this stage is mounted on the correct side so that the spindle and blade project forward. The spindle bracket has slotted mounting holes which allow the angle of the blade to be increased or decreased.

# ASSEMBLY

- Using the bolts pre-installed in the hub, attach the 16" disk to throw dirt out away from the hub and grease seals. Be sure to alternate bolts while tightening to avoid distorting the disk's shape or breaking the marker hub.
- Final position of the extension must be set by the operator and is discussed in the operation section of this manual.

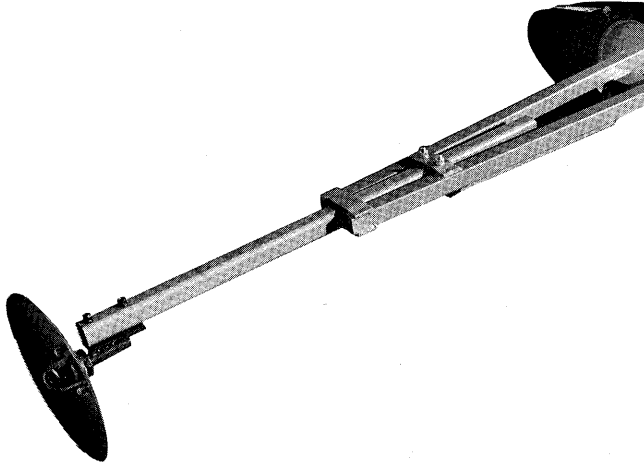

- Refer to the "Marker Hydraulics" section which follows for connector of the marker cylinders, hoses and additional hydraulic components.
- Install amber reflector to front lower portion of marker arm on each side.

## Marker Hydraulics

All pull type planter bar models may be equipped with a dual valve or single valve hydraulic package. The dual valve system requires a separate pair of tractor outlets for each marker. The optional single valve system utilizes a sequencing valve that allows both markers to be alternately operated from the same pair of outlets and by a single control lever.

Proceed with installation of the marker cylinder and hydraulic hoses and fittings using the illustrations and instructions which apply.

**WARNING: Always leave the marker assembly laying horizontally or secured with safety pin when installing hydraulics. Never rely on the hydraulic cylinder to hold the marker in the raised or folded position while working on or around planter.**

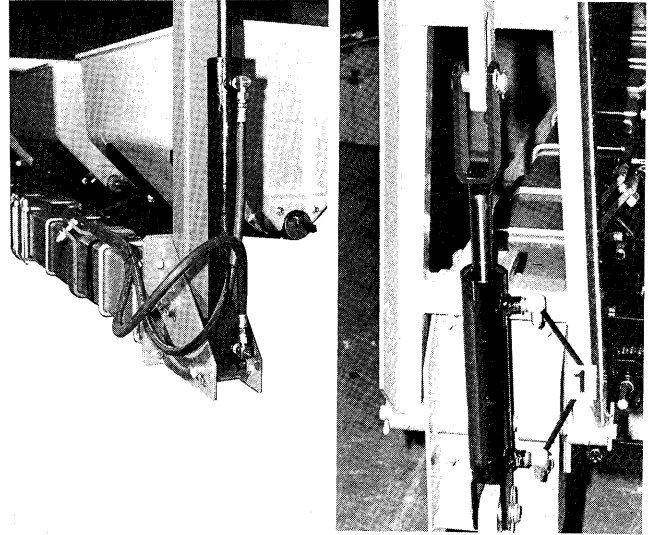

- Install 90° 3/8" male pipe x 9/16"-18JIC elbow in each port of 2" x 8" conventional hydraulic cylinder...or 90° 1/2" NPT x 3/4"-16JIC elbow in each port of 2 1/2" x 20" low profile hydraulic cylinder.
- Attach base end of cylinder to marker mounting bracket. Then turn elbow fittings, if necessary, to project rearward and down.
- Attach hoses to each elbow, routing them around the back of the marker and along the frame bar. When securing hoses to the frame, allow for flexing of marker arm.
- Attach sequencing valve and flow control valve mounting bracket to planter bar frame with four 5/16" x 1" cap screws, lock washers and hex nuts.
- Assemble all valves, fittings and hoses as shown for your particular unit. Due to the variations between single and dual valve systems, refer to the appropriate illustration for correct assembly of all hydraulic hardware.
- Secure all hoses to planter bar frame with nylon tie straps. Route hoses to tractor under clamps on planter tongue and tighten clamp bolts.

**WARNING: Always stand clear of marker assembly and blade when in operation.**

# ASSEMBLY

Before operating the marker assemblies, first connect all hydraulic hoses and cycle the cylinder several times with the ram end disconnected to purge air from the system. After the cylinders are operating smoothly, attach the ram end clevis to the marker arm.

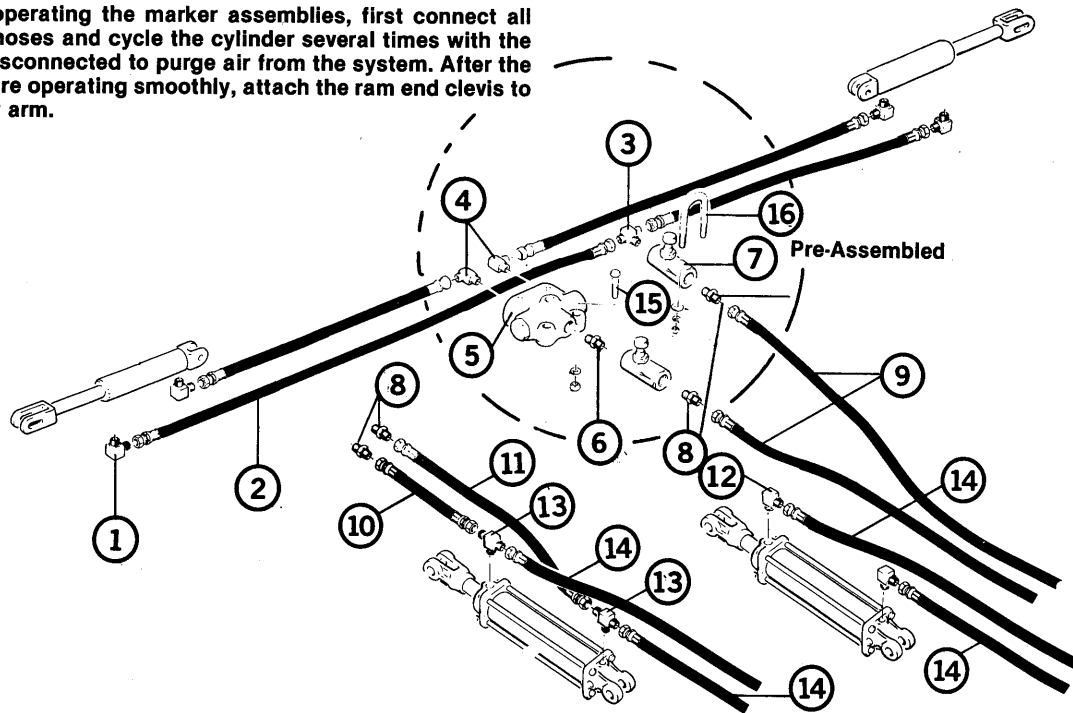

## Legend

1. 3/8" NPT x 9/16"-18 JIC Elbow (Used with Conventional Markers\*)  
1/2" NPT x 3/4"-16JIC Elbow (Used with Low Profile Marker\*\*)
2. 1/4" Hydraulic Hose W/9/16"-18JIC Swivel Both Ends (Used With Conventional Markers\*)  
4 Row 30" - 95" 6 Row 30" - 110"  
4 Row Wide - 95"  
3/8" Hydraulic Hose W/3/4"-16JIC Swivel Both Ends (Used with Low Profile Markers\*\*)   
6 Row Wide - 130" 8 Row 30" - 140"
3. 3/8" NPT x 9/16"-18JIC Male Tee (Conventional Marker\*)  
3/8" NPT x 3/4"-16JIC Male Tee (Low Profile Marker\*\*)
4. 90° 9/16"-18JIC x 3/4"-16 O-Ring Elbow (Conventional Marker\*)  
90° 3/4"-16JIC x 3/4"-16 O-Ring Elbow (Low Profile Marker\*\*)
5. Sequencing Valve
6. 3/8" NPT x 3/4"-16 O-Ring Straight Adapter
7. Flow Control Valve, 3/8" NPT
8. 3/8" NPT x 9/16"-18JIC Straight Adapter (Used On Dual Valve, Conventional Marker Systems\*)  
3/8" NPT x 3/4"-16JIC Straight Adapter (Used on all models except those with Dual Valve Conventional Marker Systems)
9. 1/4" x 140" Hydraulic Hose, 9/16"-18JIC X 1/2" NPT (Dual Valve, Conventional Marker System\*)  
3/8" x 140" Hydraulic Hose, 3/4"-16JIC X 1/2" NPT (Dual Valve, Low Profile Marker System\*\*)
10. 3/8" x 20" Hydraulic Hose, 3/4"-16JIC Swivel, Both Ends (Used on all Single Valve Systems)
11. 3/8" x 27" Hydraulic Hose, 3/4"-16JIC Swivel, Both Ends (Used on all Single Valve Systems)
12. 1/2" NPT x 3/4"-16JIC Elbow
13. 1/2" NPT x 3/4"-16JIC Tee
14. 3/8" x 105" and 3/8" x 117" Hydraulic Hose, 1/2" NPT x 3/4"-16JIC Swivel
15. 3/8" x 2" Hex Head Cap Screw, Lock Washer, and Hex Nut.
16. 5/16" U-Bolt, Flat Washers, Lock Washers and Hex Nuts
17. 3/8" x 76" Hydraulic Hose, 3/4"-16JIC Swivel Both Ends. (8 Row 30" Only)
18. 3/4"-16JIC Tube Tee
19. 3/8" x 125" Hydraulic Hose, 3/4"-16JIC Swivel to 1/2" NPT
20. 3/8" x 34" Hydraulic Hose, 3/4"-16JIC Swivel Both Ends (8 Row 30 W/Single Valve System Only)
21. 3/4"-16JIC Swivel Tee

\*Conventional Markers are used on the 4 Row 30", 4 Row Wide and 6 Row 30" models.

\*\*Low Profile Markers are used on the 6 Row Wide and 8 Row 30" models.

**IMPORTANT:** The flow control valves must be installed with the arrows pointed toward the tractor.

**CAUTION:** Before the marker assembly is first put into use, the flow control valves must be adjusted to prevent damage to the marker assembly. Loosen the lock nut on each knurled adjustment knob and screw the adjustment all the way closed. Then open each valve approximately 1/2 turn. After the marker has been cycled several times, final adjustments can be made.

# ASSEMBLY

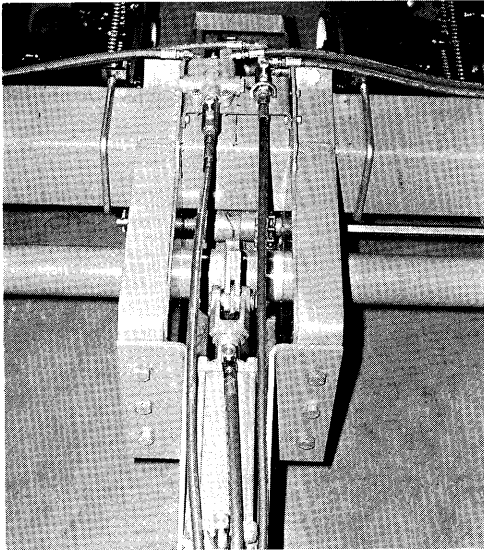

Dual Valve System

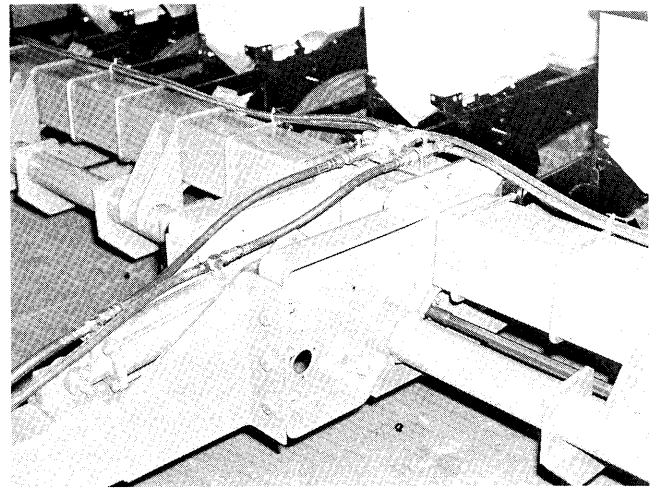

Single Valve System

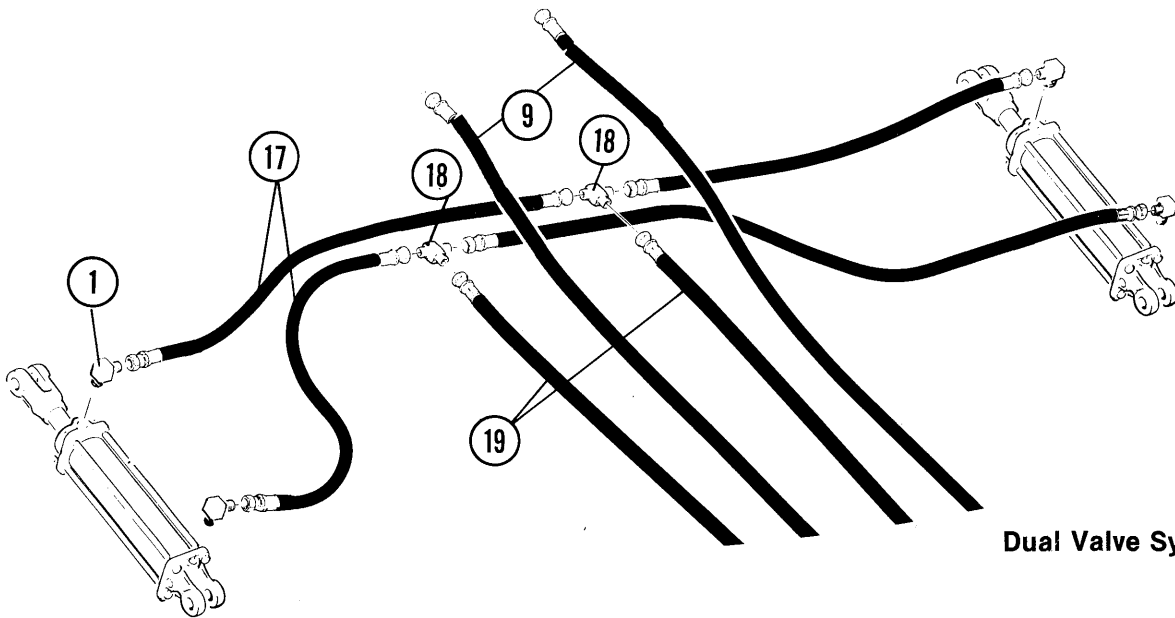

Dual Valve System

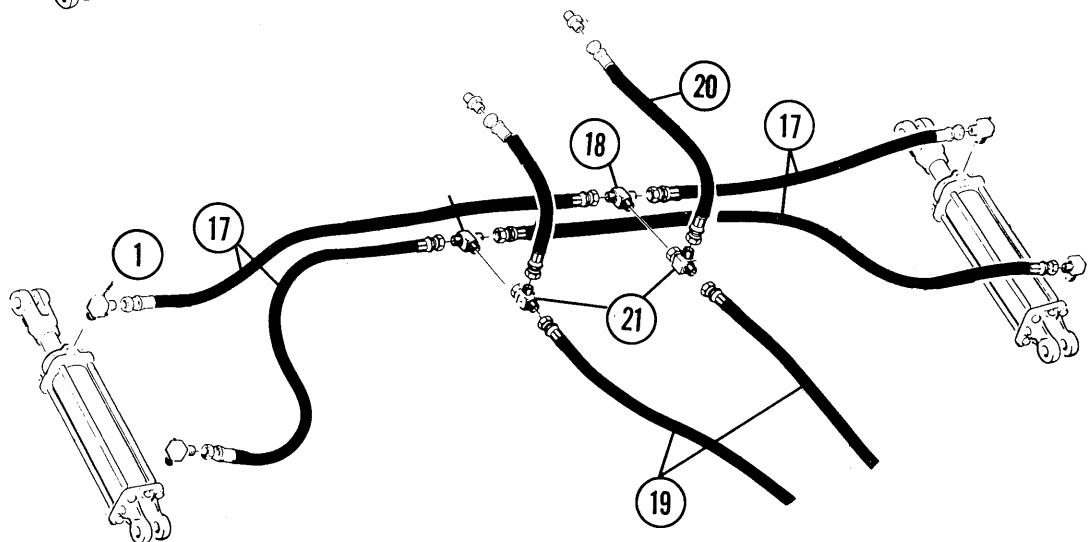

Single Valve System

# OPTIONAL EQUIPMENT ASSEMBLY

## Regular Duty Down Pressure Springs

If extra row units are to be installed between the regularly spaced planter units, the springs should be installed on the inside of the row unit frame. Otherwise, they should be installed on the outside of the frame as instructed below:

1. Install eyebolt in top and bottom support arms with a flat washer on each side of support and secure in place with cotter pin.
2. Hook down pressure spring in lower eyebolt.
2. Place flat washer on 7/16" x 4" full thread capscrew and install through top eyebolt, 7/16" jam nut and spring plug. Tighten bolt until sufficient down pressure is obtained.

**Important: Make sure length of stretched spring is equal on each side of row unit. Spring tension must be further adjusted by the operator to match ground conditions.**

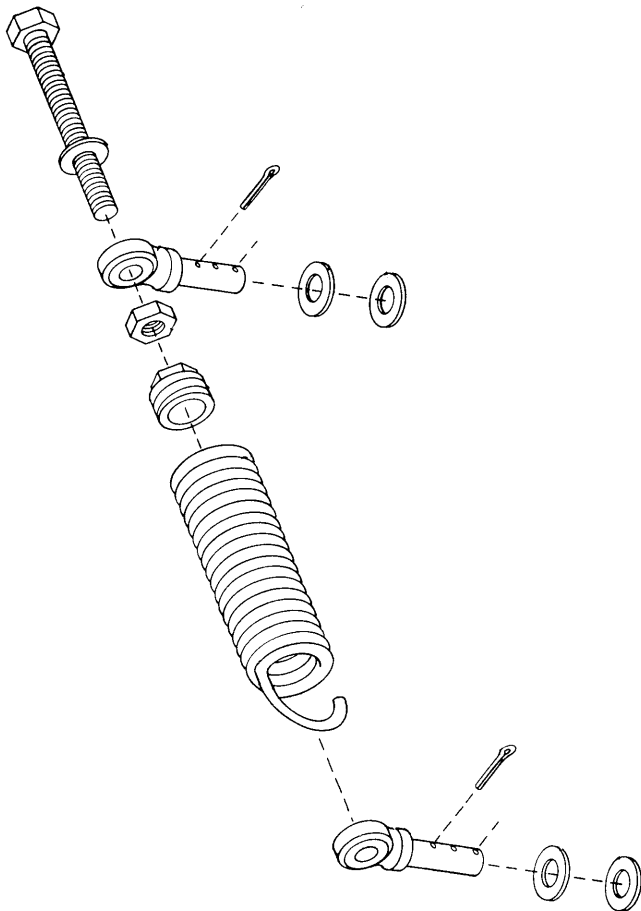

## Heavy Duty Down Pressure Springs

1. Install support plate on U-bolts directly behind support angles as part of row unit installation procedure. (The support plate is held in place with the same hardware that is used to attach row unit.)
2. Attach spring tube to upper row unit support arms with four-1/2" x 1 1/2" cap screws and locknuts.
3. Hook tension springs to support plates. Then install 1/2" x 3" cap screws, flat washers, and jam nuts as shown; threading cap screw into spring plug.

**Note: It may be necessary to lift planter bar to start the bolts into the spring plugs.**

4. Equally tighten both adjustment bolts to obtain the desired amount of down pressure tension.

**IMPORTANT: It is necessary for the operator to adjust springs for ground conditions. If springs are overtightened, it is possible in some cases that the row units actually lift the planter bar to the point that the drive wheel do not contact the ground sufficiently for proper operation.**

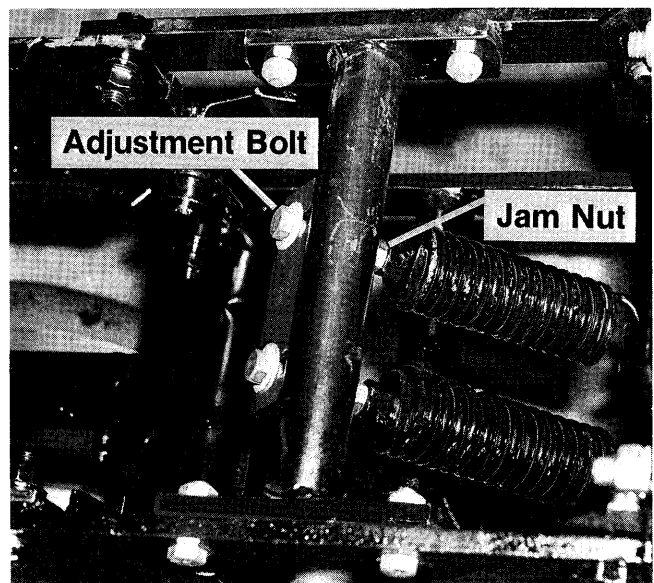

# ASSEMBLY

## Coulters

The heavy duty coulters attachment is available with either a 16" fluted blade or rippled blade for not till or minimum till planting.

1. Attach coulters bracket to row unit frame with four 1/2" x 1 1/4" cap screws and locknuts, but do not tighten completely at this time.
2. Install coulters blade with six- 3/8" x 3/4" cap screws. Tighten bolts alternately to avoid distorting the blade.
3. Shift mounting bracket within the limits of the adjustment slots until coulters is aligned with row opener disks. Then finish tightening mounting bolts.
4. Three positions are provided for adjustment of coulters operating depth. To change depth position, loosen the locknut that secures the 5/8" x 3 1/2" cap screw. Then loosen and remove 3/4" x 4" cap screw reposition coulters as desired. Reinstall 3/4" cap screw and tighten both locknuts securely.

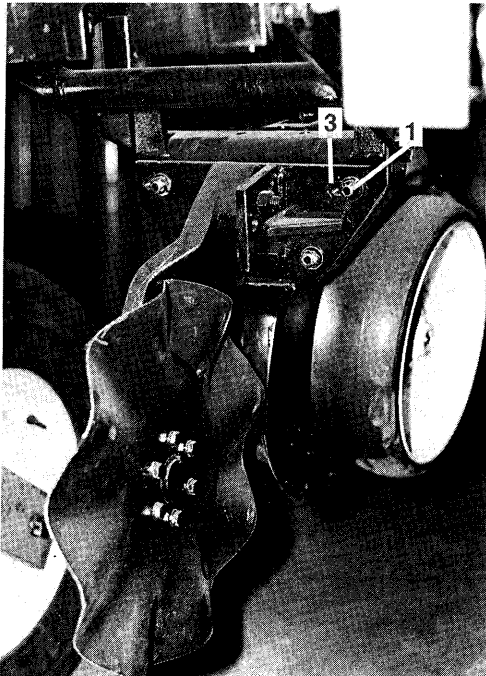

## Fertilizer Bar Installation

1. Attach bar end brackets to the fertilizer bar with 1/2" x 3 3/4" cap screws, lock washers and hex nuts.
2. Lift right and left bar assemblies into position and attach inside end of each bar to tongue assembly and side panel with top existing tongue mounting bolts on each side.
3. Attach outer end of each bar support to the planter toolbar with one 7" x 7" x 3/4" U-bolt, lock washers and hex nuts.

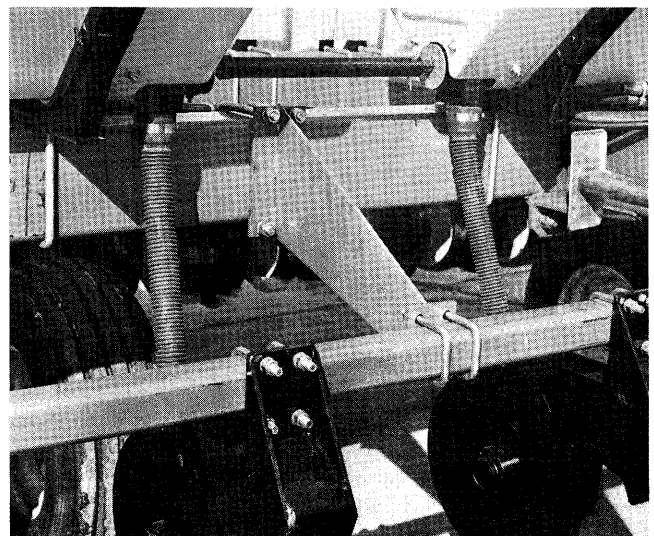
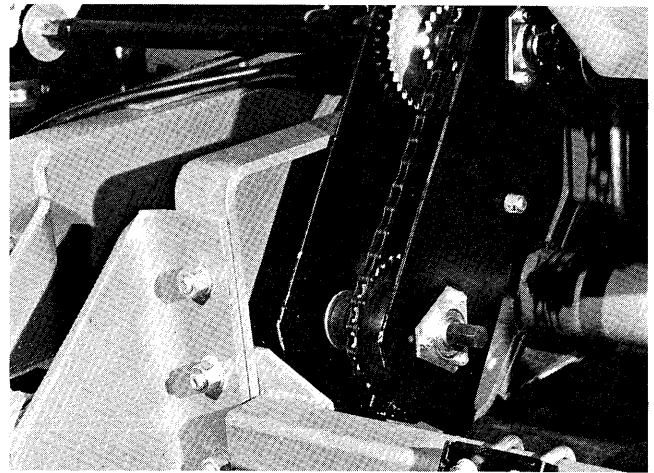

# ASSEMBLY

## Double Disk Openers

Both the liquid and dry fertilizer attachments use the same 15" double disk openers. Attach drop tubes to each opener by positioning the bottom of the tube on the drop tube retainer and attaching the top of the tube with one 5/16" x 1 1/2" cap screw and locknut.

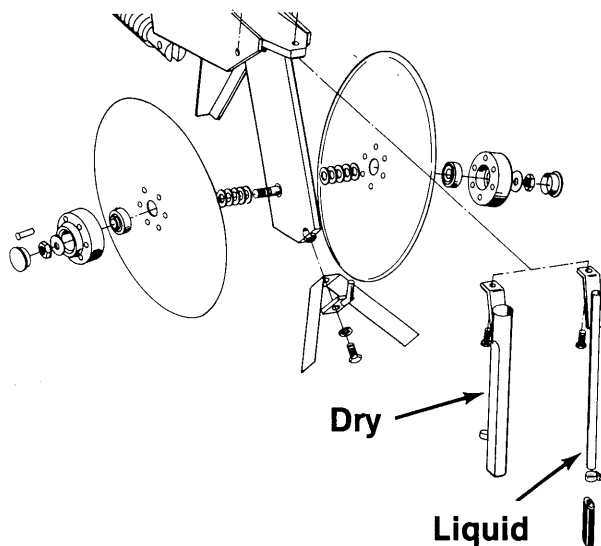

Attach disk openers to the fertilizer bar so that disks are positioned two inches to the side of the row unit openers. When installing openers for dry fertilizer, position the opener on the side nearest the hopper outlet.

The down pressure springs on the double disk openers are factory preset at 250 pounds, but may be further adjusted for various soil conditions. To adjust spring tension, loosen the jam nut with a 15/16" wrench and adjust the tension adjustment bolt with a 1" wrench. Turning the adjustment bolt clockwise increases down pressure. Retighten the jam nut upon completion of tension adjustment.

**WARNING:** Do not operate the double disk openers at full down pressure tension when planting in rocky ground. Chipping of the disk blades may occur.

## Dry Fertilizer Attachment

### Transmission And Drive - 4 Row and 6 Row Models

1. Assemble three 7/8" hex bore bearings and flanges and install on the outside of the center section side panels- two on the left panel and one on the right.

2. Install 7/8"x10" hex jack shaft through left side panel bearing and slide 24 tooth sprocket, 48-tooth sprocket and 7/8" lock collar onto shaft. Then extend shaft on through right side panel bearing. Install cotter pin through left end of shaft, slide all components tight against left sidewall and tighten lock collar.
3. Install double spool chain idler to inside of left center section side panel (in hole provided to the rear of the jackshaft) with 1/2"x3 carriage bolt.

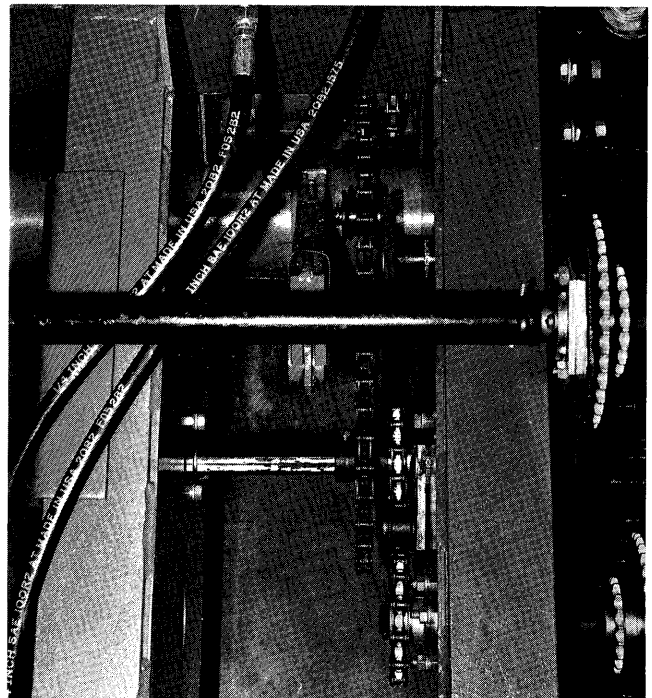

4. Install 50 link drive chain between clutch assembly and 48 tooth sprocket on jackshaft. Route chain under the planter axle, around the clutch sprocket and between the idler spools as shown. Pivot idler bracket to sufficiently tension chain and tighten mounting bolt.
5. Attach transmission with 5/8" U-bolt and transmission mount and 3/8"x1" HHCS. Do not tighten mounting bolts at this time.

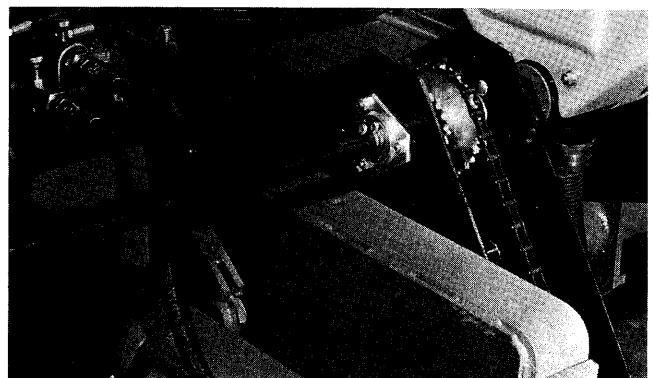

# ASSEMBLY

6. Install lower transmission shaft through bearing and flangettes installed on left transmission side panel; 24 tooth sprocket; 36/18 tooth sprocket; flat washer, lock collar and finally through the front center section side panel bearing. Install rubber spacers on the shaft and secure flat washer against the sprockets and spacers with 1/4" cotter pin.

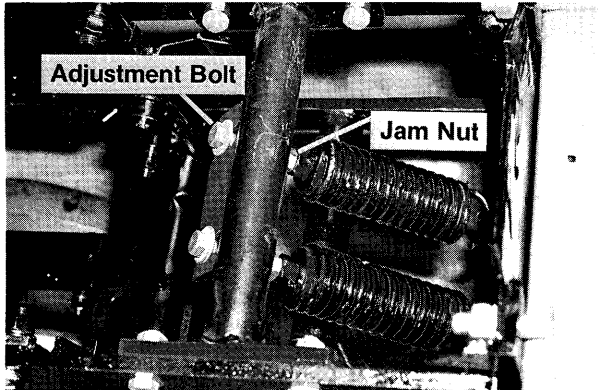

7. From inside the center section, install 24 tooth sprocket and cotter pin through the right end of the shaft.
8. Slide lock collar against the center section side plate and secure in place.
9. Install single spool chain idler to left side panel with 1/2"x1 1/2" carriage bolt.
10. Install 26 link drive chain between jackshaft drive sprocket and lower transmission drive shaft sprocket. Pivot idler to maintain proper tension.

## Transmission and Drive 8 Row Models

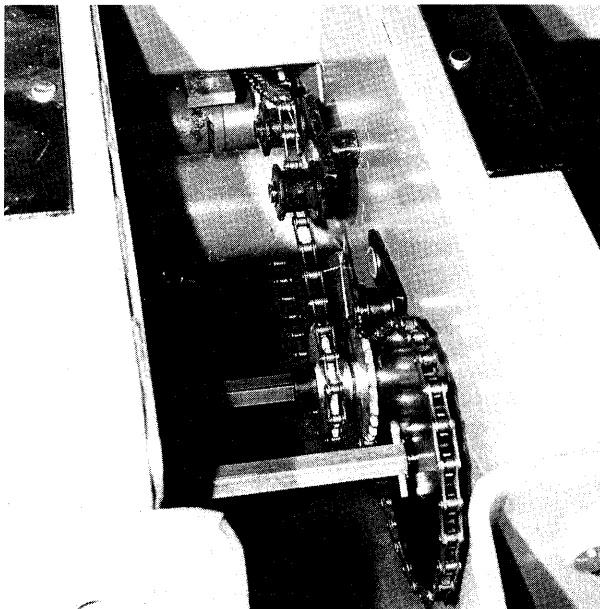

1. Assemble four 7/8" hex bore bearings and flangettes and install on the outside of the center section side panels- two on each side.
2. Install 7/8" x 10" hex jack shaft through left side panel bearing and slide two 24 tooth sprockets, and 7/8" lock collar onto shaft. Then extend shaft on through right side panel bearing. Install cotter pin through left end of shaft, slide all components tight against left sidewall and tighten lock collar.
3. Install double spool chain idler to inside of left center section side panel (in hold provided to the rear of the jackshaft) with 1/2" x 3" carriage bolt.
4. Install 43 link drive chain between clutch assembly and 24 tooth sprocket on jackshaft. Route chain under the planter axle, around the clutch sprocket and between the idler spools as shown. Pivot idler bracket to sufficiently tension chain and tighten mounting bolt.
5. Attach transmission between center section side panels using 5/8"x8 1/2" HHCS, flat washers, lock washers and hex nuts and mounting bracket and 3/8" x 1" HHCS. Do not tighten mounting bolt, at this time.
6. Install lower transmission shaft bearing in left side panel and through 48 tooth sprocket. Then extend shaft on through left transmission side panel, two flat washers, 36/18 tooth sprocket, 24 tooth sprocket, an additional flat washer and finally through the right transmission and center section side panels.
7. Install cotter pin through shaft to secure 48 tooth sprocket in position. (It may be necessary to slide transmission to the right for access). Install lock collar on end of shaft that extends through left side panel.

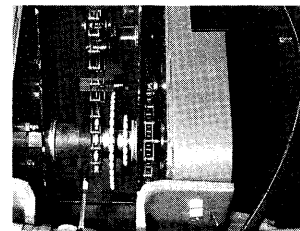

8. Install single spool chain idler to left side panel with 1/2"x1 1/2" carriage bolt.
9. Install 32 link drive chain between jackshaft drive sprocket and 48 tooth lower transmission drive shaft sprocket. Pivot idler to maintain proper tension.
10. Make sure transmission is positioned where it won't interfere with the sprockets or chain drive and secure in position.



# ASSEMBLY

## Hopper Installation

1. Install the hopper mounting brackets on the planter bar in the locations illustrated on the following pages. Do not tighten attachment bolts at this time.
2. Remove the cotter pin and flat washer from one end of the fertilizer shaft and slide the entire assembly through the outlet housing into the hopper. Secure in place by reinstalling the washer and cotter pin. Check rotation to make sure the auger springs will carry fertilizer to the outer ends of the hopper when in operation. If rotation is wrong, remove the auger assembly, turn it 180° and reinstall.

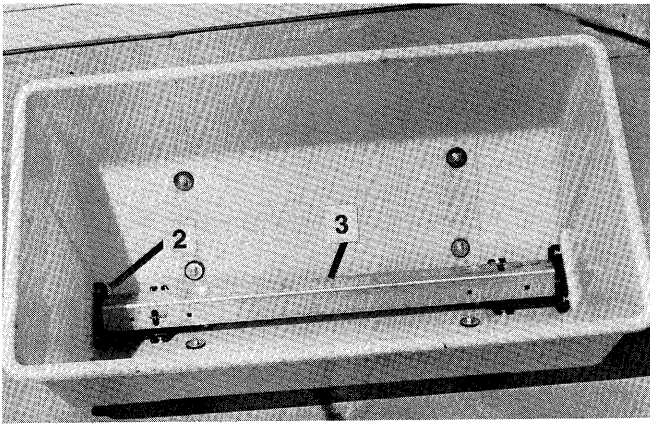

3. Install auger shields over augers and secure in place with two hair pins on each.
4. Install two hopper braces in hopper with bolts provided. Each brace is drilled for installation of a rubber lid strap. Make sure this hole is closest to the front of the hopper. Place one of the rubber washers between each end of the brace and the inside surface of the hopper. Attaching bolts should be installed with the head to the outside of the hopper and a flat washer between the head and the outside hopper surface.
5. Position the hopper lid so the latches will be to the front of the hopper and install two rubber straps between hopper braces and underside of lid. Install a rubber washer between the bolt head and the rubber strap...and a lock washer and nut on the outside of the braces. The bolt holding the strap to the lid should have a flat washer under the bolt head on the lid top...and a flat washer, lock washer and hex nut next to the strap on the bottom side of the lid.

6. Install the hoppers on the hopper mounts with the round hole in the saddle toward the front. Attach the front side of the hopper to the mount with two 7/16" x 3" clevis pins and cotter pins.

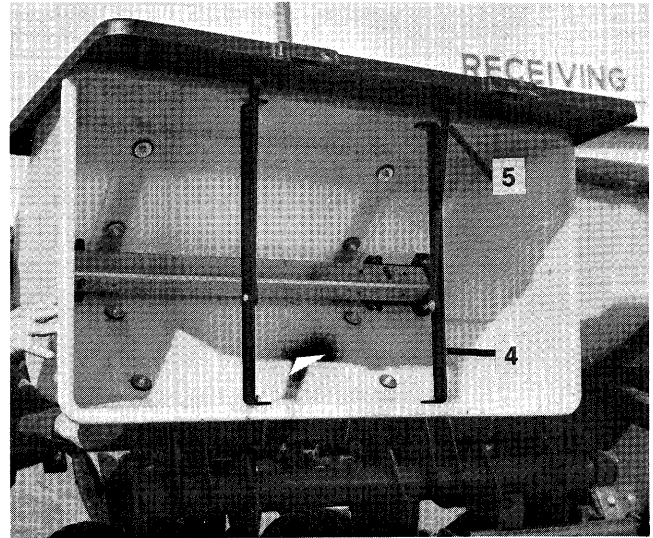

7. Install coupler/drive shafts beginning at the transmission and working outward toward each end. Slide the square end of the coupler over the auger shaft so that at least 3/4" or more of the shaft extends into the coupler. Attach opposite end of the coupler/drive shaft with 3/16" cotter pin. Four holes in the auger shaft allows for 1 1/2" or 3" to extend beyond the end of the hopper. In most installations the short end is toward the transmission. Make sure all coupler/drive shafts are installed with the cotter pin toward the transmission.

# ASSEMBLY

---

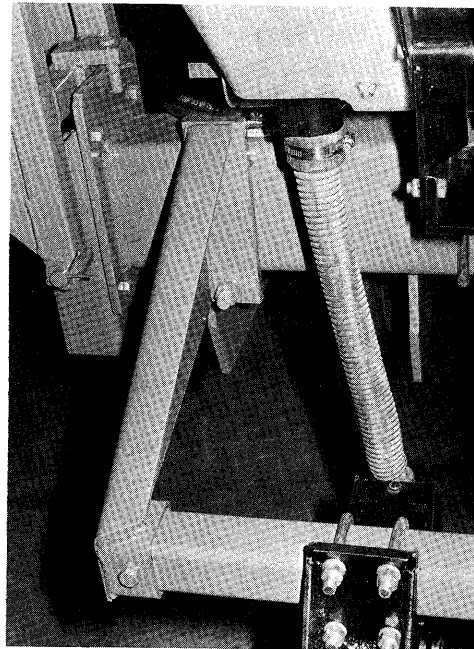
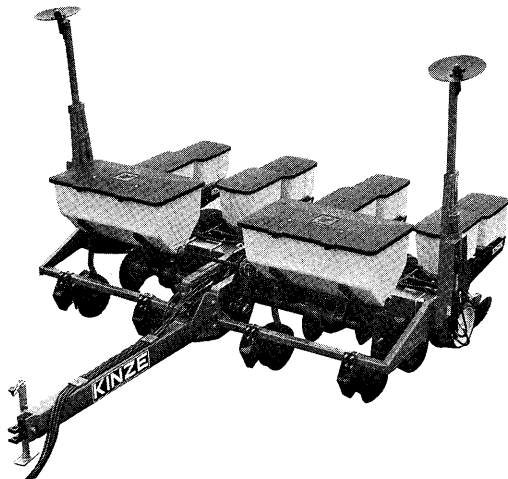

8. Once the coupler/drive shafts have been connected, bolt the rear of the hopper saddle to the hopper support with two  $\frac{1}{2}$ " x  $\frac{1}{4}$ " cap screws.
9. Align all hoppers and the transmission both horizontally and vertically and tighten all mounting bolts. Slots in the transmission and mounting bracket allow for up and down and forward and backward adjustment.
10. Connect all fertilizer drop tubes between hopper outlets and double disk opener drop tubes. Make sure tubes are straight; and secure with hose clamps.

# ASSEMBLY

## DRY FERTILIZER COUPLERS

### 8 ROW 30"

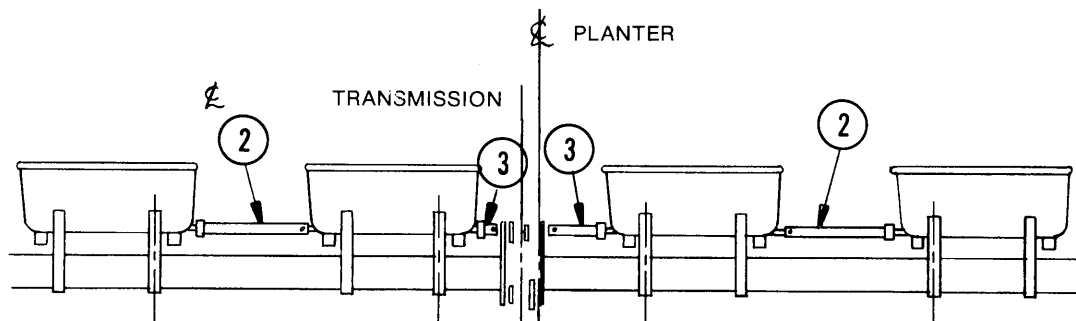

### 4 ROW 30"

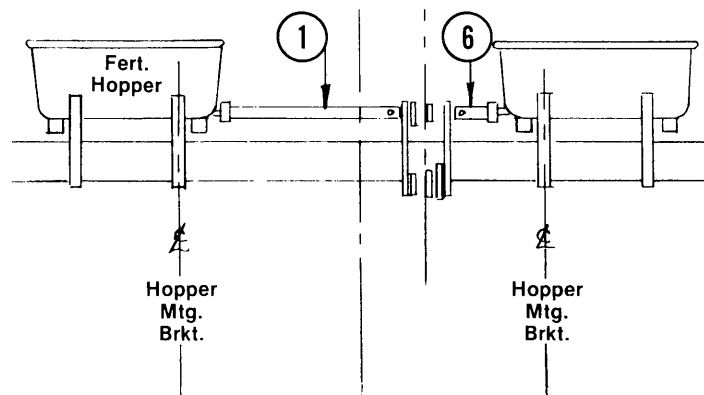

ITEM	PART NO.	DESCRIPTION
1.	A684	Drive Coupling, 24 5/8"
2.	A555	Drive Coupling, 16 1/8"
3.	A554	Drive Coupling, 4 5/8"
4.	A557	Drive Coupling, 23 1/8"
5.	A665	Drive Coupling, 7 5/8"
6.	A881	Drive Coupling, 1 5/8"
7.	A884	Drive Coupling, 22"
8.	A561	Drive Coupling, 30 5/8"

# ASSEMBLY

---

## 4 ROW WIDE

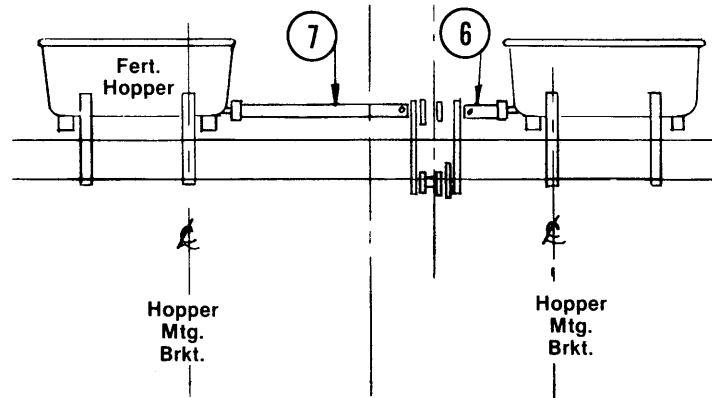

---

## 6 ROW 30"

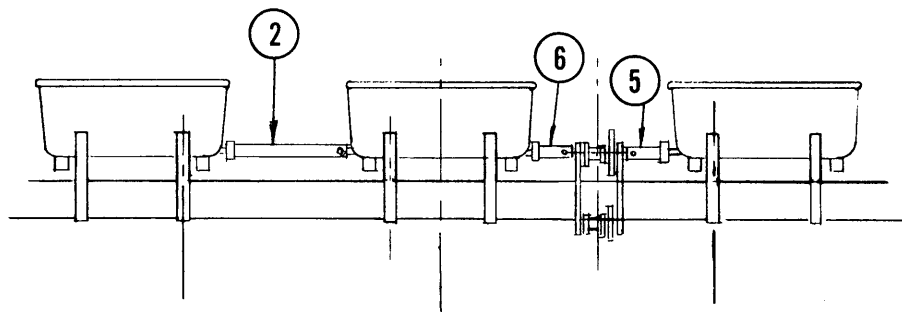

---

## 6 ROW WIDE

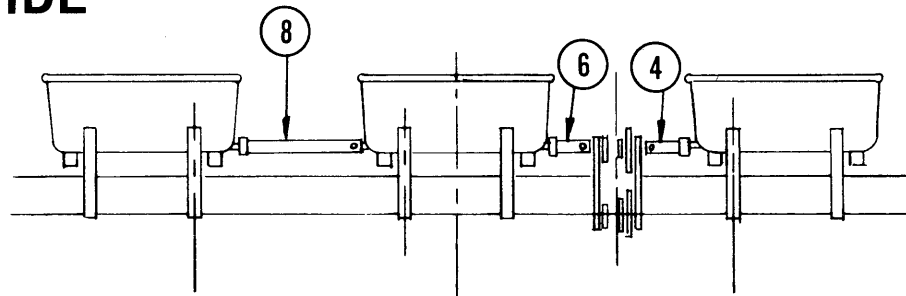

# ASSEMBLY

## Liquid Fertilizer Attachment Squeeze Pump and Drive Installation

1. Install squeeze pump mounting bracket on tongue assembly using top two 3/4" x 2 1/2" tongue mounting bolts.

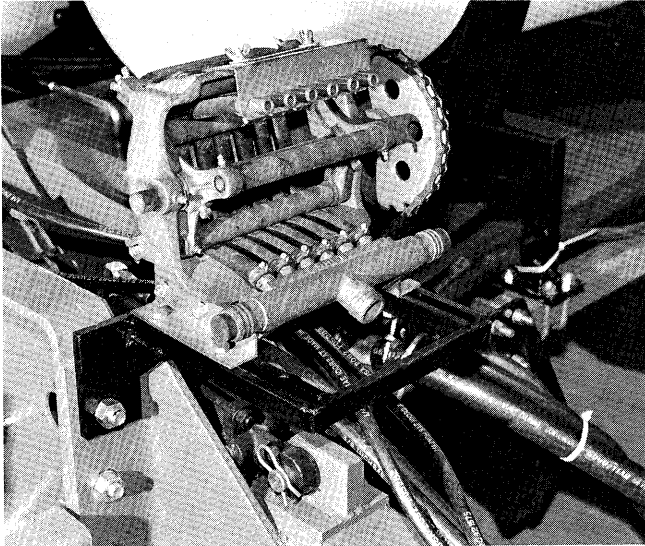

2. Assemble two 7/8" hex bore bearings and flangettes and install on the inside of both right and left center section side panels.
3. Install 7/8" x 16" hex shaft through left side panel bearing and slide 3/4" spacer, 24 tooth sprocket and 7/8" lock collar onto the shaft. Extend shaft on through bearing in right side panel leaving approximately 5"-6" exposed on the outboard side of the left panel. Slide lock collar up against sprocket and tighten.
4. Install squeeze pump sprocket adapter, selected drive sprocket and sprocket retainer on the left end of hex drive shaft.
5. Install chain idler to inside of left center section side panel (in hole provided) with 1/2" x 3" carriage bolt.
6. Install 43 link drive chain between clutch assembly and fertilizer drive shaft. Route chain under the planter axle, around the clutch sprocket and between the idler spools as shown. Pivot idler bracket to sufficiently tension chain and tighten mounting bolt.
7. Attach squeeze pump to mounting bracket with four 7/16"x2" cap screws, lock washers, flat washers and hex nuts. Do not tighten at this time.

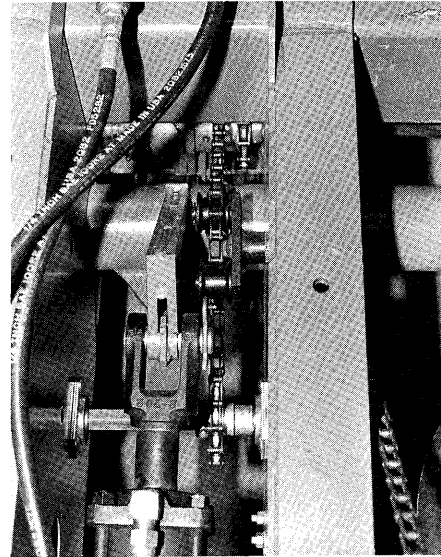

8. Install adapter, driven sprocket and sprocket retainer on left end of squeeze pump shaft. Then install 75 link drive chain between squeeze pump drive and driven sprockets.
9. Slide squeeze pump forward to obtain approximately 1/4" deflection on the drive chain.

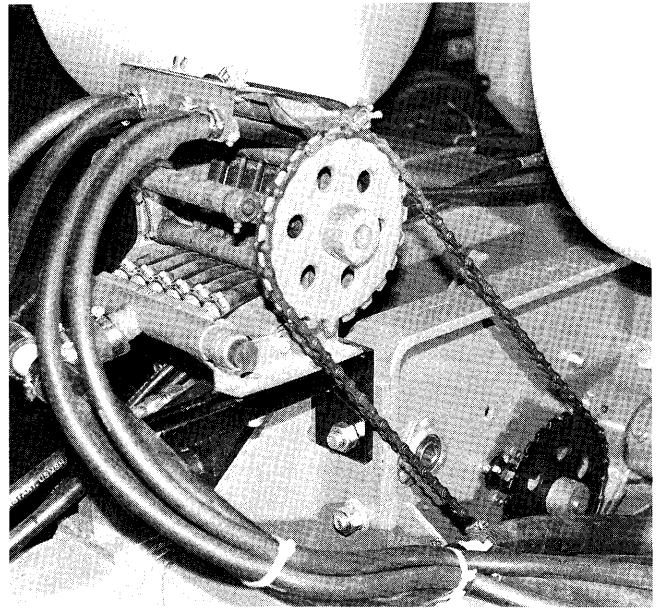

## Tank And Hose Installation

1. Attach two tank saddle brackets for each tank on tool bar and fertilizer bar with 1/2" U-bolts around fertilizer bar and 5/8" U-bolts around tool bar as shown.
2. Attach tank saddle to tank saddle bracket with four 1/2" x 1 1/2" cap screws.

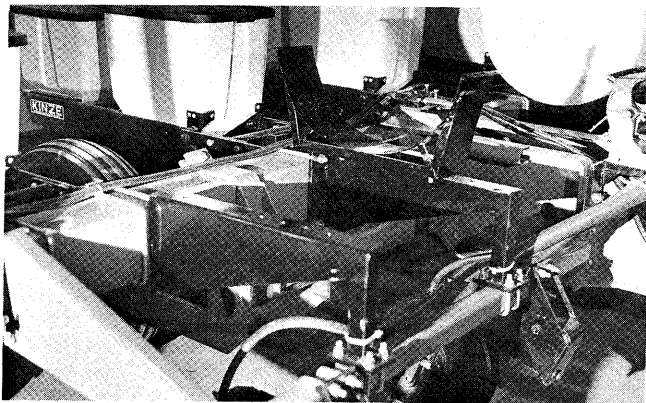

3. Install outlet elbow in bottom of each tank.
4. Install tanks on tank saddles with J-bolts, lock washers and hex nuts as shown.

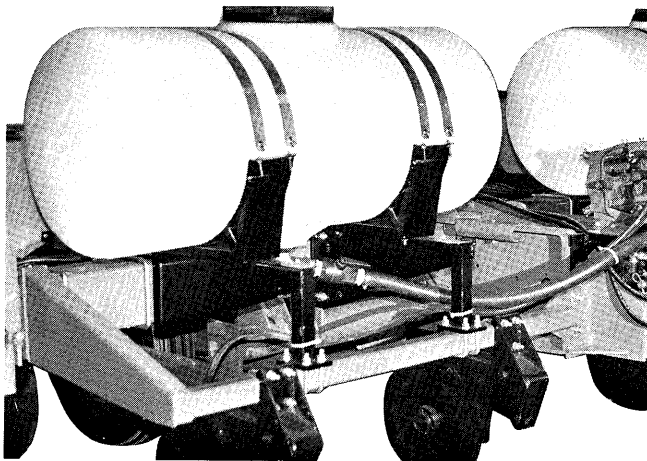

5. Attach a short piece of 1 1/4" hose to each outlet elbow and then install adapter fittings and shut-off valve.

**NOTE: The 1 1/4" hose for connecting tanks to squeeze pumps is provided in a roll and must be cut to length. Attach hose to each fitting or connection with hose clamps provided.**

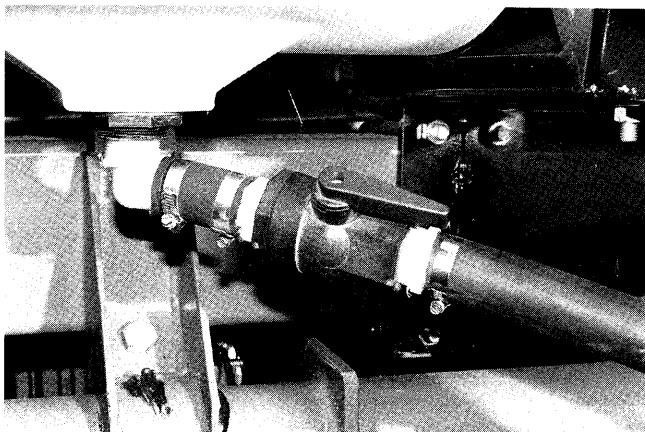

6. Attach additional 1 1/4" hose to each ball valve to extend to center of planter bar. Then join hoses from each tank with 1 1/4" hose barb tee.

**NOTE: Make sure hoses between tanks and front of squeeze pump are long enough on pull type planters to allow forward movement of the squeeze pump. This is important to allow for chain tension adjustment.**

7. Cut approximately 2" out of left hose and install second 1 1/4" hose barb tee. Then attach sufficient length of hose to extend to outer end of tank for quick fill attachment.

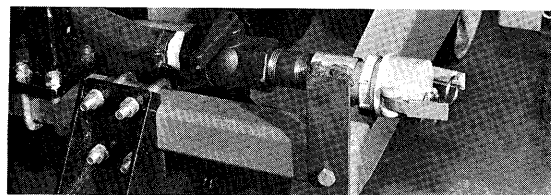
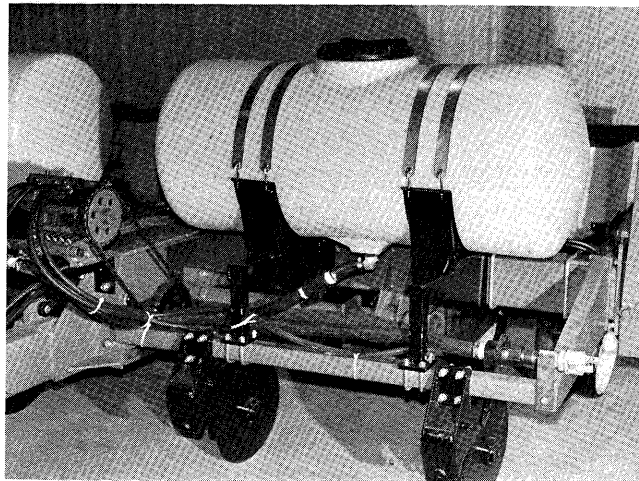

8. Attach quick fill bracket with threaded pipe fitting to fertilizer bar end bracket as shown.
9. Assemble male adapter, 1 1/4" ball valve, pipe nipple and quick fill fitting to bracket as shown.
10. Connect 1 1/4" hose between squeeze pump intake manifold and barb tee which connects tanks. Install rubber plugs in unused manifold inlets.

**CAUTION: Avoid excessive pressure when using the quick fill attachment. The rubber plugs installed in the manifold may be forced out under pressure.**

11. Connect fertilizer hoses between squeeze pump outlet manifold and double disk openers. The plastic hose comes in a roll and must be cut to length for each row. Begin with the two outside first, allowing enough hose for up and down movement of disk openers.
12. Secure all hoses to the planter frame with nylon tie straps.

# LUBRICATION

---

The following pages show the location of all lubrication points. Proper lubrication of all moving parts will help insure efficient operation of your Kinze unit and prolong the life of friction producing parts. Those parts equipped with grease fittings should be lubricated at the frequency indicated with an SAE multipurpose type grease. Be sure to clean the fitting thoroughly before using grease gun. The frequency of lubrication recommended is based on normal operating conditions. Severe or unusual conditions may require more frequent attention.

## Sealed Bearings

A number of sealed bearings are used on your Kinze Planter Bar to provide trouble free operation. These are located in such areas as the drive shaft, row units, and transmission bearings. Sealed bearings are lubricated for life, and due to the seals, relubrication is not practical.

## Corn Meter Lubrication

To provide efficient operation of the finger type plateless corn meters and extend the life of components, sprinkle a teaspoon of powdered graphite over the top of the seed each day. The graphite will filter down into the seed pickup mechanism and insure lubrication.

## Drive Chains

The transmission and row unit drive chains should be lubricated approximately every 8-10 hours with a quality engine oil or equivalent SAE 10 weight oil. A good quality spray lubricant may also be used for periodic chain lubrication. Extreme operating conditions such as dirt, temperature, or speed may require more frequent lubrication. If any of the chains become stiff, it should be removed and soaked and washed in solvent to loosen and remove dirt from the joints. Then soak the chain in oil so the lubricant can penetrate between the rollers and bushings.

## Wheel Bearings

Wheel bearings should be repacked with clean heavy duty axle grease approximately once a year or at the beginning of each planting season. This applies to all drive wheels, transport wheels and marker hubs. Transport wheels may require less frequent service depending upon amount of road travel. Following the procedure outlined for wheel bearing replacement with the exception that bearings and bearing caps are reused.

---

## Fertilizer Options

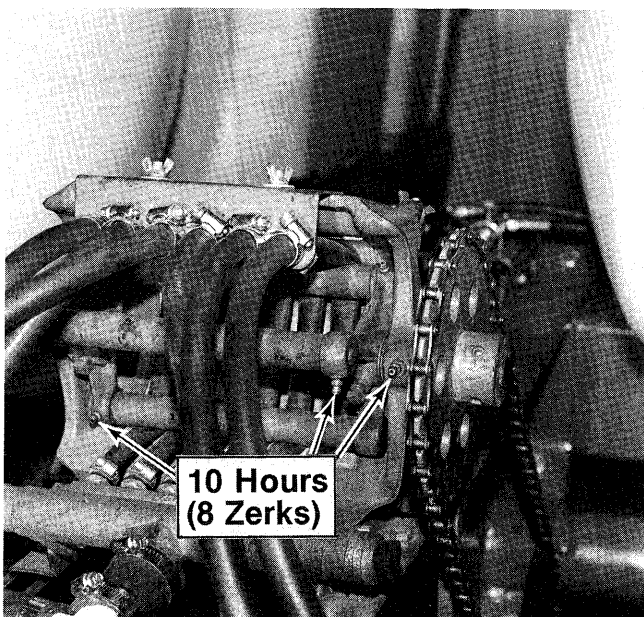

Liquid Fertilizer Pump

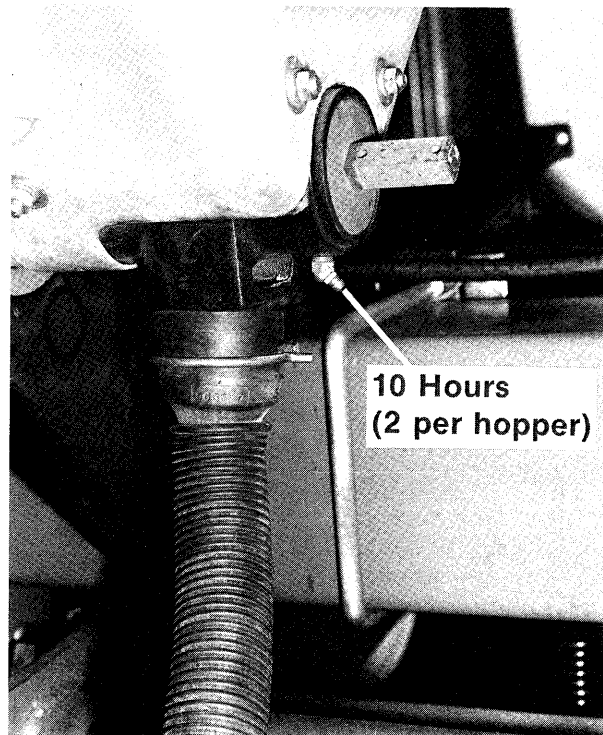

Dry Fertilizer Hopper

# LUBRICATION

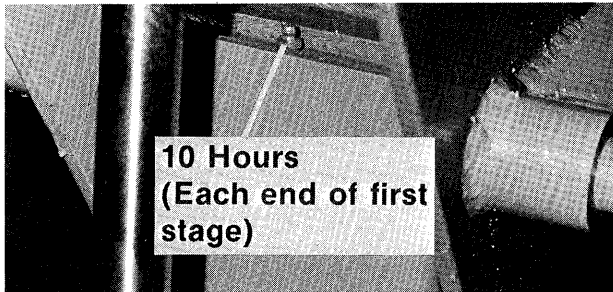

**Double Folding Low Profile Marker  
(All Models Applicable)**

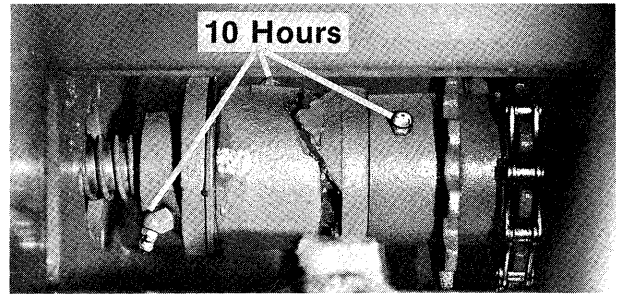

**Clutch Assembly**

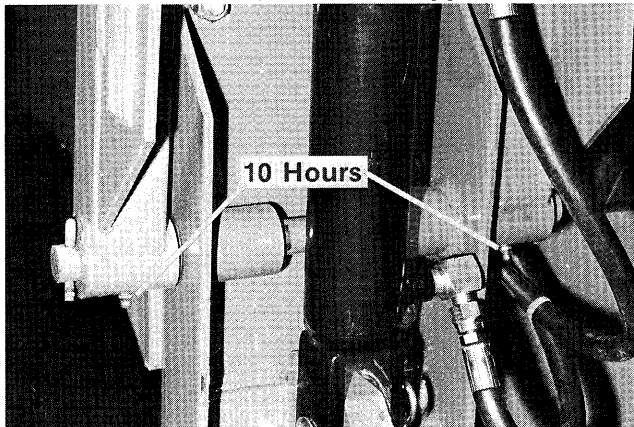

**Conventional Marker Assembly  
(All applicable models)**

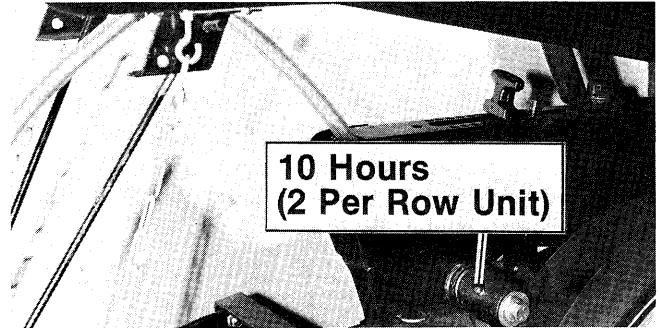

**Gauge Wheel Pivot**

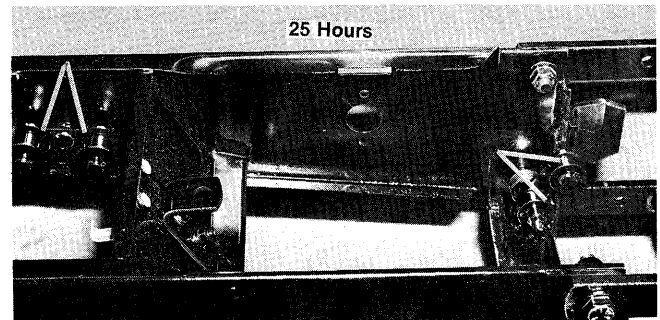

The parallel arm (8) bushings should be lubricated every 50 hours and the idler spools every 25 hours with a quality engine oil or equivalent SAE 10 weight oil.

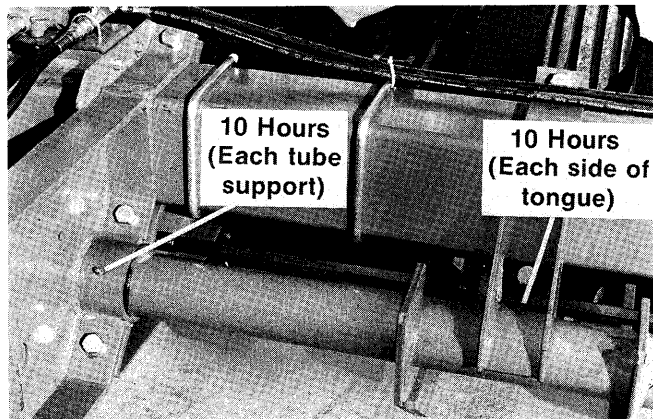
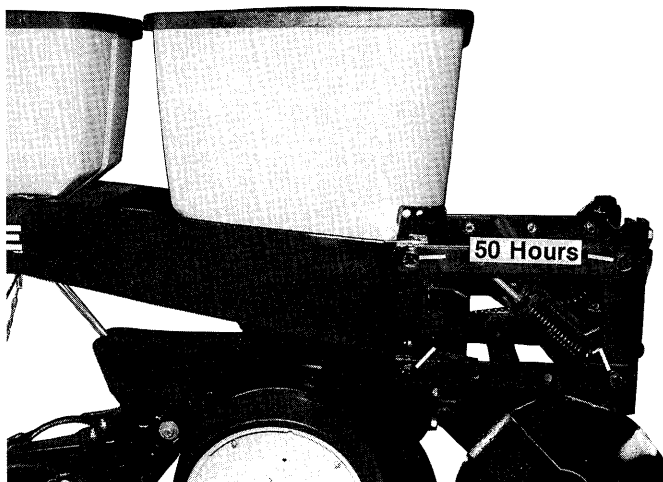

**Wheel Bracket Supports**

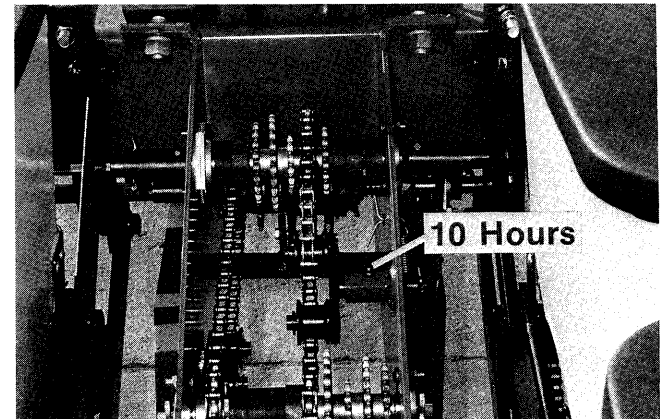

**Transmission**



# OPERATION

---

The following information is general in nature and was written to aid the operator in preparation of the tractor and planter bar for use, and to provide general operating procedures. The operator's experience, familiarity with the machine and the following information should combine for efficient planter operation and good working habits. The operator's manual for the row units used with your Kinze Planter Bar should also be readily available and consulted for planter operation.

## Initial Preparation of the Planter Bar

Lubricate the Planter Bar and row units per the lubrication information in this manual and the row unit operator's manual. Make sure all tires have been properly inflated.

Check all drive chains for proper tension and lubrication.

## Tractor Preparation and Hookup

1. Adjust tractor drawbar so that it is 13 to 17 inches above the ground. Then adjust the drawbar so that the hitch pin hole is directly below the center line of the PTO shaft. Make sure the drawbar is in a stationary position.
2. Back tractor up to planter bar and connect with hitch pin. Make sure hitch pin is secured with locking pin or cotter pin.
3. Connect hydraulic hoses to tractor ports in a sequence which is both familiar and comfortable to the operator.

Before applying pressure to the hydraulic system, make sure all connections are tight and that hoses and fittings have not been damaged. Hydraulic fluid escaping under pressure can have sufficient force to penetrate skin, causing injury or infection.

**IMPORTANT:** Always wipe hose ends to remove any dirt before connecting couplers to tractor ports.

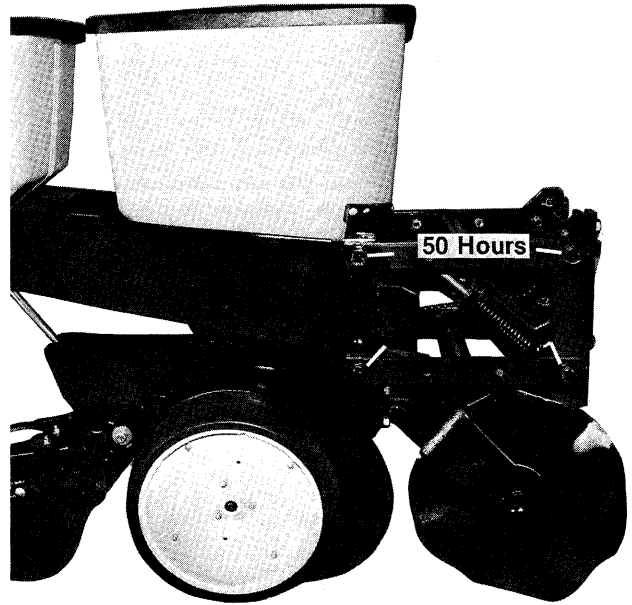

4. Raise jack stand and remount horizontally on storage bracket on side of planter bar tongue.
5. Lower planter bar to the planting position and check tongue for levelness. If tongue slopes up or down, disconnect planter bar and adjust hitch clevis up or down as necessary.

## Transporting The Planter Bar

**Always make necessary safety preparations prior to transporting the planter bar on public roads. This includes installing Slow Moving Vehicle (SMV) emblem and use of adequate lights or safety warning after dark.**

The pull type planter bar is equipped with a clutch that disconnects the drive when the unit is raised for transportation. However, for safety and to decrease wear, the drive chains should be removed to the side of the drive wheel sprocket prior to towing the machine for any distance.

# OPERATION

## Leveling The Planter Bar

For proper operation of the planter bar and row units, it is important that the unit operate level.

Unless the tractor drawbar is adjustable for height, the fore and aft level adjustment must be maintained by the position of the hitch clevis. Three holes in the tongue hitch bracket allow the clevis to be raised or lowered. When installing clevis mounting bolt, make sure lock washer is in place and tighten hex nut to proper torque setting.

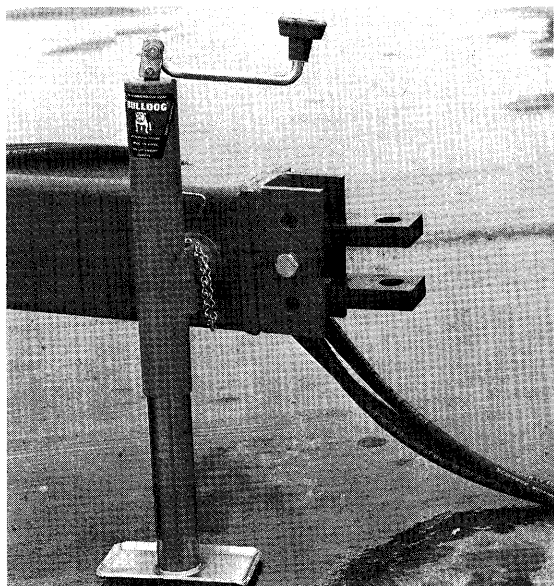

Always check fore and aft levelness with the planter bar lowered to proper operating depth. Then sight across tongue or place a bubble level on the tongue and frame itself.

In order to maintain lateral levelness, it is important that tire pressure be maintained at pressures specified.

## Transmission Adjustment

The transmission is designed to allow simple and rapid changes in sprocket combination to obtain the desired planting population. Since both the transmission drive shaft and the row unit drive shaft are hexagonal in shape, the sprockets need only be slid into alignment with the idlers after first removing the rubber spacers and loosening the drive chain. The combination of small sprockets may require shortening the drive chain.

A decal positioned next to the transmission and the information provided in your row unit operator's manual or planting rate chart in this manual will aid you in the selection of the correct sprocket combinations. After positioning both sprockets, replace rubber spacers between sprockets or on the ends as necessary. Then restore tension on the drive chain.

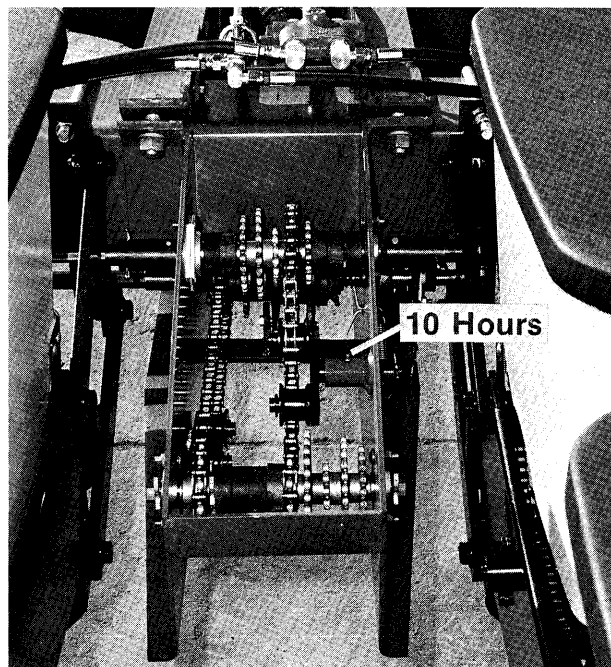

## Tire Pressure

Tire pressure should be checked regularly and maintained as follows:

Drive Gauge - 7:60 x 15" 4-Ply 40 lbs. PSI

**IMPORTANT:** Tire pressure must be correctly maintained in all drive wheel tires to insure levelness of planter bar and proper operation of planter. Also, all rate charts are based on rolling radius of 7:60 x 15 tires inflated to 40 PSI.

# OPERATION

## Hydraulic Marker Operation

The pull type planter bars are equipped with either a single or double valve hydraulic system. The double valve system allows the markers to be operated independently of the planter lift cylinders. Each time a marker is completely raised, the sequencing valve will direct flow to lower the opposite marker.

Planter bars equipped with a single valve system will require that the planter be raised in order to lift the marker. Each time the unit is raised, the markers will alternately be raised. Then, as the planter bar is lowered, the opposite marker will lower. It is possible to experience an inconvenience with this system if the unit must be raised at points other than at the end of the field. For example, if the planter bar is raised to cross a waterway, the opposite marker will be lowered when the unit is dropped back into the ground. Therefore, it will be necessary to stop, and again raise and lower the bar to restore correct marker operation.

**⚠ WARNING: Always stand clear of the gauge marker assembly and blade when it is in operation.**

Both the left and right marker assemblies on all planter bars, whether single or dual valve systems, have two flow control valves built into the hydraulic system. This permits the operator to manually adjust the proper speed of "lift" and "lower" for each marker as there is a valve for each direction on both cylinders.

**CAUTION: The flow controls should be properly adjusted before the marker assembly is first put into use to prevent equipment damage.**

To properly match the marker cylinder speed to your tractor's hydraulic system, loosen the lock nut which secures the knurled adjustment knob in place. The raise or lower time is increased by closing the valve (clockwise). This restricts oil flow and slows the speed of the marker cylinder. To increase the cylinder speed and decrease raise or lower time turn the valve counterclockwise to open the valve. This action has no effect on the transport wheel cylinders on single valve systems.

**NOTE: After the flow controls have been adjusted, the marker speed will decrease with cold oil supply. Make sure that all adjustments are made with warm oil.**

**⚠ WARNING: Always position marker lock-up pin in "safety" position when transporting or storing planter bar. See Safety Precaution.**

## Marker Adjustment

To determine the correct length at which to set the marker assemblies, multiply the number of rows by the row spacing in inches. This provides the total planting width. Then adjust the marker extension so that the distance from the marker disk to the center line of the planter bar is equal to the total planting width previously obtained. Both the planter and marker assembly should be lowered to the ground when measurements are being taken. Also, the measurement should be taken from the point where the disk contacts the ground. Adjust right and left marker assemblies equally and securely tighten clamping bolts. An example of marker length adjustment follows:

Number of Rows	x Row Spacing (inches) =	Dimension between planter bar center line and marker blade
6 x 30"	= 180" marker dimension	

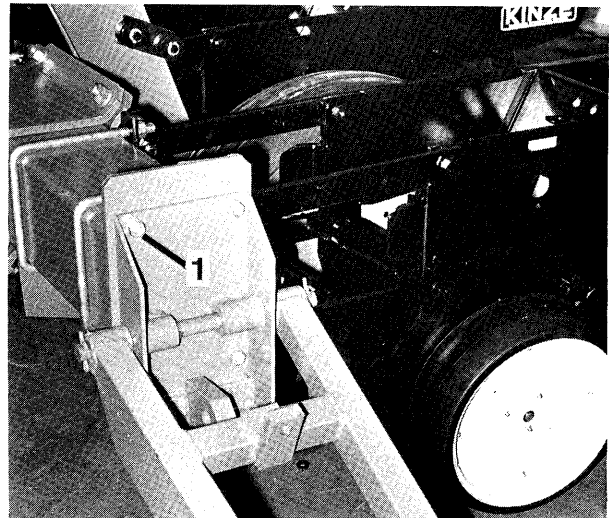

The marker disk is installed so the concave side of the disk is outward to throw dirt away from the grease seals. To provide further variation in the size of the mark, the spindle bracket is slotted so the hub and blade can be angled forward or rearward to throw more or less dirt. To adjust the hub and spindle, loosen the 1/2" x 3 1/2" capscrews and move the bracket as required. Then tighten bolts to the specified torque.

# OPERATION

## Tractor Speed

Depending upon seed population being planted and sprocket combinations, ground speeds may range from 2 to 7 miles per hour. However, optimum speed for most conditions is 5 to 5.5 MPH. Seed population may increase at higher planting speeds, particularly at higher population rate settings.

Consult the operator's manual and planting rate charts for your row units for further tractor speed information. Planting rate charts for Kinze row units equipped with plateless corn or soybean meters can be found at the end of the operation section of this manual.

## Planting Depth

Planting depth is maintained by the row unit gauge wheels. To increase or decrease the planting depth, first raise the planter bar to remove weight from the wheels. Then lift the depth adjustment handle and reposition it forward to decrease depth or rearward to increase planting depth. Adjust all units to the same depth initially. Then lower the planter bar and check operation and planting depth of all row units. It may be necessary to readjust certain rows to obtain consistent operation.

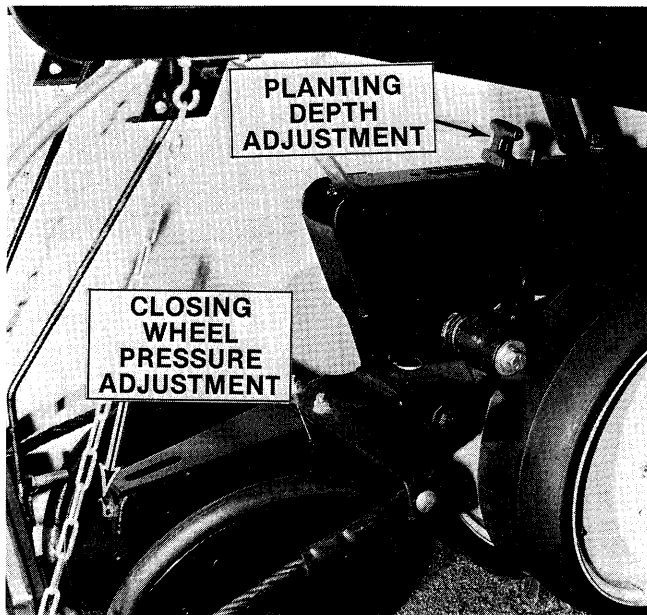

## Closing Wheel Pressure

After adjusting for planting depth, check the operation of the closing wheels. The closing wheels should gently close the row without sinking in or compacting the soil. To increase spring pressure on the closing wheels, turn the adjustment bolt, located at the rear of the closing wheel

arm in a clockwise direction. Turning the bolt in the counterclockwise direction decreases spring tension.

Adjust all row units to a similar setting. Tension setting can be determined by checking the position of the tension spring through the viewing slot on top of the closing wheel arm.

When planting in light soil at average depth (approximately 2") start by setting the dimension between the bolt head and the rear edge of the spring plug at 2 inches. For medium soil at average depth, increase spring tension to obtain 1½" between the bolt head and spring plug.

For heavy soil and average planting depths of 2 to 3 inches, set the bolt dimension at approximately 1".

**IMPORTANT:** In field conditions that require a light soil setting of more than 2", it is recommended that a jam nut be placed on the bolt and tightened against the spring plug. This will prevent bolt loss when operating with minimum spring tension.

## Plateless Drive Release

The plateless drive clutch is equipped with a release mechanism that allows the drive to be disconnected from the seed metering unit. Disconnecting the drive allows the operator to check insecticide and/or herbicide application rates without dropping seed. It also allows one or more of the rows to be disconnected when finishing fields.

To disengage the drive, lift the release handle and pull outward until the handle locks in the slot in the side of the hopper side panel. To engage the row unit, simply lift and unlatch the handle. Spring tension will return the mechanism to the drive position.

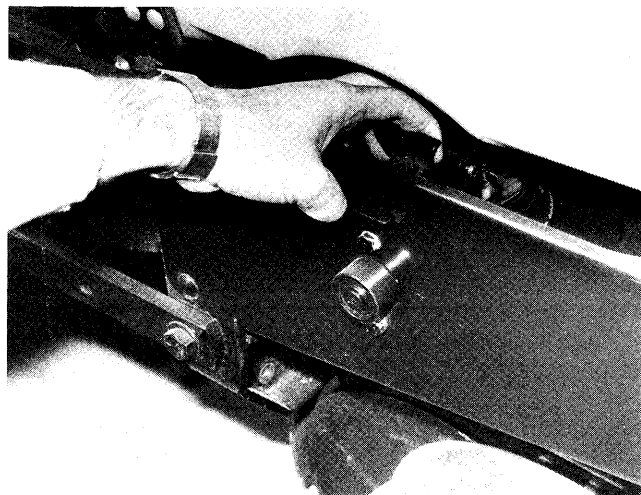

# OPERATION

## Feed Cup Meters

The feed cup meter consists of the feed cup beans, sorghum-regular rate or sorghum-low rate. The seed guide and seed cup housing are both notched to insure correct installation by aligning with a projection on the feed cup adapter. Make sure all parts are seated when assembling the meter.

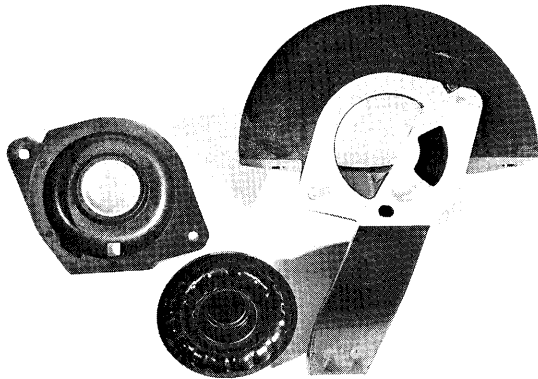
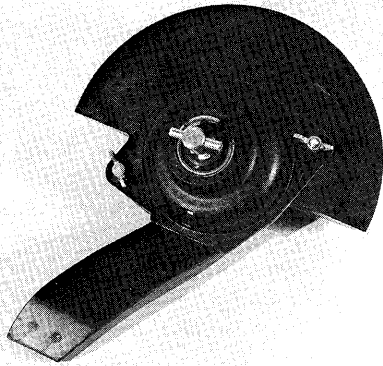

When planting low rate sorghum or milo, it may be necessary to adjust the seed clearance to obtain the desired planting rates. Three washer shims have been supplied with each seed meter, and must be used on either side of the feed cup.

For precision planting of small seeds (9/64" in diameter or smaller) place all three shims between the feed cup and the housing. When seeds are approximately 10/64" in diameter, place one washer between the feed cup and the housing and two washers between the feed cup and seed guide. Progressively large seeds (11/64" or larger) will require one washer shim between the feed cup and housing and two between the feed cup and seed guide; or all three shims between the feed cup and seed guide.

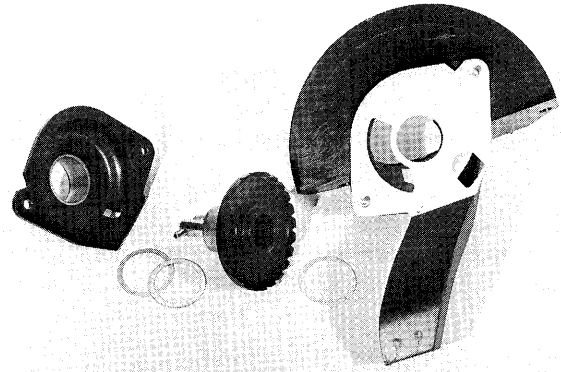

### Low Rate Sorghum Cup and Guide

Assemble the feed housing, shims, feed cup and seed guide insuring that notches in parts are aligned. Make sure seed cup housing and seed guide are seated and secure seed meters together with wing nuts.

Refer to planting rate chart for recommended seed drive transmission sprocket combinations.

### Shear Pin Protection

The transmission and row unit components are protected from damage by the cotter shear pin which connects each drill shaft to the transmission.

If excessive load on the drill shaft should cause the pin to shear, it is important to determine where binding has occurred before replacing the pin. Turn the drill shaft by hand, checking for misalignment of the shaft and for the possibility of seized parts. If necessary, loosen the mounting bolts on each bearing drive sprocket assembly; then align sprockets and retighten mounting bolts.

When the drill shaft can be turned by hand (with the aid of a wrench) replace the cotter pin with one of identical 3/16" x 2" size.

To prevent future binding or breakage of components, follow prescribed lubrication schedules.

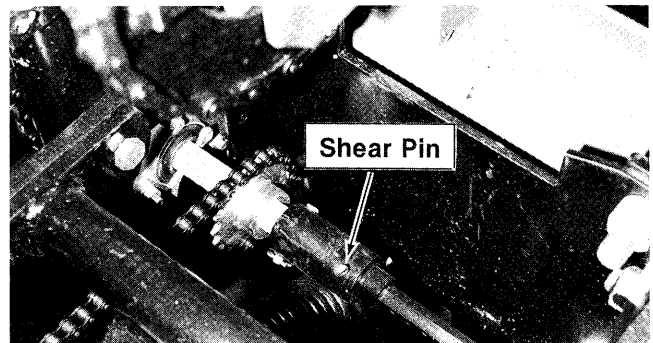

# OPERATION

## Down Pressure Spring Adjustment

The optional conventional or heavy duty down pressure springs are designed to increase penetration in hard soil and keep the row unit from bouncing in rough field conditions.

To increase down pressure with either type of system, loosen the jam nuts and turn the adjusting bolts clockwise. Tighten lock nuts as soon as desired down pressure is obtained to maintain setting.

**IMPORTANT:** Do not attempt to set down pressure at maximum pressure in hard soil conditions. This can cause the row units to carry the planter and raise the drive wheels to the point that excessive slippage may occur.

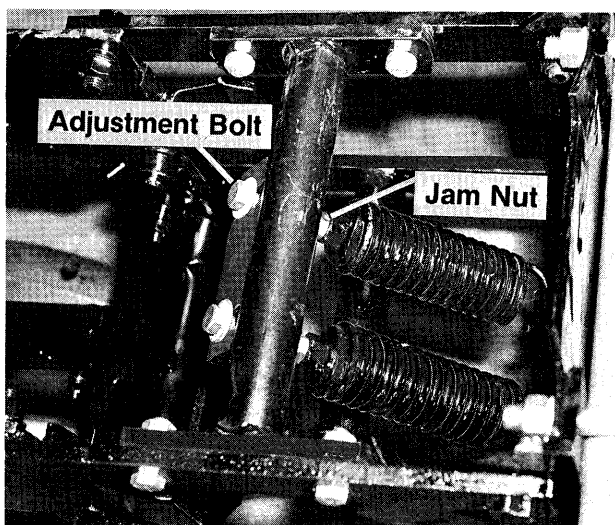

**WARNING:** Do not operate the double disk openers at full down pressure tension when planting in rocky ground. Chipping of the disk blades may occur.

The scrapers on each blade may also be adjusted to make up for wear that may occur. Make sure the scraper is adjusted as close as possible to the blade without touching.

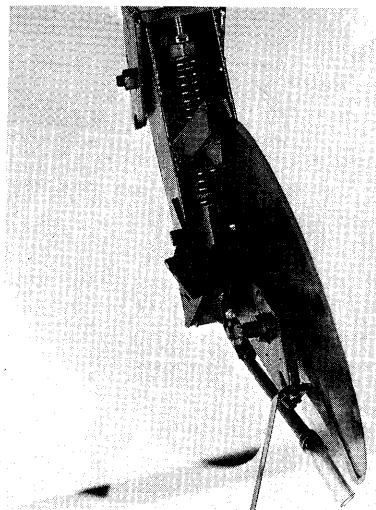

The opener assembly is designed to be locked in a raised position when the fertilizer attachment is not in use or during storage. To lock the opener, first raise the planter and place blocks under the openers. Then lower the planter until the hole in the pivot section aligns with the hole in the mounting bracket. Remove the lockup pin from the storage position in the mounting bracket and install it through the lockup hole and secure with cotter pins.

## Double Disk Opener

The double disk openers should be positioned during assembly to place the fertilizer approximately 2" to either side of the row and from 4 to 6 inches deep depending upon soil conditions and down pressure.

The down pressure springs are factory preset at 250 pounds down pressure but may be adjusted for various soil conditions. To adjust spring tension, loosen the jam nut with a 15/16" wrench and use a 1" wrench to turn the adjustment bolt clockwise to increase tension or counterclockwise to decrease tension. Securely tighten the jam nut upon completion of tension adjustment.

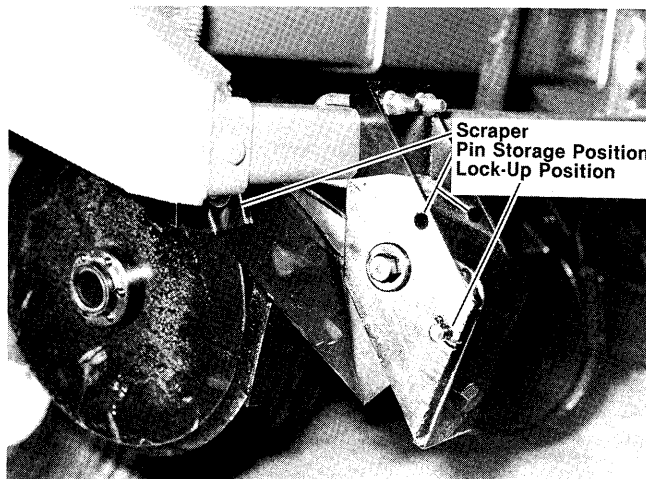

# OPERATION

## Dry Fertilizer Attachment

The rate of dry fertilizer application is determined by the drive and driven sprocket combinations on the fertilizer transmission. Sprocket combinations are changed in the same manner as the row unit transmission. After removing the rubber spacers and loosening the drive chain, slide the selected sprockets into alignment with the idlers. Then, restore proper chain tension and replace spacers between sprockets. Refer to the application charts at the end of "Operation" for selection of sprocket combinations.

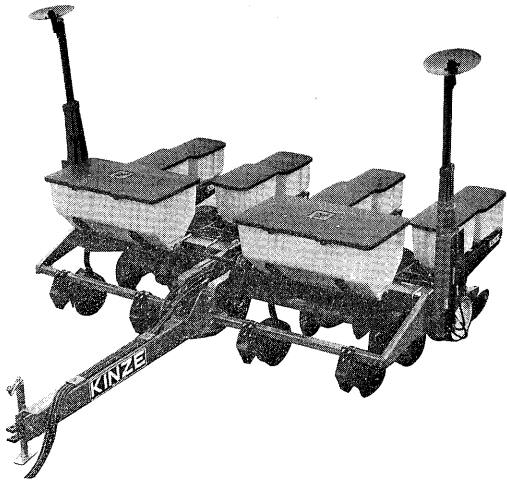

The dry fertilizer attachment meters granules by volume rather than weight. For this reason, and given the variances in brands and fertilizer analysis, the weight metered during actual application may vary considerably. Use the chart for reference only. It is suggested that a container be used to catch and measure application (as explained following the application chart) to obtain a closer estimate.

Since most fertilizers easily accumulate moisture, it is important that fertilizer be kept dry during use and storage. In addition to waste, deposits of fertilizer left in the hopper can cause metal corrosion.

The dry fertilizer attachment uses two fiberglass hoppers on the 4 row models, three hoppers on the 6 row models and four hoppers on the 8 row models. Each hopper is designed to hold approximately 550 pounds depending upon the type of fertilizer being used.

**⚠ WARNING:** Agricultural chemicals can be dangerous if not selected and handled with care. Always read and follow directions supplied by the chemical manufacturer.

## Cleaning

The dry fertilizer hoppers are designed to tip forward for dumping and ease of cleaning. To dump hoppers, first disconnect the drive shaft from the transmission or adjacent hopper. Loosen hose clamps and remove hoses from each hopper.

Finally, remove the two cap screws from the hopper bracket at the rear of each hopper. Rotate hopper lids to the back side of the hopper and carefully tip hopper forward. After dumping contents, flush all loose fertilizer from the hopper and hoses.

At the end of the planting season, or when fertilizer attachment is not going to be used for a period of time, the hoppers should be disassembled, cleaned and coated with a rust preventative.

To disassemble spreader assemblies, remove the hairpins and baffle from the top of the auger. Then remove the cotter pin from the auger shaft adjacent to the large flat washer and pull auger assembly from the hopper. The bearings pass through the outer castings and need not be removed. Remove the cotter pin and washer from outer end of the auger shaft and remove all auger components for cleaning. Coat all parts with rust preventative before reassembly.

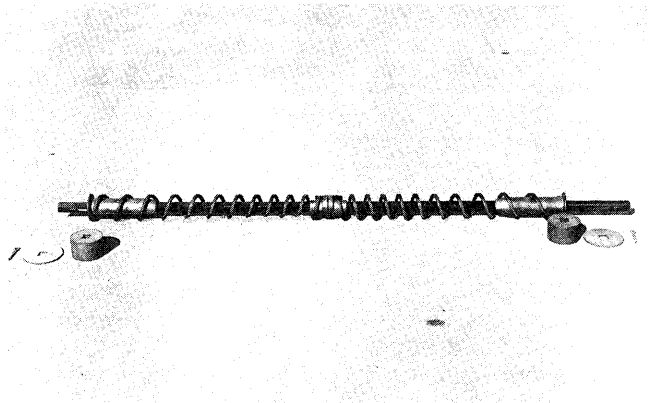

**NOTE:** Left hand and right hand springs are used on each auger shaft. Make sure springs auger fertilizer to the outer ends of the hopper when rotated in the direction of rotation they turn on the planter.

## Liquid Fertilizer Attachment

The rate of liquid fertilizer application is determined by the combination of sprockets on the squeeze pump driven and drive shaft. When changing sprocket combinations, make sure sprockets and idler are in alignment, sprocket retaining collars are tight and chain tension is sufficiently restored.

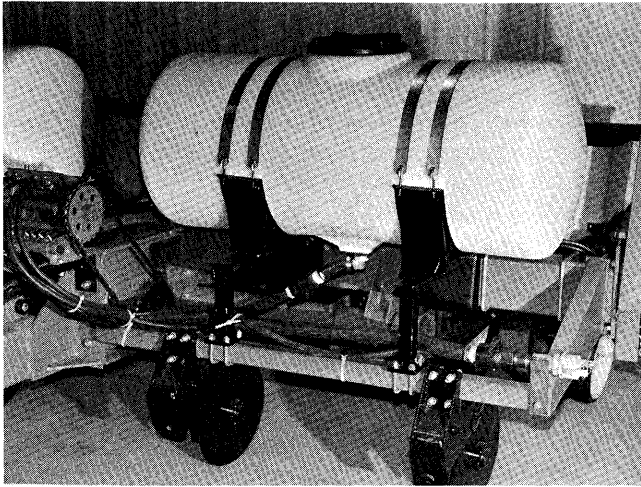

The delivery rate chart found at the end of the "Operation" section provides an approximate application rate only. Actual delivery will vary with temperature and the particular fertilizer being used.

**⚠ WARNING: Agricultural chemicals can be dangerous if not selected and handled with care. Always read and follow directions supplied by the chemical manufacturer.**

Shut off valves provided under each tank, should be closed to shut off flow when the planter sets overnight or for extended periods of time. It is also important to close the tank valves whenever service on the pump or hoses is being performed. To prolong the life of the hoses in the squeeze pump, the discharge manifold must be repositioned to the rearward position to prevent hose distortion.

The discharge manifold must be in the forward position when the pump is in operation. To reposition the manifold, loosen the wing nuts and slide the manifold forward and sideways or rearward as required and retighten nuts.

**CAUTION: Avoid excessive pressure when using the quick fill attachment. The rubber plugs installed in the manifold may be forced out under pressure.**

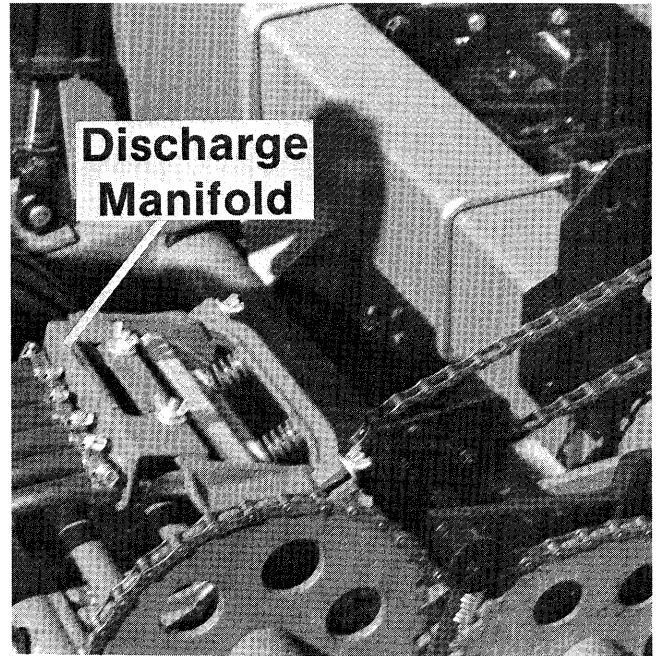

If either of the end pump hoses should run off the back plate, loosen the hose clamp on the intake manifold and rotate the hose as follows.

For the right hand hose (facing the pump from front of planter) twist the hose  $\frac{1}{4}$  turn in the clockwise direction.

For the left hand hose (facing front of pump) twist the hose  $\frac{1}{4}$  turn in the counter-clockwise direction.

*Retighten hose clamp.*

## Cleaning

The tanks and all hoses are made of sturdy plastic and rubber to resist corrosion. However, the tank should be rinsed with water after each season or extended period of non-use. Do not allow sludge to build up in the bottom of the tank or allow fertilizer to crystallize because of cold temperature or evaporation.

At the end of the planting season, thoroughly clean all parts with clean water and flush the tanks hoses and metering pump prior to storage.



# OPERATION

## Planting Rate for Plateless Corn Meter

Seed Populations Per Acre			Average Seed Placement In Inches	Sprocket Combinaitons		Recommended Speed Range In MPH
30 Inch Rows	36 Inch Rows	38 Inch Rows		Drive Sprocket	Driven Sprocket	
56,200	46,800	44,300	3-3/4	30	14	2 to 3
48,700	40,600	38,510	4-1/4	26	14	2 to 3 1/2
43,700	36,400	34,500	4 3/4	30	18	3 to 4
41,300	34,400	32,600	5 1/8	22	14	3 to 4 1/2
37,800	31,600	29,900	5 1/2	26	18	3 to 4 1/2
35,700	29,800	28,200	5 7/8	30	22	3 to 5
32,100	26,800	25,400	6 1/2	22	18	3 to 5 1/2
30,700	25,800	24,400	6 3/4	26	22	3 to 6
30,100	25,200	23,900	7	30	26	3 to 6
29,950	24,950	23,700	7 1/8	16	14	3 to 6
27,800	23,200	21,950	7 1/2	30	28	4 to 6 1/2
26,200	21,900	20,600	8	22	22	4 to 7
24,300	20,300	19,200	8 5/8	26	28	4 to 7
23,300	19,400	18,400	9	16	18	4 to 7
22,200	18,500	17,600	9 1/2	22	26	4 to 7
20,700	17,200	16,300	10 1/8	22	28	4 to 7
20,400	16,900	16,100	10 1/4	14	18	4 to 7
19,100	15,900	15,100	11	16	22	4 to 7
16,700	13,950	13,200	12 5/8	14	22	4 to 7
16,200	13,500	12,800	13	16	26	4 to 7
14,950	12,500	11,900	14	16	28	4 to 7
14,200	11,800	11,200	14 7/8	14	26	4 to 7
13,200	10,950	10,400	16	14	28	4 to 7

Above chart for planters equipped with 7.60-15 inch drive tires and 1:1 drive sprocket ratios. Recommended tire pressure 40 PSI.

**IMPORTANT: The above sprocket combinations are best for average conditions. Changes in sprocket combinations may be required to obtain desired planting population.**

The size and shape of seeds will effect the planting rate. Medium round corn is generally the most preferred while small flat is the least desirable. Higher than optimum speeds may result in population rate increases or higher incidents of doubles and triples, particularly with small flat seeds.

# OPERATION

## Planting Rate For Plateless Soybean Meters

Approximate Pounds Per Acre		Sprocket Combinations		Recommended Speed Range In MPH
30 Inch Rows	36 Inch To 40 Inch Rows	Drive Sprocket	Driven Sprocket	
125	98	30	14	3 to 5
110	88	26	14	3 to 5
100	80	30	18	3 to 5
96	76	22	14	3 to 5
92	73	26	18	3 to 5
86	68	30	22	3 to 5
78	61	22	18	3 to 5½
75	59	26	22	3 to 6
72	58	30	26	3 to 6
71	57	16	14	3 to 6
67	53	30	28	4 to 6½
63	50	22	22	4 to 7
58	46	26	28	4 to 7
55	44	16	18	4 to 7
54	43	22	26	4 to 7
50	40	22	28	4 to 7
49	39	14	18	4 to 7
48	38	16	22	4 to 7
43	34	14	22	4 to 7
41	33	16	26	4 to 7
40	32	16	28	4 to 7
37	30	14	26	4 to 7
35	28	14	28	4 to 7

Above chart for planters equipped with 7.60-15 inch drive tires and 1:1 drive sprocket ratios. Recommended tire pressure 40 PSI.

**IMPORTANT:** Soybean rates may vary widely depending upon size of the seed.

Approximate rates for row spacings, other than those shown above, may be calculated using the rate setting that is one half the desired setting. Refer to the following example:

15-inch rows at a desired planting rate of 80 lbs. per acre. Use the 30" chart since 15" spacing is ½ of 30". Then follow the column down to the 40 lbs. per acre setting, which is ½ of the desired 80 lbs. per acre rate. This indicates that the 16 tooth drive sprocket/28 tooth driven sprocket will provide the desired planting rate.

If lower rates are desired, special drive sprockets are available on a special order basis.

# OPERATION

## Planting Rate For Plateless Regular Rate Sorghum Meters

Approximate Pounds Per Acre		Sprocket Cominations		Recommended Speed Range In MPH
30 Inch Rows	36 Inch To 40 Inch Rows	Drive Sprocket	Driven Sprocket	
21	16.7	30	14	2 to 3
17.5	13.9	26	14	2 to 3½
16.2	12.9	30	18	3 to 4
15.1	12.0	22	14	3 to 4½
13.8	10.9	26	18	3 to 4½
12.9	10.2	30	22	3 to 5
11.8	9.4	22	18	3 to 5½
11.2	8.9	26	22	3 to 6
11.1	8.8	30	26	3 to 6
10.9	8.6	16	14	3 to 6
10.0	7.9	30	28	4 to 6½
9.6	7.6	22	22	4 to 7
9.1	7.2	26	28	4 to 7½
8.8	7.0	16	18	4 to 8
8.5	6.7	22	26	4 to 8
8.0	6.3	22	28	4 to 8
7.9	6.3	14	18	4 to 8
7.6	6.0	16	22	4 to 8
6.8	5.4	16	26	4 to 8
6.3	5.0	16	28	4 to 8
6.2	4.9	14	26	4 to 8
5.9	4.7	14	28	4 to 8

Above chart for planters equipped with 7:60-15 inch drive tires and 1:1 drive sprocket ratio. Recommended tire pressure 40 PSI.

# OPERATION

## Planting Rate For Plateless Low Rate Sorghum Meters

Approximate Pounds Per Acre		Sprocket Combinations		Recommended Speed Range In MPH
30 Inch Rows	36 Inch to 40 Inch Rows	Drive Sprocket	Driven Sprocket	
6.2	4.9	30	14	2 to 3
5.4	4.3	26	14	2 to 3½
4.8	3.8	30	18	3 to 4
4.6	3.6	22	14	3 to 4½
4.2	3.3	26	18	3 to 4½
4.0	3.1	30	22	3 to 5
3.6	2.8	22	18	3 to 5½
3.4	2.7	26	22	3 to 6
3.4	2.7	30	26	3 to 6
3.3	2.6	16	14	3 to 6
3.1	2.4	30	28	4 to 6½
2.9	2.3	22	22	4 to 7
2.7	2.1	26	28	4 to 7
2.6	2.1	16	18	4 to 7
2.5	2.0	22	26	4 to 7
2.3	1.8	22	28	4 to 7
2.3	1.8	14	18	4 to 7
2.1	1.7	16	22	4 to 7
1.9	1.5	14	22	4 to 7
1.8	1.4	16	26	4 to 7
1.7	1.3	16	28	4 to 7
1.6	1.2	14	26	4 to 7
1.5	1.2	14	28	4 to 7

Above chart for planters equipped with 7:60-15 inch drive tires and 1:1 drive sprocket ratios. Recommended tire pressure 40 PSI.

# OPERATION

## DRY INSECTICIDE APPLICATION RATES

<b>Clay Granules</b> <b>Approximate Rate In Pounds Per Acre At 5 MPH</b>			
Meter Setting	30 Inch Rows	36 Inch Rows	38 Inch Rows
10	4.1	3.4	3.3
12	5.4	4.5	4.3
14	6.8	5.7	5.4
16	8.1	6.8	6.5
18	9.4	7.9	7.5
20	10.7	9.0	8.5
22	12.1	10.1	9.6
24	13.4	11.2	10.6
26	14.7	12.3	11.6
28	16.1	13.4	12.7
30	18.1	15.1	14.3
32	20.1	16.8	15.8
34	22.7	19.0	18.0
36	25.4	21.2	20.1
<b>Sand Granules</b> <b>Approximate Rate In Pounds Per Acre At 5 MPH</b>			
Meter Setting	30 Inch Rows	36 Inch Rows	38 Inch Rows
6	4.8	4.0	3.8
8	6.8	5.7	5.4
10	8.6	7.2	6.8
12	10.5	8.7	8.3
14	12.1	10.1	9.6
16	13.7	11.4	10.8
18	16.1	13.4	12.7
20	18.5	15.4	14.6
22	21.4	17.9	16.9
24	24.1	20.1	19.1
26	28.1	23.4	22.2

Variations in pounds per acre may occur with changes in seed planting rates.

Rate is affected by changes in temperature and climatic conditions. Changes in speed or field conditions may also affect metering rates.

# OPERATION

## DRY HERBICIDE APPLICATION RATES

<b>Clay Granules</b> <b>Approximate Rate In Pounds Per Acre At 5 MPH</b>			
<b>Meter Setting</b>	<b>30 Inch Rows</b>	<b>36 Inch Rows</b>	<b>38 Inch Rows</b>
6	4.1	3.4	3.3
8	5.4	4.5	4.3
10	6.7	5.6	5.3
12	8.1	6.7	6.4
14	9.4	7.9	7.5
16	10.7	8.1	8.6
18	12.1	10.1	9.6
20	13.4	11.2	10.6
22	14.4	12.3	11.7
24	16.1	14.5	12.7
26	18.7	15.6	14.8
28	20.4	17.1	16.2
30	23.4	19.5	18.5

Variations in pounds per acre may occur with changes in seed planting rates.

Rate is affected by changes in temperature and climatic conditions. Changes in speed or field conditions may also affect metering rates.

# OPERATION

## DRY FERTILIZER APPLICATION RATES

Approximate Rate in Pounds Per Acre					
Drive Sprocket	Driven Sprocket	30 Inch Rows	36 Inch Rows	38 Inch Rows	40 Inch Rows
18	36	87	73	68	65
18	30	101	85	79	76
24	36	127	107	99	95
24	30	151	129	118	113
18	18	181	152	141	136
18	16	208	175	162	156
36	30	215	180	168	161
24	18	242	203	189	181
24	16	269	225	210	201
36	18	357	300	278	267
36	16	390	327	304	293

**NOTE: Calculated using 7:60 x 15 drive tire with 40 PSI.**

This chart was calculated with a bulk density of 65 pounds per cubic foot.

To check the exact number of pounds your fertilizer attachment will actually deliver on a 40 inch row spacing, proceed as follows:

Remove one spout from one of the fertilizer hoppers and attach a container under the opening. Engage the fertilizer attachment and drive forward for 130 feet. Weigh the amount of fertilizer caught in the container and multiply that amount by 100. The result will be the pounds of fertilizer delivered per acre when planting in 40-inch row. To convert this delivery rate for narrow rows, multiply by the following conversion factors:

30" Multiply by 1.33      36" Multiply by 1.11      38" Multiply by 1.05

# OPERATION

## LIQUID FERTILIZER APPLICATION RATES

Driver	Driven	ROW SPACE Gal. Per Acre				Driver	Driven	ROW SPACE Gal. Per Acre			
		40	38	36	30			40	38	36	30
8	9	19.1	20.4	21.0	25.3	22	23	20.6	22.0	22.7	27.2
8	10	17.2	18.3	18.9	22.7	22	26	18.3	19.4	20.1	24.1
8	15	11.4	12.1	12.5	15.0	22	30	15.1	16.7	17.3	20.7
8	22	7.7	8.2	8.5	10.2	22	31	15.0	16.0	16.6	19.9
8	23	7.5	8.0	8.3	5.6	23	8	61.9	65.9	68.1	81.7
8	26	6.7	7.1	7.3	8.8	23	9	55.0	58.6	60.5	72.6
8	30	5.8	6.2	6.4	7.7	23	10	49.4	52.6	54.4	65.3
8	31	9.9	5.9	6.1	7.4	23	15	32.8	35.0	36.2	43.4
9	8	24.1	25.6	26.5	31.8	23	22	22.6	24.0	24.8	29.8
9	10	19.3	20.6	21.3	25.5	23	26	18.9	20.1	20.8	25.0
9	15	12.9	13.7	14.2	17.0	23	30	16.5	17.6	18.2	21.8
9	22	8.8	9.4	9.7	11.6	23	31	15.9	16.9	17.5	21.0
9	23	8.4	8.9	9.2	11.1	26	8	69.8	74.3	76.8	92.2
9	26	7.5	8.0	8.3	9.9	26	9	62.1	66.1	68.3	81.7
9	30	6.4	6.9	7.1	8.5	26	10	55.9	59.5	61.5	73.8
9	31	6.2	6.6	6.9	8.2	26	15	37.2	39.6	40.9	49.1
10	8	26.9	28.6	29.6	35.5	26	22	25.4	27.0	27.9	33.5
10	9	23.9	25.4	26.2	31.5	26	23	24.3	25.8	26.7	32.1
10	15	14.4	15.3	15.8	19.0	26	30	19.3	19.7	20.3	24.4
10	22	9.7	10.3	10.6	12.8	26	31	18.1	19.0	19.6	23.5
10	23	9.2	9.8	10.2	12.2	30	8	80.1	85.8	88.7	106.4
10	26	8.2	8.7	9.0	10.8	30	9	71.6	76.2	78.7	94.5
10	30	7.1	7.5	7.8	9.4	30	10	64.5	68.6	70.9	85.1
10	31	6.9	7.3	7.6	9.1	30	15	43.0	45.7	47.3	56.7
15	8	40.4	43.0	44.5	53.3	30	22	29.2	31.1	32.2	38.6
15	9	35.9	38.2	39.5	47.4	30	23	27.9	29.7	30.7	36.9
15	10	32.2	34.3	35.5	42.6	30	26	24.7	26.3	27.2	32.6
15	22	14.6	15.6	16.1	19.3	30	31	20.8	22.0	22.7	27.2
15	23	14.0	14.9	15.4	18.4	31	8	83.2	88.5	91.5	109.8
15	26	12.5	13.3	13.7	16.5	31	9	73.9	78.7	81.3	97.6
15	30	10.7	11.4	11.8	14.2	31	10	66.6	70.9	73.3	88.0
15	31	10.3	11.0	11.3	13.6	31	15	44.5	47.1	48.7	58.4
22	8	59.1	62.9	65.0	78.0	31	22	30.3	32.0	33.1	39.7
22	9	52.4	55.8	57.7	69.2	31	23	29.0	30.6	31.7	38.0
22	10	47.3	50.3	52.0	62.4	31	26	25.6	27.2	28.1	33.8
22	15	31.4	33.4	34.5	41.4	31	30	22.1	23.6	24.5	29.2

Approximate application rates using 7.60 x 15 drive tire at 40 PSI and based on a solution weighing 10 pounds per gallon.



# SEED METER TROUBLESHOOTING

## Finger Pick-Up Meter

Problem	Possible Cause	Probable Remedy
One row not planting seed	<p>Drive release not engaged</p> <p>Foreign material in hopper</p> <p>Pin sheared in drive release sprocket</p>	<p>Engage drive release mechanism</p> <p>Clean hopper and finger pick-up mechanism</p> <p>Replace pin—inspect meter for obstructions or defective parts</p>
Drive release does not engage properly	Drive release shaft is not aligned properly with finger pick-up drive shaft	Align drive mechanism by shifting hopper support
Unit is skipping	<p>Foreign material or obstruction in meter</p> <p>Finger holder improperly adjusted</p> <p>Broken fingers</p> <p>Planting too slowly</p>	<p>Clean out and inspect</p> <p>Adjust to proper setting</p> <p>Replace fingers and/or springs as required</p> <p>Increase planting speed to within recommended range</p>
Planting too many doubles	<p>Planting too fast</p> <p>Loose finger holder</p> <p>Worn brush in finger pick-up</p>	<p>Stay within recommended speed range</p> <p>Adjust to specs.</p> <p>Replace brush</p>

## Feed Cup Meter

Problem	Possible Cause	Probable Remedy
One row not planting seed	<p>Drive release not engaged</p> <p>Pin sheared in drive release sprocket</p> <p>Foreign material in hopper</p>	<p>Engage drive release mechanism</p> <p>Replace pin—inspect for obstructions in meter</p> <p>Inspect hopper &amp; meter for foreign material (such as paper)</p>

## Feed Cup Meter

(continued)

Problem	Possible Cause	Probable Remedy
Drive release parts breaking	<p>Drive coupler not aligned properly with feed cup shaft</p> <p>Feed cup not turning freely</p>	<p>Align drive mechanism by shifting hopper support</p> <p>Inspect feed cup and bushings carefully</p>
Planting lower rate than desired	<p>Worn feed cup</p> <p>Obstruction in feed cup or hopper</p> <p>Wrong feed cup</p> <p>Seed treatment building up in feed cup</p> <p>Wrong seed guide plate used with bean cup</p> <p>Improper number of shims used with low-rate sorghum feed cup</p>	<p>Replace feed cup</p> <p>Clean and inspect</p> <p>Replace with proper feed cup for seed being planted</p> <p>Clean thoroughly</p> <p>Replace with proper guide/cup combination</p> <p>Adjust number of shims as required</p>
Planting higher rate than desired	<p>Wrong feed cup</p> <p>Feed cup housing not installed correctly</p> <p>Improper number of shims used with low-rate sorghum feed cup</p>	<p>Replace with proper feed cup</p> <p>Inspect feed cup installation Check for proper seating of feed cup housing</p> <p>Adjust number of shims as required</p>
Bunching of seed	<p>Drive coupler not aligned properly</p> <p>Feed cup housing not seated properly</p> <p>Weak idler spring</p> <p>Obstruction in hopper</p>	<p>Align drive mechanism by shifting hopper support</p> <p>Check installation of feed cup housing</p> <p>Replace as required</p> <p>Clean hopper and meter of all foreign material</p>

### Feed Cup Meter

(continued)

Problem	Possible Cause	Probable Remedy
Feed cup meters hard driving	Build up of seed treatment in feed cups  Drive not properly aligned with meter input shaft  Planter drive rusty and dirty	Clean feed cups and housings  Align drive mechanism by shifting hopper support  Clean and lubricate or replace drive chain

# MAINTENANCE

---

## Mounting Bolts and Hardware

Before operating the planter bar for the first time, check to be sure all nuts and bolts are tight. Check all nuts and bolts again after approximately the first 50 hours of operation and at the beginning of each planting season thereafter.

All bolts used on Kinze planter bars are Grade 5 (high strength) as indicated by three radial dashes on the bolt head. Refer to the torque valve chart in the "Assembly" Section of this manual when tightening bolts.

**NOTE: Overtightening bolts can cause as much damage as undertightening. Tightening a bolt beyond the recommended range can reduce its shock load capacity.**

## Chain Tension Adjustment

Drive chains from the drive gauge wheels to the clutch assembly are equipped to spring tensioned idlers to minimize chain adjustment.

To increase the tension on the seed drive transmission idler proceed as follows:

1. Remove clip pin from tightener assembly shaft and remove spring arm.
2. Rotate arm counterclockwise to the next notch for increased tension. The arm can be turned over for half notch increments.
3. Replace arm and spring clip and reconnect tension spring to check chain tension.

All other idlers are held by a set screw in a fixed position. To increase chain tension, loosen the set screw and pivot the idler assembly against the chain to obtain sufficient tension on the longest span. Retighten set screw securely.

**CAUTION: Do not attempt to shorten the drive chains between the drive wheels and drive shaft on the pull type planter bar. If the chain is being replaced, ensure replacement is the same length. If a shorter chain is used, there is a possibility that the drive shaft could be bent or drive chain broken when the planter bar is fully raised.**

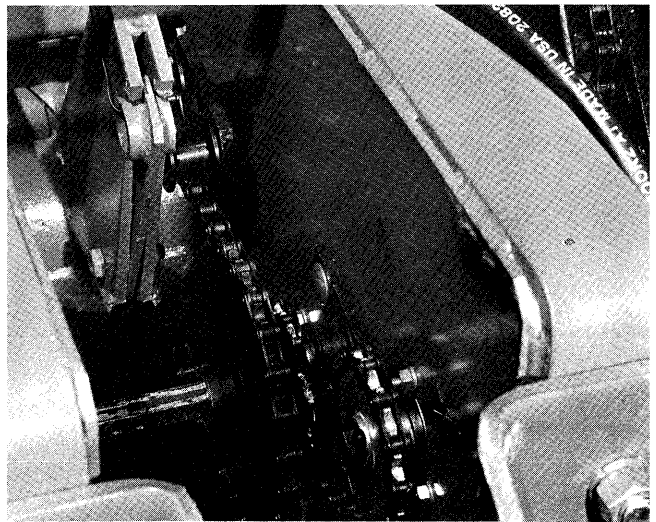
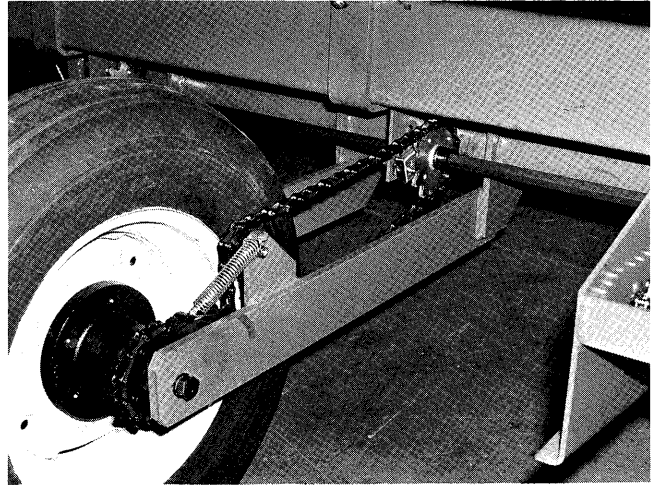

# MAINTENANCE

## Corn Meter Inspection/Cleaning

To inspect or service the finger pickup corn meter, remove the meter from the seed hopper by removing the two 5/16" nuts which secure the mechanism to the hopper. Remove the housing from the meter assembly by removing three 1/4"x5/8" cap screws. This will permit access to the finger pickup.

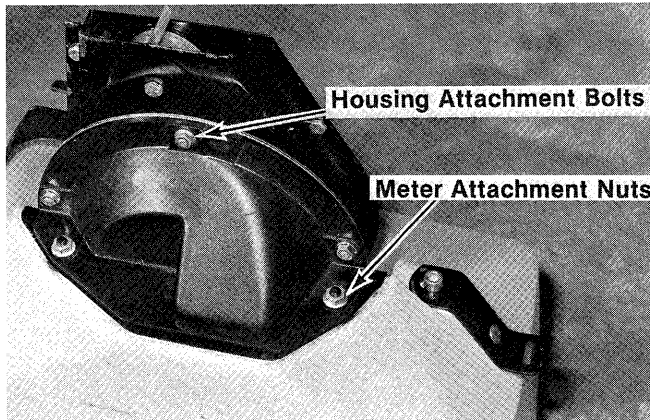

Rotate the seed meter drive by hand to ensure that the springs are holding the tabs of the fingers against the carrier plate where indicated in the photo and that the fingers are being raised in the correct area.

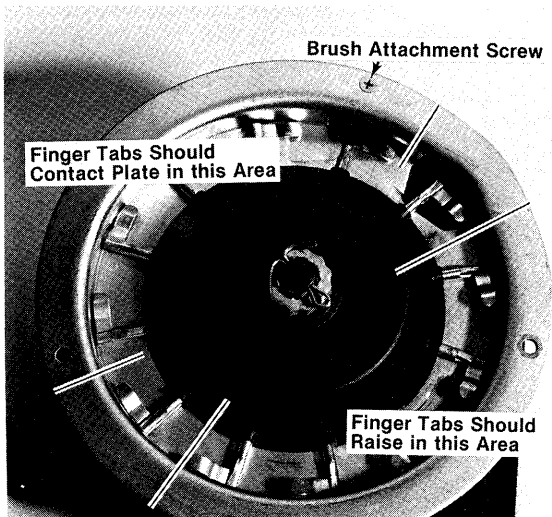

A build-up of debris or chaff may prevent proper finger operation and will require disassembly and cleaning of the corn meter as follows:

1. Remove cotter pin, lock nut and adjusting nut from drive shaft.
2. Carefully lift finger holder, along with fingers and cam off of the shaft and clean.

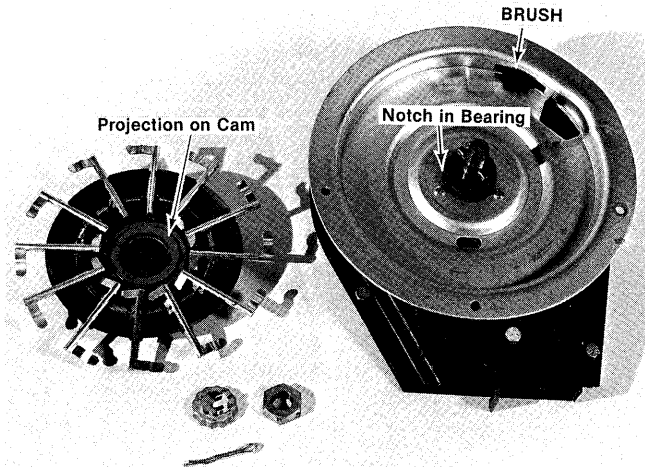

3. Check brush for wear and replace if necessary or following every 100 hours of operation.

NOTE: It is not necessary to remove finger holder to remove brush at prescribed intervals.

4. To replace fingers or springs, remove springs from fingers and remove finger from holder by lifting it out of the friction fit slot.
5. After cleaning and/or replacing defective parts, reassemble the meter in the reverse order. When replacing fingers, make sure the open end of the spring loop is toward the inside of the finger holder.

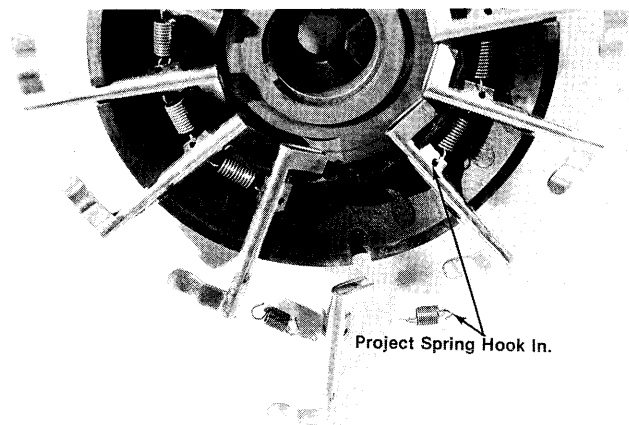

6. Make sure fingers are installed in holder so that holder will be positioned flush with the carrier plate when assembled. A projection on the cam is designed to align with a notch in the bearing to insure proper operation when assembled.

# MAINTENANCE

7. With finger holder flush against the carrier, install adjusting nut until it contacts the finger holder with a slight resistance. Continue to turn the nut an additional  $\frac{1}{8}$  turn.
8. Turn finger holder by hand to make sure it is positioned firmly against the carrier, but is not overtightened and can be rotated with moderate force.
9. Install lock nut and cotter pin and reinstall housing.

## SEED BELT

To inspect or replace the seed belt, remove the four  $\frac{1}{4}$ "x $\frac{1}{2}$ " cap screws around the edge of the housing cover and the nut from the belt idler mounting bolt.

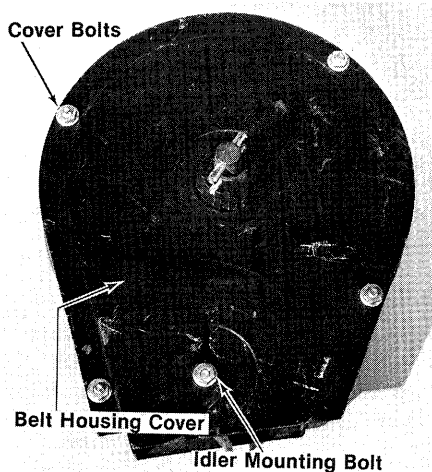

If the belt is being replaced, make sure it is reinstalled to correctly orient the paddles as shown. A diagram molded into the drive wheel also illustrates the correct orientation.

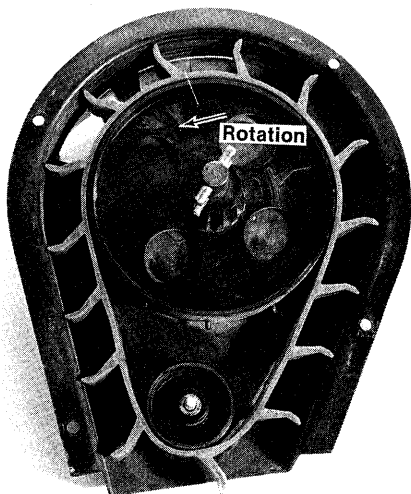

## SEQUENCING VALVE INSPECTION

The sequencing valve consists of a chambered body containing a spool and a series of check valves to direct hydraulic flow. Should the valve malfunction, the components may be removed for inspection. The spool is accessible by removing either side plug and one check valve is accessible from the top of the valve body. It is necessary to disconnect the outlet hoses from the back of the valve to gain access to the remaining retainers and check valves. Inspect all parts for pitting, contamination or foreign material. Also check seating surfaces inside the valve. Replace any parts found to be defective.

**IMPORTANT: Make sure correct check ball and spring are installed in each check valve bore upon reassembly.**

## SEQUENCING VALVE

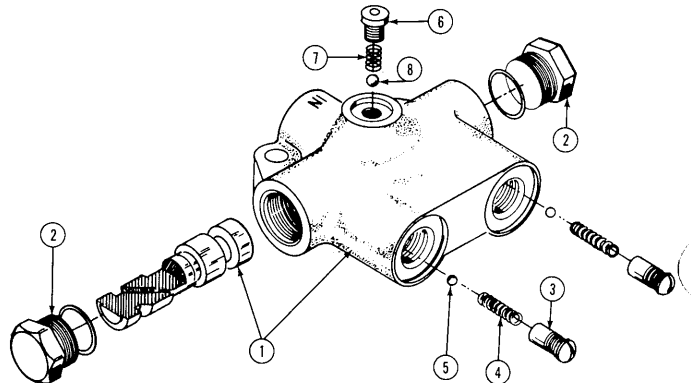

ITEM	PART NO.	DESCRIPTION
1.	R272	Valve Body and Spool
2.	R271	Plug Assembly, O-Ring Boss
3.	R273	Retainer, Check Valve
4.	R277	Spring, Check Valve
5.	R275	Ball, Check, 3/16" Diameter
6.	R274	Plug Assembly, O-Ring Boss
7.	R278	Spring
8.	R276	Ball, 1/4" Diameter

## FLOW CONTROL VALVE INSPECTION

The flow control valves should be adjusted for raise and lower speed as part of the assembly procedure or upon initial operation (see page 42) If the valve fails to function properly or requires frequent adjustment, the needle valve should be removed for inspection. Check for foreign material and contamination on both the valve and the seating area of the valve body. Replace any components found to be defective.

## FLOW CONTROL VALVE

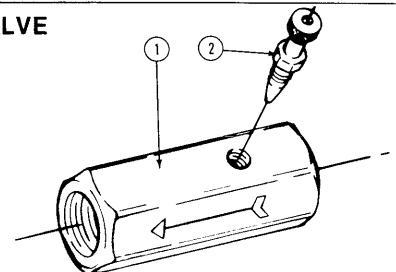

ITEM	PART NO.	DESCRIPTION
1.	A270	Flow Control Valve Assembly, 3/8" NPT (KLF 375)
2.	R103	Needle Valve Assembly

# MAINTENANCE

---

## Wheel or Marker Bearing Lubrication or Replacement

1. Jack tire clear of ground and remove wheel or marker disk.
2. Remove hub cap from hub.
3. Remove cotter pin, axle nut, and washer.
4. Slide hub from axle or spindle.
5. Remove bearing cups and discard if bearings are being replaced. Clean hub and dry.
6. Press in new bearing cups with thickest edge facing in.
7. Pack bearings with heavy duty wheel bearing grease thoroughly forcing grease between roller cone and bearing cage. Also fill the space between the bearing cups in the hub with grease.
8. Place inner bearing in place and press in new grease seal.
9. Clean axle or spindle and install hub.
10. Install outer bearing, washer, or outer seal and slotted hex nut. Tighten slotted hex nut while rotating hub until there is some drag. This assures that all bearing surfaces are in contact. Back off slotted nut to nearest locking slot and install cotter pin.
11. Fill hub caps approximately  $\frac{3}{4}$  full of wheel bearing grease and install on hub.
12. Install wheel or disk on hub and tighten evenly and securely.

## Storage

Store the planter bar in a dry sheltered area if possible.

Remove all trash that may be wrapped on sprockets or shafts and remove dirt that can draw and hold moisture.

Clean all drive chains and coat with a rust preventative spray, or better yet, remove chains and submerge in oil.

Lubricate planter bar and row units at all lubrications points.

If possible, remove weight from all tires particularly if the unit is stored outdoors, in which case it is best to remove wheels and tires for storage in a cool dry area.

Inspect the planter bar and row units for parts that are in need of replacement and order during the "off" season.

If the planter bar is equipped with a dry fertilizer attachment, clean the fertilizer hoppers, openers and all rubber spouts.

Make sure all seed, herbicide and insecticide hoppers are empty and clean.

If the planter bar is equipped with a liquid fertilizer attachment, open the shut off valve and flush water through the system.

Clean plateless seed meters and store in a dry area.

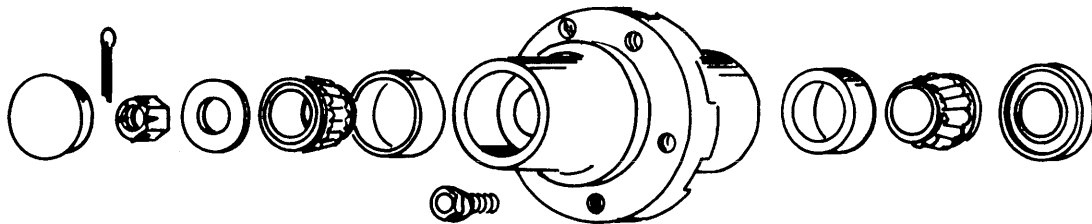





# PARTS LIST INDEX

---

Introduction .....	52
Drive and Drill Shaft .....	53
Main Frame and Axle Assembly 4R30, 4RW, 6R-30", 6RW .....	54
Main Frame and Axle Assembly 8R30" .....	56
Drive Line .....	58
Wheel Assembly .....	60
Sequencing Valve, Flow Control Valve .....	61
Transmission Assembly .....	62
Conventional Marker Assembly .....	64
Low Profile Marker Assembly .....	66
Marker Hub Assembly .....	68
Hydraulic System 8R-30" Single Valve Low Profile Marker .....	69
Hydraulic System 8R-30" Dual Valve Low Profile Marker .....	70
Hydraulic System 6 RW Single Valve Low Profile Marker .....	71
Hydraulic System 4R-30, 4RW, 6R-30" Single and Dual Valve .....	
Conventional Marker .....	72
Lift Cylinder .....	73
Lift Cylinder .....	74
Conventional Marker Cylinder .....	75
Conventional Marker Cylinder .....	76
Low Profile Marker Cylinder .....	77
Decals and Reflectors .....	78
Fertilizer Bar .....	79
Double Disk Fertilizer Opener .....	80
Dry Fertilizer Hopper and Mount .....	82
Dry Fertilizer Couplers .....	84
Dry Fertilizer Transmission .....	86
Liquid Fertilizer Assembly .....	90
Liquid Fertilizer Squeeze Pump 4 Row Model .....	92
Liquid Fertilizer Squeeze Pump 6 Row Model .....	94
Liquid Fertilizer Squeeze Pump 8 Row Model .....	96
Liquid Fertilizer Tank Assembly .....	98

# INTRODUCTION

## PULL TYPE PLANTER BAR



DESCRIPTION	MODELS AFFECTED
Main Frame Assembly	4 Row 30", 4 Row Wide 6 Row 30", 6 Row Wide 8 Row 30"
Gauge Drive Wheel Assembly	All
Seed Drive Transmission	All
Conventional Marker Assembly	4R30, 4R Wide 6R30
Low Profile Marker Assembly	6R Wide, 8R30
Conventional Marker Cylinder	4R30, 4R Wide 6R30
Low Profile Marker Cylinder	6R Wide, 8R30
Hydraulic System	All
Fertilizer Opener Disk	All (Option)
Dry Fertilizer Hopper Assembly	All (Option)
Dry Fertilizer Transmission	All (Option)
Liquid Fertilizer Assembly	All (Option)

# PULL TYPE PLANTER

---

## 7/8" HEX DRIVE SHAFT

Planter Size	Left Hand		Right Hand	
	Length	Part No.	Length	Part No.
4 Row 30"	25"	D914-25	21"	D914-21
4 Row Wide	33"	D914-33	29"	D914-29
6 Row 30"	55"	D914-55		
6 Row Wide	71"	D914-71		
8 Row 30"	85"	D914-85	81"	D914-81

## 9/16" HEX DRILL SHAFT

Planter Size	Left Hand		Right Hand	
	Length	Part No.	Length	Part No.
4 Row 30"	47"	D739-47	37"	D739-37
4 Row Wide	60"	D739-60	48"	D739-48
6 Row 30"	77"	D739-77	67"	D739-67
6 Row Wide	98"	D739-98	86"	D739-86
8 Row 30"	107"	D739-107	98"	D739-98

# MAIN FRAME AND AXLE ASSEMBLY

4 Row 30", 4 Row Wide  
6 Row 30", 6 Row Wide

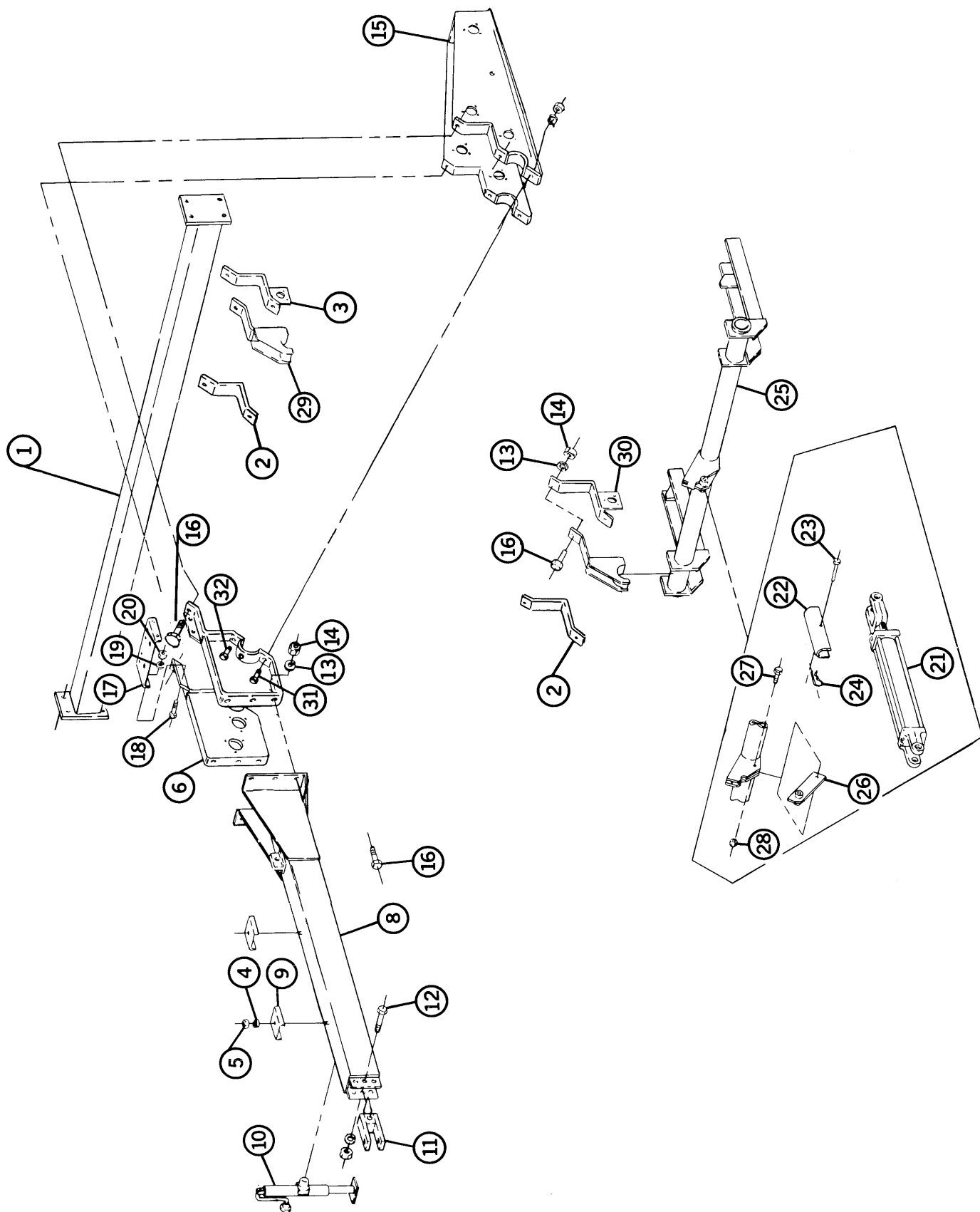

# MAIN FRAME AND AXLE ASSEMBLY

4 Row 30", 4 Row Wide  
6 Row 30", 6 Row Wide

ITEM	PART NO.	DESCRIPTION
1.	A336	Toolbar, 128', 4R30
	A524	Toolbar, 136", 4RW
	A525	Toolbar, 169", 6R30
	A526	Toolbar, 214", 6RW
2.	D457	Half Clamp, (used on 6R30, 6RW)
3.	A333	Axle Clamp Weld, Rear, L.H., (Used on 4R30, 4RW, 6R30 and 6RW)
4.	10228	Lock Washer, 1/2"
5.	10102	Hex Nut, 1/2"-13
6.	A808	Hitch Mount, R.H.
7.	A809	Hitch Mount, L.H.
8.	A788	Tongue Weld
9.	D740	Clamp, Hose
10.	4100-1	Jack
	R255	Repair Kit (Pin and Chain)
11.	A346	Clevis
12.	10029	HHCS, 3/4"-10x4 1/2"
13.	10231	Lockwasher, 3/4"
14.	10105	Hex Nut, 3/4"-10
15.	A350	Transmission (Case, Seed Drive)
16.	10027	HHCS, 3/4"-10x2 1/2"
17.	D965	Valve, Plate
18.	10019	HHCS, 5/16"-18x1", 4R30, 4RW, 6R30
	10133	HHCS, 5/16"-18x1 1/2", 6RW
19.	10232	Lock Washer, 5/16"
20.	10106	Hex Nut, 5/16"-18
21.	A280	Cylinder Assembly, 3 1/2"x8"
	A747	Cylinder Assembly, 3 1/2"x8"
22.	D987	Transport Lock Up
23.	10561	Clevis Pin, 1/2"x3"
24.	10670	Clip Pin, No. 3
25.	A338	Axle Weld, 4R30
	A352	Axle Weld, 4RW
	A354	Axle Weld, 6R30
	A356	Axle Weld, 6RW
26.	A341	Cylinder Mount Weld
27.	10017	HHCS, 1/2"-13x1 1/2"
28.	10111	Lock Nut, 1/2"-13
29.	A335	Axle Clamp Weld, Front
30.	A332	Axle Clamp Weld, Rear, R.H. (Used on 4R30 and 4RW)
31.	10026	HHCS, 3/4"-10x2"
32.	10028	HHCS, 3/4"-10x3"

# MAIN FRAME AND AXLE ASSEMBLY

8 Row 30"

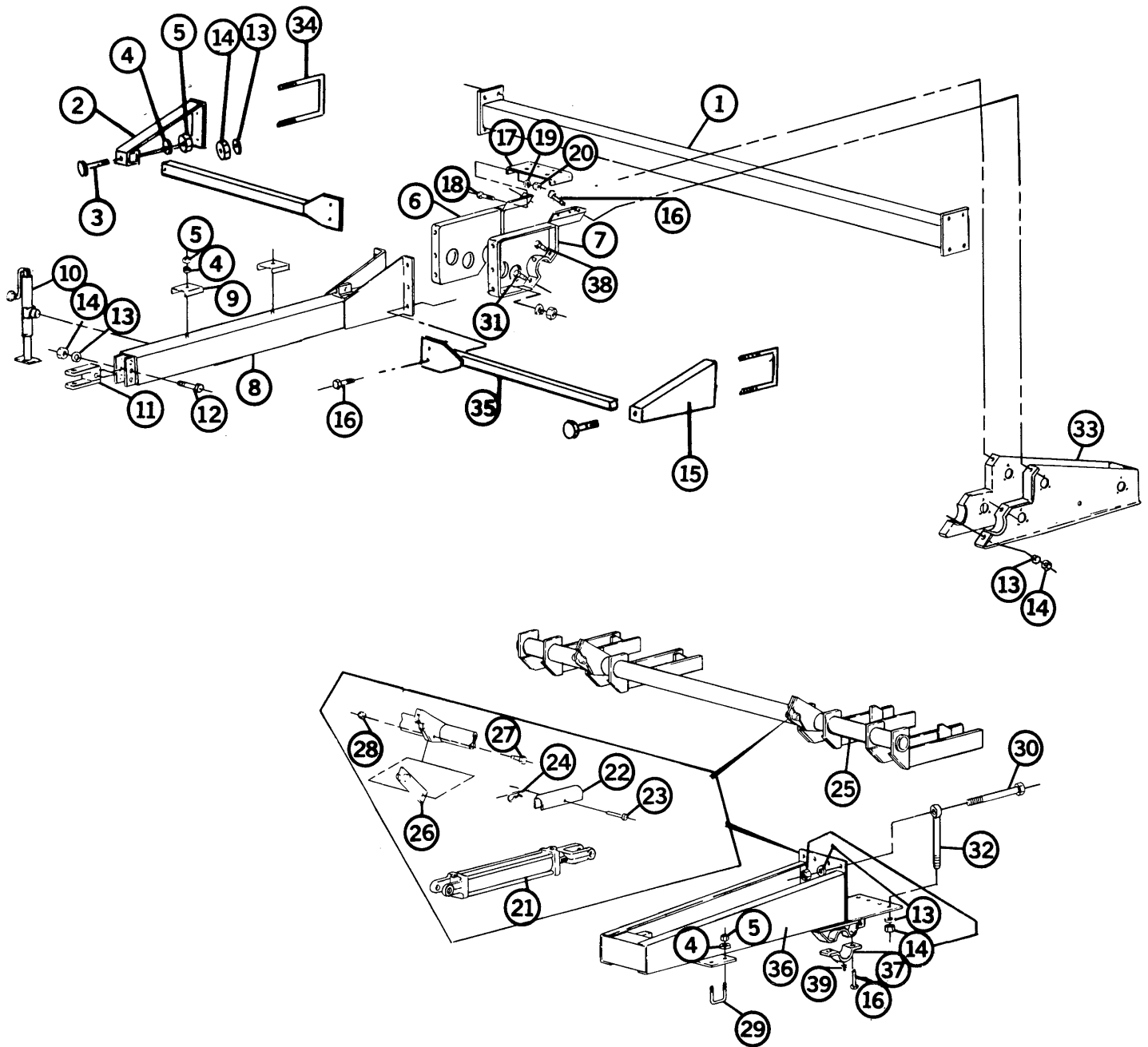

# MAIN FRAME AND AXLE ASSEMBLY

8 Row 30"

ITEM	PART NO.	DESCRIPTION
1.	A527	Tool Bar, 229"
2.	A870	Fertilizer Bar Support, R.H.
3.	10032	HHCS, 1/2"-13x3 3/4"
4.	10228	Lock Washer, 1/2"
5.	10102	Hex Nut, 1/2"-13
6.	A808	Hitch Mount, R.H.
7.	A809	Hitch Mount, L.H.
8.	A788	Tongue
9.	D740	Clamp, Hose
10.	4100-1	Jack
	R255	Repair Kit, Pin and Chain
11.	A346	Clevis
12.	10026	HHCS, 3/4"-10x4 1/2"
13.	10231	Lock Washer, 3/4"
14.	10105	Hex Nut, 3/4"-10
15.	A869	Fertilizer Bar Support, L.H.
16.	10027	HHCS, 3/4"-10x2 1/2"
17.	D965	Valve Plate
18.	10133	HHCS, 5/16"-18x1 1/2"
19.	10232	Lock Washer, 5/16"
20.	10106	Hex Nut, 5/16"-18
21.	A280	Cylinder, Lift, 3 1/2"x8"
	A747	Cylinder, Lift, 3 1/2"x8"
22.	D987	Transport Lock-up
23.	10561	Clevis Pin, 1/2"x3"
24.	10670	Clip Pin, No. 3
25.	A661	Axle Weld
26.	A341	Mount, Cylinder, Weld
27.	10017	HHCS, 1/2"-13x1 1/2"
28.	10111	Lock Nut, 1/2"-13
29.	D1138	U-bolt, 1/2"x2 1/2"x2 1/2"
30.	10030	HHCS, 3/4"-10x9"
31.	10026	HHCS, 3/4"-10x2"
32.	D830	Eye Bolt, 3/4"-10x9"
33.	A350	Transmission Case, Seed Drive
34.	D1748	U-bolt, 7"x7"x 3/4"-10
35.	A877	Bar Weld
36.	A880	Cylinder Mounting Bracket Weld
37.	A663	Clamp, Half
38.	10028	HHCS, 3/4"-10x3"
39.	10640	Grease Fitting

# DRIVE LINE

---

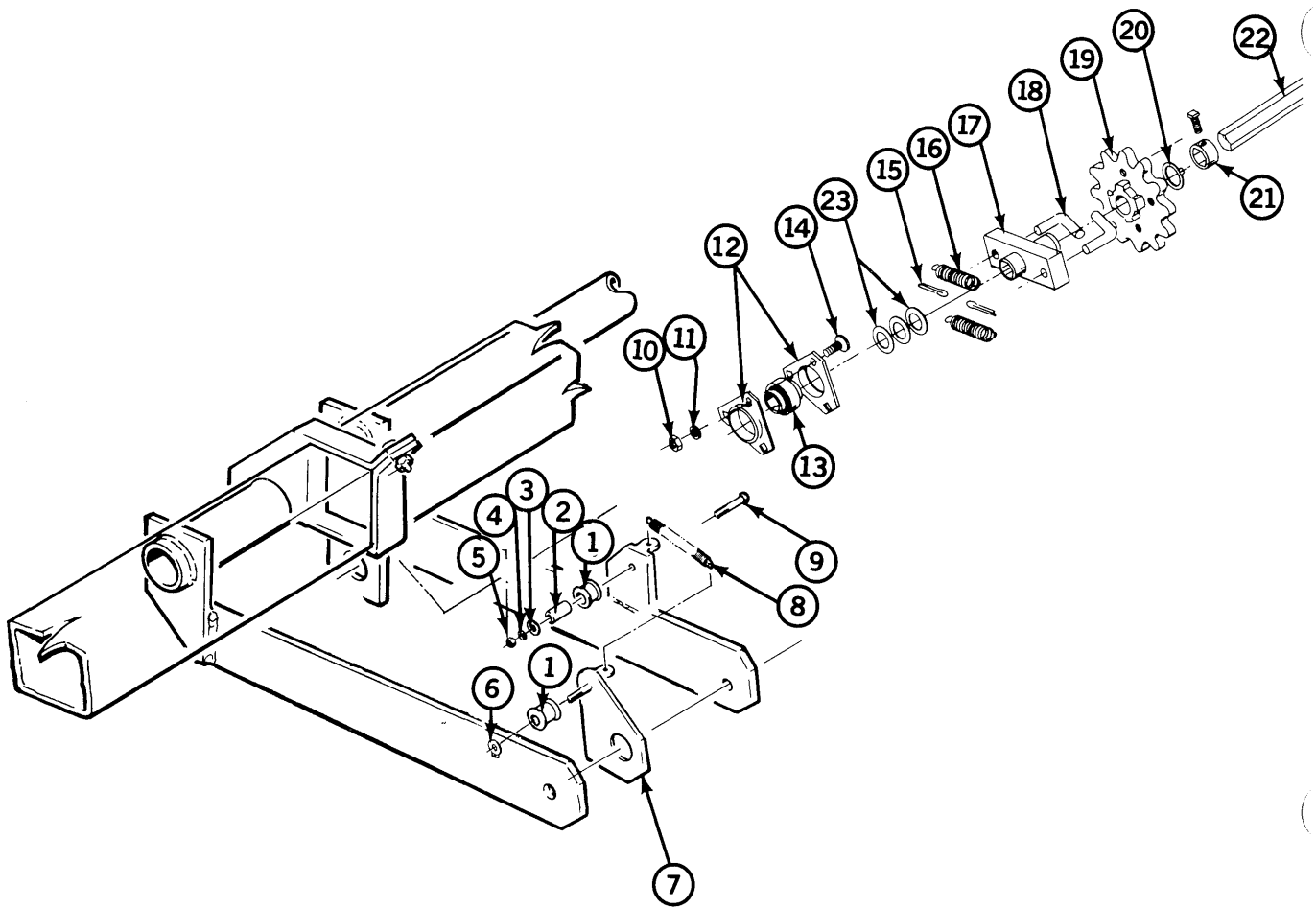



# DRIVE LINE

---

ITEM	PART NO.	DESCRIPTION
1.	D916	Idler Spool
2.	D973	Bushing , Idler
3.	10210	Flat Washer, 3/8" USS
4.	10229	Lock Washer, 3/8"
5.	10101	Hex Nut, 3/8"-16
6.	10435	Snap Ring
7.	A819	Bracket, Idler, R.H. (Shown)
	A820	Bracket, Idler, L.H.
8.	D913	Spring
9.	10049	HHCS, 3/8"-16x2 1/2"
10.	10106	Hex Nut, 5/16"-18
11.	10232	Lock Washer, 5/16"
12.	3400-1	Flangette
13.	2100-3	Bearing 7/8" Hex Bore
14.	10312	Carriage Bolt, 5/16"-18x 3/4"
15.	10464	Cotter Pin, 3/16"x1"
16.	D1256	Spring
17.	A378	Block and Hub Assembly
18.	D1255	"L" Pin
19.	A376	Hub/Sprocket Assembly
20.	10430	Retaining Ring
21.	A271	Lock Collar
22.	D914-25	Drive Shaft, 25", L.H., 4R30
	D914-21	Drive Shaft, 21", R.H., 4R30
	D914-33	Drive Shaft, 33", L.H., 4 RW
	D914-29	Drive Shaft, 29", R.H., 4RW
	D914-55	Drive Shaft, 55", L.H., 6R30
	D914-71	Drive Shaft, 71", L.H., 6RW
	D914-85	Drive Shaft, 85", L.H., 8R30
	D914-81	Drive Shaft, 81", L.H., 8R30
23.	10233	Machinery Bushing, As Required
A.	A821	Idler Assembly, L.H. (Items 1, 6 and 7)
B.	A822	Idler Assembly, R.H. (Items 1, 6 and 7) Shown
C.	A585	Idler Assembly, Stationary (Items 1 - 5 and 9)
D.	A261L	Ratchet Clutch, L.H. (Used on 4R30, W, 6R30, W and 8R30) (Includes Items 15-20)
	A261R	Ratchet Clutch, R.H. (Used on 4R30, W, and 8R30)( Includes Items 15-20)

# WHEEL ASSEMBLY

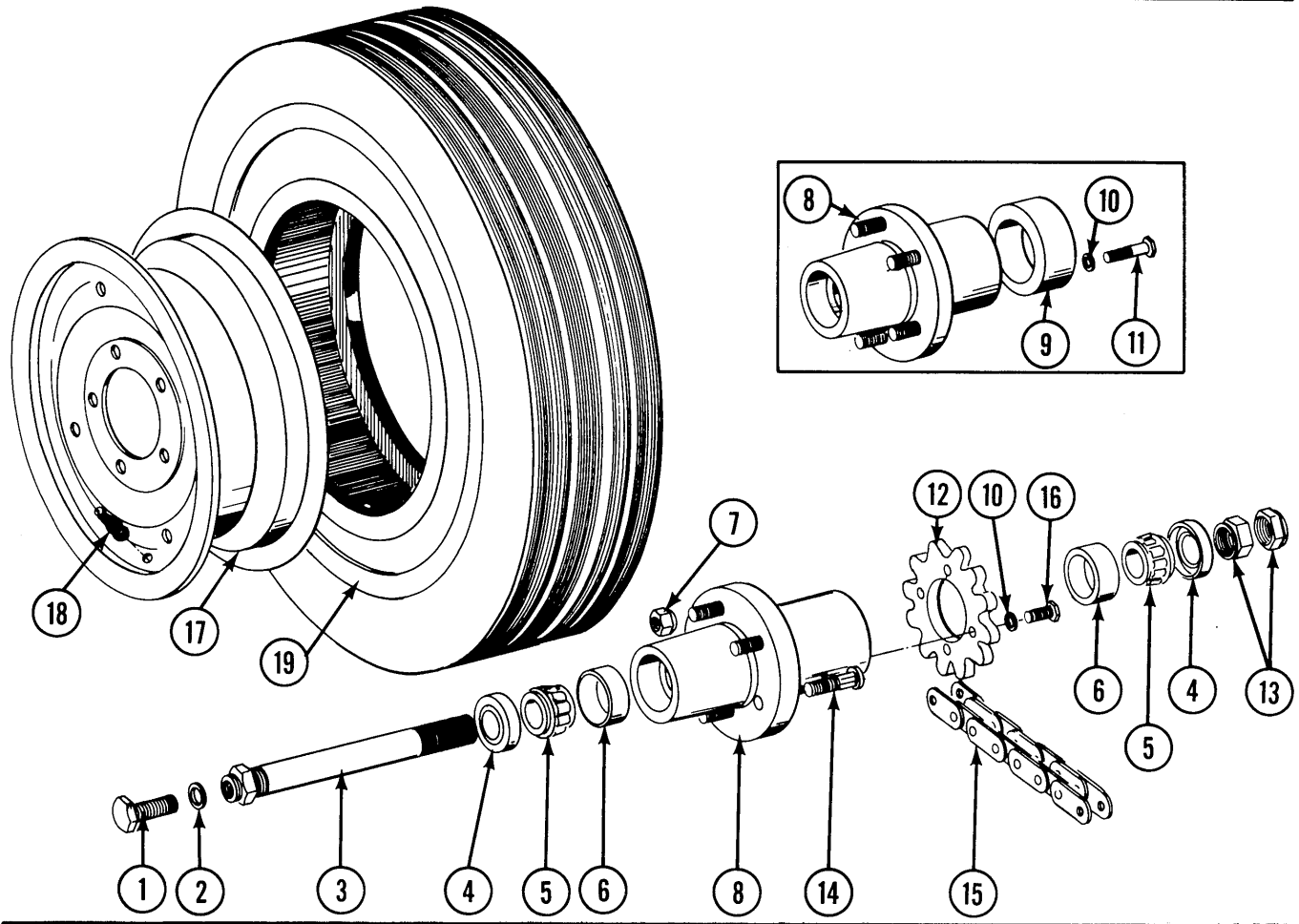

ITEM	PART NO.	DESCRIPTION
1.	10026	HHCS, 3/4"-10x2
2.	10231	Lockwasher, 3/4"
3.	A652	Spindle Weld
4.	A252	Seal, Grease
5.	A251	Bearing
6.	R190	Cup
7.	R267	Nut, Wheel, 1/2"-20 UNF
8.	A255	Hub, W Cups and Studs (Requires Spacer)
	A547	Hub, W Cups and Studs
9.	D915	Spacer
10.	10232	Lockwasher, 5/16"
11.	10031	HHCS, 5/16"-18x1 3/4"
12.	2500-17	Sprocket, Bolt-on, 12 Tooth
13.	D831	Nut, Shoulder, 1 1/4"
14.	R204	Stud, Wheel, 1/2"-20 UNFx1 7/8"
15.	3200-58	Chain, No. 2050, 58 Pitch, Includes Connector Link
	R195	Connector Link, 2050
16.	10019	HHCS, 5/16"-18x1"
17.	A241	Wheel, 15"x5, 5 Bolt
18.	D1166	Valve Stem
19.	D844	Tire, 7.60x15"x 4 ply
A.	A269	Drive Hub Assembly, Uses Spacer with sprocket (Items 1-14)
	A683	Drive Hub Assembly w/Sprocket (Items 1-8, 10, 12-14 and 16)
B.	A379	Drive Hub Assembly Less Sprocket (Items 1-8 and 13)
C.	A374	Tire and Rim Assembly, 7.60x15" (Items 17-19)

# SEQUENCING VALVE

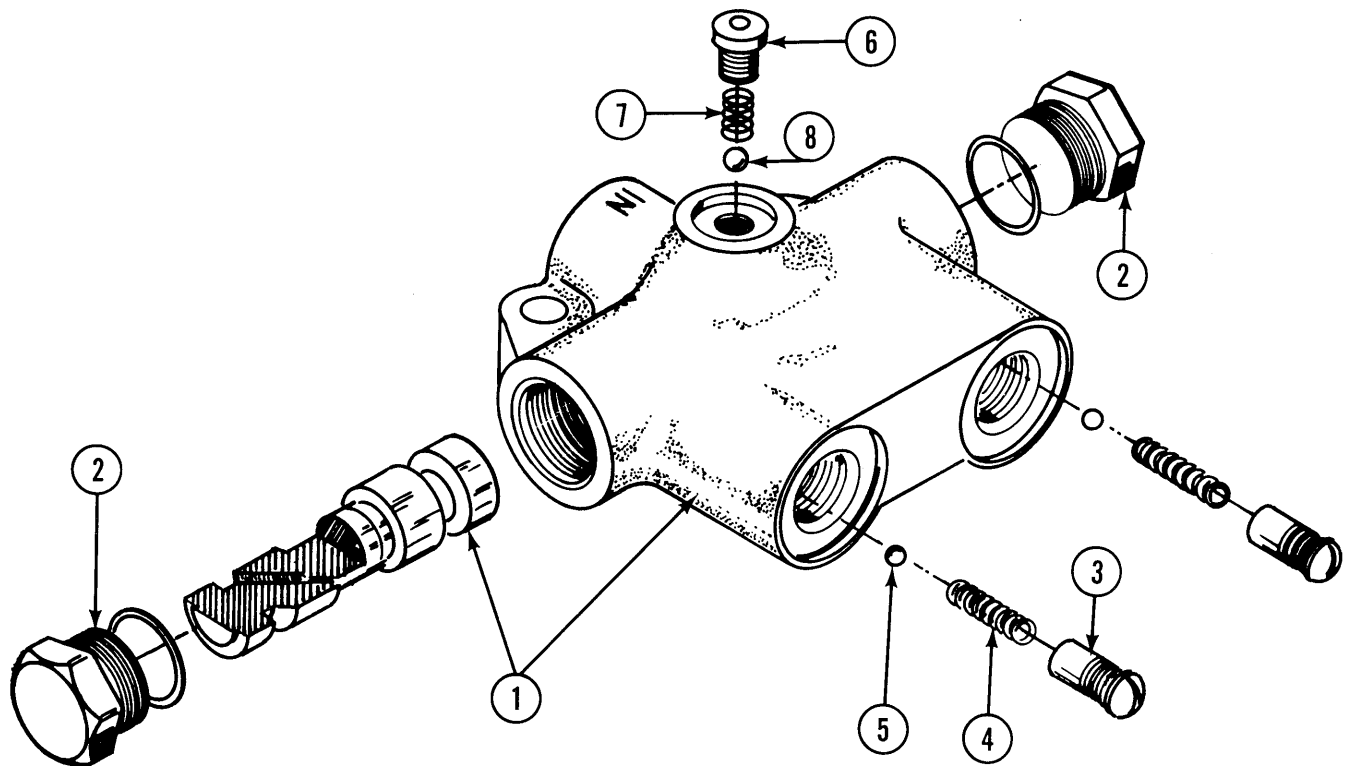

ITEM	PART NO.	DESCRIPTION
1.	R272	Valve Body and Spool
2.	R271	Plug Assembly, O-Ring Boss
3.	R273	Retainer, Check Valve
4.	R277	Spring, Check Valve
5.	R275	Ball, Check, 3/16" Diameter
6.	R274	Plug Assembly, O-Ring Boss
7.	R278	Spring
8.	R276	Ball, 1/4" Diameter
A.	A282	Sequencing Valve, Complete

# FLOW CONTROL VALVE

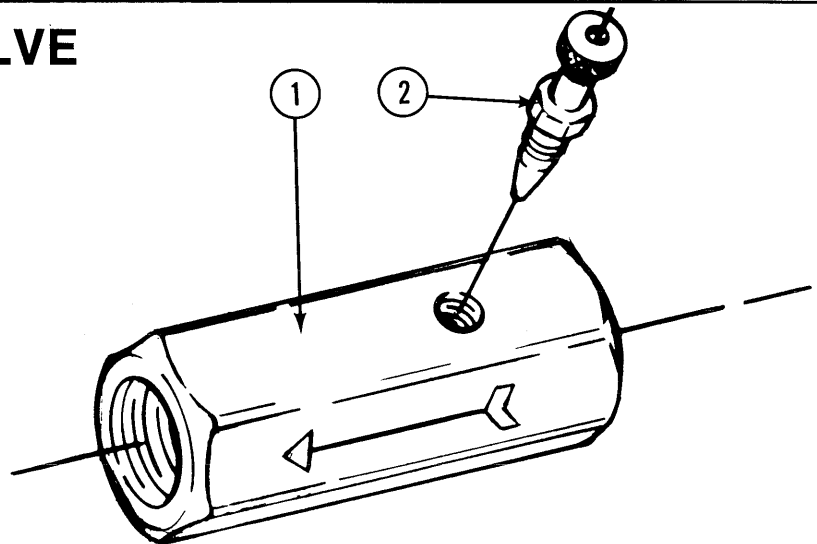

ITEM	PART NO.	DESCRIPTION
1.	A270	Flow Control Valve Assembly, 3/8" NPT (KLF 375)
2.	R103	Needle Valve Assembly

# TRANSMISSION ASSEMBLY

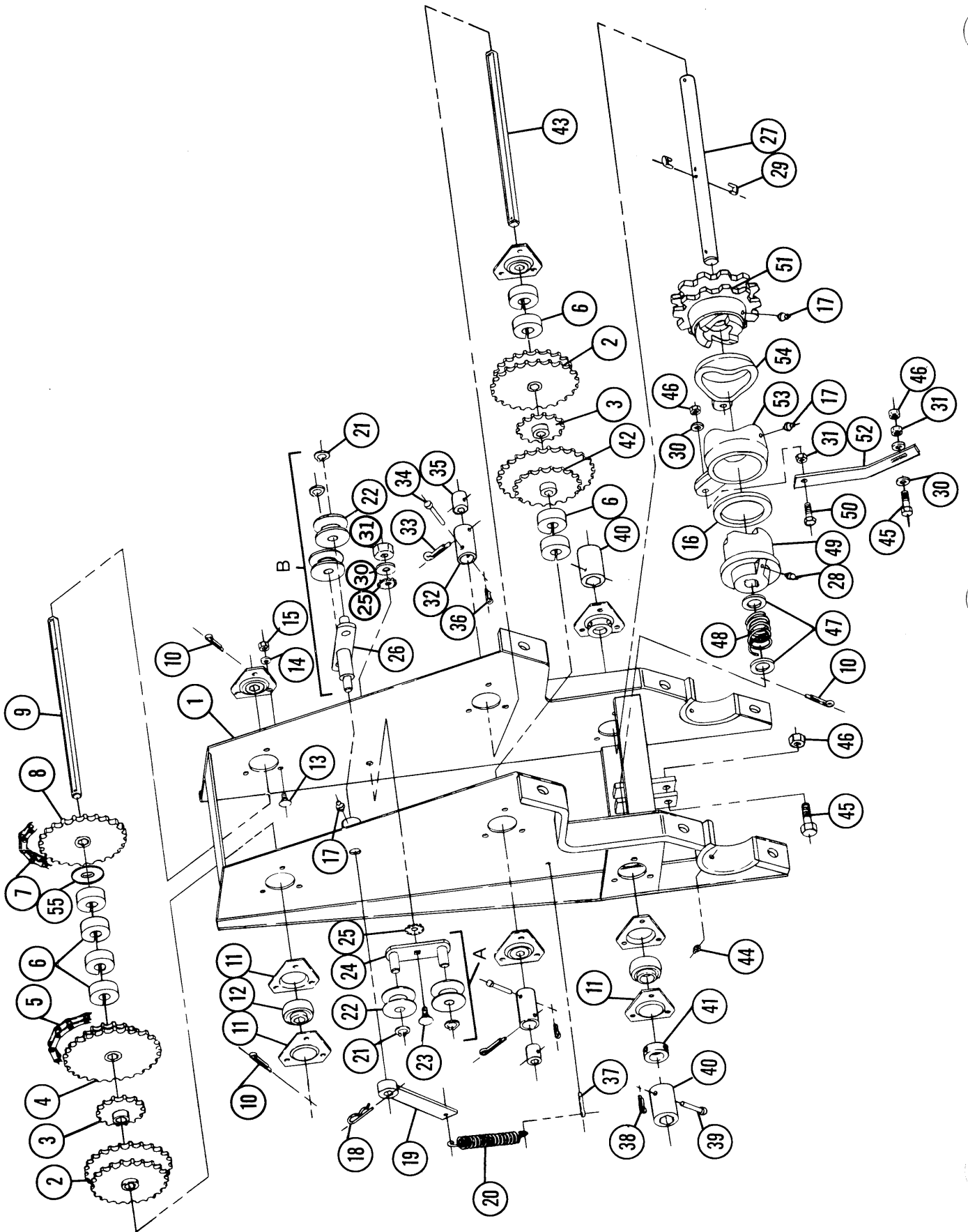

# TRANSMISSION ASSEMBLY

---

ITEM	PART NO.	DESCRIPTION
1.	A350	Transmission Case
2.	2500-2	Sprocket, 22T-26T, Hex Bore
3.	2500-1	Sprocket, 14T, Hex Bore
4.	2500-3	Sprocket, 16T-30T, Hex Bore
5.	3300-40	Drive Chain, #2040, 40 Pitch Includes Connector
6.	D832	Spacer, Rubber
7.	3300-52	Drive Chain, #2040, 52 Pitch Includes Connector
	3300-6	Chain #2040, Add To Chain With Extended Drill Sprocket
8.	2500-14	Sprocket, 24 Tooth, Hex Bore
	B138	Extended Drill Sprocket, 48 Tooth
9.	D946	Shaft, Hex, 7/8" x 10 3/4"
10.	10465	Cotter Pin, 1/4" x 1 1/4"
11.	3400-1	Flangette, Bearing
12.	2100-3	Bearing, 7/8" Hex Bore
13.	10312	Carriage Bolt, 5/16" - 18 x 3/4"
14.	10232	Lock Washer, 5/16"
15.	10106	Hex Nut, 5/16" - 18
16.	10234	Washer, 3 1/8" O.D. x 2 5/32" I.D. x 1/8"
17.	10640	Grease Fitting, 1/4" - 28
18.	10670	Hair Pin, #3
19.	A272	Idler Arm
20.	D913	Spring
21.	10435	Retaining Ring, 5/8"
22.	D1067	Spool, Idler
23.	10305	Carriage Bolt, 3/8" - 16 x 1"
24.	A2009	Idler Bracket
25.	10524	Lock Washer, Internal/External, 3/8"
26.	A242	Idler Bracket
27.	D964	Shaft, Clutch
28.	10643	Grease Fitting, 45°, 1/4" - 28
29.	D1107	Key
30.	10210	Flat Washer, 3/8"
31.	10101	Hex Nut, 3/8" - 16
32.	D748	Coupler
33.	10462	Cotter Pin, 3/16" x 2"
34.	10548	Clevis Pin, 1/4" x 1 3/4"
35.	D747	Coupler, 9/16" Hex Bore
36.	10455	Cotter Pin, 1/16" x 1 1/2"
37.	10466	Cotter Pin, 1/4" x 3/4"
38.	10456	Cotter Pin, 1/8" x 3/4"
39.	10565	Clevis Pin, 5/16" x 2"
40.	D1653	Coupler, Hex, 7/8"
41.	2400-1	Bearing, With Lock Collar
42.	2500-6	Sprocket, 18T-28T, Hex Bore
43.	D926	Shaft, 7/8" x 11 1/2" Hex
44.	10641	Grease Fitting, 1/8" NPT
45.	10048	Screw, Hex Head Cap, 3/8" - 16x 2"
46.	10108	Hex Lock Nut, 3/8" - 16
47.	10235	Bushing, 7/8"
48.	D1133	Spring
49.	B128	Hub, Clutch
50.	10047	Screw, Hex Head Cap, 3/8" - 16 x 1 3/4"
51.	B131	Sprocket/Hub, 12 Tooth
52.	D498	Bar, Linkage
53.	B129	Cam, Floating
54.	B130	Cam, Fixed
55.	10233	Machinery Bushing For Use With Extended Drill Sprocket
A.	A2008	Idler Assembly, Complete (Includes Items 21, 22 and 24)
B.	A503	Idler Assembly, Complete (Includes Items 21, 22 and 26)
C.	A351	Transmission Assembly, Complete

# CONVENTIONAL MARKER ASSEMBLY

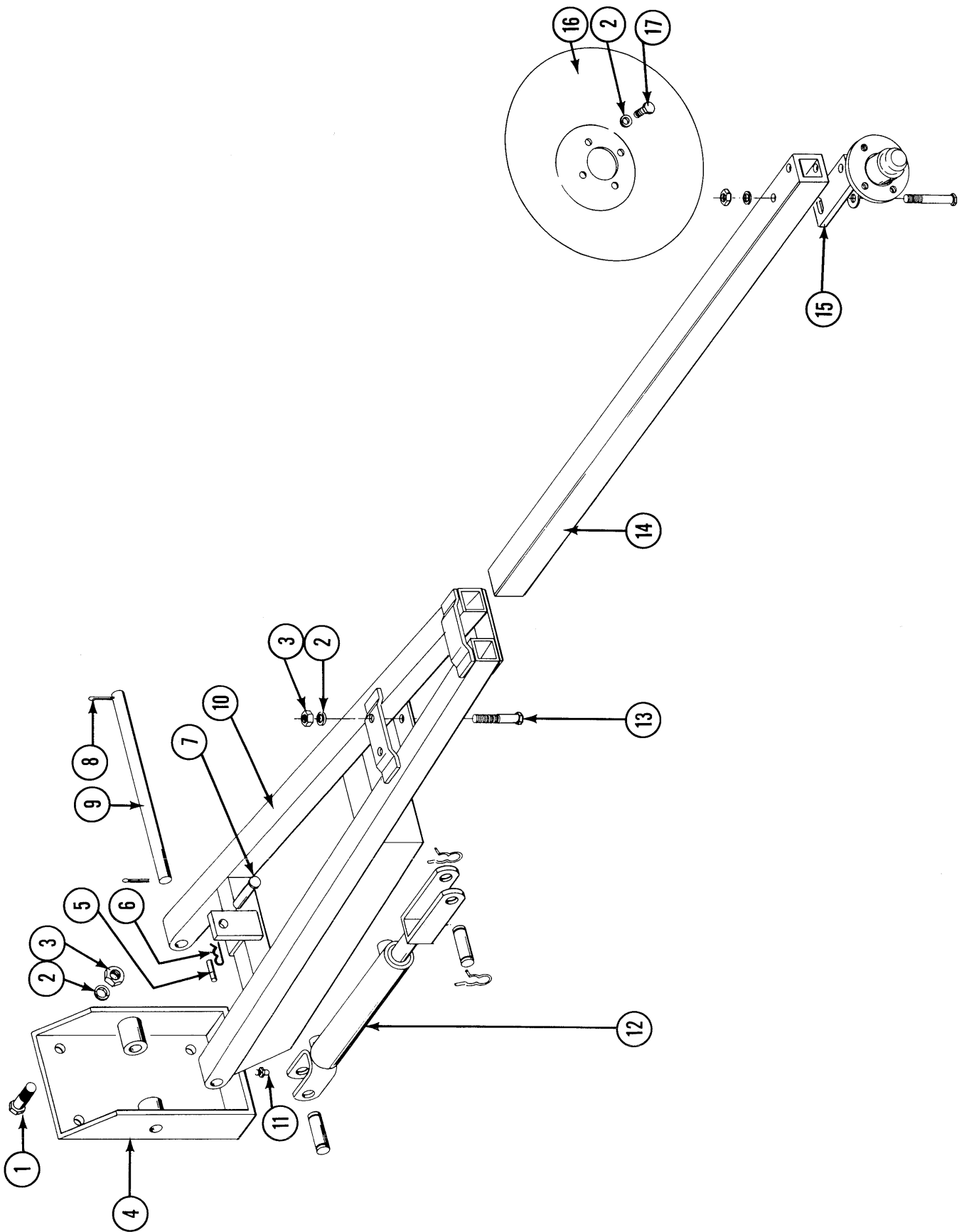

# CONVENTIONAL MARKER ASSEMBLY

---

ITEM	PART NO.	DESCRIPTION
1.	10039	HHCS, 1/2"-13x1 3/4"
2.	10228	Lockwasher, 1/2"
3.	10102	Hex Nut, 1/2"-13
4.	A224	Marker Mount
5.	10609	Roll Pin, 5/32"x1"
6.	10670	Hair Pin Clip, No. 3
7.	D462	Marker Lockup Pin
8.	10460	Cotter Pin, 1/4"x2"
9.	D438	Shaft
10.	A225	Marker Arm Weld, 45", 4R30 and 4RW
	A538	Marker Arm Weld, 64"x 6R30
11.	10640	Grease Fitting, 1/4"-28
12.	A211	Cylinder Assembly, 2x8
	A745	Cylinder Assembly, 2x8
13.	10033	HHCS, 1/2"-13x3 1/2"
14.	D453-1	Extension Tube, 20", 4R30
	D453-2	Extension Tube, 40", 6R30
	D453-3	Extension Tube, 50", 4RW
15.	A305	Marker Hub Assembly, L.H. (Includes Hardware)
	A306	Marker Hub Assembly, R.H. (Includes Hardware)
16.	D746	Disc, 16"
17.	10722	HHCS, 1/2"-20x1"
A.	A563	Lockup Pin Assembly (Includes Items 5, 6, and 7)

# LOW PROFILE - DOUBLE FOLD MARKER ASSEMBLY

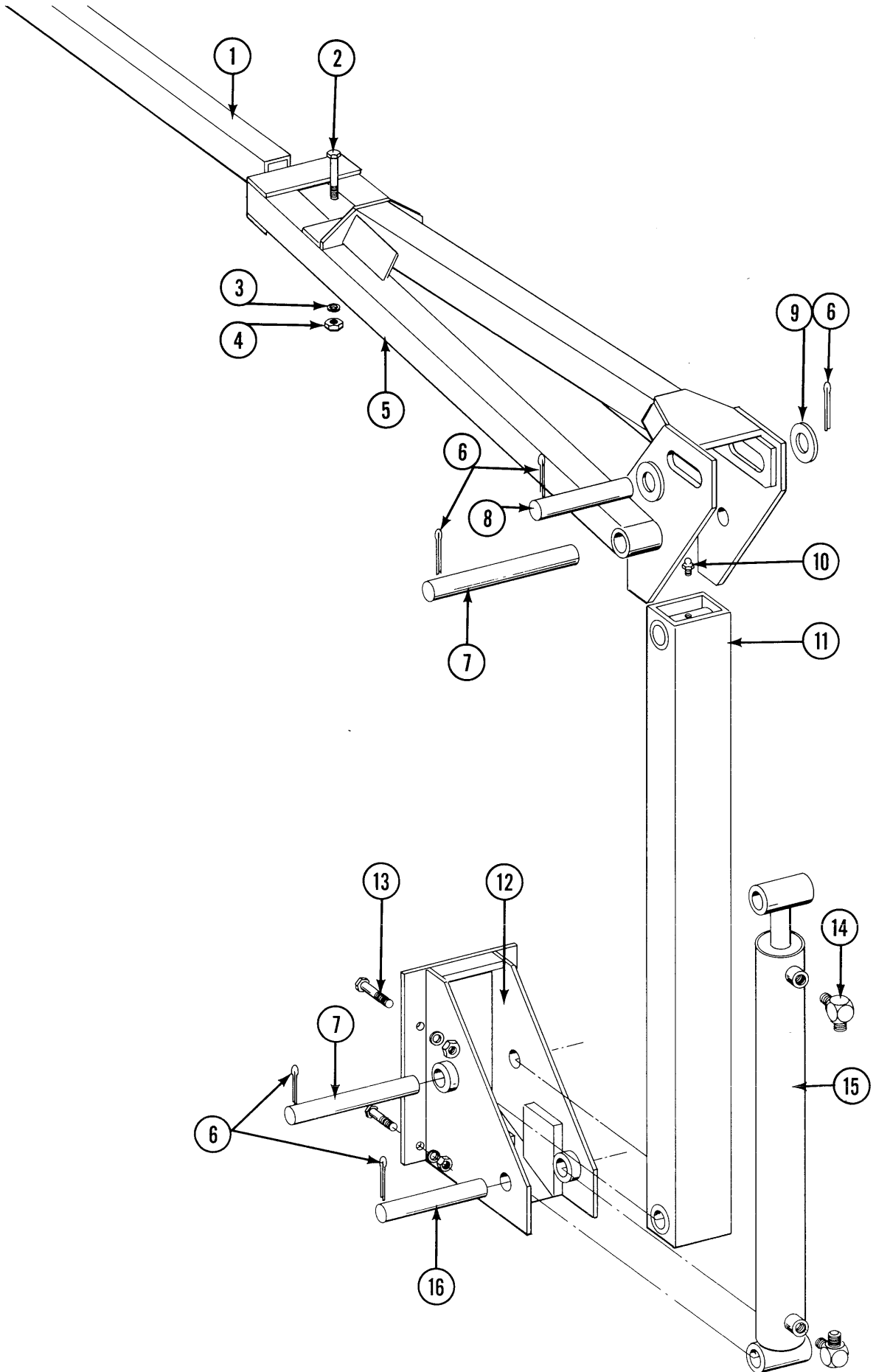



# LOW PROFILE - DOUBLE FOLD MARKER ASSEMBLY

---

ITEM	PART NO.	DESCRIPTION
1.	D453-3	Extension Tube, 50", 8R30
	D453-5	Extension Tube, 55", 6RW
2.	10033	HHCS, 1/2"-13x3 1/2"
3.	10228	Lockwasher, 1/2"
4.	10102	Hex Nut, 1/2"-13
5.	A831	Marker Arm, 34", 6RW
	A832	Marker Arm, 45", 8R30
6.	10460	Cotter Pin, 1/4"x2"
7.	D1702	Pivot Pin
8.	D1701	Pin, Cylinder, Upper
9.	10226	Washer, 1 1/4" SAE
10.	10641	Grease Fitting, 1/8" NPT
11.	A828	Arm, First Stage
12.	A827	Marker Mount
13.	10039	HHCS, 1/2"- 13x1 3/4"
14.	2501-8-8	Elbow, 90°, 1/2" NPT to 37° 3/4"-16JIC
15.	A233	Cylinder, 2 1/2"x20"
16.	D653	Pin, Cylinder, Lower

# MARKER HUB ASSEMBLY CONVENTIONAL AND LOW PROFILE

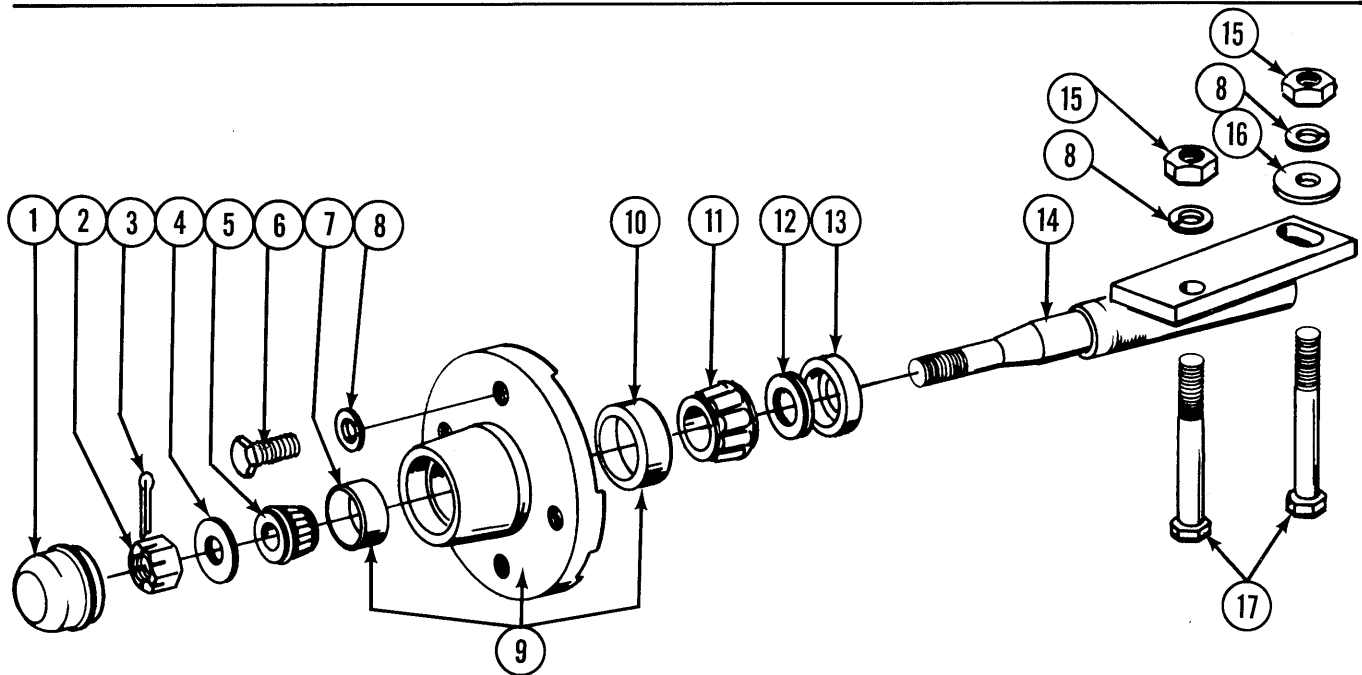

ITEM	PART NO.	DESCRIPTION
1.	D840	Hub Cap
2.	10725	Hex Nut, Slotted, 5/8"-18
3.	10470	Cotter Pin, 5/32"x1"
4.	10724	Washer, 5/8"
5.	A257	Bearing, Outer
6.	10722	HHCS, 1/2"-20x1"
7.	R151	Cup, Outer
8.	10228	Lockwasher, 1/2"
9.	A167	Hub w/cups
10.	R150	Cup, Inner
11.	A245	Bearing, Inner
12.	A899	Seal, Rubber
13.	A243	Seal, Grease
14.	A172L	Spindle Assembly, L.H. (shown)
	A172R	Spindle Assembly, R.H.
15.	10102	Hex Nut, 1/2"-13
16.	10216	Washer, 1/2" USS
17.	10033	HHCS, 1/2"-13x3 1/2"
A.	A305	Hub and Spindle Assembly L.H.
	A306	Hub and Spindle Assembly R.H.

# HYDRAULIC SYSTEM

# SINGLE VALVE LOW PROFILE MARKER

8 ROW 30"

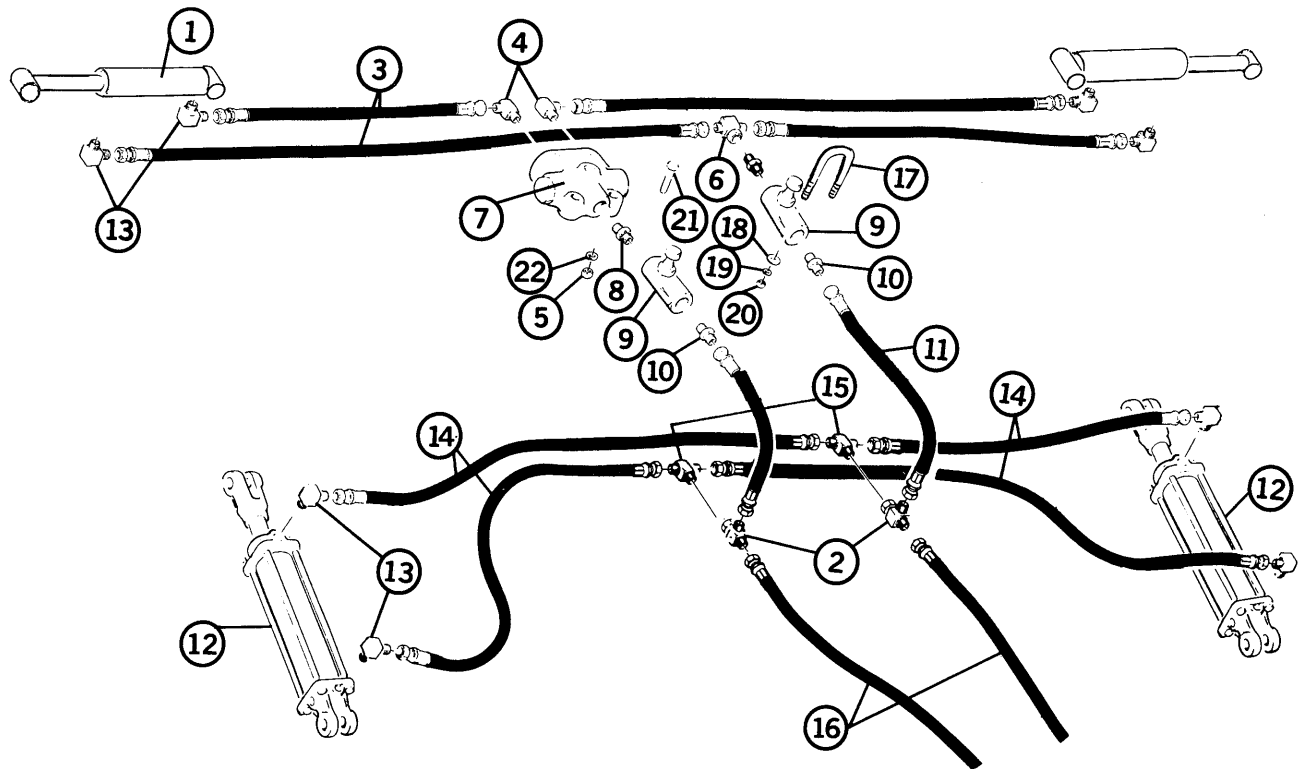

ITEM	PART NO.	DESCRIPTION
1.	A233	Cylinder, Marker, 2½" x 20"
2.	6602-8	Swivel Tee
3.	A1025	Hose Assembly, 3/8" x 148" (2 used)
	A1026	Hose Assembly, 3/8" x 152" (2 used)
4.	6801-8	Elbow, 90°
5.	10101	Hex Nut, 3/8" - 16
6.	2601-8-6	Side Tee, Male
7.	A282	Valve, Sequence
8.	6401-8-6	Adapter, Straight
9.	A270	Valve, Flow Control
10.	2404-8-6	Adapter, Straight
11.	A1044	Hose Assembly, 3/8" x 34"
12.	A280	Cylinder, Lift, 3½" x 8"
	A747	Cylinder Lift, 3½" x 8"
13.	2501-8-8	Elbow, 90°
14.	A1039	Hose Assembly, 3/8" x 76"
15.	2603-8	Tube Tee, 37°
16.	A1043	Hose Assembly, 3/8" x 125"
17.	D1253	U-Bolt, 5/16" - 18 x 2¼" x 1½"
18.	10219	Flat Washer, 5/16" USS
19.	10232	Lock Washer, 5/16"
20.	10106	Hex Nut, 5/16" - 18
21.	10048	HHCS, 3/8" - 16 x 2"
22.	10229	Lock Washer, 3/8"
	D1512	Tie Strap, 6" (Not Shown)

# HYDRAULIC SYSTEM

# DUAL VALVE LOW PROFILE MARKER

8 ROW 30"

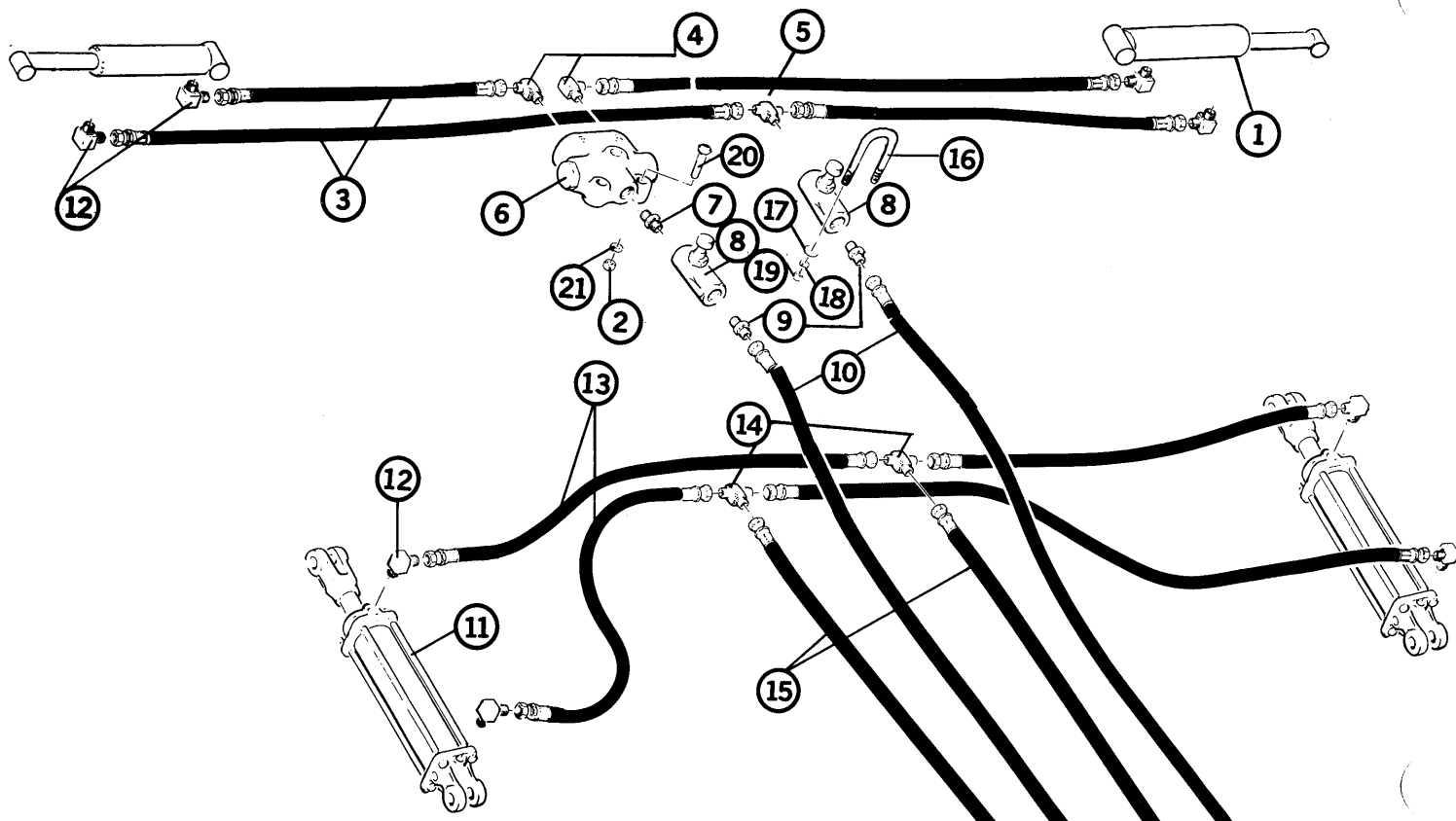

ITEM	PART NO	DESCRIPTION
1.	A233	Cylinder, Marker, 2½" x 20"
2.	10101	Hex Nut, 3/8" - 16
3.	A1025	Hose Assembly, 3/8" x 148" (2 used)
	A1026	Hose Assembly, 3/8" x 152" (2 used)
4.	6801-8	Elbow 90°
5.	2601-8-6	Side Tee, Male
6.	A282	Valve, Sequence
7.	6401-8-6	Adapter, Straight
8.	A270	Valve, Flow Control
9.	2404-8-6	Adapter, Straight
10.	A1012	Hose Assembly, 3/8" x 140"
11.	A280	Cylinder, Lift, 3½" x 8"
	A747	Cylinder Lift 3½" x 8"
12.	2501-8-8	Elbow, 90°
13.	A1039	Hose Assembly, 3/8" x 76"
14.	2603-8	Tube Tee, 37°
15.	A1043	Hose Assembly, 3/8" x 125"
16.	D1253	U-Bolt, 5/16" - 18 x 2¼" x 1½"
17.	10219	Flat Washer, 5/16" USS
18.	10232	Lock Washer, 5/16"
19.	10106	Hex Nut, 5/16" - 18
20.	10048	HHCS, 3/8" - 16 x 2"
21.	10229	Lock Washer, 3/8"
	D1512	Tie Strap, 6" (Not Shown)

# HYDRAULIC SYSTEM

# SINGLE AND DUAL VALVE LOW PROFILE MARKER

6 ROW WIDE

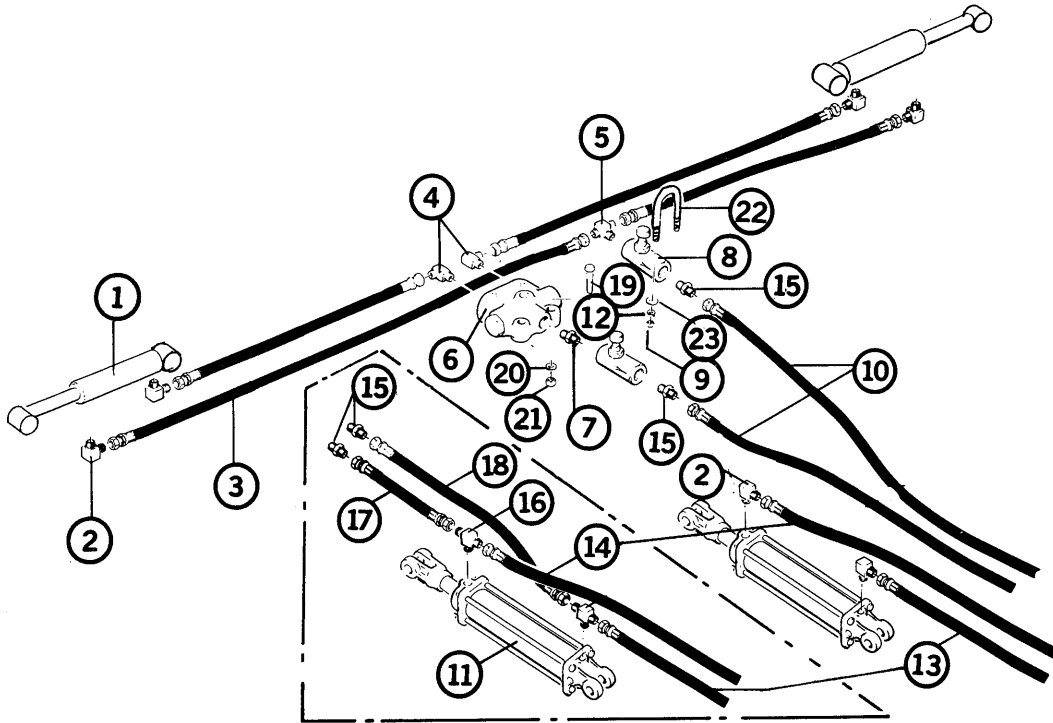

ITEM	PART NO.	DESCRIPTION
1.	A233	Cylinder, Marker, 2½" x 20"
2.	2501-8-8	Elbow, 90°
3.	A1041	Hose Assembly, 3/8" x 130"
4.	6801-8	Elbow, 90°
5.	2601-8-6	Side Tee, Male
6.	A282	Valve, Sequence
7.	6401-8-6	Adapter, Straight
8.	A270	Valve, Flow Control
9.	10106	Hex Nut, 5/16" - 18
10.	A1012	Hose Assembly, 3/8" x 140"
11.	A280	Cylinder, Lift, 3½" x 8"
	A747	Cylinder Lift, 3½" x 8"
12.	10232	Lock Washer, 5/16"
13.	A1007	Hose Assembly, 3/8" x 105"
14.	A1009	Hose Assembly, 3/8" x 117"
15.	2404-8-6	Adapter, Straight
16.	2601-8-8	Side Tee, Male
17.	A1002	Hose Assembly, 3/8" x 20"
18.	A1003	Hose Assembly, 3/8" x 27"
19.	10048	HHCS, 3/8" - 16 x 2"
20.	10229	Lock Washer, 3/8"
21.	10101	Hex Nut, 3/8" - 16
22.	D1253	U-Bolt, 5/16" - 18 x 2¼" x 1½"
23.	10219	Washer, 5/16" USS
	D1512	Tie Strap, 6" (Not Shown)

# HYDRAULIC SYSTEM

# SINGLE AND DUAL VALVE CONVENTIONAL MARKER

4 ROW 30", 4 ROW WIDE, 6 ROW 30"

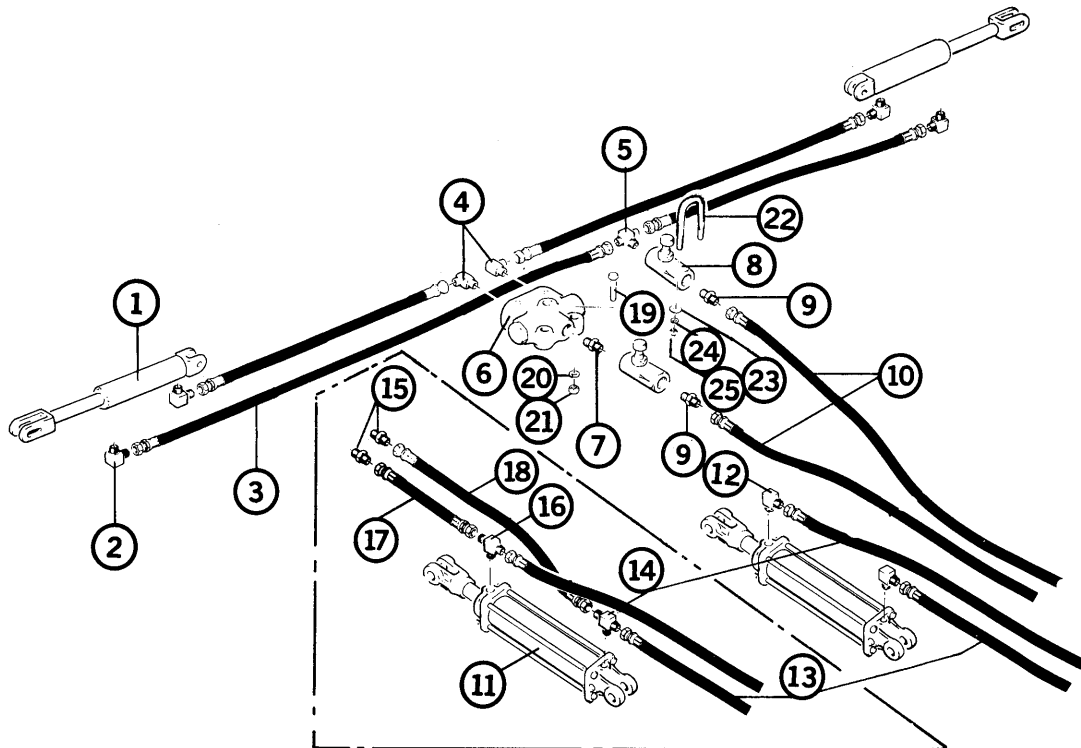

ITEM	PART NO.	DESCRIPTION
1.	A211	Cylinder, Marker, 2" x 8"
	A745	Cylinder, Marker, 2" x 8"
2.	2501-6-6	Elbow, 90°
3.	A1102	Hose Assembly, 1/4" x 95", 4R30, 4RW
	A1103	Hose Assembly, 1/4" x 110", 6R30
4.	6801-6-8	Elbow, 90°
5.	2601-6-6	Side Tee, Male
6.	A282	Valve, Sequence
7.	6401-8-6	Adapter, Straight
8.	A270	Valve, Flow Control
9.	2404-6-6	Adapter, Straight
10.	A1108	Hose Assembly, 1/4" x 140"
11.	A280	Cylinder, Lift, 3 1/2" x 8"
	A747	Cylinder, Lift, 3 1/2" x 8"
12.	2501-8-8	Elbow, 90°
13.	A1007	Hose Assembly, 3/8" x 105"
14.	A1009	Hose Assembly, 3/8" x 117"
15.	2404-8-6	Adapter, Straight
16.	2601-8-8	Side Tee, Male
17.	A1002	Hose Assembly, 3/8" x 20"
18.	A1003	Hose Assembly, 3/8" x 27"
19.	10048	HHCS, 3/8" - 16 x 2"
20.	10229	Lock Washer, 3/8"
21.	10101	Hex Nut, 3/8" - 16
22.	D1253	U-Bolt, 5/16" - 18 x 2 1/4" x 1 1/2"
23.	10219	Washer, 5/16" USS
24.	10232	Lock Washer, 5/16"
25.	10106	Hex Nut, 5/16" - 18
	D1512	Tie Strap, 6" (Not Shown)

# LIFT CYLINDER

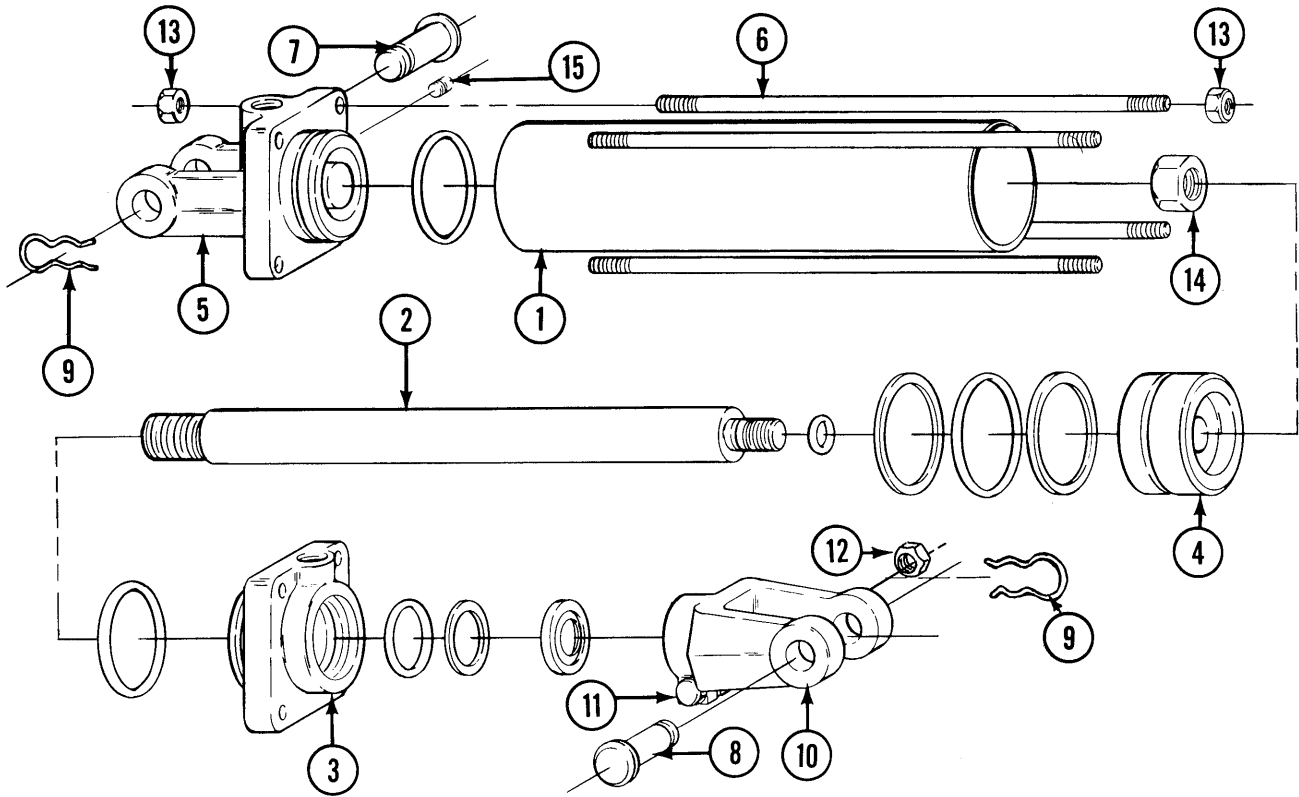

ITEM	PART NO.	DESCRIPTION
1.	R173	Tube Assembly
2.	R174	Shaft Assembly
3.	R175	Guide, Piston Rod
4.	R176	Piston
5.	R177	Clevis, Bottom
6.	R178	Tie Rod
7.	R179	Clevis Pin, w/Clips
8.	R180	Clevis Pin, w/Clips
9.	R193	Clip, Hair Pin
10.	R456	Clevis, Shaft End
11.	10047	Screw, Hex Head Cap, 3/8"-16x1 3/4"
12.	10101	Hex Nut, 3/8"-16
13.	R181	Hex Nut, 1/2"-13, Grade 5
14.	R203	Hex Lock Nut, 1"-14 UNF, Grade 5
15.	R187	Pipe Plug, 1/2" NPT
A.	A280	Cylinder, Lift, Complete, 3 1/2"x8"
	R153	Seal Kit
		Includes
		(1) Rod Wiper - 1 1/2"
		(2) Back Up Washer, 31/8 I.D.x3 1/2 O.D.
		(1) Back Up Washer, 1 1/2 I.D.x1 7/8 O.D.
		(3) O-Ring, 3 1/8 I.D.x3 1/2 O.D.
		(1) O-Ring, 1 1/2 I.D.x1 7/8 O.D.
		(1) O-Ring, 7/8 I.D.x 1 O.D.

# LIFT CYLINDER

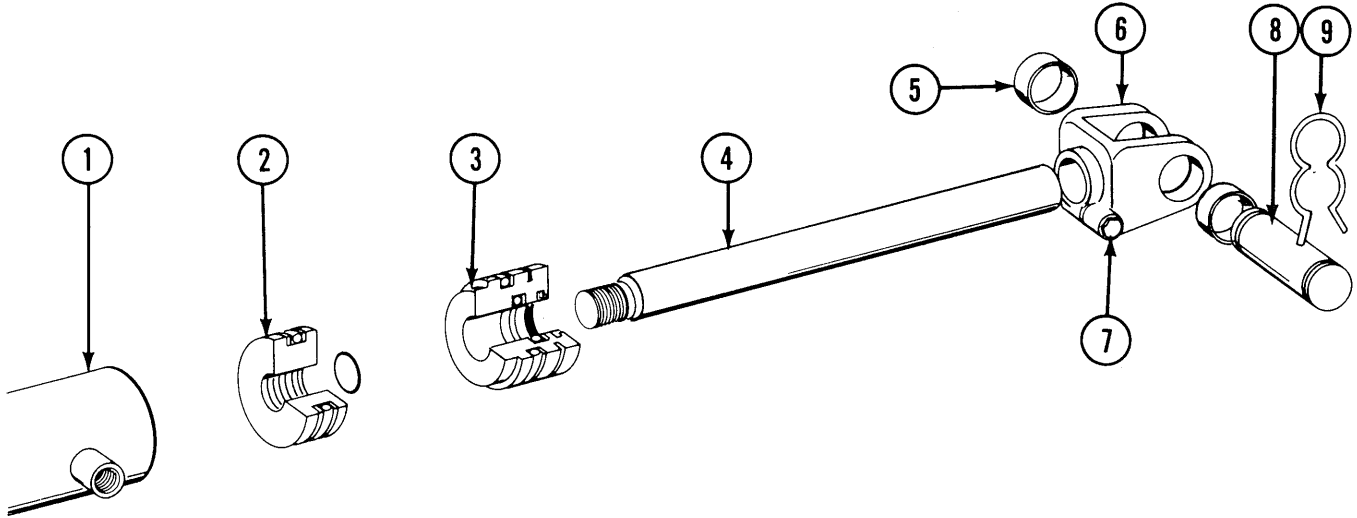

ITEM	PART NO.	DESCRIPTION
1.	R377	Tube Assembly
2.	R372	Piston
3.	R371	Head Gland
4.	R378	Shaft Assembly
5.	R374	Bushing, Steel
6.	R373	Clevis
7.	10075	Clevis Bolt 3/8"-24x1 3/4"
8.	R375	Clevis Pin
9.	R193	Clip, Hair Pin
A.	A747	Cylinder, Lift, Complete, 3 1/2 x 8
	R376	Seal Kit
		Includes
		(1) O-Ring 1.14 I.D.x1.254 O.D.
		(1) O-Ring 1.475 I.D.x1.895 O.D.
		(1) O-Ring 3.10 I.D. x 3.52 O.D.
		(1) Back Up Washer 1 1/2 I.D. x 1 7/8 O.D.
		(3) Back Up Washer 3 1/8 I.D. x 3 1/2 O.D.
		(1) Rod Wiper
		(1) Retaining Ring, Int. 3 1/2"



# CONVENTIONAL MARKER CYLINDER

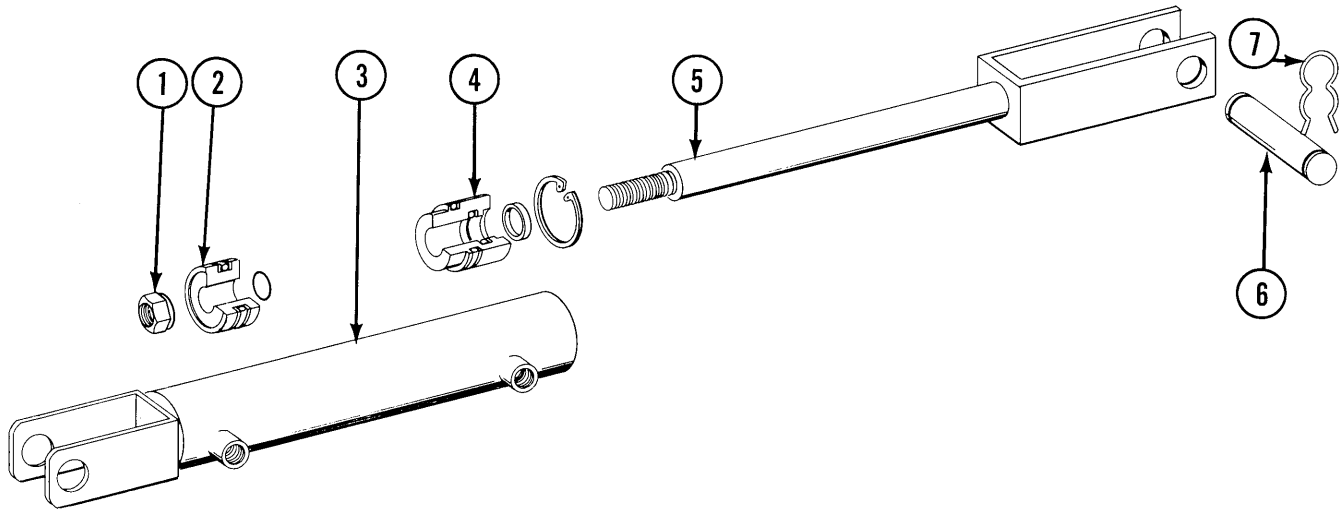

ITEM	PART NO.	DESCRIPTION
1.	R366	Hex Nut, 3/4" NF
2.	R365	Piston
3.	R362	Tube Assembly
4.	R364	Head Gland
5.	R363	Shaft Assembly
6.	R367	Clevis Pin
7.	R193	Clip, Hair Pin Ony
	R368	Seal Kit Includes (1) O-Ring .614 I.D. x .754 O.D. (1) O-Ring 1.109 I.D. x 1.387 O.D. (2) O-Ring 1.600 I.D. x 2.200 O.D. (1) Back Up Washer 1 1/8" I.D. x 1 3/8" O.D. (1) Rod Wiper 2" I.D. (1) Retaining Ring Internal 2" (2) Back Up Washer 1 5/8 I.D. x 2 O.D.
A.	A745	Cylinder, Complete, 2"x8"

# CONVENTIONAL MARKER CYLINDER

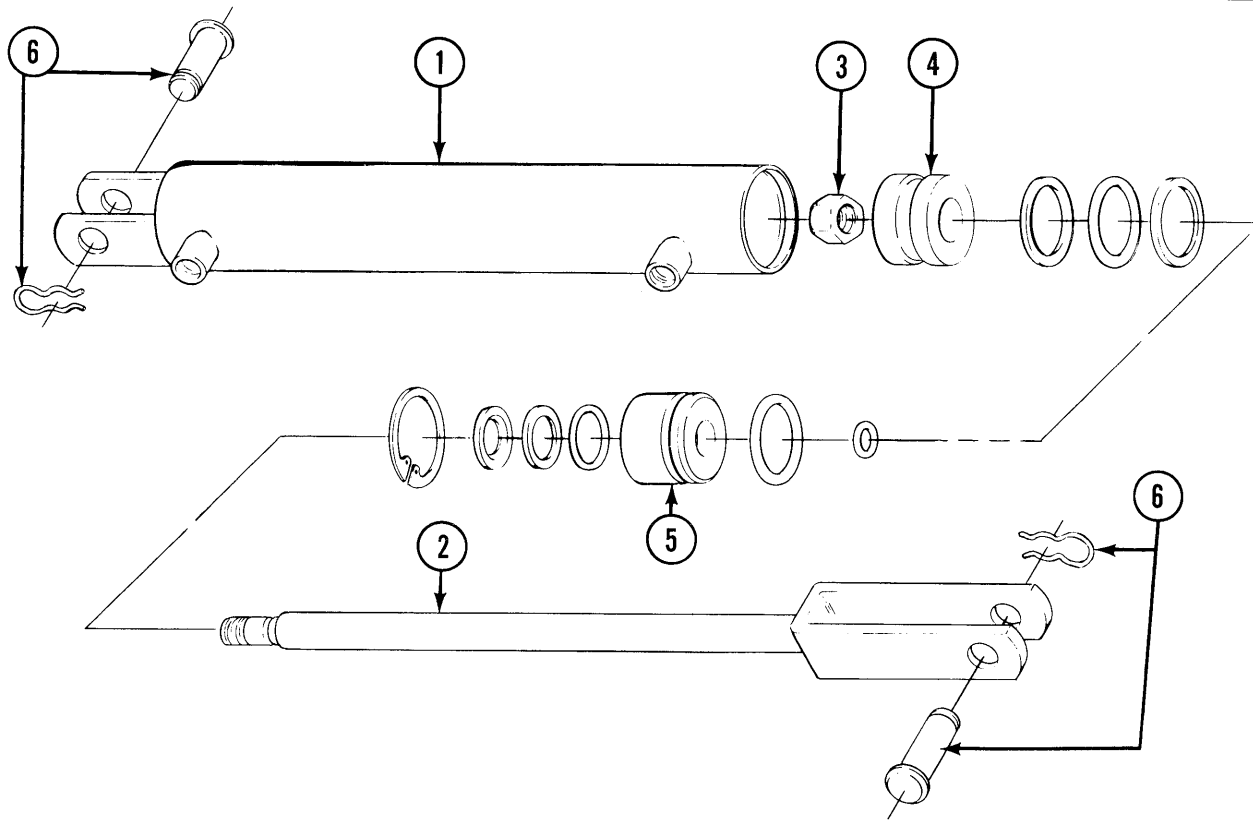

ITEM	PART NO.	DESCRIPTION
1.	R157	Cylinder Body
2.	R158	Piston Rod
3.	R159	Hex Nut, 7/8" UNF
4.	R160	Piston
5.	R161	Piston Rod Guide
6.	R162	Clevis Pin W/Clip
	R193	Clip, Hair Pin, Only
	R154	Seal Kit
		Includes
		(1) O-Ring, 3/4" I.D x 7/8" O.D.
		(1) O-Ring, 1 1/8" I.D. x 1 3/8" O.D.
		(1) Back Up Washer
		(1) Rod Wiper
		(2) Back Up Washer
		(2) O-Ring, 1 5/8" I.D. x 2" O.D.
		(1) Retaining Ring
A.	A211	Cylinder - Complete 2"x8"

# LOW PROFILE - DOUBLE FOLDING MARKER CYLINDER

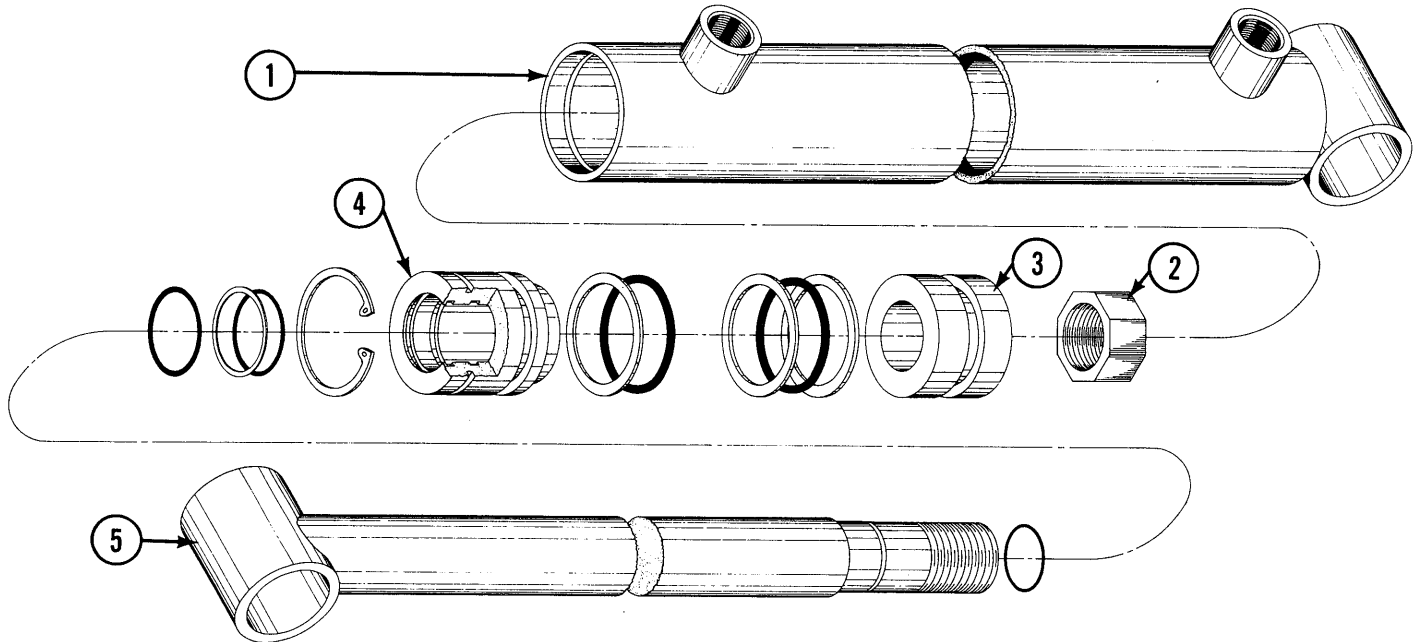

ITEM	PART NO.	DESCRIPTION
1.	R134	Cylinder Tube Assembly
2.	R138	Hex Nut, 7/8" UNF
3.	R137	Piston
4.	R136	Head Gland
5.	R135	Shaft Assembly
A.	A233 R139	Cylinder Assembly, Complete, 2½" x 20" Seal Kit Includes (1) Lock Ring (1) O-Ring (018) (1) O-Ring (218) (1) Back Up (23) (2) O-Ring (330) (3) Back Up (33) (1) Wiper

# DECALS AND REFLECTORS

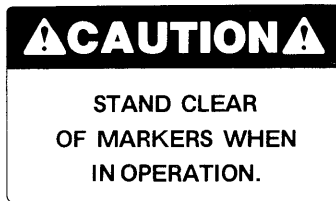

1



2

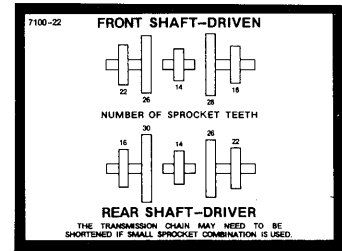

3



4

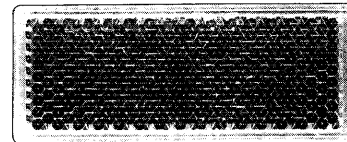

5



6

ITEM	PART NO.	DESCRIPTION
1.	7100-4	Decal, Caution - Markers
2.	7100-3	Decal, Warning - Hitch
3.	7100-22	Decal, Sprocket Combinations - Seed Drive Transmission,
4.	7100-1	Kinze Decal
5.	7200-1	Reflector, Red (Used on Rear of Planter Box)
	7200-2	Reflector, Amber (Used on Front of Toolbar)
6.	D937	Serial Number Plate

# FERTILIZER BAR

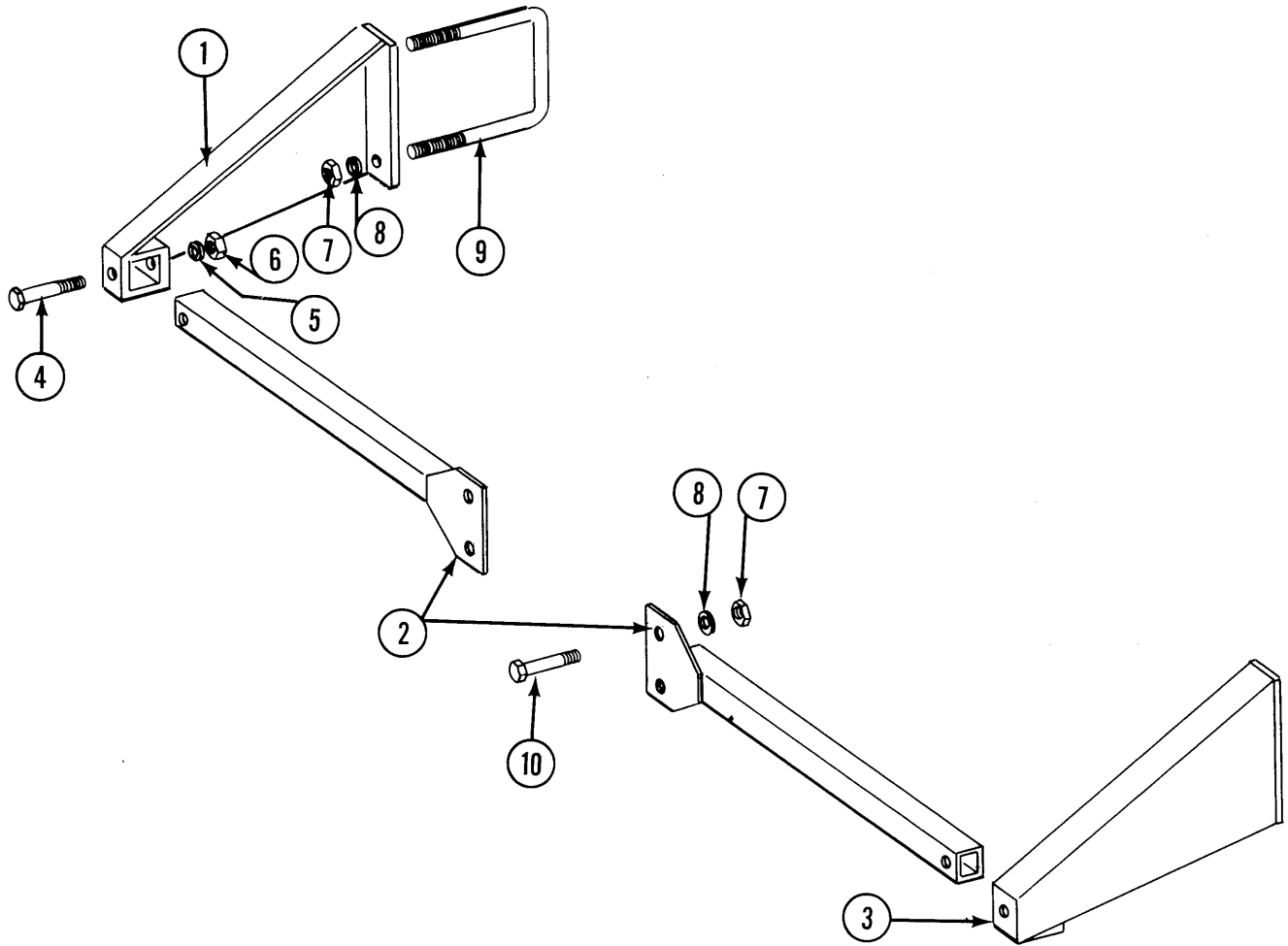

ITEM	PART NO.	DESCRIPTION
1.	A870	Fertilizer Bar Support, Right Side
2.	A873	Bar Weld, 56 1/4", 4R30
	A874	Bar Weld, 60 1/4", 4RW
	A875	Bar Weld, 76 3/4", 6R30
	A876	Bar Weld, 99 1/4", 6RW
	A877	Bar Weld, 106 3/4", 8R30
3.	A869	Fertilizer Bar Support, Left Side
4.	10032	HHCS, 1/2" - 13 x 3 3/4"
5.	10228	Lockwasher, 1/2"
6.	10102	Hex Nut, 1/2" - 13
7.	10105	Hex Nut 3/4" - 10
8.	10231	Lockwasher, 3/4"
9.	D1748	U-Bolt 7" x 7" x 3/4" - 10
10.	10027	HHCS, 3/4" - 10 x 2 1/2"

# DOUBLE DISK FERTILIZER OPENER

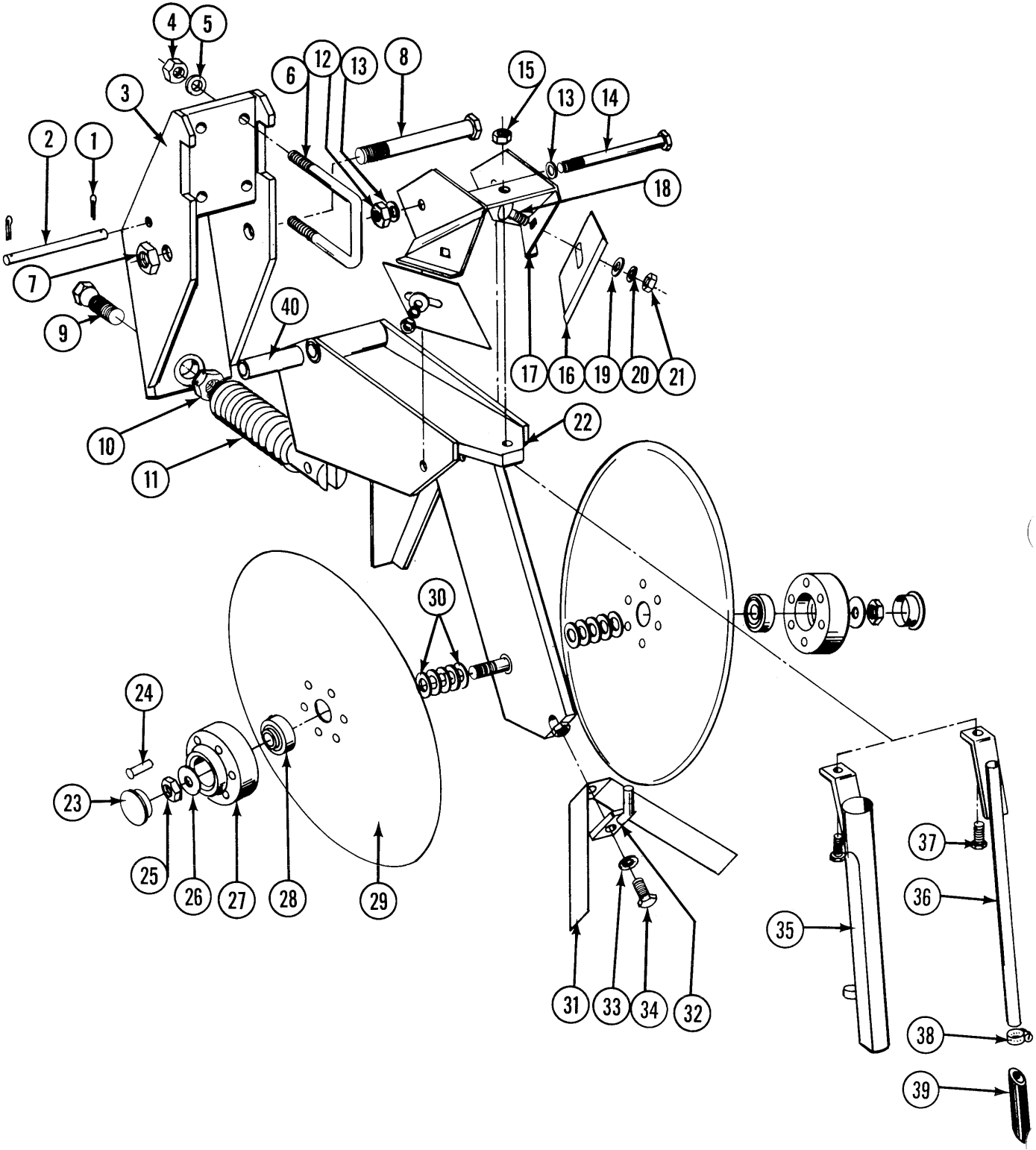

# DOUBLE DISK FERTILIZER OPENER

---

ITEM	PART NO.	DESCRIPTION
1.	10451	Cotter Pin, 1/8"x1"
2.	D1657	Lock Up Pin
3.	A785	Mounting Bracket Weld
4.	10102	Hex Nut, 1/2"-13
5.	10228	Lockwasher, 1/2"
6.	D1138	U-Bolt, 2 1/2"x2 1/2"x1 1/2"-13
7.	10107	Hex Lock Nut, 5/8"—11
8.	10046	HHCS, 5/8"-11x5"
9.	D962	Hex Head Adjusting Bolt, 5/8"-18
10.	10499	Jam Nut, 5/8"-18
11.	A328	Spring
12.	10111	Lock Nut, 1/2"-13
13.	10216	Flatwasher 1/2"
14.	10045	HHCS, 1/2"-13x4 1/2
15.	10109	Hex Lock Nut, 5/16"-18
16.	D1673	Scraper
17.	A810	Scraper Mount
18.	10305	Carriage Bolt, 3/8"-16x1"
19.	10210	Flat Washer, 3/8" USS
20.	10229	Lockwasher, 3/8"
21.	10101	Hex Nut, 3/8"-16
22.	A308	Fertilizer Opener Weld
23.	D1132	Hub Cap
24.	10651	Rivet, 1/4"x13/8"
25.	10503	Jam Nut, R.H. 5/8"-11
	10504	Jam Nut, L.H. 5/8"-11
26.	10217	Washer, 5/8" USS
27.	B134	Bearing Hub
28.	A2014	Bearing
29.	D1030	Disk Blade
30.	10213	Machine Bushing, 1 3/64x11/16x .030
31.	D1163	Scraper, Inner
32.	A312	Mount, Tube, Weld
33.	10232	Lockwasher, 5/16"
34.	10019	HHCS, 5/16"-18x1"
35.	A310	Drop Tube, Dry Fertilizer
36.	A318	Drop Tube, Liquid Fertilizer
37.	10133	HHCS, 5/16"-18x1 1/2"
38.	10673	Hose Clamp
39.	D1797	Drop Tube Extension
40.	D487	Bushing
A.	A320	Disk and Brg. Assembly (Items 24, 27 - 29)
B.	A786	Double Disk Fertilizer Opener, Less drop tubes and U-Bolts

# DRY FERTILIZER HOPPER AND MOUNT

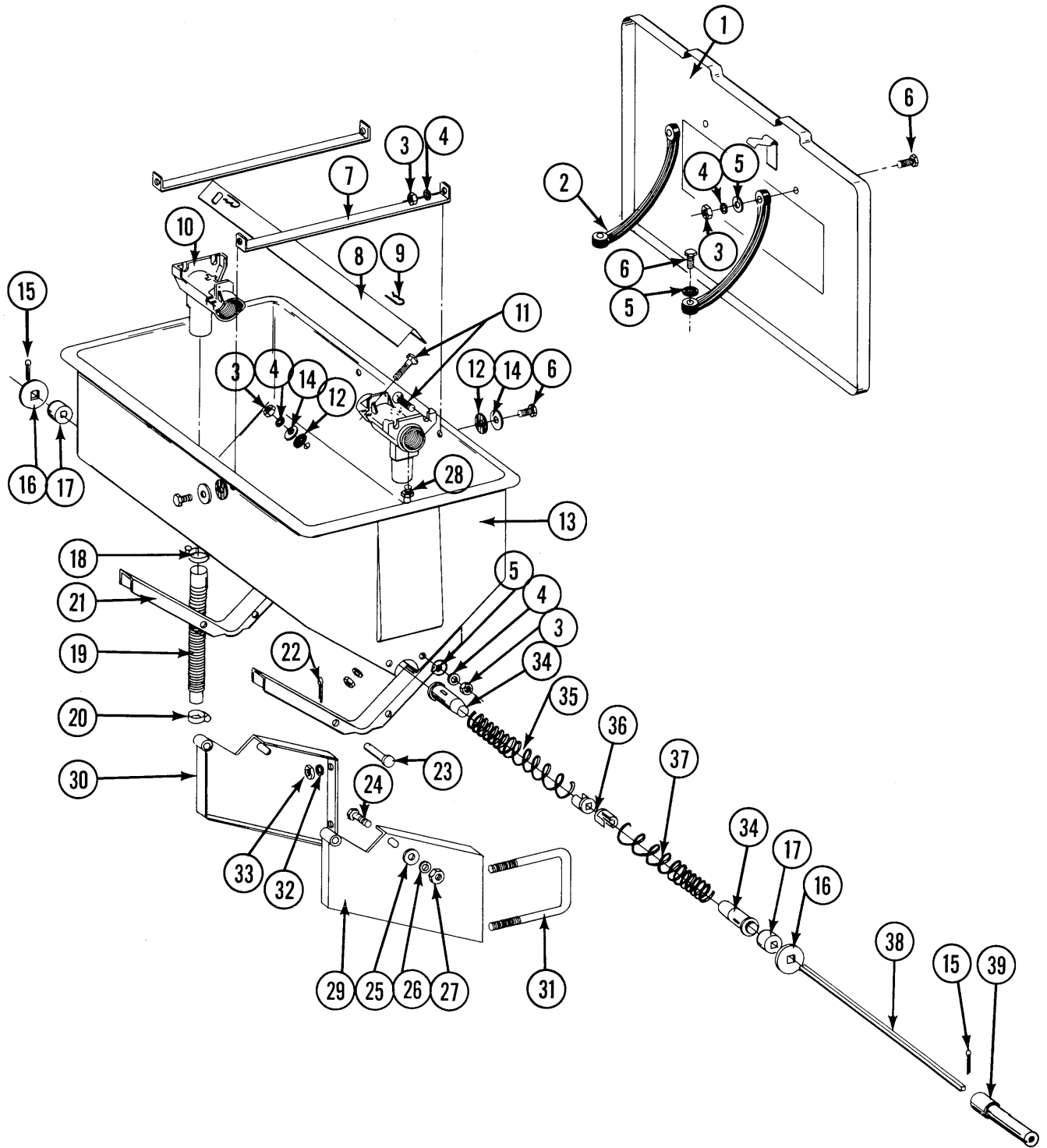



# DRY FERTILIZER HOPPER AND MOUNT

---

ITEM	PART NO.	DESCRIPTION
1.	A2101	Lid, Includes Clips and Pop Rivets
	D1380	Clip
	10655	Pop Rivet, 3/16" x 13/32"
2.	D1210	Strap, Rubber
3.	10106	Hex Nut, 5/16" - 18
4.	10232	Lockwasher, 5/16"
5.	10219	Washer, 5/16" USS
6.	10019	HHCS, 5/16" - 18 x 1"
7.	D1209	Strap, Reinforcing
8.	D1207	Baffle
9.	10670	Hair Pin Clip, #3
10.	D1200	Housing, Outlet
11.	10303	Carriage Bolt, 5/16" - 18 x 1"
12.	D1213	Washer, Rubber
13.	D1379	Hopper, Dry Fertilizer
14.	10201	Washer, Special
15.	10464	Cotter Pin, 3/16" x 1"
16.	D1212	Washer, Special
17.	D1206	Bearing, Shaft
18.	10676	Hose Clamp, #36
19.	D1214	Tube, Rubber
20.	10675	Hose Clamp, #20
21.	D1208	Saddle
22.	10456	Cotter Pin, 1/8" x 3/4"
23.	10562	Clevis Pin, 7/16" x 3"
24.	10037	HHCS, 1/2" - 13 x 1 1/4"
25.	10206	Washer, 1/2" SAE
26.	10228	Lockwasher, 1/2"
27.	10102	Hex Nut, 1/2" - 13
28.	10641	Grease Fitting, 1/8" NPT x 45°
29.	A863	Mount, Hopper L.H.
30.	A864	Mount, Hopper R.H.
31.	D1114	U-Bolt, 7" x 7" x 5/8" - 11
32.	10230	Lockwasher, 5/8"
33.	10104	Hex Nut, 5/8" - 11
34.	D1202	Guide, Auger
35.	D1204	Spring, Auger, RH
36.	D1203	Plug, Spring
37.	D1205	Spring, Auger, L.H.
38.	D1201	Shaft, Auger
39.		Drive Coupler
A.	A896	Hopper Assembly, Dry Fertilizer (Items 3,4,5,9-14 and 21)
B.	A581	Auger Assembly, Complete (Items 15,16,17 and 34-38)

# DRY FERTILIZER COUPLERS

## 8 ROW 30"

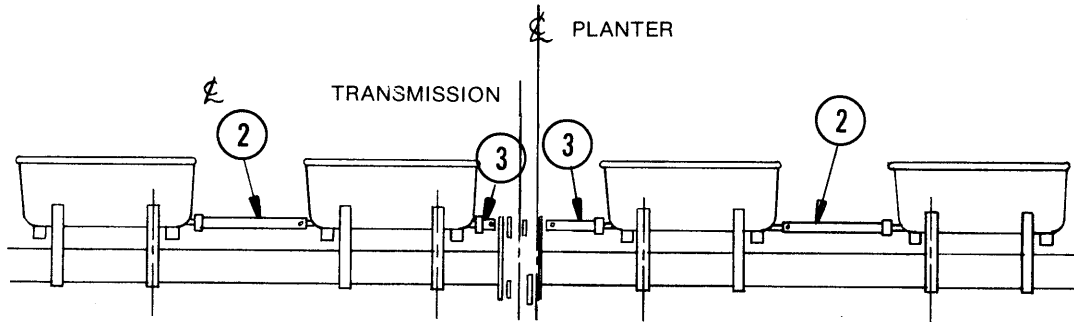

## 4 ROW 30"

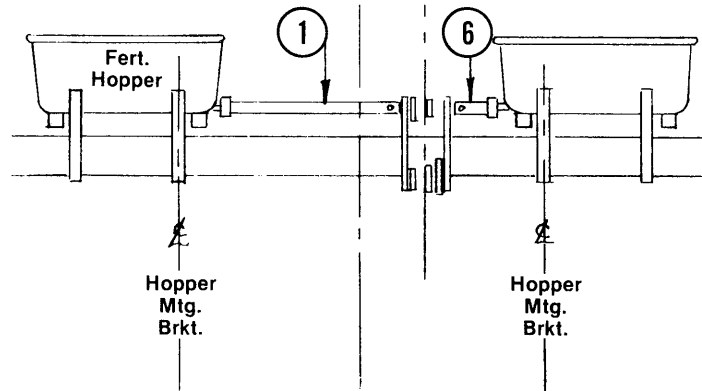

ITEM	PART NO.	DESCRIPTION
1.	A684	Drive Coupling, 24 5/8"
2.	A555	Drive Coupling, 16 1/8"
3.	A554	Drive Coupling, 4 5/8"
4.	A557	Drive Coupling, 23 1/8"
5.	A665	Drive Coupling, 7 5/8"
6.	A881	Drive Coupling, 1 5/8"
7.	A884	Drive Coupling, 22"
8.	A561	Drive Coupling, 30 5/8"

# DRY FERTILIZER COUPLERS

---

## 4 ROW WIDE

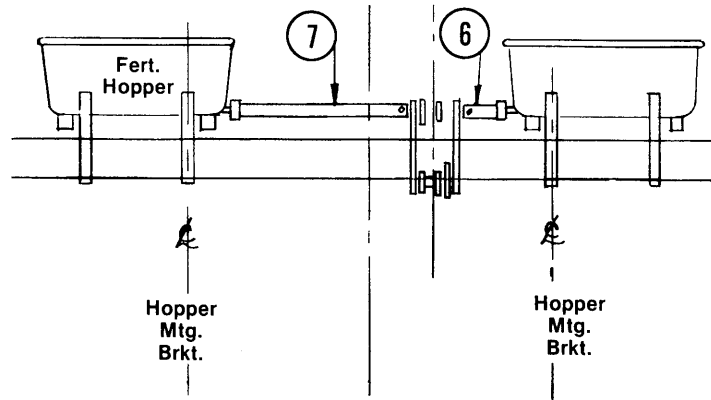

---

## 6 ROW 30"

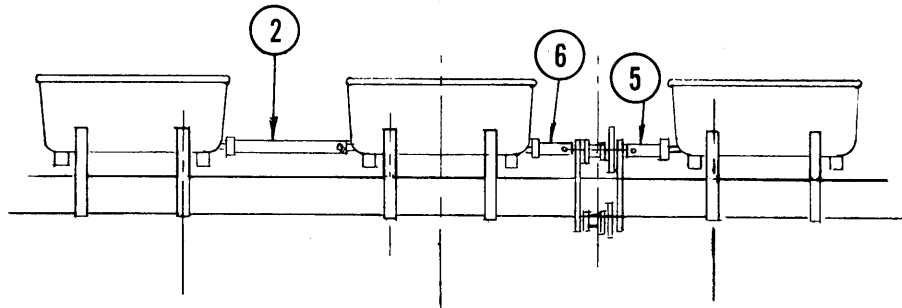

---

## 6 ROW WIDE

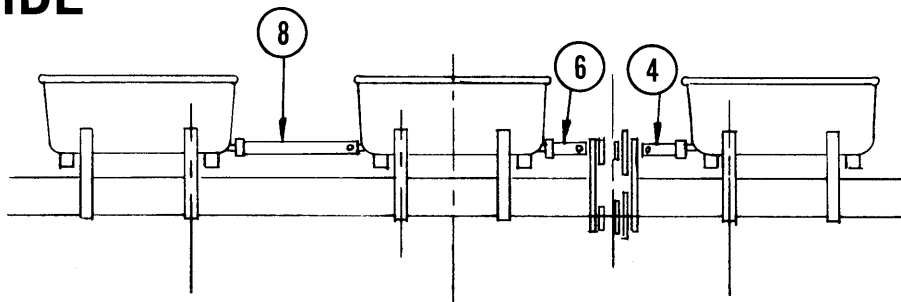

# DRY FERTILIZER TRANSMISSION

4-6 ROW

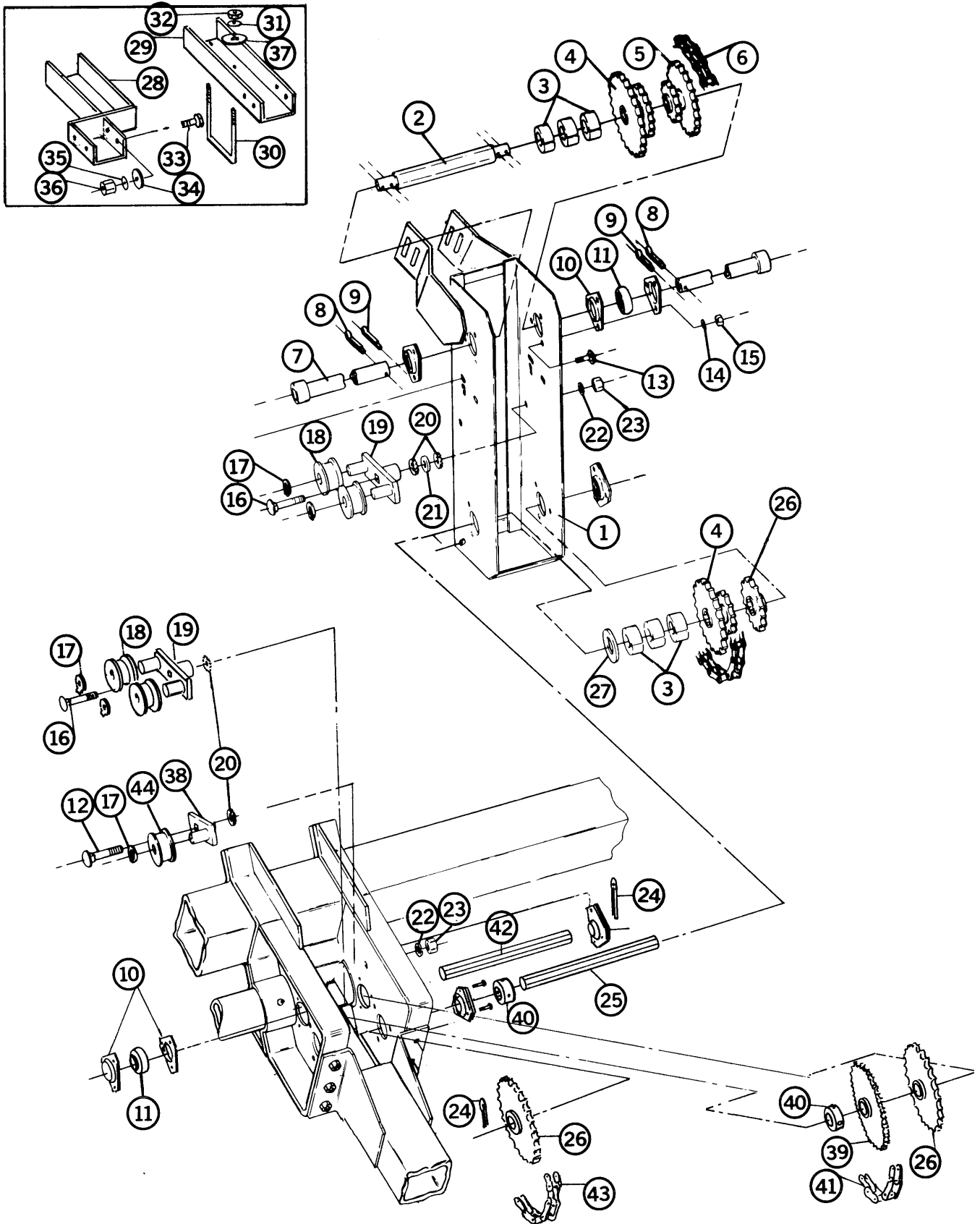

# DRY FERTILIZER TRANSMISSION

# 4-6 ROW

ITEM	PART NO.	DESCRIPTION
1.	A859	Transmission Case
2.	D943	Shaft, Upper
3.	D832	Spacer, Rubber
4.	2500-12	Sprocket, 18-36 Tooth
5.	2500-3	Sprocket, 16-30 Tooth
6.	3300-44 R194	Chain, No. 2040, 44 Links, Includes Connector Link Connector Link, No. 2040
7.		Coupler
8.	10462	Cotter Pin, 3/16"x2"
9.	10459	Cotter Pin, 3/16"x1 1/2"
10.	3400-1	Flangette
11.	2100-3	Bearing 7/8" Hex Bore
12.	10313	Carriage Bolt, 1/2"-13x1 1/2"
13.	10312	Carriage Bolt, 5/16"-18x 3/4"
14.	10232	Lock Washer, 5/16"
15.	10106	Hex Nut, 5/16"-18
16.	10314	Carriage Bolt, 1/2"-13x3"
17.	10435	Ring, Retainer
18.	D1067	Spool, Idler
19.	A293	Bracket, Idler
20.	10527	Lock Washer, Int/Ext, 1/2"
21.	10216	Washer, 1/2" USS
22.	10228	Lock Washer, 1/2"
23.	10102	Hex Nut, 1/2"-13
24.	10465	Cotter Pin, 1/4"x1 1/4"
25.	D1750 D1753	Shaft, Lower, 12", Used on 4 Row's Shaft Lower, 30", Used on 6 Row's
26.	2500-14	Sprocket, 24 Tooth
27.	10200	Washer, 1" USS
28.	A917	Bracket Weld, Transmission Mount used on 4R30
29.	D1736	Channel Transmission Mount used on 4RW, 6R30 and 6RW
30.	D1114	U-bolt, 5/8"-11x7"x7"
31.	10230	Lock Washer, 5/8"
32.	10104	Hex Nut, 5/8"-11
33.	10001	HHCS, 3/8"-16x1"
34.	10210	Washer, 3/8" USS
35.	10229	Lock Washer, 3/8"
36.	10101	Hex Nut, 3/8"-16
37.	10217	Flat Washer, 5/8" USS
38.	A882	Bracket, Idler
39.	B138	Sprocket, 48 Tooth
40.	A271	Lock Collar
41.	3300-50 R194	Chain, No. 2040, 50 Pitch, Includes Connector Link Connector Link, No. 2040
42.	D1751	Hex Shaft, 10"
43.	3300-26 R194	Chain, No. 2040, 26 Pitch Includes Connector Link Connector Link, No. 2040
44.	D1068	Spool, Idler
A.	A872	Transmission Assembly, Complete (Items 1-6, 9-11 and 13-27) 4R30, 4RW
B.	A885	Transmission Assembly, Complete (Items 1-6, 9-11 and 13-27) 6R30 and 6RW
C.	A883	Idler Assembly (Items 17, 44 and 38)
D.	A294	Idler Assembly (Items 17-19)

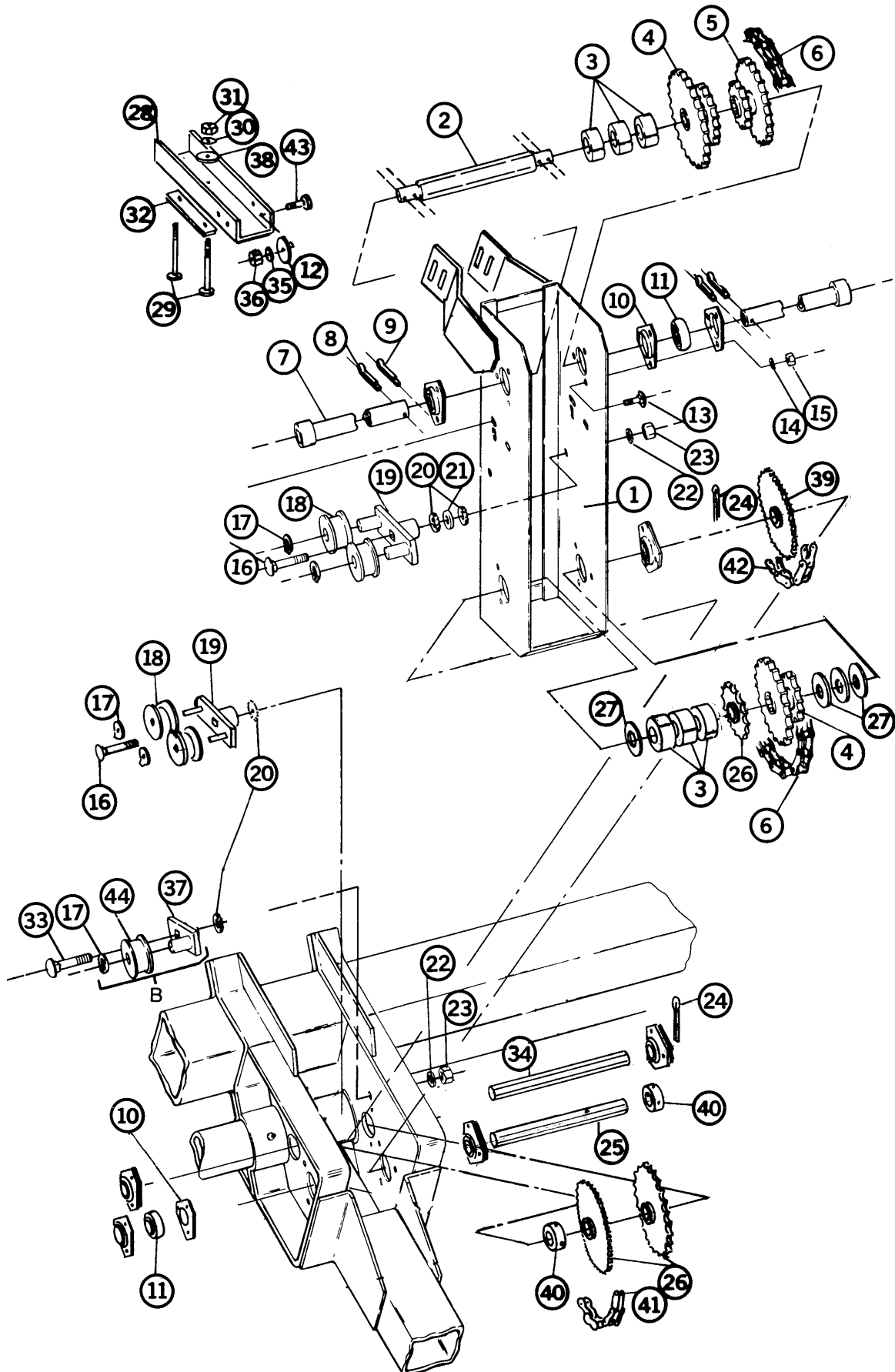

ITEM	PART NO.	DESCRIPTION
1.	A859	Transmission Case
2.	D943	Shaft, Upper
3.	D832	Spacer, Rubber
4.	2500-12	Sprocket, 18-36 Tooth
5.	2500-3	Sprocket, 16-30 Tooth
6.	3300-44 R194	Chain, 2040, 44 Pitch, Includes Connector Link Connector Link, No. 2040
7.		Coupler
8.	10462	Cotter Pin, 3/16"x2"
9.	10459	Cotter Pin, 3/16"x1 1/2"
10.	3400-1	Flangette
11.	2100-3	Bearing, 7/8" Hex Bore
12.	10210	Flat Washer, 3/8" USS
13.	10312	Carriage Bolt, 5/16"-18x3/4"
14.	10232	Lock Washer, 5/16"
15.	10106	Hex Nut, 5/16"-18
16.	10314	Carriage Bolt, 1/2"-13x3"
17.	10435	Ring, Retaining
18.	D1067	Spool Idler
19.	A293	Bracket, Idler
20.	10527	Lock Washer, Int/Ext 1/2"
21.	10216	Washer, 1/2" USS
22.	10228	Lock Washer, 1/2"
23.	10102	Hex Nut, 1/2"-13
24.	10465	Cotter Pin, 1/4"x1 1/4"
25.	D1907	Shaft, Lower, 12"
26.	2500-14	Sprocket, 24 Tooth
27.	10200	Washer, 1" USS
28.	D1736	Channel Transmission Mount
29.	10093	HHCS, 5/8"- 11 x 8 1/2"
30.	10230	Lock Washer, 5/8"
31.	10104	Hex Nut, 5/8" - 11
32.	D1908	Mounting Bracket
33.	10313	Carriage Bolt, 1/2"-13 x1 1/2
34.	D1751	Shaft, 10"
35.	10229	Lock Washer, 3/8"
36.	10101	Hex Nut, 3/8"-16
37.	A882	Bracket, Idler
38.	10217	Flat Washer, 5/8" USS
39.	B138	Sprocket, 48 Tooth
40.	A271	Lock Collar
41.	3300-43  R194 R199	Chain, #2040, 43 Pitch, Includes Connector Link and Off- set Link Connector Link, #2040 Offset Link, #2040
42.	3300-32	Chain, #2040, 32 Pitch, Includes Connector Link
43.	10001	HHCS, 3/8"-16x1"
44.	D1068	Spool, Idler
A.	A294	Idler Assembly, (Items 17-19
B.	A883	Idler Assembly (Items 17, 37, and 44)
C.	A949	Transmission Assembly, Complete (Items 1-6, 9-11, 13-27 and 39)

# LIQUID FERTILIZER ASSEMBLY

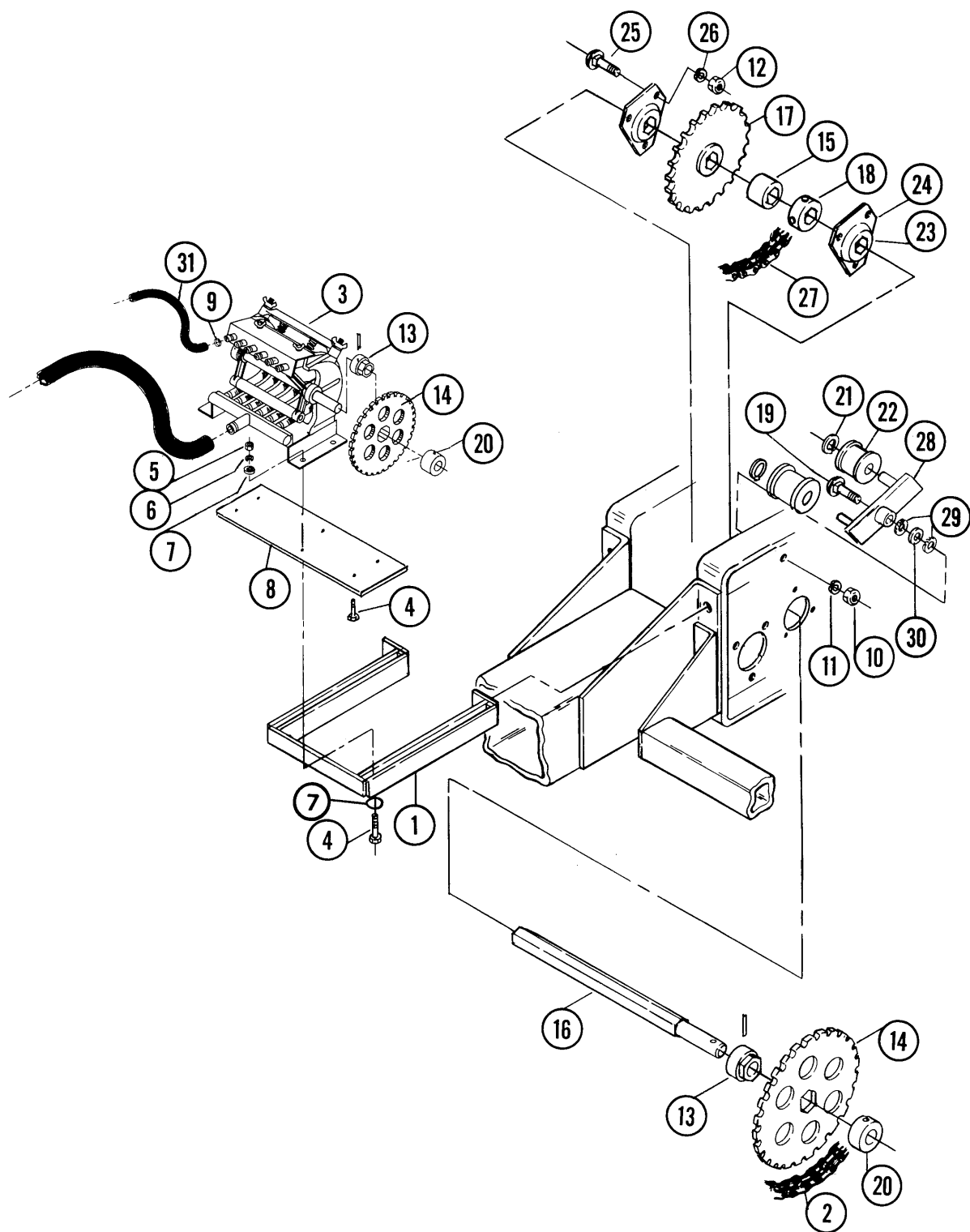



# LIQUID FERTILIZER ASSEMBLY

---

ITEM	PART NO.	DESCRIPTION
1.	A549	Mounting Bracket, Squeeze Pump
2.	3300-75	Chain, #2040, 75 Pitch, Includes Connector and Offset Link
	R194	Connector Link
	R199	Offset Link
3.	A321	Squeeze Pump, 4 Row
	A322	Squeeze Pump, 6 Row
	A323	Squeeze Pump, 8 Row
4.	10066	HHCS, 7/16" - 14 x 2"
5.	10100	Hex Nut, 7/16" - 14
6.	10237	Lock Washer, 7/16"
7.	10199	Flat Washer, 7/16"
8.	D1714	Plate, Sq. Pump Mount (8R30 only)
9.	10673	Hose Clamp, #8
10.	10102	Hex Nut, 1/2" - 13
11.	10228	Lock Washer, 1/2"
12.	10106	Hex Nut, 5/16" - 18
13.	D1216	Sprocket Adapter
	10600	Roll Pin, 5/16" x 2 1/4"
14.	D1217	Sprocket, 8 Tooth (1)
	D1218	Sprocket, 9 Tooth (1)
	D1219	Sprocket, 10 Tooth (1)
	D1220	Sprocket, 15 Tooth (1)
	D1221	Sprocket, 22 Tooth (1)
	D1222	Sprocket, 23 Tooth (1)
	D1223	Sprocket, 26 Tooth (1)
	D1224	Sprocket, 30 Tooth (1)
	D1225	Sprocket, 31 Tooth (1)
15.	D1199-2	Spacer, 3/4"
16.	D1248	Shaft, 16"
17.	2500-14	Sprocket, 24 Tooth
18.	A271	Lock Collar
19.	10314	Carriage Bolt, 1/2" - 13 x 3"
20.	D1215	Sprocket Retainer
21.	10435	Retaining Ring
22.	D1067	Idler Spool
23.	2100-3	Bearing, 7/8" Hex Bore
24.	3400-1	Flangette
25.	10303	Carriage Bolt, 5/16" - 18 x 1"
26.	10232	Lockwasher, 5/16"
27.	3300-43	Chain, #2040, 43 Pitch, Includes Connector and Offset Link
28.	A285	Bracket, Idler
29.	10527	Lockwasher, Internal/External, 1/2"
30.	10216	Washer, 1/2" USS
31.	4400-1	Hose, 1/2" x 30', 4 Row
	4400-2	Hose, 1/2" x 50', 6 Row
	4400-3	Hose, 1/2" x 100', 8 Row
A.	A284	Idler Assembly (Items 21, 22 and 28)
	A2102	Sprocket and Adapter Package (Includes D1215 - D1225 )

# LIQUID FERTILIZER SQUEEZE PUMP - 4 ROW MODEL

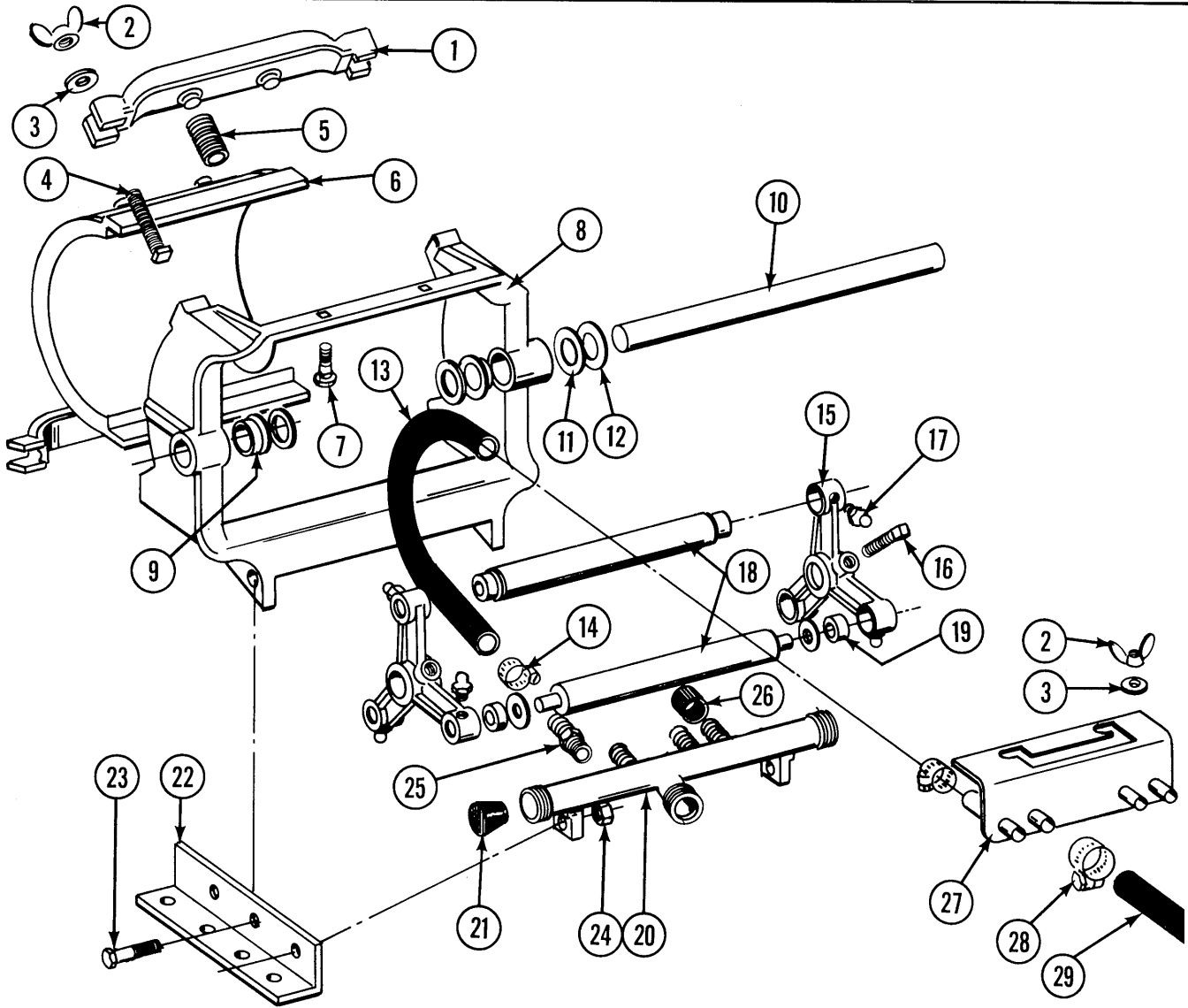

# LIQUID FERTILIZER SQUEEZE PUMP - 4 ROW MODEL

---

ITEM	PART NO.	DESCRIPTION
1.	R216	Spring Anchor Bar
2.	10144	Wing Nut, 5/16"-18
3.	10219	Flat Washer, 5/16" USS
4.	10130	Sq. Head Machine Bolt, 5/16"-18x1 3/4"
5.	R214	Back Spring
6.	R212	Back Plate
7.	10303	Round Head Machine bolt, 5/16"-18x1"
8.	R208	Pump Frame
9.	R207	Bushing (Nylon)
10.	R210	Pump Shaft
11.	R225	Shim 1/32"
12.	R226	Shim, 3/64"
13.	R215	Metering Hose, 1/2"x13"
14.	10681	Hose Clamp
15.	R223	Roller Arm
16.	10131	Set Screw, 5/16"-18x 3/4"
17.	10640	Grease Fitting, 1/4"-28
18.	R209	Roller
19.	R227	Bushing, Nylon
20.	R228	Intake Manifold
21.	R217	Manifold Plug
22.	R213	Base Angle
23.	10004	HHCS, 3/8"-16x1 1/4"
24.	10101	Hex Nut, 3/8"-16
25.	R232	Hose Adapter
26.	R211	Rubber Cap
27.	R224	Discharge Manifold
28.	10673	Hose Clamp, No. 8
29.	4400-1	Hose, 1/2"x30'
A.	A321	Squeeze Pump Complete

# LIQUID FERTILIZER SQUEEZE PUMP - 6 ROW MODEL

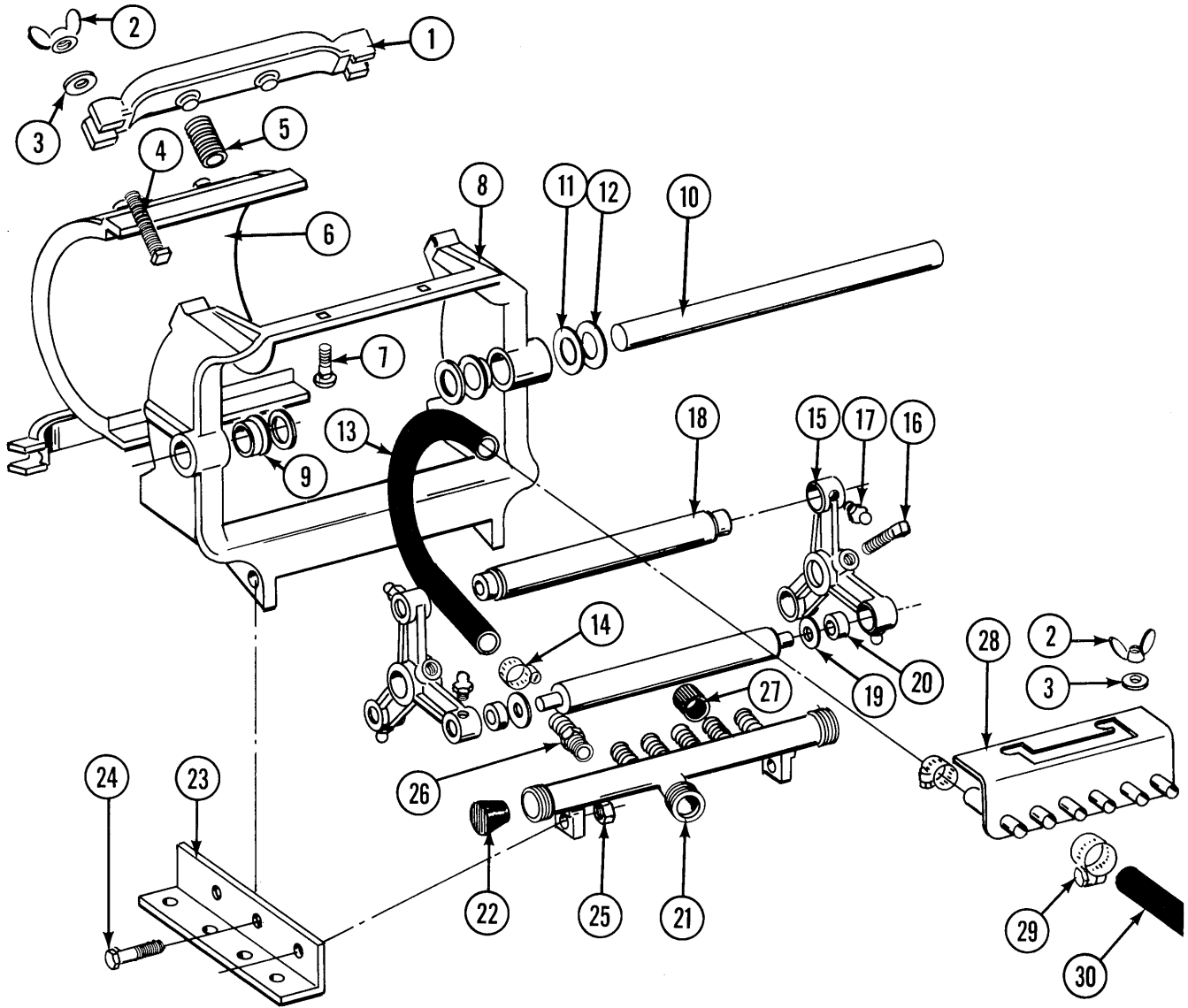

# LIQUID FERTILIZER SQUEEZE PUMP - 6 ROW MODEL

---

ITEM	PART NO.	DESCRIPTION
1.	R216	Spring Anchor Bar
2.	10144	Wing Nut, 5/16"-18
3.	10219	Flat Washer, 5/16"
4.	10130	Square Head Machine Bolt, 5/16"-18x1 3/4"
5.	R214	Back Spring
6.	R212	Back Plate
7.	10303	Round Head Machine Bolt, 5/16"-18x1"
8.	R208	Pump Frame
9.	R207	Bushing, Nylon
10.	R210	Pump Shaft
11.	R225	Shim, 1/32"
12.	R226	Shim, 3/64"
13.	R215	Metering Hose, 1/2"x13"
14.	10681	Hose Clamp
15.	R231	Roller Arm
16.	10131	Set Screw, 5/16"-18x 3/4"
17.	10640	Grease Fitting, 1/4"-28
18.	R233	Roller
19.	R229	Washer, nylon
20.	R230	Bearing, roller
21.	R228	Intake Manifold
22.	R217	Manifold Plug
23.	R213	Base Angle
24.	10004	HHCS, 3/8"-16x1 1/4"
25.	10101	Hex Nut, 3/8"-16
26.	R232	Hose Adapter
27.	R211	Rubber Cap
28.	R224	Discharge Manifold
29.	10673	Hose Clamp, No. 8
30.	4400-2	Hose, 1/2"x50
A.	A322	Squeeze Pump Complete

# LIQUID FERTILIZER SQUEEZE PUMP - 8 ROW MODEL

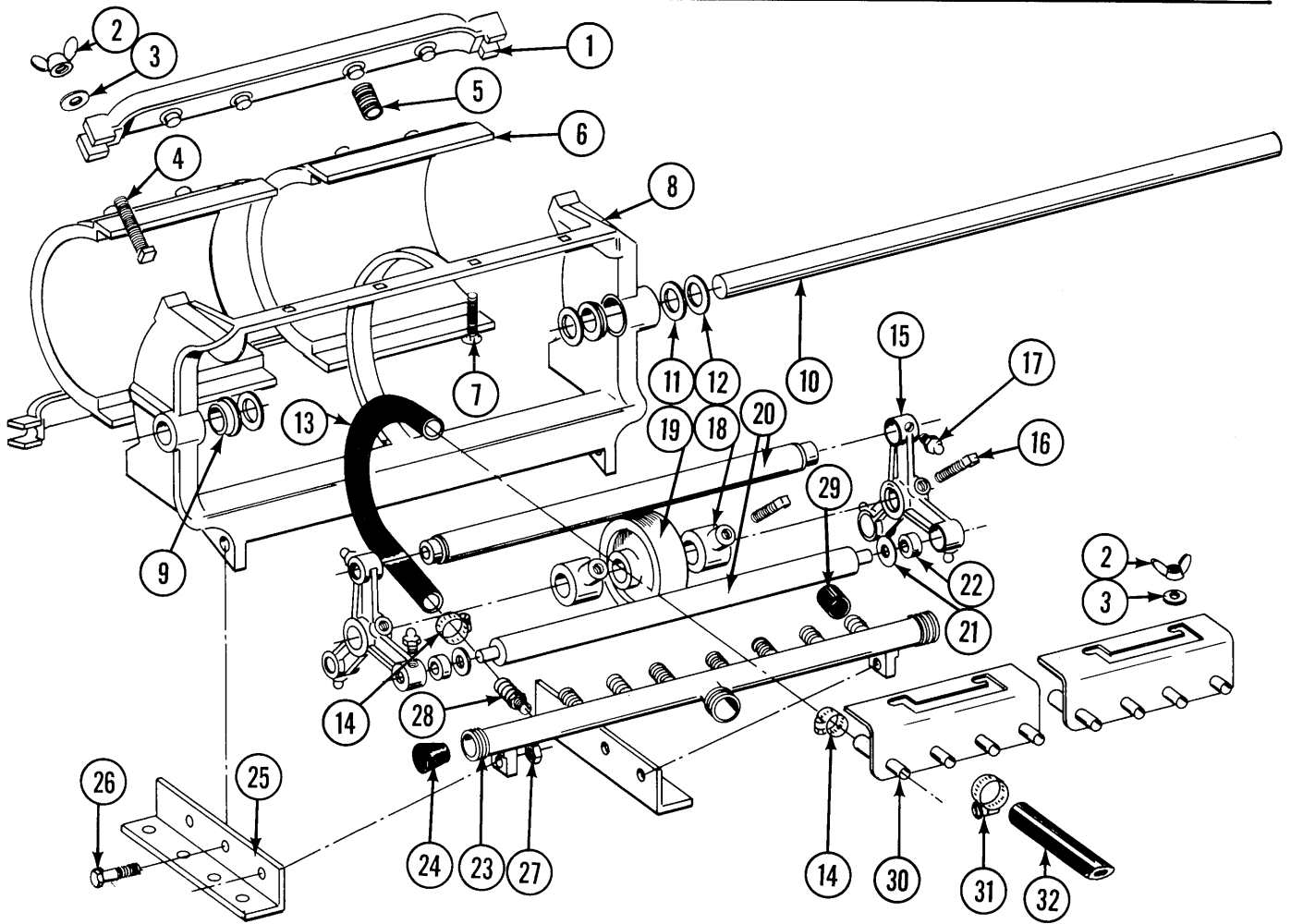

# LIQUID FERTILIZER SQUEEZE PUMP - 8 ROW MODEL

---

ITEM	PART NO.	DESCRIPTION
1.	R221	Spring Anchor Bar
2.	10144	Wing Nut, 5/16"-18
3.	10219	Flat Washer, 5/16"
4.	10130	Square Head Machine Bolt, 5/16"-18x1 3/4"
5.	R214	Back Spring
6.	R212	Back Plate
7.	10303	Round Head Machine Bolt 5/16"-18x1"
8.	R222	Pump Frame
9.	R207	Bushing, Nylon
10.	R220	Pump Shaft
11.	R225	Shim, 1/32"
12.	R226	Shim, 3/64"
13.	R215	Metering Hose, 1/2"x13"
14.	10681	Hose Clamp
15.	R231	Roller Arm
16.	10131	Set Screw, 5/16"-18x 3/4"
17.	10640	Grease Fitting, 1/4"-28
18.	R282	Set Collar
19.	R281	Back Up Roller
20.	R283	Roller
21.	R229	Washer, Nylon
22.	R230	Bearing, Roller
23.	R284	Intake Manifold
24.	R217	Manifold Plug
25.	R279	Base Angle, Left
	R280	Base Angle, Right
26.	10004	HHCS, 3/8"-16x1 1/4"
27.	10101	Hex Nut, 3/8"-16
28.	R232	Hose Adapter
29.	R211	Rubber Cap
30.	R236	Discharge Manifold
31.	10673	Hose Clamp, No. 8
32.	4400-3	Hose, 1/2"x100'
A.	A323	Squeeze Pump Complete

# LIQUID FERTILIZER TANK ASSEMBLY

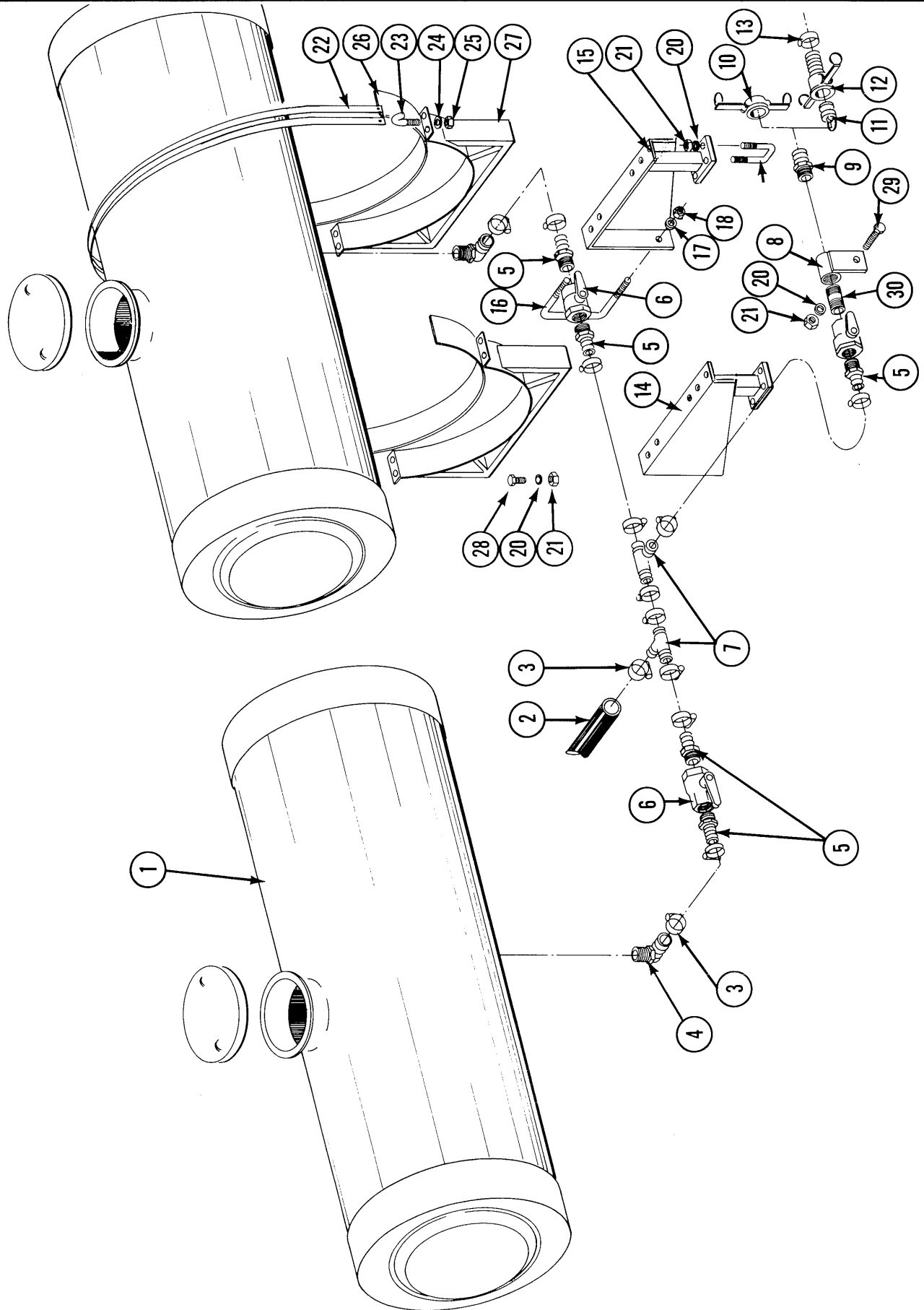



# LIQUID FERTILIZER TANK ASSEMBLY

---

ITEM	PART NO.	DESCRIPTION
1.	D1808	Tank W/lid and 1¼ Pipe Boss, 24" x 100 gal.
	R511	1¼ Pipe Boss
	R512	Lid, 13"
2.	4200-1	Hose, 1¼" x 22', 4R
	4200-2	Hose, 1¼" x 27', 6R
	4200-3	Hose, 1¼" x 32', 8R
3.	10674	Hose Clamp, #24
4.	10742	Elbow, 90°, 1¼" NPT to 1¼" Barb
5.	10745	Adapter, 1¼" NPT to 1¼" Barb Fitting
6.	A499	Ball Valve, 1¼" Nylon
7.	10750	Tee, 1¼", Plastic
8.	A918	Quick Fill Adapter Mount
9.	D1514	Q Cam, 1¼"
10.	D1515	Dust Cap, 1¼"
11.	D1517	Dust Plug
12.	D1516	Q CHB, 1½"
13.	10672	Hose Clamp, #28
14.	A878	Tank Mounting Bracket, R.H.
15.	A879	Tank Mounting Bracket, L.H.
16.	D1114	U-Bolt, 5/8" - 11 x 7 x 7
17.	10230	Lock Washer, 5/8"
18.	10104	Hex Nut, 5/8" - 11
19.	D1339	U-Bolt, ½" - 13 x 3" x 2½'
20.	10228	Lockwasher, ½"
21.	10102	Hex Nut, ½" - 13
22.	D1335	Tank Band, 24"
23.	D1337	J-Bolt, 5/16"
24.	10232	Lockwasher, 5/16"
25.	10106	Hex Nut, 5/16" - 18
26.	D1807	Tank Pad, 6" width (14' Roll)
27.	A919	Tank Saddle, 24"
28.	10017	HHCS, ½" - 13 x 1½"
29.	10032	HHCS, ½" - 13 x 3¾"
30.	10094	Pipe Nipple, 1¼" x 3"
	D1162	28" Tie Strap (Not Shown)
	D1512	6" Tie Strap (Not Shown)
	D2117	14½" Tie Strap (Not Shown)

# NUMERICAL INDEX

## PART NO. PAGE PART NO. PAGE PART NO. PAGE PART NO. PAGE

A167 ... 68  
 A172R ... 68  
 A172L ... 68  
 A211 ... 65, 72, 76  
 A224 ... 65  
 A225 ... 65  
 A233 ... 67, 69, 70, 71, 77  
 A241 ... 60  
 A242 ... 63  
 A243 ... 68  
 A245 ... 68  
 A251 ... 60  
 A252 ... 60  
 A255 ... 60  
 A257 ... 68  
 A261R ... 59  
 A261L ... 59  
 A269 ... 60  
 A270 ... 61, 69, 70, 71, 72  
 A271 ... 59, 87, 89, 91  
 A272 ... 63  
 A280 ... 55, 57, 69, 70, 71, 72, 73  
 A282 ... 61, 69, 70, 71, 72  
 A284 ... 91  
 A285 ... 91  
 A293 ... 87, 89  
 A294 ... 87, 89  
 A305 ... 65, 68  
 A306 ... 65, 68  
 A308 ... 81  
 A310 ... 81  
 A312 ... 81  
 A318 ... 81  
 A320 ... 81  
 A321 ... 91, 93  
 A322 ... 91, 95  
 A323 ... 91, 97  
 A328 ... 81  
 A332 ... 55  
 A333 ... 55  
 A335 ... 55  
 A336 ... 55  
 A338 ... 55  
 A341 ... 55, 57  
 A346 ... 55, 57  
 A350 ... 55, 57, 63  
 A351 ... 63  
 A352 ... 55  
 A354 ... 55  
 A356 ... 55  
 A374 ... 60  
 A376 ... 59  
 A378 ... 59  
 A379 ... 60  
 A499 ... 99  
 A503 ... 63  
 A524 ... 55  
 A525 ... 55  
 A526 ... 55  
 A527 ... 57  
 A538 ... 65  
 A547 ... 60  
 A549 ... 91  
 A554 ... 84  
 A555 ... 84  
 A557 ... 84  
 A561 ... 84  
 A563 ... 65  
 A581 ... 83  
 A585 ... 59  
 A652 ... 60  
 A661 ... 57  
 A663 ... 57  
 A665 ... 84  
 A683 ... 60  
 A684 ... 84  
 A745 ... 65, 72, 75  
 A747 ... 55, 57, 69, 70, 71, 72, 74

A785 ... 81  
 A786 ... 81  
 A788 ... 55, 57  
 A808 ... 55, 57  
 A809 ... 55, 57  
 A810 ... 81  
 A819 ... 59  
 A820 ... 59  
 A821 ... 59  
 A822 ... 59  
 A827 ... 67  
 A828 ... 67  
 A831 ... 67  
 A832 ... 67  
 A859 ... 87, 89  
 A863 ... 83  
 A864 ... 83  
 A869 ... 57, 79  
 A870 ... 57, 79  
 A872 ... 87  
 A873 ... 79  
 A874 ... 79  
 A875 ... 79  
 A876 ... 79  
 A877 ... 57, 79  
 A878 ... 99  
 A879 ... 99  
 A880 ... 57  
 A881 ... 84  
 A882 ... 87, 89  
 A883 ... 87, 89  
 A884 ... 84  
 A885 ... 87  
 A896 ... 83  
 A899 ... 68  
 A917 ... 87  
 A918 ... 99  
 A919 ... 99  
 A949 ... 89  
 A1002 ... 71, 72  
 A1003 ... 71, 72  
 A1007 ... 71, 72  
 A1009 ... 71, 72  
 A1012 ... 70, 71  
 A1025 ... 69, 70  
 A1026 ... 69, 70  
 A1039 ... 69, 70  
 A1041 ... 71  
 A1043 ... 69, 70  
 A1044 ... 69  
 A1102 ... 72  
 A1103 ... 72  
 A1108 ... 72  
 A2008 ... 63  
 A2009 ... 63  
 A2014 ... 81  
 A2101 ... 83  
 A2102 ... 91  
 B  
 B128 ... 63  
 B129 ... 63  
 B130 ... 63  
 B131 ... 63  
 B134 ... 81  
 B138 ... 63, 87, 89  
 D  
 D438 ... 65  
 D453-1 ... 65  
 D453-2 ... 65  
 D453-3 ... 65, 67  
 D453-5 ... 67  
 D457 ... 55  
 D462 ... 65  
 D487 ... 81  
 D498 ... 63  
 D653 ... 67  
 D740 ... 55, 57  
 D746 ... 65  
 D747 ... 63

D748 ... 63  
 D830 ... 57  
 D831 ... 60  
 D832 ... 63, 87, 89  
 D840 ... 68  
 D844 ... 60  
 D913 ... 59, 63  
 D914-21 ... 59  
 D914-25 ... 59  
 D914-29 ... 59  
 D914-33 ... 59  
 D914-55 ... 59  
 D914-71 ... 59  
 D914-81 ... 59  
 D914-85 ... 59  
 D915 ... 60  
 D916 ... 59  
 D926 ... 63  
 D937 ... 78  
 D943 ... 87, 89  
 D946 ... 63  
 D962 ... 81  
 D964 ... 63  
 D965 ... 55, 57  
 D973 ... 59  
 D987 ... 55, 57  
 D1030 ... 81  
 D1067 ... 63, 87, 89, 91  
 D1068 ... 87, 89  
 D1107 ... 63  
 D1114 ... 83, 87, 99  
 D1132 ... 81  
 D1133 ... 63  
 D1138 ... 57, 81  
 D1162 ... 99  
 D1163 ... 81  
 D1166 ... 60  
 D1199-2 ... 91  
 D1200 ... 83  
 D1201 ... 83  
 D1202 ... 83  
 D1203 ... 83  
 D1204 ... 83  
 D1205 ... 83  
 D1206 ... 83  
 D1207 ... 83  
 D1208 ... 83  
 D1209 ... 83  
 D1210 ... 83  
 D1212 ... 83  
 D1213 ... 83  
 D1214 ... 83  
 D1215 ... 91  
 D1216 ... 91  
 D1217 ... 91  
 D1218 ... 91  
 D1219 ... 91  
 D1220 ... 91  
 D1221 ... 91  
 D1222 ... 91  
 D1223 ... 91  
 D1224 ... 91  
 D1225 ... 91  
 D1248 ... 91  
 D1253 ... 69, 70, 71, 72  
 D1255 ... 59  
 D1256 ... 59  
 D1335 ... 99  
 D1337 ... 99  
 D1339 ... 99  
 D1379 ... 83  
 D1380 ... 83  
 D1512 ... 69, 70, 71, 72, 99  
 D1514 ... 99  
 D1515 ... 99  
 D1516 ... 99  
 D1517 ... 99  
 D1653 ... 63  
 D1657 ... 81  
 D1673 ... 81

D1701 ... 67  
 D1702 ... 67  
 D1714 ... 91  
 D1736 ... 87, 89  
 D1748 ... 57, 79  
 D1750 ... 87  
 D1751 ... 87, 89  
 D1753 ... 87  
 D1797 ... 81  
 D1807 ... 99  
 D1808 ... 99  
 D1907 ... 89  
 D1908 ... 89  
 D2117 ... 99  
 #  
 2100-3 ... 59, 63, 87, 89, 91  
 2400-1 ... 63  
 2404-6-6 ... 72  
 2404-8-6 ... 69, 70, 71, 72  
 2500-1 ... 63  
 2500-2 ... 63  
 2500-3 ... 63, 87, 89  
 2500-6 ... 63  
 2500-12 ... 87, 89  
 2500-14 ... 63, 87, 89, 91  
 2500-17 ... 60  
 2501-6-6 ... 72  
 2501-8-8 ... 67, 69, 70, 71, 72  
 2601-6-6 ... 72  
 2601-8-6 ... 69, 70, 71  
 2601-8-8 ... 71, 72  
 2603-8 ... 69, 70  
 3300-6 ... 63  
 3200-58 ... 60  
 3300-26 ... 87  
 3300-32 ... 89  
 3300-40 ... 63  
 3300-43 ... 89, 91  
 3300-44 ... 87, 89  
 3300-50 ... 87  
 3300-52 ... 63  
 3300-75 ... 91  
 3400-1 ... 59, 63, 87, 89, 91  
 4100-1 ... 55, 57  
 4200-1 ... 99  
 4200-2 ... 99  
 4200-3 ... 99  
 4400-1 ... 91, 93  
 4400-2 ... 91, 95  
 4400-3 ... 91, 97  
 6401-8-6 ... 69, 70, 71, 72  
 6602-8 ... 69  
 6801-6-8 ... 72  
 6801-8 ... 69, 70, 71  
 7100-1 ... 78  
 7100-3 ... 78  
 7100-4 ... 78  
 7100-22 ... 78  
 7200-1 ... 78  
 7200-2 ... 78  
 10001 ... 87, 89  
 10004 ... 93, 95, 97  
 10017 ... 55, 57, 99  
 10019 ... 55, 60, 81, 83  
 10026 ... 55, 57, 60  
 10027 ... 55, 57, 79  
 10028 ... 55, 57  
 10029 ... 55  
 10030 ... 57  
 10031 ... 60  
 10032 ... 57, 79, 99  
 10033 ... 65, 67, 68  
 10037 ... 83  
 10039 ... 65, 67  
 10045 ... 81  
 10046 ... 81  
 10047 ... 63, 73  
 10048 ... 63, 69, 70, 71, 72  
 10049 ... 59

# NUMERICAL INDEX

## PART NO. PAGE

10066...91  
 10075...74  
 10093...89  
 10094...99  
 10100...91  
 10101...59, 63, 69, 70, 71,  
 72, 73, 81, 87, 89,  
 93, 95, 97  
 10102...55, 57, 65, 67, 68,  
 79, 81, 83, 87, 89,  
 91, 99  
 10104...83, 87, 89, 99  
 10105...55, 57, 79  
 10106...55, 57, 59, 63, 69,  
 70, 71, 72, 83, 87,  
 89, 91, 99  
 10107...81  
 10108...63  
 10109...81  
 10111...55, 57, 81  
 10130...93, 95, 97  
 10131...93, 95, 97  
 10133...55, 57, 81  
 10144...93, 95, 97  
 10199...91  
 10200...87, 89  
 10201...83  
 10206...83  
 10210...59, 63, 81, 87, 89  
 10213...81  
 10216...68, 81, 87, 89, 91  
 10217...81, 87, 89  
 10219...69, 70, 71, 72, 83,  
 93, 95, 97  
 10226...67  
 10228...55, 57, 65, 67, 68,  
 79, 81, 83, 87, 89,  
 91, 99  
 10229...59, 69, 70, 71, 72,  
 81, 87, 89  
 10230...83, 87, 89, 99  
 10231...55, 57, 60, 79  
 10232...55, 57, 59, 60, 63,  
 69, 70, 71, 72, 81,  
 83, 87, 89, 91, 99  
 10233...59, 63  
 10234...63  
 10235...63  
 10237...91  
 10303...83, 91, 93, 95, 97  
 10305...63, 81  
 10312...59, 63, 87, 89  
 10313...87, 89  
 10314...87, 89, 91  
 10430...59  
 10435...59, 63, 87, 89, 91  
 10451...81  
 10455...63  
 10456...63, 83  
 10459...87, 89  
 10460...65, 67  
 10462...63, 87, 89  
 10464...59, 83  
 10465...63, 87, 89  
 10466...63  
 10470...68  
 10499...81  
 10503...81  
 10504...81  
 10524...63  
 10527...87, 89, 91  
 10548...63  
 10561...55, 57  
 10562...83  
 10565...63  
 10600...91  
 10609...65  
 10640...57, 63, 65, 93, 95,  
 97  
 10641...63, 67, 83

## PART NO. PAGE

10643...63  
 10651...81  
 10655...83  
 10670...55, 57, 63, 65, 83  
 10672...99  
 10673...81, 91, 93, 95, 97  
 10674...99  
 10675...83  
 10676...83  
 10681...93, 95, 97  
 10722...65, 68  
 10724...68  
 10725...68  
 10742...99  
 10745...99  
 10750...99  
 R's  
 R103...61  
 R134...77  
 R135...77  
 R136...77  
 R137...77  
 R138...77  
 R139...77  
 R150...68  
 R151...68  
 R153...73  
 R154...76  
 R157...76  
 R158...76  
 R159...76  
 R160...76  
 R161...76  
 R162...76  
 R173...73  
 R174...73  
 R175...73  
 R176...73  
 R177...73  
 R178...73  
 R179...73  
 R180...73  
 R181...73  
 R187...73  
 R190...60  
 R193...73, 74, 75, 76  
 R194...87, 89, 91  
 R195...60  
 R199...89, 91  
 R203...73  
 R204...60  
 R207...93, 95, 97  
 R208...93, 95  
 R209...93  
 R210...93, 95  
 R211...93, 95, 97  
 R212...93, 95, 97  
 R213...93, 95  
 R214...93, 95, 97  
 R215...93, 95, 97  
 R216...93, 95  
 R217...93, 95, 97  
 R220...97  
 R221...97  
 R222...97  
 R223...93  
 R224...93, 95  
 R225...93, 95, 97  
 R226...93, 95, 97  
 R227...93  
 R228...93, 95  
 R229...95, 97  
 R230...95, 97  
 R231...95, 97  
 R232...93, 95, 97  
 R233...95  
 R236...97  
 R255...55, 57  
 R267...60  
 R271...61

## PART NO. PAGE

R272...61  
 R273...61  
 R274...61  
 R275...61  
 R276...61  
 R277...61  
 R278...61  
 R279...97  
 R280...73, 97  
 R281...97  
 R282...97  
 R283...97  
 R284...97  
 R362...75  
 R363...75  
 R364...75  
 R365...75  
 R366...75  
 R367...75  
 R368...75  
 R371...74  
 R372...74  
 R373...74  
 R374...74  
 R375...74  
 R376...74  
 R377...74  
 R378...74  
 R456...73  
 R511...99  
 R512...99

