

MODEL SINGLE FRAME PLANTER

**OPERATOR & PARTS
MANUAL**

M0118

This page left blank intentionally.

TO THE OWNER

We at Kinze Manufacturing wish to thank you for your patronage and appreciate your confidence in Kinze farm machinery. Your Kinze Planter has been carefully designed and sturdily built to provide years of dependable operation in return for your investment.

This manual has been prepared to aid you in the assembly, operation, and maintenance of the planter. Refer to it when necessary to maintain the machine in efficient operating condition.

Throughout this manual the symbol  and the words, **Note**, **Caution** and **Warning** are used to call your attention to important safety information. The definition of each of these terms used, follows:

NOTE: Indicates a special point of information.

CAUTION: Indicates that a failure to observe can cause damage to the machine or equipment.

 **WARNING:** Indicates that a failure to observe can cause damage to equipment and/or personal injury.

This manual is applicable to:

Single Frame Pull Type Planter - Model Number PTSA

Serial Number 11098 and on.

Record the model number and serial number of your planter with date purchased below:

Date Purchased _____

Serial Number _____

Model Number _____

DANGER

THIS PLANTER IS DESIGNED TO BE DRIVEN BY GROUND TIRES ONLY. THE USE OF HYDRAULIC, ELECTRIC OR PTO DRIVES MAY CREATE SERIOUS SAFETY HAZARDS TO YOU AND THE PEOPLE NEAR BY. IF YOU INSTALL SUCH DRIVES YOU MUST FOLLOW ALL APPROPRIATE SAFETY STANDARDS AND PRACTICES TO PROTECT YOU AND OTHERS NEAR THIS PLANTER FROM INJURY.

WARNING

THIS MACHINE HAS BEEN DESIGNED AND BUILT WITH YOUR SAFETY IN MIND. ANY ALTERATION TO THE DESIGN OR CONSTRUCTION MAY CREATE SAFETY HAZARDS. DO NOT MAKE ANY ALTERATIONS OR CHANGES TO THE EQUIPMENT, BUT IF ANY ALTERATIONS OR CHANGES ARE MADE YOU MUST FOLLOW ALL APPROPRIATE SAFETY STANDARDS AND PRACTICES TO PROTECT YOU AND OTHERS NEAR THIS MACHINE FROM INJURY.

TABLE OF CONTENTS

New Machine Warranty	1
Introduction	1
General Information	1
Serial Number	1
Safety Precautions	2
Lubrications	3
Sealed Bearings	3
Chains	3
Wheel Bearings	3
Lubrication Chart	3
Operations	4
Initial Preparation of Planter	4
Tractor Preparation and Hook-Up	4
Transporting the Planter	4
Leveling the Planter	4
Transmission Adjustment	5
Tire Pressure	5
Hydraulic Marker Operation	5
Marker Adjustment	6
Tractor Speed	6
Shear Pin Protection	6
Double Disk Opener	6
Dry Fertilizer Attachment	7
Plateless Corn Meter Planting Rates	8
Dry Fertilizer Application Rates	9
Maintenance	10
Mounting Bolts and Hardware	10
Chain Tension Adjustment	10
Sequencing Valve Inspection	10
Flow Control Inspection	10
Wheel or Marker Bearings Lubrication or Replacement	11
Preparation for Storage	11
Assembly	12
Hardware	12
Torque Values Chart	12
Final Inspection	12
Parts List Index	13



NEW MACHINE WARRANTY

No warranties express or implied are made or will be deemed to have been made by Kinze of the products sold under this Agreement except as follows:

Kinze warrants to the original purchaser for use that if any part of the product proves to be defective in material or workmanship within one year from date of original purchase, and is reported to Kinze within 10 days after such defect is discovered, Kinze will (at our option) either replace or repair said part. Return of the defective part to Kinze and submission of a completed warranty request must be accomplished within 30 days of the date that the replacement is made available.

This warranty does not apply to damage resulting from misuse, neglect, accident or improper installation or maintenance. A part will not be considered defective if it substantially fulfills performance specifications. Labor, shipping, field service, travel or administrative expenses incurred in connection with warranty replacements are not covered. Tires are not warranted by Kinze Manufacturing, Inc. and such claims must be pursued through the tire manufacturer's warranty.

INTRODUCTION

The single frame pull type planter is available with dry fertilizer application equipment and heavy duty coulters. For information on installation and use of row units and heavy duty coulters refer to the assembly and operation section of the Kinze Row Unit Manual.

General Information

The information and photos used in this manual were current at the time of printing. However, due to Kinze's continual attempt to improve its product, in-line production changes may cause your machine to appear slightly different in detail. Kinze Manufacturing reserves the right to change specifications or design without notice and without incurring obligation to install the same on machines previously manufactured.

Right hand or left hand as used throughout this manual is determined by facing in the direction the machine will travel when in use, unless otherwise stated.

ATTENTION: Effective 12/1/87 amendments were made to the KINZE New Machine Warranty. Refer to insert ~~Warranty~~ **Warranty**.

Kinze warrants all replacement parts for a period of 90 days from date of purchase by the customer. Parts warranty is subject to the same provisions, restrictions and exclusions as new machine warranty and carries the same return and reporting requirements.

The foregoing warranty is exclusive and in lieu of all other warranties or merchantability, fitness for purpose and of any other type, whether express or implied. Kinze neither assumes nor authorizes anyone to assume for it any other obligation or liability other than stated above, and will not be liable for consequential damages. Purchaser accepts these terms and warranty limitations unless the product is returned within the fifteen days for full refund of purchase price.

Kinze reserves the right to make changes or to add improvements at any time without notice or obligations.

Kinze New Machine Warranty applies only to those products sold and installed within the boundaries of the United States and Canada.

Serial Number

The serial number provides important information about your planter and may be required to obtain the correct replacement part.

The serial number plate is located on the planter frame to be readily available. It is suggested that the serial number and purchase date also be recorded in the space provided on the inside front cover of this manual. Always provide the serial number and model number to your Kinze dealer when ordering parts or anytime correspondence is made with Kinze Manufacturing.

SAFETY PRECAUTIONS

Safe and careful operation of the tractor and planter at all times will contribute significantly to the prevention of accidents.

Since a large portion of farm accidents occur as a result of fatigue or carelessness, safety practices should be of utmost concern. Read and understand the instructions provided in this manual as well as those provided in your row unit operator's manual. Listed below are a few other safety suggestions that should become common practice.

- Never permit any persons other than the operator to ride on the tractor.
- Never ride on the planter frame or allow others to do so.
- Limit towing speeds to 15 MPH. Tow only with farm tractor of at least 50 H.P. size.
- Always make sure there are no persons near the planter when gauge marker assemblies are in operation.
- Always lower the planter when not in use and cycle the hydraulic control lever to relieve pressure in cylinders and hoses.
- Always make necessary safety preparations prior to transporting the machine on public roads. This includes installing Slow Moving Vehicle (SMV) emblem and use of adequate lights or safety warnings after dark, except where prohibited by law.
- Watch for obstructions such as wires, tree limbs, etc., when folding marker assemblies.
- Always install marker lock up/safety pins before transporting or parking any planter equipped with conventional marker assemblies.
- Always install all cylinder lock up brackets before towing the planter or working under the unit.

(“Safety” Position Shown)

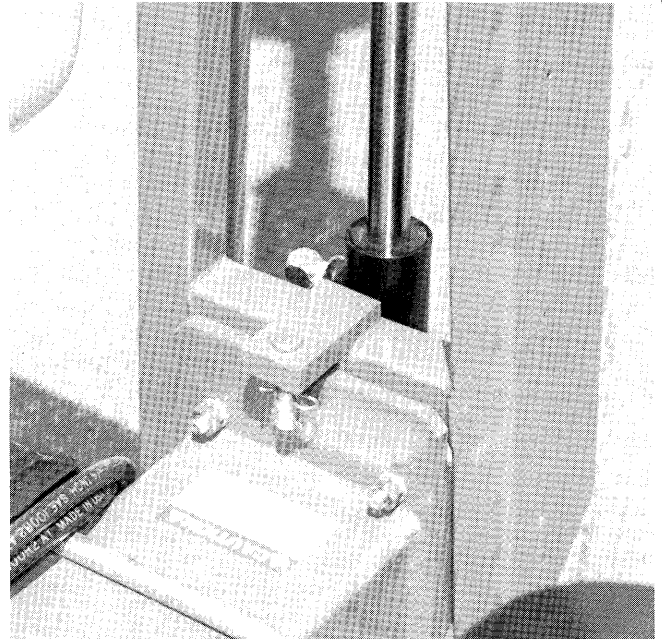

Marker Assembly

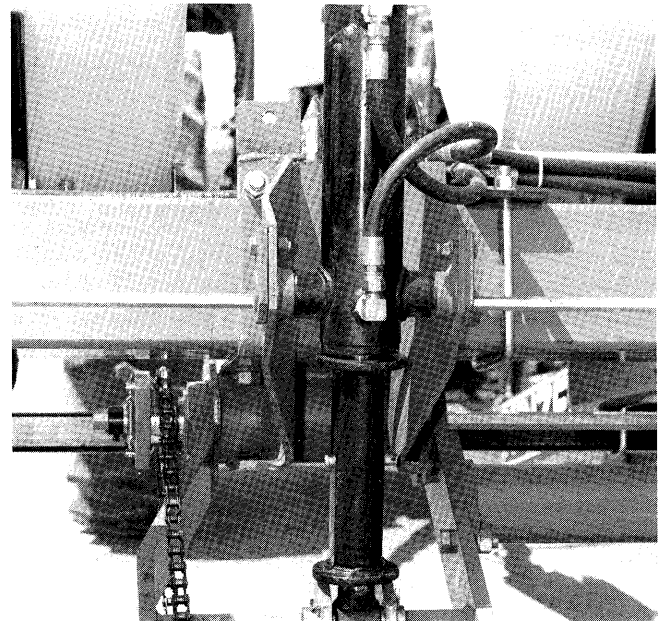

Lift Cylinder Lock Up Bracket

LUBRICATION

This page shows the location of all lubrication points. Proper lubrication of all moving parts will help insure efficient operation of your Kinze planter and prolong the life of friction producing parts. Those parts equipped with grease fittings should be lubricated at the frequency indicated with an SAE multipurpose type grease. Be sure to clean the fitting thoroughly before using grease gun. The frequency of lubrication recommended is based on normal operating conditions. Severe or unusual conditions may require more frequent attention.

Sealed Bearings

A number of sealed bearings are used on your Kinze Planter to provide trouble free operation. These are located in such areas as the drive shaft, row units, and transmission bearings. Sealed bearings are lubricated for life, and due to the seals, relubrication is not practical.

Drive Chains

The planter and row unit drive chains should be lubricated approximately every 8-10 hours with a quality engine oil or equivalent SAE 10 weight oil. A good quality spray lubricant may also be used for periodic chain lubrication. Extreme operating conditions such as dirt, temperature, or speed may require more frequent lubrication. If any of the chains become stiff, it should be removed and soaked and washed in solvent to loosen and remove dirt from the joints. Then soak the chain in oil so the lubricant can penetrate between the rollers and bushings.

Wheel Bearings

Wheel bearings should be repacked with clean heavy duty axle grease approximately once a year or at the beginning of each planting season. This applies to all drive transport wheels and marker hubs. Following the procedure outlined for wheel bearing replacement with the exception that bearings and bearing caps are reused.

Lubrication Chart

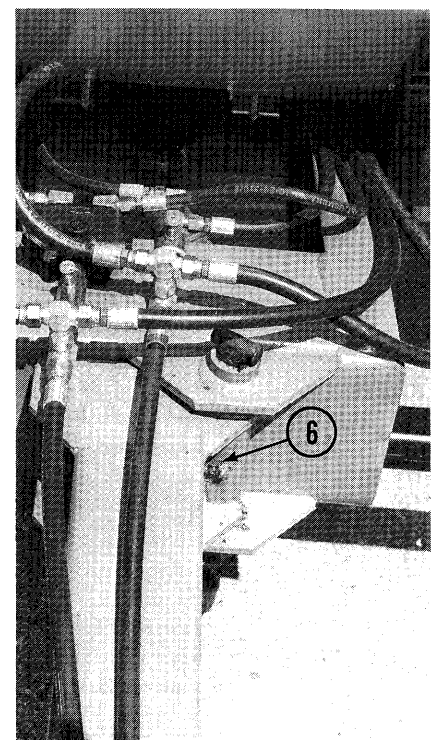
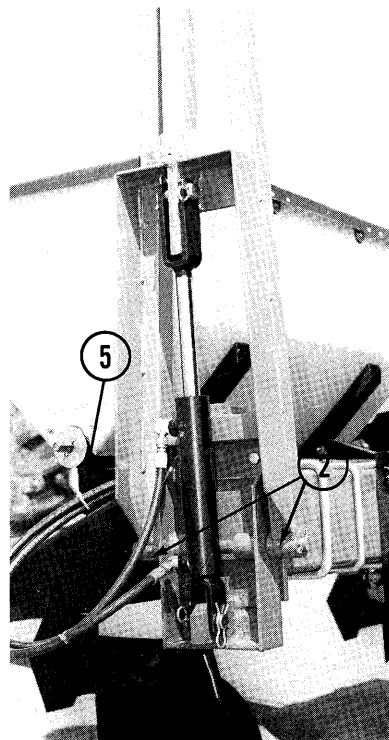
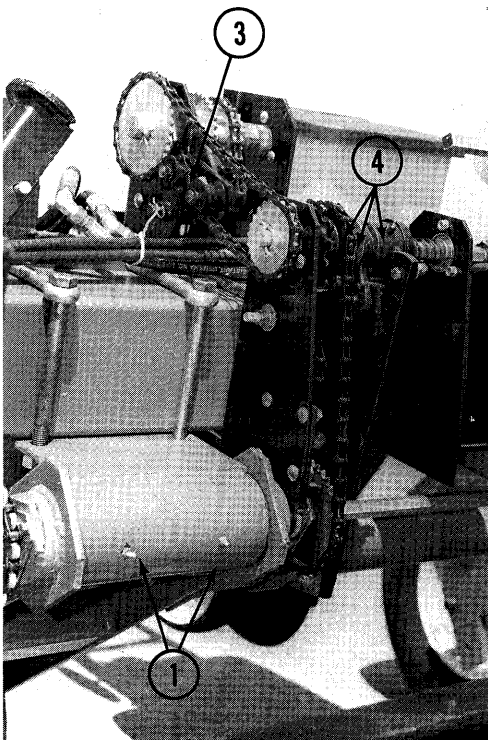

Ref. No.	Description	No. of Zerks	Frequency
1.	Wheel Mount Assembly	2 Per Mount	10 Hours
2.	Marker Assembly	2 Per Marker	10 Hours
3.	Transmission Assembly	1	10 Hours
4.	Clutch Throw Out Assembly	3	10 Hours
5.	Dry Fertilizer Hopper	2 Per Hopper	10 Hours
6.	Hitch Pivot Pin	1	As Required

OPERATION

Marker Adjustment

To determine the correct length at which to set the marker assemblies, multiply the number of rows by the row spacing in inches. This provides the total planting width. Then adjust the marker extension so that the distance from the marker disk to the center line of the planter is equal to the total planting width previously obtained. Both the planter and marker assembly should be lowered to the ground when measurements are being taken. Also, the measurement should be taken from the point where the disk contacts the ground. Adjust right and left marker assemblies equally and securely tighten clamping bolts. An example of marker length adjustment follows:

Number of Rows x Row Spacing (Inches) =	Dimension between planter center line and marker blade
3 x 60" = 180" marker dimension	

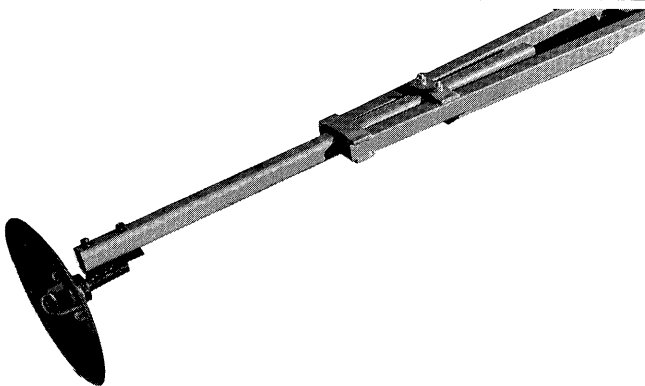

The marker disk is installed so the concave side of the disk is outward to throw dirt away from the grease seals. To provide further variation in the size of the mark, the spindle bracket is slotted so the hub and blade can be angled forward or rearward to throw more or less dirt. To adjust the hub and spindle, loosen the 1/2" x 3 1/2" capscrews and move the bracket as required. Then tighten bolts to the specified torque.

When attaching the 16" disk to the hub alternate bolts while tightening to avoid distorting the disk's shape or breaking the marker hub.

Tractor Speed

Depending upon seed population being planted and sprocket combinations, ground speeds may range from 2 to 7 miles per hour. However, optimum speed for most conditions is 5 to 5.5 MPH. Seed population may increase at higher planting speeds, particularly at higher population rate settings.

Consult the operator's manual and planting rate charts for your row units for further tractor speed information. Planting rate charts for Kinze row units equipped with plateless corn meters can be found at the end of the operation section of this manual.

Shear Pin Protection

The transmission and row unit components are protected from damage by cotter shear pins on the transmissions and the throw out clutch.

If excessive load should cause a pin to shear, it is important to determine where binding has occurred before replacing the pin.

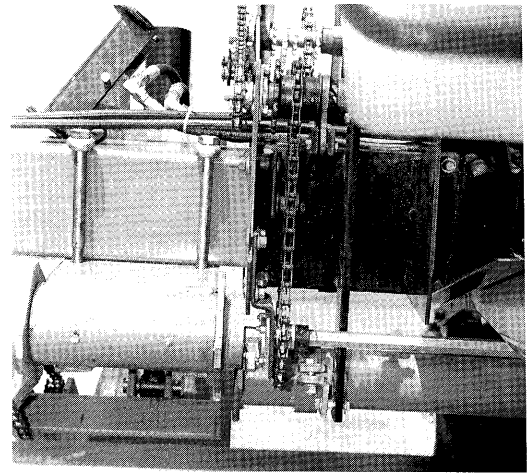

To prevent future binding or breakage of components, follow prescribed lubrication schedules.

Double Disk Opener

The double disk openers should be positioned during assembly to place the fertilizer approximately 2" to either side of the row and from 4 to 6 inches deep depending upon soil conditions and down pressure.

The down pressure springs are factory preset at 250 pounds down pressure but may be adjusted for various soil conditions. To adjust spring tension, loosen the jam nut with a 15/16" wrench and use a 1" wrench to turn the adjustment bolt clockwise to increase tension or counterclockwise to decrease tension. Securely tighten the jam nut upon completion of tension adjustment.

WARNING: Do not operate the double disk openers at full down pressure tension when planting in rocky ground. Chipping of the disk blades may occur.

OPERATION

The scrapers on each blade may also be adjusted to make up for wear that may occur. Make sure the scraper is adjusted as close as possible to the blade without touching.

The opener assembly is designed to be locked in a raised position when the fertilizer attachment is not in use or during storage. To lock the opener, first raise the planter and place blocks under the openers. Then lower the planter until the hole in the pivot section aligns with the hole in the mounting bracket. Remove the lockup pin from the storage position in the mounting bracket and install it through the lockup hole and secure with cotter pins.

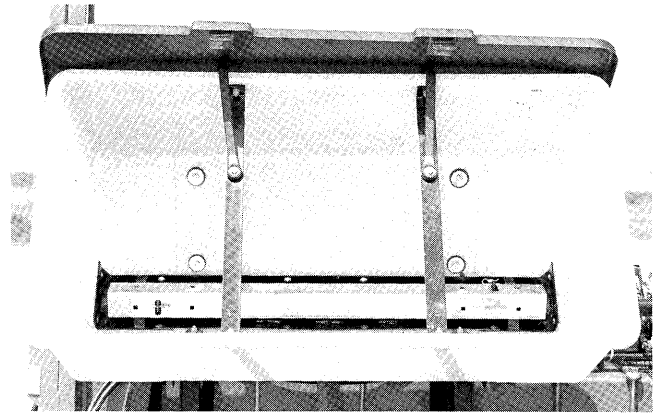
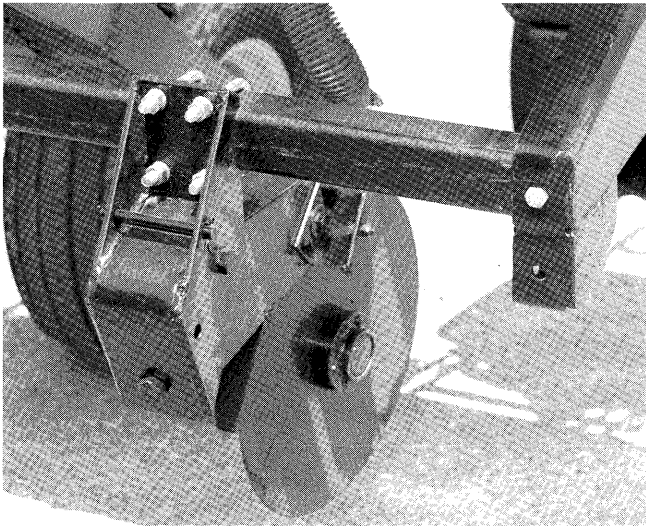

Dry Fertilizer Attachment

The rate of dry fertilizer application is determined by the drive and driven sprocket combinations on the fertilizer transmission. Sprocket combinations are changed in the same manner as the row unit transmission. After removing the rubber spacers and loosening the drive chain, slide the selected sprockets into alignment with the idlers. Then, restore proper chain tension and replace spacers between sprockets. Refer to the application charts at the end of "Operation" for selection of sprocket combinations.

The dry fertilizer attachment meters granules by volume rather than weight. For this reason, and given the variances in brands and fertilizer analysis, the weight metered during actual application may vary considerably. Use the chart for reference only. It is suggested that a container be used to catch and measure application to obtain a closer estimate.

Since most fertilizers easily accumulate moisture, it is important that fertilizer be kept dry during use and storage. In addition to waste, deposits of fertilizer left in the hopper can cause metal corrosion.

The dry fertilizer attachment uses fiberglass hoppers. Each hopper is designed to hold approximately 550 pounds depending upon the type of fertilizer being used.

! **WARNING: Agricultural chemicals can be dangerous if not selected and handled with care. Always read and follow directions supplied by the chemical manufacturer.**

OPERATION

Planting Rate For Plateless Corn Meter

Seed Populations Per Acre			Average Seed Placement In Inches	Sprocket Combinaitons		Recommended Speed Range In MPH
60 Inch Rows	36 Inch Rows			Drive Sprocket	Driven Sprocket	
28,100	46,800		3-3/4	30	14	2 to 3
24,350	40,600		4-1/4	26	14	2 to 3 1/2
21,850	36,400		4 3/4	30	18	3 to 4
20,650	34,400		5 1/8	22	14	3 to 4 1/2
18,900	31,600		5 1/2	26	18	3 to 4 1/2
17,850	29,800		5 7/8	30	22	3 to 5
16,050	26,800		6 1/2	22	18	3 to 5 1/2
15,350	25,800		6 3/4	26	22	3 to 6
15,050	25,200		7	30	26	3 to 6
14,975	24,950		7 1/8	16	14	3 to 6
13,900	23,200		7 1/2	30	28	4 to 6 1/2
13,100	21,900		8	22	22	4 to 7
12,150	20,300		8 5/8	26	28	4 to 7
11,650	19,400		9	16	18	4 to 7
11,100	18,500		9 1/2	22	26	4 to 7
10,350	17,200		10 1/8	22	28	4 to 7
10,200	16,900		10 1/4	14	18	4 to 7
9,550	15,900		11	16	22	4 to 7
8,350	13,950		12 5/8	14	22	4 to 7
8,100	13,500		13	16	26	4 to 7
7,475	12,500		14	16	28	4 to 7
7,100	11,800		14 7/8	14	26	4 to 7
6,600	10,950		16	14	28	4 to 7

Above chart for planters equipped with 11L-14 inch drive tires and 1:1 drive sprocket ratios. Recommended tire pressure 40 PSI.

IMPORTANT: The above sprocket combinations are best for average conditions. Changes in sprocket combinations may be required to obtain desired planting population.

The size and shape of seeds will effect the planting rate. Medium round corn is generally the most preferred while small flat is the least desirable. Higher than optimum speeds may result in population rate increases or higher incidents of doubles and triples, particulary with small flat seeds.

IMPORTANT: To prevent miscalculations, make field checks to be sure you are planting at the desired rate.

OPERATION

FERTILIZER RATES — KG./HA. 36 Inch Rows

Sprockets		Planting Speed - Miles Per Hour									
Driven	Drive	1	2	3	4	5	6	7	8	9	10
36	18	142	142	142	142	142	142	142	142	142	142
30	18	171	171	171	171	171	171	171	171	171	171
36	24	190	190	190	190	190	190	190	190	190	181
30	24	228	228	228	228	228	228	228	217	217	217
18	18	285	285	285	285	285	285	271	271	258	258
36	36	285	285	285	285	285	285	271	271	258	258
16	18	320	320	320	320	320	305	305	290	290	290
30	36	342	342	342	342	342	325	309	309	309	309
18	24	380	380	380	380	362	362	343	343	343	325
16	24	427	427	427	427	407	386	386	386	366	366
18	36	569	569	569	542	515	515	488	488	461	461
16	36	641	641	610	580	580	549	549	519	519	519

FERTILIZER RATES — KG./HA. 60 Inch Rows

Sprockets		Planting Speed - Miles Per Hour									
Driven	Drive	1	2	3	4	5	6	7	8	9	10
36	18	171	171	171	171	171	171	171	171	171	171
30	18	205	205	205	205	205	205	205	205	205	205
36	24	228	228	228	228	228	228	228	228	228	217
30	24	273	273	273	273	273	273	273	260	260	260
18	18	342	342	342	342	342	342	325	325	309	309
36	36	342	342	342	342	342	342	325	325	309	309
16	18	384	384	384	384	384	366	366	348	348	348
30	36	410	410	410	410	410	390	371	371	371	371
18	24	456	456	456	456	434	434	412	412	412	390
16	24	513	513	513	513	488	464	464	464	439	439
18	36	683	683	683	651	618	618	586	586	553	553
16	36	769	769	732	696	696	659	659	622	622	622

FERTILIZER RATES - KG/HA. 90 Inch Rows

Sprockets		Planting Speed - Miles Per Hour									
Driven	Drive	1	2	3	4	5	6	7	8	9	10
36	18	114	114	114	114	114	114	114	114	114	114
30	18	137	137	137	137	137	137	137	137	137	137
36	24	152	152	152	152	152	152	152	152	152	145
30	24	182	182	182	182	182	182	182	174	174	174
18	18	228	228	228	228	228	228	217	217	206	206
36	36	228	228	228	228	228	228	217	217	206	206
16	18	256	256	256	256	256	244	244	232	232	232
30	36	273	273	273	273	273	260	247	247	247	247
18	24	304	304	304	304	289	289	275	275	275	260
16	24	342	342	342	342	325	309	309	309	293	293
18	36	456	456	456	434	412	412	390	390	369	369
16	36	513	513	488	464	464	439	439	415	415	415

MAINTENANCE

Mounting Bolts and Hardware

Before operating the planter for the first time, check to be sure all nuts and bolts are tight. Check all nuts and bolts again after approximately the first 50 hours of operation and at the beginning of each planting season thereafter.

All bolts used on the Kinze planter are Grade 5 (high strength) unless otherwise noted. Refer to the torque value chart in the Assembly Section of this manual when tightening bolts.

NOTE: Overtightening bolts can cause as much damage as undertightening. Tightening a bolt beyond the recommended range can reduce its shock load capacity.

Chain Tension Adjustment

All chain idlers are held in a fixed position by a carriage bolt, washers and hex nut. To increase chain tension, loosen the nut and pivot the idler assembly against the chain to obtain sufficient tension on the longest span. Retighten hex nut.

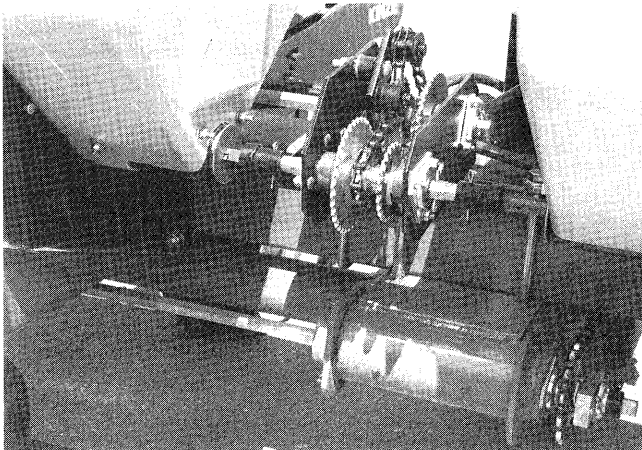
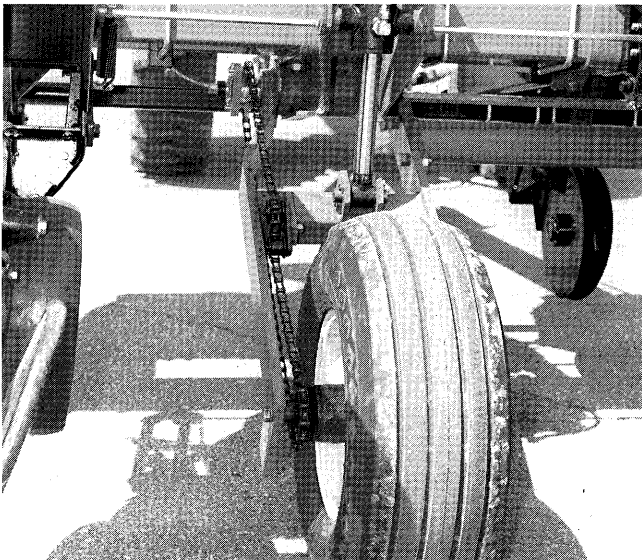

Sequencing Valve Inspection

The sequencing valve consists of a chambered body containing a spool and a series of check valves to direct hydraulic flow. Should the valve malfunction, the components may be removed for inspection. The spool is accessible by removing either side plug and one check valve is accessible from the top of the valve body. It is necessary to disconnect the outlet hoses from the back of the valve to gain access to the remaining retainers and check valves. Inspect all parts for pitting, contamination or foreign material. Also check seating surfaces inside the valve. Replace any parts found to be defective.

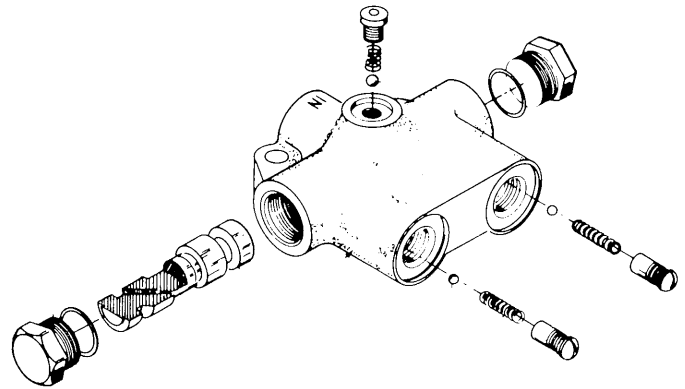

IMPORTANT: Make sure correct check ball and spring are installed in each check valve bore upon reassembly.

Flow Control Valve Inspection

The flow control valves should be adjusted for raise and lower speed as part of the assembly procedure or upon initial operation. If the valve fails to function properly or requires frequent adjustment, the needle valve should be removed for inspection. Check for foreign material and contamination on both the valve and the seating area of the valve body. Replace any components found to be defective.

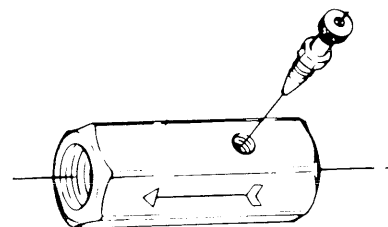

IMPORTANT: The flow control valves must be installed with the arrows pointed toward the tractor.

MAINTENANCE

Wheel or Marker Bearing Lubrication or Replacement

1. Raise tire clear of ground and remove wheel or marker disk.
2. Remove hub cap from hub. (Where applicable)
3. Remove cotter pin, axle nut(s) and washer. (Where applicable)
4. Slide hub from axle or spindle.
5. Remove bearing cups and discard if bearings are being replaced. Clean hub and dry.
6. Press in new bearing cups with thickest edge facing in.
7. Pack bearings with heavy duty wheel bearing grease thoroughly forcing grease between roller cone and bearing cage. Also fill the space between the bearing cups in the hub with grease.
8. Place inner bearing in place and press in new grease seal.
9. Clean axle or spindle and install hub.
10. Install outer bearing, washer or outer seal and slotted hex nut. Tighten slotted hex nut while rotating hub until there is some drag. This assures that all bearing surfaces are in contact. Back off slotted nut to nearest locking slot and install cotter pin. On hub assemblies assembled with jam nuts instead of slotted hex nut, reinstall and tighten jam nuts.
11. Fill hub caps approximately 3/4 full of wheel bearing grease and install on hub.
12. Install wheel or disk on hub and tighten evenly and securely.

Storage

Store the planter in a dry sheltered area if possible.

Remove all trash that may be wrapped on sprockets or shafts and remove dirt that can draw and hold moisture.

Clean all drive chains and coat with a rust preventative spray, or better yet, remove chains and submerge in oil.

Lubricate planter and row units at all lubrication points.

If possible, remove weight from all tires, particularly if the unit is stored outdoors in which case it is best to remove wheels and tires for storage in a cool dry area.

Inspect the planter and row units for parts that are in need of replacement and order during the "off" season.

Make sure all seed, herbicide and insecticide hoppers are empty and clean.

Clean seed meters and store in a dry area.

If the planter is equipped with a dry fertilizer attachment, clean the fertilizer hoppers, openers and all rubber spouts.

Cleaning Fertilizer Hoppers

The dry fertilizer hoppers are designed to tip forward for dumping and ease of cleaning. To dump hoppers, first disconnect the drive shaft from the transmission or adjacent hopper. Loosen hose clamps and remove hose from each hopper.

Finally, remove the two caps screws from the hopper bracket at the rear of each hopper. Rotate hopper lids to the back side of the hopper and carefully tip hopper forward. After dumping contents, flush all loose fertilizer from the hopper and hose.

At the end of the planting season, or when fertilizer attachment is not going to be used for a period of time, the hoppers should be disassembled, cleaned and coated with a rust preventative.

To disassemble spreader assemblies, remove the hairpins and baffle from the top of the auger. Then remove the cotter pin from the auger shaft adjacent to the large flat washer and pull auger assembly from the hopper. The bearings pass through the outer castings and need not be removed. Remove the cotter pin and washer from outer end of the auger shaft and remove all auger components for cleaning. Coat all parts with rust preventative before reassembly.

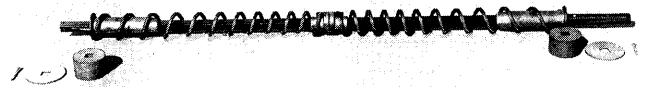

NOTE: Left hand and right hand springs are used on each auger shaft. Make sure springs auger fertilizer to the center of the hopper when rotated in the direction of rotation they turn on the planter.

ASSEMBLY

Prior to assembly, inspect all components for possible damage incurred during shipment. Notify the freight or carrier agent immediately of any damage found. Any parts shortages should be noted and reported to Kinze Manufacturing, Inc. immediately.



Hardware

All bolts furnished with the planter are SAE Grade 5 unless otherwise noted. All bolts are distinguished by the radial lines on the bolt head. (See chart).

In many cases bolts have been pre-installed in the holes in which they go during assembly. It is suggested that bolts be left somewhat loose until parts have been assembled. This especially applies to bearing flanges, idlers, etc. Then tighten all bolts to the torque value specified below unless otherwise noted.

Make a final inspection of the assembled planter

- Lubricate per instructions
- Check for loose hydraulic hoses and fittings
- Check for loose bolts, nuts, etc.
- Check all drive chains for proper alignment and tension.
- Make sure all drive shafts and idlers rotate freely and do not bind.
- Make sure all row units are mounted properly and that they are squared on the frame.
- Cycle all hydraulics to insure all the air has been purged from the hydraulic system.

DRY TORQUE VALUES - FT.LBS.			
Bolt Diameter	Grade 2 No Radial Lines 	Grade 5 Three Radial Lines 	Grade 8 Six Radial Lines 
5/16"	11	17	110
3/8"	23	35	
1/2"	55	85	
5/8"		170	
3/4"		360	
1"		670	
1 1/4"		910	

NOTE: Bolts having lock nuts should be tightened to approximately 50% of amounts shown in above chart. Also bolts lubricated prior to installation should be torqued to 70% of value shown on chart.

PARTS LIST INDEX

Bar and Hitch Assembly	14-15
Wheel Mount Assembly	16-17
Transmission Assembly	19-19
Clutch Throwout Assembly	20-21
Hydraulic System, 5R60 Low Profile Markers	22
Hydraulic System, 3R60 Conventional Markers	23
Low Profile Double Fold Marker Assembly	24-25
Conventional Marker Assembly	26-27
Marker Hub Assembly	28
Lift Cylinder	29
Low Profile Double Folding Marker Cylinder	30
Conventional Marker Cylinder	31-32
Ratchet and Sprocket Assembly	33
Double Disk Fertilizer Opener	34-35
Dry Fertilizer Transmission Assembly	36-37
Dry Fertilizer Hopper and Mount	38-39
Decals, Reflectors and Tie Straps	40

BAR AND HITCH ASSEMBLY

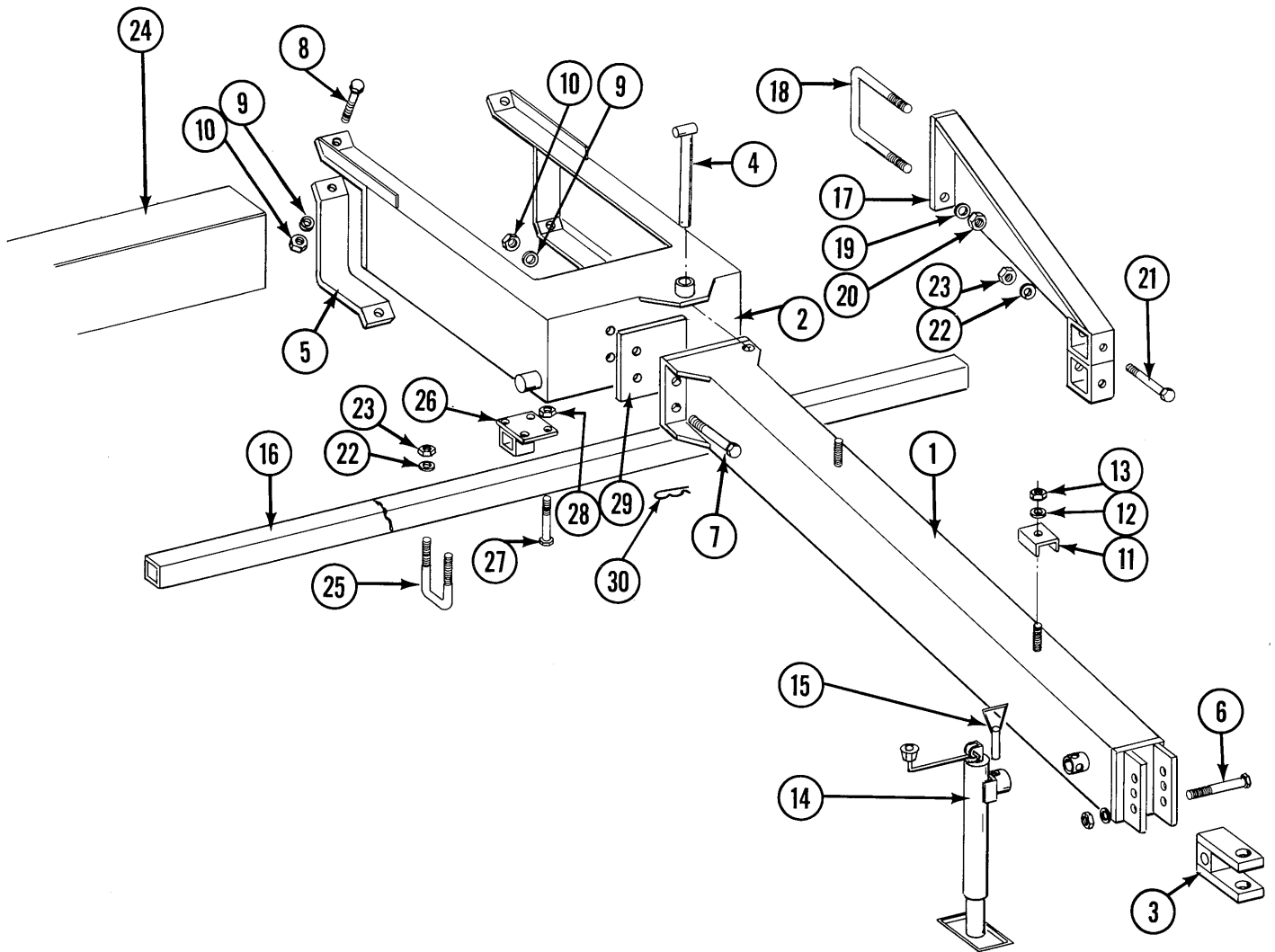

BAR AND HITCH ASSEMBLY

ITEM	PART NO.	DESCRIPTION
1.	A1276	Tongue Tube Weld
2.	A1275	Hitch Mount Weld
3.	A346	Clevis Weld
4.	A135	Pivot Pin, Hitch
5.	D457	Clamp, Half
6.	10050	HHCS, 3/4"-10x5"
7.	10026	HHCS, 3/4"-10x2"
8.	10027	HHCS, 3/4"-10x2 1/2"
9.	10231	Lock Washer, 3/4"
10.	10105	Hex Nut, 3/4"-10
11.	D1656	Clamp
12.	10229	Lock Washer, 3/8"
13.	10101	Hex Nut, 3/8"-16
14.	4100-1	Jack Assembly
15.	R255	Pin Kit
16.	D1685-9	Fertilizer Opener Mounting Bar, 3R60, 154"
	D1685-10	Fertilizer Opener Mounting Bar, 5R60, 274"
17.	A2233	Fertilizer Bar Support L.H. (shown)
	A2234	Fertilizer Bar Support R.H.
18.	D1748	U-Bolt, 7"x7"x 3/4"-10
19.	10231	Lock Washer, 3/4"
20.	10105	Hex Nut, 3/4"-10
21.	10032	HHCS, 1/2"-13x3 3/4"
22.	10228	Lock Washer, 1/2"
23.	10102	Hex Nut, 1/2"-13
24.	A1241	Bar Weld, 3R60, 164"
	A1242	Bar Weld, 5R60, 284"
25.	D1138	U-Bolt, 2 1/2"x2 1/2"x 1 1/2"-13
26.	A1379	Spacer Weld
27.	10035	HHCS 1/2"-13x4"
28.	10111	Hex Lock Nut 1/2"-13
29.	D2370	Shim
30.	10460	Cotter Pin, 1/4" x 2"

WHEEL MOUNT ASSEMBLY

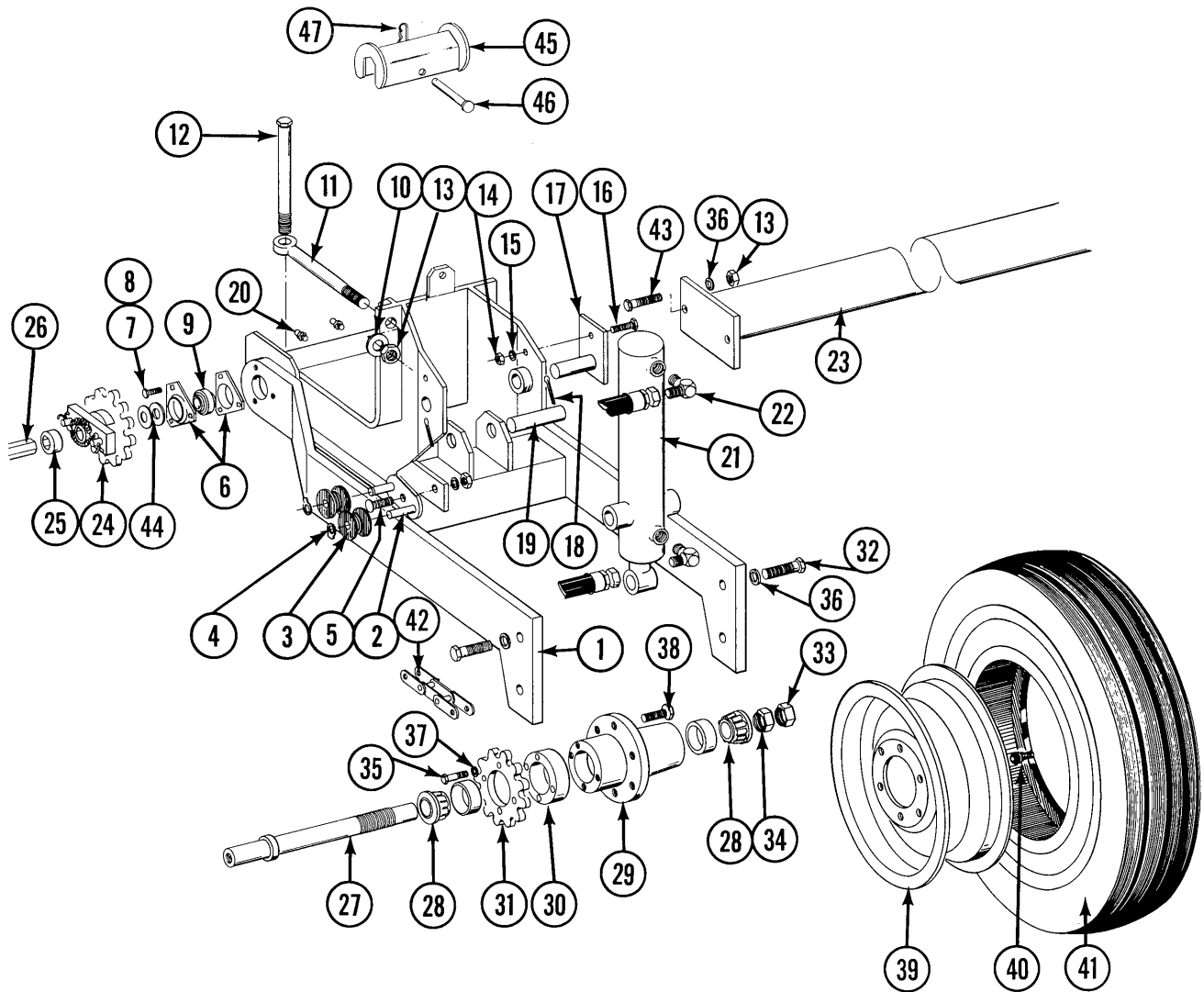

ITEM	PART NO.	DESCRIPTION
1.	A907	Wheel Mount Weld, L.H. (shown)
	A908	Wheel Mount Weld, R.H.
2.	A288	Idler Weld
3.	D1067	Idler Spool
4.	10435	Ring Retaining
5.	10313	Carriage Bolt 1/2"-13x1 1/2" on R.H. side with 10228 Lock Washer and 10102 Nut.
	10088	Carriage Bolt 1/2"-13x1 1/2" on L.H. Side with 10228 Lock Washer and 10086 Nut.
6.	3400-1	Flangette
7.	10019	HHCS, 5/16"-18x1"
8.	10232	Lock Washer, 5/16"

WHEEL MOUNT ASSEMBLY

ITEM	PART NO.	DESCRIPTION
9.	2100-3	Bearing
10.	10231	Lock Washer, 3/4"
11.	D830	Eyebolt
12.	10030	HHCS, 3/4"-10x9"
13.	10105	Hex Nut, 3/4"-10
14.	10102	Hex Nut, 1/2"-13
15.	10228	Lock Washer, 1/2"
16.	10017	HHCS, 1/2"-13x1 1/2"
17.	A2152	Trunion Cylinder Pin
18.	10460	Cotter Pin, 1/4"
19.	D535	Lower Pin, Trunion Cylinder
20.	10641	Grease Fitting
21.	A921	Cylinder Lift, 3"x10"
22.	2501-8-8	Elbow, 90°
23.	A909	Tie Bar Weld
24.	A261L	Ratchet Clutch Assembly, L.H.
	A261R	Ratchet Clutch Assembly, R.H.
25.	A271	Lock Collar
26.	D914-84	Hex Drive Shaft, 3R60, 84"
	D914-204	Hex Drive Shaft, 5R60, 204"
27.	A894	Spindle
28.	A895	Bearing Cone
29.	A926	6 Bolt Hub w/cups
	R434	Cups
30.	D915	Spacer
31.	2500-17	Sprocket
32.	10026	HHCS, 3/4"-10x2"
33.	10087	Jam Nut, 1 1/2"-12
34.	10092	Hex Nut, 1 1/2"-12
35.	10031	HHCS, 5/16"-18x1 3/4"
36.	10231	Lock Washer, 3/4"
37.	10232	Lock Washer, 5/16"
38.	R270	Lug Bolt, 9/16"-18x1 1/4"
39.	A240	Rim, 14"x8"
40.	D1165	Valve Stem
41.	D839	Tire, L11-14
42.	3200-78	Chain, No. 2050, 78 Pitch, Including Connector Link
	R195	Connector Link, No. 2050
43.	10027	HHCS 3/4"-10x2 1/2"
44.	10233	Machinery Bushing, As required
45.	A2201	Lock Up
46.	10561	Clevis Pin, 1/2" x 3"
47.	10670	Hairpin Clip, No. 3
48.	D2822	Shield, Chain, R.H. (Not Shown)
	D2823	Shield, Chain L.H. (Not Shown)
49.	D2824	Bar, Mounting (Not Shown)
50.	10003	HHCS, 3/8" x 1 1/2" (Not Shown)
51.	10101	Hex Nut, 3/8" - (Not Shown)
52.	10229	Lock Washer, 3/8" (Not Shown)
A.	A289	Idler Assembly, (Items 2, 3, and 4)
B.	A932	Drive Hub Assembly, 6 Bolt (Items 27 thru 38)
C.	A541	Tire and Rim Assembly (Items 39 thru 41)

TRANSMISSION ASSEMBLY

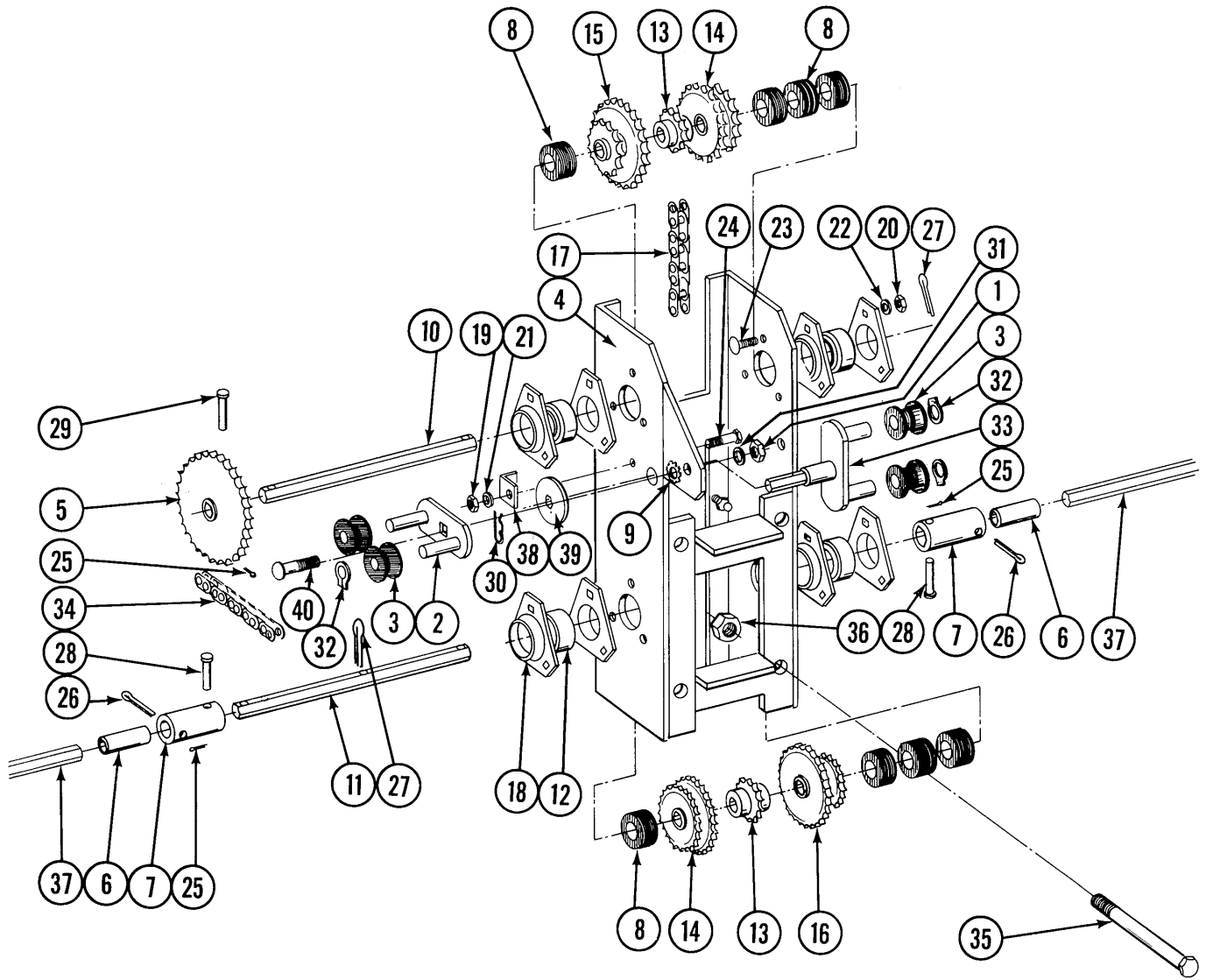

TRANSMISSION ASSEMBLY

ITEM	PART NO.	DESCRIPTION
1.	10102	Hex Nut, 1/2" - 13
2.	A288	Idler Arm Weld
3.	D1067	Idler Spool
4.	A2235	Transmission Case
5.	B146	Sprocket
6.	D747	Drill Shaft Driver, 9/16" Hex
7.	D748	Coupler, Drill Shaft Driver
8.	D832	Spacer
9.	10527	Washer, Int./Ext. 1/2"
10.	D925	Upper Shaft
11.	D2236	Lower Shaft
12.	2100-3	Bearing, 7/8" Hex Bore
13.	2500-1	Sprocket, 14 Tooth
14.	2500-2	Sprocket, 22-26 Tooth
15.	2500-3	Sprocket, 16-30 Tooth
16.	2500-6	Sprocket, 18-28 Tooth
17.	3300-40	Chain, No. 2040, Included Connector Link
	R194	Connector Link, No. 2040
18.	3400-1	Flangette
19.	10101	Hex Nut, 3/8" - 16
20.	10106	Hex Nut, 5/16" - 18
21.	10229	Lock Washer, 3/8"
22.	10232	Lock Washer, 5/16"
23.	10303	Carriage Bolt, 5/16" - 18 x 1"
24.	10301	Carriage Bolt, 3/8" - 16 x 1 1/2"
25.	10455	Cotter Pin, 1/16" x 1/2"
26.	10462	Cotter Pin, 3/16" x 2"
27.	10463	Cotter Pin, 1/4" x 1 1/2"
28.	10548	Clevis Pin, 1/4" x 1 3/4"
29.	10558	Clevis Pin, 5/16" x 1 3/4"
30.	10670	Hair Pin Clip, No. 3
31.	10228	Lock Washer, 1/2"
32.	10435	Retaining Ring
33.	A242	Tightener Weld
34.	3300-44	Chain, No. 2040, 44 Pitch
		Includes Connector Link
	R194	Connector Link, No. 2040
35.	10093	HHCS 5/8" - 11 x 8 1/2"
36.	10107	Lock Nut 5/8" - 11
37.	D739-26	Hex Drill Shaft, 3R60, R.H., 26"
	D739-84	Hex Drill Shaft, 3R60, L.H. 84"
	D739-86	Hex Drill Shaft, 5R60, R.H., 86"
	D739-143	Hex Drill Shaft, 5R60, L.H., 143"
38.	D2495	Angle
39.	A1668	Tightener
40.	10313	Carriage Bolt, 1/2" - 13 x 1 1/2"
A.	A503	Idler Assembly (Items 3, 32, and 33)
B.	A289	Idler Assembly, (Items 2, 3, and 32)

CLUTCH THROWOUT ASSEMBLY

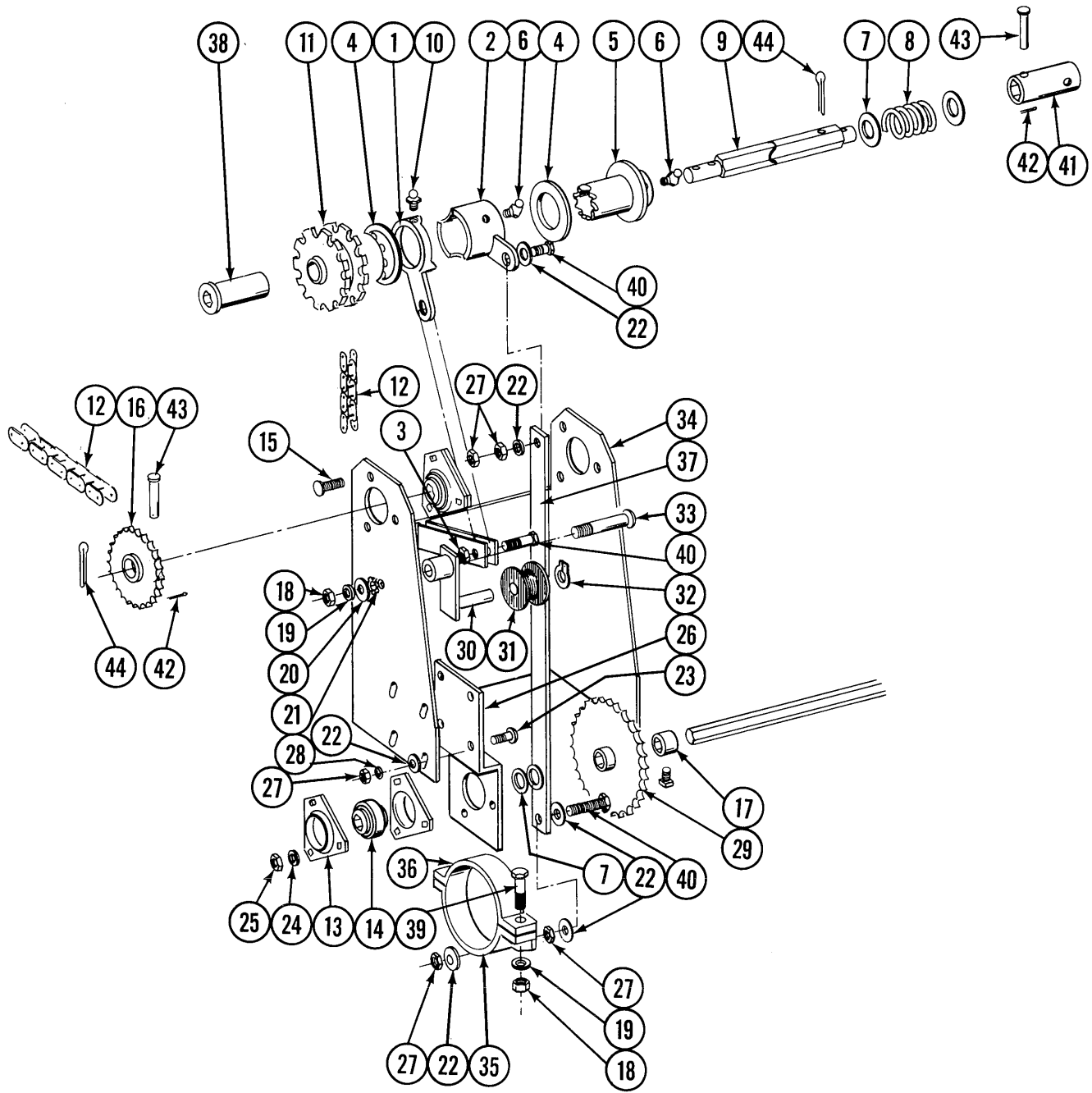

CLUTCH THROWOUT ASSEMBLY

ITEM	PART NO.	DESCRIPTION
1.	B130	Cam, Fixed
2.	B129	Cam, Floating
3.	10108	Lock Nut, 3/8"
4.	10234	Washer
5.	B158	Hub, Clutch
6.	10643	Fitting, Grease, 1/4" - 28 , 45°
7.	10233	Bushing
8.	D2599	Spring
9.	D2765	Shaft, Clutch, 16"
10.	10640	Fitting, Grease 1/4" - 28
11.	B157	Sprocket, Double
12.	3300-44	Chain, No. 2040, 44 Pitch Including Connector Link
	R194	Connector Link, No. 2040
13.	3400-1	Flangette
14.	2100-3	Bearing
15.	10312	Carriage Bolt, 5/16" - 18 x 3/4"
16.	B147	Sprocket 24T (Round Bore)
17.	A271	Lock Collar
18.	10102	Hex Nut, 1/2" - 13
19.	10228	Lock Washer, 1/2"
20.	10216	Flat Washer, 1/2"
21.	10527	Lock Washer, Int., Ext. - 1/2"
22.	10210	Flat Washer, 3/8"
23.	10305	Carriage Bolt, 3/8" - 16 x 1"
24.	10232	Lock Washer, 5/16"
25.	10106	Hex Nut, 5/16" - 18
26.	D2224	Clutch Mounting Bracket
27.	10101	Hex Nut, 3/8"
28.	10229	Lock Washer, 3/8"
29.	B146	Sprocket, 36T
30.	A302	Idler Weld
31.	D1067	Idler Spool
32.	10435	Retaining Ring
33.	10314	Carriage Bolt, 1/2" - 13 x 3"
34.	A1239	Case Weld
35.	A1238	Clamp Weld
36.	A579	Clamp Half
37.	D2228	Clutch Throwout Lever
38.	D2517	Bushing
39.	10016	HHCS, 1/2" - 13 x 2"
40.	10048	HHCS, 3/8" x 2"
41.	D1653	Coupler
42.	10456	Cotter Pin, 1/8" x 3/4"
43.	10565	Clevis Pin, 5/16" x 2"
44.	10465	Cotter Pin 1/4" x 1 1/4"
A.	A582	Idler Assembly (Items 30-32)

HYDRAULIC SYSTEM

5R60 LOW PROFILE MARKERS

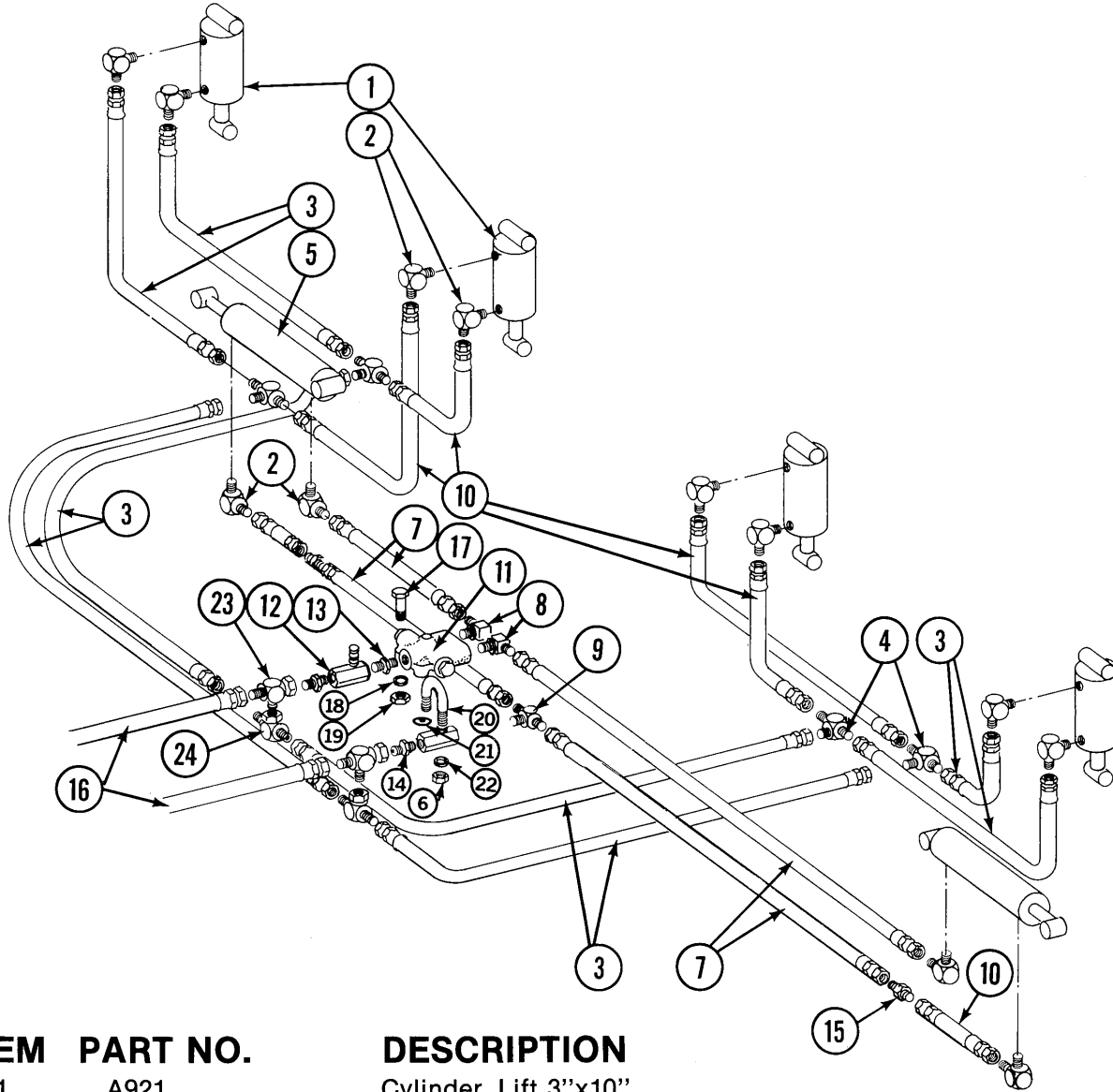

ITEM	PART NO.	DESCRIPTION
1.	A921	Cylinder, Lift 3"x10"
2.	2501-8-8	Elbow, 90°
3.	A1022	Hose Assembly, 3/8"x60"
4.	2603-8	Tube, Tee, 37°
5.	A233	Cylinder, Marker, 2½"x20"
6.	10106	Hex Nut, 5/16"-18
7.	A1029	Hose Assembly, 3/8"x190"
8.	6801-8	Elbow, 90°
9.	2601-8-8	Side Tee
10.	A1002	Hose Assembly, 3/8"x20"
11.	A282	Valve, Sequence
12.	A248	Valve, Flow Control, KLF 500
13.	6401-8-8	Adapter, Straight
14.	2404-8-8	Adapter, Straight
15.	2403-8	Male Adapter
16.	A1014	Hose Assembly, 3/8"x120"
17.	10048	HHCS, 3/8"-16x2"
18.	10229	Lock Washer, 3/8"
19.	10101	Hex Nut, 3/8"-16
20.	D1253	U-Bolt, 5/16"-18x2¼"x1½"
21.	10219	Flat Washer, 5/16"
22.	10232	Lock Washer, 5/16"
23.	6602-8	Run, Tee
24.	6600-8	Swivel, Tee

HYDRAULIC SYSTEM

3R60 CONVENTIONAL MARKERS

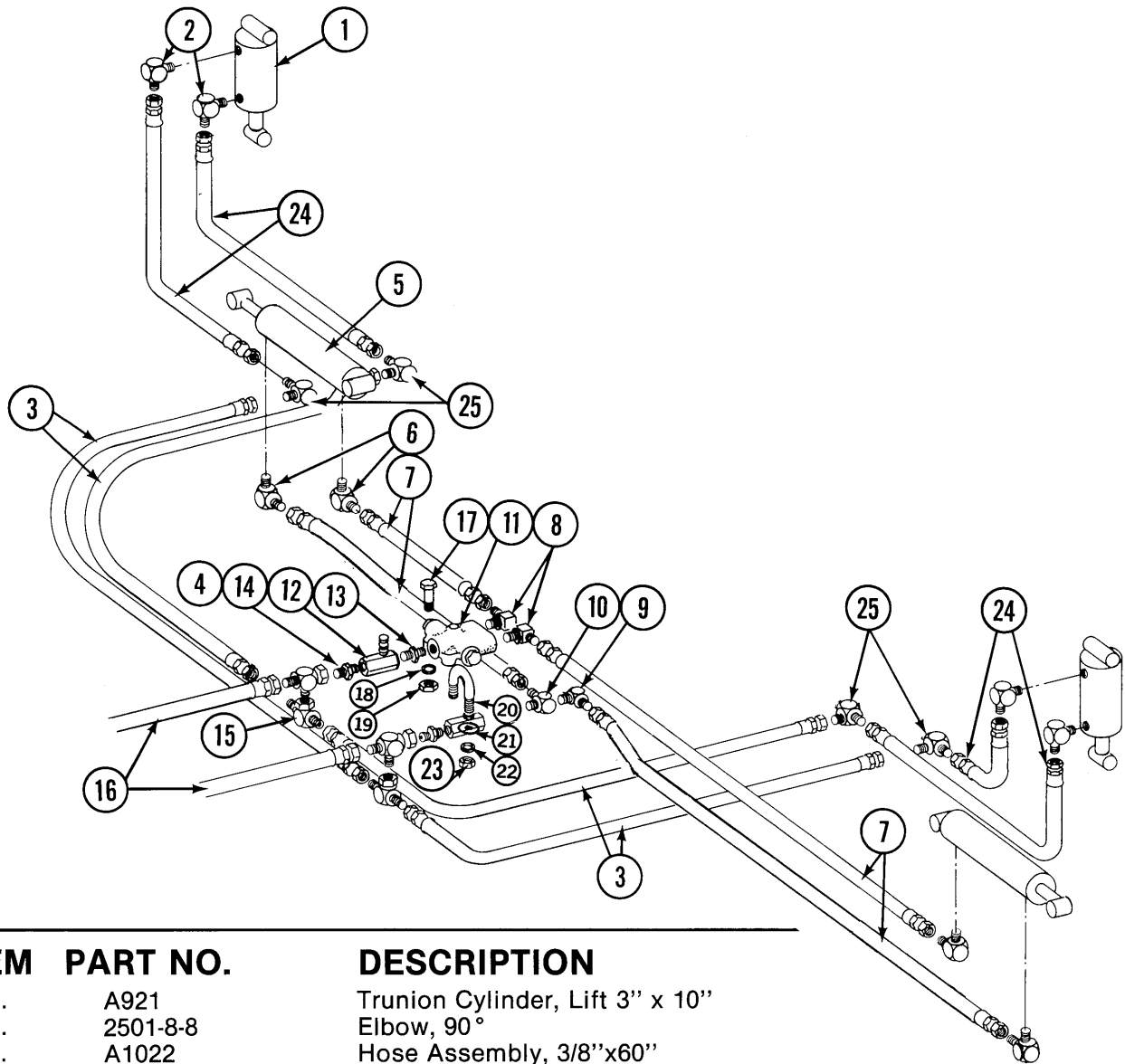

ITEM	PART NO.	DESCRIPTION
1.	A921	Trunion Cylinder, Lift 3" x 10"
2.	2501-8-8	Elbow, 90°
3.	A1022	Hose Assembly, 3/8"x60"
4.	6602-8	Run, Tee
5.	A1674A	Cylinder, Marker, 2"x8"
	A1674B	Cylinder, Marker, 2"x8"
6.	2501-6-6	Elbow, 90°
7.	A1109	Hose Assembly, 1/4"x145"
8.	6801-6-8	Elbow, 90°
9.	6500-6	Elbow, 90°
10.	2605-6-6	Run Tee, Male
11.	A282	Valve, Sequence
12.	A270	Valve, Flow Control
13.	6401-8-6	Adapter, Striaight
14.	2404-8-6	Adapter, Straight
15.	6600-8	Swivel, Tee
16.	A1014	Hose Assembly, 3/8"x120"
17.	10048	HHCS, 3/8"-16"x2"
18.	10229	Lock Washer, 3/8"
19.	10101	Hex Nut, 3/8"-16
20.	D1253	U-Bolt, 5/16"-18x2 1/4"x1 1/2"
21.	10219	Flat Washer, 5/16"
22.	10232	Lock Washer, 5/16"
23.	10106	Hex Nut, 5/16"-18
24.	A1002	Hose Assembly, 3/8"x20"
25.	2500-8	Elbow, 90°

LOW PROFILE - DOUBLE FOLD MARKER ASSEMBLY

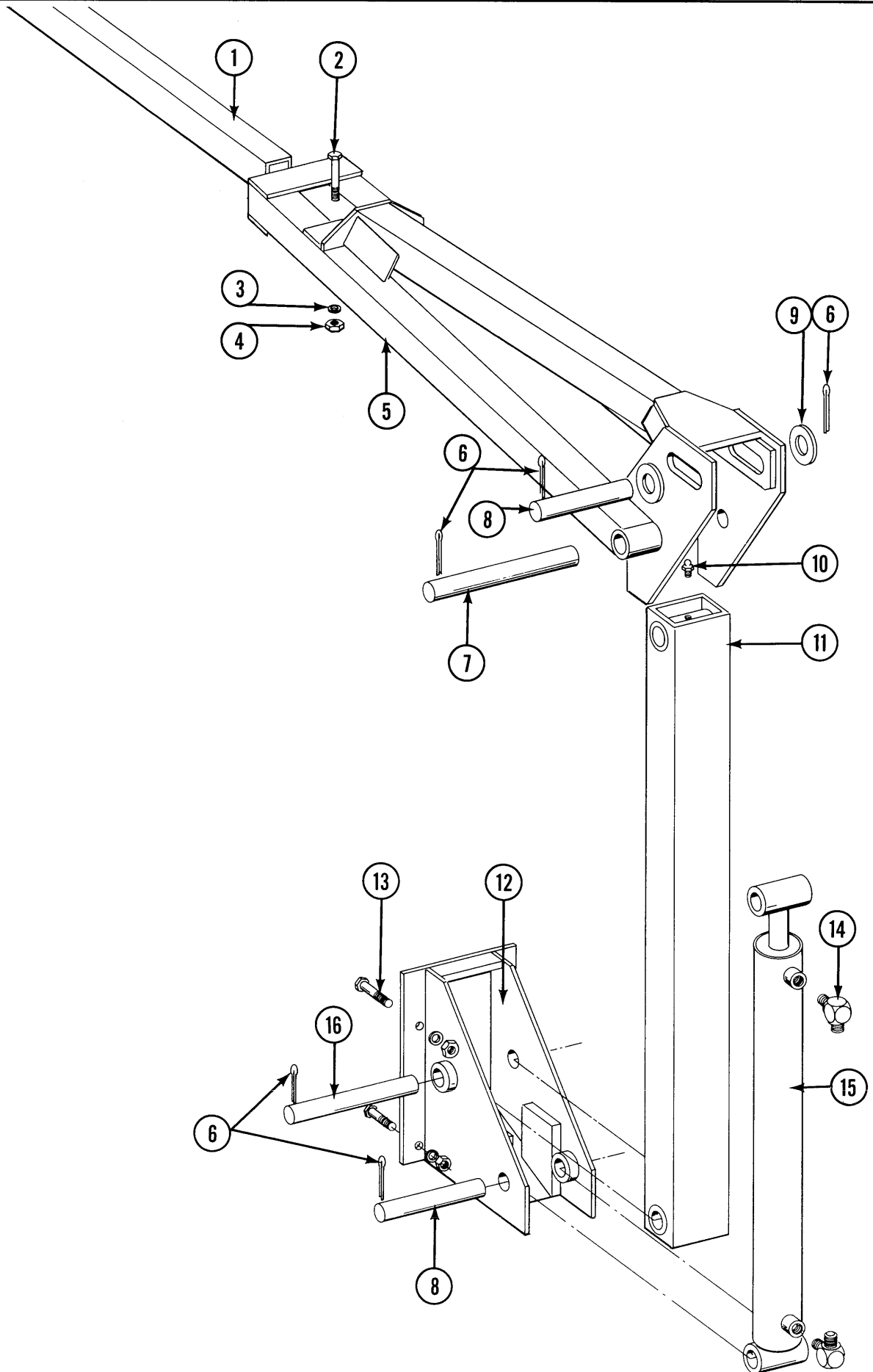

LOW PROFILE - DOUBLE FOLD MARKER ASSEMBLY

ITEM	PART NO.	DESCRIPTION
1.	D453-4	Extension Tube, 60", 5R60
2.	10033	HHCS, 1/2"-13x3 1/2"
3.	10228	Lockwasher, 1/2"
4.	10102	Hex Nut, 1/2"-13
5.	A831	Marker Arm, 34", 5R60
6.	10460	Cotter Pin, 1/4"x2"
7.	D1702	Pivot Pin
8.	D1701	Pin, Cylinder, Upper
9.	10226	Washer, 1 1/4" SAE
10.	10641	Grease Fitting, 1/8" NPT
11.	A828	Arm, First Stage
12.	A827	Marker Mount
13.	10039	HHCS, 1/2"- 13x1 3/4"
14.	2501-8-8	Elbow, 90°, 1/2" NPT to 37° 3/4"-16JIC
15.	A233	Cylinder, 2 1/2"x20"
16.	D653	Pin, Cylinder, Lower

CONVENTIONAL MARKER ASSEMBLY

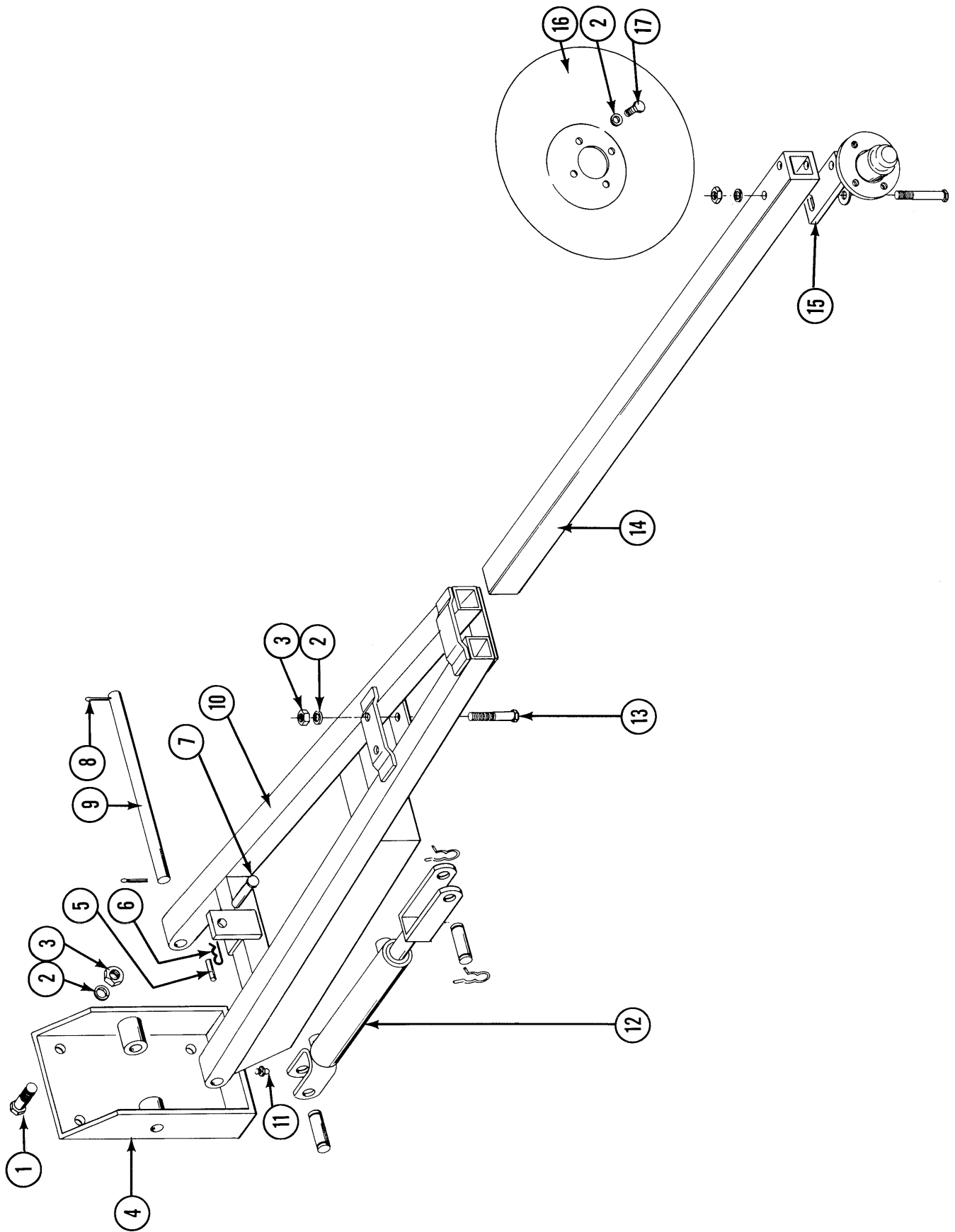

CONVENTIONAL MARKER ASSEMBLY

ITEM	PART NO.	DESCRIPTION
1.	10167	HHCS, 1/2" - 13 x 2" Grade 2
2.	10228	Lockwasher, 1/2"
3.	10102	Hex Nut, 1/2" - 13
4.	A224	Marker Mount
5.	10609	Roll Pin, 5/32" x 1"
6.	10670	Hair Pin Clip, No. 3
7.	D462	Marker Lockup Pin
8.	10460	Cotter Pin, 1/4" x 2"
9.	D438	Shaft
10.	A538	Marker Arm Weld, 64" x 3R60
11.	10640	Grease Fitting, 1/4" - 28
12.	A1674A	Cylinder Assembly, 2 x 8
	A1674B	Cylinder Assembly, 2 x 8
13.	10033	HHCS, 1/2" - 13 x 3 1/2"
14.	D453-2	Extension Tube, 40", 3R60
15.	A1659	Marker Hub Assembly, L.H.
	A1658	Marker Hub Assembly, R.H.
16.	D746	Disc, 16"
17.	10722	HHCS, 1/2" - 20 x 1"

MARKER HUB ASSEMBLY

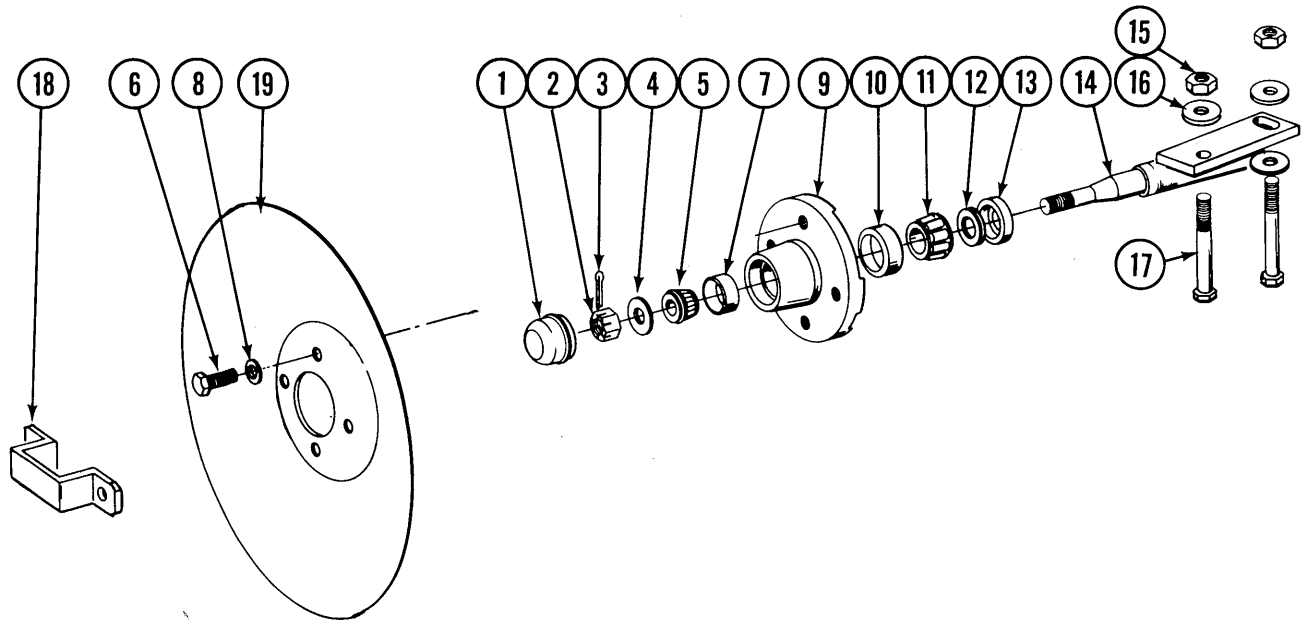

ITEM	PART NO.	DESCRIPTION
1.	D840	Hub Cap
2.	10725	Hex Nut, Slotted, 5/8" - 18
3.	10470	Cotter Pin, 5/32" x 1"
4.	10724	Washer, 5/8"
5.	A257	Bearing, Outer
6.	10722	HHCS, 1/2" - 20 x 1"
7.	R151	Cup, Outer
8.	10228	Lock Washer, 1/2"
9.	A167	Hub w/Cups
10.	R150	Cup, Inner
11.	A245	Bearing Inner
12.	A899	Seal, Rubber
13.	A243	Seal, Grease
14.	A1677	Spindle Weld, L.H., Less Hardware (Shown)
	A1676	Spindle Weld, R.H., Less Hardware
15.	10102	Hex Nut, 1/2" - 13
16.	10168	Machinery Bushing, 1/2" x 7 Ga.
17.	10033	HHCS, 1/2" - 13 x 3 1/2"
18.	D2597	Retainer
19.	D746	Disc, 16"
A.	A1679	Hub and Spindle Assembly L.H. (Items 1-14)
	A1678	Hub and Spindle Assembly R.H. (Items 1-14)

LIFT CYLINDER

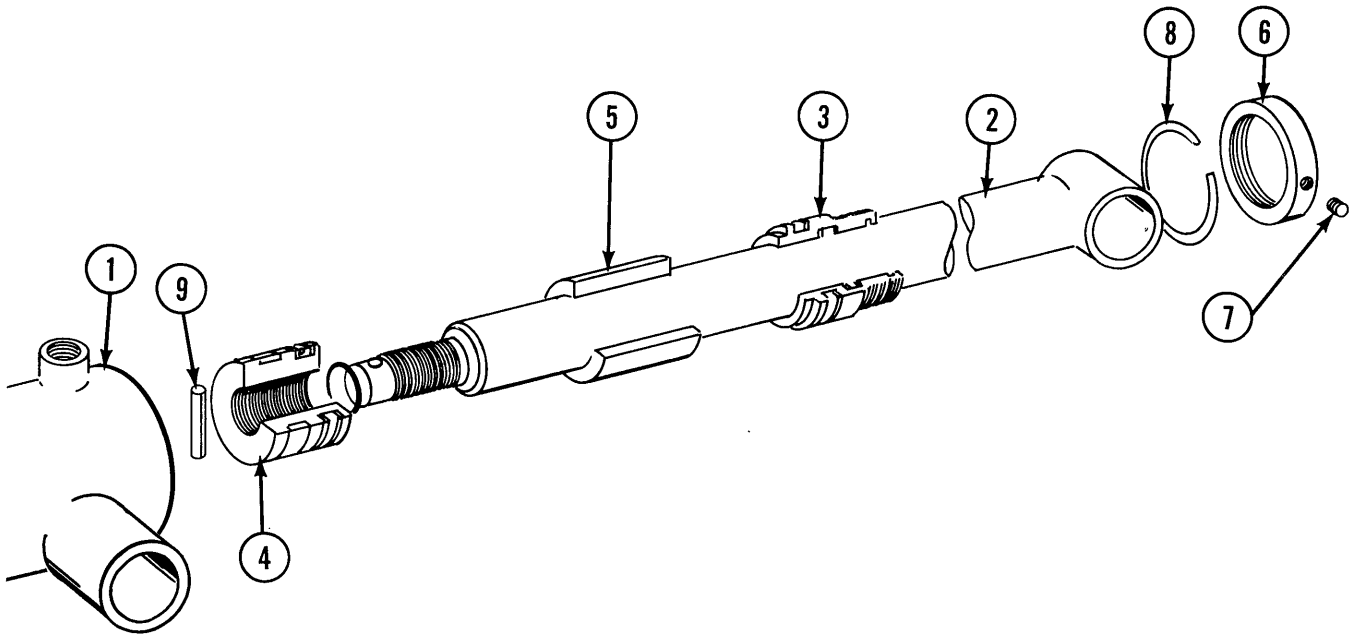

ITEM	PART NO.	DESCRIPTION
1.	R521	Tube Assembly
2.	R520	Shaft Assembly
3.	R128	Head Gland
4.	R129	Piston
5.	R130	Stroke Collar
6.	R131	Head Gland Nut
7.	10114	Set Screw, No. 10-32 x 1/4
8.	R132	Wire Ring
9.	10604	Roll Pin
	R133	Seal Kit
A.	A921	Cylinder Assembly Complete, 3"x10"

LOW PROFILE - DOUBLE FOLDING MARKER CYLINDER

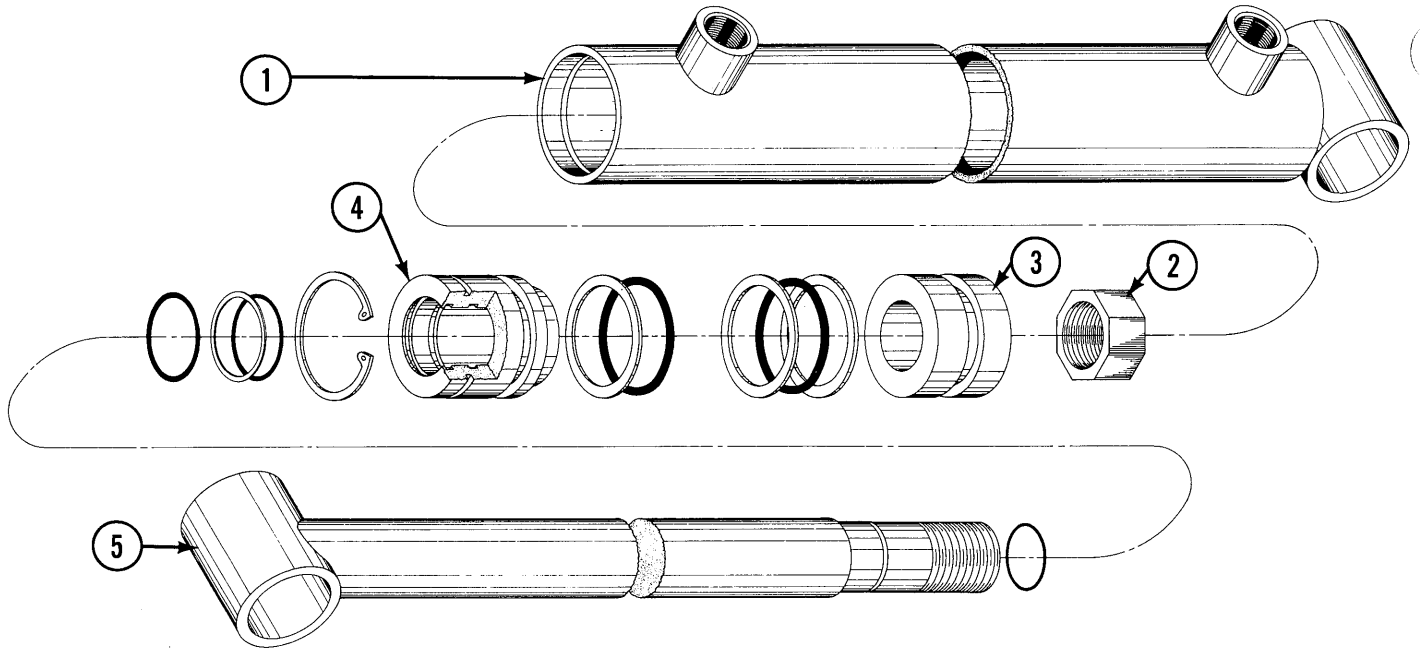

ITEM	PART NO.	DESCRIPTION
1.	R134	Cylinder Tube Assembly
2.	R138	Hex Nut, 7/8" UNF
3.	R137	Piston
4.	R136	Head Gland
5.	R135	Shaft Assembly
A.	A233 R139	Cylinder Assembly, Complete, 2½" x 20" Seal Kit Includes (1) Lock Ring (1) O-Ring (018) (1) O-Ring (218) (1) Back Up (23) (2) O-Ring (330) (3) Back Up (33) (1) Wiper

CONVENTIONAL MARKER CYLINDER

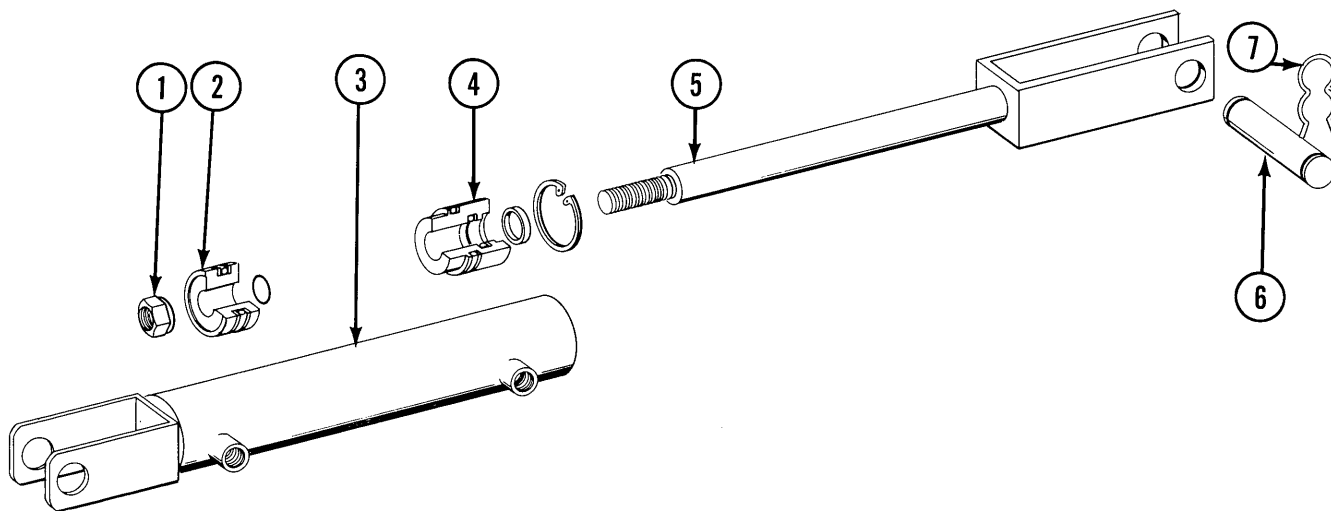

ITEM	PART NO.	DESCRIPTION
1.	R366	Hex Nut, 3/4" NF
2.	R365	Piston
3.	R362	Tube Assembly
4.	R364	Head Gland
5.	R363	Shaft Assembly
6.	R367	Clevis Pin
7.	R193	Clip, Hair Pin Ony
	R368	Seal Kit Includes (1) O-Ring .614 I.D. x .754 O.D. (1) O-Ring 1.109 I.D. x 1.387 O.D. (2) O-Ring 1.600 I.D. x 2.200 O.D. (1) Back Up Washer 1 1/8" I.D. x 1 3/8" O.D. (1) Rod Wiper 2" I.D. (1) Retaining Ring Internal 2" (2) Back Up Washer 1 5/8 I.D. x 2 O.D.
*A.	A1674A	Cylinder, Complete, 2"x8"

* To identify - 13081 stamped on barrel.

CONVENTIONAL MARKER CYLINDER

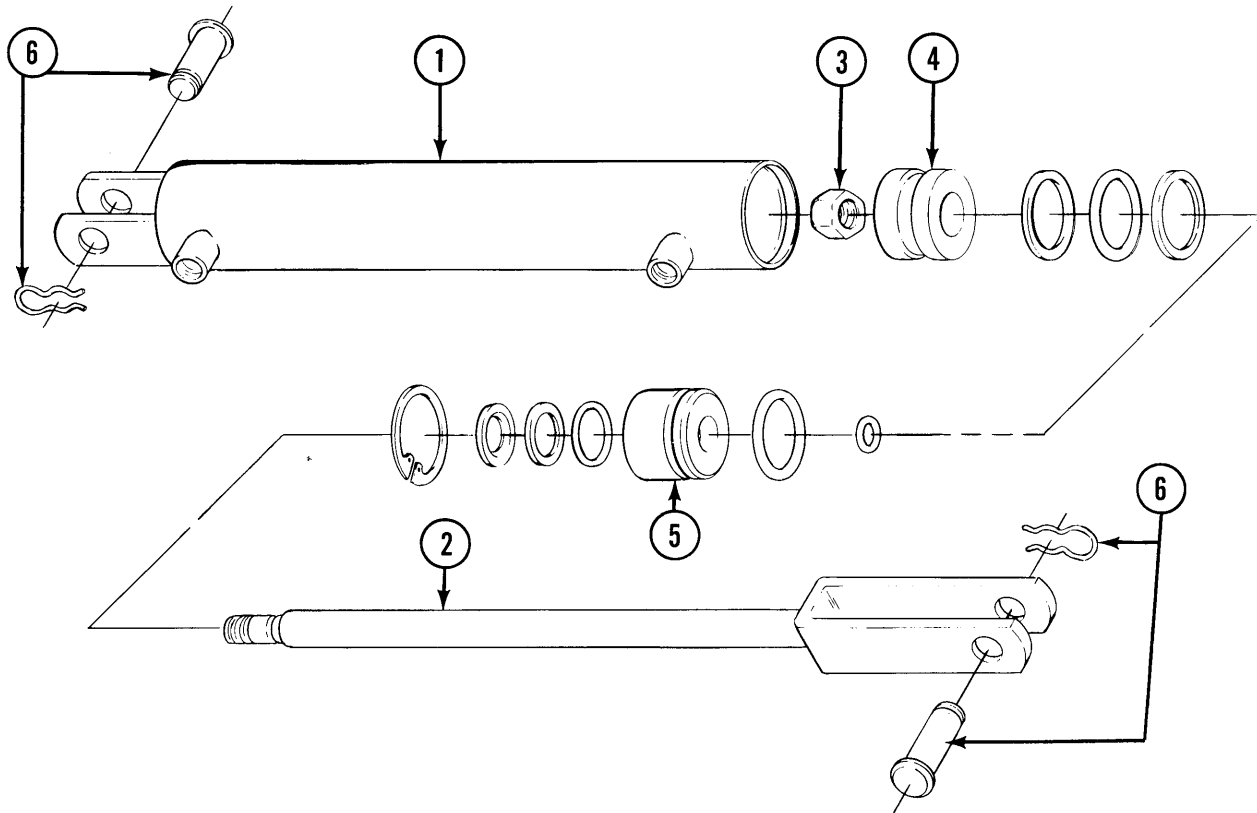

ITEM	PART NO.	DESCRIPTION
1.	R157	Cylinder Body
2.	R158	Piston Rod
3.	R159	Hex Nut, 7/8" UNF
4.	R160	Piston
5.	R161	Piston Rod Guide
6.	R162	Clevis Pin W/Clip
	R193	Clip, Hair Pin, Only
	R154	Seal Kit
		Includes
		(1) O-Ring, 3/4" I.D x 7/8" O.D.
		(1) O-Ring, 1 1/8" I.D. x 1 3/8" O.D.
		(1) Back Up Washer
		(1) Rod Wiper
		(2) Back Up Washer
		(2) O-Ring, 1 5/8" I.D. x 2" O.D.
		(1) Retaining Ring
*A.	A1674B	Cylinder - Complete 2"x8"

* To identify - no markings on barrel.

RATCHET AND SPROCKET ASSEMBLY

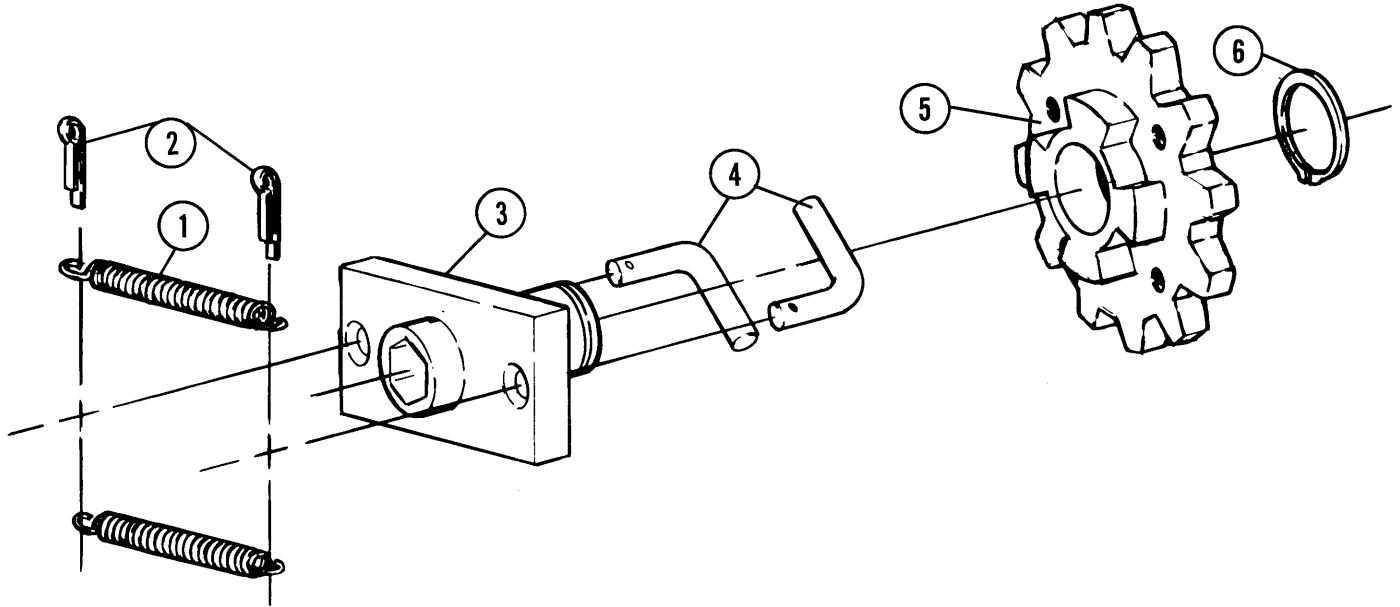

ITEM	PART NO.	DESCRIPTION
1.	D1256	Spring
2.	10464	Cotter Pin, 3/16"x1"
3.	A378	Block and Hub Assembly
4.	D1255	"L" Pin
5.	A376	Hub/Sprocket Assembly
6.	10430	Retaining Ring, 1 1/4"
A.	A261L	Ratchet Clutch Assembly Complete - Left
	A261R	Ratchet Clutch Assembly Complete - Right

DOUBLE DISK FERTILIZER OPENER

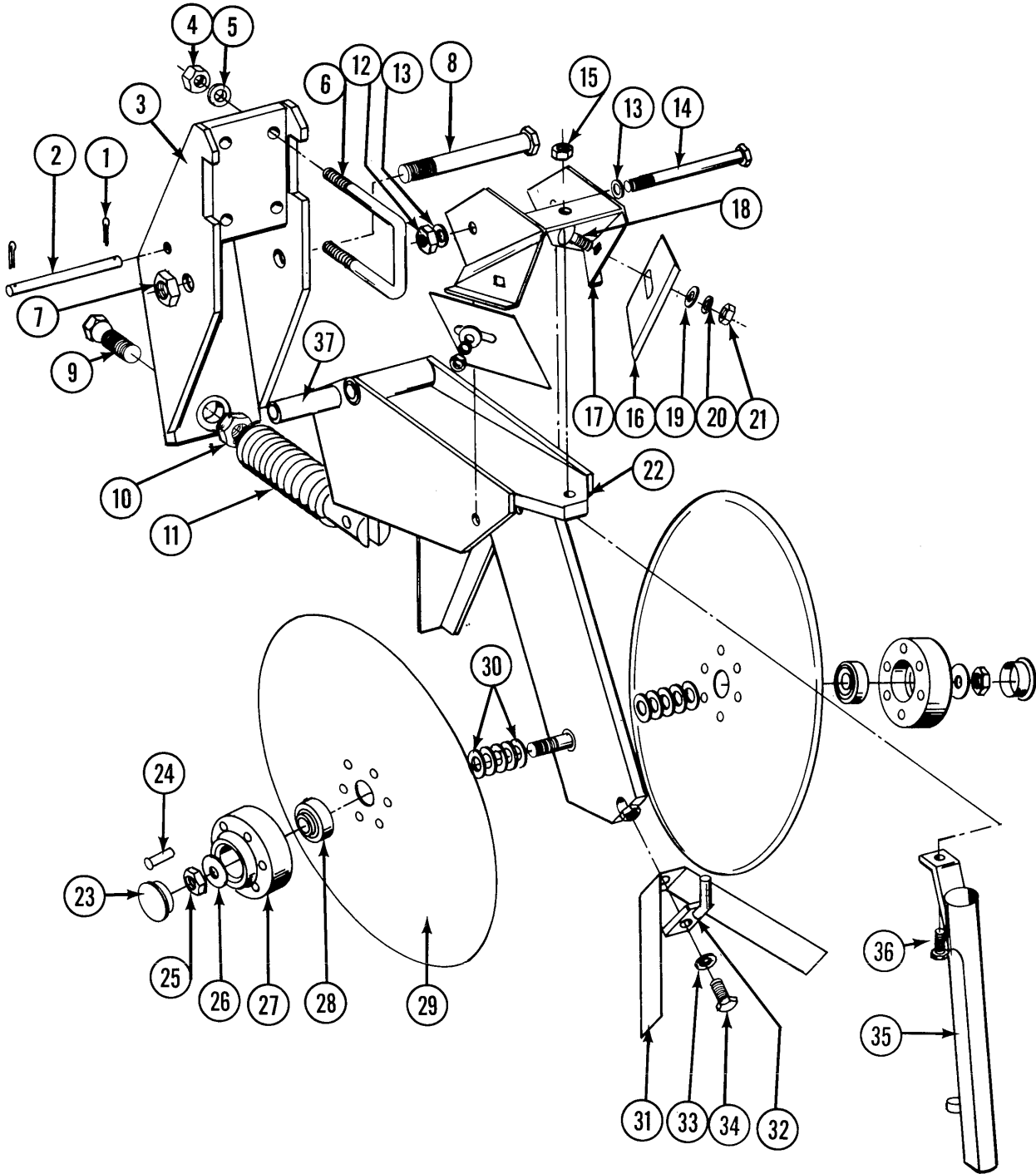

DOUBLE DISK FERTILIZER OPENER

ITEM	PART NO.	DESCRIPTION
1.	10451	Cotter Pin, 1/8" x 1"
2.	D1657	Lock Up Pin
3.	A785	Mounting Bracket
4.	10102	Hex Nut, 1/2" - 13
5.	10228	Lockwasher, 1/2"
6.	D1339	U-Bolt, 2 1/2" x 2 1/2" x 1/2" - 13
7.	10107	Hex Lock Nut, 5/8" - 11
8.	10046	HHCS, 5/8" - 11 x 5"
9.	D962	Hex Head Adjusting Bolt, 5/8" - 18
10.	10499	Jam Nut, 5/8" - 18
11.	A328	Spring
12.	10111	Lock Nut, 1/2" - 13
13.	10216	Flat Washer 1/2"
14.	10045	HHCS, 1/2" - 13 x 4 1/2"
15.	10109	Hex Lock Nut, 5/16" - 18
16.	D1673	Scraper
17.	A810	Scraper Mount
18.	10305	Carriage Bolt, 3/8" - 16 x 1"
19.	10210	Flat Washer, 3/8" USS
20.	10229	Lock Washer, 3/8"
21.	10101	Hex Nut, 3/8" - 16
22.	A308	Fertilizer Opener Weld
23.	D1132	Cap
24.	10651	Rivet, 1/4" x 1 3/8"
25.	10503	Jam Nut, R.H., 5/8" - 11
	10504	Jam Nut, L.H., 5/8" - 11
26.	10217	Washer, 5/8" USS
27.	B134	Bearing Hub
28.	A2014	Bearing
29.	D1030	Disk Blade
30.	10213	Machine Bushing, 1 3/64 x 11/16 x .030
31.	D2589	Scraper, Inner
32.	A312	Mount, Tube Weld
33.	10232	Lock Washer, 5/16"
34.	10019	HHCS, 5/16" - 18 x 1"
35.	A1369	Drop Tube, Dry Fertilizer
36.	10133	HHCS, 5/16" - 18 x 1 1/2"
37.	D487	Bushing
A.	A320	Disk and Brg. Assembly (Items 24, 27 - 29)
B.	A786	Double Disk Fertilizer Opener, Less Drop Tubes and U-Bolts

DRY FERTILIZER TRANSMISSION ASSEMBLY

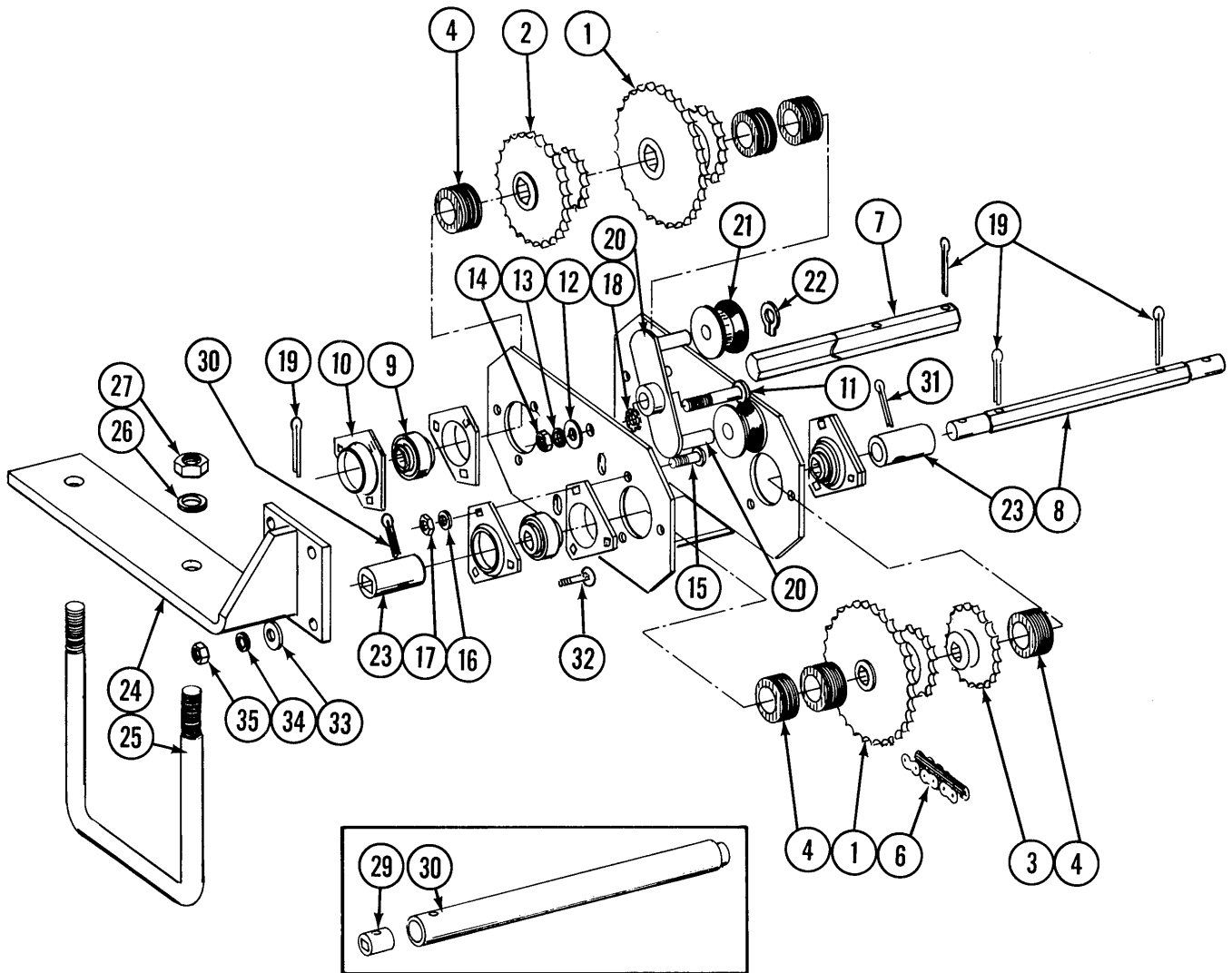

DRY FERTILIZER TRANSMISSION ASSEMBLY

ITEM	PART NO.	DESCRIPTION
1.	2500-12	Sprocket, 18-36 Tooth
2.	2500-3	Sprocket, 16-30 Tooth
3.	2500-14	Sprocket, 24 Tooth
4.	D832	Rubber Spacer
5.	A2232	Case Weld
6.	3300-32	Chain, No. 2040, 32 Pitches Including Connector Link
	R194	Connector Link, No. 2040
7.	D2321	Shaft
8.	D2317	Shaft
9.	2100-3	Bearing
10.	3400-1	Flangette
11.	10314	Carriage Bolt, 1/2"-13x3"
12.	10216	Washer, 1/2" USS
13.	10228	Lockwasher, 1/2"
14.	10102	Hex Nut, 1/2"-13
15.	10303	Carriage Bolt, 5/16"-18x1"
16.	10232	Lock Washer, 5/16"
17.	10106	Hex Nut, 5/16"-18
18.	10527	Lockwasher, Int. Ext. 1/2"
19.	10463	Cotter Pin, 1/4"x1 1/2"
20.	A293	Idler Weld
21.	D1067	Idler Spool
22.	10435	Retaining Ring
23.	D2770	Drive Coupler, 2 1/8", 3R60
24.	A1362	Mount Weld, Fertilizer Transmission
25.	D1114	U-Bolt, 7"x7"x5/8"-11
26.	10230	Lockwasher, 5/8"
27.	10104	Hex Nut, 5/8"-11
28.	10462	Cotter Pin, 3/16"x2"
29.	D2768	Insert, Square Drive
30.	A2242	Coupler, 12 5/8", 3 R60
31.	10464	Cotter Pin, 3/16" x 1"
32.	10305	Carriage Bolt, 3/8" - 16 x 1"
33.	10210	Flat Washer, 3/8"
34.	10229	Lock Washer, 3/8"
35.	10101	Hex Nut, 3/8" - 16
A.	A294	Idler Assembly (Items 20 thru 22)

DRY FERTILIZER HOPPER AND MOUNT

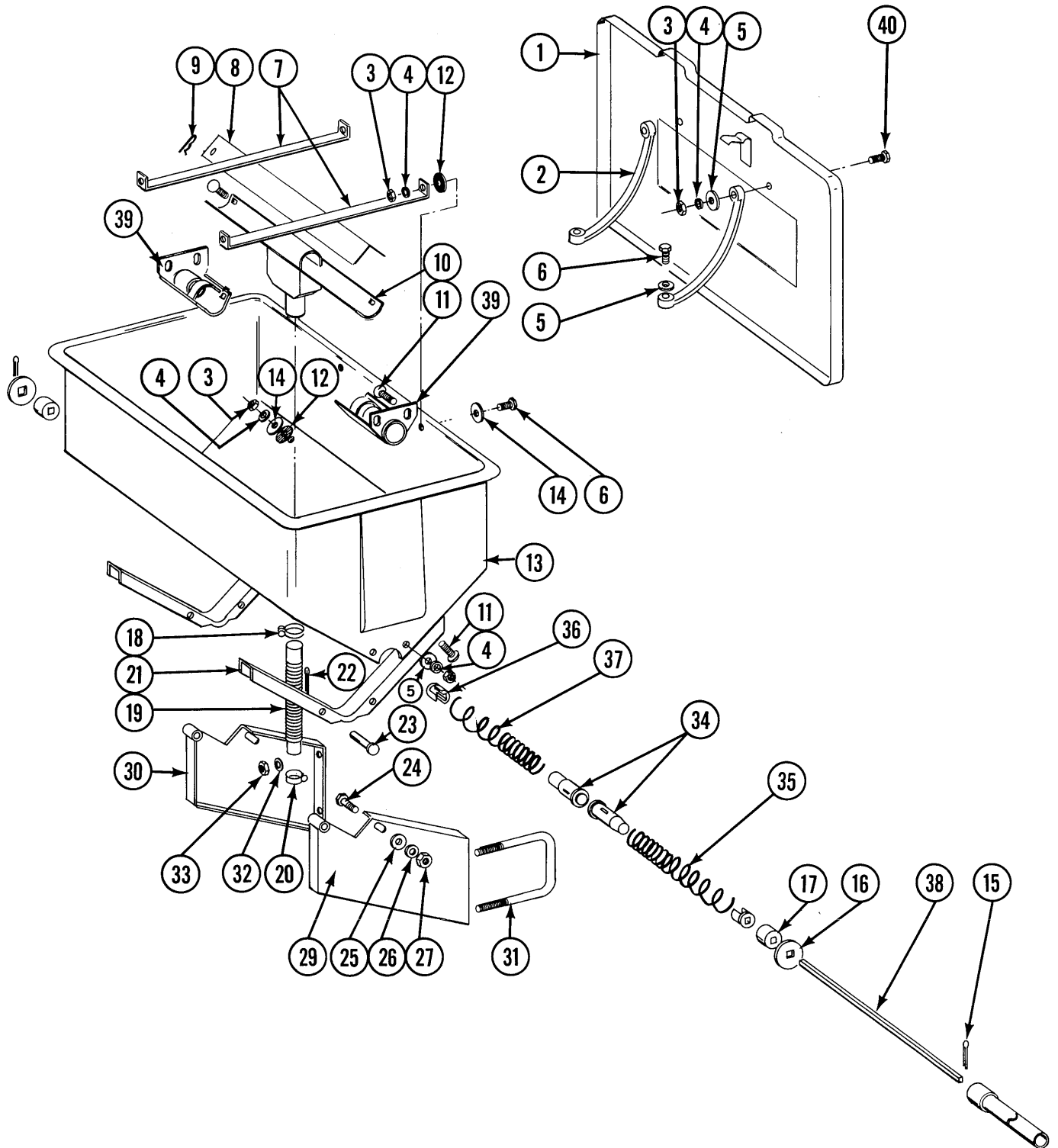

DRY FERTILIZER HOPPER AND MOUNT

ITEM	PART NO.	DESCRIPTION
1.	A2101	Lid, Includes Clips and Pop Rivets
	D1380	Clip
	10655	Pop Rivets, 3/16" x 13/32"
2.	D1210	Strap, Rubber
3.	10106	Hex Nut, 5/16" - 18
4.	10232	Lock Washer, 5/16"
5.	10219	Washer, 5/16" USS
6.	10019	HHCS, 5/16" - 18 x 1"
7.	D1209	Strap, Reinforcing
8.	D1207	Baffle
9.	10670	Hair Pin Clip, No. 3
10.	A1366	Center Drop, Dry Fertilizer
11.	10303	Carriage Bolt, 5/16" - 18 x 1"
12.	D1213	Washer, Rubber
13.	D2329	Hopper, Dry Fertilizer
14.	10201	Washer, Special, 3/8"
15.	10464	Cotter Pin, 3/16" x 1"
16.	D1212	Washer, Special
17.	D1206	Bearing, Shaft
18.	10676	Hose Clamp, No. 36
19.	D1925	Tube, Rubber
20.	10672	Hose Clamp, No. 28
21.	D1208	Saddle
22.	10456	Cotter Pin, 1/8" x 3/4"
23.	10562	Clevis Pin, 7/16" x 3"
24.	10037	HHCS, 1/2" - 13 x 1 1/4"
25.	10206	Washer, 1/2" SAE
26.	10228	Lock Washer, 1/2"
27.	10102	Hex Nut, 1/2" - 13
28.	10640	Grease Fitting for Auger Bearing (Not Shown)
29.	A863	Mount, Hopper L.H., Includes Items 22 thru 27 also
30.	A864	Mount Hopper, R.H., Includes Items 22 thru 27 also
31.	D1114	U-Bolt, 7" x 7" x 5/8" 11
32.	10230	Lock Washer, 5/8"
33.	10104	Hex Nut, 5/8" - 11
34.	D1202	Guide, Auger
35.	D1204	Spring, Auger, R.H.
36.	D1203	Plug, Spring
37.	D1205	Spring, Auger, L.H.
38.	D1201	Shaft, Auger
39.	A1368	Auger Bearing
40.	10171	HHCS, 5/16" - 18 x 1 1/4"

DECALS, REFLECTORS, AND TIE STRAPS



1

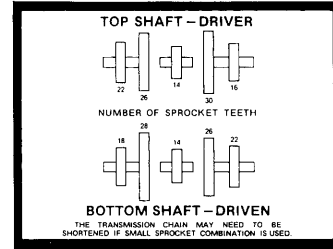

4

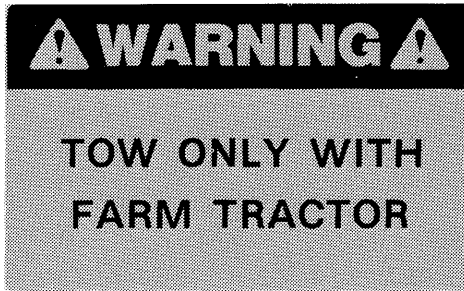

2

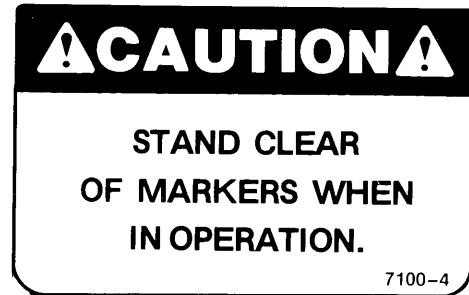

5



3

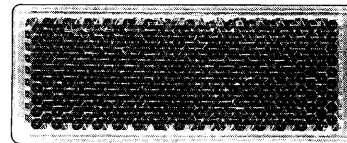

6



7

ITEM	PART NO.	DESCRIPTION
1.	7100-1	Decal - KINZE
2.	7100-3	Decal - Warning
3.	D937	Serial Number Plate
4.	7100-6	Decal, Sprocket Combination - Seed Drive Transmission
5.	7100-4	Decal, Caution - Markers
6.	7200-1	Reflector, Red
	7200-2	Reflector, Amber
7.	D1512	Tie Strap, 6"
	D1162	Tie Strap, 28"
	D2117	Tie Strap, 14 1/2"