

MODEL TWIN-LINE® PLANTERS

**OPERATOR & PARTS
MANUAL**

M0134

1/86

This page left blank intentionally.

TABLE OF CONTENTS

To The Owner	1-1
New Machine Warranty	1-1
Introduction	2-1
General Information	2-1
Serial Number	2-1
Safety Precautions	3-1
Safety Warning Signs, 8 Row Models	4-1 and 4-3
Safety Warning Signs, 24 Row Model	4-2 and 4-3
Operation	5-1
Initial Preparation Of The Planter	5-1
Tractor Preparation And Hookup	5-1
Leveling The Planter	5-1
Tire Pressure	5-2
Transmission Adjustment	5-2
Contact Drive Wheel Spring Adjustment	5-2
Shear Protection	5-2
Hydraulic Operation	5-3
Valve Block Located On Main Frame, 8 Row Models	5-3
Valve Block Located On Main Frame, 24 Row Model	5-3
Valve Block Located On Hitch, 8 And 24 Row Models	5-4
Tongue Lock Operation, 8 And 24 Row Models	5-4
Marker Operation, 8 And 24 Row Models	5-5
Planter Lift System Operation, 8 Row Models	5-5
Raised Field Position	5-5
Raised Transport Position	5-5
Planter Lift System Operation, 24 Row Model	5-6
Raised Field Position	5-6
Raised Transport Position	5-6/5-7
Transport To Plant Operation Procedure, 8 Row Models	5-7/5-8
Plant To Transport Operation Procedure, 8 Row Models	5-8/5-9
Transport To Plant Operation Procedure, 24 Row Model	5-9/5-12
Plant To Transport Operation Procedure, 24 Row Model	5-12/5-13
Point Row Wrap Spring Clutch	5-14
Marker Adjustment	5-15
Transporting The Planter	5-15
Tractor Speed	5-15
Field Test	5-15
Fertilizer Opener	5-16
Dry Fertilizer Attachment	5-17
Liquid Fertilizer Attachment	5-18
Planting Rates For Plateless Corn Meters	5-19
Planting Rates For Plateless Soybean Meters	5-20/5-23
Planting Rates For Plateless Intermediate Rate Sorghum Meters	5-24
Planting Rates For Plateless Low Rate Sorghum Meters	5-25
Dry Insecticide Application Rates	5-26
Dry Herbicide Application Rates	5-27
Dry Fertilizer Application Rates	5-28
Liquid Fertilizer Applications Rates	5-29

TABLE OF CONTENTS

Lubrication	6-1
Sealed Bearings	6-1
Drive Chain	6-1
Wheel Bearings	6-1
Point Row Wrap Spring Clutches	6-1
Gearboxes, 24 Row Model	6-1
Lubrication Locations, 8 Row Models	6-2/6-3
Lubrication Locations, 24 Row Model	6-4/6-6
Maintenance	7-1
Mounting Bolts And Hardware	7-1
Torque Values Chart	7-1
Chain Tension Adjustment	7-1
Point Row Wrap Spring Clutch Inspection	7-2
Trouble Shooting Chart	7-2/7-3
Solenoid Valve Inspection	7-4
Trouble Shooting Chart	7-4
Flow Control Valve Inspection	7-4
Pressure Relief Valve Inspection	7-4
Wheel Or Marker Bearing Lubrication Or Replacement	7-5
Preparation For Storage	7-5
Wiring Diagram, 8 Row Models	7-6
Wiring Diagram, 24 Row Model	7-7
Parts List Index, 8 Row Models	P-1
Parts List Index, 24 Row Model	P-49
Parts Section Numerical Index, 8 Row Models	a
Parts Section Numerical Index, 24 Row Model	c

TO THE OWNER

We at Kinze Manufacturing wish to thank you for your patronage and appreciate your confidence in Kinze farm machinery. Your Kinze planter has been carefully designed and sturdily built to provide years of dependable operation in return for your investment.

This manual has been prepared to aid you in the assembly, operation, and maintenance of the planter. Do not use or operate this equipment until this manual has been read and understood.

Throughout this manual the symbol  and the words **Note, Caution and Warning** are used to call your attention to important safety information. The definition of each of these terms used follows:

NOTE: Indicates a special point of information.

CAUTION: Indicates that a failure to observe can cause damage to the machine or equipment.

 **WARNING:** Indicates that a failure to observe can cause damage to equipment and/or personal injury.

This manual is applicable to:

Twin-Line Planter
Model Number TL
Serial Number 30101 and on

Record the model number and serial number of your planter with date purchased:

Date Purchased _____

Serial Number _____

Model Number _____

NEW MACHINE WARRANTY

No warranties express or implied are made or will be deemed to have been made by Kinze of the products sold under this Agreement except as follows:

Kinze warrants to the original purchaser for use that if any part of the product proves to be defective in material or workmanship within one year from date of original purchase, and is reported to Kinze within 10 days after such defect is discovered, Kinze will (at our option) either replace or repair said part. Return of the defective part to Kinze and submission of a completed warranty request must be accomplished within 30 days of the date that the replacement is made available.

This warranty does not apply to damage resulting from misuse, neglect, accident or improper installation or maintenance. A part will not be considered defective if it substantially fulfills performance specifications. Labor, shipping, field service, travel or administrative expenses incurred in connection with warranty replacements are not covered. Tires are not warranted by Kinze Manufacturing, Inc. and such claims must be pursued through the tire manufacturer's warranty.

Kinze warrants all replacement parts for a period of 90 days from date of purchase by the customer. Parts warranty is subject to the same provisions, restrictions and exclusions as new machine warranty and carries the same return and reporting requirements.

The foregoing warranty is exclusive and in lieu of all other warranties of merchantability, fitness for purpose and of any other type, whether express or implied. Kinze neither assumes nor authorizes anyone to assume for it any other obligation or liability other than stated above, and will not be liable for consequential damages. Purchaser accepts these terms and warranty limitations unless the product is returned within the fifteen days for full refund of purchase price.

Kinze reserves the right to make changes or to add improvements at any time without notice or obligations.

ATTENTION: Effective 12/1/87 amendments were made to the KINZE New Machine Warranty. Refer to insert W12187.

INTRODUCTION

The Twin-Line planter is available in various configurations and row spacings. Optional interplant row spacing is obtainable with the addition of pusher type row units.

The Twin-Line planter permits installation of liquid or dry fertilizer application equipment and 1" or 2" no-till coulters. For further information on installation and use of optional equipment on all models, refer to the Assembly and Operation Sections of this manual and your Kinze Row Unit Manual.

GENERAL INFORMATION

The information and photos used in this manual were current at the time of printing. However, due to Kinze's continual attempt to improve its product, possible in-line production changes may cause your machine to appear slightly different in detail. Kinze Manufacturing reserves the right to change specifications or design without notice and without incurring obligation to install the same on machines previously manufactured.

Right hand or left hand as used throughout this manual is determined by facing in the direction the machine will travel when in use unless otherwise stated.

SERIAL NUMBER

The serial number plate is located on the planter frame to be readily available. It is suggested that the serial number and purchase date also be recorded in the space provided on the inside front cover page of this manual.

The serial number provides important information about your planter and may be required to obtain the correct replacement part. Always provide the serial number and model number to your Kinze dealer when ordering parts or anytime correspondence is made with Kinze Manufacturing.

8 Row With Push Units

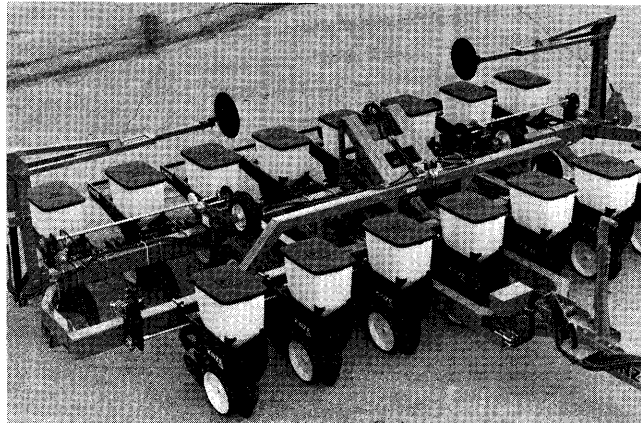

24 Row With Dry Fertilizer

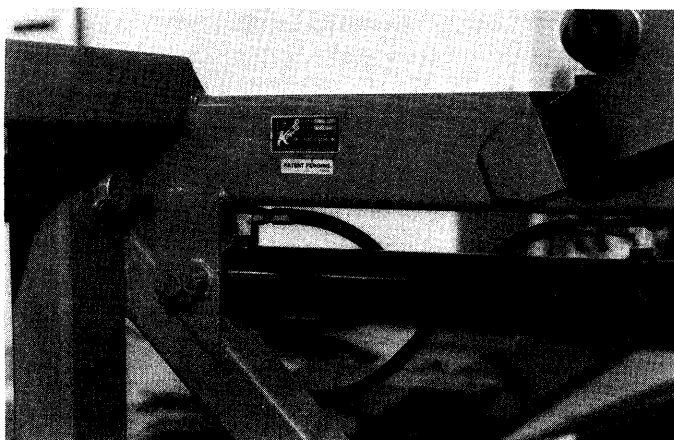
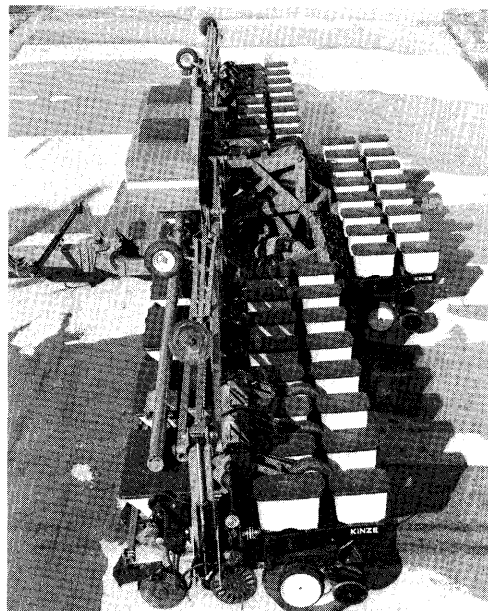

SAFETY PRECAUTIONS

Safe and careful operation of the tractor and planter at all times will contribute significantly to the prevention of accidents.

Since a large portion of farm accidents occur as a result of fatigue or carelessness, safety practices should be of utmost concern. Read and understand the instructions provided in this manual as well as those provided in your Kinze Row Unit Operator's Manual. Listed below are a few other safety suggestions that should become common practice.

- Never permit any persons other than the operator to ride on the tractor.
- Never ride on the planter frame or allow others to do so.
- Limit towing speeds to 15 MPH. Tow only with farm tractor.
- Always make sure there are no persons near the planter when marker assemblies are in operation or when rotating the planter.
- Always make necessary safety preparations prior to transporting the machine on public roads. This includes installing Slow Moving Vehicle (SMV) emblem and use of adequate lights or safety warnings after dark, except where prohibited by law.
- Watch for obstructions such as wires, tree limbs, etc., when folding markers.
- Rear of planter swings wide in turns. Always allow sufficient room to clear obstacles when turning.



8 Row Models

- Never work under the planter while in raised position without using manual safety lockup.

- Avoid transporting planter with hoppers loaded whenever possible. When it is necessary to transport the planter with the hoppers loaded, the added weight should be distributed evenly on the planter frame before rotating the planter.
- Never allow the planter to be operated by anyone who is unfamiliar with the operation of all functions of the unit. All operators should read and thoroughly understand the instructions given in this manual prior to moving the unit.
- Before operating the planter for the first time and periodically thereafter, check to be sure the lug nuts on the transport wheels are tight. This is especially important if the planter is going to be transported for a long distance.
- To avoid injury always lower planting units to the ground before unhitching planter when planter is in planting position. Tongue can raise suddenly.
- Install lockup brackets on markers prior to towing the planter or working around the unit.

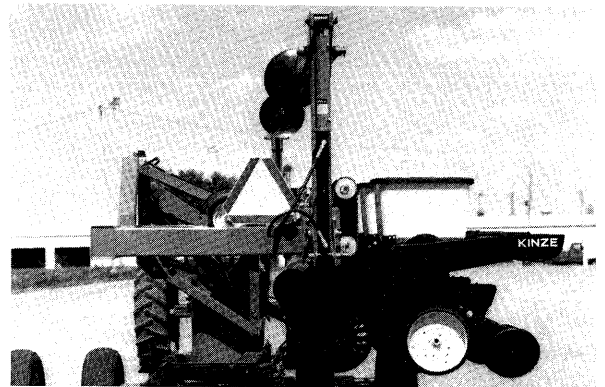

- This planter is designed to be **DRIVEN BY GROUND TIRES ONLY**. The use of hydraulic, electric or PTO drives may create serious safety hazards to you and the people near by. If you install such drives you must follow all appropriate safety standards and practices to protect you and others near this planter from injury.
- This machine has been designed and built with your safety in mind. Any alteration to the design or construction may create safety hazards. Do not make any alterations or changes to the equipment, but if any alterations or changes are made you must follow all appropriate safety standards and practices to protect you and others near this machine from injury.

The “WARNING” signs illustrated on this page are placed on the machine to warn of hazards. “The warnings found on these signs are for your personal safety and those around you.” OBSERVE THESE WARNINGS!

- Keep these signs clean so they can be observed readily. Wash with soap and water or cleaning solution as required.
- Replace “WARNING” signs should they become damaged, painted over or if they are missing.
- When replacing decals, clean the machine surface thoroughly using soap and water or cleaning solution to remove all dirt and grease.

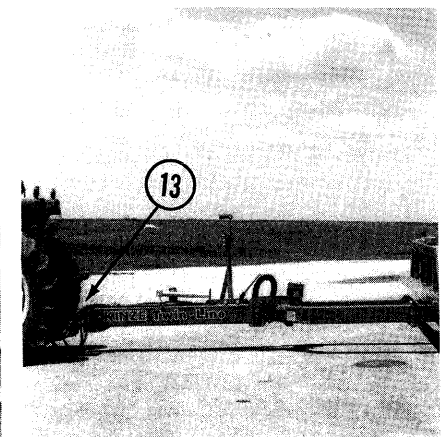
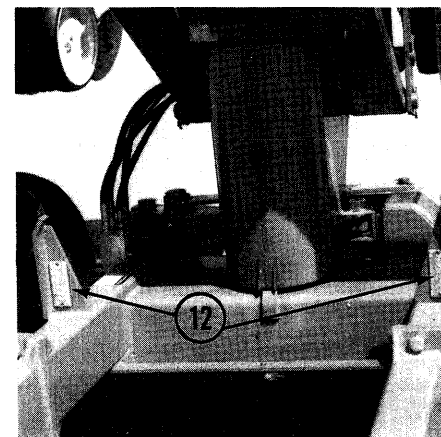
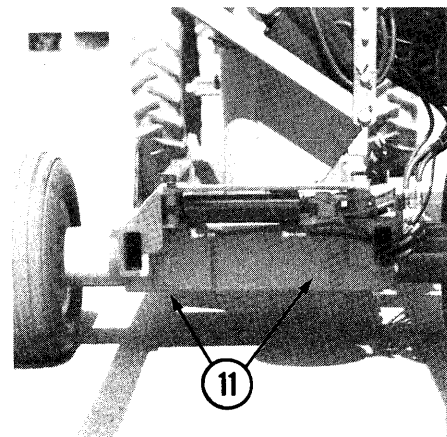
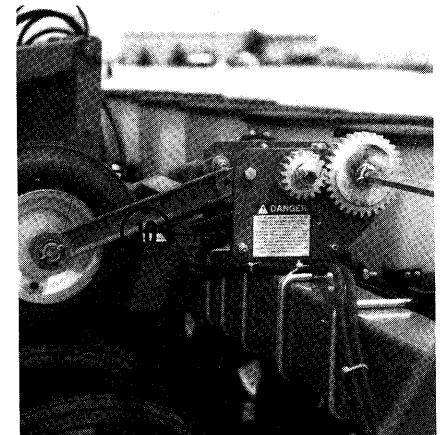
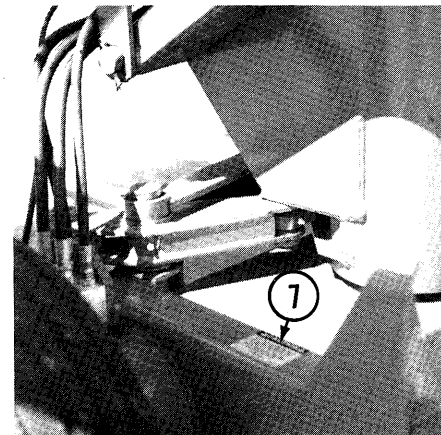
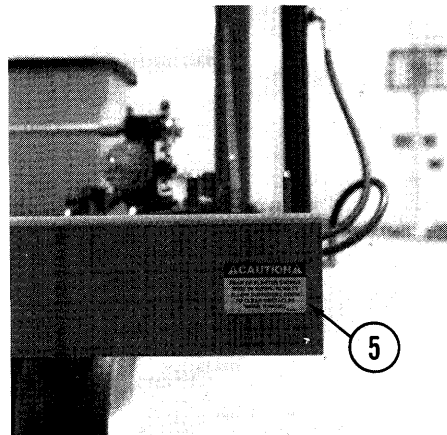
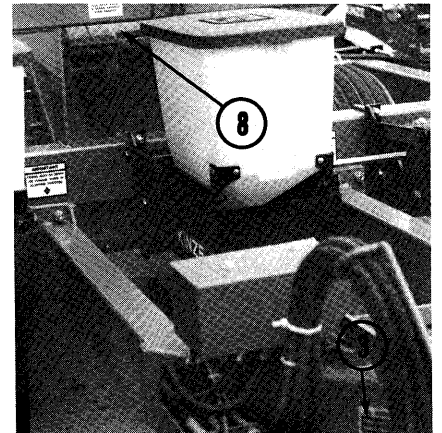
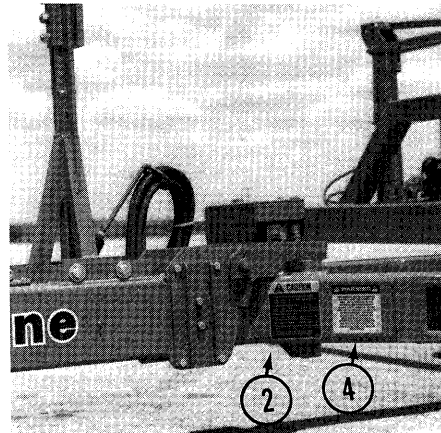
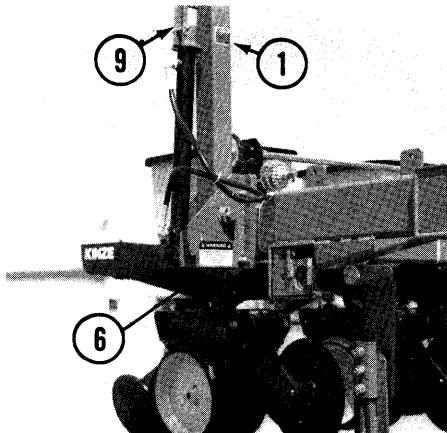

The “WARNING” signs illustrated on this page are placed on the machine to warn of hazards. “The warnings found on these signs are for your personal safety and those around you.” OBSERVE THESE WARNINGS!

- Keep these signs clean so they can be observed readily. Wash with soap and water or cleaning solution as required.
- Replace “WARNING” signs should they become damaged, painted over or if they are missing.
- When replacing decals, clean the machine surface thoroughly using soap and water or cleaning solution to remove all dirt and grease.

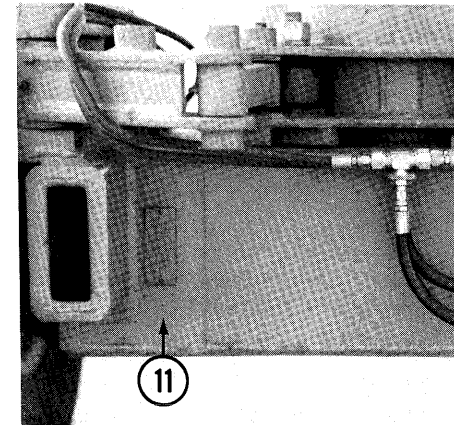
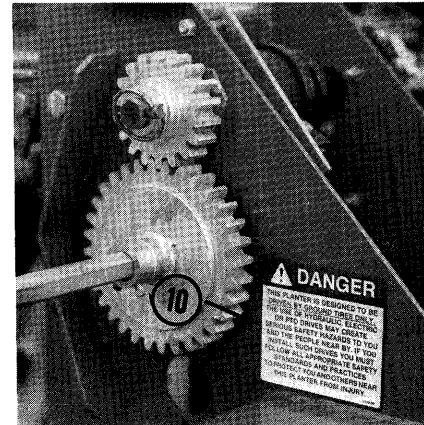
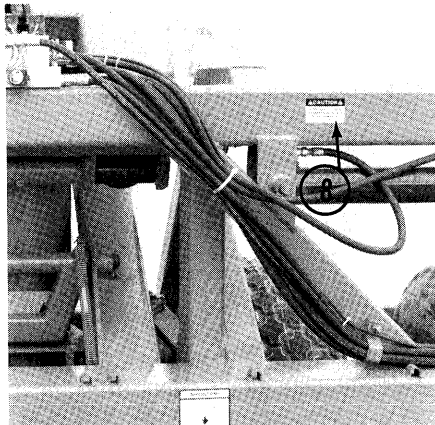
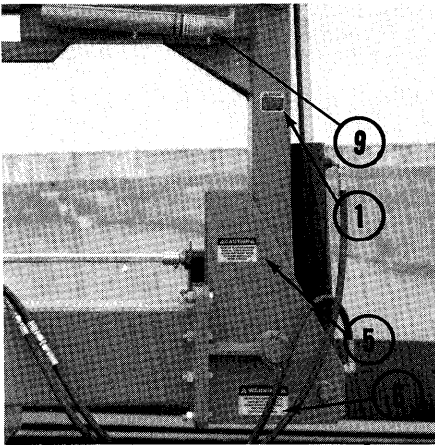

SAFETY WARNING SIGNS



1. Part No. 7100-42

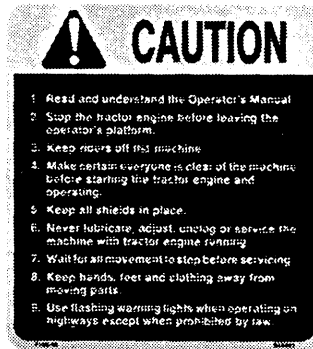

2. Part No. 7100-46

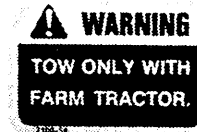

3. Part No. 7100-56



4. Part No. 7100-90

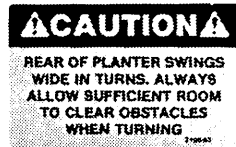

5. Part No. 7100-63

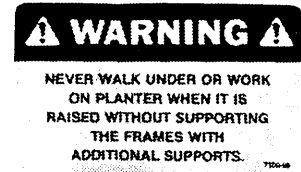

6. Part No. 7100-68

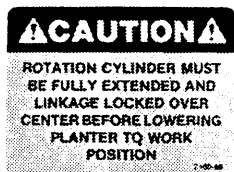

7. Part No. 7100-69

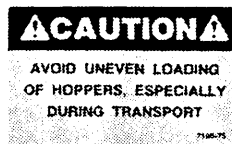

8. Part No. 7100-75



9. Part No. 7100-83



10. Part No. 7100-89

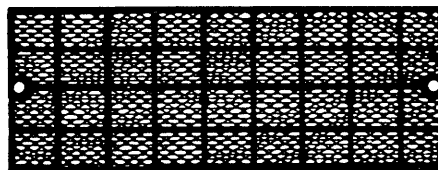

11. Part No. 7200-3 Red
12. Part No. 7200-4 Amber

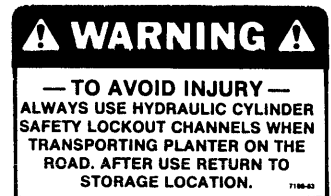

13. Part No. 7100-43

OPERATION

The following information is general in nature and was written to aid the operator in preparation of the tractor and planter for use, and to provide general operating procedures. The operator's experience, familiarity with the machine and the following information should combine for efficient planter operation and good working habits. The operator's manual for the row units used with your Kinze planter should also be readily available and consulted for planter operation.

INITIAL PREPARATION OF THE PLANTER

Lubricate the planter and row units per the lubrication information in this manual and the row unit operator's manual. Make sure all tires have been properly inflated. Check all drive chains for proper tension and lubrication.

TRACTOR PREPARATION AND HOOKUP

1. Adjust tractor drawbar so that it is 13 to 17 inches above the ground. Then adjust the drawbar so that the hitch pin hole is directly below the center line of the PTO shaft. Make sure the drawbar is in a stationary position.
2. Back tractor to planter and connect with hitch pin. Make sure hitch pin is secured with locking pin or cotter pin.
3. Connect hydraulic hoses to tractor ports in a sequence which is both familiar and comfortable to the operator.

WARNING: Before applying pressure to the hydraulic system, make sure all connections are tight and that hoses and fittings have not been damaged. Hydraulic fluid escaping under pressure can have sufficient force to penetrate skin, causing injury or infection.

CAUTION: Always wipe hose ends to remove any dirt before connecting couplers to tractor ports.

4. Ensure electrical control harness is securely connected.
5. Raise jack stand and remount horizontally on storage bracket.
6. Lower planter to the planting position and check hitch for levelness. If hitch slopes up or down, disconnect planter and adjust hitch clevis up or down as necessary.

LEVELING THE PLANTER

For proper operation of the planter and row units, it is important that the unit operate level.

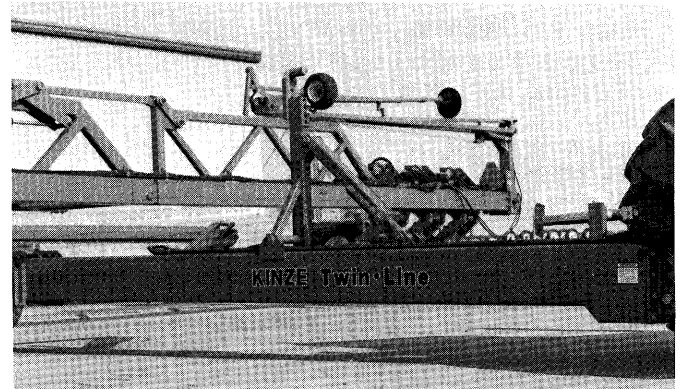

Three holes in the hitch bracket allow the clevis to be raised or lowered. In addition, the clevis may be turned over for a finer adjustment between mounting holes. When installing clevis mounting bolt, make sure lock nut is tightened to proper torque setting.

Always check fore and aft levelness with the planter lowered to proper operating depth. Recheck once planter is in the field.

In order to maintain lateral levelness, it is important that tire pressure be maintained at pressures specified. Adjusting bolts on each drive wheel module allow for additional adjustment for leveling the wings.

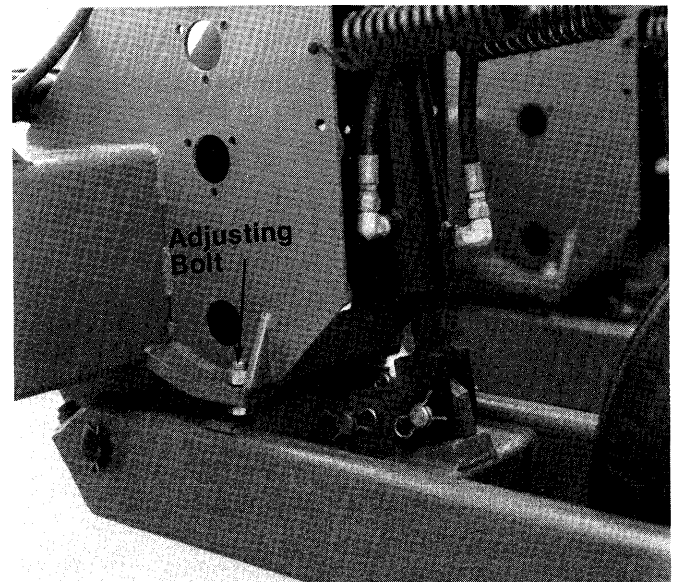

On planters equipped with push units or fertilizer it may be necessary to adjust wing height once the planter has been loaded and in the field. This is especially true in soft field conditions when wing tires may penetrate the ground more than the center portion of the planter.

OPERATION

TIRE PRESSURE

Tire pressure should be checked regularly and maintained as follows:

8 Row Models

11L x 15, Transport/Ground Drive Gauge - 40 PSI
4.8 x 8, Contact Drive - 50 PSI

24 Row Models

16.5L x 16.1, Transport - 40 PSI
7.50 x 20, Ground Drive Gauge - 40 PSI
4.8 x 8, Contact Drive - 50 PSI

TRANSMISSION ADJUSTMENT

The transmission is designed to allow simple rapid changes in sprocket combination to obtain the desired planting population. Since both the transmission drive shaft and row unit drive shaft are hexagonal in shape, the sprockets need only be slid into alignment with the idlers after first removing the lynch pins. A combination of small sprockets may require shortening the drive chain.

A decal positioned next to the transmission provides proper chain routing. The planting rate charts found in the Operation Section of this manual will aid you in selecting the correct sprocket combinations. After positioning both sprockets, replace the lynch pins. Then restore tension on the drive chain.

IMPORTANT: After each sprocket combination adjustment, make field check to be sure you are planting at the desired rate.

CONTACT DRIVE WHEEL SPRING ADJUSTMENT



There are two down pressure springs on each contact drive wheel. The down pressure is factory preset and should need no further adjustment.

On 8 row models the spring tension is set leaving 2 3/4" between the spring plug and the bolt head.

On 24 row models the spring tension is set leaving 3 3/4" between the spring plug and the bolt head.

SHEAR PROTECTION

The planter drive line and row unit and fertilizer components are protected from damage by shear pins.

If excessive load should cause a pin to shear, it is important to determine where binding has occurred before replacing the pin.

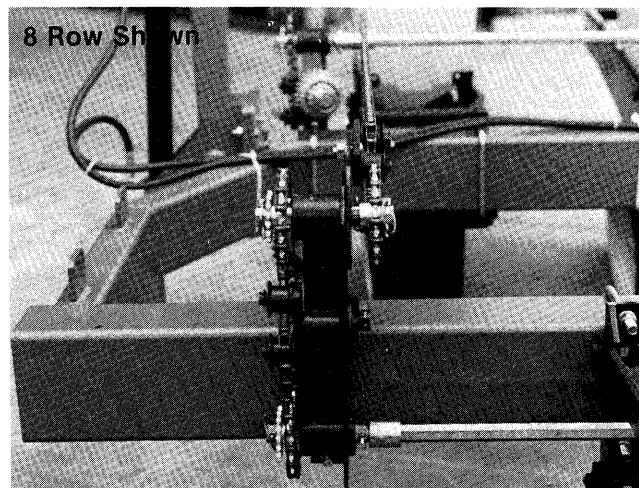

CAUTION: In the top coupler on each transmission assembly a 5/16", grade 2, cap screw is used and in the bottom coupler on each transmission assembly a 1/4" cotter pin is used. Never replace this hardware with any other size or grade hardware.

To prevent future binding or breakage of components, follow prescribed lubrication schedules.

On models equipped with universal joints, be sure universal joints on drives are in time.

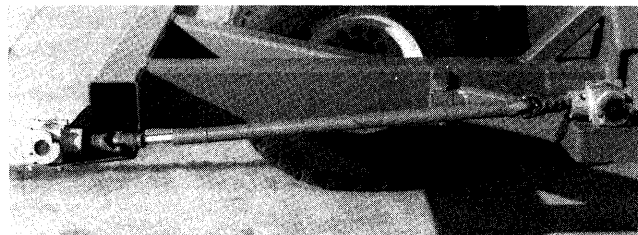

OPERATION

HYDRAULIC OPERATION

All Twin-Line planters are equipped for a triple valve hydraulic system.

One set of outlets is used to raise and lower the planter, one set is used to operate the markers and one set is used to operate the rotate to transport functions.

WARNING: Make sure all hydraulic hoses are properly connected before operating the planter. Never connect or disconnect hydraulic hoses without first stopping the tractor engine and moving the hydraulic operating levers in both directions to relieve any pressure in the system.

NOTE: To purge air from the hydraulic hoses, lower the planter to the planting position and hold the tractor hydraulic control lever in that position until the cylinders are fully retracted. Tractor reservoir should be sufficiently full of hydraulic fluid.

VALVE BLOCK LOCATED ON MAIN FRAME (8 Row Models)

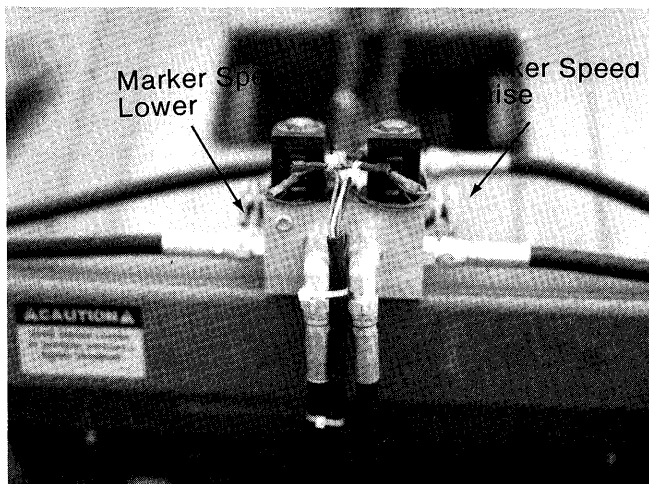

The valve block located on the main frame assembly is made up of the marker solenoids and flow controls.

The two solenoids on the top control which marker will operate when the tractor hydraulic lever is moved. (See Marker Operation.)

The speed at which the markers will travel is controlled by the knurled adjustment knob or flow control on the side of the valve block. The knob on the right side of the block will control the speed of the marker coming down. The knob on the left side of the block will control the speed of the marker coming up. Screw the knobs all the way in and turn back out about 1 1/2 turns and check marker speed. Travel time should be approximately 6 seconds. To increase speed of the marker turn the knob out. To decrease the speed of the marker turn the knob in. Temperature of the hydraulic oil will effect the marker speed, so an additional adjustment may be necessary. Once marker adjustment has been made, tighten the knurled lock nut against the valve block.

VALVE BLOCK LOCATED ON MAIN FRAME (24 Row Models)

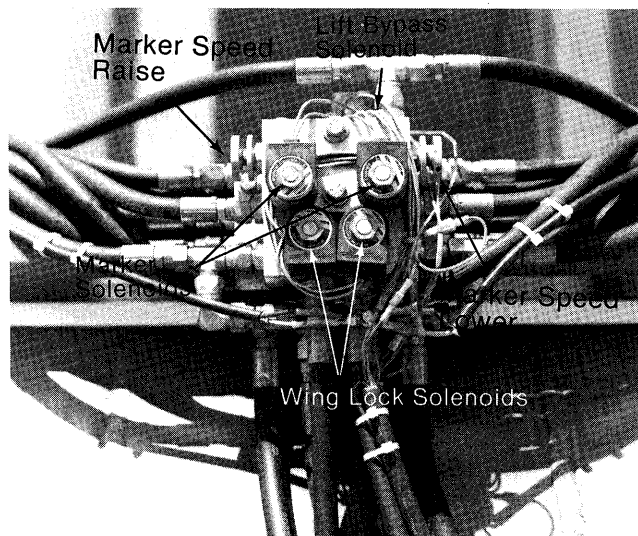

The valve block assemblies located on the main frame of the planter are made up of the marker solenoids and flow controls, the lift bypass solenoid and the wing lock solenoids.

The two solenoids, located to the front of the top portion of the upper block, control which marker will operate when the tractor hydraulic lever is moved. (See Marker Operation.)

OPERATION

The speed at which the markers will travel is controlled by the knurled adjustment knob or flow control on the side of the valve block. The knob on the right side of the block will control the speed of the marker coming down. The knob on the left side of the block will control the speed of the marker coming up. Screw the knobs all the way in and turn back out about 1 1/2 turn and check marker speed. Travel time should be approximately 12 seconds. To increase speed of the marker turn the knob out. To decrease the speed of the marker turn the knob in. Temperature of the hydraulic oil will effect the marker speed so an additional adjustment may be necessary. Once marker adjustment has been made, tighten the knurled lock nut against the valve block.

The solenoid valves located to the rear of the top portion of the upper block are used in conjunction with the planter lift system to lock the wings when the planter is being raised to transport position. (See Planter Lift System Operation.) NOTE: These solenoids operate in pairs.

The solenoid valve located on the front side of the lower block is used in conjunction with the planter lift system when the planter is being raised to transport position. (See Planter Lift System Operation.)

VALVE BLOCK LOCATED ON HITCH (8 and 24 Row Models)

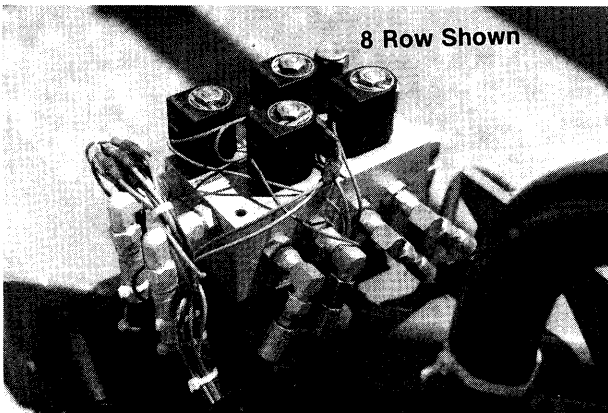

The valve block assembly located on the hitch of the planter is made up of two pairs of solenoid valves. Each pair is controlled by a momentary contact selector switch on the planter control panel on the tractor. One pair rotates the planter to the transport or plant position and one pair extends the planter tongue. The switch must be held in contact when operated. (See Planter Operation Procedures.)

CAUTION: Valve block shown with cover removed for illustration purposes only. Cover should always be installed except for service.

TONGUE LOCK OPERATION (8 and 24 Row Models)

8 Row Shown

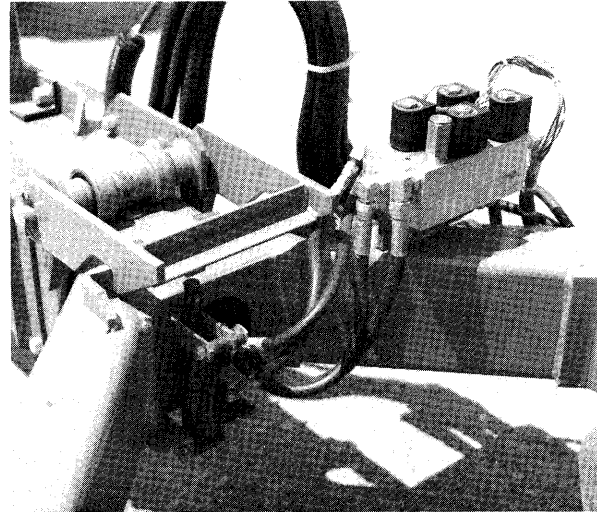

A tongue lock is located on the rear section of the tongue. The purpose of the lock is to take pressure off the tongue cylinder and to lock the tongue into the planting position. The lock must release before the tongue will extend. This is accomplished when the 1 1/2" x 2" lift lock cylinder raises the lock. A pressure relief valve located on top of the aluminum valve block on the tongue will not allow hydraulic oil to the tongue cylinder until 500 PSI of oil pressure is developed at the latch cylinder. This ensures that the latch will release first.

The relief valve pressure setting can be adjusted after removing the cap on top of the valve. Using an allen wrench turn the valve in to increase pressure and out to decrease pressure. The valve is preset at 500 PSI and should be operated at that setting.

OPERATION

MARKER OPERATION 8 and 24 Row Models

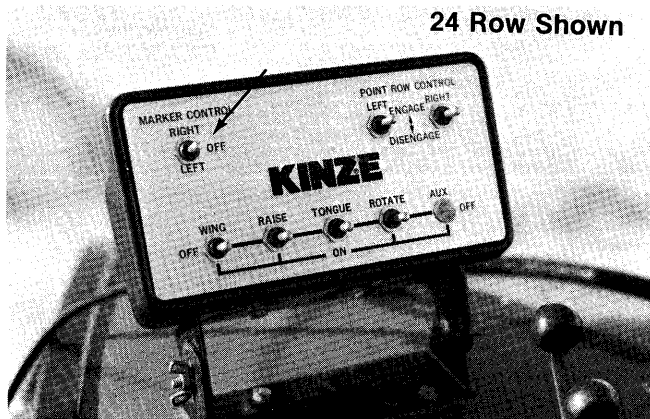

Two solenoid valves along with a three position selector switch permits the operator to raise or lower the desired marker.

1. On the control panel select which marker you want lowered.
2. Operate hydraulic control lever to lower marker.
3. If opposite marker is to be used next, flip control switch to other side.
4. At end of field, using hydraulic control lever raise the down marker.
5. After making the turn, using the hydraulic lever lower the preselected marker.
6. Continue to follow this procedure.

NOTE: Switch should be left in "off" position when planter is not in use. If left in "on" position overnight it will drain the tractor battery.

If the electrical system fails to operate properly:
Check fuse
Check wiring connections
Check control switch
Check solenoid - Solenoid housing will be magnetized when energized.

PLANTER LIFT SYSTEM OPERATION (8 Row Models)

The planter lift system consists of two cylinders located near the center of the machine.

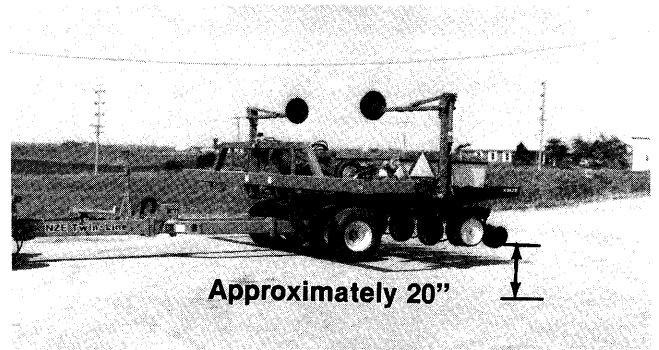

RAISED FIELD POSITION

There are two raised positions on the planter. One is the raised field position used in making turns or passing over waterways during field operation. Here the planter should be raised approximately 20" so the row units will sufficiently clear the ground.

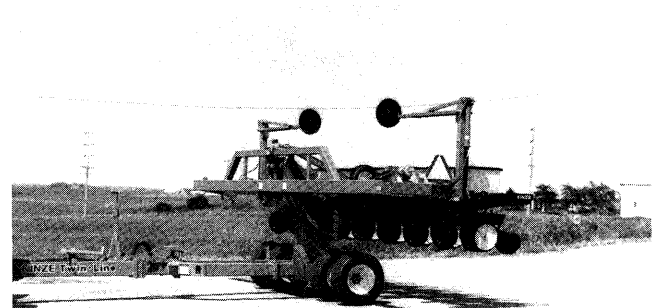

RAISED TRANSPORT POSITION

The other raised position is the raised transport position. Here the planter must be raised until the automatic safety lift lock is engaged to lock the planter in the raised position. This ensures sufficient room for the row units to clear the transport wheels when the planter is rotated. (See "Transport Operation" procedures.)

OPERATION

PLANTER LIFT SYSTEM OPERATION (24 Row Model)

The planter lift system consists of two master cylinders located near the center of the machine and 3 slave cylinders on each outer wing.

With the master/slave hydraulic lift system, oil is forced into the butt end of the center master cylinders when the hydraulic lever on the tractor is moved to the raised position. As the master cylinders are extended, oil from the rod end of the master cylinder is forced into the butt end of the slave cylinders on the planters wings.

The displacement of each master cylinder is equal to the total displacement of all the slave cylinders on each wing and since the two center master cylinders are tied together in a common lift assembly, the wings and center frame will raise and lower at the same rate keeping the planter level.

The master/slave lift system on the Twin-Line is unique in that the center master cylinders have more stroke than the slave cylinders. The masters have a twenty inch stroke and the slaves have an eight inch stroke.

The slave cylinders are provided with a bypass port which will allow oil to bypass the cylinder piston. If the system gets out of phase it can be rephased by holding the tractor hydraulic lever at the lower end of the cylinder stroke until all the cylinders are fully extended or retracted. This will generally take 15 to 20 seconds.

The bypass on the raised or extended end of each wing cylinder is controlled by an electric solenoid valve which is located on the main frame valve block and is controlled with the control switch located on the planter control console. This switch is marked "RAISE".

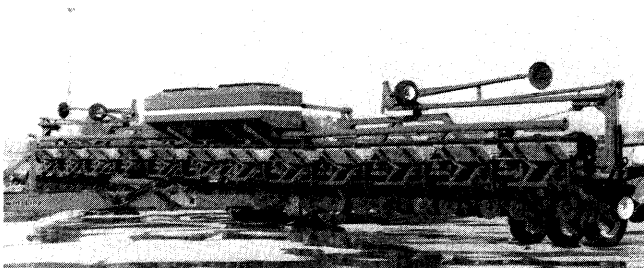

RAISED FIELD POSITION

There are two raised positions on the planter. One is the raised field position which is when the planter wing cylinders are fully extended and the

master cylinders in the center are at half their stroke, but because the bypass solenoid is not energized the wing cylinder can not bypass oil preventing the planter from raising any higher. This position will raise the row units approximately 20 inches off the ground. This position is used in making turns or passing over waterways during field operation.

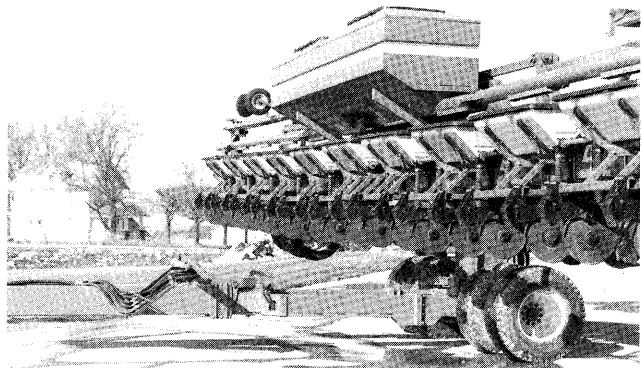

RAISED TRANSPORT POSITION

The other raised position is the raised transport position. Here the planter must be raised high enough so that the row units will clear the transport wheels when the planter is rotated. To do this the planter is first raised to raised field position and the wings locked in the rigid position. (See "Transport Operation" procedures.) By holding down the "RAISE" switch on the control console to energize the bypass solenoid and holding the tractor hydraulic lever in the raise position the planter will continue to raise until the master cylinders are fully extended. At this point an automatic safety lock will lock the planter in the raised position.

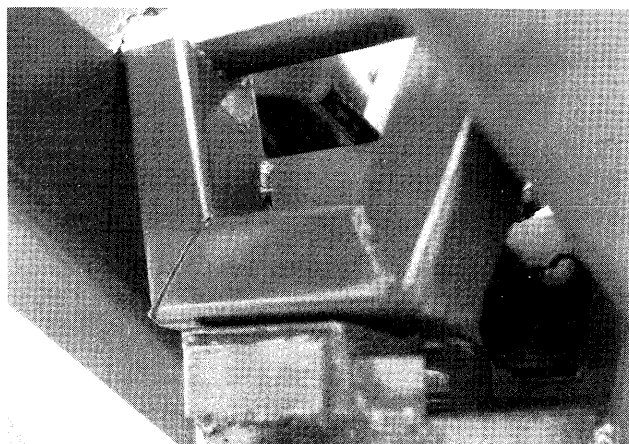

OPERATION

NOTE: Any time the planter is raised beyond the raised field position the bypass solenoid must be energized to allow oil to bypass around the pistons in the wing lift cylinders. The planter will also lift at a slower rate because of the restriction of the bypass. Also once the planter is lowered from the raised transport position the planter must be completely lowered to the ground and the hydraulic lever on the tractor held until all cylinders are fully retracted and the system is rephased.

TRANSPORT TO PLANT OPERATION PROCEDURE (8 Row Models)



CAUTION: If tongue is retracted too far and drops off of the latch ramp, do not attempt to extend tongue until after rotating the planter frame away from the latch post. Latch post would catch on latch ramp and result in damage to the latch post.

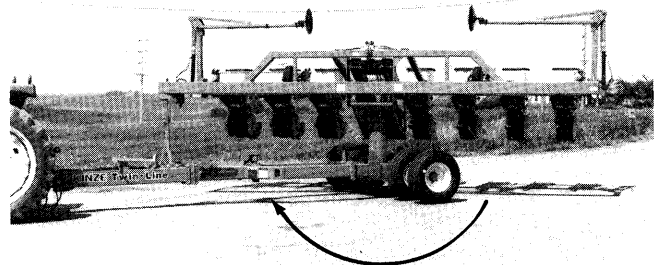
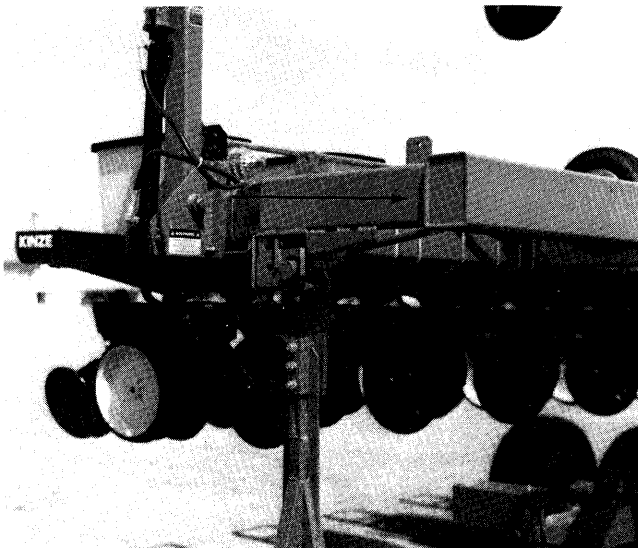
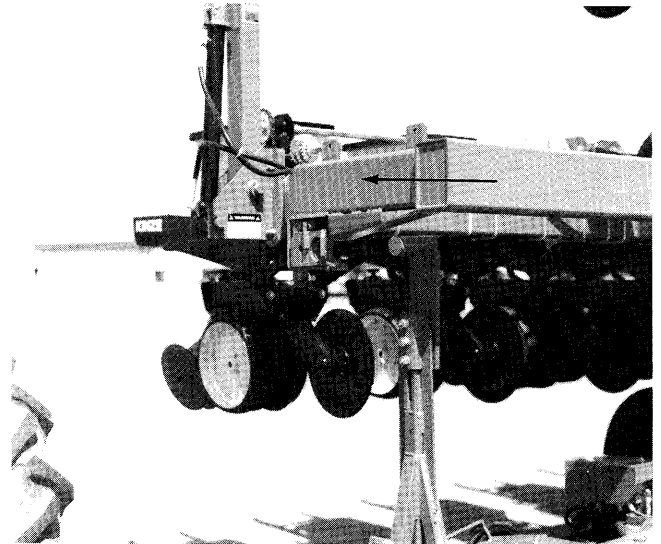

1. Release transport latch.
 - A. Press "TONGUE" switch and hold.
 - B. Engage hydraulic tongue/rotation lever until tongue is retracted approximately 1" or only far enough to release latch.

CAUTION: Retracting tongue too far at this point can cause the latch post on the tongue to strike attachments on the front tool bar.

2. Rotate planter to field position.
 - A. Press "ROTATE" switch and hold.
 - B. Engage and hold hydraulic tongue/rotation lever until rotation cylinder is fully extended and rotation toggle is locked over center.

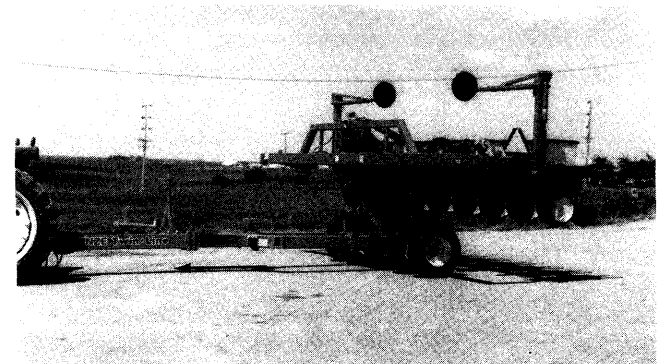

OPERATION

3. Retract tongue.

- A. Press "TONGUE" switch and hold.
- B. Engage and hold hydraulic tongue/rotation lever until tongue is fully retracted and tongue lock hook drops into place.

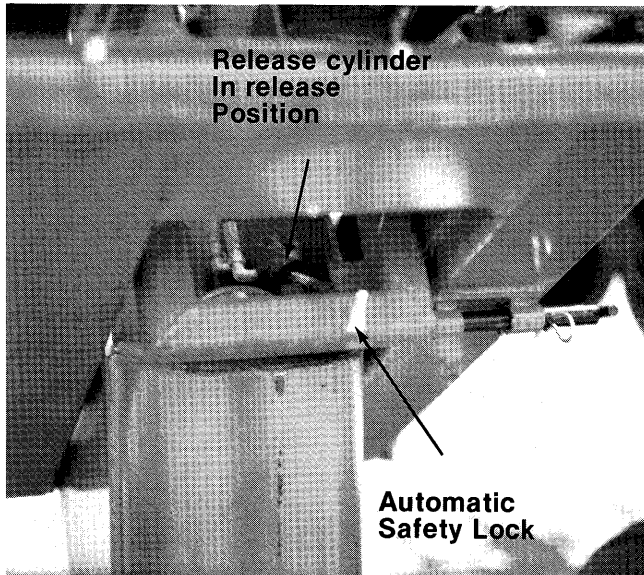

4. Release automatic safety lift lock.

- A. Engage and hold hydraulic lift lever in down position momentarily to allow safety lock release cylinder to move into release position.
- B. Engage hydraulic lift lever to raise planter and allow release cylinder to release safety lock.

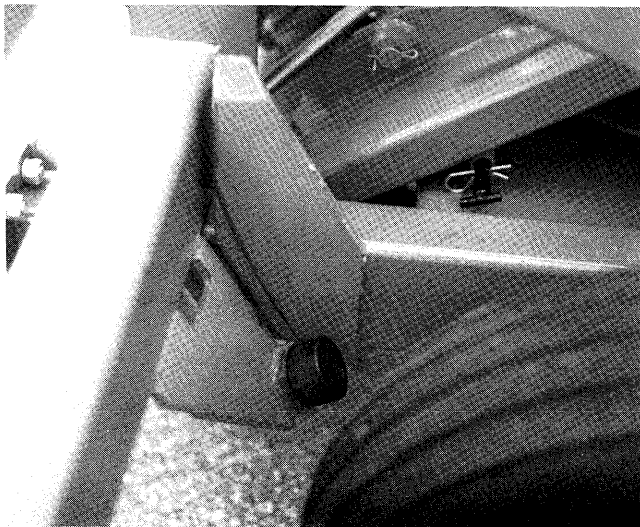

CAUTION: To prevent damage to the frame, units or tires, make sure the frame has been completely rotated to planting position so that the cams on the center section are tracking properly in the guides on the axle and pivot assembly.



- 5. Engage hydraulic lift lever in the down position until planter is completely down with lift cylinders fully retracted and contact drive wheels are down on the transport wheels with spring tension.

PLANT TO TRANSPORT OPERATION PROCEDURE (8 Row Models)

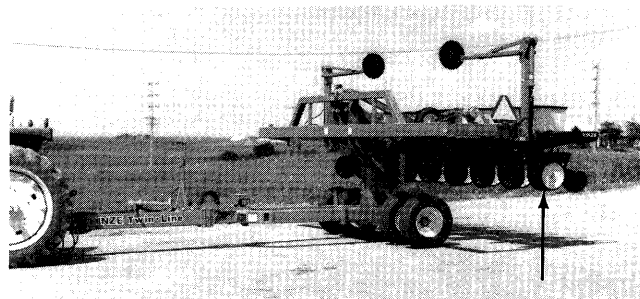

1. Raise planter to transport position.

- A. Engage hydraulic lift lever until the automatic safety lift lock is secured.



NOTE: Engagement of the safety lift lock can be observed from the tractor seat.

OPERATION

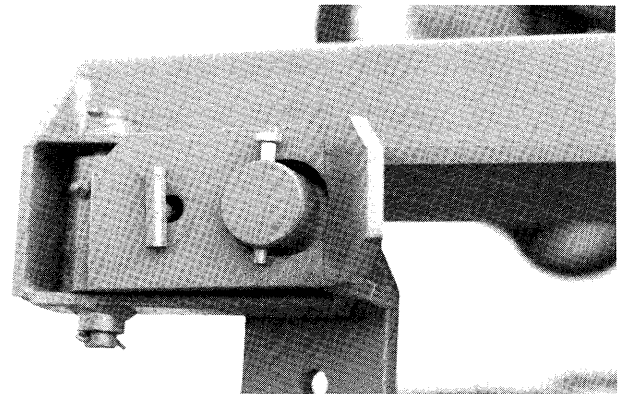
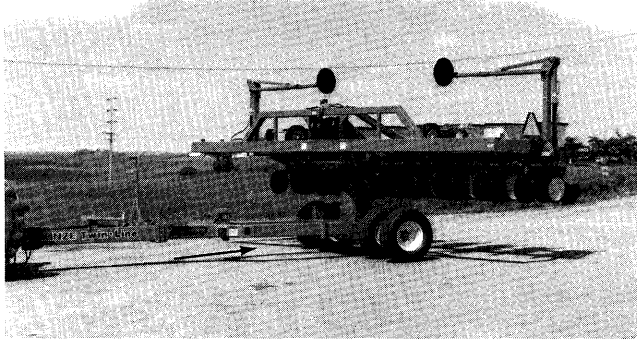
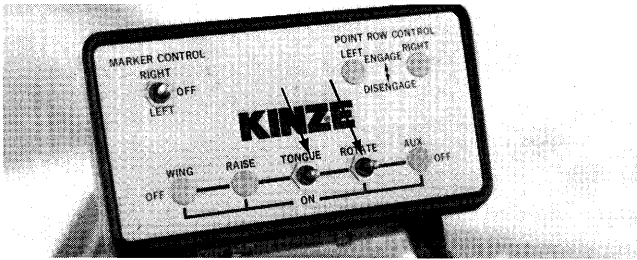

! WARNING: The manual safety lockup located on the under side of the center lift arm assembly is an added safety device. Never allow anyone to work around or under the planter without first securing the manual safety lock in the manual safety lockup for added safety.

2. Extend tongue.
 - A. Press "TONGUE" switch down and hold.
 - B. Engage hydraulic tongue/rotation lever until tongue is fully extended. Tongue lock will automatically release.

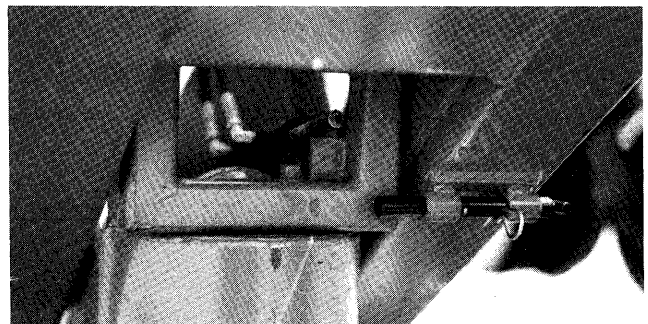
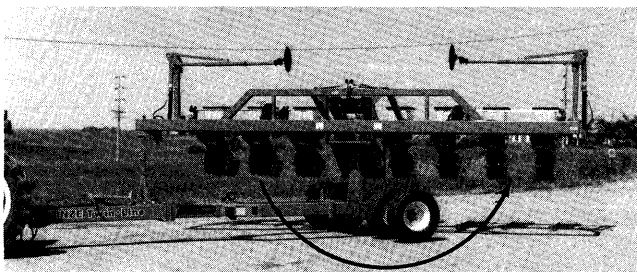

3. Rotate frame.
 - A. Press "ROTATE" switch and hold.
 - B. Engage hydraulic tongue/rotation lever to rotate the planter until the transport latch is secured.

! WARNING: If the planter sets for a period of time, always extend the tongue before transporting to ensure the transport latch is secured. Hydraulic pressure can leak off and allow the latch to release. If the planter is transported long distances or without being connected to the tractor, install a 3/8" x 2 1/2" cap screw into the transport latch post on the hitch.

TRANSPORT TO PLANT OPERATION PROCEDURE (24 Row Models)

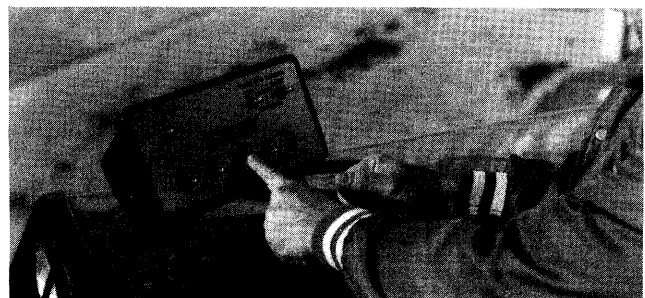

OPERATION

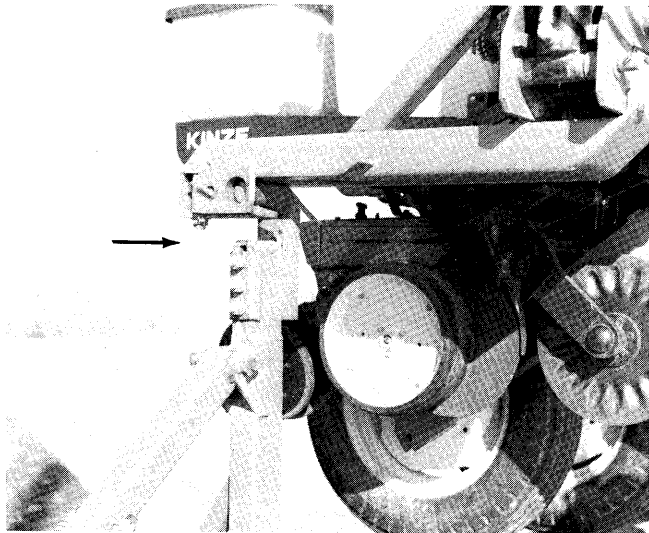

1. Release transport latch.
 - A. Press "TONGUE" switch and hold.
 - B. Engage hydraulic tongue/rotation lever until tongue is retracted approximately 1" or only enough to release latch.

CAUTION: Retracting tongue too far at this point can cause the latch post on the tongue to strike attachments on the front tool bar.

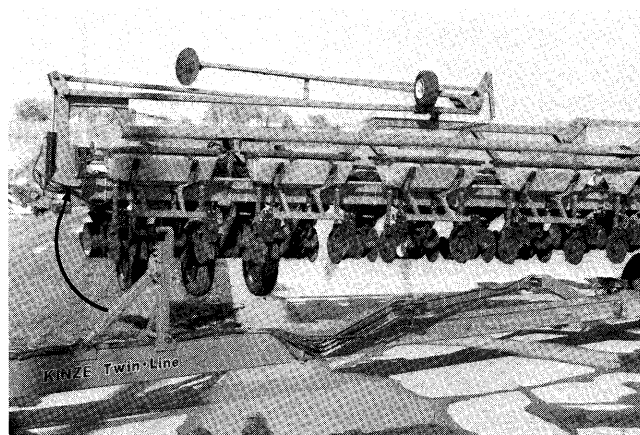
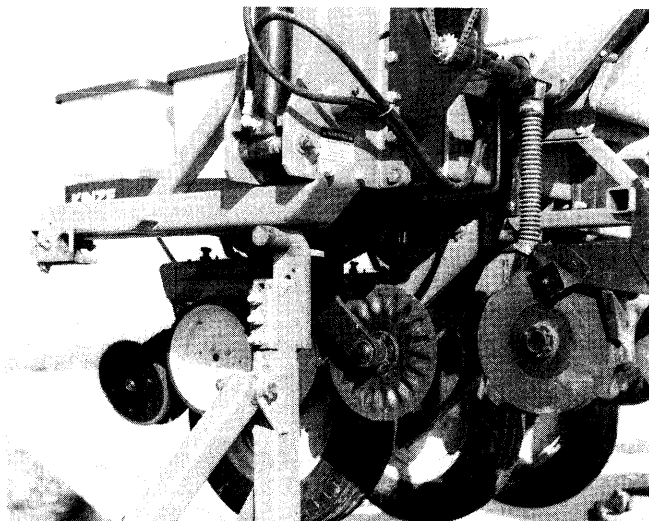
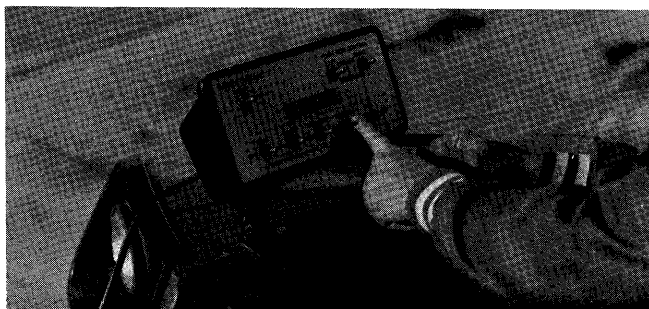

2. Rotate planter to field position.
 - A. Press "ROTATE" switch and hold.
 - B. Engage and hold hydraulic tongue/rotation lever until rotation cylinders are fully extended and rotation toggles are locked over center.

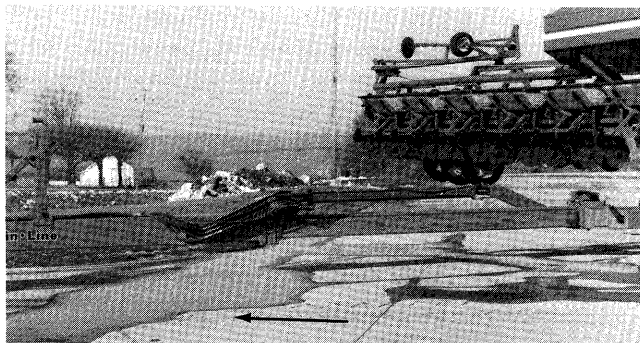

3. Retract tongue.
 - A. Press "TONGUE" switch and hold.
 - B. Engage and hold hydraulic tongue/rotation lever until tongue is fully retracted and tongue lock hook drops into place.

NOTE: Due to the large displacement of the tongue cylinder, it takes approximately 1 1/2 minutes to retract this cylinder.

4. Release automatic safety lift lock.

OPERATION

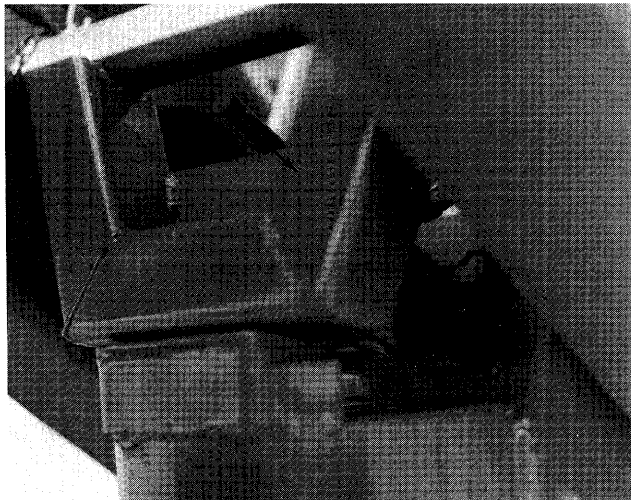

- A. Engage and hold hydraulic lift lever in down position momentarily to allow safety lock release cylinder to move into release position.

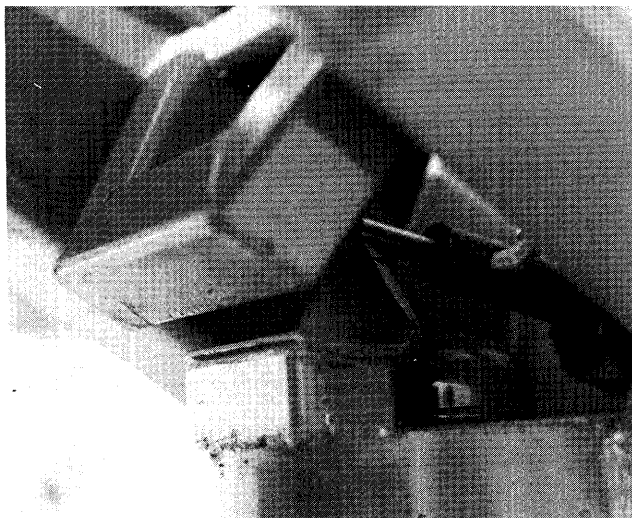

- B. Engage hydraulic lift lever to raise planter and allow release cylinder to release safety lock.

NOTE: It may be necessary to hold "RAISE" switch down to allow the planter to raise high enough to release the lock.

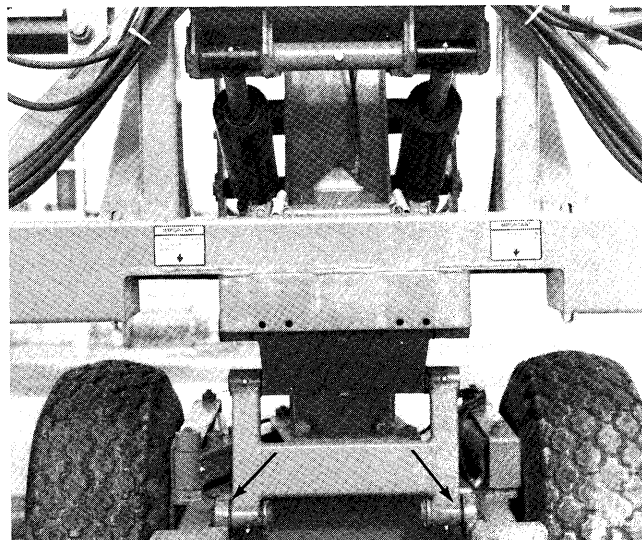

CAUTION: To prevent damage to the frame, units or tires, make sure the frame has been completely rotated to planting position so that the cams on the center section are tracking properly in the guides on the axle and pivot assembly.

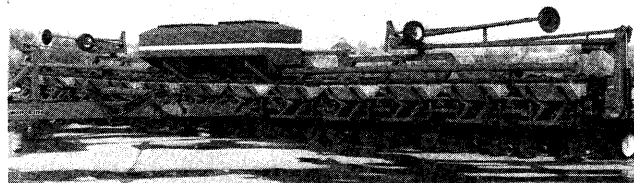

5. Rephase hydraulic lift system.
A. Hold the hydraulic lift lever in the down position for several more seconds until the master/slave cylinders are completely retracted to ensure the system is completely rephased.

OPERATION



6. Release wing locks so wings may flex.
 - A. Press "WING" switch and hold.
 - B. Engage and hold hydraulic marker/wing lock lever until wing lock cylinders are fully retracted.

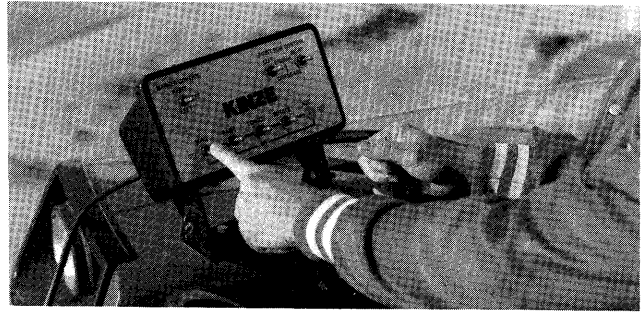

2. Lock wings in transport position.
 - A. Press "WING" switch down and hold.
 - B. Engage hydraulic marker/wing lock lever until wing lock cylinders are fully extended and wing locks are locked over center.

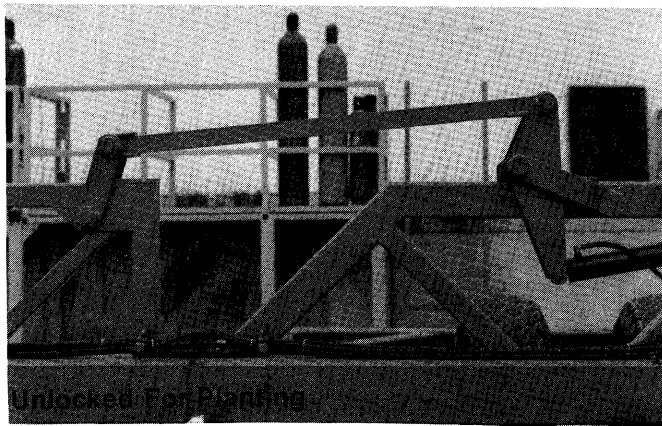
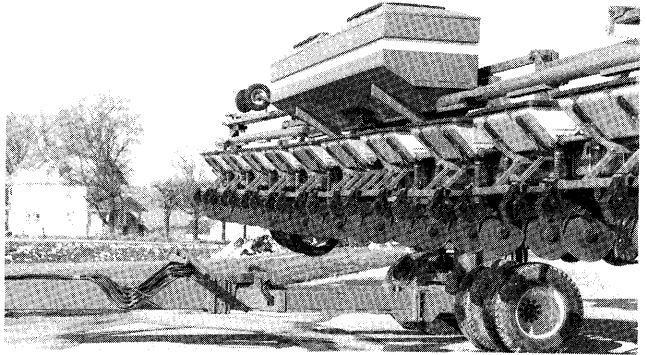
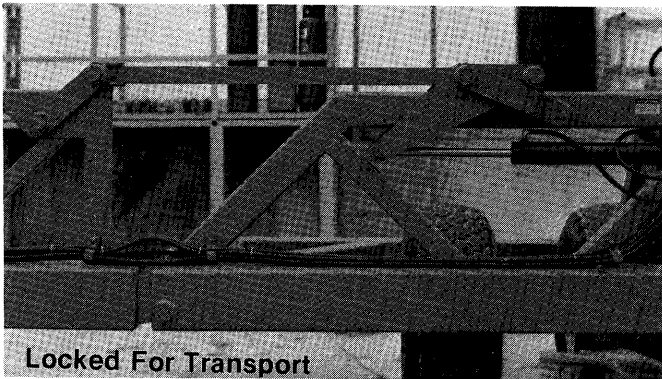

3. Raise planter to transport position.
 - A. Press "RAISE" switch down and hold.
 - B. Engage hydraulic lift lever until master cylinders are fully extended and the automatic safety lock is secured.

PLANT TO TRANSPORT OPERATION PROCEDURE (24 Row Models)

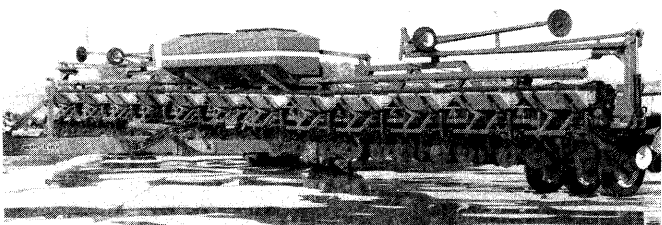

1. Raise planter to raised field position.

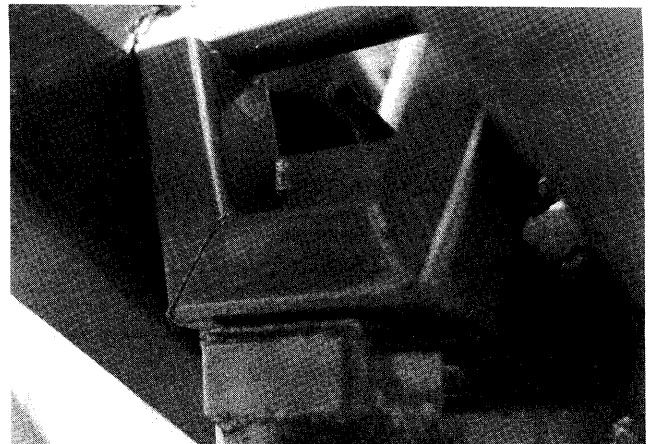

OPERATION

NOTE: Before transporting the planter, visually check to see that safety lock is secured. This may require getting off the tractor to observe.

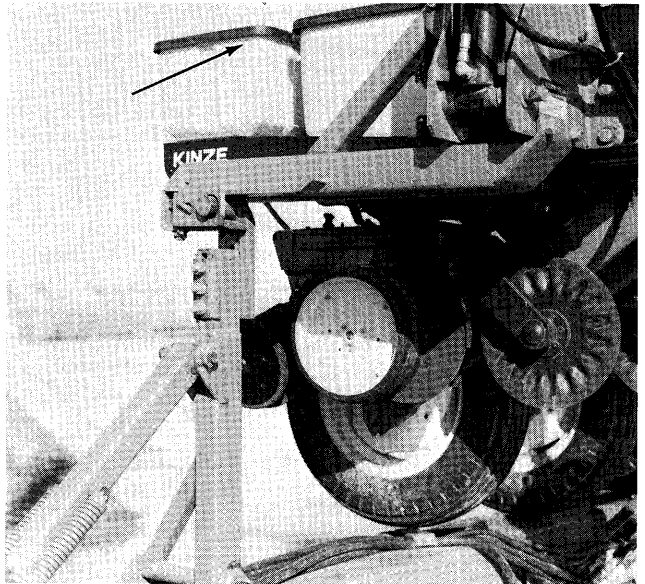
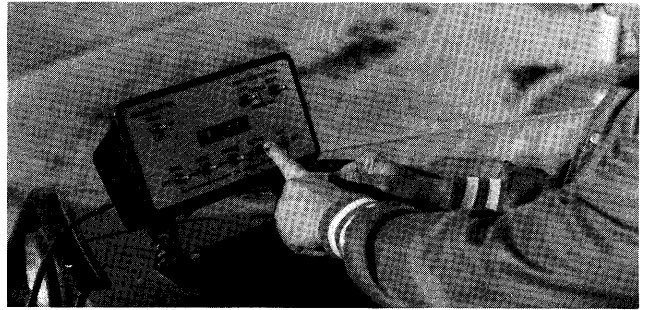
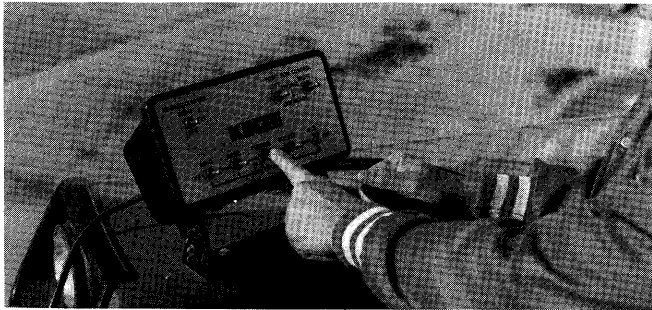

Locked Position

5. Rotate frame.

- A. Press "ROTATE" switch and hold.
- B. Engage hydraulic tongue/rotation lever to rotate the planter until the transport latch is secured.

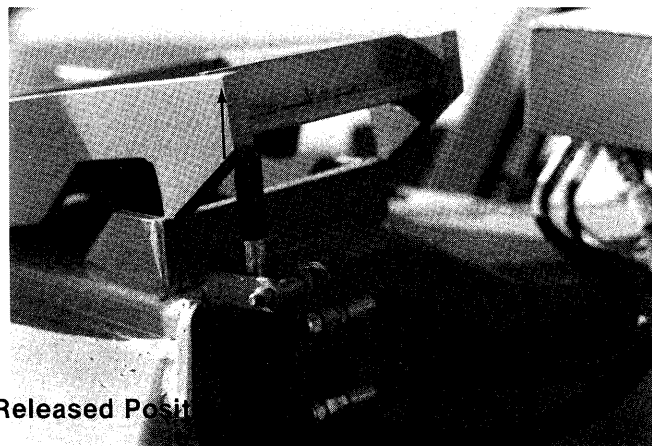

Released Position

4. Extend tongue.

- A. Press "TONGUE" switch down and hold.
- B. Engage hydraulic tongue/rotation lever until tongue is fully extended. Tongue lock will automatically release.

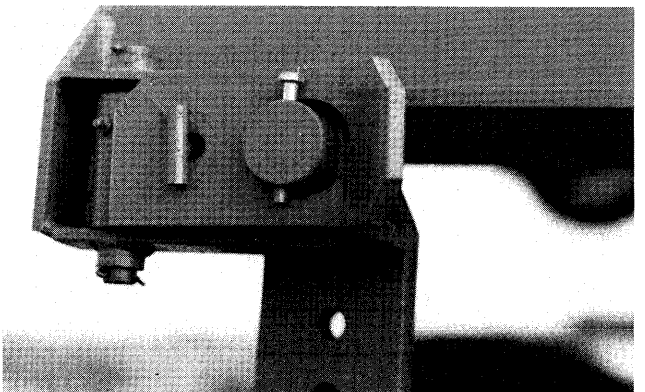

WARNING: If the planter sets for a period of time, always extend the tongue before transporting to ensure the transport latch is secured. Hydraulic pressure can leak off and allow the latch to release. If the planter is transported long distances or without being connected to the tractor hydraulic, install a 3/8" x 2 1/2" cap screw into the transport latch post on the hitch.

OPERATION

POINT ROW WRAP SPRING CLUTCH

With the Twin-Line planter you have the capability to shut off either half of the planter for finishing up fields or for long point row situations. This is done with the use of electric wrap spring clutches which disengage the drive on either half of the planter.

Standard equipment on 24 row...optional on 8 row.



The operational switches for the clutches are located on the planter control panel on the tractor.

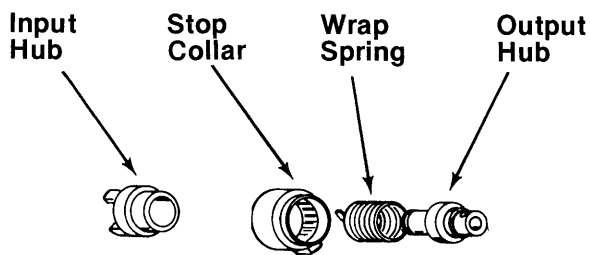

The wrap spring clutch consists basically of a wrap spring riding on an input hub and an output hub. During normal operation the wrap spring is wrapped tightly over the hubs connecting them in a positive engagement. The greater the force of rotation the tighter the grip of the spring on the hubs. Rotation in the opposite direction or stopping the spring from rotating prevents the transmission of torque from the input hub to the output hub stopping the planter drive.

The input end of the spring is bent outward and is referred to as the control tang. The control tang fits into a slot in the nylon stop collar that is located between the input and output hubs and over the wrap spring. If the stop collar is allowed to rotate with the input hub, the clutch is engaged. If the stop collar is stopped from rotating the spring tang connected to it is forced back and the spring opens. This allows the input hub to continue rotating without transmitting torque to the output hub and therefore stopping the planter drive.

The stop collar is controlled by the use of an electric solenoid and an actuator arm. When the operational switch on the tractor control panel is in the "ON" position the solenoid coil is not energized and the actuator arm will not contact the stop on the stop collar allowing it to rotate with the hubs and drive the planter.

When the operational switch is in the "OFF" position the solenoid coil is energized and the plunger in the solenoid coil pulls the actuator arm against the stop on the stop collar, disengaging the wrap spring and stopping the planter drive.

24 Row Shown

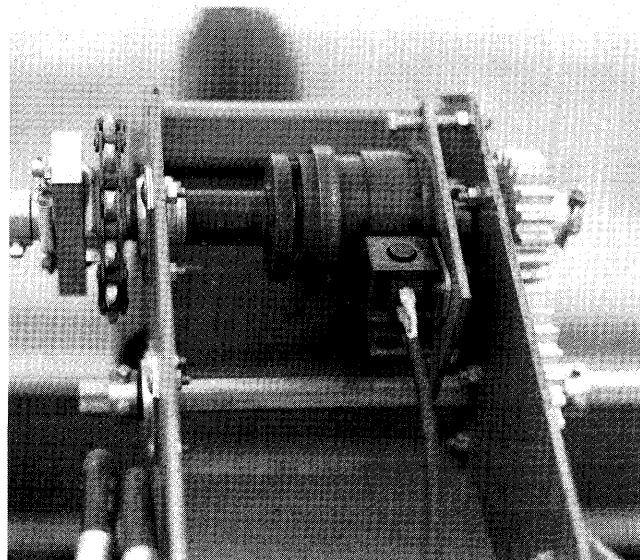

OPERATION

MARKER ADJUSTMENT

To determine the correct length at which to set the marker assemblies, multiply the number of rows by the row spacing in inches. This provides the total planting width. Then adjust the marker extension so that the distance from the marker blade to the center line of the planter is equal to the total planting width previously obtained. Both the planter and marker assembly should be lowered to the ground when measurements are being taken. Also, the measurement should be taken from the point where the blade contacts the ground. Adjust right and left marker assemblies equally and securely tighten clamping bolts. An example of marker length adjustment follows:

$$\begin{array}{rcl} \text{Number of Rows} & \times & \text{Row Spacing (Inches)} \\ & & = \text{Dimension between planter center line and marker blade} \end{array}$$

$$24 \times 30'' = 720'' \text{ Marker Dimension}$$

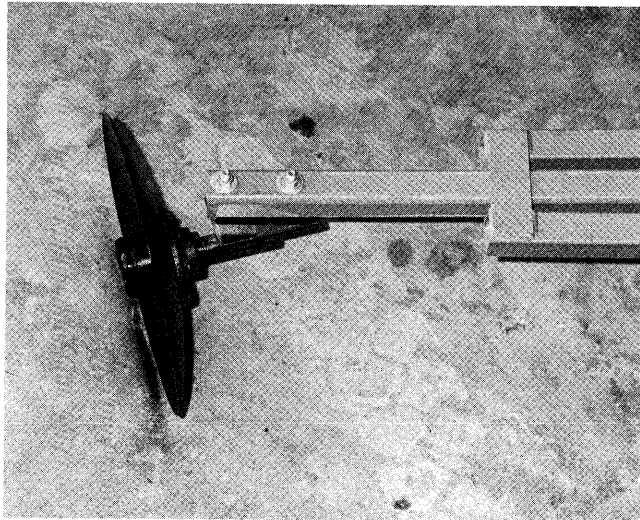

The marker blade is installed so the concave side of the blade is outward to throw dirt away from the grease seals. The spindle bracket is slotted so the hub and blade can be angled forward or rearward to throw more or less dirt. To adjust the hub and spindle, loosen the $\frac{1}{2}'' \times 3\frac{1}{2}''$ capscrews and move the bracket as required. Then tighten bolts to the specified torque.

We recommend a field test be made to ensure the markers are properly adjusted. After the field test is made, make any minor adjustments necessary.

TRANSPORTING THE PLANTER

⚠ WARNING: Always make necessary safety preparations prior to transporting the planter on public roads. This includes installing Slow Moving Vehicle (SMV) emblem and use of adequate lights or safety warning after dark.

CAUTION: Avoid transporting planter with hoppers loaded whenever possible. When it is necessary to transport the planter with the hoppers loaded, the added weight should be distributed evenly on the planter frame before rotating the planter.

TRACTOR SPEED

Planters are designed to operate within a speed range of 2 to 8 M.P.H. Variations in ground speed will produce variations in rates. Corn meter populations will tend to be disproportionately higher at high ground speeds. While soybean and sorghum seed cup populations will tend to be disproportionately lower.

FIELD TEST

We recommend a field test be made to ensure proper seed placement and operation of row units. See Rate Charts at end of this section.

Also check for any marker adjustment that may be needed.

After the planter has been field tested, re-inspect the unit.

- Hoses - Fittings
- Bolts - Nuts
- Drive Chains

OPERATION

FERTILIZER OPENER

The double disc fertilizer openers should be positioned during assembly to place the fertilizer no closer than 2" to either side of the row and if planter frame is level, fertilizer depth will be approximately 4". Soil conditions can affect depth slightly.

The down pressure springs are factory preset at 250 pounds down pressure but may be adjusted for various soil conditions. To adjust spring tension, loosen the jam nut with 15/16" wrench and use a 1" wrench to turn the adjustment bolt clockwise to increase tension or counterclockwise to decrease tension. Securely tighten the jam nut upon completion of tension adjustment. Do not attempt to set opener depth with spring pressure. The opener is designed to operate against depth stop and spring up when encountering a foreign object or hard ground.

CAUTION: Do not operate the double disc openers at full down pressure tension when planting in rocky ground. Chipping of the blades may occur.

The opener blades should have a minimum of 2" of contact with each other. Blade adjustment can be made by moving inside spacer washers to the outer side of the blade. After making such an adjustment, check to be sure bearing assembly rivets are not hitting shank.

The scrapers on each blade may also be adjusted to make up for wear that may occur. Make sure the scraper is adjusted to allow only slight contact with the blade.

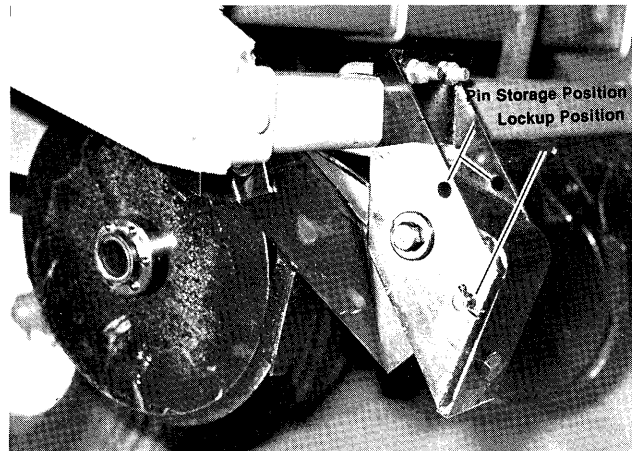

The opener assembly is designed to be locked in a raised position when the fertilizer attachment is not in use or during storage. To lock the opener, first raise the planter and place blocks under the openers. Then lower the planter until the hole in the pivot section aligns with the hole in the mounting bracket. Remove the lockup pin from the storage position in the mounting bracket and install it through the lockup hole and secure with cotter pins.

OPERATION

DRY FERTILIZER ATTACHMENT

The rate of dry fertilizer application is determined by sprocket combinations in the fertilizer transmission. After loosening the drive chain, slide the selected sprockets into alignment with the idlers. Then restore proper chain tension. Refer to the application charts for selection of sprocket combinations.

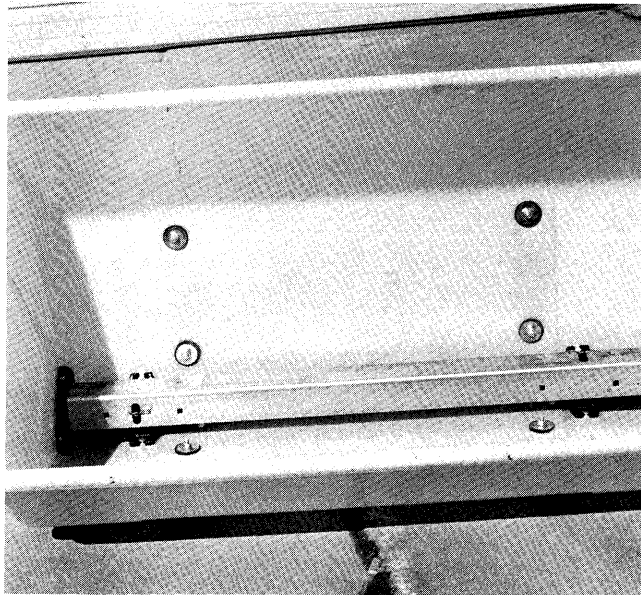

The dry fertilizer attachment meters granules by volume rather than weight. For this reason, and given the variances in brands and fertilizer analysis, the weight metered during actual application may vary considerably. Use the chart for reference only. It is suggested that a container be used to catch and measure application (as explained following the application chart) to obtain a closer estimate.

Since most fertilizers easily absorb moisture, it is important that fertilizer be kept dry during use and storage. In addition to waste, deposits of fertilizer left in the hopper can cause metal corrosion. Hoppers should be emptied at the end of each days use.

IMPORTANT: Certain analysis of fertilizer if placed too close to the seed may cause germination or seedling damage especially if used in amounts in excess of fertilizer manufacturers recommendations. Check with your fertilizer dealer or manufacturer for the correct amount and placement.

⚠ WARNING: Agricultural chemicals can be dangerous if not selected and handled with care. Always read and follow directions supplied by the chemical manufacturer.

Cleaning

The dry fertilizer hoppers are designed to tip forward for dumping and ease of cleaning. To dump hoppers, first disconnect the drive shaft from the transmission or adjacent hopper. **LOOSEN HOSE CLAMPS AND REMOVE HOSES FROM EACH HOPPER.**

Finally, remove the two caps screws from the hopper bracket at the rear of each hopper. Rotate hopper lids to the back side of the hopper and carefully tip hopper forward. After dumping contents, flush all loose fertilizer from the hopper and hoses.

At the end of the planting season, or when fertilizer attachment is not going to be used for a period of time, the hoppers should be disassembled, cleaned and coated with a rust preventative.

To disassemble spreader assemblies, remove the hair pins and baffle from the top of the auger. Then remove the cotter pin from the auger shaft adjacent to the large flat washer and pull auger assembly from the hopper. The bearings pass through the outer castings and need not be removed. Remove the cotter pin and washer from outer end of the auger shaft and remove all auger components for cleaning. Coat all parts with rust preventative before reassembly.

NOTE: Left hand and right hand springs are used on each auger shaft. Make sure springs auger fertilizer to the outer ends of the hopper when rotated in the direction of rotation they turn on the planter.

IMPORTANT: Frequent lubrication of auger bearings is critical for reliable operation.

OPERATION

LIQUID FERTILIZER ATTACHMENT

The rate of liquid fertilizer application is determined by the combination of sprockets on the squeeze pump driven and drive shafts. When changing sprocket combinations, make sure sprockets are in alignment, sprocket retaining collars are tight and chain tension is sufficiently restored.

The delivery rate chart found at the end of this section provides an approximate application rate only. Actual delivery will vary with temperature and the particular fertilizer being used.

IMPORTANT: Certain analysis of fertilizer if placed too close to the seed may cause germination or seedling damage especially if used in amounts in excess of fertilizer manufacturers recommendations. Check with your fertilizer dealer or manufacturer for the correct amount and placement.

⚠ WARNING: Agricultural chemicals can be dangerous if not selected and handled with care. Always read and follow directions supplied by the chemical manufacturer.

Shut off valves provided at various locations, should be closed to shut off flow when the planter sets overnight or for extended periods of time. It is also important to close the tank valves whenever service on the pump or hoses is being performed. To prolong the life of the hoses in the squeeze pump, the discharge manifold must be repositioned to the rearward position to prevent hose distortion.

The discharge manifold must be in the forward position when the pump is in operation. To reposition the manifold, loosen the wing nuts and slide the manifold forward and sideways or rearward as required and retighten nuts.

CAUTION: Avoid excessive pressure when using the quick fill attachment. The rubber plugs installed in the manifold may be forced out under pressure.

If either of the end pump hoses should run off the back plate, loosen the hose clamp on the intake manifold and rotate the hose as follows.

For the *right hand hose* (facing the pump from front of planter) twist the hose $\frac{1}{4}$ turn in the clockwise direction.

For the *left hand hose* (facing front of pump) twist the hose $\frac{1}{4}$ turn in the counter-clockwise direction.

Retighten hose clamp.

Cleaning

The tanks and all hoses are made of sturdy plastic and rubber to resist corrosion. However, the tank should be rinsed with water after each season or extended period of non-use. Do not allow fertilizer to crystallize because of cold temperature or evaporation.

At the end of the planting season, thoroughly clean all parts with clean water and flush the tanks, hoses, and metering pump prior to storage.

OPERATION

PLANTING RATES FOR PLATELESS CORN METERS SEED POPULATIONS/ACRE FOR DIFFERENT ROW WIDTHS

30 Inch	36 Inch	38 Inch	Transmission Sprockets		Recommended Speed Range (MPH)	Average Seed Spacing In Inches
			Drive	Driven		
12,200	10,200	9,600	14	30	4 to 8	17.1
13,100	10,900	10,300	14	28	4 to 8	16.0
14,100	11,700	11,100	14	26	4 to 8	14.9
14,900	12,500	11,800	16	28	4 to 8	14.0
15,700	13,100	12,400	18	30	4 to 8	13.3
16,100	13,400	12,700	16	26	4 to 8	13.0
16,600	13,900	13,100	14	22	4 to 8	12.6
18,100	15,100	14,300	18	26	4 to 8	11.6
19,000	15,900	15,000	16	22	4 to 8	11.0
19,100	16,000	15,100	22	30	4 to 8	10.9
20,300	17,000	16,100	14	18	4 to 8	10.3
20,500	17,100	16,200	22	28	4 to 8	10.2
21,400	17,800	16,900	18	22	4 to 8	9.8
22,100	18,400	17,400	22	26	4 to 8	9.5
22,600	18,900	17,900	26	30	4 to 8	9.2
22,800	19,100	18,000	14	16	4 to 8	9.1
23,200	19,400	18,300	16	18	4 to 8	9.0
24,200	20,200	19,100	26	28	4 to 7 1/2	8.6
24,400	20,300	19,200	28	30	4 to 7 1/2	8.6
25,900	21,800	20,600	22	22	4 to 7	8.0
27,800	23,400	22,100	30	28	4 to 6 1/2	7.5
28,100	23,500	22,200	28	26	4 to 6 1/2	7.4
29,400	24,500	23,200	18	16	4 to 6 1/2	7.1
29,800	24,900	23,500	16	14	3 to 6	7.0
30,100	25,200	23,800	30	26	3 to 6	6.9
30,800	25,800	24,300	26	22	3 to 6	6.8
31,900	26,600	25,200	22	18	3 to 5 1/2	6.5
33,200	27,700	26,200	28	22	3 to 5 1/2	6.3
33,600	28,000	26,500	18	14	3 to 5 1/2	6.2
35,600	29,700	28,100	30	22	3 to 5	5.9
35,900	30,000	28,300	22	16	3 to 5	5.8
37,700	31,500	29,800	26	18	3 to 4 1/2	5.5
41,000	34,300	32,400	22	14	3 to 4 1/2	5.1
42,400	35,400	33,500	26	16	3 to 4 1/2	4.9
43,500	36,300	34,300	30	18	2 to 4	4.8
45,700	38,200	36,100	28	16	2 to 4	4.6
48,500	40,500	38,300	26	14	2 to 3 1/2	4.3
52,200	43,600	41,200	28	14	2 to 3 1/2	4.0
55,900	46,700	44,100	30	14	2 to 3	3.7

Above chart for planters equipped with Kinze drive. Recommended ground drive tire pressure 40 PSI. Recommended contact drive tire pressure 50 PSI.

IMPORTANT: The above sprocket combinations are best for average conditions. Changes in sprocket combinations may be required to obtain desired planting population.

The size and shape of seeds will effect the planting rate. Medium round corn is generally the most preferred while small flat is least desirable. Higher than optimum speeds may result in population rate increases or higher incidence of doubles and triples, particularly with small flat seeds.

IMPORTANT: TO PREVENT PLANTING MISCALCULATIONS, MAKE FIELD CHECKS TO BE SURE YOU ARE PLANTING AT THE DESIRED RATE.

NOTE: The extended drill sprocket package will cut the planter transmission speed in half. Therefore, when referring to the rate charts remember that the seeding rate will be approximately 1/2 of the chart reading. Planting speed can affect actual seeding rate, so make a field check and adjust setting up or down in the transmission to obtain the desired seed drop. 5-19

OPERATION

PLANTING RATES FOR PLATELESS SOYBEAN METERS

APPROXIMATE POUNDS/ACRE FOR DIFFERENT ROW WIDTHS - MEDIUM SEEDS

15 Inch	30 Inch	36 Inch	38 Inch	Transmission Sprockets		Recommended Speed Range (MPH)
				Drive	Driven	
64	32	27	25	14	30	4 to 8
68	34	28	27	14	28	4 to 8
73	36	30	29	14	26	4 to 8
77	38	32	30	16	28	4 to 8
79	40	33	31	18	30	4 to 8
80	40	33	32	16	26	4 to 8
82	41	34	32	14	22	4 to 8
86	43	36	34	18	26	4 to 8
90	45	38	36	16	22	4 to 8
91	45	38	36	22	30	4 to 8
96	48	40	38	14	18	4 to 8
97	49	41	38	22	28	4 to 8
101	51	42	40	18	22	4 to 8
105	52	44	41	22	26	4 to 8
107	54	45	42	26	30	4 to 8
109	54	45	43	14	16	4 to 8
110	55	46	44	16	18	4 to 8
115	58	48	45	26	28	4 to 7 1/2
116	58	48	46	28	30	4 to 7 1/2
124	62	52	49	22	22	4 to 7
133	66	55	52	30	28	4 to 6 1/2
134	67	56	53	28	26	4 to 6 1/2
140	70	58	55	18	16	4 to 6 1/2
142	71	59	56	16	14	3 to 6
143	72	60	56	30	26	3 to 6
147	73	61	58	26	22	3 to 6
152	76	63	60	22	18	3 to 5 1/2
158	79	66	62	28	22	3 to 5 1/2
159	80	66	63	18	14	3 to 5 1/2
169	85	70	67	30	22	3 to 5
171	85	71	67	22	16	3 to 5
179	90	75	71	26	18	3 to 5
191	95	79	75	22	14	3 to 5
196	98	82	77	26	16	3 to 5
201	100	84	79	30	18	3 to 5
208	104	87	82	28	16	3 to 5
218	109	91	86	26	14	3 to 5
232	116	97	92	28	14	3 to 5
246	123	102	97	30	14	3 to 5

Above chart for planters equipped with Kinze drive. Recommended ground drive tire pressure 40 PSI. Recommended contact drive tire pressure 50 PSI.

IMPORTANT: Soybeans vary in size from about 3500 seeds/lb. to about 1800 seeds/lb. The size marked on each bag is an average. Seeds within each bag may vary in size by as much as 50% greater or 50% smaller than the average.

The above chart was based on uniformly sized soybeans. Your actual planting rate will vary somewhat from the above table. Generally, larger beans will give lower rates and smaller beans will give higher rates.

IMPORTANT: TO PREVENT PLANTING MISCALCULATIONS, MAKE FIELD CHECKS TO BE SURE YOU ARE PLANTING AT THE DESIRED RATE.

Rates for 18 and 19 inch row spacing are two times 36 and 38 inch row spacing.

NOTE: The extended drill sprocket package will cut the planter transmission speed in half. Therefore, when referring to the rate charts remember that the seeding rate will be approximately 1/2 of the chart reading. Planting speed can affect actual seeding rate, so make a field check and adjust setting up or down in the transmission to obtain the desired seed drop. 5-20

OPERATION

PLANTING RATES FOR PLATELESS SOYBEAN METERS

APPROXIMATE BEANS/ACRE FOR DIFFERENT ROW WIDTHS - SMALL SEEDS

15 Inch	30 Inch	36 Inch	38 Inch	Seeds/Foot	Seed Spacing (Inches)	Transmission Sprockets		Recommended Speed Range (MPH)
						Drive	Driven	
241,500	120,700	100,600	95,300	7	1.7	14	30	4 to 8
257,100	128,500	107,100	101,500	7	1.6	14	28	4 to 8
275,400	137,700	114,700	108,700	8	1.5	14	26	4 to 8
289,300	144,600	120,500	114,200	8	1.4	16	28	4 to 8
300,400	150,200	125,100	118,600	9	1.4	18	30	4 to 8
303,700	151,900	126,600	119,900	9	1.4	16	26	4 to 8
310,200	155,100	129,300	122,500	9	1.4	14	22	4 to 8
324,500	162,200	135,200	128,100	9	1.3	18	26	4 to 8
340,900	170,400	142,000	134,600	10	1.2	16	22	4 to 8
343,700	171,900	143,200	135,700	10	1.2	22	30	4 to 8
364,600	182,300	151,900	143,900	10	1.1	14	18	4 to 8
368,300	184,100	153,500	145,400	11	1.1	22	28	4 to 8
383,500	191,700	159,800	151,400	11	1.1	18	22	4 to 8
396,600	198,300	165,300	156,600	11	1.1	22	26	4 to 8
406,200	203,100	169,300	160,400	12	1.0	26	30	4 to 8
410,100	205,100	170,900	161,900	12	1.0	14	16	4 to 8
416,600	208,300	173,600	164,500	12	1.0	16	18	4 to 8
435,200	217,600	181,400	171,800	12	1.0	26	28	4 to 7 1/2
437,500	218,700	182,300	172,700	13	1.0	28	30	4 to 7 1/2
468,700	234,400	195,300	185,000	13	0.9	22	22	4 to 7
502,200	251,100	209,300	198,200	14	0.8	30	28	4 to 6 1/2
504,800	252,400	210,300	199,300	14	0.8	28	26	4 to 6 1/2
527,300	263,700	219,700	208,100	15	0.8	18	16	4 to 6 1/2
535,700	267,800	223,200	211,500	15	0.8	16	14	3 to 6
540,800	270,400	225,300	213,500	15	0.8	30	26	3 to 6
553,900	277,000	230,800	218,700	16	0.8	26	22	3 to 6
572,900	286,400	238,700	226,100	16	0.7	22	18	3 to 5 1/2
596,600	298,300	248,600	235,500	17	0.7	28	22	3 to 5 1/2
602,600	301,300	251,100	237,900	17	0.7	18	14	3 to 5 1/2
639,200	319,600	266,300	252,300	18	0.7	30	22	3 to 5
644,500	322,200	268,500	254,400	18	0.7	22	16	3 to 5
677,000	338,500	282,100	267,300	19	0.6	26	18	3 to 5
721,100	360,500	300,500	284,600	21	0.6	22	14	3 to 5
740,300	370,200	308,500	292,200	21	0.6	26	16	3 to 5
758,500	379,300	316,100	299,400	22	0.6	30	18	3 to 5
787,500	393,700	328,100	310,800	23	0.5	28	16	3 to 5
825,200	412,600	343,800	325,700	24	0.5	26	14	3 to 5
876,500	438,300	365,200	346,000	25	0.5	28	14	3 to 5
929,100	464,500	387,100	366,700	27	0.5	30	14	3 to 5

Above chart for planters equipped with Kinze drive. Recommended ground drive tire pressure 40 PSI. Recommended contact drive tire pressure 50 PSI.

IMPORTANT: Soybeans vary in size from about 3500 seeds/lb. to about 1800 seeds/lb. The size marked on each bag is an average. Seeds within each bag may vary in size by as much as 50% greater or 50% smaller than the average.

The above chart was based on uniformly sized soybeans. Your actual planting rate will vary somewhat from the above table. Generally, larger beans will give lower rates and smaller beans will give higher rates.

IMPORTANT: TO PREVENT PLANTING MISCALCULATIONS, MAKE FIELD CHECKS TO BE SURE YOU ARE PLANTING AT THE DESIRED RATE.

Rates for 18 and 19 inch row spacing are two times 36 and 38 inch row spacing.

NOTE: The extended drill sprocket package will cut the planter transmission speed in half. Therefore, when referring to the rate charts remember that the seeding rate will be approximately 1/2 of the chart reading. Planting speed can affect actual seeding rate, so make a field check and adjust setting up or down in the transmission to obtain the desired seed drop. 5-21

OPERATION

PLANTING RATES FOR PLATELESS SOYBEAN METERS

APPROXIMATE BEANS/ACRE FOR DIFFERENT ROW WIDTHS - MEDIUM SEEDS

15 Inch	30 Inch	36 Inch	38 Inch	Seeds/Foot	Seed Spacing (Inches)	Transmission Sprockets		Recommended Speed Range (MPH)
						Drive	Driven	
159,700	79,900	66,500	63,000	5	2.6	14	30	4 to 8
170,800	85,000	70,800	67,100	5	2.5	14	28	4 to 8
182,100	91,100	75,900	71,900	5	2.3	14	26	4 to 8
191,300	95,700	79,700	75,500	5	2.2	16	28	4 to 8
198,600	99,300	82,800	78,400	6	2.1	18	30	4 to 8
200,900	100,400	83,700	79,300	6	2.1	16	26	4 to 8
205,200	102,600	85,500	81,000	6	2.0	14	22	4 to 8
214,600	107,300	89,400	84,700	6	2.0	18	26	4 to 8
225,500	112,700	93,900	89,000	6	1.9	16	22	4 to 8
227,300	113,700	94,700	89,700	7	1.8	22	30	4 to 8
241,100	120,600	100,500	95,200	7	1.7	14	18	4 to 8
243,600	121,800	101,500	96,100	7	1.7	22	28	4 to 8
253,600	126,800	105,700	100,100	7	1.7	18	22	4 to 8
262,300	131,200	109,300	103,500	8	1.6	22	26	4 to 8
268,700	134,300	111,900	106,100	8	1.6	26	30	4 to 8
271,300	135,600	113,000	107,100	8	1.5	14	16	4 to 8
275,600	137,800	114,800	108,800	8	1.5	16	18	4 to 8
287,900	143,900	119,900	113,600	8	1.5	26	28	4 to 7 1/2
289,300	144,700	120,600	114,200	8	1.4	28	30	4 to 7 1/2
310,000	155,000	129,200	122,400	9	1.4	22	22	4 to 7
332,100	166,100	138,400	131,100	10	1.3	30	28	4 to 6 1/2
333,800	166,900	139,100	131,800	10	1.3	28	26	4 to 6 1/2
348,800	174,400	145,300	137,700	10	1.2	18	16	4 to 6 1/2
354,300	177,100	147,600	139,800	10	1.2	16	14	3 to 6
357,700	178,800	149,000	141,200	10	1.2	30	26	3 to 6
366,400	183,200	152,700	144,600	10	1.1	26	22	3 to 6
378,900	189,400	157,900	149,600	11	1.1	22	18	3 to 5 1/2
394,500	197,300	164,400	155,700	11	1.1	28	22	3 to 5 1/2
398,600	199,300	166,100	157,300	11	1.1	18	14	3 to 5 1/2
422,700	211,400	176,100	166,900	12	1.0	30	22	3 to 5
426,300	213,100	177,600	168,300	12	1.0	22	16	3 to 5
447,800	223,900	186,600	176,800	13	0.9	26	18	3 to 5
476,900	238,500	198,700	188,300	14	0.9	22	14	3 to 5
489,600	244,800	204,000	193,300	14	0.9	26	16	3 to 5
501,700	250,800	209,000	198,000	14	0.8	30	18	3 to 5
520,800	260,400	217,000	205,600	15	0.8	28	16	3 to 5
545,800	272,900	227,400	215,400	16	0.8	26	14	3 to 5
579,700	289,900	241,500	228,800	17	0.7	28	14	3 to 5
614,500	307,200	256,000	242,600	18	0.7	30	14	3 to 5

Above chart for planters equipped with Kinze drive. Recommended ground drive tire pressure 40 PSI. Recommended contact drive tire pressure 50 PSI.

IMPORTANT: Soybeans vary in size from about 3500 seeds/lb. to about 1800 seeds/lb. The size marked on each bag is an average. Seeds within each bag may vary in size by as much as 50% greater or 50% smaller than the average.

The above chart was based on uniformly sized soybeans. Your actual planting rate will vary somewhat from the above table. Generally, larger beans will give lower rates and smaller beans will give higher rates.

IMPORTANT: TO PREVENT PLANTING MISCALCULATIONS, MAKE FIELD CHECKS TO BE SURE YOU ARE PLANTING AT THE DESIRED RATE.

Rates for 18 and 19 inch row spacing are two times 36 and 38 inch row spacing.

NOTE: The extended drill sprocket package will cut the planter transmission speed in half. Therefore, when referring to the rate charts remember that the seeding rate will be approximately 1/2 of the chart reading. Planting speed can affect actual seeding rate, so make a field check and adjust setting up or down in the transmission to obtain the desired seed drop. 5-22

OPERATION

PLANTING RATES FOR PLATELESS SOYBEAN METERS

APPROXIMATE BEANS/ACRE FOR DIFFERENT ROW WIDTHS - LARGE SEEDS

15 Inch	30 Inch	36 Inch	38 Inch	Seeds/Foot	Seed Spacing (Inches)	Transmission Sprockets		Recommended Speed Range (MPH)
						Drive	Driven	
106,900	53,500	44,600	42,200	3	3.9	14	30	4 to 8
113,900	56,900	47,400	44,900	3	3.7	14	28	4 to 8
121,900	61,000	50,800	48,100	3	3.4	14	26	4 to 8
128,100	64,100	53,400	50,600	4	3.3	16	28	4 to 8
133,000	66,500	55,400	52,500	4	3.2	18	30	4 to 8
134,500	67,300	56,000	53,100	4	3.1	16	26	4 to 8
137,400	68,700	57,200	54,200	4	3.1	14	22	4 to 8
143,700	71,900	59,900	56,700	4	2.9	18	26	4 to 8
151,000	75,500	62,900	59,600	4	2.8	16	22	4 to 8
152,200	76,100	63,400	60,100	4	2.8	22	30	4 to 8
161,400	80,700	67,300	63,700	5	2.6	14	18	4 to 8
163,100	81,500	68,000	64,400	5	2.6	22	28	4 to 8
169,800	84,900	70,800	67,000	5	2.5	18	22	4 to 8
175,600	87,800	73,200	69,300	5	2.4	22	26	4 to 8
179,900	90,000	75,000	71,000	5	2.3	26	30	4 to 8
181,600	90,800	75,700	71,700	5	2.3	14	16	4 to 8
184,500	92,300	76,900	72,800	5	2.3	16	18	4 to 8
192,700	96,400	80,300	76,100	6	2.2	26	28	4 to 7 1/2
193,700	96,900	80,700	76,500	6	2.2	28	30	4 to 7 1/2
207,600	103,800	86,500	81,900	6	2.0	22	22	4 to 7
222,400	111,200	92,700	87,800	6	1.9	30	28	4 to 6 1/2
223,500	111,800	93,100	88,200	6	1.9	28	26	4 to 6 1/2
233,500	116,800	97,300	92,200	7	1.8	18	16	4 to 6 1/2
237,200	118,600	98,800	93,600	7	1.8	16	14	3 to 6
239,500	119,800	99,800	94,500	7	1.7	30	26	3 to 6
245,300	122,700	102,200	96,800	7	1.7	26	22	3 to 6
253,700	126,900	105,700	100,100	7	1.7	22	18	3 to 5 1/2
264,200	132,100	110,100	104,300	8	1.6	28	22	3 to 5 1/2
266,900	133,400	111,200	105,300	8	1.6	18	14	3 to 5 1/2
283,100	141,500	117,900	111,700	8	1.5	30	22	3 to 5
285,400	142,700	118,900	112,700	8	1.5	22	16	3 to 5
299,800	149,900	124,900	118,400	9	1.4	26	18	3 to 5
319,300	159,700	133,100	126,100	9	1.3	22	14	3 to 5
327,900	164,000	136,600	129,400	9	1.3	26	16	3 to 5
335,900	168,000	140,000	132,600	10	1.2	30	18	3 to 5
348,700	174,400	145,300	137,700	10	1.2	28	16	3 to 5
365,500	182,700	152,300	144,300	10	1.1	26	14	3 to 5
388,200	194,100	161,700	153,200	11	1.1	28	14	3 to 5
411,400	205,700	171,400	162,400	12	1.0	30	14	3 to 5

Above chart for planters equipped with Kinze drive. Recommended ground drive tire pressure 40 PSI. Recommended contact drive tire pressure 50 PSI.

IMPORTANT: Soybeans vary in size from about 3500 seeds/lb. to about 1800 seeds/lb. The size marked on each bag is an average. Seeds within each bag may vary in size by as much as 50% greater or 50% smaller than the average.

The above chart was based on uniformly sized soybeans. Your actual planting rate will vary somewhat from the above table. Generally, larger beans will give lower rates and smaller beans will give higher rates.

IMPORTANT: TO PREVENT PLANTING MISCALCULATIONS, MAKE FIELD CHECKS TO BE SURE YOU ARE PLANTING AT THE DESIRED RATE.

Rates for 18 and 19 inch row spacing are two times 36 and 38 inch row spacing.

NOTE: The extended drill sprocket package will cut the planter transmission speed in half. Therefore, when referring to the rate charts remember that the seeding rate will be approximately 1/2 of the chart reading. Planting speed can affect actual seeding rate, so make a field check and adjust setting up or down in the transmission to obtain the desired seed drop. 5-23

OPERATION

PLANTING RATES FOR PLATELESS INTERMEDIATE RATE SORGHUM METERS

APPROXIMATE POUNDS/ACRE FOR DIFFERENT ROW WIDTHS — MEDIUM SEEDS

10 Inch	15 Inch	20 Inch	30 Inch	36 Inch	38 Inch	40 Inch	Transmission Sprockets		Recommended Speed Range (MPH)
							Drive	Driven	
14.3	9.6	7.2	4.8	4.0	3.8	3.6	14	30	4 to 8
15.2	10.1	7.6	5.0	4.2	4.0	3.8	14	28	4 to 8
16.1	10.8	8.1	5.4	4.5	4.2	4.0	14	26	4 to 8
16.9	11.3	8.5	5.7	4.7	4.5	4.2	16	28	4 to 8
17.6	11.8	8.8	5.9	4.9	4.7	4.4	18	30	4 to 8
17.9	12.0	8.9	6.0	5.0	4.7	4.5	16	26	4 to 8
18.5	12.3	9.3	6.2	5.2	4.9	4.7	14	22	4 to 8
19.8	13.2	9.9	6.6	5.5	5.2	4.9	18	26	4 to 8
20.7	13.9	10.4	6.9	5.8	5.5	5.2	16	22	4 to 8
20.9	13.9	10.4	7.0	5.8	5.5	5.2	22	30	4 to 8
22.2	14.8	11.1	7.4	6.2	5.9	5.5	14	18	4 to 8
22.4	14.9	11.2	7.5	6.2	5.9	5.6	22	28	4 to 8
23.4	15.6	11.7	7.8	6.5	6.2	5.9	18	22	4 to 8
24.1	16.1	12.1	8.1	6.7	6.4	6.0	22	26	4 to 8
24.8	16.5	12.3	8.3	6.9	6.5	6.2	26	30	4 to 8
24.9	16.6	12.5	8.3	6.9	6.6	6.2	14	16	4 to 8
25.4	16.9	12.7	8.4	7.1	6.7	6.4	16	18	4 to 8
26.5	17.6	13.2	8.8	7.4	7.0	6.6	26	28	4 to 7½
26.6	17.8	13.3	8.9	7.4	7.0	6.7	28	30	4 to 7½
28.5	19.0	14.3	9.5	7.9	7.5	7.1	22	22	4 to 7
30.6	20.4	15.3	10.2	8.5	8.1	7.6	30	28	4 to 6½
30.7	20.5	15.4	10.3	8.6	8.1	7.7	28	26	4 to 6½
32.1	21.4	16.1	10.7	8.9	8.4	8.0	18	16	4 to 6½
32.6	21.7	16.3	10.9	9.1	8.6	8.1	16	14	3 to 6
32.9	21.9	16.4	11.0	9.1	8.7	8.3	30	26	3 to 6
33.7	22.5	16.9	11.2	9.4	8.9	8.4	26	22	3 to 6
34.9	23.2	17.5	11.7	9.7	9.2	8.7	22	18	3 to 5½
36.4	24.2	18.1	12.1	10.1	9.6	9.1	28	22	3 to 5½
36.7	24.4	18.3	12.2	10.2	9.6	9.2	18	14	3 to 5½
38.9	26.0	19.5	13.0	10.8	10.3	9.7	30	22	3 to 5
39.2	26.1	19.6	13.1	10.9	10.3	9.8	22	16	3 to 5
41.2	27.5	20.6	13.7	11.5	10.8	10.3	26	18	3 to 5
44.3	29.5	22.1	14.7	12.3	11.7	11.1	22	14	3 to 5
45.5	30.4	22.7	15.2	12.7	12.0	11.4	26	16	3 to 5
46.5	31.0	23.2	15.5	12.9	12.2	11.7	30	18	3 to 5
48.4	32.3	24.2	16.1	13.5	12.7	12.1	28	16	3 to 5
50.8	33.8	25.4	16.9	14.1	13.6	12.7	26	14	3 to 5
53.8	35.9	26.9	18.0	14.9	14.2	13.5	28	14	3 to 5
56.8	37.9	28.4	18.9	15.8	14.9	14.2	30	14	3 to 5

Above chart for planters equipped with Kinze drive. Recommended ground drive tire pressure 40 PSI. Recommended contact drive tire pressure 50 PSI.

IMPORTANT: Seeds vary in size from about 12000 seeds/lb. to about 25000 seeds/lb. The size marked on each bag is an average. Seeds within each bag may vary in size by as much as 50% greater or 50% smaller than the average.

The above chart was based on uniformly sized seeds. Your actual planting rate will vary somewhat from the above table. Generally, larger seeds will give lower rates and smaller seeds will give higher rates

IMPORTANT: TO PREVENT PLANTING MISCALCULATIONS, MAKE FIELD CHECKS TO BE SURE YOU ARE PLANTING AT THE DESIRED RATE.

Rates for 18 and 19 inch row spacing are two times 36 and 38 inch row spacing.

NOTE: The extended drill sprocket package will cut the planter transmission speed in half. Therefore, when referring to the rate charts remember that the seeding rate will be approximately 1/2 of the chart reading. Planting speed can affect actual seeding rate, so make a field check and adjust setting up or down in the transmission to obtain the desired seed drop.

OPERATION

PLANTING RATES FOR PLATELESS LOW RATE SORGHUM METERS

APPROXIMATE POUNDS/ACRE FOR DIFFERENT ROW WIDTHS - MEDIUM SEEDS

15 Inch	30 Inch	36 Inch	38 Inch	Transmission Sprockets		Recommended Speed Range (MPH)
				Drive	Driven	
2.9	1.5	1.2	1.1	14	30	4 to 8
3.1	1.5	1.3	1.2	14	28	4 to 8
3.3	1.6	1.4	1.3	14	26	4 to 8
3.4	1.7	1.4	1.4	16	28	4 to 8
3.6	1.8	1.5	1.4	18	30	4 to 8
3.6	1.8	1.5	1.4	16	26	4 to 8
3.8	1.9	1.6	1.5	14	22	4 to 8
4.0	2.0	1.7	1.6	18	26	4 to 8
4.2	2.1	1.8	1.7	16	22	4 to 8
4.3	2.1	1.8	1.7	22	30	4 to 8
4.5	2.3	1.9	1.8	14	18	4 to 8
4.6	2.3	1.9	1.8	22	28	4 to 8
4.7	2.4	2.0	1.9	18	22	4 to 8
4.9	2.5	2.0	1.9	22	26	4 to 8
5.0	2.5	2.1	2.0	26	30	4 to 8
5.1	2.5	2.1	2.0	14	16	4 to 8
5.2	2.6	2.1	2.0	16	18	4 to 8
5.4	2.7	2.2	2.1	26	28	4 to 7 1/2
5.4	2.7	2.3	2.1	28	30	4 to 7 1/2
5.8	2.9	2.4	2.3	22	22	4 to 7
6.2	3.1	2.6	2.5	30	28	4 to 6 1/2
6.2	3.1	2.6	2.5	28	26	4 to 6 1/2
6.5	3.3	2.7	2.6	18	16	4 to 6 1/2
6.6	3.3	2.8	2.6	16	14	3 to 6
6.7	3.3	2.8	2.6	30	26	3 to 6
6.9	3.4	2.9	2.7	26	22	3 to 6
7.1	3.5	3.0	2.8	22	18	3 to 5 1/2
7.4	3.7	3.1	2.9	28	22	3 to 5 1/2
7.5	3.7	3.1	2.9	18	14	3 to 5 1/2
7.9	4.0	3.3	3.1	30	22	3 to 5
8.0	4.0	3.3	3.1	22	16	3 to 5
8.4	4.2	3.5	3.3	26	18	3 to 5
9.0	4.5	3.7	3.6	22	14	3 to 5
9.3	4.6	3.9	3.7	26	16	3 to 5
9.5	4.7	3.9	3.7	30	18	3 to 5
9.8	4.9	4.1	3.9	28	16	3 to 5
10.3	5.2	4.3	4.1	26	14	3 to 5
10.9	5.5	4.6	4.3	28	14	3 to 5
11.5	5.8	4.8	4.6	30	14	3 to 5

Above chart for planters equipped with Kinze drive. Recommended ground drive tire pressure 40 PSI. Recommended contact drive tire pressure 50 PSI.

IMPORTANT: Seeds vary in size from about 12000 seeds/lb. to about 25000 seeds/lb. The size marked on each bag is an average. Seeds within each bag may vary in size by as much as 50% greater or 50% smaller than the average.

The above chart was based on uniformly sized seeds. Your actual planting rate will vary somewhat from the above table. Generally, larger seeds will give lower rates and smaller seeds will give higher rates.

IMPORTANT: TO PREVENT PLANTING MISCALCULATIONS, MAKE FIELD CHECKS TO BE SURE YOU ARE PLANTING AT THE DESIRED RATE.

Rates for 18 and 19 inch row spacing are two times 36 and 38 inch row spacing.

NOTE: The extended drill sprocket package will cut the planter transmission speed in half. Therefore, when referring to the rate charts remember that the seeding rate will be approximately 1/2 of the chart reading. Planting speed can affect actual seeding rate, so make field check and adjust setting up or down in the transmission to obtain the desired seed drop.

OPERATION

DRY INSECTICIDE APPLICATION RATES

APPROXIMATE POUNDS/ACRE FOR DIFFERENT ROW WIDTHS - CLAY GRANULES

Meter Setting	15 Inch	30 Inch	36 Inch	38 Inch
10	10.2	5.1	4.3	4.0
11	11.2	5.6	4.7	4.4
12	12.6	6.3	5.3	5.0
13	14.2	7.1	5.9	5.6
14	15.8	7.9	6.6	6.2
15	17.6	8.8	7.3	6.9
16	19.8	9.9	8.3	7.8
17	22.0	11.0	9.2	8.7
18	23.6	11.8	9.8	9.3
19	27.0	13.5	11.3	10.7
20	29.2	14.6	12.2	11.5
21	32.0	16.0	13.3	12.6
22	33.8	16.9	14.1	13.3
23	35.4	17.7	14.8	14.0
24	38.8	19.4	16.2	15.3
25	43.0	21.5	17.9	17.0
26	47.4	23.7	19.8	18.7
27	49.6	24.8	20.7	19.6
28	52.4	26.2	21.8	20.7
29	57.4	28.7	23.9	22.7
30	61.0	30.5	25.4	24.1

APPROXIMATE POUNDS/ACRE FOR DIFFERENT ROW WIDTHS - SAND GRANULES

5	6.0	3.0	2.5	2.4
6	10.0	5.0	4.2	3.9
7	11.0	5.5	4.6	4.3
8	13.0	6.5	5.4	5.1
9	16.0	8.0	6.7	6.3
10	18.4	9.2	7.7	7.3
11	21.0	10.5	8.8	8.3
12	23.0	11.5	9.6	9.1
13	26.0	13.0	10.8	10.3
14	29.0	14.5	12.1	11.4
15	32.0	16.0	13.3	12.6
16	36.0	18.0	15.0	14.2
17	40.0	20.0	16.7	15.8
18	45.0	22.5	18.8	17.8
19	50.0	25.0	20.8	19.7
20	53.0	26.5	22.1	20.9
21	57.0	28.5	23.8	22.5
22	61.0	30.5	25.4	24.1
23	66.0	33.0	27.5	26.1
24	71.0	35.5	29.6	28.0
25	76.0	38.0	31.7	30.0

IMPORTANT: The above chart represents average values and should be used only as a starting point. Your actual rate will vary depending upon the insecticide you are using, your planting speed, and your plant population.

Your actual rate must be checked in the field with the actual insecticide that you are using and at the speed and population at which you will be planting.

Rates for 18 and 19 inch row spacing are two times 36 and 38 inch row spacing.

OPERATION

DRY HERBICIDE APPLICATION RATES

APPROXIMATE POUNDS/ACRE FOR DIFFERENT ROW WIDTHS — CLAY GRANULES

Meter Setting	15 Inch	30 Inch	36 Inch	38 Inch
10	9.6	4.8	4.0	3.8
11	10.8	5.4	4.5	4.3
12	12.0	6.0	5.0	4.7
13	13.4	6.7	5.6	5.3
14	15.0	7.5	6.3	5.9
15	17.0	8.5	7.1	6.7
16	18.6	9.3	7.8	7.3
17	20.4	10.2	8.5	8.1
18	22.0	11.0	9.2	8.7
19	24.0	12.0	10.0	9.5
20	26.0	13.0	10.8	10.3
21	28.0	14.0	11.7	11.1
22	30.0	15.0	12.5	11.8
23	32.4	16.2	13.5	12.8
24	35.0	17.5	14.6	13.8
25	37.4	18.7	15.6	14.8
26	40.0	20.0	16.7	15.8
27	43.0	21.5	17.9	17.0
28	46.6	23.3	19.4	18.4
29	50.0	25.0	20.8	19.7
30	55.0	27.5	22.9	21.7

IMPORTANT: The above chart represents average values and should be used only as a starting point. Your actual rate will vary depending upon the herbicide you are using, your planting speed, and your plant population.

Your actual rate must be checked in the field with the actual herbicide that you are using and at the speed and population at which you will be planting.

Rates for 18 and 19 inch row spacing are two times 36 and 38 inch row spacing.

OPERATION

DRY FERTILIZER APPLICATION RATES

Approximate Rate in Pounds Per Acre Regular Rate Augers				
Drive Sprocket	Driven Sprocket	30 Inch Rows	36 Inch Rows	38 Inch Rows
18	36	87	73	68
18	30	101	85	79
24	36	127	107	99
24	30	151	129	118
18	18	181	152	141
18	16	208	175	162
36	30	215	180	168
24	18	242	203	180
24	16	269	225	210
36	18	357	300	278
36	16	390	327	304
* High Rate Augers				
18	16	312	263	243
36	30	323	270	252
24	18	363	305	284
24	16	404	338	315
36	18	536	450	417
36	16	585	491	456

* Uneven delivery may result in attempting to use lower rates than indicated by the chart.

Above chart for planters equipped with Kinze drive. Recommended ground drive tire pressure 40 PSI. Recommended contact drive tire pressure 50 PSI.

This chart was calculated with a bulk density of 65 pounds per cubic foot.

IMPORTANT: Fertilizer application rates can vary from the weights calculated in the above chart. To prevent application miscalculations, make field checks to be sure you are applying fertilizer at the desired rate.

To check the exact number of pounds your fertilizer attachment will actually deliver on a 40 inch row spacing, proceed as follows:

Remove one spout from one of the fertilizer hoppers and attach a container under the opening. Engage the fertilizer attachment and drive forward for 130 feet. Weigh the amount of fertilizer caught in the container and multiply that amount by 100. The result will be the pounds of fertilizer delivered per acre when planting in 40-inch rows. To convert this delivery rate for narrower rows, multiply by the following conversion factors:

30'' Multiply by 1.33
 36'' Multiply by 1.11
 38'' Multiply by 1.05

OPERATION

LIQUID FERTILIZER APPLICATION RATES

Drive	Driven	ROW SPACE Gal. Per Acre			Drive	Driven	ROW SPACE Gal. Per Acre		
		38	36	30			38	36	30
8	9	20.4	21.0	25.3	22	8	62.9	65.0	78.0
8	10	18.3	18.9	22.7	22	9	55.8	57.7	69.2
8	15	12.1	12.5	15.0	22	10	50.3	52.0	62.4
8	22	8.2	8.5	10.2	22	15	33.4	34.5	41.4
8	23	8.0	8.3	9.6	22	23	22.0	22.7	27.2
8	26	7.1	7.3	8.8	22	26	19.4	20.1	24.1
8	31	5.9	6.1	7.4	22	31	16.0	16.6	19.9
9	8	25.6	26.5	31.8	23	8	65.9	68.1	81.7
9	10	20.6	21.3	25.5	23	9	58.6	60.5	72.6
9	15	13.7	14.2	17.0	23	10	52.6	54.4	65.3
9	22	9.4	9.7	11.6	23	15	35.0	36.2	43.4
9	23	8.9	9.2	11.1	23	22	24.0	24.8	29.8
9	26	8.0	8.3	9.9	23	26	20.1	20.8	25.0
9	31	6.6	6.9	8.2	23	31	16.9	17.5	21.0
10	8	28.6	29.6	35.5	26	8	74.3	76.8	92.2
10	9	25.4	26.2	31.5	26	9	66.1	68.3	81.7
10	15	15.3	15.8	19.0	26	10	59.5	61.5	73.8
10	22	10.3	10.6	12.8	26	15	39.6	40.9	49.1
10	23	9.8	10.2	12.2	26	22	27.0	27.9	33.5
10	26	8.7	9.0	10.8	26	23	25.8	26.7	32.1
10	31	7.3	7.6	9.1	26	31	19.0	19.6	23.5
15	8	43.0	44.5	53.3	31	8	88.5	91.5	109.8
15	9	38.2	39.5	47.4	31	9	78.7	81.3	97.6
15	10	34.3	35.5	42.6	31	10	70.9	73.3	88.0
15	22	15.6	16.1	19.3	31	15	47.1	48.7	58.4
15	23	14.9	15.4	18.4	31	22	32.0	33.1	39.7
15	26	13.3	13.7	16.5	31	23	30.6	31.7	38.0
15	31	11.0	11.3	13.6	31	26	27.2	28.1	33.8

Above chart for planters equipped with Kinze drive. Recommended ground drive tire pressure 40 PSI. Recommended contact drive tire pressure 50 PSI.

This chart was calculated based on a solution weighing ten pounds per gallon.

IMPORTANT: Fertilizer application rates can vary from the above chart. To prevent application miscalculations, make field checks to be sure you are applying fertilizer at the desired rate.

LUBRICATION

The following pages show the locations of all lubrication points. Proper lubrication of all moving parts will help ensure efficient operation of your Kinze planter and prolong the life of friction producing parts. Those parts equipped with grease fittings should be lubricated at the frequency indicated with an SAE multipurpose type grease. Be sure to clean the fitting thoroughly before using grease gun. The frequency of lubrication recommended is based on normal operating conditions. Severe or unusual conditions may require more frequent attention.

Refer to the Kinze Row Unit Manual for lubrication of all row units.

SEALED BEARINGS

A number of sealed bearings are used on your Kinze planter to provide trouble free operation. These are located in such areas as the drive shaft, row units, and transmission bearings. Sealed bearings are lubricated for life, and due to the seals, relubrication is not practical.

DRIVE CHAINS

The transmission and drive chains should be lubricated approximately every 8-10 hours with a quality engine oil or equivalent SAE 30 weight oil. A good quality spray lubricant may also be used for periodic chain lubrication. Extreme operating conditions such as dirt, temperature, or speed may require more frequent lubrication. If a chain becomes stiff, it should be removed, soaked and washed in solvent to loosen and remove dirt from the joints. Then soak the chain in oil so the lubricant can penetrate between the rollers and bushings.

WHEEL BEARINGS

Wheel bearings should be repacked with clean, heavy-duty axle grease approximately once a year or at the beginning of each planting season. This applies to all drive wheels, transport wheels and marker hubs. Transport wheels may require less frequent service depending upon amount of road travel. Follow the procedure outlined for wheel bearing replacement with the exception that bearings and bearing cups are reused.

POINT ROW WRAP SPRING CLUTCHES

The point row wrap spring clutches are permanently lubricated and require no periodic maintenance. **Do not lubricate. Keep clutches clean.**

GEARBOXES (24 Row Model)

The gearboxes used on the drill shaft drive line are permanently packed in No. 2 multipurpose grease and do not require any additional lubrication.

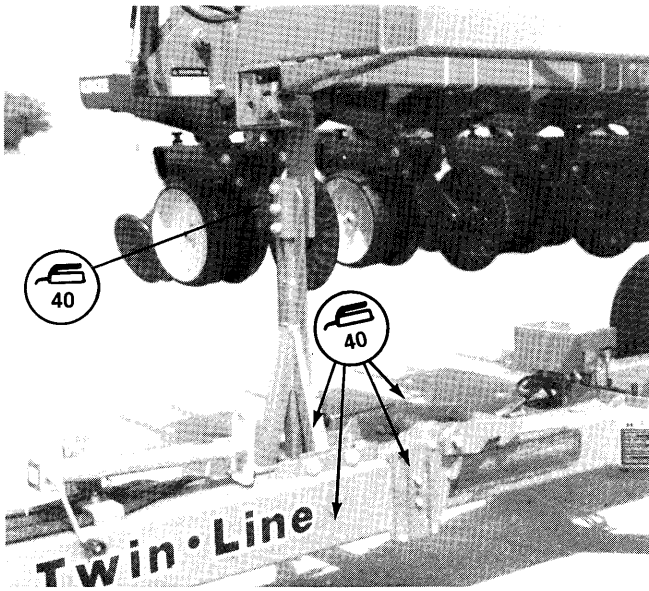
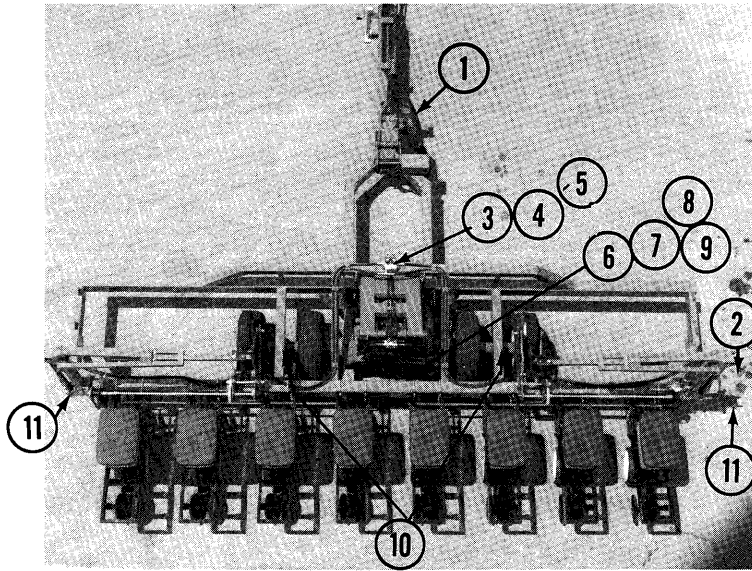

- 1. Outer Hitch - 4 Zerks
- 2. Transport Latch - 1 Zerk

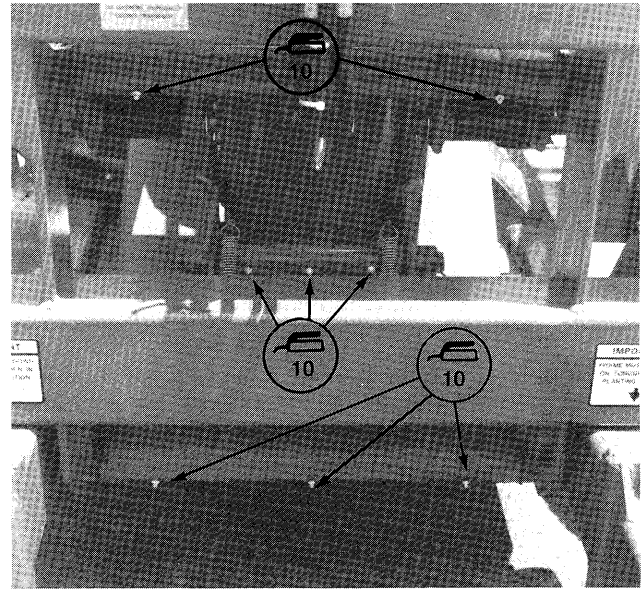

- 3. Upper Parallel Lift Arm, Front - 2 Zerks
- 4. Lower Parallel Lift Arm, Front - 3 Zerks
- 5. Lift Lock - 3 Zerks



Frequency of lubrication in hours.

LUBRICATION

8 Row Models

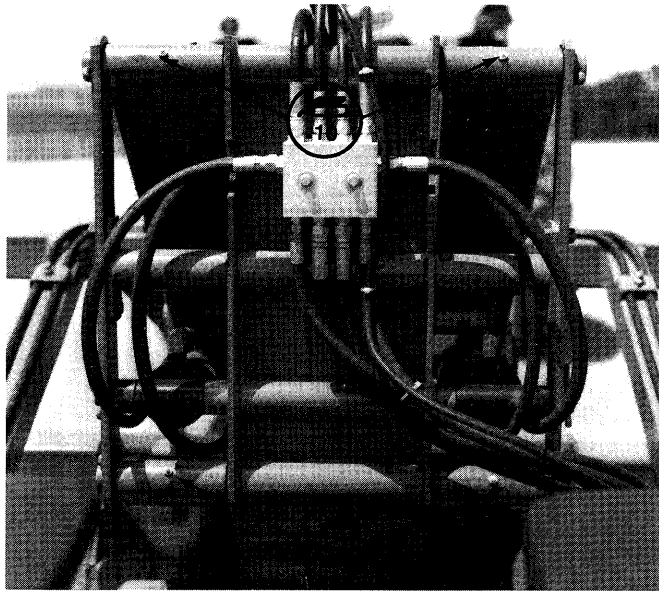

6. Upper Parallel Lift Arm, Rear - 2 Zerks
7. Lower Parallel Lift Arm, Rear - 2 Zerks

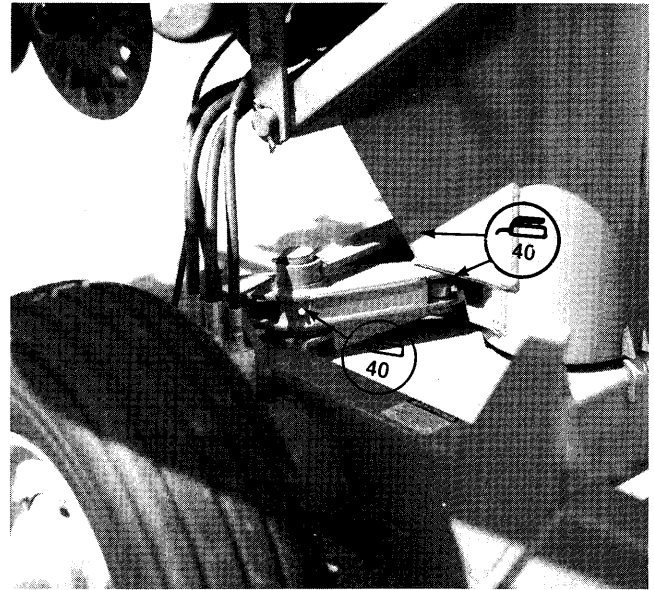

8. Rotation Lock Link - 2 Zerks
9. Rotation Lock Plate - 1 Zerk

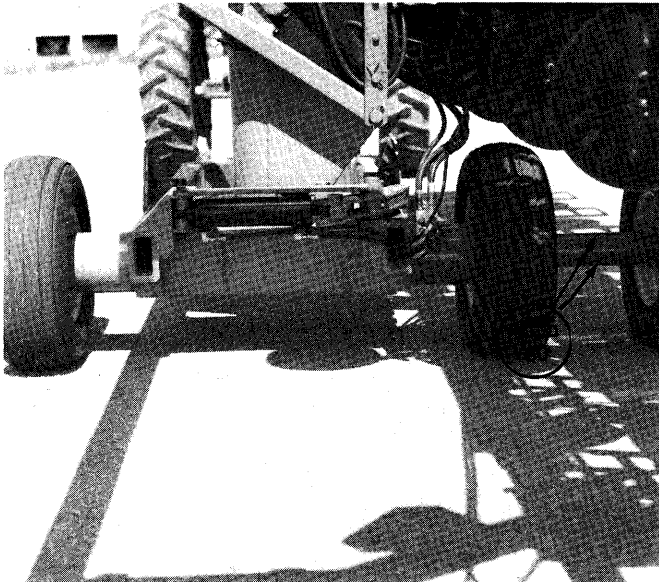

10. Transport Wheel Hub - 2 Zerks Per Hub

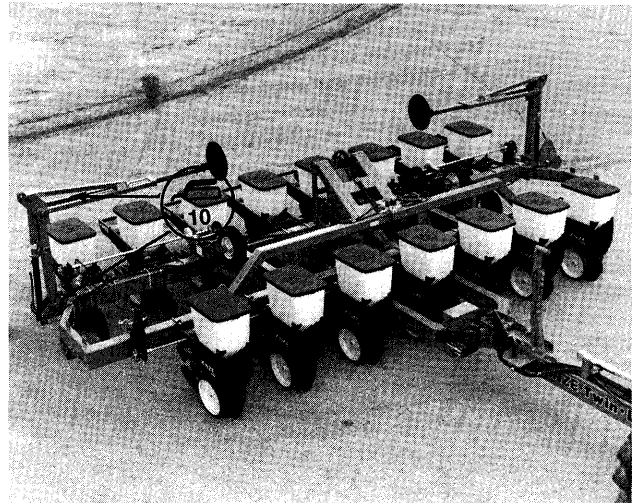

11. Low Profile Double Fold Marker -
2 Zerks Per Marker

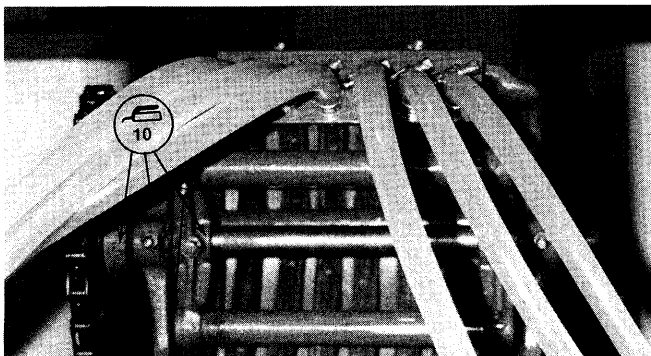

12. Squeeze Pump - 8 Zerks Per Pump

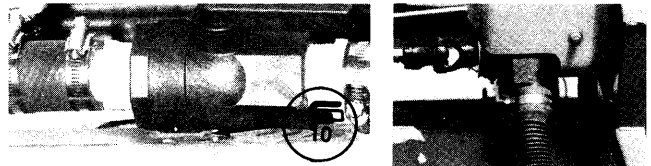

13. Shut Off Valve (Liquid Fertilizer) -
1 Zerk Per Valve
14. Dry Fertilizer Hopper - 2 Zerks
Per Hopper

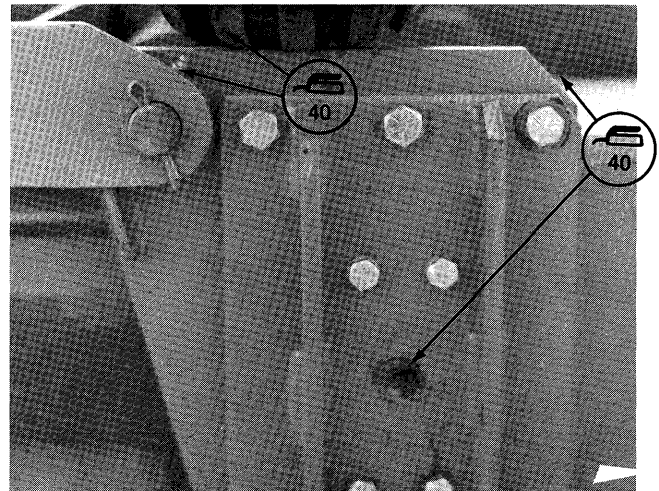
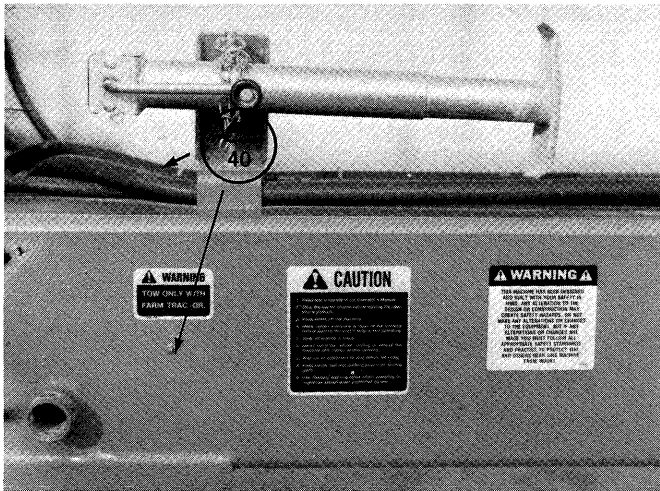
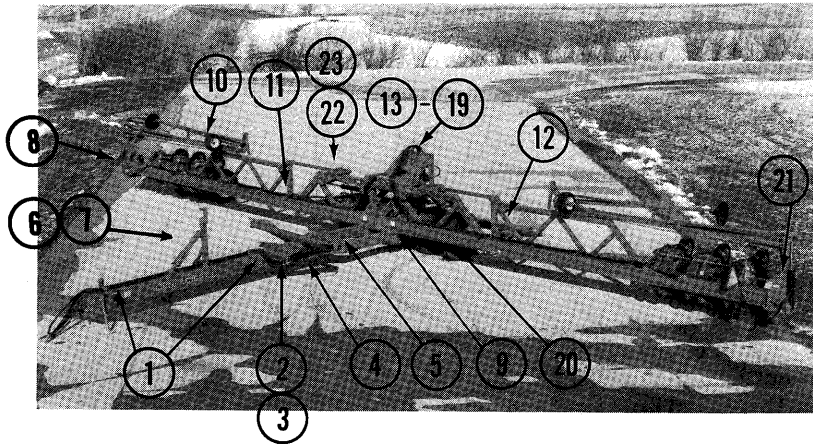

1. Outer Hitch, Front - 2 Zerks

2. Outer Hitch, Rear - 2 Zerks
3. Tongue Lock - 2 Zerks

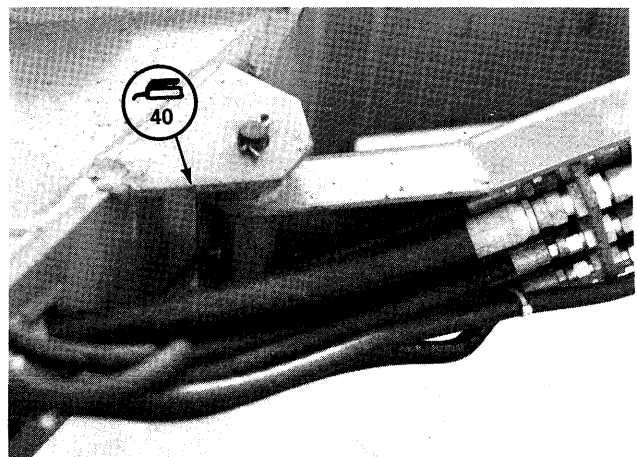
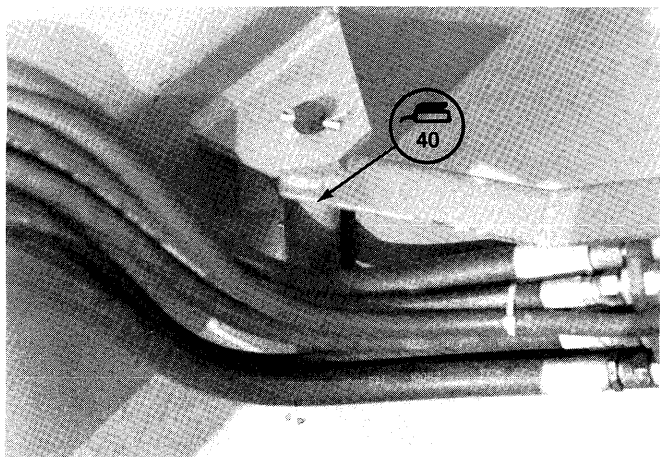

4. Hose Takeup, Front - 1 Zerk

5. Hose Takeup, Rear - 1 Zerk



Frequency of Lubrication In Hours

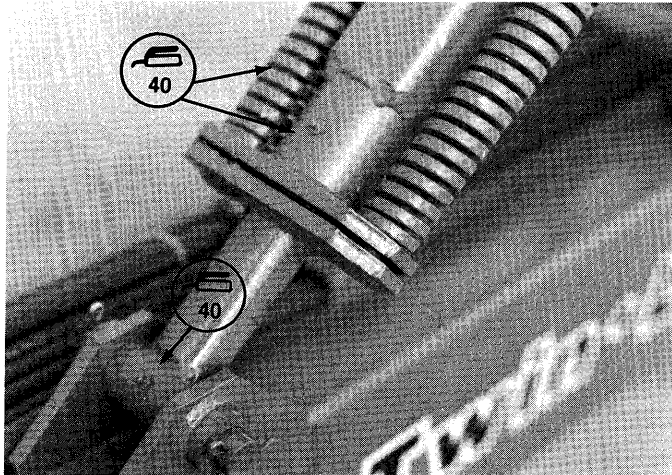

6. Spring Mount - 1 Zerk
7. Spring Tube - 2 Zerks

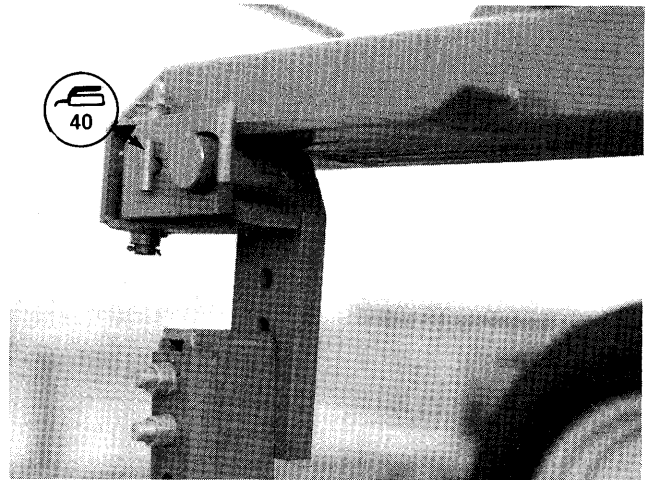

8. Transport Latch - 1 Zerk

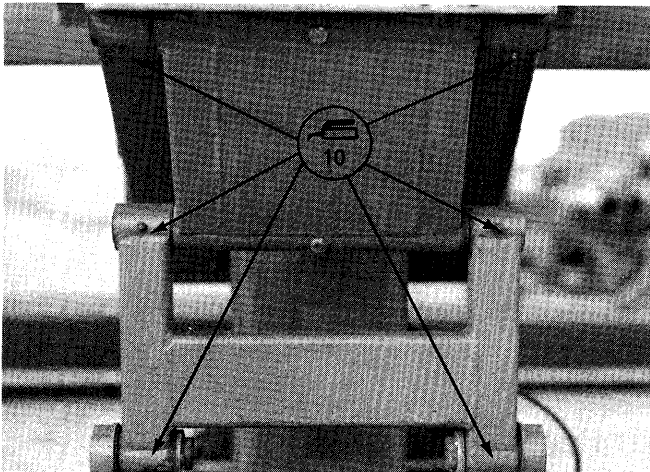

9. Anti-Rotation Assembly - 6 Zerks

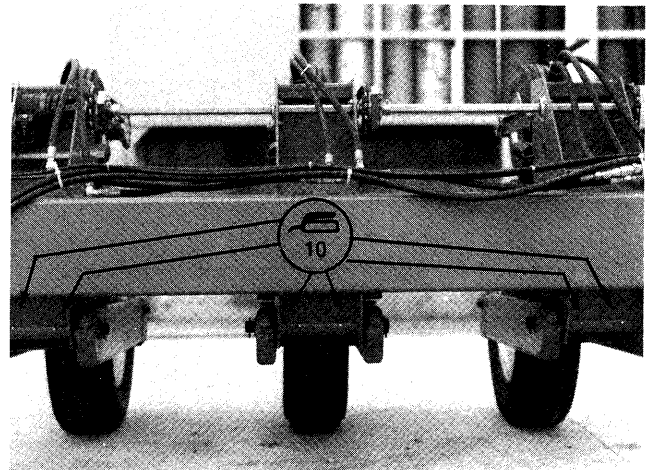

10. Wheel Tower - 2 Zerks Per Tower

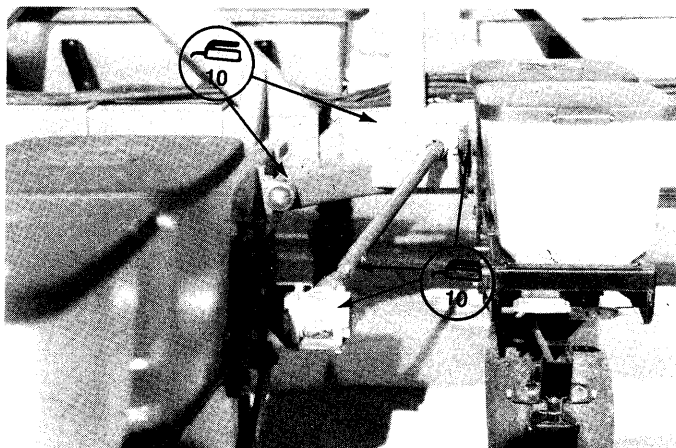

11. Wing Hinge - 2 Zerks Per Wing
12. Drill Shaft (U-Joint - 2 Zerks Per Side)
(Coupling Shaft - 1 Zerk Per Side)

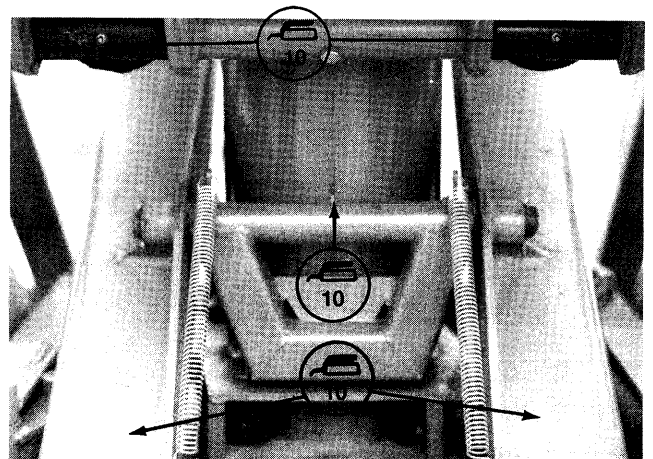

13. Lift Lock - 1 Zerk
14. Upper Parallel Lift Arms, Front - 2 Zerks
15. Lower Parallel Lift Arms, Front - 2 Zerks

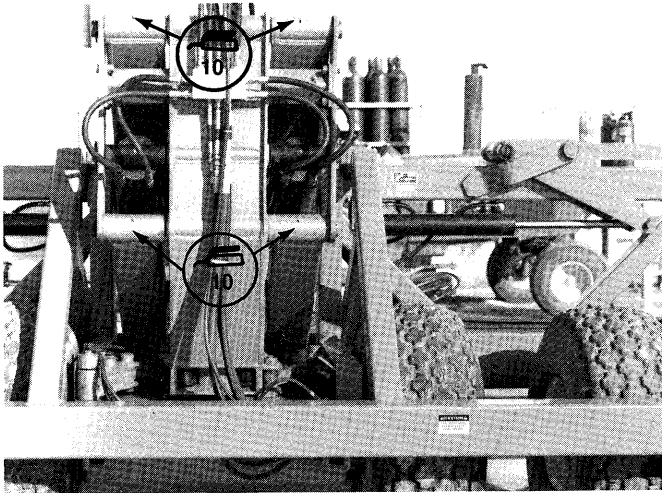

16. Upper Parallel Lift Arms, Rear - 2 Zerks
 17. Lower Parallel Lift Arms, Rear - 2 Zerks

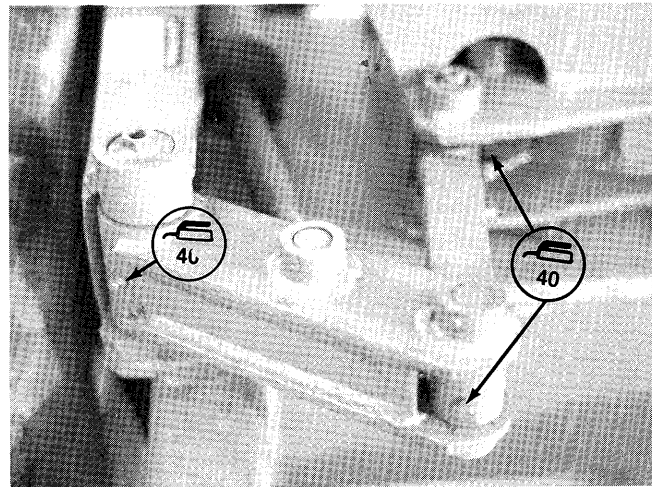

18. Rotation Lock Plate - 1 Zerk Per Plate
 19. Rotation Lock Link - 2 Zerks Per Link

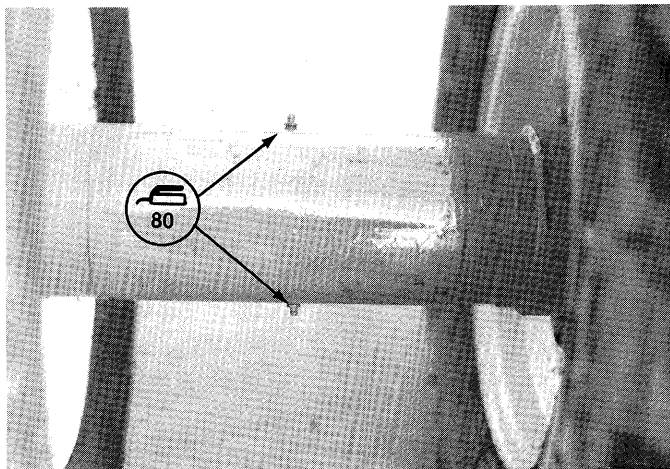

20. Transport Wheel Hub - 2 Zerks Per Hub

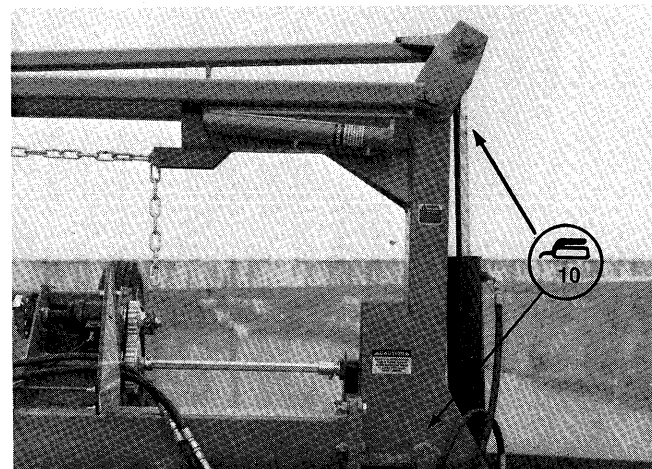

21. Low Profile Triple Fold Marker -
 2 Zerks Per Marker

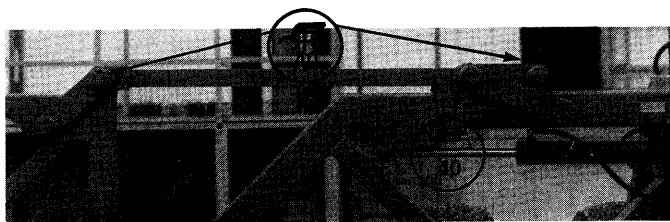

22. Wing Lock Link - 2 Zerks Per Link
 23. Wing Lock Plate - 2 Zerks Per Plate

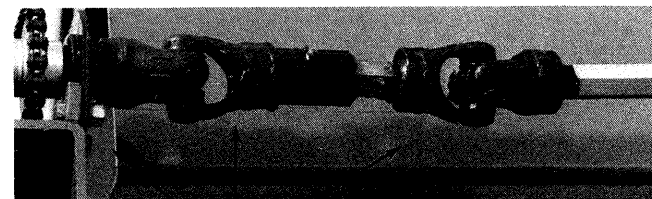

24. Push Unit Shaft (U-Joint - 2 Zerks Per Side)
 Coupling Shaft - 1 Zerk Per Side

MAINTENANCE

MOUNTING BOLTS AND HARDWARE



Before operating the planter for the first time, check to be sure all nuts and bolts are tight. Check all nuts and bolts again after approximately the first 50 hours of operation and at the beginning of each planting season thereafter.

All bolts used on the Kinze planter are Grade 5 (high strength) unless otherwise noted. Refer to the torque value chart in the assembly section of this manual when tightening bolts.

NOTE: Overtightening bolts can cause as much damage as undertightening. Tightening a bolt beyond the recommended range can reduce its shock load capacity.

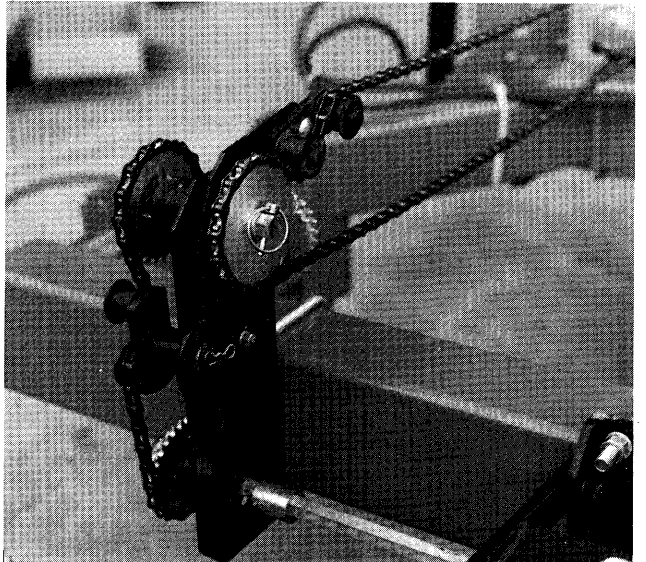
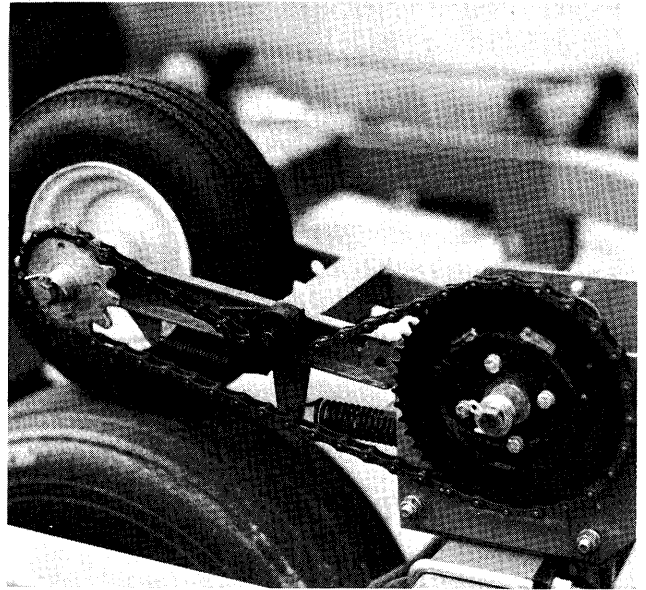
WARNING: Before operating the planter for the first time and periodically thereafter, check to be sure the lug nuts on the transport wheels are tight. This is especially important if the planter is going to be transported for a long distance. (8 Row 175 Ft. Lbs./24 Row - 425 Ft. Lbs.)



DRY TORQUE VALUES - Ft. Lbs.						
Bolt Dia.	Grade 2 No Radial Lines 		Grade 5 Three Radial Lines 		Grade 8 Six Radial Lines 	
	Course	Fine	Course	Fine	Course	Fine
1/4	66	75	8	10	12	14
5/16	11	13	17	19	25	27
3/8	20	23	31	35	44	49
7/16	32	36	50	55	70	78
1/2	49	55	76	85	106	120
9/16	70	79	109	122	153	172
5/8	97	110	150	170	212	240
3/4	173	192	266	297	376	420
7/8	166	184	430	474	606	668
1	250	274/280	644	705/721	909	995/1019
1 1/8	354	397	794	890	1288	1444
1 1/4	500	553	1120	1241	1817	2012
1 3/8	655	746	1470	1672	2382	2712
1 1/2	870	979	1950	2194	3161	3557

NOTE: Bolts having lock nuts should be tightened to approximately 50% of amounts shown in chart. Bolts lubricated prior to installation should be torqued to 70% of value shown on chart.

CHAIN TENSION ADJUSTMENT

Many of the drive chains are spring loaded and therefore self-adjusting. The only adjustment needed is to shorten the chain if wear stretches the chain and reduces spring tension. The pivot point of these idlers should be checked periodically to ensure they will rotate freely.

The remaining idlers are fixed position idlers and are adjusted by loosening a bolt on the idler and rotating the idler until all slack has been removed from the chain. Tighten the bolt. Rotate the planter shaft and check to ensure all slack has been removed from the chain. The fixed position idler is used where sprocket changes need to be made such as in the seed transmission and dry fertilizer transmission.

The liquid fertilizer squeeze pump chain is adjusted by sliding the pump forward or backward to obtain the proper chain adjustment.

MAINTENANCE

POINT ROW WRAP SPRING CLUTCH INSPECTION

The point row wrap spring clutch is permanently lubricated and requires no periodic maintenance. **Do not lubricate. Keep clutches clean.**

The right hand clutch operates clockwise and the left hand clutch operates counterclockwise. Therefore, some of the parts of the clutch such as the wrap spring differ from one side of the planter to the other. Be sure to use the correct repair part for the clutch being repaired.

If the clutch or clutches fail to operate first determine if the problem is electrical or mechanical. Place the operational switch in the "OFF" position. This should energize the solenoid coil. If the solenoid is operating properly, the plunger on the solenoid will retract causing a clicking sound. If the plunger does not retract,

check the coil for power either with a test light or by touching the plunger with a metal object. If the coil is working properly, the plunger will be magnetized. If the plunger is not magnetized, check the wiring harness at the coil terminals with a test light or volt meter. Power at this point would indicate that the coil is probably burned out and must be replaced. Should there be no power at this point, check the wiring harness back to the tractor until the problem is located.

If power is getting to the solenoid coil and the plunger will not retract, place the operational switch in the "ON" position and check to see if the plunger can move in and out freely. If not, move the plunger in and out until it is freed up or replace the solenoid assembly. Corrosion or foreign material can cause the plunger to stick. A small amount of penetrating oil may free up the plunger. Caution should be taken to prevent oil from getting on the hubs or spring.

TROUBLE SHOOTING		
PROBLEM	POSSIBLE CAUSE	POSSIBLE SOLUTION
Neither clutch will disengage.	Fuse blown in control box. Poor terminal connection in wiring harness. Wiring damage in wiring harness. Low voltage at coil. (12 volts required.)	Replace fuse. Repair or replace. Repair or replace. Check battery connections.
One clutch will not disengage.	Shear pin in row unit transmission sheared. Electrical failure.	Replace with one of equal size and grade. Check solenoid, wiring harness and coil terminals.
One clutch will not engage.	Actuator arm and plunger stuck in disengaged position. Actuator arm stop out of adjustment. Wrap spring broken or stretched. The coils near the center of a stretched spring will be uneven with the rest of the coils. Foreign substance such as oil or grease on the input or output hubs. Something touching the stop collar. Clutch assembled incorrectly.	Remove, free up and reinstall. Adjust stop so that actuator arm clears stop on stop collar by approximately 1/16" when clutch is rotated.* Disassemble clutch and replace spring. Disassemble clutch. Clean hubs and spring and reassemble. Check to ensure collar is free to turn with clutch. Check clutch and diagram for correct assembly.

MAINTENANCE

Clutch slipping.	Foreign substance such as oil or grease on the input or output hubs causing the spring to slip on the hub. Wrap spring stretched.	Disassemble clutch and clean hubs and spring. Reassemble. Disassemble clutch and inspect spring for uneven coils near the center of the spring. Replace spring.
Clutch will not re-engage while planter is moving forward.	Spring in actuator arm not strong enough to push arm away from stop collar when operational switch is turned to the "ON" position.	Remove spring and stretch spring slightly. Reinstall spring. If that fails, file the stop on the stop collar slightly so that the stop is not as aggressive.

*On 8 row models adjust sleeve on actuator limit stop. On 24 row models adjust nut on plunger in solenoid assembly.

NOTE: To identify parts see Point Wrap Spring Clutch Assembly pages in Parts Section of this manual.

MAINTENANCE

SOLENOID VALVE INSPECTION

The solenoid valve consists of a chambered body containing a cartridge valve which is activated by an electrical coil.

If the solenoid or solenoids fail to operate first determine if the problem is electrical or hydraulic. If the valve is working properly a click will be heard when the solenoid coil is energized. This

will be the valve stem opening up. If no sound is heard, check the solenoid coil by touching the top of the coil housing with a metallic object such as a pliers or screwdriver. If the coil is working properly the coil housing will be strongly magnetized when energized. If the voltage to the coil is low the coil will be weakly magnetized when energized and no click will be heard.

TROUBLE SHOOTING		
PROBLEM	POSSIBLE CAUSE	POSSIBLE SOLUTION
None of the solenoids will operate.	Low voltage. Blown Fuse. Battery connection. Wiring harness damaged.	Must be connected to 12 volt only. Neg. ground. Replace fuse in back of control panel on tractor with 15 amp. only. Clean and tighten. Repair or replace.
One solenoid valve will not operate.	Bad switch. Cut wire in harness. Bad coil. Poor connection at coil.	Replace on control panel. Find and repair. Replace. Check.
Valve operating when not energized.	Valve stem stuck open. O-ring leaking. Foreign material under poppet.	Replace cartridge. Install new o-ring kit. Remove cartridge and clean.

FLOW CONTROL VALVE INSPECTION

The flow control valves should be adjusted for raise and lower speed as part of the assembly procedure or upon initial operation. If the valve fails to function properly or requires frequent adjustment, it should be removed for inspection. Check for foreign material and contamination on both the valve and the seating area of the valve body. Replace any components found to be defective.

PRESSURE RELIEF VALVE INSPECTION

If the pressure relief valve fails to release the tongue lock or function properly, remove the valve from the valve block and check for foreign material or check to see if the o-ring is leaking internally. Replace if found to be defective.

MAINTENANCE

WHEEL OR MARKER BEARING LUBRICATION OR REPLACEMENT

1. Raise tire clear of ground and remove wheel or marker blade.
2. Remove hub cap from hub.
3. Remove cotter pin, axle nut, and washer.
4. Slide hub from axle or spindle.
5. Remove bearing cups and discard if bearings are being replaced. Clean hub and dry.
6. Press in new bearing cups with thickest edge facing in.
7. Pack bearings with heavy duty wheel bearing grease thoroughly forcing grease between roller cone and bearing cage. Also fill the space between the bearing cups in the hub with grease.
8. Place inner bearing in place and press in new grease seal.
9. Clean axle or spindle and install hub.
10. Install outer bearing, washer, or outer seal and slotted hex nut. Tighten slotted hex nut while rotating hub until there is some drag. This assures that all bearing surfaces are in contact. Back off slotted nut to nearest locking slot and install cotter pin.
11. Fill hub caps approximately 3/4 full of wheel bearing grease and install on hub.
12. Install wheel or blade on hub and tighten evenly and securely.

PREPARATION FOR STORAGE

Store the planter in a dry sheltered area if possible.

Remove all trash that may be wrapped on sprockets or shafts and remove dirt that can draw and hold moisture.

Clean all drive chains and coat with a rust preventative spray, or better yet, remove chains and submerge in oil.

Lubricate planter and row units at all lubrication points.

If possible, remove weight from all tires particularly if the unit is stored outdoors, in which case it is best to remove wheels and tires for storage in a cool dry area.

Inspect the planter and row units for parts that are in need of replacement and order during the "off" season.

If the planter is equipped with a dry fertilizer attachment, clean the fertilizer hoppers, openers and all rubber spouts.

Make sure all seed, herbicide and insecticide hoppers are empty and clean.

If the planter is equipped with a liquid fertilizer attachment, open the shut off valve and flush water through the system.

Clean seed meters and store in a dry area. (Refer to row unit manual for proper procedures)

Grease exposed areas of cylinder rods before storing planter.

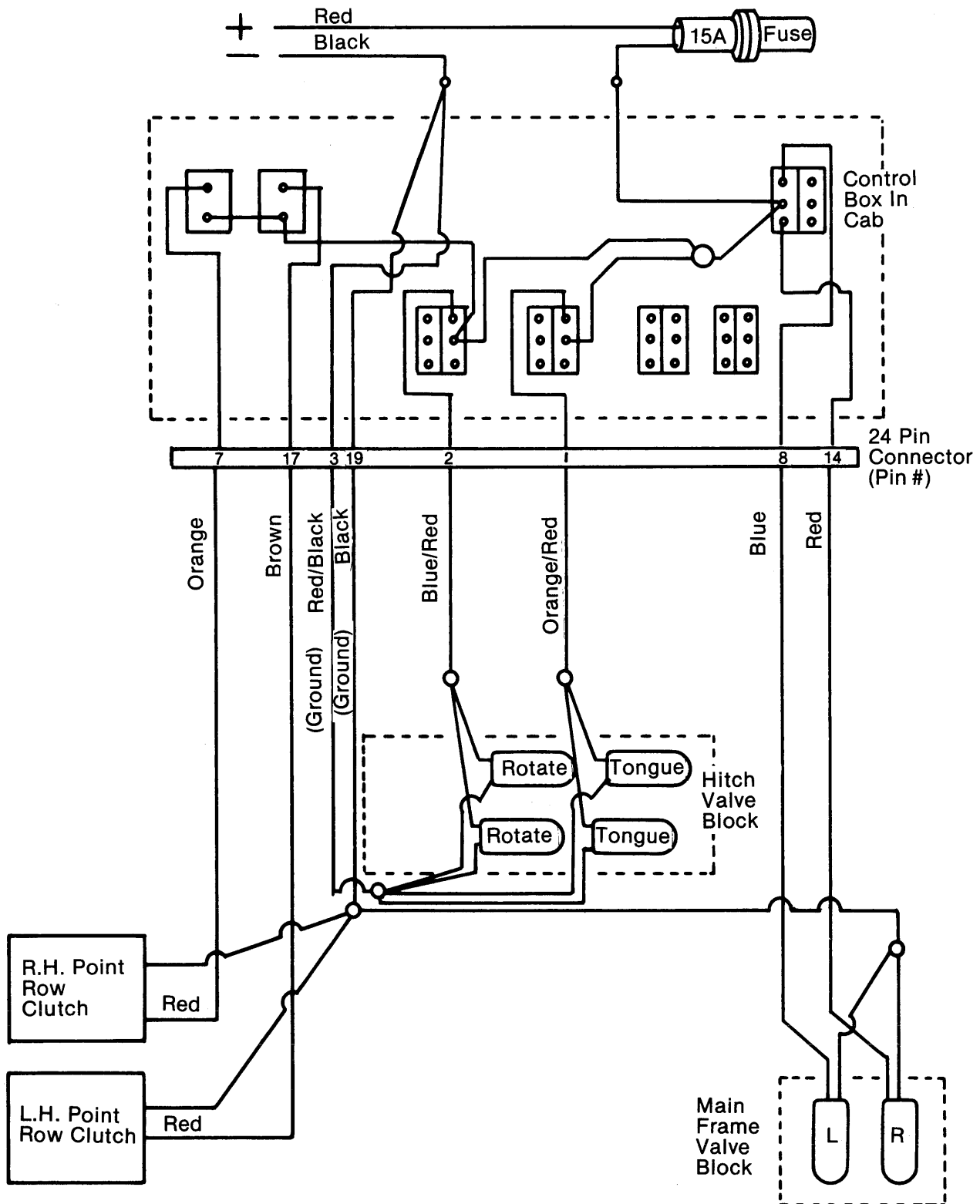

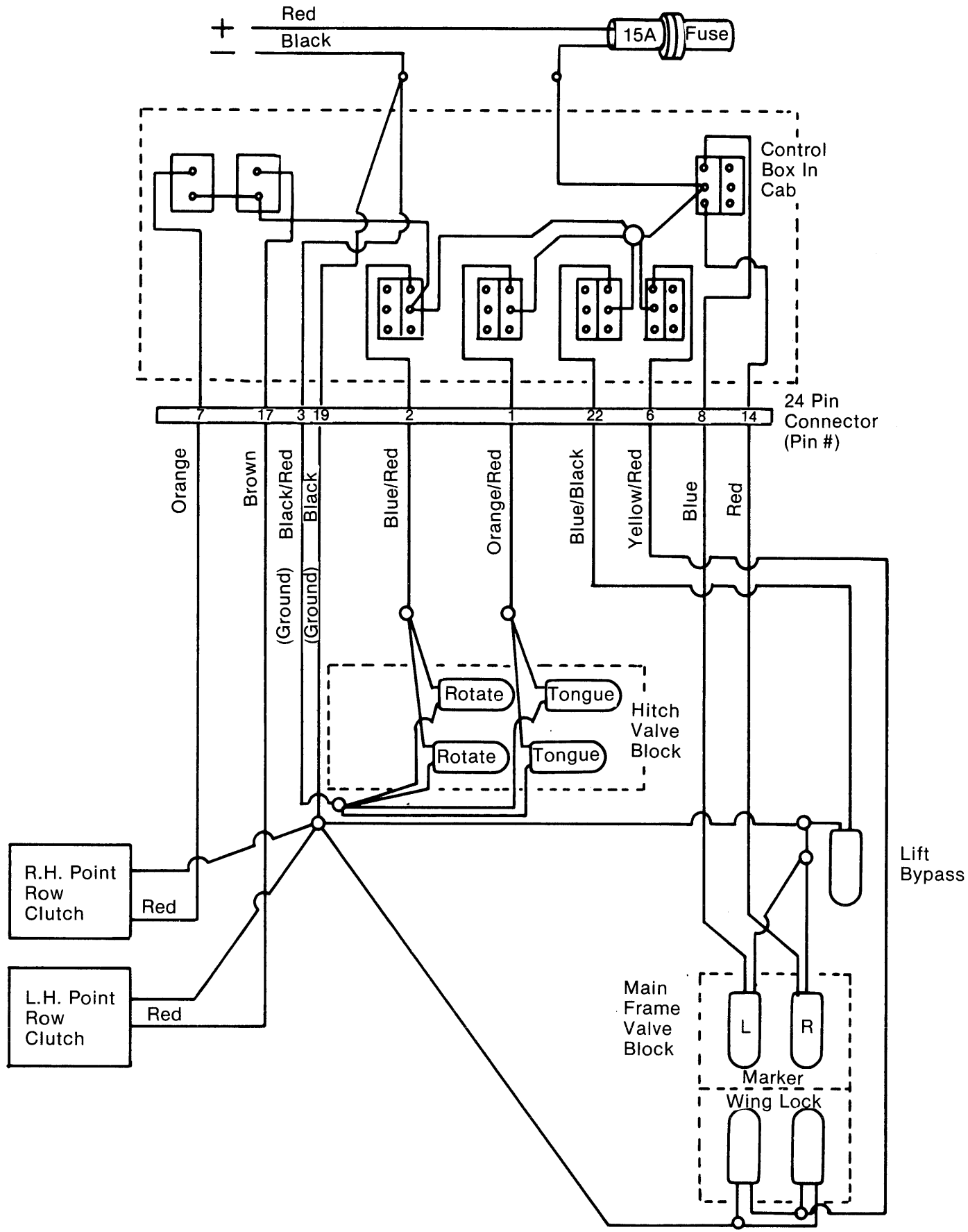



PARTS LIST INDEX, 8 ROW MODELS

Outer Hitch Assembly	P2/P3
Inner Hitch Assembly	P4/P5
Frame Assembly	P6/P7
Lift Arms and Bell Assembly	P8/P9
Axle and Rotation Assembly	P10/P11
Contact Drive Wheel Assembly and Drive Line	P12/P13
Transmission Assembly and Drill Shaft	P14/P15
Point Row Wrap Spring Clutch Assembly	P16/P17
6 Bolt Transport Wheel Assembly	P18
Low Profile Double Fold Marker Assembly	P19
Marker Hub Assembly	P20
Electrical Components	P21
Hydraulic System, Marker	P22/P23
Hydraulic System, Planter Lift	P24/P25
Hydraulic System, Tongue/Rotation	P26/P27
Solenoid Valve	P28
Flow Control Valve	P28
Pressure Relief Valve	P28
Tongue Cylinder, 8 Row 30	P29
Tongue Cylinder, 8 Row Wide	P29
Tongue Lock Cylinder, 8 Row 30 and Wide	P30
Lift Lock Cylinder, 8 Row 30 and Wide	P30
Lift Cylinder, 8 Row 30 and Wide	P31
Rotation Cylinder, 8 Row 30 and Wide	P31
Marker Cylinder, 8 Row 30 and Wide	P32
Fertilizer Opener Mounts	P33
Fertilizer Opener	P34/P35
Dry Fertilizer Hopper Assembly	P36/P37
Dry Fertilizer Transmission and Drive Line	P38/P39
Dry Fertilizer Couplers and Hopper Mount	P40
Liquid Fertilizer Squeeze Pump	P41
Squeeze Pump Mounting Brackets, Sprockets and Drive	P42/P43
Liquid Fertilizer Tanks, Saddles, Mounts, Hoses and Fittings	P44/P45
Decals, Reflectors and Tie Straps	P46/P47
Numerical Index, Parts Section	a

OUTER HITCH ASSEMBLY

8 Row Models

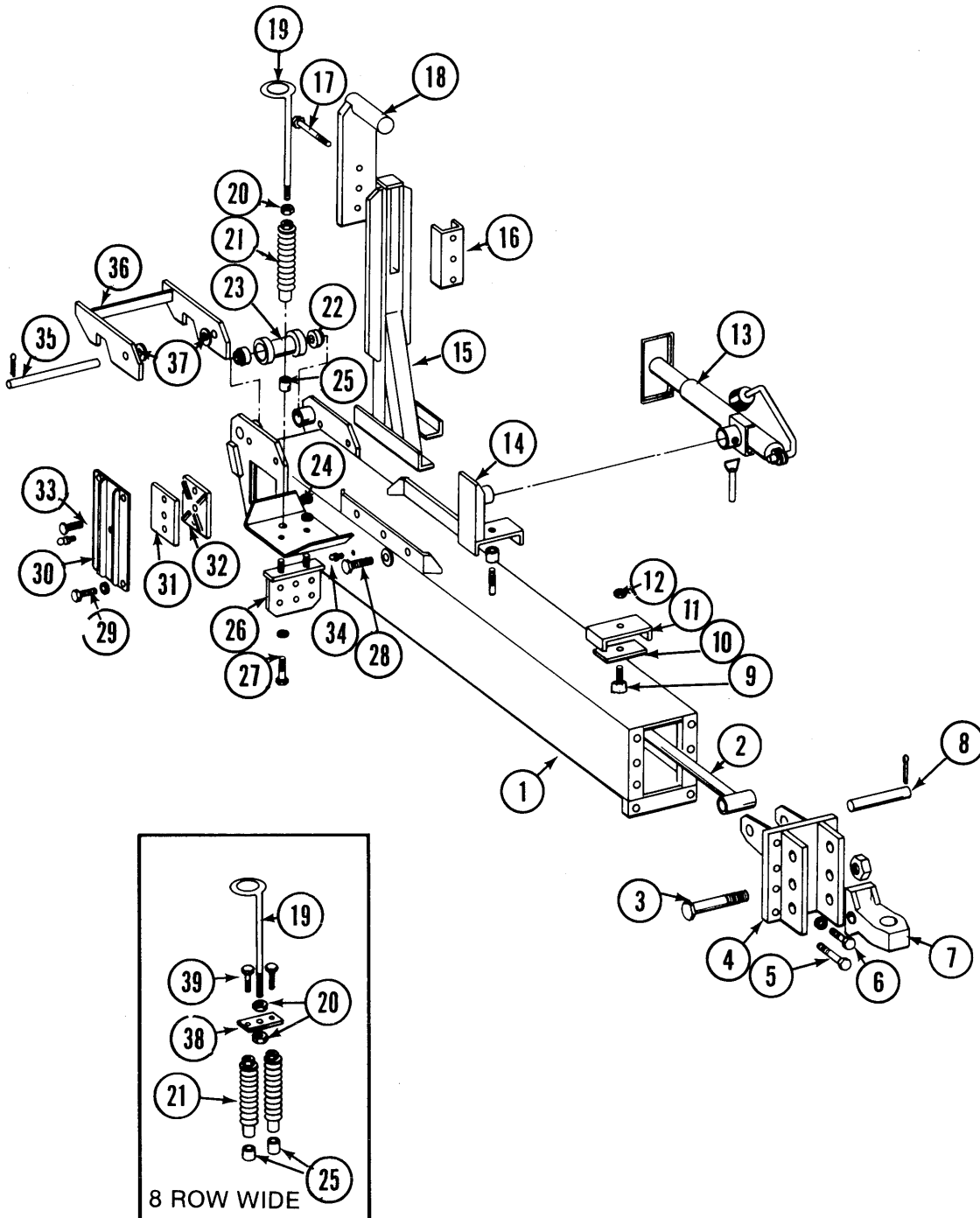

OUTER HITCH ASSEMBLY

ITEM	PART NO.	DESCRIPTION
1.	A3867	Outer Hitch, 8 Row 30
	A3879	Outer Hitch, 8 Row 36
2.		Cylinder, See Tongue Cylinder Page
3.	10169	HHCS, 1 1/4" - 7 x 6"
	10157	Hex Nut, 1 1/4" - 7
4.	A3862	Cylinder Mount
5.	10010	HHCS, 5/8" - 11 x 3"
	10230	Lock Washer, 5/8"
	10104	Hex Nut, 5/8" - 11
6.	10005	HHCS, 5/8" - 11 x 1 3/4"
	10230	Lock Washer, 5/8"
7.	B0156	Clevis
8.	D5173	Pin, 1 1/4" x 5 1/8"
	10462	Cotter Pin, 3/16" x 2"
9.	D3788-01	Tubing, Plastic
10.	D3552	Strip, Rubber
11.	D3548	Clamp
12.	10111	Lock Nut, 1/2" - 13
13.	A0941	Jack Assembly
	R0517	Pin
	R0516	Crank Assembly
	R0515	Bevel Gears
14.	A2749	Clamp
15.	A3853	Mount
16.	D5120	Mount
17.	10036	HHCS, 5/8" - 11 x 4"
	10230	Lock Washer, 5/8"
	10104	Hex Nut, 5/8" - 11
18.	A3851	Transport Latch Post
19.	D5170	Hose Takeup, 12"
20.	10102	Hex Nut, 1/2" - 13
21.	A3864	Spring w/Plug
22.	A2565	Bearing
23.	A3873	Roller
24.	10228	Lock Washer, 1/2"
	10102	Hex Nut, 1/2" - 13
25.	D0951	Sleeve
26.	A2627	Bulkhead
27.	10016	HHCS, 1/2" - 13 x 2"
	10228	Lock Washer, 1/2" - 13
28.	10005	HHCS, 5/8" - 11 x 1 3/4"
	10217	Washer, 5/8" USS
	10230	Lock Washer, 5/8"
	10104	Hex Nut, 5/8" - 11
29.	10017	HHCS, 1/2" - 13 x 1 1/2"
	10228	Lock Washer, 1/2"
	10102	Hex Nut, 1/2" - 13
30.	A3858	Wear Mount w/Grease Fitting
	10641	Grease Fitting, 1/8" NPT
31.	D5154	Shim (As Required)
32.	D5153	Wear Pad, Bronze
33.	10014	HHCS, 1/2" - 13 x 1"
	10228	Lock Washer, 1/2"
34.	10640	Grease Fitting, 1/4" - 28
35.	D4014	Pin, 1 1/4" x 12"
	10460	Cotter Pin, 1/4" x 2"
36.	A3872	Tongue Lock
37.	10139	Washer, 1 1/4" USS
38.	D5757	Bracket
39.	10017	HHCS, 1/2" - 13 x 1 1/2"

INNER HITCH ASSEMBLY

8 Row Models

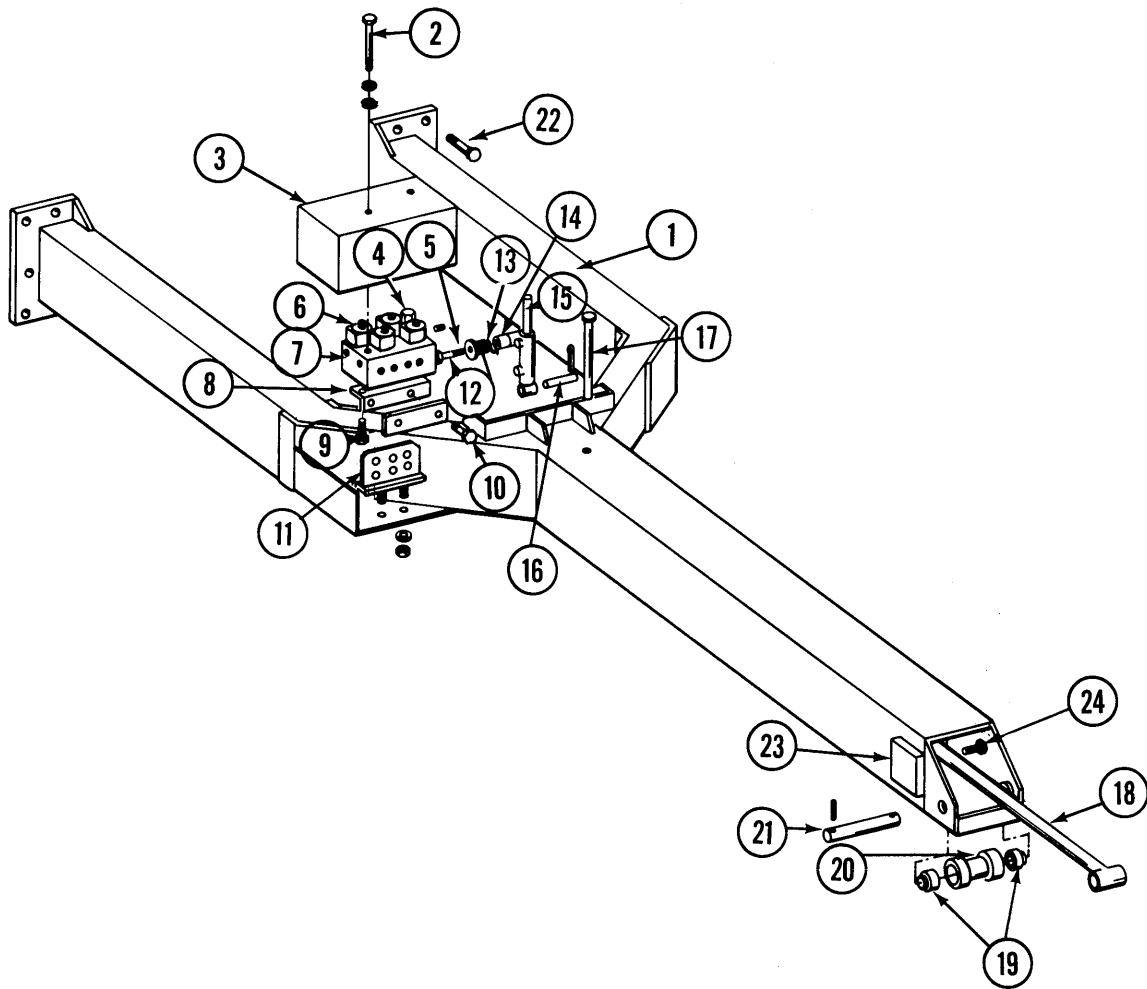

INNER HITCH ASSEMBLY

ITEM	PART NO.	DESCRIPTION
1.	A3868	Inner Hitch, 8 Row 30
	A3880	Inner Hitch, 8 Row 36
2.	10061	HHCS, 3/8" - 16 x 3 1/2"
	10229	Lock Washer, 3/8"
3.	A3881	Cover
4.		Valve, See Pressure Relief Valve Page
5.	10350	Pipe Plug, 1/4"
6.		Solenoid Valve, See Solenoid Valve Page
7.	D5039	Valve Block
8.	D5152	Angle
9.	10001	HHCS, 3/8" - 16 x 1"
	10229	Lock Washer, 3/8"
10.	10001	HHCS, 3/8" - 16 x 1"
	10108	Lock Nut, 3/8" - 16
11.	A2627	Bulkhead
12.	10049	HHCS, 3/8" - 16 x 2 1/2"
	10210	Washer, 3/8" USS
	10108	Lock Nut, 3/8" - 16
13.	D5171	Spring
14.	D2971-01	Sleeve, 1 1/8"
	D2971-03	Sleeve, 7/16"
15.		Cylinder, See Tongue Lock Cylinder Page
16.	D3637	Pin, 3/8" x 3"
	10457	Cotter Pin, 5/32" x 1 1/2"
17.	A3863	Pin, 1 1/4" x 7 1/2"
	10460	Cotter Pin, 1/4" x 2"
18.		Cylinder, See Tongue Cylinder Page
19.	A2565	Bearing
20.	A3875	Roller
21.	D5183	Pin, 1 1/4" x 7"
	10606	Spring Pin, 1/4" x 2"
22.	10027	HHCS, 3/4" - 10 x 2 1/2"
	10231	Lock Washer, 3/4"
	10105	Hex Nut, 3/4" - 10
23.	D5153	Wear Pad, Bronze
	D5154	Shim (As Required)
24.	10014	HHCS, 1/2" - 13 x 1"
	10216	Washer, 1/2" USS

FRAME ASSEMBLY

8 Row Models

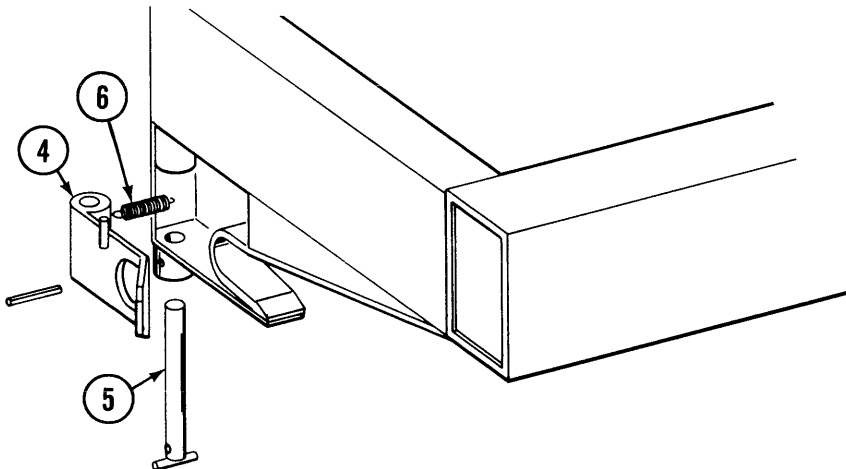
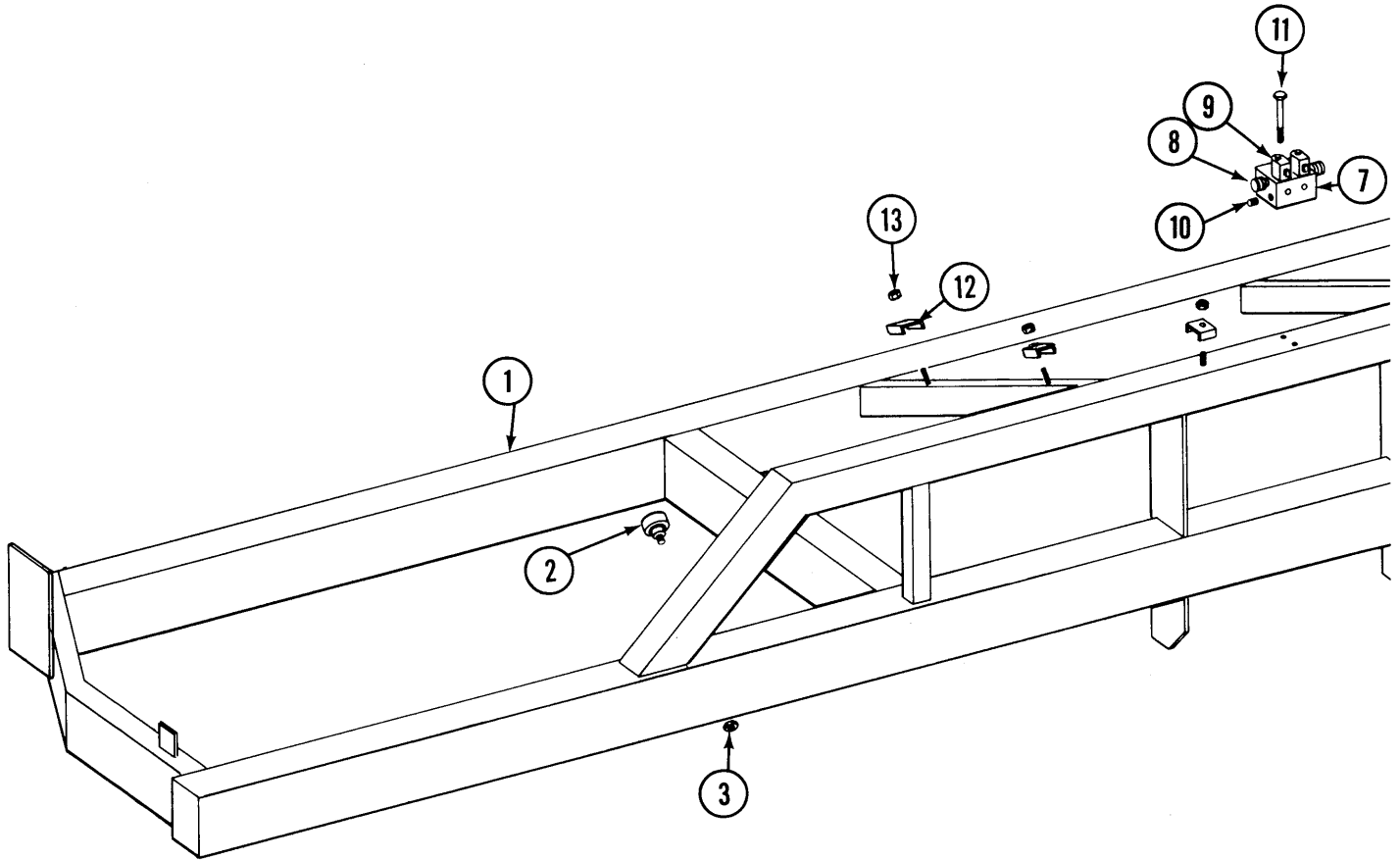

FRAME ASSEMBLY

ITEM	PART NO.	DESCRIPTION
1.	A3781	Frame, 8 Row 30
	A3789	Frame, 8 Row 36
2.	A2566	Cam Follower
3.	10281	Hex Nut, 1 1/4" - 12
4.	A3785	Transport Latch w/Grease Fitting
	10641	Grease Fitting, 1/8" NPT
5.	A3786	Pin, 7/8" x 7 1/2"
	10602	Spring Pin, 1/4" x 1 1/2"
6.	D3791	Spring
7.	D4474	Valve Block
8.		Valve, See Flow Control Valve Page
9.		Valve, See Solenoid Valve Page
10.	10350	Pipe Plug, 1/4" Hex Socket
11.	10061	HHCS, 3/8" - 16 x 3 1/2"
	10229	Lock Washer, 3/8"
12.	D4863	Hose Clamp
13.	10111	Lock Nut, 1/2" - 13

LIFT ARMS AND BELL ASSEMBLY

8 Row Models

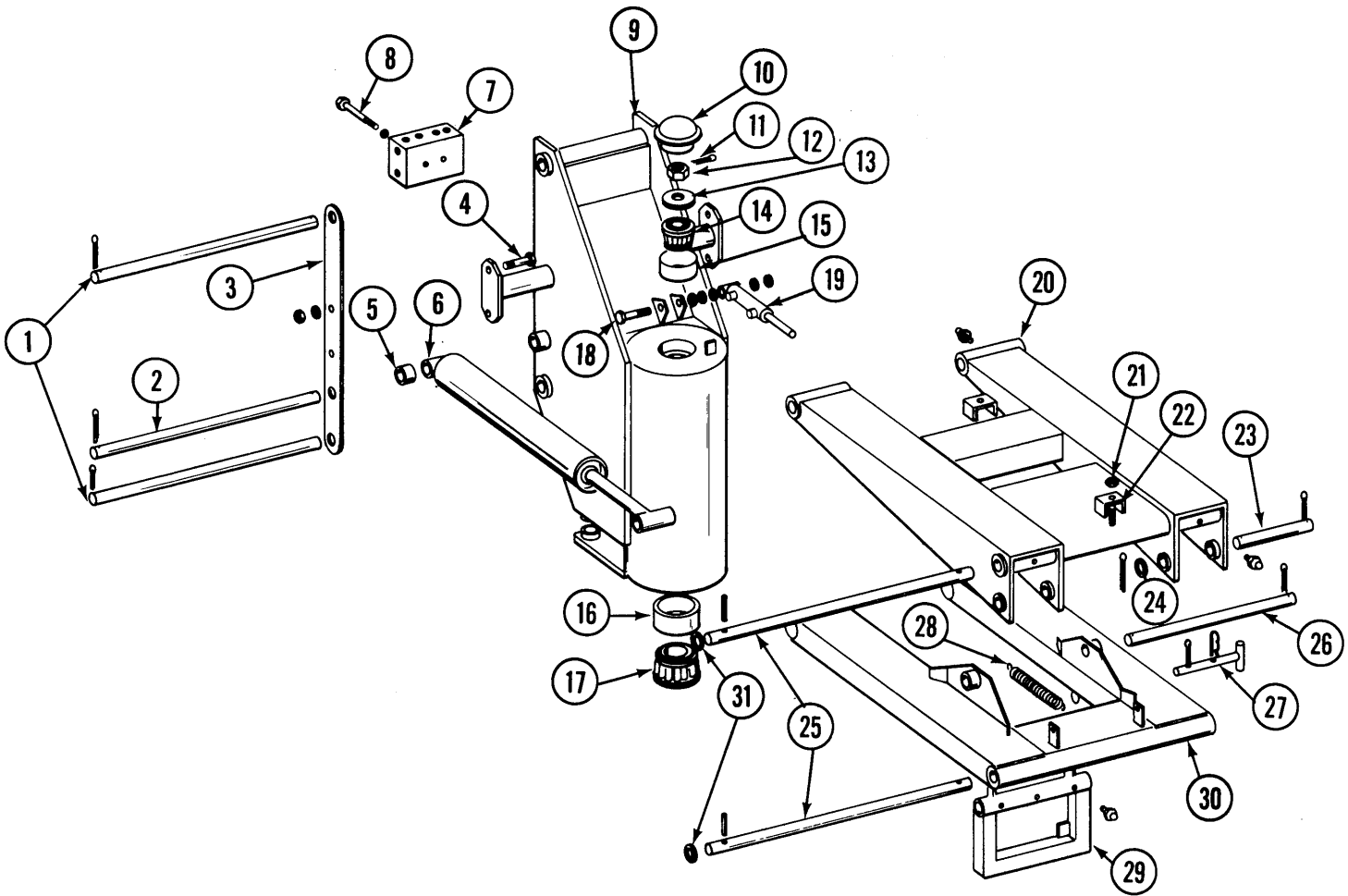

LIFT ARMS AND BELL ASSEMBLY

ITEM	PART NO.	DESCRIPTION
1.	D4989	Pin, 1 3/4" x 27 1/2"
	10471	Cotter Pin, 3/8" x 2 1/2"
2.	D4987	Pin, 1 1/4" x 27 1/2"
	10468	Cotter Pin, 3/8" x 2"
3.	D4957	Tie Bar
4.	10167	HHCS, 1/2" - 13 x 2"
	10228	Lock Washer, 1/2"
	10102	Hex Nut, 1/2" - 13
5.	D0752-07	Sleeve
6.		Cylinder, See Lift Cylinder Page
7.	D5425	Block
8.	10061	HHCS, 3/8" - 16 x 3 1/2"
	10229	Lock Washer, 3/8"
9.	A3856	Outer Bell
10.	D4927	Cap
11.	10460	Cotter Pin, 1/4" x 2"
12.	10070	Hex Slotted Nut, 1 1/4" - 12
13.	10139	Washer, 1 1/4" USS
14.	A0705	Bearing
15.	R0322	Cup
16.	R0323	Cup
17.	A0779	Bearing
18.	10056	HHCS, 3/4" - 10 x 3 1/2"
	10194	Washer, 3/4" SAE
	10105	Hex Nut, 3/4" - 10
19.		Cylinder, See Lift Lock Cylinder Page
20.	A3801	Upper Parallel Arm w/Grease Fittings
	10641	Grease Fitting, 1/8" NPT
21.	10111	Lock Nut, 1/2"
22.	D4863	Hose Clamp
23.	D5142	Cylinder, Pin, 1 1/4" x 7 3/4"
	10460	Cotter Pin, 1/4" x 2"
24.	10139	Washer, 1 1/4" USS
25.	D4988	Pin, 1 3/4" x 28 3/4"
	10600	Spring Pin, 5/16" x 2 1/4"
	10355	Spring Pin, 1/2" x 2 1/4"
26.	D5056	Pin, 1 1/4" x 16 1/2"
	10460	Cotter Pin, 1/4" x 2"
27.	A3806	Manual Safety Lockup, 7/8" x 8"
	10459	Cotter Pin, 3/16" x 1 1/2"
	10671	Hair Pin Clip, 3/16" x 3 1/2"
28.	D0829	Spring
29.	A3834	Lift Lock w/Grease Fittings
	10641	Grease Fitting, 1/8" NPT
30.	A3802	Lower Parallel Arm w/Grease Fittings
	10641	Grease Fitting, 1/8" NPT
31.	10356	Machinery Bushing, 1 3/4", 10 Gauge
	10357	Machinery Bushing, 1 3/4", 18 Gauge

AXLE AND ROTATION ASSEMBLY

8 Row Models

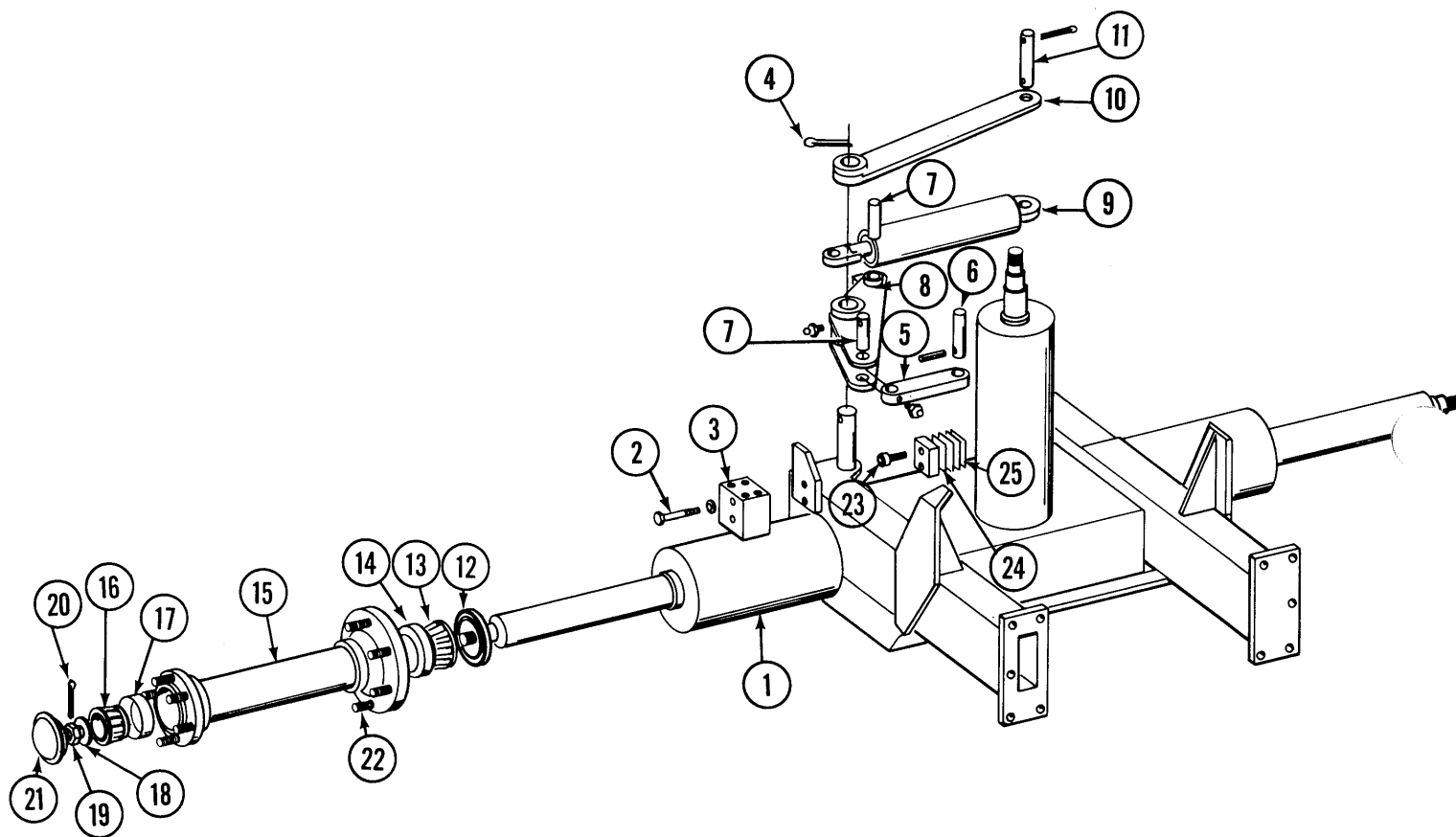

AXLE AND ROTATION ASSEMBLY

ITEM	PART NO.	DESCRIPTION
1.	A3841	Axle Assembly, 8 Row 30
	A3842	Axle Assembly, 8 Row 36
2.	10035	HHCS, 1/2" - 13 x 4"
	10206	Washer, 1/2" SAE
3.	D5042	Block
4.	10362	Cotter Pin, 1/4" x 3"
5.	A3846	Rotation Lock Link w/Bushings and Grease Fittings
	D4910	Bushing
	10641	Grease Fitting, 1/8" NPT
6.	D3403	Pin, 1 1/4" x 4 1/2"
	10332	Spring Pin, 7/32" x 2"
	10610	Spring Pin, 3/8" x 2"
7.	D5127	Pin, 1 1/4" x 3 1/4"
	10332	Spring Pin, 7/32" x 2"
	10610	Spring Pin, 3/8" x 2"
8.	A3855	Rotation Lock Plate w/Bushing and Grease Fitting
	D4468	Bushing
	10641	Grease Fitting, 1/8" NPT
9.		Cylinder, See Rotation Cylinder Page
10.	A3877	Bar
11.	D5138	Pin, 1 1/4" x 6 3/4"
	10460	Cotter Pin, 1/4" x 2"
12.	A0532	Seal
13.	A0531	Cup
14.	R0191	Bearing
15.	A3835	Hub w/Grease Fitting (6 Bolt)
	10641	Grease Fitting, 1/8" NPT
16.	R0322	Bearing
17.	A0705	Cup
18.	10139	Washer, 1 1/4" USS
19.	10070	Hex Slotted Nut, 1 1/4" - 12
20.	10460	Cotter Pin, 1/4" x 2"
21.	D4927	Cap
22.	D5068	Hub Bolt
	10358	Flange Nut, 9/16" - 18
23.	10361	Cap Screw, FHD Hex Socket, 1/2" - 13 x 1 1/2"
24.	D5077	Pad
25.	D3398	Shim

CONTACT DRIVE WHEEL ASSEMBLY AND DRIVE LINE

8 Row Models

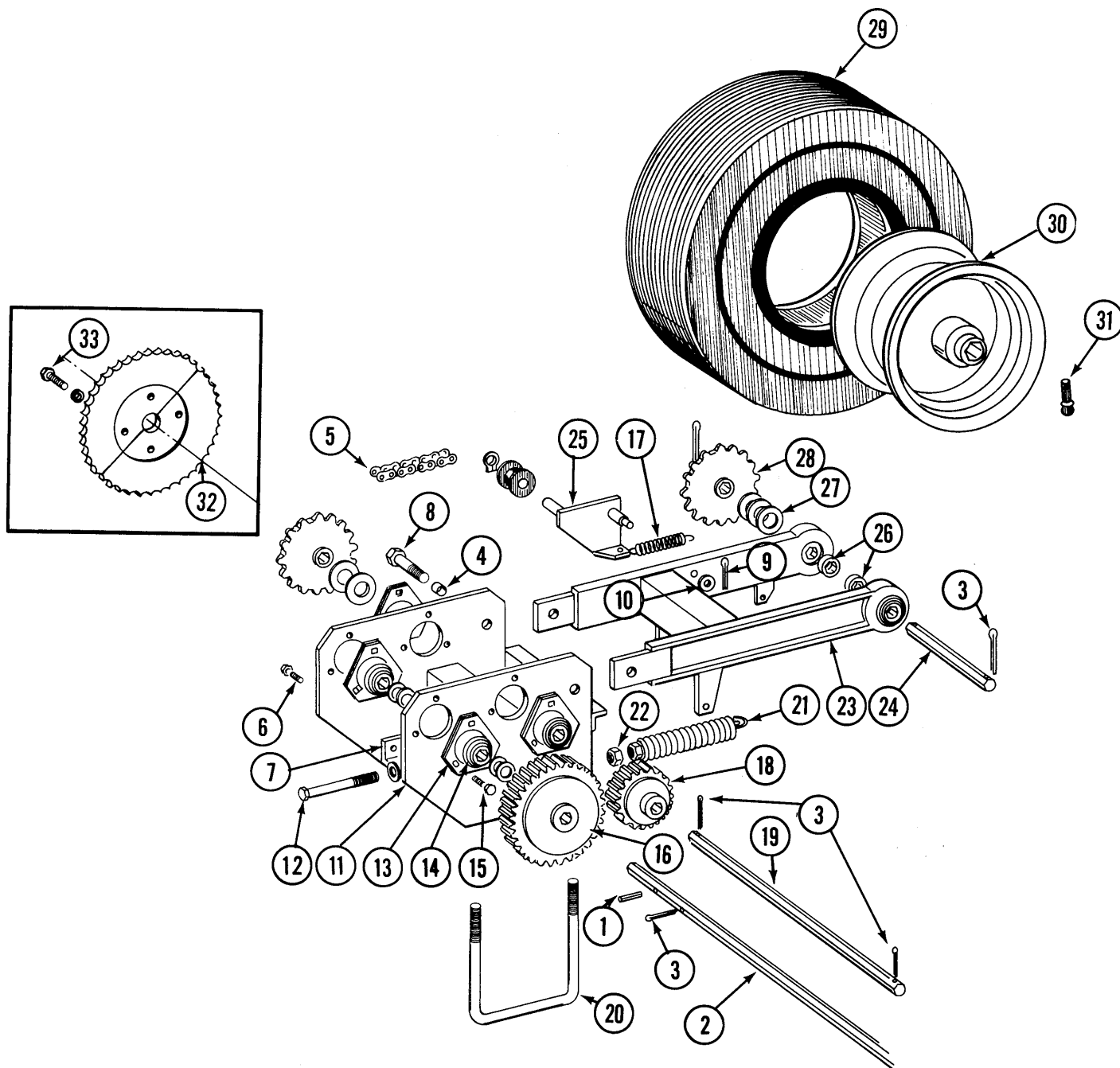

CONTACT DRIVE WHEEL ASSEMBLY AND DRIVE LINE

ITEM	PART NO.	DESCRIPTION
1.	10602	Spring Pin, 1/4" x 1 1/2"
2.	D5035	Shaft, 7/8" x 59 1/4", 8 Row 30
	D5199	Shaft, 7/8" x 78 1/4", 8 Row 36
3.	10460	Cotter Pin, 1/4" x 2"
4.	B0123	Bushing
5.	3200-46	Chain, No. 2050, 46 Pitch Including Connector Link
	3200-06	Chain, No. 2050 (Add to chain when using extended drill sprocket.)
	R0195	Connector Link, No. 2040
6.	10017	HHCS, 1/2" - 13 x 1 1/2"
	10228	Lock Washer, 1/2"
	10102	Hex Nut, 1/2" - 13
7.	D5064	Angle Mount
8.	10008	HHCS, 5/8" - 11 x 2"
	10230	Lock Washer, 5/8"
	10217	Washer, 5/8" USS
	10107	Lock Nut, 5/8" - 11
9.	10453	Cotter Pin, 3/16" x 1"
10.	10205	Washer, 5/8" SAE
11.	A3825	Side Plate
12.	10024	Hex Head Adjusting Bolt, 7/16" - 14 x 4"
	10206	Washer, 1/2" SAE
13.	3400-01	Flangette
14.	2100-03	Bearing, 7/8 Hex Bore
15.	10303	Carriage Bolt, 5/16" - 18 x 1"
	10232	Lock Washer, 5/16"
	10106	Hex Nut, 5/16" - 18
16.	A4053	Gear, 32 Tooth
17.	D3791	Spring
18.	A4054	Gear, 18 Tooth
19.	D5036	Shaft, 7/8" x 15"
20.	D1134	U-Bolt, 7" x 5" x 5/8" - 11
	10230	Lock Washer, 5/8"
	10104	Hex Nut, 5/8" - 11
21.	A2052	Spring w/Plug
22.	10502	Hex Jam Nut, 7/16" - 14
23.	A3828	Arm, R.H. (Shown)
	A3829	Arm, L.H.
24.	D5037	Shaft, 7/8" x 12 1/2"
25.	A3558	Idler w/Spool and Ring, R.H.
	A3559	Idler w/Spool and Ring, L.H.
	10435	Ring
	D0916	Spool
26.	D3660-08	Sleeve, Hex
27.	10233	Bushing, 1 1/2"
28.	2500-18	Sprocket, 12 Tooth
29.	D4700	Tire, 4.8 x 8, 6 Ply
30.	A3553	Wheel
31.	D4701	Valve Stem
32.	A2359	Sprocket, 48 Tooth (Extended Drill Sprocket)
33.	10002	HHCS, 3/8" - 16 x 3/4"
	10229	Lock Washer, 3/8"
A.	6211X	Extended Drill Sprocket Package, Includes: (2) A2359, (2) 3200-06, (8) 10002 and (8) 10229

TRANSMISSION ASSEMBLY AND DRILL SHAFT

8 Row Models

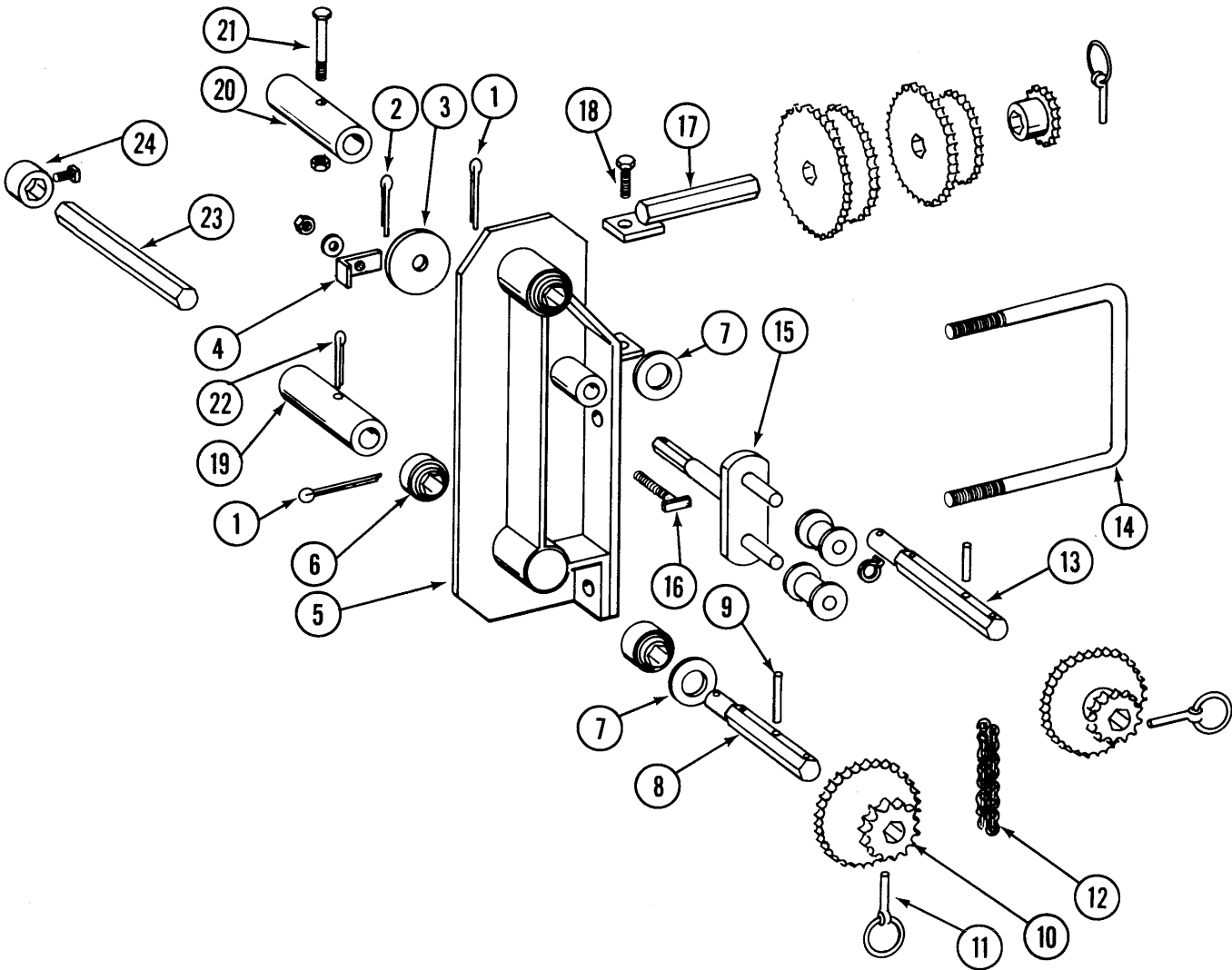

TRANSMISSION ASSEMBLY AND DRILL SHAFT

ITEM	PART NO.	DESCRIPTION
1.	10465	Cotter Pin, 1/4" x 1 1/4"
2.	10670	Hair Pin Clip, No. 3
3.	A1668	Tightner
4.	D2495	Angle
5.	A3419	Plate, L.H.
	A3420	Plate, R.H. (Shown)
6.	2100-03	Bearing, 7/8 Hex Bore
7.	10233	Machinery Bushing
8.	D4484	Shaft (3/16" Shear)
	D5215	Shaft (1/4" Shear)
9.	10602	Spring Pin, 1/4" x 1 1/2"
10.	2500-25	Sprocket, 14 Tooth
	2500-26	Sprocket, 18-28 Tooth
	2500-27	Sprocket, 16-30 Tooth
	2500-28	Sprocket, 22-26 Tooth
11.	D2558	Lynch Pin, 1/4"
12.	3300-40	Chain, No. 2040, 40 Pitch Including Connector Link
	R0194	Connector Link, No. 2040
13.	D4748	Shaft
14.	D1113	U-Bolt, 5" x 7" x 5/8" - 11
	10230	Lock Washer, 5/8"
	10104	Hex Nut, 5/8" - 11
15.	A0503	Idler w/Spools and Rings
	D1067	Spool
	10435	Ring
16.	A3428	T-Bolt
	10229	Lock Washer, 3/8"
	10101	Hex Nut, 3/8" - 16
17.	A1785	Rod, Sprocket Storage
18.	10019	HHCS, 5/16" - 18 x 1"
	10109	Lock Nut, 5/16" - 18
19.	D4504	Coupler (3/16" Shear)
	D5212	Coupler (1/4" Shear)
20.	D4749	Coupler
21.	10339	HHCS, 5/16" - 18 x 2", Grade 2
	10109	Lock Nut, 5/16" - 18
22.	10462	Cotter Pin, 3/16" x 2"
	10460	Cotter Pin, 1/4" x 2"
23.	D0914-104.5	Drill Shaft, 8 Row 30, R.H.
	D0914-94	Drill Shaft, 8 Row 30, L.H.
	D0914-130	Drill Shaft, 8 Row 36, R.H.
	D0914-119	Drill Shaft, 8 Row 36, L.H.
24.	D0917	Lock Collar, 7/8 Hex, Less Set Screws
	10145	Set Screw, 5/16" - 18 x 1/2"

POINT ROW WRAP SPRING CLUTCH ASSEMBLY

8 Row Models
L.H. Side of Planter Shown

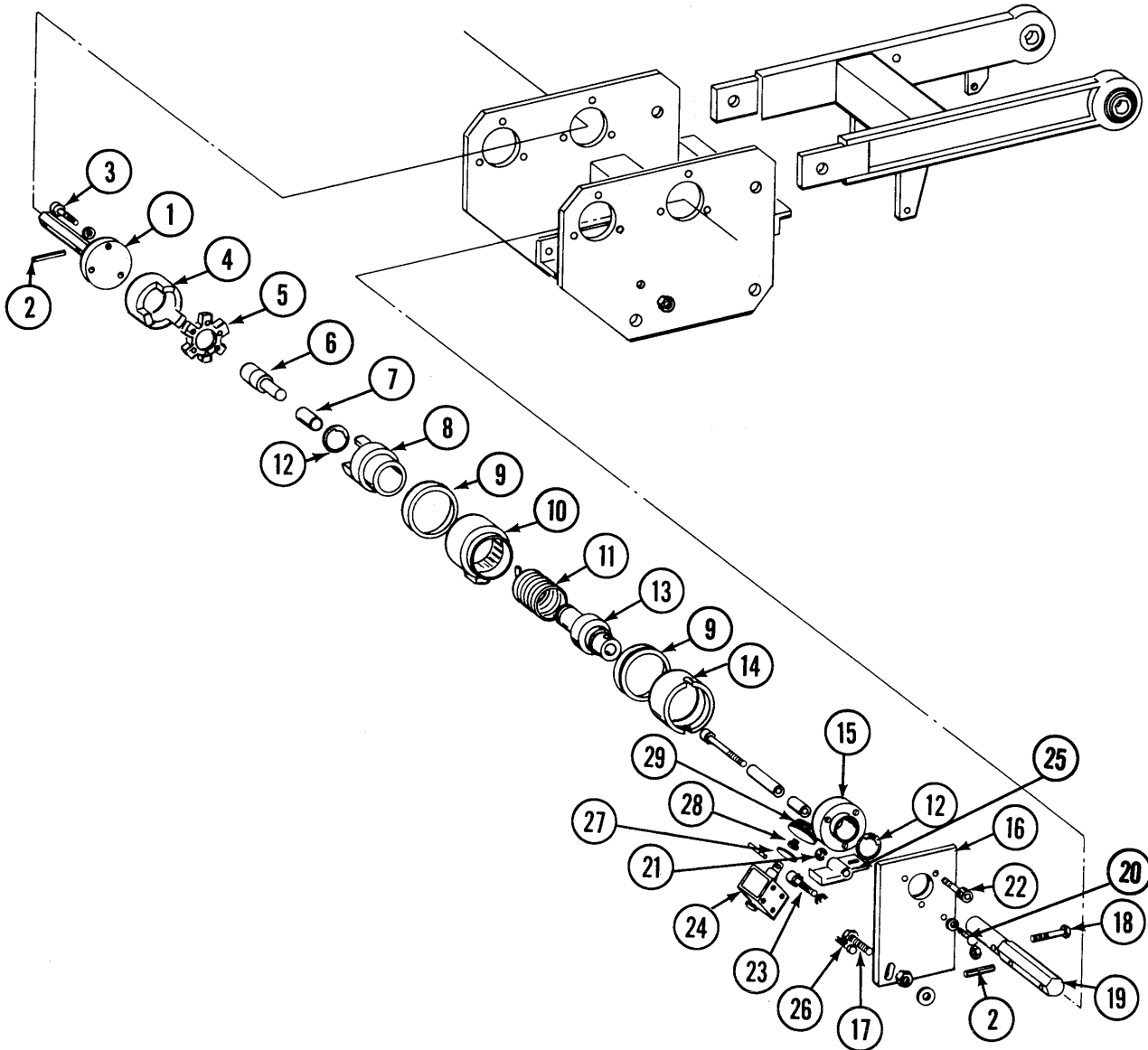

POINT ROW WRAP SPRING CLUTCH ASSEMBLY

ITEM	PART NO.	DESCRIPTION
1.	A3948	Shaft w/Face Plate
2.	10603	Spring Pin, 1/4" x 1 1/4"
3.	10019	HHCS, 5/16" - 18 x 1"
	10232	Lock Washer, 5/16"
4.	D5328	Coupler
5.	D5327	Spider
6.	A2022	Bearing
7.	D5329	Sleeve
8.	R0467	Input Hub
9.	R0473	Dust Shield
10.	R0471	Stop Collar
11.	R0470	Spring, CW, 2"
	R0469	Spring, CCW, 2"
12.	R0478	Retaining Ring
13.	R0462	Output Hub
14.	R0472	Dust Cover
15.	R0468	Plate Bearing
16.	R0464	Plate, CW
	R0463	Plate, CCW
17.	10062	HHCS, 3/8" - 16 x 3", Grade 5
	10101	Hex Nut, 3/8" - 16
	10210	Washer, 3/8" USS
	10108	Lock Nut, 3/8" - 16
18.	10339	HHCS, 5/16" - 18 x 2"
	10109	Lock Nut, 5/16" - 18
19.	D5331	Shaft
20.	10261	Screw, Socket Button Head, No. 10-32 x 3/8"
	10243	Washer, Flat, No. 10
21.	R0479	Retaining Ring
22.	10260	Screw, Socket Head Cap, 1/4" - 20 x 1/2"
23.	R0475	Actuator Limit Stop
24.	R0466	Coil Assembly w/Plunger
25.	R0465	Actuator Arm
26.	10259	Screw, Socket Head Cap, No. 10-32 x 7/8"
	10257	Washer, Split Lock, No. 10
	10243	Washer, Flat, No. 10
27.	R0647	Boot Sleeve
28.	R0474	Spring, Actuator Return
29.	R0646	Boot
A.	6697X	Point Row Wrap Spring Clutch Package Complete w/Short Wiring Harness, 8 Row 30 and 8 Row Wide

6 BOLT TRANSPORT WHEEL ASSEMBLY

8 Row Models

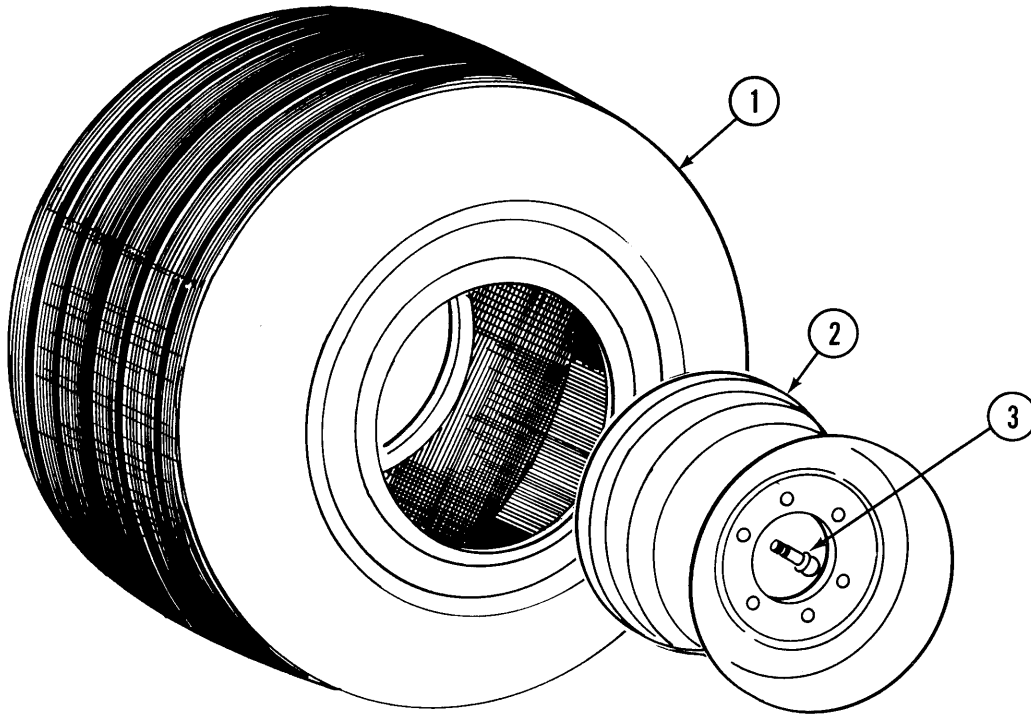

ITEM	PART NO.	DESCRIPTION
1.	D4807	Tire, 11L x 15, 6 Ply Tubeless
2.	A3792	Wheel, Outer
	A3793	Wheel, Inner
3.	D1165	Valve Stem

LOW PROFILE DOUBLE FOLD MARKER ASSEMBLY

8 Row Models

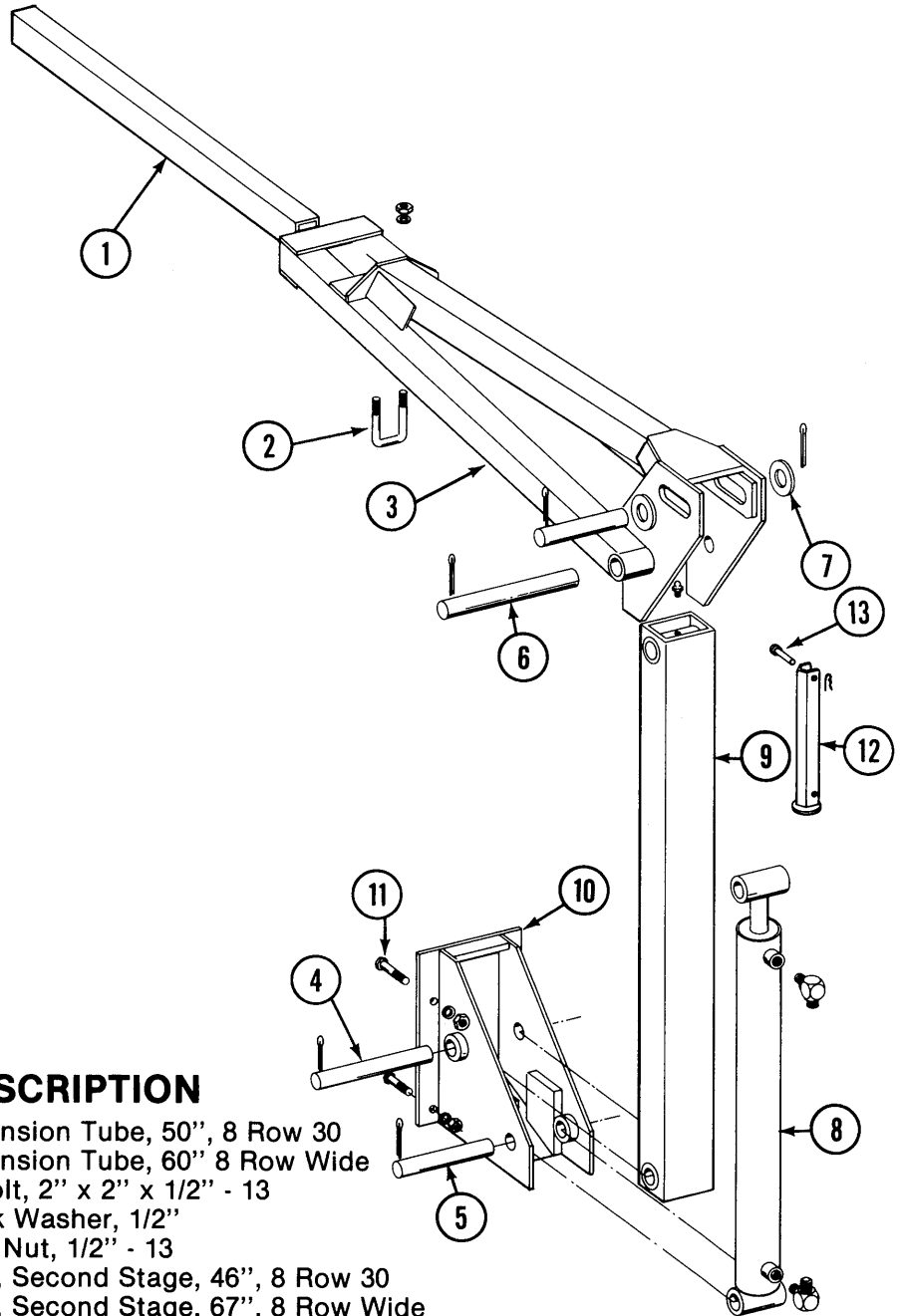

ITEM	PART NO.	DESCRIPTION
1.	D0453-03 D0453-04	Extension Tube, 50", 8 Row 30 Extension Tube, 60" 8 Row Wide
2.	D2721 10228 10102	U-Bolt, 2" x 2" x 1/2" - 13 Lock Washer, 1/2" Hex Nut, 1/2" - 13
3.	A2300 A2301	Arm, Second Stage, 46", 8 Row 30 Arm, Second Stage, 67", 8 Row Wide
4.	D0653 10460	Pin, 1 1/4" x 7 3/4" Cotter Pin, 1/4" x 2"
5.	D1701 10460	Pin, 1 1/4" x 6 1/2" Cotter Pin, 1/4" x 2"
6.	D1702 10460	Pin, 1 1/4" x 10 1/4" Cotter Pin, 1/4" x 2"
7.	10226	Washer, 1 1/4" SAE
8.		Cylinder, See Marker Cylinder Page
9.	A0828 10641	Arm w/Grease Fittings, First Stage, 38" Grease Fitting, 1/8"
10.	A0827	Mount
11.	10167 10228 10102	HHCS, 1/2" - 13 x 2", Grade 2 Lock Washer, 1/2" Hex Nut, 1/2" - 13
12.	A2913	Lockup
13.	10561 10670	Clevis Pin, 1/2" x 3" Hair Pin Clip, No. 3

MARKER HUB ASSEMBLY

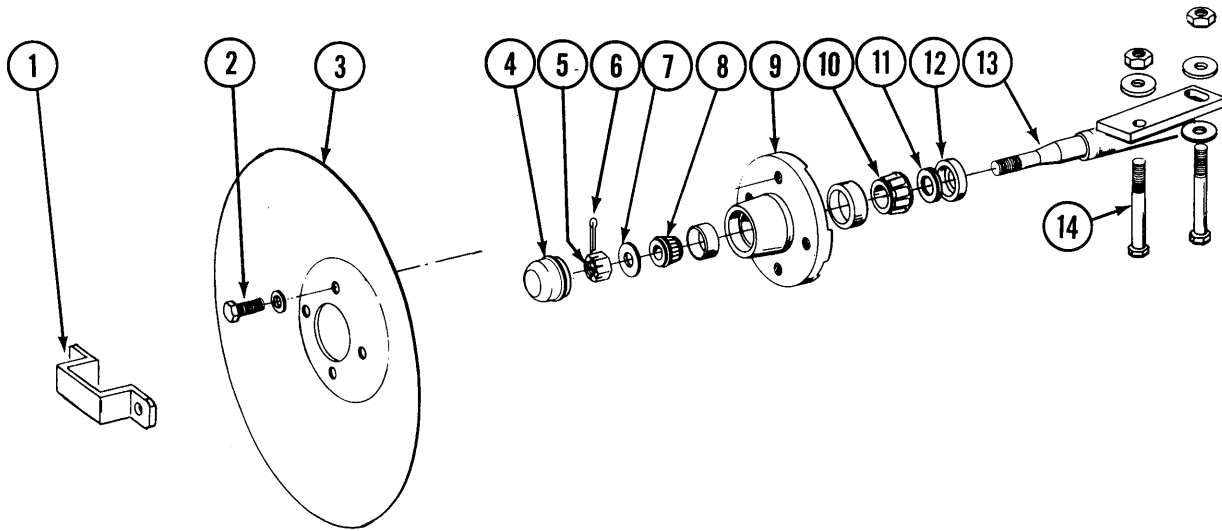

ITEM	PART NO.	DESCRIPTION
1.	D2597	Retainer
2.	10722	HHCS, 1/2" - 20 x 1"
	10228	Lock Washer, 1/2"
3.	D0746	Blade, 16"
4.	D0840	Cap
5.	10725	Hex Nut, Slotted, 5/8" - 18
6.	10470	Cotter Pin, 5/32" x 1"
7.	10724	Washer, 5/8"
8.	A0257	Bearing, Outer
9.	A0167	Hub w/Cups
	R0151	Cup, Outer
	R0150	Cup, Inner
10.	A0245	Bearing, Inner
11.	A0899	Seal, Rubber
12.	A0243	Seal, Grease
13.	A1677	Spindle, L.H. Less Hardware (Shown)
	A1676	Spindle, R.H. Less Hardware
14.	10033	HHCS, 1/2" - 13 x 3 1/2"
	10168	Machinery Bushing, 1/2", 7 Ga.
	10102	Hex Nut, 1/2" - 13
A.	A1679	Hub and Spindle Assembly, L.H. (Includes Items 2 and 4 thru 13)
	A1678	Hub and Spindle Assembly, R.H. (Includes Items 2 and 4 thru 13)

ELECTRICAL COMPONENTS

8 Row Models

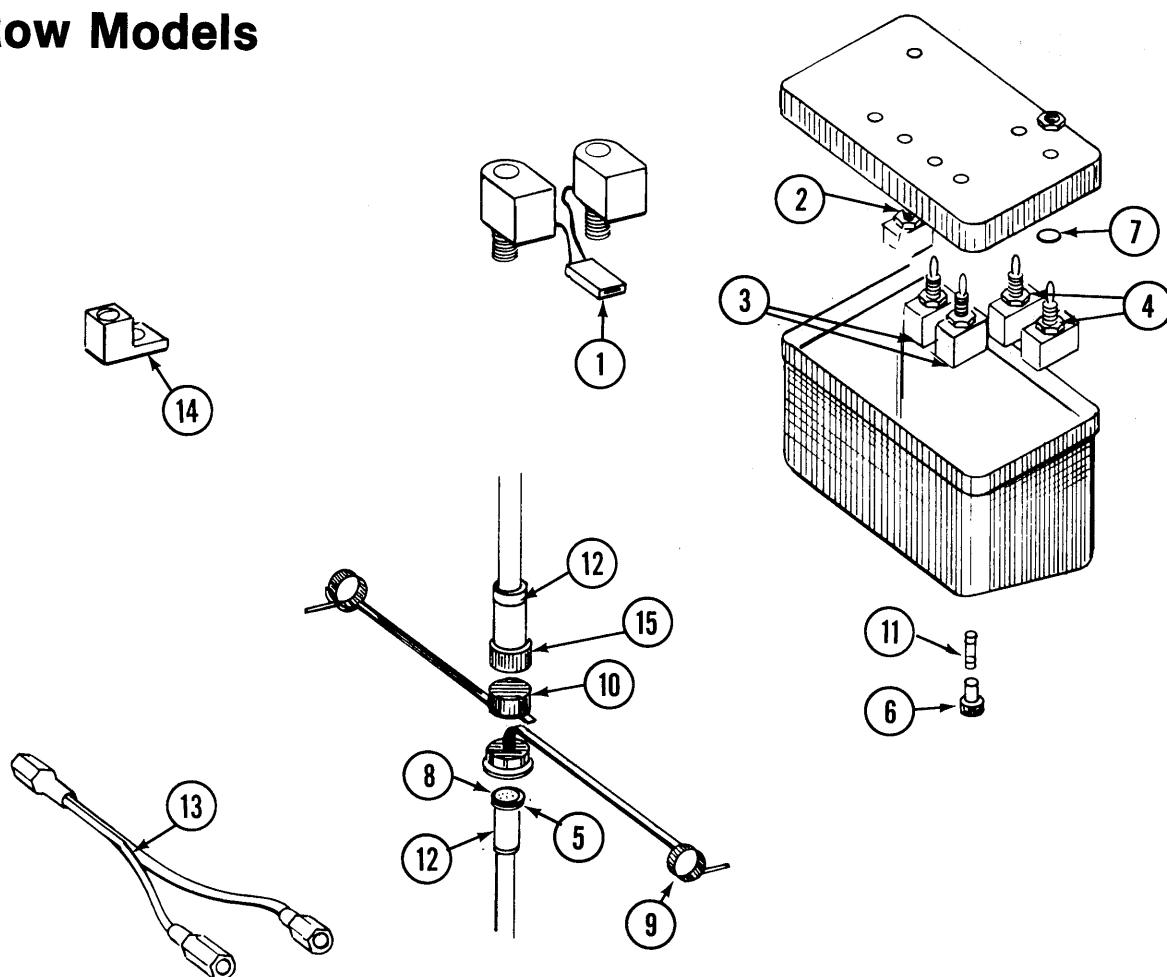

ITEM	PART NO.	DESCRIPTION
1.	10269	Terminal, Male Tab
2.	A2528	Switch, 3 Position Toggle
3.	A2526	Switch, 2 Way Momentary Contact
4.	A2527	Switch, 2 Position Toggle (Point Row)
5.	D4565	Connector
6.	A2612	Fuse Holder
7.	D3860	O-Ring
8.	D4613	Seal, Peripheral
9.	D4563	Dust Cap
10.	D4564	Dust Cover
11.	D2829	Fuse, AGC-15
12.	A3492	Cable Clamp w/Screws and Inserts
13.	A3589	Harness
14.	A3584	Clamp, Ground
15.	A3491	Connector w/Coupling Ring
	R0807	Coupling Ring
A.	A3871	Control Box Assembly w/Harness, 8 Row 30 and Wide
B.	A3866	Wiring Harness, Tractor to Valve Block Assembly on Hitch, 8 Row 30, 180"
	A3885	Wiring Harness, Tractor to Valve Block Assembly on Hitch, 8 Row 36, 198"
C.	A3869	Wiring Harness, Valve Block Assembly on Hitch to Valve Block Assembly on Main Frame, 8 Row 30 and Wide
D.	A3751	Wiring Harness, Point Row (2 Per Planter), Valve Block Assembly on Main Frame to Clutch, 8 Row 30 and Wide

HYDRAULIC SYSTEM, MARKER

8 Row Models

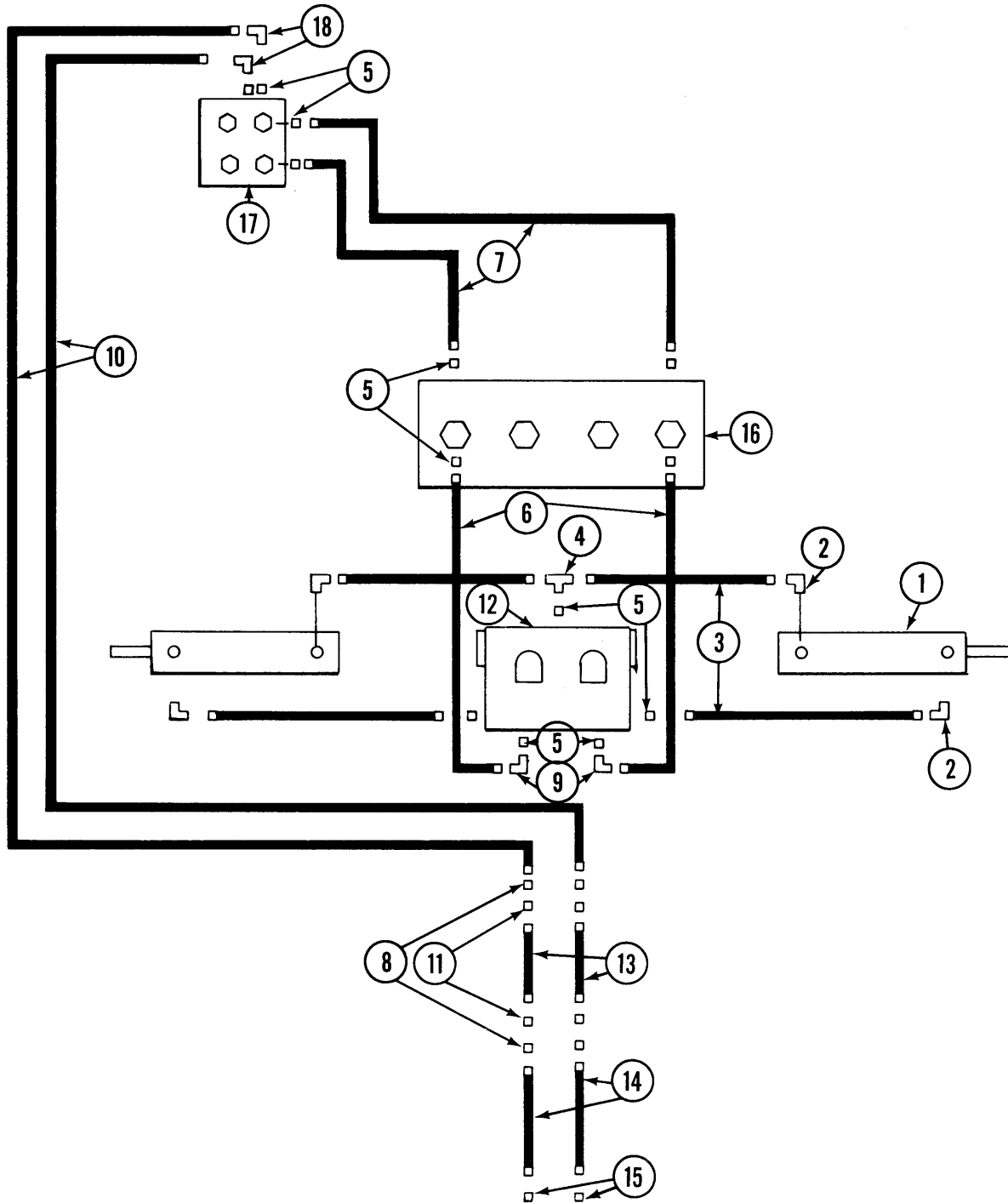

HYDRAULIC SYSTEM, MARKER

ITEM	PART NO.	DESCRIPTION
1.		Cylinder, See Marker Cylinder Page
2.	2501-08-08	Elbow
3.	A3111	Hose Assembly, 3/8" x 200", 8 Row 30
	A1057	Hose Assembly, 3/8" x 216", 8 Row 36
4.	6600-08	Tee, Swivel
5.	6400-08	Connector, Male O-Ring
6.	A1022	Hose Assembly, 3/8" x 60"
7.	A1018	Hose Assembly, 3/8" x 40"
8.	2700-08	Bulkhead Tube Union
9.	6500-08	Elbow, Swivel
10.	A1092	Hose Assembly, 3/8" x 104"
11.	306-08	Lock Nut, 3/4" - 16
12.		Block, See Frame Assembly Page
13.	A1020	Hose Assembly, 3/8" x 48", 8 Row 30
	A1055	Hose Assembly, 3/8" x 66", 8 Row 36
14.	A1009	Hose Assembly, 3/8" x 117"
15.	D4086	Tip, Pioneer Male
16.		Block, See Lift Arm and Bell Assembly Page
17.		Block, See Axle and Rotation Assembly Page
18.	6500-08	Elbow, 8 Row 36 Only

HYDRAULIC SYSTEM, PLANTER LIFT

8 Row Models

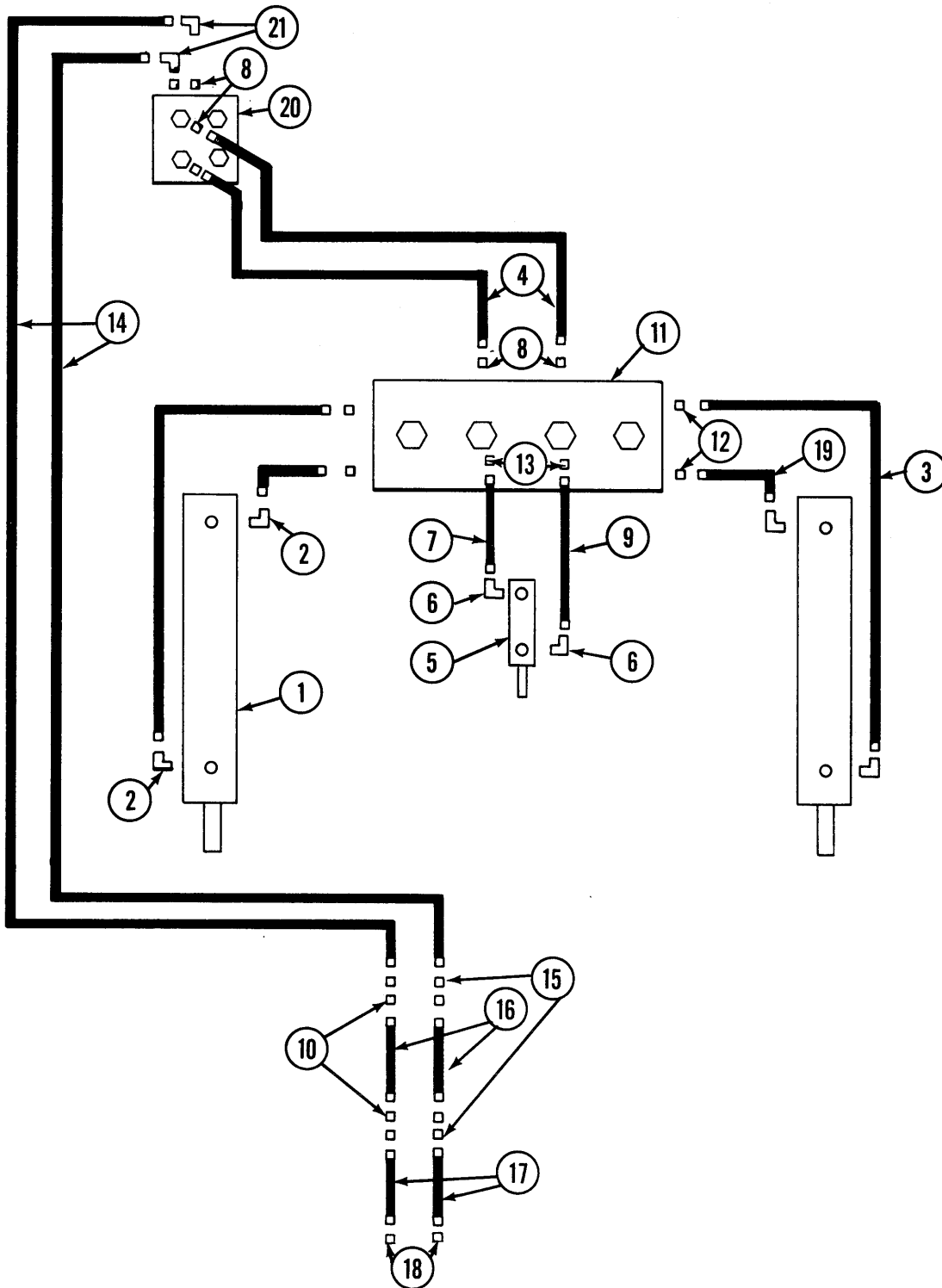

HYDRAULIC SYSTEM, PLANTER LIFT

ITEM	PART NO.	DESCRIPTION
1.		Cylinder, See Lift Cylinder Page
2.	2501-08-08	Elbow
3.	A1020	Hose Assembly, 3/8" x 48"
4.	A1404	Hose Assembly, 3/8" x 41"
5.		Cylinder, See Lift Lock Cylinder Page
6.	2501-06-04	Elbow
7.	A1149	Hose Assembly, 1/4" x 27"
8.	6400-10	Connector, Male O-Ring
9.	A1138	Hose Assembly, 1/4" x 29"
10.	306-10	Lock Nut, 7/8" - 14
11.		Block, See Lift Arm and Bell Assembly Page
12.	6400-08	Connector, Male O-Ring
13.	6400-06-08	Connector, Male O-Ring
14.	A1421	Hose Assembly, 1/2" x 107"
15.	2700-10	Bulkhead Tube Union
16.	A1420	Hose Assembly, 1/2" x 48", 8 Row 30
	A1422	Hose Assembly, 1/2" x 66", 8 Row 36
17.	A1419	Hose Assembly, 1/2" x 117"
18.	D4086	Tip, Pioneer Male
19.	A1018	Hose Assembly, 3/8" x 40"
20.		Block, See Axle and Rotation Assembly Page
21.	6500-10	Elbow, 8 Row 36 Only

HYDRAULIC SYSTEM, TONGUE/ROTATION

8 Row Models

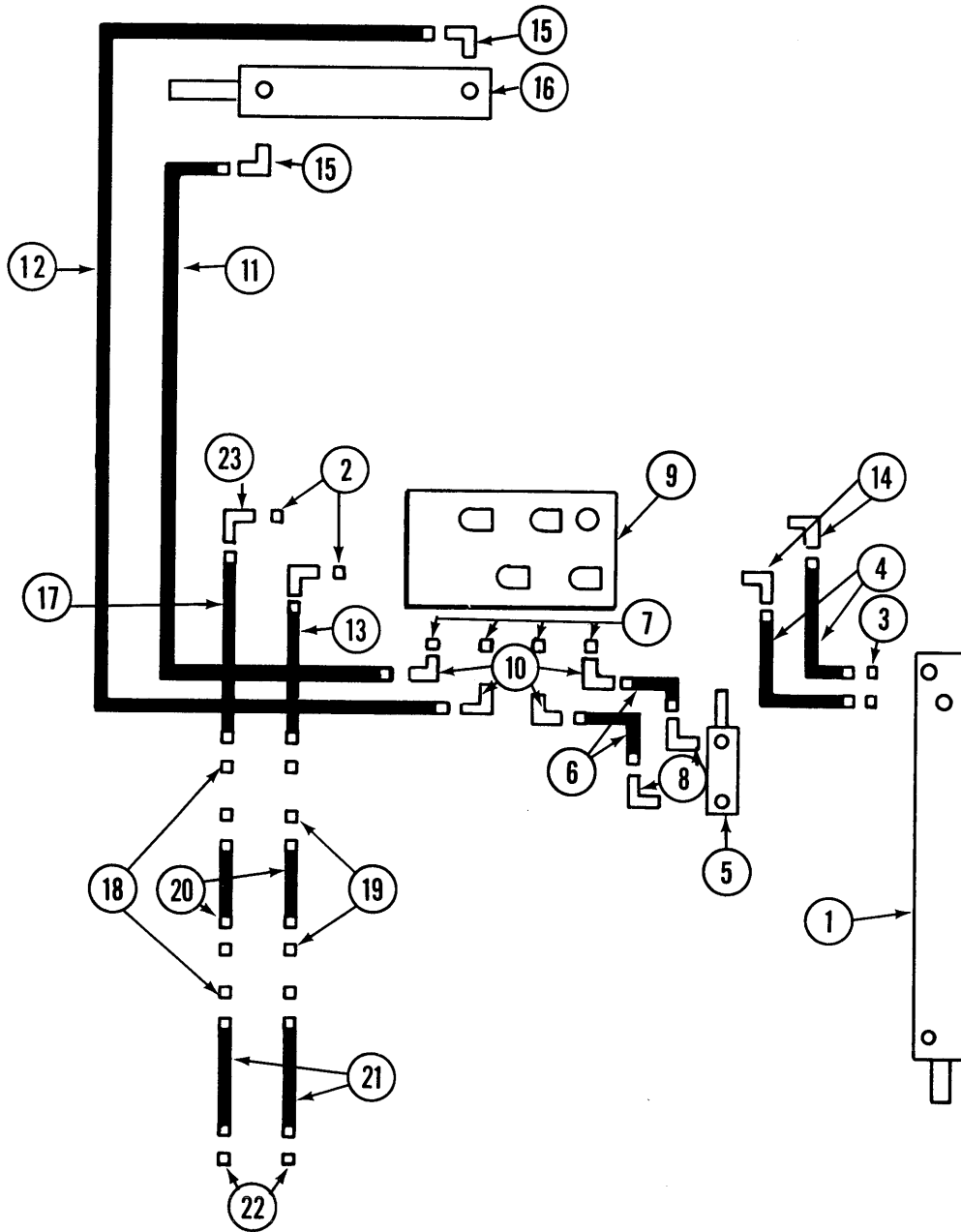

HYDRAULIC SYSTEM, TONGUE/ROTATION

ITEM	PART NO.	DESCRIPTION
1.		Cylinder, See Tongue Cylinder Page
2.	6400-08	Connector, Male O-Ring
3.	2404-08-08	Adapter, Straight Male
4.	A1085	Hose Assembly, 3/8" x 24 1/2"
5.		Cylinder, See Tongue Lock Cylinder Page
6.	A1148	Hose Assembly, 1/4" x 16"
7.	6400-06-08	Connector, Male O-Ring
8.	2501-06-04	Elbow
9.		Block, See Inner Hitch Assembly Page
10.	6500-06	Elbow
11.	A1105	Hose Assembly, 1/4" x 125"
12.	A1134	Hose Assembly, 1/4" x 116"
13.	A3110	Hose Assembly, 3/8" x 12"
14.	6801-08	Elbow
15.	2501-06-08	Elbow
16.		Cylinder, See Rotation Cylinder Page
17.	A1000	Hose Assembly, 3/8" x 15"
18.	2700-08	Bulkhead Tube Union
19.	306-08	Lock Nut, 3/4" - 16
20.	A1020	Hose Assembly, 3/8" x 48", 8 Row 30
	A3111	Hose Assembly, 3/8" x 66", 8 Row 36
21.	A1009	Hose Assembly, 3/8" x 117"
22.	D4086	Tip, Pioneer Male
23.	6500-08	Elbow

SOLENOID VALVE

ITEM	PART NO.	DESCRIPTION
1.	R0760	Plate
2.	R0761	Hex Nut
3.	R0762	Coil
4.	R0763	Cartridge
A.	A2484	Solenoid Valve Complete
B.	R0764	Seal Kit, Includes: (2) O-Rings (1) Backup Ring

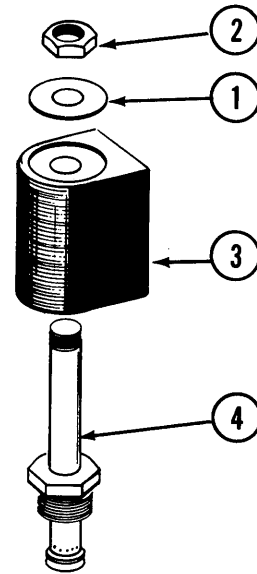

FLOW CONTROL VALVE

ITEM	PART NO.	DESCRIPTION
A.	A3413	Flow Control Valve
B.	R0764	Seal Kit, Includes: (2) O-Rings (1) Backup Ring

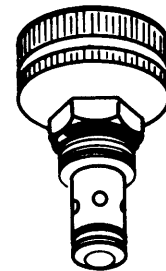

PRESSURE RELIEF VALVE

ITEM	PART NO.	DESCRIPTION
A.	A3598	Pressure Relief Valve, 500 PSI
B.	R0764	Seal Kit, Includes: (2) O-Rings (1) Backup Ring



TONGUE CYLINDER

8 Row 30

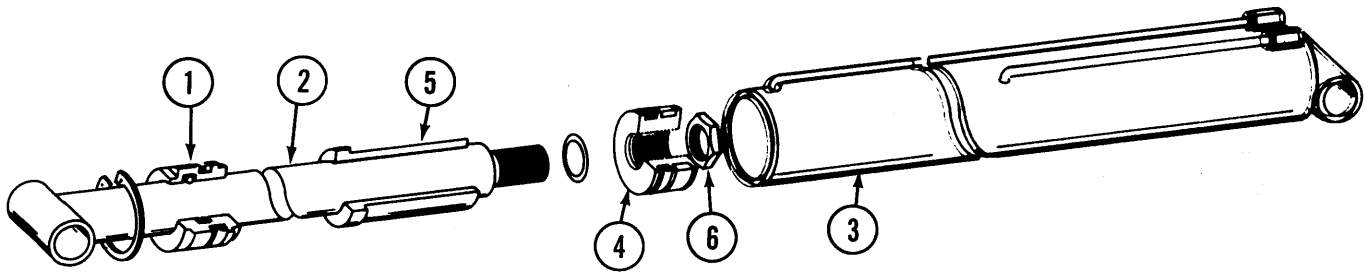

ITEM	PART NO.	DESCRIPTION
1.	D4528	Gland
2.	A3660	Shaft Assembly
3.	A3661	Tube Assembly
4.	D4527	Piston
5.	A3445	Stroke Collar
6.	10509	Hex Jam Nut, 1 1/4" - 12 UNF
A.	A3658	Cylinder w/Extended Case, 3" x 24"
B.	R0790	Seal Kit, Includes: (2) O-Rings, (1) BU Ring, (1) Wiper, (1) Retaining Ring, (1) Wear Ring, (1) T-Seal, (1) Polypak

TONGUE CYLINDER

8 Row Wide

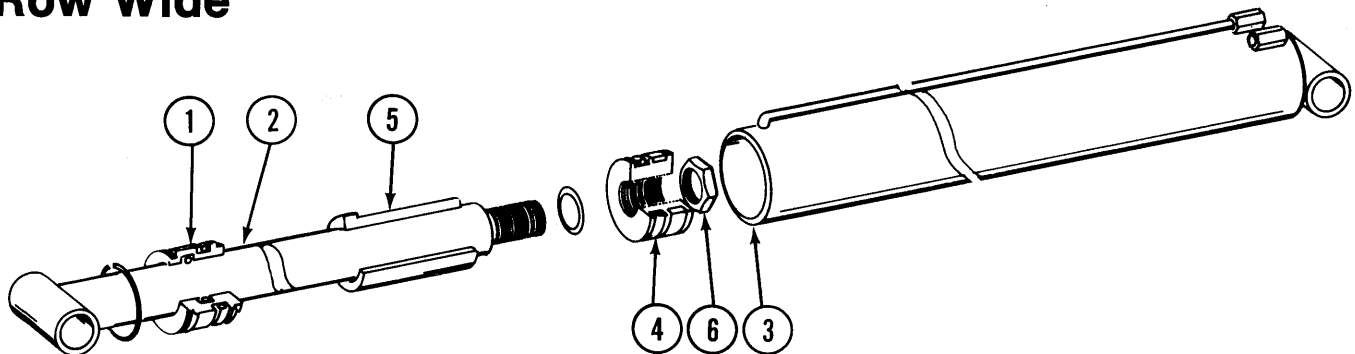

ITEM	PART NO.	DESCRIPTION
1.	D4528	Gland
2.	A3662	Shaft Assembly
3.	A3663	Tube Assembly
4.	D4527	Piston
5.	A3445	Stroke Collar
6.	10509	Hex Jam Nut, 1 1/4" - 12 UNF
A.	A3659	Cylinder w/Extended Case, 3" x 44"
B.	R0790	Seal Kit, Includes: (2) O-Rings, (1) BU Ring, (1) Wiper, (1) Retaining Ring, (1) Wear Ring, (1) T-Seal, (1) Polypak

TONGUE LOCK CYLINDER

8 Row Models

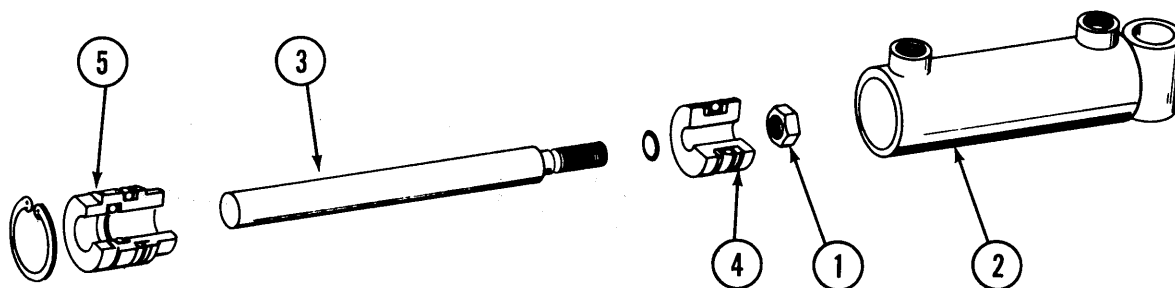

ITEM	PART NO.	DESCRIPTION
1.	10289	Hex Nut, 1/2" - 20
2.	A3442	Tube Assembly
3.	D4522-01	Shaft
4.	D4523	Piston
5.	D4524	Gland
A.	A3443	Cylinder, 1 1/2" x 2"
B.	R0777	Seal Kit, Includes: (1) O-Rings, (1) Wiper, (1) Retaining Ring, (1) Polypak, (1) T-Seal w/BU Rings

LIFT LOCK CYLINDER

8 Row Models

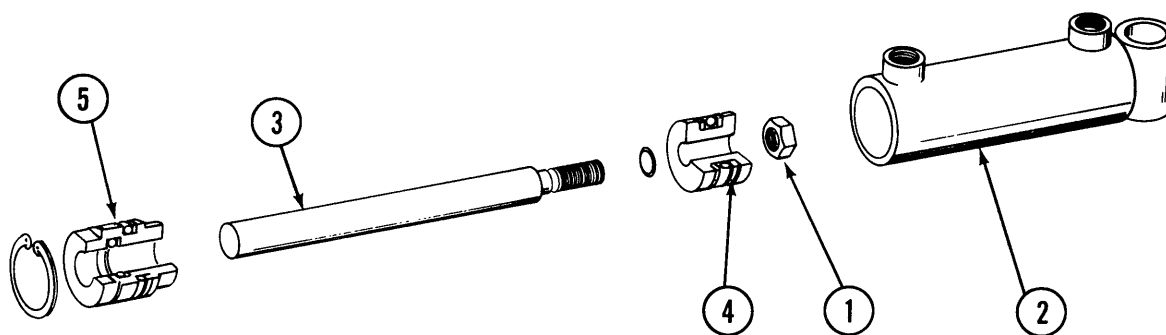

ITEM	PART NO.	DESCRIPTION
1.	10289	Hex Nut, 1/2" - 20
2.	A3753	Tube Assembly
3.	D4522-01	Shaft
4.	D4523	Piston
5.	D4524	Gland
A.	A3752	Cylinder, 1 1/2" x 2 1/2"
B.	R0777	Seal Kit, Includes: (2) O-Rings, (1) Wiper, (1) Retaining Ring, (1) Polypak, (1) T-Seal w/BU Rings

LIFT CYLINDER

8 Row Models

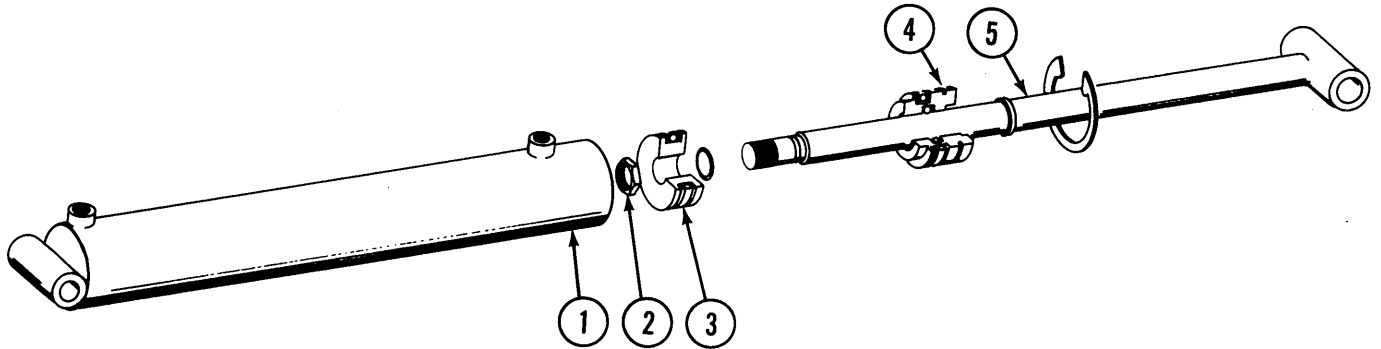

ITEM	PART NO.	DESCRIPTION
1.	A3684	Tube Assembly
2.	10509	Hex Jam Nut, 1 1/4" - 12 UNF
3.	D4521	Piston
4.	D4509	Gland
5.	A3683	Shaft Assembly
A.	A3667	Cylinder, 3 1/2" x 20"
B.	R0778	Seal Kit, Includes: (2) O-Rings, (2) BU Rings, (1) Retaining Ring, (1) Wiper, (1) Polypak, (1) T-Seal w/BU

ROTATION CYLINDER

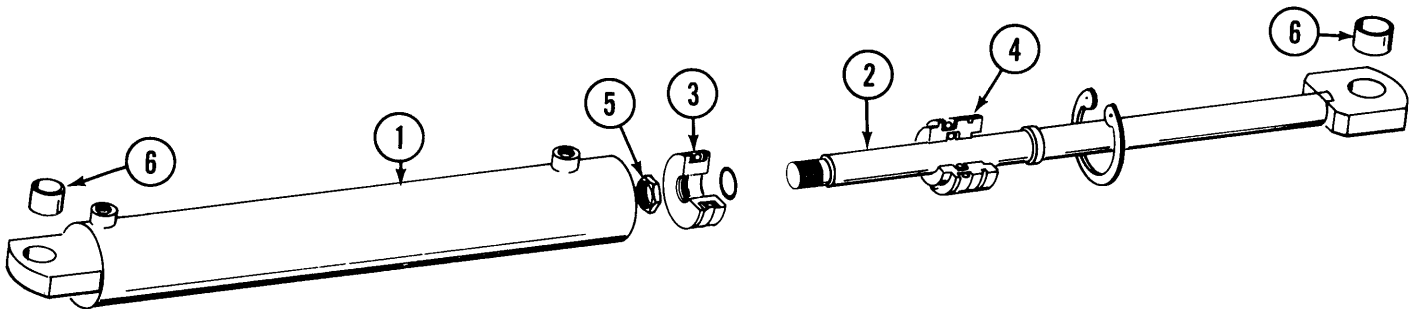

ITEM	PART NO.	DESCRIPTION
1.	A3772	Tube Assembly
2.	A3773	Shaft Assembly
3.	D4510	Piston
4.	D4509	Gland
5.	10509	Hex Jam Nut, 1 1/4" - 12
6.	D5087	Spring Bushing
A.	A3771	Cylinder, 3 1/2" x 10"
B.	R0774	Seal Kit, Includes: (2) O-Rings, (2) BU Rings, (1) Retaining Ring, (1) Wear Ring, (1) Wiper, (1) Polypak, (1) T-Seal w/BU Rings

MARKER CYLINDER

8 Row Models

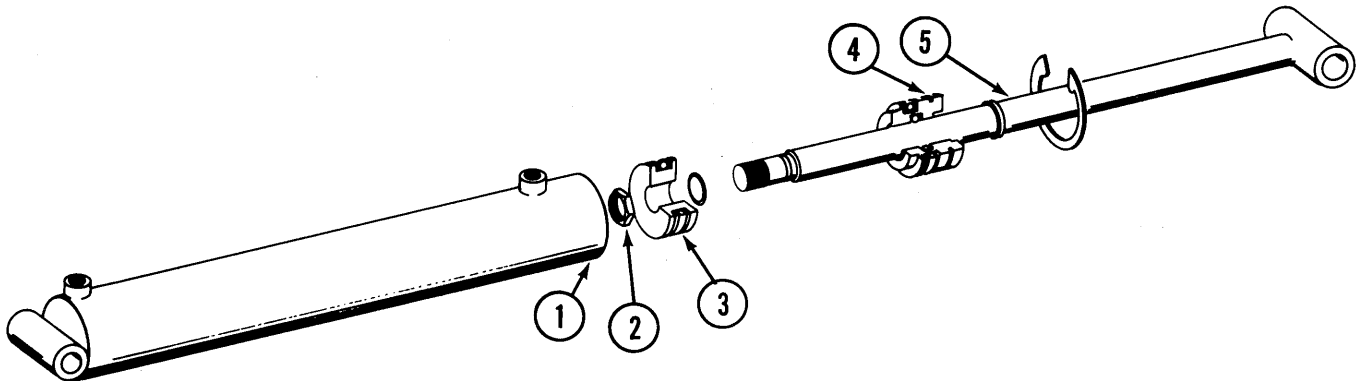

ITEM	PART NO.	DESCRIPTION
1.	A3514	Tube Assembly
2.	10327	Hex Nut, 3/4" - 16 UNF, Grade 2
3.	D4632	Piston
4.	D4634	Gland
5.	A3515	Shaft Assembly
A.	A3439	Cylinder, 2" x 20"
B.	R0808	Seal Kit, Includes: (2) O-Rings, (1) Retaining Ring, (1) Wiper, (1) Polypak, (1) T-Seal w/BU Rings

FERTILIZER OPENER MOUNTS

8 Row Models

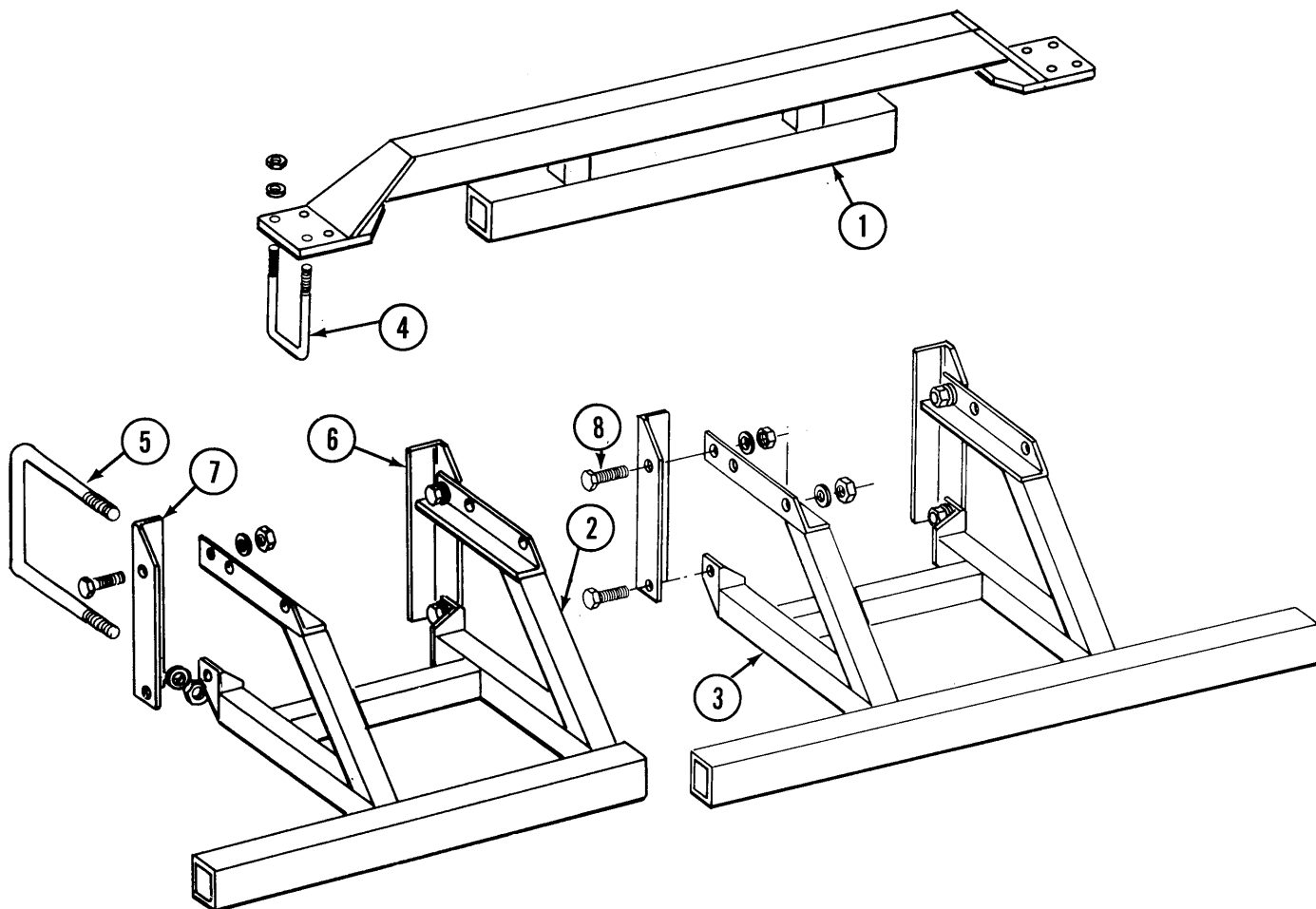

ITEM	PART NO.	DESCRIPTION
1.	A3889	Opener Mount, Center, 8 Row 30
2.	A3888	Opener Mount, R.H. (shown), 8 Row 30
	A3887	Opener Mount, L.H., 8 Row 30
3.	A3886	Opener Mount, Standard, 8 Row 30 and Wide
4.	D1339	U-Bolt, 2 1/2" x 2 1/2" x 1/2" - 13
	10228	Lock Washer, 1/2"
	10102	Hex Nut, 1/2" - 13
5.	D1747	U-Bolt, 5" x 7" x 3/4" - 10
	10231	Lock Washer, 3/4"
	10105	Hex Nut, 3/4" - 10
6.	D4782	Angle, L.H.
7.	D4781	Angle, R.H.
8.	10007	HHCS, 5/8" - 11 x 1 1/2"
	10230	Lock Washer, 5/8"
	10104	Hex Nut, 5/8" - 11

FERTILIZER OPENER

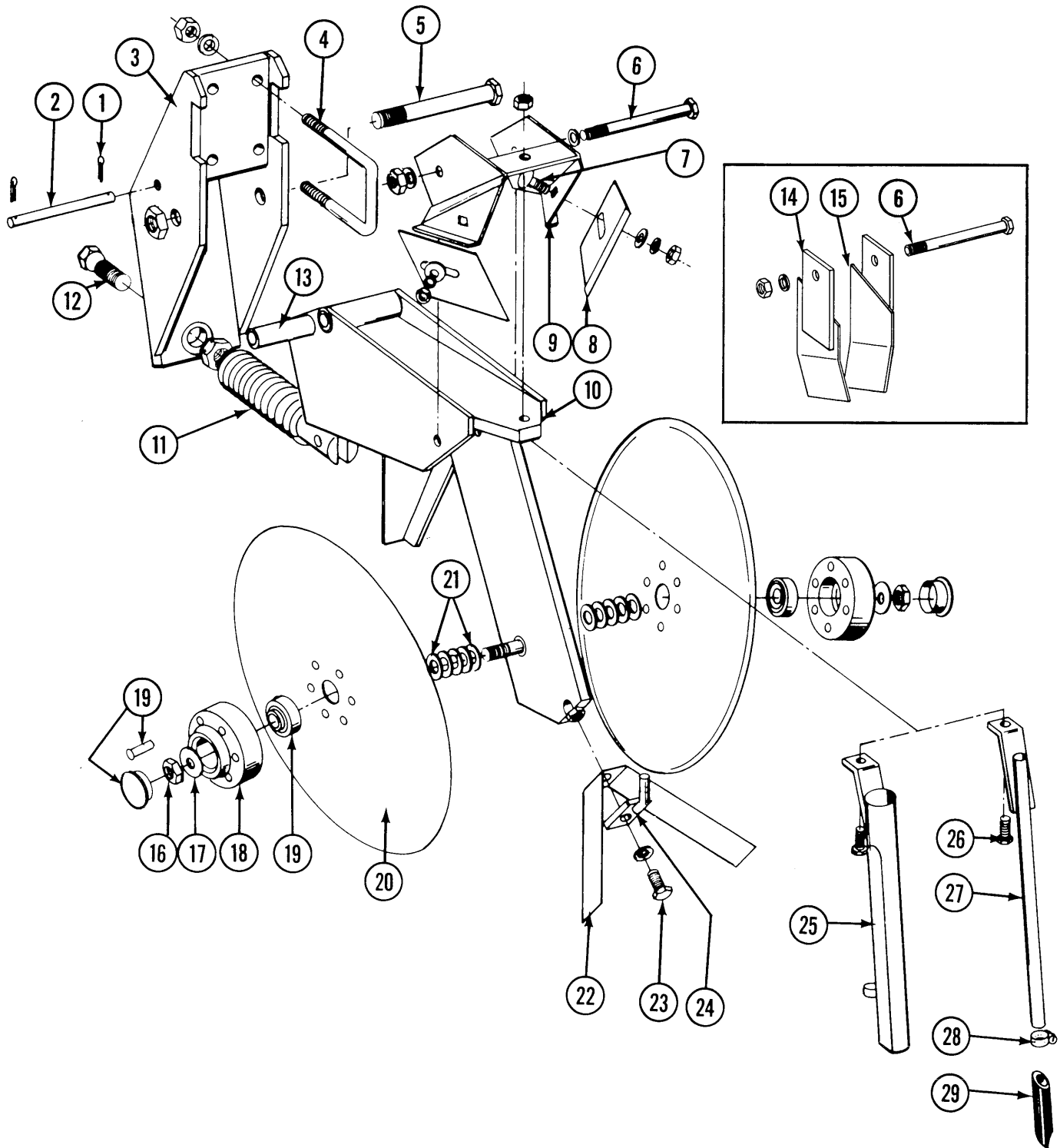

FERTILIZER OPENER

ITEM	PART NO.	DESCRIPTION
1.	10451	Cotter Pin, 1/8" x 1"
2.	D1657	Pin, Lockup
3.	A0785	Bracket, Mounting
4.	D1339	U-Bolt, 2 1/2" x 2 1/2"x1/2"-13
	10228	Lock Washer, 1/2"
	10102	Hex Nut, 1/2"-13
5.	10046	HHCS, 5/8" - 11 x 5"
	10107	Lock Nut, 5/8" - 11
6.	10045	HHCS, 1/2" - 13 x 4 1/2"
	10216	Flat Washer, 1/2"
	10111	Lock Nut, 1/2" - 13
7.	10305	Carriage Bolt, 3/8" - 16 x 1"
	10210	Flat Washer 3/8" USS
	10229	Lock Washer, 3/8"
	10101	Hex Nut, 3/8" - 16
8.	D1673	Scraper, Standard
9.	A0810	Scraper Mount, Standard
10.	A0308	Shank
11.	A0328	Spring
12.	D0962	Hex Head Adjusting Bolt, 5/8" -18
	10499	Jam Nut, 5/8" - 18
13.	D0487	Bushing
14.	A3665	Scraper, L.H., Special
15.	A3666	Scraper, R.H., Special
16.	10503	Jam Nut, R.H., 5/8" - 11
	10504	Jam Nut, L.H., 5/8" - 11
17.	10204	Machinery Bushing, 21/32"
18.	B0134	Hub
19.	1K139	Bearing W/Cap and Rivets
	D1132	Cap
	10651	Rivet, 1/4" x 1 3/8"
20.	D1030	Blade
21.	10213	Machine Bushing, 11/16"
22.	D2589	Scraper, Inner
23.	10019	HHCS 5/16" - 18 x 1"
	10232	Lock Washer, 5/16"
24.	A0312	Mount
25.	A1369	Drop Tube, Dry Fertilizer
26.	10133	HHCS, 5/16" - 18 x 1 1/2"
	10109	Lock Nut, 5/16" - 18
27.	A0318	Drop Tube, Liquid Fertilizer
28.	10681	Clamp, Hose, No. 6
29.	D1797	Extension
A.	A0320	Disk and Bearing Assembly (Includes Items 18-20)
B.	6156X	Double Disk Fertilizer Opener With U-Bolts, Less Drop Tubes (Standard Scrapers)

DRY FERTILIZER HOPPER ASSEMBLY

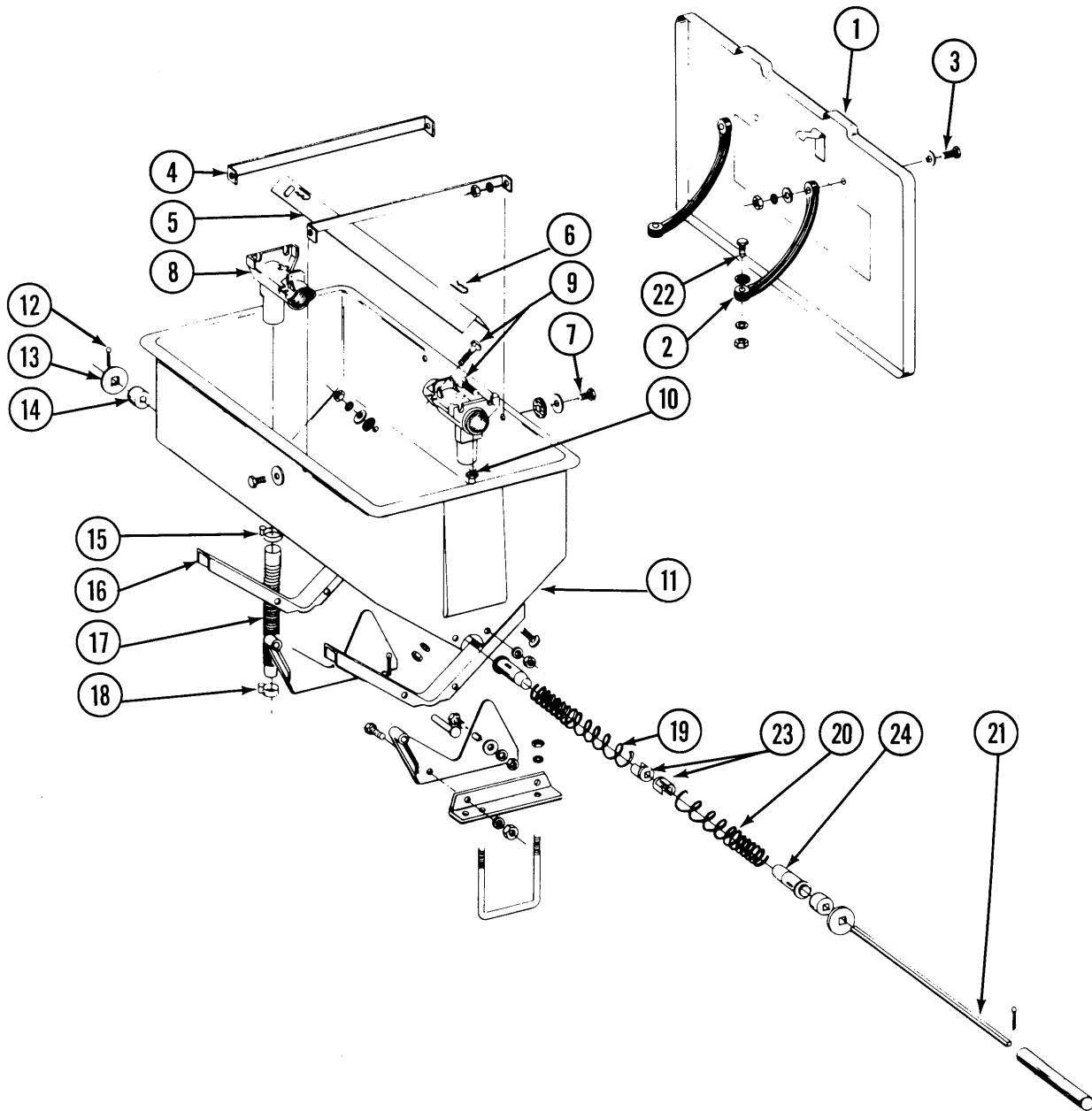

DRY FERTILIZER HOPPER ASSEMBLY

ITEM	PART NO.	DESCRIPTION
1.	A2101	Lid, Includes Clips and Pop Rivets
	D1380	Clip
	10655	Pop Rivet, 3/16" x 13/32"
2.	D1210	Strap, Rubber
3.	10171	HHCS, 5/16" - 18 x 1 1/4"
	10219	Washer, 5/16" USS
	10232	Lock Washer, 5/16"
	10106	Hex Nut, 5/16" - 18
4.	D1209	Strap, Reinforcing
5.	D1207	Baffle
6.	10670	Hair Pin Clip, No. 3
7.	10171	HHCS, 5/16" - 18 x 1 1/4"
	10201	Washer, Special
	D1213	Washer, Rubber
	10232	Lock Washer, 5/16"
	10106	Hex Nut, 5/16" - 18
8.	D1200	Housing, Outlet
9.	10303	Carriage Bolt, 5/16" - 18 x 1", Grade 2
	10219	Washer, 5/16" USS
	10232	Lock Washer, 5/16"
	10106	Hex Nut, 5/16" - 18
10.	10641	Grease Fitting, 1/8" NPT, 45°
11.	D1379	Hopper
12.	10464	Cotter Pin, 3/16" x 1"
13.	D1212	Washer, Special
14.	D1206	Bearing
15.	10676	Clamp, No. 36
16.	D1208	Saddle
17.	D3790	Tube, Rubber
18.	10672	Clamp, No. 28
19.	D1204	Spring, R.H., Regular Rate
	D4476	Spring, R.H., High Rate
20.	D1205	Spring, L.H., Regular Rate
	D4477	Spring, L.H., High Rate
21.	D1201	Shaft
22.	10133	HHCS, 5/16" - 18 x 1 1/2"
	10219	Washer, 5/16"
	10232	Lock Washer, 5/16"
	10106	Hex Nut, 5/16" - 18
23.	D1203	Plug
24.	D1202	Guide

DRY FERTILIZER TRANSMISSION AND DRIVE LINE

8 Row Models

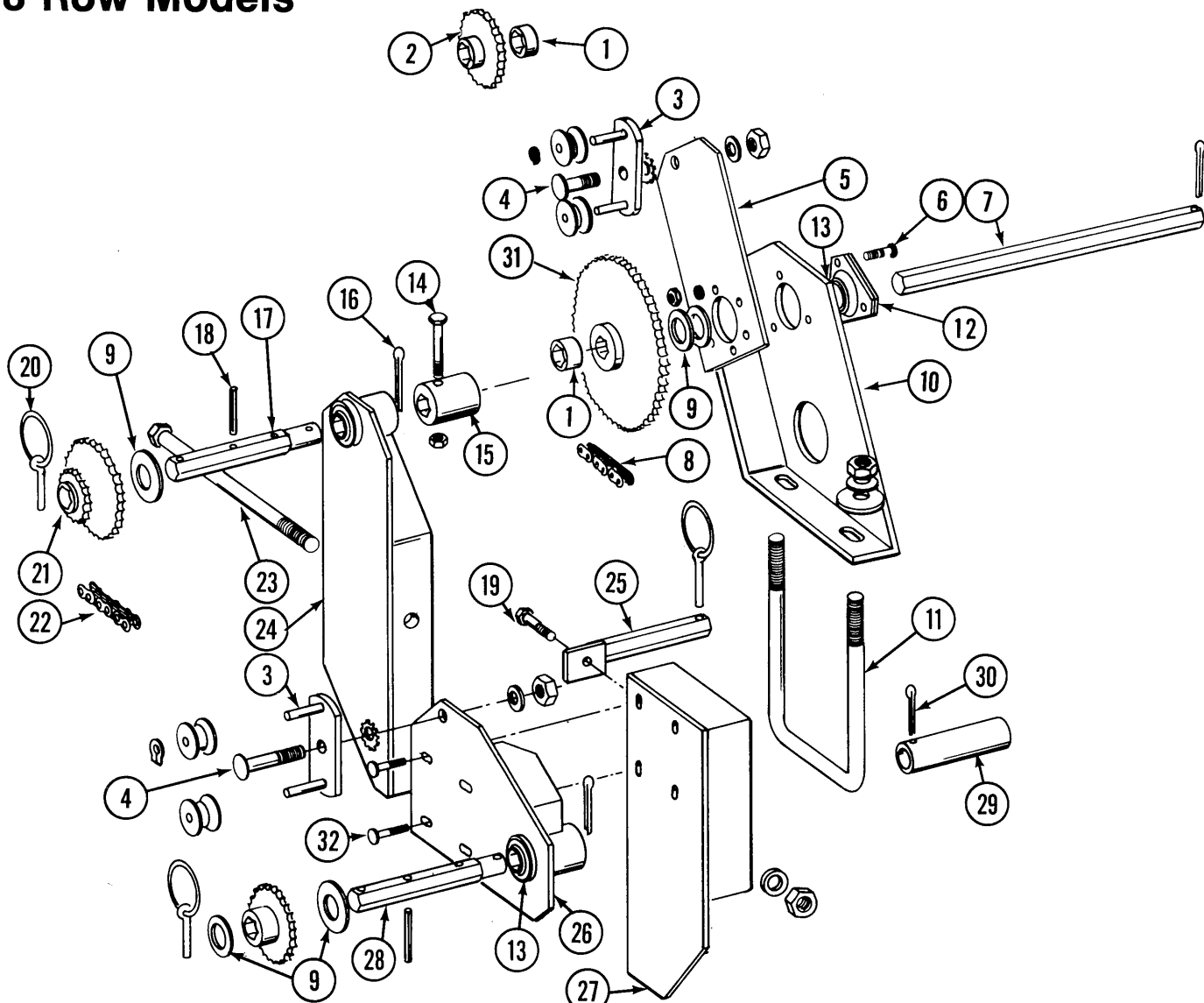

ITEM	PART NO.	DESCRIPTION
1.	D0917 10145	Lock Collar, Less Set Screws Set Screw, 5/16" - 18 x 1/2"
2.	2500-37	Sprocket, 24 Tooth
3.	A0289 D1067 10435	Idler w/Spools and Rings Spool Ring
4.	10313 10527 10216 10102	Carriage Bolt, 1/2" - 13 x 1 1/2" Washer, Internal/External, 1/2" Washer, 1/2" Hex Nut, 1/2" - 13
5.	D4762	Bracket, Idler
6.	10338 10232 10106	Carriage Bolt, 5/16" - 18 x 1 1/4" Lock Washer, 5/16" - 18 Hex Nut, 5/16" - 18
7.	D5134-7.125	Shaft
8.	3300-109	Chain, No. 2040, 109 Pitch Including Connector Link and Offset Link
	R0199	Offset Link, No. 2040
	R0194	Connector Link, No. 2040
9.	10233	Machinery Bushing, 1"

DRY FERTILIZER TRANSMISSION AND DRIVE LINE

ITEM	PART NO.	DESCRIPTION
10.	A1784	Support, R.H.
	A2721	Support, L.H. (Shown)
11.	D1134	U-Bolt, 7" x 5" x 5/8" - 11
	10217	Washer, 5/8" USS
	10230	Lock Washer, 5/8"
	10104	Hex Nut, 5/8" - 11
12.	3400-01	Flangette
13.	2100-03	Bearing, 7/8" Hex Bore
14.	10339	HHCS, 5/16" - 18 x 2", Grade 2
	10109	Lock Nut, 5/16" - 18
15.	D4749	Coupler
16.	10463	Cotter Pin, 1/4" x 1 1/2"
17.	D4922	Shaft, 6 5/8", Used with 1 5/8" Sprocket
	D4748	Shaft, 6 3/8", Used with 1 3/8" Sprocket
18.	10602	Spring Pin, 1/4" x 1 1/2"
19.	10019	HHCS, 5/16" - 18 x 1"
	10109	Lock Nut, 5/16" - 18
20.	D2558	Lynch Pin, 1/4"
21.	2500-03	Sprocket, 16-30 Tooth, 1 5/8"
	2500-12	Sprocket, 18-36 Tooth, 1 5/8"
	2500-14	Sprocket, 24 Tooth, 1 5/8"
	2500-27	Sprocket, 16-30 Tooth, 1 3/8"
	2500-36	Sprocket, 18-36 Tooth, 1 3/8"
	2500-37	Sprocket, 24 Tooth, 1 3/8"
22.	3300-58	Chain, No. 2040, 58 Pitch Including Connector Link
	R0194	Connector Link, No. 2040
23.	10012	HHCS, 5/8" - 11 x 6 1/2"
	10230	Lock Washer, 5/8" - 11
	10104	Hex Nut, 5/8" - 11
24.	A3601	Transmission Mount, Rear, L.H.
	A3602	Transmission Mount, Rear, R.H. (Shown)
25.	A1786	Rod, Sprocket Storage
26.	A3900	Mounting Plate, R.H. (Shown)
	A3901	Mounting Plate, L.H.
27.	A3899	Transmission Mount, Front, L.H.
	A3898	Transmission Mount, Front, R.H. (Shown)
28.	D5214	Shaft, 7 1/8", Used with 1 5/8" Sprocket
	D5765	Shaft, 6 7/8" Used with 1 3/8" Sprocket
29.	D5218	Coupler, 4"
30.	10460	Cotter Pin, 1/4" x 2"
31.	B0138	Sprocket, 48 Tooth
32.	10305	Carriage Bolt, 3/8" - 16 x 1"
	10210	Washer, 3/8"
	10229	Lock Washer, 3/8"
	10101	Hex Nut, 3/8" - 16

DRY FERTILIZER COUPLERS AND HOPPER MOUNT

8 Row Models

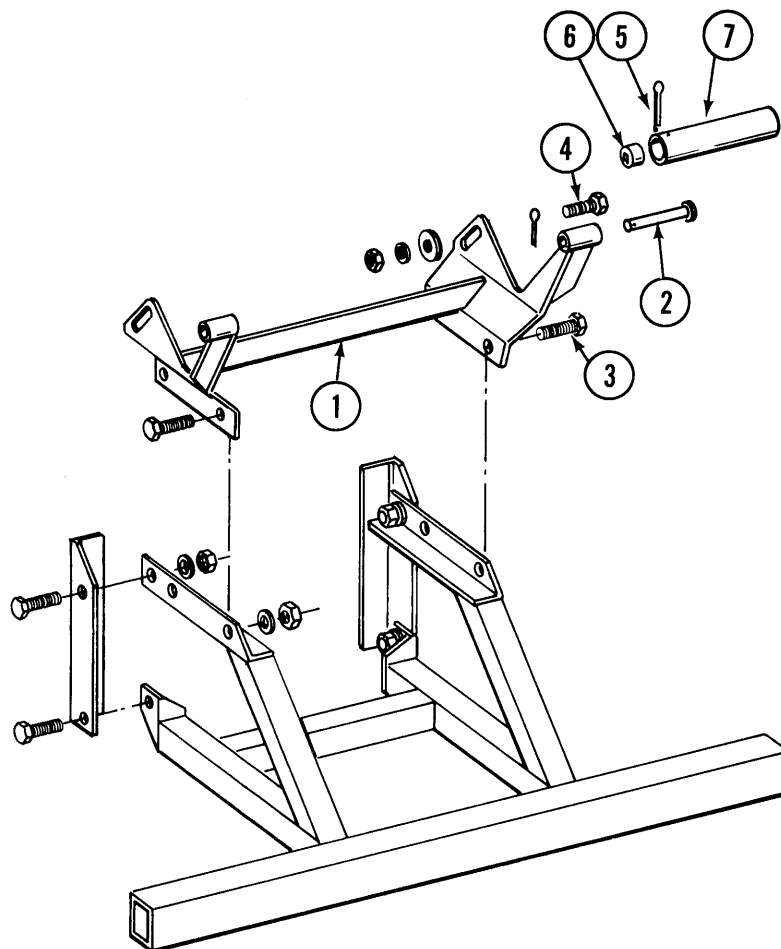

ITEM	PART NO.	DESCRIPTION
1.	A3627	Hopper Support
2.	10561	Clevis Pin, 1/2" x 3"
	10451	Cotter Pin, 1/8" x 1"
3.	10017	HHCS, 1/2" - 13 x 1 1/2"
	10228	Lock Washer, 1/2"
	10102	Hex Nut, 1/2" - 13
4.	10037	HHCS, 1/2" - 13 x 1 1/4"
	10206	Washer, 1/2" SAE
	10228	Lock Washer, 1/2"
	10102	Hex Nut, 1/2" - 13
5.	10462	Cotter Pin, 3/16" x 2"
6.	D2768	Insert, Square
7.	A3599	Coupler, 15 5/8", 8 Row 30
	A2312	Coupler, 23 1/8", 8 Row Wide

LIQUID FERTILIZER SQUEEZE PUMP

8 Row Models

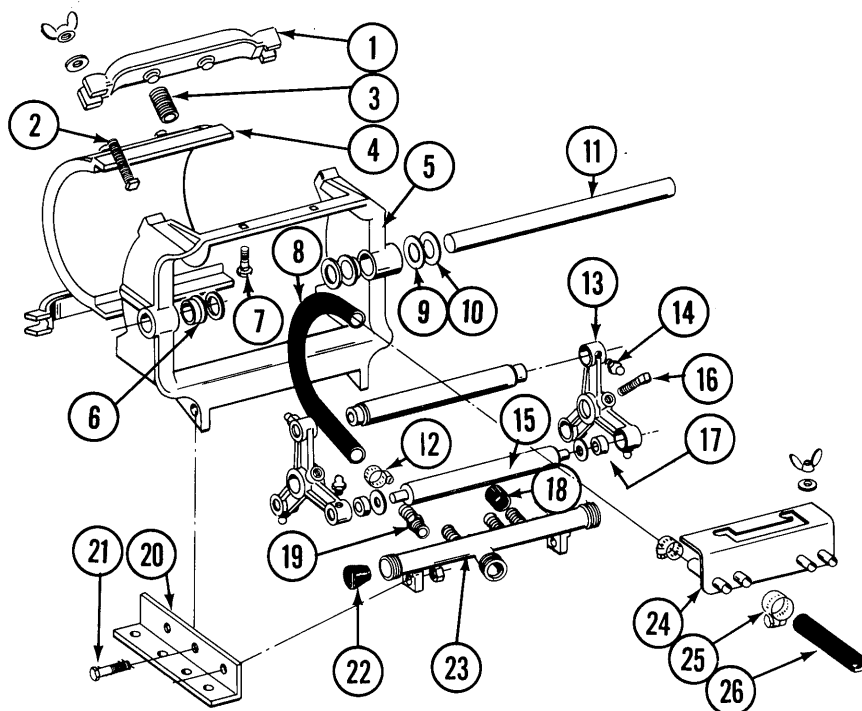

ITEM	PART NO.	DESCRIPTION
1.	R0216	Spring Anchor Bar
2.	10130	Sq. Head Machine Bolt, 5/16" - 18 x 1 3/4"
	10219	Washer, 5/16" USS
	10144	Wing Nut, 5/16" - 18
3.	R0214	Spring
4.	R0212	Plate
5.	R0208	Frame
6.	R0207	Bushing (Nylon)
7.	10303	Round Head Machine Bolt, 5/16" - 18 x 1"
	10219	Washer, 5/16" USS
	10144	Wing Nut, 5/16" - 18
8.	R0215	Metering Hose, 1/2" x 13"
9.	R0225	Shim, 1/32"
10.	R0226	Shim, 3/64"
11.	R0210	Shaft
12.	10681	Clamp, No. 6
13.	R0223	Roller Arm
14.	10640	Grease Fitting, 1/4" - 28
15.	R0209	Roller
16.	10131	Set Screw, 5/16" - 18 x 3/4"
17.	R0227	Bushing, Nylon
18.	R0211	Rubber Cap
19.	R0232	Hose Adapter
20.	R0213	Base Angle
21.	10004	HHCS, 3/8" - 16 x 1 1/4"
	10101	Hex Nut, 3/8" - 16
22.	R0217	Manifold Plug
23.	R0228	Intake Manifold
24.	R0224	Discharge Manifold
25.	10673	Clamp, No. 8
26.	4300-10	Hose, 1/2" x 60'
A.	A0321	Squeeze Pump Complete, 4 Rows

SQUEEZE PUMP MOUNTING BRACKETS, SPROCKETS AND DRIVE

8 Row Models

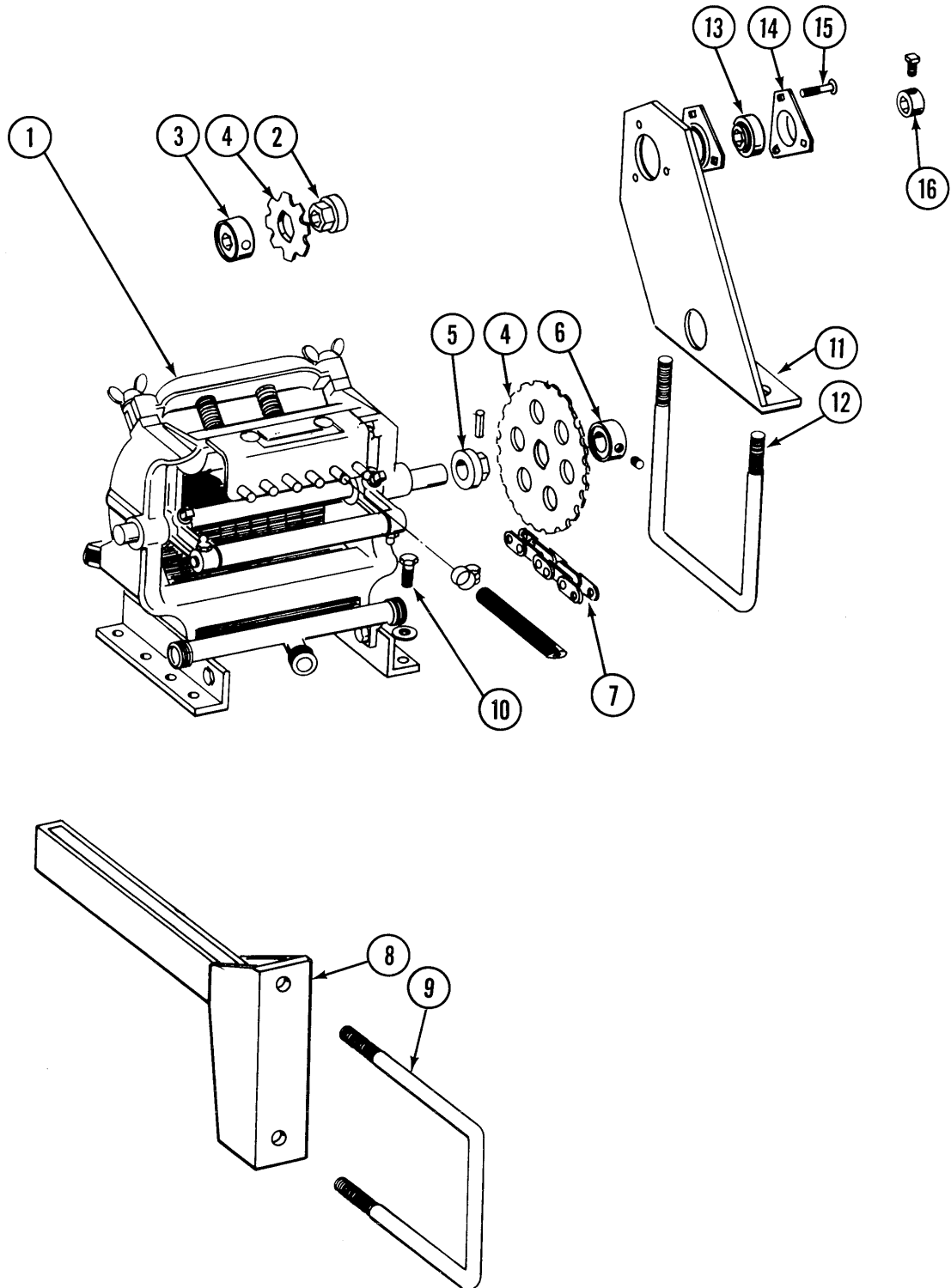

SQUEEZE PUMP MOUNTING BRACKETS, SPROCKETS AND DRIVE

ITEM	PART NO.	DESCRIPTION
1.		Squeeze Pump, See Liquid Fertilizer Squeeze Pump Page
2.	A2354	Adapter w/Set Screws
	10120	Set Screws, 3/8" - 16 x 1/2"
3.	A2355	Lock Collar w/Set Screws
	10120	Set Screw, 3/8" - 16 x 1/2"
4.	D1217	Sprocket, 8 Tooth
	D1218	Sprocket, 9 Tooth
	D1219	Sprocket, 10 Tooth
	D1220	Sprocket, 15 Tooth
	D1221	Sprocket, 22 Tooth
	D1222	Sprocket, 23 Tooth
	D1223	Sprocket, 26 Tooth
	D1225	Sprocket, 31 Tooth
5.	D1216	Adapter (Less Roll Pins) w/Set Screws
	10600	Roll Pin, 5/16" x 2 1/4"
	10120	Set Screw, 3/8" - 16 x 1/2"
6.	D1215	Lock Collar w/Set Screws
	10120	Set Screw, 3/8" - 16 x 1/2"
7.	3300-89	Chain, No. 2040, 89 Pitch Including Connector and Offset Link
	R0194	Connector Link, No. 2040
	R0199	Offset Link, No. 2040
8.	A2793	Mount
9.	D1113	U-Bolt, 5" x 7" x 5/8" -11
	10230	Lock Washer, 5/8"
	10104	Hex Nut, 5/8" - 11
10.	10067	HHCS, 7/16" - 14 x 3"
	10081	Washer, 7/16" USS
	10237	Lock Washer, 7/16"
	10100	Hex Nut, 7/16" - 14
11.	A1784	Bracket (Shown)
	A2721	Bracket
12.	D1134	U-Bolt, 7" x 5" x 5/8" -11
	10230	Lock Washer, 5/8"
	10104	Hex Nut, 5/8" - 11
13.	2100-03	Bearing, 7/8" Hex
14.	3400-01	Flangette
15.	10303	Carriage Bolt, 5/16" - 18 x 1"
	10232	Lock Washer, 5/16"
	10106	Hex Nut, 5/16" - 18
16.	D0917	Lock Collar, Less Set Screws
	10145	Set Screw, 5/16" - 18 x 1/2"

LIQUID FERTILIZER TANKS, SADDLES, MOUNTS, HOSES AND FITTINGS

8 Row Models

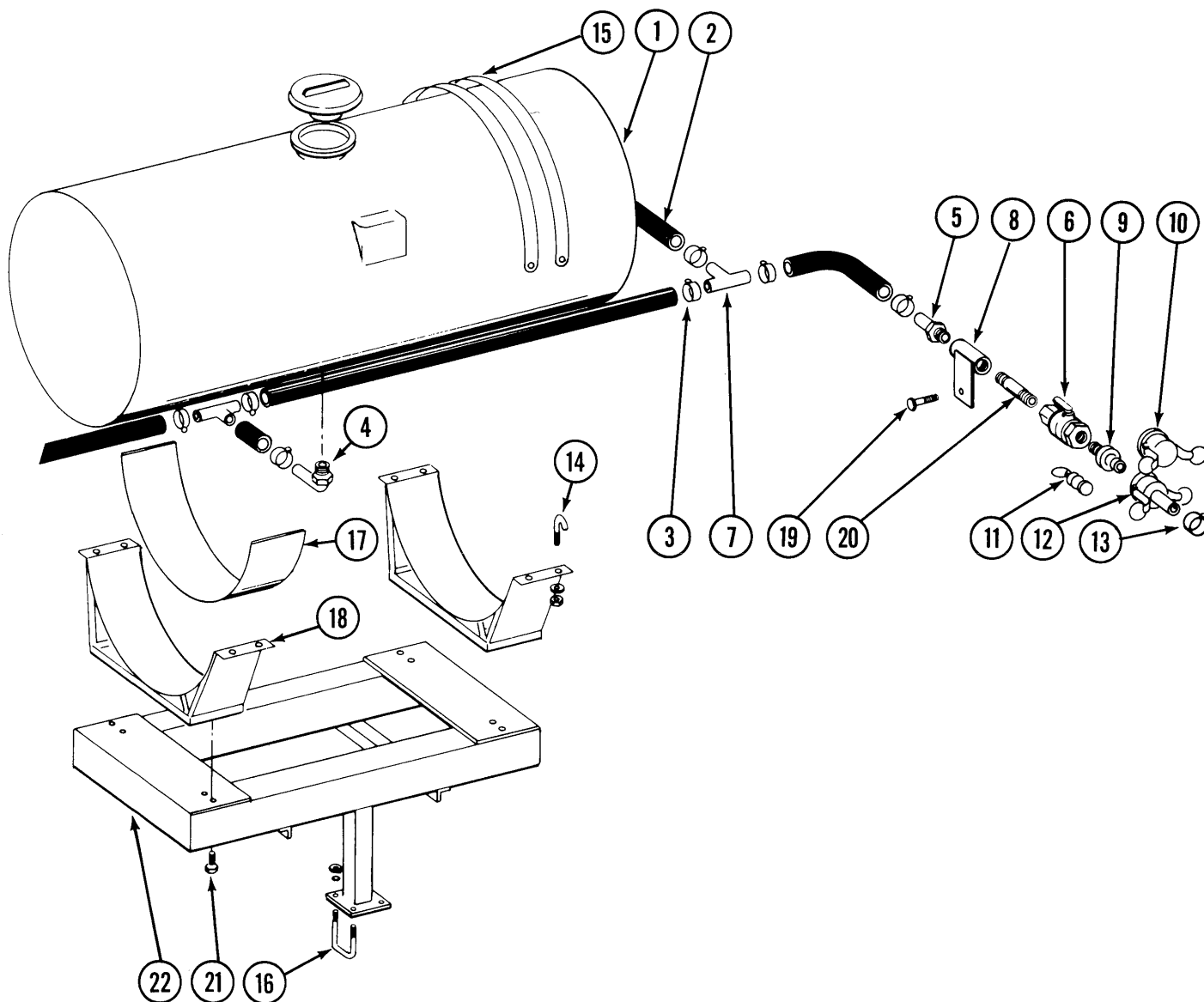

LIQUID FERTILIZER TANKS, SADDLES, MOUNTS, HOSES AND FITTINGS

ITEM	PART NO.	DESCRIPTION
1.	D1812	Tank w/Lid and Fittings, 30" x 150 Gallon
	R0513	3/4" Nylon E-Fitting
	R0508	1 1/4" Nylon E-Fitting
	R0509	Fillwell
	R0510	Lid, 10"
2.	4200-01	Hose, 1 1/4" x 22', 8 Row 30 and Wide
3.	10674	Clamp, No. 24
4.	10742	Elbow, 90°, 1 1/4" NPT to 1 1/4" Barb
5.	10745	Adapter, 1 1/4" NPT to 1 1/4" Barb Fitting
6.	A0499	Ball Valve, 1 1/4" Nylon
7.	10750	Tee, 1 1/4", Plastic
8.	A0918	Mount
9.	D1514	QCAM Adapter
10.	D1515	Dust Cap, 1 1/4"
11.	D1517	Dust Plug
12.	D1516	QCHB Adapter
13.	10672	Clamp, No. 28
14.	D1337	J-Bolt, 5/16"
	10109	Lock Nut, 5/16" - 18
15.	D1520	Tank Band, 30"
16.	D1339	U-Bolt, 2 1/2" x 2 1/2" x 1/2" - 13
	10228	Lock Washer, 1/2"
	10102	Hex Nut, 1/2" - 13
17.	D1862	Pad, 8" x 14'
18.	A2529	Saddle, 30"
19.	10017	HHCS, 1/2" - 13 x 1 1/2"
	10228	Lock Washer, 1/2"
	10102	Hex Nut, 1/2" - 13
20.	10094	Pipe Nipple, 1 1/4" x 3"
21.	10017	HHCS, 1/2" - 13 x 1 1/2"
	10228	Lock Washer, 1/2"
	10102	Hex Nut, 1/2" - 13
22.	A4016	Mount

DECALS, REFLECTORS AND TIE STRAPS

8 Row Models

CAUTION

1. Read and understand the Operator's Manual.
2. Stop the tractor engine before leaving the operator's platform.
3. Keep riders off the machine.
4. Make certain everyone is clear of the machine before starting the tractor engine and operating.
5. Keep all shields in place.
6. Never lubricate, adjust, unclog or service the machine with tractor engine running.
7. Wait for all movement to stop before servicing.
8. Keep hands, feet and clothing away from moving parts.
9. Use flashing warning lights when operating on highways except when prohibited by law.

WARNING
TOW ONLY WITH FARM TRACTOR.

KINZEE®

Twin • Line

CAUTION
REAR OF PLANTER SWINGS WIDE IN TURNS. ALWAYS ALLOW SUFFICIENT ROOM TO CLEAR OBSTACLES WHEN TURNING.

IMPORTANT
Always rephase the hydraulic system after transporting.
1. Lower the planter to the ground.
2. Hold the hydraulic lever for 15 seconds to rephase the hydraulic system.
3. Resume normal operation.

WARNING
TO AVOID INJURY - Stand clear - Keep others away - Avoid or towed implements. Before transporting, ensure fully extended hydraulic cylinders and support linkage pins, when provided.

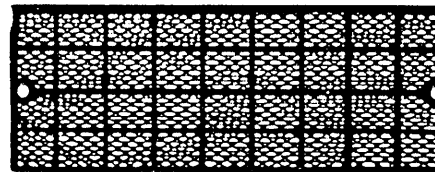
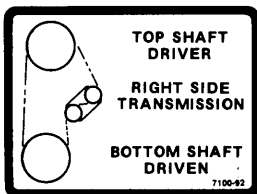
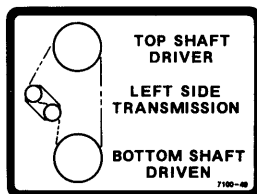

WARNING
— TO AVOID INJURY — ALWAYS USE HYDRAULIC CYLINDER SAFETY LOCKOUT CHANNELS WHEN TRANSPORTING PLANTER ON THE ROAD. AFTER USE RETURN TO STORAGE LOCATION.

CAUTION
ROTATION CYLINDER MUST BE FULLY EXTENDED AND LINKAGE LOCKED OVER CENTER BEFORE LOWERING PLANTER TO WORK POSITION.

IMPORTANT
FRAME MUST BE DOWN ON TONGUE WHEN IN PLANTING POSITION

CAUTION
AVOID UNEVEN LOADING OF HOPPERS, ESPECIALLY DURING TRANSPORT.

WARNING
NEVER WALK UNDER OR WORK ON PLANTER WHEN IT IS RAISED WITHOUT SUPPORTING THE FRAMES WITH ADDITIONAL SUPPORTS.

DANGER
THIS PLANTER IS DESIGNED TO BE DRIVEN BY GROUND TIRES ONLY. THE USE OF HYDRAULIC, ELECTRIC OR PTO DRIVES MAY CREATE SERIOUS SAFETY HAZARDS TO YOU AND THE PEOPLE NEAR BY. IF YOU INSTALL SUCH DRIVES YOU MUST FOLLOW ALL APPROPRIATE SAFETY STANDARDS AND PRACTICES TO PROTECT YOU AND OTHERS NEAR THIS PLANTER FROM INJURY.

WARNING
THIS MACHINE HAS BEEN DESIGNED AND BUILT WITH YOUR SAFETY IN MIND. ANY ALTERATION TO THE DESIGN OR CONSTRUCTION MAY CREATE SAFETY HAZARDS. DO NOT MAKE ANY ALTERATIONS OR CHANGES TO THE EQUIPMENT, BUT IF ANY ALTERATIONS OR CHANGES ARE MADE YOU MUST FOLLOW ALL APPROPRIATE SAFETY STANDARDS AND PRACTICE TO PROTECT YOU AND OTHERS NEAR THIS MACHINE FROM INJURY.

WARNING
TO AVOID INJURY -- Always lower planting units to the ground before unhooking planter. Tongue can raise suddenly.

DECALS, REFLECTORS AND TIE STRAPS

ITEM	PART NO.	DESCRIPTION
1.	7100-46	Decal, Caution
2.	7100-56	Decal, Caution
3.	7100-54	Decal, Kinze
4.	7100-65	Decal, Twin-Line
5.	7100-63	Decal, Caution
6.	7100-64	Decal, Important
7.	7100-42	Decal, Warning
8.	7100-49	Decal, Transmission, L.H.
9.	7100-92	Decal, Transmission, R.H.
10.	7100-83	Decal, Warning
11.	7200-03	Reflector, Red
	7200-04	Reflector, Amber
12.	7100-68	Decal, Warning
13.	7100-69	Decal, Caution
14.	7100-70	Decal, Note
15.	7100-75	Decal, Caution
16.	7100-43	Decal, Warning
17.	7100-89	Decal, Danger
18.	7100-90	Decal, Warning
19.	D1512	Tie Strap, 7"
	D2117	Tie Strap, 14 1/2"
	D1162	Tie Strap, 28"
	D2984	Tie Strap, 33"
20.	R0155	Blue Paint, Aerosol
	R0439	Blue Paint, Quart
	R0440	Blue Paint, Gallon (Not Shown)



PARTS LIST INDEX, 24 ROW MODEL

Outer Hitch Assembly	P50/P51
Inner Hitch Assembly	P52/P53
Transport Latch Assembly	P54/P55
Hose Takeup Assembly	P56
Wing Assembly	P57
Center Frame Assembly	P58/P59
Lift Arms And Bell Assembly	P60/P61
Axle And Rotation Assembly	P62/P63
Contact Drive Wheel and Arm Assembly	P64
Transmission Assembly	P65
Drive Shaft Drive Line	P66
Extended Drill Sprocket Package	P67
Drill Shaft Drive Line	P68
Gearbox	P69
Point Row Wrap Spring Clutch Assembly	P70
10 Bolt Transport Wheel Assembly	P71
6 Bolt Lift Wheel Assembly	P72
Marker Hub Assembly	P73
Low Profile Triple Fold Marker Assembly	P74/P75
Electrical Components	P76
Tongue Cylinder	P77
Tongue Lock Cylinder	P77
Wing Lift Cylinder	P78
Center Section Lift Cylinder	P78
Lift Lock Cylinder	P79
Rotation Cylinder	P79
Wing Lock Cylinder	P80
Marker Cylinder	P80
Solenoid Valve	P81
Flow Control Valve	P81
Pressure Relief Valve	P81
Hydraulic System, Marker and Wing Lock	P82/P83
Hydraulic System, Planter Lift	P84/P85
Hydraulic System, Tongue/Rotation	P86/P87
Push Unit Drive And Transmission Assembly	P88/P89
Push Unit Drill Shaft Drive Line	P90/P91
Decals, Reflectors And Tie Straps	P92/P93
Numerical Index, Parts Section	C

OUTER HITCH ASSEMBLY

24 Row Model

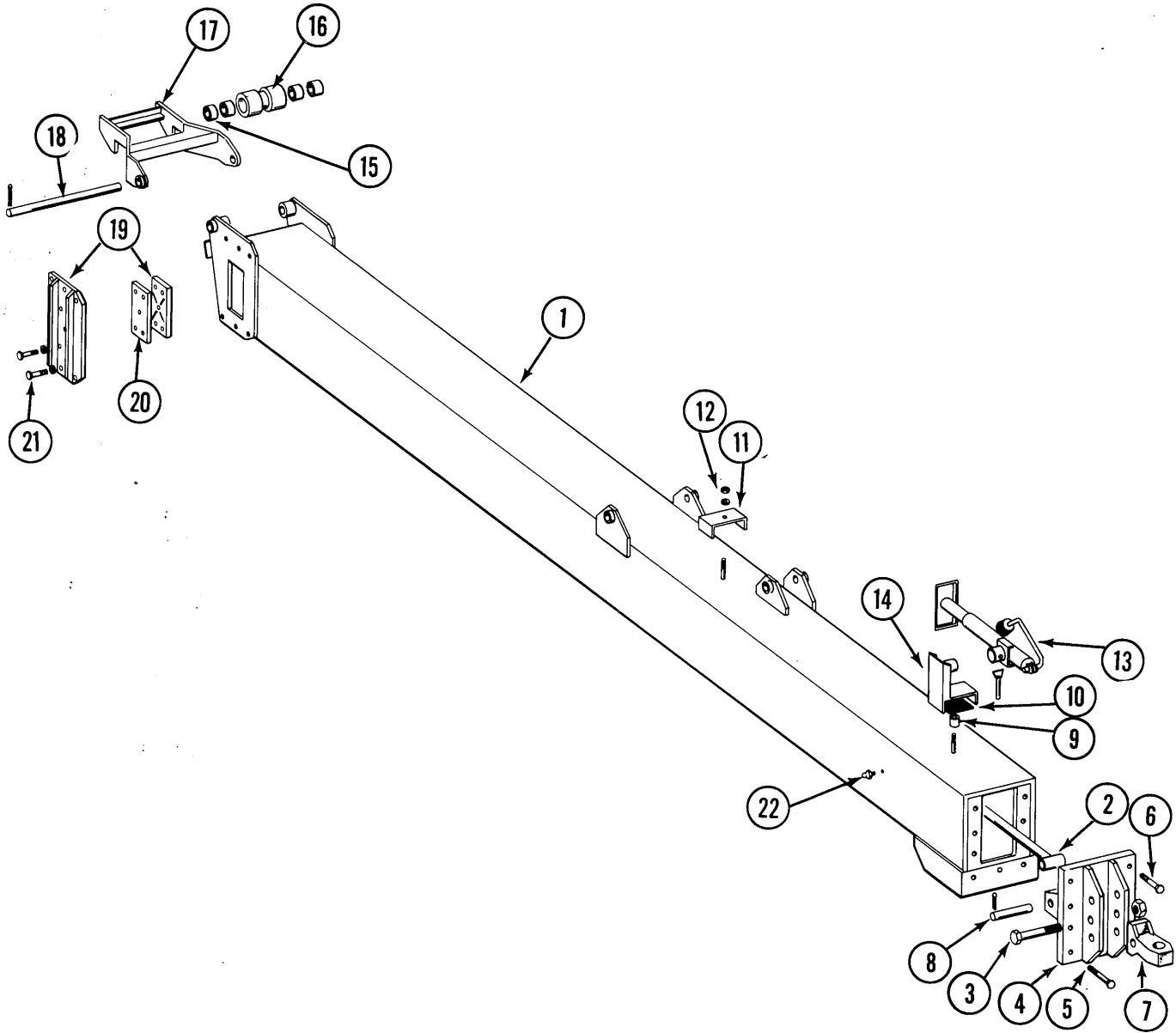

OUTER HITCH ASSEMBLY

ITEM	PART NO.	DESCRIPTION
1.	A3963	Outer Hitch
2.		Cylinder, See Tongue Cylinder Page
3.	10169	HHCS, 1 1/4" - 7 x 6"
	10157	Hex Nut, 1 1/4" - 7
4.	A3964	Hitch Cap
5.	10119	HHCS, 1" - 8 x 3"
	10118	Lock Washer, 1"
	10117	Hex Nut, 1" - 8
6.	10026	HHCS, 3/4" - 10 x 2"
	10231	Lock Washer, 3/4"
7.	D0558	Clevis
8.	D4230	Pin, 1 1/4" x 7 1/2"
	10460	Cotter Pin, 1/4" x 2"
9.	D3788-01	Tubing, Plastic
10.	D3552	Strip, Rubber
11.	D4232	Clamp
12.	10111	Lock Nut, 1/2" - 13
13.	A0941	Jack Assembly
	R0517	Pin
	R0516	Crank Assembly
	R0515	Bevel Gears
14.	A2962	Clamp
15.	A2565	Bearing
16.	A2942	Roller
17.	A3973	Tongue Lock w/Grease Fittings
	10641	Grease Fitting, 1/8" NPT
18.	D5490	Pin, 1 1/4" x 16 1/2"
	10460	Cotter Pin, 1/4" x 2"
19.	A2958	Retainer Assembly w/Grease Fitting, Bronze Wear Pad and Hardware
	10641	Grease Fitting, 1/8" NPT
	D4219	Wear Pad, Bronze
	10016	HHCS, 1/2" - 13 x 2"
	10216	Washer, 1/2" USS
	10228	Lock Washer, 1/2"
20.	D4341	Shim
21.	10008	HHCS, 5/8" - 11 x 2"
	10230	Lock Washer, 5/8"
	10104	Hex Nut, 5/8" - 11
22.	10640	Grease Fitting, 1/4" - 28

INNER HITCH ASSEMBLY

24 Row Model

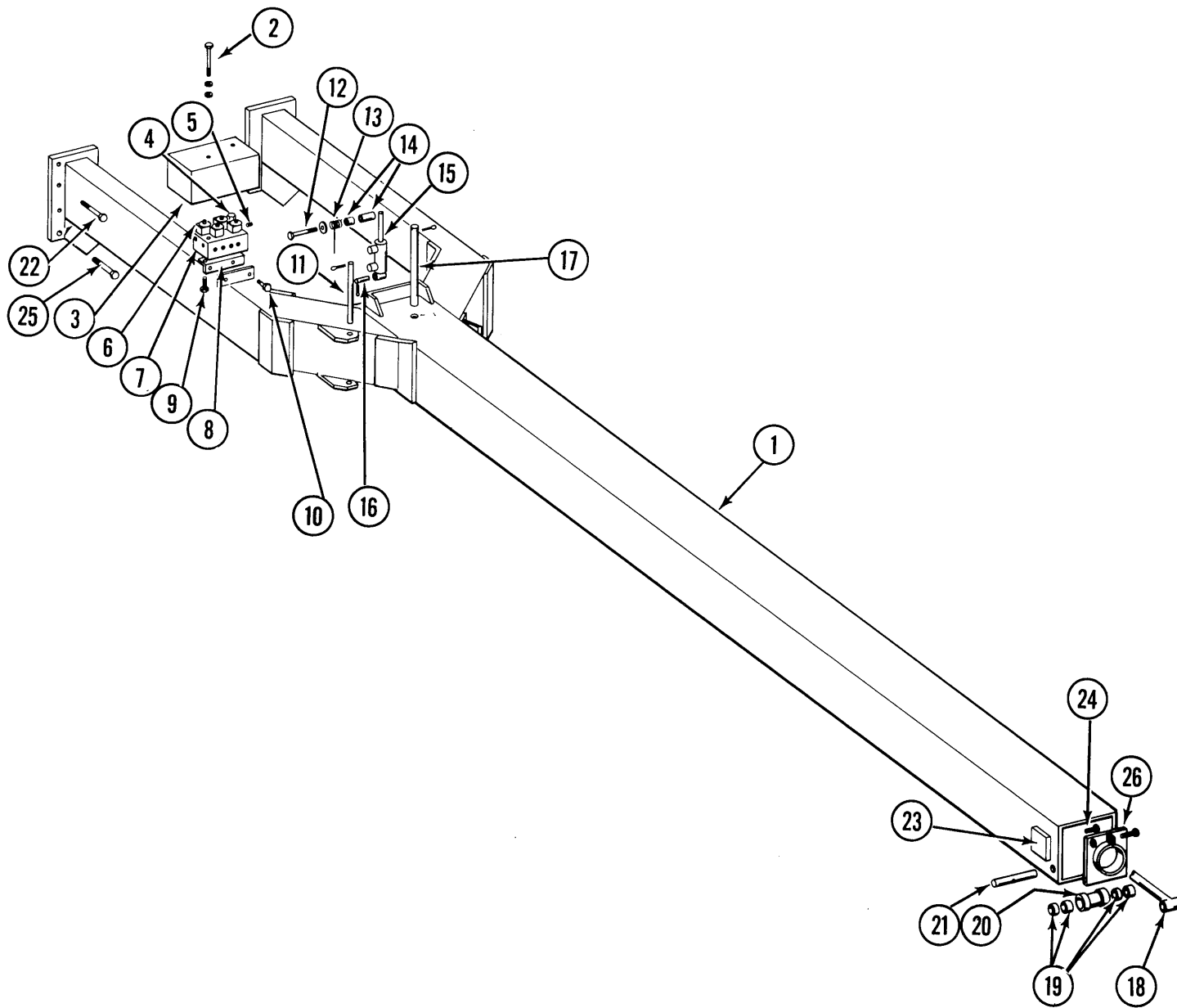

INNER HITCH ASSEMBLY

ITEM	PART NO.	DESCRIPTION
1.	A3962	Inner Hitch
2.	10061	HHCS, 3/8" - 16 x 3 1/2"
	10229	Lock Washer, 3/8"
3.	A4018	Cover
4.		Valve, See Pressure Relief Valve Page
5.	10350	Pipe Plug, 1/4"
6.		Solenoid Valve, See Solenoid Valve Page
7.	D5039	Valve Block
8.	D5152	Angle
9.	10001	HHCS, 3/8" - 16 x 1"
	10229	Lock Washer, 3/8"
10.	10001	HHCS, 3/8" - 16 x 1"
	10108	Lock Nut, 3/8" - 16
11.	D5442	Pin, 7/8" x 10 3/4"
	10463	Cotter Pin, 1/4" x 1 1/2"
12.	10049	HHCS, 3/8" - 16 x 2 1/2"
	10210	Washer, 3/8" USS
	10108	Lock Nut, 3/8" - 16
13.	D5171	Spring
14.	D2971-01	Sleeve, 1 1/8"
	D2971-03	Sleeve, 7/16"
15.		Cylinder, See Tongue Lock Cylinder Page
16.	D3637	Pin, 3/8" x 3"
	10457	Cotter Pin, 5/32" x 1 1/2"
17.	D5369	Pin, 1 1/4" x 13"
	10460	Cotter Pin, 1/2" x 2"
18.		Cylinder, See Tongue Cylinder Page
19.	A2565	Bearing
20.	A2942	Roller
21.	D3537-02	Pin, 1 1/4" x 11"
22.	10056	HHCS, 3/4" - 10 x 3 1/2"
	10231	Lock Washer, 3/4"
	10105	Hex Nut, 3/4" - 10
23.	D4219	Wear Pad, Bronze
	D4341	Shim (As Required)
24.	10014	HHCS, 1/2" - 13 x 1"
	10228	Lock Washer, 1/2"
25.	10076	HHCS, 1" - 8 x 3 1/2"
	10118	Lock Washer, 1"
	10117	Hex Nut, 1" - 8
26.	A3954	Stablizer
	10003	HHCS, 3/8" - 16 x 1 1/2"
	10108	Lock Nut, 3/8" - 16

TRANSPORT LATCH ASSEMBLY

24 Row Model

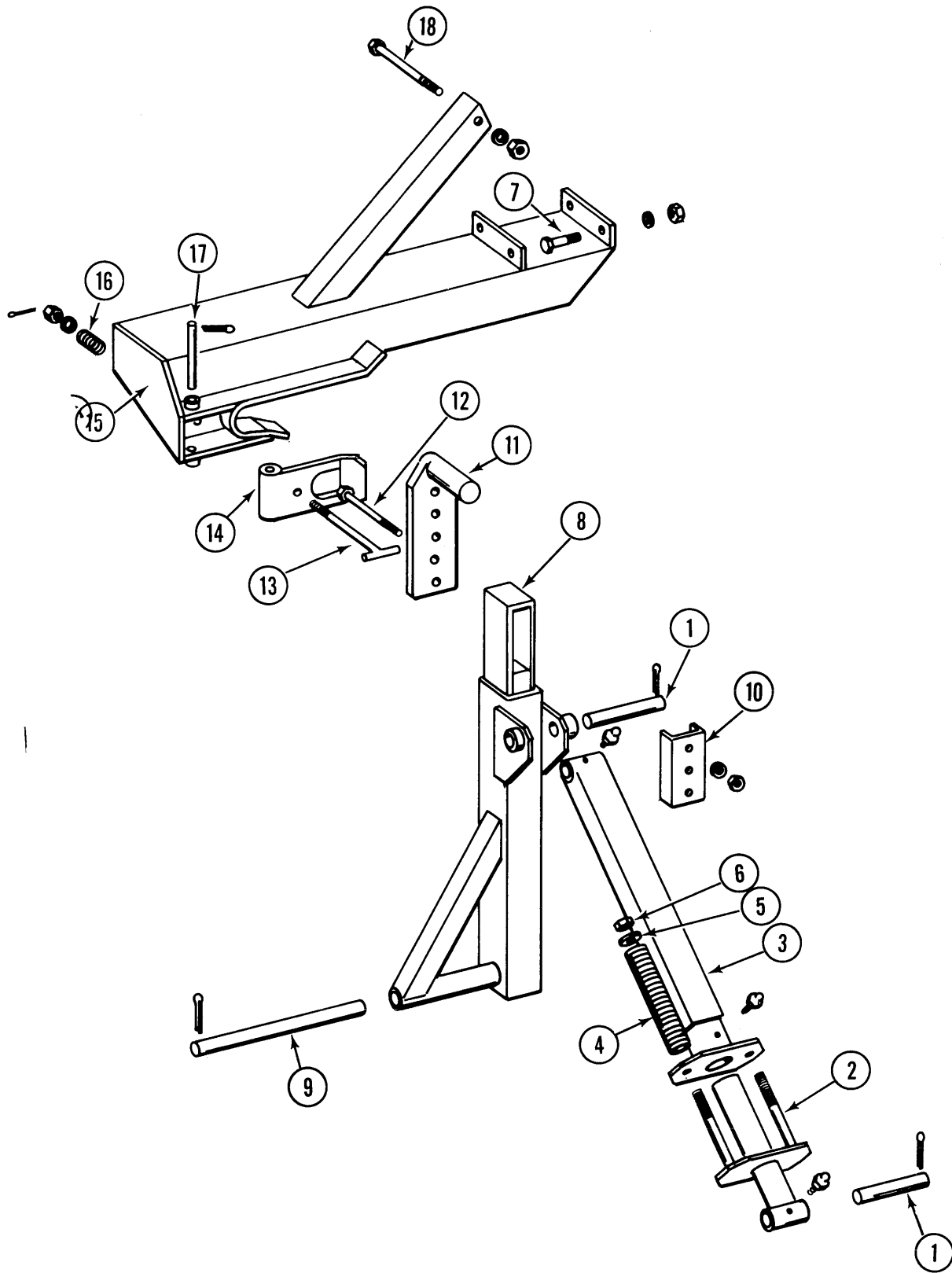

TRANSPORT LATCH ASSEMBLY

ITEM	PART NO.	DESCRIPTION
1.	D4108	Pin, 1 1/4" x 7"
	10460	Cotter Pin, 1/4" x 2"
2.	A4025	Spring Mount w/Grease Fitting
	10641	Grease Fitting, 1/8" NPT
3.	A4062	Tube w/Grease Fittings
	10641	Grease Fitting, 1/8" NPT
4.	D5518	Spring
5.	10084	Washer
6.	10083	Hex Nut, 7/8" - 14
7.	10026	HHCS, 3/4" - 10 x 2"
	10231	Lock Washer, 3/4"
	10105	Hex Nut, 3/4" - 10
	A4020	Transport Post
9.	D5506	Pin, 1 1/4" x 16"
	10460	Cotter Pin, 1/4" x 2"
10.	D3856	Bracket
11.	A4022	Transport Latch Post
12.	10057	HHCS, 3/4" - 10 x 7"
	10231	Lock Washer, 3/4"
	10105	Hex Nut, 3/4" - 10
	A3574	T-Bolt, 1/2" x 9"
13.	10216	Washer, 1/2" USS
	10335	Hex Jam Nut, 1/2" - 13
	10470	Cotter Pin, 5/32" x 1"
	A3575	Transport Latch w/Grease Fitting
	10641	Grease Fitting, 1/8" NPT
15.	A4023	Transport Latch Mount
16.	D4721	Spring
17.	D4732	Pin, 7/8" x 6 1/4"
	10463	Cotter Pin, 1/4" x 1 1/2"
18.	10050	HHCS, 3/4" - 10 x 5"
	10231	Lock Washer, 3/4"
	10105	Hex Nut, 3/4" - 10

HOSE TAKEUP ASSEMBLY

24 Row Model

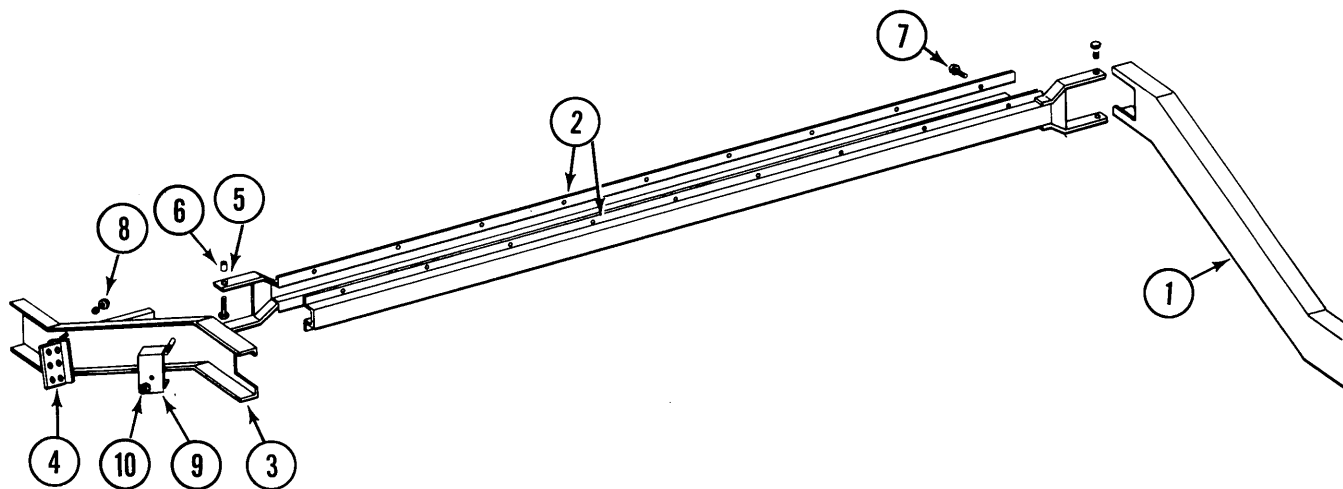

ITEM	PART NO.	DESCRIPTION
1.	A3978	Hose Takeup w/Grease Fitting
	10641	Grease Fitting, 1/8" NPT
2.	A3979	Hose Takeup, Middle
3.	A3988	Hose Takeup w/Grease Fitting
	10641	Grease Fitting, 1/8" NPT
4.	A2627	Bulkhead, Less Fittings
5.	D4695	Special HHCS, 5/8" - 11 x 2"
	10107	Lock Nut, 5/8" - 11
6.	B0123	Bushing
7.	10002	HHCS, 3/8" - 16 x 3/4"
	10229	Lock Washer, 3/8"
	10101	Hex Nut, 3/8" - 16
8.	10228	Lock Washer, 1/2" - 13
	10102	Hex Nut, 1/2" - 13
9.	D3548	Hose Clamp
10.	10111	Lock Nut, 1/2" - 13

WING ASSEMBLY

24 Row Model

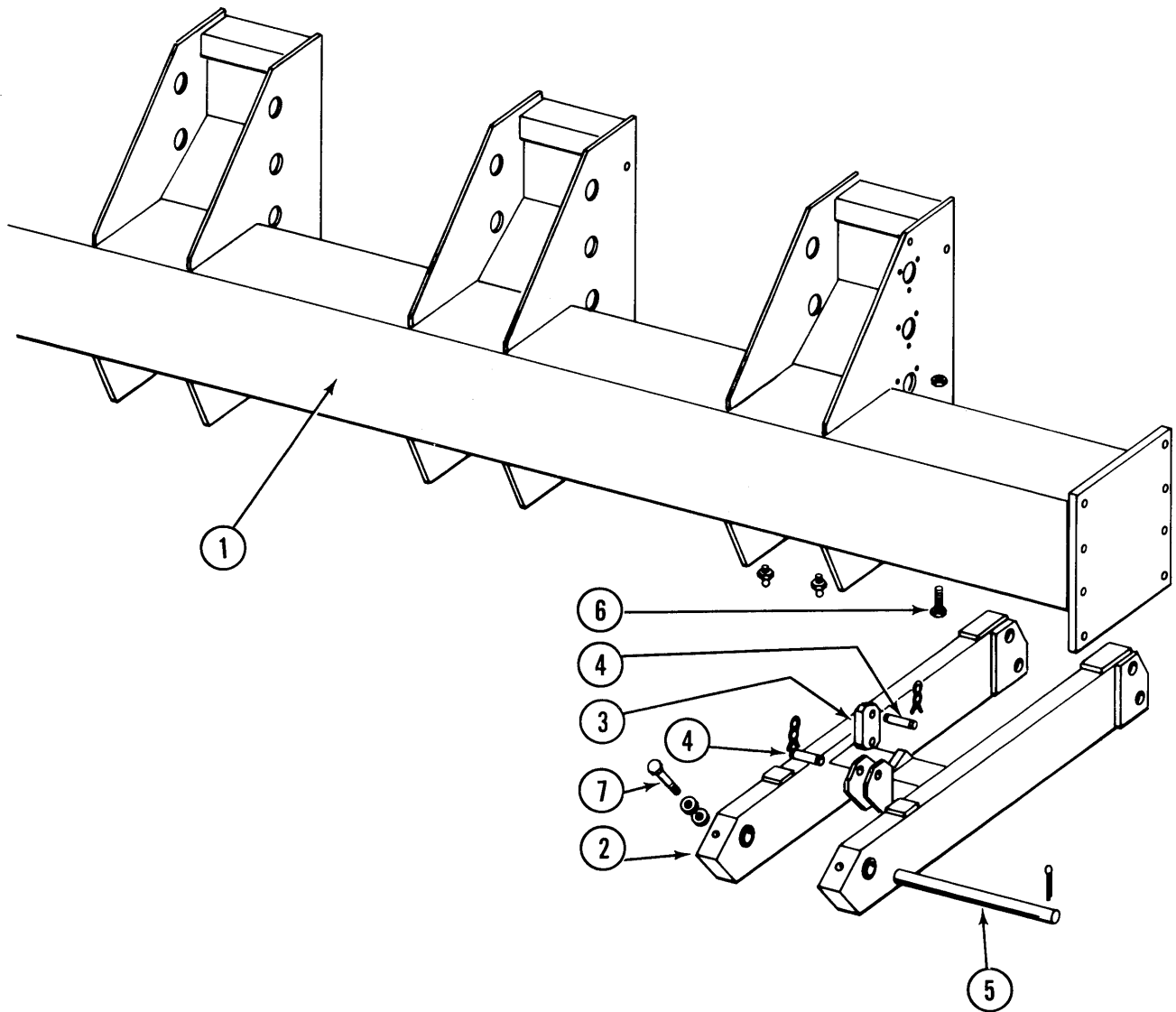

ITEM	PART NO.	DESCRIPTION
1.	A3908	Wing w/Grease Fittings, R.H.
	A3907	Wing w/Grease Fittings, L.H.
	10643	Grease Fitting, 1/4" - 28 45°
	10641	Grease Fitting, 1/8" NPT
2.	A3911	Arm
3.	D4498	Bar
4.	R0375	Pin
	R0193	Hair Pin Clip
5.	D5190	Pin, 1 1/4" x 15"
	10460	Cotter Pin, 1/4" x 2"
6.	10290	Hex Head Adjusting Bolt, 3/4" - 10 x 3"
	10105	Hex Nut, 3/4" - 10
7.	10010	HHCS, 5/8" - 11 x 3"
	10217	Washer, 5/8" USS

CENTER FRAME ASSEMBLY

24 Row Model

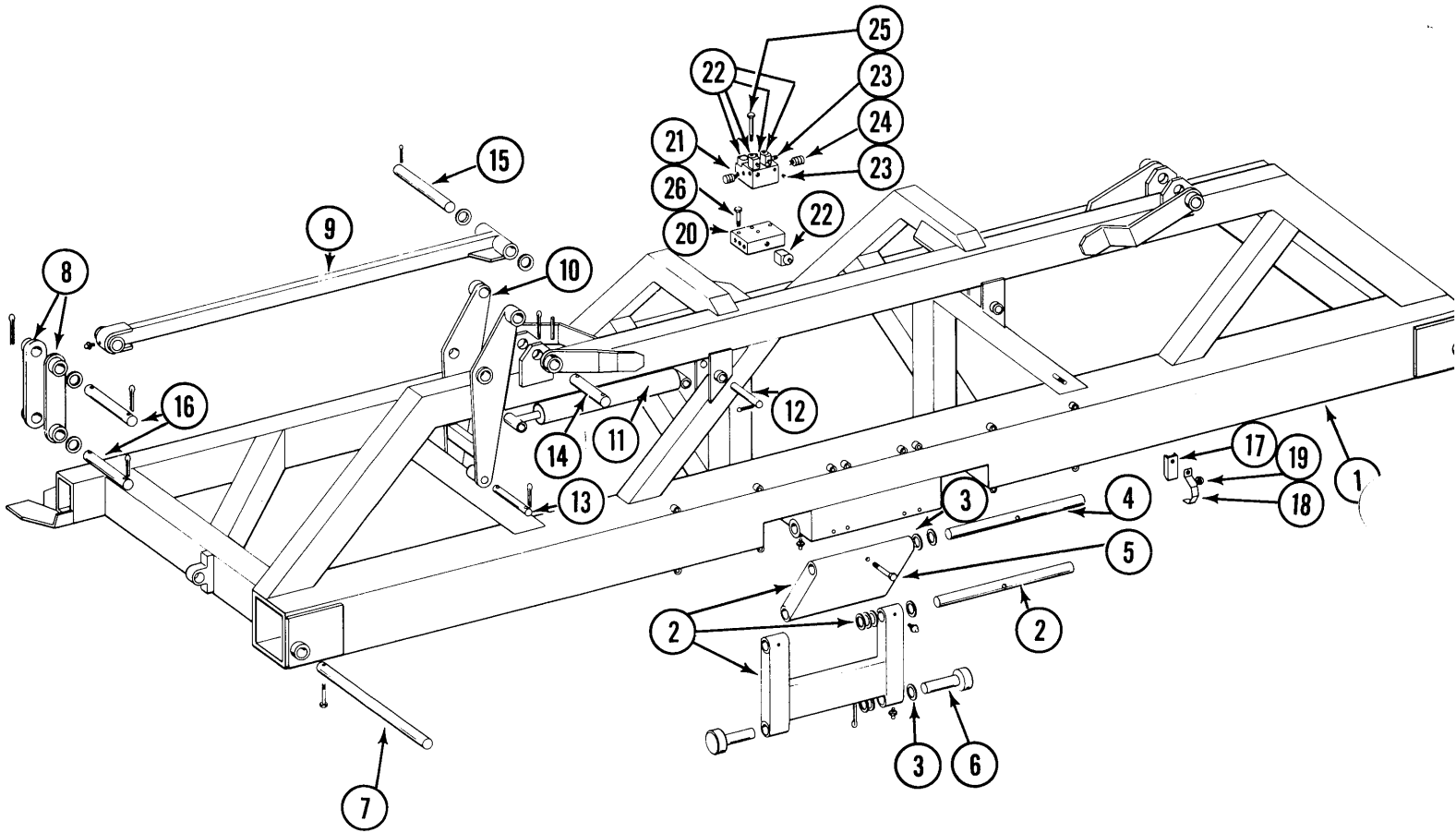

CENTER FRAME ASSEMBLY

ITEM	PART NO.	DESCRIPTION
1.	A3944	Frame w/Grease Fittings
	10641	Grease Fitting, 1/8" NPT
2.	A3967	Anti-Rotation Assembly w/Pin, Grease Fittings, Special Washers and Hardware
	D5393	Pin, 2 1/8" x 25 1/2"
	D5330	Special Washer, Hardened
	10641	Grease Fitting, 1/8" NPT
	10036	HHCS, 5/8" - 11 x 4"
	10230	Lock Washer, 5/8"
	10104	Hex Nut, 5/8" - 11
3.	D5330	Special Washer, Hardened
4.	D5393	Pin, 2 1/8" x 25 1/2"
5.	10036	HHCS, 5/8" - 11 x 4"
	10230	Lock Washer, 5/8"
	10104	Hex Nut, 5/8" - 11
6.	D5356	Wear Pad
	10362	Cotter Pin, 1/4" x 3"
7.	D5424	Pin, 2 1/8" x 30 1/2"
	10036	HHCS, 5/8" - 11 x 4"
	10107	Lock Nut, 5/8" - 11
8.	A3935	Link
9.	A3934	Wing Lock Link w/Grease Fittings
	10641	Grease Fitting, 1/8" NPT
10.	A3943	Wing Lock Plate w/Grease Fittings
	10641	Grease Fitting, 1/8" NPT
11.		Cylinder, See Wing Lock Cylinder Page
12.	D0652	Pin, 1 1/4" x 9 1/2"
	10460	Cotter Pin, 1/4" x 2"
13.	D0671	Pin, 1 1/4" x 10 3/4"
	10460	Cotter Pin, 1/4" x 2"
14.	D5422	Pin, 2 1/8" x 6 1/4"
	10461	Cotter Pin, 3/8" x 3"
15.	D5421	Pin, 2 1/8" x 15"
	10461	Cotter Pin, 3/8" x 3"
16.	D5423	Pin, 2 1/8" x 10 1/4"
	10461	Cotter Pin, 3/8" x 3"
17.	D5492	Clamp
18.	D5493	Clamp
19.	10111	Lock Nut, 1/2" - 13
20.	D5450	Valve Block
21.	D5362	Valve Block
22.		Valve, See Flow Control Valve Page
23.	10350	Pipe Plug, 1/4" Hex Socket
24.		Valve, See Flow Control Valve Page
25.	10326	HHCS, 3/8" - 16 x 3 3/4"
	10229	Lock Washer, 3/8"
26.	10325	HHCS, 3/8" - 16 x 2 3/4"
	10229	Lock Washer, 3/8"

LIFT ARMS AND BELL ASSEMBLY

24 Row Model

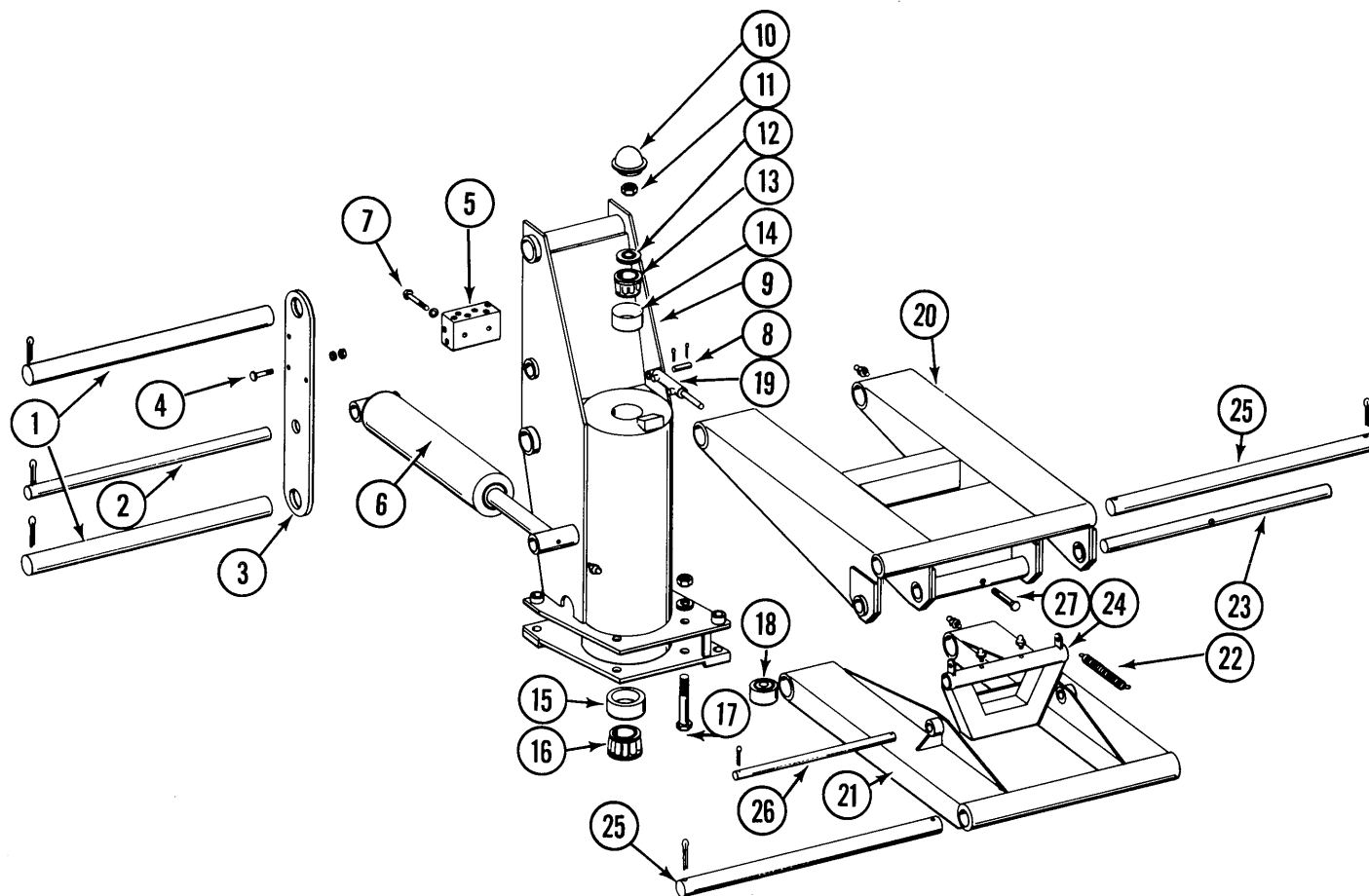

LIFT ARMS AND BELL ASSEMBLY

ITEM	PART NO.	DESCRIPTION
1.	D5266	Pin, 2 7/16" x 34 3/4"
	10461	Cotter Pin, 3/8" x 3"
2.	D5265	Pin, 2 1/8" x 34 3/4"
	10471	Cotter Pin, 3/8" x 2 1/2"
3.	D5339	Bar
4.	10027	HHCS, 3/4" - 10 x 2 1/2"
	10231	Lock Washer, 3/4"
	10105	Hex Nut, 3/4" - 10
5.	D5465	Block
6.		Cylinder, See Lift Cylinder Page
7.	10326	HHCS, 3/8" - 16 x 3 3/4"
	10229	Lock Washer, 3/8"
8.	D3637	Pin, 3/8" x 3"
	10457	Cotter Pin, 5/32" x 1 1/2"
9.	A3917	Outer Bell
10.	D4927	Cap
11.	10351	Hex Slotted Nut, 1 1/2" - 12
12.	10352	Washer, 1 1/2" USS
13.	A0779	Bearing
14.	R0323	Cup
15.	R0191	Cup
16.	A0531	Bearing
17.	D5286	Special Bolt, 1 1/4" - 7 x 6 1/2"
	10236	Lock Washer, 1 1/4"
	10239	Hex Nut, 1 1/4" - 7
18.	A2776	Cam Follower
19.		Cylinder, See Lift Cylinder Page
20.	A3931	Upper Parallel Arm w/Grease Fittings
	10641	Grease Fitting, 1/8" NPT
21.	A3924	Lower Parallel Arm w/Grease Fittings
	10641	Grease Fitting, 1/8" NPT
22.	D0829	Spring
23.	D5271	Pin, 2 1/8" x 32 1/2"
24.	A3932	Lift Lock w/Grease Fittings
	10641	Grease Fitting, 1/8" NPT
25.	D5267	Pin, 2 7/16" x 45 1/2"
	10461	Cotter Pin, 3/8" x 3"
26.	D5264	Pin, 1 3/4" x 22 1/4"
	10460	Cotter Pin, 1/4" x 2"
27.	10036	HHCS, 5/8" - 11 x 4"
	10230	Lock Washer, 5/8"
	10104	Hex Nut, 5/8" - 11

AXLE AND ROTATION ASSEMBLY

24 Row Model

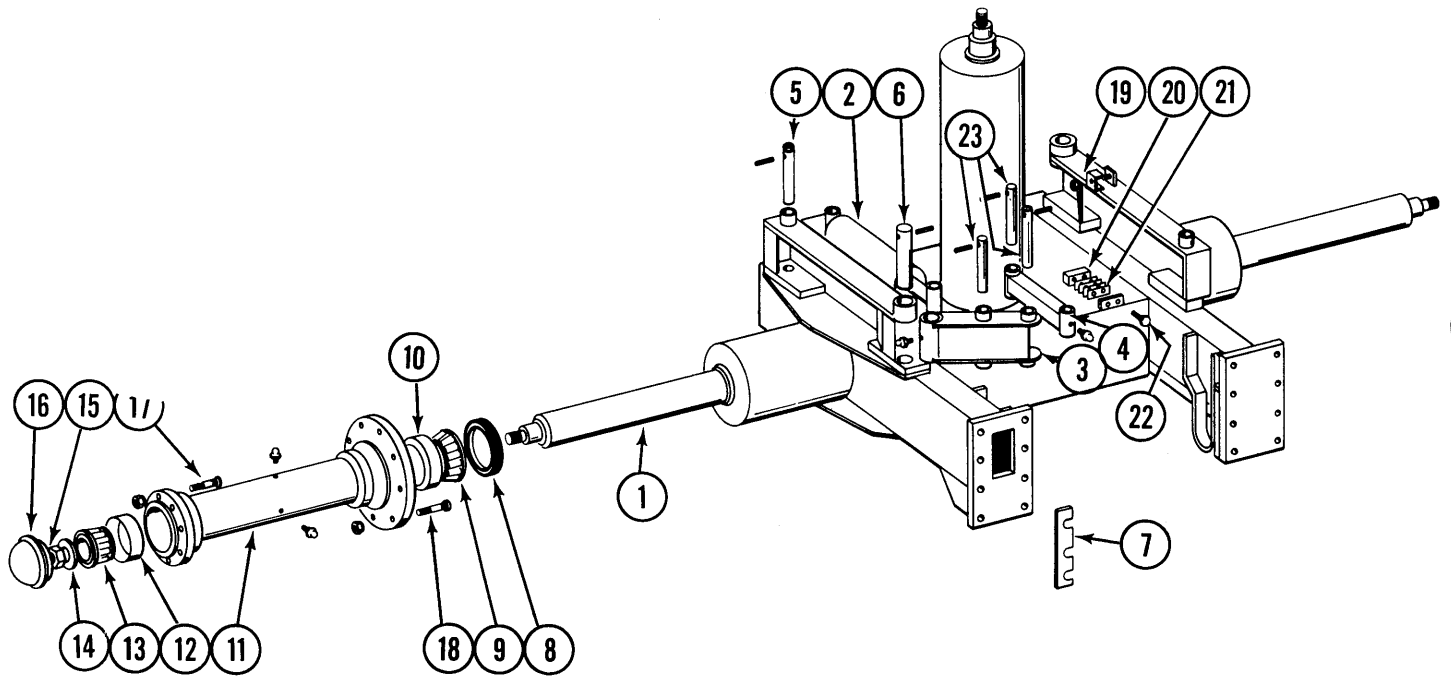

AXLE AND ROTATION ASSEMBLY

ITEM	PART NO.	DESCRIPTION
1.	A3905	Axle Assembly
2.		Cylinder, See Rotation Cylinder Page
3.	A3966	Rotation Lock Plate w/Spring Bushing and Grease Fittings
	D5038	Spring Bushing
	10641	Grease Fitting, 1/8" NPT
4.	A3959	Rotation Lock Link w/Spring Bushing and Grease Fittings
	D4467	Spring Bushing
	10641	Grease Fitting, 1/8" NPT
5.	A4024	Pin, 1 1/4" x 8"
	10332	Spring Pin, 7/32" x 2"
	10610	Spring Pin, 3/8" x 2"
6.	D5427	Pin, 2 1/8" x 8 1/4"
	10333	Spring Pin, 7/32" x 3"
	10293	Spring Pin, 3/8" x 3"
7.	D5530	Shim
8.	A3747	Seal
9.	A2508	Bearing
10.	D3239	Cup
11.	A3882	Hub w/Grease Fittings (10 Bolt)
	10641	Grease Fitting, 1/8" NPT
12.	R0323	Cup
13.	A0779	Bearing
14.	10352	Washing, 1 1/2" USS
15.	10351	Hex Slotted Nut, 1 1/2" - 12
16.	D4927	Cap
17.	D5226	Stud Bolt, Special, 3/4" - 16 x 2 5/8"
	10625	Hex Flange Nut, 3/4" - 16
18.	R0257	Stud Bolt, 3/4" - 16 x 2 5/8"
	10625	Hex Flange Nut, 3/4" - 16
19.	D1157	Clamp, Hose
20.	D5335	Tap Block
21.	D5334	Shim
22.	10017	HHCS, 1/2" - 13 x 1 1/2"
23.	D3404	Pin, 1 1/4" x 5 1/2"
	10332	Spring Pin, 7/32" x 2"
	10610	Spring Pin, 3/8" x 2"

CONTACT DRIVE WHEEL AND ARM ASSEMBLY

24 Row Model

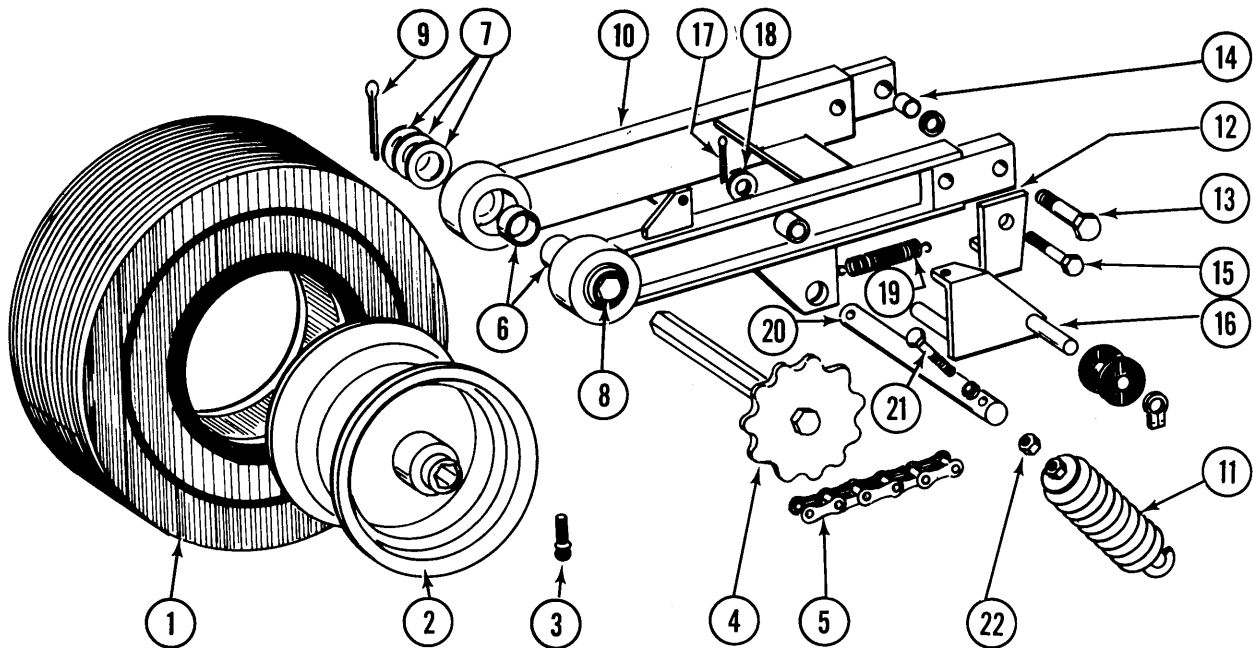

ITEM	PART NO.	DESCRIPTION
1.	D4700	Tire, 4.8 x 8, 6 Ply
2.	A3553	Rim, 3.75 x 8
3.	D4701	Valve Stem
4.	A3554	Sprocket w/Shaft, 12 Tooth
5.	3200-58 R0195	Chain, No. 2050, 58 Pitch Including Connector Link Connector Link, No. 2050
6.	D3660-08	Sleeve, Hex
7.	10233	Machinery Bushing, 1"
8.	2100-03	Bearing, 7/8 Hex Bore
9.	10460	Cotter Pin, 1/4" x 2", R.H.
	10463	Cotter Pin, 1/4" x 1 1/2", L.H.
10.	A3998	Wheel Arm, R.H.
	A3999	Wheel Arm, L.H. (Shown)
11.	A2068	Spring
12.	A4002	Stop
13.	10008	HHCS, 5/8" - 11 x 2"
	10205	Washer, 5/8" SAE
	10107	Lock Nut, 5/8" - 11
14.	B0123	Bushing
15.	10053	HHCS, 1/2" - 13 x 2 1/2"
	10228	Lock Washer, 1/2"
	10102	Hex Nut, 1/2" - 13
16.	A3558	Idler w/Spool and Ring, R.H.
	A3559	Idler w/Spool and Ring, L.H.
	10435	Ring
	D0916	Spool
17.	10453	Cotter Pin, 3/16" x 1"
18.	10205	Washer, 5/8" SAE
19.	D3791	Spring
20.	D4805	Pin, 1" x 9 1/4"
21.	10015	Hex Head Adjusting Bolt, 1/2" - 13 x 5"
	10216	Washer, 1/2" SAE
22.	10501	Jam Nut, 1/2"

TRANSMISSION ASSEMBLY

24 Row Model

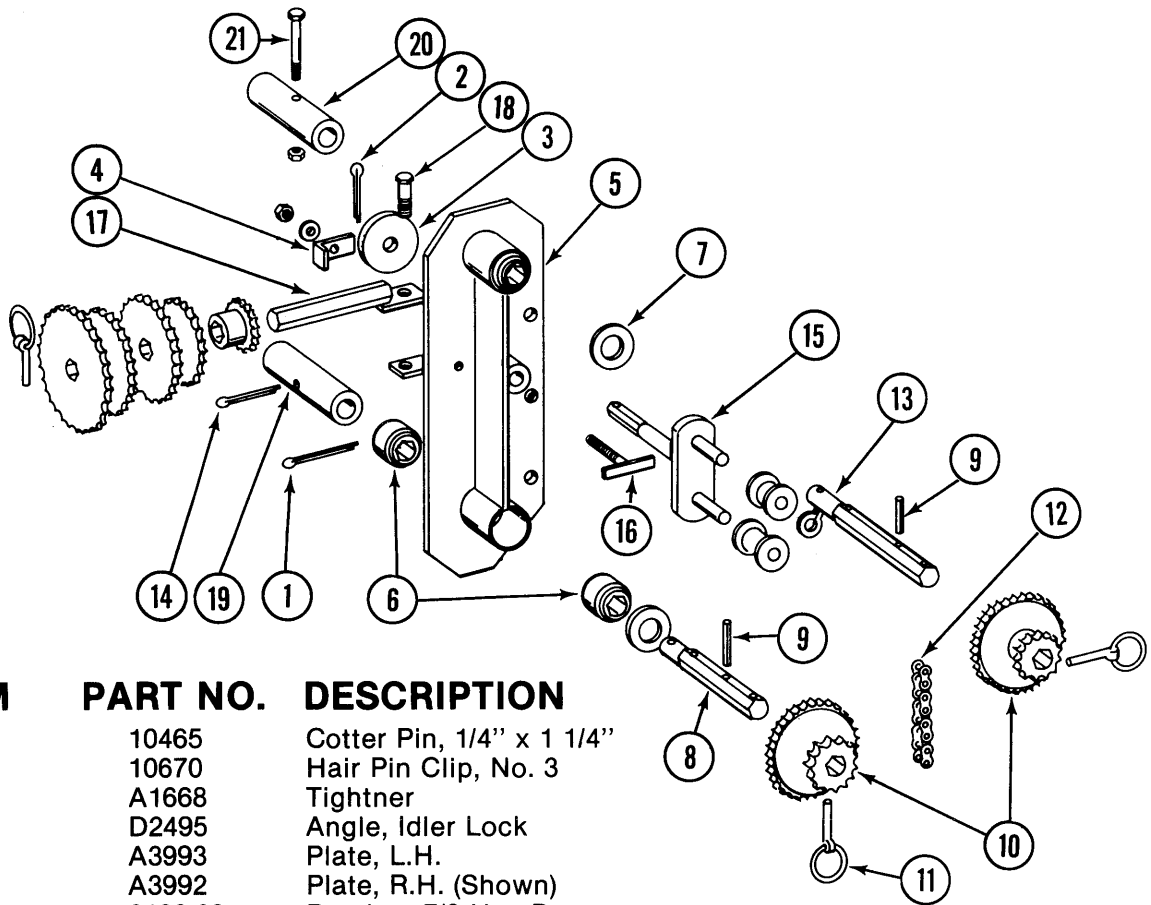

ITEM	PART NO.	DESCRIPTION
1.	10465	Cotter Pin, 1/4" x 1 1/4"
2.	10670	Hair Pin Clip, No. 3
3.	A1668	Tightner
4.	D2495	Angle, Idler Lock
5.	A3993	Plate, L.H.
	A3992	Plate, R.H. (Shown)
6.	2100-03	Bearing, 7/8 Hex Bore
7.	10233	Machinery Bushing, 1"
8.	D5215	Shaft, Bottom, 7/8" x 6 3/8"
9.	10602	Spring Pin, 1/4" x 1 1/2"
10.	2500-25	Sprocket, 14 Tooth
	2500-26	Sprocket, 18-28 Tooth
	2500-27	Sprocket, 16-30 Tooth
	2500-28	Sprocket, 22-26 Tooth
11.	D2558	Pin, Lynch, 1/4"
12.	3300-40	Chain, No. 2040, 40 Pitch Including Connector Link
	R0194	Connector Link, No. 2040
13.	D4748	Shaft, Top, 7/8" x 6 3/8"
14.	10460	Cotter Pin, 1/4" x 2"
15.	A0503	Idler w/Spools and Rings
	D1067	Spool
	10435	Ring
16.	A3997	T-Bolt
	10229	Lock Washer, 3/8"
	10101	Hex Nut, 3/8" - 16
17.	A1786	Rod, Sprocket Storage
18.	10019	HHCS, 5/16" - 18 x 1"
	10109	Lock Nut, 5/16" - 18
19.	D5212	Coupler, Bottom, 1 3/4"
20.	D4749	Coupler, Top, 1 3/4"
21.	10339	HHCS, 5/16" - 18 x 2", Grade 2
	10109	Lock Nut, 5/16" - 18

DRIVE SHAFT DRIVE LINE

24 Row Model

L.H. Side of Planter Shown

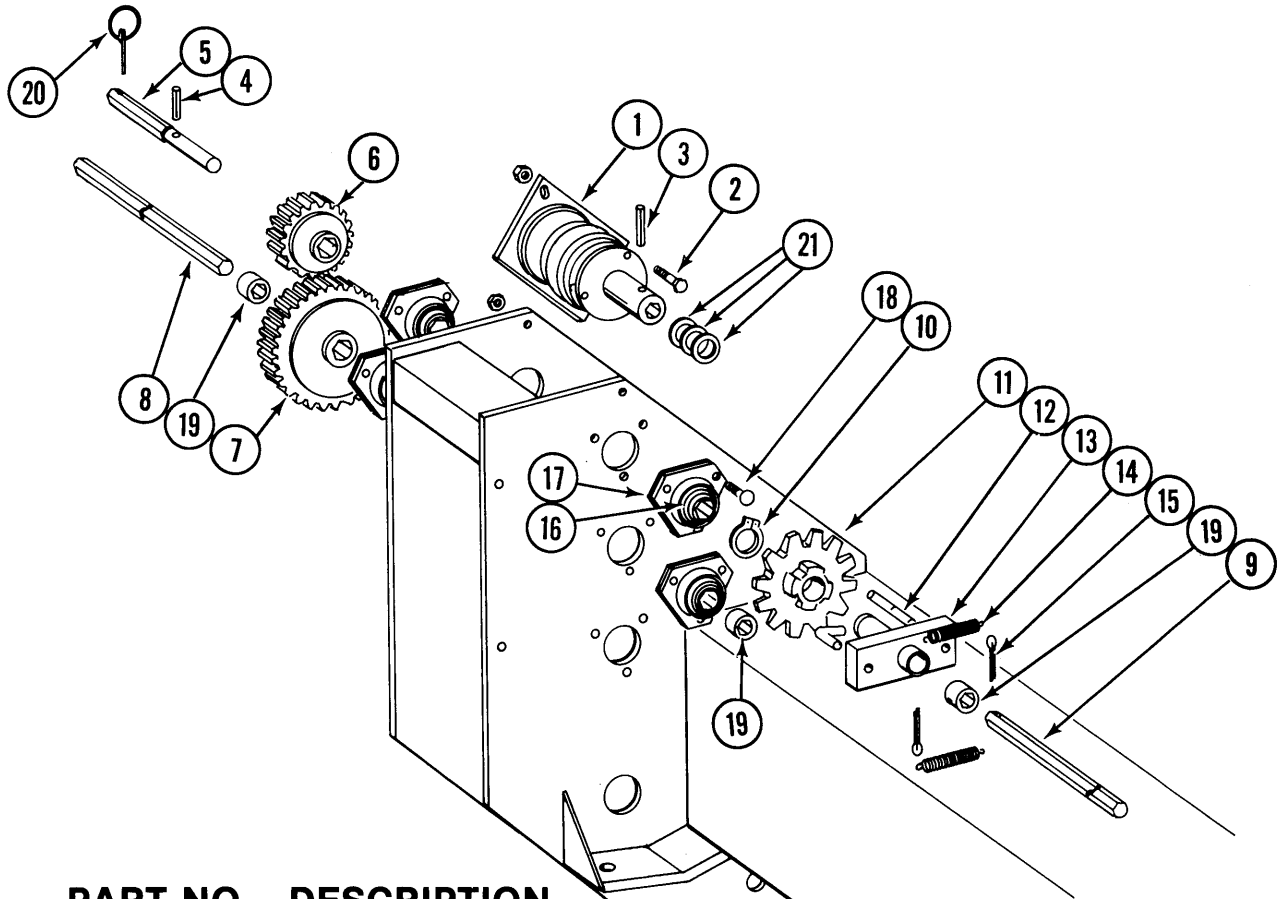

ITEM	PART NO.	DESCRIPTION
1.		Point Row Wrap Spring Clutch Assembly, See Point Row Wrap Spring Clutch Assembly Page
2.	10049	HHCS, 3/8" - 16 x 2 1/2"
	10101	Hex Nut, 3/8" - 16
	10108	Lock Nut, 3/8" - 16
3.	10602	Spring Pin, 1/4" x 1 1/2"
4.	10600	Spring Pin, 5/16" x 2 1/4"
5.	D5477	Shaft, 7"
6.	A4054	Gear, 18 Tooth
7.	A4053	Gear, 32 Tooth
8.	D0914-33.5	Drive Shaft, 7/8" x 33 1/2"
9.	D5475	Shaft, 7/8" x 66"
10.	10430	Ring
11.	A0376	Hub/Sprocket Assembly
12.	D1255	"L" Pin
13.	A0378	Block and Hub Assembly
14.	D1256	Spring
15.	10464	Cotter Pin, 3/16" x 1"
16.	2100-03	Bearing, 7/8 Hex Bore
17.	3400-01	Flangette
18.	10303	Carriage Bolt, 5/16" - 18 x 1"
	10232	Lock Washer, 5/16"
	10106	Hex Nut, 5/16" - 18
19.	D0917	Lock Collar, 7/8 Hex, Less Set Screws
	10145	Set Screw 5/16" - 18 x 1/2"
20.	D2558	Pin, Lynch, 1/4"
21.	10233	Machinery Bushing, 1"
A.	A0261L	Ratchet and Sprocket Assembly, L.H.
	A0261R	Ratchet and Sprocket Assembly, R.H. (Includes Items 10 thru 15)

EXTENDED DRILL SPROCKET PACKAGE

24 Row Model

L.H. Side of Planter Shown

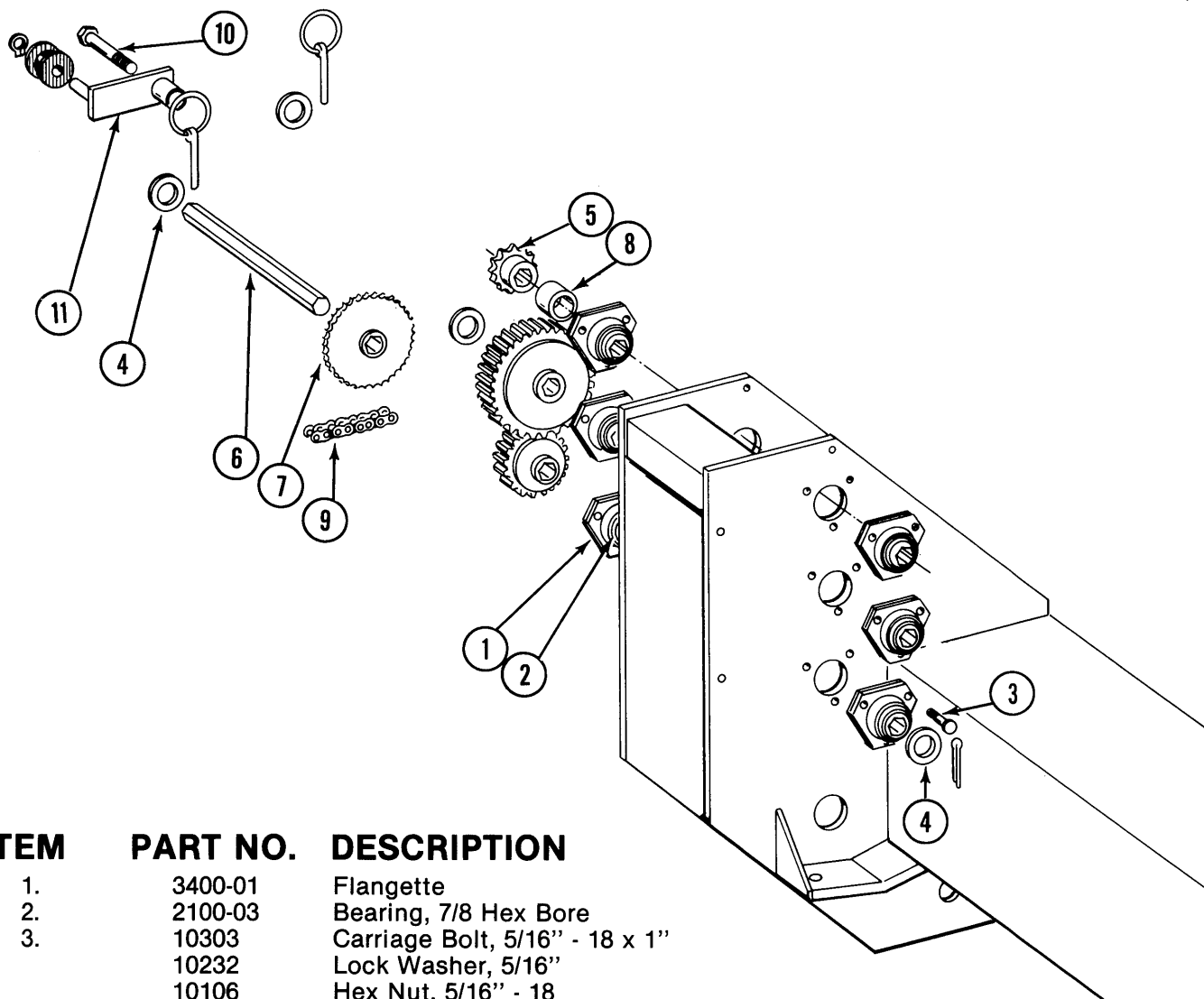

ITEM	PART NO.	DESCRIPTION
1.	3400-01	Flangette
2.	2100-03	Bearing, 7/8 Hex Bore
3.	10303	Carriage Bolt, 5/16" - 18 x 1"
	10232	Lock Washer, 5/16"
	10106	Hex Nut, 5/16" - 18
4.	10233	Machinery Bushing, 1"
5.	A4057	Sprocket, 14 Tooth
6.	D4773	Shaft, 7/8" x 14 1/2"
	D2558	Lynch Pin, 1/4"
	10463	Cotter Pin, 1/4" x 1 1/2"
7.	A4058	Sprocket, 28 Tooth
8.	D1199-06	Spacer
9.	3200-027	Chain, No. 2050, 27 Pitch Including Connector Link and Offset Link
	R0195	Connector Link, No. 2050
	R0200	Offset Link, No. 2050
10.	10036	HHCS, 5/8" - 11 x 4"
	10230	Lock Washer, 5/8"
	10104	Hex Nut, 5/8" - 11
11.	A4060	Idler w/Spool and Ring
	10435	Ring
	D1067	Spool
A.	6714X	Extended Drill Sprocket Package, Includes: (4) 2100-03, (2) 3200-27, (8) 3400-01, (2) 10036, (2) 10104, (12) 10106, (2) 10230, (12) 10232, (6) 10233, (12) 10303, (2) 10463, (2) A4057, (2) A4058, (2) A4060, (4) D2558, (2) D1100-06, (2) D4773

DRILL SHAFT DRIVE LINE

24 Row Model

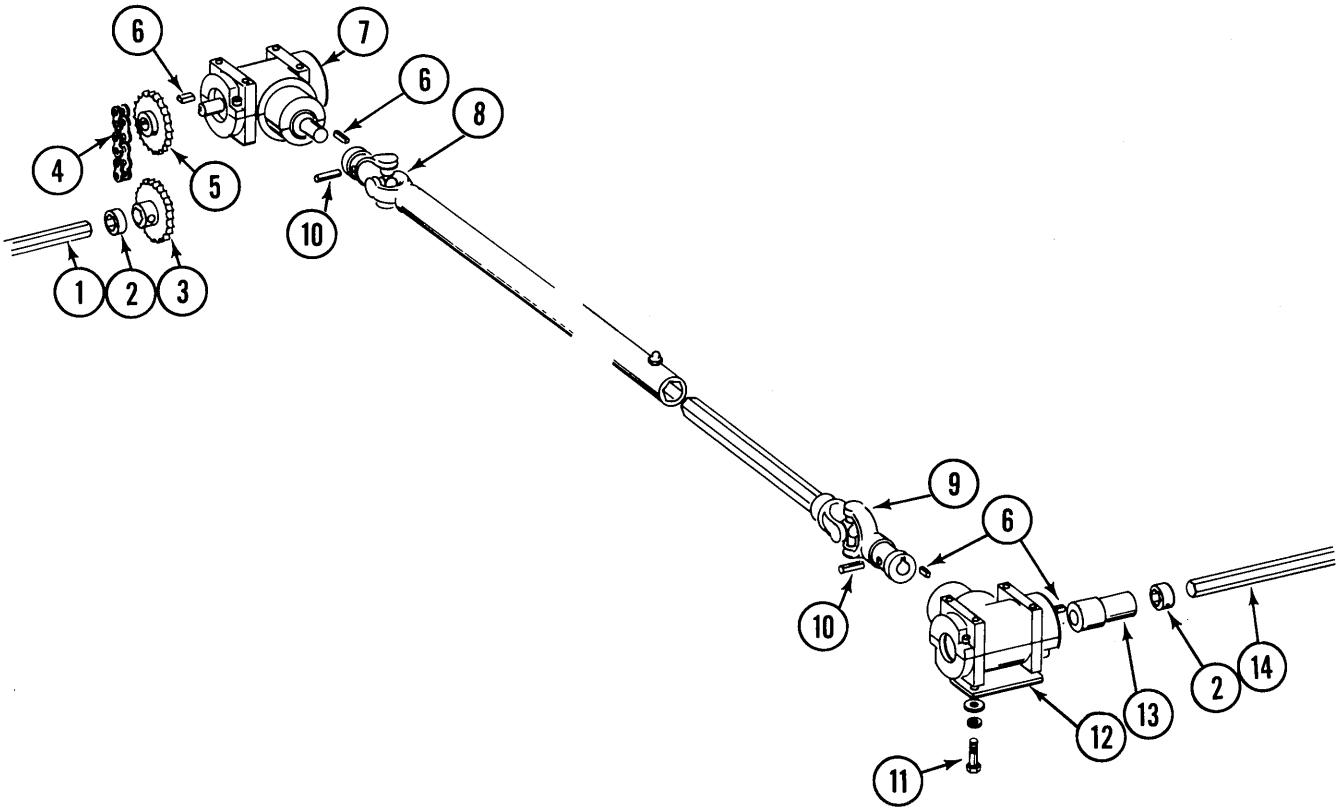

ITEM	PART NO.	DESCRIPTION
1.	D0914-230	Shaft, 7/8" Hex
2.	D0917	Lock Collar, 7/8 Hex, Less Set Screws
	10145	Set Screws, 5/16" - 18 x 1/2"
3.	A5078	Lock Collar Sprocket w/Set Screws , 19 Tooth
	10145	Set Screw, 5/16" - 18 x 1/2"
4.	3303-43	Chain, No. 41, 43 Pitch Including Connector Link and Offset Link
	R0196	Connector Link, No. 41
	R0201	Offset Link, No. 41
5.	A3960	Sprocket w/Set Screws, 19 Tooth
	10405	Hex Socket Head Set Screw, 1/4" - 20 x 1/4"
6.	D5406-01	Key
7.		Gearbox, See Gearbox Page
8.	A4015	U-Joint w/Grease Fittings and Set Screws
	10641	Grease Fitting, 1/8" NPT
	10343	Grease Fitting, 1/8" - 27 90°
	10405	Hex Socket Head Set Screw, 1/4" - 20 x 1/4"
9.	A4014	U-Joint w/Grease Fitting and Set Screws
	10343	Grease Fitting, 1/8" - 27 90°
	10405	Hex Socket Head Set Screw, 1/4" - 20 x 1/4"
10.	10602	Spring Pin, 1/4" x 1 1/2"
11.	10019	HHCS, 5/16" - 18 x 1"
	10219	Washer, 5/16" USS
	10232	Lock Washer, 5/16"
12.	D5472	Shim
13.	A4030	Coupler
14.	D0914-106	Drill Shaft, R.H.
	D0914-96	Drill Shaft, L.H.

GEARBOX

24 Row Model

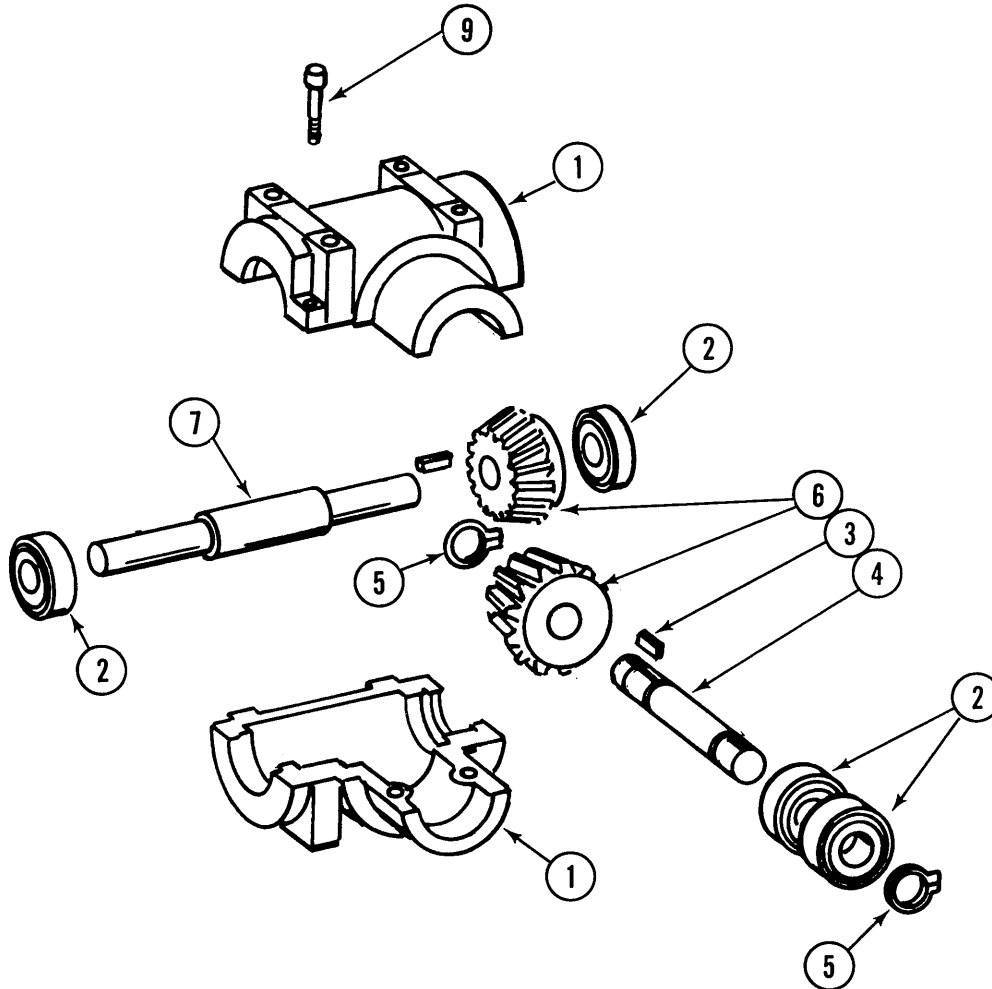

ITEM	PART NO.	DESCRIPTION
1.	R0859	Housing Half
2.	R0861	Bearing
3.	R0863	Key
4.	R0865	Shaft
5.	R0864	Retaining Ring
6.	R0862	Gear
7.	R0860	Shaft
8.	10350	Hex Socket Pipe Plug, 1/4" (Not Shown)
9.	10374	Hex Socket Head Cap Screw, 1/4" - 20 x 1"
	10375	Washer, Internal/External, 1/4"
A.	A3950	Gearbox Complete

POINT ROW WRAP SPRING CLUTCH ASSEMBLY

24 Row Model

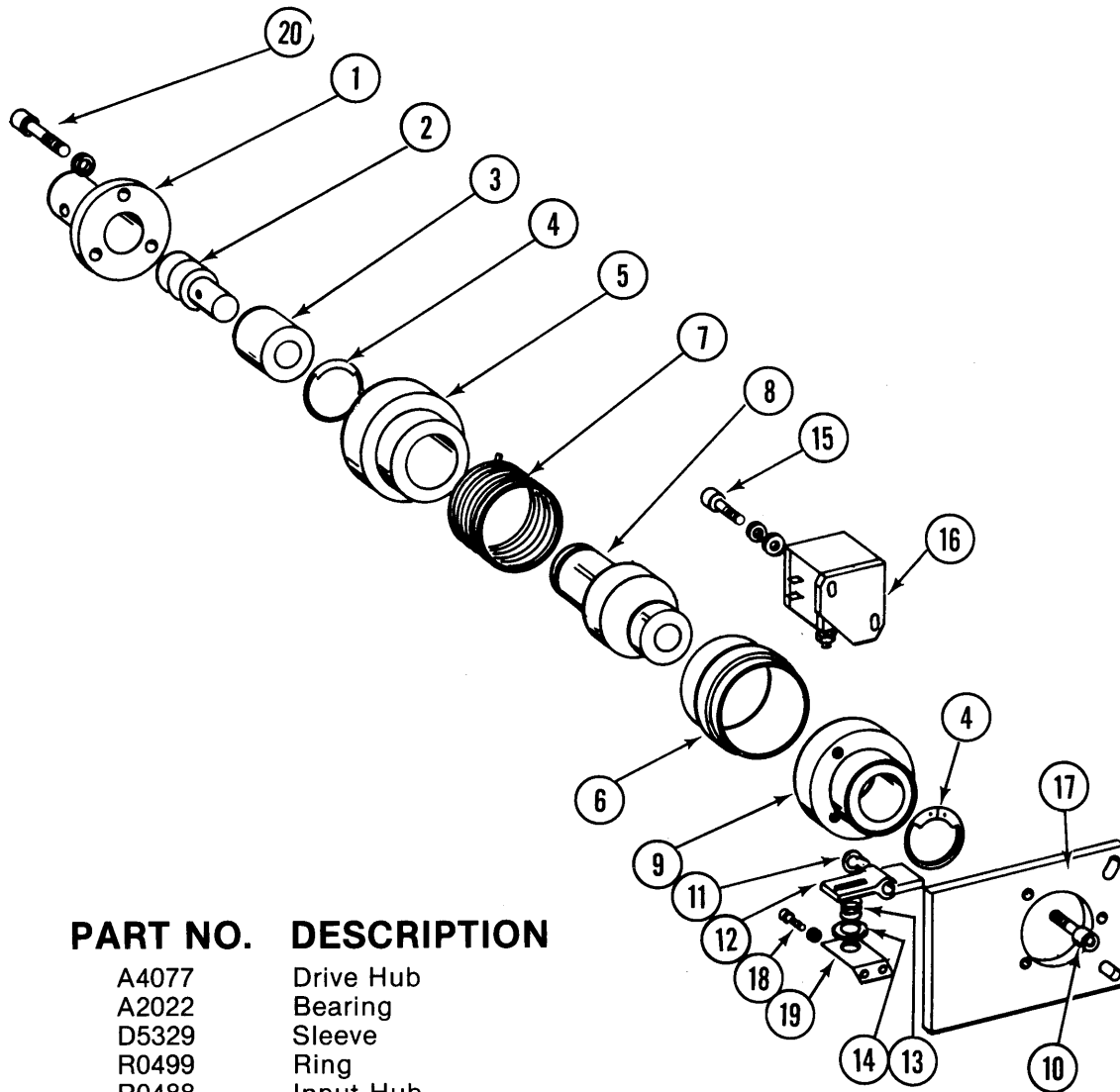

ITEM	PART NO.	DESCRIPTION
1.	A4077	Drive Hub
2.	A2022	Bearing
3.	D5329	Sleeve
4.	R0499	Ring
5.	R0488	Input Hub
6.	R0493	Stop Collar Assembly, CCW
	R0494	Stop Collar Assembly, CW
7.	R0563	Spring, CCW
	R0564	Spring, CW
8.	R0480	Output Hub
9.	R0490	Plate Bearing
10.	10255	Socket Head Cap Screw, 5/16" - 18 x 1/2"
11.	R0479	Ring
12.	R0465	Actuator Arm
13.	R0495	Spring, Actuator Return
14.	R0487	Sleeve
15.	10253	Socket Head Cap Screw, No. 10 - 32 x 1/2"
	10257	Lock Washer, No. 10
	10243	Washer, No. 10
16.	R0485	Solenoid Assembly w/Plunger, CCW
	R0484	Solenoid Assembly w/Plunger, CW
17.	R0481	Plate Assembly, CCW
	R0482	Plate Assembly, CW
18.	10254	Socket Head Cap Screw, No. 8 - 32 x .38
	10256	Lock Washer, No. 8
	10258	Washer, No. 8
19.	R0486	Bracket
20.	10252	Socket Head Cap Screw, 1/4" - 20 x .88

10 BOLT TRANSPORT WHEEL ASSEMBLY

24 Row Model

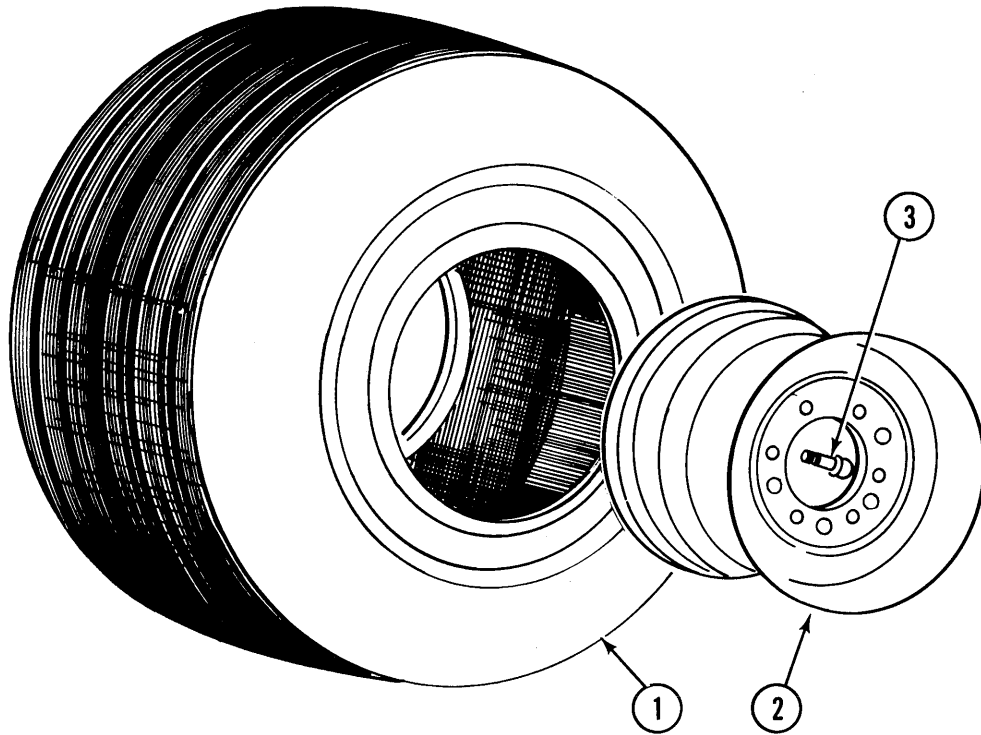

ITEM	PART NO.	DESCRIPTION
1.	D5242	Tire, 16.5L x 16.1 Tubeless
2.	A3918	Wheel, Outer
	A3919	Wheel, Inner
3.	D1166	Valve Stem

6 BOLT LIFT WHEEL ASSEMBLY

24 Row Model

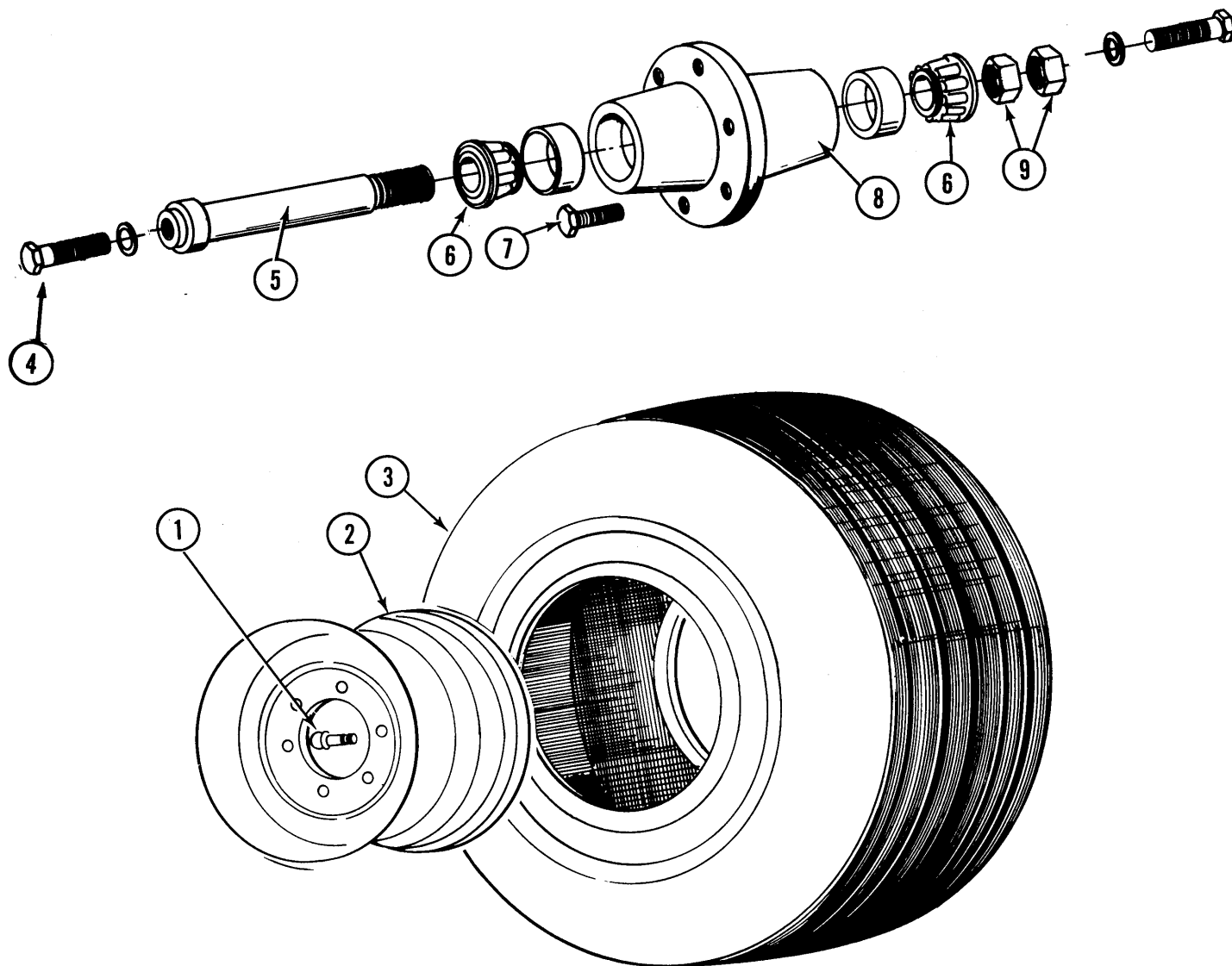

ITEM	PART NO.	DESCRIPTION
1.	D1166	Valve Stem
2.	A2908	Rim, 20 x 5.50F
3.	D2648	Tire, 7.50 x 20", 6 Ply Tubless
4.	10329	HHCS, 7/8" - 9 x 3 1/2"
	10330	Lock Washer, 7/8"
5.	A3521	Spindle
6.	A0895	Bearing
7.	R0270	Lug Bolt, 9/16" - 18
8.	A2148	Hub w/Cups, 6 Bolt
	R0434	Cup
9.	10087	Jam Nut, 1 1/2" - 12

MARKER HUB ASSEMBLY

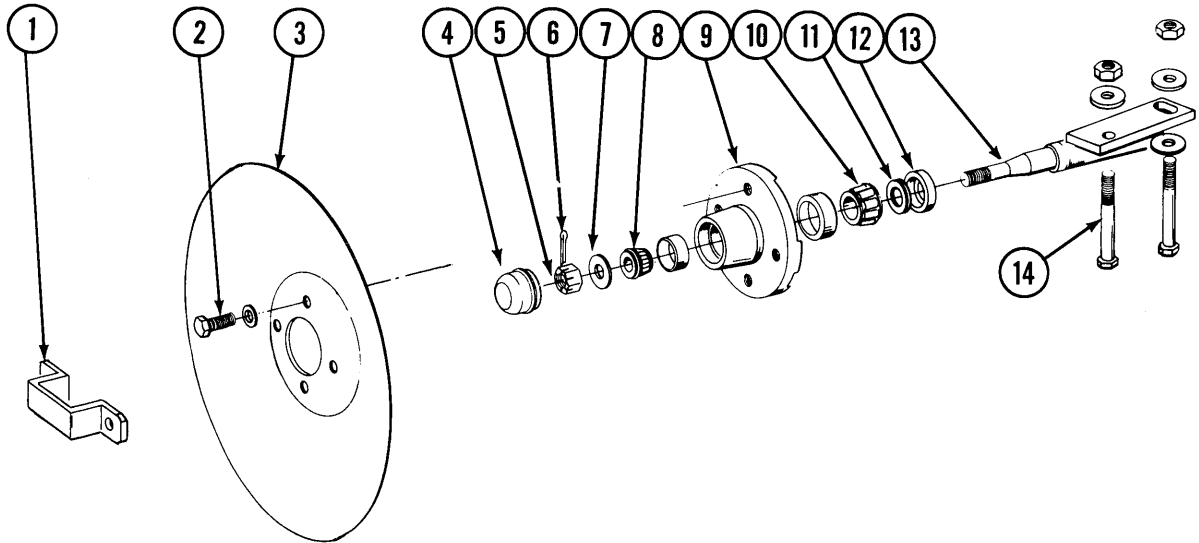

ITEM	PART NO.	DESCRIPTION
1.	D2597	Retainer
2.	10722	HHCS, 1/2" - 20 x 1"
	10228	Lock Washer, 1/2"
3.	D0746	Blade, 16"
4.	D0840	Cap
5.	10725	Hex Nut, Slotted, 5/8" - 18
6.	10470	Cotter Pin, 5/32" x 1"
7.	10724	Washer, 5/8"
8.	A0257	Bearing, Outer
9.	A0167	Hub w/Cups
	R0151	Cup, Outer
	R0150	Cup, Inner
10.	A0245	Bearing, Inner
11.	A0899	Seal, Rubber
12.	A0243	Seal, Grease
13.	A1677	Spindle, L.H., Less Hardware (Shown)
	A1676	Spindle, R.H. Less Hardware
14.	10033	HHCS, 1/2" - 13 x 3 1/2"
	10168	Machinery Bushing, 1/2", 7 Ga.
	10102	Hex Nut, 1/2" - 13
A.	A1679	Hub and Spindle Assembly L.H. (Includes Items 2 and 4 thru 13)
	A1678	Hub and Spindle Assembly R.H. (Includes Items 2 and 4 thru 13)

LOW PROFILE TRIPLE FOLD MARKER ASSEMBLY

24 Row Model

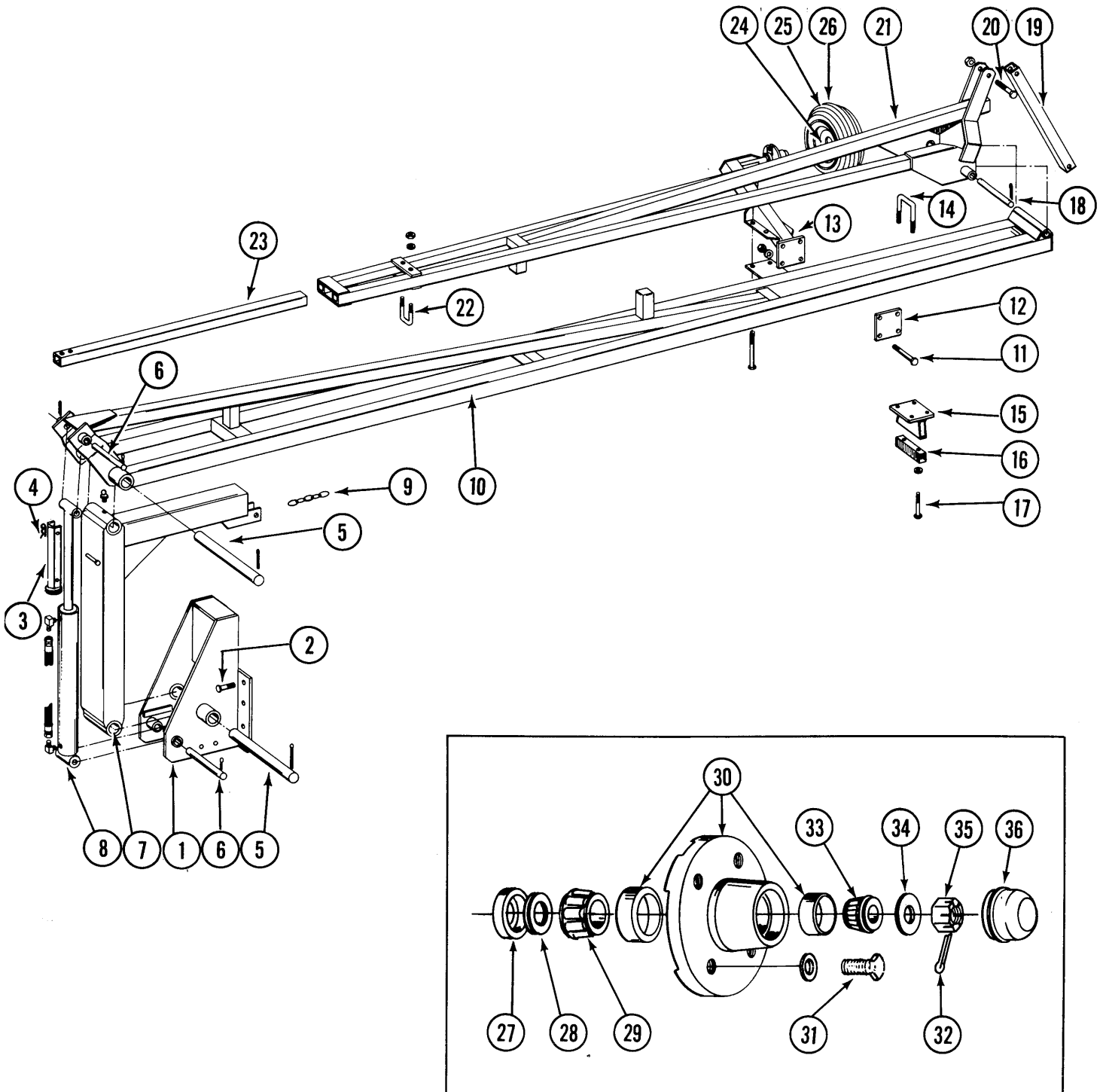

LOW PROFILE TRIPLE FOLD MARKER ASSEMBLY

ITEM	PART NO.	DESCRIPTION
1.	A4031	Mount, L.H.
	A3910	Mount, R.H.
2.	10027	HHCS, 3/4" - 10 x 2 1/2"
	10231	Lock Washer, 3/4"
	10105	Hex Nut, 3/4" - 10
3.	A2913	Lockup
4.	10561	Clevis Pin, 1/2" x 3"
	10670	Hair Pin Clip, No. 3
5.	D0677	Pin, 2 1/8" x 15 1/2"
	10461	Cotter Pin, 3/8" x 3"
6.	D0671	Pin, 1 1/4" x 10 3/4"
	10460	Cotter Pin, 1/4" x 2"
7.	A0158	Arm w/Grease Fittings, First Stage
	10641	Grease Fitting, 1/8" NPT
8.		Cylinder, See Marker Cylinder Page
9.	3302-03	Chain, 7-0S, 100 Links
10.	A0175-03	Arm, Second Stage
11.	10063	HHCS, 3/8" - 16 x 4"
	10229	Lock Washer, 3/8"
	10101	Hex Nut, 3/8" - 16
12.	D0692	Pad
13.	A0160R	Support w/Spindle, Less Hub, R.H.
	A0160L	Support w/Spindle, Less Hub, L.H.
14.	D1339	U-Bolt, 2 1/2" x 2 1/2" x 1/2" - 13
	10228	Lock Washer, 1/2"
	10102	Hex Nut, 1/2" - 13
15.	A4008	Stand
16.	D2698	Stop, Rubber
17.	10047	HHCS, 3/8" - 16 x 1 3/4"
	10210	Washer, 3/8" USS
	10229	Lock Washer, 3/8"
	10101	Hex Nut, 3/8" - 16
18.	D0704	Pin, 1 1/4" x 14"
	10460	Cotter Pin, 1/4" x 2"
19.	D0703	Bracket
20.	10033	HHCS, 1/2" - 13 x 3 1/2"
	10228	Lock Washer, 1/2"
	10111	Lock Nut, 1/2" - 13
21.	A0178-04	Arm, Third Stage
22.	D2721	U-Bolt, 2" x 2" x 1/2" - 13
	10228	Lock Washer, 1/2"
	10102	Hex Nut, 1/2" - 13
23.	D0453-03	Extension Tube, 50"
24.	A0246	Rim, T8 x 7 x 4
25.	D0841	Tire, 16 x 6.5 x 8
26.	D1364	Tube, 16 x 6.5 x 8
27.	A0243	Seal
28.	A0899	Seal
29.	A0245	Bearing
30.	A0167	Hub w/Cups
	R0151	Cup, Outer
	R0150	Cup, Inner
31.	10722	HHCS, 1/2" - 20 x 1"
	10228	Lock Washer, 1/2"
32.	10470	Cotter Pin, 5/32" x 1"
33.	A0257	Bearing
34.	10724	Washer, 5/8" SAE
35.	10725	Hex Slotted Nut, 5/8" - 18
36.	D0840	Cap

ELECTRICAL COMPONENTS

24 Row Model

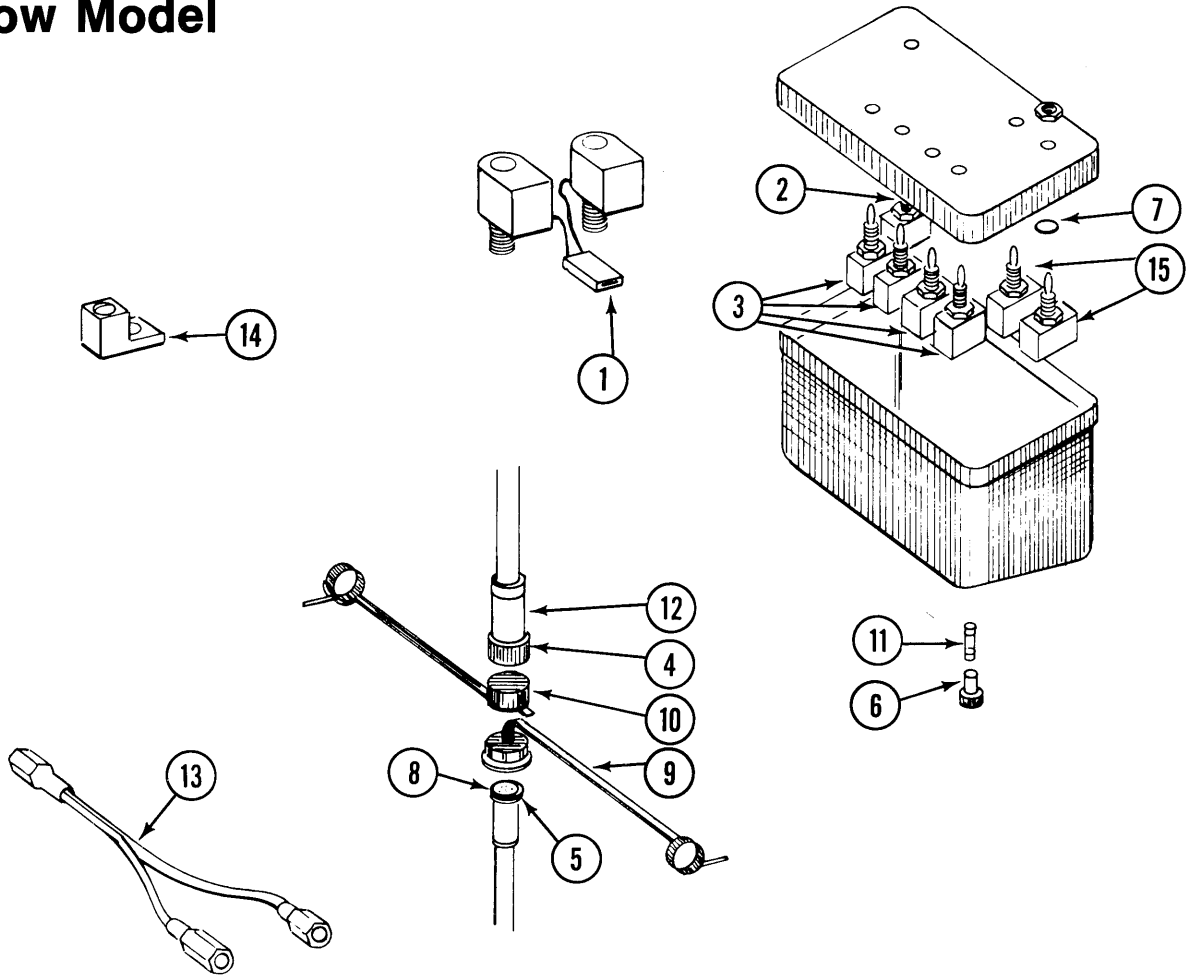

ITEM	PART NO.	DESCRIPTION
1.	10269	Terminal, Male Tab
2.	A2528	Switch, 3 Position Toggle
3.	A2526	Switch, 2 Way Momentary Contact
4.	A3491	Connector w/Coupling Ring
	R0807	Coupling Ring
5.	D4565	Connector
6.	A2612	Fuse Holder
7.	D3860	O-Ring
8.	D4613	Seal, Peripheral
9.	D4563	Dust Cap
10.	D4564	Dust Cover
11.	D2829	Fuse, AGC-15
12.	A3492	Cable Clamp w/Screws and Inserts
13.	A3589	Harness
14.	A3584	Clamp, Ground
15.	A2527	Switch, 2 Position Toggle (Point Row)
A.	A4047	Control Box Assembly w/Short Harness
B.	A4050	Wiring Harness, Tractor to Valve Block Assembly on Hitch
C.	A4051	Wiring Harness, Valve Block Assembly on Hitch to Valve Block Assembly on Main Frame
D.	A4052	Wiring Harness, Point Row (2 Per Planter)

TONGUE CYLINDER

24 Row Model

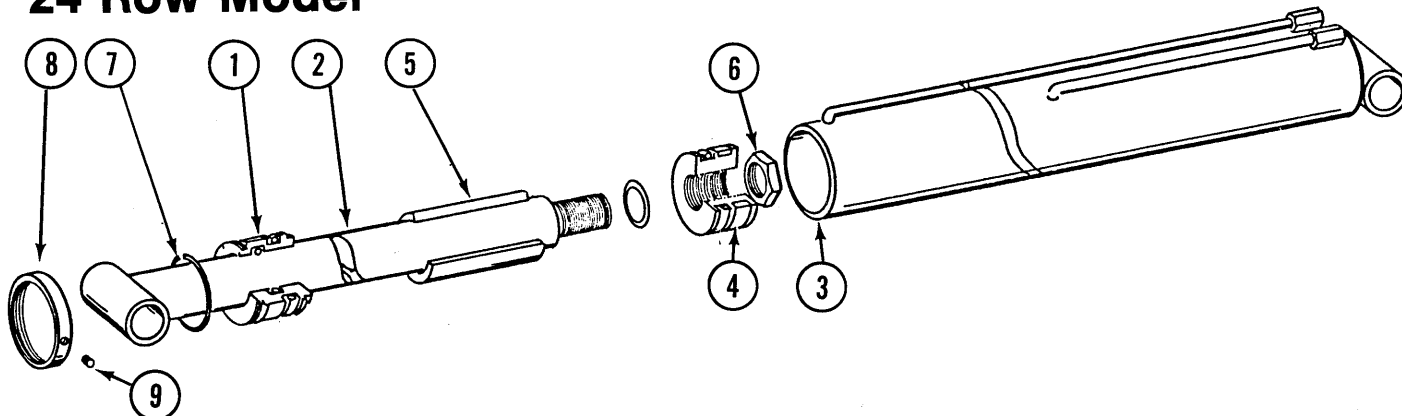

ITEM	PART NO.	DESCRIPTION
1.	D4923	Gland
2.	A3743	Shaft Assembly
3.	A3742	Tube Assembly
4.	D4752	Piston
5.	D4930-01	Stroke Collar
6.	10509	Hex Jam Nut, 1 1/4" - 12 UNF
7.	R0110	Wire Ring
8.	R0106	Head Gland Nut
9.	10114	Set Screw, No. 10-32
A.	A3670	Cylinder, 4" x 13'6"
B.	R0830	Seal Kit, Includes: (2) O-Rings, (1) BU Ring, (1) Wiper, (3) Wear Rings, (1) T-Seal, (1) Polypak

TONGUE LOCK CYLINDER

24 Row Model

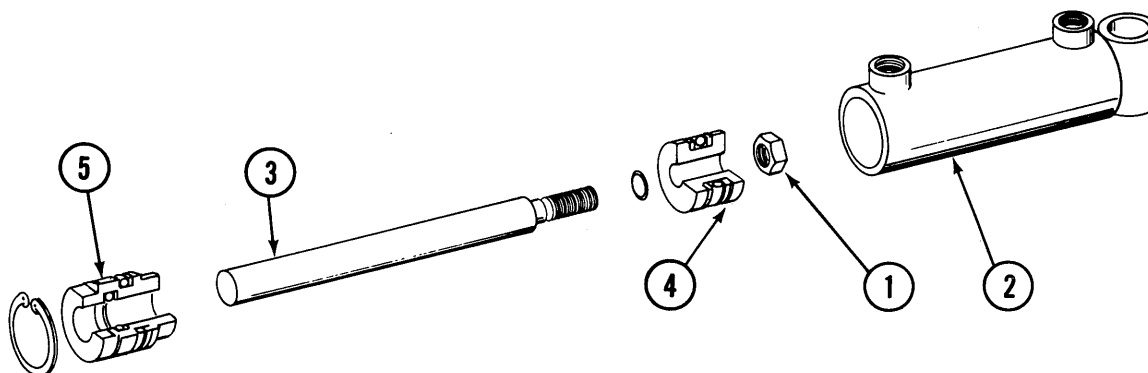

ITEM	PART NO.	DESCRIPTION
1.	10289	Hex Nut, 1/2" - 20
2.	A3442	Tube Assembly
3.	D4522-01	Shaft
4.	D4523	Piston
5.	D4524	Gland
A.	A3443	Cylinder, 1 1/2" x 2"
B.	R0777	Seal Kit, Includes: (2) O-Rings, (1) Wiper, (1) Retaining Ring, (1) Polypak, (1) T-Seal w/BU Rings

WING LIFT CYLINDER

24 Row Model

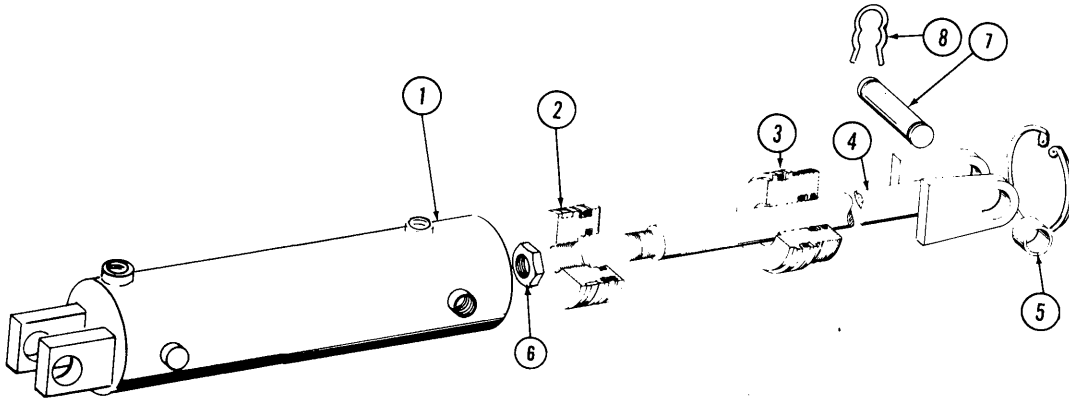

ITEM	PART NO.	DESCRIPTION
1.	A3717	Tube Assembly
2.	D4896	Piston
3.	D4895	Gland
4.	A3715	Shaft Assembly
5.	R0374	Bushing
6.	10324	Hex Jam Nut, 1" - 14
7.	R0375	Pin
8.	R0193	Clip
A.	A3669	Cylinder, 3 1/4" x 8", Less Pins and Clips
B.	R0832	Seal Kit, Includes: (2) O-Rings, (1) BU Ring, (1) Retaining Ring, (1) Wear Ring, (1) Wiper, (1) Polypak, (1) Piston Seal

CENTER SECTION LIFT CYLINDER

24 Row Model

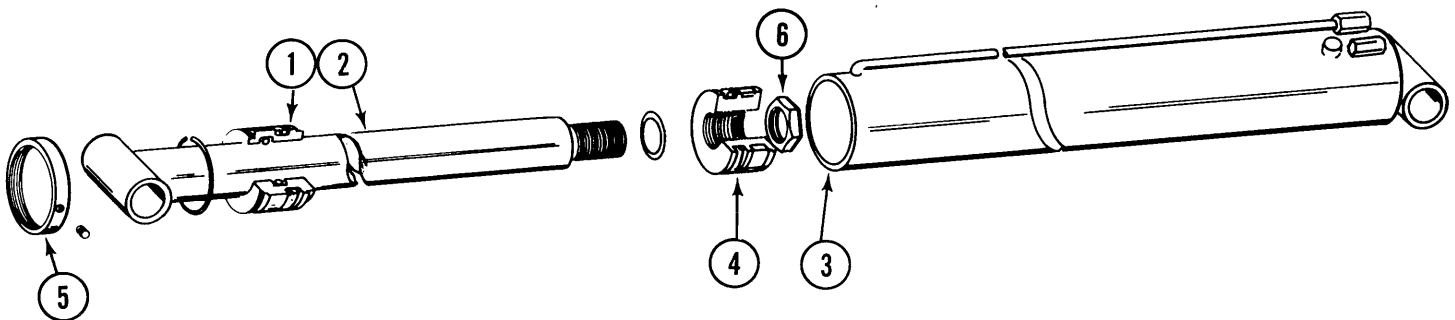

ITEM	PART NO.	DESCRIPTION
1.	D4914	Gland
2.	A3740	Shaft Assembly
3.	A3739	Tube Assembly
4.	D4915	Piston
5.	D4919	Threaded End Cap
6.	10347	Hex Jam Nut, 2" - 12 UNF
A.	A3668	Cylinder, 6" x 20"
B.	R0831	Seal Kit, Includes: (2) O-Rings, (1) BU Ring, (1) Wear Ring, (1) Wiper, (1) Polypak, (1) Piston Seal

LIFT LOCK CYLINDER

24 Row Model

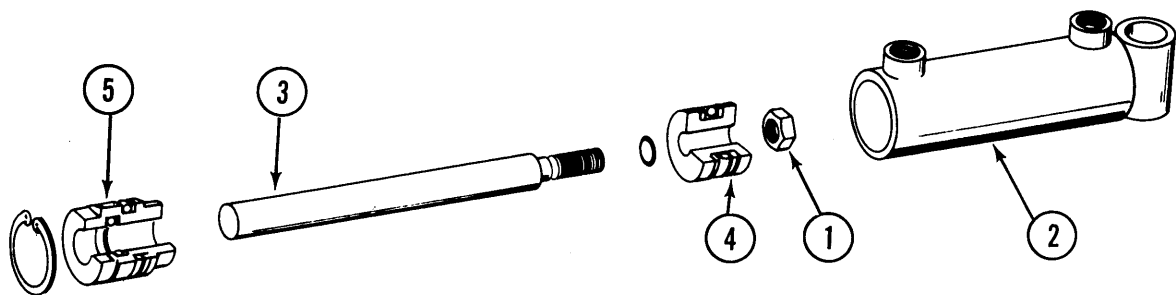

ITEM	PART NO.	DESCRIPTION
1.	10289	Hex Nut, 1/2" - 20
2.	A3753	Tube Assembly
3.	D4522-01	Shaft
4.	D4523	Piston
5.	D4524	Gland
A.	A3752	Cylinder, 1 1/2" x 2 1/2"
B.	R0777	Seal Kit, Includes: (2) O-Rings, (1) Wiper, (1) Retaining Ring, (1) Polypak, (1) T-Seal w/BU Rings

ROTATION CYLINDER

24 Row Model

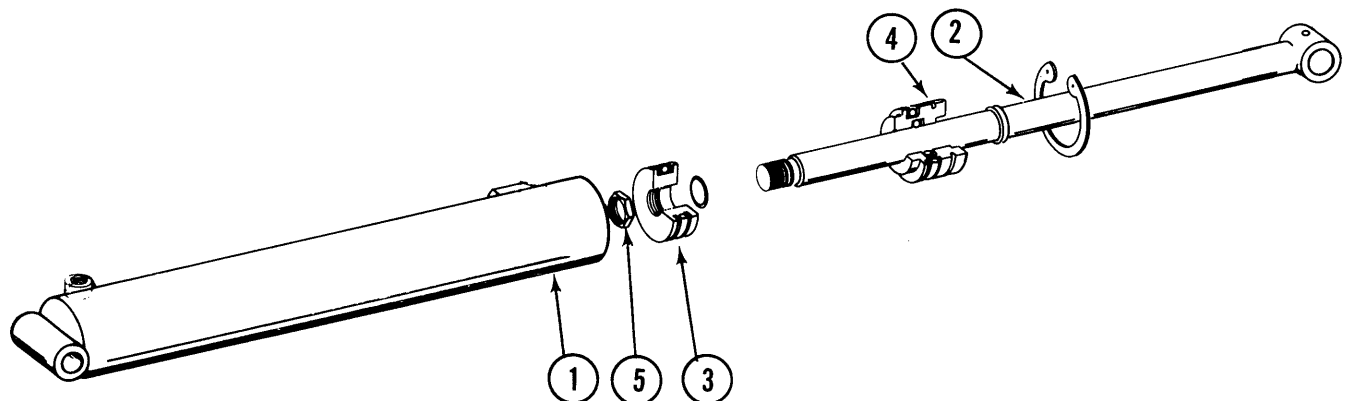

ITEM	PART NO.	DESCRIPTION
1.	A4067	Tube Assembly
2.	A4068	Shaft Assembly
3.	D4752	Piston
4.	D4542	Head Gland
5.	10509	Hex Jam Nut, 1 1/4" - 12
A.	A3030	Cylinder, 4" x 10"
B.	R0827	Seal Kit, Includes: (2) O-Rings, (1) BU Ring, (1) Retaining Ring, (1) Wiper, (1) Polypak, (1) Wear Ring, (1) T-Seal w/BU Rings

WING LOCK CYLINDER/MARKER CYLINDER

24 Row Model

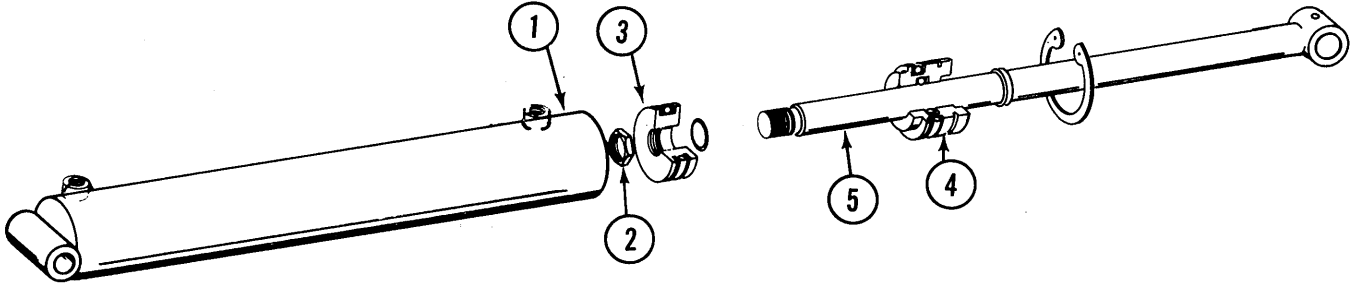

ITEM	PART NO.	DESCRIPTION
1.	A3684	Tube Assembly
2.	10509	Hex Jam Nut, 1 1/4" - 12 UNF
3.	D4521	Piston
4.	D4509	Gland
5.	A3683	Shaft Assembly
A.	A3667	Cylinder, 3 1/2" x 20"
B.	R0778	Seal Kit, Includes (2) O-Rings, (1) Retaining Ring, (1) Wiper, (1) Polypak, (1) T-Seal w/BU Rings, (2) BU Rings

SOLENOID VALVE

ITEM	PART NO.	DESCRIPTION
1.	R0760	Plate
2.	R0761	Hex Nut
3.	R0762	Coil
4.	R0763	Cartridge
A.	A2484	Solenoid Valve Complete
B.	R0764	Seal Kit, Includes: (2) O-Rings (1) Backup Ring

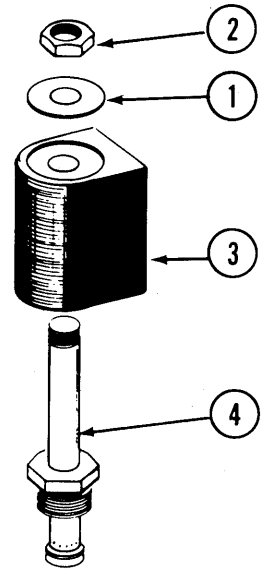

FLOW CONTROL VALVE

ITEM	PART NO.	DESCRIPTION
A.	A3413	Flow Control Valve
B.	R0764	Seal Kit, Includes: (2) O-Rings (1) Backup Ring

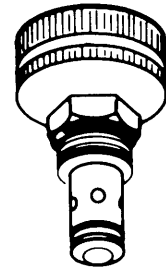

PRESSURE RELIEF VALVE

ITEM	PART NO.	DESCRIPTION
A.	A3598	Pressure Relief Valve, 500 PSI
B.	R0764	Seal Kit, Includes: (2) O-Rings (1) Backup Ring



HYDRAULIC SYSTEM, MARKER AND WING LOCK

24 Row Model

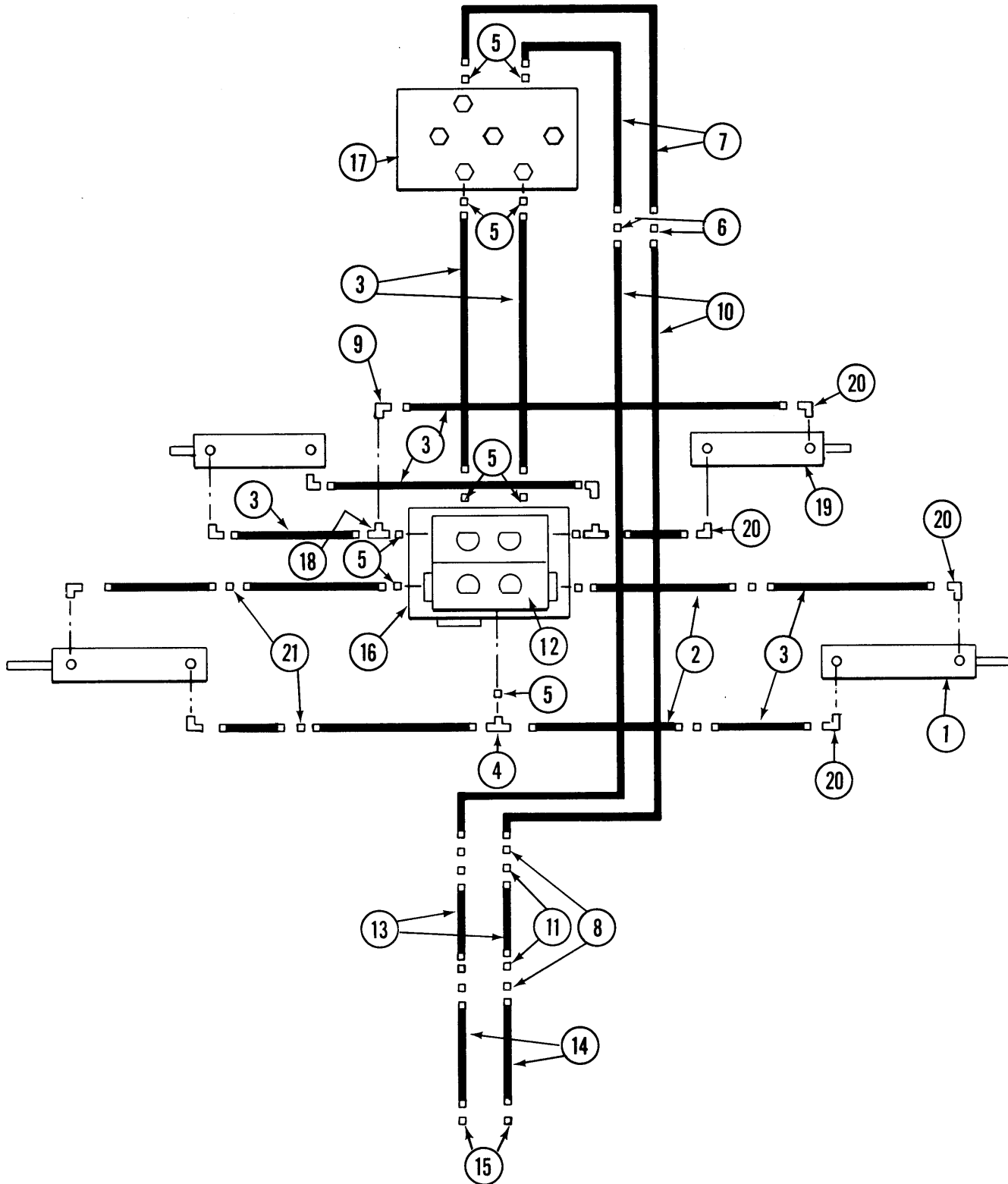

HYDRAULIC SYSTEM, MARKER AND WING LOCK

ITEM	PART NO.	DESCRIPTION
1.		Cylinder, See Marker Cylinder Page
2.	A1051	Hose Assembly, 3/8" x 360"
3.	A1022	Hose Assembly, 3/8" x 60"
4.	6600-08	Tee
5.	6400-08	Connector, Male O-Ring
6.	2403-08	Male Union
7.	A1002	Hose Assembly, 3/8" x 20"
8.	2700-08	Bulkhead Tube Union
9.	6500-08	Elbow
10.	A3114	Hose Assembly, 3/8" x 156"
11.	306-08	Lock Nut, 3/4" - 16
12.		Block, See Frame Assembly Page
13.	A3111	Hose Assembly, 3/8" x 200"
14.	A1091	Hose Assembly, 3/8" x 216"
15.	D4086	Tip, Pioneer Male
16.		Block, See Center Frame Assembly Page
17.		Block, See Lift Arms and Bell Assembly Page
18.	6602-08	Tee
19.		Cylinder, See Wing Lock Cylinder Page
20.	2501-08-08	Elbow

HYDRAULIC SYSTEM, PLANTER LIFT

24 Row Model

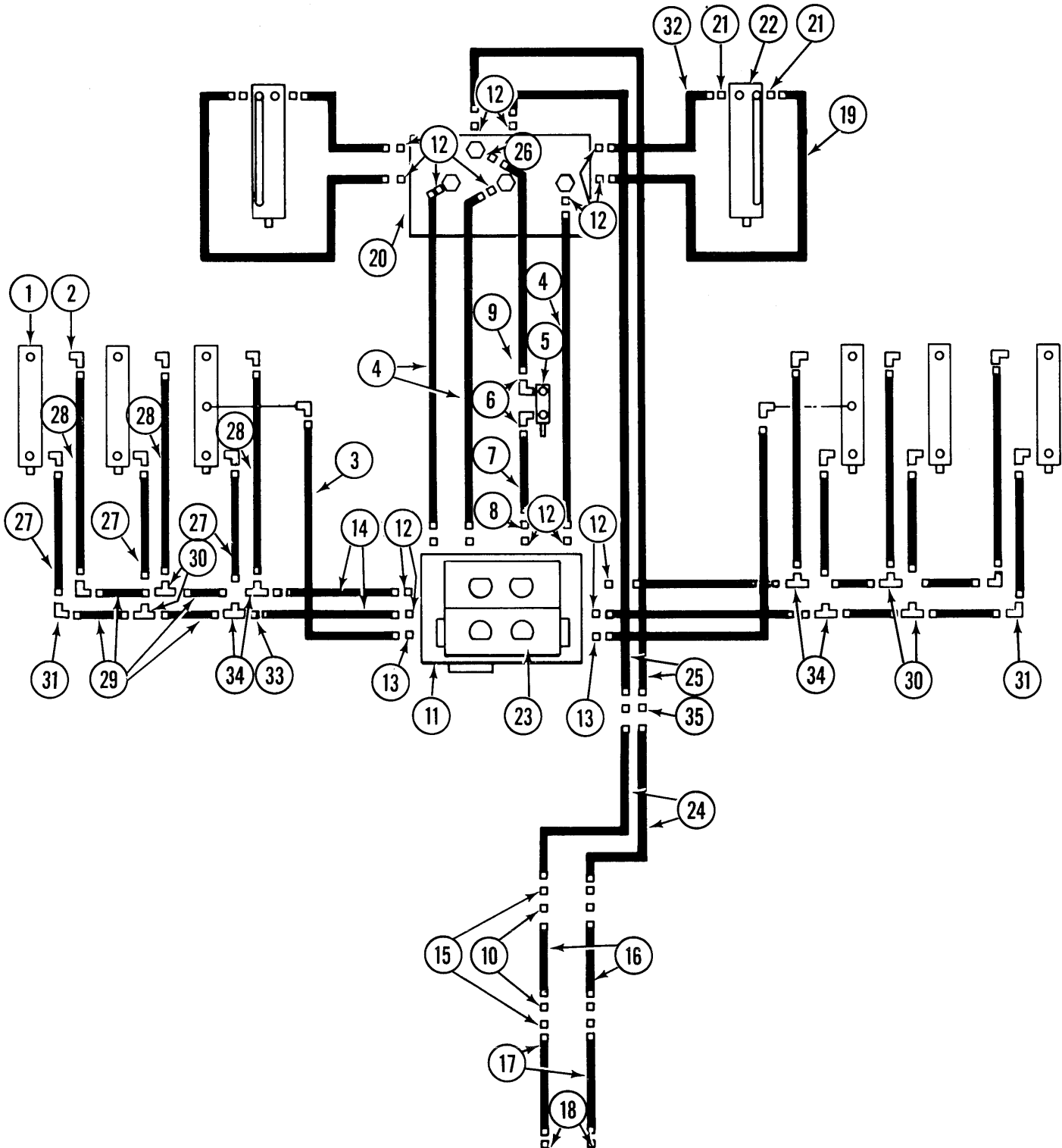

HYDRAULIC SYSTEM, PLANTER LIFT

ITEM	PART NO.	DESCRIPTION
1.		Cylinder, See Wing Lift Cylinder Page
2.	2501-08-08	Elbow
3.	A3116	Hose Assembly, 3/8" x 314"
4.	A1425	Hose Assembly, 1/2" x 60"
5.		Cylinder, See Lift Cylinder Page
6.	2501-06-04	Elbow
7.	A1139	Hose Assembly, 1/4" x 40"
8.	2406-10-06	Reducer
9.	A1154	Hose Assembly, 1/4" x 72"
10.	306-10	Lock Nut, 7/8" - 14
11.		Block, See Center Frame Assembly Page
12.	6400-10	Connector, Male O-Ring
13.	6400-08	Connector, Male O-Ring
14.	A1426	Hose Assembly, 1/2" x 278"
15.	2700-10	Bulkhead Tube Union
16.	A3304	Hose Assembly, 3/4" x 200"
17.	A1419	Hose Assembly, 1/2" x 117"
18.	D4086	Tip, Pioneer Male
19.	A1424	Hose Assembly, 1/2" x 30"
20.		Block, See Lift Arm and Bell Assembly Page
21.	2404-10-08	Adapter
22.		Cylinder, See Center Section Lift Cylinder Page
23.		Block, See Center Frame Assembly Page
24.	A3306	Hose Assembly, 3/4" x 20"
25.	A3305	Hose Assembly, 3/4" x 156"
26.	6400-06-08	Connector, Male O-Ring
27.	A1044	Hose Assembly, 3/8" x 34"
28.	A1019	Hose Assembly, 3/8" x 44"
29.	A1003	Hose Assembly, 3/8" x 27"
30.	2603-08	Tee
31.	2500-08	Elbow
32.	A1413	Hose Assembly, 1/2" x 26"
33.	2406-10-08	Reducer
34.	6602-08	Tee
35.	2403-10	Male Union

HYDRAULIC SYSTEM, TONGUE/ROTATION

24 Row Model

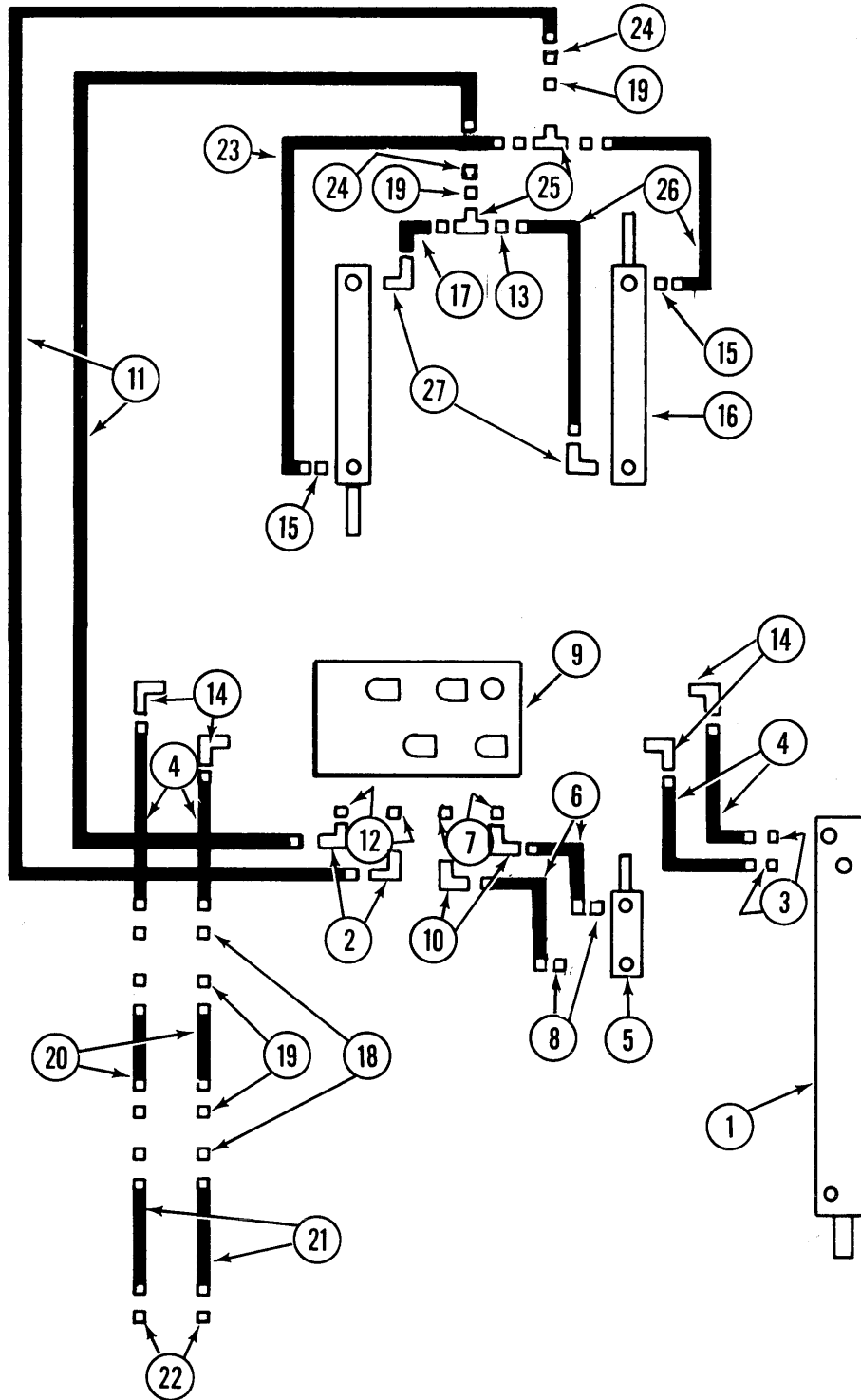

HYDRAULIC SYSTEM, TONGUE/ROTATION

ITEM	PART NO.	DESCRIPTION
1.		Cylinder, See Tongue Cylinder Page
2.	6500-08	Elbow
3.	2404-08-08	Adapter
4.	A1003	Hose Assembly, 3/8" x 27"
5.		Cylinder See Tongue Lock Cylinder Page
6.	A1137	Hose Assembly, 1/4" x 23"
7.	6400-06-08	Connector, Male O-Ring
8.	2404-06-04	Adapter
9.		Block, See Inner Hitch Assembly Page
10.	6500-06	Elbow
11.	A3115	Hose Assembly, 3/8" x 146"
12.	6400-08	Connector, Male O-Ring
13.	2406-08-06	Reducer
14.	6801-08	Elbow
15.	2404-06-08	Adapter
16.		Cylinder, See Rotation Cylinder Page
17.	A1148	Hose Assembly, 1/4" x 16"
18.	2700-08	Bulkhead Tube Union
19.	306-08	Lock Nut, 3/4" - 16
20.	A3111	Hose Assembly, 3/8" x 200"
21.	A1091	Hose Assembly, 3/8" x 216"
22.	D4086	Tip, Pioneer Male
23.	A1152	Hose Assembly, 1/4" x 26"
24.	D5545	Restrictor
25.	2703-08	Tee
26.	A1144	Hose Assembly, 1/4" x 54"
27.	2501-06-08	Elbow

PUSH UNIT DRIVE AND TRANSMISSION ASSEMBLY

24 Row Model

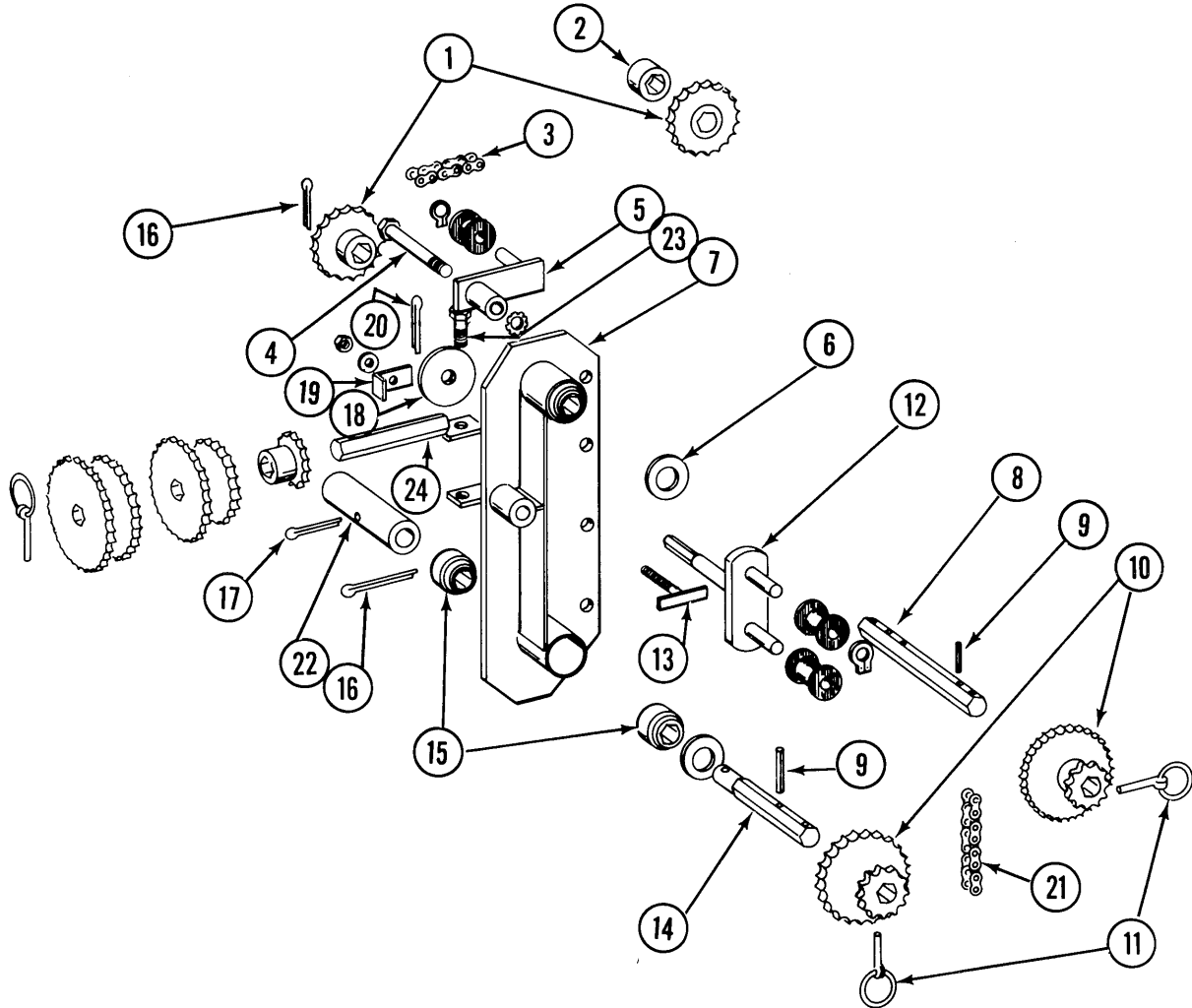

PUSH UNIT DRIVE AND TRANSMISSION ASSEMBLY

ITEM	PART NO.	DESCRIPTION
1.	2500-14	Sprocket, 24 Tooth
2.	D0917	Lock Collar, Less Set Screws
	10145	Set Screw, 5/16" - 18 x 1/2"
3.	3300-45	Chain, No. 2040, 45 Pitch including Connector Link and Offset Link
	R0194	Connector Link, No. 2040
	R0199	Offset Link, No. 2040
4.	10032	HHCS, 1/2" - 13 x 3 3/4"
	10527	Washer, Internal/External, 1/2"
	10228	Lock Washer, 1/2"
	10102	Hex Nut, 1/2" - 13
5.	A3629	Idler w/Spool and Ring
	10435	Ring
	D1067	Spool
6.	10233	Machinery Bushing, 1"
7.	A4003	Plate, L.H. (Shown)
	A4004	Plate, R.H.
8.	D5528	Shaft, 8 3/4"
9.	10602	Spring Pin, 1/4" x 1 1/2"
10.	2500-25	Sprocket, 14 Tooth
	2500-26	Sprocket, 18-28 Tooth
	2500-27	Sprocket, 16-30 Tooth
	2500-28	Sprocket, 22-26 Tooth
11.	D2558	Pin, Lynch, 1/4"
12.	A0503	Idler w/Spools and Rings
	D1067	Spool
	10435	Ring
13.	A3428	T-Bolt
	10229	Lock Washer, 3/8"
	10101	Hex Nut, 3/8" - 16
14.	D5215	Shaft, 6 3/8"
15.	2100-03	Bearing, 7/8 Hex Bore
16.	10463	Cotter Pin, 1/4" x 1 1/2"
17.	10460	Cotter Pin, 1/4" x 2"
18.	A1668	Tightener
19.	D2495	Angle, Idler Lock
20.	10670	Hair Pin Clip, No. 3
21.	3300-40	Chain, No. 2040, 40 Pitch Including Connector Link
	R0194	Connector Link, No. 2040
22.	D5212	Coupler, 1 3/4"
23.	10019	HHCS, 5/16" - 18 x 1"
	10109	Lock Nut, 5/16" - 18
24.	A1786	Rod, Sprocket Storage

PUSH UNIT DRILL SHAFT DRIVE LINE

24 Row Model

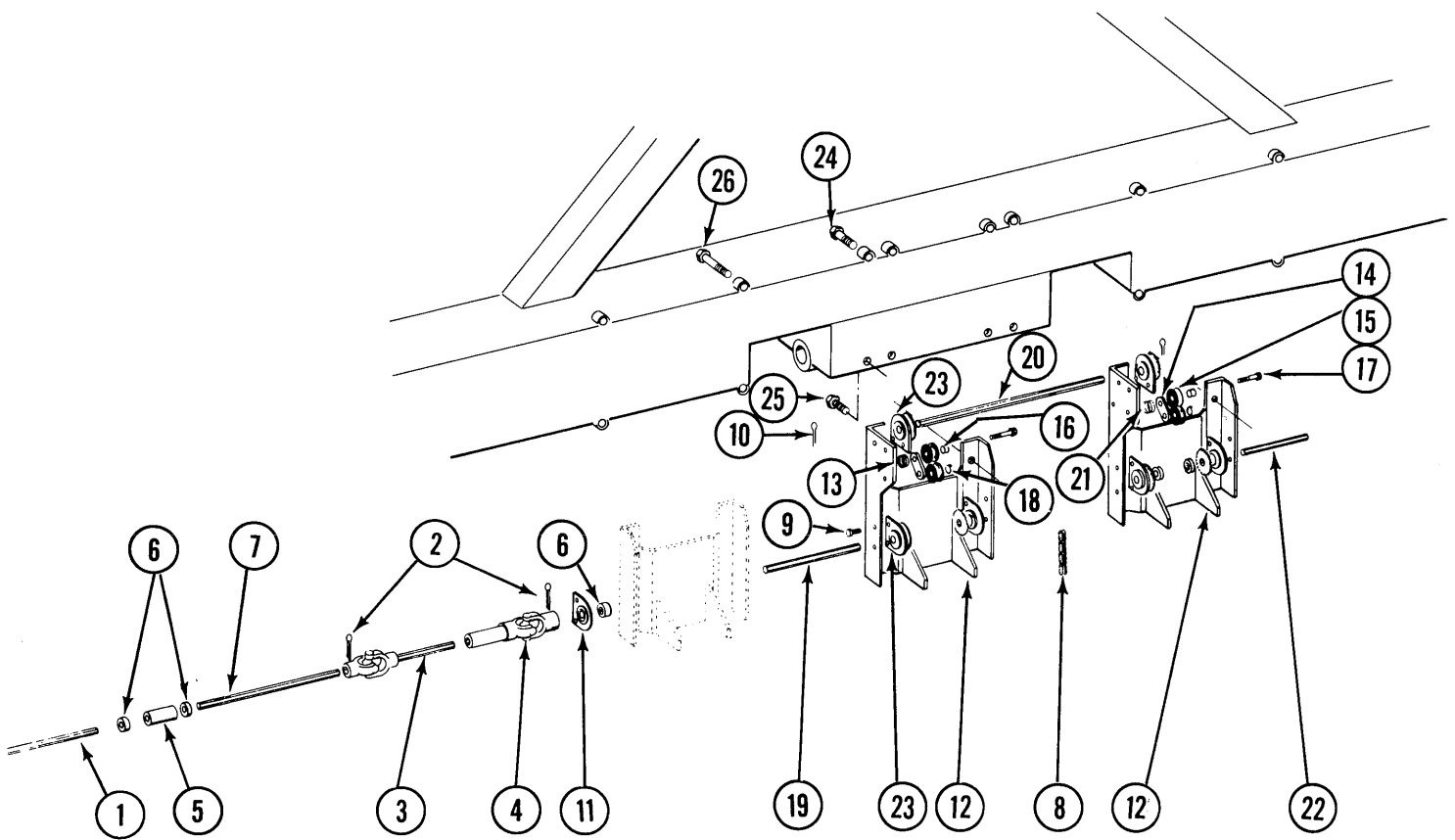

PUSH UNIT DRILL SHAFT DRIVE LINE

ITEM	PART NO.	DESCRIPTION
1.	D0914-222	Wing Shaft, R.H. and L.H., 222"
2.	10460	Cotter Pin, 1/4" x 2"
3.	A3646	Universal Joint w/Grease Fitting
	10343	Grease Fitting, 1/8" - 27 90°
4.	A3647	Universal Joint w/Grease Fittings
	10640	Grease Fitting, 1/4" - 28
	10343	Grease Fitting, 1/8" - 27 90°
5.	D1719	Coupler, 4"
6.	D0917	Lock Collar, Less Set Screws
	10145	Set Screw, 5/16" - 18 x 1/2"
7.	D5531	Wing Shaft, R.H. and L.H., 23"
8.	3303-67	Chain, No. 41, 67 Pitch Including Connector and Offset Link
	R0196	Connector Link, No. 41
	R0201	Offset Link, No. 41
9.	10001	HHCS, 3/8" - 16 x 1"
	10229	Lock Washer, 3/8"
	10101	Hex Nut, 3/8" - 16
10.	10463	Cotter Pin, 1/4" x 1 1/2"
11.	A2180	Hanger Bearing, 7/8" Hex
12.	A4037	Mounting Plate, Special
13.	D1065	Spring
14.	A2056	Idler, Less Spool and Rings
15.	D1068	Spool
16.	D1026	Bushing
17.	10061	HHCS, 3/8" - 16 x 3 1/2"
	10210	Washer, 3/8" USS
	10229	Lock Washer, 3/8"
	10101	Hex Nut, 3/8" - 16
18.	10435	Ring
19.	D5533	Shaft, R.H., 76"
	D5532	Shaft, L.H., 64"
20.	D4775	Shaft, 33 1/4"
21.	D2134	Spring
22.	D0914-12.25	Shaft
23.	A1720	Bearing/Sprocket, 7/8" Hex
24.	10009	HHCS, 5/8" - 11 x 2 1/2"
	10230	Lock Washer, 5/8"
	10104	Hex Nut, 5/8" - 11
25.	10007	HHCS, 5/8" - 11 x 1 1/2"
	10230	Lock Washer, 5/8"
	10104	Hex Nut, 5/8" - 11
26.	10013	HHCS, 5/8" - 11 x 3 1/2"
	10230	Lock Washer, 5/8"
	10104	Hex Nut, 5/8" - 11

DECALS, REFLECTORS AND TIE STRAPS

24 Row Model

3

CAUTION

1. Read and understand the Operator's Manual.
2. Stop the tractor engine before leaving the operator's platform.
3. Keep riders off the machine.
4. Make certain everyone is clear of the machine before starting the tractor engine and operating.
5. Keep all shields in place.
6. Never lubricate, adjust, oil, or service the machine with tractor engine running.
7. Wait for all movement to stop before servicing.
8. Keep hands, feet and clothing away from moving parts.
9. Use flashing warning lights when operating on highways except when prohibited by law.

KINZEE®

Twin • Line

1

4

WARNING

TOW ONLY WITH FARM TRACTOR.

2

CAUTION

REAR OF PLANTER SWINGS WIDE IN TURNS. ALWAYS ALLOW SUFFICIENT ROOM TO CLEAR OBSTACLES WHEN TURNING.

5

IMPORTANT

Always rephase the hydraulic system after transporting.

1. Lower the planter to the ground.
2. Hold the hydraulic lever for 15 seconds to rephase the hydraulic system.
3. Resume normal operation.

6

WARNING

TO AVOID INJURY... Stand clear... Keep others away when raising or lowering markers. Before transporting planter, fully extend hydraulic cylinders and install locking pins where provided.

7

DANGER

THIS PLANTER IS DESIGNED TO BE DRIVEN BY GROUND TIRES ONLY. THE USE OF HYDRAULIC, ELECTRIC OR PTO DRIVES MAY CREATE SERIOUS SAFETY HAZARDS TO YOU AND THE PEOPLE NEAR BY. IF YOU INSTALL SUCH DRIVES YOU MUST FOLLOW ALL APPROPRIATE SAFETY STANDARDS AND PRACTICES TO PROTECT YOU AND OTHERS NEAR THIS PLANTER FROM INJURY.

8

WARNING

— TO AVOID INJURY — ALWAYS USE HYDRAULIC CYLINDER SAFETY LOCKOUT CHANNELS WHEN TRANSPORTING PLANTER ON THE ROAD. AFTER USE RETURN TO STORAGE LOCATION.

10

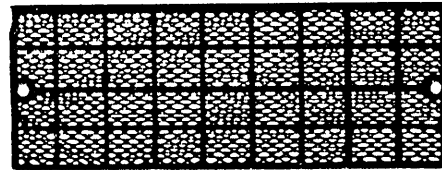

11

WARNING

NEVER WALK UNDER OR WORK ON PLANTER WHEN IT IS RAISED WITHOUT SUPPORTING THE FRAMES WITH ADDITIONAL SUPPORTS.

12

CAUTION

ROTATION CYLINDER MUST BE FULLY EXTENDED AND LINKAGE LOCKED OVER CENTER BEFORE LOWERING PLANTER TO WORK POSITION.

13

IMPORTANT

FRAME MUST BE DOWN ON TONGUE WHEN IN PLANTING POSITION

14

CAUTION

AVOID UNEVEN LOADING OF HOPPERS, ESPECIALLY DURING TRANSPORT

15

INSTRUCTION

TRANSPORT TO PLANTING

1. RELEASE TRANSPORT LOCK.
2. ROTATE PLANTER.
3. RELEASE LIFT LOCK.
4. LOWER PLANTER AND REPHASE SYSTEM.
5. RELEASE WING LOCKS.
6. RAISE TO RAISED FIELD POSITION.
7. RETRACT TONGUE.

16

INSTRUCTION

PLANTING TO TRANSPORT

1. SECURE WING LOCKS.
2. RAISE TO RAISED FIELD POSITION.
3. FULLY EXTEND TONGUE.
4. RAISE TO LOCKED TRANSPORT POSITION.
5. ROTATE PLANTER.

17

18

WARNING

THIS MACHINE HAS BEEN DESIGNED AND BUILT WITH YOUR SAFETY IN MIND. ANY ALTERATION TO THE DESIGN OR CONSTRUCTION MAY CREATE SAFETY HAZARDS. DO NOT MAKE ANY ALTERATIONS OR CHANGES TO THE EQUIPMENT, BUT IF ANY ALTERATIONS OR CHANGES ARE MADE YOU MUST FOLLOW ALL APPROPRIATE SAFETY STANDARDS AND PRACTICE TO PROTECT YOU AND OTHERS NEAR THIS MACHINE FROM INJURY.

9

DECALS, REFLECTORS AND TIE STRAPS

ITEM	PART NO.	DESCRIPTION
1.	7100-46	Decal, Caution
2.	7100-56	Decal, Caution
3.	7100-54	Decal, Kinze
4.	7100-65	Decal, Twin-Line
5.	7100-63	Decal, Caution
6.	7100-64	Decal, Important
7.	7100-42	Decal, Warning
8.	7100-89	Decal, Danger
9.	D1512	Tie Strap, 7"
	D2117	Tie Strap, 14 1/2"
	D1162	Tie Strap, 28"
	D2984	Tie Strap, 33"
10.	7100-83	Decal, Warning
11.	7200-03	Reflector, Red
	7200-04	Reflector, Amber
12.	7100-68	Decal, Warning
13.	7100-69	Decal, Caution
14.	7100-70	Decal, Note
15.	7100-75	Decal, Caution
16.	7100-73	Decal, Transport to Planting
17.	7100-74	Decal, Planting to Transport
18.	7100-90	Decal, Warning
19.	R0155	Blue Paint, Aerosol
	R0439	Blue Paint, Quart
	R0440	Blue Paint, Gallon

NUMERICAL INDEX

8 Row Models

PART NO.	PAGE	PART NO.	PAGE	PART NO.	PAGE	PART NO.	PAGE
A0167	P20	A3428	P15	A3899	P39	D2597	P20
A0243	P20	A3439	P32	A3900	P39	D2721	P19
A0245	P20	A3442	P30	A3901	P39	D2768	P40
A0257	P20	A3443	P30	A3948	P17	D2829	P21
A0289	P38	A3445	P29	A4016	P45	D2971-01	P5
A0308	P35	A3491	P21	A4053	P13	D2971-03	P5
A0312	P35	A3492	P21	A4054	P13	D2984	P47
A0318	P35	A3514	P32	B0123	P13	D3398	P11
A0320	P35	A3515	P32	B0134	P35	D3403	P11
A0321	P41	A3553	P13	B0138	P39	D3548	P3
A0328	P35	A3558	P13	B0156	P3	D3552	P3
A0499	P45	A3559	P13	D0453-03	P19	D3637	P5
A0503	P15	A3584	P21	D0	P19	D3660-08	P13
A0531	P11	A3589	P21	D0487	P35	D3788-01	P3
A0532	P11	A3598	P28	D0653	P19	D3790	P37
A0705	P9, P11	A3599	P40	D0746	P20	D3791	P7, P13
A0779	P9	A3601	P39	D0752-07	P9	D3860	P21
A0785	P35	A3602	P39	D0829	P9	D4014	P3
A0810	P35	A3627	P40	D0840	P20	D4086	P23, P25, P27
A0827	P19	A3658	P29	D0914-104.5	P15	D4468	P11
A0828	P19	A3659	P29	D0914-119	P15	D4474	P7
A0899	P20	A3660	P29	D0914-130	P15	D4476	P37
A0918	P45	A3661	P29	D0914-94	P15	D4477	P37
A0941	P3	A3662	P29	D0916	P13	D4484	P15
A1000	P27	A3663	P29	D0917	P15, P38, P43	D4504	P15
A1009	P23, P27	A3665	P35	D0951	P3	D4509	P31
A1018	P23, P25	A3666	P35	D0962	P35	D4510	P31
A1020	P23, P25, P27	A3667	P31	D1030	P35	D4521	P31
A1022	P23	A3683	P31	D1067	P15, P38	D4522-01	P30
A1055	P23	A3684	P31	D1113	P15, P43	D4523	P30
A1057	P23	A3751	P21	D1132	P35	D4524	P30
A1085	P27	A3752	P30	D1134	P13, P39, P43	D4527	P29
A1092	P23	A3753	P30	D1162	P47	D4528	P29
A1105	P27	A3771	P31	D1165	P18	D4563	P21
A1134	P27	A3772	P31	D1200	P37	D4564	P21
A1138	P25	A3773	P31	D1201	P37	D4565	P21
A1148	P27	A3781	P7	D1202	P37	D4613	P21
A1149	P25	A3785	P7	D1203	P37	D4632	P32
A1369	P35	A3786	P7	D1204	P37	D4634	P32
A1404	P25	A3789	P7	D1205	P37	D4700	P13
A1419	P25	A3792	P18	D1206	P37	D4701	P13
A1420	P25	A3793	P18	D1207	P37	D4748	P15, P39
A1421	P25	A3801	P9	D1208	P37	D4749	P15, P39
A1422	P22	A3802	P9	P1209	P37	D4762	P38
A1668	P15	A3806	P9	D1210	P37	D4781	P33
A1676	P20	A3825	P13	D1212	P37	D4782	P33
A1677	P20	A3828	P13	D1213	P37	D4807	P18
A1678	P20	A3829	P13	D1215	P43	D4863	P7, P9
A1679	P20	A3834	P9	D1216	P43	D4910	P11
A1784	P39, P43	A3835	P11	D1217	P43	D4922	P39
A1785	P15	A3841	P11	D1218	P43	D4927	P9, P11
A1786	P39	A3842	P11	D1219	P43	D4957	P9
A2022	P17	A3846	P11	D1220	P43	D4987	P9
A2052	P13	A3851	P3	D1221	P43	D4988	P9
A2101	P37	A3853	P3	D1222	P43	D4989	P9
A2300	P19	A3855	P11	D1223	P43	D5035	P13
A2301	P19	A3856	P9	D1225	P43	D5036	P13
A2312	P40	A3858	P3	D1337	P45	D5037	P13
A2354	P43	A3862	P3	D1339	P33, P35, P45	D5039	P5
A2355	P43	A3863	P5	D1379	P37	D5042	P11
A2359	P13	A3864	P3	D1380	P37	D5056	P9
A2484	P28	A3866	P21	D1512	P47	D5064	P13
A2526	P21	A3867	P3	D1514	P45	D5068	P11
A2527	P21	A3868	P5	D1515	P45	D5077	P11
A2528	P21	A3869	P21	D1516	P45	D5087	P31
A2529	P45	A3871	P21	D1517	P45	D5120	P3
A2565	P3, P5	A3872	P3	D1520	P45	D5127	P11
A2566	P7	A3873	P3	D1657	P35	D5134-7.125	P38
A2612	P21	A3875	P5	D1673	P35	D5138	P11
A2627	P3, P5	A3877	P11	D1701	P19	D5142	P9
A2721	P39, P43	A3879	P3	D1702	P19	D5152	P5
A2749	P3	A3880	P5	D1747	P33	D5153	P3, P5
A2793	P43	A3881	P5	D1797	P35	D5154	P3, P5
A2913	P19	A3885	P21	D1812	P45	D5170	P3
A3110	P27	A3886	P33	D1862	P45	D5171	P5
A3111	P23, P27	A3887	P33	D2117	P47	D5173	P3
A3413	P28	A3888	P33	D2495	P15	D5183	P5
A3419	P15	A3889	P33	D2558	P15, P39	D5199	P13
A3420	P15	A3898	P39	D2589	P35	D5212	P15

NUMERICAL INDEX

8 Row Models

PART NO.	PAGE	PART NO.	PAGE	PART NO.	PAGE	PART NO.	PAGE
D5214	P39	10007	P33	10281	P7	3200-06	P13
D5215	P15	10008	P13	10289	P30	3200-46	P13
D5218	P39	10010	P3	10303	P13, P37, P41, P43	3300-109	P38
D5327	P17	10012	P39	10305	P35, P39	3300-40	P15
D5328	P17	10014	P3, P5	10313	P38	3300-58	P39
D5329	P17	10016	P3	10327	P32	3300-89	P43
D5331	P17	10017	P3, P13, P40, P45	10332	P11	3400-01	P13, P39, P43
D5425	P9	10019	P15, P17, P35, P39	10338	P38	4200-01	P45
D5757	P3	10024	P13	10339	P15, P17, P39	4300-10	P41
D5765	P39	10027	P5	10350	P5, P7	6156X	P35
R0150	P20	10033	P20	10355	P9	6211X	P13
R0151	P20	10035	P11	10356	P9	6400-06-08	P25, P27
R0155	P47	10036	P3	10357	P9	6400-08	P23, P25, P27
R0191	P11	10037	P40	10358	P11	6400-10	P25
R0194	P15, P38, P39, P43	10045	P35	10361	P11	6500-06	P27
R0195	P13	10046	P35	10362	P11	6500-08	P23, P27
R0199	P38, P43	10049	P5	10435	P13, P15, P38	6500-10	P25
R0207	P41	10056	P9	10451	P35, P40	6600-08	P23
R0208	P41	10061	P5, P7, P9	10453	P13	6697X	P17
R0209	P41	10062	P17	10457	P5	6801-08	P27
R0210	P41	10067	P43	10459	P9	7100-42	P47
R0211	P41	10070	P9, P11	10460	P3, P5, P9, P11, P13, P15, P19, P39	7100-43	P47
R0212	P41	10081	P43	10462	P3, P15, P40	7100-46	P47
R0213	P41	10094	P45	10463	P39	7100-49	P47
R0214	P41	10100	P43	10464	P37	7100-54	P47
R0215	P41	10101	P15, P17, P35, P39, P41	10465	P15	7100-56	P47
R0216	P41	10102	P3, P9, P13, P19, P20, P33, P35, P38, P40, P45	10468	P9	7100-63	P47
R0217	P41	10104	P3, P13, P15, P33, P39, P43	10470	P20	7100-64	P47
R0223	P41	10105	P5, P9, P33	10471	P9	7100-65	P47
R0224	P41	10106	P13, P37, P38, P43	10499	P35	7100-68	P47
R0225	P41	10107	P13, P35	10502	P13	7100-69	P47
R0226	P41	10108	P5, P17	10503	P35	7100-70	P47
R0227	P41	10109	P15, P17, P35, P39, P45	10504	P35	7100-75	P47
R0228	P41	10111	P3, P7, P9, P35	10505	P29, P31	7100-83	P47
R0232	P41	10120	P43	10509	P38	7100-89	P47
R0322	P9, P11	10130	P41	10527	P38	7100-90	P47
R0323	P9	10131	P41	10561	P19, P40	7100-92	P47
R0439	P47	10133	P35, P37	10600	P9, P43	7200-03	P47
R0440	P47	10139	P3, P9, P11	10602	P7, P13, P15, P39	7200-04	P47
R0462	P17	10144	P41	10603	P17		
R0463	P17	10145	P15, P38, P43	10606	P5		
R0464	P17	10157	P3	10610	P11		
R0465	P17	10167	P9, P19	10640	P3, P41		
R0466	P17	10168	P20	10641	P3, P7, P9, P11, P19, P37		
R0467	P17	10169	P3	10651	P35		
R0468	P17	10171	P37	10655	P37		
R0469	P17	10194	P9	10670	P15, P19, P37		
R0470	P17	10201	P37	10671	P9		
R0471	P17	10204	P35	10672	P37, P45		
R0472	P17	10205	P13	10673	P41		
R0473	P17	10206	P11, P13, P40	10674	P45		
R0474	P17	10210	P5, P17, P35, P39	10676	P37		
R0475	P17	10213	P35	10681	P35, P41		
R0478	P17	10216	P5, P35, P38	10722	P20		
R0479	P17	10217	P3, P13, P39	10724	P20		
R0508	P45	10219	P37, P41	10725	P20		
R0509	P45	10226	P19	10742	P45		
R0510	P45	10228	P3, P9, P13, P19, P20, P33, P35, P40, P45	10745	P45		
R0513	P45	10229	P5, P7, P9, P13, P15, P35, P39	10750	P45		
R0515	P3	10230	P3, P13, P15, P33, P39, P43	2100-03	P13, P15, P39, P43		
R0516	P3	10231	P5, P33	2404-08-08	P27		
R0517	P3	10232	P13, P17, P35, P37, P38, P43	2500-03	P39		
R0646	P17	10233	P13, P15, P38	2500-12	P39		
R0647	P17	10237	P43	2500-14	P39		
R0760	P28	10243	P17	2500-18	P13		
R0761	P28	10257	P17	2500-25	P15		
R0762	P28	10259	P17	2500-26	P15		
R0763	P28	10260	P17	2500-27	P15, P39		
R0764	P28	10261	P17	2500-28	P15		
R0774	P31	10269	P21	2500-36	P39		
R0777	P30			2500-37	P38, P39		
R0778	P31			2501-06-04	P25, P27		
R0790	P29			2501-06-08	P27		
R0808	P32			2501-08-08	P23, P25		
1K139	P35			2700-08	P23, P27		
10001	P5			2700-10	P25		
10002	P13			306-08	P23, P27		
10004	P41			306-10	P25		
10005	P3						

NUMERICAL INDEX

24 Row Models

PART NO.	PAGE	PART NO.	PAGE	PART NO.	PAGE	PART NO.	PAGE
A0158	P75	A3553	P64	A4052	P76	D4522-01	P77, P79
A0160L	P75	A3554	P64	A4053	P66	D4523	P77, P79
A0160R	P75	A3558	P64	A4054	P66	D4524	P77, P79
A0167	P73, P75	A3559	P64	A4057	P67	D4542	P79
A0175-03	P75	A3574	P55	A4062	P55	D4563	P76
A0178-04	P75	A3575	P55	A4058	P67	D4564	P76
A0243	P73, P75	A3584	P76	A4060	P67	D4565	P76
A0245	P73, P75	A3589	P76	A4067	P79	D4613	P76
A0246	P75	A3598	P81	A4068	P79	D4695	P56
A0257	P73, P75	A3629	P89	A4077	P70	D4700	P64
A0261L	P66	A3646	P91	A5078	P68	D4701	P64
A0261R	P66	A3647	P91	B0123	P56, P64	D4721	P55
A0376	P66	A3667	P80	D0453-03	P75	D4732	P55
A0378	P66	A3668	P78	D0558	P51	D4748	P65
A0503	P65, P89	A3669	P78	D0652	P59	D4749	P65
A0531	P61	A3670	P77	D0671	P59, P75	D4752	P77, P79
A0779	P61, P63	A3683	P80	D0677	P75	D4773	P67
A0895	P72	A3684	P80	D0692	P75	D4775	P91
A0899	P73, P75	A3715	P78	D0703	P75	D4805	P64
A0941	P51	A3717	P78	D0704	P75	D4895	P78
A1002	P83	A3739	P78	D0746	P73	D4896	P78
A1003	P85, P87	A3740	P78	D0829	P61	D4914	P78
A1019	P85	A3742	P77	D0840	P73, P75	D4915	P78
A1022	P83	A3743	P77	D0841	P75	D4919	P78
A1044	P85	A3747	P63	D0914-106	P68	D4923	P77
A1051	P83	A3752	P79	D0914-12.25	P91	D4927	P61, P63
A1091	P83, P87	A3753	P79	D0914-222	P91	D4930-01	P77
A1137	P87	A3882	P63	D0914-230	P68	D5038	P63
A1139	P85	A3905	P63	D0914-33.5	P66	D5039	P53
A1144	P87	A3907	P57	D0914-96	P68	D5152	P53
A1148	P87	A3908	P57	D0916	P64	D5171	P53
A1152	P87	A3910	P75	D0917	P66, P68, P89, P91	D5190	P57
A1154	P85	A3911	P57	D1026	P91	D5212	P65, P89
A1413	P85	A3917	P61	D1065	P91	D5215	P65, P89
A1424	P85	A3918	P71	D1067	P65, P67, P89	D5226	P63
A1425	P85	A3919	P71	D1068	P91	D5242	P71
A1426	P85	A3924	P61	D1157	P63	D5264	P61
A1668	P65, P89	A3931	P61	D1162	P93	D5265	P61
A1676	P73	A3932	P61	D1166	P71, P72	D5266	P61
A1677	P73	A3934	P59	D1199-06	P67	D5267	P61
A1678	P73	A3935	P59	D1255	P66	D5271	P61
A1679	P73	A3943	P59	D1256	P66	D5286	P61
A1720	P91	A3944	P59	D1339	P75	D5329	P70
A1786	P65, P89	A3950	P69	D1364	P75	D5330	P59
A2022	P70	A3954	P53	D1512	P93	D5334	P63
A2056	P91	A3959	P63	D1719	P91	D5335	P63
A2068	P64	A3960	P68	D2117	P93	D5339	P61
A2148	P72	A3962	P53	D2134	P91	D5356	P59
A2180	P91	A3963	P51	D2495	P65, P89	D5362	P59
A2484	P81	A3964	P51	D2558	P65, P66, P67, P89	D5369	P53
A2508	P63	A3966	P63	D2597	P73	D5393	P59
A2526	P76	A3967	P59	D2648	P72	D5406-01	P68
A2527	P76	A3973	P51	D2698	P75	D5421	P59
A2528	P76	A3978	P56	D2721	P75	D5422	P59
A2565	P51, P53	A3979	P56	D2829	P76	D5423	P59
A2612	P76	A3988	P56	D2971-01	P53	D5424	P59
A2627	P56	A3992	P65	D2971-03	P53	D5427	P63
A2776	P61	A3993	P65	D2984	P93	D5442	P53
A2908	P72	A3997	P65	D3239	P63	D5450	P59
A2913	P75	A3998	P64	D3404	P63	D5465	P61
A2942	P51, P53	A3999	P64	D3537-02	P53	D5472	P68
A2958	P51	A4002	P64	D3548	P56	D5475	P66
A2962	P51	A4003	P89	D3552	P51	D5477	P66
A3030	P79	A4004	P89	D3637	P53, P61	D5490	P51
A3111	P83, P87	A4008	P75	D3660-08	P64	D5492	P59
A3114	P83	A4014	P68	D3788-01	P51	D5493	P59
A3115	P87	A4015	P68	D3791	P64	D5506	P55
A3116	P85	A4018	P53	D3856	P55	D5518	P55
A3300	P85	A4020	P55	D3860	P76	D5528	P89
A3304	P85	A4022	P55	D4086	P83, P85, P87	D5530	P63
A3305	P85	A4023	P55	D4108	P55	D5531	P91
A3306	P85	A4024	P63	D4219	P51, P53	D5532	P91
A3413	P81	A4030	P68	D4230	P51	D5533	P91
A3428	P89	A4031	P75	D4232	P51	D5545	P87
A3442	P77	A4037	P91	D4341	P51, P53	R0106	P77
A3443	P77	A4047	P76	D4467	P63	R0110	P77
A3491	P76	A4050	P76	D4498	P57	R0150	P73, P75
A3492	P76	A4051	P76	D4509	P80	R0151	P73, P75
A3521	P72			D4521	P80	R0155	P93

NUMERICAL INDEX

24 Row Models

PART NO.	PAGE	PART NO.	PAGE	PART NO.	PAGE	PART NO.	PAGE
R0191	61	10056	P53	10435	P64, P65, P67, P89, P91	7100-63	P93
R0193	P57, P78	10057	P55	10453	P64	7100-64	P93
R0194	P65, P89	10061	P53, P91	10457	P53, P61	7100-65	P93
R0195	P64, P67	10063	P75	10460	P51, P53, P55, P57, P59, P61, P64, P65, P75, P89, P91	7100-68	P93
R0196	P68, P91	10076	P53	10461	P59, P61, P75	7100-69	P93
R0199	P89	10083	P55	10463	P53, P55, P64, P67, P89, P91	7100-70	P93
R0200	P67	10084	P55	10464	P66	7100-73	P93
R0201	P68, P91	10087	P72	10465	P65	7100-74	P93
R0257	P63	10101	P56, P65, P66, P75, P89, P91	10470	P55, P73, P75	7100-75	P93
R0270	P72	10102	P56, P64, P73, P75, P89	10471	P61	7100-83	P93
R0323	P61, P63	10104	P51, P59, P61, P67, P91	10501	P64	7100-89	P93
R0374	P78	10105	P53, P55, P57, P61, P75	10509	P77, P79, P80	7100-90	P93
R0375	P57, P78	10106	P66, P67	10527	P89	7200-03	P93
R0434	P72	10107	P56, P59, P64	10561	P75	7200-04	P93
R0439	P93	10108	P53, P66	10600	P66		
R0440	P93	10109	P65, P89	10602	P65, P66, P68, P89		
R0465	P70	10111	P51, P56, P59, P75	10610	P63		
R0479	P70	10114	P77	10625	P63		
R0480	P70	10117	P51, P53	10640	P51, P91		
R0481	P70	10118	P51, P53	10641	P51, P55, P56, P57, P59, P61, P63, P68, P75		
R0482	P70	10119	P51	10643	P57		
R0484	P70	10145	P66, P68, P89, P91	10670	P65, P75, P89		
R0485	P70	10157	P51	10722	P73, P75		
R0486	P70	10168	P73	10724	P73, P75		
R0487	P70	10169	P51	10725	P73, P75		
R0488	P70	10205	P64	2100-03	P64, P65, P66, P67, P89		
R0490	P70	10210	P53, P75, P91	2403-08	P83		
R0493	P70	10216	P51, P55, P64	2403-10	P85		
R0494	P70	10217	P57	2404-06-04	P87		
R0495	P70	10219	P68	2404-06-08	P87		
R0499	P70	10228	P51, P53, P56, P64, P73, P75, P89	2404-08-08	P87		
R0515	P51	10229	P53, P56, P59, P61, P65, P75, P89, P91	2404-10-08	P85		
R0516	P51	10230	P51, P59, P61, P67, P91	2406-08-06	P87		
R0517	P51	10231	P51, P53, P55, P61, P75	2406-10-06	P85		
R0563	P70	10232	P66, P67, P68	2406-10-08	P85		
R0564	P70	10233	P64, P65, P66, P67, P89	2500-08	P85		
R0760	P81	10236	P61	2500-14	P89		
R0761	P81	10239	P61	2500-25	P65, P89		
R0762	P81	10243	P70	2500-26	P65, P89		
R0763	P81	10252	P70	2500-27	P65, P89		
R0764	P81	10253	P70	2500-28	P65, P89		
R0777	P77, P79	10254	P70	2501-06-04	P85		
R0778	P80	10255	P70	2501-06-08	P87		
R0807	P76	10256	P70	2501-08-08	P83, P85		
R0827	P79	10257	P70	2603-08	P85		
R0830	P77	10258	P70	2700-08	P83, P87		
R0831	P78	10269	P76	2700-10	P85		
R0832	P78	10289	P77, P79	2703-08	P87		
R0859	P69	10290	P57	306-08	P83, P87		
R0860	P69	10293	P63	306-10	P85		
R0861	P69	10303	P66, P67	3200-27	P67		
R0862	P69	10325	P59	3200-58	P64		
R0863	P69	10326	P59, P61	3300-40	P65, P89		
R0864	P69	10329	P72	3300-45	P89		
R0865	P69	10330	P72	3302-03	P75		
10001	P53, P91	10332	P63	3303-43	P68		
10002	P56	10333	P63	3303-67	P91		
10003	P53	10335	P55	3400-01	P66, P67		
10007	P91	10339	P65	6400-06-08	P85, P87		
10008	P51, P53, P64	10343	P68, P91	6400-08	P83, P85, P87		
10009	P91	10350	P53, P59, P69	6400-10	P85		
10010	P57	10351	P61, P63	6500-06	P87		
10013	P91	10352	P61, P63	6500-08	P83, P87		
10014	P53	10362	P59	6600-08	P83		
10015	P64	10374	P69	6602-08	P83, P85		
10016	P51	10375	P69	6714X	P67		
10017	P63	10405	P68	6801-08	P87		
10019	P65, P68, P89	10430	P66	7100-42	P93		
10026	P51, P55			7100-46	P93		
10027	P61, P75			7100-54	P93		
10032	P89			7100-56	P93		
10033	P73, P75						
10036	P59, P61, P67						
10047	P75						
10049	P53, P66						
10050	P55						
10053	P64						