

MODEL 1105/1205/1305/1500 DUAL AUGER GRAIN CARTS OPERATOR MANUAL

M0277-01

Rev. 4/21

This manual is applicable to: Model 1105/1305/1500 - 2018 Production and on
 Model 1205 - 2019 Production and on

Record model number and serial number of your grain cart along with date purchased:

Model Number _____

Serial Number _____

Date Purchased _____

SERIAL NUMBER

Record your serial number and purchase date above for quick reference.

The serial number provides important information about your grain cart and is required to obtain correct replacement parts. Always provide grain cart model and serial number to your Kinze Dealer when ordering parts or anytime correspondence is made with Kinze Manufacturing, Inc.

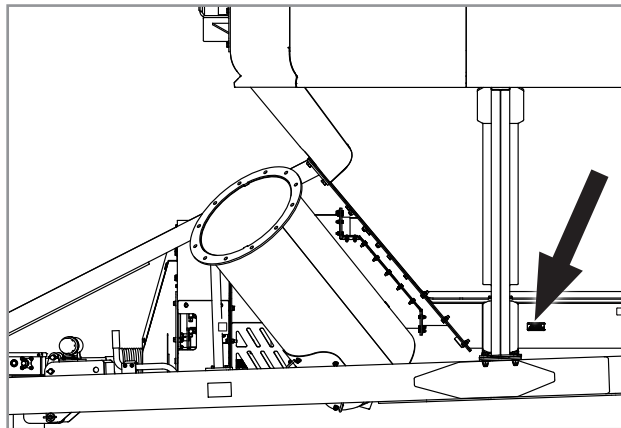

Serial number plate location

Kinze® and the Kinze® logo are registered trademarks of Kinze Manufacturing, Inc.

Shur-Co®, LLC is a registered trademark of Shur-Co.

Microsoft® Excel®, and Internet Explorer® are registered trademarks of Microsoft Corporation.

Grain Tracker™ is a trademark of Digi-Star LLC

All other trademarks are the property of their respective owners.

Page intentionally blank.

1105-1205-1305-1500 Grain Cart PREDELIVERY/DELIVERY CHECKLIST

TO THE DEALER

Predelivery service includes assembly, lubrication, adjustment and test. This service ensures cart is delivered to retail customer/end user ready for field use.

PREDELIVERY CHECKLIST

Use this checklist to inspect cart after it is completely assembled. Check off each item as it is found satisfactory or after proper adjustment is made.

- Wheel nuts torqued to 350 ft-lb (474 N-m).
- Tires inflated to specified air pressure. (If Applicable)
- All grease fittings lubricated and gearbox oil level checked.
- All safety decals and SMV sign are correctly located and legible. Replace if damaged.
- SMV decal is in place and shipping cover removed.
- Safety/warning lights working properly.
- Test run augers. Do not operate tractor PTO above 750 PTO RPM with augers empty.
- Check driveline. See "Driveline Inspection" in Lubrication and Maintenance section.
- Check track alignment. See "Track Alignment" in Maintenance section. (If Applicable)
- Safety screens over horizontal auger are in place and properly secured.
- Auxiliary safety chains are properly installed and hardware torqued to specification.
- Paint all parts scratched in shipment.

This wagon has been thoroughly checked and to the best of my knowledge is ready for delivery to the customer.

(Signature Of Set-Up Person/Dealer Name/Date)

OWNER REGISTER

Name _____ Delivery Date _____
 Street Address _____ Model No. _____ Serial No. _____
 City, State/Province _____ Dealer Name _____
 ZIP/Postal Code _____ Dealer No. _____

DELIVERY CHECKLIST

Check off each item as it is fully explained to retail customer/end user when grain cart is delivered.

- Durability and longevity is dependent on regular maintenance as directed in Operator Manual.
- Tell retail customer/end user about all safety precautions that must be observed while using this cart.
- Advise retail customer/end user of specified tractor requirement for use with this cart.
- Along with retail customer/end user check reflective decals and SMV sign are clearly visible with cart attached to tractor. Check safety/warning lights are in working condition. Tell retail customer/end user to check and follow federal, state/provincial, and local regulations before towing on a road or highway.
- Along retail customer/end user check hitch height when attached to tractor is sufficient to prevent severe bends in PTO U-joint angles. Check PTO is correct length for making turns and operating on uneven terrain.
- Give Operator and Parts Manuals to retail customer/end user and explain all operating adjustments.
- Complete Warranty And Delivery Report form.

To the best of my knowledge this machine has been delivered ready for field use and customer has been fully informed as to proper care and operation.

(Signature Of Delivery Person/Dealer Name/Date)

AFTER DELIVERY CHECKLIST

Suggested items to check during first season of use:

- Check cart performance with retail customer/end user.
- Review with retail customer/end user importance of proper maintenance and adherence with all safety precautions.
- Check for parts that may need to be adjusted or replaced.
- Retorque all wheel nuts to 350 ft-lb (474 N-m).
- Check track belt alignment (if applicable).
- Safety shields and screens are in place.
- Safety and reflective decals, and SMV sign are correctly located and decals are legible. Replace if damaged or missing.
- Check safety/warning lights are properly installed and working properly.
- Check recommended lubrication procedures are being followed.

(Signature Of Follow-Up Person/Dealer Name/Date)

Tear Along Perforation

**All registrations must be submitted online at ["business.kinze.com"](http://business.kinze.com) within 5 business days of delivery.
Retain a copy of this form for auditing purposes.**

OVERVIEW

To the Owner1-1
 Warranty1-3
 General Information1-3
 Introduction.....1-3
 General Safety Rules1-8
 Safety Instructions, Signs, and Decals1-9
 Safety Signs And Decals1-10

OPERATION

Machine Preparation2-1
 Tractor Requirements2-1
 Tractor Preparation and Hookup.....2-1
 Handheld Remote Control2-4
 Cart Operation2-5
 PTO Torque Limiting/Overrunning Clutch Protection2-8
 Belt Engagement Indicator.....2-8
 Hydraulic Flow Gate2-8
 Auger Inspection Cover2-9
 Grain Tank Clean Out Sweep.....2-10
 Vertical Auger Work Light2-11
 Cameras2-11
 Manual and Electric Roll Tarp.....2-12
 Roll Tarp Remote Control Troubleshooting.....2-15
 Track System Components - Models 1105/1205/1305...2-16
 Track Transport Speeds - All Track Models.....2-17
 Track System Minimum Turning Radius Limitations -
 All Track Models2-18
 Track System Break-In Procedures -
 All Track Models2-18
 Track System Operational Guidelines -
 All Track Models2-19
 Electronic Scale - GT 400.....2-20
 Electronic Scale Printing Options.....2-22
 Electronic Scale - GT 560 AutoLog2-23
 Electronic Scale Troubleshooting2-26
 Data Downloader Troubleshooting2-28
 Track system troubleshooting.....2-30

LUBRICATION AND MAINTENANCE

Check Track Alignment - 1105/1205/1305 only3-11
 Drive Belts and Pulleys.....3-2
 Driveline Inspection3-28
 Electronic Scale3-44
 Gearbox3-31
 Gearbox Oil Level.....3-2
 Grease Fittings3-3
 Handheld Remote Electrical Pinout3-42
 Horizontal Auger Bearings3-1
 Horizontal Auger Replacement.....3-31
 Hydraulic Control Schematic - Remote3-41
 Lower Vertical Auger Replacement3-30
 Mounting Bolts and Hardware3-18
 Preparation for Storage3-39
 PTO Shaft Coupling3-2
 Row Crop Inside Tire Repair or Removal3-34
 Splines3-1
 Tire Servicing3-21
 Torque Values Chart - Plated Hardware.....3-18
 Track Alignment - Model 1500 Only3-33
 Track Alignment procedure - 1105/1205/1305 Only3-12
 Track Endwheel and Midwheel Bearings -
 1500 Models Only3-1
 Track Endwheel/Midwheel Bearing Replacement -
 Model 1500 only.....3-36
 Track Installation - 1105/1205/1305 Only3-17
 Track Removal - 1105/1205/1305 only3-14
 Track System Inspection - All Track Models.....3-13
 Track System Maintenance -
 1105/1205/1305 Track Models Only3-9
 Track Tension - Model 1500 only3-32
 Upper Vertical Auger Replacement3-29
 V-Belt Replacement3-26
 V-Belt Tension Adjustment and Alignment3-22
 Vertical Auger Counter Balance Valves3-20
 Wheel Bearing Replacement3-38
 Wheel Bearings3-1
 Wheel Nuts3-20
 Wiring Diagram.....3-43



This page intentionally blank.

Kinze Manufacturing, Inc. thanks you for your patronage. We appreciate your confidence in Kinze farm machinery. Your Kinze grain cart has been carefully designed to provide dependable operation in return for your investment.

This manual has been prepared to aid you in the operation and maintenance of the grain cart. It should be considered a permanent part of the machine and remain with the machine when you sell it.

It is the responsibility of the user to read and understand the Operator Manual in regards to safety, operation, lubrication and maintenance before operation of this equipment. It is the user's responsibility to inspect and service the machine routinely as directed in the Operator Manual. We have attempted to cover all areas of safety, operation, lubrication and maintenance; however, there may be times when special care must be taken to fit your conditions.

Throughout this manual the symbol  and the words **DANGER**, **WARNING**, and **CAUTION** are used to call attention to safety information that if not followed, will or could result in death or injury. **NOTICE** and **NOTE** are used to call your attention to important information. The definition of each of these terms follows:

 DANGER	Indicates an imminently hazardous situation that, if not avoided, will result in death or serious injury. This signal word is to be limited to the most extreme situations, typically for machine components which, for functional purposes, cannot be guarded.
 WARNING	Indicates a potentially hazardous situation that, if not avoided, could result in death or serious injury, and includes hazards that are exposed when guards are removed. It may also be used to alert against unsafe practices.
 CAUTION	Indicates a potentially hazardous situation that, if not avoided, may result in minor or moderate injury. It may also be used to alert against unsafe practices.
NOTICE	Used to address safety practices not related to personal injury.

NOTE: Special point of information or machine adjustment instructions.

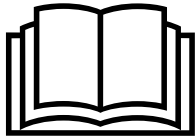
 **WARNING**

Improperly operating or working on this equipment could result in death or serious injury. Read and follow all instructions in Operator Manual before operating or working on this equipment.

 **WARNING**

Some photos in this manual may show safety covers, shields, or lockup devices removed for visual clarity. **NEVER OPERATOR OR WORK ON** machine without all safety covers, shields, and lockup device in place as required.

NOTE: Photos in this manual may be of prototype machines. Production machines may vary in appearance.

NOTE: Some photos and illustrations in this manual show optional attachments installed. Contact your Kinze Dealer for purchase of optional attachments.

Warranty

The Kinze Limited Warranty for your new machine is stated on the retail purchaser's copy of the Warranty And Delivery Receipt form. Additional copies of the Limited Warranty can be obtained through your Kinze Dealer.

Warranty, within the warranty period, is provided as part of Kinze's support program for registered Kinze products which have been operated and maintained as described in this manual. Evidence of equipment abuse or modification beyond original factory specifications will void the warranty. Normal maintenance, service and repair is not covered by Kinze warranty.

To register your Kinze product for warranty, a Warranty And Delivery Receipt form must be completed by the Kinze Dealer and signed by the retail purchaser, with copies to the Dealer, and to the retail purchaser. Registration must be completed and submitted to Kinze Manufacturing, Inc. within 5 business days of delivery of the Kinze product to the retail purchaser. Kinze Manufacturing, Inc. reserves the right to refuse warranty on serial numbered products which have not been properly registered.

If service or replacement of failed parts which are covered by the Limited Warranty are required, it is the user's responsibility to deliver the machine along with the retail purchaser's copy of the Warranty And Delivery Receipt to the Kinze Dealer for service. Kinze warranty does not include cost of travel time, mileage, hauling or labor. Any prior arrangement made between the Dealer and the retail purchaser in which the Dealer agrees to absorb all or part of this expense should be considered a courtesy to the retail purchaser.

Kinze warranty does not include cost of travel time, mileage, hauling, or labor.

General Information



Model 1305 Tracked Corner Auger Grain Cart w/optional electric roll tarp and cameras

Information used in these instructions was current at time of printing. However, due to Kinze's ongoing product improvement, production changes may cause your machine to appear slightly different in detail. Kinze Manufacturing, Inc. reserves the right to change specifications or design without notice and without incurring obligation to install the same on machines previously manufactured.

Right hand (R.H.) and left hand (L.H.), as used throughout this manual, are determined by facing direction machine travels in use unless otherwise stated.

1105 Grain Cart

Feature	Specification
Total Capacity*	1100 Bushels (1200 Bushels Heaped)
Bushels/Minute - Average*	750 Bushels/minute
Vertical Auger	22" Dia flighting in 23½" Dia. tube. Lower portion of lower vertical auger hard faced flighting.
Bearings - Vertical Auger	2"
Horizontal Auger	20" LH
Bearings - Horizontal Auger	6-bolt (rear) cast iron hubs with tapered roller bearings, (front) 2" ball bearing
Gearbox	Bevel and spur gear with 2:1 ratio
Drive Belts	Two 4-band, multi-strand V-belts
Drive Sheaves	8 groove - 8" drive/16" driven
PTO - 1000 RPM	PTO auger drive with overrunning and torque limiting clutch
PTO Yoke	1¾"-20 spline
Spindle	Four 4½"
Hub	two 20 bolt 13.189 bolt center cast ductile iron or four 10 bolt 13.189 bolt center cast ductile iron
Safety Chains	Two ½" grade 70 transport chains
Adjustable Discharge Spout	Remotely adjustable spout with +/- 14° of up/down motion and fitted with flexible discharge nozzle
Hydraulic Requirements	2 SCV's (remote) with standard 2320 minimum system psi
Flotation Tire Size	Low ground pressure radial flotation IF1250/50R32 CFO (R1)
Row Crop Tire Size	520/85 R42 165 A8/B
Row Crop Tire Width	30" - 40" (76 - 102 cm) rows (space between duals - adjustable)
Track Width	36" (91 cm)
Track Length (Ground Contact)	100" (254 cm)
Track End Wheels (Per Track)	Four, 31½" (80 cm) diameter
Track Mid Wheels (Per Track)	Eight, 13.77" (34.9 cm) diameter

* Approximate with 15% moisture corn. Capacity and bushels/minute will vary with moisture content of grain and/or PTO RPM.

	Flotation Tire	Row Crop	Tracked
Weight - Empty	24,900 lbs (11294 kg)	27,500 lbs (12474 kg)	31,000 lbs (14061 kg)
Hitch Weight - Empty	3,950 lbs (1792 kg)	3,950 lbs (1792 kg)	3,950 lbs (1792 kg)
Hitch Weight - Loaded	6,280 lbs (2849 kg)	6,280 lbs (2849 kg)	6,280 lbs (2849 kg)
Width - Overall	14'-0" (4.2M)	12'-7" (30") 15'-4" (40")	13'-0" (3.9M)
Height - Overall	11'-4" (3.45M)	11'-4" (3.45M)	11'-4" (3.45M)
Length - Overall	31'-7" (9.62M)	31'-7" (9.62M)	31'-7" (9.62M)

1205 Grain Cart

Feature	Specification
Total Capacity*	1125 Bushels (1225 Bushels Heaped)
Bushels/Minute - Average*	750 Bushels/minute
Vertical Auger	22" Dia flighting in 24" Dia. tube. Lower portion of lower vertical auger hard faced flighting.
Bearings - Vertical Auger	2"
Horizontal Auger	20" LH
Bearings - Horizontal Auger	6-bolt (rear) cast iron hubs with tapered roller bearings, (front) 2" ball bearing
Gearbox	Bevel & spur gear with 2:1 ratio
Drive Belts	Two 4-band, multi-strand V-belts
Drive Sheaves	8 groove - 8" drive/16" driven
PTO - 1000 RPM	PTO auger drive with overrunning and torque limiting clutch
PTO Yoke	1¾"-20 spline
Spindle	Four 4½" or two 6" high alloy
Hub	two 20 bolt 20.125 bolt center cast ductile iron or four 10 bolt 13.189 bolt center cast ductile iron
Safety Chains	Two ½" grade 70 transport chains
Adjustable Discharge Spout	Remotely adjustable spout with +/- 14° of up/down motion and fitted with flexible discharge nozzle
Hydraulic Requirements	2 SCV's (remote) with standard 2320 minimum system psi
Flotation Tire Size	Low ground pressure radial flotation IF1250/50R32 CFO (R1)
Track Width	36" (91 cm)
Track Length (Ground Contact)	100" (254 cm)
Track End Wheels (Per Track)	Four, 31½" (80 cm) diameter
Track Mid Wheels (Per Track)	Eight, 13.77" (34.9 cm) diameter

* Approximate with 15% moisture corn. Capacity and bushels/minute will vary with moisture content of grain and/or PTO RPM.

	Flotation Tire	Tracked
Weight - Empty	25,190 lbs (11296 kg)	31,470 lbs (14275 kg)
Hitch Weight - Empty	4,000 lbs (1814 kg)	4,000 lbs (1814 kg)
Hitch Weight - Loaded	6,540 lbs (2966 kg)	6,540 lbs (2966 kg)
Width - Overall	14'-0" (4.2M)	13'-0" (3.9M)
Height - Overall	10'-10" (3.9M)	10'-10" (3.9M)
Length - Overall	34'-11" (10.6M)	34'-11" (10.6M)

1305 Grain Cart

Feature	Specification
Total Capacity*	1300 Bushels (1400 Bushels Heaped)
Bushels/Minute - Average*	750 Bushels/minute
Vertical Auger	22" Dia flighting in 23½" Dia. tube. Lower portion of lower vertical auger hard faced flighting.
Bearings - Vertical Auger	2"
Horizontal Auger	20" LH
Bearings - Horizontal Auger	6-bolt (rear) cast iron hubs with tapered roller bearings, (front) 2" ball bearing
Gearbox	Bevel and spur gear with 2:1 ratio
Drive Belts	Two 4-band, multi-strand V-belts
Drive Sheaves	8 groove - 8" drive/16" driven
PTO - 1000 RPM	PTO auger drive with overrunning and torque limiting clutch
PTO Yoke	1¾"-20 spline
Spindle	Four 4½" or two 6" high alloy
Hub	two 20 bolt 20.125 bolt center cast ductile iron or four 10 bolt 13.189 bolt center cast ductile iron
Safety Chains	Two ½" grade 70 transport chains
Adjustable Discharge Spout	Remotely adjustable spout with +/- 14° of up/down motion and fitted with flexible discharge nozzle
Hydraulic Requirements	2 SCV's (remote) with standard 2320 minimum system psi
Flotation Tire Size	Low ground pressure radial flotation IF1250/50R32 CFO (R1)
Row Crop Tire Size	520/85 R42 165 A8/B
Row Crop Tire Width	30" - 40" (76 - 102 cm) rows (space between duals - adjustable)
Track Width	36" (91 cm)
Track Length Contact	100" (254 cm)
Track End Wheels (Per Track)	Four, 31½" (80 cm) diameter
Track Mid Wheels (Per Track)	Eight, 13.77" (34.9 cm) diameter

* Approximate with 15% moisture corn. Capacity and bushels/minute will vary with moisture content of grain and/or PTO RPM.

	Flotation Tire	Row Crop	Tracked
Weight - Empty	25,400 lbs (11521 kg)	28,470 lbs (12914 kg)	31,680 lbs (14370 kg)
Hitch Weight - Empty	4,040 lbs (1832 kg)	4,040 lbs (1832 kg)	4,040 lbs (1832 kg)
Hitch Weight - Loaded	6,600 lbs (2994 kg)	6,600 lbs (2994 kg)	6,600 lbs (2994 kg)
Width - Overall	14'-0" (4.2M)	12'-7" (30") 15'-4" (40")	13'-0" (3.9M)
Length - Overall	34'-11" (10.6M)	34'-11" (10.6M)	34'-11" (10.6M)
Height - Overall	11'-4" (3.45M)	11'-4" (3.45M)	11'-4" (3.45M)
Height - Grain Discharge	14'-1" (4.2M)	14'-1" (4.2M)	14'-1" (4.2M)

1500 Grain Cart



Feature	Specification
Total Capacity*	1500 Bushels (1600 Bushels Heaped)
Bushels/Minute - Average*	750 Bushels/minute
Vertical Auger	22" Dia flighting in 23½" Dia. tube. Lower portion of lower vertical auger hard faced flighting.
Bearings - Vertical Auger	2"
Horizontal Auger	20" LH
Bearings - Horizontal Auger	6-bolt (rear) cast iron hubs with tapered roller bearings, (front) 2" ball bearing.
Gearbox	Bevel & spur gear with 2:1 ratio.
Drive Belts	Two 4-band, multi-strand V-belts.
Drive Sheaves	8 groove - 9¼" drive/18.7" driven.
PTO - 1000 RPM	PTO auger drive with overrunning and torque limiting clutch.
PTO Yoke	1¾"-20 spline.
Safety Chains	Two ½" 40,500 lbs rated, grade 70, certified to ASAE S338.5.
Adjustable Discharge Spout	Remotely adjustable spout with +/- 14° of up/down motion and fitted with flexible discharge nozzle.
Hydraulic Requirements	2 SCV's (remote) with standard 2320 minimum system psi.
Track Width	36" (91 cm)
Track Length (Ground Contact)	108" (274 cm)
Track End Wheels (Per Track)	Two cast iron segmented 36½" diameter.
Track Mid Wheels (Per Track)	Four 16" steel.
Weight - Empty	35,180 lbs (15957 kg)
Hitch Weight - Empty	5,250 lbs (2381 kg)
Hitch Weight - Loaded	7,380 lbs (3347 kg)
Transport Width	13'-0" (3.9M)
Length - Overall	38'-10" (11.8M)
Height - Overall	11'-4" (3.45M)

* Approximate with 15% moisture corn. Capacity and bushels/minute will vary with moisture content of grain and/or PTO RPM.

1. Read and understand instructions provided in this manual and warning labels. Review these instructions frequently!
2. This machine is designed and built with your safety in mind. Do not make any alterations or changes to this machine. Any alteration to design or construction may create safety hazards.
3. A large portion of farm accidents happen from fatigue or carelessness. Safe and careful operation of tractor and grain cart will help prevent accidents.
4. Never allow cart to be operated by anyone unfamiliar with operation of all functions of the unit. Operators must read and thoroughly understand all instructions given in this manual before operating or working on equipment.
5. Be aware of bystanders, particularly children! Always look around to make sure it is safe to start tow vehicle engine or move grain cart. This is particularly important with higher noise levels and quiet cabs, as you may not hear people shouting.
6. Make sure cart weight does not exceed towing capacity of tractor, or bridge and road limits. This is critical to maintain safe control and prevent death or injury, or property and equipment damage.
7. Never ride or allow others to ride on cart
8. Store cart in an area away from human activity. DO NOT permit children to play on or around stored unit.
9. Keep hands, feet, and clothing away from moving parts. Do not wear loose-fitting clothing which may catch in moving parts.
10. Always wear protective clothing, shoes, gloves, and hearing and eye protection applicable for the situation.
11. Do not allow anyone to stand between tongue or hitch and towing vehicle when backing up to cart.
13. Prevent electrocution, other injuries, or property and equipment damage. Watch for obstructions such as wires, tree limbs, etc. when operating machine. Be aware of clearances during turns and when folding/unfolding grain chute.
14. Pick levellest possible route when transporting across fields.
15. Never operate grain cart without PTO driveline guards, tractor master shield and implement shields in place. Make certain PTO driveline guards turn freely and are properly attached.
16. Make sure parked machine is on a hard, level surface. Wheel chocks may be needed to prevent unit from rolling.
17. Follow all federal, state/provincial and local regulations when towing farm equipment on a public highway. Use safety chain (not an elastic or nylon/plastic tow strap) to retain connection between towing and towed machines in the event of primary attaching system separation.
18. Make sure all safety/warning lights, SMV sign, and reflective decals are in place and working properly before transporting machine on public roads.
19. Tow only with farm tractor of a minimum 90 HP. Allow for unit length when making turns.
20. Track carts should be limited to road use only when empty and speed to less than 15 MPH.
21. Maintain field drive speeds that are appropriate to the load condition and field condition.
22. Reduce speed prior to turns to avoid the risk of overturning. Avoid sudden uphill turns on steep slopes. Always drive at a safe speed relative to local conditions and ensure your speed is slow enough for a safe emergency stop.
23. Always keep the tractor in gear to provide engine braking when going downhill. Do not coast.
24. Always disengage PTO, shutoff tractor engine and remove the ignition key before leaving tractor seat, lubricating or working on grain cart, or when cleaning out debris.
25. Always make sure U-joint yokes are securely locked on tractor and implement shaft before operating cart.
26. Be especially observant of the operating area and terrain. Watch for holes, rocks or other hidden hazards. Always inspect area before operation. DO NOT operate near edge of drop-offs or banks, or on steep slopes as overturn may result. Operate up and down (not across) intermediate slopes. Avoid sudden starts and stops. Be extra careful when working on inclines.
27. Never step across any driveline. Do not attach drivelines with bolts or pins longer than recommended. Never operate cart with damaged PTO driveline guards.

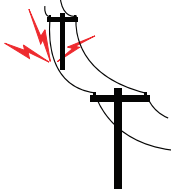

Following are some common hazard warnings associated with this equipment. Pay close attention to all safety, operating, and maintenance information in this manual and decals applied to your equipment.

 DANGER	Contacting or coming close to power lines or other high energy sources will cause death or serious injury.
	Keep away from power lines or high energy sources at all times.

 WARNING	Loss of control can cause death or serious injury, or damage to property and equipment. Tow only with farm tractor weight rated and configured for this equipment. Use safety chains and transport as specified in the Operator and Parts Manual.
	

 WARNING	Improperly operating or working on this equipment could result in death or serious injury. Read and follow all instructions in Operator Manual before operating or working on this equipment.
	

 WARNING	Contact with rotating driveline will cause death or serious injury. Keep away at all times when operating.
	Never operate without all guards and equipment shields properly installed.

 WARNING	Explosive separation of rim and tire parts can cause death or serious injury. Overinflation, rim and tire servicing, improper use of rims and tires, or worn or improperly maintained tires could result in a tire explosion.
	

Safety Signs And Decals



All safety/warning lights, reflective decals, and SMV sign must be in place and visible before transporting machine on public roads or death, serious injury, and damage to property and equipment may result. Check federal, state/provincial, and local regulations before transporting equipment on public roads.

Safety signs and decals are placed on the machine to warn of hazards and provide important operating and maintenance instructions. Information on these signs are for your personal safety and the safety of those around you. FOLLOW ALL SAFETY INSTRUCTIONS!

- Keep signs clean so they can be easily seen. Wash with soap and water or cleaning solution as required.
- Replace safety signs if damaged, painted over, or missing.
- Check reflective decals and SMV sign periodically. Replace if they show any loss of reflective properties.
- When replacing decals, clean machine surface thoroughly with soap and water or cleaning solution to remove all dirt and grease.

NOTE: Safety sign and decal locations are shown in the Parts Manual for this machine.

NOTE: Style and locations of SMV sign, reflective decals, and safety/warning lights conform to ANSI/ASABE S279.14 JUL 2008 and ANSI/ASABE S276.6 JAN 2005.

MACHINE PREPARATION

Lubricate grain cart per lubrication information in this manual prior to initial operation and at prescribed intervals. Make sure all tires are properly inflated or track tension is properly adjusted before each use. Check drive V-belts for proper tension and alignment. Torque all wheel lug nuts to specified torque.

TRACTOR REQUIREMENTS

Consult your dealer for information on horsepower requirements and tractor compatibility. Two remote SCV's are required for remote joystick operation and five SCV's are required for standard cab operation . A 12 volt DC electrical system is required on all sizes to operate safety/warning lights, auger-mounted work light, optional electronic scale system, or electronic roll tarp.

TRACTOR PREPARATION AND HOOKUP

1. Slide tractor drawbar in as far as possible and still allow PTO shaft to have sufficient clearance to prevent damage to driveline components when making sharp turns and operating over uneven ground.

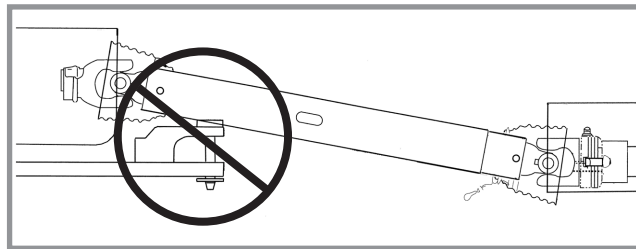

Avoid clevis hitch interference

NOTICE

Clevis hitch (hammer strap style) drawbars may need to be removed to prevent damage to PTO assembly.



PTO shaft positioned for tractor hookup

NOTICE

Adjust tractor drawbar to prevent severe bends in PTO U-joint angles and to allow sufficient clearance between tractor drawbar/hitch pin and PTO shaft.

2. Position PTO as far right of hitch as possible until parking jack is raised.

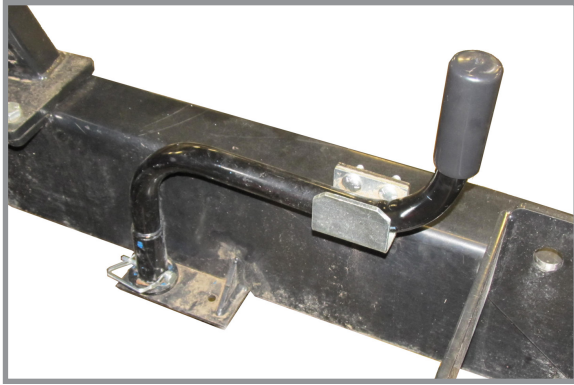

Jack handle stowed

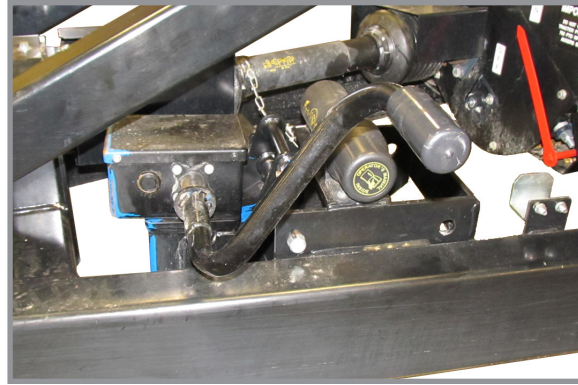

Jack handle installed

3. Remove hairpin clip and jack handle from storage location.
4. Install jack handle on jack shaft and raise cart.

NOTICE

Clean and grease PTO shaft coupling each time PTO is installed. Apply coating of high-speed industrial coupling grease, such as Chevron® Coupling Grease, that meets AGMA CG-1 and CG-2 standards to extend shaft spline life.

5. Connect cart to tractor hitch. Use a high quality hitch pin of sufficient length and strength and secure pin with a locking device.
6. Raise jack. Return jack handle to storage location and install hairpin clip.

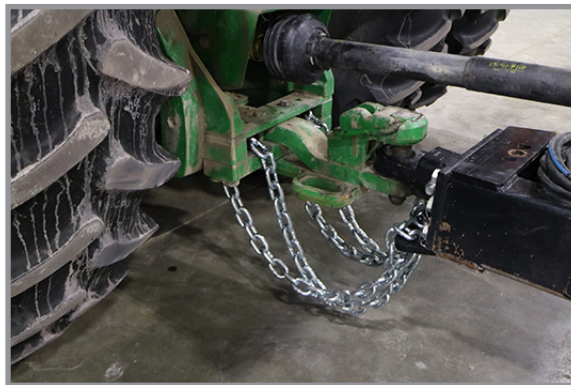

Safety chains

7. Attach cart PTO connecting yoke to tractor PTO shaft. Spring loaded yoke pin must engage groove in tractor PTO shaft. Slip tube grease fitting must be visible through hole of outer tube.
8. Transport safety chain must be used to ensure connection is retained between cart and tractor in the event of a hitch pin/drawbar failure. Torque attaching hardware to 840 ft-lb (1138 N-m).

**WARNING**

Pressurized hydraulic fluid can penetrate body tissue and result in death, serious infection, or other injuries. Fluid injected under skin must be **IMMEDIATELY** removed by a surgeon familiar with this type of injury. Make sure connections are tight and hoses and fittings are not damaged before applying system pressure. Leaks can be invisible. Keep away from suspected leaks. Relieve pressure before searching for leaks or performing any system maintenance.

NOTICE

Wipe hose ends to remove any dirt before connecting couplers to tractor parts or contamination may cause equipment failure.

9. Connect hydraulic hoses to tractor.
10. Connect seven terminal breakaway connector for the lighting system on cart to seven pin connector on tractor. If your tractor is not equipped with SAE Standard 7 terminal connector, obtain through your local tractor supply dealer. Check clearance lights, signal lights, and auxiliary work light are working properly.
11. Connect optional electric roll tarp and camera harnesses. Check for proper operation.

Handheld Remote Control

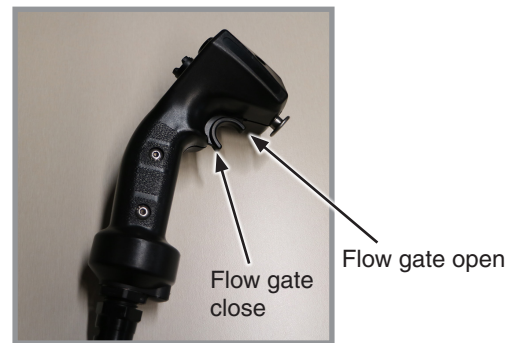
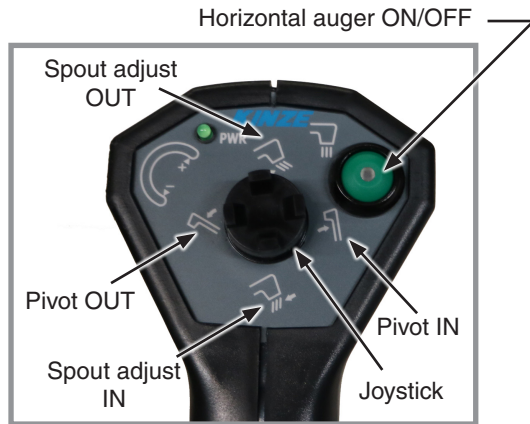





Joystick side view

- Push trigger to open flow gate.
- Pull trigger to close flow gate.
- Press horizontal AUGER ON/OFF button to start the horizontal auger. Press button again to stop horizontal auger. Indicator light on button is lit when auger is on.
- Pivot IN/OUT moves vertical auger +/- 10° from cart.
- Spout IN/OUT adjusts “tippy spout” position.
- Push JOYSTICK LEFT or RIGHT to position vertical auger out from cart.
- Push JOYSTICK UP or DOWN to position vertical auger spout.

CART OPERATION



 WARNING	Contact with rotating driveline will cause death or serious injury. Keep away at all times when operating.
	Never operate without all guards and equipment shields properly installed.

 WARNING	Towing loaded grain carts on public roads and bridges can result in death, serious injury, and damage to property and equipment.
	Never tow a loaded grain cart on public roads and bridges.

 WARNING	Limited window visibility can conceal people, animals, or objects and result in death, injury, and damage to property or equipment.
	Check completely around cart before moving!

 WARNING	Wide loads or loads with a high center of gravity may cause instability or rollover when operating on hillsides or in rough terrain.
--	--

 WARNING	Do not transport cart with vertical auger extended. This can cause loss of control and could result in death, serious injury, or damage to property or equipment.
--	---

 WARNING	Falling from equipment can cause death or serious injury.
	Use three points of contact when working on equipment.
	Never ride on equipment!

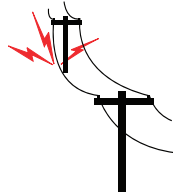
**DANGER**

Contacting or coming close to power lines or other high energy sources will cause death or serious injury.

Keep away from power lines or high energy sources at all times.

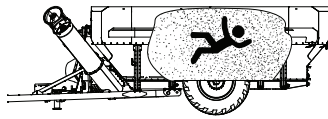
**DANGER**

Entering the grain cart can result in death or serious injury.

- Never enter grain cart when there is an energy source attached to the cart.
- Flowing grain can trap and suffocate.

Unload Grain Cart

NOTICE



Operating tractor PTO above 750 RPM with augers empty will damage equipment.

Make sure grain is flowing properly before increasing to higher RPM's. Read Operator's Manual for instructions.

NOTICE

Roll tarp must be completely open during unloading operations or suction will damage equipment.

NOTE: Vertical auger tilt must be in fully retracted position to fold/unfold.

1. Open roll tarp completely.
2. Unfold vertical auger.
3. Engage PTO at low tractor RPM.
4. Engage horizontal auger.
5. Start to open flow gate and increase tractor RPM.
6. Set grain flow and tractor RPM to desired level.
7. Adjust auger tilt and/or tip spout.
8. Slow tractor RPM as cart reaches empty
9. Close flow gate
10. Disengage horizontal auger.
11. Allow vertical auger to clean out and disengage PTO.
12. Ensure auger tilt is in full vertical position.
13. Fold auger to storage position.

PTO TORQUE LIMITING/OVERRUNNING CLUTCH PROTECTION

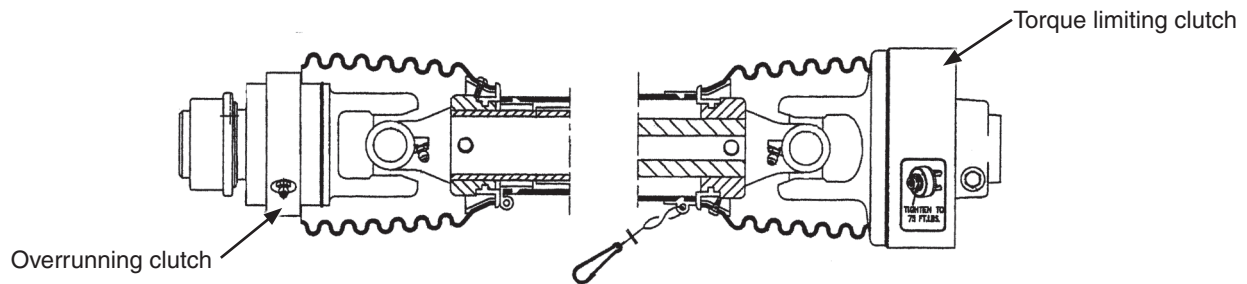

The torque limiting clutch disengages if auger becomes obstructed to prevent driveline and gearbox damage. The torque limiting clutch resets automatically when PTO RPM is reduced.

The overrunning clutch allows auger system to freewheel and protects tractor and cart from shock damage with PTO brake-equipped tractors.

BELT ENGAGEMENT INDICATOR

An indicator pointer on front side of belt housing shows if horizontal auger is engaged (ON) or disengaged (OFF).

indicator should be OFF when PTO is engaged to reduce start up torque requirements.

As belt tension is disengaged (OFF) you will hear linkage snap over center and release belt tension.

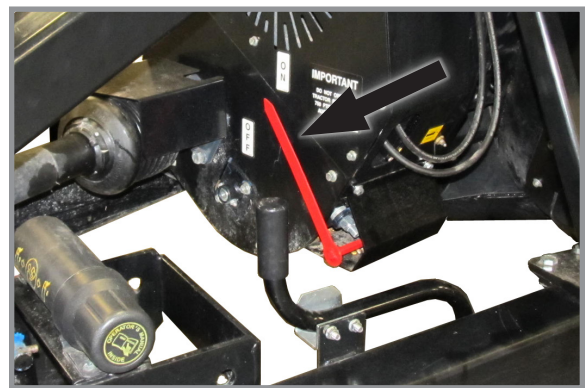

Belt engagement indicator

HYDRAULIC FLOW GATE

Hydraulic flow gate controls volume of grain to horizontal auger. An indicator on front panel shows position of flow gate.

1. Engage PTO for the vertical auger at low RPM.
2. Engage belt drive clutch to start the horizontal auger.
3. Open gate half way.
4. Adjust flow gate to desired unloading rate.

NOTE: Recommended initial flow gate position for rice is half open.

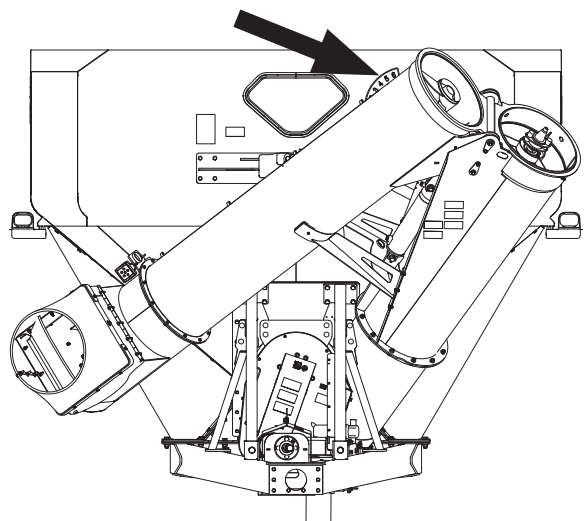

Flow gate position indicator

AUGER INSPECTION COVER

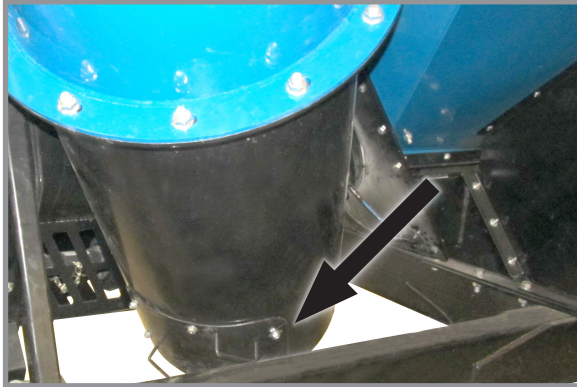

Vertical Auger Cleanout door



Horizontal Auger Cleanout door

 DANGER	Never open inspection cover while PTO and/or augers are running.
---	---

Grain Carts are equipped with two inspection covers one at the bottom of the vertical auger and one located on the grain transfer that are used for clean out purposes.

The inspection covers should be removed any time total clean out of the wagon is required, such as when changing crops, to preserve grain identity, or in preparation for storage.

At the end of each season or after extended use, the inspection covers should be removed and the auger chamber cleaned of all debris and accumulated grain to prevent rust and mold.

Reinstall covers and tighten hardware evenly after clean out is complete.

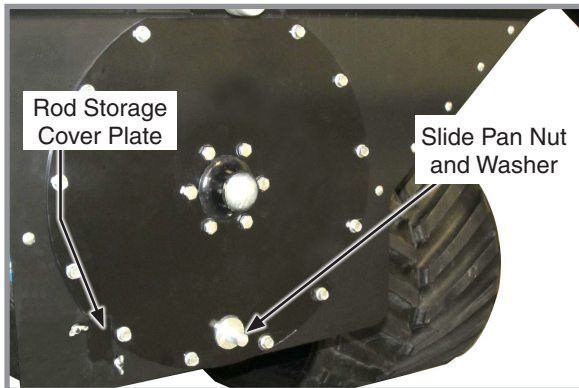
GRAIN TANK CLEAN OUT SWEEP

Rear Inspection Cover

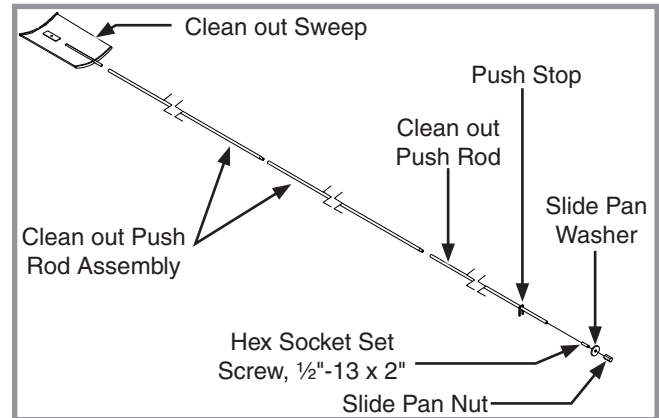
**DANGER**

Never use clean out sweep while PTO and/or augers are running.

**DANGER**

Never remove dump door while PTO and/or augers are running.

**DANGER**

Never work around PTO, gerabox, or belt drive system or allow anyone else to do so while PTO is running.

To access the grain tank clean out sweep, remove the slide pan nut and heavy washer at the bottom of the rear inspection cover. Remove the cap screws that secures clean out sweep and remove the covers and dump door(s) on the underside of the grain tank. Set hardware aside.

Remove the auger inspection cover at the front of the wagon by removing nuts.

Remove the wing nuts holding the rod storage cover plate and remove extension rods. Connect extension rods together and attach to clean out sweep. Attach hex socket set screw, slide pan washer, and slide pan nut to the rod end containing the push stop, creating a handle.

Attach extension rods and pull the clean out sweep as far back as possible then push it as far forward as possible. Repeat this procedure several times. Inspect the inside of the wagon to ensure clean out is complete.

Reinstall auger inspection covers and dump door(s) at front of wagon and dump door on underside of grain tank at rear of wagon. Store clean out sweep extension rods and reinstall and tighten all hardware.

VERTICAL AUGER WORK LIGHT

Work light is mounted in a fixed location on the vertical auger and cannot be moved. Limited adjustments can be made by swiveling light on its base.

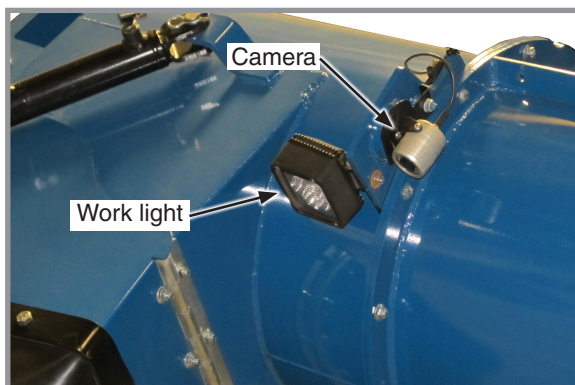
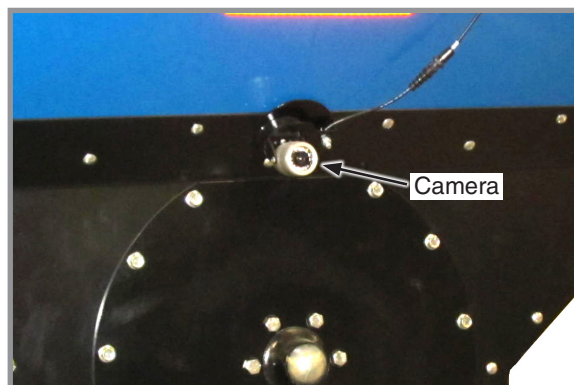
**Vertical auger****Rear of cart**

MANUAL AND ELECTRIC ROLL TARP

NOTE: Mount the circuit breaker as close to the power source as possible. Direct connection to the battery or a primary battery-direct power buss is advised. Run 6ga minimum wire size to the tarp system connector plug.

Electric Roll Tarp can be operated with remote or Manual switches.

Close Tarp: Push switch to **CLOSE** and hold. Observe trap and release switch when tub is fully closed.

Open Tarp: Push switch to **OPEN** and hold. Observe tarp and release switch when tub is fully opened.

Power-up/down:

The transmitter will power up when the lid is opened. The transmitter will power down when the lid is closed or when the lid is left open three minutes after the last button is pushed.

Standard operation:

After power-up, the first channel will be immediately active and the LED indicator for this channel will be flashing. The *Open/On* and *Close/Off* buttons are operational for the indicated active channel. While pressed, the LED indicator will flash faster, indicating channel operation.

The *Select* button will cycle between enabled channels. If only one channel is enabled, there will be no apparent change when the *Select* button is pressed.

Channel programming mode:

The Shur-Co® SMART1+ has five channels. Pressing the *Select* button toggles through these channels. Unused channels can be disabled if desired, using the following process, but your transmitter is fully operational as shipped. This process may be skipped. Unused transmitter channels will not perform any functions.

Hold the *Select* button down for 10 seconds and the transmitter will enter *Channel Programming Mode*. Each time *Channel Programming Mode* is entered, the status of all five channels must be reset.

While In Channel Programming Mode, the programmable channel will be indicated by a solid lit LED.

NOTE: The transmitter will NOT activate any motor or lighting system while the transmitter is in *Channel Programming Mode*.

Press the *Open/On* button to enable the current channel (designated by the indicator light). Press the *Close/Off* button to disable the current channel. The indicator light will automatically jump to the next channel.

After programming all five channels, the transmitter will display the programmed channel status for all channels for three seconds. All enabled channel LEDs will be lit solid and all disabled channel LEDs will not be lit. Buttons will not function during this three second period.

The transmitter will automatically exit *Channel Programming Mode* after three seconds and return to *Operational Mode*.

NOTE: If there is not at least one enabled channel after programming, the transmitter will not save the changes and will revert back to the previously saved channel settings.

TIP: To cancel your changes and exit Channel Programming Mode, close the transmitter cover.

Channel programming example:

The transmitter in this example is labeled with the following five channels:

- Tarp System
- Front Hopper
- Back Hopper
- Lights
- Auxiliary

These channel labels are for a standard agricultural transmitter. Your transmitter label may differ.

The task is to enable the *Tarp System*, *Front Hopper* and *Back Hopper* channels.

1. Hold down the *Select* button for 10 seconds. The transmitter will enter *Learn Mode*. The *Tarp System* channel LED will be lit. All other channel LEDs are off.
2. Press the *Open/On* button to enable the *Tarp System* channel. The *Front Hopper* LED will now be lit.
3. Press the *Open/On* button to enable the *Front Hopper*. The *Back Hopper* LED will be lit.
4. Press the *Open/On* button to enable the *Back Hopper*. The *Lights* channel LED will be lit.
5. Press the *Close/Off* button to disable the lights. The *Auxiliary* LED will be lit.
6. Press the *Close/Off* button to disable the *Auxiliary* channel LED.
7. The transmitter will display all activated channels for three seconds. The transmitter will automatically exit *Channel Programming* and revert to *Operational Mode*. The *Tarp System* LED will be flashing, indicating that the channel is active and ready for operation.

SMART1+ to receiver programming:

Shur-Co® SMARTrailer® wireless systems are typically pre-programmed at the factory or by the dealer and should be ready to use as shipped. Re-programming is necessary after replacement transmitters or receivers are installed. Use the following method to program the RF receiver to accept and respond to signals from up to five transmitters. The receiver will not accept or respond to signals from transmitters that have not been programmed using this method.

1. Remove the receiver cover, pulling gently on the cover to prevent damage to wires that are connected to the rocker switch.
2. Check to be sure the electric tarp is connected to the power supply. The receiver must be connected to power to be programmed. If a battery disconnect switch is installed, make sure it is turned on.
3. The receiver can learn to recognize and respond to up to five transmitters. Gather all of the transmitters to be introduced to the receiver. Open the transmitter lid(s) in order to turn them on.
4. Set the transmitter(s) to the appropriate channel (*Tarp System*, etc.).

NOTE: Read the following steps in their entirety before proceeding. Steps 6 to 8 must be completed within 20 seconds.

5. Press and hold the blue programming button on the back of the RF module for 5 seconds. The RF module is located in the back of the cover.

Single SMART1+™ remote:

1. On remote, press Open/On button five times. Red light on receiver will flash after each button press. After receiving last signal, light will flash twice, then begin flickering, indicating it has been successfully programmed.
2. Verify remote and receiver are operating correctly, then refasten solenoid cover.

Multiple SMART1+™ remotes:

1. Press Open/On button on first remote. Red light will flash after receiving signal.
2. Repeat above step for each remote being used.
3. Receiver will accept up to five signals. Press Open/On button additional times on last remote being programmed to achieve total of five signals. Red light on receiver will flash twice after last (fifth) signal, then begin flickering, indicating it has been successfully programmed (see programming example).
4. Verify each remote and receiver are operating correctly, THEN REFASTEN SOLENOID COVER.

Receiver programming example:

In this example, the receiver controls the electric tarp motor. The task is to program the receiver to recognize three transmitters.

1. Remove the receiver cover and turn on the three transmitters.
2. Set all three transmitters to the tarp system channel.
3. Press and hold programming button on receiver for five seconds. Red light on receiver will flash to indicate it has entered Programming Mode. Release programming button. Light will now turn off.
4. Press Open/On button on first remote. Red light on receiver will flash to indicate it has received signal and memory slot #1 has been filled.
5. Press Open/On button on second remote. Red light on receiver will flash to indicate it has received signal and memory slot #2 has been filled.
6. Press Open/On button on third remote. Red light on receiver will flash to indicate it has received signal and memory slot #3 has been filled.
7. Press Open/On button on third remote again. Red light on receiver will flash to indicate it has received signal and memory slot #4 has been filled.
8. Press Open/On button on third remote again. Red light will flash twice to indicate it has received signal and memory slot #5 has been filled. It will then begin flickering, which indicates receiver has exited programming mode.
9. Verify front hopper Open and Close operations are functioning CORRECTLY ON ALL.
10. Refasten the receiver cover to motor assembly.

ROLL TARP REMOTE CONTROL TROUBLESHOOTING

PROBLEM	SOLUTION
No lights on remote turn on when I open the lid.	Close lid for three seconds, then reopen lid.
	Make sure there are no magnets close to the transmitter.
	Open transmitter case and make sure battery is placed correctly in the remote.
	Remove battery and bend contacts closer together. Put battery back in and try again.
	The battery may be dead and must be replaced. Replacement quantity is 2 "AAA" batteries.
I can operate the system with rocker switch but not the remote. The SMART1+ channel light is blinking, and when I press the Open/On button, the light blinks faster.	SMART1+ is damaged and must be replaced.
	Make sure remote is set to the right channel. If you cannot set remote to the desired channel, it must be reprogrammed (see transmitter programming instructions).
	Make sure no other transmitters are being used near your system.
	Determine if the transmitter is the problem by testing it with a different receiver or by using a second remote. If receiver was the problem, reprogram receiver (see the receiver programming instructions). If this doesn't work, receiver should be replaced.
The SMART1+ channel light is blinking, but when I press the Open/On or Close/Off button, the light goes out or just continues to blink at the same speed.	Make sure you are within a couple feet of the receiver and try again. If transmitter works at short range but not at greater distances, you have a range problem, so a new battery may be needed. If the remote battery is not the cause, call the Help Line.
	Remove battery and bend contacts closer together. Put battery back in and try again.
	The battery may be dead and must be replaced. Replacement quantity is 2 "AAA" batteries.
	SMART1+ is damaged and must be replaced.

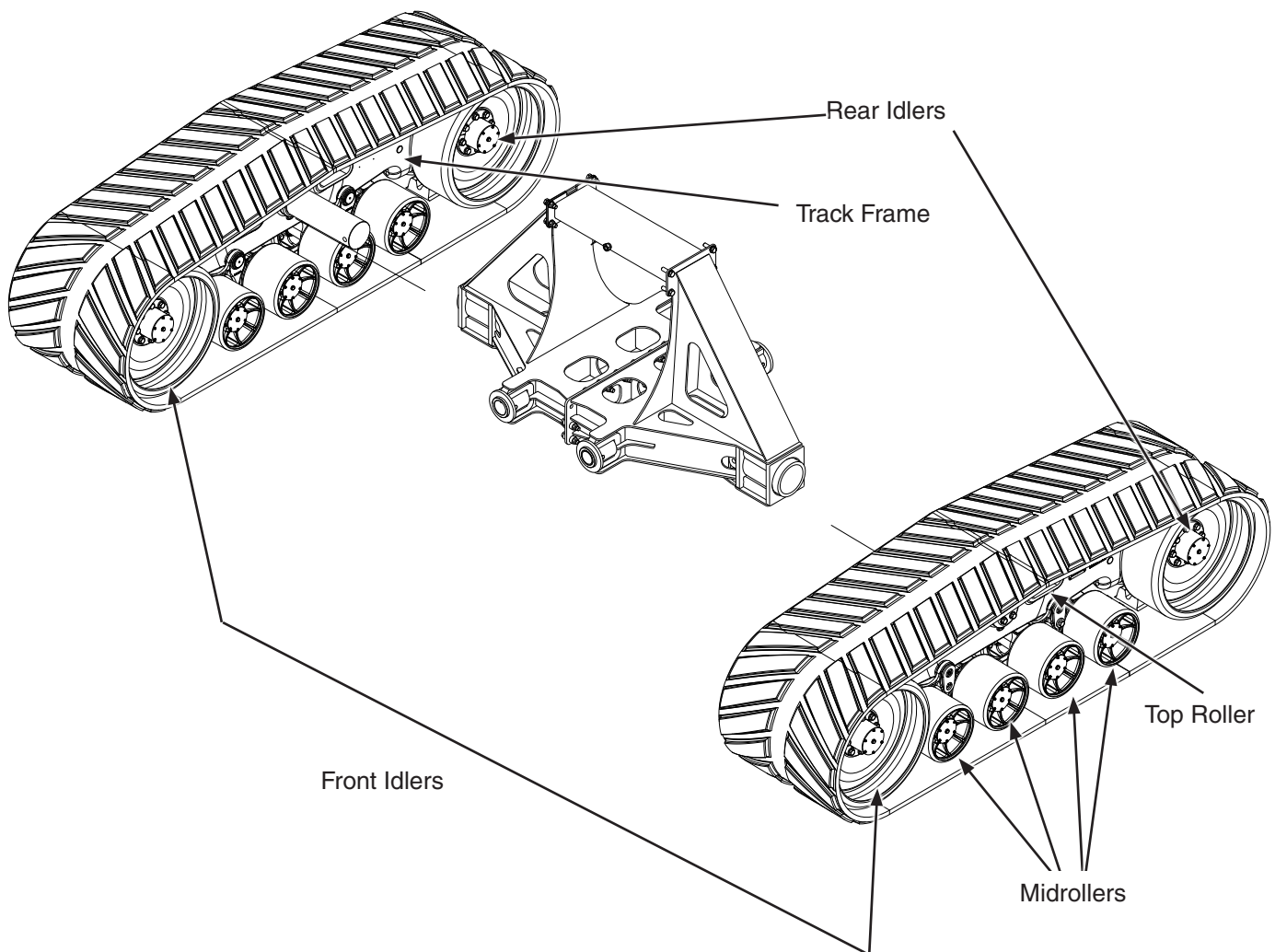
TRACK SYSTEM COMPONENTS - MODELS 1105/1205/1305**Frame**

The main frame consists of a casting, and the front alignment yoke and rear tension link are cast members.

Axles

Front and rear axles are machined from the yoke castings, allowing for dimensional stability and few moving parts. They feature oil bath hubs mounted on tapered bearings and mechanical seals for extreme working conditions. Each hub has its own oil reservoir with access port for maintenance and checking oil levels. Refer to Lubrication and Maintenance section for oil fill and greasing information.

Idlers and Midrollers

The idlers have the function of guiding the rubber track by acting on the lateral surfaces of the guide lugs. Rotation of belts is recommended to extend life.

TRACK SYSTEM COMPONENTS - MODELS 1105/1205/1305 (CONTINUED)

Tensioning System

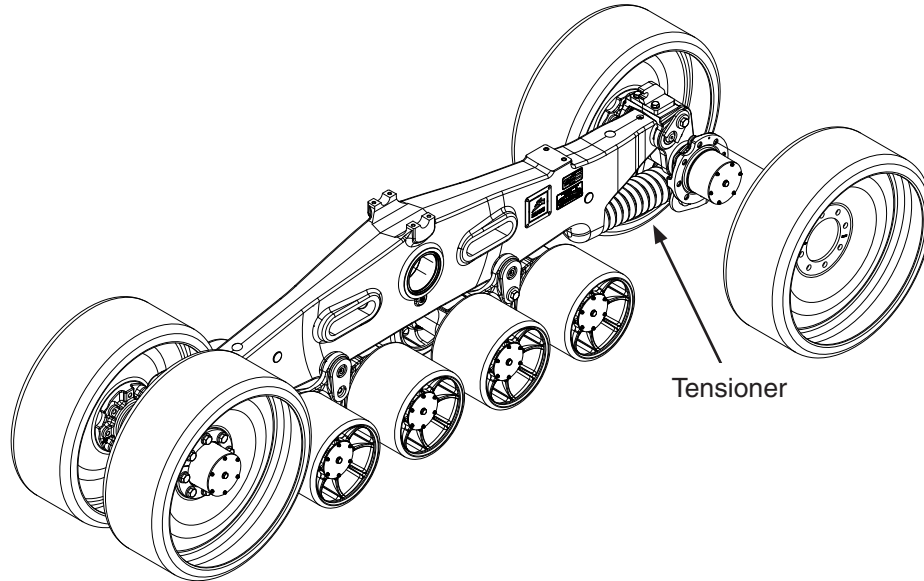

The tensioning system is located between the 2 rear idlers. The tension force is provided by a mechanical spring mechanism. Track tension is provided by the spring and does not need adjustment during operating and changing field conditions. Provisions are made to compress the spring allowing for removal of idlers and track assemblies during maintenance and servicing. Special tools are available from Kinze to compress the spring and detension the tracks.

Rubber Tracks

Rubber tracks are manufactured with high quality rubber and high strength steel cabling inside. The tread layout ensures good flotation, excellent life, and self-cleaning characteristics.

TRACK TRANSPORT SPEEDS - ALL TRACK MODELS

Model	Operating Condition	Transport Speed (Maximum)	Transport Duration (Maximum)
1500	Empty	15 mph (24 kph)	30 minutes
1105/1205/1305	Empty	25 mph (40 kph)	30 minutes

NOTE: Track carts should be limited to road use only when empty.

If additional distances are required, a 30 minute cool down period is recommended before transport is resumed. Absolute speed and duration levels may vary, depending on system type and ambient conditions. Recommended speed and duration information help avoid system heat buildup that could cause reduction in track life.

TRACK SYSTEM MINIMUM TURNING RADIUS LIMITATIONS - ALL TRACK MODELS

On either field or road, the minimum turning radius is 3 times the overall length of the tractor plus the implement.

Track systems operate best when running straight or in gentle turns. If a track system is pivot or spot-turned, the opportunity exists for soil and dirt to be ingested into the system. Even though the track system has a tension recoil system, if that tension recoil is exceeded, high loads in the frame and track can be generated which may cause track or system damage.

NOTICE

Minimum turning radius limits should be strictly observed to avoid damage to track system.

TRACK SYSTEM BREAK-IN PROCEDURES - ALL TRACK MODELS

Guide lug wear is reduced when correct break-in procedures are followed. During the break-in period, rolling components undergo a polishing-in process to achieve a smooth steel to rubber interface with the guide lug. Rubber uses dust and dirt as a dry lubricant during break-in and operation to minimize heat and reduce rubber stickiness. New tracks should be exposed to dry and dusty soil conditions as soon as possible. Operation without dust or soil in the system, especially during high speed roading, generates high levels of damaging heat. If roading must be done, a dry lubricant such as soil, talc, graphite, oil dry should be applied to the guide lugs periodically during roading until field operation resumes.

TRACK SYSTEM OPERATIONAL GUIDELINES - ALL TRACK MODELS

- Any application differing from the ones prescribed in this manual is to be considered improper and potentially dangerous.
- Correct track tension is required for best performance and track life.
- Track system can work in extreme conditions: for operator and machine safety, be sure to know your surroundings.
- Track system is free to pivot around the main axle following ground conformation.
- During transition over uneven ground terrain, check for interferences and move slowly to avoid over-oscillating the undercarriage.
- Overall width and height of machine/equipment with track system could differ from the original width and height with tires. Be sure to know actual machine height and width as well as width restrictions prior to operation.
- Cross large ground irregularities with suitable speed reduction and/or proper incidence angle. In particular, when high, sharp bumps are crossed move forward slowly to avoid shocks on the machine.
- The track system does not damage standard road-bed constructions. Operators must know and respect road traffic laws.

Rubber tracks have not been designed for extended use on the road. Kinze is not responsible for track and system damage resulting for extended road use. Long road periods and/or roading at higher than recommended maximum speeds may cause premature wear or failure of the track or wheels. To reduce damage during roading, decrease overall machine weight and decrease machine speed, refer to [“Track Transport Speeds - ALL Track Models” on page 2-17](#) for further information.

- Long runs on side slopes increase the wear on the side of guide lugs and idlers.
- Keep material out of the undercarriage. Inspect undercarriage daily and remove any material as necessary. In some conditions inspect more frequently.
- If a machine becomes stuck, clear away as much material from the undercarriage as possible prior to pulling the machine out.
- Avoid short turning radius turns and operation(s) especially when loaded. Spot turning creates debris ingestion and can also induce high torque loading in the system.
- Configure drawbar and hitch correctly during field operation(s).
- Use caution when operating track systems in loose, flowing material. Loose material can become trapped between track and idlers, resulting in track damage.
- Keep material out of the undercarriage. This may require scraping material out of tight places and in some conditions require frequent inspection and cleaning.

ELECTRONIC SCALE - GT 400

Electronic scale option includes two load cells, one hitch weigh beam, a tractor-mounted scale indicator console and cables, brackets, and mounting hardware.

To measure what is unloaded, press “TARE” before starting to unload. Weight being unloaded displays as a negative value. Record this information and press “NET/GROSS” to return to gross weight.

To measure what is loaded (For example when doing a field yield check.), press “ZERO” to zero cart weight before loading.

NOTE: Scale is most accurate when cart is sitting still on level ground when weighing.

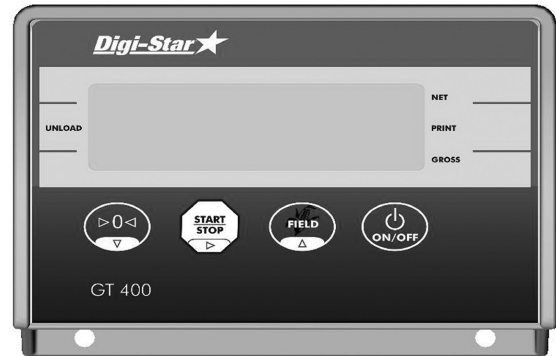

GT 400 Indicator

Suggested Operating Procedures

NOTE: Movement of cart causes scale indicator reading to fluctuate.

Step 1 Press  to turn on scale.

NOTE: Allow one (1) minute for scale to warm up (allow 5-10 minutes in cold weather).

Step 2 Press and hold  to zero balance.

NOTE: Zero balance indicator when empty at least once a day or more as required. If zero balance is not correct it only affects gross weight reading, not accuracy of displayed net weight.

Step 3 Load cart.

Step 4 Press  to begin unloading.

Display reads zero. Arrows point to Net and Unload.

Step 5 Unload cart. Negative reading on scale indicator is pounds unloaded.

Step 6 Press  when unloading is complete.

Indicator displays remaining weight left on scale. Data is automatically added to accumulator and saved to Printer or DDL (data downloader kit).

Repeat Steps 4 - 6 each time cart is unloaded.

Entering Field ID

A user-entered, 6 character identification number is used for referencing fields, trucks, owners or other information.

Step 1 Press .

FIELD displays and a flashing cursor or character displays in the first position.

Step 2 Press .

Hold for 4 seconds to increase scroll rate.

Step 3 Press .

Press .

Step 4 Press .

See GT 400 manual provided and Troubleshooting Section of this manual for additional information.

Scale Setup and Calibration Numbers

Flotation and Track

Setup Number: 127100

Calibration Number: 42546

Row Crop

Setup Number: 126000

Calibration Number: 77639

GT 560 Operation

NOTE: Indicator must be on active screen before loading or unloading.

Suggested Operating Procedures - With AutoLog

NOTE: Movement of cart causes scale indicator reading to fluctuate.

Step 1 Press 

Step 2 Press and hold  for two seconds to zero balance the GT 560 indicator if the container is empty. Active screen is displayed.

NOTE: To operate GT 560 with AutoLog, the GT 560 must be connected to a PTO or switch sensor and AutoLog must be turned ON.

Step 3 Press 

Step 4 Press  and  to select field name.

Step 5 Press  to select required field name.

Step 6 Press  to select required ID.

NOTE: Make sure active screen displays.

Step 7 If AutoLog is enabled, start the PTO or open the discharge door. The GT 560 will display zero and enter the net mode.

Step 8 Unload grain. Upper Display shows amount unloaded. Gross value (total amount left on cart) displays on second line of Lower Display.

Step 9 If AutoLog is enabled, stop the PTO or close the door. The data record will be stored in memory of indicator. The data record screen will display the last data record for 10 seconds, then return to active screen.

Refer to GT 560 manual for additional information.

Scale Setup and Calibration Numbers	
<u>Flotation and Track</u>	
Setup Number:	127100
Calibration Number:	42546
<u>Row Crop</u>	
Setup Number:	126000
Calibration Number:	77639

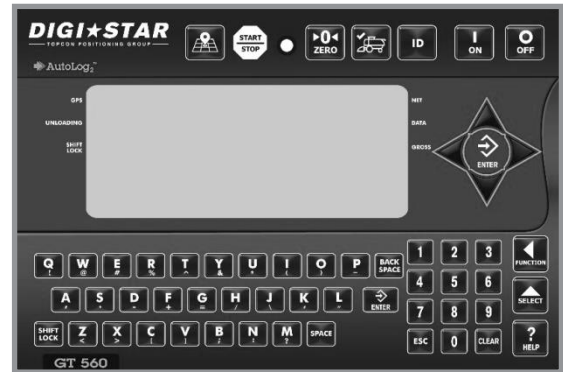

GT 560 Indicator

Suggested Operating Procedures - Without AutoLog

NOTE: Movement of cart causes scale indicator reading to fluctuate.

Step 1 Press 

Step 2 Press and hold  for two seconds to zero balance the GT 560 indicator if the container is empty. Active screen is displayed.

NOTE: To operate GT 560 without AutoLog, the AutoLog feature must be turned OFF.

Step 3 Press 

Step 4 Press  and  to select field name.

Step 5 Press  to select required field name.

Step 6 Press  to select required ID.

NOTE: Make sure active screen displays.

Step 7 Press  before unloading grain from container. The GT 560 will display zero and and enter the net mode.

Step 8 Unload grain. Upper Display shows amount unloaded. Gross value (total amount left on cart) displays on second line of Lower Display.

Step 9 When unloading is complete, the data record will be stored in memory of indicator. The data record screen will display the last data record for 10 seconds, then return to active screen.

Step 10 Press  when finished unloading grain.
Refer to GT 560 manual for additional information.

ELECTRONIC SCALE PRINTING OPTIONS

Three printing options are available for use with the electronic scale with print-ready indicator console:

1. Printer connected directly to the indicator console.
2. (GT 560 ONLY) USB Flash Drive to transfer data between indicator and PC with Windows Operating System.
3. Data Downloader Kit which stores information in a downloader module for remote printing using any computer and printer with Windows 98/2000/XP/Vista operating systems. Module stores up to 1600 lines (64K bytes) of load data.

These printing options allow recording of load ID number, time, date, and weight.

PRINTER OPTION

A power and data cable is included with printer.

See User's Manual supplied with printer for additional information.



DATA DOWNLOADER (DDL) OPTION

The Data Downloader Kit option includes:

1. Module cable to connect indicator to downloader module.
2. Interface cable to connect downloader module to computer serial "com" port.
3. Downloader module which plugs into memory converter cable to store information and into interface cable to print information.
4. Program CD.

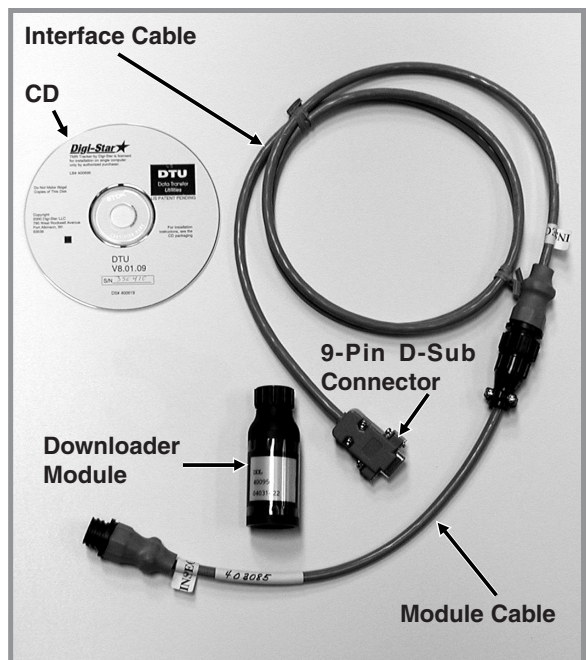

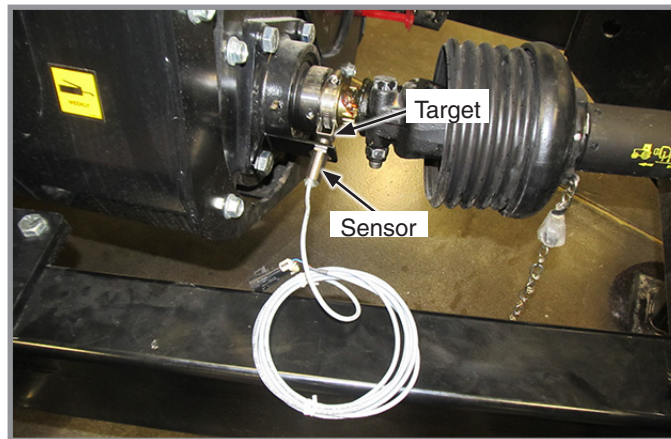
ELECTRONIC SCALE - GT 560 AUTOLOG

The GT 560 indicator has many features but it also boasts simple handsoff operation using a RPM sensor on the PTO shaft to trigger the start of the unloading process and the end of the unloading process. AutoLog prevents operator mistakes that could cause you to lose data on loads because the operator “Forgot” to push the “Start/Stop” key. You can still use “Start/Stop” key before unloading and again after unloading in case the sensor is damaged or not functioning for any reason. Weight, date, time, and additional information is stored automatically after each load is completed.

See GT 560 AutoLog Operators Manual provided and Troubleshooting Section of this manual for additional information.

The Data Downloader (DDL) stores and transfers data between indicator and a computer.

System requirements:

- Windows 98/2000/XP/Vista Operating System
- Serial Port
- 32 Mb of RAM
- Pentium 100 PC Or Higher
- 100 Mb Of Free Disk
- CD-Rom Drive

Step 1. Insert Data Transfer Utilities software (DTU) into CD-Rom.

Step 2. Connect interface and module cables.

Step 3. Connect interface cable (9-pin D-sub connector) to serial port on your computer.

NOTE: Cable must be securely connected to a COM port to function.

Step 4. Connect module cable to “Serial/J904” port on indicator. Press “PRINT” key. When printing is complete remove module cable only.

Step 5. Fasten downloader module to interface cable.

NOTE: To lock downloader module to interface cable, twist fastener on downloader module.

Step 6. Follow DTU software instructions to transfer data files to a Microsoft Excel spreadsheet (or comparable program):

Step 7. Save scale output to a text file (instructions included with DTU software).

Step 8. With Microsoft Excel open (a) Select “Data” file menu, select “Import External Data”, then “Import Data”. (b) Select text file to be transferred. (c) Text import wizard displays. (d) In original data type section select “delimited” and click NEXT button. (e) In delimiters section select SPACE check box and click NEXT button. (f) Click FINISH.

Step 9. Import to “Existing Worksheet” or “New Worksheet” and click OK.

Step 10. Text file now appears in separate cells and columns.

PRINT ACCUMULATOR

This option stores an accumulated value in a memory location called "PRTACC". Each time a "PRINT" command is executed, the weight value on the display is added to the "PRTACC" value.

Three print formats are available:

"PRTAC1" and "PRTAC2" print formats include:

- Scale ID
- Weight
- Weight Tag (Net, Gross, Load/Unload)
- Accumulated Weight
- Print Accumulator Tag
- Date and Time

NOTE: "PRTAC1" displays data on one line and "PRTAC2" displays data on two lines.

"PRTAC3" includes Unit of Measure and Lock-On Status in addition to features listed above and displays data on one line.

Suggested Operation Procedures

Step 1. Press and hold "NET/GROSS" for 3 seconds.

NOTE: "SCALID" is displayed followed by current ID.

Step 2. Use left arrow (PRINT/TARE) and up arrow (NET/GROSS) keys to enter a new Scale ID.

Step 3. Press "ON" to view accumulated data.

NOTE: Press "ZERO" to clear total when accumulated weight is displayed.

Step 4. Press "ON" to resume weighing.

Step 5. Press and hold "PRINT/TARE" for 3 seconds to send data from serial port and store accumulated data.

ELECTRONIC SCALE TROUBLESHOOTING

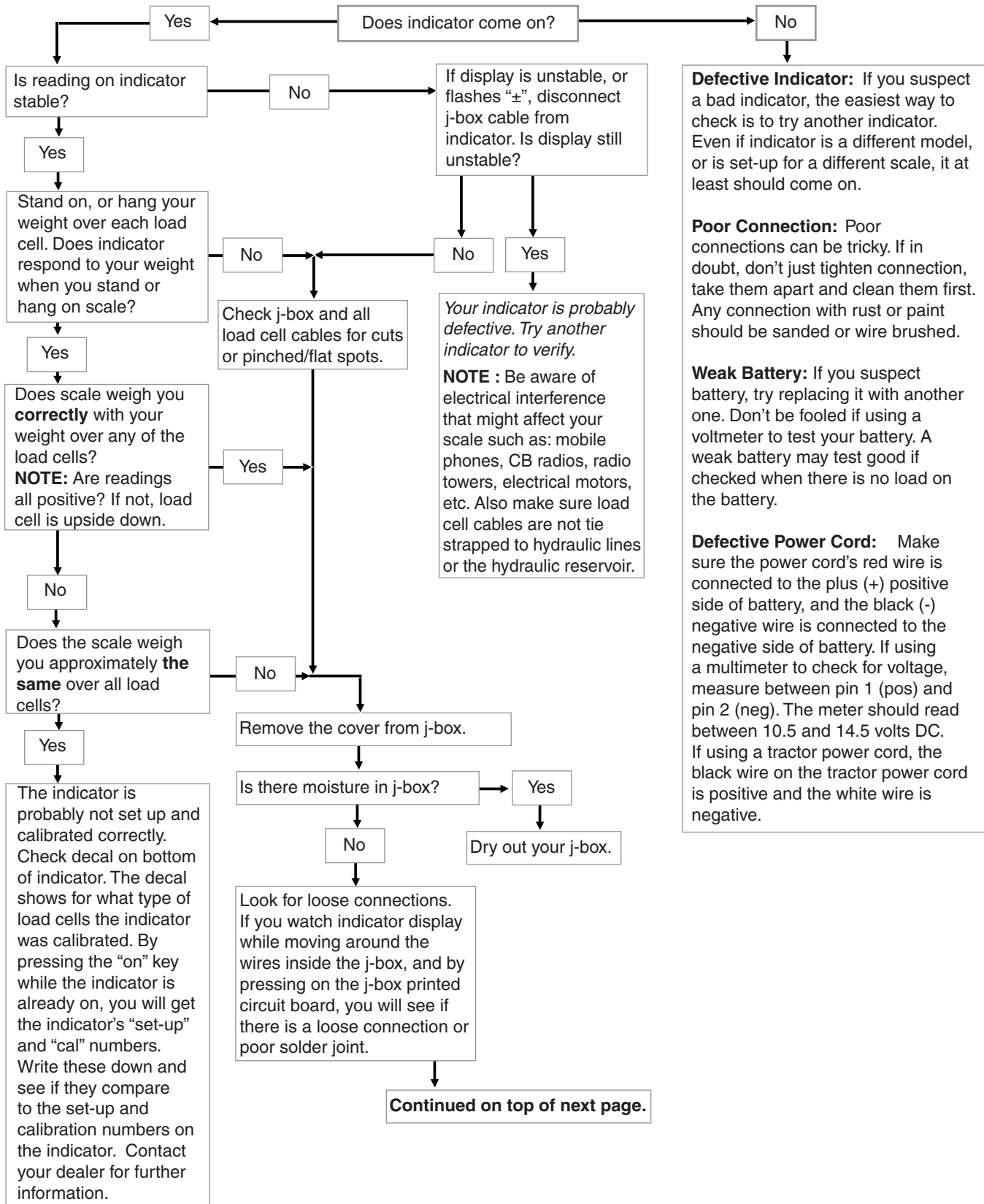

ELECTRONIC SCALE TROUBLESHOOTING

Continued from bottom of previous page.

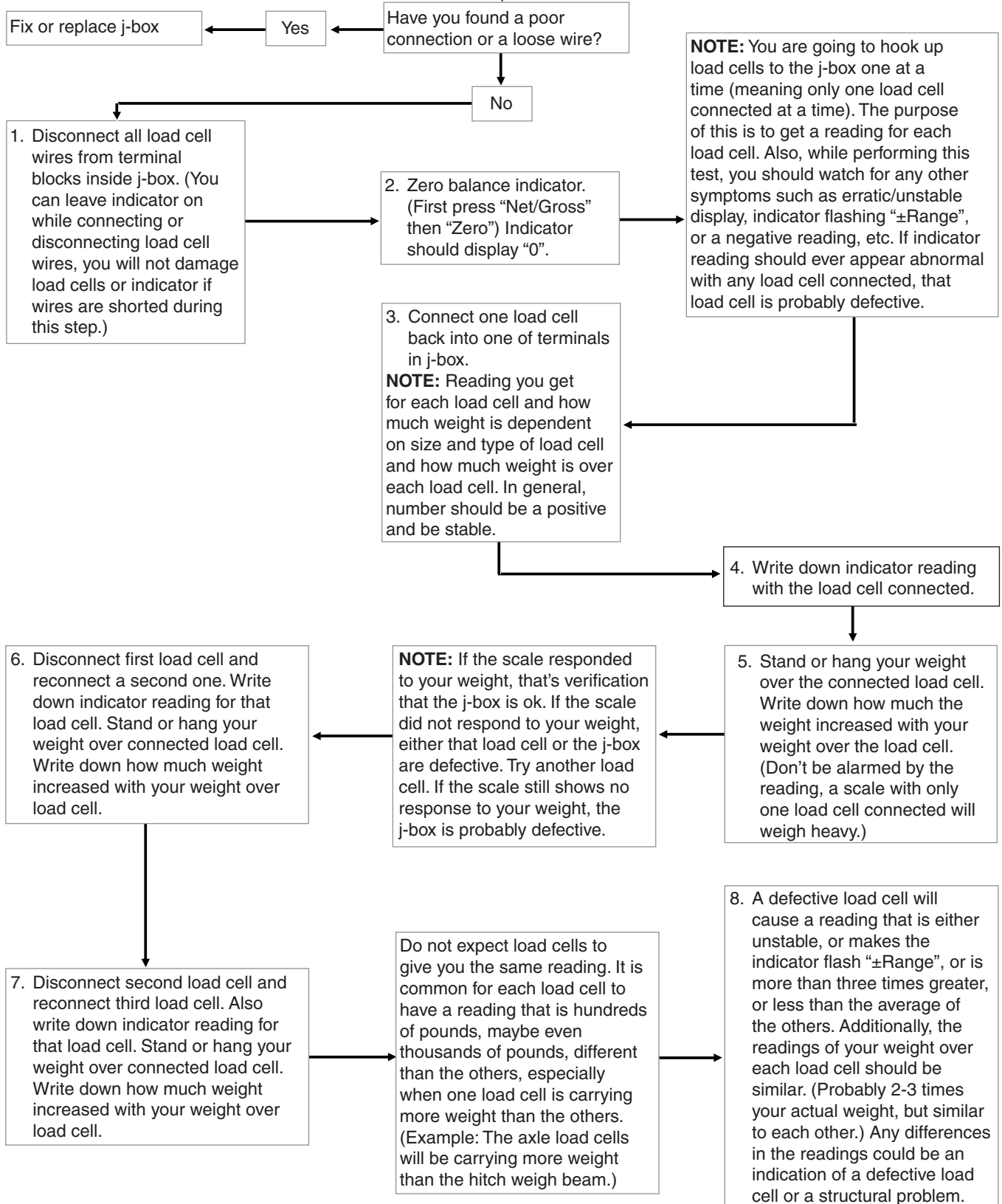

DATA DOWNLOADER TROUBLESHOOTING

PROBLEM	POSSIBLE CAUSE	SOLUTION
Warning no device match was found.	Poor connection to cable.	Check for proper connection to cable.
	Poor connection of cable to serial port of computer.	Check for proper connection of cable to serial port of computer.
	Not connected to correct serial port.	Check port setting in the DTU program to be sure DDL is on the correct serial port.
	Faulty DDL.	Try another DDL.
	Other software installed that uses same serial port.	If any other installed software that requires a serial port is trying to run and there is only one serial port, the second software will not be able to run. If the DTU software had been loaded first and then the (eg. Palm Pilot) software, the Palm software could have a problem. This is a hardware allocation problem. For sites that need to run both, a second serial port must be added or you have to turn off all other software packages that may be using the 1 serial port.
No such file or directory.	File was not saved.	Resave file.
	File saved as incorrect format.	Save file as a text file (.txt).
	Data was not saved in a valid Windows file folder and/or directory.	Resave file in valid Windows file folder and/or directory.
Data will not transfer to PC.	Poor connection to cable.	Check for proper connection to cable.
	Poor connection of cable to serial port of computer.	Check for proper connection of cable to serial port of computer.
	Not connected to correct serial port.	Check port setting in the DTU program to be sure DDL is on the correct serial port.
Some information is not listed.	64K capacity of the DDL is filled.	Check capacity.
	Information may of been overwritten.	Resave file.
Dialog box and program locks up (not responding).	Computer error.	CRTL-ALT-DEL and end task, then restart computer.

DATA DOWNLOADER TROUBLESHOOTING

PROBLEM	POSSIBLE CAUSE	SOLUTION
Warning - no device match was found.	Poor connection to cable.	Check for proper connection to cable.
	Poor connection of cable to serial port of computer.	Check for proper connection of cable to serial port of computer.
	Not connected to correct serial port.	Check port setting in the DTU program to be sure DDL is on the correct serial port.
	Faulty DDL.	Try another DDL.
	Other software installed that uses same serial port.	If any other installed software that requires a serial port is trying to run and there is only one serial port, the second software will not be able to run. If the DTU software had been loaded first and then the (eg. Palm Pilot) software, the Palm software could have a problem. This is a hardware allocation problem. For sites that need to run both, a second serial port must be added or you have to turn off all other software packages that may be using the 1 serial port.
No such file or directory.	File was not saved.	Resave file.
	File saved as incorrect format.	Save file as a text file (.txt).
	Data was not saved in a valid Windows file folder and/or directory.	Resave file in valid Windows file folder and/or directory.
Data will not transfer to PC.	Poor connection to cable.	Check for proper connection to cable.
	Poor connection of cable to serial port of computer.	Check for proper connection of cable to serial port of computer.
	Not connected to correct serial port.	Check port setting in the DTU program to be sure DDL is on the correct serial port.
Some information is not listed.	64K capacity of the DDL is filled.	Check capacity.
	Information may of been overwritten.	Resave file.
Dialog box and program locks up (not responding).	Computer error.	CRTL-ALT-DEL and end task, then restart computer.

TRACK SYSTEM TROUBLESHOOTING

PROBLEM	POSSIBLE CAUSE	SOLUTION
Uneven tread wear	High amount of roading	Swap tracks side to side
Splits/opening on the side or top of tread	High amount of roading or overheat of tread	Swap tracks side to side. Replace tracks if necessary.
Chunking on guide lug sides	Track not aligned properly	Align track
	Side slope operation	Contact dealer
Breakaway of track guide lugs	Debris/material ingestion into track system	Contact dealer
Correct tensioning not possible	Verify position of track detensioning bolt at rear idler assembly.	Bolt fully retracted with no preload on spring applied
High temperature of idler or roller axle hub.	Bearing failure	Replace damaged bearing.
	Lack of lubricant	Check oil level in reservoir.
Mud/dirt buildup on idlers/midrollers	Operation in muddy, wet or sticky soil types	Clean mud/dirt regularly to prevent track damage.

Proper lubrication of all moving parts will help ensure efficient operation of your Kinze Grain Cart and prolong the life of friction producing parts.

SPLINES

Clean and grease all splines before assembly to prolong life, and to prevent damage and ease disassembly when removing.

NOTICE

To extend life of shaft splines, apply a coating of high-speed industrial coupling grease, such as Chevron® Coupling Grease, that meets AGMA CG-1 and CG-2 Standards.

WHEEL BEARINGS

Wheel bearings should be checked and lubricated annually.

Raise wheel off the ground and remove the dust cap. Check for endplay in bearings by moving tire in and out. Rotate tire to check for roughness in bearings. If bearings sound rough, the hub should be removed and bearings inspected and replaced if necessary. See "Wheel Bearing Replacement" in Maintenance section of this manual.

If bearing replacement is not necessary, while wheel is raised and dust cap removed, pump grease into hub until grease comes out through bearing rollers. Replace dust cap.



10 Bolt Hub Shown

TRACK ENDWHEEL AND MIDWHEEL BEARINGS - 1500 MODELS ONLY

Check bearings annually or after every 1000 hours of use, whichever comes first.

If bearings sound rough, hub should be removed and bearings inspected and replaced if necessary. If bearing replacement is not necessary, pump grease into spindle until grease comes out around seal protector on axles and midwheels.

See Maintenance section of this manual if endwheel or midwheel bearing replacement is necessary.

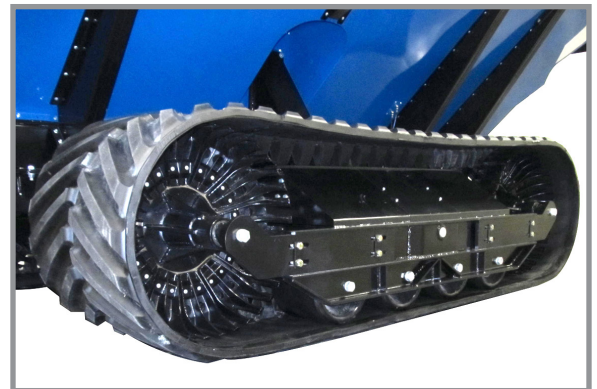

1500 Track Model

HORIZONTAL AUGER BEARINGS

Check and lubricate bearing hubs annually.

Remove hub and inspect bearings. If bearings sound rough. If bearing replacement is not necessary, pump grease into hub until grease comes out through seals.

NOTICE

Remove any grease purged through grease seal on V-belt side of forward horizontal auger hub.

See Maintenance section of this manual if bearing replacement is necessary.

DRIVE BELTS AND PULLEYS

NOTICE

Keep all oil and grease off V-belts and belt pulleys. Do not use belt dressing on V-belts.



4-Band V-Belts (2) Shown

See “V-Belt Tension Adjustment and Alignment” in Maintenance section for additional information.

GEARBOX OIL LEVEL

Gearbox Oil Capacity 1 $\frac{1}{2}$ Gallons . . . SAE 90 weight oil.

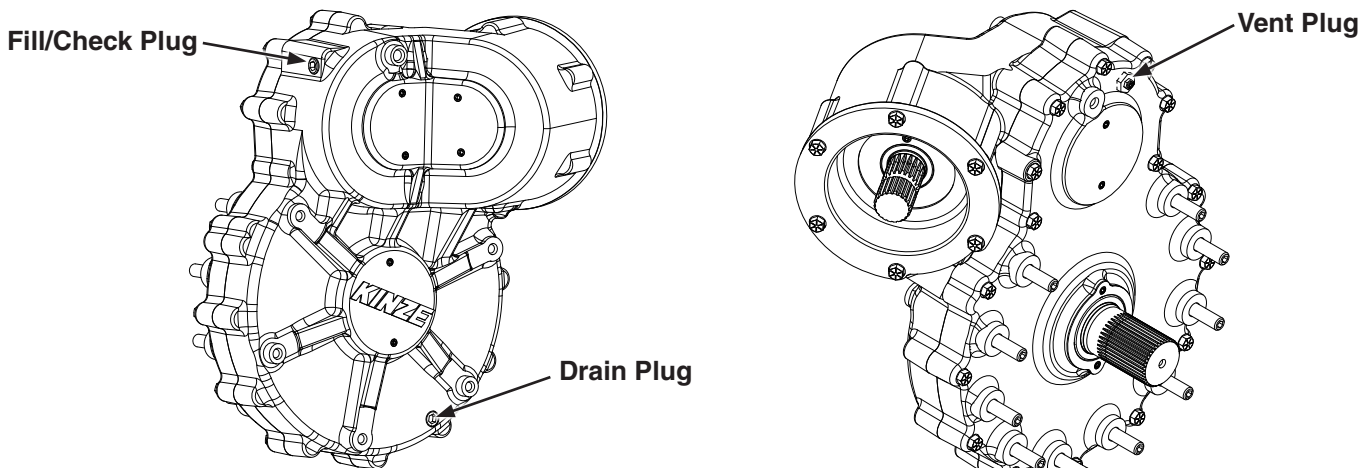

Remove plug from fill/check plug hole on the gearbox. Oil level should be even with fill/check plug hole. Inspect oil at end of each annual season of use for moisture and contaminants, if found, change oil before storage.

PTO SHAFT COUPLING

Clean and grease PTO shaft coupling each time PTO is installed.

Apply a coating of high-speed industrial coupling grease, such as Chevron® Coupling Grease meeting AGMA CG-1 and CG-2 Standards to extend life of shaft splines.

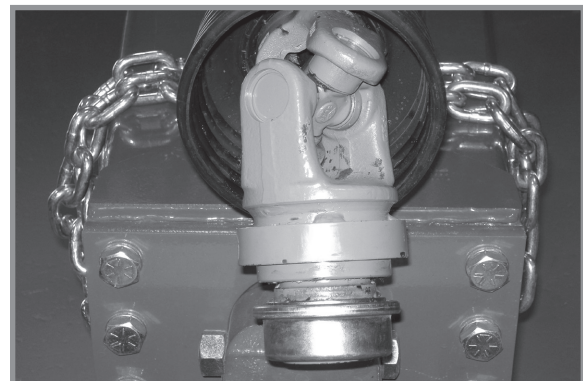

GREASE FITTINGS

Those parts equipped with grease fittings should be lubricated at the frequency indicated with an SAE multipurpose grease. Be sure to clean the fitting thoroughly before using grease gun. The frequency of lubrication recommended on the following pages is based on normal operating conditions. Severe or unusual conditions may require more frequent attention.

NOTICE	Extreme operating conditions such as dirt, temperature or speed may require more frequent lubrication.
---------------	---

NOTE: Disconnect PTO from tractor. Retract PTO assembly and rotate shield to expose grease fitting on PTO slide.

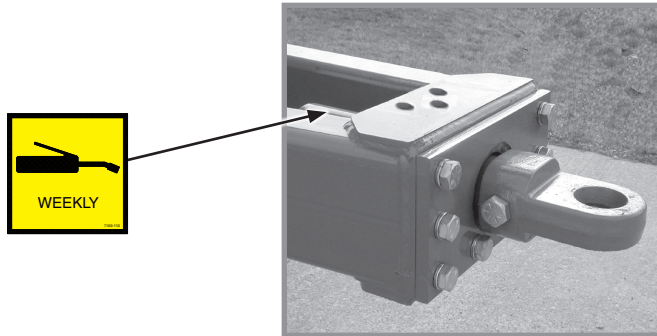

Swivel Hitch (Qty. 1)



Row Crop Carts (10 Bolt Hub)
Wheel Bearings (Qty. 1 Per Wheel Hub)

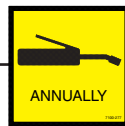

Flotation Carts (20 Bolt Hub)
Wheel Bearings (Qty. 1 Per Wheel Hub)

NOTICE	Dust cap must be loosened or removed while greasing to prevent damage to seal.
---------------	---

NOTE: Numbers on illustrations below corresponds to photos on following pages showing lubrication frequencies.

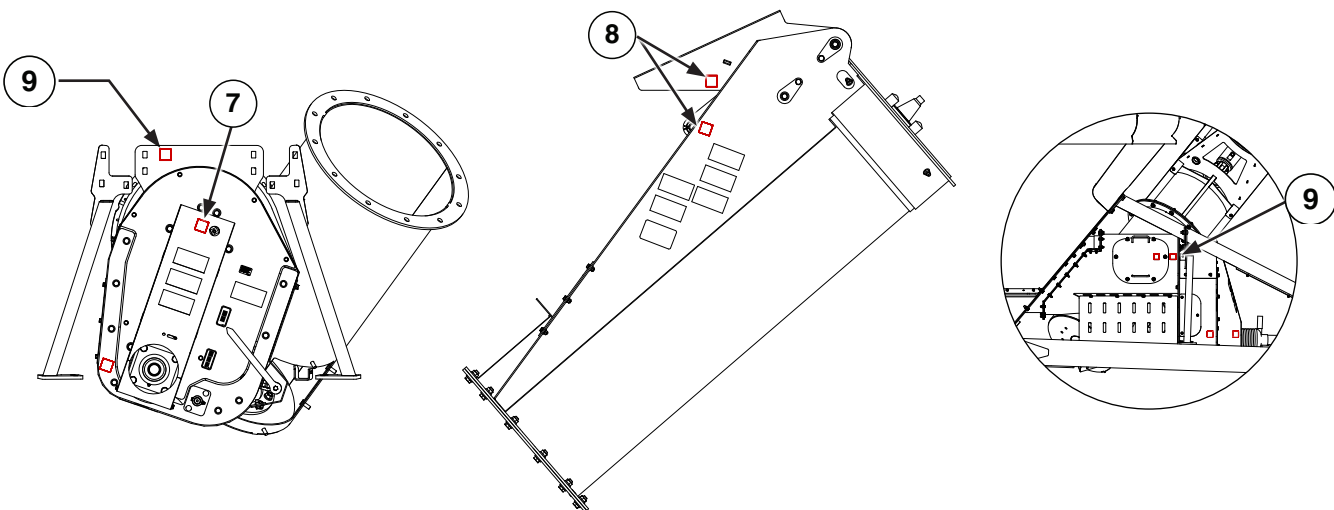
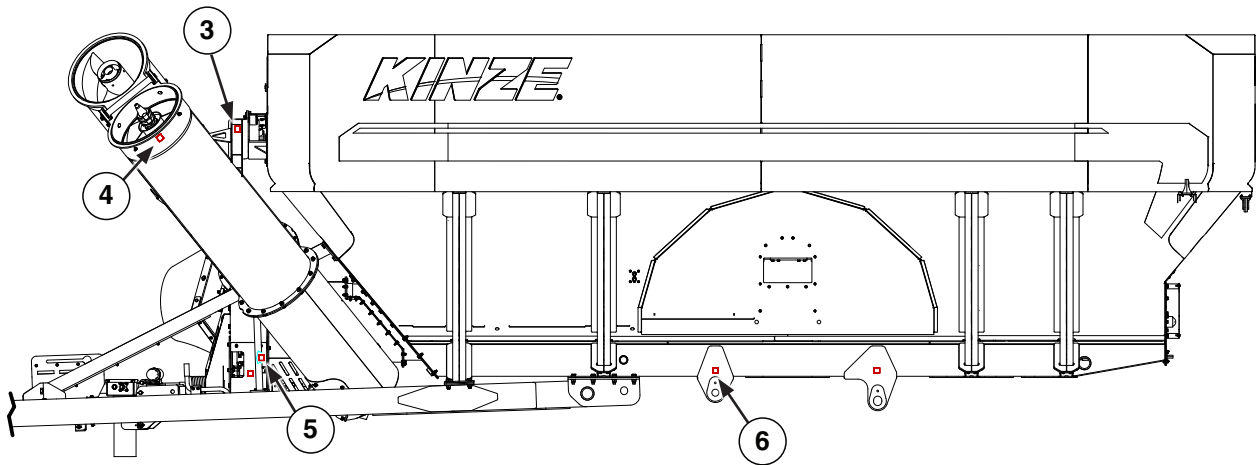
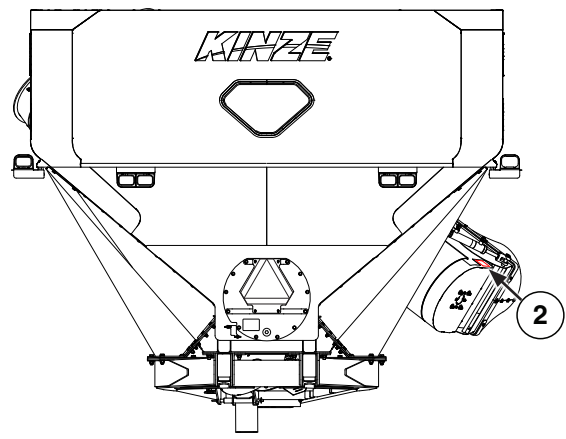
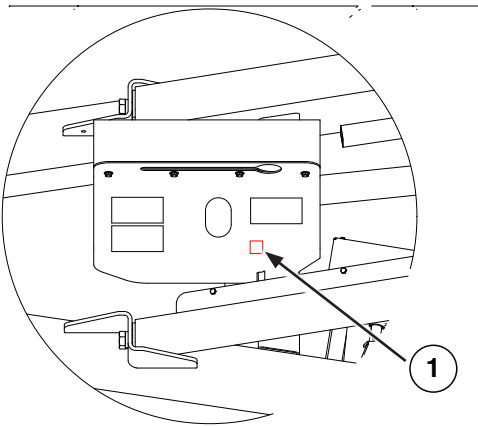

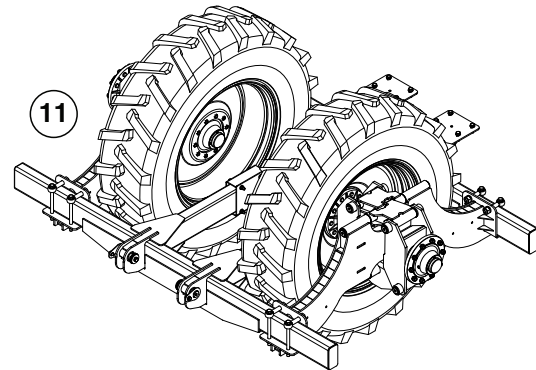
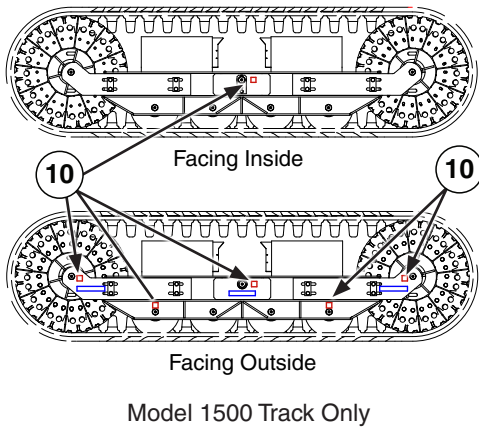

NOTE: For 1105/1205/1305 Track Models, proceed to page 3-10 for Lubrication Information.

1. Intermediate Drive Line - 1 Zerk



2. Vertical Auger Upper Bearing - 1 Zerk

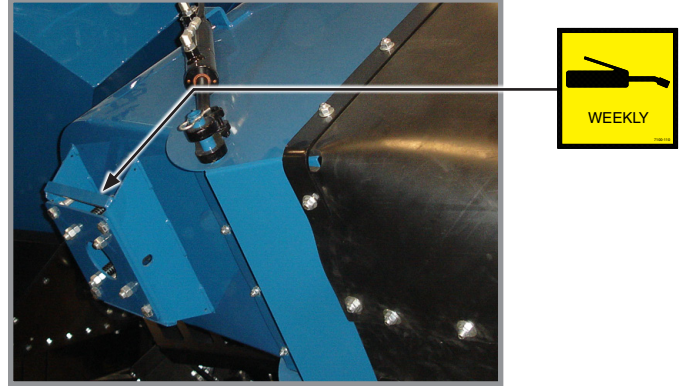

3. Cam Rollers - 1 Zerk

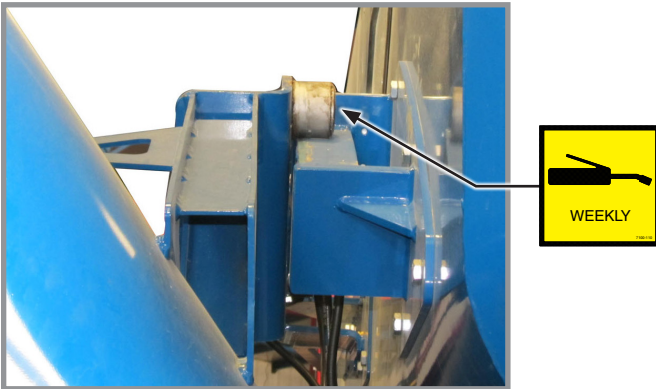

4. Vertical Auger Center Bearing - 1 Zerk



5. Grease Bank - 1 Zerk



6. Axle Mount - 4 Zerks

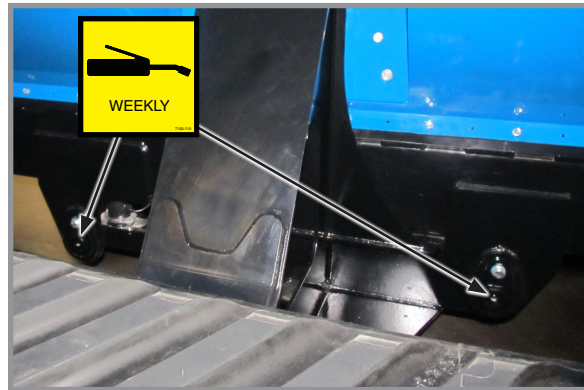

7. Bearing - 1 Zerk

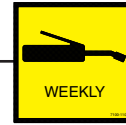
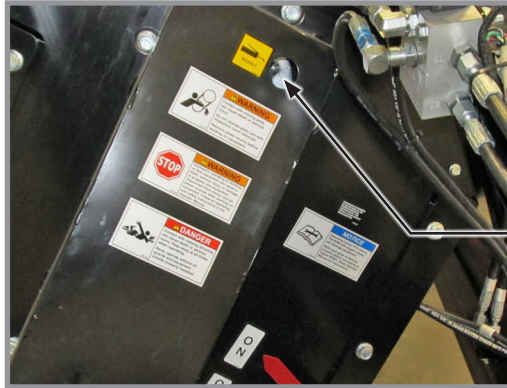

8. Fold Linkage And Hinge - 6 Zerks

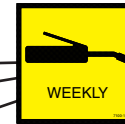
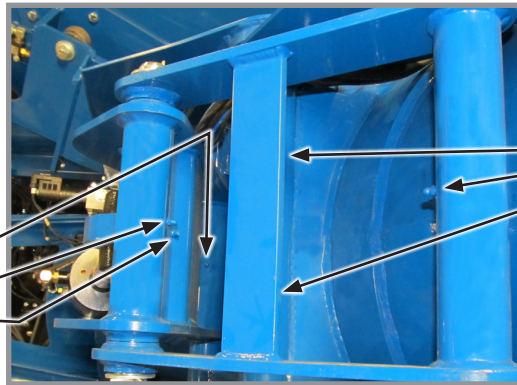

9. Inside Bearing - 1 Zerk

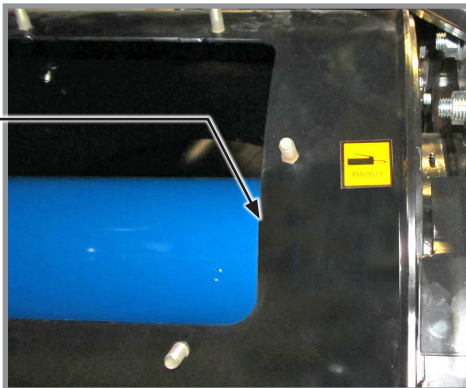

9. Rotate Bearing - 2 Zerks

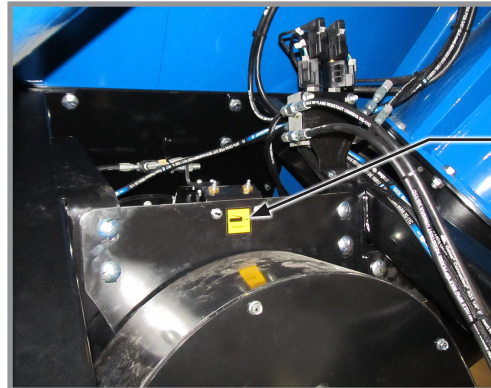

- 10. Model 1500 Track Only - Axle Pin - 1 Zerk Per Side
Spindle Bolt - 12 Zerks Per Assembly, 6 Zerks Per Side



* Pump grease into spindles until grease comes out around seal protector on axles and midwheels.

- 11. Row Crop Axle



TRACK SYSTEM MAINTENANCE

Every 50 Hours or Weekly

GREASE UPPER CARRIER HUBS, UNDERCARRIAGE AND TRACK SYSTEM PIVOT POINTS

Visually check oil in mid rollers through clear covers.

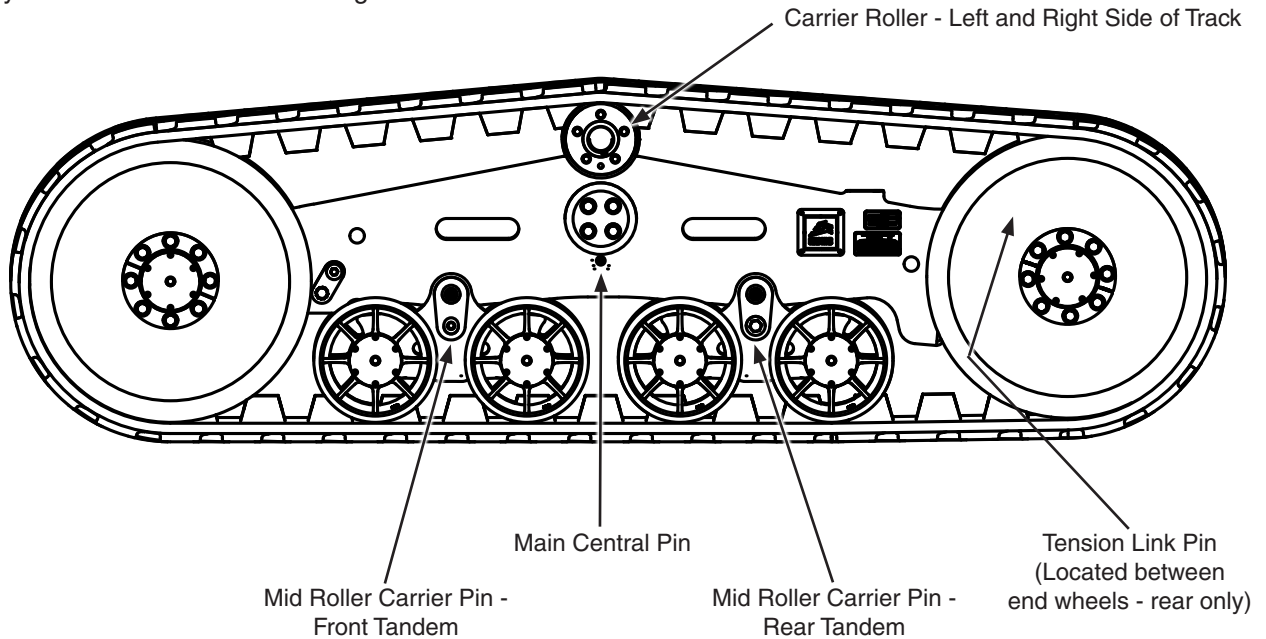

Every 100 Hours or Monthly

CHECK TRACK TENSION

System is self-tensioned via spring. Visually check track tension.

CHECK WHEEL BOLT TORQUE

NOTE: Always torque after wheel removal regardless of hours.



Wheel Bolt Torque Chart		
Size	Torque (N-m)	Torque (ft-lb)
M20	620 +/- 124	457 +/- 91

Every 500 Hours or Yearly

REPACK CARRIER ROLLER WHEEL BEARINGS

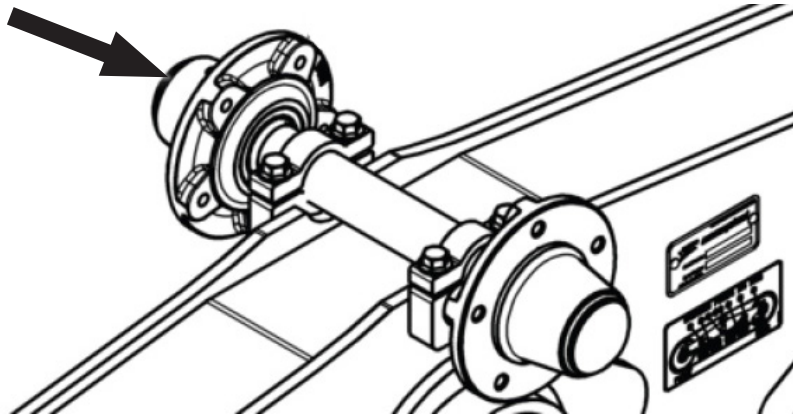

Bearing Lock Nut Torque Chart		
Size	Torque (N-m)	Torque (ft-lb)
N-06	10 +/- 2	7.4 +/- 1.5

NOTE: Torque lock nut while rotating or oscillating hub. If any lock nut slot and lock washer tang are aligned, bend the aligned tang into the slot to lock in place. If no slot or tang aligns, tighten the locknut until the most nearly aligned slot and tang line up. Bend the aligned tang into the slot to lock in place.

Every 2000 Hours or Every 5 Years

DRAIN AND REPLACE IDLER AND MIDROLLER RESERVOIRS

Use 10W30 Universal Transmission/Hydraulic Oil

	Torque		Oil Qty.	
	N-m	in-lb	ML	OZ
Mid Roller Clear Cover	4.5 ± 1	40 ± 9	290 ± 15	9.8 ± 0.5
Mid Roller Plastic Fill Plug	3 ± 1	27 ± 9		
Idler Metal Cover	15 ± 3	132 ± 27	500 ± 25	17 ± 1
Idler Metal Fill Plug	34 ± 7	300 ± 62		



Off Season Storage

For optimum life, tracks should be stored indoors, in dry environment with a temperature between 40° - 77° (5° - 25° C). The tracks should not be exposed to direct sunlight or heat. No petrochemicals and related vapors, no electrical devices producing ozone should be placed in the same area.

Should it be necessary to disassemble the tracks from the undercarriage, lay them on the ground on one edge avoiding bending radius less than 30" (750 mm). Do not lay the rubber components on dirty surfaces contaminated by oil, grease or other chemical products

Do not paint rubber components.

CHECK TRACK ALIGNMENT - 1105/1205/1305 ONLY

1. Prior to checking track alignment the implement should be empty.

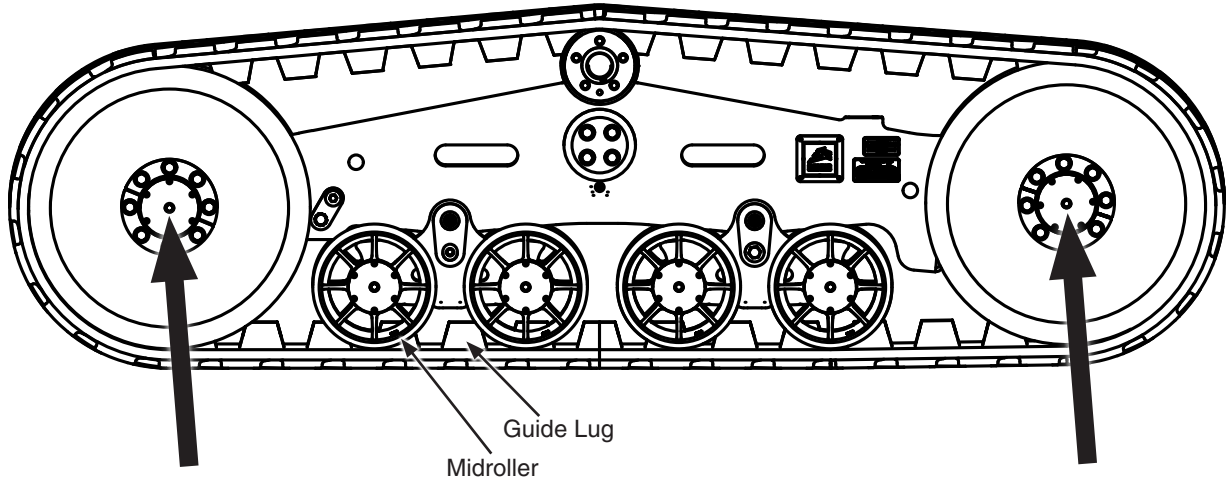

2. Measure the inside distance left to right. Undercarriage toe must be parallel to within $\frac{1}{4}$ " (6mm). A suitable location for measurement is noted by arrows, shown on the diagram above, between the idler hub covers.
3. Pull the implement on a flat surface for a suitable time frame, allowing the belts to relax and move freely on the undercarriage rollers.
4. Drive in a straight line for roughly 200 feet and coast the tractor to a stop. Place the tractor in PARK and apply the emergency brake. Do not apply braking action during this process as sudden stops can affect track position during the alignment process.
5. Using a $\frac{1}{4}$ " x 4" x 8" shim slide between the front midroller and guide lugs. Bridge guide lugs with the shim maintaining pressure on 2 lugs minimum.
6. If the shim fits freely between the lugs and midroller on both sides of the undercarriage the alignment is correct. If the shim binds and does not fit between the midrollers/guide lugs track adjustment is necessary.

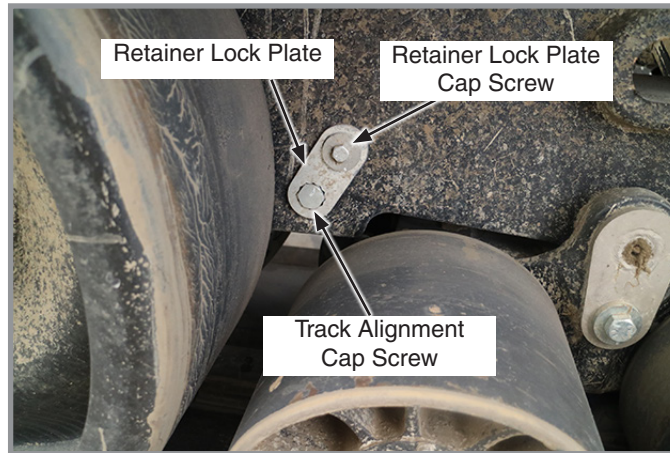
TRACK ALIGNMENT PROCEDURE - 1105/1205/1305 ONLY

1. Remove the retainer lock plate cap screw and lock plate from the inboard and outboard sides of the track needing adjustment.
2. Loosen track alignment cap screw counterclockwise 1 - 1½ turns on the side of the undercarriage you want the track to move towards.
3. Tighten the track alignment cap screw on the opposite side to specification. (Cap screw torque is (221 ft-lb) 300 N-m. Tighten cap screw loosened in step 2 to the same specification.

NOTE: A single full turn is the standard increment during adjustment. Lessen this amount as final adjustment is approached.

4. Recheck track alignment and adjust until suitable clearance is obtained on both sides of the guide lugs.

NOTE: Lock plates are reversible for double the index increments. If needed, increase torque on the special cap screw slightly allowing advancement to a suitable lock plate position.

5. When alignment is complete, reinstall the lock plates and tighten cap screws to their required torque specification of (95 ft-lb) 130 N-m).

TRACK SYSTEM INSPECTION - ALL TRACK MODELS

Track System

Inspect track system for material build-up on frames and wheels. Clean material from undercarriage.

Idlers and Midrollers

Check the general condition of the idlers and midrollers, making sure material buildup is not occurring. If any material buildup is found, it must be removed or track damage may result.

Rubber Track Guide Lugs

Guide lugs keep the track on the track system. Proper alignment of the track is essential to improving overall life and decreasing operating costs. If track is misaligned or operating on side slope, guide lug wear or damage may occur. Also guide lug damage may occur if proper break-in procedures are not followed or system is operated outside the maximum speed recommendations listed in this manual. Monitoring guide lugs condition will alert the operator to an issue and generally if corrected early prior to loss of performance or durability.

Track Carcass

Inspect track surface to remove imbedded stones or debris. This contamination can work its way into the track and damage the steel cable.

Steel wire may come out from the track carcass without affecting the performance of the track. Remove loose wires by cutting them at the rubber surface.

Track Tread

Muddy soils usually cause limited wear, while roading long distances can bring about accelerated tread wear. Due to the crown of the road, and deflection in the system, the tread closest to the machine will tend to wear faster than the tread on the outer portion of the track. Adhere to speed and weight limitations. Refer to “Track Transport Speeds - ALL Track Models” on page 2-17.

Adjusting Track Tension - 1105/1205/1305 Only

Tension is pre-set at the factory and requires no adjustment during operation. Provision is made to detension the track system allowing for removal of the rubber track.

TRACK REMOVAL - 1105//1305 ONLY

IMPORTANT: A detensioning kit (PN A24944) is required for track removal and available from Kinze. Contact your Kinze dealer.

NOTE: A Porta Power is also required for track removal. Kinze recommends Blackhawk 10 Ton Porta Power Model B65115.



1. Remove plugs on rear track frame.



2. Attach a cylinder end cap to each end of the Porta Power.

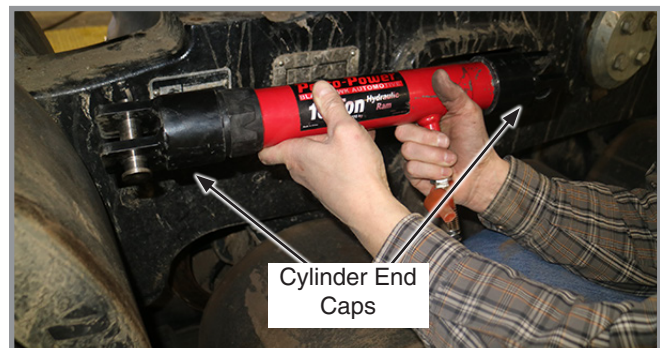

TRACK REMOVAL - 1105/1205/1305 ONLY (CONTINUED)

3. Install one end of Porta Power on existing hook located between rear idlers.



4. Place detensioning mount where plugs were removed in step 1. Install other end of Porta Power on mount and secure with two M16 bolts.



NOTE: Ensure Porta Power hose is positioned as shown to avoid interference when removing idler wheel.

5. Pump the Porta Power until the tensioning spring is fully compressed.

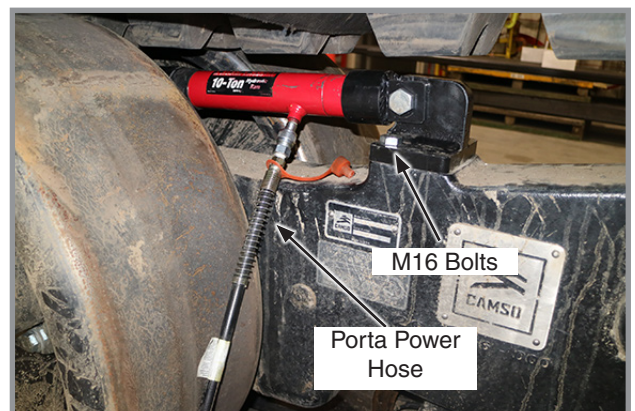

TRACK REMOVAL - 1105/1205/1305 ONLY (CONTINUED)

6. Remove the rear M20 idler wheel bolts and torque plate castings. Remove idler wheel.

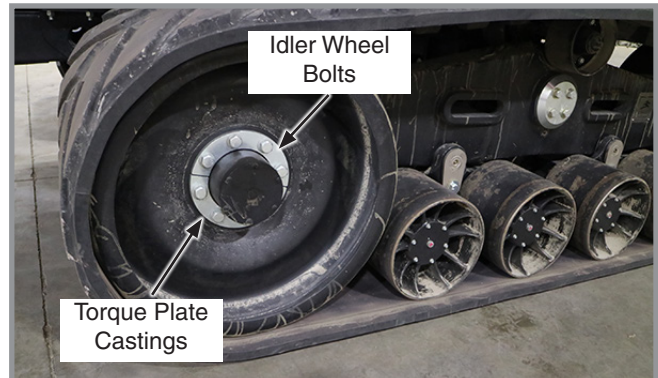

7. Install cylinder lock plate on Porta Power cylinder. Install locking pin in cylinder lock plate.

**WARNING**

Idler wheels weigh 200 lbs (90 kg) and will roll easily on a firm surface. Place a block under removed wheels to prevent rolling and potential injury.

8. Utilizing existing fork lift pockets or properly rated jack and safety stands, raise the undercarriage until there is sufficient clearance between the midwheels and track guide lugs.

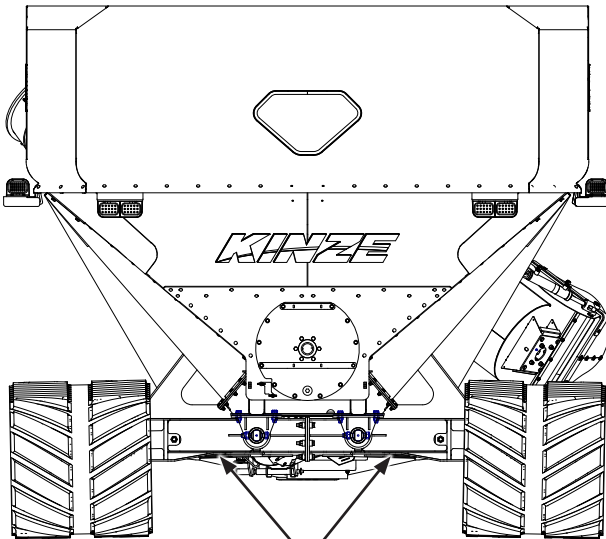

TRACK REMOVAL (CONTINUED)

9. Using a suitable lifting device, lift the track belt slightly to provide clearance between the carrier and track guide lugs.

NOTE: If using a forklift or other steel lifting device, ensure the tines or lifting surface does not have sharp edges or track damage may occur.

10. Lift the track up and away from the undercarriage, placing in a suitable location. Place track on its side.

TRACK INSTALLATION - 1105/1205/1305 ONLY

1. Raise the undercarriage to allow for the lower surface of the belt to slide underneath.
2. Lift the track and install on the top carrier rollers. Push the bottom of the track under the midrollers aligning with the front and rear idlers.
3. Install the idler wheels removed previously, ensuring the guide lugs are positioned properly between the midrollers and idlers. Torque M20 bolts on idler wheels to 457 ft-lb (620 N-m).
4. Lower the undercarriage assembly to the ground.
5. Remove lock from Porta Power cylinder.
6. Release pressure from Porta Power and remove.

MOUNTING BOLTS AND HARDWARE



WARNING



Parts separation can result in death, serious injury, and damage to property and equipment. Check all hardware is tight before operating the grain cart the first time. Check all hardware again after first 50 hours of operation and beginning of each season. Check wheel nuts daily during first use and weekly afterward.

NOTICE

Over-tightening hardware can reduce its shock load capacity and cause equipment failure.

Hardware used on Kinze grain carts are Grade 5 (high strength) unless otherwise noted. Grade 5 cap screws are marked with three radial lines on the head. Hardware must be replaced with equal size, strength, and thread type.

TORQUE VALUES CHART - PLATED HARDWARE

Diameter	Grade 2 (No marks) 				Grade 5 (3 marks) 				Grade 8 (6 marks) 			
	Coarse		Fine		Coarse		Fine		Coarse		Fine	
	ft-lb	N-m	ft-lb	N-m	ft-lb	N-m	ft-lb	N-m	ft-lb	N-m	ft-lb	N-m
1/4"	50 in-lb	5	56 in-lb	6	76 in-lb	8	87 in-lb	9	9	12	10	13
5/16"	8	10	9	12	13	17	14	19	18	24	20	27
3/8"	15	20	17	23	23	31	26	35	33	44	37	50
7/16"	25	33	27	36	37	50	41	55	52	70	58	78
1/2"	35	47	40	54	57	77	64	86	80	108	90	122
9/16"	50	67	60	81	80	108	90	122	115	156	130	176
5/8"	70	95	80	108	110	149	125	169	160	217	180	244
3/4"	130	176	145	196	200	271	220	298	280	379	315	427
7/8"	125	169	140	189	320	433	350	474	450	610	500	678
1"	190	257	205	278	480	650	530	718	675	915	750	1016
1 1/8"	265	359	300	406	600	813	670	908	960	1301	1075	1457
1 1/4"	375	508	415	562	840	1138	930	1261	1360	1844	1500	2033
1 3/8"	490	664	560	759	1100	1491	1250	1694	1780	2413	2030	2752
1 1/2"	650	881	730	989	1450	1966	1650	2237	2307	3127	2670	3620

NOTE: Torque unplated hardware and bolts with lock nuts approximately 1/3 higher than above values. Torque bolts lubricated before installation to 70% of value shown in chart.

SPECIAL TORQUE VALUES

Wheel nuts	350 ft-lb (474 N-m)
------------	---------------------

Cylinder Rod Piston Retaining Nut Torque Chart

	Non-Nylock Nut	Nylock Nut
1/2"-20	55-70 ft-lb (75-95 N-m)	45-55 ft-lb (61-75 N-m)
3/4"-16	115-125 ft-lb (156-169 N-m)	100-115 ft-lb (136-156 N-m)
7/8"-14	150-180 ft-lb (203-244 N-m)	130-150 ft-lb (176-203 N-m)
1"-14	275-330 ft-lb (373-447 N-m)	250-275 ft-lb (339-373 ft-lb)
1 1/8"-12	300-375 ft-lb (407-508 N-m)	275-300 ft-lb (373-407 N-m)
1 1/4"-12	300-375 ft-lb (407-508 N-m)	275-300 ft-lb (373-407 N-m)

 **DANGER**

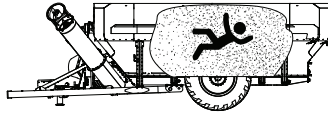

Grain entrapment will result in death or serious injury. Never enter grain cart unless completely empty. Always use safety lines and have another person present when working on grain carts.

 **DANGER**

Falling grain auger cart can crush and will cause death or serious injury. Never work around or under cart when raised without installing blocks to support cart. Use care when removing and installing components to prevent pulling or pushing cart off axles.

WARNING



Contacting rotating auger will cause death or serious injury. Never open or close dump door with auger operating.

Remove power source before working on equipment.

 **WARNING**



Pressurized hydraulic fluid can penetrate body tissue and result in death, serious infection, or other injuries. Fluid injected under skin must be IMMEDIATELY removed by a surgeon familiar with this type of injury. Make sure connections are tight and hoses and fittings are not damaged before applying system pressure. Leaks can be invisible. Keep away from suspected leaks. Relieve pressure before searching for leaks or performing any system maintenance.

VERTICAL AUGER COUNTER BALANCE VALVES

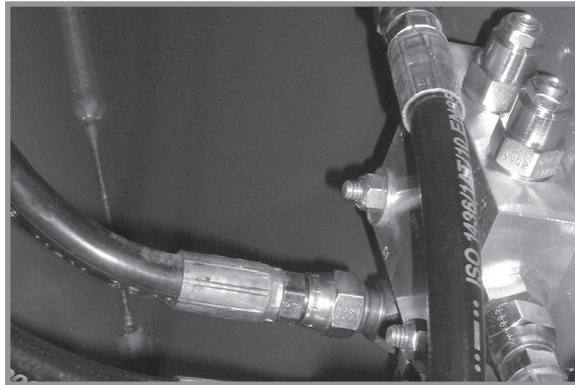

Counter balance valves prevent auger fold cylinder from extending or retracting without applied hydraulic pressure. If valve(s) fail to lock auger in position or fail to function properly, remove valve(s) from valve block and check for foreign material. Replace valve if defective.

WHEEL NUTS



10 Bolt Hub Shown

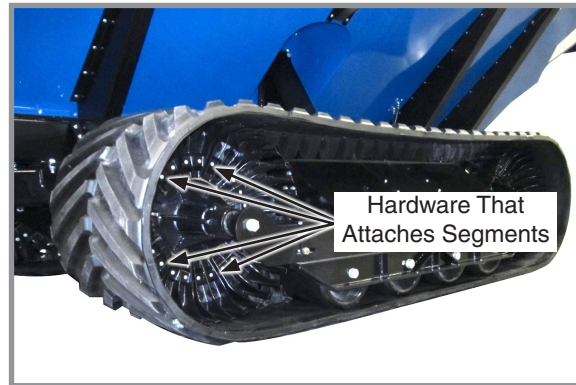

Soft Track Assembly

Wheels are attached to hubs with ten press fit studs through hub flanges and wheel nuts. Clean threads with a wire brush and oil lightly to retard corrosion when removing and installing wheels.

Torque wheel nuts to 350 ft. lbs. and retorque daily during first 3 days of use and weekly thereafter.

NOTE: Model 1500 Only: Torque hardware which attaches the segments to hubs to 220 ft. lbs.

NOTE: Models 1105/1205/1305 Only: Retorque all track system idler and midroller bolts daily during first 3 days of use and monthly thereafter. Torque bolts to 457 ft-lbs (620 N-m).

TIRE SERVICING

WARNING

Explosive separation of rim and tire parts can cause death or serious injury. Overinflation, rim and tire servicing, improper use of rims and tires, or worn or improperly maintained tires could result in a tire explosion.



To prevent tire explosions:

- Maintain proper tire pressure. Inflating a tire above or below the recommended pressure can cause tire damage.
- Mount tires only by properly trained personnel using proper equipment.
- Replace tires with cuts or bubbles. Replace damaged rims. Replace missing lug bolts and nuts.
- Do not weld or heat wheel assembly. Heating increases tire pressure.

INFLATION SPECIFICATIONS

WARNING

Over-inflation of tires can result in explosive separation of rim and tire and cause death or serious injury. Different size rims are designed for different tire pressures. Inflate to correct pressure for specific rim size.



Check tire pressure before each use.

1250/50R32 189 A8 (1105/1205/1305 Flotation Cart) 46 PSI (320 kPa)

520/85 R42 169B (1105/1305 Row Crop Cart) 35 PSI (241 kPa)

V-BELT TENSION ADJUSTMENT AND ALIGNMENT

**WARNING**

Never operate cart when inspection cover is removed, or work around belt drive system or allow anyone else to do so while PTO is running or death or serious injury may result.

NOTICE

Do not use belt dressing V-belts. Keep all oil and grease off V-belts and multi-groove pulleys. Low belt tension will reduce belt life.

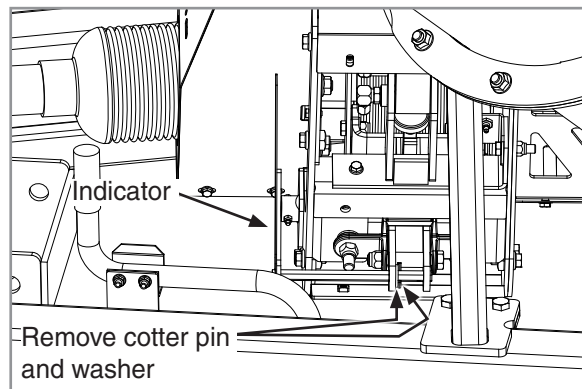
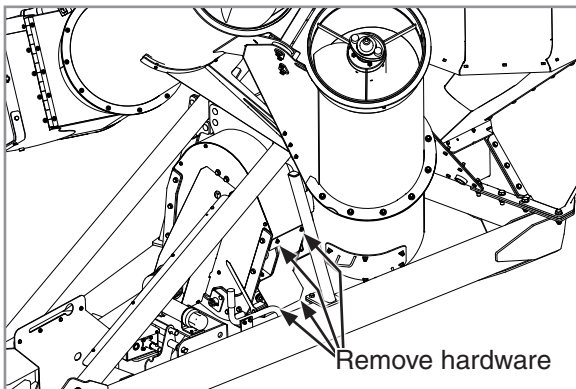

1. Remove cover and indicator.

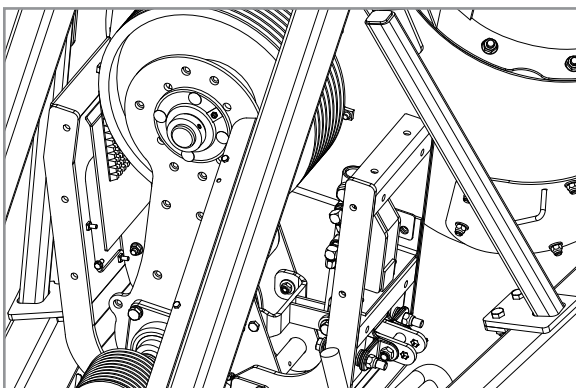
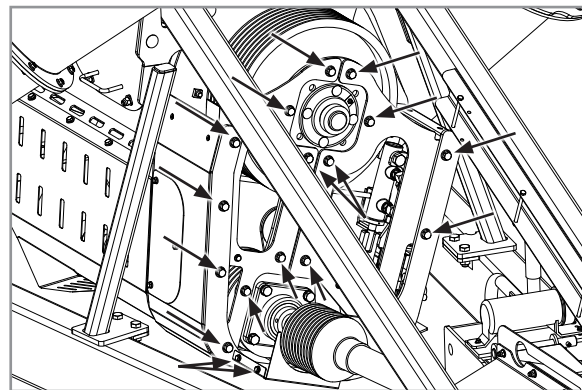
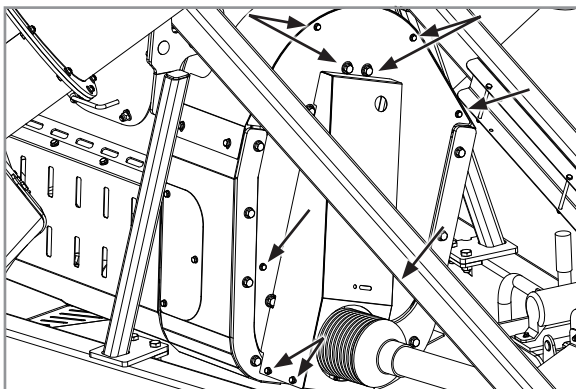

Shown with covers removed.

2. Remove covers.

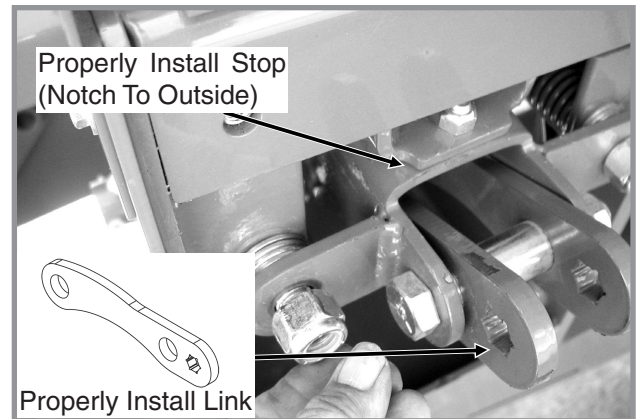
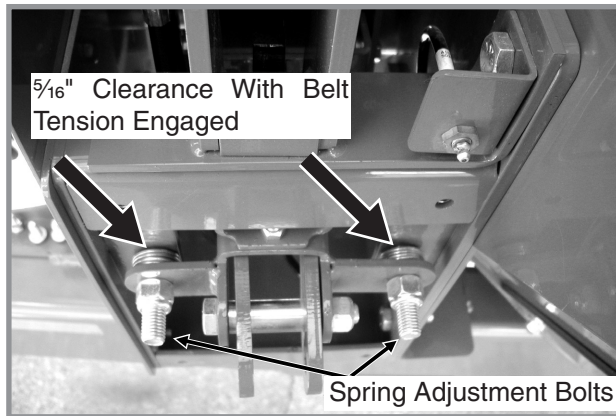

3. Inspect all linkages to make sure all components have been installed correctly and are moving freely.
4. Hydraulically engage the belt tensioner.
5. Check for free space (clearance) on the spring adjustment bolts between washers and mount.

There should be approximately $\frac{5}{16}$ "- $\frac{1}{2}$ " (or the thickness of two-four washers) of clearance. Remove washers as required.

6. To remove washers, proceed as follows:
 - (a) Hydraulically disengage belt tension.
 - (b) Remove the $\frac{5}{8}$ " locking nuts and remove the spring adjustment bolts far enough to remove the required number of washers.
 - (c) Reinstall washers to head side of the bolt (d) Reinstall locking nut and tighten until nut "bottoms out" on the spring adjustment bolts.
7. After inspection and adjustments have been completed, reinstall side cover, indicator and cover.

V-belts are tensioned by a spring-loaded idler. Two springs are used to maintain even pressure across the V-belts. Set spring tension at $2\frac{3}{4}$ " as shown at right.

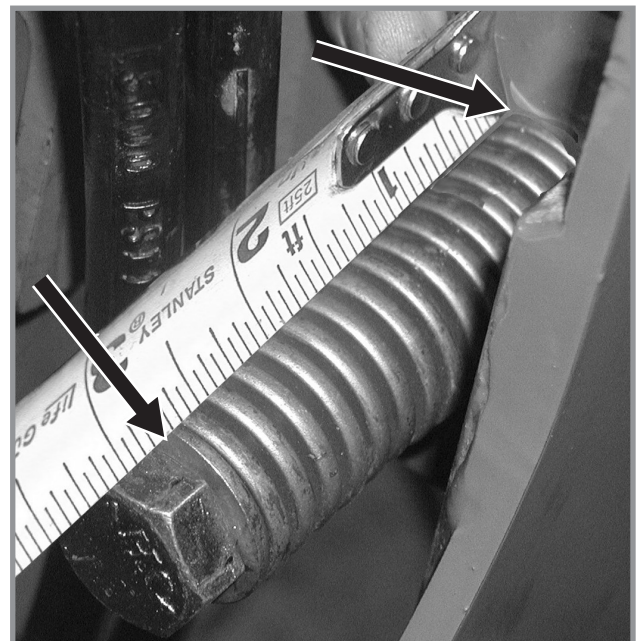

8. Collapse belt tension springs by tightening nylon lock nuts.

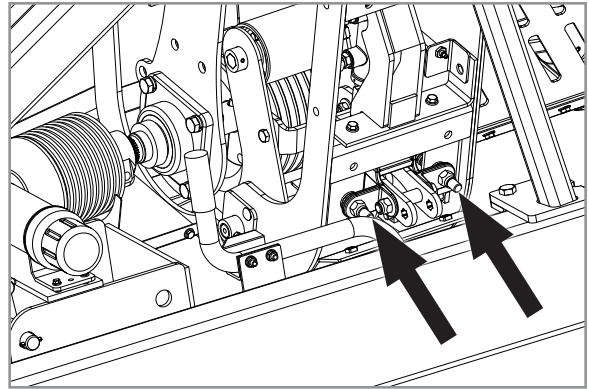

9. Remove two bolts which secure idler assembly to tower auger housing. Slide idler assembly to the side for clearance to remove belt from lower pulley.

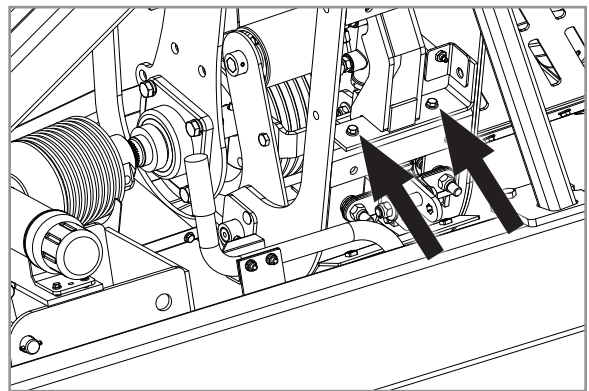

10. Remove belts and install new belts.

NOTE: Replace V-belts as a matched pair.

11. Reinstall idler assembly.

12. Release belt engagement by loosening nylon lock nuts.

13. Adjust belt slide to within $\frac{1}{8}$ " of belts when tight.

NOTE: Slide must not contact belts during operation.

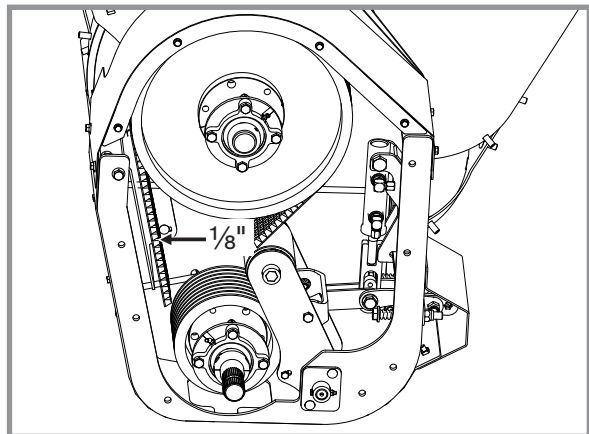

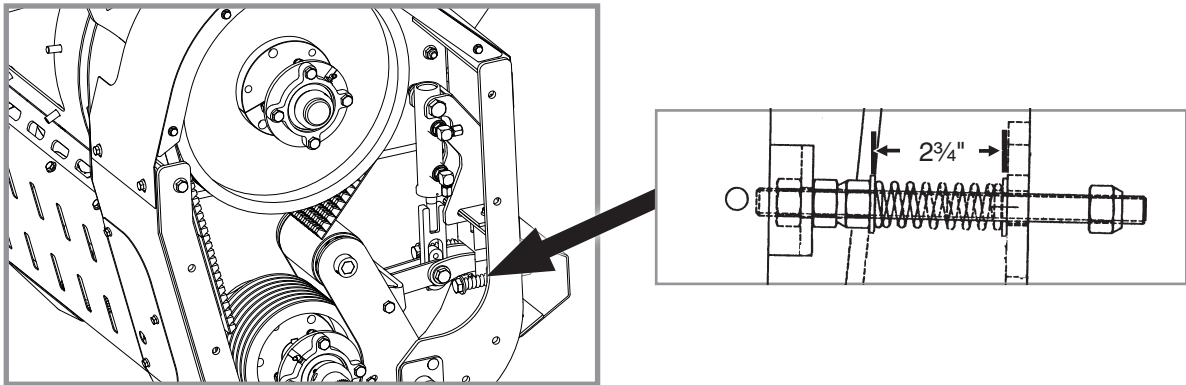

14. Check and adjust belt tension.

NOTE: Do not use belt dressing on V-belts. Keep all oil and grease off V-belts and belt pulleys. Drive and driven sheaves (pulleys) do not need to be loosened to remove/replace V-belts. Low belt tension will reduce V-belt life.

15. Install all covers removed in previous steps **before operating cart**. Cycle hydraulic cylinder engaged in STEP 6, between extended and retracted positions to check proper engagement/disengagement of belt tension idler.

V-BELT ALIGNMENT

Lay Straight Edge Across Face Of
Drive And Driven Belt Pulleys

Pulleys must be aligned with the fixed idler position.
Clearance of $2\frac{2}{3}$ " must be maintained between rear of belt pulleys and idler.

1. Tighten taper-lock bushing hardware.
2. Lay a straight edge across face of the drive and driven belt pulleys to ensure alignment between the grooves on the belts and pulleys and between the idler.

NOTE: Pulleys do not need to be loosened to remove/replace V-belts.

NOTE: V-belts should be replaced as a matched pair. See "V-Belt Replacement".

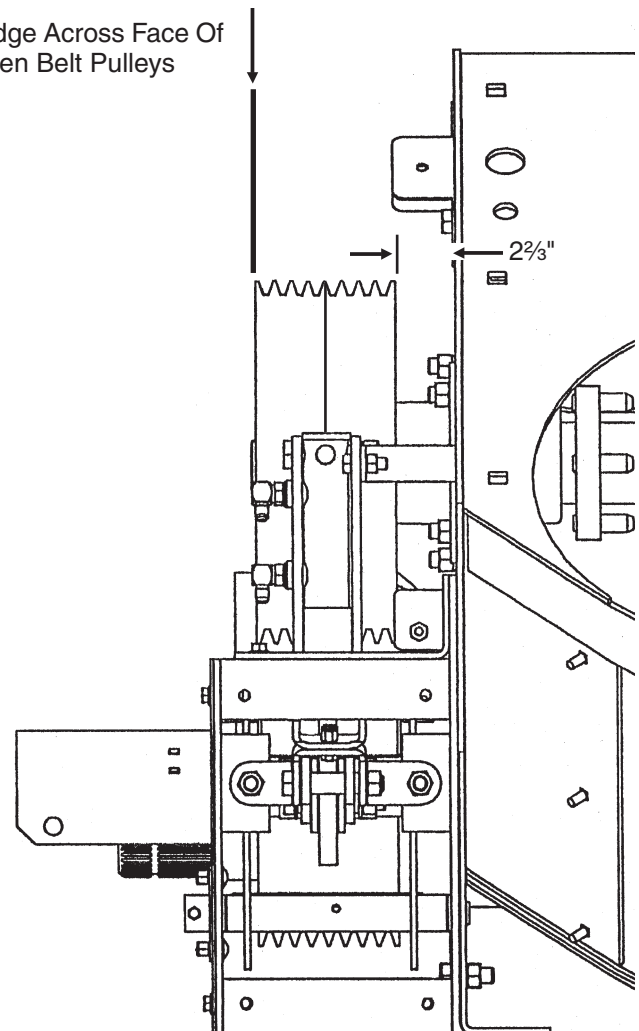

V-BELT REPLACEMENT

NOTE: Drive and driven sheaves (pulleys) do not need to be loosened to remove/replace belts.

NOTE: Cart must be attached to a tractor to use hydraulic system in later steps.

1. Disconnect PTO shaft from tractor.

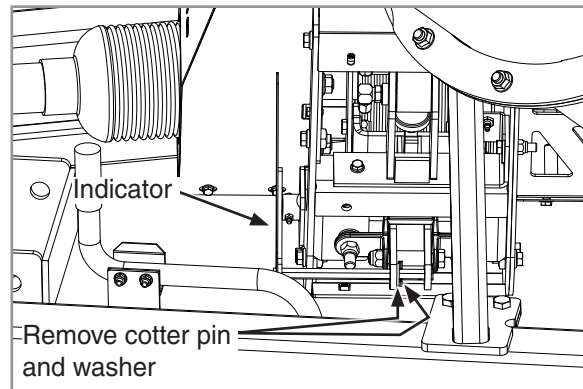
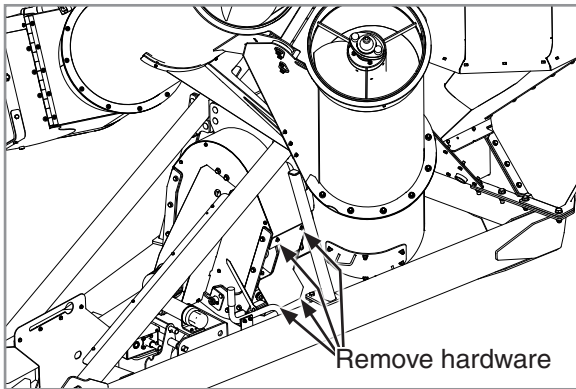

2. Remove cover and indicator.

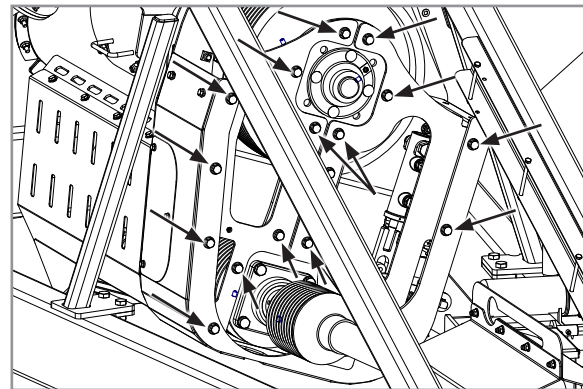
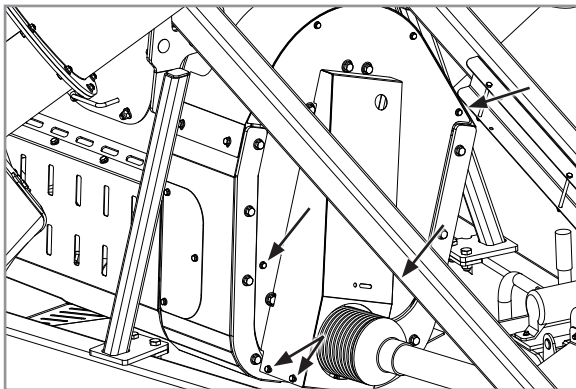

3. Remove additional covers.

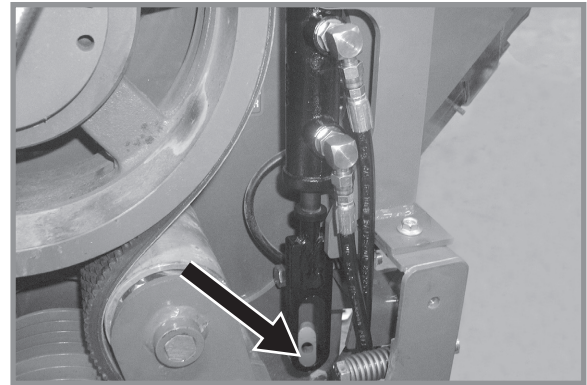
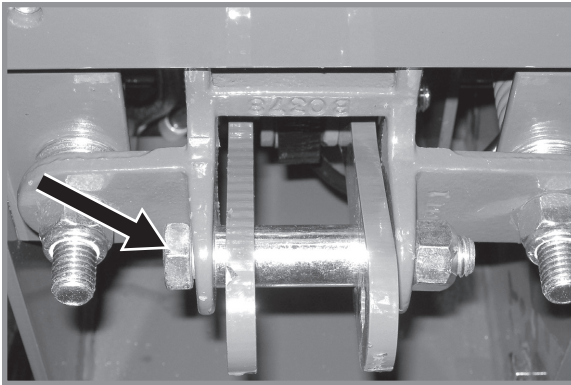

4. Remove linkage bolt.
5. Push idler assembly away from belt.

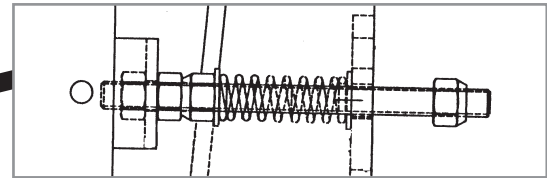

6. Check and adjust spring dimension. See "V-Belt Tension Adjustment And Alignment"

NOTE: Replace V-belts as a matched pair.

7. Remove belts and install new belts.

NOTICE	<p>Slide must not contact belts during operation. Do not use belt dressing on V-belts. Keep all oil and grease off V-belts and belt pulleys. Low belt tension will reduce V-belt life.</p>
--------	--

8. Reinstall linkage.
9. Adjust belt slide to within 1/8" of belts when tight.
10. Install all remaining parts removed in previous steps in reverse order before operating cart.

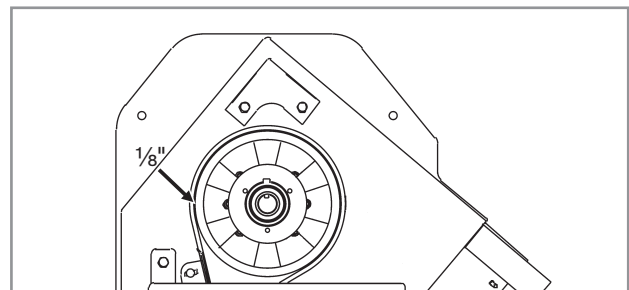

DRIVELINE INSPECTION

Inspect driveline **after first 20 loads, at beginning of each season, and after every 150 loads or annually thereafter.**

Remove inspection cover and proceed as follows:

- Make a general inspection of driveline looking for loose hardware.
- Inspect belt alignment and tension. See “V-Belt Tension Adjustment And Alignment” in the Maintenance section of this manual.
- Inspect the three cap screws in each belt pulley bushing and tighten evenly to torque specifications.
- Inspect pulley drive keys making sure they are properly located and tight.
- Inspect all grease hoses for damage and proper routing.
- Lubricate all grease fittings. See Lubrication section of this manual.
- Check gearbox oil level.
- Inspect bearings and seals in gearbox.
- Inspect PTO attaching hardware and safety shields.
- Repair or replace worn or damaged parts.

UPPER VERTICAL AUGER REPLACEMENT

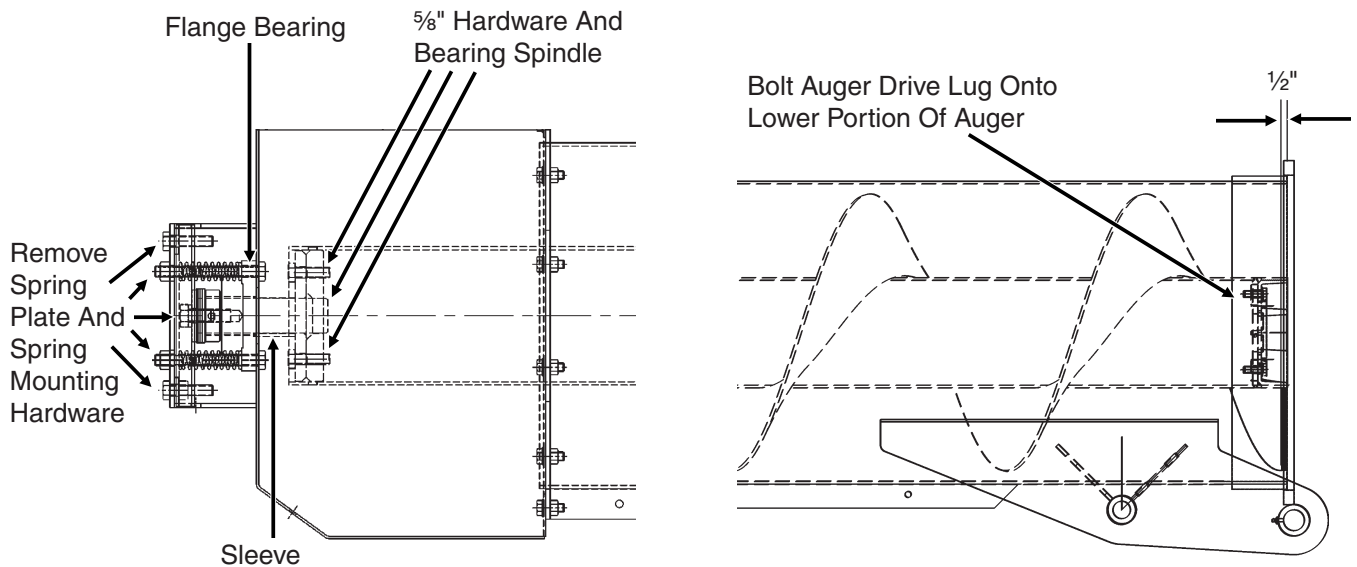

1. Position the vertical auger in a horizontal position as illustrated.
2. Remove $\frac{3}{4}$ " hardware from center of bearing, $\frac{5}{8}$ " spring plate hardware and $\frac{5}{8}$ " spring mounting hardware.
3. Remove spring plate, flange bearing and sleeve.
4. Pull auger out of the bottom of the auger housing.
5. Remove $\frac{5}{8}$ " hardware securing bearing spindle and remove bearing spindle.
6. Install bearing spindle onto replacement auger. Install replacement auger inside auger housing. Locate auger with $\frac{1}{2}$ " (See Illustration) between bottom of hinge plate and end of auger assembly.
7. Reinstall sleeve, flange bearing and spring plate.

LOWER VERTICAL AUGER REPLACEMENT

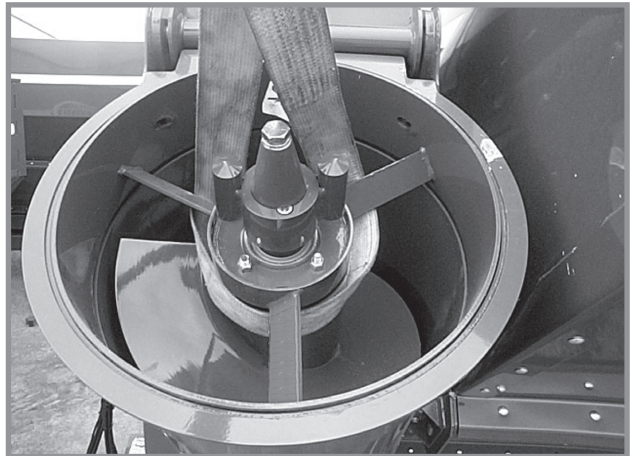
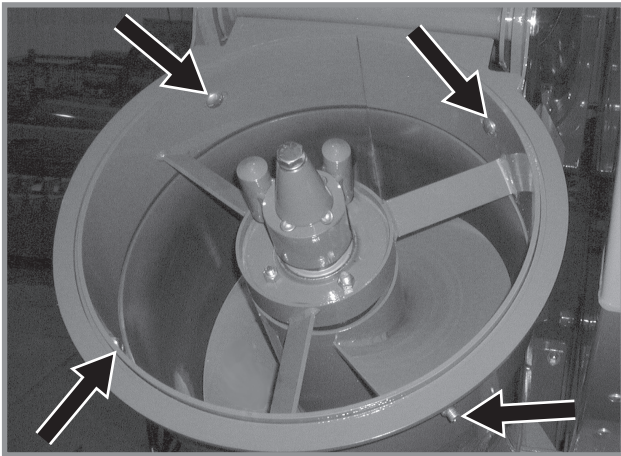

1. Position vertical auger in the storage/transport folded position as shown.
2. Remove four $\frac{1}{2}$ " x $1\frac{1}{2}$ " hanger bearing bracket carriage bolts at upper end of lower vertical auger. Carefully work hanger bearing bracket loose from auger housing.

NOTE: Do not bend hanger bearing bracket when moving auger.

1. Position strap around auger as shown above. Be sure strap is tight against auger center tube. Pull auger and hanger bearing assembly out of auger housing.
2. Remove $\frac{3}{4}$ " x 5" cap screw at top of lower vertical auger and remove hanger bearing bracket components from auger.

3. Remove four $\frac{5}{8}$ " x 2" cap screws that attach bullet spindle to top of lower vertical auger.

4. Install bullet spindle onto top of replacement auger aligning $\frac{3}{8}$ " hole in auger with $\frac{3}{8}$ " hole in bullet spindle.

5. Position hanger bearing bracket components onto top of replacement auger. Torque $\frac{3}{4}$ " x 5" cap screw at top of lower auger to 200 ft. lbs.

6. Lower replacement auger into lower auger housing and onto lower drive lugs.

7. Position hanger bearing bracket with the split in the bracket in "up" position. Install four hanger bearing carriage bolts and nuts and tighten.

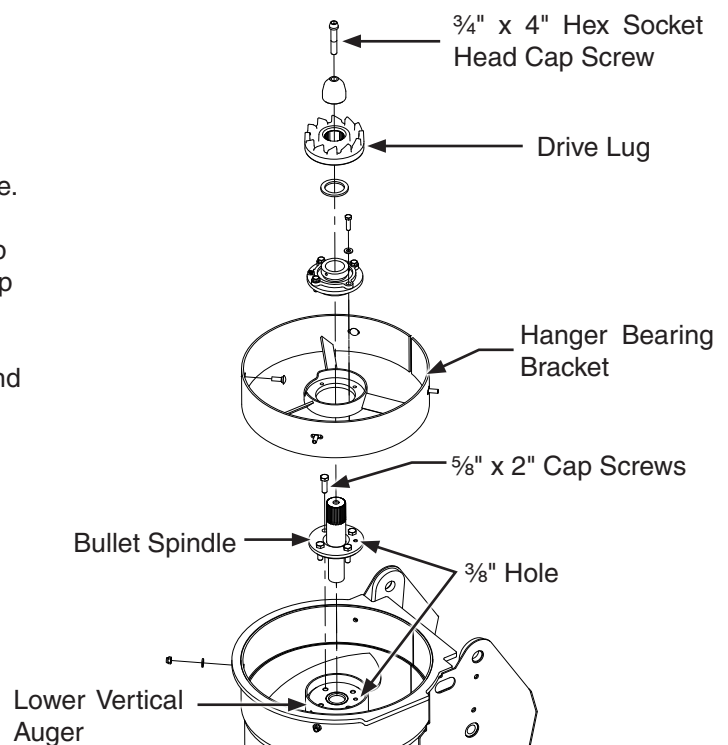

HORIZONTAL AUGER REPLACEMENT

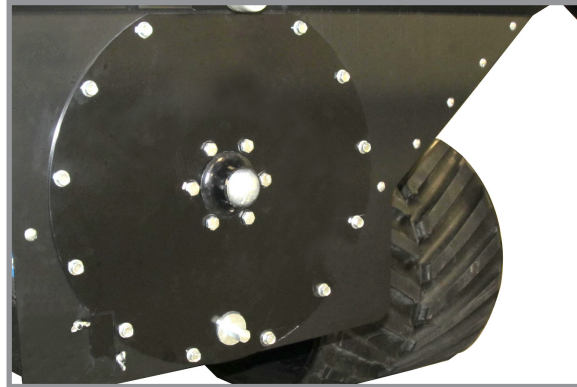

Rear Inspection Cover

1. Remove 12 cap screws and lock nuts from rear inspection cover. Remove inspection cover and bearing hub assembly.
2. Pull horizontal auger through opening at rear of cart.
3. Install replacement horizontal auger with full pitch portion of auger to front and half pitch portion of auger to rear of cart.
4. Auger pilot plate on front of auger has one 3 $\frac{3}{8}$ " pilot hole and four $\frac{3}{4}$ " drive pin holes. Auger pilot plate at rear of cart has one 3 $\frac{3}{8}$ " pilot hole and four $\frac{3}{4}$ " drive pin holes.
5. Check auger engages drive pins at front and rear. Check rear spindle, hub, and bearings for roughness or wear. Replace worn or damaged parts and readjust bearing preload if necessary. Assemble hub with spindle into rear inspection cover.
6. Reinstall inspection cover, making sure drive pins on rear bearing hub engage mating auger holes properly. Torque hardware to specifications.

GEARBOX

The gearbox is equipped with a relief fitting which acts as a breather. The upper hole on the gearbox is used to check oil level or to add oil. Oil level should be even with the plug hole. See "Gearbox Oil Level" in Lubrication section of this manual for oil specifications and capacities.

A drain hole is located on the opposite side (bottom) of the gearbox.

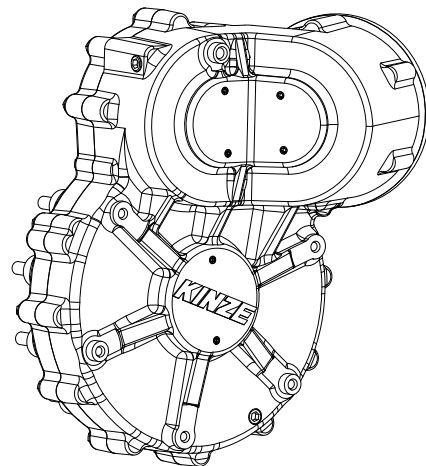

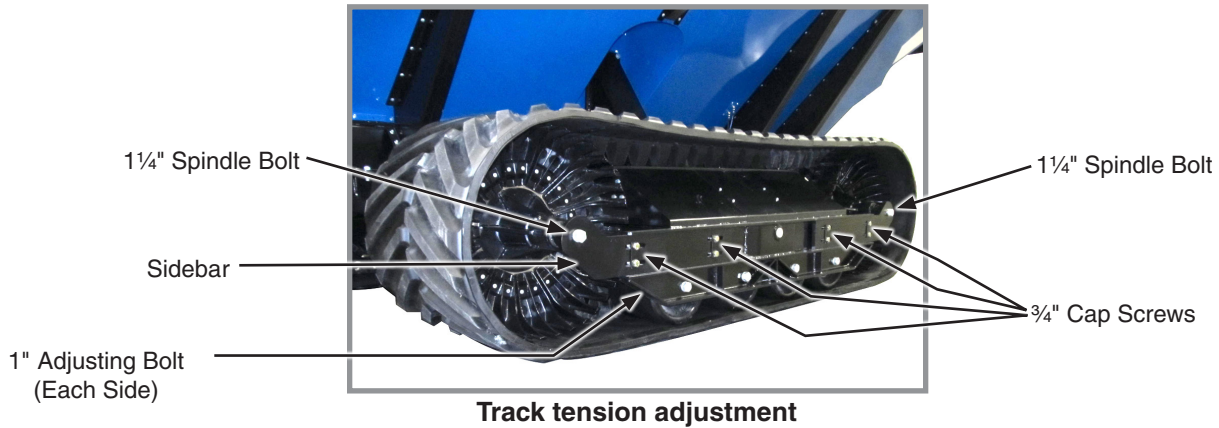
TRACK TENSION - MODEL 1500 ONLY

There should be approximately 2" sag in track at midpoint between front and rear end wheels.

1. Lay a straight edge across complete length of track. Measure distance between track and straight edge at midpoint.

NOTE: It is normal for centering lugs to lightly touch the bottom of channel at top center of track chassis.

2. Loosen four $\frac{3}{4}$ " attachment cap screws on inside sidebar and four $\frac{3}{4}$ " attachment cap screws on outside sidebar on one end (front or rear) of track assembly.
3. Turn 1" adjusting bolt on end of each sidebar in or out equal amounts according to adjustment needed.
4. Retighten four $\frac{3}{4}$ " cap screws on each sidebar.
5. Lay a straight edge across complete length of track. Measure distance between track and straight edge at midpoint and repeat steps as needed. It may be necessary to repeat procedure on opposite end of track assembly.
6. Torque hardware to 220 ft-lb (298 N-m).

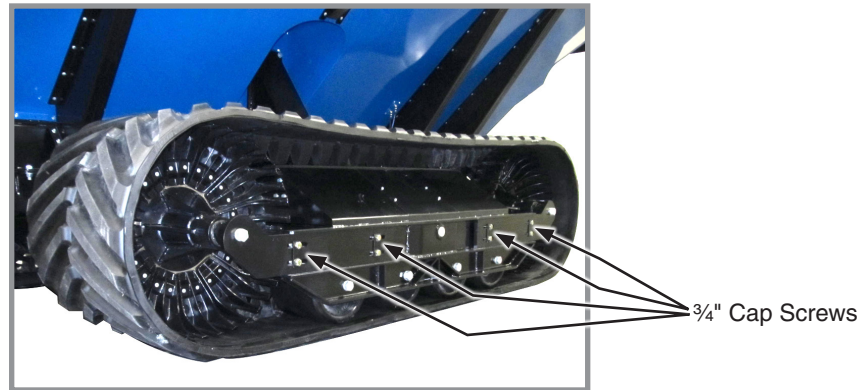
TRACK ALIGNMENT - MODEL 1500 ONLY

Track alignment

NOTICE

Check track alignment daily to prevent damage and ensure maximum track life.

Track centering lugs should run centered between end wheel segments as lugs enter end wheels when tracks are rotated. Misalignment may cause rubbing between track guide lugs and end wheel segments.

NOTE: Extending sidebar (turning 1" adjusting bolt clockwise) closest to end wheel showing evidence of misalignment or retracting sidebar (turning the 1" adjusting bolt counterclockwise) on end wheel on opposite side will move centering lugs away from end wheel.

1. Loosen four $\frac{3}{4}$ " attachment cap screws on each sidebar and extend or retract sidebar(s) until proper alignment is obtained.
2. Retighten four $\frac{3}{4}$ " cap screws on each sidebar.
3. Torque hardware to 220 ft-lb (298 N-m). Tighten inside and outside sidebars equally.

ROW CROP INSIDE TIRE REPAIR OR REMOVAL

Complete tire/axle assembly must be removed in order to repair or remove inside tire.

NOTICE: Cart must be fully unloaded before axle/tire removal.

1. Make sure cart is on level ground firm enough to support weight of cart when raised. Hitch cart to tractor to stabilize it.

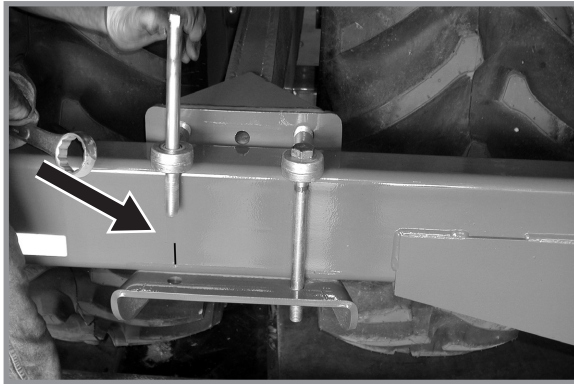

2. Place hydraulic jack under cart undercarriage/frame just ahead of tire/axle assembly. Mark position of axle front and rear. Remove eyebolts that secure tire assemblies to front and rear undercarriages.
3. Raise cart until weight is removed from assembly and there is enough clearance between axle assembly and undercarriage so tire/axle assembly can be raised slightly to remove.



4. Place blocking under cart at rear undercarriage/frame and lower jack until frame is supported by blocking. Place blocking to provide a wide base of support.



Falling cart can cause death or serious injury. Care must be taken to prevent pulling or pushing the cart off the support blocking while removing and installing the assembly. Never work around or under the cart with the tire/axle assembly removed.

5. Remove tire/axle assembly using a forklift or loader.

- Remove wheel nuts and remove tire from hub.

After tire repair is completed, reinstall tire/wheel onto hub. Lubricate wheel nut threads. Install and torque wheel nuts to 350 ft-lb (474 N-m). See "Wheel Nuts".

WARNING

Moving cart with outer wheel removed can cause death, serious injury, or damage to property and equipment. Tipping may occur because of narrow wheel base.

NOTE: Reinstalled tire with offset in rim to same side as previously installed.

- Reposition tire/axle assembly under cart at previously marked axle adjustment.
- Install eyebolts and cap screws.
- Torque 1½" eyebolts to 930 ft.-lb (1261 N-m) and 7/8" hardware to 350 ft-lb (474 N-m).

NOTE: Retorque wheel nuts:

- After 4 hours use.
- After 16 hours use.
- Weekly during season.

NOTE: Below illustrations viewed from rear of cart. Offsets in rims are exaggerated to show positioning.

RH050490(WGN17/WGN57)

30"

37½"

Dual wheel installation with offset in rims positioned outward for 30" row spacing.

Dual wheel installation with offset in rims positioned inward for wide row spacing.

TRACK ENDWHEEL/MIDWHEEL BEARING REPLACEMENT - MODEL 1500 ONLY

1. Position jack at axle and raise side of machine.
2. Mark position of inside and outside sidebars nearest end wheel being serviced.
3. Loosen four 3/4" cap screws and 1 1/4" spindle bolt on each sidebar.
4. Loosen 1" adjusting bolt on each sidebar.

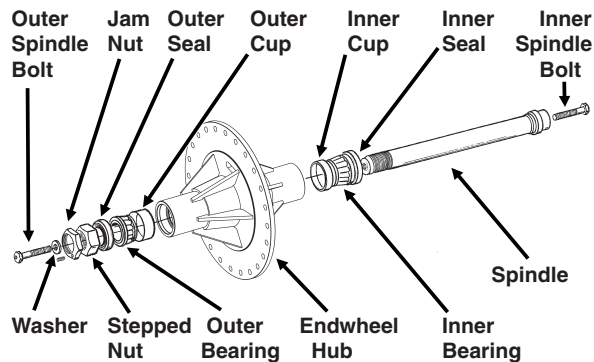
Endwheel Procedure:

Remove sidebars on side next to endwheel being serviced.

Remove wheel cap screws and special washers that secure nuts for front half of endwheel segments and remove segments.

Remove endwheel.

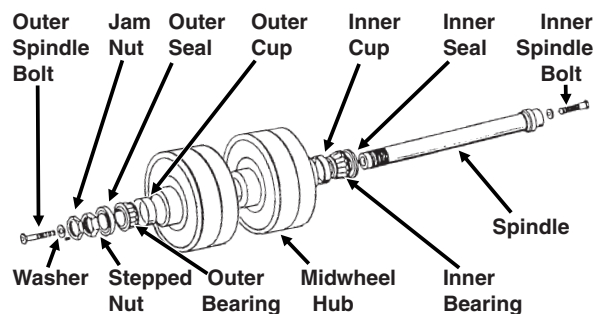
Midwheel Procedure:

Remove sidebars on side next to midwheel being serviced.

Remove endwheel (See endwheel procedure above) nearest midwheel being serviced.

NOTE: If there is a midwheel between endwheel and midwheel being serviced, it must also be removed.

Drop midwheel to clear track carriage and roll it to closest end of track for removal.

5. Remove double nuts and slide spindle from hub.
6. Remove bearings, seals and cups and discard. Clean and dry hub.
7. Press in new bearing cups with thickest edge facing in.
8. Pack bearings with heavy duty wheel bearing grease thoroughly forcing grease between roller cone and bearing cage. Fill space between bearing cups in hub with grease.
9. Place inner bearing in place and install seal.
10. Clean spindle and install in hub.
11. Install outer bearing, seal and stepped nut. Tighten stepped nut until there is some drag when the spindle is rotated. This assures that all bearing surfaces are in contact. Back off stepped nut $\frac{1}{4}$ turn or until there is only slight drag when rotating hub. Install jam nut to lock against stepped nut.

12. Endwheel Procedure:

After endwheel has been reinstalled and segment hardware torqued to 220 ft. lbs., reinstall sidebars. Extend sidebars to previously marked positions and tighten all hardware. Torque $\frac{3}{4}$ " cap screws to 220 ft. lbs. and $1\frac{1}{4}$ " spindle bolt to 1360 ft. lbs. Check track alignment and track tension. Adjust if necessary.

NOTE: Retorque endwheel segment, capscrew, and spindle bolt hardware as follows:

- a. After 4 hours use.
- b. After 16 hours use.
- c. Weekly during season.

Midwheel Procedure:

Raise midwheel assembly into position under the track carriage, install inner and outer spindle bolts and torque to 1360 ft. lbs. Install endwheel. Install the sidebars. Extend sidebars to the previously marked positions and tighten all hardware. Torque $\frac{3}{4}$ " cap screws to 220 ft. lbs. and $1\frac{1}{4}$ " spindle bolt to 1360 ft. lbs. Check track alignment and track tension. Adjust if necessary.

NOTE: Retorque capscrews and spindle bolt hardware as follows:

- a. After 4 hours use.
- b. After 16 hours use.
- c. Weekly during season.

NOTE: Each midwheel and endwheel spindle bolt is equipped with a grease fitting (2 per assembly) for lubrication.

WHEEL BEARING REPLACEMENT

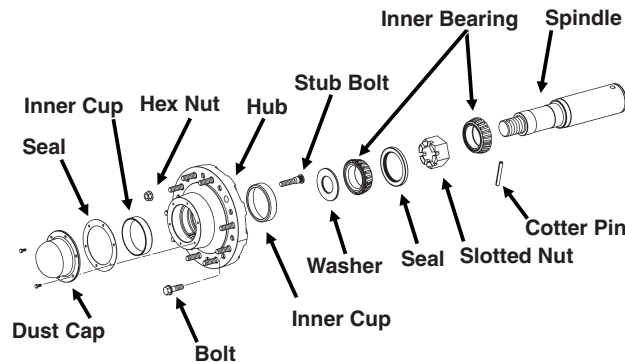

NOTE: See “Inside Tire Repair Or Removal” section of this manual for instruction on tire removal/access to inner wheel hubs on Row Crop carts.

1. Raise tire clear of ground and remove wheel.
2. Remove dust cap attachment hardware and remove cap from wheel hub.
3. Remove cotter pin, axle nut and 2" washer.
4. Slide hub from axle spindle, using a hub puller if necessary.
5. Remove bearings and cups from hub and discard. Thoroughly clean and dry wheel hub.
6. Press in new bearing cups with thickest edges facing in.
7. Pack bearing with heavy duty wheel bearing grease, thoroughly forcing grease between roller cone and bearing cage. Also fill the space between the bearing cups in the hub with grease.
8. Place inner bearing in hub and press in new grease seal with lip pointing towards bearing.
9. Clean axle spindle and install hub.
10. Install outer bearing, 2" washer and slotted hex nut. Tighten slotted hex nut while rotating the hub until there is some drag. This ensures that all bearing surfaces are in contact. Back off slotted nut to nearest locking slot and install cotter pin. Check for endplay in bearings.
11. Fill dust cap half full of wheel bearing grease and install on hub with attachment bolts.
12. Lubricate wheel nuts and install wheel. Remove jack. Torque wheel nuts to 350 ft-lb.

NOTE: Wheel hubs on Kinze grain carts contain high strength ductile iron material. Replace hub with proper part.

PREPARATION FOR STORAGE

Store machine in a dry sheltered area.

Remove all trash that may be wrapped on shafts and remove dirt that can draw moisture.

Remove auger inspection cover at front of cart and dump door on underside of grain tank at rear of cart. Clean out all accumulated grain and debris from auger chamber.

Wash machine inside and out.

Lubricate machine at all lubrication points.

If possible, remove weight from all tires, particularly if unit is stored outdoors.

Repaint any areas where paint has been removed. This is particularly important in the inside of grain tank. Rust in this area will shorten cart life and prevent grain from smoothly sliding to bottom of tank.

Inspect machine for parts in need of replacement and order during "off" season.

Coat exposed surface of all cylinder piston rods with grease or rust preventative spray.

HYDRAULIC HOSE LIFE

**WARNING**

Pressurized hydraulic fluid can penetrate body tissue and result in death, serious infection, or other injuries. Fluid injected under skin must be IMMEDIATELY removed by a surgeon familiar with this type of injury. Make sure connections are tight and hoses and fittings are not damaged before applying system pressure. Leaks can be invisible. Keep away from suspected leaks. Relieve pressure before searching for leaks or performing any system maintenance.



Proper storage of hydraulic hoses can significantly increase the life of the hoses, for a period of three to five years. After this period, service life of hoses may decrease, depending on variables such as variances in rubber materials and storage environment. Refer to the guidelines below for best practices when storing.

- Store in a clean, cool and dry area
- Avoid direct sunlight or moisture
- Do not store near high power electrical equipment
- Avoid contact with corrosive chemicals
- Avoid ultraviolet light
- Avoid areas with obvious signs of insects or rodents

Unusually long periods of storage or poor storage environment may lead to performance issues or premature failure. Always inspect all hoses prior to use for extensive wear, cuts, or holes. If such flaws are identified, replace immediately to avoid potential failure, property damage or bodily injury.

HYDRAULIC CONTROL SCHEMATIC - REMOTE

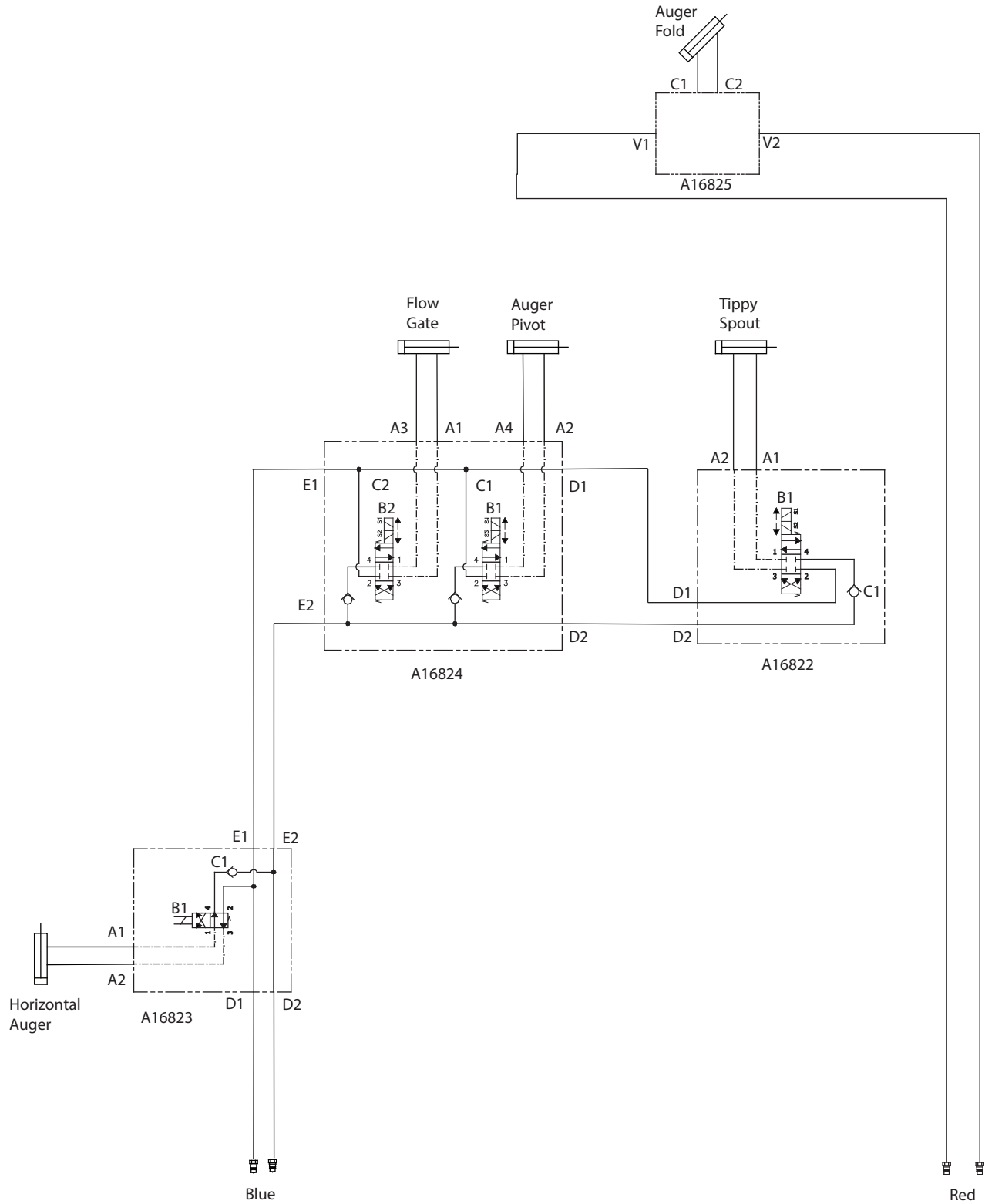

HANDHELD REMOTE ELECTRICAL PINOUT

Wire	From	To	Gauge	Wire Color	Function	Controls	Switch Position
W1	P1-1	SW1-1 SW2-C SW3-1 SW4-1 DS1-1	18	Red	+12V	Common Power	--
W2	P1-2	DS1-2 SW1DS1-1	18	Green	Chassis Ground	Chassis Ground	--
W3	P1-3	SW1-2	18	Black	Switched 12V	Auger On/Off	SW1 OPEN/ CLOSED
W5	P1-4	SW2-1	18	Yellow	Switched 12V	Pivot Down	Stick Left
W6	P1-5	SW2-3	18	Orange	Switched 12V	Pivot Up	Stick Right
W8	P1-6	SW2-4	18	Blue	Switched 12V	Spout Up	Stick Up
W7	P1-7	SW2-2	18	Brown	Switched 12V	Spout Down	Stick Down
NC	P1-8	--	--	--	114017 PLUG	NC	NA
W10	P1-9	SW4-2	18	Violet	Switched 12V	Flow Gate Closed	Bottom Trigger
W9	P1-10	SW3-2	18	White	Switched 12V	Flow Gate Open	Top Trigger
NC	P1-11	--	--	--	114017 PLUG	NC	NA
NC	P1-12	--	--	--	114017 PLUG	NC	NA

WIRING DIAGRAM



Additional auxiliary work lights are available from Kinze Repair Parts which may be wired into existing auxiliary light wires in the harness. The vertical auger work light is wired into the black terminal connector.

Grain cart safety/warning lights are the LED type and meet ASAE standards. Check with tractor manufacturer for correct wiring harness to be wired into lights on your tractor.

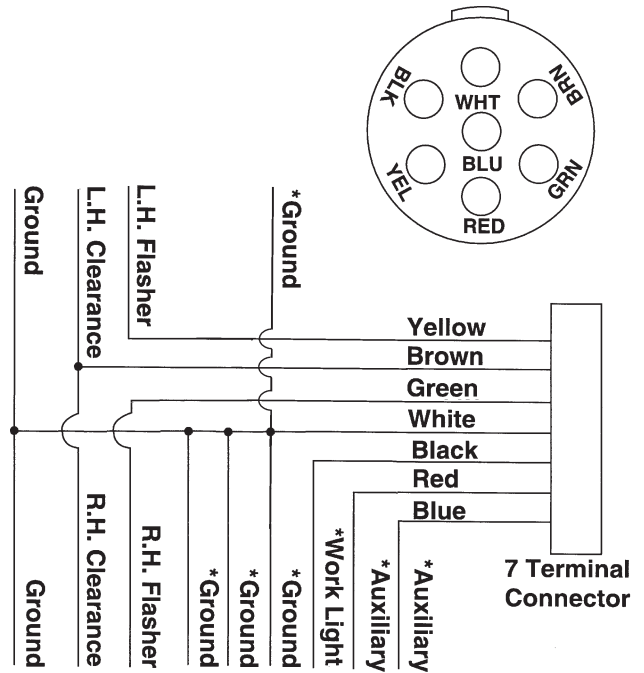

ELECTRONIC SCALE

The major elements of the electronic scale are the indicator, two 50,000 lb. rated compression type load cells at the rear of the axle assembly (applicable to track and flotation type carts) and four spindle type weigh axles (applicable to row crop carts), 3 $\frac{3}{4}$ " hitch weigh beam, the junction box (j-box) and the battery power cable.

For additional information see "Electronic Scale Troubleshooting" for step-by-step procedures for troubleshooting failures that may be encountered with the electronic scale.

The only tools required are as follows:

- Small Screwdriver (Straight Blade)
- No. 2 Phillips Screwdriver

