

# MODEL 3005 RIGID FRAME PLANTER

## OPERATOR MANUAL

**M0298-01**

**Rev. 6/21**

This manual applies to: Model: 3005 Rigid Frame Planters  
2021 Production Year And On

Record serial number of your planter and date purchased:

Model Number 3005  
Serial Number \_\_\_\_\_  
Date Purchased \_\_\_\_\_

Monitor Serial Number _____
Measured Pulses Per Mile/Km (Radar Distance Sensor) _____
Measured Pulses Per Mile/ Km (Magnetic Distance Sensor) _____

### SERIAL NUMBER

The serial number plate is located on the planter frame as shown below. The serial number provides important information about your planter and is needed to obtain correct replacement parts. Always provide model number and serial number to your Kinze Dealer when ordering parts or when contacting Kinze Manufacturing, Inc.



**This page left blank intentionally.**

**TO THE DEALER**

Predelivery service includes assembly, lubrication, adjustment, and test. This service makes sure planter is delivered to the retail customer/end user ready for field use.

**PREDELIVERY CHECKLIST**

Use the following checklist and inspect planter after it is completely assembled. Check off each item found satisfactory or after proper adjustment is made.

- Row units properly spaced and optional attachments correctly assembled.
- All grease fittings in place and lubricated.
- All working parts are moving freely. Bolts are tight and cotter pins are spread.
- All drive chains properly tensioned and aligned.
- Check for oil leaks and proper hydraulic operation.
- Hydraulic hoses are routed correctly to prevent damage to hoses.
- Inflate tires to specified air pressure. Tighten wheel lug bolts to specified torque.
- All safety decals correctly located and legible as shown in Parts Manual. Replace if damaged.
- All reflective decals and SMV sign correctly located as shown in Parts Manual and visible when the planter is in transport position.
- Safety/warning lights correctly installed and working properly.
- Paint all parts scratched in shipment or assembly.
- All safety lockup devices are on planter and correctly located.
- Seed meters performance checked on test stand.
- Auxiliary safety chain properly installed and hardware torqued to specification.

***This planter has been thoroughly checked and to the best of my knowledge is ready for delivery to the retail customer/end user.***

\_\_\_\_\_  
(Signature Of Set-Up Person/Dealer Name/Date)

**RETAIL CUSTOMER/END USER**

Name \_\_\_\_\_ Delivery Date \_\_\_\_\_  
 Street Address \_\_\_\_\_ Model No. 3005 Serial No. \_\_\_\_\_  
 City, State/Province \_\_\_\_\_ Dealer Name \_\_\_\_\_  
 ZIP/Postal Code \_\_\_\_\_ Dealer No. \_\_\_\_\_

---

## DELIVERY CHECKLIST

Use the following checklist when planter is delivered as a reminder of very important information which should be conveyed to the retail customer/end user. Check off each item as it is fully explained to the customer.

- Life expectancy of this or any other machine is dependent on regular lubrication as directed in the Operator Manual.
- All applicable safety precautions.
- Along with retail customer/end user, check reflective decals and SMV sign are clearly visible with planter in transport position and attached to tractor. Check safety/warning lights are in working condition. Tell retail customer/end user to check federal, state/provincial, and local regulations before towing or transporting on a road or highway.
- Give Operator Manual, Parts Manual, and all Instruction Sheets to the customer and explain all operating adjustments.
- Read warranty to customer.
- Complete Warranty and Delivery Report form.

***To the best of my knowledge this machine has been delivered ready for field use and retail customer/end user has been fully informed as to proper care and operation.***

---

(Signature Of Delivery Person/Dealer Name/Date)

## AFTER DELIVERY CHECKLIST

The following is a list of items we suggest to check during the first season of use of the equipment.

- Check planter performance with retail customer/end user.
- Review importance of proper maintenance and adherence to all safety precautions with retail customer/end user.
- Check for parts that may need to be adjusted or replaced.
- Check all safety decals, reflective decals, and SMV sign are correctly located as shown in the Parts Manual and that decals are legible. Replace if damaged or missing.
- Check safety/warning lights are working properly.

---

(Signature Of Follow-Up Person/Dealer Name/Date)

**All registrations must be submitted online at "[business.kinze.com](http://business.kinze.com)" within 5 business days of delivery.  
Retain a copy of this form for auditing purposes.**

*Tear Along Perforation*

**OVERVIEW**

To the Owner . . . . .	1-1
Warranty . . . . .	1-3
Specifications . . . . .	1-4
Specifications . . . . .	1-5
General Safety Rules . . . . .	1-6
Safety Instructions, Signs, and Decals . . . . .	1-7

**MACHINE OPERATION**

Initial Preparation . . . . .	2-1
Tractor Requirements . . . . .	2-2
Tractor Preparation and Hookup . . . . .	2-2
Hydraulic Lift Operation . . . . .	2-4
Safety lockups . . . . .	2-5
Level Planter . . . . .	2-5
Split Row Self-Leveling Hitch Extension . . . . .	2-5
Transporting Planter . . . . .	2-6
Contact Drive Spring Adjustment . . . . .	2-6
Seed Rate Transmission Adjustment . . . . .	2-7
Standard and Half Rate (2 to 1) Drives . . . . .	2-7
Shear Protection . . . . .	2-8
Wrap Spring Wrench . . . . .	2-9
Tire Scraper . . . . .	2-9
Hydraulic Row Marker Operation . . . . .	2-10
Row Marker Speed Adjustment . . . . .	2-11
Row Marker Adjustments . . . . .	2-12
Ridge Planting . . . . .	2-13
Planting Speed . . . . .	2-13
Field Test . . . . .	2-14
Check Seed Population . . . . .	2-14
Determining Pounds Per Acre (Brush-Type Meter) . . . . .	2-15
Determining Bushels Per Acre . . . . .	2-15
Water Tank . . . . .	2-16

**ROW UNIT OPERATION**

Planting Depth . . . . .	3-1
"V" Closing Wheel Adjustment (Rubber or Cast Iron) . . . . .	3-1
Closing Wheel Shield (Rubber or Cast Iron "V" Closing Wheels) . . . . .	3-2
Brush-Type Seed Meter 2.0 . . . . .	3-3
Finger Pickup Seed Meter . . . . .	3-5
Seed Meter Cleanout . . . . .	3-8
Seed Hoppers . . . . .	3-8
Seed Meter Drive Release . . . . .	3-9
Row Unit Extension Brackets . . . . .	3-9
Row Unit Chain Routing . . . . .	3-10
Quick Adjustable Down Force Springs Option . . . . .	3-11

Row Unit Mounted No Till Coulter . . . . .	3-12
Coulter Mounted Residue Wheels . . . . .	3-12
Spiked Closing Wheel . . . . .	3-13
Granular Chemical Hopper and Drive . . . . .	3-14
Granular Chemical Banding Options . . . . .	3-15
Split Row Lockups . . . . .	3-16
Split Row Clutch Sprocket . . . . .	3-18

**FERTILIZER**

Notched Single Disc Openers . . . . .	4-1
Depth/Gauge Wheel Attachment for Notched Single Disc Fertilizer Opener . . . . .	4-3
HD Single Disc Fertilizer Opener . . . . .	4-4
Dry Fertilizer Attachment . . . . .	4-6
Granular Chemical Application Field Check . . . . .	4-7
Liquid Fertilizer Attachment . . . . .	4-9

**RATE CHARTS . . . . . 5-1****LUBRICATION AND MAINTENANCE**

Lubrication . . . . .	6-1
Lubrication Symbols . . . . .	6-1
Sealed Bearings . . . . .	6-1
Wrap Spring Wrench Assembly . . . . .	6-1
Drive Chains . . . . .	6-2
Bushings . . . . .	6-4
Split Row Push Row Unit Lockups . . . . .	6-4
Liquid Fertilizer Piston Pump . . . . .	6-5
Crankcase Oil Level . . . . .	6-5
Wheel Bearings . . . . .	6-5
Grease Fittings . . . . .	6-6
Mounting Bolts and Hardware . . . . .	6-11
Torque Values Chart - Plated Hardware . . . . .	6-12
Tire Pressure . . . . .	6-13
Model 3005 Operating Tire Pressure . . . . .	6-13
Chain Tension Adjustment . . . . .	6-14
Finger Pickup Seed Meter Inspection/Adjustment . . . . .	6-15
Cleaning Finger Pickup Seed Meter For Storage . . . . .	6-16
Brush-Type Seed Meter 2.0 Maintenance . . . . .	6-17
Cleaning Brush-Type Seed Meter For Storage . . . . .	6-20
Gauge Wheel Adjustment . . . . .	6-20
Gauge Wheel Arm Bushing/Seal Replacement . . . . .	6-21
Gauge Wheel Arm Pivot Spindle Replacement . . . . .	6-22
15" Seed Opener Disc Blade/Bearing Assembly . . . . .	6-24
Seed Tube Guard/Inner Scraper . . . . .	6-26
Row Unit Mounted No Till Coulter . . . . .	6-27
Coulter Mounted Residue Wheels . . . . .	6-27

Granular Chemical Attachment . . . . . 6-28

Row Marker Sequencing/Flow  
Control Valve Inspection . . . . . 6-29

Row Marker Bearing Lubrication or Replacement . . . . . 6-30

Wheel Bearing Repack or Replacement . . . . . 6-31

Fertilizer Check Valve Cleaning and Repair . . . . . 6-31

Piston Pump Storage . . . . . 6-32

Preparing Planter for Storage . . . . . 6-32

Electrical Wiring Diagram for Light Package . . . . . 6-33

Hydraulic Hose Life . . . . . 6-34

Hydraulic System Schematic . . . . . 6-35

Hydraulic System Schematic  
(with Split Row Self-Leveling Hitch) . . . . . 6-36

**TROUBLESHOOTING**

Closing Wheel Troubleshooting . . . . . 8-1

Lift Circuit Operation Troubleshooting . . . . . 8-2

Piston Pump Troubleshooting . . . . . 8-3

Row Marker Operation Troubleshooting . . . . . 8-4

Seed Meter (Brush-Type) Troubleshooting . . . . . 8-5





Seed Meter (Finger Pickup) Troubleshooting . . . . . 8-6

Kinze Manufacturing, Inc. would like to thank you for your patronage. We appreciate your confidence in Kinze farm machinery. Your Kinze planter has been carefully designed to provide dependable operation in return for your investment.

**This manual has been prepared to aid you in planter operation and maintenance. It should be considered a permanent part of the machine and remain with the machine when you sell it.**

It is the responsibility of the user to read and understand this Operator Manual before operating this equipment. It is the user's responsibility to inspect and service the machine routinely as directed in this Operator Manual. We have attempted to cover all areas of safety, operation, lubrication and maintenance; however, there may be times when special care must be taken to fit your conditions.

Throughout this manual the symbol  and the words **DANGER**, **WARNING**, and **CAUTION** are used to call attention to safety information that if not followed, will or could result in death or injury. **NOTICE** and **NOTE** are used to call your attention to important information. The definition of each of these terms follows:

	<p>Indicates an imminently hazardous situation that, if not avoided, will result in death or serious injury. This signal word is to be limited to the most extreme situations, typically for machine components which, for functional purposes, cannot be guarded.</p>
	<p>Indicates a potentially hazardous situation that, if not avoided, could result in death or serious injury, and includes hazards that are exposed when guards are removed. It may also be used to alert against unsafe practices.</p>
	<p>Indicates a potentially hazardous situation that, if not avoided, may result in minor or moderate injury. It may also be used to alert against unsafe practices.</p>
	<p>Used to address safety practices not related to personal injury.</p>

**NOTE:** Special point of information or machine adjustment instructions.

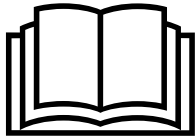
 **WARNING**

Improperly operating or working on this equipment could result in death or serious injury. Read and follow all instructions in Operator Manual before operating or working on this equipment.

 **WARNING**

Some photos in this manual may show safety covers, shields, or lockup devices removed for visual clarity. **NEVER OPERATOR OR WORK ON** machine without all safety covers, shields, and lockup device in place as required.

**NOTE:** Photos in this manual may be of prototype machines. Production machines may vary in appearance.

**NOTE:** Some photos and illustrations in this manual show optional attachments installed. Contact your Kinze Dealer for purchase of optional attachments.



The Kinze Limited Warranty for your new machine is stated on the retail purchaser's copy of the Warranty And Delivery Receipt form. Additional copies of the Limited Warranty can be obtained through your Kinze Dealer.

Warranty, within the warranty period, is provided as part of Kinze's support program for registered Kinze products which have been operated and maintained as described in this manual. Evidence of equipment abuse or modification beyond original factory specifications will void the warranty. Normal maintenance, service and repair is not covered by Kinze warranty.

To register your Kinze product for warranty, a Warranty And Delivery Receipt form must be completed by the Kinze Dealer and signed by the retail purchaser, with copies to the Dealer, and to the retail purchaser. Registration must be completed and submitted to Kinze Manufacturing, Inc. within 5 business days of delivery of the Kinze product to the retail purchaser. Kinze Manufacturing, Inc. reserves the right to refuse warranty on serial numbered products which have not been properly registered.

If service or replacement of failed parts which are covered by the Limited Warranty are required, it is the user's responsibility to deliver the machine along with the retail purchaser's copy of the Warranty And Delivery Receipt to the Kinze Dealer for service. Kinze warranty does not include cost of travel time, mileage, hauling or labor. Any prior arrangement made between the Dealer and the retail purchaser in which the Dealer agrees to absorb all or part of this expense should be considered a courtesy to the retail purchaser.

*Kinze warranty does not include cost of travel time, mileage, hauling or labor.*

## GENERAL INFORMATION

This manual covers all production years of the Model 3005 planter. Contact your Kinze dealer for additional options which may be available for your specific model year planter.

Information in this manual was current at time of printing. However, due to Kinze's ongoing product improvement, production changes may cause your machine to appear slightly different in detail. Kinze Manufacturing, Inc. reserves the right to change specifications or design without notice and without incurring obligation to install the same on machines previously manufactured. To obtain the most recent version of your publication, please contact your Kinze dealer.

Right hand (R.H.) and left hand (L.H.), as used throughout this manual, are determined by facing in the direction the machine will travel when in use, unless otherwise stated.

## TOOLS REQUIRED

Hardware Size / Tool Required			
$\frac{1}{4}" = \frac{7}{16}"$	$\frac{7}{16}" = \frac{5}{8}"$ (nut for $\frac{7}{16}"$ hardware uses $\frac{11}{16}"$ tool)	$\frac{3}{4}" = 1\frac{1}{8}"$	$1\frac{1}{4}" = 1\frac{7}{8}"$
$\frac{5}{16}" = \frac{1}{2}"$	$\frac{1}{2}" = \frac{3}{4}"$	$\frac{7}{8}" = 1\frac{5}{16}"$	$1\frac{1}{2}" = 2\frac{1}{4}"$
$\frac{3}{8}" = \frac{9}{16}"$	$\frac{5}{8}" = 1\frac{5}{16}"$	$1" = 1\frac{1}{2}"$	

**SPECIFICATIONS**

<b>Planter Size</b>	<b>4 Row 30"</b>	<b>6 Row 30"</b>	<b>8 Row 30"</b>
Single Frame Length	11'4" (3.5M)	11'4" (3.5M)	11'4" (3.5M)
Double Frame Length	13'8" (4.2M)	13'8" (4.2M)	13'8" (4.2M)
Width	12'8" (3.9M)	17'8" (5.4M)	21'10" (6.7M)
Base Machine Weight* W/Double Frame	2538 lb (1151.22 kg) - 2948 lb (1337.19 kg)	3864 lb (1752.68 kg) - 4398 lb (1994.90 kg)	4874 lb (2210.81 kg) - 5548 lb (2516.53 kg)
* Base machine weights include planter frame including row markers, drive components, tires and wheels, hydraulic cylinders, transport safety chain and Kinze pull row units (closing wheel arms less wheels) with seed hopper and lid and dual quick adjustable down force springs.			
**Weight based off a typical configuration of a complete machine.			
Seed Capacity	1.90 bu. (Mechanical / Hopper)		
Transport/Field Tire	7.50" x 20" 8 ply rib implement tires with center groove		
Contact Drive Tire	4.10" x 6"		
Field Lift	Master / slave rephasing cylinders		
Row Markers	Hydraulic alternating sequence valve (dual valve optional), single fold, depth bands.		

**TRACTOR HYDRAULIC REQUIREMENTS**

<b>Configuration</b>	<b>Requirements</b>		<b>Description</b>
Base machine with mechanical meters and row markers	1 SCV	10 gpm (38 L/min)	#1 SCV: Planter lift and auto sequencing row markers
Base machine with mechanical meters and dual valve conversion on row markers	2 SCV	10 gpm (38 L/min)	#1 SCV: Planter lift
			#2 SCV: Row markers

1. Read and understand instructions provided in this manual and warning labels. Review these instructions frequently!
  2. This machine is designed and built with your safety in mind. Do not make any alterations or changes to this machine. Any alteration to design or construction may create safety hazards.
  3. A large portion of farm accidents happen from fatigue or carelessness. Safe and careful operation of tractor and planter will help prevent accidents.
  4. Never allow planter to be operated by anyone unfamiliar with operation of all functions of the unit. Operators must read and thoroughly understand all instructions given in this manual before operating or working on equipment.
  5. Be aware of bystanders, particularly children! Always look around to make sure it is safe to start tow vehicle engine or move planter. This is particularly important with higher noise levels and quiet cabs, as you may not hear people shouting.
  6. Make sure planter weight does not exceed towing capacity of tractor, or bridge and road limits. This is critical to maintain safe control and prevent death or injury, or property and equipment damage.
  7. Never ride or allow others to ride on planter.
  8. Store planter in an area away from human activity. DO NOT permit children to play on or around the stored unit.
  9. Keep hands, feet, and clothing away from moving parts. Do not wear loose-fitting clothing which may catch in moving parts.
  10. Always wear protective clothing, shoes, gloves, hearing, and eye protection applicable for the situation.
  11. Do not allow anyone to stand between tongue or hitch and towing vehicle when backing up to planter.
  13. Prevent electrocution, other injuries, or property and equipment damage. Watch for obstructions such as wires, tree limbs, etc. when operating machine. Be aware of clearances during turns and when folding/unfolding planter.
  14. Reinstall all guards removed for maintenance activities. Never leave guards off during operation.
  15. Use of aftermarket hydraulic, electric, or PTO drives may create serious safety hazards to you and people nearby. If you install such drives, follow all appropriate safety standards and practices to protect you and others near this planter from injury.
  16. Follow all federal, state/provincial, and local regulations when towing farm equipment on a public highway. Use safety chain (not an elastic or nylon/plastic tow strap) to retain connection between towing and towed machines in the event of primary attaching system separation.
  17. Make sure all safety/warning lights, SMV sign, and reflective decals are in place and working properly before transporting the machine on public roads.
  18. Limit towing speed to 15 MPH (24.14 km/h). Tow only with farm tractor of a minimum 90 HP. Allow for unit length when making turns.
  19. Reduce speed prior to turns to avoid the risk of overturning. Always drive at a safe speed relative to local conditions and ensure your speed is slow enough for a safe emergency stop.
  20. Chemical application is often an integral part of planting. Follow label instructions for proper chemical mixing, handling and container disposal methods.
  21. Be familiar with safety procedures for immediate first aid should you accidentally contact chemical substances.
  22. Use the proper protective clothing and safety equipment when handling chemicals.
  23. Chemicals are supplied with Material Safety Data Sheets (MSDS) that provide full information about the chemical, its effects on exposure, and first aid needs in the event of an emergency. Keep your MSDS file up-to-date and available for first responders in case of emergency.
  24. When servicing ground engaging components such as opening disks and firming points, use special care to avoid points and edges worn sharp during use.
  25. Use professional help if you are unfamiliar with working on hydraulic systems. Pressurized hydraulic fluid can penetrate body tissue and result in death, serious infection, or other injuries.
  26. Disposing of waste improperly can threaten the environment. To dispose of your equipment properly contact your local environmental or recycling center.
- Never pour waste onto the ground, down a drain, or into any water source.
- When disposing of waste such as oil, use leakproof containers. Be sure to use containers that do not resemble food or beverage which may mislead someone into consuming them. Dispose of oil per your local, regional requirements.
- When disposing of any fertilizer chemicals used, contact the supplier of the chemicals.
- Model 3005 planter consists of 85% recyclable metals, 10% recyclable plastic and rubber, and 5% waste.

Following are some common hazard warnings associated with this equipment. Pay close attention to all safety, operating, and maintenance information in this manual and decals applied to your equipment.

 	<p>Contacting or coming close to power lines or other high energy sources will cause death or serious injury.</p> <p>Keep away from power lines or high energy sources at all times.</p>
 	<p>Loss of control can cause death or serious injury, or damage to property and equipment. Tow only with farm tractor weight rated and configured for this equipment. Use safety chains and transport as specified in the Operator and Parts Manual.</p>
 	<p>Improperly operating or working on this equipment could result in death or serious injury. Read and follow all instructions in Operator Manual before operating or working on this equipment.</p>
 	<p>Contact with rotating driveline will cause death or serious injury. Keep away at all times when operating.</p> <p>Never operate without all guards and equipment shields properly installed.</p>
 	<p>Explosive separation of rim and tire parts can cause death or serious injury. Overinflation, rim and tire servicing, improper use of rims and tires, or worn or improperly maintained tires could result in a tire explosion.</p>

## Safety Signs And Decals

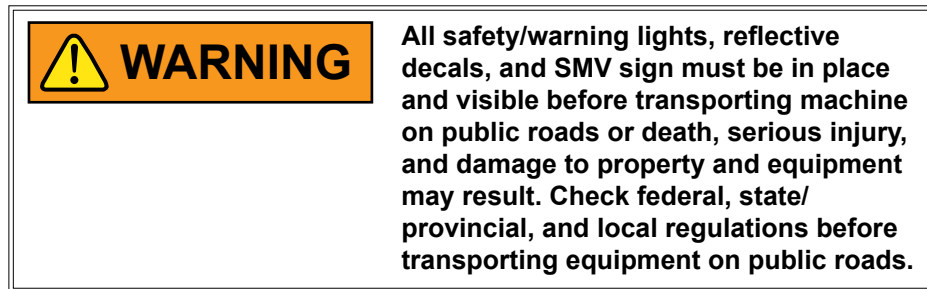

Safety signs and decals are placed on the machine to warn of hazards and provide important operating and maintenance instructions. Information on these signs are for your personal safety and the safety of those around you. FOLLOW ALL SAFETY INSTRUCTIONS!

- Keep signs clean so they can be easily seen. Wash with soap and water or cleaning solution as required.
- Replace safety signs if damaged, painted over, or missing.
- Check reflective decals and SMV sign periodically. Replace if they show any loss of reflective properties.
- When replacing decals, clean machine surface thoroughly with soap and water or cleaning solution to remove all dirt and grease.



**NOTE:** Safety sign and decal locations are shown in the Parts Manual for this machine.

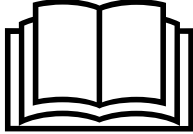

**NOTE:** Style and locations of SMV sign, reflective decals, and safety/warning lights conform to ANSI/ASABE S279.14 JUL 2008 and ANSI/ASABE S276.6 JAN 2005.

Following information is general in nature to aid in preparation of tractor and planter for use, and to provide general operating procedures. Operator experience, familiarity with the machine, and the following information should combine for efficient planter operation and good working habits.

 <b>WARNING</b>	<p>Improperly operating or working on this equipment could result in death or serious injury. Read and follow all instructions in Operator Manual before operating or working on this equipment.</p>
	

## INITIAL PREPARATION

 <b>WARNING</b>	<p>Loose transport wheel lug bolts can result in wheel separation from planter and cause death, serious injury, and damage to property and equipment. Torque transport wheel lug bolts before operating planter for the first time and periodically after.</p>
	

 <b>WARNING</b>	<p>Explosive separation of rim and tire parts can cause death or serious injury. Overinflation, rim and tire servicing, improper use of rims and tires, or worn or improperly maintained tires could result in a tire explosion.</p>
	

1. Torque transport wheel  $\frac{9}{16}$ "- 18 lug bolts to 125 ft-lb (169 N-m).
2. Inflate transport/ground drive tires to 40 psi (275.7 kPa).
3. Inflate contact drive tires to 50 psi (344.7 kPa).



## TRACTOR REQUIREMENTS

### NOTICE

**All Hydraulic Requirements: Minimum Pressure 2350 PSI (16202.6 kPa); Maximum Pressure 3000 PSI (20684.2 kPa). Check tractor hydraulics to ensure that maximum pressure cannot be exceeded.**

Consult your dealer for information on horsepower requirements and tractor compatibility. Requirements vary with planter options, tillage, and terrain.

A 12 volt DC electrical system is required for all 3005 series planters.

One dual remote hydraulic outlet (SCV) is required for machines equipped with a standard single valve hydraulic system. Two dual remote hydraulic outlets (SCV) are required for machines equipped with the optional dual valve hydraulic system.

## TRACTOR PREPARATION AND HOOKUP

1. Adjust tractor drawbar 13 to 17 inches (33 to 43 cm) above ground. Adjust drawbar so hitch pin hole is directly below center line of PTO shaft. Make sure drawbar is in a stationary position.
2. Back tractor to planter and connect with a minimum  $\frac{3}{4}$ " (19 mm) diameter hitch pin. Secure with a locking or cotter pin.



**NOTE: DO NOT install safety chain using clevis mounting hardware. Safety chain MUST be installed separately.**

3. Provided transport safety chain must be used to keep planter and tractor connected in case of a hitch pin/drawbar failure. Attach safety chain at an unused clevis mounting hole on the planter hitch. Torque hardware to 840 ft-lb (1138.8 N-m).



**Drawbar and safety chain connection**



 <b>WARNING</b>	<p>Pressurized hydraulic fluid can penetrate body tissue and result in death, serious infection, or other injuries. Fluid injected under skin must be <b>IMMEDIATELY</b> removed by a surgeon familiar with this type of injury. Make sure connections are tight and hoses and fittings are not damaged before applying system pressure. Leaks can be invisible. Keep away from suspected leaks. Relieve pressure before searching for leaks or performing any system maintenance.</p>
	

<b>NOTICE</b>	<p>Wipe hose ends to remove any dirt before connecting couplers to tractor ports or contamination may cause equipment failure.</p>
---------------	--

4. Connect hydraulic hoses to tractor ports in a sequence familiar and comfortable to the operator.

**NOTE: If tractor is equipped with an adjustable flow outlet (SCV), set to full flow position.**

5. Connect ASABE Standards 7 terminal connector for safety/warning lights on planter to ASABE Standards receptacle on tractor. If your tractor is not equipped with an ASABE Standards receptacle, check with your tractor manufacturer for availability. Check warning lights on planter work in conjunction with warning lights on tractor.



Jack stand installed



Jack stand stored

6. Raise jack stand and remount horizontally on storage bracket.

**HYDRAULIC LIFT OPERATION**



**WARNING**

Uncontrolled movement of equipment can cause loss of control and could result in death, serious injury, or damage to property and equipment. Install all safety pins before transporting equipment.



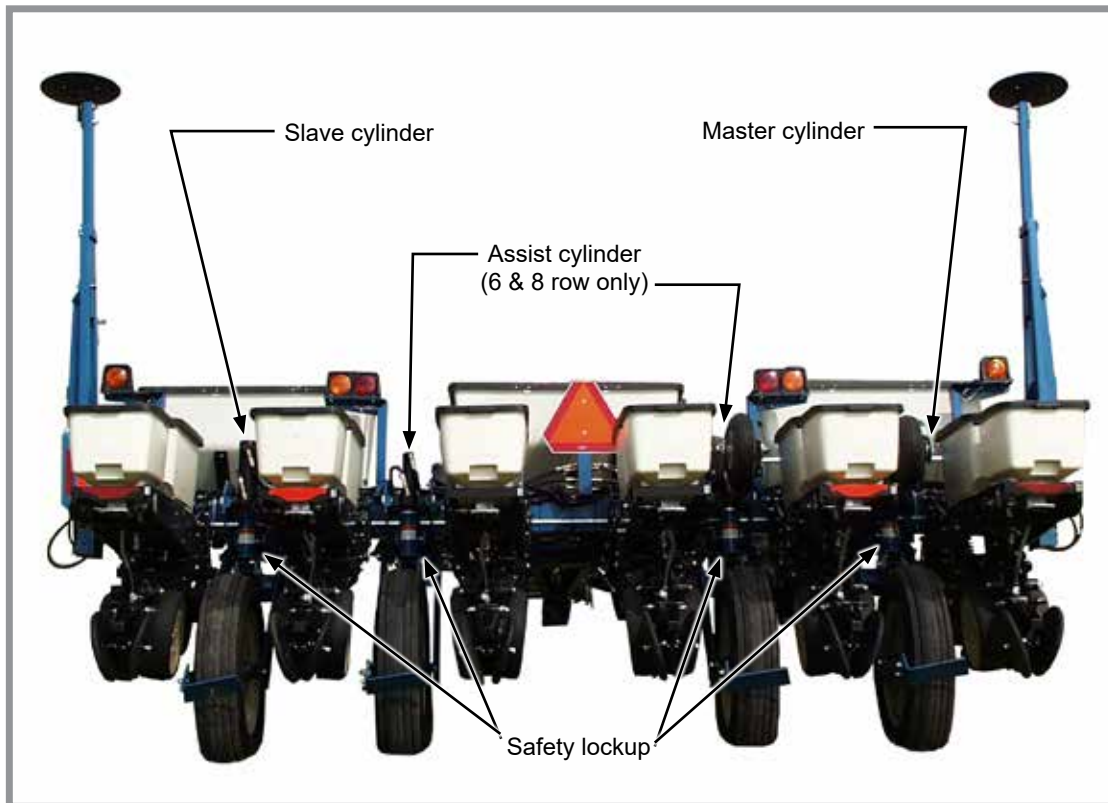

**Lift cylinder locations (6 row shown)**

The planter lift system consists of a master cylinder on outer R.H side of planter and a slave cylinder on outer L.H. side of planter. Lift assist cylinders are used on inner wheel modules of 6 and 8 row sizes.

With a master/slave hydraulic lift system, oil is forced into the butt end of master and lift assist cylinders when the hydraulic lever on the tractor is moved to the raise position. As the master cylinder extends, oil from the master cylinder rod end is forced into the slave cylinder butt end. Displacement on the master cylinder rod end is equal to displacement on the slave cylinder butt end. This causes the two cylinders to move at the same rate so the planter raises and lowers evenly.

Assist cylinders on 6 and 8 row planters are plumbed in parallel in the lift circuit with master/slave cylinders to provide additional lift capacity.

Hydraulic schematics are located in the maintenance section of this manual.

**Note:** Planter lifts unevenly if lift cylinders are out of phase. A valve in the piston of each master and slave cylinder allows system to rephase when cylinders are cycled by lowering planter to ground and holding hydraulic lever for 5-10 seconds. Cycle system until planter lifts and lowers evenly.

## SAFETY LOCKUPS

Safety lockups are provided for each cylinder (including optional Split Row self-leveling hitch) and must be in place when working on a raised planter, transporting, or during storage.



Safety lockup installed



Safety lockup in storage location

Place a safety lockup on each cylinder rod and secure in place with pin. Keep safety lockups in storage locations on planter when not in use.

## LEVEL PLANTER

Lateral adjustment is maintained by tire pressure. Check tires are inflated to specification.

Front and rear level adjustment is maintained by hitch clevis position unless tractor drawbar is adjustable for height. Planter frame and row unit parallel arms must be level for proper planter and row unit operation. Bottom of toolbar should be 20" to 22" (50.8 to 56.88 cm) from planting surface.

1. Lower planter to planting position and check planter is level front to rear. Go to step 2 if hitch is too high or low.

**NOTE: DO NOT install safety chain using clevis hardware. Move safety chain location if necessary.**

2. Remove clevis hitch hex head cap screw and lock nut using a torque wrench. Replace if off-torque is below 75 ft-lb (101.6 N-m) or there is corrosion or damage.

**NOTE: Clevis must be free to move on hitch. DO NOT OVERTIGHTEN hardware.**

3. Align clevis to hitch holes at new location and install hex head cap screw and lock nut. Tighten lock nut until threads are fully engaged and hex head cap screw and lock nut are firmly against hitch bracket.
4. Recheck with planter in field.

## SPLIT ROW SELF-LEVELING HITCH EXTENSION

Split Row self-leveling hitch extension raises planter to raise level front to rear when Split Row push row units are used.



Split Row self-leveling hitch extension

**TRANSPORTING PLANTER**

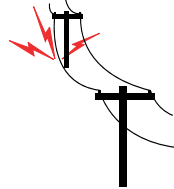

Contacting or coming close to power lines or other high energy sources will cause death or serious injury.

Keep away from power lines or high energy sources at all times.



All safety/warning lights, reflective decals, and SMV sign must be in place and visible before transporting machine on public roads or death, serious injury, and damage to property and equipment may result. Check federal, state/provincial, and local regulations before transporting equipment on public roads.

- Tow only with farm tractor rated and configured for equipment.
  - Know your route and be aware of any obstructions.
  - Follow all road and bridge load limit restrictions.
  - Never exceed maximum transport towing speed of 20 mph (32 kph).
1. Raise planter to full turn around height.
  2. Install safety lockups. See “Safety Lockups” in Machine Operation.
  3. Turn on hazard lights.

**CONTACT DRIVE SPRING ADJUSTMENT**

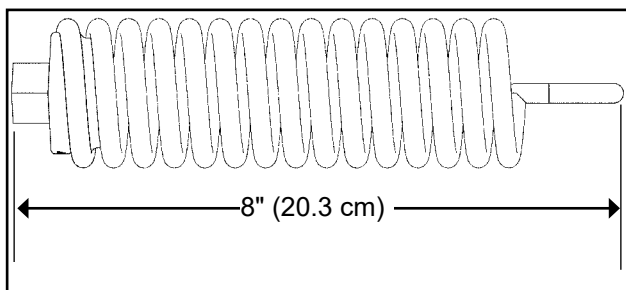

Spring length measurement (Factory setting)



Down pressure spring location

There are two down pressure springs on each contact drive wheel. Spring tension is factory preset and normally requires no adjustment.

Basic setting for spring tension is approximately 200 lb (90.72 kg) of down force at tire contact point.

**NOTE: Measurement must be taken in planting position with proper tire pressure.**

## SEED RATE TRANSMISSION ADJUSTMENT

Seed rate transmissions allow simple, rapid changes of sprockets to obtain desired planting population. By removing lynch pins on hexagon shafts, sprockets can be interchanged with those from the sprocket storage rod bolted to the transmission.

Chain tension is controlled by a spring-loaded dual-sprocket idler. The idler assembly is equipped with an easy-release idler arm to remove spring tension for replacing sprockets.

Planting rate charts in the Seed Meter Operation section will aid you in selecting correct sprocket combinations.

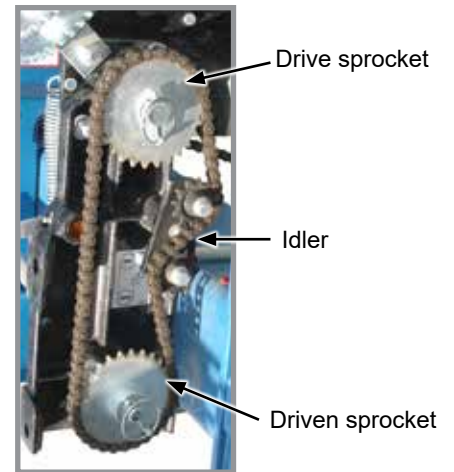

Seed rate transmission chain tension

## STANDARD AND HALF RATE (2 TO 1) DRIVES

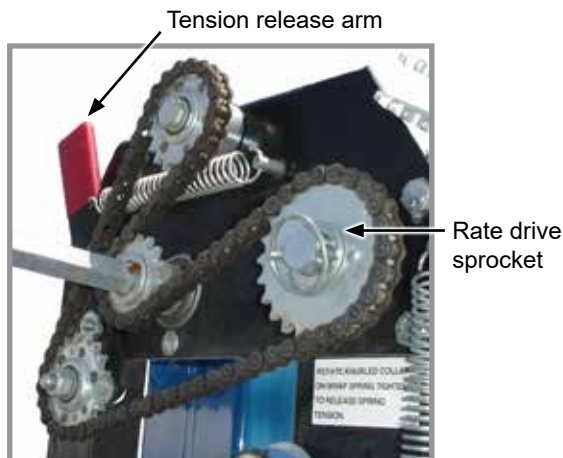

Seed planting rate charts are based on the standard rate drive using a 17 tooth sprocket unless otherwise specified.

**NOTE: Half rate (2 to 1) drive is recommended only when desired population falls below that on planting rate charts.**

Replacing the standard 17 tooth drive sprocket located on the inner side of the top transmission shaft, with the 34 tooth half rate (2 to 1) drive reduction sprocket reduces planter transmission speed and planting and application rates by approximately 50%.

**NOTE: Do a field check after each sprocket combination adjustment to make sure you are planting at the desired rate.**

**SHEAR PROTECTION**

Shear pins protect the planter driveline and row unit components from damage.

1. Determine where binding has occurred before replacing a pin. Turn shaft by hand (with the aid of a wrench) and check for misalignment and seized parts.
2. When shaft can be turned by hand (with the aid of a wrench) replace shear pins with same size and type. Spare shear pins are in wheel module storage area.

<b>NOTICE</b>	<b>Misaligned drill shaft/transmission coupler can cause equipment damage.</b>
---------------	--

3. Check driveline alignment and follow prescribed lubrication schedules to prevent component binding or breakage.

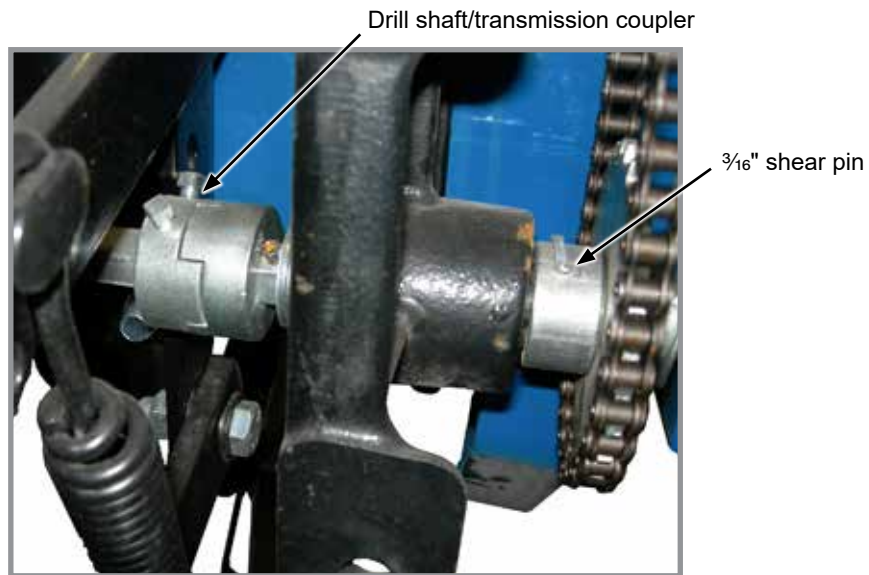

**Transmission shaft and drill shaft coupler**

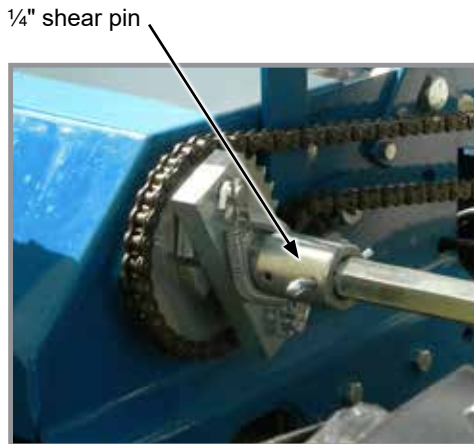

**Liquid fertilizer driveline**



**Dry fertilizer driveline**

## WRAP SPRING WRENCH

Chain idlers use wrap spring wrenches to release and adjust transmission chain tension.

Rotate wrap spring wrench knurled collar while rotating chain idler away from chain to release chain tension.

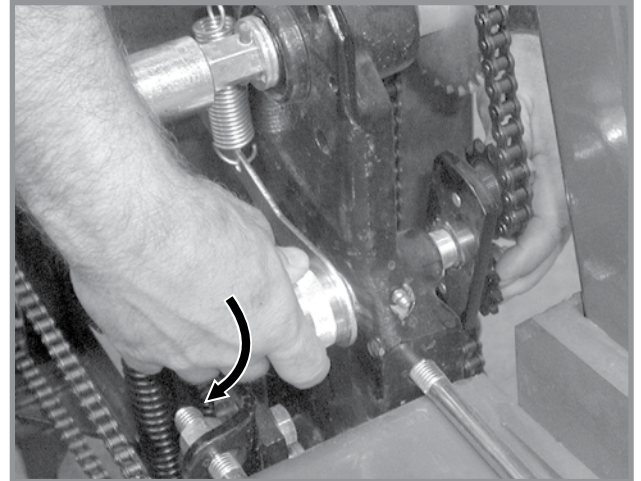

Release chain tension

Rotate chain idler into chain while rotating handle to tension idler spring.

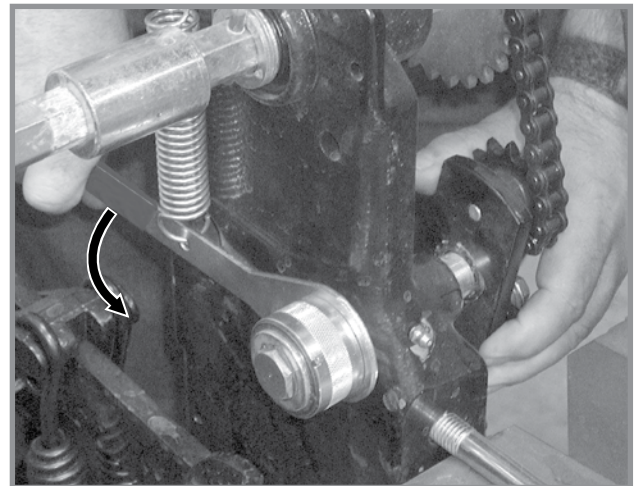

Increase chain tension

## TIRE SCRAPER

A tire scraper prevents buildup of dirt and mud between wheel arm assembly and tire.

Adjust scraper so it does not contact tire.



Tire scraper

**HYDRAULIC ROW MARKER OPERATION**

**DANGER**

Contacting or coming close to power lines or other high energy sources will cause death or serious injury.

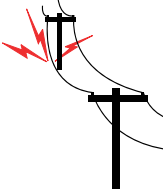

Keep away from power lines or high energy sources at all times.

**WARNING**

Row marker can lower at any time and could cause death or serious injury. Stay away from row markers! Install safety lockup device when not in use.





**Marker arm safety lockup pin location**

Row markers have a safety lockup pin and hairpin clip located behind each arm. Keep pin in place whenever row markers are not used.

Model 3005 planters are equipped with a single or optional dual valve hydraulic system to control row markers.

A single valve system lifts a row marker when the planter is raised. Row markers lower on alternate sides each time planter is lowered. If a planter is raised to cross a waterway, the row marker on opposite side of the one just raised lowers when planter is lowered back to ground. Stop, raise, and lower planter again to lower marker on side raised when crossing waterway.

**NOTE: Install safety lockup pins if row markers are not used during planting to prevent markers from lowering.**



An optional dual valve hydraulic system allows planter to be raised and lowered without operating row markers. Row markers are controlled on alternating sides through a tractor SCV. The sequencing valve directs flow to marker on opposite side each time a row marker is raised. When lower row marker is selected, row marker on opposite side of row marker last raised is lowered. When raising planter for a waterway the row marker stays down, clears the ground, does not disturb the waterway, and continues to mark when planter is lowered.

Both row markers can be down at the same time. Lower planter and row marker. Move tractor lift control (single valve) or marker control (dual valve) to raise and immediately return it to lower. This shifts the row marker control valve and lowers remaining row marker.

## ROW MARKER SPEED ADJUSTMENT

### NOTICE

Excessive row marker travel speed can damage row markers. Adjust flow controls before row markers are first used.



Row marker flow control valves

Two flow control valves determine amount of oil flow restriction controlling row marker travel speeds. One flow control valve controls lowering speed and one controls raising speed of both markers.

**NOTE 1:** Hydraulics operate slowly when oil is cold. Make all adjustments with oil warm.

**NOTE 2:** On a tractor where oil flow cannot be controlled, tractor flow rate may be greater than rate marker cylinder can accept. Hold tractor hydraulic control lever until cylinder reaches end of its stroke. This occurs most often on tractors with an open center hydraulic system.

**NOTE 3:** On tractors with a closed center hydraulic system, set hydraulic flow control so detent functions properly.

1. Loosen jam nut and turn control clockwise (IN) to slow speed or counterclockwise (OUT) to increase speed.
2. Tighten jam nut after adjustments are made.

## ROW MARKER ADJUSTMENTS

1. Multiply number of rows by the average row spacing in inches to determine total planting width.

**NOTE: Refer to IS1106 for Split Row option adjustments.**

Row Marker Lengths	
4 Row 30"	120" (304.8 cm)
6 Row 30"	180" (457.2 cm)
8 Row 30"	240" (609.6 cm)

2. Lower planter and row marker assembly to ground.
3. Measure from planter center line to a point where blade contacts ground.
4. Adjust row marker extension so distance from marker disc blade to center line of planter is equal to total planting width. Adjust right and left row marker assemblies equally and securely tighten clamping bolts.

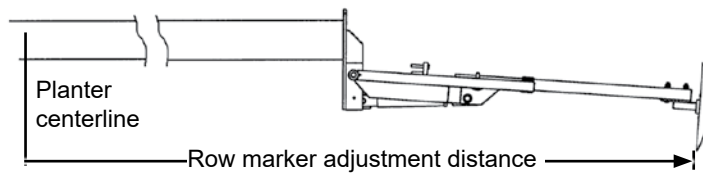

### NOTICE

Setting marker disc blade assembly at a sharper angle than needed adds stress to row marker assembly and shortens bearing and blade life. Set blade angle only as needed to leave a clear mark.

Marker disc blade is installed with concave side facing inward. Spindle assembly is slotted so hub and blade can be angled to throw more or less dirt.

5. Loosen hardware and move assembly as required.
6. Tighten bolts to specified torque. See [“Torque Values Chart - Plated Hardware”](#) in Maintenance Section.
7. Do a field test to ensure markers are properly adjusted.

**NOTE: A notched marker blade is available from Kinze through your Kinze Dealer for use in more severe no till conditions.**

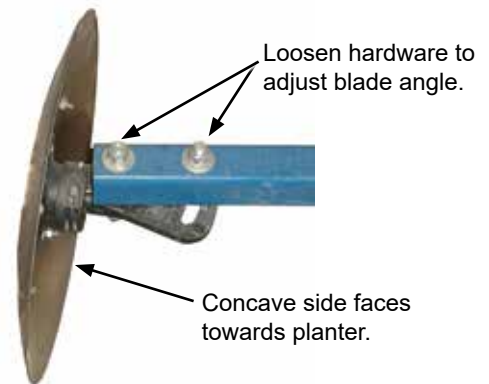

Row marker disc blade angle adjustment

## RIDGE PLANTING

Planter toolbar height can be raised 3" (8 cm) for ridge planting.

1. Relocate 20" transport axles to lower rear holes in ground drive wheel arm.

New axle location.



Transport axle

2. Mount contact drive wheel arm and springs to lower set of mounting holes in wheel module mount.
3. Raise hitch height to keep planter level front and rear.

Move contact drive wheel arm here.

Move springs here.

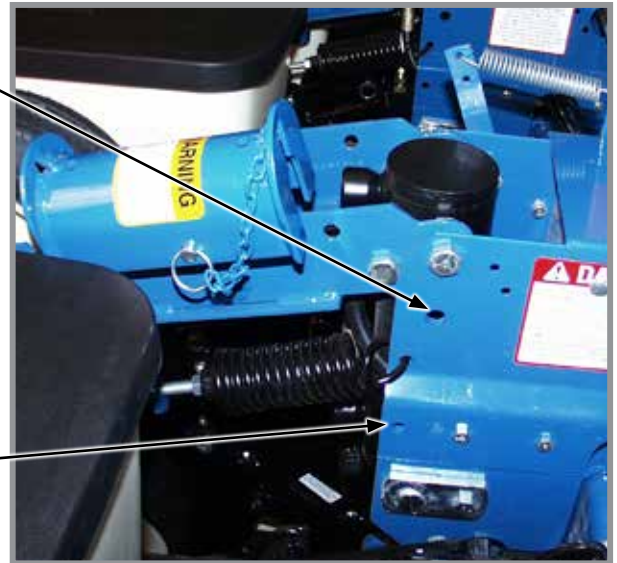

Wheel module mount

## PLANTING SPEED

Planters are designed to operate within a speed range of 2 to 8 mph (3.2 - 12.8 kph). See [“Rate Charts” on page 5-1](#) “Rate Charts”. Variations in ground speed produce variations in rates. Finger pickup seed meter populations tend to be disproportionately higher at high ground speeds.

**NOTE:** Seed spacing can be adversely affected at speeds above 5.5 mph (8.8 kph).

## FIELD TEST

Perform a field test with any change of field and/or planting conditions, seed size or planter adjustment to ensure proper seed placement and operation of row units. See [“Rate Charts”](#), [“Check Seed Population”](#) and [“Granular Chemical Application Field Check”](#).

- Check planter for front to rear and lateral level operation. See [“Level Planter”](#).
- Check **all** row units to be certain they are running level. Row unit parallel arms should be approximately parallel to the ground when planting.
- Check row markers for proper operation and adjustment. See [“Row Marker Adjustments”](#) and [“Row Marker Speed Adjustment”](#).
- Check for proper application rates and placement of granular chemicals on **all** rows. See [“Granular Chemical Application Field Check”](#).
- Check for desired depth placement and seed population on **all** rows. See [“Check Seed Population”](#).
- Check for proper application rates of fertilizer on **all** rows. See proper “Fertilizer Application Rate Chart”.

Reinspect machine after field testing.

- Hoses And Fittings
- Bolts And Nuts
- Cotter Pins And Spring Pins
- Drive Chain Alignment

## CHECK SEED POPULATION

1. Tie up one or more sets of closing wheels by running a chain or rubber tarp strap between the hopper support panel and closing wheels. It may be necessary to decrease closing wheel arm spring tension.

Chain, rubber tarp strap, or similar.

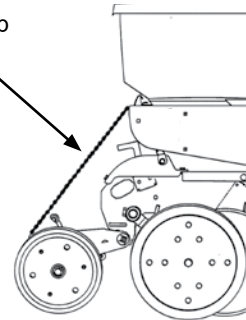

2. Plant a short distance and check to see if seed is visible in the seed trench. Adjust planting depth to a shallower setting if seed is not visible and recheck.

Planting depth adjustment handle

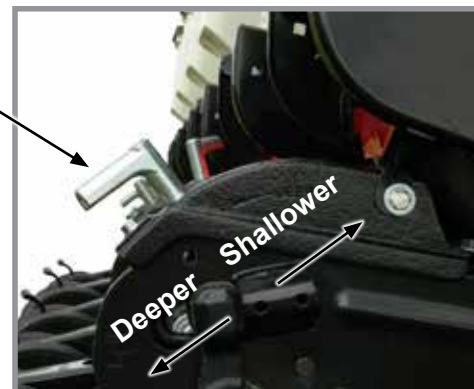

Planting depth adjustment

3. Measure  $\frac{1}{1000}$  of an acre (hectare). See chart for correct distance for row width being planted. For example, if planting 30" (70 cm) rows  $\frac{1}{1000}$  of an acre (hectare) would be 17' 5" (14.28 m).

$\frac{1}{1000}$ Hectare Seed Population Count Row Width/Distance		
Row Width	15" (35 cm)	30" (70 cm)
Distance	34'10" (6.56 m)	17'5" (14.28 m)

**NOTE: Seeds may bounce or roll when planting with closing wheels raised and planting depth set shallow affecting seed spacing accuracy.**

4. Count seeds in measured distance.
5. Multiply number of seeds placed in  $\frac{1}{1000}$  of an acre (hectare) by 1000. This gives total population.

EXAMPLE: 30" (70 cm) row spacing 17' 5" (14.28 m) equals  $\frac{1}{1000}$  acre.  
26 seeds counted x 1000 = 26,000 seeds per acre

Seed count can be affected by drive wheel and seed meter drive ratio, tire pressure, and/or seed meter malfunction.

1. If seed check shows average distance between seeds in inches is significantly different than seed rate chart indicates, first check drive ratio between drive wheel and seed meter. Check drive wheel air pressure, check for incorrect sprocket(s) in driveline and check drive and driven sprockets on transmission(s) for proper selection.
2. Check for seed meter malfunction. For example, if spacing between kernels of corn at the transmission setting being used is 8" (20 cm) and a gap of 16" (40 cm) is observed, a finger has lost its seed and not functioned properly. If two seeds are found within a short distance of each other, the finger has metered two seeds instead of one.
3. See ["Seed Meter \(Finger Pickup\) Troubleshooting" on page 8-6](#) and/or ["Seed Meter \(Brush-Type\) Troubleshooting" on page 8-5](#) in the Troubleshooting Section of this manual.

## DETERMINING POUNDS PER ACRE (BRUSH-TYPE METER)

Seeds per acre ÷ Seeds per pound (from label) = Pounds per acre

If seeds per pound information is not available use the following averages:

- 2,600 seeds per pound for medium size soybeans
- 15,000 seeds per pound for medium size milo/grain sorghum
- 4,500 seeds per pound for medium size cotton

## DETERMINING BUSHELS PER ACRE

Pounds per acre ÷ Seed unit weight = Bushels per acre

Average Unit Weight of:

- 1 Bushel Soybeans = 60 Pounds
- 1 Bushel Milo/Grain Sorghum = 56 Pounds
- 1 Bushel Cotton = 32 Pounds

If seed population check shows planting rate is significantly different than seed rate chart shows or if a particular meter is not planting accurately, see ["Brush-Type Seed Meter 2.0 Maintenance"](#) and ["Seed Meter \(Brush-Type\) Troubleshooting"](#).

## WATER TANK

The water tank is to only be filled with clean water or preferably potable water (water meeting local standards for drinking). The tank holds 4 gallons (15 L) of water. Be sure to check for regulations pertaining to this use. Tank should be filled with new water at the beginning of each planting season and drained at the end of each planting season.

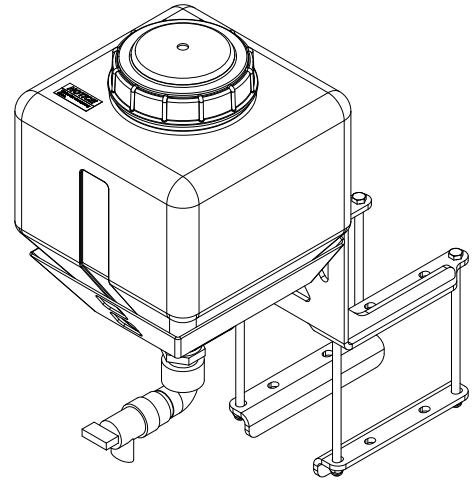

### NOTICE

**Drain tank if environmental conditions are 32° Fahrenheit (0° Celsius) or below to prevent tank from cracking.**

The water tank is to be used in the event of an accidental exposure to chemical. Chemicals are supplied with Material Safety Data Sheets (MSDS) that provide full information about the chemical, its effects on exposure, and first aid needs in the event of an emergency. Keep your MSDS file up-to-date and available for first responders in case of emergency.

If the water tank is used seek medical assistance immediately for further treatment.

## PLANTING DEPTH

Planting depth is maintained by adjustable row unit gauge wheels. Depth adjustment range is approximately ½" to 3½" (1.27 to 8.89 cm).

1. Raise planter to remove weight from wheels.
2. Push down on depth adjustment handle and reposition it forward to decrease or rearward to increase planting depth. Initially adjust all units to the same setting.
3. Lower planter and check operation and planting depth of all row units. Readjust individual rows as needed for uniform operation.

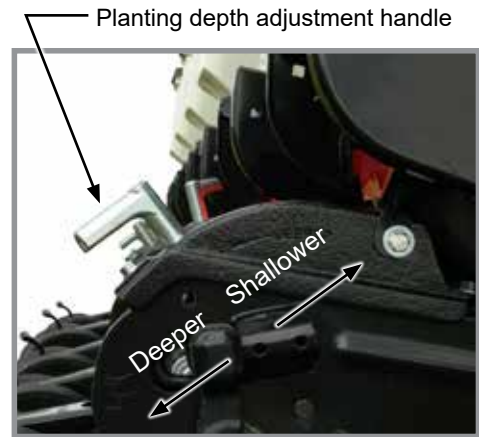

Planting depth adjustment

## “V” CLOSING WHEEL ADJUSTMENT (RUBBER OR CAST IRON)

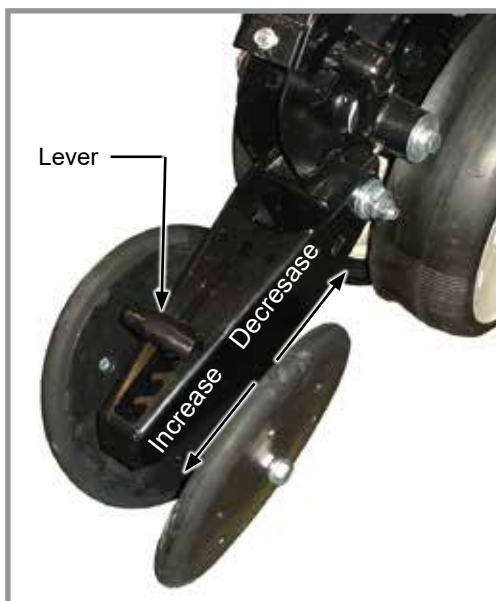

“V” Closing wheels installed offset

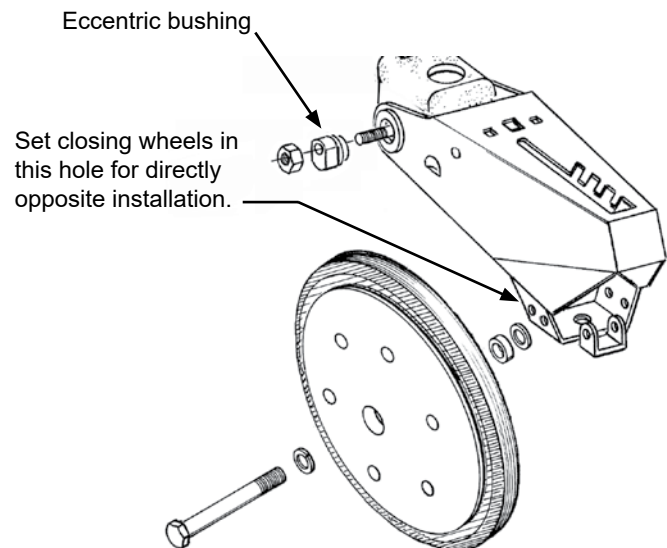

“V” closing wheels should have enough down pressure to close the seed trench and ensure good soil to seed contact. Move 5-position quick adjustable down force lever on the top of closing wheel arm to the rear to increase closing wheel spring pressure. Move lever forward to decrease pressure. Adjust all row units to a similar setting. Light soil usually requires less down force at average depth (approximately 2" (5 cm)) while heavy soil requires increased down force.

Eccentric bushings in the wheel arm stop allow for lateral adjustment of the “V” closing wheel assembly. Use a ¾" wrench to loosen hardware attaching closing wheel arm to wheel arm stop. Use another ¾" wrench to turn eccentric bushings until **closing wheels are aligned with seed trench**. Tighten hardware.

Closing wheels can be installed “offset” (to improve residue flow) or “directly” opposite. Use forward installation holes if set “directly” opposite.

**CLOSING WHEEL SHIELD (RUBBER OR CAST IRON "V" CLOSING WHEELS)**



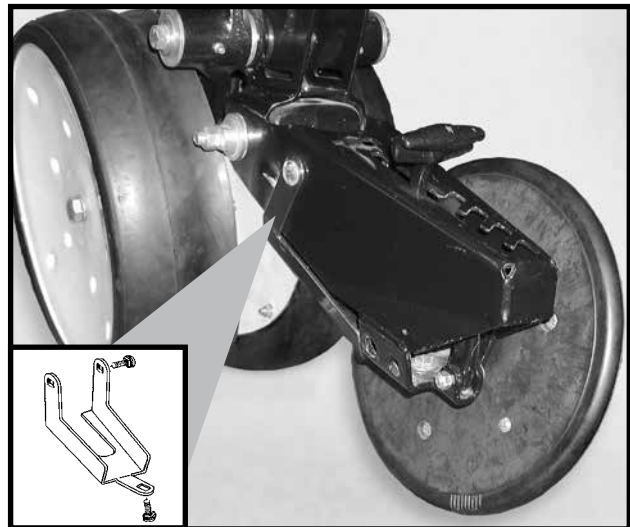





Optional closing wheel shield is installed on underside of closing wheel arm to help prevent root balls and stalks from clogging closing wheels.



**Closing wheel shield  
(Shown with closing wheel removed)**



**BRUSH-TYPE SEED METER 2.0**

	<b>Crop</b>	<b>Disc Color-Code (Disc Part No.)</b>	<b>Upper Brush Retainer</b>	<b>Cells</b>	<b>Seed Size Range</b>	<b>*Lubricant</b>
	Soybean	Black (GB1123)	GB1084	60	2200 to 4000 seeds/lb.	<b>Graphite</b> Talc
	Soybean	Dark Gray (GB1171)	GB1084	54	2000 to 3000 seeds/lb.	<b>Graphite</b> Talc
	Specialty Soybean	Dark Blue (GB1124)	GB1084	48	1400 to 2200 seeds/lb.	<b>Graphite</b> Talc
	Small Milo/Grain Sorghum	Orange (GB1130)	GB1107	30	14,000 to 20,000 seeds/lb.	Talc
	Large Milo Grain Sorghum	Light Blue (GB1131)	GB1107	30	10,000 to 16,000 seeds/lb.	Talc
	High-Rate Small Milo/Grain Sorghum	Red (GB1132)	GB1107	60	12,000 to 18,000 seeds/lb.	Talc
	High-Rate Large Milo/Grain Sorghum	Yellow (GB1133)	GD8237	60	10,000 to 14,000 seeds/lb.	Talc
	Wheat	Purple (GB1134)	GB1084	54	N/A Volumetric	<b>Graphite</b> Talc

\*For More information on application rate see Additives section.

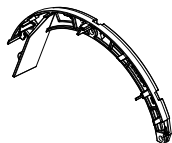

Use GB1084 upper brush retainer when using wheat and soybean discs.



Use GB1107 milo insert when using milo/ grain sorghum discs.

Turn seed disc counterclockwise when installing on meter hub while tightening two wing nuts that retain disc. Seed disc should have slight resistance when rotated counterclockwise after wing nuts are tight.

Brush-type seed meter attaches to seed hopper same as finger pickup seed meter. Secure to bottom of seed hopper with two  $\frac{5}{16}$ " thumbscrews. Tighten thumbscrews slightly with pliers. **DO NOT OVER TIGHTEN.**

Misalignment between drive coupler and seed meter input shaft may cause erratic seed spacing from momentary stoppage of seed disc. Check alignment and adjust as needed.

Refer to planting rate charts in this manual for recommended seed drive transmission sprocket combinations.

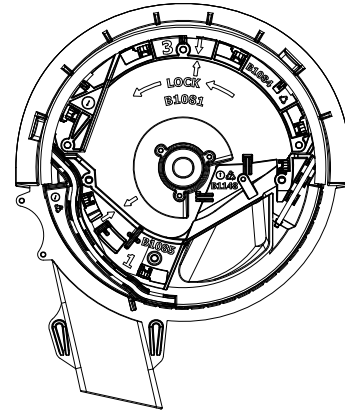

Shown without seed disc installed



## NOTICE

Replace hopper lids after hoppers are filled to prevent accumulation of dust or dirt in seed meter which will cause premature wear.

**NOTE:** Clean seed is required to ensure accurate seed metering from brush-type seed meters. Remove seed discs daily and check seed meter or brushes for buildup of foreign material, such as hulls, stems, etc.

**FINGER PICKUP SEED METER**

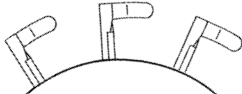
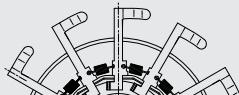

Crop	Fingers	*Lubricant
Corn	 <p>Part No.: GR1848 - Finger Assembly, Corn</p>	Graphite Talc
No. 1 and/or No. 2 size Confectionery Sunflower Seeds	 <p>Part No.: GR1848 - Finger Assembly, Corn</p>	Talc
No. 3 and/or No. 4 size Oil Sunflower Seeds	 <p>Part No.: GR2154 - Finger Assembly, Oil</p>	Talc
Blank fingers replace alternate fingers to reduce planting rate by half while allowing the finger wheel to maintain a minimum of 40 RPM when planting low rates.	 <p>Part No.: GD11787 - Half Rate Blank Finger</p>	Graphite Talc

\*For More information on application rate see [“Additives” on page 3-6.](#)

**NOTE:** Always field check seed population to verify planting rates.

**NOTE:** Refer to planting [“Rate Charts”](#) in this manual for recommended seed drive transmission sprocket combinations.

**ADDITIVES**

<b>Lubricant Application Rate</b>	
<b>Graphite</b>	
Conventional Hoppers	1 Tbs./Hopper Fill
<b>80/20 Talc-Graphite</b>	
Conventional Hoppers	½ C.**
**Must be evenly mixed during fill.	
<b>Talc</b>	
Conventional Hoppers	¼ C.*
*Double amount of talc for sunflowers.	

GRAPHITE

The use of graphite is the primary recommendation to promote seed flow, provide lubrication for the seed meter and to help dissipate static charge buildup. Among the available dry seed lubricants graphite is the most effective and easiest to use and it requires no mechanical agitation

Conventional Hoppers

Mix one tablespoon of **powdered graphite** with seed each time hoppers are filled. Regular graphite use prolongs life of the seed meter components, improves seed spacing, and may reduce buildup of seed treatments.

**NOTE: DO NOT apply graphite only in center of hopper. It will filter too quickly through the seed and not distribute as evenly as desired.**

Apply graphite around outer perimeter of hopper.



Adding graphite to conventional hopper

**NOTE: Additional graphite may be required to retard buildup of seed treatments on meter components. More frequent cleaning of monitor seed tubes may be necessary due to use of additional graphite.**

### 80/20 TALC-GRAPHITE

Talc-Graphite lubricant is to be used for treated seed, providing benefits of both talc and graphite. It absorbs moisture to prevent bridging, minimizes static electricity for improved seed flow, and lubricates seed and meters.

#### Conventional Hoppers

Mix ½ C. of 80/20 talc-graphite evenly with seed each time hoppers are filled. Regular graphite use prolongs life of the seed meter components, improves seed spacing, and may reduce buildup of seed treatments.

**NOTE: Talc-Graphite lubricant MUST be mixed evenly during fill.**

### TALC

**Talc seed lubricant** may be used as a drying agent in addition to graphite lubrication. The drying agent may improve seed release and/or **to retard buildup of seed treatments on meter components.**

1. Fill hopper ½ full of seed, add ¼ cup (conventional) of talc and **mix thoroughly**.
2. Finish filling hopper, add another ¼ cup (conventional) of talc and **mix thoroughly**.
3. Adjust rate of talc use as needed so all seeds are coated, while avoiding a buildup of talc in bottom of hopper.

Humid conditions and/or small sized seeds with extra seed treatment may require additional talc to maintain meter performance.

**NOTE: Liquid seed treatments or inoculants may create buildup on the seed disc or brushes. Check frequently for proper population and/or seed delivery when using any liquid seed treatment.**

Completely mix all treatments with seed following manufacturers' recommendations. Seed treatment dumped on top of seed after hopper is filled may not mix properly and cause seed bridging, reducing population or stopping meter from planting.

## SEED METER CLEANOUT

**NOTE: Use of damaged seed or seed containing foreign material will cause plugging of seed cell orifices and require more frequent seed meter cleanout to prevent underplanting.**

Thorough seed meter cleanout is important to maintain genetic purity.

1. Disengage seed drive and remove seed hopper and meter.
2. Dump seed from right rear corner of hopper into a container.
3. Disassemble seed disc by removing wing nuts.
4. Empty Meter.
4. Thoroughly inspect brushes in meter to ensure all seed is removed.
5. Replace seed disc. Install wing nuts.

## SEED HOPPERS



Seed hopper is retained by an over-center latch. Wear gloves to prevent injury to hands while releasing the latch.

Mechanical seed hopper has a capacity of 1.9 bushels.

Vacuum seed hopper has a capacity of 1.75 bushels.

Use clean seed and make certain there are no foreign objects inside when filling seed hopper. **Replace hopper lids after hoppers are filled to prevent accumulation of dust or dirt in seed meter which can cause premature wear.** See [“Finger Pickup Seed Meter”](#) and/or [“Brush-Type Seed Meter 2.0”](#).

Periodically empty hoppers completely to remove any foreign objects and to ensure proper seed meter operation.

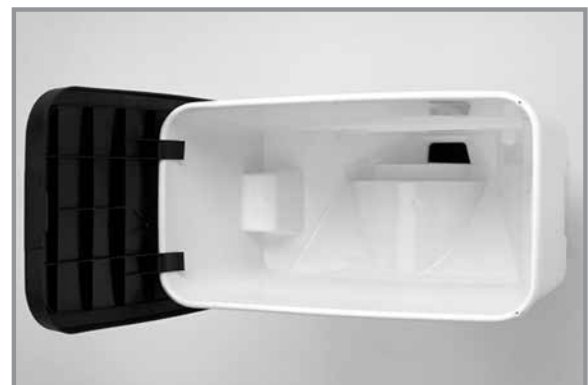

**Mechanical seed hopper**

Disengage meter drive and hopper latch and lift hopper off hopper support. See [“Seed Meter Drive Release”](#).

## SEED METER DRIVE RELEASE

A clutch release mechanism disengages seed meter drive from seed meter to remove seed hopper. Disconnecting drive allows operator to check granular chemical application rates without dropping seed. It also allows one or more rows to be disconnected when finishing fields.

Turn knob  $\frac{1}{4}$  turn counterclockwise to disengage or  $\frac{1}{4}$  turn clockwise to engage.

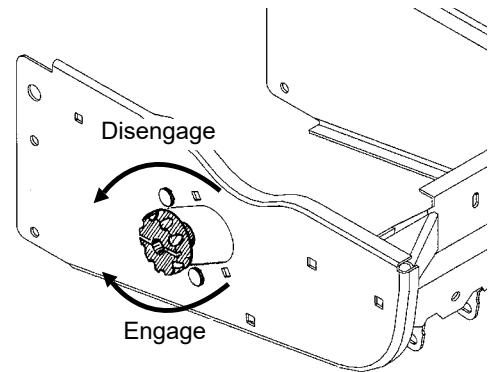

**Seed meter drive release**

## ROW UNIT EXTENSION BRACKETS

Row unit extension brackets extend row units rearward 4" (10.2 cm) to provide clearance for coulter mounted residue wheels and HD single disc fertilizer openers.

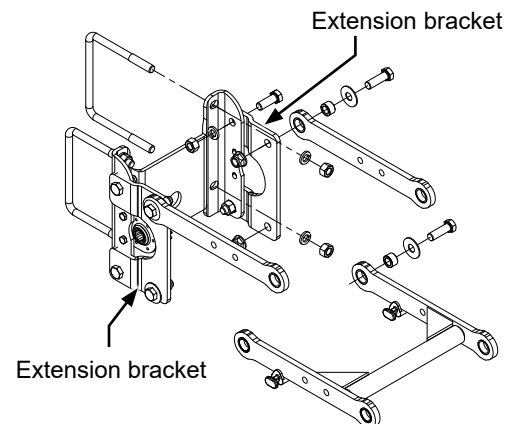

**Row unit extension brackets**

### ROW UNIT CHAIN ROUTING

Row unit drive chains must be properly tensioned and aligned for proper operation and to minimize wear.

Inspect and replace weak, worn or broken springs, idlers, and idler bushings.

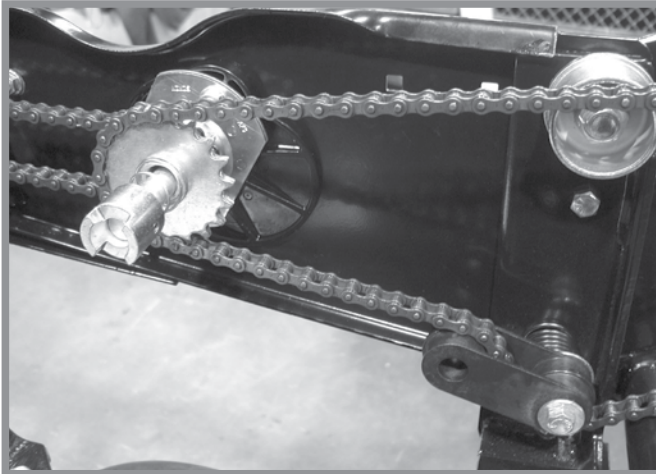

**Pull row unit meter drive**



**Push row unit meter drive**

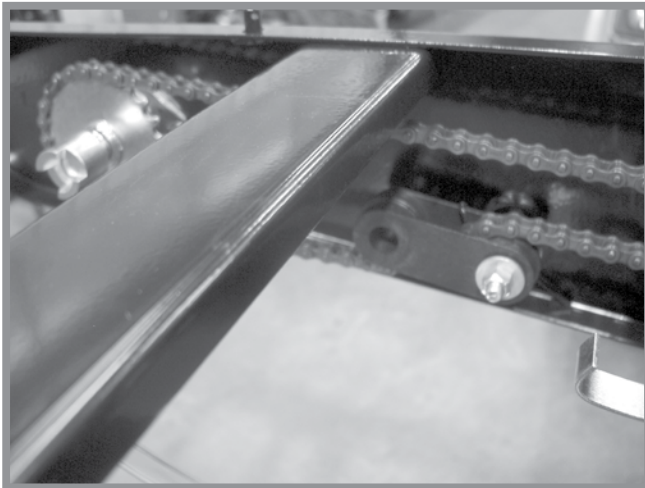

**Row unit granular chemical drive**

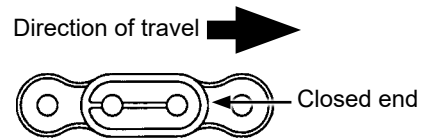

**NOTE: Install connector link with closed end facing direction of travel.**

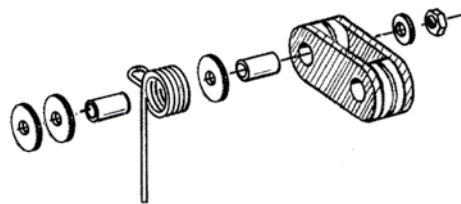

**NOTE: Reverse idler when worn on one side for extended use.**



**QUICK ADJUSTABLE DOWN FORCE SPRINGS OPTION**

Quick adjustable down force springs increase penetration in hard soil and keep row unit from bouncing in rough field conditions. Two springs per row, one on each side parallel arms, are used unless equipped with row unit mounted no till coulters. Four springs per row are used with row unit mounted no till coulters.

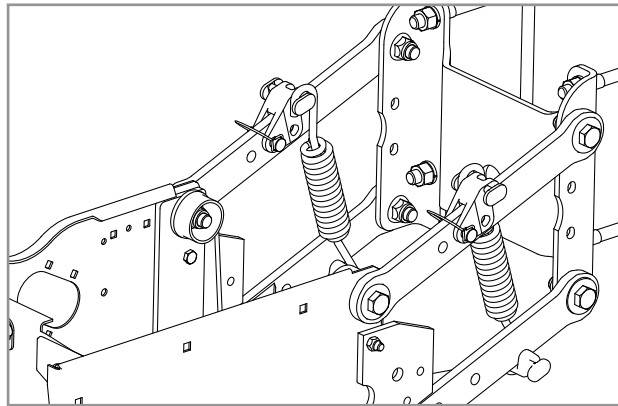

**Two Springs Per Row (Dual)**

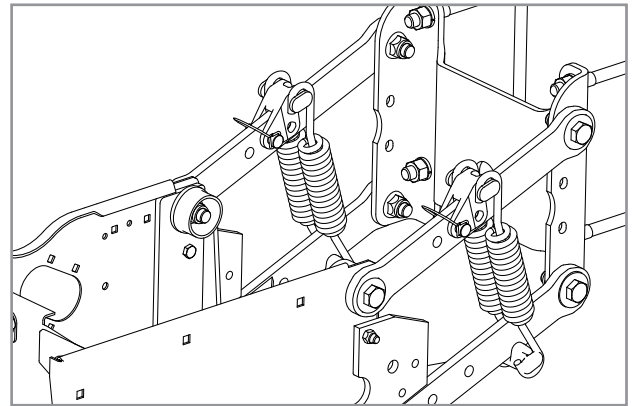

**Four Springs Per Row (Quad)  
(Row Unit Mounted No Till Coulters Only)**

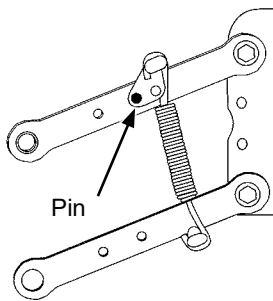

**Position 1 (Least)**

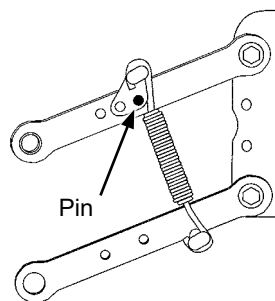

**Position 2**

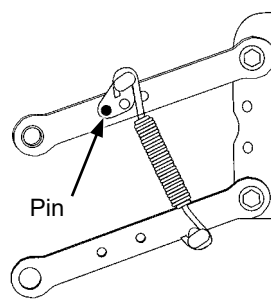

**Position 3**

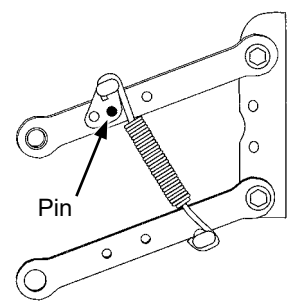

**Position 4 (Most)**

There are four positions to set down pressure spring tension.

<b>NOTICE</b>	<b>Springs must be installed with open side of spring hooks toward seed hoppers to prevent binding on spring mount adjustment pins.</b>
---------------	---

1. Raise planter and remove spring mount pin at top of spring.
2. Slide mount to desired position and install pin.

**NOTE: Adjust springs for field conditions. Too much down pressure in hard field conditions can cause row units to lift planter and keep drive wheels from making contact. Too much down pressure in soft field conditions can cause row unit to run too deep.**

Heavy Duty Spring Down Force Pressure*		
	2 Springs	4 Springs
Position	Heavy Duty P/N: D21337	Heavy Duty P/N: D21337
1	43 lb (19.5 kg)	80 lb (36.3 kg)
2	86 lb (39.0 kg)	144 lb (65.3 kg)
3	167 lb (75.7 kg)	307 lb (139.3 kg)
4	249 lb (113.0 kg)	470 lb (213.2 kg)
*Pressure does not include weight of row unit, seed, or options.		

## ROW UNIT MOUNTED NO TILL COULTER

Row unit mounted no till coulters with 1" bubbled, 1" fluted (8 flutes) or ¾" fluted (13 flutes) blades may be used on pull row units and push row units (¾" fluted shown). Four quick adjustable down force springs are required per row when using row unit mounted no till coulters. See "Quick Adjustable Down Force Springs Options".

Align coulters to row unit double disc openers. Adjust by loosening four attaching bolts, moving coulters, and tightening four attaching bolts. Coulters can be adjusted to one of four ½" incremental settings in the forked arm. Initial location is the top hole.

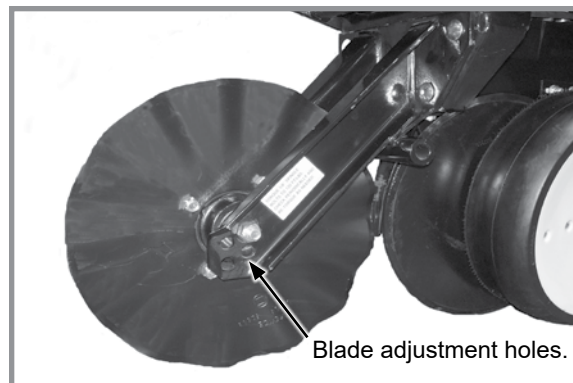

**Row Unit Mounted No Till Coulters**

Move blade as it wears to one of the three lower holes to maintain coulters at or slightly above opener discs as needed. Adjust coulters below depth of double disc opener blades in very hard soil conditions such as compacted wheel tracks to improve opener penetration and cutting of surface residue.

Check operating depth by setting planter down on a level concrete floor and checking relationship between coulters and row unit opener blades. Make sure planter is level and coulters are square with planter frame and aligned with row unit disc opener.

**NOTE: Torque 5/8" spindle hardware to 120 ft-lb (162.7 N-m).**

## COULTER MOUNTED RESIDUE WHEELS

Coulters mounted residue wheels are designed for use on pull row units and push row units. Row unit extension brackets are required on the four center pull row units if the planter is equipped with coulters mounted residue wheels.

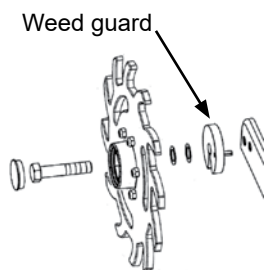

**NOTE: Opening in weed guard must face down.**



**Coulters mounted residue wheels**

Residue wheels attach to row unit mounted coulters with two cap screws and sleeves allowing unit to free-float. A 2-position spindle bolt mounting positions wheels interlocked or staggered. Depth adjustment is made with a spring-loaded cam and pin with 8 positions in 7/16" (6 mm) increments. A high point on the cam allows wheels to be locked up.

A weed guard on the inboard side of each wheel helps prevent weed wrap which can cause premature bearing failure.

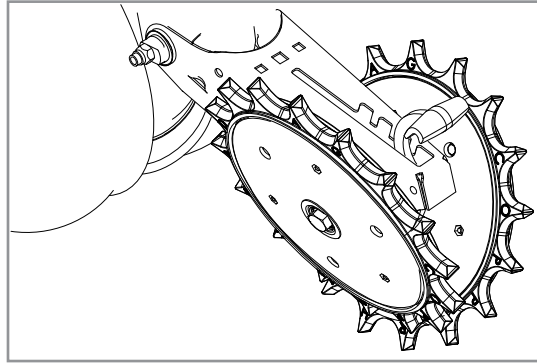

**SPIKED CLOSING WHEEL****Row Unit Spiked Closing Wheel**

Spiked closing wheels crumble the sidewall, allowing roots to penetrate soil. They can be used on pull row units and push row units.

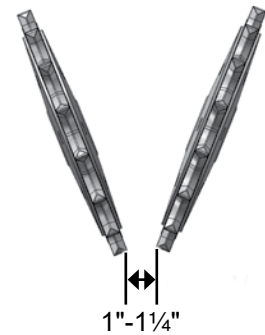
Align spiked closing wheels straight across from each other, in most forward holes on closing wheel arm. Set the wheels 1" - 1¼" (2.5 - 3.1 cm) apart at the closest point.



## GRANULAR CHEMICAL HOPPER AND DRIVE

 <b>WARNING</b>	<p>Agricultural chemicals can cause death or serious injury to persons, animals, and plants or seriously damage soil, equipment, or property. Read and follow all chemical and equipment manufacturers labels and instructions.</p>
	

The granular chemical hopper has a 1.4 cubic feet capacity.

Make sure no foreign objects get into hopper when it is being filled. Replace hopper lids after filling to prevent accumulation of dirt and moisture.

A metering gate on bottom of hopper regulates the application rate. See “Dry Insecticide and Dry Herbicide Application Rate Charts” in this manual. Calibrate using chemical manufacturers’ instructions.



**Granular chemical hopper**

Granular chemical clutch drive coupler and meter shaft can be disengaged and engaged by turning throwout knob at rear of hopper support panel.

Rotate knob  $\frac{1}{4}$  turn counterclockwise to disengage and  $\frac{1}{4}$  turn clockwise to engage.

Slotted holes in hopper support panel and clutch housing allow for alignment adjustment between clutch drive coupler and meter shaft.

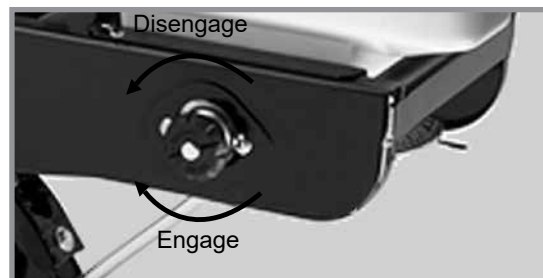

**Granular chemical drive release**

## GRANULAR CHEMICAL BANDING OPTIONS

Granular chemical banding options allow 4½" slope-compensating banding, straight drop in-furrow placement or 14" rear banding.

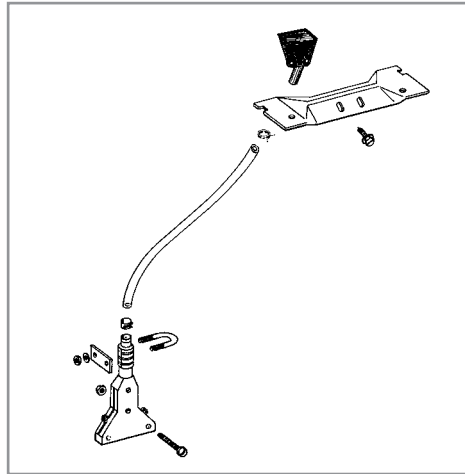

**NOTE: Granular chemical rear bander is not compatible with covering discs/single press wheel option.**



**4½" Slope-Compensating Bander**

**SPLIT ROW LOCKUPS**

Split row lockups are designed to allow the push row units to be locked in the raised position.

 <p><b>CAUTION</b></p>	<p>Improper lifting of row units can cause serious injury. An empty row unit requires minimum 84 lb (38.1 kg) lift. Set down pressure springs to minimum, lower planter to ground, and empty seed hopper before attempting to lift with this lever.</p>
	

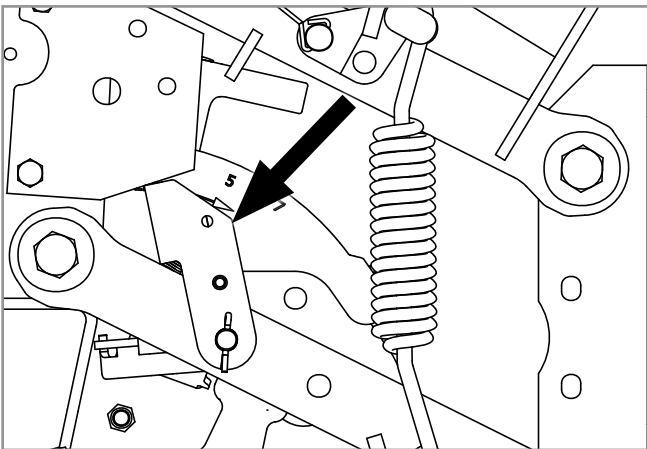

**Push Row Unit Locked In Raised Position**

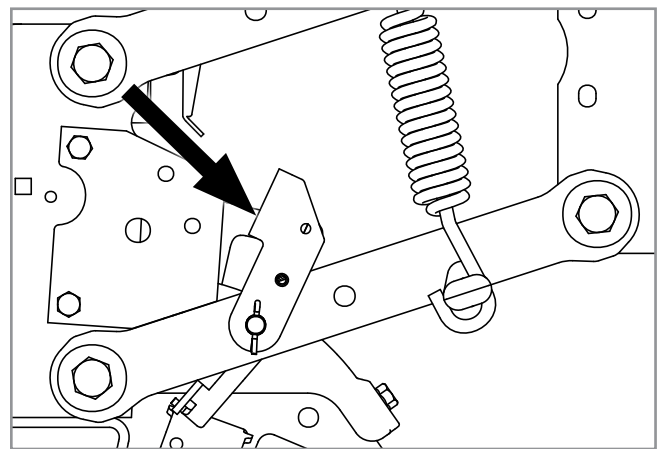

**Lockup Released For Field Operation**

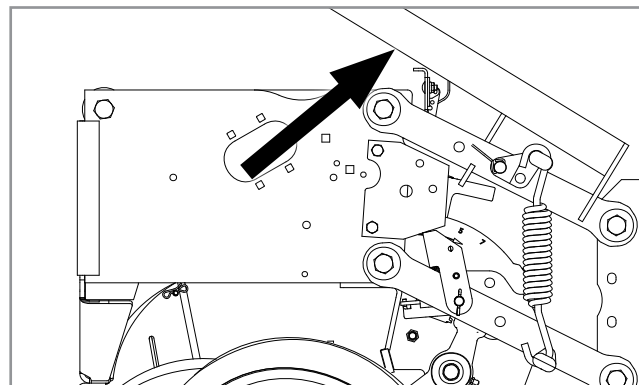

**Lift lever positioned on push row unit**

**To lock in raised position:**

1. Set row unit down pressure springs to minimum setting.
2. Lower the planter to the planting position.
3. Empty seed hoppers.
4. On each split row lockup, flip the spring tab forward.
5. Using the lift lever, raise the push row unit to allow the spring loaded lockups to snap into locked position under the row unit stops.
6. Repeat Steps 4 and 5 on remaining push row units.

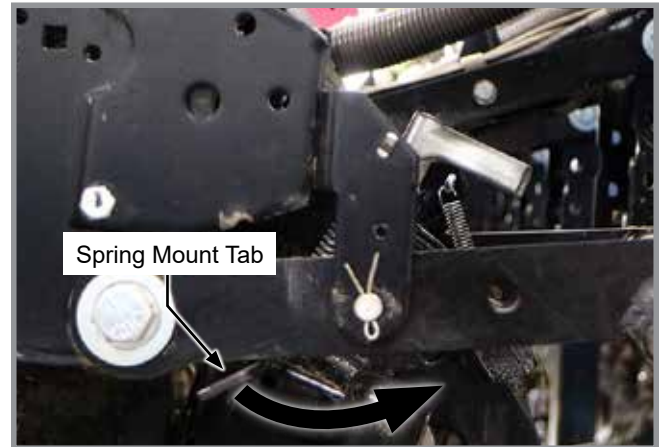
**To release lockups:**

1. Lower the planter to the planting position.
2. On each split row lockup, flip the spring tab rearward.
3. Using the lift lever, raise the push row unit to allow the spring loaded lockups to snap out of locked position. Lower row unit to the ground.
4. Repeat Step 3 on remaining push row units.

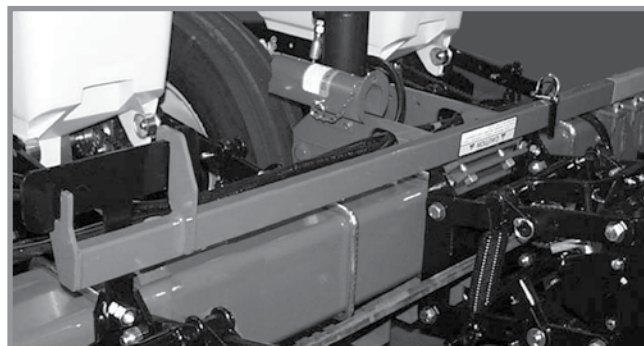

Lift lever in storage location

## SPLIT ROW CLUTCH SPROCKET

Push row unit clutch sprocket disengages Split Row drive from push row unit drill shaft when only pull row units are used.

### DISENGAGE

Rotate knurled collar  $\frac{1}{4}$  turn. Rock drill shaft slightly using a  $\frac{7}{8}$ " wrench to take pressure off of spring loaded pins in clutch to allow pins to "pop" out, disengaging drive.

### ENGAGE

Rotate knurled collar  $\frac{1}{4}$  turn and turn drill shaft with a  $\frac{7}{8}$ " wrench until drive pins engage drive sprocket.

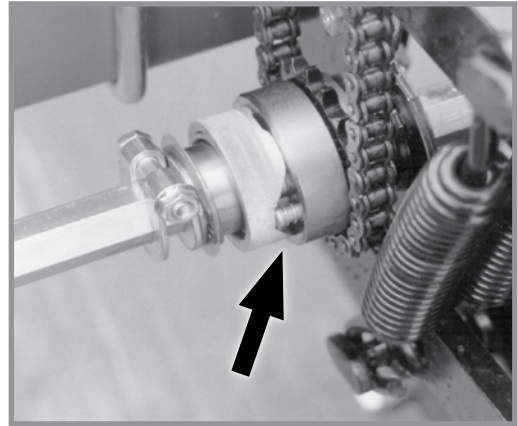

Split Row clutch sprocket



**NOTCHED SINGLE DISC OPENERS**

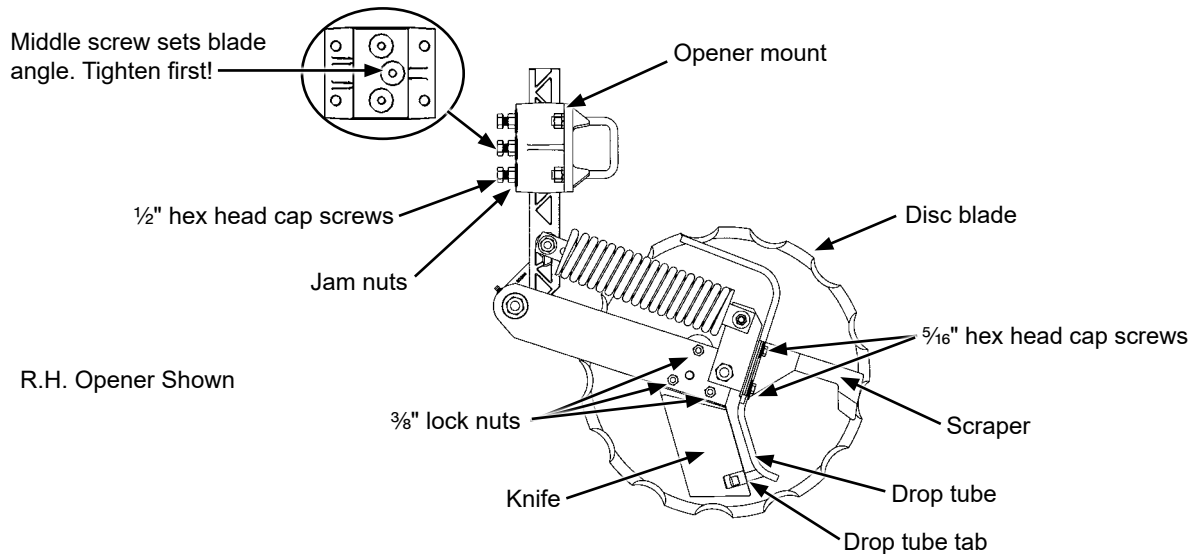

**Notched single disc opener adjustments**

<p><b>CAUTION</b></p>	<p>Compressed spring may fly out of this assembly if attempting to disassemble and cause injury. Do not take apart this assembly.</p>
	<p>Disc blades are sharp and can cut causing serious injury. Wear gloves when working on or turning disc blades by hand.</p>
<p><b>NOTICE</b></p>	<p>Never strike knife with heavy object. Damage to knife will occur.</p>
	<p>If knife to disc blade clearance is too large, soil or residue can wedge between knife and blade, and blade will not turn.</p>

1. Adjust knife to disc blade contact. Loosen or tighten  $\frac{3}{8}$ " lock nuts to adjust knife's entire leading edge against disc blade. Turn blade and check for slight resistance without freewheeling. Readjust knife to blade's tight spot as needed.

**NOTICE**

**Adjust liquid drop tube out of path of soil flow across knife. Drop tube and tab wear quickly if not correctly adjusted.**

2. Adjust scraper and drop tube. Loosen two  $\frac{5}{16}$ " hex head cap screws. Adjust scraper until just touching disc blade. Adjust drop tube until it is centered between knife and disc blade. Tighten screws. Turn blade and check for slight resistance without freewheeling. Repeat as needed. Insert flat bladed pry bar or screwdriver between knife and drop tube above drop tube tab. Carefully bend tube until  $\frac{1}{4}$ "- $\frac{3}{8}$ " (6.35 - 9.5 mm) from disc blade.

**NOTE: Maximum disc blade depth 4" (10.2 cm).**

3. Adjust blade depth. Loosen three  $\frac{1}{2}$ " hex head cap screws and jam nuts in opener mount. Adjust opener assembly up or down to desired blade depth. Tighten center hex head cap screw and jam nut first to set proper disc blade angle. Tighten remaining hex head cap screws and jam nuts. Torque hex head cap screws and jam nuts to 57 ft-lb (77.29 N-m). Check fertilizer hose clearance and adjust as necessary.

---

**DEPTH/GAUGE WHEEL ATTACHMENT FOR NOTCHED SINGLE DISC FERTILIZER OPENER**

**Notched single disc opener depth/gauge wheel**

Depth/gauge wheel attachment for notched single disc fertilizer opener is used where additional gauging is required to maintain desired fertilizer opener depth. Depth/gauge wheel is attached to notched single disc fertilizer opener using a mounting block fastened to the pivot arm with  $\frac{5}{8}$ " hardware through disc blade bearing.

Depth adjustment is made using 3 adjustment holes in depth/gauge wheel mounting block. Moving depth/gauge wheel increases/decreases depth in approximate 1" (2.5 cm) increments in relation to blade depth setting made at vertical mounting post.

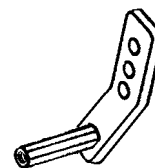

**HD SINGLE DISC FERTILIZER OPENER**

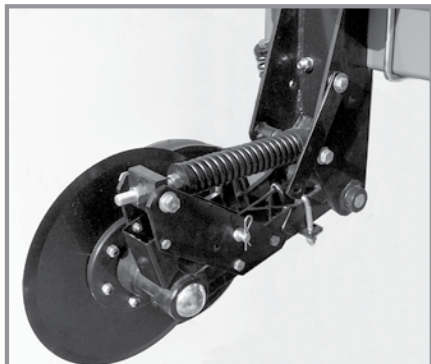

**HD single disc opener**

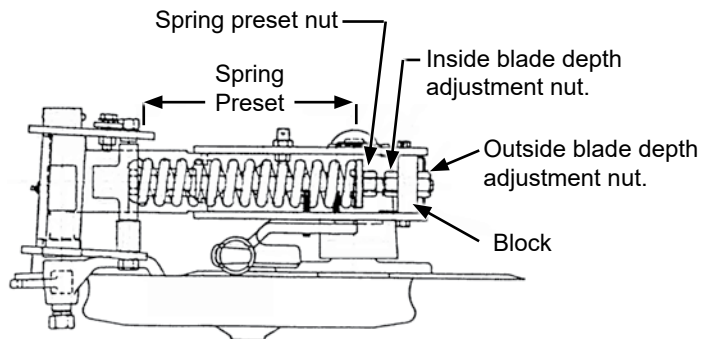

**R.H. configuration shown (Overhead view)**

Recommended placement of fertilizer with HD single disc fertilizer opener is 3½" - 4" (8.8 - 10.1 cm) from row.

<b>NOTICE</b>	<b>Never place fertilizer closer than 2" (5 cm) to row or seeds may be damaged.</b>
---------------	---

Maximum blade depth is approximately 5" (12.7 cm) with planter frame level and at 20" (50.8 cm) operating height. Soil conditions can affect depth slightly.

Raise planter to remove weight from fertilizer opener. Loosen inside adjustment nut with 1½" wrench. Turn outside nut clockwise to decrease or counterclockwise to increase blade depth. One full turn of blade depth adjustment nut changes blade depth ⅜". Tighten inside nut tight against block. Adjust all fertilizer openers to same depth.

Fertilizer opener down pressure can be adjusted from 250 lb (113.4 kg) to 640 lb (290.3 kg).

<b>NOTICE</b>	<b>Do not operate HD single disc fertilizer openers at full down pressure tension on rocky ground or disc blades will chip.</b>
---------------	---

**NOTE: DO NOT adjust spring preset dimension less than 9½" (24.13 cm).**

**NOTE: Excessive down pressure can cause planter frame up-lift and affect machine performance. Planter frame should be 20" (50.8 cm) from ground in planting position. Excessive down pressure in loose soil conditions can cause openers to run too deep and push dirt ahead of opener and may stop soil press wheel and opener blade from turning.**

Raise planter to remove weight from fertilizer opener. Turn spring preset nut clockwise to increase and counterclockwise to decrease down pressure. Adjust all rows to a similar setting. Minimal spring pressure for acceptable operation is recommended. See chart for spring length setting specifications.

Spring Preset	
Length	Down Pressure
11" (27.9 cm)	250 lb (113.4 kg)
10¾" (27.3 cm)	320 lb (145.1 kg)
<b>*10½" (26.7 cm)</b>	370 lb (167.8 kg)
10¼" (26 cm)	450 lb (204.1 kg)
10" (25.4 cm)	520 lb (235.8 kg)
9¾" (24.8 cm)	580 lb (263.1 kg)
9½" (24.1 cm)	640 lb (290.3 kg)
*Initial setting	

Adjust spring loaded dry fertilizer drop tube/scrapper periodically to maintain ⅛" (3 mm) gap between drop tube and opener blade. If this dimension is not maintained fertilizer may not drop in proper location.

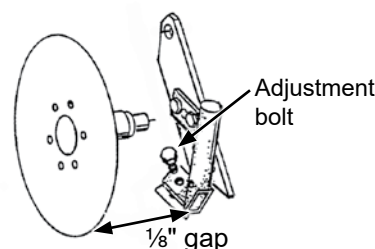

Loosen scraper adjustment bolt. Slotted hole in scraper allows up or down adjustment.

Adjust liquid drop tube/scrapper so there is slight contact between blade and scraper lower leading edge, and 1/4" (6.35 mm) clearance between liquid drop tube trailing edge and blade. Blade should turn with minimum amount of drag.

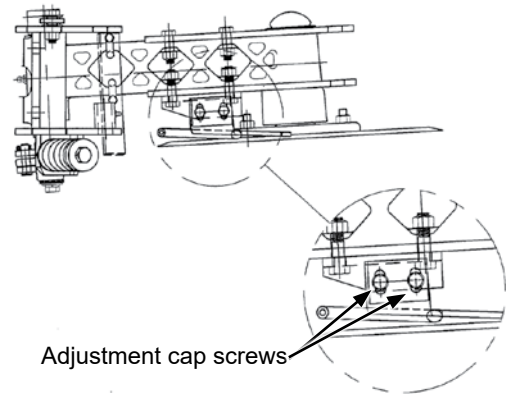

**NOTE: Soil press wheel is not for gauging fertilizer opener operating depth.**

Additional press wheel down pressure may be desirable in heavy moist soils. Turn press wheel spring adjustment bolt clockwise to increase down pressure.

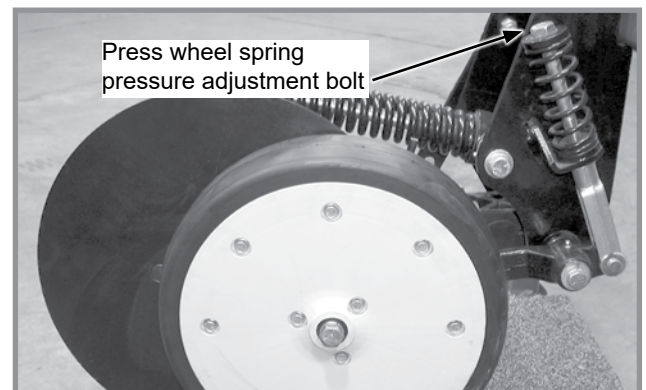

**Soil press wheel down pressure adjustment**

HD single disc fertilizer opener can be raised and locked up when fertilizer attachment is not used or during storage.

**NOTE: A lockup bar automatically raises and locks soil press wheel when blade assembly is raised.**

1. Place planter in planting position.
2. Remove outside blade depth adjustment.
3. Raise planter until adjustment bolt clears adjustment block.
4. Raise spring to clear blade assembly and raise blade assembly until storage strap can be positioned on lockup pin. Install hair pin clip.
5. Reinstall depth adjustment nut and tighten

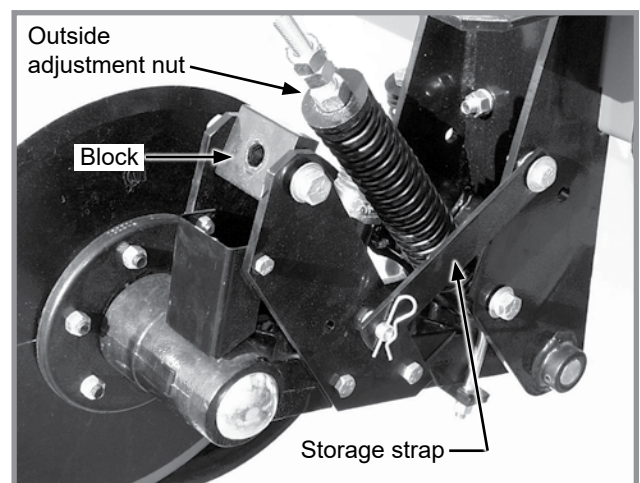

**Locking up HD single disc opener**

**DRY FERTILIZER ATTACHMENT**



**Agricultural chemicals can cause death or serious injury to persons, animals, and plants or seriously damage soil, equipment, or property. Read and follow all chemical and equipment manufacturers labels and instructions.**

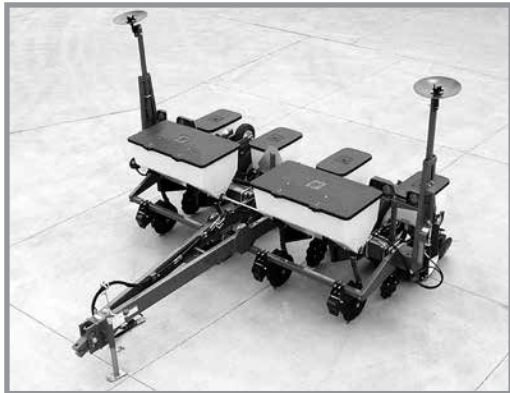

**Dry fertilizer option installed**

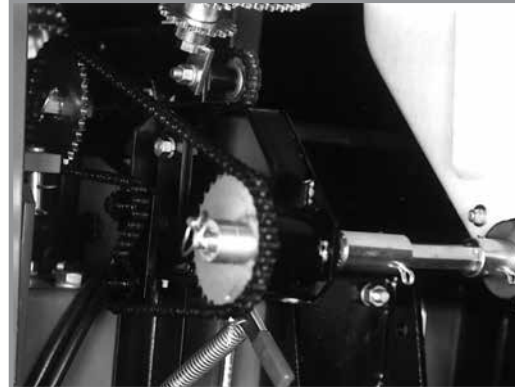

**Fertilizer drive rate transmission**

Rate of fertilizer application is determined by drive/driven sprocket combination on fertilizer drive rate transmission and auger position in the hoppers.

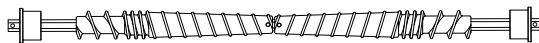

**Augers positioned for high rate delivery**

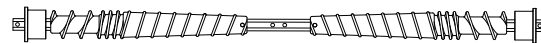

**Augers positioned for low rate delivery**

**NOTE: Uneven delivery of fertilizer will occur if high rate auger position is used at too low a rate setting.**

Remove ¼" stainless steel cap screws holding augers in place on shaft and reposition augers to change delivery rate.

A fertilizer transmission is located directly ahead of row unit transmission on right side of planter and allows simple, rapid changes in sprockets to obtain desired fertilizer application rates. Chain tension is controlled by a spring loaded idler adjusted with a ratchet arm located to inside of transmission. Sprockets can be changed with those on the sprocket storage rod by removing hexagon shaft pins. Fertilizer rate charts in Rate Chart section will help you select correct sprocket combinations.

**NOTE: Make a field check after each sprocket combination adjustment to be sure you are applying fertilizer at desired rate.**

**NOTICE**



**Placing fertilizer too close to seeds or in excessive amounts can cause germination or seedling damage. Check with your fertilizer dealer or manufacturer for correct amount and placement.**

Because dry fertilizer attachment meters granules by volume rather than weight, differences in brands, and fertilizer analysis, weight metered during actual application may vary considerably. Use chart for reference only. Use a container to catch and measure application for a better estimate.

Keep fertilizer dry during use and storage since most fertilizers easily absorb moisture. In addition to waste, deposits of fertilizer left in hopper can cause metal corrosion. Empty hoppers at end of each day.

## GRANULAR CHEMICAL APPLICATION FIELD CHECK

Temperature, humidity, speed, ground conditions, flowability of different material, or meter obstructions can affect granular chemical rate of delivery.

 <b>WARNING</b>	<p><b>Agricultural chemicals can cause death or serious injury to persons, animals, and plants or seriously damage soil, equipment, or property. Read and follow all chemical and equipment manufacturers labels and instructions.</b></p>
	

Perform a field check to determine application rates.

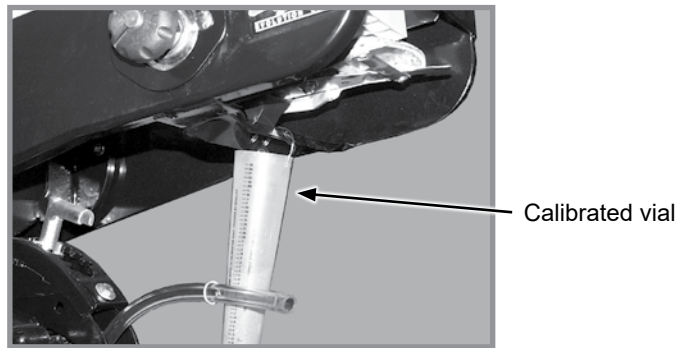

**Granular chemical field check**

1. Fill insecticide and/or herbicide hoppers.
2. Attach a calibrated vial to each granular chemical meter.

**NOTE: Disengage clutch to avoid dropping seed during test.**

3. Lower planter and drive 1320 feet (402.336 meters) at planting speed.
4. Weigh chemical in ounces caught in one vial.
5. Multiply that amount by factor shown to determine pounds per acre.

Pounds Per Acre	
Row Width	Factor
30"	.83
36"	.69
38"	.65

**EXAMPLE:** You are planting 30" rows. You have planted for 1320 feet at the desired planting speed. You caught 12.0 ounces of chemical in one vial. 12.0 ounces times 0.83 equals 9.96 pounds per acre.

**NOTE: Check calibration of all rows.**

### METERING GATE

Use metering gate setting as a starting point for distributing insecticide or herbicide. Charts are based on 5 mph (8 kph) planting speed. Use a higher gate setting for speeds faster than 5 mph (8 kph) and a lower setting for speeds slower than 5 mph (8 kph).

CLEANING

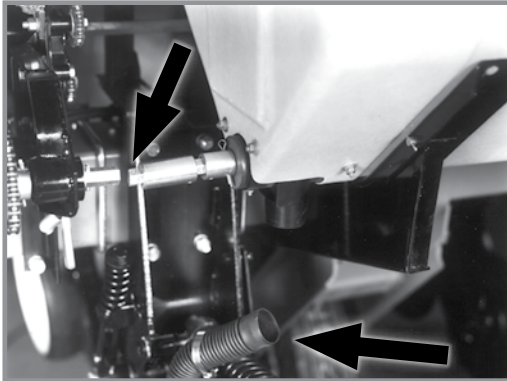

**Disconnect drive shaft and hoses**

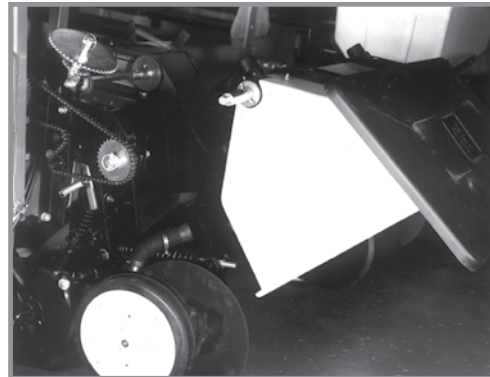

**Rotate lid to back and rotate hopper forward**

Dry fertilizer hoppers tip forward for dumping and ease of cleaning. Disconnect drive shaft from transmission and/or adjacent hopper. **LOOSEN HOSE CLAMPS AND REMOVE HOSES FROM EACH HOPPER.** Remove rear 1/2" x 1/4" cap screw from between each hopper saddle and hopper mount. Rotate each hopper lid to back side of hopper and carefully tip hopper forward. Flush all loose fertilizer from hoppers and hoses after dumping contents.

At end of planting season or when fertilizer attachment is not used for a period of time, hoppers should be disassembled, cleaned, and metal surfaces coated with a rust preventative. Remove 1/4" cotter pin and bearing from one end of shaft. Pull auger assembly from opposite end of hopper. Remove stainless steel cap screws from auger shaft and remove all auger components for cleaning. Coat all parts with rust preventative before reassembly. Reinstall auger halves in low or high rate position.

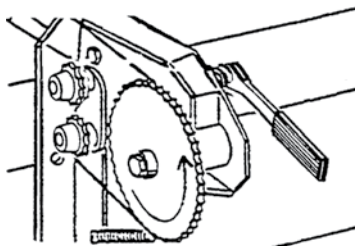

Transmission direction of rotation

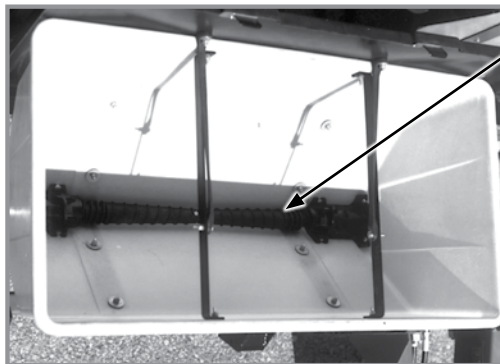

**Auger installation**

**NOTE:** Install auger assembly so the flighting moves material to outer openings in hopper when augers rotate in direction they turn during operation.

Slide auger assembly through outlet housing into hopper. Secure in place by reinstalling bearing and cotter pin. Rotating shaft in direction shown to see if flighting (spirals) on auger move toward ends of hopper. If not, remove auger assembly, turn 180°, and reinstall.

**NOTE: Frequent lubrication of auger bearings is critical to ensure augers turn freely. Check lubrication section for frequency.**

Be certain augers turn freely. If not, loosen 5/16" carriage bolts in outlet housings, rotate auger several times, and retighten carriage bolts. This allows housings and augers to realign.

**NOTE: Do not operate fertilizer attachment without auger baffles in place.**

Install auger baffles over augers and secure in place with two hair pin clips in each hopper.



## LIQUID FERTILIZER ATTACHMENT

### **WARNING**



Agricultural chemicals can cause death or serious injury to persons, animals, and plants or seriously damage soil, equipment, or property. Read and follow all chemical and equipment manufacturers labels and instructions.

### **CAUTION**

Overfilling tank can cause siphoning, tank collapse, personal injury, and damage to property and equipment. Do not overfill tank. Do not leave planter unattended when filling tank. Close fill valve and open tank lid if siphoning occurs. Follow all chemical manufacturers first aid, cleanup, and handling instructions.

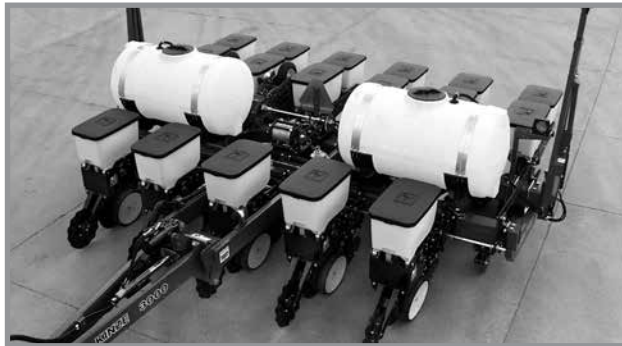

Liquid fertilizer option installed



Check Valve

**NOTE:** Optional low rate check valves are available for in-line installation between liquid fertilizer squeeze or piston pump and openers to ensure equal distribution of product at low rates. Check valves also eliminate anti-siphon loops.

OPTIONAL PISTON PUMP

**NOTE: Keep manuals shipped with pump and flow divider with this manual.**

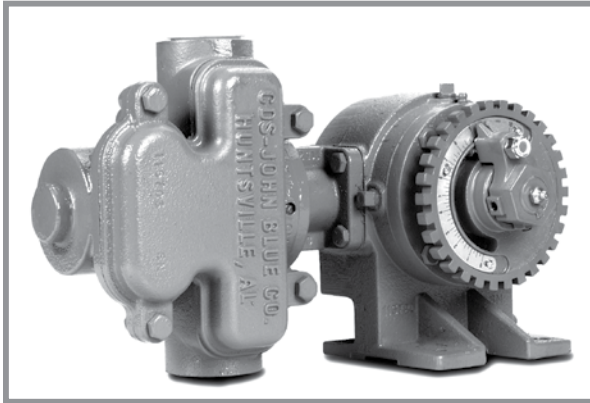

Piston pump

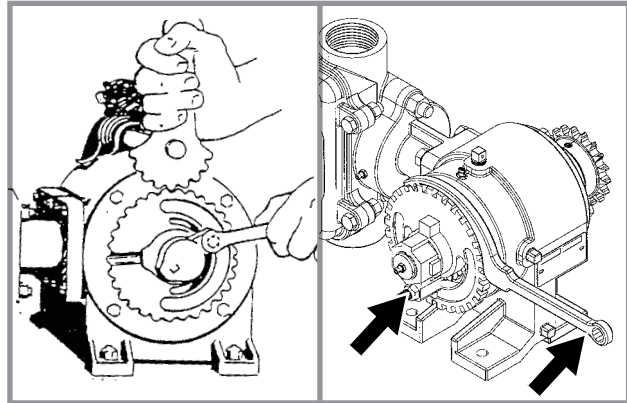

Adjusting delivery rate

**NOTE: Delivery rate chart in Rate Chart section of this manual provides approximate application rate only. Delivery varies with temperature and fertilizer.**

Loosen  $\frac{3}{8}$ " lock nut that secures arm with pointer and rotate scale flange with adjustment wrench until pointer is over desired scale setting. Tighten  $\frac{3}{8}$ " lock nut. **DO NOT OVERTIGHTEN.**

**NOTE: Periodically check flow to all rows. Set rate is delivered to remaining rows if one or more lines are plugged.**

CLEANING

Clean tanks, hoses, and metering pump thoroughly with water at end of planting season or prior to an extended period of non-use. Do not allow fertilizer to crystallize from cold temperature or evaporation.

On machines equipped with piston pump, take apart and clean strainer located between piston pump and ball valve daily. Remove the end cap to clean the screen. See Piston Pump Storage in Maintenance Section of this manual.

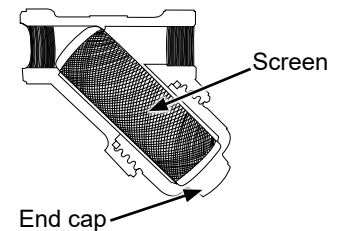

## GENERAL PLANTING RATE INFORMATION

These planting rate charts apply to Kinze Model 3005 Rigid Frame Planters.

### NOTICE

Sprocket combinations in these charts are for average conditions. Changes in sprocket combinations may be required for desired planting population. **ALWAYS MAKE FIELD CHECKS TO BE SURE YOU ARE PLANTING AT THE DESIRED RATE.**

### NOTICE

Seed additives added in the hopper may affect finger pickup seed meter performance and accelerate wear.

**NOTE:** Seed size and shape may affect planting rate.

**NOTE:** Not all row spacings listed apply to all size planters.

### Finger Pickup Corn Meter

Larger grades generally plant more accurately at the high end of the ground speed range than smaller grades. Higher than optimum speeds may result in population rate increase or higher incidence of doubles, particularly with small seed. Medium round corn seed is most desirable for planting accuracy at optimum speed.

### Finger Pickup Oil Sunflower Meter

Larger grades generally plant more accurately at the high end of the ground speed range than smaller grades. Higher than optimum speeds may result in population rate increase or higher incidence of doubles, particularly with small seed. No. 3 and/or No. 4 size oil sunflower seeds are recommended for use in finger pickup seed meters equipped with oil sunflower fingers. No. 1 and/or No. 2 size confectionery sunflower seeds are recommended for use in finger pickup seed meters equipped with corn fingers.

### Brush-Type Seed Meter (Soybean, Milo/Grain Sorghum, Acid-Delinted Cotton)

Rate charts are given in seeds per acre as well as seed spacing in inches rounded to the nearest tenth of an inch. Because of the large range in seed size, pounds per acre is not a suggested method of selecting transmission settings. Smaller size seed pounds per acre may be below what was expected and large seed pounds per acre may appear above expectations. To determine pounds per acre, use the formula given in "Determining Pounds Per Acre (Brush-Type Seed Meter)" in "Check Seed Population" in Machine Operation section of this manual.

**NOTE:** Speeds above 6.0 MPH (10 KPH) can adversely affect seed spacing.

**NOTE:** Planting speed can affect actual seeding rate. Make a field check and adjust transmission setting to obtain desired seed drop.

### Standard Rate (1 To 1) 17 Tooth Drive Sprocket

When planting 30"/36"/38" (70/91/97 cm) rows with brush-type seed meters using 17 tooth standard rate (1 to 1) sprocket, use charts on page 5-3, 5-5, and 5-6. When planting 15"/18"/19" (38/46/48 cm) rows using 17 tooth sprocket, use chart on page 5-4.

### Half Rate (2 To 1) 34 Tooth Drive Sprocket

When using 34 tooth half rate (2 to 1) sprocket with brush-type seed meters, seeding rate is approximately 50% of chart readings. ***Half rate (2 to 1) drive is recommended only when Interplant push units are used and desired population falls below that shown on planting rate charts.***

**PLANTING RATES FOR FINGER PICKUP SEED METERS (STANDARD DRIVE)  
APPROXIMATE SEEDS/ACRE FOR VARIOUS ROW WIDTHS**

30" Rows	36" Rows	38" Rows	Transmission Sprockets		Recomm. Speed Range (MPH)	Average Seed Spacing In Inches
			Drive	Driven		
16,186	13,488	12,778	17	28	4 to 6	12.9
16,785	13,988	13,251	17	27	4 to 6	12.5
17,431	14,526	13,761	17	26	4 to 6	12.0
18,090	15,075	14,281	19	28	4 to 6	11.6
18,128	15,107	14,312	17	25	4 to 6	11.5
18,760	15,633	14,810	19	27	4 to 6	11.1
18,883	15,736	14,908	17	24	4 to 6	11.1
19,481	16,234	15,380	19	26	4 to 6	10.7
19,704	16,420	15,556	17	23	4 to 6	10.6
20,261	16,884	15,995	19	25	4 to 6	10.3
21,104	17,587	16,662	19	24	4 to 6	9.9
21,898	18,249	17,288	23	28	4 to 6	9.5
22,022	18,352	17,386	19	23	4 to 6	9.5
22,709	18,924	17,928	23	27	4 to 6	9.2
22,850	19,042	18,040	24	28	4 to 6	9.2
23,583	19,652	18,618	23	26	4 to 6	8.9
23,697	19,747	18,708	24	27	4 to 6	8.8
23,802	19,835	18,791	25	28	4 to 6	8.8
23,853	19,877	18,831	17	19	4 to 6	8.8
24,526	20,438	19,363	23	25	4 to 6	8.5
24,608	20,507	19,427	24	26	4 to 6	8.5
24,684	20,570	19,487	25	27	4 to 6	8.5
24,755	20,629	19,543	26	28	4 to 6	8.4
25,548	21,290	20,169	23	24	4 to 6	8.2
25,592	21,327	20,205	24	25	4 to 6	8.2
25,633	21,361	20,237	25	26	4 to 6	8.2
25,671	21,393	20,267	26	27	4 to 6	8.1
25,707	21,422	20,295	27	28	4 to 6	8.1
26,659	22,216	21,046	23	23	4 to 6	7.8
27,646	23,038	21,826	28	27	4 to 6	7.6
27,684	23,070	21,856	27	26	4 to 6	7.6
27,770	23,141	21,923	25	24	4 to 6	7.5
27,818	23,181	21,961	24	23	4 to 6	7.5
28,709	23,924	22,665	28	26	4 to 6	7.3
28,791	23,993	22,730	27	25	4 to 6	7.3
28,977	24,147	22,876	25	23	4 to 6	7.2
29,795	24,829	23,522	19	17	4 to 6	7.0
29,858	24,881	23,572	28	25	4 to 6	7.0
29,991	24,993	23,677	27	24	4 to 6	7.0
30,136	25,113	23,792	26	23	4 to 6	7.0
31,102	25,918	24,554	28	24	3 to 6	6.7
31,295	26,079	24,707	27	23	3 to 6	6.7
32,271	26,893	25,477	23	19	3 to 5.5	6.5
32,454	27,045	25,622	28	23	3 to 5.5	6.5
33,674	28,062	26,585	24	19	3 to 5.5	6.2
35,077	29,231	27,693	25	19	3 to 5	6.0
36,068	30,056	28,474	23	17	3 to 5	5.8
36,480	30,400	28,800	26	19	3 to 5	5.7
37,636	31,363	29,713	24	17	3 to 5	5.6
37,883	31,570	29,908	27	19	3 to 5	5.5
39,204	32,670	30,951	25	17	3 to 4.5	5.3
39,287	32,739	31,016	28	19	3 to 4.5	5.3
40,772	33,977	32,189	26	17	3 to 4.5	5.1
42,340	35,284	33,427	27	17	3 to 4.5	4.9
43,908	36,590	34,665	28	17	3 to 4.5	4.8

NOTE: See ["General Planting Rate Information"](#) on page 5-1 and ["Check Seed Population"](#) on page 2-14 for additional information. Always check seed population in the field to ensure planting rates are correct.

**PLANTING RATES FOR BRUSH-TYPE SEED METERS (STANDARD DRIVE)  
APPROXIMATE SEEDS/ACRE FOR VARIOUS ROW WIDTHS**

Transmission Sprockets		60 Cell Soybean Or High-Rate Milo/ Grain Sorghum			Average Seed Spacing in Inches	48 Cell Specialty Soybean Or High-Rate Acid-Delinted Cotton			Average Seed Spacing in Inches	Speed Range (MPH)
Drive	Driven	30" Rows	36" Rows	38" Rows		30" Rows	36" Rows	38" Rows		
17	28	80,928	67,440	63,891	2.6	64,742	53,952	51,113	3.2	2 to 8
17	27	83,926	69,938	66,257	2.5	67,141	55,950	53,006	3.1	2 to 8
17	26	87,154	72,628	68,805	2.4	69,723	58,102	55,044	3.0	2 to 8
19	28	90,449	75,374	71,407	2.3	72,359	60,299	57,126	2.9	2 to 8
19	27	93,799	78,166	74,052	2.2	75,039	62,533	59,242	2.8	2 to 8
17	24	94,416	78,680	74,539	2.2	75,533	62,944	59,631	2.8	2 to 8
17	23	98,521	82,101	77,780	2.1	78,817	65,681	62,224	2.7	2 to 8
19	25	101,303	84,419	79,976	2.1	81,042	67,535	63,981	2.6	2 to 8
19	24	105,524	87,937	83,309	2.0	84,419	70,350	66,647	2.5	2 to 8
23	28	109,491	91,243	86,440	1.9	87,593	72,994	69,152	2.4	2 to 8
19	23	110,112	91,760	86,931	1.9	88,090	73,408	69,545	2.4	2 to 8
24	28	114,252	95,210	90,199	1.8	91,402	76,168	72,159	2.3	2 to 8
24	27	118,483	98,736	93,539	1.8	94,786	78,989	74,831	2.2	2 to 8
17	19	119,263	99,386	94,155	1.8	95,410	79,509	75,324	2.2	2 to 8
24	26	123,040	102,534	97,137	1.7	98,432	82,027	77,710	2.1	2 to 8
26	28	123,773	103,144	97,715	1.7	99,018	82,515	78,172	2.1	2 to 8
24	25	127,962	106,635	101,023	1.6	102,370	85,308	80,818	2.0	2 to 8
26	27	128,357	106,964	101,334	1.6	102,686	85,571	81,067	2.0	2 to 8
23	23	133,294	111,078	105,232	1.6	106,635	88,862	84,186	2.0	2 to 8
27	26	138,420	115,350	109,279	1.5	110,736	92,280	87,423	1.9	2 to 8
24	23	139,089	115,907	109,807	1.5	111,271	92,726	87,846	1.9	2 to 8
25	23	144,884	120,737	114,382	1.4	115,907	96,590	91,506	1.8	2 to 8
19	17	148,975	124,146	117,612	1.4	119,180	99,317	94,090	1.8	2 to 8
27	24	149,955	124,963	118,386	1.4	119,964	99,970	94,709	1.7	2 to 8
28	24	155,509	129,591	122,770	1.3	124,407	103,673	98,216	1.7	2 to 8
23	19	161,355	134,463	127,386	1.3	129,084	107,570	101,909	1.6	2 to 8
28	23	162,270	135,225	128,108	1.3	129,816	108,180	102,486	1.6	2 to 8
24	19	168,371	140,309	132,924	1.2	134,696	112,247	106,339	1.6	2 to 8
25	19	175,386	146,155	138,463	1.2	140,309	116,924	110,770	1.5	2 to 8
23	17	180,338	150,282	142,372	1.2	144,270	120,226	113,898	1.5	2 to 8
26	19	182,402	152,001	144,001	1.1	145,922	121,601	115,201	1.4	2 to 7
27	19	189,417	157,848	148,540	1.1	151,534	126,278	118,832	1.4	2 to 7
28	19	196,433	163,694	155,078	1.1	157,146	130,955	124,062	1.3	2 to 7
26	17	203,861	169,884	160,943	1.0	163,089	135,907	128,754	1.3	2 to 7
27	17	211,702	176,418	167,133	0.9	169,362	141,134	133,706	1.2	2 to 7
28	17	219,542	182,952	173,323	0.9	175,634	146,362	138,658	1.2	2 to 7

NOTE: See ["General Planting Rate Information"](#) on page 5-1 and ["Check Seed Population"](#) on page 2-14 for additional information.

NOTE: Half Rate (2 To 1) Drive Reduction rates are approximately 50% of given numbers.

NOTE: Always field check seed population to ensure planting rates are correct.

**PLANTING RATES FOR BRUSH-TYPE SEED METER (STANDARD DRIVE)  
APPROXIMATE SEEDS/ACRE FOR 15"/18"/19" ROW WIDTHS**

Transmission Sprockets		60 Cell Soybean Or High-Rate Milo/ Grain Sorghum			Average Seed Spacing in Inches	48 Cell Specialty Soybean Or High-Rate Acid-Delinted Cotton			Average Seed Spacing in Inches	Speed Range (MPH)
Drive	Driven	15" Rows	18" Rows	19" Rows		15" Rows	18" Rows	19" Rows		
17	28	161,856	134,880	127,782	2.6	129,484	107,904	102,226	3.2	2 to 8
17	27	167,852	139,876	132,514	2.5	134,282	111,900	106,012	3.1	2 to 8
17	26	174,308	145,256	137,610	2.4	139,446	116,204	110,088	3.0	2 to 8
19	28	180,898	150,748	142,814	2.3	144,718	120,598	114,252	2.9	2 to 8
19	27	187,598	156,332	148,104	2.2	150,078	125,066	118,484	2.8	2 to 8
17	24	188,832	157,360	149,078	2.2	151,066	125,888	119,262	2.8	2 to 8
17	23	197,042	164,202	155,560	2.1	157,634	131,362	124,448	2.7	2 to 8
19	25	202,606	168,838	159,952	2.1	162,084	135,070	127,962	2.6	2 to 8
19	24	211,048	175,874	166,618	2.0	168,838	140,700	133,294	2.5	2 to 8
23	28	218,982	182,486	172,880	1.9	175,186	145,988	138,304	2.4	2 to 8
19	23	220,224	183,520	173,862	1.9	176,180	146,816	139,090	2.4	2 to 8
24	28	228,504	190,420	180,398	1.8	182,804	152,336	144,318	2.3	2 to 8
24	27	236,966	197,472	187,078	1.8	189,572	157,978	149,662	2.2	2 to 8
17	19	238,526	198,772	188,310	1.8	190,820	159,018	150,648	2.2	2 to 8
24	26	246,080	205,068	194,274	1.7	196,864	164,054	155,420	2.1	2 to 8
26	28	247,546	206,288	195,430	1.7	198,036	165,030	156,344	2.1	2 to 8
24	25	255,924	213,270	202,046	1.6	204,740	170,616	161,636	2.0	2 to 8
26	27	256,714	213,928	202,668	1.6	205,372	171,142	162,134	2.0	2 to 8
23	23	266,588	222,156	210,464	1.6	213,270	177,724	168,372	2.0	2 to 8
27	26	276,840	230,700	218,558	1.5	221,472	184,560	174,846	1.9	2 to 8
24	23	278,178	231,814	219,614	1.5	222,542	185,452	175,692	1.9	2 to 8
25	23	289,768	241,474	228,764	1.4	231,814	193,180	183,012	1.8	2 to 8
19	17	297,950	248,292	235,224	1.4	238,360	198,634	188,180	1.8	2 to 8
27	24	299,910	249,926	236,772	1.4	239,928	199,940	189,418	1.7	2 to 8
28	24	311,018	259,182	245,540	1.3	248,814	207,346	196,432	1.7	2 to 8
23	19	322,710	268,926	254,772	1.3	258,168	215,140	203,818	1.6	2 to 8
28	23	324,540	270,450	256,216	1.3	259,632	216,360	204,966	1.6	2 to 8
24	19	336,742	280,618	265,848	1.2	269,392	224,494	212,678	1.6	2 to 8
25	19	350,772	292,310	276,926	1.2	280,618	233,848	221,540	1.5	2 to 8
23	17	360,676	300,564	284,744	1.2	288,540	240,452	227,796	1.5	2 to 8
26	19	364,804	304,002	288,002	1.1	291,844	243,202	230,402	1.4	2 to 7
27	19	378,834	315,756	297,080	1.1	303,068	252,556	237,664	1.4	2 to 7
28	19	392,866	327,388	310,156	1.1	314,292	261,910	248,124	1.3	2 to 7
26	17	407,722	339,768	321,886	1.0	326,178	271,814	257,508	1.3	2 to 7
27	17	423,404	352,836	334,266	0.9	338,724	282,268	267,412	1.2	2 to 7
28	17	439,084	365,904	346,646	0.9	351,268	292,724	277,316	1.2	2 to 7

NOTE: See ["General Planting Rate Information"](#) on page 5-1 and ["Check Seed Population"](#) on page 2-14 for additional information.

NOTE: Half Rate (2 To 1) Drive Reduction rates are approximately 50% of given numbers.

NOTE: Always field check seed population to ensure planting rates are correct.

**PLANTING RATES FOR BRUSH-TYPE SEED METERS (STANDARD DRIVE)  
APPROXIMATE SEEDS/ACRE FOR VARIOUS ROW WIDTHS**

Transmission Sprockets		36 Cell Acid-Delinted Large Cotton			Average Seed Spacing In Inches	30 Cell Milo / Grain Sorghum or Acid-Delinted Cotton			Average Seed Spacing in Inches	Speed Range (MPH)
Drive	Driven	30" Rows	36" Rows	38" Rows		30" Rows	36" Rows	38" Rows		
17	28	48,557	40,464	38,335	4.3	40,464	33,720	31,945	5.2	2 to 8
17	27	50,356	41,963	39,754	4.2	41,963	34,969	33,129	5.0	2 to 8
17	26	52,292	43,577	41,283	4.0	43,577	36,314	34,403	4.8	2 to 8
19	28	54,269	45,224	42,844	3.9	45,225	37,687	35,704	4.6	2 to 8
19	27	56,279	46,900	44,431	3.7	46,900	39,083	37,026	4.5	2 to 8
17	24	56,650	47,208	44,723	3.7	47,208	39,340	37,270	4.4	2 to 8
17	23	59,113	49,261	46,668	3.5	49,261	41,051	38,890	4.2	2 to 8
19	25	60,782	50,651	47,986	3.4	50,652	42,210	39,988	4.1	2 to 8
19	24	63,314	52,762	49,985	3.3	52,762	43,968	41,654	4.0	2 to 8
23	28	65,695	54,746	51,864	3.2	54,746	45,621	43,220	3.8	2 to 8
19	23	66,067	55,056	52,159	3.2	55,056	45,880	43,465	3.8	2 to 8
24	28	68,551	57,126	54,119	3.0	57,126	47,605	45,099	3.7	2 to 8
24	27	71,090	59,242	56,123	2.9	59,242	49,368	46,770	3.5	2 to 8
17	19	71,558	59,632	56,493	2.9	59,631	49,693	47,077	3.5	2 to 8
24	26	73,824	61,520	58,282	2.8	61,520	51,267	48,569	3.4	2 to 8
26	28	74,264	61,886	58,629	2.8	61,886	51,572	48,858	3.4	2 to 8
24	25	76,772	63,981	60,614	2.7	63,981	53,317	50,511	3.3	2 to 8
26	27	77,014	64,178	60,800	2.7	64,178	53,482	50,667	3.3	2 to 8
23	23	79,976	66,647	63,139	2.6	66,647	55,539	52,616	3.1	2 to 8
27	26	83,052	69,210	65,567	2.5	69,210	57,675	54,640	3.0	2 to 8
24	23	83,453	69,544	65,884	2.5	69,544	57,954	54,904	3.0	2 to 8
25	23	86,930	72,442	68,629	2.4	72,442	60,368	57,191	2.9	2 to 8
19	17	89,385	74,488	70,567	2.3	74,488	62,073	58,806	2.8	2 to 8
27	24	89,973	74,978	71,032	2.3	74,978	62,481	59,193	2.8	2 to 8
28	24	93,305	77,755	73,662	2.2	77,755	64,796	61,385	2.7	2 to 8
23	19	96,813	80,678	76,432	2.2	80,678	67,231	63,693	2.6	2 to 8
28	23	97,362	81,135	76,864	2.1	81,135	67,613	64,054	2.6	2 to 8
24	19	101,023	84,185	79,754	2.1	84,185	70,155	66,462	2.5	2 to 8
25	19	105,232	87,693	83,078	2.0	87,693	73,078	69,231	2.4	2 to 8
23	17	108,233	90,169	85,423	1.9	90,169	75,141	71,186	2.3	2 to 8
26	19	109,441	91,201	86,401	1.9	91,201	76,001	72,001	2.3	2 to 7
27	19	113,650	94,709	89,124	1.8	94,709	78,924	74,770	2.2	2 to 7
28	19	117,860	98,216	93,047	1.8	98,216	81,847	77,539	2.1	2 to 7
26	17	122,317	101,930	96,566	1.7	101,930	84,942	80,471	2.1	2 to 7
27	17	127,021	105,851	100,280	1.6	105,851	88,209	83,566	2.0	2 to 7
28	17	131,725	109,771	103,994	1.6	109,771	91,476	86,661	1.9	2 to 7

**NOTE:** See [“General Planting Rate Information” on page 5-1](#) and [“Check Seed Population” on page 2-14](#) for additional information.

**NOTE:** Half Rate (2 To 1) Drive Reduction rates are approximately 50% of given numbers.

**NOTE:** Always field check seed population to ensure planting rates are correct.

**PLANTING RATES FOR BRUSH-TYPE SEED METERS (STANDARD DRIVE)  
APPROXIMATE HILLS/ACRE FOR VARIOUS ROW WIDTHS**

Due to variations in cotton seed size, meters equipped with 12 cell acid-delinted hill-drop cotton discs plant from 3 to 6 seeds per cell. Select proper disc for seed size range to be planted.

To determine planter transmission setting, determine desired hill spacing and select transmission ratio closest to hill spacing in inches on chart. To decrease population increase spacing. To increase population decrease spacing.

To determine population per acre, determine average seeds per hill and hills per acre by doing a field check. Measure  $\frac{1}{1000}$  of an acre ( $\frac{1}{1000}$  acre = Length of row 17' 5" for 30" row widths, 14' 6" for 36" row widths and 13' 10" for 38" row widths). Multiply average seeds per hill by hills per acre. EXAMPLE: 4 seeds per hill x (13 hills x 1000) = 52,000

Transmission Sprockets		NUMBER OF HILLS PER ACRE 12 Cell Hill-Drop Cotton, Acid-Delinted			Average Hill Spacing In Inches	Speed Range (MPH)
Drive	Driven	30" Rows	36" Rows	38" Rows		
17	28	16,186	13,488	12,778	12.9	2 to 8
17	27	16,785	13,988	13,251	12.5	2 to 8
17	26	17,431	14,526	13,761	12.0	2 to 8
19	28	18,090	15,075	14,281	11.6	2 to 8
19	27	18,760	15,633	14,810	11.1	2 to 8
17	24	18,883	15,736	14,908	11.1	2 to 8
17	23	19,704	16,420	15,556	10.6	2 to 8
19	25	20,261	16,884	15,995	10.3	2 to 8
19	24	21,105	17,587	16,662	9.9	2 to 8
23	28	21,898	18,249	17,288	9.5	2 to 8
19	23	22,022	18,352	17,386	9.5	2 to 8
24	28	22,850	19,042	18,040	9.2	2 to 8
24	27	23,697	19,747	18,708	8.8	2 to 8
17	19	23,853	19,877	18,831	8.8	2 to 8
24	26	24,608	20,507	19,427	8.5	2 to 8
26	28	24,755	20,629	19,543	8.4	2 to 8
24	25	25,592	21,327	20,205	8.2	2 to 8
26	27	25,671	21,393	20,267	8.1	2 to 8
23	23	26,659	22,216	21,046	7.8	2 to 8
27	26	27,684	23,070	21,856	7.6	2 to 8
24	23	27,818	23,181	21,961	7.5	2 to 8
25	23	28,977	24,147	22,876	7.2	2 to 8
19	17	29,795	24,829	23,522	7.0	2 to 8
27	24	29,991	24,993	23,677	7.0	2 to 8
28	24	31,102	25,918	24,554	6.7	2 to 8
23	19	32,271	26,893	25,477	6.5	2 to 8
28	23	32,454	27,045	25,622	6.5	2 to 8
24	19	33,674	28,062	26,585	6.2	2 to 8
25	19	35,077	29,231	27,693	6.0	2 to 8
23	17	36,068	30,056	28,474	5.8	2 to 8
26	19	36,480	30,400	28,800	5.7	2 to 7
27	19	37,883	31,570	29,908	5.5	2 to 7
28	19	39,287	32,739	31,016	5.3	2 to 7
26	17	40,772	33,977	32,189	5.1	2 to 7
27	17	42,340	35,284	33,427	4.9	2 to 7
28	17	43,908	36,590	34,665	4.8	2 to 7

NOTE: See ["General Planting Rate Information"](#) on page 5-1 and ["Check Seed Population"](#) on page 2-14 for additional information.

NOTE: Half Rate (2 To 1) Drive Reduction rates are approximately 50% of given numbers.

NOTE: Always field check seed population to ensure planting rates are correct.



**PLANTING RATES FOR BRUSH-TYPE SEED METERS (STANDARD DRIVE)  
APPROXIMATE SEEDS/ACRE FOR 15"/18"/19"/30"/36"/38" ROW WIDTHS**

Transmission Sprockets		54 Cell Soybean						Average Seed Spacing In Inches	Speed Range (MPH)
Drive	Driven	7.5" Rows or 15" Rows	18" Rows	19" Rows	30" Rows	36" Rows	38" Rows		
15	28	128,529	107,107	101,470	64,264	53,554	50,735	3.3	2 to 8
15	27	133,289	111,074	105,228	66,644	55,537	52,614	3.1	2 to 8
15	26	138,415	115,346	109,275	69,208	57,673	54,638	3	2 to 8
15	25	143,952	119,960	113,646	71,976	59,980	56,823	2.9	2 to 8
17	28	145,666	121,388	114,999	72,833	60,694	57,500	2.9	2 to 8
17	27	151,061	125,884	119,258	75,530	62,942	59,629	2.8	2 to 8
17	26	156,871	130,726	123,845	78,435	65,363	61,923	2.7	2 to 8
19	28	162,803	135,669	128,529	81,401	67,835	64,264	2.6	2 to 8
19	27	168,833	140,694	133,289	84,416	70,347	66,644	2.5	2 to 8
17	24	169,943	141,619	134,166	84,972	70,810	67,083	2.5	2 to 8
17	23	177,332	147,777	139,999	88,666	73,888	70,000	2.4	2 to 8
19	25	182,339	151,949	143,952	91,170	75,975	71,976	2.3	2 to 8
19	24	189,937	158,281	149,950	94,968	79,140	74,975	2.2	2 to 8
23	28	197,077	164,231	155,587	98,539	82,115	77,794	2.1	2 to 8
19	23	198,195	165,162	156,470	99,097	82,581	78,235	2.1	2 to 8
24	28	205,646	171,371	162,352	102,823	85,686	81,176	2	2 to 8
24	27	213,262	177,718	168,365	106,631	88,859	84,182	2	2 to 8
17	19	214,665	178,888	169,473	107,333	89,444	84,736	1.9	2 to 8
24	26	221,465	184,554	174,840	110,732	92,277	87,420	1.9	2 to 8
26	28	222,783	185,652	175,881	111,391	92,826	87,941	1.9	2 to 8
24	25	230,323	191,936	181,834	115,162	95,968	90,917	1.8	2 to 8
26	27	231,034	192,528	182,395	115,517	96,264	91,198	1.8	2 to 8
23	23	239,920	199,933	189,410	119,960	99,967	94,705	1.7	2 to 8
27	26	249,148	207,623	196,695	124,574	103,812	98,348	1.7	2 to 8
24	23	250,351	208,626	197,646	125,176	104,313	98,823	1.7	2 to 8
25	23	260,783	217,319	205,881	130,391	108,659	102,940	1.6	2 to 8
19	17	268,146	223,455	211,694	134,073	111,727	105,847	1.6	2 to 8
27	24	269,910	224,925	213,087	134,955	112,462	106,543	1.5	2 to 8
28	24	279,907	233,255	220,979	139,953	116,628	110,489	1.5	2 to 8
23	19	290,429	242,024	229,286	145,215	121,012	114,643	1.4	2 to 8
28	23	292,076	243,397	230,587	146,038	121,699	115,293	1.4	2 to 8
24	19	303,057	252,547	239,255	151,528	126,274	119,628	1.4	2 to 8
25	19	315,684	263,070	249,224	157,842	131,535	124,612	1.3	2 to 8
23	17	324,598	270,498	256,261	162,299	135,249	128,131	1.3	2 to 8
26	19	328,311	273,593	259,193	164,156	136,796	129,597	1.3	2 to 8
27	19	340,939	284,116	269,162	170,469	142,058	134,581	1.2	2 to 8
28	19	353,566	294,639	279,131	176,783	147,319	139,566	1.2	2 to 8
26	17	366,936	305,780	289,687	183,468	152,890	144,843	1.1	2 to 8
27	17	381,049	317,541	300,828	190,525	158,771	150,414	1.1	2 to 8
28	17	395,162	329,302	311,970	197,581	164,651	155,985	1.1	2 to 8

**NOTE:** See [“General Planting Rate Information” on page 5-1](#) and [“Check Seed Population” on page 2-14](#) for additional information.

**NOTE:** Half Rate (2 To 1) Drive Reduction rates are approximately 50% of given numbers.

**NOTE:** Always field check seed population to ensure planting rates are correct.

**PLANTING RATES FOR BRUSH-TYPE SEED METERS (HALF RATE DRIVE)  
APPROXIMATE SEEDS/ACRE FOR 15" ROW WIDTH**

Transmission Sprockets		Population Factor	Rye 400 SDS/REV, 35.9 SDS/GRAM		Wheat 465 SDS/REV, 39.6 SDS/GRAM		Speed Range (MPH)
Drive	Driven		Population (sds/acre)	Population (lbs/acre)	Population (sds/acre)	Population (lbs/acre)	
19	17	2482.92	993,399	61	1,155,079	64	4 to 6
28	25	2488.15	995,490	61	1,157,511	64	4 to 6
27	24	2499.26	999,934	61	1,162,678	65	4 to 6
26	23	2511.33	1,004,765	62	1,168,295	65	4 to 6
17	15	2517.77	1,007,341	62	1,171,291	65	4 to 6
28	24	2591.82	1,036,969	64	1,205,741	67	4 to 6
27	23	2607.92	1,043,409	64	1,213,230	68	4 to 6
23	19	2689.26	1,075,952	66	1,251,069	70	4 to 6
28	23	2704.51	1,082,054	67	1,258,164	70	4 to 6
24	19	2806.18	1,122,733	69	1,305,464	73	4 to 6
19	15	2813.98	1,125,852	69	1,309,090	73	4 to 6
25	19	2923.10	1,169,513	72	1,359,857	76	4 to 6
23	17	3005.64	1,202,535	74	1,398,254	78	4 to 6
26	19	3040.03	1,216,294	75	1,414,252	79	4 to 6
24	17	3136.32	1,254,820	77	1,459,048	81	4 to 6
27	19	3156.95	1,263,075	78	1,468,647	82	4 to 6
25	17	3267.00	1,307,103	80	1,519,841	85	4 to 6
28	19	3273.88	1,309,855	81	1,523,041	85	4 to 6
26	17	3397.68	1,359,388	84	1,580,635	88	4 to 6
23	15	3406.39	1,362,873	84	1,584,687	88	4 to 6
27	17	3528.36	1,411,671	87	1,641,428	91	4 to 6
24	15	3554.50	1,422,128	87	1,653,587	92	4 to 6
28	17	3659.04	1,463,956	90	1,702,222	95	4 to 6
25	15	3702.60	1,481,384	91	1,722,487	96	4 to 6
26	15	3850.70	1,540,639	95	1,791,386	100	4 to 6
27	15	3998.81	1,599,895	98	1,860,286	104	4 to 6
28	15	4146.91	1,659,150	102	1,929,185	107	4 to 6

**NOTE: Seed size and type affect the output rate of the meter. For a method to improve the population accuracy with your desired seed, please see the following pages.**

**NOTE: See "Mechanical Meter" in "General Planting Rate Information" on page 5-1 and "Check Seed Population" on page 2-14 pages for additional information.**

**NOTE: When using Half Rate (2 To 1) Drive Reduction Package, rates are approximately 50% of given numbers.**

**NOTE: Always field check seed population to ensure planting rates are correct.**

To more accurately predict population when using the 54 Cell Wheat disc, two things are needed:

1. Seeds/gram
2. Grams/revolution of seed disc

Seeds per gram can be found by weighing a small sample of desired seed (a cup or less) and counting number of seeds in sample.

$$\frac{\text{Seeds}}{\text{Grams}} = \frac{\text{number of seeds in sample}}{\text{weight of sample in grams}} \quad \frac{396 \text{ Seeds}}{10 \text{ Grams}} = 39.6 \frac{\text{seeds}}{\text{gram}}$$

To find grams/revolution a gram scale, a stopwatch, a small container to catch seed, and a method for spinning the meter at a constant, known rpm (see your local Kinze dealer with a T4000 Seed Meter Test Stand) are needed.

1. Zero gram scale with the small container on it.
2. Load meter with correct disc.
3. Load meter with desired seed.
4. Start spinning meter at a known, constant rpm.
5. Start stopwatch as you place container under meter.
6. Catch seed with container for 10-30 seconds.
7. Stop the stopwatch as you remove container from underneath meter.
8. Weigh container.
9. Enter meter rpm, weight of sample, and duration of sample collection into the equation below:

$$\frac{\text{Grams}}{\text{Rev}} = \frac{\text{Sample Weight} * 60}{\text{Disc RPM} * \text{Sample Duration}}$$

EX: For a sample taken for 30 seconds with meter spinning at 50rpm and weighs 293 grams

$$\frac{293 \text{ Grams} * 60}{50 \text{ RPM} * 30 \text{ Seconds}} = 11.7 \frac{\text{Grams}}{\text{Rev}}$$

10. Find desired output rate. For seeds per acre, use seeds/rev. For pounds per acre, use lbs/rev.

a. Seeds/rev:

$$\frac{\text{Seeds}}{\text{Rev}} = \frac{\text{Seeds}}{\text{Grams}} * \frac{\text{Grams}}{\text{Rev}} \quad \left| \quad 39.6 \frac{\text{Seeds}}{\text{Grams}} * 11.7 \frac{\text{Grams}}{\text{Rev}} = 465 \frac{\text{Seeds}}{\text{Rev}} \right.$$

b. Lbs./rev:

$$\frac{\text{Pounds}}{\text{Rev}} = \frac{\frac{\text{Grams}}{\text{Rev}}}{453.6 \frac{\text{Grams}}{\text{Pound}}} \quad \left| \quad \frac{11.7 \frac{\text{Grams}}{\text{Rev}}}{453.6 \frac{\text{Grams}}{\text{Pound}}} = 0.0258 \frac{\text{Pounds}}{\text{Rev}} \right.$$

11. Find the correct population factor by dividing the desired population by the measured output rate.

Seeds/acre:

$$\frac{\text{Target Population}}{\text{Output Rate}} = \text{Population Factor} \quad \left| \quad \frac{1,000,000 \frac{\text{Seeds}}{\text{Acre}}}{465 \frac{\text{Seeds}}{\text{Rev.}}} = 2150.54$$

pounds/acre:

$$\frac{\text{Target Population}}{\text{Output Rate}} = \text{Population Factor} \quad \left| \quad \frac{56 \frac{\text{lbs}}{\text{Acre}}}{0.0258 \frac{\text{lbs}}{\text{rev}}} = 2170.54$$

12. Find the closest Population Factor in the Rate Chart to identify the correct transmission sprockets. For the examples list above, the closest Population Factor is 2142.22 which corresponds to a 27 tooth Drive sprocket and 28 tooth Driven sprocket.

**NOTE: Multiple trials are recommended to increase the accuracy of the predicted rate.**

**DRY INSECTICIDE APPLICATION RATES  
APPROXIMATE POUNDS/ACRE AT 5 MPH FOR VARIOUS ROW WIDTHS**

Meter Setting	30" Rows	36" Rows	38" Rows
<b>CLAY GRANULES</b>			
10	4.9	4.1	3.9
11	5.4	4.5	4.3
12	6.1	5.1	4.8
13	6.9	5.7	5.4
14	7.7	6.4	6.0
15	8.5	7.1	6.7
16	9.6	8.0	7.6
17	10.7	8.9	8.4
18	11.4	9.5	9.0
19	13.1	10.9	10.3
20	14.2	11.8	11.2
21	15.5	12.9	12.3
22	16.4	13.7	12.9
23	17.2	14.3	13.6
24	18.8	15.7	14.9
25	20.9	17.4	16.5
26	23.0	19.2	18.1
27	24.1	20.0	19.0
28	25.4	21.2	20.1
29	27.8	23.2	22.0
30	29.6	24.7	23.4
<b>SAND GRANULES</b>			
5	2.9	2.4	2.3
6	4.9	4.0	3.8
7	5.3	4.4	4.2
8	6.3	5.3	5.0
9	7.8	6.5	6.1
10	8.9	7.4	7.0
11	10.2	8.5	8.0
12	11.2	9.3	8.8
13	12.6	10.5	10.0
14	14.1	11.7	11.1
15	15.5	12.9	12.3
16	17.5	14.6	13.8
17	19.4	16.2	15.3
18	21.8	18.2	17.2
19	24.3	20.2	19.1
20	25.7	21.4	20.3
21	27.6	23.0	21.8
22	29.6	24.7	23.4
23	32.0	26.7	25.3
24	34.4	28.7	27.2
25	36.9	30.7	29.1

**NOTE:** Above chart represents average values and should be used only as a starting point. Granular chemical flows through given meter opening at a nearly uniform rate regardless of roller speed. Your actual rate will vary with specific insecticide, planting speed, and plant population. Planting speed/ground speed has the greatest effect on application rate.

Your actual rate must be field checked with actual insecticide you are using at speed and population you are planting. See ["Granular Chemical Application Field Check" on page 4-7](#) for additional information.

**DRY HERBICIDE APPLICATION RATES**  
**APPROXIMATE POUNDS/ACRE AT 5 MPH FOR VARIOUS ROW WIDTHS**

**CLAY GRANULES**

Meter Setting	30" Rows	36" Rows	38" Rows
10	4.7	3.9	3.7
11	5.2	4.4	4.1
12	5.8	4.9	4.6
13	6.5	5.4	5.1
14	7.3	6.1	5.7
15	8.2	6.9	6.5
16	9.0	7.5	7.1
17	9.9	8.2	7.8
18	10.7	8.9	8.4
19	11.6	9.7	9.2
20	12.6	10.5	10.0
21	13.6	11.3	10.7
22	14.6	12.1	11.5
23	15.7	13.1	12.4
24	17.0	14.1	13.4
25	18.1	15.1	14.3
26	19.4	16.2	15.3
27	20.9	17.4	16.5
28	22.6	18.8	17.8
29	24.3	20.2	19.1
30	26.7	22.2	21.1

**NOTE:** Above chart represents average values and should be used only as a starting point. Granular chemical flows through given meter opening at a nearly uniform rate regardless of roller speed. Your actual rate will vary depending on specific herbicide, planting speed, and plant population. Planting speed/ground speed has the greatest effect on application rate.

Your actual rate must be field checked with actual herbicide you are using at speed and population you are planting. See [“Granular Chemical Application Field Check” on page 4-7](#) page for additional information.

**DRY FERTILIZER APPLICATION RATES  
APPROXIMATE RATE IN POUNDS PER ACRE**

Drive Sprocket	Driven Sprocket	Low Rate Position			High Rate Position		
		30" Rows	36" Rows	38" Rows	30" Rows	36" Rows	38" Rows
15	35	32	26	25	94	78	74
15	33	36	30	28	109	91	86
15	30	39	33	31	120	100	95
19	33	45	37	36	135	114	107
19	30	50	42	39	153	126	120
15	19	58	48	46	174	144	136
30	35	61	51	48	188	156	148
30	33	67	55	52	200	166	157
33	35	69	58	55	206	172	163
35	33	76	63	61	214	193	183
33	30	81	67	64	241	200	190
19	15	93	77	73	278	230	219
30	19	116	96	91	347	288	274
33	19	127	105	100	382	317	301
35	19	133	111	106	402	335	318
30	15	146	121	115	440	365	347
33	15	161	134	127	482	400	380
35	15	168	141	133	510	424	403

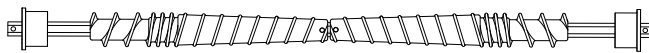

High rate setting

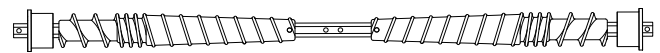

Low rate setting

**NOTE: Uneven delivery may result from attempting to use lower rates than indicated by chart.**

**Above chart is for planters equipped with contact drive. Check tires for correct operating pressure.**

**Chart calculated with a bulk density of 65 pounds per cubic foot.**

**NOTE: Fertilizer application rates can vary from weights calculated in above chart. Make field checks to be sure you are applying fertilizer at desired rate.**

To check exact number of pounds your fertilizer attachment will actually deliver on a 30" row spacing:

1. Remove one spout from one fertilizer hopper and attach a container under opening.
2. Engage fertilizer attachment and drive forward 174'.
3. Weigh amount of fertilizer caught in container and multiply by 100. Result is pounds of fertilizer delivered per acre when planting in 30" rows. To convert this delivery rate for wider rows, multiply by following conversion factors:

36" multiply by 0.83

38" multiply by 0.79

**LIQUID FERTILIZER PISTON PUMP APPLICATION RATES  
GALLONS PER ACRE**

**Applies to Model LM-2455-R And NGP-6055 Pump With 18 Tooth Sprocket**

<b>Pump Setting</b>	<b>1</b>	<b>2</b>	<b>3</b>	<b>4</b>	<b>5</b>	<b>6</b>	<b>7</b>	<b>8</b>	<b>9</b>	<b>10</b>
4 Row 30"	8.3	16.5	24.8	32.6	41.3	49.5	57.8	66.0	74.3	83.5
4 Row 36"	6.9	13.7	20.6	27.5	34.4	41.3	48.2	55.0	61.9	68.8
4 Row 38"	6.5	13.0	19.5	26.0	32.6	39.1	45.6	52.1	58.7	65.2
6 Row 30"	5.5	11.0	16.5	22.0	27.5	33.0	38.5	44.0	49.5	55.0
6 Row 36"	4.6	9.2	13.7	18.3	22.9	27.5	32.1	36.7	41.3	45.9
6 Row 38"	4.4	8.7	13.0	17.4	21.7	26.0	30.4	34.8	39.1	43.4
8 Row 30"	4.1	8.3	12.4	16.5	20.6	24.8	28.9	33.0	37.1	41.3

**Above chart is for planters equipped with contact drive. Check tires for correct operating pressure.**

**Chart is based on average wheel slippage and liquid viscosities.**

**Measure and weigh one gallon of actual fertilizer solution to determine exact application rate. This chart was calculated based on a solution weighing ten pounds per gallon.**

**NOTE: Fertilizer application rates can vary from the above chart. To prevent application miscalculations, make field checks to be sure you are applying fertilizer to all rows at the desired rate.**

**NOTE: Periodically check flow to all rows. Desired rate is delivered to remaining rows keeping total application rate at desired rate if one or more lines are plugged.**

To check exact number of gallons your fertilizer attachment delivers on a 30" row spacing:

1. Remove hose from one fertilizer opener and insert it into a collection container secured to planter frame.
2. Engage fertilizer attachment and drive forward for 174'.
3. Measure fluid ounces caught in container and multiply by 100. Divide that by 128. Result is gallons of fertilizer delivered per acre when planting in 30" rows.
4. Rinse collection container and repeat test on other rows if necessary. To convert delivery rate for wider rows, multiply by following conversion factors:

36" multiply by 0.83

38" multiply by 0.79



## LUBRICATION

Following pages show locations of all lubrication points. Proper lubrication of moving parts helps ensure efficient operation of your Kinze planter and prolongs the life of friction producing parts.

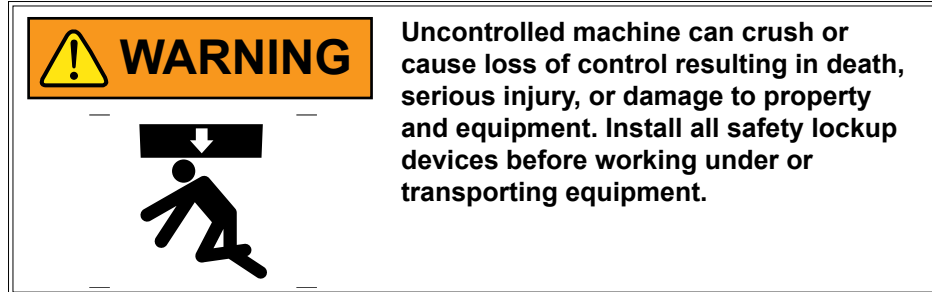

## LUBRICATION SYMBOLS

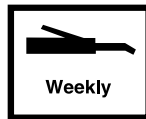
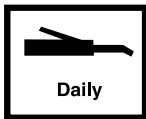

Lubricate at frequency indicated with an SAE multipurpose grease.

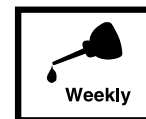

Lubricate at frequency indicated with a high quality SAE 10 weight oil or a quality spray lubricant.

## SEALED BEARINGS

A number of sealed bearings are used on your Kinze planter to provide trouble free operation. These are located in such areas as the drive shaft, row units, and transmission bearings. Sealed bearings are lubricated for life and not serviceable.

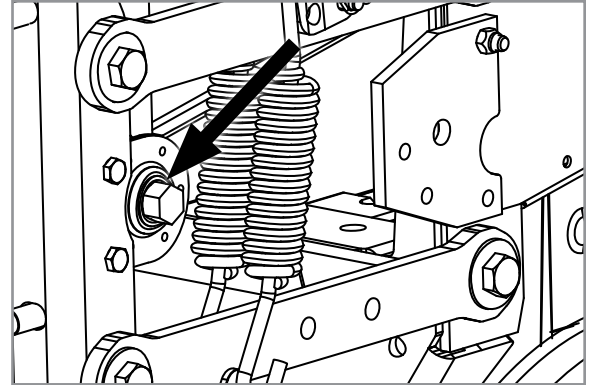

## WRAP SPRING WRENCH ASSEMBLY

Components may require occasional lubrication to operate correctly. Disassembly is required to lubricate.

1. Remove ¼"-20 x ½" cap screw that secures idler assembly to wrap spring wrench tightener shaft.
2. Remove wrap spring wrench from planter.
3. Tip wrap spring wrench on its side and lubricate with a high quality spray lubricant. Lubricant must be absorbed into wrap spring area.
4. Reinstall wrap spring wrench on planter.



Wrap Spring Wrench Lubrication

### DRIVE CHAINS

Lubricate all transmission and drive chains daily with a high quality chain lubricant. Extreme operating conditions such as dirt, temperature, or speed may require more frequent lubrication. If a chain becomes stiff, it should be removed, soaked, and washed in solvent to loosen and remove dirt from joints. Soak chain in oil so lubricant can penetrate between rollers and bushings.

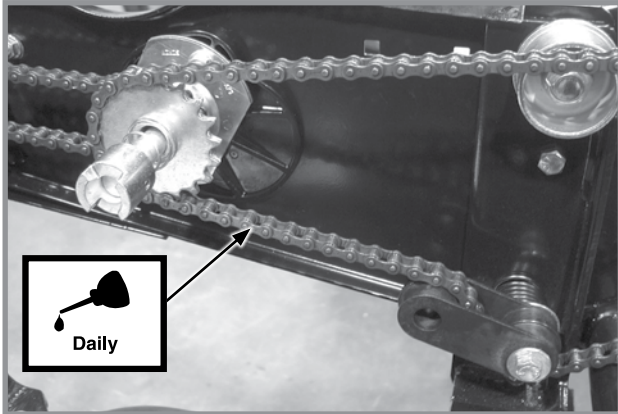

**Pull Row Unit Drive Chains**

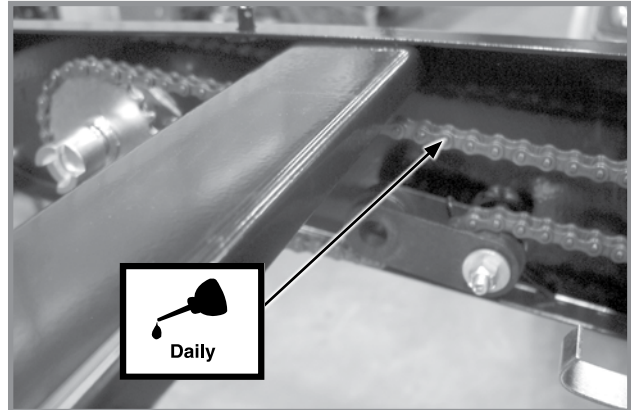

**Row Unit Granular Chemical Drive Chains**

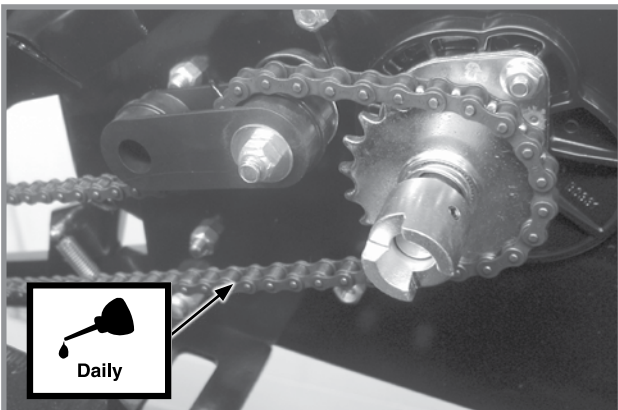

**Push Row Unit Drive Chains**

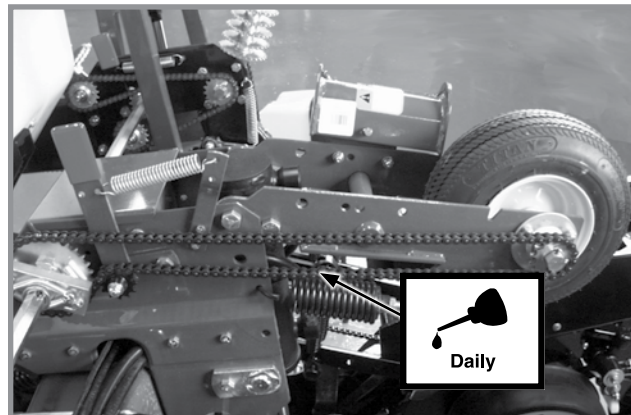

**Contact Wheel Drive Chains**

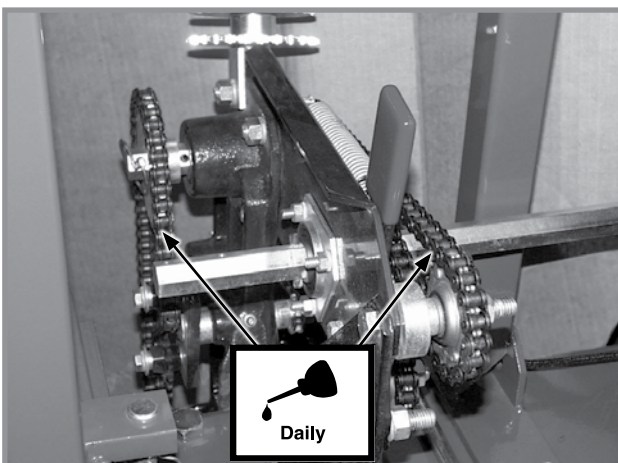

**Seed Rate Transmission Assembly and Reverser Plate Chains**

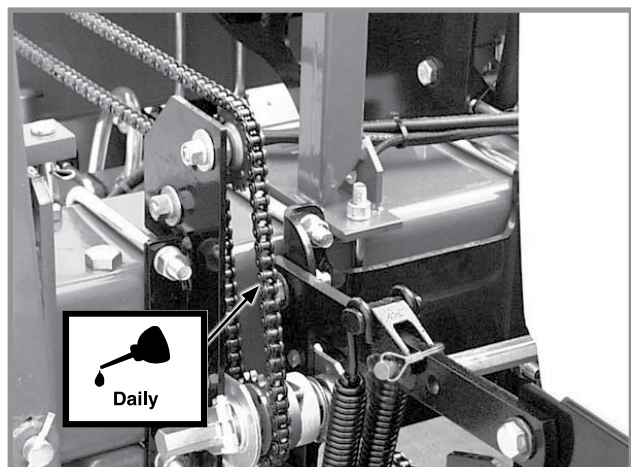

**Split Row Drive Chain (Double Frame)**

**DRIVE CHAINS (CONTINUED)**

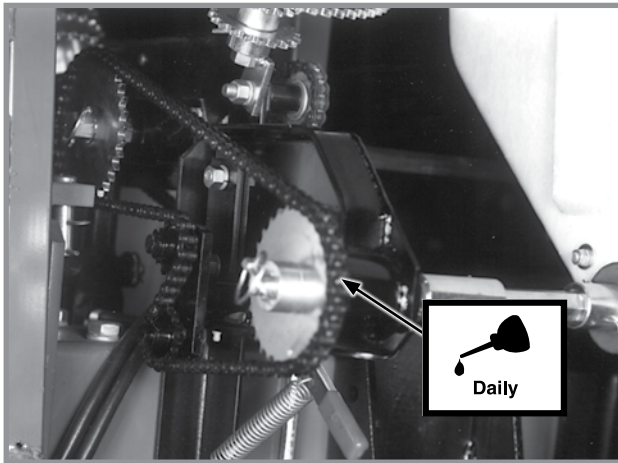

**Dry Fertilizer Drive Chain**

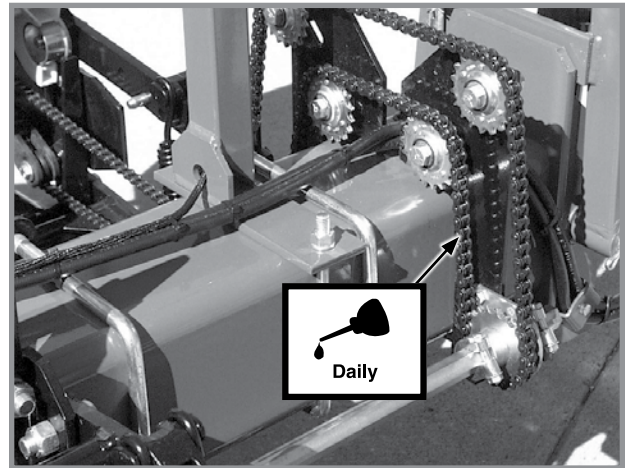

**Split Row Drive Chain (Single Frame)**

## BUSHINGS

Lubricate bushings at frequency indicated.

Check each bolt for proper torque. If bolt is loose, removed it and inspect bushing for cracks and wear. Replace bushing if necessary. Use **only hardened flat washers**. Replace damaged flat washers with proper part. Torque hardware to 130 ft-lb (176 N-m).

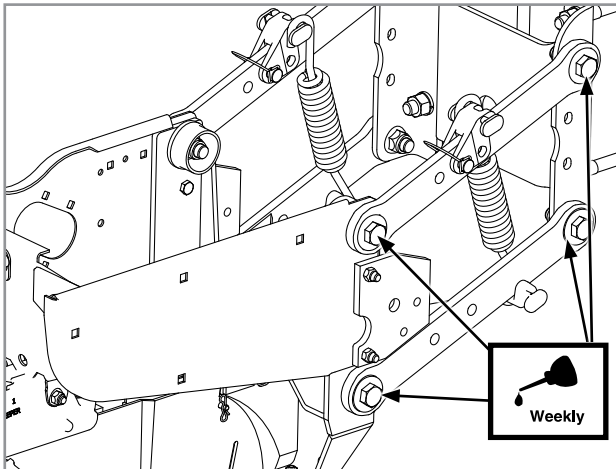

**Pull Row Unit And/Or Push Row Unit Parallel Linkages (8 Per Row)**

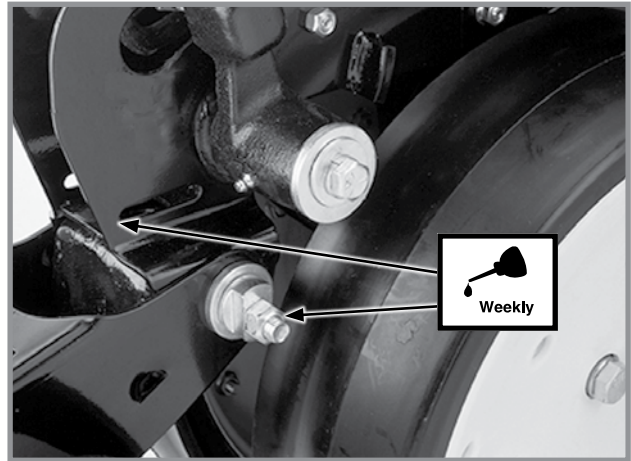

**Row Unit "V" Closing Wheel, Covering Discs/ Single Press Wheel And/Or Drag Closing Wheel Eccentric Bushings (2 Per Row)**

## SPLIT ROW PUSH ROW UNIT LOCKUPS

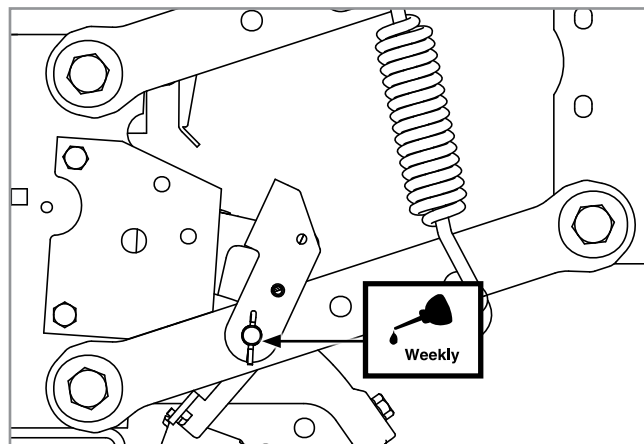

**2 Per Row**

## LIQUID FERTILIZER PISTON PUMP CRANKCASE OIL LEVEL

Check crankcase oil daily and maintain at plug level. Fill as needed with EP 90 weight gear oil. Total oil capacity is approximately  $\frac{3}{4}$  pint.

Refer to operator and instruction manual supplied with pump and flow divider for additional information.

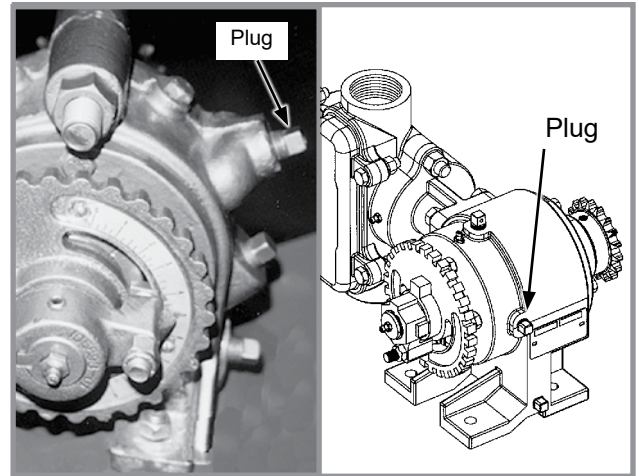

Piston pump oil fill plug location

## WHEEL BEARINGS

Inspect all drive, transport, and marker hub wheel bearings annually and repack/replace as needed.

1. Raise wheel off ground.
2. Check bearing endplay by moving wheel side to side.
3. Rotate wheel to check bearing roughness. If bearings sound rough, hub should be removed and bearings inspected and replaced as needed.

To repack wheel hubs, follow procedure outlined for wheel bearing replacement except bearings and bearing cups are reused.

**GREASE FITTINGS**

Lubricate parts with grease fittings at frequency indicated with an SAE multipurpose grease. Clean fitting thoroughly before greasing. Frequency of lubrication is based on normal operating conditions. Severe or unusual conditions may require more frequent attention.

**NOTE: Numbers on illustration below correspond to photos on following pages showing lubrication frequencies.**

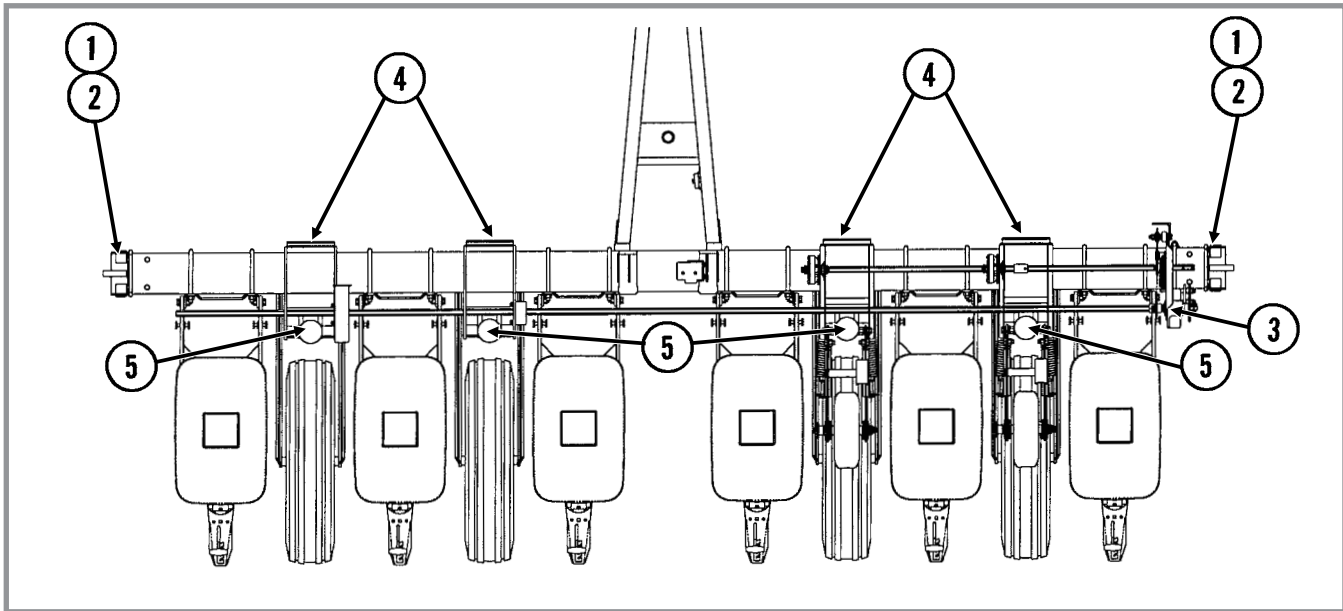

**Model 3005 6 Row 30" (70 cm) Planter Shown**

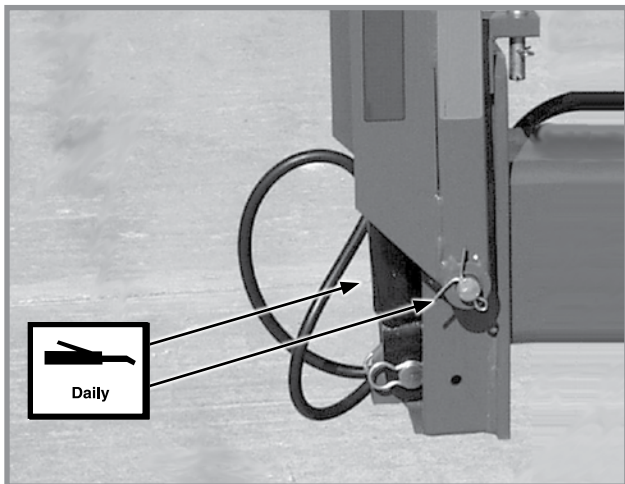

1. Conventional Row Marker Assembly - 4 Per Assembly

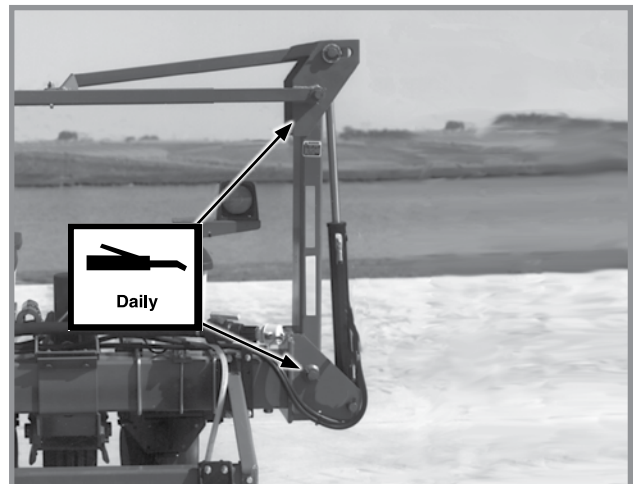

2. Low Profile Row Marker Assembly - 2 Per Assembly

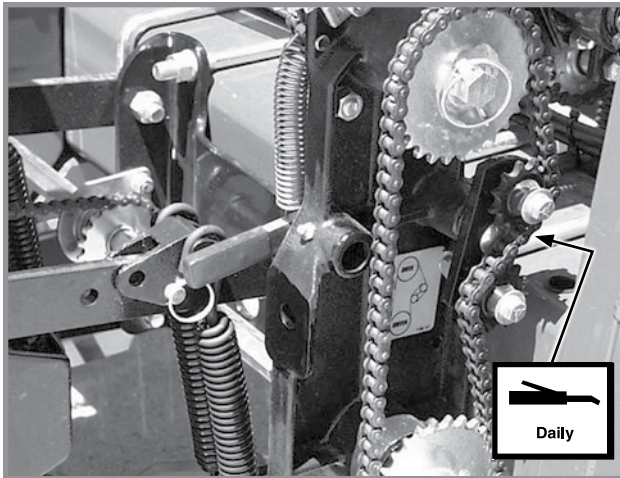

3. Seed Rate Transmission Assembly - 1 (Idler)

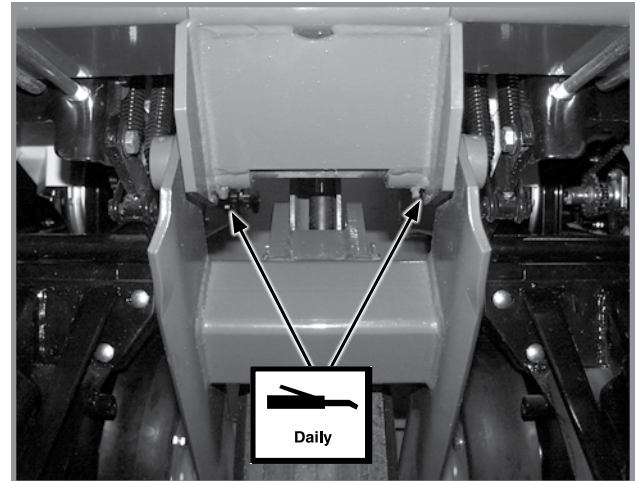

4. Wheel Module Assembly - 2 Per Module

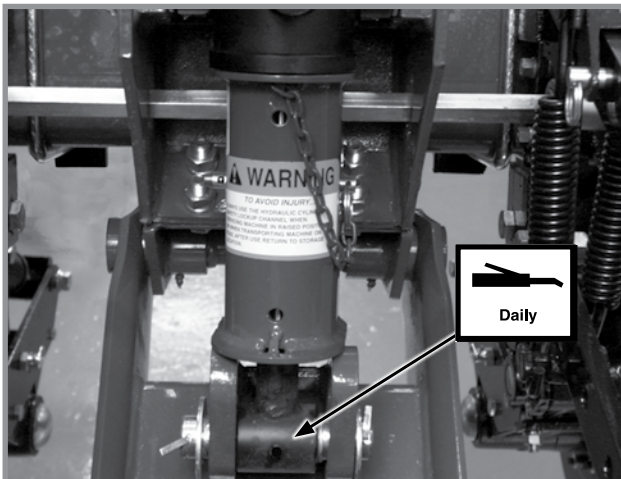

5. Lift Cylinders (Master, Slave And Assist) - 1 Per Cylinder.

**Row Unit**

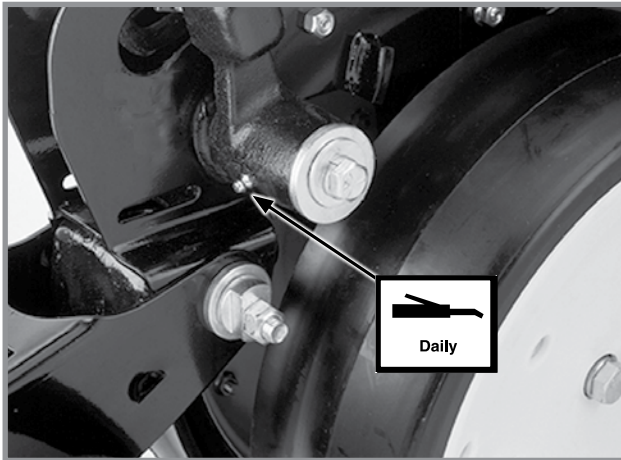

Gauge Wheel Arms - 1 Per Arm  
 (Seals installed with lip facing out to allow grease to purge dirt from seal. Pump grease into arm until fresh grease appears between washers and arm.)

**Split Row Attachment**

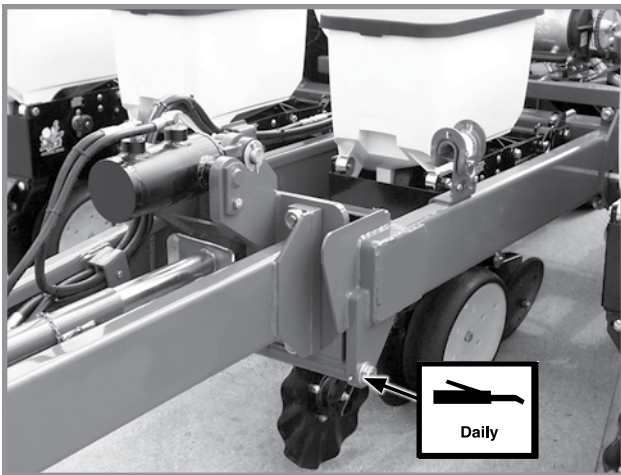

Split Row Self-Leveling Hitch Extension - 2



Fertilizer Openers

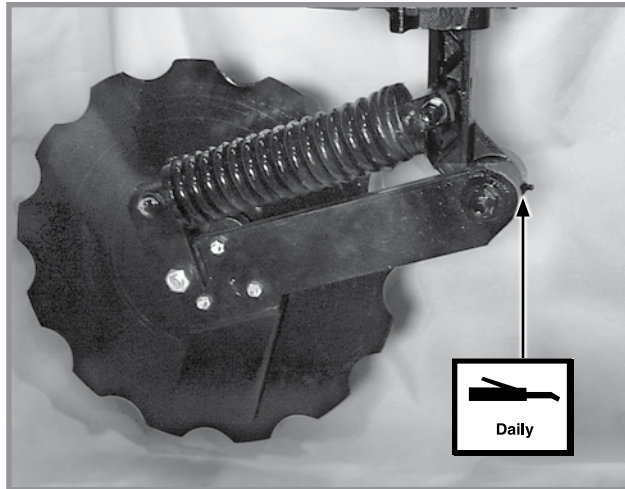

Notched Single Disc Fertilizer Opener - 1

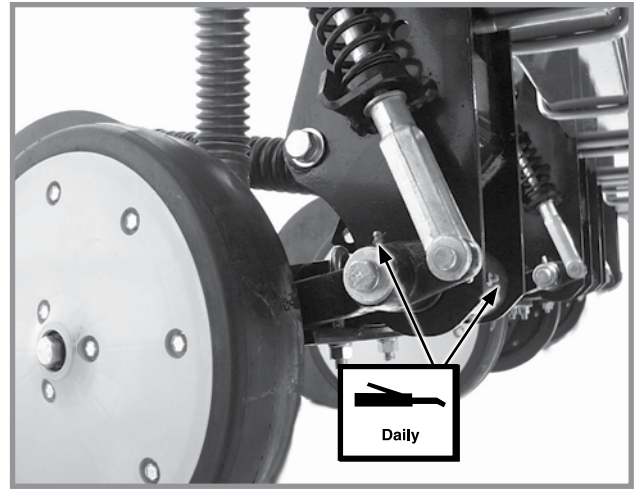

HD Single Disc Fertilizer Opener - 2  
(Located On Wheel Arm And Opener Mount)

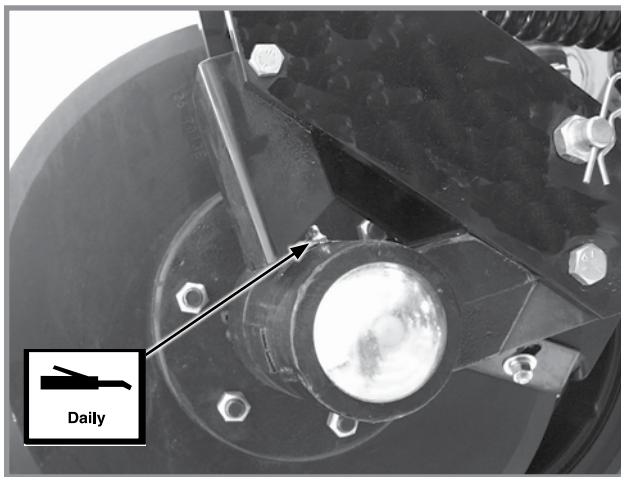

HD Single Disc Fertilizer Opener - 1  
(Located On Disc Opener Spindle Hub)

**Dry Fertilizer Attachment**

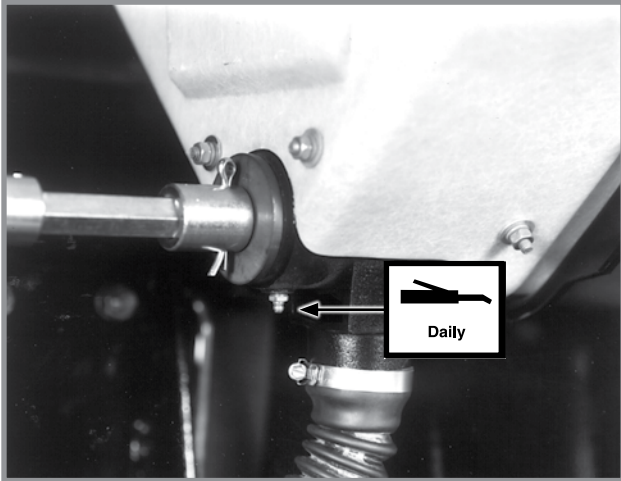

Dry Fertilizer Hopper - 2 Per Hopper

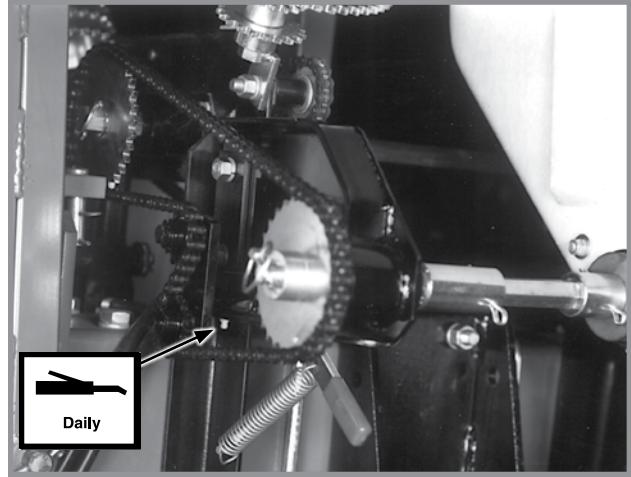

Dry Fertilizer Transmission - 1 Per Transmission

**Liquid Fertilizer Attachment**

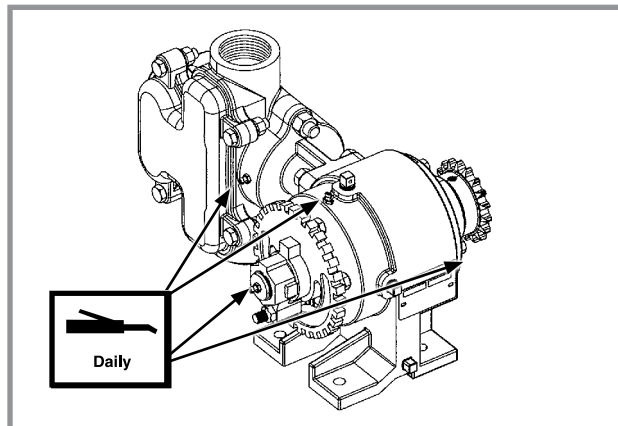



Liquid Fertilizer Piston Pump - 4 (Fill on outboard stuffing box until lubricant seeps out of drain hole in bottom.)

## MOUNTING BOLTS AND HARDWARE



Before operating planter for the first time, check all hardware is tight. Check all hardware again after first 50 hours of operation and beginning of each planting season.

All hardware used on the Kinze planter is Grade 5 (high strength) unless otherwise noted. Grade 5 cap screws are marked with three radial lines on the head. Hardware must be replaced with equal size, strength, and thread type.

 <b>WARNING</b>	<b>Loose transport wheel lug bolts can result in wheel separation from planter and result in death, serious injury, and damage to property and equipment. Check transport wheel lug nut torque before operating planter for the first time and periodically thereafter.</b>
	

<b>NOTICE</b>	<b>Over-tightening hardware can reduce its shock load capacity and cause equipment failure.</b>
---------------	---

**TORQUE VALUES CHART - PLATED HARDWARE**

Diameter	Grade 2 (No marks) 		Grade 5 (3 marks) 		Grade 8 (6 marks) 	
	Coarse	Fine	Coarse	Fine	Coarse	Fine
1/4"	50 in-lb	56 in-lb	76 in-lb	87 in-lb	9 ft-lb (12 N-m)	10 ft-lb (14 N-m)
5/16"	8 ft-lb (11 N-m)	9 ft-lb (12 N-m)	13 ft-lb (18 N-m)	14 ft-lb (19 N-m)	18 ft-lb (24 N-m)	20 ft-lb (27 N-m)
3/8"	15 ft-lb (20 N-m)	17 ft-lb (23 N-m)	23 ft-lb (31 N-m)	26 ft-lb (35 N-m)	33 ft-lb (45 N-m)	37 ft-lb (50 N-m)
7/16"	25 ft-lb (34 N-m)	27 ft-lb (37 N-m)	37 ft-lb (50 N-m)	41 ft-lb (56 N-m)	52 ft-lb (71 N-m)	58 ft-lb (79 N-m)
1/2"	35 ft-lb (48 N-m)	40 ft-lb (54 N-m)	57 ft-lb (77 N-m)	64 ft-lb (87 N-m)	80 ft-lb (108 N-m)	90 ft-lb (122 N-m)
9/16"	50 ft-lb (68 N-m)	60 ft-lb (81 N-m)	80 ft-lb (108 N-m)	90 ft-lb (122 N-m)	115 ft-lb (156 N-m)	130 ft-lb (176 N-m)
5/8"	70 ft-lb (95 N-m)	80 ft-lb (108 N-m)	110 ft-lb (149 N-m)	125 ft-lb (169 N-m)	160 ft-lb (217 N-m)	180 ft-lb (244 N-m)
3/4"	130 ft-lb (176 N-m)	145 ft-lb (197 N-m)	200 ft-lb (271 N-m)	220 ft-lb (298 N-m)	280 ft-lb (380 N-m)	315 ft-lb (427 N-m)
7/8"	125 ft-lb (169 N-m)	140 ft-lb (190 N-m)	320 ft-lb (434 N-m)	350 ft-lb (475 N-m)	450 ft-lb (610 N-m)	500 ft-lb (678 N-m)
1"	190 ft-lb (258 N-m)	205 ft-lb (278 N-m)	480 ft-lb (651 N-m)	530 ft-lb (719 N-m)	675 ft-lb (915 N-m)	750 ft-lb (1017 N-m)
1 1/8"	265 ft-lb (359 N-m)	300 ft-lb (407 N-m)	600 ft-lb (814 N-m)	670 ft-lb (908 N-m)	960 ft-lb (1302 N-m)	1075 ft-lb (1458 N-m)
1 1/4"	375 ft-lb (508 N-m)	415 ft-lb (563 N-m)	840 ft-lb (1139 N-m)	930 ft-lb (1261 N-m)	1360 ft-lb (1844 N-m)	1500 ft-lb (2034 N-m)
1 3/8"	490 ft-lb (664 N-m)	560 ft-lb (759 N-m)	1100 ft-lb (1491 N-m)	1250 ft-lb (1695 N-m)	1780 ft-lb (2413 N-m)	2030 ft-lb (2752 N-m)
1 1/2"	650 ft-lb (881 N-m)	730 ft-lb (990 N-m)	1450 ft-lb (1966 N-m)	1650 ft-lb (2237 N-m)	2307 ft-lb (3128 N-m)	2670 ft-lb (3620 N-m)

**NOTE: Torque unplated hardware and bolts with lock nuts approximately 1/3 higher than above values. Torque bolts lubricated prior to installation to 70% of value shown in chart.**

**SPECIAL TORQUE VALUES & INSTRUCTIONS**

Row unit parallel linkage bushing hardware	130 ft-lb (176 Nm)
5/8" No till coultter spindle hardware	120 ft-lb (162 Nm)
Row Unit Disc Opener Blade Bolt**	110 ft-lb (149 Nm)
	**Left hand side is left hand thread.
5/8" - 18 Wheel Lug Nuts and Lug Bolts	200 ft-lb (271 Nm)
9/16" - 18 Wheel Lug Nuts and Lug Bolts	125 ft-lb (169 Nm)

### TIRE PRESSURE



**WARNING**

Explosive separation of rim and tire parts can cause death or serious injury. Overinflation, rim and tire servicing, improper use of rims and tires, or worn or improperly maintained tires could result in a tire explosion.



To prevent tire explosion:

- **Maintain proper tire pressure. Inflating a tire above or below the recommended pressure can cause tire damage.**
- **Mount tires only by properly trained personnel using proper equipment.**
- **Replace any tire with cuts or bubbles. Replace any damaged rims. Replace missing lug bolts and nuts.**
- **Do not weld or heat wheel assembly. Heating increases tire pressure.**

### MODEL 3005 OPERATING TIRE PRESSURE

Transport/ground drive - 7.50" x 20" . . . . . Inflate to 40 psi (275.7 kPa)

Contact drive - 4.10" x 6" . . . . . Inflate to 50 psi (344.7 kPa)



## CHAIN TENSION ADJUSTMENT

Drive chains equipped with a spring loaded idler are self-adjusting. The only adjustment is to shorten chain if wear stretches chain and reduces spring tension. Check idler pivot periodically to ensure they rotate freely.

Split Row push row unit drive chain adjustment is made by loosening idler sprocket mounting hardware and sliding sprockets in slotted mounting holes.

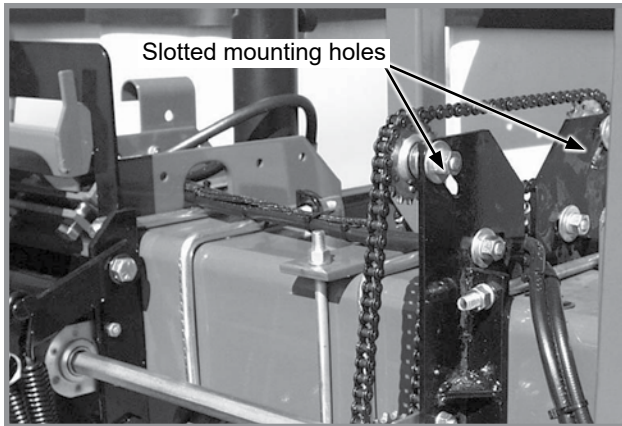

**Split Row drive chain tension adjustment**

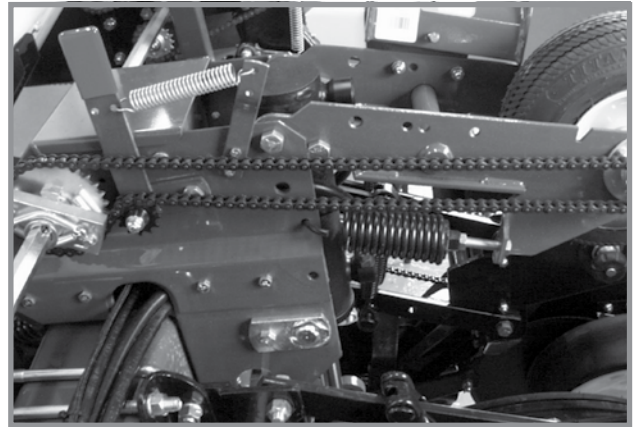

**Drive chain tension adjustment**

Additional chain links are in the storage box inside wheel module.

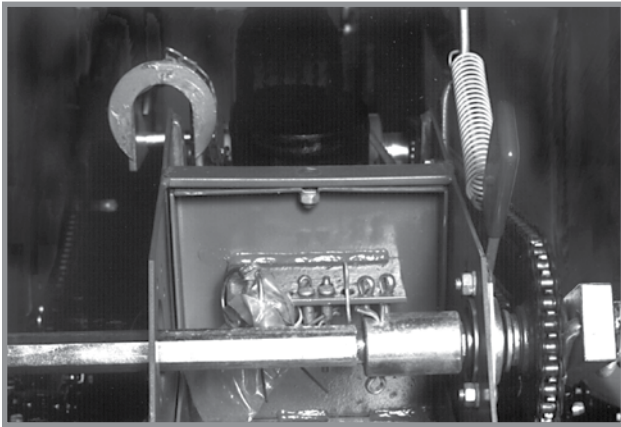

**Chain link storage**

See "Wrap Spring Wrench Assembly" in Lubrication of this section for additional information.

## FINGER PICKUP SEED METER INSPECTION/ADJUSTMENT

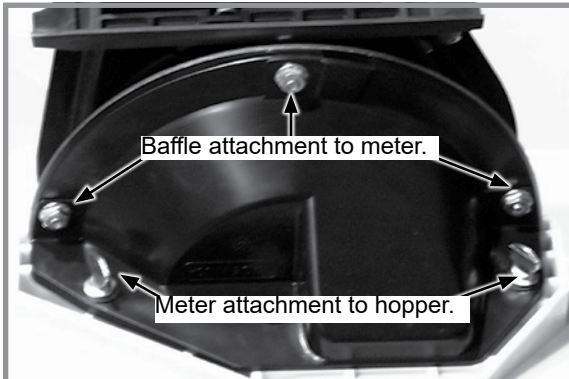

**Removing meter and baffle**

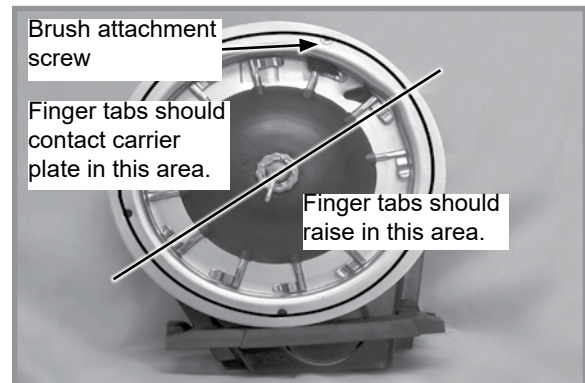

**Proper finger operation**

1. Remove two thumbscrews and meter from seed hopper and remove three cap screws and baffle from meter assembly.
2. Rotate seed meter drive by hand to ensure springs are holding tabs of fingers against carrier plate and fingers raise in correct area as shown in above photo.

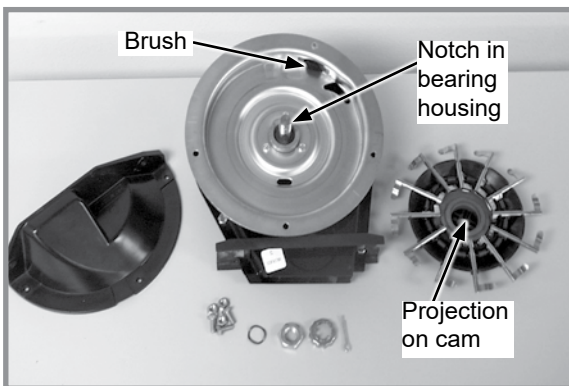

**Finger pickup meter parts**

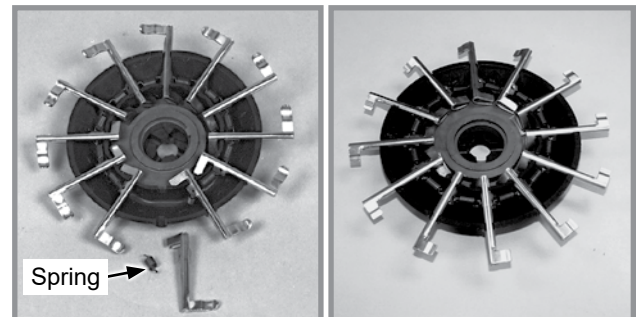

**Corn Finger Assembly**  
(Position Spring Opening  
Toward Holder)

**Oil Sunflower Finger  
Assembly**

Buildup of debris or chaff may prevent proper finger operation and requires disassembly and cleaning of finger pickup meter.

1. Remove cotter pin, cover nut and adjusting nut and wave washer (If applicable) from drive shaft.
2. Carefully lift finger holder with fingers and cam off shaft and clean.
3. Check brush for wear and replace if necessary or after every 100 acres per row of operation (Approximately 800 acres of corn or sunflowers on a 8 row machine or 1200 acres on an 12 row machine).

**NOTE: It is not necessary to remove finger holder to replace brush.**

4. Remove springs from fingers and remove finger from holder by lifting it out of friction fit slot. Life expectancy of these parts is about 600-900 acres per row of operation under average conditions.
5. Reassemble meter in reverse order after cleaning and replacing defective parts. Make sure open end of spring loop is toward inside of finger holder when replacing fingers.
6. Install fingers in holder so holder is flush with carrier plate when assembled. A cam projection aligns with a mating notch in bearing housing to ensure proper operation when assembled.

7. Check indentations on carrier plate for wear before installing finger holder on carrier plate. Excessive wear of carrier plate at indentations will cause over planting especially with small sizes of seed. Inspect carrier plate annually. Life expectancy should be 250-300 acres per row of operation under average conditions.
8. Install wave washer and adjusting nut with finger holder flush against carrier. Tighten adjusting nut to fully compress wave washer. Back off nut 1/2 to 2 flats to obtain rolling torque of 22 to 25 inch pounds.
9. Turn finger holder by hand to make sure it is firmly against carrier plate, but can be rotated with moderate force.
10. Install cover nut and cotter pin. Reinstall baffle.

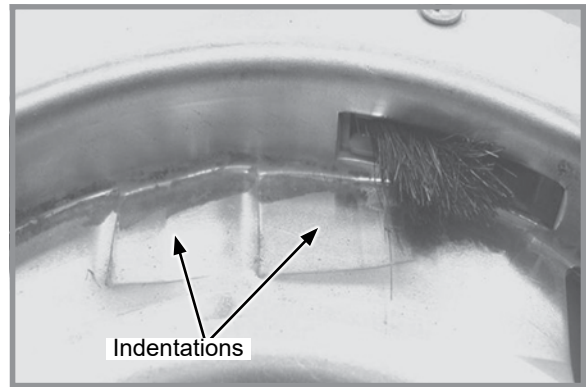

**Worn carrier plate**

**NOTE: Check adjusting nut tightness on each unit after first day of use and periodically thereafter.**

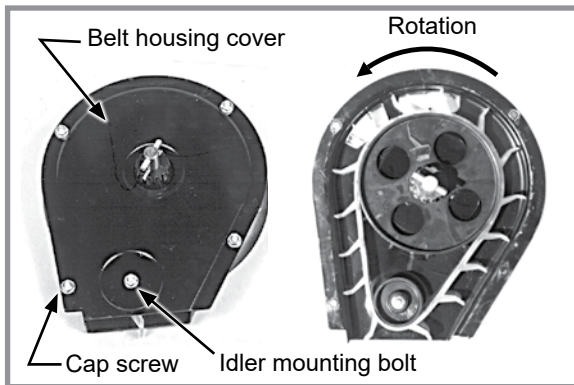

**Belt idler**

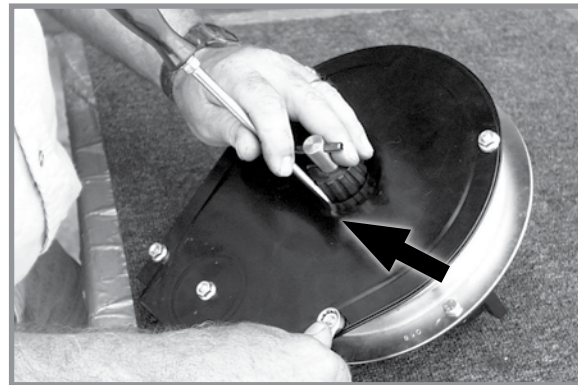

**Centering belt housing cover**

Remove four cap screws around edge of housing cover and nut from belt idler mounting bolt. Paddles must be correctly oriented as shown above. If belt is replaced. A diagram molded into drive sprocket shows correct orientation.

**NOTICE**

**Do not over-tighten hardware or components may be damaged.**

Reinstall housing cover. DO NOT TIGHTEN hardware. Wedge a screwdriver between sprocket hub and housing cover as shown above. Pry cover down until centered on belt housing and tighten hardware. Rotate meter drive shaft and check idler alignment. Seed belt should "run" centered on idler or with only slight contact with belt housing or cover.

**CLEANING FINGER PICKUP SEED METER FOR STORAGE**

1. Disassemble meter and blow out any foreign material.
2. Wash ONLY in mild soap and water. Do not use gasoline, kerosene, or any other petroleum based product. Dry thoroughly.
3. Coat lightly with a rust inhibitor.
4. Rotate finger assembly so finger does not touch brush.
5. Reassemble and store in a dry, rodent-free location.



## BRUSH-TYPE SEED METER 2.0 MAINTENANCE

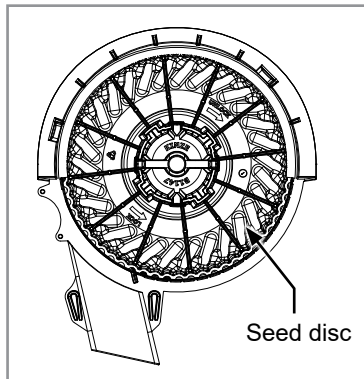

**Brush-type seed meter seed disc installed**

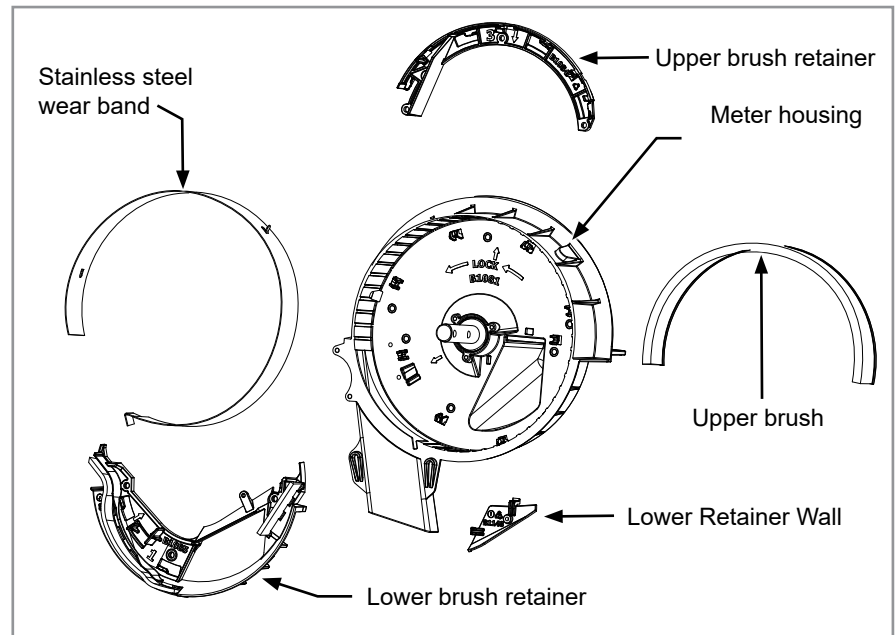

**Brush-type seed meter 2.0 parts**

Use clean, high quality seed. Damaged or cracked seed, hulls, or foreign materials can become lodged in upper brush and greatly reduce meter accuracy. Remove seed disc daily and check for buildup of foreign material on seed disc, particularly in seed loading slots. Clean disc by washing it with soap and water. Check for cracked seed, hulls, etc. lodged between brush retainer and stainless steel wear band which can greatly reduce accuracy of the meter because upper brush will not be able to retain seed in seed disc pocket. Thoroughly clean brush areas of meter housing.

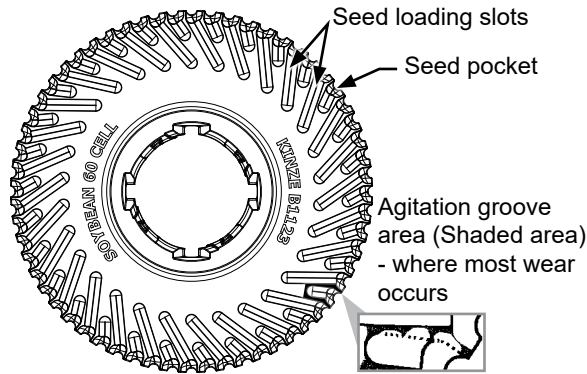

SEED DISC WEAR

Most seed disc wear is found in the agitation groove area (area between seed loading slots). Wear affects planting accuracy at high RPM. Lay a straight edge across disc surface at agitation groove area and measure gap between disc and straight edge. If agitation groove areas are worn in excess of .030" and accuracy starts to drop off at higher meter RPM, replace seed disc. Estimated seed disc life expectancy under normal operating conditions is approximately 200 acres per row. Severe operating conditions such as dust, lack of lubrication or abrasive seed coating could reduce seed disc life expectancy to under 100 acres per row.

STAINLESS STEEL WEAR BAND

<b>NOTICE</b>	<b>If wear band wears through or if meter is used without wear band in place, meter housing may be damaged.</b>
---------------	---

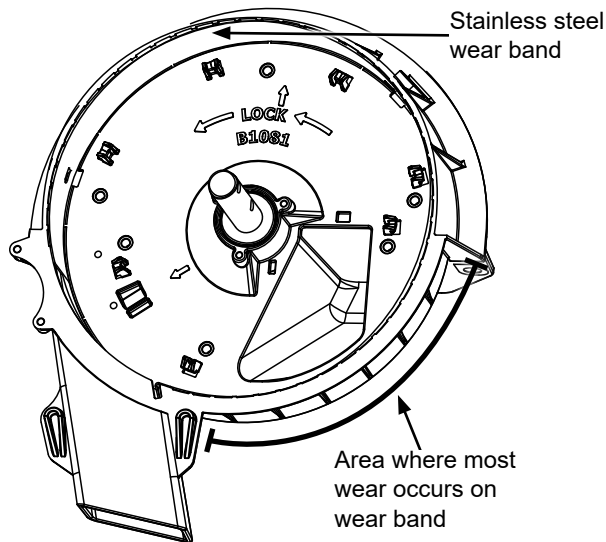

Stainless steel wear band

Stainless steel wear band protects meter housing from wear and is .030" thick. Replace wear band when there is approximately .020" of wear in primary wear area. Estimated life expectancy of stainless steel wear band is 240-800 acres per row.

## ASSEMBLY

Assemble meter by putting parts back in the housing in the order they are numbered:

1. Lower brush retainer
2. Upper brush
3. Upper brush retainer

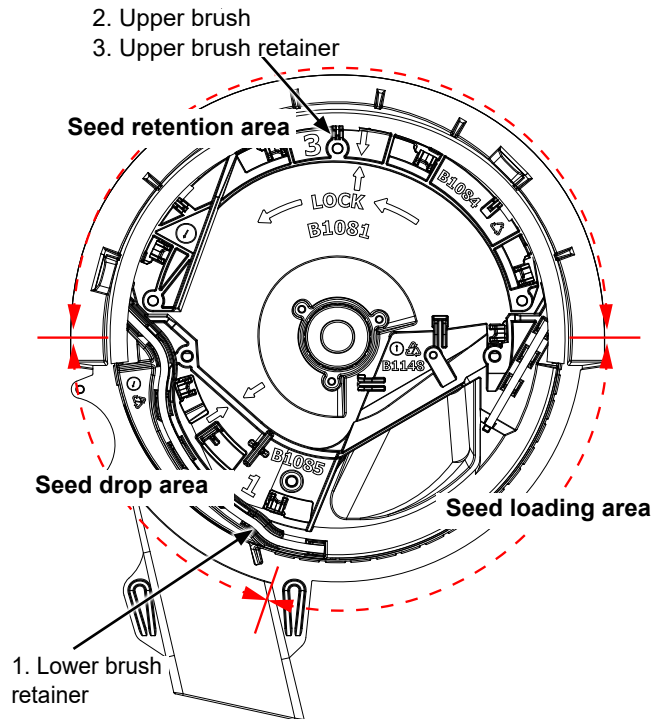

## LOWER BRUSH

Lower brush moves seed down seed loading slots to seed pockets, isolates seed in reservoir from entering seed tube, and cleans seed loading slots. Estimated lower brush life expectancy is 240-800 acres per row. Replace lower brush if bristles are deformed or missing, or if there are cracks in brush retainer. Once all parts are properly in place, rotate to lock position.

## UPPER BRUSH

Upper brush holds seed in seed disc pocket in seed retention area. Brush must apply enough pressure against seed in seed disc pocket as disc rotates through seed retention area to prevent seed from dropping out of disc pocket. A damaged spot, excessive brush wear, or foreign material lodged in brush may greatly reduce meter performance.

Replace upper brush at 120-400 acres per row of use or sooner if damage or excessive wear is found. Position upper brush into inner perimeter of seed retention area. Make sure base of brush is tight against bottom of meter housing. Install brush retainer. Once all parts are properly in place, rotate to lock position.

**NOTE: Use P/N: GB1084 upper brush retainer for all seed discs. It is recommended for milo/grain sorghum to use P/N: GB1107 milo retainer for additional brush retention.**

## CLEANING BRUSH-TYPE SEED METER FOR STORAGE

1. Remove meter from seed hopper by removing two thumbscrews securing meter to hopper.
2. Remove seed disc and wash with soap and water and dry thoroughly.
3. Remove three hex head screws from brush retainer. Remove brush retainer and upper brush.
4. Remove three hex head screws from lower brush. Remove lower brush and stainless steel wear band.
5. Wash all parts and meter housing with soap and water and dry thoroughly.
6. Inspect all parts and replace worn parts.
7. Reassemble meter except for seed disc. Store meter in a dry, rodent-free space with seed disc removed.

## GAUGE WHEEL ADJUSTMENT

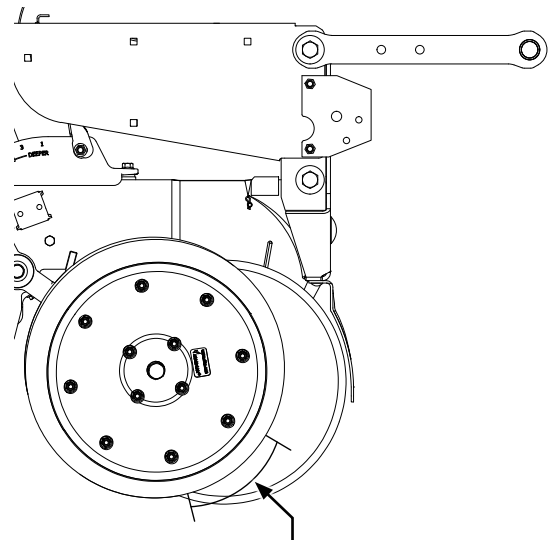
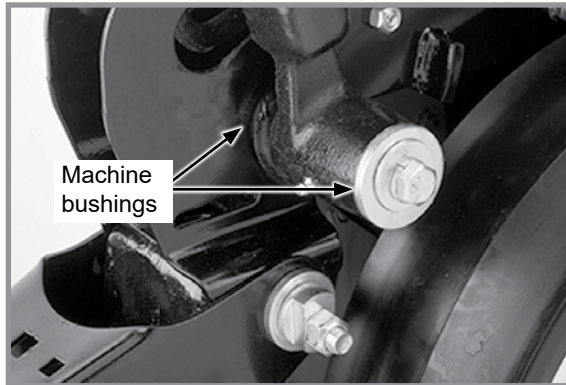

Shim gauge wheel to lightly contact opener disc blade in this area for 4" to 6". Check adjustment in operating position.

### Gauge Wheel Adjustment

Add or remove machine bushings between shank and gauge wheel arm to adjust contact between gauge wheels and opener blades. Gauge wheels should lightly contact opener blades to prevent accumulation of dirt or trash. Gauge wheels and opener blades should turn with only slight resistance.

Store remaining machine bushings between gauge wheel arm and flat washer on outer side of gauge wheel arm.

Use the following guidelines:

**NOTE: Set depth adjustment handle at 3x2 position and lift gauge wheel to stop one side at a time.**

Contact should be no less than one half of the rotation of the wheel, while not sticking in any position (it does not have to be continuous). Wheel should rotate in the direction of travel of the row unit. Wheel can be held in position by supporting the spindle bolt head.

## GAUGE WHEEL ARM BUSHING/SEAL REPLACEMENT

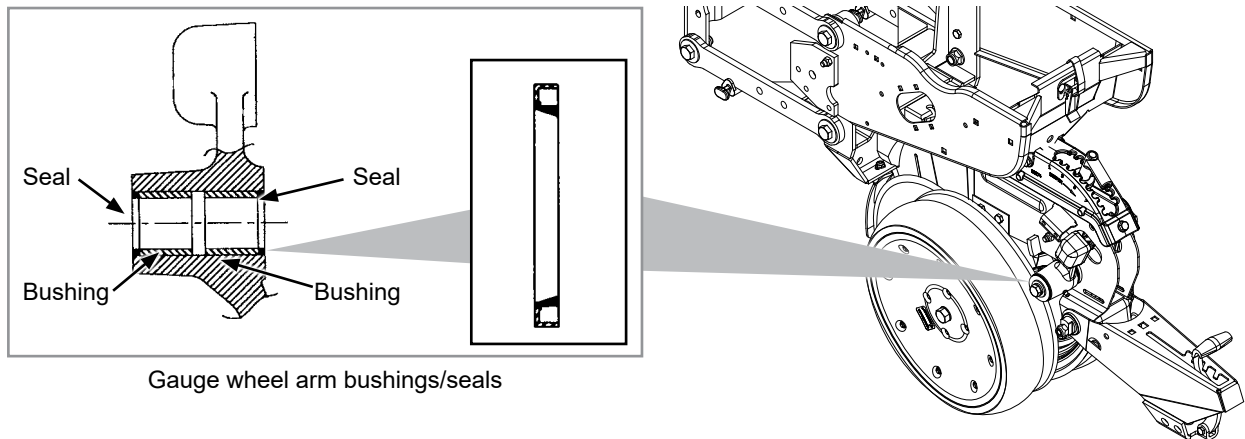

**NOTE: Gauge Wheel Arm Bushing and Seal Driver Kit (G1K296) is available through your Kinze Dealer.**

1. Remove gauge wheel from arm.
2. Remove gauge wheel arm from shank assembly.
3. Remove seal and bushing and discard. Clean and dry inner bore.
4. Drive/press replacement bushing inside bore of arm to a depth of .125" below flush.
5. Coat wiping edge of seal with grease.
6. Drive/press seal into place with lip to outside.

**NOTE: Use extra care to protect the sealing lip during installation. Apply uniform pressure to assemble the seal into the bore of the arm. Never apply a direct hammer blow to the seal surface.**

7. Inspect gauge wheel pivot spindle.
8. Reinstall gauge wheel arm assembly and gauge wheel.

**NOTE: Use special machine bushing between gauge wheel arm and gauge wheel.**

9. Shim for proper gauge wheel tire/disc blade clearance.
10. Lubricate with an SAE multipurpose grease.

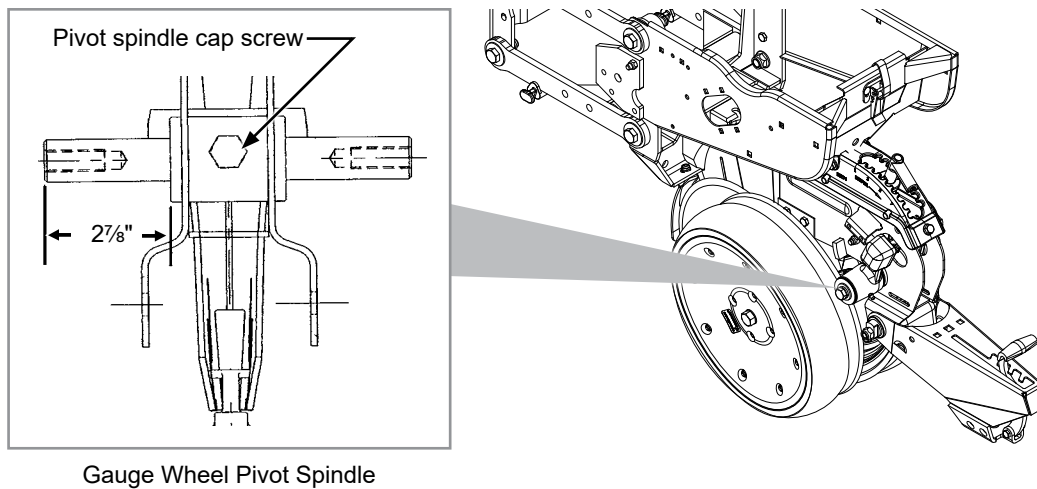
**GAUGE WHEEL ARM PIVOT SPINDLE REPLACEMENT**

Gauge Wheel Pivot Spindle

1. Remove gauge wheel and arm assemblies from shank assembly.
2. Remove  $\frac{1}{2}$ " x  $\frac{3}{4}$ " cap screw that locks pivot spindle in place and remove spindle.
3. Install replacement spindle and position as shown. Exact centering is critical.
4. Install  $\frac{1}{2}$ " x  $\frac{3}{4}$ " cap screw and torque to lock pivot spindle in place.
5. Install gauge wheel and arm assemblies. Shim for proper gauge wheel tire/disc blade clearance.

**This page left blank intentionally.**

## 15" SEED OPENER DISC BLADE/BEARING ASSEMBLY

Approximately  $1" \pm \frac{1}{2}"$  ( $3 \pm .5$  cm) of blade-to-blade contact should be maintained to properly open and form seed trench. As blade diameter decreases due to wear, it is necessary to relocate machine bushings from inside to outside to maintain  $1" \pm \frac{1}{2}"$  ( $3 \pm .5$  cm) of contact.

**NOTE: Proper blade clearance is critical. Blades should have  $1" \pm \frac{1}{2}"$  ( $3 \pm .5$  cm) contact in this area. When blades are turned by hand in opposite directions against each other, there should be only light resistance to turning. Re-adjust blade scraper if necessary to center it between the blades.**

**NOTE: If proper blade-to-blade contact cannot be maintained after relocating machine bushings or if blade diameter wears below  $14\frac{1}{2}"$  (37 cm), blades should be replaced.**

### NOTICE

Excessive blade contact may result in premature disc opener bearing/hub failures and excessive wear on seed tube guard/inner scraper. When properly adjusted, if one blade is held in fixed position, opposite blade should rotate with less than 5 pounds force (22 newtons) at outer edge of blade.

### NOTICE

Left hand side of opener uses a left hand threaded cap screw. **DO NOT OVER TIGHTEN.** Damage to shank threads require replacement of row unit shank assembly.

### REPLACE DISC BLADE/BEARING ASSEMBLY

1. Remove gauge wheel.
2. Remove scraper.
3. Remove bearing dust cap.
4. Remove cap screw, washer and disc blade/bearing assembly. Machine bushings between shank and disc blade are used to maintain approximate  $1" \pm \frac{1}{2}"$  ( $3 \pm .5$  cm) of blade-to-blade contact.
5. Install machine bushing(s), new disc blade bearing assembly, washer and cap screw. Torque  $\frac{5}{8}"$ -11 Grade 5 cap screw to value shown in "Torque Values Chart".

**NOTE: Replace disc blades only with disc blades of equal thickness.**

6. Replace bearing dust cap.
7. Install scraper.
8. Install gauge wheel. It may be necessary to replace bearing only if there is excessive endplay or if bearing sounds or feels rough when disc blade is rotated.

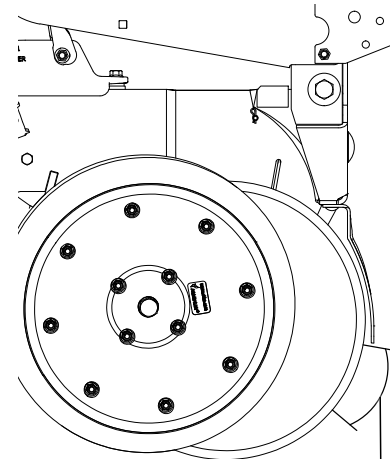

Approximately  $1" \pm \frac{1}{2}"$  ( $3 \pm .5$  cm) of blade-to-blade contact.



## REPLACE BEARING ONLY

1. Remove gauge wheel, scraper, bearing cap, cap screw, washer and disc blade/bearing assembly.
2. Remove ¼" rivets from bearing housing to expose bearing.
3. After installing new bearing, install three evenly spaced ¼" cap screws into three of six holes in bearing housing to hold bearing and bearing housing in place. Install rivets in other three holes. Remove ¼" cap screws and install rivets in those three holes.
4. Reinstall disc blade/bearing assembly, washer and cap screw. Torque ⅝"-11 cap screw to value shown in "Torque Values Chart" at the beginning of this section.
5. Replace bearing dust cap.
6. Install scraper and gauge wheel.

## SEED TUBE GUARD/INNER SCRAPER

Seed tube guard protects seed tube and acts as inner scraper for seed opener disc blades.

Remove seed tube and check for wear. Excessive wear on seed tube indicates a worn seed tube guard. Replace seed tube guard if it measures  $\frac{5}{8}$ " (16 mm) or less at lower end. A new seed tube guard measures approximately  $\frac{7}{8}$ " (22.2 mm).

**NOTE:** No till planting or planting in hard ground conditions, especially when planter is not equipped with no till coulters, and/or excessive blade-to-blade contact increases seed tube guard wear and requires more frequent inspection and/or replacement.

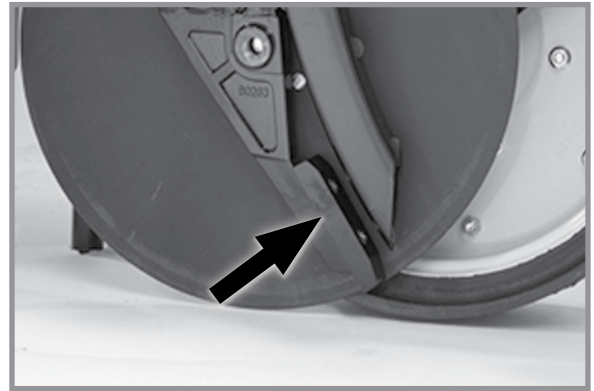

Seed tube guard/inner scraper  
(Gauge wheel/seed opener disc blade removed)

### NOTICE

Over tightening hex socket head cap screws may damage shank threads and require replacement of shank. An excessively worn seed tube guard may allow blades to wear into row unit shank, also requiring replacement of shank.

Remove seed tube and two hex socket head cap screws that attach seed tube guard. Hold replacement seed tube guard centered between seed opener disc blades. Install hex socket head cap screws. **DO NOT TIGHTEN.** Using a clamp or vise-grip, squeeze opener blades together in front of seed tube guard. Tighten seed tube guard retaining screws. Remove clamps. Distance between seed tube guard and opener blades should be equal on both sides. Reinstall seed tube.

## ROW UNIT MOUNTED NO TILL COULTER



Row unit mounted no till coulters

Check nuts and hardware periodically for proper torque.

**NOTE: Torque  $\frac{5}{8}$ " spindle hardware to 120 ft-lb (162 N-m).**

Be sure coulters are positioned square with row unit and aligned in front of row unit disc opener.

Coulters can be adjusted to one of four settings. Initially coulters are set in highest position. As coulters wear they can be adjusted to one of three lower settings. See "Row Unit Mounted No Till Coulters" in Row Unit Operation section of this manual.

Replace 16" diameter coulters when worn to 14½" (37 cm).

## COULTERS MOUNTED RESIDUE WHEELS



Coulters mounted residue wheels

Wheel hubs are equipped with sealed bearings. If bearings sound or feel rough when wheel is rotated, replace them.

## SPIKED CLOSING WHEEL

Inner parts of spiked closing wheel will begin to wear at approximately 70% of life. Flip/reverse wheel to utilize remaining life of wheel.

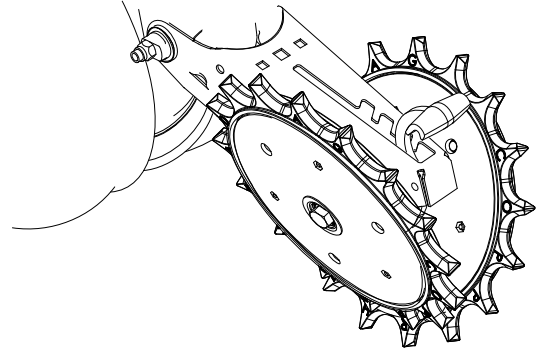

Row Unit Spiked Closing Wheel

## GRANULAR CHEMICAL ATTACHMENT

Before storing planter, disengage granular chemical drive by rotating throwout knob  $\frac{1}{4}$  turn counterclockwise. Remove drive chain and empty and clean all granular chemical hoppers. Clean drive chains and coat them with a rust preventive spray or submerge chains in oil. Inspect and replace worn or broken parts.

Install hoppers and chains. Check chain alignment.

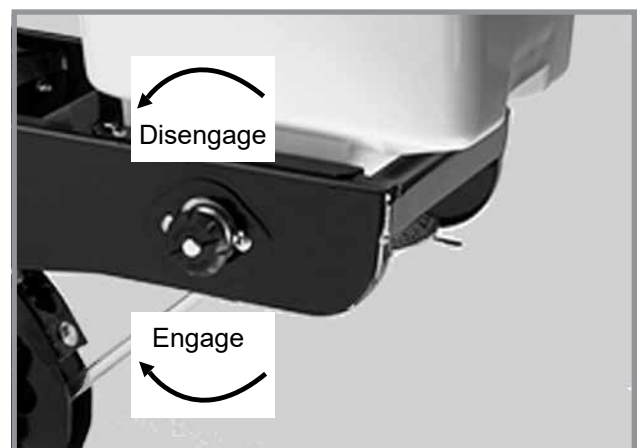

## ROW MARKER SEQUENCING/FLOW CONTROL VALVE INSPECTION

**WARNING**

Pressurized hydraulic fluid can penetrate body tissue and result in death, serious infection, or other injuries. Fluid injected under skin must be **IMMEDIATELY** removed by a surgeon familiar with this type of injury. Make sure connections are tight and hoses and fittings are not damaged before applying system pressure. Leaks can be invisible. Keep away from suspected leaks. Relieve pressure before searching for leaks or performing any system maintenance.



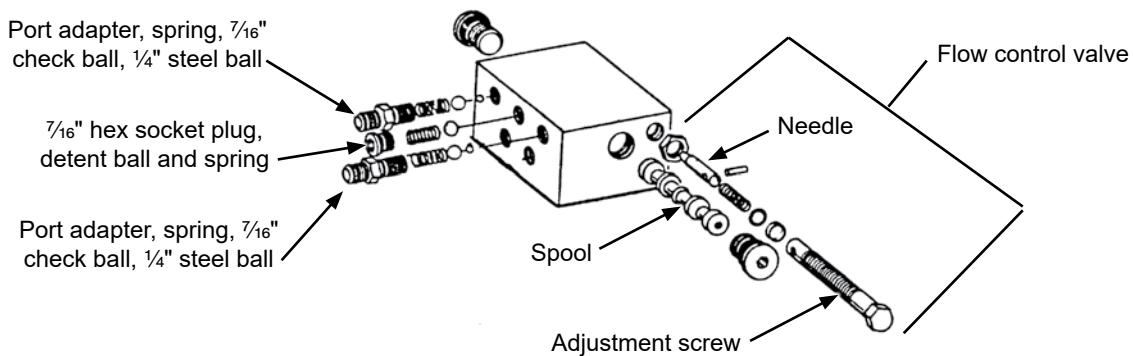

The valve block assembly consists of the row marker sequencing and flow control valves in one assembly. Sequencing valve portion consists of a chambered body containing a spool and series of check valves to direct hydraulic oil flow.

1. Remove valve block assembly from planter.
2. Remove detent assembly and port adapter assemblies from rear of valve block.

### NOTICE

**Damage to spool may occur if detent assembly and port adapter assemblies are not removed prior to removal of spool.**

3. Remove plug from both sides of valve block and remove spool.
4. Inspect all parts for pitting, contamination, or foreign material. Check seating surfaces inside valve. Replace defective parts.
5. Lubricate spool with a light oil and reinstall. Check spool moves freely in valve body.

**NOTE: Make sure correct check ball(s) and spring are installed in each valve bore upon reassembly.**

A flow control valve is located on each side of block assembly. Adjust flow control valves for raise and lower speed as part of assembly procedure or upon initial operation. If valve fails to function properly or requires frequent adjustment, remove needle valve for inspection. Check for foreign material and contamination. Make sure needle moves freely in adjustment screw. Replace defective components.

**NOTE: Hydraulics operate slowly when oil is cold. Make all adjustments with warm oil.**

## ROW MARKER BEARING LUBRICATION OR REPLACEMENT

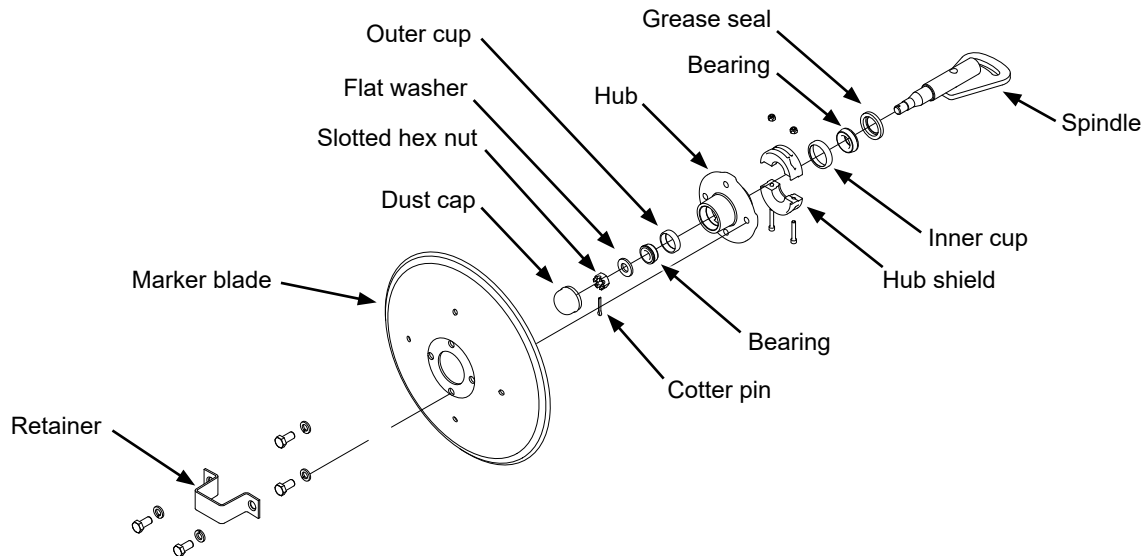

1. Remove retainer and marker blade.
2. Remove dust cap from hub.
2. Remove hub shield. Note direction of installation.
3. Remove cotter pin, slotted hex nut, and washer.
4. Slide hub from spindle.
5. Remove bearings and cups and discard if bearings are being replaced. Clean hub and dry. Remove bearings only and not cups if repacking.
6. Press in new bearing cups with thickest edge facing in. (Bearing replacement procedure only.)
7. Pack bearings with heavy duty wheel bearing grease thoroughly forcing grease between roller cone and bearing cage. Fill the space between the bearing cups in the hub with grease.
8. Install rubber seal into grease seal. Place inner bearing in place and press in new rubber seal/grease seal.
9. Clean spindle and install hub.
10. Install outer bearing, washer and slotted hex nut. Tighten slotted hex nut while rotating hub until there is some drag. This ensures all bearing surfaces are in contact. Back off slotted nut to nearest locking slot and install cotter pin.
11. Fill dust caps approximately  $\frac{3}{4}$  full of wheel bearing grease and install on hub.
12. Install hub shield.
13. Install marker blade and retainer on hub. Tighten hardware evenly.

## WHEEL BEARING REPACK OR REPLACEMENT

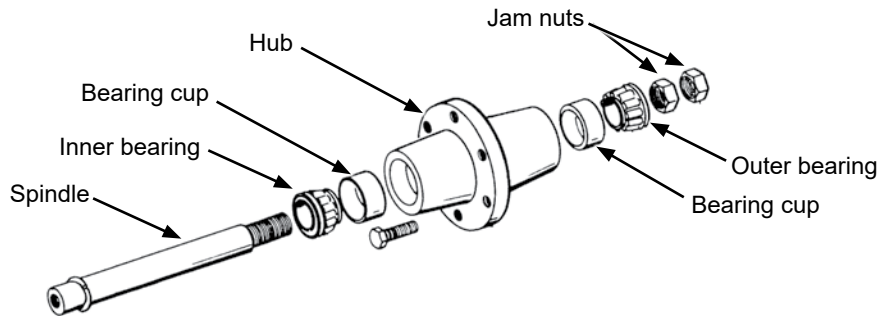

1. Raise tire clear of ground and remove wheel.
2. Remove double jam nuts and slide hub from spindle.
3. Remove bearings and cups and discard if bearings are being replaced. Clean hub and dry. Remove bearings only and not cups if repacking.
4. Press in new bearing cups with thickest edge facing in. (Bearing replacement procedure only.)
5. Pack bearings with heavy duty wheel bearing grease thoroughly forcing grease between roller cone and bearing cage. Fill space between bearing cups and hub with grease.
6. Place inner bearing in place.
7. Clean spindle and install hub.
8. Install outer bearing and jam nut. Tighten jam nut while rotating hub until there is some drag. This ensures all bearing surfaces are in contact. Back off jam nut  $\frac{1}{4}$  turn or until there is only slight drag when rotating hub. Install second jam nut to lock against first.
9. Install wheel on hub. Tighten hardware evenly.

## FERTILIZER CHECK VALVE CLEANING AND REPAIR

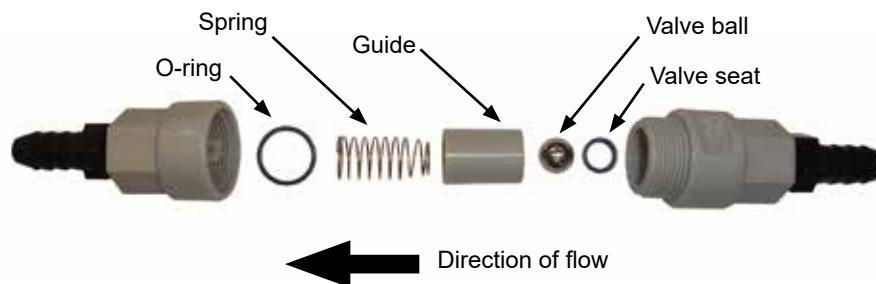

1. Unscrew valve body and separate halves. Note direction and location of parts.
2. Clean and inspect parts. Flush with clean water. Replace damaged parts.
3. Reassemble exactly as shown. O-ring and valve seat must be firmly in place inside each half of valve body.

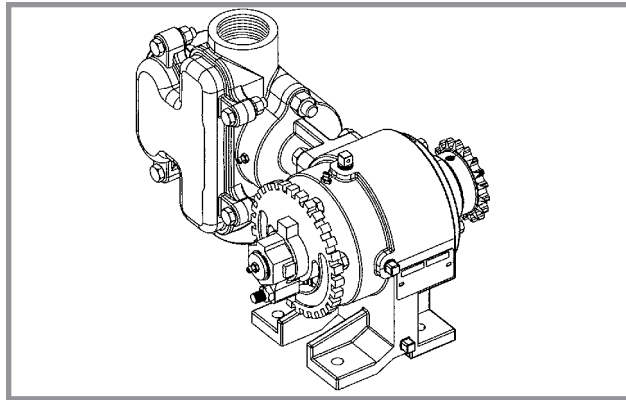

Liquid fertilizer piston pump

## PISTON PUMP STORAGE

### NOTICE

Entrance of air into pump will cause rapid and severe corrosion. **KEEP AIR OUT OF PUMP!**

**NOTE: SUSPENSION FERTILIZER must be flushed from pump for ANY storage period.**

1. Flush pump with 5 to 10 gallons (19 to 38 liters) of fresh water and circulate until all corrosive salts are dissolved in pump.
2. Set pump on 10. Draw in a mixture of half diesel fuel and 10 weight oil until discharge is clean. Plug inlet and outlet.

## PREPARING PLANTER FOR STORAGE

- Store planter in a dry sheltered area if possible. Refer to “Safety Lockups” in Machine Operation section for proper safety lockup installation during storage.
- Remove all trash that may be wrapped on sprockets or shafts and remove dirt that can draw and hold moisture.
- Clean all drive chains and coat with a rust preventative spray, or remove chains and submerge in oil.
- Lubricate planter and row units at all lubrication points.
- Inspect planter for parts that are in need of replacement and order during “off” season.
- Make sure seed and granular chemical hoppers are empty and clean.
- Clean seed meters and store in a dry, rodent-free area.
- Remove seed discs from brush-type seed meters, clean and store meters with discs removed.
- Grease or paint disc openers/blades and row marker disc blades to prevent rust.
- Flush liquid fertilizer tanks, hoses and metering pump with clean water. See “Piston Pump Storage” if applicable.
- Empty and clean dry fertilizer hoppers. Disassemble and clean metering augers. Reassemble and coat all metal parts with rust preventative.



**ELECTRICAL WIRING DIAGRAM FOR LIGHT PACKAGE**

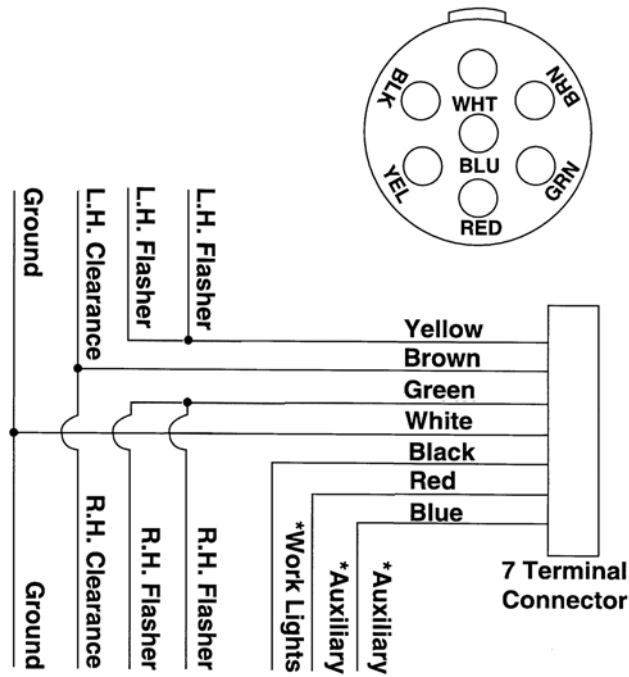

\* Optional customer-supplied auxiliary lights and wires may be wired into existing plug terminals.

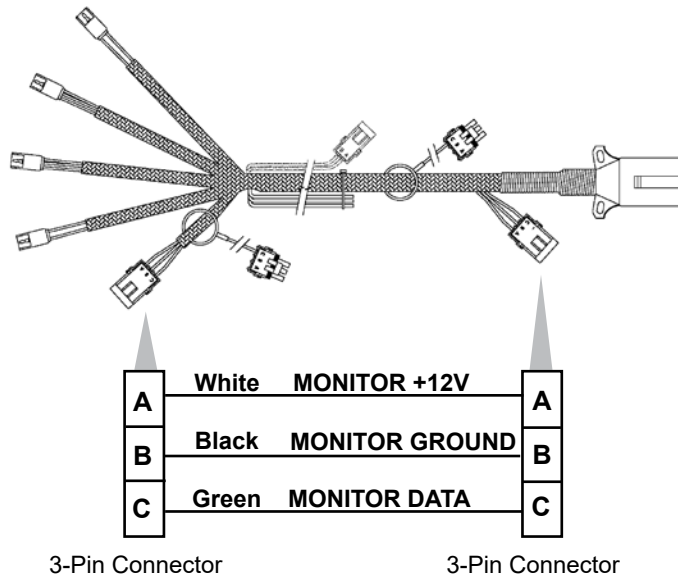

Light package supplied on Model 3005 planter meets ASABE Standards. For correct wiring harness to be wired into lights on your tractor, check with tractor manufacturer.

## HYDRAULIC HOSE LIFE

**WARNING**

**Pressurized hydraulic fluid can penetrate body tissue and result in death, serious infection, or other injuries. Fluid injected under skin must be IMMEDIATELY removed by a surgeon familiar with this type of injury. Make sure connections are tight and hoses and fittings are not damaged before applying system pressure. Leaks can be invisible. Keep away from suspected leaks. Relieve pressure before searching for leaks or performing any system maintenance.**



Proper storage of hydraulic hoses can significantly increase the life of the hoses, for a period of three to five years. After this period, service life of hoses may decrease, depending on variables such as variances in rubber materials and storage environment. Refer to the guidelines below for best practices when storing.

- Store in a clean, cool and dry area
- Avoid direct sunlight or moisture
- Do not store near high power electrical equipment
- Avoid contact with corrosive chemicals
- Avoid ultraviolet light
- Avoid areas with obvious signs of insects or rodents

Unusually long periods of storage or poor storage environment may lead to performance issues or premature failure. Always inspect all hoses prior to use for extensive wear, cuts, or holes. If such flaws are identified, replace immediately to avoid potential failure, property damage or bodily injury.

HYDRAULIC SYSTEM SCHEMATIC

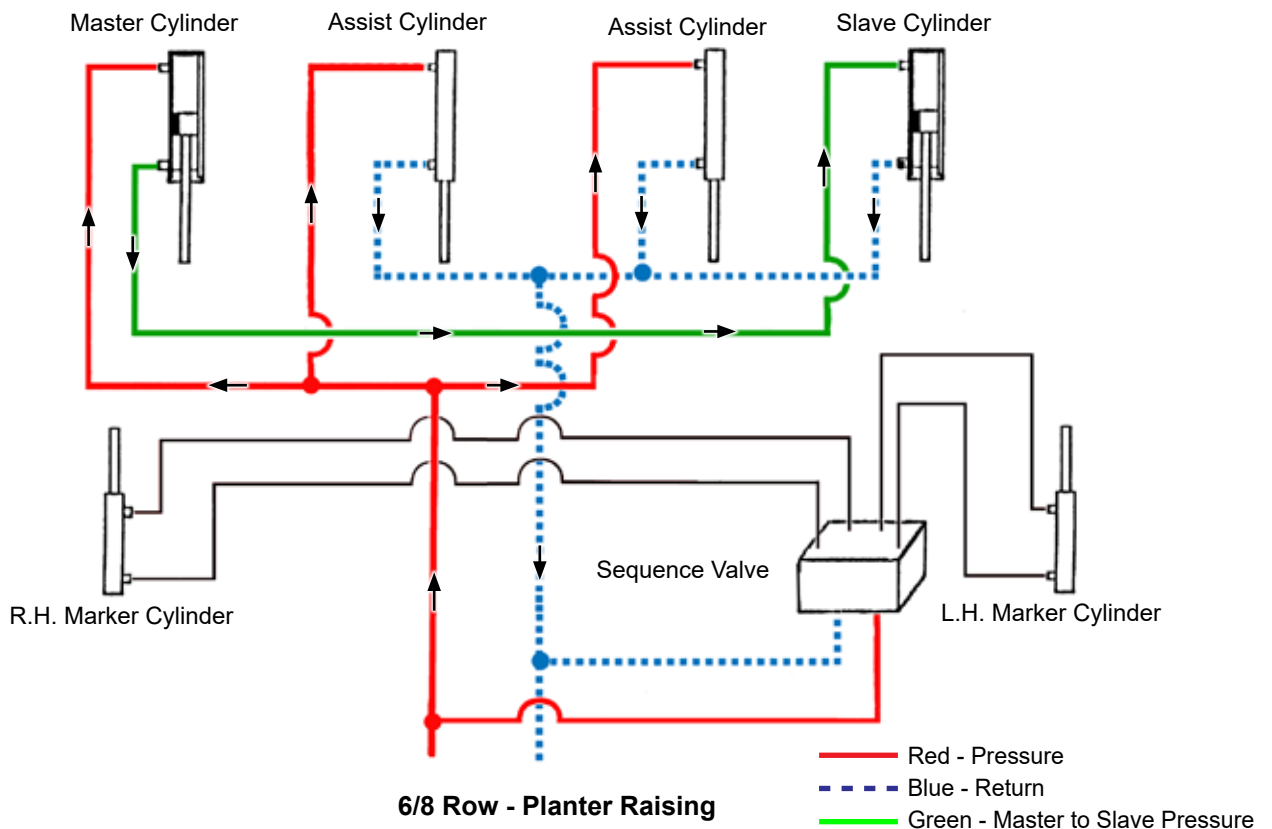
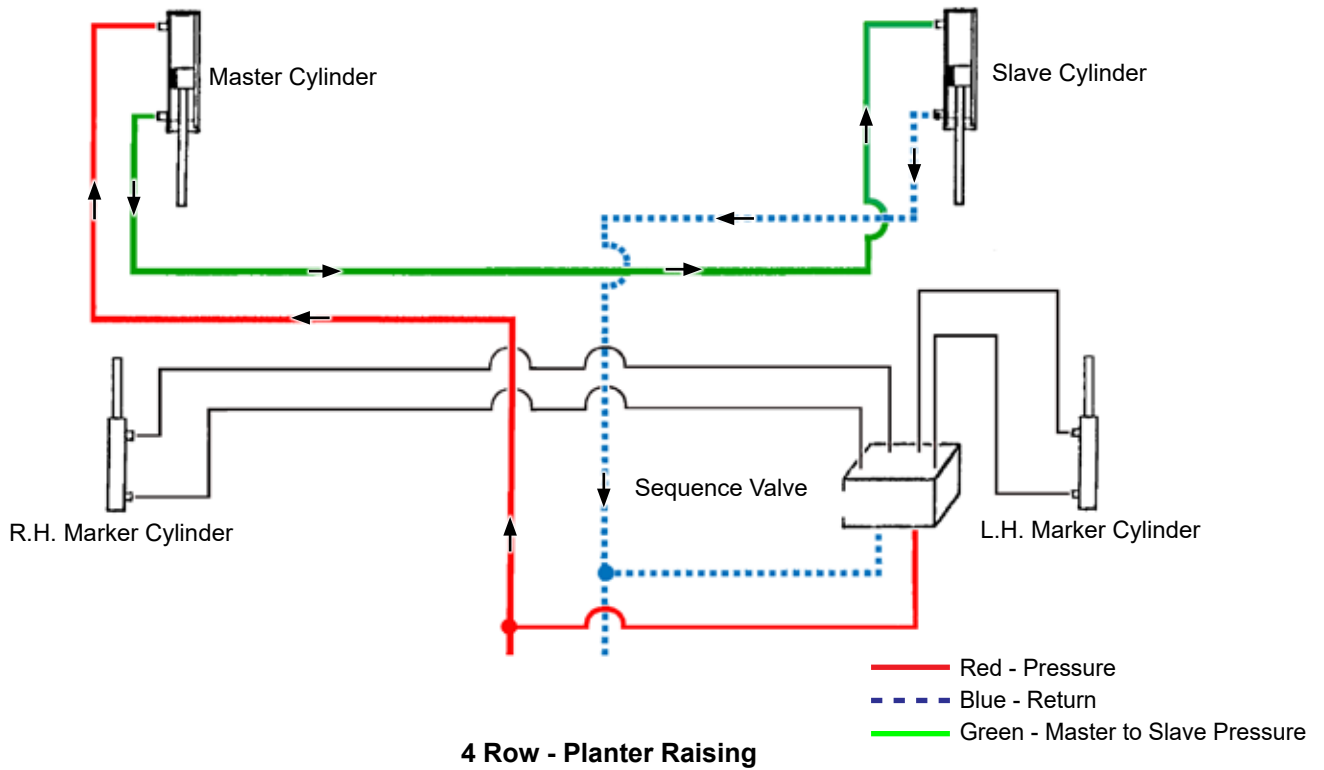

HYDRAULIC SYSTEM SCHEMATIC (WITH SPLIT ROW SELF-LEVELING HITCH)

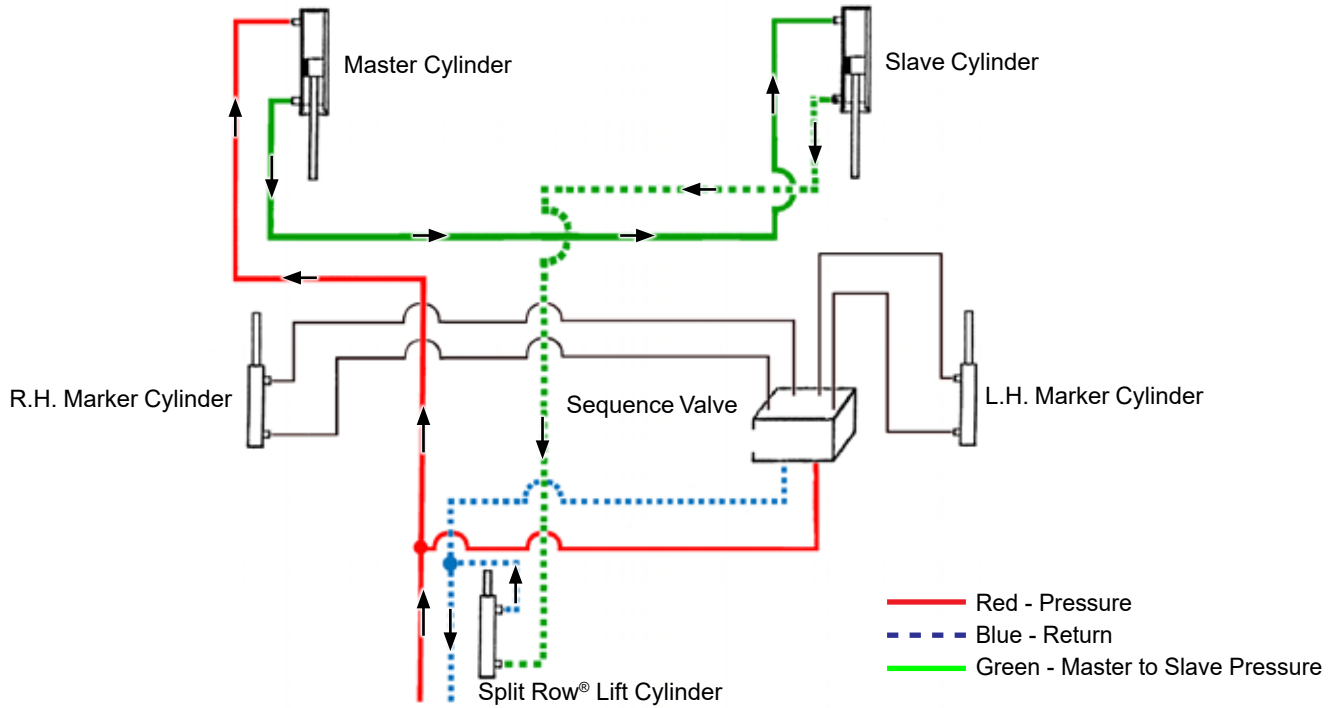

4 Row - Planter Raising

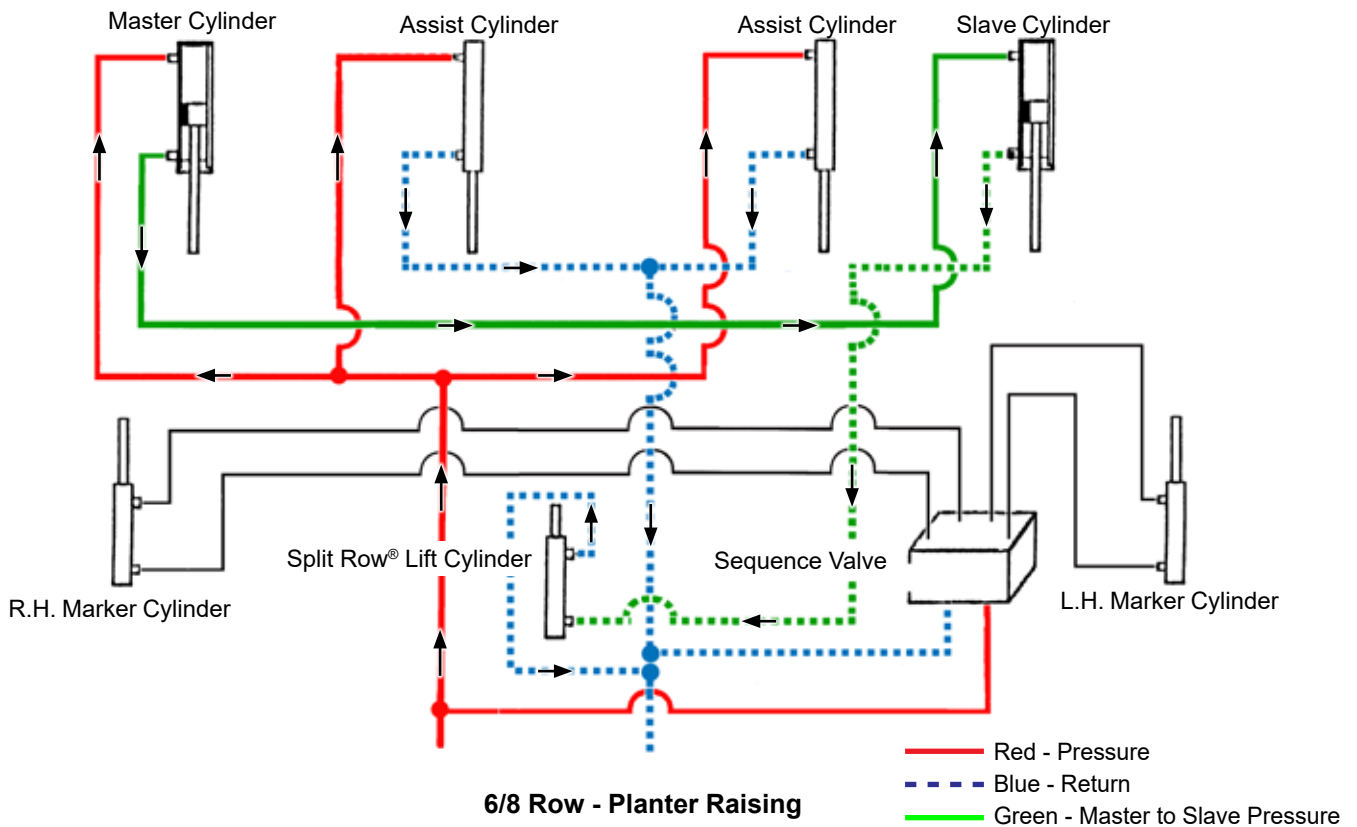

6/8 Row - Planter Raising

---

**CLOSING WHEEL TROUBLESHOOTING**

<b>PROBLEM</b>	<b>POSSIBLE CAUSE</b>	<b>SOLUTION</b>
Closing wheel(s) leave severe imprint in soil.	Too much closing wheel down pressure.	Adjust closing wheel pressure.
Closing wheel(s) not firming soil around seed.	Insufficient closing wheel down pressure.	Adjust closing wheel pressure. Severe no till conditions may require use of cast iron closing wheels.
"V" closing wheel running on top of seed furrow.	Improper centering.	Align. See <a href="#">"V" Closing Wheel Adjustment (Rubber or Cast Iron)" on page 3-1.</a>

**LIFT CIRCUIT OPERATION TROUBLESHOOTING**

PROBLEM	POSSIBLE CAUSE	TROUBLESHOOTING*	SOLUTION
Planter raising uneven.	Master cylinder leaking.	Raise planter slowly until master cylinder reaches end of stroke. If master cylinder is leaking it will lag behind the slave cylinder, causing the tire to squat less. If planter settles when hydraulic lever is released, check assist cylinders.	Check piston rephasing valve for contamination. Before removing rephasing valve, measure set screw setting by turning set screw clockwise and counting the revolutions until it bottoms out. After cleaning rephasing valve, bottom the screw out and back it out the same number of revolutions as the original setting. Replace rephasing valve and adjust as stated above or replace piston. Install seal kit. Consult your Kinze Dealer for leak testing and rephasing valve adjustment if necessary.
	Slave cylinder leaking.	Raise and lower planter. As planter lowers, side with leaking slave cylinder will drop rapidly. Install wheel lockups on master and assist cylinders. Retract slave cylinder and observe which tire settles. If planter settles when hydraulic lever is released, check assist cylinders.	Check piston rephasing valve for contamination. Prior to removing rephasing valve, measure the set screw setting by turning the set screw clockwise and counting the revolutions until it bottoms out. After cleaning rephasing valve, bottom the screw out and back it out the same number of revolutions as the original setting. Replace rephasing valve and adjust as stated above or replace piston. Install seal kit. Consult your Kinze Dealer for leak testing and rephasing valve adjustment if necessary.
Planter raising even; however, planter settles when hydraulic lever is released.	Assist cylinder is leaking.	Install lockups on master cylinder. Retract assist cylinders and observe which tire settles.	Seal on piston is leaking. Install seal kit.

\*Operate hydraulics slowly to accentuate the problem. Rephase after each lowering cycle.

**PISTON PUMP TROUBLESHOOTING**

<b>PROBLEM</b>	<b>POSSIBLE CAUSE</b>	<b>SOLUTION</b>
Pump hard or impossible to prime.	Valves fouled or in wrong place.	Inspect and clean valves.
	Air leak in suction line.	Repair leak.
	Pump set too low.	Adjust pump setting.
	Packing washers worn out.	Replace.
Low metering.	Valves fouled or in wrong place.	Inspect and clean valves.
	Air leak in suction line.	Repair leak.
	Pump set too low.	Adjust pump setting.
	Broken valve spring.	Replace spring.
Over metering.	Broken discharge valve spring.	Replace spring.
	Trash under valves.	Inspect and clean valves.
	Improper rate setting.	Adjust pump setting.
Leaks through when stopped.	Broken discharge valve spring.	Replace spring.
	Trash under valves.	Inspect and clean valves.
Fertilizer solution leaking under stuffing box.	Packing washers worn out.	Replace.
Pump using excessive oil.	Oil seals or o-ring worn and leaking.	Replace.
Pump operates noisily.	Crankcase components worn excessively.	Inspect and replace if necessary.

**ROW MARKER OPERATION TROUBLESHOOTING**

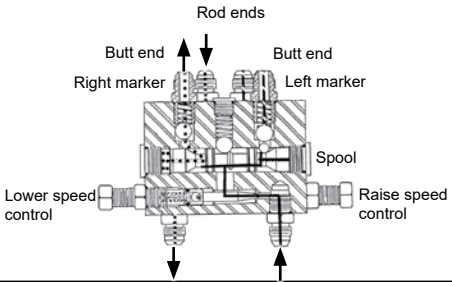
PROBLEM	POSSIBLE CAUSE	SOLUTION
<p>Same marker always operating.</p> 	<p>Inadequate oil flow to sequencing valve. Most commonly associated with single valve system (lift and markers on same remote).</p>	<p><b>TEST: Raise planter and install transport lockups. Attempt to raise and lower planter. All hydraulic oil will be directed to markers. If markers function properly, the sequence valve is OK.</b> Adjust marker speed so planter is up before marker arm is completely up.</p>
<p>Both markers lowering and only one raising at a time.</p>	<p>Hoses from cylinders to valve connected backwards.</p>	<p>Check hosing diagram in manual and correct.</p>
<p>Both markers lower and raise at same time</p>	<p>Foreign material under check ball in sequencing valve.</p>	<p>Remove hose fitting, spring and balls. Clean. May be desirable to remove spool and clean as well.</p>
	<p>Check ball missing or installed incorrectly in sequencing valve.</p>	<p>Disassemble and correct. See above illustration.</p>
<p>Marker (in raised position) settling down.</p>	<p>Damaged O-ring in marker cylinder or cracked piston.</p>	<p>Disassemble cylinder and inspect for damage and repair.</p>
	<p>Spool in sequencing valve not shifting completely because detent ball or spring is missing.</p>	<p>Check valve assembly and install parts as needed.</p>
	<p>Spool in sequencing valve shifting back toward center position.</p>	<p>Restrict flow of hydraulic oil from tractor to sequencing valve.</p>
<p>Neither marker will move.</p>	<p>Flow control closed too far.</p>	<p>Loosen locking nut and turn flow control adjustment bolt out or counterclockwise until desired speed is set.</p>
<p>Markers moving too fast.</p>	<p>Flow control open too far.</p>	<p>Loosen locking nut and turn flow control adjustment bolt in or clockwise until desired speed is set.</p>
<p>Sporadic marker operation speed.</p>	<p>Needle sticking open in flow control valve.</p>	<p>Remove flow control, inspect and repair or replace.</p>



### SEED METER (BRUSH-TYPE) TROUBLESHOOTING

PROBLEM	POSSIBLE CAUSE	SOLUTION
Low count.	Meter RPM too high.	Reduce planting speed.
	Seed sensor not picking up all seeds dropped.	Clean seed tube. Switch meter to different row. If problem stays with same row, replace sensor.
	Lack of lubrication causing seeds not to release from disc properly.	Use graphite or talc as recommended.
	Seed size too large for seed disc.	Switch to smaller seed or appropriate seed disc. See <a href="#">"Brush-Type Seed Meter 2.0" on page 3-3</a> for proper seed disc for size of seed being used.
	Seed treatment buildup in meter.	Reduce amount of treatment used and/or thoroughly mix treatment with seed. Add talc.
Low count at low RPM and higher count at higher RPM.	Foreign material lodged in upper brush.	Remove seed disc and remove foreign material from between brush retainer and bristles. Clean thoroughly.
	Worn upper brush.	Replace. See <a href="#">"Lubrication and Maintenance" on page 6-1</a> .
Low count at higher RPM and normal count at low RPM.	Seed disc worn in the agitation groove area.	Replace disc. See <a href="#">"Lubrication and Maintenance" on page 6-1</a> .
High count.	Seed size too small for seed disc.	Switch to larger seed or appropriate seed disc.
	Incorrect seed rate transmission setting.	Reset transmission. Refer to proper rate chart in "Machine Operation" section of manual.
	Upper brush too wide (fanned out) for small seed size.	Replace upper brush.
High count. (Milo/Grain Sorghum)	Incorrect brush retainer.	Make sure GD8237 brush retainer is installed to keep upper brush from fanning out.
Upper brush laid back.	Seed treatment buildup on brush.	Remove brush. Wash with soap and water. Dry thoroughly before reinstalling. See <a href="#">"Lubrication and Maintenance" on page 6-1</a> .
	Buildup of foreign material at base of brush.	Remove brush retainer and brush. Clean thoroughly. Reinstall.

**SEED METER (FINGER PICKUP) TROUBLESHOOTING**

<b>PROBLEM</b>	<b>POSSIBLE CAUSE</b>	<b>SOLUTION</b>
One row not planting seed.	Drive release not engaged.	Engage drive release mechanism.
	Foreign material in hopper.	Clean hopper and finger carrier mechanism.
	Seed hopper empty.	Fill seed hopper.
	Row unit drive chain off of sprocket or broken.	Check drive chain.
Drive release does not engage properly.	Drive release shaft is not aligned properly with meter drive shaft.	Align drive mechanism.
Unit is skipping.	Foreign material or obstruction in meter.	Clean and inspect.
	Finger holder improperly adjusted.	Adjust to specifications. (22 to 25 in. lbs. rolling torque)
	Broken fingers.	Replace fingers and/or springs as required.
	Planting too slowly.	Increase planting speed to within recommended range.
Planting too many doubles.	Planting too fast.	Stay within recommended speed range.
	Loose finger holder.	Adjust to specifications. (22 to 25 in. lbs. rolling torque)
	Worn brush in carrier plate.	Inspect and replace if necessary.
Overplanting.	Worn carrier plate.	Inspect and replace if necessary.
	Seed hopper additive being used.	Reduce or eliminate additive or increase graphite.
Underplanting.	Seed belt installed backwards.	Remove and install correctly.
	Weak or broken springs.	Replace.
	Spring not properly installed.	Remove finger holder and correct.
	Seed belt catching or dragging.	Replace belt.
	Brush dislodging seed.	Replace brush.
Irregular or incorrect seed spacing.	Driving too fast.	Check chart for correct speed.
	Wrong tire pressure.	Inflate tires to correct air pressure.
	Drive wheels slipping.	Reduce down pressure on row unit down force springs.
	Wrong sprockets.	Check seed rate charts for correct sprocket combinations.
Seed spacing not as indicated in charts.	Wrong tire pressure.	Inflate tires to correct air pressure.
	Inconsistent seed size.	Perform field check and adjust sprockets accordingly.
	Wrong sprockets.	Check chart for correct sprocket combination.
	Charts are approximate.	Slight variations due to wear in meter components and tire slippage due to field conditions may produce seed spacing variations.
	Stiff or worn drive chains.	Replace chains.
Scattering of seeds.	Planting too fast.	Reduce planting speed.
	Seed tube improperly installed.	Check seed tube installation.
	Seed tube worn or damaged.	Replace seed tube.
Seed tubes and/or openers plugging.	Allowing planter to roll backward when lowering.	Lower planter only when tractor is moving forward.
Inconsistent seed depth.	Rough seed bed.	Adjust down pressure springs. Reduce planting speed.
	Partially plugged seed tube.	Inspect and clean.
	Seed tube improperly installed.	Install properly.