

MODEL 3140 STACK FOLD PLANTER

OPERATOR'S MANUAL

M0256-01

Rev. 6/19

This manual is applicable to: Model 3140 Stack Fold Planter
2015 Production Year and on

Record the model number and serial number of your planter along with date purchased:

Model Number _____ 3140 _____

Serial Number _____

Date Purchased _____

Monitor Serial Number _____
Measured Pulses Per Mile/Km (Radar Distance Sensor) _____
Measured Pulses Per Mile/ Km (Magnetic Distance Sensor) _____

SERIAL NUMBER

The serial number plate is located on the planter frame to be readily available. It is suggested that your serial number and purchase date also be recorded above.

The serial number provides important information about your planter and may be required to obtain the correct replacement part. Always provide the model number and serial number to your Kinze Dealer when ordering parts or anytime correspondence is made with Kinze Manufacturing, Inc.

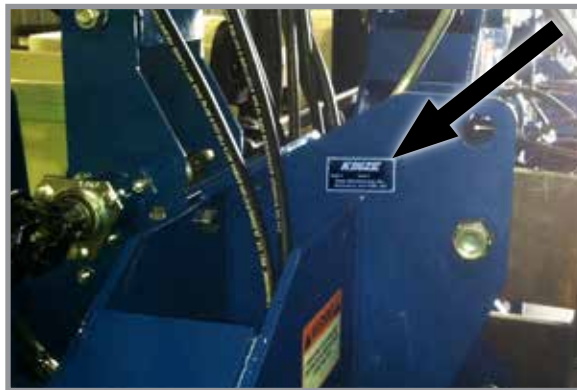

Serial number plate location - R.H. side of 3-point mount

This page left blank intentionally.

TO THE DEALER

Predelivery service includes assembly, lubrication, adjustment, and test. This service makes sure planter is delivered to the retail customer/end user ready for field use.

PREDELIVERY CHECKLIST

Use the following checklist and inspect planter after it is completely assembled. Check off each item found satisfactory or after proper adjustment is made.

- Row units properly spaced and optional attachments correctly assembled.
- Vacuum components properly installed (as applicable).
- All grease fittings in place and lubricated.
- All working parts move freely, bolts are tight, and cotter pins are spread.
- Check all drive chains for proper tension and alignment.
- Check for oil leaks and proper hydraulic operation.
- Hydraulic hoses correctly routed to prevent damage.
- Inflate tires to specified air pressure and torque wheel lug bolts and lug nuts as specified in the manual.
- All safety decals correctly located and legible. Replace if damaged.
- All reflective decals and SMV sign correctly located and visible when the planter is in transport position.
- Safety/warning lights correctly installed and working properly.
- Paint all parts scratched in shipment or assembly.
- All safety lockup devices on the planter and correctly located.
- Auxiliary safety chain properly installed and hardware torqued to specification.

This planter has been thoroughly checked and to the best of my knowledge is ready for delivery to the retail customer/end user.

(Signature Of Set-Up Person/Dealer Name/Date)

RETAIL CUSTOMER/END USER

Name _____ Delivery Date _____
 Street Address _____ Model No. 3140 Serial No. _____
 City, State/Province _____ Dealer Name _____
 ZIP/Postal Code _____ Dealer No. _____

DELIVERY CHECKLIST

Use the following checklist at time planter is delivered as a reminder of very important information which should be conveyed to retail customer/end user. Check off each item as it is fully explained.

- Check for proper operation of vacuum fan (If applicable) with tractor to be used with planter.
- Life expectancy of this or any other machine is dependent on regular lubrication as directed in the Operator Manual.
- All applicable safety precautions.
- Along with retail customer/end user, check reflective decals and SMV sign are clearly visible with planter in transport position and attached to tractor. Check safety/warning lights are in working condition. Tell retail customer/end user to check federal, state/provincial, and local regulations before towing or transporting on a road or highway.
- Give Operator Manual, Parts Manual, and all Instruction Sheets to retail customer/end user and explain all operating adjustments.
- Read warranty to retail customer/end user.
- Complete Warranty and Delivery Report form.

To the best of my knowledge this machine has been delivered ready for field use and customer has been fully informed as to proper care and operation.

(Signature Of Delivery Person/Dealer Name/Date)

AFTER DELIVERY CHECKLIST

The following is a list of items we suggest to check during the first season of use of the equipment.

- Check planter performance with retail customer/end user.
- Check performance of vacuum or mechanical seed metering system with retail customer/end user.
- Review importance of proper maintenance and adherence to all safety precautions with retail customer/end user.
- Check for parts that may need to be adjusted or replaced.
- Check all safety decals, reflective decals, and SMV sign are correctly located as shown in the Parts Manual and that decals are legible. Replace if damaged or missing.
- Check safety/warning lights are working properly.

(Signature Of Follow-Up Person/Dealer Name/Date)

**All registrations must be submitted online at "business.kinze.com" within 5 business days of delivery.
Retain a copy of this form for auditing purposes.**

Tear Along Perforation

MACHINE OPERATION

Initial Preparation of the Planter	2-1
Tractor Requirements	2-2
Tractor Preparation and Hookup	2-2
Cylinder Information	2-7
Hydraulic Hose Information	2-8
Leveling the Planter	2-10
Transporting Planter	2-10
Contact Wheel Spring Adjustment	2-10
Parking Stand Adjustment	2-11
Wheel Module Height Adjustment	2-11
Seed Rate Transmission Adjustment	2-12
Wrap Spring Wrench Operation	2-12
Contact Wheel Drive Sprockets	2-13
Shear Protection	2-14
Digital Vacuum readout	2-14
Vacuum Meter System	2-15
Analog Vacuum or Pressure Gauge	2-15
Vacuum Fan Motor Valve Block Assembly	2-15
Hydraulic Operation	2-16
Row Marker Hydraulic Operation	2-17
Row Marker Speed Adjustment	2-18
Row Marker Adjustments	2-19
Wing Flex	2-20
Wing Down Flex Cylinder	2-21
Point Row Clutches	2-22
Two-Speed Point Row Clutches	2-23
Dual Lift Assist Wheels	2-24
Accumulator	2-24
Piston Pump Mount/Drive Spring Adjustment	2-25
Flow Control Valve Adjustment	2-25
Planting Speed	2-25
Field Test	2-26
Check Seed Population	2-26
Determining Pounds Per Acre (Brush-Type Meter)	2-28
Determining Bushels Per Acre	2-28
Field Check Granular Chemical Application	2-29

ROW UNIT OPERATION

Planting Depth	3-1
“V” Closing Wheel Adjustment (Rubber or Cast Iron)	3-1
Closing Wheel Shield (Rubber or Cast Iron “V” Closing Wheels)	3-1
Drag Closing Attachment	3-2
Covering Discs/Single Press Wheel Adjustment	3-2
Seed Hoppers	3-3
Seed Meter Drive Release	3-3

Row Unit Extension Brackets	3-3
Row Unit Chain Routing	3-4
Quick Adjustable Down Force Springs Option (Standard or Heavy Duty)	3-5
Brush-Type Seed Meter	3-6
Brush-Type Seed Meter 2.0	3-7
Finger Pickup Seed Meter	3-8
Vacuum Settings	3-9
Seed Meter Cleanout	3-13
Additives	3-14
Bayer Fluency Agent	3-15
Frame Mounted Coulter (Pull Row)	3-16
Residue Wheels (Frame Mounted Coulter)	3-16
Row Unit Mounted Disc Furrower (Pull Row)	3-17
Row Unit Mounted Bed Leveler (Pull Row)	3-17
Row Unit Mounted Residue Wheel	3-18
Row Unit Mounted No Till Coulter	3-19
Coulter Mounted Residue Wheels	3-19
Spiked Closing Wheel	3-20
Granular Chemical Hopper and Drive	3-21
Spring Tooth Incorporator	3-21
Granular Chemical Banding Options	3-22
Granular Chemical Bander Shield	3-22

RATE CHARTS 4-1**LUBRICATION AND MAINTENANCE**

Lubrication	5-1
Lubrication Symbols	5-1
Sealed Bearings	5-1
Wrap Spring Wrench Assembly	5-1
Drive Chains	5-2
Bushings	5-3
Wheel Bearings	5-4
Grease Fittings	5-4
Mounting Bolts and Hardware	5-7
Tire Servicing	5-8
Model 3140 Operating Tire Pressure	5-8
Finger Pickup Seed Meter Inspection/Adjustment	5-9
Cleaning Finger Pickup Seed Meter For Storage	5-10
Brush-Type Seed Meter Maintenance	5-11
Cleaning Brush-Type Seed Meter For Storage	5-12
Vacuum Manifold Maintenance	5-12
Vacuum Seed Meter Maintenance	5-13
Seed Meter Cleanout	5-13
Chain Tension Adjustment	5-14
Drag Closing Attachment	5-14

Gauge Wheel Adjustment 5-14

Gauge Wheel Arm Bushing/Seal Replacement 5-15

Gauge Wheel Arm Pivot Spindle Replacement 5-15

15" Seed Opener Disc Blade/Bearing Assembly 5-16

Seed Tube Guard/Inner Scraper 5-18

Frame Mounted Coulter 5-18

Residue Wheels
(For Use With Frame Mounted Coulter) 5-18

Row Unit Mounted Disc Furrower 5-19

Row Unit Mounted Bed Leveler 5-19

Row Unit Mounted No Till Coulter 5-19

Coulter Mounted Residue Wheels 5-20

Row Unit Mounted Residue Wheel 5-20

Granular Chemical Attachment 5-21

Spring Tooth Incorporator 5-21

Single and Two-Speed Point Row Clutch Maintenance 5-22

Cam Follower Adjustment 5-23

Relief Valve Cartridge 5-24

Check Valve (Vacuum Fan) 5-24

Flow Control Valve 5-24

Row Marker Sequencing/Flow Control Valve Inspection 5-25

Row Marker Bearing Lubrication or Replacement 5-26

Wheel Bearing Repack or Replacement 5-27

Preparation for Storage 5-28

Electrical Wiring Diagram for Light Package 5-29

Electrical Wiring Diagrams for Point Row Clutches 5-30

Electrical Wiring Diagrams for
Two-Speed Point Row Clutches 5-31

Hydraulic Hose Life 5-33

Hydraulic Schematic - Vacuum Fan Motor System 5-34

Hydraulic Schematic - Fold System 5-35

Hydraulic Schematic - Row Marker System 5-35

Hydraulic Schematic - Dual Lift Assist Wheel Package 5-36

Hydraulic Schematic - Dual Lift Assist Wheel Package
(Plumbed Into 3 Point Circuit) 5-36

Hydraulic Schematic - Wing Down Flex
Cylinder Package 5-37

Hydraulic Schematic - Wing Down Flex Cylinder Package
and Dual Lift Assist Wheel Package 5-37

TROUBLESHOOTING

Brush-Type Seed Meter 6-1

Closing Wheel 6-1

Vacuum Seed Meter 6-2

Finger Pickup Seed Meter 6-4

Point Row Clutch 6-5





Row Marker Operation 6-6

Kinze Manufacturing, Inc. would like to thank you for your patronage. We appreciate your confidence in Kinze farm machinery. Your Kinze planter has been carefully designed to provide dependable operation in return for your investment.

This manual has been prepared to aid you in planter operation and maintenance. It should be considered a permanent part of the machine and remain with the machine when you sell it.

It is the responsibility of the user to read and understand this Operator Manual before operating this equipment. It is the user's responsibility to inspect and service the machine routinely as directed in this Operator Manual. We have attempted to cover all areas of safety, operation, lubrication and maintenance; however, there may be times when special care must be taken to fit your conditions.

Throughout this manual the symbol  and the words **DANGER**, **WARNING**, and **CAUTION** are used to call attention to safety information that if not followed, will or could result in death or injury. **NOTICE** and **NOTE** are used to call your attention to important information. The definition of each of these terms follows:

	<p>Indicates an imminently hazardous situation that, if not avoided, will result in death or serious injury. This signal word is to be limited to the most extreme situations, typically for machine components which, for functional purposes, cannot be guarded.</p>
	<p>Indicates a potentially hazardous situation that, if not avoided, could result in death or serious injury, and includes hazards that are exposed when guards are removed. It may also be used to alert against unsafe practices.</p>
	<p>Indicates a potentially hazardous situation that, if not avoided, may result in minor or moderate injury. It may also be used to alert against unsafe practices.</p>
	<p>Used to address safety practices not related to personal injury.</p>

NOTE: Special point of information or machine adjustment instructions.

The Kinze Limited Warranty for your new machine is stated on the retail purchaser's copy of the Warranty And Delivery Receipt form. Additional copies of the Limited Warranty can be obtained through your Kinze Dealer.

Warranty, within the warranty period, is provided as part of Kinze's support program for registered Kinze products which have been operated and maintained as described in this manual. Evidence of equipment abuse or modification beyond original factory specifications will void the warranty. Normal maintenance, service and repair is not covered by Kinze warranty.

To register your Kinze product for warranty, a Warranty And Delivery Receipt form must be completed by the Kinze Dealer and signed by the retail purchaser, with copies to the Dealer, and to the retail purchaser. Registration must be completed and submitted to Kinze Manufacturing, Inc. within 5 business days of delivery of the Kinze product to the retail purchaser. Kinze Manufacturing, Inc. reserves the right to refuse warranty on serial numbered products which have not been properly registered.

If service or replacement of failed parts which are covered by the Limited Warranty are required, it is the user's responsibility to deliver the machine along with the retail purchaser's copy of the Warranty And Delivery Receipt to the Kinze Dealer for service. Kinze warranty does not include cost of travel time, mileage, hauling or labor. Any prior arrangement made between the Dealer and the retail purchaser in which the Dealer agrees to absorb all or part of this expense should be considered a courtesy to the retail purchaser.

Kinze warranty does not include cost of travel time, mileage, hauling or labor.



Model 3140 12 Row 38" Vacuum Planter (Less Optional Row Markers) Shown In Transport Position

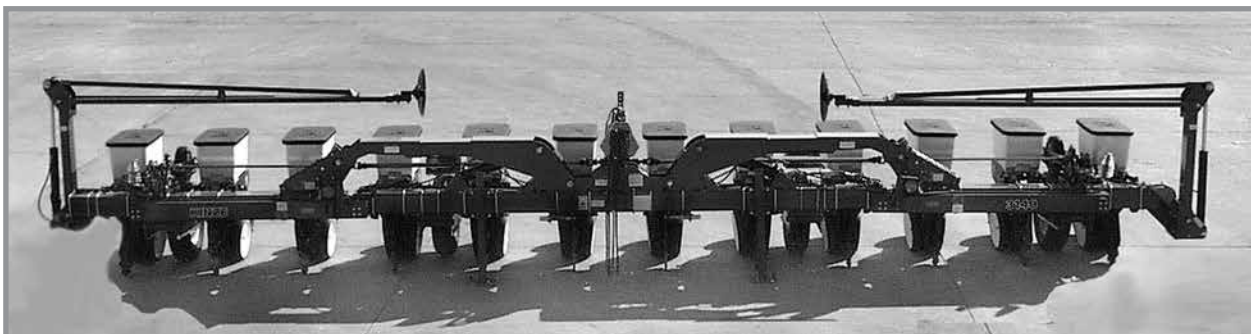

Model 3140 12 Row 30" Mechanical Planter (With Optional Row Markers) Shown In Planting Position

GENERAL INFORMATION

The Model 3110 Mounted Planter is available with vacuum or mechanical meters, conventional hoppers, and various other options. Contact your Kinze dealer for additional options which may be available for your specific model year planter.

Information in this manual was current at time of printing. However, due to Kinze's ongoing product improvement, production changes may cause your machine to appear slightly different in detail. Kinze Manufacturing, Inc. reserves the right to change specifications or design without notice and without incurring obligation to install the same on machines previously manufactured. To obtain the most recent version of your publication, please contact your Kinze dealer.

Right hand (R.H.) and left hand (L.H.), as used throughout this manual, are determined by facing in the direction the machine will travel when in use, unless otherwise stated.

SPECIFICATIONS

Planter Size	12 Row 30"	12 Row 36"/38"	12 Row 38"/40"	16 Row 30"
Width - Transport (Without Markers)	16'-1" (4.9M)	18'-5" (5.6M)	21'-1" (6.4M)	21'-1" (6.4M)
Width - Transport (Includes Markers)	17'-9" (5.4M)	19'-6" (5.9M)	22'-2" (6.8M)	23'-0" (7.0M)
Width - Planting	30'-0" (9.1M)	37'-4" (11.4M)	40'-0" (12.2M)	40'-0" (12.2M)
Height - Transport (Without Markers)	12'-6" (3.8M)	12'-6" (3.8M)	12'-6" (3.8M)	12'-6" (3.8M)
Height - Transport (With Markers)	15'-6" (4.7M)	15'-6" (4.7M)	15'-6" (4.7M)	15'-6" (4.7M)
Weight (Mechanical)	6236 lb. (2828.6 kg)	6541 lb. (2966.9 kg)	6621 lb. (3003.2 kg)	7480 lb. (3392.9 kg)
Weight (Vacuum)	6794 lb. (3081.7 kg)	7127 lb. (3232.7 kg)	7214 lb. (3272.2 kg)	8109 lb. (3678.2 kg)
Toolbar (Mechanical)	7" x 7" x 1/4" wall	7" x 7" x 1/4" wall	7" x 7" x 3/8" wall	7" x 7" x 3/8" wall
Toolbar (Vacuum)	7" x 7" x 3/8" wall	7" x 7" x 3/8" wall	7" x 7" x 3/8" wall	7" x 7" x 3/8" wall
Seed Capacity	1.75 bu. (62 liters) (Vacuum/Hopper); 1.90 bu. (67 liters) (Mechanical/Hopper)			
Tires	Four 7.60" x 15" 8 ply - adjustable height			
Drive System	Two 4.10" x 6" spring-loaded contact drive tires with no. 40 chain			
Seed Transmission	Two wheel module-mounted, quick-adjust with machined sprockets and no. 40 chain			
Drive/Drill Shafts	7/8" hex drive/drill shafts			

TRACTOR HYDRAULIC REQUIREMENTS - MECHANICAL

Configuration	Requirements		Description
Base machine with mechanical meters	1 SCV	10 gpm (38 L/min)	#1 SCV: Planter fold
Base machine with mechanical meters and optional row marker package	2 SCV	20 gpm (76 L/min)	#1 SCV: Planter fold
			#2 SCV: Row markers with sequencing/flow control valve
Base machine with mechanical meters, optional row markers and dual lift assist package	3 SCV*	20 gpm (76 L/min)	#1 SCV: Planter fold
			#2 SCV: Row markers with sequencing/flow control valve
			#3 SCV: Dual lift assist
Base machine with mechanical meters, optional row markers, dual lift assist package, and wing down flex package	4 SCV*	20 gpm (76 L/min)	#1 SCV: Planter fold
			#2 SCV: Row markers with sequencing/flow control valve
			#3 SCV: Dual lift assist
			#4 SCV: wing down flex

*Some options may be combined to reduce the number of SCV outlets required.

TRACTOR HYDRAULIC REQUIREMENTS - VACUUM

Configuration	Requirements		Description
Base machine with vacuum meters (external case drain required for vacuum hydraulic circuit)	2 SCV	25 gpm (95 L/min)	#1 SCV: Vacuum meters
			#2 SCV: Planter fold
Base machine with vacuum meters and optional row marker package (external case drain required for vacuum hydraulic circuit)	3 SCV	35 gpm (132 L/min)	#1 SCV: Vacuum metering
			#2 SCV: Planter fold
			#3 SCV: Row markers with sequencing/flow control valve
Base machine with vacuum meters, optional row marker package, and dual lift assist package option (external case drain required for vacuum hydraulic circuit)	3 SCV*	35 gpm (132 L/min)	#1 SCV: Vacuum meters
			#2 SCV: Planter fold
			#3 SCV: Row markers with sequencing/flow control valve
			#4 SCV: Dual lift assist package
			#5 SCV: Wing down flex package
Base machine with vacuum meters, optional row marker package, dual lift assist package option and wing down flex package	5 SCV*	35 gpm (132 L/min)	#1 SCV: Vacuum meters
			#2 SCV: Planter fold
			#3 SCV: Row markers with sequencing/flow control valve
			#4 SCV: Dual lift assist package



*Some options may be combined to reduce the number of SCV outlets required.

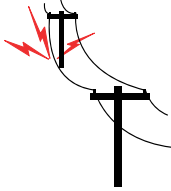

1. Read and understand instructions provided in this manual and warning labels. Review these instructions frequently!
 2. This machine is designed and built with your safety in mind. Do not make any alterations or changes to this machine. Any alteration to design or construction may create safety hazards.
 3. A large portion of farm accidents happen from fatigue or carelessness. Safe and careful operation of tractor and planter will help prevent accidents.
 4. Never allow planter to be operated by anyone unfamiliar with operation of all functions of the unit. Operators must read and thoroughly understand all instructions given in this manual before operating or working on equipment.
 5. Be aware of bystanders, particularly children! Always look around to make sure it is safe to start tow vehicle engine or move planter. This is particularly important with higher noise levels and quiet cabs, as you may not hear people shouting.
 6. Make sure planter weight does not exceed towing capacity of tractor, or bridge and road limits. This is critical to maintain safe control and prevent death or injury, or property and equipment damage.
 7. Never ride or allow others to ride on planter.
 8. Store planter in an area away from human activity. DO NOT permit children to play on or around the stored unit.
 9. Keep hands, feet, and clothing away from moving parts. Do not wear loose-fitting clothing which may catch in moving parts.
 10. Always wear protective clothing, shoes, gloves, hearing, and eye protection applicable for the situation.
 11. Do not allow anyone to stand between tongue or hitch and towing vehicle when backing up to planter.
 13. Prevent electrocution, other injuries, or property and equipment damage. Watch for obstructions such as wires, tree limbs, etc. when operating machine. Be aware of clearances during turns and when folding/unfolding planter.
 14. Reinstall all guards removed for maintenance activities. Never leave guards off during operation.
 15. Use of aftermarket hydraulic, electric, or PTO drives may create serious safety hazards to you and people nearby. If you install such drives, follow all appropriate safety standards and practices to protect you and others near this planter from injury.
 16. Follow all federal, state/provincial, and local regulations when towing farm equipment on a public highway. Use safety chain (not an elastic or nylon/plastic tow strap) to retain connection between towing and towed machines in the event of primary attaching system separation.
 17. Make sure all safety/warning lights, SMV sign, and reflective decals are in place and working properly before transporting the machine on public roads.
 18. Limit towing speed to 15 MPH. Tow only with farm tractor of a minimum 90 HP. Allow for unit length when making turns.
 19. Reduce speed prior to turns to avoid the risk of overturning. Always drive at a safe speed relative to local conditions and ensure your speed is slow enough for a safe emergency stop.
 20. Chemical application is often an integral part of planting. Follow label instructions for proper chemical mixing, handling and container disposal methods.
 21. Be familiar with safety procedures for immediate first aid should you accidentally contact chemical substances.
 22. Use the proper protective clothing and safety equipment when handling chemicals.
 23. Chemicals are supplied with Material Safety Data Sheets (MSDS) that provide full information about the chemical, its effects on exposure, and first aid needs in the event of an emergency. Keep your MSDS file up-to-date and available for first responders in case of emergency.
 24. When servicing ground engaging components such as opening disks and firming points, use special care to avoid points and edges worn sharp during use.
 25. Use professional help if you are unfamiliar with working on hydraulic systems. Pressurized hydraulic fluid can penetrate body tissue and result in death, serious infection, or other injuries.
 26. Disposing of waste improperly can threaten the environment. To dispose of your equipment properly contact your local environmental or recycling center.
- Never pour waste onto the ground, down a drain, or into any water source.
- When disposing of waste such as oil, use leakproof containers. Be sure to use containers that do not resemble food or beverage which may mislead someone into consuming them. Dispose of oil per your local, regional requirements.
- When disposing of any fertilizer chemicals used, contact the supplier of the chemicals.
- Model 3140 planter consists of 85% recyclable metals, 10% recyclable plastic and rubber, and 5% waste.

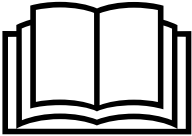
Following are some common hazard warnings associated with this equipment. Pay close attention to all safety, operating, and maintenance information in this manual and decals applied to your equipment.

	<p>Contacting or coming close to power lines or other high energy sources will cause death or serious injury.</p>
	<p>Keep away from power lines or high energy sources at all times.</p>

	<p>Improperly operating or working on this equipment could result in death or serious injury. Read and follow all instructions in Operator Manual before operating or working on this equipment.</p>
	

	<p>Falling equipment can cause death or serious injury. Install all lockup devices or lower planter to ground before working on equipment.</p>
	

	<p>Explosive separation of rim and tire parts can cause death or serious injury. Overinflation, rim and tire servicing, improper use of rims and tires, or worn or improperly maintained tires could result in a tire explosion.</p>
	

SAFETY SIGNS AND DECALS

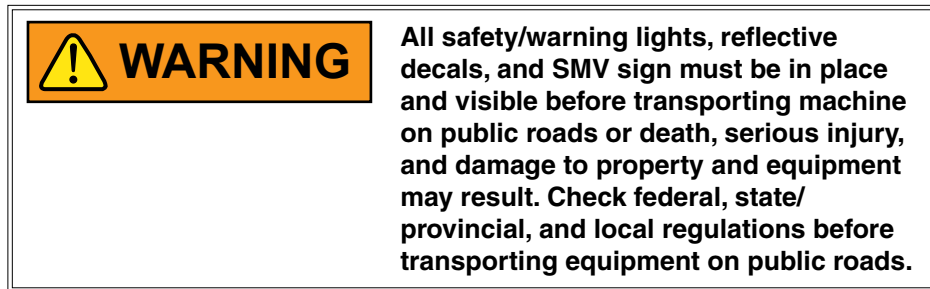

Safety signs and decals are placed on the machine to warn of hazards and provide important operating and maintenance instructions. Information on these signs are for your personal safety and the safety of those around you. FOLLOW ALL SAFETY INSTRUCTIONS!

- **Keep signs clean so they can be easily seen. Wash with soap and water or cleaning solution as required.**
- **Replace safety signs if damaged, painted over, or missing.**
- **Check reflective decals and SMV sign periodically. Replace if they show any loss of reflective properties.**
- **When replacing decals, clean machine surface thoroughly with soap and water or cleaning solution to remove all dirt and grease.**

NOTE: Safety sign and decal locations are shown in the Parts Manual for this machine.

NOTE: Style and locations of SMV sign, reflective decals, and safety/warning lights conform to ANSI/ASABE S279.14 JUL 2008 and ANSI/ASABE S276.6 JAN 2005.

This page left blank intentionally.

The following information is general in nature and was written to aid the operator in preparation of the tractor and planter for use, and to provide general operating procedures. The operator's experience, familiarity with the machine and the following information should combine for efficient planter operation and good working habits.

NOTICE

Always raise planter out of ground when making sharp turns or backing up or tractor and equipment may be damaged.

The Kinze Vacuum Seed Metering System includes seed meters, seed discs and an air system consisting of a hydraulic driven vacuum fan which draws air through manifolds and hoses and the seed meters on each row unit.

 **WARNING**

Moving fan blades can cause amputation or severe injury. Never operate vacuum fan with cover removed.

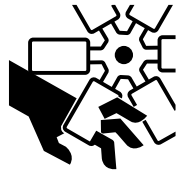

The dual lift assist wheel option requires a customer-supplied quick hitch to operate without the center link pin. 8 row wide planters require removal of the center section gauge wheels to accommodate dual lift assist wheels.

INITIAL PREPARATION OF THE PLANTER

Lubricate the planter and row units per the lubrication information in this manual. Make sure all tires have been properly inflated. See "Tire Servicing". Check all drive chains for proper tension, alignment and lubrication.

TRACTOR REQUIREMENTS

NOTICE

All Hydraulic Requirements: Minimum Pressure 2350 PSI (16202.6 kPa); Maximum Pressure 3000 PSI (20684.2 kPa). Check tractor hydraulics to ensure that maximum pressure cannot be exceeded.

Approximate minimum tractor horsepower (HP) required for field work is listed below:

12 Row Narrow - 150 HP And Up

12 Row Wide And 16 Row Narrow - 180 HP And Up

NOTE: Tractor must have adequate 3 point hitch lift capacity to lift weight of machine, attachments, seed and dry chemicals. Shipping weights do not include seed, dry chemicals or additional optional attachments.

Tractor front end stability is necessary for safe and efficient operation. Therefore, it may be necessary to add front ballast to your tractor for satisfactory field operation, as well as adequate transport stability. Refer to your tractor operator's manual for front ballast recommendations.

Vacuum

A 12 volt DC electrical system is required on all sizes to operate planter safety/warning lights.

One SCV remote hydraulic outlet is required to operate the row markers, one to operate planter fold and one plus a zero pressure case drain is required to operate the seed metering system vacuum fan.

Maximum hydraulic flow rate of 13 GPM (49 L/min) @ 2000 PSI (13789.5 kPa) is required to operate the seed metering system vacuum fan.

NOTE: A Flow Control Needle Valve Kit, to provide a flow control option for tractors that are not equipped with a method for finite adjustment of hydraulic flow, is available from Kinze Repair Parts through your Kinze Dealer.

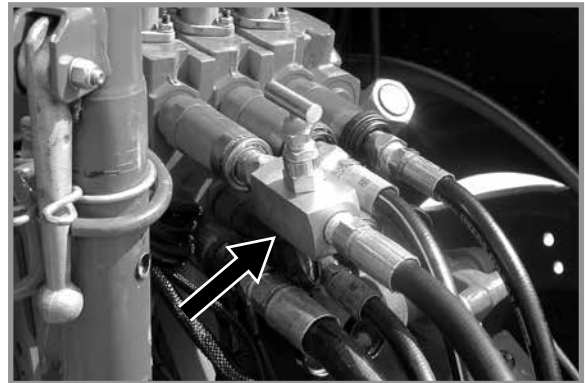

G1K426 Needle Valve Kit

TRACTOR PREPARATION AND HOOKUP

1. Set tractor rear wheel spacing at double the planter row spacing. For example: On a planter set for 38" rows, set the tractor wheel spacing at 76" (193 cm) center-to-center. On wide front end tractors set front wheel spacing equal to rear wheel spacing. Check tractor operator's manual for correct front and rear tire pressure.
2. Adjust lift links on tractor so the planter will lift level from side to side and raise high enough for planter transport clearance. Set the sway blocks on the tractor in position to prevent side sway. Be sure the individual lift link arms are in the float position.

- Back tractor up to planter. Position lower hitch pins and bushings as shown in the following diagrams for your type of tractor hitch. Line up holes and insert hitch pins and lock in place with pins provided. It may be necessary to change the length of the upper link with the adjusting handle.

Lower Hitch Pins

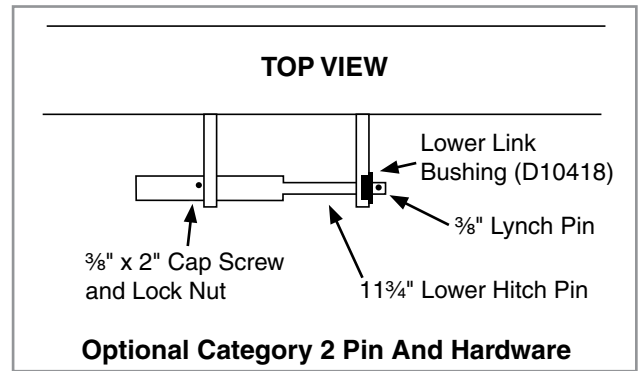
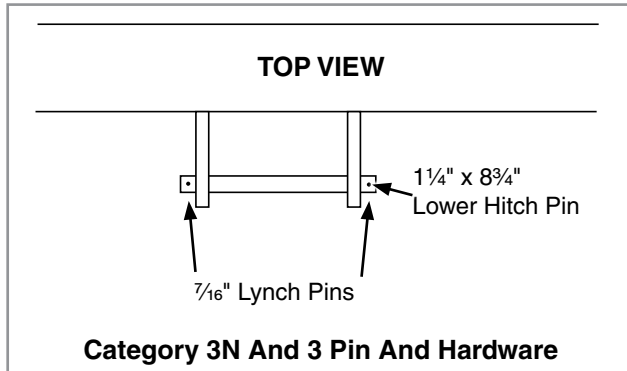

The upper hitch point has two holes. The hitch pin must be positioned in the lower hole for use with tractors equipped with Category 2 quick hitch. The lower hole is also recommended for use on tractors without a quick hitch. Some Category 2 tractors without a quick hitch are designed to accommodate the upper attaching holes. Consult tractor manufacturer.

The hitch pin must be positioned in the upper hole for use with tractors equipped with Category 3N and 3 hitches.

Upper Hitch Pin

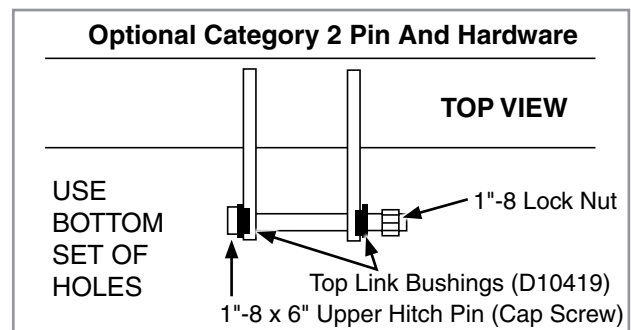
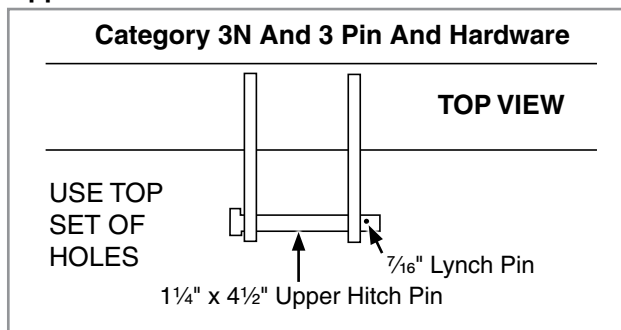

When using a quick hitch (customer-supplied), match pin location to pin spacing in the quick hitch. Adjust the tractor upper link until the quick hitch is vertical when in the planting position.

Dual lift assist wheel equipped machines require use of a quick hitch (customer-supplied) and the top link pin is not used.

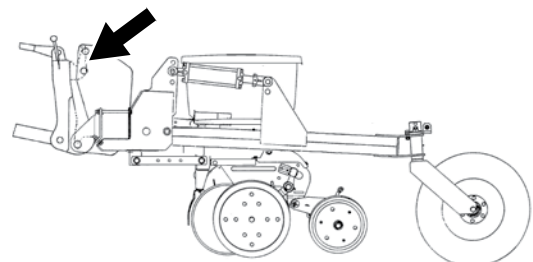



WARNING

Never transport machine with lift assist wheels without quick hitch. If this type of hitch is not in place, a sudden stop could allow the toolbar to rotate forward causing personal injury or damage to the equipment.

- The planter is equipped with safety/warning lights which should be used whenever the planter is being transported. The connector is a 7 terminal breakaway connector conforming to ASAE standards. If your tractor is not equipped for safety/warning lights, check with your tractor dealer.

Vacuum

Connect harness on planter to digital vacuum gauge console on tractor. Connect power lead from digital vacuum gauge console to power source. A power lead adapter may be required.



WARNING



Pressurized hydraulic fluid can penetrate body tissue and result in death, serious infection, or other injuries. Fluid injected under skin must be IMMEDIATELY removed by a surgeon familiar with this type of injury. Make sure connections are tight and hoses and fittings are not damaged before applying system pressure. Leaks can be invisible. Keep away from suspected leaks. Relieve pressure before searching for leaks or performing any system maintenance.



NOTICE

Wipe hose ends to remove any dirt before connecting couplers to tractor ports or contamination may cause equipment failure.

- Connect hydraulic hoses to tractor ports in a sequence that is both familiar and comfortable to the operator. See "Hydraulic Operation".

Before attaching hoses, move tractor SCV levers back and forth to relieve any pressure in the tractor hydraulic system.

The vacuum seed metering system vacuum fan operation hydraulic hoses are as follows:

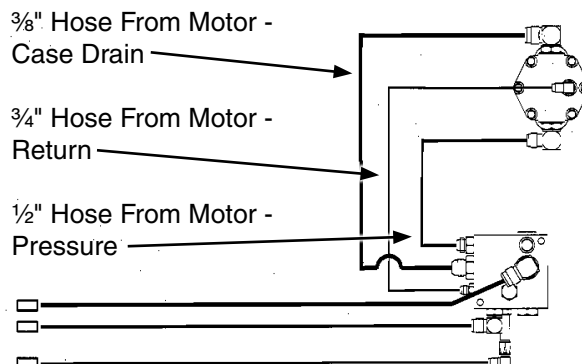

NOTICE

Before the markers are operated, make sure all marker lockups are in working position.

**DANGER**

Before applying pressure to the hydraulic system, make sure all connections are tight and that hoses and fittings have not been damaged. Hydraulic fluid escaping under pressure can have sufficient force to penetrate skin causing injury or infection.

6. With planter on a level surface, raise the planter slowly and watch for any interference.

When raising a planter equipped with dual lift assist wheels, the front of the planter should raise and then the back using the lift assist wheels to raise the rear of the planter. When lowering the planter, the lift assist wheels should begin to lower the rear of the planter before lowering the front of the planter. If the dual lift assist wheels are plumbed into the 3 point hitch lift circuit, adjust the flow control valve so the rear of the planter lowers before the front of the planter and the front of the planter raises before the rear of the planter. See "Flow Control Valve Adjustment". With planter lowered to planting position, adjust tractor linkage to level the toolbar. See "Leveling The Planter".

With planter (equipped with dual lift assist wheels) raised for transport, maintain a minimum of 3" (7.6 cm) clearance between planter and quick hitch.

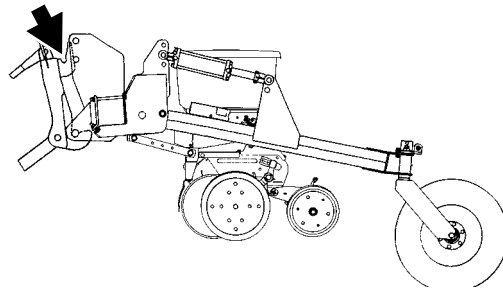

On planters equipped with the optional Dual Lift Assist Wheel Package, adjustment holes on the lift assist cylinder mounts allow for adjustment of lift height.

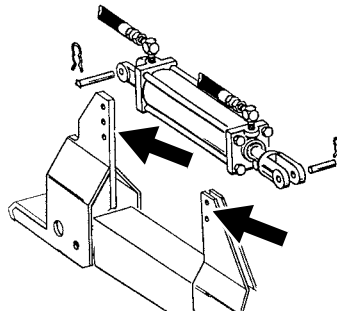

7. Remove pin from each parking stand and raise each to the transport position. Secure stands in raised position with pin in lowest hole.
8. Lower the planter so the drive wheels rest on the ground and check to be sure planter is level. Readjust top link as required to level row units. See "Leveling The Planter".

CYLINDER INFORMATION

	Wing Fold Cylinder, 12 Row 30" (A9036)	Wing Fold Cylinder, 12 Row 36"/38"/40" and 16 Row 30" (A9060)	Row Marker (Cushion) Cylinder (A8895)	Wing Down Flex Cylinder (A9055)	Dual Lift Assist Cylinder (A5482)
Intended Use	Double acting applications.	Double acting applications.	Double acting applications.	Double acting applications.	Double acting applications.
Piston	Ductile iron	Ductile iron	Ductile iron	Ductile iron	Ductile iron
Gland	Ductile iron	Ductile iron	Ductile iron	Ductile iron	Ductile iron
Tube	ST 52 Dom	ST 52 Dom	ST 52 Dom	ST 52 Dom	ST 52 Dom
Rod	1045 Nitro rod	1045 Nitro rod	1045 Nitro rod	1045 Nitro rod	1045 Nitro rod
End Mounts	Sleeve	Sleeve	Sleeve	Sleeve	Sleeve
Tube Seal	Buna O-ring with polytemp back-up	Buna O-ring with polytemp back-up	Buna O-ring with polytemp back-up	Buna O-ring with polytemp back-up	Buna O-ring with polytemp back-up
Rod Seal	Polyester alloy u-cup	Polyester alloy u-cup	Polyester alloy u-cup	Polyester alloy u-cup	Polyester alloy u-cup
Rod Wiper	Polyester alloy snap in	Polyester alloy snap in	Polyester alloy snap in	Polyester alloy snap in	Polyester alloy snap in
Piston Seal	T-seal hnbr	T-seal hnbr	T-seal hnbr	T-seal hnbr	T-seal hnbr
Specifications					
Product Category	Hydraulic cylinder	Hydraulic cylinder	Hydraulic cylinder	Hydraulic cylinder	Hydraulic cylinder
Maximum Stroke	20" (50.8 cm)	20" (50.8 cm)	20.062" (50.95 cm)	3.5" (8.9 cm)	3.5" (8.9 cm)
Working Pressure	3000 psi (20684.27 kPa)	3000 psi (20684.27 kPa)	3000 psi (20684.27 kPa)	3000 psi (20684.27 kPa)	3000 psi
Bore Size	3.5" (8.89 cm)	4" (10.16 cm)	2.5" (6.35 cm)	4" (10.16 cm)	8" (20.32 cm)
Shaft Diameter	1.5" (3.8 cm)	1.75" (4.44 cm)	1.25" (3.17 cm)	1.75" (4.44 cm)	---
Cylinder Configuration	Simple	Simple	Simple	Simple	Simple
Cylinder Action	Double	Double	Double	Double	Double
Material	Steel, Ductile iron	Steel, Ductile iron	Steel, Ductile iron	Steel, Ductile iron	Steel, Ductile iron
Mounting Method	Sleeve	Sleeve	Sleeve	Sleeve	Sleeve
Mount Location	End Cap	End Cap	End Cap	End Cap	End Cap
Cylinder Style	Welded	Welded	Welded	Welded	Welded

HYDRAULIC HOSE INFORMATION

Part Number	A8261	A12015	A3352	A8262	A3353	A12014
Description	Hose Assembly, ½" x 13½" (10F-10F)	Hose Assembly, ¾" x 17" (6F-6F)	Hose Assembly, ¾" x 13½" (12F-12F)	Hose Assembly, ½" x 36" (10F-10F)	Hose Assembly, ¾" x 33" (12F-12F)	Hose Assy 3/8x34 (06F-06F)
Product Category	Hydraulic Hose	Hydraulic Hose	Hydraulic Hose	Hydraulic Hose	Hydraulic Hose	Hydraulic Hose
Product Form	Hose; Assembly	Hose; Assembly	Hose; Assembly	Hose; Assembly	Hose; Assembly	Hose; Assembly
I.D.	.500" (12.7 mm)	.375" (9.52 mm)	.750" (19.05 mm)	.500" (12.7 mm)	.750" (19.05 mm)	.375" (9.52 mm)
O.D.	.800" (20.32 mm)	.630" (16 mm)	1.110" (28.19 mm)	.800" (20.32 mm)	1.110" (28.19 mm)	.630" (16 mm)
Minimum Bend Radius	2.8" (7.11 cm)	2" (5.08 cm)	3.8" (9.65 cm)	2.8" (7.11 cm)	3.8" (9.65 cm)	2" (5.08 cm)
Working Pressure	3250 PSI (22407.96 kPa)	3250 PSI (22407.96 kPa)	3500 PSI (24131.65 kPa)	3250 PSI (22407.96 kPa)	3500 PSI (24131.65 kPa)	3250 PSI (22407.96 kPa)
Temperature Range	-40°F - +212°F (-40°C - +100°C)	-40°F - +212°F (-40°C - +100°C)	-40°F - +212°F (-40°C - +100°C)	-40°F - +212°F (-40°C - +100°C)	-40°F - +212°F (-40°C - +100°C)	-40°F - +212°F (-40°C - +100°C)
Material	Modified Nitrile Type C2	Modified Nitrile Type C2	Modified Nitrile Type C2	Modified Nitrile Type C2	Modified Nitrile Type C2	Modified Nitrile Type C2
Specialized Construction	High tensile steel wire	High tensile steel wire	High tensile steel wire	High tensile steel wire	High tensile steel wire	High tensile steel wire
Media	Hydraulic Fluid	Hydraulic Fluid	Hydraulic Fluid	Hydraulic Fluid	Hydraulic Fluid	Hydraulic Fluid
Application	Agricultural; Construction	Agricultural; Construction	Agricultural; Construction	Agricultural; Construction	Agricultural; Construction	Agricultural; Construction

Part Number	A8247	A3337	A3266	A1188	A1103	A1113
Description	Hose Assembly, ½" x 60" (8M-10F)	Hose Assembly, ¾" x 60" (8M-12F)	Hose Assembly, ¾" x 60" (8M-6F)	Hose Assembly, ¼" x 66" (06F-06F)	Hose Assembly, ¼" x 110" (6F-6F)	Hose Assembly, ¼" x 80" (6F-6F)
Product Category	Hydraulic Hose	Hydraulic Hose	Hydraulic Hose	Hydraulic Hose	Hydraulic Hose	Hydraulic Hose
Product Form	Hose; Assembly	Hose; Assembly	Hose; Assembly	Hose; Assembly	Hose; Assembly	Hose; Assembly
I.D.	.500" (12.7 mm)	.750" (19.05 mm)	.375" (9.52 mm)	.250" (6.35 mm)	.250" (6.35 mm)	.250" (6.35 mm)
O.D.	.800" (20.32 mm)	1.110" (28.19 mm)	.630" (16 mm)	.530" (13.46 mm)	.530" (13.46 mm)	.530" (13.46 mm)
Minimum Bend Radius	2.8" (7.11 cm)	3.8" (9.65 cm)	2" (5.08 cm)	2" (5.08 cm)	4" (10.16 cm)	4" (10.16 cm)
Working Pressure	3250 PSI (22407.96 kPa)	3500 PSI (24131.65 kPa)	3250 PSI (22407.96 kPa)	3250 PSI (22407.96 kPa)	3275 PSI (22580.33 kPa)	3275 PSI (22580.33 kPa)
Temperature Range	-40°F - +212°F (-40°C - +100°C)	-40°F - +212°F (-40°C - +100°C)	-40°F - +212°F (-40°C - +100°C)	-40°F - +212°F (-40°C - +100°C)	-40°F - +212°F (-40°C - +100°C)	-40°F - +212°F (-40°C - +100°C)
Material	Modified Nitrile Type C2	Modified Nitrile Type C2	Modified Nitrile Type C2	Modified Nitrile Type C2	Modified Nitrile Type C2	Modified Nitrile Type C2
Specialized Construction	High tensile steel wire	High tensile steel wire	High tensile steel wire	High tensile steel wire	High tensile steel wire	High tensile steel wire
Media	Hydraulic Fluid	Hydraulic Fluid	Hydraulic Fluid	Hydraulic Fluid	Hydraulic Fluid	Hydraulic Fluid
Application	Agricultural; Construction	Agricultural; Construction	Agricultural; Construction	Agricultural; Construction	Agricultural; Construction	Agricultural; Construction

HYDRAULIC HOSE INFORMATION

Part Number	A1170	A1198	A1102	A1116	A1140	A7600
Description	Hose Assembly, ¼" x 90" (6F-6F)	Hose Assembly, ¼" x 60" (8M-6F)	Hose Assembly, ¼" x 95" (6F-6F)	Hose Assembly, ¼" x 136" (6F-6F)	Hose Assembly, ¼" x 52" (6F-6F)	Hose Assembly, ¼" x 260" (6F-6F)
Product Category	Hydraulic Hose	Hydraulic Hose	Hydraulic Hose	Hydraulic Hose	Hydraulic Hose	Hydraulic Hose
Product Form	Hose; Assembly	Hose; Assembly	Hose; Assembly	Hose; Assembly	Hose; Assembly	Hose; Assembly
I.D.	.250" (6.35 mm)	.250" (6.35 mm)	.250" (6.35 mm)	.250" (6.35 mm)	.250" (6.35 mm)	.250" (6.35 mm)
O.D.	.530" (13.46 mm)	.530" (13.46 mm)	.530" (13.46 mm)	.530" (13.46 mm)	.530" (13.46 mm)	.530" (13.46 mm)
Minimum Bend Radius	4" (10.16 cm)	4" (10.16 cm)	4" (10.16 cm)	4" (10.16 cm)	4" (10.16 cm)	4" (10.16 cm)
Working Pressure	3275 PSI (22580.33 kPa)	3275 PSI (22580.33 kPa)	3275 PSI (22580.33 kPa)	3275 PSI (22580.33 kPa)	3275 PSI (22580.33 kPa)	3275 PSI (22580.33 kPa)
Temperature Range	-40°F - +212°F (-40°C - +100°C)	-40°F - +212°F (-40°C - +100°C)	-40°F - +212°F (-40°C - +100°C)	-40°F - +212°F (-40°C - +100°C)	-40°F - +212°F (-40°C - +100°C)	-40°F - +212°F (-40°C - +100°C)
Material	Modified Nitrile Type C2	Modified Nitrile Type C2	Modified Nitrile Type C2	Modified Nitrile Type C2	Modified Nitrile Type C2	Modified Nitrile Type C2
Specialized Construction	High tensile steel wire	High tensile steel wire	High tensile steel wire	High tensile steel wire	High tensile steel wire	High tensile steel wire
Media	Hydraulic Fluid	Hydraulic Fluid	Hydraulic Fluid	Hydraulic Fluid	Hydraulic Fluid	Hydraulic Fluid
Application	Agricultural; Construction	Agricultural; Construction	Agricultural; Construction	Agricultural; Construction	Agricultural; Construction	Agricultural; Construction

Part Number	A7601	---	---	---	---	---
Description	Hose Assembly, ¼" x 80" (6M-6F)	---	---	---	---	---
Product Category	Hydraulic Hose	---	---	---	---	---
Product Form	Hose; Assembly	---	---	---	---	---
I.D.	.250" (6.35 mm)	---	---	---	---	---
O.D.	.530" (13.46 mm)	---	---	---	---	---
Minimum Bend Radius	4" (10.16 cm)	---	---	---	---	---
Working Pressure	3275 PSI (22580.33 kPa)	---	---	---	---	---
Temperature Range	-40°F - +212°F (-40°C - +100°C)	---	---	---	---	---
Material	Modified Nitrile Type C2	---	---	---	---	---
Specialized Construction	High tensile steel wire	---	---	---	---	---
Media	Hydraulic Fluid	---	---	---	---	---
Application	Agricultural; Construction	---	---	---	---	---

LEVELING THE PLANTER

For proper performance of the planter and row units, it is important that the planter frame and row unit parallel arms operate approximately level. The toolbar should operate at a 20" to 22" (51-56 cm) height, measured from the planting surface to the bottom of the toolbar.

When operating the planter, make sure the right and left lower link arms on the tractor are adjusted equally before attaching the planter. After the planter has been lowered to the correct operating height, stop the tractor and stand beside the planter and check to be sure the frame is level fore and aft. If the row units angle up or down, adjust the center link on the tractor to level the machine.

It is important for the planter to operate level laterally. Tire pressure must be maintained at pressures specified and drive wheel height must be adjusted equally. See "Wheel Module Height Adjustment".

TRANSPORTING PLANTER

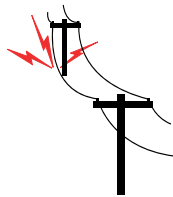

Contacting or coming close to power lines or other high energy sources will cause death or serious injury.

Keep away from power lines or high energy sources at all times.



All safety/warning lights, reflective decals, and SMV sign must be in place and visible before transporting machine on public roads or death, serious injury, and damage to property and equipment may result. Check federal, state/provincial, and local regulations before transporting equipment on public roads.

- Tow only with farm tractor rated and configured for equipment.
- Know your route and be aware of any obstructions.
- Follow all road and bridge load limit restrictions.
- Never exceed maximum transport towing speed of 20 mph (32 kph).

CONTACT WHEEL SPRING ADJUSTMENT

There are two down pressure springs on each contact drive wheel. The spring tension is factory preset and should require no further adjustment.

The tension is set leaving 1" (2.5 cm) between the spring plug and the mounting shaft as shown below.

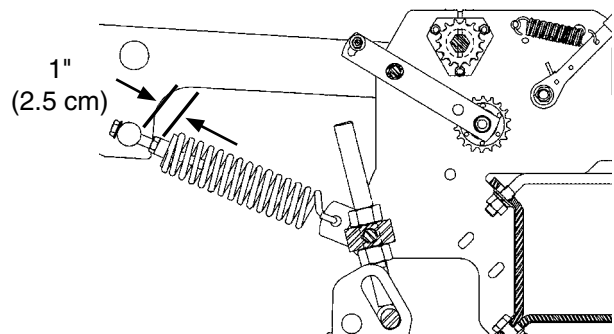

PARKING STAND ADJUSTMENT

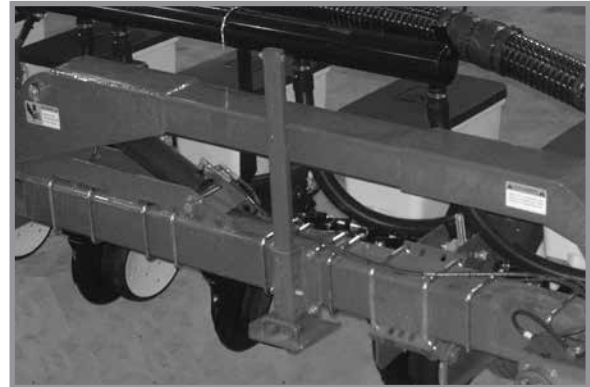
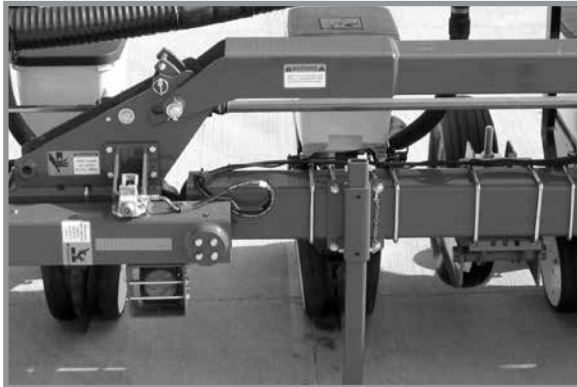

Vacuum Shown

Two parking stands, located on the front side of the main frame, are standard on all Model 3140 planters. The stands must be positioned so they are not directly behind the tractor tire or they will interfere when the planter is raised.

Each parking stand has six positioning holes. By using these positioning holes, you can set the main frame parking height from 19" to 25" (48 to 63.5 cm).

Raise the stands to the top position and pin when planting; lower and pin for parking and storage.

WHEEL MODULE HEIGHT ADJUSTMENT

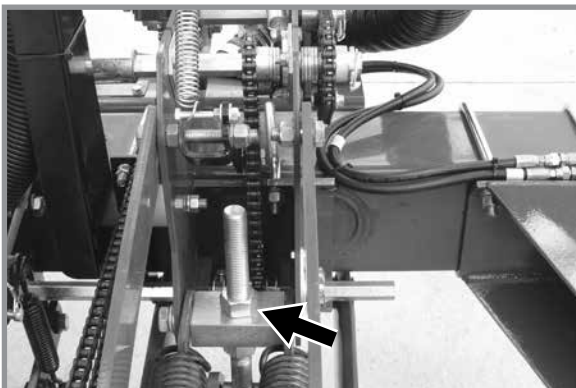

Drive Wheel Module Assembly

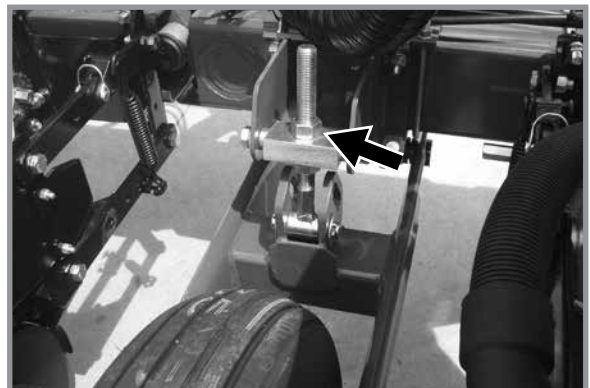

Center Section Gauge Wheel Assembly

The drive wheel module assembly and center section gauge wheel assembly are designed so the drive wheel height can be adjusted to maintain a frame height of 20" to 22" (51-56 cm) in all planting applications. This is particularly useful when the planter is used for ridge planting or planting on beds. The wheel module assembly has an adjustment range of 7" (18 cm). To adjust the wheel assembly, loosen the upper nut using a 1½" wrench or a 15" adjustable wrench and turn the lower nut using a 1½" wrench or 15" adjustable wrench (clockwise to decrease frame height or counterclockwise to increase frame height). Tighten the upper nut after adjustment is complete. Set all wheels equally.

SEED RATE TRANSMISSION ADJUSTMENT

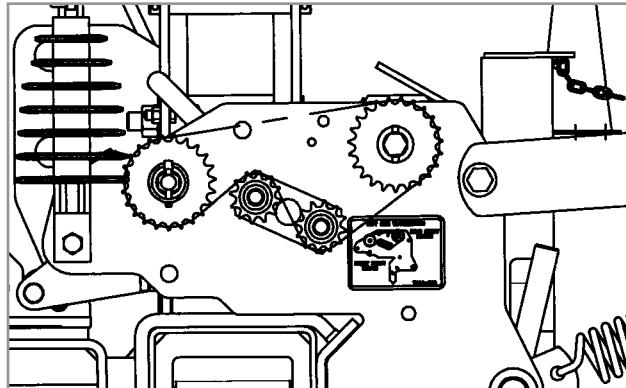

Planting population rate changes are made at the seed rate transmissions. The seed rate transmissions are designed to allow simple, rapid changes of sprockets to obtain the desired planting population. By removing the lynch pins on the hexagon shafts, sprockets can be interchanged with those from the sprocket storage rod bolted near each transmission.

Chain tension is controlled by spring-loaded, dual-sprocket idlers. The idler assembly is adjusted with a easy-release arm. This arm has a release position to remove spring tension for replacing sprockets. The amount of spring tension on the chain is controlled by the idler arm. See "Wrap Spring Wrench Operation".

A decal positioned near each transmission illustrates proper chain routing. The planting rate charts found in "Rate Charts" will aid you in selecting the correct sprocket combinations.

WRAP SPRING WRENCH OPERATION

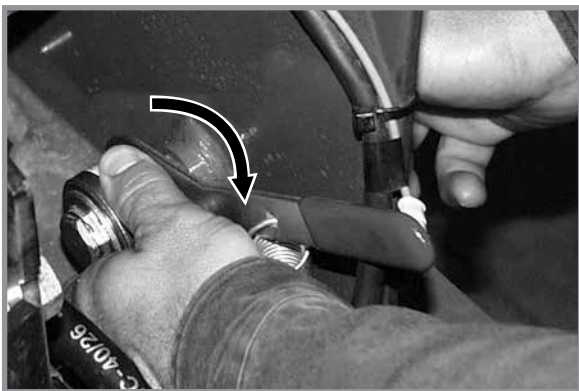

Release Chain Tension



Increase Chain Tension

Chain idlers are equipped with wrap spring wrenches. L.H. wrap spring wrenches have a blue release collar and R.H. wrap spring wrenches have a grey or black release collar.

Rotate collar on wrap spring wrench and pull handle to release chain tension.

Rotate chain idler into chain and pull handle to tension idler spring.

CONTACT WHEEL DRIVE SPROCKETS

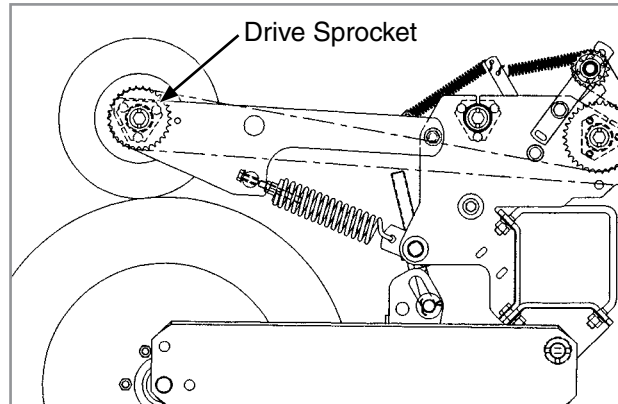

NOTE: 15 tooth, 19 tooth or 30 tooth drive sprockets at each contact drive wheel can be interchanged from the sprocket storage rod bolted near each transmission. The 15 and 19 tooth sprockets require use of a 218 pitch No. 40 chain. The 30 tooth sprocket requires use of a 224 pitch No. 40 chain.

Chain tension is controlled by a spring-loaded sprocket idler. The amount of spring tension on the chain is controlled by the idler arm.

The planting rate charts found in "Rate Charts" section will aid you in selecting the correct sprocket.

NOTE: 15, 19 and 30 tooth drive sprockets are NOT applicable to all rate charts. Check chart titles to ensure the proper rate charts are selected.

NOTE: After each sprocket combination adjustment, make a field test to be sure you are planting at the desired rate.

HALF RATE (2 TO 1) DRIVE

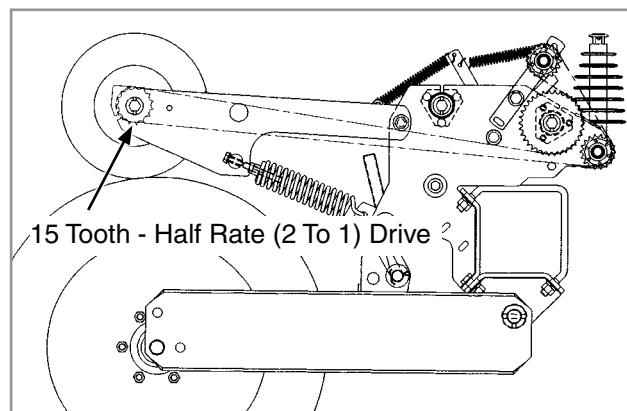

Half rate (2 to 1) drive is recommended only when the desired population falls below that shown on the planting rate charts. Replace the 30 tooth drive sprocket and shorter No. 40 110 pitch chain on each contact wheel with a 15 tooth sprocket. This will reduce the planter transmission speed and reduce planting and application rates by approximately 50%.

NOTE: After each sprocket combination adjustment, make a field check to be sure you are planting at the desired rate.

SHEAR PROTECTION

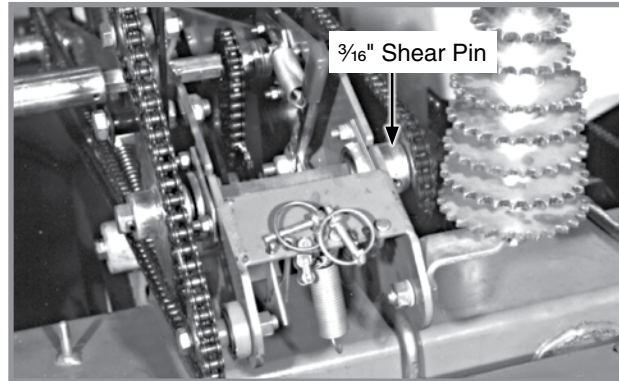

Transmission Shaft

The planter driveline and seed and granular chemical drivelines are protected from damage by shear pins.

If excessive load should cause a pin to shear, it is important to determine where binding has occurred before replacing the pin. Replace shear pins with same size and type.

To prevent future binding or breakage of components, check driveline alignment and follow prescribed lubrication schedules.

NOTE: Drill shaft/transmission coupler alignment is critical.

DIGITAL VACUUM READOUT

Digital vacuum readout is incorporated into in-cab display. Refer to the display operation manual for instructions.

VACUUM METER SYSTEM

Kinze vacuum meter seed metering system includes seed meters, seed discs, and an air system consisting of a hydraulic driven vacuum fan which draws air through manifolds, hoses, and seed meters on each row unit.

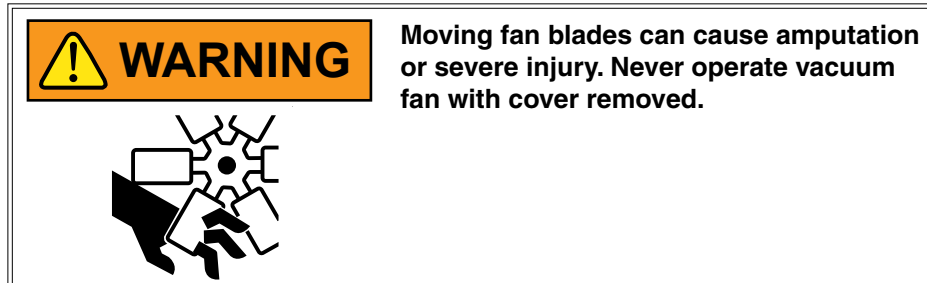

ANALOG VACUUM OR PRESSURE GAUGE

Analog vacuum or pressure gauge connects directly to vacuum meter (vacuum) or bulk fill (pressure) manifold and is tied into digital sending units.

Only adjustment is to "zero" needle with no vacuum or pressure present. If there is a significant difference between gauge and a reading taken at meters, a different manifold location should be found to connect hose to gauge and digital sending unit.

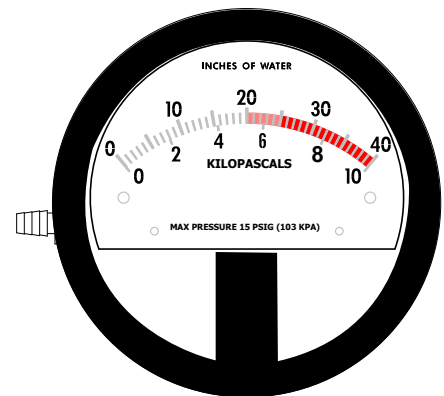

Analog Gauge

NOTE: Analog gauges are identical EXCEPT for plug and hose barb locations in side of gauge housing. DO NOT connect vacuum meter or bulk fill hose to wrong gauge. Check plug and hose barb installation if readout is erratic or appears inaccurate.

VACUUM FAN MOTOR VALVE BLOCK ASSEMBLY

A pressure relief valve in the hydraulic circuit prevents build up of oil pressure over 35 PSI in case drain line when vacuum fan motor is operating. This valve will vent oil outside valve block through a drain hole in the aluminum valve block. This can occur whenever case drain is improperly connected or pressure in motor circuit builds.

See "Hydraulic Diagram - Vacuum Fan Motor System" in Lubrication and Maintenance section.

Valve block contains a check valve that prevents vacuum fan from operating in wrong direction if pressure is applied to return side of motor and allows fan to coast to a stop when tractor hydraulic control is returned to neutral position.

NOTE: Fan turns at a reduced speed if reverse pressure is applied.

HYDRAULIC OPERATION

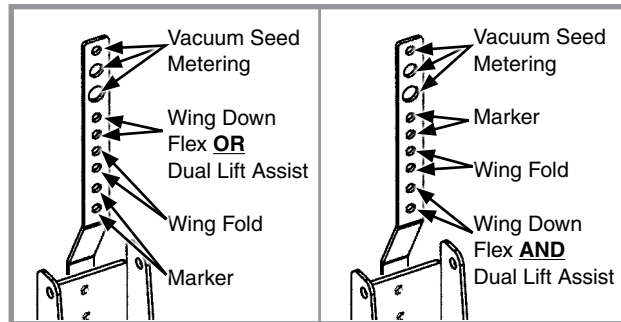

Vacuum

Planter may require up to four selective control valves (SCV). A single SCV is needed to fold the wings; a second SCV and case drain is required for operation of the vacuum seed metering system; a third SCV is required for the Row Marker Package; and a fourth SCV is required for the Dual Lift Assist Wheel Package and/or the Wing Down Flex Cylinder Package unless these are connected into the tractor 3 point lift system.

Mechanical

Planter requires a single control valve for folding the wings. A second control valve is required for the Row Marker Package. A third valve is required for the Dual Lift Assist Wheel Package and/or the Wing Down Flex Cylinder Package unless these are connected into the tractor 3 point lift system.

DANGER

Contacting or coming close to power lines or other high energy sources will cause death or serious injury.

Keep away from power lines or high energy sources at all times.



NOTE: If a cylinder has been disconnected or removed for any reason, do not attach the rod end of the cylinder until the cylinder is cycled several times to remove any air that may be trapped in the system.

The wings are folded and unfolded using a single hydraulic control valve. When the wings are unfolded, the spring-actuated hydraulic latches lock the wings to the fold links so they pivot as one unit.

NOTICE

Always be sure planter is in the fully raised position before folding the planter wings to ensure wing row units do not collide with center section seed hoppers.

ROW MARKER HYDRAULIC OPERATION

 WARNING	Row marker can lower at any time and could cause death or serious injury. Stay away from row markers! Install safety lockup device when not in use.
	

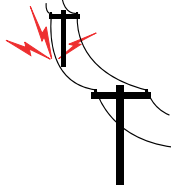
 DANGER	Contacting or coming close to power lines or other high energy sources will cause death or serious injury.
	Keep away from power lines or high energy sources at all times.

The single valve marker system uses a sequencing valve which directs hydraulic flow to operate the markers alternately. Each time a marker is raised, the sequencing valve will direct flow to lower the opposite marker.

Both markers can be used at the same time if desired. To do this, lower the planter and the marker that has been selected. Move the tractor SCV control to the raise position and immediately return it to the lower position. This will shift the marker control valve and the remaining marker will be lowered.

ROW MARKER SPEED ADJUSTMENT

Flow control valves located in the marker sequencing/flow control valve assembly control lowering and raising speed of markers. One flow control valve sets lowering speed of both markers and one sets raising speed of both markers. To adjust marker speed, loosen jam nut and turn control(s) clockwise, or IN to slow travel speed and counterclockwise, or OUT, to increase travel speed. Flow control(s) determine amount of oil flow restriction through valves, therefore varying travel speed of markers. Tighten jam nut after adjustments are complete.

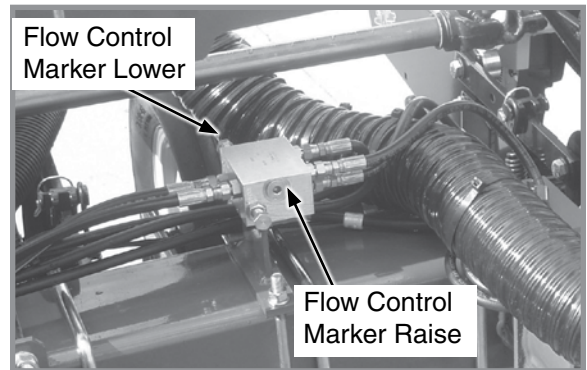

NOTE: Backing flow control valve out too far can cause the o-ring seal on valve to fail when hydraulics are operated.

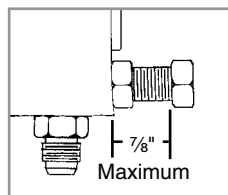

NOTICE	<p>The flow controls should be properly adjusted before the marker assemblies are first put into use. Excessive marker travel speed can damage the marker assembly.</p>
---------------	---

WARNING	<p>Row marker can lower at any time and could cause death or serious injury. Stay away from row markers! Install safety lockup device when not in use.</p>

NOTE: When oil is cold, hydraulics operate slowly. Make sure all adjustments are made with warm oil. Do not overtighten lock nut.

NOTE: On a tractor where oil flow can not be controlled, the rate of flow of oil from tractor may be greater than rate at which the marker cylinder can accept oil. Tractor hydraulic control lever will have to be held until cylinder reaches end of its stroke. This occurs most often on tractors with open center hydraulic systems. On tractors with closed center hydraulic systems, the tractor's hydraulic flow control can be set so the tractor's detent will function properly.

ROW MARKER ADJUSTMENTS

1. Multiply number of rows by the average row spacing in inches to determine total planting width.

Row Marker Lengths	
12 Row 30"	360" (914.4 cm)
12 Row 36"	432" (1097.3 cm)
12 Row 38"	456" (1158.2 cm)
12 Row 40"	480" (1219.2 cm)
16 Row 30"	480" (1219.2 cm)

2. Lower planter and row marker assembly to ground.
3. Measure from planter center line to a point where blade contacts ground.
4. Adjust row marker extension so distance from marker disc blade to center line of planter is equal to total planting width. Adjust right and left row marker assemblies equally and securely tighten clamping bolts.

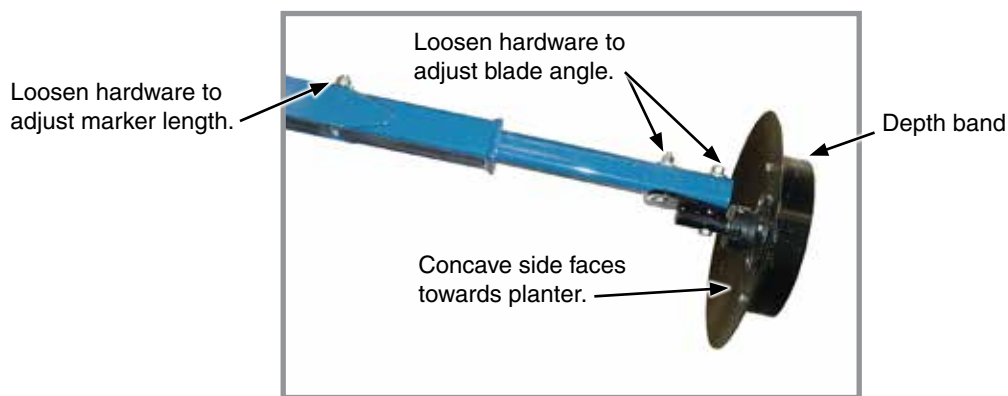

Row marker disc blade angle adjustment

NOTICE

Setting marker disc blade assembly at a sharper angle than needed adds stress to row marker assembly and shortens bearing and blade life. Set blade angle only as needed to leave a clear mark.

Marker disc blade is installed with concave side facing inward. Spindle assembly is slotted so hub and blade can be angled to throw more or less dirt.

5. Loosen hardware and move assembly as required.
6. Tighten bolts to specified torque.
7. Do a field test to ensure markers are properly adjusted.

NOTE: A notched marker blade is available from Kinze through your Kinze Dealer for use in more severe no till conditions.

DANGER

Contacting or coming close to power lines or other high energy sources will cause death or serious injury.

Keep away from power lines or high energy sources at all times.

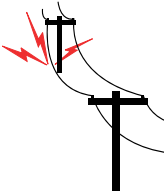

DANGER

Wings must be unfolded before detaching machine from tractor.

WARNING

Always install hydraulic cylinder safety lockups when servicing the machine in raised position or when transporting the machine on the road.

WING FLEX

Two hooks located over each wing hinge area can be positioned so toolbar (a) is locked rigid, (b) so planter wings have 8° up flex or (c) with Wing Down Flex Cylinder Package (See “Wing Down Flex Cylinder”) installed, so planter wings have 8° up flex and 8° down flex.

Hooks Positioned For Rigid Operation

Hooks Positioned For 8° Up Flex

To change the hook from one position to the other:

1. Lower the planter to the ground so weight is off of the toolbar and relieve hydraulic pressure in the wing fold cylinders.
2. Remove lynch pin and 6³/₄" pin.
3. Loosen ³/₄" hook mounting hardware and rotate the hooks back off of the hinge pin. (It may be necessary to raise the outer end of the wing up several inches to take pressure off of the hooks to allow them to rotate.)
4. Remove ¹/₂" x 6" cap screw and sleeve.

(Continued on next page)

2-20

Rev. 1/18

WING FLEX (CONTINUED)

5. Remove $\frac{3}{4}$ " hook mounting hardware.
6. Install hooks in new position. Tighten $\frac{3}{4}$ " hardware.
7. Install sleeve and $\frac{1}{2}$ " cap screw in opposite hole.

NOTE: The $\frac{3}{4}$ " hook mounting hardware should be snug, yet loose enough to allow the hooks to be rotated by hand.

8. Install $6\frac{3}{4}$ " pin and lynch pins.

WING DOWN FLEX CYLINDER

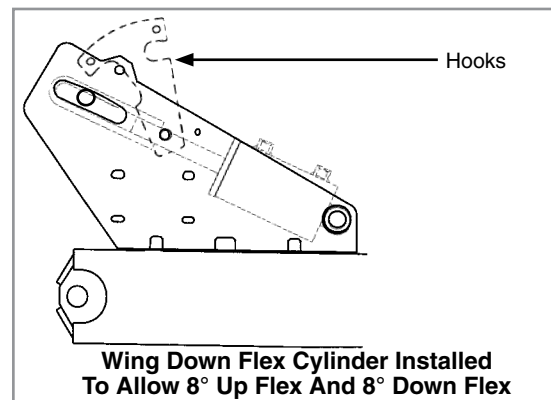
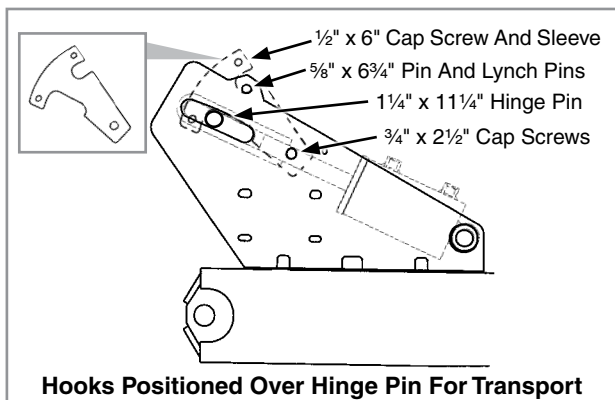

To prevent the planter wings from sagging during transport should hydraulic pressure be lost, the hooks located over each hinge area should be repositioned prior to folding the planter. Apply hydraulic pressure to the wing down flex cylinders until they are completely retracted and the wings are rotated up slightly. ($\frac{3}{4}$ " **hook mounting hardware should be snug, yet loose enough to allow the hooks to be rotated by hand.**) Remove lynch pin and $6\frac{3}{4}$ " pin, rotate hooks to hook over hinge pin as shown below and reinstall $6\frac{3}{4}$ " pin above hooks. Relieve hydraulic pressure on down flex cylinders and allow wings to come back to level. Fold planter and install lockups on wing fold cylinders. Reverse procedure to unfold planter.

NOTICE

Always be sure planter is in the fully raised position before folding the planter wings to ensure wing row units do not collide with center section seed hoppers.

POINT ROW CLUTCHES

With the use of electric-activated clutches, which disengage the drive, either half of the planter may be shut off for finishing up fields or for long point row situations.

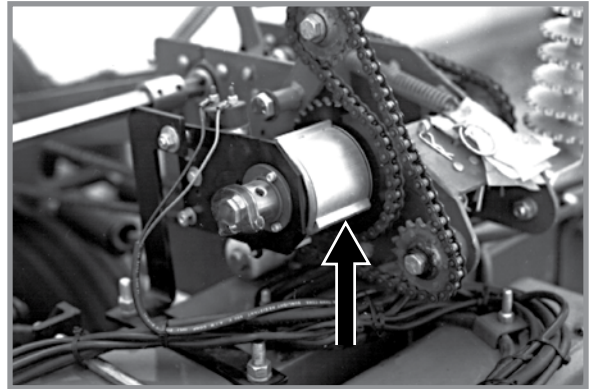

L.H. Side Of Planter Shown

The selector switch for the clutches is located in the point row clutch control box which is installed on the tractor.

NOTE: Switch should be left in OFF position when planter is not in use. If left in ON (left or right) position, the tractor battery will be discharged.



Point Row Clutch Control Box

NOTE: Since the liquid fertilizer piston pump have their own drive wheels, liquid fertilizer application will not be affected by use of the point row clutch.

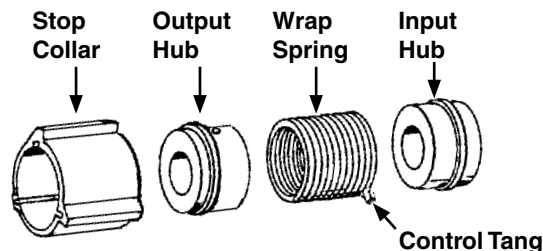

The point row clutch consists of a wrap spring riding on an input hub and an output hub. During operation the wrap spring is wrapped tightly over the hubs connecting them in a positive engagement. The greater the force of rotation the tighter the grip of the spring on the hubs. Rotation in the opposite direction or stopping the spring from rotating prevents the transmission of torque from the input hub to the output hub stopping the planter drive.

The input end of the spring is bent outward and is referred to as the control tang. The control tang fits into a slot in the stop collar that is located between the input and output hubs and over the wrap spring. If the stop collar is allowed to rotate with the input hub, the clutch is engaged. If the stop collar is stopped from rotating the control tang connected to it is forced back and the spring opens. This allows the input hub to continue rotating without transmitting torque to the output hub; therefore, stopping the planter drive.

The stop collar is controlled by the use of an electric solenoid and an actuator arm. When the selector switch on the tractor control box is in the OFF position the solenoid coil is NOT ENERGIZED and the actuator arm will not contact the stop on the stop collar allowing it to rotate with the hubs and drive the planter.

When the operational switch is in the "DISENGAGE" (right or left) position the solenoid coil IS ENERGIZED and the plunger in the solenoid coil pulls the actuator arm against the stop on the stop collar, disengaging the wrap spring and stopping the planter drive.

TWO-SPEED POINT ROW CLUTCHES

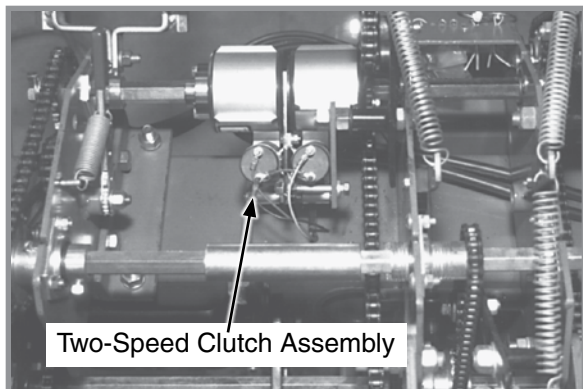

Left Side Of Planter Viewed From Rear Of Planter

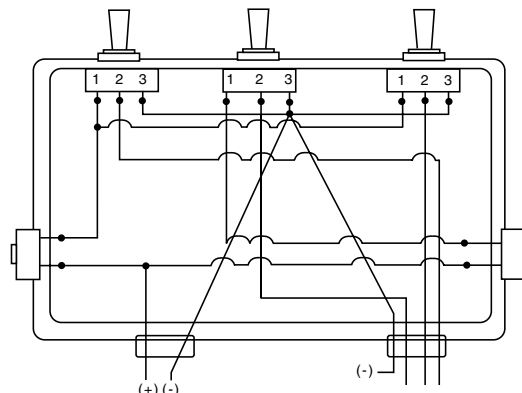

Top View Of Control Box

The optional Two-Speed Point Row Clutch Package is designed to allow on-the-go population rate adjustment as well as the capability to shut off either half of the planter for finishing up fields or for long point row situations.

The point row clutches are controlled by the point row clutch switches on the control box. The point row switch is used to shut off either the left or right half of the planter. Activating the reduced rate switch engages one solenoid on each clutch assembly and reduces the planting rate for the entire planter.

NOTE: Point row switch should be left in OFF position and rate switch left in FULL RATE position when planter is not in use. If left in ON and/or REDUCED RATE positions, the tractor battery will be discharged.

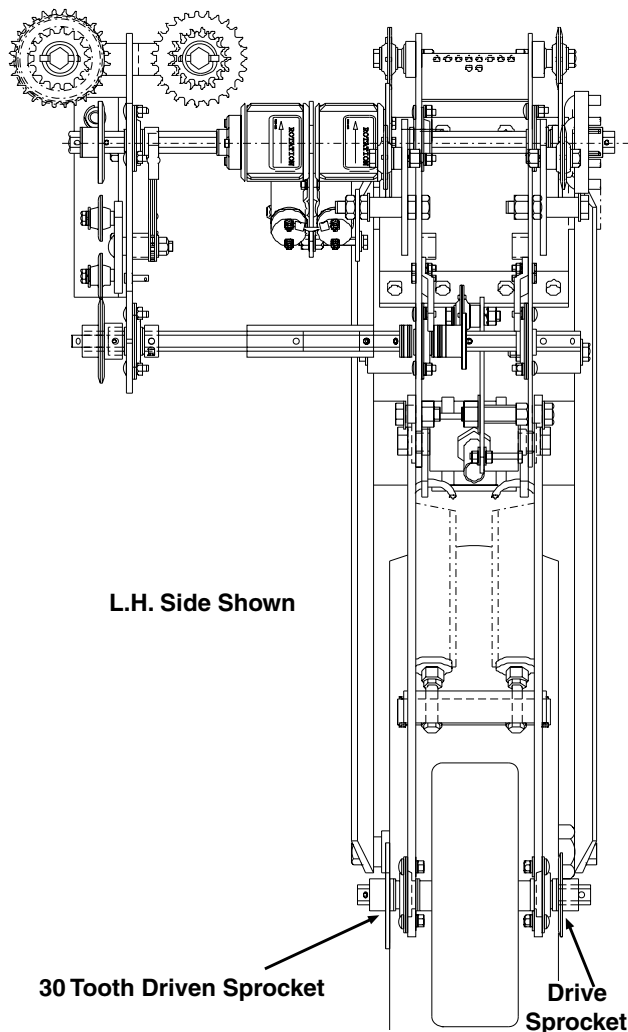

L.H. Side Shown

30 Tooth Driven Sprocket

Drive Sprocket

TRANSMISSION RATE REDUCTION		
DRIVE	DRIVEN	% REDUCTION IN POPULATION
15	30	50
17	30	43
23*	30	23
24	30	20
25*	30	17
26*	30	13
27	30	10

* Use sprockets off seed drive transmission

7100-214

The ratio of population reduction is determined by the sprocket ratio between the drive and driven sprockets at the contact drive tire. A rate reduction decal like the one shown below is located on the wheel module.

DUAL LIFT ASSIST WHEELS

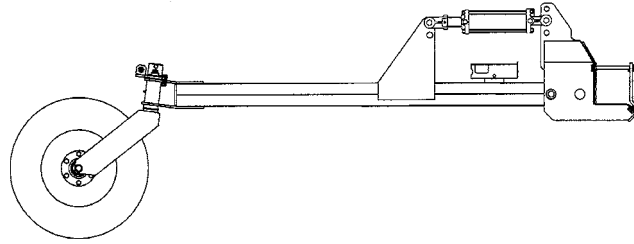

Dual lift assist wheel equipped machines require use of a quick hitch (customer-supplied) and the top link pin is not used.

A single control valve operates the dual lift assist wheels.

When raising a planter equipped with dual lift assist wheels, the front of the planter should raise and then the back using the lift assist wheels to raise the rear of the planter. When lowering the planter, the lift assist wheels should begin to lower the rear of the planter before lowering the front of the planter.

If the machine is equipped with both the Dual Lift Assist Wheel Package and Wing Down Flex Cylinder Package, a single control valve operates both options. As the dual lift assist wheel cylinders extend to raise the toolbar, the wing down flex cylinders retract to flex the wings up 5° for added clearance when turning.

The flow control valve must be adjusted so that the wing down flex cylinders start to retract before the lift assist cylinders start to raise the toolbar. This will prevent the wings from drooping as the toolbar is raised.

Dual lift assist wheels hydraulics can also be plumbed into the 3 point lift circuit. A flow control valve determines the correct sequence of events to allow the dual lift assist wheel cylinders to operate at the correct time in conjunction with the 3 point hitch lift circuit. See "Flow Control Valve Adjustment".

See "Tractor Preparation And Hookup" for additional information.

ACCUMULATOR

An accumulator is standard in Dual Lift Assist Wheel Packages for Model 3140 Stack Folding 16 Row 30" Planters to absorb shock loads to the lift assist wheel arms during transport.

After initial dealer installation no maintenance should be necessary on the sealed system.



WARNING

Do not disassemble accumulator. See dealer for service. Note manufacturer's caution decal on accumulator.

PISTON PUMP MOUNT/DRIVE SPRING ADJUSTMENT

Adjust the pump drive tension springs by tightening the hex head adjustment bolts to maintain positive tire contact. The initial setting should result in a $\frac{1}{8}$ " gap between coils. Tighten jam nut against spring plug to hold setting.

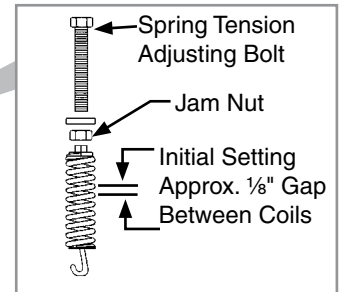
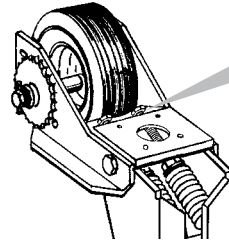

FLOW CONTROL VALVE ADJUSTMENT

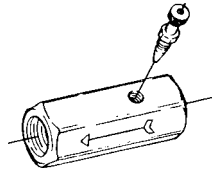

The flow control valve determines the amount of oil flow to the lift assist cylinders.

To adjust oil flow, loosen the jam nut and turn the control clockwise or "in" to restrict flow and counterclockwise or "out" to increase the flow.

PLANTING SPEED

Planters are designed to operate within a speed range of 2 to 8 mph (3.2 - 12.8 kph). See "Rate Charts". Variations in ground speed produce variations in rates. Finger pickup seed meter populations tend to be disproportionately higher at high ground speeds.

NOTE: Seed spacing can be adversely affected at speeds above 5.5 mph (8.8 kph).

FIELD TEST

Perform a field test with any change of field and/or planting conditions, seed size or planter adjustment to ensure proper seed placement and operation of row units.

- Check planter for front to rear and lateral level operation. See “Leveling the Planter”.
- Check **all** row units to be certain they are running level. Row unit parallel arms should be approximately parallel to the ground when planting.
- Check row markers for proper operation and adjustment. See “Row Marker Adjustments” and “Row Marker Speed Adjustment”.
- Check for proper application rates and placement of granular chemicals on **all** rows. See “Field Check Granular Chemical Application”.
- Check for desired depth placement and seed population on **all** rows. See “Check Seed Population” and appropriate Rate Chart.
- Check for proper application rates of fertilizer on **all** rows. See proper “Fertilizer Application Rate Chart”.

Reinspect machine after field testing.

- Hoses And Fittings
- Bolts And Nuts
- Cotter Pins And Spring Pins
- Drive Chain Alignment

CHECK SEED POPULATION

1. Tie up one or more sets of closing wheels by running a chain or rubber tarp strap between the hopper support panel and closing wheels. It may be necessary to decrease closing wheel arm spring tension.
2. Plant a short distance and check to see if seed is visible in the seed trench. Adjust planting depth to a shallower setting if seed is not visible and recheck.

Chain, rubber tarp strap, or similar.

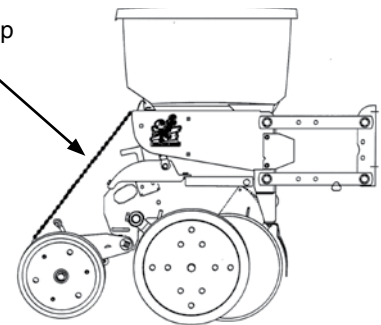

Planting depth adjustment handle



Planting depth adjustment

3. Measure $\frac{1}{1000}$ of an acre. See chart for correct distance for row width being planted. For example, if planting 30" rows $\frac{1}{1000}$ of an acre would be 17' 5".

$\frac{1}{1000}$ Acre Seed Population Count Row Width/Distance						
Row Width	15"	18"	19"	30"	36"	38"
Distance	34'10"	29'0"	27'8"	17'5"	14'6"	13'10"

NOTE: Seeds may bounce or roll when planting with closing wheels raised and planting depth set shallow affecting seed spacing accuracy.

4. Count seeds in measured distance.
5. Multiply number of seeds placed in $\frac{1}{1000}$ of an acre by 1000. This gives total population.

EXAMPLE: 30" row spacing 17' 5" equals $\frac{1}{1000}$ acre.

26 seeds counted x 1000 = 26,000 seeds per acre

Seed count can be affected by drive wheel and seed meter drive ratio, tire pressure, and/or seed meter malfunction.

1. If seed check shows average distance between seeds in inches is significantly different than seed rate chart indicates, first check drive ratio between drive wheel and seed meter. Check drive wheel air pressure, check for incorrect sprocket(s) in driveline and check drive and driven sprockets on transmission(s) for proper selection.
2. Check for seed meter malfunction. For example, if spacing between kernels of corn at the transmission setting being used is 8" and a gap of 16" is observed, a finger has lost its seed and not functioned properly. If two seeds are found within a short distance of each other, the finger has metered two seeds instead of one.
3. See "Finger Pickup Seed Meter Troubleshooting" and/or "Brush-Type Seed Meter Troubleshooting" in the Troubleshooting Section of this manual.

DETERMINING POUNDS PER ACRE (BRUSH-TYPE METER)

Seeds per acre ÷ Seeds per pound (from label) = Pounds per acre

If seeds per pound information is not available use the following averages:

2,600 seeds per pound for medium size soybeans

15,000 seeds per pound for medium size milo/grain sorghum

4,500 seeds per pound for medium size cotton

DETERMINING BUSHELS PER ACRE

Pounds per acre ÷ Seed unit weight = Bushels per acre

Average Unit Weight of:

1 Bushel Soybeans = 60 Pounds

1 Bushel Milo/Grain Sorghum = 56 Pounds

1 Bushel Cotton = 32 Pounds

If seed population check shows planting rate is significantly different than seed rate chart shows or if a particular meter is not planting accurately, see "Brush-Type Seed Meter Maintenance" and "Brush-Type Seed Meter Troubleshooting".

FIELD CHECK GRANULAR CHEMICAL APPLICATION

Temperature, humidity, speed, ground conditions, flowability of different material, or meter obstructions can affect granular chemical rate of delivery.



WARNING



Agricultural chemicals can cause death or serious injury to persons, animals, and plants or seriously damage soil, equipment, or property. Read and follow all chemical and equipment manufacturers labels and instructions.

Perform a field check to determine application rates.

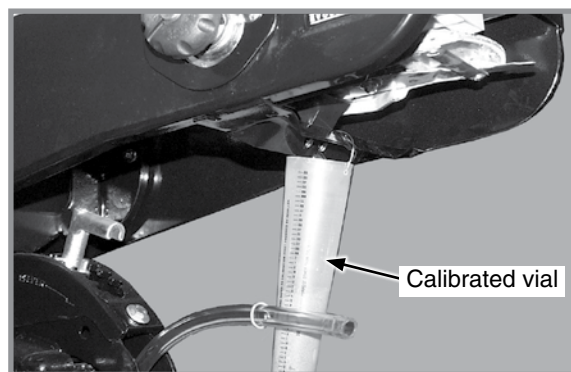

Granular chemical field check

1. Fill insecticide and/or herbicide hoppers.
2. Attach a calibrated vial to each granular chemical meter.

NOTE: Disengage clutch to avoid dropping seed during test.

3. Lower planter and drive 1320 feet at planting speed.
4. Weigh chemical in ounces caught in one vial.
5. Multiply that amount by factor shown to determine pounds per acre.

Pounds Per Acre	
Row Width	Factor
30"	.83
36"	.69
38"	.65

EXAMPLE: You are planting 30" rows. You have planted for 1320 feet at desired planting speed. You caught 12.0 ounces of chemical in one vial. 12.0 ounces times 0.83 equals 9.96 pounds per acre.

NOTE: Check calibration of all rows.

METERING GATE

Use metering gate setting as a starting point for distributing insecticide or herbicide. Charts are based on 5 mph (8 kph) planting speed. Use a higher gate setting for speeds faster than 5 mph (8 kph) and a lower setting for speeds slower than 5 mph (8 kph).

This page left blank intentionally.

PLANTING DEPTH

Planting depth is maintained by adjustable row unit gauge wheels. Depth adjustment range is approximately ½" to 3½" (1.27 to 8.89 cm).

1. Raise planter to remove weight from wheels.
2. Push down on depth adjustment handle and reposition it forward to decrease or rearward to increase planting depth. Initially adjust all units to the same setting.
3. Lower planter and check operation and planting depth of all row units. Readjust individual rows as needed for uniform operation.



Planting depth adjustment

“V” CLOSING WHEEL ADJUSTMENT (RUBBER OR CAST IRON)

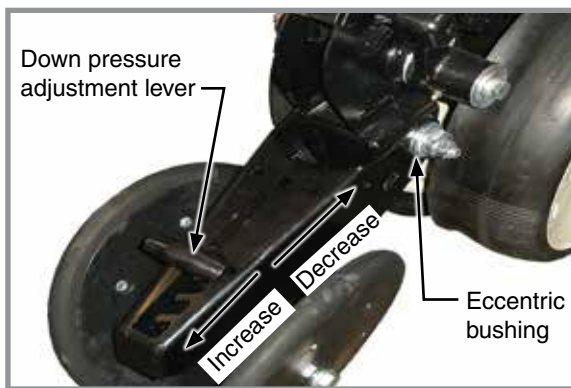

“V” Closing wheel adjustments

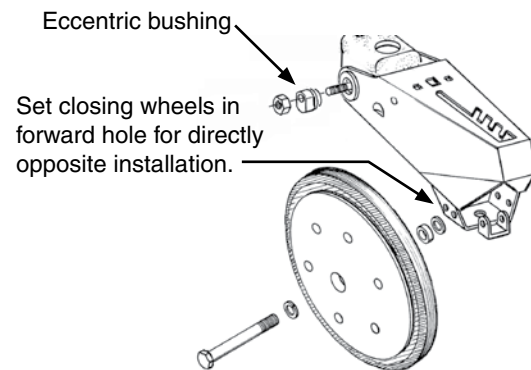

“V” closing wheels should have enough down pressure to close the seed trench and ensure good soil to seed contact. Move 5-position quick adjustable down force lever on the top of closing wheel arm to the rear to increase closing wheel spring pressure. Move lever forward to decrease pressure. Adjust all row units to a similar setting. Light soil usually requires less down force at average depth (approximately 2" (5 cm)) while heavy soil requires increased down force.

Eccentric bushings in the wheel arm stop allow for lateral adjustment of the “V” closing wheel assembly. Use a ¾" wrench to loosen hardware attaching closing wheel arm to wheel arm stop. Use another ¾" wrench to turn eccentric bushings until **closing wheels are aligned with seed trench**. Tighten hardware.

Closing wheels can be installed “offset” (to improve residue flow) or “directly” opposite. Use forward installation holes if set “directly” opposite.

CLOSING WHEEL SHIELD (RUBBER OR CAST IRON “V” CLOSING WHEELS)

Optional closing wheel shield is installed on underside of closing wheel arm to help prevent root balls and stalks from clogging closing wheels.

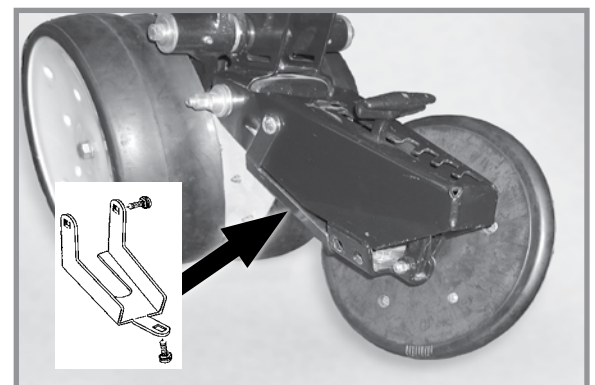

Closing wheel shield (Closing wheel removed)

DRAG CLOSING ATTACHMENT

Drag closing attachment pulls loose soil over seed trench.

NOTE: Use of a seed firming wheel or other seed firming device is recommended with drag closing attachment.

Front and rear adjustment is made using slotted holes in blades. Adjust all rows the same. Wheel arm stop eccentric bushings provide lateral adjustment. Use a 3/4" wrench to loosen closing wheel arm to wheel arm stop hardware. Use another 3/4" wrench to turn eccentric bushings until drag closing attachment is aligned with seed trench. Tighten hardware.

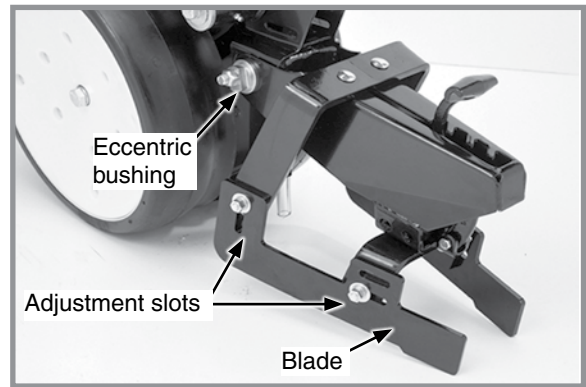

Drag closing attachment

COVERING DISCS/SINGLE PRESS WHEEL ADJUSTMENT

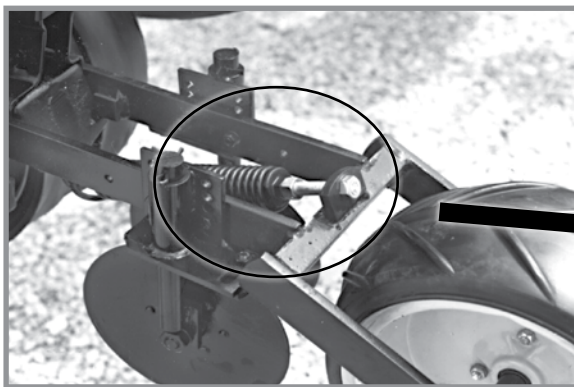

Press wheel down force adjustment

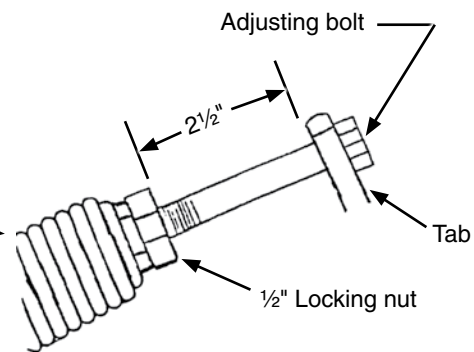

Check operation of covering discs/single press wheels after adjusting planting depth. Initial press wheel down force spring setting is 2 1/2" (6.3 cm) between mounting arm tab and locking nut. Loosen 1/2" locking nut and turn adjusting bolt in to increase down force or out to decrease down force. Tighten locking nut against spring plug. Adjust all row units to a similar setting.

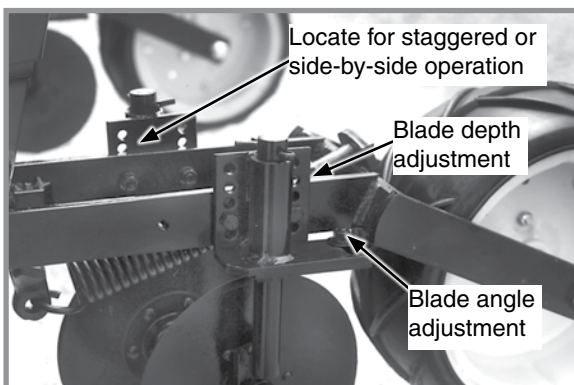

Covering disc adjustments

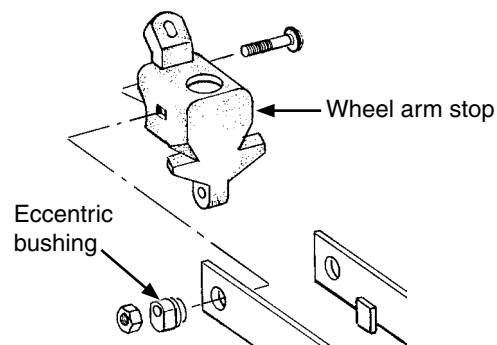

Eccentric bushings in the wheel arm stop allow for lateral adjustment of covering discs/single press wheel assembly. Use a 3/4" wrench to loosen hardware attaching closing wheel arm to wheel arm stop. Use another 3/4" wrench to turn eccentric bushings until covering discs/single press wheel assembly is aligned with seed trench. Tighten hardware. Two sets of holes in mounting arm locate covering discs for staggered or side-by-side operation. Five sets of holes in each disc bracket allow 1/2" (1.27 cm) incremental blade depth adjustment. Slotted holes in disc mount and bracket allow for 0° - 15° blade angle adjustment. Adjust covering discs on all row units to similar settings.

SEED HOPPERS

Mechanical seed hopper has a capacity of 1.9 bushels (67 liters).

Vacuum seed hopper has a capacity of 1.75 bushels (62 liters).

Use clean seed and make certain there are no foreign objects inside when filling seed hopper. **Replace hopper lids after hoppers are filled to prevent accumulation of dust or dirt in seed meter which can cause premature wear.** See "Finger Pickup Seed Meter" and/or "Brush-Type Seed Meter".

Periodically empty hoppers completely to remove any foreign objects and to ensure proper seed meter operation.

Disengage meter drive and hopper latch and lift hopper off hopper support. See "Seed Meter Drive Release".

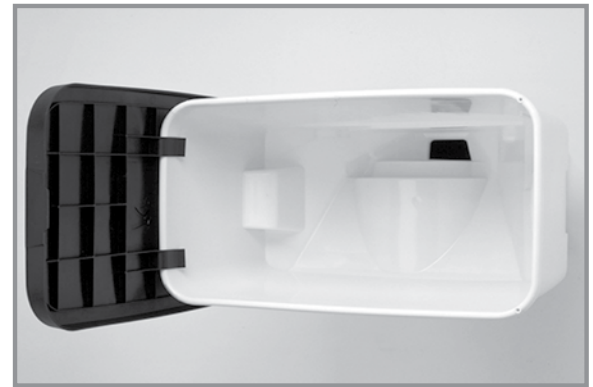

Mechanical seed hopper

SEED METER DRIVE RELEASE

A clutch release mechanism disengages seed meter drive from seed meter to remove seed hopper. Disconnecting drive allows operator to check granular chemical application rates without dropping seed. It also allows one or more rows to be disconnected when finishing fields.

Turn knob $\frac{1}{4}$ turn counterclockwise to disengage or $\frac{1}{4}$ turn clockwise to engage.

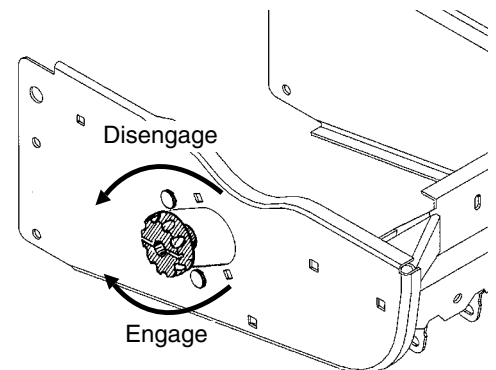

Seed meter drive release

ROW UNIT EXTENSION BRACKETS

Row unit extension brackets extend row units rearward 4" to provide clearance for coulter mounted residue wheels and HD single disc fertilizer openers.

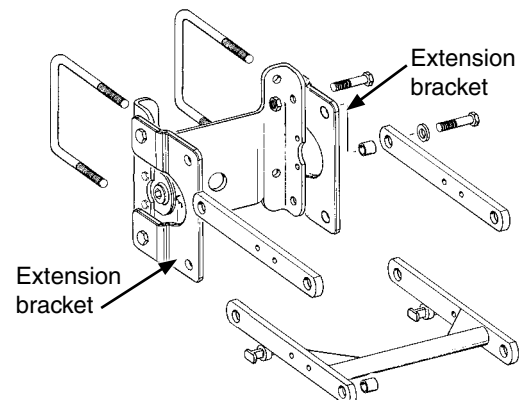

Row unit extension brackets

ROW UNIT CHAIN ROUTING

Row unit drive chains must be properly tensioned and aligned for proper operation and to minimize wear.

Inspect and replace weak, worn or broken springs, idlers, and idler bushings.

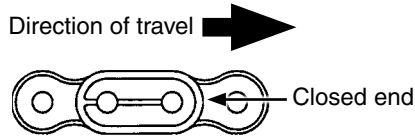

NOTE: Install connector link with closed end facing direction of travel.

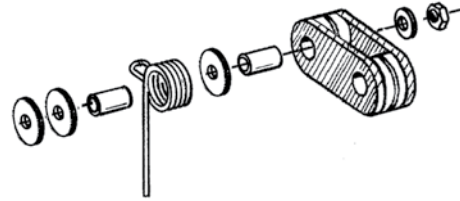

NOTE: Reverse idler when worn on one side for extended use.

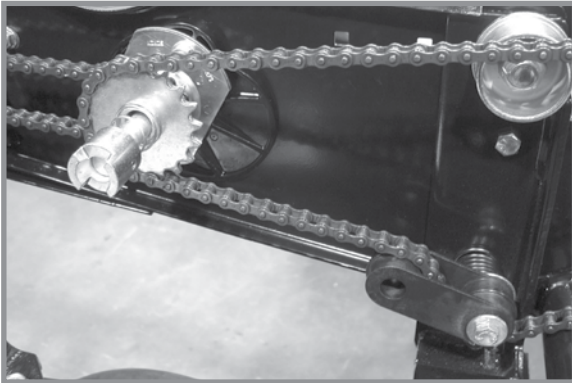

Mechanical Pull Row Unit Meter Drive

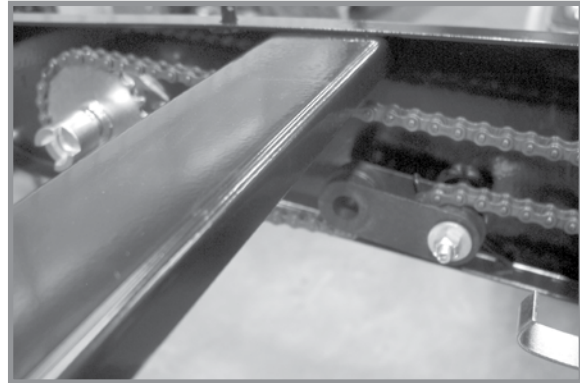

Row Unit Granular Chemical Drive

QUICK ADJUSTABLE DOWN FORCE SPRINGS OPTION (STANDARD OR HEAVY DUTY)

Standard and heavy duty quick adjustable down force springs are available in increase penetration in hard soil and keep row unit from bouncing in rough field conditions. Two springs per row, one on each side parallel arms, are used unless equipped with row unit mounted no till coulters. Row unit mounted no till coulters require four springs per row.

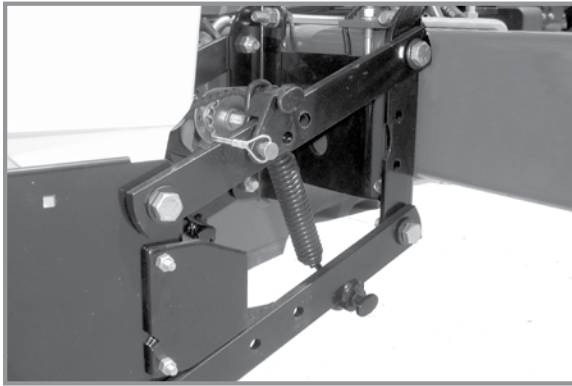

Two springs per row (Dual)

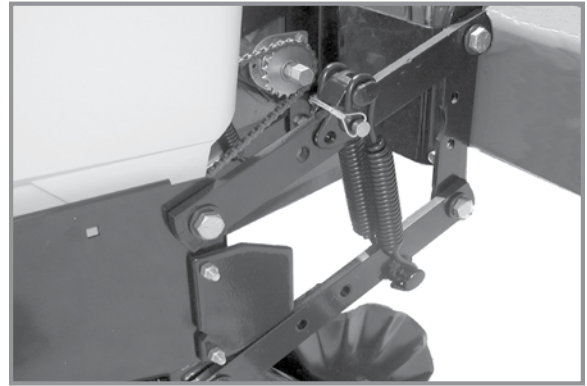

Four springs per row (Quad)

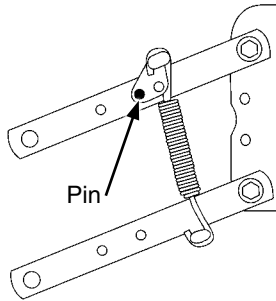

Position 1 (Least)

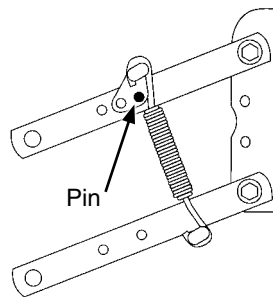

Position 2

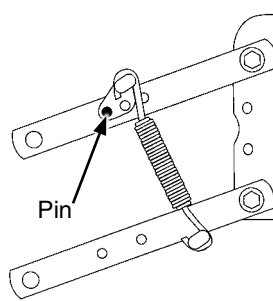

Position 3

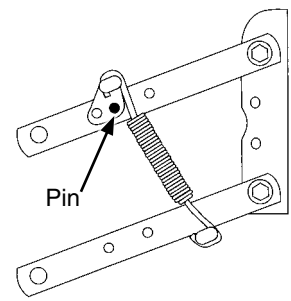

Position 4 (Most)

There are four positions to set down pressure spring tension.

Standard and Heavy Duty Spring Down Force Pressure*				
Position	2 Springs		4 Springs	
	Standard D8249	Heavy Duty D21337	Standard D8249	Heavy Duty D21337
1	41lb (18.6 kg)	43 lb (19.5 kg)	74 lb (33.6 kg)	80 lb (36.3 kg)
2	73 lb (33.1 kg)	86 lb (39.0 kg)	120 lb (54.4 kg)	144 lb (65.3 kg)
3	136 lb (61.7 kg)	167 lb (75.7 kg)	255 lb (115.7 kg)	307 lb (139.3 kg)
4	207 lb (93.9 kg)	249 lb (113.0 kg)	369 lb (167.4 kg)	470 lb (213.2 kg)











*Pressure does not include weight of row unit, seed, or options.

NOTICE	Springs must be installed with open side of spring hooks toward seed hoppers to prevent binding on spring mount adjustment pins.
---------------	---

1. Raise planter and remove spring mount pin at top of spring.
2. Slide mount to desired position and install pin.

NOTE: Adjust springs for field conditions. Too much down pressure in hard field conditions can cause row units to lift planter and keep drive wheels from making contact. Too much down pressure in soft field conditions can cause row unit to run too deep.

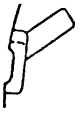





BRUSH-TYPE SEED METER

	Crop	Disc Color-Code (Disc Part No.)	Upper Brush Retainer	Cells	Seed Size Range	*Lubricant
	Soybean	Black (GA5794)	GD11122	60	2200 to 4000 seeds/lb. (4840 to 8800 seeds/kg)	Graphite Talc
	Specialty Soybean	Dark Blue (GA6184)	GD11122	48	1400 to 2200 seeds/lb. (3080 to 4840 seeds/kg)	Graphite Talc
	Small Milo/Grain Sorghum	Red (GA5982)	GD8237	30	14,000 to 20,000 seeds/lb. (30800 to 44000 seeds/kg)	Talc
	Large Milo Grain Sorghum	Light Blue (GA6187)	GD8237	30	10,000 to 16,000 seeds/lb. (22000 to 35200 seeds/kg)	Talc
	High-Rate Small Milo/Grain Sorghum	Red (GA5795)	GD8237	60	12,000 to 18,000 seeds/lb. (26400 to 39600 seeds/kg)	Talc
	High-Rate Large Milo/Grain Sorghum	Yellow (GA6633)	GD8237	60	10,000 to 14,000 seeds/lb. (22000 to 30800 seeds/kg)	Talc
	Cotton, Acid-Delinted	White (GA5796)	GD11122	30	4200 to 5200 seeds/lb. (9240 to 11440 seeds/kg)	Talc
	Large Cotton, Acid Delinted	Tan (GA6168)	GD11122	36	3800 to 4400 seeds/lb. (8360 to 9680 seeds/kg)	Talc
	High-Rate Cotton, Acid-Delinted	Light Green (GA6478)	GD11122	48	4200 to 5200 seeds/lb. (9240 to 11440 seeds/kg)	Talc
	Hill-Drop Cotton, Acid-Delinted	Brown (GA6182)	GD11122	12 (3 to 6 seeds/ cell)	4000 to 5200 seeds/lb. (8800 to 11440 seeds/kg)	Talc
	Small Hill-Drop Cotton, Acid-Delinted	Dark Green (GA7255)	GD11122	12 (3 to 6 seeds/ cell)	5000 to 6200 seeds/lb. (11000 to 13640 seeds/kg)	Talc

*For More information on application rate see Additives section.

	<p>Use GD11122 upper brush retainer when using cotton and soybean discs.</p>		<p>Use GD8237 upper brush retainer when using milo/grain sorghum discs.</p>
---	--	---	---

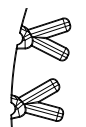
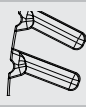
BRUSH-TYPE SEED METER 2.0

Crop		Disc Color-Code (Disc Part No.)	Upper Brush Retainer	Cells	Seed Size Range	*Lubricant
	Soybean	Black (GB1123)	GB1084	60	2200 to 4000 seeds/lb.	Graphite Talc
	Soybean	Dark Gray (GB1171)	GB1084	54	2000 to 3000 seeds/lb.	Graphite Talc
	Specialty Soybean	Dark Blue (GB1124)	GB1084	48	1400 to 2200 seeds/lb.	Graphite Talc
	Small Milo/Grain Sorghum	Orange (GB1130)	GB1107	30	14,000 to 20,000 seeds/lb.	Talc
	Large Milo Grain Sorghum	Light Blue (GB1131)	GB1107	30	10,000 to 16,000 seeds/lb.	Talc
	High-Rate Small Milo/Grain Sorghum	Red (GB1132)	GB1107	60	12,000 to 18,000 seeds/lb.	Talc
	High-Rate Large Milo/Grain Sorghum	Yellow (GB1133)	GD8237	60	10,000 to 14,000 seeds/lb.	Talc
	Wheat	Purple (GB1134)	GB1084	54	N/A Volumetric	Graphite Talc

*For More information on application rate see Additives section.

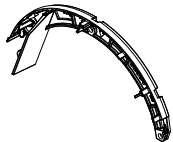

Use GB1084 upper brush retainer when using wheat and soybean discs.



Use GB1107 milo insert when using milo/ grain sorghum discs.

Turn seed disc counterclockwise when installing on meter hub while tightening two wing nuts that retain disc. Seed disc should have slight resistance when rotated counterclockwise after wing nuts are tight.

Brush-type seed meter attaches to seed hopper same as finger pickup seed meter. Secure to bottom of seed hopper with two 5/16" thumbscrews. Tighten thumbscrews slightly with pliers. **DO NOT OVER TIGHTEN.**

Misalignment between drive coupler and seed meter input shaft may cause erratic seed spacing from momentary stoppage of seed disc. Check alignment and adjust as needed.

Refer to planting rate charts in this manual for recommended seed drive transmission sprocket combinations.





Shown without seed disc installed

NOTICE	Replace hopper lids after hoppers are filled to prevent accumulation of dust or dirt in seed meter which will cause premature wear.
---------------	--

NOTE: Clean seed is required to ensure accurate seed metering from brush-type seed meters. Remove seed discs daily and check seed meter or brushes for buildup of foreign material, such as hulls, stems, etc.

FINGER PICKUP SEED METER

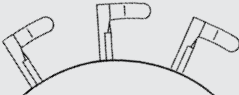
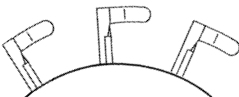
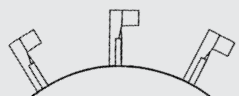









Crop	Fingers	*Lubricant
Corn	 Part No.: GR1848 - Finger Assembly, Corn	Graphite Talc
No. 1 and/or No. 2 size Confectionery Sunflower Seeds	 Part No.: GR1848 - Finger Assembly, Corn	Talc
No. 3 and/or No. 4 size Oil Sunflower Seeds	 Part No.: GR2154 - Finger Assembly, Oil	Talc
Blank fingers replace alternate fingers to reduce planting rate by half while allowing the finger wheel to maintain a minimum of 40 RPM when planting low rates.	 Part No.: GD11787 - Half Rate Blank Finger	Graphite Talc

***For More information on application rate see Additives section.**

NOTE: Always field check seed population to verify planting rates.



NOTE: Refer to planting rate charts in this manual for recommended seed drive transmission sprocket combinations.

VACUUM SETTINGS

Crop		**Seed Disc Kit	Seed Disc Part No.	Ejector Wheel (Color)	Cells	Seed Size Range	Singulator Zone Setting	Vacuum Setting Inches of Water (kPa)	Lubricant
	Corn ‡ Large Sweet Corn	G9040X	B0678 (Light Blue)	1 row 5 punches (Light Blue)	40	35-70 lbs/80k (2500-5000 seeds/kg)	2	18-20 (4.5-5.0)	Graphite* Talc* Bayer Fluency† (if mandated)
	Soybean	G9041X	B0848 (Black)	2 rows 6 punches (Black)	120	2200-4000 seeds/lb (4850-8820 seeds/kg)	0	10-14 (2.5-3.5)	Graphite* Talc* Bayer Fluency† (if mandated)
	Soybean Disc	---	GB1174 (Black)	1 row 6 punches (Green)	60	2200-4000 seeds/lb (4850-8820 seeds/kg)	0	10-14 (2.5-3.5)	Graphite* Talc* Bayer Fluency† (if mandated)
	Sugar Beet	G9043X	B0683 (Dark Orange)	1 row 6 punches (Dark Orange)	60	Pelletized	2	15 (3.75)	Graphite* Talc* Bayer Fluency† (if mandated)
	Milo	G9043X	B0683 (Dark Orange)	1 row 6 punches (Dark Orange)	60	10,000-20,000 seeds/lb (22000-44000 seeds/kg)	2	15 (3.75)	Graphite* Talc* Bayer Fluency† (if mandated)
	Sunflower ‡ Small Sweet Corn	G9042X	B0684 (Gray)	1 row 5 punches (Gray)	40	Oil seeds #2, 3, 4	2	12-18 (3.0-4.5)	Graphite* Talc* Bayer Fluency† (if mandated)
	Sunflower	G9042X	B0684 (Gray)	1 row 5 punches (Gray)	40	Oil seeds #5	2	5-8 (1.25-2.0)	Graphite* Talc* Bayer Fluency† (if mandated)
	Specialty Disc 1	G9272X	B0912 (Green)	1 row 6 punches (Green)	60	Cotton	2	15-20 (3.75-5.0)	Graphite* Talc as needed* Bayer Fluency† (if mandated)

Continued on next page.

VACUUM SETTINGS

Crop	**Seed Disc Kit	Seed Disc Part No.	Ejector Wheel (Color)	Cells	Seed Size Range	Singulator Zone Setting	Vacuum Setting Inches of Water (kPa)	Lubricant
 Specialty Disc 2	G9273X	B0914 (Brown)	1 row 6 punches (Green)	60	Black turtle & navy edible beans	2	15-20 (3.75-5.0)	Graphite* Talc as needed* Bayer Fluency† (if mandated)
 Specialty Disc 3	G9308X	B0913 (Dark Blue)	1 row 6 punches (Green)	60	Pinto & Great Northern edible beans & low-rate soybean	2	15-20 (3.75-5.0)	Graphite* Talc as needed* Bayer Fluency† (if mandated)
 Wheat Disc	G10050X	GB1170 (Purple)	Brush Type	54	N/A Volumetric	0	6-16 (15-41)	Graphite* Talc as needed* Bayer Fluency† (if mandated)

Install selected seed disc. Position vacuum cover on meter by aligning keyhole slots over bolt heads. Push cover on meter and turn counter clockwise to lock in place.

*For More information on application rate, see Additives section.

**Includes seed disc, ejector wheel, and spring.

†Bayer Fluency Agent is only required to be used in place of graphite or talc lubricants on vacuum equipped planters that are sowing neonicotinoid treated seeds in Canada. Refer to the Bayer Fluency Agent section for more information.

‡Conventional hoppers only, not applicable with bulk fill.

NOTE: See ["Check Seed Population" on page 2-26](#) for more information. Always field check seed population to ensure planting rates are correct.

NOTE: Singulator settings are marked from 0 - 3.

NOTE: Mixing seed sizes and shapes affects meter performance. Use consistent seed size and shape.

NOTE: Use 1 tablespoon powdered graphite with each standard hopper fill of seed. Seed treatment, foreign material, dirt or seed chaff may cause gradual reduction of seed disc fill (population). See "Additives" pages for more information.

NOTE: Excessive seed treatment, humidity, and light-weight seed can affect meter performance. Use ½ cup of talc with each standard hopper fill of seed and mix thoroughly to coat all seeds and adjust rates as needed. Use of talc aids seed flow into meter, singulation, and disc seed drop.

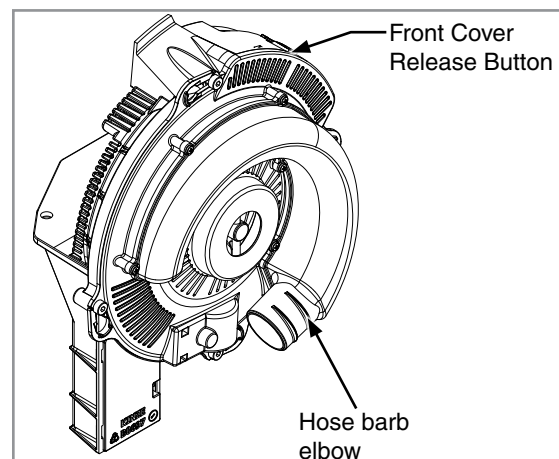
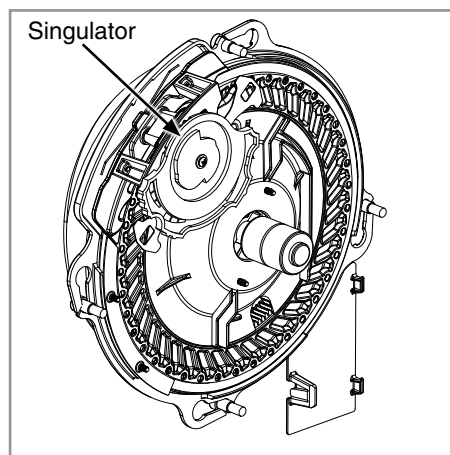

NOTE: Foreign material in seed disc orifices, such as seed chips, hulls, stems, etc., may affect seed delivery. Clean seed ensures accurate seed metering from vacuum seed meter. Remove Seed discs daily to check for buildup of foreign material in seed disc orifices.

Air inlet screens allow air to enter system and aids in keeping field residue or other foreign material out of meter.

See ["Vacuum Seed Meter Maintenance" on page 5-13](#) and ["Preparation for Storage" on page 5-28](#) in Lubrication and Maintenance section for more information.

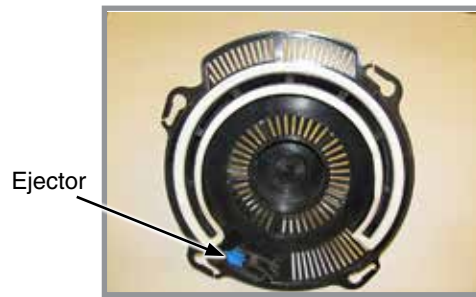

NOTE: Damaged seed or seed containing foreign material will cause plugging of seed disc orifices and require more frequent seed meter cleanout to prevent underplanting.

Wheel-Type Ejectors

Wheel-type ejectors expel seed remnants from seed disc orifices. These ejectors are disc specific and colored coded to match disc.

NOTICE

Replace hopper lids after hoppers are filled to prevent accumulation of dust or dirt in seed meter which will cause premature wear.

NOTE: Seed size, seed shape, seed treatments, travel speed, and planting rate affect meter performance.

1. Select seed disc and ejector to match crop and population.

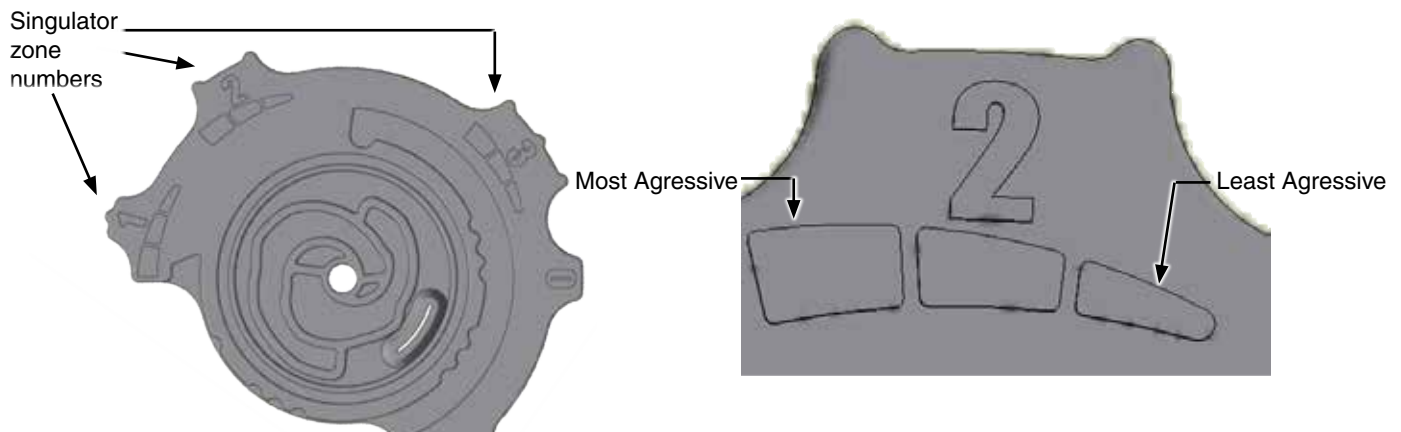

Singulator Adjustment Wheel

2. Adjust singulator wheel to initial setting. Seed size, seed shape, seed treatments, travel speed and planting rate all affect meter performance.
3. With vacuum fan running, lower planter to planting position and drive forward a short distance to load seed into seed disc cells.
4. Adjust vacuum level to initial setting according to tables on page.

NOTE: Vacuum reading will be much lower when seed disc cells are empty. Load all seed cells before setting vacuum level.

NOTE: Operate vacuum fan 3-5 minutes to bring oil up to normal operating temperature prior to making final vacuum level adjustment.

4. Adjust vacuum level to initial setting according to tables on page.

NOTE: Vacuum reading will be much lower when seed disc cells are empty. Load all seed cells before setting vacuum level.

NOTE: Operate vacuum fan 3-5 minutes to bring oil up to normal operating temperature prior to making final vacuum level adjustment.

SEED METER CLEANOUT

NOTE: Use of damaged seed or seed containing foreign material will cause plugging of seed cell orifices and require more frequent seed meter cleanout to prevent underplanting.

Thorough seed meter cleanout is important to maintain genetic purity.

1. Disengage seed drive and remove seed hopper and meter.
2. Dump seed from right rear corner of hopper into a container.
3. Lay hopper on its right side. Push release button and rotate seed meter vacuum cover clockwise to align keyhole slots with bolt heads. Lift off cover.
4. Rotate seed disc hub clockwise to unlock and remove seed disc.
5. Empty meter.
6. Thoroughly inspect meter to ensure all seed is removed.
7. Replace seed disc. Install vacuum cover.

ADDITIVES

Lubricant Application Rate	
Graphite	
Conventional Hoppers	1 Tbs./Hopper Fill
80/20 Talc-Graphite	
Conventional Hoppers	½ C.**
**Must be evenly mixed during fill.	
Talc	
Conventional Hoppers	¼ C.*
*Double amount of talc for sunflowers.	

GRAPHITE

The use of graphite is the primary recommendation to promote seed flow, provide lubrication for the seed meter and to help dissipate static charge buildup. Among the available dry seed lubricants graphite is the most effective and easiest to use and it requires no mechanical agitation

Conventional Hoppers

Mix one tablespoon of **powdered graphite** with seed each time hoppers are filled. Regular graphite use prolongs life of the seed meter components, improves seed spacing, and may reduce buildup of seed treatments.

NOTE: DO NOT apply graphite only in center of hopper. It will filter too quickly through the seed and not distribute as evenly as desired.

Apply graphite around outer perimeter of hopper.



Adding graphite to conventional hopper

NOTE: Additional graphite may be required to retard buildup of seed treatments on meter components. More frequent cleaning of monitor seed tubes may be necessary due to use of additional graphite.

80/20 TALC-GRAPHITE

Talc-Graphite lubricant is to be used for treated seed, providing benefits of both talc and graphite. It absorbs moisture to prevent bridging, minimizes static electricity for improved seed flow, and lubricates seed and meters.

Conventional Hoppers

Mix ½ C. of 80/20 talc-graphite evenly with seed each time hoppers are filled. Regular graphite use prolongs life of the seed meter components, improves seed spacing, and may reduce buildup of seed treatments.

NOTE: Talc-Graphite lubricant MUST be mixed evenly during fill.

TALC

Talc seed lubricant may be used as a drying agent in addition to graphite lubrication. The drying agent may improve seed release and/or **to retard buildup of seed treatments on meter components.**

1. Fill hopper ½ full of seed, add ¼ cup (conventional) of talc and **mix thoroughly.**
2. Finish filling hopper, add another ¼ cup (conventional) of talc and **mix thoroughly.**
3. Adjust rate of talc use as needed so all seeds are coated, while avoiding a buildup of talc in bottom of hopper.

Humid conditions and/or small sized seeds with extra seed treatment may require additional talc to maintain meter performance.

NOTE: Liquid seed treatments or inoculants may create buildup on the seed disc or brushes. Check frequently for proper population and/or seed delivery when using any liquid seed treatment.

Completely mix all treatments with seed following manufacturers' recommendations. Seed treatment dumped on top of seed after hopper is filled may not mix properly and cause seed bridging, reducing population or stopping meter from planting.

BAYER FLUENCY AGENT

Bayer Fluency Agent is an alternate seed lubricant by Bayer Crop Science. The intent of this product is to replace graphite and talc lubricants and to lower the amount of dust emissions from planter vacuum fans.

This product, as tested by Kinze, is compatible with Kinze's bulk fill system and vacuum meters. Due to limited testing, wear life characteristics of meters and bulk fill systems that use Bayer Fluency Agent are not yet known. Please follow Bayer Fluency Agent instructions for rates and mixing directions.

NOTE: Presently, Bayer Fluency Agent is only required to be used in Canada with Bulk Fill or Vacuum planters that plant corn or beans treated with neonicotinoids. Farms outside of Canada, farms not using seed treated with neonicotinoids, and farms not using pneumatic metering devices do not need to use Bayer Fluency Agent. All planters not equipped with vacuums or fans are exempt from using Bayer Fluency Agent.

FRAME MOUNTED COULTER (PULL ROW)

Frame mounted coulters with 1" bubbled, 1" fluted (8 flutes) or 3/4" fluted (13 flutes) blades are used on pull row units only.

Springs provide down pressure on coulters for maximum penetration while exerting less shock load on row unit.

Initial coulters blade location is in top hole. Relocate blade to one of lower two holes (1" increments) as wear occurs or for deeper blade operation.

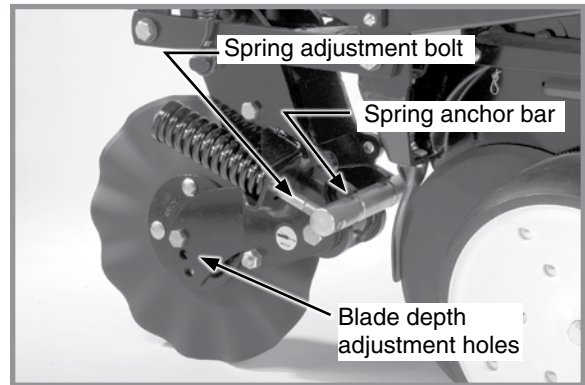

Frame mounted coulter adjustment

DOWN PRESSURE ADJUSTMENT

NOTICE	Excessive down pressure can damage coulter components when coulter strikes an obstacle. Do not set down pressure higher than needed for consistent soil penetration.
---------------	---

Raise planter. Turn spring adjustment bolts clockwise to increase or counterclockwise to decrease down pressure. Set both springs to specification shown in following table:

Frame Mounted Coulter Spring Downpressure Settings		
End flush with spring anchor bar	Extended 1/2" through spring anchor bar	All threads used
275 lb (124.7 kg)	400 lb (181.4 kg)	500 lb (226.8 kg)

RESIDUE WHEELS (FRAME MOUNTED COULTER)

NOTICE	Tined wheel forward mounting positions cannot be used on four rows behind axle due to inadequate clearance.
---------------	--

Residue wheels attach to frame mounted coulters with two cap screws and sleeves allowing the unit to free-float. A 2-position spindle bolt mounting positions wheels interlocked or staggered. Depth adjustment is made with a spring-loaded cam and pin with 11 positions in 1/4" (6 mm) increments. A high point on the cam allows wheels to be locked up.

A weed guard on the inboard side of each wheel helps prevent weed wrap which can cause premature bearing failure.

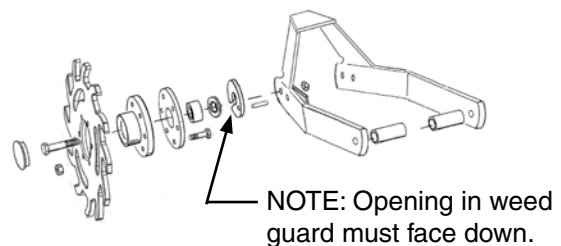

ROW UNIT MOUNTED DISC FURROWER (PULL ROW)

Disc furrowers are used to clear crop residue, dirt clods, and dry soil from in front of row units for a clean and smooth seed bed. The disc furrower may be equipped with 12" solid blades or 12" notched blades. Notched blades are for heavier residue conditions and cut crop residue and move it aside to prevent plugging or pushing.

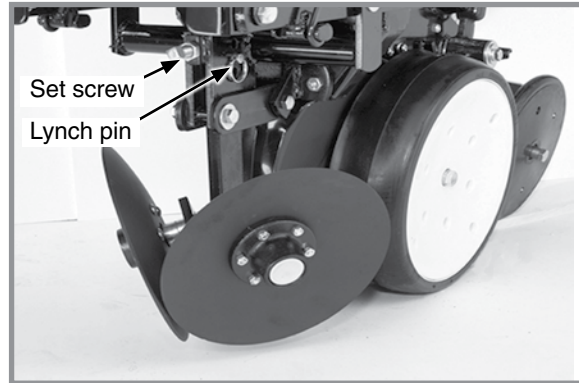
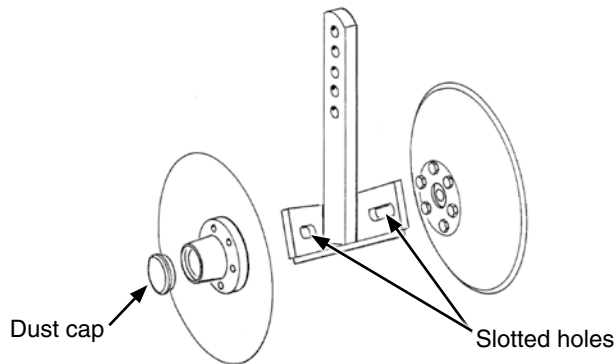

Disc furrower adjustment

Vertical adjustment can be made in $\frac{1}{3}$ " (8 mm) increments. Remove lynch pin in vertical support arm and move arm up or down. Reinstall lynch pin. Finer adjustment can be made by removing lynch pin and using $\frac{5}{8}$ " x $2\frac{1}{4}$ " set screw to clamp support arm in position. Slotted holes in support arm allow front to rear disc blade adjustment. Blades can be adjusted so front edges meet or cutting edge of one blade overlaps edge of other blade.

NOTE: Dust cap must be removed to make adjustments.

ROW UNIT MOUNTED BED LEVELER (PULL ROW)

NOTE: Row unit mounted bed leveler is not compatible with row spacings less than 36".

Vertical adjustment can be made in $\frac{1}{3}$ " (8 mm) increments. Remove lynch pin in vertical support arm and move arm up or down. Reinstall lynch pin. Finer adjustment can be made by removing lynch pin and using $\frac{5}{8}$ " x $2\frac{1}{4}$ " set screw to clamp support arm in position.

Slotted holes in support arm allow blade adjustment. Blades can be tilted up or down.

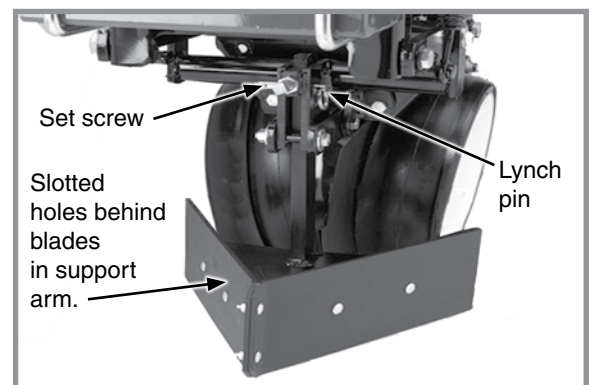

Bed leveler adjustment

ROW UNIT MOUNTED RESIDUE WHEEL

Row unit mounted residue wheels are used on pull and push row units.

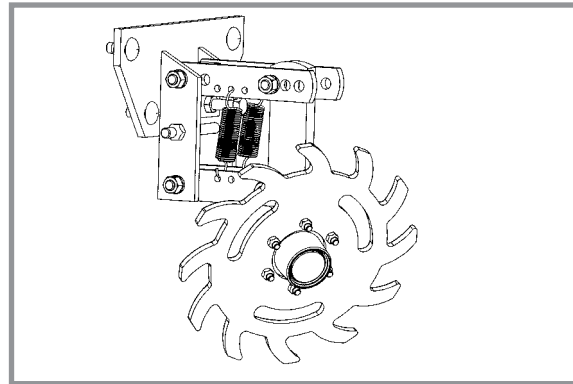

Row Unit Mounted Residue Wheel

Two adjustable springs on each residue wheel parallel links provide down force adjustment. Position 1 provides minimum down pressure and position 3 maximum down pressure.

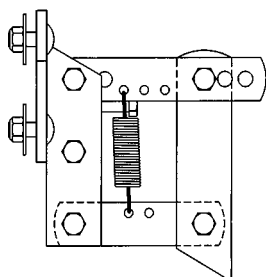

Position 1 (Least)

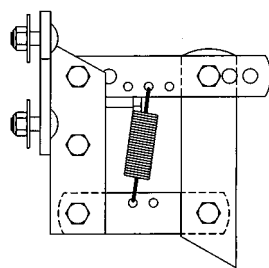

Position 2

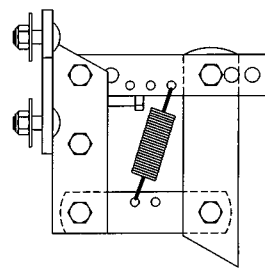

Position 3 (Most)

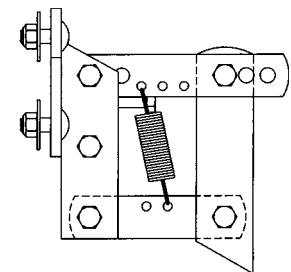

Additional uplift or float

Raise row unit and reposition springs to adjust down pressure.

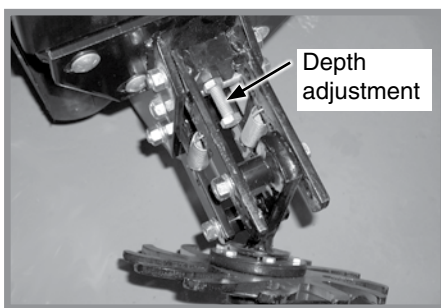

Wheel depth adjustment

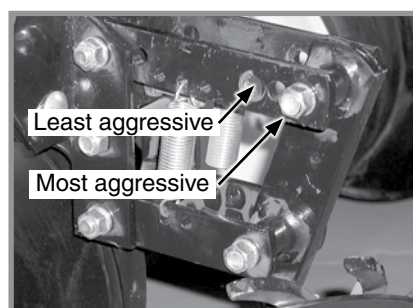

Wheel angle adjustment

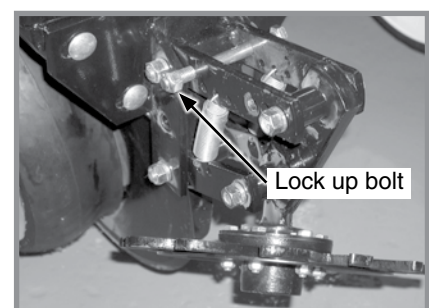

Wheel lock up

A full threaded bolt and jam nut located on the upper link sets maximum depth for loose soil conditions. Initial setting is 1 3/4" (4 cm) above row unit double disc opener depth.

Three holes in upper link adjust wheel angle. With wheel mount in most vertical position, using the rear hole in the upper link, the residue wheel is most aggressive. Moving wheel mount to a forward hole reduces aggressiveness of residue wheel for use in mulch till applications where soil is loose.

To lock residue wheel up, remove 1/2" x 5" lockup bolt, raise residue wheel and install bolt.

ROW UNIT MOUNTED NO TILL COULTER

Row unit mounted no till coulters with 1" bubbled, 1" fluted (8 flutes) or 3/4" fluted (13 flutes) blades may be used on pull row units and push row units (3/4" fluted shown). Four quick adjustable down force springs are required per row when using row unit mounted no till coulters. See "Quick Adjustable Down Force Springs Options".

Align coulters to row unit double disc openers. Adjust by loosening four attaching bolts, moving coulters, and tightening four attaching bolts. Coulters can be adjusted to one of four 1/2" (13 mm) incremental settings in the forked arm. Initial location is the top hole.

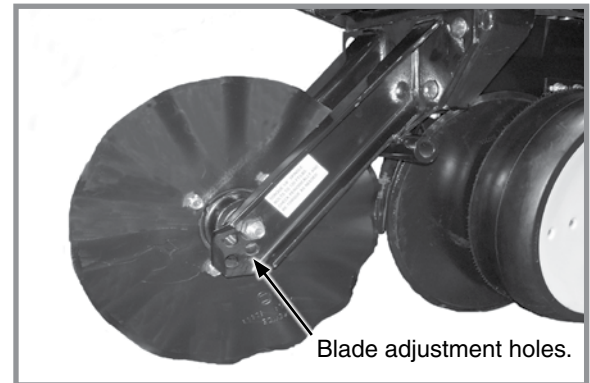

Row Unit Mounted No Till Coulters

Move blade as it wears to one of the three lower holes to maintain coulters at or slightly above opener discs as needed. Adjust coulters below depth of double disc opener blades in very hard soil conditions such as compacted wheel tracks to improve opener penetration and cutting of surface residue.

Check operating depth by setting planter down on a level concrete floor and checking relationship between coulters and row unit opener blades. Make sure planter is level and coulters are square with planter frame and aligned with row unit disc opener.

NOTE: Torque 5/8" spindle hardware to 120 ft-lb (162.7 N-m).

COULTER MOUNTED RESIDUE WHEELS

Coulters mounted residue wheels are designed for use on pull row units and push row units. Row unit extension brackets are required on the four center pull row units if the planter is equipped with coulters mounted residue wheels.

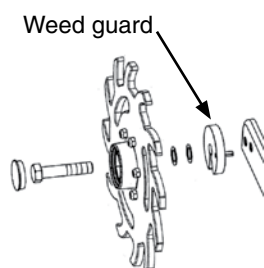

NOTE: Opening in weed guard must face down.



Coulters mounted residue wheels

Residue wheels attach to row unit mounted coulters with two cap screws and sleeves allowing unit to free-float. A 2-position spindle bolt mounting positions wheels interlocked or staggered. Depth adjustment is made with a spring-loaded cam and pin with 11 positions in 1/4" (6 mm) increments. A high point on the cam allows wheels to be locked up.

A weed guard on the inboard side of each wheel helps prevent weed wrap which can cause premature bearing failure.

SPIKED CLOSING WHEEL

Spiked closing wheels crumble the sidewall, allowing roots to penetrate soil. They can be used on pull row units and push row units.

Align spiked closing wheels straight across from each other, in most rearward holes on closing wheel arm. Set the wheels 1" - 1¼" apart at the closet point. If large amounts of contouring is being done, mount wheels in the forward most hole. This will reduce drifting of row unit.

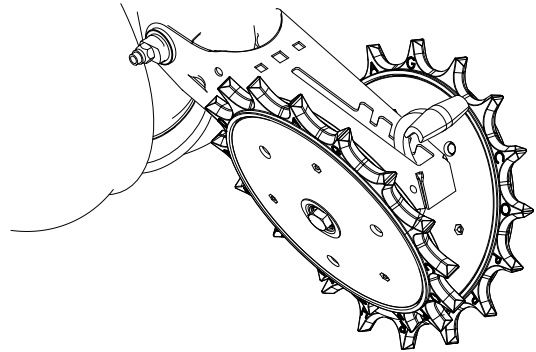

Row Unit Spiked Closing Wheel

GRANULAR CHEMICAL HOPPER AND DRIVE



WARNING



Agricultural chemicals can cause death or serious injury to persons, animals, and plants or seriously damage soil, equipment, or property. Read and follow all chemical and equipment manufacturers labels and instructions.

The granular chemical hopper has a 1.4 cubic feet capacity.

Make sure no foreign objects get into hopper when it is being filled. Replace hopper lids after filling to prevent accumulation of dirt and moisture.

A metering gate on bottom of hopper regulates the application rate. See “Dry Insecticide and Dry Herbicide Application Rate Charts” in this manual. Calibrate using chemical manufacturers’ instructions.



Granular chemical hopper

Granular chemical clutch drive coupler and meter shaft can be disengaged and engaged by turning throwout knob at rear of hopper support panel.

Rotate knob ¼ turn counterclockwise to disengage and ¼ turn clockwise to engage.

Slotted holes in hopper support panel and clutch housing allow for alignment adjustment between clutch drive coupler and meter shaft.

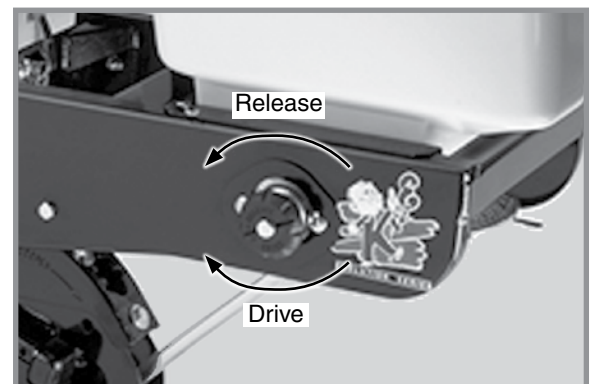

Granular chemical drive release

SPRING TOOTH INCORPORATOR

Spring tooth incorporator smooths soil behind row unit and incorporates granular chemicals.

Adjust two mounting chains on each spring tooth incorporator so there is approximately ⅛" (3 mm) slack in chain when unit is lowered to planting position.

NOTE: Spring tooth incorporator is not compatible with covering discs/single press wheel option.

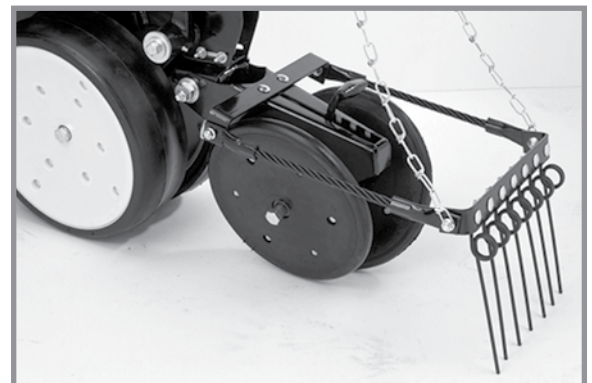

Spring tooth incorporator

GRANULAR CHEMICAL BANDING OPTIONS

Granular chemical banding options allow 4½" slope-compensating banding, straight drop in-furrow placement or 14" rear banding.

NOTE: Granular chemical rear bander is not compatible with covering discs/single press wheel option.

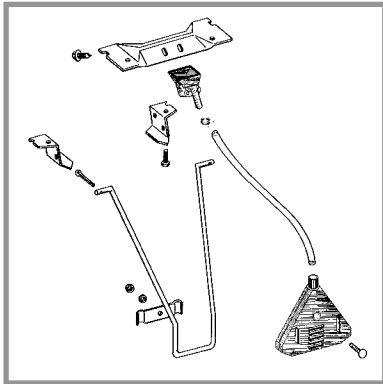

14" rear banding

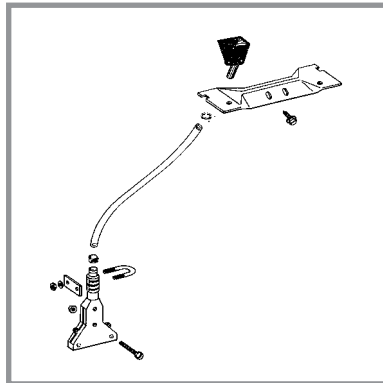

4½" slope-compensating bander

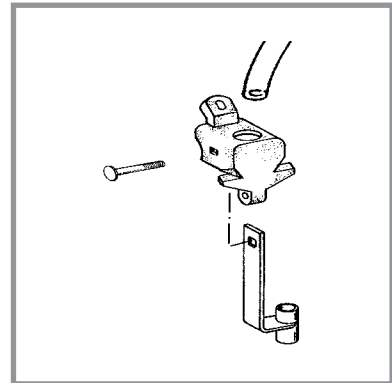

Straight drop in-furrow placement

GRANULAR CHEMICAL BANDER SHIELD

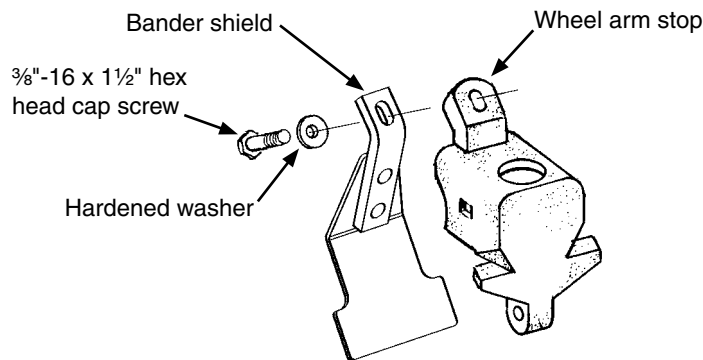

Optional granular chemical bander shield is installed on underside of wheel arm stop to shield crop residue from lodging in granular chemical bander.

GENERAL PLANTING RATE INFORMATION

These planting rate charts apply to Kinze Model 3140 planters.

NOTICE

Sprocket combinations in these charts are for average conditions. Changes in sprocket combinations may be required for desired planting population. **ALWAYS MAKE FIELD CHECKS TO BE SURE YOU ARE PLANTING AT THE DESIRED RATE.**

NOTICE

Seed additives added in the hopper may affect finger pickup seed meter performance and accelerate wear.

NOTE: Seed size and shape may affect planting rate.

NOTE: Not all row spacings listed apply to all size planters.

NOTE: Speeds above 6.0 MPH (10 KPH) can adversely affect seed spacing.

MECHANICAL

Finger Pickup Corn Meter

Larger grades generally plant more accurately at the high end of the ground speed range than smaller grades. Higher than optimum speeds may result in population rate increase or higher incidence of doubles, particularly with small seed. Medium round corn seed is most desirable for planting accuracy at optimum speed.

Finger Pickup Oil Sunflower Meter

Larger grades generally plant more accurately at the high end of the ground speed range than smaller grades. Higher than optimum speeds may result in population rate increase or higher incidence of doubles, particularly with small seed. No. 3 and/or No. 4 size oil sunflower seeds are recommended for use in finger pickup seed meters equipped with oil sunflower fingers. No. 1 and/or No. 2 size confectionery sunflower seeds are recommended for use in finger pickup seed meters equipped with corn fingers.

Brush-Type Seed Meter (Soybean, Milo/Grain Sorghum, Acid-Delinted Cotton)

Rate charts are given in seeds per acre as well as seed spacing in inches rounded to nearest tenth of an inch. Because of large range in seed size, pounds per acre is not a suggested method of selecting transmission settings. Smaller size seed pounds per acre may be below what was expected and large seed pounds per acre may appear above expectations. To determine pounds per acre, use formula given in "Determining Pounds Per Acre (Brush-Type Seed Meter)" in "Check Seed Population" in Machine Operation section of this manual.

NOTE: Planting speed can affect actual seeding rate. Make a field check and adjust transmission setting to obtain desired seed drop.

NOTE: Seed population per acre with 15" rows double rate for 30" rows, as well as 18" rows versus 36" rows and 19" rows versus 38" rows, at listed sprocket combination. See following pages.

NOTE: Half Rate (2 to 1) Drive Reduction Package may be required to obtain desired population and seed spacing when planting 15" row soybeans or other crops. Half Rate Drive with brush-type seed meters reduces planter transmission speed. Seeding rate will be approximately 50% of chart reading when using Half Rate (2 To 1) Drive Reduction Package.

**EXAMPLE: 30" row spacing using 60 cell seed discs in brush-type seed meters.
 $80,928 \div 2 = 40,464$ Population (2.6" Seed Spacing x 2 = 5.2" Seed Spacing)**

VACUUM

NOTE: Contact wheel drive sprocket references are located in each rate chart title.

NOTE: 15, 19, and 30 tooth drive sprockets are NOT applicable to all rate charts. Check chart titles to ensure proper rate chart is selected. 15 tooth sprocket requires 218 pitch No. 40 chain. 19 tooth sprocket requires 218 pitch No. 40 chain. 30 tooth sprocket requires 224 pitch No. 40 chain.

NOTE: DO NOT USE 44 tooth sprockets (60 cell soybean discs) with Liquid Fertilizer Package.

**PLANTING RATES FOR FINGER PICKUP SEED METERS (STANDARD DRIVE)
APPROXIMATE SEEDS/ACRE FOR VARIOUS ROW WIDTHS**

30" Rows	36" Rows	38" Rows	40" Rows	Transmission Sprocket		Recomm. Speed Range (MPH)	Average Seed Spacing in Inches
				Drive	Driven		
16,186	13,488	12,778	12,139	17	28	4 to 6	12.9
16,785	13,988	13,251	12,589	17	27	4 to 6	12.5
17,431	14,526	13,761	13,073	17	26	4 to 6	12.0
18,090	15,075	14,281	13,567	19	28	4 to 6	11.6
18,128	15,107	14,312	13,596	17	25	4 to 6	11.5
18,760	15,633	14,810	14,070	19	27	4 to 6	11.1
18,883	15,736	14,908	14,162	17	24	4 to 6	11.1
19,481	16,234	15,380	14,611	19	26	4 to 6	10.7
19,704	16,420	15,556	14,778	17	23	4 to 6	10.6
20,261	16,884	15,995	15,195	19	25	4 to 6	10.3
21,104	17,587	16,662	15,829	19	24	4 to 6	9.9
21,898	18,249	17,288	16,424	23	28	4 to 6	9.5
22,022	18,352	17,386	16,517	19	23	4 to 6	9.5
22,709	18,924	17,928	17,032	23	27	4 to 6	9.2
22,850	19,042	18,040	17,138	24	28	4 to 6	9.2
23,583	19,652	18,618	17,687	23	26	4 to 6	8.9
23,697	19,747	18,708	17,772	24	27	4 to 6	8.8
23,802	19,835	18,791	17,852	25	28	4 to 6	8.8
23,853	19,877	18,831	17,889	17	19	4 to 6	8.8
24,526	20,438	19,363	18,395	23	25	4 to 6	8.5
24,608	20,507	19,427	18,456	24	26	4 to 6	8.5
24,684	20,570	19,487	18,513	25	27	4 to 6	8.5
24,755	20,629	19,543	18,566	26	28	4 to 6	8.4
25,548	21,290	20,169	19,161	23	24	4 to 6	8.2
25,592	21,327	20,205	19,194	24	25	4 to 6	8.2
25,633	21,361	20,237	19,225	25	26	4 to 6	8.2
25,671	21,393	20,267	19,254	26	27	4 to 6	8.1
25,707	21,422	20,295	19,280	27	28	4 to 6	8.1
26,659	22,216	21,046	19,994	23	23	4 to 6	7.8
27,646	23,038	21,826	20,735	28	27	4 to 6	7.6
27,684	23,070	21,856	20,763	27	26	4 to 6	7.6
27,770	23,141	21,923	20,827	25	24	4 to 6	7.5
27,818	23,181	21,961	20,863	24	23	4 to 6	7.5
28,709	23,924	22,665	21,532	28	26	4 to 6	7.3
28,791	23,993	22,730	21,594	27	25	4 to 6	7.3
28,977	24,147	22,876	21,733	25	23	4 to 6	7.2
29,795	24,829	23,522	22,346	19	17	4 to 6	7.0
29,858	24,881	23,572	22,393	28	25	4 to 6	7.0
29,991	24,993	23,677	22,493	27	24	4 to 6	7.0
30,136	25,113	23,792	22,602	26	23	4 to 6	7.0
31,102	25,918	24,554	23,326	28	24	3 to 6	6.7
31,295	26,079	24,707	23,471	27	23	3 to 6	6.7
32,271	26,893	25,477	24,203	23	19	3 to 5.5	6.5
32,454	27,045	25,622	24,341	28	23	3 to 5.5	6.5
33,674	28,062	26,585	25,256	24	19	3 to 5.5	6.2
35,077	29,231	27,693	26,308	25	19	3 to 5	6.0
36,068	30,056	28,474	27,051	23	17	2 to 5	5.8
36,480	30,400	28,800	27,360	26	19	3 to 5	5.7
37,636	31,363	29,713	28,227	24	17	3 to 5	5.6
37,883	31,570	29,908	28,413	27	19	3 to 5	5.5
39,204	32,670	30,951	29,403	25	17	3 to 4.5	5.3
39,287	32,739	31,016	29,465	28	19	3 to 4.5	5.3
40,772	33,977	32,189	30,579	26	17	3 to 4.5	5.1
42,340	35,284	33,427	31,755	27	17	3 to 4.5	4.9
43,908	36,590	34,665	32,931	28	17	3 to 4.5	4.8

NOTE: See "General Planting Rate Information" and "Checking Seed Population" pages for additional information. Always check seed population in the field to ensure planting rates are correct.

**PLANTING RATES FOR BRUSH-TYPE SEED METERS (STANDARD DRIVE)
APPROXIMATE SEEDS/ACRE FOR VARIOUS ROW WIDTHS**

Transmission Sprockets		60 Cell Soybean or High-Rate Milo/Grain Sorghum				Average Seed Spacing in Inches	48 Cell Specialty Soybean or High-Rate Acid-Delinted Cotton				Average Seed Spacing in Inches	Speed Range (MPH)
Drive	Driven	30" Rows	36" Rows	38" Rows	40" Rows		30" Rows	36" Rows	38" Rows	40" Rows		
17	28	80,928	67,440	63,891	60,696	2.6	64,742	53,952	51,113	48,557	3.2	2 to 8
17	27	83,926	69,938	66,257	62,944	2.5	67,141	55,950	53,006	50,355	3.1	2 to 8
17	26	87,154	72,628	68,805	65,365	2.4	69,723	58,102	55,044	52,292	3.0	2 to 8
19	28	90,449	75,374	71,407	67,837	2.3	72,359	60,299	57,126	54,270	2.9	2 to 8
19	27	93,799	78,166	74,052	70,349	2.2	75,039	62,533	59,242	56,279	2.8	2 to 8
17	24	94,416	78,680	74,539	70,812	2.2	75,533	62,944	59,631	56,650	2.8	2 to 8
17	23	98,521	82,101	77,780	73,891	2.1	78,817	65,681	62,224	59,113	2.7	2 to 8
19	25	101,303	84,419	79,976	75,977	2.1	81,042	67,535	63,981	60,782	2.6	2 to 8
19	24	105,524	87,937	83,309	79,143	2.0	84,419	70,350	66,647	63,314	2.5	2 to 8
23	28	109,491	91,243	86,440	82,118	1.9	87,593	72,994	69,152	65,694	2.4	2 to 8
19	23	110,112	91,760	86,931	82,584	1.9	88,090	73,408	69,545	66,067	2.4	2 to 8
24	28	114,252	95,210	90,199	85,689	1.8	91,402	76,168	72,159	68,551	2.3	2 to 8
24	27	118,483	98,736	93,539	88,862	1.8	94,786	78,989	74,831	71,090	2.2	2 to 8
17	19	119,263	99,386	94,155	89,447	1.8	95,410	79,509	75,324	71,558	2.2	2 to 8
24	26	123,040	102,534	97,137	92,280	1.7	98,432	82,027	77,710	73,824	2.1	2 to 8
26	28	123,773	103,144	97,715	92,829	1.7	99,018	82,515	78,172	74,263	2.1	2 to 8
24	25	127,962	106,635	101,023	95,971	1.6	102,370	85,308	80,818	76,777	2.0	2 to 8
26	27	128,357	106,964	101,334	96,268	1.6	102,686	85,571	81,067	77,014	2.0	2 to 8
23	23	133,294	111,078	105,232	99,970	1.6	106,635	88,862	84,186	79,976	2.0	2 to 8
27	26	138,420	115,350	109,279	103,815	1.5	110,736	92,280	87,423	83,052	1.9	2 to 8
24	23	139,089	115,907	109,807	104,317	1.5	111,271	92,726	87,846	83,454	1.9	2 to 8
25	23	144,884	120,737	114,382	108,663	1.4	115,907	96,590	91,506	86,930	1.8	2 to 8
19	17	148,975	124,146	117,612	111,731	1.4	119,180	99,317	94,090	89,385	1.8	2 to 8
27	24	149,955	124,963	118,386	112,466	1.4	119,964	99,970	94,709	89,973	1.7	2 to 8
28	24	155,509	129,591	122,770	116,632	1.3	124,407	103,673	98,216	93,306	1.7	2 to 8
23	19	161,355	134,463	127,386	121,017	1.3	129,084	107,570	101,909	96,814	1.6	2 to 8
28	23	162,270	135,225	128,108	121,703	1.3	129,816	108,180	102,483	97,362	1.6	2 to 8
24	19	168,371	140,309	132,924	126,278	1.2	134,696	112,247	106,339	101,022	1.6	2 to 8
25	19	175,386	146,155	138,463	131,540	1.2	140,309	116,924	110,770	105,232	1.5	2 to 8
23	17	180,338	150,282	142,372	135,254	1.2	144,270	120,226	113,898	108,203	1.5	2 to 8
26	19	182,402	152,001	144,001	136,801	1.1	145,922	121,601	115,201	109,441	1.4	2 to 7
27	19	189,417	157,848	148,540	142,063	1.1	151,534	126,278	118,832	113,650	1.4	2 to 7
28	19	196,433	163,694	155,078	147,325	1.1	157,146	130,955	124,062	117,860	1.3	2 to 7
26	17	203,861	169,884	160,943	152,896	1.0	163,089	135,907	128,754	122,317	1.3	2 to 7
27	17	211,702	176,418	167,133	158,776	0.9	169,362	141,134	133,706	127,021	1.2	2 to 7
28	17	219,542	182,952	173,323	164,657	0.9	175,634	146,362	138,658	131,726	1.2	2 to 7

NOTE: See "General Planting Rate Information" and "Checking Seed Population" pages for additional information.

NOTE: When using the Half Rate (2 to 1) Drive Reduction Package, rates will be approximately 50% of given numbers.

NOTE: Always check seed population in the field to ensure planting rates are correct.

**PLANTING RATES FOR BRUSH-TYPE SEED METERS (STANDARD DRIVE)
APPROXIMATE SEEDS/ACRE FOR VARIOUS ROW WIDTHS**

Transmission Sprockets		36 Cell Acid-Delinted Large Cotton				Average Seed Spacing In Inches	30 Cell Milo/Grain Sorghum Or Acid-Delinted Cotton				Average Seed Spacing In Inches	Speed Range (MPH)
Drive	Driven	30" Rows	36" Rows	38" Rows	40" Rows		30" Rows	36" Rows	38" Rows	40" Rows		
17	28	48,557	40,464	38,335	36,418	4.3	40,464	33,720	31,945	30,348	5.2	2 to 8
17	27	50,356	41,963	39,754	37,766	4.2	41,963	34,969	33,129	31,472	5.0	2 to 8
17	26	52,292	43,577	41,283	39,219	4.0	43,577	36,314	34,403	32,683	4.8	2 to 8
19	28	54,269	45,224	42,844	40,702	3.9	45,225	37,687	35,704	33,918	4.6	2 to 8
19	27	56,279	46,900	44,431	42,209	3.7	46,900	39,083	37,026	35,175	4.5	2 to 8
17	24	56,650	47,208	44,723	42,487	3.7	47,208	39,340	37,270	35,406	4.4	2 to 8
17	23	59,113	49,261	46,668	44,335	3.5	49,261	41,051	38,890	36,946	4.2	2 to 8
19	25	60,782	50,651	47,986	45,586	3.5	50,652	42,210	39,988	37,989	4.1	2 to 8
19	24	63,314	52,762	49,985	47,486	3.3	52,762	43,968	41,654	39,572	4.0	2 to 8
23	28	65,695	54,746	51,864	49,271	3.2	54,746	45,621	43,220	41,059	3.8	2 to 8
19	23	66,067	55,056	52,159	49,550	3.2	55,056	45,880	43,465	41,292	3.8	2 to 8
24	28	68,551	57,126	54,119	51,413	3.0	57,126	47,605	45,099	42,844	3.7	2 to 8
24	27	71,090	59,242	56,123	53,317	2.9	59,242	49,368	46,770	44,431	3.5	2 to 8
17	19	71,558	59,632	56,493	53,668	2.9	59,631	49,693	47,077	44,724	3.5	2 to 8
24	26	73,824	61,520	58,282	55,368	2.8	61,520	51,267	48,569	46,140	3.4	2 to 8
26	28	74,264	61,886	58,629	55,697	2.8	61,886	51,572	48,858	46,415	3.4	2 to 8
24	25	76,772	63,981	60,614	57,583	2.7	63,981	53,317	50,511	47,986	3.3	2 to 8
26	27	77,014	64,178	60,800	57,761	2.7	64,178	53,482	50,667	48,134	3.3	2 to 8
23	23	79,976	66,647	63,139	59,982	2.6	66,647	55,539	52,616	49,985	3.1	2 to 8
27	26	83,052	69,210	65,567	62,289	2.5	69,210	57,675	54,640	51,908	3.0	2 to 8
24	23	83,453	69,544	65,884	62,590	2.5	69,544	57,954	54,904	52,158	3.0	2 to 8
25	23	86,930	72,442	68,629	65,198	2.4	72,442	60,368	57,191	54,332	2.9	2 to 8
19	17	89,385	74,488	70,567	67,039	2.3	74,488	62,073	58,809	55,866	2.8	2 to 8
27	24	89,973	74,978	71,032	67,480	2.3	74,978	62,481	59,193	56,233	2.8	2 to 8
28	24	93,305	77,755	73,662	69,979	2.2	77,755	64,796	61,385	58,316	2.7	2 to 8
23	19	96,813	80,678	76,432	72,610	2.2	80,678	67,231	63,693	60,508	2.6	2 to 8
28	23	97,362	81,135	76,864	73,022	2.1	81,135	67,613	64,054	60,851	2.6	2 to 8
24	19	101,023	84,185	79,754	75,767	2.1	84,185	70,155	66,462	63,139	2.5	2 to 8
25	19	105,232	87,693	83,078	78,924	2.0	87,693	73,078	69,231	65,770	2.4	2 to 8
23	17	108,233	90,169	85,423	81,152	1.9	90,169	75,141	71,186	67,627	2.3	2 to 8
26	19	109,441	91,201	86,401	82,081	1.9	91,201	76,001	72,001	68,401	2.3	2 to 7
27	19	113,650	94,709	89,124	85,238	1.8	94,709	78,924	74,770	71,031	2.2	2 to 7
28	19	117,860	98,216	93,047	88,395	1.8	98,216	81,847	77,539	73,662	2.1	2 to 7
26	17	122,317	101,930	96,566	91,738	1.7	101,930	84,942	80,471	76,448	2.1	2 to 7
27	17	127,021	105,851	100,280	95,266	1.6	105,851	88,209	83,566	79,388	2.0	2 to 7
28	17	131,725	109,771	103,994	98,794	1.6	109,771	91,476	86,661	82,328	1.9	2 to 7

NOTE: See "General Planting Rate Information" and "Checking Seed Population" pages for additional information.

NOTE: When using the Half Rate (2 to 1) Drive Reduction Package, rates will be approximately 50% of given numbers.

NOTE: Always check seed population in the field to ensure planting rates are correct.

**PLANTING RATES FOR BRUSH-TYPE SEED METERS (STANDARD DRIVE)
APPROXIMATE HILLS/ACRE FOR VARIOUS ROW WIDTHS**

Due to variations in cotton seed size, meters equipped with 12 cell acid-delinted hill-drop cotton discs will plant from 3 to 6 seeds per cell. Select proper disc for seed size range to be planted.

To determine planter transmission setting, determine desired hill spacing and select the transmission ratio closest to the hill spacing in inches on the chart. To decrease population increase spacing. To increase population decrease spacing.

To determine population per acre, determine average seeds per hill and hills per acre by doing a field check. Measure $\frac{1}{1000}$ of an acre ($\frac{1}{1000}$ acre = Length of row 17' 5" for 30" row widths, 13' 10" for 38" row widths and 13' 1" for 40" row widths). Multiply average seeds per hill by hills per acre. EXAMPLE: 4 seeds per hill x (13 hills x 1000) = 52,000

Transmission Sprockets Drive Driven		NUMBER OF HILLS PER ACRE 12 Cell Hill-Drop Cotton, Acid-Delinted				Average Hill Spacing in Inches	Speed Range (MPH)
		30" Rows	36" Rows	38" Rows	40" Rows		
17	28	16,186	13,488	12,778	12,139	12.9	2 to 8
17	27	16,785	13,988	13,251	12,588	12.5	2 to 8
17	26	17,431	14,526	13,761	13,073	12.0	2 to 8
19	28	18,090	15,075	14,281	13,568	11.6	2 to 8
19	27	18,760	15,633	14,810	14,070	11.1	2 to 8
17	24	18,883	15,736	14,908	14,163	11.1	2 to 8
17	23	19,704	16,420	15,556	14,778	10.6	2 to 8
19	25	20,261	16,884	15,995	15,196	10.3	2 to 8
19	24	21,105	17,587	16,662	15,829	9.9	2 to 8
23	28	21,898	18,249	17,288	16,424	9.5	2 to 8
19	23	22,022	18,352	17,386	16,517	9.5	2 to 8
24	28	22,850	19,042	18,040	17,138	9.2	2 to 8
24	27	23,697	19,747	18,708	17,773	8.8	2 to 8
17	19	23,853	19,877	18,831	17,890	8.8	2 to 8
24	26	24,608	20,507	19,427	18,456	8.5	2 to 8
26	28	24,755	20,629	19,543	18,566	8.4	2 to 8
24	25	25,592	21,327	20,205	19,194	8.2	2 to 8
26	27	25,671	21,393	20,267	19,254	8.1	2 to 8
23	23	26,659	22,216	21,046	19,994	7.8	2 to 8
27	26	27,684	23,070	21,856	20,763	7.6	2 to 8
24	23	27,818	23,181	21,961	20,864	7.5	2 to 8
25	23	28,977	24,147	22,876	21,733	7.2	2 to 8
19	17	29,795	24,829	23,522	22,346	7.0	2 to 8
27	24	29,991	24,993	23,677	22,493	7.0	2 to 8
28	24	31,102	25,918	24,554	23,327	6.7	2 to 8
23	19	32,271	26,893	25,477	24,204	6.5	2 to 8
28	23	32,454	27,045	25,622	24,408	6.5	2 to 8
24	19	33,674	28,062	26,585	25,256	6.2	2 to 8
25	19	35,077	29,231	27,693	26,308	6.0	2 to 8
23	17	36,068	30,056	28,474	27,051	5.8	2 to 8
26	19	36,480	30,400	28,800	27,360	5.7	2 to 7
27	19	37,883	31,570	29,908	28,413	5.5	2 to 7
28	19	39,287	32,739	31,016	29,465	5.3	2 to 7
26	17	40,772	33,977	32,189	30,579	5.1	2 to 7
27	17	42,340	35,284	33,427	31,755	4.9	2 to 7
28	17	43,908	36,590	34,665	32,932	4.8	2 to 7

NOTE: See "General Planting Rate Information" and "Checking Seed Population" pages for additional information.

NOTE: When using the Half Rate (2 to 1) Drive Reduction Package, rates will be approximately 50% of given numbers.

NOTE: Always check seed population in the field to ensure planting rates are correct.

**PLANTING RATES FOR BRUSH-TYPE SEED METERS (STANDARD DRIVE)
APPROXIMATE SEEDS/ACRE FOR 15"/18"/19"/30"/36"/38" ROW WIDTHS**

Transmission Sprockets		54 Cell Soybean						Average Seed Spacing In Inches	Speed Range (MPH)
Drive	Driven	7.5" Rows or 15" Rows	18" Rows	19" Rows	30" Rows	36" Rows	38" Rows		
15	28	128,529	107,107	101,470	64,264	53,554	50,735	3.3	2 to 8
15	27	133,289	111,074	105,228	66,644	55,537	52,614	3.1	2 to 8
15	26	138,415	115,346	109,275	69,208	57,673	54,638	3	2 to 8
15	25	143,952	119,960	113,646	71,976	59,980	56,823	2.9	2 to 8
17	28	145,666	121,388	114,999	72,833	60,694	57,500	2.9	2 to 8
17	27	151,061	125,884	119,258	75,530	62,942	59,629	2.8	2 to 8
17	26	156,871	130,726	123,845	78,435	65,363	61,923	2.7	2 to 8
19	28	162,803	135,669	128,529	81,401	67,835	64,264	2.6	2 to 8
19	27	168,833	140,694	133,289	84,416	70,347	66,644	2.5	2 to 8
17	24	169,943	141,619	134,166	84,972	70,810	67,083	2.5	2 to 8
17	23	177,332	147,777	139,999	88,666	73,888	70,000	2.4	2 to 8
19	25	182,339	151,949	143,952	91,170	75,975	71,976	2.3	2 to 8
19	24	189,937	158,281	149,950	94,968	79,140	74,975	2.2	2 to 8
23	28	197,077	164,231	155,587	98,539	82,115	77,794	2.1	2 to 8
19	23	198,195	165,162	156,470	99,097	82,581	78,235	2.1	2 to 8
24	28	205,646	171,371	162,352	102,823	85,686	81,176	2	2 to 8
24	27	213,262	177,718	168,365	106,631	88,859	84,182	2	2 to 8
17	19	214,665	178,888	169,473	107,333	89,444	84,736	1.9	2 to 8
24	26	221,465	184,554	174,840	110,732	92,277	87,420	1.9	2 to 8
26	28	222,783	185,652	175,881	111,391	92,826	87,941	1.9	2 to 8
24	25	230,323	191,936	181,834	115,162	95,968	90,917	1.8	2 to 8
26	27	231,034	192,528	182,395	115,517	96,264	91,198	1.8	2 to 8
23	23	239,920	199,933	189,410	119,960	99,967	94,705	1.7	2 to 8
27	26	249,148	207,623	196,695	124,574	103,812	98,348	1.7	2 to 8
24	23	250,351	208,626	197,646	125,176	104,313	98,823	1.7	2 to 8
25	23	260,783	217,319	205,881	130,391	108,659	102,940	1.6	2 to 8
19	17	268,146	223,455	211,694	134,073	111,727	105,847	1.6	2 to 8
27	24	269,910	224,925	213,087	134,955	112,462	106,543	1.5	2 to 8
28	24	279,907	233,255	220,979	139,953	116,628	110,489	1.5	2 to 8
23	19	290,429	242,024	229,286	145,215	121,012	114,643	1.4	2 to 8
28	23	292,076	243,397	230,587	146,038	121,699	115,293	1.4	2 to 8
24	19	303,057	252,547	239,255	151,528	126,274	119,628	1.4	2 to 8
25	19	315,684	263,070	249,224	157,842	131,535	124,612	1.3	2 to 8
23	17	324,598	270,498	256,261	162,299	135,249	128,131	1.3	2 to 8
26	19	328,311	273,593	259,193	164,156	136,796	129,597	1.3	2 to 8
27	19	340,939	284,116	269,162	170,469	142,058	134,581	1.2	2 to 8
28	19	353,566	294,639	279,131	176,783	147,319	139,566	1.2	2 to 8
26	17	366,936	305,780	289,687	183,468	152,890	144,843	1.1	2 to 8
27	17	381,049	317,541	300,828	190,525	158,771	150,414	1.1	2 to 8
28	17	395,162	329,302	311,970	197,581	164,651	155,985	1.1	2 to 8

NOTE: See "General Planting Rate Information" and "Check Seed Population" pages for additional information.

NOTE: When using Half Rate (2 To 1) Drive Reduction Package, rates are approximately 50% of given numbers.

NOTE: Always field check seed population to ensure planting rates are correct.

This page left blank intentionally.

PLANTING RATES FOR BRUSH-TYPE SEED METERS (HALF RATE DRIVE)
APPROXIMATE SEEDS/ACRE FOR 15" ROW WIDTH

Transmission Sprockets		Population Factor	Rye 400 SDS/REV, 35.9 SDS/GRAM		Wheat 465 SDS/REV, 39.6 SDS/GRAM		Speed Range (MPH)
Drive	Driven		Population (sds/acre)	Population (lbs/acre)	Population (sds/acre)	Population (lbs/acre)	
15	28	1190.12	476,159	29	553,656	31	4 to 6
15	27	1234.20	493,795	30	574,163	32	4 to 6
15	26	1281.67	512,787	32	596,245	33	4 to 6
15	25	1332.94	533,298	33	620,095	35	4 to 6
17	28	1348.80	539,647	33	627,477	35	4 to 6
15	24	1388.48	555,519	34	645,932	36	4 to 6
17	27	1398.76	559,634	34	650,718	36	4 to 6
15	23	1448.84	579,672	36	674,017	38	4 to 6
17	26	1452.56	581,158	36	675,745	38	4 to 6
19	28	1507.49	603,134	37	701,298	39	4 to 6
17	25	1510.66	604,405	37	702,775	39	4 to 6
19	27	1563.32	625,473	38	727,272	41	4 to 6
17	24	1573.60	629,588	39	732,056	41	4 to 6
19	26	1623.45	649,530	40	755,244	42	4 to 6
17	23	1642.02	656,961	40	763,885	43	4 to 6
19	25	1688.39	675,511	42	785,454	44	4 to 6
15	19	1753.86	701,708	43	815,915	45	4 to 6
19	24	1758.74	703,658	43	818,181	46	4 to 6
23	28	1824.85	730,111	45	848,940	47	4 to 6
19	23	1835.20	734,251	45	853,754	48	4 to 6
23	27	1892.44	757,152	47	880,382	49	4 to 6
24	28	1904.19	761,855	47	885,850	49	4 to 6
15	17	1960.20	784,262	48	911,905	51	4 to 6
23	26	1965.23	786,273	48	914,242	51	4 to 6
24	27	1974.72	790,071	49	918,660	51	4 to 6
25	28	1983.54	793,598	49	922,761	51	4 to 6
17	19	1987.71	795,269	49	924,703	52	4 to 6
23	25	2043.84	817,724	50	950,813	53	4 to 6
24	26	2050.67	820,459	50	953,993	53	4 to 6
25	27	2057.00	822,991	51	956,937	53	4 to 6
26	28	2062.88	825,342	51	959,671	53	4 to 6
23	24	2128.99	851,795	52	990,429	55	4 to 6
24	25	2132.70	853,277	52	992,152	55	4 to 6
25	26	2136.11	854,644	53	993,742	55	4 to 6
26	27	2139.28	855,911	53	995,215	55	4 to 6
27	28	2142.22	857,087	53	996,582	56	4 to 6
15	15	2221.56	888,830	55	1,033,492	58	4 to 6
28	27	2303.84	921,750	57	1,071,769	60	4 to 6
27	26	2307.01	923,016	57	1,073,242	60	4 to 6
26	25	2310.42	924,384	57	1,074,832	60	4 to 6
25	24	2314.13	925,865	57	1,076,554	60	4 to 6
24	23	2318.15	927,475	57	1,078,426	60	4 to 6
28	26	2392.45	957,202	59	1,112,991	62	4 to 6
27	25	2399.28	959,937	59	1,116,171	62	4 to 6

Continued on the next page.

**PLANTING RATES FOR BRUSH-TYPE SEED METERS (HALF RATE DRIVE)
APPROXIMATE SEEDS/ACRE FOR 15" ROW WIDTH**

Transmission Sprockets		Population Factor	Rye 400 SDS/REV, 35.9 SDS/GRAM		Wheat 465 SDS/REV, 39.6 SDS/GRAM		Speed Range (MPH)
Drive	Driven		Population (sds/acre)	Population (lbs/acre)	Population (sds/acre)	Population (lbs/acre)	
26	24	2406.69	962,899	59	1,119,616	62	4 to 6
25	23	2414.74	966,120	59	1,123,361	63	4 to 6
19	17	2482.92	993,399	61	1,155,079	64	4 to 6
28	25	2488.15	995,490	61	1,157,511	64	4 to 6
27	24	2499.26	999,934	61	1,162,678	65	4 to 6
26	23	2511.33	1,004,765	62	1,168,295	65	4 to 6
17	15	2517.77	1,007,341	62	1,171,291	65	4 to 6
28	24	2591.82	1,036,969	64	1,205,741	67	4 to 6
27	23	2607.92	1,043,409	64	1,213,230	68	4 to 6
23	19	2689.26	1,075,952	66	1,251,069	70	4 to 6
28	23	2704.51	1,082,054	67	1,258,164	70	4 to 6
24	19	2806.18	1,122,733	69	1,305,464	73	4 to 6
19	15	2813.98	1,125,852	69	1,309,090	73	4 to 6
25	19	2923.10	1,169,513	72	1,359,857	76	4 to 6
23	17	3005.64	1,202,535	74	1,398,254	78	4 to 6
26	19	3040.03	1,216,294	75	1,414,252	79	4 to 6
24	17	3136.32	1,254,820	77	1,459,048	81	4 to 6
27	19	3156.95	1,263,075	78	1,468,647	82	4 to 6
25	17	3267.00	1,307,103	80	1,519,841	85	4 to 6
28	19	3273.88	1,309,855	81	1,523,041	85	4 to 6
26	17	3397.68	1,359,388	84	1,580,635	88	4 to 6
23	15	3406.39	1,362,873	84	1,584,687	88	4 to 6
27	17	3528.36	1,411,671	87	1,641,428	91	4 to 6
24	15	3554.50	1,422,128	87	1,653,587	92	4 to 6
28	17	3659.04	1,463,956	90	1,702,222	95	4 to 6
25	15	3702.60	1,481,384	91	1,722,487	96	4 to 6
26	15	3850.70	1,540,639	95	1,791,386	100	4 to 6
27	15	3998.81	1,599,895	98	1,860,286	104	4 to 6
28	15	4146.91	1,659,150	102	1,929,185	107	4 to 6

NOTE: Seed size and type affect the output rate of the meter. For a method to improve the population accuracy with your desired seed, please see the following pages.

NOTE: See “Mechanical Meter General Planting Rate Information” and “Check Seed Population” pages for additional information.

NOTE: When using Half Rate (2 To 1) Drive Reduction Package, rates are approximately 50% of given numbers.

NOTE: Always field check seed population to ensure planting rates are correct.

To more accurately predict population when using the 54 Cell Wheat disc, two things are needed:

1. Seeds/gram
2. Grams/revolution of seed disc

Seeds per gram can be found by weighing a small sample of desired seed (a cup or less) and counting number of seeds in sample.

$$\frac{\text{Seeds}}{\text{Grams}} = \frac{\text{number of seeds in sample}}{\text{weight of sample in grams}} \quad \frac{396 \text{ Seeds}}{10 \text{ Grams}} = 39.6 \frac{\text{seeds}}{\text{gram}}$$

To find grams/revolution a gram scale, a stopwatch, a small container to catch seed, and a method for spinning the meter at a constant, known rpm (see your local Kinze dealer with a T4000 Seed Meter Test Stand) are needed.

1. Zero gram scale with the small container on it.
2. Load meter with correct disc.
3. Load meter with desired seed.
4. Start spinning meter at a known, constant rpm.
5. Start stopwatch as you place container under meter.
6. Catch seed with container for 10-30 seconds.
7. Stop the stopwatch as you remove container from underneath meter.
8. Weigh container.
9. Enter meter rpm, weight of sample, and duration of sample collection into the equation below:

$$\frac{\text{Grams}}{\text{Rev}} = \frac{\text{Sample Weight} * 60}{\text{Disc RPM} * \text{Sample Duration}}$$

EX: For a sample taken for 30 seconds with meter spinning at 50rpm and weighs 293 grams

$$\frac{293 \text{ Grams} * 60}{50 \text{ RPM} * 30 \text{ Seconds}} = 11.7 \frac{\text{Grams}}{\text{Rev}}$$

10. Find desired output rate. For seeds per acre, use seeds/rev. For pounds per acre, use lbs/rev.

1. Seeds/rev:

$$\frac{\text{Seeds}}{\text{Rev}} = \frac{\text{Seeds}}{\text{Grams}} * \frac{\text{Grams}}{\text{Rev}} \quad \left| \quad 39.6 \frac{\text{Seeds}}{\text{Grams}} * 11.7 \frac{\text{Grams}}{\text{Rev}} = 465 \frac{\text{Seeds}}{\text{Rev}} \right.$$

2. Lbs./rev:

$$\frac{\text{Pounds}}{\text{Rev}} = \frac{\frac{\text{Grams}}{\text{Rev}}}{453.6 \frac{\text{Grams}}{\text{Pound}}} \quad \left| \quad \frac{11.7 \frac{\text{Grams}}{\text{Rev}}}{453.6 \frac{\text{Grams}}{\text{Pound}}} = 0.0258 \frac{\text{Pounds}}{\text{Rev}} \right.$$

11. Find the correct population factor by dividing the desired population by the measured output rate.

Seeds/acre:

$$\frac{\text{Target Population}}{\text{Output Rate}} = \text{Population Factor} \quad \left| \quad \frac{1,000,000 \frac{\text{Seeds}}{\text{Acre}}}{465 \frac{\text{Seeds}}{\text{Rev.}}} = 2150.54$$

pounds/acre:

$$\frac{\text{Target Population}}{\text{Output Rate}} = \text{Population Factor} \quad \left| \quad \frac{56 \frac{\text{lbs}}{\text{Acre}}}{0.0258 \frac{\text{lbs}}{\text{rev}}} = 2170.54$$

12. Find the closest Population Factor in the Rate Chart to identify the correct transmission sprockets. For the examples list above, the closest Population Factor is 2142.22 which corresponds to a 27 tooth Drive sprocket and 28 tooth Driven sprocket.

NOTE: Multiple trials are recommended to increase the accuracy of the predicted rate.

**PLANTING RATES FOR (VACUUM) CORN/POPCORN/SUNFLOWER 40 CELL DISC
15 TOOTH CONTACT WHEEL DRIVE SPROCKET
APPROXIMATE SEEDS/ACRE FOR VARIOUS ROW WIDTHS**

30" Rows	36" Rows	38" Rows	40" Rows	Transmission Sprockets		Recomm. Speed (MPH)	Average Spacing in Inches
				Drive	Driven		
23,802	19,835	18,791	17,851	15	28	4 to 6	8.8
24,683	20,569	19,487	18,513	15	27	4 to 6	8.5
25,633	21,361	20,236	19,225	15	26	4 to 6	8.2
26,658	22,215	21,046	19,994	15	25	4 to 6	7.8
26,975	22,480	21,296	20,232	17	28	4 to 6	7.7
27,769	23,141	21,923	20,827	15	24	4 to 6	7.5
27,974	23,312	22,085	20,981	17	27	4 to 6	7.5
28,976	24,147	22,876	21,732	15	23	4 to 6	7.2
29,050	24,208	22,934	21,788	17	26	4 to 6	7.2
30,149	25,124	23,802	22,611	19	28	4 to 6	6.9
30,212	25,177	23,852	22,659	17	25	4 to 6	6.9
31,266	26,054	24,683	23,449	19	27	4 to 6	6.7
31,472	26,226	24,846	23,603	17	24	4 to 6	6.6
32,468	27,056	25,633	24,351	19	26	4 to 6	6.4
32,840	27,366	25,926	24,630	17	23	4 to 6	6.3
33,767	28,139	26,658	25,325	19	25	4 to 6	6.2
35,076	29,231	27,692	26,308	15	19	4 to 6	5.9
35,173	29,312	27,769	26,381	19	24	4 to 6	5.9
36,496	30,413	28,812	27,372	23	28	4 to 6	5.8
36,704	30,586	28,976	27,527	19	23	4 to 6	5.7
37,848	31,539	29,880	28,386	23	27	4 to 6	5.6
38,083	31,735	30,066	28,562	24	28	4 to 6	5.5
39,203	32,669	30,950	29,402	15	17	4 to 6	5.4
39,493	32,911	31,179	29,621	24	27	4 to 6	5.3
39,753	33,128	31,385	29,815	17	19	4 to 6	5.3
40,876	34,063	32,271	30,656	23	25	4 to 6	5.1
41,256	34,381	32,571	30,943	26	28	4 to 6	5.1
42,578	35,482	33,615	31,934	23	24	4 to 6	4.9
42,653	35,544	33,674	31,990	24	25	4 to 6	4.9
42,843	35,703	33,824	32,132	27	28	4 to 6	4.9
44,430	37,025	35,076	33,323	23	23	4 to 6	4.7
46,076	38,396	36,375	34,557	28	27	4 to 6	4.6
46,138	38,449	36,426	34,604	27	26	4 to 6	4.5
46,362	38,635	36,601	34,771	24	23	4 to 6	4.5
47,848	39,873	37,774	35,886	28	26	4 to 6	4.4
47,985	39,987	37,882	35,989	27	25	4 to 6	4.4
48,293	40,245	38,126	36,221	25	23	4 to 6	4.3
49,657	41,381	39,203	37,243	19	17	4 to 6	4.2
49,984	41,653	39,461	37,488	27	24	4 to 6	4.3
50,226	41,854	39,651	37,669	26	23	4 to 6	4.2
51,835	43,196	40,922	38,876	28	24	4 to 6	4.0
52,157	43,465	41,176	39,118	27	23	4 to 6	4.0
53,784	44,819	42,461	40,337	23	19	4 to 6	3.9
54,089	45,074	42,702	40,566	28	23	4 to 6	3.9
56,122	46,768	44,307	42,091	24	19	4 to 6	3.7
58,461	48,717	46,153	43,845	25	19	4 to 6	3.6
60,112	50,092	47,456	45,083	23	17	4 to 6	3.5
60,799	50,666	47,999	45,599	26	19	4 to 6	3.4
62,725	52,271	49,520	47,044	24	17	4 to 6	3.3
63,137	52,614	49,845	47,353	27	19	4 to 6	3.3
65,338	54,448	51,583	49,004	25	17	4 to 6	3.2
65,476	54,563	51,691	49,107	28	19	4 to 6	3.2
67,952	56,627	53,646	50,964	26	17	4 to 6	3.2
68,126	56,771	53,784	51,094	23	15	4 to 6	3.0
70,565	58,804	55,710	52,924	27	17	4 to 6	2.9

NOTE: See "General Planting Rate Information" and "Checking Seed Population" pages for additional information. Always check seed population in the field to ensure planting rates are correct.

**PLANTING RATES FOR (VACUUM) CORN/POPCORN/SUNFLOWER 40 CELL DISC
19 TOOTH CONTACT WHEEL DRIVE SPROCKET
APPROXIMATE SEEDS/ACRE FOR VARIOUS ROW WIDTHS**

30" Rows	36" Rows	38" Rows	40" Rows	Transmission Sprockets		Recomm. Speed (MPH)	Average Spacing In Inches
				Drive	Driven		
30,149	25,124	23,802	22,611	15	28	4 to 6	6.9
31,266	26,054	24,683	23,449	15	27	4 to 6	6.7
32,468	27,056	25,633	24,351	15	26	4 to 6	6.4
33,767	28,139	26,658	25,325	15	25	4 to 6	6.2
34,169	28,474	26,975	25,627	17	28	4 to 6	6.1
35,173	29,312	27,769	26,381	15	24	4 to 6	5.9
35,435	29,528	27,974	26,575	17	27	4 to 6	5.9
36,704	30,586	28,976	27,527	15	23	4 to 6	5.7
36,797	30,665	29,050	27,598	17	26	4 to 6	5.7
38,189	31,824	30,149	28,642	19	28	4 to 6	5.5
38,269	31,891	30,212	28,702	17	25	4 to 6	5.5
39,603	33,003	31,266	29,703	19	27	4 to 6	5.3
39,864	33,219	31,472	29,897	17	24	4 to 6	5.3
41,126	34,272	32,468	30,845	19	26	4 to 6	5.1
41,597	34,664	32,840	31,198	17	23	4 to 6	5.1
42,771	35,643	33,767	32,079	19	25	4 to 6	4.9
44,430	37,025	35,076	33,323	15	19	4 to 6	4.7
44,554	37,128	35,173	33,415	19	24	4 to 6	4.7
46,229	38,524	36,496	34,672	23	28	4 to 6	4.5
46,490	38,743	36,704	34,868	19	23	4 to 6	4.5
47,941	39,951	37,848	35,956	23	27	4 to 6	4.4
48,238	40,199	38,083	36,178	24	28	4 to 6	4.3
49,657	41,381	39,203	37,243	15	17	4 to 6	4.2
50,025	41,687	39,493	37,519	24	27	4 to 6	4.2
50,354	41,962	39,753	37,765	17	19	4 to 6	4.2
51,775	43,147	40,876	38,832	23	25	4 to 6	4.0
52,258	43,549	41,256	39,194	26	28	4 to 6	4.0
53,933	44,945	42,578	40,450	23	24	4 to 6	3.9
54,027	45,023	42,653	40,520	24	25	4 to 6	3.9
54,268	45,224	42,843	40,702	27	28	4 to 6	3.9
56,278	46,898	44,430	42,208	23	23	4 to 6	3.7
58,362	48,636	46,076	43,772	28	27	4 to 6	3.6
58,443	48,703	46,138	43,832	27	26	4 to 6	3.6
58,725	48,937	46,362	44,044	24	23	4 to 6	3.6
60,607	50,506	47,848	45,455	28	26	4 to 6	3.4
60,781	50,650	47,985	45,586	27	25	4 to 6	3.4
61,172	50,976	48,293	45,879	25	23	4 to 6	3.4
62,899	52,415	49,657	47,174	19	17	4 to 6	3.3
63,313	52,761	49,984	47,485	27	24	4 to 6	3.3
63,618	53,015	50,226	47,714	26	23	4 to 6	3.3
65,657	54,715	51,835	49,243	28	24	4 to 6	3.2
66,066	55,054	52,157	49,549	27	23	4 to 6	3.1
68,126	56,771	53,784	51,094	23	19	4 to 6	3.0
68,513	57,093	54,089	51,385	28	23	4 to 6	3.0
71,088	59,240	56,122	53,316	24	19	4 to 6	2.9
74,050	61,709	58,461	55,537	25	19	4 to 6	2.8
76,141	63,451	60,112	57,106	23	17	4 to 6	2.7
77,012	64,176	60,799	57,759	26	19	4 to 6	2.7
79,451	66,209	62,725	59,589	24	17	4 to 6	2.6
79,974	66,645	63,137	59,981	27	19	4 to 6	2.6
82,762	68,968	65,338	62,072	25	17	4 to 6	2.5
82,936	69,114	65,476	62,202	28	19	4 to 6	2.5
86,073	71,727	67,952	64,554	26	17	4 to 6	2.4
86,293	71,911	68,126	64,720	23	15	4 to 6	2.4
89,383	74,486	70,565	67,037	27	17	4 to 6	2.3

NOTE: See "General Planting Rate Information" and "Checking Seed Population" pages for additional information. Always check seed population in the field to ensure planting rates are correct.

**PLANTING RATES FOR (VACUUM) MILO/SUGAR BEET/SPECIALTY 60 CELL DISCS
15 TOOTH CONTACT WHEEL DRIVE SPROCKET
APPROXIMATE SEEDS/ACRE FOR VARIOUS ROW WIDTHS**

30" Rows	36" Rows	38" Rows	40" Rows	Transmission Sprockets		Recomm. Speed (MPH)	Average Spacing in Inches
				Drive	Driven		
35,703	29,752	28,186	26,777	15	28	4 to 6	5.9
37,025	30,854	29,230	27,769	15	27	4 to 6	5.6
38,449	32,041	30,355	28,837	15	26	4 to 6	5.4
39,987	33,323	31,569	29,990	15	25	4 to 6	5.2
40,463	33,719	31,945	30,347	17	28	4 to 6	5.2
41,653	34,711	32,884	31,240	15	24	4 to 6	5.0
41,962	34,968	33,128	31,471	17	27	4 to 6	5.0
43,464	36,220	34,314	32,598	15	23	4 to 6	4.8
43,576	36,313	34,402	32,682	17	26	4 to 6	4.8
45,223	37,686	35,703	33,918	19	28	4 to 6	4.6
45,319	37,766	35,778	33,989	17	25	4 to 6	4.6
46,898	39,082	37,025	35,174	19	27	4 to 6	4.5
47,207	39,339	37,269	35,405	17	24	4 to 6	4.4
48,702	40,585	38,449	36,527	19	26	4 to 6	4.3
49,259	41,050	38,889	36,945	17	23	4 to 6	4.2
50,650	42,209	39,987	37,988	19	25	4 to 6	4.1
52,615	43,845	41,538	39,461	15	19	4 to 6	4.0
52,761	43,967	41,653	39,571	19	24	4 to 6	4.0
54,744	45,620	43,219	41,058	23	28	4 to 6	3.8
55,055	45,879	43,464	41,291	19	23	4 to 6	3.8
56,772	47,310	44,820	42,579	23	27	4 to 6	3.7
57,124	47,604	45,098	42,843	24	28	4 to 6	3.7
58,805	49,004	46,425	44,103	15	17	4 to 6	3.6
59,240	49,367	46,769	44,430	24	27	4 to 6	3.5
59,630	49,692	47,076	44,722	17	19	4 to 6	3.5
61,314	51,095	48,405	45,985	23	25	4 to 6	3.4
61,885	51,571	48,856	46,414	26	28	4 to 6	3.4
63,868	53,224	50,422	47,901	23	24	4 to 6	3.3
63,979	53,316	50,510	47,985	24	25	4 to 6	3.3
64,265	53,554	50,735	48,199	27	28	4 to 6	3.3
66,645	55,538	52,615	49,984	23	23	4 to 6	3.1
69,113	57,595	54,563	51,835	28	27	4 to 6	3.0
69,208	57,674	54,638	51,906	27	26	4 to 6	3.0
69,543	57,952	54,902	52,157	24	23	4 to 6	3.0
71,772	59,810	56,662	53,829	28	26	4 to 6	2.9
71,977	59,981	56,824	53,983	27	25	4 to 6	2.9
72,440	60,367	57,190	54,330	25	23	4 to 6	2.9
74,486	62,071	58,805	55,864	19	17	4 to 6	2.8
74,976	62,480	59,191	56,232	27	24	4 to 6	2.8
75,338	62,782	59,477	56,503	26	23	4 to 6	2.8
77,753	64,794	61,384	58,314	28	24	4 to 6	2.7
78,236	65,196	61,765	58,677	27	23	4 to 6	2.7
80,676	67,230	63,691	60,507	23	19	4 to 6	2.6
81,133	67,611	64,053	60,850	28	23	4 to 6	2.6
84,183	70,153	66,461	63,138	24	19	4 to 6	2.5
87,691	73,076	69,230	65,768	25	19	4 to 6	2.4
90,167	75,139	71,184	67,625	23	17	4 to 6	2.3
91,199	75,999	71,999	68,399	26	19	4 to 6	2.3
94,087	78,406	74,279	70,565	24	17	4 to 6	2.2
94,706	78,922	74,768	71,030	27	19	4 to 6	2.2
98,008	81,673	77,374	73,506	25	17	4 to 6	2.1
98,214	81,845	77,537	73,660	28	19	4 to 6	2.1
101,928	84,940	80,469	76,446	26	17	4 to 6	2.1
102,189	85,158	80,676	76,642	23	15	4 to 6	2.0
105,848	88,207	83,564	79,386	27	17	4 to 6	2.0

NOTE: See "General Planting Rate Information" and "Checking Seed Population" pages for additional information. Always check seed population in the field to ensure planting rates are correct.

**PLANTING RATES FOR (VACUUM) MILO/SUGAR BEET/SPECIALTY 60 CELL DISCS
19 TOOTH CONTACT WHEEL DRIVE SPROCKET
APPROXIMATE SEEDS/ACRE FOR VARIOUS ROW WIDTHS**

30" Rows	36" Rows	38" Rows	40" Rows	Transmission Sprockets		Recomm. Speed (MPH)	Average Spacing in Inches
				Drive	Driven		
45,223	37,686	35,703	33,918	15	28	4 to 6	4.6
46,898	39,082	37,025	35,174	15	27	4 to 6	4.5
48,702	40,585	38,449	36,527	15	26	4 to 6	4.3
50,650	42,209	39,987	37,988	15	25	4 to 6	4.1
51,253	42,711	40,463	38,440	17	28	4 to 6	4.1
52,761	43,967	41,653	39,571	15	24	4 to 6	4.0
53,152	44,293	41,962	39,864	17	27	4 to 6	3.9
55,055	45,879	43,464	41,291	15	23	4 to 6	3.8
55,196	45,997	43,576	41,397	17	26	4 to 6	3.8
57,283	47,736	45,223	42,962	19	28	4 to 6	3.7
57,404	47,836	45,319	43,053	17	25	4 to 6	3.6
59,405	49,504	46,898	44,554	19	27	4 to 6	3.5
59,796	49,830	47,207	44,847	17	24	4 to 6	3.5
61,689	51,408	48,702	46,267	19	26	4 to 6	3.4
62,395	51,996	49,259	46,796	17	23	4 to 6	3.4
64,157	53,464	50,650	48,118	19	25	4 to 6	3.3
66,645	55,538	52,615	49,984	15	19	4 to 6	3.1
66,830	55,692	52,761	50,123	19	24	4 to 6	3.1
69,343	57,786	54,744	52,007	23	28	4 to 6	3.0
69,736	58,113	55,055	52,302	19	23	4 to 6	3.0
71,911	59,926	56,772	53,933	23	27	4 to 6	2.9
72,358	60,298	57,124	54,268	24	28	4 to 6	2.9
74,486	62,071	58,805	55,864	15	17	4 to 6	2.8
75,037	62,531	59,240	56,278	24	27	4 to 6	2.8
75,531	62,943	59,630	56,648	17	19	4 to 6	2.8
77,664	64,720	61,314	58,248	23	25	4 to 6	2.7
78,387	65,323	61,885	58,791	26	28	4 to 6	2.7
80,900	67,416	63,868	60,675	23	24	4 to 6	2.6
81,040	67,534	63,979	60,780	24	25	4 to 6	2.6
81,402	67,835	64,265	61,052	27	28	4 to 6	2.6
84,417	70,348	66,645	63,313	23	23	4 to 6	2.5
87,544	72,953	69,113	65,658	28	27	4 to 6	2.4
87,664	73,053	69,208	65,748	27	26	4 to 6	2.4
88,087	73,406	69,543	66,066	24	23	4 to 6	2.4
90,911	75,759	71,772	68,183	28	26	4 to 6	2.3
91,171	75,975	71,977	68,378	27	25	4 to 6	2.3
91,758	76,465	72,440	68,818	25	23	4 to 6	2.3
94,349	78,624	74,486	70,761	19	17	4 to 6	2.2
94,969	79,141	74,976	71,227	27	24	4 to 6	2.2
95,428	79,523	75,338	71,571	26	23	4 to 6	2.2
98,487	82,072	77,753	73,865	28	24	4 to 6	2.1
99,098	82,582	78,236	74,324	27	23	4 to 6	2.1
102,189	85,158	80,676	76,642	23	19	4 to 6	2.0
102,769	85,641	81,133	77,077	28	23	4 to 6	2.0
106,632	88,860	84,183	79,974	24	19	4 to 6	2.0
111,075	92,563	87,691	83,306	25	19	4 to 6	1.9
114,211	95,176	90,167	85,659	23	17	4 to 6	1.8
115,518	96,265	91,199	86,639	26	19	4 to 6	1.8
119,177	99,314	94,087	89,383	24	17	4 to 6	1.8
119,961	99,968	94,706	89,971	27	19	4 to 6	1.7
124,143	103,452	98,008	93,107	25	17	4 to 6	1.7
124,404	103,670	98,214	93,303	28	19	4 to 6	1.7
129,109	107,591	101,928	96,831	26	17	4 to 6	1.6
129,440	107,866	102,189	97,080	23	15	4 to 6	1.6
134,074	111,729	105,848	100,556	27	17	4 to 6	1.6

NOTE: See "General Planting Rate Information" and "Checking Seed Population" pages for additional information. Always check seed population in the field to ensure planting rates are correct.

**PLANTING RATES FOR (VACUUM) SPECIALTY 60 CELL DISC
30 TOOTH CONTACT WHEEL DRIVE SPROCKET
APPROXIMATE SEEDS/ACRE FOR VARIOUS ROW WIDTHS**

30" Rows	36" Rows	38" Rows	40" Rows	Transmission Sprockets		Recomm. Speed (MPH)	Average Spacing in Inches
				Drive	Driven		
71,406	59,505	56,373	53,554	15	28	4 to 6	2.9
74,050	61,708	58,461	55,538	15	27	4 to 6	2.8
76,898	64,082	60,709	57,674	15	26	4 to 6	2.7
79,974	66,645	63,138	59,981	15	25	4 to 6	2.6
80,926	67,439	63,889	60,695	17	28	4 to 6	2.6
83,306	69,422	65,768	62,480	15	24	4 to 6	2.5
83,924	69,936	66,255	62,943	17	27	4 to 6	2.5
86,928	72,440	68,628	65,196	15	23	4 to 6	2.4
87,151	72,626	68,804	65,364	17	26	4 to 6	2.4
90,447	75,372	71,406	67,835	19	28	4 to 6	2.3
90,637	75,531	71,556	67,978	17	25	4 to 6	2.3
93,797	78,164	74,050	70,348	19	27	4 to 6	2.2
94,414	78,678	74,537	70,810	17	24	4 to 6	2.2
97,404	81,170	76,898	73,053	19	26	4 to 6	2.1
98,519	82,099	77,778	73,889	17	23	4 to 6	2.1
101,301	84,417	79,974	75,975	19	25	4 to 6	2.1
105,229	87,691	83,076	78,922	15	19	4 to 6	2.0
105,521	87,935	83,306	79,141	19	24	4 to 6	2.0
109,488	91,240	86,438	82,116	23	28	4 to 6	1.9
110,109	91,758	86,928	82,582	19	23	4 to 6	1.9
113,544	94,620	89,640	85,158	23	27	4 to 6	1.8
114,249	95,207	90,196	85,687	24	28	4 to 6	1.8
117,609	98,008	92,849	88,207	15	17	4 to 6	1.8
118,480	98,734	93,537	88,860	24	27	4 to 6	1.8
119,260	99,383	94,152	89,445	17	19	4 to 6	1.8
122,627	102,189	96,811	91,970	23	25	4 to 6	1.7
123,770	103,141	97,713	92,827	26	28	4 to 6	1.7
127,737	106,447	100,845	95,802	23	24	4 to 6	1.6
127,959	106,632	101,020	95,969	24	25	4 to 6	1.6
128,530	107,108	101,471	96,397	27	28	4 to 6	1.6
133,290	111,075	105,229	99,968	23	23	4 to 6	1.6
138,227	115,189	109,127	103,670	28	27	4 to 6	1.5
138,417	115,347	109,276	103,813	27	26	4 to 6	1.5
139,086	115,905	109,804	104,314	24	23	4 to 6	1.5
143,543	119,619	113,324	107,658	28	26	4 to 6	1.5
143,954	119,961	113,648	107,965	27	25	4 to 6	1.5
144,881	120,734	114,380	108,661	25	23	4 to 6	1.4
148,971	124,143	117,609	111,729	19	17	4 to 6	1.4
149,952	124,960	118,383	112,464	27	24	4 to 6	1.4
150,676	125,563	118,955	113,007	26	23	4 to 6	1.4
155,505	129,588	122,767	116,629	28	24	4 to 6	1.3
156,471	130,393	123,530	117,353	27	23	4 to 6	1.3
161,351	134,459	127,383	121,014	23	19	4 to 6	1.3
162,266	135,222	128,105	121,700	28	23	4 to 6	1.3
168,367	140,306	132,921	126,275	24	19	4 to 6	1.2
175,382	146,152	138,459	131,536	25	19	4 to 6	1.2
180,334	150,278	142,369	135,250	23	17	4 to 6	1.2
182,397	151,998	143,998	136,798	26	19	4 to 6	1.1
188,175	156,812	148,559	141,131	24	17	4 to 6	1.1
189,413	157,844	149,536	142,059	27	19	4 to 6	1.1
196,015	163,346	154,749	147,011	25	17	4 to 6	1.1
196,428	163,690	155,075	147,321	28	19	4 to 6	1.1
203,856	169,880	160,939	152,892	26	17	4 to 6	1.0
204,378	170,315	161,351	153,284	23	15	4 to 6	1.0
211,696	176,414	167,129	158,772	27	17	4 to 6	1.0

NOTE: See "General Planting Rate Information" and "Checking Seed Population" pages for additional information. Always check seed population in the field to ensure planting rates are correct.

**PLANTING RATES FOR (VACUUM) SOYBEAN 120 CELL DISC
15 TOOTH CONTACT WHEEL DRIVE SPROCKET
APPROXIMATE SEEDS/ACRE FOR VARIOUS ROW WIDTHS**

30" Rows	36" Rows	38" Rows	40" Rows	Transmission Sprockets		Recomm. Speed (MPH)	Average Spacing in Inches
				Drive	Driven		
71,406	59,505	56,373	53,554	15	28	4 to 6	2.9
74,050	61,708	58,461	55,538	15	27	4 to 6	2.8
76,898	64,082	60,709	57,674	15	26	4 to 6	2.7
79,974	66,645	63,138	59,981	15	25	4 to 6	2.6
80,926	67,439	63,889	60,695	17	28	4 to 6	2.6
83,306	69,422	65,768	62,480	15	24	4 to 6	2.5
83,924	69,936	66,255	62,943	17	27	4 to 6	2.5
86,928	72,440	68,628	65,196	15	23	4 to 6	2.4
87,151	72,626	68,804	65,364	17	26	4 to 6	2.4
90,447	75,372	71,406	67,835	19	28	4 to 6	2.3
90,637	75,531	71,556	67,978	17	25	4 to 6	2.3
93,797	78,164	74,050	70,348	19	27	4 to 6	2.2
94,414	78,678	74,537	70,810	17	24	4 to 6	2.2
97,404	81,170	76,898	73,053	19	26	4 to 6	2.1
98,519	82,099	77,778	73,889	17	23	4 to 6	2.1
101,301	84,417	79,974	75,975	19	25	4 to 6	2.1
105,229	87,691	83,076	78,922	15	19	4 to 6	2.0
105,521	87,935	83,306	79,141	19	24	4 to 6	2.0
109,488	91,240	86,438	82,116	23	28	4 to 6	1.9
110,109	91,758	86,928	82,582	19	23	4 to 6	1.9
113,544	94,620	89,640	85,158	23	27	4 to 6	1.8
114,249	95,207	90,196	85,687	24	28	4 to 6	1.8
117,609	98,008	92,849	88,207	15	17	4 to 6	1.8
118,480	98,734	93,537	88,860	24	27	4 to 6	1.8
119,260	99,383	94,152	89,445	17	19	4 to 6	1.8
122,627	102,189	96,811	91,970	23	25	4 to 6	1.7
123,770	103,141	97,713	92,827	26	28	4 to 6	1.7
127,737	106,447	100,845	95,802	23	24	4 to 6	1.6
127,959	106,632	101,020	95,969	24	25	4 to 6	1.6
128,530	107,108	101,471	96,397	27	28	4 to 6	1.6
133,290	111,075	105,229	99,968	23	23	4 to 6	1.6
138,227	115,189	109,127	103,670	28	27	4 to 6	1.5
138,417	115,347	109,276	103,813	27	26	4 to 6	1.5
139,086	115,905	109,804	104,314	24	23	4 to 6	1.5
143,543	119,619	113,324	107,658	28	26	4 to 6	1.5
143,954	119,961	113,648	107,965	27	25	4 to 6	1.5
144,881	120,734	114,380	108,661	25	23	4 to 6	1.4
148,971	124,143	117,609	111,729	19	17	4 to 6	1.4
149,952	124,960	118,383	112,464	27	24	4 to 6	1.4
150,676	125,563	118,955	113,007	26	23	4 to 6	1.4
155,505	129,588	122,767	116,629	28	24	4 to 6	1.3
156,471	130,393	123,530	117,353	27	23	4 to 6	1.3
161,351	134,459	127,383	121,014	23	19	4 to 6	1.3
162,266	135,222	128,105	121,700	28	23	4 to 6	1.3
168,367	140,306	132,921	126,275	24	19	4 to 6	1.2
175,382	146,152	138,459	131,536	25	19	4 to 6	1.2
180,334	150,278	142,369	135,250	23	17	4 to 6	1.2
182,397	151,998	143,998	136,798	26	19	4 to 6	1.1
188,175	156,812	148,559	141,131	24	17	4 to 6	1.1
189,413	157,844	149,536	142,059	27	19	4 to 6	1.1
196,015	163,346	154,749	147,011	25	17	4 to 6	1.1
196,428	163,690	155,075	147,321	28	19	4 to 6	1.1
203,856	169,880	160,939	152,892	26	17	4 to 6	1.0
204,378	170,315	161,351	153,284	23	15	4 to 6	1.0
211,696	176,414	167,129	158,772	27	17	4 to 6	1.0

NOTE: See "General Planting Rate Information" and "Checking Seed Population" pages for additional information. Always check seed population in the field to ensure planting rates are correct.

**PLANTING RATES FOR (VACUUM) SOYBEAN 120 CELL DISC
19 TOOTH CONTACT WHEEL DRIVE SPROCKET
APPROXIMATE SEEDS/ACRE FOR VARIOUS ROW WIDTHS**

30" Rows	36" Rows	38" Rows	40" Rows	Transmission Sprockets		Recomm. Speed (MPH)	Average Spacing in Inches
				Drive	Driven		
90,447	75,372	71,406	67,835	15	28	4 to 6	2.3
93,797	78,164	74,050	70,348	15	27	4 to 6	2.2
97,404	81,170	76,898	73,053	15	26	4 to 6	2.1
101,301	84,417	79,974	75,975	15	25	4 to 6	2.1
102,507	85,422	80,926	76,880	17	28	4 to 6	2.0
105,521	87,935	83,306	79,141	15	24	4 to 6	2.0
106,303	88,586	83,924	79,727	17	27	4 to 6	2.0
110,109	91,758	86,928	82,582	15	23	4 to 6	1.9
110,392	91,993	87,151	82,794	17	26	4 to 6	1.9
114,566	95,472	90,447	85,925	19	28	4 to 6	1.8
114,807	95,673	90,637	86,106	17	25	4 to 6	1.8
118,809	99,008	93,797	89,107	19	27	4 to 6	1.8
119,591	99,659	94,414	89,693	17	24	4 to 6	1.7
123,379	102,816	97,404	92,534	19	26	4 to 6	1.7
124,791	103,992	98,519	93,593	17	23	4 to 6	1.7
128,314	106,928	101,301	96,236	19	25	4 to 6	1.6
133,290	111,075	105,229	99,968	15	19	4 to 6	1.6
133,661	111,384	105,521	100,245	19	24	4 to 6	1.6
138,685	115,571	109,488	104,014	23	28	4 to 6	1.5
139,472	116,227	110,109	104,604	19	23	4 to 6	1.5
143,822	119,852	113,544	107,866	23	27	4 to 6	1.5
144,715	120,596	114,249	108,536	24	28	4 to 6	1.4
148,971	124,143	117,609	111,729	15	17	4 to 6	1.4
150,075	125,062	118,480	112,556	24	27	4 to 6	1.4
151,062	125,885	119,260	113,297	17	19	4 to 6	1.4
155,328	129,440	122,627	116,496	23	25	4 to 6	1.3
156,775	130,646	123,770	117,581	26	28	4 to 6	1.3
161,800	134,833	127,737	121,350	23	24	4 to 6	1.3
162,081	135,067	127,959	121,561	24	25	4 to 6	1.3
162,805	135,670	128,530	122,103	27	28	4 to 6	1.3
168,834	140,695	133,290	126,626	23	23	4 to 6	1.2
175,087	145,906	138,227	131,316	28	27	4 to 6	1.2
175,328	146,107	138,417	131,496	27	26	4 to 6	1.2
176,175	146,812	139,086	132,131	24	23	4 to 6	1.2
181,822	151,518	143,543	136,366	28	26	4 to 6	1.1
182,341	151,951	143,954	136,756	27	25	4 to 6	1.1
183,516	152,930	144,881	137,637	25	23	4 to 6	1.1
188,697	157,248	148,971	141,523	19	17	4 to 6	1.1
189,939	158,282	149,952	142,454	27	24	4 to 6	1.1
190,856	159,047	150,676	143,142	26	23	4 to 6	1.1
196,973	164,145	155,505	147,730	28	24	4 to 6	1.1
198,197	165,164	156,471	148,648	27	23	4 to 6	1.1
204,378	170,315	161,351	153,284	23	19	4 to 6	1.0
205,537	171,281	162,266	154,153	28	23	4 to 6	1.0
213,264	177,720	168,367	159,948	24	19	4 to 6	1.0
222,150	185,125	175,382	166,613	25	19	4 to 6	0.9
228,423	190,352	180,334	171,317	23	17	4 to 6	0.9
231,036	192,530	182,397	173,277	26	19	4 to 6	0.9
238,354	198,629	188,175	178,766	24	17	4 to 6	0.9
239,923	199,935	189,413	179,942	27	19	4 to 6	0.9
248,286	206,905	196,015	186,214	25	17	4 to 6	0.8
248,809	207,340	196,428	186,606	28	19	4 to 6	0.8
	215,181	203,856	193,663	26	17	4 to 6	0.8
	215,733	204,378	194,160	23	15	4 to 6	0.8
	223,457	211,696	201,112	27	17	4 to 6	0.8

NOTE: See "General Planting Rate Information" and "Checking Seed Population" pages for additional information. Always check seed population in the field to ensure planting rates are correct.

This page left blank intentionally.

**PLANTING RATES FOR (VACUUM) WHEAT 54 CELL DISC
(HALF RATE DRIVE [15 TOOTH])
APPROXIMATE SEEDS/ACRE FOR 15" ROW WIDTH**

Transmission Sprockets		RPM/GS (Seed Disc RPM To Ground Speed (MPH))	8INH2O, no sigulator		8INH2O, sigulator 3.3		Speed Range (MPH)
Drive	Driven		SDS/REV	Population	SDS/REV	Population	
15	28	2.039	909	744,562	554	453,298	5 to 7
15	27	2.115	903	764,594	551	465,585	5 to 7
15	26	2.196	897	785,948	547	478,707	5 to 7
15	25	2.284	891	808,755	543	492,751	5 to 7
17	28	2.311	888	815,760	542	497,071	5 to 7
15	24	2.379	883	833,164	539	507,816	5 to 7
17	27	2.397	882	837,650	539	510,588	5 to 7
15	23	2.483	876	859,343	535	524,013	5 to 7
17	26	2.489	875	860,943	535	525,004	5 to 7
19	28	2.583	868	884,424	531	539,571	5 to 7
17	25	2.589	868	885,771	530	540,408	5 to 7
19	27	2.679	861	907,980	527	554,221	5 to 7
17	24	2.697	860	912,286	526	556,903	5 to 7
19	26	2.782	854	932,998	522	569,822	5 to 7
17	23	2.814	852	940,653	521	574,605	5 to 7
19	25	2.893	846	959,608	518	586,466	5 to 7
15	19	3.006	838	986,010	513	603,032	5 to 7
19	24	3.014	837	987,957	513	604,256	5 to 7
23	28	3.127	829	1,014,147	508	620,748	5 to 7
19	23	3.145	828	1,018,206	508	623,310	5 to 7
23	27	3.243	821	1,040,464	504	637,378	5 to 7
24	28	3.263	819	1,044,993	503	640,247	5 to 7
15	17	3.359	813	1,066,386	499	653,818	5 to 7
23	26	3.368	812	1,068,291	499	655,029	5 to 7
24	27	3.384	811	1,071,881	498	657,311	5 to 7
25	28	3.399	810	1,075,206	497	659,426	5 to 7
17	19	3.406	809	1,076,779	497	660,427	5 to 7
23	25	3.502	803	1,097,745	493	673,790	5 to 7
24	26	3.514	802	1,100,276	493	675,407	5 to 7
25	27	3.525	801	1,102,616	493	676,902	5 to 7
26	28	3.535	801	1,104,786	492	678,288	5 to 7
23	24	3.648	793	1,128,951	488	693,762	5 to 7
24	25	3.655	792	1,130,291	487	694,622	5 to 7
25	26	3.661	792	1,131,527	487	695,416	5 to 7
26	27	3.666	792	1,132,671	487	696,150	5 to 7
27	28	3.671	791	1,133,732	487	696,831	5 to 7
15	15	3.807	782	1,162,044	482	715,055	5 to 7
28	27	3.948	772	1,190,735	476	733,619	5 to 7
27	26	3.953	772	1,191,825	476	734,326	5 to 7
26	25	3.959	772	1,193,001	476	735,089	5 to 7
25	24	3.966	771	1,194,273	476	735,915	5 to 7
24	23	3.973	771	1,195,655	475	736,812	5 to 7
28	26	4.100	762	1,220,871	471	753,227	5 to 7
27	25	4.112	762	1,223,163	470	754,723	5 to 7
26	24	4.124	761	1,225,641	470	756,341	5 to 7
25	23	4.138	760	1,228,328	469	758,097	5 to 7
19	17	4.255	752	1,250,825	465	772,837	5 to 7
28	25	4.264	752	1,252,531	465	773,957	5 to 7
27	24	4.283	750	1,256,146	464	776,334	5 to 7
26	23	4.304	749	1,260,061	463	778,909	5 to 7
17	15	4.315	748	1,262,143	463	780,280	5 to 7
28	24	4.442	740	1,285,788	458	795,893	5 to 7

Continued on next page.

**PLANTING RATES FOR (VACUUM) WHEAT 54 CELL DISC
(HALF RATE DRIVE [15 TOOTH])
APPROXIMATE SEEDS/ACRE FOR 15" ROW WIDTH**

Transmission Sprockets		RPM/GS (Seed Disc RPM To Ground Speed (MPH))	8INH2O, no sigulator		8INH2O, sigulator 3.3		Speed Range (MPH)
Drive	Driven		SDS/REV	Population	SDS/REV	Population	
27	23	4.469	738	1,290,855	457	799,250	5 to 7
23	19	4.609	729	1,316,059	452	816,013	5 to 7
28	23	4.635	728	1,320,711	451	819,119	5 to 7
24	19	4.809	717	1,351,123	445	839,524	5 to 7
19	15	4.822	716	1,353,411	445	841,067	5 to 7
25	19	5.009	704	1,384,810	438	862,343	5 to 7
23	17	5.151	695	1,407,761	433	878,034	5 to 7
26	19	5.210	692	1,417,121	431	884,470	5 to 7
24	17	5.375	682	1,442,697	426	902,174	5 to 7
27	19	5.410	680	1,448,057	425	905,906	5 to 7
25	17	5.599	668	1,475,915	419	925,450	5 to 7
28	19	5.610	668	1,477,616	418	926,651	5 to 7
26	17	5.823	655	1,507,414	412	947,862	5 to 7
23	15	5.837	654	1,509,452	411	949,325	5 to 7
27	17	6.046	642	1,537,193	405	969,410	5 to 7
24	15	6.091	640	1,542,943	403	973,616	5 to 7
28	17	6.270	630	1,565,254	398	990,094	5 to 7
25	15	6.345	625	1,574,226	395	996,797	5 to 7
26	15	6.599	611	1,603,300	388	1,018,868	5 to 7
27	15	6.853	598	1,630,167	381	1,039,830	5 to 7
28	15	7.106	584	1,654,826	374	1,059,683	5 to 7

**DRY INSECTICIDE APPLICATION RATE APPROXIMATE POUNDS/ACRE
AT 5 MPH FOR VARIOUS ROW WIDTHS**

Meter Setting	30" Rows	36" Rows	38" Rows	40" Rows
CLAY GRANULES				
10	4.9	4.1	3.9	3.7
11	5.4	4.5	4.3	4.1
12	6.1	5.1	4.8	4.6
13	6.9	5.7	5.4	5.2
14	7.7	6.4	6.0	5.8
15	8.5	7.1	6.7	6.4
16	9.6	8.0	7.6	7.2
17	10.7	8.9	8.4	8.0
18	11.4	9.5	9.0	8.6
19	13.1	10.9	10.3	9.8
20	14.2	11.8	11.2	10.7
21	15.5	12.9	12.3	11.6
22	16.4	13.7	12.9	12.3
23	17.2	14.3	13.6	12.9
24	18.8	15.7	14.9	14.1
25	20.9	17.4	16.5	15.7
26	23.0	19.2	18.1	17.3
27	24.1	20.0	19.0	18.1
28	25.4	21.2	20.1	19.1
29	27.8	23.2	22.0	20.9
30	29.6	24.7	23.4	22.2
SAND GRANULES				
5	2.9	2.4	2.3	2.2
6	4.9	4.0	3.8	3.7
7	5.3	4.4	4.2	3.9
8	6.3	5.3	5.0	4.8
9	7.8	6.5	6.1	5.9
10	8.9	7.4	7.0	6.7
11	10.2	8.5	8.0	7.7
12	11.2	9.3	8.8	8.4
13	12.6	10.5	10.0	9.5
14	14.1	11.7	11.1	10.6
15	15.5	12.9	12.3	11.6
16	17.5	14.6	13.8	13.1
17	19.4	16.2	15.3	14.6
18	21.8	18.2	17.2	16.4
19	24.3	20.2	19.1	18.2
20	25.7	21.4	20.3	19.3
21	27.6	23.0	21.8	20.7
22	29.6	24.7	23.4	22.2
23	32.0	26.7	25.3	24.0
24	34.4	28.7	27.2	25.8
25	36.9	30.7	29.1	26.7

NOTE: The chart above represents average values and should be used only as a starting point. The granular chemical flows through the given meter opening at a nearly uniform rate regardless of roller speed. Your actual rate will vary depending upon the insecticide you are using, your planting speed and your plant population. Planting speed/ground speed has the greatest effect on application rate.



Your actual rate must be checked in the field with the actual insecticide that you are using and at the speed and population at which you will be planting. See "Checking Granular Chemical Application Rate" page for additional information.

DRY HERBICIDE APPLICATION RATES
APPROXIMATE POUNDS/ACRE AT 5 MPH FOR VARIOUS ROW WIDTHS
CLAY GRANULES

Meter Setting	30" Rows	36" Rows	38" Rows	40" Rows
10	4.7	3.9	3.7	3.5
11	5.2	4.4	4.1	3.9
12	5.8	4.9	4.6	4.4
13	6.5	5.4	5.1	4.9
14	7.3	6.1	5.7	5.5
15	8.2	6.9	6.5	6.2
16	9.0	7.5	7.1	6.8
17	9.9	8.2	7.8	7.4
18	10.7	8.9	8.4	8.0
19	11.6	9.7	9.2	8.7
20	12.6	10.5	10.0	9.5
21	13.6	11.3	10.7	10.2
22	14.6	12.1	11.5	11.0
23	15.7	13.1	12.4	11.8
24	17.0	14.1	13.4	12.8
25	18.1	15.1	14.3	13.6
26	19.4	16.2	15.3	14.6
27	20.9	17.4	16.5	15.7
28	22.6	18.8	17.8	17.0
29	24.3	20.2	19.1	18.2
30	26.7	22.2	21.1	20.0

NOTE: The chart above represents average values and should be used only as a starting point. The granular chemical flows through the given meter opening at a nearly uniform rate regardless of roller speed. Your actual rate will vary depending upon the herbicide you are using, your planting speed and your plant population. Planting speed/ground speed has the greatest effect on application rate.

Your actual rate must be checked in the field with the actual herbicide that you are using and at the speed and population at which you will be planting. See "Checking Granular Chemical Application Rate" page for additional information.

 WARNING	<p>Agricultural chemicals can cause death or serious injury to persons, animals, and plants or seriously damage soil, equipment, or property. Read and follow all chemical and equipment manufacturers labels and instructions.</p>
	

This page left blank intentionally.

LUBRICATION

Following pages show locations of all lubrication points. Proper lubrication of moving parts helps ensure efficient operation of your Kinze planter and prolongs the life of friction producing parts.

LUBRICATION SYMBOLS

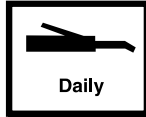

Lubricate at frequency indicated with SAE multipurpose grease.

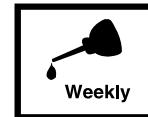

Lubricate at frequency indicated with high quality SAE 10 weight oil or spray lubricant.

SEALED BEARINGS

Sealed bearings are used on your Kinze planter to provide trouble free operation.

These are located on drive shafts, row units, and transmission bearings. Sealed bearings are lubricated for life and are not serviceable.

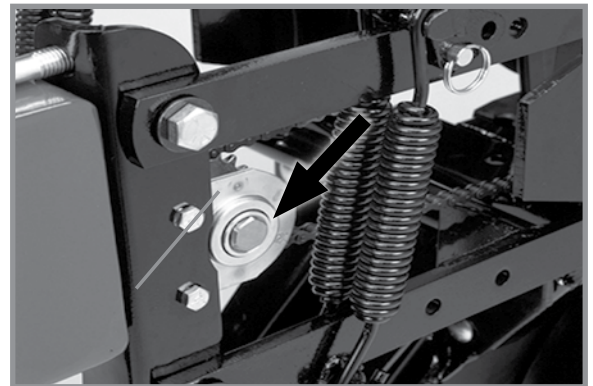

Sealed bearing (Typical)

WRAP SPRING WRENCH ASSEMBLY

1. Remove ¼"-20 x ½" cap screw securing idler assembly to wrap spring wrench tightener shaft and
2. Remove wrap spring wrench from planter.
3. Tip wrap spring wrench on its side and lubricate with a high quality spray lubricant. Lubricant must be absorbed into wrap spring area.
4. Reinstall wrap spring wrench on planter.



Wrap spring wrench lubrication

DRIVE CHAINS

Lubricate all transmission and drive chains daily with a high quality chain lubricant. Extreme operating conditions such as dirt, temperature, or speed may require more frequent lubrication. If a chain becomes stiff, it should be removed, soaked, and washed in solvent to loosen and remove dirt from joints. Soak chain in oil so lubricant can penetrate between rollers and bushings.

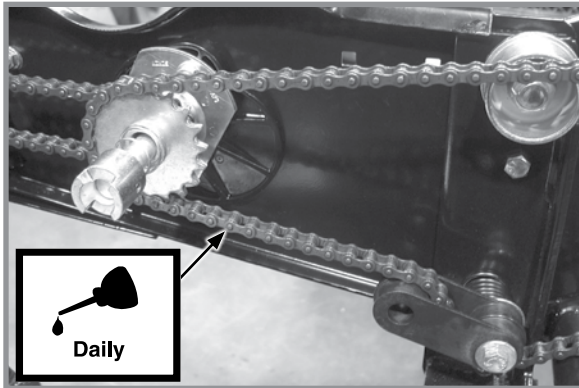

Row Unit Drive Chains (Mechanical Shown)

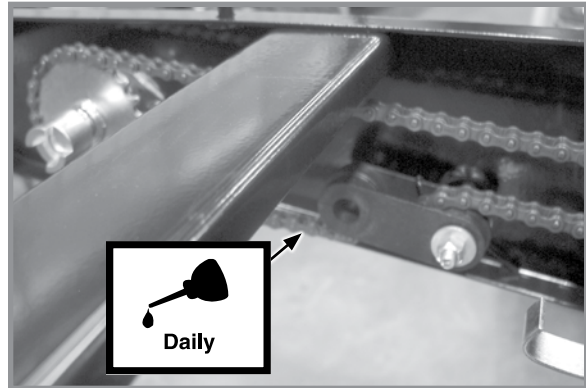

Row Unit Granular Chemical Drive Chains

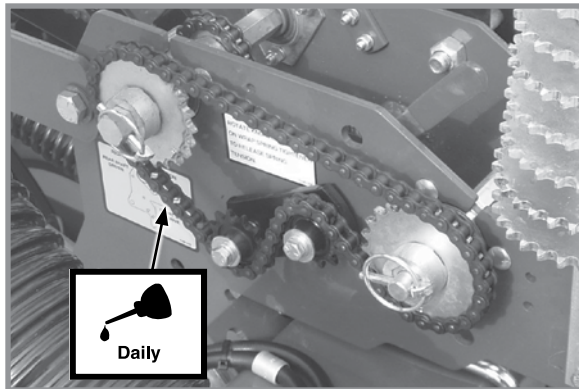

Seed Rate Transmission Drive Chains

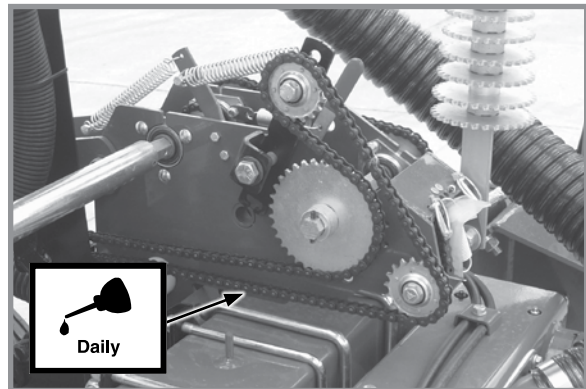

Contact Wheel Drive Chains (Without Point Row Clutches)

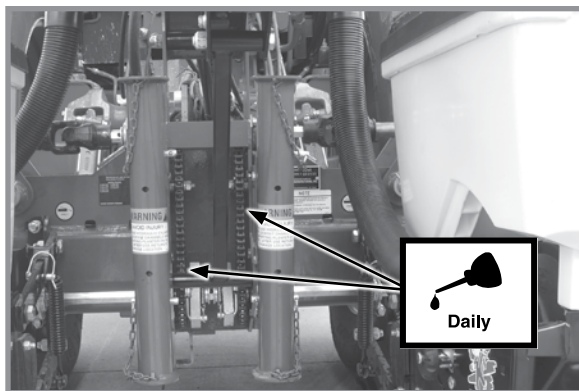

Center Drop Assembly Drive Chains

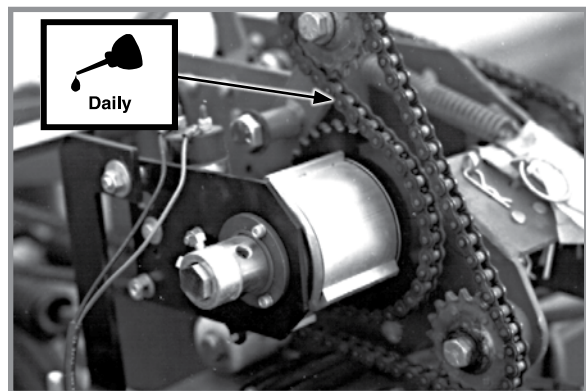

Contact Wheel Drive Chains (With Point Row Clutches)

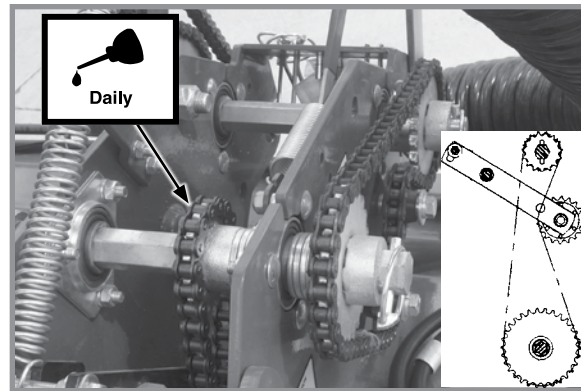

Inner Wheel Module Drive Chains

BUSHINGS

Lubricate bushings at frequency indicated.

Check each bolt for proper torque. If bolt is loose, removed it and inspect bushing for cracks and wear. Replace bushing if necessary. Use **only hardened flat washers**. Replace damaged flat washers with proper part. Torque hardware to 130 ft-lb (176.2 N-m).

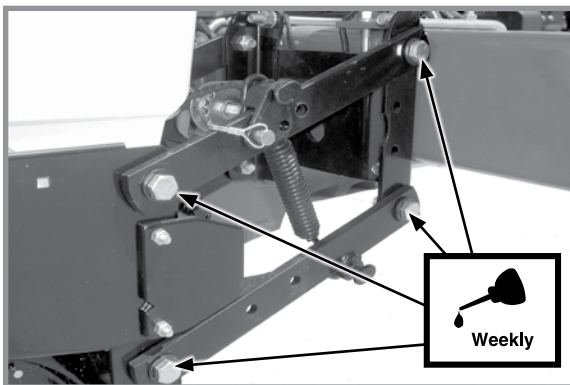

Pull row unit and/or push row unit parallel linkages (8 per row)

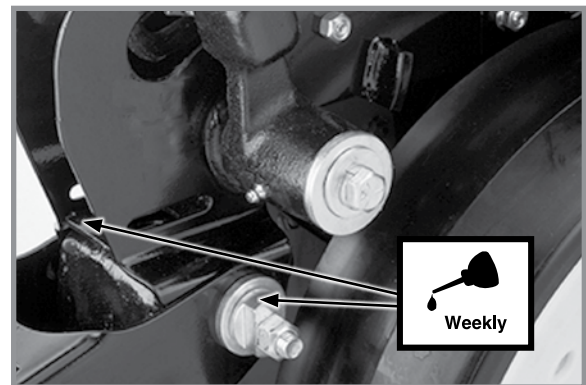

Row unit “v” closing wheel, covering discs/ single press wheel and/or drag closing wheel eccentric bushings (2 per row)

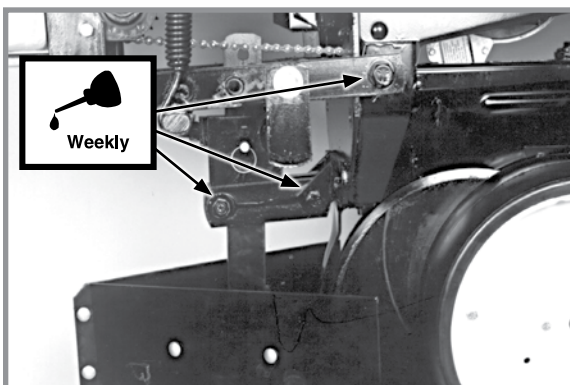

Bed leveler parallel linkages (6 per row)

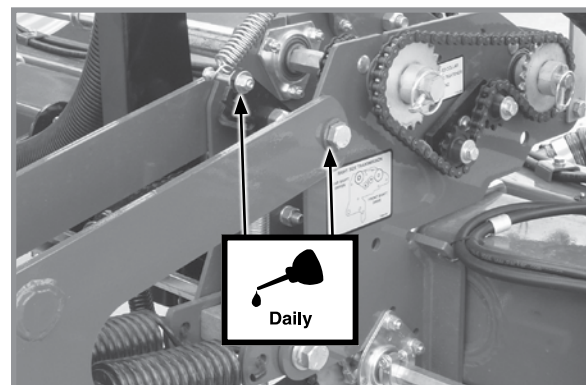

Contact Wheel Arm (2 Per Wheel Assembly)

WHEEL BEARINGS

All drive, transport, and marker hub wheel bearings should be repacked annually and checked for wear.

1. Raise wheel off ground.
2. Check for bearing endplay by moving wheel side to side.
3. Rotate wheel to check for bearing roughness. If bearings sound rough, remove hub and inspect bearings.

NOTE: To repack wheel hubs, follow procedure outlined for wheel bearing replacement except bearings and bearing cups are reused.

GREASE FITTINGS

Parts equipped with grease fittings should be lubricated at frequency indicated with an SAE multipurpose grease. Clean fitting thoroughly before using grease gun. Frequency of lubrication recommended is based on normal operating conditions. Severe or unusual conditions may require more frequent attention.

NOTE: Numbers on photo below correspond to photos on following pages showing lubrication frequencies.

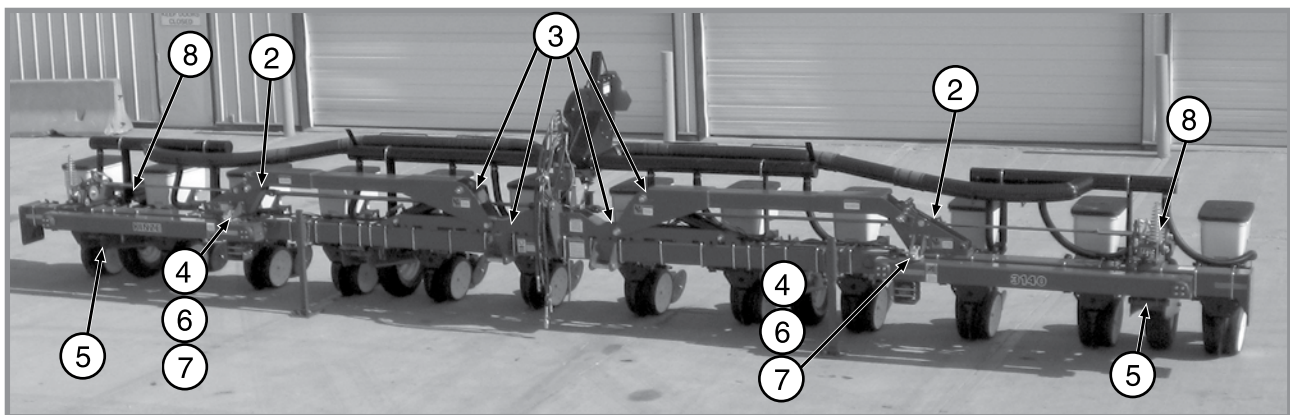

12 Row 38" Shown

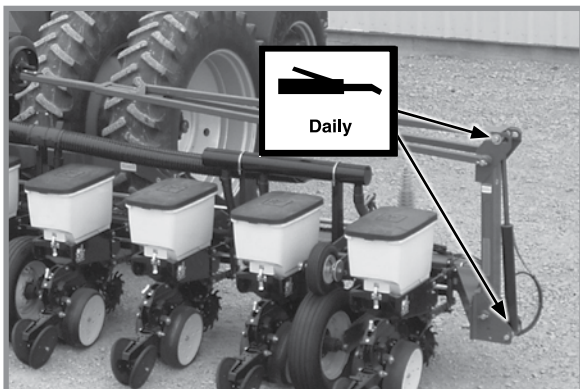

1. Row Markers - 4 Zerks Per Assembly On 8 Row 38"/40" And 12 Row 30" Sizes. 2 Zerks Per Assembly On 12 Row 36"/38", 12 Row 38"/40" And 16 Row 30" Sizes.

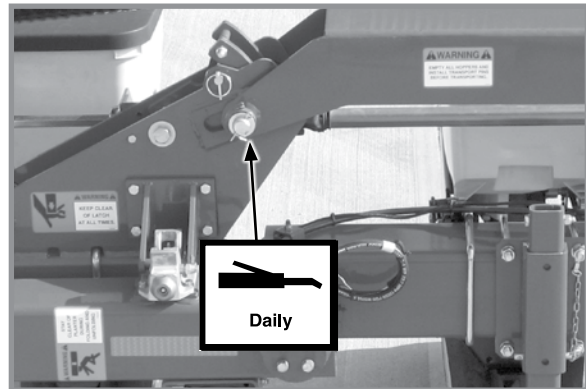

2. Wing Hinge - 2 Zerks Per Hinge Area

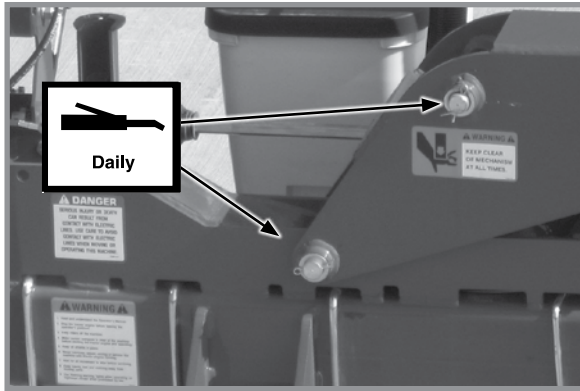

3. Center Hinge - 4 Zerks Per Hinge Area

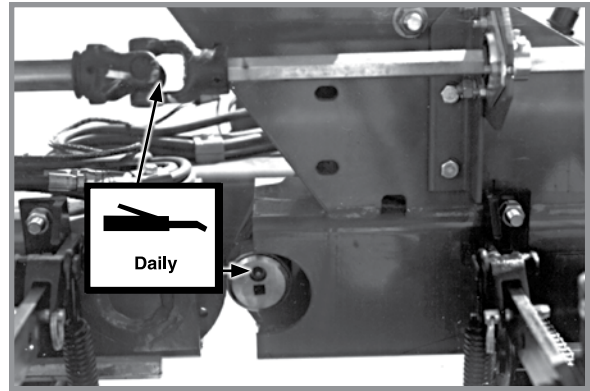

6. Cam Follower - 1 Zerk Per Cam
7. U-Joint Assembly - 1 Zerk Per Assembly

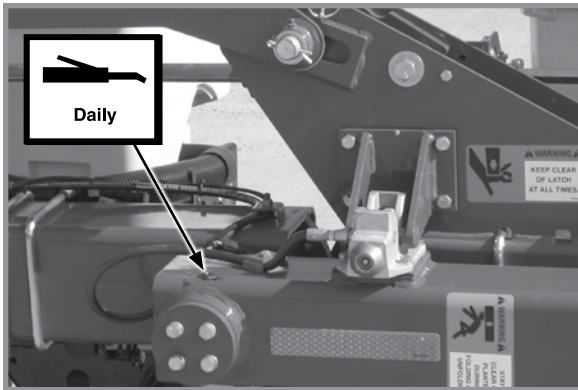

4. Link Assembly - 4 Zerks Per Link

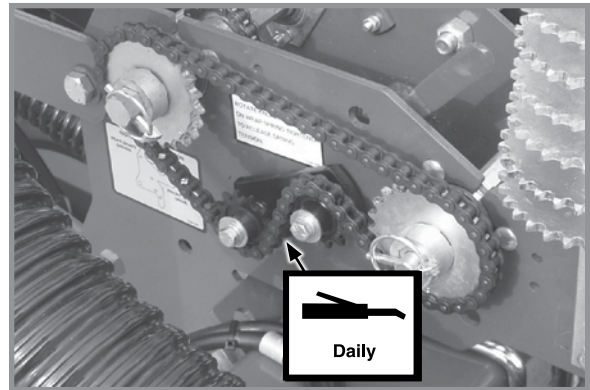

8. Seed Rate Transmission Assemblies - Zerk (Idler)

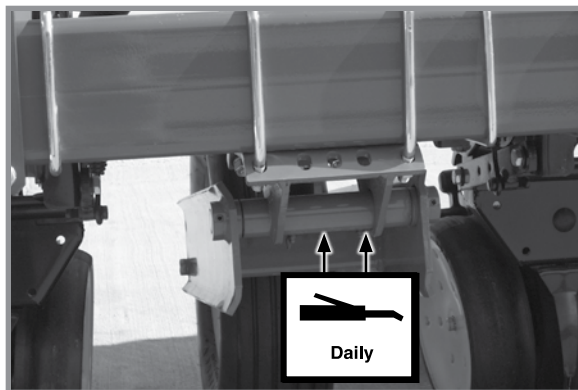

5. Drive Wheel Arm Pivot - 2 Zerks Per Pivot

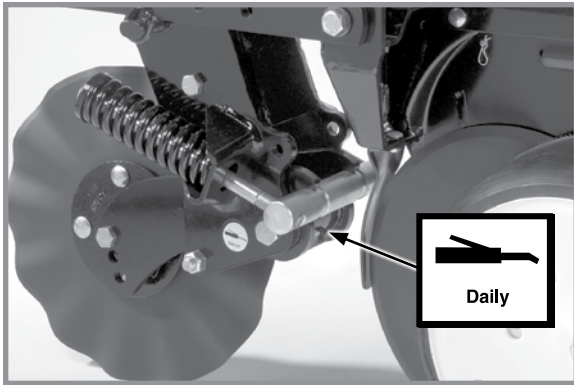

Frame mounted Coulter - 1 Per Arm

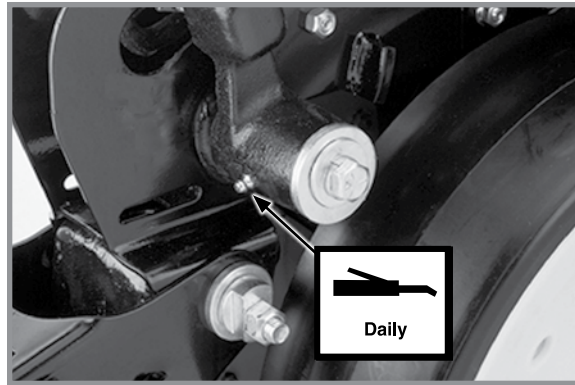

Gauge wheel arms - 1 per arm

(Seals in gauge wheel arm are installed with lip facing out to allow grease to purge dirt away from seal. Pump grease into arm until fresh grease appears between washers and arm.)

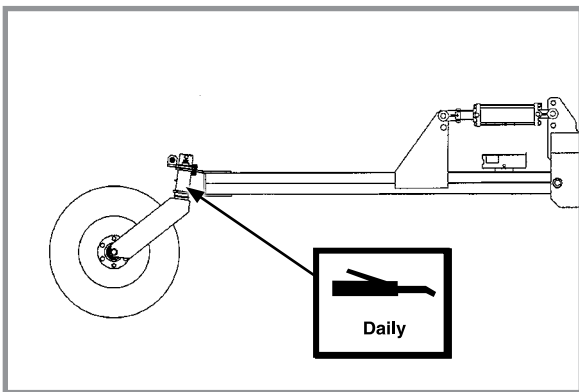

Lift Assist Arm - 1 Zerk Per Arm

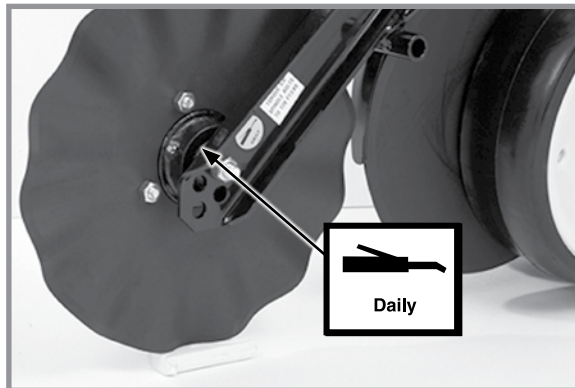

(If Applicable) Row Unit Mounted No Till Coulter Hubs- 1 Zerk Per Hub
(Pump grease into hub until grease comes out around the seals. Spin hub while filling with grease.)

MOUNTING BOLTS AND HARDWARE

WARNING

Loose transport wheel lug bolts can result in wheel separation from planter and result in death, serious injury, and damage to property and equipment. Check transport wheel lug nut torque before operating planter for the first time and periodically thereafter.

NOTICE

Over-tightening hardware can reduce its shock load capacity and cause equipment failure.

Hardware used on Kinze planters are Grade 5 (high strength) unless otherwise noted. Grade 5 cap screws are marked with three radial lines on the head. Hardware must be replaced with equal size, strength, and thread type.

TORQUE VALUES CHART - PLATED HARDWARE

Diameter	Grade 2 (No marks)		Grade 5 (3 marks)		Grade 8 (6 marks)	
	Coarse	Fine	Coarse	Fine	Coarse	Fine
1/4"	50 in-lb	56 in-lb	76 in-lb	87 in-lb	9 ft-lb (12 N-m)	10 ft-lb (14 N-m)
5/16"	8 ft-lb (11 N-m)	9 ft-lb (12 N-m)	13 ft-lb (18 N-m)	14 ft-lb (19 N-m)	18 ft-lb (24 N-m)	20 ft-lb (27 N-m)
3/8"	15 ft-lb (20 N-m)	17 ft-lb (23 N-m)	23 ft-lb (31 N-m)	26 ft-lb (35 N-m)	33 ft-lb (45 N-m)	37 ft-lb (50 N-m)
7/16"	25 ft-lb (34 N-m)	27 ft-lb (37 N-m)	37 ft-lb (50 N-m)	41 ft-lb (56 N-m)	52 ft-lb (71 N-m)	58 ft-lb (79 N-m)
1/2"	35 ft-lb (48 N-m)	40 ft-lb (54 N-m)	57 ft-lb (77 N-m)	64 ft-lb (87 N-m)	80 ft-lb (108 N-m)	90 ft-lb (122 N-m)
9/16"	50 ft-lb (68 N-m)	60 ft-lb (81 N-m)	80 ft-lb (108 N-m)	90 ft-lb (122 N-m)	115 ft-lb (156 N-m)	130 ft-lb (176 N-m)
5/8"	70 ft-lb (95 N-m)	80 ft-lb (108 N-m)	110 ft-lb (149 N-m)	125 ft-lb (169 N-m)	160 ft-lb (217 N-m)	180 ft-lb (244 N-m)
3/4"	130 ft-lb (176 N-m)	145 ft-lb (197 N-m)	200 ft-lb (271 N-m)	220 ft-lb (298 N-m)	280 ft-lb (380 N-m)	315 ft-lb (427 N-m)
7/8"	125 ft-lb (169 N-m)	140 ft-lb (190 N-m)	320 ft-lb (434 N-m)	350 ft-lb (475 N-m)	450 ft-lb (610 N-m)	500 ft-lb (678 N-m)
1"	190 ft-lb (258 N-m)	205 ft-lb (278 N-m)	480 ft-lb (651 N-m)	530 ft-lb (719 N-m)	675 ft-lb (915 N-m)	750 ft-lb (1017 N-m)
1 1/8"	265 ft-lb (359 N-m)	300 ft-lb (407 N-m)	600 ft-lb (814 N-m)	670 ft-lb (908 N-m)	960 ft-lb (1302 N-m)	1075 ft-lb (1458 N-m)
1 1/4"	375 ft-lb (508 N-m)	415 ft-lb (563 N-m)	840 ft-lb (1139 N-m)	930 ft-lb (1261 N-m)	1360 ft-lb (1844 N-m)	1500 ft-lb (2034 N-m)
1 3/8"	490 ft-lb (664 N-m)	560 ft-lb (759 N-m)	1100 ft-lb (1491 N-m)	1250 ft-lb (1695 N-m)	1780 ft-lb (2413 N-m)	2030 ft-lb (2752 N-m)
1 1/2"	650 ft-lb (881 N-m)	730 ft-lb (990 N-m)	1450 ft-lb (1966 N-m)	1650 ft-lb (2237 N-m)	2307 ft-lb (3128 N-m)	2670 ft-lb (3620 N-m)

NOTE: Torque unplated hardware and bolts with lock nuts approximately 1/3 higher than above values. Torque bolts lubricated prior to installation to 70% of value shown in chart.

NOTE: Torque Vacuum fan impeller assembly to motor shaft 5/8"-18 hex jam nut 50 ft-lb (67.8 N-m).

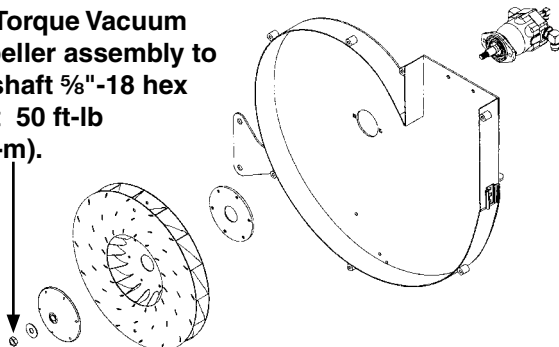

SPECIAL TORQUE VALUES & INSTRUCTIONS

Row unit parallel linkage bushing hardware	130 ft-lb (176 Nm)
5/8" No till coultter spindle hardware	120 ft-lb (162 Nm)
Ground Drive Tire Lug Bolts	90 ft-lb (122 Nm)

CYLINDER ROD PISTON RETAINING NUT TORQUE CHART

	Non-Nylock Nut	Nylock Nut
1/2"-20	55-70 ft-lb (75-95 N-m)	45-55 ft-lb (61-75 N-m)
3/4"-16	115-125 ft-lb (156-169 N-m)	100-115 ft-lb (136-156 N-m)
7/8"-14	150-180 ft-lb (203-244 N-m)	130-150 ft-lb (176-203 N-m)
1"-14	275-330 ft-lb (373-447 N-m)	250-275 ft-lb (339-373 ft-lb)
1 1/8"-12	300-375 ft-lb (407-508 N-m)	275-300 ft-lb (373-407 N-m)
1 1/4"-12	300-375 ft-lb (407-508 N-m)	275-300 ft-lb (373-407 N-m)

TIRE SERVICING

WARNING Explosive separation of rim and tire parts can cause death or serious injury. Overinflation, rim and tire servicing, improper use of rims and tires, or worn or improperly maintained tires could result in a tire explosion.



To prevent tire explosions:

- Maintain proper tire pressure. Inflating a tire above or below the recommended pressure can cause tire damage.
- Mount tires only by properly trained personnel using proper equipment.
- Replace tires with cuts or bubbles. Replace damaged rims. Replace missing lug bolts and nuts.
- Do not weld or heat wheel assembly. Heating increases tire pressure.

INFLATION SPECIFICATIONS

WARNING Overinflation of tires can result in explosive separation of rim and tire and cause death or serious injury. Different size rims are designed for different tire pressures. Inflate to correct pressure for specific rim size.



MODEL 3140 OPERATING TIRE PRESSURE

Ground Drive/Gauge 7.60" x 15"40 psi (275.7 kPa)

Contact drive - 4.10" x 6"50 psi (344.7 kPa)



FINGER PICKUP SEED METER INSPECTION/ADJUSTMENT

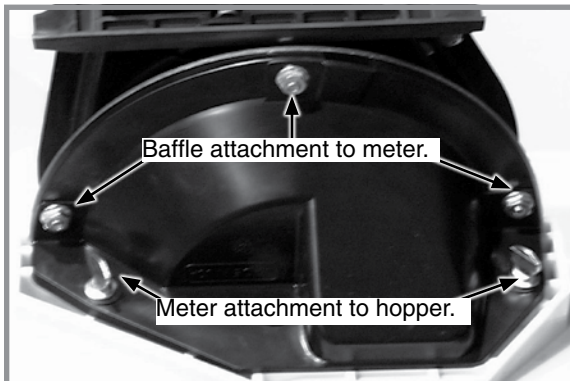

Removing meter and baffle

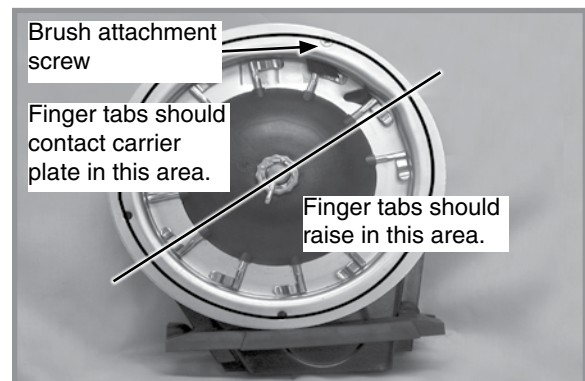

Proper finger operation

1. Remove two thumbscrews and meter from seed hopper and remove three cap screws and baffle from meter assembly.
2. Rotate seed meter drive by hand to ensure springs are holding tabs of fingers against carrier plate and fingers raise in correct area as shown in above photo.

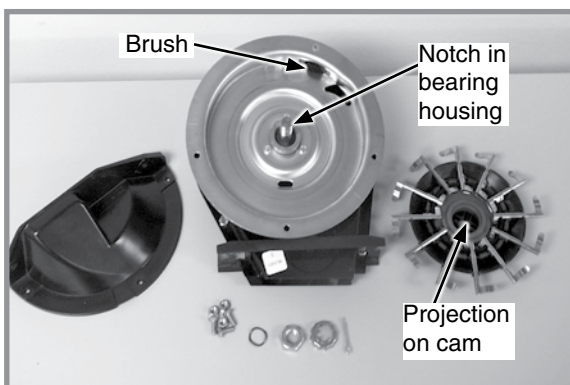

Finger pickup meter parts

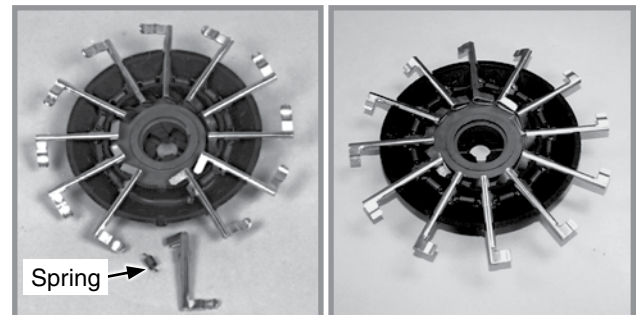

Corn Finger Assembly
(Position Spring Opening
Toward Holder)

**Oil Sunflower Finger
Assembly**

Buildup of debris or chaff may prevent proper finger operation and requires disassembly and cleaning of finger pickup meter.

1. Remove cotter pin, cover nut and adjusting nut and wave washer (If applicable) from drive shaft.
2. Carefully lift finger holder with fingers and cam off shaft and clean.
3. Check brush for wear and replace if necessary or after every 100 acres (41 hectares) per row of operation (Approximately 800 acres (324 hectares) of corn or sunflowers on a 8 row machine or 1200 acres (486 hectares) on an 12 row machine).

NOTE: It is not necessary to remove finger holder to replace brush.

4. Remove springs from fingers and remove finger from holder by lifting it out of friction fit slot. Life expectancy of these parts is about 600-900 acres (243-364 hectares) per row of operation under average conditions.
5. Reassemble meter in reverse order after cleaning and replacing defective parts. Make sure open end of spring loop is toward inside of finger holder when replacing fingers.
6. Install fingers in holder so holder is flush with carrier plate when assembled. A cam projection aligns with a mating notch in bearing housing to ensure proper operation when assembled.

7. Check indentations on carrier plate for wear before installing finger holder on carrier plate. Excessive wear of carrier plate at indentations will cause over planting especially with small sizes of seed. Inspect carrier plate annually. Life expectancy should be 250-300 acres (100-125 hectares) per row of operation under average conditions.
8. Install wave washer and adjusting nut with finger holder flush against carrier. Tighten adjusting nut to fully compress wave washer. Back off nut $\frac{1}{2}$ to 2 flats to obtain rolling torque of 22 to 25 inch pounds (2.5 N-m to 2.8 N-m).
9. Turn finger holder by hand to make sure it is firmly against carrier plate, but can be rotated with moderate force.
10. Install cover nut and cotter pin. Reinstall baffle.

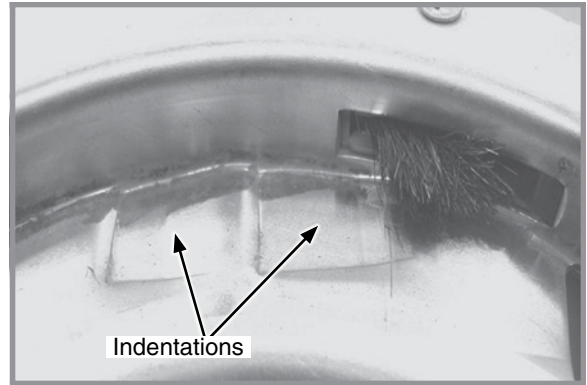
**Worn carrier plate**

NOTE: Check adjusting nut tightness on each unit after first day of use and periodically thereafter.

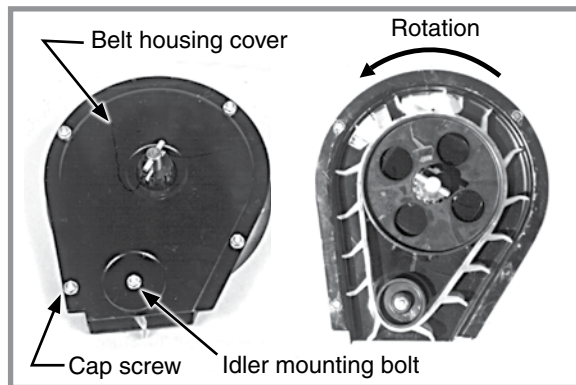
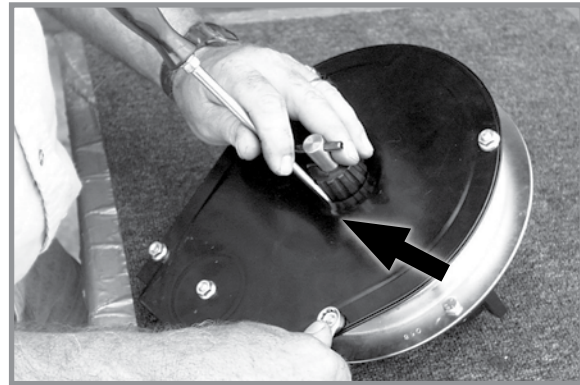
**Belt idler****Centering belt housing cover**

Remove four cap screws around edge of housing cover and nut from belt idler mounting bolt. Paddles must be correctly oriented as shown above. If belt is replaced. A diagram molded into drive sprocket shows correct orientation.

NOTICE

Do not over-tighten hardware or components may be damaged.

Reinstall housing cover. **DO NOT TIGHTEN** hardware. Wedge a screwdriver between sprocket hub and housing cover as shown above. Pry cover down until centered on belt housing and tighten hardware. Rotate meter drive shaft and check idler alignment. Seed belt should "run" centered on idler or with only slight contact with belt housing or cover.

CLEANING FINGER PICKUP SEED METER FOR STORAGE

1. Disassemble meter and blow out any foreign material.
2. Wash **ONLY** in mild soap and water. Do not use gasoline, kerosene, or any other petroleum based product. Dry thoroughly.
3. Coat lightly with a rust inhibitor.
4. Rotate finger assembly so finger does not touch brush.
5. Reassemble and store in a dry, rodent-free location.

BRUSH-TYPE SEED METER MAINTENANCE

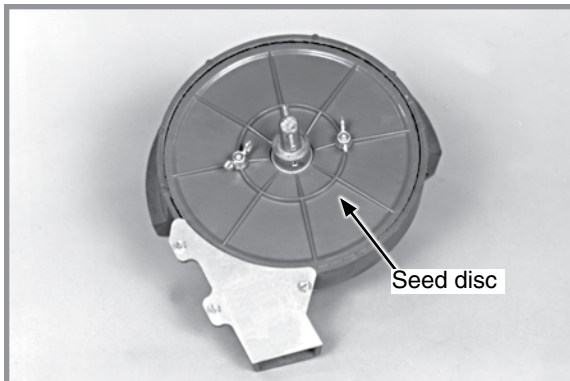

Brush-type seed meter seed disc installed

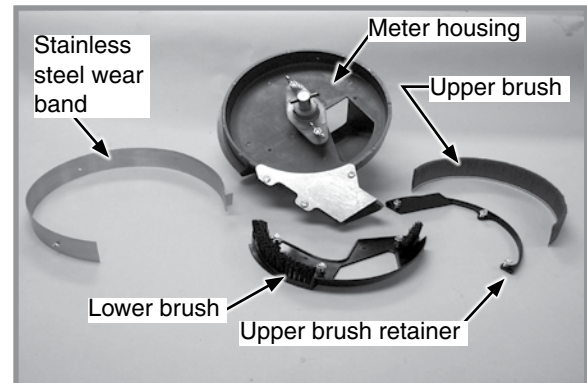

Brush-type seed meter parts

Use clean, high quality seed. Damaged or cracked seed, hulls, or foreign materials can become lodged in upper brush and greatly reduce meter accuracy. Remove seed disc daily and check for buildup of foreign material on seed disc, particularly in seed loading slots. Clean disc by washing it with soap and water. Check for cracked seed, hulls, etc. lodged between brush retainer and stainless steel wear band which can greatly reduce accuracy of the meter because upper brush will not be able to retain seed in seed disc pocket. Thoroughly clean brush areas of meter housing.

SEED DISC WEAR

Most seed disc wear is found in the agitation groove area (area between seed loading slots). Wear affects planting accuracy at high RPM. Lay a straight edge across disc surface at agitation groove area and measure gap between disc and straight edge. If agitation groove areas are worn in excess of .030" (7.6 mm) and accuracy starts to drop off at higher meter RPM, replace seed disc. Estimated seed disc life expectancy under normal operating conditions is approximately 200 acres (81 hectares) per row. Severe operating conditions such as dust, lack of lubrication or abrasive seed coating could reduce seed disc life expectancy to under 100 acres (40.5 hectares) per row.

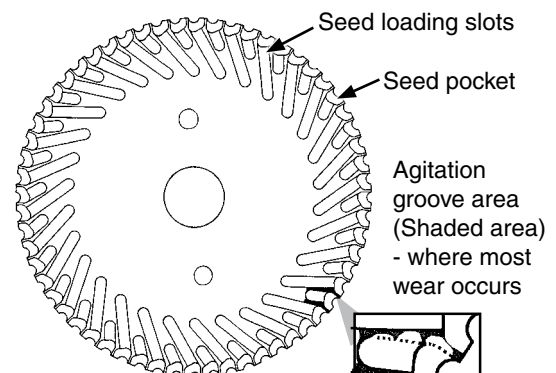

STAINLESS STEEL WEAR BAND

NOTICE

If wear band wears through or if meter is used without wear band in place, meter housing may be damaged.

Stainless steel wear band protects meter housing from wear and is .030" (.076 cm) thick. Replace wear band when there is approximately .020" (.050 cm) of wear in primary wear area. Estimated life expectancy of stainless steel wear band is 240-800 acres (97-324 hectares) per row.

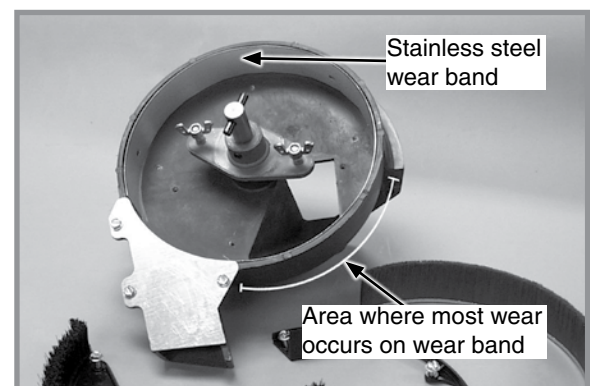

Stainless steel wear band

UPPER BRUSH

Upper brush holds seed in seed disc pocket in seed retention area. Brush must apply enough pressure against seed in seed disc pocket as disc rotates through seed retention area to prevent seed from dropping out of disc pocket. A damaged spot, excessive brush wear, or foreign material lodged in brush may greatly reduce meter performance.

Replace upper brush at 120-400 acres (49-162 hectares) per row of use or sooner if damage or excessive wear is found. Position upper brush into inner perimeter of seed retention area. Make sure base of brush is tight against bottom of meter housing. Install brush retainer and three hex head screws. Tighten screws in sequence shown in photo at right.

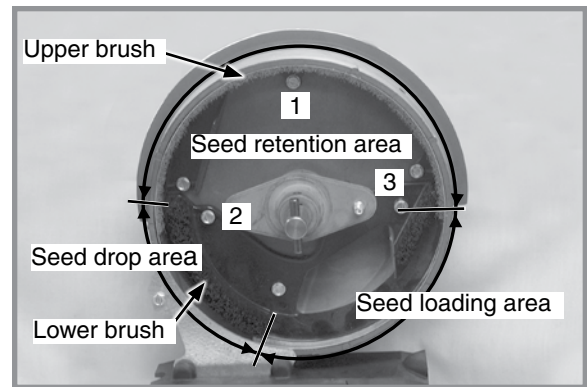

Upper brush installation

NOTE: Use GD11122 upper brush retainer for soybean and cotton discs. Use GD8237 upper brush retainer for milo/grain sorghum discs.

LOWER BRUSH

Lower brush moves seed down seed loading slots to seed pockets, isolates seed in reservoir from entering seed tube, and cleans seed loading slots. Estimated lower brush life expectancy is 240-800 acres (97-324 hectares) per row. Replace lower brush if bristles are deformed or missing, or if there are cracks in brush retainer.

CLEANING BRUSH-TYPE SEED METER FOR STORAGE

1. Remove meter from seed hopper by removing two thumbscrews securing meter to hopper.
2. Remove seed disc and wash with soap and water and dry thoroughly.
3. Remove three hex head screws from brush retainer. Remove brush retainer and upper brush.
4. Remove three hex head screws from lower brush. Remove lower brush and stainless steel wear band.
5. Wash all parts and meter housing with soap and water and dry thoroughly.
6. Inspect all parts and replace worn parts.
7. Reassemble meter except for seed disc. Store meter in a dry, rodent-free space with seed disc removed.

VACUUM MANIFOLD MAINTENANCE

Dust accumulates in manifolds and hoses during normal operation. Clean manifolds annually. Abnormally dusty planting conditions may require more frequent cleaning.

1. Remove vacuum hose from each seed meter.
2. Operate vacuum fan at full hydraulic flow from tractor for two minutes to clear manifolds, hoses, and fittings of dust and debris.
3. Shut down fan and replace hoses

VACUUM SEED METER MAINTENANCE

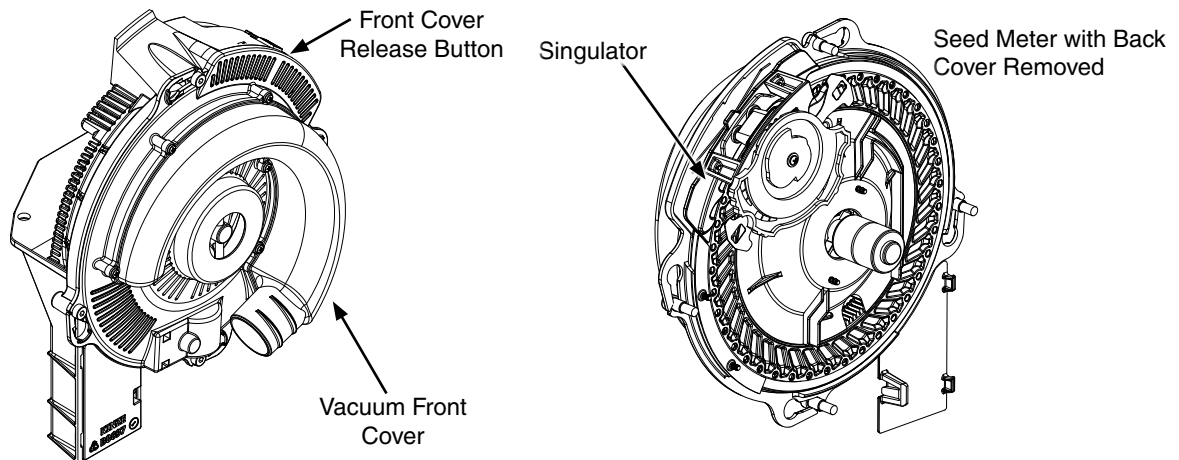

Before each planting season inspect seed discs and singulator and clean or replace as needed.

Use clean, high quality seed for maximum meter accuracy. Damaged or cracked seed, hulls, and foreign material may become lodged in seed disc orifices and greatly reduce meter accuracy.

Inspect and clean seed discs daily checking for any buildup of foreign material and blocked orifices. If seed disc orifices are plugged frequently with seed remnants, remnants ejector wheel may need to be replaced. Clean seed disc by washing it with soap and water. Dry thoroughly.

Inspect singulator blades and guide for wear after every 200 acres (81 hectares) per row of operation. If adjustment of singulator blade does not affect meter performance or if blades appear worn, singulator blade may need to be replaced.

Replace seed disc or vacuum seal if abnormally high vacuum is required or if consistent operation cannot be achieved.

See ["Preparation for Storage" on page 5-28](#) for additional Vacuum Seed Metering System maintenance.

NOTE: Remove seed discs from meters for annual storage and store them vertically on a dowel or pipe.

SEED METER CLEANOUT

NOTE: Use of damaged seed or seed containing foreign material will cause plugging of seed cell orifices and require more frequent seed meter cleanout to prevent underplanting.

Thorough seed meter cleanout is important to maintain genetic purity.

1. Disengage seed drive and remove seed hopper and meter.
2. Dump seed from right rear corner of hopper into a container.
3. Lay hopper on its right side. Push release button and rotate seed meter vacuum cover clockwise to align keyhole slots with bolt heads. Lift off cover.
4. Rotate seed disc hub clockwise to unlock and remove seed disc.
5. Empty meter.
6. Thoroughly inspect meter to ensure all seed is removed.
7. Replace seed disc. Install vacuum cover.

CHAIN TENSION ADJUSTMENT

Drive chains have spring loaded idlers and are self-adjusting. Remove link to shorten chain if wear stretches chain and reduces spring tension. Check idler pivot points to make sure they rotate freely. See “Wrap Spring Wrench Assembly” in this section for additional information.

Additional chain links are stored inside planter frame.

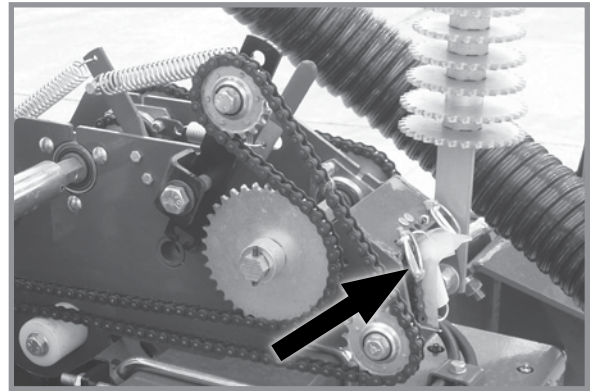

Additional chain links

DRAG CLOSING ATTACHMENT

Inspect each drag closing attachment and replace any worn or broken parts before storing planter. Check for loose hardware and tighten as needed.

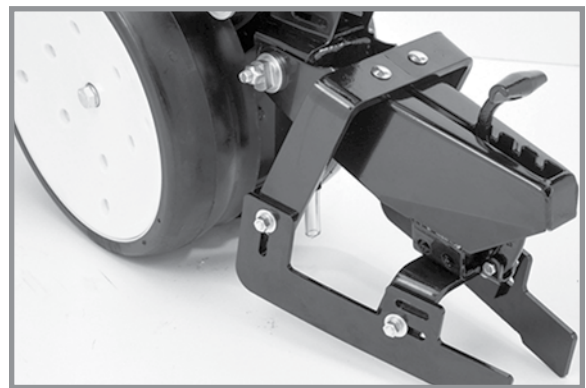

Drag Closing Attachment

GAUGE WHEEL ADJUSTMENT

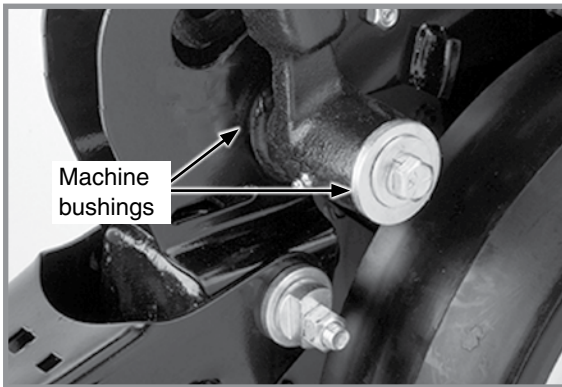

Machine bushings

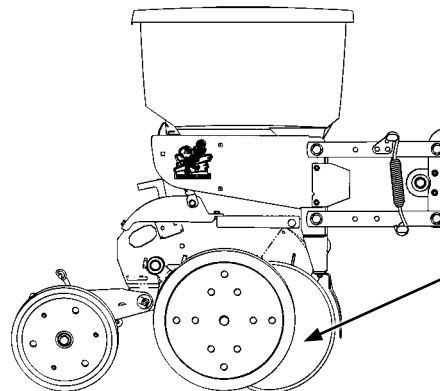

Shim gauge wheel to lightly contact opener disc blade. Check adjustment in field position.

Gauge wheel adjustment

Gauge wheels should lightly contact opener blades to prevent accumulation of dirt or trash. Gauge wheels and opener blades should turn with only slight resistance.

Add or remove machine bushings between shank and gauge wheel arm to adjust clearance between gauge wheels and opener blades. Store remaining machine bushings between gauge wheel arm and flat washer on outer side of gauge wheel arm.

NOTE: It may be desirable to space gauge wheel further from blade when operating in sticky soils.

GAUGE WHEEL ARM BUSHING/SEAL REPLACEMENT

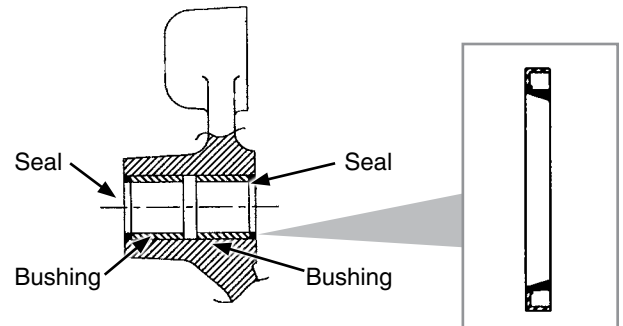
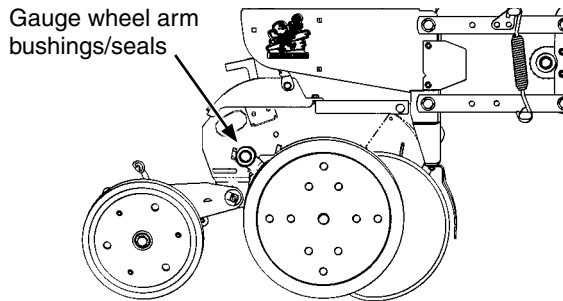

NOTE: Gauge Wheel Arm Bushing and Seal Driver Kit (G1K296) is available through your Kinze Dealer.

1. Remove gauge wheel from arm.
2. Remove gauge wheel arm from shank assembly.
3. Remove seal and bushing and discard. Clean and dry inner bore.
4. Drive/press replacement bushing inside bore of arm to a depth of .125" (3.2 mm) below flush.
5. Coat wiping edge of seal with grease.
6. Drive/press seal into place with lip to outside.

NOTE: Use extra care to protect the sealing lip during installation. Apply uniform pressure to assemble the seal into the bore of the arm. Never apply a direct hammer blow to the seal surface.

7. Inspect gauge wheel pivot spindle.
8. Reinstall gauge wheel arm assembly and gauge wheel.

NOTE: Use special machine bushing between gauge wheel arm and gauge wheel.

9. Shim for proper gauge wheel tire/disc blade clearance.
10. Lubricate with an SAE multipurpose grease.

GAUGE WHEEL ARM PIVOT SPINDLE REPLACEMENT

1. Remove gauge wheel and arm assemblies from shank assembly.
2. Remove 1/2" x 3/4" cap screw that locks pivot spindle in place and remove spindle.
3. Install replacement spindle and position as shown. Exact centering is critical.
4. Install 1/2" x 3/4" cap screw and torque to lock pivot spindle in place.
5. Install gauge wheel and arm assemblies. Shim for proper gauge wheel tire/disc blade clearance.

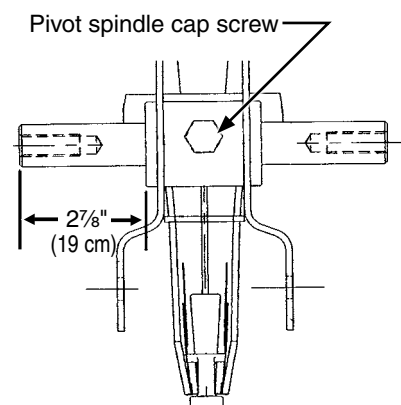

15" SEED OPENER DISC BLADE/BEARING ASSEMBLY

NOTICE

Excessive blade contact may result in premature disc opener bearing/hub failures and excessive wear on seed tube guard/inner scraper. When properly adjusted, if one blade is held in fixed position, opposite blade should rotate with less than 5 pounds force (22 newtons) at outer edge of blade.

Maintain approximately $1" \pm \frac{1}{2}"$ (3 ± 5 cm) of blade-to-blade contact to properly open and form seed trench. As blade diameter decreases due to wear, it is necessary to relocate machine bushings from inside to outside to maintain $1" \pm \frac{1}{2}"$ (3 ± 5 cm) of contact.

NOTE: Proper blade clearance is critical. Blades should have $1" \pm \frac{1}{2}"$ (3 ± 5 cm) contact in this area. When blades are turned by hand in opposite directions against each other, there should be only light resistance to turning. Re-adjust blade scraper if necessary to center it between the blades.

NOTE: Replace blades if proper blade-to-blade contact cannot be maintained after relocating machine bushings or if blade diameter wears below $14\frac{1}{2}"$ (36.8 cm).

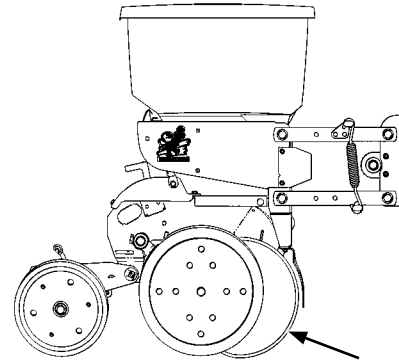

Approximately $1" \pm \frac{1}{2}"$ (3 ± 5 cm) blade-to-blade contact.

REPLACE DISC BLADE/BEARING ASSEMBLY

NOTE: Only bearing may need to be replaced if there is excessive endplay or if bearing sounds or feels rough when disc blade is rotated.

1. Remove gauge wheel, scraper, and bearing dust cap.
2. Remove cap screw, washer and disc blade/bearing assembly. Machine bushings between shank and disc blade are used to maintain approximate $1" \pm \frac{1}{2}"$ (3 ± 5 cm) of blade-to-blade contact.

NOTICE

Left hand side of opener uses a left hand threaded cap screw. **DO NOT OVER TIGHTEN.** Damage to shank threads require replacement of row unit shank assembly.

3. Install machine bushing(s), new disc blade bearing assembly, washer and cap screw. Torque $\frac{5}{8}"$ -11 Grade 5 cap screw to 110 ft-lb (149.14 N-m).

NOTE: Replace disc blades only with disc blades of equal thickness.

4. Install bearing dust cap, scraper, and gauge wheel.

REPLACE BEARING ONLY

1. Remove gauge wheel, scraper, bearing cap, cap screw, washer and disc blade/bearing assembly.
2. Remove $\frac{1}{4}"$ rivets from bearing housing to expose bearing.
3. Installing new bearing. install three evenly spaced $\frac{1}{4}"$ cap screws into three of six holes in bearing housing to hold bearing and bearing housing in place. Install rivets in other three holes. Remove $\frac{1}{4}"$ cap screws and install rivets in those three holes.
4. Reinstall disc blade/bearing assembly, washer and cap screw. Torque $\frac{5}{8}"$ -11 cap screw to 110 ft-lb (149.14 N-m).
5. Install bearing dust cap, scraper, and gauge wheel.

SEED TUBE GUARD/INNER SCRAPER

Seed tube guard protects seed tube and acts as inner scraper for seed opener disc blades.

Remove seed tube and check for wear. Excessive wear on seed tube indicates a worn seed tube guard. Replace seed tube guard if it measures $\frac{5}{8}$ " (1.6 cm) or less at lower end. A new seed tube guard measures approximately $\frac{7}{8}$ " (2.2 cm).

NOTE: No till planting or planting in hard ground conditions, especially when planter is not equipped with no till coulters, and/or excessive blade-to-blade contact increases seed tube guard wear and requires more frequent inspection and/or replacement.

Remove seed tube and two hex socket head cap screws that attach seed tube guard. Hold replacement seed tube guard centered between seed opener disc blades. Install hex socket head cap screws. **DO NOT TIGHTEN.** Using a clamp or vise-grip, squeeze opener blades together in front of seed tube guard. Tighten seed tube guard retaining screws. Remove clamps. Distance between seed tube guard and opener blades should be equal on both sides. Reinstall seed tube.

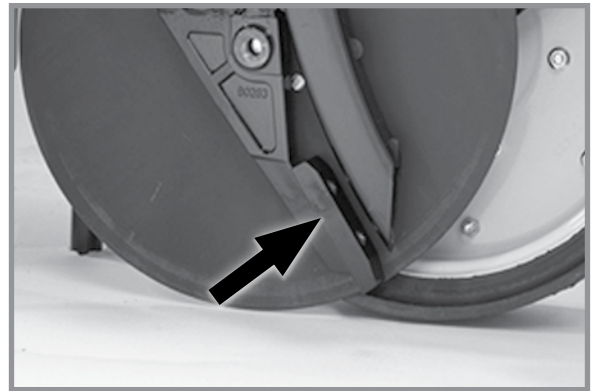

Seed tube guard/inner scraper
(Gauge wheel/seed opener disc blade removed)

NOTICE

Over tightening hex socket head cap screws may damage shank threads and require replacement of shank. An excessively worn seed tube guard may allow blades to wear into row unit shank, also requiring replacement of shank.

FRAME MOUNTED COULTER

NOTE: Torque $\frac{5}{8}$ " spindle hardware to 120 ft-lb (162.7 N-m)

See "Frame Mounted Coulters" in Row Unit Operation section of this manual for depth and spring adjustment.

Replace 16" diameter coulters blade (1" fluted, 1" bubbled or $\frac{3}{4}$ " fluted) when worn to 14 $\frac{1}{2}$ " (37 cm) (maximum allowable wear).

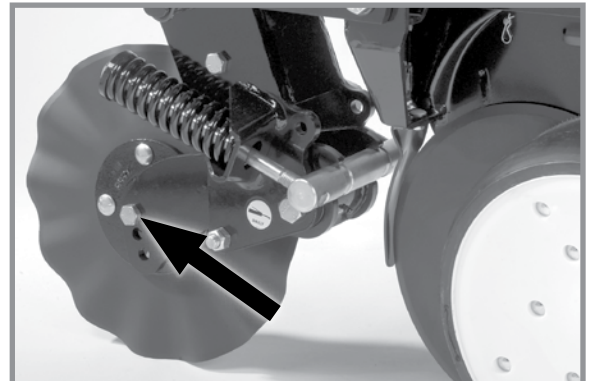

Frame mounted coulters spindle

RESIDUE WHEELS (FOR USE WITH FRAME MOUNTED COULTER)

Wheel hub is equipped with sealed bearings. Replace bearings if a bearing sounds or feels rough when wheel is rotated.

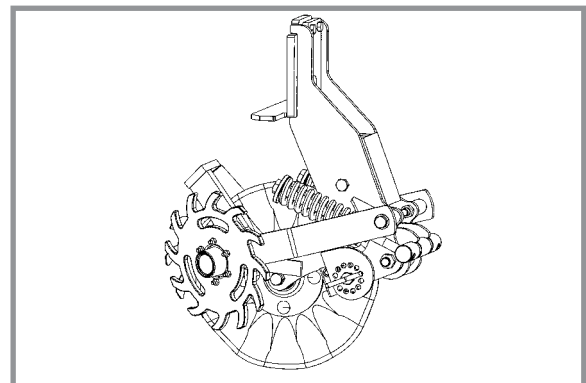

Frame mounted coulters residue wheels

ROW UNIT MOUNTED DISC FURROWER

Lubricate bushings in support arm mounting bracket at frequency indicated in Lubrication of this section. Check each bolt for proper torque. If bolt is loose, it should be removed and bushing inspected for cracks and wear. Replace bushings as necessary.

NOTE: Use only hardened flat washers. Replace damaged flat washers with proper part. Torque bolts to 130 ft-lb (176.2 N-m).

Blade hubs are equipped with sealed bearings. Replace bearings if a bearing sounds or feels rough when wheel is rotated.

Replace solid or notched 12" diameter blades when worn to 11" (28 cm).

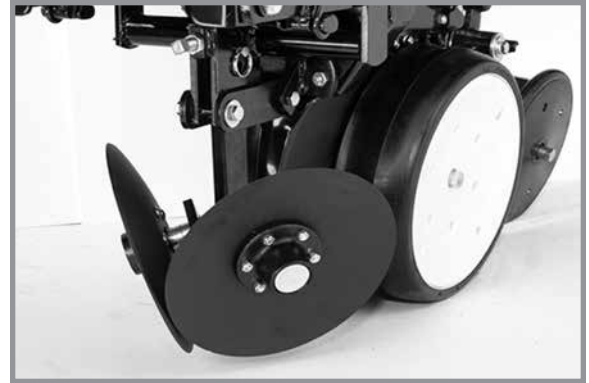

Row unit mounted disc furrower

ROW UNIT MOUNTED BED LEVELER

Lubricate bushings in mounting bracket and links at frequency indicated in Lubrication of this section. Check each bolt for proper torque. If bolt is loose, it should be removed and bushing inspected for cracks and wear. Replace bushing if necessary.

NOTE: Use only hardened flat washers. Replace damaged flat washers with proper part. Torque bolts to 130 ft-lb (176.2 N-m).



Row unit mounted bed leveler

ROW UNIT MOUNTED NO TILL COULTER

Check nuts and hardware periodically for proper torque. Be sure coulters are positioned square with row unit and aligned in front of row unit disc opener.

NOTE: Torque 5/8" spindle hardware to 120 ft-lb (162 N-m).

Coulter blade can be adjusted to one of four settings. Initially blade is set in highest position. As blade wears it can be adjusted to one of three lower settings. See "Row Unit Mounted No Till Coulter" in Row Unit Operation section of this manual.

Replace 16" diameter coulters when worn to 14½" (37 cm).



Row unit mounted no till coulters

COULTER MOUNTED RESIDUE WHEELS

Wheel hubs are equipped with sealed bearings. If bearings sound or feel rough when wheel is rotated, replace them.



Coultter mounted residue wheels

ROW UNIT MOUNTED RESIDUE WHEEL

Wheel hub is equipped with sealed bearings. If a bearing sounds or feels rough when wheel is rotated, replace them.

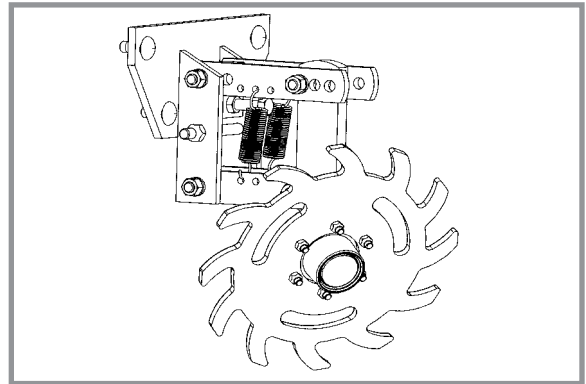

SPIKED CLOSING WHEEL

Inner parts of spiked closing wheel will begin to wear at approximately 70% of life. Flip/reverse wheel to utilize remaining life of wheel.

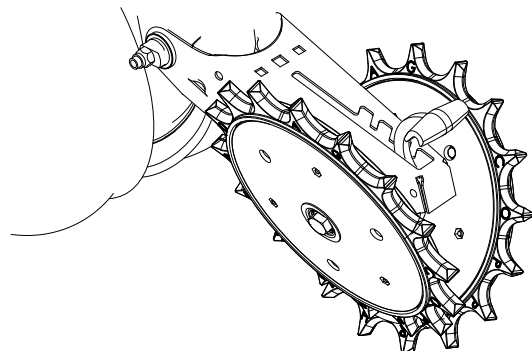

Row Unit Spiked Closing Wheel

GRANULAR CHEMICAL ATTACHMENT

Before storing planter, disengage granular chemical drive by rotating throwout knob $\frac{1}{4}$ turn counterclockwise. Remove drive chain and empty and clean all granular chemical hoppers. Clean drive chains and coat them with a rust preventive spray or submerge chains in oil. Inspect and replace worn or broken parts.

Install hoppers and chains. Check chain alignment.

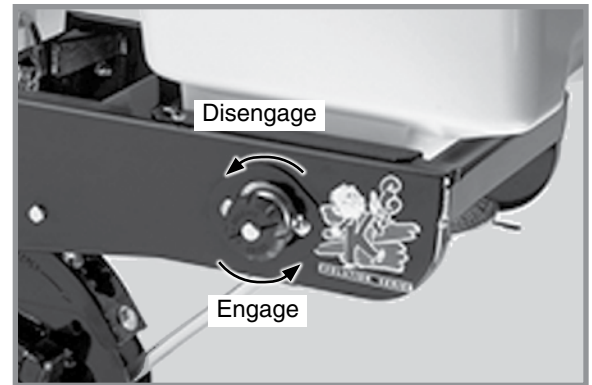

Granular chemical throwout knob

SPRING TOOTH INCORPORATOR

Before storing planter, inspect each spring tooth incorporator and replace worn or broken parts. Check for loose hardware and tighten as needed.

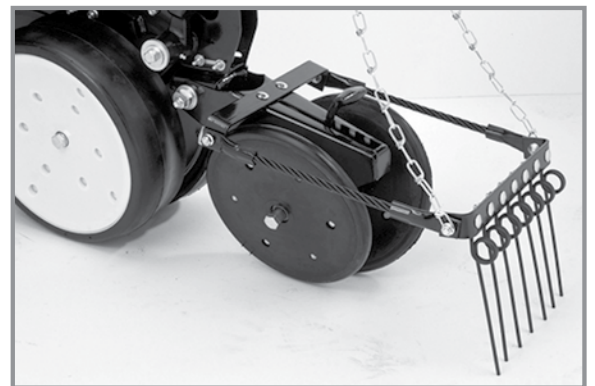

Spring tooth incorporator

SINGLE AND TWO-SPEED POINT ROW CLUTCH MAINTENANCE

Point row clutch is permanently lubricated and sealed and requires no periodic maintenance. Two-speed point row clutch is similar in design and operation to standard point row clutch except for two-speed function.

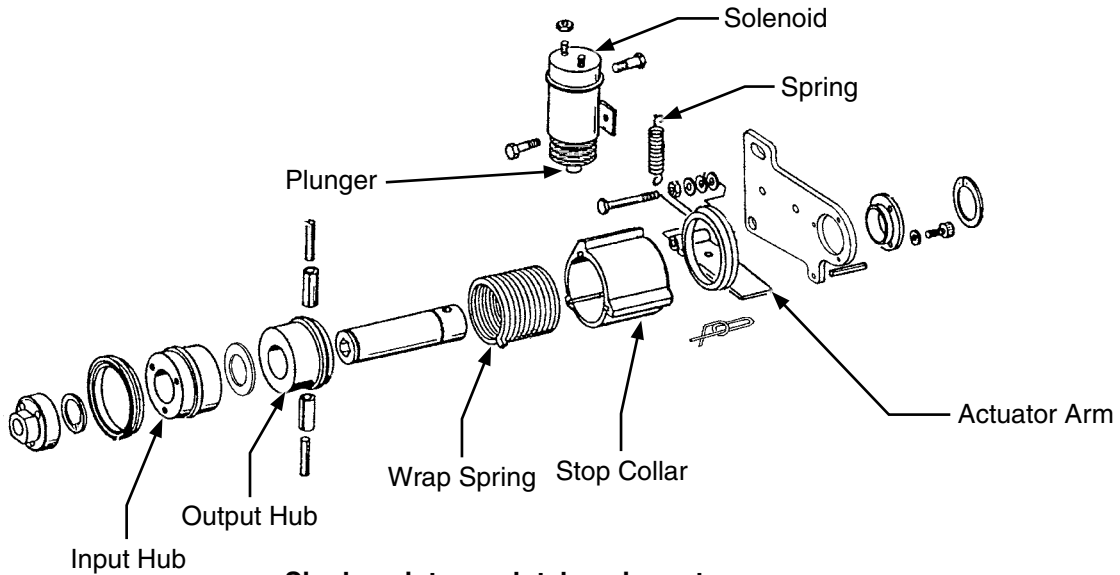

Single point row clutch main parts

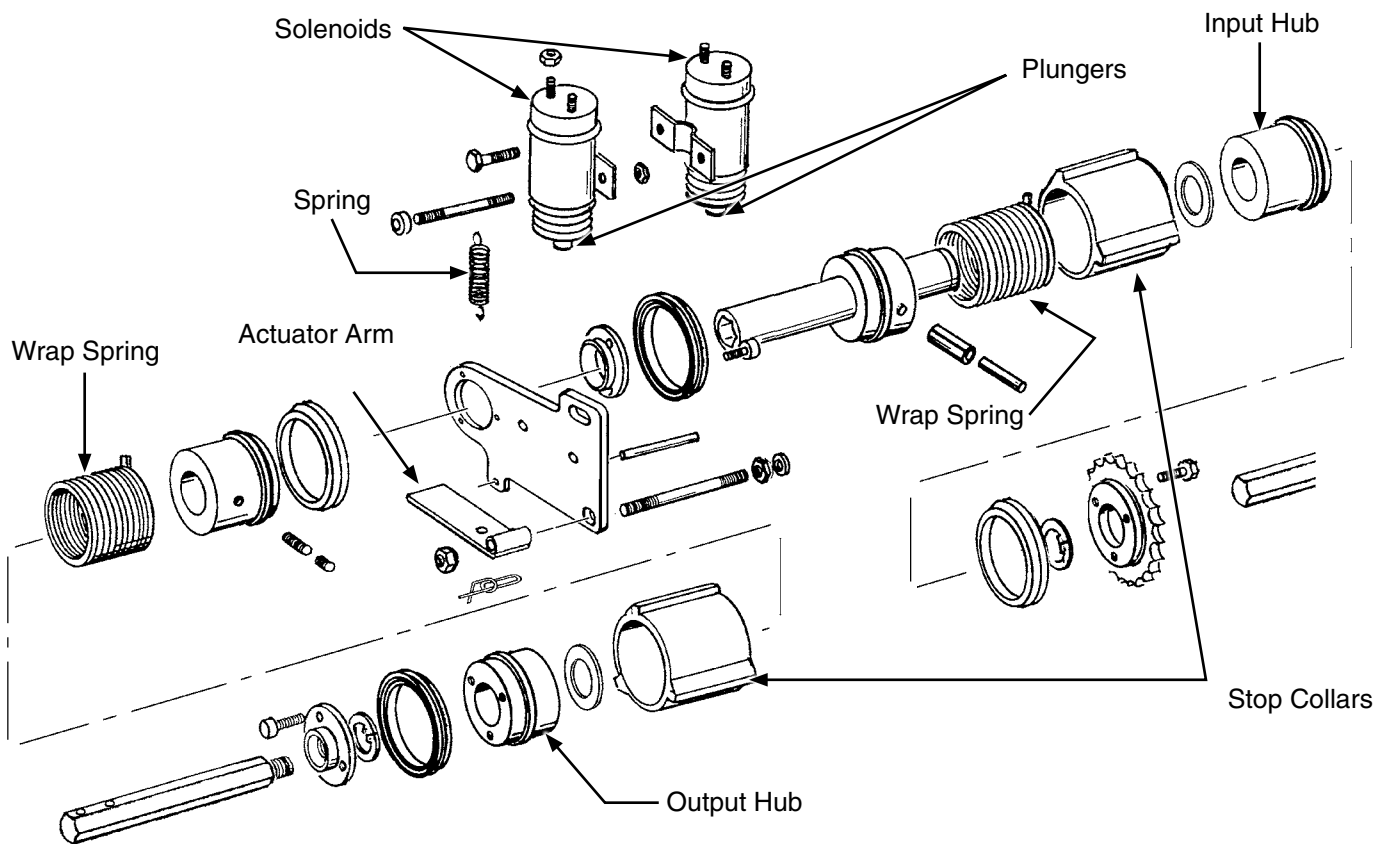

Two-speed point row clutch main parts

The right hand clutch operates clockwise and the left hand clutch operates counterclockwise. Therefore, some of the parts of the clutch such as the wrap spring differ from one side of the planter to the other. Be sure to use the correct repair part if a clutch must be repaired.

The control box is equipped with a resettable circuit breaker. To reset the circuit breaker, press the red button on the circuit breaker until it snaps into place. If the circuit breaker continues to trip, check to see what is causing it to trip. See "Point Row Clutch Troubleshooting".

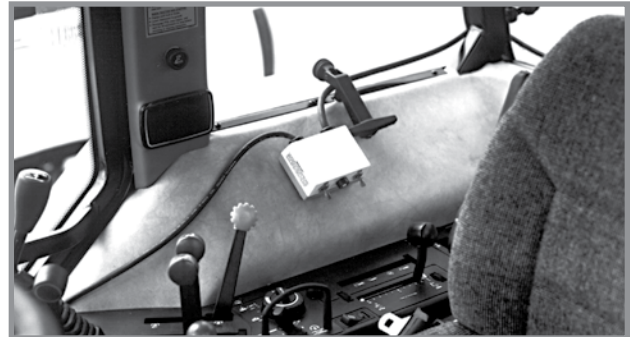

If the circuit breaker on the control box is not tripped, determine if the problem is electrical or mechanical. Place the operational switch in the RIGHT or LEFT position. Check the clutch and wiring harness for power with a test light or volt meter. If the solenoid is operating properly, the plunger on the solenoid will retract causing a clicking sound. The plunger will also be magnetized which can be checked by touching the plunger with a metal object.

ACTUATOR ARM ADJUSTMENT

Gap between actuator arm and stop on stop collar should be $\frac{1}{8}$ " ($\pm\frac{1}{32}$ ") (.3 cm ($\pm.8$ mm)) when solenoid is NOT engaged.

Loosen nut on mounting pin and move pin in slot until there is a $\frac{1}{8}$ " ($\pm\frac{1}{32}$ ") (.3 cm ($\pm.8$ mm)) gap between arm and stop on stop collar. Retighten nut.

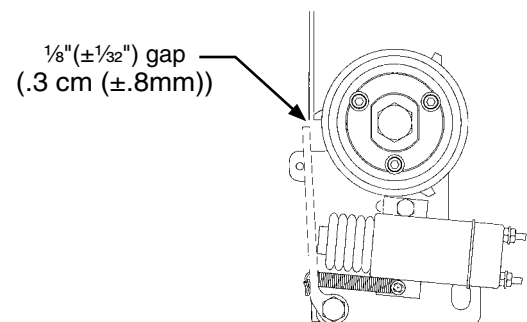

NOTE: If the "Reduced Rate/Full Rate" functions fail to engage or disengage, see troubleshooting chart for possible cause

CAM FOLLOWER ADJUSTMENT

Each wing hinge is equipped with a cam follower which floats against a curved guide on the center frame. Check cam followers periodically and maintain adjustment as shown below.

NOTE: Always check cam follower adjustment and make cam follower adjustments with the planter on a flat surface and lowered to the planting position.

To adjust cam followers:

1. Loosen $\frac{3}{4}$ " cap screw on cam follower.
2. Using a $\frac{1}{2}$ " ratchet extension, rotate and hold cam follower in place.
3. Torque $\frac{3}{4}$ " cap screw to 150 ft. lbs. (203 Nm)

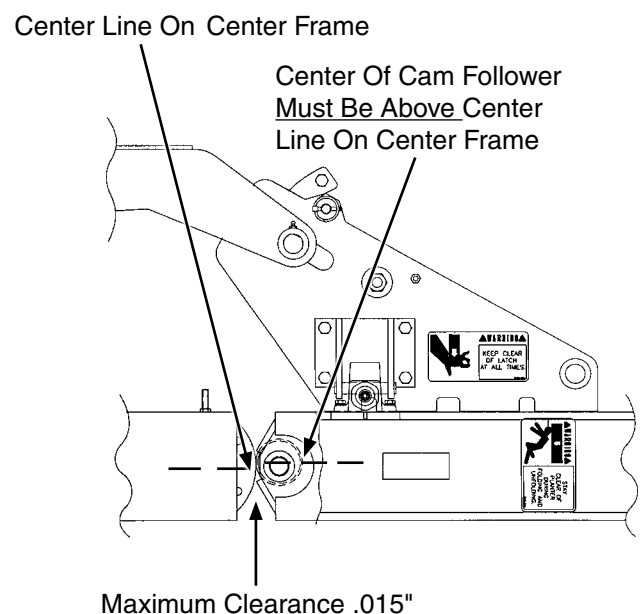

NOTICE

Connect hydraulic motor case drain to a case drain return line with zero pressure on tractor or hydraulic motor will be damaged. DO NOT connect hydraulic motor case drain to SCV outlet. Contact tractor manufacturer for specific details on “zero pressure return”.

RELIEF VALVE CARTRIDGE

Pressure relief valve located in valve block below vacuum fan motor assembly helps prevent damage to vacuum fan motor by limiting pressure in the motor case drain line. It is set to open at 35 PSI (241.21 kPa). If valve fails to function properly, it should be removed for inspection. Check for foreign material and contamination on valve and the seating area of valve body. Replace if defective.

NOTE: Case drain pressure will build if the case drain hose to the tractor is connected where pressure is present.

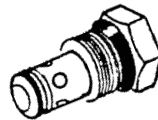
CHECK VALVE (VACUUM FAN)

Check valve located in valve block below vacuum fan motor assembly operates as a return line check to prevent vacuum fan motor reverse operation. Remove and inspect valve if it does not operate properly. Check for foreign material and if O-ring is leaking internally. Replace if defective.

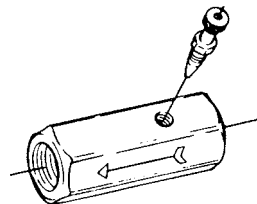
FLOW CONTROL VALVE

The optional dual lift assist wheels flow control valve should be adjusted as part of the assembly procedure or upon initial operation.

If the valve fails to function properly or requires frequent adjustment, the needle valve should be removed for inspection. Check for foreign material and contamination on both the valve and the seating area of the valve body. Replace any components found to be defective.

NOTE: The flow control valve must be installed with the arrow pointed toward the planter.

NOTE: When oil is cold, hydraulics operate slowly. Make sure all adjustments are made with warm oil.

ROW MARKER SEQUENCING/FLOW CONTROL VALVE INSPECTION

WARNING

Pressurized hydraulic fluid can penetrate body tissue and result in death, serious infection, or other injuries. Fluid injected under skin must be **IMMEDIATELY** removed by a surgeon familiar with this type of injury. Make sure connections are tight and hoses and fittings are not damaged before applying system pressure. Leaks can be invisible. Keep away from suspected leaks. Relieve pressure before searching for leaks or performing any system maintenance.



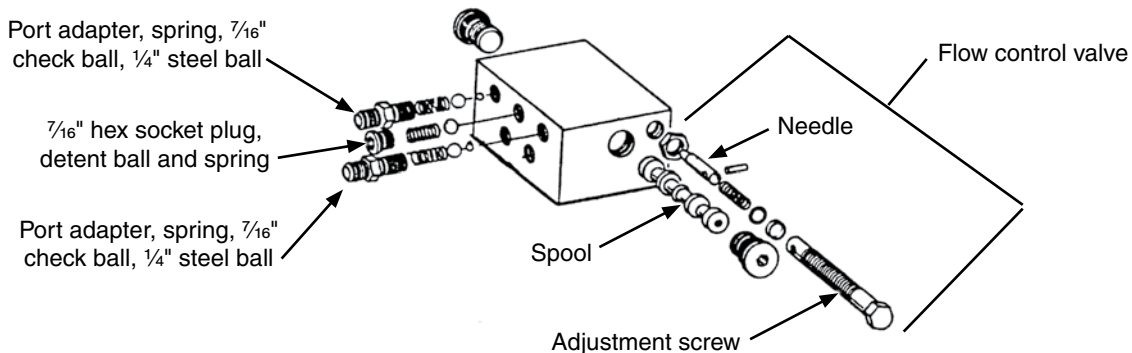

The valve block assembly consists of the row marker sequencing and flow control valves in one assembly. Sequencing valve portion consists of a chambered body containing a spool and series of check valves to direct hydraulic oil flow.

1. Remove valve block assembly from planter.
2. Remove detent assembly and port adapter assemblies from rear of valve block.

NOTICE

Damage to spool may occur if detent assembly and port adapter assemblies are not removed prior to removal of spool.

3. Remove plug from both sides of valve block and remove spool.
4. Inspect all parts for pitting, contamination, or foreign material. Check seating surfaces inside valve. Replace defective parts.
5. Lubricate spool with a light oil and reinstall. Check spool moves freely in valve body.

NOTE: Make sure correct check ball(s) and spring are installed in each valve bore upon reassembly.

A flow control valve is located on each side of block assembly. Adjust flow control valves for raise and lower speed as part of assembly procedure or upon initial operation. If valve fails to function properly or requires frequent adjustment, remove needle valve for inspection. Check for foreign material and contamination. Make sure needle moves freely in adjustment screw. Replace defective components.

NOTE: Hydraulics operate slowly when oil is cold. Make all adjustments with warm oil.

ROW MARKER BEARING LUBRICATION OR REPLACEMENT

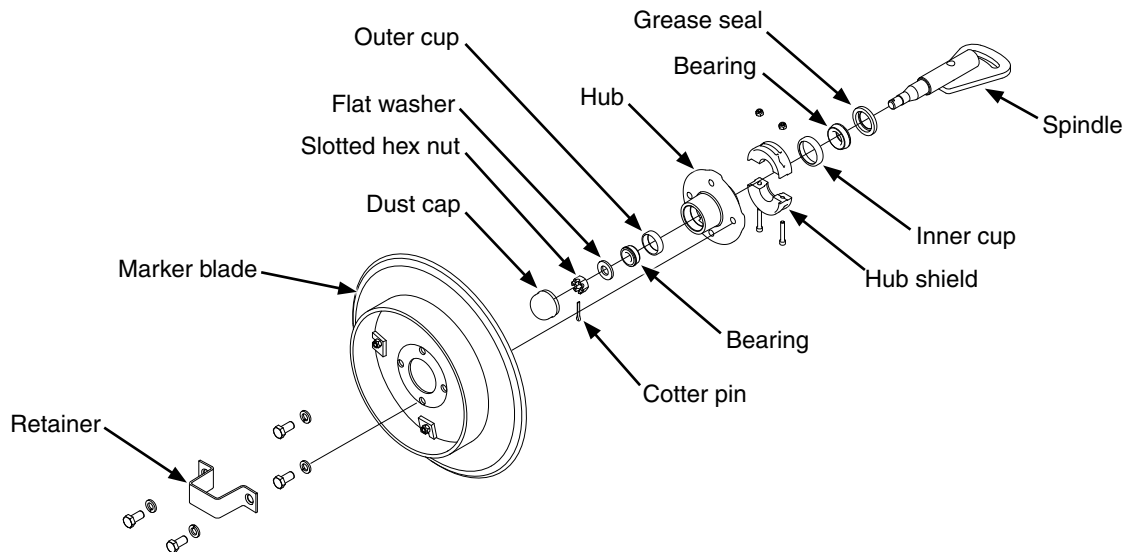

1. Remove retainer and marker blade.
2. Remove dust cap from hub.
2. Remove hub shield. Note direction of installation.
3. Remove cotter pin, slotted hex nut, and washer.
4. Slide hub from spindle.
5. Remove bearings and cups and discard if bearings are being replaced. Clean hub and dry. Remove bearings only and not cups if repacking.
6. Press in new bearing cups with thickest edge facing in. (Bearing replacement procedure only.)
7. Pack bearings with heavy duty wheel bearing grease thoroughly forcing grease between roller cone and bearing cage. Fill the space between the bearing cups in the hub with grease.
8. Install rubber seal into grease seal. Place inner bearing in place and press in new rubber seal/grease seal.
9. Clean spindle and install hub.
10. Install outer bearing, washer and slotted hex nut. Tighten slotted hex nut while rotating hub until there is some drag. This ensures all bearing surfaces are in contact. Back off slotted nut to nearest locking slot and install cotter pin.
11. Fill dust caps approximately $\frac{3}{4}$ full of wheel bearing grease and install on hub.
12. Install hub shield.
13. Install marker blade and retainer on hub. Tighten hardware evenly.

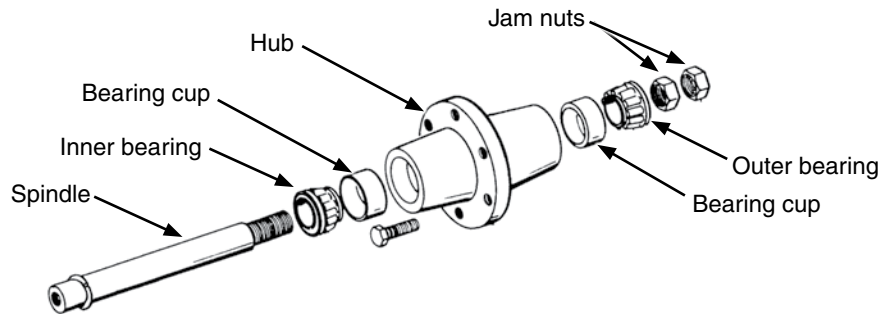
WHEEL BEARING REPACK OR REPLACEMENT

1. Raise tire clear of ground and remove wheel.
2. Remove double jam nuts and slide hub from spindle.
3. Remove bearings and cups and discard if bearings are being replaced. Clean hub and dry. Remove bearings only and not cups if repacking.
4. Press in new bearing cups with thickest edge facing in. (Bearing replacement procedure only.)
5. Pack bearings with heavy duty wheel bearing grease thoroughly forcing grease between roller cone and bearing cage. Fill space between bearing cups and hub with grease.
6. Place inner bearing in place.
7. Clean spindle and install hub.
8. Install outer bearing and jam nut. Tighten jam nut while rotating hub until there is some drag. This ensures all bearing surfaces are in contact. Back off jam nut $\frac{1}{4}$ turn or until there is only slight drag when rotating hub. Install second jam nut to lock against first.
9. Install wheel on hub. Tighten hardware evenly.

PREPARATION FOR STORAGE

Store planter in a dry sheltered area if possible.

Remove all trash wrapped on sprockets or shafts and remove dirt that can draw and hold moisture.

Clean all drive chains and coat with a rust preventative spray, or remove chains and submerge in oil.

Lubricate planter and row units at all lubrication points.

Inspect planter for parts that in need of replacement and order during "off" season.

Make sure all seed and granular chemical hoppers are empty and clean.

Remove seed discs from seed meters, clean and store meters in a rodent-free, dry area with discs removed. Store seed discs vertically on a dowel or pipe.

Remove vacuum hose from each seed meter. Operate vacuum fan at full hydraulic flow from tractor for two minutes to clear manifolds, hoses and fittings of dust and debris.

Clean breather on analog vacuum and pressure gauges.

Disassemble, clean and grease all U-joint slides.

Grease or paint disc openers/blades and row marker disc blades to prevent rust.

Flush liquid fertilizer tanks, hoses and metering pump with clean water. See "Piston Pump Storage" if applicable.

ELECTRICAL WIRING DIAGRAM FOR LIGHT PACKAGE

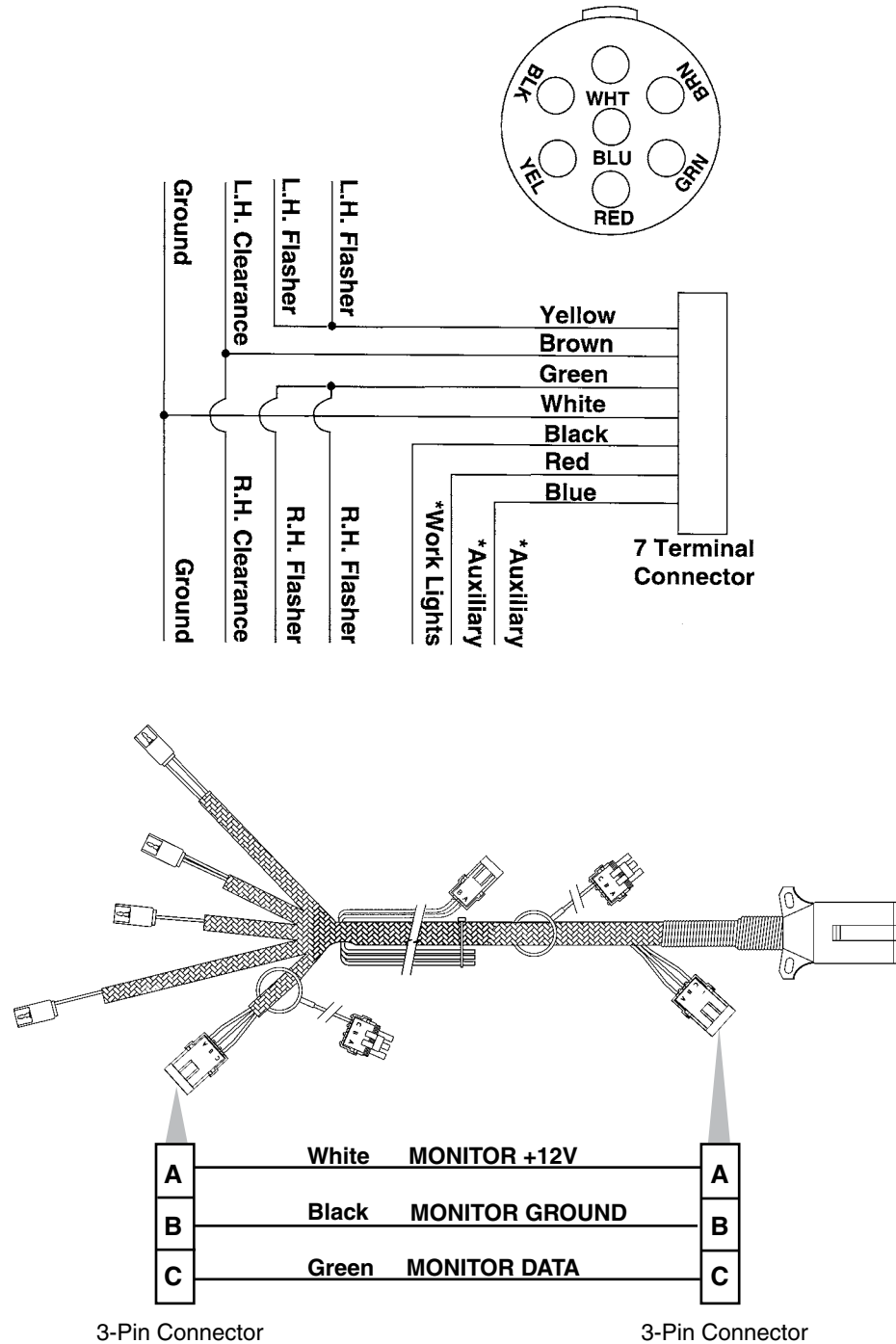

*** Optional customer-supplied auxiliary lights and wires may be wired into existing plug terminals.**

The light package supplied on the Model 3140 planter meets ASAE Standards. For the correct wiring harness to be wired into the lights on your tractor, check with the tractor manufacturer.

ELECTRICAL WIRING DIAGRAMS FOR POINT ROW CLUTCHES

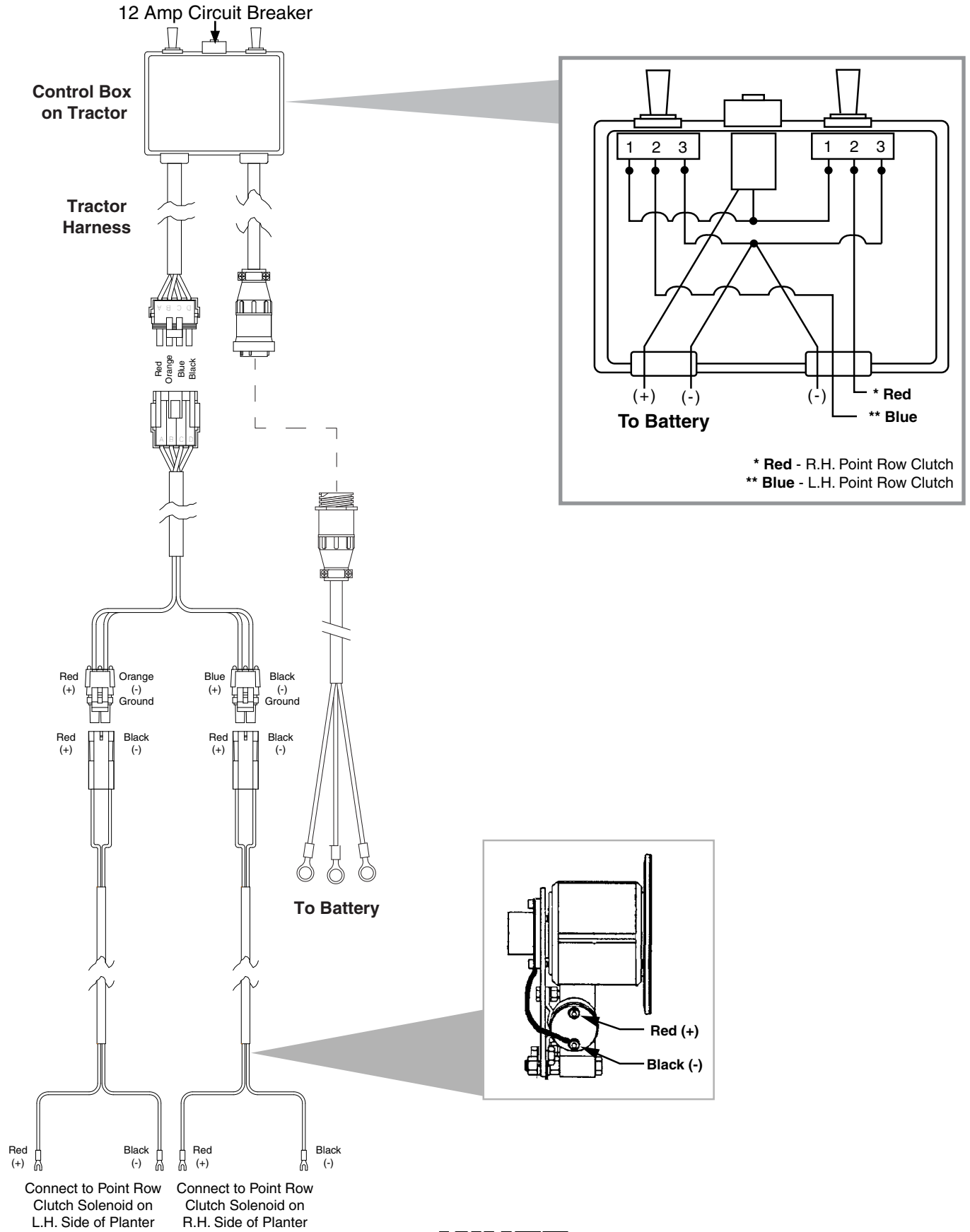

ELECTRICAL WIRING DIAGRAMS FOR TWO-SPEED POINT ROW CLUTCHES

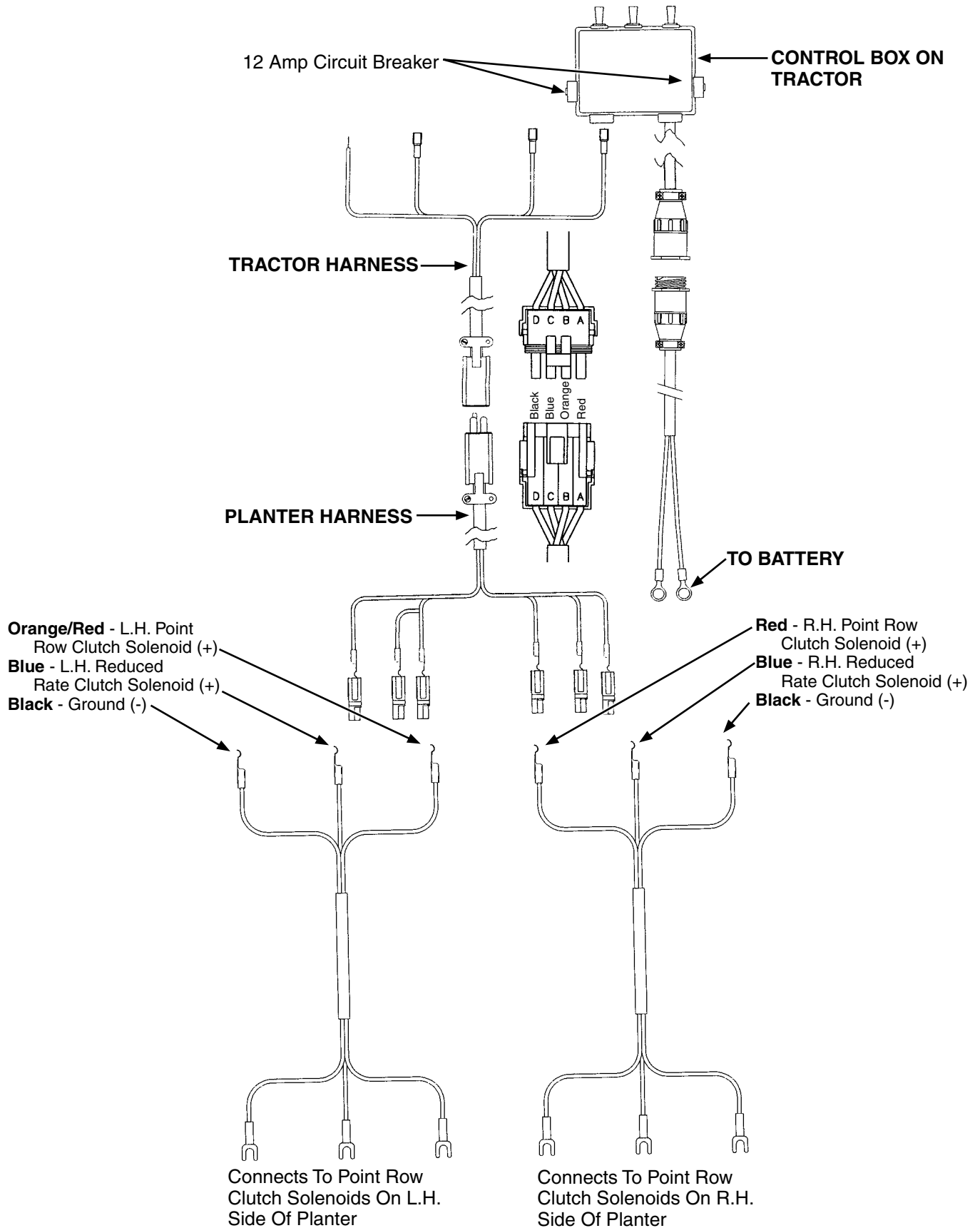

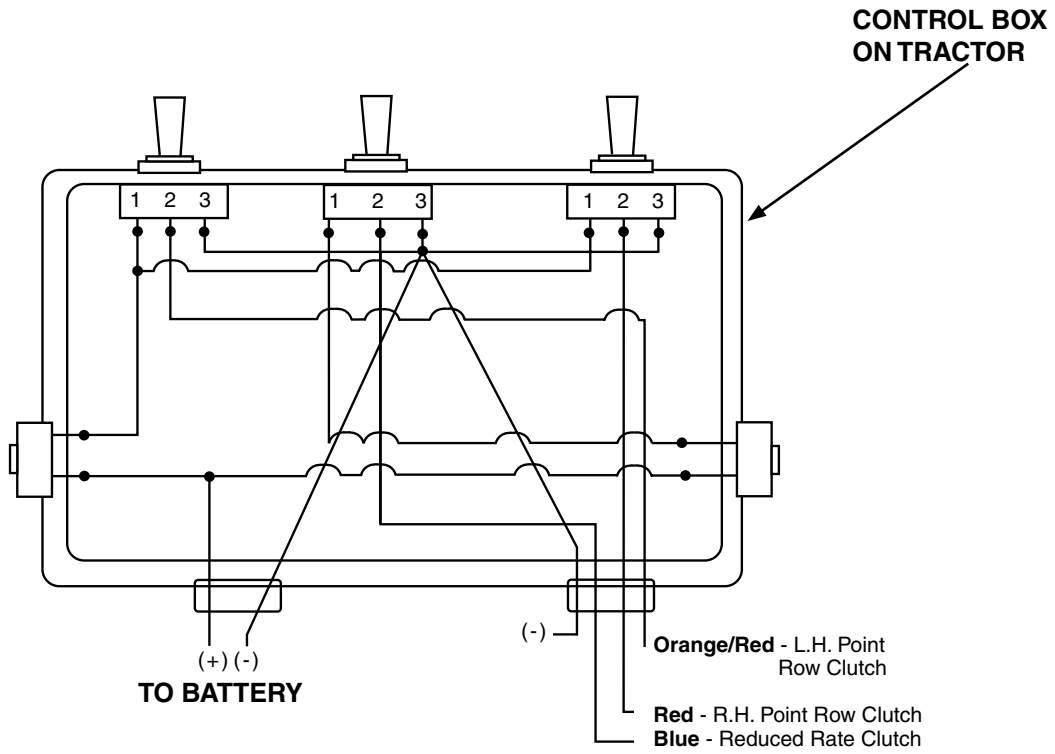

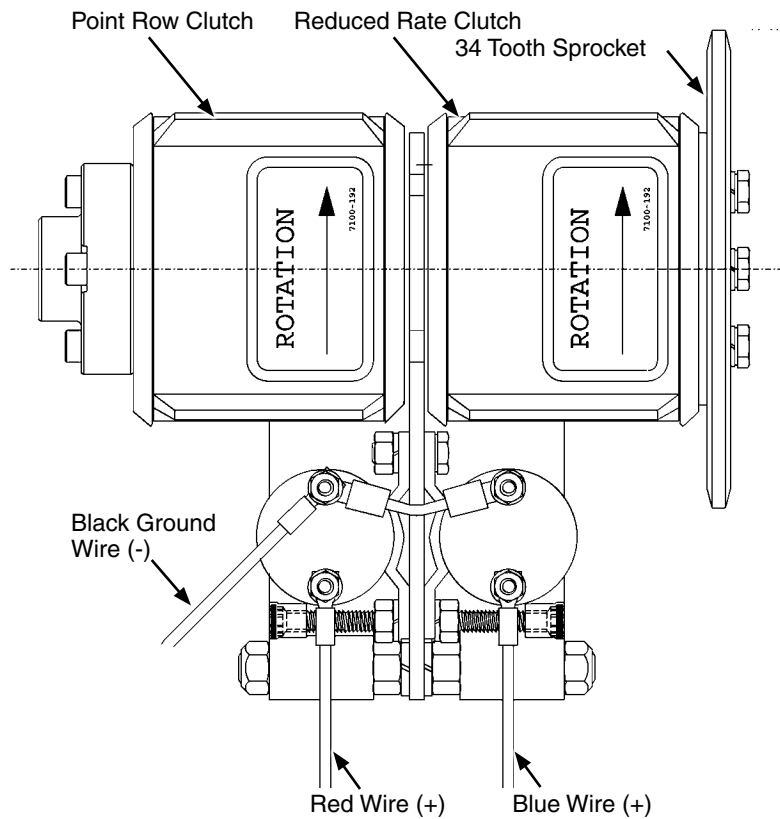

TWO-SPEED POINT ROW CLUTCH FOR L.H. SIDE OF PLANTER SHOWN



HYDRAULIC HOSE LIFE

 WARNING	Pressurized hydraulic fluid can penetrate body tissue and result in death, serious infection, or other injuries. Fluid injected under skin must be IMMEDIATELY removed by a surgeon familiar with this type of injury. Make sure connections are tight and hoses and fittings are not damaged before applying system pressure. Leaks can be invisible. Keep away from suspected leaks. Relieve pressure before searching for leaks or performing any system maintenance.
	

Proper storage of hydraulic hoses can significantly increase the life of the hoses, for a period of three to five years. After this period, service life of hoses may decrease, depending on variables such as variances in rubber materials and storage environment. Refer to the guidelines below for best practices when storing.

- Store in a clean, cool and dry area
- Avoid direct sunlight or moisture
- Do not store near high power electrical equipment
- Avoid contact with corrosive chemicals
- Avoid ultraviolet light
- Avoid areas with obvious signs of insects or rodents

Unusually long periods of storage or poor storage environment may lead to performance issues or premature failure. Always inspect all hoses prior to use for extensive wear, cuts, or holes. If such flaws are identified, replace immediately to avoid potential failure, property damage or bodily injury.

HYDRAULIC SCHEMATIC - VACUUM FAN MOTOR SYSTEM

NOTICE

Connect hydraulic motor case drain to a case drain return line with zero pressure on tractor or hydraulic motor will be damaged. DO NOT connect hydraulic motor case drain to SCV outlet. Contact tractor manufacturer for specific details on "zero pressure return".

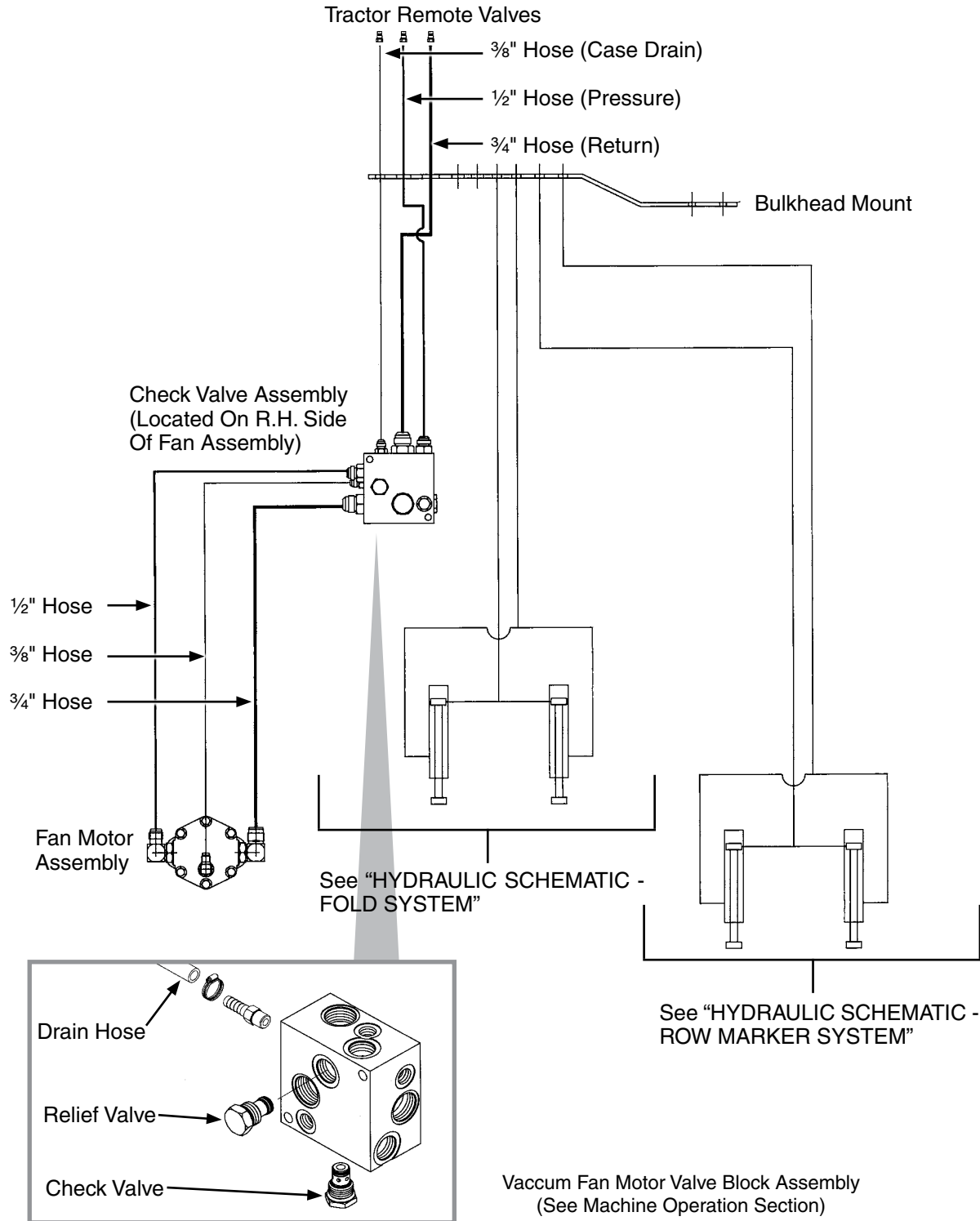

HYDRAULIC SCHEMATIC - FOLD SYSTEM

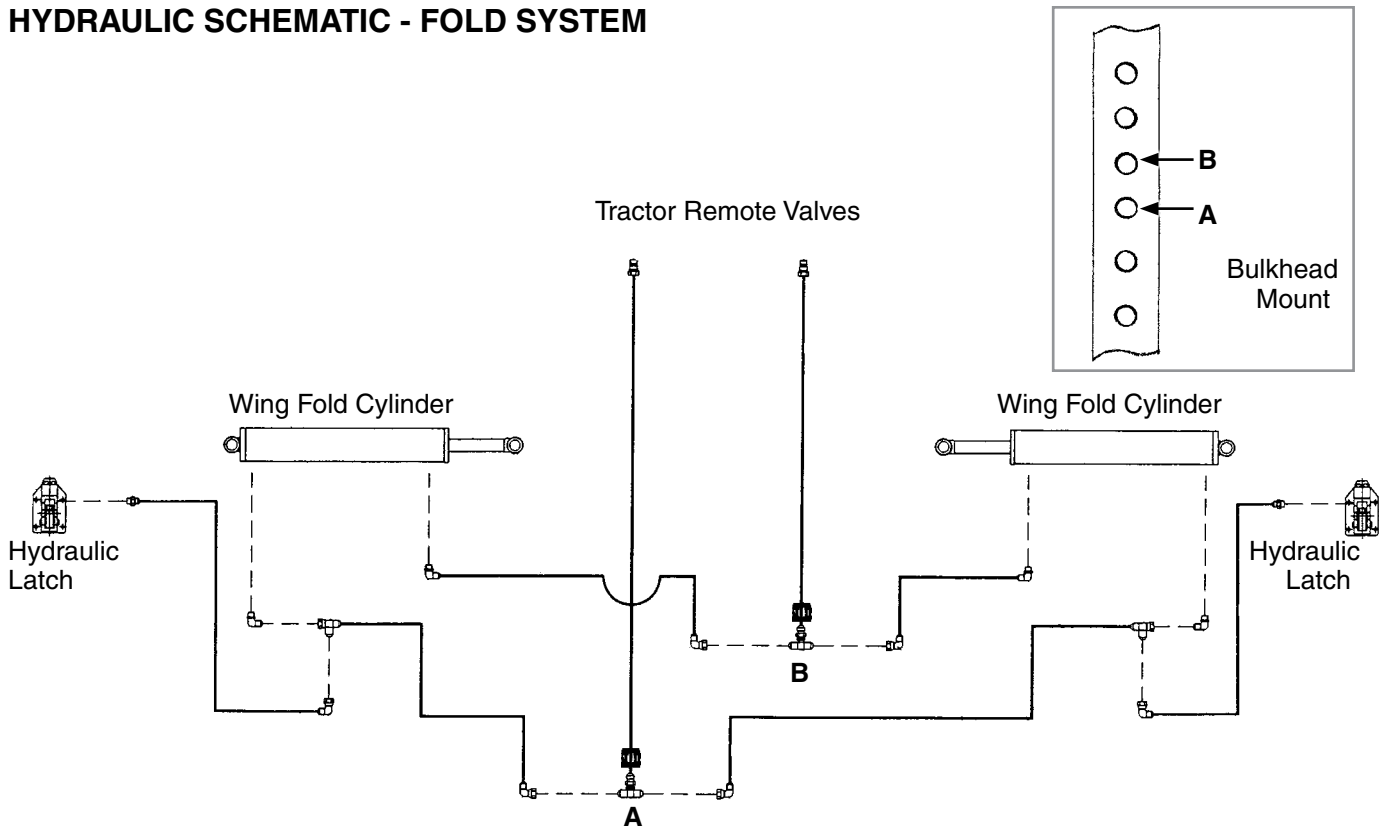

HYDRAULIC SCHEMATIC - ROW MARKER SYSTEM

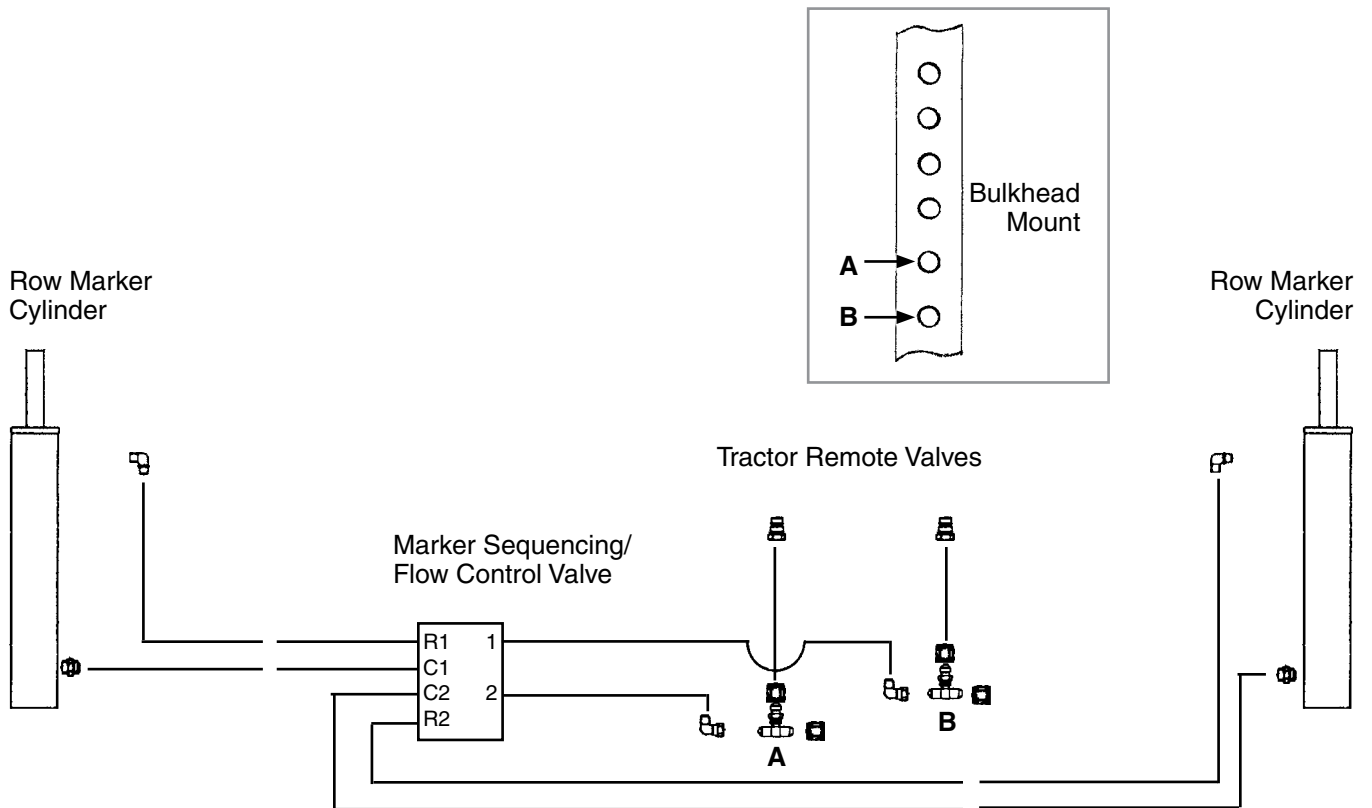

HYDRAULIC SCHEMATIC - DUAL LIFT ASSIST WHEEL PACKAGE

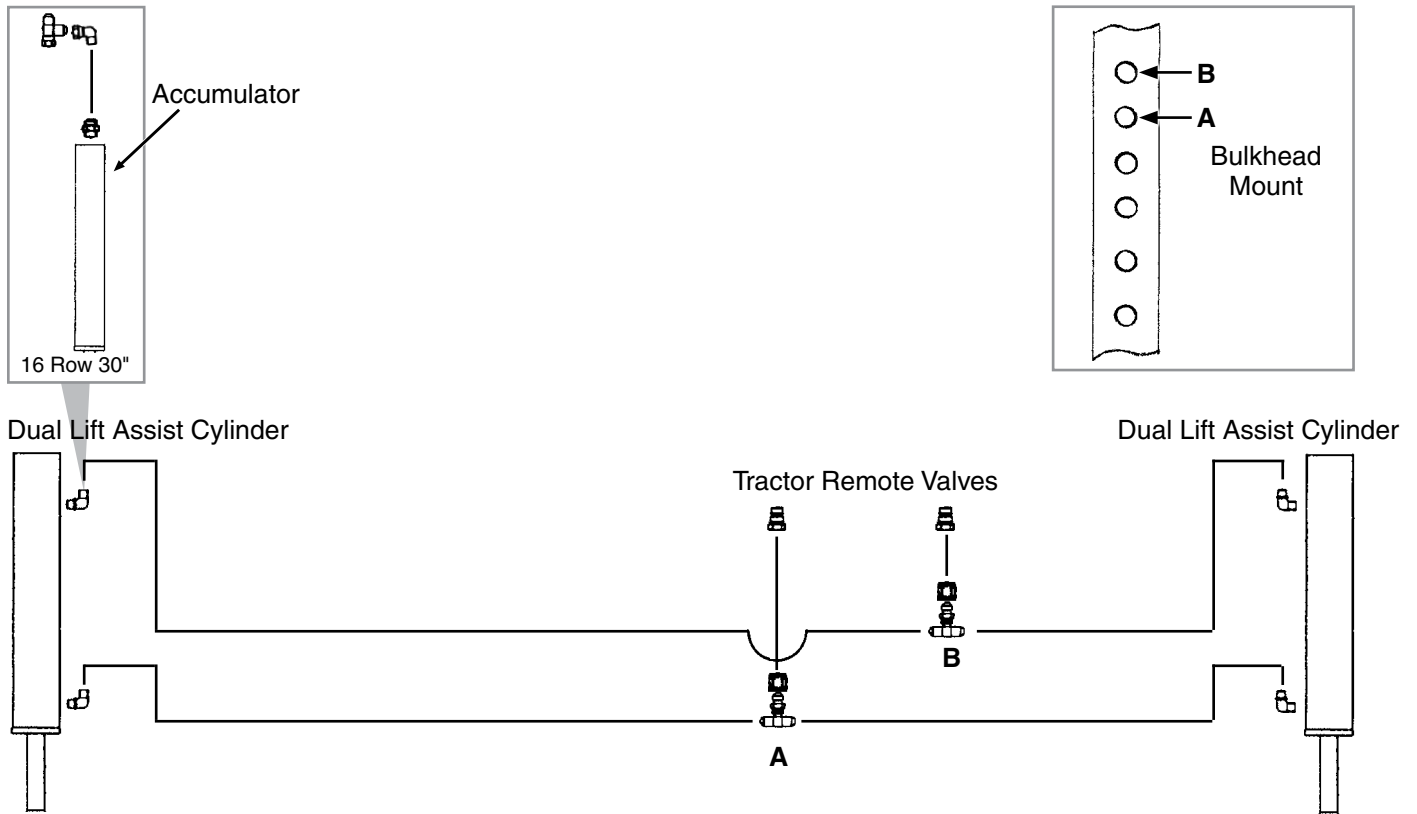

HYDRAULIC SCHEMATIC - DUAL LIFT ASSIST WHEEL PACKAGE (PLUMBED INTO 3 POINT CIRCUIT)

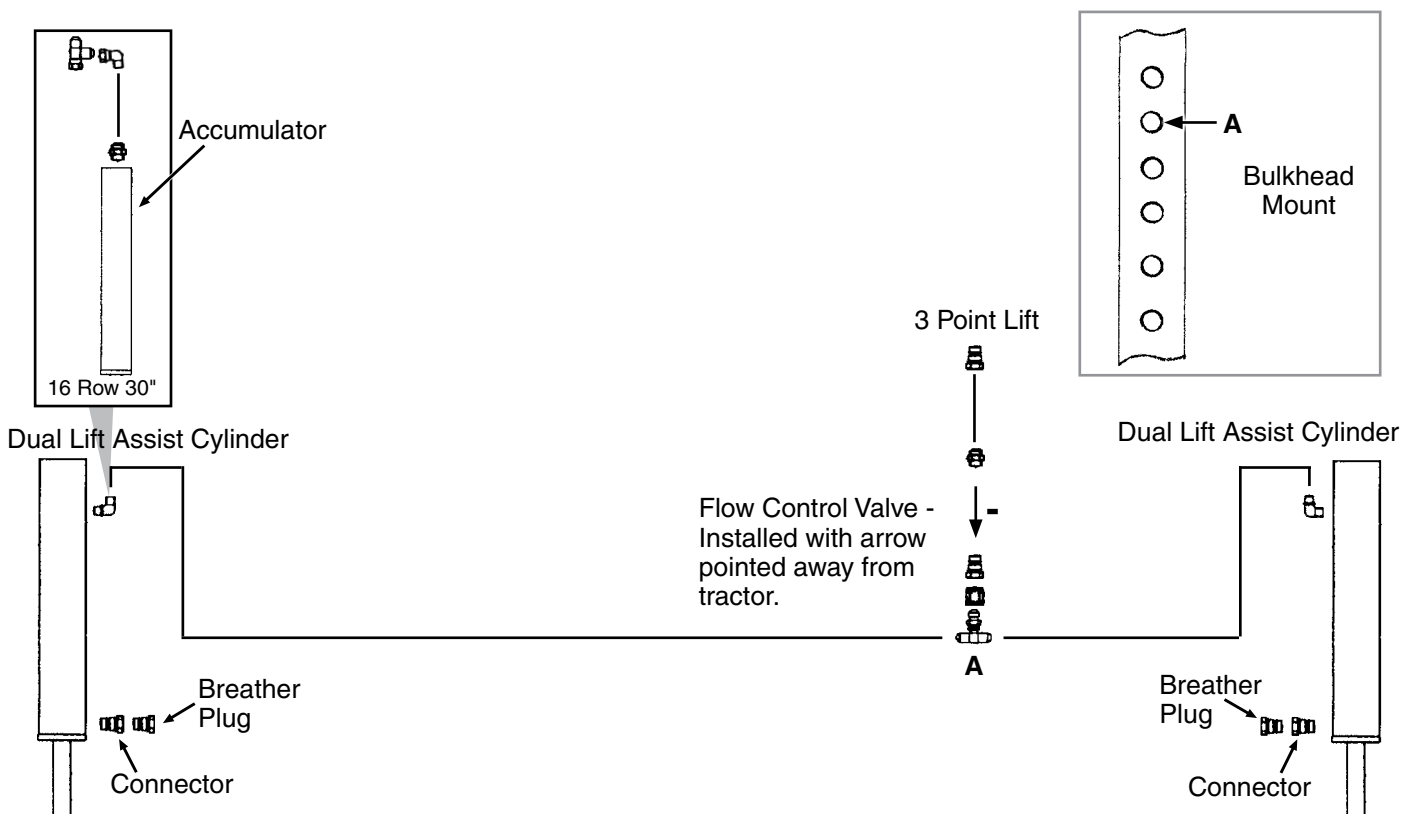

HYDRAULIC SCHEMATIC - WING DOWN FLEX CYLINDER PACKAGE

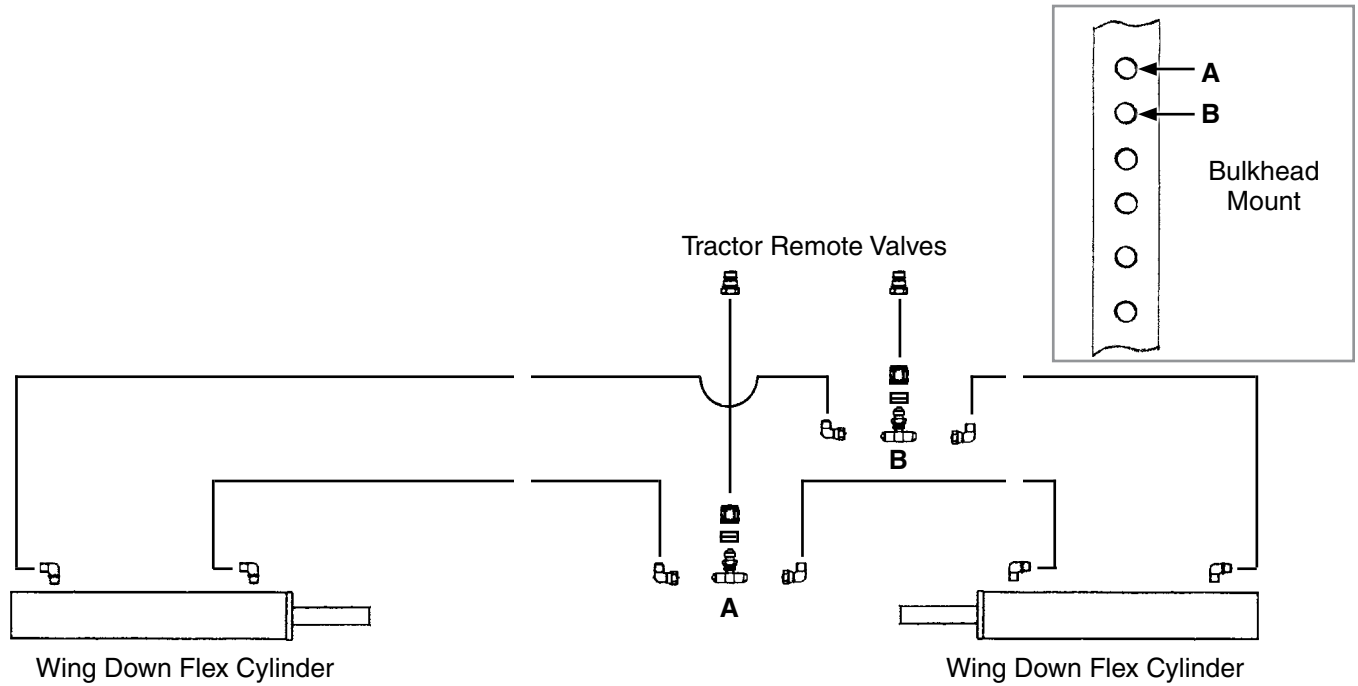

HYDRAULIC SCHEMATIC - WING DOWN FLEX CYLINDER PACKAGE AND DUAL LIFT ASSIST WHEEL PACKAGE

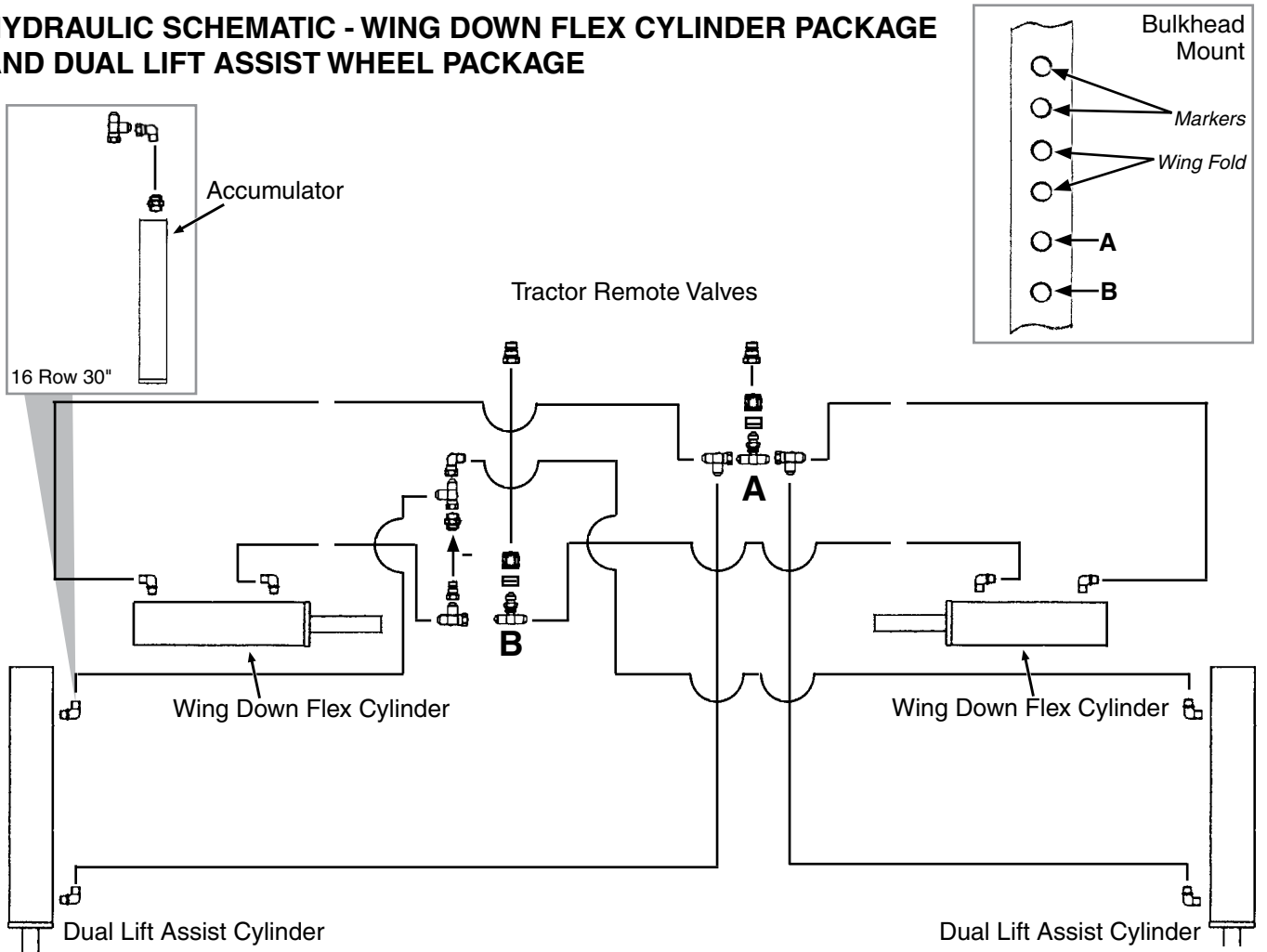

This page left blank intentionally.

BRUSH-TYPE SEED METER

PROBLEM	POSSIBLE CAUSE	SOLUTION
Low count.	Meter RPM too high.	Reduce planting speed.
	Misalignment between drive clutch and meter.	See "Seed Meter Drive Adjustment".
	Seed sensor not picking up all seeds dropped.	Clean seed tube. Switch meter to different row. If problem stays with same row, replace sensor.
	Lack of lubrication causing seeds not to release from disc properly.	Use graphite or talc as recommended.
	Seed size too large for seed disc being used.	Switch to smaller seed or appropriate seed disc. See "Brush-Type Seed Meter" for proper seed disc for size of seed being used.
	Seed treatment buildup in meter.	Reduce amount of treatment used and/or thoroughly mix treatment with seed. Add talc.
Low count at low RPM and higher count at higher RPM.	Foreign material lodged in upper brush.	Remove seed disc and remove foreign material from between brush retainer and bristles. Clean thoroughly.
	Worn upper brush.	Replace. See "Maintenance".
Low count at higher RPM and normal count at low RPM.	Seed disc worn in the agitation groove area.	Replace disc. See "Maintenance".
High count.	Seed size too small for seed disc.	Switch to larger seed or appropriate seed disc.
	Incorrect seed rate transmission setting.	Reset transmission. Refer to proper rate chart in "Machine Operation" section of manual.
	Upper brush too wide (fanned out) for small seed size.	Replace upper brush.
High count. (Milo/Grain Sorghum)	Incorrect brush retainer being used.	Make sure GD8237 brush retainer is installed to keep upper brush from fanning out.
Upper brush laid back.	Seed treatment buildup on brush.	Remove brush. Wash with soap and water. Dry thoroughly before reinstalling. See "Maintenance".
	Buildup of foreign material at base of brush.	Remove brush retainer and brush. Clean thoroughly. Reinstall.

CLOSING WHEEL

PROBLEM	POSSIBLE CAUSE	SOLUTION
Closing wheel(s) leave severe imprint in soil.	Too much closing wheel down pressure.	Adjust closing wheel pressure.
Closing wheel(s) not firming soil around seed.	Insufficient closing wheel down pressure.	Adjust closing wheel pressure. Severe no till conditions may require use of cast iron closing wheels.
"V" closing wheel running on top of seed furrow.	Improper centering.	Align. See "V Closing Wheel Adjustment".
Single closing wheel not directly over seed.	Improper centering.	Align. See "Covering Discs/Single Press Wheel Adjustment".

VACUUM SEED METER

PROBLEM	POSSIBLE CAUSE	SOLUTION
Low seed count.	Meter RPM too high.	Reduce planting rate or planting speed.
	Singulator blade setting too aggressive.	Adjust singulator blade.
	Vacuum level too low.	Increase fan speed.
	Seed sensor not picking up all seeds dropped.	Clean seed tube. Move meter to different row.
	Seeds sticking to seed disc.	Use graphite or talc to aid release.
	Seed treatment buildup in seed disc recesses.	Reduce amount of treatment used and or mix thoroughly. Add talc.
	Seed size too large for disc used.	Use appropriate disc for seed size.
	Wrong seed disc.	Use appropriate disc for seed type and size.
	Failed/worn drive components.	Inspect and replace parts as required.
	Plugged orifices in seed disc.	Inspect and clean disc. Check remnant ejector.
	Loss of vacuum at meter.	Check for foreign material between vacuum cover and disc. Inspect parts for wear/damage. Clean or replace as required.
	Seed bridging in hopper.	Add graphite to improve seed flow.
	Faulty vacuum gauge reading.	Repair/replace gauge.
	Dirt in vacuum manifold.	Check vacuum manifold for dirt and clean.
	Seed baffle (If applicable) not allowing seed flow due to bridging of seed.	Mix talc thoroughly to coat all seeds. Remove seed baffle. See Row Unit Operation section.
Seed disc worn.	Replace.	
Vacuum seal worn.	Replace.	
Not planting seed.	Seed hoppers empty.	Fill seed hopper.
	Seed tube plugged/damaged.	Clean or replace tube.
	Meter drive damaged.	Repair/replace drive components.
	Low/no vacuum.	Inspect vacuum system and repair as necessary.
	Singulator blade setting too aggressive.	Adjust singulator blade.
	Faulty vacuum gauge.	Repair/replace vacuum gauge.
	Seed bridging in hopper.	Add graphite to improve seed flow.
	Loss of vacuum at meter.	Check for foreign material between vacuum cover and disc. Inspect parts for wear/ damage. Clean and/or replace as required.
	Wrong seed disc.	Use appropriate disc for seed type and size.
	Meter drive clutch not engaged.	Engage drive clutch.
	Fan not running.	Start fan.
Dirt in vacuum manifold.	Check vacuum manifold for dirt and clean.	

Continued on next page.

VACUUM SEED METER - Continued

PROBLEM	POSSIBLE CAUSE	SOLUTION
Not planting seed. (Continued)	Seed baffle (if applicable) not allowing seed flow due to bridging of seed.	Mix talc thoroughly to coat all seeds. Remove seed baffle. Row Unit Operation section.
	High vacuum.	Adjust vacuum level to appropriate level.
	Wrong seed disc.	Replace seed disc.
	Singulator setting not aggressive enough.	Adjust singulator.
	Faulty vacuum gauge.	Check gauge line for dirt/obstruction. Repair/replace vacuum gauge.
Poor seed spacing.	Obstruction in seed tube.	Clean seed tube.
	Dirty/damaged seed disc.	Inspect seed disc for damage, foreign material in orifices or seed treatment buildup in recesses. Clean or replace.
	Wrong vacuum setting.	Adjust vacuum to appropriate level.
	Excess foreign material in seed.	Inspect and clean meter and seed discs. Use clean, undamaged seed.
	Incorrect singulator setting.	Adjust singulator to appropriate setting.
	Inconsistent driveline.	Inspect drive components for rust, misalignment, worn or damaged parts. Replace/repair as required.
	Toolbar not level or wrong height.	Adjust hitch to level toolbar and row units.
	Planting too fast for conditions.	Reduce speed.
	Rough field conditions.	Reduce speed.
Irregular seed population.	Driving too fast.	Reduce speed.
Unable to achieve desired vacuum level.	Tractor hydraulic flow set too low.	Increase flow to fan motor.
	Incorrect hydraulic connections.	Check all hydraulic connections and hose routings.
	Damaged fan components.	Inspect motor and impeller for wear/damage and repair/replace as necessary.
	Vacuum hose pinched/kinked/blocked.	Inspect air lines for any damage or obstruction. Clean air lines and manifold by removing end cap from manifold and running fan at high speed.
	Vacuum hose loose/disconnected.	Inspect and reattach all air hoses.
	Tractor not producing required hydraulic flow/pressure.	Have tractor serviced by qualified technician.
	Dirt in vacuum gauge line.	Check gauge line for dirt/obstruction and clean.

FINGER PICKUP SEED METER

PROBLEM	POSSIBLE CAUSE	SOLUTION
One row not planting seed.	Drive release not engaged.	Engage drive release mechanism.
	Foreign material in hopper.	Clean hopper and finger carrier mechanism.
	Seed hopper empty.	Fill seed hopper.
	Row unit drive chain off of sprocket or broken.	Check drive chain.
Unit is skipping.	Foreign material or obstruction in meter.	Clean and inspect.
	Finger holder improperly adjusted.	Adjust to specifications. (22 to 25 in. lbs. rolling torque)
	Broken fingers.	Replace fingers and/or springs as required.
	Planting too slowly.	Increase planting speed to within recommended range.
Planting too many doubles.	Planting too fast.	Stay within recommended speed range.
	Loose finger holder.	Adjust to specifications. (22 to 25 in. lbs. rolling torque)
	Worn brush in carrier plate.	Inspect and replace if necessary.
Overplanting.	Worn carrier plate.	Inspect and replace if necessary.
	Seed hopper additive being used.	Reduce or eliminate additive or increase graphite.
Underplanting.	Seed belt installed backwards.	Remove and install correctly.
	Weak or broken springs.	Replace.
	Spring not properly installed.	Remove finger holder and correct.
	Seed belt catching or dragging.	Replace belt.
	Brush dislodging seed.	Replace brush.
Irregular or incorrect seed spacing.	Driving too fast.	Check chart for correct speed.
	Wrong tire pressure.	Inflate tires to correct air pressure.
	Drive wheels slipping.	Reduce down pressure on row unit down force springs.
	Wrong sprockets.	Check seed rate charts for correct sprocket combinations.
Seed spacing not as indicated in charts.	Wrong tire pressure.	Inflate tires to correct air pressure.
	Inconsistent seed size.	Do field check and adjust sprockets accordingly.
	Wrong sprockets.	Check chart for correct sprocket combination.
	Charts are approximate.	Slight variations due to wear in meter components and tire slippage due to field conditions may produce seed spacing variations.
	Stiff or worn drive chains.	Replace chains.
Scattering of seeds.	Planting too fast.	Reduce planting speed.
	Seed tube improperly installed.	Check seed tube installation.
	Seed tube worn or damaged.	Replace seed tube.
Seed tubes and/or openers plugging.	Allowing planter to roll backward when lowering.	Lower planter only when tractor is moving forward.
Inconsistent seed depth.	Rough seed bed.	Adjust down pressure springs. Reduce planting speed.
	Partially plugged seed tube.	Inspect and clean.
	Seed tube improperly installed.	Install properly.

POINT ROW CLUTCH

PROBLEM	POSSIBLE CAUSE	SOLUTION
None of the clutches will disengage.	Main fuse blown in control console.	Replace defective fuse.
	Poor terminal connection in wiring harness.	Repair or replace.
	Wiring damage in wiring harness.	Repair or replace.
	Low voltage at coil. (12 volts required)	Check battery connections.
One section of planter will not re-engage.	Shear pin at seed drive transmission(s) sheared.	Replace pin with one of equal size and grade.
One clutch will not engage.	Fuses blown.	Replace defective fuses.
	Actuator arm and plunger stuck in disengaged position.	Remove, free up and reinstall.
	Actuator arm out of adjustment.	Adjust actuator arm mounting pin in slot so that actuator arm clears stop on stop collar by approximately 1/8" when clutch is rotated.
	Wrap spring broken or stretched.	Disassemble clutch and replace spring.
	Something touching the stop collar.	Check to ensure collar is free to turn with clutch.
	Clutch assembled incorrectly.	Check clutch and diagram for correct assembly.
Clutch slipping.	Wrap spring stretched.	"Lock" clutch output shaft from turning. Place torque wrench on input shaft and rotate in direction of drive. After input shaft has rotated a short distance the wrap spring should tighten onto the input hub. If slippage occurs at less than 100 ft. lbs. replace spring. If spring still slips after installing new spring, replace input hub.
Planter section will not re-engage while planter is moving forward.	Spring in actuator arm not strong enough to push arm away from stop collar when operational switch is turned to the ON position.	Remove spring from inside solenoid and stretch spring slightly or replace. Reinstall spring. If that fails, file the stop on the stop collar slightly so that the stop is not as aggressive.
Frequent solenoid burnout.	Fuses too large.	Replace fuses on front panel with 10 amp slow blow fuses.
Frequent fuse burnout.	Low voltage (12 volts required).	Check power source voltage for partially discharged battery, etc.
	Damage to wiring harness.	Locate damage and repair or replace harness.
Clutch or clutches will not disengage.	Input and output shafts out of alignment.	Align input and output shafts to prevent drag.
	Input or output shaft is pushed in too far creating a coupler.	Reposition input and output shafts.

ROW MARKER OPERATION

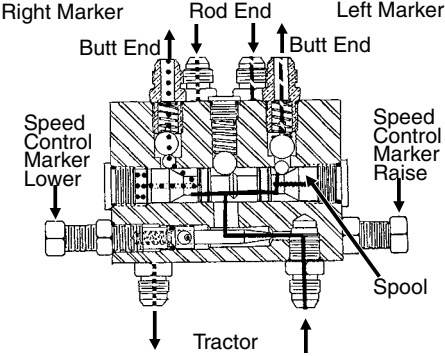
PROBLEM	POSSIBLE CAUSE	SOLUTION
Both markers lowering and only one raising at a time.	Hoses from cylinders to valve connected backwards.	Check to ensure proper hose routing. (See illustration below.)
Same marker always operating.	Spool in sequencing valve not shifting. 	Remove spool, inspect for foreign material, making sure all ports in spool are open. Clean and re-install.
Both markers lower and raise at same time.	Foreign material under check ball in sequencing valve.	Remove hose fitting, spring and balls and clean. May be desirable to remove spool and clean as well.
	Check ball missing or installed incorrectly in sequencing valve.	Disassemble and correct. See illustration in Parts Section.
Marker (in raised position) settling down.	Damaged o-ring in marker cylinder or cracked piston.	Disassemble cylinder and inspect for damage and repair.
	Spool in sequencing valve not shifting completely because detent ball or spring is missing.	Check valve assembly and install parts as needed.
	Spool in sequencing valve shifting back toward center position.	Restrict flow of hydraulic oil from tractor to sequencing valve.
Neither marker will move.	Flow control closed too far.	Loosen locking nut and turn flow control adjustment bolt out or counterclockwise until desired speed is set.
Markers moving too fast.	Flow control open too far.	Loosen locking nut and turn flow control adjustment bolt in or clockwise until desired speed is set.
Sporadic marker operation speed.	Needle sticking open in flow control valve.	Remove flow control, inspect and repair or replace.