

PREDELIVERY/DELIVERY CHECKLIST

TO THE DEALER

Preelivery service includes assembly, lubrication, adjustment and test. This service helps to ensure that the planter will be delivered to the customer ready for field use.

PREDELIVERY CHECKLIST

After the planter has been completely assembled, use the following checklist and inspect the planter. Check off each item as it is found satisfactory or after proper adjustment is made.

- Recheck to be sure row units are properly spaced and optional attachments are correctly assembled.
- Be sure all grease fittings are in place and lubricated.
- Check planter and make sure all working parts are moving freely, bolts are tight and cotter pins are spread.
- Check all drive chains for proper tension and alignment.
- Check for oil leaks and proper hydraulic operation.
- Check to be sure hydraulic hoses are routed correctly to prevent damage to hoses.
- Inflate tires to specified PSI air pressure. Tighten wheel lug bolts to specified torque.
- Check to be sure all safety decals are correctly located and legible. Replace if damaged.
- Check to be sure the reflective decals are correctly located and visible when the planter is in transport position.
- Check to be sure SMV sign is in place.
- Check to be sure safety/warning lights are installed correctly and working properly.
- Paint all parts scratched in shipment or assembly.
- Be sure all safety lockups are on the planter and correctly located.
- Check seed meters on test stand to ensure proper performance.

This planter has been thoroughly checked and to the best of my knowledge is ready for delivery to the customer.

(Signature of Set-Up Person/Dealer Name/Date)

OWNER REGISTER

Name _____ Delivery Date _____

Street Address _____ Model No. _____ Serial No. _____

City, State/Province _____ Dealer Name _____

ZIP/Postal Code _____ Dealer No. _____

DELIVERY CHECKLIST

At the time the planter is delivered, the following checklist is to be used as a reminder of very important information which should be conveyed to the customer. Check off each item as it is fully explained to the customer.

- Advise the customer that the life expectancy of this or any other machine is dependent on regular lubrication as directed in the Operator & Parts Manual.
- Tell the customer about all applicable safety precautions.
- Along with the customer, check to be sure the reflective decals and SMV sign are clearly visible with the planter in transport position and attached to the tractor. Check to be sure safety/warning lights are in working condition. Tell the customer to check federal, state/provincial and local regulations before transporting on a road or highway.
- Give the Operator & Parts Manual to the customer and explain all operating adjustments.
- Read warranty to customer.
- Complete Warranty And Delivery Report form.

To the best of my knowledge this machine has been delivered ready for field use and customer has been fully informed as to proper care and operation.

(Signature of Delivery Person/Dealer Name/Date)

AFTER DELIVERY CHECKLIST

The following is a list of items we suggest to check during the first season of use of the equipment.

- Check with the customer as to the performance of the planter.
- Review with the customer the importance of proper maintenance and adherence with all safety precautions.
- Check for parts that may need to be adjusted or replaced.
- Check to be sure all safety warning signs (decals), reflective decals and SMV sign are correctly located and legible. Replace if damaged or missing.
- Check to be sure safety/warning lights are working properly.

(Signature of Follow-Up Person/Dealer Name/Date)

**RETURN THIS COMPLETED FORM TO KINZE® IMMEDIATELY along with Warranty And Delivery Report.
Retain photocopy of this form at dealership for After Delivery Check.**

Tear Along Perforation

TABLE OF CONTENTS

TO THE OWNER	1-1
WARRANTY	1-2
INTRODUCTION	2-1
SPECIFICATIONS	3-1
SAFETY PRECAUTIONS	4-1
SAFETY WARNING SIGNS	5-1
MACHINE OPERATION	
Accumulator	6-68
Checking Granular Chemical Application Rate	6-71
Checking Seed Population	6-70
Contact Drive Wheel Spring Adjustment	6-4
Dual Lift Assist Wheels	6-68
Electronic Seed Monitor System	
KPM I Monitor	6-10
KPM II Monitor	6-16
KPM II Stack-Mode Monitor	6-38
Field Test	6-69
Flow Control Valve Adjustment	6-68
General Planting Rate Information	6-72
Half Rate (2 To 1) Drive	6-5
Hydraulic Operation	6-7
Hydraulic Row Marker Operation	6-7
Initial Preparation Of The Planter	6-1
Leveling The Planter	6-3
Metric Conversion Table	6-69
Parking Stand Adjustment	6-4
Piston Pump Mount/Drive Spring Adjustment	6-68
Planting And Application Rate Charts	6-73
Planting Speed	6-69
Point Row Clutches	6-66
Row Marker Length Adjustment	6-8
Row Marker Speed Adjustment	6-7
Seed Rate Transmission Adjustment	6-5
Shear Protection	6-6
Standard Rate Drive	6-5
Tire Pressure	6-4
Tractor Preparation And Hookup	6-1
Tractor Requirements	6-1
Transporting The Planter	6-68
Two-Speed Point Row Clutches	6-67
Wheel Module Height Adjustment	6-3
Wing Down Flex Cylinder	6-9
Wing Flex	6-8
Wrap Spring Wrench Operation	6-6
ROW UNIT OPERATION	
Brush-Type Seed Meter	7-5
Closing Wheel Shield	7-2
Coulter Mounted Residue Wheels	7-19
Covering Discs/Single Press Wheel Adjustment	7-2
Drag Closing Attachment	7-3
Dual Gauge Wheels	7-11
Finger Pickup Seed Meter	7-4
Frame Mounted Coulters And Attachments	7-12
Granular Chemical Bander Shield	7-20
Granular Chemical Banding Options	7-20
Granular Chemical Hopper And Drive	7-19
Planting Depth	7-1
Quick Adjustable Down Force Springs	7-10
Row Unit Chain Routing	7-9
Row Unit Extension Bracket	7-8
Row Unit Mounted Bed Leveler	7-17
Row Unit Mounted Disc Furrower	7-16
Row Unit Mounted No Till Coulter	7-18
Row Unit Mounted Residue Wheel	7-17

TABLE OF CONTENTS

ROW UNIT OPERATION (Continued)

Seed Hopper	7-7
Seed Meter Drive Adjustment	7-8
Seed Meter Drive Release	7-7
Spring Tooth Incorporator	7-20
“V” Closing Wheel Adjustment (Rubber And Cast Iron)	7-1

LUBRICATION

Bushings	8-2
Drive Chains	8-1
Grease Fittings	8-4
Lubrication Symbols	8-1
Point Row Clutches	8-8
Sealed Bearings	8-1
Wheel Bearings	8-4
Wrap Spring Wrench Assembly	8-4

MAINTENANCE

15" Seed Opener Disc Blade/Bearing Assembly	9-10
Brush-Type Seed Meter Maintenance	9-5
Brush-Type Seed Meter Troubleshooting	9-7
Cam Follower Adjustment	9-20
Chain Tension Adjustment	9-1
Closing Wheel Troubleshooting	9-8
Coulter Mounted Residue Wheels	9-14
Drag Closing Attachment	9-8
Electrical Wiring Diagrams	
Light Package	9-25
Point Row Clutches	9-26
Two-Speed Point Row Clutches	9-27
Finger Pickup Seed Meter Cleaning	9-3
Finger Pickup Seed Meter Inspection/Adjustment	9-2
Finger Pickup Seed Meter Troubleshooting	9-4
Flow Control Valve Inspection	9-20
Frame Mounted Coulters And Attachments	9-11
Gauge Wheel Adjustment	9-8
Gauge Wheel Arm Bushing And/Or Seal Replacement	9-9
Gauge Wheel Arm Pivot Spindle Replacement	9-9
Granular Chemical Attachment	9-15
Hydraulic Schematics	
Dual Lift Assist Wheel Package	9-30
Dual Lift Assist Wheel Package (Plumbed Into 3 Point Circuit)	9-30
Fold System	9-29
Row Marker System	9-29
Wing Down Flex Cylinder Package	9-31
Wing Down Flex Cylinder Package And Dual Lift Assist Wheel Package	9-31
KPM I/KPM II/KPM II Stack-Mode Electronic Seed Monitor System Troubleshooting	9-16
Mounting Bolts And Hardware	9-1
Point Row Clutch Inspection	9-17
Point Row Clutch Troubleshooting	9-18
Preparation For Storage	9-24
Row Marker Bearing Lubrication Or Replacement	9-23
Row Marker Operation Troubleshooting	9-22
Row Marker Sequencing/Flow Control Valve Inspection	9-21
Row Unit Mounted Bed Leveler	9-13
Row Unit Mounted Disc Furrower	9-12
Row Unit Mounted No Till Coulter	9-14
Row Unit Mounted Residue Wheel	9-13
Seed Tube Guard/Inner Scraper	9-11
Spring Tooth Incorporator	9-15
Torque Values Chart	9-1
Two-Speed Point Row Clutch	9-19
Wheel Bearing Lubrication Or Replacement	9-23

PARTS LIST INDEX	P1
-------------------------------	-----------

PARTS SECTION NUMERICAL INDEX	a
--	----------

TO THE OWNER

KINZE Manufacturing, Inc. would like to thank you for your patronage. We appreciate your confidence in KINZE® farm machinery. Your KINZE® planter has been carefully designed and sturdily built to provide dependable operation in return for your investment.

This manual has been prepared to aid you in the operation and maintenance of the planter. It should be considered a permanent part of the machine and remain with the machine when you sell it.

It is the responsibility of the user to read and understand the Operator & Parts Manual in regards to safety, operation, lubrication and maintenance before operation of this equipment. It is the user's responsibility to inspect and service the machine routinely as directed in the Operator & Parts Manual. We have attempted to cover all areas of safety, operation, lubrication and maintenance; however, there may be times when special care must be taken to fit your conditions.

Throughout this manual the symbol  and/or the words **NOTE, IMPORTANT, CAUTION, WARNING** or **DANGER** are used to call your attention to important information. The definition of each of these terms follows:

NOTE: Indicates a special point of information or addresses a machine adjustment.

IMPORTANT: Indicates information which, if not heeded, could result in damage to the machine.



CAUTION: Indicates a potentially hazardous situation which, if not avoided, may result in minor or moderate personal injury.



WARNING: Indicates a potentially hazardous situation which, if not avoided, could result in death or serious personal injury.



DANGER: Indicates an imminently hazardous situation which, if not avoided, will result in death or serious personal injury.



WARNING: Some photos in this manual may show safety covers, shields or lockup devices removed for visual clarity. **NEVER OPERATE** the machine without all safety covers, shields and lockup devices in place.

NOTE: Some photos in this manual may have been taken of prototype machines. Production machines may vary in appearance.

NOTE: Some photos and illustrations in this manual show optional attachments installed. Contact your KINZE® Dealer for purchase of optional attachments.

WARRANTY

The KINZE® Limited Warranty for your new machine is stated on the back of the retail purchaser's copy of the Warranty And Delivery Report form. Additional copies of the Limited Warranty can be obtained through your KINZE® Dealer.

Warranty, within the warranty period, is provided as part of KINZE's support program for registered KINZE® products which have been operated and maintained as described in this manual. Evidence of equipment abuse or modification beyond original factory specifications will void the warranty. Normal maintenance, service and repair is not covered by KINZE® warranty.

To register your KINZE® product for warranty, a Warranty And Delivery Report form must be completed by the KINZE® Dealer and signed by the retail purchaser, with copies to the Dealer, to the retail purchaser and to KINZE Manufacturing, Inc. Registration must be completed and sent to KINZE Manufacturing, Inc. within 30 days of delivery of the KINZE® product to the retail purchaser. KINZE Manufacturing, Inc. reserves the right to refuse warranty on serial numbered products which have not been properly registered.

If service or replacement of failed parts which are covered by the Limited Warranty are required, it is the user's responsibility to deliver the machine along with the retail purchaser's copy of the Warranty And Delivery Report to the KINZE® Dealer for service. KINZE® warranty does not include cost of travel time, mileage, hauling or labor. Any prior arrangement made between the Dealer and the retail purchaser in which the Dealer agrees to absorb all or part of this expense should be considered a courtesy to the retail purchaser.

KINZE® warranty does not include cost of travel time, mileage, hauling or labor.

INTRODUCTION

The Model 3140 Stack Folding 3 Point Mounted Planter is available in various row spacings and permits installation of various options.

GENERAL INFORMATION

The information used in this manual was current at the time of printing. However, due to KINZE's continual attempt to improve its product, production changes may cause your machine to appear slightly different in detail. KINZE Manufacturing, Inc. reserves the right to change specifications or design without notice and without incurring obligation to install the same on machines previously manufactured.

Right hand (R.H.) and left hand (L.H.), as used throughout this manual, are determined by facing in the direction the machine will travel when in use, unless otherwise stated.

D10079911a

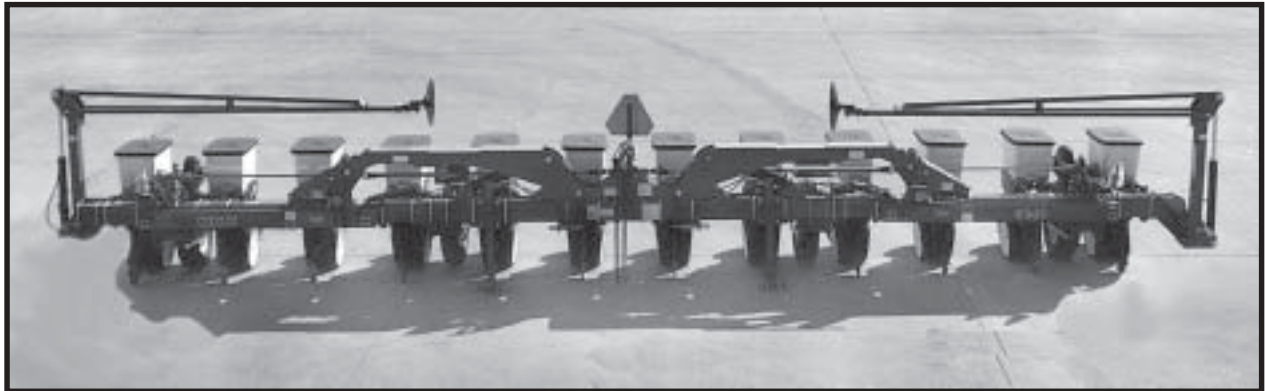

Model 3140 12 Row 30" Planter (With Optional Row Markers) Shown In Planting Position

LF021003-1

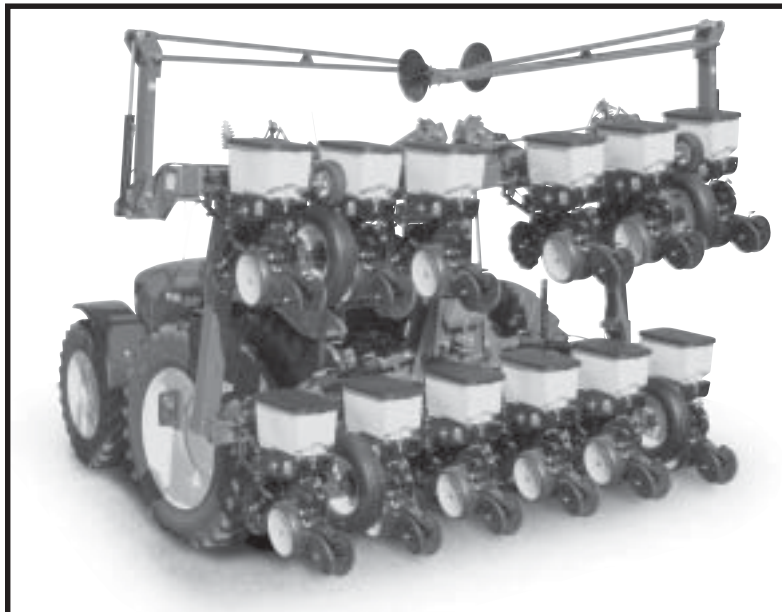

Model 3140 12 Row 30" Planter (With Optional Row Markers) Shown In Transport Position

INTRODUCTION

SPECIFICATIONS

TYPE - 3 Point Mounted Stack Folding

ROW UNIT TYPE - Pull Row Units

ROW SPACING

- 8 Row Wide (38" - 40" Rows)
- 12 Row Narrow (30" Rows)
- 12 Row Wide (36" - 38" Rows)
- 12 Row Wide (38" - 40" Rows)
- 16 Row Narrow (30" Rows)

DRIVE SYSTEM

- Spring-loaded contact drive system.
- Two 4.10" x 6" contact drive tires.
- Four 7.60" x 15" ground tires.
- Two wheel module-mounted seed transmissions with No. 40 chains and spring-loaded idlers.
- Optional point row clutches.
- $\frac{7}{8}$ " hex drill and drive shafts.

HYDRAULICS

- Wing Fold - Single remote.
- Row Marker Package Option - Single remote with sequencing/flow control valve.
- Dual Lift Assist Wheel Package Option - *Single remote.
- Wing Down Flex Cylinder Package Option - *Single remote.

*A single remote can operate both Dual Lift Assist Wheel Package and Wing Down Flex Cylinder Package Options.

HITCH - Category 3N - 3 (Optional Category 2)

SPECIFICATIONS

DIMENSIONS & WEIGHTS

PLANTER SIZE	TRANSPORT WIDTH	TRANSPORT HEIGHT *	WEIGHT**
8 Row 38" - 40" – W/O Markers	16' 1"	11' 2"	5368 lbs.
8 Row 38" - 40" – W/Markers	16' 11"	13' 2"	6042 lbs.
12 Row 30" – W/O Markers	16' 1"	11' 2'	6224 lbs.
12 Row 30" – W/Markers	17' 9"	13' 2"	6885 lbs.
12 Row 36" - 38" – W/O Markers	18' 5"	12' 6"	6529 lbs.
12 Row 36" - 38" – W/Markers	19' 6"	15' 6"	7406 lbs.
12 Row 38" - 40" – W/O Markers	21' 1"	12' 6"	6609 lbs.
12 Row 38" - 40" – W/Markers	22' 2"	15' 6"	7490 lbs.
16 Row 30" – W/O Markers	21' 1"	12' 6"	7464 lbs.
16 Row 30" – W/Markers	23' 0"	15' 6"	8450 lbs.

* Lower link pins at 42" height.

** Base machine weight includes toolbar and 3 point hitch, wheel modules with tires and wheels, seed transmission(s) with drive components, parking stands, optional row markers with hydraulic cylinders and hoses (where applicable) and KINZE® pull row units (closing wheel arms less closing wheels) with seed hopper and lid, quick adjustable dual down force springs.

MACHINE OPTIONS

- Row Markers - Low profile two-fold with depth band on marker blades.
- Electronic Seed Monitors
 - KPM I
 - KPM II With Magnetic Distance Sensor Or Radar Distance Sensor
 - KPM II Stack-Mode With Magnetic Distance Sensor Or Radar Distance Sensor
- Point Row Clutch Package - Allows half width planting.
- Two-Speed Point Row Clutch Package - Allows half width planting and reduced rate planting
(Available through KINZE® Repair Parts)
- Half Rate (2 To 1) Drive Reduction Package
- Dual Lift Assist Wheel Package (8 Row Wide size requires removal of center section gauge wheels to accommodate dual lift assist wheels.)
- Wing Down Flex Cylinder Package
- Piston Pump Mount/Drive Package (Less Pump)

ROW UNIT OPTIONS/ATTACHMENTS

- Finger Pickup Or Brush-Type Seed Meters
- Closing Wheel Options
 - Rubber "V" Closing Wheels
 - Cast Iron "V" Closing Wheels
 - Covering Discs/Single Press Wheel
 - Drag Closing Attachment
- Dual Gauge Wheels
- Hopper Panel Extension Package
- Granular Chemical Application
- Spring Tooth Incorporator
- Row Unit Extension Brackets
- Row Unit Mounted No Till Coulter
- Row Unit Mounted Disc Furrowers
- Row Unit Mounted Bed Leveler
- Row Unit Mounted Residue Wheel
- Coulter Mounted Residue Wheels
- Frame Mounted Coulter - STYLE A & STYLE B
- Disc Furrowers For STYLE A Frame Mounted Coulter
- Residue Wheel Attachment For STYLE B Frame Mounted Coulter

SAFETY PRECAUTIONS

Safe and careful operation of the tractor and planter at all times will contribute significantly to the prevention of accidents.

Since a large portion of farm accidents occur as a result of fatigue or carelessness, safety practices should be of utmost concern. Read and understand the instructions provided in this manual and on the warning signs. Review these instructions frequently. Listed below are other safety suggestions that should become common practice.

 **Never permit any persons other than the operator to ride on the tractor.**

 **Never ride on the planter or allow others to do so.**

 **Be aware of bystanders, particularly children! Always look around to make sure it is safe to start the engine of the towing vehicle or move the planter. This is particularly important with higher noise levels and quiet cabs, as you may not hear people shouting.**

 **Always keep hands, feet and clothing away from moving parts. Do not wear loose fitting clothing which may catch in moving parts.**

 **Always wear protective clothing, substantial shoes and suitable hearing and eye sight protectors applicable for the situation.**

 **Use a tractor equipped with a roll-over-protective-system and fasten your seatbelt prior to starting the engine.**

 **Do not allow anyone to stand between the hitch and the towing vehicle when backing up to the planter.**

 **Limit transport speed to 15 MPH. Transport only with farm tractor of sufficient size and horsepower. (See Machine Operation Section)**

 **Never allow the planter to be operated by anyone who is unfamiliar with the operation of all functions of the unit. All operators should read and thoroughly understand the instructions given in this manual prior to moving the unit.**

 **Always make sure safety/warning lights, SMV sign and reflective decals are in place and visible prior to transporting the machine on public roads. In this regard, check federal, state/provincial and local regulations.**

 **Never work under the planter while in raised position.**

 **Always make sure there are no persons near the planter when marker assemblies are in operation.**

 **Watch for obstructions such as wires, tree limbs, etc., when folding markers.**

 **To avoid serious injury or death, care must be taken when operating row markers around overhead power lines.**





















D10079904



 **Install safety lockups on wing fold cylinders prior to transporting the planter or working around the unit.**

 **Lower the planter when not in use and cycle the hydraulic control lever to relieve pressure in hoses.**

SAFETY PRECAUTIONS

-  Before applying pressure to the hydraulic system, make sure all connections are tight and that hoses and fittings have not been damaged. Hydraulic fluid escaping under pressure can have sufficient force to penetrate skin causing injury or infection.
-  This planter is designed to be **DRIVEN BY GROUND TIRES ONLY**. The use of hydraulic, electric or PTO drives may create serious safety hazards to you and the people nearby. If you install such drives you must follow all appropriate safety standards and practices to protect you and others near this planter from injury.
-  Due to the transport height of the wings, watch for obstructions such as wires, tree limbs, etc.
-  Never transport folding machines with lift assist wheels without quick hitch. If this type of hitch is not in place, a sudden stop could allow the toolbar to rotate forward causing personal injury or damage to the equipment.
-  Always make sure there are no persons near the planter when planter wings are being lowered from transport position.
-  If a marker or wing lift cylinder has been disconnected or removed for any reason, do not attach the rod end of the cylinder until the cylinder is cycled several times to remove air that may be trapped in the system.
-  Allow for unit length when making turns.
-  Reduce speed prior to turns to avoid the risk of overturning.
-  Wings must be unfolded before detaching machine from tractor.
-  Check to be sure all safety/warning lights are working before transporting the machine on public roads.
-  Always drive at a safe speed relative to local conditions and ensure your speed is low enough for an emergency stop to be safe and secure. Keep speed to a minimum.
-  Avoid sudden uphill turns on steep slopes.
-  Always keep the tractor in gear to provide engine braking when going downhill. Do not coast.
-  Be a safe and courteous driver. Always yield to oncoming traffic in all situations, including narrow bridges, intersections, etc.
-  Store the planter in an area away from human activity. **DO NOT** permit children to play on or around the stored unit.
-  Make sure the parked machine is on a hard, level surface.
-  Rim and tire servicing can be dangerous. Explosive separation of a tire and rim parts can cause serious injury or death.
-  Agricultural chemicals used with this unit can be dangerous. Improper selection or use can seriously injure persons, animals, plants, soil and other property. **BE SAFE:** Select the right chemical for the job. Handle it with care. Follow the instructions of the chemical manufacturer.
-  Serious injury or death can result from contact with electric lines. Use care to avoid contact with electric lines when moving or operating this machine.
-  This machine has been designed and built with your safety in mind. Do not make any alterations or changes to this machine. Any alteration to the design or construction may create safety hazards.
-  Good maintenance is your responsibility. Poor maintenance is an invitation to trouble.

SAFETY WARNING SIGNS

The “WARNING” signs illustrated on these pages are placed on the machine to warn of hazards. The warnings found on these signs are for your personal safety and the safety of those around you. **OBSERVE THESE WARNINGS!**

- Keep these signs clean so they can be readily observed. Wash with soap and water or cleaning solution as required.
- Replace “WARNING” signs should they become damaged, painted over or if they are missing.
- Check reflective decals and SMV sign periodically. Replace if they show loss of any of their reflective property.
- When replacing decals, clean the machine surface thoroughly using soap and water or cleaning solution to remove all dirt and grease.

NOTE: The production date of the machine will determine style and locations of SMV sign, reflectors and/or reflective decals and safety/warning lights to conform to ANS/ASAE S279.12 DEC 02 and ANS/ASAE 276.5 FEB 03.

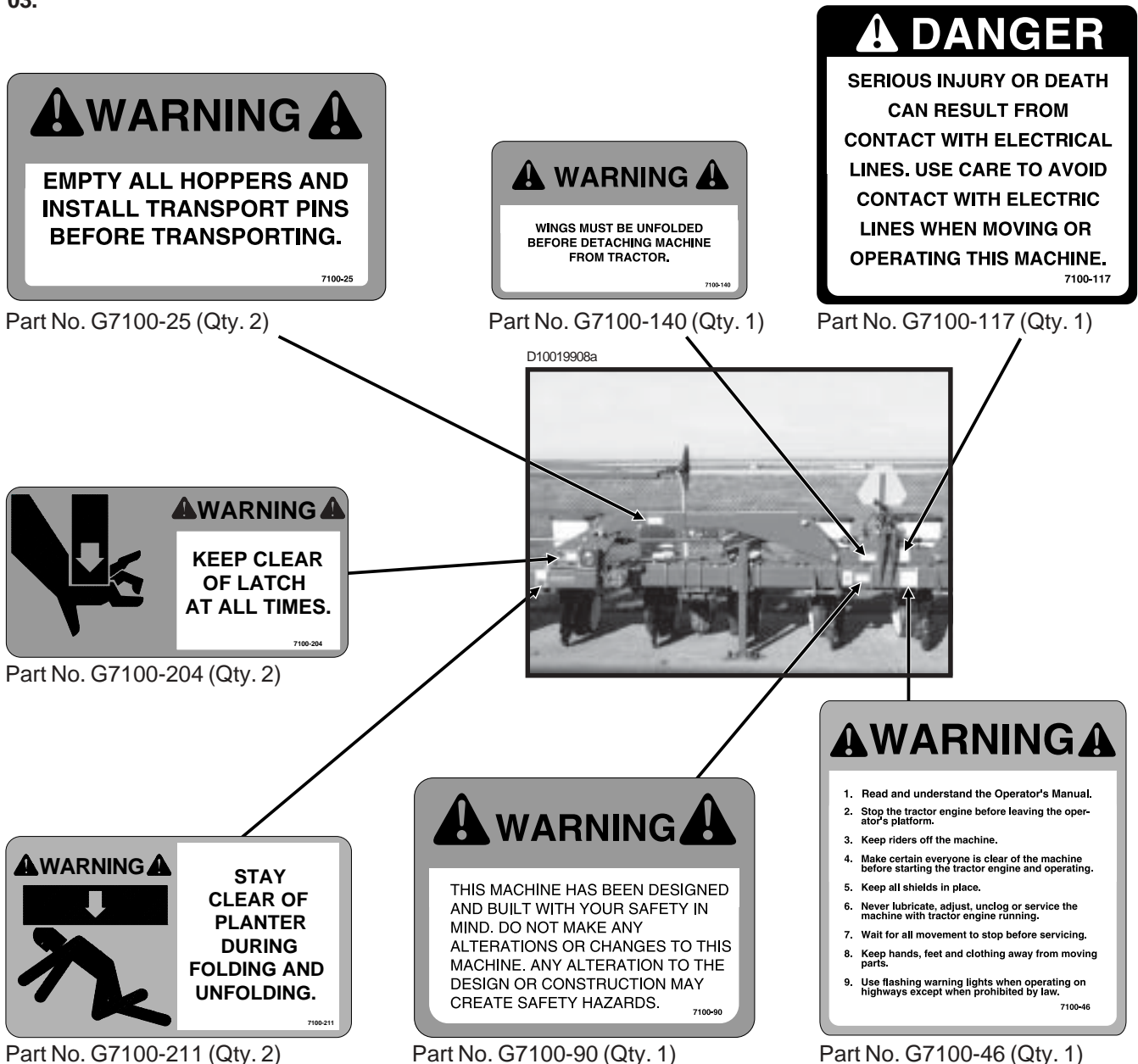

SAFETY WARNING SIGNS

D10019936



 DANGER

THIS PLANTER IS DESIGNED TO BE DRIVEN BY GROUND TIRES ONLY. THE USE OF HYDRAULIC, ELECTRIC OR PTO DRIVES MAY CREATE SERIOUS SAFETY HAZARDS TO YOU AND THE PEOPLE NEARBY. IF YOU INSTALL SUCH DRIVES YOU MUST FOLLOW ALL APPROPRIATE SAFETY STANDARDS AND PRACTICES TO PROTECT YOU AND OTHERS NEAR THIS PLANTER FROM INJURY.

7100-89

Part No. G7100-89 (Qty. 2)

 WARNING

TO AVOID INJURY --
STAND CLEAR—KEEP OTHERS AWAY WHEN RAISING OR LOWERING MARKERS. BEFORE TRANSPORTING PLANTER FULLY EXTEND HYDRAULIC CYLINDERS AND INSTALL LOCKING PINS WHERE PROVIDED.

7100-42

Part No. G7100-42 (Qty. 2 Per Marker)

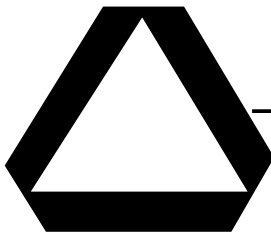

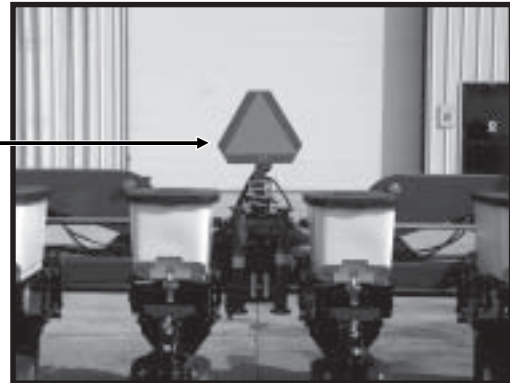

Part No. GD2199 (Qty. 1)

D10019932a



D10079904

 WARNING 

TO AVOID INJURY
ALWAYS USE HYDRAULIC CYLINDER SAFETY LOCKOUT CHANNELS WHEN TRANSPORTING PLANTER ON THE ROAD. AFTER USE RETURN TO STORAGE LOCATION.

7100-83

Part No. G7100-83 (Qty. 2)

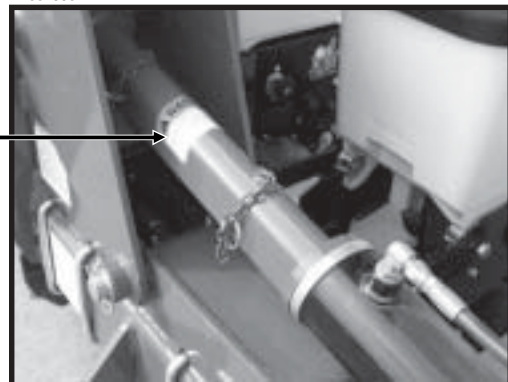

SAFETY WARNING SIGNS

D10019914

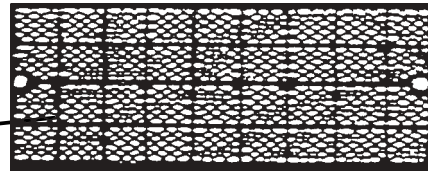
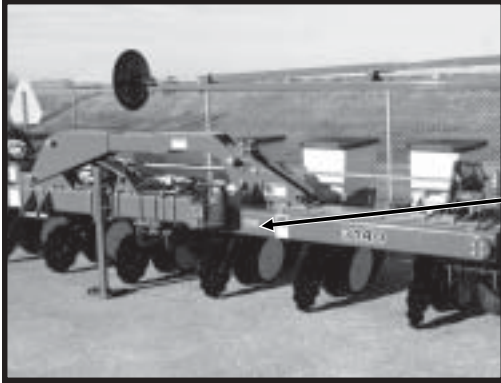

Part No. G7200-04 (Qty. 2)
Amber Reflector - Front Of Machine
(If Applicable)

D10079903

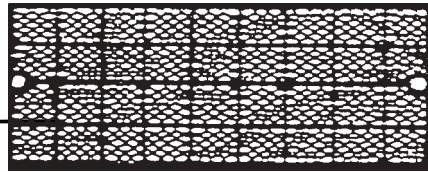
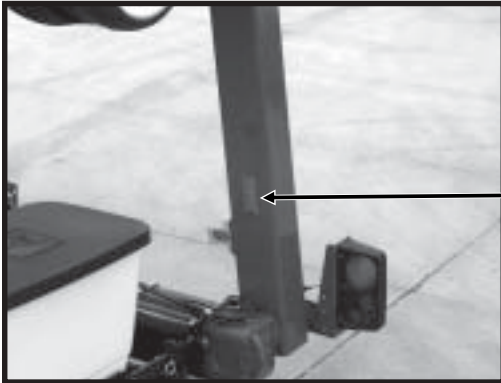

Part No. G7200-03 (Qty. 2)
Red Reflector - Rear Of Machine
(If Applicable)

D10240118a

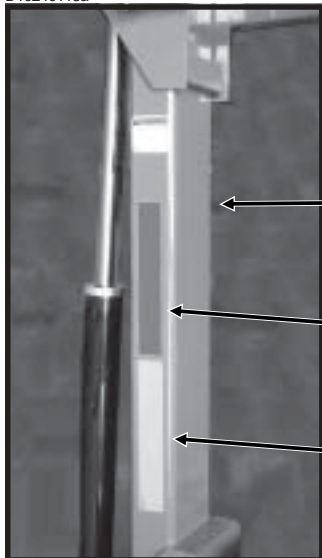

Part No. G7100-259 (Qty. 2)
Amber Reflective Decal - Front Side Of Marker Arm
(If Applicable)

Part No. G7100-258 (Qty. 2)
Red Reflective Decal - Rear Side Of Marker Arm
(If Applicable)

Part No. G7100-260 (Qty. 2)
Orange Reflective Decal - Rear Side Of Marker Arm
(If Applicable)

SAFETY WARNING SIGNS

(A7455b)

8 And 12 Row (If Applicable)

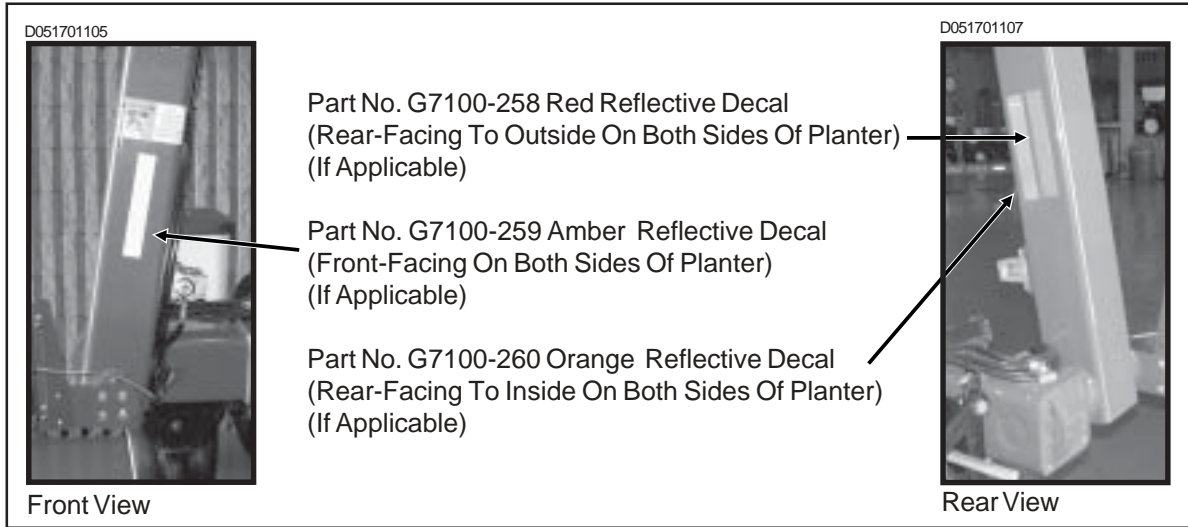

Part No. G7100-258 Red Reflective Decal
(Rear-Facing To Outside On Both Sides Of Planter)
(If Applicable)

Part No. G7100-259 Amber Reflective Decal
(Front-Facing On Both Sides Of Planter)
(If Applicable)

Part No. G7100-260 Orange Reflective Decal
(Rear-Facing To Inside On Both Sides Of Planter)
(If Applicable)

Front View

Rear View

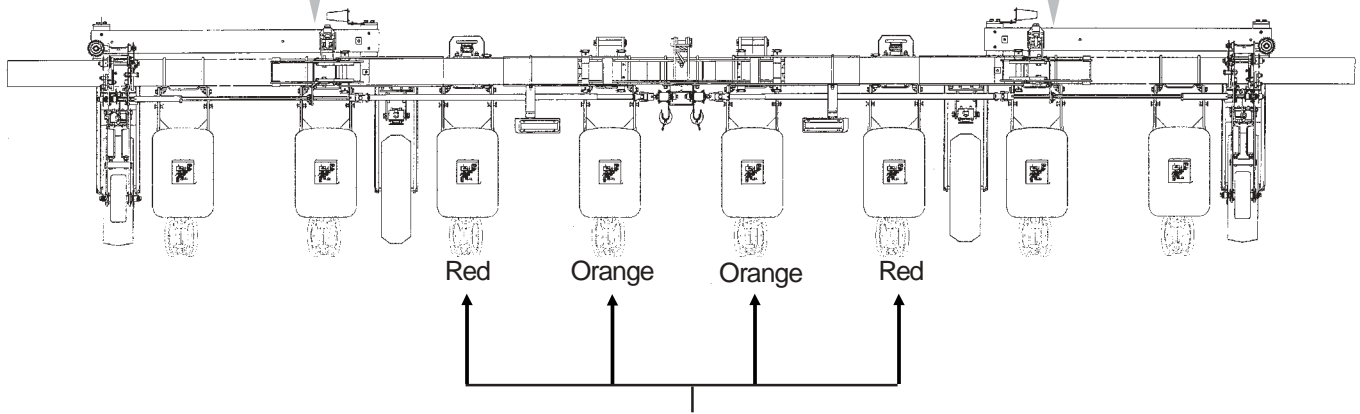

Part No. G7100-261 Red Reflective Decal
(On The Hopper Supports Located As Shown Above And At Right)
(Standard) (If Applicable)

Part No. G7100-263 Orange Reflective Decal
(On The Hopper Supports Located As Shown Above And At Right)
(Standard) (If Applicable)

D060800114

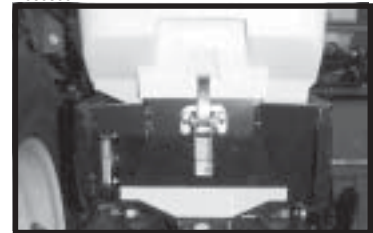

Part No. G7100-258 Red Reflective Decal
(On The Granular Chemical Hopper Panel Extensions Located As Shown Above And At Right)
(With Optional Granular Chemical) (If Applicable)

Part No. G7100-260 Orange Reflective Decal
(On The Granular Chemical Hopper Panel Extensions Located As Shown Above And At Right)
(With Optional Granular Chemical) (If Applicable)

D062300102



SAFETY WARNING SIGNS

(A7458)

16 Row (If Applicable)

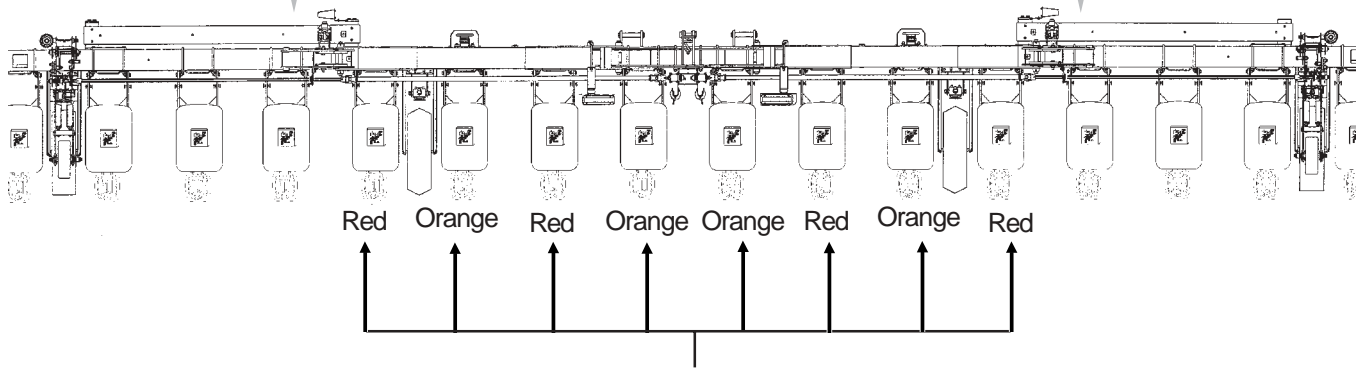
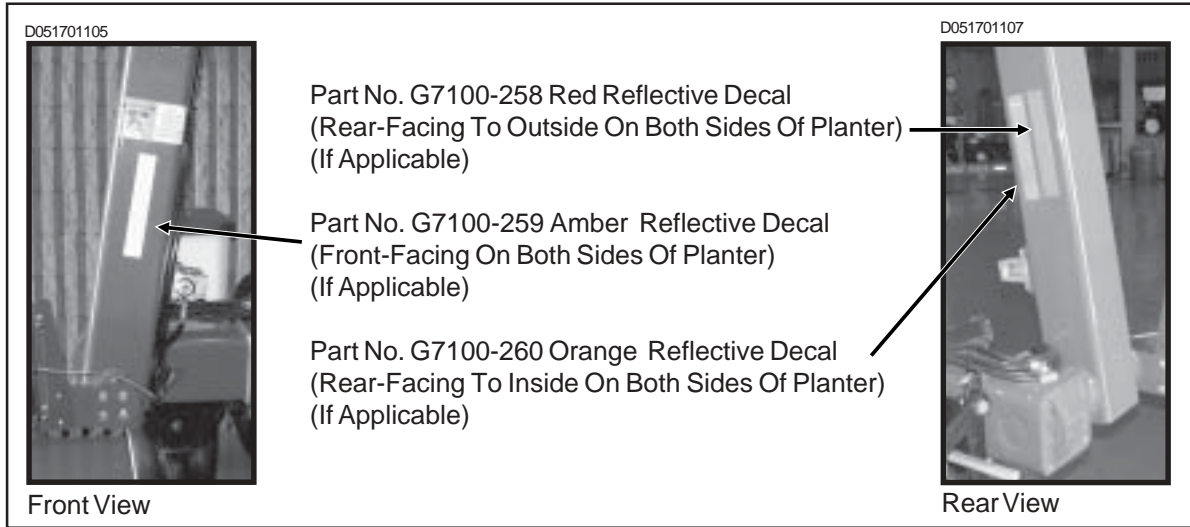

Part No. G7100-261 Red Reflective Decal
(On The Hopper Supports Located As Shown Above And At Right)
(Standard) (If Applicable)

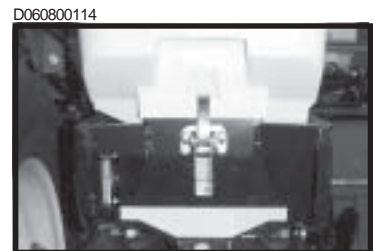

Part No. G7100-263 Orange Reflective Decal
(On The Hopper Supports Located As Shown Above And At Right)
(Standard) (If Applicable)



Part No. G7100-258 Red Reflective Decal
(On The Granular Chemical Hopper Panel Extensions Located As Shown Above And At Right)
(With Optional Granular Chemical) (If Applicable)

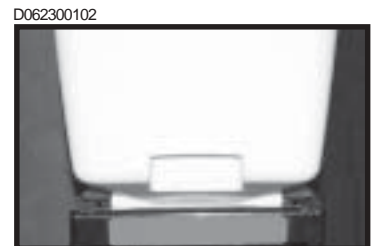

Part No. G7100-260 Orange Reflective Decal
(On The Granular Chemical Hopper Panel Extensions Located As Shown Above And At Right)
(With Optional Granular Chemical) (If Applicable)

SAFETY WARNING SIGNS

D06039901



 **WARNING** 

AGRICULTURAL CHEMICALS CAN BE DANGEROUS. IMPROPER SELECTION OR USE CAN SERIOUSLY INJURE PERSONS, ANIMALS, PLANTS, SOIL OR OTHER PROPERTY. BE SAFE. SELECT THE RIGHT CHEMICAL FOR THE JOB. HANDLE WITH CARE. FOLLOW THE INSTRUCTIONS ON THE CONTAINER LABEL AND OF THE EQUIPMENT MANUFACTURER.

7100-115

Part No. G7100-115 (Qty. 1 Per Lid - Located On Underside Of Optional Granular Chemical Hopper Lid)

 **WARNING**

TO AVOID INJURY ...

ALWAYS USE THE HYDRAULIC CYLINDER SAFETY LOCKUP CHANNEL WHEN SERVICING MACHINE IN RAISED POSITION OR WHEN TRANSPORTING MACHINE ON THE ROAD. AFTER USE RETURN TO STORAGE LOCATION.

7100-47

Part No. G7100-47 (Qty. 2 - Dual Lift Assist Wheel Package)

A7443/A5482(SFP52)

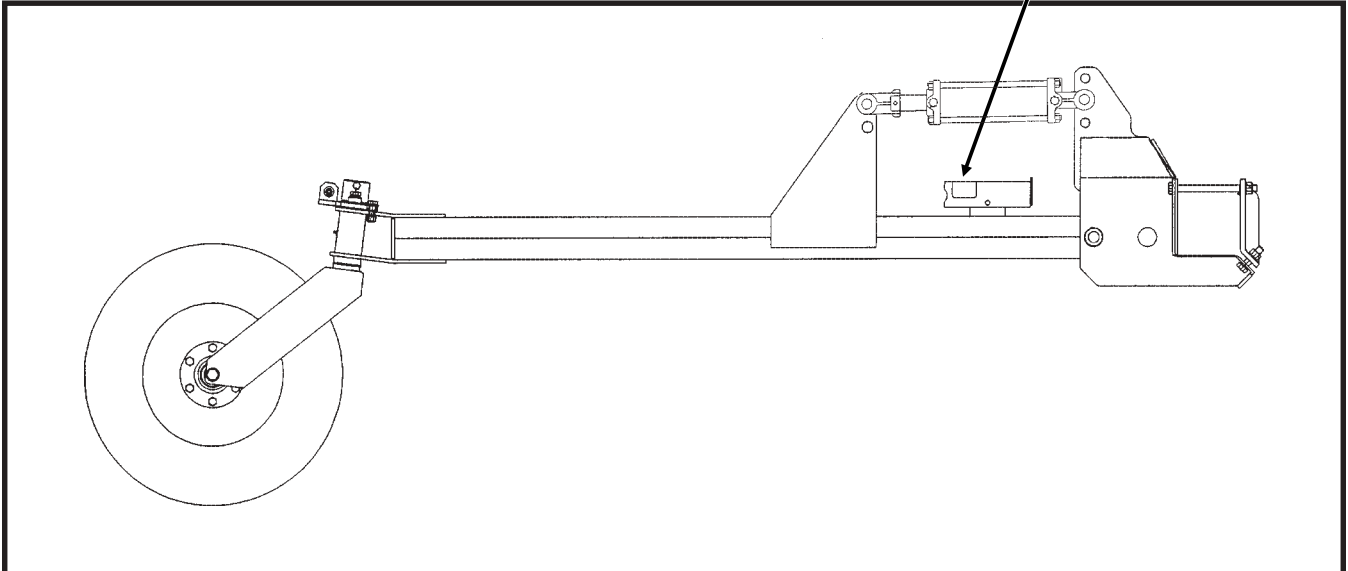

MACHINE OPERATION

The following information is general in nature and was written to aid the operator in preparation of the tractor and planter for use, and to provide general operating procedures. The operator's experience, familiarity with the machine and the following information should combine for efficient planter operation and good working habits.

IMPORTANT: Always raise the planter out of the ground when making sharp turns or backing up.

The dual lift assist wheel option requires customer-supplied quick hitch to operate without center link pin. 8 row wide planters require removal of the center section gauge wheels to accommodate dual lift assist wheels.

INITIAL PREPARATION OF THE PLANTER

Lubricate the planter and row units per the lubrication information in this manual. Make sure all tires have been properly inflated. See "Tire Pressure". Check all drive chains for proper tension, alignment and lubrication.

TRACTOR REQUIREMENTS

Approximate required minimum tractor horsepower (HP) required for field work is listed below:

- 8 Row Wide - 125 HP And Up
- 12 Row Narrow - 150 HP And Up
- 12 Row Wide And 16 Row Narrow - 180 HP And Up

NOTE: Tractor must have adequate 3 point hitch lift capacity to lift weight of machine, attachments, seed and dry chemicals. Shipping weights do not include seed, dry chemicals or additional optional attachments.

Tractor front end stability is necessary for safe and efficient operation. Therefore, it may be necessary to add front ballast to your tractor for satisfactory field operation, as well as adequate transport stability. Refer to your tractor operator's manual for front ballast recommendations.

TRACTOR PREPARATION AND HOOKUP

1. Set tractor rear wheel spacing at double the planter row spacing. For example: On a planter set for 38" rows, set the tractor wheel spacing at 76". On wide front end tractors set front wheel spacing equal to rear wheel spacing. Check tractor operator's manual for correct front and rear tire pressure.
2. Adjust lift links on tractor so planter will lift level from side to side and raise high enough for planter transport clearance. Set the sway blocks on the tractor in position to prevent side sway. Be sure the individual lift link arms are in the float position.
3. Back tractor up to planter. Position lower hitch pins and bushings as shown in the following diagrams for your type of tractor hitch. Line up holes and insert hitch pins and lock in place with pins provided. It may be necessary to change the length of the upper link with the adjusting handle.

Lower Hitch Pins

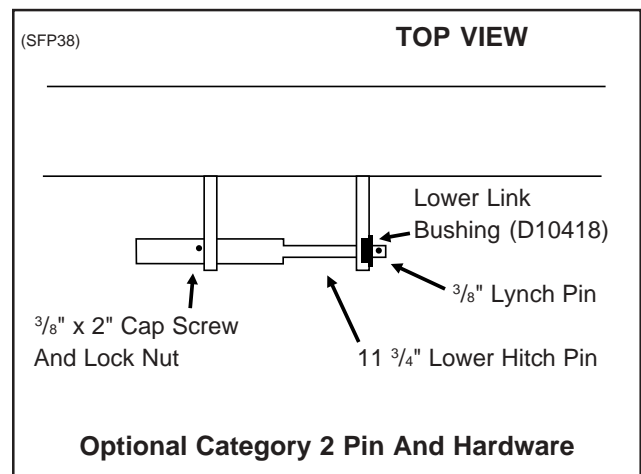
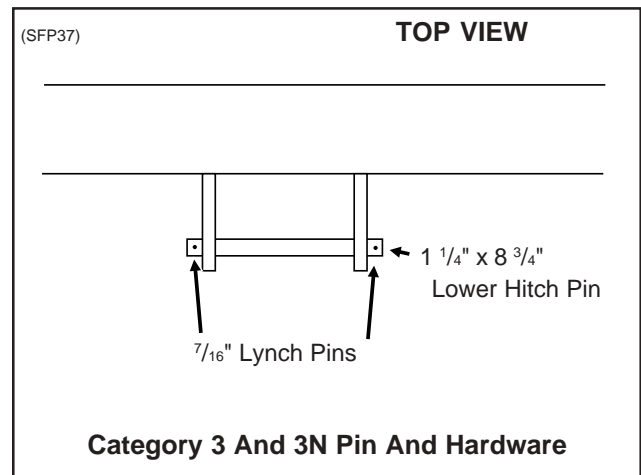

MACHINE OPERATION

The upper hitch point has two holes. The hitch pin must be positioned in the lower hole for use with tractors equipped with Category 2 quick hitch. The lower hole is also recommended for use on tractors without a quick hitch. Some Category 2 tractors without a quick hitch are designed to accommodate the upper attaching holes. Consult tractor manufacturer.

The hitch pin must be positioned in the upper hole for use with tractors equipped with Category 3 and 3N hitches.

When using a quick hitch (customer-supplied), match pin location to pin spacing in the quick hitch. Adjust the tractor upper link until the quick hitch is vertical when in the planting position.

Dual lift assist wheel equipped machines require use of a quick hitch (customer-supplied) and the top link pin is not used.

(SFP30f)

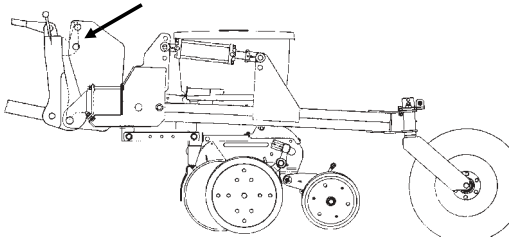

WARNING: Never transport machine with lift assist wheels without quick hitch. If this type of hitch is not in place, a sudden stop could allow the toolbar to rotate forward causing personal injury or damage to the equipment.

Upper Hitch Pin

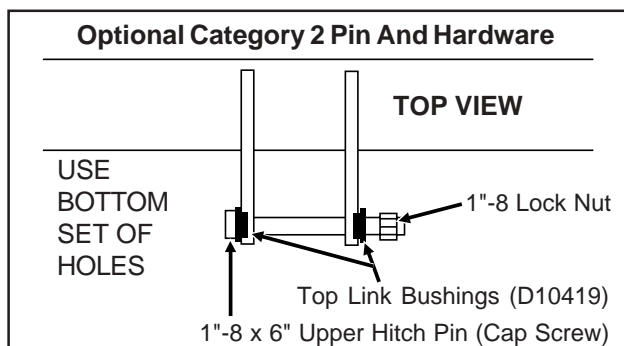
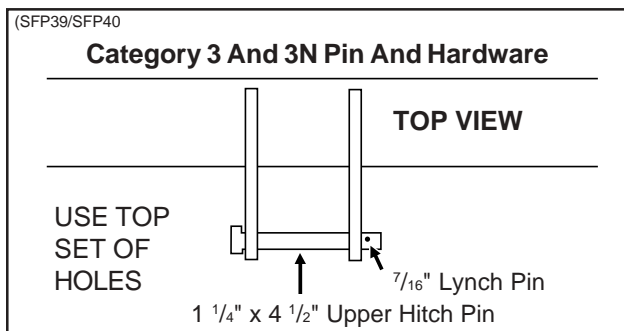

- The planter is equipped with safety/warning lights which should be used whenever the planter is being transported. The connector is a 7 terminal breakaway connector conforming to ASAE standards. If your tractor is not equipped for safety/warning lights, check with your tractor dealer.
- Connect hydraulic hoses to tractor ports in a sequence that is both familiar and comfortable to the operator. See "Hydraulic Operation".

Before attaching hoses, move tractor SCV levers back and forth to relieve any pressure in the tractor hydraulic system.

IMPORTANT: Always wipe hose ends to remove any dirt before connecting couplers to tractor ports.

IMPORTANT: Before the markers are operated, make sure all marker lockups are in working position.



DANGER: Before applying pressure to the hydraulic system, make sure all connections are tight and that hoses and fittings have not been damaged. Hydraulic fluid escaping under pressure can have sufficient force to penetrate skin causing injury or infection.

- With planter on a level surface, raise the planter slowly and watch for any interference.

When raising a planter equipped with dual lift assist wheels, the front of the planter should raise and then the back using the lift assist wheels to raise the rear of the planter. When lowering the planter, the lift assist wheels should begin to lower the rear of the planter before lowering the front of the planter. If the dual lift assist wheels are plumbed into the 3 point hitch lift circuit, adjust the flow control valve so the rear of the planter lowers before the front of the planter and the front of the planter raises before the rear of the planter. See "Flow Control Valve Adjustment". With planter lowered to planting position, adjust tractor linkage to level the toolbar. See "Leveling The Planter".

MACHINE OPERATION

With planter (equipped with dual lift assist wheels) raised for transport, maintain a minimum of 3" clearance between planter and quick hitch.

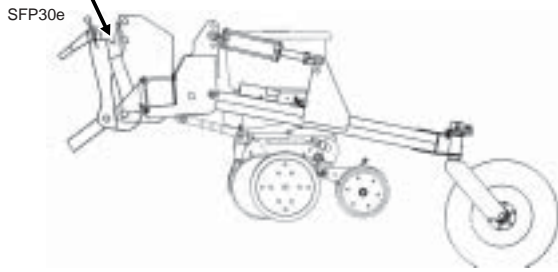

On planters equipped with the optional Dual Lift Assist Wheel Package, adjustment holes on the lift assist cylinder mounts allow for adjustment of lift height.

(SFP13b)

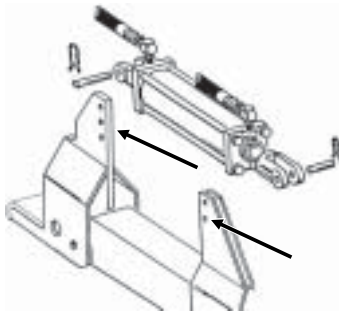

7. Remove pin from each parking stand and raise each to the transport position. Secure stands in raised position with pin in lowest hole.
8. Lower the planter so the drive wheels rest on the ground and check to be sure planter is level. Readjust top link as required to level row units. See "Leveling The Planter".

IMPORTANT: As a general safety practice and to avoid damage to the tractor hydraulic system, always lower the planter when not in use.

LEVELING THE PLANTER

For proper operation of the planter and row units, it is important that the planter frame and row unit parallel arms be level. The toolbar should operate at a 20" to 22" height, measured to the bottom of the toolbar.

When operating the planter, make sure the right and left lower link arms on the tractor are adjusted equally before attaching the planter. After the planter has been lowered to the correct operating height, stop the tractor and stand beside the planter and check to be sure the frame is level fore and aft. If the row units angle up or down, adjust the center link on the tractor accordingly.

It is important for the planter to operate level laterally. Tire pressure must be maintained at pressures specified and drive wheel height must be adjusted equally. See "Wheel Module Height Adjustment".

WHEEL MODULE HEIGHT ADJUSTMENT

D10019912

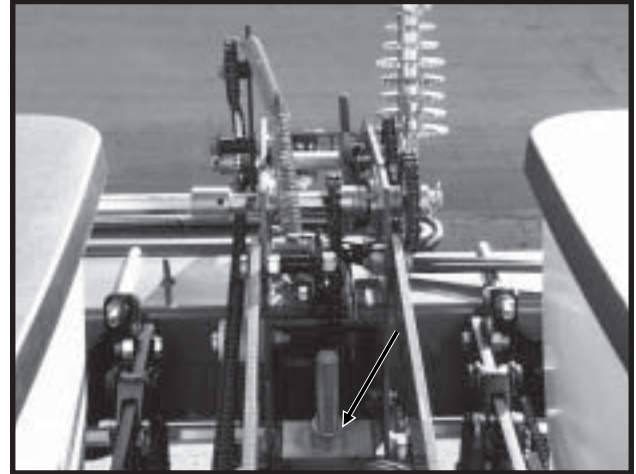

Drive Wheel Module Assembly

D10019934

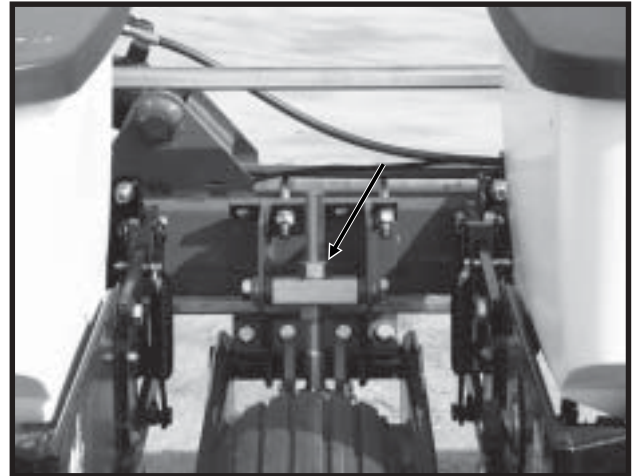

Center Section Gauge Wheel Assembly (Shown With Light Assembly Removed For Visual Clarity)

The drive wheel module assembly and center section gauge wheel assembly is designed so the drive wheel height can be adjusted to maintain a frame height of 20" to 22" in all planting situations. This is particularly useful when the planter is used for ridge planting or planting on beds. The wheel module assembly has an adjustment range of 7". To adjust the wheel assembly, loosen the upper nut using a 1 1/2" wrench or a 15" adjustable wrench and turn the lower nut using a 1 1/2" wrench or 15" adjustable wrench (clockwise to decrease frame height or counterclockwise to increase frame height). Tighten the upper nut after adjustment is complete. Set all wheels equally.

MACHINE OPERATION

PARKING STAND ADJUSTMENT

D10019908a

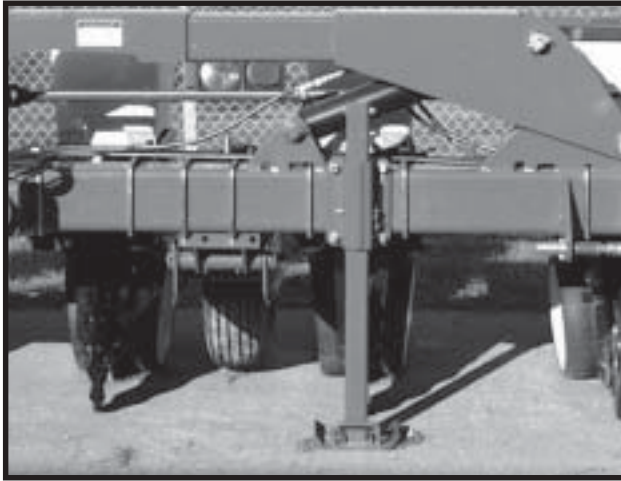

81014-75a



Two parking stands, located on the front side of the main frame, are standard on all Model 3140 planters. The stands must be positioned so they are not directly behind the tractor tire or they will hit when the planter is raised.

Raise to top position and pin when planting. Lower and pin for parking and storage.

Each parking stand has six positioning holes. By using these positioning holes, you can set the main frame parking height from 19" to 25".

CONTACT DRIVE WHEEL SPRING ADJUSTMENT

There are two down pressure springs on each contact drive wheel. The down pressure is factory preset and should need no further adjustment.

The spring tension is set leaving 1" between the spring plug and the mounting shaft as shown below.

(SPF61)

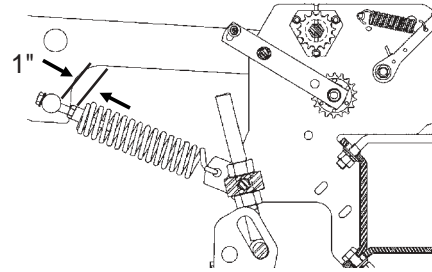

TIRE PRESSURE

Tire pressure should be checked regularly and maintained as follows:

7.60" x 15" 8 Ply Ground Drive/Gauge	40 PSI
4.10" x 6" Contact Drive	50 PSI

NOTE: Tire pressure must be correctly maintained in all drive wheel tires to ensure level and proper operation of planter. All rate charts are based on above tire pressures.

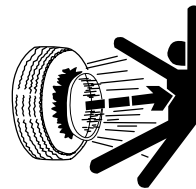

DANGER: Rim and tire servicing can be dangerous. Explosive separation of tire and rim parts can cause serious injury or death.

MACHINE OPERATION

SEED RATE TRANSMISSION ADJUSTMENT

D10019935



Planting population rate changes are made at the seed transmissions. The planter transmissions are designed to allow simple, rapid changes in sprockets to obtain the desired planting population. By removing the lynch pins on the hexagon shafts, sprockets can be interchanged with those from the sprocket storage rod bolted to each transmission.

Chain tension is controlled by spring-loaded, dual-sprocket idlers. The idler assembly is adjusted with a easy-release arm. This arm has a release position to remove spring tension for replacing sprockets. The amount of spring tension on the chain is controlled by the idler arm.

A decal positioned near each transmission illustrates proper chain routing. The planting rate charts found at the back of this section will aid you in selecting the correct sprocket combinations.

STANDARD RATE DRIVE

A7293

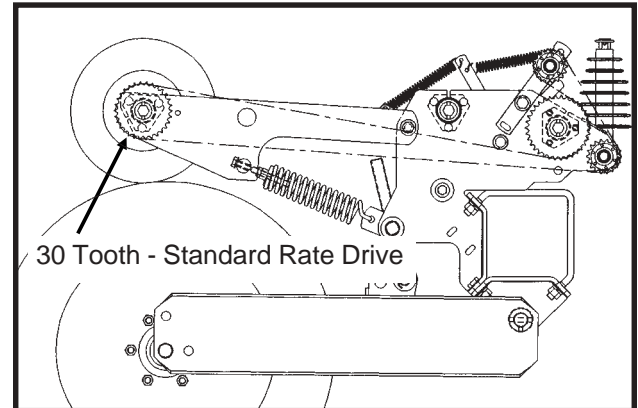

Seed planting rate charts are based on the standard rate drive. The standard rate drive uses a 30 tooth sprocket on each contact drive tire. Using the 15 tooth half rate (2 to 1) drive sprocket in place of the 30 tooth sprocket will reduce the planting and application rates by approximately 50%. See "Half Rate (2 To 1) Drive".

HALF RATE (2 TO 1) DRIVE

Half rate (2 to 1) drive is recommended only when the desired population falls below that shown on the planting rate charts.

Replacing the 30 tooth drive sprocket, located on the contact drive tire shaft, with the 15 tooth half rate (2 to 1) drive reduction sprocket will reduce the planter transmission speed and reduce planting and application rates by approximately 50%. See "General Planting Rate Information" at the back of this section.

NOTE: After each sprocket combination adjustment, make a field check to be sure you are planting at the desired rate.

A7293a

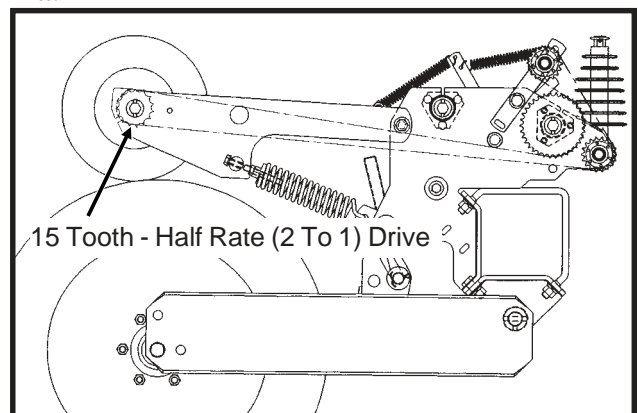

MACHINE OPERATION

SHEAR PROTECTION

The planter driveline and row unit components are protected from damage by shear pins.

81689-3

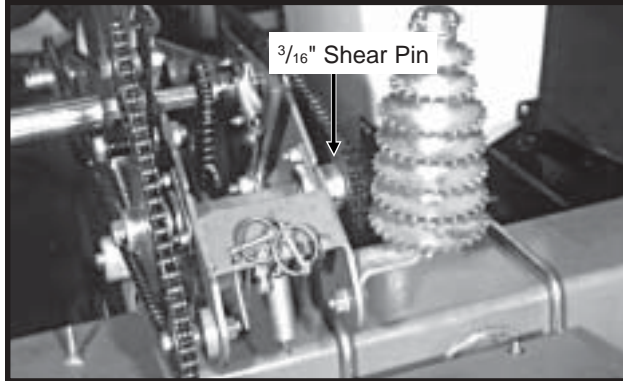

Transmission Shaft

If excessive load should cause a pin to shear, it is important to determine where binding has occurred before replacing the pin. Replace shear pins with same size and type.

To prevent future binding or breakage of components, check driveline alignment and follow prescribed lubrication schedules.

NOTE: Drill shaft/transmission coupler alignment is critical.

WRAP SPRING WRENCH OPERATION

If the chain idler is equipped with a wrap spring wrench, chain tension is released and/or added as shown below.

To release chain tension, rotate the knurled collar on the wrap spring wrench while rotating the chain idler away from the chain.

D10290305



To add chain tension, rotate chain idler into the chain while rotating handle to tension idler spring.

D10290304

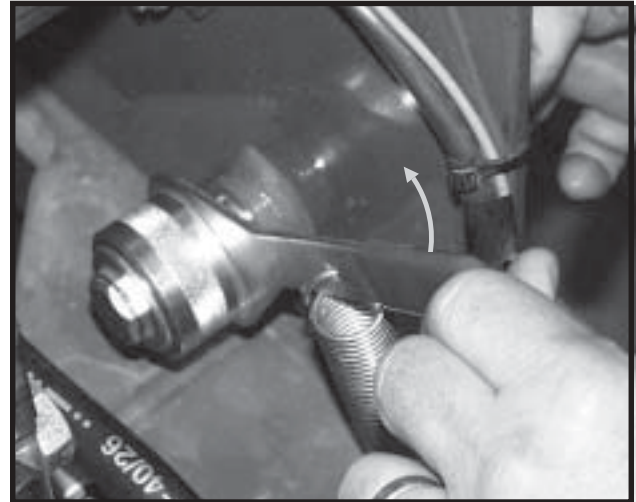

MACHINE OPERATION

HYDRAULIC OPERATION

Model 3140 Stack Folding Planters require a single control valve for folding the wings. A second control valve is required for the Row Marker Package. A third valve is required for the Dual Lift Assist Wheel Package and/or the Wing Down Flex Cylinder Package unless these are connected into the tractor 3 point lift system.

! DANGER: To avoid serious injury or death, care must be taken when operating row markers around overhead power lines.

81014-39(HYD2)

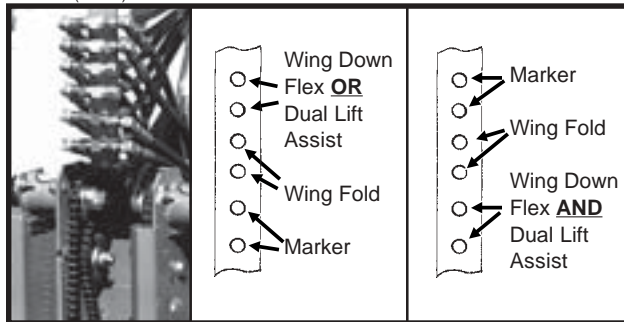

! DANGER: If a cylinder has been disconnected or removed for any reason, do not attach the rod end of the cylinder until the cylinder is cycled several times to remove any air that may be trapped in the system.

The wings are folded and unfolded using a single hydraulic control valve. When the wings are unfolded, the spring-actuated hydraulic latches lock the wings to the fold links so they pivot as one unit.

IMPORTANT: Always be sure planter is in the fully raised position before folding the planter wings.

HYDRAULIC ROW MARKER OPERATION

The single valve marker system uses a sequencing valve which directs hydraulic flow to operate the markers alternately. Each time a marker is raised, the sequencing valve will direct flow to lower the opposite marker.

Both markers can be used at the same time if desired. To do this, lower the planter and the marker that has been selected. Move the tractor SCV lever to the raised position and immediately return it to the lower position. This will shift the marker control valve and the remaining marker will be lowered.

! WARNING: Always stand clear of marker assemblies and blades when planter is operating.

! DANGER: To avoid serious injury or death, care must be taken when operating row markers around overhead power lines.

ROW MARKER SPEED ADJUSTMENT

Flow control valves located in the marker sequencing/flow control valve assembly control the lowering and raising speed of the markers. One valve controls marker raising speed and one valve controls marker lowering speed.

To adjust marker speed, loosen the jam nut and turn the control(s) clockwise, or IN to slow the travel speed and counterclockwise, or OUT, to increase the travel speed. The flow control(s) determine the amount of oil flow restriction through the valves, therefore determining travel speed of the markers. Tighten jam nut after adjustments are complete.

NOTE: Backing the flow control valve out too far can cause the o-ring seal on the valve to fail when hydraulics are operated.

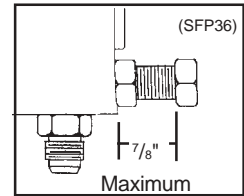

81014-13

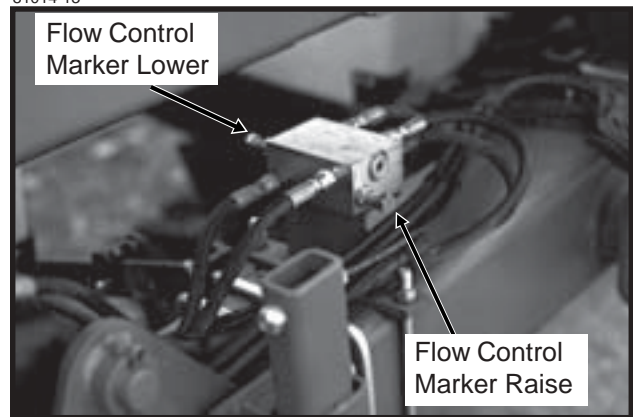

IMPORTANT: The flow controls should be properly adjusted before the marker assemblies are first put into use. Excessive marker travel speed can damage the marker assembly.

! DANGER: To avoid serious injury or death, care must be taken when operating row markers around overhead power lines.

NOTE: When oil is cold, hydraulics operate slowly. Make sure all adjustments are made with warm oil. Do not overtighten lock nut.

NOTE: On a tractor where the oil flow can not be controlled, the rate of flow of oil from the tractor may be greater than the rate at which the marker cylinder can accept the oil. The tractor hydraulic control lever will have to be held until the cylinder reaches the end of its stroke. This occurs most often on tractors with an open center hydraulic system. On tractors with a closed center hydraulic system, the tractor's hydraulic flow control can be set so the tractor's detent will function properly.

MACHINE OPERATION

ROW MARKER LENGTH ADJUSTMENT

To determine the correct length at which to set the marker assemblies, multiply the number of rows by the average row spacing in inches. This provides the total planting width. Adjust the marker extension so the distance from the marker blade to the center line of the planter is equal to the total planting width previously obtained. Both the planter and marker assembly should be lowered to the ground when the measurements are being taken. Measurement should be taken from the point where the blade contacts the ground. Adjust right and left marker assemblies equally and securely tighten clamping bolts. An example of marker length adjustment follows:

Number Of Rows	x	Row Spacing (Inches)	=	Dimension Between Planter Center Line And Marker Blade
-------------------	---	----------------------------	---	--

12 Rows	x	30" Row Spacing	=	360" Marker Dimension
---------	---	--------------------	---	--------------------------

The marker blade is installed so the concave side of the blade is outward to throw dirt away from the grease seals. The spindle assembly is slotted so the hub and blade can be angled to throw more or less dirt. To adjust the hub and spindle, loosen the 1/2" hardware and move the assembly as required. Tighten bolts to the specified torque.

IMPORTANT: A marker blade assembly that is set at a sharper angle than necessary will add unnecessary stress to the complete marker assembly and shorten the life of bearings and blades. Set the blade angle only as needed to leave a clear mark.

A field test is recommended to ensure the markers are properly adjusted. After the field test is made, make any minor adjustments as necessary.

60569-53

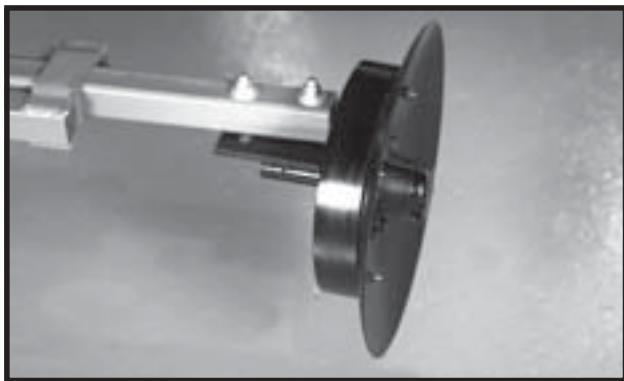

A notched marker blade, for use in more severe no till conditions, is available from KINZE® through your KINZE® Dealer.

WING FLEX

Two hooks located over each wing hinge area can be positioned so the toolbar is (a) locked rigid, (b) so the planter wings have 8° up flex or (c) with the Wing Down Flex Cylinder Package (See "Wing Down Flex Cylinder") installed, so the planter wings have 8° up flex and 8° down flex.

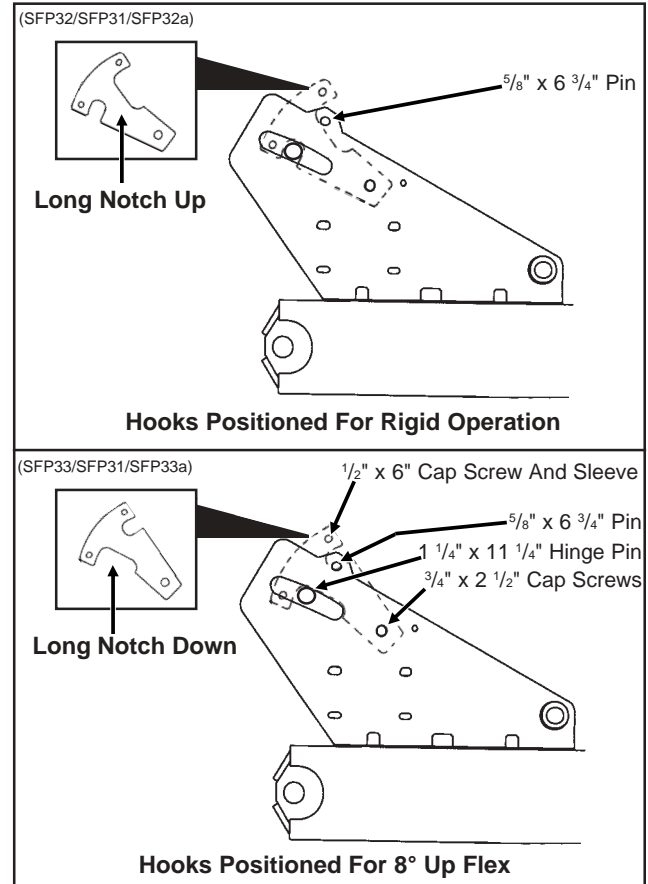

To change the hook from one position to the other:

1. Lower the planter to the ground so weight is off of the toolbar and relieve hydraulic pressure in the wing fold cylinders.
 2. Remove lynch pin and 6 3/4" pin.
 3. Loosen 3/4" hook mounting hardware and rotate the hooks back off of the hinge pin.
(It may be necessary to raise the outer end of the wing up several inches to take pressure off of the hooks to allow them to rotate.)
 4. Remove 1/2" x 6" cap screw and sleeve.
 5. Remove 3/4" hook mounting hardware.
- (continued)

MACHINE OPERATION

6. Install hooks in new position. DO NOT tighten $\frac{3}{4}$ " hardware at this time.
7. Install sleeve and $\frac{1}{2}$ " cap screw in opposite hole.

NOTE: The $\frac{3}{4}$ " hook mounting hardware should be snug, yet loose enough to allow the hooks to be rotated by hand.

8. Install 6 $\frac{3}{4}$ " pin and lynch pins.



WARNING: Always make sure there are no persons near the planter when planter wings are being lowered from transport position.



DANGER: Serious injury or death can result from contact with electric lines. Use care to avoid contact with electric lines when moving or operating this machine.



DANGER: Wings must be unfolded before detaching machine from tractor.



WARNING: Always install hydraulic cylinder safety lockups when servicing the machine in raised position or when transporting the machine on the road.

WING DOWN FLEX CYLINDER

(SFP31/SFP33a/SFP35)

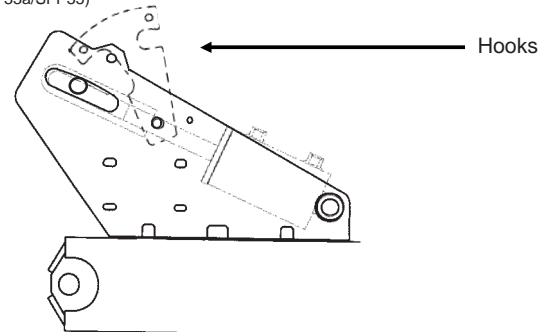

Wing Down Flex Cylinder Installed To Allow 8° Up Flex And 8° Down Flex

To prevent the planter wings from sagging during transport should hydraulic pressure be lost, the hooks located over each hinge area should be repositioned prior to folding the planter. Apply hydraulic pressure to the wing down flex cylinders until they are completely retracted and the wings are rotated up slightly. ($\frac{3}{4}$ " hook mounting hardware should be snug, yet loose enough to allow the hooks to be rotated by hand.) Remove lynch pin and 6 $\frac{3}{4}$ " pin, rotate hooks to hook over hinge pin as shown below and reinstall 6 $\frac{3}{4}$ " pin above hooks. Relieve hydraulic pressure on down flex cylinders and allow wings to come back to level. Fold planter and install lockups on wing fold cylinders. Reverse procedure to unfold planter.

IMPORTANT: Always be sure planter is in the fully raised position before folding the planter wings.

(SFP31/SFP33/SFP35)

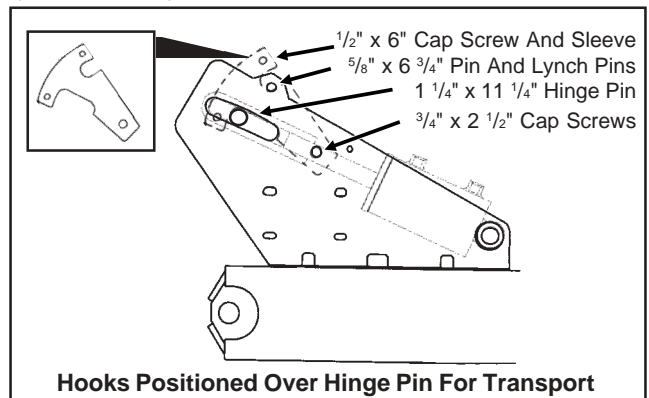

KPM I ELECTRONIC SEED MONITOR

(MTR28)

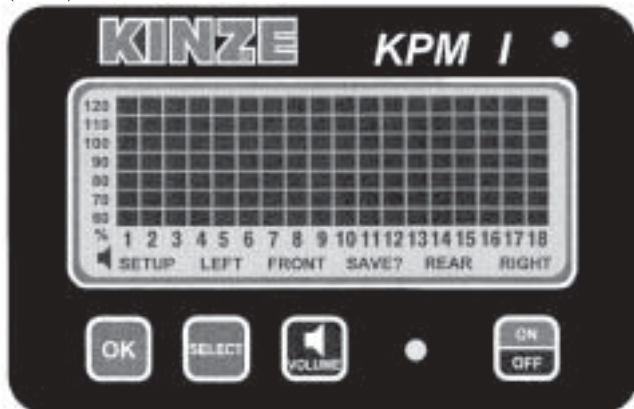

The electronic seed monitor system consists of a console, which is mounted on the tractor; seed tubes with computerized sensors, one of which is installed in each planter row unit; a primary harness*, which connects the console to the planter harness; and a planter harness (junction Y-harness and/or harness extension where applicable), to which the individual seed tube sensors connect.

Seed flow for up to 36 rows, in two 18 row sections (left/right or rear/front), may be monitored with one monitor. For less complicated applications (18 rows or less), all rows may be programmed in one section and the other section left disabled.

The monitor system is powered by the tractor battery (requires 12 volts DC). The console receives information from each of the sensors and translates this information.

The single backlit Liquid Crystal Display (LCD) shows the active section, the number of monitored rows per section, the relative seed rate for each row (using a bar graph display) and scrolls various alarm and warning messages when an alarm condition exists. A continuous audible alarm will sound upon system malfunction or underflow conditions for any monitored row. Alarms must be acknowledged by the user. Various warnings may sound the alarm or flash one or more icons.

The monitor will power down if no activity is detected within one hour. No activity means there has been no new seed flow and no operator push key input. (If Applicable)

* **NOTE:** The primary harness, on all 3000 Series Planters, is hard-wired into the safety/warning light harness or control console harness included as standard equipment with the planter.

Monitor Key Functions	6-10
LCD Functions	6-10
Changing The Audible Alarm Volume	6-11
Warnings And Alarms	6-11
Replacing A Faulty Sensor	6-12
Field Operation	6-13
Programming/Connecting Seed Tubes	6-13

MONITOR KEY FUNCTIONS

Each key press is acknowledged by the monitor with a short beep.

OK

- Ends and saves the new setup during installation.
- Acknowledges and silences alarms in the operation mode.

SELECT

- Selects the application mode (rear/front or left/right) at the beginning of installation setup.
- Selects the active section(s) (rear, rear/front, left, right or left/right) in the operation mode.
- Has no affect on a system configured to monitor only one section.

VOLUME

- Pressing the key will turn the audible alarm on.
- Holding the key for periods of 2 seconds increases the volume until it reaches the maximum, at which time it rolls over to the minimum level.

ON/OFF

- Powers the unit on and off.

LCD FUNCTIONS

The monitor collects data on the planting rates from all active rows and calculates an average. This average will determine the 100% mark. Seed rate for each row is then compared to the average value and the result is displayed on the bar graph.

The information regarding each section is displayed alternately every 5 seconds. While operating a system with two sections programmed, one or both sections may be selected any time. When only one section is selected, the monitor calculates the average based on the remaining active rows from that section.

STEP 1 Press SELECT key once to show one section. The flashing icon shows the section that is not selected. The selected section is continuously displayed on the LCD.

EXAMPLE: The system is setup to display rear/front sections. Press SELECT key. The FRONT icon will be flashing and the REAR section will be displayed on the bar graph. After 1 minute the FRONT icon will stop flashing. The monitor will stay in this REAR only display through power down and power up. Each time the monitor is turned on while in REAR only mode, the FRONT icon will flash for 1 minute. Also if seed flow is sensed in the FRONT section while planting, the FRONT icon will resume flashing.

STEP 2 Press SELECT key again to activate both sections.

EXAMPLE: Press SELECT key a second time. The information regarding each section will display alternately every 5 seconds.

For simple applications, where only one section is programmed, the display will automatically lock on that section. Pressing SELECT key will have no affect.

NOTE: When alternating between two sections, the display will lock on the section containing the first recognized alarm until the alarm is acknowledged by pressing the OK key or the alarm condition is removed.

CHANGING THE AUDIBLE ALARM VOLUME

STEP 1 Press and hold down the VOLUME key.

STEP 2 The SETUP and VOLUME icons will turn on and the alarm will sound continuously. The intensity of the sound will change every 2 seconds. After the maximum volume is reached, the next change will set the volume to minimum and will continue to get louder every 2 seconds. When the desired volume is reached, release the key.

WARNINGS AND ALARMS

- 1. System Alarms** - A system alarm is activated when the monitor detects a faulty sensor or one of several other communication faults.

The corresponding row number starts flashing and the alarm sounds. All segments on the corresponding bar graph are turned off. Pushing the OK key to acknowledge the warning will turn the audible alarm off. The row number will continue to flash until the alarm condition is removed. If the monitor detects a faulty sensor and there is no planting activity present, the monitor will scroll "CHECK CONNECTION".

Another type of system alarm occurs when the monitor detects a data communication bus error. The three possible data communication bus errors are:

LCD Display	Error Condition
SYS HI	The data communication lead (green) has been shorted to the power lead (white).
SYS LO	The data communication lead (green) has been shorted to the ground lead (black).
SYS EC	An internal error has been detected.

- 2. Under Flow Alarms** - If the seed rate for one or more rows is less than 55% of the calculated average, the corresponding 60% segment will stay on, the corresponding row number starts flashing and the alarm sounds. Pushing the OK key to acknowledge the alarm will turn the alarm off. The 60% segment of the bar graph remains on and the row number continues to flash until the alarm condition is corrected.

NOTE: All alarms present within a short time before planting stops, are frozen on the screen and the text LOW or FAIL will display on the LCD. If the under flow is between 0% and 10%, this warrants a "FAIL" condition. If the under flow is between 10% and 55%, a "LOW" condition is generated. If multiple rows have an under flow condition, "FAIL" will display if any one or more rows is between 0% and 10%. This allows the user to identify and fix the problem rows.

NOTE: This warning will not trigger unless a minimum time of continuous planting has passed.

NOTE: If all the rows show a seed rate of zero, the condition will not generate an alarm. It will be assumed the planter has stopped. The row numbers and the bottom 60% segment will remain on for all selected rows.

3. **Multiple Alarms** - If more than one alarm condition occurs at the same time, pushing the OK key will acknowledge all alarms that are currently displayed. For example, if one row on the front and one row on the rear are alarming, pushing the OK key will only acknowledge one of them. However, if there are two alarms on the front, both alarms would be acknowledged with one push of the OK key.
4. **Section Not Selected Warning** - If the monitor was programmed for two sections and only one is currently selected for display (by pressing the SELECT key), the icon of the disabled section will flash for a period of 1 minute, then turn off at each power up. If seed flow is sensed in the disabled section, the icon for that section (front, left or right) will begin to flash.
5. **Seed Planting Stopped Warning** - When the monitor detects no seed flow on all rows, the monitor will emit 3 short beeps to alert the user. This warning will occur each time the planter is stopped, each time the planter is raised at the end of a row or if the mechanical drive fails while planting.

NOTE: This warning will not trigger unless a minimum time of continuous planting has passed.

6. **Seed Counting Sensor In Calibration Warning** - All seed counting sensors run a self-calibration sequence on power up. While in calibration the bottom segment of each corresponding bar graph will flash if the monitor detects movement or planting activity. If the monitor does not detect this, the message "WAIT CALIBRATION" will be scrolled.

7. **Seed Counting Sensor Too Dirty Warning** - After the seed counting sensors end their internal self-calibration, the monitor may detect one or more sensors are either too dirty or blocked. If the monitor detects planting or movement, the corresponding bar graph remains flashing. The monitor will display "CLEAN SENSORS" on the LCD if no movement or planting is detected, prompting the user to clean the tubes. If the tubes are dirty, they will still show seed flow with less accuracy. If the tubes are blocked the user will get an alarm as soon as planting starts. The corresponding bar graph will remain flashing until the problem is corrected and the monitor is powered down and then powered back up.
8. **Low Battery Warning** - The monitor is constantly monitoring its input voltage to quickly detect low power conditions. If the monitor detects that the input voltage has dropped below 11.0V, it will display "LOW POWER" on the LCD, provided that the monitor does not detect planting.

NOTE: After the alarms have been acknowledged and if the alarm condition is still present, the LCD will continue to display the alarm condition.

REPLACING A FAULTY SENSOR

To replace a faulty sensor; (a) disconnect the faulty sensor and check the monitor to be sure the correct sensor was disconnected, (b) turn the monitor off, (c) after a few seconds, turn the monitor back on and (d) plug in the replacement sensor. The monitor will chirp twice to acknowledge the new sensor was learned and saved.

To replace more than one faulty sensor, proceed as stated above beginning with the lowest numbered row in the rear or left section and continue to replace sensors in increasing order. Then move on to the front or right section and continue in ascending row number order.

NOTE: If the monitor is not turned off and then on, the replacement sensor(s) will be ignored until the next power on, at which point they will be randomly learned by the monitor.

FIELD OPERATION

(MTR28e/MTR28c/MTR28d/MTR28b)

Press the ON/OFF key to turn the monitor on and off.



Information regarding each section is displayed alternately every 5 seconds.

REAR/FRONT CONFIGURATION

- Press the SELECT key once to show REAR section only.
- Press the SELECT key a second time to return to each section being displayed alternately every 5 seconds.
- Press the SELECT key a third time to show REAR section only again.



LEFT/RIGHT CONFIGURATION

- Press the SELECT key once to show LEFT section only.
- Press the SELECT key a second time to show RIGHT section only.
- Press the SELECT key a third time to return to each section being displayed alternately every 5 seconds.



NOTE: SELECT key has no function when only a single section is being used.

Press the VOLUME key to increase or decrease volume. See “Changing The Audible Alarm Volume”.



Press the OK key to silence alarms. See “Warnings And Alarms”.



PROGRAMMING/CONNECTING SEED TUBES

STEP 1 All the seed tubes w/sensors must be disconnected from the harness and the monitor must be off.

STEP 2 Press the ON key. The monitor automatically enters the setup procedure. If the monitor was accidentally powered on with no sensors attached, the user can turn the monitor off at this point and the previous configuration is not lost.

STEP 3 Press the SELECT key. Each time you press the SELECT key the mode will toggle between rear/front and left/right. The selected display will be solid and the configuration not currently selected will be flashing. By default the monitor starts in rear/front mode.

01229910

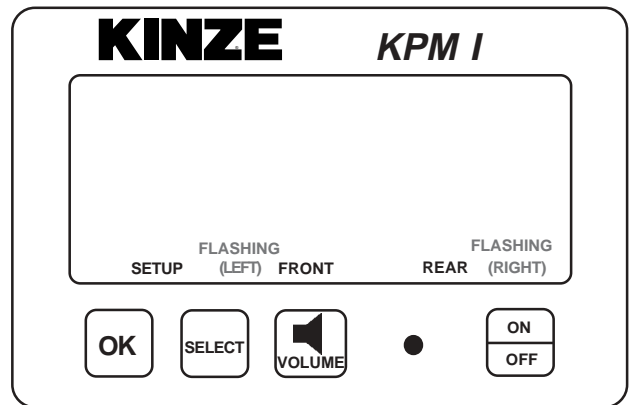

01229911

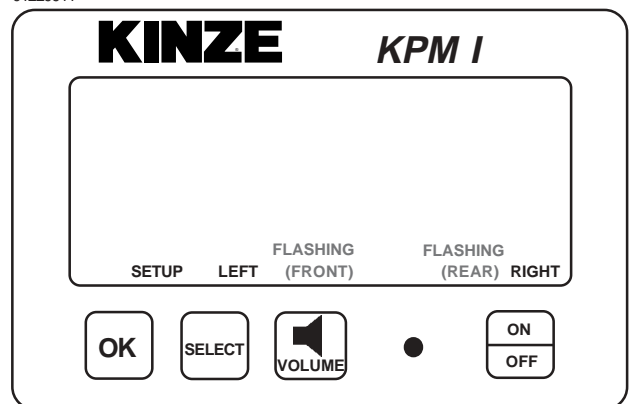

NOTE: Model 3140 planters will use the rear configuration only.

STEP 4 Press and hold the OK key to confirm the selection and continue holding until the row numbers appear on the display. During confirmation, the display will alternate between “NEW” and “SYS” to alert the user that the previous configuration will be lost. With the rear/front mode selected, the monitor automatically starts with the rear section. The REAR icon shows solid and the FRONT icon starts to flash. With the left/right mode selected, the monitor automatically starts with the left section. The LEFT icon shows solid and the RIGHT icon starts to flash.

01229912

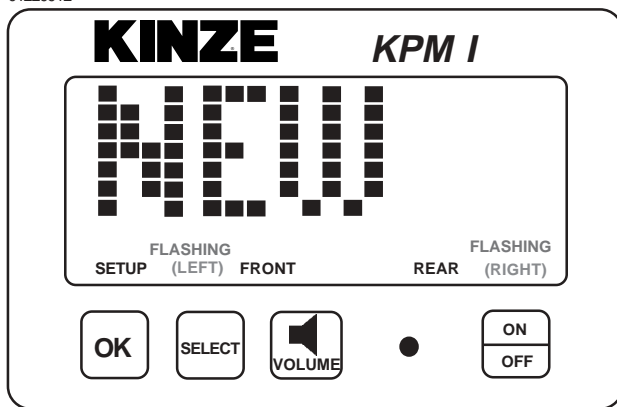

STEP 5 Plug each seed tube w/sensor into the harness in a predetermined order. Row 1 first, row 2 second and so on up to 18 rows. When a sensor is plugged in, the corresponding row number on the LCD display will stay solid, the monitor will chirp twice and the LED (Light Emitting Diode) on the seed tube sensor will turn on for approximately 30 seconds to show connection is made. NOTE: Unless there is a faulty sensor, the installer should just have to connect the sensors in the proper order without checking the monitor is acknowledging each sensor.

01229915

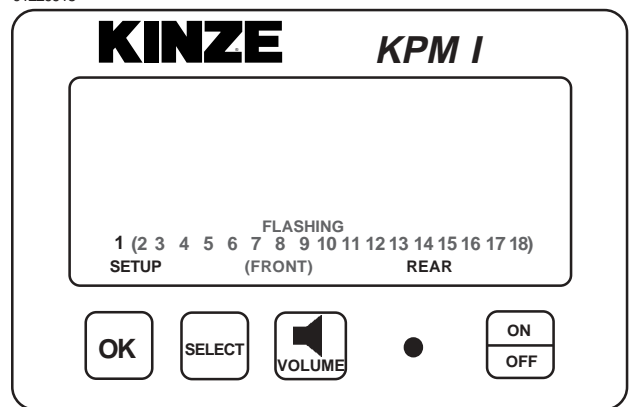

01229912a

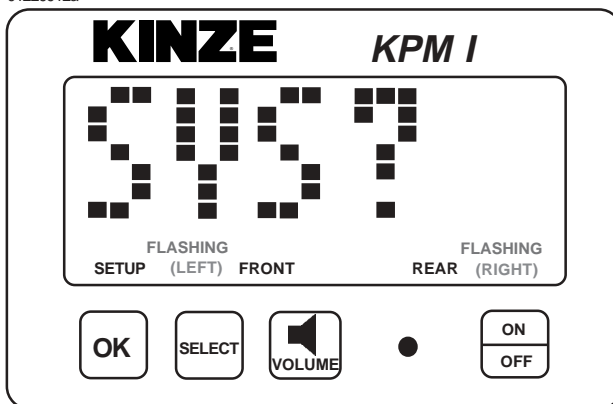

STEP 6 When all the seed tubes w/sensors for the current section are installed, check to be sure the monitor displays solid numbers for the number of sensors connected.

01229916

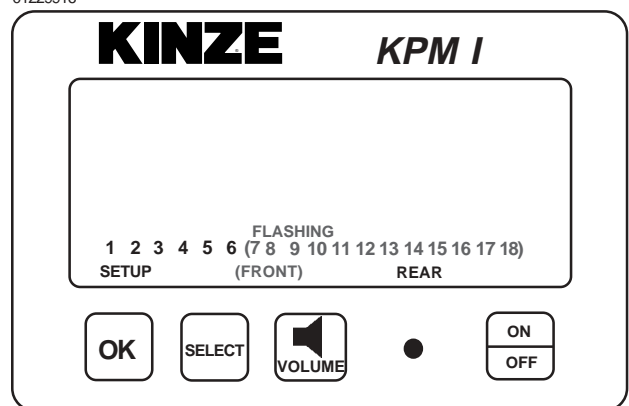

STEP 7 If this condition is satisfied, press and hold the OK key to save the setup for the current section. The SAVE? icon will show followed by continuous short beeps indicating the monitor is preparing to save. The installer has 5 seconds to decide if he wants to save the current configuration. During this time the short beeps will sound. To complete the save, hold the OK key pressed until the word “DONE” shows on the screen followed by a long beep and the SAVE? icon turns off. When the OK key is released the monitor will continue with the second section installation.

STEP 8 Follow STEPS 5 through 7 to install the second section. If no seed tubes are installed on the second section, press and hold the OK key until the word “DONE” shows on the screen followed by a long beep and the SAVE? icon turns off.

01229917

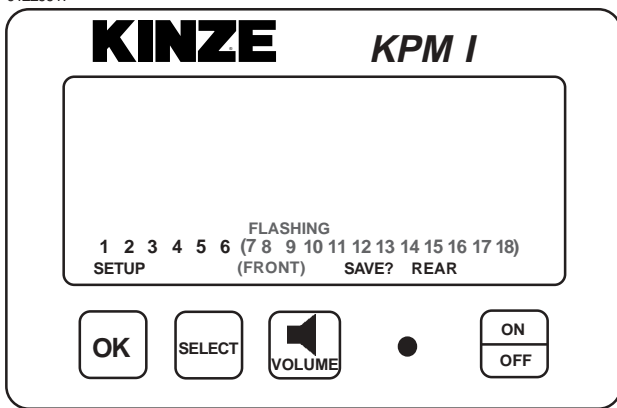

01229919

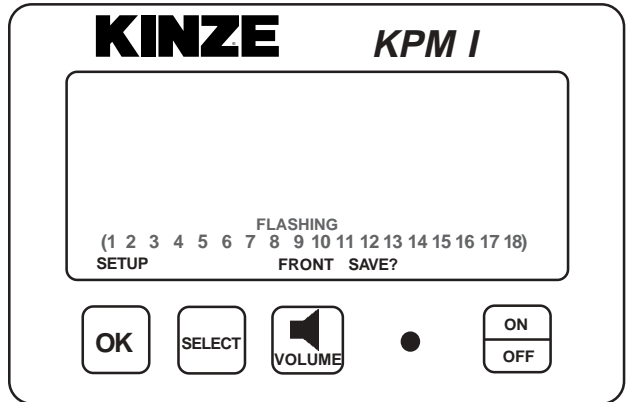

01229920

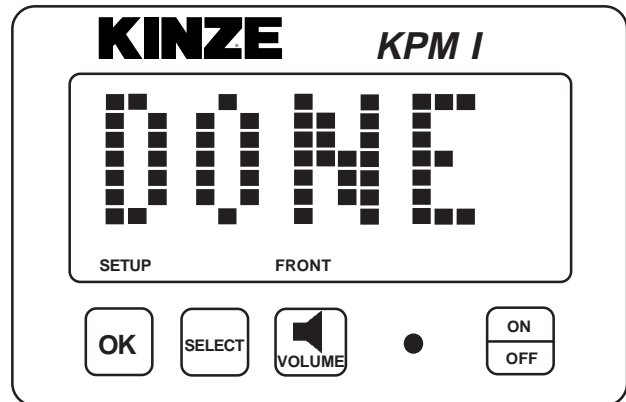

01229918

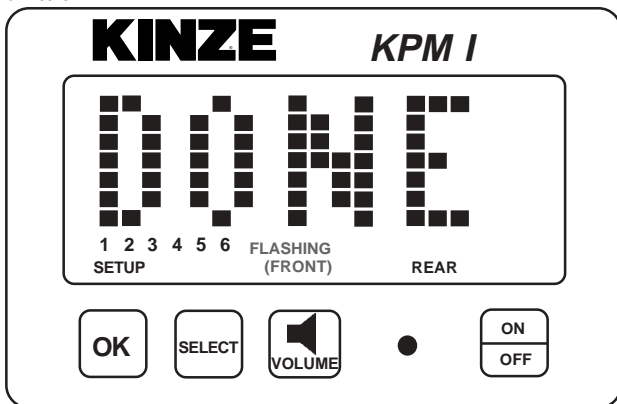

NOTE: Individual seed tubes may be unplugged for special situations. An alarm will sound which can be silenced by touching the OK key. The monitor will recognize each seed tube when reconnected.

See “KPM I/KPM II/KPM II Stack-Mode Electronic Seed Monitor Troubleshooting” in the Maintenance Section.

KPM II ELECTRONIC SEED MONITOR

(MTR29)

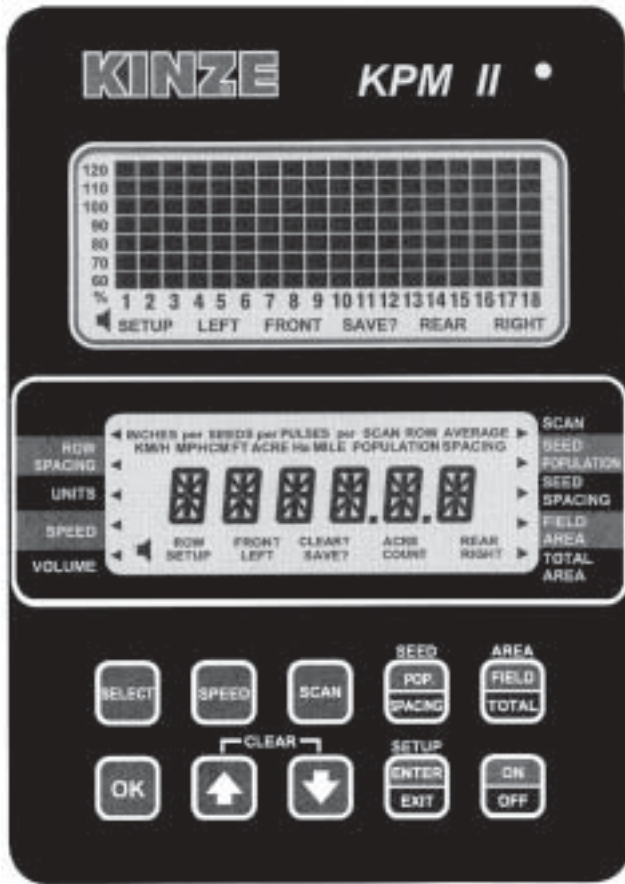

The electronic seed monitor system consists of a console, which is mounted on the tractor; seed tubes with computerized sensors, one of which is installed in each planter row unit; a primary harness*, which connects the console to the planter harness; and a planter harness (junction Y-harness and/or harness extensions where applicable) to which the individual seed tube sensors and rotation sensors connect. The monitor works with a magnetic (pickup) distance sensor or radar distance sensor.

* **NOTE:** The primary harness, on all 3000 Series Planters, is hard-wired into the safety/warning light harness or control console harness included as standard equipment with the planter.

Seed flow for up to 36 rows, in two 18 row sections (left/right or rear/front), may be monitored with one monitor. For less complicated applications (18 rows or less), all rows may be programmed in one section and the other left disabled.

The monitor system is powered by the tractor battery (requires 12 volts DC). The console receives information from each of the sensors and translates this information.

The console has two backlit Liquid Crystal Displays (LCD). The upper display shows the active section, the number of monitored rows per section, the relative seed rate for each row (using a bar graph display) and scrolls various alarm and warning messages when an alarm condition exists. A continuous audible alarm will sound upon system malfunction or underflow conditions for any monitored row. Alarms must be acknowledged by the user. Various warnings may sound the alarm or flash one or more icons. The lower display is used to display alphanumeric data such as row spacing, units (Metric or English), speed, volume, seed population, seed spacing, field area, total area and distance sensor pulses per mile/kilometer.

The monitor will power down if no activity is detected within one hour. No activity means there has been no new seed flow and no operator push key input. (If Applicable)

Monitor Key Functions	6-17
Upper LCD Functions	6-18
Lower LCD Functions	6-19
Programming	
Changing The Audible Alarm Volume	6-21
Units (Metric Or English)	6-22
Row Spacing	6-22
Speed	6-24
Clearing Total Area	6-25
Area Counter/Speedometer Mode	6-26
Warnings And Alarms	6-26
Replacing A Faulty Sensor	6-27
Field Operation	6-27
Clearing Field Area	6-28
Programming/Connecting Seed Tubes, Radar/Magnetic Distance Sensors And/Or Shaft Rotation Sensors	6-29
Row-By-Row Alarm Level Setting	6-37

MONITOR KEY FUNCTIONS

Push keys allow the user to select or change the operating mode, the active displays or the current configuration. Depending on the operating mode or the current display selected, some keys are valid while some are not. Each key press, if valid, is acknowledged by a short beep and an action is taken. If the key press has no action associated, the key press is considered invalid, and the user will not get any feedback.

SELECT

- Selects the application mode (rear/front or left/right) at the beginning of installation in the setup mode.
- Selects the active section(s) (rear, rear/front, left, right or left/right) in the operation mode.
- Has no affect on a system configured to monitor only one section.
- While programming the monitor, the key will select the digit to change.

SPEED

- Immediately displays the current ground speed.

SCAN

- If the current average population or average spacing is displayed, this key sequentially displays the seed population/spacing on each row.
- If the display shows functions other than average seed population or spacing, pressing SCAN will sequentially display speed, average seed population and average seed spacing.
- Pressing a second time freezes the display on the current row.
- Pressing a third time restarts the sequential display.

SEED POPULATION/SEED SPACING

- Immediately displays the average seed POPULATION and the average seed SPACING of all active rows.
- Each press alternates between seed spacing and seed population.

AREA FIELD/AREA TOTAL

- Immediately displays the field or total area planted since the field/total area was last cleared.
- Each press alternates between field area and total area.

OK

- Ends and saves the new setup during installation.
- Acknowledges and silences alarms in the operation mode.

UP ARROW AND DOWN ARROW

- Scrolls sequentially through the display options on the lower LCD display.
- Freezes on the current row in the scan mode.
- Scrolls sequentially through the rows when the population scan is frozen.
- Used to enter programmable values in the programming mode.
- The UP and DOWN Arrow keys can be pressed at the same time to start the CLEAR function.

SETUP ENTER/SETUP EXIT

- Enters and exits the programming mode.

ON/OFF

- Powers the unit on and off.

UPPER LCD FUNCTIONS

(MTR29H)

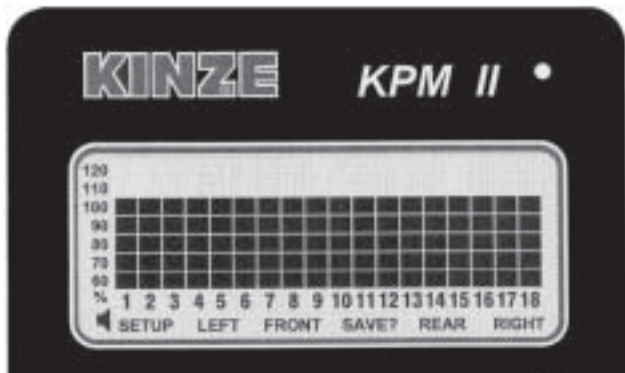

The monitor collects data on the planting rates from all active rows and calculates an average. This average will determine the 100% mark. Seed rate for each row is then compared to the average value and the result is displayed on the bar graph.

The information regarding each section is displayed alternately every 5 seconds. While operating a system with two sections programmed, one or both sections may be selected any time. When only one section is selected, the monitor calculates the average based on the remaining active rows from that section.

STEP 1 Press SELECT key once to show one section. The flashing icon shows the section that is not selected. The selected section icon is continuously displayed on the LCD.

EXAMPLE: The system is setup to display rear/front sections. Press SELECT key. The FRONT icon will be flashing and the REAR section will be displayed on the bar graph. After 1 minute the front row icon will stop flashing. The monitor will stay in this REAR only display through power down and power up. Each time the monitor is turned on while in REAR only mode, the FRONT icon will flash for 1 minute. Also if seed flow is sensed in the FRONT section while planting, the FRONT icon will resume flashing.

When the front section is disabled, the row spacing will automatically double to maintain the proper implement width in the monitor. A 23 row 15" configuration changes to a 12 row 30" configuration with a touch of the SELECT key.

STEP 2 Press SELECT key again to activate both sections.

EXAMPLE: Press SELECT key a second time. The information regarding each section will display alternately every 5 seconds.

For simple applications, where only one section is programmed, the display will automatically lock on that section. Pressing the SELECT key will have no affect.

NOTE: When alternating between two sections, the display will lock on the section containing the first recognized alarm until the alarm is acknowledged by pressing the OK key or the alarm condition is removed.

LOWER LCD FUNCTIONS

(MTR29g)

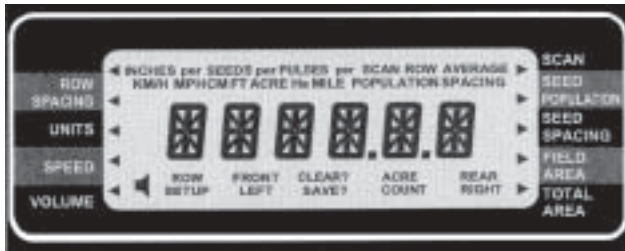

- The UP and DOWN arrow keys will sequentially change what is being displayed on the lower LCD. Pressing the UP or DOWN arrow keys will move the arrow head icon (on the left and right hand side of the display) to another item. For example, if the arrow icon is pointing to SPEED, ground speed will be displayed on the LCD. Pressing the UP arrow key will move the icon to UNITS. The display will change to display all the icons used to represent the current (English or Metric) measurement system.
- The shortcut keys SPEED, SEED POPULATION/SPACING and AREA FIELD/TOTAL allow direct access to their respective displays. For example, no matter what is currently being displayed on the lower LCD, pressing the SPEED key will change the display to the current speed. Pressing the SEED POPULATION/SPACING or AREA FIELD/TOTAL keys will alternate between the two functions assigned to those keys.
- Pressing the SCAN key while displaying seed spacing or population will cause a sequential display of each individual row. Pressing the SCAN key a second time will freeze the display on the currently displayed row. The UP or DOWN arrow keys can be used to change the currently displayed row. Pressing the SCAN key will restart the automatic advancing of the scan function.
- Pressing the SCAN key while displaying speed will cause a sequential display of speed, average planter population and average seed spacing. Pressing the SCAN key a second time will freeze the display on the currently displayed reading.

ROW SPACING

Press the arrow keys to ROW SPACING to display the current spacing between rows in inches or centimeters. The ROW SPACING icons turn on, displaying a 3 digit, one decimal place format. In the area count mode, this function displays the implement width in feet or meters, using a 3 digit, no decimal places format.

UNITS

Press the arrow keys to UNITS to display all the icons from the currently selected English or Metric measurement system. For the English system, the icons are: INCH, MPH, FT, ACRE and MILE. For the Metric system, the icons are: M, KM/H and Ha.

SPEED

Press the SPEED key to display the current speed in MPH or KM/H, using a 3 digit, one decimal place format.

VOLUME

Press the arrow keys to VOLUME to display the presently selected audible alarm volume. The SPEAKER icon turns on.

SCAN

Press the SCAN key to display the seed spacing or seed population (see Steps 1-3 following) of each individual row. (1) Pressing the SCAN key while displaying any other function will cause the monitor to sequentially display speed, average seed population and average seed spacing. (2) Pressing the SCAN key a second time will freeze the display. (3) Pressing the SCAN key a third time restarts the sequential display. The UP and DOWN arrow keys can be used to change the current display.

SEED POPULATION/SEED SPACING

Each SEED POP/SPACING key press alternates between seed population and seed spacing.

Seed population displays the average number of seeds or the row average number of seeds per acre or seeds per hectare for all the active rows. The average is displayed using a 6 digits, no decimal places format. The AVERAGE POPULATION icon will turn on. When in the scan mode, the scan arrow and SCAN ROW POPULATION will appear. The ROW number icon and the current row will be displayed on the left and the population will be displayed on the right in 1000's using 3 digits, one decimal place (e.g. 32.9 means 32,900). When in scan freeze mode, the scan arrow and ROW POPULATION will turn on (scan arrow may be flashing). The UP and DOWN keys may be used to lock on the desired row.

Seed spacing displays the average distance or the row average distance between seeds for all active rows in inches per seed or centimeters per seed using a 3 digit, one decimal place format. When the average is displayed the AVERAGE SPACING icons are turned on. When in the scan mode, the scan arrow and SCAN ROW SPACING icons will appear. The ROW number icon and the current row will be displayed on the left and the spacing will be displayed on the right. The display will sequence to the next row every 5 seconds. When in scan freeze mode, the scan arrow and SPACING will turn on (scan arrow may be flashing). The UP and DOWN keys may be used to lock on the desired row.

FIELD AREA/TOTAL AREA

Each AREA FIELD/TOTAL key press alternates between field area and total area.

Field area displays the total number of acres or hectares using a 6 digit, one decimal place format.

NOTE: When FIELD AREA is selected, the UP or DOWN key must be held in slightly longer than normal so the monitor will not mistake this action with a CLEAR, which consists of the UP and DOWN arrow keys pressed simultaneously. A beep will sound when the function activates.

Total area displays the total number of acres or hectares using a 6 digit, one decimal place format. The total area counter updates every time the field area counter increments. Clearing the total area counter will also clear the field area counter.

When the monitor is programmed as a rear only or rear/front configuration and shaft rotation sensors are installed, pressing the UP arrow to move beyond row spacing lights an arrow on an unlabeled area above ROW SPACING. This is the automatically set division line between the L.H. shaft sensor and the R.H. shaft sensor. The display shows the first row on the rear section and the front section assigned to the R.H. shaft rotation sensor.

EXAMPLE: On a 12 Row 30" planter with Interplant® Package, the display would appear as follows:

092597-21



THIS DISPLAY IS NOT ACCESSIBLE ON LEFT/RIGHT CONFIGURATIONS OR SYSTEMS WITHOUT SHAFT ROTATION SENSORS.

PROGRAMMING - Changing The Audible Alarm Volume

STEP 1 To enter the programming mode, press and hold the SETUP key. The monitor will emit several short beeps, followed by a long beep. On the lower LCD, the SETUP icon turns on and the arrow head icon will flash, indicating that the user can select an item to program.

NOTE: The monitor must be in a programmable function (row spacing, units, speed, volume or area) to enter setup. The monitor will not enter setup in seed population or seed spacing.

STEP 2 Press the UP or DOWN arrow keys to move the flashing arrow to VOLUME. As the arrow icon moves, the lower LCD will display the current setting of the item selected.

STEP 3 Press the OK key and the flashing arrow becomes solid and the audible alarm will sound.

NOTE: The lower LCD will display the current volume and the SPEAKER icon is turned on. Settings are from 0 to 9.

- Use the UP or DOWN arrow keys to change the setting. With every UP arrow key push, the alarm will increment by one step between the minimum and the maximum. If the maximum level (9) is reached the volume rolls over to the minimum level (0).
- Pressing the DOWN arrow key lowers the volume until the minimum level (0) is reached, at which point the volume rolls over to the maximum level (9).

STEP 4 To exit without saving, press and release the OK key. The monitor will restore the lower LCD to show the setting of the item, and the arrow icon will flash, allowing the user to select another item to program.

To exit and save, press and hold the OK key. The monitor will emit several short beeps and SAVE? icon is turned on. After a short time a long beep is heard, and the lower LCD will display the word "DONE". Release the OK key. If the OK key is released BEFORE the word "DONE" is displayed, the changes WILL NOT BE SAVED. The word "DONE" MUST be displayed in order for the save to have occurred.

NOTE: The programming mode may be exited at any time, by pressing the SETUP key. Pressing this key will return the monitor to its normal operation. All items changed and saved will come into effect immediately. Any items changed, but not saved will revert to the original programmed value.

PROGRAMMING - Units (Metric Or English)

STEP 1 To enter the programming mode, press and hold the SETUP key. The monitor will emit several short beeps, followed by a long beep. On the lower LCD, the SETUP icon turns on and the arrow head icon will flash, indicating that the user can select an item to program.

NOTE: The monitor must be in a programmable function (row spacing, units, speed, volume or area) to enter setup. The monitor will not enter setup in seed population or seed spacing.

STEP 2 Press the UP or DOWN arrow keys to move the flashing arrow to UNITS. As the arrow icon moves, the lower LCD will display the current setting of the item selected.

STEP 3 Press the OK key and the flashing arrow becomes solid and the audible alarm will sound.

NOTE: The lower LCD will alternately display all Metric icons or all English icons, indicating the Metric or English mode respectively.

- Use the UP or DOWN arrow keys to change the setting.

STEP 4 To exit without saving, press and release the OK key. The monitor will restore the lower LCD to show the setting of the item, and the arrow icon will flash, allowing the user to select another item to program.

To exit and save, press and hold the OK key. The monitor will emit several short beeps and SAVE? icon is turned on. After a short time a long beep is heard, and the lower LCD will display the word "DONE". Release the OK key. If the OK key is released BEFORE the word "DONE" is displayed, the changes WILL NOT BE SAVED. The word "DONE" MUST be displayed in order for the save to have occurred.

NOTE: The programming mode may be exited at any time, by pressing the SETUP key. Pressing this key will return the monitor to its normal operation. All items changed and saved will come into effect immediately. Any items changed, but not saved will revert to the original programmed value.

PROGRAMMING - Row Spacing

STEP 1 Prior to entering the programming mode, the application mode (rear/front or left/right) must be active. If the monitor is programmed in a rear/front configuration, both sections will be active (alternating every 5 seconds). You can then set the row spacing to the Interplant® System row spacing.

EXAMPLE: On a 12 Row 30" with Interplant® Package set the row spacing to 15.0 with front active.

When the monitor is in normal field operation mode, disabling the front section will automatically change the row spacing to 30".

STEP 2 To enter the programming mode, press and hold the SETUP key. The monitor will emit several short beeps, followed by a long beep. On the lower LCD, the SETUP icon turns on and the arrow head icon will flash, indicating that the user can select an item to program.

NOTE: The monitor must be in a programmable function (row spacing, units, speed, volume or area) to enter setup. The monitor will not enter setup in seed population or seed spacing.

STEP 3 Press the UP or DOWN arrow keys to move the flashing arrow to ROW SPACING. As the arrow icon moves, the lower LCD will display the current setting of the item selected.

STEP 4 Press the OK key and the flashing arrow becomes solid and the audible alarm will sound.

NOTE: The lower LCD will display the current row spacing (in inches or centimeters) and ROW SPACING icon is turned on.

- The least significant digit of the displayed value will be blinking.
- This value can be changed by pressing either the UP or DOWN arrow keys.
- Once this digit is correct, press the MODE SELECT key and the blinking digit will move to the next significant digit, where the process can be repeated.

NOTE: The monitor limits the entry of row spacing to a minimum of 10.0 inches (25.4 cm) and to a maximum of 99.9 inches (253.7 cm). If the monitor is configured to a rear/front configuration, the limits change to a minimum of 5.0 inches (12.7 cm) and a maximum of 49.9 inches (126.8 cm).

STEP 5 To exit without saving, press and release the OK key. The monitor will restore the lower LCD to show the setting of the item and the arrow icon will flash, allowing the user to select another item to program.

To exit and save, press and hold the OK key. The monitor will emit several short beeps and SAVE? icon is turned on. After a short time a long beep is heard, and the lower LCD will display the word "DONE". Release the OK key. If the OK key is released BEFORE the word "DONE" is displayed, the changes WILL NOT BE SAVED. The word "DONE" MUST be displayed in order for the save to have occurred.

To exit setup mode, press the SETUP key.

NOTE: The programming mode may be exited at any time, by pressing the SETUP key. Pressing this key will return the monitor to its normal operation. All items changed and saved will come into effect immediately. Any items changed, but not saved will revert to the original programmed value.

PROGRAMMING - Speed

STEP 1 To enter the programming mode, press and hold the SETUP key. The monitor will emit several short beeps, followed by a long beep. On the lower LCD, the SETUP icon turns on and the arrow head icon will flash, indicating that the user can select an item to program.

NOTE: The monitor must be in a programmable function (row spacing, units, speed, volume or area) to enter setup. The monitor will not enter setup in seed population or seed spacing.

STEP 2 Press the UP or DOWN arrow keys to move the flashing arrow to SPEED. As the arrow icon moves, the lower LCD will display the current setting of the item selected.

STEP 3 Press the OK key and the flashing arrow becomes solid and the audible alarm will sound. The R.H. digit on the display will be blinking.

The speed constant is used to record how many pulses are generated per mile (or kilometer) from the ground speed sensor. The lower LCD will display the current pulses per mile (or kilometer) using a 6 digit, no decimal place format. The PULSES per MILE (or PULSES per KM) icons are turned on.

NOTE: It is highly recommended that a field calibration be done to establish the PPM/PPKM (Pulses Per Mile/Kilometer) number on a new machine installation. Several factors can affect this value such as wheel slip on the magnetic distance sensor, mounting angle and height on the radar distance sensor, etc. IT IS NOT UNCOMMON FOR THE SPEED ON THE MONITOR TO VARY SLIGHTLY FROM THE TRACTOR SPEEDOMETER. *Adjusting the PPM/PPKM in the monitor to make the speed agree can cause serious errors in acre/hectare and population counts. Do field checks to verify populations and seed spacings.*

NOTE: On new system installations, the monitor will default to 500 PPM (310 PPKM). This will have to be changed to obtain accurate readings from the monitor.

- In field conditions, measure 330 feet ($\frac{1}{16}$ mile) or 100 meters, depending on the unit of measurement selected.

- Pull the tractor up to the starting line.

- Press the UP and DOWN arrow keys at the same time and hold them down until the CLEAR? icon is displayed and the monitor beeps several times. When the data is actually cleared, the monitor will emit a long beep and the number of pulses is cleared.

- Drive the tractor for 330 feet ($\frac{1}{16}$ mile) or 100 meters and stop.

- The monitor will count the number of pulses and display them.

STEP 4 To exit without saving, press and release the OK key. The monitor will restore the lower LCD to show the previous setting of the item, and the arrow icon will flash, allowing the user to select another item to program.

To exit and save, press and hold the OK key. The monitor will emit several short beeps and SAVE? icon is turned on. After a short time a long beep is heard, and the lower LCD will display the word "DONE". Release the OK key. If the OK key is released BEFORE the word "DONE" is displayed, the changes WILL NOT BE SAVED. The word "DONE" MUST be displayed in order for the save to have occurred.

NOTE: The programming mode may be exited at any time, by pressing the SETUP key. Pressing this key will return the monitor to its normal operation. All items changed and saved will come into effect immediately. Any items changed, but not saved will revert to the original programmed value.

NOTE: If a discrepancy occurs and digits must be changed, follow STEPS 1 and 2 to enter the programming mode and proceed as follows:

- Press the OK key and the flashing arrow becomes solid. The least significant digit of the displayed value will be blinking.
- This value can be changed by pressing either the UP or DOWN arrow keys.
- Once this digit is correct, press the SELECT key and the blinking digit will move to the next significant digit, where the process can be repeated.

The monitor limits the entry of pulses per mile or kilometer to a minimum of 500 PPM (310 PPKM), and to a maximum of 500,000 PPM (310,686 PPKM).

KEY Action	Flashing Digit	Display Value
Press The UP Key	Right Most Digit	2031, 2032, 2033
Press The SELECT Key	Second Digit From Right	2033
Press The DOWN Key	Second Digit From Right	2023, 2013, 2003, 2093, 2083
Press The SELECT Key Twice	Left Most Digit	2083
Press The DOWN Key	Left Most Digit	1083, 0500 (Min. Value), 9500, 8500

PROGRAMMING - Clearing Total Area

NOTE: Clearing the total area counter will also clear the field area counter.

STEP 1 To enter the programming mode, press and hold the SETUP key. The monitor will emit several short beeps followed by a long beep. On the lower LCD, the SETUP icon turns on and the arrow head icon will flash, indicating that the user can select an item to program.

NOTE: The monitor must be in a programmable function (row spacing, units, speed, volume or area) to enter setup. The monitor will not enter setup in seed population or seed spacing.

STEP 2 Press the UP or DOWN arrow keys to move the flashing arrow to TOTAL AREA. As the arrow icon moves, the lower LCD will display the current setting of the item selected.

STEP 3 Press the OK key and the flashing arrow becomes solid and the audible alarm will sound.

- The lower LCD will display the total area and the ACRE (or Ha) icon turns on.
- With the flashing arrow on TOTAL AREA, press the OK key.

• To reset the counter, press the UP and DOWN arrow keys at the same time and hold them down for a short period of time to clear the data. The CLEAR? icon will be displayed and the monitor will beep several times. When the data is actually cleared, the monitor will emit a long beep, and the total area is reset to zeros. After the long beep, the previous recorded total area is not retrievable. Once cleared, the user **may not** choose to exit programming mode without saving as described in STEP 4.

STEP 4 To exit and save, press and hold the OK key. The monitor will emit several short beeps and SAVE? icon is turned on. After a short time a long beep is heard, and the lower LCD will display the word "DONE". Release the OK key. If the OK key is released BEFORE the word "DONE" is displayed, the changes WILL NOT BE SAVED. The word "DONE" MUST be displayed in order for the save to have occurred.

NOTE: The programming mode may be exited at any time, by pressing the SETUP key. Pressing this key will return the monitor to its normal operation. All items changed and saved will come into effect immediately. Any items changed, but not saved will revert to the original programmed value.

AREA COUNTER/SPEEDOMETER MODE

If the monitor is installed with only a radar distance sensor (no seed tubes attached), the monitor becomes a speedometer. If (a) the monitor is connected to a radar distance sensor, (b) the signal cable from the back of the console is connected to a sensing switch (Part No. G1K249 Acre Counter Switch Kit) instead of the seed tubes and (c) the implement width in feet (or meters) is programmed into the monitor, the monitor will function as an area counter.

The seed spacing and seed population functions are not available in this mode. If the monitor is powered down, the seed tubes connected and the monitor powered up, the monitor will again show seed population and seed spacing in inches or centimeters. Row spacing reverts back to its programmed setting.

WARNINGS AND ALARMS

- 1. System Alarms** - A system alarm is activated when the monitor detects a faulty sensor or one of several other communication faults.

The corresponding row number starts flashing and the audible alarm sounds. All segments on the corresponding bar graph are turned off. Pushing the OK key to acknowledge the warning will turn the alarm off. The row number will continue to flash until the alarm condition is removed. If the monitor detects a faulty sensor and there is no planting activity present, the monitor will scroll "CHECK CONNECTION".

If the distance sensor is detected as faulty, the monitor will display either "PICKUP" or "RADAR", depending on the type of sensor installed, and the audible alarm will sound. The user can push the OK key to acknowledge the alarm. When the distance sensor is faulty, the monitor will change to a bar graph only mode where the rows are still displayed relative to each other. No area related information (speed, field area, total area, seed spacing or seed population) will be accumulated or displayed.

If a rotation shaft sensor is faulty, "LSHAFT", "RSHAFT" or "SHAFTS" will display.

Another type of system alarm occurs when the monitor detects a data communication bus error.

The three possible data communication bus errors are:

LCD Display	Error Condition
SYS HI	The data communication lead (green) has been shorted to the power lead (white).
SYS LO	The data communication lead (green) has been shorted to the ground lead (black).
SYS EC	An internal error has been detected.

- 2. Under Flow Alarms** - If the seed rate for one or more rows is less than 55% of the calculated average, the corresponding 60% segment will stay on, the corresponding row number starts flashing and the alarm sounds. Pushing the OK key to acknowledge the warning will turn the alarm off. The 60% segment of the bar graph remains on and the row number continues to flash until the alarm condition is corrected.

NOTE: All alarms present within a short time before planting stops are frozen on the screen and the text LOW or FAIL will display on the LCD. If the under flow is between 0% and 10%, this warrants a "FAIL" condition. If the under flow is between 10% and 55%, a "LOW" condition is generated. If multiple rows have an under flow condition, "FAIL" will display if any one or more rows is between 0% and 10%. This allows the user to identify and fix the problem rows.

NOTE: This warning will not trigger unless a minimum time of continuous planting has passed.

NOTE: If all the rows show a seed rate of zero, the condition will not generate an alarm. It will be assumed the planter has stopped. The row numbers and the bottom 60% segment will remain on for all selected rows.

- 3. Multiple Alarms** - If more than one alarm condition occurs at the same time, pushing the OK key will acknowledge all alarms that are currently displayed. For example, if one row on the front and one row on the rear are alarming, pushing the OK key will only acknowledge one of them. However, if there are two alarms on the front, both alarms would be acknowledged with one push of the OK key.

4. **Section Not Selected Warning** - If the monitor was programmed for two sections and only one is currently selected for display (by pressing the SELECT key), the icon of the disabled section will flash for a period of 1 minute, then turn off at each power up. If seed flow is sensed in the disabled section, the icon for that section (front, left or right) will begin to flash.
5. **Seed Planting Stopped Warning** - When the monitor detects no seed flow on all rows, the monitor will emit 3 short beeps to alert the user. This warning will occur each time the planter is stopped, each time the planter is raised at the end of a row or if the mechanical drive fails while planting.

NOTE: This warning will not trigger unless a minimum time of continuous planting has passed.

6. **Seed Counting Sensor In Calibration Warning** - All seed counting sensors run a self-calibration sequence on power up. While in calibration the bottom segment of each corresponding bar graph will flash if the monitor detects movement or planting activity. If the monitor does not detect this, the message "WAIT CALIBRATION" will be scrolled.
7. **Seed Counting Sensor Too Dirty Warning** - After the seed counting sensors end their internal self-calibration, the monitor may detect one or more sensors are either too dirty or blocked. If the monitor detects planting or movement, the corresponding bar graph remains flashing. The monitor will display "CLEAN SENSORS" on the top LCD if no movement or planting is detected, prompting the user to clean the tubes. If the tubes are dirty, they will still show seed flow with less accuracy. If the tubes are blocked the user will get an alarm as soon as planting starts. The corresponding bar graph will remain flashing until the problem is corrected and the monitor is powered down and then powered back up.
8. **Low Battery Warning** - The monitor is constantly monitoring its input voltage to quickly detect low power conditions. If the monitor detects that the input voltage has dropped below 11.0V, it will display "LO SYS" on the lower LCD, provided that the monitor does not detect speed or planting.

NOTE: After the alarms have been acknowledged and if the alarm condition is still present, the LCD will continue to display the alarm condition.

REPLACING A FAULTY SENSOR

To replace a faulty sensor; (a) disconnect the faulty sensor and check the monitor to be sure the correct sensor was disconnected, (b) turn the monitor off, (c) after a few seconds, turn the monitor back on and (d) plug in the replacement sensor. The monitor will chirp twice to acknowledge the new sensor was learned and saved.

To replace more than one faulty sensor, proceed as stated above beginning with the lowest numbered row in the rear/left section and continue to replace sensors in ascending order. Then move on to the front/right section and continue in ascending order.

If the monitor detects a faulty distance sensor, the lower LCD will immediately move to the speed display, show the word "PICKUP" or "RADAR" depending on the distance sensor installed, and the alarm will sound.

NOTE: If the monitor is not turned off and then on, the replacement sensor(s) will be ignored until the next power on, at which point the sensors will be randomly learned by the monitor.

FIELD OPERATION

Press the ON/OFF key to turn the monitor on and off.



(MTR28e)

Information regarding each section is displayed alternately every 5 seconds.

REAR/FRONT CONFIGURATION

- Press the SELECT key once to show REAR section only. (Monitor sets correct row spacing.)
- Press the SELECT key a second time to return to each section being displayed alternately every 5 seconds. (Monitor sets correct row spacing.)
- Press the SELECT key a third time to show REAR section only again.



(MTR28c)

LEFT/RIGHT CONFIGURATION (If Applicable)

- Press the SELECT key once to show LEFT section only.
- Press the SELECT key a second time to show RIGHT section only.
- Press the SELECT key a third time to return to each section being displayed alternately every 5 seconds.



(MTR28c)

NOTE: SELECT key has no function when only a single section is being used.

At power up, the lower LCD will show speed (MPH or KM/H).

(MTR29g/MTR29b/MTR29a/MTR29c/MTR29f/MTR29c/MTR29f)

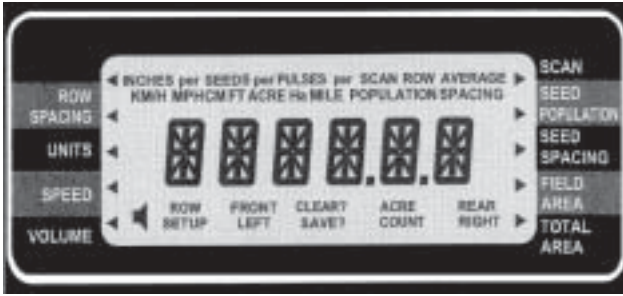

Press the UP or DOWN arrow keys to move the flashing arrow on the lower LCD to change what is displayed on the lower LCD.



Press the shortcut keys SPEED, SEED POPULATION/SEED SPACING or AREA FIELD/TOTAL for direct access to these displays.



(MTR29c/MTR29d/MTR29b/MTR29c)

Press the SEED POPULATION/SEED SPACING or AREA FIELD/TOTAL keys to alternate between the two functions assigned to that key.



Press the SEED POPULATION/SEED SPACING key to choose average seed spacing/population per acre.



Press the SCAN key to display individual rows starting at row 1.



Press the SCAN key again to lock on current row.

Press the SCAN key again to resume scrolling.

Use the UP or DOWN arrow keys to move to a particular row.



Press the SEED POPULATION/SEED SPACING key to go back to planter average.



CLEARING FIELD AREA

(MTR29n/MTR28b)

To reset the counter, press the UP or DOWN arrow keys to move the arrow in the lower display to FIELD AREA.



Press the UP and DOWN arrow keys at the same time and hold them down for a short period of time to clear the data. The CLEAR? icon will be displayed and the monitor will beep several times. When the data is actually cleared, the monitor will emit a long beep, and the field area is reset to zero. After the long beep, the previous field area recorded is not retrievable.



NOTE: Clearing the field area counter will not clear the total area counter. See "Programming-Clearing Total Area" for clearing total area.

Press the OK key to silence alarms. See "Warnings And Alarms".



PROGRAMMING/CONNECTING SEEDTUBES, RADAR/MAGNETIC DISTANCE SENSORS AND/OR SHAFT ROTATION SENSORS

STEP 1 All sensors (including the seed tubes w/ sensors, radar, magnetic distance and shaft rotation sensors) must be unplugged from the harness and/or console and the monitor must be off.

NOTE: If the monitor detects a radar sensor but no seed tubes at power up, it will automatically go into AREA COUNT mode. See “Area Counter/Speedometer Mode”.

NOTE: Disconnect magnetic distance sensor between MDS adapter and planter harness. DO NOT disconnect between MDS and MDS adapter.

01189909

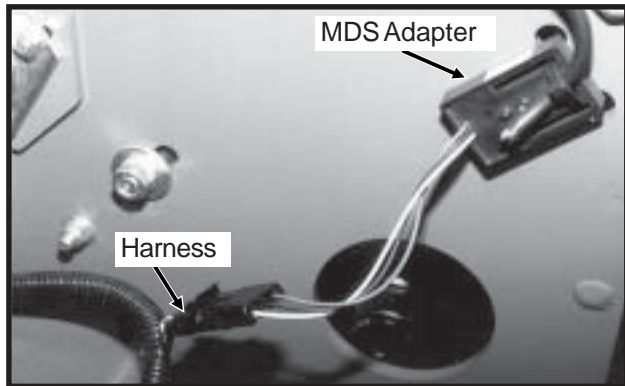

01189910

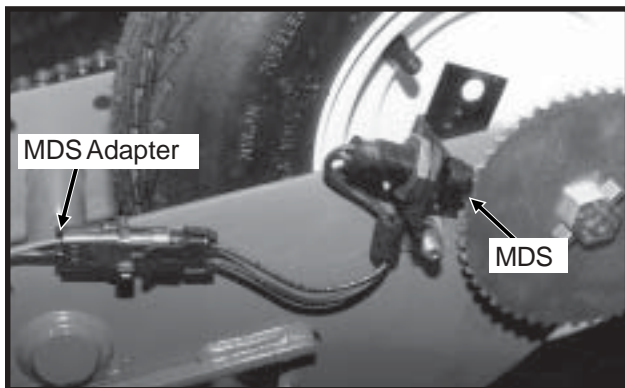

STEP 2 Press the ON key. The monitor automatically enters the setup procedure.

STEP 3 The monitor automatically defaults to front/rear. Press the SELECT key. Each time you press the SELECT key the mode will toggle between rear/front and left/right. The selected display will be solid and the configuration not currently selected will be flashing. By default the monitor starts in the rear/front mode.

01139923

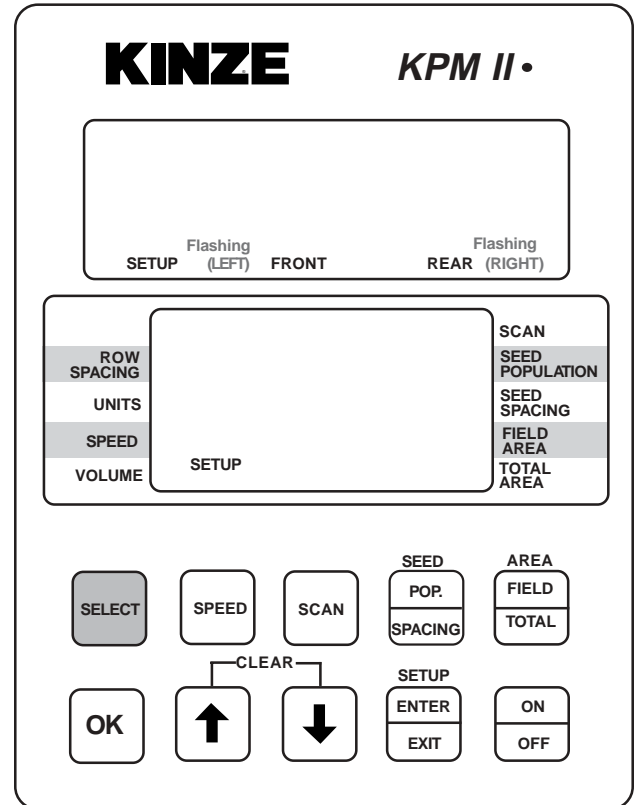

01139924

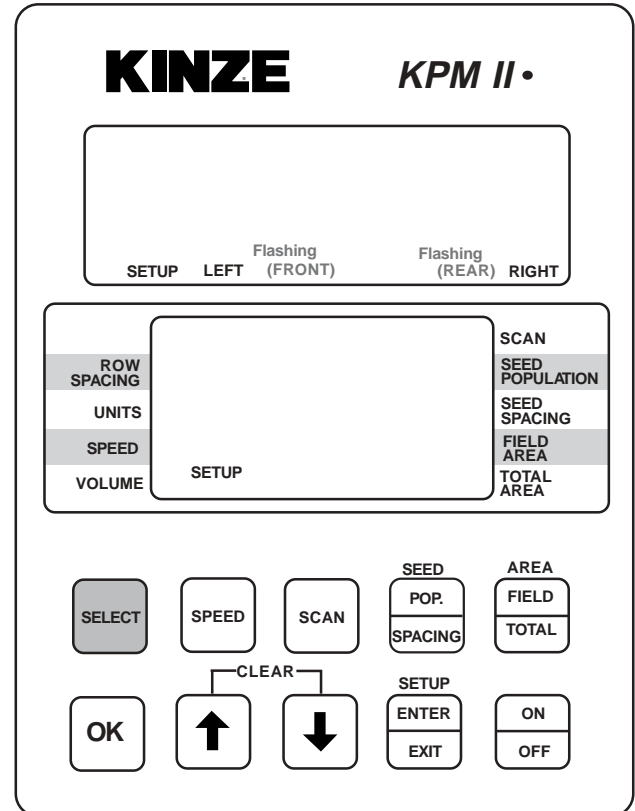

NOTE: Model 3140 planters select the rear configuration only.

STEP 4 Press and hold the OK key to confirm selection. The upper display will alternate between “NEW” and “SYS?”.

The alarm will sound four short beeps followed by one long beep. At this point your selection has been saved and row numbers will appear flashing on the upper display.

01139922

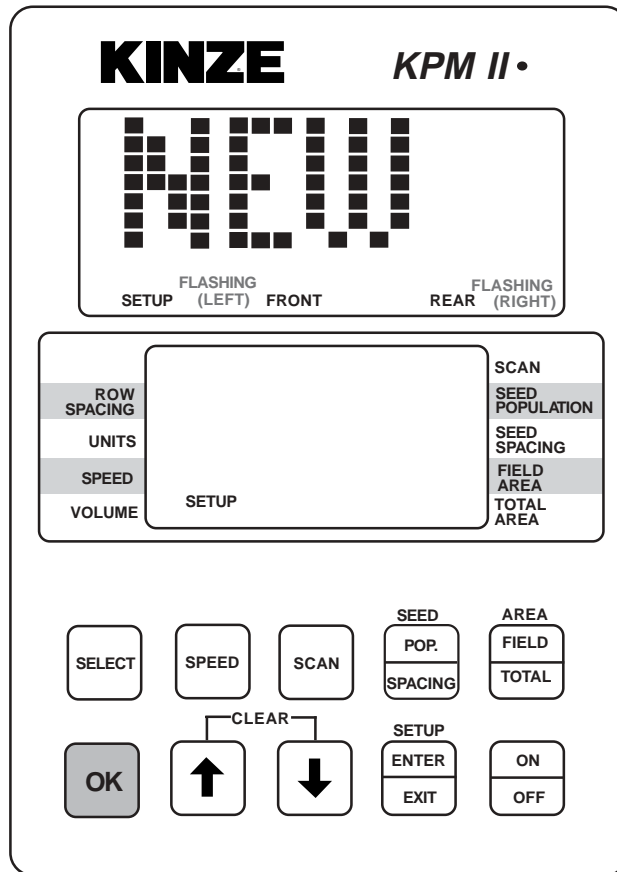

01139922

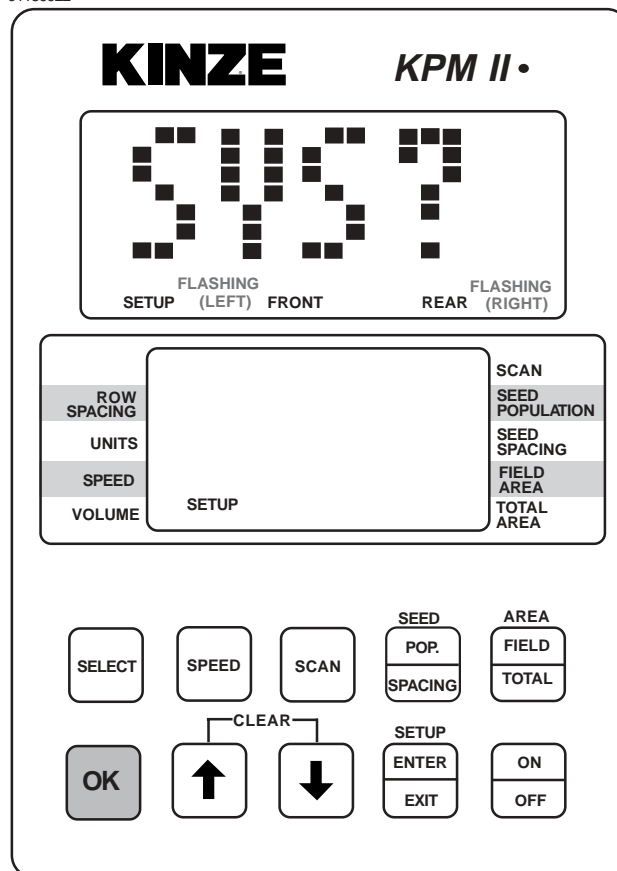

STEP 5 Determine which row you want as number one and plug the seed tube w/sensor into the harness.

Continue plugging in sensors along with shaft rotation sensors if so equipped. Row 1 first, row 2 second and so on up to 18 rows. When a sensor is plugged in, the corresponding row number on the upper LCD display will stay solid, the monitor will chirp twice and a red LED (Light Emitting Diode) on the seed tube sensor will turn on for approximately 30 seconds to show connection is made.

D04219901

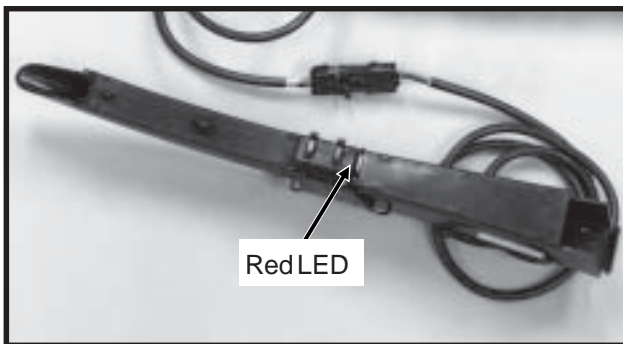

01139921

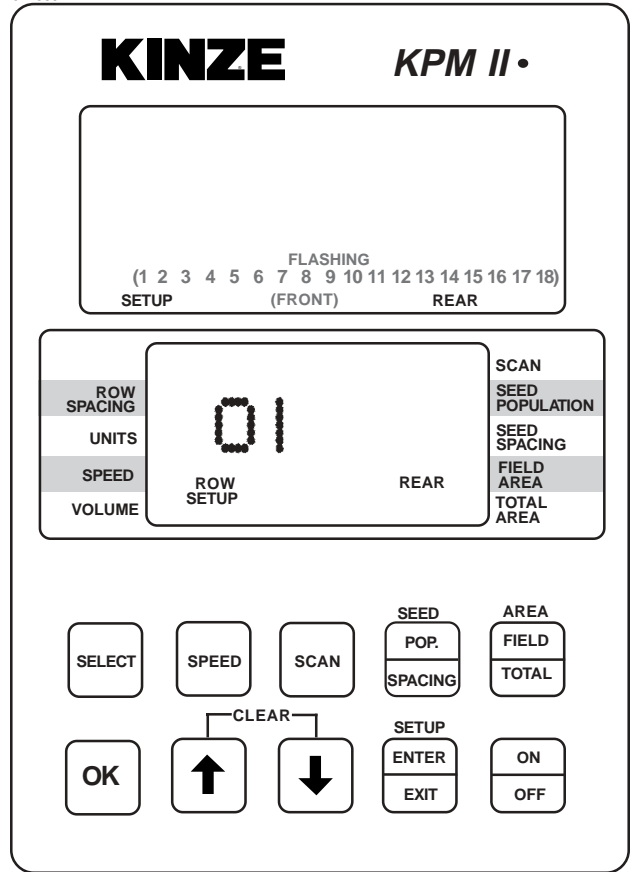

01139911

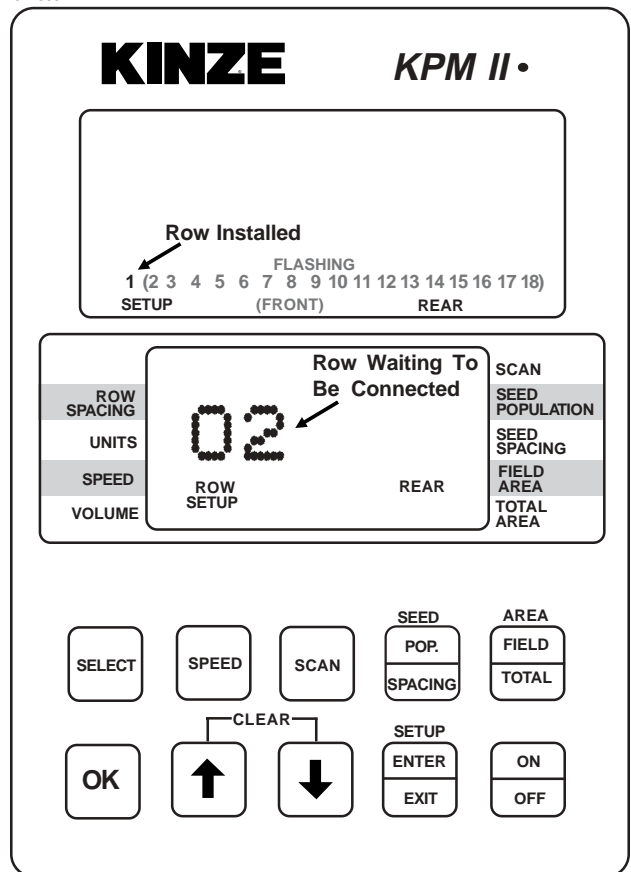

STEP 6 If the monitor system includes shaft rotation sensors, these can be installed at any time as the seed tubes are connected. The first shaft rotation sensor installed will be assigned to the rows on the L.H. half of the planter and the second shaft rotation sensor connected will be assigned to the rows on the R.H. half of the planter.

01189906

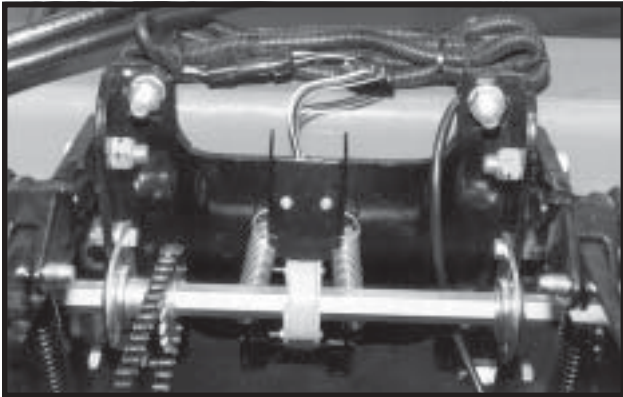

“LSHAFT” will display on the lower LCD when the first shaft rotation sensor is installed. “RSHAFT” will display when the second shaft rotation sensor is installed.

01139919

KINZE
KPM II •

FLASHING

1 (2 3 4 5 6 7 8 9 10 11 12 13 14 15 16 17 18)

SETUP
(FRONT)
REAR

ROW SPACING
UNITS
SPEED
VOLUME

LSHAFT

SCAN
SEED POPULATION
SEED SPACING
FIELD AREA
TOTAL AREA

SELECT

SPEED

SCAN

SEED
POP.
SPACING

AREA
FIELD
TOTAL

OK

↑

↓

SETUP
ENTER
EXIT

ON
OFF

01139916

KINZE
KPM II •

FLASHING

1 2 3 4 5 6 7 8 9 10 11 12 (13 14 15 16 17 18)

SETUP
(FRONT)
REAR

ROW SPACING
UNITS
SPEED
VOLUME

RSHAFT

SCAN
SEED POPULATION
SEED SPACING
FIELD AREA
TOTAL AREA

SELECT

SPEED

SCAN

SEED
POP.
SPACING

AREA
FIELD
TOTAL

OK

↑

↓

SETUP
ENTER
EXIT

ON
OFF

STEP 7 When all the seed tubes for the current section (Rear/Front or Left/Right) are installed, check to be sure the monitor displays solid numbers for the number of seed tubes connected. Press and hold the OK key to save the setup for the current section. The SAVE? icon will display followed by continuous short beeps indicating the monitor is preparing to save. The installer has 5 seconds to decide to save the current configuration. During this time, four short beeps will sound followed by a long beep and the SAVE? icon will turn off and the word "DONE" shows on the screen. The monitor will continue to the second section installation. (If Applicable)

01139914

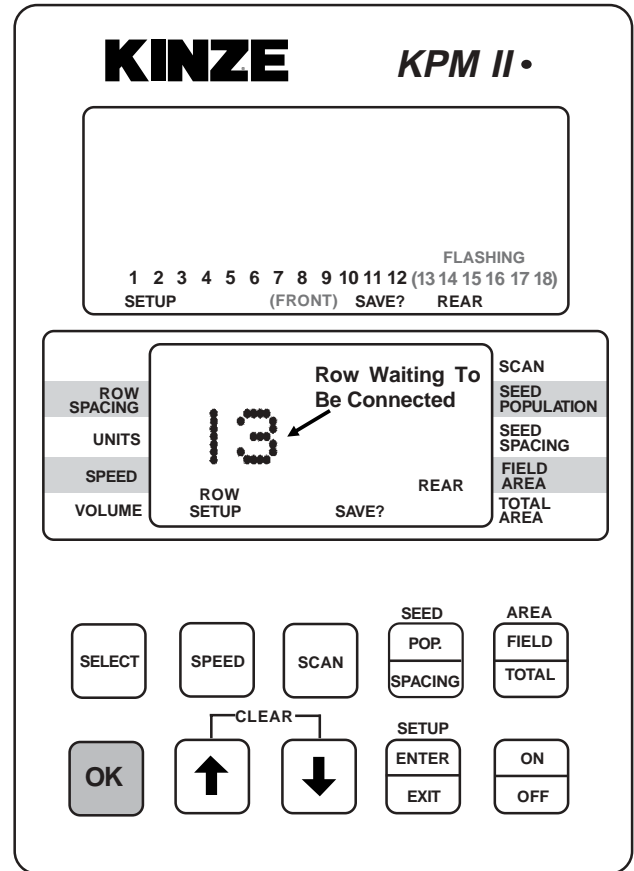

01139913

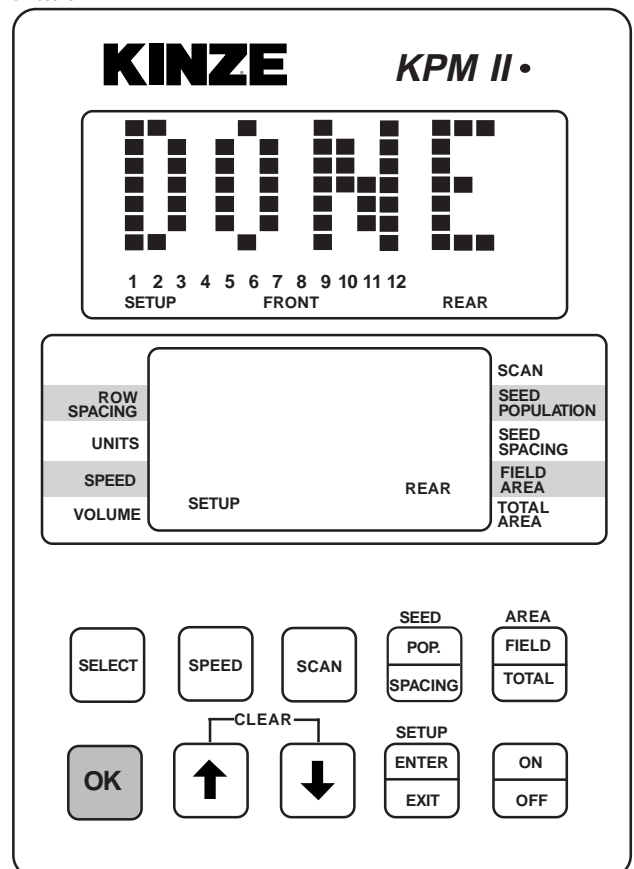

STEP 8 Follow STEPS 5 through 7 to install the second section. If no seed tubes are installed on the second section, press and hold the OK key. The word "DONE" will appear on upper display. The alarm will sound four short beeps followed by one long beep and the SAVE? icon turns off. The monitor has exited the setup mode. When you release the OK key the upper display will scroll "WAITING CALIBRATION". The lower display will show "GNDSPD" and the audible alarm will sound continually until the distance sensor is connected. See STEP 9.

01139912

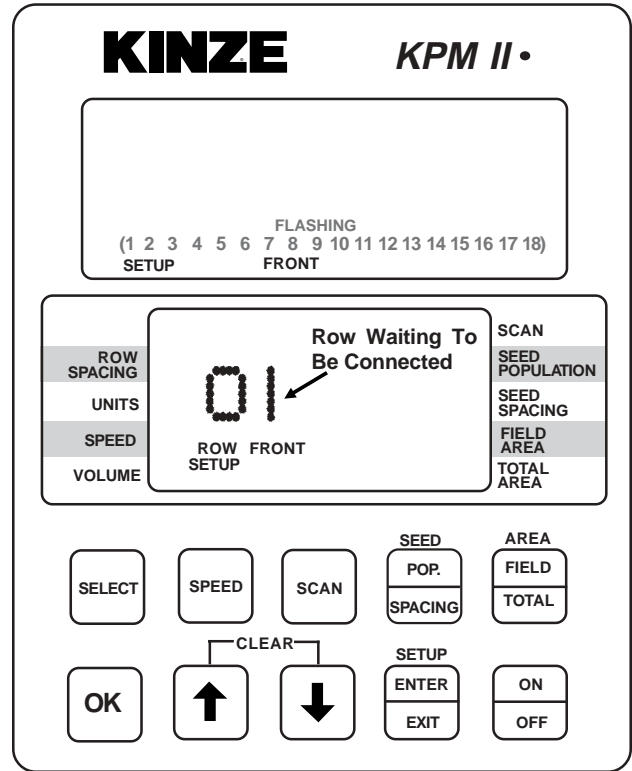

01139920

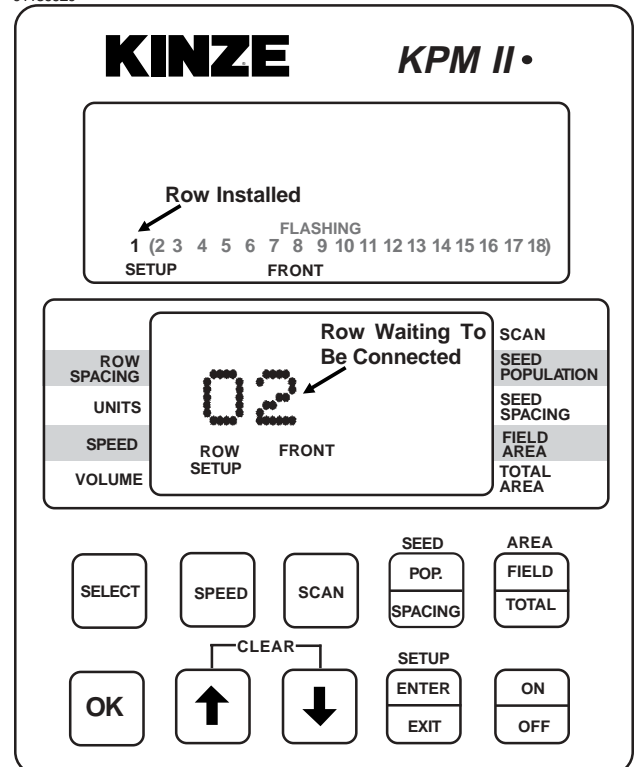

STEP 8 (Continued)

01139910

KINZE
KPM II •

Rows Installed

1 2 3 4 5 6 7 8 9 10 11 (12 13 14 15 16 17 18)

FLASHING
SETUP FRONT SAVE?

ROW SPACING
UNITS
SPEED
VOLUME

Row Waiting To Be Connected



ROW FRONT
SETUP SAVE?

SCAN
SEED POPULATION
SEED SPACING
FIELD AREA
TOTAL AREA

SELECT

SPEED

SCAN

SEED
POP.
SPACING

AREA
FIELD
TOTAL

OK

↑
CLEAR

↓

SETUP
ENTER
EXIT

ON
OFF

01139910a

KINZE
KPM II •

DONE

1 2 3 4 5 6 7 8 9 10 11 (12 13 14 15 16 17 18)

FLASHING
SETUP FRONT

ROW SPACING
UNITS
SPEED
VOLUME

FRONT
SETUP

SCAN
SEED POPULATION
SEED SPACING
FIELD AREA
TOTAL AREA

SELECT

SPEED

SCAN

SEED
POP.
SPACING

AREA
FIELD
TOTAL

OK

↑
CLEAR

↓

SETUP
ENTER
EXIT

ON
OFF

STEP 9 With the lower display showing “GNDSPD”, connect the distance sensor. The monitor will display “PICKUP” if a magnetic distance sensor is connected or “RADAR” if a radar distance sensor is installed. Only one distance sensor can be connected at a time.

NOTE: To connect the radar distance sensor, install the 10" monitor/radar adapter between the console and radar distance sensor to adapt the monitor system to various tractor radar systems.

NOTE: To reprogram the system to monitor more or less rows (up to the maximum of 18 per section, 36 total), all sensors must be unplugged, followed by the complete setup procedure.

NOTE: Individual seed tubes may be unplugged for special situations. An alarm will sound which can be silenced by touching the OK key. The monitor will recognize the seed tube(s) when reconnected.

10250115

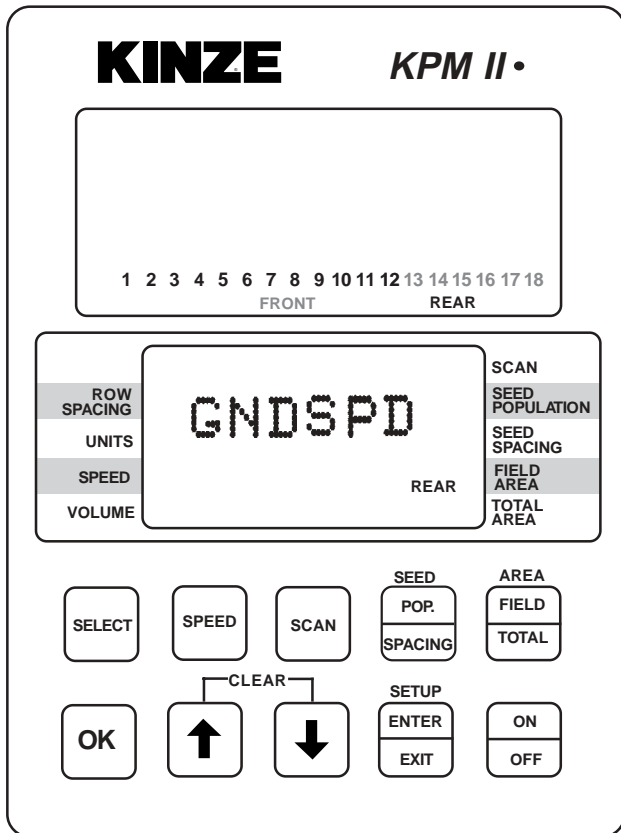

01139909

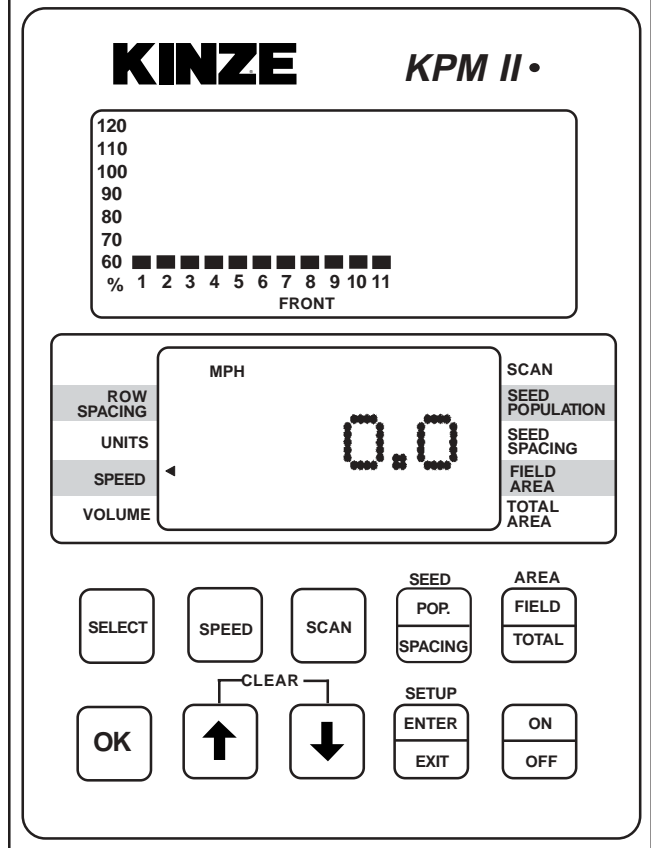

ROW-BY-ROW ALARM LEVEL SETTING
*(Requires Version V0.06 Or Higher Software -
 KPM II Monitors Only)*

This feature allows the audio alarm to be disabled on selected rows in applications such as planting seed corn.

NOTE: The system should be programmed to monitor all planter rows prior to performing these steps.

STEP 1 Enter the programming mode by pressing and holding the SETUP key. The monitor will emit several short beeps, followed by a long beep. On the lower LCD, the SETUP icon will turn on and the arrow head icon will flash, indicating the user can select an item to program.

NOTE: The monitor must be in a programmable function (row spacing, unit, speed, volume or area) to enter setup. The monitor will not enter setup in seed population or seed spacing.

STEP 2 Press the UP or DOWN arrow keys to move the flashing arrow to SEED POPULATION. As the arrow icon moves, the lower LCD will display the current setting of each item selected.

STEP 3 Press the OK key. Row number starts flashing.

STEP 4 Arrow UP or DOWN to desired row.

STEP 5 Press SELECT key. "AVG" starts flashing.

STEP 6 Arrow UP or DOWN to choose one of the following options.

- HIGH - For Early Alarm (70%)
- AVG - For Standard Alarm Setting (55%)
- LOW - For Failed Alarm Only (25%)
- OFF - To Disable Row Alarm

STEP 7 Press and hold the OK key to save alarm setting. There will be four short beeps, one long beep and the word "DONE" will appear when the save is completed.

STEP 8 Repeat STEPS 3 through 7 for each row on which you wish to adjust the alarm setting.

STEP 9 When finished, press the SETUP key to exit setup mode.

NOTE: The programming mode may be exited at any time by pressing the SETUP key. Pressing this key will return the monitor to its normal operation. All items changed and saved will come into effect immediately. Any items changed, but not saved will revert to the original programmed value.

NOTE: Repeat STEPS 3 through 7 to change seed monitor back to the original settings when special row-by-row alarm level settings are no longer required.

NOTE:
See "Programming - Row Spacing" for programming applicable row spacing.

See "KPM I/KPM II/KPM II Stack-Mode Electronic Seed Monitor Troubleshooting" in the Maintenance Section.

04130116

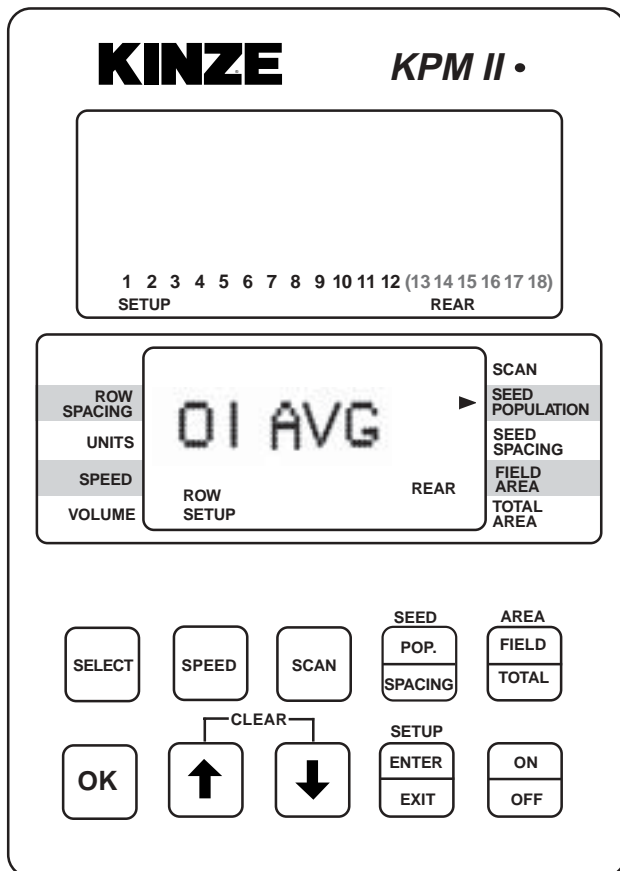

KPM II STACK-MODE ELECTRONIC SEED MONITOR

(MTR41e)

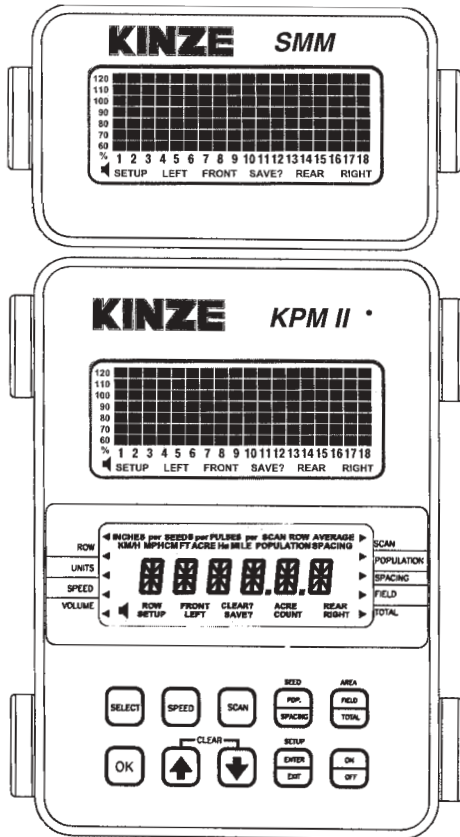

NOTE: SMM console may not be applicable to all models.

The KPM II Stack-Mode electronic seed monitor system consists of (a) a KPM II Stack-Mode console, which is mounted on the tractor; (b) seed tubes with sensors, one of which is installed in each planter row unit; (c) a magnetic distance sensor, which is installed on the planter, or a radar distance sensor, which is installed on the tractor; (d) shaft rotation sensors, which are installed on the planter drill shafts; and (e) a planter harness (junction Y-harness and/or extension harness where applicable), to which the individual seed tube sensors connect. The primary harness, which connects the monitor console to the planter harness, is hard-wired into the safety/warning light harness or control console harness included as standard equipment with the planter.

The software design of the KPM II Stack-Mode console allows the use of an add-on SMM console for simultaneous viewing of the seed flow bar graphs for standard and/or Interplant® System rows (up to 36 rows in two sections). A total of 72 rows may be displayed in multiple sections (rear/front, left/right or four sections). The SMM console must be used to allow utilization of the four section feature.

The monitor system is powered by the tractor battery (requires 12 volts DC). The console receives information from each of the sensors and translates this information.

The KPM II Stack-Mode console has two backlit Liquid Crystal Displays (LCD). The upper display shows the active section, the number of monitored rows per section, the relative seed rate for each row (using a bar graph display) and scrolls various alarm and warning messages when an alarm condition exists. A continuous audible alarm will sound upon system malfunction or underflow conditions for any monitored row. Alarms must be acknowledged by the user. Various warnings may sound the alarm or flash one or more icons. The lower display is used to display alphanumeric data such as row spacing, units (Metric or English), speed, volume, seed population, seed spacing, field area, total area and distance sensor pulses per mile/kilometer.

The SMM console has one backlit Liquid Crystal Display (LCD) which functions the same as the upper display on the KPM II Stack-Mode console except it does not scroll alarm and warning messages. The SMM console must be programmed into the system before printed text will display on the LCD.

The monitor system will power down if no activity is detected within one hour. No activity means there has been no new seed flow and no operator push key input.

Monitor Key Functions	6-39
Upper LCD Functions	6-40
Lower LCD Functions	6-41
Programming	
Changing The Audible Alarm Volume	6-43
Units (Metric Or English)	6-44
Row Spacing	6-44
Speed	6-46
Clearing Total Area	6-47
Area Counter/Speedometer Mode	6-48
Warnings And Alarms	6-48
Replacing A Faulty Sensor	6-49
Field Operation	6-50
Clearing Field Area	6-51
Programming/Connecting SMM Console, Shaft Rotation Sensors, Seed Tubes And/Or Radar/Magnetic Distance Sensors	6-52
Row-By-Row Alarm Level Setting	6-64

MONITOR KEY FUNCTIONS

Push keys allow the user to select or change the operating mode, the active displays or the current configuration. Depending on the operating mode or the current display selected, some keys are valid while some are not. Each key press, if valid, is acknowledged by a short beep and an action is taken. If the key press has no action associated, the key press is considered invalid, and the user will not get any feedback.

SELECT

- Selects the application mode (rear/front, left/right or four sections up to a maximum of 72 rows) at the beginning of installation in the setup mode.
- Selects the active section(s) (rear, rear/front, left, right or left/right) in the operation mode.
- Has no affect on a system configured to monitor only one section.
- While programming the monitor, the key will select the digit to change.

SPEED

- Immediately displays the current ground speed.

SCAN

- If the current average population or average spacing is displayed, this key sequentially displays the seed population/spacing on each row.
- If the display shows functions other than average seed population or spacing, pressing SCAN will sequentially display speed, average seed population and average seed spacing.
- Pressing a second time freezes the display on the current row.
- Pressing a third time restarts the sequential display.

SEED POPULATION/SEED SPACING

- Immediately displays the average seed POPULATION and the average seed SPACING of all active rows.
- Each press alternates between seed spacing and seed population.

AREA FIELD/AREA TOTAL

- Immediately displays the field or total area planted since the field/total area was last cleared.
- Each press alternates between field area and total area.

OK

- Ends and saves the new setup during installation.
- Acknowledges and silences alarms in the operation mode.

UP ARROW AND DOWN ARROW

- Scrolls sequentially through the display options on the lower LCD display.
- Freezes on the current row in the scan mode.
- Scrolls sequentially through the rows when the population scan is frozen.
- Used to enter programmable values in the programming mode.
- The UP and DOWN Arrow keys can be pressed at the same time to start the CLEAR function.

SETUP ENTER/SETUP EXIT

- Enters and exits the programming mode.

ON/OFF

- Powers the unit on and off.

UPPER LCD FUNCTIONS

(MTR29h)

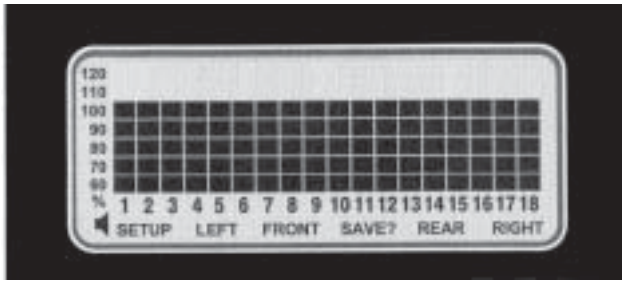

The monitor collects data on the planting rates from all active rows and calculates an average. This average will determine the 100% mark. Seed rate for each row is then compared to the average value and the result is displayed on the bar graph.

With only the KPM II Stack-Mode console programmed into the system, the information regarding each section is displayed alternately every 5 seconds. While operating a system with two sections programmed, one or both sections may be selected any time. When only one section is selected, the monitor calculates the average based on the remaining active rows from that section.

With the SMM console programmed into the system, two sections are viewed at the same time. If the system configuration is for four sections, the display will alternate every 5 seconds between a pair of sections. The select key will lock the display on rear sections. The SMM console shows RIGHT in the left/right configuration, FRONT in the rear/front configuration and FRONT RIGHT/ REAR RIGHT in four sections configuration. The KPM II Stack-Mode console shows LEFT in the left/right configuration, REAR in the rear/front configuration and FRONT LEFT/REAR LEFT in four sections configuration.

STEP 1 Press SELECT key once to show one section. The flashing icon shows the section that is not selected. The selected section icon is continuously displayed on the LCD.

EXAMPLE: The system is setup to display rear section on KPM II Stack-Mode console and front section on SMM console. Press SELECT key. The FRONT icon will be flashing and the REAR section will be displayed on the bar graph. The SMM console is only backlit. After 1 minute the front row icon will stop flashing. The monitor will stay in this REAR only display through power down and power up. Each time the monitor is turned on while in REAR only mode, the FRONT icon will flash for 1 minute.

If seed flow is sensed in the FRONT section while planting, the FRONT icon will resume flashing.

When the front section is disabled, the row spacing will automatically double to maintain the proper implement width in the monitor. A 23 or 24 row 15" configuration changes to a 12 row 30" configuration with a touch of the SELECT key.

STEP 2 Press SELECT key again to activate both sections.

For simple applications, where only one section is programmed, the display will automatically lock on that section. Pressing the SELECT key will have no affect.

NOTE: When alternating between two sections, the display will lock on the section containing the first recognized alarm until the alarm is acknowledged by pressing the OK key or the alarm condition is removed.

LOWER LCD FUNCTIONS

(MTR29g)

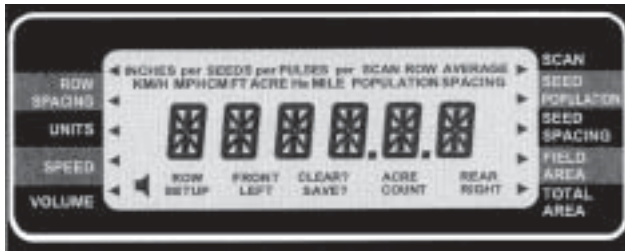

- The UP and DOWN arrow keys will sequentially change what is being displayed on the lower LCD. Pressing the UP or DOWN arrow keys will move the arrow head icon (on the left and right hand side of the display) to another item. For example, if the arrow icon is pointing to SPEED, ground speed will be displayed on the LCD. Pressing the UP arrow key will move the icon to UNITS. The display will change to display all the icons used to represent the current (English or Metric) measurement system.
- The shortcut keys SPEED, SEED POPULATION/SPACING and AREA FIELD/TOTAL allow direct access to their respective displays. For example, no matter what is currently being displayed on the lower LCD, pressing the SPEED key will change the display to the current speed. Pressing the SEED POPULATION/SPACING or AREA FIELD/TOTAL keys will alternate between the two functions assigned to those keys.
- Pressing the SCAN key while displaying seed spacing or population will cause a sequential display of each individual row. Pressing the SCAN key a second time will freeze the display on the currently displayed row. The UP or DOWN arrow keys can be used to change the currently displayed row. Pressing the SCAN key will restart the automatic advancing of the scan function.
- Pressing the SCAN key while displaying speed will cause a sequential display of speed, average planter population and average seed spacing. Pressing the SCAN key a second time will freeze the display on the currently displayed reading.

ROW SPACING

Press the arrow keys to ROW SPACING to display the current spacing between rows in inches or centimeters. The ROW SPACING icons turn on, displaying a 3 digit, one decimal place format. In the area count mode, this function displays the implement width in feet or meters, using a 3 digit, no decimal places format.

UNITS

Press the arrow keys to UNITS to display all the icons from the currently selected English or Metric measurement system. For the English system, the icons are: INCH, MPH, FT, ACRE and MILE. For the Metric system, the icons are: M, KM/H and Ha.

SPEED

Press the SPEED key to display the current speed in MPH or KM/H, using a 3 digit, one decimal place format.

VOLUME

Press the arrow keys to VOLUME to display the presently selected audible alarm volume. The SPEAKER icon turns on.

SCAN

Press the SCAN key to display the seed spacing or seed population (see Steps 1-3 following) of each individual row. (1)Pressing the SCAN key while displaying any other function will cause the monitor to sequentially display speed, average seed population and average seed spacing. (2)Pressing the SCAN key a second time will freeze the display. (3)Pressing the SCAN key a third time restarts the sequential display. The UP and DOWN arrow keys can be used to change the current display.

MACHINE OPERATION

KPM II STACK-MODE

SEED POPULATION/SEED SPACING

Each SEED POP/SPACING key press alternates between seed population and seed spacing.

Seed population displays the average number of seeds or the row average number of seeds per acre or seeds per hectare for all the active rows. The average is displayed using a 6 digits, no decimal places format. The AVERAGE POPULATION icon will turn on. When in the scan mode, the scan arrow and SCAN ROW POPULATION will appear. The ROW number icon and the current row will be displayed on the left and the population will be displayed on the right in 1000's using 3 digits, one decimal place (e.g. 32.9 means 32,900). When in scan freeze mode, the scan arrow and ROW POPULATION will turn on (scan arrow may be flashing). The UP and DOWN keys may be used to lock on the desired row.

Seed spacing displays the average distance or the row average distance between seeds for all active rows in inches per seed or centimeters per seed using a 3 digit, one decimal place format. When the average is displayed the AVERAGE SPACING icons are turned on. When in the scan mode, the scan arrow and SCAN ROW SPACING icons will appear. The ROW number icon and the current row will be displayed on the left and the spacing will be displayed on the right. The display will sequence to the next row every 5 seconds. When in scan freeze mode, the scan arrow and SPACING will turn on (scan arrow may be flashing). The UP and DOWN keys may be used to lock on the desired row.

FIELD AREA/TOTAL AREA

Each AREA FIELD/TOTAL key press alternates between field area and total area.

Field area displays the total number of acres or hectares using a 6 digit, one decimal place format.

NOTE: When FIELD AREA is selected, the UP or DOWN key must be held in slightly longer than normal so the monitor will not mistake this action with a CLEAR, which consists of the UP and DOWN arrow keys pressed simultaneously. A beep will sound when the function activates.

Total area displays the total number of acres or hectares using a 6 digit, one decimal place format. The total area counter updates every time the field area counter increments. Clearing the total area counter will also clear the field area counter.

When the monitor is programmed as a rear only or rear/front configuration and shaft rotation sensors are installed, pressing the UP arrow to move beyond row spacing lights an arrow on an unlabeled area above ROW SPACING. This is the automatically set division line between the L.H. shaft sensor and the R.H. shaft sensor. The display shows the first row on the rear section and the front section assigned to the R.H. shaft rotation sensor.

EXAMPLE: On a 12 Row 30" planter with Interplant® Package, the display would appear as follows:

092597-21



THIS DISPLAY IS NOT ACCESSIBLE ON LEFT/RIGHT CONFIGURATIONS OR SYSTEMS WITHOUT SHAFT ROTATION SENSORS.

PROGRAMMING - Changing The Audible Alarm Volume

STEP 1 To enter the programming mode, press and hold the SETUP key. The monitor will emit several short beeps, followed by a long beep. On the lower LCD, the SETUP icon turns on and the arrow head icon will flash, indicating that the user can select an item to program.

NOTE: The monitor must be in a programmable function (row spacing, units, speed, volume or area) to enter setup. The monitor will not enter setup in seed population or seed spacing.

STEP 2 Press the UP or DOWN arrow keys to move the flashing arrow to VOLUME. As the arrow icon moves, the lower LCD will display the current setting of the item selected.

STEP 3 Press the OK key and the flashing arrow becomes solid and the audible alarm will sound.

NOTE: The lower LCD will display the current volume and the SPEAKER icon is turned on. Settings are from 0 to 9.

- Use the UP or DOWN arrow keys to change the setting. With every UP arrow key push, the alarm will increment by one step between the minimum and the maximum. If the maximum level (9) is reached the volume rolls over to the minimum level (0).
- Pressing the DOWN arrow key lowers the volume until the minimum level (0) is reached, at which point the volume rolls over to the maximum level (9).

STEP 4 To exit without saving, press and release the OK key. The monitor will restore the lower LCD to show the setting of the item, and the arrow icon will flash, allowing the user to select another item to program.

To exit and save, press and hold the OK key. The monitor will emit several short beeps and SAVE? icon is turned on. After a short time a long beep is heard, and the lower LCD will display the word "DONE". Release the OK key. If the OK key is released BEFORE the word "DONE" is displayed, the changes WILL NOT BE SAVED. The word "DONE" MUST be displayed in order for the save to have occurred.

NOTE: The programming mode may be exited at any time, by pressing the SETUP key. Pressing this key will return the monitor to its normal operation. All items changed and saved will come into effect immediately. Any items changed, but not saved will revert to the original programmed value.

MACHINE OPERATION

KPM II STACK-MODE

PROGRAMMING - Units (Metric Or English)

STEP 1 To enter the programming mode, press and hold the SETUP key. The monitor will emit several short beeps, followed by a long beep. On the lower LCD, the SETUP icon turns on and the arrow head icon will flash, indicating that the user can select an item to program.

NOTE: The monitor must be in a programmable function (row spacing, units, speed, volume or area) to enter setup. The monitor will not enter setup in seed population or seed spacing.

STEP 2 Press the UP or DOWN arrow keys to move the flashing arrow to UNITS. As the arrow icon moves, the lower LCD will display the current setting of the item selected.

STEP 3 Press the OK key and the flashing arrow becomes solid and the audible alarm will sound.

NOTE: The lower LCD will alternately display all Metric icons or all English icons, indicating the Metric or English mode respectively.

- Use the UP or DOWN arrow keys to change the setting.

STEP 4 To exit without saving, press and release the OK key. The monitor will restore the lower LCD to show the setting of the item, and the arrow icon will flash, allowing the user to select another item to program.

To exit and save, press and hold the OK key. The monitor will emit several short beeps and SAVE? icon is turned on. After a short time a long beep is heard, and the lower LCD will display the word "DONE". Release the OK key. If the OK key is released BEFORE the word "DONE" is displayed, the changes WILL NOT BE SAVED. The word "DONE" MUST be displayed in order for the save to have occurred.

NOTE: The programming mode may be exited at any time, by pressing the SETUP key. Pressing this key will return the monitor to its normal operation. All items changed and saved will come into effect immediately. Any items changed, but not saved will revert to the original programmed value.

PROGRAMMING - Row Spacing

STEP 1 Prior to entering the programming mode, the application mode (rear/front, left/right or four sections) must be active. If the monitor is programmed in a rear/front configuration, both sections will be active (alternating every 5 seconds if the SMM console is not used). You can then set the row spacing to the Interplant® System row spacing.

EXAMPLE: On a 12 Row 30" with Interplant® Package set the row spacing to 15.0 with front active.

When the monitor is in normal field operation mode, disabling the front section will automatically change the row spacing to 30".

STEP 2 To enter the programming mode, press and hold the SETUP key. The monitor will emit several short beeps, followed by a long beep. On the lower LCD, the SETUP icon turns on and the arrow head icon will flash, indicating that the user can select an item to program.

NOTE: The monitor must be in a programmable function (row spacing, units, speed, volume or area) to enter setup. The monitor will not enter setup in seed population or seed spacing.

STEP 3 Press the UP or DOWN arrow keys to move the flashing arrow to ROW SPACING. As the arrow icon moves, the lower LCD will display the current setting of the item selected.

STEP 4 Press the OK key and the flashing arrow becomes solid and the audible alarm will sound.

NOTE: The lower LCD will display the current row spacing (in inches or centimeters) and ROW SPACING icon is turned on.

- The least significant digit of the displayed value will be blinking.
- This value can be changed by pressing either the UP or DOWN arrow keys.
- Once this digit is correct, press the MODE SELECT key and the blinking digit will move to the next significant digit, where the process can be repeated.

NOTE: The monitor limits the entry of row spacing to a minimum of 10.0 inches (25.4 cm) and to a maximum of 99.9 inches (253.7 cm). If the monitor is configured to a rear/front configuration, the limits change to a minimum of 5.0 inches (12.7 cm) and a maximum of 49.9 inches (126.8 cm).

STEP 5 To exit without saving, press and release the OK key. The monitor will restore the lower LCD to show the setting of the item and the arrow icon will flash, allowing the user to select another item to program.

To exit and save, press and hold the OK key. The monitor will emit several short beeps and SAVE? icon is turned on. After a short time a long beep is heard, and the lower LCD will display the word "DONE". Release the OK key. If the OK key is released BEFORE the word "DONE" is displayed, the changes WILL NOT BE SAVED. The word "DONE" MUST be displayed in order for the save to have occurred.

To exit setup mode, press the SETUP key.

NOTE: The programming mode may be exited at any time, by pressing the SETUP key. Pressing this key will return the monitor to its normal operation. All items changed and saved will come into effect immediately. Any items changed, but not saved will revert to the original programmed value.

PROGRAMMING - Speed

STEP 1 To enter the programming mode, press and hold the SETUP key. The monitor will emit several short beeps, followed by a long beep. On the lower LCD, the SETUP icon turns on and the arrow head icon will flash, indicating that the user can select an item to program.

NOTE: The monitor must be in a programmable function (row spacing, units, speed, volume or area) to enter setup. The monitor will not enter setup in seed population or seed spacing.

STEP 2 Press the UP or DOWN arrow keys to move the flashing arrow to SPEED. As the arrow icon moves, the lower LCD will display the current setting of the item selected.

STEP 3 Press the OK key and the flashing arrow becomes solid and the audible alarm will sound. The R.H. digit on the display will be blinking.

The speed constant is used to record how many pulses are generated per mile (or kilometer) from the ground speed sensor. The lower LCD will display the current pulses per mile (or kilometer) using a 6 digit, no decimal place format. The PULSES per MILE (or PULSES per KM) icons are turned on.

NOTE: It is highly recommended that a field calibration be done to establish the PPM/PPKM (Pulses Per Mile/Kilometer) number on a new machine installation. Several factors can affect this value such as wheel slip on the magnetic distance sensor, mounting angle and height on the radar distance sensor, etc. IT IS NOT UNCOMMON FOR THE SPEED ON THE MONITOR TO VARY SLIGHTLY FROM THE TRACTOR SPEEDOMETER. *Adjusting the PPM/PPKM in the monitor to make the speed agree can cause serious errors in acre/hectare and population counts.* Do field checks to verify populations and seed spacings.

NOTE: On new system installations, the monitor will default to 500 PPM (310 PPKM). This will have to be changed to obtain accurate readings from the monitor.

- In field conditions, measure 330 feet ($\frac{1}{16}$ mile) or 100 meters, depending on the unit of measurement selected.

- Pull the tractor up to the starting line.

- Press the UP and DOWN arrow keys at the same time and hold them down until the CLEAR? icon is displayed and the monitor beeps several times. When the data is actually cleared, the monitor will emit a long beep and the number of pulses is cleared.

NOTE: If the PPM/PPKM number starts to count pulses with the tractor not moving, check the radar for vibration or other kinds of interference.

- Drive the tractor for 330 feet ($\frac{1}{16}$ mile) or 100 meters and stop.

- The monitor will count the number of pulses and display them.

STEP 4 To exit without saving, press and release the OK key. The monitor will restore the lower LCD to show the previous setting of the item, and the arrow icon will flash, allowing the user to select another item to program.

To exit and save, press and hold the OK key. The monitor will emit several short beeps and SAVE? icon is turned on. After a short time a long beep is heard, and the lower LCD will display the word "DONE". Release the OK key. If the OK key is released BEFORE the word "DONE" is displayed, the changes WILL NOT BE SAVED. The word "DONE" MUST be displayed in order for the save to have occurred.

NOTE: The programming mode may be exited at any time, by pressing the SETUP key. Pressing this key will return the monitor to its normal operation. All items changed and saved will come into effect immediately. Any items changed, but not saved will revert to the original programmed value.

NOTE: If a discrepancy occurs and digits must be changed, follow STEPS 1 and 2 to enter the programming mode and proceed as follows:

- Press the OK key and the flashing arrow becomes solid. The least significant digit of the displayed value will be blinking.
- This value can be changed by pressing either the UP or DOWN arrow keys.
- Once this digit is correct, press the SELECT key and the blinking digit will move to the next significant digit, where the process can be repeated.

The monitor limits the entry of pulses per mile or kilometer to a minimum of 500 PPM (310 PPKM), and to a maximum of 500,000 PPM (310,686 PPKM).

KEY Action	Flashing Digit	Display Value
Press The UP Key	Right Most Digit	2031, 2032, 2033
Press The SELECT Key	Second Digit From Right	2033
Press The DOWN Key	Second Digit From Right	2023, 2013, 2003, 2093, 2083
Press The SELECT Key Twice	Left Most Digit	2083
Press The DOWN Key	Left Most Digit	1083, 0500 (Min. Value), 9500, 8500

PROGRAMMING - Clearing Total Area

NOTE: Clearing the total area counter will also clear the field area counter.

STEP 1 To enter the programming mode, press and hold the SETUP key. The monitor will emit several short beeps followed by a long beep. On the lower LCD, the SETUP icon turns on and the arrow head icon will flash, indicating that the user can select an item to program.

NOTE: The monitor must be in a programmable function (row spacing, units, speed, volume or area) to enter setup. The monitor will not enter setup in seed population or seed spacing.

STEP 2 Press the UP or DOWN arrow keys to move the flashing arrow to TOTAL AREA. As the arrow icon moves, the lower LCD will display the current setting of the item selected.

STEP 3 Press the OK key and the flashing arrow becomes solid and the audible alarm will sound.

- The lower LCD will display the total area and the ACRE (or Ha) icon turns on.
- With the flashing arrow on TOTAL AREA, press the OK key.

• To reset the counter, press the UP and DOWN arrow keys at the same time and hold them down for a short period of time to clear the data. The CLEAR? icon will be displayed and the monitor will beep several times. When the data is actually cleared, the monitor will emit a long beep, and the total area is reset to zeros. After the long beep, the previous recorded total area is not retrievable. Once cleared, the user **may not** choose to exit programming mode without saving as described in STEP 4.

STEP 4 To exit and save, press and hold the OK key. The monitor will emit several short beeps and SAVE? icon is turned on. After a short time a long beep is heard, and the lower LCD will display the word "DONE". Release the OK key. If the OK key is released BEFORE the word "DONE" is displayed, the changes WILL NOT BE SAVED. The word "DONE" MUST be displayed in order for the save to have occurred.

NOTE: The programming mode may be exited at any time, by pressing the SETUP key. Pressing this key will return the monitor to its normal operation. All items changed and saved will come into effect immediately. Any items changed, but not saved will revert to the original programmed value.

AREA COUNTER/SPEEDOMETER MODE

If the monitor is installed with only a radar distance sensor (no seed tubes attached), the monitor becomes a speedometer. If (a) the monitor is connected to a radar distance sensor, (b) the signal cable from the back of the console is connected to a sensing switch (Part No. G1K249 Acre Counter Switch Kit) instead of the seed tubes and (c) the implement width in feet (or meters) is programmed into the monitor, the monitor will function as an area counter.

The seed spacing and seed population functions are not available in this mode. If the monitor is powered down, the seed tubes connected and the monitor powered up, the monitor will again show seed population and seed spacing in inches or centimeters. Row spacing reverts back to its programmed setting.

WARNINGS AND ALARMS

- 1. System Alarms** - A system alarm is activated when the monitor detects a faulty sensor or one of several other communication faults.

The corresponding row number starts flashing and the audible alarm sounds. All segments on the corresponding bar graph are turned off. Pushing the OK key to acknowledge the warning will turn the alarm off. The row number will continue to flash until the alarm condition is removed. If the monitor detects a faulty sensor and there is no planting activity present, the monitor will scroll "CHECK CONNECTION".

If the distance sensor is detected as faulty, the monitor will display either "PICKUP" or "RADAR", depending on the type of sensor installed, and the audible alarm will sound. The user can push the OK key to acknowledge the alarm. When the distance sensor is faulty, the monitor will change to a bar graph only mode where the rows are still displayed relative to each other. No area related information (speed, field area, total area, seed spacing or seed population) will be accumulated or displayed.

If a rotation shaft sensor is faulty, "LSHAFT", "RSHAFT" or "SHAFTS" will display.

Another type of system alarm occurs when the monitor detects a data communication bus error.

The four possible data communication bus errors are:

LCD Display	Error Condition
SYS HI	The data communication lead (green) has been shorted to the power lead (white).
SYS LO	The data communication lead (green) has been shorted to the ground lead (black).
SYS EC	An internal error has been detected.
COP	Cycled power ON/OFF to quickly.

- 2. Under Flow Alarms** - If the seed rate for one or more rows is less than 55% of the calculated average, the corresponding 60% segment will stay on, the corresponding row number starts flashing and the alarm sounds. Pushing the OK key to acknowledge the warning will turn the alarm off. The 60% segment of the bar graph remains on and the row number continues to flash until the alarm condition is corrected.

NOTE: All alarms present within a short time before planting stops are frozen on the screen and the text LOW or FAIL will display on the LCD. If the under flow is between 0% and 10%, this warrants a "FAIL" condition. If the under flow is between 10% and 55%, a "LOW" condition is generated. If multiple rows have an under flow condition, "FAIL" will display if any one or more rows is between 0% and 10%. This allows the user to identify and fix the problem rows.

NOTE: This warning will not trigger unless a minimum time of continuous planting has passed.

NOTE: If all the rows show a seed rate of zero, the condition will not generate an alarm. It will be assumed the planter has stopped. The row numbers and the bottom 60% segment will remain on for all selected rows.

- 3. Multiple Alarms** - If more than one alarm condition occurs at the same time, pushing the OK key will acknowledge all alarms that are currently displayed. For example, if one row on the front and one row on the rear are alarming, pushing the OK key will only acknowledge one of them. However, if there are two alarms on the front, both alarms would be acknowledged with one push of the OK key.

4. **Section Not Selected Warning** - If the monitor was programmed for two sections and only one is currently selected for display (by pressing the SELECT key), the icon of the disabled section will flash for a period of 1 minute, then turn off at each power up. If seed flow is sensed in the disabled section, the icon for that section (front, left or right) will begin to flash.
5. **Seed Planting Stopped Warning** - When the monitor detects no seed flow on all rows, the monitor will emit 3 short beeps to alert the user. This warning will occur each time the planter is stopped, each time the planter is raised at the end of a row or if the mechanical drive fails while planting.

NOTE: This warning will not trigger unless a minimum time of continuous planting has passed.

6. **Seed Counting Sensor In Calibration Warning** - All seed counting sensors run a self-calibration sequence on power up. While in calibration the bottom segment of each corresponding bar graph will flash if the monitor detects movement or planting activity. If the monitor does not detect this, the message "WAIT CALIBRATION" will be scrolled.
7. **Seed Counting Sensor Too Dirty Warning** - After the seed counting sensors end their internal self-calibration, the monitor may detect one or more sensors are either too dirty or blocked. If the monitor detects planting or movement, the corresponding bar graph remains flashing. The monitor will display "CLEAN SENSORS" on the top LCD if no movement or planting is detected, prompting the user to clean the tubes. If the tubes are dirty, they will still show seed flow with less accuracy. If the tubes are blocked the user will get an alarm as soon as planting starts. The corresponding bar graph will remain flashing until the problem is corrected and the monitor is powered down and then powered back up.
8. **Low Battery Warning** - The monitor is constantly monitoring its input voltage to quickly detect low power conditions. If the monitor detects that the input voltage has dropped below 11.0V, it will display "LO SYS" on the lower LCD on the KPM II Stack-Mode console, provided that the monitor does not detect speed or planting.

NOTE: After the alarms have been acknowledged and if the alarm condition is still present, the LCD will continue to display the alarm condition.

REPLACING A FAULTY SENSOR

NOTE: Stack-Mode Seed Sensors are identified by a blue 3-pin connector. Replace Stack-Mode Seed Sensors with like components only.

To replace a faulty sensor; (a) disconnect the faulty sensor and check the monitor to be sure the correct sensor was disconnected, (b) turn the monitor off, (c) after a few seconds, turn the monitor back on and (d) plug in the replacement sensor. The monitor will chirp twice to acknowledge the new sensor was learned and saved.

To replace more than one faulty sensor, proceed as stated above for rear/front or left/right configurations beginning with the lowest numbered row in the rear or left section and continue to replace sensors in ascending order. Then move on to the front or right section and continue in ascending order. For four section configurations, begin with rear/left and continue to rear/right, then front/left and ending with front/right.

If the monitor detects a faulty distance sensor, the lower LCD will immediately move to the speed display, show the word "PICKUP" or "RADAR" depending on the distance sensor installed, and the alarm will sound.

NOTE: If the monitor is not turned off and then on, the replacement sensor(s) will be ignored until the next power on, at which point the sensors will be randomly learned by the monitor.

MACHINE OPERATION

KPM II STACK-MODE

FIELD OPERATION

Press the ON/OFF key to turn the monitor on.



(MTR28e)

Information regarding each section is displayed alternately every 5 seconds.

REAR/FRONT CONFIGURATION (Without SMM Console Installed)

- Press the SELECT key once to show REAR section only. (Monitor sets correct row spacing.)
- Press the SELECT key a second time to return to each section being displayed alternately every 5 seconds on KPM II Stack-Mode console. (Monitor sets correct row spacing.)
- Press the SELECT key a third time to show REAR section only again.



(MTR28c)

REAR/FRONT CONFIGURATION (With SMM Console Installed)

- Press the SELECT key once to show REAR section only on KPM II Stack-Mode console. (Monitor sets correct row spacing.)
- Press the SELECT key a second time to show FRONT section on SMM console and REAR section on KPM II Stack-Mode console. (Monitor sets correct row spacing.)
- Press the SELECT key a third time to show REAR section only again.



(MTR28c)

FOUR SECTION CONFIGURATION (With SMM Console Installed)

- Press the SELECT key once to show REAR and LEFT sections on KPM II Stack-Mode console and REAR and RIGHT sections on SMM console. (Monitor sets correct row spacing.)
- Press the SELECT key a second time to return to all four sections, alternating right front and right rear on SMM console and alternating left front and left rear on KPM II Stack-Mode console. (Monitor sets correct row spacing.)
- Press the SELECT key a third time to show REAR and LEFT sections on KPM II Stack-Mode console and REAR and RIGHT sections on SMM console again.



(MTR28c)

NOTE: SELECT key has no function when only a single section is being used.

At power up, the lower LCD will show speed (MPH or KM/H).

(MTR29g/MTR29b/MTR29a/MTR29c/MTR29f/MTR29c/MTR29f)

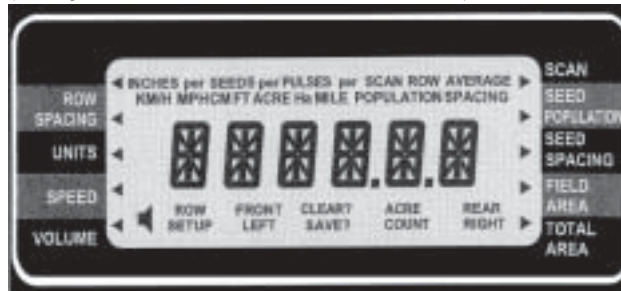

Press the UP or DOWN arrow keys to move the flashing arrow on the lower LCD to change what is displayed on the lower LCD.



Press the shortcut keys SPEED, SEED POPULATION/SEED SPACING or AREA FIELD/TOTAL for direct access to these displays.



(MTR29c/MTR29d/MTR29b/MTR29c)

Press the SEED POPULATION/SEED SPACING or AREA FIELD/TOTAL keys to alternate between the two functions assigned to that key.



Press the SEED POPULATION/SEED SPACING key to choose average seed spacing/population per acre.



Press the SCAN key to display individual rows starting at row 1.



Press the SCAN key again to lock on current row.

Press the SCAN key again to resume scrolling.

Use the UP or DOWN arrow keys to move to a particular row.



Press the SEED POPULATION/SEED SPACING key to go back to planter average.



CLEARING FIELD AREA

(MTR29n/MTR28b)

To reset the counter, press the UP or DOWN arrow keys to move the arrow in the lower display to FIELD AREA.



Press the UP and DOWN arrow keys at the same time and hold them down for a short period of time to clear the data. The CLEAR? icon will be displayed and the monitor will beep several times. When the data is actually cleared, the monitor will emit a long beep, and the field area is reset to zero. After the long beep, the previous field area recorded is not retrievable.



NOTE: Clearing the field area counter will not clear the total area counter. See “Programming-Clearing Total Area” for clearing total area.

Press the OK key to silence alarms. See “Warnings And Alarms”.



MACHINE OPERATION

KPM II STACK-MODE

PROGRAMMING/CONNECTING SMM CONSOLE, SHAFT ROTATION SENSORS, SEED TUBES AND/OR RADAR/MAGNETIC DISTANCE SENSORS

STEP 1 All sensors (including the seed tubes w/ sensors, radar, magnetic distance, SMM console and shaft rotation sensors) must be unplugged from the harness and/or console and the monitor must be off.

NOTE: If the monitor detects a radar sensor but no seed tubes at power up, it will automatically go into AREA COUNT mode. See “Area Counter/Speedometer Mode”.

NOTE: Disconnect magnetic distance sensor between MDS adapter and planter harness. DO NOT disconnect between MDS and MDS adapter.

01189909

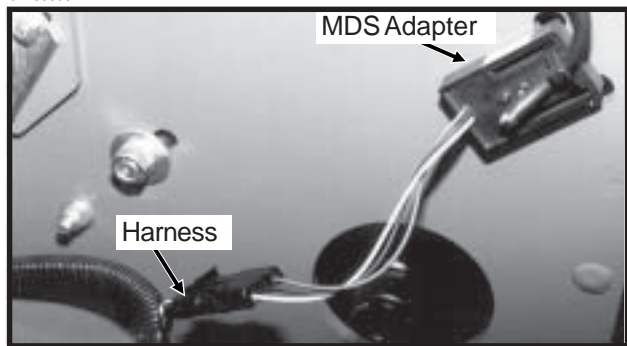

01189910



STEP 2 Press the ON key. The monitor automatically enters the setup procedure. Monitor will scroll “NO SENSOR” on top LCD of KPM II Stack-Mode console.

STEP 3 The monitor automatically defaults to rear/front. Press the SELECT key once for left/right and twice for four sections (front right/front left/rear right/rear left). The selected display will be solid and the configuration not currently selected will be flashing.

12060211

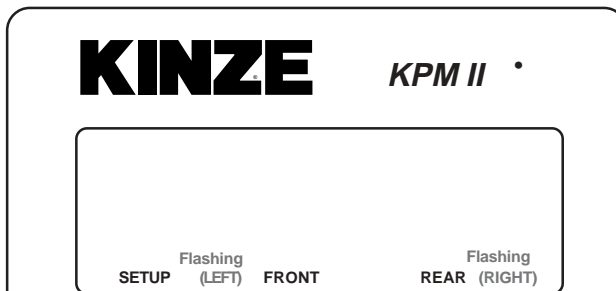

ROW	SETUP	SCAN
UNITS		SEED
SPEED		SEED
VOLUME		FIELD
		TOTAL

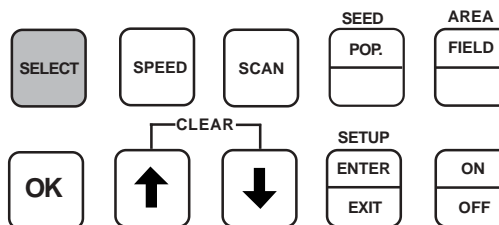

NOTE: SMM console may not be applicable to all models.

MACHINE OPERATION

KPM II STACK-MODE

12060211

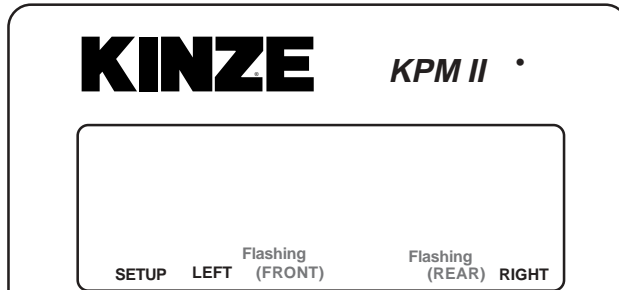

ROW	SETUP	SCAN
UNITS		SEED
SPEED		FIELD
VOLUME		TOTAL

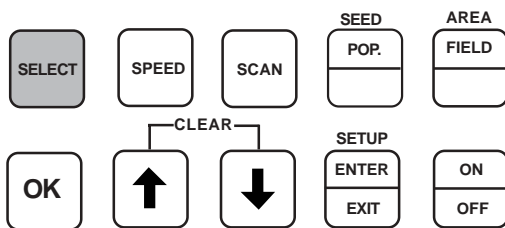

NOTE: SMM console may not be applicable to all models.

NOTE: Model 3140 planters select the rear/front configuration.

STEP 4 Press and hold the OK key to confirm selection. The upper display will alternate between “NEW” and “SYS?”.

The alarm will sound four short beeps followed by one long beep. At this point your selection has been saved and row numbers will appear flashing on the upper display.

12060211

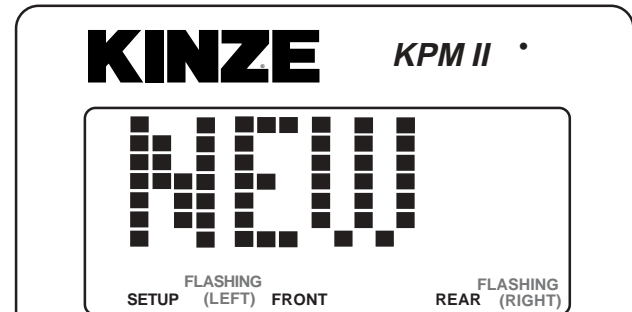

ROW SPACING	SETUP	SCAN
UNITS		SEED POPULATION
SPEED		SEED SPACING
VOLUME		FIELD AREA TOTAL AREA

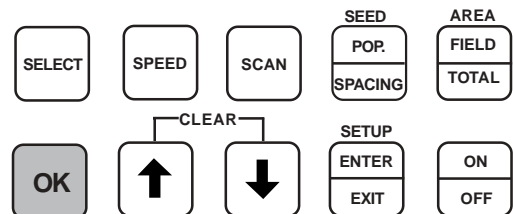

NOTE: SMM console may not be applicable to all models.

MACHINE OPERATION

KPM II STACK-MODE

NOTE: Illustrated using rear/front configuration. The KPM II Stack-Mode console shows LEFT in the left/right configuration, REAR in the rear/front configuration and FRONT LEFT/REAR LEFT in the four sections configuration.

STEP 5 (If Applicable) Connect SMM console into junction Y-harness which was installed between the KPM II Stack-Mode console and the primary harness. The SMM console will show a lighted screen and KPM will show on the lower LCD.

12060211



12060211

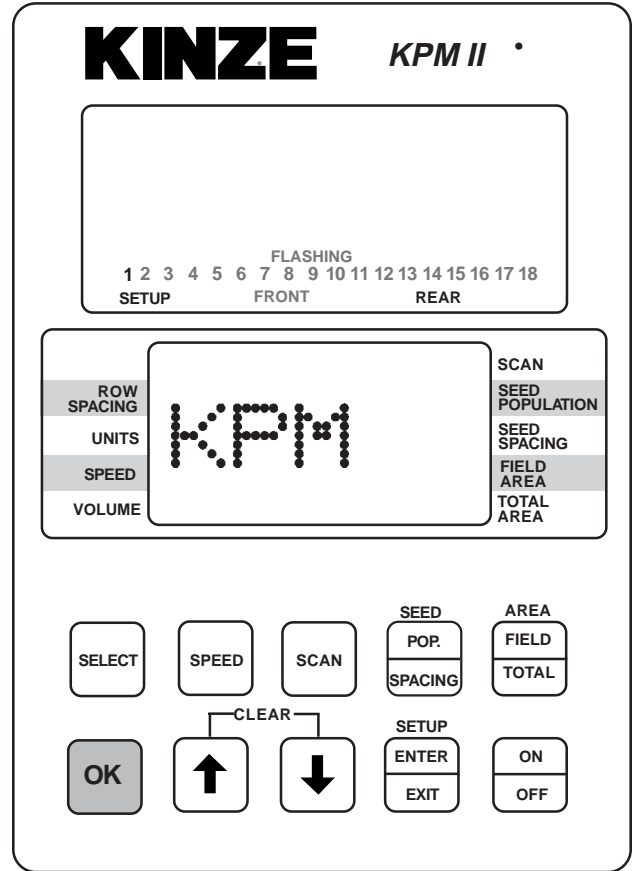
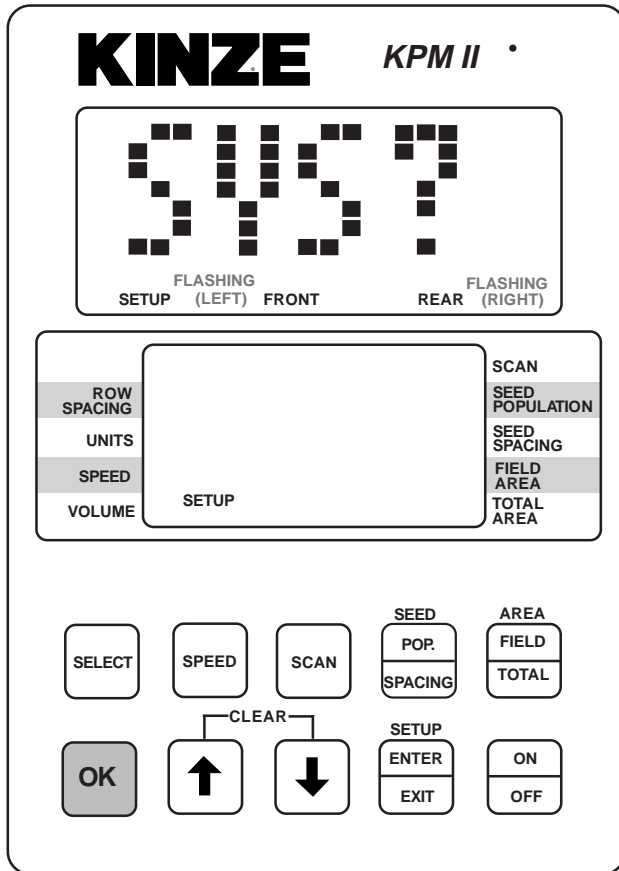

NOTE: SMM console may not be applicable to all models.

NOTE: SMM console may not be applicable to all models.

MACHINE OPERATION

KPM II STACK-MODE

STEP 6 If the monitor system includes shaft rotation sensors, these should be installed at this time. Plug in the L.H. shaft first, then the R.H. shaft. L.H. and R.H. is determined by facing in the direction the machine will travel when in use.

01189906

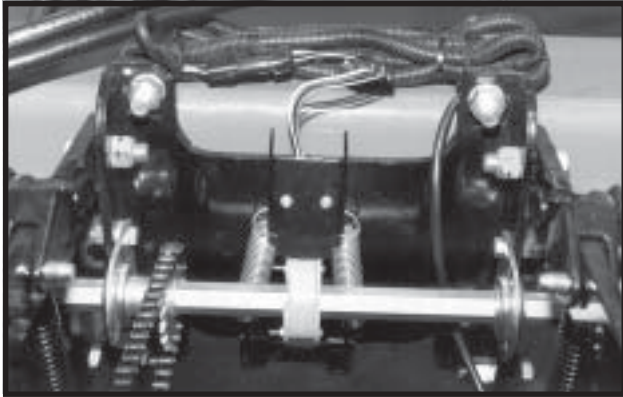

“LSHAFT” or “SHAFT 1” will display on the lower LCD when the first shaft rotation sensor is installed. “RSHAFT” or “SHAFT 2” will display when the second shaft rotation sensor is installed.

NOTE: Illustrated using rear/front configuration. The KPM II Stack-Mode console shows LEFT in the left/right configuration, REAR in the rear/front configuration and FRONT LEFT/REAR LEFT in the four sections configuration.

12060211

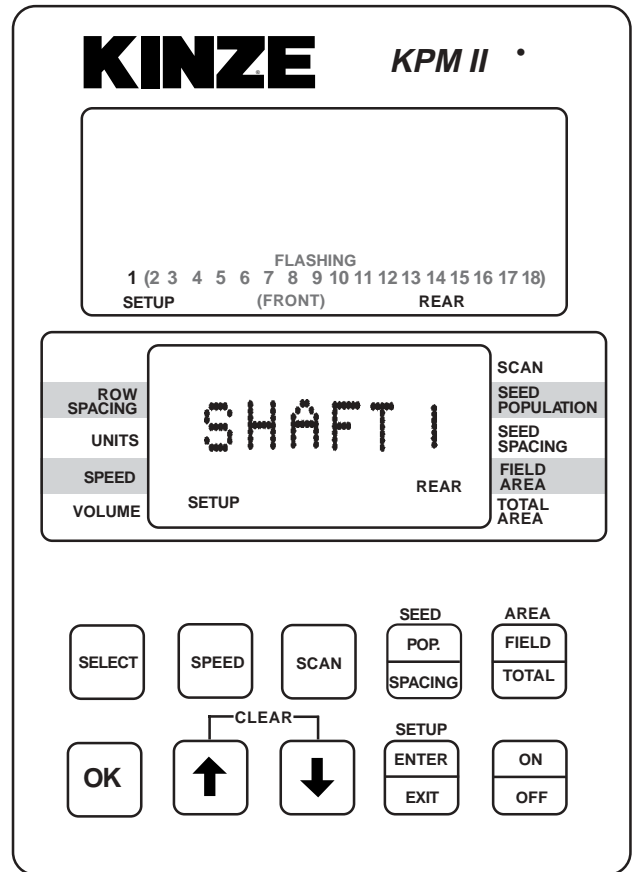

NOTE: SMM console may not be applicable to all models.

MACHINE OPERATION

KPM II STACK-MODE

STEP 6 (Continued)

12060211

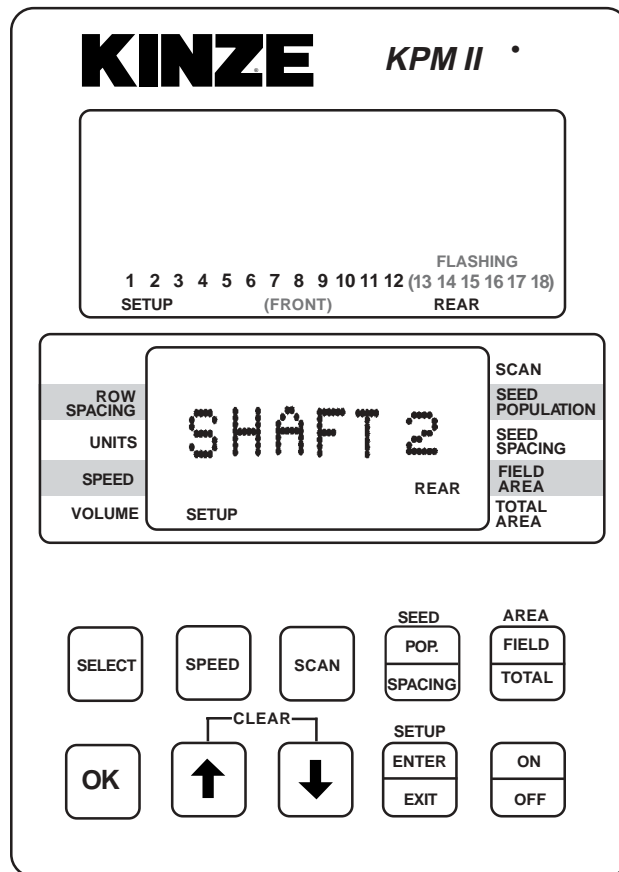

NOTE: SMM console may not be applicable to all models.

STEP 7 Determine which row you want as number one and plug the seed tube w/sensor into the harness.

Continue plugging in sensors along with shaft rotation sensors if so equipped. Row 1 first, row 2 second and so on up to 18 rows. When a sensor is plugged in, the corresponding row number on the upper LCD display will stay solid, the monitor will chirp twice and a red LED (Light Emitting Diode) on the seed tube sensor will turn on for approximately 30 seconds to show connection is made.

D120602101

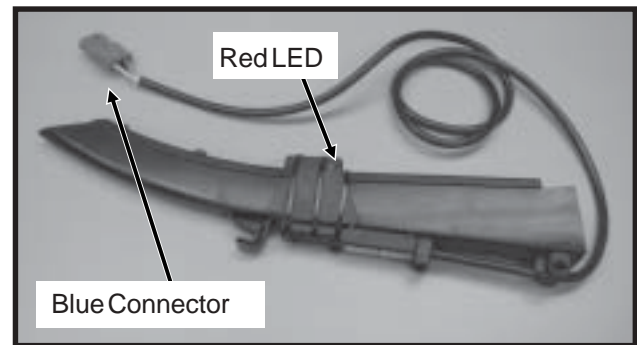

NOTE: Illustrated using rear/front configuration. The KPM II Stack-Mode console shows LEFT in the left/right configuration, REAR in the rear/front configuration and REAR LEFT/FRONT LEFT in the four sections configuration.

STEP 7 (Continued)

12060211

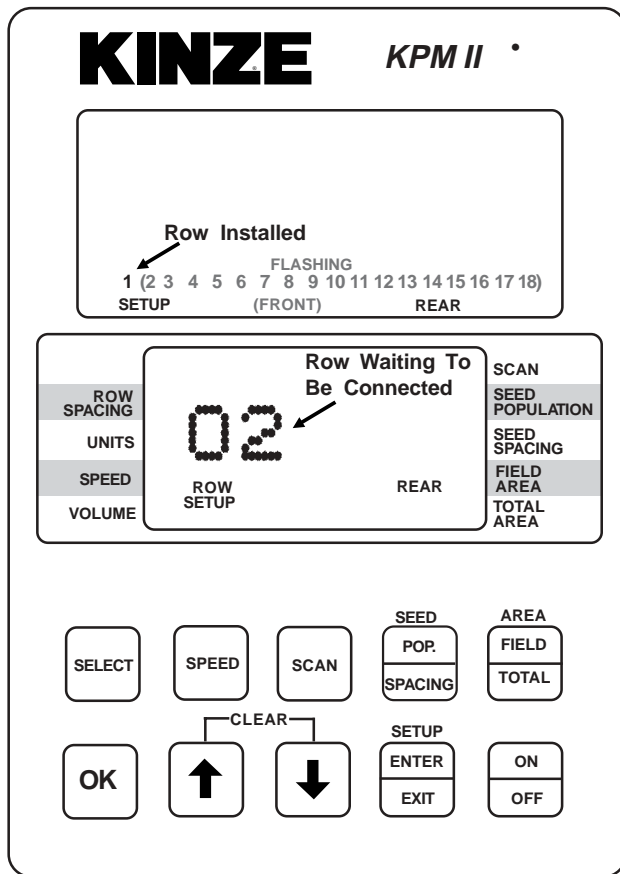

NOTE: SMM console may not be applicable to all models.

MACHINE OPERATION

KPM II STACK-MODE

STEP 8 When all the seed tubes for the current section (rear/front, left/right or four section) are installed, check to be sure the upper LCD on the KPM II Stack-Mode console displays solid numbers for the number of seed tubes connected. Press and hold the OK key to save the setup for the current section. The SAVE? icon will display followed by continuous short beeps indicating the monitor is preparing to save. The installer has 5 seconds to decide to save the current configuration. During this time, four short beeps will sound followed by a long beep and the SAVE? icon will turn off and the word "DONE" shows on the screen. The monitor will continue to the second section installation (If Applicable).

NOTE: Illustrated using rear/front configuration. The KPM II Stack-Mode console shows LEFT in the left/right configuration, REAR in the rear/front configuration and FRONT LEFT/REAR LEFT in the four sections configuration.

12060211

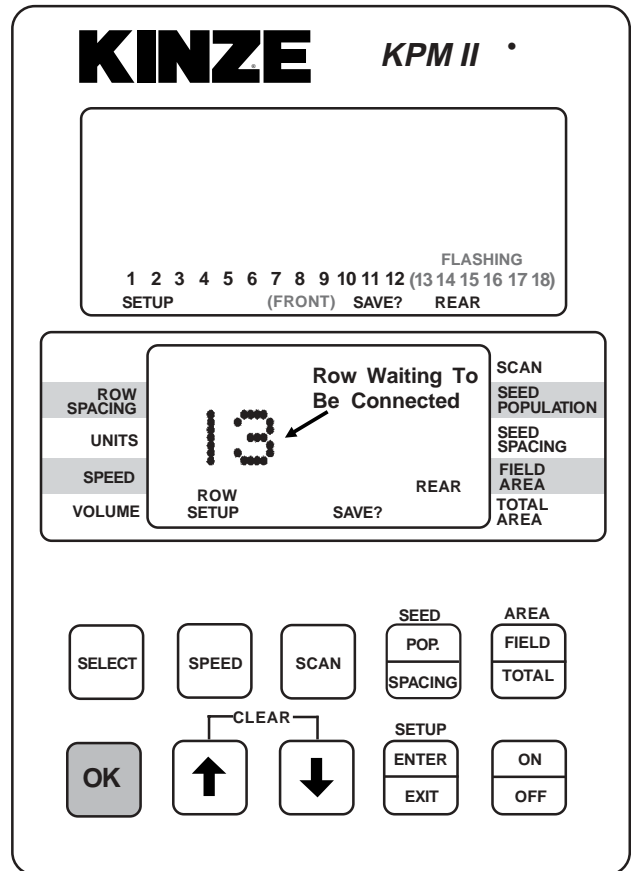

NOTE: SMM console may not be applicable to all models.

STEP 8 (Continued)

12060211

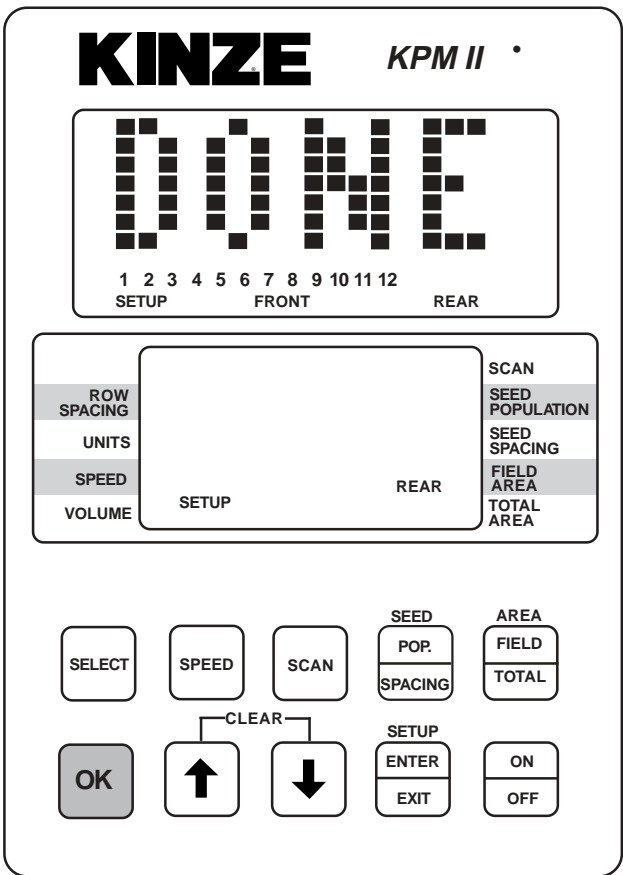

NOTE: SMM console may not be applicable to all models.

MACHINE OPERATION

KPM II STACK-MODE

STEP 9 Follow STEPS 6, 7 and 8 to install the second section. If no seed tubes are installed on the second section, press and hold the OK key. The word "DONE" will appear on upper display. The alarm will sound four short beeps followed by one long beep and the SAVE? icon turns off. The monitor has exited the setup mode. When you release the OK key the upper display will scroll "WAITING CALIBRATION". The lower display will show "GNDSPD" and the alarm will sound continually until the distance sensor is connected. See STEP 10.

NOTE: The SMM console LCD remains blank (except the backlighting screen) until the entire system is saved.

NOTE: Illustrated using rear/front configuration. The KPM II Stack-Mode console shows LEFT in the left/right configuration, REAR in the rear/front configuration and FRONT LEFT/REAR LEFT in the four sections configuration. The SMM console shows RIGHT in the left/right configuration, FRONT in the front/rear configuration and FRONT RIGHT/REAR RIGHT in four sections configuration.

12060212

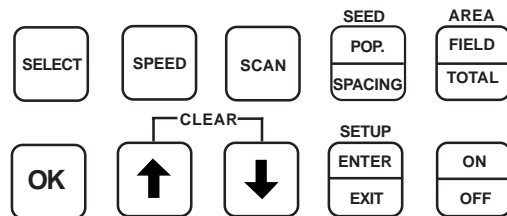
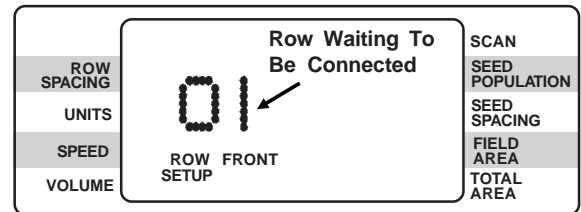
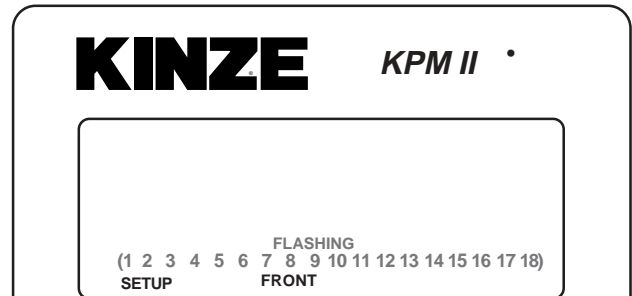
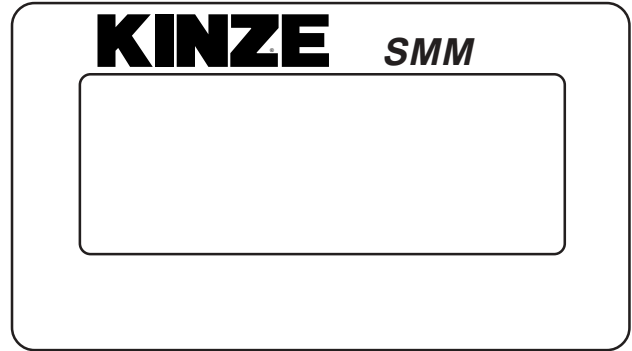

NOTE: SMM console may not be applicable to all models.

MACHINE OPERATION

KPM II STACK-MODE

STEP 9 (Continued)

12060213

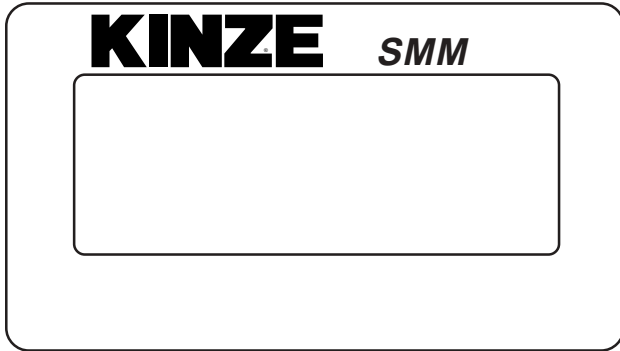

12060214

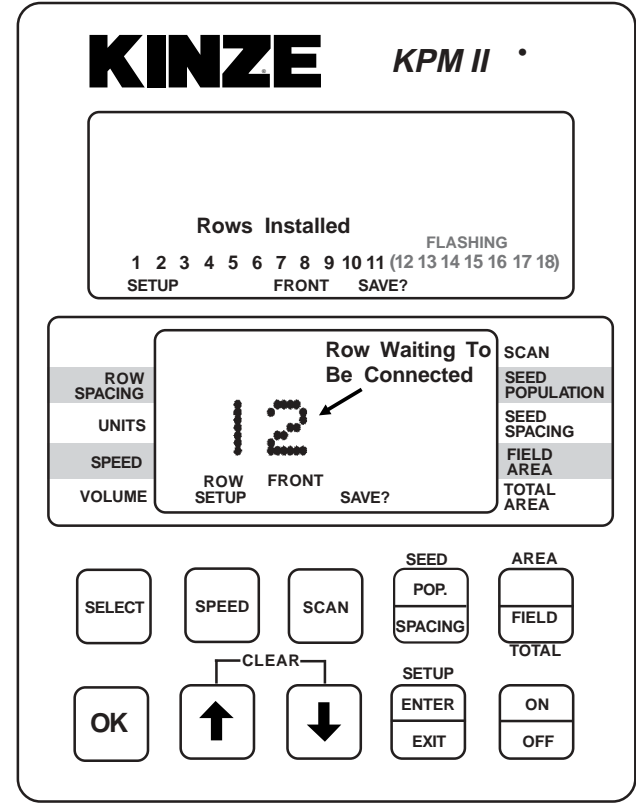
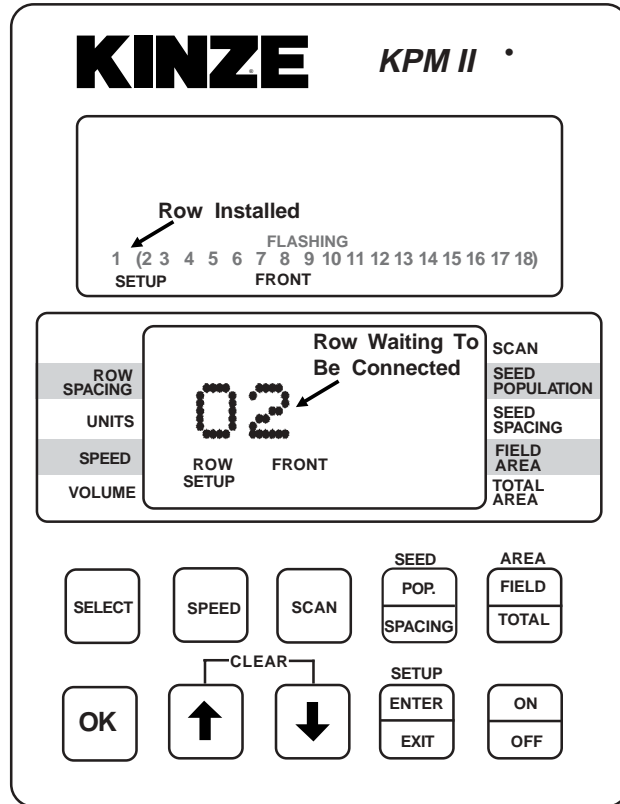
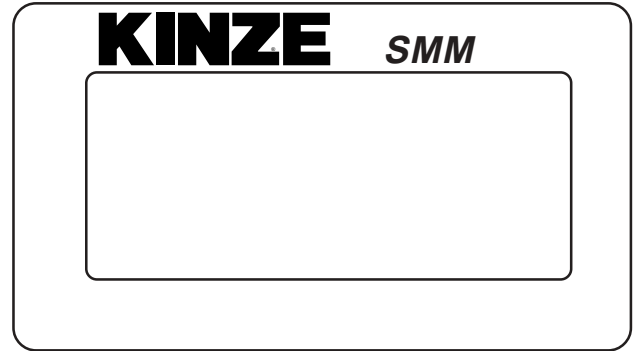

NOTE: SMM console may not be applicable to all models.

NOTE: SMM console may not be applicable to all models.

MACHINE OPERATION

KPM II STACK-MODE

STEP 9 (Continued)

12060215

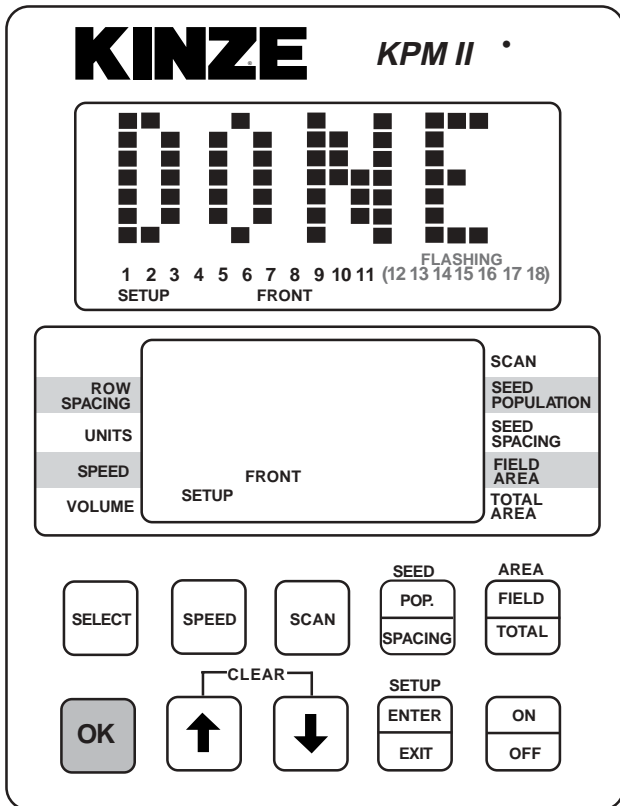
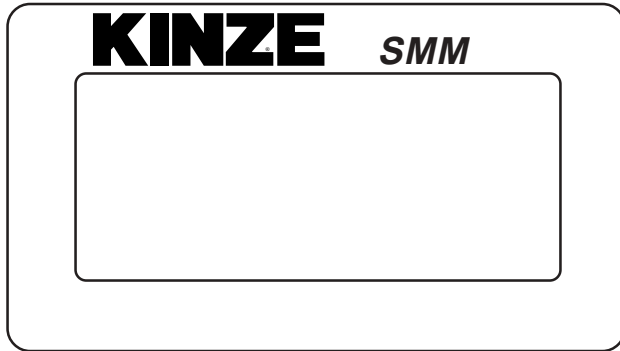

NOTE: SMM console may not be applicable to all models.

STEP 10 With the lower display showing “GNDSPD”, connect the distance sensor. The monitor will display “PICKUP” if a magnetic distance sensor is connected or “RADAR” if a radar distance sensor is installed. Only one distance sensor can be connected at a time.

NOTE: Illustrated using rear/front configuration. The KPM II Stack-Mode console shows LEFT in the left/right configuration, REAR in the rear/front configuration and FRONT LEFT/REAR LEFT in the four sections configuration. The SMM console shows RIGHT in the left/right configuration, FRONT in the rear/front configuration and FRONT RIGHT/REAR RIGHT in four sections configuration.

NOTE: To connect the radar distance sensor, install the 10" monitor/radar adapter between the console and radar distance sensor to adapt the monitor system to various tractor radar systems. DO NOT CONNECT 10" MONITOR/RADAR ADAPTER PRIOR TO THIS STEP.

MACHINE OPERATION

KPM II STACK-MODE

STEP 10 (Continued)

12060216

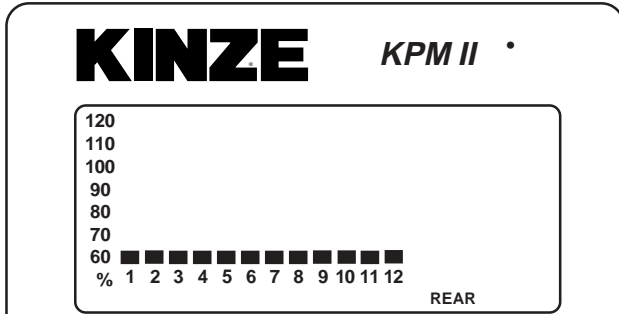
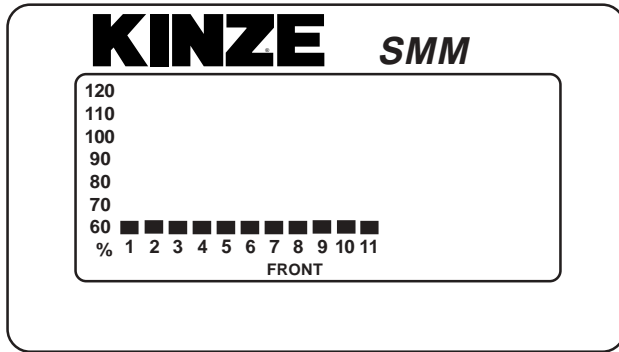

ROW SPACING	GNDSPD	SCAN
UNITS		SEED POPULATION
SPEED		SEED SPACING
VOLUME		FIELD AREA TOTAL AREA

REAR

SELECT	SPEED	SCAN	SEED POP. SPACING	AREA FIELD TOTAL
OK	CLEAR ↑ ↓		SETUP ENTER EXIT	ON OFF

NOTE: SMM console may not be applicable to all models.

NOTE: To reprogram the system to monitor more or less rows (up to the maximum of 18 per section, 72 total in four section configuration), all sensors must be unplugged, followed by the complete setup procedure.

NOTE: Individual seed tubes may be unplugged for special situations. An alarm will sound which can be silenced by touching the OK key. The monitor will recognize the seed tube(s) when reconnected.

12060217

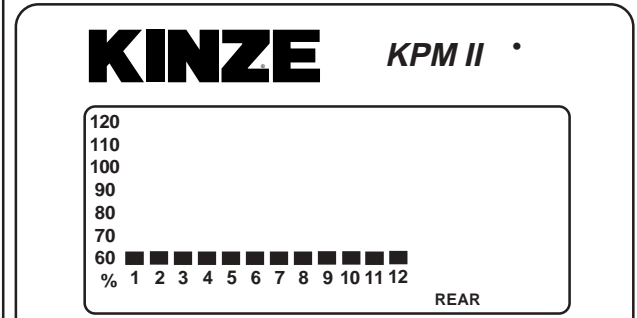
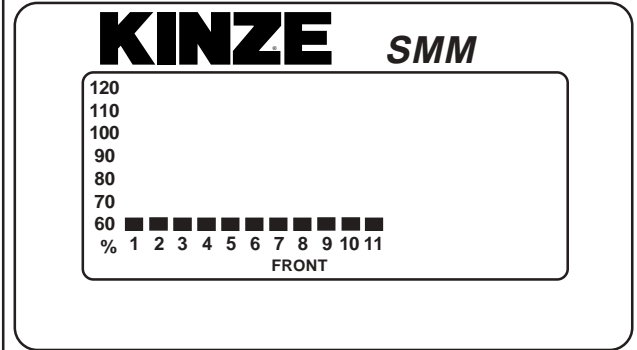

ROW SPACING	MPH 0.0	SCAN
UNITS		SEED POPULATION
SPEED		SEED SPACING
VOLUME		FIELD AREA TOTAL AREA

SELECT	SPEED	SCAN	SEED POP. SPACING	AREA FIELD TOTAL
OK	CLEAR ↑ ↓		SETUP ENTER EXIT	ON OFF

NOTE: SMM console may not be applicable to all models.

ROW-BY-ROW ALARM LEVEL SETTING
*(Requires Version V2.05 Or Higher Software -
 KPM II Stack-Mode Monitors Only)*

This feature allows the audio alarm to be disabled on selected rows in applications such as planting seed corn.

NOTE: The system should be programmed to monitor all planter rows prior to performing these steps.

NOTE: Illustrated using rear/front configuration. The KPM II Stack-Mode console shows LEFT in the left/right configuration, REAR in the rear/front configuration and FRONT LEFT/REAR LEFT in the four sections configuration. The SMM console shows RIGHT in the left/right configuration, FRONT in the rear/front configuration and FRONT RIGHT/REAR RIGHT in four sections configuration.

STEP 1 Enter the programming mode by pressing and holding the SETUP key. The monitor will emit several short beeps, followed by a long beep. On the lower LCD, the SETUP icon will turn on and the arrow head icon will flash, indicating the user can select an item to program.

NOTE: The monitor must be in a programmable function (row spacing, unit, speed, volume or area) to enter setup. The monitor will not enter setup in seed population or seed spacing.

STEP 2 Press the UP or DOWN arrow keys to move the flashing arrow to SEED POPULATION. As the arrow icon moves, the lower LCD will display the current setting of each item selected.

12060218

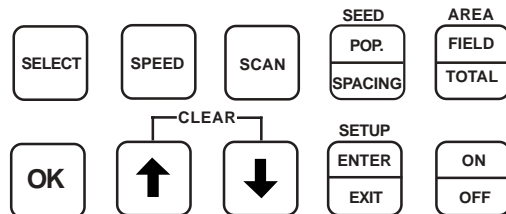
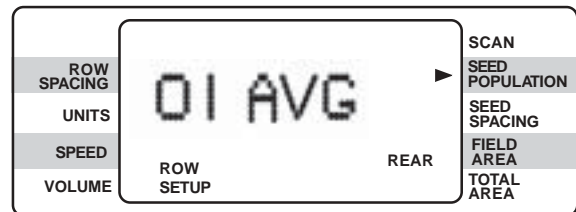
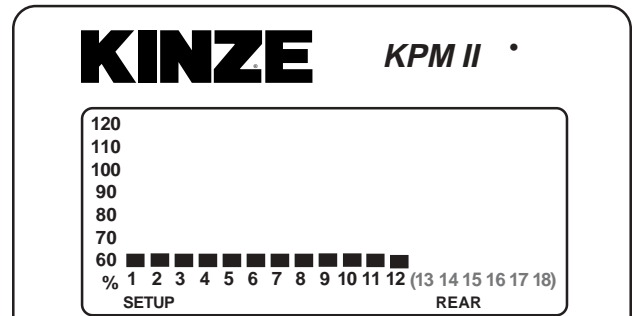
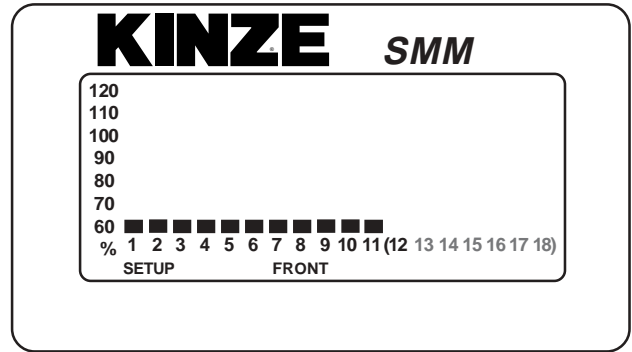

NOTE: SMM console may not be applicable to all models.

STEP 3 Press the OK key. Row number starts flashing.

STEP 4 Arrow UP or DOWN to desired row.

STEP 5 Press SELECT key. "AVG" starts flashing.

STEP 6 Arrow UP or DOWN to choose one of the following options.

HIGH - For Early Alarm (70%)
AVG - For Standard Alarm Setting (55%)
LOW - For Failed Alarm Only (25%)
OFF - To Disable Row Alarm

STEP 7 Press and hold the OK key to save alarm setting. There will be four short beeps, one long beep and the word "DONE" will appear when the save is completed.

STEP 8 Repeat STEPS 3 through 7 for each row on which you wish to adjust the alarm setting.

STEP 9 When finished, press the SETUP key to exit setup mode.

NOTE: The programming mode may be exited at any time by pressing the SETUP key. Pressing this key will return the monitor to its normal operation. All items changed and saved will come into effect immediately. Any items changed, but not saved will revert to the original programmed value.

NOTE: Repeat STEPS 3 through 7 to change seed monitor back to the original settings when special row-by-row alarm level settings are no longer required.

NOTE:

See "Programming - Row Spacing" for programming applicable row spacing.

See "KPM I/KPM II/KPM II Stack-Mode Electronic Seed Monitor Troubleshooting" in the Maintenance Section.

MACHINE OPERATION

POINT ROW CLUTCHES

81014-12a

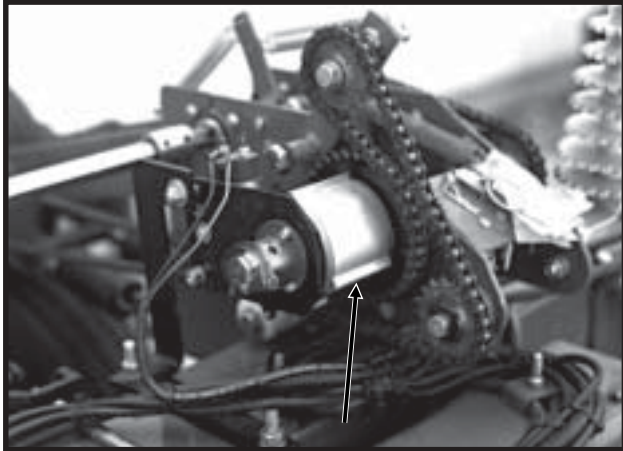

L.H. Side Of Planter Shown

With the use of electric-activated clutches, which disengage the drive, the operator has the capability to shut off either half of the planter for finishing up fields or for long point row situations.

76740-48



Point Row Clutch Control Box

The selector switch for the clutches is located on the tractor.

NOTE: Switch should be left in OFF position when planter is not in use. If left in ON (left or right) position, the tractor battery will be drained.

(EF40c)

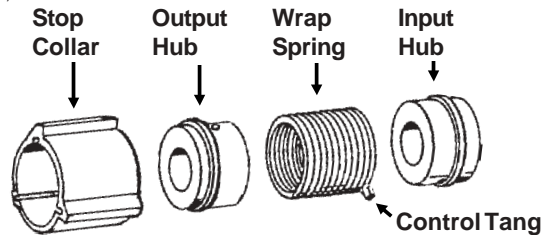

The point row clutch consists of a wrap spring riding on an input hub and an output hub. During operation the wrap spring is wrapped tightly over the hubs connecting them in a positive engagement. The greater the force of rotation the tighter the grip of the spring on the hubs. Rotation in the opposite direction or stopping the spring from rotating prevents the transmission of torque from the input hub to the output hub stopping the planter drive.

The input end of the spring is bent outward and is referred to as the control tang. The control tang fits into a slot in the stop collar that is located between the input and output hubs and over the wrap spring. If the stop collar is allowed to rotate with the input hub, the clutch is engaged. If the stop collar is stopped from rotating the control tang connected to it is forced back and the spring opens. This allows the input hub to continue rotating without transmitting torque to the output hub; therefore, stopping the planter drive.

The stop collar is controlled by the use of an electric solenoid and an actuator arm. When the selector switch on the tractor control box is in the OFF position the solenoid coil is NOT ENERGIZED and the actuator arm will not contact the stop on the stop collar allowing it to rotate with the hubs and drive the planter.

When the operational switch is in the "DISENGAGE" (right or left) position the solenoid coil IS ENERGIZED and the plunger in the solenoid coil pulls the actuator arm against the stop on the stop collar, disengaging the wrap spring and stopping the planter drive.

MACHINE OPERATION

TWO-SPEED POINT ROW CLUTCHES

82488-24

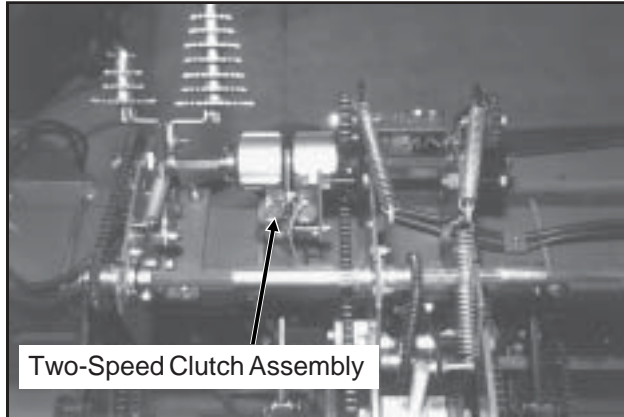

Left Side Of Planter Viewed From Rear Of Planter

The Two-Speed Point Row Clutch Package is designed to allow on-the-go population rate adjustment as well as the capability to shut off either half of the planter for finishing up fields or for long point row situations.

The point row clutches are controlled by the point row clutch switch on the control box. The point row switch is used to shut off either the left or right half of the planter. Activating the reduced rate switch engages one solenoid on each clutch assembly and reduces the planting rate for the entire planter.

NOTE: Point row switch should be left in OFF position and rate switch left in FULL RATE position when planter is not in use. If left in ON and/or REDUCED RATE positions, the tractor battery will be drained.

(INS242)

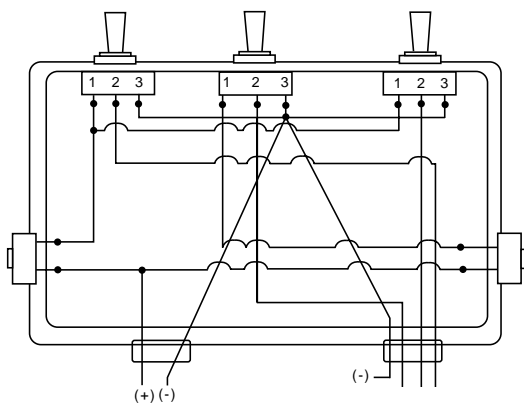

Top View Of Control Box

The ratio of population reduction is determined by the sprocket ratio between the drive and driven sprockets at the contact drive tire. A rate reduction decal like the one shown below is located on the wheel module.

(7100-214)

TRANSMISSION RATE REDUCTION		
DRIVE	DRIVEN	% REDUCTION IN POPULATION
15	30	50
17	30	43
23*	30	23
24	30	20
25*	30	17
26*	30	13
27	30	10

* Use sprockets off seed drive transmission

7100-214

(INS124)

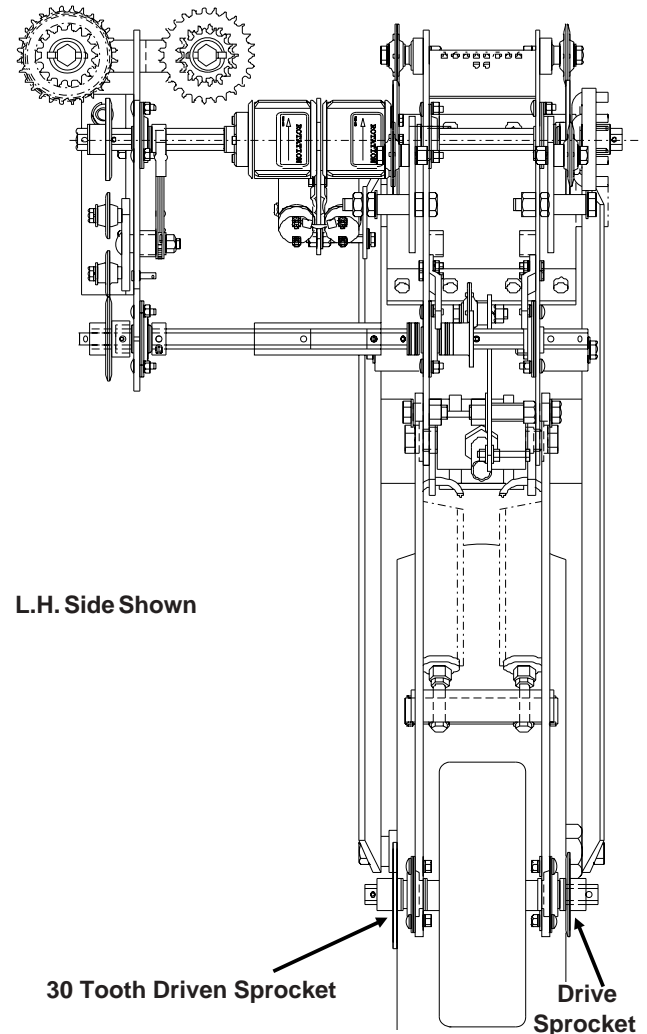

L.H. Side Shown

30 Tooth Driven Sprocket

Drive Sprocket

MACHINE OPERATION

DUAL LIFT ASSIST WHEELS

(SFP52a)

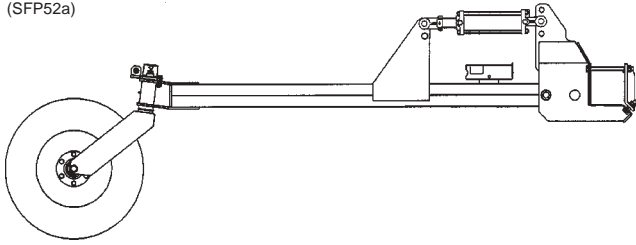

Dual lift assist wheel equipped machines require use of a quick hitch (customer-supplied) and the top link pin is not used.

A single control valve operates the dual lift assist wheels.

When raising a planter equipped with dual lift assist wheels, the front of the planter should raise and then the back using the lift assist wheels to raise the rear of the planter. When lowering the planter, the lift assist wheels should begin to lower the rear of the planter before lowering the front of the planter.

If the machine is equipped with both the Dual Lift Assist Wheel Package and Wing Down Flex Cylinder Package, a single control valve operates both options. As the dual lift assist wheel cylinders extend to raise the toolbar, the wing down flex cylinders retract to flex the wings up 5° for added clearance when turning.

The flow control valve must be adjusted so that the wing down flex cylinders start to retract before the lift assist cylinders start to raise the toolbar. This will prevent the wings from drooping as the toolbar is raised.

Dual lift assist wheels hydraulics can also be plumbed into the 3 point lift circuit. A flow control valve determines the correct sequence of events to allow the dual lift assist wheel cylinders to operate at the correct time in conjunction with the 3 point hitch lift circuit. See "Flow Control Valve Adjustment".

See "Tractor Preparation And Hookup" for additional information.

ACCUMULATOR

The accumulator is standard in Dual Lift Assist Wheel Packages for 16 Row 30" Model 3140 Stack Folding Planters to absorb shock loads to the lift assist wheel arms during transport.

After initial dealer installation no maintenance should be necessary on the sealed system.



WARNING: Do not disassemble accumulator. See dealer for service. Note manufacturer's caution decal on accumulator.

PISTON PUMP MOUNT/DRIVE SPRING ADJUSTMENT

(SFP65a/SFP65d)

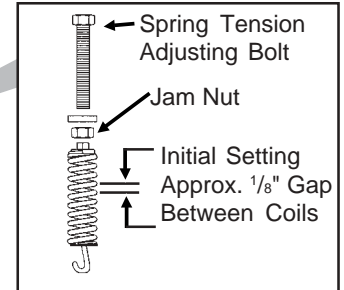
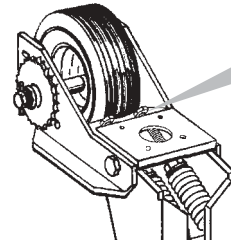

Adjust the pump drive tension springs by tightening the hex head adjustment bolts to assure positive tire contact. The initial setting should be set with approximately a 1/8" gap between coils. Tighten jam nut against spring plug to hold setting.

FLOW CONTROL VALVE ADJUSTMENT

WB001 (MT2)

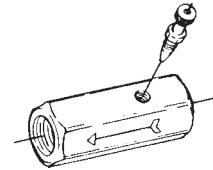

The flow control valve determines the amount of oil flow to the lift assist cylinders.

To adjust oil flow, loosen the jam nut and turn the control clockwise or "in" to restrict flow and counterclockwise or "out" to increase the flow.

TRANSPORTING THE PLANTER



WARNING: Always make sure safety/warning lights, reflective decals and SMV sign are in place and visible prior to transporting the machine on public roads. In this regard, check and comply with all federal, state/provincial and local regulations.



WARNING: Always install all safety lockup devices before transporting the planter.

MACHINE OPERATION

METRIC CONVERSION TABLE

Multiply	By	To Get
Inches (in.)	x 2.54	= centimeters (cm)
Inches (in.)	x 25.4	= millimeters (mm)
Feet (ft.)	x 30.48	= centimeters (cm)
Acres	x 0.405	= hectares (ha)
Miles per hour (mph)	x 1.609	= kilometers per hour (Km/h)
Pounds (lbs.)	x 0.453	= kilograms (kg)
Bushels (bu.)	x 35.238	= liters (l)
Gallons (gal.)	x 3.785	= liters (l)
Pounds per square inch (psi)	x 6.894	= kilopascals (kPa) (100 kPa = 1 bar)
Inch pounds (in. lbs.)	x 0.113	= newtons-meters (N•m)
Foot pounds (ft. lbs.)	x 1.356	= newtons-meters (N•m)
Centimeters (cm)	x .394	= inches (in.)
Millimeters (mm)	x .0394	= inches (in.)
Centimeters (cm)	x .0328	= feet (ft.)
Hectares (ha)	x 2.469	= acres
Kilometers per hour (Km/h)	x 0.621	= miles per hour (mph)
Kilograms (kg)	x 2.208	= pounds (lbs.)
Liters (l)	x 0.028	= bushels (bu.)
Liters (l)	x 0.264	= gallons (gal.)
Kilopascals (kPa) (100 kPa = 1 bar)	x 0.145	= pounds per square inch (psi)
Newtons-meters (N•m)	x 8.85	= inch pounds (in. lbs.)
Newtons-meters (N•m)	x 0.738	= foot pounds (ft. lbs.)

PLANTING SPEED

Planters are designed to operate within a speed range of 2 to 8 MPH. See “Rate Charts”. Variations in ground speed will produce variations in rates. Finger pickup seed meter populations will tend to be disproportionately higher at high ground speeds.

NOTE: Due to a multitude of variables, seed spacing can be adversely affected at speeds above 5.5 MPH.

FIELD TEST

With any change of field and/or planting conditions, seed size or planter adjustment, we recommend a field test be made to ensure proper seed placement and operation of row units. See “Rate Charts”, “Checking Seed Population” and “Checking Granular Chemical Application Rate” at the end of this section.

- Check the planter for fore to aft and lateral level operation. See “Leveling The Planter”.
- Check **all** row units to be certain they are running level. When planting, the row unit parallel arms should be approximately parallel to the ground.
- Check row markers for proper operation and adjustment. See “Row Marker Length Adjustment”, “Row Marker Speed Adjustment” and “Hydraulic Row Marker Operation”.
- Check for proper application rates and placement of granular chemicals on **all** rows. See “Checking Granular Chemical Application Rate”.
- Check for desired depth placement and seed population on **all** rows. See “Checking Seed Population”.

After the planter has been field tested, reinspect the machine.

- Hoses And Fittings
- Bolts And Nuts
- Cotter Pins And Roll Pins

MACHINE OPERATION

CHECKING SEED POPULATION

1. Tie up one or more sets of closing wheels by running a chain or rubber tarp strap between the hopper support panel and closing wheels. It may be necessary to decrease closing wheel arm spring tension.

(RU113b)

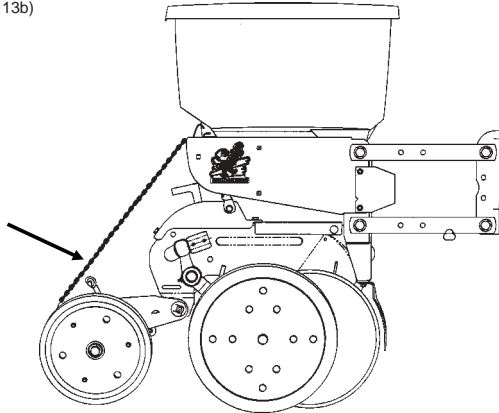

2. Plant a short distance and check to see if seed is visible in the seed trench. Adjust planting depth to a shallower setting if seed is not visible and recheck.

04059914a

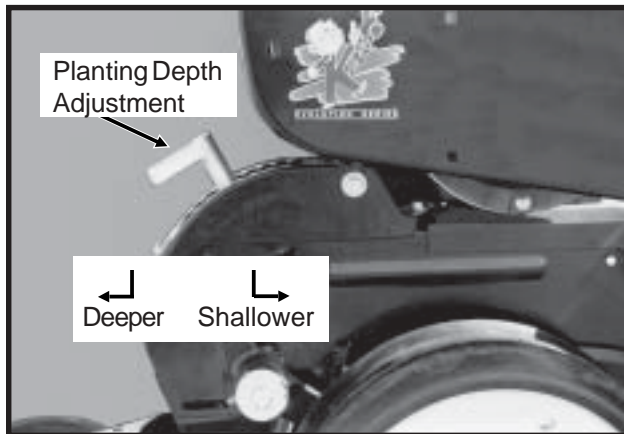

3. Measure $\frac{1}{1000}$ of an acre. See chart for correct distance for row width being planted. For example, if planting 30" rows $\frac{1}{1000}$ of an acre would be 17' 5".

LENGTH OF ROW IN FEET AND INCHES				
Fraction Of Acre	Row Width			
	30"	36"	38"	40"
$\frac{1}{1000}$	17' 5"	14' 6"	13' 10"	13' 1"

NOTE: When planting with closing wheels raised and planting depth set shallow, seeds may bounce or roll affecting seed spacing accuracy.

4. Count seeds in measured distance.
5. Multiply the number of seeds placed in $\frac{1}{1000}$ of an acre by 1000. This will give you total population.

EXAMPLE: With 30" row spacing 17' 5" equals $\frac{1}{1000}$ acre.

26 Seeds				
Counted	x	1000	=	26,000 Seeds Per Acre

Seed count can be affected by drive ratio between drive wheel and seed meter, tire pressure and/or seed meter malfunction.

If seed check shows the average distance between seeds in inches is significantly different than the seed rate chart indicates, first check drive ratio between drive wheel and seed meter. Check drive wheel air pressure, check for incorrect sprocket(s) in driveline and check drive and driven sprockets on transmission for proper selection.

Second, check for seed meter malfunction. For example, if spacing between kernels of corn at the transmission setting being used is 8" and a gap of 16" is observed, a finger has lost its seed and not functioned properly. If two seeds are found within a short distance of each other, the finger has metered two seeds instead of one.

See "Finger Pickup Seed Meter Troubleshooting" and/or "Brush-Type Seed Meter Troubleshooting" in the Maintenance Section of this manual.

MACHINE OPERATION

Determining Pounds Per Acre (Brush-Type Seed Meter)

To determine pounds per acre:

Seeds Per Acre On Chart	÷	Seeds Per Pound From Seed Tag On Bag	=	Pounds Per Acre
-------------------------------	---	---	---	-----------------------

To determine bushels per acre:

Pounds Per Acre	÷	Unit Weight Of Seed	=	Bushels Per Acre
--------------------	---	------------------------	---	---------------------

The unit weight of:

- 1 Bushel Soybeans = 60 Pounds
- 1 Bushel Milo/Grain Sorghum = 56 Pounds
- 1 Bushel Cotton = 32 Pounds

If seeds per pound information is not available the following is an average:

- 2,600 seeds per pound for medium size soybeans
- 15,000 seeds per pound for medium size milo/grain sorghum
- 4,500 seeds per pound for medium size cotton

If seed population check shows planting rate is significantly different than seed rate chart shows or if a particular meter is not planting accurately, see "Brush-Type Seed Meter Maintenance" and "Brush-Type Seed Meter Troubleshooting".

CHECKING GRANULAR CHEMICAL APPLICATION RATE

Many things can affect the rate of delivery of granular chemicals such as temperature, humidity, speed, ground conditions, flowability of different material or any obstruction in the meter.



WARNING: Agricultural chemicals can be dangerous if not selected and handled with care. Always read and follow directions supplied by the chemical manufacturer.

A field check is important to determine correct application rates.

D05149901

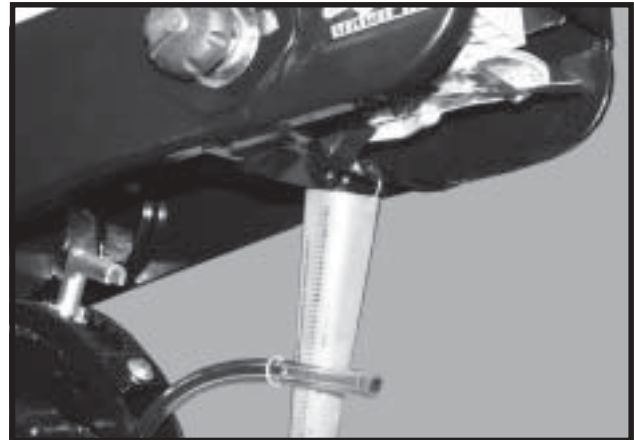

To check, fill insecticide and/or herbicide hoppers. Attach a calibrated vial to each granular chemical meter. Lower the planter and proceed as follows.

NOTE: It is not necessary for seed meter clutch to be engaged during test. Disengage clutch to avoid dropping seed.

Drive 1320 feet at planting speed. Weigh the chemical in ounces that was caught in one vial. Multiply that amount by the factor shown to determine pounds per acre.

POUNDS PER ACRE FACTOR FOR GIVEN ROW WIDTH	
Row Width	Factor
30"	0.83
36"	0.69
38"	0.65
40"	0.62

EXAMPLE: You are planting 30" rows. You have planted for 1320 feet at the desired planting speed. You caught 12.0 ounces of chemical in one vial. 12.0 ounces times 0.83 equals 9.96 pounds per acre.

NOTE: It is important to check calibration of all rows.

Metering Gate

Use the metering gate setting for distributing insecticide or herbicide as a starting point. The charts are based on a 5 miles per hour planting speed. For speeds faster than 5 miles per hour a higher gate setting should be used. For speeds slower than 5 miles per hour a lower gate setting should be used.

MACHINE OPERATION

GENERAL PLANTING RATE INFORMATION

These planting rate charts are applicable to KINZE® Model 3140 Stack Folding Planters. See “Tire Pressure” for recommended tire pressures.

Not all row spacings listed are applicable to all size planters.

IMPORTANT: The sprocket combinations listed in these charts are best for average conditions. Changes in sprocket combinations may be required to obtain desired planting population. TO PREVENT PLANTING MISCALCULATIONS, MAKE FIELD CHECKS TO BE SURE YOU ARE PLANTING AT THE DESIRED RATE.

The size and shape of seed may affect the planting rate.

Finger Pickup Corn Meter

Larger grades will generally plant more accurately at the high end of the ground speed range than smaller grades. Higher than optimum speeds may result in population rate increase or higher incidence of doubles, particularly with small seed. Medium round corn seed is most desirable for planting accuracy at optimum speed.

Finger Pickup Oil Sunflower Meter

Larger grades will generally plant more accurately at the high end of the ground speed range than smaller grades. Higher than optimum speeds may result in population rate increase or higher incidence of doubles, particularly with small seed. No. 3 and/or No. 4 size oil sunflower seeds are recommended for use in the finger pickup seed meter equipped with oil sunflower fingers. No. 1 and/or No. 2 size confectionary sunflower seeds are recommended for use in the finger pickup seed meter equipped with corn fingers.

NOTE: Seed additives, added to the seed in the hopper, may adversely affect performance of the finger pickup seed meter and accelerate wear. See “Finger Pickup Seed Meter” in the Row Unit Operation section.

Brush-Type Seed Meter (Soybean, Milo/Grain Sorghum, Acid-Delinted Cotton)

Rate charts are given in seeds per acre as well as seed spacing in inches rounded to the nearest tenth of an inch. Because of the large range in seed size, pounds per acre is not a suggested method of selecting transmission settings. When using smaller size seeds it may appear the pounds per acre is below what was expected and vice versa on large seed. To determine pounds per acre, use the formula given in “Determining Pounds Per Acre (Brush-Type Seed Meter)” in the “Checking Seed Population” section of this manual.

NOTE: Due to a multitude of variables, seed spacing can be adversely affected at speeds above 5.5 MPH.

In some cases a **Half Rate (2 To 1) Drive Reduction Package** may be required to obtain the desired population and seed spacing.

NOTE: Use of the Half Rate (2 to 1) Drive Reduction Package will reduce the planter transmission speed. The seeding rate will be approximately 50% of the chart reading when using the Half Rate (2 to 1) Drive Reduction Package. Planting speed can affect actual seeding rate. Make a field check and adjust setting in the transmissions as needed to obtain the desired seed drop.

EXAMPLE: 30" row spacing using 60 cell seed disc in brush-type seed meter.
 $80,928 \div 2 = 40,464$ Population
 $2.6" \text{ Seed Spacing} \times 2 = 5.2" \text{ Seed Spacing}$

D10019918

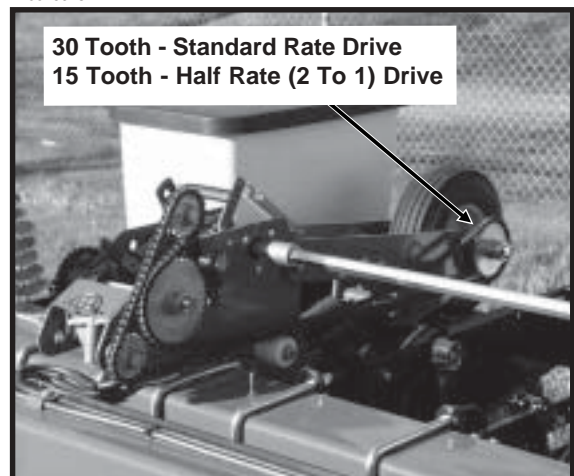

MACHINE OPERATION

PLANTING RATES FOR FINGER PICKUP SEED METERS (STANDARD DRIVE) APPROXIMATE SEEDS/ACRE FOR VARIOUS ROW WIDTHS

30" Rows	36" Rows	38" Rows	40" Rows	Transmission Sprockets		Recomm. Speed Range (MPH)	Average Seed Spacing In Inches
				Drive	Driven		
16,186	13,488	12,778	12,139	17	28	4 to 6	12.9
16,785	13,988	13,251	12,589	17	27	4 to 6	12.5
17,431	14,526	13,761	13,073	17	26	4 to 6	12.0
18,090	15,075	14,281	13,567	19	28	4 to 6	11.6
18,128	15,107	14,312	13,596	17	25	4 to 6	11.5
18,760	15,633	14,810	14,070	19	27	4 to 6	11.1
18,883	15,736	14,908	14,162	17	24	4 to 6	11.1
19,481	16,234	15,380	14,611	19	26	4 to 6	10.7
19,704	16,420	15,556	14,778	17	23	4 to 6	10.6
20,261	16,884	15,995	15,195	19	25	4 to 6	10.3
21,104	17,587	16,662	15,829	19	24	4 to 6	9.9
21,898	18,249	17,288	16,424	23	28	4 to 6	9.5
22,022	18,352	17,386	16,517	19	23	4 to 6	9.5
22,709	18,924	17,928	17,032	23	27	4 to 6	9.2
22,850	19,042	18,040	17,138	24	28	4 to 6	9.2
23,583	19,652	18,618	17,687	23	26	4 to 6	8.9
23,697	19,747	18,708	17,772	24	27	4 to 6	8.8
23,802	19,835	18,791	17,852	25	28	4 to 6	8.8
23,853	19,877	18,831	17,889	17	19	4 to 6	8.8
24,526	20,438	19,363	18,395	23	25	4 to 6	8.5
24,608	20,507	19,427	18,456	24	26	4 to 6	8.5
24,684	20,570	19,487	18,513	25	27	4 to 6	8.5
24,755	20,629	19,543	18,566	26	28	4 to 6	8.4
25,548	21,290	20,169	19,161	23	24	4 to 6	8.2
25,592	21,327	20,205	19,194	24	25	4 to 6	8.2
25,633	21,361	20,237	19,225	25	26	4 to 6	8.2
25,671	21,393	20,267	19,254	26	27	4 to 6	8.1
25,707	21,422	20,295	19,280	27	28	4 to 6	8.1
26,659	22,216	21,046	19,994	23	23	4 to 6	7.8
27,646	23,038	21,826	20,735	28	27	4 to 6	7.6
27,684	23,070	21,856	20,763	27	26	4 to 6	7.6
27,770	23,141	21,923	20,827	25	24	4 to 6	7.5
27,818	23,181	21,961	20,863	24	23	4 to 6	7.5
28,709	23,924	22,665	21,532	28	26	4 to 6	7.3
28,791	23,993	22,730	21,594	27	25	4 to 6	7.3
28,977	24,147	22,876	21,733	25	23	4 to 6	7.2
29,795	24,829	23,522	22,346	19	17	4 to 6	7.0
29,858	24,881	23,572	22,393	28	25	4 to 6	7.0
29,991	24,993	23,677	22,493	27	24	4 to 6	7.0
30,136	25,113	23,792	22,602	26	23	4 to 6	7.0
31,102	25,918	24,554	23,326	28	24	3 to 6	6.7
31,295	26,079	24,707	23,471	27	23	3 to 6	6.7
32,271	26,893	25,477	24,203	23	19	3 to 5.5	6.5
32,454	27,045	25,622	24,341	28	23	3 to 5.5	6.5
33,674	28,062	26,585	25,256	24	19	3 to 5.5	6.2
35,077	29,231	27,693	26,308	25	19	3 to 5	6.0
36,068	30,056	28,474	27,051	23	17	2 to 5	5.8
36,480	30,400	28,800	27,360	26	19	3 to 5	5.7
37,636	31,363	29,713	28,227	24	17	3 to 5	5.6
37,883	31,570	29,908	28,413	27	19	3 to 5	5.5
39,204	32,670	30,951	29,403	25	17	3 to 4.5	5.3
39,287	32,739	31,016	29,465	28	19	3 to 4.5	5.3
40,772	33,977	32,189	30,579	26	17	3 to 4.5	5.1
42,340	35,284	33,427	31,755	27	17	3 to 4.5	4.9
43,908	36,590	34,665	32,931	28	17	3 to 4.5	4.8

NOTE: See "General Planting Rate Information" and "Checking Seed Population" pages for additional information. Always check seed population in the field to ensure planting rates are correct.

MACHINE OPERATION

Z214/RH

PLANTING RATES FOR BRUSH-TYPE SEED METERS (STANDARD DRIVE)

APPROXIMATE SEEDS/ACRE FOR VARIOUS ROW WIDTHS

Transmission Sprockets		60 Cell Soybean Or High-Rate Milo/ Grain Sorghum				Average Seed Spacing In Inches	48 Cell Specialty Soybean Or High-Rate Acid-Delinted Cotton				Average Seed Spacing In Inches	Speed Range (MPH)
Drive	Driven	30" Rows	36" Rows	38" Rows	40" Rows		30" Rows	36" Rows	38" Rows	40" Rows		
17	28	80,928	67,440	63,891	60,696	2.6	64,742	53,952	51,113	48,557	3.2	2 to 8
17	27	83,926	69,938	66,257	62,944	2.5	67,141	55,950	53,006	50,355	3.1	2 to 8
17	26	87,154	72,628	68,805	65,365	2.4	69,723	58,102	55,044	52,292	3.0	2 to 8
19	28	90,449	75,374	71,407	67,837	2.3	72,359	60,299	57,126	54,270	2.9	2 to 8
19	27	93,799	78,166	74,052	70,349	2.2	75,039	62,533	59,242	56,279	2.8	2 to 8
17	24	94,416	78,680	74,539	70,812	2.2	75,533	62,944	59,631	56,650	2.8	2 to 8
17	23	98,521	82,101	77,780	73,891	2.1	78,817	65,681	62,224	59,113	2.7	2 to 8
19	25	101,303	84,419	79,976	75,977	2.1	81,042	67,535	63,981	60,782	2.6	2 to 8
19	24	105,524	87,937	83,309	79,143	2.0	84,419	70,350	66,647	63,314	2.5	2 to 8
23	28	109,491	91,243	86,440	82,118	1.9	87,593	72,994	69,152	65,694	2.4	2 to 8
19	23	110,112	91,760	86,931	82,584	1.9	88,090	73,408	69,545	66,067	2.4	2 to 8
24	28	114,252	95,210	90,199	85,689	1.8	91,402	76,168	72,159	68,551	2.3	2 to 8
24	27	118,483	98,736	93,539	88,862	1.8	94,786	78,989	74,831	71,090	2.2	2 to 8
17	19	119,263	99,386	94,155	89,447	1.8	95,410	79,509	75,324	71,558	2.2	2 to 8
24	26	123,040	102,534	97,137	92,280	1.7	98,432	82,027	77,710	73,824	2.1	2 to 8
26	28	123,773	103,144	97,715	92,829	1.7	99,018	82,515	78,172	74,263	2.1	2 to 8
24	25	127,962	106,635	101,023	95,971	1.6	102,370	85,308	80,818	76,777	2.0	2 to 8
26	27	128,357	106,964	101,334	96,268	1.6	102,686	85,571	81,067	77,014	2.0	2 to 8
23	23	133,294	111,078	105,232	99,970	1.6	106,635	88,862	84,186	79,976	2.0	2 to 8
27	26	138,420	115,350	109,279	103,815	1.5	110,736	92,280	87,423	83,052	1.9	2 to 8
24	23	139,089	115,907	109,807	104,317	1.5	111,271	92,726	87,846	83,454	1.9	2 to 8
25	23	144,884	120,737	114,382	108,663	1.4	115,907	96,590	91,506	86,930	1.8	2 to 8
19	17	148,975	124,146	117,612	111,731	1.4	119,180	99,317	94,090	89,385	1.8	2 to 8
27	24	149,955	124,963	118,386	112,466	1.4	119,964	99,970	94,709	89,973	1.7	2 to 8
28	24	155,509	129,591	122,770	116,632	1.3	124,407	103,673	98,216	93,306	1.7	2 to 8
23	19	161,355	134,463	127,386	121,017	1.3	129,084	107,570	101,909	96,814	1.6	2 to 8
28	23	162,270	135,225	128,108	121,703	1.3	129,816	108,180	102,483	97,362	1.6	2 to 8
24	19	168,371	140,309	132,924	126,278	1.2	134,696	112,247	106,339	101,022	1.6	2 to 8
25	19	175,386	146,155	138,463	131,540	1.2	140,309	116,924	110,770	105,232	1.5	2 to 8
23	17	180,338	150,282	142,372	135,254	1.2	144,270	120,226	113,898	108,203	1.5	2 to 8
26	19	182,402	152,001	144,001	136,801	1.1	145,922	121,601	115,201	109,441	1.4	2 to 7
27	19	189,417	157,848	148,540	142,063	1.1	151,534	126,278	118,832	113,650	1.4	2 to 7
28	19	196,433	163,694	155,078	147,325	1.1	157,146	130,955	124,062	117,860	1.3	2 to 7
26	17	203,861	169,884	160,943	152,896	1.0	163,089	135,907	128,754	122,317	1.3	2 to 7
27	17	211,702	176,418	167,133	158,776	0.9	169,362	141,134	133,706	127,021	1.2	2 to 7
28	17	219,542	182,952	173,323	164,657	0.9	175,634	146,362	138,658	131,726	1.2	2 to 7

NOTE: See “General Planting Rate Information” and “Checking Seed Population” pages for additional information.

NOTE: When using the Half Rate (2 to 1) Drive Reduction Package, rates will be approximately 50% of given numbers.

NOTE: Always check seed population in the field to ensure planting rates are correct.

MACHINE OPERATION

RH/Z215

PLANTING RATES FOR BRUSH-TYPE SEED METERS (STANDARD DRIVE)

APPROXIMATE SEEDS/ACRE FOR VARIOUS ROW WIDTHS

Transmission Sprockets		36 Cell Acid-Delinted Large Cotton				Average Seed Spacing In Inches	30 Cell Milo/Grain Sorghum Or Acid-Delinted Cotton				Average Seed Spacing In Inches	Speed Range (MPH)
Drive	Driven	30" Rows	36" Rows	38" Rows	40" Rows		30" Rows	36" Rows	38" Rows	40" Rows		
17	28	48,557	40,464	38,335	36,418	4.3	40,464	33,720	31,945	30,348	5.2	2 to 8
17	27	50,356	41,963	39,754	37,766	4.2	41,963	34,969	33,129	31,472	5.0	2 to 8
17	26	52,292	43,577	41,283	39,219	4.0	43,577	36,314	34,403	32,683	4.8	2 to 8
19	28	54,269	45,224	42,844	40,702	3.9	45,225	37,687	35,704	33,918	4.6	2 to 8
19	27	56,279	46,900	44,431	42,209	3.7	46,900	39,083	37,026	35,175	4.5	2 to 8
17	24	56,650	47,208	44,723	42,487	3.7	47,208	39,340	37,270	35,406	4.4	2 to 8
17	23	59,113	49,261	46,668	44,335	3.5	49,261	41,051	38,890	36,946	4.2	2 to 8
19	25	60,782	50,651	47,986	45,586	3.5	50,652	42,210	39,988	37,989	4.1	2 to 8
19	24	63,314	52,762	49,985	47,486	3.3	52,762	43,968	41,654	39,572	4.0	2 to 8
23	28	65,695	54,746	51,864	49,271	3.2	54,746	45,621	43,220	41,059	3.8	2 to 8
19	23	66,067	55,056	52,159	49,550	3.2	55,056	45,880	43,465	41,292	3.8	2 to 8
24	28	68,551	57,126	54,119	51,413	3.0	57,126	47,605	45,099	42,844	3.7	2 to 8
24	27	71,090	59,242	56,123	53,317	2.9	59,242	49,368	46,770	44,431	3.5	2 to 8
17	19	71,558	59,632	56,493	53,668	2.9	59,631	49,693	47,077	44,724	3.5	2 to 8
24	26	73,824	61,520	58,282	55,368	2.8	61,520	51,267	48,569	46,140	3.4	2 to 8
26	28	74,264	61,886	58,629	55,697	2.8	61,886	51,572	48,858	46,415	3.4	2 to 8
24	25	76,772	63,981	60,614	57,583	2.7	63,981	53,317	50,511	47,986	3.3	2 to 8
26	27	77,014	64,178	60,800	57,761	2.7	64,178	53,482	50,667	48,134	3.3	2 to 8
23	23	79,976	66,647	63,139	59,982	2.6	66,647	55,539	52,616	49,985	3.1	2 to 8
27	26	83,052	69,210	65,567	62,289	2.5	69,210	57,675	54,640	51,908	3.0	2 to 8
24	23	83,453	69,544	65,884	62,590	2.5	69,544	57,954	54,904	52,158	3.0	2 to 8
25	23	86,930	72,442	68,629	65,198	2.4	72,442	60,368	57,191	54,332	2.9	2 to 8
19	17	89,385	74,488	70,567	67,039	2.3	74,488	62,073	58,809	55,866	2.8	2 to 8
27	24	89,973	74,978	71,032	67,480	2.3	74,978	62,481	59,193	56,233	2.8	2 to 8
28	24	93,305	77,755	73,662	69,979	2.2	77,755	64,796	61,385	58,316	2.7	2 to 8
23	19	96,813	80,678	76,432	72,610	2.2	80,678	67,231	63,693	60,508	2.6	2 to 8
28	23	97,362	81,135	76,864	73,022	2.1	81,135	67,613	64,054	60,851	2.6	2 to 8
24	19	101,023	84,185	79,754	75,767	2.1	84,185	70,155	66,462	63,139	2.5	2 to 8
25	19	105,232	87,693	83,078	78,924	2.0	87,693	73,078	69,231	65,770	2.4	2 to 8
23	17	108,233	90,169	85,423	81,152	1.9	90,169	75,141	71,186	67,627	2.3	2 to 8
26	19	109,441	91,201	86,401	82,081	1.9	91,201	76,001	72,001	68,401	2.3	2 to 7
27	19	113,650	94,709	89,124	85,238	1.8	94,709	78,924	74,770	71,031	2.2	2 to 7
28	19	117,860	98,216	93,047	88,395	1.8	98,216	81,847	77,539	73,662	2.1	2 to 7
26	17	122,317	101,930	96,566	91,738	1.7	101,930	84,942	80,471	76,448	2.1	2 to 7
27	17	127,021	105,851	100,280	95,266	1.6	105,851	88,209	83,566	79,388	2.0	2 to 7
28	17	131,725	109,771	103,994	98,794	1.6	109,771	91,476	86,661	82,328	1.9	2 to 7

NOTE: See "General Planting Rate Information" and "Checking Seed Population" pages for additional information.

NOTE: When using the Half Rate (2 to 1) Drive Reduction Package, rates will be approximately 50% of given numbers.

NOTE: Always check seed population in the field to ensure planting rates are correct.

MACHINE OPERATION

PLANTING RATES FOR BRUSH-TYPE SEED METERS (STANDARD DRIVE) APPROXIMATE HILLS/ACRE FOR VARIOUS ROW WIDTHS

Due to variations in cotton seed size, meters equipped with 12 cell acid-delinted hill-drop cotton discs will plant from 3 to 6 seeds per cell. Select proper disc for seed size range to be planted.

To determine planter transmission setting, determine desired hill spacing and select the transmission ratio closest to the hill spacing in inches on the chart. To decrease population increase spacing. To increase population decrease spacing.

To determine population per acre, determine average seeds per hill and hills per acre by doing a field check. Measure $\frac{1}{1000}$ of an acre ($\frac{1}{1000}$ acre = Length of row 17' 5" for 30" row widths, 13' 10" for 38" row widths and 13' 1" for 40" row widths). Multiply average seeds per hill by hills per acre. EXAMPLE: 4 seeds per hill x (13 hills x 1000) = 52,000

Transmission Sprockets Drive Driven		NUMBER OF HILLS PER ACRE 12 Cell Hill-Drop Cotton, Acid-Delinted				Average Hill Spacing In Inches	Speed Range (MPH)
		30" Rows	36" Rows	38" Rows	40" Rows		
17	28	16,186	13,488	12,778	12,139	12.9	2 to 8
17	27	16,785	13,988	13,251	12,588	12.5	2 to 8
17	26	17,431	14,526	13,761	13,073	12.0	2 to 8
19	28	18,090	15,075	14,281	13,568	11.6	2 to 8
19	27	18,760	15,633	14,810	14,070	11.1	2 to 8
17	24	18,883	15,736	14,908	14,163	11.1	2 to 8
17	23	19,704	16,420	15,556	14,778	10.6	2 to 8
19	25	20,261	16,884	15,995	15,196	10.3	2 to 8
19	24	21,105	17,587	16,662	15,829	9.9	2 to 8
23	28	21,898	18,249	17,288	16,424	9.5	2 to 8
19	23	22,022	18,352	17,386	16,517	9.5	2 to 8
24	28	22,850	19,042	18,040	17,138	9.2	2 to 8
24	27	23,697	19,747	18,708	17,773	8.8	2 to 8
17	19	23,853	19,877	18,831	17,890	8.8	2 to 8
24	26	24,608	20,507	19,427	18,456	8.5	2 to 8
26	28	24,755	20,629	19,543	18,566	8.4	2 to 8
24	25	25,592	21,327	20,205	19,194	8.2	2 to 8
26	27	25,671	21,393	20,267	19,254	8.1	2 to 8
23	23	26,659	22,216	21,046	19,994	7.8	2 to 8
27	26	27,684	23,070	21,856	20,763	7.6	2 to 8
24	23	27,818	23,181	21,961	20,864	7.5	2 to 8
25	23	28,977	24,147	22,876	21,733	7.2	2 to 8
19	17	29,795	24,829	23,522	22,346	7.0	2 to 8
27	24	29,991	24,993	23,677	22,493	7.0	2 to 8
28	24	31,102	25,918	24,554	23,327	6.7	2 to 8
23	19	32,271	26,893	25,477	24,204	6.5	2 to 8
28	23	32,454	27,045	25,622	24,408	6.5	2 to 8
24	19	33,674	28,062	26,585	25,256	6.2	2 to 8
25	19	35,077	29,231	27,693	26,308	6.0	2 to 8
23	17	36,068	30,056	28,474	27,051	5.8	2 to 8
26	19	36,480	30,400	28,800	27,360	5.7	2 to 7
27	19	37,883	31,570	29,908	28,413	5.5	2 to 7
28	19	39,287	32,739	31,016	29,465	5.3	2 to 7
26	17	40,772	33,977	32,189	30,579	5.1	2 to 7
27	17	42,340	35,284	33,427	31,755	4.9	2 to 7
28	17	43,908	36,590	34,665	32,932	4.8	2 to 7

NOTE: See "General Planting Rate Information" and "Checking Seed Population" pages for additional information.

NOTE: When using the Half Rate (2 to 1) Drive Reduction Package, rates will be approximately 50% of given numbers.

NOTE: Always check seed population in the field to ensure planting rates are correct.

MACHINE OPERATION

DRY INSECTICIDE APPLICATION RATES

APPROXIMATE POUNDS/ACRE AT 5 MPH FOR VARIOUS ROW WIDTHS

Meter Setting	30" Rows	36" Rows	38" Rows	40" Rows
CLAY GRANULES				
10	4.9	4.1	3.9	3.7
11	5.4	4.5	4.3	4.1
12	6.1	5.1	4.8	4.6
13	6.9	5.7	5.4	5.2
14	7.7	6.4	6.0	5.8
15	8.5	7.1	6.7	6.4
16	9.6	8.0	7.6	7.2
17	10.7	8.9	8.4	8.0
18	11.4	9.5	9.0	8.6
19	13.1	10.9	10.3	9.8
20	14.2	11.8	11.2	10.7
21	15.5	12.9	12.3	11.6
22	16.4	13.7	12.9	12.3
23	17.2	14.3	13.6	12.9
24	18.8	15.7	14.9	14.1
25	20.9	17.4	16.5	15.7
26	23.0	19.2	18.1	17.3
27	24.1	20.0	19.0	18.1
28	25.4	21.2	20.1	19.1
29	27.8	23.2	22.0	20.9
30	29.6	24.7	23.4	22.2
SAND GRANULES				
5	2.9	2.4	2.3	2.2
6	4.9	4.0	3.8	3.7
7	5.3	4.4	4.2	3.9
8	6.3	5.3	5.0	4.8
9	7.8	6.5	6.1	5.9
10	8.9	7.4	7.0	6.7
11	10.2	8.5	8.0	7.7
12	11.2	9.3	8.8	8.4
13	12.6	10.5	10.0	9.5
14	14.1	11.7	11.1	10.6
15	15.5	12.9	12.3	11.6
16	17.5	14.6	13.8	13.1
17	19.4	16.2	15.3	14.6
18	21.8	18.2	17.2	16.4
19	24.3	20.2	19.1	18.2
20	25.7	21.4	20.3	19.3
21	27.6	23.0	21.8	20.7
22	29.6	24.7	23.4	22.2
23	32.0	26.7	25.3	24.0
24	34.4	28.7	27.2	25.8
25	36.9	30.7	29.1	26.7

NOTE: The above chart represents average values and should be used only as a starting point. The granular chemical flows through the given meter opening at a nearly uniform rate regardless of roller speed. Your actual rate will vary depending upon the insecticide you are using, your planting speed and your plant population. Planting speed/ground speed has the greatest effect on application rate.

Your actual rate must be checked in the field with the actual insecticide that you are using and at the speed and population at which you will be planting. See "Checking Granular Chemical Application Rate" page for additional information.



WARNING: Agricultural chemicals can be dangerous if not selected and handled with care. Always read and follow directions supplied by the chemical manufacturer.

MACHINE OPERATION

DRY HERBICIDE APPLICATION RATES

APPROXIMATE POUNDS/ACRE AT 5 MPH FOR VARIOUS ROW WIDTHS

CLAY GRANULES

Meter Setting	30" Rows	36" Rows	38" Rows	40" Rows
10	4.7	3.9	3.7	3.5
11	5.2	4.4	4.1	3.9
12	5.8	4.9	4.6	4.4
13	6.5	5.4	5.1	4.9
14	7.3	6.1	5.7	5.5
15	8.2	6.9	6.5	6.2
16	9.0	7.5	7.1	6.8
17	9.9	8.2	7.8	7.4
18	10.7	8.9	8.4	8.0
19	11.6	9.7	9.2	8.7
20	12.6	10.5	10.0	9.5
21	13.6	11.3	10.7	10.2
22	14.6	12.1	11.5	11.0
23	15.7	13.1	12.4	11.8
24	17.0	14.1	13.4	12.8
25	18.1	15.1	14.3	13.6
26	19.4	16.2	15.3	14.6
27	20.9	17.4	16.5	15.7
28	22.6	18.8	17.8	17.0
29	24.3	20.2	19.1	18.2
30	26.7	22.2	21.1	20.0

NOTE: The above chart represents average values and should be used only as a starting point. The granular chemical flows through the given meter opening at a nearly uniform rate regardless of roller speed. Your actual rate will vary depending upon the herbicide you are using, your planting speed and your plant population. Planting speed/ground speed has the greatest effect on application rate.

Your actual rate must be checked in the field with the actual herbicide that you are using and at the speed and population at which you will be planting. See "Checking Granular Chemical Application Rate" page for additional information.



WARNING: Agricultural chemicals can be dangerous if not selected and handled with care. Always read and follow directions supplied by the chemical manufacturer.

ROW UNIT OPERATION

PLANTING DEPTH

Planting depth is maintained by the row unit gauge wheels. To increase or decrease the planting depth, first raise the planter to remove weight from the wheels. Then push down on the depth adjustment handle and reposition it forward to decrease depth or rearward to increase planting depth. Adjust all units to the same setting initially. Then lower the planter and check operation and planting depth of all row units. It may be necessary to readjust some rows to obtain uniform operation. Available depth adjustment range is approximately $\frac{1}{2}$ " to $3\frac{1}{2}$ ".



WARNING: Never work under the planter while in raised position without using safety lockups.

04059914a

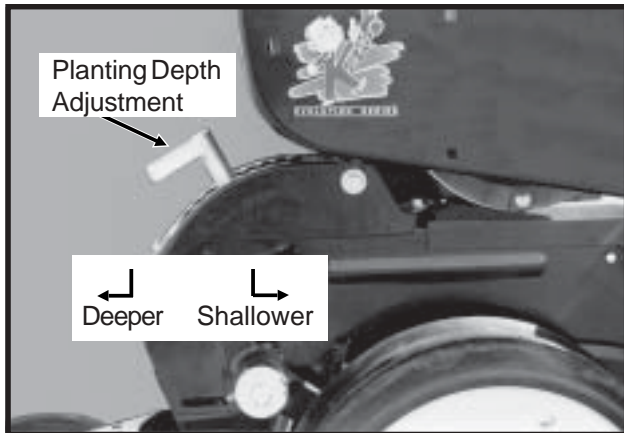

"V" CLOSING WHEEL ADJUSTMENT (Rubber And Cast Iron)



WARNING: Raise planter and install safety lockups before making closing wheel adjustments.

After adjusting planting depth, check the operation of the "V" closing wheels. The "V" closing wheels should have enough down pressure to close the seed trench and ensure good soil to seed contact. To increase spring pressure on the closing wheels, move the 5-position quick adjustable down force lever located on the top of the closing wheel arm to the rear. Moving the lever forward decreases spring tension.

Adjust all row units to a similar setting.

LF212299-15

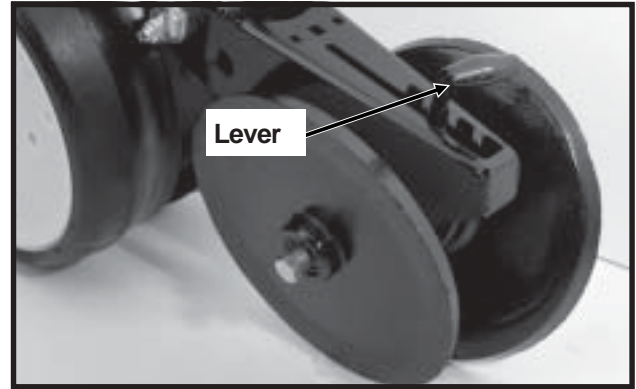

Light soil usually requires less down force at average depth (approximately 2") while heavy soil requires increased down force.

Eccentric bushings in the wheel arm stop allow for lateral adjustment of the "V" closing wheel assembly. Using a $\frac{3}{4}$ " wrench, loosen the hardware which attaches the closing wheel arm to the wheel arm stop. Using another $\frac{3}{4}$ " wrench turn the eccentric bushings until the **closing wheels are aligned with the seed trench**. Tighten hardware.

LF2122299-15

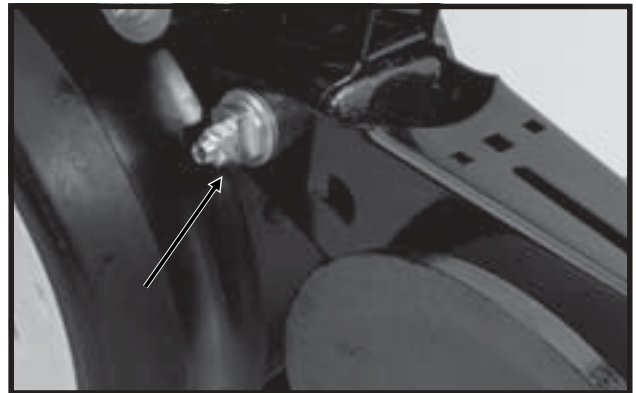

Bushings used for installation of the closing wheels can be moved from side to side for closing wheel spacing adjustment and the closing wheels can be installed in two locations either "offset" (to improve residue flow) or "directly" opposite. If set "directly" opposite, the forward installation holes should be used. Under normal conditions the narrow position is preferred.

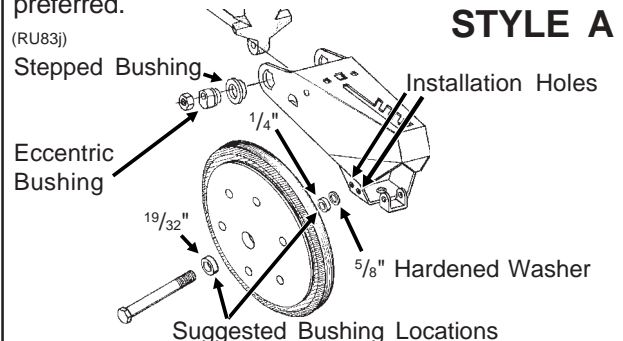

ROW UNIT OPERATION

The closing wheels can be installed in two locations either "offset" (to improve residue flow) or "directly" opposite. If set "directly" opposite, the forward installation holes should be used.

STYLE B

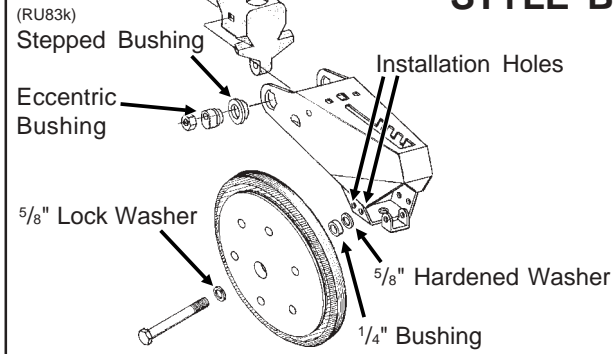

CLOSING WHEEL SHIELD (Rubber And Cast Iron "V" Closing Wheels)

D11090208a

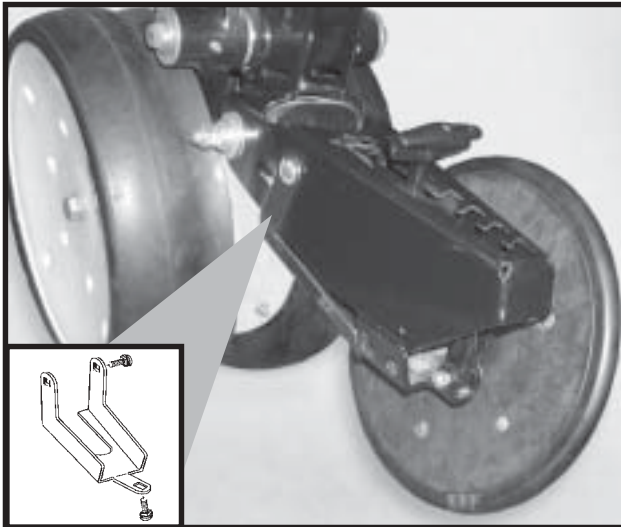

Shown With Closing Wheel Removed For Visual Clarity

The optional closing wheel shield is designed to be installed onto the underside of the closing wheel arm to help prevent root balls and stalks from plugging the closing wheels.

COVERING DISCS/SINGLE PRESS WHEEL ADJUSTMENT



WARNING: Raise planter and install safety lockups before making covering discs/single press wheel adjustments.

72359-31



After adjusting planting depth, check the operation of the covering discs/single press wheels.

Initial press wheel down force setting should be with 2 1/2" between mounting arm tab and locking nut. To adjust down force spring, loosen 1/2" locking nut and turn adjusting bolt in to increase down force or out to decrease down force. Tighten locking nut against spring plug. Adjust all row units to a similar setting.

RH993(PLTR12)

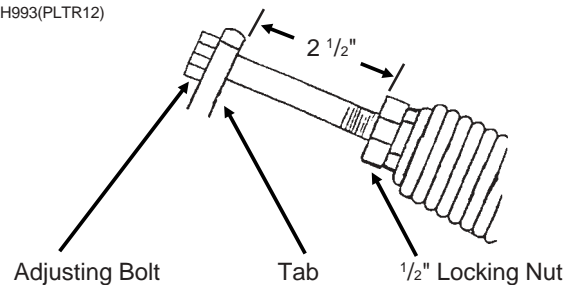

ROW UNIT OPERATION

Eccentric bushings in the wheel arm stop allow for lateral adjustment of the covering discs/single press wheel assembly. Using a $\frac{3}{4}$ " wrench, loosen the hardware which attaches the assembly to the wheel arm stop. Using another $\frac{3}{4}$ " wrench, turn the eccentric bushings until the press wheel is aligned with the seed trench.

(RU94b)

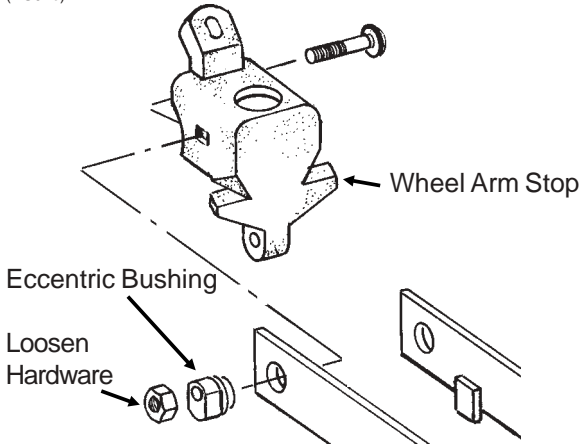

Two sets of holes in the mounting arm allow the covering discs to be located for staggered or side-by-side operation as desired.

72359-35

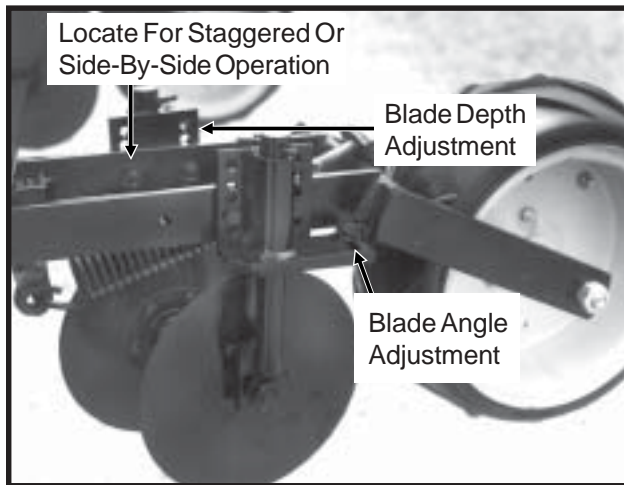

Five sets of holes in each disc bracket allow for $\frac{1}{2}$ " incremental blade depth adjustment.

Slotted holes in the disc mount and bracket allow for 0 - 15° blade angle adjustment.

Adjust covering discs on all row units to similar settings.

DRAG CLOSING ATTACHMENT

LF212299-18

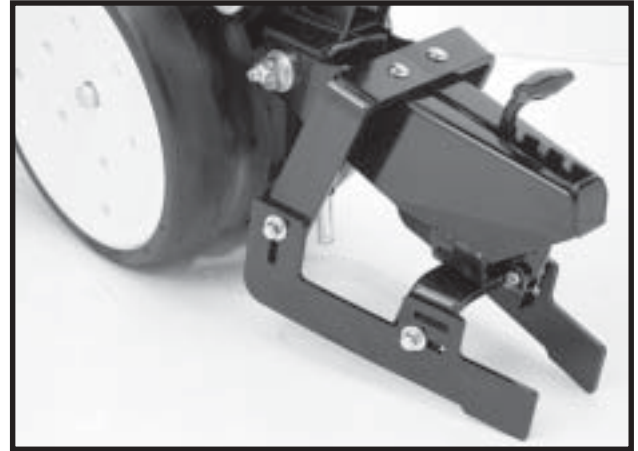

The drag closing attachment is designed to pull loose soil over the seed trench.

Front and rear adjustment is made using the slotted holes in the blades. Adjust all rows the same.

NOTE: Use of a seed firming wheel or other seed firming device is recommended with the drag closing attachment.



WARNING: Raise planter and install safety lockups before making drag closing attachment adjustments.

(RU90d)

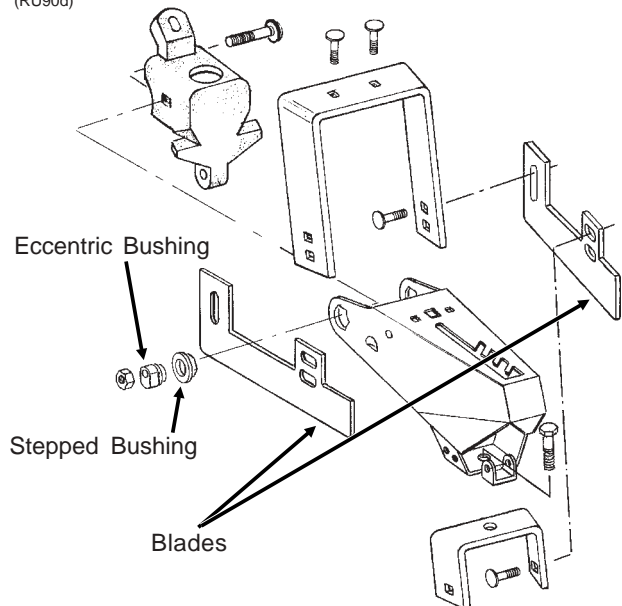

Eccentric bushings allow for lateral adjustment of the drag closing attachment. Using a $\frac{3}{4}$ " wrench, loosen the hardware which attaches the assembly to the wheel arm stop. Using another $\frac{3}{4}$ " wrench, turn the eccentric bushings until the drag closing attachment is aligned with the seed trench.

ROW UNIT OPERATION

FINGER PICKUP SEED METER

Refer to the planting rate chart for recommended seed drive transmission sprocket combinations.

D091604102

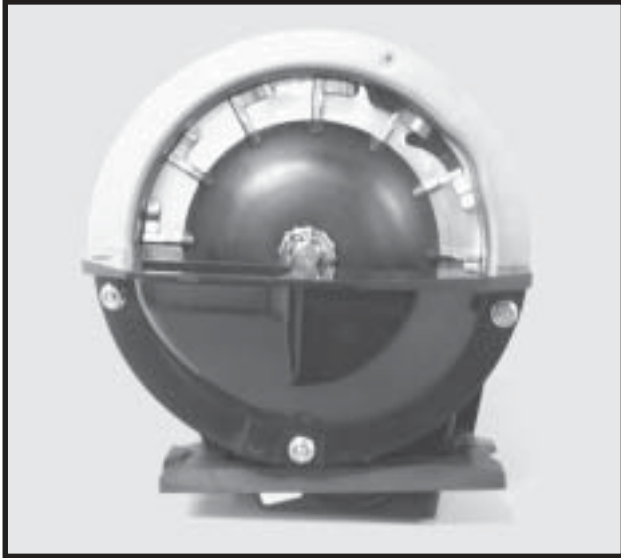

Shown With Corn Fingers Installed

The following seed fingers are available for use with the finger pickup seed meter:

(PLTR91/PLTR92/PLTR91a)

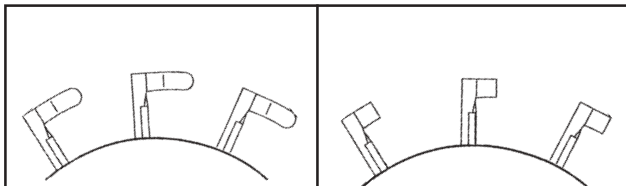

Corn Fingers

Oil Sunflower Fingers

No. 3 and/or No. 4 size oil sunflower seeds are recommended for use in the finger pickup seed meter equipped with oil sunflower fingers.

No. 1 and/or No. 2 size confectionary sunflower seeds are recommended for use in the finger pickup seed meter equipped with corn fingers.

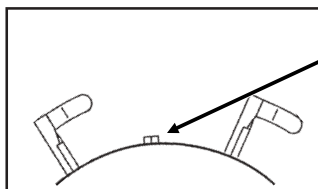

Half Rate Blank Finger

Blank fingers are used to replace alternate fingers in the finger wheel to reduce the planting rate by half while allowing the finger wheel to maintain a minimum of 40 RPM when planting low rates.

NOTE: Always check seed population in the field to ensure planting rates are correct.

NOTE: Powdered graphite is recommended for finger pickup seed meter lubrication to ensure efficient operation of the mechanism and to extend the life of its components. Mix one teaspoon of powdered graphite with the seed twice daily. Apply graphite on top of seed around the outer perimeter of the hopper as shown below. Graphite application frequency and volume may need to be increased if using additional seed treatments.

NOTE: Do NOT apply graphite only in the center of the hopper. It will filter too quickly through the seed and not distribute as evenly as desired.

D05230121b



NOTE: Follow manufacturer's recommendations when applying and mixing other seed treatments. If the additive is to be applied on top of the seed, apply around the outer perimeter of the hopper as with graphite.

See "General Planting Rate Information", "Finger Pickup Seed Meter Troubleshooting" and "Finger Pickup Seed Meter Inspection/Adjustment" for additional information.

CLEANOUT

To maintain genetic purity, thorough seed meter cleanout is important.

To clean the seed meter, disengage the seed drive and remove the seed hopper and meter. Dump the seed from the right rear corner of the hopper into a container. Turn the seed drive several times. Invert hopper to dump seed again. Shake the hopper and listen for any remaining seed. Turn seed drive and shake and dump hopper until all seed is removed.

ROW UNIT OPERATION

BRUSH-TYPE SEED METER

LF212299-13a



Shown Without Seed Disc Installed

60607-40a(PLTR13)

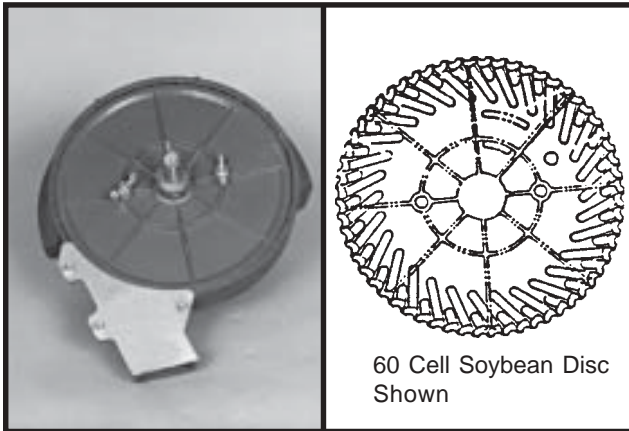

60 Cell Soybean Disc Shown

The following seed discs are available for use with the brush-type seed meter:

Soybean: 60 cells to meter seed sizes from 2200 to 4000 seeds per pound (Black color-coded).

(PLTR14)

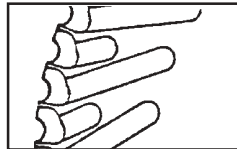

Specialty soybean: 48 cells to meter seed sizes from 1400 to 2200 seeds per pound (Dark blue color-coded).

(PLTR15)

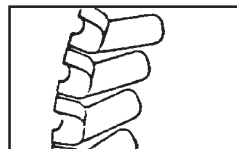

Small milo/grain sorghum: 30 cells to meter seed sizes from 14,000 to 20,000 seeds per pound (Red color-coded).

(PLTR16)

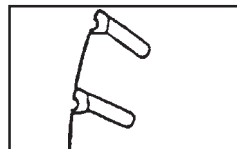

Large milo/grain sorghum:

30 cells to meter seed sizes from 10,000 to 16,000 seeds per pound (Light blue color-coded).

(PLTR17)

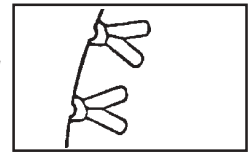

High-rate small milo/grain sorghum:

60 cells to meter seed sizes from 12,000 to 18,000 seeds per pound (Red color-coded).

(PLTR18)

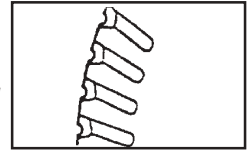

High-rate large milo/grain sorghum:

60 cells to meter seed sizes from 10,000 to 14,000 seeds per pound (Yellow color-coded).

(PLTR19)

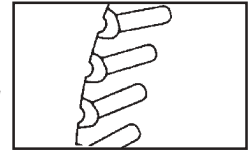

Cotton, acid-delinted: 30 cells to meter seed sizes from 4200 to 5200 seeds per pound (White color-coded).

(PLTR20)

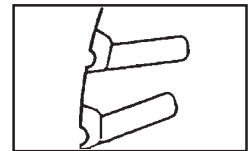

Large cotton, acid-delinted:

36 cells to meter seed sizes from 3800 to 4400 seeds per pound (Tan color-coded).

(PLTR21)

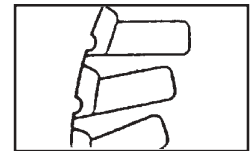

High-rate cotton, acid-delinted:

48 cells to meter seed sizes from 4200 to 5200 seeds per pound (Light green color-coded).

(PLTR22)

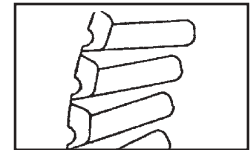

Hill-drop cotton, acid-delinted:

12 cells, 3 to 6 seeds/cell, to meter seed sizes from 4000 to 5200 seeds per pound

(Brown color-coded).

(PLTR23)

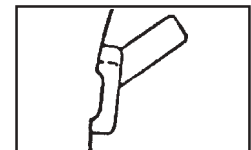

Small hill-drop cotton, acid-delinted:

12 cells, 3 to 6 seeds/cell, to meter seed sizes from 5000 to 6200 seeds per pound (Dark green color-coded).

(PLTR23)

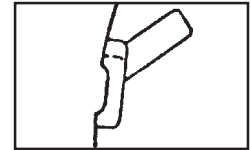

(RU14c)

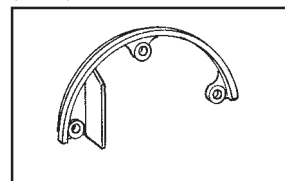

Use GD11122 upper brush retainer when using soybean and cotton discs.

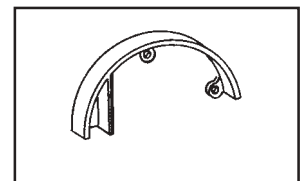

Use GD8237 upper brush retainer when using milo/grain sorghum discs.

ROW UNIT OPERATION

When installing the seed disc onto the meter hub, turn the disc counterclockwise while tightening the two wing nuts that retain the disc. The seed disc should have only slight resistance when rotated counterclockwise after wing nuts are tight.

The brush-type seed meter attaches to the seed hopper in the same manner as the finger pickup seed meter. Secure to bottom of seed hopper with two $\frac{5}{16}$ " thumbscrews. Tighten thumbscrews slightly with pliers. **DO NOT OVER TIGHTEN.**

Erratic seed spacing may result from misalignment between the drive coupler and seed meter input shaft. Misalignment may cause momentary stoppage of seed disc. Check alignment after initial installation. If adjustment is required, refer to "Meter Drive Adjustment" for correct procedure.

Refer to the planting rate charts in this manual for recommended seed drive transmission sprocket combinations.

One tablespoon of **powdered graphite** should be mixed with the seed each time the hoppers are filled. Regular graphite use will prolong the life of the brush-type seed meter components, improve seed spacing, and may reduce buildup of seed treatments. Apply graphite around the outer perimeter of the hopper as shown below.

D05300104b



NOTE: Do NOT apply graphite only in the center of the hopper. It will filter too quickly through the seed and not distribute as evenly as desired.

NOTE: Additional graphite or talc may be required to retard buildup of seed treatments on meter components. Frequency of monitor seed tube cleaning may be affected due to use of additional graphite or talc.

Talc seed lubricant may be used in lieu of or in addition to graphite to reduce seed treatment buildup on seed disc and meter components. Coat seed disc and brushes with talc before installing meter. Fill hopper $\frac{1}{2}$ full of seed, add $\frac{1}{4}$ cup of talc and **mix thoroughly**. Finish filling hopper, add another $\frac{1}{4}$ cup of talc and **mix thoroughly**. Adjust rate of talc use as needed so all seeds are coated, while avoiding a buildup of talc in the bottom of the hopper. Humid conditions and/or small sized seeds with extra seed treatment may require as much as one cup of talc per hopper to prevent seed treatment buildup on seed disc and/or brushes.

NOTE: Some liquid seed treatments or inoculants may create buildup on the seed disc or brushes. Check frequently for proper population and/or seed delivery when using any liquid seed treatment. All seed treatment should be thoroughly mixed with the seed per the manufacturers' recommendations. Seed treatment dumped on top of the seed after the hopper is filled, and not mixed properly may cause bridging of the seed in the meter, reducing population or stopping the meter from planting.

NOTE: Foreign material, such as hulls, stems, etc., may affect seed delivery. Clean seed is required to ensure accurate seed metering from the brush-type seed meter. Seed discs should be removed daily to check for buildup of foreign material, such as hulls, in the seed meter or the brushes.

CLEANOUT

To maintain genetic purity, thorough seed meter cleanout is important.

To clean the seed meter, disengage the seed drive and remove the seed hopper and meter. Dump the seed from the right rear corner of the hopper into a container. Disassemble seed disc by removing wing nuts. Empty the meter. Thoroughly inspect brushes in meter to ensure all seed is removed. Replace seed disc and install wing nuts.

ROW UNIT OPERATION

SEED HOPPER

LF212199-7a



The seed hopper has a capacity of 1.9 bushels.

When filling the seed hopper use clean seed and make certain there are no foreign objects in the hopper. **Replace hopper lids after hoppers are filled to prevent the accumulation of dust or dirt in the seed meter which will cause premature wear.** See "Finger Pickup Seed Meter Lubrication" and/or "Brush-Type Seed Meter Lubrication".

Periodically empty the hoppers completely to remove any foreign objects and to ensure proper seed meter operation. To empty hopper, disengage meter drive and hopper latch and lift hopper off the hopper support. See "Seed Meter Drive Release".

SEED METER DRIVE RELEASE

The seed meter drive is equipped with a clutch release mechanism that allows the drive to be disengaged from the seed metering unit for removal of the seed hopper. Disconnecting the drive allows the operator to check granular chemical application rates without dropping seed. It also allows one or more of the rows to be disconnected when finishing fields.

D04199906

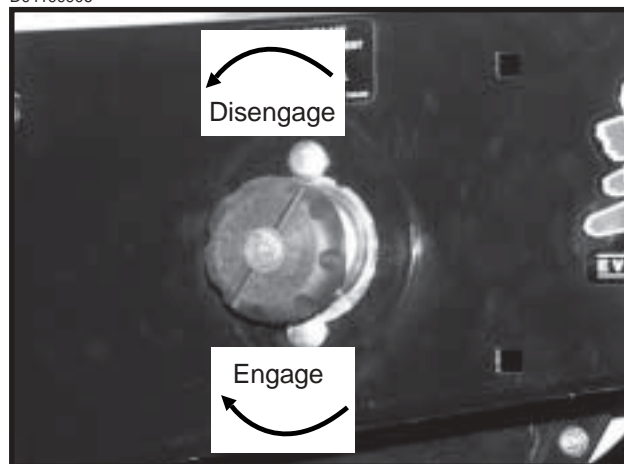

To disengage the drive, turn the knob $\frac{1}{4}$ turn counter-clockwise. To engage the drive, turn the knob $\frac{1}{4}$ turn clockwise.

ROW UNIT OPERATION

SEED METER DRIVE ADJUSTMENT

NOTE: The seed meter drive coupler must be properly aligned with the meter input shaft.

Improper alignment between the drive coupler and input shaft of the meter can cause the meter housing to flex as the meter rotates. This continual flexing of the meter housing can cause damage to the housing. Any time the hopper support panel is removed or replaced, vertical and horizontal alignment should be checked.

Erratic seed spacing may result from misalignment between the drive coupler and seed meter input shaft. Misalignment may cause momentary stoppage of brush-type meter seed disc. Check alignment after initial installation.

Although the meter drive has a self-aligning feature, the slotted mounting hole in the hopper support panel and clutch plate allow for alignment adjustment between the drive coupler and meter shaft. If the drive clutch is centered in the hole in the hopper support panel the drive should be in alignment.

D04209903

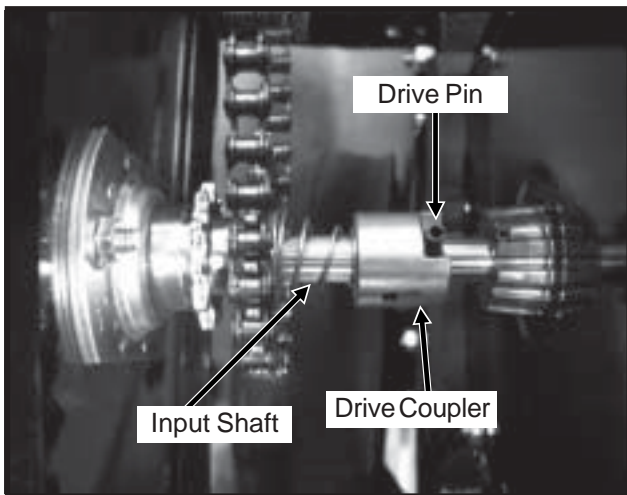

To check alignment:

- Engage drive coupler over pin on meter shaft.
- Drive shaft on clutch should be centered in sprocket bore.
- If adjustment is needed, proceed as follows.

To adjust drive clutch:

- Slightly loosen both $\frac{5}{16}$ " carriage bolts.
- Move clutch assembly to correct any misalignment.
- Tighten both $\frac{5}{16}$ " carriage bolts.

NOTE: Removing chain idler tension will allow easier clutch alignment adjustments.

D04199906

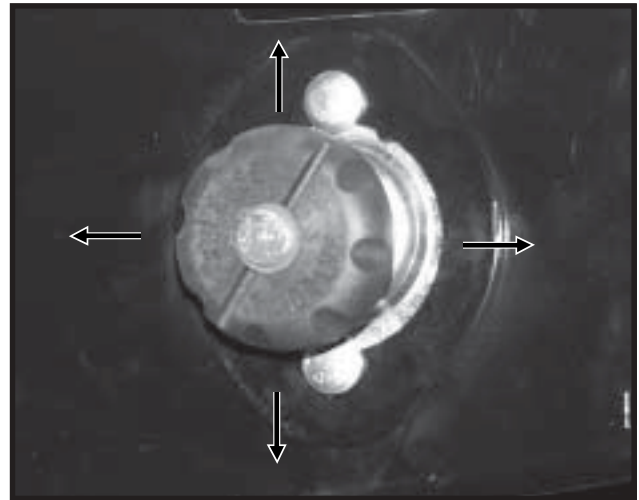

ROW UNIT EXTENSION BRACKETS

RUB005/RUB007/RUB015(INS33a)

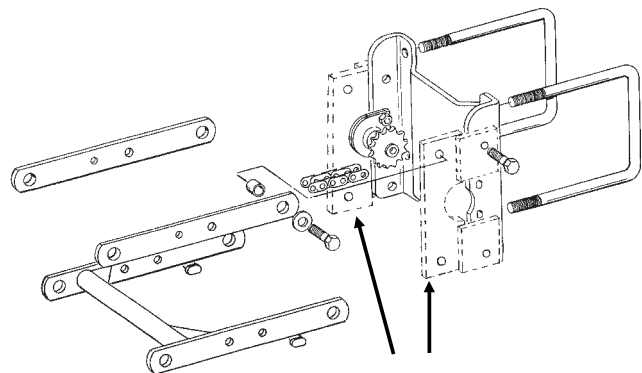

Model 3140 planters equipped with coulters mounted residue wheels require the use of row unit extension brackets on the row units located on the planter wings. The brackets extend the row units rearward 4" to provide required clearance.

ROW UNIT OPERATION

ROW UNIT CHAIN ROUTING

For proper operation and to minimize wear, the row unit drive chains must be properly tensioned and aligned.

Inspect and replace weak, worn or broken springs and/or idlers and idler bushings.

NOTE: When idler shows signs of wear, it can be reversed for prolonged use.

LF212199-5a(RU80g)

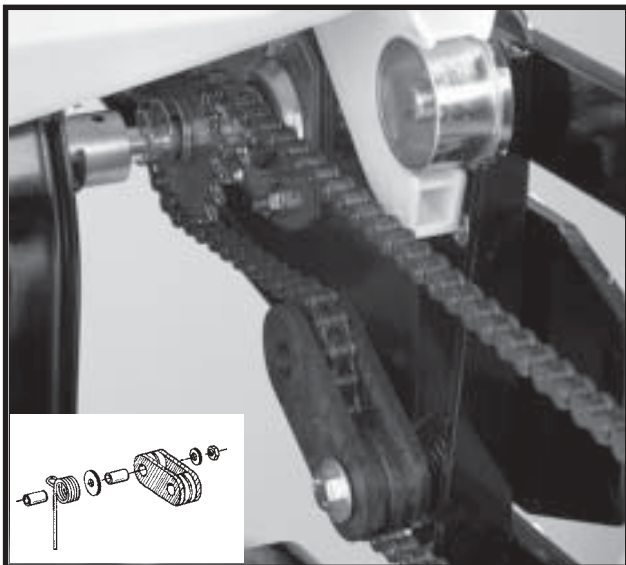

Pull Row Unit Meter Drive

D05139901b(RU92)

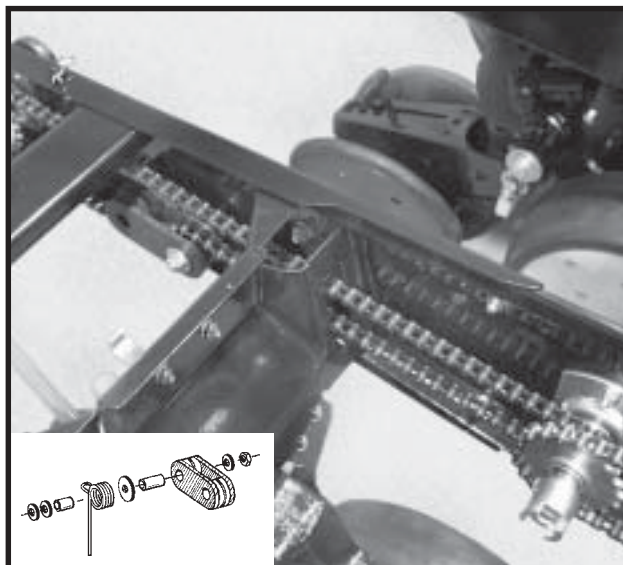

Row Unit Granular Chemical Drive

NOTE: Make sure connector link is installed with closed end oriented properly as shown below.

(PLTR24)



Direction Of Chain Travel →

ROW UNIT OPERATION

QUICK ADJUSTABLE DOWN FORCE SPRINGS

Quick adjustable down force springs are designed to increase penetration in hard soil and keep the row unit from bouncing in rough field conditions.

Two springs per row, one on the L.H. parallel arms and one on the R.H. parallel arms, are used unless equipped with row unit mounted no till coulters. Four springs per row are used with row unit mounted no till coulters.

D06300305

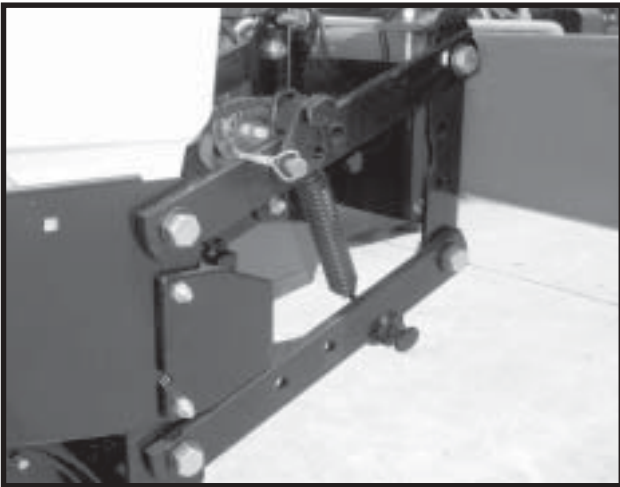

Two Springs Per Row (Dual)

D07010301

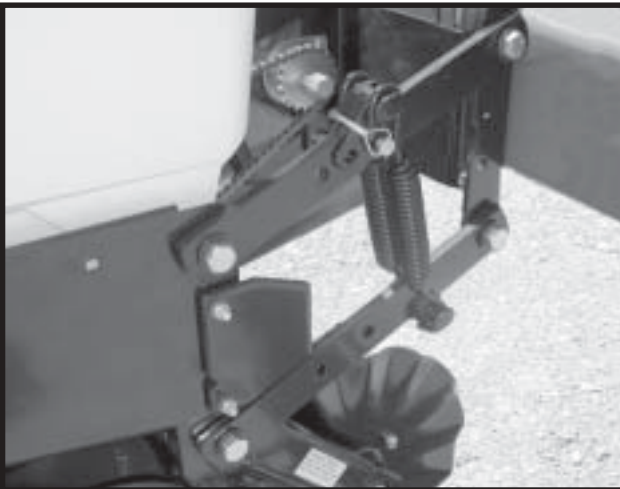

**Four Springs Per Row (Quad)
(Used Only In Conjunction With Row Unit Mounted
No Till Coulters)**

There are four positions for spring tension adjustment. Position 1 allows for minimum down pressure and position 4 for maximum down pressure.

L0096(PLTR27e)

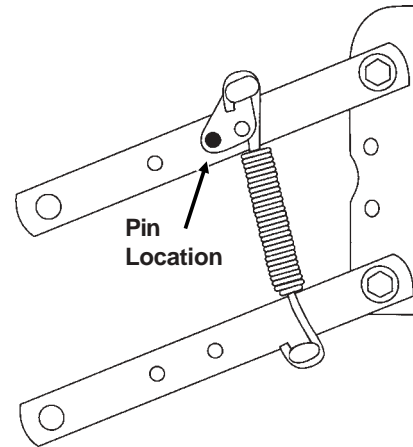

Position 1 (Minimum)

(PLTR28e)

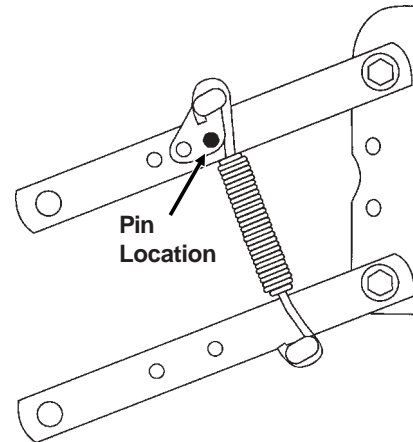

Position 2

(PLTR29e)

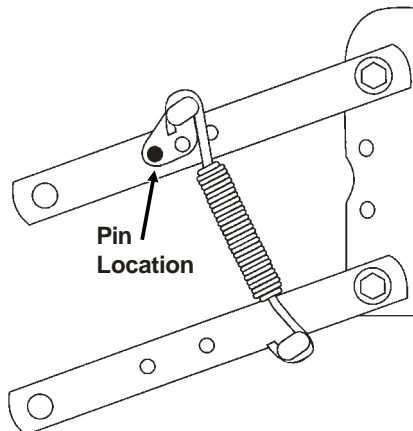

Position 3

ROW UNIT OPERATION

(PLTR30e)

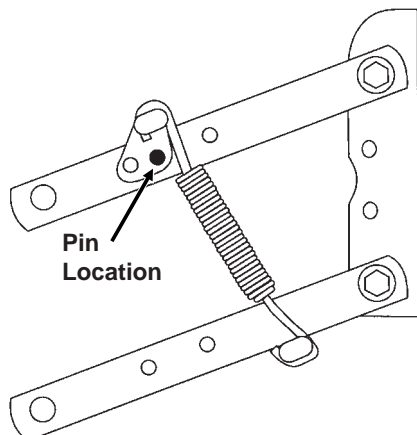

Position 4 (Maximum)

To adjust spring tension, raise planter and remove spring mount pin at top of spring. Slide mount to desired position and install pin.

NOTE: It is necessary for the operator to adjust springs according to field conditions. If springs are adjusted for too much down pressure for field conditions, it is possible for the row units to lift the planter to the extent that the drive wheels do not make sufficient contact. Too much down pressure in soft field conditions can cause the row unit to run too deep.



WARNING: Always install safety lockups or lower machine to the ground before working under or around the machine.

NOTE: Springs must always be installed with open side of spring hooks toward seed hopper to prevent binding on spring mount adjustment pin.

DUAL GAUGE WHEELS

Dual gauge wheels are used to provide added width for additional row unit flotation in light sandy soil.

In some applications such as narrow row widths (less than 36") or where clearance is a problem, the added width of the dual gauge wheel may prevent its use.

LF212199-1

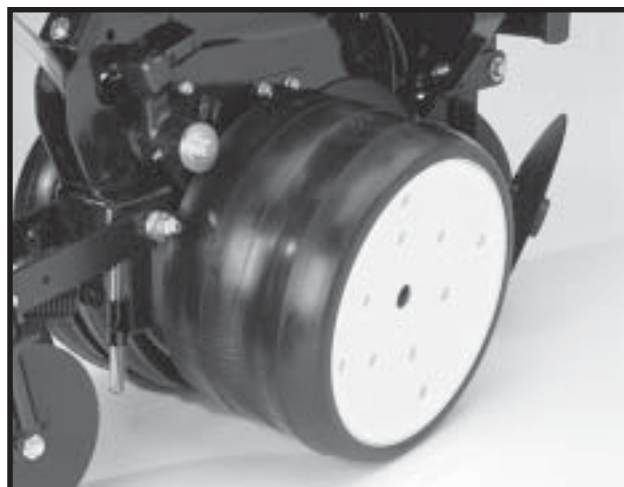

ROW UNIT OPERATION

FRAME MOUNTED COULTER - STYLE A

LF212299-20

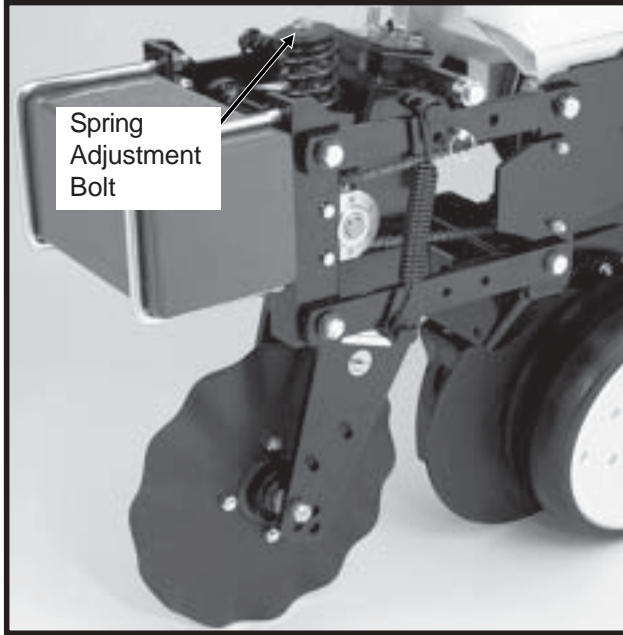

Frame mounted coulters with 1" bubbled, 1" fluted (8 flutes) or $\frac{3}{4}$ " fluted (13 flutes) blades may be used on pull row units only. (Not compatible with push row units.)

The frame mounted coulters is designed to allow required spring down pressure on the coulters for maximum penetration while exerting less shock load on the row unit.

The frame mounted coulters can be used with or without the depth control bar installed. In most applications, especially in rocky planting conditions, the depth control bar **should not be used**. Use of the depth control bar transfers down force from the coulters to the row unit making less down force available to the coulters blade.

DEPTH ADJUSTMENT (Without Depth Control Bar Installed)

56314-14a

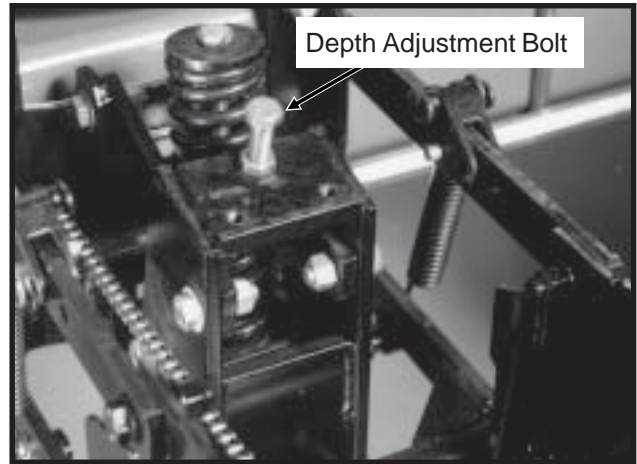

When the depth control bar is not used, operating depth of the coulters blade is determined by adjusting the depth adjustment bolt and positioning of the blade assembly in the fork mount. The depth adjustment bolt will stop downward travel of the coulters arm assembly. One turn of the adjusting bolt will change depth setting approximately $\frac{1}{4}$ ". Initial setting of the depth adjustment bolt should be with approximately $1\frac{3}{8}$ " of thread showing. With this setting and the toolbar height at 20", the coulters depth will be approximately 2" with coulters mounting spindle in top hole. Turn the adjustment bolt clockwise to decrease operating depth. Turn the depth adjustment bolt counterclockwise to increase operating depth.

LF212299-20

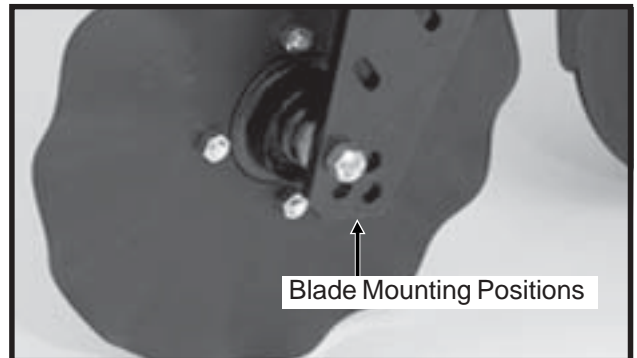

ROW UNIT OPERATION

DEPTH ADJUSTMENT

(With Depth Control Bar Installed)

LF212199-4

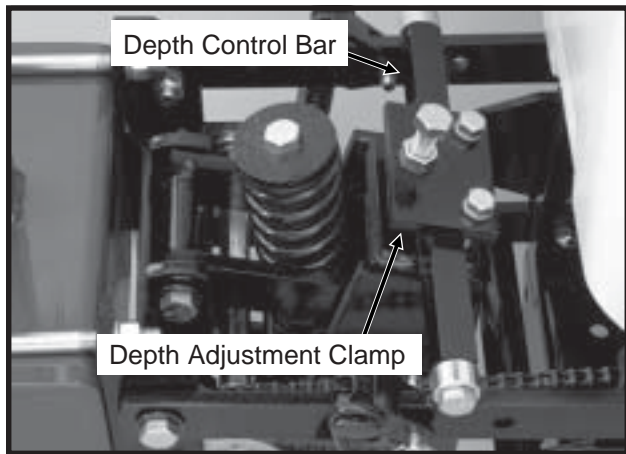

In certain applications it is desirable to use the depth control bar. In uneven terrain, use of the depth control bar allows greater depth control. The up and down movement of the row unit allows the coulter to move up and down at a rate of approximately $\frac{1}{2}$ that of the row unit, maintaining a more uniform operating depth. When using the disc furrower attachment, the depth control bar should always be used, as operating depth of the coulter is critical for the disc furrowers to operate with minimal gouging.

When using the depth control bar, down force springs must be located in the forward position and the depth adjustment bolt used only to attach the depth adjustment clamp to the coulter assembly. Operating depth of the coulter blade is adjusted by positioning the blade assembly in the fork mount. Four blade mounting adjustment positions are available at $\frac{1}{2}$ " increments. Initial position of the blade assembly should be in the top hole. This position will locate the coulter blade approximately $\frac{1}{4}$ " deeper than the row unit opener blade. In heavy residue it may be desirable to position the blade assembly in the second position to insure that the residue is cut and not forced down into the seed zone. Additional holes are used to compensate for coulter blade wear.

LF212299-20

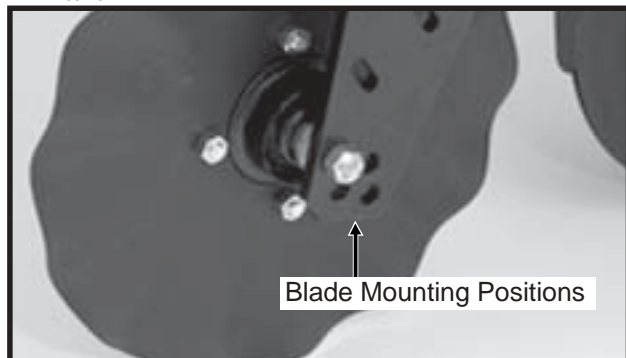

SPRING ADJUSTMENT

Down force adjustment is made by tightening or loosening the spring adjustment bolt. With the planter in the raised position, turn the bolt clockwise to increase down force or counterclockwise to decrease down force. Set all rows equally.

Compressed Spring Length (Including Washer)	Pounds Down Pressure With Blade $\frac{1}{2}$ " Above Maximum Down Position	Pounds Down Pressure With Blade 4" Above Maximum Down Position
13 $\frac{5}{16}$ "	90	230
12 $\frac{5}{16}$ "	190	330
Suggested initial setting.		
11 $\frac{5}{16}$ "	300	430

A5649rev.(PLTR44)

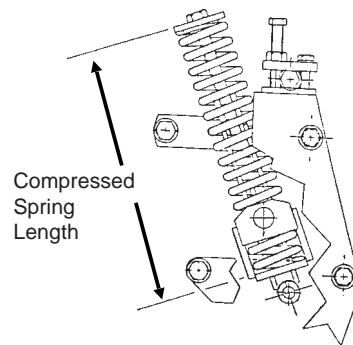

IMPORTANT: Excessive down force may cause increased wear on components.

COULTER BLADE ADJUSTMENT

The coulter blade can be aligned with the row unit disc opener by moving the spacer washers from one side of the coulter blade hub to the other.

56314-12

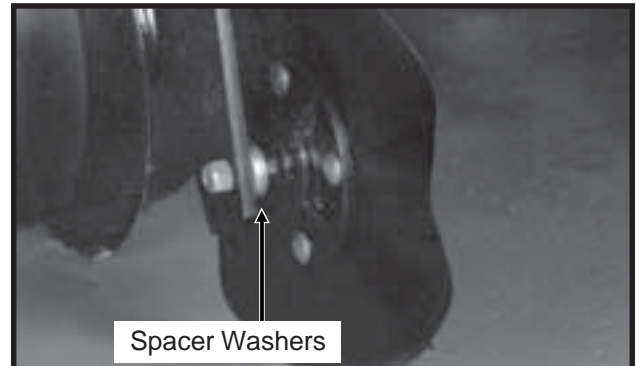

Field adjustment should be made as needed. Operating height of the planter frame will affect operating depth of the frame mounted coulter.

NOTE: Torque $\frac{5}{8}$ " spindle bolts to 120 ft. lbs.

ROW UNIT OPERATION

FRAME MOUNTED COULTER - STYLE B

LF083002101

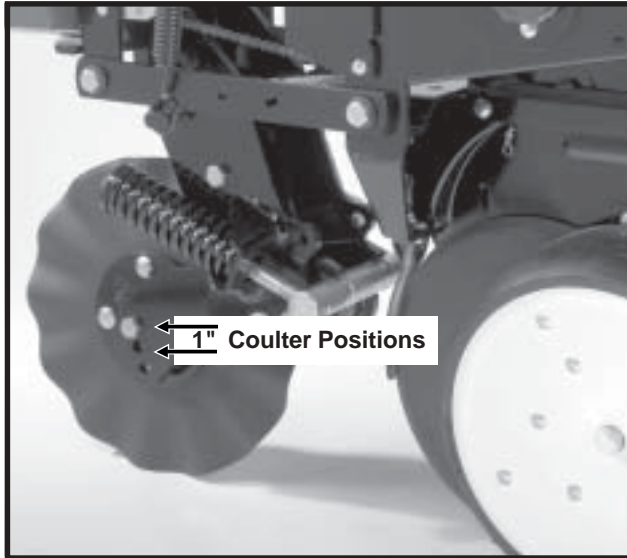

Frame mounted coulters with 1" bubbled, 1" fluted (8 flutes) or 3/4" fluted (13 flutes) blades may be used on pull row units only. (Not compatible with push row units.)

The frame mounted coulter is designed to apply necessary spring down pressure on the coulter for maximum penetration while exerting less shock load on the row unit.

The initial location of the coulter blade is in the top hole. The blade can be relocated to one of the lower two holes (1" increments) as wear occurs or if deeper operation of the blade is desired.

LF083002101

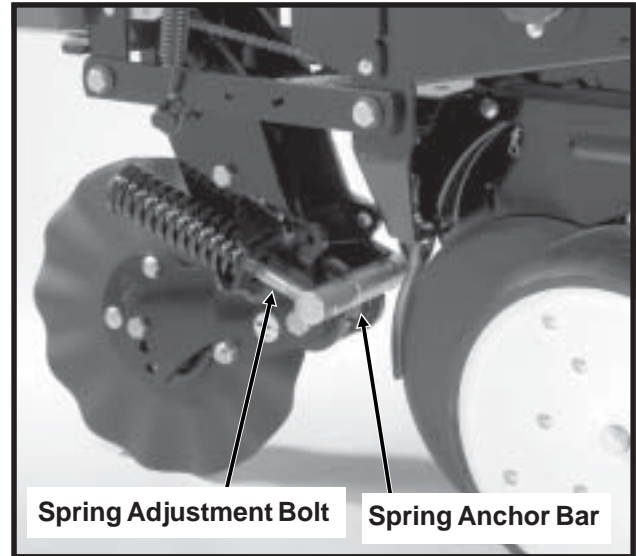

DOWN PRESSURE ADJUSTMENT

Down force adjustment is made by tightening or loosening the two spring adjustment bolts. With the planter in raised position, turn the bolts clockwise to increase down pressure or counterclockwise to decrease down force. Set both springs the same.

Down force on the blade is shown below in lbs.

End Of Spring Adjustment Bolt Flush With Spring Anchor Bar (Shown Above)	End Of Spring Adjustment Bolt Extended 1/2" Through Spring Anchor Bar	All Threads Used (Maximum)
275 lbs.	400 lbs.	500 lbs.

NOTE: Avoid setting down pressure higher than is required for consistent soil penetration. Excessive pressure will increase the chances of damage to coulter components when the coulter strikes an obstacle.

ROW UNIT OPERATION

DISC FURROWER

(For Use With Style A Frame Mounted Coulters)

The disc furrower for use with the frame mounted coulters may be equipped with either 12" solid blades or 12" notched blades.

Disc furrowers are used to clear crop residue, dirt clods and dry soil from in front of the row units for a clean and smooth seed bed. Notched blades are used for heavier residue conditions. The notched blades cut crop residue and move it aside to prevent plugging or pushing.

56314-19

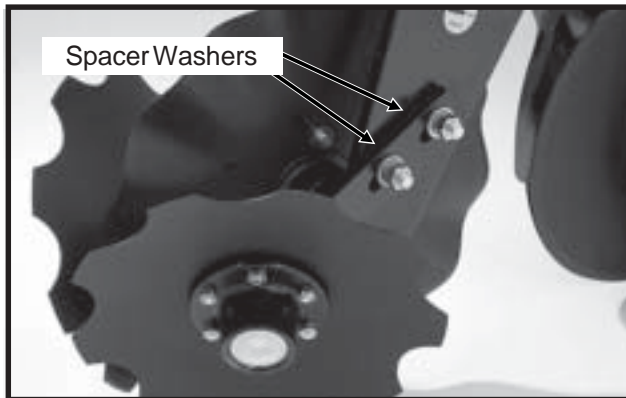

Blades can be adjusted so front edges meet by adding spacer washers between the disc furrower arm and frame mounted coulters fork mount.

Slotted holes in the frame mounted coulters fork mount and in the disc furrower arm allow for vertical and horizontal adjustment. Blades can be adjusted so the front edges meet or one blade can be moved to the rear and the other to the front of the slot so the cutting edge of one blade overlaps the edge of the other blade.

56314-17a

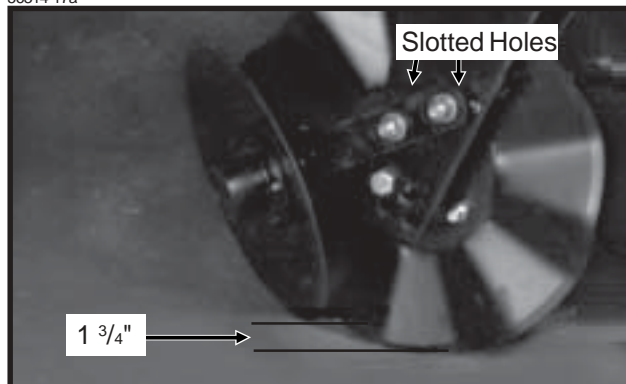

Initial setting for each disc furrower blade is 1 3/4" shallower than the coulters blade. Further adjustment may be desired for various applications.

NOTE: The depth control bar should always be used when the frame mounted coulters is equipped with disc furrowers.

RESIDUE WHEELS

(For Use With Style B Frame Mounted Coulters)

The residue wheels for use with the frame mounted coulters may be used on pull row units only.

LF083002102



The residue wheels are attached to the frame mounted coulters with two cap screws and sleeves allowing the unit to free-float. A 2-position spindle bolt mounting allows the treaded wheels to be mounted interlocked or staggered. Depth adjustment is made using a spring-loaded cam and pin with 11 positions in 1/4" increments. A high point on the cam allows the wheels to be locked up so they do not contact the ground. A weed guard, located on the inboard side of each wheel, aids in the prevention of weed wrap which can cause premature bearing failure.

(RU135d)

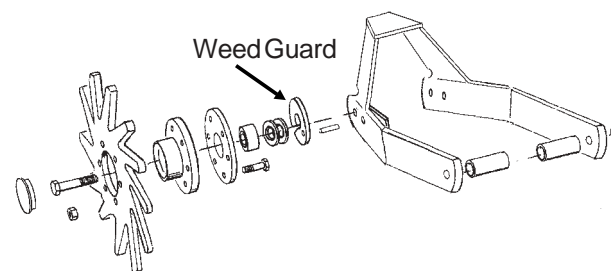

NOTE: Opening in weed guard must point down.

ROW UNIT OPERATION

ROW UNIT MOUNTED DISC FURROWER

The row unit mounted disc furrower is for use on pull row units only and may be equipped with either 12" solid blades or 12" notched blades.

Disc furrowers are used to clear crop residue, dirt clods and dry soil from in front of the row units for a clean and smooth seed bed. Notched blades are used for heavier residue conditions. The notched blades cut crop residue and move it aside to prevent plugging or pushing.

LF212299-22

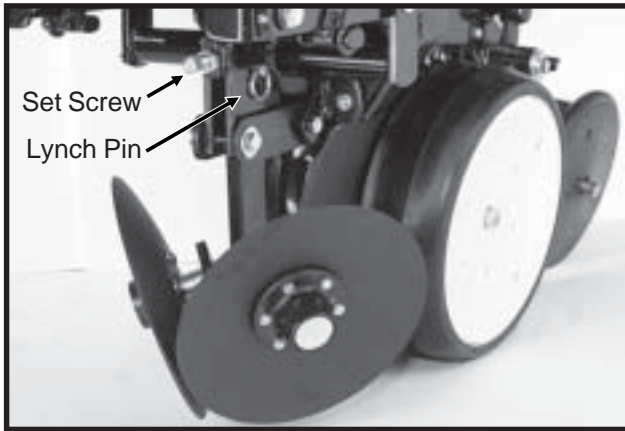

Vertical adjustment in $\frac{1}{3}$ " increments is possible by removing the lynch pin which secures the vertical support arm and moving the support arm up or down as required. Re-install lynch pin. Finer adjustment can be attained by removing the lynch pin and using the $\frac{5}{8}$ " x $2 \frac{1}{4}$ " set screw to clamp the support arm in the required position.

(RU98e)

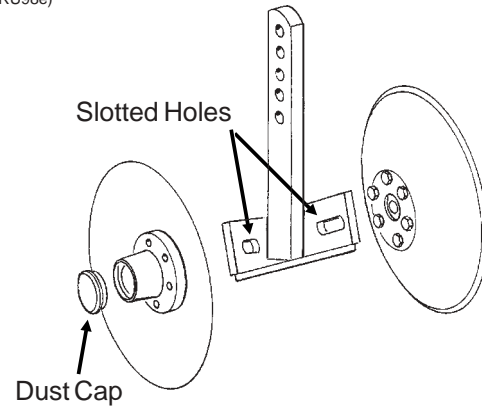

Slotted holes in the support arm where the blades are mounted allow fore and aft adjustment of the disc blades. Blades can be adjusted so the front edges meet or one blade can be moved to the rear and the other to the front of the slot so the cutting edge of one blade overlaps the edge of the other blade. The dust cap must be removed to make these adjustments.

ROW UNIT OPERATION

ROW UNIT MOUNTED BED LEVELER

LF212299-25a

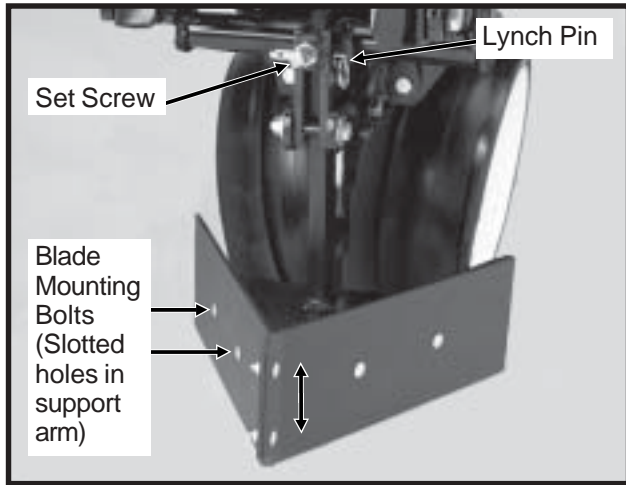

Row unit mounted bed levelers may be used on pull row units only.

Vertical adjustment in $\frac{1}{3}$ " increments is possible by removing the lynch pin which secures the vertical support arm and moving the support arm up or down as required. Re-install lynch pin. Finer adjustment can be attained by removing the lynch pin and using the $\frac{5}{8}$ " x $2 \frac{1}{4}$ " set screw to clamp the support arm in the required position.

Slotted holes in the support arm where the blades are mounted allow tilting of the blades. The blades can be tilted up or down at the front for desired adjustment.

NOTE: The row unit mounted bed leveler is not compatible with row spacings less than 36".

ROW UNIT MOUNTED RESIDUE WHEEL

The row unit mounted residue wheel may be used on pull row units and push row units.

D101701113

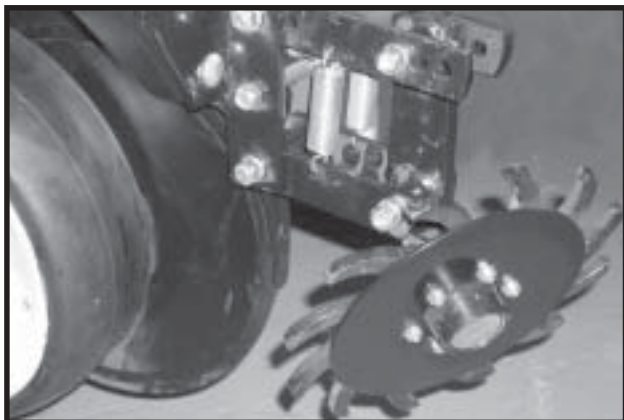

Two adjustable springs on the parallel links on each residue wheel allow for down force adjustment. Position 1 as shown below provides minimum down pressure and position 3 maximum down pressure.

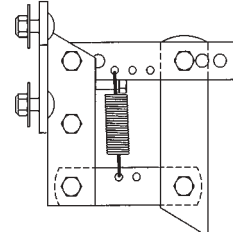

Position 1 (Minimum)(PLTR31a)

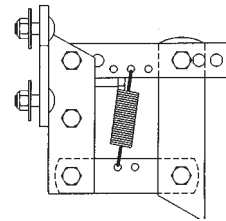

Position 2 (PLTR32a)

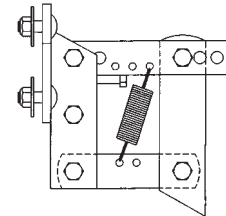

Position 3 (Maximum)(PLTR33a)

For additional uplift or float, position springs as shown below.

(PLTR34a)

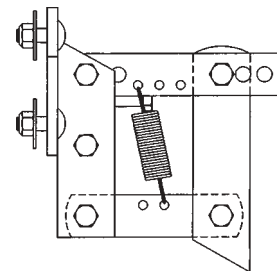

To adjust down force springs, raise the row unit out of the ground and reposition springs as shown for the desired down pressure.

ROW UNIT OPERATION

D101701112

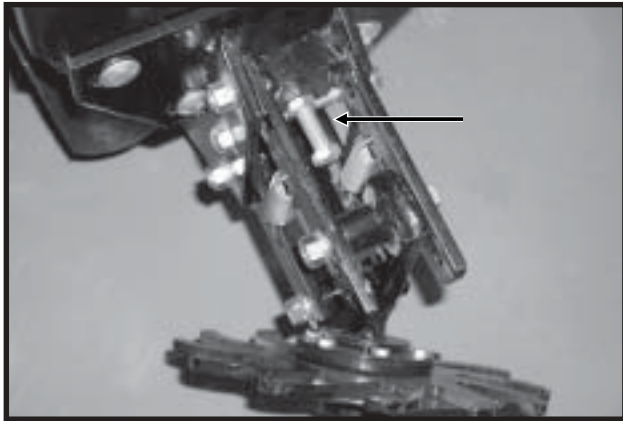

A full threaded bolt and jam nut located on the upper link allows maximum depth to be set for loose soil conditions. Initial setting should be 1 3/4" above the depth of the row unit double disc opener.

Three holes in the upper link allow for wheel angle adjustment. With the wheel mount in the most vertical position, using the rear hole in the upper link, the residue wheel is most aggressive. Moving the wheel mount to one of the forward holes reduces the aggressiveness of the wheel for use in mulch till applications where the soil is loose.

D101701202

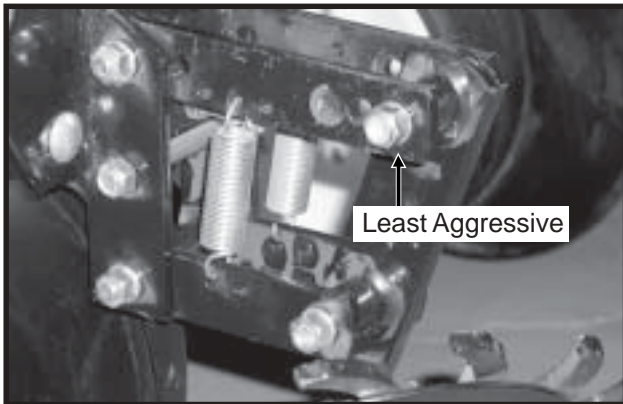

To lock the residue wheel up out of the ground, remove the 1/2" x 5" lockup bolt, raise the residue wheel and install bolt.

D011701203

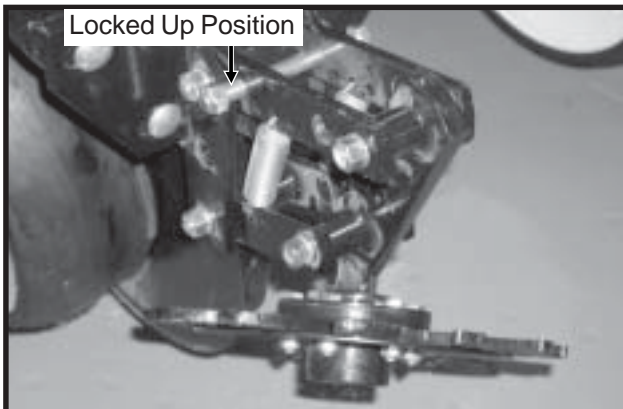

ROW UNIT MOUNTED NO TILL COULTER

LF212299-19a

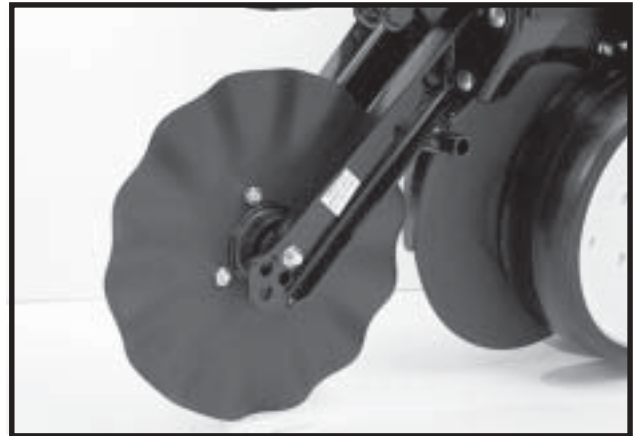

Row unit mounted no till coulters with 1" bubbled, 1" fluted (8 flutes) or 3/4" fluted (13 flutes) blades may be used on pull row units and push row units. (3/4" fluted shown)

Four quick adjustable down force springs are required per row when using row unit mounted no till coulters. See "Quick Adjustable Down Force Springs".

For proper operation, the coulters blade should be aligned in relation to the row unit double disc openers. The coulters assembly can be adjusted by loosening the four attaching bolts, moving coulters arm to align and tightening the four attaching bolts.

The coulters blade can be adjusted to one of four 1/2" incremental settings in the forked arm. Initial location of the coulters is in the top hole. As the coulters blade wears, the blade should be adjusted downward to one of the three lower settings to maintain the coulters blade at or slightly below the opener discs. In very hard soil conditions such as compacted wheel tracks, opener penetration and cutting of surface residue may be improved by adjusting the coulters to operate below the depth of the double disc opener blades.

Operating depth can be checked by setting the planter down on a level concrete floor and checking the relationship between the coulters blade and row unit opener blade. Make sure the planter is level and coulters is square with the planter frame and aligned with the row unit disc opener.

NOTE: Torque 5/8" spindle bolts to 120 ft. lbs.

ROW UNIT OPERATION

COULTER MOUNTED RESIDUE WHEELS



Coultter mounted residue wheels are designed for use on pull row units. Row unit extension brackets are required on the pull row units on the planter wings if the planter is equipped with coultter mounted residue wheels.

The coultter mounted residue wheels are attached to the row unit mounted no till coultter with one cap screw and sleeve allowing the unit to free-float. A 2-position spindle bolt mounting allows the tined wheels to be mounted interlocked or staggered. Depth adjustment is made using a spring-loaded cam and pin with 11 positions in 1/4" increments. A high point on the cam allows the wheels to be locked up so they do not contact the ground. A weed guard, located on the inboard side of each wheel, aids in the prevention of weed wrap which can cause premature bearing failure.

(RU104n)

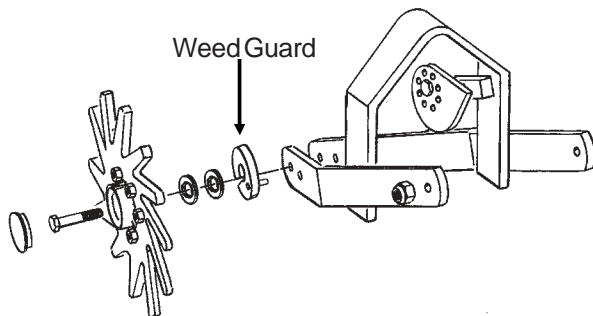

NOTE: Opening in weed guard must point down.

GRANULAR CHEMICAL HOPPER AND DRIVE

LF212299-6



The granular chemical hopper has a 1.4 cubic feet capacity.

Be sure no foreign objects get into the hopper when it is being filled. Replace the hopper lids after filling the hoppers to prevent the accumulation of dirt and moisture.

The metering gate located on the bottom of the hopper regulates the application rate. See "Dry Insecticide And Dry Herbicide Application Rate Charts" in this manual. Calibrate using the chemical manufacturers' instructions.



WARNING: Agricultural chemicals can be dangerous. Improper selection or use can seriously injure persons, animals, plants, soil or other property. **BE SAFE:** Select the right chemical for the job. Handle it with care. Follow the instructions on the container label.

The granular chemical clutch drive coupler and meter shaft can be disengaged and engaged by turning the throwout knob located at the rear of the hopper support panel. To engage the drive, turn the knob 1/4 turn clockwise. To disengage the drive, turn the knob 1/4 turn counterclockwise. Slotted holes in the hopper support panel and clutch housing allow for alignment adjustment between the clutch drive coupler and meter shaft.

LF212299-4

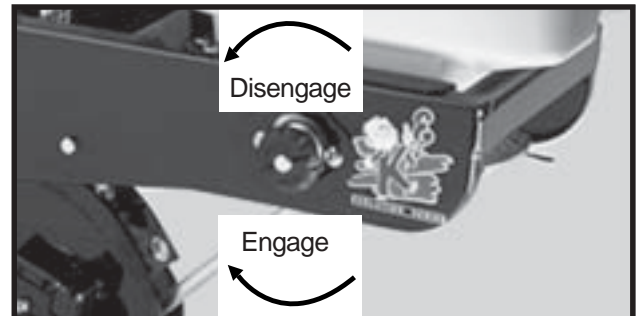

ROW UNIT OPERATION

GRANULAR CHEMICAL BANDING OPTIONS

Granular chemical banding options allow 4 1/2" slope-compensating banding, straight drop in-furrow placement or 14" rear banding.

NOTE: The granular chemical rear bander is not compatible with the covering discs/single press wheel option.

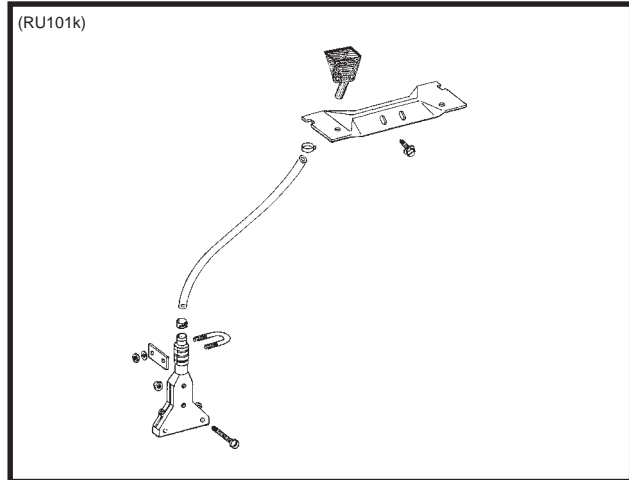

4 1/2" Slope-Compensating Bander

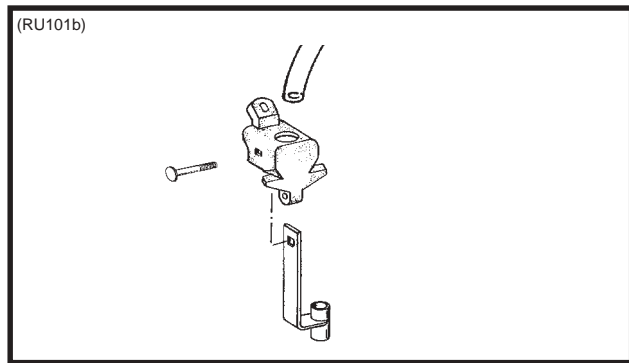

Straight Drop In-Furrow Placement

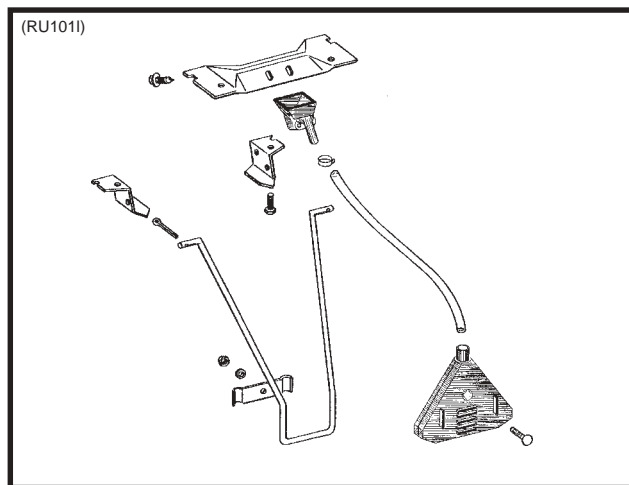

14" Rear Bander

GRANULAR CHEMICAL BANDER SHIELD

The optional granular chemical bander shield is designed to be installed onto the underside of the wheel arm stop to shield crop residue from lodging in the granular chemical bander.

(RU83m)

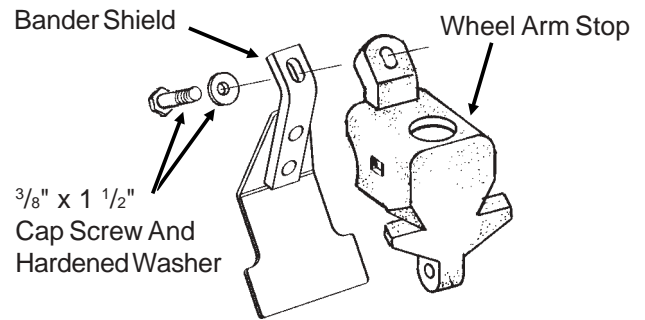

SPRING TOOTH INCORPORATOR

The spring tooth incorporator smooths the soil behind the row unit and incorporates granular chemicals. The two mounting chains on each spring tooth incorporator should be adjusted so there is approximately 1/8" slack in the chain when the unit is lowered to planting position.

NOTE: The spring tooth incorporator is not compatible with the covering discs/single press wheel option.

LF212299-26

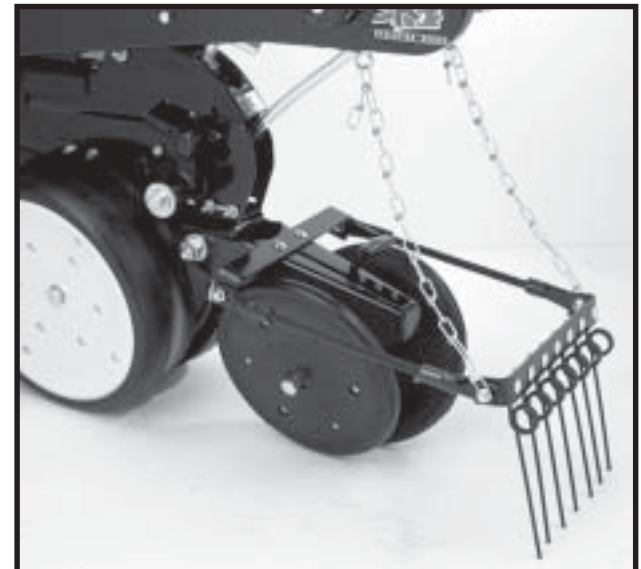

LUBRICATION

The following pages show the locations of all lubrication points. Proper lubrication of all moving parts will help ensure efficient operation of your KINZE® planter and prolong the life of friction producing parts.



WARNING: Always install safety lockups or lower the planter to the ground before working under the machine.

LUBRICATION SYMBOLS

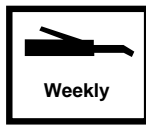
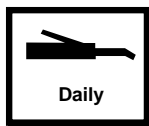

Lubricate at frequency indicated with an SAE multipurpose type grease.



Lubricate at frequency indicated with a high quality SAE 10 weight oil or a quality spray lubricant.

SEALED BEARINGS

LF212199-3

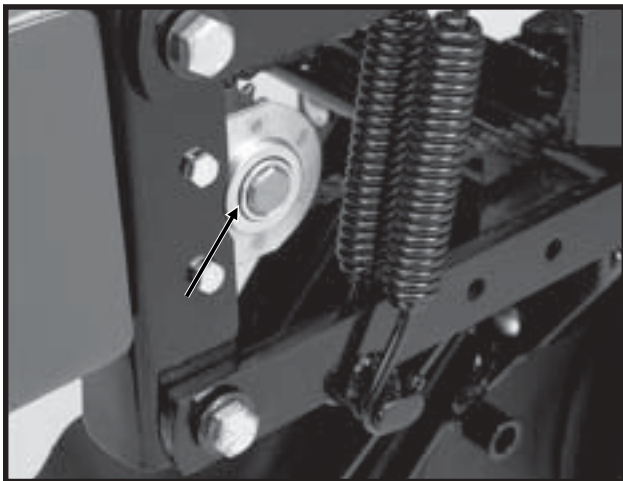

A number of sealed bearings are used on your KINZE® planter to provide trouble free operation. These are located in such areas as the drive shaft, row units and transmission bearings. Sealed bearings are lubricated for life. Due to the seals, relubrication is not practical.

DRIVE CHAINS

All transmission and drive chains should be lubricated daily with a high quality chain lubricant. Extreme operating conditions such as dirt, temperature or speed may require more frequent lubrication. If a chain becomes stiff, it should be removed, soaked and washed in solvent to loosen and remove dirt from the joints. Then soak the chain in oil so the lubricant can penetrate between the rollers and bushings.

LF212199-5a

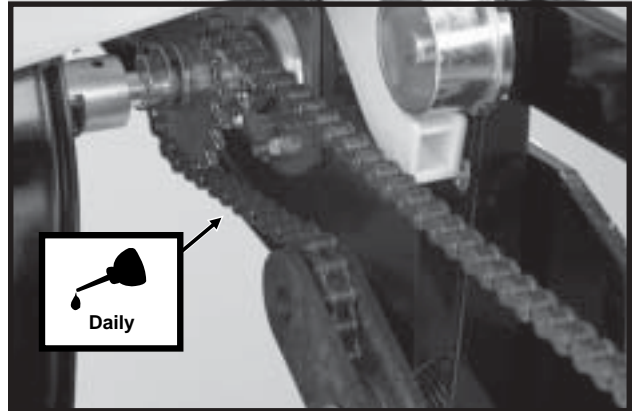

Pull Row Unit Drive Chains

D05139901b

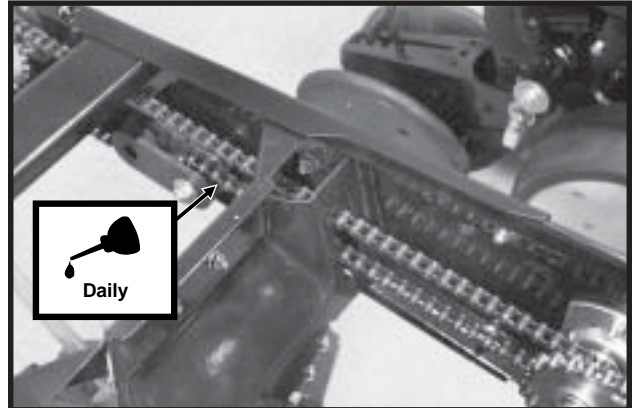

Row Unit Granular Chemical Drive Chains

81014-87a

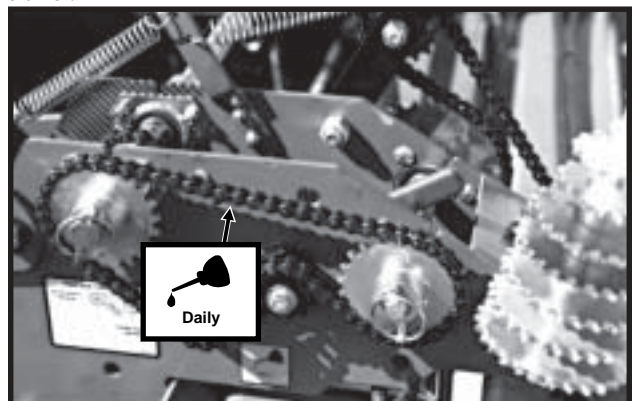

Seed Rate Transmission Drive Chain(s)

LUBRICATION

81014-84

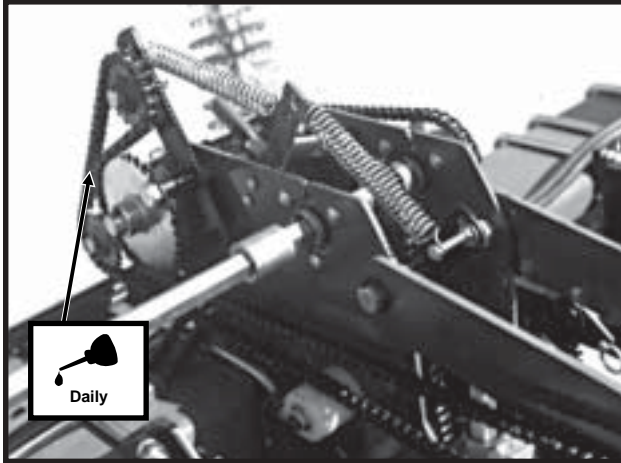

**Contact Wheel Drive Chain(s)
(Without Point Row Clutches)**

D10019919

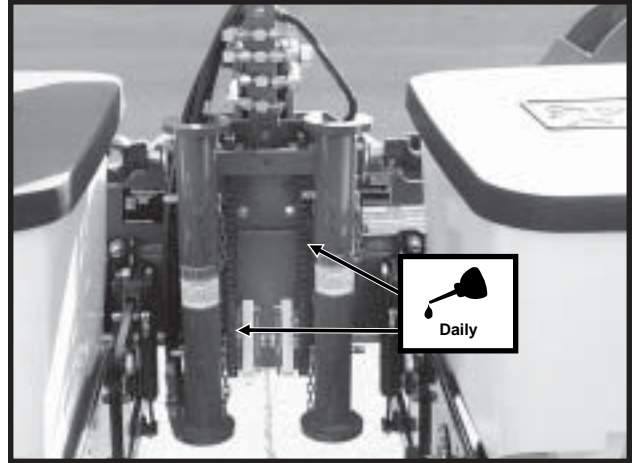

Center Drop Assembly Drive Chains

81014-12

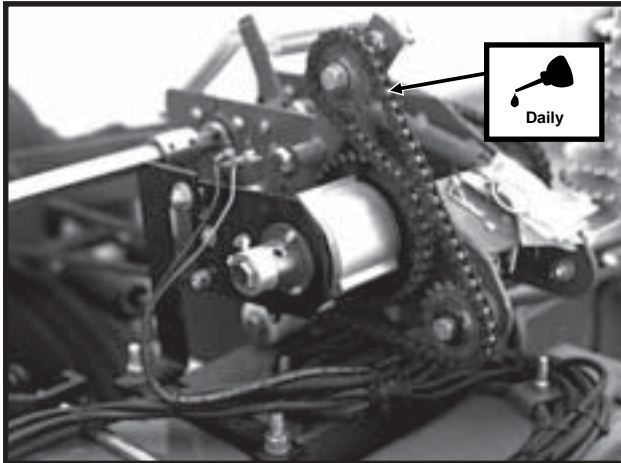

**Contact Wheel Drive Chain(s)
(With Point Row Clutches)**

BUSHINGS

Lubricate bushings at the frequency indicated.

Using a torque wrench, check each bolt for proper torque. If bolt is loose, it should be removed and the bushing inspected for cracks and wear. Replace bushing if necessary **Only hardened flat washers should be used. Replace damaged flat washers with proper part. Torque bolts to 130 ft. lbs.**

81014-95/A7455(SFP26)

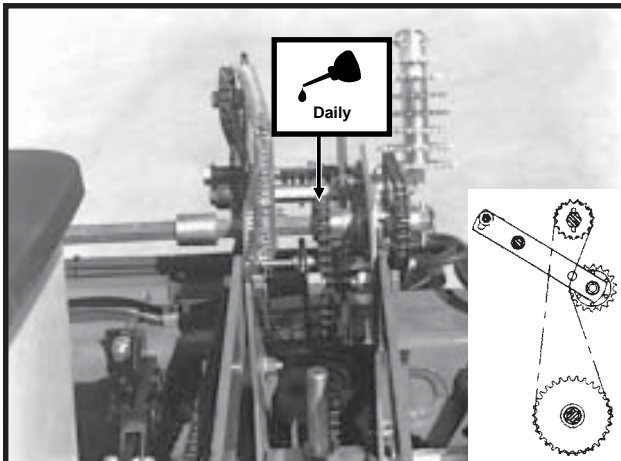

Inner Wheel Module Drive Chain(s)

D06300305

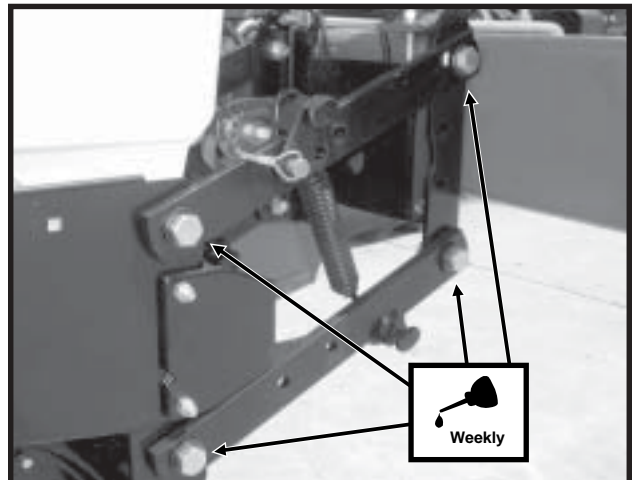

Pull Row Unit Parallel Linkages (8 Per Row)

LUBRICATION

D06189901

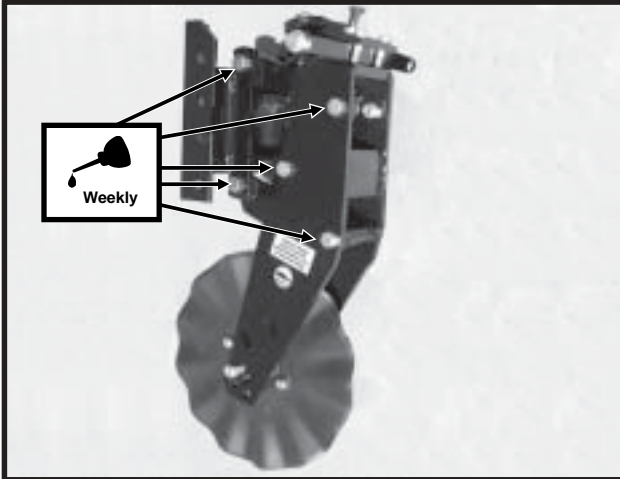

Frame Mounted Coulter Parallel Linkages - STYLE A (10 Per Row)

Shown not installed on row unit for visual clarity.

LF212199-2

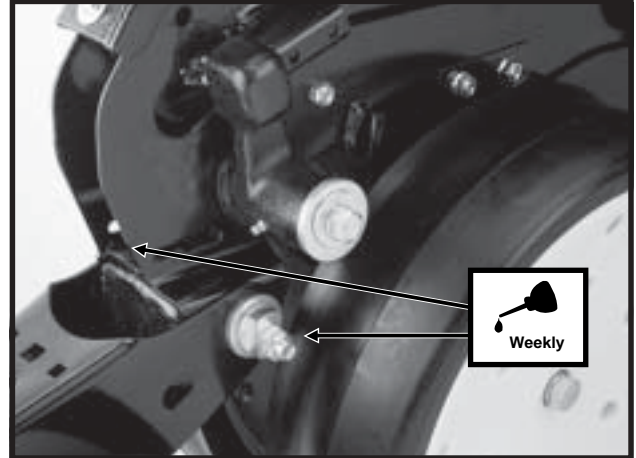

Row Unit "V" Closing Wheel, Covering Discs/ Single Press Wheel And/Or Drag Closing Wheel Eccentric Bushings (2 Per Row)

LF212299-22

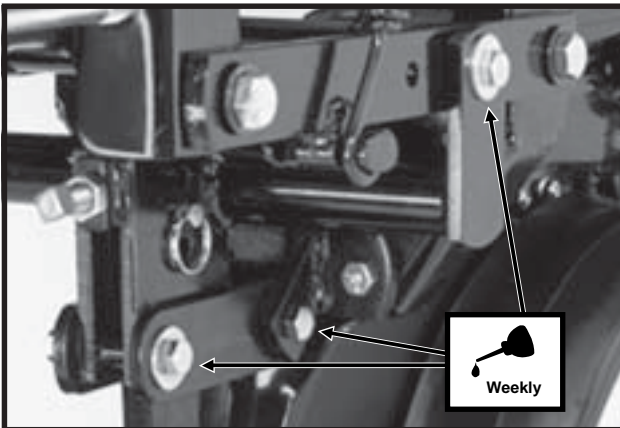

Row Unit Mounted Disc Furrower Parallel Linkages (6 Per Row)

D10019931

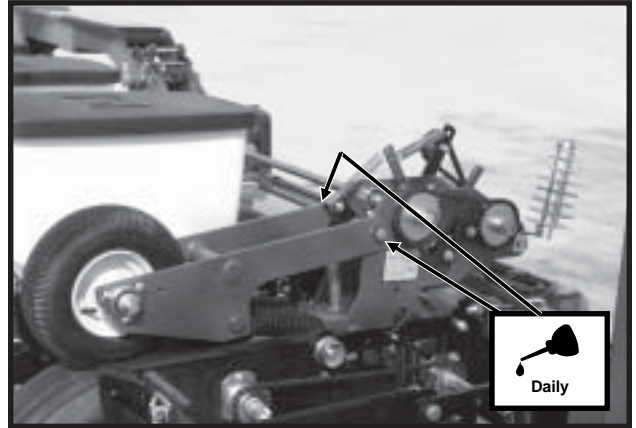

Contact Drive Wheel Arm (2 Per Wheel Assembly)

59386-26

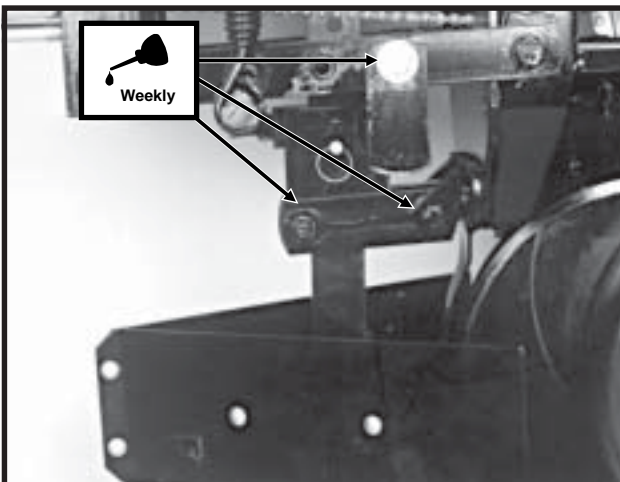

Row Unit Mounted Bed Leveler Parallel Linkages (6 Per Row)

LUBRICATION

WHEEL BEARINGS

All wheel bearings should be repacked annually and checked for wear. This applies to all drive wheels and marker hubs.

To check for wear, raise the wheel off the ground. Check for endplay in the bearings by moving the tire in and out. Rotate the tire to check for roughness in the bearings. If bearings sound rough, the hub should be removed and the bearings inspected and replaced. See "Maintenance Section".

To repack wheel hubs, follow the procedure outlined for wheel bearing replacement with the exception that bearings and bearing cups are reused.

WRAP SPRING WRENCH ASSEMBLY

If the chain idler is equipped with a wrap spring wrench, the wrench components may require occasional lubrication to operate correctly. Disassembly is required to lubricate. (a) Remove the 1/4"-20 x 1/2" cap screw that secures the idler with sprockets to the wrench tightener shaft. (b) Remove the wrap spring wrench from the planter. (c) Tip the wrap spring wrench on its side and lubricate using a high quality spray lubricant. Lubricant must be absorbed into the wrap spring area. (d) Reinstall wrench on planter.

D101303102



LUBRICATION

GREASE FITTINGS

Those parts equipped with grease fittings should be lubricated at the frequency indicated with an SAE multipurpose type grease. Be sure to clean the fitting thoroughly before using grease gun. The frequency of lubrication recommended is based on normal operating conditions. Severe or unusual conditions may require more frequent attention.

WARNING: Always install safety lockups or lower to the ground before working under or around the machine.

NOTE: Numbers on photo below correspond to photos on following pages showing lubrication frequencies.

D10079911a

12 Row 30" Shown

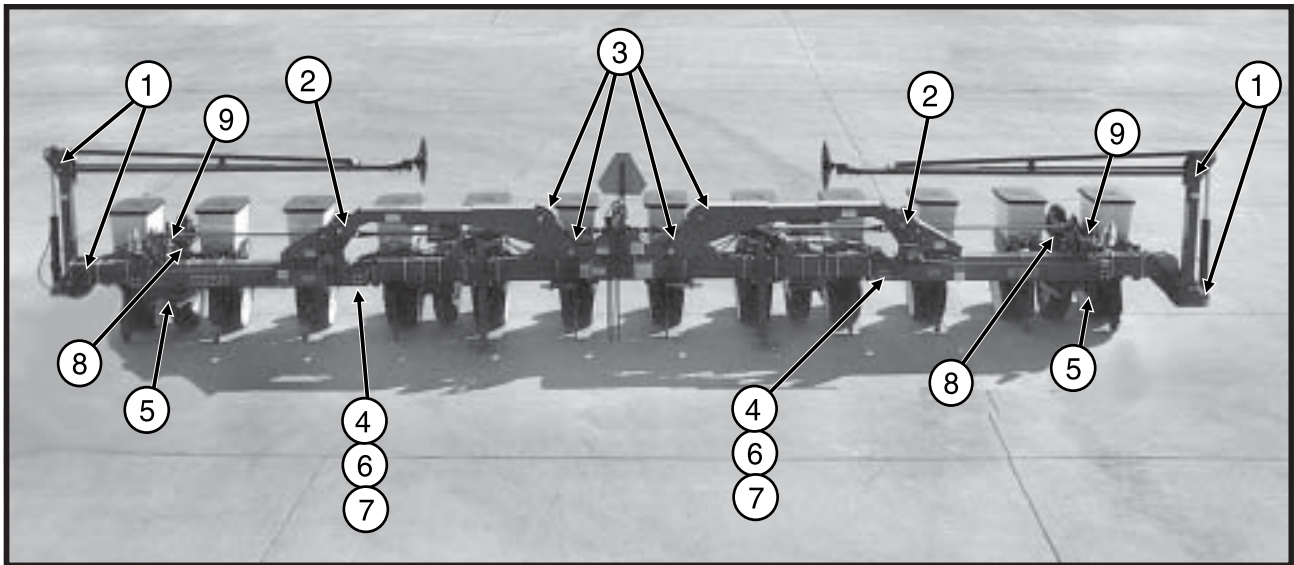

D10019936

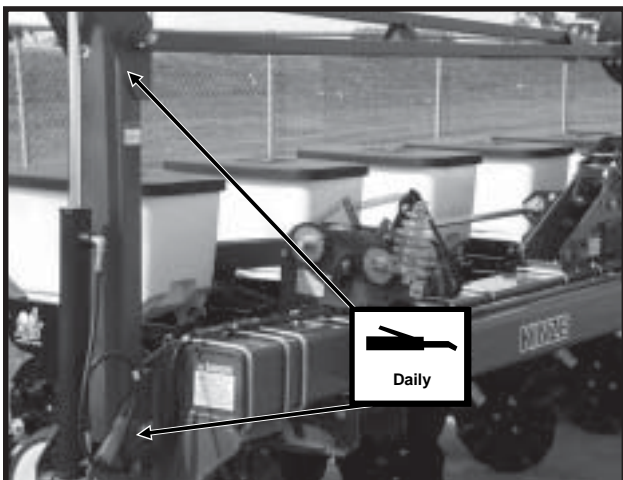

1. Row Markers - 4 Zerks Per Assembly On 8 Row 38"/40" And 12 Row 30" Sizes. 2 Zerks Per Assembly On 12 Row 36"/38", 38"/40" And 16 Row 30" Sizes.

81014-75a



2. Wing Hinge - 2 Zerks Per Hinge Area

LUBRICATION

D10019908

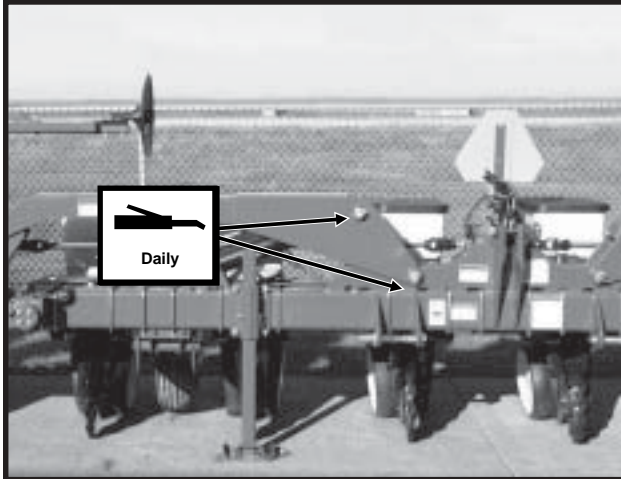

3. Center Hinge - 4 Zerks Per Hinge Area

81014-62

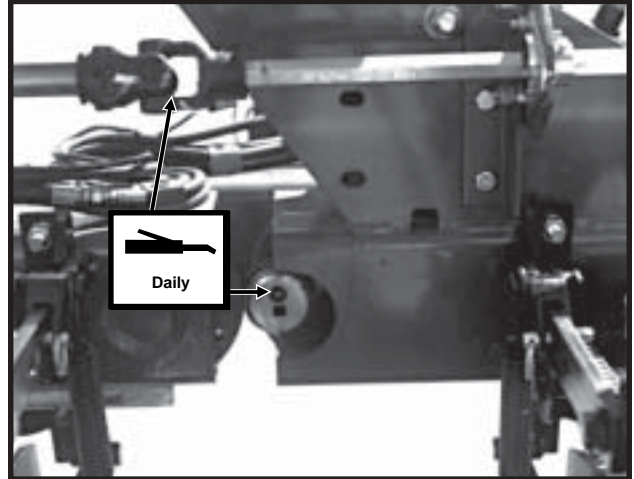

6. Cam Follower - 1 Zerk Per Cam
7. U-Joint Assembly - 1 Zerk Per Assembly

81014-75a



4. Link Assembly - 4 Zerks Per Link

D10019931

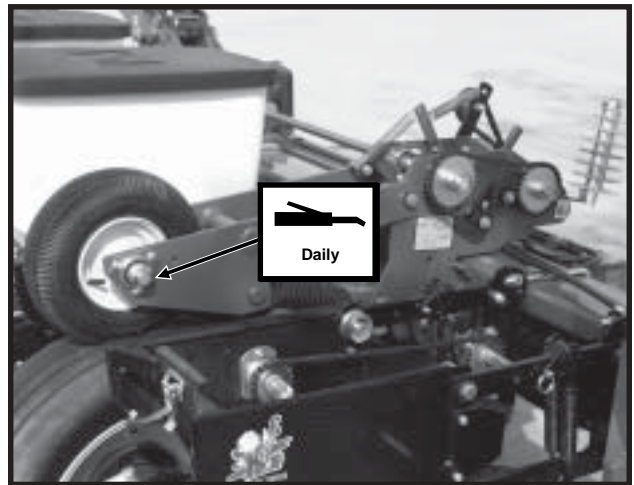

8. (If Applicable) Contact Wheel Arm Bearing - 2 Zerks Per Arm Assembly (**Rotate tire while filling with grease.**)

D10019915

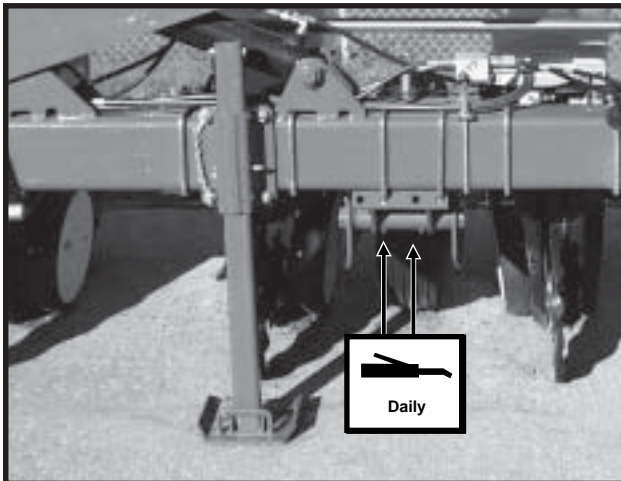

5. Drive Wheel Arm Pivot - 2 Zerks Per Pivot

D10019935

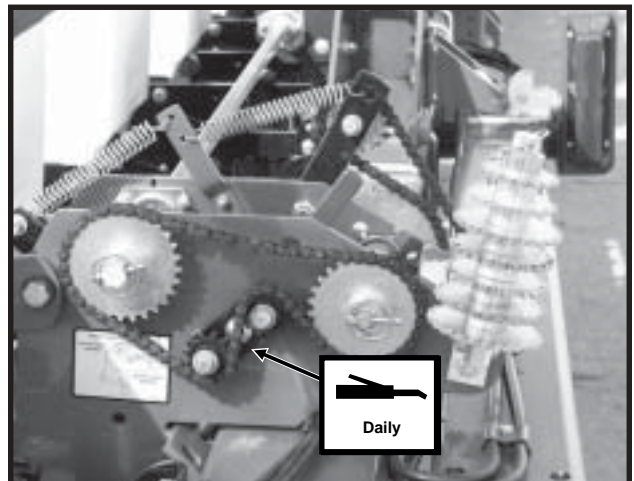

9. Seed Rate Transmission Assemblies - Zerk (Idle)

LUBRICATION

Row Unit

LF212199-2

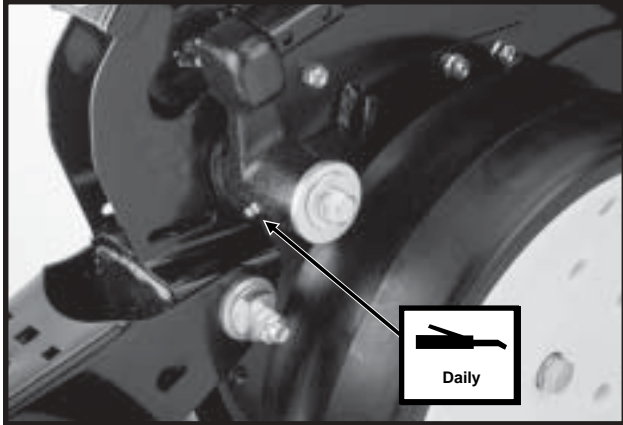

Gauge Wheel Arms - 1 Zerk Per Arm
(Seals in gauge wheel arm are installed with lip facing out to allow grease to purge dirt away from seal. Pump grease into arm until fresh grease appears between washers and arm.)

LF212299-19

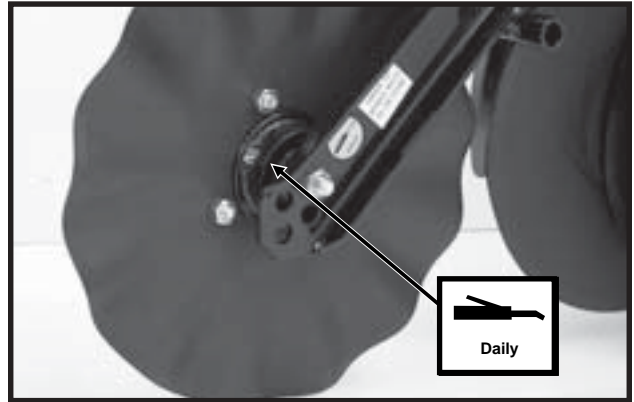

(If Applicable) Row Unit Mounted No Till Coulter Hubs -
1 Zerk Per Hub
(Pump grease into hub until grease comes out around the seals. Spin hub while filling with grease.)

56673-6

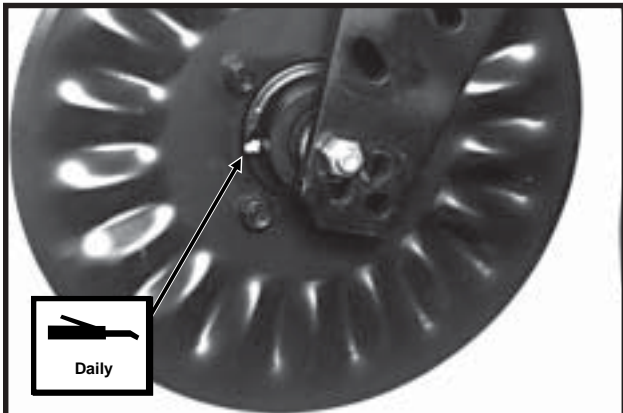

(If Applicable) Frame Mounted Coulter Hubs -
STYLE A - 1 Zerk Per Hub
(Pump grease into hub until grease comes out around the seals. Spin hub while filling with grease.)

LF083002101

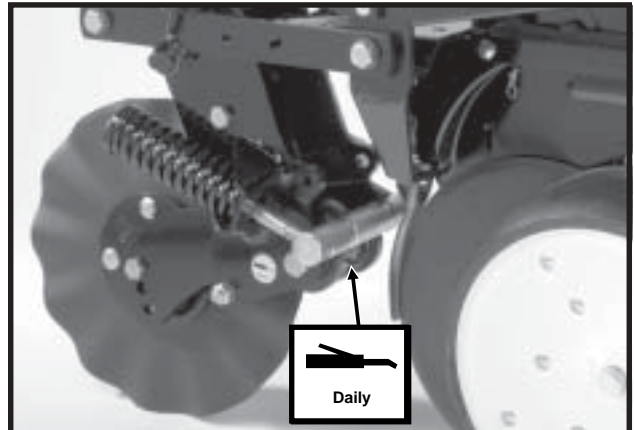

(If Applicable) Frame Mounted Coulter - STYLE B -
1 Zerk Per Arm

LUBRICATION

Dual Lift Assist Wheel Package

A7443(SFP52a)

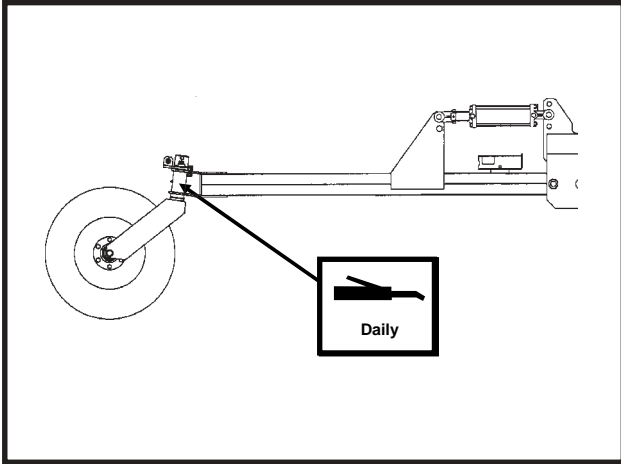

Lift Assist Arm - 1 Zerk Per Arm

POINT ROW CLUTCHES

81014-12a

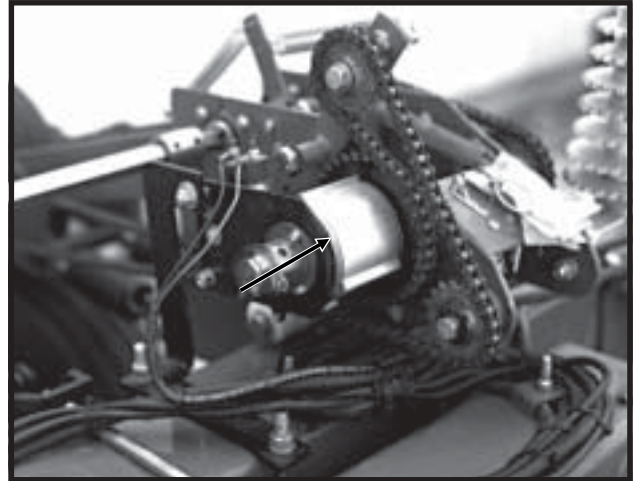

The point row clutches are permanently lubricated and require no periodic maintenance. **DO NOT LUBRICATE. KEEP CLUTCHES CLEAN.**

MAINTENANCE

MOUNTING BOLTS AND HARDWARE

Before operating the planter for the first time, check to be sure all hardware is tight. Check all hardware again after approximately the first 50 hours of operation and at the beginning of each planting season thereafter.

All hardware used on the KINZE® planter is Grade 5 (high strength) unless otherwise noted. Cap screws are marked with three radial lines on the head. If hardware must be replaced, be sure to replace it with hardware of equal size, strength and thread type. Refer to the torque values chart when tightening hardware.

Row Unit Parallel Linkage Bushing Bolts - 130 Ft. Lbs. (See "Bushings" in the Lubrication Section of this manual.)

IMPORTANT: Over tightening hardware can cause as much damage as under tightening. Tightening hardware beyond the recommended range can reduce its shock load capacity.





WARNING: Before operating the planter for the first time and periodically thereafter, check to be sure the lug nuts on the wheels are tight. This is especially important if the planter is to be transported for a long distance.

Ground Drive Tire Lug Nuts - 90 Ft. Lbs.

5/8" No Till Coulter Spindle Bolts - 120 Ft. Lbs.

TORQUE VALUES CHART - PLATED HARDWARE						
Bolt Diameter	Grade 2		Grade 5		Grade 8	
	Coarse	Fine	Coarse	Fine	Coarse	Fine
1/4"	50 In. Lbs.	56 In. Lbs.	76 In. Lbs.	87 In. Lbs.	9 Ft. Lbs.	10 Ft. Lbs.
5/16"	8 Ft. Lbs.	9 Ft. Lbs.	13 Ft. Lbs.	14 Ft. Lbs.	18 Ft. Lbs.	20 Ft. Lbs.
3/8"	15 Ft. Lbs.	17 Ft. Lbs.	23 Ft. Lbs.	26 Ft. Lbs.	33 Ft. Lbs.	37 Ft. Lbs.
7/16"	25 Ft. Lbs.	27 Ft. Lbs.	37 Ft. Lbs.	41 Ft. Lbs.	52 Ft. Lbs.	58 Ft. Lbs.
1/2"	35 Ft. Lbs.	40 Ft. Lbs.	57 Ft. Lbs.	64 Ft. Lbs.	80 Ft. Lbs.	90 Ft. Lbs.
9/16"	50 Ft. Lbs.	60 Ft. Lbs.	80 Ft. Lbs.	90 Ft. Lbs.	115 Ft. Lbs.	130 Ft. Lbs.
5/8"	70 Ft. Lbs.	80 Ft. Lbs.	110 Ft. Lbs.	125 Ft. Lbs.	160 Ft. Lbs.	180 Ft. Lbs.
3/4"	130 Ft. Lbs.	145 Ft. Lbs.	200 Ft. Lbs.	220 Ft. Lbs.	280 Ft. Lbs.	315 Ft. Lbs.
7/8"	125 Ft. Lbs.	140 Ft. Lbs.	320 Ft. Lbs.	350 Ft. Lbs.	450 Ft. Lbs.	500 Ft. Lbs.
1"	190 Ft. Lbs.	205 Ft. Lbs.	480 Ft. Lbs.	530 Ft. Lbs.	675 Ft. Lbs.	750 Ft. Lbs.
1 1/8"	265 Ft. Lbs.	300 Ft. Lbs.	600 Ft. Lbs.	670 Ft. Lbs.	960 Ft. Lbs.	1075 Ft. Lbs.
1 1/4"	375 Ft. Lbs.	415 Ft. Lbs.	840 Ft. Lbs.	930 Ft. Lbs.	1360 Ft. Lbs.	1500 Ft. Lbs.
1 3/8"	490 Ft. Lbs.	560 Ft. Lbs.	1100 Ft. Lbs.	1250 Ft. Lbs.	1780 Ft. Lbs.	2030 Ft. Lbs.
1 1/2"	650 Ft. Lbs.	730 Ft. Lbs.	1450 Ft. Lbs.	1650 Ft. Lbs.	2307 Ft. Lbs.	2670 Ft. Lbs.

NOTE: Unplated hardware and bolts with lock nuts should be torqued approximately 1/3 higher than the above values. Bolts lubricated prior to installation should be torqued to 70% of value shown in chart.

 GRADE 2 No Marks	 GRADE 5 3 Marks	 GRADE 8 6 Marks
--	---	---

CHAIN TENSION ADJUSTMENT

The drive chains have a spring loaded idler and therefore are self-adjusting. The only adjustment needed is to shorten the chain if wear stretches the chain and reduces spring tension. The pivot point of these idlers should be checked periodically to ensure they rotate freely.

See "Drive Chains" in the Lubrication Section.

(MT18a)

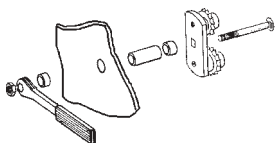

NOTE: The nut on the mounting bolt (on applicable idler assemblies) must be kept tight or chain tension will not be maintained and adjustment wrench will not function properly.

Additional chain links can be found in the storage area located in the wheel module.

D10019917

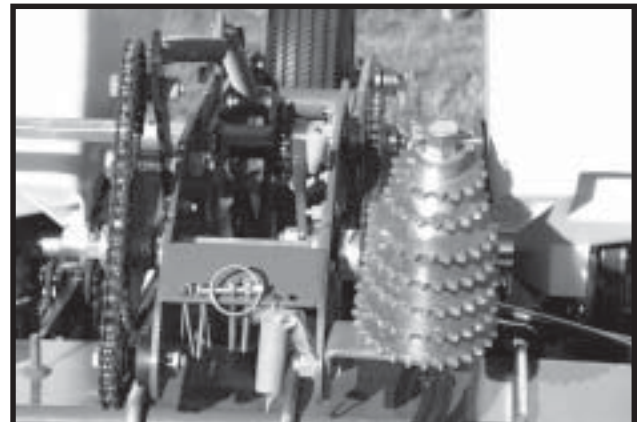

MAINTENANCE

FINGER PICKUP SEED METER INSPECTION/ADJUSTMENT

To inspect or service the finger pickup seed meter, remove the meter from the seed hopper by removing the two thumbscrews which secure the mechanism to the hopper. Remove the baffle from the meter assembly by removing three cap screws. This will permit access to the finger pickup.

D04229901

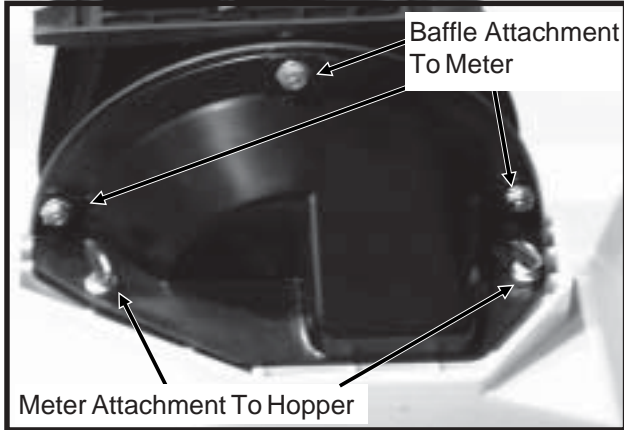

Rotate the seed meter drive by hand to ensure that the springs are holding the tabs of the fingers against the carrier plate where indicated in the photo and that the fingers are being raised in the correct area.

D092004101a

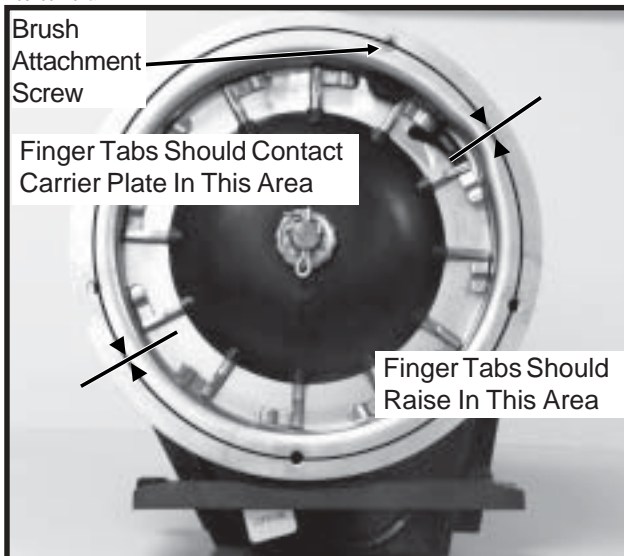

A build-up of debris or chaff may prevent proper finger operation and will require disassembly and cleaning of the finger pickup meter as follows:

1. Remove cotter pin, cover nut and adjusting nut and wave washer (If Applicable) from drive shaft.
2. Carefully lift finger holder, along with fingers and cam, off of the shaft. Clean.

D092004102

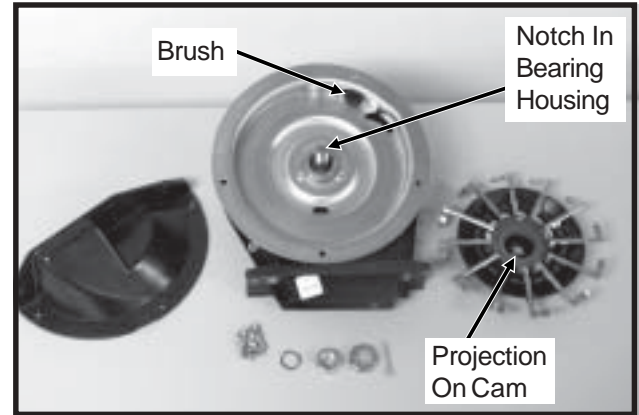

3. Check brush for wear and replace if necessary or following every 100 acres per row of operation.

EXAMPLE: Approximately 800 acres of corn or sunflowers on a 8 row machine or 1200 acres on an 12 row machine.

NOTE: It is not necessary to remove finger holder to replace brush.

4. To replace fingers or springs, remove springs from fingers and remove finger from holder by lifting it out of the friction fit slot. Under average conditions, life expectancy of these parts should be 600-900 acres per row of operation.
5. After cleaning and/or replacing defective parts, reassemble the meter in the reverse order. When replacing fingers, make sure the open end of the spring loop is toward the inside of the finger holder.

60620-22

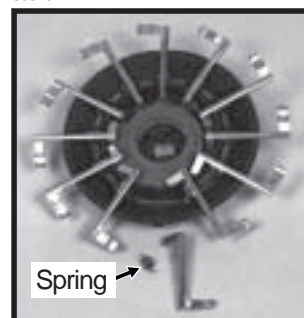

Corn Finger Assembly
(Position Spring Opening Toward Holder)

D07299902



Oil Sunflower Finger Assembly

6. Make sure fingers are installed in holder so that holder will be positioned flush with the carrier plate when assembled. A projection on the cam is designed to align with a mating notch in the bearing housing to ensure proper operation when assembled.

MAINTENANCE

D092004103

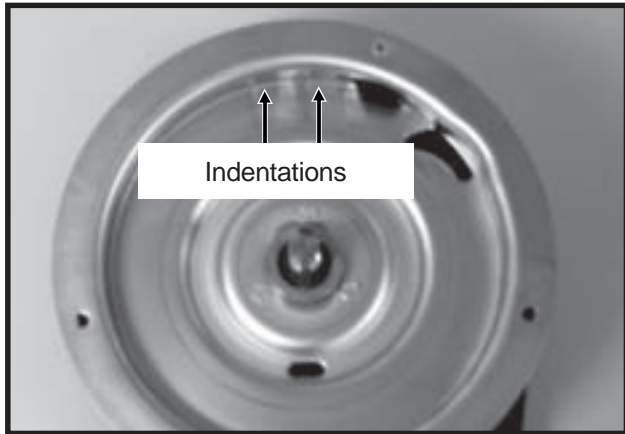

Photo Shows Worn Carrier Plate

- Before installing the finger holder on the carrier plate, check the indentations on the carrier plate for wear. Excessive wear of the carrier plate at the indentations will cause over planting especially when using small sizes of seed.

Inspect the carrier plate annually. Under average conditions, the life expectancy of the carrier plate should be 250-300 acres per row of operation.

- With finger holder flush against the carrier, install wave washer and adjusting nut. Tighten adjusting nut to fully compress wave washer. Then back off nut $\frac{1}{2}$ to 2 flats ($\frac{1}{12}$ to $\frac{1}{3}$ turn) to obtain rolling torque of 22 to 25 inch pounds.

D07299903/D07309912

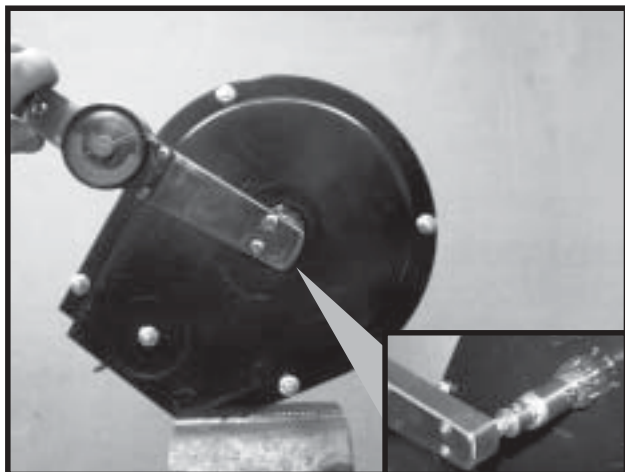

- Turn finger holder by hand to make sure it is positioned firmly against the carrier plate, but is not over tightened and can be rotated with moderate force.
- Install cover nut and cotter pin and reinstall baffle.

NOTE: Check tightness of adjusting nut on each unit after first day of use and periodically thereafter.

To inspect or replace the seed belt, remove the four cap screws around the edge of the housing cover and the nut from the belt idler mounting bolt.

60620-13a/60887-97

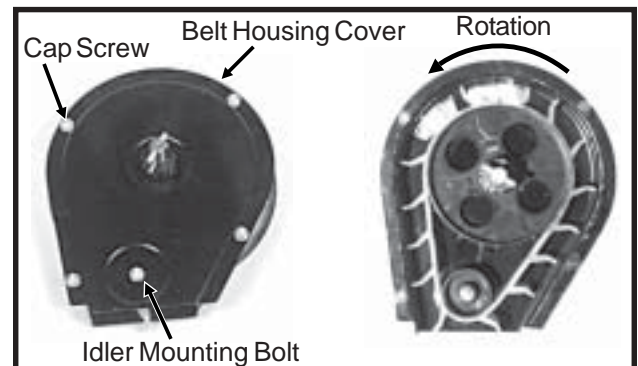

If the belt is being replaced, make sure it is installed to correctly orient the paddles as shown. A diagram molded into the drive sprocket also illustrates the correct orientation.

Reinstall the housing cover. **DO NOT TIGHTEN** hardware at this time. Wedge a screwdriver between the sprocket hub and housing cover as shown below. Pry cover down until it is centered on the belt housing and tighten hardware. Check idler alignment by rotating meter drive shaft. The seed belt should “run” centered on the idler or with only slight contact with the belt housing or cover.

IMPORTANT: Do not over tighten hardware.

D06200030



FINGER PICKUP SEED METER CLEANING

- Disassemble meter.
- Blow out any foreign material present in the meter mechanism.
- Wash in mild soap and water. **DO NOT USE GASOLINE, KEROSENE OR ANY OTHER PETROLEUM BASED PRODUCT.**
- Dry thoroughly.
- Coat lightly with a rust inhibitor.
- Reassemble and store in a dry place.

MAINTENANCE

FINGER PICKUP SEED METER TROUBLESHOOTING

PROBLEM	POSSIBLE CAUSE	SOLUTION
One row not planting seed.	Drive release not engaged.	Engage drive release mechanism.
	Foreign material in hopper.	Clean hopper and finger carrier mechanism.
	Seed hopper empty.	Fill seed hopper.
	Row unit drive chain off of sprocket or broken.	Check drive chain.
Drive release does not engage properly.	Drive release shaft is not aligned properly with meter drive shaft.	Align drive mechanism. See "Seed Meter Drive Adjustment".
Unit is skipping.	Foreign material or obstruction in meter.	Clean and inspect.
	Finger holder improperly adjusted.	Adjust to specifications. (22 to 25 in. lbs. rolling torque)
	Broken fingers. required.	Replace fingers and/or springs as required.
	Planting too slowly.	Increase planting speed to within recommended range.
Planting too many doubles.	Planting too fast.	Stay within recommended speed range.
	Loose finger holder.	Adjust to specifications. (22 to 25 in. lbs. rolling torque)
	Worn brush in carrier plate.	Inspect and replace if necessary.
Overplanting.	Worn carrier plate. Seed hopper additive being used.	Inspect and replace if necessary. Reduce or eliminate additive or increase graphite.
Underplanting.	Seed belt installed backwards.	Remove and install correctly.
	Weak or broken springs.	Replace.
	Spring not properly installed.	Remove finger holder and correct.
	Seed belt catching or dragging.	Replace belt.
	Brush dislodging seed.	Replace brush.
Irregular or incorrect seed spacing.	Driving too fast.	Check chart for correct speed.
	Wrong tire pressure.	Inflate tires to correct air pressure.
	Drive wheels slipping.	Reduce down pressure on row unit down force springs.
	Wrong sprockets.	Check seed rate charts for correct sprocket combinations.
Seed spacing not as indicated in charts.	Wrong tire pressure.	Inflate tires to correct air pressure.
	Inconsistent seed size.	Do field check and adjust sprockets accordingly.
	Wrong sprockets.	Check chart for correct sprocket combination.
	Charts are approximate.	Slight variations due to wear in meter components and tire slippage due to field conditions may produce seed spacing variations.
	Stiff or worn drive chains.	Replace chains.
Scattering of seeds.	Planting too fast.	Reduce planting speed.
	Seed tube improperly installed.	Check seed tube installation.
	Seed tube worn or damaged.	Replace seed tube.
Seed tubes and/or openers plugging.	Allowing planter to roll backward when lowering.	Lower planter only when tractor is moving forward.
Inconsistent seed depth.	Rough seed bed.	Adjust down pressure springs. Reduce planting speed.
	Partially plugged seed tube.	Inspect and clean.
	Seed tube improperly installed.	Install properly.

MAINTENANCE

BRUSH-TYPE SEED METER MAINTENANCE

60607-10a

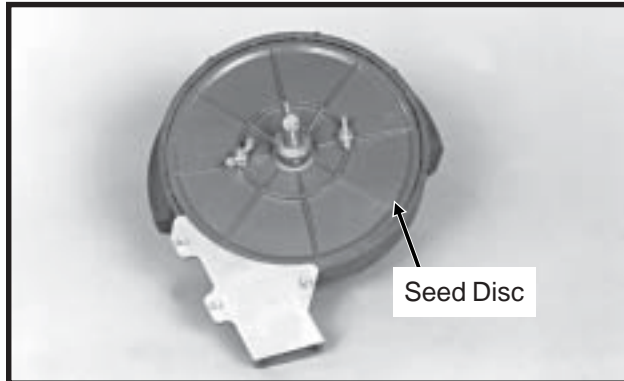

D04239911

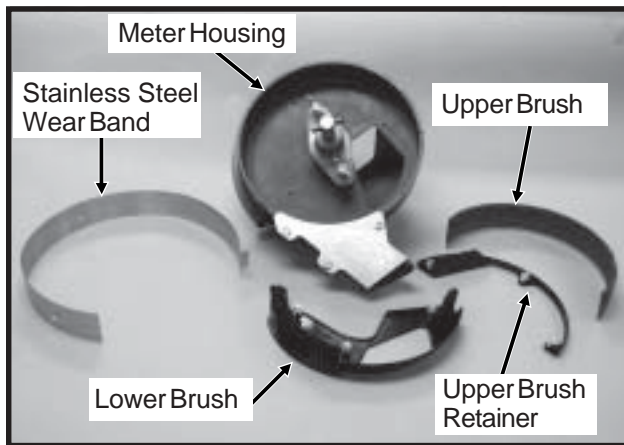

Only clean, high quality seed should be used for maximum meter accuracy. Damaged or cracked seed, hulls or foreign materials may become lodged in the upper brush and greatly reduce meter accuracy. It is suggested that the seed disc be removed daily, inspected and cleaned. Check for buildup of foreign material on the seed disc, particularly in the seed loading slots. Clean the disc by washing it with soap and water. Check for cracked seed, hulls, etc. lodged between the brush retainer and stainless steel wear band which can greatly reduce the accuracy of the meter because the upper brush will not be able to retain the seed in the seed disc pocket. Clean the brush areas of the meter housing thoroughly.

D04239912a



IMPORTANT: Replace hopper lids after hoppers are filled to prevent accumulation of dust or dirt in the seed meter which will cause premature wear.

Cleaning brush-type seed meter for storage:

1. Remove meter from seed hopper by removing the two thumbscrews which secure the meter to the hopper.
2. Remove seed disc and wash with soap and water and dry thoroughly.
3. Remove upper brush by removing the three hex head screws from the brush retainer and removing brush retainer and upper brush.
4. Remove the three hex head screws from the lower brush and remove lower brush and stainless steel wear band.
5. Wash all parts and meter housing with soap and water and dry thoroughly.
6. Inspect all parts for wear and replace worn parts.
7. Reassemble meter except for seed disc. **Meter should be stored in a rodent-free space with seed disc removed.**

Seed Disc Wear

HD112690(PLTR40b)

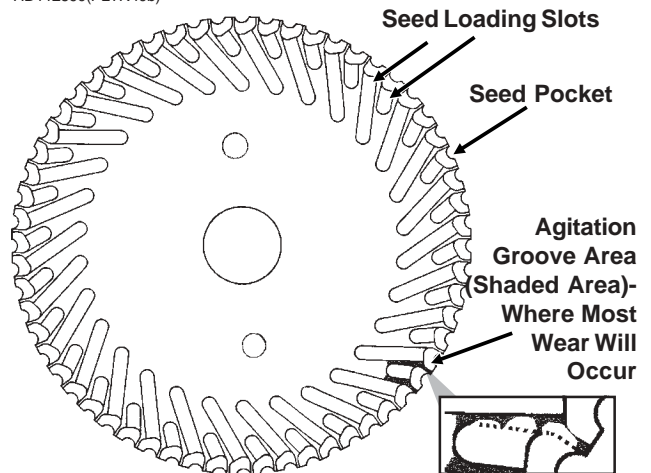

Most wear on the seed disc will be found in the agitation groove area (area between the seed loading slots). Wear will affect planting accuracy at high RPM. To measure for wear, lay a straight edge across the surface of the disc and measure the gap between the disc (at the agitation groove area) and the straight edge. If the agitation groove areas are worn in excess of .030" and accuracy starts to drop off at higher meter RPM, the seed disc should be replaced.

Estimated life expectancy of the seed disc under normal operating conditions should be approximately 200 acres per row. Severe operating conditions such as dust, lack of lubrication or abrasive seed coating could reduce life expectancy of the seed disc to under 100 acres per row.

MAINTENANCE

Upper Brush

LF212299-13a

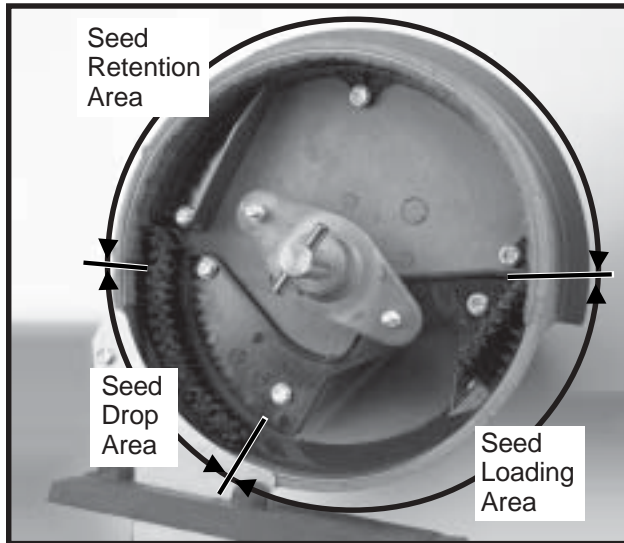

The upper brush holds seed in the seed disc pocket in the seed retention area.

The brush must apply enough pressure against the seed in the seed disc pocket as the disc rotates through the seed retention area to prevent the seed from dropping out of the disc pocket. A damaged spot, excessive wear on the brush or foreign material lodged in the brush may greatly reduce meter performance.

The upper brush should be replaced at approximately 120-400 acres per row of use or sooner if damage or excessive wear is found.

Installation Of Upper Brush

Position upper brush into inner perimeter of seed retention area. Make sure the base of the brush is tight against the bottom of the meter housing. Install brush retainer and three hex head screws. Tighten center screw first, left screw second and right screw last.

NOTE: Use GD11122 upper brush retainer when using soybean and cotton discs. Use GD8237 upper brush retainer when using milo/grain sorghum discs. GD11122 brush retainer shown.

LF212299-13a

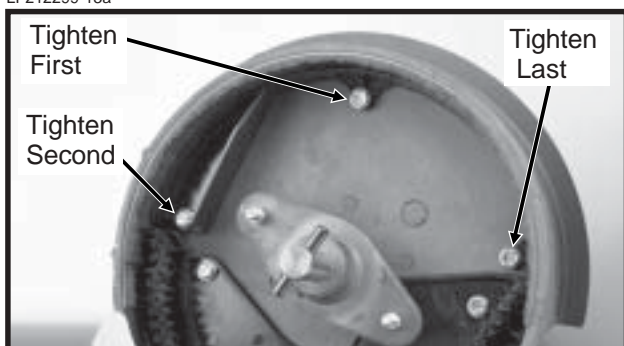

Stainless Steel Wear Band

D04239917a

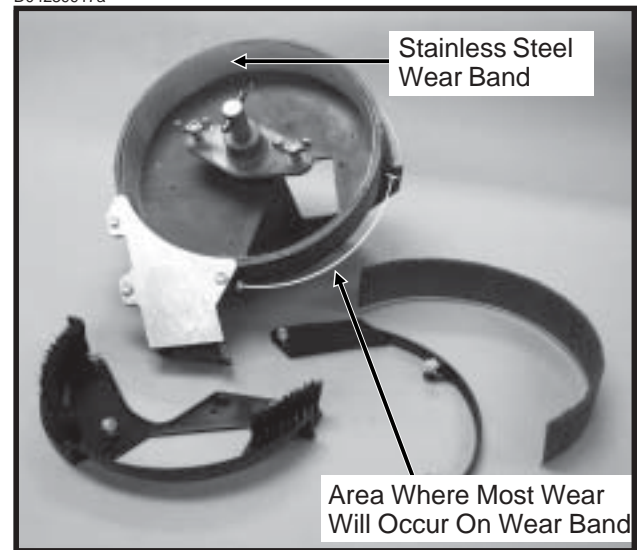

The purpose of the stainless steel wear band is to protect the meter housing from wear. The band is .030" thick and should be replaced when approximately .020" of wear is found in the primary area of wear. If the wear band is allowed to wear through or if the meter is used without the wear band in place, damage to the meter housing may occur.

Estimated life expectancy of the stainless steel wear band is 240-800 acres per row.

Lower Brush

D04239911

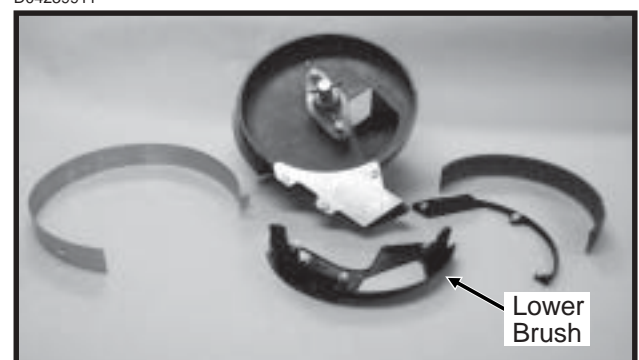

The lower brush has several functions. One function is to move seed down the seed loading slots to the seed pockets. The second function is to isolate seed in the reservoir from entering the seed tube and a third is to clean the seed loading slots.

Estimated life expectancy of the lower brush is 240-800 acres per row. The lower brush should be replaced if the bristles are deformed or missing or if there are cracks in the brush retainer.

MAINTENANCE

BRUSH-TYPE SEED METER TROUBLESHOOTING

PROBLEM	POSSIBLE CAUSE	SOLUTION
Low count.	Meter RPM too high.	Reduce planting speed.
	Misalignment between drive clutch and meter.	See "Seed Meter Drive Adjustment".
	Seed sensor not picking up all seeds dropped.	Clean seed tube. Switch meter to different row. If problem stays with same row, replace sensor.
	Lack of lubrication causing seeds not to release from disc properly.	Use graphite or talc as recommended.
	Seed size too large for seed disc being used.	Switch to smaller seed or appropriate seed disc. See "Brush-Type Seed Meter" for proper seed disc for size of seed being used.
	Seed treatment buildup in meter.	Reduce amount of treatment used and/or thoroughly mix treatment with seed. Add talc.
Low count at low RPM and higher count at higher RPM.	Foreign material lodged in upper brush.	Remove seed disc and remove foreign material from between brush retainer and bristles. Clean thoroughly.
	Worn upper brush.	Replace. See "Maintenance".
Low count at higher RPM and normal count at low RPM.	Seed disc worn in the agitation groove area.	Replace disc. See "Maintenance".
High count.	Seed size too small for seed disc.	Switch to larger seed or appropriate seed disc.
	Incorrect seed rate transmission setting.	Reset transmission. Refer to proper rate chart in "Machine Operation" section of manual.
	Upper brush too wide (fanned out) for small seed size.	Replace upper brush.
High count. (Milo/Grain Sorghum)	Incorrect brush retainer being used.	Make sure GD8237 brush retainer is installed to keep upper brush from fanning out.
Upper brush laid back.	Seed treatment buildup on brush.	Remove brush. Wash with soap and water. Dry thoroughly before reinstalling. See "Maintenance".
	Buildup of foreign material at base of brush.	Remove brush retainer and brush. Clean thoroughly. Reinstall.

MAINTENANCE

CLOSING WHEEL TROUBLESHOOTING

PROBLEM	POSSIBLE CAUSE	SOLUTION
Closing wheel(s) leave severe imprint in soil.	Too much closing wheel down pressure.	Adjust closing wheel pressure.
Closing wheel(s) not firming soil around seed.	Insufficient closing wheel down pressure.	Adjust closing wheel pressure. Severe no till conditions may require use of cast iron closing wheels.
"V" closing wheel running on top of seed furrow.	Improper centering.	Align. See "V Closing Wheel Adjustment".
Single closing wheel not directly over seed.	Improper centering.	Align. See "Covering Discs/Single Press Wheel Adjustment".

DRAG CLOSING ATTACHMENT

LF212299-18

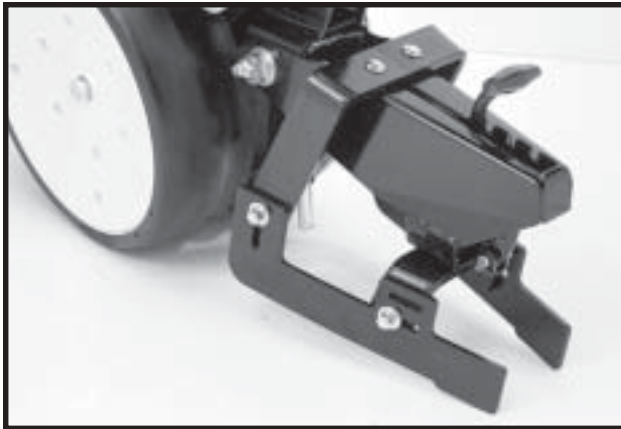

Prior to storage of the planter, inspect each drag closing attachment and replace any worn or broken parts. Check for loose hardware and tighten as needed.

GAUGE WHEEL ADJUSTMENT

To prevent an accumulation of dirt or trash, gauge wheels should lightly contact the opener blades. Gauge wheels and opener blades should turn with only slight resistance.

To adjust clearance between gauge wheels and opener blades, add or remove machine bushings between the shank and gauge wheel arm. Store remaining machine bushings between gauge wheel arm and flat washer on outer side of gauge wheel arm.

NOTE: It may be desirable to space gauge wheel further from blade when operating in sticky soils.

LF212199-2

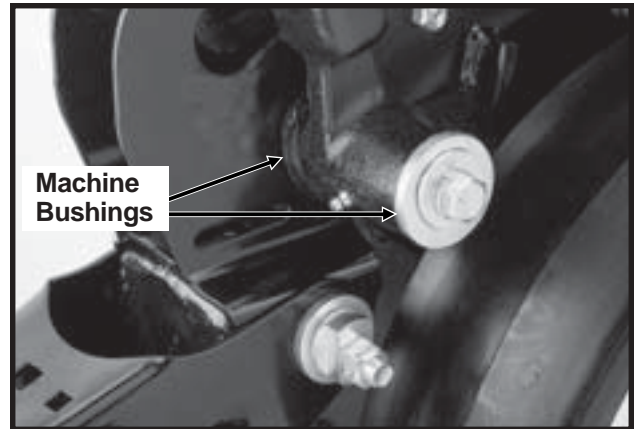

(RU113)

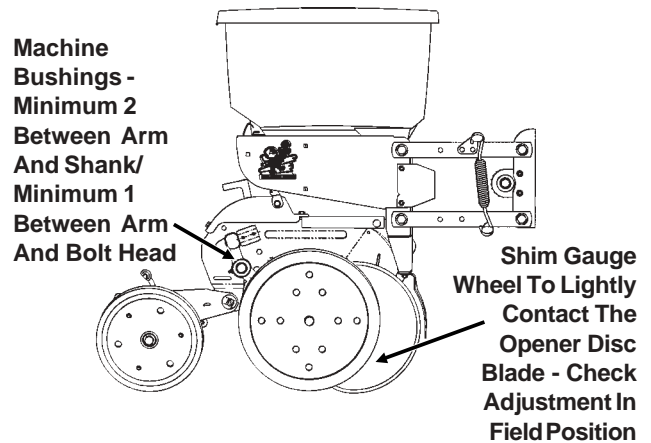

MAINTENANCE

GAUGE WHEEL ARM BUSHING AND/OR SEAL REPLACEMENT

(RU113)

Gauge Wheel Arm Bushings/Seals

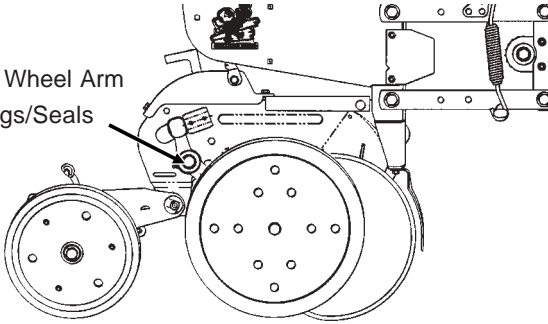

NOTE: A Gauge Wheel Arm Bushing And Seal Driver Kit (G1K296), for use in bushing and seal replacement, is available through your KINZE® Dealer.

To replace gauge wheel arm assembly bushing(s) and/or seal(s):

1. Remove gauge wheel from arm.
2. Remove the gauge wheel arm assembly from the shank assembly.
3. Remove seal and bushing and discard. Clean and dry inner bore.

(A7975/RU122)

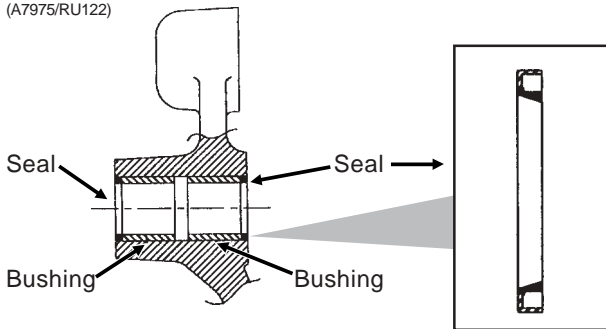

4. Drive/press replacement bushing inside bore of arm to a depth of .125" below flush.
5. Coat wiping edge of seal with grease.
6. Drive/press seal into place with lip to the outside as shown above.

NOTE: Use extra care to protect the sealing lip during installation. Apply uniform pressure to assemble the seal into the bore of the arm. Never apply a direct hammer blow to the seal surface.

7. Inspect gauge wheel pivot spindle.
8. Reinstall gauge wheel arm assembly and gauge wheel.

NOTE: Special machine bushing between gauge wheel arm and gauge wheel.

9. Shim for proper gauge wheel tire/disc blade clearance.
10. Lubricate with an SAE multipurpose type grease.

GAUGE WHEEL ARM PIVOT SPINDLE REPLACEMENT

(RU113)

Gauge Wheel Pivot Spindle

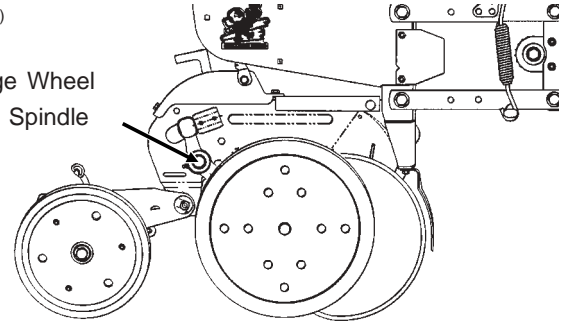

To replace gauge wheel pivot spindle:

1. Remove the gauge wheel and arm assemblies from the shank assembly.
2. Remove $\frac{1}{2}$ " x $\frac{3}{4}$ " cap screw that locks the pivot spindle in place and remove the spindle.

D06189902

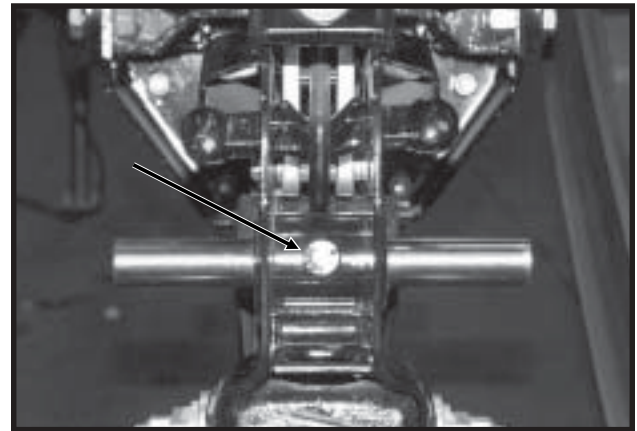

3. Install the replacement spindle and position as shown below. Exact centering is critical.

(A7966)

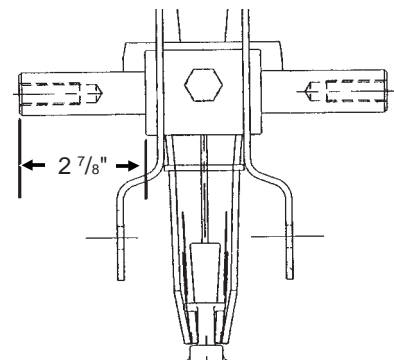

4. Install $\frac{1}{2}$ " x $\frac{3}{4}$ " cap screw and torque to lock pivot spindle in place.
5. Install gauge wheel and arm assemblies. Shim for proper gauge wheel tire/disc blade clearance.

MAINTENANCE

15" SEED OPENER DISC BLADE/ BEARING ASSEMBLY

Approximately 1 - 1 1/2" of blade-to-blade contact should be maintained to properly open and form the seed trench. As the blade diameter decreases, due to wear, it will be necessary to relocate machine bushings from inside to outside to maintain approximately 1 - 1 1/2" of contact.

NOTE: If proper blade-to-blade contact cannot be maintained after relocating machine bushings or if blade diameter wears below 14 1/2", the blade should be replaced.

IMPORTANT: Excessive blade contact may result in premature disc opener bearing/hub failures and excessive wear on seed tube guard/inner scraper. When properly adjusted, if one blade is held in fixed position, the opposite blade should be able to be rotated with minimal force (Less than 5 pounds force at outer edge of blade).

(RU113)

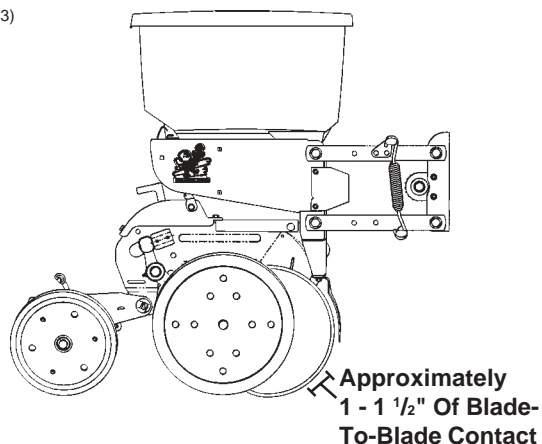

To replace disc blade/bearing assembly:

1. Remove gauge wheel.
2. Remove scraper.
3. Remove bearing dust cap.
4. Remove cap screw, washer and disc blade/bearing assembly. The machine bushings between the shank and disc blade are used to maintain the approximate 1 - 1 1/2" of blade-to-blade contact.

IMPORTANT: Left hand side of opener uses a left hand threaded cap screw. DO NOT OVERTIGHTEN. Damage to shank threads will require replacement of row unit shank assembly.

5. Install machine bushing(s), new disc blade/bearing assembly, washer and cap screw. Torque 5/8"-11 Grade 5 cap screw to value shown in "Torque Values Chart".

NOTE: Replace disc blade only with disc blade of equal thickness.

6. Replace bearing dust cap.
7. Install scraper.
8. Install gauge wheel.

It may be necessary to replace only the bearing if there is excessive endplay or if the bearing sounds or feels rough when the disc blade is rotated.

To replace bearing:

1. Remove gauge wheel, scraper, bearing cap, cap screw, washer and disc blade/bearing assembly.
2. Remove 1/4" rivets from bearing housing to expose bearing.
3. After installing new bearing, install three evenly spaced 1/4" cap screws into three of the six holes in the bearing housing to hold the bearing and bearing housing in place. Install rivets in the other three holes. Remove 1/4" cap screws and install rivets in those three holes.
4. Reinstall disc blade/bearing assembly, washer and cap screw. Torque 5/8"-11 cap screw to value shown in "Torque Values Chart" at the beginning of this section.
5. Replace bearing dust cap.
6. Install scraper and gauge wheel.

MAINTENANCE

SEED TUBE GUARD/INNER SCRAPER

The seed tube guard protects the seed tube and acts as the inner scraper for the seed opener disc blades.

Remove the seed tube and check for wear. Excessive wear on the seed tube indicates a worn seed tube guard. Replace the seed tube guard if it measures $\frac{5}{8}$ " or less at the lower end. A new seed tube guard measures approximately $\frac{7}{8}$ ".

LF212199-12

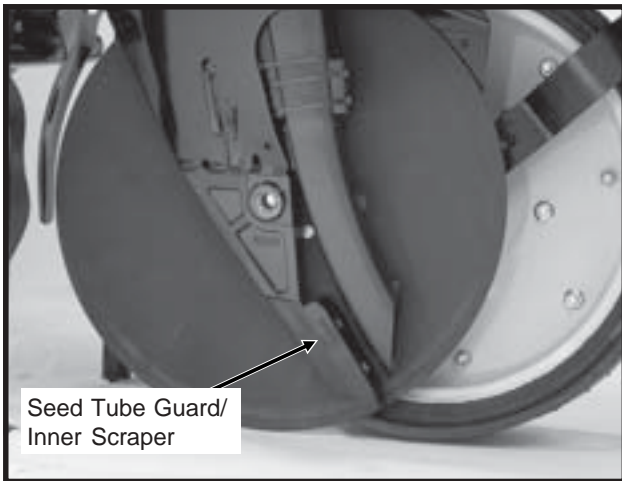

Shown With Gauge Wheel And Seed Opener Disc Blade Removed For Visual Clarity

IMPORTANT: No till planting or planting in hard ground conditions, especially when the planter is not equipped with no till coulters, and/or excessive blade-to-blade contact will increase seed tube guard wear and necessitate more frequent inspection and/or replacement.

To replace the seed tube guard, remove the seed tube and the two hex socket head cap screws which attach the seed tube guard. Hold the replacement seed tube guard centered between the seed opener disc blades. Install, but DO NOT tighten, the hex socket head cap screws. Using a clamp or vise-grip, squeeze the opener blades together in front of the seed tube guard. Tighten the seed tube guard retaining screws. Remove the clamps. The distance between the seed tube guard and opener blades should be equal on both sides. Reinstall seed tube.

IMPORTANT: Over tightening the hex socket head cap screws may damage the threads in the shank and require replacement of the shank. A seed tube guard that is worn excessively may allow the blades to wear into the row unit shank, also requiring replacement of the shank.

FRAME MOUNTED COULTER - STYLE A

LF212299-20

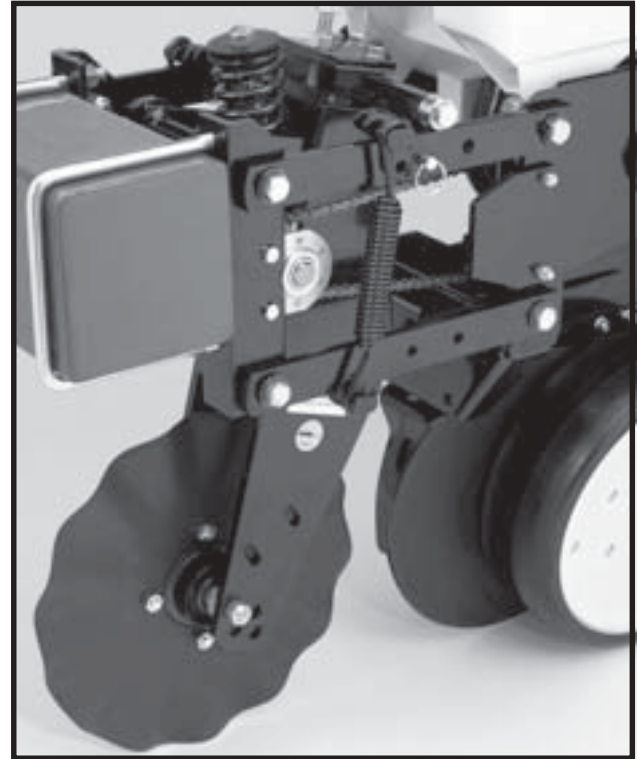

If properly maintained and lubricated (If Applicable) the bearings in the frame mounted coulters hub may never need to be replaced. Lubricate (If Applicable) at frequency indicated in the Lubrication Section of this manual. Check periodically to be sure nuts and hardware are tightened to proper torque specification. Be sure the coulters are positioned square with the planter frame and aligned in front of row unit disc opener.

NOTE: Torque $\frac{5}{8}$ " spindle bolts to 120 ft. lbs.

See "Frame Mounted Coulters" in Row Unit Operation Section of this manual for depth and spring adjustment.

When the 16" diameter coulters blade (1" fluted, 1" bubbled or $\frac{3}{4}$ " fluted) is worn to 14 $\frac{1}{2}$ " (maximum allowable wear), it should be replaced.

(If Applicable) Timely lubrication at the frequency indicated in the Lubrication Section of this manual is necessary to purge moisture and dirt from bearing and seal. This will also lubricate the seal. Add grease until it comes out around the seal.

MAINTENANCE

FRAME MOUNTED COULTER - STYLE B

LF083002101

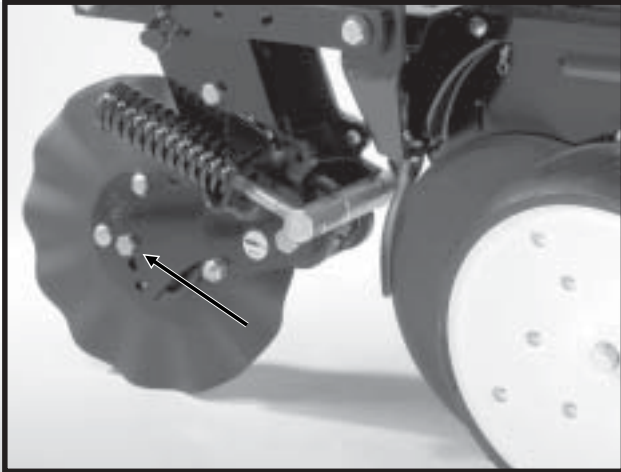

NOTE: Torque $\frac{5}{8}$ " spindle bolts to 120 ft. lbs.

See "Frame Mounted Coulters - Style B" in Row Unit Operation Section of this manual for depth and spring adjustment.

When the 16" diameter coulters blade (1" fluted, 1" bubbled or $\frac{3}{4}$ " fluted) is worn to 14 $\frac{1}{2}$ " (maximum allowable wear), it should be replaced.

DISC FURROWER (For Use With Style A Frame Mounted Coulters)

LF212299-21



The blade hubs are equipped with sealed bearings. If bearings sound or feel rough when the blade is rotated, replace the bearings.

When the 12" diameter blades (solid or notched) are worn to 11", they should be replaced.

RESIDUE WHEELS (For Use With Style B Frame Mounted Coulters)

LF083002102

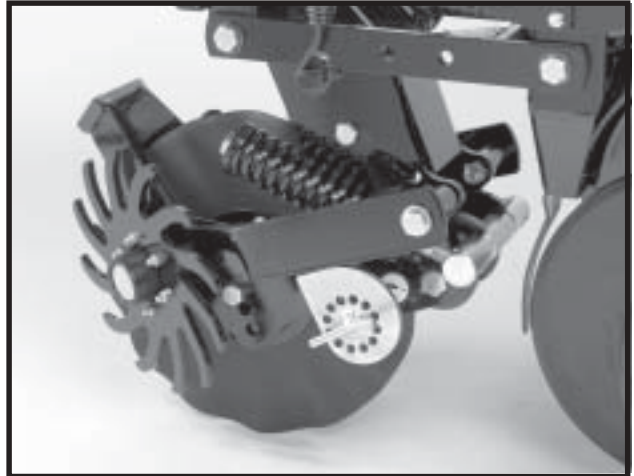

The wheel hub is equipped with sealed bearings. If bearings sound or feel rough when the blade is rotated, replace the bearings.

ROW UNIT MOUNTED DISC FURROWER

LF212299-22

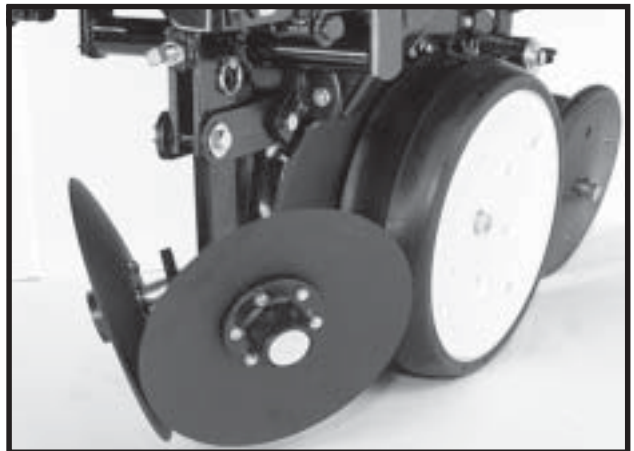

Lubricate the bushings in the support arm and mounting bracket at the frequency indicated in the Lubrication Section of this manual. Using a torque wrench, check each bolt for proper torque. If the bolt is loose, it should be removed and the bushing inspected for cracks and wear. Replace bushings as necessary. **Only hardened flat washers should be used. Replace damaged flat washers with proper part. Torque bolts to 130 ft. lbs.**

The blade hubs are equipped with sealed bearings. If bearings sound or feel rough when the blade is rotated, replace the bearings.

When the 12" diameter blades (solid or notched) are worn to 11", they should be replaced.

MAINTENANCE

ROW UNIT MOUNTED BED LEVELER

LF212299-25a

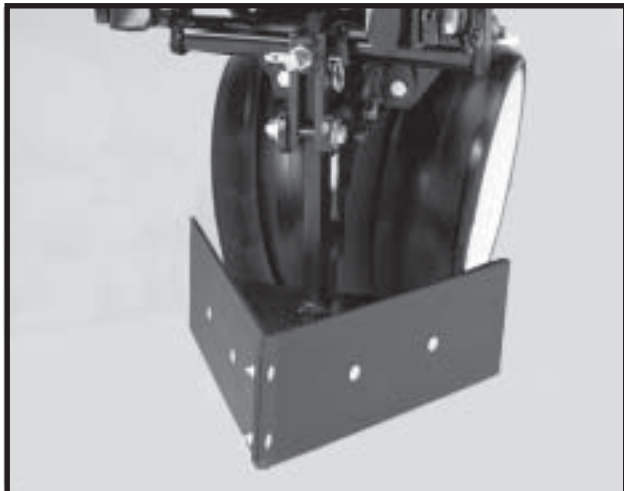

59386-26

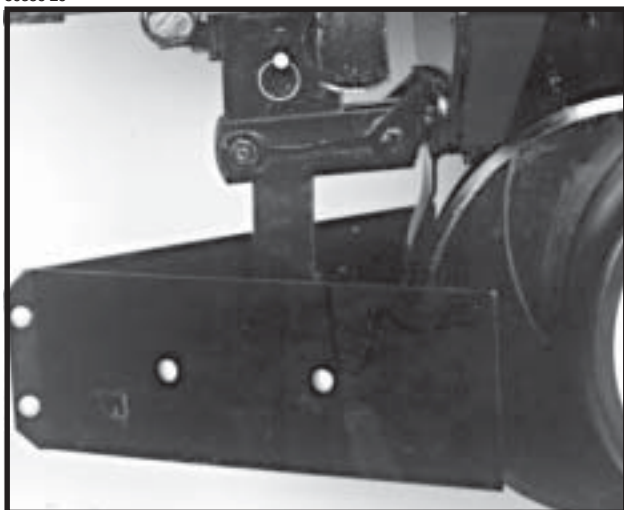

Lubricate the bushings in the mounting bracket and links at the frequency indicated in the Lubrication Section of this manual. Using a torque wrench, check each bolt for proper torque. If the bolt is loose, it should be removed and the bushing inspected for cracks and wear. Replace bushing if necessary. **Only hardened flat washers should be used. Replace damaged flat washers with proper part. Torque bolts to 130 ft. lbs.**

ROW UNIT MOUNTED RESIDUE WHEEL

D101701113



The wheel hub is equipped with sealed bearings. If a bearings sound or feel rough when the wheel is rotated, replace the bearings.

MAINTENANCE

ROW UNIT MOUNTED NO TILL COULTER

LF212299-19a



Lubricate (If Applicable) at frequency indicated in the Lubrication Section of this manual. Check periodically to be sure nuts and hardware are tightened to proper torque specification.

NOTE: Torque $\frac{5}{8}$ " spindle bolts to 120 ft. lbs.

Be sure the coulters are positioned square with the row unit and aligned in front of row unit disc opener.

The coulters blade can be adjusted to one of four settings. Initially the blade is set in the highest position. As the blade wears it can be adjusted to one of the three lower settings. See "Row Unit Mounted No Till Coulters" in Row Unit Operation Section of this manual.

When the 16" diameter coulters blade is worn to 14 $\frac{1}{2}$ " (maximum allowable wear), it should be replaced.

(If Applicable) Timely lubrication at the frequency indicated in the Lubrication Section of this manual is necessary to purge moisture and dirt from bearings and seals. This will also lubricate the seals. Add grease until it comes out around the seals. Spin hub while filling with grease.

COULTER MOUNTED RESIDUE WHEELS

LF212299-23

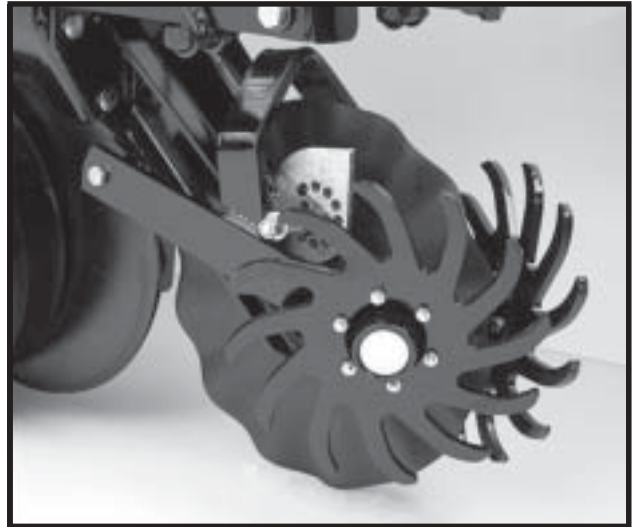

The wheel hubs are equipped with sealed bearings. If bearings sound or feel rough when the wheel is rotated, replace the bearings.

MAINTENANCE

GRANULAR CHEMICAL ATTACHMENT

Prior to storage of the planter, disengage the granular chemical drive by rotating the throwout knob $\frac{1}{4}$ turn counterclockwise. Remove the drive chain and empty and clean all granular chemical hoppers. Clean the drive chains and coat them with a rust preventive spray or submerge chains in oil. Inspect and replace any worn or broken parts.

Install hoppers and chains. Check chain alignment.

LF212299-4

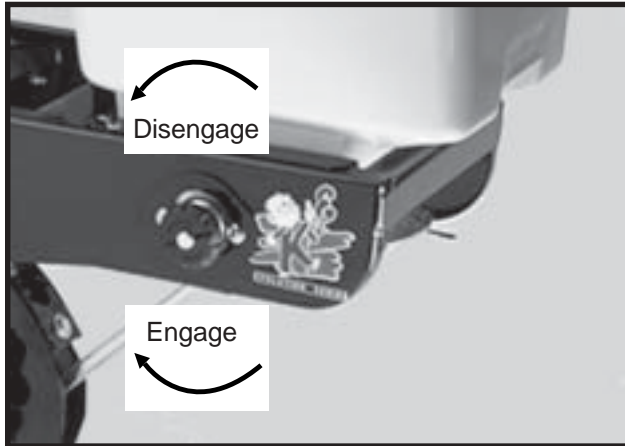

SPRING TOOTH INCORPORATOR

Prior to storage of the planter, inspect each spring tooth incorporator and replace any worn or broken parts. Check for loose hardware and tighten as needed.

LF212299-26

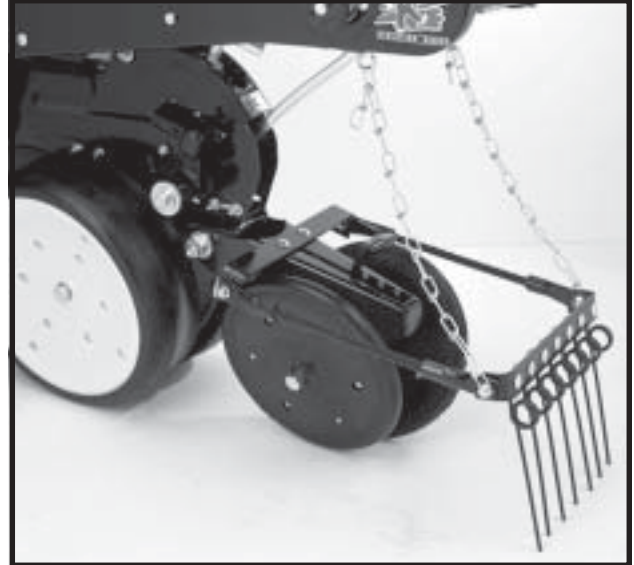

MAINTENANCE

KPM I/KPM II/KPM II STACK-MODE ELECTRONIC SEED MONITOR TROUBLESHOOTING

PROBLEM	POSSIBLE CAUSE	SOLUTION
Single sensor communication alarm comes on (alarm on with no bar graph and a flashing row number on a single row).	Faulty seed tube sensor.	Replace sensor.
	Break in the harness just before the seed tube sensor.	Inspect for break in harness and repair. If break can't be found, replace harness section.
	Dirty or corroded connector.	Clean connector.
Sensor communication alarms come on for all sensors (alarm on with no bar graphs and flashing row numbers on all rows).	Faulty monitor.	Replace monitor.
	Break in the harness just after the monitor.	Inspect for break in harness and repair. If break can't be found, replace harness section.
	Dirty or corroded connector.	Clean connector.
Sensor communication alarms come on for some sensors (alarm on with no bar graphs and flashing row numbers on all rows).	Break in the harness.	Inspect for break in harness and repair. If break can't be found, replace harness section corresponding with the alarming sensors.
	Dirty or corroded connector.	Clean connector.
Faulty monitor values (such as speed, area, etc.) being displayed. (KPM II And KPM II Stack-Mode Only)	Incorrect monitor settings.	Change settings to properly correspond to the system.
	Faulty radar/magnetic distance sensor.	Replace sensor.
	Improperly mounted radar sensor.	Properly mount sensor.
Underplanting or no planting alarm on a single sensor when planting (alarm on with a single bar graph segment on and a flashing row number on a single row).	Seed tube sensor is blocked.	Clean sensor.
	Faulty seed tube sensor.	Replace sensor.
Seed tube sensor dirty or blocked warning comes on (after calibration, bar graph keeps flashing for a single row).	Seed tube sensor is dirty.	Clean sensor.
	Faulty seed tube sensor.	Replace sensor.
LED on the seed tube sensor will not come on.	Faulty seed tube sensor.	Replace sensor.
	Dirty or corroded connector.	Clean connector.
	Break in the harness just before the sensor.	Repair harness.
Erroneous MPH readings at idle. (Radar Distance Sensor Only)	Radar sensor not located in a stable location.	Relocate to a more stable location.

MAINTENANCE

POINT ROW CLUTCH INSPECTION

The point row clutch is permanently lubricated and sealed and requires no periodic maintenance.

81014-12a

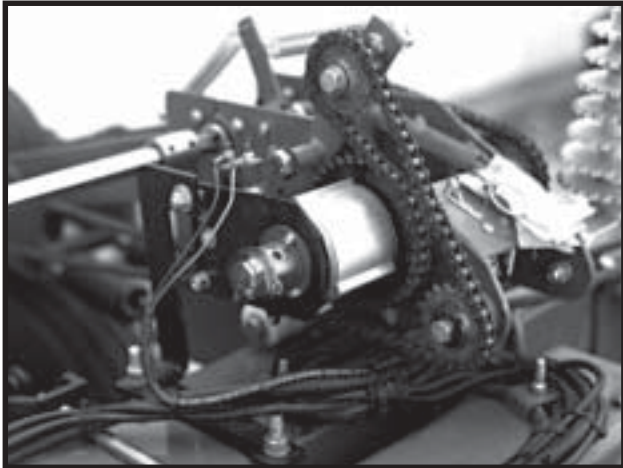

The right hand clutch operates clockwise and the left hand clutch operates counterclockwise. Therefore, some of the parts of the clutch such as the wrap spring differ from one side of the planter to the other. Be sure to use the correct repair part if a clutch must be repaired.

The control box is equipped with a resettable circuit breaker. To reset the circuit breaker, press the red button on the circuit breaker until it snaps into place. If the circuit breaker continues to trip, check to see what is causing it to trip. See "Point Row Clutch Troubleshooting".

76740-48



If the circuit breaker on the control box is not tripped, determine if the problem is electrical or mechanical. Place the operational switch in the RIGHT or LEFT position. Check the clutch and wiring harness for power with a test light or volt meter. If the solenoid is operating properly, the plunger on the solenoid will retract causing a clicking sound. The plunger will also be magnetized which can be checked by touching the plunger with a metal object.

(TWL70c)

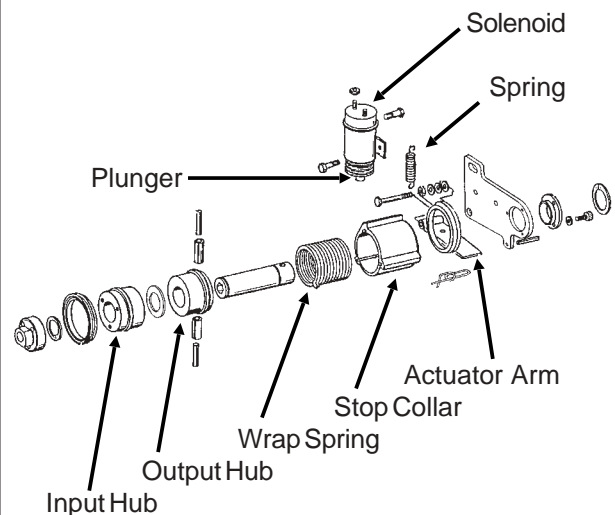

(A7110)

ACTUATOR ARM ADJUSTMENT

NOTE: Gap between actuator arm and stop on stop collar should be $\frac{1}{8}$ " ($\pm \frac{1}{32}$ ") when the solenoid is NOT engaged.

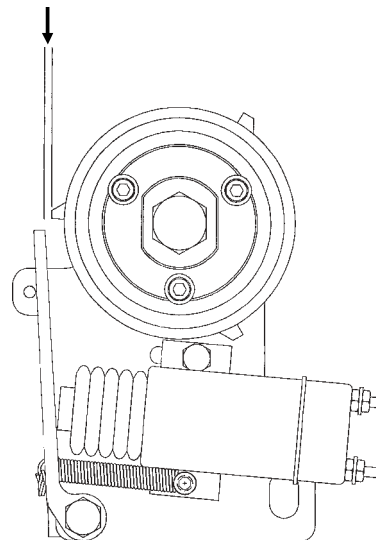

NOTE: To adjust gap between actuator arm and stop, loosen nut on mounting pin and move pin in slot until there is $\frac{1}{8}$ " ($\pm \frac{1}{32}$ ") gap between arm and stop on stop collar. Retighten nut.

MAINTENANCE

POINT ROW CLUTCH TROUBLESHOOTING

PROBLEM	POSSIBLE CAUSE	SOLUTION
Neither clutch will disengage.	Circuit breaker tripped.	Press red button on control box.
	Poor terminal connection in wiring harness.	Repair or replace.
	Wiring damage in wiring harness.	Repair or replace.
	Low voltage at coil. (12 volts required)	Check battery connections.
One side of planter will not re-engage.	Shear pin in row unit transmission sheared.	Replace with one of equal size and grade.
One clutch will not engage.	Actuator arm and plunger stuck in disengaged position.	Remove, free up and reinstall.
	Actuator arm out of adjustment.	Adjust actuator arm mounting pin in slot so that actuator arm clears stop on stop collar as shown in "Point Row Clutch Inspection".
	Wrap spring broken or stretched.	Disassemble clutch and replace spring.
	Foreign substance such as oil or grease on the input or output hubs.	Disassemble clutch. Clean hubs and spring and reassemble.
	Something touching the stop collar.	Check to ensure collar is free to turn with clutch.
	Clutch assembled incorrectly.	Check clutch and diagram for correct assembly.
Clutch slipping.	Wrap spring stretched.	"Lock" clutch output shaft from turning. Place torque wrench on input shaft and rotate in direction of drive. After input shaft has rotated a short distance the wrap spring should tighten onto the input hub. If slippage occurs at less than 100 ft. lbs. replace spring. If spring still slips after installing new spring, replace input hub.
Planter will not re-engage while planter is moving forward.	Spring in actuator arm not strong enough to push arm away from stop collar when operational switch is turned to the ON position.	Remove spring from inside solenoid and stretch spring slightly or replace. Reinstall spring. If that fails, file the stop on the stop collar slightly so that the stop is not as aggressive.
Frequent fuse burnout.	Low voltage (12 volts required).	Check power source voltage for partially discharged battery, etc.
	Damage to wiring harness.	Locate damage and repair or replace harness.
Clutch or clutches will not disengage.	Input and output shafts out of alignment.	Align input and output shafts to prevent drag.
	Input or output shaft is pushed in too far creating a coupler.	Reposition input and output shafts.

MAINTENANCE

TWO-SPEED POINT ROW CLUTCH

The two-speed point row clutch is similar in design and operation to the standard point row clutch except for the two-speed function. If a two-speed clutch or clutches fail to operate properly, refer to "Point Row Clutch Inspection" and "Point Row Clutch Troubleshooting" for additional information.

NOTE: If the "Reduced Rate/Full Rate" functions fail to engage or disengage, see troubleshooting chart for possible cause.

(SFP45b)

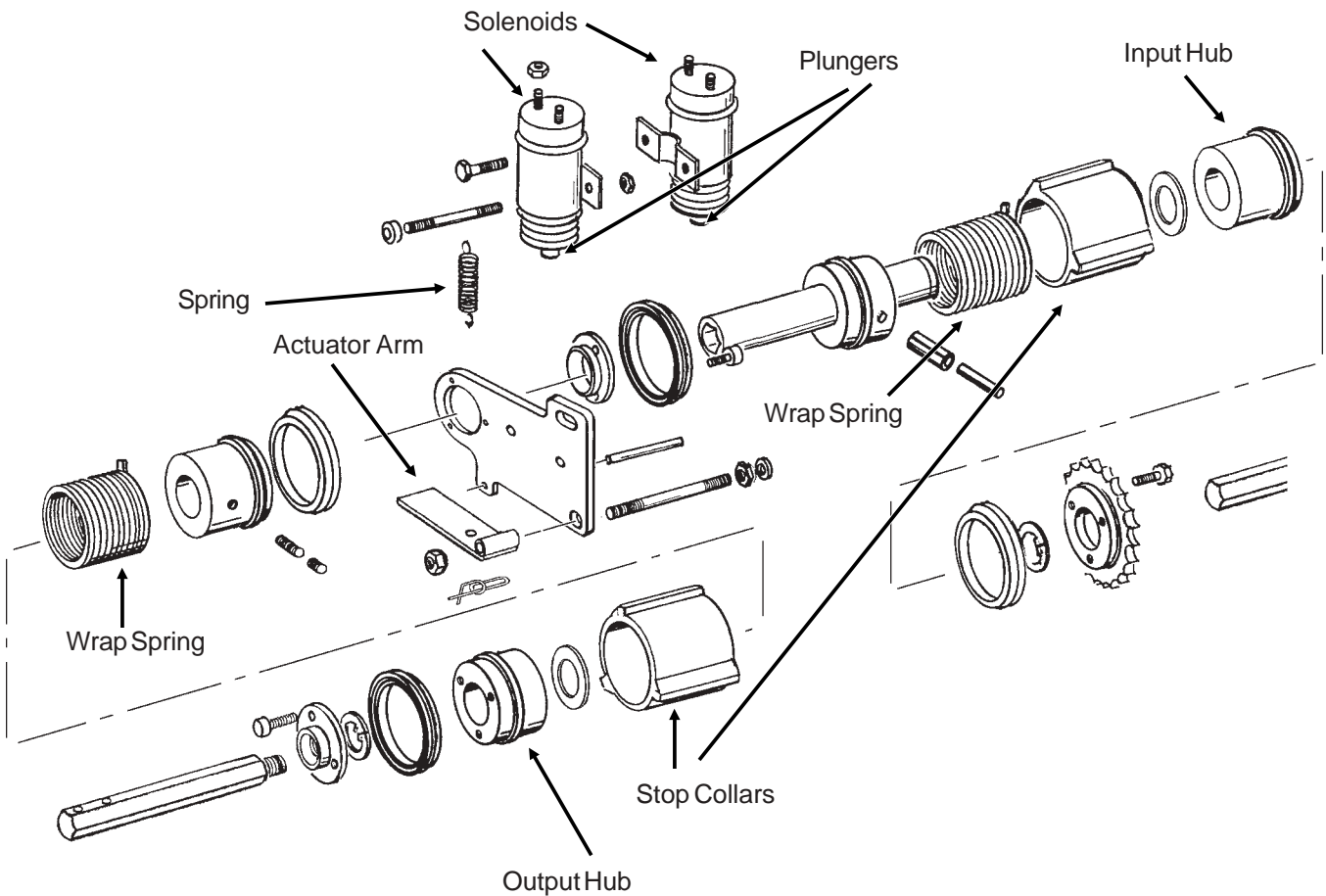

MAINTENANCE

CAM FOLLOWER ADJUSTMENT

Each wing hinge is equipped with a cam follower which floats against a curved guide on the center frame. Check cam followers periodically and maintain adjustment as shown below.

NOTE: Always check cam follower adjustment and make cam follower adjustments with the planter on a flat surface and lowered to the planting position.

A7386(SFP41)

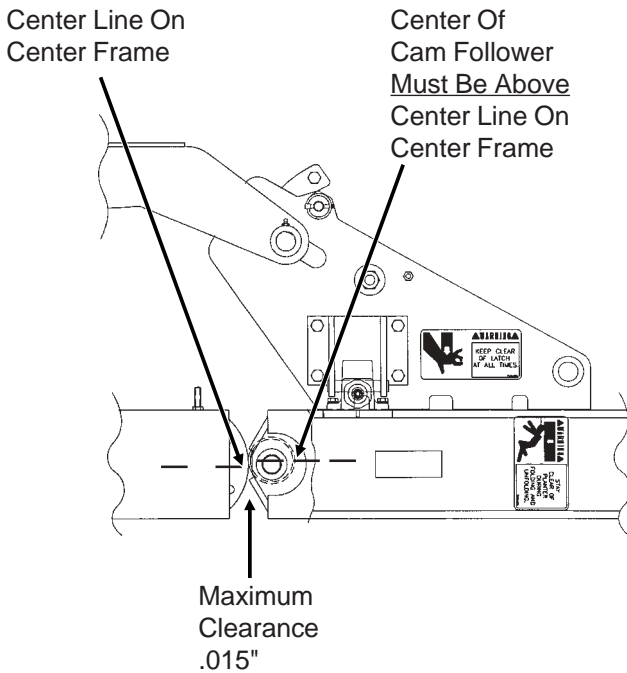

To adjust cam followers:

1. Loosen $\frac{3}{4}$ " cap screw on cam follower.
2. Using a $\frac{1}{2}$ " ratchet extension, rotate and hold cam follower in place.
3. Tighten $\frac{3}{4}$ " cap screw to 150 ft. lbs.

FLOW CONTROL VALVE INSPECTION

The optional dual lift assist wheels flow control valve should be adjusted as part of the assembly procedure or upon initial operation.

If the valve fails to function properly or requires frequent adjustment, the needle valve should be removed for inspection. Check for foreign material and contamination on both the valve and the seating area of the valve body. Replace any components found to be defective.

NOTE: The flow control valve must be installed with the arrow pointed toward the planter.

NOTE: When oil is cold, hydraulics operate slowly. Make sure all adjustments are made with warm oil.

WB001(MT2)

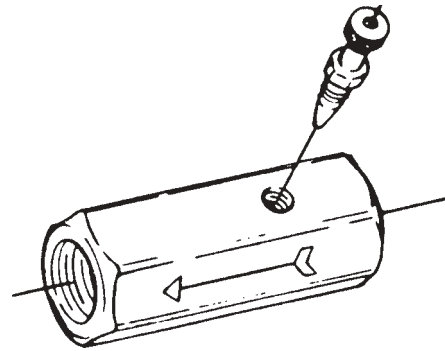

MAINTENANCE

ROW MARKER SEQUENCING/FLOW CONTROL VALVE INSPECTION

The valve block assembly consists of the marker sequencing and flow control valves in one assembly.

The sequencing valve portion consists of a chambered body containing a spool and series of check valves to direct hydraulic oil flow. Should the valve malfunction, the components may be removed for inspection.

1. Remove valve block assembly from planter.
2. Remove detent assembly and port adapter assemblies from rear of valve block.

IMPORTANT: Damage to the spool may occur if the detent assembly and port adapter assemblies are not removed prior to removal of the spool.

3. Remove plug from both sides of valve block and remove spool.
4. Inspect all parts for pitting, contamination or foreign material. Also check seating surfaces inside the valve. Replace any parts found to be defective.
5. Lubricate spool with a light oil and re-install. Check to be sure spool moves freely in valve body.

IMPORTANT: Make sure correct ball(s) and spring are installed in each valve bore upon reassembly.

A flow control valve is located on each side of the block assembly. The flow control valves should be adjusted for raise and lower speed as part of the assembly procedure or upon initial operation. If the valve fails to function properly or requires frequent adjustment, the needle valve should be removed for inspection. Check for foreign material and contamination. Be sure needle moves freely in adjustment screw. Replace any component found to be defective.

(PLTR43)

Port Adapter, Spring, $\frac{7}{16}$ " Check Ball, $\frac{1}{4}$ " Steel Ball

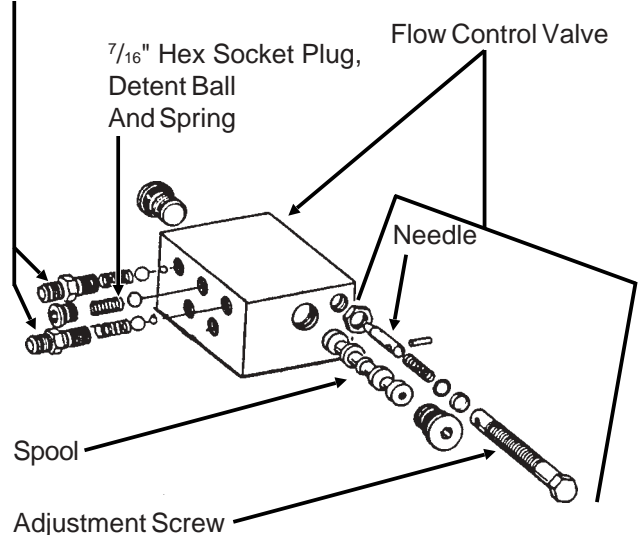

NOTE: When oil is cold, hydraulics operate slowly. Make sure all adjustments are made with warm oil.

MAINTENANCE

ROW MARKER OPERATION TROUBLESHOOTING

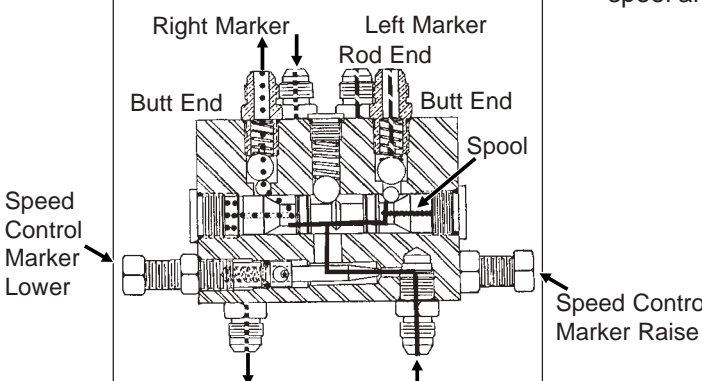
PROBLEM	POSSIBLE CAUSE	SOLUTION
Both markers lowering and only one raising at a time.	Hoses from cylinders to valve connected backwards.	Check hosing diagram in manual and correct.
Same marker always operating.	<p>Spool in sequencing valve not shifting.</p> 	Remove spool, inspect for foreign material, making sure all ports in spool are open. Clean and reinstall.
Both markers lower and raise at same time.	Foreign material under check ball in sequencing valve.	Remove hose fitting, spring and balls and clean. May be desirable to remove spool and clean as well.
	Check ball missing or installed incorrectly in sequencing valve.	Disassemble and correct. See illustration in Parts Section.
Marker (in raised position) settling down.	Damaged o-ring in marker cylinder or cracked piston.	Disassemble cylinder and inspect for damage and repair.
	<p>Spool in sequencing valve not shifting completely because detent ball or spring is missing.</p> <p>Spool in sequencing valve shifting back toward center position.</p>	<p>Check valve assembly and install parts as needed.</p> <p>Restrict flow of hydraulic oil from tractor to sequencing valve.</p>
Neither marker will move.	Flow control closed too far.	Loosen locking nut and turn flow control adjustment bolt out or counterclockwise until desired speed is set.
Markers moving too fast.	Flow control open too far.	Loosen locking nut and turn flow control adjustment bolt in or clockwise until desired speed is set.
Sporadic marker operation speed.	Needle sticking open in flow control valve.	Remove flow control, inspect and repair or replace.

MAINTENANCE

ROW MARKER BEARING LUBRICATION OR REPLACEMENT

1. Remove marker blade.
2. Remove dust cap from hub.
3. Remove cotter pin, nut and washer.
4. Slide hub from spindle.
5. Remove bearings and cups and discard if bearings are being replaced. Clean hub and dry. Remove bearings only and not cups if repacking.
6. Press in new bearing cups with thickest edge facing in. (Bearing replacement procedure only.)
7. Pack bearings with heavy duty wheel bearing grease thoroughly forcing grease between roller cone and bearing cage. Also, fill the space between the bearing cups in the hub with grease.
8. Place inner bearing in place and press in new rubber seal and grease seal.
9. Clean spindle and install hub.
10. Install outer bearing, washer and slotted hex nut. Tighten slotted hex nut while rotating hub until there is some drag. This assures that all bearing surfaces are in contact. Back off slotted nut to nearest locking slot and install cotter pin.
11. Fill dust caps approximately $\frac{3}{4}$ full of wheel bearing grease and install on hub.
12. Install blade and dust cap retainer on hub and tighten evenly and securely.

(PLTR45/PLTR99/PLTR98/PLTR102)

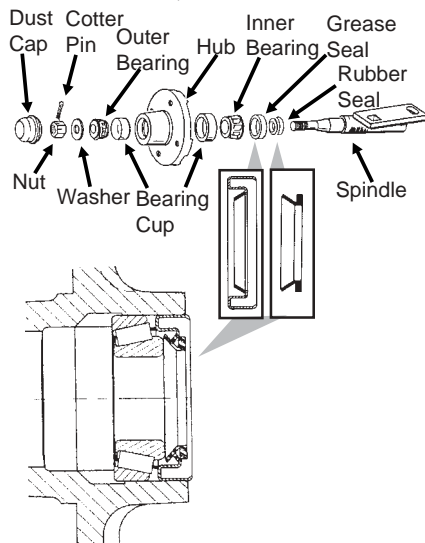

WHEEL BEARING LUBRICATION OR REPLACEMENT

1. Raise tire clear of ground and remove wheel.
2. Remove double jam nuts and slide hub from spindle.
3. Remove bearings and cups and discard if bearings are being replaced. Clean hub and dry. Remove bearings only and not cups if repacking.
4. Press in new bearing cups with thickest edge facing in. (Bearing replacement procedure only.)
5. Pack bearings with heavy duty wheel bearing grease thoroughly forcing grease between roller cone and bearing cage. Also fill the space between the bearing cups in the hub with grease.
6. Place inner bearing and seal (Where Applicable) in place.
7. Clean spindle and install hub.
8. Install outer bearing and jam nut. Tighten jam nut while rotating hub until there is some drag. This assures that all bearing surfaces are in contact. Back off jam nut $\frac{1}{4}$ turn or until there is only slight drag when rotating the hub. Install second jam nut to lock against first.
9. Install wheel on hub. Tighten wheel bolts evenly and torque to value shown in "Torque Values Chart" at the beginning of this section.

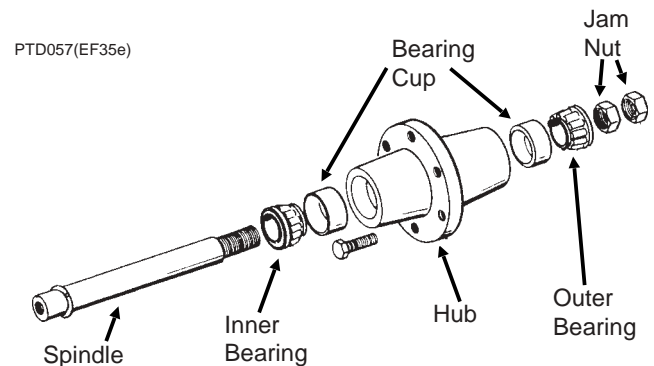

MAINTENANCE

PREPARATION FOR STORAGE

Store the planter in a dry sheltered area if possible.

Remove all trash that may be wrapped on sprockets or shafts and remove dirt that can draw and hold moisture.

Clean all drive chains and coat with a rust preventative spray, or remove chains and submerge in oil.

Lubricate planter and row units at all lubrication points.

If possible, remove weight from all tires particularly if the unit is stored outdoors, in which case it is best to remove wheels and tires for storage in a cool, dry area.

Inspect the planter and row units for parts that are in need of replacement and order during the "off" season.

Make sure all seed and granular chemical hoppers are empty and clean.

Clean seed meters and store in a rodent-free, dry area.

Remove seed discs from brush-type seed meters, clean and store meters with discs removed.

Grease exposed areas of cylinder rods before storing planter.

Grease or paint disc openers/blades and marker blades to prevent rust.

Disassemble, clean and grease all U-joint slides.

MAINTENANCE

ELECTRICAL WIRING DIAGRAM FOR LIGHT PACKAGE

STYLE A

(Used On Machines Equipped With Double Light Assemblies Only)

(WGN66a)

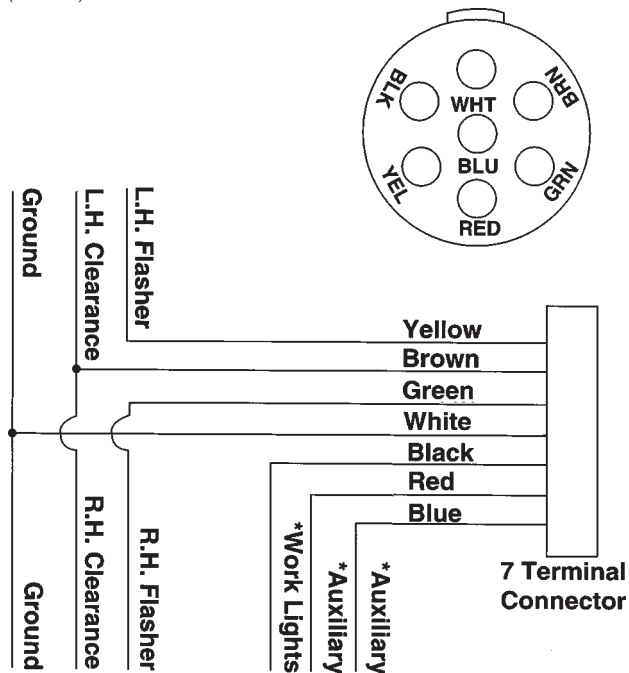

* Optional customer-supplied auxiliary lights and wires may be wired into existing plug terminals.

(ELC9)

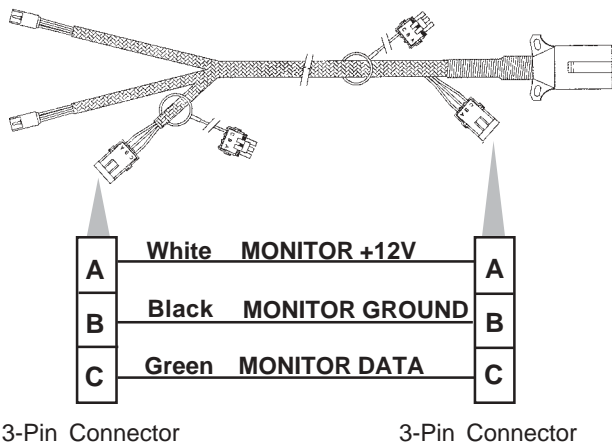

STYLE B

(Used On Machines Equipped With Single And Double Light Assemblies)

(WGN66b)

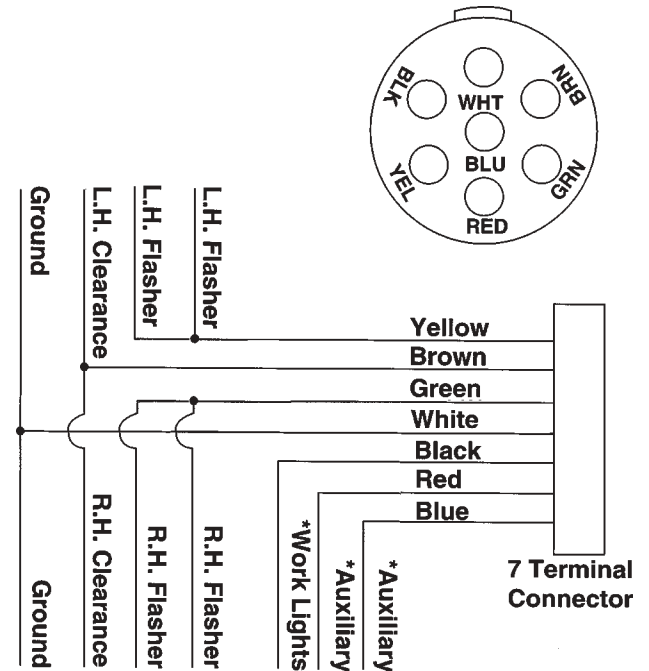

* Optional customer-supplied auxiliary lights and wires may be wired into existing plug terminals.

(ELC9a)

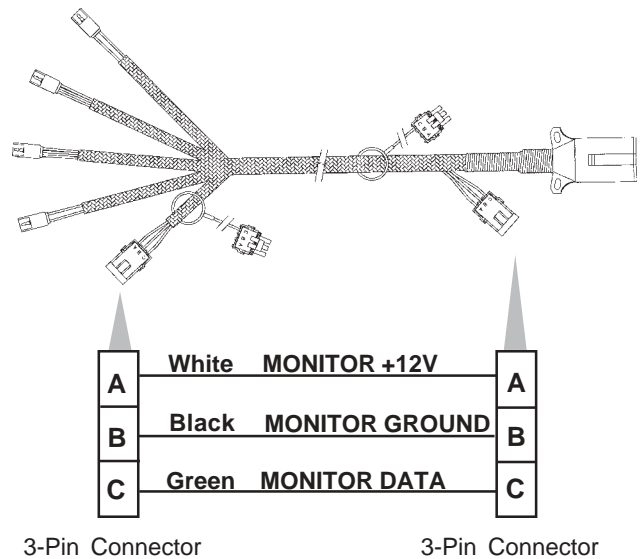

Light package supplied on the Model 3140 planter meets ASAE Standards. For the correct wiring harness to be wired into the lights on your tractor, check with the tractor manufacturer.

MAINTENANCE

ELECTRICAL WIRING DIAGRAMS FOR POINT ROW CLUTCHES

(EF10b/INS241/SFP6)

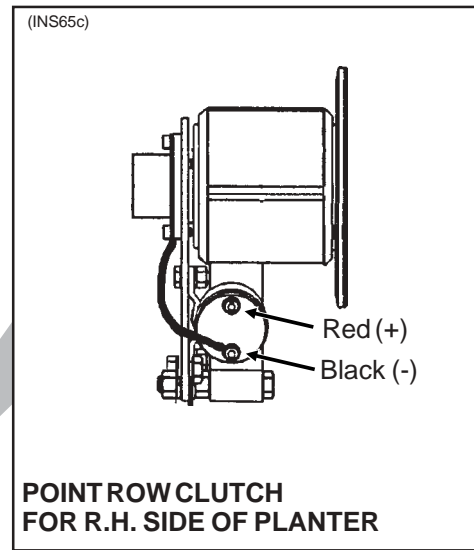
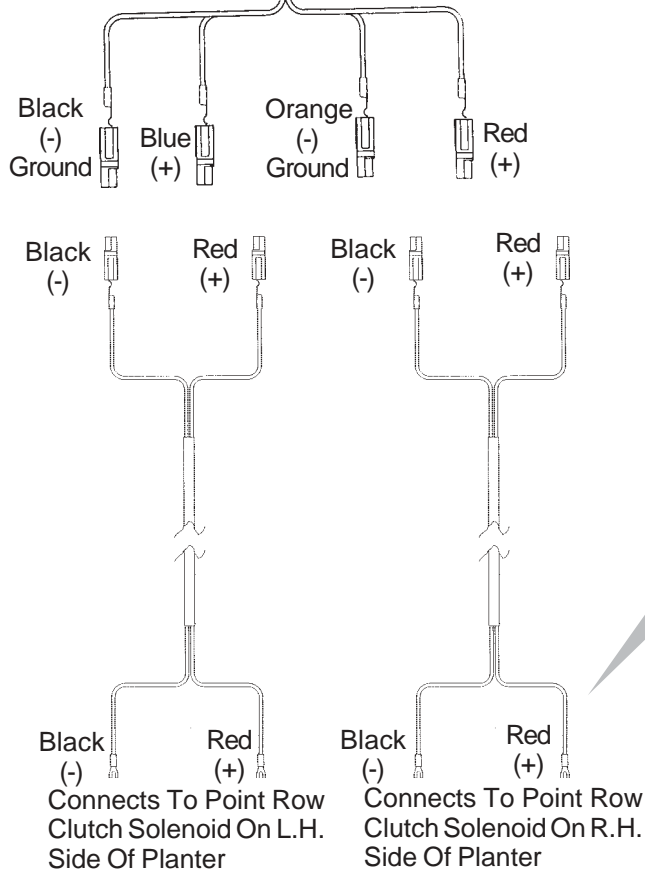
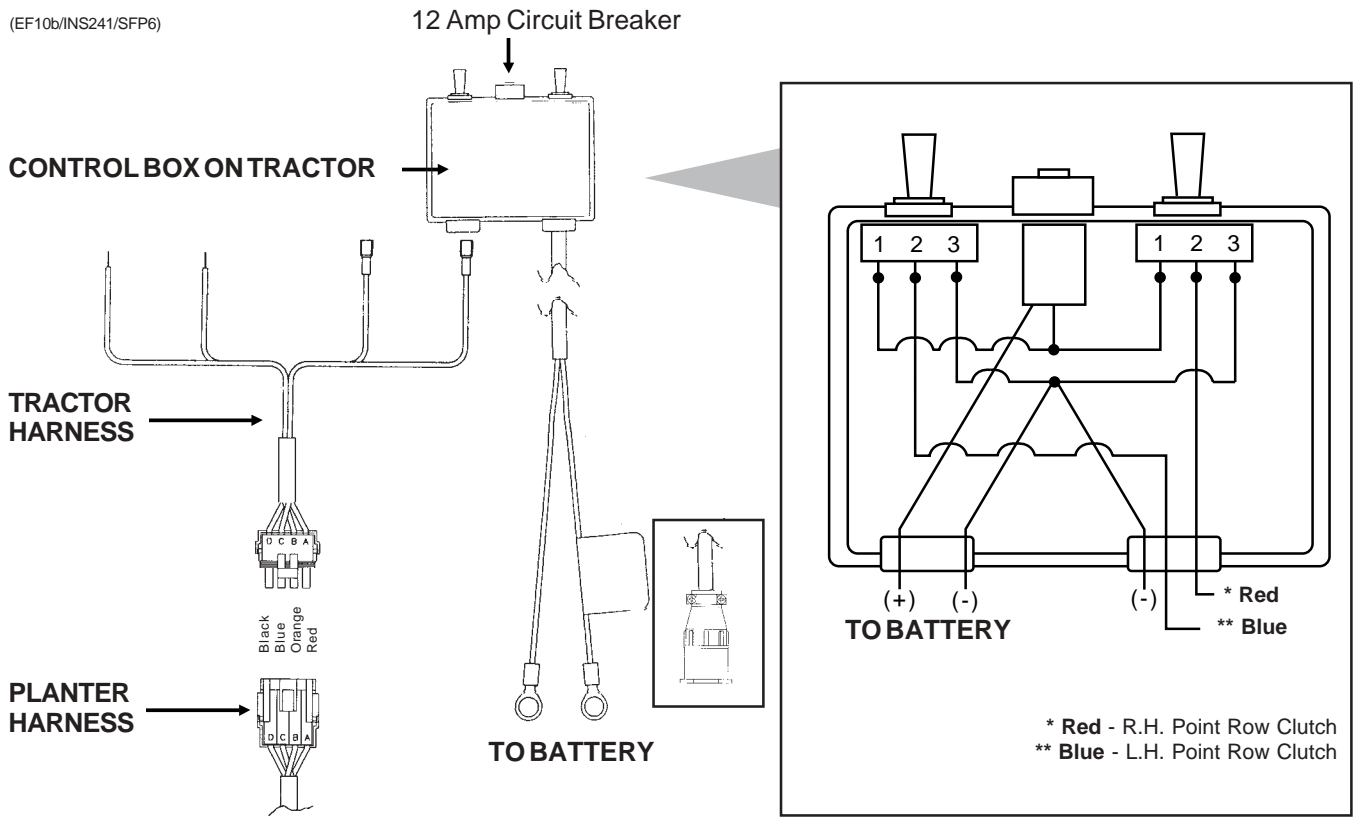

MAINTENANCE

ELECTRICAL WIRING DIAGRAMS FOR TWO-SPEED POINT ROW CLUTCHES

(SFP46f/TWL71a/ELC27)

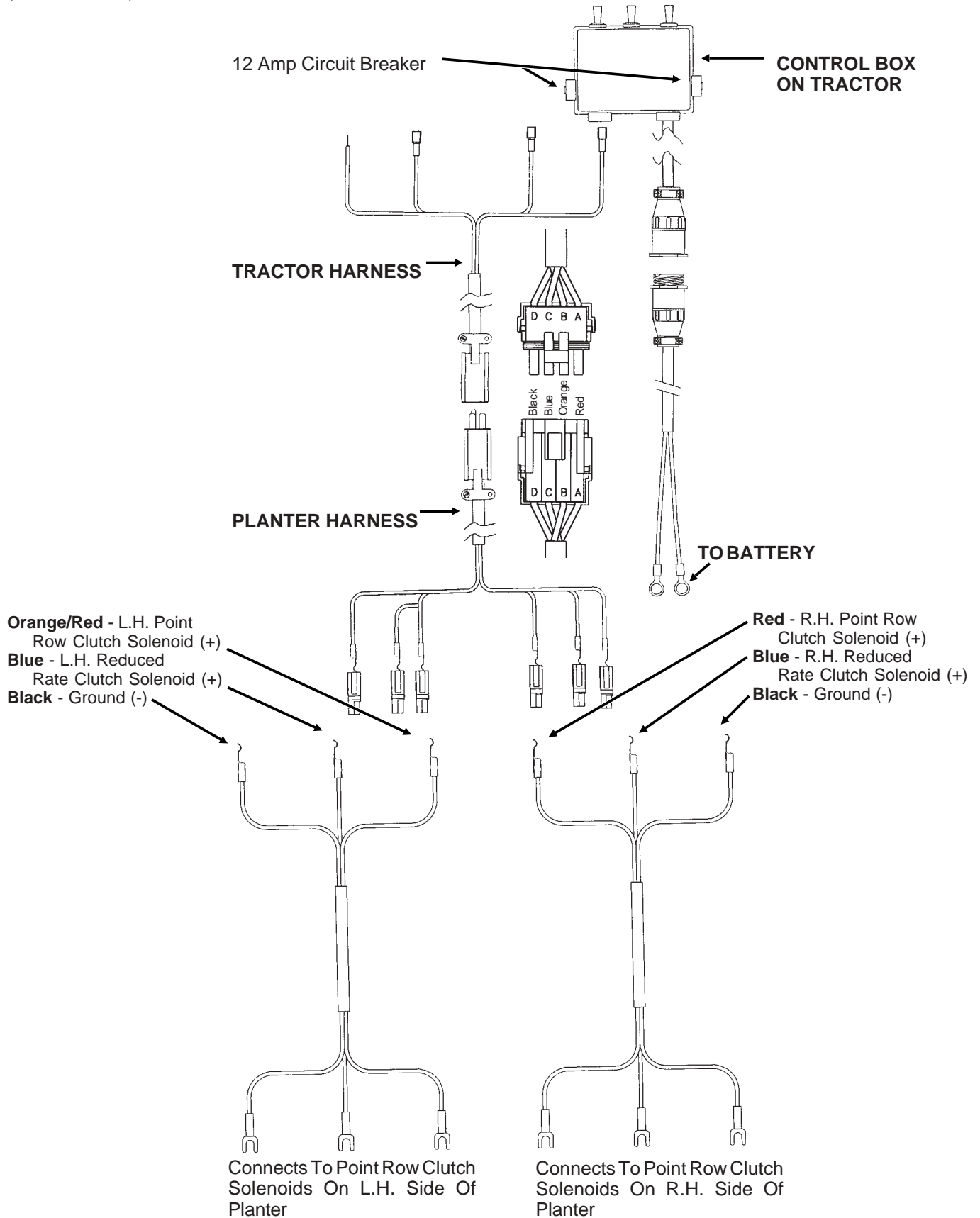

MAINTENANCE

(INS242)

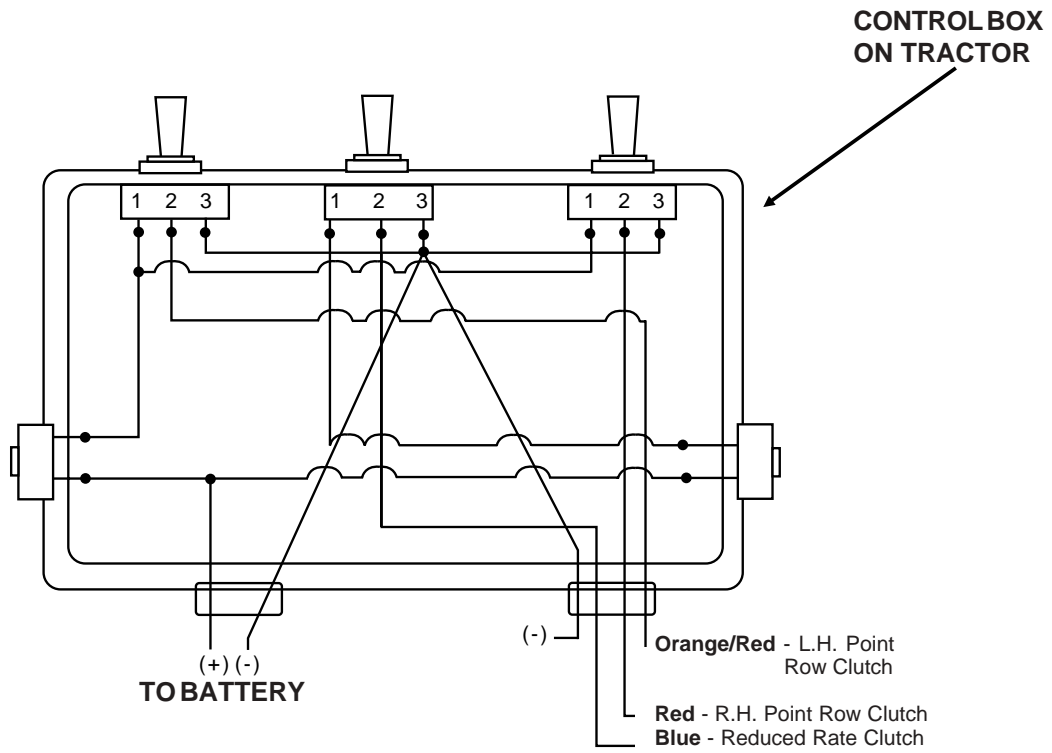

TWO-SPEED POINT ROW CLUTCH FOR L.H. SIDE OF PLANTER SHOWN

(INS126c)

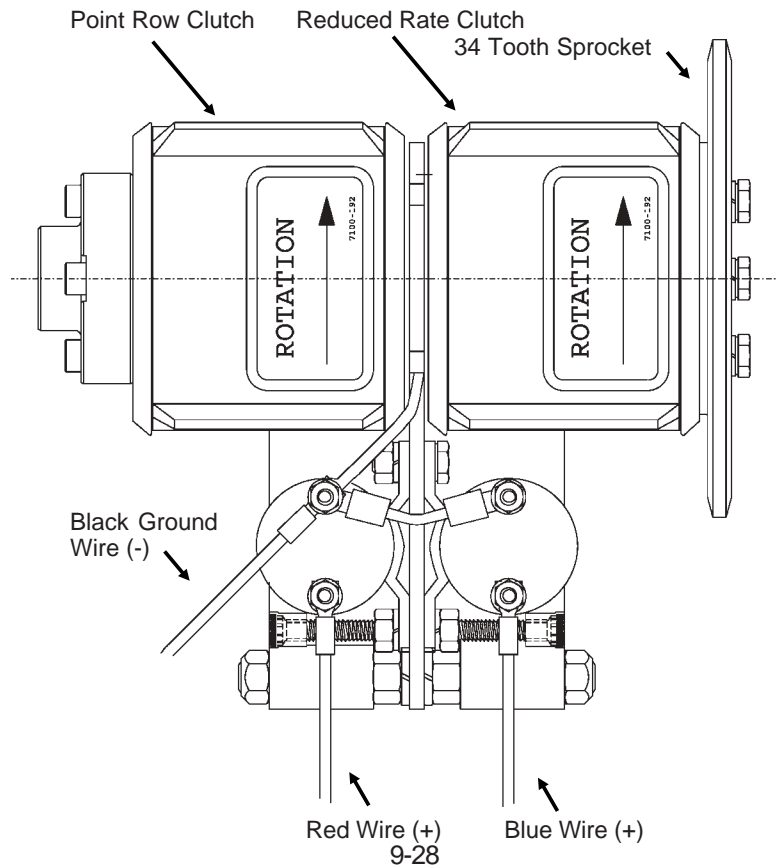

MAINTENANCE

HYDRAULIC SCHEMATIC - FOLD SYSTEM

(HYD1/HYD2/HYD16)

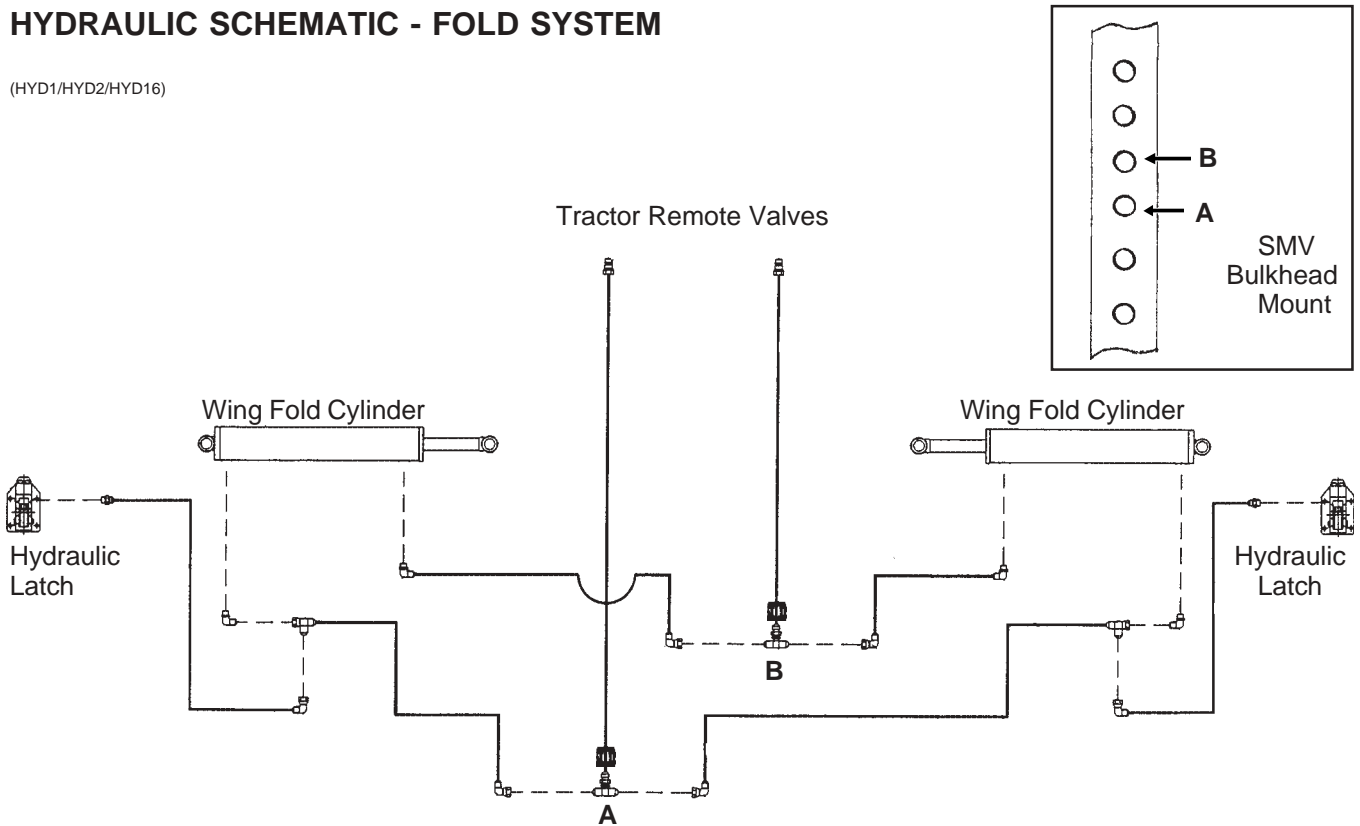

HYDRAULIC SCHEMATIC - ROW MARKER SYSTEM

(HYD2-17)

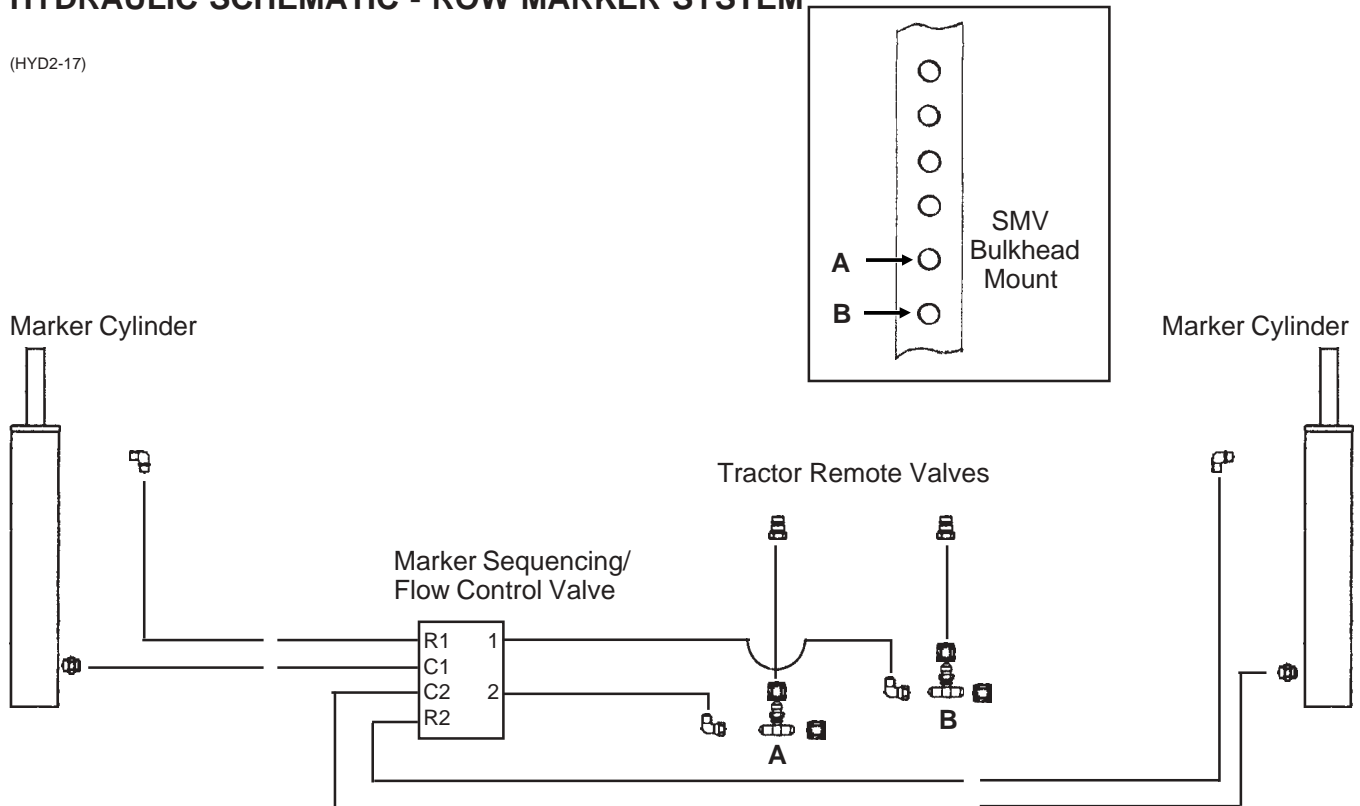

MAINTENANCE

HYDRAULIC SCHEMATIC - DUAL LIFT ASSIST WHEEL PACKAGE

(HYD2-17)

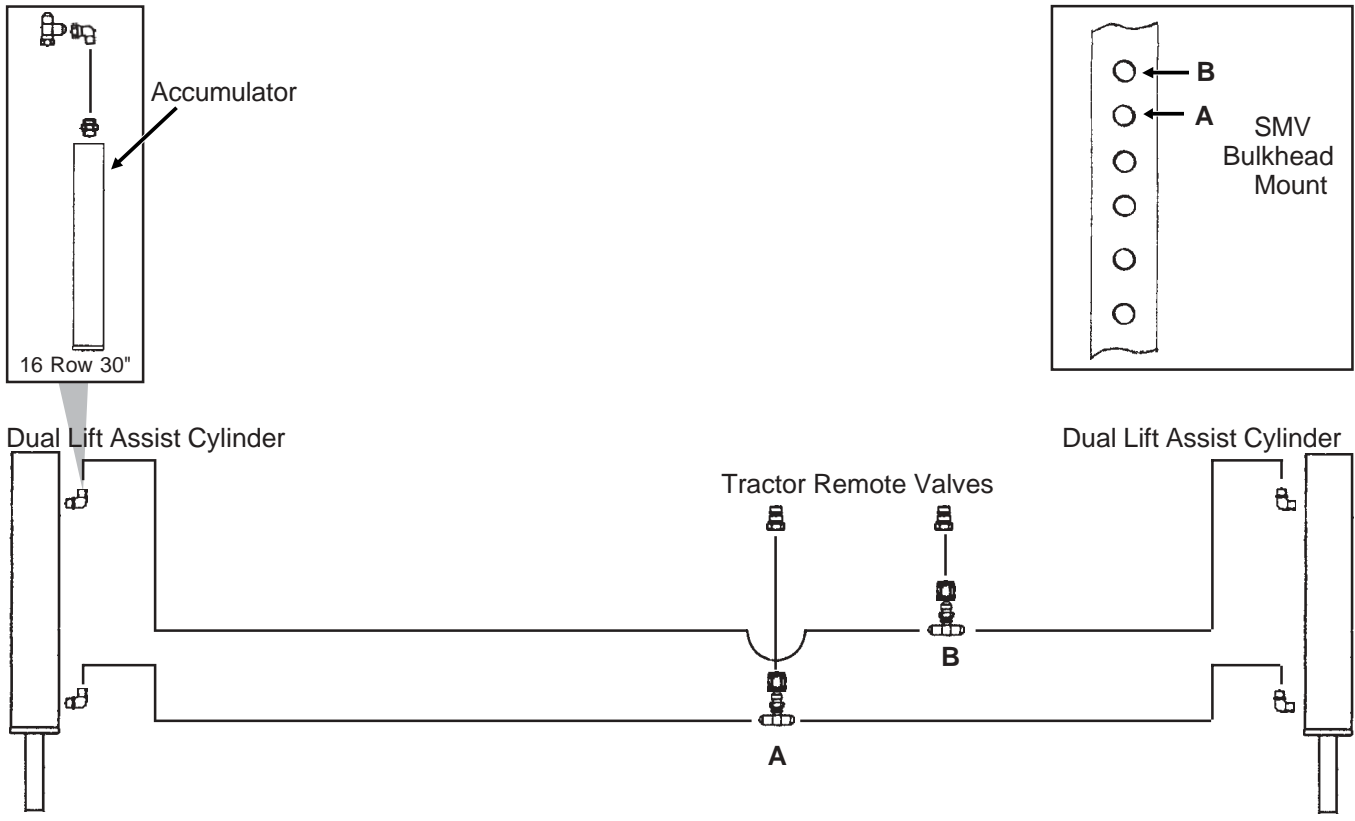

HYDRAULIC SCHEMATIC - DUAL LIFT ASSIST WHEEL PACKAGE (Plumbed Into 3 Point Circuit)

(HYD2-17)

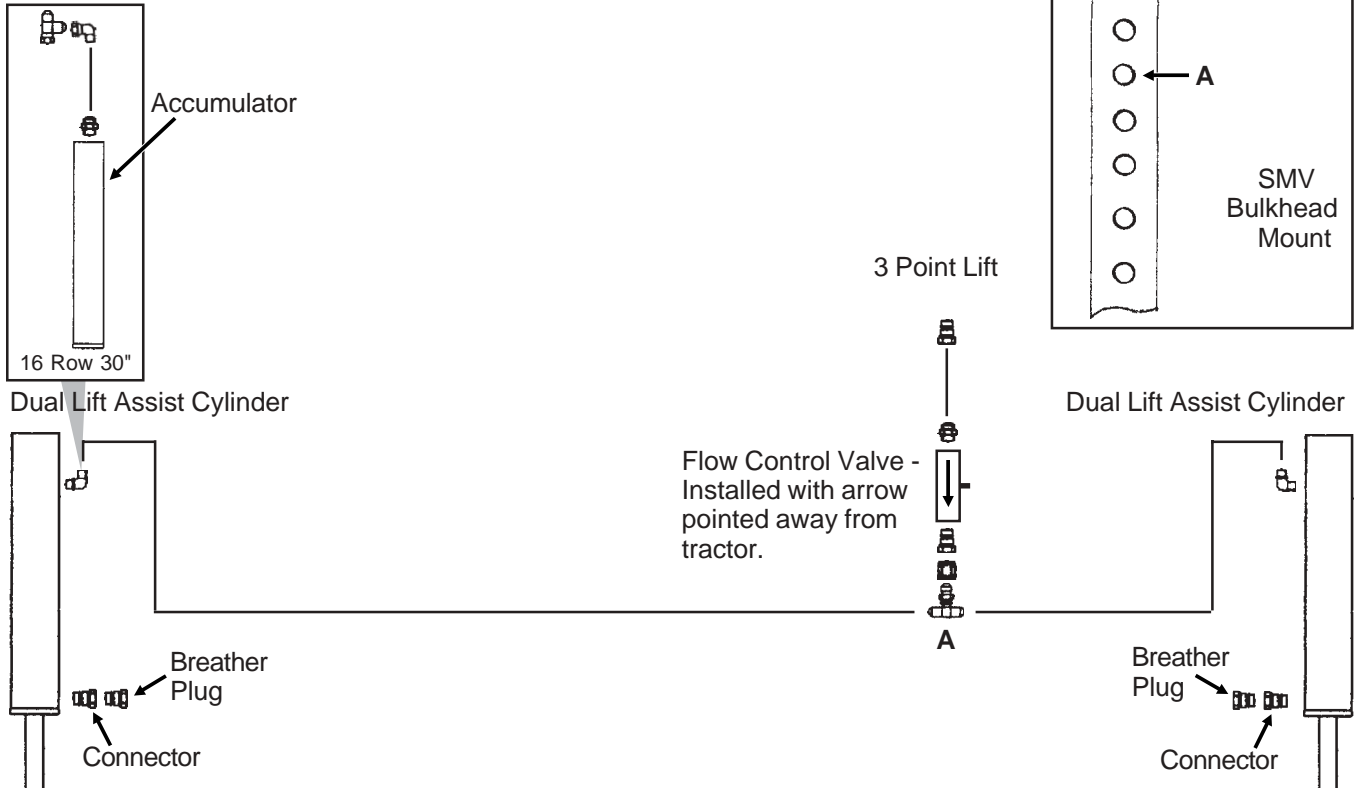

MAINTENANCE

HYDRAULIC SCHEMATIC - WING DOWN FLEX CYLINDER PACKAGE

(HYD2-17)

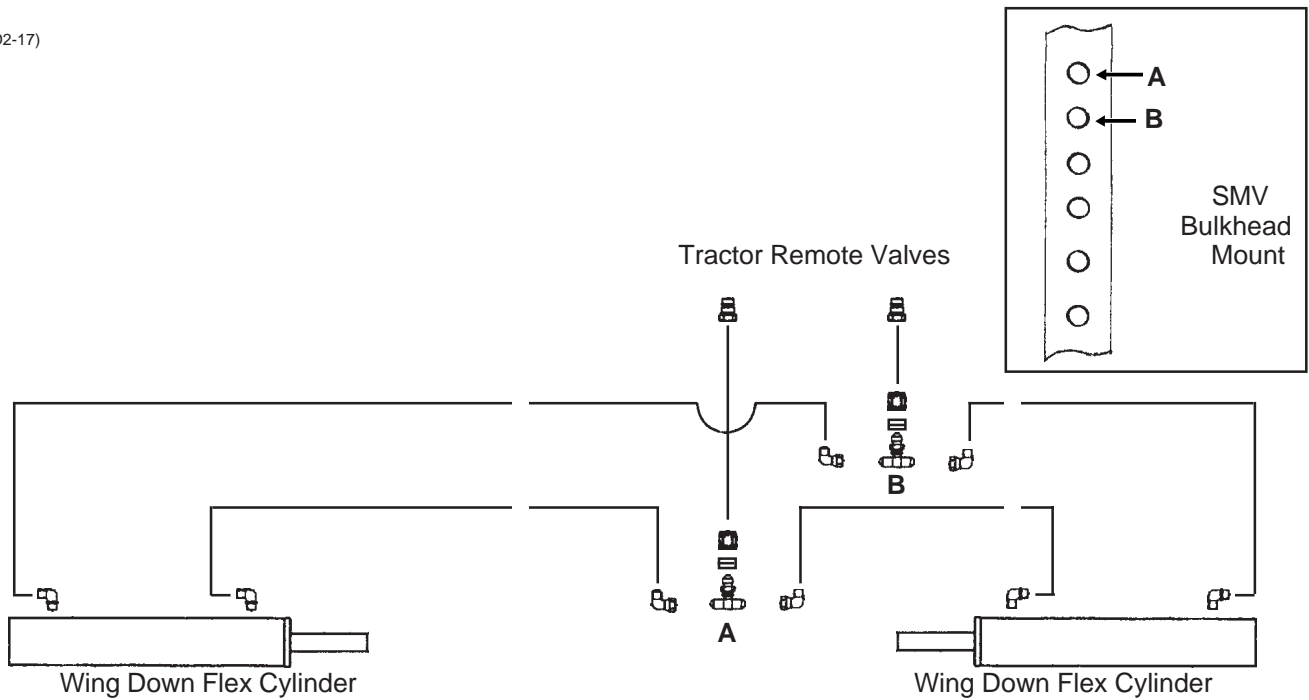

HYDRAULIC SCHEMATIC - WING DOWN FLEX CYLINDER PACKAGE AND DUAL LIFT ASSIST WHEEL PACKAGE

(HYD2-17)

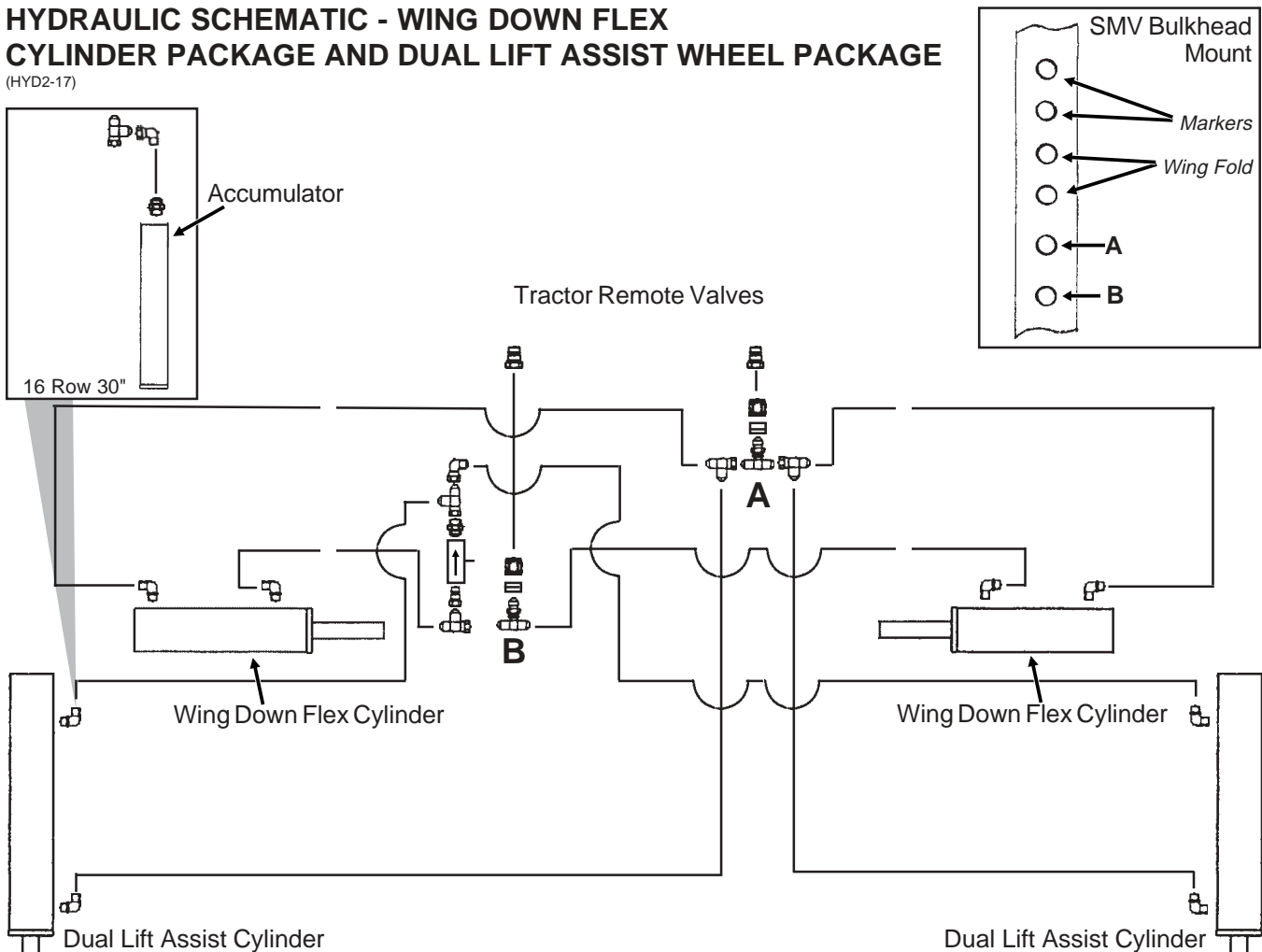

MAINTENANCE

PARTS LIST INDEX

ROW UNIT

15" Seed Opener Disc Blade/Bearing Assembly And Scrapers	P5
Brush-Type Seed Meter	P15
Coulter Mounted Residue Wheels	P28
Covering Discs/Single Press Wheel	P8
Drag Closing Attachment	P11
Finger Pickup Seed Meter	P14
Frame Mounted Coulters And Attachments	P30
Gauge Wheels	P6
Granular Chemical Banding Options	P19
Granular Chemical Hopper And Hopper Panel Extension	P16
Granular Chemical Meter And Meter Drive	P18
Hopper Support And Meter Drive	P12
Parallel Arms, Mounting Support Plate And Quick Adjustable Down Force Springs	P4
Row Unit Mounted Bed Leveler	P22
Row Unit Mounted Disc Furrower	P24
Row Unit Mounted No Till Coulter	P21
Row Unit Mounted Residue Wheel	P26
Seed Hopper And Lid	P13
Shank Assembly, Seed Tube And Depth Adjustment	P2
Spring Tooth Incorporator	P20
"V" Closing Wheels	P10

BASE MACHINE

Center Drop Assembly And Driveline	P62
Center Frame Assembly	P34
Center Section Gauge Wheel	P44
Contact Drive Wheel Assembly	P42
Cylinders	P70
Dual Lift Assist Wheels	P46
Electrical Components And Light Brackets	P84
Flow Control Valve	P77
Ground Drive Wheel Assembly	P40
Hydraulic Systems	P78
Module Drive	P50
Point Row Clutch	P52
Point Row Clutch Electrical Components	P54
Row Marker Assemblies	P64
Row Marker Sequencing/Flow Control Valve And Mount	P76
Row Marker Spindle/Hub/Blade	P68
Seed Rate Transmission And Module Drive Assembly	P48
Two-Speed Point Row Clutch	P56
Two-Speed Point Row Clutch Electrical Components	P58
Two-Speed Point Row Clutch Transmission And Module Drive	P60
Wing Assembly	P36
Wing Down Flex Cylinder Package	P38

ELECTRONIC SEED MONITOR

KPM I/KPM II Electronic Seed Monitor	P86
KPM II Stack-Mode Electronic Seed Monitor	P88

FERTILIZER

Liquid Fertilizer Piston Pump Mount/Drive	P90
Decals, Paint And Miscellaneous	P92

Numerical Index	a
-----------------------	---

SHANK ASSEMBLY, SEED TUBE AND DEPTH ADJUSTMENT

RUB023/RUB024RUB022(RU80)

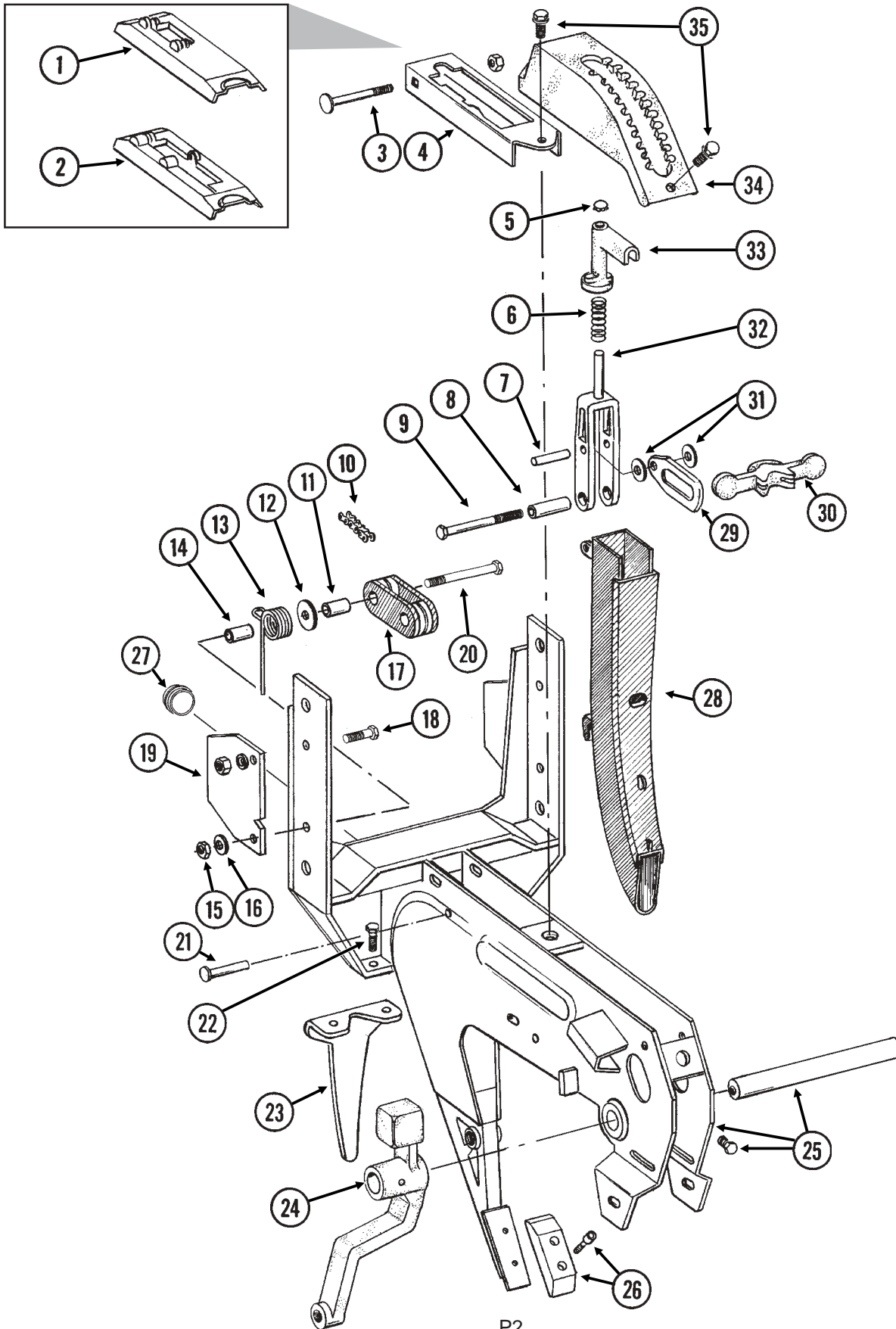

SHANK ASSEMBLY, SEED TUBE AND DEPTH ADJUSTMENT

ITEM	PART NO.	QTY. (Per Row)	DESCRIPTION
1.		-	Shank Cover, See "Brush-Type Seed Meter", Page P15
2.		-	Shank Cover, See "Finger Pickup Seed Meter", Page P14
3.	G10304	1	Carriage Bolt, $\frac{3}{8}$ "-16 x 3"
	G10108	1	Lock Nut, $\frac{3}{8}$ "-16
4.	GD10986	1	Cover
5.	GD3612	1	Cap Plug
6.	GD10993	1	Spring
7.	GD13361	1	Pin, $\frac{3}{8}$ " x 1 $\frac{2}{3}$ "
8.	GD11259	1	Sleeve, $\frac{3}{8}$ " I.D. x $\frac{5}{8}$ " O.D. x 1 $\frac{25}{32}$ " Long
9.	G11008	1	Hex Head Cap Screw, $\frac{3}{8}$ "-24 x 2 $\frac{1}{2}$ ", Grade 8
	G11007	1	Lock Nut, $\frac{3}{8}$ "-24, Grade C
10.	G3303-98	1	Chain, No. 41, 98 Pitch Including Connector Link
	G3303-16	-	Chain, No. 41, 16 Pitch Including Connector Link (Used W/Row Unit Extension Brackets)
	GR0196	1	Connector Link, No. 41
11.	GD1026	1	Sleeve, 1 $\frac{3}{16}$ " Long
12.	G10201	1	Special Washer, $\frac{3}{8}$ " x 1 $\frac{1}{2}$ " O.D.
13.	GD1065	1	Idler Spring
14.	GD7318	1	Sleeve, 1" Long
15.	G10108	1	Lock Nut, $\frac{3}{8}$ "-16
16.	G10210	1	Washer, $\frac{3}{8}$ " USS
17.	GD11962	1	Idler
18.	G10003	3	Hex Head Cap Screw, $\frac{3}{8}$ "-16 x 1 $\frac{1}{2}$ "
	G10108	3	Lock Nut, $\frac{3}{8}$ "-16
19.	GD10867	2	Stop
20.	G10326	1	Hex Head Cap Screw, $\frac{3}{8}$ "-16 x 3 $\frac{3}{4}$ "
21.	G10551	1	Clevis Pin, $\frac{1}{4}$ " x 2 $\frac{1}{2}$ "
	G10669	1	Hair Pin Clip, No. 22
22.	G10312	2	Carriage Bolt, $\frac{5}{16}$ "-18 x $\frac{3}{4}$ "
	G10620	2	Flange Nut, $\frac{5}{16}$ "-18
23.	GD1033	1	Shield
24.		-	See "Gauge Wheels", Pages P6 And P7
25.	GA8600	1	Shank W/Gauge Wheel Pivot Spindle And Set Screw
	GD11001	-	Spindle
	G10438	-	Hex Head Cap Screw, $\frac{1}{2}$ "-13 x $\frac{3}{4}$ "
26.		-	See "15" Seed Opener Disc Blade/Bearing Assembly And Scrapers", Page P5
27.	GD11845	1	Dust Cap
28.	GD1130	-	Seed Tube (No Monitor) See "KPM I/KPM II Electronic Seed Monitor" And "KPM II Stack-Mode Electronic Seed Monitor" For Seed Tube With Sensor, Pages P86-P89
29.	GB0285	1	Collar, Depth Adjustment
30.	GB0265	1	Pivot Link, Depth Adjustment
31.	G10207	2	Washer, $\frac{7}{8}$ " O.D. x $\frac{13}{32}$ " I.D. x .134" (If Applicable)
32.	GB0267	1	Lever, Depth Adjustment
33.	GB0266	1	Handle, Depth Adjustment
34.	GB0274	1	Cover, Depth Adjustment
35.	G11015	2	Hex Washer Head Cap Screw, $\frac{3}{8}$ "-16 x 1 $\frac{1}{4}$ "

PARALLEL ARMS, MOUNTING SUPPORT PLATE AND QUICK ADJUSTABLE DOWN FORCE SPRINGS

RUB021/RUB022(D10575/RU78f/RU79a)

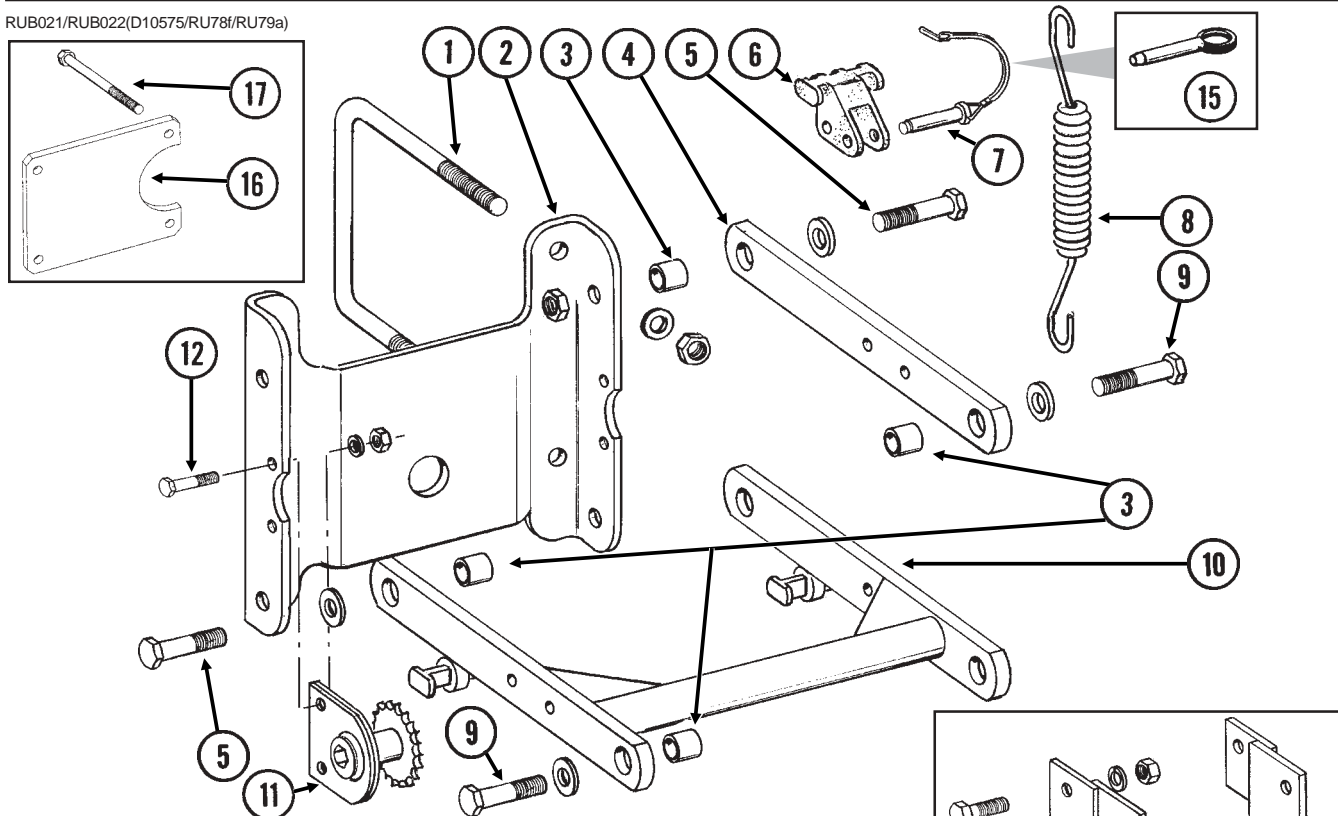

ITEM	PART NO.	QTY. (Per Row)	DESCRIPTION
1.	GD1114 G10230 G10104	2 4 4	U-Bolt, 7" x 7" x 5/8"-11 Lock Washer, 5/8" Hex Nut, 5/8"-11
2.	GD10036	1	Mounting Support Plate
3.	GB0218	4	Bushing, 21/32" I.D. x 7/8" O.D. x 19/32" Long
4.	GD11422	2	Upper Parallel Arm
5.	G10732 GD7805 G10412	4 4 4	Hex Head Cap Screw, 5/8"-18 x 2" Special Washer, 5/8", Hardened Lock Nut, 5/8"-18
6.	GB0186	2	Spring Anchor
7.	GD14217	2	Tab Lock Pin, 7/16" x 1 1/2"
8.	GD8249	2-4	Spring
9.		-	See "Hopper Support And Meter Drive", Page P12
10.	GA5651	1	Lower Parallel Arm
11.	GA1720	1	Bearing/Sprocket, 7/8" Hex Bore
12.	G10001 G10229 G10101	2 2 2	Hex Head Cap Screw, 3/8"-16 x 1" Lock Washer, 3/8" Hex Nut, 3/8"-16
13.	G10007 G10230 G10104	4 4 4	Hex Head Cap Screw, 5/8"-11 x 1 1/2" Lock Washer, 5/8" Hex Nut, 5/8"-11
14.	GA7410	2	Extension Bracket
15.	G10545	2	Detent Pin, 1/2" x 1 1/3" Grip
16.	GD10575	1	Backing Plate (16 Row Only)
17.	G10152 G10230 G10104	4 4 4	Hex Head Cap Screw, 5/8"-11 x 9" Lock Washer, 5/8" Hex Nut, 5/8"-11

A. G6326X - U-Bolt Package For 7" x 7" Toolbar, Includes: (2) GD1114, (4) G10230, (4) G10104 P4

15" SEED OPENER DISC BLADE/BEARING ASSEMBLY AND SCRAPERS

RUB023/RUB025(RU82e)

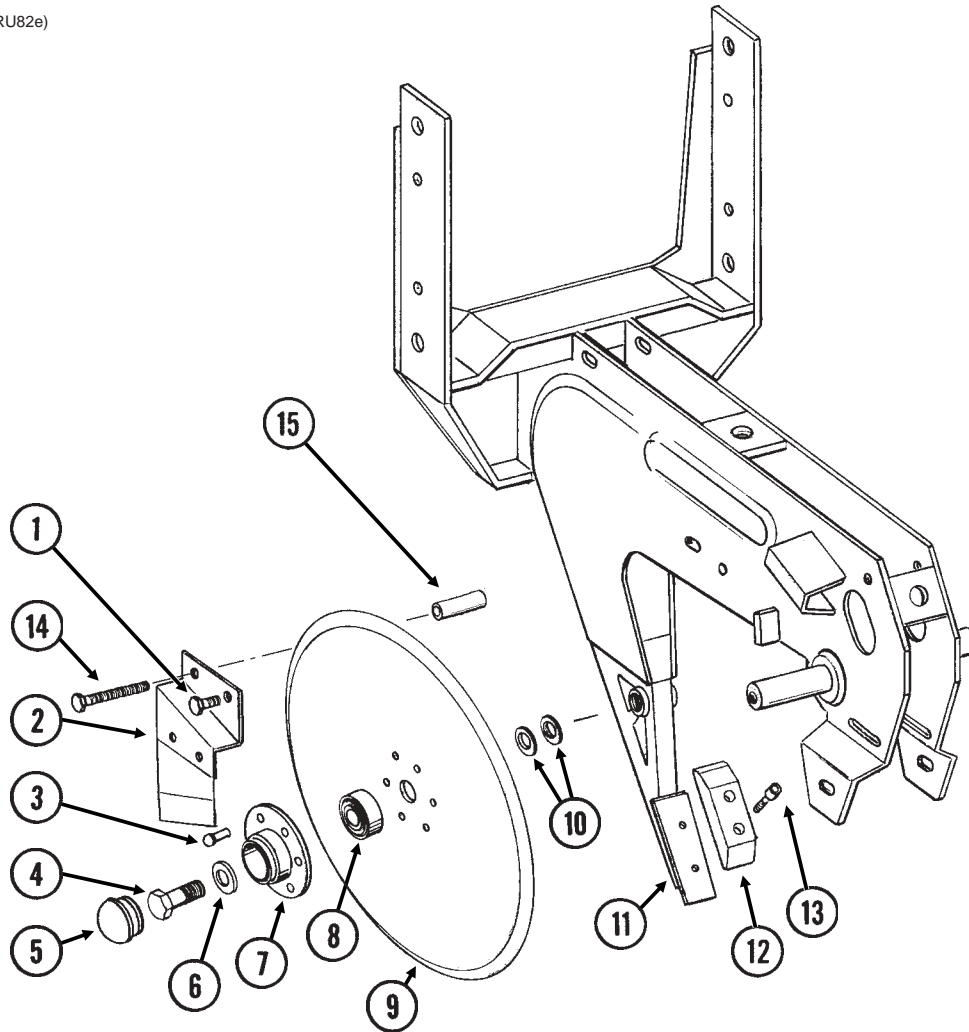

ITEM	PART NO.	QTY. (Per Row)	DESCRIPTION
1.	G10328	2	Hex Head Cap Screw, $\frac{3}{8}$ "-16 x $\frac{5}{8}$ "
	G10622	2	Flange Nut, $\frac{3}{8}$ "-16
2.	GA2012R	1	Disc Scraper, R.H.
	GA2012L	-	Disc Scraper, L.H. (Shown)
3.	G10427	12	Rivet, $\frac{1}{4}$ " x $\frac{1}{2}$ "
4.	GD11017	1	Special Hex Head Cap Screw, $\frac{5}{8}$ "-11 x 1 $\frac{1}{2}$ ", L.H. Thread
	G10007	1	Hex Head Cap Screw, $\frac{5}{8}$ "-11 x 1 $\frac{1}{2}$ "
5.	GD11845	2	Dust Cap
6.	G10204	2	Special Machine Bushing, $\frac{5}{8}$ " x 1" O.D.
7.	GD10473	2	Bearing Housing
8.	GA2014	2	Bearing
9.	GD11306	2	Disc Blade, 3.5 mm x 15"
10.	G10213	-	Machine Bushing, $\frac{5}{8}$ " (.030" Thick)(As Required)
11.		-	See "Shank Assembly", Pages P2 And P3
12.	GB0301	1	Seed Tube Guard/Inner Scraper
13.	G10912	2	Hex Socket Head Cap Screw, $\frac{5}{16}$ "-18 x 1", Grade 8
14.	G10325	1	Hex Head Cap Screw, $\frac{3}{8}$ "-16 x 2 $\frac{3}{4}$ "
	G10622	1	Flange Nut, $\frac{3}{8}$ "-16
15.	GD11259	1	Sleeve, $\frac{3}{8}$ " I.D. x $\frac{5}{8}$ " O.D. x 1 $\frac{25}{32}$ " Long

A. GA8324 - Disc Blade/Bearing Assembly, Less Bearing Cap (Items 3 And 7-9)

GAUGE WHEELS

RUB027/RUB023(RU84a/RU84b)

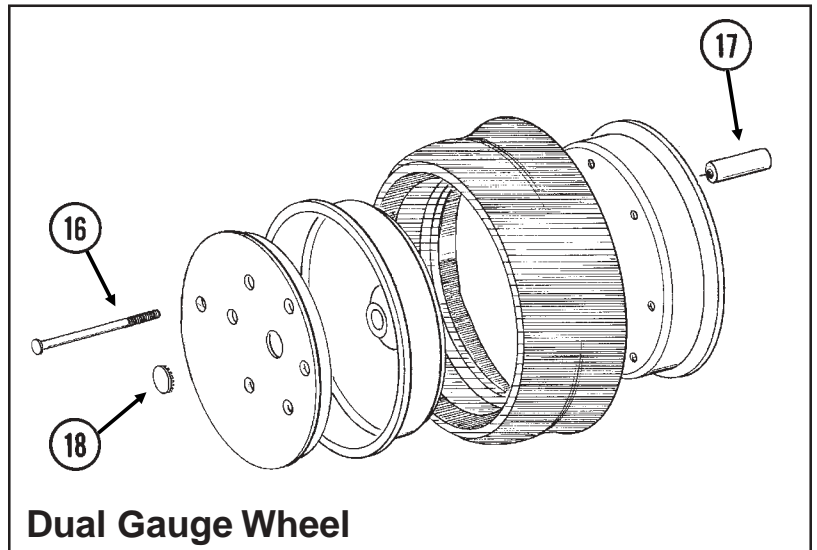
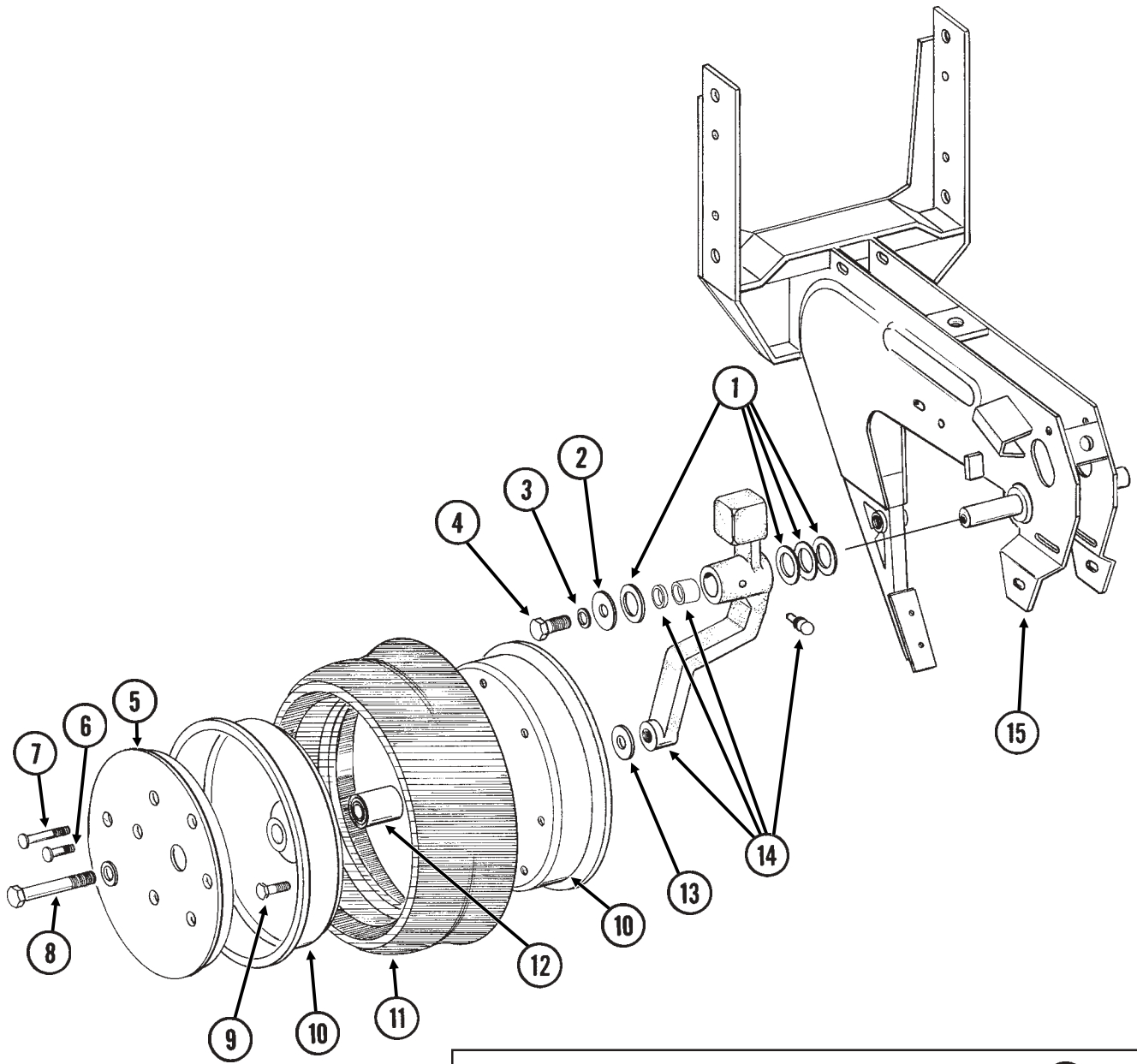

GAUGE WHEELS

ITEM	PART NO.	QTY. (Per Row)	DESCRIPTION
1.	G10940	-	Machine Bushing, 1" (.048" Thick)
2.	G10216	2	Washer, 1/2" USS
3.	G10228	2	Lock Washer, 1/2"
4.	G10014	1	Hex Head Cap Screw, 1/2"-13 x 1"
5.	GD11453	2	Cover
6.	G10338	12	Carriage Bolt, 5/16"-18 x 1 1/4"
	G10620	12	Flange Nut, 5/16"-18
7.	G10924	8	Carriage Bolt, 5/16"-18 x 1 3/4"
	G10620	8	Flange Nut, 5/16"-18
8.	G10010	2	Hex Head Cap Screw, 5/8"-11 x 3"
	G10230	2	Lock Washer, 5/8"
9.	G10018	14	Hex Head Cap Screw, 5/16"-18 x 5/8"
	G10109	14	Lock Nut, 5/16"-18
10.	GD11423	4	Half Wheel
11.	GD1086	2	Tire
12.	GA6171	2	Bearing
13.	G10204	2	Special Machine Bushing, 5/8" x 1" O.D.
14.	GA7975	1	Wheel Arm W/Grease Fitting, Bushings And Seals, L.H. (Shown)
	GA7976	1	Wheel Arm W/Grease Fitting, Bushings And Seals, R.H.
	G10640	1	Grease Fitting, 1/4"-28 (Per Arm)
	GB0276	2	Bushing, 1" I.D. x 1 1/4" O.D. x 1" Long (Per Arm)
	GD10991	2	Seal (Per Arm)
15.		-	See "Shank Assembly", Pages P2 And P3
16.	G10944	8	Carriage Bolt, 5/16"-18 x 6" (Replaces Item 7)
	G10620	8	Flange Nut, 5/16"-18
17.	GD8811	8	Dual Gauge Wheel Sleeve, 4 1/8"
18.	GD11936	1	Plug, 1 1/8"
A.	GA7949	-	Gauge Wheel Complete (Items 5-7 And 9-12)

COVERING DISCS/SINGLE PRESS WHEEL

RUA054/RUB026(RU94d)

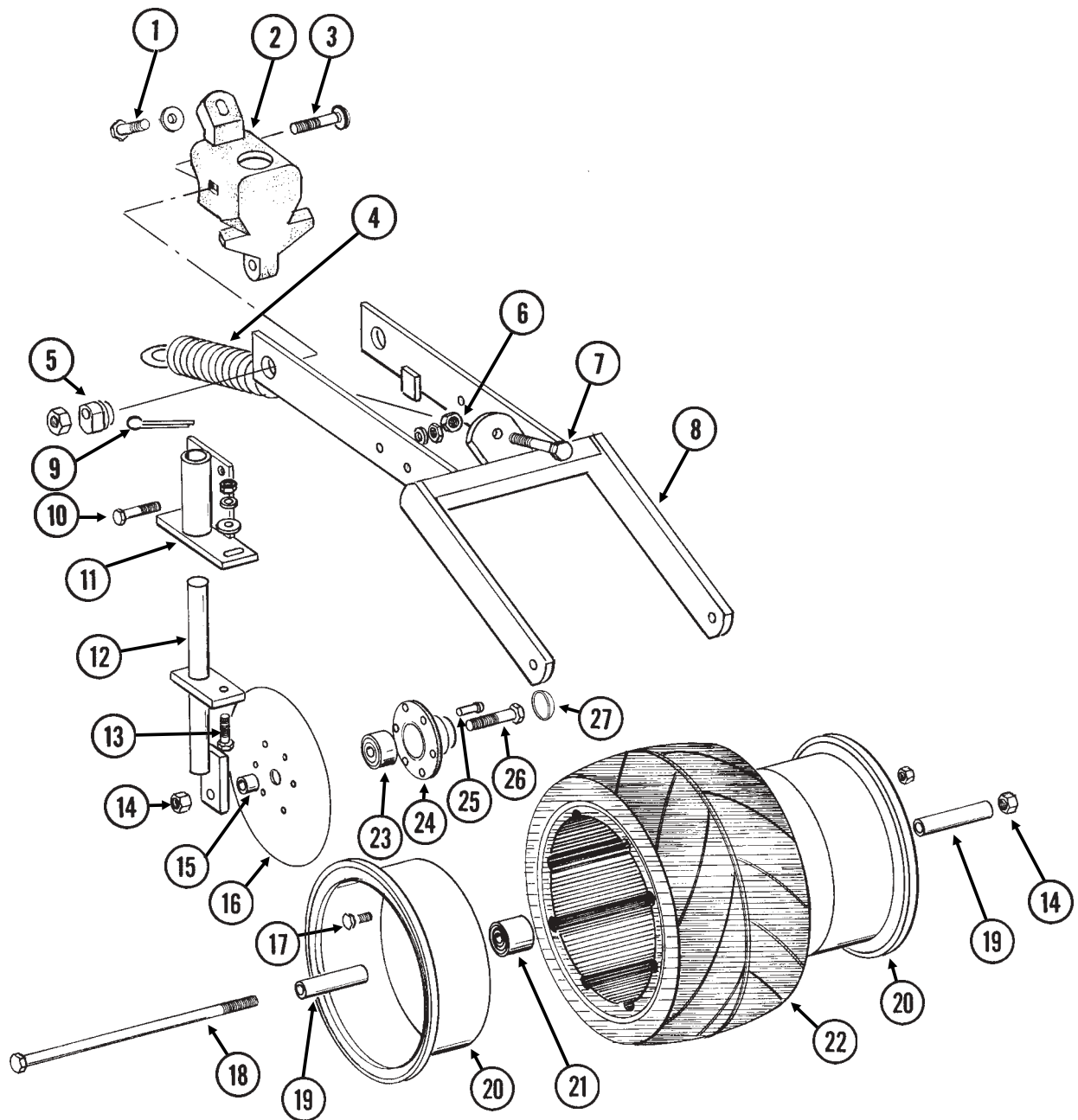

COVERING DISCS/SINGLE PRESS WHEEL

ITEM	PART NO.	QTY. (Per Row)	DESCRIPTION
1.	G10001	1	Hex Head Cap Screw, $\frac{3}{8}$ "-16 x 1"
	G10210	1	Washer, $\frac{3}{8}$ " USS
2.	GB0268	1	Wheel Arm Stop
3.	G10801	2	Carriage Bolt, $\frac{1}{2}$ "-13 x 2 $\frac{1}{4}$ "
	G10315	-	Carriage Bolt, $\frac{1}{2}$ "-13 x 2 $\frac{1}{2}$ " (Used W/Straight Drop In-Furrow Granular Chemical Bracket)
	G10102	2	Hex Nut, $\frac{1}{2}$ "-13
4.	GA2054	1	Spring
5.	GB0239	2	Eccentric Bushing
6.	G10102	1	Hex Nut, $\frac{1}{2}$ "-13
7.	G10015	1	Adjusting Bolt, $\frac{1}{2}$ "-13 x 5"
8.	GA6619	1	Mounting Arm
9.	G10463	2	Cotter Pin, $\frac{1}{4}$ " x 1 $\frac{1}{2}$ "
10.	G10171	4	Hex Head Cap Screw, $\frac{5}{16}$ "-18 x 1 $\frac{1}{4}$ "
	G10232	4	Lock Washer, $\frac{5}{16}$ "
	G10106	4	Hex Nut, $\frac{5}{16}$ "-18
11.	GA6620	2	Bracket
12.	GA6618	2	Mount
13.	G10303	2	Carriage Bolt, $\frac{5}{16}$ "-18 x 1"
	G10219	2	Washer, $\frac{5}{16}$ " USS
	G10232	2	Lock Washer, $\frac{5}{16}$ "
	G10106	2	Hex Nut, $\frac{5}{16}$ "-18
14.	G10107	3	Lock Nut, $\frac{5}{8}$ "-11
15.	GD1109	2	Bushing, $\frac{41}{64}$ " I.D. x $\frac{7}{8}$ " O.D. x $\frac{1}{4}$ " Long
16.	GD9290	2	Disc Blade, 8"
17.	G10018	7	Hex Head Cap Screw, $\frac{5}{16}$ "-18 x $\frac{5}{8}$ "
	G10109	7	Lock Nut, $\frac{5}{16}$ "-18
18.	G10152	1	Hex Head Cap Screw, $\frac{5}{8}$ "-11 x 9"
19.	GD3180-12	2	Sleeve, $\frac{5}{8}$ " I.D. x $\frac{7}{8}$ " O.D. x 2 $\frac{7}{8}$ " Long
20.	GD9562	2	Half Wheel
21.	GA6171	1	Bearing
22.	GD9305	1	Tire
23.	GA2014	2	Bearing
24.	GD10473	2	Bearing Housing
25.	G10427	12	Rivet, $\frac{1}{4}$ " x $\frac{1}{2}$ "
26.	G10006	2	Hex Head Cap Screw, $\frac{5}{8}$ "-11 x 2 $\frac{1}{4}$ "
27.	GD11845	2	Dust Cap
A.	GA6733	-	Single Press Wheel Complete W/Bearing (Items 17 And 20-22)
B.	GA6801	-	Covering Disc Blade Complete W/Bearing (Items 16 And 23-25)

"V" CLOSING WHEELS

RUB026(RU83g/RU83L/RU83h)

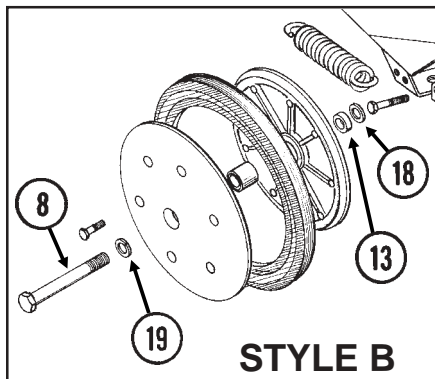

STYLE B

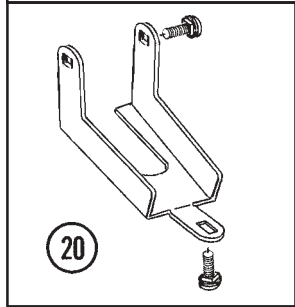

20

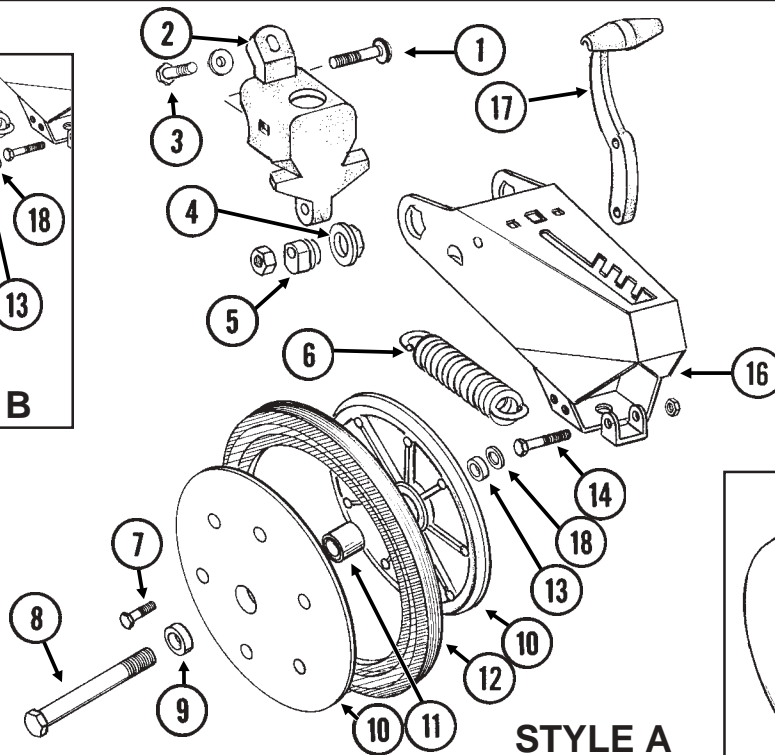

STYLE A

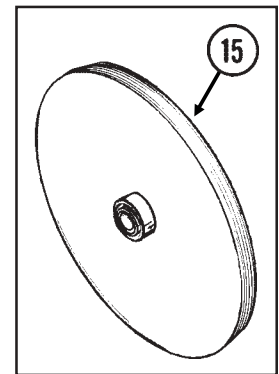

ITEM	PART NO.	QTY. (Per Row)	DESCRIPTION
1.	G10801 G10315	2 -	Carriage Bolt, 1/2"-13 x 2 1/4" Carriage Bolt, 1/2"-13 x 2 1/2" (Used W/Straight Drop In-Furrow Granular Chemical Bracket)
	G10111	2	Lock Nut, 1/2"-13
2.	GB0268	1	Wheel Arm Stop
3.	G10001	1	Hex Head Cap Screw, 3/8"-16 x 1"
	G10210	1	Washer, 3/8" USS
4.	GB0282	2	Stepped Bushing
5.	GB0239	2	Eccentric Bushing
6.	GD8460	1	Spring
7.	G10064	6	Hex Head Cap Screw, 1/4"-20 x 1"
8.	G10013	2	Hex Head Cap Screw, 5/8"-11 x 3 1/2"
	G10107	2	Lock Nut, 5/8"-11
9.	GB0218	2	Bushing, 21/32" I.D. x 7/8" O.D. x 19/32" Long
10.	GD9120	4	Nylon Half Wheel
11.	GA6171	2	Bearing
12.	GD1085	2	Rubber Tire, 1" x 12"
13.	GD1109	2	Bushing, 41/64" I.D. x 7/8" O.D. x 1/4" Long
14.	G10133	1	Hex Head Cap Screw, 5/16"-18 x 1 1/2"
	G10109	1	Lock Nut, 5/16"-18
15.	GA6597	-	Cast Iron Closing Wheel W/Bearing
	GA6171	-	Bearing
16.	GA8322	1	Arm
17.	GB0254	1	Lever
18.	GD7805	2	Special Washer, 5/8", Hardened
19.	G10230	2	Lock Washer, 5/8"
20.	G1K345	-	Closing Wheel Shield Kit W/Hardware And Instruction
	G10308	3	Carriage Bolt, 3/8"-16 x 3/4"
	G10210	1	Washer, 3/8" USS
	G10229	3	Lock Washer, 3/8"
	G10101	3	Hex Nut, 3/8"-16

A.	GA6434	-	Rubber Closing Wheel Complete W/Bearing (Items 7 And 10-12)
----	--------	---	---

DRAG CLOSING ATTACHMENT

RUB050(RU90a)

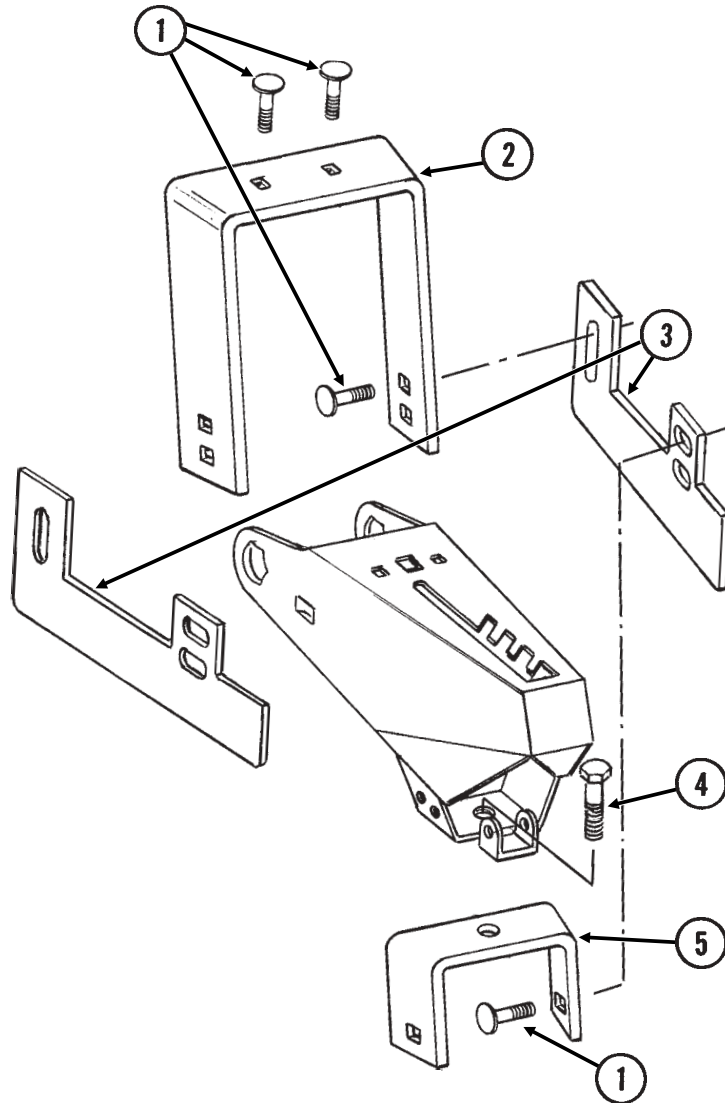

ITEM	PART NO.	QTY.	DESCRIPTION
		(Per Row)	
1.	G10599	6	Carriage Bolt, 3/8"-16 x 1 1/4"
	G10210	6	Washer, 3/8" USS
	G10229	6	Lock Washer, 3/8"
	G10101	6	Hex Nut, 3/8"-16
2.	GD11508	1	Front Bracket
3.	GD11313	2	Blade
4.	G10007	1	Hex Head Cap Screw, 5/8"-11 x 1 1/2"
	G10230	1	Lock Washer, 5/8"
	G10104	1	Hex Nut, 5/8"-11
5.	GD11509	1	Rear Bracket
A.	G7566X	-	Drag Closing Attachment Complete (Items 1-5)

HOPPER SUPPORT AND METER DRIVE

RUB028/RUB029(RU86h/RU86f)

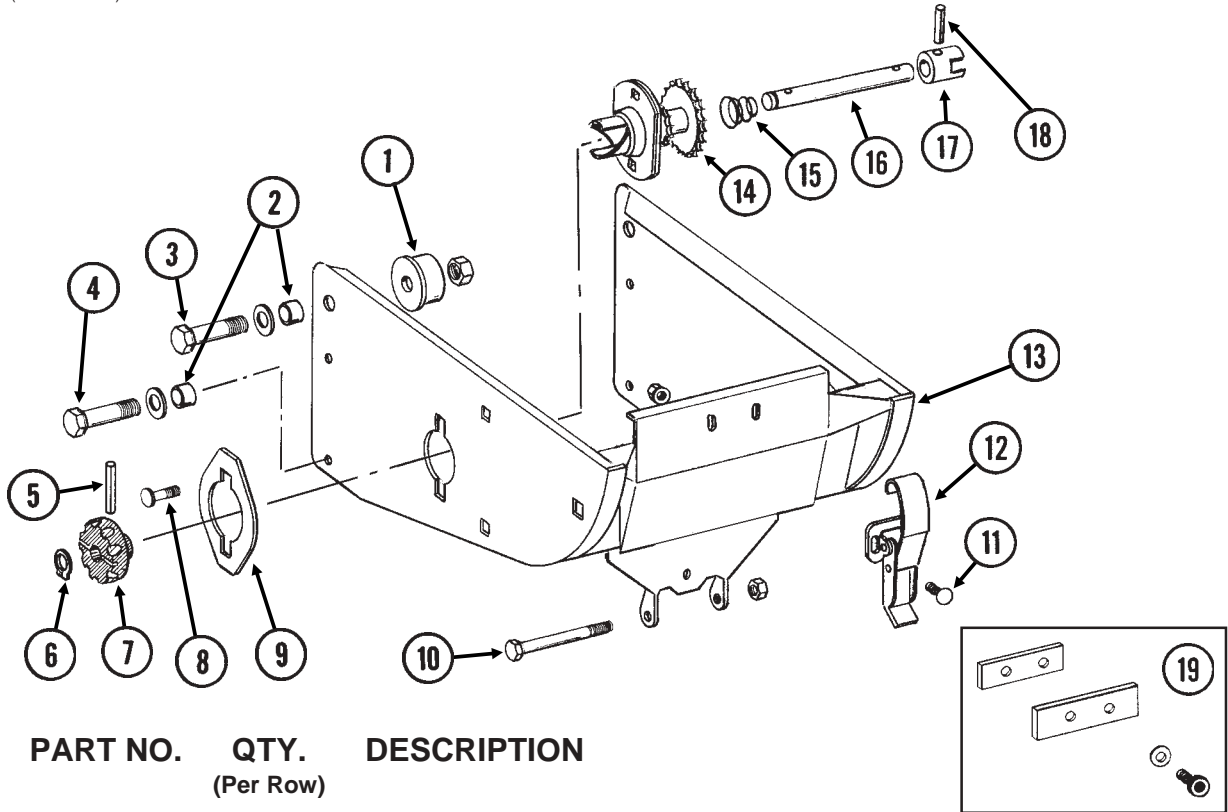

ITEM	PART NO.	QTY. (Per Row)	DESCRIPTION
1.	GB0314	2	Hopper Mount
2.	GB0218	4	Bushing, 2 ¹ / ₃₂ " I.D. x 7 ⁷ / ₈ " O.D. x 1 ⁹ / ₃₂ " Long
3.	G10752	2	Hex Head Cap Screw, 5 ⁵ / ₈ "-18 x 2 1 ¹ / ₄ "
	GD7805	2	Special Washer, 5 ⁵ / ₈ ", Hardened
	G10412	2	Lock Nut, 5 ⁵ / ₈ "-18
4.	G10751	2	Hex Head Cap Screw, 5 ⁵ / ₈ "-18 x 1 3 ³ / ₄ "
	GD7805	2	Special Washer, 5 ⁵ / ₈ ", Hardened
	G10412	2	Lock Nut, 5 ⁵ / ₈ "-18
5.	G10602	1	Spring Pin, 1 ¹ / ₄ " x 1 1 ¹ / ₂ "
6.	G10567	1	External Retaining Ring, 5 ⁵ / ₈ "
7.	GD11239	1	Knob
8.	G10338	2	Carriage Bolt, 5 ⁵ / ₁₆ "-18 x 1 1 ¹ / ₄ "
	G10620	2	Flange Nut, 5 ⁵ / ₁₆ "-18
9.	GD11305	1	Plate
10.	G10061	1	Hex Head Cap Screw, 3 ³ / ₈ "-16 x 3 1 ¹ / ₂ "
	G10210	2	Washer, 3 ³ / ₈ " USS
	G10108	1	Lock Nut, 3 ³ / ₈ "-16
11.	G10309	2	Carriage Bolt, 1 ¹ / ₄ "-20 x 5 ⁵ / ₈ ", Grade 2
	G10621	2	Flange Nut, 1 ¹ / ₄ "-20
12.	GA2007	1	Hopper Hold Down Latch
13.	GA8304	1	Hopper Support
14.	GA9538	1	Double Sprocket And Bearing, Drive Clutch, 11/19 Tooth
15.	GD11413	1	Spring
16.	GD10958	1	Shaft
17.	GB0278	1	Coupler
18.	G10546	1	Spring Pin, 3 ³ / ₁₆ " x 1 1 ¹ / ₄ "
19.	G1K312	-	Seed Hopper Support Panel Kit W/Hardware And Instruction (2 Rows)
	G10211	-	Washer, 1 ¹ / ₄ " SAE
	G10252	-	Hex Socket Head Screw, 1 ¹ / ₄ "-20 x 7 ⁷ / ₈ ", Grade 8
A.	GA9539	-	Meter Drive Assembly Complete (Items 5-7 And 14-18)

SEED HOPPER AND LID

RUA030(RU87d/RU87c/RU128/RU87a/RU87e)

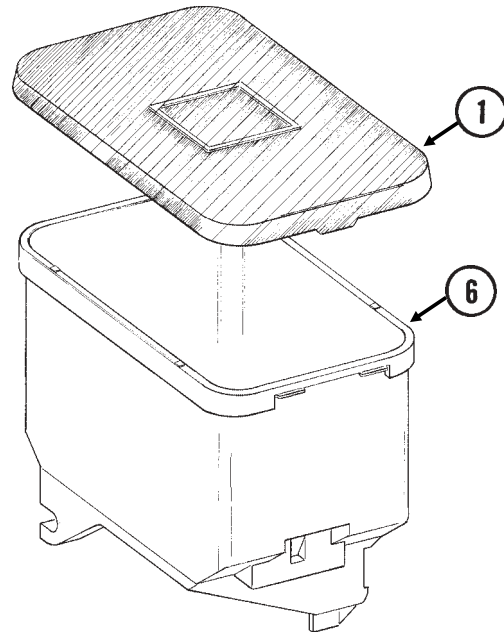
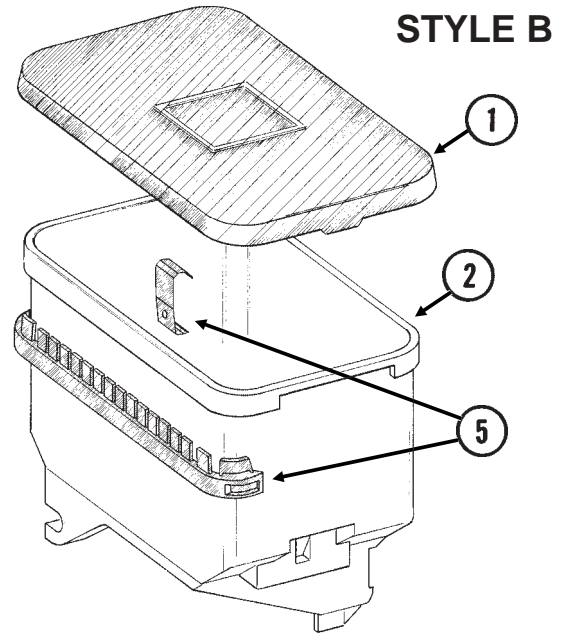
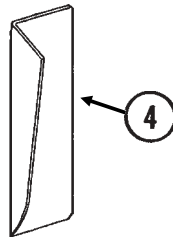
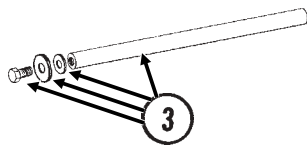
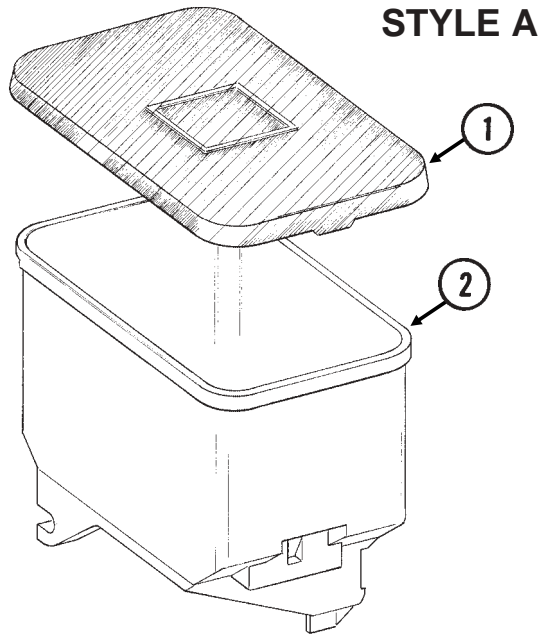

ITEM	PART NO.	QTY. (Per Row)	DESCRIPTION
1.	GD11279	1	Lid
2.	GA8370	1	Seed Hopper (Sub GA9714)
3.	G1K313	1	Seed Hopper Cross Brace Kit (STYLE A Seed Hopper)
	G10989	2	Hex Washer Head Cap Screw, $\frac{3}{8}$ "-16 x $\frac{3}{4}$ "
	G10201	2	Special Washer, $\frac{3}{8}$ " x 1 $\frac{1}{2}$ " O.D.
	G10210	2	Washer, $\frac{3}{8}$ " USS
4.	GD11747	1	Seed Reserve Baffle (Optional)
5.	G1K335	1	Seed Hopper Reinforcement Kit (STYLE B Seed Hopper)
6.	GA9714	1	Seed Hopper, Reinforced

FINGER PICKUP SEED METER

RUA015/RUA056/RUA057(RU13j/RU13d)

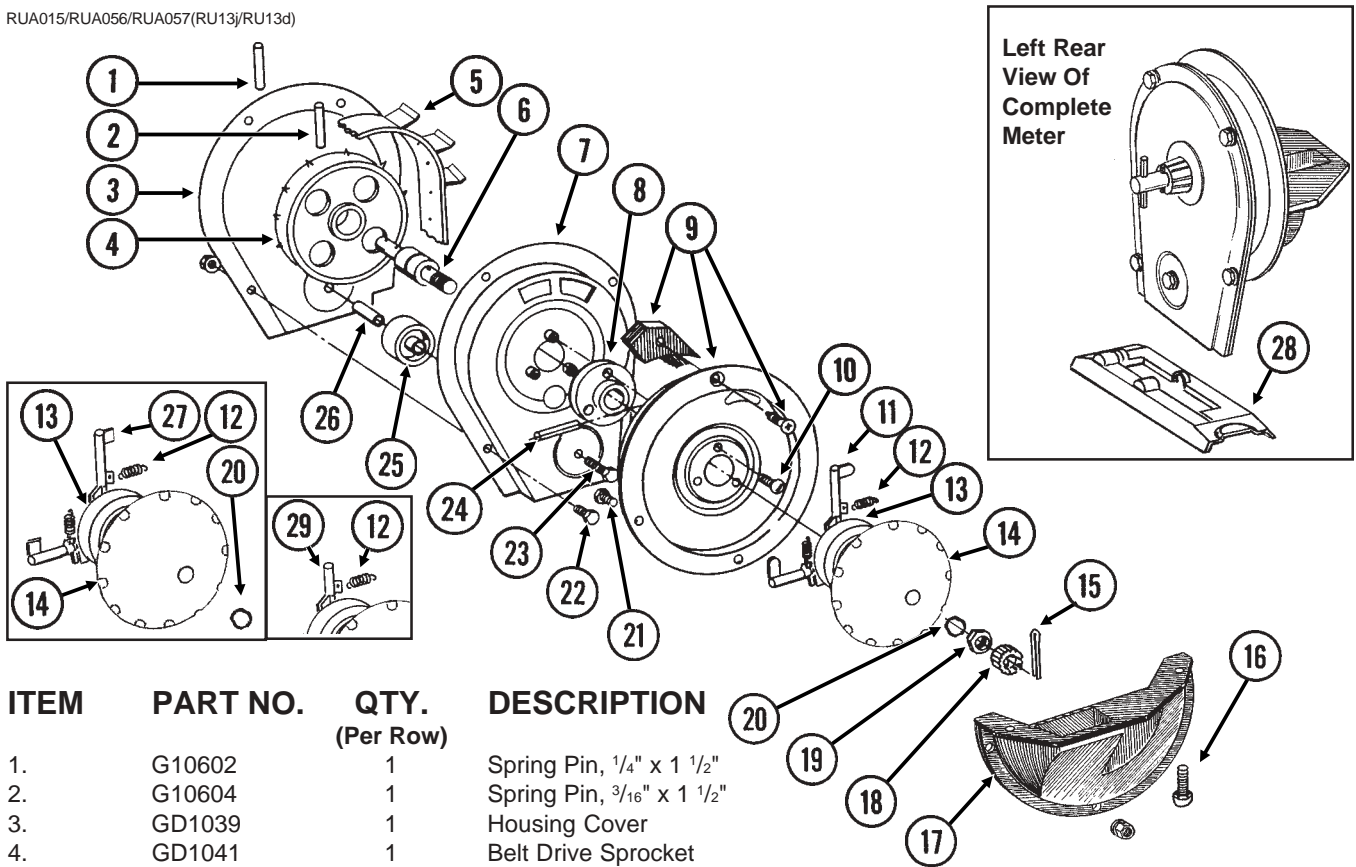

ITEM	PART NO.	QTY. (Per Row)	DESCRIPTION
1.	G10602	1	Spring Pin, 1/4" x 1 1/2"
2.	G10604	1	Spring Pin, 3/16" x 1 1/2"
3.	GD1039	1	Housing Cover
4.	GD1041	1	Belt Drive Sprocket
5.	GD11286	1	Seed Belt
6.	GA2019	1	Bearing
7.	GA2018	1	Conveyor Housing
8.	GB0110	1	Bearing Housing
9.	GR1569	1	Carrier Plate W/Brush And Screw
	GA2020	-	Brush
	G10690	-	Rolling Thread Screw, No. 10 x 3/4"
10.	G10401	3	Slotted Hex Washer Head Screw, No. 10-32 x 5/8"
11.	GD10733	12	Finger, Corn
12.	GD6501	12	Spring
13.	GB0111	1	Cam
14.	GD11528	1	Finger Holder
15.	G10470	1	Cotter Pin, 5/32" x 1"
16.	G11009	2	Locking Thumbscrew, 5/16"-18 x 3/4"
17.	GD11311	1	Seed Baffle
18.	GD1083	1	Cover Nut
19.	G10500	1	Jam Nut, 5/8"-18 UNF
20.	GA8343	1	Wave Washer, 5/8" (Triple Wave)
21.	G10020	3	Hex Head Cap Screw, 1/4"-20 x 5/8"
	G10323	3	Hex Flange Nut, 1/4"-20
22.	G10022	4	Hex Head Cap Screw, 1/4"-20 x 1/2"
	G10621	4	Flange Nut, 1/4"-20
23.	G10021	1	Hex Head Cap Screw, 1/4"-20 x 1 1/2"
	G10621	1	Flange Nut, 1/4"-20
24.	G10603	1	Spring Pin, 1/4" x 1 1/4"
25.	GD1042	1	Idler
26.	GB0120	1	Bushing, 17/64" I.D. x 1 1/32" Long
27.	GD10226	12	Finger, Oil Sunflower
28.	GD11373	1	Shank Cover, Finger Pickup Seed Meter
29.	GD11787	-	Half Rate Blank Finger
A.	GR1487	-	Finger Assembly, Corn (Items 11-14 And 20)
B.	GR1327	-	Finger Assembly, Oil Sunflower (Items 12-14, 20 And 27)

BRUSH-TYPE SEED METER

RUA037/RUA056/RUA057(RU14a)

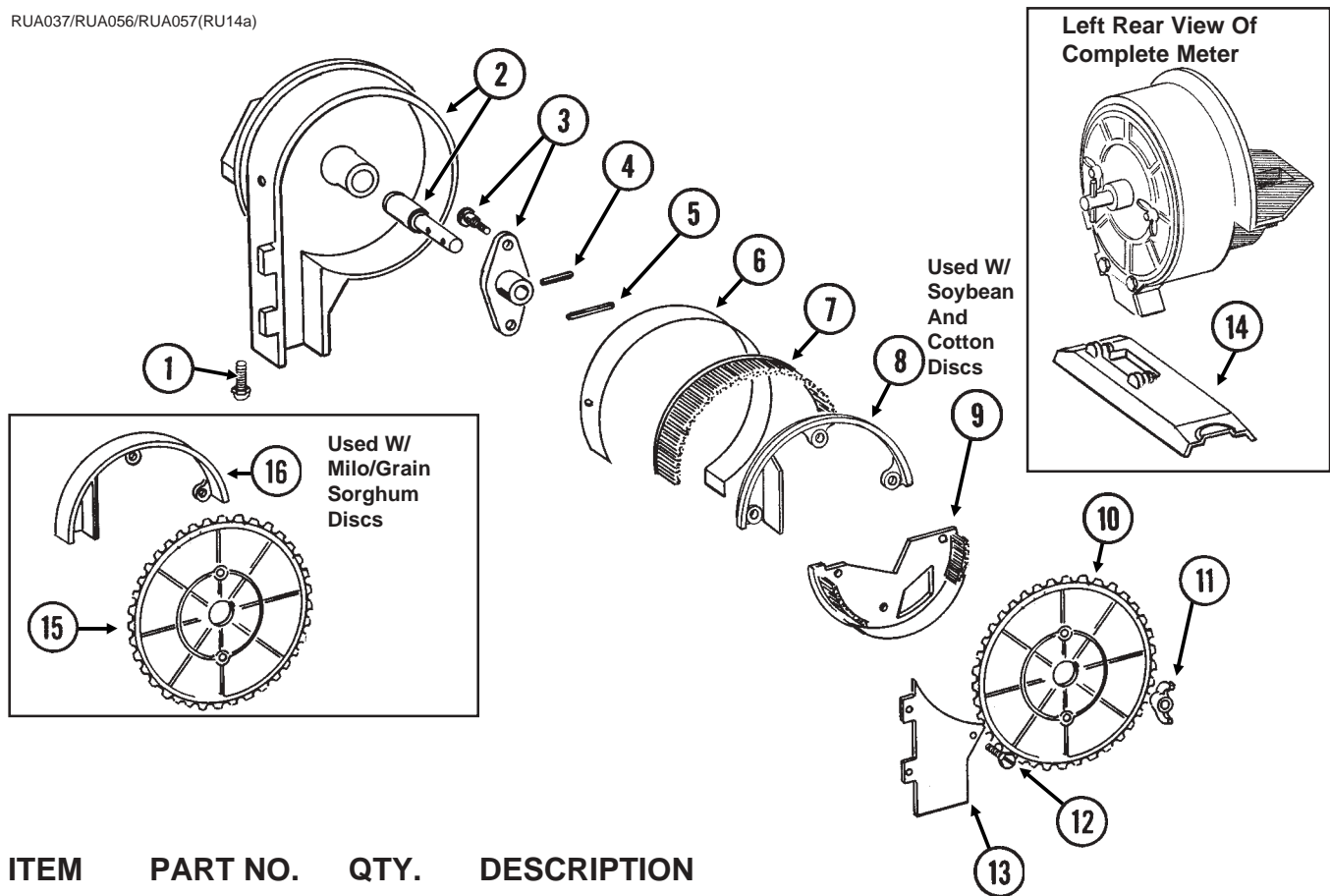

ITEM	PART NO.	QTY.	DESCRIPTION
		(Per Row)	
1.	G11009	2	Locking Thumbscrew, 5/16"-18 x 3/4"
2.	GA6027	1	Housing W/Bearing
	GA5698	-	Bearing
3.	GA6038	1	Hub W/Shoulder Bolts
	GD1755	-	Shoulder Bolt, 1/4"-20 (2 Used)
4.	G10603	1	Spring Pin, 1/4" x 1 1/4"
5.	G10602	1	Spring Pin, 1/4" x 1 1/2"
6.	GD8778	1	Wear Strip
7.	GA5699	1	Upper Brush
8.	GD11122	1	Upper Brush Retainer (Used W/Soybean And Cotton Discs)
9.	GA5834	1	Lower Brush
10.	GA5794	-	Seed Disc, Soybean, 60 Cell, Black Color-Coded
	GA6184	-	Seed Disc, Specialty Soybean, 48 Cell, Dark Blue Color-Coded
	GA5796	-	Seed Disc, Cotton, Acid-Delinted, 30 Cell, White Color-Coded
	GA6168	-	Seed Disc, Large Cotton, Acid-Delinted, 36 Cell, Tan Color-Coded
	GA6478	-	Seed Disc, High-Rate Cotton, Acid-Delinted, 48 Cell, Light Green Color-Coded
	GA6182	-	Seed Disc, Hill-Drop Cotton, Acid-Delinted, 12 Cell, Brown Color-Coded
	GA7255	-	Seed Disc, Small Hill-Drop Cotton, Acid-Delinted, 12 Cell, Dark Green Color-Coded
11.	G10531	2	Wing Nut W/Nylon Insert, 1/4"-20
12.	G10584	9	Slotted Tap Screw, No. 10-24 x 1/2"
	G10634	-	Slotted Tap Screw, No. 10-24 x 5/8" (Use As Required)
13.	GD7878	1	Cover
14.	GD11374	1	Shank Cover, Brush-Type Seed Meter
15.	GA5982	-	Seed Disc, Small Milo/Grain Sorghum, 30 Cell, Red Color-Coded
	GA6187	-	Seed Disc, Large Milo/Grain Sorghum, 30 Cell, Light Blue Color-Coded
	GA5795	-	Seed Disc, High-Rate Small Milo/Grain Sorghum, 60 Cell, Red Color-Coded
	GA6633	-	Seed Disc, High-Rate Large Milo/Grain Sorghum, 60 Cell, Yellow Color-Coded
16.	GD8237	-	Upper Brush Retainer (Used W/Milo/Grain Sorghum Discs)

GRANULAR CHEMICAL HOPPER AND HOPPER PANEL EXTENSION

RUA052/RUA053/RUB028(RU92k)

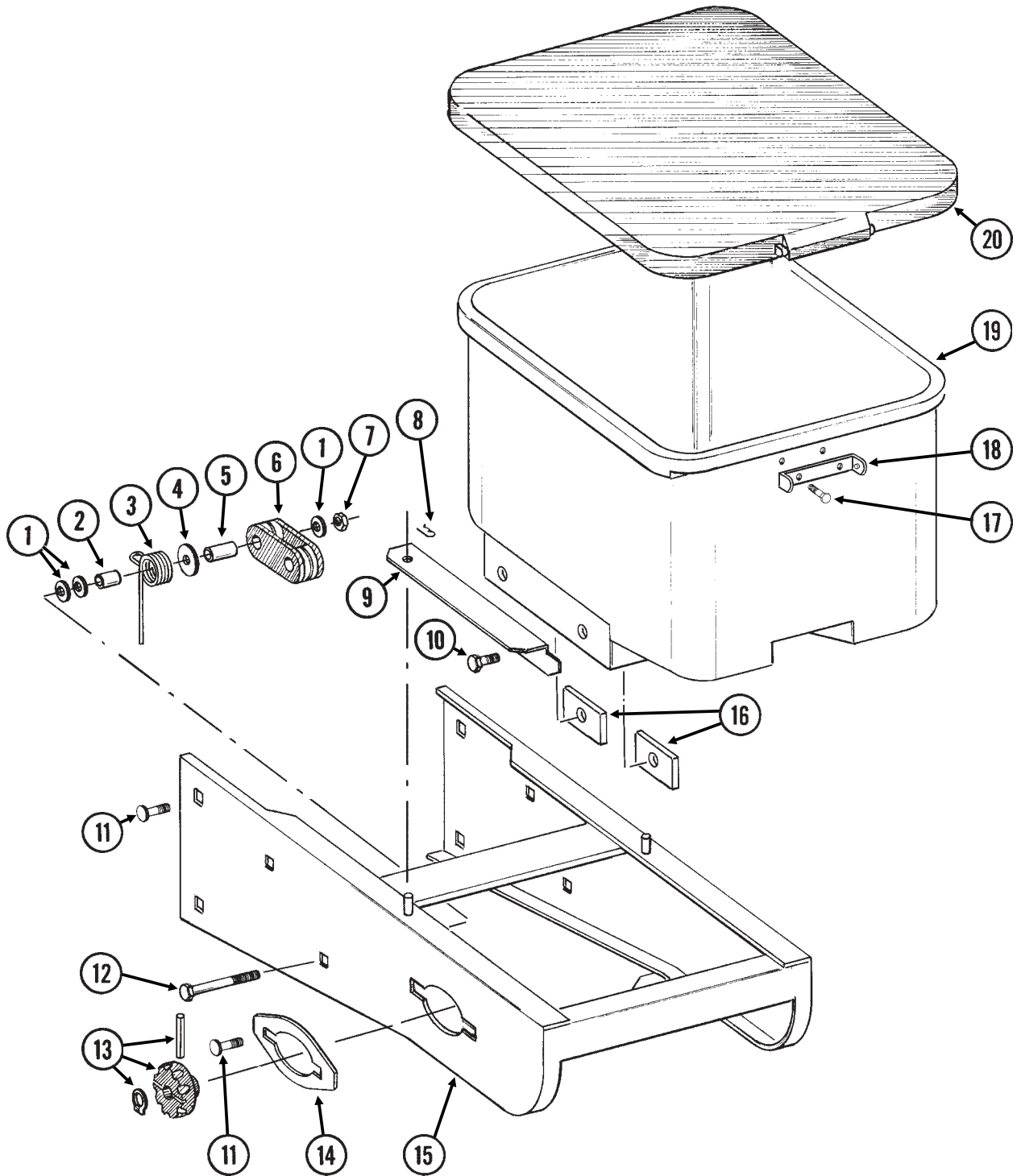

GRANULAR CHEMICAL HOPPER AND HOPPER PANEL EXTENSION

ITEM	PART NO.	QTY. (Per Row)	DESCRIPTION
1.	G10210	3	Washer, $\frac{3}{8}$ " USS
2.	GD2971-10	1	Sleeve, $\frac{9}{16}$ " Long
3.	GD11219	1	Spring
4.	G10201	1	Special Washer, $\frac{3}{8}$ " x 1 $\frac{1}{2}$ " O.D.
5.	GD1026	1	Sleeve, 1 $\frac{3}{16}$ " Long
6.	GD11962	1	Idler
7.	G10108	1	Lock Nut, $\frac{3}{8}$ "-16
8.	G10670	2	Hair Pin Clip, No. 3
9.	GD1059L	1	Support, L.H. (Shown)
	GD1059R	1	Support, R.H.
10.	G10002	4	Hex Head Cap Screw, $\frac{3}{8}$ "-16 x $\frac{3}{4}$ "
	G10229	4	Lock Washer, $\frac{3}{8}$ "
11.	G10312	8	Carriage Bolt, $\frac{5}{16}$ "-18 x $\frac{3}{4}$ "
	G10620	8	Flange Nut, $\frac{5}{16}$ "-18
12.	G10325	1	Hex Head Cap Screw, $\frac{3}{8}$ "-16 x 2 $\frac{3}{4}$ "
13.		-	See "Granular Chemical Meter And Meter Drive", Page P18
14.	GD11305	1	Plate
15.	A8422	1	Hopper Panel Extension (Non-Stock Item) (Sub Wholegoods Order Code 700-01080)
16.	GD11424	4	Block
17.	G10023	2	Hex Head Cap Screw, $\frac{1}{4}$ "-20 x $\frac{3}{4}$ "
	G10621	2	Flange Nut, $\frac{1}{4}$ "-20
18.	GD1060	1	Hinge
19.	GA8371	1	Hopper
20.	GA4444	1	Lid

GRANULAR CHEMICAL METER AND METER DRIVE

RUA051/RUB028(RU91a)

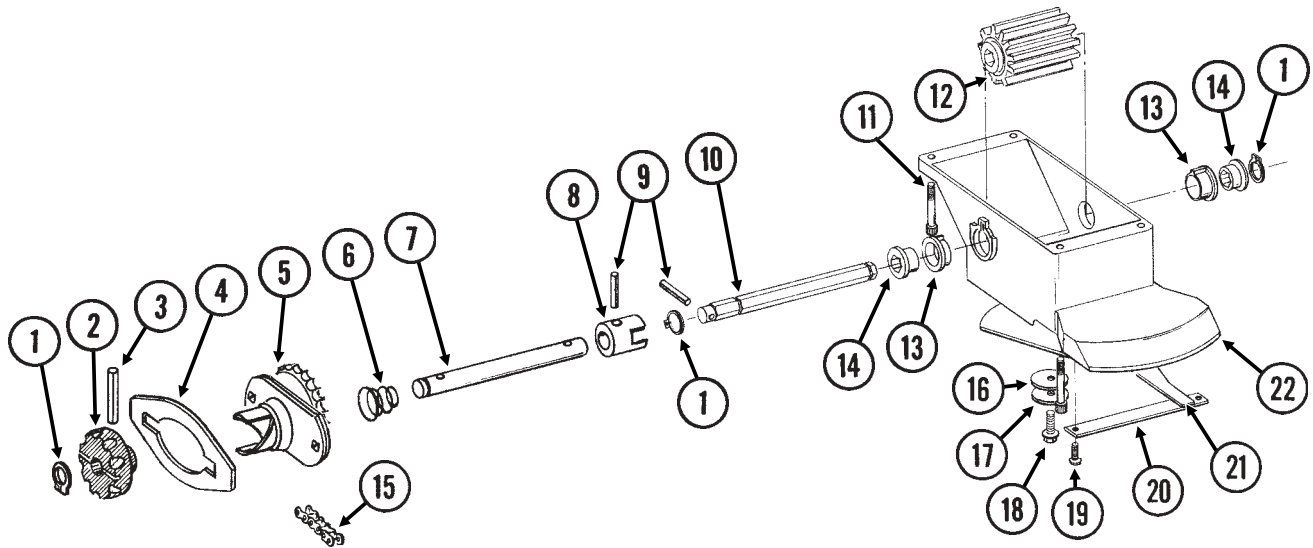

ITEM	PART NO.	QTY. (Per Row)	DESCRIPTION
1.	G10567	3	External Retaining Ring, 5/8"
2.	GD11239	1	Knob
3.	G10602	1	Spring Pin, 1/4" x 1 1/2"
4.	-	-	See "Granular Chemical Hopper And Hopper Panel Extension", Pages P16 And P17
5.	GA8364	1	Sprocket And Bearing, Drive Clutch, 24 Tooth
6.	GD11413	1	Spring
7.	GD11240	1	Shaft
8.	GB0278	1	Coupler
9.	G10546	2	Spring Pin, 3/16" x 1 1/4"
10.	GD11297	1	Shaft
11.	G10921	4	Hex Socket Head Cap Screw, No. 10-24 x 7/8"
	G10257	4	Lock Washer, No. 10
12.	GD7148	1	Feed Roller, Hex Bore
13.	GB0115	2	Bearing
14.	GD7258	2	Hex Bushing
15.	G3303-114	1	Chain, No. 41, 114 Pitch Including Connector Link
	GR0196	1	Connector Link, No. 41
16.	G10660	1	Wave Washer, 1/2"
17.	G10209	1	Washer, 1/4" USS
18.	G10570	1	Slotted Hex Self-Tapping Screw, 1/4"-20 x 3/4"
19.	G11073	2	Slotted Hex Self-Tapping Screw, No. 10 x 3/8"
20.	GD1061	1	Support Strap
21.	GD1063	1	Metering Gate
22.	GB0116	1	Granular Housing
A.	GA8326	-	Granular Chemical Meter Complete (Items 1, 9, 10, 12-14 And 16-22)

GRANULAR CHEMICAL BANDING OPTIONS

RUA061/RUA073(RU101m/RU83m)

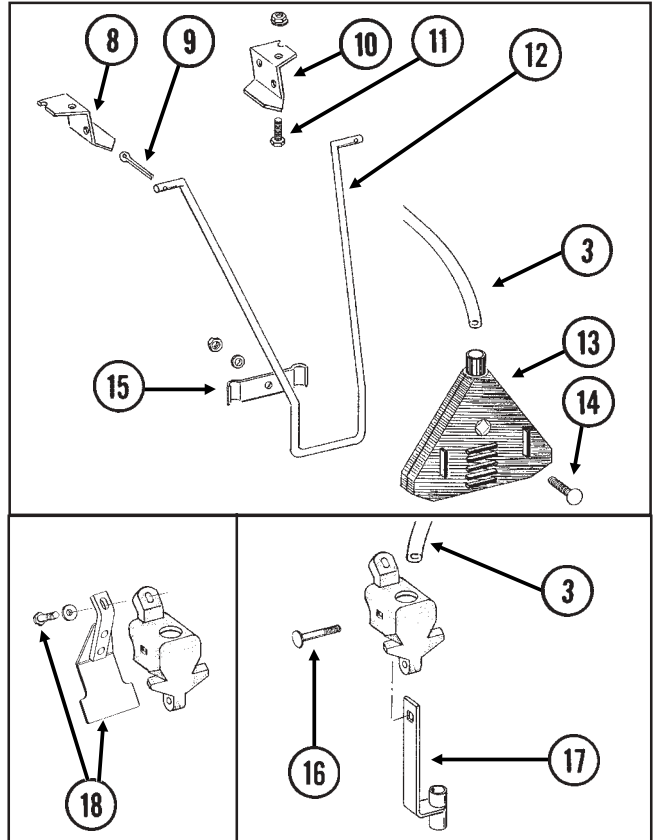
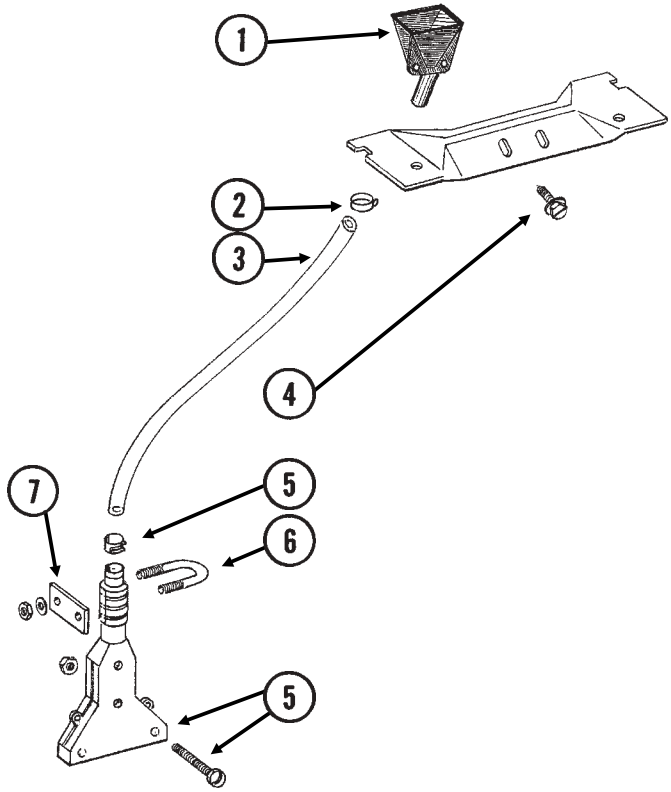

ITEM	PART NO.	QTY.	DESCRIPTION
1.	GD2423	1	Funnel
2.	G10673	1	Hose Clamp, No. 8
3.	GD2947	1	Hose, 7/16" x 28"
4.	G10523	2	Slotted Pan Head Self-Tapping Screw, No. 10 x 1/2"
5.	GA6907	1	Slope-Compensating Bander W/Hardware (4 1/2" Band Width)
	G10864	1	Uni-Clamp
	G10757	2	Pan Head Screw, No. 10-32 x 1 1/4"
	G10758	2	Hex Nut, No. 10-32
6.	GD10963	1	U-Bolt, 1 1/2" x 1 5/16" x 1/4"-20
	G10209	2	Washer, 1/4" USS
	G10110	2	Lock Nut, 1/4"-20
7.	GD10984	1	Spacer
8.	GD1115L	-	Hanger Bracket, L.H.
9.	G10452	-	Cotter Pin, 1/8" x 1/2"
10.	GD1115R	-	Hanger Bracket, R.H.
11.	G10310	-	Carriage Bolt, 1/4"-20 x 3/4", Grade 2
	G10227	-	Lock Washer, 1/4"
	G10103	-	Hex Nut, 1/4"-20
12.	GD1116	-	Hanger
13.	GA2075	-	Diffuser, 14" Band
14.	G10306	-	Carriage Bolt, 3/8"-16 x 2"
	G10229	-	Lock Washer, 3/8"
	G10101	-	Hex Nut, 3/8"-16
15.	GD1118	-	Clamp
16.	G10315	1	Carriage Bolt, 1/2"-13 x 2 1/2" (Replaces Existing 1/2" x 2 1/4" Hardware)
17.	GA6741	1	Bracket (Straight Drop In-Furrow)
18.	G1K385	-	Bander Shield Kit W/Hardware And Instruction
	G10003	1	Hex Head Cap Screw, 3/8"-16 x 1 1/2"
	GD14659	1	Special Washer, 3/8", Hardened

SPRING TOOTH INCORPORATOR

RUA055(RU95)

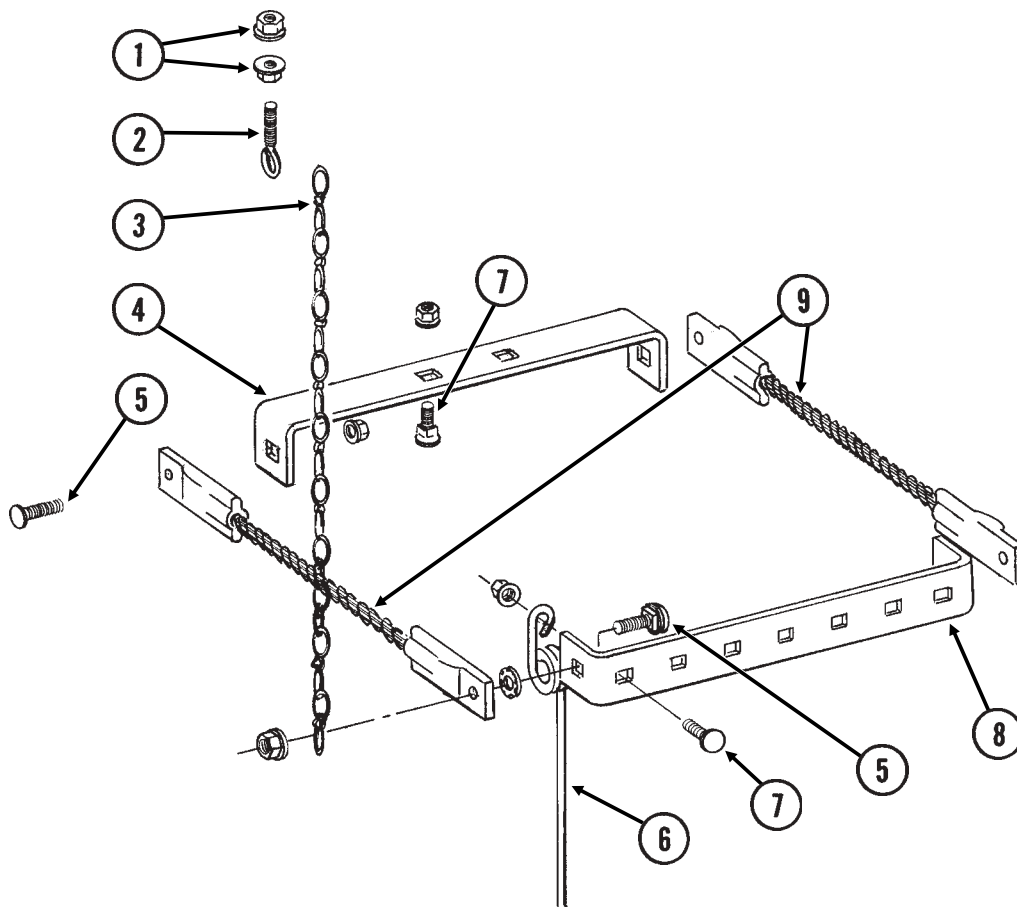

ITEM	PART NO.	QTY. (Per Row)	DESCRIPTION
1.	G10621	4	Flange Nut, 1/4"-20
2.	GD2460	2	Eyebolt, 1/4"-20
3.	G3305-01	4	Twin Loop Chain, 9 Links
4.	GD1143	1	Front Bracket
5.	G10305	4	Carriage Bolt, 3/8"-16 x 1"
	G10529	4	External Tooth Lock Washer, 3/8"
	G10622	4	Flange Nut, 3/8"-16
6.	GD1145	7	Spring Tooth
7.	G10308	9	Carriage Bolt, 3/8"-16 x 3/4"
	G10622	9	Flange Nut, 3/8"-16
8.	GD1144	1	Rear Bracket
9.	GA2094	2	Cable Assembly

ROW UNIT MOUNTED NO TILL COULTER

RUA061(RU102/RU102c)

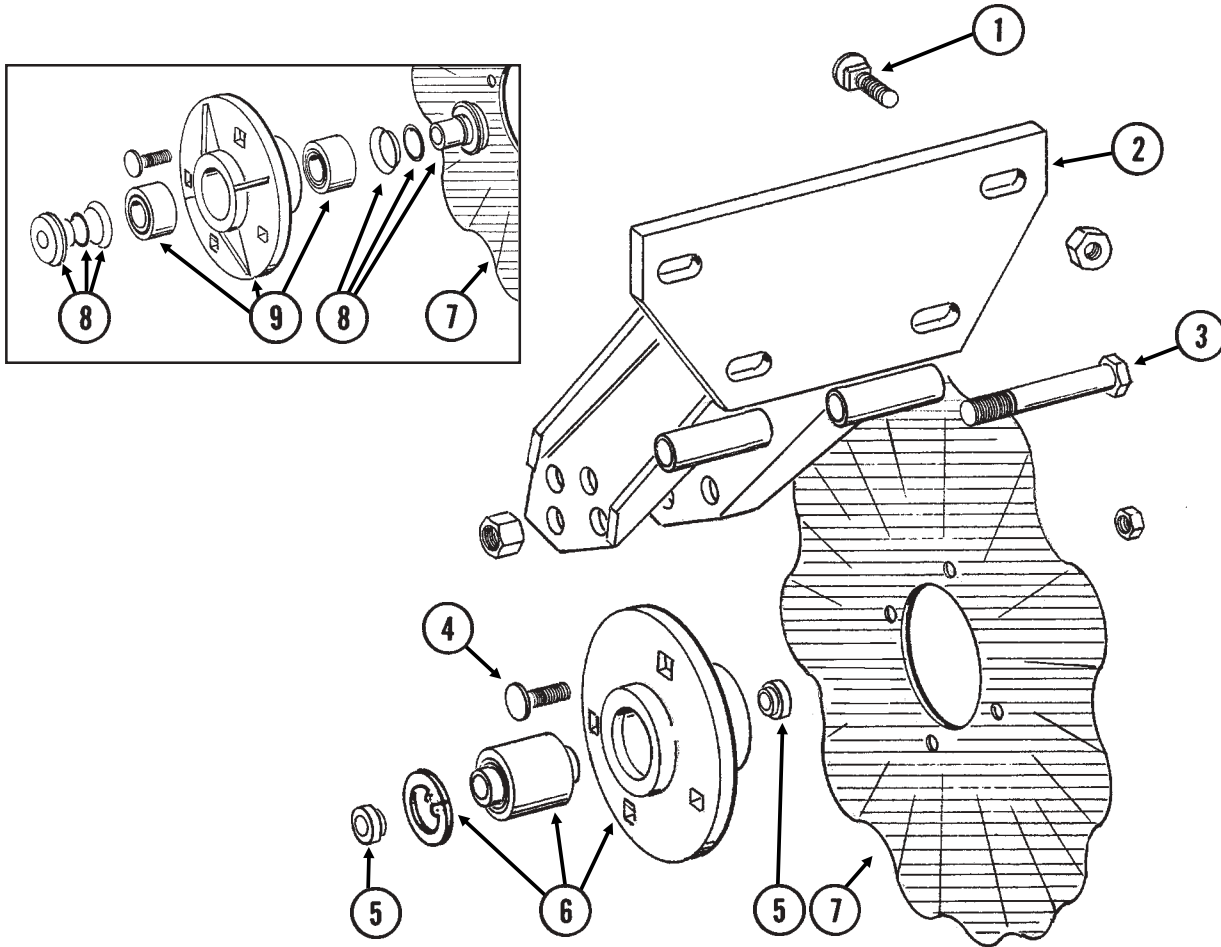

ITEM	PART NO.	QTY. (Per Row)	DESCRIPTION
1.	G10574	4	Carriage Bolt, 1/2"-13 x 1 1/4"
	G10111	4	Lock Nut, 1/2"-13
2.	GA5625	1	Arm
3.	G10036	1	Hex Head Cap Screw, 5/8"-11 x 4"
	G10107	1	Lock Nut, 5/8"-11
4.	G10574	4	Carriage Bolt, 1/2"-13 x 1 1/4"
	G10111	4	Lock Nut, 1/2"-13
5.	GD11677	2	Adapter
6.	GA8641	1	Hub W/Bearing And Retaining Ring
	GA8603	-	Double Row Bearing
	GD11652	-	Retaining Ring, 2 7/16"
7.	GD7803	-	Disc Blade, Fluted, 1", 8 Flutes (Shown)
	GD7804	-	Disc Blade, Bubbled, 1"
	GD9254	-	Disc Blade, Fluted, 3/4", 13 Flutes
8.	G1K330	2	Adapter Kit W/O-Ring And Spring Washer
	GD8844	2	O-Ring
	GD8843	2	Spring Washer
9.	GA5640	1	Hub W/Bearings And Grease Fitting (Sub G1K289)
	GA5622	-	Bearing (2 Used Per Hub)
	G10640	-	Grease Fitting, 1/4"-28

ROW UNIT MOUNTED BED LEVELER

RUA059/RUA060(RU99/RU100)

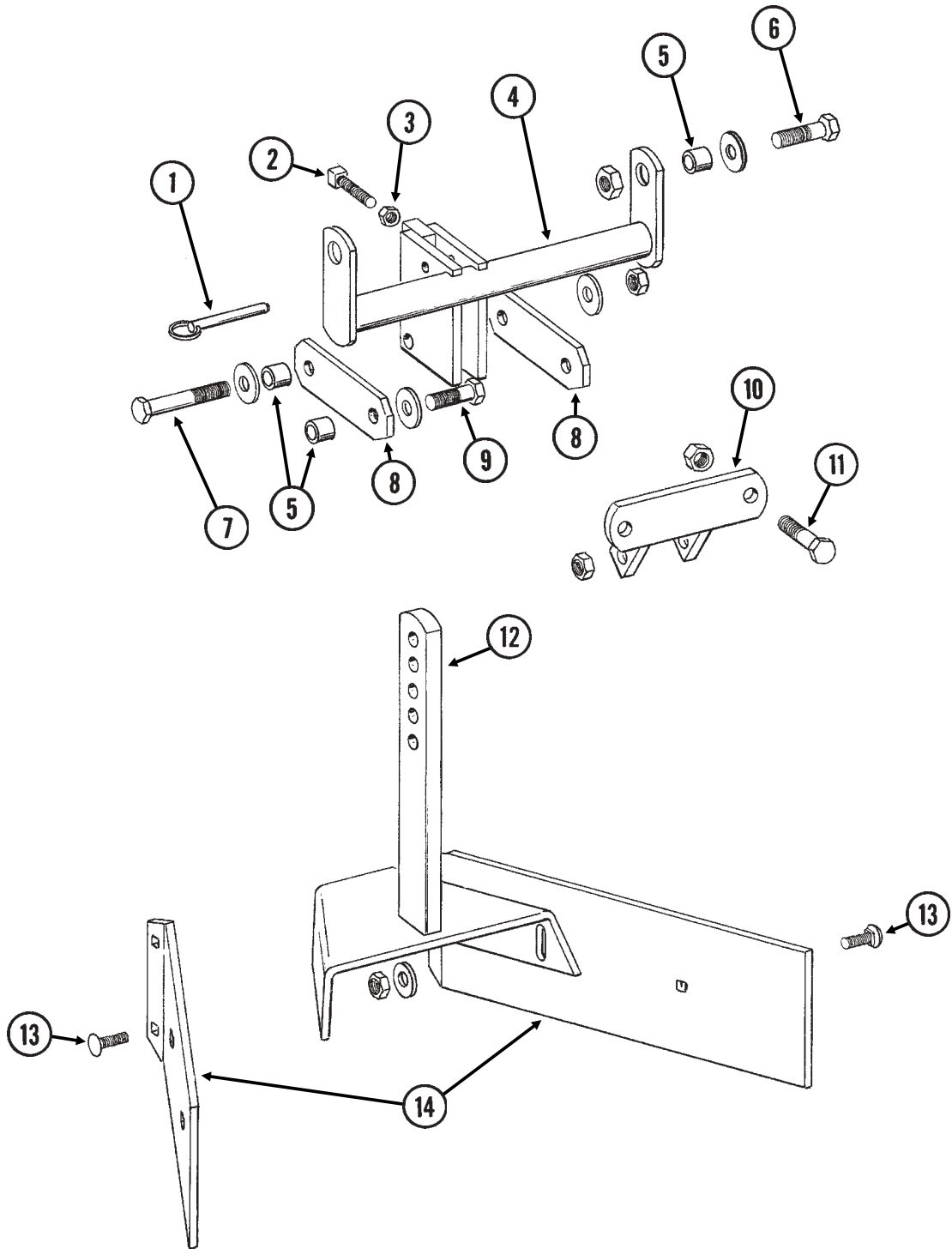

ROW UNIT MOUNTED BED LEVELER

ITEM	PART NO.	QTY. (Per Row)	DESCRIPTION
1.	G10536	1	Detent Pin, 1/2" x 2 1/2" Grip
2.	G10597	1	Square Head Set Screw, 5/8"-11 x 2 1/4"
3.	G10503	1	Hex Jam Nut, 5/8"-11, Grade 2
4.	GA5719	1	Mounting Bracket
5.	GD7889	6	Bushing, 1" O.D. x 9/16" I.D. x 7/16" Long
6.	G10039	2	Hex Head Cap Screw, 1/2"-13 x 1 3/4"
	G10216	2	Washer, 1/2" USS
	G10111	2	Lock Nut, 1/2"-13
7.	G10585	1	Hex Head Cap Screw, 1/2"-13 x 3 1/4"
	G10216	2	Washer, 1/2" USS
	G10111	1	Lock Nut, 1/2"-13
8.	GD7890	2	Link
9.	G10017	2	Hex Head Cap Screw, 1/2"-13 x 1 1/2"
	G10216	2	Washer, 1/2" USS
	G10111	2	Lock Nut, 1/2"-13
10.	GA5715	1	Anchor
11.	G10017	2	Hex Head Cap Screw, 1/2"-13 x 1 1/2"
	G10111	2	Lock Nut, 1/2"-13
12.	GA5892	1	Leveler
13.	G10303	6	Carriage Bolt, 5/16"-18 x 1"
	G10219	4	Washer, 5/16" USS
	G10109	6	Lock Nut, 5/16"-18
14.	GD8266	2	Blade

ROW UNIT MOUNTED DISC FURROWER

RUA059/RUA058(RU99/RU98g)

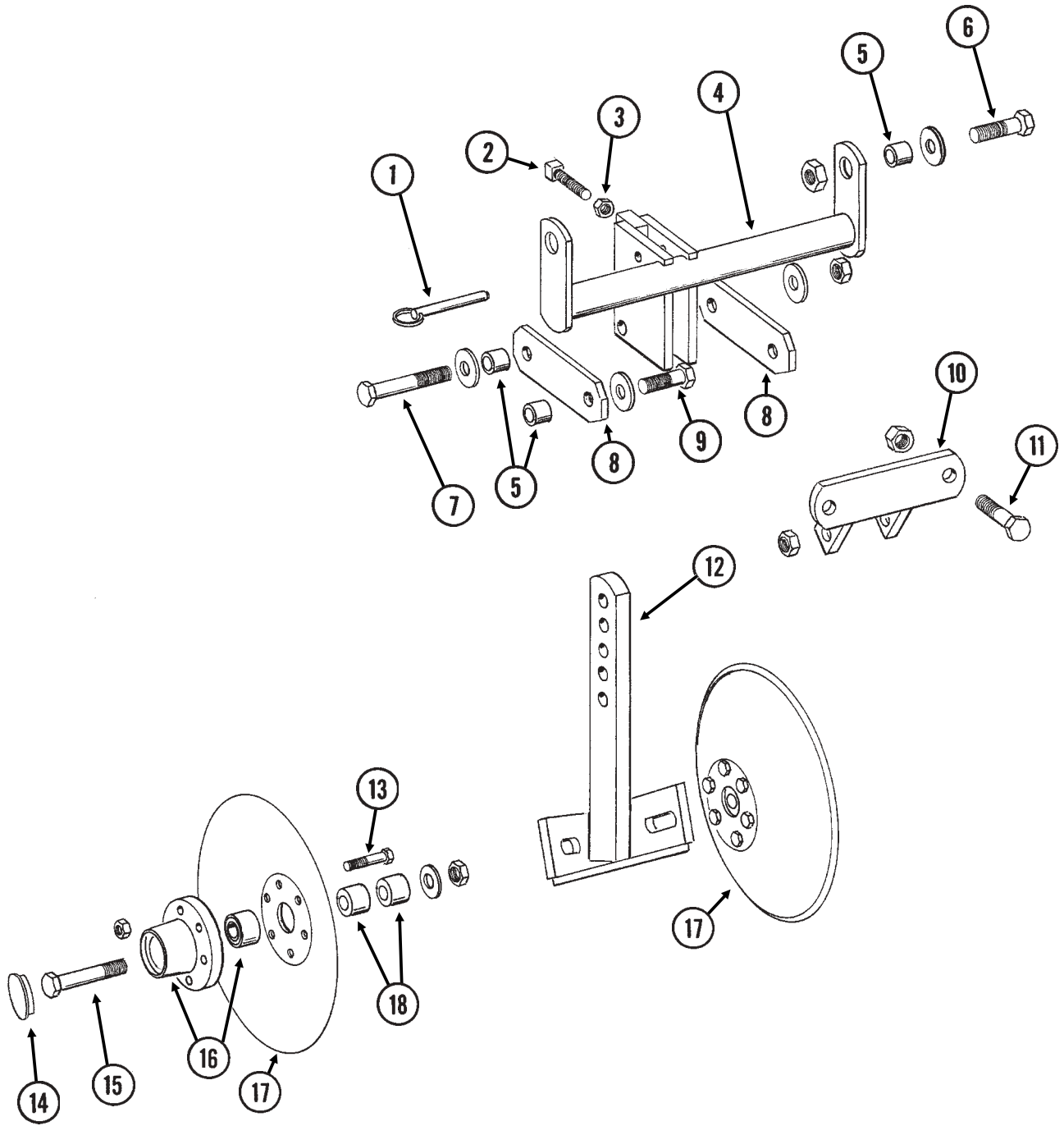

ROW UNIT MOUNTED DISC FURROWER

ITEM	PART NO.	QTY. (Per Row)	DESCRIPTION
1.	G10536	1	Detent Pin, 1/2" x 2 1/2" Grip
2.	G10597	1	Square Head Set Screw, 5/8"-11 x 2 1/4"
3.	G10503	1	Hex Jam Nut, 5/8"-11, Grade 2
4.	GA5719	1	Mounting Bracket
5.	GD7889	6	Bushing, 1" O.D. x 9/16" I.D. x 7/16" Long
6.	G10039	2	Hex Head Cap Screw, 1/2"-13 x 1 3/4"
	G10216	2	Washer, 1/2" USS
	G10111	2	Lock Nut, 1/2"-13
7.	G10585	1	Hex Head Cap Screw, 1/2"-13 x 3 1/4"
	G10216	2	Washer, 1/2" USS
	G10111	1	Lock Nut, 1/2"-13
8.	GD7890	2	Link
9.	G10017	2	Hex Head Cap Screw, 1/2"-13 x 1 1/2"
	G10216	2	Washer, 1/2" USS
	G10111	2	Lock Nut, 1/2"-13
10.	GA5715	1	Anchor
11.	G10017	2	Hex Head Cap Screw, 1/2"-13 x 1 1/2"
	G10111	2	Lock Nut, 1/2"-13
12.	GA5718	1	Support Arm
13.	G10572	6	Truss Head Slotted Machine Screw, 5/16"-18 x 7/8"
	G10106	6	Hex Nut, 5/16"-18
14.	GD1132	2	Dust Cap
15.	G10318	2	Hex Head Cap Screw, 5/8"-11 x 4 1/2"
	GD7805	2	Special Washer, 5/8", Hardened
	G10107	2	Lock Nut, 5/8"-11
16.	GA5654	2	Hub W/Bearings
	GA2014	-	Bearing
17.	GD7823	-	Disc Blade, Solid, 12" (Shown)
	GD8307	-	Disc Blade, Notched, 12"
18.	GD7817-01	2	Spacer, 11/16" I.D. x 3/4" Long
	GD7817-04	2	Spacer, 11/16" I.D. x 1/2" Long

ROW UNIT MOUNTED RESIDUE WHEEL

(RU103d)

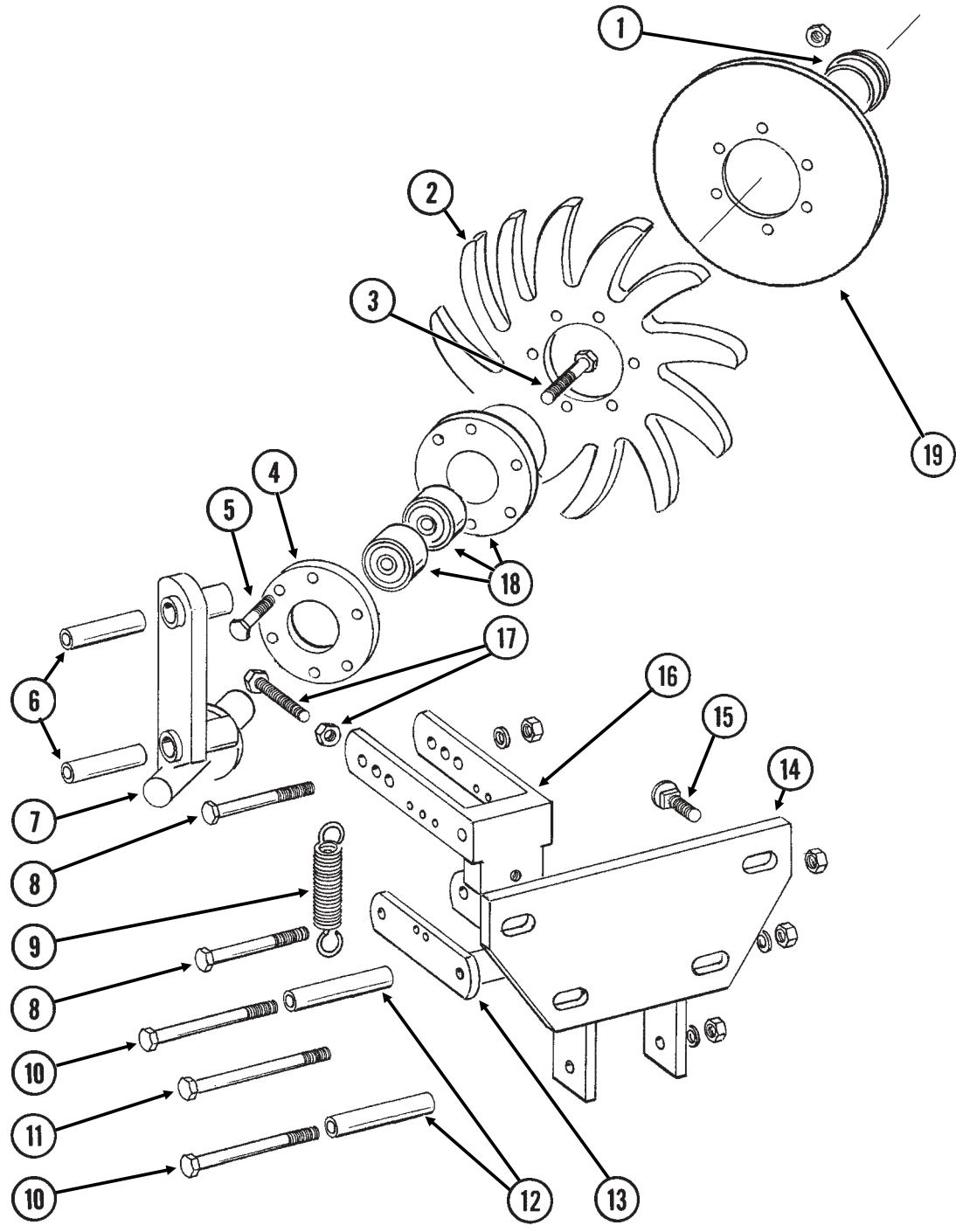

ROW UNIT MOUNTED RESIDUE WHEEL

ITEM	PART NO.	QTY. (Per Row)	DESCRIPTION
1.	GD1132	1	Dust Cap
2.	GD10552	1	Wheel, 12 Tine, $\frac{3}{8}$ " x 12"
3.	G10006	1	Hex Head Cap Screw, $\frac{5}{8}$ "-11 x 2 $\frac{1}{4}$ "
4.	GD9724	1	Backing Plate
5.	G10133	6	Hex Head Cap Screw, $\frac{5}{16}$ "-18 x 1 $\frac{1}{2}$ "
	G10109	6	Lock Nut, $\frac{5}{16}$ "-18
6.	GD9720	2	Spacer, $\frac{1}{2}$ " x 2 $\frac{3}{16}$ " Long
7.	GA6838	1	Wheel Mount
8.	G10033	2	Hex Head Cap Screw, $\frac{1}{2}$ "-13 x 3 $\frac{1}{2}$ "
	G10228	2	Lock Washer, $\frac{1}{2}$ "
	G10102	2	Hex Nut, $\frac{1}{2}$ "-13
9.	GD5857	2	Spring
10.	G10045	2	Hex Head Cap Screw, $\frac{1}{2}$ "-13 x 4 $\frac{1}{2}$ "
	G10228	2	Lock Washer, $\frac{1}{2}$ "
	G10102	2	Hex Nut, $\frac{1}{2}$ "-13
11.	G10348	1	Hex Head Cap Screw, $\frac{1}{2}$ "-13 x 5" (Lockup Bolt)
	G10111	1	Lock Nut, $\frac{1}{2}$ "-13
12.	GD9715	2	Spacer, $\frac{1}{2}$ " x 3" Long
13.	GA6834	1	Lower Link
14.	GA6832	1	Mount
15.	G10574	4	Carriage Bolt, $\frac{1}{2}$ "-13 x 1 $\frac{1}{4}$ "
	G10111	4	Lock Nut, $\frac{1}{2}$ "-13
16.	GA6833	1	Upper Link
17.	G10371	1	Hex Head Cap Screw, $\frac{1}{2}$ "-13 x 3", Full Thread
	G10501	1	Hex Jam Nut, $\frac{1}{2}$ "-13, Grade 2
18.	GA5654	1	Hub W/Bearings
	GA2014	-	Bearing
19.	GD12534	-	Cover
A.	GA7446	-	Wheel Assembly, 12 Tine (Items 2, 4, 5 And 18)

COULTER MOUNTED RESIDUE WHEELS

RUA063(RU104p)

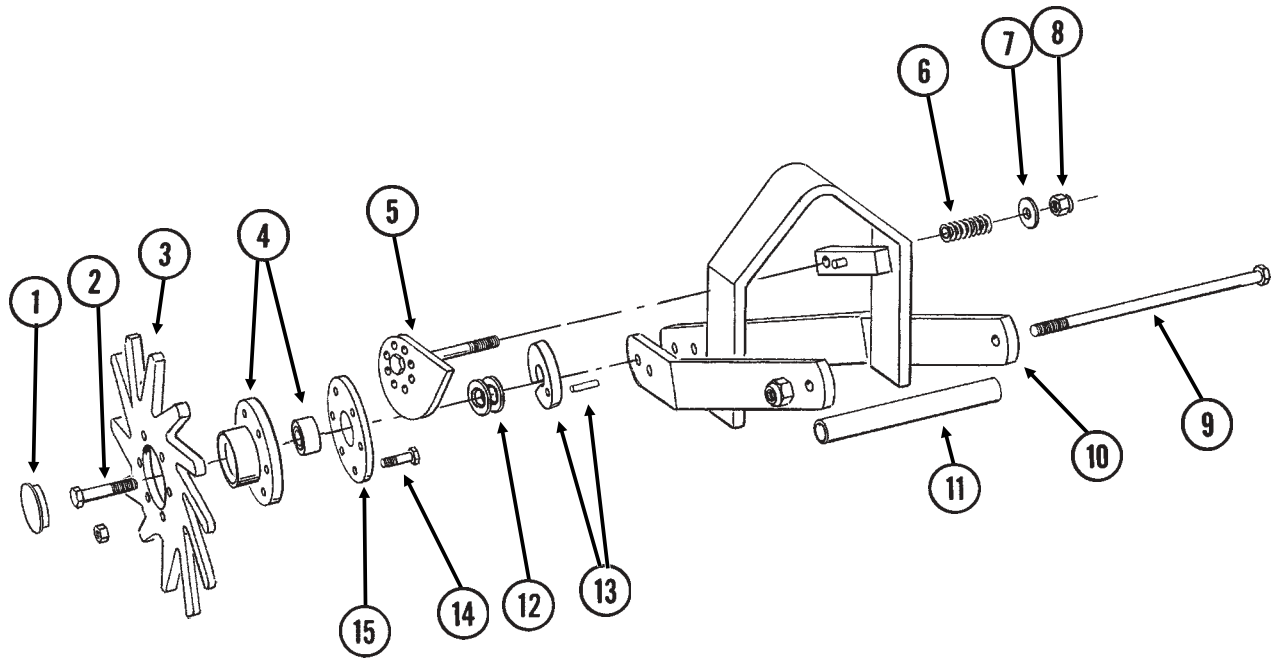

COULTER MOUNTED RESIDUE WHEELS

ITEM	PART NO.	QTY. (Per Row)	DESCRIPTION
1.	GD1132	2	Dust Cap
2.	G10010	2	Hex Head Cap Screw, $\frac{5}{8}$ "-11 x 3"
	G10503	2	Hex Jam Nut, $\frac{5}{8}$ "-11, Grade 2
3.	GD10552	2	Wheel, 12 Tine, $\frac{3}{8}$ " x 12"
4.	GA5654	2	Hub W/Bearings
	GA2014	-	Bearing
5.	GA7412	1	Cam
6.	GD10519	1	Spring
7.	G10206	1	Washer, $\frac{1}{2}$ " SAE
8.	G10974	1	Lock Nut W/Nylon Insert, $\frac{1}{2}$ "-13
9.	G11098	1	Hex Head Cap Screw, $\frac{1}{2}$ "-13 x 9 $\frac{1}{2}$ ", Grade 8
	GD14674	2	Special Washer, $\frac{1}{2}$ ", Hardened
	G10974	1	Lock Nut W/Nylon Insert, $\frac{1}{2}$ "-13
10.	GA7271	1	Mount
11.	GD10526	1	Sleeve, 7 $\frac{1}{2}$ "
12.	G10213	4	Machine Bushing, $\frac{5}{8}$ " (.030" Thick)
13.	GA8760	2	Weed Guard W/Spring Pin
	G10765	-	Spring Pin, $\frac{1}{4}$ " x 1"
14.	G10133	12	Hex Head Cap Screw, $\frac{5}{16}$ "-18 x 1 $\frac{1}{2}$ "
	G10109	12	Lock Nut, $\frac{5}{16}$ "-18
15.	GD9724	2	Backing Plate
A.	GA7446	-	Wheel Assembly, 12 Tine, R.H. (Items 3, 4, 14 And 15) (Shown)
	GA7445	-	Wheel Assembly, 12 Tine, L.H. (Items 3, 4, 14 And 15)

FRAME MOUNTED COULTER W/DISC FURROWER

RUA058/RUA064/RUA070/RUA071/RUA072/RUA068(RU1071/RU107b)

STYLE A

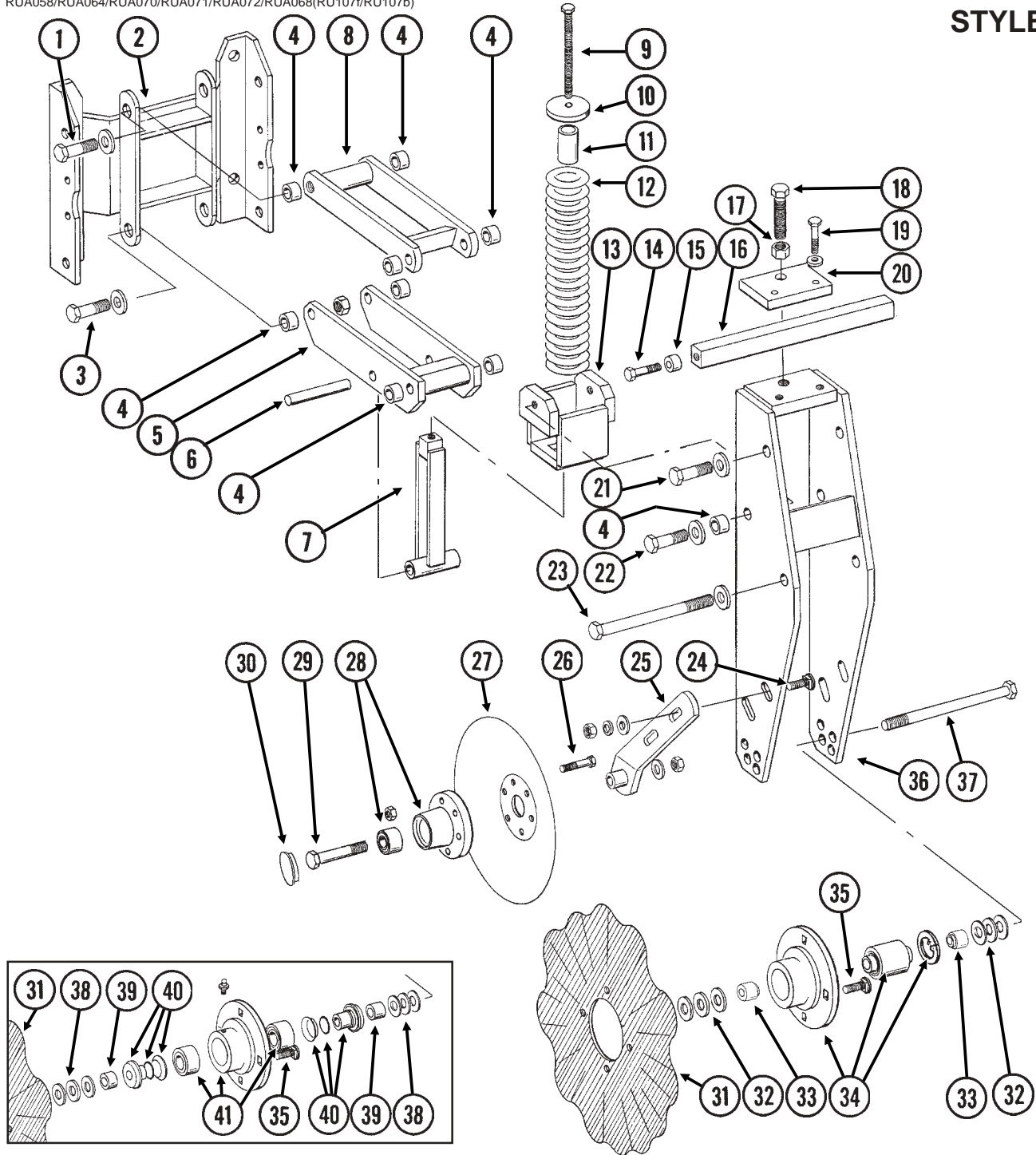

ITEM PART NO. QTY. DESCRIPTION
(Per Row)

1.	G10008	2	Hex Head Cap Screw, 5/8"-11 x 2"
	GD7805	2	Special Washer, 5/8", Hardened
2.	GA5798	1	Support Plate
3.	G10008	2	Hex Head Cap Screw, 5/8"-11 x 2"
	GD7805	2	Special Washer, 5/8", Hardened
	G10107	2	Lock Nut, 5/8"-11
4.	GB0218	10	Bushing, 2 1/32" I.D. x 7/8" O.D. x 1 9/32" Long
5.	GA5631	1	Lower Parallel Link
6.	GD7815	1	Pin, 5/8" x 4 1/4"
7.	GA5635	1	Spring Guide

P30

Rev. 1/03

FRAME MOUNTED COULTER W/DISC FURROWER

ITEM	PART NO.	QTY. (Per Row)	DESCRIPTION
8.	GA5630	1	Upper Parallel Link
9.	G10573	1	Hex Head Cap Screw, 5/8"-11 x 5 1/2", Full Thread
10.	GB0196	1	Washer
11.	GD7817-09	1	Spacer, 1 1/16" I.D. x 1 3/4" Long
12.	GD7831	1	Compression Spring
13.	GA5637	1	Spring Socket
14.	GD7818	2	Special Bolt
15.	GD7817-01	2	Spacer, 1 1/16" I.D. x 3/4" Long
16.	GD7816	1	Depth Control Bar
17.	G10104	1	Hex Nut, 5/8"-11
18.	G10582	1	Hex Head Cap Screw, 5/8"-11 x 4", Full Thread
19.	G10581	2	Hex Head Cap Screw, 1/2"-13 x 2 1/4"
	G10228	2	Lock Washer, 1/2"
20.	GD7811	1	Depth Adjustment Clamp
21.	G10008	2	Hex Head Cap Screw, 5/8"-11 x 2"
	GD7805	2	Special Washer, 5/8", Hardened
	GD1109	-	Bushing, 41/64" I.D. x 7/8" O.D. x 1/4" Long (As Required)
	G10107	1	Lock Nut, 5/8"-11
22.	G10055	2	Hex Head Cap Screw, 5/8"-11 x 1 1/4"
	GD7805	2	Special Washer, 5/8", Hardened
23.	G10012	1	Hex Head Cap Screw, 5/8"-11 x 6 1/2"
	GD7805	2	Special Washer, 5/8", Hardened
	GD1109	-	Bushing, 41/64" I.D. x 7/8" O.D. x 1/4" Long (As Required)
	G10107	1	Lock Nut, 5/8"-11
24.	G10747	4	Carriage Bolt, 1/2"-13 x 2"
	G10206	-	Washer, 1/2" SAE (As Required)
	G10228	4	Lock Washer, 1/2"
	G10102	4	Hex Nut, 1/2"-13
25.	GA5636	2	Arm
26.	G10572	12	Truss Head Slotted Machine Screw, 5/16"-18 x 7/8"
	G10106	12	Hex Nut, 5/16"-18
27.	GD7823	2	Disc Blade, Solid, 12" (Shown)
	GD8307	-	Disc Blade, Notched, 12"
28.	GA5654	2	Hub W/Bearings
	GA2014	4	Bearing
29.	G10036	2	Hex Head Cap Screw, 5/8"-11 x 4"
	G10107	2	Lock Nut, 5/8"-11
30.	GD1132	2	Dust Cap
31.	GD7803	1	Disc Blade, Fluted, 1", 8 Flutes (Shown)
	GD7804	-	Disc Blade, Bubbled, 1"
	GD9254	-	Disc Blade, Fluted, 3/4", 13 Flutes
32.	G10213	-	Machine Bushing, 5/8" (.030" Thick) (As Required)
	G10918	-	Machine Bushing, 5/8", 14 Gauge (As Required)
33.	GD11698	2	Adapter
34.	GA8641	1	Hub W/Bearing And Retaining Ring
	GA8603	-	Double Row Bearing
	GD11652	-	Retaining Ring, 2 7/16"
35.	G10574	4	Carriage Bolt, 1/2"-13 x 1 1/4"
	G10111	4	Lock Nut, 1/2"-13
36.	GA5643	1	Fork Mount
37.	G10068	1	Hex Head Cap Screw, 5/8"-11 x 6"
	G10107	1	Lock Nut, 5/8"-11
38.	G10217	-	Washer, 5/8" USS (As Required)
39.	GD7817-04	2	Spacer, 1 1/16" I.D. x 1/2" Long
40.	G1K330	2	Adapter Kit W/O-Ring And Spring Washer
	GD8844	-	O-Ring
	GD8843	-	Spring Washer
41.	GA5640	1	Hub W/Bearings And Grease Fitting (Sub G1K290)
	GA5622	-	Bearing (2 Used Per Hub)
	G10640	-	Grease Fitting, 1/4"-28

FRAME MOUNTED COULTER W/RESIDUE WHEELS

(RU135c/RU135g/RU135h)

STYLE B

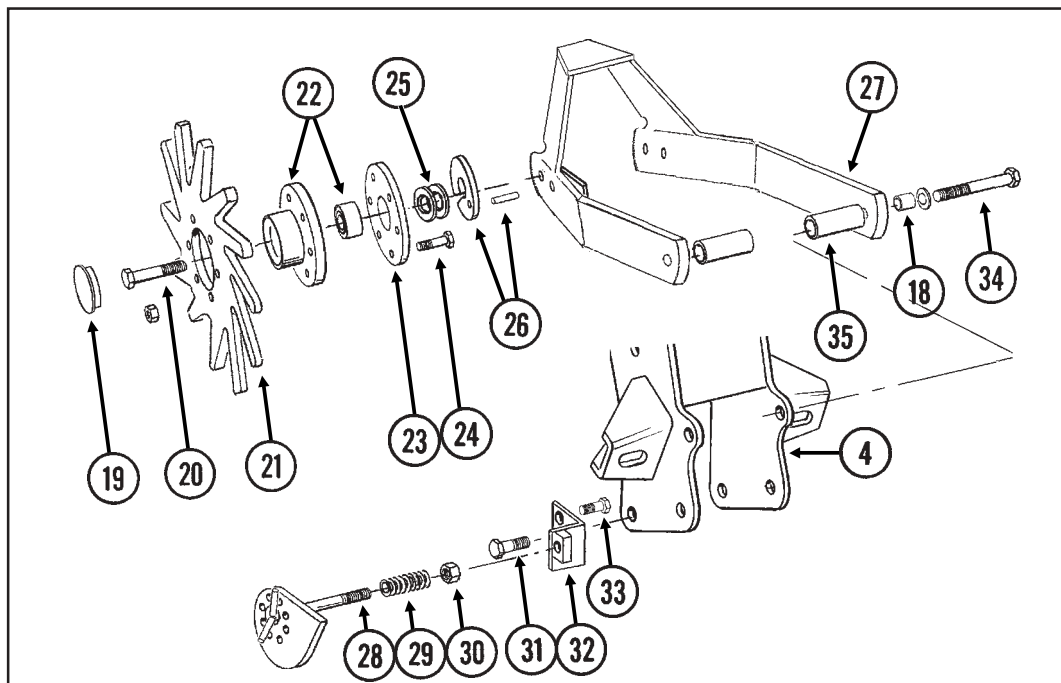
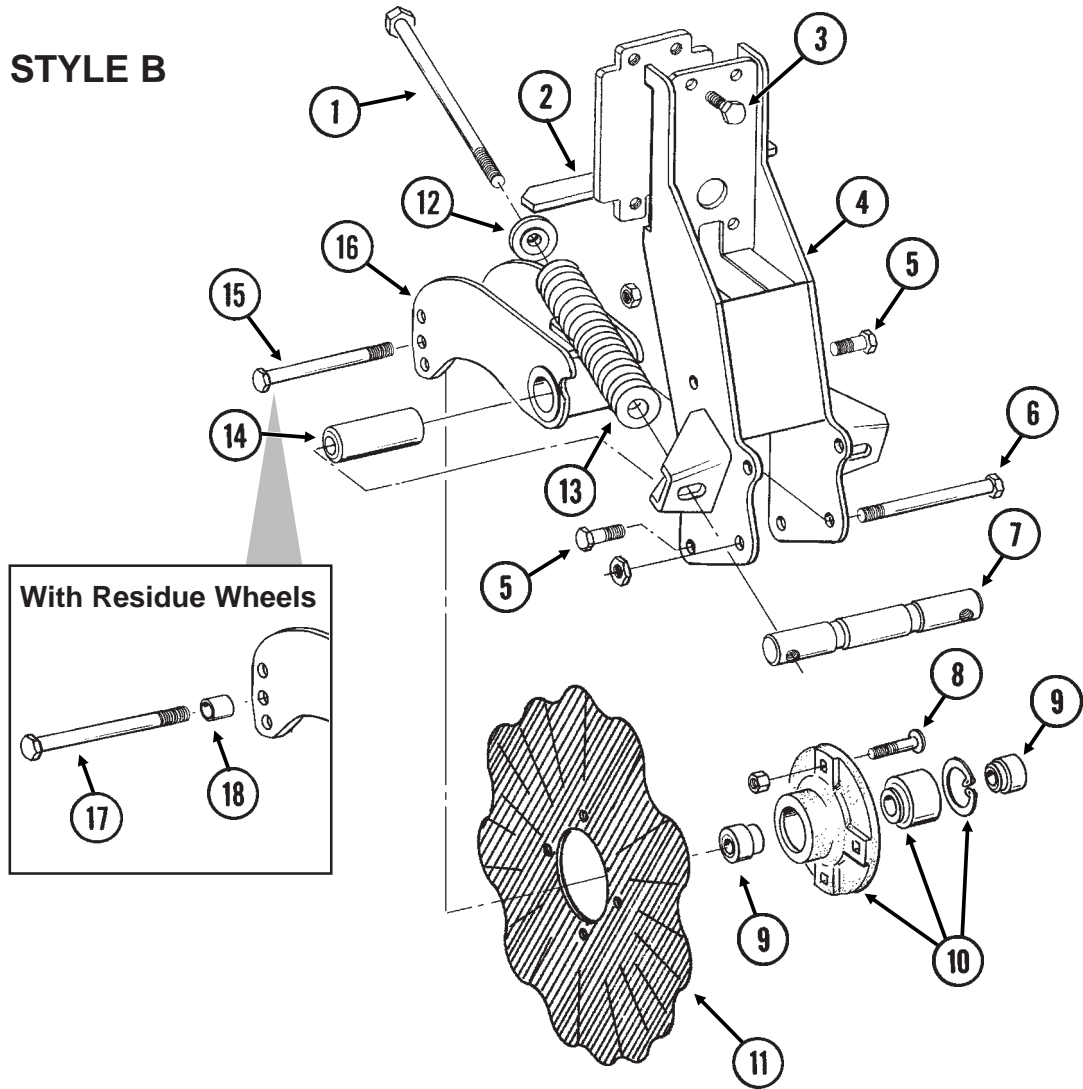

FRAME MOUNTED COULTER W/RESIDUE WHEELS

ITEM	PART NO.	QTY. (Per Row)	DESCRIPTION
1.	G11010	2	Hex Head Cap Screw, 3/4"-10 x 12"
2.	GA9844	1	Plate W/Angle
3.	G10039	4	Hex Head Cap Screw, 1/2"-13 x 1 3/4"
4.	GA9131	1	Coulter Frame
5.	G10007	4	Hex Head Cap Screw, 5/8"-11 x 1 1/2"
	G10107	4	Lock Nut, 5/8"-11
6.	G10400	1	Hex Head Cap Screw, 3/4"-10 x 6 1/2"
	G10112	1	Lock Nut, 3/4"-10
7.	GD12826	1	Spring Anchor Bar
8.	G10574	4	Carriage Bolt, 1/2"-13 x 1 1/4"
	G10111	4	Lock Nut, 1/2"-13
9.	GD12827	2	Adapter
10.	GA8641	1	Hub W/Bearing And Retaining Ring
	GA8603	1	Double Row Bearing
	GD11652	1	Retaining Ring, 2 7/16"
11.	GD7803	1	Disc Blade, Fluted, 1", 8 Flutes (Shown)
	GD7804	-	Disc Blade, Bubbled, 1"
	GD9254	-	Disc Blade, Fluted, 3/4", 13 Flutes
12.	GB0213	2	Spring Seat
13.	GD12817	2	Compression Spring
14.	GD12829	1	Sleeve
15.	G10046	1	Hex Head Cap Screw, 5/8"-11 x 5"
	G10107	1	Lock Nut, 5/8"-11
16.	GA9845	1	Coulter Arm W/Grease Fitting
	G10643	-	Grease Fitting, 45°, 1/4"-28
17.	G10011	1	Hex Head Cap Screw, 5/8"-11 x 5 1/2"
	G10107	1	Lock Nut, 5/8"-11
18.	GB0218	3	Bushing, 21/32" I.D. x 7/8" O.D. x 19/32" Long
19.	GD1132	2	Dust Cap
20.	G10010	2	Hex Head Cap Screw, 5/8"-11 x 3"
	G10530	2	Hex Jam Nut, 5/8"-11, Grade 2
21.	GD10552	2	Wheel, 12 Tine, 3/8" x 12"
22.	GA5654	2	Hub W/Bearings
	GA2014	-	Bearing
23.	GD9724	2	Backing Plate
24.	G10133	12	Hex Head Cap Screw, 5/16"-18 x 1 1/2"
	G10109	12	Lock Nut, 5/16"-18
25.	G10213	4	Machine Bushing, 5/8" (.030" Thick)
26.	GA9862	2	Weed Guard W/Spring Pin
	G10765	-	Spring Pin, 1/4" x 1"
27.	GA9865	1	Mount
28.	GA9861	1	Cam
29.	GD10519	1	Spring
30.	G10974	1	Lock Nut W/Nylon Insert, 1/2"-13
31.	G10005	1	Hex Head Cap Screw, 5/8"-11 x 1 3/4"
	G10107	4	Lock Nut, 5/8"-11
32.	GA9864	1	Support
33.	G10014	1	Hex Head Cap Screw, 1/2"-13 x 1"
	G10102	1	Hex Nut, 1/2"-13
34.	G10011	2	Hex Head Cap Screw, 5/8"-11 x 5 1/2"
	G10205	2	Washer, 5/8" SAE
	G10730	2	Lock Nut W/Nylon Insert, 5/8"-11
35.	GD14170	2	Sleeve, 3"
A.	GA7446	-	Wheel Assembly, 12 Tine, R.H. (Items 21-24) (Shown)
	GA7445	-	Wheel Assembly, 12 Tine, L.H. (Items 21-24)

CENTER FRAME ASSEMBLY

PFA074/PHA040/PHA046(SFP21/SFP20/SFP19/D13659)

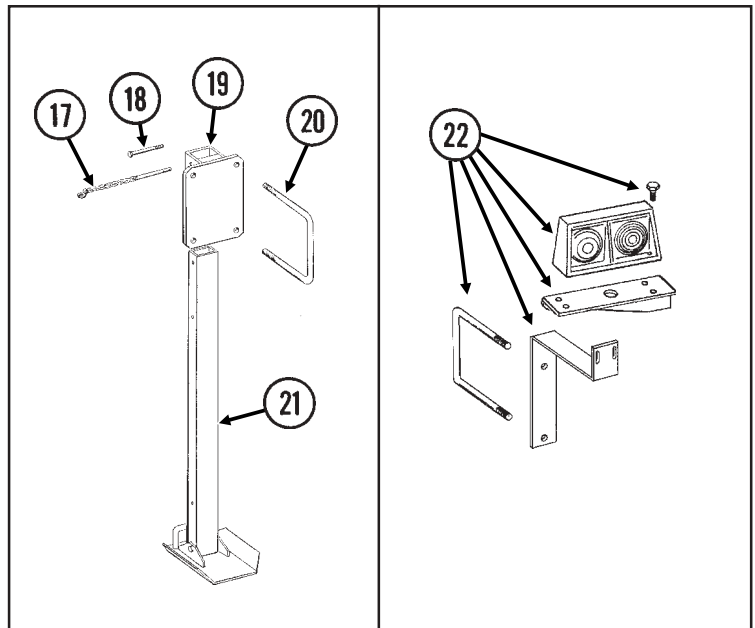
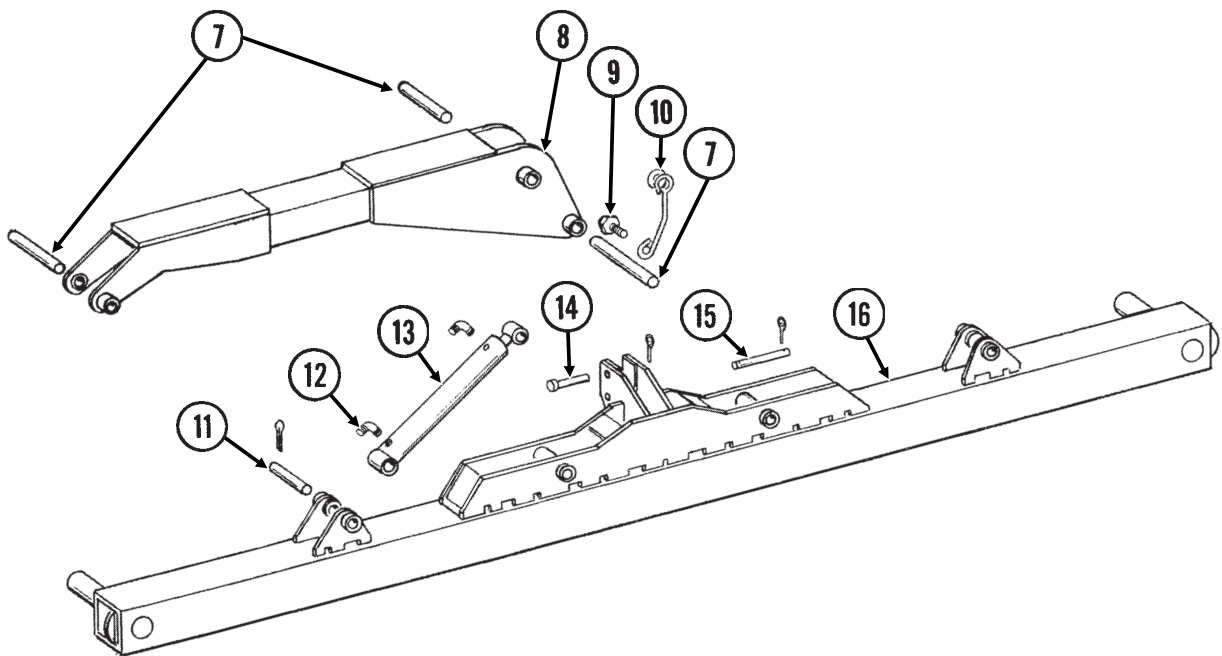
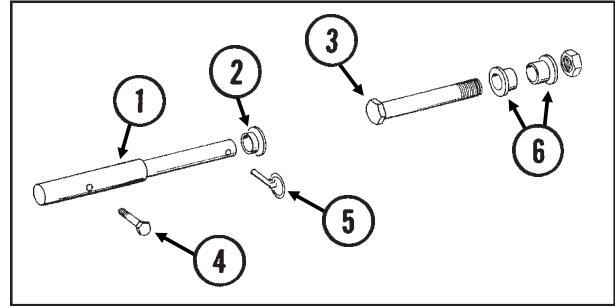

CENTER FRAME ASSEMBLY

ITEM	PART NO.	QTY.	DESCRIPTION
1.	GD9750	2	Pin, 11 3/4" Long, Category 2 - Lower Hitch
2.	GD10418	2	Bushing, Category 2
3.	G10151	1	Hex Head Cap Screw, 1"-8 x 6", Category 2 - Upper Hitch
	G10396	1	Lock Nut, 1"-8
4.	G10048	2	Hex Head Cap Screw, 3/8"-16 x 2"
	G10108	2	Lock Nut, 3/8"-16
5.	GD2558	2	Lynch Pin, 1/4"
6.	GD10419	2	Top Link Bushing, Category 2
7.	GD10450	6	Pin, 1 1/4" x 11 1/4"
	G10159	12	Machine Bushing, 1 1/4", 10 Gauge
	G10139	-	Washer, 1 1/4" USS
	G10460	12	Cotter Pin, 1/4" x 2"
8.	GA7349	2	Arm W/Grease Fittings, 74", 8 Row 38"/40" And 12 Row 30"
	GA7359	2	Arm W/Grease Fittings, 93 1/2", 12 Row 36"/38"/40" And 16 Row 30"
	G10641	-	Grease Fitting, 1/8" NPT
9.	G10689	1	Carriage Bolt, 5/8"-11 x 2"
	G10217	1	Washer, 5/8" USS
	G10107	1	Lock Nut, 5/8"-11
10.	GD10456	1	Hose Holder
11.	GD10486	2	Pin, 1 1/4" x 9"
	G10159	4	Machine Bushing, 1 1/4", 10 Gauge
	G10460	4	Cotter Pin, 1/4" x 2"
12.			See "Fold Hydraulic System", Page P78
13.			See "Wing Fold Cylinder", Pages P70 And P71
14.	GA4666	1	Pin, 1 1/4" x 4 1/2", Category 3 - Upper Hitch
	GD2557	1	Lynch Pin, 7/16"
15.	GD9333	2	Pin, 1 7/16" x 8 3/4", Category 3 - Lower Hitch
	GD2557	4	Lynch Pin, 7/16"
16.	A7331	1	Center Toolbar W/Grease Fittings, 7" x 7" x 167", 8 Row 38"/40" And 12 Row 30" (Non-Stock Item)
	A7804	1	Center Toolbar W/Grease Fittings, 7" x 7" x 226", 12 Row 36"/38"/40" And 16 Row 30" (Non-Stock Item)
	G10640	4	Grease Fitting, 1/4"-28
17.	GA7466	2	Detent Pin W/Chain
18.	G10585	2	Hex Head Cap Screw, 1/2"-13 x 3 1/4"
	G10111	2	Lock Nut, 1/2"-13
19.	GA7334	2	Mount
20.	GD1114	4	U-Bolt, 7" x 7" x 5/8"-11
	G10230	8	Lock Washer, 5/8"
	G10104	8	Hex Nut, 5/8"-11
21.	GA7467	2	Parking Stand
22.		-	See "Electrical Components And Light Brackets", Pages P84 And P85
A.	G1K231	-	Category 3 To Category 2 Conversion Kit (Items 1-6)

WING ASSEMBLY

PFA75/PFA55/PFA076/PFA074(SFP18a/SFP18b/SFP15/SFP16a)

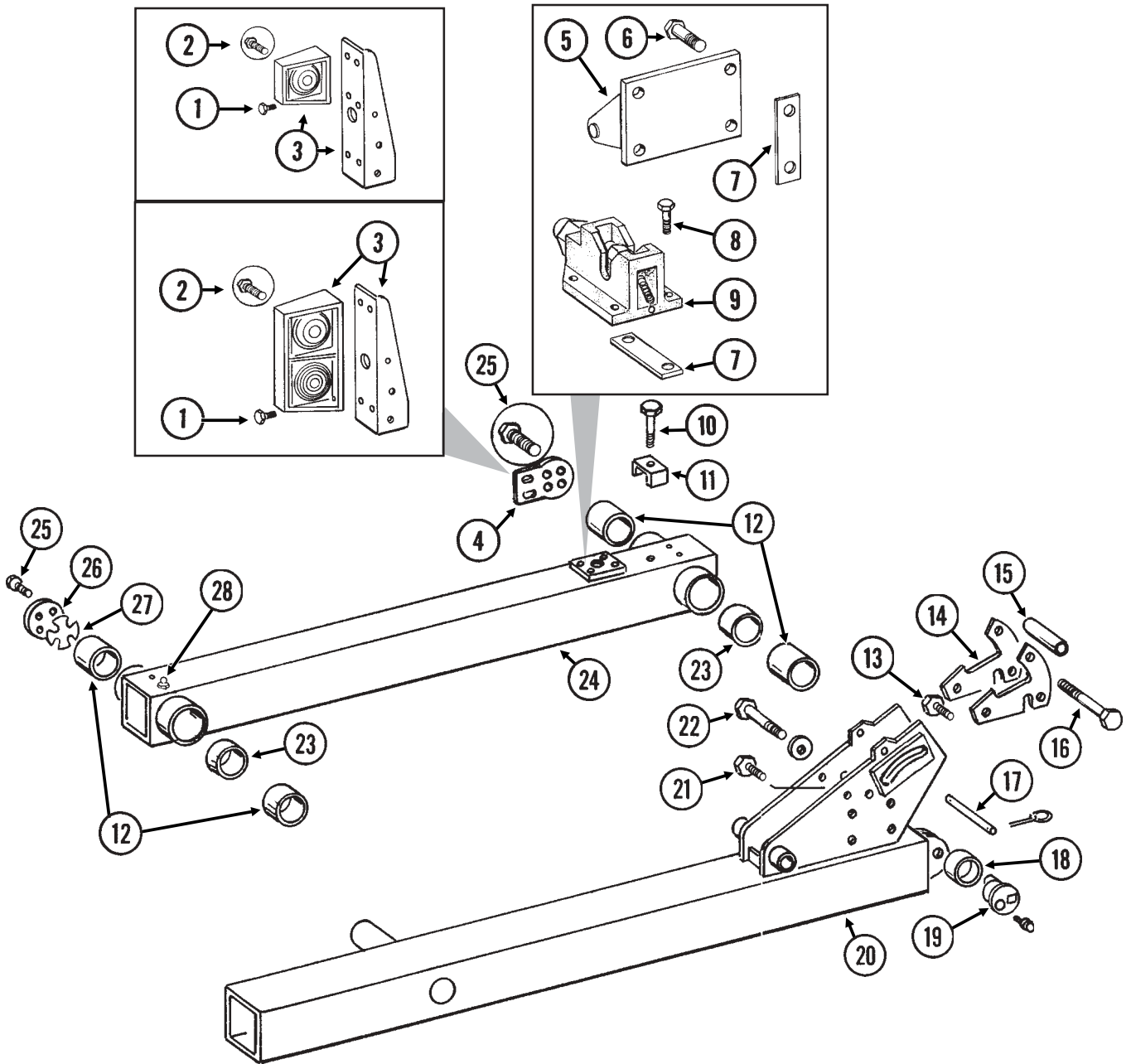

WING ASSEMBLY

ITEM	PART NO.	QTY.	DESCRIPTION
1.	G10064	8	Hex Head Cap Screw, 1/4"-20 x 1"
	G10110	8	Lock Nut, 1/4"-20
2.	G10023	4	Hex Head Cap Screw, 1/4"-20 x 3/4"
	G10209	4	Washer, 1/4" USS
	G10110	4	Lock Nut, 1/4"-20
3.			See "Electrical Components And Light Brackets", Pages P84 And P85
4.	GA7384	2	Light Bracket Mount
5.	GA7346	2	Catch
6.	G10039	8	Hex Head Cap Screw, 1/2"-13 x 1 3/4"
	G10216	8	Washer, 1/2" USS
	G10228	8	Lock Washer, 1/2"
	G10102	8	Hex Nut, 1/2"-13
7.	GD10432	1	Shim, 1 1/4" x 4 1/2" x .030" (As Required)
	GD10433	1	Shim, 1 1/4" x 4 1/2" x .060" (As Required)
8.	G10003	8	Hex Head Cap Screw, 3/8"-16 x 1 1/2"
	G10229	8	Lock Washer, 3/8"
9.	GA7383	2	Hydraulic Latch
10.	G10047	-	Hex Head Cap Screw, 3/8"-16 x 1 3/4"
	G10003	-	Hex Head Cap Screw, 3/8"-16 x 1 1/2"
	G10229	-	Lock Washer, 3/8"
11.	GD5892	-	Hose Clamp, 5/8" x 1 1/2" x 1 1/2"
12.	GD10378	4	Bronze Bushing, 3"
13.	G10025	2	Hex Head Cap Screw, 3/4"-10 x 1 1/2"
	GD9052	2	Special Washer, 3/4" I.D. x 2" O.D., Hardened
14.	GD10449	4	Hook
15.	GD10555	2	Sleeve
16.	G10871	2	Hex Head Cap Screw, 1/2"-13 x 6"
	G10111	2	Lock Nut, 1/2"-13
17.	GD10556	2	Pin, 5/8" x 6 3/4"
18.	GD10532	2	Sleeve
19.	GA6497	2	Cam Follower W/Grease Fitting
	G10640	-	Grease Fitting, 1/4"-28
20.	GA7329	1	Wing, L.H., 90 3/4", 8 Row 38"/40" And 12 Row 30" (Shown)
	GA7328	1	Wing, R.H., 90 3/4", 8 Row 38"/40" And 12 Row 30"
	GA7807	1	Wing, L.H., 100", 12 Row 36"/38"
	GA7806	1	Wing, R.H., 100", 12 Row 36"/38"
	GA7361	1	Wing, L.H., 117", 12 Row 38"/40" And 16 Row 30"
	GA7360	1	Wing, R.H., 117", 12 Row 38"/40" And 16 Row 30"
	G10112	4	Lock Nut, 3/4"-10
	GD2558	4	Lynch Pin, 1/4"
21.	G10001	2	Hex Head Cap Screw, 3/8"-16 x 1" (Hook Stop)
	G10108	2	Lock Nut, 3/8"-16
22.	G10027	4	Hex Head Cap Screw, 3/4"-10 x 2 1/2"
	G10218	4	Washer, 3/4" USS
23.	GD10379	2	Sleeve, 2 1/2"
24.	GA7326	2	Link Assembly, 71 1/4", 8 Row 38"/40" And 12 Row 30" (Includes Items 4 And 7) (Shown)
	GA7357	-	Link Assembly, 87 1/2", 12 Row 36"/38"/40" And 16 Row 30" (Includes Items 4 And 7)
25.	G10039	16	Hex Head Cap Screw, 1/2"-13 x 1 3/4"
	G10228	16	Lock Washer, 1/2"
26.	GD10478	2	End Cap
27.	GD10741	-	Shim (.015") (As Required)
	GD11155	-	Shim (.060") (As Required)
28.	G10763	8	Grease Fitting, Extended, 1/8"-27

WING DOWN FLEX CYLINDER PACKAGE

PFA076(SFP17a)

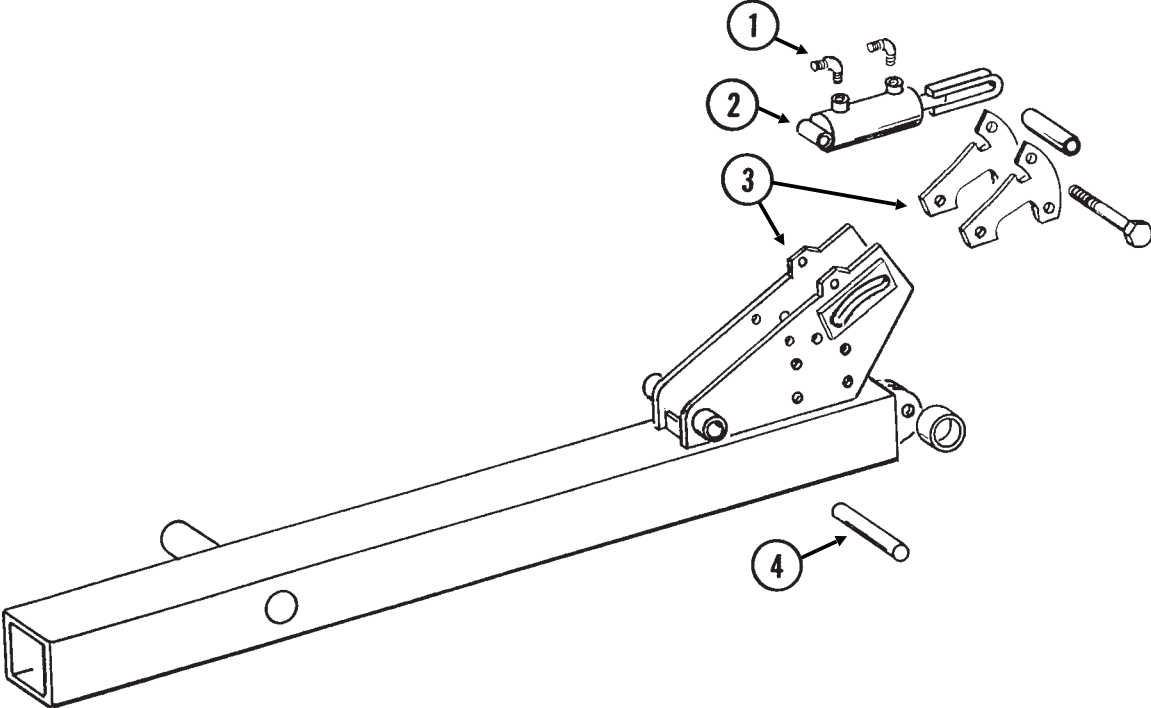

WING DOWN FLEX CYLINDER PACKAGE

ITEM	PART NO.	QTY. (Per Assy.)	DESCRIPTION
1.		-	See "Wing Down Flex Cylinder Package Hydraulic System", Page P82 Or "Dual Lift Assist Wheel Package And Wing Down Flex Cylinder Package Hydraulic System", Page P83
2.		-	See "Wing Down Flex Cylinder", Page P73
3.		-	See "Wing Assembly", Pages P36 And P37
4.	GD10486	1	Pin, 1 1/4" x 9"
	G10460	2	Cotter Pin, 1/4" x 2"

GROUND DRIVE WHEEL ASSEMBLY

PLA029/PLA028/PTD085/HTA014/PLA05(SFP14b)

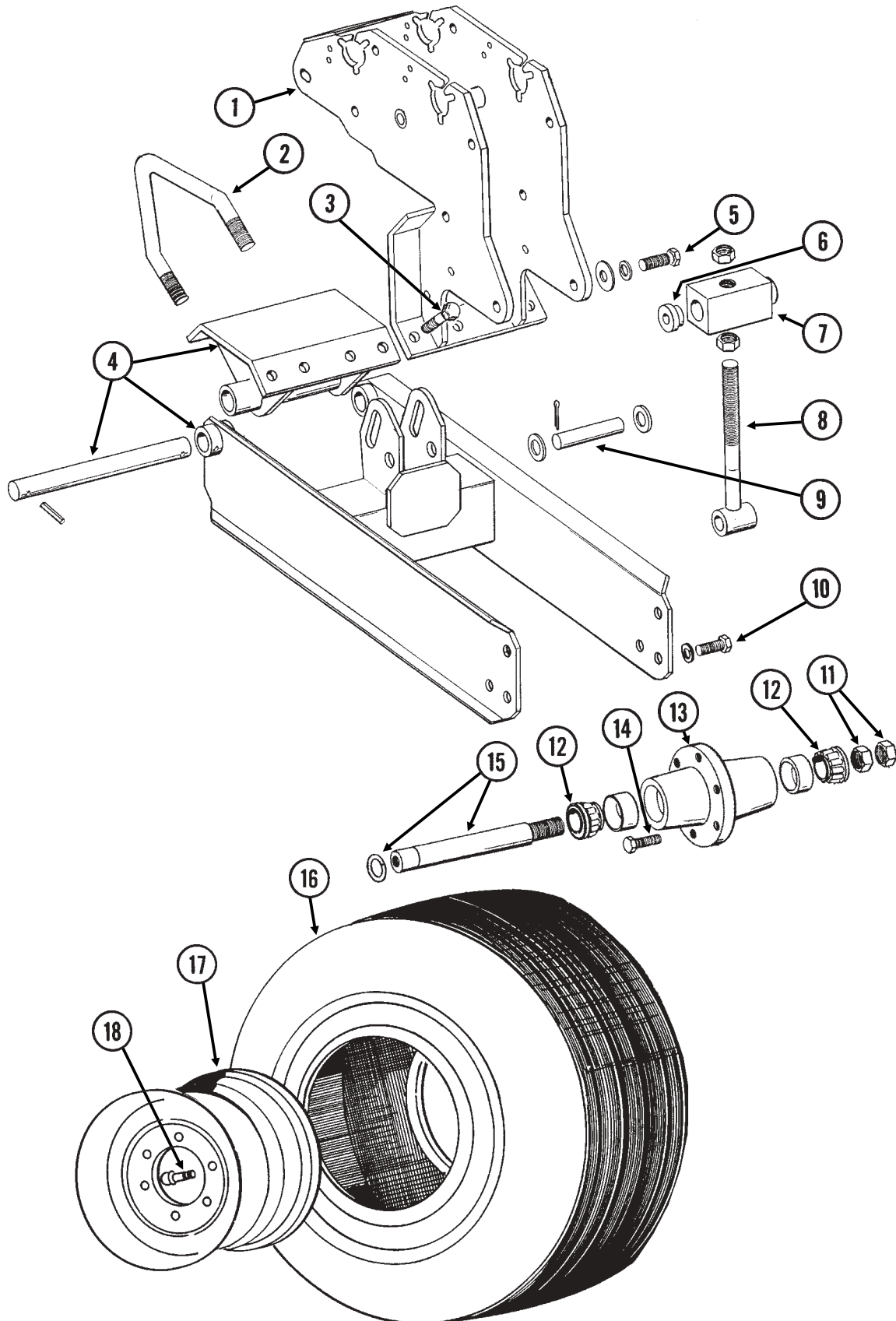

GROUND DRIVE WHEEL ASSEMBLY

ITEM	PART NO.	QTY.	DESCRIPTION
		(Per Assy.)	
1.		-	See "Seed Rate Transmission And Module Drive Assembly", Pages P48 And P49
2.	GD8175	2	U-Bolt, 7" x 7" (Diamond) x 5/8"-11
	GD7805	4	Special Washer, 5/8", Hardened
	G10230	4	Lock Washer, 5/8"
	G10104	4	Hex Nut, 5/8"-11
3.	G10005	4	Hex Head Cap Screw, 5/8"-11 x 1 3/4"
	GD7805	4	Special Washer, 5/8", Hardened
	G10230	4	Lock Washer, 5/8"
	G10104	4	Hex Nut, 5/8"-11
4.	GA7294	1	Arm W/Pin, Lower Clamp And Spring Pins
	GD5804	1	Pin, 1 1/4" x 12"
	GA7295	1	Clamp W/ Grease Fittings
	G10641	-	Grease Fitting, 1/8" NPT
	G10610	-	Spring Pin, 3/8" x 2"
5.	G10026	2	Hex Head Cap Screw, 3/4"-10 x 2"
	G10194	2	Washer, 3/4" SAE
	G10231	2	Lock Washer, 3/4"
6.	GD10403	2	Concentric Spacer
7.	GD10328	1	Adjustment Block
8.	GA4705	1	Adjusting Screw
	G10117	2	Hex Nut, 1"-8
9.	GD7041	1	Pin, 1" x 4"
	G10082	2	Washer, 1" SAE
	G10459	2	Cotter Pin, 3/16" x 1 1/2"
10.	G10026	2	Hex Head Cap Screw, 3/4"-10 x 2"
	G10231	2	Lock Washer, 3/4"
11.	G11081	-	Hex Jam Nut, 1 1/2"-12, Grade 2
12.	GA0895	2	Bearing
13.	GA2148	1	Hub W/Cups, 6 Bolt
	GR0434	-	Cup
14.	GR0270	6	Lug Bolt, 9/16"-18
15.	GA2558	1	Spindle W/Round External Retaining Ring, 9 1/2"
	GD11490	-	Round External Retaining Ring
16.	GD0844	1	Tire, 7.60" x 15", 8 Ply (Specify Brand*)
17.	GA5196	1	Wheel W/Valve Protector, 5" x 15"
18.	GD1166	1	Valve Stem
A.	GA2147	-	Hub And Spindle Assembly (Items 11, 12, 13 And 15)

* Specific brand requests will be supplied only as available from current KINZE® Repair Parts stock. If a specific brand requested is not in stock, the brand available will be supplied.

CONTACT DRIVE WHEEL ASSEMBLY

PLA027(SFP9c/SFP9d)

R.H. Side Shown

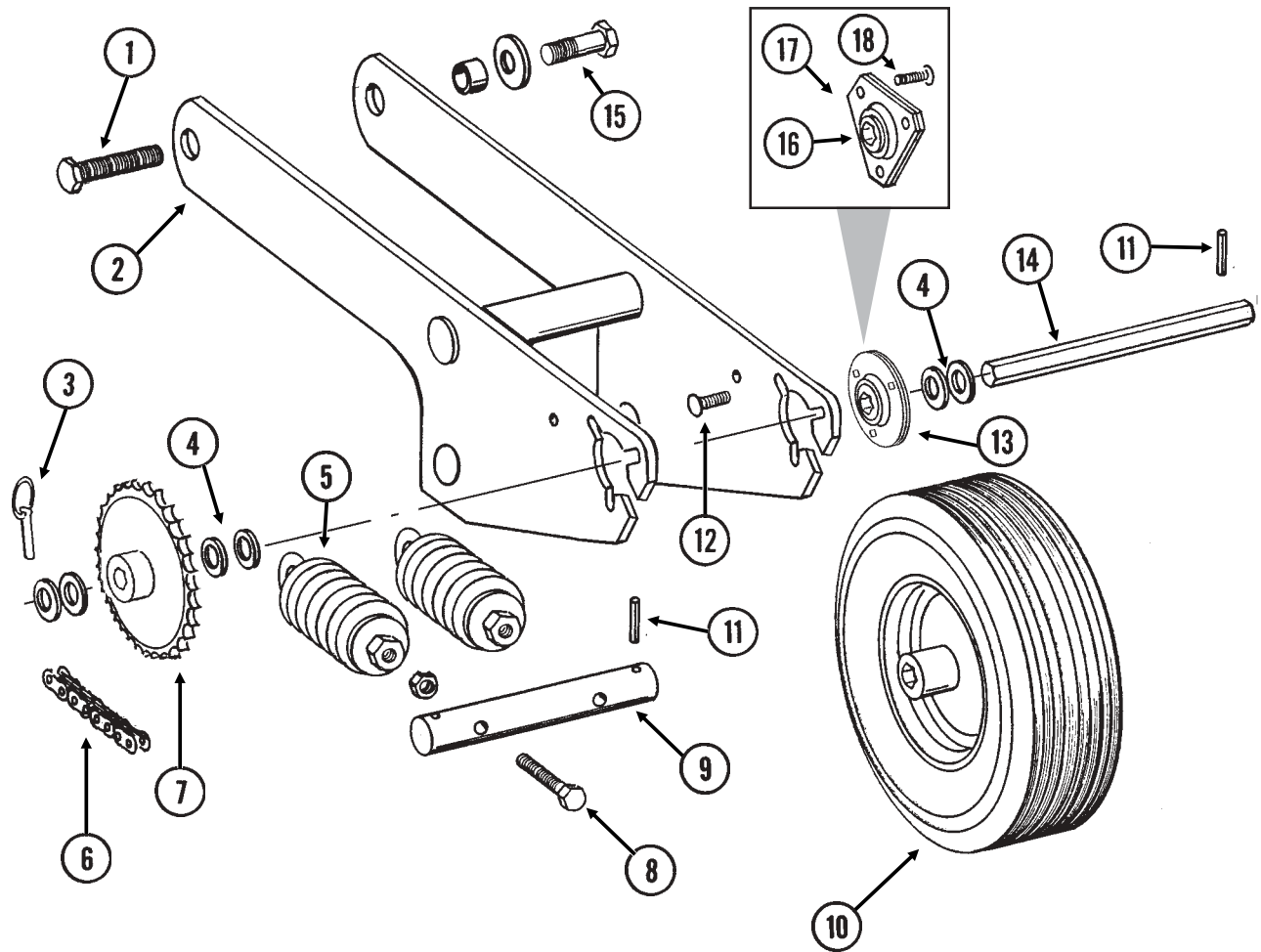

CONTACT DRIVE WHEEL ASSEMBLY

ITEM	PART NO.	QTY. (Per Assy.)	DESCRIPTION
1.		-	See "Module Drive", Pages P50 And P51 (Item 10)
2.	GA7297	1	Arm
3.	GD2558	1	Lynch Pin, 1/4"
4.	G10233	-	Machine Bushing, 1", 10 Gauge
5.	GA2068	2	Spring W/Plug
6.	G3310-224	1	Chain, No. 40, 224 Pitch Including Connector Link
	G3310-218	1	Chain, No. 40, 218 Pitch Including Connector Link (Used With Half Rate (2 To 1) Drive Sprocket)
	GR0912	-	Connector Link, No. 40
7.	GA5114	1	Sprocket, 30 Tooth, Standard Rate Drive
	GA5105	-	Sprocket, 15 Tooth, Half Rate (2 To 1) Drive
8.	G10861	2	Hex Head Cap Screw, 1/2"-13 x 5", Full Thread
	G10206	2	Washer, 1/2" SAE
	G10501	2	Hex Jam Nut, 1/2"-13, Grade 2
9.	GD10329	1	Shaft
10.	GA5090	1	Tire And Rim Assembly (Specify Brand*)
	GD5753	1	Tire, 4.10" x 6" (Specify Brand*)
	GD5752	1	Tube
11.	G10602	2	Spring Pin, 1/4" x 1 1/2"
12.	G10303	6	Carriage Bolt, 5/16"-18 x 1"
	G10232	6	Lock Washer, 5/16"
	G10106	6	Hex Nut, 5/16"-18
13.	GA9846	-	Flanged Bearing, 7/8" Hex Bore
14.	GD10332	1	Shaft, 7/8" x 11"
15.	G10005	1	Hex Head Cap Screw, 5/8"-11 x 1 3/4"
	GD7805	1	Special Washer, 5/8", Hardened
	GD3180-15	1	Sleeve, 5/8" I.D. x 7/8" O.D. x 15/32" Long
	G10107	1	Lock Nut, 5/8"-11
16.	G3400-01	4	Flangette
17.	G2100-03	2	Bearing, 7/8" Hex Bore, Spherical
18.	G10303	-	Carriage Bolt, 5/16"-18 x 1"
	G10219	-	Washer, 5/16" USS (As Required)
	G10232	-	Lock Washer, 5/16"
	G10106	-	Hex Nut, 5/16"-18

* Specific brand requests will be supplied only as available from current KINZE® Repair Parts stock. If a specific brand requested is not in stock, the brand available will be supplied. Different brand tires may have different diameters. Change in tire brand may affect rates. Field checks are recommended after any change in contact tires.

CENTER SECTION GAUGE WHEEL

PLA029/PLA028/HTA014/PLA05(SFP10b)

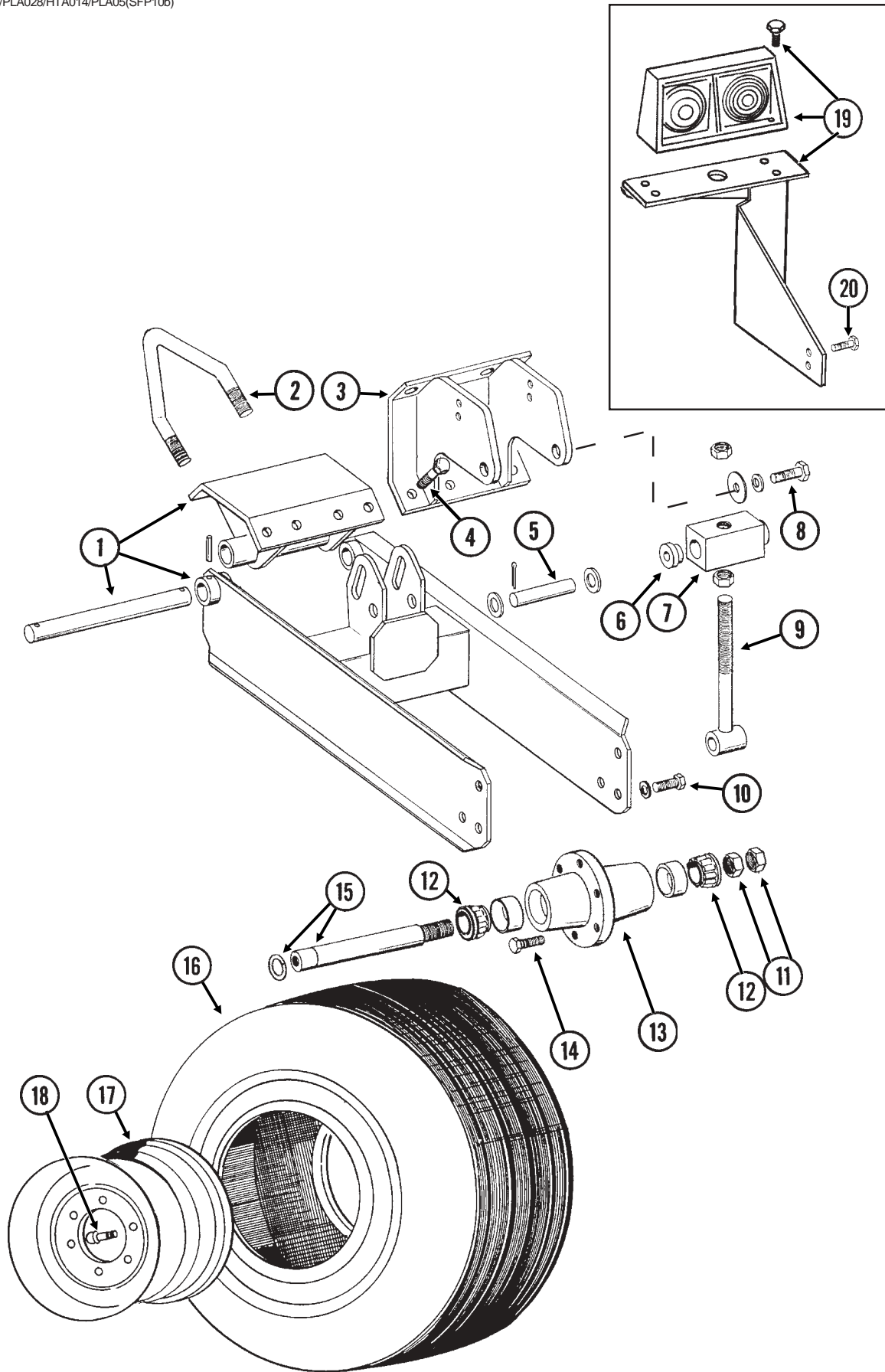

CENTER SECTION GAUGE WHEEL

ITEM	PART NO.	QTY.	DESCRIPTION
		(Per Assy.)	
1.	GA7294	1	Arm W/Pin, Lower Clamp And Spring Pins
	GD5804	1	Pin, 1 1/4" x 12"
	GA7295	1	Clamp W/ Grease Fittings
	G10641	-	Grease Fitting, 1/8" NPT
	G10610	-	Spring Pin, 3/8" x 2"
2.	GD8175	2	U-Bolt, 7" x 7" (Diamond) x 5/8"-11
	GD7805	4	Special Washer, 5/8", Hardened
	G10230	4	Lock Washer, 5/8"
	G10104	4	Hex Nut, 5/8"-11
3.	GA7322	1	Upper Clamp
4.	G10005	4	Hex Head Cap Screw, 5/8"-11 x 1 3/4"
	GD7805	4	Special Washer, 5/8", Hardened
	G10230	4	Lock Washer, 5/8"
	G10104	4	Hex Nut, 5/8"-11
5.	GD7041	1	Pin, 1" x 4"
	G10082	2	Washer, 1" SAE
	G10459	2	Cotter Pin, 3/16" x 1 1/2"
6.	GD10403	2	Concentric Spacer
7.	GD10328	1	Adjustment Block
8.	G10026	2	Hex Head Cap Screw, 3/4"-10 x 2"
	G10194	2	Washer, 3/4" SAE
	G10231	2	Lock Washer, 3/4"
9.	GA4705	1	Adjusting Screw
	G10117	2	Hex Nut, 1"-8
10.	G10026	2	Hex Head Cap Screw, 3/4"-10 x 2"
	G10231	2	Lock Washer, 3/4"
11.	G11081	-	Hex Jam Nut, 1 1/2"-12, Grade 2
12.	GA0895	2	Bearing
13.	GA2148	1	Hub W/Cups, 6 Bolt
	GR0434	-	Cup
14.	GR0270	6	Lug Bolt, 9/16"-18
15.	GA2558	1	Spindle W/Round External Retaining Ring, 9 1/2"
	GD11490	-	Round External Retaining Ring
16.	GD0844	1	Tire, 7.60" x 15", 8 Ply (Specify Brand*)
17.	GA5196	1	Wheel W/Valve Protector, 5" x 15"
18.	GD1166	1	Valve Stem
19.			See "Electrical Components And Light Brackets", Pages P84 And P85
20.	G10019	4	Hex Head Cap Screw, 5/16"-18 x 1"
	G10232	4	Lock Washer, 5/16"
	G10106	4	Hex Nut, 5/16"-18
A.	GA2147	-	Hub And Spindle Assembly (Items 11, 12, 13 And 15)
B.	GA7447	-	Ground Drive Wheel Assembly (Items 1-18)

* Specific brand requests will be supplied only as available from current KINZE® Repair Parts stock. If a specific brand requested is not in stock, the brand available will be supplied.

DUAL LIFT ASSIST WHEELS

PLA031/PLA030/CCU008/HTA014/PLA05(SFP11e/MT23a)

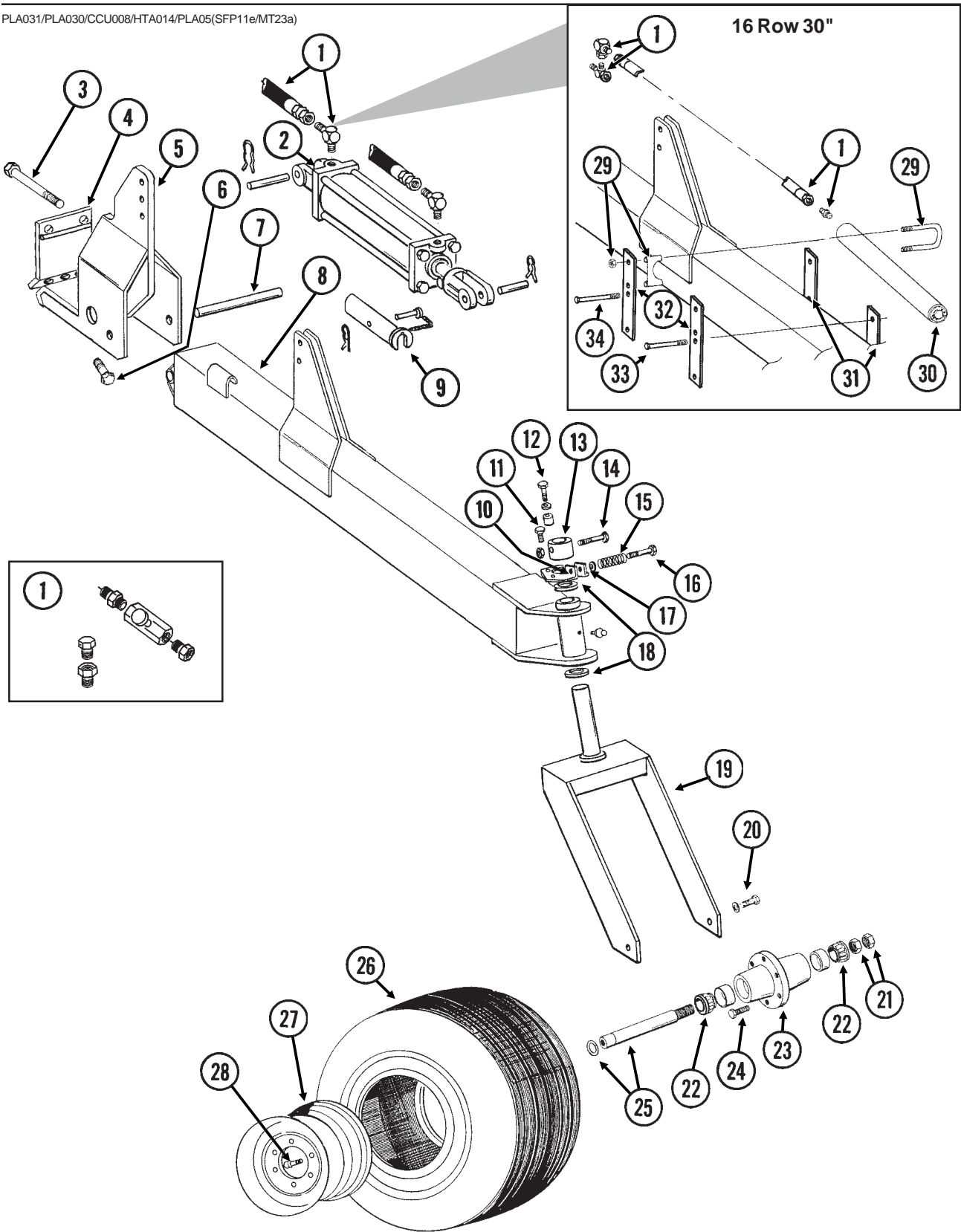

DUAL LIFT ASSIST WHEELS

ITEM	PART NO.	QTY.	DESCRIPTION
		(Per Assy.)	
1.		-	See "Dual Lift Assist Wheel Package Hydraulic System", Page P80 And P81 Or "Dual Lift Assist Wheel Package And Wing Down Flex Cylinder Package Hydraulic System", Page P83
2.		-	See "Dual Lift Assist Cylinder", Pages P74 And P75
3.	G10059	2	Hex Head Cap Screw, $\frac{3}{4}$ "-10 x $9\frac{1}{2}$ "
	GD2169	2	Special Washer, $\frac{25}{32}$ " I.D. x $1\frac{1}{4}$ " O.D., Hardened
	G10105	2	Hex Nut, $\frac{3}{4}$ "-10
4.	GA7867	-	Clamp
5.	GA7860	-	Mount
6.	G10028	3	Hex Head Cap Screw, $\frac{3}{4}$ "-10 x 3"
	GD2169	3	Special Washer, $\frac{25}{32}$ " I.D. x $1\frac{1}{4}$ " O.D., Hardened
	G10105	3	Hex Nut, $\frac{3}{4}$ "-10
7.	GD8311	2	Pin, $1\frac{1}{4}$ " x $10\frac{1}{2}$ "
	G10460	4	Cotter Pin, $\frac{1}{4}$ " x 2"
8.	GA7345	1	Lift Assist Frame W/Grease Fittings
	G10641	1	Grease Fitting, $\frac{1}{8}$ " NPT
	G10343	1	Grease Fitting, 90°, $\frac{1}{8}$ "-27
9.	GA8174	1	Lockup W/Pin
10.	GA6455	1	Roller Ring, L.H.
11.	G10008	2	Hex Head Cap Screw, $\frac{5}{8}$ "-11 x 2"
	GB0218	2	Bushing, $\frac{21}{32}$ " I.D. x $\frac{7}{8}$ " O.D. x $\frac{19}{32}$ " Long
	GD7805	4	Special Washer, $\frac{5}{8}$ ", Hardened
	G10230	2	Lock Washer, $\frac{5}{8}$ "
	G10104	2	Hex Nut, $\frac{5}{8}$ "-11
12.	G10007	2	Hex Head Cap Screw, $\frac{5}{8}$ "-11 x $1\frac{1}{2}$ "
	GB0218	2	Bushing, $\frac{21}{32}$ " I.D. x $\frac{7}{8}$ " O.D. x $\frac{19}{32}$ " Long
	GD7805	4	Special Washer, $\frac{5}{8}$ ", Hardened
	G10230	2	Lock Washer, $\frac{5}{8}$ "
	GD9179	2	Sleeve
13.	GD9170	1	Roller
14.	G10032	1	Hex Head Cap Screw, $\frac{1}{2}$ "-13 x $3\frac{3}{4}$ "
	G10228	1	Lock Washer, $\frac{1}{2}$ "
	G10102	1	Hex Nut, $\frac{1}{2}$ "-13
15.	GD9208	1	Spring
16.	G10713	1	Hex Head Cap Screw, $\frac{7}{16}$ "-14 x 6"
	G10081	2	Washer, $\frac{7}{16}$ " USS
	G10113	1	Lock Nut, $\frac{7}{16}$ "-14
17.	GA6454	1	Roller Ring, R.H.
18.	G10234	2	Machine Bushing, 2 $\frac{1}{8}$ ", 10 Gauge
19.	GA6443	1	Caster Wheel Arm
20.	G10026	2	Hex Head Cap Screw, $\frac{3}{4}$ "-10 x 2"
	G10231	2	Lock Washer, $\frac{3}{4}$ "
21.	G11081	2	Hex Jam Nut, 1 $\frac{1}{2}$ "-12, Grade 2
22.	GA0895	2	Bearing
23.	GA2148	1	Hub W/Cups, 6 Bolt
	GR0434	-	Cup
24.	GR0270	6	Lug Bolt, $\frac{9}{16}$ "-18
25.	GA2558	1	Spindle W/Round External Retaining Ring, 9 $\frac{1}{2}$ "
	GD11490	-	Round External Retaining Ring
26.	GD0844	1	Tire, 7.60" x 15", 8 Ply (Specify Brand*)
27.	GA5196	1	Wheel W/Valve Protector, 5" x 15"
28.	GD1166	1	Valve Stem
29.	GA8768	2	Accumulator Clamp, 3"
30.	GA8769	1	Accumulator, 16 Row 30"
31.	GD11814	2	Clamp, 16 Row 30"
32.	GD11813	2	Mount, 16 Row 30"
33.	G10687	2	Hex Head Cap Screw, $\frac{3}{8}$ "-16 x $5\frac{1}{2}$ "
	G10108	2	Lock Nut, $\frac{3}{8}$ "-16
34.	G10756	2	Hex Head Cap Screw, $\frac{3}{8}$ "-16 x 6"
	G10108	2	Lock Nut, $\frac{3}{8}$ "-16
A.	GA2147	-	Hub And Spindle Assembly (Items 21, 22, 23 And 25)

* Specific brand requests will be supplied only as available from current KINZE® Repair Parts stock. If a specific brand requested is not in stock, the brand available will be supplied.

SEED RATE TRANSMISSION AND MODULE DRIVE ASSEMBLY

(SFP24f/SFP24g)

R.H. Side Shown

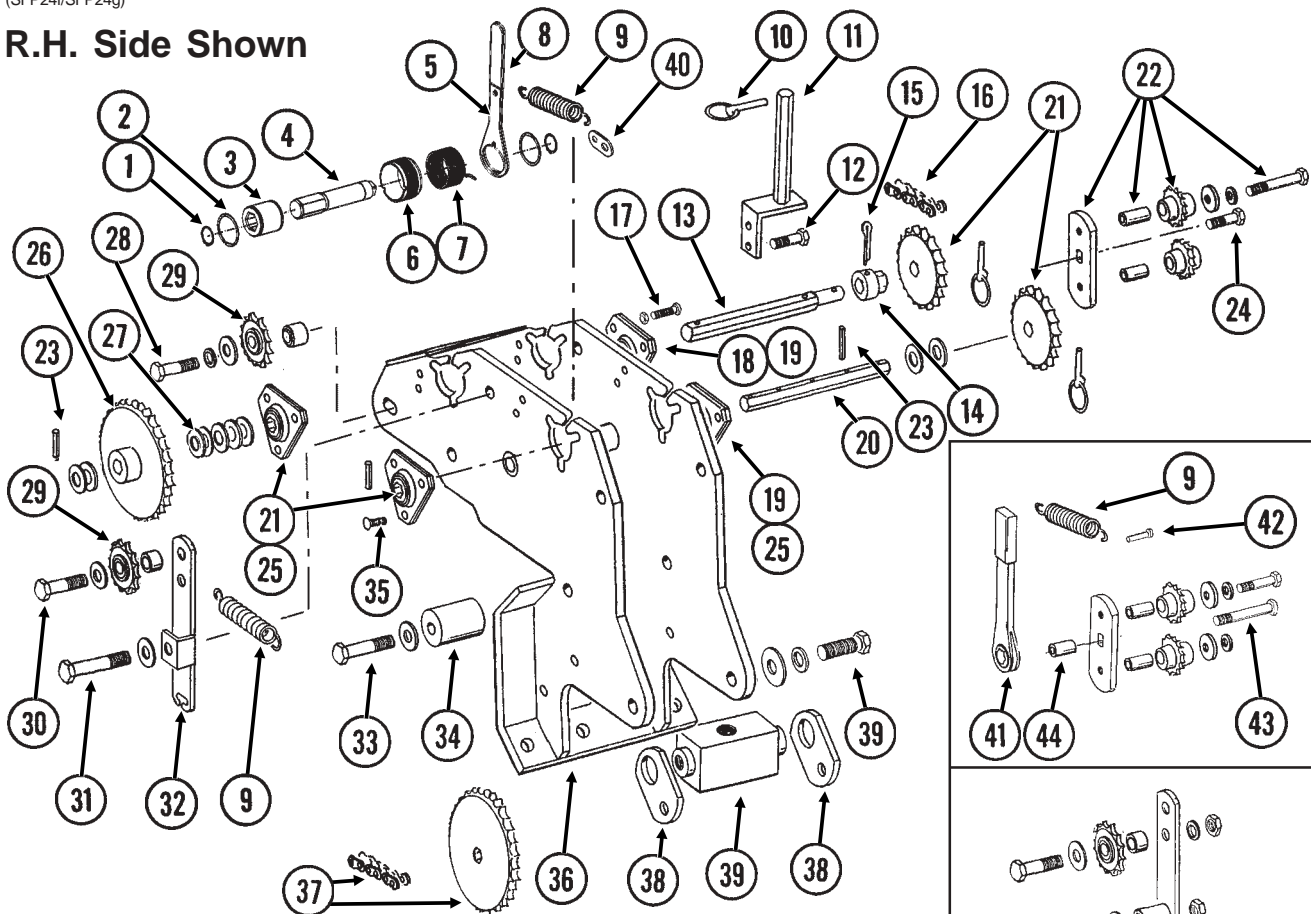

ITEM	PART NO.	QTY.	DESCRIPTION
		(Per Assy.)	
1.	G11075	2	Internal Inverted Snap Ring, 7/8"
2.	G10496	2	External Inverted Snap Ring, 1 1/2"
3.	GD14432	1	Sleeve
4.	GD14426	1	Tightener Shaft, 3 3/8"
5.	GD14431	1	Handle
6.	GD14430	1	Release Collar, Gold, R.H. (Shown)
	GD14429	-	Release Collar, Silver, L.H.
7.	GD14414	1	Torsion Spring, R.H.
	GD14413	-	Torsion Spring, L.H. (Shown)
8.	G11078	1	Vinyl Cap
9.	GD5857	2	Spring
10.	GD2558	3	Lynch Pin, 1/4"
11.	GA4630	1	Sprocket Storage Rod
12.	G10037	1	Hex Head Cap Screw, 1/2"-13 x 1 1/4"
	G10216	1	Washer, 1/2" USS
	G10228	1	Lock Washer, 1/2"
	G10102	1	Hex Nut, 1/2"-13
13.	GD10336	1	Shaft, 7/8" x 11"
14.	GD7127	1	Shear Coupler
15.	G10462	1	Cotter Pin, 3/16" x 2"
16.	G3310-68	1	Chain, No. 40, 68 Pitch Including Connector Link
	GR0912	-	Connector Link, No. 40
17.	G10338	1	Carriage Bolt, 5/16"-18 x 1 1/4"
	G10232	1	Lock Washer, 5/16"
	G10106	1	Hex Nut, 5/16"-18
	G10109	1	Lock Nut, 5/16"-18
18.	GA5548	1	Special Bearing
19.	G3400-01	4	Flangette
20.	GD10337	1	Shaft, 7/8" x 10 1/2"

SEED RATE TRANSMISSION AND MODULE DRIVE ASSEMBLY

ITEM	PART NO.	QTY.	DESCRIPTION
		(Per Assy.)	
21.	GA5106	1	Sprocket, 17 Tooth
	GA5107	1	Sprocket, 19 Tooth
	GA5108	2	Sprocket, 23 Tooth
	GA5109	1	Sprocket, 24 Tooth
	GA5110	1	Sprocket, 25 Tooth
	GA5111	1	Sprocket, 26 Tooth
	GA5112	1	Sprocket, 27 Tooth
	GA5113	1	Sprocket, 28 Tooth
22.	GA7336	1	Idler W/Bolt-On Sprockets
	GD7426	-	Sprocket, 12 Tooth
	GD1026	-	Sleeve, 1 3/16" Long
	G10210	-	Washer, 3/8" USS
	G10229	-	Lock Washer, 3/8"
	G10047	-	Hex Head Cap Screw, 3/8"-16 x 1 3/4"
23.	G10602	7	Spring Pin, 1/4" x 1 1/2"
24.	G10022	1	Hex Head Cap Screw, 1/4"-20 x 1/2"
	G10227	1	Lock Washer, 1/4"
	G10209	1	Washer, 1/4" USS
25.	G2100-03	3	Bearing, 7/8" Hex Bore, Spherical
26.	GA5202	1	Sprocket, 34 Tooth, See "Point Row Clutch", Pages P52 And P53, For Machines Equipped With Point Row Clutches
27.	G10233	-	Machine Bushing, 1", 10 Gauge (As Required)
28.	G10397	1	Hex Head Cap Screw, 1/2"-13 x 2 3/4"
	G10128	1	Machine Bushing, 1/2", 14 Gauge
	GB0258	1	Stepped Spacer, 7/8"
	G10216	1	Washer, 1/2" USS
	G10228	1	Lock Washer, 1/2"
	G10102	1	Hex Nut, 1/2"-13
29.	GA7154	2	Sprocket W/Bearing, 18 Tooth
30.	G10581	1	Hex Head Cap Screw, 1/2"-13 x 2 1/4"
	G10128	1	Machine Bushing, 1/2", 14 Gauge
	GD7889	1	Bushing, 1" O.D. x 9/16" x 7/16" Long
	G10228	1	Lock Washer, 1/2"
	G10102	1	Hex Nut, 1/2"-13
31.	G10036	1	Hex Head Cap Screw, 5/8"-11 x 4"
	GD7805	1	Special Washer, 5/8", Hardened
	G10503	1	Hex Jam Nut, 5/8"-11, Grade 2
	G10107	1	Lock Nut, 5/8"-11
32.	GD13422	1	Idler Arm, R.H. Side Of Planter (Shown)
	GD13394	-	Idler Arm, L.H. Side Of Planter
33.	G10033	1	Hex Head Cap Screw, 1/2"-13 x 3 1/2"
	G10206	1	Washer, 1/2" SAE
	G10228	1	Lock Washer, 1/2"
	G10102	1	Hex Nut, 1/2"-13
34.	GD10407	1	Chain Support
35.	G10303	12	Carriage Bolt, 5/16"-18 x 1"
	G10232	12	Lock Washer, 5/16"
	G10106	12	Hex Nut, 5/16"-18
36.	GA10063	1	Module
37.		-	See "Contact Drive Wheel Assembly", Page P42 And P43
38.	GD15696	2	Strap
39.		-	See "Ground Drive Wheel Assembly", Pages P40 And P41
40.	GD14595	1	Spring Tension Link
41.	GA4235	-	Ratchet Arm W/Protective Closure
	G10445	-	Protective Closure
42.	G10478	-	Clevis Pin, 5/16" x 1"
	G10409	-	Retaining Ring, 5/16"
43.	G10863	-	Carriage Bolt, 1/2"-13 x 2 3/4"
	G10111	-	Lock Nut, 1/2"-13
44.	GD3180-05	-	Sleeve, 5/8" I.D. x 7/8" O.D. x 1 3/16" Long
45.	GA6533	-	Idler Arm
A.	G1K380	1	Wrap Spring Wrench Replacement Kit, Gold Collar, R.H. (Items 1-8 And 24) (Shown)
	G1K381	-	Wrap Spring Wrench Replacement Kit, Silver Collar, L.H. (Items 1-8 And 24) P49

MODULE DRIVE

(SFP25d/SFP25f)

R.H. Side Shown

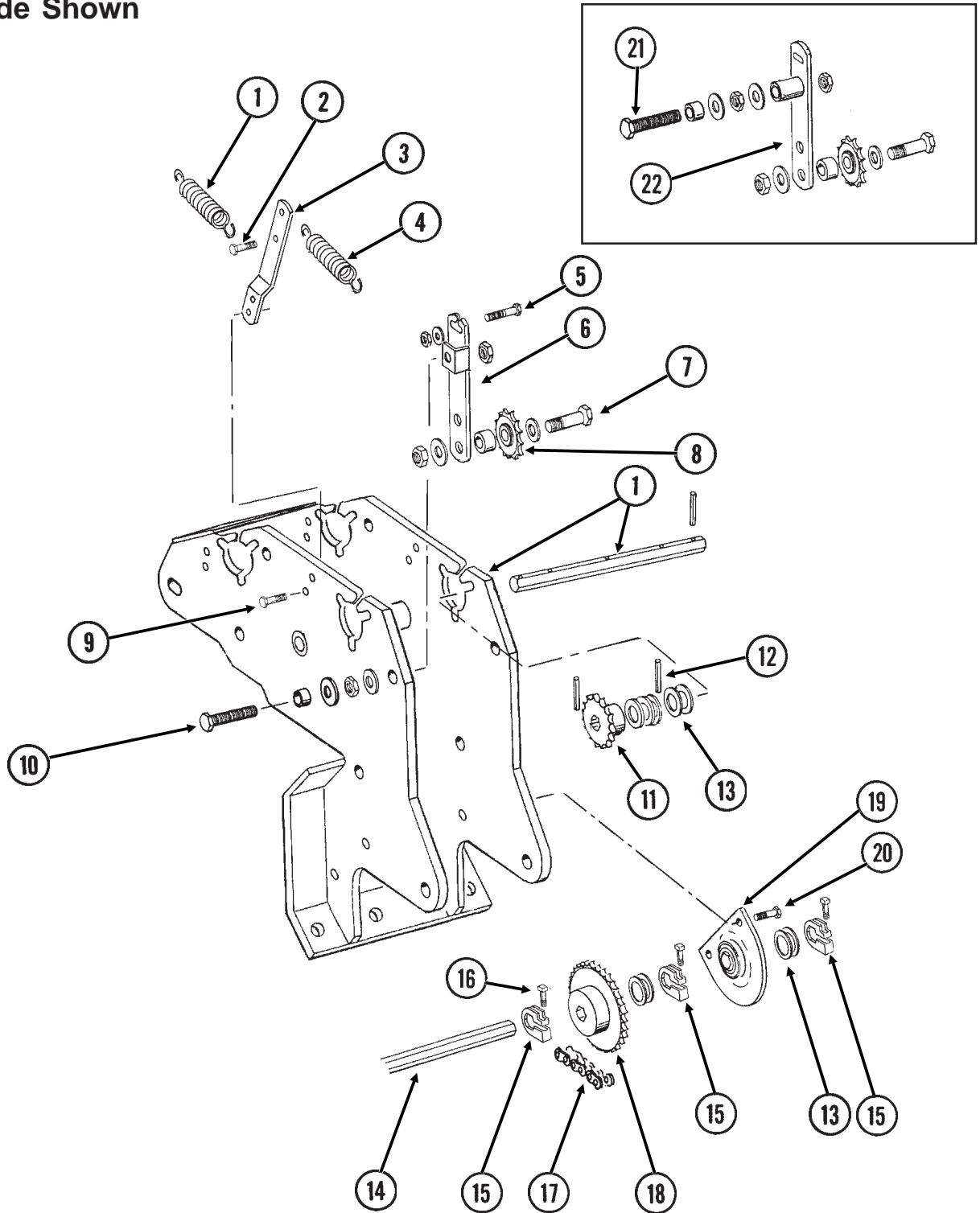

MODULE DRIVE

ITEM	PART NO.	QTY.	DESCRIPTION
		(Per Assy.)	
1.		-	See "Seed Rate Transmission And Module Drive Assembly", Pages P48 And P49
2.	G10040	1	Hex Head Cap Screw, 1/4"-20 x 1 3/4"
	G10103	1	Hex Nut, 1/4"-20
3.	GD5860	1	Bar
4.	GD5857	1	Spring
5.	G10069	1	Hex Head Cap Screw, 5/16"-18 x 2 1/4"
	G10219	1	Washer, 5/16" USS
	G10106	1	Hex Nut, 5/16"-18
6.	GD13394	-	Idler Arm, R.H. Side Of Planter (Shown)
	GD13422	1	Idler Arm, L.H. Side Of Planter
7.	G10581	1	Hex Head Cap Screw, 1/2"-13 x 2 1/4"
	G10128	1	Machine Bushing, 1/2", 14 Gauge
	GD7889	1	Bushing, 1" O.D. x 9/16" I.D. x 7/16" Long
	G10228	1	Lock Washer, 1/2"
	G10102	1	Hex Nut, 1/2"-13
8.	GA7154	1	Sprocket W/Bearing, 18 Tooth
9.	G10064	1	Hex Head Cap Screw, 1/4"-20 x 1"
	G10227	1	Lock Washer, 1/4"
	G10103	1	Hex Nut, 1/4"-20
10.	G11028	1	Hex Head Cap Screw, 5/8"-11 x 4 1/2", Full Thread
	GD7805	1	Special Washer, 5/8", Hardened
	GD3180-15	1	Sleeve, 5/8" I.D. x 7/8" O.D. x 15/32" Long
	G10104	1	Hex Nut, 5/8"-11
	G10205	1	Washer, 5/8" SAE
	G10107	1	Lock Nut, 5/8"-11
11.	GA5105	1	Sprocket, 15 Tooth
12.	G10602	7	Spring Pin, 1/4" x 1 1/2"
13.	G10233	9	Machine Bushing, 1", 10 Gauge
14.	GD0914-74	1	Hex Shaft, 7/8" x 74" (On Wing), 8 Row 38"/40" And 12 Row 30" (No Holes)
	GD0914-98	-	Hex Shaft, 7/8" x 98" (On Wing), 12 Row 36"/38"/40" And 16 Row 30" (No Holes)
15.	GD11045	3	Lock Clamp
16.	G10130	3	Square Head Machine Bolt, 5/16"-18 x 1 3/4"
	G10923	3	Flange Nut, 5/16"-18, No Serration
17.	G3310-75	1	Chain, No. 40, 75 Pitch Including Connector Link And Offset Link
	GR0912	-	Connector Link, No. 40
	GR0911	-	Offset Link, No. 40
18.	GA5114	1	Sprocket, 30 Tooth
19.	GA2180	1	Hanger Bearing, 7/8" Hex Bore
20.	G10004	2	Hex Head Cap Screw, 3/8"-16 x 1 1/4"
	G10210	2	Washer, 3/8" USS
	G10229	2	Lock Washer, 3/8"
	G10101	2	Hex Nut, 3/8"-16
21.	G10582	-	Hex Head Cap Screw, 5/8"-11 x 4", Full Thread
	GD7805	-	Special Washer, 5/8", Hardened
	GD3180-15	-	Sleeve, 5/8" I.D. x 7/8" O.D. x 15/32" Long
	G10104	-	Hex Nut, 5/8"-11
	G10205	-	Washer, 5/8" SAE
	G10107	-	Lock Nut, 5/8"-11
22.	GA6533	-	Idler Arm
A.	G1K269	-	Lock Clamp Kit (Items 15 And 16)

POINT ROW CLUTCH (6 AND 8 ROW)

PRC019/PRC020(SFP5d/A10054)

R.H. Point Row Clutch Shown
(Used On L.H. Side Of Planter)

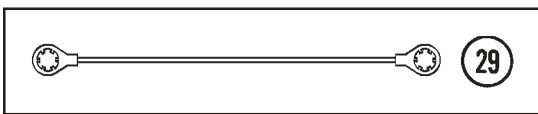
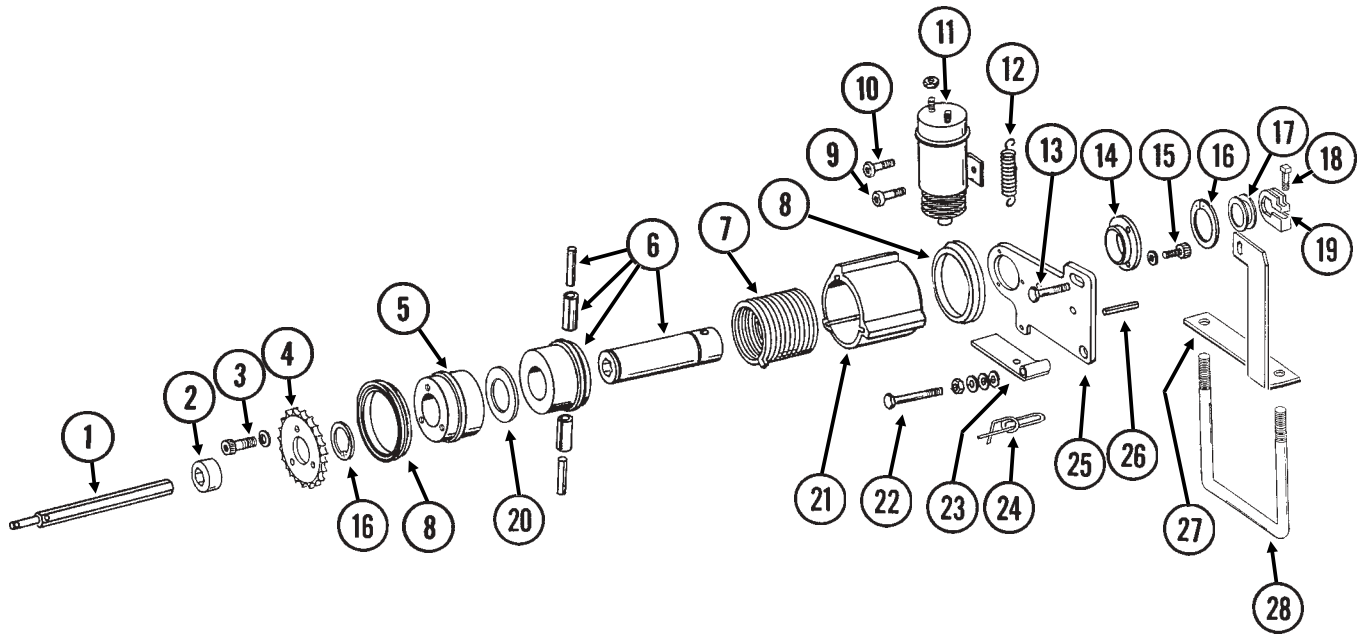

POINT ROW CLUTCH (6 AND 8 ROW)

ITEM	PART NO.	QTY.	DESCRIPTION
(Per Assy.)			
1.	GD10527	1	Input Shaft, 7/8" x 15 1/2"
2.	GD10200	1	Sleeve, 3/4" Long
3.	G10023	3	Hex Head Cap Screw, 1/4"-20 x 3/4"
	G10227	3	Lock Washer, 1/4"
4.	GD10525	1	Sprocket, 34 Tooth
5.	GD10104	1	Input Hub
6.	GA7137	1	Hub/Sleeve Assembly W/Spring Pins
	G10804	-	Spring Pin, 5/32" x 7/8"
	G10765	-	Spring Pin, 1/4" x 1"
7.	GD9672	1	Spring, R.H. (Shown)
	GD9671	-	Spring, L.H.
8.	GD14512	2	V-Ring Seal
9.	G10900	1	Hex Socket Head Cap Screw, 1/4"-20 x 1 3/4", Grade 8
	G10227	1	Lock Washer, 1/4"
	G10103	2	Hex Nut, 1/4"-20
10.	G10023	1	Hex Head Cap Screw, 1/4"-20 x 3/4"
	G10227	1	Lock Washer, 1/4"
	G10103	1	Hex Nut, 1/4"-20
11.	GA8393	1	Solenoid Complete
	GR1306	1	Snap Ring
	GR1303	1	Spring
	GR1304	1	Boot
	GR1305	1	Plunger
12.	GD10123	1	Spring
13.	G10003	1	Hex Head Cap Screw, 3/8"-16 x 1 1/2"
	G10203	2	Washer, 3/8" SAE
	G10101	1	Hex Nut, 3/8"-16
14.	GD9667	1	Bushing
15.	G10253	3	Hex Socket Head Screw, No. 10-32 x 1/2"
	G10257	3	Lock Washer, No. 10
16.	G10496	2	External Inverted Snap Ring, 1 1/2"
17.	G10233	-	Machine Bushing, 1", 10 Gauge
18.	G10130	-	Square Head Machine Bolt, 5/16"-18 x 1 3/4"
	G10923	-	Flange Nut, 5/16"-18, No Serration
19.	GD11045	-	Lock Clamp
20.	GD14513	1	Felt Washer
21.	GD10102	1	Stop Collar
22.	G10049	1	Hex Head Cap Screw, 3/8"-16 x 2 1/2"
	G10101	1	Hex Nut, 3/8"-16
	G10203	1	Washer, 3/8" SAE
	G10229	2	Lock Washer, 3/8"
	G10497	1	Hex Jam Nut, 3/8"-16, Grade 2
23.	GD10510	1	Actuator Arm
24.	GD11120	1	Rue Ring Cotter, 5/16"
25.	GD10103	1	Mounting Plate
26.	G10859	1	Spring Pin, 3/16" x 2 1/4"
27.	GD10529	1	Bracket, L.H. (Shown)
	GD10528	-	Bracket, R.H.
28.	GD7145	1	U-Bolt, 7" x 7" x 1/2"-13
	G10111	2	Lock Nut, 1/2"-13
29.	GA10054	1	Ground Cable, Green
A.	G1K269	-	Lock Clamp Kit (Items 18 And 19)
B.	GA7418	-	Point Row Clutch Assembly, R.H. (Shown) (Items 3-12, 14-16, 20-26 And 29)
	GA7417	-	Point Row Clutch Assembly, L.H. (Items 3-12, 14-16, 20-26 And 29)

POINT ROW CLUTCH ELECTRICAL COMPONENTS

(EF10b/ELC34/ELC35/EF10c/SFP6/TWL18/TWL76)

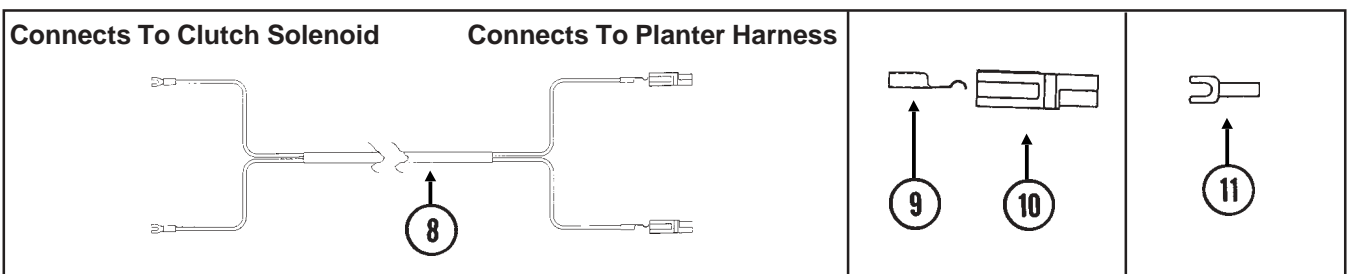
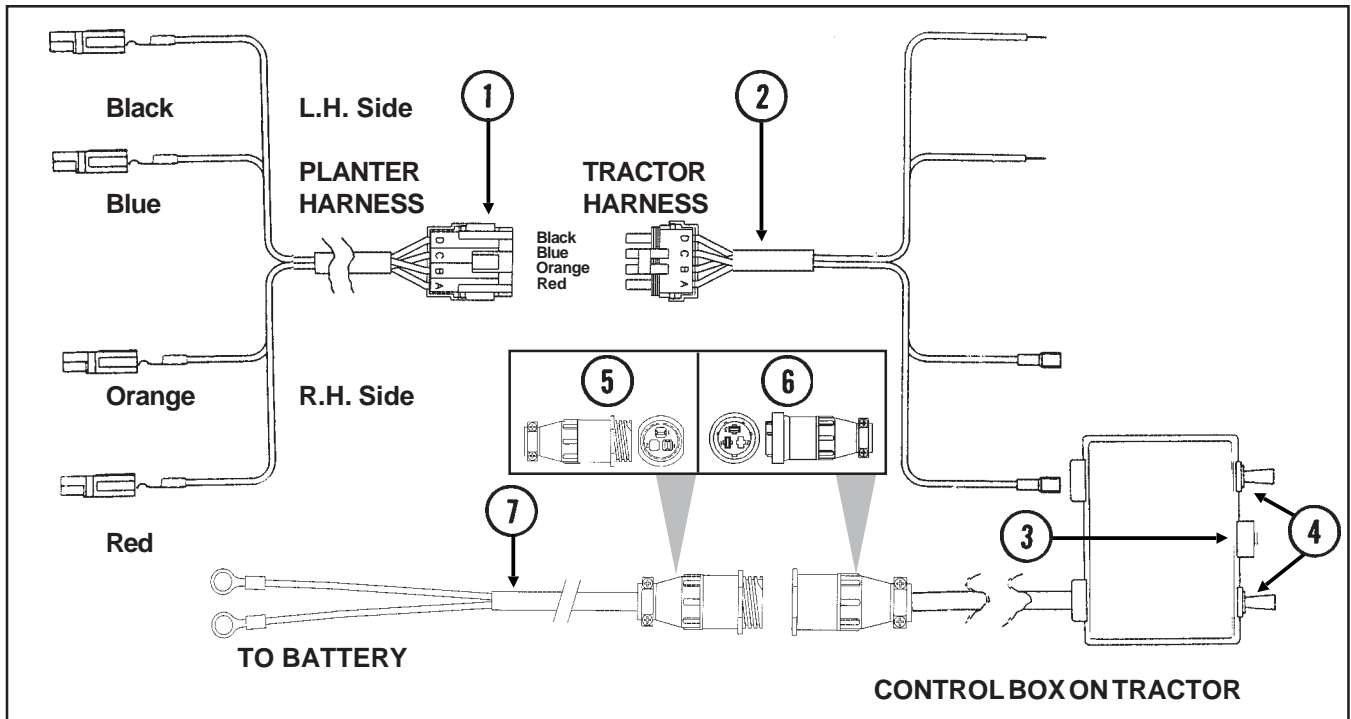
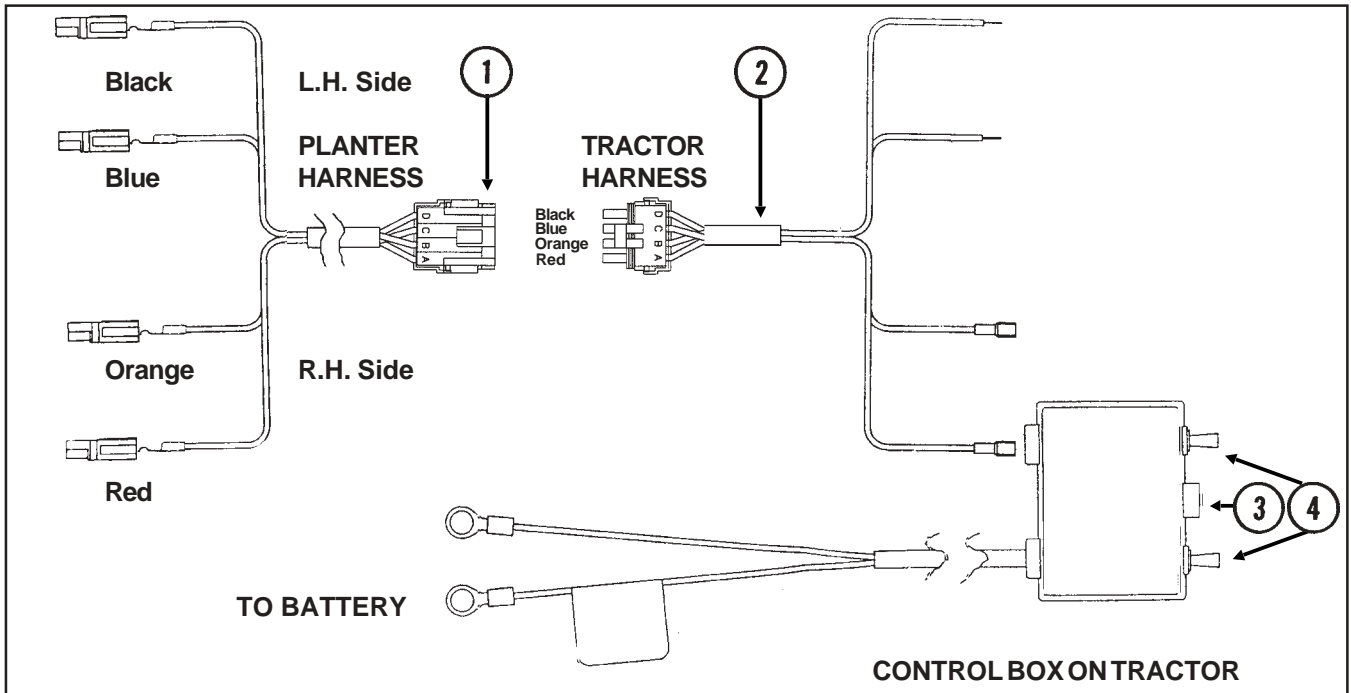

POINT ROW CLUTCH ELECTRICAL COMPONENTS

ITEM	PART NO.	QTY. (Per Assy.)	DESCRIPTION
1.	GR1450	-	Harness W/4-Pin Connector, 60"
	GA8328	-	4-Pin Connector W/Female Housing, 4 Seals And 4 Pin Contacts
2.	GR1447	-	Harness W/4-Pin Connector, 152"
	GA8329	-	4-Pin Connector W/Male Housing, 4 Seals And 4 Socket Contacts
3.	GA7165	-	Circuit Breaker, 12 Amp
4.	GA7144	-	Two Position Switch
5.	G1K267	-	Power Lead Adapter Connector Kit, Includes: (1) 3-Pin Connector, (1) Cable Clamp, (3) Male Terminal Pins
6.	G1K268	-	Console Cable Connector Kit, Includes: (1) 3-Pin Connector, (1) Cable Clamp, (1) Lock Ring, (3) Female Terminal Pins
7.	GA7856	1	Power Lead Adapter
8.	GA7416	1	Wiring Harness, 288"
9.	GD9530	-	Contact
10.	GD9529	-	Housing, Black
	GD12726	-	Housing, Red
11.	G10996	-	Fork Terminal

TWO-SPEED POINT ROW CLUTCH

PRC023(SFP45b/A7274/A10054)

L.H. Two-Speed Point Row Clutch Shown
(Used On L.H. Side Of Planter)

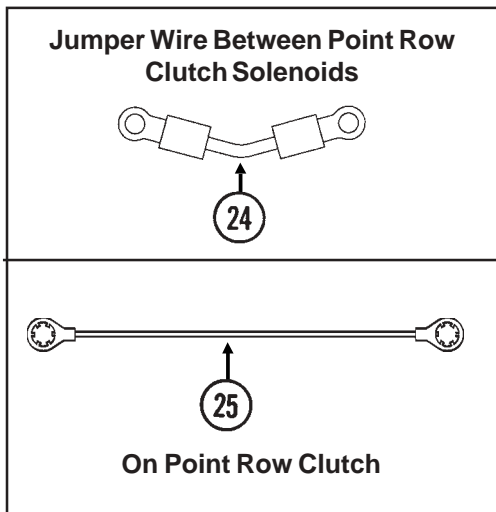
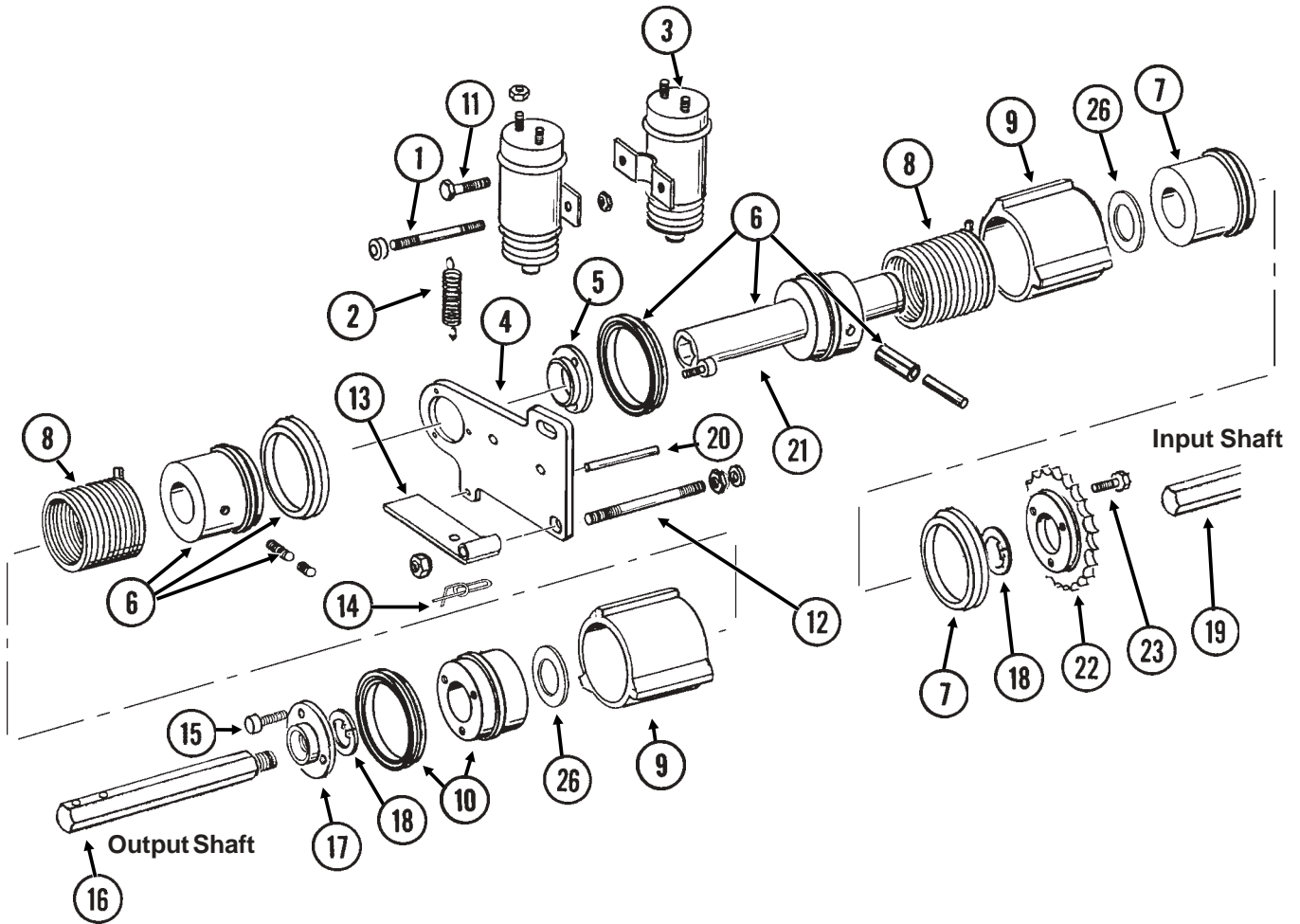

TWO-SPEED POINT ROW CLUTCH

ITEM	PART NO.	QTY. (Per Assy.)	DESCRIPTION
1.	GD10635	1	Threaded Rod, 1/4"-20 x 3 1/2"
	G10103	2	Hex Nut, 1/4"-20
	G10227	2	Lock Washer, 1/4"
	GD10282	2	Allen Nut, 1/4"-20
2.	GD10123	2	Spring
3.	GA8393	2	Solenoid Complete
	GR1306	-	Snap Ring
	GR1303	-	Spring
	GR1304	-	Boot
	GR1305	-	Plunger
4.	GD10103	1	Mounting Plate
5.	GD10586	1	Bushing
6.	GA7463	1	Hub/Sleeve Assembly W/Seals, Sleeve, Pins And Screws
	GD10584	-	Sleeve
	G10873	-	Hex Socket Set Screw, 5/16"-18 x 3/4"
	G10872	-	Hex Socket Set Screw, 5/16"-18 x 1/4"
	G10804	-	Spring Pin, 5/32" x 7/8"
	G10765	-	Spring Pin, 1/4" x 1"
	GD10120	-	Seal
	7.	GA9571	1
GD10120	-	Seal	
8.	GD9671	2	Spring, L.H. (Shown)
	GD9672	-	Spring, R.H.
9.	GD10585	2	Stop Collar
10.	GA9572	1	Hub W/Seal
	GD10120	-	Seal
11.	G10023	1	Hex Head Cap Screw, 1/4"-20 x 3/4"
	G10227	1	Lock Washer, 1/4"
	G10103	1	Hex Nut, 1/4"-20
12.	GD10636	1	Threaded Rod, 3/8"-16 x 4 1/4"
	G10108	2	Lock Nut, 3/8"-16
	G10229	2	Lock Washer, 3/8"
	G10101	2	Hex Nut, 3/8"-16
13.	GD10510	2	Actuator Arm
14.	GD11120	2	Rue Ring Cotter, 5/16"
15.	G10857	3	Hex Head Cap Screw, 1/4"-20 x 1 1/4"
	G10227	3	Lock Washer, 1/4"
16.	GD10694	1	Shaft, R.H. Thread (Shown)
	GD10693	-	Shaft, L.H. Thread
17.	GD10638	1	Coupler W/R.H. Threads (Shown)
	GD10587	-	Coupler W/L.H. Threads
18.	G10496	2	External Inverted Snap Ring, 1 1/2"
19.	GD10698	1	Input Shaft, 7/8" x 17 1/2"
20.	G10859	1	Spring Pin, 3/16" x 2 1/4"
21.	G10876	3	Hex Socket Head Screw, No. 10-32 x 1/4"
22.	GD10673	1	Sprocket, 34 Tooth
23.	G10374	3	Hex Socket Head Screw, 1/4"-20 x 1"
24.	GA7274	1	Jumper Wire W/Ring Terminals, 2 3/16"
25.	GA10054	1	Ground Cable, Green
26.	GD14513	2	Felt Washer

TWO-SPEED POINT ROW CLUTCH ELECTRICAL COMPONENTS

(SFP46d/SFP46e/TWL71a/TWL76/ELC34/ELC35/TWL18)

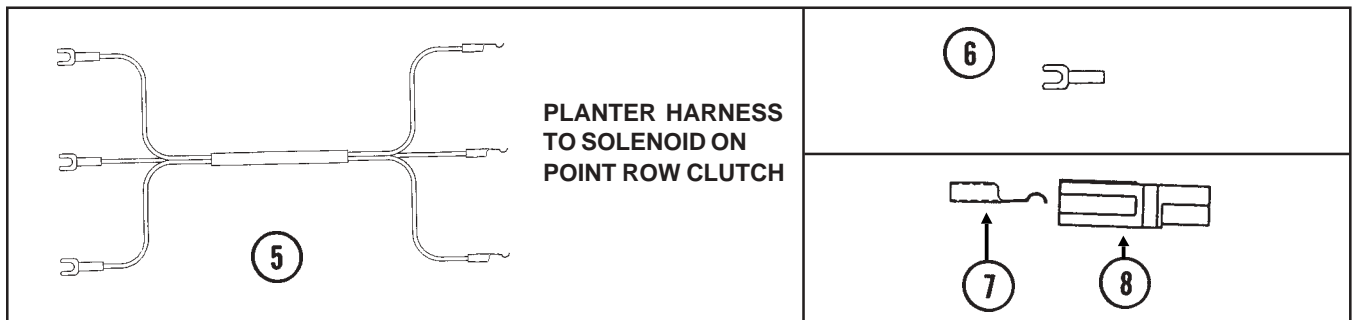
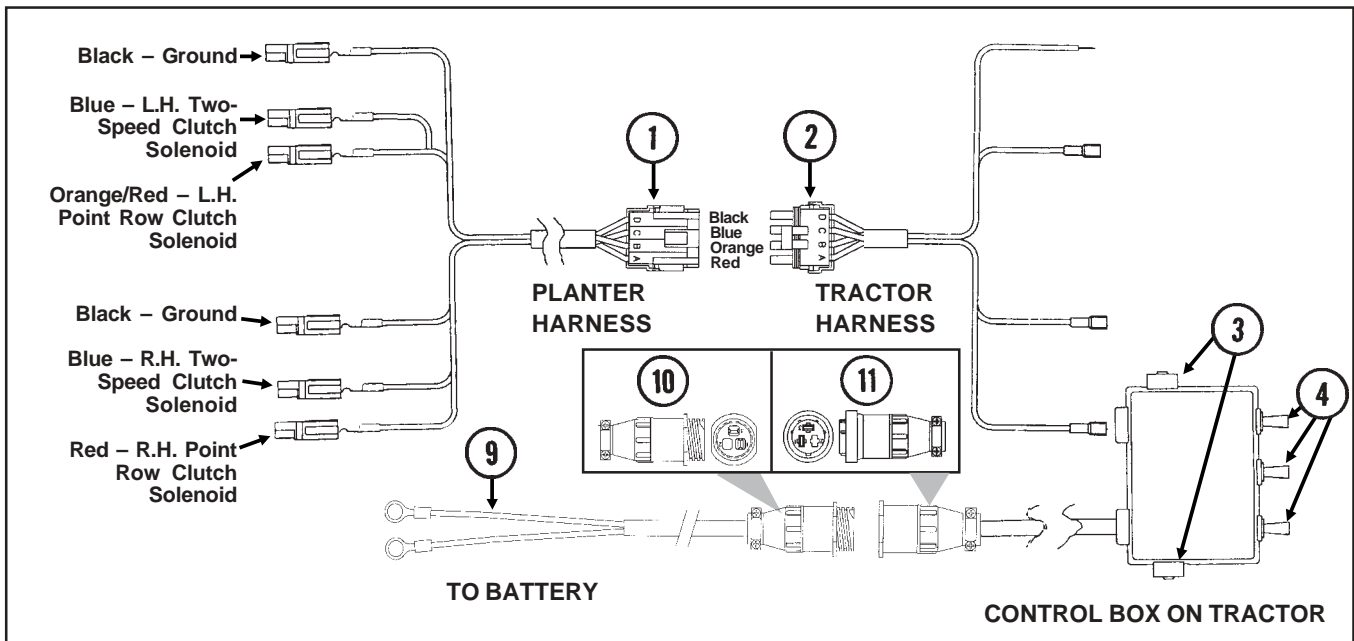
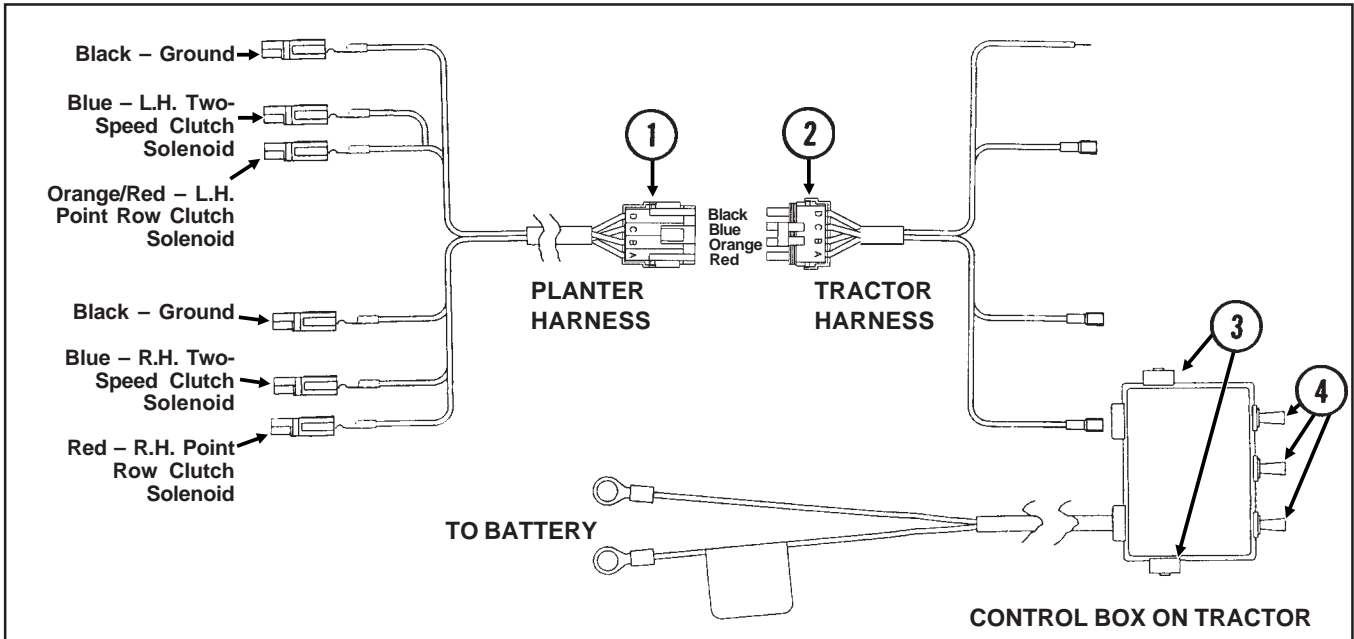

TWO-SPEED POINT ROW CLUTCH ELECTRICAL COMPONENTS

ITEM	PART NO.	QTY. (Per Assy.)	DESCRIPTION
1.	GR1448	-	Harness W/4-Pin Connector, 60"
	GA8328	-	4-Pin Connector W/Female Housing, 4 Seals And 4 Pin Contacts
2.	GR1449	-	Harness W/4-Pin Connector, 152"
	GA8329	-	4-Pin Connector W/Male Housing, 4 Seals And 4 Socket Contacts
3.	GA7165	2	Circuit Breaker, 12 Amp
4.	GA7144	3	Two-Position Switch
5.	GA7577	1	Wiring Harness, 288"
6.	G10996	-	Fork Terminal
7.	GD9530	-	Contact
8.	GD9529	-	Housing, Black
	GD12726	-	Housing, Red
9.	GA7856	1	Power Lead Adapter
10.	G1K267	-	Power Lead Adapter Connector Kit, Includes: (1) 3-Pin Connector, (1) Cable Clamp, (3) Male Terminal Pins
11.	G1K268	-	Console Cable Connector Kit, Includes: (1) 3-Pin Connector, (1) Cable Clamp, (1) Lock Ring, (3) Female Terminal Pins

TWO-SPEED POINT ROW CLUTCH TRANSMISSION AND MODULE DRIVE

PTD085/PTD084/PLA027/PTD082(SFP44b/FF49)

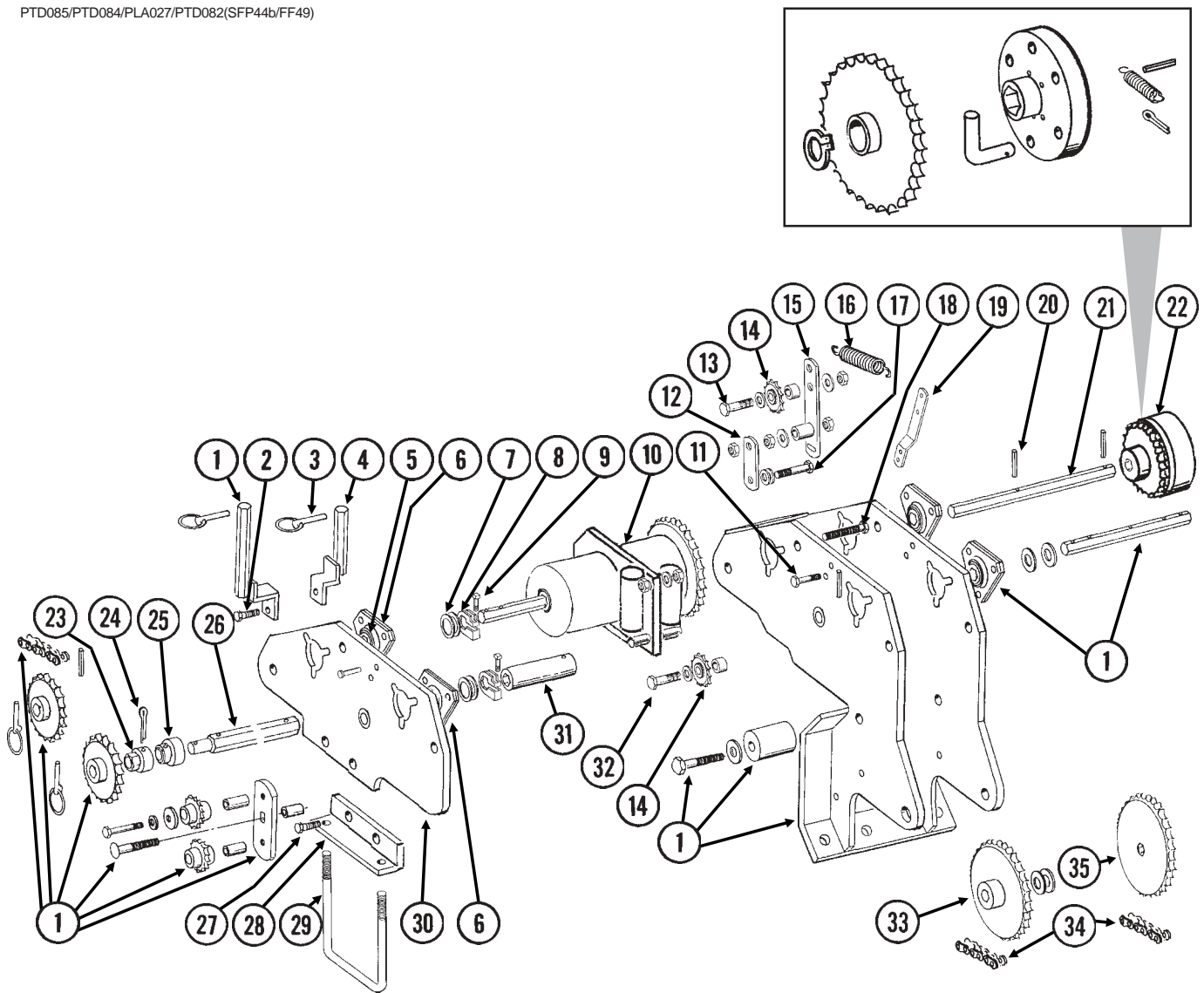

ITEM	PART NO.	QTY.	DESCRIPTION
------	----------	------	-------------

(Per Assy.)

1.		-	See "Seed Rate Transmission And Module Drive Assembly", Pages P48 And P49
2.	G10017	1	Hex Head Cap Screw, 1/2"-13 x 1 1/2"
	G10228	1	Lock Washer, 1/2"
	G10102	1	Hex Nut, 1/2"-13
3.	GD2558	2	Lynch Pin, 1/4"
4.	GA7313	1	Sprocket Storage Rod
5.	G2100-03	1	Bearing, 7/8" Hex Bore, Spherical
6.	G3400-01	4	Flangette
7.	G10233	-	Machine Bushing, 1", 10 Gauge
8.	GD11045	2	Lock Clamp
9.	G10130	2	Square Head Machine Bolt, 5/16"-18 x 1 3/4"
	G10923	2	Flange Nut, 5/16"-18, No Serration
10.		-	See "Two-Speed Point Row Clutch", Pages P56 And P57
11.	G10064	2	Hex Head Cap Screw, 1/4"-20 x 1"
	G10227	2	Lock Washer, 1/4"
	G10103	2	Hex Nut, 1/4"-20
12.	GD10697	1	Bracket

TWO-SPEED POINT ROW CLUTCH TRANSMISSION AND MODULE DRIVE

ITEM	PART NO.	QTY. (Per Assy.)	DESCRIPTION	
13.	G10581	1	Hex Head Cap Screw, 1/2"-13 x 2 1/4"	
	G10128	1	Machine Bushing, 1/2", 14 Gauge	
	GD7889	1	Bushing, 1" O.D. x 9/16" I.D. x 7/16" Long	
	G10228	1	Lock Washer, 1/2"	
	G10102	1	Hex Nut, 1/2"-13	
14.	GA7154	2	Sprocket W/Bearing, 18 Tooth	
15.	GA6533	1	Idler Arm	
16.	GD5857	1	Spring	
17.	G10062	1	Hex Head Cap Screw, 3/8"-16 x 3"	
	G10203	4	Washer, 3/8" SAE	
	G10101	2	Hex Nut, 3/8"-16	
18.	G10582	1	Hex Head Cap Screw, 5/8"-11 x 4", Full Thread	
	GD7805	1	Special Washer, 5/8", Hardened	
	G10503	3	Hex Jam Nut, 5/8"-11, Grade 2	
19.	GD5860	1	Bar	
20.	G10602	-	Spring Pin, 1/4" x 1 1/2"	
21.	GD10698	1	Input Shaft, 7/8" x 17 1/2"	
22.	A7550	1	Overrunning Sprocket Assembly, R.H. (Non-Stock Item)	
	A7549	-	Overrunning Sprocket Assembly, L.H. (Non-Stock Item)	
	G10430	1	External Retaining Ring, 1 1/4"	
	GD1255	6	L-Pin	
	G10546	6	Spring Pin, 3/16" x 1 1/4"	
	G10470	6	Cotter Pin, 5/32" x 1"	
	GD10366	6	Spring	
	GA7317	1	Block	
	GA7574	1	Sprocket W/Bushing, 34 Tooth	
	23.	GD7127	1	Shear Coupler
	24.	G10462	1	Cotter Pin, 3/16" x 2"
25.	GA5548	1	Special Bearing	
26.	GD10336	1	Shaft, 7/8" x 11"	
27.	G10007	1	Hex Head Cap Screw, 5/8"-11 x 1 1/2"	
	G10205	1	Washer, 5/8" SAE	
	G10230	1	Lock Washer, 5/8"	
	G10104	1	Hex Nut, 5/8"-11	
28.	GD10696	1	Mounting Angle	
29.	GD1114	1	U-Bolt, 7" x 7" x 5/8"-11	
	G10230	2	Lock Washer, 5/8"	
	G10104	2	Hex Nut, 5/8"-11	
30.	GA7571	1	Transmission Bracket, L.H. (Shown)	
	GA7570	-	Transmission Bracket, R.H.	
31.	GD10109	1	Coupler, 6"	
32.	G10397	1	Hex Head Cap Screw, 1/2"-13 x 2 3/4"	
	G10128	1	Machine Bushing, 1/2", 14 Gauge	
	GB0258	1	Stepped Spacer, 7/8"	
	G10228	1	Lock Washer, 1/2"	
	G10102	1	Hex Nut, 1/2"-13	
	GA5114	1	Sprocket, 30 Tooth	
34.	G3310-224	2	Chain, No. 40, 224 Pitch Including Connector Link	
	GR0912	-	Connector Link, No. 40	
35.	GA5109	1	Sprocket, 24 Tooth	
	GA5105	1	Sprocket, 15 Tooth	
	GA5106	1	Sprocket, 17 Tooth	
	GA5112	1	Sprocket, 27 Tooth	
	GA5108	-	Sprocket, 23 Tooth (From Transmission)	
	GA5110	-	Sprocket, 25 Tooth (From Transmission)	
	GA5111	-	Sprocket, 26 Tooth (From Transmission)	
A.	G1K269	-	Lock Clamp Kit (Items 8 And 9)	

CENTER DROP ASSEMBLY AND DRIVELINE

PTD081/PTD080/PTD077/PFA052/PTD016(PLTR157e/SFP23d/SFP22/PT6)

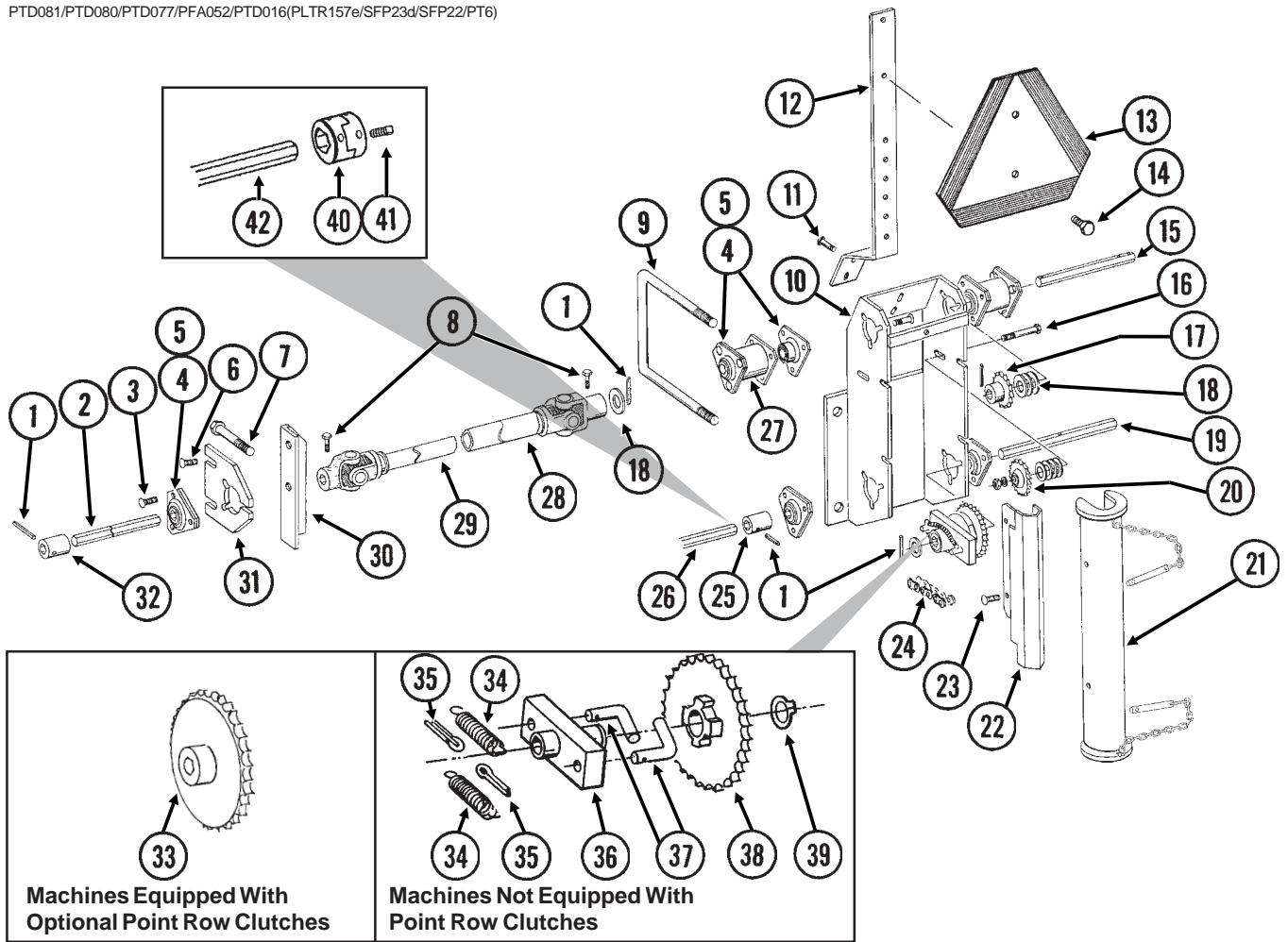

ITEM	PART NO.	QTY.	DESCRIPTION
1.	G10602	5	Spring Pin, 1/4" x 1 1/2"
2.	GD2548-58	2	Hex Shaft, 7/8" x 58", 8 Row 38"/40" And 12 Row 30" (1 Hole)
	GD2548-60	-	Hex Shaft, 7/8" x 60", 12 Row 36"/38" (1 Hole)
	GD2548-70	-	Hex Shaft, 7/8" x 70", 12 Row 38"/40" (1 Hole)
	GD2548-90	-	Hex Shaft, 7/8" x 90", 16 Row 30" (1 Hole)
3.	G10303	18	Carriage Bolt, 5/16"-18 x 1"
	G10232	18	Lock Washer, 5/16"
	G10106	18	Hex Nut, 5/16"-18
4.	G2100-03	8	Bearing, 7/8" Hex Bore, Spherical
5.	G3400-01	12	Flangette
6.	G10574	4	Carriage Bolt, 1/2"-13 x 1 1/4"
	G10228	4	Lock Washer, 1/2"
	G10102	4	Hex Nut, 1/2"-13
7.	G10017	4	Hex Head Cap Screw, 1/2"-13 x 1 1/2"
	G10216	4	Washer, 1/2" USS
	G10228	4	Lock Washer, 1/2"
	G10102	4	Hex Nut, 1/2"-13
8.	G10880	4	Hex Head Cap Screw, 1/4"- 20 x 2 1/4"
	G10110	4	Lock Nut, 1/4"-20
9.	GD1114	2	U-Bolt, 7" x 7" x 5/8"-11
	G10230	4	Lock Washer, 5/8"
	G10104	4	Hex Nut, 5/8"-11
10.	GA7301	1	Transfer Case
11.	G10001	2	Hex Head Cap Screw, 3/8"-16 x 1"
	G10229	2	Lock Washer, 3/8"
	G10101	2	Hex Nut, 3/8"-16

CENTER DROP ASSEMBLY AND DRIVELINE

ITEM	PART NO.	QTY.	DESCRIPTION
12.	GD10454	1	SMV/Bulkhead Mount, 8 Row 38"/40" And 12 Row 30"
	GD10507	-	SMV/Bulkhead Mount, 12 Row 36"/38"/40" And 16 Row 30"
	GD11870	-	SMV/Bulkhead Mount, 12 Row 36"/38"/40" And 16 Row 30" (W/Dual Lift Assist Wheel And Wing Down Flex Cylinder Packages)
13.	GD2199	1	SMV Sign
14.	G10023	2	Hex Head Cap Screw, 1/4"-20 x 3/4"
	G10110	2	Lock Nut, 1/4"-20
15.	GD10348	2	Top Shaft, 7/8" x 7 1/2"
16.	G10581	2	Hex Head Cap Screw, 1/2"-13 x 2 1/4"
	G10206	12	Washer, 1/2" SAE
	G10228	2	Lock Washer, 1/2"
	G10102	2	Hex Nut, 1/2"-13
17.	GA5105	2	Sprocket, 15 Tooth
18.	G10233	10	Machine Bushing, 1", 10 Gauge
19.	GD10349	1	Bottom Shaft, 7/8" x 9 1/2" (Machines Without Point Row Clutches Only)
20.	GA7154	3	Sprocket W/Bearing, 18 Tooth
21.	GA8172	2	Safety Lockup W/Detent Pins, 20"
	G10536	-	Detent Pin, 1/2" x 2 1/2" Grip
22.	GD10412	2	Lockup Mount
23.	G10305	4	Carriage Bolt, 3/8"-16 x 1"
	G10229	4	Lock Washer, 3/8"
	G10101	4	Hex Nut, 3/8"-16
24.	G3310-74	2	Chain, No. 40, 74 Pitch Including Connector Link
	GR0912	-	Connector Link, No. 40
25.	GD5212	2	Coupler, 1 3/4"
26.	GD2548-81	2	Hex Shaft, 7/8" x 81", 8 Row 38"/40" And 12 Row 30" (1 Hole)
	GD2548-99	-	Hex Shaft, 7/8" x 99", 12 Row 36"/38" (1 Hole)
	GD2548-111	-	Hex Shaft, 7/8" x 111", 12 Row 38"/40" And 16 Row 30" (1 Hole)
27.	GA7302	2	Spacer
28.	GA8002	2	U-Joint W/Grease Fitting, Female, 66 3/8", 8 Row 38"/40" And 12 Row 30"
	GA8045	-	U-Joint W/Grease Fitting, Female, 82 1/2", 12 Row 36"/38"/40" And 16 Row 30"
	GR1365	-	Yoke, 7/8" Hex
	GR1294	-	Cross And Bearing Kit
	GR1352	-	Inboard Yoke
	GR1300	-	Grease Fitting, 67.5° Metric
	GR1301	-	Spring Pin, 8mm x 50mm
29.	GA8001	2	U-Joint W/Grease Fitting, Male, 40 13/32"
	GR1365	-	Yoke, 7/8" Hex
	GR1294	-	Cross And Bearing Kit
	GR1295	-	Inboard Yoke
	GR1300	-	Grease Fitting, 67.5° Metric
	GR1301	-	Spring Pin, 8mm x 50mm
30.	GD10521	1	Angle, L.H.
	GD10520	-	Angle, R.H.
31.	GD10343	2	Mount
32.	GD5212	2	Coupler, 1 3/4", 12 Row 30" And 16 Row 30"
	GD9378	-	Coupler, 12", 8 Row 38"/40" And 12 Row 36"/38"/40"
33.	GA5114	-	Sprocket, 30 Tooth (Machines With Point Row Clutches)
34.	GD1256	2	Spring
35.	G10464	2	Cotter Pin, 3/16" x 1"
36.	GA0378	1	Block And Hub Assembly
37.	GD1255	2	L-Pin
38.	GA5165	1	Sprocket, 30 Tooth
39.	G10430	1	External Retaining Ring, 1 1/4"
40.	GB0287	4	Coupler
41.	G10131	8	Square Head Set Screw, 5/16"-18 x 3/4"
42.	GD0914-81	2	Hex Shaft, 7/8" x 81", 8 Row 38"/40" And 12 Row 30" (No Holes)
	GD0914-99	-	Hex Shaft, 7/8" x 99", 12 Row 36"/38" (No Holes)
	GD0914-111	-	Hex Shaft, 7/8" x 111", 12 Row 38"/40" And 16 Row 30" (No Holes)
A.	GA9843	-	Ratchet/Sprocket Assembly (Items 34-39) (Shown)
	GA5164	-	Ratchet/Sprocket Assembly (Items 34-39)

ROW MARKER ASSEMBLY, TWO-FOLD LOW PROFILE 8 ROW 38"/40" AND 12 ROW 30"

MKR019/MKR008/MKR28(MKR11f)

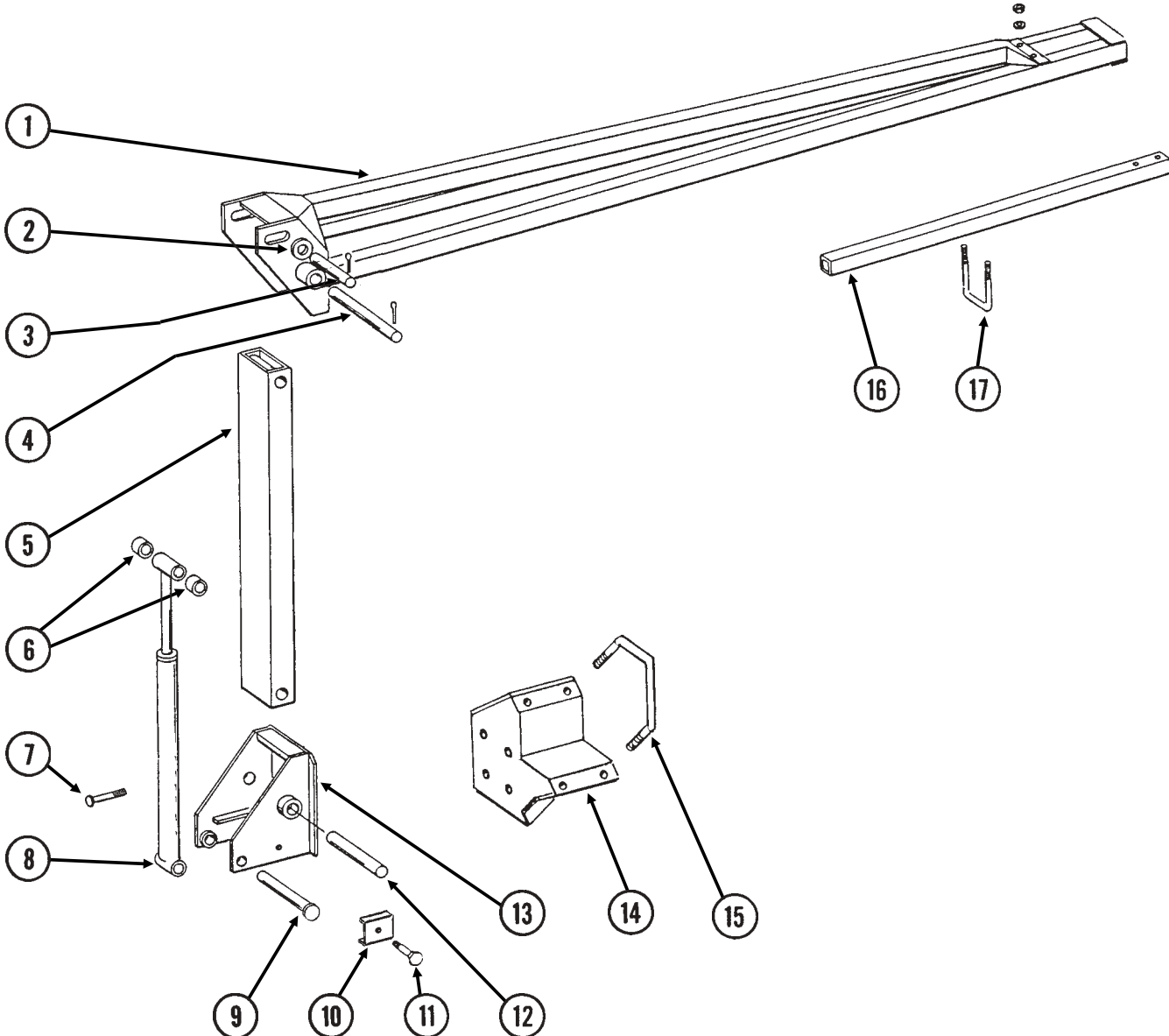

ROW MARKER ASSEMBLY, TWO-FOLD LOW PROFILE

8 ROW 38"/40" AND 12 ROW 30"

ITEM	PART NO.	QTY.	DESCRIPTION
		(Per Assy.)	
1.	GA4353	1	Arm W/Grease Fittings, Second Stage, 110", 12 Row 30"
	G10641	-	Grease Fitting, 1/8" NPT
	GA5192	-	Arm, Second Stage, 67", 8 Row 38"/40"
2.	G10226	-	Washer, 1 1/4" SAE (As Required)
	G10159	-	Machine Bushing, 1 1/4", 10 Gauge (As Required)
	G10322	-	Machine Bushing, 1 1/4", 18 Gauge (As Required)
3.	GD2161	1	Pin, 1 1/4" x 8 1/4"
	G10460	2	Cotter Pin, 1/4" x 2"
4.	GD3214	1	Pin, 1 1/4" x 12 1/4"
	G10460	2	Cotter Pin, 1/4" x 2"
5.	GA5173	1	Arm W/Grease Fittings, First Stage
	G10641	-	Grease Fitting, 1/8" NPT
6.	GD0752-41	4	Sleeve, 1"
7.	G10008	4	Hex Head Cap Screw, 5/8"-11 x 2"
	G10205	8	Washer, 5/8" SAE
	G10230	4	Lock Washer, 5/8"
	G10104	4	Hex Nut, 5/8"-11
8.		-	See "Row Marker Cylinder", Page P72
9.	GD15386	1	Pin, 1 1/4" x 7 5/8"
	G10460	1	Cotter Pin, 1/4" x 2"
10.	GD5892	1	Hose Clamp, 5/8" x 1 1/2" x 1 1/2"
11.	G10133	1	Hex Head Cap Screw, 5/16"-18 x 1 1/2"
	G10232	1	Lock Washer, 5/16"
	G10106	1	Hex Nut, 5/16"-18
12.	GD0652	1	Pin, 1 1/4" x 9 1/2"
	G10460	2	Cotter Pin, 1/4" x 2"
13.	GA5130	1	Mount
14.	GA7347	1	Mount
15.	GD8175	2	U-Bolt, 7" x 7" (Diamond) x 5/8"-11
	G10205	4	Washer, 5/8" SAE
	G10230	4	Lock Washer, 5/8"
	G10104	4	Hex Nut, 5/8"-11
16.	GD0453-08	1	Extension Tube, 65", 8 Row 38"/40"
	GD0453-07	-	Extension Tube, 45", 12 Row 30"
17.	GD2721	1	U-Bolt, 2" x 2" x 1/2"-13
	G10228	2	Lock Washer, 1/2"
	G10102	2	Hex Nut, 1/2"-13

ROW MARKER ASSEMBLY, TWO-FOLD LOW PROFILE 12 ROW 36"/38"/40" AND 16 ROW 30"

MKR019/MKR023/MKR027/MKR029(MKR12d/MKR13/MKR14d)

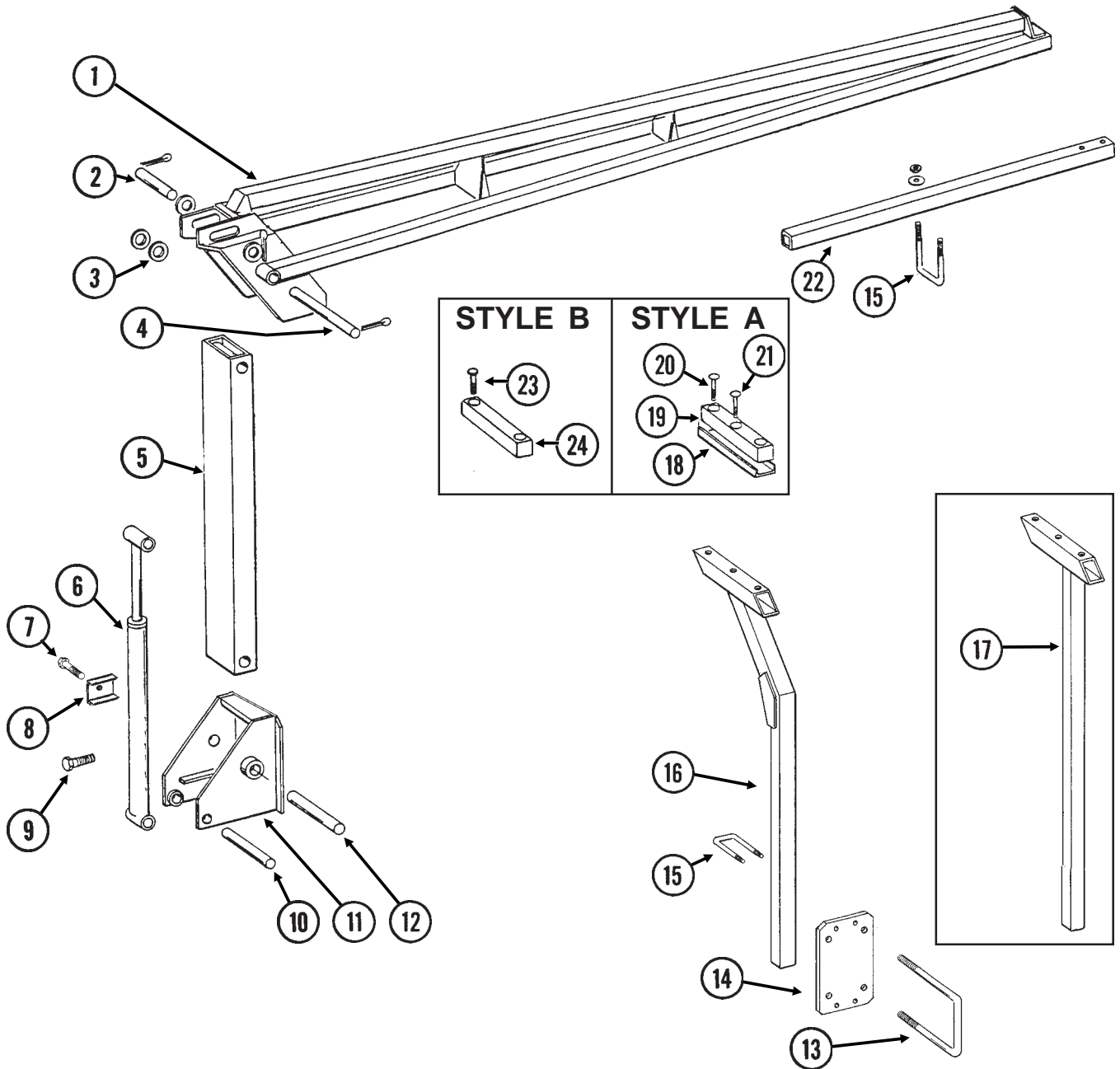

ROW MARKER ASSEMBLY, TWO-FOLD LOW PROFILE

12 ROW 36"/38"/40" AND 16 ROW 30"

ITEM	PART NO.	QTY. (Per Assy.)	DESCRIPTION
1.	GA7116	1	Arm, Second Stage, 138 1/4", 12 Row 36"/38"/40"
	GA7118	-	Arm, Second Stage, 172 1/4", 16 Row 30"
2.	GD1701	1	Pin, 1 1/4" x 6 1/2"
	G10460	2	Cotter Pin, 1/4" x 2"
3.	G10322	4	Machine Bushing, 1 1/4", 18 Gauge
	G10159	-	Machine Bushing, 1 1/4", 10 Gauge (As Required)
4.	GD0737	1	Pin, 1 1/4" x 13 1/4"
	G10460	2	Cotter Pin, 1/4" x 2"
5.	GA0151	1	Arm W/Grease Fittings, First Stage
	G10641	-	Grease Fitting, 1/8" NPT
6.		-	See "Row Marker Cylinder", Page P72
7.	G10133	1	Hex Head Cap Screw, 5/16"-18 x 1 1/2"
	G10232	1	Lock Washer, 5/16"
	G10106	1	Hex Nut, 5/16"-18
8.	GD5875	1	Hose Clamp, 9/16" x 2 1/2" x 2"
9.	G10008	4	Hex Head Cap Screw, 5/8"-11 x 2"
	G10230	4	Lock Washer, 5/8"
	G10104	4	Hex Nut, 5/8"-11
10.	GD0652	1	Pin, 1 1/4" x 9 1/2"
	G10460	2	Cotter Pin, 1/4" x 2"
11.	GA7415	1	Mount
12.	GD7209	1	Pin, 1 1/4" x 11 1/2"
	G10049	1	Hex Head Cap Screw, 3/8"-16 x 2 1/2"
	G10108	1	Lock Nut, 3/8"-16
13.	GD1114	2	U-Bolt, 7" x 7" x 5/8"-11
	G10230	4	Lock Washer, 5/8"
	G10104	4	Hex Nut, 5/8"-11
14.	GD10577	1	Plate, 7" x 11 1/2"
15.	GD2721	3	U-Bolt, 2" x 2" x 1/2"-13
	G10228	6	Lock Washer, 1/2"
	G10102	6	Hex Nut, 1/2"-13
16.	GA7354	-	Stand, R.H.
17.	GA7353	1	Stand, L.H.
18.	GD6772	1	Retainer (Sub GA9088)
19.	GD4512	1	Rubber Stop (Sub GA9088)
20.	G10039	2	Hex Head Cap Screw, 1/2"-13 x 1 3/4"
	G10206	2	Washer, 1/2" SAE
	G10228	2	Lock Washer, 1/2"
	G10102	2	Hex Nut, 1/2"-13
21.	G10033	1	Hex Head Cap Screw, 1/2"-13 x 3 1/2"
	G10206	1	Washer, 1/2" SAE
	G10228	1	Lock Washer, 1/2"
	G10102	1	Hex Nut, 1/2"-13
22.	GD0453-10	-	Extension Tube, 73", 12 Row 36"/38"
	GD0453-09	1	Extension Tube, 75", 12 Row 38"/40"
	GD0453-03	-	Extension Tube, 50", 16 Row 30"
23.	G10017	2	Hex Head Cap Screw, 1/2"-13 x 1 1/2"
	G10228	2	Lock Washer, 1/2"
	G10102	2	Hex Nut, 1/2"-13
24.	GA9088	1	Molded Stop, 12 1/4" Long (Replaces GD4512 And GD6772)

ROW MARKER SPINDLE/HUB/BLADE

MKR020(MKR4a)

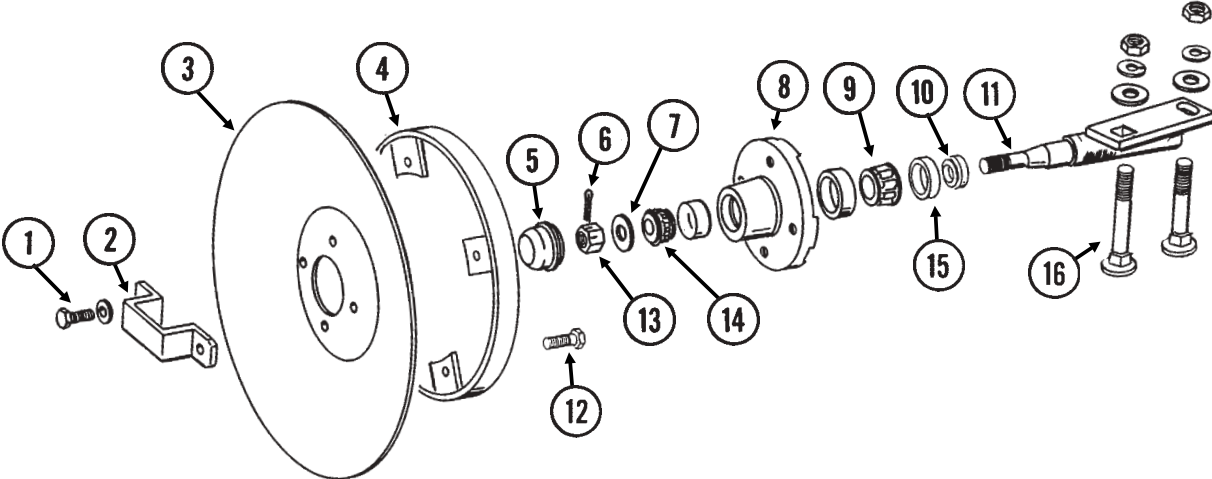

ROW MARKER SPINDLE/HUB/BLADE

ITEM	PART NO.	QTY. (Per Assy.)	DESCRIPTION
1.	G10722	4	Hex Head Cap Screw, 1/2"-20 x 1"
	G10228	4	Lock Washer, 1/2"
2.	GD2597	1	Retainer
3.	GD0746	1	Disc Blade, Solid, 16" (Shown)
	GD10283	-	Disc Blade, Notched, 16" (Optional)
4.	GA5853	1	Depth Band
5.	GD0840	1	Dust Cap
6.	G10544	1	Cotter Pin, 5/32" x 1"
7.	G10724	1	Washer, 5/8" SAE
8.	GA0167	1	Hub W/Cups
	GR0151	-	Outer Cup
	GR0150	-	Inner Cup
9.	GA0245	1	Bearing
10.	GA0899	1	Rubber Seal
11.	GA1677	1	Spindle, L.H. (Shown)
	GA1676	-	Spindle, R.H.
12.	G10019	4	Hex Head Cap Screw, 5/16"-18 x 1"
	G10109	4	Lock Nut, 5/16"-18
13.	G10725	1	Slotted Hex Nut, 5/8"-18
14.	GA0257	1	Bearing
15.	GA0243	1	Grease Seal
16.	G10844	2	Carriage Bolt, 1/2"-13 x 3 1/2"
	G10168	2	Machine Bushing, 1/2", 7 Gauge
	G10228	2	Lock Washer, 1/2"
	G10102	2	Hex Nut, 1/2"-13
A.	GA1679	-	Hub And Spindle Assembly, L.H. (Items 1, 2, 5-11 And 13-15)
	GA1678	-	Hub And Spindle Assembly, R.H. (Items 1, 2, 5-11 And 13-15)

WING FOLD CYLINDER, 8 ROW 38"/40" AND 12 ROW 30"

CYL29(CYL16a)

3/4"-16 O-Ring Ports

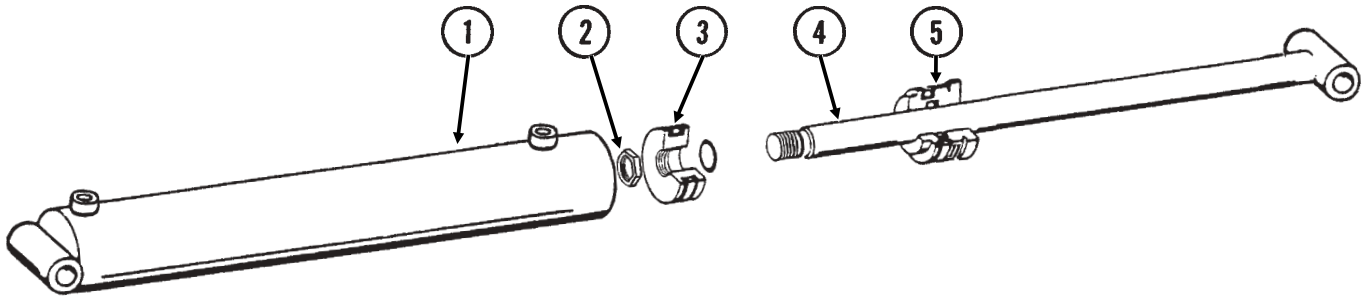

ITEM	PART NO.	QTY.	DESCRIPTION
1.	A7501	1	Barrel (Non-Stock Item)
2.	GR0987	1	Lock Nut, 1 1/4"-12
3.	GD6568	1	Piston
4.	GA4312	1	Rod Assembly
5.	GD6569	1	Gland
A.	GA7338	-	Cylinder Complete, 3 1/2" x 20" <i>(Part Number Stamped On Barrel)</i>
B.	GR0988	-	Seal Kit, Includes: (2) O-Rings, (1) BU Ring, (1) U-Cup, (1) Wiper, (1) Uniring

WING FOLD CYLINDER, 8 ROW 38"/40" AND 12 ROW 30"

CYL29(CYL16a)

3/4"-16 O-Ring Ports

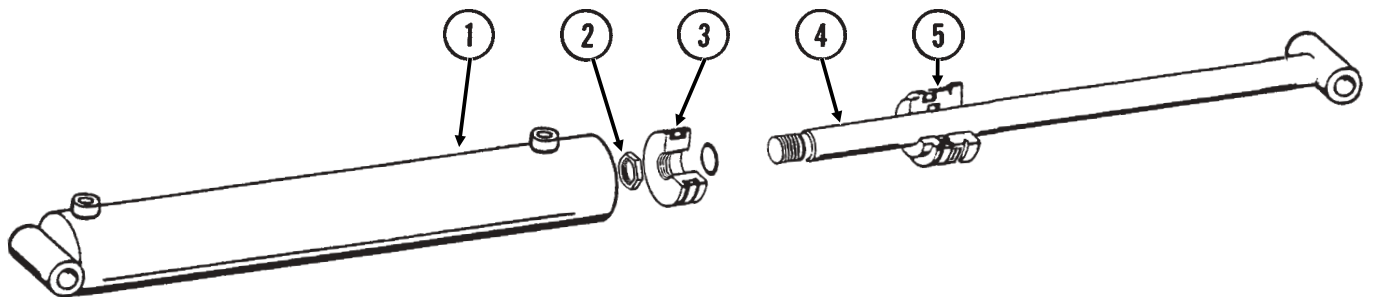

ITEM	PART NO.	QTY.	DESCRIPTION
1.	A9535	1	Barrel (Non-Stock Item)
2.	G10958	1	Lock Nut, 1"-14
3.	GD12691	1	Piston
4.	GA9033	1	Rod Assembly
5.	GD12548	1	Gland
A.	GA9036	-	Cylinder Complete, 3 1/2" x 20" <i>(Part Number Stamped On Barrel)</i>
B.	GR1553	-	Seal Kit, Includes: (2) O-Rings, (1) BU Ring, (1) U-Cup, (1) Wiper, (1) T-Seal

WING FOLD CYLINDER, 12 ROW 36"/38"/40" AND 16 ROW 30"

CYL29(CYL16b)

3/4"-16 O-Ring Ports

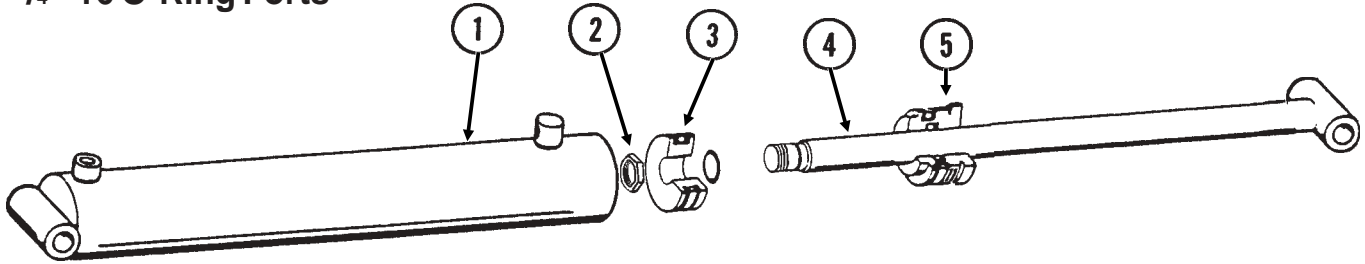

ITEM	PART NO.	QTY.	DESCRIPTION
1.	A7525	1	Barrel (Non-Stock Item)
2.	GR0987	1	Lock Nut, 1 1/4"-12
3.	GD10639	1	Piston
4.	GA7526	1	Rod Assembly
5.	GD7164	1	Gland
A.	GA7521	-	Cylinder Complete, 4" x 20" <i>(Part Number Stamped On Barrel)</i>
B.	GR1357	-	Seal Kit, Includes: (2) O-Rings, (1) BU Washer, (1) U-Cup, (1) Wiper, (1) Seal

WING FOLD CYLINDER, 12 ROW 36"/38"/40" AND 16 ROW 30"

CYL29(CYL16b)

3/4"-16 O-Ring Ports

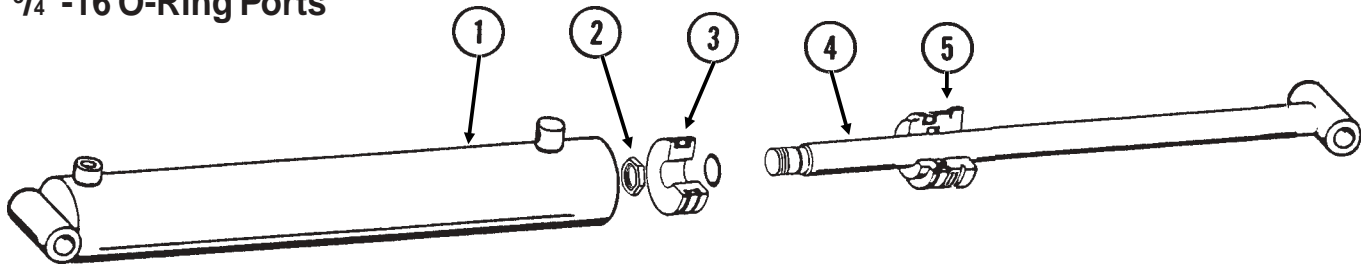

ITEM	PART NO.	QTY.	DESCRIPTION
1.	A9059	1	Barrel (Non-Stock Item)
2.	G10972	1	Lock Nut, 1 1/4"-12
3.	GD12660	1	Piston
4.	GA9057	1	Rod Assembly
5.	GD12659	1	Gland
A.	GA9060	-	Cylinder Complete, 4" x 20" <i>(Part Number Stamped On Barrel)</i>
B.	GR1554	-	Seal Kit, Includes: (2) O-Rings, (1) BU Ring, (1) U-Cup, (1) Wiper, (1) T-Seal

ROW MARKER CYLINDER

CYL032(CYL32d)

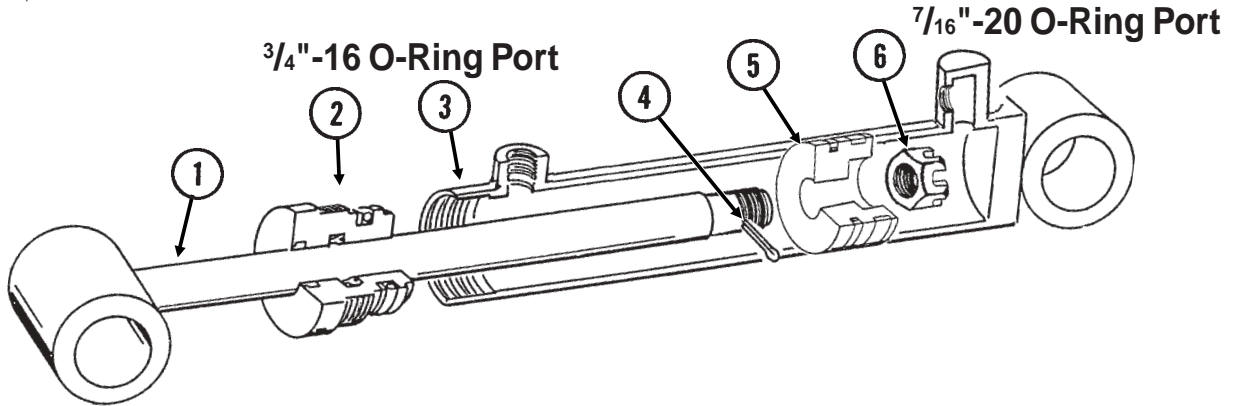

ITEM	PART NO.	QTY.	DESCRIPTION
1.	GA7219	1	Rod Assembly
2.	GD10207	1	Gland
3.	A7524	1	Barrel (Non-Stock Item)
4.	G10827	1	Cotter Pin, 1/8" x 1 3/4"
5.	GD10206	1	Piston
6.	G10962	1	Slotted Hex Nut, 7/8"-14
A.	GA7523	-	Cylinder Complete, 2 1/2" x 20 1/16" <i>(Part Number Stamped On Barrel)</i> (Sub GA8895)
B.	GR1309	-	Seal Kit, Includes: (1) Seal, (2) O-Rings, (1) BU Ring, (1) U-Cup, (1) Wiper, (1) Cast Iron Ring

ROW MARKER (Cushion) CYLINDER

CYL032(CYL32d)

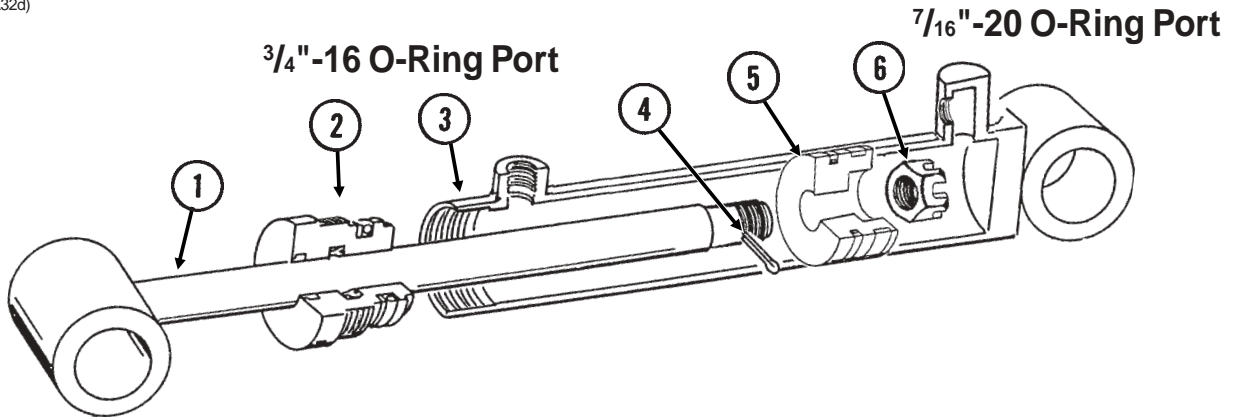

ITEM	PART NO.	QTY.	DESCRIPTION
1.	GA8871	1	Rod Assembly
2.	GD10207	1	Gland
3.	A7524	1	Barrel (Non-Stock Item)
4.	G10827	1	Cotter Pin, 1/8" x 1 3/4"
5.	GD11983	1	Piston
6.	G10962	1	Slotted Hex Nut, 7/8"-14
A.	GA8895	-	Cylinder Complete, 2 1/2" x 20 1/16" <i>(Part Number Stamped On Barrel)</i>
B.	GR1521	-	Seal Kit, Includes: (1) T-Seal, (2) O-Rings, (1) BU Ring, (1) U-Cup, (1) Wiper, (1) Cast Iron Ring

WING DOWN FLEX CYLINDER

CYL060(CYL31b)

3/4"-16 O-Ring Ports

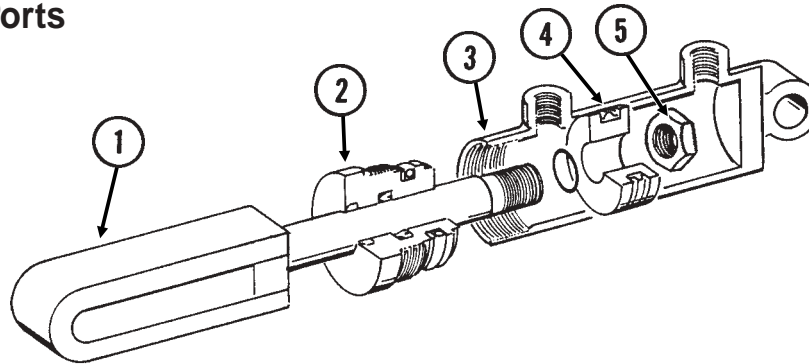

ITEM	PART NO.	QTY.	DESCRIPTION
1.	GA7503	1	Rod Assembly
2.	GD7164	1	Gland
3.	A7502	1	Barrel (Non-Stock Item)
4.	GD10639	1	Piston
5.	GR0987	1	Lock Nut, 1 1/4"-12
A.	GA7348	-	Cylinder Complete, 4" x 3 1/2" <i>(Part Number Stamped On Barrel)</i>
B.	GR1357	-	Seal Kit, Includes: (1) Seal, (2) O-Rings, (1) BU Washer, (1) U-Cup, (1) Wiper

WING DOWN FLEX CYLINDER

CYL060(CYL31b)

3/4"-16 O-Ring Ports

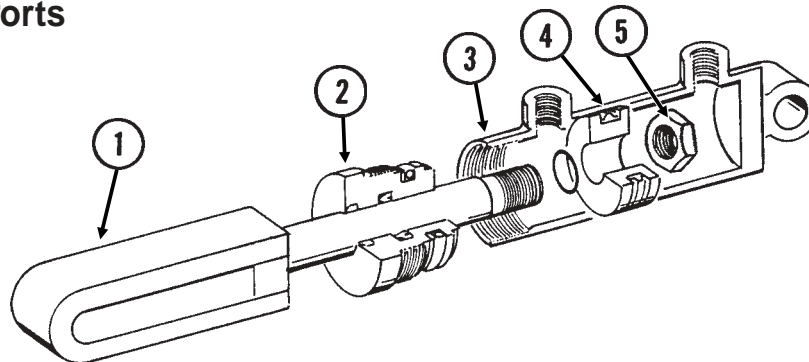

ITEM	PART NO.	QTY.	DESCRIPTION
1.	GA9052	1	Rod Assembly
2.	GD12659	1	Gland
3.	A9054	1	Barrel (Non-Stock Item)
4.	GD12660	1	Piston
5.	G10972	1	Lock Nut, 1 1/4"-12
A.	GA9055	-	Cylinder Complete, 4" x 3 1/2" <i>(Part Number Stamped On Barrel)</i>
B.	GR1554	-	Seal Kit, Includes: (2) O-Rings, (1) BU Ring, (1) U-Cup, (1) Wiper, (1) T-Seal

DUAL LIFT ASSIST CYLINDER

CYL048(CYL22c)

1/2" NPT Ports

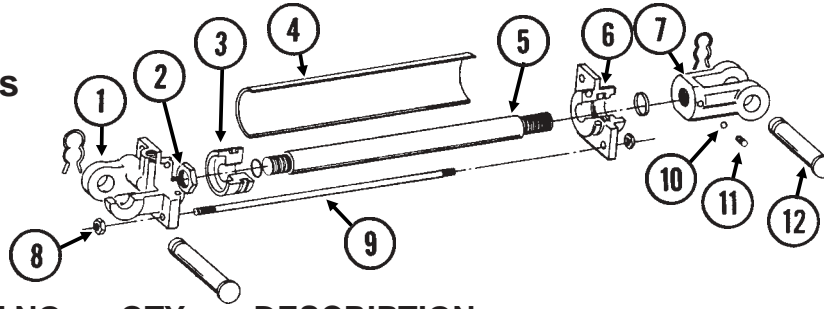

ITEM	PART NO.	QTY.	DESCRIPTION
1.	GR1027	1	Clevis
2.	GR0663	1	Hex Lock Nut, 1"-14 UNS
3.	GR1026	1	Piston
4.	R1023	1	Barrel (Non-Stock Item)
5.	GR0709	1	Shaft
6.	GR1025	1	Gland
7.	GR0714	1	Clevis
8.	GR0181	8	Hex Nut, 1/2"-13
9.	GR1024	4	Tie Rod
10.	GR0716	1	Nylon Ball
11.	G10072	1	Hex Socket Set Screw, 3/8"-16 x 3/8"
12.	GR0717	2	Pin W/Clip
	GR0193	-	Hair Pin Clip
A.	GA5482A	-	Cylinder Complete W/Pins And Clips, 3 1/2" x 8"
B.	GR1028	-	Seal Kit, Includes: (1) Wiper, (4) BU Rings, (4) O-Rings, (1) U-Cup

IDENTIFICATION NOTE: "Energy" cast in clevis.

DUAL LIFT ASSIST CYLINDER

CYL048(CYL23)

1/2" NPT Ports

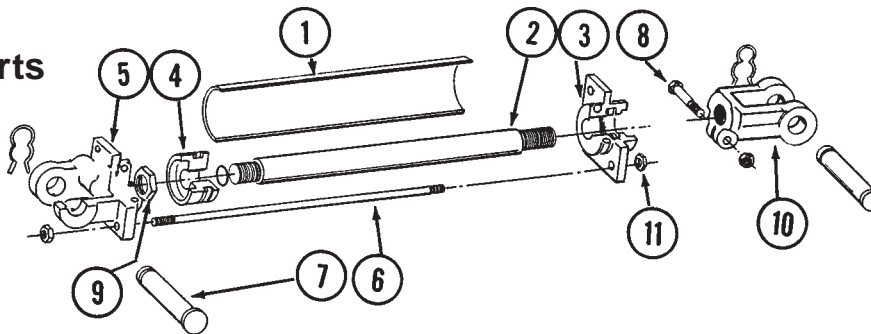

ITEM	PART NO.	QTY.	DESCRIPTION
1.	R1274	1	Barrel (Non-Stock Item)
2.	GR1273	1	Shaft
3.	GR1271	1	Gland
4.	GR1272	1	Piston
5.	GR1270	1	Clevis
6.	GR1024	4	Tie Rod
7.	GR0717	2	Pin W/Clip
	GR0193	-	Hair Pin Clip
8.	G10047	1	Hex Head Cap Screw, 3/8"-16 x 1 3/4"
	G10101	1	Hex Nut, 3/8"-16
9.	GR1278	1	Special Nut, 1"-14 UNS
10.	GR1276	1	Clevis
11.	GR0181	8	Hex Nut, 1/2"-13
A.	GA5482B	-	Cylinder Complete W/Pins And Clips, 3 1/2" x 8"
B.	GR1279	-	Seal Kit, Includes: (3) BU Seals, (5) O-Rings, (1) C/R Seal

IDENTIFICATION NOTE: Decal on barrel identifies "Lion Hydraulics".

DUAL LIFT ASSIST CYLINDER

CYL048(CYL22c)

3/4"-16 O-Ring Ports

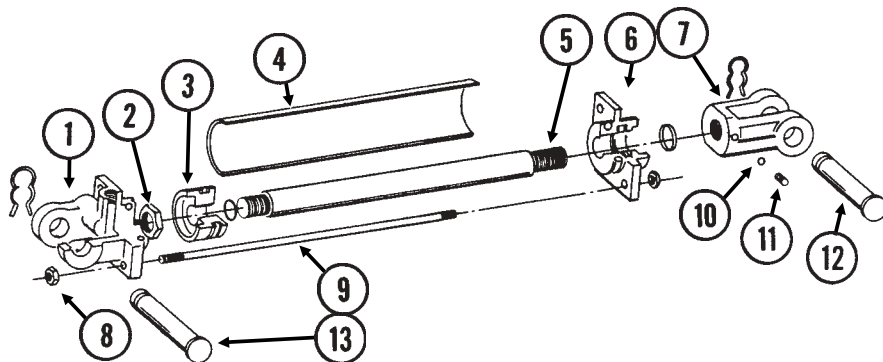

ITEM	PART NO.	QTY.	DESCRIPTION
1.	GR1511	1	Clevis
2.	G10948	1	Lock Nut, 1 1/8"-12
3.	GR1512	1	Piston
4.	R1510	-	Barrel (Non-Stock Item)
5.	GR1508	1	Shaft
6.	GR1509	1	Gland
7.	GR1507	1	Clevis
8.	G10102	8	Hex Nut, 1/2"-13
9.	GR1506	4	Tie Rod
10.	GR0716	1	Nylon Ball
11.	G10072	1	Hex Socket Set Screw, 3/8"-16 x 3/8"
12.	GR1504	1	Pin W/Clip
	GR0193	-	Hair Pin Clip
13.	GR0717	1	Pin W/Clip
	GR0193	-	Hair Pin Clip
A.	GA5482C	-	Cylinder Complete W/Pins And Clips, 3 1/2" x 8"
B.	GR1505	-	Seal Kit, Includes: (1) Wiper, (2) BU Rings, (3) O-Rings, (1) U-Cup, (1) Seal

IDENTIFICATION NOTE: "Energy" and date-code "3899" (week 38/year 1999 or later) cast in barrel.

ROW MARKER SEQUENCING/FLOW CONTROL VALVE AND MOUNT

VVB025 VVB037(PT9a/SFP7)

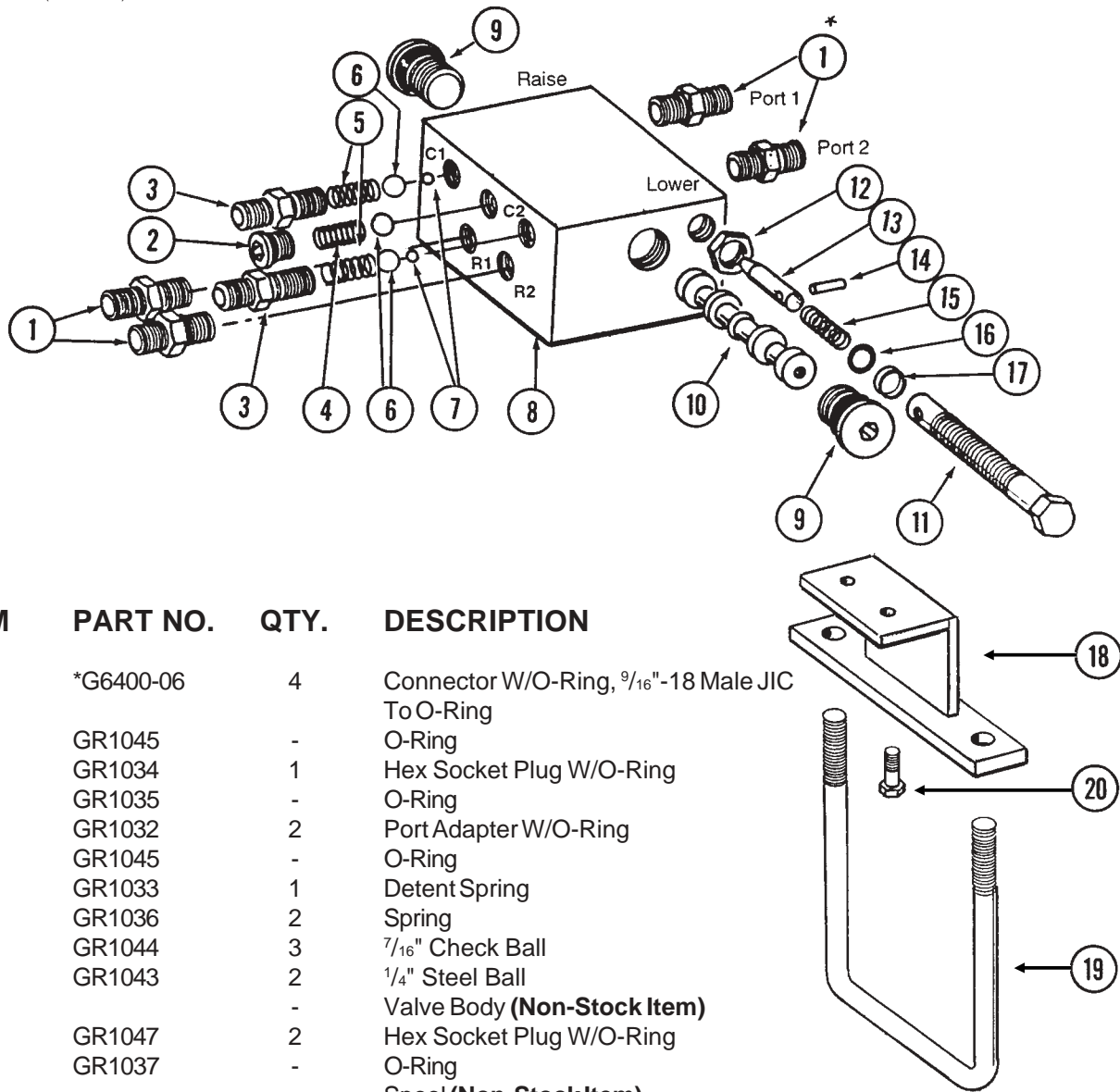

ITEM	PART NO.	QTY.	DESCRIPTION
1.	*G6400-06	4	Connector W/O-Ring, 9/16"-18 Male JIC To O-Ring
	GR1045	-	O-Ring
2.	GR1034	1	Hex Socket Plug W/O-Ring
	GR1035	-	O-Ring
3.	GR1032	2	Port Adapter W/O-Ring
	GR1045	-	O-Ring
4.	GR1033	1	Detent Spring
5.	GR1036	2	Spring
6.	GR1044	3	7/16" Check Ball
7.	GR1043	2	1/4" Steel Ball
8.		-	Valve Body (Non-Stock Item)
9.	GR1047	2	Hex Socket Plug W/O-Ring
	GR1037	-	O-Ring
10.		-	Spool (Non-Stock Item)
11.	GR1042	2	Adjustment Screw
12.	GR1048	2	Hex Jam Nut, 1/2"-20
13.	GR1038	2	Needle
14.	GR1039	2	Spring Pin
15.	GR1046	2	Compression Spring
16.	GR1040	2	O-Ring
17.	GR1041	2	Teflon BU Ring
18.	GA7341	1	Mount
19.	GD7145	1	U-Bolt, 7" x 7" x 1/2"-13
	G10228	2	Lock Washer, 1/2"
	G10102	2	Hex Nut, 1/2"-13
20.	G10001	2	Hex Head Cap Screw, 3/8"-16 x 1"
	G10229	2	Lock Washer, 3/8"
A.	GA5552	-	Valve Assembly Complete (Items 1-17)
B.	GA5572	-	Flow Control Portion Only (Items 11-17)

*Not used on sizes with 3/8" hoses.

FLOW CONTROL VALVE

WB001(MT2)

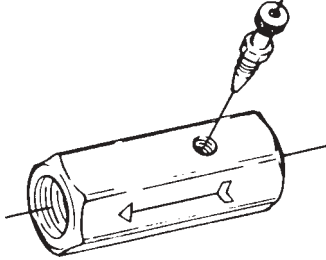

ITEM	PART NO.	QTY.	DESCRIPTION
A.	GA0270	-	Flow Control Valve ("Parker" Stamped On Valve Body)
	GR0767	-	Needle Valve Only

FOLD HYDRAULIC SYSTEM

A7386(HYD1/HYD2/HYD16)

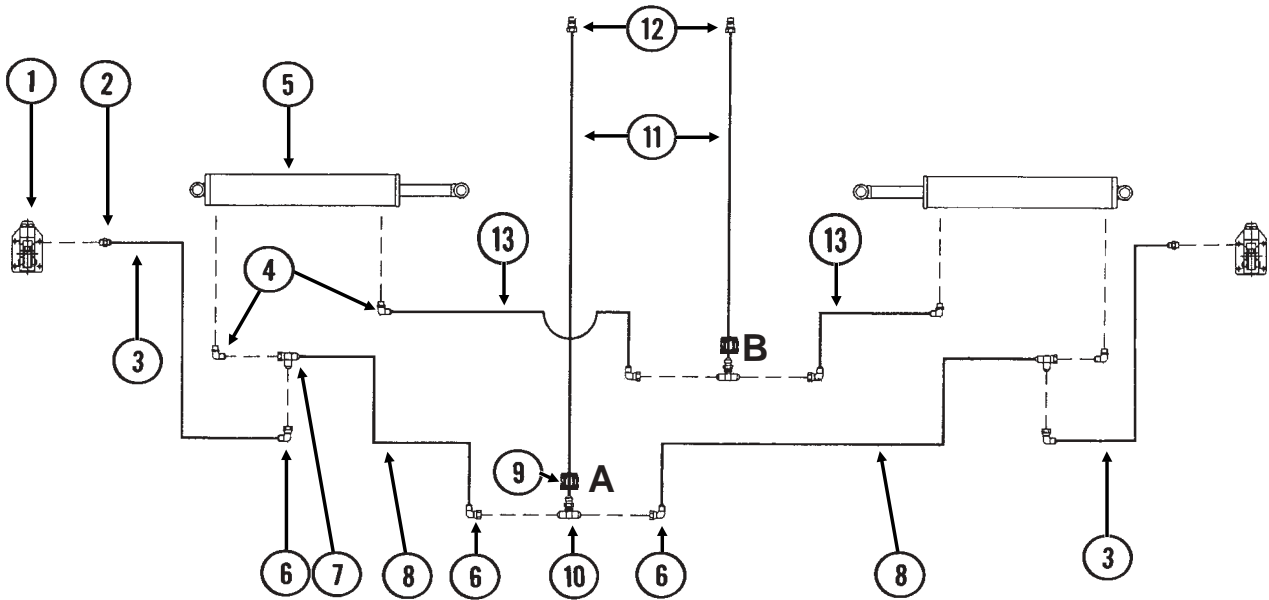
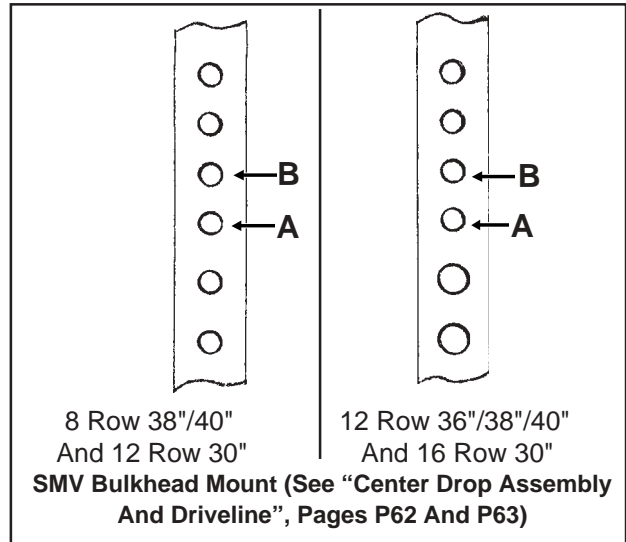

ITEM	PART NO.	QTY.	DESCRIPTION
1.		-	Hydraulic Latch, See "Wing Assembly", Pages P36 And P37 (Item 9)
2.	G6400-06-04	2	Connector W/O-Ring, 9/16"-18 Male JIC To 7/16"-20 O-Ring
	GR1465	-	O-Ring
3.	*A1188	2	Hose Assembly, 1/4" x 66", 8 Row 38"/40" And 12 Row 30"
	*A1103	-	Hose Assembly, 1/4" x 110", 12 Row 36"/38"/40" And 16 Row 30"
4.	G6801-06-08	2-4	Elbow W/O-Ring, 90°, 9/16"-18 Male JIC To 3/4"-16 O-Ring
	GR1037	-	O-Ring
	G6400-06-08	2	Connector W/O-Ring, 9/16"-18 Male JIC To 3/4"-16 O-Ring
	GR1037	-	O-Ring
5.		-	See "Wing Fold Cylinder", Pages P70 And P71
6.	G6500-06	6	Swivel Elbow, 90°, 9/16"-18 Male JIC To Female
7.	G6602-06	2	Swivel Tee, 9/16"-18 JIC
8.	*A1113	4	Hose Assembly, 1/4" x 80", 8 Row 38"/40" And 12 Row 30"
	*A1170	-	Hose Assembly, 1/4" x 90", 12 Row 36"/38"/40" And 16 Row 30"
9.	G306-06	2	Lock Nut, 9/16"-18
10.	G2703-06	2	Bulkhead Tee, 9/16"-18 Male JIC
11.	*A1198	2	Hose Assembly, 1/4" x 60"
12.	GD4086	2	ISO Coupler
13.	*A1113	2	Hose Assembly, 1/4" x 80", 8 Row 38"/40" And 12 Row 30"
	*A1102	-	Hose Assembly, 1/4" x 95", 12 Row 36"/38"/40" And 16 Row 30"

* Hydraulic hose is not stocked by KINZE® Repair Parts, but can be made available on a special order basis. Call for quote.

ROW MARKER HYDRAULIC SYSTEM

(HYD2-17)

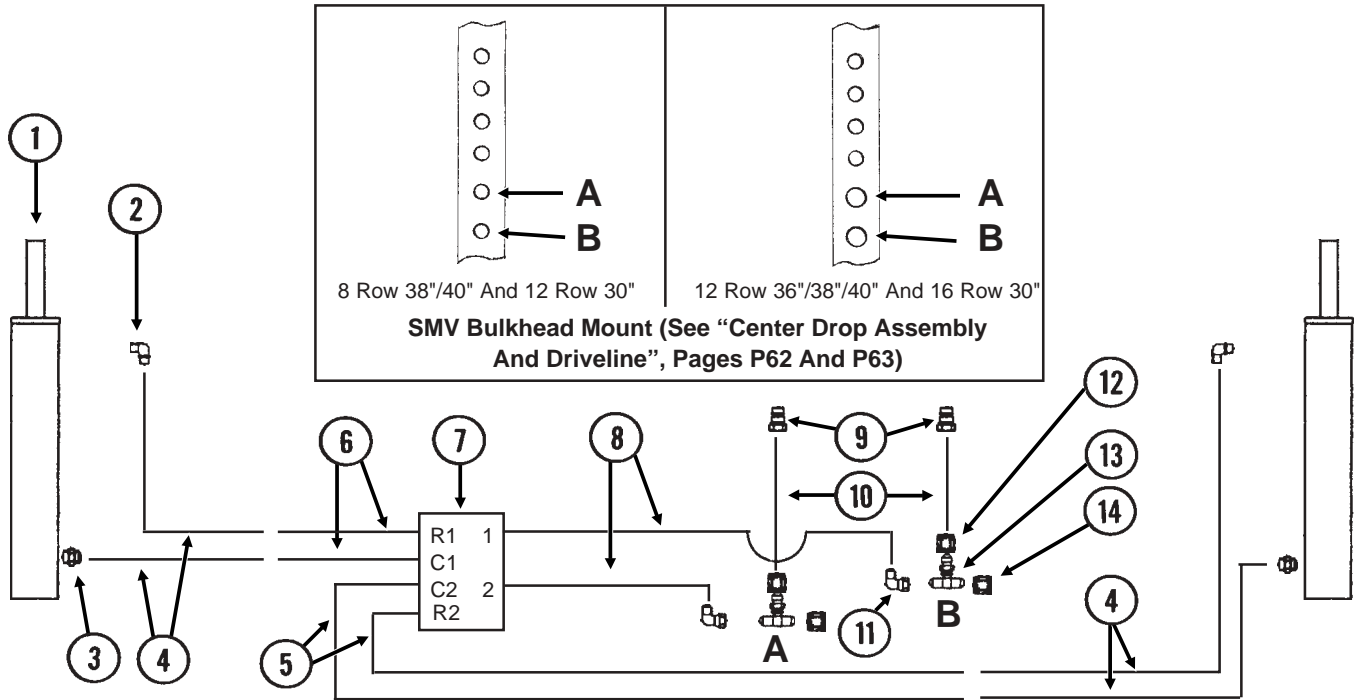

ITEM PART NO. QTY. DESCRIPTION

1.		-	See "Row Marker Cylinder", Page P70
2.	G6801-06-08	2	Elbow W/O-Ring, 90°, 9/16"-18 Male JIC To 3/4"-16 O-Ring, 8 Row 38"/40" And 12 Row 30"
	G6801-08	-	Elbow W/O-Ring, 90°, 3/4"-16 Male JIC To O-Ring, 12 Row 36"/38"/40" And 16 Row 30"
	GR1037	-	O-Ring
3.	G6400-06-04	-	Connector W/O-Ring, 9/16"-18 Male JIC To 7/16"-20 O-Ring, 8 Row 38"/40" And 12 Row 30"
	G6400-08-04	-	Connector W/O-Ring, 3/4"-16 Male JIC To 7/16"-20 O-Ring, 12 Row 36"/38"/40" And 16 Row 30"
	GR1465	-	O-Ring
4.	*A1176	4	Hose Assembly, 1/4" x 48", 8 Row 38"/40" And 12 Row 30"
	*A1072	-	Hose Assembly, 3/8" x 48", 12 Row 36"/38"/40" And 16 Row 30"
5.	*A1118	2	Hose Assembly, 1/4" x 295", 8 Row 38"/40" And 12 Row 30"
	*A3200	-	Hose Assembly, 3/8" x 354", 12 Row 36"/38"
	*A3192	-	Hose Assembly, 3/8" x 370", 12 Row 38"/40" And 16 Row 30"
6.	*A1109	2	Hose Assembly, 1/4" x 145", 8 Row 38"/40" And 12 Row 30"
	*A3201	-	Hose Assembly, 3/8" x 176", 12 Row 36"/38"
	*A3191	-	Hose Assembly, 3/8" x 192", 12 Row 38"/40" And 16 Row 30"
7.		-	See "Row Marker Sequencing/Flow Control Valve And Mount", Page P76
8.	*A1114	2	Hose Assembly, 1/4" x 85", 8 Row 38"/40" And 12 Row 30"
	*A3193	-	Hose Assembly, 3/8" x 100", 12 Row 36"/38"/40" And 16 Row 30"
9.	GD4086	2	ISO Coupler
10.	*A1198	2	Hose Assembly, 1/4" x 60", 8 Row 38"/40" And 12 Row 30"
	*A1047	-	Hose Assembly, 3/8" x 60", 12 Row 36"/38"/40" And 16 Row 30"
11.	G6500-06	2	Swivel Elbow, 90°, 9/16"-18 Male JIC To Female, 8 Row 38"/40" And 12 Row 30"
	G6500-08	-	Swivel Elbow, 90°, 3/4"-16 Male JIC To Female, 12 Row 36"/38"/40" And 16 Row 30"
12.	G306-06	2	Lock Nut, 9/16"-18, 8 Row 38"/40" And 12 Row 30"
	G306-08	-	Lock Nut, 3/4"-16, 12 Row 36"/38"/40" And 16 Row 30"
13.	G2703-06	2	Bulkhead Tee, 9/16"-18 Male JIC, 8 Row 38"/40" And 12 Row 30"
	G2703-08	-	Bulkhead Tee, 3/4"-16 Male JIC, 12 Row 36"/38"/40" And 16 Row 30"
14.	G304-C-06	2	Cap Nut, 9/16"-18, 8 Row 38"/40" And 12 Row 30"
	G304-C-08	-	Cap Nut, 3/4"-16, 12 Row 36"/38"/40" And 16 Row 30"

* Hydraulic hose is not stocked by KINZE® Repair Parts, but can be made available on a special order basis. Call for quote.

DUAL LIFT ASSIST WHEEL PACKAGE HYDRAULIC SYSTEM

(HYD2-17)

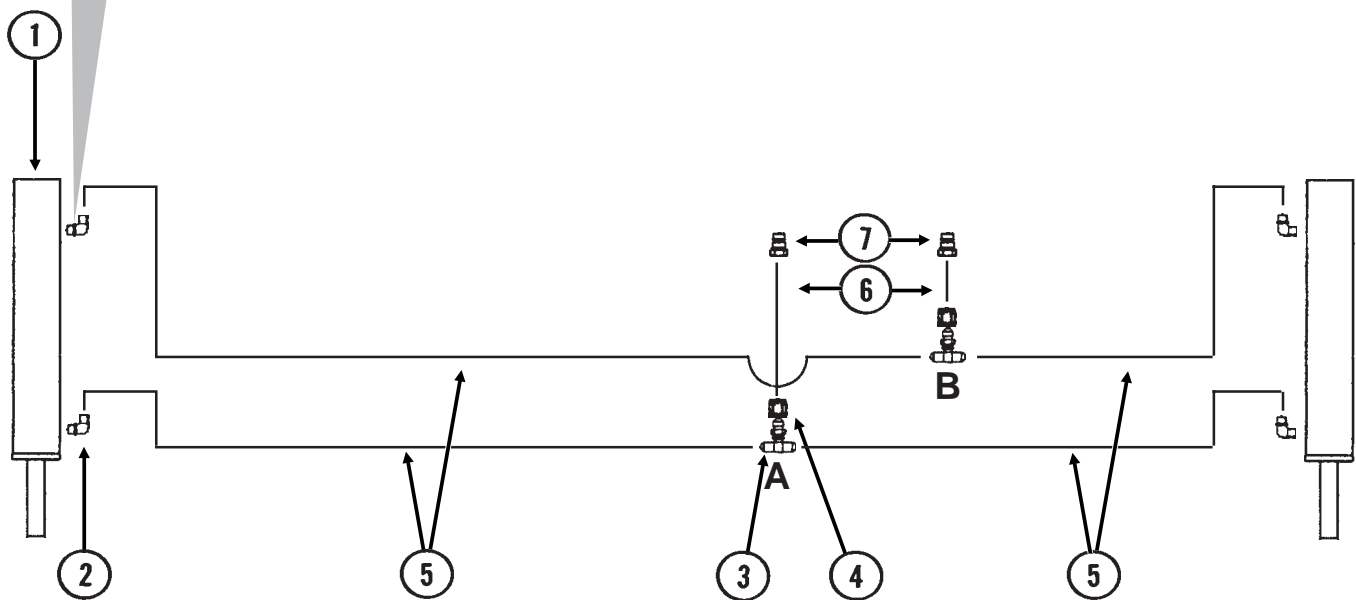
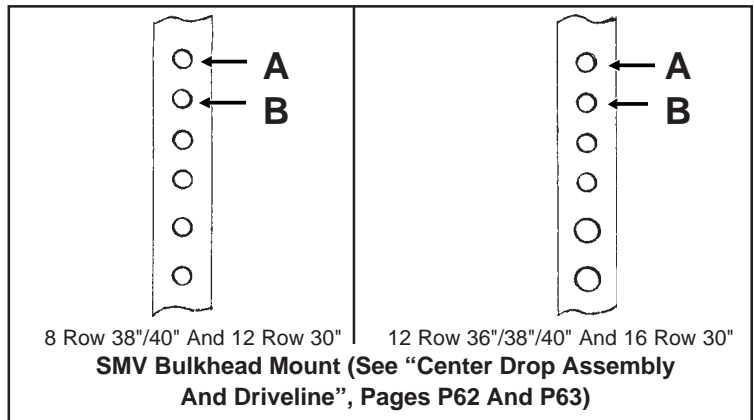
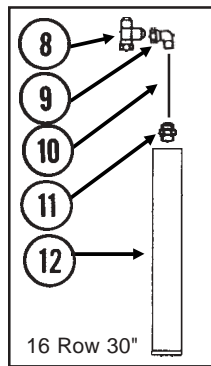

ITEM	PART NO.	QTY.	DESCRIPTION
1.		-	See "Dual Lift Assist Cylinder", Pages P74 And P75
2.	G2501-06-08	4	Elbow, 90°, 9/16"-18 Male JIC To 1/2" NPT
	G6801-06-08	-	Elbow W/O-Ring, 90°, 9/16"-18 Male JIC To 3/4"-16 O-Ring
	GR1037	-	O-Ring
3.	G2703-06	2	Bulkhead Tee, 9/16"-18 Male JIC
4.	G306-06	2	Lock Nut, 9/16"-18
5.	*A1116	4	Hose Assembly, 1/4" x 136"
6.	*A1198	2	Hose Assembly, 1/4" x 60"
7.	GD4086	2	ISO Coupler
8.	G6602-06	1	Swivel Tee, 9/16"-18 JIC
9.	G6500-06	1	Swivel Elbow, 90°, 9/16"-18 Male JIC To Female
10.	*A1140	1	Hose Assembly, 1/4" x 52"
11.	G6400-06-08	1	Connector W/O-Ring, 9/16"-18 Male JIC To 3/4"-16 O-Ring
	GR1037	-	O-Ring
12.		-	Accumulator, See "Dual Lift Assist Wheels", Pages P46 And P47

* Hydraulic hose is not stocked by KINZE® Repair Parts, but can be made available on a special order basis. Call for quote.

DUAL LIFT ASSIST WHEEL PACKAGE HYDRAULIC SYSTEM (Plumbed Into 3 Point Lift Circuit)

(HYD2-17)

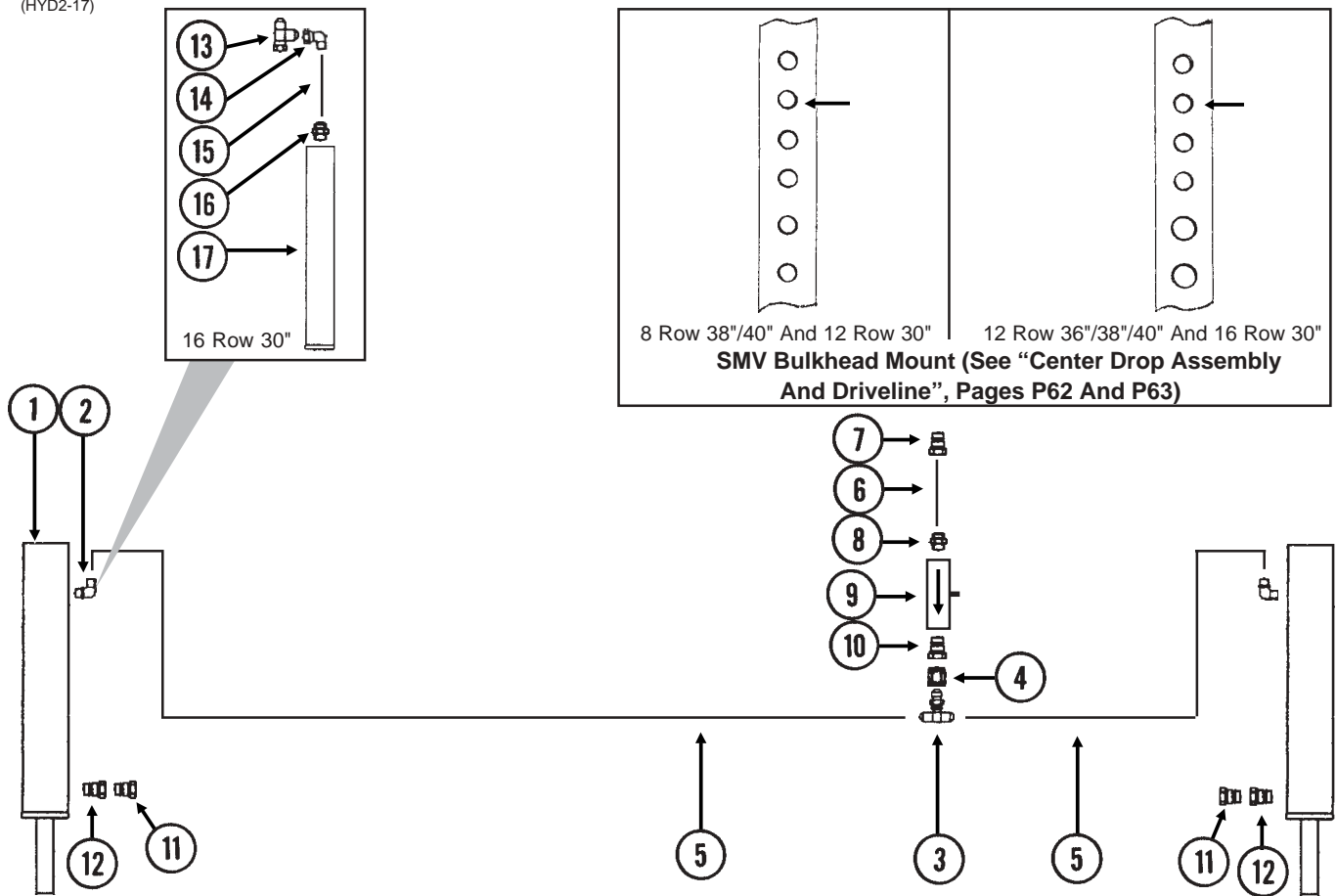

ITEM	PART NO.	QTY.	DESCRIPTION
1.		-	See "Dual Lift Assist Cylinder", Pages P74 And P75
2.	G2501-06-08	2	Elbow, 90°, 9/16"-18 Male JIC To 1/2" NPT
	G6801-06-08	-	Elbow W/O-Ring, 90°, 9/16"-18 Male JIC To 3/4"-16 O-Ring
	GR1037	-	O-Ring
3.	G2703-06	1	Bulkhead Tee, 9/16"-18 Male JIC
4.	G306-06	1	Lock Nut, 9/16"-18
5.	*A1116	2	Hose Assembly, 1/4" x 136"
6.	*A1198	1	Hose Assembly, 1/4" x 60"
7.	GD4086	1	ISO Coupler
8.	G2404-06-06	1	Adapter, 9/16"-18 Male JIC To 3/8" NPT
9.		-	See "Flow Control Valve", Page P77
10.	G6505-06-06	1	Connector, 9/16"-18 Female JIC To 3/8" Male NPT
11.	GA7861	2	Breather Plug, 1/2" NPT
12.	G6405-08-08	2	Connector W/O-Ring, 1/2" Female NPT To 3/4"-16 Male O-Ring
	GR1037	-	O-Ring
13.	G6602-06	1	Swivel Tee, 9/16"-18 JIC
14.	G6500-06	1	Swivel Elbow, 90°, 9/16"-18 Male JIC To Female
15.	*A1140	1	Hose Assembly, 1/4" x 52"
16.	G6400-06-08	1	Connector W/O-Ring, 9/16"-18 Male JIC To 3/4"-16 O-Ring
	GR1037	-	O-Ring
17.		-	Accumulator, See "Dual Lift Assist Wheels", Pages P46 And P47

* Hydraulic hose is not stocked by KINZE® Repair Parts, but can be made available on a special order basis. Call for quote.

WING DOWN FLEX CYLINDER PACKAGE HYDRAULIC SYSTEM

(HYD2-17)

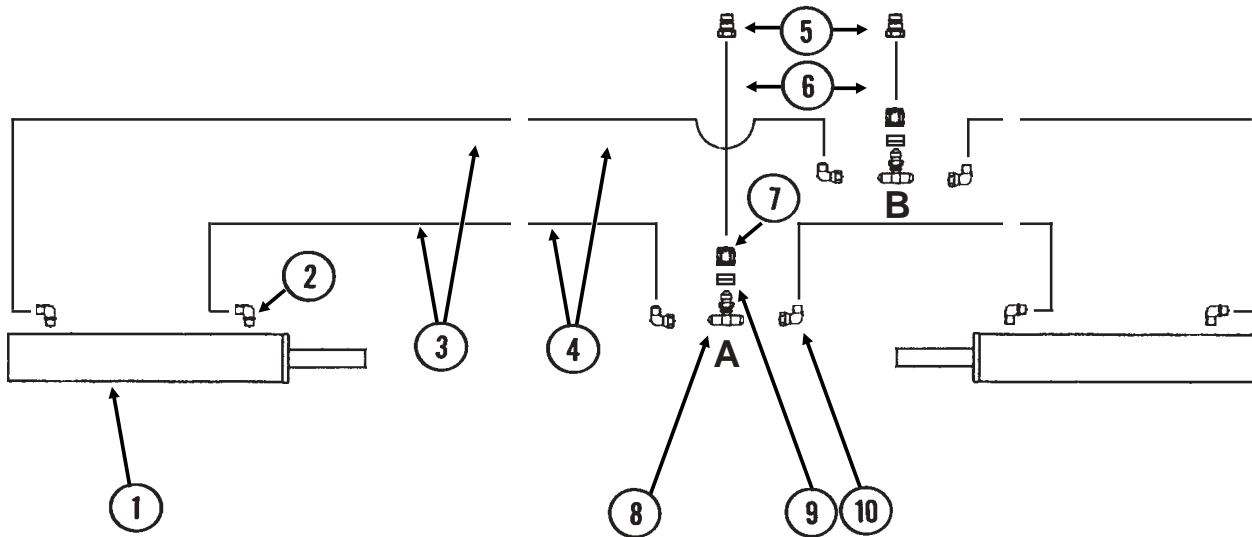
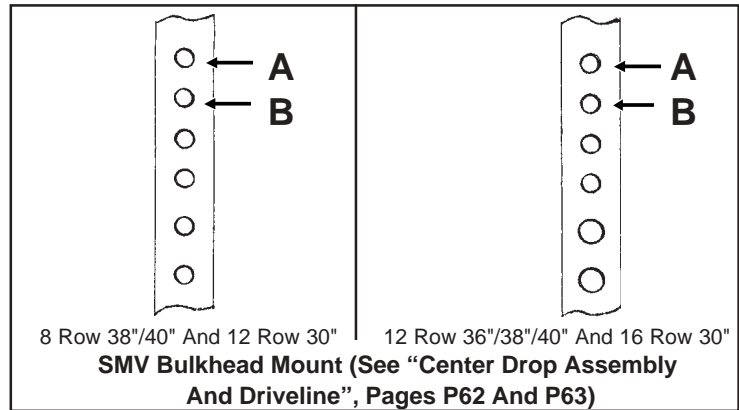

ITEM	PART NO.	QTY.	DESCRIPTION
1.		-	See "Wing Down Flex Cylinder", Page P73
2.	G6801-06-08	4	Elbow W/O-Ring, 90°, 9/16"-18 Male JIC To 3/4"-16 O-Ring
	GR1037	-	O-Ring
3.	*A7600	4	Hose Assembly, 1/4" x 260"
4.	*A7601	4	Hose Assembly, 1/4" x 80", 12 Row 36"/38"/40" And 16 Row 30" Only
5.	GD4086	2	ISO Coupler
6.	*A1198	2	Hose Assembly, 1/4" x 60"
7.	G306-06	2	Lock Nut, 9/16"-18
8.	G2703-06	2	Bulkhead Tee, 9/16"-18 Male JIC
9.	G10159	4	Machine Bushing, 1 1/4", 10 Gauge
10.	G6500-06	4	Swivel Elbow, 90°, 9/16"-18 Male JIC To Female

* Hydraulic hose is not stocked by KINZE® Repair Parts, but can be made available on a special order basis. Call for quote.

DUAL LIFT ASSIST WHEEL PACKAGE AND WING DOWN FLEX CYLINDER PACKAGE HYDRAULIC SYSTEM

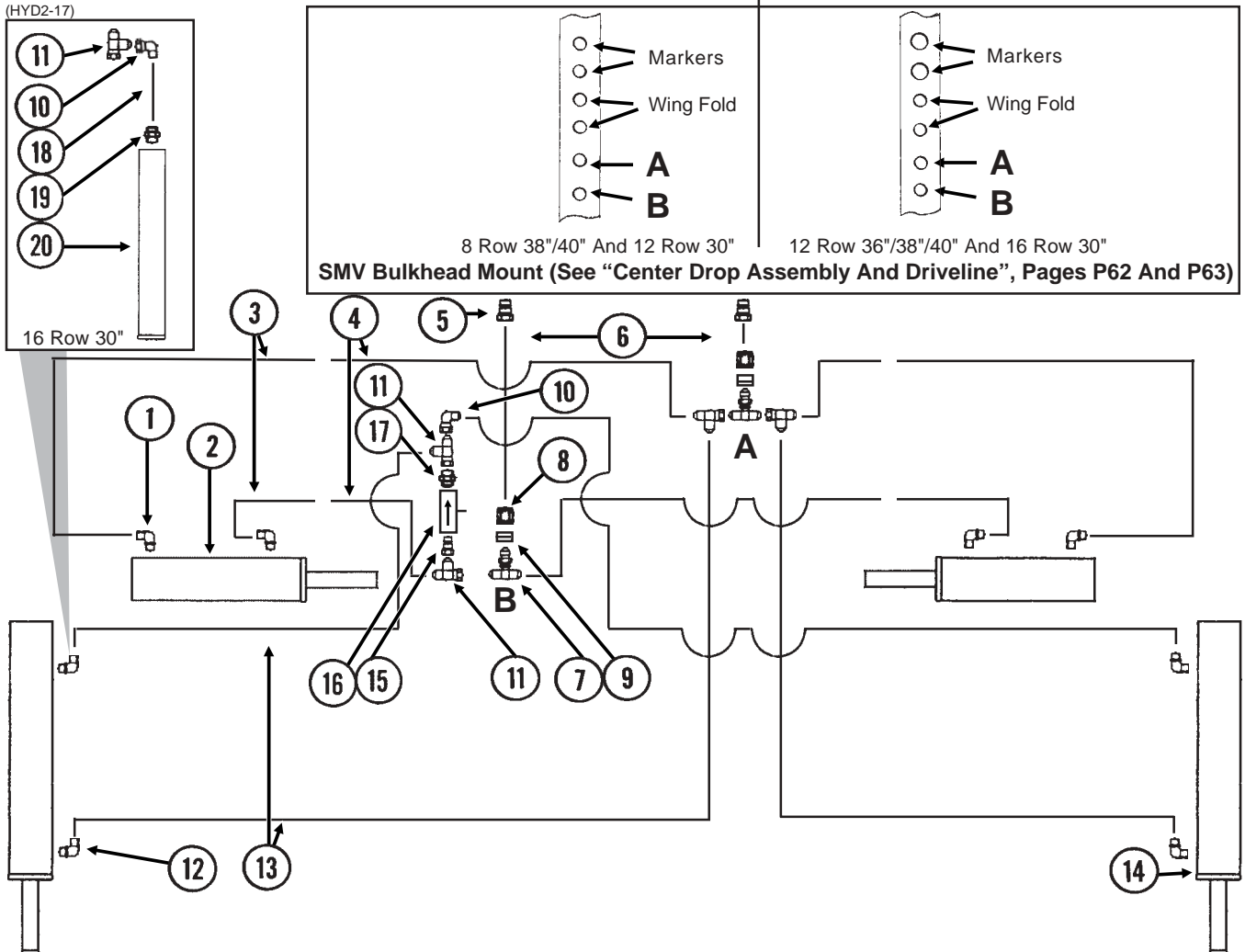

ITEM	PART NO.	QTY.	DESCRIPTION
1.	G6801-06-08 GR1037	4 -	Elbow W/O-Ring, 90°, 9/16"-18 Male JIC To 3/4"-16 O-Ring O-Ring
2.		-	See "Wing Down Flex Cylinder", Page P73
3.	*A7600	4	Hose Assembly, 1/4" x 260"
4.	*A7601	4	Hose Assembly, 1/4" x 80", 12 Row 36"/38"/40" And 16 Row 30" Only
5.	GD4086	2	ISO Coupler
6.	*A1198	2	Hose Assembly, 1/4" x 60"
7.	G2703-06	2	Bulkhead Tee, 9/16"-18 Male JIC
8.	G306-06	2	Lock Nut, 9/16"-18
9.	G10159	4	Machine Bushing, 1 1/4", 10 Gauge
10.	G6500-06	1-2	Swivel Elbow, 90°, 9/16"-18 Male JIC To Female
11.	G6602-06	4-5	Swivel Tee, 9/16"-18 JIC
12.	G2501-06-08 G6801-06-08 GR1037	4 - -	Elbow, 90°, 9/16"-18 Male JIC To 1/2" NPT Elbow W/O-Ring, 90°, 9/16"-18 Male JIC To 3/4"-16 O-Ring O-Ring
13.	*A1116	4	Hose Assembly, 1/4" x 136"
14.		-	See "Dual Lift Assist Cylinder", Pages P74 And P75
15.	G6505-06-06	1	Connector, 9/16"-18 Female JIC To 3/8" Male NPT
16.		-	See "Flow Control Valve", Page P77
17.	G2404-06-06	1	Adapter, 9/16"-18 Male JIC To 3/8" NPT
18.	*A1140	1	Hose Assembly, 1/4" x 52"
19.	G6400-06-08 GR1037	1 -	Connector W/O-Ring, 9/16"-18 Male JIC To 3/4"-16 O-Ring O-Ring
20.		-	Accumulator, See "Dual Lift Assist Wheels", Pages P46 And P47

* Hydraulic hose is not stocked by KINZE® Repair Parts, but can be made available on a special order basis. Call for quote.

ELECTRICAL COMPONENTS AND LIGHT BRACKETS

(ELC9/A9507/MTR27a/ELC8/SFP18b/SFP18a/SFP10b/D13659)

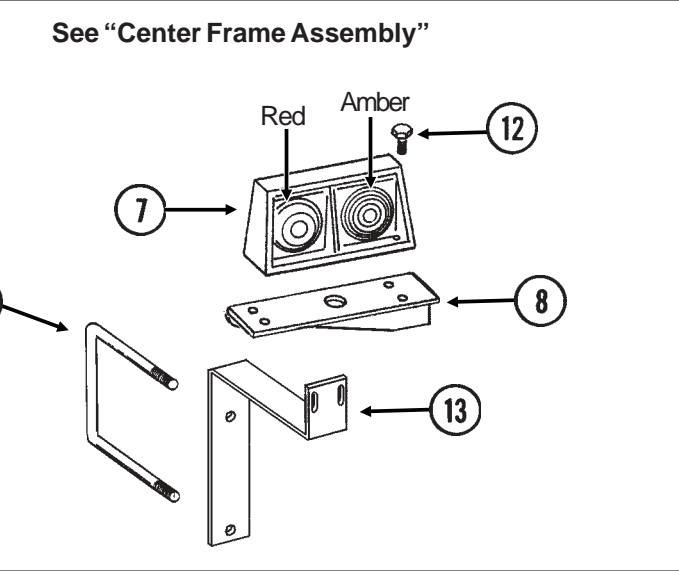
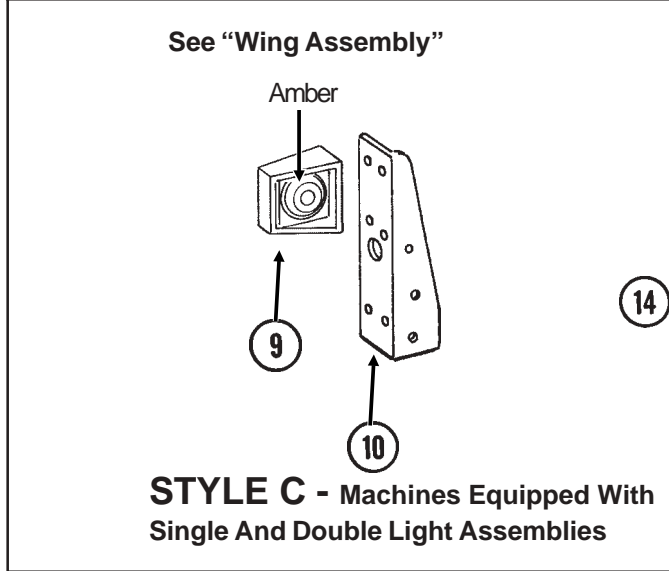
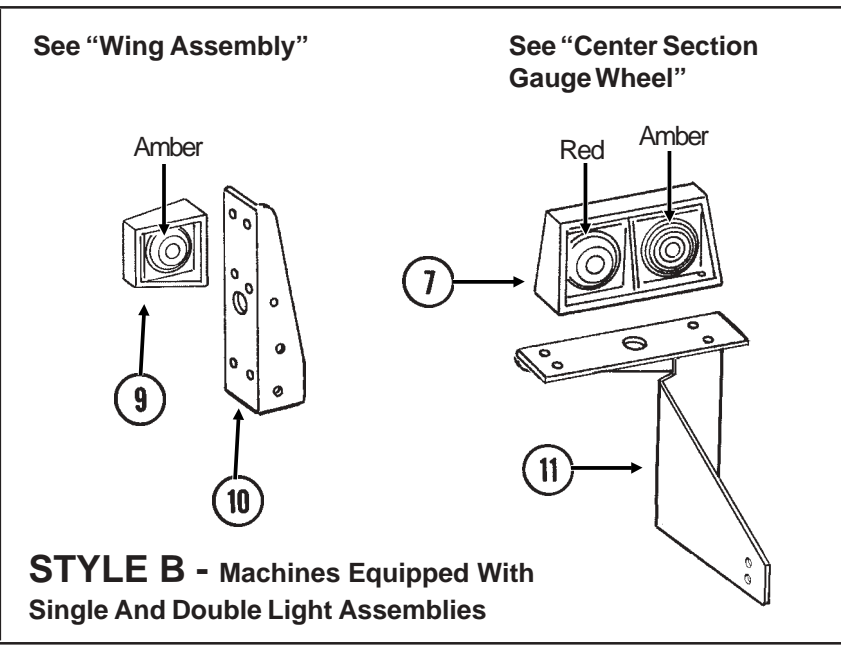
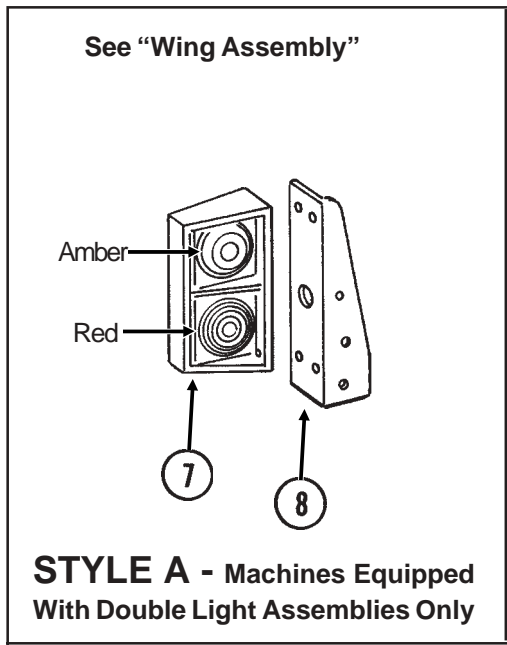
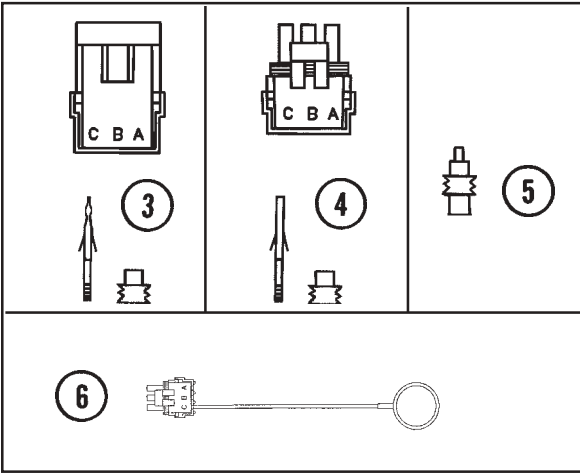
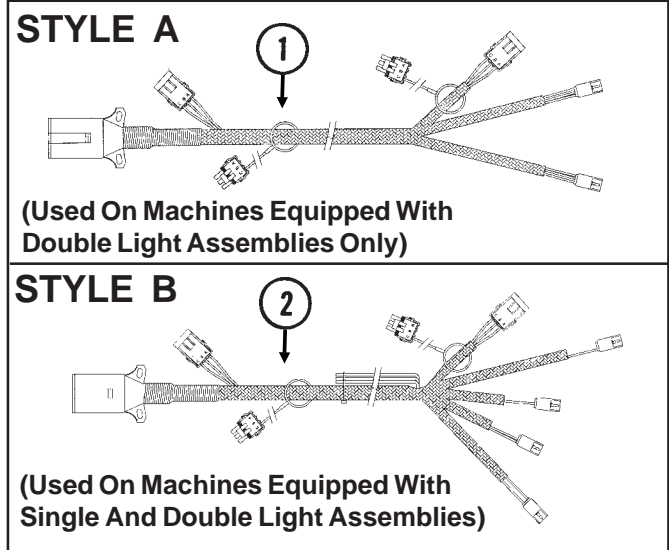

ELECTRICAL COMPONENTS AND LIGHT BRACKETS

ITEM	PART NO.	QTY.	DESCRIPTION	
1.	GA6816	-	Wiring Harness W/7 Terminal Female Connector, 185", 8 Row 38"/40" And 12 Row 30" (2 Light Connections)	
	GA7387	-	Wiring Harness W/7 Terminal Female Connector, 209", 12 Row 36"/38"/40" And 16 Row 30" (2 Light Connections)	
	GA5385	-	7 Terminal Female Connector	
2.	GA9507	-	Wiring Harness W/7 Terminal Female Connector, 186", 8 Row 38"/40" And 12 Row 30" (4 Light Connections)	
	GA9508	-	Wiring Harness W/7 Terminal Female Connector, 210", 12 Row 36"/38"/40" And 16 Row 30" (4 Light Connections)	
	GA5385	-	7 Terminal Female Connector	
3.	G1K248	-	3-Pin Female Connector Kit (Black), Includes: (3) 3-Pin Female Housings, (9) Pin Contacts, (9) Seals	
4.	G1K252	-	3-Pin Male Connector Kit (Black), Includes: (3) 3-Pin Male Housings, (9) Socket Contacts, (9) Seals	
5.	GD11089	-	Sealing Plug	
6.	GA8047	-	Dust Plug (Black)	
7.	GA6699	1	Double Light Assembly (Shown)	
	GA6700	1	Double Light Assembly	
	GR1203	-	Red Lens	
	GR1204	-	Amber Lens	
	GR1205	-	Cover	
	GR1206	-	Rubber Grommet (4)	
	GR1207	-	Lamp Unit	
	GR1208	-	Bulb	
	8.	GD9707	1	Light Bracket, L.H. (Shown)
		GD9708	-	Light Bracket, R.H.
9.	GA6701	1	Single Amber Light Assembly (Shown)	
	GR1204	-	Amber Lens	
	GR1206	-	Rubber Grommet (4)	
	GR1207	-	Lamp Unit	
	GR1208	-	Bulb	
10.	GD13391	1	Light Bracket, L.H. (Shown)	
	GD13392	-	Light Bracket, R.H.	
11.	GA9506	1	Light Bracket, R.H. (Shown)	
	GA9505	1	Light Bracket, L.H.	
12.	G10064	8	Hex Head Cap Screw, 1/4"-20 x 1"	
	G10209	8	Washer, 1/4" USS	
	G10110	8	Lock Nut, 1/4"-20	
13.	GD13659	2	Light Bracket Mount	
14.	GD7145	2	U-Bolt, 7" x 7" x 1/2"-13	
	G10228	4	Lock Washer, 1/2"	
	G10102	4	Hex Nut, 1/2"-13	

KPM I/KPM II ELECTRONIC SEED MONITOR

(MTR42a/MTR39a)

Shaft Rotation Sensor

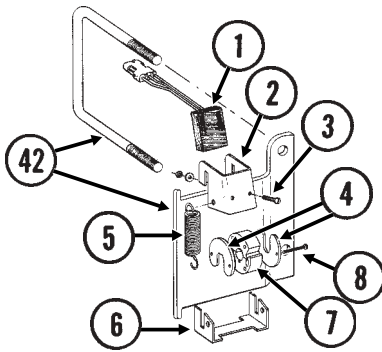

Radar Distance Sensor (KPM II Only)

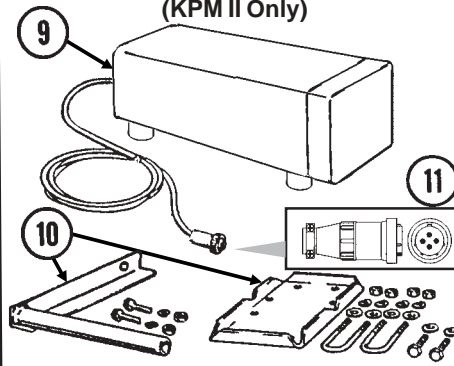

Magnetic Distance Sensor (MDS) (KPM II Only)

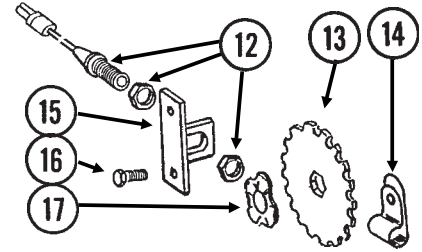

Power Lead Adapter

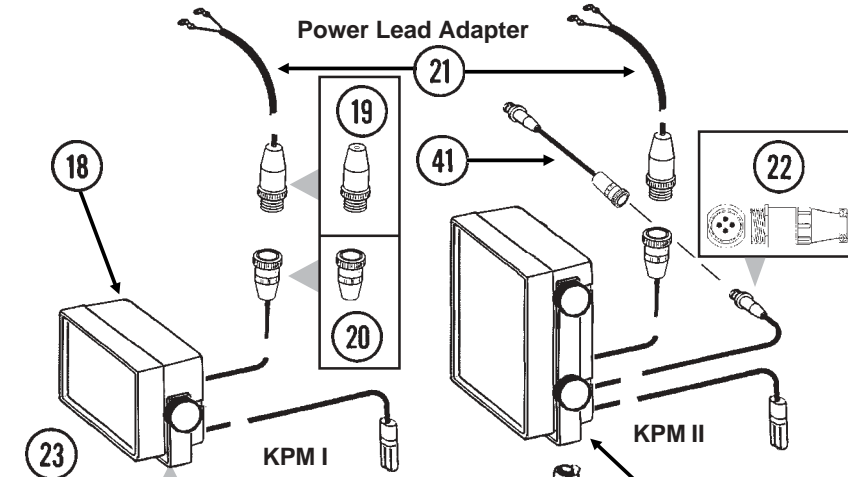

Radar Y-Cable

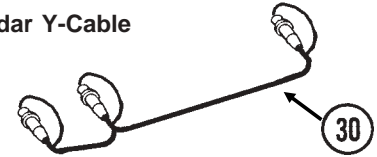

Extension Harness

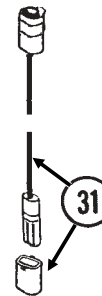

Splice Harness

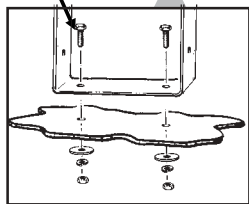
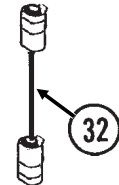

KPM I

KPM II

Planter Harness

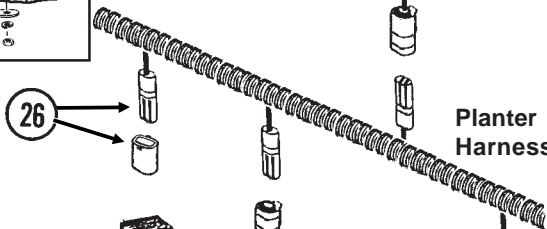

Magnetic Distance Sensor (MDS) Adapter

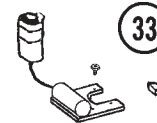
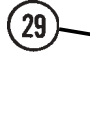

Acre Counter Switch Kit (KPM II Only)

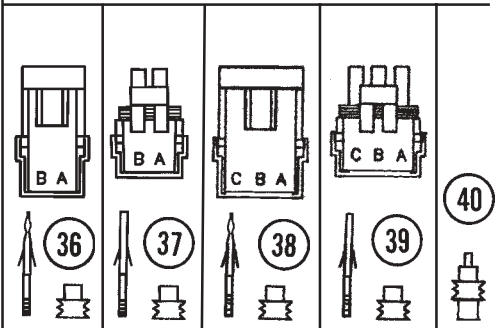
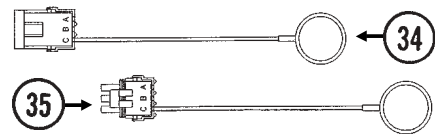

ITEM	PART NO.	QTY.	DESCRIPTION
1.	GR1415	1	Rotation Sensor
2.	GD11169	1	Mount
3.	G10757	2	Pan Head Screw, No. 10-32 x 1 1/4"
	G10243	2	Washer, No. 10 SAE
	G10758	2	Hex Nut, No. 10-32
4.	GD11474	2	Cover
5.	GD5857	2	Spring
6.	GD11170	1	Spring Mount
7.	GR1414	1	Actuator

P86

Rev. 10/04

KPM I/KPM II ELECTRONIC SEED MONITOR

ITEM	PART NO.	QTY.	DESCRIPTION
8.	G10927	2	Pan Head Machine Screw, No. 8-32 x 1 1/4", Stainless Steel
	G10931	2	Lock Washer, No. 8, Internal/External, Stainless Steel
	G10928	2	Hex Nut, No. 8-32, Stainless Steel
9.	GA7858	-	Radar Distance Sensor W/20' Cable
10.	GA8026	-	Radar Sensor Pipe/Mounting Bracket Package
11.	G1K323	-	4-Pin Connector Kit W/Female Housing, 4 Pins And Cable Clamp
12.	GA5600	1	Magnetic Distance Sensor
13.	GD8751	-	Magnetic Distance Sensor Pulse Wheel
14.	GD6291	-	Insulated Clamp, 3/8"
15.	GD8770	1	Bracket
16.	G10004	2	Hex Head Cap Screw, 3/8"-16 x 1 1/4"
	G10229	2	Lock Washer, 3/8"
	G10101	2	Hex Nut, 3/8"-16
17.	GD8771	1	Spring Wave Washer
18.	GA10570	1	KPM I Backlit Console W/Mounting Bracket, Fuse Holder And Fuse, Power Lead Adapter (Item 21), Brush (Item 27) And Dust Plug (Item 34)
	GR1390	-	Mounting Bracket, KPM I
	GR1392	-	Console Mounting Bracket Hardware Package (Includes 2 Knobs And 1/4" Hardware)
	GA10601	-	Fuse Holder
	GD7639	-	Fuse
19.	G1K267	-	Power Lead Adapter Connector Kit, Includes: (1) Cable Clamp, (1) 3-Pin Connector, (3) Male Terminal Pins
20.	G1K268	-	Console Cable Connector Kit, Includes: (1) Cable Clamp, (1) 3-Pin Connector, (1) Lock Ring, (3) Female Terminal Pins
21.	GA7856	1	Power Lead Adapter
22.	G1K322	-	4-Pin Connector Kit W/Male Housing, 4 Female Socket Contacts And Cable Clamp
23.	G10022	2	Hex Head Cap Screw, 1/4"-20 x 1/2"
	G10211	2	Washer, 1/4" SAE
	G10227	2	Lock Washer, 1/4"
	G10103	2	Hex Nut, 1/4"-20
24.	GA10575	-	KPM II Backlit Console W/Mounting Bracket, Fuse Holder And Fuse, Power Lead Adapter (Item 21), Brush (Item 27), Dust Plug (Item 34) And Monitor/Radar Adapter, 10" (Item 41)
	GR1391	-	Mounting Bracket, KPM II
	GR1393	-	Console Mounting Bracket Hardware Package (Includes 4 Knobs And 1/4" Hardware)
	GA10601	-	Fuse Holder
	GD7639	-	Fuse
25.		-	Included In Light Wiring Harness, See Item 1 Or 2, Pages P84 And P85
26.	GA8021	1	Planter Harness W/Dust Caps, 4 Row (7 Connectors)
	GA8022	-	Planter Harness W/Dust Caps, 6 Row (9 Connectors)
	GA7850	-	Planter Harness W/Dust Caps, 8 Row (12 Connectors)
	GA7851	-	Planter Harness W/Dust Caps, 12 Row (16 Connectors)
	GD11993	-	Dust Cap
27.	GR0594	-	Brush
28.	GA8495	-	Seed Tube W/Computerized Sensor
	GR1395	-	Sensor Only
	GR1461	-	Seed Tube (With Holes For Computerized Sensor Installation)
	GD2117	-	Tie Strap, 14 1/2"
29.	GA7859	1	Magnetic Distance Sensor Adapter (Analog To Digital)
30.	GR0586	1	Radar Y-Cable (Used To Connect Radar Distance Sensor For Multiple Functions)
31.	GA7854	-	Extension Harness W/Dust Cap, 15'
	GA7855	-	Extension Harness W/Dust Cap, 30'
	GD11993	-	Dust Cap
32.	GA7857	-	Extension Harness, 1'
33.	G1K249	-	Acre Counter Switch Kit
34.	GA8046	-	Dust Plug (Black)
35.	GA8047	-	Dust Plug (Black)
36.	G1K320	-	2-Pin Male Connector Kit (Black), Includes: (3) 2-Pin Male Housings, (6) Socket Contacts, (6) Seals
37.	G1K321	-	2-Pin Female Connector Kit (Black), Includes: (3) 2-Pin Female Housings, (6) Pin Contacts, (6) Seals
38.	G1K248	-	3-Pin Female Connector Kit (Black), Includes: (3) 3-Pin Female Housings, (9) Pin Contacts, (9) Seals
39.	G1K252	-	3-Pin Male Connector Kit (Black), Includes: (3) 3-Pin Male Housings, (9) Socket Contacts, (9) Seals
40.	GD11089	-	Sealing Plug
41.	GA9144	-	Monitor/Radar Adapter, 10"
42.	G1K364	-	Rotation Sensor Mount Kit, Includes: (2) Mounts, (2) GD1113 5" x 7" U-Bolts, (4) 10230 Lock Washers, (4) G10104 Hex Nuts, (1) Instruction
A.	GA6147	-	Magnetic Distance Sensor And Mounting Package (Items 12-17)

KPM II STACK-MODE ELECTRONIC SEED MONITOR

(MTR43I)

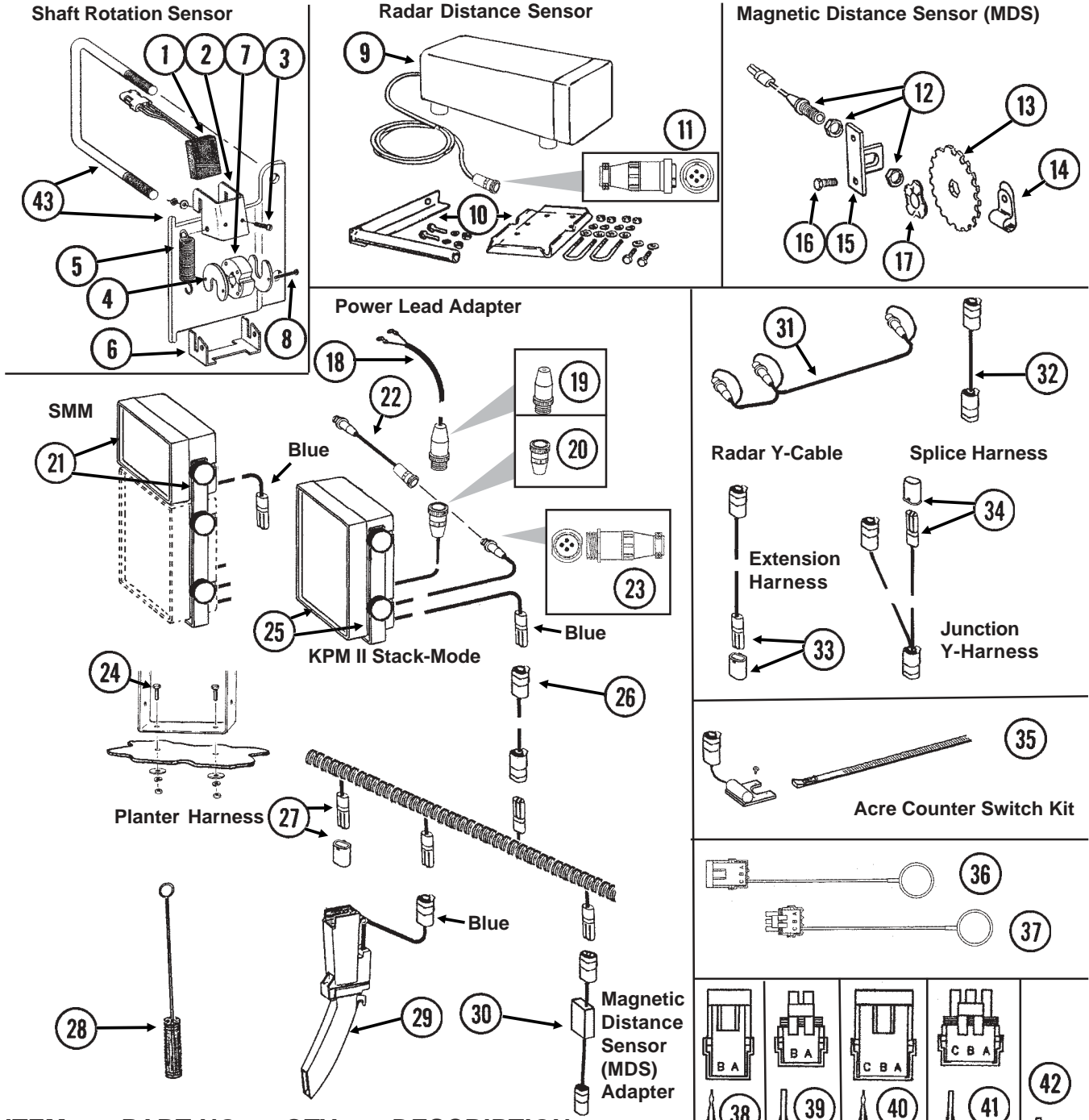

ITEM	PART NO.	QTY.	DESCRIPTION
1.	GR1415	1	Rotation Sensor
2.	GD11169	1	Mount
3.	G10757	2	Pan Head Screw, No. 10-32 x 1 1/4"
	G10243	2	Washer, No. 10 SAE
	G10758	2	Hex Nut, No. 10-32
4.	GD11474	2	Cover
5.	GD5857	2	Spring
6.	GD11170	1	Spring Mount
7.	GR1414	1	Actuator
8.	G10927	2	Pan Head Machine Screw, No. 8-32 x 1 1/4", Stainless Steel
	G10931	2	Lock Washer, No. 8, Internal/External, Stainless Steel
	G10928	2	Hex Nut, No. 8-32, Stainless Steel
9.	GA7858	-	Radar Distance Sensor W/20' Cable
10.	GA8026	-	Radar Sensor Pipe/Mounting Bracket Package
11.	G1K323	-	4-Pin Connector Kit W/Female Housing, 4 Pins And Cable Clamp
12.	GA5600	1	Magnetic Distance Sensor

P88

KPM II STACK-MODE ELECTRONIC SEED MONITOR

ITEM	PART NO.	QTY.	DESCRIPTION
13.	GD8751	-	Magnetic Distance Sensor Pulse Wheel
14.	GD6291	-	Insulated Clamp, 3/8"
15.	GD8770	1	Bracket
16.	G10001	2	Hex Head Cap Screw, 3/8"-16 x 1"
	G10229	2	Lock Washer, 3/8"
	G10101	2	Hex Nut, 3/8"-16
17.	GD8771	1	Spring Wave Washer
18.	GA7856	1	Power Lead Adapter
19.	G1K267	-	Power Lead Adapter Connector Kit, Includes: (1) Cable Clamp, (1) 3-Pin Connector, (3) Male Terminal Pins
20.	G1K268	-	Console Cable Connector Kit, Includes: (1) Cable Clamp, (1) 3-Pin Connector, (1) Lock Ring, (3) Female Terminal Pins
21.	GA9857	1	SMM Backlit Console W/Mounting Bracket And Dust Plug (Item 36)
	GR1631	-	Mounting Bracket, KPM II Stack-Mode And SMM Consoles
	GR1632	-	Console Mounting Bracket Hardware Package (Includes 2 Knobs And 1/4" Hardware)
22.	GA9144	-	Monitor/Radar Adapter, 10"
23.	G1K322	-	4-Pin Connector Kit W/Male Housing, 4 Female Socket Contacts And Cable Clamp
24.	G10022	2	Hex Head Cap Screw, 1/4"-20 x 1/2"
	G10211	2	Washer, 1/4" SAE
	G10227	2	Lock Washer, 1/4"
	G10103	2	Hex Nut, 1/4"-20
25.	GA10575	-	KPM II Backlit Console W/Mounting Bracket, Fuse Holder And Fuse, Power Lead Adapter (Item 18), Brush (Item 28), Dust Plug (Item 36) And Monitor/Radar Adapter, 10" (Item 22)
	GR1391	-	Mounting Bracket, KPM II
	GR1393	-	Console Mounting Bracket Hardware Package (Includes 4 Knobs And 1/4" Hardware)
	GA10601	-	Fuse Holder
	GD7639	-	Fuse
26.		-	Included In Light Wiring Harness, See Item 1 Or 2, Pages P84 And P85
27.	GA8021	1	Planter Harness W/Dust Caps, 4 Row (7 Connectors)
	GA8022	-	Planter Harness W/Dust Caps, 6 Row (9 Connectors)
	GA7850	-	Planter Harness W/Dust Caps, 8 Row (12 Connectors)
	GA7851	-	Planter Harness W/Dust Caps, 12 Row (16 Connectors)
	GD11993	-	Dust Cap
28.	GR0594	-	Brush
29.	GA9847	-	Seed Tube W/Computerized Sensor (KPM II Stack-Mode)
	GR1629	-	Sensor Only (KPM II Stack-Mode)
	GR1461	-	Seed Tube (With Holes For Computerized Sensor Installation)
	GD2117	-	Tie Strap, 14 1/2"
30.	GA7859	1	Magnetic Distance Sensor Adapter (Analog To Digital)
31.	GR0586	1	Radar Y-Cable (Used To Connect Radar Distance Sensor For Multiple Functions)
32.	GA7857	-	Extension Harness, 1'
33.	GA7854	-	Extension Harness W/Dust Cap, 15'
	GA7855	-	Extension Harness W/Dust Cap, 30'
	GD11993	-	Dust Cap
34.	GA7853	-	Junction Y-Harness W/Dust Cap
	GD11993	-	Dust Cap
35.	G1K249	-	Acre Counter Switch Kit
36.	GA8046	-	Dust Plug (Black)
	GA9978	-	Dust Plug (Blue)
37.	GA8047	-	Dust Plug (Black)
	GA9979	-	Dust Plug (Blue)
38.	G1K321	-	2-Pin Female Connector Kit (Black), Includes: (3) 2-Pin Female Housings, (6) Pin Contacts, (6) Seals
39.	G1K320	-	2-Pin Male Connector Kit (Black), Includes: (3) 2-Pin Male Housings, (6) Socket Contacts, (6) Seals
40.	G1K248	-	3-Pin Female Connector Kit (Black), Includes: (3) 3-Pin Female Housings, (9) Pin Contacts, (9) Seals
	G1K362	-	3-Pin Female Connector Kit (Blue), Includes: (3) 3-Pin Female Housings, (9) Pin Contacts, (9) Seals
41.	G1K252	-	3-Pin Male Connector Kit (Black), Includes: (3) 3-Pin Male Housings, (9) Socket Contacts, (9) Seals
	G1K363	-	3-Pin Male Connector Kit (Blue), Includes: (3) 3-Pin Male Housings, (9) Socket Contacts, (9) Seals
42.	GD11089	-	Sealing Plug
43.	G1K364	-	Rotation Sensor Mount Kit, Includes: (2) Mounts, (2) GD1113
A.	GA6147	-	5" x 7" U-Bolts, (4) G10230 Lock Washers, (4) G10104 Hex Nuts, (1) Instruction Magnetic Distance Sensor And Mounting Package (Items 12-17)

LIQUID FERTILIZER PISTON PUMP MOUNT/DRIVE

(SFP65/SFP23g)

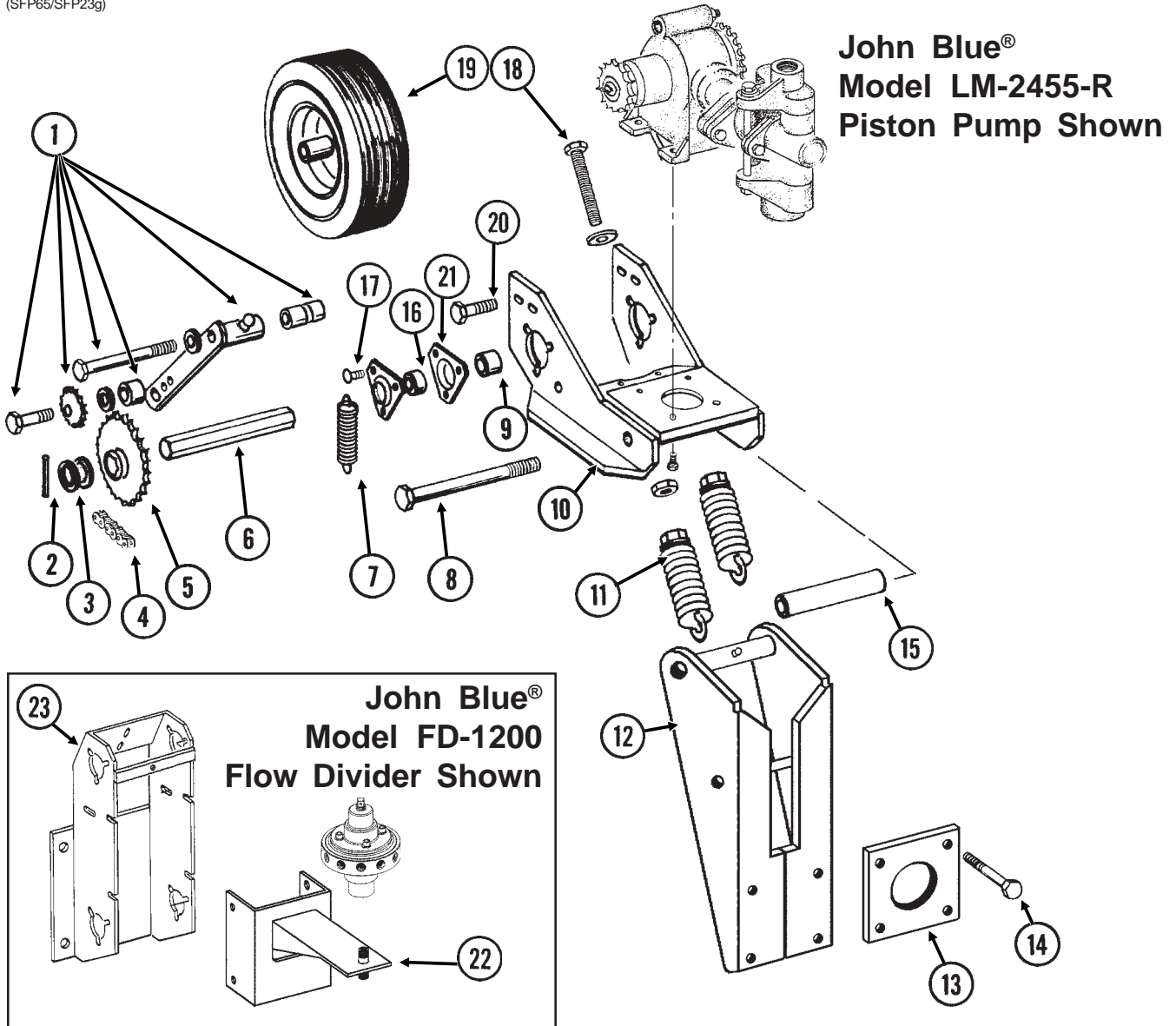

**John Blue®
Model LM-2455-R
Piston Pump Shown**

**John Blue®
Model FD-1200
Flow Divider Shown**

ITEM	PART NO.	QTY.	DESCRIPTION
------	----------	------	-------------

(Per Assy.)

1.	GA7244	1	Idler W/Sprocket, Bushing, Spacer And Hardware
	GA7154	-	Sprocket W/Bearing, 18 Tooth
	GD7889	-	Bushing, 1" O.D. x 9/16" I.D. x 7/16" Long
	G10581	-	Hex Head Cap Screw, 1/2"-13 x 2 1/4"
	G10216	-	Washer, 1/2" USS
	G10228	-	Lock Washer, 1/2"
	G10102	-	Hex Nut, 1/2"-13
	G10830	-	Hex Head Cap Screw, 5/8"-11 x 7 1/2"
	G10205	-	Washer, 5/8" SAE
	G10230	-	Lock Washer, 5/8"
	G10104	-	Hex Nut, 5/8"-11
	GD10254	-	Spacer, 2 3/4"
	G10640	-	Grease Fitting, 1/4"-28
2.	G10602	2	Spring Pin, 1/4" x 1 1/2"
3.	G10233	5	Machine Bushing, 1", 10 Gauge

P90

Rev. 10/04

LIQUID FERTILIZER PISTON PUMP MOUNT/DRIVE

ITEM	PART NO.	QTY.	DESCRIPTION
		(Per Assy.)	
4.	G3310-80	1	Chain, No. 40, 80 Pitch Including Connector Link
	GR0912	-	Connector Link, No. 40
5.	GA7180	1	Sprocket, 40 Tooth
6.	GD6825-11.25	1	Hex Shaft, 7/8" x 11 1/4" (2 Holes)
7.	GD5857	1	Spring
8.	G10093	1	Hex Head Cap Screw, 5/8"-11 x 8 1/2"
	G10230	1	Lock Washer, 5/8"
	G10104	1	Hex Nut, 5/8"-11
9.	GD10200	2	Sleeve, 3/4" Long
10.	GA7246	1	Base Mount
11.	GA2068	2	Spring W/Plug
12.	GA9677	1	Pump Mount W/Grease Fitting
	G10640	-	Grease Fitting, 1/4"-28
13.	GD13656	1	Pump Mount Plate
14.	G10871	4	Hex Head Cap Screw, 1/2"-13 x 6"
	G10228	4	Lock Washer, 1/2"
	G10102	4	Hex Nut, 1/2"-13
15.	GD10244-01	1	Sleeve, 7/16"
16.	G2100-03	2	Bearing, 7/8" Hex Bore, Spherical
17.	G10302	6	Carriage Bolt, 5/16"-18 x 7/8"
	G10221	6	Washer, 5/16" SAE
	G10232	6	Lock Washer, 5/16"
	G10106	6	Hex Nut, 5/16"-18
18.	G10861	2	Hex Head Cap Screw, 1/2"-13 x 5", Full Thread
	G10216	2	Washer, 1/2" USS
	G10102	2	Hex Nut, 1/2"-13
19.	GA5090	-	Tire And Rim Assembly (Specify Brand*)
	GD5753	1	Tire, 4.10" x 6" (Specify Brand*)
	GD5752	1	Tube
20.	G10003	1	Hex Head Cap Screw, 3/8"-16 x 1 1/2"
	G10210	2	Washer, 3/8" USS
	G10101	2	Hex Nut, 3/8"-16
21.	G3400-01	4	Flangette
22.	GA9676	1	Flow Divider Mount
23.		-	See "Center Drop Assembly And Driveline", Pages P62 And P63

* Specific brand requests will be supplied only as available from current KINZE® Repair Parts stock. If a specific brand requested is not in stock, the brand available will be supplied. Different brand tires may have different diameters. Change in tire brand may affect rates. Field checks are recommended after any change in contact tires.

DECALS, PAINT AND MISCELLANEOUS

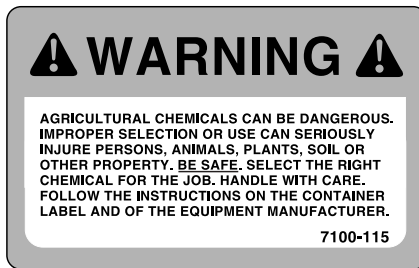
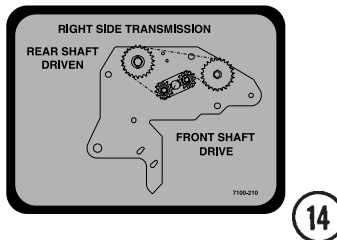
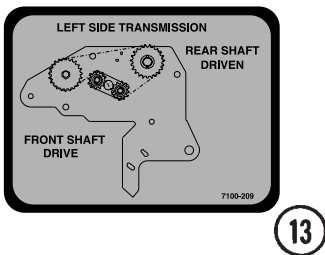
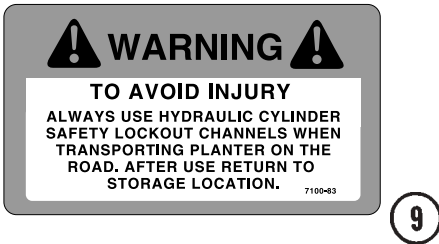
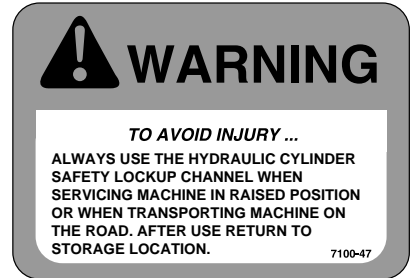
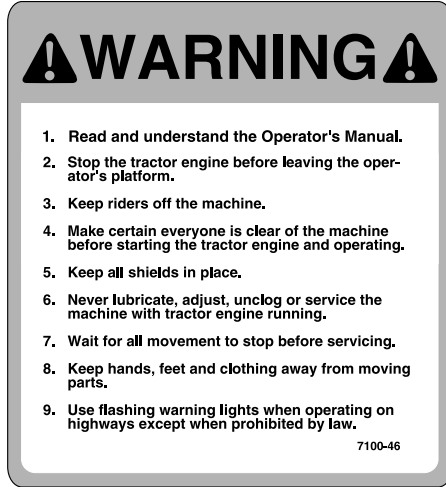
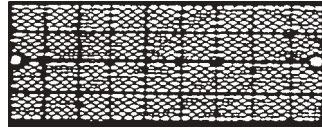
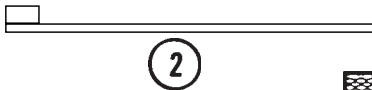
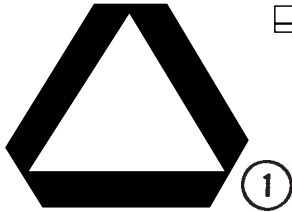

DECALS, PAINT AND MISCELLANEOUS

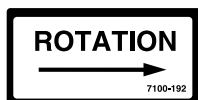
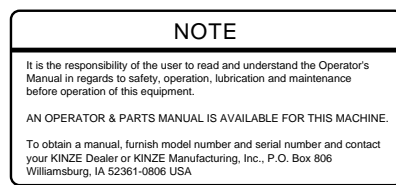
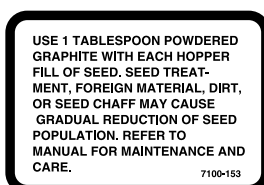

3140

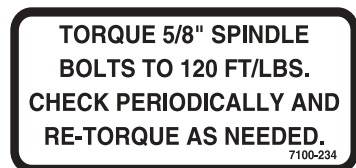

TRANSMISSION RATE REDUCTION		
DRIVE	CHISEL	% REDUCTION
15"	36	50
17"	36	40
23"	36	33
24"	36	30
26"	36	17
28"	36	15
30"	36	10

* Use sprockets off seed drive transmission. 7100-200

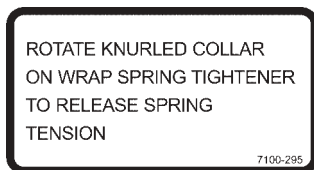
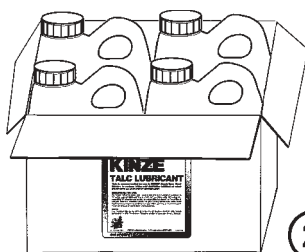

ITEM	PART NO.	QTY.	DESCRIPTION
1.	GD2199	1	SMV Sign
2.	GD1512	-	Tie Strap, 7 1/2"
	GD2117	-	Tie Strap, 14 1/2"
3.	G7200-03	2	Reflector, Red
	G7200-04	2	Reflector, Amber
4.	G7100-25	2	Decal, Warning
5.	G7100-42	4	Decal, Warning
6.	G7100-46	1	Decal, Warning
7.	G7100-47	2	Decal, Warning (Dual Lift Assist Wheel Package Option)
8.	G7100-104	1	Decal, KINZE®, 3" x 12"
9.	G7100-83	2	Decal, Warning
10.	G7100-89	2	Decal, Danger
11.	G7100-90	1	Decal, Warning
12.	G7100-247	-	Decal, Logo, 4 3/8" x 4 1/2" (Row Unit)
	G7100-252	-	Decal, Logo, 3 1/2" x 3 5/8" (Hopper Panel Extension)
13.	G7100-209	1	Decal, Transmission, L.H.
14.	G7100-210	1	Decal, Transmission, R.H.
15.	G7100-248	-	Decal, Meter Alignment (1 Per Row Unit)

(Continued On Following Page)

DECALS, PAINT AND MISCELLANEOUS

ITEM	PART NO.	QTY.	DESCRIPTION
16.	G7100-204	2	Decal, Warning
17.	G7100-115	-	Decal, Warning (1 Per Granular Chemical Hopper)
18.	G7100-211	2	Decal, Warning
19.	G7100-140	1	Decal, Warning
20.	G7100-117	1	Decal, Danger
21.	G7100-153	-	Decal, Information (1 Per Brush-Type Seed Meter)
22.	G7100-217	-	Decal, Note
23.	G7100-111	-	Decal, Oil Daily
24.	G7100-116	-	Decal, Grease Daily
25.	G7100-192	-	Decal, Point Row Clutch Rotation
26.	G7100-241	1	Decal, 3140
27.	G7100-234	-	Decal, Bolt Torque
28.	G7100-214	-	Decal, Two-Speed Point Row Clutch Rate Reduction
29.	GR1570MPP	-	Talc Lubricant, Four 8 Pound Containers
30.	GR0155	-	Blue Paint, Aerosol Can
	GR0155MPP	-	Blue Paint, Twelve Aerosol Cans
31.	GR0146	-	Powdered Graphite, 1 Pound Container
	GR0146MPP	-	Powdered Graphite, Twenty-Four 1 Pound Containers
32.	GD10057-01	-	Hose Identification Sleeve, Red AA (Lift Extend)
	GD10057-02	-	Hose Identification Sleeve, Red BB (Lift Retract)
	GD10057-03	-	Hose Identification Sleeve, Blue AA (Marker Extend)
	GD10057-04	-	Hose Identification Sleeve, Blue BB (Marker Retract)
	GD10057-05	-	Hose Identification Sleeve, Black AA (Option Extend)
	GD10057-06	-	Hose Identification Sleeve, Black BB (Option Retract)
33.	G7100-258	-	Reflective Decal, Red, 1 1/2" x 9", Rectangular (If Applicable)
	G7100-259	-	Reflective Decal, Amber, 1 1/2" x 9", Rectangular (If Applicable)
	G7100-260	-	Reflective Decal, Orange, 1 1/2" x 9", Rectangular (If Applicable)
34.	G7100-261	-	Reflective Decal, Red, 1 3/4" x 9", Die-Cut (If Applicable)
	G7100-262	-	Reflective Decal, Amber, 1 3/4" x 9", Die-Cut (If Applicable)
	G7100-263	-	Reflective Decal, Orange, 1 3/4" x 9", Die-Cut (If Applicable)
35.	GM0170	-	Operator & Parts Manual, Model 3140
36.	G7100-295	-	Decal, Spring Tension Release

NUMERICAL INDEX

Part No.	Page	Part No.	Page	Part No.	Page
A1047	P79	G10032	P47	G10159	P35, P65, P67, P82, P83
A1072	P79	G10033	P27, P49, P67	G10168	P69
A1102	P78	G10036	P21, P31, P49	G10171	P9
A1103	P78	G10037	P48	G10194	P41, P45
A1109	P79	G10039	P23, P25, P33, P37, P67	G10201	P3, P13, P17
A1113	P78	G10040	P51	G10203	P53, P61
A1114	P79	G10045	P27	G10204	P5, P7
A1116	P80, P81, P83	G10046	P33	G10205	P33, P51, P61, P65, P90
A1118	P79	G10047	P37, P49, P74	G10206	P29, P31, P43, P49, P63, P67
A1140	P80, P81, P83	G10048	P35	G10207	P3
A1170	P78	G10049	P53, P67	G10209	P18, P19, P37, P49, P85
A1176	P79	G10055	P31	G10210	P3, P9, P10, P11, P12, P13, P17, P49, P51, P91
A1188	P78	G10059	P47	G10211	P12, P87, P89
A1198	P78, P79, P80, P81, P82, P83	G10061	P12	G10213	P5, P29, P31, P33
A3191	P79	G10062	P61	G10216	P7, P23, P25, P37, P48, P49, P62, P90, P91
A3192	P79	G10064	P10, P37, P51, P60, P85	G10217	P31, P35
A3193	P79	G10068	P31	G10218	P37
A3200	P79	G10069	P51	G10219	P9, P23, P43, P51
A3201	P79	G10072	P74, P75	G10221	P91
A7331	P35	G10081	P47	G10226	P65
A7501	P70	G10082	P41, P45	G10227	P19, P49, P51, P53, P57, P60, P87, P89
A7502	P73	G10093	P91	G10228	P7, P27, P31, P37, P47, P48, P49, P51, P60, P61, P62, P63, P65, P67, P69, P76, P85, P90, P91
A7524	P72	G10101	P4, P10, P11, P19, P51, P53, P57, P61, P62, P63, P74, P87, P89, P91	G10229	P4, P10, P11, P17, P19, P37, P49, P51, P53, P57, P62, P63, P76, P87, P89
A7525	P71	G10102	P9, P27, P31, P33, P37, P47, P48, P49, P51, P60, P61, P62, P63, P65, P67, P69, P75, P76, P85, P90, P91	G10230	P4, P7, P10, P11, P35, P41, P45, P47, P61, P62, P65, P67, P90, P91
A7549	P61	G10103	P19, P51, P53, P57, P60, P87, P89	G10231	P41, P45, P47
A7550	P61	G10104	P4, P11, P31, P35, P41, P45, P47, P51, P61, P62, P65, P67, P90, P91	G10232	P9, P43, P45, P48, P49, P62, P65, P67, P91
A7600	P82, P83	G10105	P47	G10233	P43, P49, P51, P53, P60, P63, P90
A7601	P82, P83	G10106	P9, P25, P31, P43, P45, P48, P49, P51, P62, P65, P67, P91	G10234	P47
A7804	P35	G10107	P9, P10, P21, P25, P30, P31, P33, P35, P43, P49, P51	G10243	P86, P88
A8422	P17	G10108	P3, P12, P17, P35, P37, P47, P57, P67	G10252	P12
A9054	P73	G10109	P7, P9, P10, P23, P27, P29, P33, P48, P69	G10253	P53
A9059	P71	G10110	P19, P37, P62, P63, P85	G10257	P18, P53
A9535	P70	G10111	P10, P21, P23, P25, P27, P31, P33, P35, P37, P49, P53	G10302	P91
G10001	P4, P9, P10, P37, P62, P76, P89	G10112	P33, P37	G10303	P9, P23, P43, P49, P62
G10002	P17	G10113	P47	G10304	P3
G10003	P3, P19, P37, P53, P91	G10117	P41, P45	G10305	P20, P63
G10004	P51, P87	G10128	P49, P51, P61	G10306	P19
G10005	P33, P41, P43, P45	G10130	P51, P53, P60	G10308	P10, P20
G10006	P9, P27	G10131	P63	G10309	P12
G10007	P4, P5, P11, P33, P47, P61	G10133	P10, P27, P29, P33, P65, P67	G10310	P19
G10008	P30, P31, P47, P65, P67	G10139	P35	G10312	P3, P17
G10010	P7, P29, P33	G10151	P35	G10315	P9, P10, P19
G10011	P33	G10152	P4, P9	G10318	P25
G10012	P31			G10322	P65, P67
G10013	P10			G10323	P14
G10014	P7, P33			G10325	P5, P17
G10015	P9			G10326	P3
G10017	P23, P25, P60, P62, P67				
G10018	P7, P9				
G10019	P45, P69				
G10020	P14				
G10021	P14				
G10022	P14, P49, P87, P89				
G10023	P17, P37, P53, P53, P57, P63				
G10025	P37				
G10026	P41, P45, P47				
G10027	P37				
G10028	P47				

NUMERICAL INDEX

Part No.	Page	Part No.	Page	Part No.	Page
G10328	P5	G10640	P7, P21, P31, P35,	G11015	P3
G10338	P7, P12, P48		P37, P90, P91	G11028	P51
G10343	P47	G10641	P35, P41, P45, P47,	G11073	P18
G10348	P27		P65, P67	G11075	P48
G10371	P27	G10643	P33	G11078	P48
G10374	P57	G10660	P18	G11081	P41, P45, P47
G10396	P35	G10669	P3	G11098	P29
G10397	P49, P61	G10670	P17	G1K231	P35
G10400	P33	G10673	P19	G1K248	P85, P87, P89
G10401	P14	G10687	P47	G1K249	P87, P89
G10409	P49	G10689	P35	G1K252	P85, P87, P89
G10412	P4, P12	G10690	P14	G1K267	P55, P59, P87, P89
G10427	P5, P9	G10713	P47	G1K268	P55, P59, P87, P89
G10430	P61, P63	G10722	P69	G1K269	P51, P53, P61
G10438	P3	G10724	P69	G1K312	P12
G10445	P49	G10725	P69	G1K313	P13
G10452	P19	G10732	P4	G1K320	P87, P89
G10459	P41, P45	G10747	P31	G1K321	P87, P89
G10460	P35, P39, P47,	G10751	P12	G1K322	P87, P89
	P65, P67	G10752	P12	G1K323	P87, P88
G10462	P48, P61	G10756	P47	G1K330	P21, P31
G10463	P9	G10757	P19, P86, P88	G1K335	P13
G10464	P63	G10758	P19, P86, P88	G1K345	P10
G10470	P14, P61	G10763	P37	G1K362	P89
G10478	P49	G10765	P29, P33, P53, P57	G1K363	P89
G10496	P48, P53, P57	G10801	P9, P10	G1K364	P87, P89
G10497	P53	G10804	P53, P57	G1K380	P49
G10500	P14	G10827	P72	G1K381	P49
G10501	P27, P43	G10830	P90	G1K385	P19
G10503	P23, P25, P29,	G10844	P69	G2100-03	P43, P49, P60, P62, P91
	P49, P61	G10857	P57	G2404-06-06	P81, P83
G10523	P19	G10859	P53, P57	G2501-06-08	P80, P81, P83
G10529	P20	G10861	P43, P91	G2703-06	P78, P79, P80, P81,
G10530	P33	G10863	P49		P82, P83
G10531	P15	G10864	P19	G2703-08	P79
G10536	P23, P25, P63	G10871	P37, P91	G304-C-06	P79
G10544	P69	G10872	P57	G304-C-08	P79
G10545	P4	G10873	P57	G306-06	P78, P79, P80, P81,
G10546	P12, P18, P61	G10876	P57		P82, P83
G10551	P3	G10880	P62	G306-08	P79
G10567	P12, P18	G10900	P53	G3303-114	P18
G10570	P18	G10912	P5	G3303-16	P3
G10572	P25, P31	G10918	P31	G3303-98	P3
G10573	P31	G10921	P18	G3305-01	P20
G10574	P21, P27, P31, P33, P62	G10923	P51, P53, P60	G3310-218	P43
G10581	P31, P49, P51, P61,	G10924	P7	G3310-224	P43, P61
	P63, P90	G10927	P87, P88	G3310-68	P48
G10582	P31, P51, P61	G10928	P87, P88	G3310-74	P63
G10584	P15	G10931	P87, P88	G3310-75	P51
G10585	P23, P25, P35	G10940	P7	G3310-80	P91
G10597	P23, P25	G10944	P7	G3400-01	P43, P48, P60, P62, P91
G10599	P11	G10948	P75	G6326X	P4
G10602	P12, P14, P15, P18,	G10958	P70	G6400-06	P76
	P43, P49, P51, P61,	G10962	P72	G6400-06-04	P78, P79
	P62, P90	G10972	P71, P73	G6400-06-08	P78, P80, P81, P83
G10603	P14, P15	G10974	P29, P33	G6400-08-04	P79
G10604	P14	G10989	P13	G6405-08-08	P81
G10610	P41, P45	G10996	P55, P59	G6500-06	P78, P79, P80, P81,
G10620	P3, P7, P12, P17	G11007	P3		P82, P83
G10621	P12, P14, P17, P20	G11008	P3	G6500-08	P79
G10622	P5, P20	G11009	P14, P15	G6505-06-06	P81, P83
G10634	P15	G11010	P33	G6602-06	P78, P80, P81, P83

NUMERICAL INDEX

Part No.	Page	Part No.	Page	Part No.	Page
G6801-06-08	P78, P79, P80, P81, P82, P83	GA2014	P5, P9, P25, P27, P29, P31, P33	GA5794	P15
G6801-08	P79	GA2018	P14	GA5795	P15
G7100-104	P93	GA2019	P14	GA5796	P15
G7100-111	P94	GA2020	P14	GA5798	P30
G7100-115	P94	GA2054	P9	GA5834	P15
G7100-116	P94	GA2068	P43, P91	GA5853	P69
G7100-117	P94	GA2075	P19	GA5892	P23
G7100-140	P94	GA2094	P20	GA5982	P15
G7100-153	P94	GA2147	P41, P45, P47	GA6027	P15
G7100-192	P94	GA2148	P41, P45, P47	GA6038	P15
G7100-204	P94	GA2180	P51	GA6147	P87, P89
G7100-209	P93	GA2558	P41, P45, P47	GA6168	P15
G7100-210	P93	GA4235	P49	GA6171	P7, P9, P10
G7100-211	P94	GA4312	P70	GA6182	P15
G7100-214	P94	GA4353	P65	GA6184	P15
G7100-217	P94	GA4444	P17	GA6187	P15
G7100-234	P94	GA4630	P48	GA6434	P10
G7100-241	P94	GA4666	P35	GA6443	P47
G7100-247	P93	GA4705	P41, P45	GA6454	P47
G7100-248	P93	GA5090	P43, P91	GA6455	P47
G7100-25	P93	GA5105	P43, P51, P61, P63	GA6478	P15
G7100-252	P93	GA5106	P49, P61	GA6497	P37
G7100-258	P94	GA5107	P49	GA6533	P49, P51, P61
G7100-259	P94	GA5108	P49, P61	GA6597	P10
G7100-260	P94	GA5109	P49, P61	GA6618	P9
G7100-261	P94	GA5110	P49, P61	GA6619	P9
G7100-262	P94	GA5111	P49, P61	GA6620	P9
G7100-263	P94	GA5112	P49, P61	GA6633	P15
G7100-295	P94	GA5113	P49	GA6699	P85
G7100-42	P93	GA5114	P43, P51, P61, P63	GA6700	P85
G7100-46	P93	GA5130	P65	GA6701	P85
G7100-47	P93	GA5164	P63	GA6733	P9
G7100-83	P93	GA5165	P63	GA6741	P19
G7100-89	P93	GA5173	P65	GA6801	P9
G7100-90	P93	GA5192	P65	GA6816	P85
G7200-03	P93	GA5196	P41, P45, P47	GA6832	P27
G7200-04	P93	GA5202	P49	GA6833	P27
G7566X	P11	GA5385	P85	GA6834	P27
GA0151	P67	GA5482A	P74	GA6838	P27
GA0167	P69	GA5482B	P74	GA6907	P19
GA0243	P69	GA5482C	P75	GA7116	P67
GA0245	P69	GA5548	P48, P61	GA7118	P67
GA0257	P69	GA5552	P76	GA7137	P53
GA0270	P77	GA5572	P76	GA7144	P55, P59
GA0378	P63	GA5600	P87, P88	GA7154	P49, P51, P61, P63, P90
GA0895	P41, P45, P47	GA5622	P21, P31	GA7165	P55, P59
GA0899	P69	GA5625	P21	GA7180	P91
GA10054	P53, P57	GA5625	P21	GA7219	P72
GA10063	P49	GA5630	P31	GA7244	P90
GA10570	P87	GA5631	P30	GA7246	P91
GA10575	P87, P89	GA5635	P30	GA7255	P15
GA10601	P87, P89	GA5636	P31	GA7271	P29
GA1676	P69	GA5637	P31	GA7274	P57
GA1677	P69	GA5640	P21, P31	GA7294	P41, P45
GA1678	P69	GA5643	P31	GA7295	P41, P45
GA1679	P69	GA5651	P4	GA7297	P43
GA1720	P4	GA5654	P25, P27, P29, P31, P33	GA7301	P62
GA2007	P12	GA5698	P15	GA7302	P63
GA2012L	P5	GA5699	P15	GA7313	P60
GA2012R	P5	GA5715	P23, P25	GA7317	P61
		GA5718	P25	GA7322	P45
		GA5719	P23, P25	GA7326	P37

NUMERICAL INDEX

Part No.	Page	Part No.	Page	Part No.	Page
GA7328	P37	GA8026	P87, P88	GB0120	P14
GA7329	P37	GA8045	P63	GB0186	P4
GA7334	P35	GA8046	P87, P89	GB0196	P31
GA7336	P49	GA8047	P85, P87, P89	GB0218	P4, P10, P12, P30, P33, P47
GA7338	P70	GA8172	P63	GB0239	P9, P10
GA7341	P76	GA8174	P47	GB0254	P10
GA7345	P47	GA8304	P12	GB0258	P49, P61
GA7346	P37	GA8322	P10	GB0265	P3
GA7347	P65	GA8324	P5	GB0266	P3
GA7348	P73	GA8326	P18	GB0267	P3
GA7349	P35	GA8328	P55, P59	GB0268	P9, P10
GA7353	P67	GA8329	P55, P59	GB0274	P3
GA7354	P67	GA8343	P14	GB0276	P7
GA7357	P37	GA8364	P18	GB0278	P12, P18
GA7359	P35	GA8370	P13	GB0282	P10
GA7360	P37	GA8371	P17	GB0285	P3
GA7361	P37	GA8393	P53, P57	GB0287	P63
GA7383	P37	GA8495	P87	GB0301	P5
GA7384	P37	GA8600	P3	GB0314	P12
GA7387	P85	GA8603	P21, P31, P33	GD0453-03	P67
GA7410	P4	GA8641	P21, P31, P33	GD0453-07	P65
GA7412	P29	GA8760	P29	GD0453-08	P65
GA7415	P67	GA8768	P47	GD0453-09	P67
GA7416	P55	GA8769	P47	GD0453-10	P67
GA7417	P53	GA8871	P72	GD0652	P65, P67
GA7418	P53	GA8895	P72	GD0737	P67
GA7445	P29, P33	GA9033	P70	GD0746	P69
GA7446	P27, P29, P33	GA9036	P70	GD0752-41	P65
GA7447	P45	GA9052	P73	GD0840	P69
GA7463	P57	GA9055	P73	GD0844	P41, P45, P47
GA7466	P35	GA9057	P71	GD0914-111	P63
GA7467	P35	GA9060	P71	GD0914-74	P51
GA7503	P73	GA9088	P67	GD0914-81	P63
GA7521	P71	GA9131	P33	GD0914-98	P51
GA7523	P72	GA9144	P87, P89	GD0914-99	P63
GA7526	P71	GA9505	P85	GD10036	P4
GA7570	P61	GA9506	P85	GD10057-01	P94
GA7571	P61	GA9507	P85	GD10057-02	P94
GA7574	P61	GA9508	P85	GD10057-03	P94
GA7577	P59	GA9538	P12	GD10057-04	P94
GA7806	P37	GA9539	P12	GD10057-05	P94
GA7807	P37	GA9571	P57	GD10057-06	P94
GA7850	P87	GA9572	P57	GD10102	P53
GA7850	P89	GA9676	P91	GD10103	P53, P57
GA7851	P87, P89	GA9677	P91	GD10104	P53
GA7853	P89	GA9714	P13	GD10109	P61
GA7854	P87, P89	GA9843	P63	GD10120	P57
GA7855	P87, P89	GA9844	P33	GD10123	P53, P57
GA7856	P55, P59, P87, P89	GA9845	P33	GD10200	P53, P91
GA7857	P87, P89	GA9846	P43	GD10206	P72
GA7858	P87, P88	GA9847	P89	GD10207	P72
GA7859	P87, P89	GA9857	P89	GD10226	P14
GA7860	P47	GA9861	P33	GD10244-01	P91
GA7861	P81	GA9862	P33	GD10254	P90
GA7867	P47	GA9864	P33	GD1026	P3, P17, P49
GA7949	P7	GA9865	P33	GD10282	P57
GA7975	P7	GA9978	P89	GD10283	P69
GA7976	P7	GA9979	P89	GD10328	P41, P45
GA8001	P63	GB0110	P14	GD10329	P43
GA8002	P63	GB0111	P14	GD1033	P3
GA8021	P87, P89	GB0115	P18	GD10332	P43
GA8022	P87, P89	GB0116	P18		

NUMERICAL INDEX

Part No.	Page	Part No.	Page	Part No.	Page
GD10336	P48, P61	GD10741	P37	GD11845	P3, P5, P9
GD10337	P48	GD1083	P14	GD11870	P63
GD10343	P63	GD1085	P10	GD11936	P7
GD10348	P63	GD1086	P7	GD11962	P3, P17
GD10349	P63	GD1086	P3	GD11983	P72
GD10366	P61	GD10958	P12	GD11993	P87, P89
GD10378	P37	GD10963	P19	GD12534	P27
GD10379	P37	GD10984	P19	GD12548	P70
GD1039	P14	GD10986	P3	GD1255	P61, P63
GD10403	P41, P45	GD10991	P7	GD1256	P63
GD10407	P49	GD10993	P3	GD12659	P71, P73
GD1041	P14	GD11001	P3	GD12660	P71, P73
GD10412	P63	GD11017	P5	GD12691	P70
GD10418	P35	GD11045	P51, P53, P60	GD12726	P55, P59
GD10419	P35	GD11089	P85, P87, P89	GD12817	P33
GD1042	P14	GD1109	P9, P10, P31	GD12826	P33
GD10432	P37	GD11120	P53, P57	GD12827	P33
GD10433	P37	GD11122	P15	GD12829	P33
GD10449	P37	GD1114	P4, P35, P61, P62, P67	GD13361	P3
GD10450	P35	GD11155	P37	GD13391	P85
GD10454	P63	GD1115L	P19	GD13392	P85
GD10456	P35	GD1115R	P19	GD13394	P49, P51
GD10473	P5, P9	GD1116	P19	GD13422	P49, P51
GD10478	P37	GD11169	P86, P88	GD13656	P91
GD10486	P35, P39	GD11170	P86, P88	GD13659	P85
GD10507	P63	GD1118	P19	GD14170	P33
GD10510	P53, P57	GD11219	P17	GD14217	P4
GD10519	P29, P33	GD11239	P12, P18	GD14413	P48
GD10520	P63	GD11240	P18	GD14414	P48
GD10521	P63	GD11259	P3, P5	GD14426	P48
GD10525	P53	GD11279	P13	GD14429	P48
GD10526	P29	GD11286	P14	GD14430	P48
GD10527	P53	GD11297	P18	GD14431	P48
GD10528	P53	GD1130	P3	GD14432	P48
GD10529	P53	GD11305	P12, P17	GD14512	P53
GD10532	P37	GD11306	P5	GD14513	P53, P57
GD10552	P27, P29, P33	GD11311	P14	GD14595	P49
GD10555	P37	GD11313	P11	GD14659	P19
GD10556	P37	GD1132	P25, P27, P29, P31, P33	GD14674	P29
GD10575	P4	GD11373	P14	GD1512	P93
GD10577	P67	GD11374	P15	GD15386	P65
GD10584	P57	GD11413	P12, P18	GD15696	P49
GD10585	P57	GD11422	P4	GD1701	P67
GD10586	P57	GD11423	P7	GD1755	P15
GD10587	P57	GD11424	P17	GD2117	P87, P89, P93
GD1059L	P17	GD1143	P20	GD2161	P65
GD1059R	P17	GD1144	P20	GD2169	P47
GD1060	P17	GD1145	P20	GD2199	P63, P93
GD1061	P18	GD11453	P7	GD2423	P19
GD1063	P18	GD11474	P86, P88	GD2460	P20
GD10635	P57	GD11490	P41, P45, P47	GD2548-111	P63
GD10636	P57	GD11508	P11	GD2548-58	P62
GD10638	P57	GD11509	P11	GD2548-60	P62
GD10639	P71, P73	GD11528	P14	GD2548-70	P62
GD1065	P3	GD11652	P21, P31, P33	GD2548-81	P63
GD10673	P57	GD1166	P41, P45, P47	GD2548-90	P62
GD10693	P57	GD11677	P21	GD2548-99	P63
GD10694	P57	GD11698	P31	GD2557	P35
GD10696	P61	GD11747	P13	GD2558	P35, P37, P43, P48, P60
GD10697	P60	GD11787	P14	GD2597	P69
GD10698	P57, P61	GD11813	P47	GD2721	P65, P67
GD10733	P14	GD11814	P47	GD2947	P19

NUMERICAL INDEX

Part No.	Page	Part No.	Page	Part No.	Page
GD2971-10	P17	GD8770	P87, P89	GR1036	P76
GD3180-05	P49	GD8771	P87, P89	GR1037	P76, P78, P79, P80, P81, P82, P83
GD3180-12	P9	GD8778	P15	GR1038	P76
GD3180-15	P43, P51	GD8811	P7	GR1039	P76
GD3214	P65	GD8843	P21, P31	GR1040	P76
GD3612	P3	GD8844	P21, P31	GR1041	P76
GD4086	P78, P79, P80, P81, P82, P83	GD9052	P37	GR1042	P76
GD4512	P67	GD9120	P10	GR1043	P76
GD5212	P63	GD9170	P47	GR1044	P76
GD5752	P43, P91	GD9179	P47	GR1045	P76
GD5753	P43, P91	GD9208	P47	GR1046	P76
GD5804	P41, P45	GD9254	P21, P31, P33	GR1047	P76
GD5857	P27, P48, P51, P61, P86, P88, P91	GD9290	P9	GR1048	P76
GD5860	P51, P61	GD9305	P9	GR1203	P85
GD5875	P67	GD9333	P35	GR1204	P85
GD5892	P37, P65	GD9378	P63	GR1205	P85
GD6291	P87, P89	GD9529	P55, P59	GR1206	P85
GD6501	P14	GD9530	P55, P59	GR1207	P85
GD6568	P70	GD9562	P9	GR1208	P85
GD6569	P70	GD9667	P53	GR1270	P74
GD6772	P67	GD9671	P53, P57	GR1271	P74
GD6825-11.25	P91	GD9672	P53, P57	GR1272	P74
GD7041	P41, P45	GD9707	P85	GR1273	P74
GD7127	P48, P61	GD9708	P85	GR1276	P74
GD7145	P53, P76, P85	GD9715	P27	GR1278	P74
GD7148	P18	GD9720	P27	GR1279	P74
GD7164	P71, P73	GD9724	P27, P29, P33	GR1294	P63
GD7209	P67	GD9750	P35	GR1295	P63
GD7258	P18	GM0170	P94	GR1300	P63
GD7318	P3	GR0146	P94	GR1301	P63
GD7426	P49	GR0146MPP	P94	GR1303	P53, P57
GD7639	P87, P89	GR0150	P69	GR1304	P53, P57
GD7803	P21, P31, P33	GR0151	P69	GR1305	P53, P57
GD7804	P21, P31, P33	GR0155	P94	GR1306	P53, P57
GD7805	P4, P10, P12, P25, P30, P31, P41, P43, P45, P47, P49, P51, P61	GR0155MPP	P94	GR1309	P72
GD7811	P31	GR0181	P74	GR1327	P14
GD7815	P30	GR0193	P74, P75	GR1352	P63
GD7816	P31	GR0196	P3, P18	GR1357	P71, P73
GD7817-01	P25, P31	GR0270	P41, P45, P47	GR1365	P63
GD7817-04	P25, P31	GR0434	P41, P45, P47	GR1390	P87
GD7817-09	P31	GR0586	P87, P89	GR1391	P87, P89
GD7818	P31	GR0594	P87, P89	GR1392	P87
GD7823	P25, P31	GR0663	P74	GR1393	P87, P89
GD7831	P31	GR0709	P74	GR1395	P87
GD7878	P15	GR0714	P74	GR1414	P86, P88
GD7889	P23, P25, P49, P51, P61, P90	GR0716	P74, P75	GR1415	P86, P88
GD7890	P23	GR0717	P74, P75	GR1447	P55
GD7890	P25	GR0767	P77	GR1448	P59
GD8175	P41, P45, P65	GR0911	P51	GR1449	P59
GD8237	P15	GR0912	P43, P48, P51, P61, P63, P91	GR1450	P55
GD8249	P4	GR0987	P70, P71, P73	GR1461	P87, P89
GD8266	P23	GR0988	P70	GR1465	P78, P79
GD8307	P25	GR1024	P74	GR1487	P14
GD8307	P31	GR1025	P74	GR1504	P75
GD8311	P47	GR1026	P74	GR1505	P75
GD8460	P10	GR1027	P74	GR1506	P75
GD8751	P87, P89	GR1028	P74	GR1507	P75
		GR1032	P76	GR1508	P75
		GR1033	P76	GR1509	P75
		GR1034	P76	GR1511	P75
		GR1035	P76	GR1512	P75

NUMERICAL INDEX

Part No.	Page	Part No.	Page	Part No.	Page
GR1521	P72				
GR1553	P70				
GR1554	P71, P73				
GR1569	P14				
GR1570MPP	P94				
GR1629	P89				
GR1631	P89				
GR1632	P89				
R1023	P74				
R1274	P74				
R1510	P75				

