

MODEL 3500 PIVOT FOLD PLANTER OPERATOR'S MANUAL

M0258-01

Rev. 9/17

This manual applies to: Model: 3500 Pivot Fold Planters (with conventional hoppers)
2015 - 2018 production

Record the model number and serial number of your planter along with date purchased:

Model Number 3500

Serial Number _____

Date Purchased _____

Monitor Serial Number _____
Measured Pulses Per Mile/Km (Radar Distance Sensor) _____
Measured Pulses Per Mile/ Km (Magnetic Distance Sensor) _____

SERIAL NUMBER

The serial number plate is located on the planter frame as shown below. The serial number provides important information about your planter and is needed to obtain correct replacement parts. Always provide model number and serial number to your Kinze Dealer when ordering parts or when contacting Kinze Manufacturing, Inc.



2015 production

This page left blank intentionally.

TO THE DEALER

Predelivery service includes assembly, lubrication, adjustment and test. This service helps to ensure planter is delivered to retail customer/end user ready for field use.

PREDELIVERY CHECKLIST

Use the following checklist after planter is completely assembled to inspect planter. Check off each item as it is found satisfactory or after proper adjustment is made.

- Row units properly spaced and optional attachments correctly assembled.
- All grease fittings in place and lubricated.
- All working parts are moving freely. Bolts are tight and cotter pins are spread.
- All drive chains properly tensioned and aligned.
- Check for oil leaks and proper hydraulic operation.
- Hydraulic hoses are routed correctly to prevent damage to hoses.
- Inflate tires to specified air pressure. Tighten wheel lug bolts to specified torque.
- All safety decals correctly located and legible as shown in Parts Manual. Replace if damaged.
- All reflective decals and SMV sign located as shown in Parts Manual and visible when planter is in transport position.
- Safety/warning lights correctly installed and working properly.
- Paint all parts scratched in shipment or assembly.
- All safety lockup devices are on planter and correctly located.
- Seed meters performance checked on test stand. Vacuum fan, analog gauge, control box, and hoses installed.
- Auxiliary safety chain is properly installed and hardware is torqued to specification.
- Vacuum fan PTO-driven pump is attached correctly to the tractor. Oil reservoir is filled to capacity and system is inspected for leaks. (If Applicable)

Planter has been thoroughly checked and to the best of my knowledge is ready for delivery to the customer.

(Signature Of Set-Up Person/Dealer Name/Date)

OWNER REGISTER

Name _____ Delivery Date _____

Street Address _____ Model No. 3500 Serial No. _____

City, State/Province _____ Dealer Name _____

ZIP/Postal Code _____ Dealer No. _____

DELIVERY CHECKLIST

Use the following checklist when planter is delivered as a reminder of important information which should be conveyed to retail customer/end user. Check off each item as it is fully explained.

- Check for proper operation of vacuum fan and PTO driven pump (If Applicable) with tractor to be used with planter.
- Life expectancy of this or any other machine is dependent on regular lubrication as directed in the Operator Manual.
- All applicable safety precautions.
- Along with retail customer/end user, check reflective decals and SMV sign are clearly visible with planter in transport position and attached to tractor. Check safety/warning lights are in working condition. Tell retail customer/end user to check federal, state/provincial, and local regulations before towing or transporting on a road or highway.
- Give Operator Manual, Parts Manual, and all Instruction Sheets to retail customer/end user and explain all operating adjustments.
- Read warranty to retail customer/end user.
- Complete Warranty and Delivery Report form.

To the best of my knowledge this machine has been delivered ready for field use and customer has been fully informed as to proper care and operation.

(Signature Of Delivery Person/Dealer Name/Date)

AFTER DELIVERY CHECKLIST

The following is a list of items we suggest to check during the first season of use of the equipment.

- Check planter performance with retail customer/end user.
- Check performance of vacuum or mechanical seed metering system with retail customer/end user.
- Review importance of proper maintenance and adherence to all safety precautions with retail customer/end user.
- Check for parts that may need to be adjusted or replaced.
- Check all safety decals, reflective decals, and SMV sign are correctly located as shown in the Parts Manual and that decals are legible. Replace if damaged or missing.
- Check safety/warning lights are working properly.

(Signature Of Follow-Up Person/Dealer Name/Date)

**All registrations must be submitted online at "business.kinze.com" within 5 business days of delivery.
Retain a copy of this form for auditing purposes.**

Tear Along Perforation



OVERVIEW

To The Owner	1-1
General Information	1-3
Warranty	1-3
Tractor Hydraulic Requirements	1-4
Specifications	1-4
General Safety Rules	1-5
Safety Instructions, Signs, and Decals	1-6
Initial Preparation	2-1
Tractor Requirements	2-2

MACHINE OPERATION

Row Marker Safety Lockup	2-3
Safety Lockup and Stroke Limiter Pin	2-3
Transport Latch Locking Pin	2-3
Hitch Length Adjustment	2-4
Jack Stand	2-5
Hydraulic Operation	2-5
PTO Pump Drive And Oil Cooler Option	2-7
Tractor Preparation and Hookup	2-8
Level Planter	2-10
Cylinder Information	2-11
Hydraulic Hose Information	2-12
Towing Planter	2-14
Planting Speed	2-14
Contact Drive Spring Adjustment	2-15
Seed Rate Transmission Adjustment	2-15
Standard and Half Rate (2 to 1) Drives	2-16
Shear Protection	2-17
Wrap Spring Wrench	2-18
Contact Wheel Drive Sprockets	2-18
Row Marker Speed Adjustment	2-19
Even-Row Push Row Unit	2-19
Row Marker Adjustments	2-20
Row Marker Even-Row Length Adjustment	2-21
Offset Hitch Adjustment	2-21
Digital Vacuum Gauge Operation	2-22
Vacuum Meter System	2-23
Analog Vacuum or Pressure Gauge	2-23
Ridge Planting	2-24
Tire Scraper	2-24
Rock Guards	2-24
Auxiliary Work Lights Package	2-24
Rear Trailer Hitch	2-25
Field Test	2-26
Check Seed Population	2-26

Determining Pounds Per Acre (Brush-Type Meter)	2-27
Determining Bushels Per Acre	2-27
Granular Chemical Application Field Check	2-28
Water Tank	2-29

ROW UNIT OPERATION

Planting Depth	3-1
“V” Closing Wheel Adjustment (Rubber or Cast Iron)	3-1
Closing Wheel Shield (Rubber or Cast Iron “V” Closing Wheels)	3-2
Drag Closing Attachment	3-2
Covering Discs/Single Press Wheel Adjustment	3-3
Seed Hoppers	3-4
Seed Meter Drive Release	3-4
Row Unit Extension Brackets	3-4
Row Unit Chain Routing	3-5
Quick Adjustable Down Force Springs Option (Standard or Heavy Duty)	3-6
Field Operation	3-8
Interplant Push Row Unit Lockups	3-9
Interplant Push Row Unit Clutch Sprocket	3-11
Interplant Push Row Unit Vacuum Hose Shutoff	3-11
Brush-Type Seed Meter	3-12
Finger Pickup Seed Meter	3-13
Vacuum Settings	3-14
Seed Meter Cleanout	3-17
Additives	3-18
Bayer Fluency Agent	3-19
Frame Mounted Coulter (Pull Row Only)	3-20
Residue Wheels (for Frame Mounted Coulter)	3-20
Row Unit Mounted Disc Furrower (Pull Row Only)	3-21
Row Unit Mounted Bed Leveler (Pull Row Only)	3-21
Row Unit Mounted Residue Wheel	3-22
Row Unit Mounted No Till Coulter	3-24
Coulter Mounted Residue Wheels	3-24
Granular Chemical Hopper and Drive	3-25
Spring Tooth Incorporator	3-25
Granular Chemical Banding Options	3-26
Granular Chemical Bander Shield	3-26

FERTILIZER

Double Disc Fertilizer Opener	4-1
Notched Single Disc Openers	4-2
Residue Wheel Attachment for Notched Single Disc Fertilizer Opener	4-4
Depth/Gauge Wheel Attachment for Notched Single Disc Fertilizer Opener	4-4
HD Single Disc Fertilizer Opener	4-5

Dry Fertilizer Attachment 4-7
 Liquid Fertilizer Attachment 4-9

RATE CHARTS 5-1

LUBRICATION AND MAINTENANCE

Lubrication 6-1
 Lubrication Symbols 6-1
 Sealed Bearings 6-1
 Wrap Spring Wrench Assembly 6-1
 Drive Chains 6-2
 Center Post 6-4
 Wheel Bearings 6-4
 Liquid Fertilizer Piston Pump Crankcase Oil Level 6-5
 PTO Pump Shaft Coupling (PTO Pump Drive
 and Oil Cooler Option) 6-5
 Bushings 6-6
 Grease Fittings 6-7
 Mounting Bolts and Hardware 6-11
 Tire Pressure 6-12
 Model 3500 Operating Tire Pressure 6-12
 Chain Tension Adjustment 6-13
 Pneumatic Down Pressure Air Compressor Tank 6-13
 Finger Pickup Seed Meter Inspection/Adjustment 6-14
 Cleaning Finger Pickup Seed Meter For Storage 6-15
 Brush-Type Seed Meter Maintenance 6-16
 Cleaning Brush-Type Seed Meter For Storage 6-17
 Vacuum Seed Meter Maintenance 6-18
 Seed Meter Cleanout 6-18
 Drag Closing Attachment 6-19
 Gauge Wheel Adjustment 6-19
 Gauge Wheel Arm Bushing and/or
 Seal Replacement 6-20
 Gauge Wheel Arm Pivot Spindle Replacement 6-20
 15" Seed Opener Disc Blade/Bearing Assembly 6-21
 Seed Tube Guard/Inner Scraper 6-22
 Frame Mounted Coulter 6-22
 Residue Wheels (For Use With Frame Mounted Coulter) 6-23
 Row Unit Mounted Disc Frower 6-23
 Row Unit Mounted Bed Leveler 6-24
 Row Unit Mounted Residue Wheel 6-24
 Row Unit Mounted No Till Coulter 6-25
 Coulter Mounted Residue Wheels 6-25
 Granular Chemical Attachment 6-26
 Spring Tooth Incorporator 6-26
 Wear Pad Adjustment/Replacement 6-27
 Row Marker Sequencing/Flow Control Valve Inspection 6-28

PTO Pump Drive and Oil Cooler Option 6-29
 Check Valve Inspection 6-29
 Relief Valve Cartridge Inspection 6-29
 Row Marker Bearing Lubrication or Replacement 6-30
 Wheel Bearing Repack or Replacement 6-31
 Fertilizer Check Valve Cleaning and Repair 6-31
 Piston Pump Storage 6-32
 Preparing Planter for Storage 6-32
 Electrical Wiring Diagram for Light Package 6-33
 Hydraulic Hose Life 6-34
 Hydraulic Diagram - Planter 6-35
 Hydraulic Diagram - Vacuum Fan Motor System 6-36
 Hydraulic Diagram - Optional PTO Pump Drive and Oil
 Cooler System 6-37

TROUBLESHOOTING





Closing Wheel Troubleshooting 7-1
 Piston Pump Troubleshooting 7-2
 Seed Meter (Brush-Type) Troubleshooting 7-4
 Seed Meter (Finger Pickup) Troubleshooting 7-5
 Vacuum Seed Meter 7-6

Kinze Manufacturing, Inc. thanks you for your patronage. We appreciate your confidence in Kinze farm machinery. Your Kinze planter has been carefully designed to provide dependable operation in return for your investment.

This manual has been prepared to aid you in the operation and maintenance of the planter. It should be considered a permanent part of the machine and remain with the machine when you sell it.

It is the responsibility of the user to read and understand the Operator Manual in regards to safety, operation, lubrication and maintenance before operation of this equipment. It is the user's responsibility to inspect and service the machine routinely as directed in the Operator Manual. We have attempted to cover all areas of safety, operation, lubrication and maintenance; however, there may be times when special care must be taken to fit your conditions.

Throughout this manual the symbol  and the words **DANGER**, **WARNING**, and **CAUTION** are used to call attention to safety information that if not followed, will or could result in death or injury. **NOTICE** and **NOTE** are used to call your attention to important information. The definition of each of these terms follows:

	Indicates an imminently hazardous situation that, if not avoided, will result in death or serious injury. This signal word is to be limited to the most extreme situations, typically for machine components which, for functional purposes, cannot be guarded.
	Indicates a potentially hazardous situation that, if not avoided, could result in death or serious injury, and includes hazards that are exposed when guards are removed. It may also be used to alert against unsafe practices.
	Indicates a potentially hazardous situation that, if not avoided, may result in minor or moderate injury. It may also be used to alert against unsafe practices.
	Used to address safety practices not related to personal injury.

NOTE: Special point of information or machine adjustment instructions.

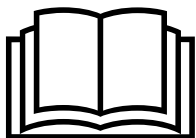
**WARNING**

Improperly operating or working on this equipment could result in death or serious injury. Read and follow all instructions in Operator Manual before operating or working on this equipment.

**WARNING**

Some photos in this manual may show safety covers, shields, or lockup devices removed for visual clarity. **NEVER OPERATOR OR WORK ON** machine without all safety covers, shields, and lockup device in place as required.

NOTE: Some photos in this manual may have been taken of prototype machines. Production machines may vary in appearance.

NOTE: Some photos and illustrations in this manual show optional attachments installed. Contact your Kinze Dealer for purchase of optional attachments.

The Kinze Limited Warranty for your new machine is stated on the retail purchaser's copy of the Warranty And Delivery Receipt form. Additional copies of the Limited Warranty can be obtained through your Kinze Dealer.

Warranty, within the warranty period, is provided as part of Kinze's support program for registered Kinze products which have been operated and maintained as described in this manual. Evidence of equipment abuse or modification beyond original factory specifications will void the warranty. Normal maintenance, service and repair is not covered by Kinze warranty.

To register your Kinze product for warranty, a Warranty And Delivery Receipt form must be completed by the Kinze Dealer and signed by the retail purchaser, with copies to the Dealer, and to the retail purchaser. Registration must be completed and submitted to Kinze Manufacturing, Inc. within 5 business days of delivery of the Kinze product to the retail purchaser. Kinze Manufacturing, Inc. reserves the right to refuse warranty on serial numbered products which have not been properly registered.

If service or replacement of failed parts which are covered by the Limited Warranty are required, it is the user's responsibility to deliver the machine along with the retail purchaser's copy of the Warranty And Delivery Receipt to the Kinze Dealer for service. Kinze warranty does not include cost of travel time, mileage, hauling or labor. Any prior arrangement made between the Dealer and the retail purchaser in which the Dealer agrees to absorb all or part of this expense should be considered a courtesy to the retail purchaser.

Kinze warranty does not include cost of travel time, mileage, hauling, or labor.



GENERAL INFORMATION

This manual covers all production years of the Model 3500 planter. Contact your Kinze dealer for additional options which may be available for your specific model year planter.

Information in this manual was current at time of printing. However, due to Kinze's ongoing product improvement, production changes may cause your machine to appear slightly different in detail. Kinze Manufacturing, Inc. reserves the right to change specifications or design without notice and without incurring obligation to install the same on machines previously manufactured. To obtain the most recent version of your publication, please contact your Kinze dealer.

Right hand (R.H.) and left hand (L.H.), as used throughout this manual, are determined by facing in direction machine travels in use, unless otherwise stated.

TOOLS REQUIRED

Hardware Size / Tool Required			
1/4" = 7/16"	7/16" = 5/8" (nut for 7/16" hardware uses 11/16" tool)	3/4" = 1 1/8"	1 1/4" = 1 7/8"
5/16" = 1/2"	1/2" = 3/4"	7/8" = 1 5/16"	1 1/2" = 2 1/4"
3/8" = 9/16"	5/8" = 15/16"	1" = 1 1/2"	

Specification		
Number of Rows	6 Row 30"	8 Row 30"
Weight Empty (Mechanical)*	5163 lb (2341.8 kg) - 5443 lb (2468.9 kg)	5886 lb (2669.8 kg) - 6269 lb (2843.6 kg)
Weight Empty (Vacuum)*	5163 lb (2341.8 kg) - 5443 lb (2468.9 kg)	5886 lb (2669.8 kg) - 6269 lb (2843.6 kg)
*Seed meter/vacuum system - 13 gpm @ 2000 psi (49 LPM @ 13790 kPa) case drain plus one SCV (pressure and return) for vacuum fan hydraulic motor.		
Axle Weight (Empty)**	4245 lb (1925.4 kg)	8420 lb (3819.2 kg)
Tongue Weight (Empty)**	918 lb (416.3 kg)	1820 lb (825.5 kg)
**Weight based off a typical configuration of a complete machine.		
Transport Height	10' 6" (3.2M)	10' 6" (3.2M)
Planting Length	19' 8" (6.0M)	19' 8" (6.0M)
Transport Length	23' 9" (7.3M)	26' 5" (8.4M)
Planting Width	16' 10" (5.2M)	21' 10" (6.7M)
Transport Width	11' 2" (3.5M)	11' 2" (3.5M)
Seed Capacity	1.75 bu. (Vacuum / Hopper); 1.90 bu. (Mechanical / Hopper)	
Transport Tires	Four 7.50" x 20" 8 ply rib implement tires w/ center groove - Inflate to 40 psi (275.7 kPa)	
Contact Drive Tires	Two 4.10" x 6" spring-loaded contact drive tires. - Inflate to 50 psi (344.7 kPa)	
Field Lift	One center post lift cylinder. (Front or rear mount.)	
Row Markers	Two-fold low profile with 16" concave, solid blades and cast iron hubs.	
*Base machine weights include planter frame including row markers, hydraulic cylinders, hoses, fittings, tires, wheels, drive and drill shafts, sprockets, chains and required drive components, parking jack, safety/warning lights, SMV sign, transport safety chain, and Kinze pull row units (closing wheel arms less closing wheels) with seed hopper, lid, and dual quick adjustable down force springs option. Vacuum includes additional weight of fan, manifolds, and hoses.		

Tractor Hydraulic Requirements



Configuration	Requirements		Description
Base machine with mechanical meters.	2 SCV	10 gpm (38 L/min)	#1 SCV: Planter lift
			#2 SCV: Markers/fold (manual selector valve)
Base machine with vacuum meters.*	3 SCV	25 gpm (95 L/min)	#1 SCV: Planter lift
			#2 SCV: Markers/fold (manual selector valve)
			#3 SCV: Vacuum fan
Base machine with vacuum meters and tractor mounted PTO pump.*	2 SCV	15 gpm (57 L/min)	#1 SCV: Planter lift
			#2 SCV: Markers/fold (manual selector valve)

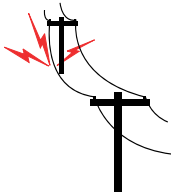

1. Read and understand instructions provided in this manual and warning labels. Review these instructions frequently!
 2. This machine is designed and built with your safety in mind. Do not make any alterations or changes to this machine. Any alteration to design or construction may create safety hazards.
 3. A large portion of farm accidents happen from fatigue or carelessness. Safe and careful operation of tractor and planter will help prevent accidents.
 4. Never allow planter to be operated by anyone unfamiliar with operation of all functions of the unit. Operators must read and thoroughly understand all instructions given in this manual before operating or working on equipment.
 5. Be aware of bystanders, particularly children! Always look around to make sure it is safe to start tow vehicle engine or move planter. This is particularly important with higher noise levels and quiet cabs, as you may not hear people shouting.
 6. Make sure planter weight does not exceed towing capacity of tractor, or bridge and road limits. This is critical to maintain safe control and prevent death or injury, or property and equipment damage.
 7. Never ride or allow others to ride on planter.
 8. Store planter in an area away from human activity. DO NOT permit children to play on or around the stored unit.
 9. Keep hands, feet, and clothing away from moving parts. Do not wear loose-fitting clothing which may catch in moving parts.
 10. Always wear protective clothing, shoes, gloves, hearing, and eye protection applicable for the situation.
 11. Do not allow anyone to stand between tongue or hitch and towing vehicle when backing up to planter.
 13. Prevent electrocution, other injuries, or property and equipment damage. Watch for obstructions such as wires, tree limbs, etc. when operating machine. Be aware of clearances during turns and when folding/unfolding planter.
 14. Reinstall all guards removed for maintenance activities. Never leave guards off during operation.
 15. Use of aftermarket hydraulic, electric, or PTO drives may create serious safety hazards to you and people nearby. If you install such drives, follow all appropriate safety standards and practices to protect you and others near this planter from injury.
 16. Follow all federal, state/provincial, and local regulations when towing farm equipment on a public highway. Use safety chain (not an elastic or nylon/plastic tow strap) to retain connection between towing and towed machines in the event of primary attaching system separation.
 17. Make sure all safety/warning lights, SMV sign, and reflective decals are in place and working properly before transporting the machine on public roads.
 18. Limit towing speed to 15 MPH. Tow only with farm tractor of a minimum 90 HP. Allow for unit length when making turns.
 19. Reduce speed prior to turns to avoid the risk of overturning. Always drive at a safe speed relative to local conditions and ensure your speed is slow enough for a safe emergency stop.
 20. Chemical application is often an integral part of planting. Follow label instructions for proper chemical mixing, handling and container disposal methods.
 21. Be familiar with safety procedures for immediate first aid should you accidentally contact chemical substances.
 22. Use the proper protective clothing and safety equipment when handling chemicals.
 23. Chemicals are supplied with Material Safety Data Sheets (MSDS) that provide full information about the chemical, its effects on exposure, and first aid needs in the event of an emergency. Keep your MSDS file up-to-date and available for first responders in case of emergency.
 24. When servicing ground engaging components such as opening disks and firming points, use special care to avoid points and edges worn sharp during use.
 25. Use professional help if you are unfamiliar with working on hydraulic systems. Pressurized hydraulic fluid can penetrate body tissue and result in death, serious infection, or other injuries.
- Never pour waste onto the ground, down a drain, or into any water source.
- When disposing of waste such as oil, use leakproof containers. Be sure to use containers that do not resemble food or beverage which may mislead someone into consuming them. Dispose of oil per your local, regional requirements.
- When disposing of any fertilizer chemicals used, contact the supplier of the chemicals.
- Model 3500 planter consists of 85% recyclable metals, 10% recyclable plastic and rubber, and 5% waste.

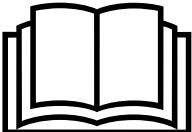
Following are some common hazard warnings associated with this equipment. Pay close attention to all safety, operating, and maintenance information in this manual and decals applied to your equipment.

 DANGER	<p>Contacting or coming close to power lines or other high energy sources will cause death or serious injury.</p>
	<p>Keep away from power lines or high energy sources at all times.</p>

 WARNING	<p>Improperly operating or working on this equipment could result in death or serious injury. Read and follow all instructions in Operator Manual before operating or working on this equipment.</p>
	

 WARNING	<p>Falling equipment can cause death or serious injury. Install all lockup devices or lower planter to ground before working on equipment.</p>
	

 WARNING	<p>Explosive separation of rim and tire parts can cause death or serious injury. Overinflation, rim and tire servicing, improper use of rims and tires, or worn or improperly maintained tires could result in a tire explosion.</p>
	

SAFETY SIGNS AND DECALS

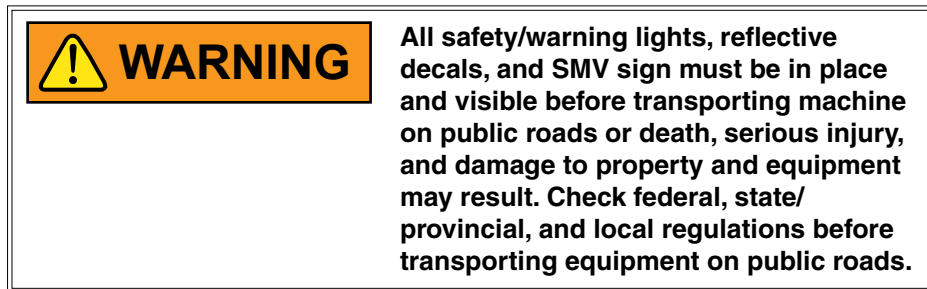

Safety signs and decals are placed on the machine to warn of hazards and provide important operating and maintenance instructions. Information on these signs are for your personal safety and the safety of those around you. FOLLOW ALL SAFETY INSTRUCTIONS!

- **Keep signs clean so they can be easily seen. Wash with soap and water or cleaning solution as required.**
- **Replace safety signs if damaged, painted over, or missing.**
- **Check reflective decals and SMV sign periodically. Replace if they show any loss of reflective properties.**
- **When replacing decals, clean machine surface thoroughly with soap and water or cleaning solution to remove all dirt and grease.**



NOTE: Safety sign and decal locations are shown in the Parts Manual for this machine.



NOTE: Style and locations of SMV sign, reflective decals, and safety/warning lights conform to ANSI/ASABE S279.14 JUL 2008 and ANSI/ASABE S276.6 JAN 2005.



This page left blank intentionally.

INITIAL PREPARATION

Following information is general in nature to aid in preparation of tractor and planter for use, and to provide general operating procedures. Operator experience, familiarity with the machine, and the following information should combine for efficient planter operation and good working habits.

 WARNING	Improperly operating or working on this equipment could result in death or serious injury. Read and follow all instructions in Operator Manual before operating or working on this equipment.
	

 WARNING	Loose transport wheel lug bolts can result in wheel separation from planter and cause death, serious injury, and damage to property and equipment. Torque transport wheel $\frac{5}{8}$"- 18 lug bolts to 180 ft-lb (244 N-m) before operating planter for the first time and periodically after.
	

 WARNING	Explosive separation of rim and tire parts can cause death or serious injury. Overinflation, rim and tire servicing, improper use of rims and tires, or worn or improperly maintained tires could result in a tire explosion.
	

1. Torque transport wheel $\frac{9}{16}$ "- 18 lug bolts to 90 ft-lb (122 N-m).
2. Inflate transport/ground drive tires to 40 psi (275.7 kPa).
3. Inflate contact drive tires to 50 psi (344.7 kPa).



TRACTOR REQUIREMENTS

NOTICE



All Hydraulic Requirements: Minimum Pressure 2350 PSI (16202.6 kPa); Maximum Pressure 3000 PSI (20684.2 kPa). Check tractor hydraulics to ensure that maximum pressure cannot be exceeded.

Consult your dealer for information on horsepower requirements and tractor compatibility. Requirements vary with planter options, tillage, and terrain.

A 12 volt DC electrical system is required to operate planter safety/warning lights, digital vacuum gauge, and optional pneumatic down pressure system or work lights.

Two dual remote hydraulic outlets (SCV) are required on all models. An additional SCV and zero pressure case drain, or PTO pump is required for vacuum equipped planters.

Hydraulic maximum flow rate of 13 GPM @ 2000 PSI (49 LPM @ 13790 kPa) is required to operate vacuum fan motor.

 WARNING	<p>Uncontrolled movement of equipment can cause loss of control and could result in death, serious injury, or damage to property and equipment. Install all safety pins before transporting equipment.</p>
	

ROW MARKER SAFETY LOCKUP



Row marker lockup installed



Row marker lockup in storage location

Install row marker safety lockup devices over marker cylinder rods whenever markers are not being used. Keep in storage position on front side of row marker arms when removed. Secure in either location with attached clevis pins.

SAFETY LOCKUP AND STROKE LIMITER PIN

Safety lockup and stroke limiter pin is inserted through the center post and kept in place by a hairpin clip.

Pin must be installed under planter frame during transport or when working on equipment when raised.

Pin must be installed above planter frame during normal operation to contact stroke limiter valve and prevent lift cylinder from overextending (Refer to hydraulic operation in this section).

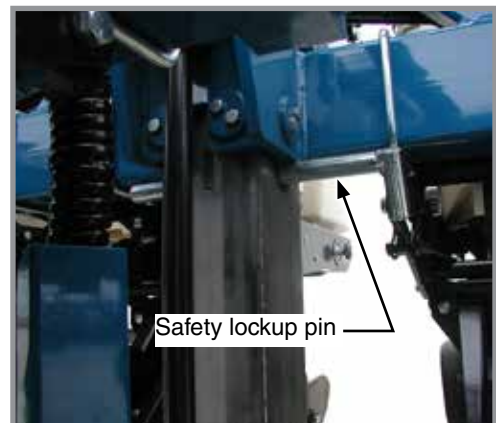

Safety lockup pin in safety position

TRANSPORT LATCH LOCKING PIN

Spring loaded transport latch on planter hitch locks in place under toolbar when planter is rotated to transport position.

Always install transport latch locking pin to lock transport latch before transporting planter.

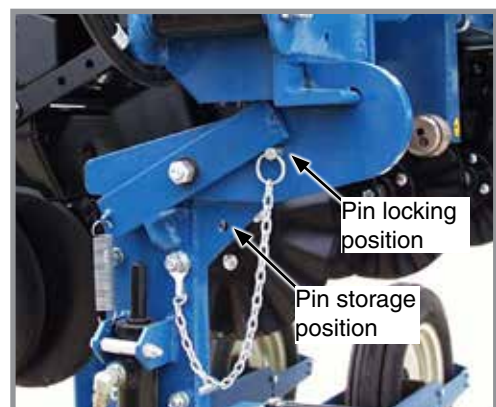

Transport latch locking pin locations

HITCH LENGTH ADJUSTMENT

The hitch consists of a telescoping outer and inner section. Hitch length can be adjusted to three locations to accommodate tractor tire options and attachments installed on planter.

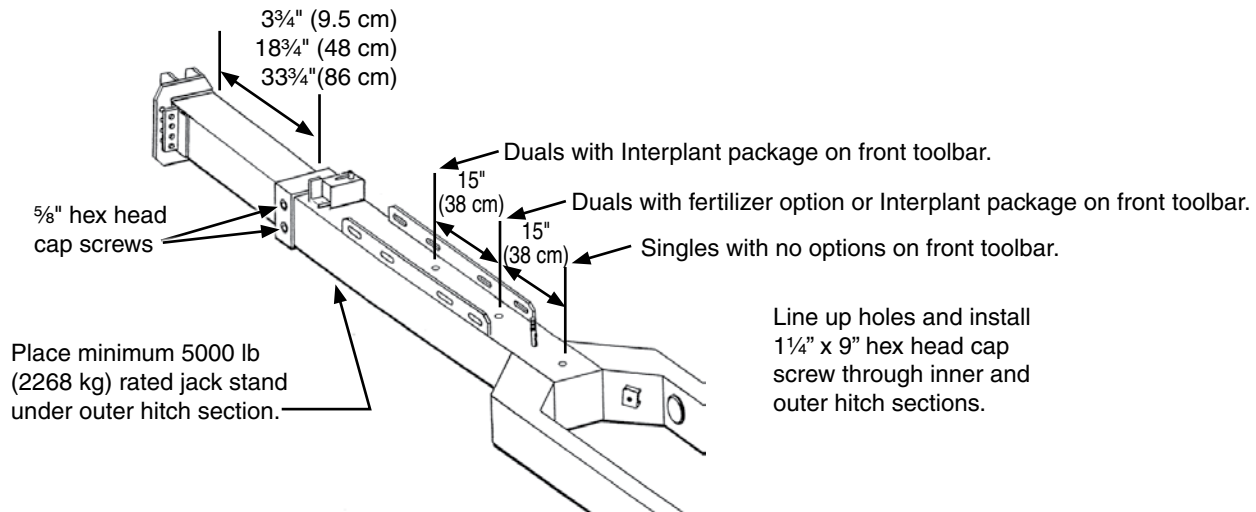

1. Lower machine to field position and block transport wheels.
2. Support outer hitch section with a minimum 5000 lb (2268 kg) rated jack stand to take weight off inner section.

NOTE: Remove and reinstall hitch mounted brackets as needed to access hitch adjustment holes.

3. Remove $1\frac{1}{4}$ " x 9" hex head cap screw, lock washer, and hex nut from hitch. Loosen two $\frac{5}{8}$ " hex head cap screws on front L.H. side of outer hitch section.

NOTICE

DO NOT set hitch length so turning is limited when machine is in road transport position or equipment may be damaged.

4. Reposition inner hitch section so hole lines up with hole in outer hitch section at desired length. Install $1\frac{1}{4}$ " x 9" hex head cap screw, lock washer, and hex nut. Torque to 840 ft-lb (1138 N-m).
5. Torque two $\frac{5}{8}$ " hex head cap screws to 110 ft-lb (149 N-m).

JACK STAND

NOTICE Install jack stand in stowed position during transport and field operation to prevent equipment damage.

An easily removable jack stand is provided to aid in connecting and disconnecting planter from tractor.

Slide notched end of jack stand over mount round bar at parking/lift or stowed position.

Install pin through mount and jack stand. Secure with lynch pin.

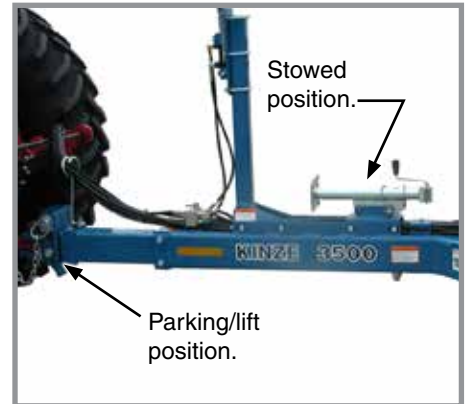

Jack stand locations

HYDRAULIC OPERATION

NOTE: PTO pump drive and oil cooler package is available from Kinze through your Kinze Dealer to increase your tractor's operating capabilities.

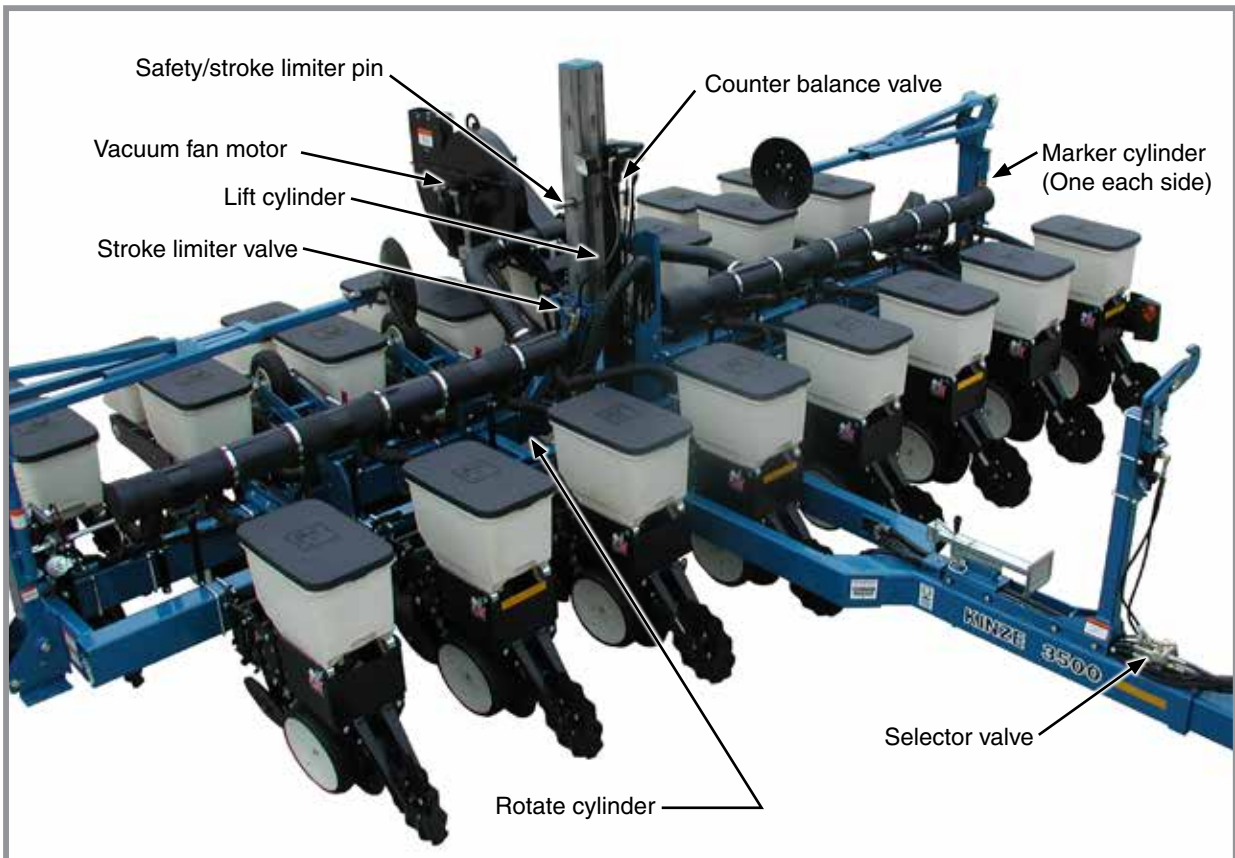

3500 hydraulic system (schematic located in Lubrication and Maintenance section)

HYDRAULIC OPERATION (CONTINUED)

PLANTER LIFT SYSTEM

Planter lift system consists of one lift cylinder located at center of machine. Cylinder mounts are located front and rear side of center post. Install cylinder in rear position for planters with rear mounted row units only. Cylinder must be installed in front position for planters with front mounted options (push row units, fertilizer, etc.). A stroke limiter valve shuts off hydraulic flow when the planter lifts to raised field position and contacts safety/stroke limiter pin. A counter balance valve holds planter in position until reverse pressure is applied.

NOTE: Planter lift cylinder is equipped with a counter balance valve. Hydraulic pressure is required to lower planter

SELECTOR VALVE, ROTATE and MARKER CYLINDERS

A hitch mounted, hand operated selector valve selects row marker or fold functions. Rotate cylinder is mounted on the frame and rotates planter to/from transport position. Row marker cylinders raise and lower row markers.

NOTE: Hydraulic pressure will prevent valve from moving. Release hydraulic pressure from system before attempting to move selector valve handle.

VACUUM FAN MOTOR AND VALVE BLOCK ASSEMBLY (If equipped)

Hydraulically operated motor requires maximum flow rate of 13 GPM @ 2000 PSI (49 LPM @ 13790 kPa) to operate properly. It must be connected to a zero pressure case drain and connected to the correct pressure and return SCV's or PTO fittings.

A pressure relief valve in the valve block assembly prevents build up of oil pressure over 35 PSI in case drain line when vacuum fan motor is in operation. This valve vents oil outside of valve block through a drain hole in the aluminum valve block. This can occur whenever the case drain is improperly connected or motor circuit pressure is too high.

See "Hydraulic Diagram - Vacuum Fan Motor System" in Lubrication and Maintenance section.

The valve block also contains a check valve that prevents vacuum fan from operating in wrong direction if pressure is applied to of motor return side and allows fan to coast to a stop when tractor hydraulic control is returned to neutral.

NOTE: Fan turns at a reduced speed if reverse pressure is applied.

RAISED FIELD POSITION

Row units raise approximately 14 inches (35.5 cm) and toolbar approximately 40 inches (101.6 cm) off ground. This position is used in making turns or passing over waterways during field operation.

Install safety/stroke limiter pin above frame assembly to make contact with stroke limiter valve. Secure with hairpin clip.

RAISED TRANSPORT POSITION

Planter raises high enough to permit row units to clear transport wheels as planter is rotated.

1. Remove hairpin clip and safety lockup pin.
2. Raise planter until lift cylinder is fully extended.
3. Reinstall safety lockup pin and hairpin clip in same hole which is now below frame assembly.
4. Lower planter onto safety lockup pin.

PTO PUMP DRIVE AND OIL COOLER OPTION

The PTO pump drive and oil cooler option is for tractors with less than required hydraulic output needed to operate hydraulic-driven vacuum fan and other planter hydraulic requirements.

A 1000 RPM PTO is required to operate the PTO-driven hydraulic pump.

PTO pump option consists of a 1 3/8"-21 or 1 3/4"-20 spline, 13.5 GPM 2000 PSI pump (49 LPM @ 13790 kPa), 10 gallon (37.8 L) capacity hydraulic reservoir, 15 GPM-rated oil cooler (56.7 L), spin-on 10-micron oil filter, and required hydraulic valves and fittings.

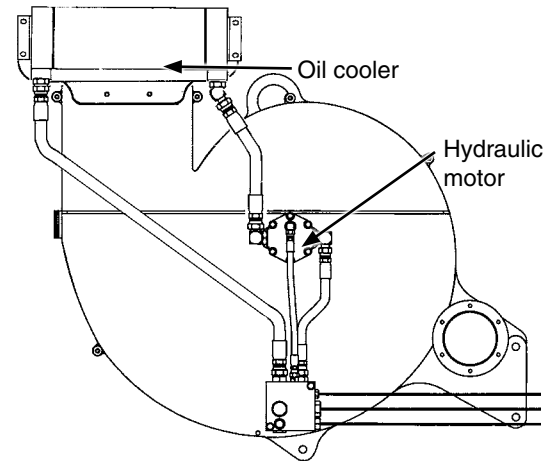

Vacuum fan assembly

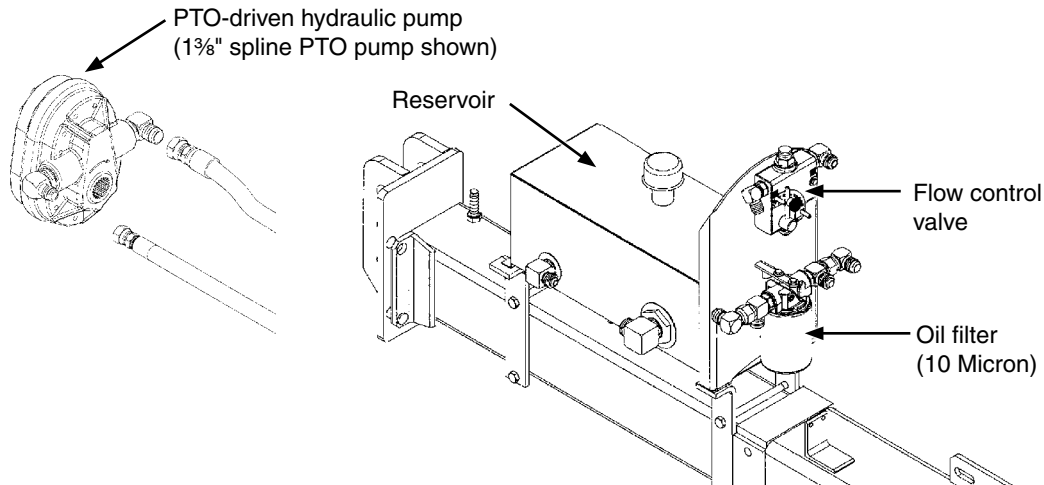

TRACTOR PREPARATION AND HOOKUP

NOTE: A 2-Point Hitch option is available for use with Category 3N or 3 three-point hitch designs to convert planter from drawn to semi-mounted. Safety chain is not used with 2-point hitch.

1. Adjust tractor drawbar 13 to 17 inches (33 - 43 cm) above ground. Adjust drawbar so hitch pin hole is directly below center line of PTO shaft. Make sure drawbar is in a stationary position.
2. Back tractor to planter and connect with a minimum $\frac{3}{4}$ " diameter hitch pin. Secure with a locking or cotter pin.

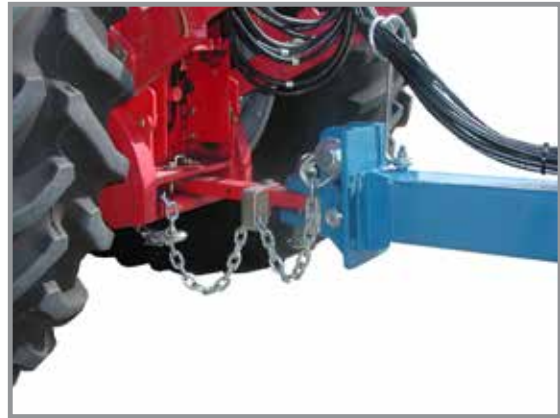

Drawbar and safety chain connection

NOTE: DO NOT install safety chain using clevis mounting hardware. Safety chain MUST be installed separately.

3. Safety chain must be used to keep planter and tractor connected in case of a hitch pin/drawbar failure. Attach safety chain at an unused clevis mounting hole on the planter hitch. Torque hardware to 840 ft-lb (1138.8 N-m).

WARNING



Pressurized hydraulic fluid can penetrate body tissue and result in death, serious infection, or other injuries. Fluid injected under skin must be **IMMEDIATELY** removed by a surgeon familiar with this type of injury. Make sure connections are tight and hoses and fittings are not damaged before applying system pressure. Leaks can be invisible. Keep away from suspected leaks. Relieve pressure before searching for leaks or performing any system maintenance.

NOTICE

Wipe hose ends to remove any dirt before connecting couplers to tractor ports or contamination may cause equipment failure.

4. Connect hydraulic hoses to tractor ports in a sequence familiar and comfortable to the operator.

NOTICE

Vacuum fan motor hydraulic hoses and case drain must be installed correctly. Motor can be damaged or equipment will not operate properly.

$\frac{3}{8}$ " hose from motor - Case Drain (CD - Orange or CD - Green)

$\frac{3}{4}$ " hose from motor - Return

$\frac{1}{2}$ " hose to motor - Pressure

NOTE: If tractor is equipped with an adjustable flow outlet (SCV), set to full flow position. For tractors not equipped with a method for finite adjustment of hydraulic flow, Flow Control Needle Valve Kit G1K426 is available from Kinze Repair Parts through your Kinze Dealer.



G1K426 needle valve kit

TRACTOR PREPARATION AND HOOKUP (CONTINUED)

5. Connect ASABE Standards 7 terminal connector for safety/warning lights on planter to ASABE Standards receptacle on tractor. If your tractor is not equipped with an ASABE Standards receptacle, check with your tractor manufacturer for availability. Check warning lights on planter work in conjunction with warning lights on tractor.

NOTE: A 12 volt battery connection is required to power the vacuum fan digital gauge. Connect “red” wire to positive (+) battery terminal and “black” wire to negative (-) battery terminal.

6. Raise jack stand and remount horizontally on storage bracket.

LEVEL PLANTER



Bottom of toolbars 20" - 22" (50.8 - 55.8 cm) from planting surface

Lateral adjustment is maintained by tire pressure. Check tires are inflated to specification.

Front and rear level adjustment is maintained by hitch clevis position unless tractor drawbar is adjustable for height. Planter frame and row unit parallel arms must be level for proper planter and row unit operation. Bottom of toolbar should be 20" to 22" (50.8 - 55.8 cm) from planting surface.

1. Lower planter to planting position and check planter is level front to rear. Go to step 2 if hitch is too high or low.

NOTE: DO NOT install safety chain using clevis hardware. Move safety chain location if necessary.

2. Remove clevis hitch hex head cap screw and lock nut using a torque wrench. Replace if off-torque is below 75 ft-lb (101.6 N-m) or there is corrosion or damage.

NOTE: Clevis must be free to move on hitch. DO NOT OVERTIGHTEN hardware.

3. Align clevis to hitch holes at new location and install hex head cap screw and lock nut. Tighten lock nut until threads are fully engaged and hex head cap screw and lock nut are firmly against hitch bracket.
4. Recheck with planter in field.

CYLINDER INFORMATION

	Row Marker Cylinder	Transport Latch Cylinder	Lift Cylinder	Rotation Cylinder
Intended Use	Double Acting Applications	Double acting applications	Double Acting Applications	Double Acting Applications
Piston	Ductile Iron	Ductile iron	Ductile Iron	Ductile Iron
Gland	Ductile Iron	Ductile iron	Ductile Iron	Ductile Iron
Tube	ST 52 DOM Tubing	Cast	ST 52 DOM Tubing	ST 52 DOM Tubing
Rod	1045 Nitro Rod	1045 Nitro rod	1045 Nitro Rod	1045 Nitro Rod
End Mounts	U-Brackets	None	Trunnion	Tang
Tube Seal	Buna O-Ring with Polytemp Back-up	O-Ring with polytemp back-up	Buna O-Ring with Polytemp Back-up	Buna O-Ring with Polytemp Back-up
Rod Seal	Polyester Alloy U-cup	Polyester alloy u-cup	Polyester Alloy U-cup	Polyester Alloy U-cup
Rod Wiper	Polyester Alloy Snap In	Polyester alloy snap in	Polyester Alloy Snap In	Polyester Alloy Snap In
Piston Seal	T-Seal HNBR	T-Seal HNBR	PTFE Seal	T-Seal HNBR
Specifications				
Product Category	Hydraulic Cylinder	Hydraulic Cylinder	Hydraulic Cylinder	Hydraulic Cylinder
Maximum Stroke	8" (20.32 cm)	2.5" (6.35 cm)	48" (121.9 cm)	16" (40.6 cm)
Working Pressure	2350-3000 PSI (16202.68-20684.27 kPa)	3000 PSI (20684.27 kPa)	3000 psi (20684.27 kPa)	3000 psi (20684.27 kPa)
Bore Size	2" (5.08 cm)	1.5" (3.81 cm)	3" (7.6 cm)	3" (7.6 cm)
Shaft Diameter	1" (2.54 cm)	.750" (1.905 cm)	1.5" (3.81 cm)	1.25" (3.1 cm)
Cylinder Configuration	Simple	Simple	Simple	Simple
Cylinder Action	Double	Double	Double	Double
Material	Steel, Ductile Iron	Steel, Ductile Iron, Cast	Steel, Ductile Iron	Steel, Ductile Iron
Mounting Method	U-Bracket	None	Trunnion	Tang
Mount Location	End Cap	End Cap	Barrel	End Cap
Cylinder Style	Welded	Machined	Welded	Welded

HYDRAULIC HOSE INFORMATION

Part Number	A15008	A1153	A1194	A1141	A1195	A1090
Description	Hose Assembly, 3/8" x 114"	Hose Assembly, 1/4" x 56"	Hose Assembly, 1/4" x 30"	Hose Assembly, 1/4" x 62"	Hose Assembly, 1/4" x 34"	Hose Assembly, 3/8" x 162"
Product Category	Hydraulic Hose	Hydraulic Hose	Hydraulic Hose	Hydraulic Hose	Hydraulic Hose	Hydraulic Hose
Product Form	Hose:Assembly	Hose:Assembly	Hose:Assembly	Hose:Assembly	Hose:Assembly	Hose; Assembly
I.D.	3/8" (9.525 mm)	1/4" (0.6 cm)	1/4" (0.6 cm)	1/4" (0.6 cm)	1/4" (0.6 cm)	3/8" (9.525 mm)
O.D.	.63" (16.002 mm)	.53" (13.4 mm)	.53" (13.4 mm)	.53" (13.4 mm)	.53" (13.4 mm)	.63" (16.002 mm)
Minimum Bend Radius	2" (5.08 cm)	4" (10.1 cm)	4" (10.1 cm)	4" (10.1 cm)	4" (10.1 cm)	2" (5.08 cm)
Working Pressure	3250 psi (22407.96 kPa)	3275 psi (22580.33 kPa)	3275 psi (22580.33 kPa)	3275 psi (22580.33 kPa)	3275 psi (22580.33 kPa)	3250 PSI (22407.96 kPa)
Temperature Range	-40°F - +212°F (-40°C - +100°C)	-40°F - +212°F (-40°C - +100°C)	-40°F - +212°F (-40°C - +100°C)	-40°F - +212°F (-40°C - +100°C)	-40°F - +212°F (-40°C - +100°C)	-40°F - +212°F (-40°C - +100°C)
Material	Modified Nitrile Type C2	Modified Nitrile Type C2	Modified Nitrile Type C2	Modified Nitrile Type C2	Modified Nitrile Type C2	Modified Nitrile Type C2
Specialized Construction	High tensile steel wire	High tensile steel wire	High tensile steel wire	High tensile steel wire	High tensile steel wire	High tensile steel wire
Media	Hydraulic Fluid	Hydraulic Fluid	Hydraulic Fluid	Hydraulic Fluid	Hydraulic Fluid	Hydraulic Fluid
Application	Agricultural; Construction	Agricultural; Construction	Agricultural; Construction	Agricultural; Construction	Agricultural; Construction	Agricultural; Construction

Part Number	A1109	A15007	A1026	A1002	A3115	A1078
Description	Hose Assembly, 1/4" x 145"	Hose Assembly, 3/8" x 272"	Hose Assembly, 3/8" x 152"	Hose Assembly, 3/8" x 20"	Hose Assembly, 3/8" x 146"	Hose Assembly, 3/8" x 174"
Product Category	Hydraulic Hose	Hydraulic Hose	Hydraulic Hose	Hydraulic Hose	Hydraulic Hose	Hydraulic Hose
Product Form	Hose:Assembly	Hose:Assembly	Hose:Assembly	Hose:Assembly	Hose; Assembly	Hose:Assembly
I.D.	1/4" (0.6 cm)	3/8" (9.525 mm)	3/8" (9.525 mm)	3/8" (9.525 mm)	3/8" (9.525 mm)	3/8" (9.525 mm)
O.D.	.53" (13.4 mm)	.63" (16.002 mm)	.63" (16.002 mm)	.63" (16.002 mm)	.63" (16.002 mm)	.63" (16.002 mm)
Minimum Bend Radius	4" (10.1 cm)	2" (5.08 cm)	2" (5.08 cm)	2" (5.08 cm)	2" (5.08 cm)	2" (5.08 cm)
Working Pressure	3275 psi (22580.33 kPa)	3250 psi (22407.96 kPa)	3250 psi (22407.96 kPa)	3250 psi (22407.96 kPa)	3250 PSI (22407.96 kPa)	3250 psi (22407.96 kPa)
Temperature Range	-40°F - +212°F (-40°C - +100°C)	-40°F - +212°F (-40°C - +100°C)	-40°F - +212°F (-40°C - +100°C)	-40°F - +212°F (-40°C - +100°C)	-40°F - +212°F (-40°C - +100°C)	-40°F - +212°F (-40°C - +100°C)
Material	Modified Nitrile Type C2	Modified Nitrile Type C2	Modified Nitrile Type C2	Modified Nitrile Type C2	Modified Nitrile Type C2	Modified Nitrile Type C2
Specialized Construction	High tensile steel wire	High tensile steel wire	High tensile steel wire	High tensile steel wire	High tensile steel wire	High tensile steel wire
Media	Hydraulic Fluid	Hydraulic Fluid	Hydraulic Fluid	Hydraulic Fluid	Hydraulic Fluid	Hydraulic Fluid
Application	Agricultural; Construction	Agricultural; Construction	Agricultural; Construction	Agricultural; Construction	Agricultural; Construction	Agricultural; Construction

Hydraulic Hose Information (Continued)

Part Number	A1041	A1021	A1055	A1018	A1076	
Description	Hose Assembly, 3/8" x 130"	Hose Assembly, 3/8" x 56"	Hose Assembly, 3/8" x 66"	Hose Assembly, 3/8" x 40"	Hose Assembly, 3/8" x 30"	
Product Category	Hydraulic Hose	Hydraulic Hose	Hydraulic Hose	Hydraulic Hose	Hydraulic Hose	
Product Form	Hose:Assembly	Hose; Assembly	Hose; Assembly	Hose; Assembly	Hose; Assembly	
I.D.	3/8" (9.525 mm)	3/8" (9.525 mm)	3/8" (9.525 mm)	3/8" (9.525 mm)	3/8" (9.525 mm)	
O.D.	.63" (16.002 mm)	.63" (16.002 mm)	.63" (16.002 mm)	.63" (16.002 mm)	.63" (16.002 mm)	
Minimum Bend Radius	2" (5.08 cm)	2" (5.08 cm)	2" (5.08 cm)	2" (5.08 cm)	2" (5.08 cm)	
Working Pressure	3250 psi (22407.96 kPa)	3250 PSI (22407.96 kPa)	3250 PSI (22407.96 kPa)	3250 PSI (22407.96 kPa)	3250 PSI (22407.96 kPa)	
Temperature Range	-40°F - +212°F (-40°C - +100°C)	-40°F - +212°F (-40°C - +100°C)	-40°F - +212°F (-40°C - +100°C)	-40°F - +212°F (-40°C - +100°C)	-40°F - +212°F (-40°C - +100°C)	
Material	Modified Nitrile Type C2	Modified Nitrile Type C2	Modified Nitrile Type C2	Modified Nitrile Type C2	Modified Nitrile Type C2	
Specialized Construction	High tensile steel wire	High tensile steel wire	High tensile steel wire	High tensile steel wire	High tensile steel wire	
Media	Hydraulic Fluid	Hydraulic Fluid	Hydraulic Fluid	Hydraulic Fluid	Hydraulic Fluid	
Application	Agricultural; Construction	Agricultural; Construction	Agricultural; Construction	Agricultural; Construction	Agricultural; Construction	

TOWING PLANTER



DANGER

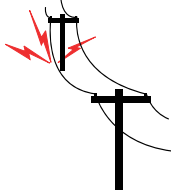

Contacting or coming close to power lines or other high energy sources will cause death or serious injury.

Keep away from power lines or high energy sources at all times.



WARNING

All safety/warning lights, reflective decals, and SMV sign must be in place and visible before transporting machine on public roads or death, serious injury, and damage to property and equipment may result. Check federal, state/provincial, and local regulations before transporting equipment on public roads.

- Tow only with farm tractor rated and configured for equipment.
- Know your route and be aware of any obstructions.
- Follow all road and bridge load limit restrictions.
- Never exceed maximum transport towing speed of 20 mph (32 kph).

PLANTING SPEED

NOTICE

Raise planter out of ground when making sharp turns or backing up or equipment damage may result.

Planters are designed to operate within a speed range of 2 to 8 mph (3.2 - 12.8 kph). See "Rate Charts". Variations in ground speed produce variations in rates. Finger pickup seed meter populations tend to be disproportionately higher at high ground speeds.

NOTE: Seed spacing can be adversely affected at speeds above 5.5 mph (8.8 kph).

CONTACT DRIVE SPRING ADJUSTMENT

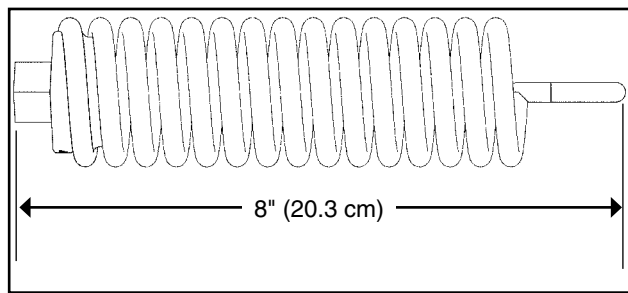

Spring length measurement (Factory setting)



Down pressure spring location

There are two down pressure springs on each contact drive wheel. Spring tension is factory preset and normally requires no adjustment.

Basic setting for spring tension is approximately 200 lb (90.72 kg) of down force at tire contact point.

NOTE: Measurement must be taken in planting position with proper tire pressure.

SEED RATE TRANSMISSION ADJUSTMENT

Seed rate transmissions allow simple, rapid changes of sprockets to obtain desired planting population. By removing lynch pins on hexagon shafts, sprockets can be interchanged with those from the sprocket storage rod bolted to the transmission.

Chain tension is controlled by a spring-loaded dual-sprocket idler. The idler assembly is equipped with an easy-release idler arm to remove spring tension for replacing sprockets.

Planting rate charts in the Seed Meter Operation section will aid you in selecting correct sprocket combinations.

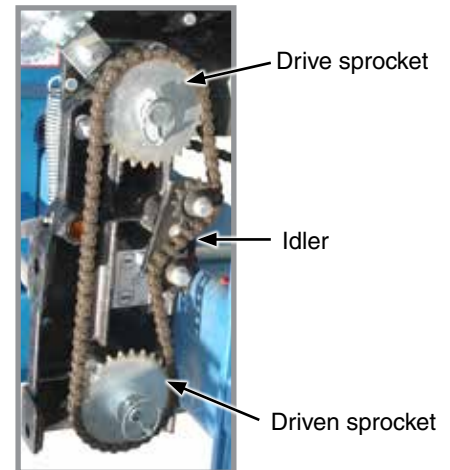

Seed rate transmission chain tension

STANDARD AND HALF RATE (2 TO 1) DRIVES

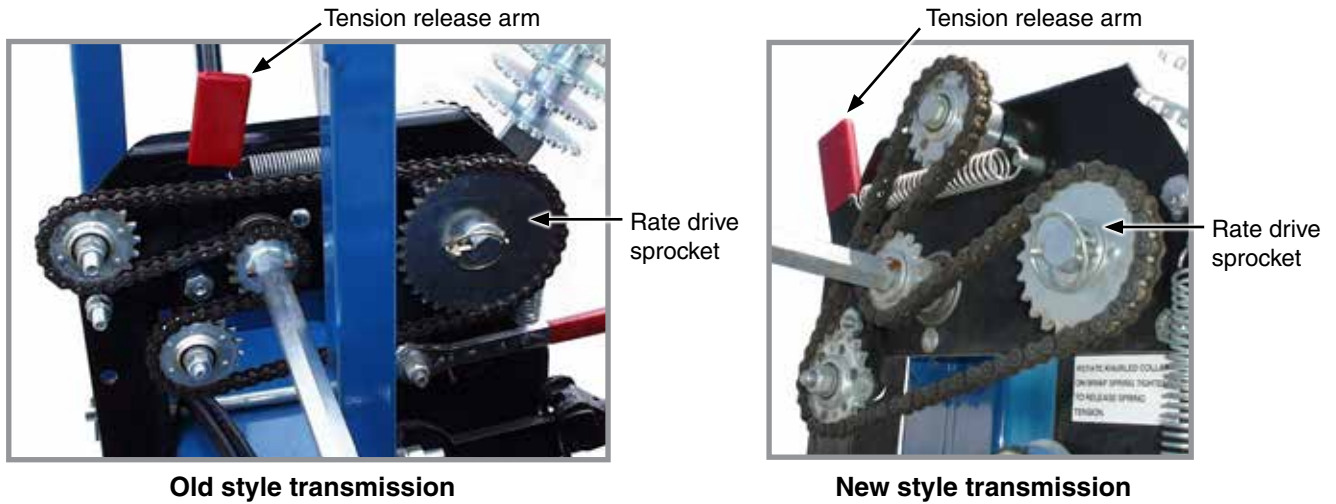

Seed planting rate charts are based on the standard rate drive using a 17 tooth sprocket unless otherwise specified.

NOTE: Half rate (2 to 1) drive is recommended only when desired population falls below that on planting rate charts.

Replacing the standard 17 tooth drive sprocket located on the inner side of the top transmission shaft, with the 34 tooth half rate (2 to 1) drive reduction sprocket reduces planter transmission speed and planting and application rates by approximately 50%.

NOTE: Do a field check after each sprocket combination adjustment to make sure you are planting at the desired rate.

SHEAR PROTECTION

Shear pins protect the planter driveline and row unit components from damage.

1. Determine where binding has occurred before replacing a pin. Turn shaft by hand (with the aid of a wrench) and check for misalignment and seized parts.
2. When shaft can be turned by hand (with the aid of a wrench) replace shear pins with same size and type. Spare shear pins are in wheel module storage area.

NOTICE

Misaligned drill shaft/transmission coupler can cause equipment damage.

3. Check driveline alignment and follow prescribed lubrication schedules to prevent component binding or breakage.

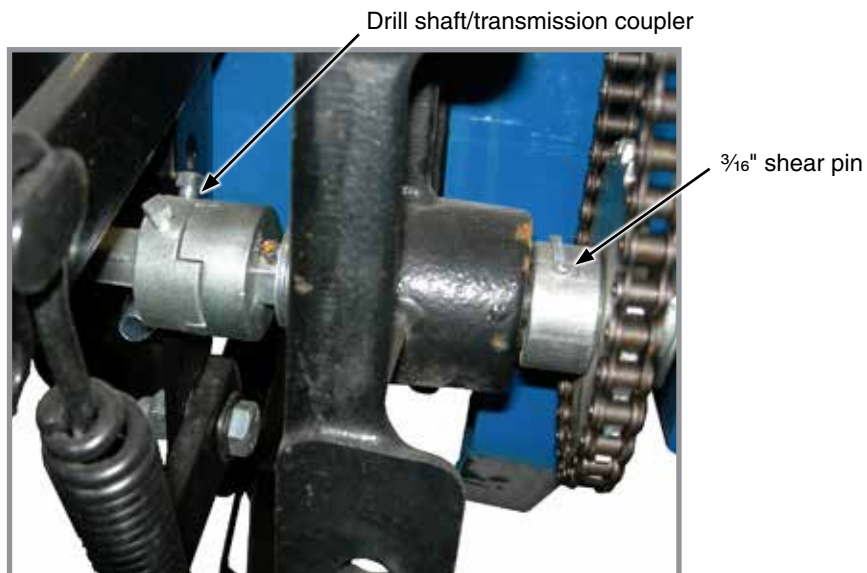

Transmission shaft and drill shaft coupler

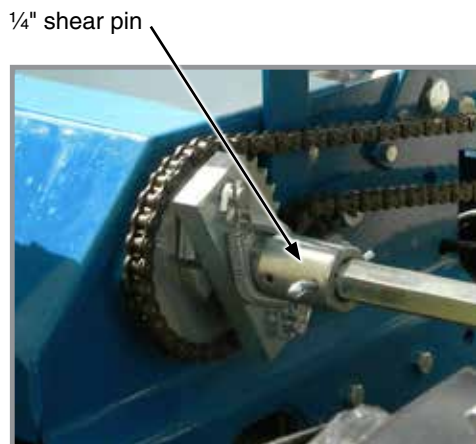

Liquid fertilizer driveline

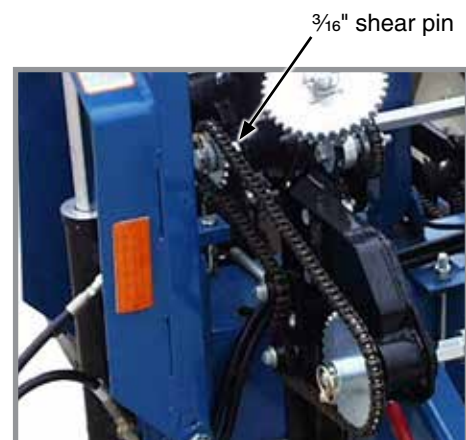

Dry fertilizer driveline

WRAP SPRING WRENCH

Chain idlers use wrap spring wrenches to release and adjust transmission chain tension.

NOTE: Wrap spring wrenches are L.H. and R.H. specific. L.H. styles have silver metal or grey plastic release collars. R.H. styles have gold metal or blue plastic release collars.

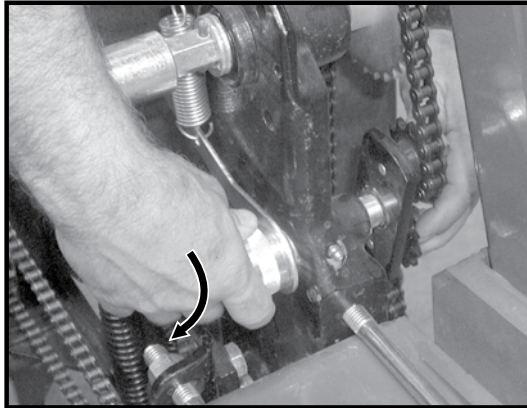

Release chain tension

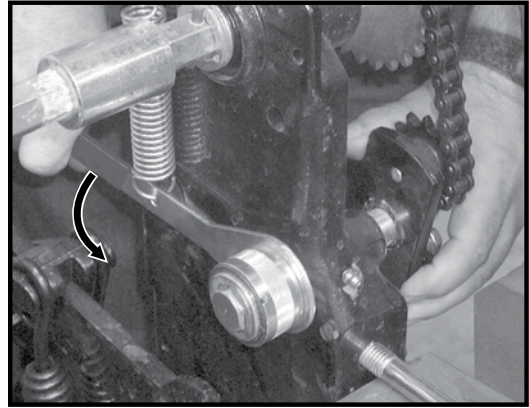

Increase chain tension

Rotate wrap spring wrench knurled collar while rotating chain idler away from chain to release chain tension.

Rotate chain idler into chain while rotating handle to tension idler spring.

CONTACT WHEEL DRIVE SPROCKETS

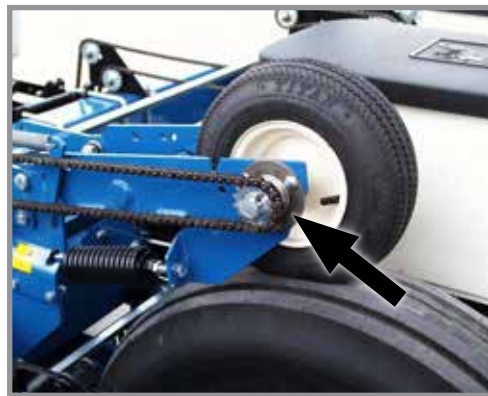

Contact wheel drive sprocket

NOTE: 15 tooth, 19 tooth or 30 tooth drive sprockets at each contact drive wheel can be interchanged from sprocket storage rod bolted to each transmission. 30 tooth sprockets require use of 124 pitch chains instead of standard 116 pitch No. 40 chains.

Chain tension is controlled by a spring-loaded sprocket idler. Amount of spring tension on chain is controlled by idler arm. Planting rate chart in Rate Chart section will aid you in selecting correct sprocket.

NOTE: 15, 19, and 30 tooth drive sprockets are NOT applicable to all rate charts. 23 tooth driven sprocket at reverser plate is changed to a 17 tooth sprocket when using 60 cell soybean seed disc. Check chart titles to ensure proper rate chart is selected.

NOTE: Make a field check after each sprocket combination adjustment to be sure you are planting at desired rate.

ROW MARKER SPEED ADJUSTMENT

NOTICE

Excessive row marker travel speed can damage row markers. Adjust flow controls before row markers are first used.



Row marker flow control valves

Two flow control valves determine amount of oil flow restriction controlling row marker travel speeds. One flow control valve controls lowering speed and one controls raising speed of both markers.

NOTE 1: Hydraulics operate slowly when oil is cold. Make all adjustments with oil warm.

NOTE 2: On a tractor where oil flow cannot be controlled, tractor flow rate may be greater than rate marker cylinder can accept. Hold tractor hydraulic control lever until cylinder reaches end of its stroke. This occurs most often on tractors with an open center hydraulic system.

NOTE 3: On tractors with a closed center hydraulic system, set hydraulic flow control so detent functions properly.

1. Loosen jam nut and turn control clockwise (IN) to slow speed or counterclockwise (OUT) to increase speed.
2. Tighten jam nut after adjustments are made.

EVEN-ROW PUSH ROW UNIT

An Even-Row Push Row Unit Package is available to add one additional push row unit on outer L.H. side of front toolbar for use with Solid Row Interplant Package.

NOTE: See “Row Marker Adjustment” for determining correct length to set row marker assemblies when planting with even-row push row unit option.

An inner hitch with a 7½" (19 cm) offset mount is available from Kinze through your Kinze Dealer to plant two 15" rows between last year's 30" rows and avoid tire damage from stalks by driving off row

NOTE: install hitch onto 2-point hitch bar using R.H. hole if 2-Point Hitch Option is used. A 7½" (19 cm) offset mount is not needed. See “Offset Hitch Adjustment” for additional information.

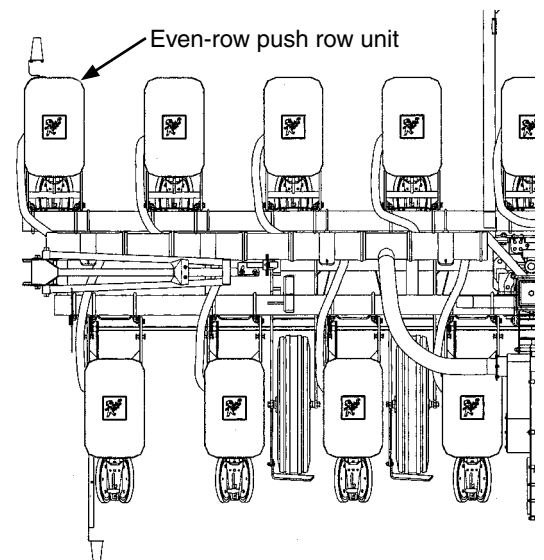

ROW MARKER ADJUSTMENTS

1. Multiply number of rows by the average row spacing in inches to determine total planting width.

Row Marker Lengths	
6 Row 30" (70 cm)	180" (457.2 cm)
8 Row 30" (70 cm)	240" (609.6 cm)

2. Lower planter and row marker assembly to ground.
3. Measure from planter center line to a point where blade contacts ground.
4. Adjust row marker extension so distance from marker disc blade to center line of planter is equal to total planting width. Adjust right and left row marker assemblies equally and securely tighten clamping bolts.

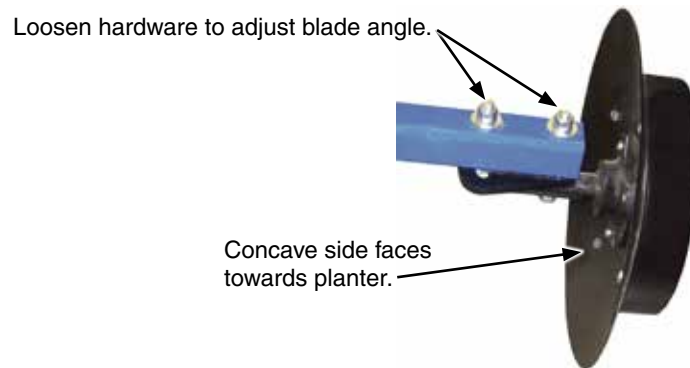

Row marker disc blade angle adjustment

NOTICE

Setting marker disc blade assembly at a sharper angle than needed adds stress to row marker assembly and shortens bearing and blade life. Set blade angle only as needed to leave a clear mark.

Marker disc blade is installed with concave side facing inward. Spindle assembly is slotted so hub and blade can be angled to throw more or less dirt.

5. Loosen hardware and move assembly as required.
6. Tighten bolts to specified torque.
7. Do a field test to ensure markers are properly adjusted.

NOTE: A notched marker blade is available from Kinze through your Kinze Dealer for use in more severe no till conditions.

ROW MARKER EVEN-ROW LENGTH ADJUSTMENT

Replace L.H. marker extension tube with marker extension tube (55" for 6 Row 30"/65" for 8 Row 30") supplied with Even-Row Push Row Unit and Mounting Package.

Reinstall marker blade assembly onto new marker extension tube.

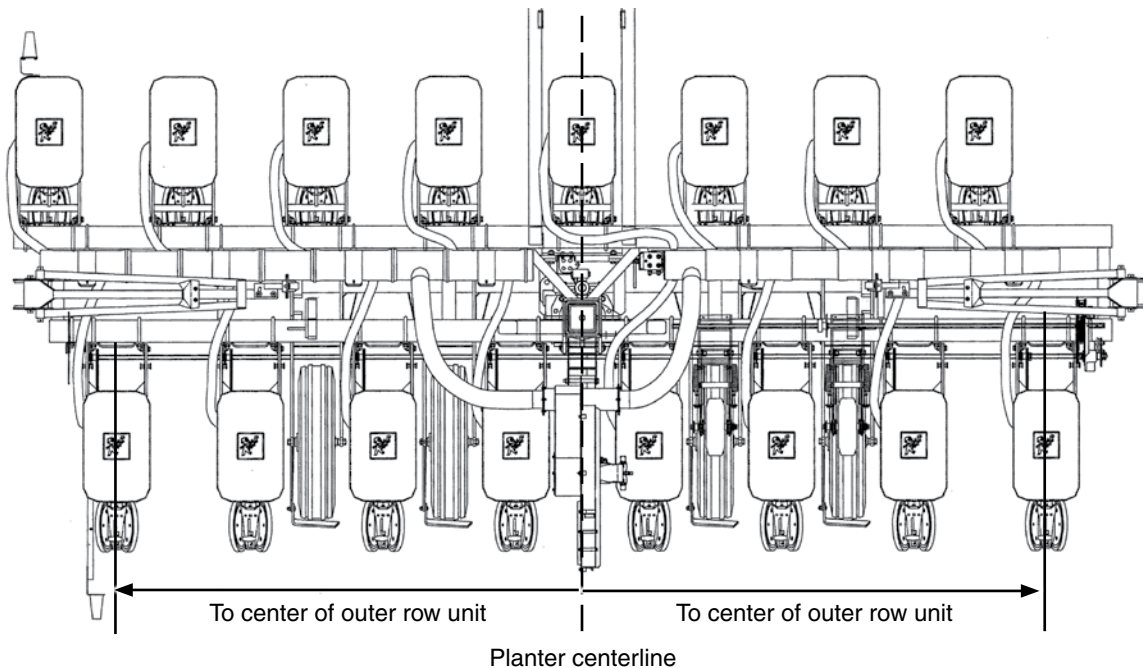

Center of planter to center of outer row unit. x 2 + 15" Row spacing. = Dimension between planter center line and marker blade.

- 6 Row 30" with 6 Interplant push row units.
(L.H. marker 90" x 2 + 15" = 195")
(R.H. marker 75" x 2 + 15" = 165")
- 8 Row 30" with 8 Interplant push row units.
(L.H. marker 120" x 2 + 15" = 255")
(R.H. marker 105" x 2 + 15" = 225")

NOTE: Readjust markers when planting 30" rows.

Number of rows x row spacing (Inches)
=

Dimension between planter center line and marker blade

- 6 Rows x 30" Spacing = 180" Marker Dimension
- 8 Rows x 30" Spacing = 240" Marker Dimension

OFFSET HITCH ADJUSTMENT

An offset hitch is available from Kinze through your Kinze Dealer. Offset hitch provides centered and offset mounting positions for hitch clevis.

If tractor hitch is offset 7½" (19 cm) right of tractor center line, add 7½" (19 cm) to marker dimension on R.H. side of planter and subtract 7½" (19 cm) from marker dimension on L.H. side of planter.

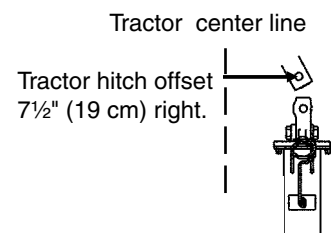

DIGITAL VACUUM GAUGE OPERATION**Digital vacuum gauge**

The digital vacuum gauge console controls vacuum fan. Use "FAN 1" setting when planter is equipped with one vacuum fan.

NOTE: Toggle switch must be OFF when planter is not in use or tractor battery will drain.

The digital vacuum gauge is factory calibrated. However, vacuum varies throughout the manifold system and it may be necessary to adjust the digital readout so it agrees with actual vacuum at the meter. With the seed discs loaded with seed, compare digital vacuum gauge readout to reading taken from analog gauge or a hand held gauge at several meters along length of planter.

Elbows at seed meter covers allow testing of meter vacuum levels without removing vacuum hoses. If there is more than 1" or 2" (2.5 cm or 5 cm) (H₂O) difference, adjust gauge by inserting a small flat bladed screwdriver into opening on back of digital gauge housing and turning potentiometer until digital gauge displays meter vacuum reading.

Compare readings at 10" (25 cm) and 20" (51 cm) of vacuum.

VACUUM METER SYSTEM

Kinze vacuum meter seed metering system includes seed meters, seed discs, and an air system consisting of a hydraulic driven vacuum fan which draws air through manifolds, hoses, and seed meters on each row unit.

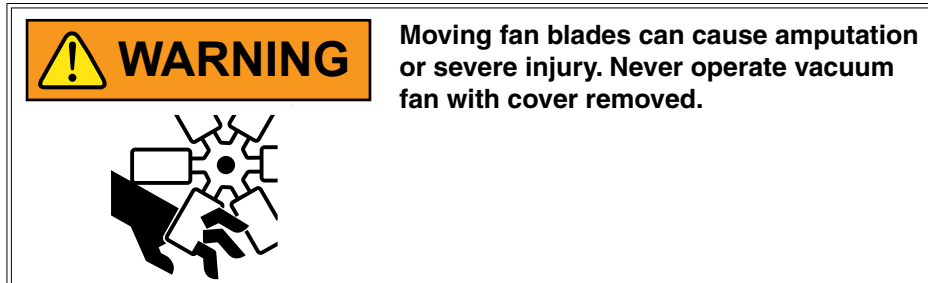

ANALOG VACUUM OR PRESSURE GAUGE

Analog vacuum or pressure gauge connects directly to vacuum meter (vacuum) or bulk fill (pressure) manifold and is teed into digital sending units.

Only adjustment is to “zero” needle with no vacuum or pressure present. If there is a significant difference between gauge and a reading taken at meters, a different manifold location should be found to connect hose to gauge and digital sending unit.

NOTE: Analog gauges are identical EXCEPT for plug and hose barb locations in side of gauge housing. DO NOT connect vacuum meter or bulk fill hose to wrong gauge. Check plug and hose barb installation if readout is erratic or appears inaccurate.

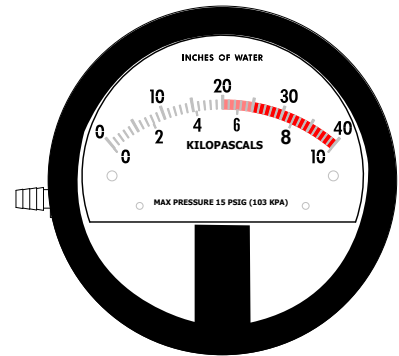

Analog Gauge

RIDGE PLANTING

Planter toolbar height can be raised 3" (8 cm) for ridge planting.

Relocate 20" transport axles to lower hole in wheel arm.

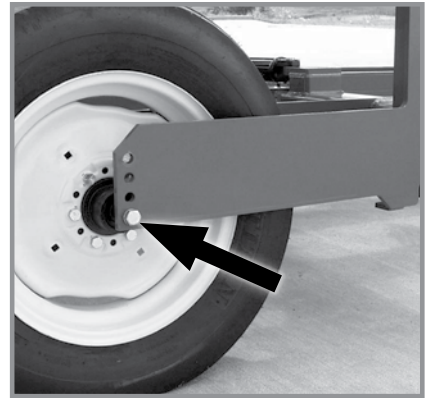

Transport axle in lowest position

TIRE SCRAPER

A tire scraper prevents buildup of dirt and mud between wheel arm assembly and tire.

Adjust scraper so it does not contact tire.



Tire scraper

ROCK GUARDS

Transport wheel rock guards are used on both sides of each transport wheel when planter is used in rocky conditions. Rock guards help prevent rocks from being picked up by wheels and damaging adjoining row units.

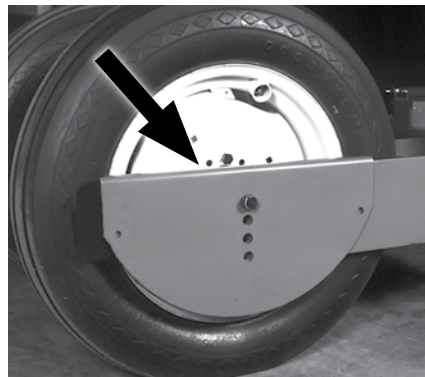

Rock guard

AUXILIARY WORK LIGHTS PACKAGE

Optional Auxiliary Work Lights Package includes two 50 watt, 3" x 5" halogen flood lamps, brackets, and hardware to mount lights at top of lift cylinder and a wiring harness to plug into existing planter light harness.



Auxiliary work lights

REAR TRAILER HITCH

NOTICE

Rear trailer hitch is designed for use with piston pump only. Maximum allowable hitch weight is 200 lb (90.71 kg). Do not exceed 6,000 lb (2,721.55 kg) gross towing weight or the equivalent of a loaded 500 gal (1,892.7 L) tank and running gear or equipment can be damaged.

Rear Trailer Hitch is used to tow a 3 or 4 wheel wagon behind planter.

A spring, chain and mounting bracket are used to support the 1¼" (38 mm) feed hose from hitch to piston pump. This extra length or loop is required to allow planter to be moved into transport position without stretching or breaking hose.

NOTE: Periodically check feed hose for kinks to prevent restricted delivery rate.

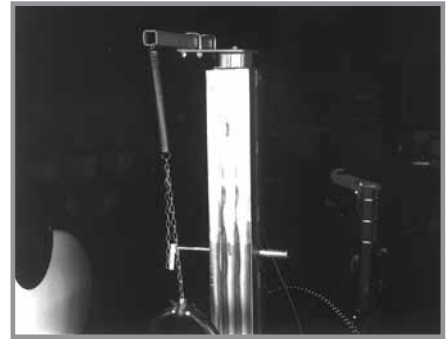

Rear hitch hose support

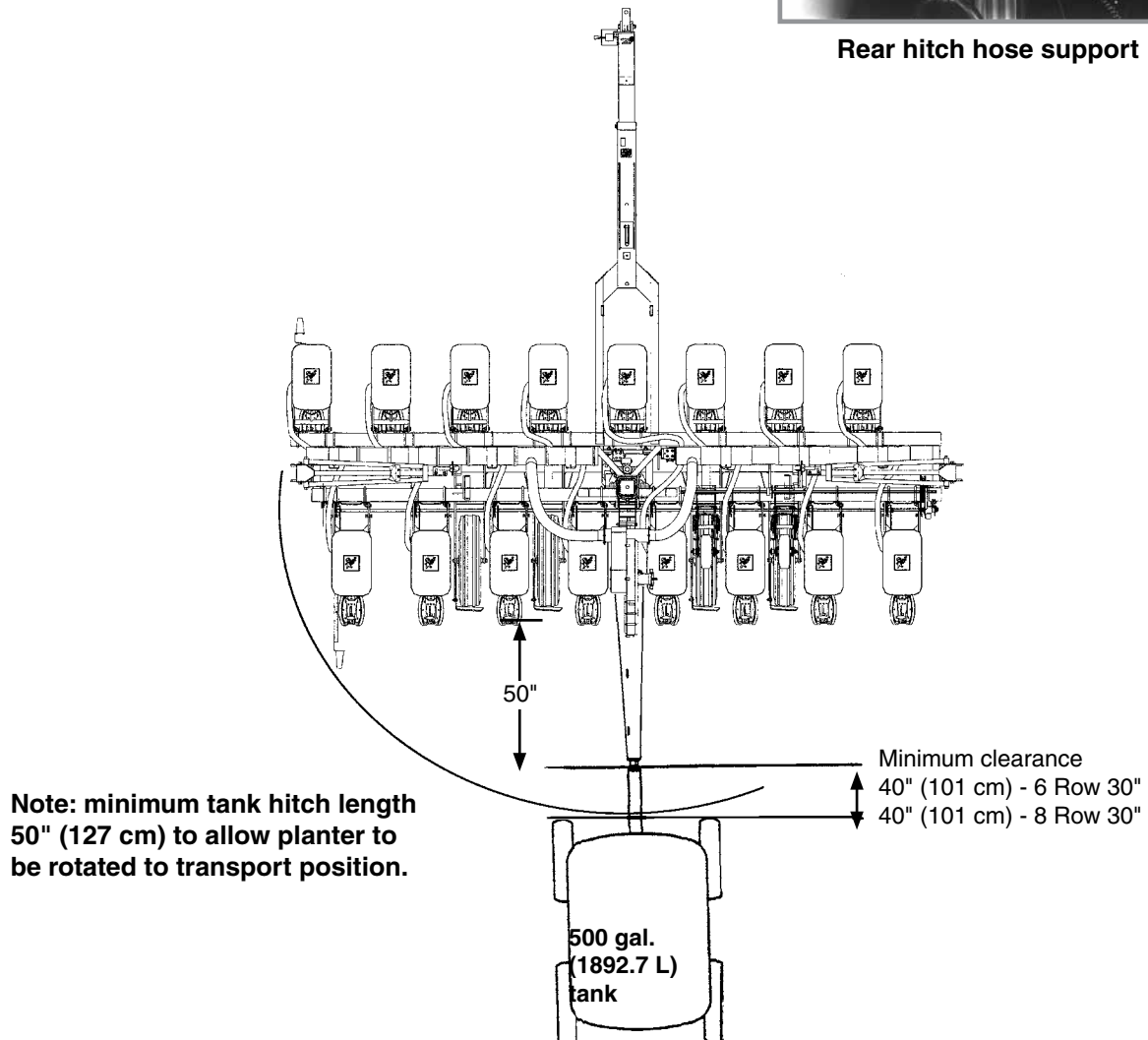

FIELD TEST

Perform a field test with any change of field and/or planting conditions, seed size or planter adjustment to ensure proper seed placement and operation of row units. See “Rate Charts”, “Check Seed Population” and “Granular Chemical Application Field Check”.

- Check planter for front to rear and lateral level operation. See “Level Planter”.
- Check **all** row units to be certain they are running level. Row unit parallel arms should be approximately parallel to the ground when planting.
- Check row markers for proper operation and adjustment. See “Row Marker Adjustments” and “Row Marker Speed Adjustment”.
- Check for proper application rates and placement of granular chemicals on **all** rows. See “Granular Chemical Application Field Check”.
- Check for desired depth placement and seed population on **all** rows. See “Check Seed Population”.
- Check for proper application rates of fertilizer on **all** rows. See proper “Fertilizer Application Rate Chart”.

Reinspect machine after field testing.

- Hoses And Fittings
- Bolts And Nuts
- Cotter Pins And Spring Pins
- Drive Chain Alignment

CHECK SEED POPULATION

1. Tie up one or more sets of closing wheels by running a chain or rubber tarp strap between the hopper support panel and closing wheels. It may be necessary to decrease closing wheel arm spring tension.

Chain, rubber tarp strap, or similar.

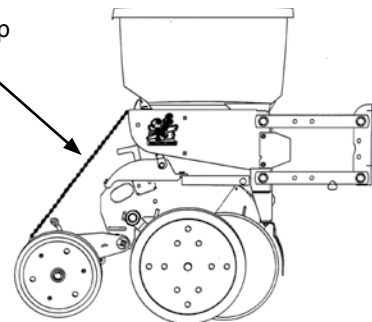

2. Plant a short distance and check to see if seed is visible in the seed trench. Adjust planting depth to a shallower setting if seed is not visible and recheck.

Planting depth adjustment handle



Planting depth adjustment

3. Measure $\frac{1}{1000}$ of an acre (hectare). See chart for correct distance for row width being planted. For example, if planting 30" (76 cm) rows $\frac{1}{1000}$ of an acre (hectare) would be 17' 5" (13.12 m).

$\frac{1}{1000}$ Hectare Seed Population Count Row Width/Distance						
Row Width	15" (38 cm)	18" (46 cm)	19" (48 cm)	30" (70 cm)	36" (91 cm)	38" (97 cm)
Distance	34'10" (6.56 m)	29'0" (5.46 m)	27'8" (5.18 m)	17'5" (14.28 m)	14'6" (10.93 m)	13'10" (10.36 m)

NOTE: Seeds may bounce or roll when planting with closing wheels raised and planting depth set shallow affecting seed spacing accuracy.

4. Count seeds in measured distance.
5. Multiply number of seeds placed in $\frac{1}{1000}$ of an acre (hectare) by 1000. This gives total population.

EXAMPLE: 30" (70 cm) row spacing 17' 5" (14.28 m) equals $\frac{1}{1000}$ acre.

26 seeds counted x 1000 = 26,000 seeds per acre

Seed count can be affected by drive wheel and seed meter drive ratio, tire pressure, and/or seed meter malfunction.

- If seed check shows average distance between seeds in inches is significantly different than seed rate chart indicates, first check drive ratio between drive wheel and seed meter. Check drive wheel air pressure, check for incorrect sprocket(s) in driveline and check drive and driven sprockets on transmission(s) for proper selection.
- Check for seed meter malfunction. For example, if spacing between kernels of corn at the transmission setting being used is 8" (20 cm) and a gap of 16" (40 cm) is observed, a finger has lost its seed and not functioned properly. If two seeds are found within a short distance of each other, the finger has metered two seeds instead of one.
- See "Finger Pickup Seed Meter Troubleshooting" and/or "Brush-Type Seed Meter Troubleshooting" in the Troubleshooting Section of this manual.

DETERMINING POUNDS PER ACRE (BRUSH-TYPE METER)

Seeds per acre \div Seeds per pound (from label) = Pounds per acre

If seeds per pound information is not available use the following averages:

2,600 seeds per pound for medium size soybeans
 15,000 seeds per pound for medium size milo/grain sorghum
 4,500 seeds per pound for medium size cotton

DETERMINING BUSHELS PER ACRE

Pounds per acre \div Seed unit weight = Bushels per acre



Average Unit Weight of:

1 Bushel Soybeans = 60 Pounds
 1 Bushel Milo/Grain Sorghum = 56 Pounds
 1 Bushel Cotton = 32 Pounds

If seed population check shows planting rate is significantly different than seed rate chart shows or if a particular meter is not planting accurately, see "Brush-Type Seed Meter Maintenance" and "Brush-Type Seed Meter Troubleshooting".

GRANULAR CHEMICAL APPLICATION FIELD CHECK

Temperature, humidity, speed, ground conditions, flowability of different material, or meter obstructions can affect granular chemical rate of delivery.

 WARNING	<p>Agricultural chemicals can cause death or serious injury to persons, animals, and plants or seriously damage soil, equipment, or property. Read and follow all chemical and equipment manufacturers labels and instructions.</p>
	

Perform a field check to determine application rates.

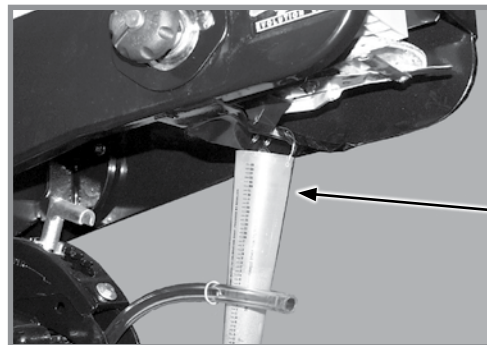

Calibrated vial

Granular chemical field check

1. Fill insecticide and/or herbicide hoppers.
2. Attach a calibrated vial to each granular chemical meter.

NOTE: Disengage clutch to avoid dropping seed during test.

3. Lower planter and drive 1320 feet (400 meters) at planting speed.
4. Weigh chemical in ounces caught in one vial.
5. Multiply that amount by factor shown to determine pounds (kilograms) per acre (hectare).

Pounds (Kg) Per Acre (Hectare)	
Row Width	Factor
30"	0.83 (0.0328)
36"	0.69 (0.0272)
38"	0.65 (0.0256)

EXAMPLE: You are planting 30" (70 cm) rows. You have planted for 1320 feet (400 meters) at the desired planting speed. You caught 12.0 ounces (337 grams) of chemical in one vial. 12.0 ounces (337 grams) times 0.83 (0.0357) equals 9.96 pounds (12 kilograms) per acre (hectare).

NOTE: Check calibration of all rows.

METERING GATE

Use metering gate setting as a starting point for distributing insecticide or herbicide. Charts are based on 5 mph (8 kph) planting speed. Use a higher gate setting for speeds faster than 5 mph (8 kph) and a lower setting for speeds slower than 5 mph (8 kph).

WATER TANK

The water tank is to only be filled with clean water or preferably potable water (water meeting local standards for drinking). The tank holds 4 gallons (15 L) of water. Be sure to check for regulations pertaining to this use. Tank should be filled with new water at the beginning of each planting season and drained at the end of each planting season.

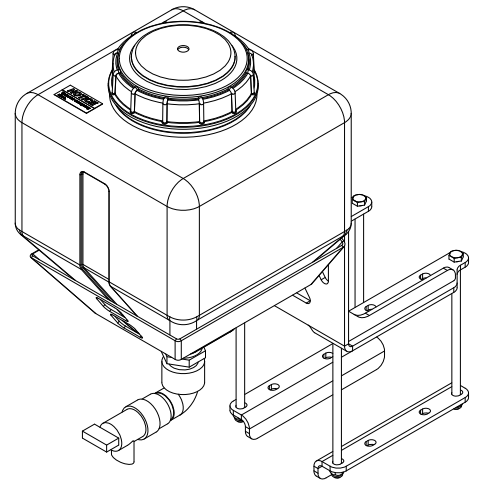

NOTICE

Drain tank if environmental conditions are 32° Fahrenheit (0° Celsius) or below to prevent tank from cracking.

The water tank is to be used in the event of an accidental exposure to chemical. Chemicals are supplied with Material Safety Data Sheets (MSDS) that provide full information about the chemical, its effects on exposure, and first aid needs in the event of an emergency. Keep your MSDS file up-to-date and available for first responders in case of emergency.

If the water tank is used seek medical assistance immediately for further treatment.

This page left blank intentionally.

PLANTING DEPTH

Planting depth is maintained by adjustable row unit gauge wheels. Depth adjustment range is approximately ½" to 3½" (1.2 to 8.8 cm).

1. Raise planter to remove weight from wheels.
2. Push down on depth adjustment handle and reposition it forward to decrease or rearward to increase planting depth. Initially adjust all units to the same setting.
3. Lower planter and check operation and planting depth of all row units. Readjust individual rows as needed for uniform operation.

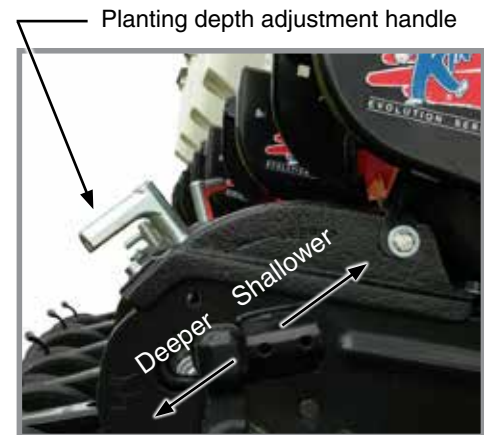

Planting depth adjustment

“V” CLOSING WHEEL ADJUSTMENT (RUBBER OR CAST IRON)

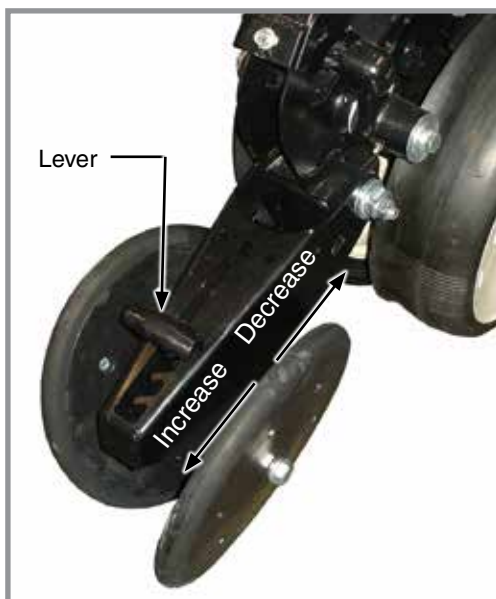

“V” Closing wheels installed offset

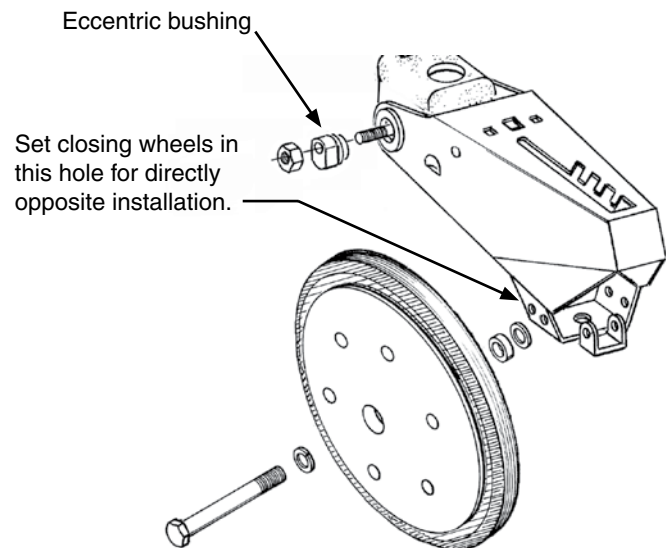

“V” closing wheels should have enough down pressure to close the seed trench and ensure good soil to seed contact. Move 5-position quick adjustable down force lever on the top of closing wheel arm to the rear to increase closing wheel spring pressure. Move lever forward to decrease pressure. Adjust all row units to a similar setting. Light soil usually requires less down force at average depth, approximately 2" (5 cm) while heavy soil requires increased down force.

Eccentric bushings in the wheel arm stop allow for lateral adjustment of the “V” closing wheel assembly. Use a ¾" wrench to loosen hardware attaching closing wheel arm to wheel arm stop. Use another ¾" wrench to turn eccentric bushings until **closing wheels are aligned with seed trench**. Tighten hardware.

Closing wheels can be installed “offset” (to improve residue flow) or “directly” opposite. Use forward installation holes if set “directly” opposite.

CLOSING WHEEL SHIELD (RUBBER OR CAST IRON "V" CLOSING WHEELS)

Optional closing wheel shield is installed on underside of closing wheel arm to help prevent root balls and stalks from clogging closing wheels.

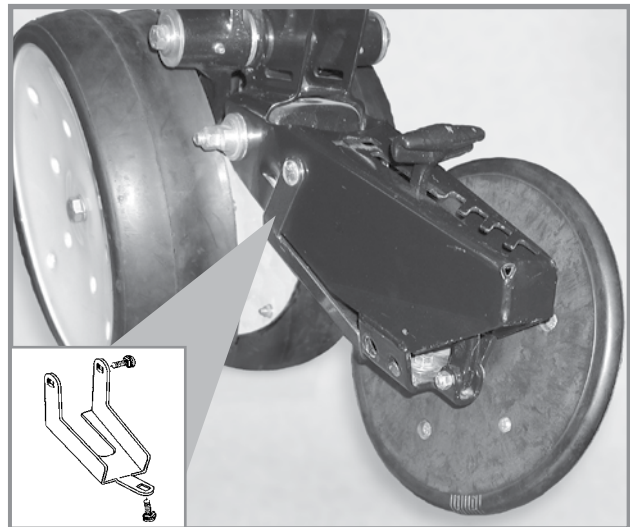

**Closing wheel shield
(Shown with closing wheel removed)**

DRAG CLOSING ATTACHMENT

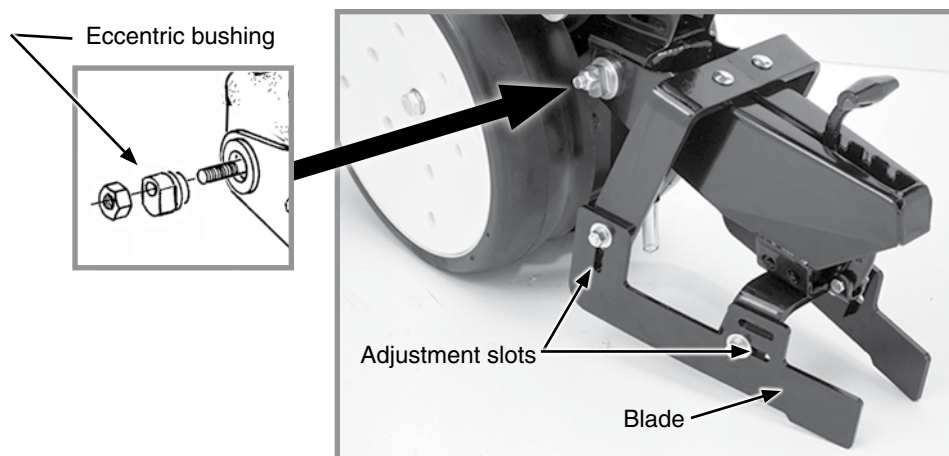

Drag closing attachment

Drag closing attachment pulls loose soil over the seed trench.

NOTE: Use of a seed firming wheel or other seed firming device is recommended with drag closing attachment.

Front and rear adjustment is made using the slotted holes in the blades. Adjust all rows the same.

Eccentric bushings in the wheel arm stop allow for lateral adjustment of the drag closing attachment. Use a $\frac{3}{4}$ " wrench to loosen hardware attaching closing wheel arm to wheel arm stop. Use another $\frac{3}{4}$ " wrench to turn eccentric bushings until drag closing attachment is aligned with seed trench. Tighten hardware.

COVERING DISCS/SINGLE PRESS WHEEL ADJUSTMENT

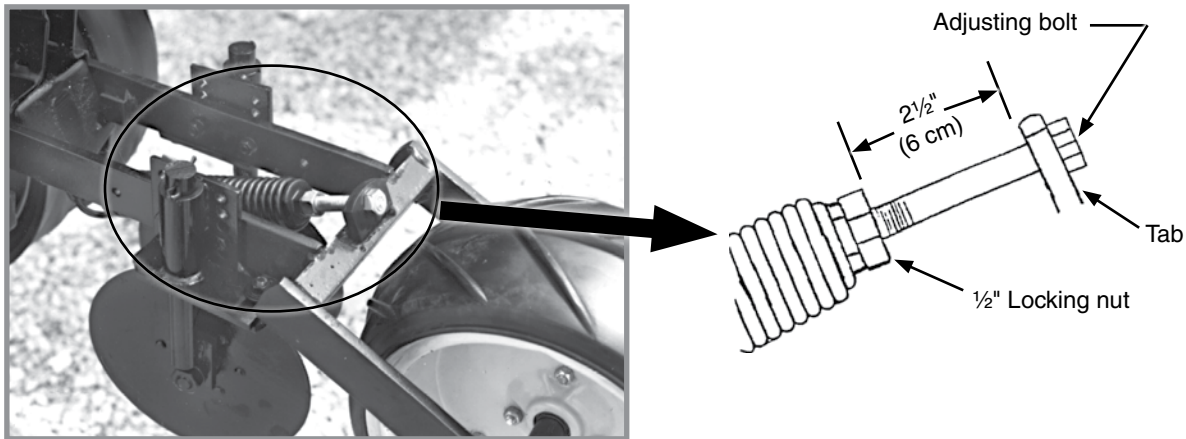

Press wheel down force adjustment

Check operation of covering discs/single press wheels after adjusting planting depth. Initial press wheel down force spring setting is 2½" (6.3 cm) between mounting arm tab and locking nut.

1. Loosen ½" (1.27 cm) locking nut and turn adjusting bolt in to increase down force or out to decrease down force.
2. Tighten locking nut against spring plug. Adjust all row units to a similar setting.

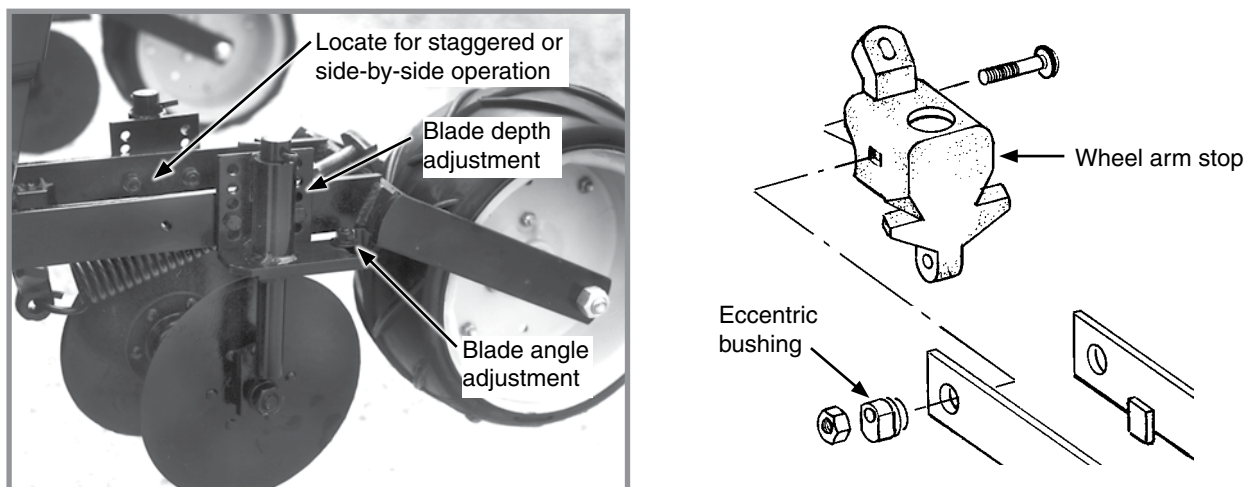

Covering disc adjustments

Eccentric bushings in the wheel arm stop allow for lateral adjustment of covering discs/single press wheel assembly. Use a ¾" wrench to loosen hardware attaching closing wheel arm to wheel arm stop. Use another ¾" wrench to turn eccentric bushings until covering discs/single press wheel assembly is aligned with seed trench. Tighten hardware.

Two sets of holes in mounting arm locate covering discs for staggered or side-by-side operation.

Five sets of holes in each disc bracket allow ½" (1.2 cm) incremental blade depth adjustment.

Slotted holes in disc mount and bracket allow for 0° - 15° blade angle adjustment.

Adjust covering discs on all row units to similar settings.

SEED HOPPERS

Mechanical seed hopper has a capacity of 1.9 bushels.

Vacuum seed hopper has a capacity of 1.75 bushels.

Use clean seed and make certain there are no foreign objects inside when filling seed hopper. **Replace hopper lids after hoppers are filled to prevent accumulation of dust or dirt in seed meter which can cause premature wear.** See “Finger Pickup Seed Meter”, “Brush-Type Seed Meter”, or “Vacuum Seed Meter”.

Periodically empty hoppers completely to remove any foreign objects and to ensure proper seed meter operation.

Disengage meter drive and hopper latch and lift hopper off hopper support. See “Seed Meter Drive Release”.



Mechanical seed hopper

SEED METER DRIVE RELEASE

A clutch release mechanism disengages seed meter drive from seed meter to remove seed hopper. Disconnecting drive allows operator to check granular chemical application rates without dropping seed. It also allows one or more rows to be disconnected when finishing fields.

Turn knob ¼ turn counterclockwise to disengage or ¼ turn clockwise to engage.

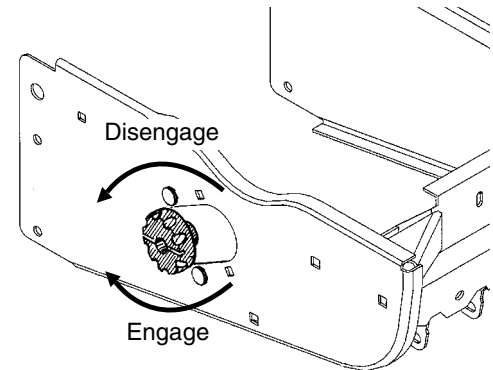

Seed meter drive release

ROW UNIT EXTENSION BRACKETS

Row unit extension brackets extend row units rearward 4" (10.1 cm) to provide clearance for coulter mounted residue wheels and HD single disc fertilizer openers.

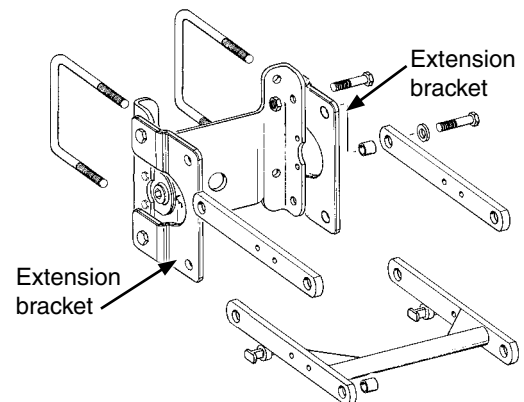

Row unit extension brackets

ROW UNIT CHAIN ROUTING

Row unit drive chains must be properly tensioned and aligned for proper operation and to minimize wear.

Inspect and replace weak, worn or broken springs, idlers, and idler bushings.

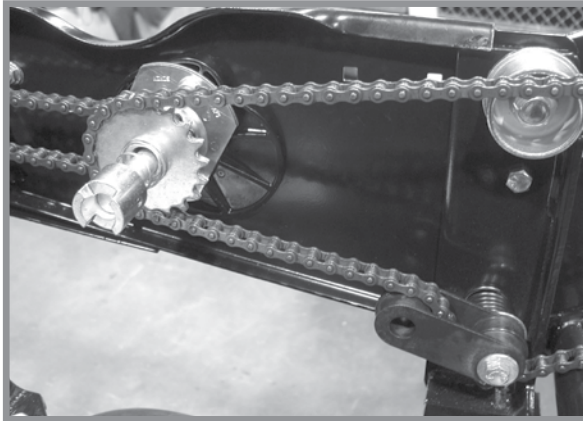

Mechanical pull row unit meter drive

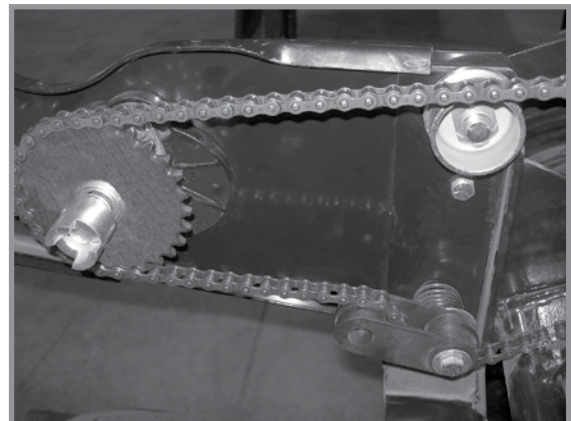

Vacuum pull row unit meter drive

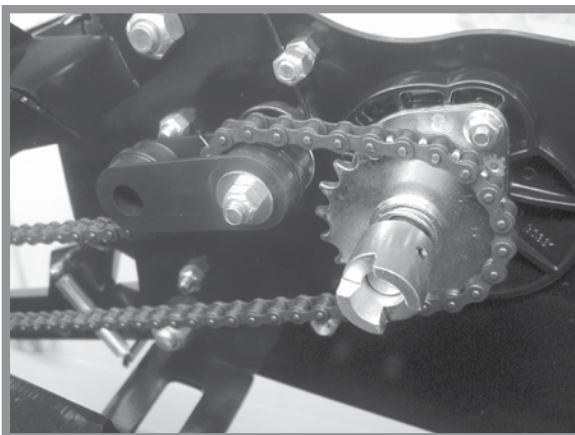

Mechanical push row unit meter drive

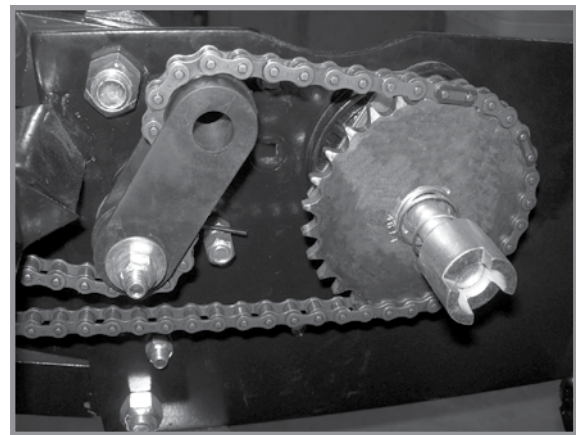

Vacuum push row unit meter drive



Row unit granular chemical drive

Direction of travel



NOTE: Install connector link with closed end facing direction of travel.

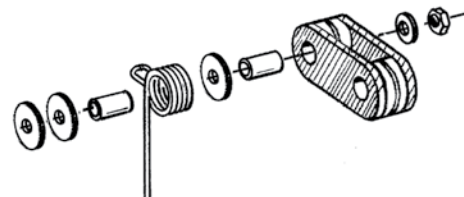

NOTE: Reverse idler when worn on one side for extended use.

QUICK ADJUSTABLE DOWN FORCE SPRINGS OPTION (STANDARD OR HEAVY DUTY)

Standard and heavy duty quick adjustable down force springs are available in increase penetration in hard soil and keep row unit from bouncing in rough field conditions. Two springs per row, one on each side parallel arms, are used unless equipped with row unit mounted no till coulters. Row unit mounted no till coulters require four springs per row.

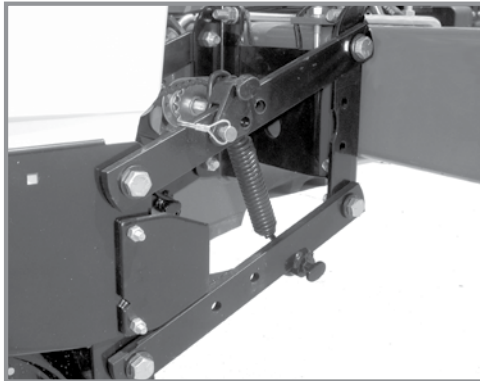

Two Springs Per Row (Dual)

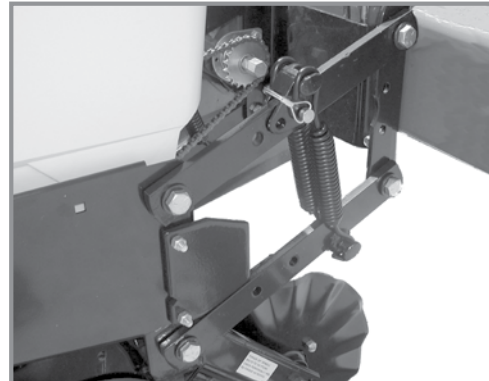

Four Springs Per Row (Quad)

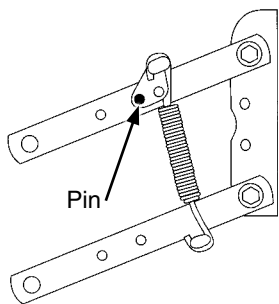

Position 1 (Least)

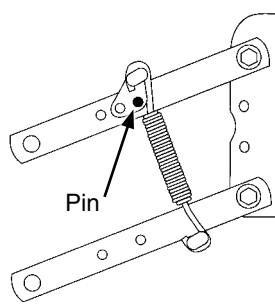

Position 2

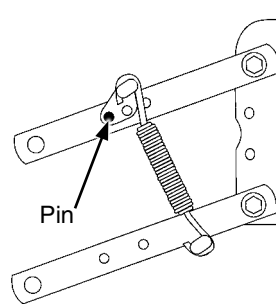

Position 3

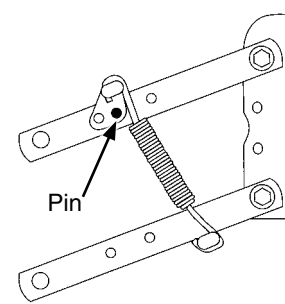

Position 4 (Most)

There are four positions to set down pressure spring tension.

Standard and Heavy Duty Spring Down Force Pressure*				
	2 Springs		4 Springs	
Position	Standard D8249	Heavy Duty D21337	Standard D8249	Heavy Duty D21337
1	41lb (18.6 kg)	43 lb (19.5 kg)	74 lb (33.6 kg)	80 lb (36.3 kg)
2	73 lb (33.1 kg)	86 lb (39.0 kg)	120 lb (54.4 kg)	144 lb (65.3 kg)
3	136 lb (61.7 kg)	167 lb (75.7 kg)	255 lb (115.7 kg)	307 lb (139.3 kg)
4	207 lb (93.9 kg)	249 lb (113.0 kg)	369 lb (167.4 kg)	470 lb (213.2 kg)

*Pressure does not include weight of row unit, seed, or options.

NOTICE	Springs must be installed with open side of spring hooks toward seed hoppers to prevent binding on spring mount adjustment pins.
---------------	---

1. Raise planter and remove spring mount pin at top of spring.
2. Slide mount to desired position and install pin.

NOTE: Adjust springs for field conditions. Too much down pressure in hard field conditions can cause row units to lift planter and keep drive wheels from making contact. Too much down pressure in soft field conditions can cause row unit to run too deep.

PNEUMATIC DOWN PRESSURE PACKAGE OPTION

Row unit down pressure can be adjusted on-the-go as field conditions change with pneumatic down pressure option. A cab-mounted control box adjusts pressure (Older models may have a digital readout). A planter-mounted 12 VDC air compressor with 3 gallon capacity air tank supplies air for the down pressure system.

Packages include upper and lower air spring mounting castings for pull row units (front and rear air spring mounting castings for push row units), 150 psi rated air springs, $\frac{3}{8}$ " O.D. nylon hoses, dual solenoid air valve and stainless steel, 160 psi, 2" liquid-filled gauge and planter wiring harness.

Pneumatic down pressure row unit extension brackets are required in some applications.

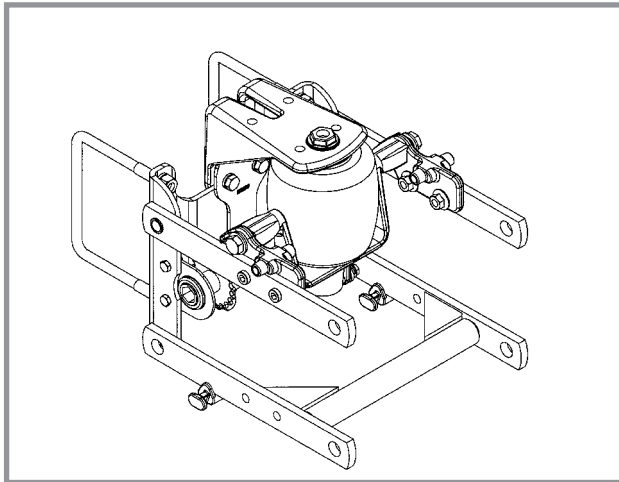

Pull Row Unit Air Spring

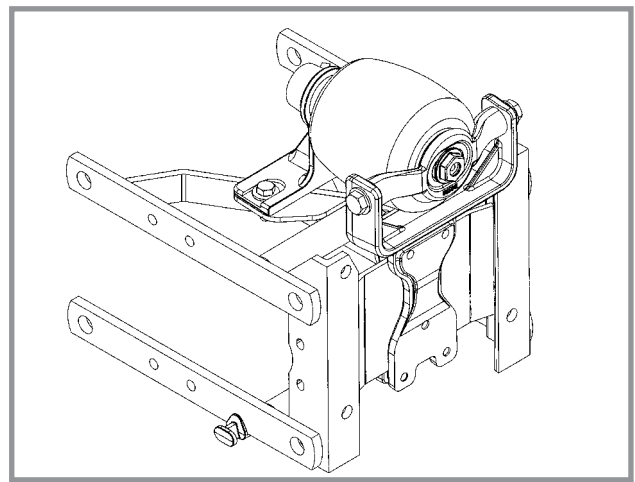

Push Row Unit Air Spring

NOTE: If additional down pressure is needed with the Pneumatic Down Pressure Package, assist springs are available through your Kinze dealer. One spring is installed on the outer side of the parallel arms on each side of the row unit as shown below.

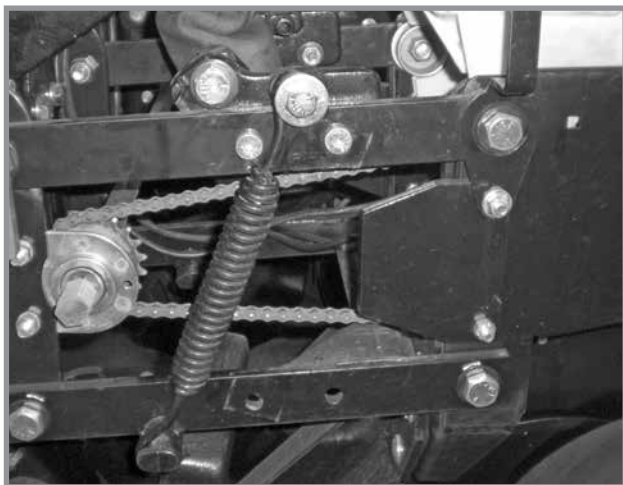

Pull Row Unit Assist Springs

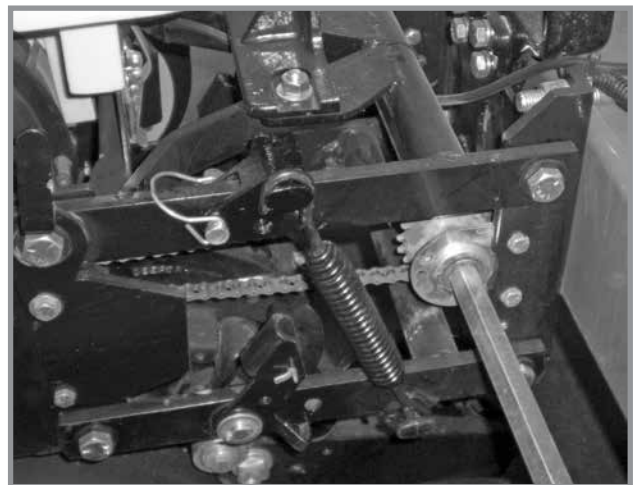

Push Row Unit Assist Springs

FIELD OPERATION

NOTE: Adjust down pressure with planter lowered and row openers in ground for most accurate adjustment. Pressure can be adjusted from tractor using control console, or at planter using manual control valves on compressor assembly.



Control console

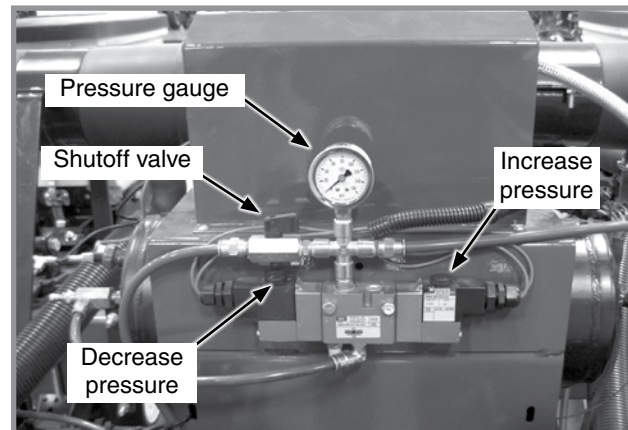

Air compressor assembly controls

ADJUST DOWN PRESSURE FROM CAB

Push toggle switch left to increase or right to decrease pressure.

ADJUST DOWN PRESSURE AT PLANTER

Push and hold decrease or increase button on compressor assembly to decrease or increase pressure.

NOTE: Value on the air pressure gauge is **NOT** down pressure force. Multiply air pressure (psi) by four (4) to calculate down pressure.

LOCK UP PUSH ROW UNITS EQUIPPED WITH PNEUMATIC DOWN PRESSURE SPRINGS

1. Press and hold button on solenoid until pressure gauge reads 5 PSI.
2. Lock up units. See "Interplant Push Unit Lockup" for instructions.
3. Turn shutoff valve handle perpendicular to valve body to turn off push row unit air supply.

INTERPLANT PUSH ROW UNIT LOCKUPS

Push row unit lockups lock interplant row units in the raised position.

 CAUTION	<p>Improper lifting of row units can cause serious injury. An empty row unit requires minimum 90 lb (40.8 kg) lift. Set down pressure springs to minimum, lower planter to ground, and empty seed hopper before attempting to lift with this lever.</p>
--	---

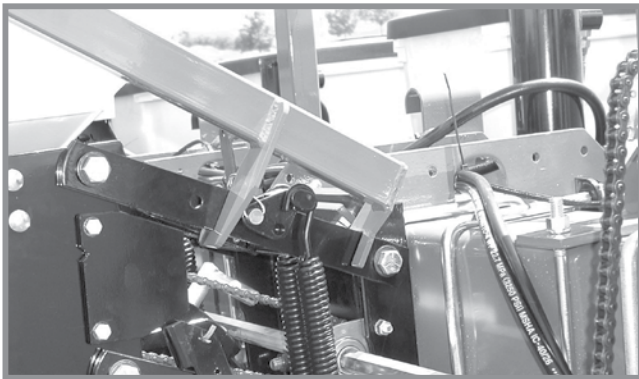

Lift lever positioned on push row unit

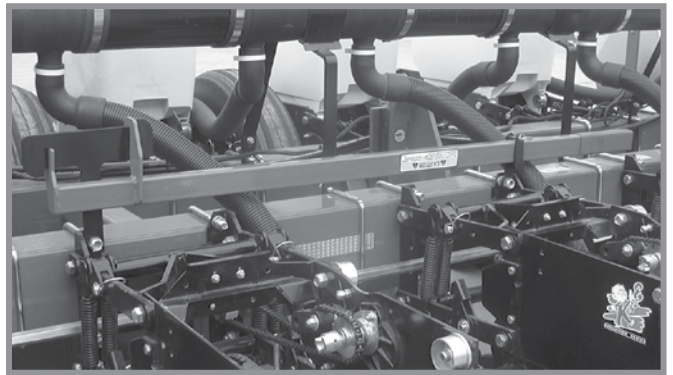

Lift lever in storage location

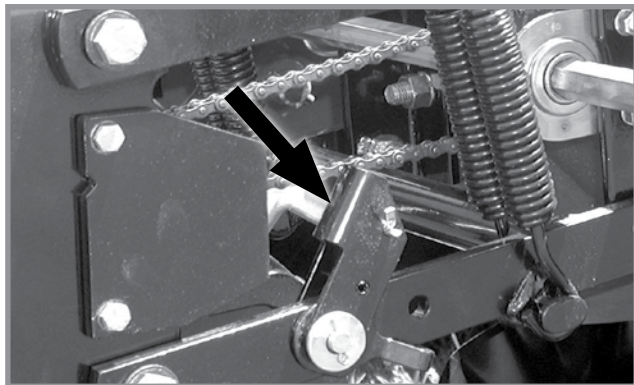

Lockup released for field operation

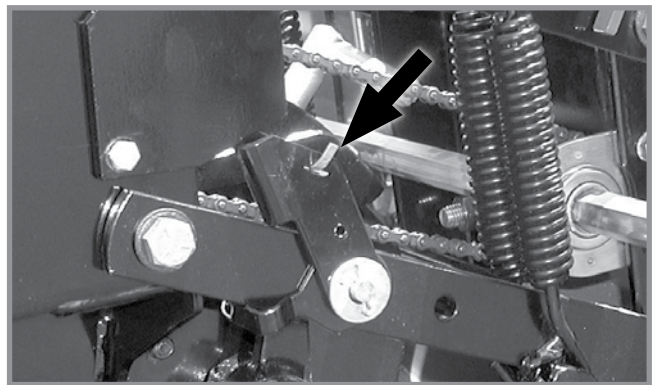

Push row unit locked in raised position

To lock in raised position:

1. Set row unit down pressure springs to minimum setting.
2. Lower the planter to the planting position.
3. Empty seed hoppers.
4. On each push row unit lockup, flip the spring tab forward.

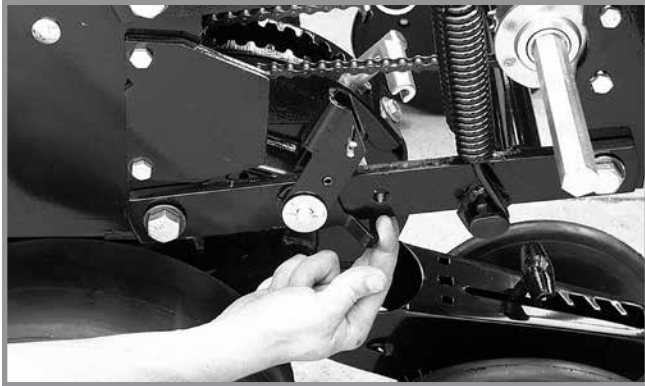

3. Using the lift lever, raise the push row unit to allow the spring loaded lockups to snap out of locked position. Lower row unit to the ground.
4. Repeat Step 3 on remaining push row units.

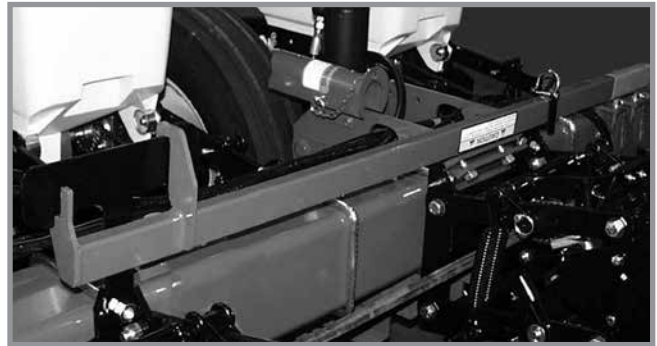
**Lift lever in storage location**

5. Using the lift lever, raise the push row unit to allow the spring loaded lockups to snap into locked position under the row unit stops.
6. Repeat Steps 4 and 5 on remaining push row units.

To release lockups:

1. Lower the planter to the planting position.
2. On each push row unit lockup, flip the spring tab rearward.

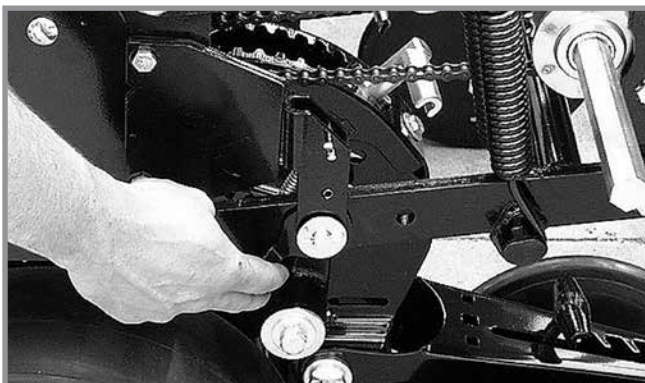

INTERPLANT PUSH ROW UNIT CLUTCH SPROCKET

Push row unit clutch sprocket disengages interplant drive from push row unit drill shaft when only pull row units are used.

DISENGAGE

Rotate knurled collar $\frac{1}{4}$ turn. Rock drill shaft slightly using a $\frac{7}{8}$ " wrench to take pressure off of spring loaded pins in clutch to allow pins to "pop" out, disengaging drive.

ENGAGE

Rotate knurled collar $\frac{1}{4}$ turn and turn drill shaft with a $\frac{7}{8}$ " wrench until drive pins engage drive sprocket.

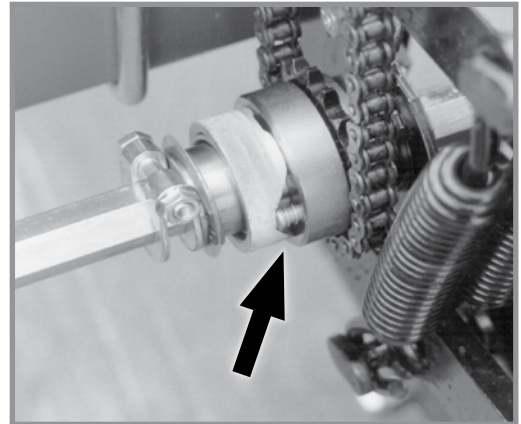

Interplant clutch sprocket



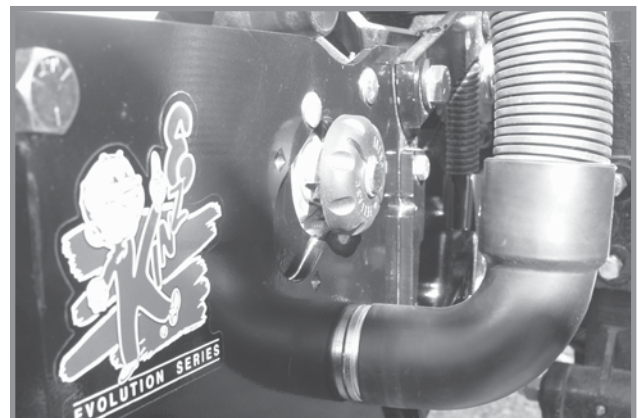
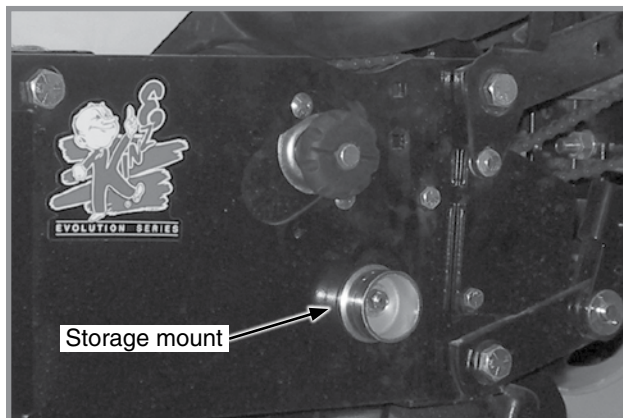







INTERPLANT PUSH ROW UNIT VACUUM HOSE SHUTOFF



Interplant vacuum hose shutoff

When push row units are not used, move row unit end of 2" (5 cm) vacuum hose on each push row unit to storage mount located on side of shank.

BRUSH-TYPE SEED METER

	Crop	Disc Color-Code (Disc Part No.)	Upper Brush Retainer	Cells	Seed Size Range	*Lubricant
	Soybean	Black (GA5794)	GD11122	60	2200 to 4000 seeds/lb. (4,840 to 8,800 seeds/kg)	Graphite Talc
	Specialty Soybean	Dark Blue (GA6184)	GD11122	48	1400 to 2200 seeds/lb. (3,080 to 4,840 seeds/kg)	Graphite Talc
	Small Milo/Grain Sorghum	Red (GA5982)	GD8237	30	14,000 to 20,000 seeds/lb. (30,800 to 44,000 seeds/kg)	Talc
	Large Milo Grain Sorghum	Light Blue (GA6187)	GD8237	30	10,000 to 16,000 seeds/lb. (22,000 to 35,200 seeds/kg)	Talc
	High-Rate Small Milo/Grain Sorghum	Red (GA5795)	GD8237	60	12,000 to 18,000 seeds/lb. (26,400 to 39,600 seeds/kg)	Talc
	High-Rate Large Milo/Grain Sorghum	Yellow (GA6633)	GD8237	60	10,000 to 14,000 seeds/lb. (22,000 to 30,800 seeds/kg)	Talc
	Cotton, Acid-Delinted	White (GA5796)	GD11122	30	4200 to 5200 seeds/lb. (9,240 to 11,440 seeds/kg)	Talc
	Large Cotton, Acid Delinted	Tan (GA6168)	GD11122	36	3800 to 4400 seeds/lb. (8,360 to 9,680 seeds/kg)	Talc
	High-Rate Cotton, Acid-Delinted	Light Green (GA6478)	GD11122	48	4200 to 5200 seeds/lb. (9,240 to 11,440 seeds/kg)	Talc
	Hill-Drop Cotton, Acid-Delinted	Brown (GA6182)	GD11122	12 (3 to 6 seeds/ cell)	4000 to 5200 seeds/lb. (8,800 to 11,400 seeds/kg)	Talc
	Small Hill-Drop Cotton, Acid-Delinted	Dark Green (GA7255)	GD11122	12 (3 to 6 seeds/ cell)	5000 to 6200 seeds/lb. (11,000 to 13,640 seeds/kg)	Talc

*For More information on application rate see Additives section.

 <p>Use GD11122 upper brush retainer when using cotton and soybean discs.</p>	 <p>Use GD8237 upper brush retainer when using milo/grain sorghum discs.</p>
---	--

Turn seed disc counterclockwise when installing on meter hub while tightening two wing nuts that retain disc. Seed disc should have slight resistance when rotated counterclockwise after wing nuts are tight.

Brush-type seed meter attaches to seed hopper same as finger pickup seed meter. Secure to bottom of seed hopper with two 5/16" thumbscrews. Tighten thumbscrews slightly with pliers. **DO NOT OVER TIGHTEN.**

Misalignment between drive coupler and seed meter input shaft may cause erratic seed spacing from momentary stoppage of seed disc. Check alignment and adjust as needed.

Refer to planting rate charts in this manual for recommended seed drive transmission sprocket combinations.





Shown without seed disc installed

NOTICE	Replace hopper lids after hoppers are filled to prevent accumulation of dust or dirt in seed meter which will cause premature wear.
---------------	--

NOTE: Clean seed is required to ensure accurate seed metering from brush-type seed meters. Remove seed discs daily and check seed meter or brushes for buildup of foreign material, such as hulls, stems, etc.

FINGER PICKUP SEED METER

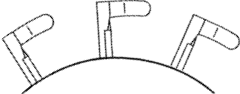
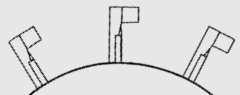









Crop	Fingers	*Lubricant
Corn	 Part No.: GR1848 - Finger Assembly, Corn	Graphite Talc
No. 1 and/or No. 2 size Confectionery Sunflower Seeds	 Part No.: GR1848 - Finger Assembly, Corn	Talc
No. 3 and/or No. 4 size Oil Sunflower Seeds	 Part No.: GR2154 - Finger Assembly, Oil	Talc
Blank fingers replace alternate fingers to reduce planting rate by half while allowing the finger wheel to maintain a minimum of 40 RPM when planting low rates.	 Part No.: GD11787 - Half Rate Blank Finger	Graphite Talc

***For More information on application rate see Additives section.**

NOTE: Always field check seed population to verify planting rates.

NOTE: Refer to planting rate charts in this manual for recommended seed drive transmission sprocket combinations.

VACUUM SETTINGS

Crop		**Seed Disc Kit	Seed Disc Part No.	Ejector Wheel (Color)	Cells	Seed Size Range	Singulator Zone Setting	Vacuum Setting Inches of Water (kPa)	Lubricant
	Corn ‡ Large Sweet Corn	G9040X	B0678 (Light Blue)	1 row 5 punches (Light Blue)	40	35-70 lbs/80k (2500-5000 seeds/kg)	2	18-20 (4.5-5.0)	Graphite* Talc* Bayer Fluency† (if mandated)
	Soybean	G9041X	B0848 (Black)	2 rows 6 punches (Black)	120	2200-4000 seeds/lb (4850-8820 seeds/kg)	0	10-14 (2.5-3.5)	Graphite* Talc* Bayer Fluency† (if mandated)
	Sugar Beet	G9043X	B0683 (Dark Orange)	1 row 6 punches (Dark Orange)	60	Pelletized	2	15 (3.75)	Graphite* Talc* Bayer Fluency† (if mandated)
	Milo	G9043X	B0683 (Dark Orange)	1 row 6 punches (Dark Orange)	60	10,000-20,000 seeds/lb (22000-44000 seeds/kg)	2	15 (3.75)	Graphite* Talc* Bayer Fluency† (if mandated)
	Sunflower ‡ Small Sweet Corn	G9042X	B0684 (Gray)	1 row 5 punches (Gray)	40	Oil seeds #2, 3, 4	2	12-18 (3.0-4.5)	Graphite* Talc* Bayer Fluency† (if mandated)
	Sunflower	G9042X	B0684 (Gray)	1 row 5 punches (Gray)	40	Oil seeds #5	2	5-8 (1.25-2.0)	Graphite* Talc* Bayer Fluency† (if mandated)
	Specialty Disc 1	G9272X	B0912 (Green)	1 row 6 punches (Green)	60	Cotton	2	15-20 (3.75-5.0)	Graphite* Talc as needed* Bayer Fluency† (if mandated)
	Specialty Disc 2	G9273X	B0914 (Brown)	1 row 6 punches (Green)	60	Black turtle & navy edible beans	2	15-20 (3.75-5.0)	Graphite* Talc as needed* Bayer Fluency† (if mandated)
	Specialty Disc 3	G9308X	B0913 (Dark Blue)	1 row 6 punches (Green)	60	Pinto & Great Northern edible beans & low-rate soybean	2	15-20 (3.75-5.0)	Graphite* Talc as needed* Bayer Fluency† (if mandated)

Install selected seed disc. Position vacuum cover on meter by aligning keyhole slots over bolt heads. Push cover on meter and turn counter clockwise to lock in place.

*For More information on application rate, see Additives section.

**Includes seed disc, ejector wheel, and spring.

†Bayer Fluency Agent is only required to be used in place of graphite or talc lubricants on vacuum equipped planters that are sowing neonicotinoid treated seeds in Canada. Refer to the Bayer Fluency Agent section for more information.

‡Conventional hoppers only, not applicable with bulk fill.

NOTE: See ["Check Seed Population" on page 2-26](#) for more information. Always field check seed population to ensure planting rates are correct.

NOTE: Singulator settings are marked from 0 - 3.

NOTE: Mixing seed sizes and shapes affects meter performance. Use consistent seed size and shape.

NOTE: Use 1 tablespoon powdered graphite with each standard hopper fill of seed. Seed treatment, foreign material, dirt or seed chaff may cause gradual reduction of seed disc fill (population). See "Additives" pages for more information.

NOTE: Excessive seed treatment, humidity, and light-weight seed can affect meter performance. Use ½ cup (118 ml) of talc with each standard hopper fill of seed and mix thoroughly to coat all seeds and adjust rates as needed. Use of talc aids seed flow into meter, singulation, and disc seed drop.

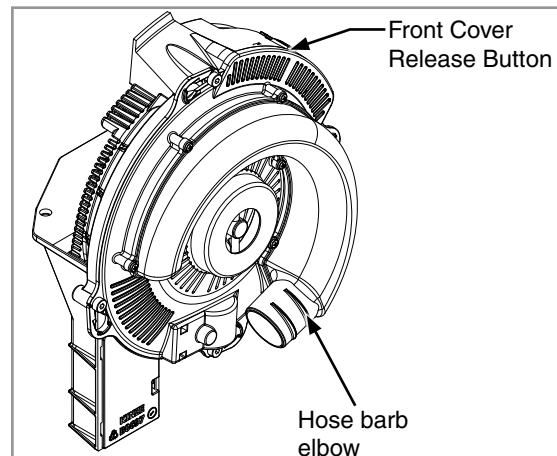
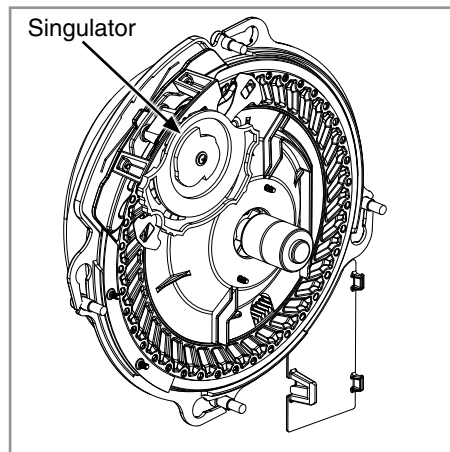

NOTE: Foreign material in seed disc orifices, such as seed chips, hulls, stems, etc., may affect seed delivery. Clean seed ensures accurate seed metering from vacuum seed meter. Remove Seed discs daily to check for buildup of foreign material in seed disc orifices.

Air inlet screens allow air to enter system and aids in keeping field residue or other foreign material out of meter.

See ["Vacuum Seed Meter Maintenance" on page 6-18](#) and ["Preparing Planter for Storage" on page 6-32](#) in Lubrication and Maintenance section for more information.

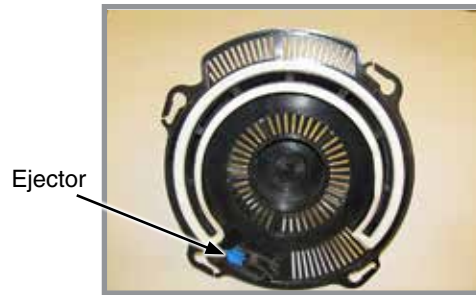

NOTE: Damaged seed or seed containing foreign material will cause plugging of seed disc orifices and require more frequent seed meter cleanout to prevent underplanting.

Wheel-Type Ejectors

Wheel-type ejectors expel seed remnants from seed disc orifices. These ejectors are disc specific and colored coded to match disc.

NOTICE	Replace hopper or tank lids after filling to prevent accumulation of dust or dirt in seed meter resulting in premature wear.
---------------	---

NOTE: Seed size, seed shape, seed treatments, travel speed, and planting rate affect meter performance.

1. Select seed disc and ejector to match crop and population.

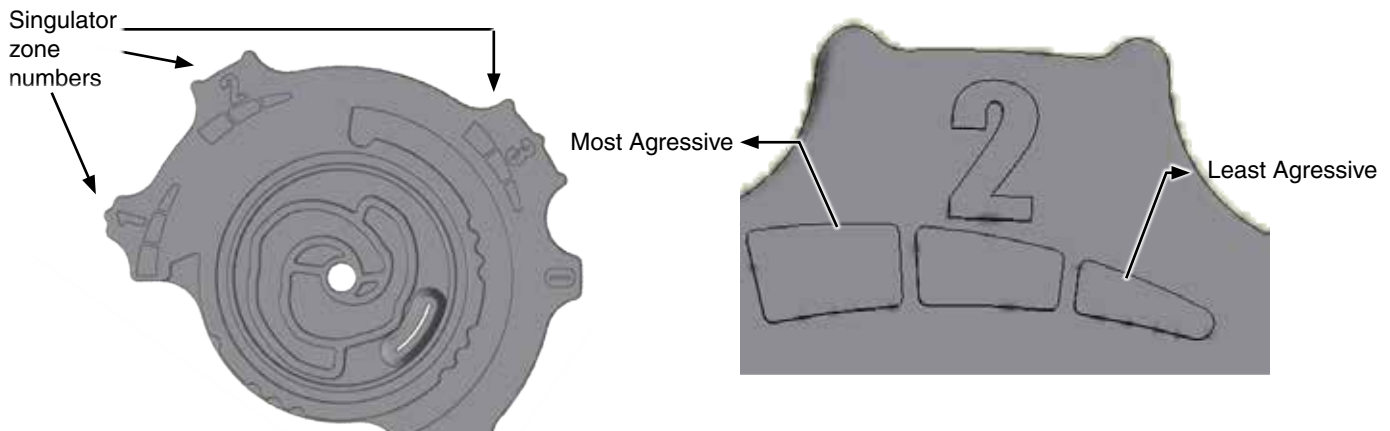

Singulator Adjustment Wheel

2. Adjust singulator wheel to initial setting. Seed size, seed shape, seed treatments, travel speed and planting rate all affect meter performance.
3. With vacuum fan running, lower planter to planting position and drive forward a short distance to load seed into seed disc cells.
4. Adjust vacuum level to initial setting according to tables on page.

NOTE: Vacuum reading will be much lower when seed disc cells are empty. Load all seed cells before setting vacuum level.

NOTE: Operate vacuum fan 3-5 minutes to bring oil up to normal operating temperature prior to making final vacuum level adjustment.

4. Adjust vacuum level to initial setting according to tables on page.

NOTE: Vacuum reading will be much lower when seed disc cells are empty. Load all seed cells before setting vacuum level.

NOTE: Operate vacuum fan 3-5 minutes to bring oil up to normal operating temperature prior to making final vacuum level adjustment.

SEED METER CLEANOUT

NOTE: Use of damaged seed or seed containing foreign material will cause plugging of seed cell orifices and require more frequent seed meter cleanout to prevent underplanting.

Thorough seed meter cleanout is important to maintain genetic purity.

1. Disengage seed drive and remove seed hopper and meter.
2. Dump seed from right rear corner of hopper into a container.
3. Lay hopper on its right side. Push release button and rotate seed meter vacuum cover clockwise to align keyhole slots with bolt heads. Lift off cover.
4. Rotate seed disc hub clockwise to unlock and remove seed disc.
5. Empty meter.
6. Thoroughly inspect meter to ensure all seed is removed.
7. Replace seed disc. Install vacuum cover.

ADDITIVES

The use of graphite is recommended to promote seed flow, provide lubrication for the seed meter and to help dissipate static charge buildup. Among the available dry seed lubricants graphite is the most effective and easiest to use and it requires no mechanical agitation

CONVENTIONAL HOPPERS

Mix one tablespoon of **powdered graphite** with seed each time hoppers are filled. Regular graphite use prolongs life of the seed meter components, improves seed spacing, and may reduce buildup of seed treatments.

NOTE: DO NOT apply graphite only in center of hopper. It will filter too quickly through the seed and not distribute as evenly as desired.

Apply graphite around outer perimeter of hopper.

ASD HOPPERS

Mix 1 pound (.5 kg) bottle of powdered graphite each time the bulk seed hopper is filled. Graphite should be added in layers as the bulk seed hoppers are filled. Regular graphite use prolongs life of the seed meter components, improves seed spacing, and may reduce buildup of seed treatments.



Adding graphite to conventional hopper



Adding graphite ASD hopper

NOTE: Additional graphite may be required to retard buildup of seed treatments on meter components. More frequent cleaning of monitor seed tubes may be necessary due to use of additional graphite.

Talc seed lubricant may be used as a drying agent in addition to graphite lubrication. The drying agent may improve seed release and/or **to retard buildup of seed treatments on meter components.**

1. Fill hopper $\frac{1}{2}$ full of seed, add $\frac{1}{4}$ cup (59 ml) (conventional); 2 pounds (1 kg) (ASD) of talc and **mix thoroughly.**
2. Finish filling hopper, add another $\frac{1}{4}$ cup (59 ml) (conventional); 2 pounds (1 kg) (ASD) of talc and **mix thoroughly.**
3. Adjust rate of talc use as needed so all seeds are coated, while avoiding a buildup of talc in bottom of hopper.

Humid conditions and/or small sized seeds with extra seed treatment may require additional talc to maintain meter performance.

NOTE: Liquid seed treatments or inoculants may create buildup on the seed disc or brushes. Check frequently for proper population and/or seed delivery when using any liquid seed treatment.

Completely mix all treatments with seed following manufacturers' recommendations. Seed treatment dumped on top of seed after hopper is filled may not mix properly and cause seed bridging, reducing population or stopping meter from planting.

Lubricant Application Rate	
Graphite	
Conventional Hoppers	1 Tbs. (15 ml)/Hopper Fill
ASD Hoppers	1 Pound (.5 kg) Bottle/Hopper
Talc	
Conventional Hoppers	$\frac{1}{4}$ " C. (59 ml*)
ASD Hoppers	4 Pounds (2 kg)/Hopper*
*Double amount of talc for sunflowers.	

BAYER FLUENCY AGENT

Bayer Fluency Agent is an alternate seed lubricant by Bayer Crop Science. The intent of this product is to replace graphite and talc lubricants and to lower the amount of dust emissions from planter vacuum fans.

This product, as tested by Kinze, is compatible with Kinze's bulk fill system and vacuum meters. Due to limited testing, wear life characteristics of meters and bulk fill systems that use Bayer Fluency Agent are not yet known. Please follow Bayer Fluency Agent instructions for rates and mixing directions.

NOTE: Presently, Bayer Fluency Agent is only required to be used in Canada with Bulk Fill or Vacuum planters that plant corn or beans treated with neonicotinoids. Farms outside of Canada, farms not using seed treated with neonicotinoids, and farms not using pneumatic metering devices do not need to use Bayer Fluency Agent. All planters not equipped with vacuums or fans are exempt from using Bayer Fluency Agent.

FRAME MOUNTED COULTER (PULL ROW ONLY)

Frame mounted coulters with 1" bubbled, 1" fluted (8 flutes) or 3/4" fluted (13 flutes) blades are used on pull row units only.

Springs provide down pressure on coulters for maximum penetration while exerting less shock load on row unit.

Initial coulters blade location is in top hole. Relocate blade to one of lower two holes (1" increments) as wear occurs or for deeper blade operation.

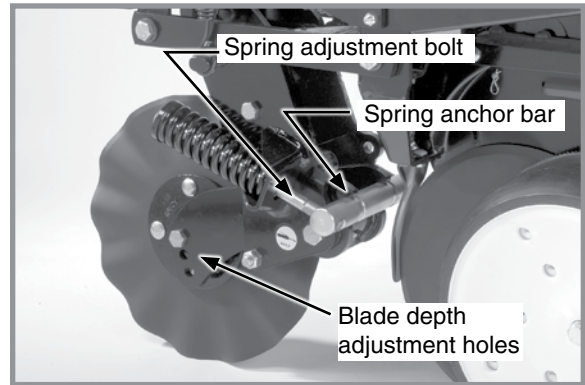

Frame mounted coulter adjustment

DOWN PRESSURE ADJUSTMENT

NOTICE

Excessive down pressure can damage coulter components when coulter strikes an obstacle. Do not set down pressure higher than needed for consistent soil penetration.

Raise planter. Turn spring adjustment bolts clockwise to increase or counterclockwise to decrease down pressure. Set both springs to specification shown in following table:

End flush with spring anchor bar	Extended 1/2" through spring anchor bar	All threads used
275 lb (124.7 kg)	400 lb (181.4 kg)	500 lb (226.8 kg)

RESIDUE WHEELS (FOR FRAME MOUNTED COULTER)

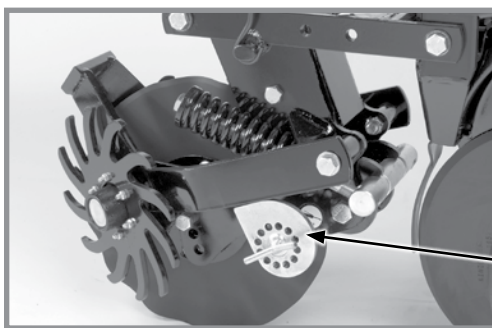

Style A residue wheel shown

Residue wheels attach to frame mounted coulters with two cap screws and sleeves allowing the unit to free-float. A 2-position spindle bolt mounting positions wheels interlocked or staggered. Depth adjustment is made with a spring-loaded cam and pin with 11 positions in 1/4" increments. A high point on the cam allows wheels to be locked up.

A weed guard on the inboard side of each wheel helps prevent weed wrap which can cause premature bearing failure.

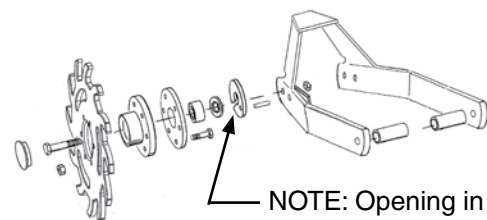

NOTE: Opening in weed guard must face down.

Style B residue wheel shown

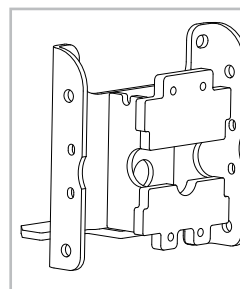

NOTE: Four center row units require special mount and extension brackets when using Frame Mounted Coulters W/Residue Wheels.

ROW UNIT MOUNTED DISC FURROWER (PULL ROW ONLY)

Disc furrowers are used to clear crop residue, dirt clods, and dry soil from in front of row units for a clean and smooth seed bed. The disc furrower may be equipped with 12" solid blades or 12" notched blades. Notched blades are for heavier residue conditions and cut crop residue and move it aside to prevent plugging or pushing.

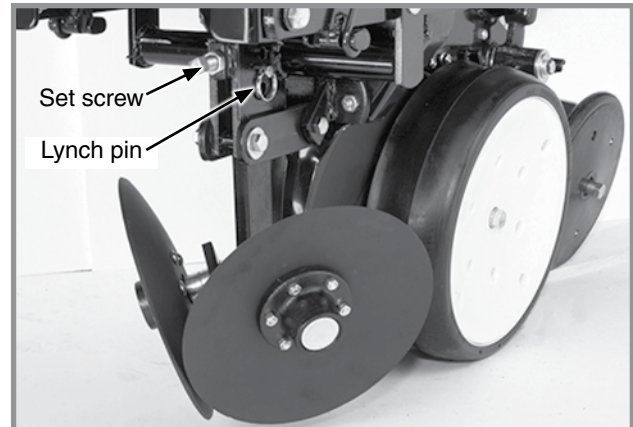
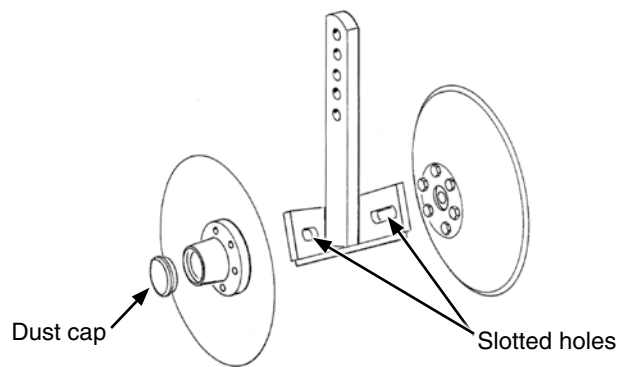

Disc furrower adjustment

Vertical adjustment can be made in $\frac{1}{8}$ " (0.8 cm) increments. Remove lynch pin in vertical support arm and move arm up or down. Reinstall lynch pin. Finer adjustment can be made by removing lynch pin and using $\frac{5}{8}$ " x $2\frac{1}{4}$ " set screw to clamp support arm in position.

Slotted holes in support arm allow front to rear disc blade adjustment. Blades can be adjusted so front edges meet or cutting edge of one blade overlaps edge of other blade.

NOTE: Dust cap must be removed to make adjustments.

ROW UNIT MOUNTED BED LEVELER (PULL ROW ONLY)

NOTE: Row unit mounted bed leveler is not compatible with row spacings less than 36".

Vertical adjustment can be made in $\frac{1}{8}$ " (0.8 cm) increments. Remove lynch pin in vertical support arm and move arm up or down. Reinstall lynch pin. Finer adjustment can be made by removing lynch pin and using $\frac{5}{8}$ " x $2\frac{1}{4}$ " set screw to clamp support arm in position.

Slotted holes in support arm allow blade adjustment. Blades can be tilted up or down.

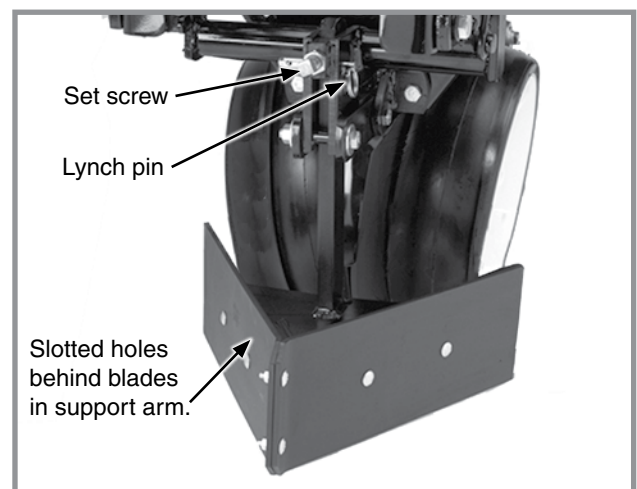

Bed leveler adjustment

ROW UNIT MOUNTED RESIDUE WHEEL

Row unit mounted residue wheel are used on pull and push row units.

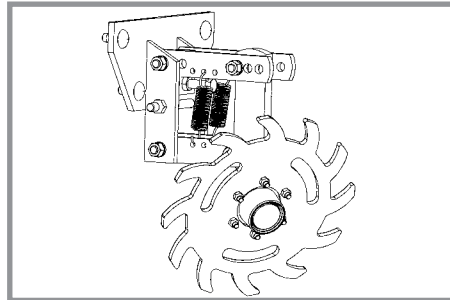

Two adjustable springs on each residue wheel parallel links provide down force adjustment. Position 1 provides minimum down pressure and position 3 maximum down pressure.

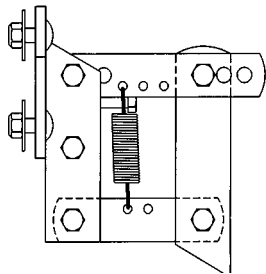

Position 1 (Least)

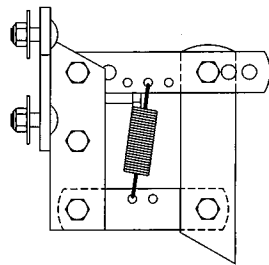

Position 2

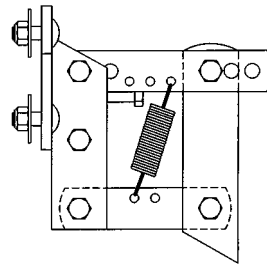

Position 3 (Most)

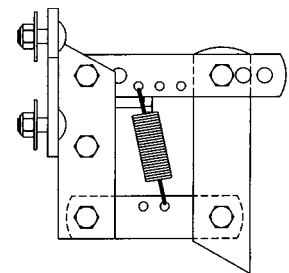

Additional uplift or float

Raise row unit and reposition springs to adjust down pressure.

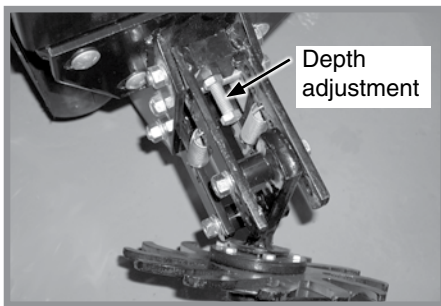

Wheel depth adjustment

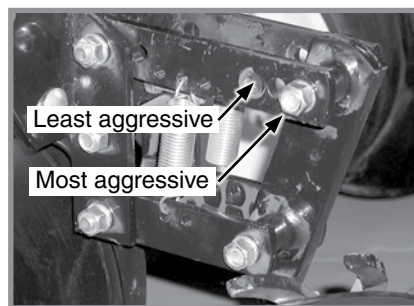

Wheel angle adjustment

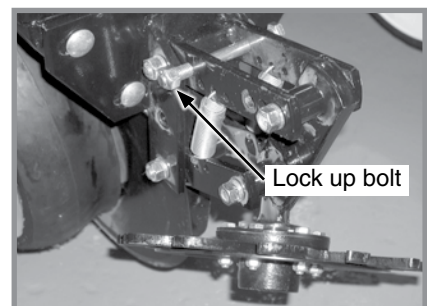

Wheel lock up

A full threaded bolt and jam nut located on the upper link sets maximum depth for loose soil conditions. Initial setting is 1 3/4" (4.4 cm) above row unit double disc opener depth.

Three holes in upper link adjust wheel angle. With wheel mount in most vertical position, using the rear hole in the upper link, the residue wheel is most aggressive. Moving wheel mount to a forward hole reduces aggressiveness of residue wheel for use in mulch till applications where soil is loose.

To lock residue wheel up, remove 1/2" x 5" lockup bolt, raise residue wheel and install bolt.

SPIKED CLOSING WHEEL

Spiked closing wheels crumble the sidewall, allowing roots to penetrate soil. They can be used on pull row units and push row units.

Align spiked closing wheels straight across from each other, in most rearward holes on closing wheel arm. Set the wheels 1" - 1¼" (2.5 - 3.1 cm) apart at the closest point. If large amounts of contouring is being done, mount wheels in the forward most hole. This will reduce drifting of row unit.

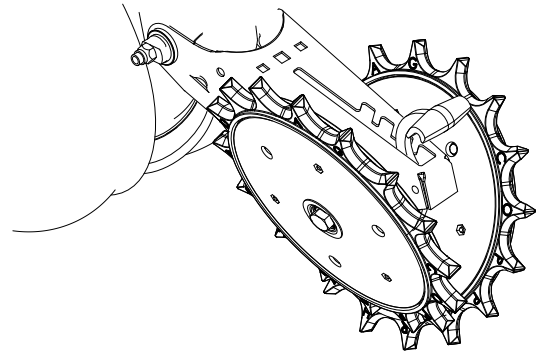

Row Unit Spiked Closing Wheel

ROW UNIT MOUNTED NO TILL COULTER



Row unit mounted no till coulters with 1" bubbled, 1" fluted (8 flutes) or $\frac{3}{4}$ " fluted (13 flutes) blades may be used on pull row units and push row units ($\frac{3}{4}$ " fluted shown). Four quick adjustable down force springs are required per row when using row unit mounted no till coulters. See "Quick Adjustable Down Force Springs Options".

Align coulters blade in relation to row unit double disc openers. Adjust by loosening four attaching bolts, moving coulters arm, and tightening four attaching bolts. Coulters blade can be adjusted to one of four $\frac{1}{2}$ " incremental settings in the forked arm. Initial location is the top hole. Move blade as it wears to one of the three lower hole to maintain coulters blade at or slightly above opener discs as needed. Adjust coulters below depth of double disc opener blades in very hard soil conditions such as compacted wheel tracks to improve opener penetration and cutting of surface residue.

Check operating depth by setting planter down on a level concrete floor and checking relationship between coulters blade and row unit opener blade. Make sure planter is level and coulters is square with planter frame and aligned with row unit disc opener.

NOTE: Torque $\frac{5}{8}$ " spindle hardware to 120 ft-lb (162.7 N-m).

COULTERS MOUNTED RESIDUE WHEELS

Coulters mounted residue wheels are designed for use on pull row units and push row units. Row unit extension brackets are required on the four center pull row units if the planter is equipped with coulters mounted residue wheels.

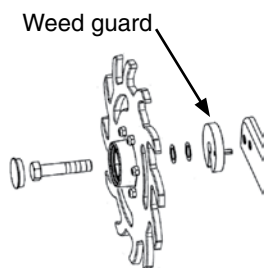

NOTE: Opening in weed guard must face down.



Residue wheels attach to row unit mounted coulters with two cap screws and sleeves allowing unit to free-float. A 2-position spindle bolt mounting positions wheels interlocked or staggered. Depth adjustment is made with a spring-loaded cam and pin with 11 positions in $\frac{1}{4}$ " (0.6 cm) increments. A high point on the cam allows wheels to be locked up.

A weed guard on the inboard side of each wheel helps prevent weed wrap which can cause premature bearing failure.

GRANULAR CHEMICAL HOPPER AND DRIVE



WARNING

Agricultural chemicals can cause death or serious injury to persons, animals, and plants or seriously damage soil, equipment, or property. Read and follow all chemical and equipment manufacturers labels and instructions.



The granular chemical hopper has a 1.4 cubic feet capacity.

Make sure no foreign objects get into hopper when it is being filled. Replace hopper lids after filling to prevent accumulation of dirt and moisture.

A metering gate on bottom of hopper regulates the application rate. See “Dry Insecticide and Dry Herbicide Application Rate Charts” in this manual. Calibrate using chemical manufacturers’ instructions.



Granular chemical hopper

Granular chemical clutch drive coupler and meter shaft can be disengaged and engaged by turning throwout knob at rear of hopper support panel.

Rotate knob $\frac{1}{4}$ turn counterclockwise to disengage and $\frac{1}{4}$ turn clockwise to engage.

Slotted holes in hopper support panel and clutch housing allow for alignment adjustment between clutch drive coupler and meter shaft.

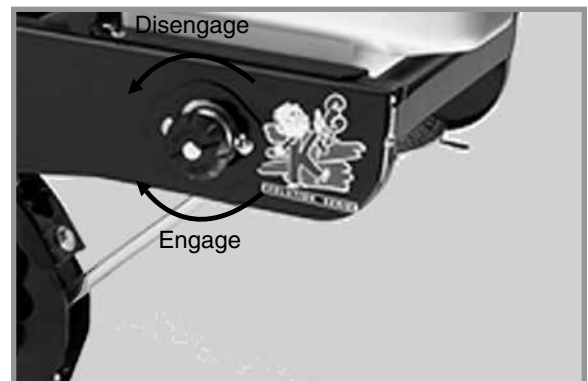

Granular chemical drive release

SPRING TOOTH INCORPORATOR

Spring tooth incorporator smooths soil behind row unit and incorporates granular chemicals.

Adjust two mounting chains on each spring tooth incorporator so there is approximately $\frac{1}{8}$ " (0.3 cm) slack in chain when unit is lowered to planting position.

NOTE: Spring tooth incorporator is not compatible with covering discs/single press wheel option.



Spring tooth incorporator

GRANULAR CHEMICAL BANDING OPTIONS

Granular chemical banding options allow 4½" slope-compensating banding, straight drop in-furrow placement or 14" rear banding.

NOTE: Granular chemical rear bander is not compatible with covering discs/single press wheel option.

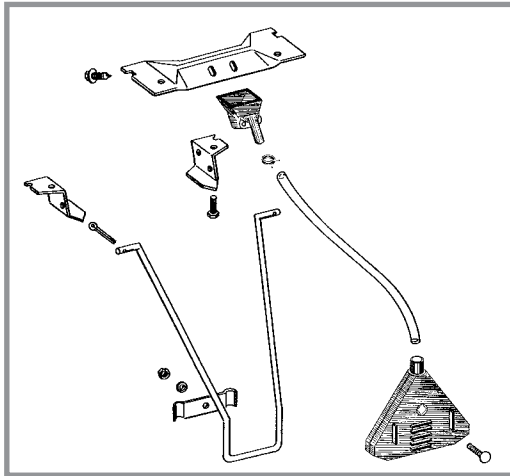

14" Rear Banding

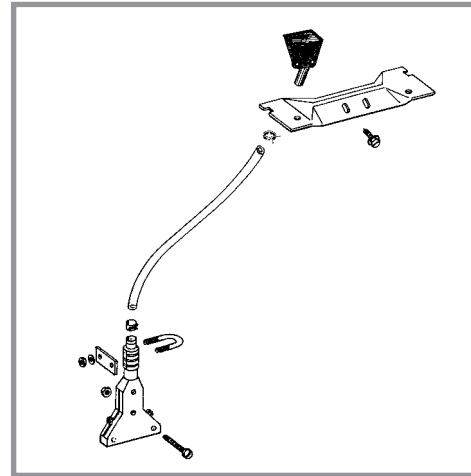

4½" Slope-Compensating Bander

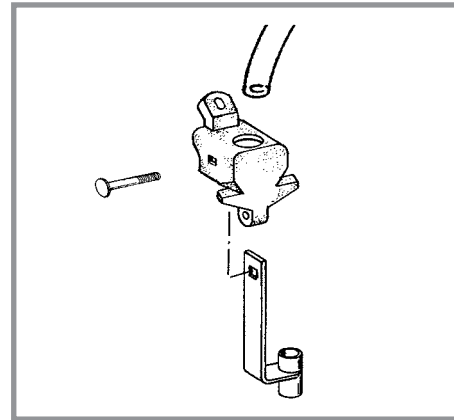

Straight Drop In-Furrow Placement

GRANULAR CHEMICAL BANDER SHIELD

Optional granular chemical bander shield is installed on underside of wheel arm stop to shield crop residue from lodging in granular chemical bander.

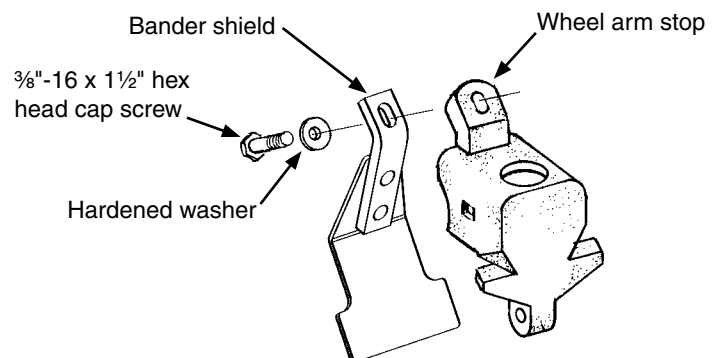

Granular chemical bander shield installation

DOUBLE DISC FERTILIZER OPENER

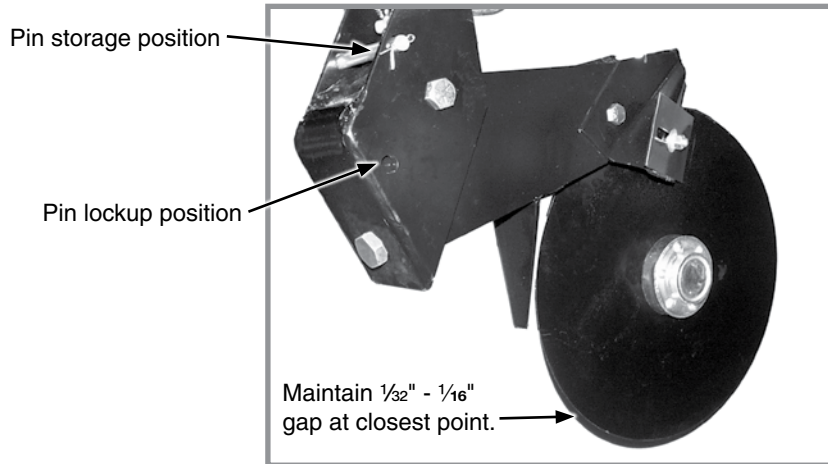

Double disc fertilizer opener

Position double disc fertilizer openers **to place fertilizer no closer than 2" (5 cm) to either side of row.** Fertilizer depth is approximately 4" (10 cm) If planter frame is level and at proper 20" (51 cm) operating height. Soil conditions can affect depth slightly.

NOTE: Do not set opener depth with spring pressure. Opener is designed to operate against a depth stop and spring up when encountering a foreign object or hard ground.

Down pressure spring is factory preset at 250 lb (113.4 kg) but can be adjusted for various soil conditions.

1. Loosen jam nut with a $1\frac{5}{16}$ " wrench.
2. Use a 1" wrench to turn adjustment bolt clockwise to increase tension or counterclockwise to decrease tension.
3. Tighten jam nut.

NOTICE

Do not operate double disc openers at full down pressure tension on rocky ground or disc blades will chip.

Maintain a gap of $\frac{1}{32}$ " to $\frac{1}{16}$ " (.8 - 1.58 mm) between opener blades at the closest point. Blade adjustment is made by moving inside spacer washers to outer side of blade. Check bearing assembly rivets are not contacting shank after making adjustment.

Outer scrapers on each disc blade can be adjusted for wear. Make sure scrapers are adjusted to allow only slight blade contact.

Opener assembly is designed to be locked in a raised position when fertilizer attachment is not in use or during storage.

1. Raise planter and place blocks under openers.
2. Lower planter until pivot section hole aligns with mounting bracket hole.
3. Remove lockup pin from mounting bracket storage position and install through lockup hole.
4. Secure with cotter pins.

NOTCHED SINGLE DISC OPENERS

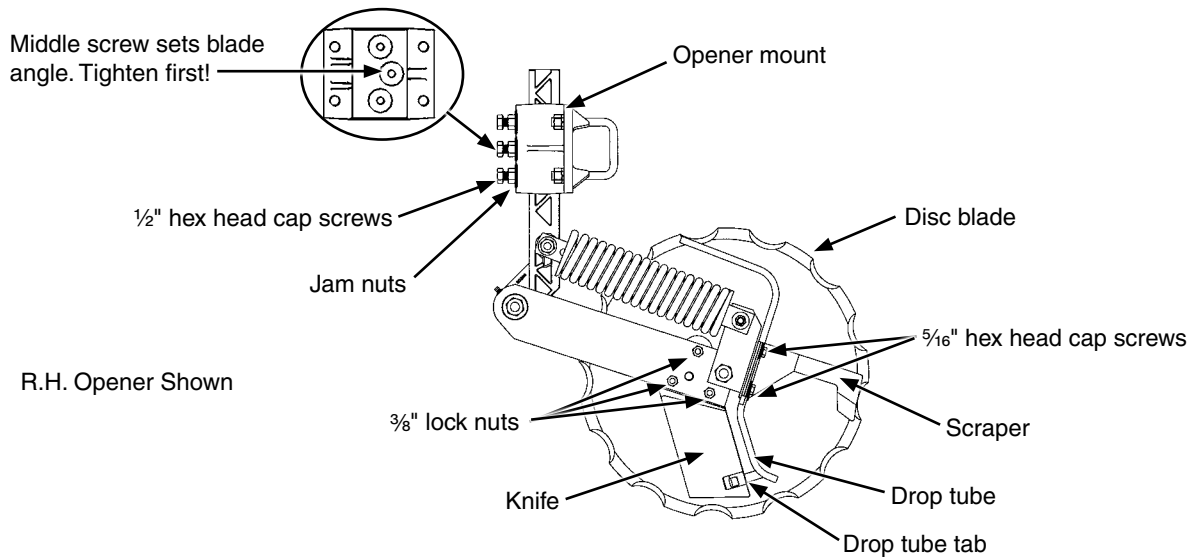

Notched single disc opener adjustments



CAUTION Compressed spring may fly out of this assembly if attempting to disassemble and cause injury. Do not take apart this assembly.

Disc blades are sharp and can cut causing serious injury. Wear gloves when working on or turning disc blades by hand.



NOTICE Never strike knife with heavy object. Damage to knife will occur.

If knife to disc blade clearance is too large, soil or residue can wedge between knife and blade, and blade will not turn.

1. Adjust knife to disc blade contact. Loosen or tighten $\frac{3}{8}$ " lock nuts to adjust knife's entire leading edge against disc blade. Turn blade and check for slight resistance without freewheeling. Readjust knife to blade's tight spot as needed.

NOTICE

Adjust liquid drop tube out of path of soil flow across knife. Drop tube and tab wear quickly if not correctly adjusted.

2. Adjust scraper and drop tube. Loosen two $\frac{5}{16}$ " hex head cap screws. Adjust scraper until just touching disc blade. Adjust drop tube until it is centered between knife and disc blade. Tighten screws. Turn blade and check for slight resistance without freewheeling. Repeat as needed. Insert flat bladed pry bar or screwdriver between knife and drop tube above drop tube tab. Carefully bend tube until $\frac{1}{4}$ "- $\frac{3}{8}$ " (6.35 - 9.5 mm) from disc blade.

NOTE: Maximum disc blade depth 4" (10.2 cm).

3. Adjust blade depth. Loosen three $\frac{1}{2}$ " hex head cap screws and jam nuts in opener mount. Adjust opener assembly up or down to desired blade depth. Tighten center hex head cap screw and jam nut first to set proper disc blade angle. Tighten remaining hex head cap screws and jam nuts. Torque hex head cap screws and jam nuts to 57 ft-lb (77.29 N-m). Check fertilizer hose clearance and adjust as necessary.

RESIDUE WHEEL ATTACHMENT FOR NOTCHED SINGLE DISC FERTILIZER OPENER



Notched single disc opener residue wheel attachment

Residue wheel attachment for notched single disc fertilizer opener is used where row unit mounted residue wheel attachments cannot be installed. Residue wheel is attached to notched single disc fertilizer opener with $\frac{5}{8}$ " x $7\frac{1}{2}$ " and $\frac{1}{2}$ " x $6\frac{1}{2}$ " hardware.

Maximum depth is set by lifting residue wheel and moving adjustment lever down to increase depth or up to decrease depth in 1" (2.5 cm) increments (in relation to blade depth setting). Adjust all rows the same. Residue wheel down force is maintained by a torsion spring and is not adjustable.

DEPTH/GAUGE WHEEL ATTACHMENT FOR NOTCHED SINGLE DISC FERTILIZER OPENER

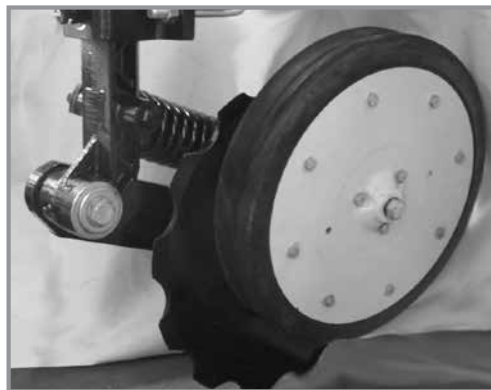

Notched single disc opener depth/gauge wheel

Depth/gauge wheel attachment for notched single disc fertilizer opener is used where additional gauging is required to maintain desired fertilizer opener depth. Depth/gauge wheel is attached to notched single disc fertilizer opener using a mounting block fastened to the pivot arm with $\frac{5}{8}$ " hardware through disc blade bearing.

Depth adjustment is made using 3 adjustment holes in depth/gauge wheel mounting block. Moving depth/gauge wheel increases/decreases depth in approximate 1" (2.5 cm) increments in relation to blade depth setting made at vertical mounting post.

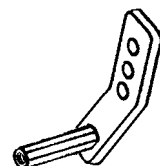

HD SINGLE DISC FERTILIZER OPENER

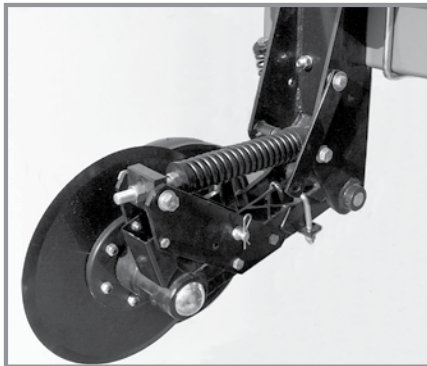

HD single disc opener

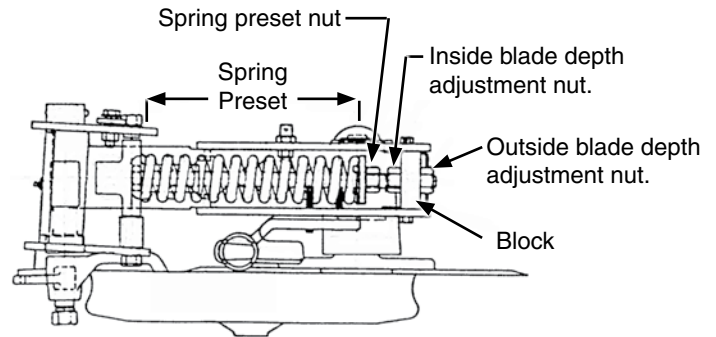

R.H. configuration shown (Overhead view)

Recommended placement of fertilizer with HD single disc fertilizer opener is 3½" - 4" (8.8 - 10.1 cm) from row.

NOTICE	Never place fertilizer closer than 2" (5 cm) to row or seeds may be damaged.
---------------	---

Maximum blade depth is approximately 5" (12.7 cm) with planter frame level and at 20" (50.8 cm) operating height. Soil conditions can affect depth slightly.

Raise planter to remove weight from fertilizer opener. Loosen inside adjustment nut with 1½" wrench. Turn outside nut clockwise to decrease or counterclockwise to increase blade depth. One full turn of blade depth adjustment nut changes blade depth ⅜". Tighten inside nut tight against block. Adjust all fertilizer openers to same depth.

Fertilizer opener down pressure can be adjusted from 250 lb (113.4 kg) to 640 lb (290.3 kg).

NOTICE	Do not operate HD single disc fertilizer openers at full down pressure tension on rocky ground or disc blades will chip.
---------------	---

NOTE: DO NOT adjust spring preset dimension less than 9½" (24.13 cm).

NOTE: Excessive down pressure can cause planter frame up-lift and affect machine performance. Planter frame should be 20" (50.8 cm) from ground in planting position. Excessive down pressure in loose soil conditions can cause openers to run too deep and push dirt ahead of opener and may stop soil press wheel and opener blade from turning.

Raise planter to remove weight from fertilizer opener. Turn spring preset nut clockwise to increase and counterclockwise to decrease down pressure. Adjust all rows to a similar setting. Minimal spring pressure for acceptable operation is recommended. See chart for spring length setting specifications.

Length	Down Pressure
11" (27.9 cm)	250 lb (113.4 kg)
10¾" (27.3 cm)	320 lb (145.1 kg)
*10½" (26.7 cm)	370 lb (167.8 kg)
10¼" (26 cm)	450 lb (204.1 kg)
10" (25.4 cm)	520 lb (235.8 kg)
9¾" (24.8 cm)	580 lb (263.1 kg)
9½" (24.1 cm)	640 lb (290.3 kg)
*Initial setting	

Adjust spring loaded dry fertilizer drop tube/scrapper periodically to maintain ⅛" (3 mm) gap between drop tube and opener blade. If this dimension is not maintained fertilizer may not drop in proper location.

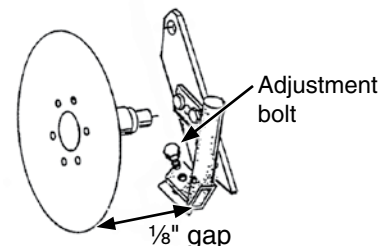

Loosen scraper adjustment bolt. Slotted hole in scraper allows up or down adjustment.
Rev. 9/17

Adjust liquid drop tube/scrapper so there is slight contact between blade and scraper lower leading edge, and 1/4" (0.6 cm) clearance between liquid drop tube trailing edge and blade. Blade should turn with minimum amount of drag.

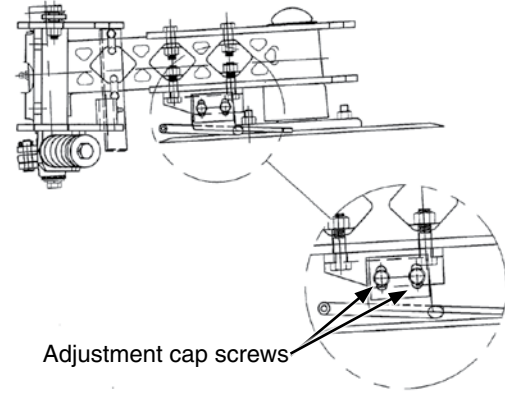

NOTE: Soil press wheel is not for gauging fertilizer opener operating depth.

Additional press wheel down pressure may be desirable in heavy moist soils. Turn press wheel spring adjustment bolt clockwise to increase down pressure.

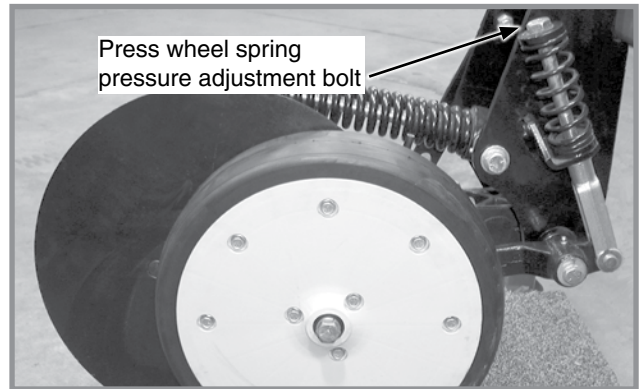

HD single disc fertilizer opener can be raised and locked up when fertilizer attachment is not used or during storage.

NOTE: A lockup bar automatically raises and locks soil press wheel when blade assembly is raised.

1. Place planter in planting position.
2. Remove outside blade depth adjustment.
3. Raise planter until adjustment bolt clears adjustment block.
4. Raise spring to clear blade assembly and raise blade assembly until storage strap can be positioned on lockup pin. Install hair pin clip.
5. Reinstall depth adjustment nut and tighten

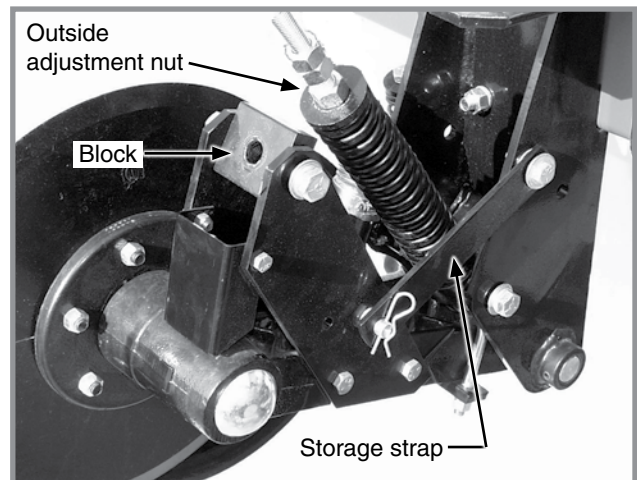

DRY FERTILIZER ATTACHMENT



WARNING



Agricultural chemicals can cause death or serious injury to persons, animals, and plants or seriously damage soil, equipment, or property. Read and follow all chemical and equipment manufacturers labels and instructions.

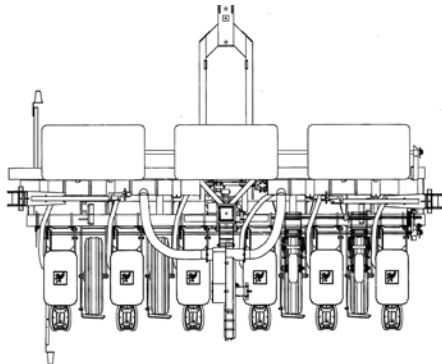

Dry fertilizer option installed

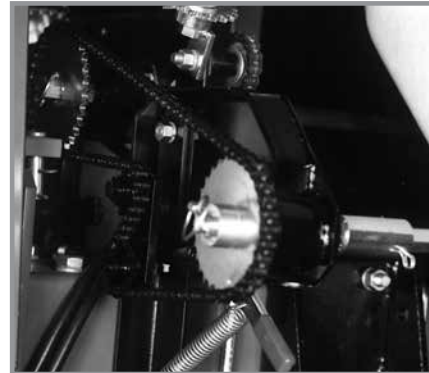

Fertilizer drive rate transmission

Rate of fertilizer application is determined by drive/driven sprocket combination on fertilizer drive rate transmission and auger position in the hoppers.



Augers positioned for high rate delivery



Augers positioned for low rate delivery

NOTE: Uneven delivery of fertilizer will occur if high rate auger position is used at too low a rate setting.

Remove 1/4" (0.6 cm) stainless steel cap screws holding augers in place on shaft and reposition augers to change delivery rate.

A fertilizer transmission is located directly ahead of row unit transmission on right side of planter and allows simple, rapid changes in sprockets to obtain desired fertilizer application rates. Chain tension is controlled by a spring loaded idler adjusted with a ratchet arm located to inside of transmission. Sprockets can be changed with those on the sprocket storage rod by removing hexagon shaft pins. Fertilizer rate charts in Rate Chart section will help you select correct sprocket combinations.

NOTE: Make a field check after each sprocket combination adjustment to be sure you are applying fertilizer at desired rate.

NOTICE

Placing fertilizer too close to seeds or in excessive amounts can cause germination or seedling damage. Check with your fertilizer dealer or manufacturer for correct amount and placement.

Because dry fertilizer attachment meters granules by volume rather than weight, differences in brands, and fertilizer analysis, weight metered during actual application may vary considerably. Use chart for reference only. Use a container to catch and measure application for a better estimate.

Keep fertilizer dry during use and storage since most fertilizers easily absorb moisture. In addition to waste, deposits of fertilizer left in hopper can cause metal corrosion. Empty hoppers at end of each day.

CLEANING

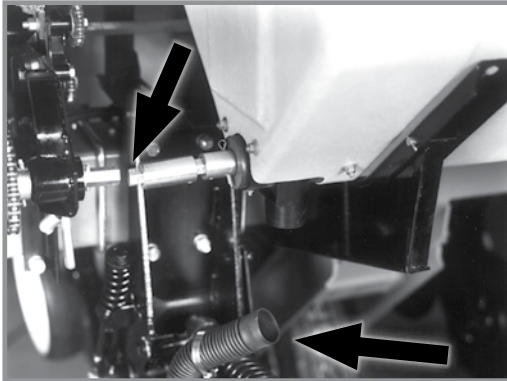

Disconnect drive shaft and hoses

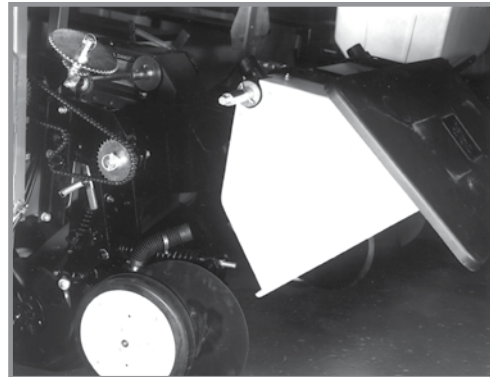

Rotate lid to back and rotate hopper forward

Dry fertilizer hoppers tip forward for dumping and ease of cleaning. Disconnect drive shaft from transmission and/or adjacent hopper. **LOOSEN HOSE CLAMPS AND REMOVE HOSES FROM EACH HOPPER.** Remove rear 1/2" x 1 1/4" cap screw from between each hopper saddle and hopper mount. Rotate each hopper lid to back side of hopper and carefully tip hopper forward. Flush all loose fertilizer from hoppers and hoses after dumping contents.

At end of planting season or when fertilizer attachment is not used for a period of time, hoppers should be disassembled, cleaned, and metal surfaces coated with a rust preventative. Remove 1/4" cotter pin and bearing from one end of shaft. Pull auger assembly from opposite end of hopper. Remove stainless steel cap screws from auger shaft and remove all auger components for cleaning. Coat all parts with rust preventative before reassembly. Reinstall auger halves in low or high rate position.

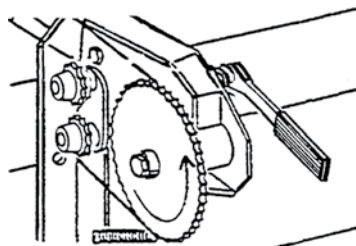

Transmission direction of rotation

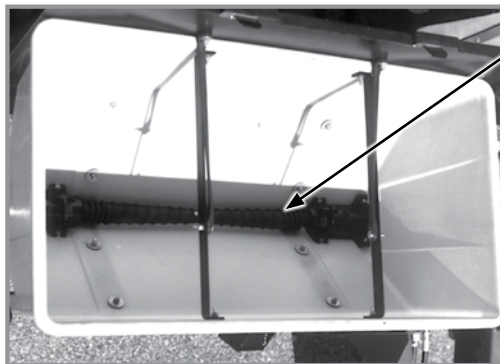

Flighting must move chemicals from center to outside of hopper.

Auger installation

NOTE: Install auger assembly so the flighting moves material to outer openings in hopper when augers rotate in direction they turn during operation.

Slide auger assembly through outlet housing into hopper. Secure in place by reinstalling bearing and cotter pin. Rotating shaft in direction shown to see if flighting (spirals) on auger move toward ends of hopper. If not, remove auger assembly, turn 180°, and reinstall.



NOTE: Frequent lubrication of auger bearings is critical to ensure augers turn freely. Check lubrication section for frequency.

Be certain augers turn freely. If not, loosen 5/16" carriage bolts in outlet housings, rotate auger several times, and retighten carriage bolts. This allows housings and augers to realign.

NOTE: Do not operate fertilizer attachment without auger baffles in place.

Install auger baffles over augers and secure in place with two hair pin clips in each hopper.

LIQUID FERTILIZER ATTACHMENT

 WARNING	<p>Agricultural chemicals can cause death or serious injury to persons, animals, and plants or seriously damage soil, equipment, or property. Read and follow all chemical and equipment manufacturers labels and instructions.</p>
	

 CAUTION	<p>Overfilling tank can cause siphoning, tank collapse, personal injury, and damage to property and equipment. Do not overfill tank. Do not leave planter unattended when filling tank. Close fill valve and open tank lid if siphoning occurs. Follow all chemical manufacturers first aid, cleanup, and handling instructions.</p>
--	--



Liquid fertilizer option installed



Old style non-reparable check valve



New style reparable check valve

NOTE: Optional low rate check valves are available for in-line installation between liquid fertilizer squeeze or piston pump and openers to ensure equal distribution of product at low rates. Check valves also eliminate anti-siphon loops.

NOTICE	<p>Placing fertilizer too close to seeds or in excessive amounts can cause germination or seedling damage. Check with your fertilizer dealer or manufacturer for correct amount and placement.</p>
---------------	--

OPTIONAL SQUEEZE PUMP

Squeeze pump rate of liquid fertilizer application is determined by combination of sprockets on squeeze pump drive and driven shafts. Make sure sprockets are in alignment, sprocket retaining collars are tight, and chain is properly tensioned is when changing sprocket combinations. Close all shut-off valves when planter sits overnight or for extended periods of time. It is also important to close tank valves when servicing on pump or hoses.

NOTE: Delivery rate chart in Rate Chart section of this manual provides approximate application rate only. Delivery varies with temperature and fertilizer.

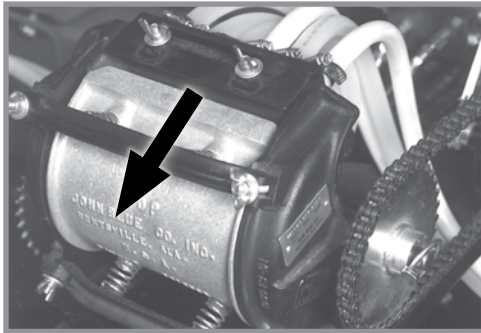

Discharge manifold rearward

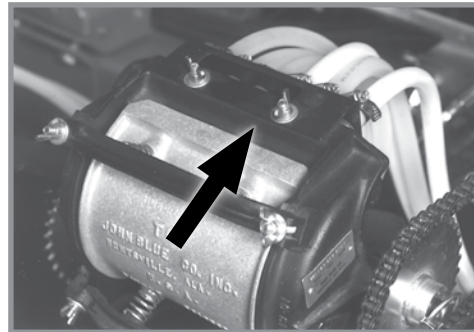

Discharge manifold forward

Discharge manifold must be repositioned rearward when not in use to prevent hose distortion and prolong hose life. Discharge manifold must be forward when pump is in operation. Loosen wing nuts and slide manifold forward and sideways or rearward as required and retighten wing nuts.

NOTICE

Avoid excessive pressure using quick fill attachment or rubber plugs installed in manifold may be forced out.

If either end pump hoses run off back plate, loosen hose clamps on intake manifold and rotate hose as follows:

1. For right hand hose (facing pump from front of planter as shown) twist hose ¼ turn to right.
2. For left hand hose (facing front of pump) twist hose ¼ turn to left.
3. Retighten hose clamps.

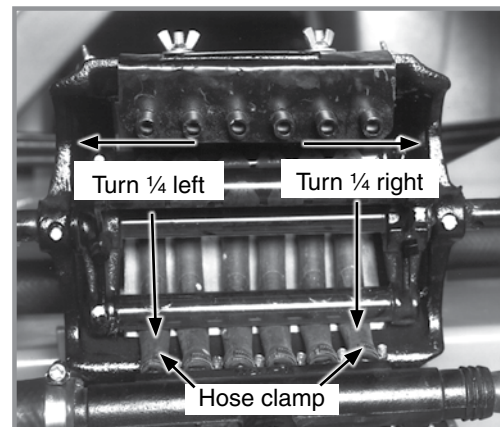

Adjusting squeeze pump end hoses

OPTIONAL PISTON PUMP

NOTE: Keep manuals shipped with pump and flow divider with this manual.

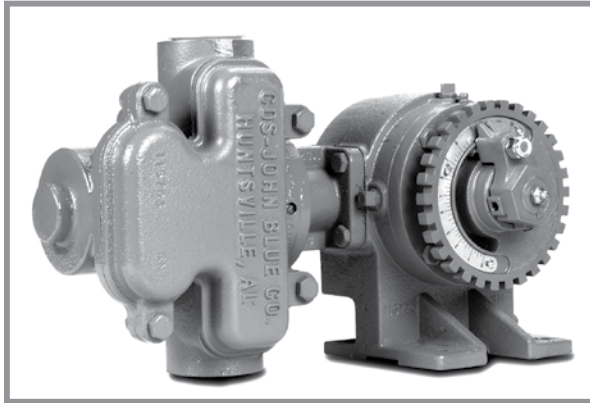

Piston pump

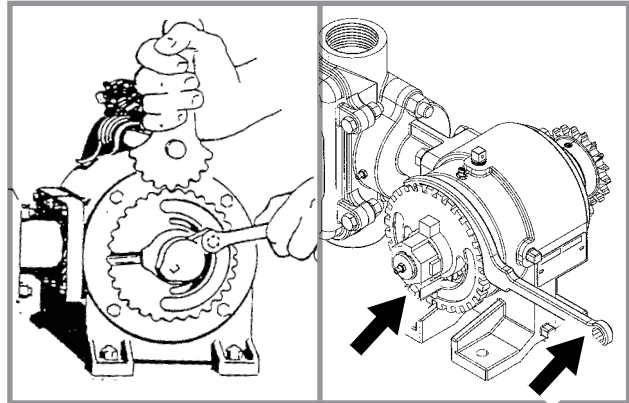

Adjusting delivery rate

NOTE: Delivery rate chart in Rate Chart section of this manual provides approximate application rate only. Delivery varies with temperature and fertilizer.

Loosen $\frac{3}{8}$ " lock nut that secures arm with pointer and rotate scale flange with adjustment wrench until pointer is over desired scale setting. Tighten $\frac{3}{8}$ " lock nut. DO NOT OVERTIGHTEN.

NOTE: Periodically check flow to all rows. Set rate is delivered to remaining rows if one or more lines are plugged.

CLEANING

Clean tanks, hoses, and metering pump thoroughly with water at end of planting season or prior to an extended period of non-use. Do not allow fertilizer to crystallize from cold temperature or evaporation.

On machines equipped with piston pump, take apart and clean strainer located between piston pump and ball valve daily. Remove the end cap to clean the screen. See Piston Pump Storage in Maintenance Section of this manual.

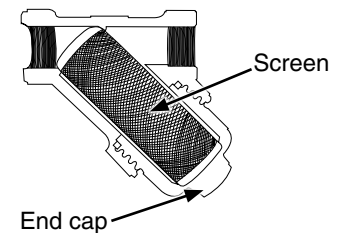

This page left blank intentionally.

GENERAL PLANTING RATE INFORMATION

NOTICE

Sprocket combinations in these charts are for average conditions. Changes in sprocket combinations may be required for desired planting population. **ALWAYS MAKE FIELD CHECKS TO BE SURE YOU ARE PLANTING AT THE DESIRED RATE.**

NOTICE

Seed additives added in the hopper may affect finger pickup seed meter performance and accelerate wear.

NOTE: Seed size and shape may affect planting rate.

NOTE: Not all row spacings listed apply to all size planters.

NOTE: Speeds above 6.0 MPH (10 KPH) can adversely affect seed spacing.

MECHANICAL

Finger Pickup Corn Meter

Larger grades generally plant more accurately at the high end of the ground speed range than smaller grades. Higher than optimum speeds may result in population rate increase or higher incidence of doubles, particularly with small seed. Medium round corn seed is most desirable for planting accuracy at optimum speed.

Finger Pickup Oil Sunflower Meter

Larger grades generally plant more accurately at the high end of the ground speed range than smaller grades. Higher than optimum speeds may result in population rate increase or higher incidence of doubles, particularly with small seed. No. 3 and/or No. 4 size oil sunflower seeds are recommended for use in finger pickup seed meters equipped with oil sunflower fingers. No. 1 and/or No. 2 size confectionery sunflower seeds are recommended for use in finger pickup seed meters equipped with corn fingers.

Brush-Type Seed Meter (Soybean, Milo/Grain Sorghum, Acid-Delinted Cotton)

Rate charts are given in seeds per acre as well as seed spacing in inches rounded to the nearest tenth of an inch. Because of the large range in seed size, pounds per acre is not a suggested method of selecting transmission settings. Smaller size seed pounds per acre may be below what was expected and large seed pounds per acre may appear above expectations. To determine pounds per acre, use the formula given in "Determining Pounds Per Acre (Brush-Type Seed Meter)" in "Check Seed Population" in Machine Operation section of this manual.

NOTE: Planting speed can affect actual seeding rate. Make a field check and adjust transmission setting to obtain desired seed drop.

Standard Rate (1 To 1) 17 Tooth Drive Sprocket

When planting 30"/36"/38" rows with brush-type seed meters using 17 tooth standard rate (1 to 1) sprocket, use charts on page 5-3, 5-5, and 5-6. When planting 15"/18"/19" rows using 17 tooth sprocket, use chart on page 5-4.

Half Rate (2 To 1) 34 Tooth Drive Sprocket

When using 34 tooth half rate (2 to 1) sprocket with brush-type seed meters, seeding rate is approximately 50% of chart readings. **Half rate (2 to 1) drive is recommended only when Interplant push units are used and desired population falls below that shown on planting rate charts.**

VACUUM

NOTE: Contact wheel drive sprocket references are located in each chart title.

NOTE: DO NOT USE 44 tooth sprockets (60 cell soybean discs) with dry fertilizer.

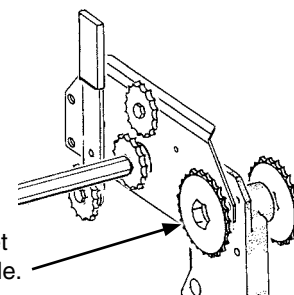
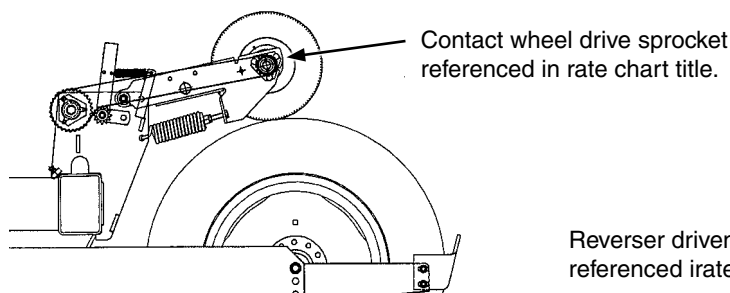

**PLANTING RATES FOR FINGER PICKUP SEED METER (STANDARD DRIVE)
APPROXIMATE SEEDS/ACRE FOR 30" ROW WIDTH**

30" Rows	Transmission Sprockets		Recommended Speed Range (MPH)	Average Seed Spacing In Inches
	Drive	Driven		
16,186	17	28	4 to 6	12.9
16,785	17	27	4 to 6	12.5
17,431	17	26	4 to 6	12.0
18,090	19	28	4 to 6	11.6
18,128	17	25	4 to 6	11.5
18,760	19	27	4 to 6	11.1
18,883	17	24	4 to 6	11.1
19,481	19	26	4 to 6	10.7
19,704	17	23	4 to 6	10.6
20,261	19	25	4 to 6	10.3
21,104	19	24	4 to 6	9.9
21,898	23	28	4 to 6	9.5
22,022	19	23	4 to 6	9.5
22,709	23	27	4 to 6	9.2
22,850	24	28	4 to 6	9.2
23,583	23	26	4 to 6	8.9
23,697	24	27	4 to 6	8.8
23,802	25	28	4 to 6	8.8
23,853	17	19	4 to 6	8.8
24,526	23	25	4 to 6	8.5
24,608	24	26	4 to 6	8.5
24,684	25	27	4 to 6	8.5
24,755	26	28	4 to 6	8.4
25,548	23	24	4 to 6	8.2
25,592	24	25	4 to 6	8.2
25,633	25	26	4 to 6	8.2
25,671	26	27	4 to 6	8.1
25,707	27	28	4 to 6	8.1
26,659	23	23	4 to 6	7.8
27,646	28	27	4 to 6	7.6
27,684	27	26	4 to 6	7.6
27,770	25	24	4 to 6	7.5
27,818	24	23	4 to 6	7.5
28,709	28	26	4 to 6	7.3
28,791	27	25	4 to 6	7.3
28,977	25	23	4 to 6	7.2
29,795	19	17	4 to 6	7.0
29,858	28	25	4 to 6	7.0
29,991	27	24	4 to 6	7.0
30,136	26	23	4 to 6	7.0
31,102	28	24	3 to 6	6.7
31,295	27	23	3 to 6	6.7
32,271	23	19	3 to 5.5	6.5
32,454	28	23	3 to 5.5	6.5
33,674	24	19	3 to 5.5	6.2
35,077	25	19	3 to 5	6.0
36,068	23	17	3 to 5	5.8
36,480	26	19	3 to 5	5.7
37,636	24	17	3 to 5	5.6
37,883	27	19	3 to 5	5.5
39,204	25	17	3 to 4.5	5.3
39,287	28	19	3 to 4.5	5.3
40,772	26	17	3 to 4.5	5.1
42,340	27	17	3 to 4.5	4.9
43,908	28	17	3 to 4.5	4.8

NOTE: See "General Planting Rate Information" and "Check Seed Population" pages for more information. Always field check seed population to verify planting rates.

PLANTING RATES FOR BRUSH-TYPE SEED METERS (STANDARD DRIVE) APPROXIMATE SEEDS/ACRE FOR 30" ROW WIDTH

Transmission Sprockets		60 Cell Soybean Or High-Rate Milo/Grain Sorghum 30" Rows	Average Seed Spacing In Inches	48 Cell Specialty Soybean Or High-Rate Acid-Delinted Cotton 30" Rows	Average Seed Spacing In Inches	Speed Range (MPH)
Drive	Driven					
17	28	80,928	2.6	64,742	3.2	2 to 8
17	27	83,926	2.5	67,141	3.1	2 to 8
17	26	87,154	2.4	69,723	3.0	2 to 8
19	28	90,449	2.3	72,359	2.9	2 to 8
19	27	93,799	2.2	75,039	2.8	2 to 8
17	24	94,416	2.2	75,533	2.8	2 to 8
17	23	98,521	2.1	78,817	2.7	2 to 8
19	25	101,303	2.1	81,042	2.6	2 to 8
19	24	105,524	2.0	84,419	2.5	2 to 8
23	28	109,491	1.9	87,593	2.4	2 to 8
19	23	110,112	1.9	88,090	2.4	2 to 8
24	28	114,252	1.8	91,402	2.3	2 to 8
24	27	118,483	1.8	94,786	2.2	2 to 8
17	19	119,263	1.8	95,410	2.2	2 to 8
24	26	123,040	1.7	98,432	2.1	2 to 8
26	28	123,773	1.7	99,018	2.1	2 to 8
24	25	127,962	1.6	102,370	2.0	2 to 8
26	27	128,357	1.6	102,686	2.0	2 to 8
23	23	133,294	1.6	106,635	2.0	2 to 8
27	26	138,420	1.5	110,736	1.9	2 to 8
24	23	139,089	1.5	111,271	1.9	2 to 8
25	23	144,884	1.4	115,907	1.8	2 to 8
19	17	148,975	1.4	119,180	1.8	2 to 8
27	24	149,955	1.4	119,964	1.7	2 to 8
28	24	155,509	1.3	124,407	1.7	2 to 8
23	19	161,355	1.3	129,084	1.6	2 to 8
28	23	162,270	1.3	129,816	1.6	2 to 8
24	19	168,371	1.2	134,696	1.6	2 to 8
25	19	175,386	1.2	140,309	1.5	2 to 8
23	17	180,338	1.2	144,270	1.5	2 to 8
26	19	182,402	1.1	145,922	1.4	2 to 7
27	19	189,417	1.1	151,534	1.4	2 to 7
28	19	196,433	1.1	157,146	1.3	2 to 7
26	17	203,861	1.0	163,089	1.3	2 to 7
27	17	211,702	0.9	169,362	1.2	2 to 7
28	17	219,542	0.9	175,634	1.2	2 to 7

NOTE: See "General Planting Rate Information" and "Check Seed Population" pages for more information.

NOTE: Rates are approximately 50% of given numbers when using the Half Rate (2 To 1) Drive Reduction Package.

NOTE: Always field check seed population to verify planting rates.

PLANTING RATES FOR BRUSH-TYPE SEED METERS (STANDARD DRIVE) APPROXIMATE SEEDS/ACRE FOR 15" ROW WIDTH

Transmission Sprockets		60 Cell Soybean Or High-Rate Milo/Grain Sorghum 15" Rows	Average Seed Spacing In Inches	48 Cell Specialty Soybean Or High-Rate Acid-Delinted Cotton 15" Rows	Average Seed Spacing In Inches	Speed Range (MPH)
Drive	Driven					
17	28	161,856	2.6	129,484	3.2	2 to 8
17	27	167,852	2.5	134,282	3.1	2 to 8
17	26	174,308	2.4	139,446	3.0	2 to 8
19	28	180,898	2.3	144,718	2.9	2 to 8
19	27	187,598	2.2	150,078	2.8	2 to 8
17	24	188,832	2.2	151,066	2.8	2 to 8
17	23	197,042	2.1	157,634	2.7	2 to 8
19	25	202,606	2.1	162,084	2.6	2 to 8
19	24	211,048	2.0	168,838	2.5	2 to 8
23	28	218,982	1.9	175,186	2.4	2 to 8
19	23	220,224	1.9	176,180	2.4	2 to 8
24	28	228,504	1.8	182,804	2.3	2 to 8
24	27	236,966	1.8	189,572	2.2	2 to 8
17	19	238,526	1.8	190,820	2.2	2 to 8
24	26	246,080	1.7	196,864	2.1	2 to 8
26	28	247,546	1.7	198,036	2.1	2 to 8
24	25	255,924	1.6	204,740	2.0	2 to 8
26	27	256,714	1.6	205,372	2.0	2 to 8
23	23	266,588	1.6	213,270	2.0	2 to 8
27	26	276,840	1.5	221,472	1.9	2 to 8
24	23	278,178	1.5	222,542	1.9	2 to 8
25	23	289,768	1.4	231,814	1.8	2 to 8
19	17	297,950	1.4	238,360	1.8	2 to 8
27	24	299,910	1.4	239,928	1.7	2 to 8
28	24	311,018	1.3	248,814	1.7	2 to 8
23	19	322,710	1.3	258,168	1.6	2 to 8
28	23	324,540	1.3	259,632	1.6	2 to 8
24	19	336,742	1.2	269,392	1.6	2 to 8
25	19	350,772	1.2	280,618	1.5	2 to 8
23	17	360,676	1.2	288,540	1.5	2 to 8
26	19	364,804	1.1	291,844	1.4	2 to 7
27	19	378,834	1.1	303,068	1.4	2 to 7
28	19	392,866	1.1	314,292	1.3	2 to 7
26	17	407,722	1.0	326,178	1.3	2 to 7
27	17	423,404	0.9	338,724	1.2	2 to 7
28	17	439,084	0.9	351,268	1.2	2 to 7

NOTE: See "General Planting Rate Information" and "Check Seed Population" pages for more information.

NOTE: Rates are approximately 50% of given numbers when using the Half Rate (2 To 1) Drive Reduction Package.

NOTE: Always field check seed population to verify planting rates.

**PLANTING RATE FOR BRUSH-TYPE SEED METERS (STANDARD DRIVE) APPROXIMATE
SEEDS/ACRE FOR 30" ROW WIDTH**

Transmission Sprockets		36 Cell Acid-Delinted Large Cotton 30" Rows	Average Seed Spacing In Inches	30 Cell Milo/Grain Sorghum Or Acid-Delinted Cotton 30" Rows	Average Seed Spacing In Inches	Speed Range (MPH)
Drive	Driven					
17	28	48,557	4.3	40,464	5.2	2 to 8
17	27	50,356	4.2	41,963	5.0	2 to 8
17	26	52,292	4.0	43,577	4.8	2 to 8
19	28	54,269	3.9	45,225	4.6	2 to 8
19	27	56,279	3.7	46,900	4.5	2 to 8
17	24	56,650	3.7	47,208	4.4	2 to 8
17	23	59,113	3.5	49,261	4.2	2 to 8
19	25	60,782	3.4	50,652	4.1	2 to 8
19	24	63,314	3.3	52,762	4.0	2 to 8
23	28	65,695	3.2	54,746	3.8	2 to 8
19	23	66,067	3.2	55,056	3.8	2 to 8
24	28	68,551	3.0	57,126	3.7	2 to 8
24	27	71,090	2.9	59,242	3.5	2 to 8
17	19	71,558	2.9	59,631	3.5	2 to 8
24	26	73,824	2.8	61,520	3.4	2 to 8
26	28	74,264	2.8	61,886	3.4	2 to 8
24	25	76,772	2.7	63,981	3.3	2 to 8
26	27	77,014	2.7	64,178	3.3	2 to 8
23	23	79,976	2.6	66,647	3.1	2 to 8
27	26	83,052	2.5	69,210	3.0	2 to 8
24	23	83,453	2.5	69,544	3.0	2 to 8
25	23	86,930	2.4	72,442	2.9	2 to 8
19	17	89,385	2.3	74,488	2.8	2 to 8
27	24	89,973	2.3	74,978	2.8	2 to 8
28	24	93,305	2.2	77,755	2.7	2 to 8
23	19	96,813	2.2	80,678	2.6	2 to 8
28	23	97,362	2.1	81,135	2.6	2 to 8
24	19	101,023	2.1	84,185	2.5	2 to 8
25	19	105,232	2.0	87,693	2.4	2 to 8
23	17	108,233	1.9	90,169	2.3	2 to 8
26	19	109,441	1.9	91,201	2.3	2 to 7
27	19	113,650	1.8	94,709	2.2	2 to 7
28	19	117,860	1.8	98,216	2.1	2 to 7
26	17	122,317	1.7	101,930	2.1	2 to 7
27	17	127,021	1.6	105,851	2.0	2 to 7
28	17	131,725	1.6	109,771	1.9	2 to 7

NOTE: See "General Planting Rate Information" and "Check Seed Population" pages for more information.

NOTE: Rates are approximately 50% of given numbers when using the Half Rate (2 To 1) Drive Reduction Package.

NOTE: Always field check seed population to verify planting rates.

PLANTING RATES FOR BRUSH-TYPE SEED METERS (STANDARD DRIVE) APPROXIMATE HILLS/ACRE FOR 30" ROW WIDTH

Due to variations in cotton seed size, meters equipped with the 12 cell acid-delinted hill-drop cotton discs will plant from 3 to 6 seeds per cell. Select proper disc for seed size range to be planted.

To determine planter transmission setting, determine desired hill spacing and select the transmission ratio closest to the hill spacing in inches on the chart. To decrease population increase spacing. To increase population decrease spacing.

To determine population per acre, determine average seeds per hill and hills per acre by doing a field check. Measure 1/1000 of an acre (1/1000 acre = Length of row 17' 5" for 30" row width). Multiply average seeds per hill by hills per acre.

EXAMPLE: 4 seeds per hill x (13 hills x 1000) = 52,000

Transmission Sprockets		NUMBER OF HILLS PER ACRE 12 Cell Hill-Drop Cotton, Acid-Delinted	Average Hill Spacing In Inches	Speed Range (MPH)
Drive	Driven	30" Rows		
17	28	16,186	12.9	2 to 8
17	27	16,785	12.5	2 to 8
17	26	17,431	12.0	2 to 8
19	28	18,090	11.6	2 to 8
19	27	18,760	11.1	2 to 8
17	24	18,883	11.1	2 to 8
17	23	19,704	10.6	2 to 8
19	25	20,261	10.3	2 to 8
19	24	21,105	9.9	2 to 8
23	28	21,898	9.5	2 to 8
19	23	22,022	9.5	2 to 8
24	28	22,850	9.2	2 to 8
24	27	23,697	8.8	2 to 8
17	19	23,853	8.8	2 to 8
24	26	24,608	8.5	2 to 8
26	28	24,755	8.4	2 to 8
24	25	25,592	8.2	2 to 8
26	27	25,671	8.1	2 to 8
23	23	26,659	7.8	2 to 8
27	26	27,684	7.6	2 to 8
24	23	27,818	7.5	2 to 8
25	23	28,977	7.2	2 to 8
19	17	29,795	7.0	2 to 8
27	24	29,991	7.0	2 to 8
28	24	31,102	6.7	2 to 8
23	19	32,271	6.5	2 to 8
28	23	32,454	6.5	2 to 8
24	19	33,674	6.2	2 to 8
25	19	35,077	6.0	2 to 8
23	17	36,068	5.8	2 to 8
26	19	36,480	5.7	2 to 7
27	19	37,883	5.5	2 to 7
28	19	39,287	5.3	2 to 7
26	17	40,772	5.1	2 to 7
27	17	42,340	4.9	2 to 7
28	17	43,908	4.8	2 to 7

NOTE: See "General Planting Rate Information" and "Check Seed Population" pages for more information.

NOTE: Rates are approximately 50% of given numbers when using the Half Rate (2 To 1) Drive Reduction Package.

NOTE: Always field check seed population to verify planting rates.

**PLANTING RATES FOR (VACUUM) CORN/SUNFLOWER 40 CELL DISC
15 TOOTH CONTACT WHEEL DRIVE/23 TOOTH REVERSER DRIVEN SPROCKETS (SEE PAGE 5-1)
APPROXIMATE SEEDS/ACRE FOR VARIOUS ROW WIDTHS**

15" Rows	30" Rows	Transmission Sprockets		Recomm. Speed (MPH)	Average Spacing In Inches
		Drive	Driven		
47,604	23,802	15	28	4 to 6	8.8
49,367	24,683	15	27	4 to 6	8.5
51,266	25,633	15	26	4 to 6	8.2
53,316	26,658	15	25	4 to 6	7.8
53,951	26,975	17	28	4 to 6	7.7
55,537	27,769	15	24	4 to 6	7.5
55,949	27,974	17	27	4 to 6	7.5
57,952	28,976	15	23	4 to 6	7.2
58,101	29,050	17	26	4 to 6	7.2
60,298	30,149	19	28	4 to 6	6.9
60,425	30,212	17	25	4 to 6	6.9
62,531	31,266	19	27	4 to 6	6.7
62,943	31,472	17	24	4 to 6	6.6
64,936	32,468	19	26	4 to 6	6.4
65,679	32,840	17	23	4 to 6	6.3
67,533	33,767	19	25	4 to 6	6.2
70,153	35,076	15	19	4 to 6	5.9
70,348	35,173	19	24	4 to 6	5.9
72,992	36,496	23	28	4 to 6	5.8
73,406	36,704	19	23	4 to 6	5.7
75,695	37,848	23	27	4 to 6	5.6
76,166	38,083	24	28	4 to 6	5.5
78,406	39,203	15	17	4 to 6	5.4
78,987	39,493	24	27	4 to 6	5.3
79,507	39,753	17	19	4 to 6	5.3
81,752	40,876	23	25	4 to 6	5.1
82,513	41,256	26	28	4 to 6	5.1
85,158	42,578	23	24	4 to 6	4.9
85,306	42,653	24	25	4 to 6	4.9
85,686	42,843	27	28	4 to 6	4.9
88,861	44,430	23	23	4 to 6	4.7
92,152	46,076	28	27	4 to 6	4.6
92,278	46,138	27	26	4 to 6	4.5
92,724	46,362	24	23	4 to 6	4.5
95,695	47,848	28	26	4 to 6	4.4
95,969	47,985	27	25	4 to 6	4.4
96,587	48,293	25	23	4 to 6	4.3
99,314	49,657	19	17	4 to 6	4.2
99,968	49,984	27	24	4 to 6	4.2
100,450	50,226	26	23	4 to 6	4.2
103,670	51,835	28	24	4 to 6	4.0
104,314	52,157	27	23	4 to 6	4.0
107,567	53,784	23	19	4 to 6	3.9
108,177	54,089	28	23	4 to 6	3.9
112,244	56,122	24	19	4 to 6	3.7
116,921	58,461	25	19	4 to 6	3.6
120,223	60,112	23	17	4 to 6	3.5
121,598	60,799	26	19	4 to 6	3.4
125,449	62,725	24	17	4 to 6	3.3
126,275	63,137	27	19	4 to 6	3.3
130,677	65,338	25	17	4 to 6	3.2
130,952	65,476	28	19	4 to 6	3.2
135,904	67,952	26	17	4 to 6	3.1
136,252	68,126	23	15	4 to 6	3.0
141,131	70,565	27	17	4 to 6	2.9

NOTE: See "General Planting Rate Information" and "Check Seed Population" pages for more information. Always field check seed population to verify planting rates.

**PLANTING RATES FOR (VACUUM) CORN/SUNFLOWER 40 CELL DISC
19 TOOTH CONTACT WHEEL DRIVE/23 TOOTH REVERSER DRIVEN SPROCKETS (SEE PAGE 5-1)
APPROXIMATE SEEDS/ACRE FOR VARIOUS ROW WIDTHS**

15" Rows	30" Rows	Transmission Sprockets		Recomm. Speed (MPH)	Average Spacing In Inches
		Drive	Driven		
60,298	30,149	15	28	4 to 6	6.9
62,531	31,266	15	27	4 to 6	6.7
64,936	32,468	15	26	4 to 6	6.4
67,533	33,767	15	25	4 to 6	6.2
68,337	34,169	17	28	4 to 6	6.1
70,348	35,173	15	24	4 to 6	5.9
70,869	35,435	17	27	4 to 6	5.9
73,406	36,704	15	23	4 to 6	5.7
73,595	36,797	17	26	4 to 6	5.7
76,377	38,189	19	28	4 to 6	5.5
76,538	38,269	17	25	4 to 6	5.5
79,206	39,603	19	27	4 to 6	5.3
79,727	39,864	17	24	4 to 6	5.3
82,252	41,126	19	26	4 to 6	5.1
83,194	41,597	17	23	4 to 6	5.1
85,543	42,771	19	25	4 to 6	4.9
88,861	44,430	15	19	4 to 6	4.7
89,107	44,554	19	24	4 to 6	4.7
92,456	46,229	23	28	4 to 6	4.5
92,982	46,490	19	23	4 to 6	4.5
95,881	47,941	23	27	4 to 6	4.4
96,477	48,238	24	28	4 to 6	4.3
99,314	49,657	15	17	4 to 6	4.2
100,050	50,025	24	27	4 to 6	4.2
100,709	50,354	17	19	4 to 6	4.2
103,552	51,775	23	25	4 to 6	4.0
104,517	52,258	26	28	4 to 6	4.0
107,867	53,933	23	24	4 to 6	3.9
108,054	54,027	24	25	4 to 6	3.9
108,536	54,268	27	28	4 to 6	3.9
112,556	56,278	23	23	4 to 6	3.7
116,725	58,362	28	27	4 to 6	3.6
116,885	58,443	27	26	4 to 6	3.6
117,450	58,725	24	23	4 to 6	3.6
121,214	60,607	28	26	4 to 6	3.4
121,561	60,781	27	25	4 to 6	3.4
122,344	61,172	25	23	4 to 6	3.4
125,798	62,899	19	17	4 to 6	3.3
126,626	63,313	27	24	4 to 6	3.3
127,238	63,618	26	23	4 to 6	3.3
131,316	65,657	28	24	4 to 6	3.2
132,131	66,066	27	23	4 to 6	3.1
136,252	68,126	23	19	4 to 6	3.0
137,025	68,513	28	23	4 to 6	3.0
142,176	71,109	24	19	4 to 6	2.9
148,101	74,050	25	19	4 to 6	2.8
152,282	76,141	23	17	4 to 6	2.7
154,025	77,012	26	19	4 to 6	2.7
158,903	79,451	24	17	4 to 6	2.6
159,949	79,974	27	19	4 to 6	2.6
165,524	82,762	25	17	4 to 6	2.5
165,873	82,936	28	19	4 to 6	2.5
172,145	86,073	26	17	4 to 6	2.4
172,587	86,293	23	15	4 to 6	2.4
178,766	89,383	27	17	4 to 6	2.3

NOTE: See "General Planting Rate Information" and "Check Seed Population" pages for more information. Always field check seed population to verify planting rates.

**PLANTING RATES FOR (VACUUM) MILO/SUGAR BEET/SPECIALTY 60 CELL DISCS
15 TOOTH CONTACT WHEEL DRIVE/23 TOOTH REVERSER DRIVEN SPROCKETS (SEE PAGE 5-1)**

APPROXIMATE SEEDS/ACRE FOR VARIOUS ROW WIDTHS

15" Rows	30" Rows	Transmission Sprockets		Recomm. Speed (MPH)	Average Spacing In Inches
		Drive	Driven		
71,406	35,703	15	28	4 to 6	5.9
74,050	37,025	15	27	4 to 6	5.6
76,898	38,449	15	26	4 to 6	5.4
79,974	39,987	15	25	4 to 6	5.2
80,926	40,463	17	28	4 to 6	5.2
83,306	41,653	15	24	4 to 6	5.0
83,924	41,962	17	27	4 to 6	5.0
86,928	43,464	15	23	4 to 6	4.8
87,151	43,576	17	26	4 to 6	4.8
90,447	45,223	19	28	4 to 6	4.6
90,637	45,319	17	25	4 to 6	4.6
93,797	46,898	19	27	4 to 6	4.5
94,414	47,207	17	24	4 to 6	4.4
97,404	48,702	19	26	4 to 6	4.3
98,519	49,259	17	23	4 to 6	4.2
101,301	50,650	19	25	4 to 6	4.1
105,229	52,615	15	19	4 to 6	4.0
105,521	52,761	19	24	4 to 6	4.0
109,488	54,744	23	28	4 to 6	3.8
110,109	55,055	19	23	4 to 6	3.8
113,544	56,772	23	27	4 to 6	3.7
114,249	57,124	24	28	4 to 6	3.7
117,609	58,805	15	17	4 to 6	3.6
118,480	59,240	24	27	4 to 6	3.5
119,260	59,630	17	19	4 to 6	3.5
122,627	61,314	23	25	4 to 6	3.4
123,770	61,885	26	28	4 to 6	3.4
127,737	63,868	23	24	4 to 6	3.3
127,959	63,979	24	25	4 to 6	3.3
128,530	64,265	27	28	4 to 6	3.3
133,290	66,645	23	23	4 to 6	3.1
138,227	69,113	28	27	4 to 6	3.0
138,417	69,208	27	26	4 to 6	3.0
139,086	69,543	24	23	4 to 6	3.0
143,543	71,772	28	26	4 to 6	2.9
143,954	71,977	27	25	4 to 6	2.9
144,881	72,440	25	23	4 to 6	2.9
148,971	74,486	19	17	4 to 6	2.8
149,952	74,976	27	24	4 to 6	2.8
150,676	75,338	26	23	4 to 6	2.8
155,505	77,753	28	24	4 to 6	2.7
156,471	78,236	27	23	4 to 6	2.7
161,351	80,676	23	19	4 to 6	2.6
162,266	81,133	28	23	4 to 6	2.6
168,367	84,183	24	19	4 to 6	2.5
175,382	87,691	25	19	4 to 6	2.4
180,334	90,167	23	17	4 to 6	2.3
182,397	91,199	26	19	4 to 6	2.3
188,175	94,087	24	17	4 to 6	2.2
189,413	94,706	27	19	4 to 6	2.2
196,015	98,008	25	17	4 to 6	2.1
196,428	98,214	28	19	4 to 6	2.1
203,856	101,928	26	17	4 to 6	2.1
204,378	102,189	23	15	4 to 6	2.0
211,696	105,848	27	17	4 to 6	2.0

**NOTE: See "General Planting Rate Information" and "Check Seed Population" pages for more information.
Always field check seed population to verify planting rates.**

**PLANTING RATES FOR (VACUUM) MILO/SUGAR BEET/ SPECIALTY 60 CELL DISCS
19 TOOTH CONTACT WHEEL DRIVE/23 TOOTH REVERSER DRIVEN SPROCKETS (SEE PAGE 5-1)**

APPROXIMATE SEEDS/ACRE FOR VARIOUS ROW WIDTHS

15" Rows	30" Rows	Transmission Sprockets		Recomm. Speed (MPH)	Average Spacing In Inches
		Drive	Driven		
90,447	45,223	15	28	4 to 6	4.6
93,797	46,898	15	27	4 to 6	4.5
97,404	48,702	15	26	4 to 6	4.3
101,301	50,650	15	25	4 to 6	4.1
102,507	51,253	17	28	4 to 6	4.1
105,521	52,761	15	24	4 to 6	4.0
106,303	53,152	17	27	4 to 6	3.9
110,109	55,055	15	23	4 to 6	3.8
110,392	55,196	17	26	4 to 6	3.8
114,566	57,283	19	28	4 to 6	3.7
114,807	57,404	17	25	4 to 6	3.6
118,809	59,405	19	27	4 to 6	3.5
119,591	59,796	17	24	4 to 6	3.5
123,379	61,689	19	26	4 to 6	3.4
124,791	62,395	17	23	4 to 6	3.4
128,314	64,157	19	25	4 to 6	3.3
133,290	66,645	15	19	4 to 6	3.1
133,661	66,830	19	24	4 to 6	3.1
138,685	69,343	23	28	4 to 6	3.0
139,472	69,736	19	23	4 to 6	3.0
143,822	71,911	23	27	4 to 6	2.9
144,715	72,358	24	28	4 to 6	2.9
148,971	74,486	15	17	4 to 6	2.8
150,075	75,037	24	27	4 to 6	2.8
151,062	75,531	17	19	4 to 6	2.8
155,328	77,664	23	25	4 to 6	2.7
156,775	78,387	26	28	4 to 6	2.7
161,800	80,900	23	24	4 to 6	2.6
162,081	81,040	24	25	4 to 6	2.6
162,805	81,402	27	28	4 to 6	2.6
168,834	84,417	23	23	4 to 6	2.5
175,087	87,544	28	27	4 to 6	2.4
175,328	87,664	27	26	4 to 6	2.4
176,175	88,087	24	23	4 to 6	2.4
181,822	90,911	28	26	4 to 6	2.3
182,341	91,171	27	25	4 to 6	2.3
183,516	91,758	25	23	4 to 6	2.3
188,697	94,349	19	17	4 to 6	2.2
189,939	94,969	27	24	4 to 6	2.2
190,856	95,428	26	23	4 to 6	2.2
196,973	98,487	28	24	4 to 6	2.1
198,197	99,098	27	23	4 to 6	2.1
204,378	102,189	23	19	4 to 6	2.0
205,537	102,769	28	23	4 to 6	2.0
213,264	106,632	24	19	4 to 6	2.0
222,150	111,075	25	19	4 to 6	1.9
228,423	114,211	23	17	4 to 6	1.8
231,036	115,518	26	19	4 to 6	1.8
238,354	119,177	24	17	4 to 6	1.8
239,923	119,961	27	19	4 to 6	1.7
248,286	124,143	25	17	4 to 6	1.7
248,809	124,404	28	19	4 to 6	1.7
	129,109	26	17	4 to 6	1.6
	129,440	23	15	4 to 6	1.6
	134,074	27	17	4 to 6	1.6

NOTE: See "General Planting Rate Information" and "Check Seed Population" pages for more information. Always field check seed population to verify planting rates.

**PLANTING RATES FOR (VACUUM) SPECIALTY 60 CELL DISC
30 TOOTH CONTACT WHEEL DRIVE/17 TOOTH REVERSER DRIVEN SPROCKETS (SEE PAGE 5-1)
APPROXIMATE SEEDS/ACRE FOR VARIOUS ROW WIDTHS**

15" Rows	30" Rows	Transmission Sprockets		Recomm. Speed (MPH)	Average Spacing In Inches
		Drive	Driven		
193,217	96,608	15	28	4 to 6	2.2
200,373	100,186	15	27	4 to 6	2.1
208,079	104,040	15	26	4 to 6	2.0
216,403	108,201	15	25	4 to 6	1.9
218,979	109,489	17	28	4 to 6	1.9
225,419	112,710	15	24	4 to 6	1.9
227,089	113,545	17	27	4 to 6	1.8
235,220	117,610	15	23	4 to 6	1.8
235,823	117,912	17	26	4 to 6	1.8
244,741	122,371	19	28	4 to 6	1.7
245,256	122,628	17	25	4 to 6	1.7
NOTE: Planting rates over 250,000 seeds/acre are not recommended with subject seed disc and/or drive ratio.	126,903	19	27	4 to 6	1.6
	127,738	17	24	4 to 6	1.6
	131,784	19	26	4 to 6	1.6
	133,291	17	23	4 to 6	1.6
	137,055	19	25	4 to 6	1.5
	142,370	15	19	4 to 6	1.5
	142,766	19	24	4 to 6	1.5
	148,133	23	28	4 to 6	1.4
	148,973	19	23	4 to 6	1.4
	153,619	23	27	4 to 6	1.4
154,573	24	28	4 to 6	1.4	
159,120	15	17	4 to 6	1.3	
160,298	24	27	4 to 6	1.3	
161,353	17	19	4 to 6	1.3	
165,909	23	25	4 to 6	1.3	
167,454	26	28	4 to 6	1.2	
172,822	23	24	4 to 6	1.2	
173,122	24	25	4 to 6	1.2	
173,895	27	28	4 to 6	1.2	
180,336	23	23	4 to 6	1.2	
187,015	28	27	4 to 6	1.1	
187,272	27	26	4 to 6	1.1	
188,176	24	23	4 to 6	1.1	
194,207	28	26	4 to 6	1.1	
194,762	27	25	4 to 6	1.1	
196,017	25	23	4 to 6	1.1	
201,551	19	17	4 to 6	1.0	
202,877	27	24	4 to 6	1.0	
203,858	26	23	4 to 6	1.0	
210,391	28	24	4 to 6	1.0	
211,698	27	23	4 to 6	1.0	
218,301	23	19	4 to 6	1.0	
219,539	28	23	4 to 6	1.0	
227,792	24	19	4 to 6	0.9	
237,284	25	19	4 to 6	0.9	
243,983	23	17	4 to 6	0.9	
246,775	26	19	4 to 6	0.8	
		24	17	4 to 6	0.8
		27	19	4 to 6	0.8
		25	17	4 to 6	0.8
		28	19	4 to 6	0.8
		26	17	4 to 6	0.8
		23	15	4 to 6	0.8
		27	17	4 to 6	0.7

NOTE: See "General Planting Rate Information" and "Check Seed Population" pages for more information. Always field check seed population to verify planting rates.

**PLANTING RATES FOR (VACUUM) SOYBEAN 120 CELL DISC
15 TOOTH CONTACT WHEEL DRIVE/23 TOOTH REVERSER DRIVEN SPROCKETS (SEE PAGE 5-1)
APPROXIMATE SEEDS/ACRE FOR VARIOUS ROW WIDTHS**

15" Rows	30" Rows	Transmission Sprockets		Recomm. Speed (MPH)	Average Spacing In Inches
		Drive	Driven		
142,811	71,406	15	28	4 to 6	2.9
148,100	74,050	15	27	4 to 6	2.8
153,796	76,898	15	26	4 to 6	2.7
159,948	79,974	15	25	4 to 6	2.6
161,852	80,926	17	28	4 to 6	2.6
166,613	83,306	15	24	4 to 6	2.5
167,847	83,924	17	27	4 to 6	2.5
173,857	86,928	15	23	4 to 6	2.4
174,303	87,151	17	26	4 to 6	2.4
180,894	90,447	19	28	4 to 6	2.3
181,275	90,637	17	25	4 to 6	2.3
187,594	93,797	19	27	4 to 6	2.2
188,828	94,414	17	24	4 to 6	2.2
194,809	97,404	19	26	4 to 6	2.1
197,038	98,519	17	23	4 to 6	2.1
202,601	101,301	19	25	4 to 6	2.1
210,458	105,229	15	19	4 to 6	2.0
211,043	105,521	19	24	4 to 6	2.0
218,977	109,488	23	28	4 to 6	1.9
220,219	110,109	19	23	4 to 6	1.9
227,087	113,544	23	27	4 to 6	1.8
228,498	114,249	24	28	4 to 6	1.8
235,218	117,609	15	17	4 to 6	1.8
236,961	118,480	24	27	4 to 6	1.8
238,519	119,260	17	19	4 to 6	1.8
245,254	122,627	23	25	4 to 6	1.7
247,539	123,770	26	28	4 to 6	1.7
	127,737	23	24	4 to 6	1.6
NOTE: Planting rates over 250,000 seeds/acre are not recommended with subject seed disc and/or drive ratio.	127,959	24	25	4 to 6	1.6
	128,530	27	28	4 to 6	1.6
	133,290	23	23	4 to 6	1.6
	138,227	28	27	4 to 6	1.5
	138,417	27	26	4 to 6	1.5
	139,086	24	23	4 to 6	1.5
	143,543	28	26	4 to 6	1.5
	143,954	27	25	4 to 6	1.5
	144,881	25	23	4 to 6	1.4
	148,971	19	17	4 to 6	1.4
	149,952	27	24	4 to 6	1.4
	150,676	26	23	4 to 6	1.4
	155,505	28	24	4 to 6	1.3
	156,471	27	23	4 to 6	1.3
	161,351	23	19	4 to 6	1.3
	162,266	28	23	4 to 6	1.3
	168,367	24	19	4 to 6	1.2
	175,382	25	19	4 to 6	1.2
	180,334	23	17	4 to 6	1.2
	182,397	26	19	4 to 6	1.1
	188,175	24	17	4 to 6	1.1
	189,413	27	19	4 to 6	1.1
	196,015	25	17	4 to 6	1.1
	196,428	28	19	4 to 6	1.1
	203,856	26	17	4 to 6	1.0
	204,378	23	15	4 to 6	1.0
	211,696	27	17	4 to 6	1.0

NOTE: See "General Planting Rate Information" and "Check Seed Population" pages for more information. Always field check seed population to verify planting rates.

**PLANTING RATES FOR (VACUUM) SOYBEAN 120 CELL DISC
19 TOOTH CONTACT WHEEL DRIVE/23 TOOTH REVERSER DRIVEN SPROCKETS (SEE PAGE 5-1)
APPROXIMATE SEEDS/ACRE FOR VARIOUS ROW WIDTHS**

15" Rows	30" Rows	Transmission Sprockets		Recomm. Speed (MPH)	Average Spacing In Inches
		Drive	Driven		
180,894	90,447	15	28	4 to 6	2.3
187,594	93,797	15	27	4 to 6	2.2
194,809	97,404	15	26	4 to 6	2.1
202,601	101,301	15	25	4 to 6	2.1
205,013	102,507	17	28	4 to 6	2.0
211,043	105,521	15	24	4 to 6	2.0
212,606	106,303	17	27	4 to 6	2.0
220,219	110,109	15	23	4 to 6	1.9
220,783	110,392	17	26	4 to 6	1.9
229,132	114,566	19	28	4 to 6	1.8
229,615	114,807	17	25	4 to 6	1.8
237,619	118,809	19	27	4 to 6	1.8
239,182	119,591	17	24	4 to 6	1.7
246,758	123,379	19	26	4 to 6	1.7
249,581	124,791	17	23	4 to 6	1.7
NOTE: Planting rates over 250,000 seeds/acre are not recommended with subject seed disc and/or drive ratio.	128,314	19	25	4 to 6	1.6
	133,290	15	19	4 to 6	1.6
	133,661	19	24	4 to 6	1.6
	138,685	23	28	4 to 6	1.5
	139,472	19	23	4 to 6	1.5
	143,822	23	27	4 to 6	1.5
	144,715	24	28	4 to 6	1.4
	148,971	15	17	4 to 6	1.4
	150,075	24	27	4 to 6	1.4
	151,062	17	19	4 to 6	1.4
155,328	23	25	4 to 6	1.3	
156,775	26	28	4 to 6	1.3	
161,800	23	24	4 to 6	1.3	
162,081	24	25	4 to 6	1.3	
162,805	27	28	4 to 6	1.3	
168,834	23	23	4 to 6	1.2	
175,087	28	27	4 to 6	1.2	
175,328	27	26	4 to 6	1.2	
176,175	24	23	4 to 6	1.2	
181,822	28	26	4 to 6	1.1	
182,341	27	25	4 to 6	1.1	
183,516	25	23	4 to 6	1.1	
188,697	19	17	4 to 6	1.1	
189,939	27	24	4 to 6	1.1	
190,856	26	23	4 to 6	1.1	
196,973	28	24	4 to 6	1.1	
198,197	27	23	4 to 6	1.1	
204,378	23	19	4 to 6	1.0	
205,537	28	23	4 to 6	1.0	
213,264	24	19	4 to 6	1.0	
222,150	25	19	4 to 6	0.9	
228,423	23	17	4 to 6	0.9	
231,036	26	19	4 to 6	0.9	
238,354	24	17	4 to 6	0.9	
239,923	27	19	4 to 6	0.9	
248,286	25	17	4 to 6	0.8	
248,809	28	19	4 to 6	0.8	
		26	17	4 to 6	0.8
		23	15	4 to 6	0.8
		27	17	4 to 6	0.8

NOTE: See "General Planting Rate Information" and "Check Seed Population" pages for more information. Always field check seed population to verify planting rates.

**DRY INSECTICIDE APPLICATION RATES
APPROXIMATE POUNDS/ACRE AT 5 MPH FOR 30" ROW WIDTH**

Meter Setting	30" Rows
CLAY GRANULES	
10	4.9
11	5.4
12	6.1
13	6.9
14	7.7
15	8.5
16	9.6
17	10.7
18	11.4
19	13.1
20	14.2
21	15.5
22	16.4
23	17.2
24	18.8
25	20.9
26	23.0
27	24.1
28	25.4
29	27.8
30	29.6
SAND GRANULES	
5	2.9
6	4.9
7	5.3
8	6.3
9	7.8
10	8.9
11	10.2
12	11.2
13	12.6
14	14.1
15	15.5
16	17.5
17	19.4
18	21.8
19	24.3
20	25.7
21	27.6
22	29.6
23	32.0
24	34.4
25	36.9

NOTE: Chart represents average values and should be used only as a starting point. Granular chemical flows through meter opening at a nearly uniform rate regardless of roller speed. Your actual rate will vary depending on insecticide, planting speed, and plant population. Planting speed/ground speed has the greatest effect on application rate.

Field check your actual rate with insecticide you are using at speed and population you will be planting. See "Granular Chemical Application Field Check" page for more information.

DRY HERBICIDE APPLICATION RATES
APPROXIMATE POUNDS/ACRE AT 5 MPH FOR 30" ROW WIDTH

Clay Granules

Meter Setting	30" Rows
10	4.7
11	5.2
12	5.8
13	6.5
14	7.3
15	8.2
16	9.0
17	9.9
18	10.7
19	11.6
20	12.6
21	13.6
22	14.6
23	15.7
24	17.0
25	18.1
26	19.4
27	20.9
28	22.6
29	24.3
30	26.7

NOTE: Above chart represents average values and should be used only as a starting point. Granular chemical flows through given meter opening at a nearly uniform rate regardless of roller speed. Your actual rate will vary depending on specific herbicide, planting speed, and plant population. Planting speed/ground speed has the greatest effect on application rate.

Field check your actual rate with herbicide you are using at speed and population you will be planting. See "Granular Chemical Application Field Check" page for more information.

DRY FERTILIZER APPLICATION RATES

APPROXIMATE RATE IN POUNDS PER ACRE

Drive Sprocket	Driven Sprocket	Low Rate Position 30" Rows	High Rate Position 30" Rows
15	35	32	94
15	33	36	109
15	30	39	120
19	33	45	135
19	30	50	153
15	19	58	174
30	35	61	188
30	33	67	200
33	35	69	206
35	33	76	214
33	30	81	241
19	15	93	278
30	19	116	347
33	19	127	382
35	19	133	402
30	15	146	440
33	15	161	482
35	15	168	510



High rate setting

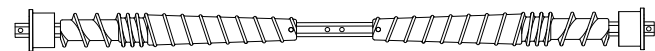

Low rate setting

NOTE: Uneven delivery may result from attempting to use lower rates than indicated by chart.

Chart is for planters equipped with contact drive. Check tires for correct operating pressure.

Chart calculated with a bulk density of 65 pounds per cubic foot.

NOTE: Fertilizer application rates can vary from weights calculated in above chart. Make field checks to be sure you are applying fertilizer at desired rate.

To check exact number of pounds your fertilizer attachment will actually deliver on a 30" row spacing:

1. Remove one spout from one fertilizer hopper and attach a container under opening.
2. Engage fertilizer attachment and drive forward 174'.
3. Weigh amount of fertilizer caught in container and multiply by 100. Result is pounds of fertilizer delivered per acre when planting in 30" rows.

LIQUID FERTILIZER SQUEEZE PUMP APPLICATION RATES**GALLONS PER ACRE**

Drive	Driven	30" Rows
15	*62	6.9
19	*62	8.8
15	46	9.3
19	46	11.8
15	34	12.6
15	32	13.4
32	*62	14.7
19	34	16.0
19	32	17.0
32	46	19.9
34	46	21.1
46	*62	21.2
15	19	22.5
32	34	26.9
34	32	30.3
19	15	36.2
46	34	38.6
46	32	41.0
32	19	48.1
34	19	51.1
*62	34	52.1

*Optional sprocket.

Chart is for planters equipped with contact drive. Check tires for correct operating pressure.

Chart calculated based on a solution weighing ten pounds per gallon.

NOTE: Fertilizer application rates can vary from weights calculated in above chart. Make field checks to be sure you are applying fertilizer at desired rate.

To check the exact number of gallons your fertilizer attachment will actually deliver on a 30" row spacing:

1. Remove hose from one fertilizer opener and insert it into a collection container secured planter frame.
2. Engage fertilizer attachment and drive forward for 174'.
3. Measure fluid ounces caught in container and multiply by 100. Divide that amount by 128. Result is gallons of fertilizer delivered per acre when planting in 30" rows.
4. Rinse collection container and repeat test on other rows if necessary.

LIQUID FERTILIZER PISTON PUMP APPLICATION RATES GALLONS PER ACRE

Applies to Model LM-2455-R And NGP-6055 Pumps With 50 Tooth Drive And 18 Tooth Driven Sprocket

Pump Setting	2	3	4	5	6	7	8	9	10
6 Row 30"	11.0	16.5	22.0	27.5	33.0	38.5	44.0	49.5	55.0
8 Row 30"	8.3	12.4	16.5	20.6	24.8	28.9	33.0	37.1	41.3

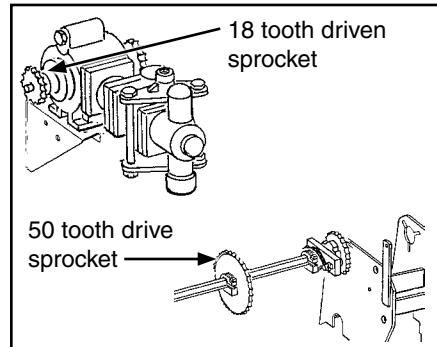

GA8069 (LM-2455-R) shown

Chart is for planters equipped with contact drive. Check tires for correct operating pressure. Chart based on average wheel slippage and liquid viscosities.

Measure and weigh one gallon of actual fertilizer solution to determine exact application rate. Chart calculated based on a solution weighing ten pounds per gallon.

NOTE: Fertilizer application rates can vary from weights calculated in above chart. Make field checks to be sure you are applying fertilizer at desired rate.

NOTE: Periodically check flow to all rows. Desired rate is delivered to remaining rows keeping total application rate at desired rate if one or more lines are plugged.

To check exact number of gallons your fertilizer attachment delivers on a 30" row spacing:

1. Remove hose from one fertilizer opener and insert it into a collection container secured to planter frame.
2. Engage fertilizer attachment and drive forward for 174'.
3. Measure fluid ounces caught in container and multiply by 100. Divide that by 128. Result is gallons of fertilizer delivered per acre when planting in 30" rows.
4. Rinse collection container and repeat test on other rows if necessary.

LUBRICATION

Following pages show locations of all lubrication points. Proper lubrication of moving parts helps ensure efficient operation of your Kinze planter and prolongs the life of friction producing parts.

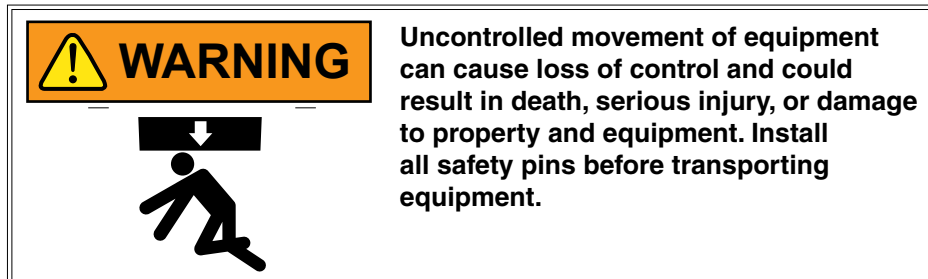

LUBRICATION SYMBOLS

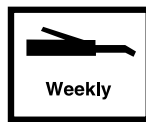
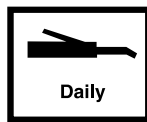

Lubricate at frequency indicated with SAE multipurpose grease.



Lubricate at frequency indicated with high quality SAE 10 weight oil or spray lubricant.

SEALED BEARINGS

Sealed bearings are used on your Kinze planter to provide trouble free operation.

These are located on drive shafts, row units, and transmission bearings. Sealed bearings are lubricated for life and are not serviceable.

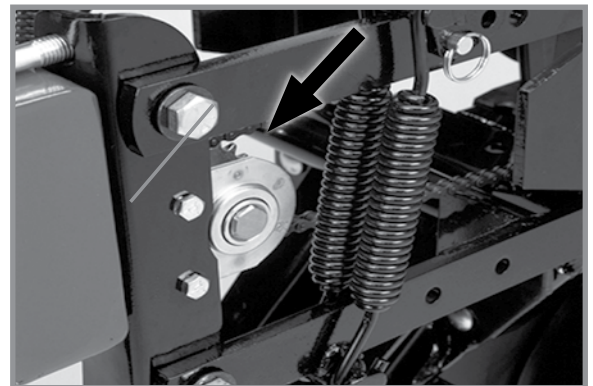

Sealed bearing (Typical)

WRAP SPRING WRENCH ASSEMBLY

1. Remove ¼"-20 x ½" cap screw securing idler assembly to wrap spring wrench tightener shaft and
2. Remove wrap spring wrench from planter.
3. Tip wrap spring wrench on its side and lubricate with a high quality spray lubricant. Lubricant must be absorbed into wrap spring area.
4. Reinstall wrap spring wrench on planter.



Wrap spring wrench lubrication

DRIVE CHAINS

Lubricate all transmission and drive chains daily with a high quality chain lubricant. Extreme operating conditions such as dirt, temperature, or speed may require more frequent lubrication. If a chain becomes stiff, it should be removed, soaked, and washed in solvent to loosen and remove dirt from joints. Soak chain in oil so lubricant can penetrate between rollers and bushings.

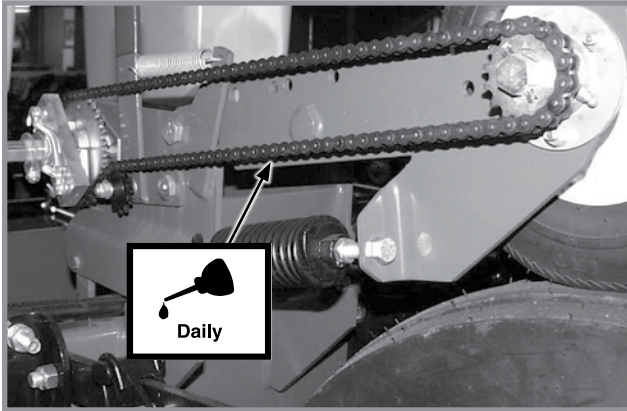

Contact Wheel Drive Chain

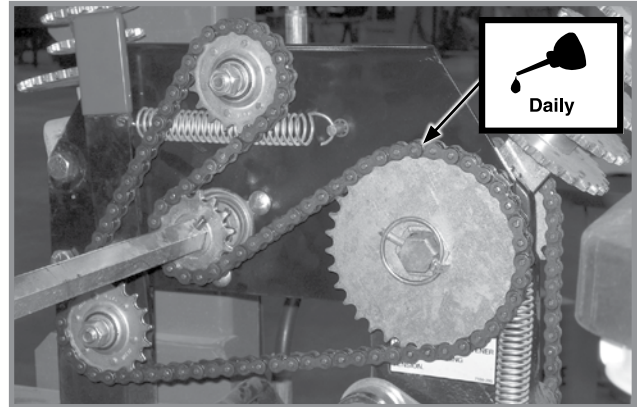

Reverser Plate Chain Drive

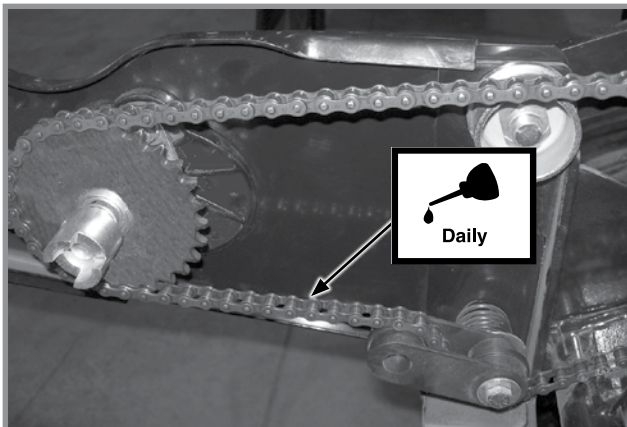

Pull Row Unit Drive Chain

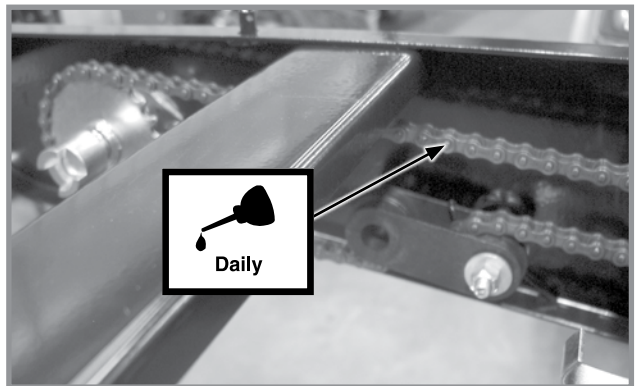

Row Unit Granular Chemical Drive Chains

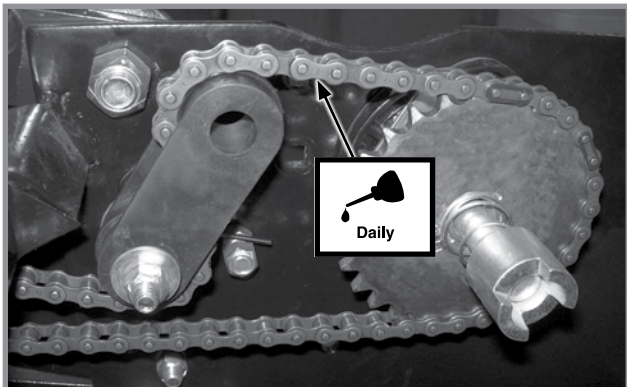

Push Row Unit Drive Chains

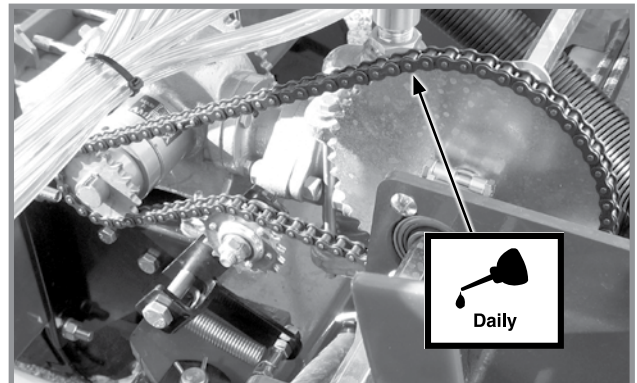

Liquid Fertilizer Piston Pump Drive Chain

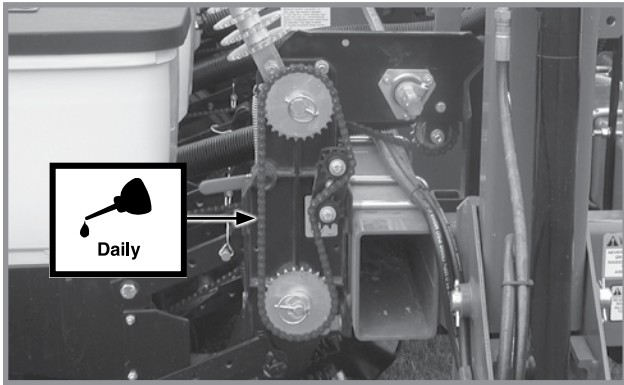

Planter Seed Rate Transmission Drive Chain

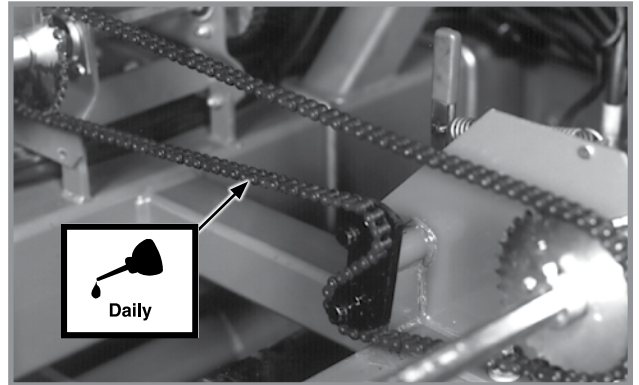

Liquid Fertilizer Squeeze Pump Drive Chain

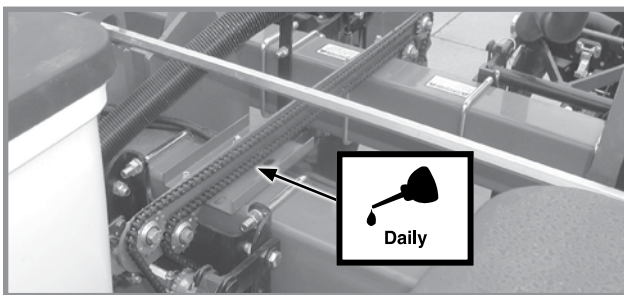

Interplant Package Drive Chain

INTERPLANT PUSH ROW UNIT LOCKUPS

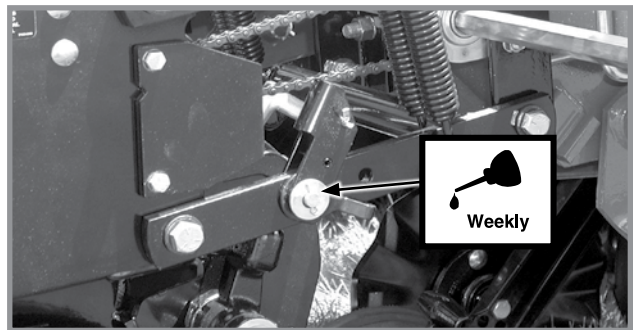

2 Per Row

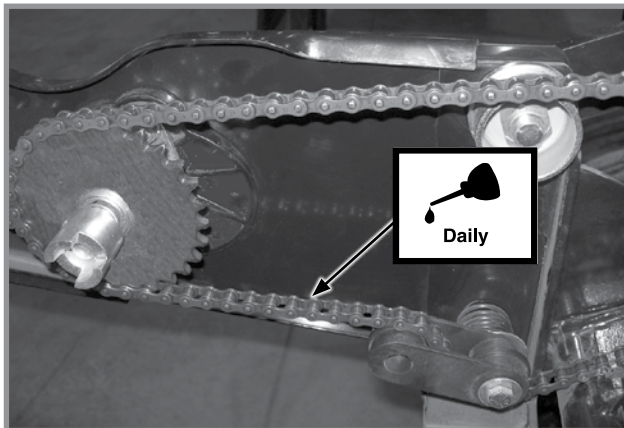

Pull Row Unit Drive Chain

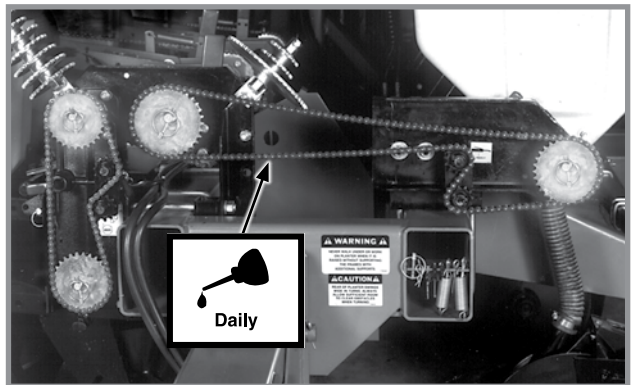

Dry Fertilizer Drive Chain

CENTER POST

NOTICE

Any oil or grease on center post and poly wear pads will attract dirt and accelerate wear. Do not lubricate center post and poly wear pads.

Center post is clad with stainless steel. Keep stainless steel surface clean and free of any lubrication to prolong service life.

See "Wear Pad Adjustment/Replacement" for more information.



Center post

WHEEL BEARINGS

All drive, transport, and marker hub wheel bearings should be repacked annually and checked for wear.

1. Raise wheel off ground.
2. Check for bearing endplay by moving wheel side to side.
3. Rotate wheel to check for bearing roughness. If bearings sound rough, remove hub and inspect bearings.

NOTE: To repack wheel hubs, follow procedure outlined for wheel bearing replacement with exception that bearings and bearing cups are reused.

LIQUID FERTILIZER PISTON PUMP CRANKCASE OIL LEVEL

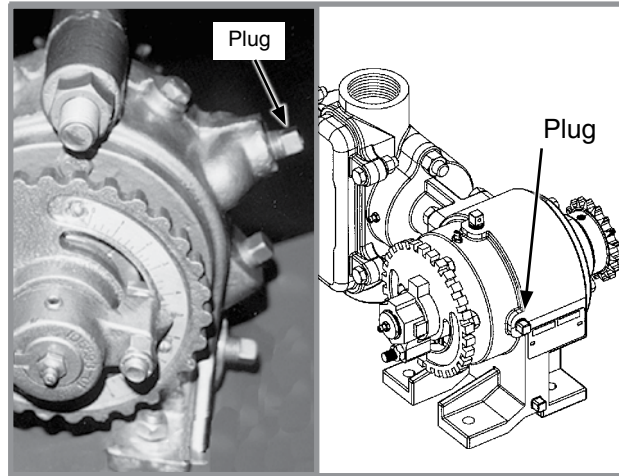

Piston pump oil fill plug location

Check crankcase oil daily and maintain at plug level. Fill as needed with EP 90 weight gear oil. Total oil capacity is approximately $\frac{3}{4}$ pint.

Refer to operator and instruction manual supplied with pump and flow divider for more information.

PTO PUMP SHAFT COUPLING (PTO PUMP DRIVE AND OIL COOLER OPTION)

NOTE: Clean and grease PTO shaft coupling each time pump is installed.

NOTE: Apply coating of high-speed industrial coupling grease, such as Chevron® Coupling Grease, that meets AGMA CG-1 and CG-2 Standards to extend shaft spline life.

Chevron® trademark is owned by Chevron Products Company. AGMA is the acronym for the American Gear Manufacturers Association.

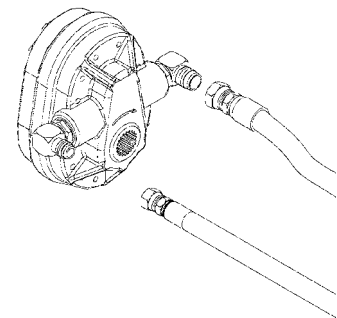

1 $\frac{3}{8}$ "-21 spline PTO pump shown

BUSHINGS

Lubricate bushings at frequency indicated.

Check each bolt for proper torque. If bolt is loose, removed it and inspect bushing for cracks and wear. Replace bushing if necessary. Use **only hardened flat washers**. Replace damaged flat washers with proper part. Torque hardware to 130 ft-lb (176.2 N-m).

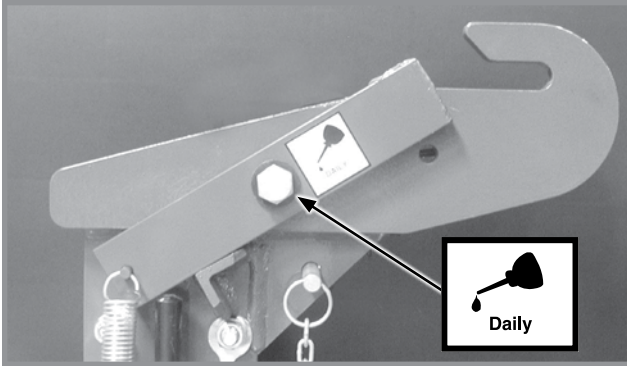

Transport Catch Pivot

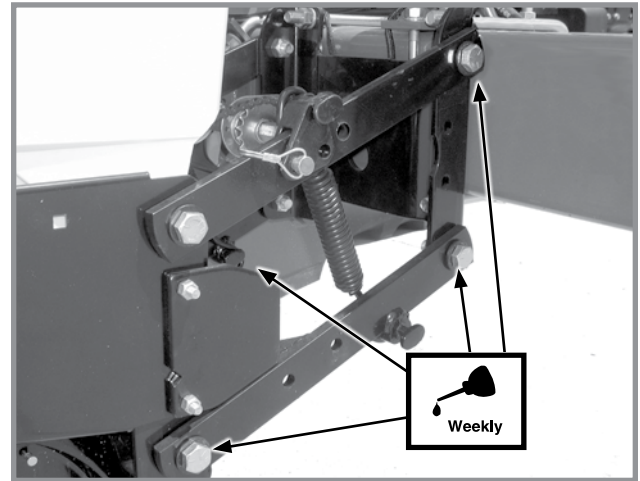

Pull Row Unit And/OR Push Row Unit Parallel Linkages (8 Per Row)

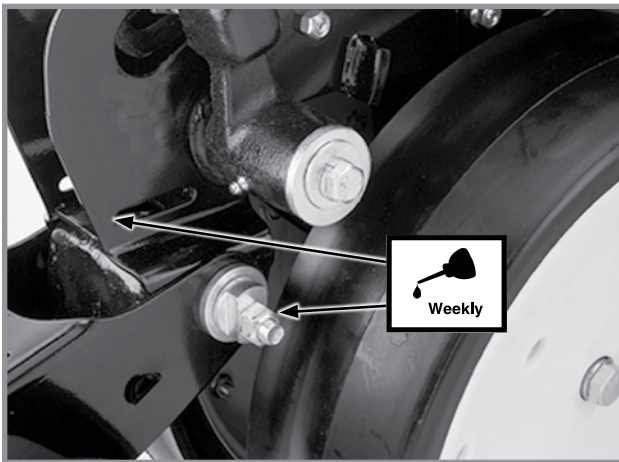

Row Unit "V" Closing Wheel, Covering Discs/ Single Press Wheel And/OR Drag Closing Wheel Eccentric Bushings (2 Per Row)

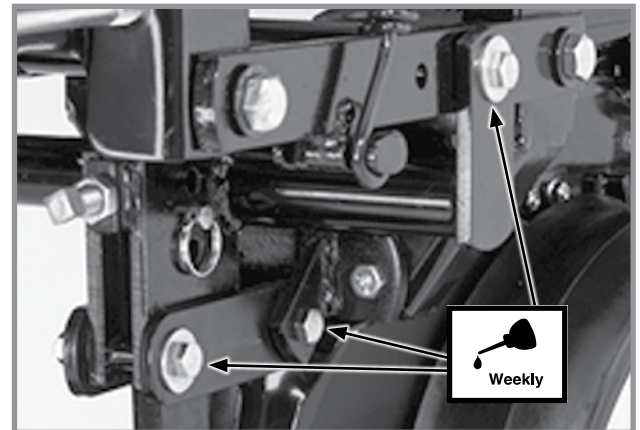

Row Unit Mounted Disc Furrower Parallel Linkages (6 Per Row)

GREASE FITTINGS

Lubricate parts with grease fittings at frequency indicated with an SAE multipurpose grease. Clean fitting thoroughly before using grease gun. Frequency of lubrication recommended is based on normal operating conditions. Severe or unusual conditions may require more frequent attention.

NOTE: Numbers on illustration below correspond to photos on following page showing lubrication frequencies.

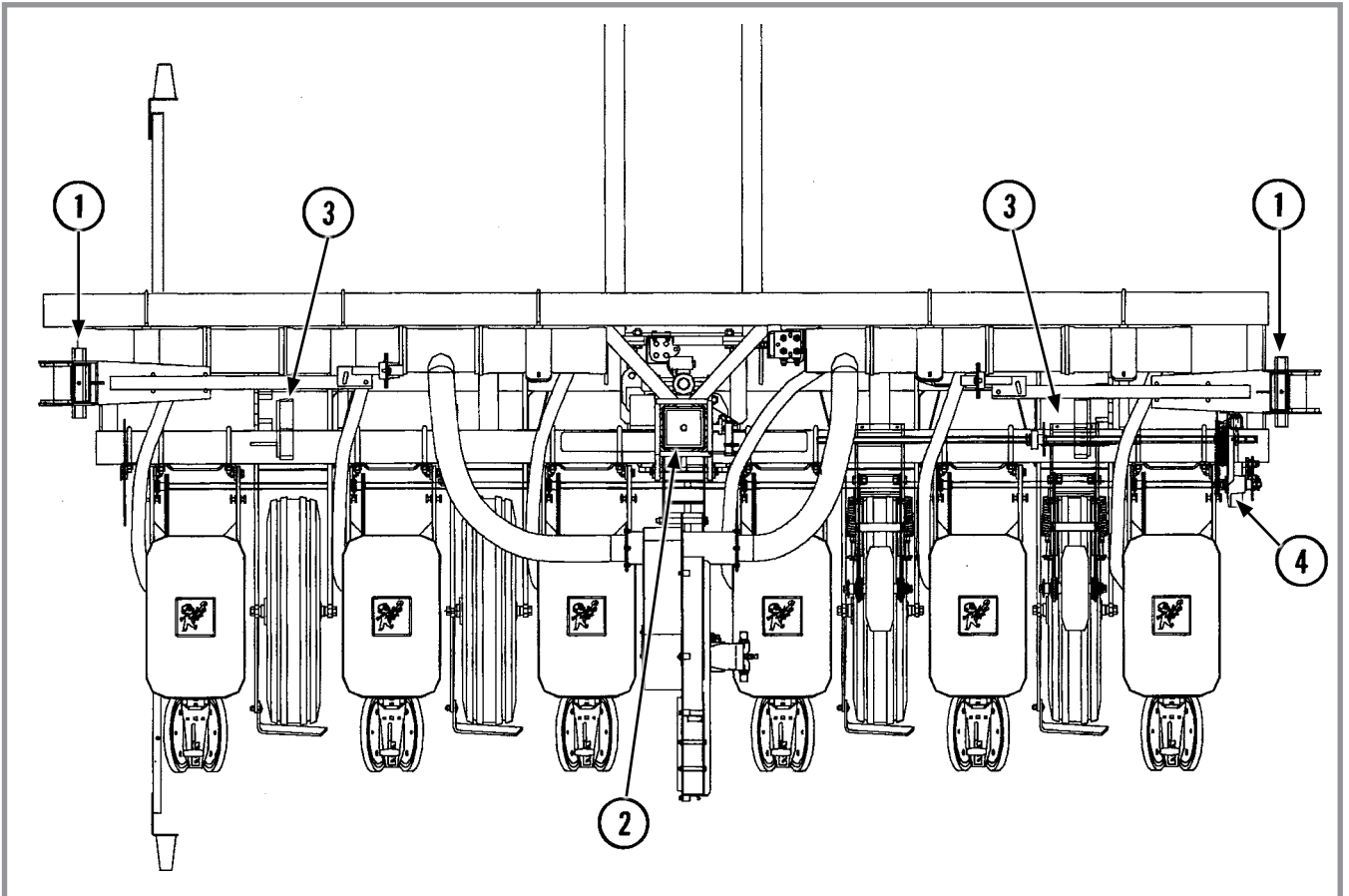

BASE MACHINE

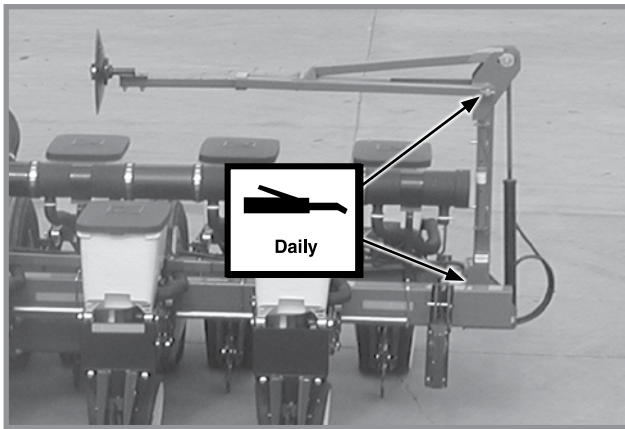

1. Row marker assembly - 2 per assembly

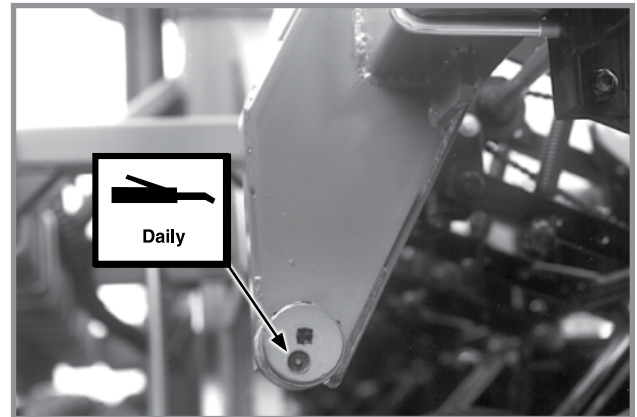

3. Cam follower - 1 per cam follower

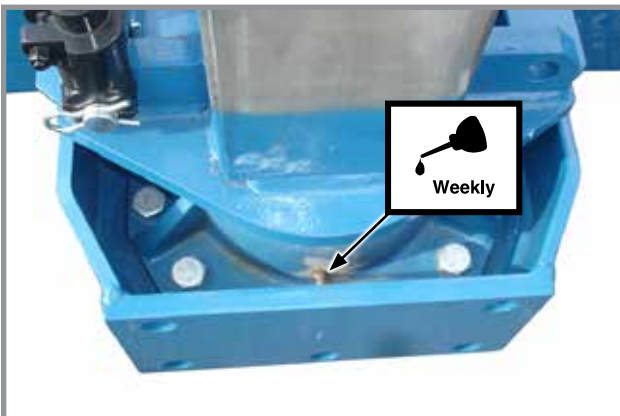

2. Center Pivot - 1

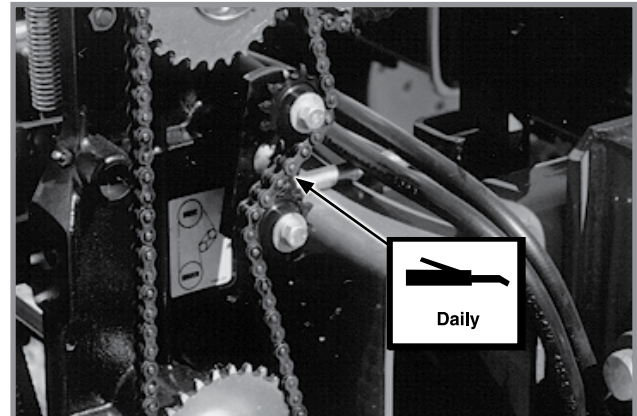

4. Seed rate transmission assembly - 1 (Idler)

ROW UNIT

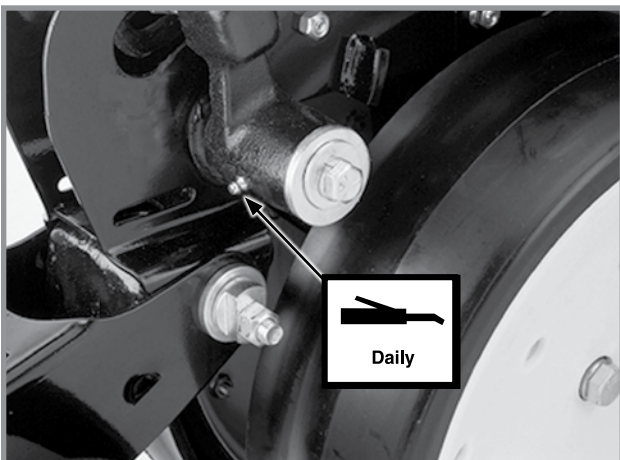

Gauge wheel arms - 1 per arm
 NOTE: Seals in gauge wheel arm are installed with lip facing out to allow grease to purge dirt away from seal. Pump grease into arm until fresh grease appears between washers and arm.)

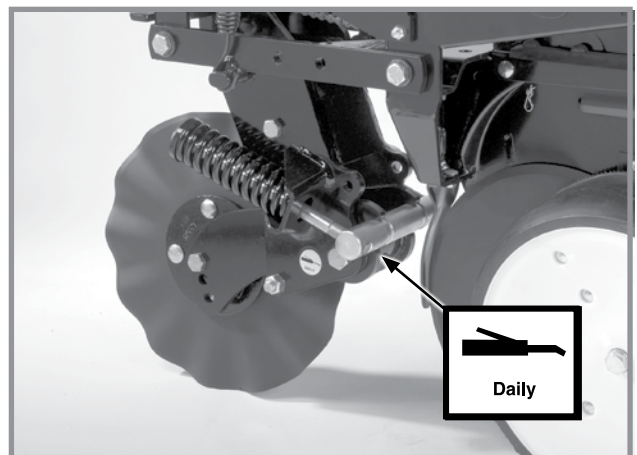

Frame mounted coulter - 1 per arm

FERTILIZER OPENERS

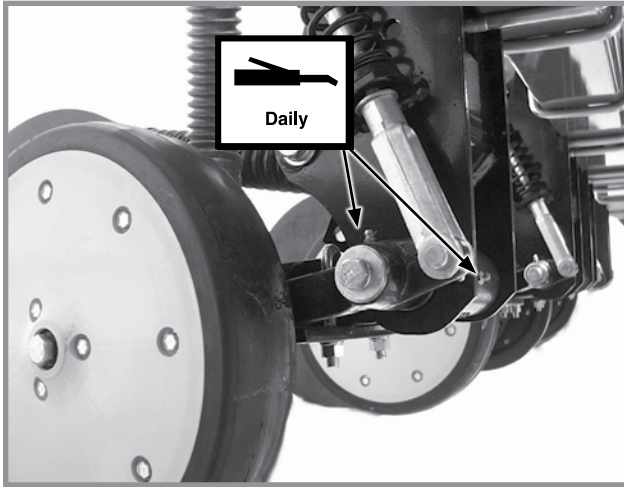

**HD Single Disc Fertilizer Opener - 2
(Located On Wheel Arm And Opener Mount)**

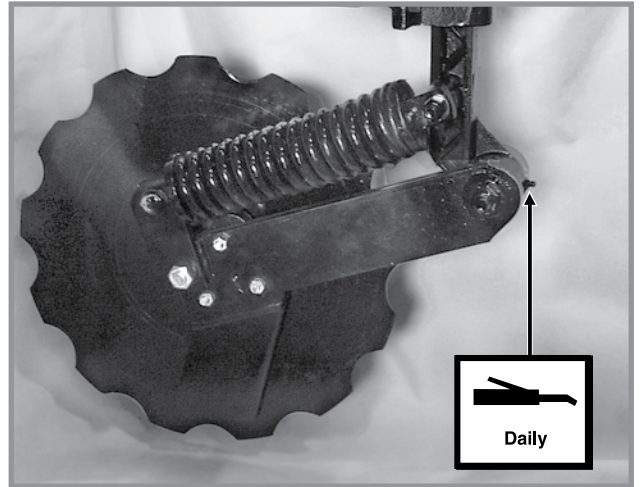

Notched Single Disc Fertilizer Opener - 1

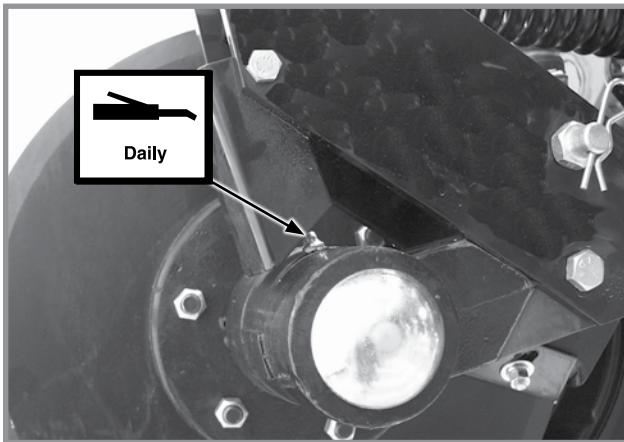

**HD Single Disc Fertilizer Opener - 1
(Located On Disc Opener Spindle Hub)**

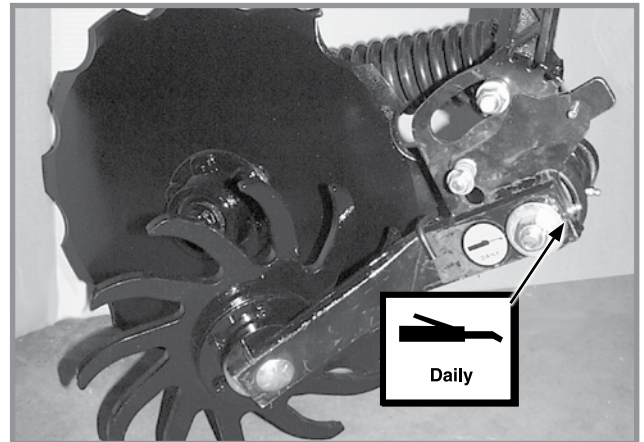

**Residue Wheel Attachment For Use With
Notched Single Disc Fertilizer Opener - 1**

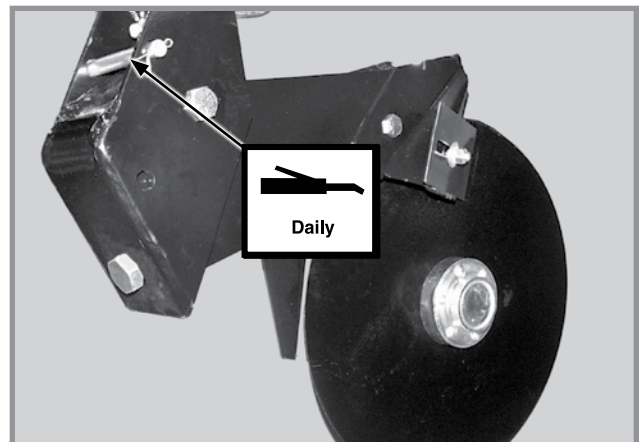

Double Disc Fertilizer Opener - 1

DRY FERTILIZER ATTACHMENT

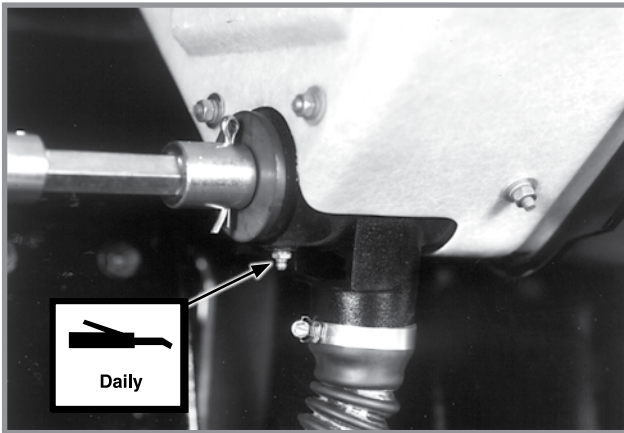

Fertilizer hopper - 2 per hopper

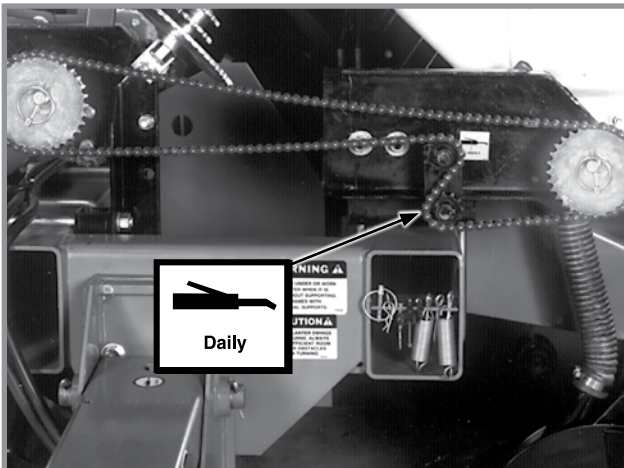

Fertilizer transmission - 1 per transmission (Idler)

LIQUID FERTILIZER SQUEEZE PUMP

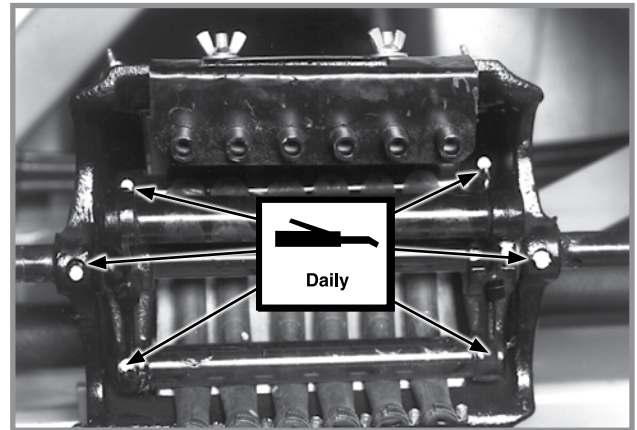

Squeeze pump - 8 per pump
NOTE: Grease fittings are on each end of roller assemblies. Rotate pump for access.

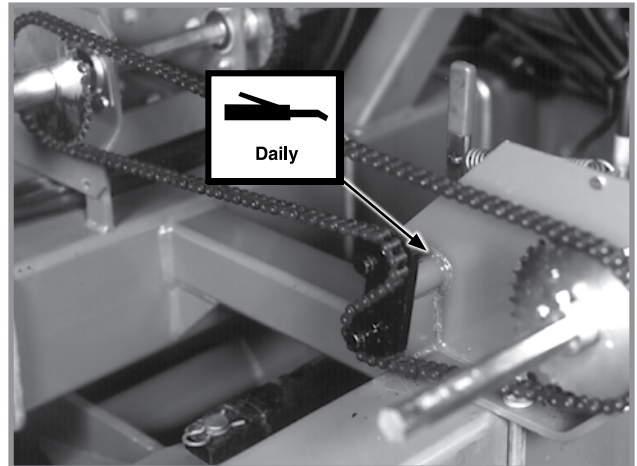

Squeeze pump drive plate - 1 per idler

LIQUID FERTILIZER PISTON PUMP

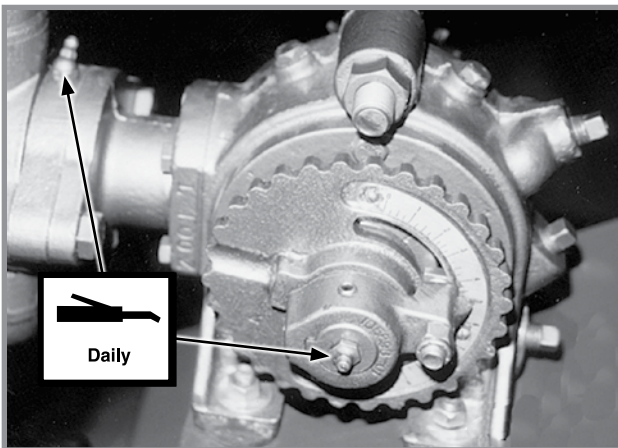

Piston Pump - 2

NOTE: Fill on outboard stuffing box until lubricant seeps out of drain hole in bottom.

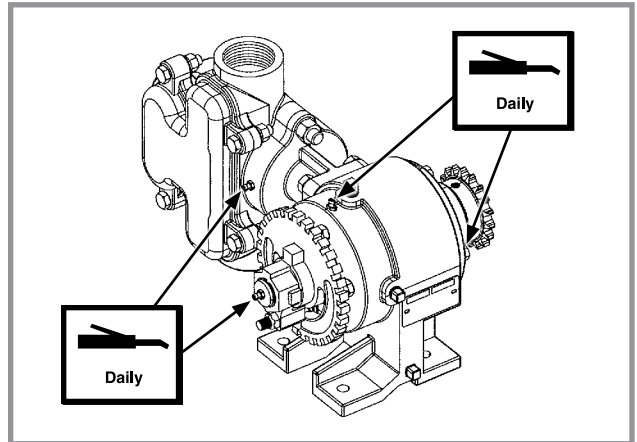

Liquid Fertilizer Piston Pump - 4
NOTE: Fill on outboard stuffing box until lubricant seeps out of drain hole in bottom.

MOUNTING BOLTS AND HARDWARE

Before operating planter for the first time, check all hardware is tight. Check all hardware again after first 50 hours of operation and beginning of each planting season.

All hardware used on the Kinze planter is Grade 5 (high strength) unless otherwise noted. Grade 5 cap screws are marked with three radial lines on the head. Hardware must be replaced with equal size, strength, and thread type.

WARNING

Loose transport wheel lug bolts can result in wheel separation from planter and result in death, serious injury, and damage to property and equipment. Check transport wheel lug nut torque before operating planter for the first time and periodically thereafter.

NOTICE

Over-tightening hardware can reduce its shock load capacity and cause equipment failure.

TORQUE VALUES CHART - PLATED HARDWARE

Diameter	Grade 2 (No marks)		Grade 5 (3 marks)		Grade 8 (6 marks)	
	Coarse	Fine	Coarse	Fine	Coarse	Fine
1/4"	50 in-lb	56 in-lb	76 in-lb	87 in-lb	9 ft-lb (12 N-m)	10 ft-lb (14 N-m)
5/16"	8 ft-lb (11 N-m)	9 ft-lb (12 N-m)	13 ft-lb (18 N-m)	14 ft-lb (19 N-m)	18 ft-lb (24 N-m)	20 ft-lb (27 N-m)
3/8"	15 ft-lb (20 N-m)	17 ft-lb (23 N-m)	23 ft-lb (31 N-m)	26 ft-lb (35 N-m)	33 ft-lb (45 N-m)	37 ft-lb (50 N-m)
7/16"	25 ft-lb (34 N-m)	27 ft-lb (37 N-m)	37 ft-lb (50 N-m)	41 ft-lb (56 N-m)	52 ft-lb (71 N-m)	58 ft-lb (79 N-m)
1/2"	35 ft-lb (48 N-m)	40 ft-lb (54 N-m)	57 ft-lb (77 N-m)	64 ft-lb (87 N-m)	80 ft-lb (108 N-m)	90 ft-lb (122 N-m)
9/16"	50 ft-lb (68 N-m)	60 ft-lb (81 N-m)	80 ft-lb (108 N-m)	90 ft-lb (122 N-m)	115 ft-lb (156 N-m)	130 ft-lb (176 N-m)
5/8"	70 ft-lb (95 N-m)	80 ft-lb (108 N-m)	110 ft-lb (149 N-m)	125 ft-lb (169 N-m)	160 ft-lb (217 N-m)	180 ft-lb (244 N-m)
3/4"	130 ft-lb (176 N-m)	145 ft-lb (197 N-m)	200 ft-lb (271 N-m)	220 ft-lb (298 N-m)	280 ft-lb (380 N-m)	315 ft-lb (427 N-m)
7/8"	125 ft-lb (169 N-m)	140 ft-lb (190 N-m)	320 ft-lb (434 N-m)	350 ft-lb (475 N-m)	450 ft-lb (610 N-m)	500 ft-lb (678 N-m)
1"	190 ft-lb (258 N-m)	205 ft-lb (278 N-m)	480 ft-lb (651 N-m)	530 ft-lb (719 N-m)	675 ft-lb (915 N-m)	750 ft-lb (1017 N-m)
1 1/8"	265 ft-lb (359 N-m)	300 ft-lb (407 N-m)	600 ft-lb (814 N-m)	670 ft-lb (908 N-m)	960 ft-lb (1302 N-m)	1075 ft-lb (1458 N-m)
1 1/4"	375 ft-lb (508 N-m)	415 ft-lb (563 N-m)	840 ft-lb (1139 N-m)	930 ft-lb (1261 N-m)	1360 ft-lb (1844 N-m)	1500 ft-lb (2034 N-m)
1 3/8"	490 ft-lb (664 N-m)	560 ft-lb (759 N-m)	1100 ft-lb (1491 N-m)	1250 ft-lb (1695 N-m)	1780 ft-lb (2413 N-m)	2030 ft-lb (2752 N-m)
1 1/2"	650 ft-lb (881 N-m)	730 ft-lb (990 N-m)	1450 ft-lb (1966 N-m)	1650 ft-lb (2237 N-m)	2307 ft-lb (3128 N-m)	2670 ft-lb (3620 N-m)

NOTE: Torque unplated hardware and bolts with lock nuts approximately 1/3 higher than above values. Torque bolts lubricated prior to installation to 70% of value shown in chart.

Torque Values - Pneumatic Down Pressure

Diameter	Torque Value
1/8" NPT	120 in-lb Maximum
1/2"-13	180 in-lb Maximum
3/4"-16	180 in-lb Maximum

NOTE: Use these torque values with pneumatic down pressure components.

Special Torque Values & Instructions

Row unit parallel linkage bushing hardware	130 ft-lb (176 Nm)
5/8" No till coulter spindle hardware	120 ft-lb (162 Nm)
Transport/ground drive lug bolts	90 ft-lb (122 Nm)
Vacuum fan impeller assembly to motor shaft 5/8"-18 hex jam nut	50 ft-lb (67.8 Nm)

Cylinder Rod Piston Retaining Nut Torque Chart

	Non-Nylock Nut	Nylock Nut
½"-20	55-70 ft-lb (75-95 N-m)	45-55 ft-lb (61-75 N-m)
¾"-16	115-125 ft-lb (156-169 N-m)	100-115 ft-lb (136-156 N-m)
7/8"-14	150-180 ft-lb (203-244 N-m)	130-150 ft-lb (176-203 N-m)
1"-14	275-330 ft-lb (373-447 N-m)	250-275 ft-lb (339-373 ft-lb)
1 1/8"-12	300-375 ft-lb (407-508 N-m)	275-300 ft-lb (373-407 N-m)
1 1/4"-12	300-375 ft-lb (407-508 N-m)	275-300 ft-lb (373-407 N-m)

TIRE PRESSURE

WARNING

Explosive separation of rim and tire parts can cause death or serious injury. Overinflation, rim and tire servicing, improper use of rims and tires, or worn or improperly maintained tires could result in a tire explosion.

To prevent tire explosions:

- Maintain proper tire pressure. Inflating a tire above or below the recommended pressure can cause tire damage.
- Mount tires only by properly trained personnel using proper equipment.
- Replace tires with cuts or bubbles. Replace damaged rims. Replace missing lug bolts and nuts.
- Do not weld or heat wheel assembly. Heating increases tire pressure.

MODEL 3500 OPERATING TIRE PRESSURE

Transport/ground drive - 7.50" x 20" Inflate to 40 psi (275.7 kPa)

Contact drive - 4.10" x 6" Inflate to 50 psi (344.7 kPa)



CHAIN TENSION ADJUSTMENT

Drive chains are equipped with spring loaded idlers and are self-adjusting. The only adjustment needed is to shorten the chains if wear stretches the chains and reduces spring tension. The pivot point of these idlers should be checked periodically to ensure they rotate freely. See "Wrap Spring Wrench Assembly" in this section for more information.

Additional chain links can be found in the storage area located inside the front planter frame.

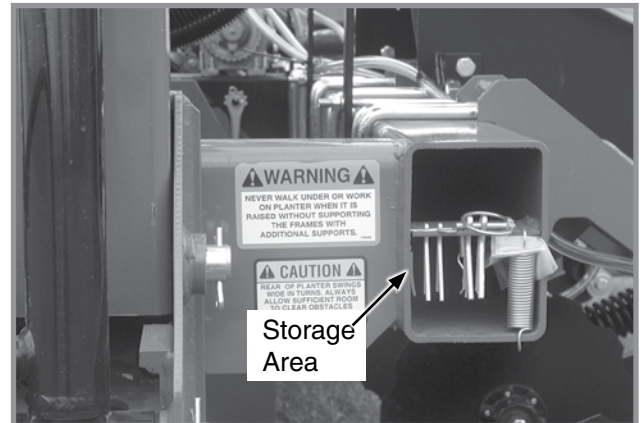

Spare chain link storage

PNEUMATIC DOWN PRESSURE AIR COMPRESSOR TANK

Moisture should be drained daily from the tank. Tank should be drained completely for storage.

To drain tank, locate drain plug on the bottom of tank. Stand off to the side of tank and pull cable attached to drain.

NOTE: If moisture is not drained from tank rust particles will form inside tank.

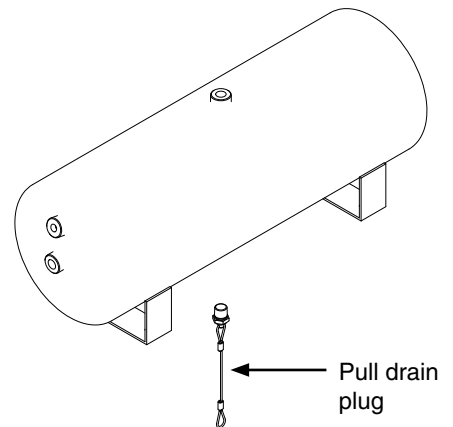

FINGER PICKUP SEED METER INSPECTION/ADJUSTMENT

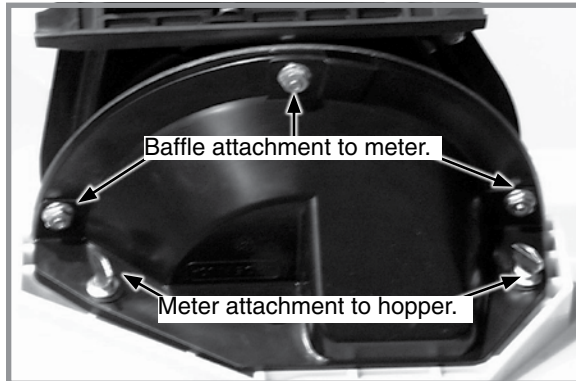

Removing meter and baffle

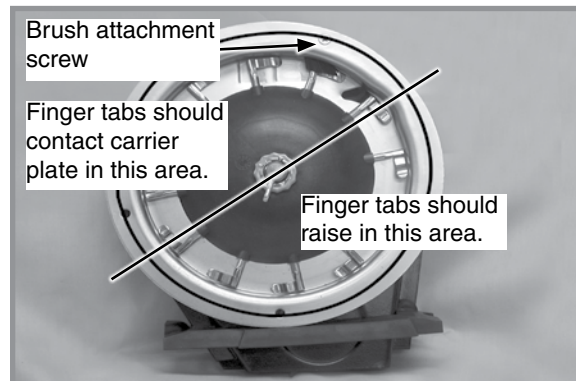

Proper finger operation

1. Remove two thumbscrews and meter from seed hopper and remove three cap screws and baffle from meter assembly.
2. Rotate seed meter drive by hand to ensure springs are holding tabs of fingers against carrier plate and fingers raise in correct area as shown in above photo.

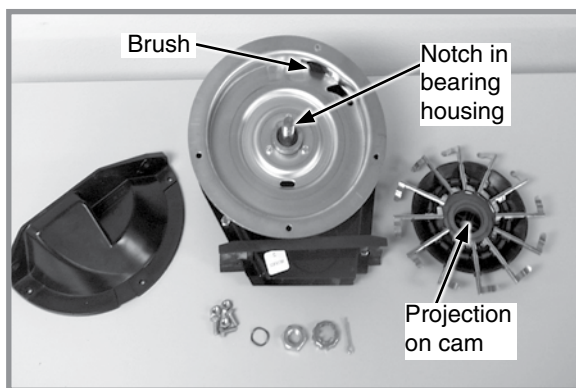

Finger pickup meter parts

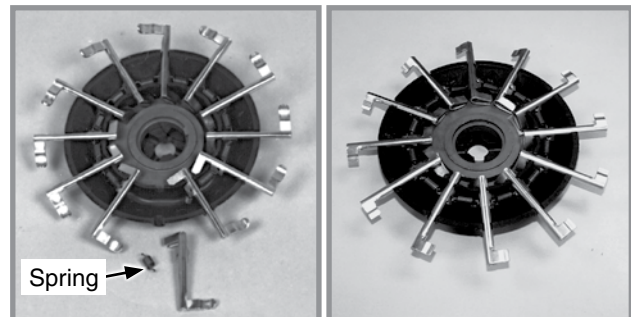

Corn Finger Assembly
(Position Spring Opening
Toward Holder)

**Oil Sunflower Finger
Assembly**

Buildup of debris or chaff may prevent proper finger operation and requires disassembly and cleaning of finger pickup meter.

1. Remove cotter pin, cover nut and adjusting nut and wave washer (If applicable) from drive shaft.
2. Carefully lift finger holder with fingers and cam off shaft and clean.
3. Check brush for wear and replace if necessary or after every 100 acres (41 hectares) per row of operation (Approximately 800 acres (324 hectares) of corn or sunflowers on a 8 row machine or 1200 acres (486 hectares) on an 12 row machine).

NOTE: It is not necessary to remove finger holder to replace brush.

4. Remove springs from fingers and remove finger from holder by lifting it out of friction fit slot. Life expectancy of these parts is about 600-900 acres (243-364 hectares) per row of operation under average conditions.
5. Reassemble meter in reverse order after cleaning and replacing defective parts. Make sure open end of spring loop is toward inside of finger holder when replacing fingers.
6. Install fingers in holder so holder is flush with carrier plate when assembled. A cam projection aligns with a mating notch in bearing housing to ensure proper operation when assembled.

7. Check indentations on carrier plate for wear before installing finger holder on carrier plate. Excessive wear of carrier plate at indentations will cause over planting especially with small sizes of seed. Inspect carrier plate annually. Life expectancy should be 250-300 acres (100-125 hectares) per row of operation under average conditions.
8. Install wave washer and adjusting nut with finger holder flush against carrier. Tighten adjusting nut to fully compress wave washer. Back off nut $\frac{1}{2}$ to 2 flats to obtain rolling torque of 22 to 25 inch pounds (2.5 N-m to 2.8 N-m).
9. Turn finger holder by hand to make sure it is firmly against carrier plate, but can be rotated with moderate force.
10. Install cover nut and cotter pin. Reinstall baffle.

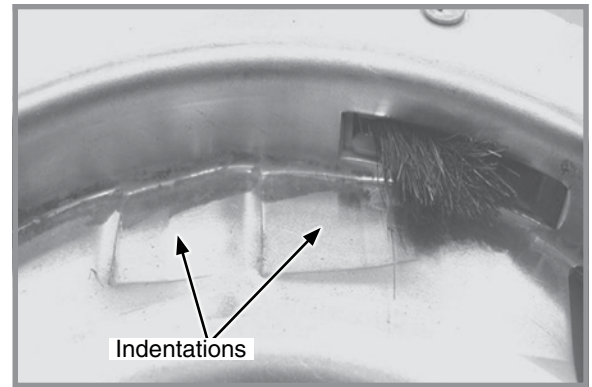

Worn carrier plate

NOTE: Check adjusting nut tightness on each unit after first day of use and periodically thereafter.

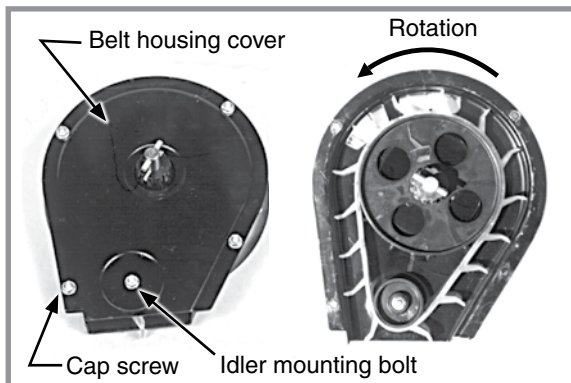

Belt idler

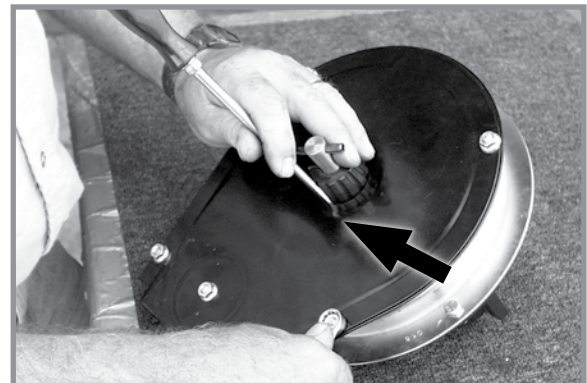

Centering belt housing cover

Remove four cap screws around edge of housing cover and nut from belt idler mounting bolt. Paddles must be correctly oriented as shown above. A diagram molded into drive sprocket shows correct orientation.

NOTICE

Do not over-tighten hardware or components may be damaged.

Reinstall housing cover. **DO NOT TIGHTEN** hardware. Wedge a screwdriver between sprocket hub and housing cover as shown above. Pry cover down until centered on belt housing and tighten hardware. Rotate meter drive shaft and check idler alignment. Seed belt should "run" centered on idler or with only slight contact with belt housing or cover.

CLEANING FINGER PICKUP SEED METER FOR STORAGE

1. Disassemble meter and blow out any foreign material.
2. Wash **ONLY** in mild soap and water. Do not use gasoline, kerosene, or any other petroleum based product. Dry thoroughly.
3. Coat lightly with a rust inhibitor.
4. Rotate finger assembly so finger does not touch brush.
5. Reassemble and store in a dry, rodent-free location.

BRUSH-TYPE SEED METER MAINTENANCE

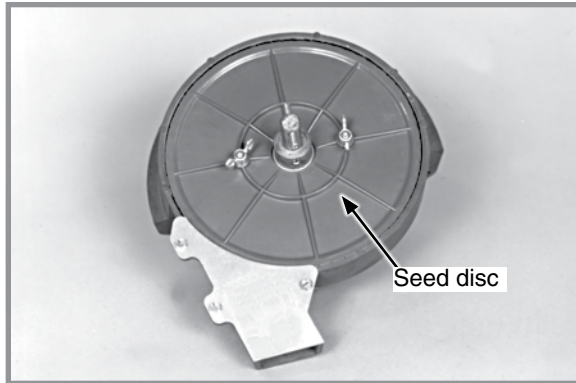

Brush-type seed meter seed disc installed

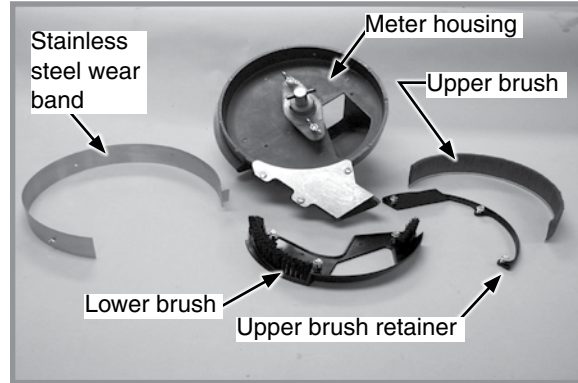

Brush-type seed meter parts

Use clean, high quality seed. Damaged or cracked seed, hulls, or foreign materials can become lodged in upper brush and greatly reduce meter accuracy. Remove seed disc daily and check for buildup of foreign material on seed disc, particularly in seed loading slots. Clean disc by washing it with soap and water. Check for cracked seed, hulls, etc. lodged between brush retainer and stainless steel wear band which can greatly reduce accuracy of the meter because upper brush will not be able to retain seed in seed disc pocket. Thoroughly clean brush areas of meter housing.

SEED DISC WEAR

Most seed disc wear is found in the agitation groove area (area between seed loading slots). Wear affects planting accuracy at high RPM. Lay a straight edge across disc surface at agitation groove area and measure gap between disc and straight edge. If agitation groove areas are worn in excess of .030" (7.6 mm) and accuracy starts to drop off at higher meter RPM, replace seed disc. Estimated seed disc life expectancy under normal operating conditions is approximately 200 acres (81 hectares) per row. Severe operating conditions such as dust, lack of lubrication or abrasive seed coating could reduce seed disc life expectancy to under 100 acres (40.5 hectares) per row.

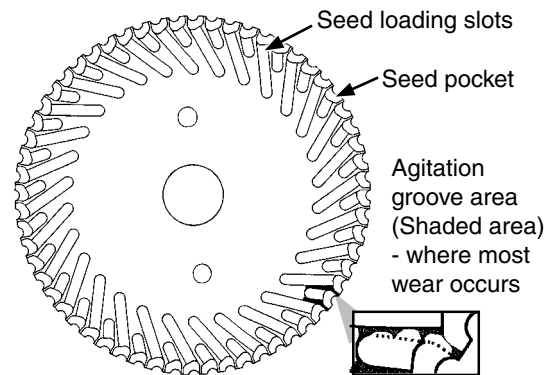

STAINLESS STEEL WEAR BAND

NOTICE	If wear band wears through or if meter is used without wear band in place, meter housing may be damaged.
---------------	---

Stainless steel wear band protects meter housing from wear and is .030" (.076 cm) thick. Replace wear band when there is approximately .020" (.050 cm) of wear in primary wear area. Estimated life expectancy of stainless steel wear band is 240-800 acres (97-324 hectares) per row.

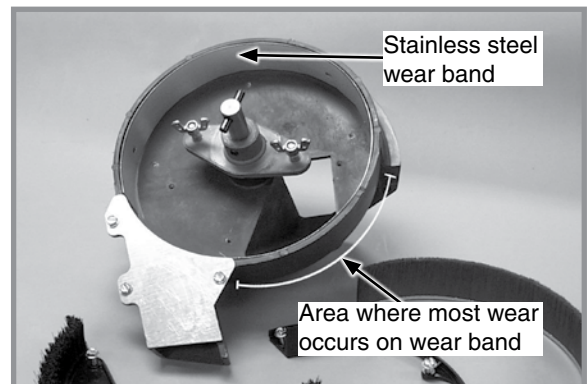

Stainless steel wear band

UPPER BRUSH

Upper brush holds seed in seed disc pocket in seed retention area. Brush must apply enough pressure against seed in seed disc pocket as disc rotates through seed retention area to prevent seed from dropping out of disc pocket. A damaged spot, excessive brush wear, or foreign material lodged in brush may greatly reduce meter performance.

Replace upper brush at 120-400 acres (49-162 hectares) per row of use or sooner if damage or excessive wear is found. Position upper brush into inner perimeter of seed retention area. Make sure base of brush is tight against bottom of meter housing. Install brush retainer and three hex head screws. Tighten screws in sequence shown in photo at right.

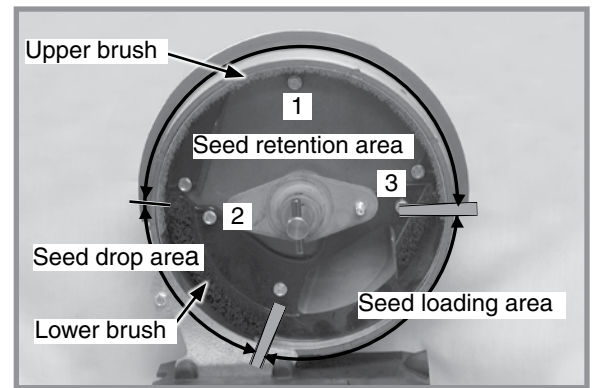

Upper brush installation

NOTE: Use GD11122 upper brush retainer for soybean and cotton discs. Use GD8237 upper brush retainer for milo/grain sorghum discs.

LOWER BRUSH

Lower brush moves seed down seed loading slots to seed pockets, isolates seed in reservoir from entering seed tube, and cleans seed loading slots. Estimated lower brush life expectancy is 240-800 acres (97-324 hectares) per row. Replace lower brush if bristles are deformed or missing, or if there are cracks in brush retainer.

CLEANING BRUSH-TYPE SEED METER FOR STORAGE

1. Remove meter from seed hopper by removing two thumbscrews securing meter to hopper.
2. Remove seed disc and wash with soap and water and dry thoroughly.
3. Remove three hex head screws from brush retainer. Remove brush retainer and upper brush.
4. Remove three hex head screws from lower brush. Remove lower brush and stainless steel wear band.
5. Wash all parts and meter housing with soap and water and dry thoroughly.
6. Inspect all parts and replace worn parts.
7. Reassemble meter except for seed disc. Store meter in a dry, rodent-free space with seed disc removed.

VACUUM SEED METER MAINTENANCE

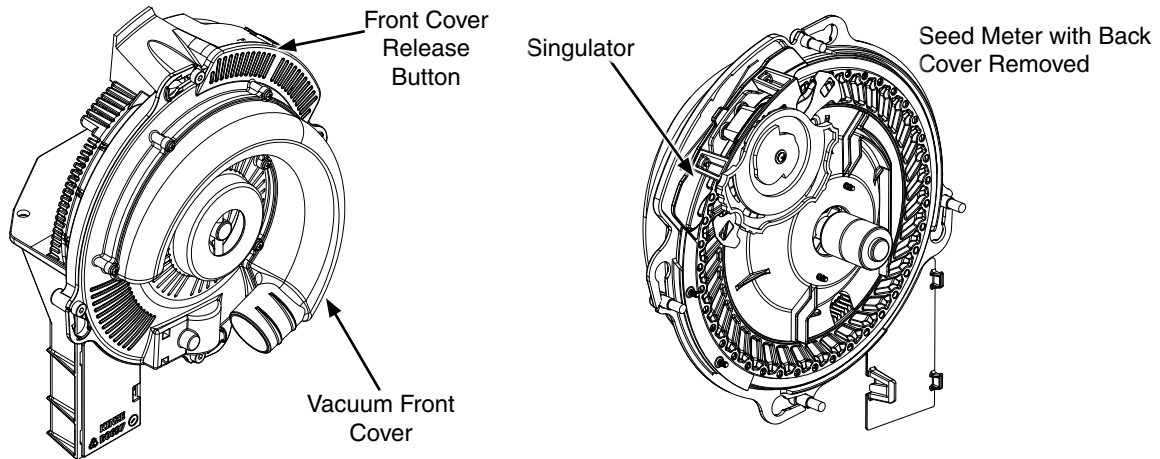

Before each planting season inspect seed discs and singulator and clean or replace as needed.

Use clean, high quality seed for maximum meter accuracy. Damaged or cracked seed, hulls, and foreign material may become lodged in seed disc orifices and greatly reduce meter accuracy.

Inspect and clean seed discs daily checking for any buildup of foreign material and blocked orifices. If seed disc orifices are plugged frequently with seed remnants, remants ejector wheel may need to be replaced. Clean seed disc by washing it with soap and water. Dry thoroughly.

Inspect singulator blades and guide for wear after every 200 acres (81 hectares) per row of operation. If adjustment of singulator blade does not affect meter performance or if blades appear worn, singulator blade may need to be replaced.

Replace seed disc or vacuum seal if abnormally high vacuum is required or if consistent operation cannot be achieved.

See ["Preparing Planter for Storage" on page 6-32](#) for additional Vacuum Seed Metering System maintenance.

NOTE: Remove seed discs from meters for annual storage and store them vertically on a dowel or pipe.

SEED METER CLEANOUT

NOTE: Use of damaged seed or seed containing foreign material will cause plugging of seed cell orifices and require more frequent seed meter cleanout to prevent underplanting.

Thorough seed meter cleanout is important to maintain genetic purity.

1. Disengage seed drive and remove seed hopper and meter.
2. Dump seed from right rear corner of hopper into a container.
3. Lay hopper on its right side. Push release button and rotate seed meter vacuum cover clockwise to align keyhole slots with bolt heads. Lift off cover.
4. Rotate seed disc hub clockwise to unlock and remove seed disc.
5. Empty meter.
6. Thoroughly inspect meter to ensure all seed is removed.
7. Replace seed disc. Install vacuum cover.

DRAG CLOSING ATTACHMENT

Inspect each drag closing attachment and replace any worn or broken parts before storing planter. Check for loose hardware and tighten as needed.

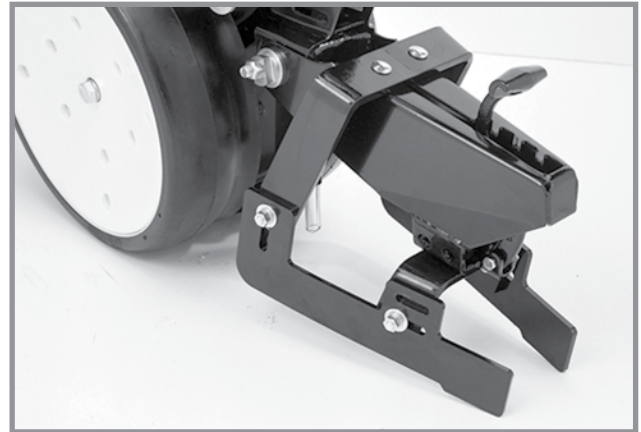

Drag Closing Attachment

GAUGE WHEEL ADJUSTMENT

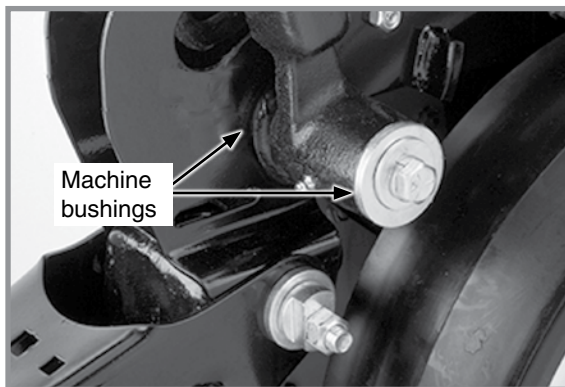

Machine bushings

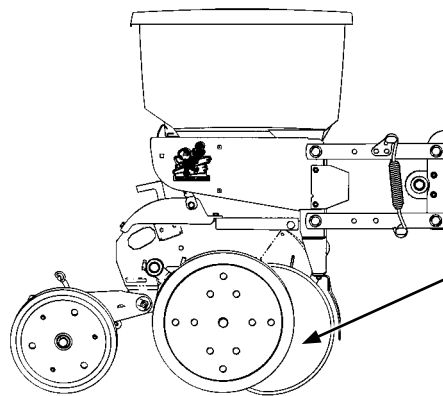

Shim gauge wheel to lightly contact opener disc blade. Check adjustment in field position.

Gauge wheel adjustment

Gauge wheels should lightly contact opener blades to prevent accumulation of dirt or trash. Gauge wheels and opener blades should turn with only slight resistance.

Add or remove machine bushings between shank and gauge wheel arm to adjust clearance between gauge wheels and opener blades. Store remaining machine bushings between gauge wheel arm and flat washer on outer side of gauge wheel arm.

NOTE: It may be desirable to space gauge wheel further from blade when operating in sticky soils.

GAUGE WHEEL ARM BUSHING AND/OR SEAL REPLACEMENT

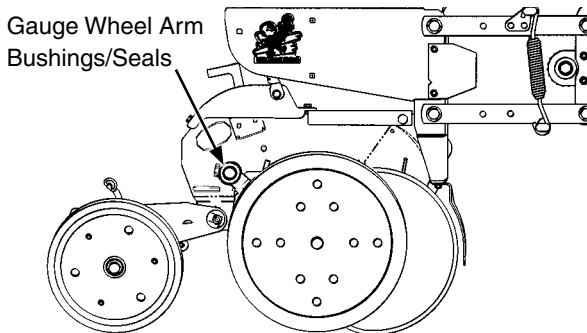

NOTE: Gauge Wheel Arm Bushing and Seal Driver Kit (G1K296) is available through your Kinze Dealer.

1. Remove gauge wheel from arm.
2. Remove gauge wheel arm from shank assembly.
3. Remove seal and bushing and discard. Clean and dry inner bore.

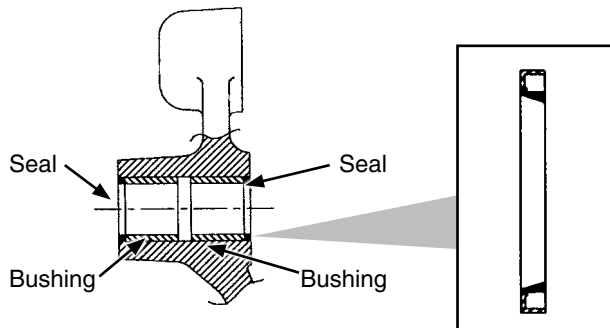

4. Drive/press replacement bushing inside bore of arm to a depth of .125" (3.2 mm) below flush.
5. Coat wiping edge of seal with grease.
6. Drive/press seal into place with lip to outside.

NOTE: Use extra care to protect the sealing lip during installation. Apply uniform pressure to assemble the seal into the bore of the arm. Never apply a direct hammer blow to the seal surface.

7. Inspect gauge wheel pivot spindle.
8. Reinstall gauge wheel arm assembly and gauge wheel.

NOTE: Use special machine bushing between gauge wheel arm and gauge wheel.

9. Shim for proper gauge wheel tire/disc blade clearance.
10. Lubricate with an SAE multipurpose grease.

GAUGE WHEEL ARM PIVOT SPINDLE REPLACEMENT

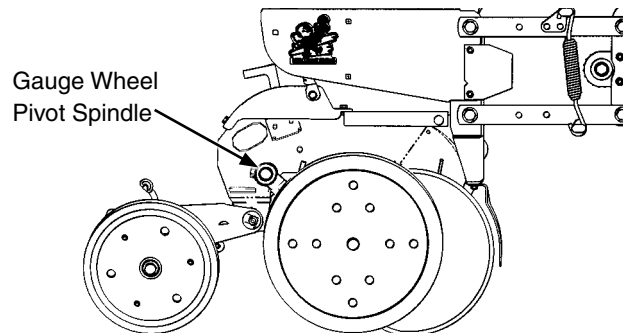

1. Remove gauge wheel and arm assemblies from shank assembly.
2. Remove 1/2" x 3/4" cap screw that locks pivot spindle in place and remove spindle.

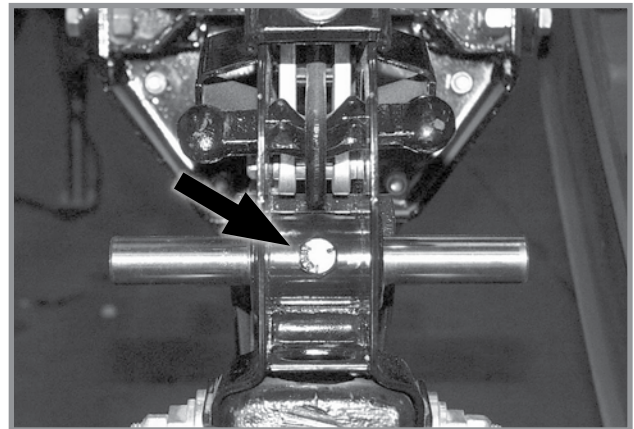

3. Install replacement spindle and position as shown below. Exact centering is critical.

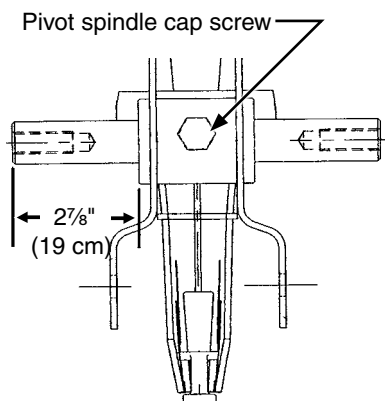

4. Install 1/2" x 3/4" cap screw and torque to lock pivot spindle in place.
5. Install gauge wheel and arm assemblies. Shim for proper gauge wheel tire/disc blade clearance.

15" SEED OPENER DISC BLADE/BEARING ASSEMBLY

NOTICE

Excessive blade contact may result in premature disc opener bearing/hub failures and excessive wear on seed tube guard/inner scraper. When properly adjusted, if one blade is held in fixed position, opposite blade should rotate with less than 5 pounds force (22 newtons) at outer edge of blade.

Maintain approximately $1" \pm \frac{1}{2}"$ ($3 \pm .5$ cm) of blade-to-blade contact to properly open and form seed trench. As blade diameter decreases due to wear, it is necessary to relocate machine bushings from inside to outside to maintain $1" \pm \frac{1}{2}"$ ($3 \pm .5$ cm) of contact.

NOTE: Proper blade clearance is critical. Blades should have $1" \pm \frac{1}{2}"$ ($3 \pm .5$ cm) contact in this area. When blades are turned by hand in opposite directions against each other, there should be only light resistance to turning. Re-adjust blade scraper if necessary to center it between the blades.

NOTE: Replace blades if proper blade-to-blade contact cannot be maintained after relocating machine bushings or if blade diameter wears below $14\frac{1}{2}"$ (37 cm).

REPLACE DISC BLADE/BEARING ASSEMBLY

NOTE: Only bearing may need to be replaced if there is excessive endplay or if bearing sounds or feels rough when disc blade is rotated.

1. Remove gauge wheel, scraper, and bearing dust cap.
2. Remove cap screw, washer and disc blade/bearing assembly. Machine bushings between shank and disc blade are used to maintain approximate $1" \pm \frac{1}{2}"$ ($3 \pm .5$ cm) of blade-to-blade contact.

NOTICE

Left hand side of opener uses a left hand threaded cap screw. **DO NOT OVER TIGHTEN.** Damage to shank threads require replacement of row unit shank assembly.

3. Install machine bushing(s), new disc blade bearing assembly, washer and cap screw. Torque $\frac{5}{8}"$ -11 Grade 5 cap screw to 110 ft-lb (149.14 N-m).

NOTE: Replace disc blades only with disc blades of equal thickness.

4. Install bearing dust cap, scraper, and gauge wheel.

REPLACE BEARING ONLY

1. Remove gauge wheel, scraper, bearing cap, cap screw, washer and disc blade/bearing assembly.
2. Remove $\frac{1}{4}"$ rivets from bearing housing to expose bearing.
3. Installing new bearing. install three evenly spaced $\frac{1}{4}"$ cap screws into three of six holes in bearing housing to hold bearing and bearing housing in place. Install rivets in other three holes. Remove $\frac{1}{4}"$ cap screws and install rivets in those three holes.
4. Reinstall disc blade/bearing assembly, washer and cap screw. Torque $\frac{5}{8}"$ -11 cap screw to 110 ft-lb (149.14 N-m).
5. Install bearing dust cap, scraper, and gauge wheel.

SEED TUBE GUARD/INNER SCRAPER

Seed tube guard protects seed tube and acts as inner scraper for seed opener disc blades.

Remove seed tube and check for wear. Excessive wear on seed tube indicates a worn seed tube guard. Replace seed tube guard if it measures $\frac{5}{8}$ " (16 mm) or less at lower end. A new seed tube guard measures approximately $\frac{7}{8}$ " (22.2 mm).

NOTE: No till planting or planting in hard ground conditions, especially when planter is not equipped with no till coulters, and/or excessive blade-to-blade contact increases seed tube guard wear and requires more frequent inspection and/or replacement.

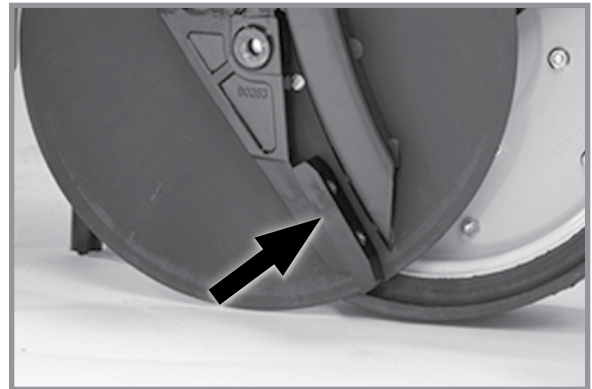

Seed tube guard/inner scraper
(Gauge wheel/seed opener disc blade removed)

NOTICE

Over tightening hex socket head cap screws may damage shank threads and require replacement of shank. An excessively worn seed tube guard may allow blades to wear into row unit shank, also requiring replacement of shank.

Remove seed tube and two hex socket head cap screws that attach seed tube guard. Hold replacement seed tube guard centered between seed opener disc blades. Install hex socket head cap screws. **DO NOT TIGHTEN.** Using a clamp or vise-grip, squeeze opener blades together in front of seed tube guard. Tighten seed tube guard retaining screws. Remove clamps. Distance between seed tube guard and opener blades should be equal on both sides. Reinstall seed tube.

FRAME MOUNTED COULTER

NOTE: Torque $\frac{5}{8}$ " spindle hardware to 120 ft-lb (162.7 N-m)

See "Frame Mounted Coulters" in Row Unit Operation section of this manual for depth and spring adjustment.

Replace 16" diameter coulters blade (1" fluted, 1" bubbled or $\frac{3}{4}$ " fluted) when worn to 14 $\frac{1}{2}$ " (37 cm) (maximum allowable wear).

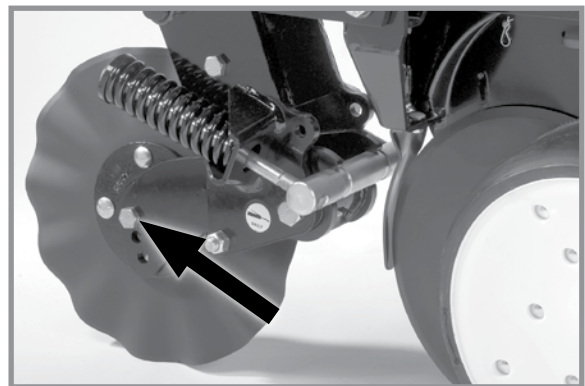

Frame mounted coulters spindle

RESIDUE WHEELS (FOR USE WITH FRAME MOUNTED COULTER)

Wheel hub is equipped with sealed bearings. Replace bearings if a bearing sounds or feels rough when wheel is rotated.

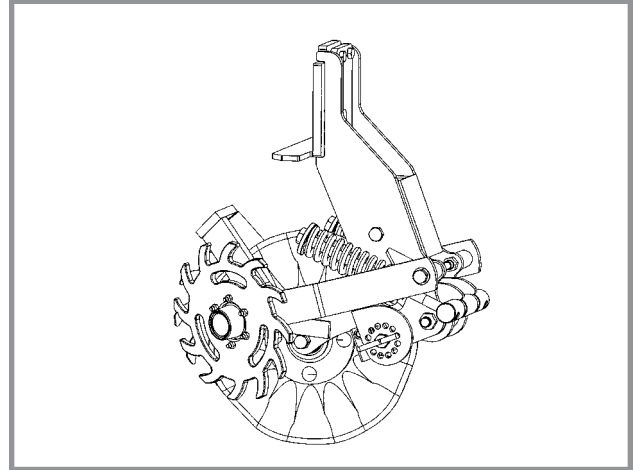

ROW UNIT MOUNTED DISC FURROWER

Lubricate bushings in support arm mounting bracket at frequency indicated in Lubrication of this section. Check each bolt for proper torque. If bolt is loose, it should be removed and bushing inspected for cracks and wear. Replace bushings as necessary.

NOTE: Use only hardened flat washers. Replace damaged flat washers with proper part. Torque bolts to 130 ft. lbs (176.2 N-m).

Blade hubs are equipped with sealed bearings. Replace bearings if a bearing sounds or feels rough when wheel is rotated.

When 12" diameter blades (solid or notched) are worn to 11" (28 cm), they should be replaced.

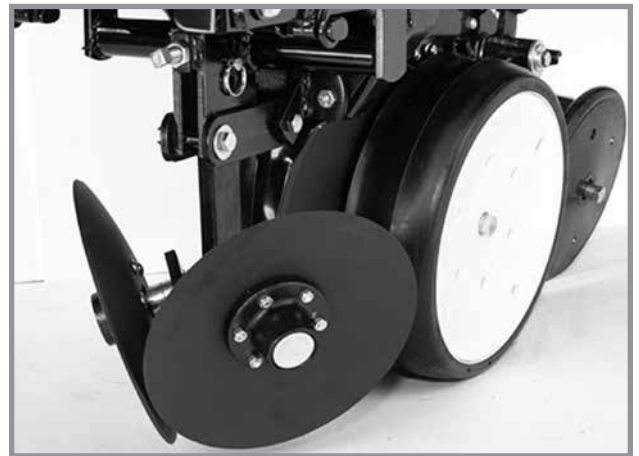

ROW UNIT MOUNTED BED LEVELER

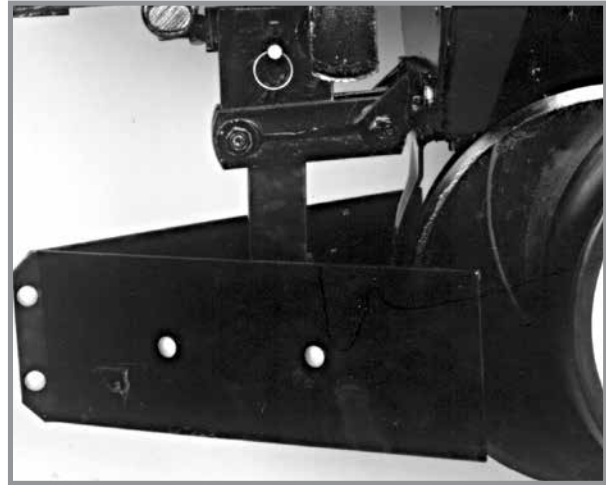
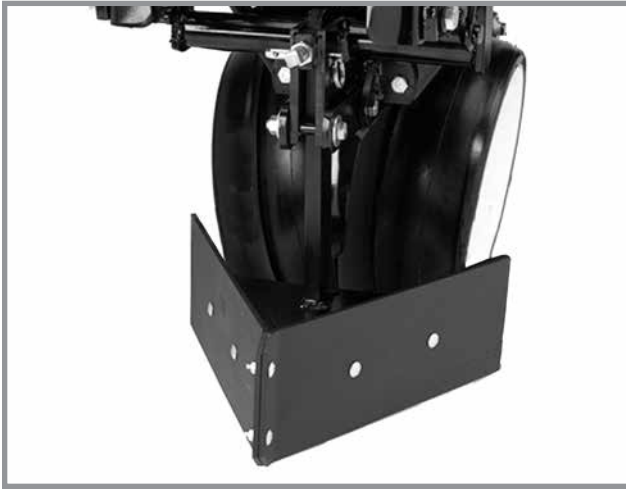

Lubricate bushings in mounting bracket and links at frequency indicated in Lubrication of this section. Check each bolt for proper torque. If bolt is loose, it should be removed and bushing inspected for cracks and wear. Replace bushing if necessary.

NOTE: Use only hardened flat washers. Replace damaged flat washers with proper part. Torque bolts to 130 ft. lbs (176.3 N-m).

ROW UNIT MOUNTED RESIDUE WHEEL

Wheel hub is equipped with sealed bearings. If a bearing sounds or feels rough when wheel is rotated, replace them.

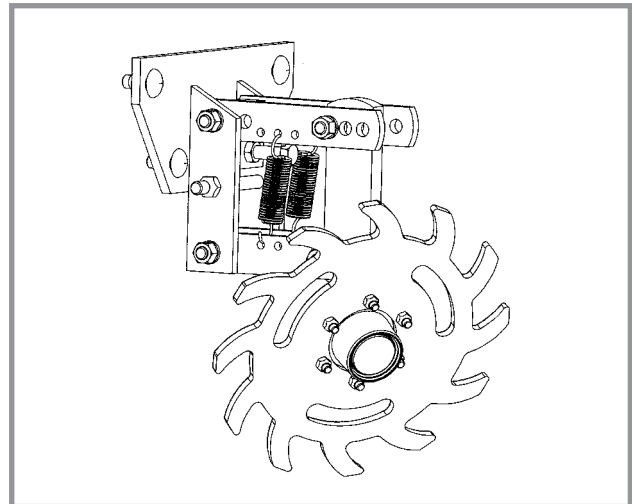

ROW UNIT MOUNTED NO TILL COULTER



(One sleeve for coulters mounted residue wheels)

Check nuts and hardware periodically for proper torque.

NOTE: Torque $\frac{5}{8}$ " spindle hardware to 120 ft-lb (162 N-m).

Be sure coulters are positioned square with row unit and aligned in front of row unit disc opener.

Coulters blade can be adjusted to one of four settings. Initially blade is set in highest position. As blade wears it can be adjusted to one of three lower settings. See "Row Unit Mounted No Till Coulters" in Row Unit Operation section of this manual.

Replace 16" diameter coulters blade when worn to 14½" (37 cm).

COULTERS MOUNTED RESIDUE WHEELS



Wheel hubs are equipped with sealed bearings. If bearings sound or feel rough when wheel is rotated, replace them.

SPIKED CLOSING WHEEL

Inner parts of spiked closing wheel will begin to wear at approximately 70% of life. Flip/reverse wheel to utilize remaining life of wheel.

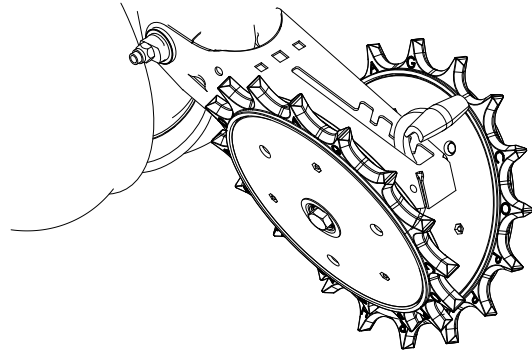

Row Unit Spiked Closing Wheel

GRANULAR CHEMICAL ATTACHMENT

Before storing planter, disengage granular chemical drive by rotating throwout knob ¼ turn counterclockwise. Remove drive chain and empty and clean all granular chemical hoppers. Clean drive chains and coat them with a rust preventive spray or submerge chains in oil. Inspect and replace worn or broken parts.

Install hoppers and chains. Check chain alignment.

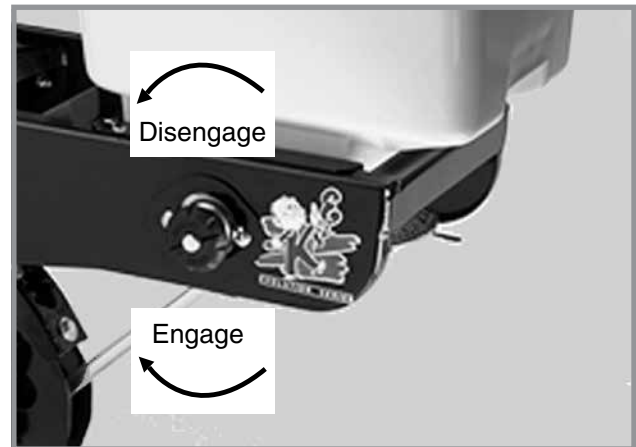

SPRING TOOTH INCORPORATOR

before storing planter, inspect each spring tooth incorporator and replace worn or broken parts. Check for loose hardware and tighten as needed.



WEAR PAD ADJUSTMENT/REPLACEMENT

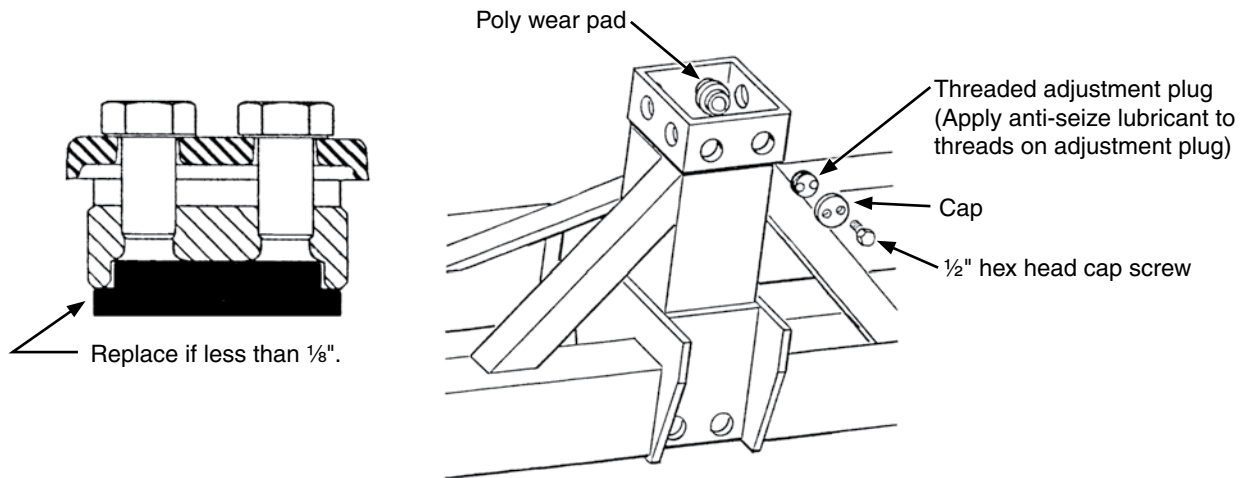

Planter center section consists of a steel tubular frame and 16 adjustable wear pad assemblies that travel up and down against a stainless steel clad center post. Each adjustable wear pad assembly consists of a poly wear pad, threaded adjustment plug, and cap. Assembly is held in place by the threaded adjustment plug and locked in place by the cap and two 1/2" hex head cap screws.

Check pad adjustment and wear annually on all wear pad assemblies.

1. Support frame with appropriate weight-rated safety stands at a comfortable working height with all row units off ground.
2. Level planter frame side to side and front to rear. with planter axle.
3. Remove two 1/2" hex head cap screws and cap. Reinstall hex head cap screws into adjustment pad and remove threaded adjustment plug and poly wear pad using hex head cap screws as a handle.
4. Replace poly wear pad if worn to less than 1/8".

NOTICE

Over tightening hex socket head cap screws may damage shank threads and require replacement of shank. An excessively worn seed tube guard may allow blades to wear into row unit shank, also requiring replacement of shank.

5. Apply anti-seize lubricant to threads of adjustment plug ONLY. Hand tighten poly wear pad and adjustment plug until poly wear pad lightly contacts stainless steel clad center post. Maximum allowable gap is no more than .060".
6. Install cap with two 1/2" cap screws. Torque cap screws to 25-30 ft-lb (33.9 - 40.6 N-m).

ROW MARKER SEQUENCING/FLOW CONTROL VALVE INSPECTION

WARNING

Pressurized hydraulic fluid can penetrate body tissue and result in death, serious infection, or other injuries. Fluid injected under skin must be **IMMEDIATELY** removed by a surgeon familiar with this type of injury. Make sure connections are tight and hoses and fittings are not damaged before applying system pressure. Leaks can be invisible. Keep away from suspected leaks. Relieve pressure before searching for leaks or performing any system maintenance.

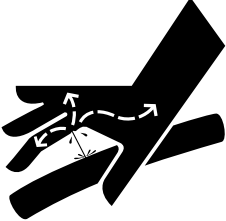

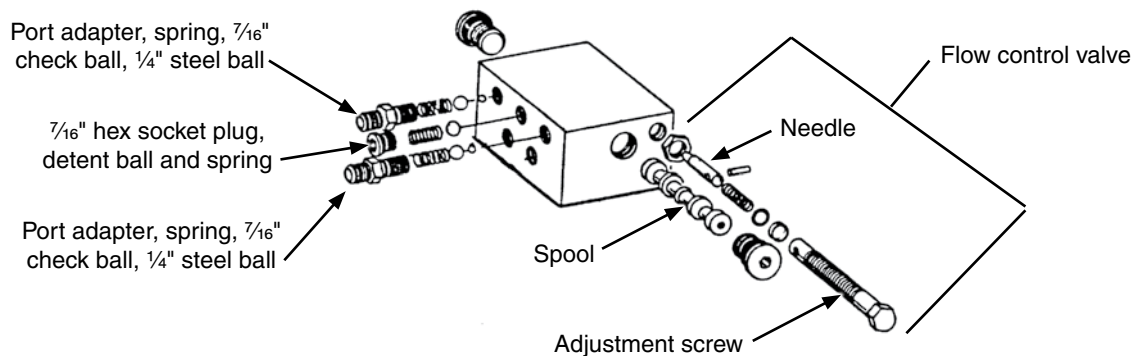

The valve block assembly consists of the row marker sequencing and flow control valves in one assembly. Sequencing valve portion consists of a chambered body containing a spool and series of check valves to direct hydraulic oil flow.

1. Remove valve block assembly from planter.
2. Remove detent assembly and port adapter assemblies from rear of valve block.

NOTICE

Damage to spool may occur if detent assembly and port adapter assemblies are not removed prior to removal of spool.

3. Remove plug from both sides of valve block and remove spool.
4. Inspect all parts for pitting, contamination, or foreign material. Check seating surfaces inside valve. Replace defective parts.
5. Lubricate spool with a light oil and reinstall. Check spool moves freely in valve body.

NOTE: Make sure correct check ball(s) and spring are installed in each valve bore upon reassembly.

A flow control valve is located on each side of block assembly. Adjust flow control valves for raise and lower speed as part of assembly procedure or upon initial operation. If valve fails to function properly or requires frequent adjustment, remove needle valve for inspection. Check for foreign material and contamination. Make sure needle moves freely in adjustment screw. Replace defective components.

NOTE: Hydraulics operate slowly when oil is cold. Make all adjustments with warm oil.

PTO PUMP DRIVE AND OIL COOLER OPTION

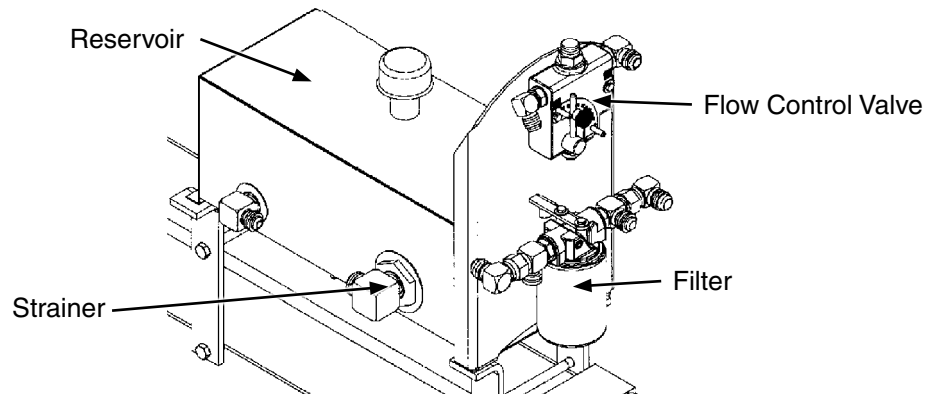

Drain reservoir, clean strainer and change filter annually.

1. Disconnect suction line (hose between reservoir and pump) from reservoir and drain. To fully drain tank, raise planter to field raised position.
2. Replace filter with good quality 10 micron filter.
3. Fill system with SAE 10W-20 multigrade wide temperature range transmission hydraulic fluid. Reservoir capacity is approximately 10 gallons.
4. Start system and run with tractor at idle and fan turned off for 1-2 minutes. Switch fan to full speed and run with tractor at idle for 1-2 minutes.
5. Check reservoir fluid level and fill as required. Hydraulic fluid level should be within 1"-2" (2.5 cm - 5 cm) from top of reservoir after pump has run and hydraulic hoses have been primed to allow fluid to expand when heated.
6. Bring tractor to PTO speed and adjust flow control to the desired vacuum level using the flow control valve lever.

CHECK VALVE INSPECTION

(In valve block below vacuum fan motor assembly)

Check valve return prevents reverse operation of vacuum fan motor. Remove and check for foreign material or if O-ring is leaking internally. Clean or replace if defective.

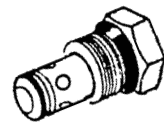

RELIEF VALVE CARTRIDGE INSPECTION

(In valve block below vacuum fan motor assembly)

NOTICE

Connect hydraulic motor case drain to a case drain return line with zero pressure on tractor or hydraulic motor will be damaged. DO NOT connect hydraulic motor case drain to SCV outlet. Contact tractor manufacturer for specific details on "zero pressure return".

Pressure relief valve helps prevent damage to vacuum fan motor by limiting pressure in motor case drain line. It is set to open at 35 PSI (241.21 kPa). Remove and check for foreign material and contamination on valve or seating area of valve body. Clean or replace if defective.



ROW MARKER BEARING LUBRICATION OR REPLACEMENT

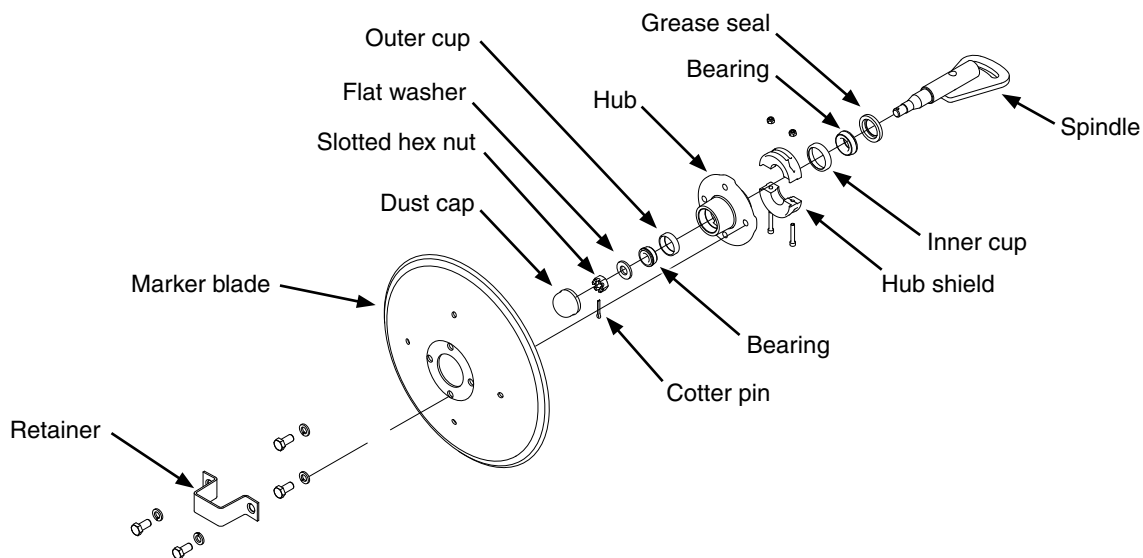

1. Remove retainer and marker blade.
2. Remove dust cap from hub.
2. Remove hub shield. Note direction of installation.
3. Remove cotter pin, slotted hex nut, and washer.
4. Slide hub from spindle.
5. Remove bearings and cups and discard if bearings are being replaced. Clean hub and dry. Remove bearings only and not cups if repacking.
6. Press in new bearing cups with thickest edge facing in. (Bearing replacement procedure only.)
7. Pack bearings with heavy duty wheel bearing grease thoroughly forcing grease between roller cone and bearing cage. Fill the space between the bearing cups in the hub with grease.
8. Install rubber seal into grease seal. Place inner bearing in place and press in new rubber seal/grease seal.
9. Clean spindle and install hub.
10. Install outer bearing, washer and slotted hex nut. Tighten slotted hex nut while rotating hub until there is some drag. This ensures all bearing surfaces are in contact. Back off slotted nut to nearest locking slot and install cotter pin.
11. Fill dust caps approximately $\frac{3}{4}$ full of wheel bearing grease and install on hub.
12. Install hub shield.
13. Install marker blade and retainer on hub. Tighten hardware evenly.

WHEEL BEARING REPACK OR REPLACEMENT

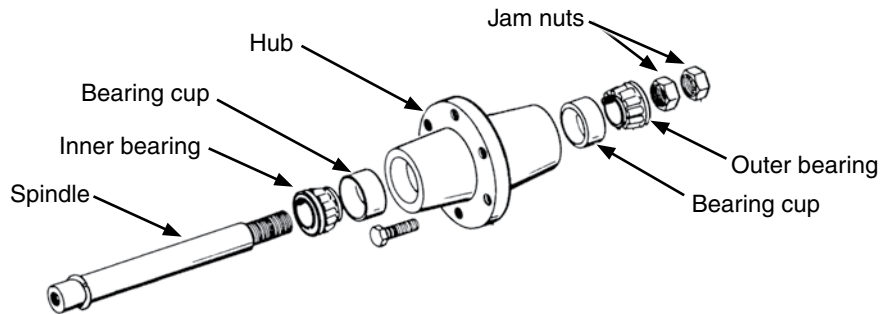

1. Raise tire clear of ground and remove wheel.
2. Remove double jam nuts and slide hub from spindle.
3. Remove bearings and cups and discard if bearings are being replaced. Clean hub and dry. Remove bearings only and not cups if repacking.
4. Press in new bearing cups with thickest edge facing in. (Bearing replacement procedure only.)
5. Pack bearings with heavy duty wheel bearing grease thoroughly forcing grease between roller cone and bearing cage. Fill space between bearing cups and hub with grease.
6. Place inner bearing in place.
7. Clean spindle and install hub.
8. Install outer bearing and jam nut. Tighten jam nut while rotating hub until there is some drag. This ensures all bearing surfaces are in contact. Back off jam nut $\frac{1}{4}$ turn or until there is only slight drag when rotating hub. Install second jam nut to lock against first.
9. Install wheel on hub. Tighten hardware evenly.

FERTILIZER CHECK VALVE CLEANING AND REPAIR

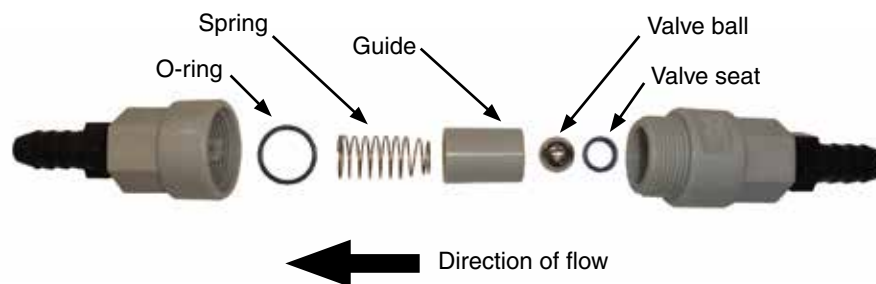

1. Unscrew valve body and separate halves. Note direction and location of parts.
2. Clean and inspect parts. Flush with clean water. Replace damaged parts.
3. Reassemble exactly as shown. O-ring and valve seat must be firmly in place inside each half of valve body.

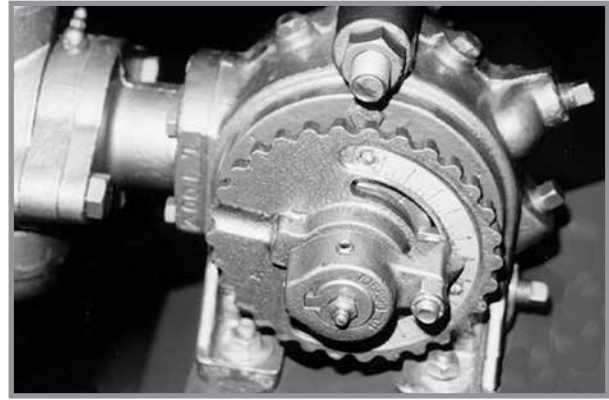
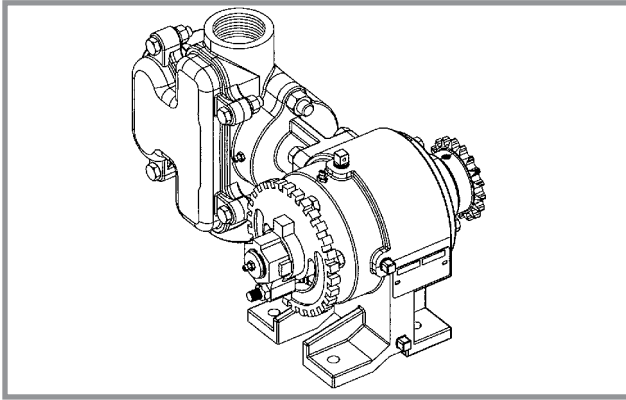

Liquid fertilizer piston pump

PISTON PUMP STORAGE

NOTICE

Entrance of air into pump will cause rapid and severe corrosion. KEEP AIR OUT OF PUMP!

NOTE: SUSPENSION FERTILIZER must be flushed from pump for ANY storage period.

1. Flush pump with 5 to 10 gallons (19 to 38 liters) of fresh water and circulate until all corrosive salts are dissolved in pump.
2. Set pump on 10. Draw in a mixture of half diesel fuel and 10 weight oil until discharge is clean. Plug inlet and outlet.

PREPARING PLANTER FOR STORAGE

- Store planter in a dry sheltered area if possible.
- Remove all trash that may be wrapped on sprockets or shafts and remove dirt that can draw and hold moisture.
- Clean all drive chains and coat with a rust preventative spray, or remove chains and submerge in oil.
- Lubricate planter and row units at all lubrication points.
- Inspect planter for parts that are in need of replacement and order during “off” season.
- Make sure seed and granular chemical hoppers are empty and clean.
- Clean seed meters and store in a dry, rodent-free area.
- Remove seed discs from brush-type seed meters, clean and store meters with discs removed.
- Grease or paint disc openers/blades and row marker disc blades to prevent rust.
- Flush liquid fertilizer tanks, hoses and metering pump with clean water. See “Piston Pump Storage” if applicable.
- Empty and clean dry fertilizer hoppers. Disassemble and clean metering augers. Reassemble and coat all metal parts with rust preventative.

ELECTRICAL WIRING DIAGRAM FOR LIGHT PACKAGE

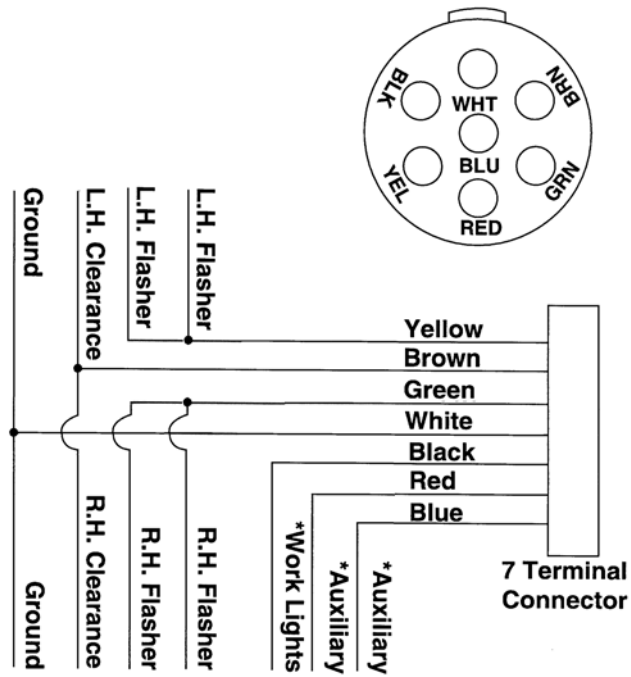

* Optional customer-supplied auxiliary lights and wires may be wired into existing plug terminals.

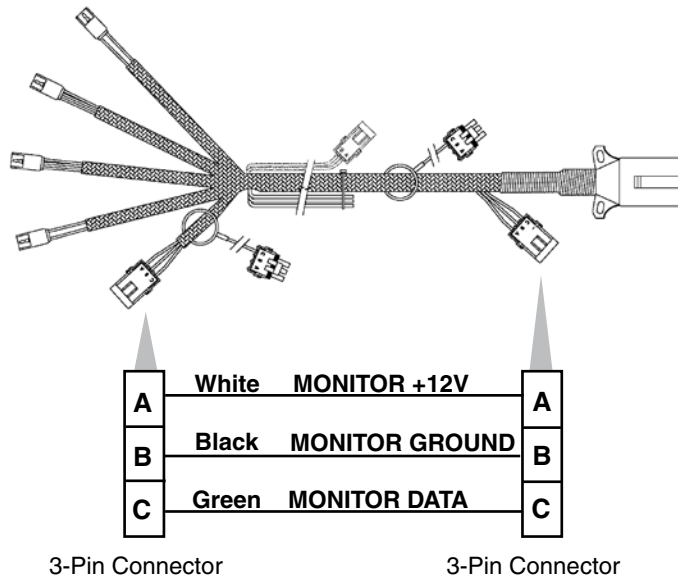

Light package meets ASABE Standards. For correct wiring harness to be wired into lights on your tractor, check with tractor manufacturer.

HYDRAULIC HOSE LIFE

**WARNING**

Pressurized hydraulic fluid can penetrate body tissue and result in death, serious infection, or other injuries. Fluid injected under skin must be IMMEDIATELY removed by a surgeon familiar with this type of injury. Make sure connections are tight and hoses and fittings are not damaged before applying system pressure. Leaks can be invisible. Keep away from suspected leaks. Relieve pressure before searching for leaks or performing any system maintenance.



Proper storage of hydraulic hoses can significantly increase the life of the hoses, for a period of three to five years. After this period, service life of hoses may decrease, depending on variables such as variances in rubber materials and storage environment. Refer to the guidelines below for best practices when storing.

- Store in a clean, cool and dry area
- Avoid direct sunlight or moisture
- Do not store near high power electrical equipment
- Avoid contact with corrosive chemicals
- Avoid ultraviolet light
- Avoid areas with obvious signs of insects or rodents

Unusually long periods of storage or poor storage environment may lead to performance issues or premature failure. Always inspect all hoses prior to use for extensive wear, cuts, or holes. If such flaws are identified, replace immediately to avoid potential failure, property damage or bodily injury.

HYDRAULIC DIAGRAM - PLANTER

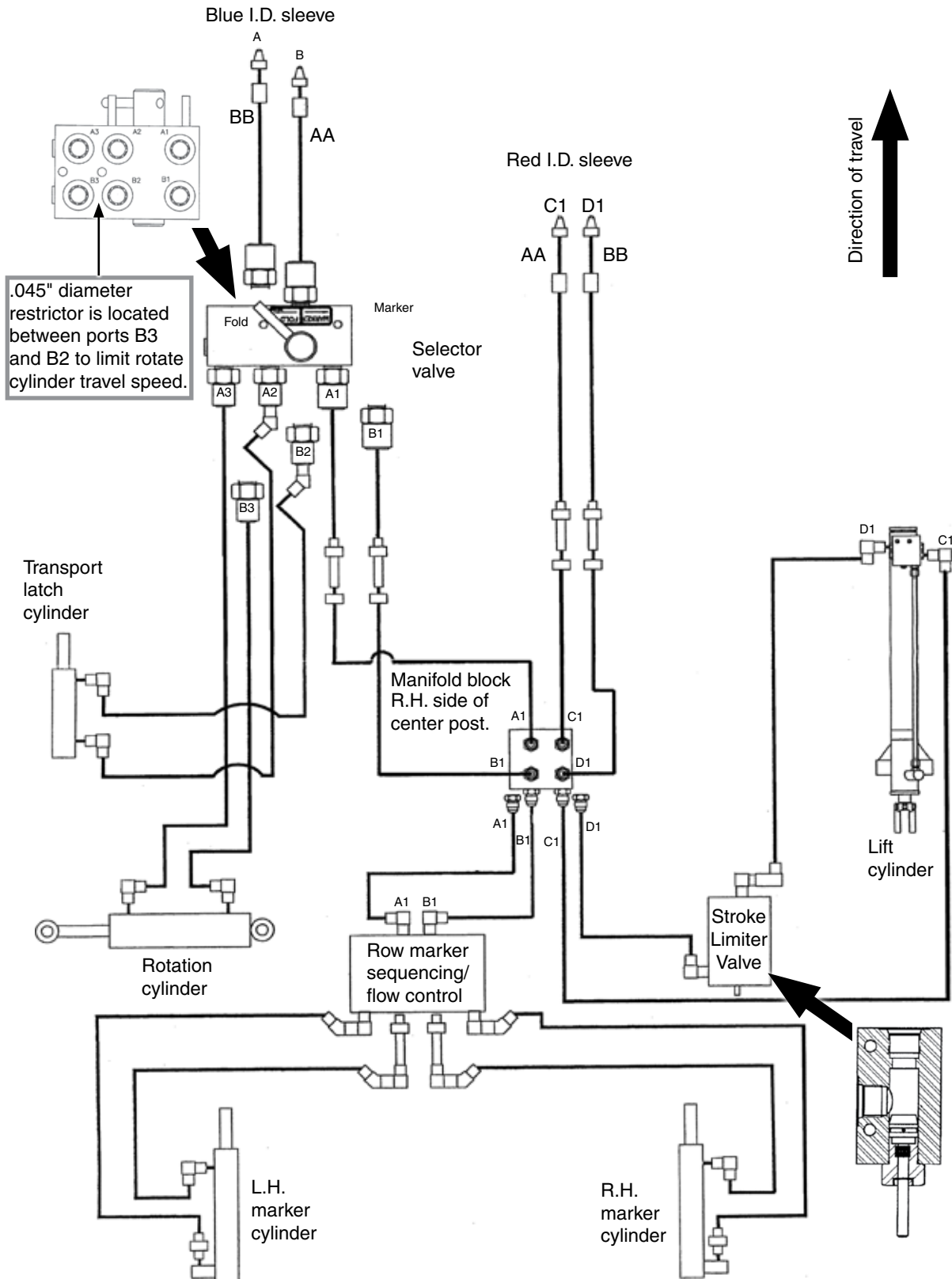

HYDRAULIC DIAGRAM - VACUUM FAN MOTOR SYSTEM

NOTICE Connect hydraulic motor case drain to a case drain return line with zero pressure on tractor or hydraulic motor will be damaged. DO NOT connect hydraulic motor case drain to SCV outlet. Contact tractor manufacturer for specific details on “zero pressure return”.

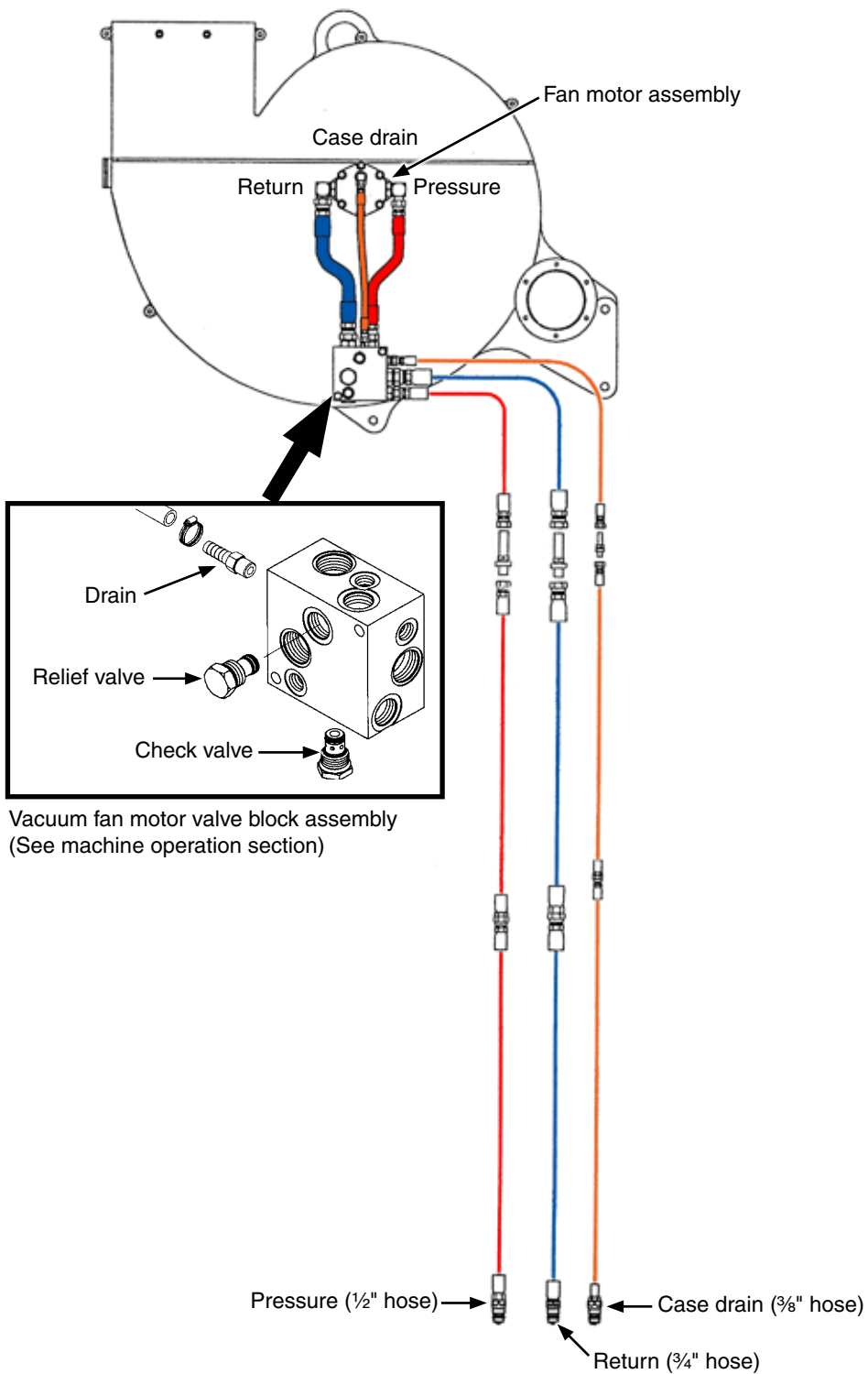

HYDRAULIC DIAGRAM - OPTIONAL PTO PUMP DRIVE AND OIL COOLER SYSTEM

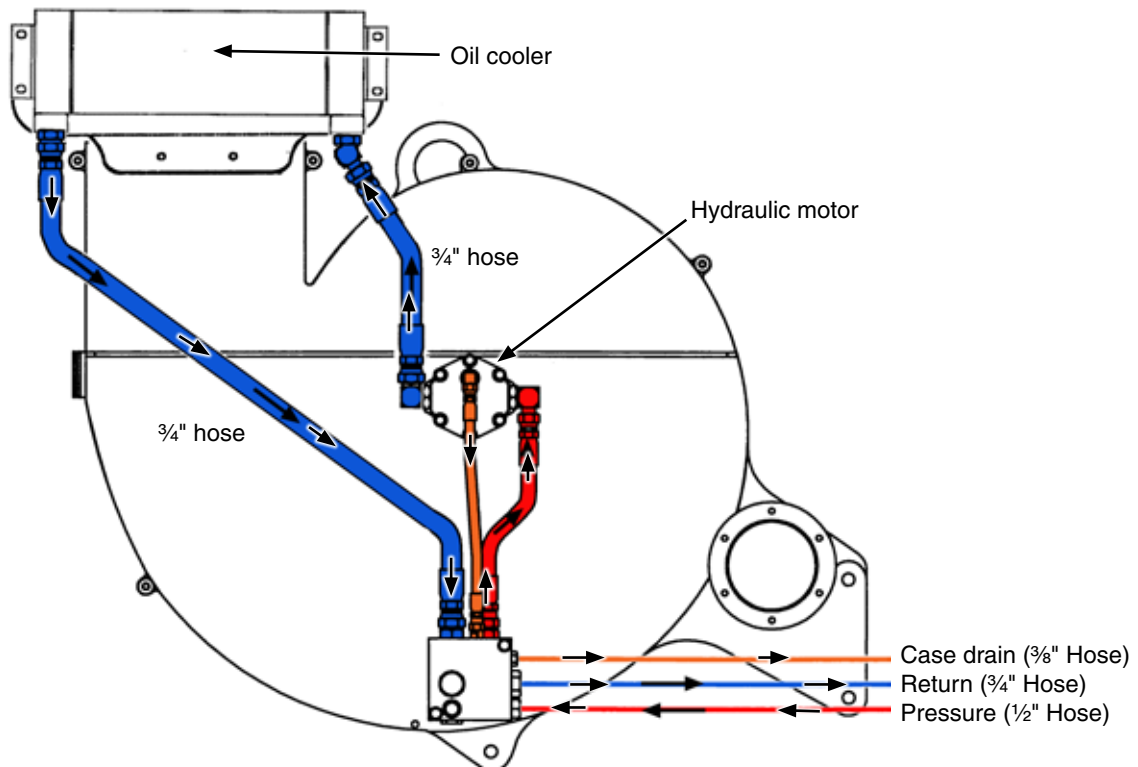
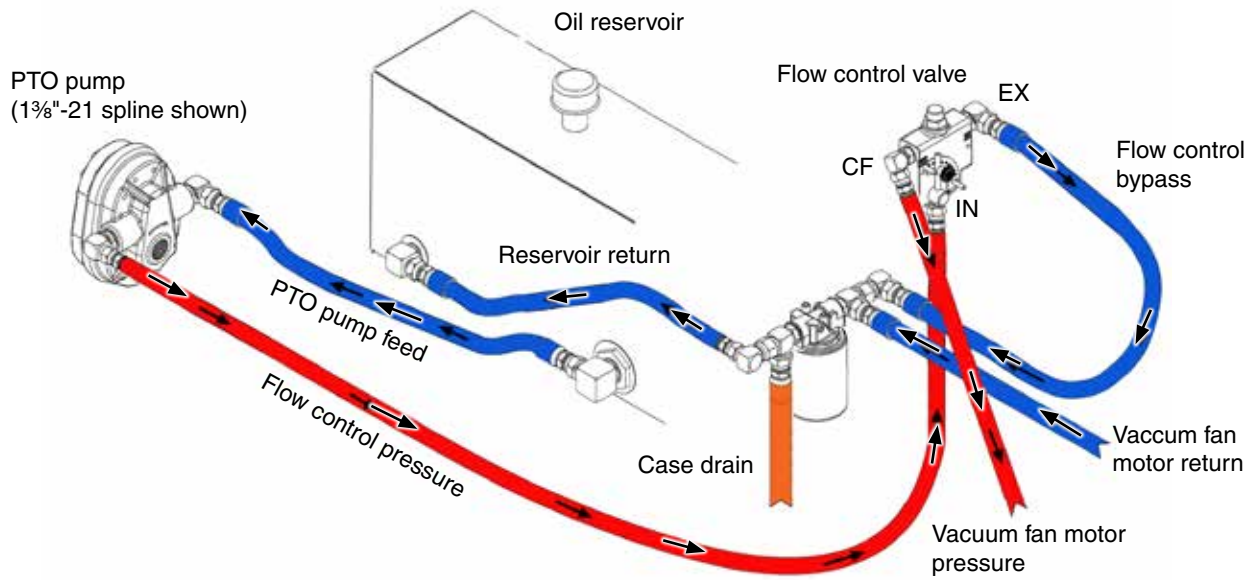

This page left blank intentionally.

CLOSING WHEEL TROUBLESHOOTING

PROBLEM	POSSIBLE CAUSE	SOLUTION
Closing wheel(s) leave severe imprint in soil.	Too much closing wheel down pressure.	Adjust closing wheel pressure.
Closing wheel(s) not firming soil around seed.	Insufficient closing wheel down pressure.	Adjust closing wheel pressure. Severe no till conditions may require use of cast iron closing wheels.
"V" closing wheel running on top of seed furrow.	Improper centering.	Align. See "V Closing Wheel Adjustment".
Single closing wheel not directly over seed.	Improper centering.	Align. See "Covering Discs/Single Press Wheel Adjustment".

PISTON PUMP TROUBLESHOOTING

PROBLEM	POSSIBLE CAUSE	SOLUTION
Pump hard or impossible to prime.	Valves fouled or in wrong place.	Inspect and clean valves.
	Air leak in suction line.	Repair leak.
	Pump set too low.	Adjust pump setting.
	Packing washers worn out.	Replace.
Low metering.	Valves fouled or in wrong place.	Inspect and clean valves.
	Air leak in suction line.	Repair leak.
	Pump set too low.	Adjust pump setting.
	Broken valve spring.	Replace spring.
Over metering.	Broken discharge valve spring.	Replace spring.
	Trash under valves.	Inspect and clean valves.
	Improper rate setting.	Adjust pump setting.
Leaks through when stopped.	Broken discharge valve spring.	Replace spring.
	Trash under valves.	Inspect and clean valves.
Fertilizer solution leaking under stuffing box.	Packing washers worn out.	Replace.
Pump using excessive oil.	Oil seals or o-ring worn and leaking.	Replace.
Pump operates noisily.	Crankcase components worn excessively.	Inspect and replace if necessary.

PTO PUMP DRIVE AND OIL COOLER OPTION TROUBLESHOOTING

PROBLEM	POSSIBLE CAUSE	SOLUTION
Pump squealing.	Lack of oil to pump.	Check for plugged suction strainer.
	Air leak in suction line.	Check oil level.
Oil temperature is high.	Low oil level.	Check oil level and add as required.
Desired fan speed cannot be achieved.	Low oil level.	Check oil level and add as required.
	Plugged filter.	Check and change as required.
Vacuum level not displayed.	Digital vacuum gauge console power OFF.	Turn ON.
	Cable not plugged in.	Check connection.
	Digital vacuum gauge console has no power.	Check fuse.

ROW MARKER OPERATION TROUBLESHOOTING

PROBLEM	POSSIBLE CAUSE	SOLUTION
Both markers lowering and only one raising at a time.	Hoses from cylinders to valve connected backwards.	Check hosing diagram in manual and correct.
Same marker always operating.	Spool in sequencing valve not shifting.	Remove spool, inspect for foreign material, making sure all ports in spool are open. Clean and reinstall.
Both markers lower and raise at same time.	Foreign material under check ball in sequencing valve.	Remove hose fitting, spring and balls and clean. May be desirable to remove spool and clean as well.
	Check ball missing or installed incorrectly in sequencing valve.	Disassemble and correct. Refer to Lubrication and Maintenance section of this manual.
Marker (in raised position) settling down.	Damaged O-ring in marker cylinder or cracked piston.	Disassemble cylinder, inspect for damage, and repair.
	Spool in sequencing valve not shifting completely because detent ball or spring is missing.	Check valve assembly and install parts as needed.
	Spool in sequencing valve shifting back toward center position.	Restrict flow of hydraulic oil from tractor to sequencing valve.
Neither marker moves.	Flow control closed too far.	Loosen locking nut and turn flow control adjustment bolt out or counterclockwise until desired speed is set.
Markers moving too fast.	Flow control open too far.	Loosen locking nut and turn flow control adjustment bolt in or out until desired speed is set.
Sporadic marker operation speed.	Needle sticking open in flow control valve.	Remove flow control, inspect and repair, or replace.

SEED METER (BRUSH-TYPE) TROUBLESHOOTING

PROBLEM	POSSIBLE CAUSE	SOLUTION
Low count.	Meter RPM too high.	Reduce planting speed.
	Seed sensor not picking up all seeds dropped.	Clean seed tube. Switch meter to different row. If problem stays with same row, replace sensor.
	Lack of lubrication causing seeds not to release from disc properly.	Use graphite or talc as recommended.
	Seed size too large for seed disc.	Switch to smaller seed or appropriate seed disc. See "Brush-Type Seed Meter" for proper seed disc for size of seed being used.
	Seed treatment buildup in meter.	Reduce amount of treatment used and/or thoroughly mix treatment with seed. Add talc.
Low count at low RPM and higher count at higher RPM.	Foreign material lodged in upper brush.	Remove seed disc and remove foreign material from between brush retainer and bristles. Clean thoroughly.
	Worn upper brush.	Replace. See "Maintenance".
Low count at higher RPM and normal count at low RPM.	Seed disc worn in the agitation groove area.	Replace disc. See "Maintenance".
High count.	Seed size too small for seed disc.	Switch to larger seed or appropriate seed disc.
	Incorrect seed rate transmission setting.	Reset transmission. Refer to proper rate chart in "Machine Operation" section of manual.
	Upper brush too wide (fanned out) for small seed size.	Replace upper brush.
High count. (Milo/Grain Sorghum)	Incorrect brush retainer.	Make sure GD8237 brush retainer is installed to keep upper brush from fanning out.
Upper brush laid back.	Seed treatment buildup on brush.	Remove brush. Wash with soap and water. Dry thoroughly before reinstalling. See "Maintenance".
	Buildup of foreign material at base of brush.	Remove brush retainer and brush. Clean thoroughly. Reinstall.

SEED METER (FINGER PICKUP) TROUBLESHOOTING

PROBLEM	POSSIBLE CAUSE	SOLUTION
One row not planting seed.	Drive release not engaged.	Engage drive release mechanism.
	Foreign material in hopper.	Clean hopper and finger carrier mechanism.
	Seed hopper empty.	Fill seed hopper.
	Row unit drive chain off of sprocket or broken.	Check drive chain.
Drive release does not engage properly.	Drive release shaft is not aligned properly with meter drive shaft.	Align drive mechanism.
Unit is skipping.	Foreign material or obstruction in meter.	Clean and inspect.
	Finger holder improperly adjusted.	Adjust to specifications. (22 to 25 in. lbs. rolling torque)
	Broken fingers.	Replace fingers and/or springs as required.
	Planting too slowly.	Increase planting speed to within recommended range.
Planting too many doubles.	Planting too fast.	Stay within recommended speed range.
	Loose finger holder.	Adjust to specifications. (22 to 25 in. lbs. rolling torque)
	Worn brush in carrier plate.	Inspect and replace if necessary.
Overplanting.	Worn carrier plate.	Inspect and replace if necessary.
	Seed hopper additive being used.	Reduce or eliminate additive or increase graphite.
Underplanting.	Seed belt installed backwards.	Remove and install correctly.
	Weak or broken springs.	Replace.
	Spring not properly installed.	Remove finger holder and correct.
	Seed belt catching or dragging.	Replace belt.
	Brush dislodging seed.	Replace brush.
Irregular or incorrect seed spacing.	Driving too fast.	Check chart for correct speed.
	Wrong tire pressure.	Inflate tires to correct air pressure.
	Drive wheels slipping.	Reduce down pressure on row unit down force springs.
	Wrong sprockets.	Check seed rate charts for correct sprocket combinations.
Seed spacing not as indicated in charts.	Wrong tire pressure.	Inflate tires to correct air pressure.
	Inconsistent seed size.	Perform field check and adjust sprockets accordingly.
	Wrong sprockets.	Check chart for correct sprocket combination.
	Charts are approximate.	Slight variations due to wear in meter components and tire slippage due to field conditions may produce seed spacing variations.
	Stiff or worn drive chains.	Replace chains.
Scattering of seeds.	Planting too fast.	Reduce planting speed.
	Seed tube improperly installed.	Check seed tube installation.
	Seed tube worn or damaged.	Replace seed tube.
Seed tubes and/or openers plugging.	Allowing planter to roll backward when lowering.	Lower planter only when tractor is moving forward.
Inconsistent seed depth.	Rough seed bed.	Adjust down pressure springs. Reduce planting speed.
	Partially plugged seed tube.	Inspect and clean.
	Seed tube improperly installed.	Install properly.

VACUUM SEED METER

PROBLEM	POSSIBLE CAUSE	SOLUTION
Low seed count.	Meter RPM too high.	Reduce planting rate or planting speed.
	Singulator blade setting too aggressive.	Adjust singulator blade.
	Vacuum level too low.	Increase fan speed.
	Seed sensor not picking up all seeds dropped.	Clean seed tube. Move meter to different row.
	Seeds sticking to seed disc.	Use graphite or talc to aid release.
	Seed treatment buildup in seed disc recesses.	Reduce amount of treatment used and or mix thoroughly. Add talc.
	Seed size too large for disc used.	Use appropriate disc for seed size.
	Wrong seed disc.	Use appropriate disc for seed type and size.
	Failed/worn drive components.	Inspect and replace parts as required.
	Plugged orifices in seed disc.	Inspect and clean disc. Check remnant ejector.
	Loss of vacuum at meter.	Check for foreign material between vacuum cover and disc. Inspect parts for wear/damage. Clean or replace as required.
	Seed bridging in hopper.	Add graphite to improve seed flow.
	Faulty vacuum gauge reading.	Repair/replace gauge.
	Dirt in vacuum manifold.	Check vacuum manifold for dirt and clean.
	Seed baffle (If applicable) not allowing seed flow due to bridging of seed.	Mix talc thoroughly to coat all seeds. Remove seed baffle. See Row Unit Operation section.
Seed disc worn.	Replace.	
Vacuum seal worn.	Replace.	
Not planting seed.	Seed hoppers empty.	Fill seed hopper.
	Seed tube plugged/damaged.	Clean or replace tube.
	Meter drive damaged.	Repair/replace drive components.
	Low/no vacuum.	Inspect vacuum system and repair as necessary.
	Singulator blade setting too aggressive.	Adjust singulator blade.
	Faulty vacuum gauge.	Repair/replace vacuum gauge.
	Seed bridging in hopper.	Add graphite to improve seed flow.
	Loss of vacuum at meter.	Check for foreign material between vacuum cover and disc. Inspect parts for wear/ damage. Clean and/or replace as required.
	Wrong seed disc.	Use appropriate disc for seed type and size.
	Meter drive clutch not engaged.	Engage drive clutch.
	Fan not running.	Start fan.
Dirt in vacuum manifold.	Check vacuum manifold for dirt and clean.	

Continued on next page.

VACUUM SEED METER - Continued

PROBLEM	POSSIBLE CAUSE	SOLUTION
Not planting seed. (Continued)	Seed baffle (if applicable) not allowing seed flow due to bridging of seed.	Mix talc thoroughly to coat all seeds. Remove seed baffle. Row Unit Operation section.
	High vacuum.	Adjust vacuum level to appropriate level.
	Wrong seed disc.	Replace seed disc.
	Singulator setting not aggressive enough.	Adjust singulator.
	Faulty vacuum gauge.	Check gauge line for dirt/obstruction. Repair/replace vacuum gauge.
Poor seed spacing.	Obstruction in seed tube.	Clean seed tube.
	Dirty/damaged seed disc.	Inspect seed disc for damage, foreign material in orifices or seed treatment buildup in recesses. Clean or replace.
	Wrong vacuum setting.	Adjust vacuum to appropriate level.
	Excess foreign material in seed.	Inspect and clean meter and seed discs. Use clean, undamaged seed.
	Incorrect singulator setting.	Adjust singulator to appropriate setting.
	Inconsistent driveline.	Inspect drive components for rust, misalignment, worn or damaged parts. Replace/repair as required.
	Toolbar not level or wrong height.	Adjust hitch to level toolbar and row units.
	Planting too fast for conditions.	Reduce speed.
	Rough field conditions.	Reduce speed.
Irregular seed population.	Driving too fast.	Reduce speed.
Unable to achieve desired vacuum level.	Tractor hydraulic flow set too low.	Increase flow to fan motor.
	Incorrect hydraulic connections.	Check all hydraulic connections and hose routings.
	Damaged fan components.	Inspect motor and impeller for wear/damage and repair/replace as necessary.
	Vacuum hose pinched/kinked/blocked.	Inspect air lines for any damage or obstruction. Clean air lines and manifold by removing end cap from manifold and running fan at high speed.
	Vacuum hose loose/disconnected.	Inspect and reattach all air hoses.
	Tractor not producing required hydraulic flow/pressure.	Have tractor serviced by qualified technician.
	Dirt in vacuum gauge line.	Check gauge line for dirt/obstruction and clean.

This page left blank intentionally.