

MODEL 3505 PIVOT FOLD PLANTER OPERATOR'S MANUAL

M0302-01

Rev. 8/21

This manual applies to: Model: 3505 Pivot Fold Planters
2021 production and on

Record the model number and serial number of your planter along with date purchased:

Model Number 3505

Serial Number _____

Date Purchased _____

<p>Monitor Serial Number _____</p> <p>Measured Pulses Per Mile/Km (Radar Distance Sensor) _____</p> <p>Measured Pulses Per Mile/ Km (Magnetic Distance Sensor) _____</p>
--

SERIAL NUMBER

The serial number plate is located on the planter frame as shown below. The serial number provides important information about your planter and is needed to obtain correct replacement parts. Always provide model number and serial number to your Kinze Dealer when ordering parts or when contacting Kinze Manufacturing, Inc.



This page left blank intentionally.

TO THE DEALER

Predelivery service includes assembly, lubrication, adjustment and test. This service helps to ensure planter is delivered to retail customer/end user ready for field use.

PREDELIVERY CHECKLIST

Use the following checklist after planter is completely assembled to inspect planter. Check off each item as it is found satisfactory or after proper adjustment is made.

- Row units properly spaced and optional attachments correctly assembled.
- All grease fittings in place and lubricated.
- All working parts are moving freely. Bolts are tight and cotter pins are spread.
- All drive chains properly tensioned and aligned.
- Check for oil leaks and proper hydraulic operation.
- Hydraulic hoses are routed correctly to prevent damage to hoses.
- Inflate tires to specified air pressure. Tighten wheel lug bolts to specified torque.
- All safety decals correctly located and legible as shown in Parts Manual. Replace if damaged.
- All reflective decals and SMV sign located as shown in Parts Manual and visible when planter is in transport position.
- Safety/warning lights correctly installed and working properly.
- Paint all parts scratched in shipment or assembly.
- All safety lockup devices are on planter and correctly located.
- Seed meters performance checked on test stand. Vacuum fan, analog gauge, control box, and hoses installed.
- Auxiliary safety chain is properly installed and hardware is torqued to specification.
- Vacuum fan PTO-driven pump is attached correctly to the tractor. Oil reservoir is filled to capacity and system is inspected for leaks. (If Applicable)
- Remove PTO tank from shipping position and mount. (If Applicable)
- Check for proper hitch clearance between tractor and PTO system. (If Applicable)

Planter has been thoroughly checked and to the best of my knowledge is ready for delivery to the customer.

(Signature Of Set-Up Person/Dealer Name/Date)

OWNER REGISTER

Name _____ Delivery Date _____

Street Address _____ Model No. 3505 Serial No. _____

City, State/Province _____ Dealer Name _____

ZIP/Postal Code _____ Dealer No. _____

DELIVERY CHECKLIST

Use the following checklist when planter is delivered as a reminder of important information which should be conveyed to retail customer/end user. Check off each item as it is fully explained.

- Check for proper operation of vacuum fan and PTO driven pump (If Applicable) with tractor to be used with planter.
- Life expectancy of this or any other machine is dependent on regular lubrication as directed in the Operator Manual.
- All applicable safety precautions.
- Along with retail customer/end user, check reflective decals and SMV sign are clearly visible with planter in transport position and attached to tractor. Check safety/warning lights are in working condition. Tell retail customer/end user to check federal, state/provincial, and local regulations before towing or transporting on a road or highway.
- Give Operator Manual, Parts Manual, and all Instruction Sheets to retail customer/end user and explain all operating adjustments.
- Read warranty to retail customer/end user.
- Complete Warranty and Delivery Report form.

To the best of my knowledge this machine has been delivered ready for field use and customer has been fully informed as to proper care and operation.

(Signature Of Delivery Person/Dealer Name/Date)

AFTER DELIVERY CHECKLIST

The following is a list of items we suggest to check during the first season of use of the equipment.

- Check planter performance with retail customer/end user.
- Check performance of vacuum or mechanical seed metering system with retail customer/end user.
- Review importance of proper maintenance and adherence to all safety precautions with retail customer/end user.
- Check for parts that may need to be adjusted or replaced.
- Check all safety decals, reflective decals, and SMV sign are correctly located as shown in the Parts Manual and that decals are legible. Replace if damaged or missing.
- Check safety/warning lights are working properly.

(Signature Of Follow-Up Person/Dealer Name/Date)

**All registrations must be submitted online at "business.kinze.com" within 5 business days of delivery.
Retain a copy of this form for auditing purposes.**

Tear Along Perforation

KINZE

OVERVIEW

To The Owner	1-1
To The Owner	1-2
Warranty	1-3
General Information	1-4
Warranty	1-4
Tractor Hydraulic Requirements	1-5
Specifications	1-5
General Safety Rules	1-7
Safety Instructions, Signs, and Decals	1-8

MACHINE OPERATION

Initial Preparation	2-1
Tractor Requirements	2-2
Row Marker Safety Lockup	2-2
Safety Lockup Pin	2-3
Stroke Limiter Pin (Conventional Only)	2-3
Transport Latch Locking Pin	2-4
Hitch Length Adjustment	2-5
Jack Stand	2-6
Hydraulic Operation - Conventional	2-6
Hydraulic Operation - Bulk Fill	2-8
PTO Pump Drive And Oil Cooler Option - 6 row only	2-10
PTO Pump Drive And Oil Cooler Option - 8 row only	2-12
Tractor Preparation and Hookup	2-14
Level Planter	2-16
Towing Planter	2-17
Planting Speed	2-17
Contact Drive Spring Adjustment	2-18
Seed Rate Transmission Adjustment	2-18
Standard and Half Rate (2 to 1) Drives	2-19
Shear Protection	2-20
Wrap Spring Wrench	2-21
Contact Wheel Drive Sprockets	2-21
Row Marker Speed Adjustment	2-22
Even-Row Push Row Unit	2-22
Row Marker Adjustments	2-23
Row Marker Even-Row Length Adjustment	2-24
Offset Hitch Adjustment	2-24
Vacuum Meter System	2-25
Analog Vacuum or Pressure Gauge	2-25
Bulk Fill System	2-26
Bulk Fill Entrainer Access	2-27
Bulk Fill Tanks - Clean Out	2-27
Ag Leader Monitoring Control (PMM)	2-28
Blue Drive Aux Mount	2-28
Ag Leader InCommand 1200 Display	2-28

Kinze True Depth Display	2-28
Ridge Planting	2-29
Tire Scraper	2-29
Rock Guards	2-29
Auxiliary Work Lights Package	2-29
Rear Trailer Hitch	2-30
Field Test	2-31
Check Seed Population	2-31
Determining Pounds Per Acre (Brush-Type Meter)	2-32
Determining Bushels Per Acre	2-32
Granular Chemical Application Field Check	2-33

ROW UNIT OPERATION

Planting Depth	3-1
"V" Closing Wheel Adjustment (Rubber or Cast Iron)	3-1
Closing Wheel Shield (Rubber or Cast Iron "V" Closing Wheels)	3-2
Brush-Type Seed Meter 2.0	3-3
Finger Pickup Seed Meter	3-5
Vacuum Settings	3-6
Seed Meter Cleanout	3-11
Additives	3-12
Bayer Fluency Agent	3-13
Seed Hoppers	3-14
Seed Meter Drive Release	3-14
Row Unit Extension Brackets	3-14
Row Unit Chain Routing	3-15
Quick Adjustable Down Force Springs Option	3-16
Pneumatic Down Pressure Package Option	3-17
Field Operation	3-18
Split Row Lockups	3-22
Split Row Push Row Unit Clutch Sprocket	3-24
Split Row Push Row Unit Vacuum Hose Shutoff	3-24
Row Unit Mounted No Till Coulter	3-25
Coulter Mounted Residue Wheels	3-25
Spiked Closing Wheel	3-26
Granular Chemical Hopper and Drive	3-27
Granular Chemical Banding Options	3-28

FERTILIZER

Notched Single Disc Openers	4-1
Depth/Gauge Wheel Attachment for Notched Single Disc Fertilizer Opener	4-3
HD Single Disc Fertilizer Opener	4-4
Dry Fertilizer Attachment	4-6
Liquid Fertilizer Attachment	4-8

RATE CHARTS 5-1

LUBRICATION AND MAINTENANCE

Lubrication 6-1

Lubrication Symbols 6-1

Sealed Bearings 6-1

Wrap Spring Wrench Assembly 6-1

Drive Chains 6-2

Center Post 6-4

Wheel Bearings 6-4

Liquid Fertilizer Piston Pump Crankcase Oil Level 6-5

PTO Pump Shaft Coupling
(PTO Pump Drive and Oil Cooler Option) 6-5

Bushings 6-6

Grease Fittings 6-7

Mounting Bolts and Hardware 6-11

Tire Pressure 6-12

Model 3505 Operating Tire Pressure 6-12

Chain Tension Adjustment 6-13

Pneumatic Down Pressure Air Compressor Tank 6-13

Finger Pickup Seed Meter Inspection/Adjustment 6-14

Cleaning Finger Pickup Seed Meter For Storage 6-15

Brush-Type Seed Meter 2.0 Maintenance 6-16

Cleaning Brush-Type Seed Meter For Storage 6-19

Vacuum Seed Meter Maintenance 6-20

Seed Meter Cleanout 6-20

Gauge Wheel Adjustment 6-21

Gauge Wheel Arm Bushing/Seal Replacement 6-22

Gauge Wheel Arm Pivot Spindle Replacement 6-23

15" Seed Opener Disc Blade/Bearing Assembly 6-24

Seed Tube Guard/Inner Scraper 6-26

Row Unit Mounted No Till Coulter 6-27

Coulter Mounted Residue Wheels 6-27

Spiked Closing Wheel 6-28

Granular Chemical Attachment 6-28

Wear Pad Adjustment/Replacement 6-29

Row Marker Sequencing/Flow Control Valve Inspection 6-30

PTO Pump Drive and Oil Cooler Option 6-31

Check Valve Inspection 6-32

Relief Valve Cartridge Inspection (6 Row Only) 6-32

Row Marker Bearing Lubrication or Replacement 6-33

Wheel Bearing Repack or Replacement 6-34

Fertilizer Check Valve Cleaning and Repair 6-34

Battery Care 6-35

Piston Pump Storage 6-36

Preparation for Storage 6-37

Electrical Wiring Diagram for Light Package 6-38

Hydraulic Hose Life 6-39

Hydraulic Diagram - Planter (6 Row) 6-40

Hydraulic Diagram - Planter (8 Row Conventional) 6-41

Hydraulic Diagram - Planter (8 Row Bulk Fill) 6-42

Hydraulic Diagram - Planter
(8 Row Conventional / Bulk Fill) 6-43

Hydraulic Diagram - Planter
(8 Row Vacuum / Bulk Fill) 6-44

Hydraulic Diagram - Vacuum Fan Motor System
(6 Row) 6-45

Hydraulic Diagram - Vacuum Fan Motor System
(8 Row) 6-46

Hydraulic Diagram - Optional PTO Pump Drive and
Oil Cooler System - 6 Row 6-47

Tractor Console Harness (A25031) 6-48

Tractor Power Harness (P/N: 10211901) 6-49

Tractor Power Harness Extension
(P/N: 10060901/10060902) 6-50

Work Light Harness (P/N: A26885) 6-51

Work Light Relay Harness (P/N: A22547) 6-52

Camera Power Harness (P/N: 10269201) 6-53

Model 3505 AUX IPN 12 Volt Power Harness
(P/N: 10331601) 6-54

Model 3505 Raise IPN Harness (P/N: 10331401) 6-55

Compressor Harness, 40' (P/N: A16391) 6-56

Rotate Harness (P/N: 10074801) 6-57

Bulk Fill PDP Harness (P/N: A26884) 6-58

IPP Harness, Wing (P/N: A25214) 6-59

Insecticide Harness (P/N: A22522) 6-60

Split Row Row Unit Power Harness (P/N: 10331701) 6-61

Row Unit Seed Meter Harness (P/N: A25038) 6-62

Row Unit Power Extension Harness (P/N: A25029) 6-63

Light Harness (P/N: A25784) 6-64

Integrated True Depth Row Unit Harness (P/N: A26709) 6-65

IPP Wing Harness (P/N: A26835) 6-66

Integrated True Depth Harness (P/N: 10337001) 6-67

Row Unit Seed Meter Harness (P/N: A25203) 6-68

TROUBLESHOOTING

Bulk Fill 7-1

Closing Wheel Troubleshooting 7-1

Piston Pump Troubleshooting 7-2

Seed Meter (Brush-Type) Troubleshooting 7-4

Seed Meter (Finger Pickup) Troubleshooting 7-5



Vacuum Seed Meter 7-6

Kinze Manufacturing, Inc. thanks you for your patronage. We appreciate your confidence in Kinze farm machinery. Your Kinze planter has been carefully designed to provide dependable operation in return for your investment.

This manual has been prepared to aid you in the operation and maintenance of the planter. It should be considered a permanent part of the machine and remain with the machine when you sell it.

It is the responsibility of the user to read and understand the Operator Manual in regards to safety, operation, lubrication and maintenance before operation of this equipment. It is the user's responsibility to inspect and service the machine routinely as directed in the Operator Manual. We have attempted to cover all areas of safety, operation, lubrication and maintenance; however, there may be times when special care must be taken to fit your conditions.

Throughout this manual the symbol  and the words **DANGER**, **WARNING**, and **CAUTION** are used to call attention to safety information that if not followed, will or could result in death or injury. **NOTICE** and **NOTE** are used to call your attention to important information. The definition of each of these terms follows:

 DANGER	<p>Indicates an imminently hazardous situation that, if not avoided, will result in death or serious injury. This signal word is to be limited to the most extreme situations, typically for machine components which, for functional purposes, cannot be guarded.</p>
 WARNING	<p>Indicates a potentially hazardous situation that, if not avoided, could result in death or serious injury, and includes hazards that are exposed when guards are removed. It may also be used to alert against unsafe practices.</p>
 CAUTION	<p>Indicates a potentially hazardous situation that, if not avoided, may result in minor or moderate injury. It may also be used to alert against unsafe practices.</p>
NOTICE	<p>Used to address safety practices not related to personal injury.</p>

NOTE: Special point of information or machine adjustment instructions.

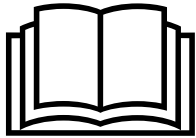

Improperly operating or working on this equipment could result in death or serious injury. Read and follow all instructions in Operator Manual before operating or working on this equipment.



Some photos in this manual may show safety covers, shields, or lockup devices removed for visual clarity. **NEVER OPERATOR OR WORK ON** machine without all safety covers, shields, and lockup device in place as required.

NOTE: Some photos in this manual may have been taken of prototype machines. Production machines may vary in appearance.

NOTE: Some photos and illustrations in this manual show optional attachments installed. Contact your Kinze Dealer for purchase of optional attachments.

The Kinze Limited Warranty for your new machine is stated on the retail purchaser's copy of the Warranty And Delivery Receipt form. Additional copies of the Limited Warranty can be obtained through your Kinze Dealer.

Warranty, within the warranty period, is provided as part of Kinze's support program for registered Kinze products which have been operated and maintained as described in this manual. Evidence of equipment abuse or modification beyond original factory specifications will void the warranty. Normal maintenance, service and repair is not covered by Kinze warranty.

To register your Kinze product for warranty, a Warranty And Delivery Receipt form must be completed by the Kinze Dealer and signed by the retail purchaser, with copies to the Dealer, and to the retail purchaser. Registration must be completed and submitted to Kinze Manufacturing, Inc. within 5 business days of delivery of the Kinze product to the retail purchaser. Kinze Manufacturing, Inc. reserves the right to refuse warranty on serial numbered products which have not been properly registered.

If service or replacement of failed parts which are covered by the Limited Warranty are required, it is the user's responsibility to deliver the machine along with the retail purchaser's copy of the Warranty And Delivery Receipt to the Kinze Dealer for service. Kinze warranty does not include cost of travel time, mileage, hauling or labor. Any prior arrangement made between the Dealer and the retail purchaser in which the Dealer agrees to absorb all or part of this expense should be considered a courtesy to the retail purchaser.

Kinze warranty does not include cost of travel time, mileage, hauling, or labor.



Model 3505 with Conventional Hoppers



Model 3505 Bulk Fill

GENERAL INFORMATION

This manual covers all production years of the Model 3505 planter. Contact your Kinze dealer for additional options which may be available for your specific model year planter.

Information in this manual was current at time of printing. However, due to Kinze's ongoing product improvement, production changes may cause your machine to appear slightly different in detail. Kinze Manufacturing, Inc. reserves the right to change specifications or design without notice and without incurring obligation to install the same on machines previously manufactured. To obtain the most recent version of your publication, please contact your Kinze dealer.

Right hand (R.H.) and left hand (L.H.), as used throughout this manual, are determined by facing in direction machine travels in use, unless otherwise stated.

TOOLS REQUIRED

Hardware Size / Tool Required			
$\frac{1}{4}'' = \frac{7}{16}''$	$\frac{7}{16}'' = \frac{5}{8}''$ (nut for $\frac{7}{16}''$ hardware uses $\frac{11}{16}''$ tool)	$\frac{3}{4}'' = 1\frac{1}{8}''$	$1\frac{1}{4}'' = 1\frac{7}{8}''$
$\frac{5}{16}'' = \frac{1}{2}''$	$\frac{1}{2}'' = \frac{3}{4}''$	$\frac{7}{8}'' = 1\frac{5}{16}''$	$1\frac{1}{2}'' = 2\frac{1}{4}''$
$\frac{3}{8}'' = \frac{9}{16}''$	$\frac{5}{8}'' = 1\frac{5}{16}''$	$1'' = 1\frac{1}{2}''$	

Specification					
Number of Rows	6 Row 30" (Conventional)	8 Row 30" (Conventional)	8 Row 30" (True Rate/Bulk Fill)	8 Row 30" (Mechanical/Bulk Fill)	8 Row 30" (Blue Drive/True Rate/Bulk Fill)
Weight - Base Machine*	5163-5443 lb (2342-2469 kg)	5886-6269 lb (2670-2844 kg)	6919 lb (3138 kg)	10890 lb (4940 kg)	6919 lb (3138 kg)
*Weight based off a typical configuration of a complete machine.					
Width - Transport	11' 2" (3.5M)	11' 2" (3.5M)	11' 2" (3.5M)	11' 2" (3.5M)	11' 2" (3.5M)
Width - Planting	16' 10" (5.2M)	21' 10" (6.7M)	21' 10" (6.7M)	21' 10" (6.7M)	21' 10" (6.7M)
Length - Transport	23' 9" (7.3M)	26' 5" (8.4M)	26' 5" (8.4M)	26' 5" (8.4M)	26' 5" (8.4M)
Length - Planting	19' 8" (6.0M)	19' 8" (6.0M)	19' 8" (6.0M)	19' 8" (6.0M)	19' 8" (6.0M)
Height - Transport	10' 6" (3.2M)	10' 6" (3.2M)	12' (3.6 M)	12' (3.6 M)	12' (3.6 M)
Height - Bulk Fill (In planting position)	---	---	8' (2.4M)	8' (2.4M)	8' (2.4M)
Seed Capacity	1.75 bu. (61.6 L) (Vacuum / Hopper); 1.90 bu. (66.8 L) (Mechanical / Hopper)		50 bu. (1.76m) (Vacuum/Mechanical)		
Tires - Transport	Four 7.50" x 20" 8 ply rib implement tires w/custom center groove				
Drive System	Two 4.10" x 6" spring-loaded contact drive tires				
Hydraulic Lift System	1 Lift Cylinder				
Row Markers	Two-fold low profile				

Tractor Hydraulic Requirements

Configuration	Requirements		Description
Mechanical Metering Configuration			
Base machine with mechanical meters	2 SCV	10 gpm	#1 SCV: Planter lift #2 SCV: Markers/fold (manual selector valve)
Base machine with mechanical meters Bulk Fill system → External case drain required for Bulk Fill hydraulic circuit. → Tractors with an open center hydraulic system will require a PTO pump. Closed center hydraulic systems, pressure compensated pumps and load sense pumps do not require a PTO pump if there is adequate flow.	2 SCV	15 gpm	#1 SCV: Planter lift/bulk fill #2 SCV: Markers/fold (with selector valve)
Base machine with mechanical meters Bulk Fill system → Tractor Mounted PTO Hydraulic Pump	2 SCV	15 gpm	#1 SCV: Planter lift #2 SCV: Markers/fold (with selector valve)



Continued on Following Page.



Configuration	Requirements		Description
Vacuum Metering Configuration			
Base Machine With Vacuum Meters - 6R → External case drain required for vacuum hydraulic circuit. → Use of a Tractor-mounted PTO hydraulic pump supplies oil flow for the vacuum hydraulic circuit reducing the required SCVs by 1 and the gpm by 10	3 SCV	30 gpm	#1 SCV: Planter lift/Bulk Fill fan #2 SCV: Markers/fold (with manual selector valve) #3 SCV: Vacuum fan
Base Machine With Vacuum Meters - 8R → External case drain required for vacuum hydraulic circuit. → Use of a Tractor-mounted PTO hydraulic pump supplies oil flow for the vacuum hydraulic circuit reducing the required SCVs by 1 and the gpm by 10	3 SCV	20 gpm	#1 SCV: Planter lift #2 SCV: Markers/fold (manual selector valve) #3 SCV: Vacuum fan
Base Machine with Vacuum Meters Bulk Fill system → External case drain required for bulk fill vacuum hydraulic circuit. → Tractors with an open center hydraulic system will require a PTO pump. Closed center hydraulic systems, pressure compensated pumps and load sense pumps do not require a PTO pump if there is adequate flow. → Use of a Tractor-mounted PTO hydraulic pump supplies oil flow for the vacuum hydraulic circuit reducing the required SCVs by 1 and the gpm by 10	3 SCV	25 gpm	#1 SCV: Planter lift/bulk fill fan #2 SCV: Markers/fold (with manual selector valve) #3 SCV: Vacuum fan
Base Machine Blue Drive/Blue Vantage with Vacuum or High Speed Meters and Bulk Fill System - 8R → One external case drain required for bulk fill / vacuum hydraulic circuit → Dual PTO standard	3 SCV	23 gpm	#1 SCV: Planter Lift #2 SCV: Markers/fold (with manual selector valve) #3 SCV: Alternator
Base Machine Blue Drive/Blue Vantage with True Rate Vacuum or True Speed High Speed Meters, True Depth hydraulic down force and Bulk Fill System - 8R → One external case drain required for bulk fill / vacuum hydraulic circuit → Dual PTO standard	3 SCV	27 gpm	#1 SCV: Planter Lift #2 SCV: Markers/fold (with manual selector valve) #3 SCV: Alternator/True Depth hydraulic down force

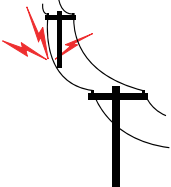

1. Read and understand instructions provided in this manual and warning labels. Review these instructions frequently!
 2. This machine is designed and built with your safety in mind. Do not make any alterations or changes to this machine. Any alteration to design or construction may create safety hazards.
 3. A large portion of farm accidents happen from fatigue or carelessness. Safe and careful operation of tractor and planter will help prevent accidents.
 4. Never allow planter to be operated by anyone unfamiliar with operation of all functions of the unit. Operators must read and thoroughly understand all instructions given in this manual before operating or working on equipment.
 5. Be aware of bystanders, particularly children! Always look around to make sure it is safe to start tow vehicle engine or move planter. This is particularly important with higher noise levels and quiet cabs, as you may not hear people shouting.
 6. Make sure planter weight does not exceed towing capacity of tractor, or bridge and road limits. This is critical to maintain safe control and prevent death or injury, or property and equipment damage.
 7. Never ride or allow others to ride on planter.
 8. Store planter in an area away from human activity. DO NOT permit children to play on or around the stored unit.
 9. Keep hands, feet, and clothing away from moving parts. Do not wear loose-fitting clothing which may catch in moving parts.
 10. Always wear protective clothing, shoes, gloves, hearing, and eye protection applicable for the situation.
 11. Do not allow anyone to stand between tongue or hitch and towing vehicle when backing up to planter.
 13. Prevent electrocution, other injuries, or property and equipment damage. Watch for obstructions such as wires, tree limbs, etc. when operating machine. Be aware of clearances during turns and when folding/unfolding planter.
 14. Reinstall all guards removed for maintenance activities. Never leave guards off during operation.
 15. Use of aftermarket hydraulic, electric, or PTO drives may create serious safety hazards to you and people nearby. If you install such drives, follow all appropriate safety standards and practices to protect you and others near this planter from injury.
 16. Follow all federal, state/provincial, and local regulations when towing farm equipment on a public highway. Use safety chain (not an elastic or nylon/plastic tow strap) to retain connection between towing and towed machines in the event of primary attaching system separation.
 17. Make sure all safety/warning lights, SMV sign, and reflective decals are in place and working properly before transporting the machine on public roads.
 18. Limit towing speed to 15 MPH. Tow only with farm tractor of a minimum 90 HP. Allow for unit length when making turns.
 19. Reduce speed prior to turns to avoid the risk of overturning. Always drive at a safe speed relative to local conditions and ensure your speed is slow enough for a safe emergency stop.
 20. Chemical application is often an integral part of planting. Follow label instructions for proper chemical mixing, handling and container disposal methods.
 21. Be familiar with safety procedures for immediate first aid should you accidentally contact chemical substances.
 22. Use the proper protective clothing and safety equipment when handling chemicals.
 23. Chemicals are supplied with Material Safety Data Sheets (MSDS) that provide full information about the chemical, its effects on exposure, and first aid needs in the event of an emergency. Keep your MSDS file up-to-date and available for first responders in case of emergency.
 24. When servicing ground engaging components such as opening disks and firming points, use special care to avoid points and edges worn sharp during use.
 25. Transporting planter with hoppers over half full or unevenly loaded can cause loss of control and could result in death, serious injury, or damage to property and equipment.
 26. Use professional help if you are unfamiliar with working on hydraulic systems. Pressurized hydraulic fluid can penetrate body tissue and result in death, serious infection, or other injuries.
- Never pour waste onto the ground, down a drain, or into any water source.
- When disposing of waste such as oil, use leakproof containers. Be sure to use containers that do not resemble food or beverage which may mislead someone into consuming them. Dispose of oil per your local, regional requirements.
- When disposing of any fertilizer chemicals used, contact the supplier of the chemicals.
- Model 3505 planter consists of 85% recyclable metals, 10% recyclable plastic and rubber, and 5% waste.

Following are some common hazard warnings associated with this equipment. Pay close attention to all safety, operating, and maintenance information in this manual and decals applied to your equipment.

	<p>Contacting or coming close to power lines or other high energy sources will cause death or serious injury.</p>
	<p>Keep away from power lines or high energy sources at all times.</p>

	<p>Improperly operating or working on this equipment could result in death or serious injury. Read and follow all instructions in Operator Manual before operating or working on this equipment.</p>
	

	<p>Falling equipment can cause death or serious injury. Install all lockup devices or lower planter to ground before working on equipment.</p>
	

	<p>Explosive separation of rim and tire parts can cause death or serious injury. Overinflation, rim and tire servicing, improper use of rims and tires, or worn or improperly maintained tires could result in a tire explosion.</p>
	

SAFETY SIGNS AND DECALS

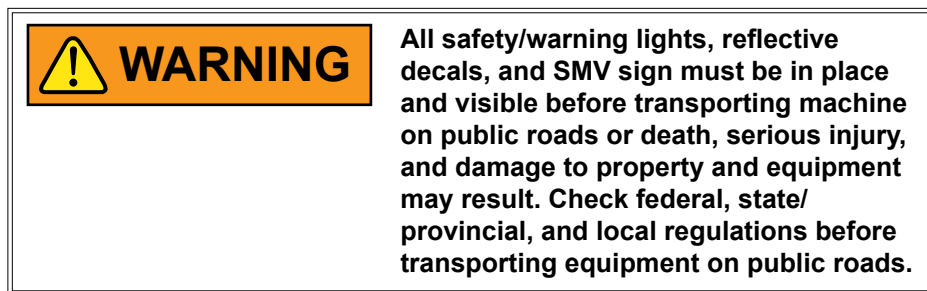

Safety signs and decals are placed on the machine to warn of hazards and provide important operating and maintenance instructions. Information on these signs are for your personal safety and the safety of those around you. FOLLOW ALL SAFETY INSTRUCTIONS!

- **Keep signs clean so they can be easily seen. Wash with soap and water or cleaning solution as required.**
- **Replace safety signs if damaged, painted over, or missing.**
- **Check reflective decals and SMV sign periodically. Replace if they show any loss of reflective properties.**
- **When replacing decals, clean machine surface thoroughly with soap and water or cleaning solution to remove all dirt and grease.**

NOTE: Safety sign and decal locations are shown in the Parts Manual for this machine.

NOTE: Style and locations of SMV sign, reflective decals, and safety/warning lights conform to ANSI/ASABE S279.14 JUL 2008 and ANSI/ASABE S276.6 JAN 2005.

This page left blank intentionally.

INITIAL PREPARATION

Following information is general in nature to aid in preparation of tractor and planter for use, and to provide general operating procedures. Operator experience, familiarity with the machine, and the following information should combine for efficient planter operation and good working habits.

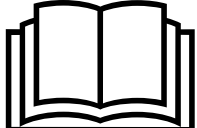

WARNING

Improperly operating or working on this equipment could result in death or serious injury. Read and follow all instructions in Operator Manual before operating or working on this equipment.





WARNING

Loose transport wheel lug bolts can result in wheel separation from planter and cause death, serious injury, and damage to property and equipment. Torque transport wheel lug bolts before operating planter for the first time and periodically after.



WARNING

Explosive separation of rim and tire parts can cause death or serious injury. Overinflation, rim and tire servicing, improper use of rims and tires, or worn or improperly maintained tires could result in a tire explosion.



1. Torque transport wheel $\frac{9}{16}$ "- 18 lug bolts to 125 ft-lb (169 N-m).
2. Inflate transport/ground drive tires to 40 psi (275.7 kPa).
3. Inflate contact drive tires to 50 psi (344.7 kPa).



TRACTOR REQUIREMENTS

NOTICE	All Hydraulic Requirements: Minimum Pressure 2350 PSI (16202.6 kPa); Maximum Pressure 3000 PSI (20684.2 kPa). Check tractor hydraulics to ensure that maximum pressure cannot be exceeded.
---------------	---

Consult your dealer for information on horsepower requirements and tractor compatibility. Requirements vary with planter options, tillage, and terrain.

A 12 volt DC electrical system is required to operate planter safety/warning lights, digital vacuum gauge, and optional pneumatic down pressure system or work lights.



Two dual remote hydraulic outlets (SCV) are required on all models. An additional SCV and zero pressure case drain, or PTO pump is required for vacuum and bulk fill equipped planters.

Hydraulic maximum flow rate is required to operate vacuum fan motor:

6 Row = 13 GPM @ 2000 PSI (49 LPM @ 13790 kPa)

8 Row = 5 GPM @ 2350 PSI (19 LPM @ 16203 kPa)

For tractor hydraulic requirements refer to: ["Tractor Hydraulic Requirements" on page 1-5](#)

 WARNING	<p>Uncontrolled movement of equipment can cause loss of control and could result in death, serious injury, or damage to property and equipment. Install all safety pins before transporting equipment.</p>
	

ROW MARKER SAFETY LOCKUP



Row marker lockup installed



Row marker lockup in storage location

Install row marker safety lockup devices over marker cylinder rods whenever markers are not being used. Keep in storage position on front side of row marker arms when removed. Secure in either location with attached clevis pins.

SAFETY LOCKUP PIN

Safety lockup pin is inserted through the center post and kept in place by a hairpin clip.

For planters with bulk fill, safety lockup pin is stored on pin holder on front latch post.

Pin must be installed under planter frame during transport or when working on equipment when raised.



Bulk Fill

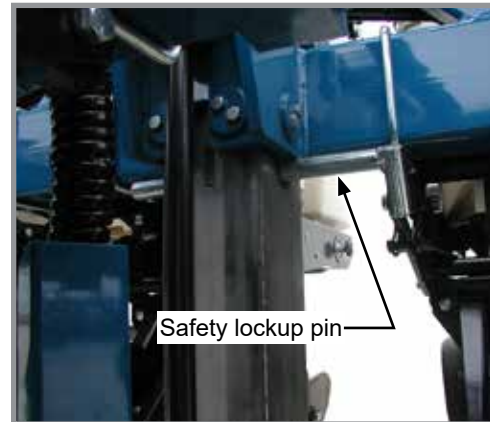

STROKE LIMITER PIN (CONVENTIONAL ONLY)

Pin must be installed above planter frame during normal operation to contact stroke limiter valve and prevent lift cylinder from overextending. Refer to Hydraulic Operation in this section.



TRANSPORT LATCH LOCKING PIN

Spring loaded transport latch on planter hitch locks in place under toolbar when planter is rotated to transport position.

Always install transport latch locking pin to lock transport latch before transporting planter.

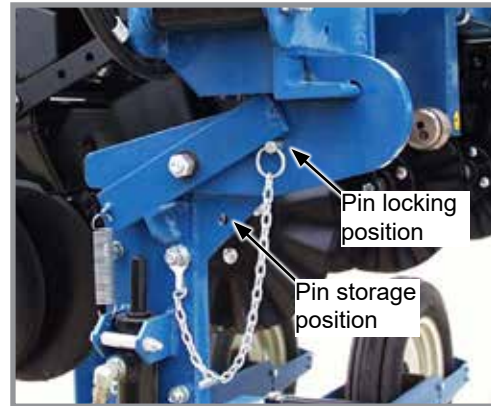

Transport latch locking pin locations

HITCH LENGTH ADJUSTMENT

The hitch consists of a telescoping outer and inner section. Hitch length can be adjusted to three locations to accommodate tractor tire options and attachments installed on planter.

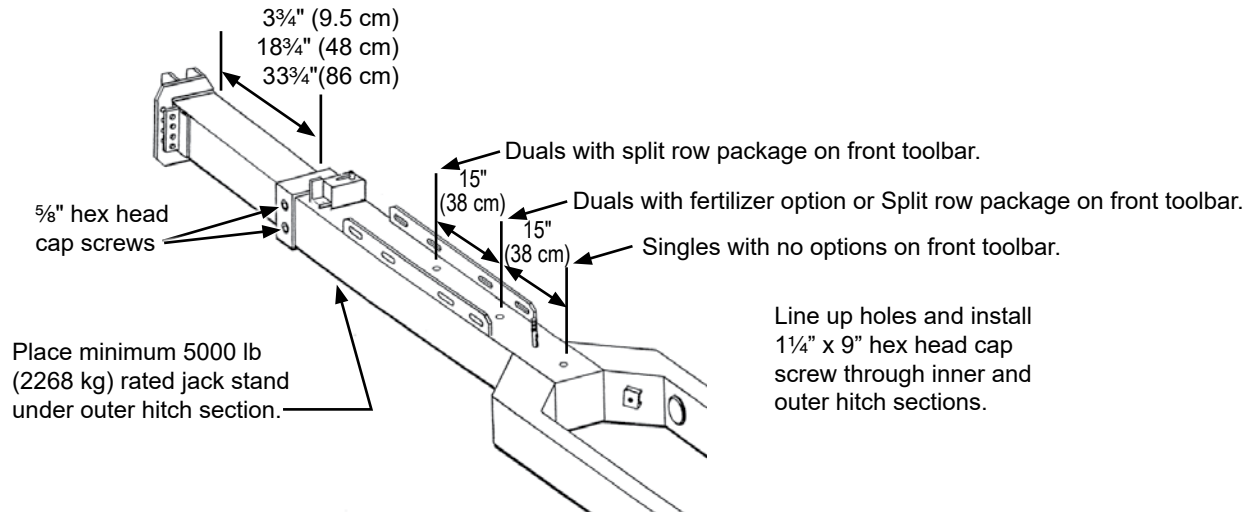

1. Lower machine to field position and block transport wheels.
2. Support outer hitch section with a minimum 5000 lb (2268 kg) rated jack stand to take weight off inner section.

NOTE: Remove and reinstall hitch mounted brackets as needed to access hitch adjustment holes.

3. Remove 1 1/4" x 9" hex head cap screw, lock washer, and hex nut from hitch. Loosen two 5/8" hex head cap screws on front L.H. side of outer hitch section.

NOTICE

DO NOT set hitch length so turning is limited when machine is in road transport position or equipment may be damaged.

4. Reposition inner hitch section so hole lines up with hole in outer hitch section at desired length. Install 1 1/4" x 9" hex head cap screw, lock washer, and hex nut. Torque to 840 ft-lb (1138 N-m).
5. Torque two 5/8" hex head cap screws to 110 ft-lb (149 N-m).

JACK STAND

NOTICE Install jack stand in stowed position during transport and field operation to prevent equipment damage.

An easily removable jack stand is provided to aid in connecting and disconnecting planter from tractor.

Slide notched end of jack stand over mount round bar at parking/lift or stowed position.

Install pin through mount and jack stand. Secure with lynch pin.

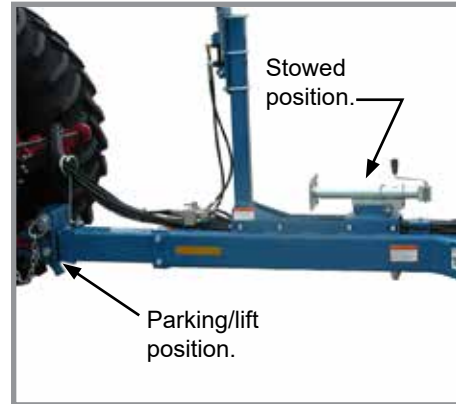

Jack stand locations

HYDRAULIC OPERATION - CONVENTIONAL

NOTE: PTO pump drive and oil cooler package is available from Kinze through your Kinze Dealer to increase your tractor's operating capabilities.

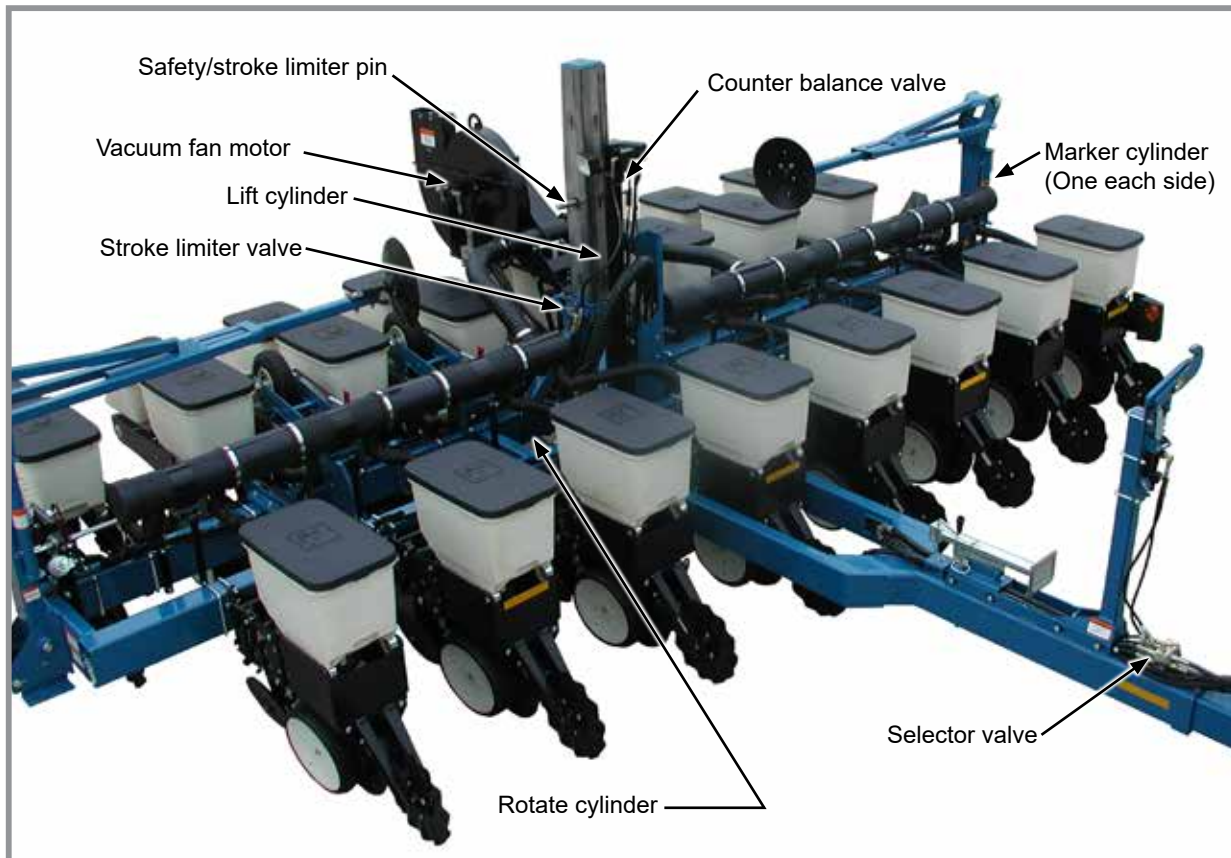

3505 hydraulic system (schematic located in Lubrication and Maintenance section)

HYDRAULIC OPERATION - CONVENTIONAL (CONTINUED)

PLANTER LIFT SYSTEM

Planter lift system consists of one lift cylinder located at center of machine. Cylinder mounts are located front and rear side of center post. Install cylinder in rear position for planters with rear mounted row units only. Cylinder must be installed in front position for planters with front mounted options (push row units, fertilizer, etc.). A stroke limiter valve shuts off hydraulic flow when the planter lifts to raised field position and contacts safety/stroke limiter pin. A counter balance valve holds planter in position until reverse pressure is applied.

NOTE: Planter lift cylinder is equipped with a counter balance valve. Hydraulic pressure is required to lower planter

SELECTOR VALVE, ROTATE AND MARKER CYLINDERS

A hitch mounted, hand operated selector valve selects row marker or fold functions. Rotate cylinder is mounted on the frame and rotates planter to/from transport position. Row marker cylinders raise and lower row markers.

NOTE: Hydraulic pressure will prevent valve from moving. Release hydraulic pressure from system before attempting to move selector valve handle.

VACUUM FAN MOTOR AND VALVE BLOCK ASSEMBLY (If equipped)

Hydraulically operated motor requires maximum flow rate of 13 GPM @ 2000 PSI (49 LPM @13790 kPa) to operate properly. It must be connected to a zero pressure case drain and connected to the correct pressure and return SCV's or PTO fittings.

A pressure relief valve in the valve block assembly prevents build up of oil pressure over 35 PSI in case drain line when vacuum fan motor is in operation. This valve vents oil outside of valve block through a drain hole in the aluminum valve block. This can occur whenever the case drain is improperly connected or motor circuit pressure is too high.

See [“Hydraulic Diagram - Vacuum Fan Motor System \(8 Row\)” on page 6-46](#) in Lubrication and Maintenance section. The valve block also contains a check valve that prevents vacuum fan from operating in wrong direction if pressure is applied to of motor return side and allows fan to coast to a stop when tractor hydraulic control is returned to neutral.

NOTE: Fan turns at a reduced speed if reverse pressure is applied.

RAISED FIELD POSITION

Row units raise approximately 14 inches (35.5 cm) and toolbar approximately 40 inches (101.6 cm) off ground. This position is used in making turns or passing over waterways during field operation.

Install safety/stroke limiter pin above frame assembly to make contact with stroke limiter valve. Secure with hairpin clip.

RAISED TRANSPORT POSITION

Planter raises high enough to permit row units to clear transport wheels as planter is rotated.

1. Remove hairpin clip and safety lockup pin.
2. Raise planter until lift cylinder is fully extended.
3. Reinstall safety lockup pin and hairpin clip in same hole which is now below frame assembly.
4. Lower planter onto safety lockup pin.

HYDRAULIC OPERATION - BULK FILL

NOTE: PTO pump drive and oil cooler package is available from Kinze through your Kinze Dealer to increase your tractor's operating capabilities.

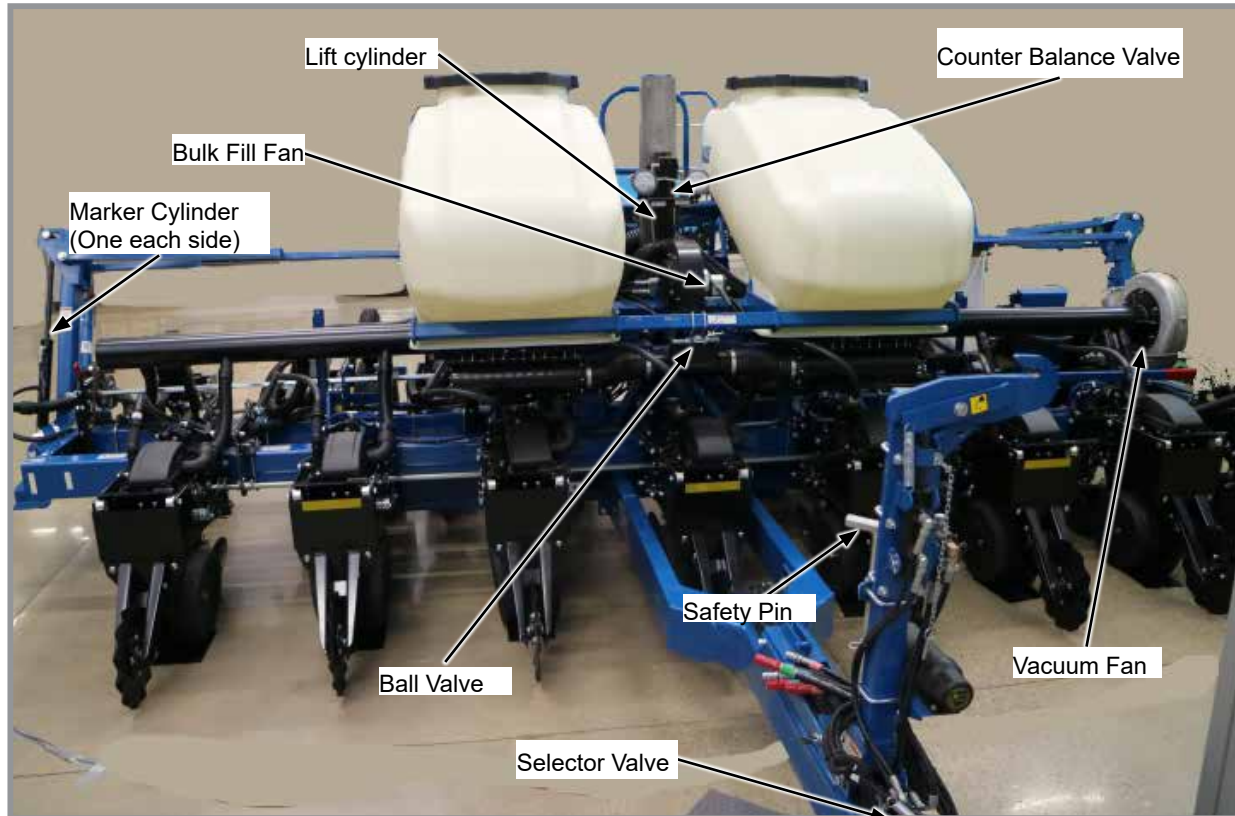

3505 hydraulic system (schematic located in Lubrication and Maintenance section)

HYDRAULIC OPERATION - BULK FILL (CONTINUED)

PLANTER LIFT SYSTEM

Planter lift system consists of one lift cylinder located at center of machine. A counterbalance valve holds planter in position until reverse pressure is applied. A lift limiter valve closes when the bearing contacts the hole for the safety pin at field turn height. A ball valve located on the front of the bulk fill mount is opened to bypass the lift limiter and allow full lift for transport.

NOTE: Planter lift cylinder is equipped with a counter balance valve. Hydraulic pressure is required to lower planter

SELECTOR VALVE, ROTATE AND MARKER CYLINDERS

A hitch mounted, hand operated selector valve selects row marker or fold functions. Rotate cylinder is mounted on the frame and rotates planter to/from transport position. Row marker cylinders raise and lower row markers.

NOTE: Hydraulic pressure will prevent valve from moving. Release hydraulic pressure from system before attempting to move selector valve handle.

VACUUM FAN AND BULK FILL MOTOR AND VALVE BLOCK ASSEMBLY (If equipped)

Hydraulically operated motor requires maximum flow rate of 5 GPM @ 2350 PSI (19 LPM @ 16202 kPa) to operate properly. It must be connected to a zero pressure case drain and connected to the correct pressure and return SCV's or PTO fittings.

See [“Hydraulic Diagram - Vacuum Fan Motor System \(6 Row\)”](#) on page 6-45 in Lubrication and Maintenance section.

The valve block also contains a check valve that prevents vacuum fan from operating in wrong direction if pressure is applied to of motor return side and allows fan to coast to a stop when tractor hydraulic control is returned to neutral.

Bulkfill air pressure is controlled by a mechanical flow control valve located on the transport catch post on hitch of planter. Hydraulic pressure from the lift circuit operates the fan when the planter is lowered and SCV is left in detent. When the planter is lifted, the fan will shut off until the unit is again lowered.

NOTE: Fan turns at a reduced speed if reverse pressure is applied.

RAISED FIELD POSITION

Row units raise approximately 14 inches (35.5 cm) and toolbar approximately 40 inches (101.6 cm) off ground. This position is used in making turns or passing over waterways during field operation.

Close ball valve to limit lift height for field operation.

RAISED TRANSPORT POSITION

Planter raises high enough to permit row units to clear transport wheels as planter is rotated.

1. Open ball valve.
2. Raise planter until lift cylinder is fully extended.
3. Install safety lockup pin and hairpin clip in same hole which is now below frame assembly.
4. Lower planter onto safety lockup pin.

PTO PUMP DRIVE AND OIL COOLER OPTION - 6 ROW ONLY

The PTO pump drive and oil cooler option is for tractors with less than required hydraulic output needed to operate hydraulic-driven vacuum fan and other planter hydraulic requirements.

A 1000 RPM PTO is required to operate the PTO-driven hydraulic pump.

PTO pump option consists of a 1 $\frac{3}{8}$ "-21 or 1 $\frac{3}{4}$ "-20 spline, 13.5 GPM 2000 PSI pump (49 LPM @13790 kPa), 10 gallon (37.8 L) capacity hydraulic reservoir, 15 GPM-rated oil cooler (56.7 L), spin-on 10-micron oil filter, and required hydraulic valves and fittings.

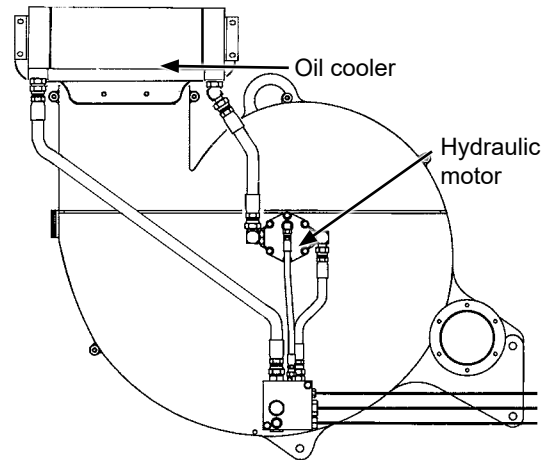

Vacuum fan assembly

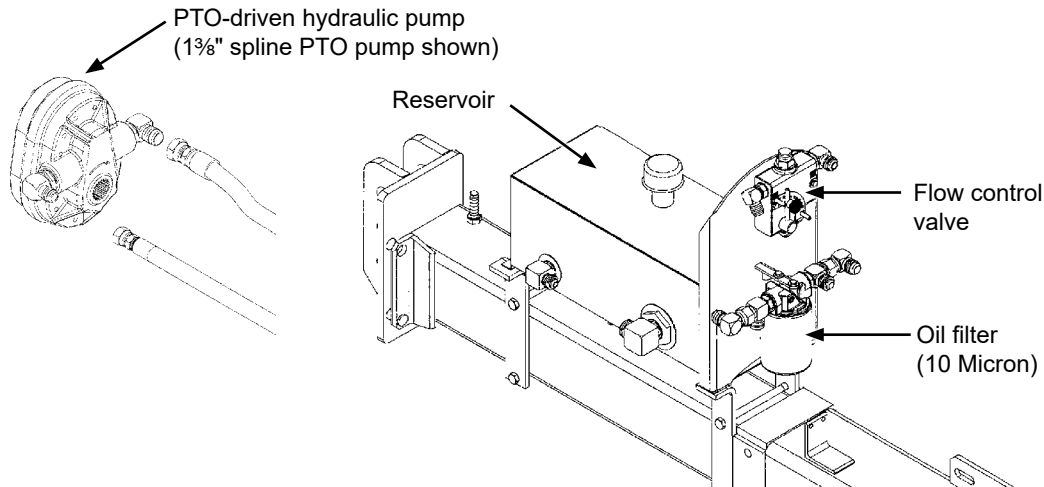

This page left blank intentionally.

PTO PUMP DRIVE AND OIL COOLER OPTION - 8 ROW ONLY

The PTO pump drive and oil cooler option is for tractors with less than required hydraulic output needed to operate hydraulic-driven vacuum fan and other planter hydraulic requirements.

A 1000 RPM PTO is required to operate the PTO-driven hydraulic pump.

PTO pump option fits to a 1 $\frac{3}{8}$ "-21 or 1 $\frac{3}{4}$ "-20 spline with mount option from Ag Power Systems (www.agpowersystems.com), 13.5 GPM 2000 PSI pump (49 LPM @13790 kPa), 10 gallon (37.8 L) capacity hydraulic reservoir, 15 GPM-rated oil cooler (56.7 L), spin-on 10-micron oil filter, and required hydraulic valves and fittings.

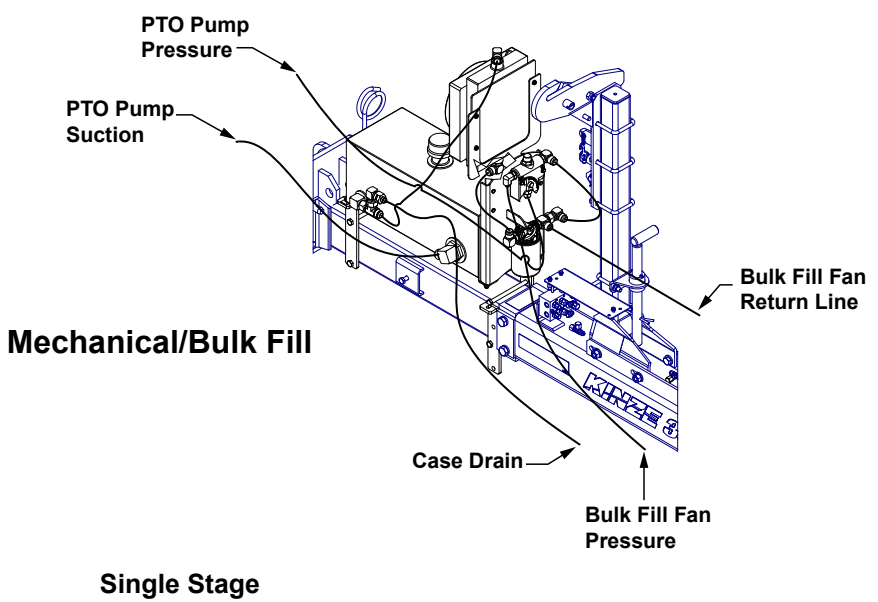
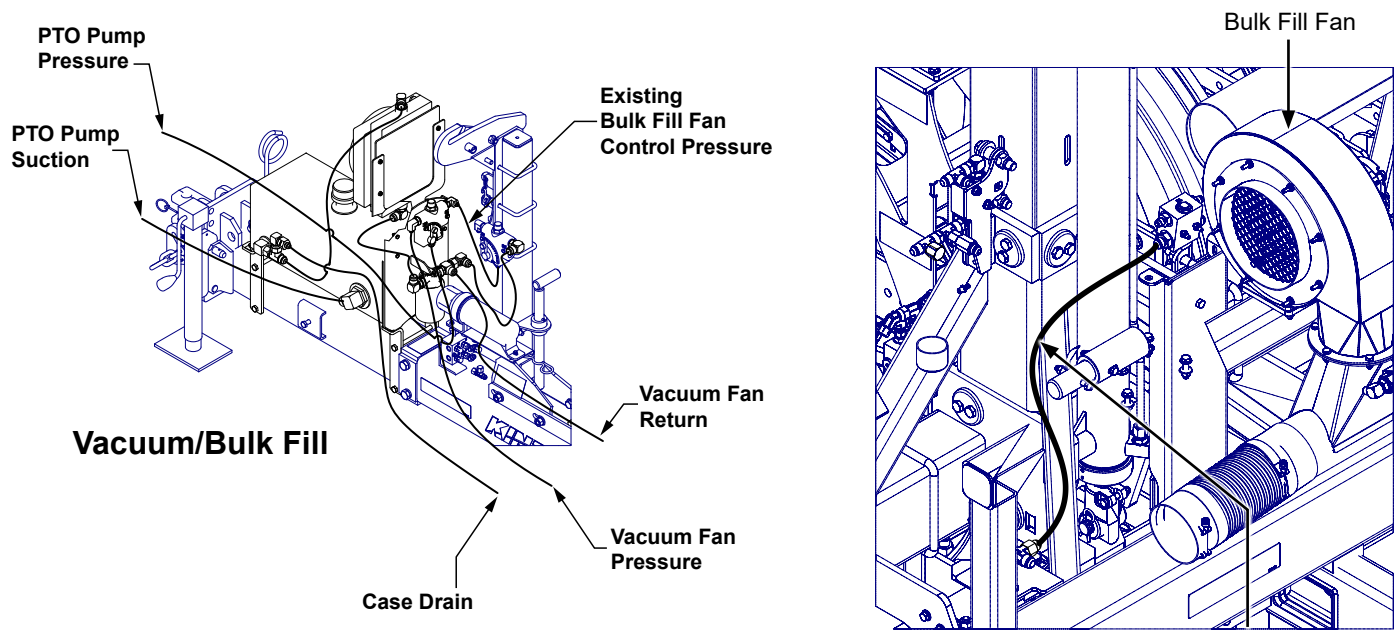

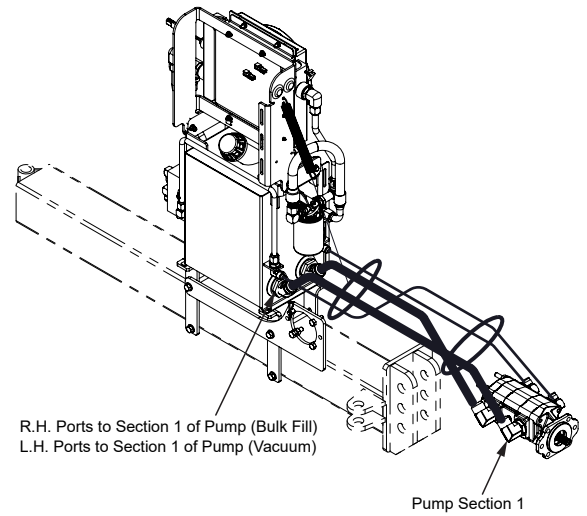
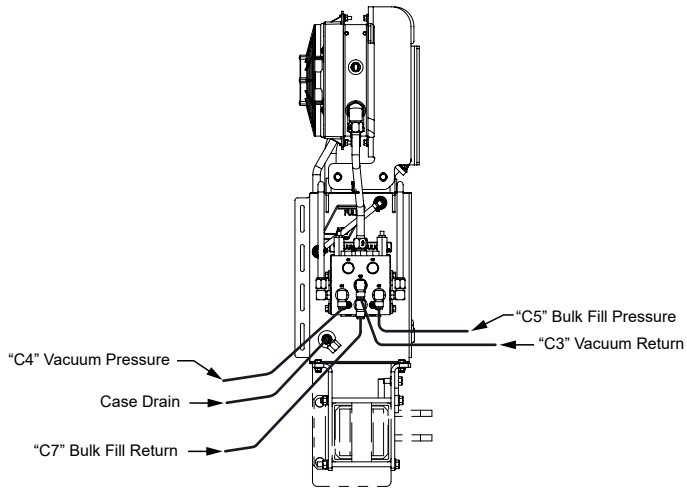

Dual Stage

TRACTOR PREPARATION AND HOOKUP

NOTE: A 2-Point Hitch option is available for use with Category 3N or 3 three-point hitch designs to convert planter from drawn to semi-mounted. Safety chain is not used with 2-point hitch.

1. Adjust tractor drawbar 13 to 17 inches (33 - 43 cm) above ground. Adjust drawbar so hitch pin hole is directly below center line of PTO shaft. Make sure drawbar is in a stationary position.
2. Back tractor to planter and connect with a minimum $\frac{3}{4}$ " diameter hitch pin. Secure with a locking or cotter pin.



Drawbar and safety chain connection

3. Safety chain must be used to keep planter and tractor connected in case of a hitch pin/drawbar failure.

WARNING

Pressurized hydraulic fluid can penetrate body tissue and result in death, serious infection, or other injuries. Fluid injected under skin must be IMMEDIATELY removed by a surgeon familiar with this type of injury. Make sure connections are tight and hoses and fittings are not damaged before applying system pressure. Leaks can be invisible. Keep away from suspected leaks. Relieve pressure before searching for leaks or performing any system maintenance.



NOTICE

Wipe hose ends to remove any dirt before connecting couplers to tractor ports or contamination may cause equipment failure.

4. Connect hydraulic hoses to tractor ports in a sequence familiar and comfortable to the operator.

NOTICE

Vacuum and bulk fill fan motor hydraulic hoses and case drain must be installed correctly. Motor can be damaged or equipment will not operate properly.

NOTE: If tractor is equipped with an adjustable flow outlet (SCV), set to full flow position. For tractors not equipped with a method for finite adjustment of hydraulic flow, Flow Control Needle Valve Kit G1K426 is available from Kinze Repair Parts through your Kinze Dealer.



G1K426 needle valve kit

Function	Hose Color	Pressure	Return
Lift/Bulk Fill	Red	A	B
Fold/Marker	Blue	A	B
Vacuum	Green	A	B
Case Drain	Orange	---	CD
Power Pack	Black	A	B

TRACTOR PREPARATION AND HOOKUP (CONTINUED)

5. Connect ASABE Standards 7 terminal connector for safety/warning lights on planter to ASABE Standards receptacle on tractor. If your tractor is not equipped with an ASABE Standards receptacle, check with your tractor manufacturer for availability. Check warning lights on planter work in conjunction with warning lights on tractor.

NOTE: A 12 volt battery connection is required to power the vacuum fan digital gauge. Connect "red" wire to positive (+) battery terminal and "black" wire to negative (-) battery terminal.

6. Raise jack stand and remount horizontally on storage bracket.

LEVEL PLANTER

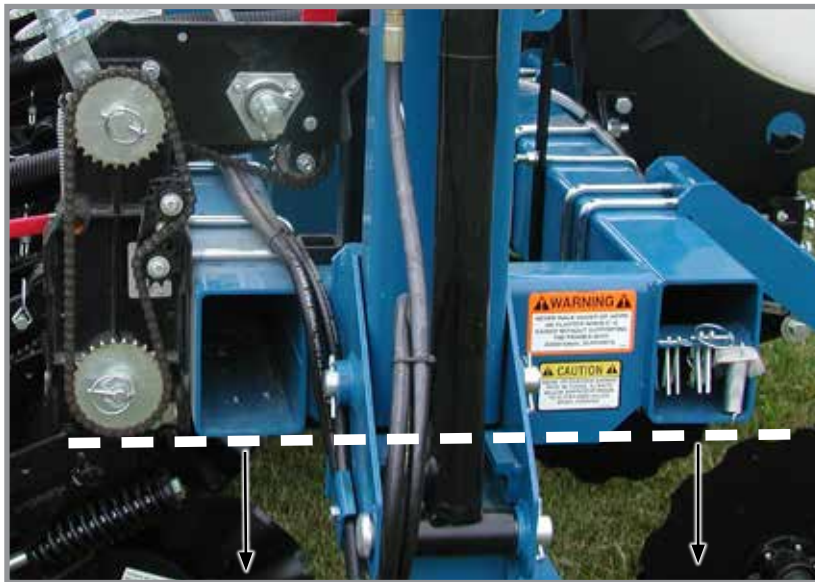

Bottom of toolbars 20" - 22" (50.8 - 55.8 cm) from planting surface

Lateral adjustment is maintained by tire pressure. Check tires are inflated to specification.

Front and rear level adjustment is maintained by hitch clevis position unless tractor drawbar is adjustable for height. Planter frame and row unit parallel arms must be level for proper planter and row unit operation. Bottom of toolbar should be 20" to 22" (50.8 - 55.8 cm) from planting surface.

1. Lower planter to planting position and check planter is level front to rear. Go to step 2 if hitch is too high or low.

NOTE: DO NOT install safety chain using clevis hardware. Move safety chain location if necessary.

2. Remove clevis hitch hex head cap screw and lock nut using a torque wrench. Replace if off-torque is below 75 ft-lb (101.6 N-m) or there is corrosion or damage.

NOTE: Clevis must be free to move on hitch. DO NOT OVERTIGHTEN hardware.

3. Align clevis to hitch holes at new location and install hex head cap screw and lock nut. Tighten lock nut until threads are fully engaged and hex head cap screw and lock nut are firmly against hitch bracket.
4. Recheck with planter in field.

TOWING PLANTER

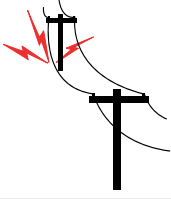
	<p>Contacting or coming close to power lines or other high energy sources will cause death or serious injury.</p>
	<p>Keep away from power lines or high energy sources at all times.</p>

	<p>All safety/warning lights, reflective decals, and SMV sign must be in place and visible before transporting machine on public roads or death, serious injury, and damage to property and equipment may result. Check federal, state/provincial, and local regulations before transporting equipment on public roads.</p>
---	---

	<p>Transporting planter with hoppers over half full or unevenly loaded can cause loss of control and could result in death, serious injury, or damage to property and equipment. Properly load planter when transporting. Be aware of extra transport weight, and road conditions and limits.</p>
--	---

- Tow only with farm tractor rated and configured for equipment.
- Know your route and be aware of any obstructions.
- Follow all road and bridge load limit restrictions.
- Never exceed maximum transport towing speed of 20 mph (32 kph).

PLANTING SPEED

	<p>Raise planter out of ground when making sharp turns or backing up or equipment damage may result.</p>
---	--

Planters are designed to operate within a speed range of 2 to 8 mph (3.2 - 12.8 kph). See ["Rate Charts" on page 5-1](#). Variations in ground speed produce variations in rates. Finger pickup seed meter populations tend to be disproportionately higher at high ground speeds.

NOTE: Seed spacing can be adversely affected at speeds above 5.5 mph (8.8 kph).

CONTACT DRIVE SPRING ADJUSTMENT

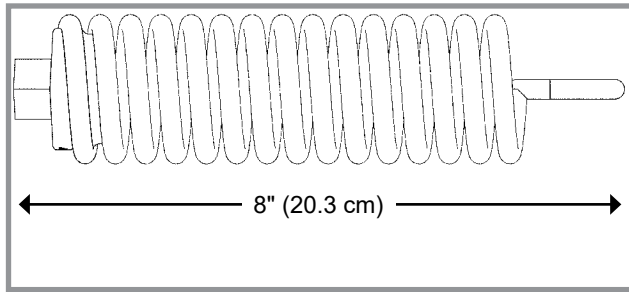

Spring length measurement (Factory setting)



Down pressure spring location

There are two down pressure springs on each contact drive wheel. Spring tension is factory preset and normally requires no adjustment.

Basic setting for spring tension is approximately 200 lb (90.72 kg) of down force at tire contact point.

NOTE: Measurement must be taken in planting position with proper tire pressure.

SEED RATE TRANSMISSION ADJUSTMENT

Seed rate transmissions allow simple, rapid changes of sprockets to obtain desired planting population. By removing lynch pins on hexagon shafts, sprockets can be interchanged with those from the sprocket storage rod bolted to the transmission.

Chain tension is controlled by a spring-loaded dual-sprocket idler. The idler assembly is equipped with an easy-release idler arm to remove spring tension for replacing sprockets.

Planting rate charts in the Seed Meter Operation section will aid you in selecting correct sprocket combinations.

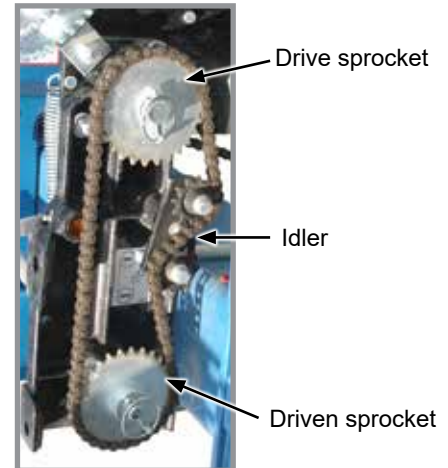

Seed rate transmission chain tension

STANDARD AND HALF RATE (2 TO 1) DRIVES

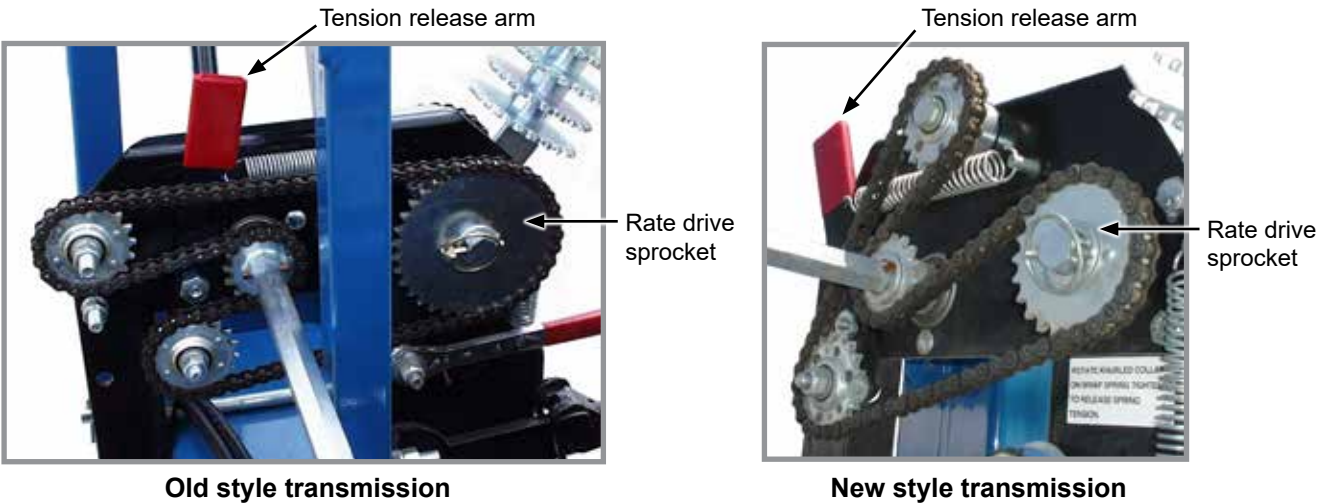

Seed planting rate charts are based on the standard rate drive using a 17 tooth sprocket unless otherwise specified.

NOTE: Half rate (2 to 1) drive is recommended only when desired population falls below that on planting rate charts.

Replacing the standard 17 tooth drive sprocket located on the inner side of the top transmission shaft, with the 34 tooth half rate (2 to 1) drive reduction sprocket reduces planter transmission speed and planting and application rates by approximately 50%.

NOTE: Do a field check after each sprocket combination adjustment to make sure you are planting at the desired rate.

SHEAR PROTECTION

Shear pins protect the planter driveline and row unit components from damage.

1. Determine where binding has occurred before replacing a pin. Turn shaft by hand (with the aid of a wrench) and check for misalignment and seized parts.
2. When shaft can be turned by hand (with the aid of a wrench) replace shear pins with same size and type. Spare shear pins are in wheel module storage area.

NOTICE	Misaligned drill shaft/transmission coupler can cause equipment damage.
---------------	--

3. Check driveline alignment and follow prescribed lubrication schedules to prevent component binding or breakage.

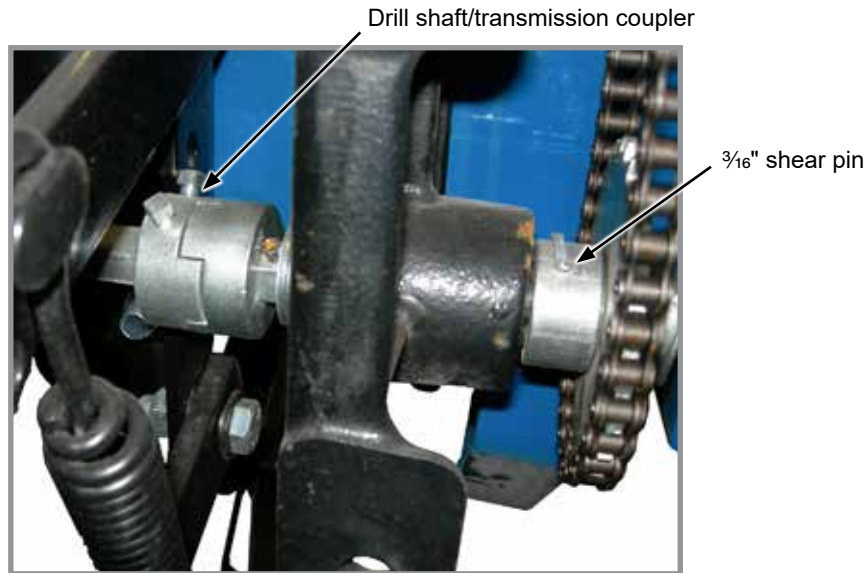

Transmission shaft and drill shaft coupler

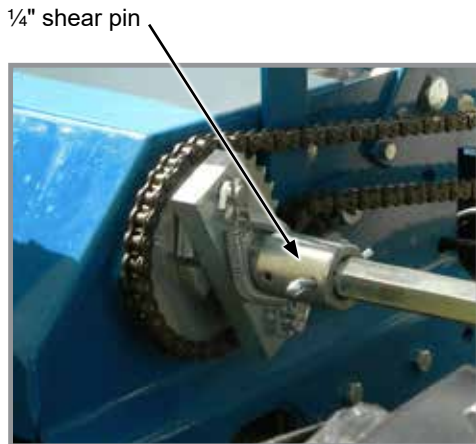

Liquid fertilizer driveline

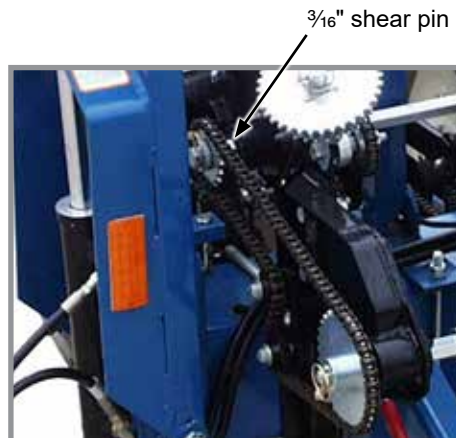

Dry fertilizer driveline

WRAP SPRING WRENCH

Chain idlers use wrap spring wrenches to release and adjust transmission chain tension.

NOTE: Wrap spring wrenches are L.H. and R.H. specific. L.H. styles have silver metal or grey plastic release collars. R.H. styles have gold metal or blue plastic release collars.

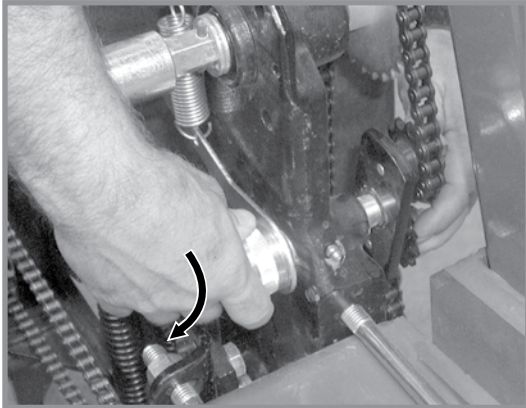

Release chain tension

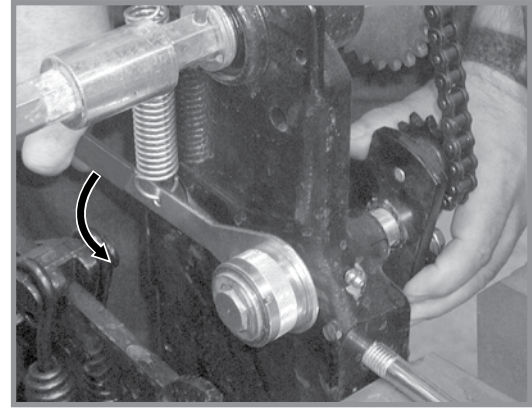

Increase chain tension

Rotate wrap spring wrench knurled collar while rotating chain idler away from chain to release chain tension.

Rotate chain idler into chain while rotating handle to tension idler spring.

CONTACT WHEEL DRIVE SPROCKETS

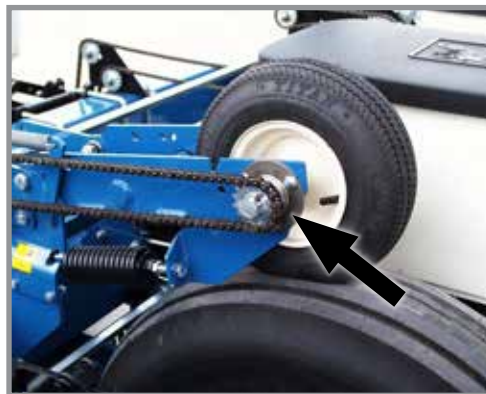

Contact wheel drive sprocket

NOTE: 15 tooth, 19 tooth or 30 tooth drive sprockets at each contact drive wheel can be interchanged from sprocket storage rod bolted to each transmission. 30 tooth sprockets require use of 124 pitch chains instead of standard 116 pitch No. 40 chains.

Chain tension is controlled by a spring-loaded sprocket idler. Amount of spring tension on chain is controlled by idler arm. Planting rate chart in Rate Chart section will aid you in selecting correct sprocket.

NOTE: 15, 19, and 30 tooth drive sprockets are NOT applicable to all rate charts. 23 tooth driven sprocket at reverser plate is changed to a 17 tooth sprocket when using 60 cell soybean seed disc. Check chart titles to ensure proper rate chart is selected.

NOTE: Make a field check after each sprocket combination adjustment to be sure you are planting at desired rate.

ROW MARKER SPEED ADJUSTMENT

NOTICE

Excessive row marker travel speed can damage row markers. Adjust flow controls before row markers are first used.



Row marker flow control valves

Two flow control valves determine amount of oil flow restriction controlling row marker travel speeds. One flow control valve controls lowering speed and one controls raising speed of both markers.

NOTE 1: Hydraulics operate slowly when oil is cold. Make all adjustments with oil warm.

NOTE 2: On a tractor where oil flow cannot be controlled, tractor flow rate may be greater than rate marker cylinder can accept. Hold tractor hydraulic control lever until cylinder reaches end of its stroke. This occurs most often on tractors with an open center hydraulic system.

NOTE 3: On tractors with a closed center hydraulic system, set hydraulic flow control so detent functions properly.

1. Loosen jam nut and turn control clockwise (IN) to slow speed or counterclockwise (OUT) to increase speed.
2. Tighten jam nut after adjustments are made.

EVEN-ROW PUSH ROW UNIT

An Even-Row Push Row Unit Package is available to add one additional push row unit on outer L.H. side of front toolbar for use with Solid Row Split Row Package.

NOTE: See “Row Marker Adjustment” for determining correct length to set row marker assemblies when planting with even-row push row unit option.

An inner hitch with a 7½" (19 cm) offset mount is available from Kinze through your Kinze Dealer to plant two 15" rows between last year's 30" rows and avoid tire damage from stalks by driving off row

NOTE: install hitch onto 2-point hitch bar using R.H. hole if 2-Point Hitch Option is used. A 7½" (19 cm) offset mount is not needed. See “Offset Hitch Adjustment” for additional information.

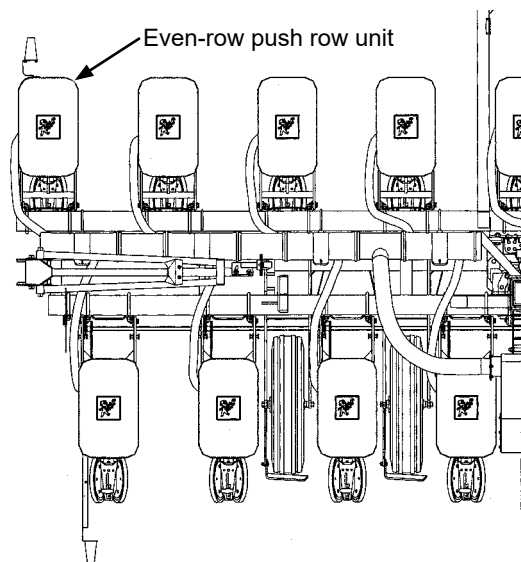

ROW MARKER ADJUSTMENTS

1. Multiply number of rows by the average row spacing in inches to determine total planting width.

Row Marker Lengths	
6 Row 30" (70 cm)	180" (457.2 cm)
8 Row 30" (70 cm)	240" (609.6 cm)

2. Lower planter and row marker assembly to ground.
3. Measure from planter center line to a point where blade contacts ground.
4. Adjust row marker extension so distance from marker disc blade to center line of planter is equal to total planting width. Adjust right and left row marker assemblies equally and securely tighten clamping bolts.

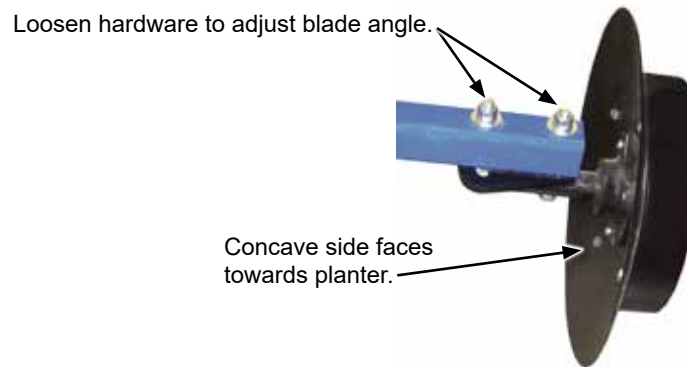

Row marker disc blade angle adjustment

NOTICE

Setting marker disc blade assembly at a sharper angle than needed adds stress to row marker assembly and shortens bearing and blade life. Set blade angle only as needed to leave a clear mark.

Marker disc blade is installed with concave side facing inward. Spindle assembly is slotted so hub and blade can be angled to throw more or less dirt.

5. Loosen hardware and move assembly as required.
6. Tighten bolts to specified torque.
7. Do a field test to ensure markers are properly adjusted.

NOTE: A notched marker blade is available from Kinze through your Kinze Dealer for use in more severe no till conditions.

ROW MARKER EVEN-ROW LENGTH ADJUSTMENT

Replace L.H. marker extension tube with marker extension tube (55" for 6 Row 30"/65" for 8 Row 30") supplied with Even-Row Push Row Unit and Mounting Package.

Reinstall marker blade assembly onto new marker extension tube.

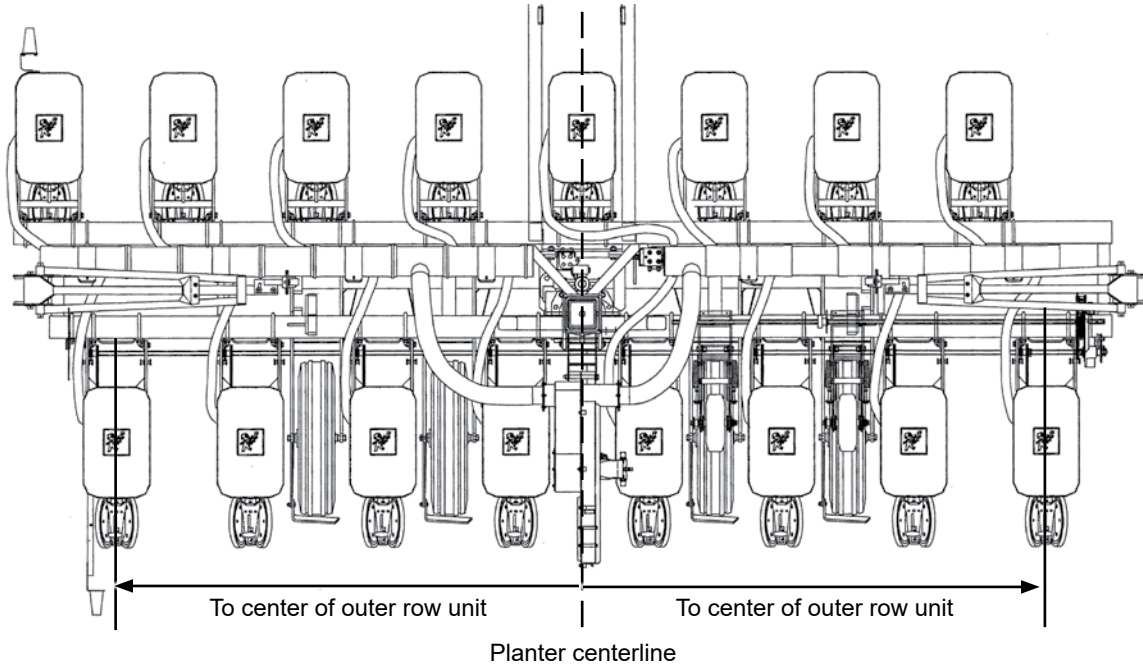

Center of planter to center of outer row unit. $\times 2 + 15'' =$ Dimension between planter center line and marker blade

- 6 Row 30" with 6 split row push row units
(L.H. marker $90'' \times 2 + 15'' = 195''$)
(R.H. marker $75'' \times 2 + 15'' = 165''$)
- 8 Row 30" with 8 split row push row units
(L.H. marker $120'' \times 2 + 15'' = 255''$)
(R.H. marker $105'' \times 2 + 15'' = 225''$)

NOTE: Readjust markers when planting 30" rows

Number of rows \times row spacing (Inches)

=

Dimension between planter center line and marker blade

6 Rows \times 30" Spacing = 180" Marker Dimension
8 Rows \times 30" Spacing = 240" Marker Dimension

OFFSET HITCH ADJUSTMENT

An offset hitch is available from Kinze through your Kinze Dealer. Offset hitch provides centered and offset mounting positions for hitch clevis.

If tractor hitch is offset 7½" (19 cm) right of tractor center line, add 7½" (19 cm) to marker dimension on R.H. side of planter and subtract 7½" (19 cm) from marker dimension on L.H. side of planter.

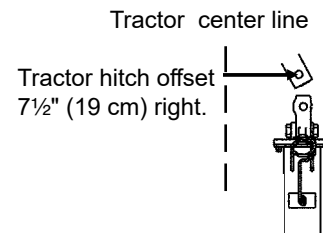

VACUUM METER SYSTEM

Kinze vacuum meter seed metering system includes seed meters, seed discs, and an air system consisting of a hydraulic driven vacuum fan which draws air through manifolds, hoses, and seed meters on each row unit.

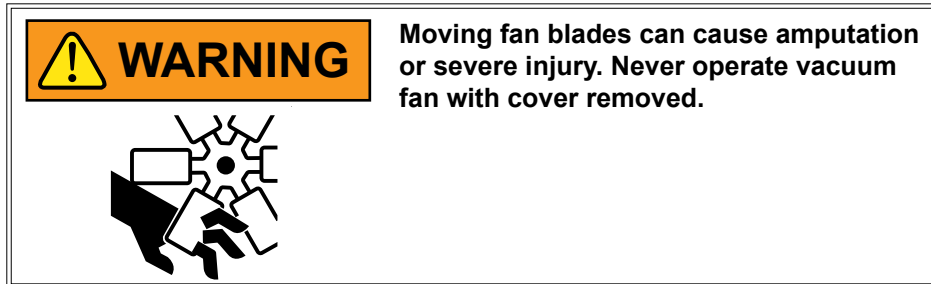

ANALOG VACUUM OR PRESSURE GAUGE

Analog vacuum or pressure gauge connects directly to vacuum meter (vacuum) or bulk fill (pressure) manifold and is tied into digital sending units.

Only adjustment is to “zero” needle with no vacuum or pressure present. If there is a significant difference between gauge and a reading taken at meters, a different manifold location should be found to connect hose to gauge and digital sending unit.

NOTE: Analog gauges are identical EXCEPT for plug and hose barb locations in side of gauge housing. DO NOT connect vacuum meter or bulk fill hose to wrong gauge. Check plug and hose barb installation if readout is erratic or appears inaccurate.

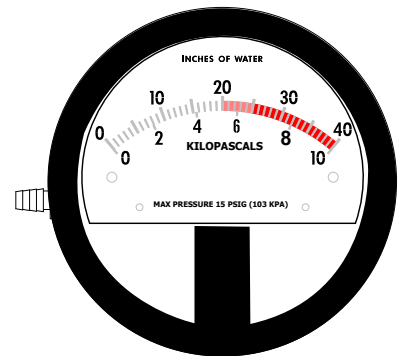

Analog Gauge

BULK FILL SYSTEM



CAUTION

Seed flying out of disconnected delivery tube at high velocity can cause injury. Do not disconnect delivery tubes when system is operating.

NOTICE

Foreign materials can plug system. Make sure seed is clean and free of debris when filling bulk fill hoppers.

NOTICE

Do not turn on system with tractor engine at full speed or system damage may occur.

NOTICE

Do not operate bulk fill system above maximum system operating pressure of 20 inches of water or seed bridging may occur.

1. **Before filling hoppers refer to “Row Unit Operation” for additives information.** Fill hoppers with seed, latch lids, and secure with pin.
2. Start bulk fill system with tractor engine at idle.
3. Increase engine speed to full and set initial system pressure using flow control valve.
4. Allow system to warm up and adjust pressure if necessary.

Recommended pressures:

- Corn – 12 inches (30 cm) of water
- Soybeans – 10 inches (25 cm) of water
- Actual pressure needed is affected by seed size, shape, and coating.



Bulk fill tank lid latch

BULK FILL ENTRAINER ACCESS

1. Shut down bulk fill system.
2. Loosen wing nut and turn retainer holding shutoff door in its storage location.
3. Remove rubber plug closest to area in entrainer needing attention.
4. Insert shutoff door into open slot and push into entrainer at a slight upward angle.
5. When work is complete, remove shutoff door, return door to storage location, and plug open slot.

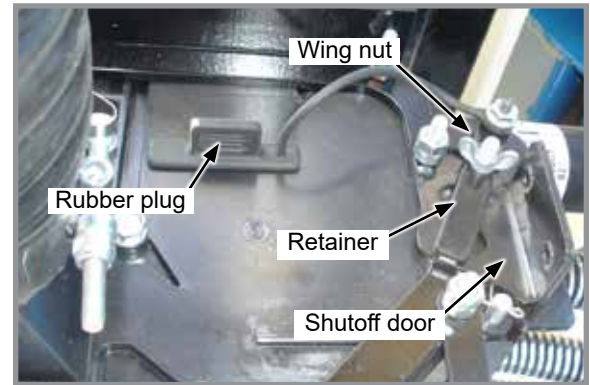

Bulk fill entrainer (end view)

BULK FILL TANKS - CLEAN OUT

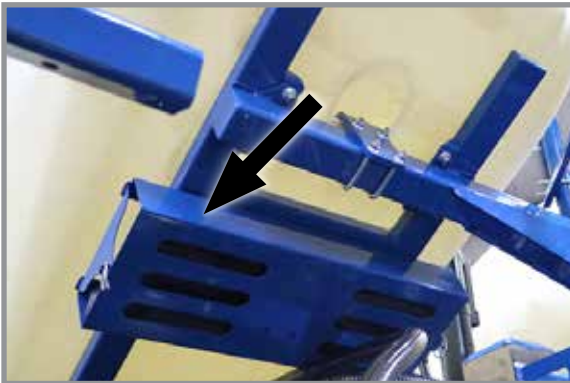

Cleanout chute storage bracket

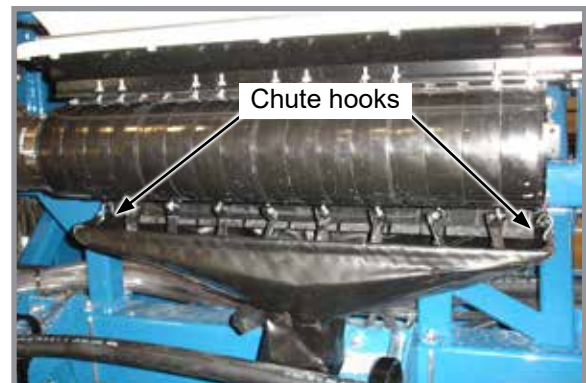

Cleanout chute installed

1. Remove bulk fill tank cleanout chute from storage location beneath catwalk.
2. Position tube of chute under entrainer and attach hooks on each end of entrainment assembly.
3. Open cleanout doors and empty tank.
4. Close all cleanout doors and return cleanout chute to storage location.

AG LEADER MONITORING CONTROL (PMM)

The PMM Magnetic Distance Sensor Package includes a planter-mounted module enclosure with cover and mounting hardware, seed tubes w/sensors, planter harness, planter monitor cable, shaft rotation sensors and magnetic distance sensor components.

Ag Leader InCommand display and associated cab harnesses are also required.

BLUE DRIVE AUX MOUNT

The Blue Drive aux mount houses all modules for controlling vacuum, bulkfill, fold, and various sensors. The intelligent planter router is also housed at this location.



AG LEADER INCOMMAND 1200 DISPLAY

The InCommand 1200 is a full-featured display for any precision farming operation. A large, full-color 12.1" HD touchscreen display is easy to read and offers powerful, year-round precision farming tools. Mapping, planter and application control, yield monitoring, real-time data logging, and more – are all controlled from the cab using the InCommand display.

Four video camera inputs provide operators a better view of equipment operation and safety by allowing them to view live video on the display.

NOTE: See InCommand operator manual for installation and programming.



Ag Leader InCommand Display

KINZE TRUE DEPTH DISPLAY

Kinze True Depth provides on demand row by row hydraulic row unit down force ranging from 100 lbs. up force to 600 lbs. down force at 2350 psi. The system includes a 7" in cab standalone screen display with antiglare screen protector and RAM mount, electronic control modules, harnesses, gauge wheel sensors, hydraulic cylinders, upper and lower cylinder mounts, and valves.

NOTE: See True Depth Operator's Manual for system operation and programming.



Kinze True Depth Display

RIDGE PLANTING

Planter toolbar height can be raised 3" (8 cm) for ridge planting.

Relocate 20" transport axles to lower hole in wheel arm.

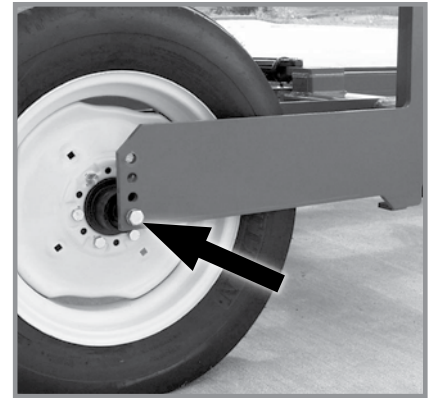

Transport axle in lowest position

TIRE SCRAPER

A tire scraper prevents buildup of dirt and mud between wheel arm assembly and tire.

Adjust scraper so it does not contact tire.



Tire scraper

ROCK GUARDS

Transport wheel rock guards are used on both sides of each transport wheel when planter is used in rocky conditions. Rock guards help prevent rocks from being picked up by wheels and damaging adjoining row units.

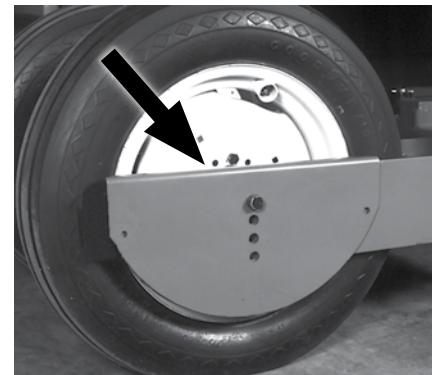

Rock guard

AUXILIARY WORK LIGHTS PACKAGE

Optional Auxiliary Work Lights Package includes two 50 watt, 3" x 5" halogen flood lamps (6 Row) or two LED flood lamps (8 row), brackets, and hardware to mount lights at top of lift cylinder and a wiring harness to plug into existing planter light harness.

If the planter is equipped with Blue Drive refer to M0288 - Kinze Blue Vantage Operator's Manual for work light control.



Auxiliary work lights

REAR TRAILER HITCH

NOTICE

Rear trailer hitch is designed for use with piston pump only. Maximum allowable hitch weight is 200 lb (90.71 kg). Do not exceed 6,000 lb (2,721.55 kg) gross towing weight or the equivalent of a loaded 500 gal (1,892.7 L) tank and running gear or equipment can be damaged.

Rear Trailer Hitch is used to tow a 3 or 4 wheel wagon behind planter.

A spring, chain and mounting bracket are used to support the 1¼" (38 mm) feed hose from hitch to piston pump. This extra length or loop is required to allow planter to be moved into transport position without stretching or breaking hose.

NOTE: Periodically check feed hose for kinks to prevent restricted delivery rate.

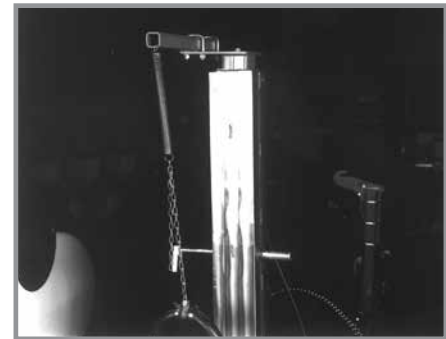

Rear hitch hose support

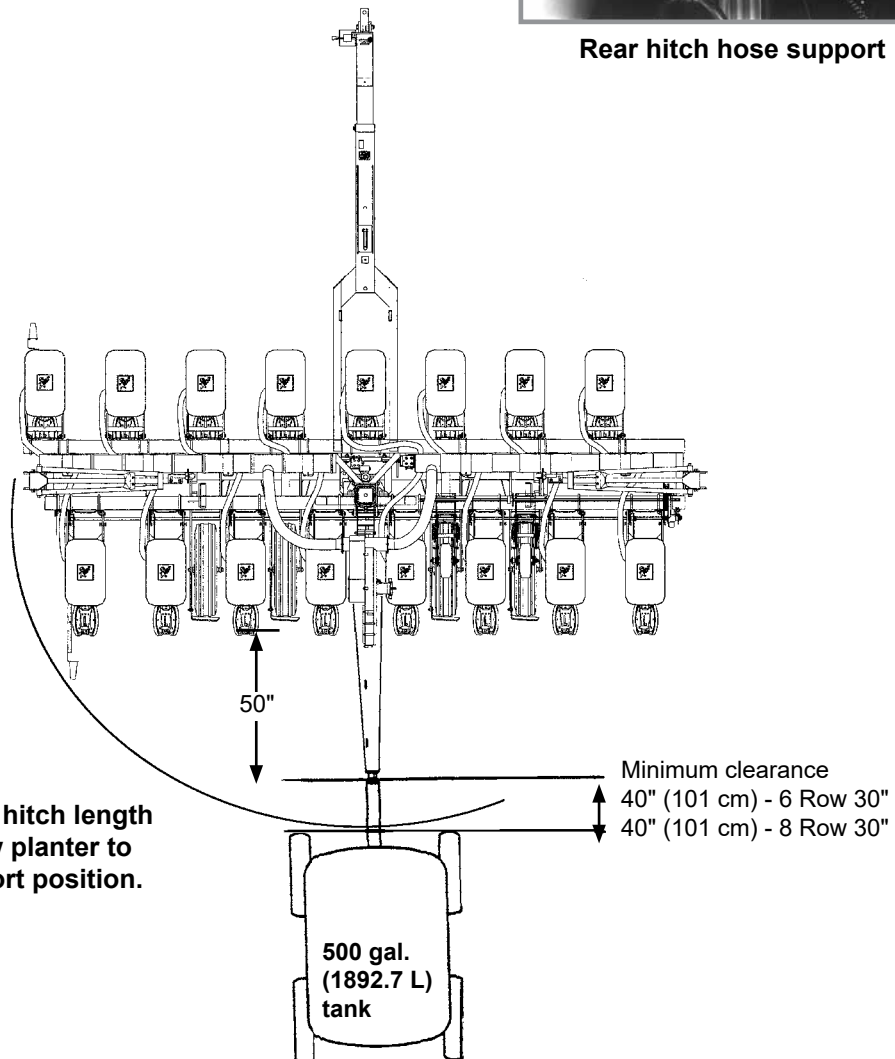

Note: minimum tank hitch length 50" (127 cm) to allow planter to be rotated to transport position.

Minimum clearance
40" (101 cm) - 6 Row 30"
40" (101 cm) - 8 Row 30"

500 gal.
(1892.7 L)
tank

FIELD TEST

Perform a field test with any change of field and/or planting conditions, seed size or planter adjustment to ensure proper seed placement and operation of row units. See [“Rate Charts” on page 5-1](#), [“Check Seed Population” on page 2-31](#) and [“Granular Chemical Application Field Check” on page 2-33](#).

- Check planter for front to rear and lateral level operation. See [“Level Planter” on page 2-16](#).
- Check **all** row units to be certain they are running level. Row unit parallel arms should be approximately parallel to the ground when planting.
- Check row markers for proper operation and adjustment. See [“Row Marker Adjustments” on page 2-23](#) and [“Row Marker Speed Adjustment” on page 2-22](#).
- Check for proper application rates and placement of granular chemicals on **all** rows. See [“Granular Chemical Application Field Check” on page 2-33](#).
- Check for desired depth placement and seed population on **all** rows. See [“Check Seed Population” on page 2-31](#).
- Check for proper application rates of fertilizer on **all** rows. See proper “Fertilizer Application Rate Chart”.

Reinspect machine after field testing.

- Hoses And Fittings
- Bolts And Nuts
- Cotter Pins And Spring Pins
- Drive Chain Alignment

CHECK SEED POPULATION

1. Tie up one or more sets of closing wheels by running a chain or rubber tarp strap between the hopper support panel and closing wheels. It may be necessary to decrease closing wheel arm spring tension.

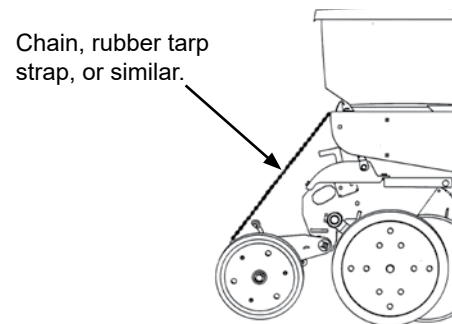

2. Plant a short distance and check to see if seed is visible in the seed trench. Adjust planting depth to a shallower setting if seed is not visible and recheck.

Planting depth adjustment handle

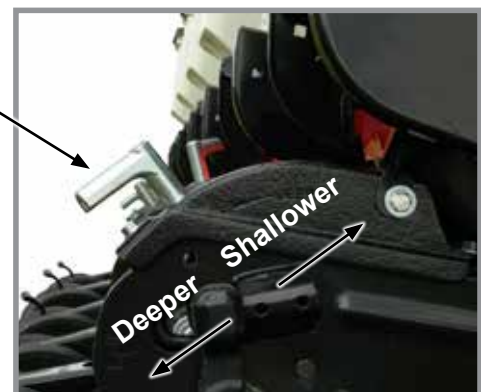

Planting depth adjustment

3. Measure $\frac{1}{1000}$ of an acre (hectare). See chart for correct distance for row width being planted. For example, if planting 30" (76 cm) rows $\frac{1}{1000}$ of an acre (hectare) would be 17' 5" (13.12 m).

$\frac{1}{1000}$ Hectare Seed Population Count Row Width/Distance						
Row Width	15" (38 cm)	18" (46 cm)	19" (48 cm)	30" (70 cm)	36" (91 cm)	38" (97 cm)
Distance	34'10" (6.56 m)	29'0" (5.46 m)	27'8" (5.18 m)	17'5" (14.28 m)	14'6" (10.93 m)	13'10" (10.36 m)

NOTE: Seeds may bounce or roll when planting with closing wheels raised and planting depth set shallow affecting seed spacing accuracy.

4. Count seeds in measured distance.
5. Multiply number of seeds placed in $\frac{1}{1000}$ of an acre (hectare) by 1000. This gives total population.

EXAMPLE: 30" (70 cm) row spacing 17' 5" (14.28 m) equals $\frac{1}{1000}$ acre.
 26 seeds counted x 1000 = 26,000 seeds per acre

Seed count can be affected by drive wheel and seed meter drive ratio, tire pressure, and/or seed meter malfunction.

1. If seed check shows average distance between seeds in inches is significantly different than seed rate chart indicates, first check drive ratio between drive wheel and seed meter. Check drive wheel air pressure, check for incorrect sprocket(s) in driveline and check drive and driven sprockets on transmission(s) for proper selection.
2. Check for seed meter malfunction. For example, if spacing between kernels of corn at the transmission setting being used is 8" (20 cm) and a gap of 16" (40 cm) is observed, a finger has lost its seed and not functioned properly. If two seeds are found within a short distance of each other, the finger has metered two seeds instead of one.
3. See ["Seed Meter \(Finger Pickup\) Troubleshooting" on page 7-5](#) and/or ["Seed Meter \(Brush-Type\) Troubleshooting" on page 7-4](#) in the Troubleshooting Section of this manual.

DETERMINING POUNDS PER ACRE (BRUSH-TYPE METER)

Seeds per acre ÷ Seeds per pound (from label) = Pounds per acre

If seeds per pound information is not available use the following averages:

- 2,600 seeds per pound for medium size soybeans
- 15,000 seeds per pound for medium size milo/grain sorghum
- 4,500 seeds per pound for medium size cotton

DETERMINING BUSHEL PER ACRE

Pounds per acre ÷ Seed unit weight = Bushels per acre



Average Unit Weight of:

- 1 Bushel Soybeans = 60 Pounds
- 1 Bushel Milo/Grain Sorghum = 56 Pounds
- 1 Bushel Cotton = 32 Pounds

If seed population check shows planting rate is significantly different than seed rate chart shows or if a particular meter is not planting accurately, see ["Brush-Type Seed Meter 2.0 Maintenance" on page 6-16](#) and ["Seed Meter \(Brush-Type\) Troubleshooting" on page 7-4](#).

GRANULAR CHEMICAL APPLICATION FIELD CHECK

Temperature, humidity, speed, ground conditions, flowability of different material, or meter obstructions can affect granular chemical rate of delivery.

 WARNING	<p>Agricultural chemicals can cause death or serious injury to persons, animals, and plants or seriously damage soil, equipment, or property. Read and follow all chemical and equipment manufacturers labels and instructions.</p>
	

Perform a field check to determine application rates.

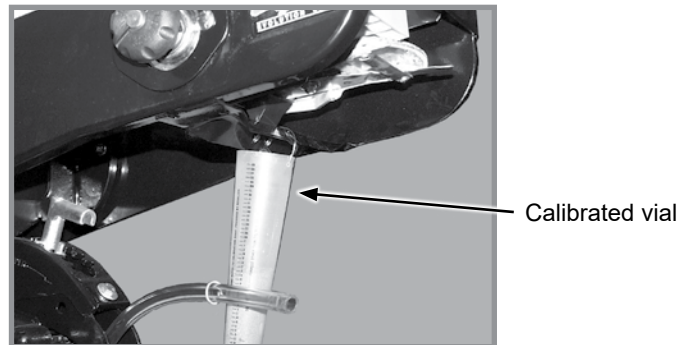

Granular chemical field check

1. Fill insecticide and/or herbicide hoppers.
2. Attach a calibrated vial to each granular chemical meter.

NOTE: Disengage clutch to avoid dropping seed during test.

3. Lower planter and drive 1320 feet (400 meters) at planting speed.
4. Weigh chemical in ounces caught in one vial.
5. Multiply that amount by factor shown to determine pounds (kilograms) per acre (hectare).

Pounds (Kg) Per Acre (Hectare)	
Row Width	Factor
30"	0.83 (0.0328)
36"	0.69 (0.0272)
38"	0.65 (0.0256)

EXAMPLE: You are planting 30" (70 cm) rows. You have planted for 1320 feet (400 meters) at the desired planting speed. You caught 12.0 ounces (337 grams) of chemical in one vial. 12.0 ounces (337 grams) times 0.83 (0.0357) equals 9.96 pounds (12 kilograms) per acre (hectare).

NOTE: Check calibration of all rows.

METERING GATE

Use metering gate setting as a starting point for distributing insecticide or herbicide. Charts are based on 5 mph (8 kph) planting speed. Use a higher gate setting for speeds faster than 5 mph (8 kph) and a lower setting for speeds slower than 5 mph (8 kph).

This page left blank intentionally.

PLANTING DEPTH

Planting depth is maintained by adjustable row unit gauge wheels. Depth adjustment range is approximately ½" to 3½" (1.2 to 8.8 cm).

1. Raise planter to remove weight from wheels.
2. Push down on depth adjustment handle and reposition it forward to decrease or rearward to increase planting depth. Initially adjust all units to the same setting.
3. Lower planter and check operation and planting depth of all row units. Readjust individual rows as needed for uniform operation.

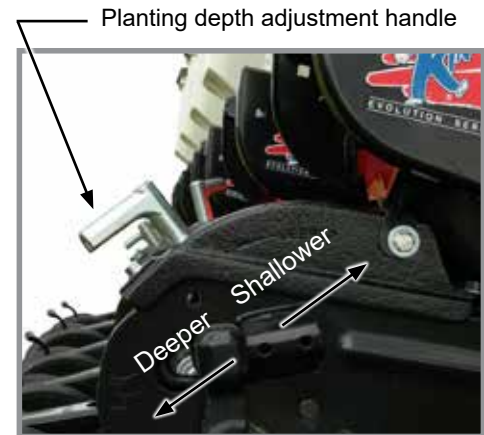

Planting depth adjustment

“V” CLOSING WHEEL ADJUSTMENT (RUBBER OR CAST IRON)

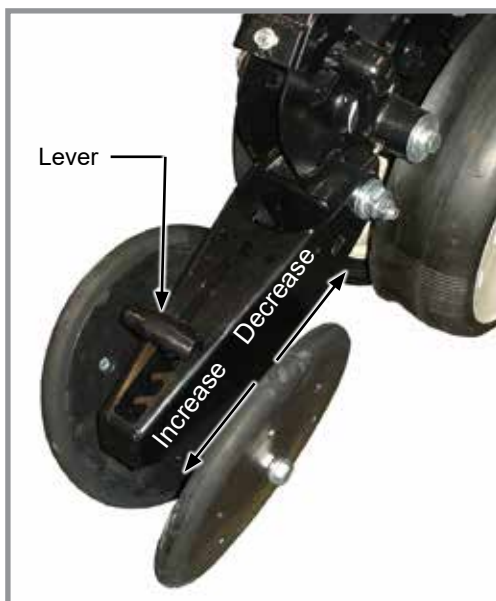

“V” Closing wheels installed offset

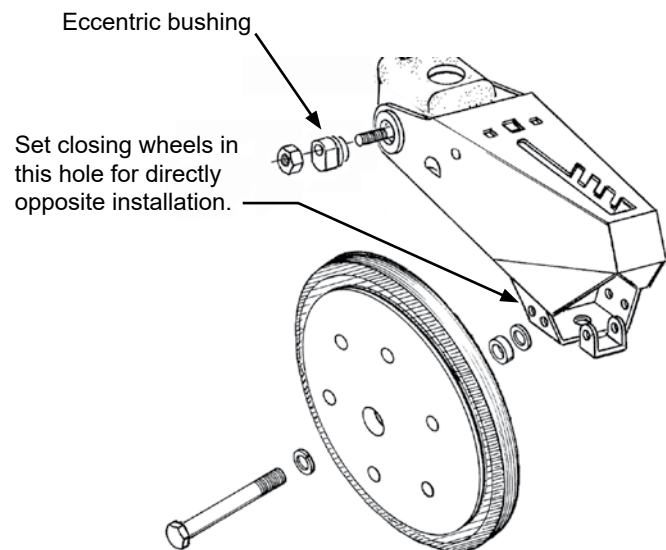

“V” closing wheels should have enough down pressure to close the seed trench and ensure good soil to seed contact. Move 5-position quick adjustable down force lever on the top of closing wheel arm to the rear to increase closing wheel spring pressure. Move lever forward to decrease pressure. Adjust all row units to a similar setting. Light soil usually requires less down force at average depth, approximately 2" (5 cm) while heavy soil requires increased down force.

Eccentric bushings in the wheel arm stop allow for lateral adjustment of the “V” closing wheel assembly. Use a ¾" wrench to loosen hardware attaching closing wheel arm to wheel arm stop. Use another ¾" wrench to turn eccentric bushings until **closing wheels are aligned with seed trench**. Tighten hardware.

Closing wheels can be installed “offset” (to improve residue flow) or “directly” opposite. Use forward installation holes if set “directly” opposite.





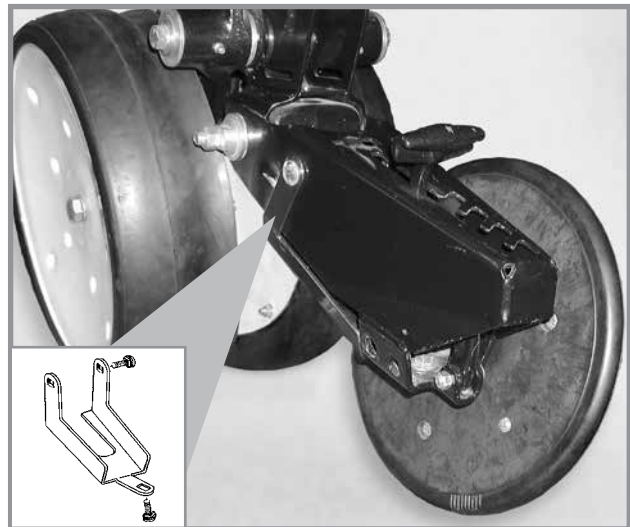



CLOSING WHEEL SHIELD (RUBBER OR CAST IRON "V" CLOSING WHEELS)

Optional closing wheel shield is installed on underside of closing wheel arm to help prevent root balls and stalks from clogging closing wheels.



**Closing wheel shield
(Shown with closing wheel removed)**

BRUSH-TYPE SEED METER 2.0

	Crop	Disc Color-Code (Disc Part No.)	Upper Brush Retainer	Cells	Seed Size Range	*Lubricant
	Soybean	Black (GB1123)	GB1084	60	2200 to 4000 seeds/lb.	Graphite Talc
	Soybean	Dark Gray (GB1171)	GB1084	54	2000 to 3000 seeds/lb.	Graphite Talc
	Specialty Soybean	Dark Blue (GB1124)	GB1084	48	1400 to 2200 seeds/lb.	Graphite Talc
	Small Milo/Grain Sorghum	Orange (GB1130)	GB1107	30	14,000 to 20,000 seeds/lb.	Talc
	Large Milo Grain Sorghum	Light Blue (GB1131)	GB1107	30	10,000 to 16,000 seeds/lb.	Talc
	High-Rate Small Milo/Grain Sorghum	Red (GB1132)	GB1107	60	12,000 to 18,000 seeds/lb.	Talc
	High-Rate Large Milo/Grain Sorghum	Yellow (GB1133)	GD8237	60	10,000 to 14,000 seeds/lb.	Talc
	Wheat	Purple (GB1134)	GB1084	54	N/A Volumetric	Graphite Talc

*For More information on application rate see Additives section.

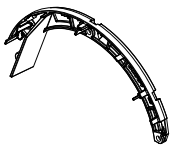

Use GB1084 upper brush retainer when using wheat and soybean discs.



Use GB1107 milo insert when using milo/ grain sorghum discs.

Turn seed disc counterclockwise when installing on meter hub while tightening two wing nuts that retain disc. Seed disc should have slight resistance when rotated counterclockwise after wing nuts are tight.

Brush-type seed meter attaches to seed hopper same as finger pickup seed meter. Secure to bottom of seed hopper with two $\frac{5}{16}$ " thumbscrews. Tighten thumbscrews slightly with pliers. **DO NOT OVER TIGHTEN.**

Misalignment between drive coupler and seed meter input shaft may cause erratic seed spacing from momentary stoppage of seed disc. Check alignment and adjust as needed.

Refer to planting rate charts in this manual for recommended seed drive transmission sprocket combinations.

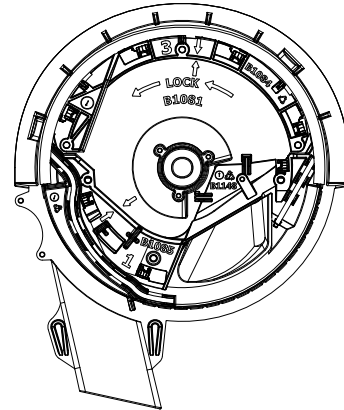

Shown without seed disc installed



NOTICE

Replace hopper lids after hoppers are filled to prevent accumulation of dust or dirt in seed meter which will cause premature wear.

NOTE: Clean seed is required to ensure accurate seed metering from brush-type seed meters. Remove seed discs daily and check seed meter or brushes for buildup of foreign material, such as hulls, stems, etc.

FINGER PICKUP SEED METER

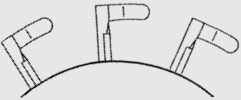
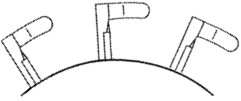
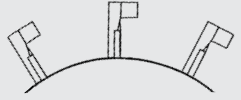









Crop	Fingers	*Lubricant
Corn	 Part No.: GR1848 - Finger Assembly, Corn	Graphite Talc
No. 1 and/or No. 2 size Confectionery Sunflower Seeds	 Part No.: GR1848 - Finger Assembly, Corn	Talc
No. 3 and/or No. 4 size Oil Sunflower Seeds	 Part No.: GR2154 - Finger Assembly, Oil	Talc
Blank fingers replace alternate fingers to reduce planting rate by half while allowing the finger wheel to maintain a minimum of 40 RPM when planting low rates.	 Part No.: GD11787 - Half Rate Blank Finger	Graphite Talc

*For More information on application rate see ["Additives" on page 3-12.](#)

NOTE: Always field check seed population to verify planting rates.



NOTE: Refer to planting rate charts in this manual for recommended seed drive transmission sprocket combinations.

VACUUM SETTINGS

Crop		**Seed Disc Kit	Seed Disc Part No.	Ejector Wheel (Color)	Cells	Seed Size Range	Singulator Zone Setting	Vacuum Setting Inches of Water (kPa)	Lubricant
	Corn ‡ Large Sweet Corn	G11043X	B1219 (Light Blue)	1 row 5 punches (Light Blue)	40	35-70 lbs/80k (2500-5000 seeds/kg)	2	18-20 (4.5-5.0)	Graphite* Talc* Bayer Fluency† (if mandated)
	Soybean	G11047X	B1232 (Black)	2 rows 6 punches (Black)	120	2200-4000 seeds/lb (4850-8820 seeds/kg)	0	10-14 (2.5-3.5)	Graphite* Talc* Bayer Fluency† (if mandated)
	Soybean Disc	G11048X	B1238 (Black)	1 row 6 punches (Green)	60	2200-4000 seeds/lb (4850-8820 seeds/kg)	0	10-14 (2.5-3.5)	Graphite* Talc* Bayer Fluency† (if mandated)
	Sugar Beet	G11045X	B1229 (Dark Orange)	1 row 6 punches (Dark Orange)	60	Pelletized	2	15 (3.75)	Graphite* Talc* Bayer Fluency† (if mandated)
	Milo	G11045X	B1229 (Dark Orange)	1 row 6 punches (Dark Orange)	60	10,000-20,000 seeds/lb (22000-44000 seeds/kg)	2	15 (3.75)	Graphite* Talc* Bayer Fluency† (if mandated)
	Sunflower ‡ Small Sweet Corn	G11044X	B1230 (Gray)	1 row 5 punches (Gray)	40	Oil seeds #2, 3, 4	2	12-18 (3.0-4.5)	Graphite* Talc* Bayer Fluency† (if mandated)
	Sunflower	G11044X	B1230 (Gray)	1 row 5 punches (Gray)	40	Oil seeds #5	2	5-8 (1.25-2.0)	Graphite* Talc* Bayer Fluency† (if mandated)
	Specialty Disc 1	G11039X	B1233 (Green)	1 row 6 punches (Green)	60	Cotton	2	15-20 (3.75-5.0)	Graphite* Talc as needed* Bayer Fluency† (if mandated)

Continued on next page.

VACUUM SETTINGS

Crop	**Seed Disc Kit	Seed Disc Part No.	Ejector Wheel (Color)	Cells	Seed Size Range	Singulator Zone Setting	Vacuum Setting Inches of Water (kPa)	Lubricant
 Specialty Disc 2	G11040X	B1235 (Brown)	1 row 6 punches (Green)	60	Black turtle & navy edible beans	2	15-20 (3.75-5.0)	Graphite* Talc as needed* Bayer Fluency [†] (if mandated)
 Specialty Disc 3	G11041X	B1234 (Dark Blue)	1 row 6 punches (Green)	60	Pinto & Great Northern edible beans & low-rate soybean	2	15-20 (3.75-5.0)	Graphite* Talc as needed* Bayer Fluency [†] (if mandated)
 Wheat Disc	G11042X	B1236 (Purple)	Brush Type	54	N/A Volumetric	0	6-16 (15-41)	Graphite* Talc as needed* Bayer Fluency [†] (if mandated)

Install selected seed disc. Position vacuum cover on meter by aligning keyhole slots over bolt heads. Push cover on meter and turn counter clockwise to lock in place.

*For More information on application rate, see Additives section.

**Includes seed disc, ejector wheel, and spring.

[†]Bayer Fluency Agent is only required to be used in place of graphite or talc lubricants on vacuum equipped planters that are sowing neonicotinoid treated seeds in Canada. Refer to "[Bayer Fluency Agent](#)" on page 3-13 section for more information.

‡Conventional hoppers only, not applicable with bulk fill.

NOTE: See [“Check Seed Population” on page 2-31](#) for more information. Always field check seed population to ensure planting rates are correct.

NOTE: Singulator settings are marked from 0 - 3.

NOTE: Mixing seed sizes and shapes affects meter performance. Use consistent seed size and shape.

NOTE: Use 1 tablespoon powdered graphite with each standard hopper fill of seed. Seed treatment, foreign material, dirt or seed chaff may cause gradual reduction of seed disc fill (population). See [“Additives” on page 3-12](#) for more information.

NOTE: Excessive seed treatment, humidity, and light-weight seed can affect meter performance. Use ½ cup (118 ml) of talc with each standard hopper fill of seed and mix thoroughly to coat all seeds and adjust rates as needed. Use of talc aids seed flow into meter, singulation, and disc seed drop.

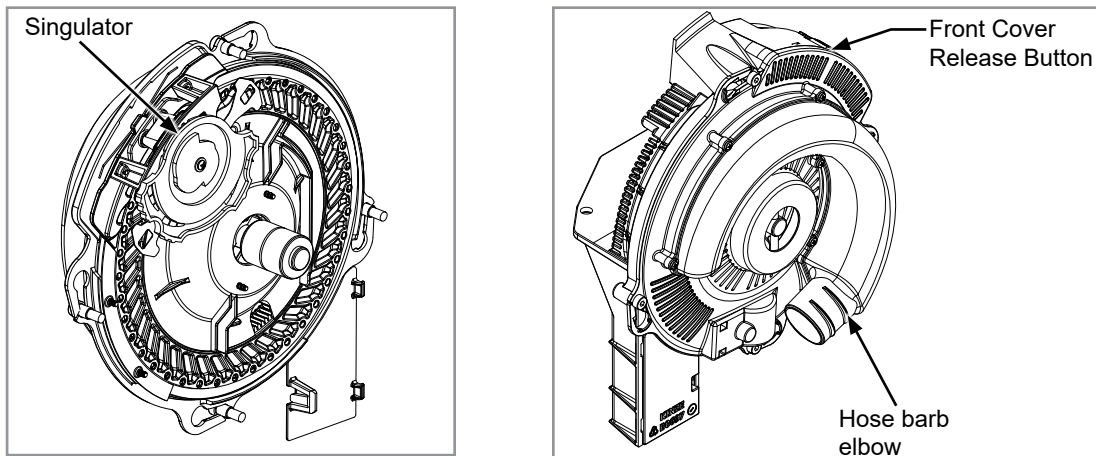

NOTE: Foreign material in seed disc orifices, such as seed chips, hulls, stems, etc., may affect seed delivery. Clean seed ensures accurate seed metering from vacuum seed meter. Remove Seed discs daily to check for buildup of foreign material in seed disc orifices.

Air inlet screens allow air to enter system and aids in keeping field residue or other foreign material out of meter.

See [“Vacuum Seed Meter Maintenance” on page 6-20](#) and [“Preparation for Storage” on page 6-37](#) in Lubrication and Maintenance section for more information.

This page left blank intentionally.

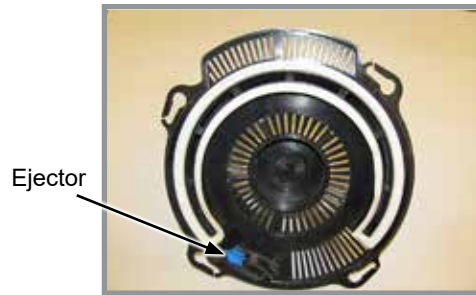

NOTE: Damaged seed or seed containing foreign material will cause plugging of seed disc orifices and require more frequent seed meter cleanout to prevent underplanting.

Wheel-Type Ejectors

Wheel-type ejectors expel seed remnants from seed disc orifices. These ejectors are disc specific and colored coded to match disc.

NOTICE	Replace hopper or tank lids after filling to prevent accumulation of dust or dirt in seed meter resulting in premature wear.
---------------	---

NOTE: Seed size, seed shape, seed treatments, travel speed, and planting rate affect meter performance.

1. Select seed disc and ejector to match crop and population.

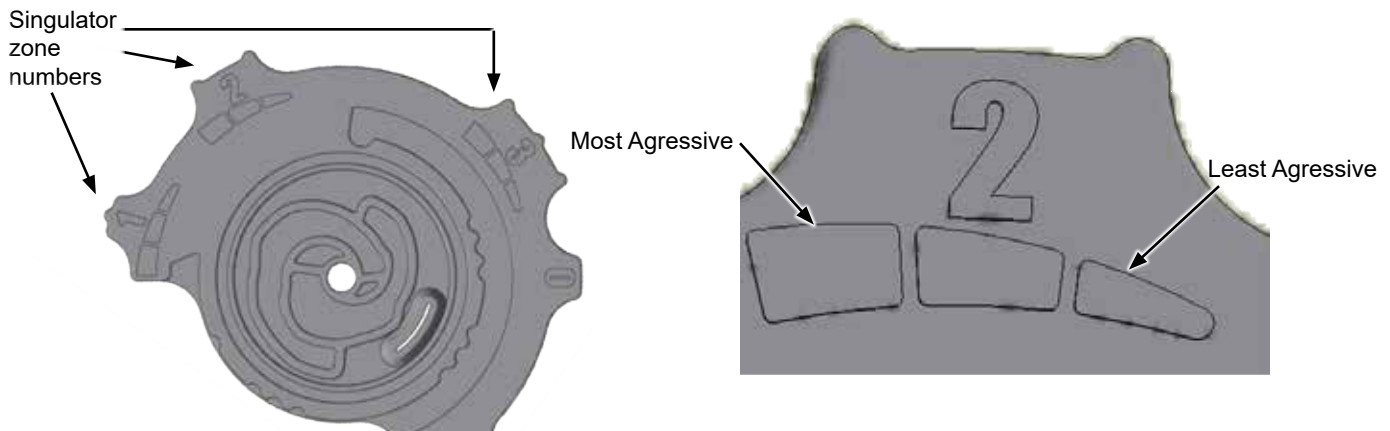

Singulator Adjustment Wheel

2. Adjust singulator wheel to initial setting. Seed size, seed shape, seed treatments, travel speed and planting rate all affect meter performance.
3. With vacuum fan running, lower planter to planting position and drive forward a short distance to load seed into seed disc cells.
4. Adjust vacuum level to initial setting according to tables on page.

NOTE: Vacuum reading will be much lower when seed disc cells are empty. Load all seed cells before setting vacuum level.

NOTE: Operate vacuum fan 3-5 minutes to bring oil up to normal operating temperature prior to making final vacuum level adjustment.

4. Adjust vacuum level to initial setting according to tables on page.

NOTE: Vacuum reading will be much lower when seed disc cells are empty. Load all seed cells before setting vacuum level.

NOTE: Operate vacuum fan 3-5 minutes to bring oil up to normal operating temperature prior to making final vacuum level adjustment.

SEED METER CLEANOUT

NOTE: Use of damaged seed or seed containing foreign material will cause plugging of seed cell orifices and require more frequent seed meter cleanout to prevent underplanting.

Thorough seed meter cleanout is important to maintain genetic purity.

1. Disengage seed drive (unplug meter with Blue Drive) and remove seed hopper and meter.
2. Dump seed from right rear corner of hopper into a container.
3. Lay hopper on its right side. Push release button and rotate seed meter vacuum cover clockwise to align keyhole slots with bolt heads. Lift off cover.
4. Rotate seed disc hub clockwise to unlock and remove seed disc.
5. Empty meter.
6. Thoroughly inspect meter to ensure all seed is removed.
7. Replace seed disc. Install vacuum cover.

ADDITIVES

Lubricant Application Rate	
Graphite	
Conventional Hoppers	1 Tbs./Hopper Fill
Bulk Fill Hoppers	1 Pound Bottle/50 Unit Fill
80/20 Talc-Graphite	
Conventional Hoppers	1/2 C.**
Bulk Fill Hoppers	8 Pounds/50 Unit Fill**
**Must be evenly mixed during fill.	
Talc	
Conventional Hoppers	1/4 C.*
Bulk Fill Hoppers	4 Pounds/50 Unit Fill*
*Double amount of talc for sunflowers.	

GRAPHITE

The use of graphite is the primary recommendation to promote seed flow, provide lubrication for the seed meter and to help dissipate static charge buildup. Among the available dry seed lubricants graphite is the most effective and easiest to use and it requires no mechanical agitation

Conventional Hoppers

Mix one tablespoon of **powdered graphite** with seed each time hoppers are filled. Regular graphite use prolongs life of the seed meter components, improves seed spacing, and may reduce buildup of seed treatments.

NOTE: DO NOT apply graphite only in center of hopper. It will filter too quickly through the seed and not distribute as evenly as desired.

Apply graphite around outer perimeter of hopper.

Bulk Fill Hoppers

Mix 1 pound of powdered graphite each time the bulk seed hopper is filled. Graphite should be added in layers as the bulk seed hoppers are filled. Regular graphite use prolongs life of the seed meter components, improves seed spacing, and may reduce buildup of seed treatments.



Adding graphite to conventional hopper



Adding graphite bulk fill hopper

NOTE: Additional graphite may be required to retard buildup of seed treatments on meter components. More frequent cleaning of monitor seed tubes may be necessary due to use of additional graphite.

80/20 TALC-GRAPHITE

Talc-Graphite lubricant is to be used for treated seed, providing benefits of both talc and graphite. It absorbs moisture to prevent bridging, minimizes static electricity for improved seed flow, and lubricates seed and meters.

Conventional Hoppers

Mix ½ C. of 80/20 talc-graphite evenly with seed each time hoppers are filled. Regular graphite use prolongs life of the seed meter components, improves seed spacing, and may reduce buildup of seed treatments.

NOTE: Talc-Graphite lubricant MUST be mixed evenly during fill.

Bulk Fill Hoppers

Mix 8 lbs. of 80/20 talc-graphite each time the bulk seed hopper is filled. Regular graphite use prolongs life of the seed meter components, improves seed spacing, and may reduce buildup of seed treatments.

NOTE: Talc-Graphite lubricant MUST be mixed evenly during fill.

TALC

Talc seed lubricant may be used as a drying agent in addition to graphite lubrication. The drying agent may improve seed release and/or **to retard buildup of seed treatments on meter components.**

1. Fill hopper ½ full of seed, add ¼ cup (conventional); 2 pounds (Bulk Fill) of talc and **mix thoroughly.**
2. Finish filling hopper, add another ¼ cup (conventional); 2 pounds (Bulk Fill) of talc and **mix thoroughly.**
3. Adjust rate of talc use as needed so all seeds are coated, while avoiding a buildup of talc in bottom of hopper.

Humid conditions and/or small sized seeds with extra seed treatment may require additional talc to maintain meter performance.

NOTE: Liquid seed treatments or inoculants may create buildup on the seed disc or brushes. Check frequently for proper population and/or seed delivery when using any liquid seed treatment.

Completely mix all treatments with seed following manufacturers' recommendations. Seed treatment dumped on top of seed after hopper is filled may not mix properly and cause seed bridging, reducing population or stopping meter from planting.

BAYER FLUENCY AGENT

Bayer Fluency Agent is an alternate seed lubricant by Bayer Crop Science. The intent of this product is to replace graphite and talc lubricants and to lower the amount of dust emissions from planter vacuum fans.

This product, as tested by Kinze, is compatible with Kinze's bulk fill system and vacuum meters. Due to limited testing, wear life characteristics of meters and bulk fill systems that use Bayer Fluency Agent are not yet known. Please follow Bayer Fluency Agent instructions for rates and mixing directions.

NOTE: Presently, Bayer Fluency Agent is only required to be used in Canada with Bulk Fill or Vacuum planters that plant corn or beans treated with neonicotinoids. Farms outside of Canada, farms not using seed treated with neonicotinoids, and farms not using pneumatic metering devices do not need to use Bayer Fluency Agent. All planters not equipped with vacuums or fans are exempt from using Bayer Fluency Agent.

SEED HOPPERS



Seed hopper is retained by an over-center latch. Wear gloves to prevent injury to hands while releasing the latch.

Mechanical seed hopper has a capacity of 1.9 bushels.

Vacuum seed hopper has a capacity of 1.75 bushels.

Use clean seed and make certain there are no foreign objects inside when filling seed hopper. **Replace hopper lids after hoppers are filled to prevent accumulation of dust or dirt in seed meter which can cause premature wear.** See “Finger Pickup Seed Meter” and/or “Brush-Type Seed Meter”.

Periodically empty hoppers completely to remove any foreign objects and to ensure proper seed meter operation.

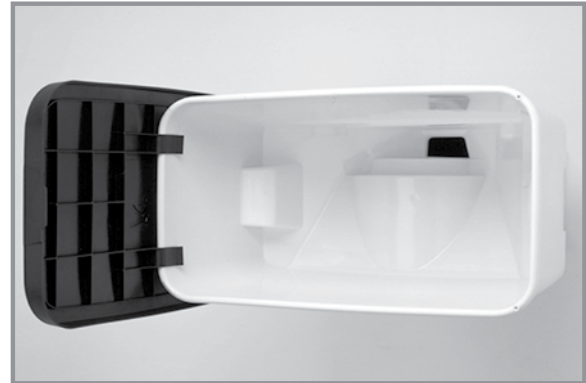

Mechanical seed hopper

Disengage meter drive and hopper latch and lift hopper off hopper support. See “Seed Meter Drive Release”.

SEED METER DRIVE RELEASE

A clutch release mechanism disengages seed meter drive from seed meter to remove seed hopper. Disconnecting drive allows operator to check granular chemical application rates without dropping seed. It also allows one or more rows to be disconnected when finishing fields.

Turn knob ¼ turn counterclockwise to disengage or ¼ turn clockwise to engage.

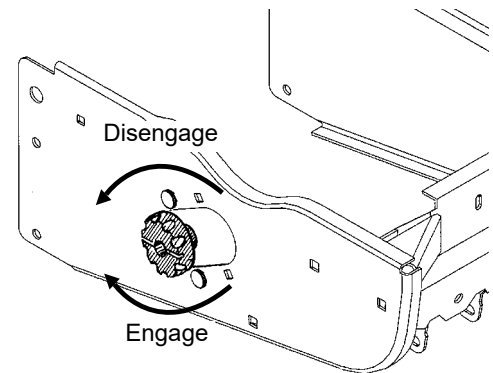

Seed meter drive release

ROW UNIT EXTENSION BRACKETS

Row unit extension brackets extend row units rearward 4" (10.1 cm) to provide clearance for coulter mounted residue wheels and HD single disc fertilizer openers.

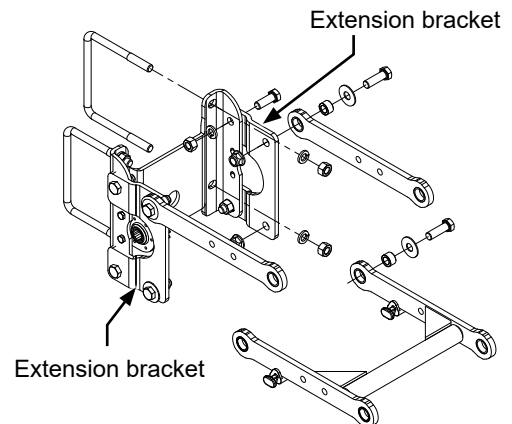

Row unit extension brackets

ROW UNIT CHAIN ROUTING

Row unit drive chains must be properly tensioned and aligned for proper operation and to minimize wear.

Inspect and replace weak, worn or broken springs, idlers, and idler bushings.

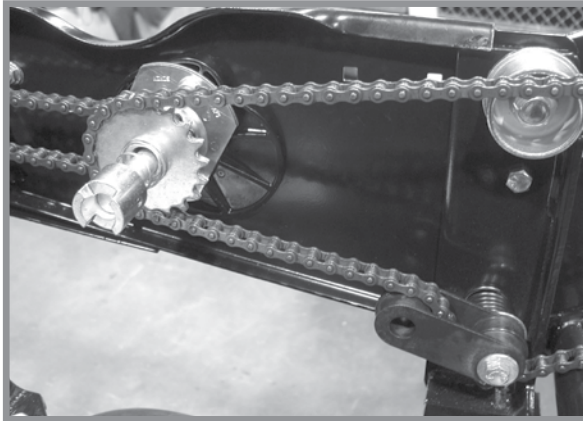

Mechanical pull row unit meter drive

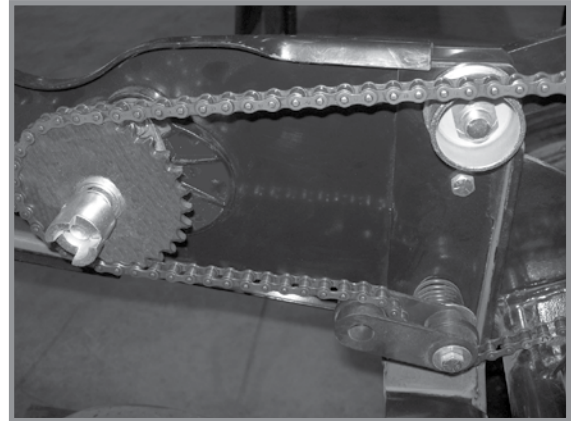

Vacuum pull row unit meter drive

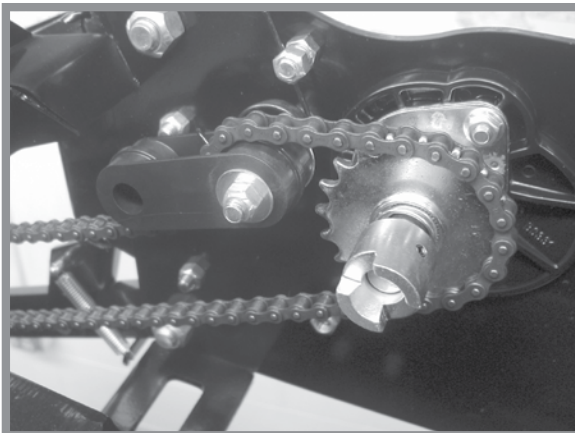

Mechanical push row unit meter drive

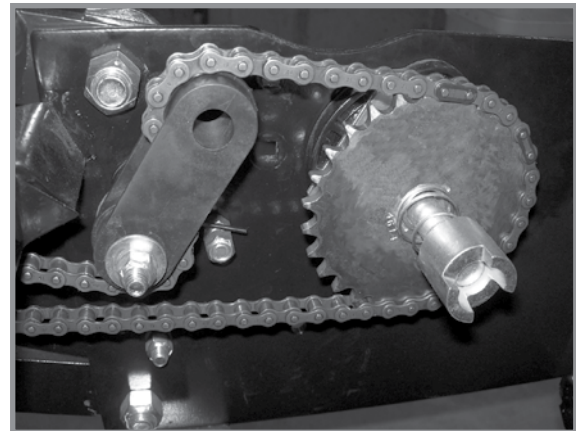

Vacuum push row unit meter drive



Row unit granular chemical drive

Direction of travel 



NOTE: Install connector link with closed end facing direction of travel.

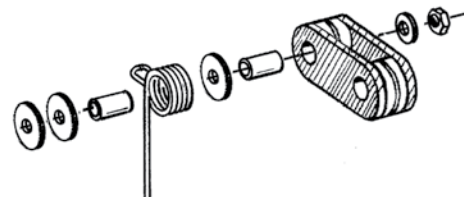

NOTE: Reverse idler when worn on one side for extended use.

QUICK ADJUSTABLE DOWN FORCE SPRINGS OPTION

Quick adjustable down force springs increase penetration in hard soil and keep row unit from bouncing in rough field conditions. Two springs per row, one on each side parallel arms, are used unless equipped with row unit mounted no till coulters. Four springs per row are used with row unit mounted no till coulters.

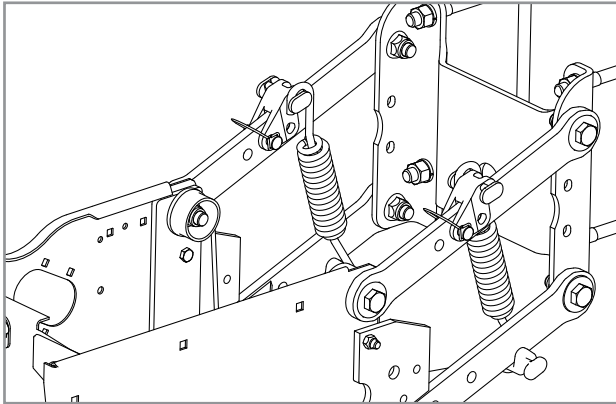

Two Springs Per Row (Dual)

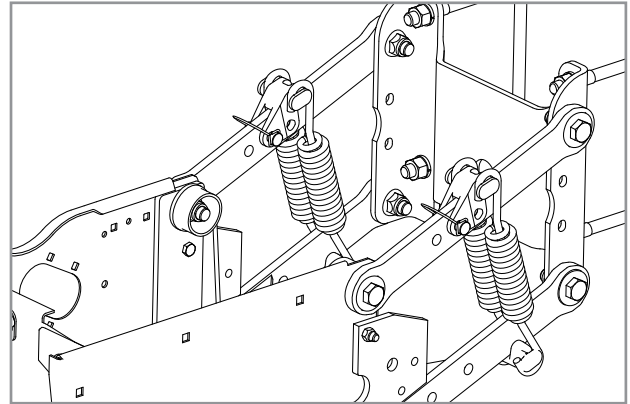

**Four Springs Per Row (Quad)
(Row Unit Mounted No Till Coulters Only)**

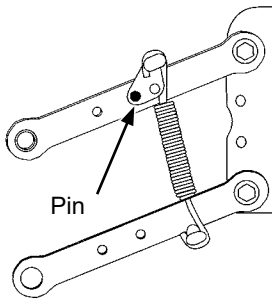

Position 1 (Least)

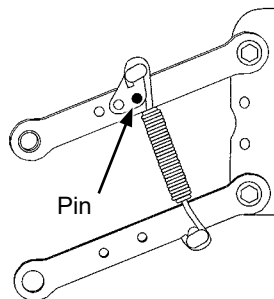

Position 2

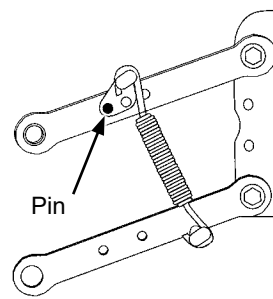

Position 3

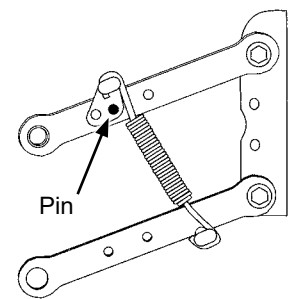

Position 4 (Most)

There are four positions to set down pressure spring tension.

NOTICE

Springs must be installed with open side of spring hooks toward seed hoppers to prevent binding on spring mount adjustment pins.

1. Raise planter and remove spring mount pin at top of spring.
2. Slide mount to desired position and install pin.

NOTE: Adjust springs for field conditions. Too much down pressure in hard field conditions can cause row units to lift planter and keep drive wheels from making contact. Too much down pressure in soft field conditions can cause row unit to run too deep.

Heavy Duty Spring Down Force Pressure*		
	2 Springs	4 Springs
Position	Heavy Duty P/N: D21337	Heavy Duty P/N: D21337
1	43 lb (19.5 kg)	80 lb (36.3 kg)
2	86 lb (39.0 kg)	144 lb (65.3 kg)
3	167 lb (75.7 kg)	307 lb (139.3 kg)
4	249 lb (113.0 kg)	470 lb (213.2 kg)

*Pressure does not include weight of row unit, seed, or options.

PNEUMATIC DOWN PRESSURE PACKAGE OPTION

Row unit down pressure can be adjusted on-the-go as field conditions change with pneumatic down pressure option. A cab-mounted control box adjusts pressure (Older models may have a digital readout). A planter-mounted 12 VDC air compressor with 3 gallon capacity air tank supplies air for the down pressure system.

Packages include upper and lower air spring mounting castings for pull row units (front and rear air spring mounting castings for push row units), 150 psi rated air springs, $\frac{3}{8}$ " O.D. nylon hoses, dual solenoid air valve and stainless steel, 160 psi, 2" liquid-filled gauge and planter wiring harness.

Pneumatic down pressure row unit extension brackets are required in some applications.

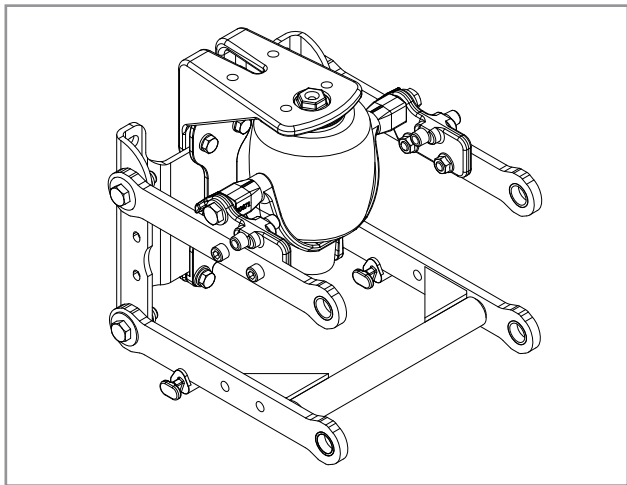

Pull Row Unit Air Spring

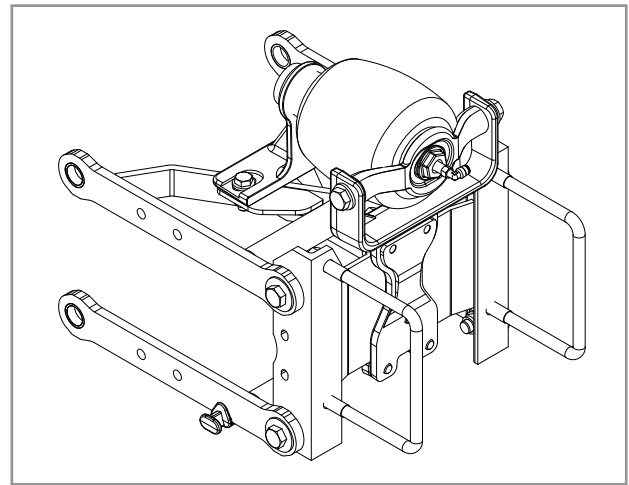

Push Row Unit Air Spring

NOTE: If additional down pressure is needed with the Pneumatic Down Pressure Package, assist springs are available through your Kinze dealer. One spring is installed on the outer side of the parallel arms on each side of the row unit as shown below.

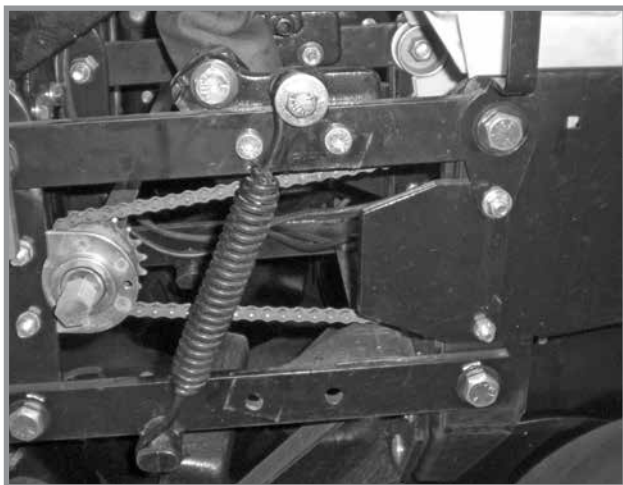

Pull Row Unit Assist Springs

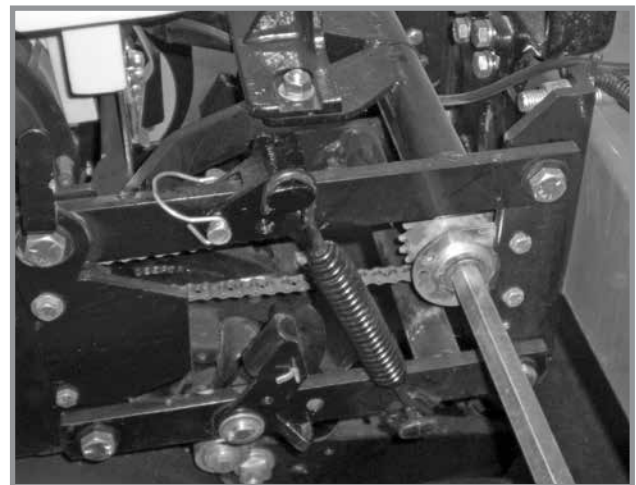

Push Row Unit Assist Springs

FIELD OPERATION

NOTE: Adjust down pressure with planter lowered and row openers in ground for most accurate adjustment. Pressure can be adjusted from tractor using control console, or at planter using manual control valves on compressor assembly.



Control console

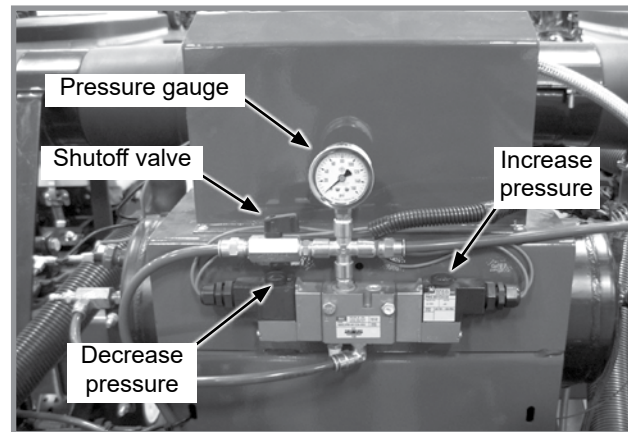

Air compressor assembly controls

ADJUST DOWN PRESSURE FROM CAB

Push toggle switch left to increase or right to decrease pressure.

ADJUST DOWN PRESSURE AT PLANTER

Push and hold decrease or increase button on compressor assembly to decrease or increase pressure.

NOTE: Value on the air pressure gauge is **NOT** down pressure force. Multiply air pressure (psi) by four (4) to calculate down pressure.

LOCK UP PUSH ROW UNITS EQUIPPED WITH PNEUMATIC DOWN PRESSURE SPRINGS

1. Press and hold button on solenoid until pressure gauge reads 5 PSI.
2. Lock up units. See ["Split Row Lockups" on page 3-22](#) for instructions.
3. Turn shutoff valve handle perpendicular to valve body to turn off push row unit air supply.

TRUE DEPTH OPTION

True Depth provides on demand row by row hydraulic row unit down force ranging from 100 lbs. up force to 600 lbs. down force at 2350 psi. The system includes a 7" in cab standalone touchscreen display with antiglare screen protector and RAM mount, electronic control modules, harnesses, gauge wheel sensors, hydraulic cylinders, upper and lower cylinder mounts, and valves. See M0286 - Kinze True Depth Operator's Manual.



True Depth

TRUE DEPTH CONSOLE INSTALLATION

TRACTOR REQUIREMENTS

Consult your dealer for information on horsepower, hydraulic and electrical requirements, and tractor compatibility. Requirements vary with planter options, tillage, and terrain.

TRACTOR INSTALLATION

Refer to Kinze Instruction Sheet IS1028 for installation of the True Depth down force system.

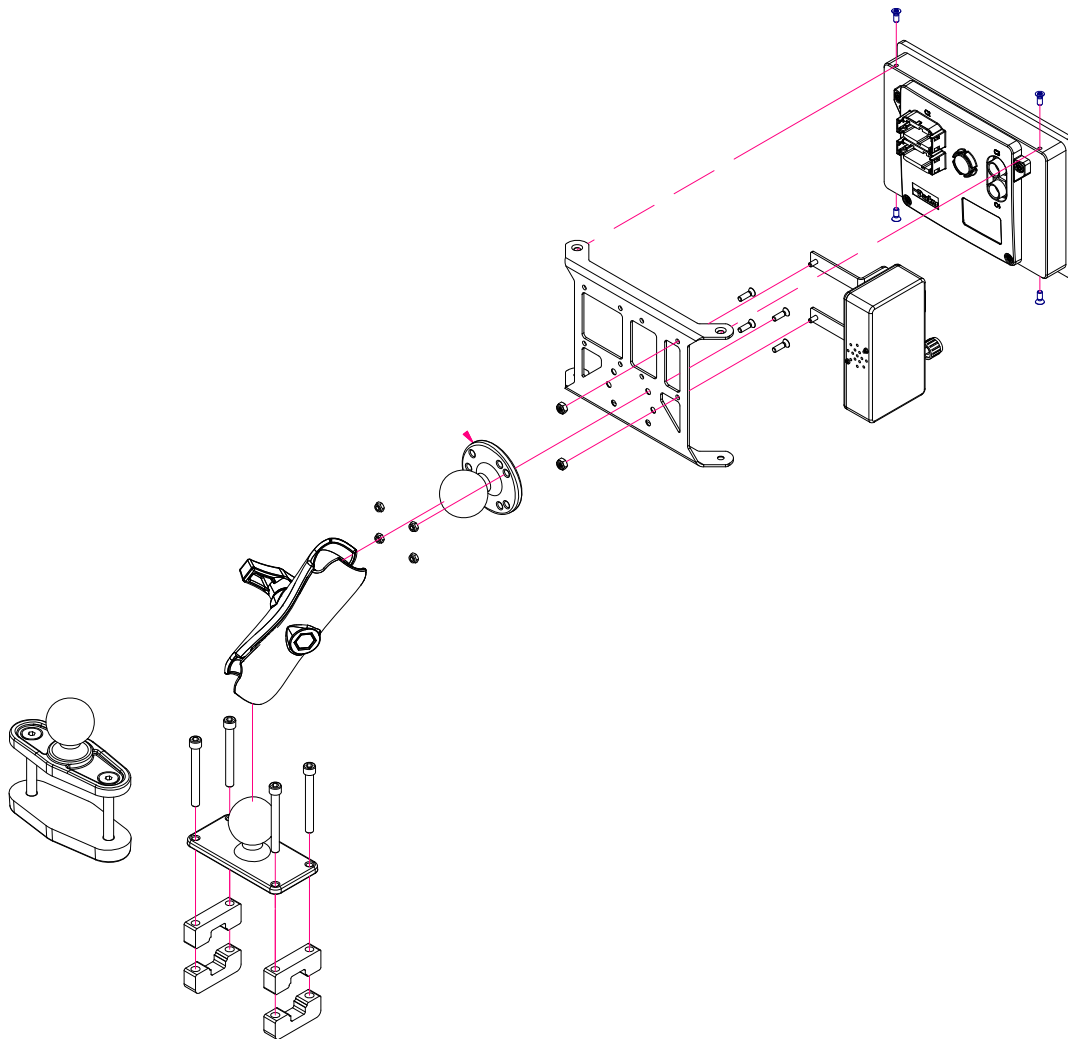

True Depth Console

TRUE DEPTH HARNESS INSTALLATION

Connect tractor power harness terminal E1 to positive battery terminal. Connect terminal E2 to negative battery terminal. Connect console harness P4 to display C1, and console harness P5 to display C2. Connect console harness P3 to the speaker box. Connect console harness P1 to tractor power harness J2. Connect the intermediate harness P1 to the tractor power harness J1.

DANGER

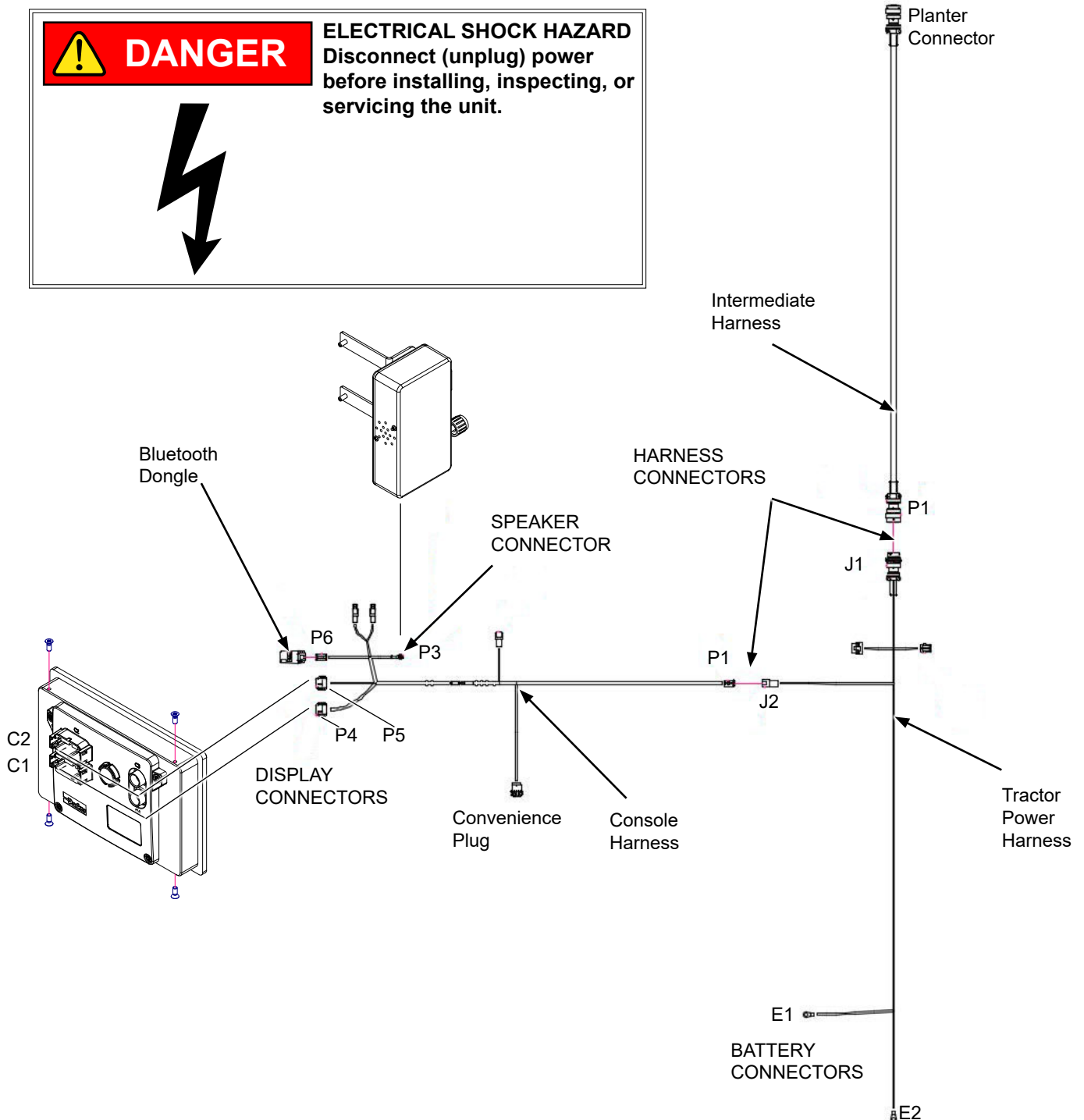

ELECTRICAL SHOCK HAZARD
Disconnect (unplug) power before installing, inspecting, or servicing the unit.



True Depth Harness Installation

SPLIT ROW LOCKUPS

Split row lockups are designed to allow the push row units to be locked in the raised position.

	<p>Improper lifting of row units can cause serious injury. An empty row unit requires minimum 84 lb (38.1 kg) lift. Set down pressure springs to minimum, lower planter to ground, and empty seed hopper before attempting to lift with this lever.</p>
	

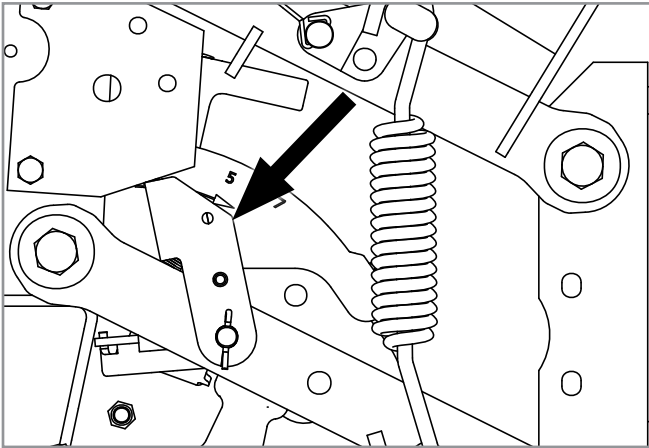

Push Row Unit Locked In Raised Position

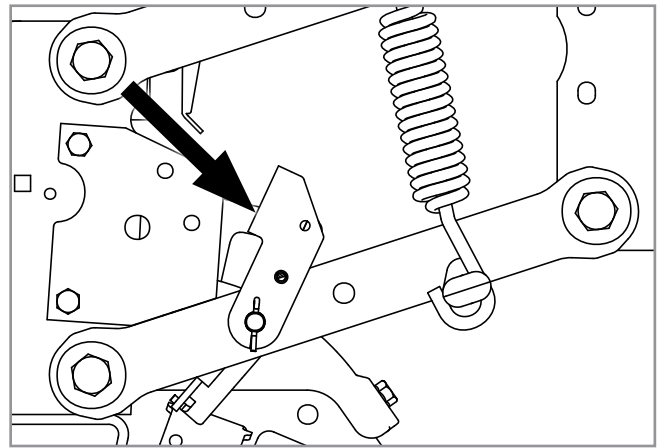

Lockup Released For Field Operation

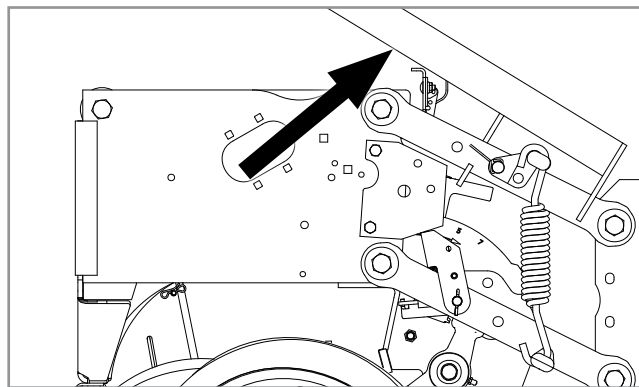

Lift lever positioned on push row unit

To lock in raised position:

1. Set row unit down pressure springs to minimum setting.
2. Lower the planter to the planting position.
3. Empty seed hoppers.
4. On each split row lockup, flip the spring tab forward.
5. Using the lift lever, raise the push row unit to allow the spring loaded lockups to snap into locked position under the row unit stops.
6. Repeat Steps 4 and 5 on remaining push row units.

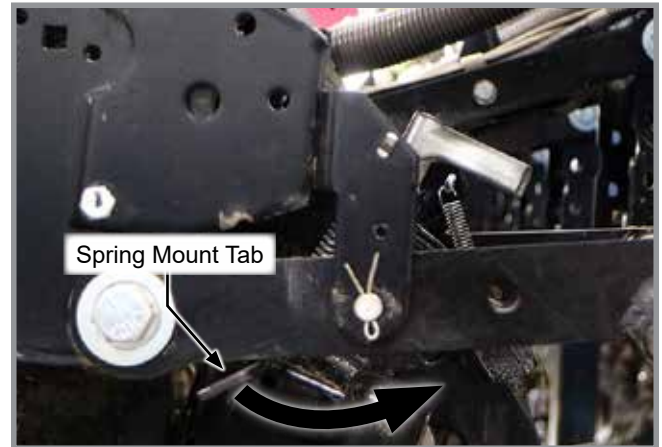
**To release lockups:**

1. Lower the planter to the planting position.
2. On each split row lockup, flip the spring tab rearward.
3. Using the lift lever, raise the push row unit to allow the spring loaded lockups to snap out of locked position. Lower row unit to the ground.
4. Repeat Step 3 on remaining push row units.

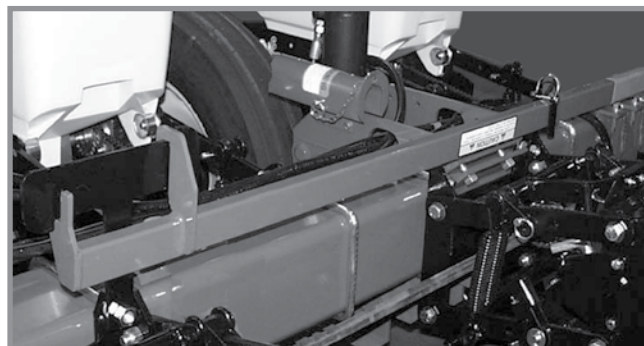

Lift lever in storage location

SPLIT ROW PUSH ROW UNIT CLUTCH SPROCKET

Push row unit clutch sprocket disengages Split Row drive from push row unit drill shaft when only pull row units are used.

DISENGAGE

Rotate knurled collar $\frac{1}{4}$ turn. Rock drill shaft slightly using a $\frac{7}{8}$ " wrench to take pressure off of spring loaded pins in clutch to allow pins to "pop" out, disengaging drive.

ENGAGE

Rotate knurled collar $\frac{1}{4}$ turn and turn drill shaft with a $\frac{7}{8}$ " wrench until drive pins engage drive sprocket.

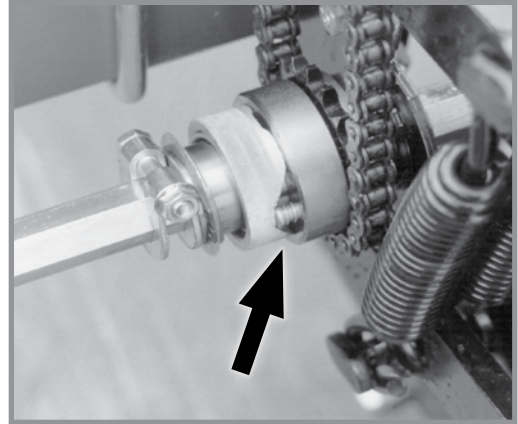

Split Row clutch sprocket

SPLIT ROW PUSH ROW UNIT VACUUM HOSE SHUTOFF

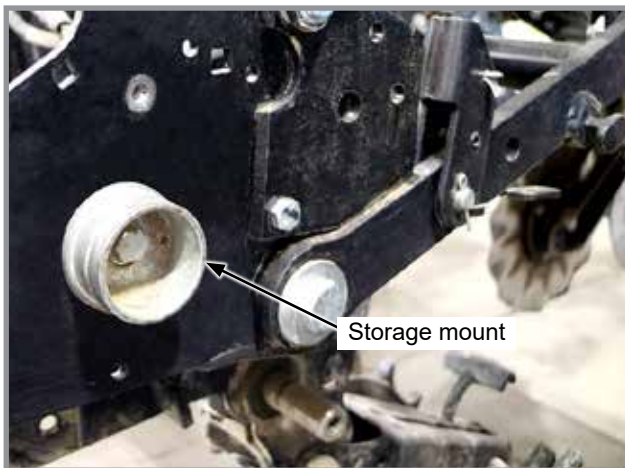

Split Row vacuum hose shutoff

When push row units are not used, move row unit end of 2" (5 cm) vacuum hose on each push row unit to storage mount located on side of shank.

ROW UNIT MOUNTED NO TILL COULTER



Row unit mounted no till coulters with 1" bubbled, 1" fluted (8 flutes) or $\frac{3}{4}$ " fluted (13 flutes) blades may be used on pull row units and push row units ($\frac{3}{4}$ " fluted shown). Four quick adjustable down force springs are required per row when using row unit mounted no till coulters. See "Quick Adjustable Down Force Springs Options".

Align coulters blade in relation to row unit double disc openers. Adjust by loosening four attaching bolts, moving coulters arm, and tightening four attaching bolts. Coulters blade can be adjusted to one of four $\frac{1}{2}$ " incremental settings in the forked arm. Initial location is the top hole. Move blade as it wears to one of the three lower hole to maintain coulters blade at or slightly above opener discs as needed. Adjust coulters below depth of double disc opener blades in very hard soil conditions such as compacted wheel tracks to improve opener penetration and cutting of surface residue.

Check operating depth by setting planter down on a level concrete floor and checking relationship between coulters blade and row unit opener blade. Make sure planter is level and coulters is square with planter frame and aligned with row unit disc opener.

NOTE: Torque $\frac{5}{8}$ " spindle hardware to 120 ft-lb (162.7 N-m).

COULTERS MOUNTED RESIDUE WHEELS

Coulters mounted residue wheels are designed for use on pull row units and push row units. Row unit extension brackets are required on the four center pull row units if the planter is equipped with coulters mounted residue wheels.

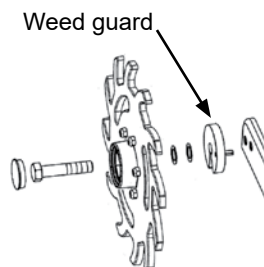

NOTE: Opening in weed guard must face down.



Coulters mounted residue wheels

Residue wheels attach to row unit mounted coulters with two cap screws and sleeves allowing unit to free-float. A 2-position spindle bolt mounting positions wheels interlocked or staggered. Depth adjustment is made with a spring-loaded cam and pin with 8 positions in $\frac{7}{16}$ " (6 mm) increments. A high point on the cam allows wheels to be locked up.

A weed guard on the inboard side of each wheel helps prevent weed wrap which can cause premature bearing failure.

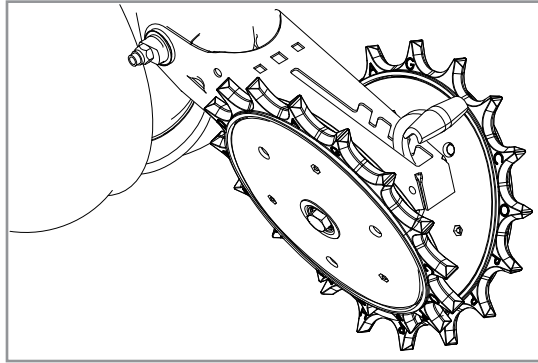

SPIKED CLOSING WHEEL**Row Unit Spiked Closing Wheel**

Spiked closing wheels crumble the sidewall, allowing roots to penetrate soil. They can be used on pull row units and push row units.

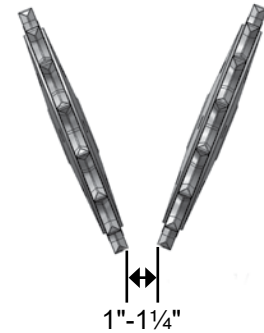
Align spiked closing wheels straight across from each other, in most forward holes on closing wheel arm. Set the wheels 1" - 1¼" (2.5 - 3.1 cm) apart at the closest point.



GRANULAR CHEMICAL HOPPER AND DRIVE

 WARNING	<p>Agricultural chemicals can cause death or serious injury to persons, animals, and plants or seriously damage soil, equipment, or property. Read and follow all chemical and equipment manufacturers labels and instructions.</p>
	

The granular chemical hopper has a 1.4 cubic feet capacity.

Make sure no foreign objects get into hopper when it is being filled. Replace hopper lids after filling to prevent accumulation of dirt and moisture.

A metering gate on bottom of hopper regulates the application rate. See “Dry Insecticide and Dry Herbicide Application Rate Charts” in this manual. Calibrate using chemical manufacturers’ instructions.



Granular chemical hopper

Granular chemical clutch drive coupler and meter shaft (not applicable to Blue Drive) can be disengaged and engaged by turning throwout knob at rear of hopper support panel.

Rotate knob $\frac{1}{4}$ turn counterclockwise to disengage and $\frac{1}{4}$ turn clockwise to engage.

Slotted holes in hopper support panel and clutch housing allow for alignment adjustment between clutch drive coupler and meter shaft.

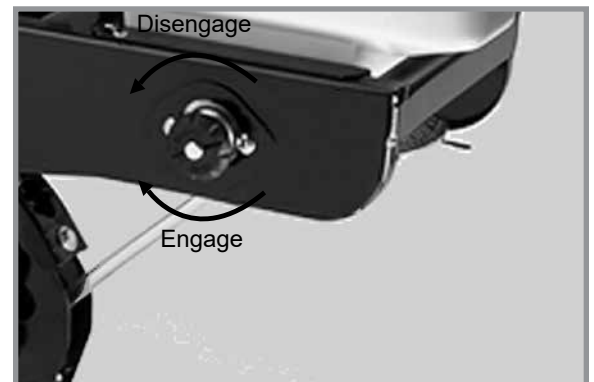

Granular chemical drive release

GRANULAR CHEMICAL BANDING OPTIONS

Granular chemical banding options allow 4½" slope-compensating banding, straight drop in-furrow placement or 14" rear banding.

NOTE: Granular chemical rear bander is not compatible with covering discs/single press wheel option.

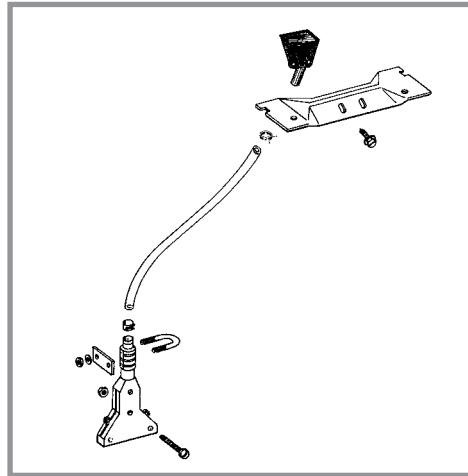

4½" Slope-Compensating Bander

NOTCHED SINGLE DISC OPENERS

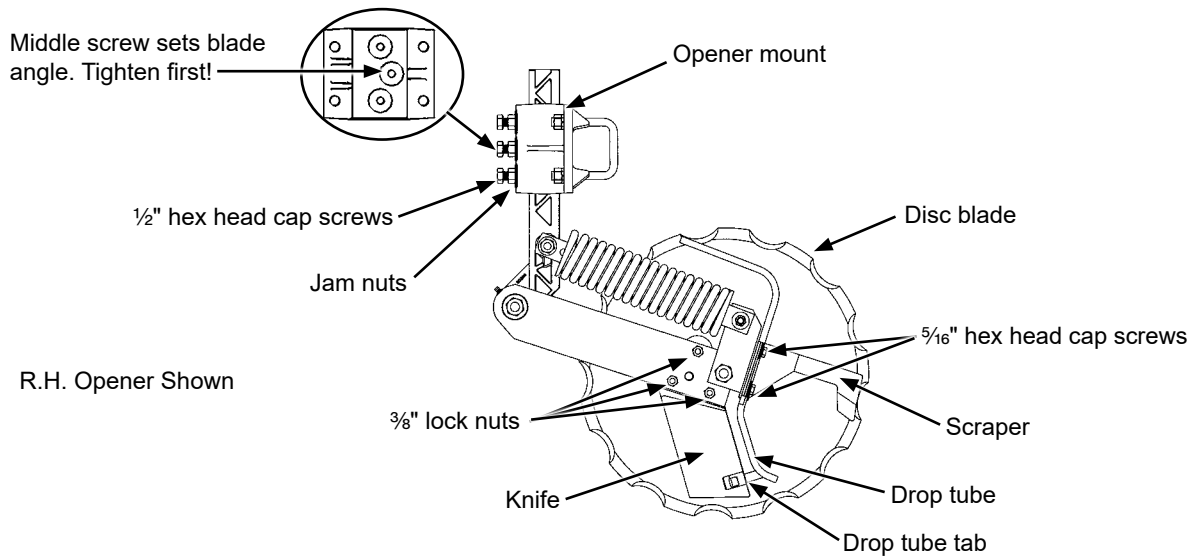

Notched single disc opener adjustments

 <p>CAUTION</p>	<p>Compressed spring may fly out of this assembly if attempting to disassemble and cause injury. Do not take apart this assembly.</p> <p>Disc blades are sharp and can cut causing serious injury. Wear gloves when working on or turning disc blades by hand.</p>
--	--

<p>NOTICE</p>	<p>Never strike knife with heavy object. Damage to knife will occur.</p> <p>If knife to disc blade clearance is too large, soil or residue can wedge between knife and blade, and blade will not turn.</p>
----------------------	--

1. Adjust knife to disc blade contact. Loosen or tighten $\frac{3}{8}$ " lock nuts to adjust knife's entire leading edge against disc blade. Turn blade and check for slight resistance without freewheeling. Readjust knife to blade's tight spot as needed.

NOTICE

Adjust liquid drop tube out of path of soil flow across knife. Drop tube and tab wear quickly if not correctly adjusted.

2. Adjust scraper and drop tube. Loosen two $\frac{5}{16}$ " hex head cap screws. Adjust scraper until just touching disc blade. Adjust drop tube until it is centered between knife and disc blade. Tighten screws. Turn blade and check for slight resistance without freewheeling. Repeat as needed. Insert flat bladed pry bar or screwdriver between knife and drop tube above drop tube tab. Carefully bend tube until $\frac{1}{4}$ "- $\frac{3}{8}$ " (6.35 - 9.5 mm) from disc blade.

NOTE: Maximum disc blade depth 4" (10.2 cm).

3. Adjust blade depth. Loosen three $\frac{1}{2}$ " hex head cap screws and jam nuts in opener mount. Adjust opener assembly up or down to desired blade depth. Tighten center hex head cap screw and jam nut first to set proper disc blade angle. Tighten remaining hex head cap screws and jam nuts. Torque hex head cap screws and jam nuts to 57 ft-lb (77.29 N-m). Check fertilizer hose clearance and adjust as necessary.

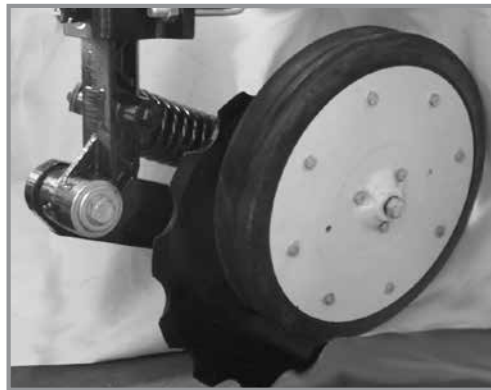
DEPTH/GAUGE WHEEL ATTACHMENT FOR NOTCHED SINGLE DISC FERTILIZER OPENER

Notched single disc opener depth/gauge wheel

Depth/gauge wheel attachment for notched single disc fertilizer opener is used where additional gauging is required to maintain desired fertilizer opener depth. Depth/gauge wheel is attached to notched single disc fertilizer opener using a mounting block fastened to the pivot arm with $\frac{5}{8}$ " hardware through disc blade bearing.

Depth adjustment is made using 3 adjustment holes in depth/gauge wheel mounting block. Moving depth/gauge wheel increases/decreases depth in approximate 1" (2.5 cm) increments in relation to blade depth setting made at vertical mounting post.

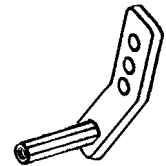

HD SINGLE DISC FERTILIZER OPENER

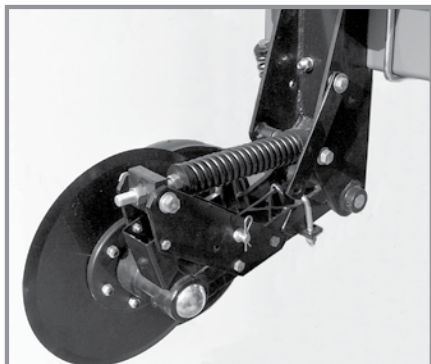

HD single disc opener

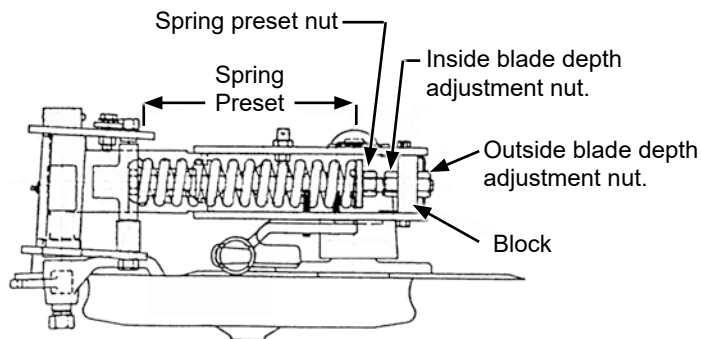

R.H. configuration shown (Overhead view)

Recommended placement of fertilizer with HD single disc fertilizer opener is 3½" - 4" (8.8 - 10.1 cm) from row.

NOTICE	Never place fertilizer closer than 2" (5 cm) to row or seeds may be damaged.
---------------	---

Maximum blade depth is approximately 5" (12.7 cm) with planter frame level and at 20" (50.8 cm) operating height. Soil conditions can affect depth slightly.

Raise planter to remove weight from fertilizer opener. Loosen inside adjustment nut with 1½" wrench. Turn outside nut clockwise to decrease or counterclockwise to increase blade depth. One full turn of blade depth adjustment nut changes blade depth ⅜". Tighten inside nut tight against block. Adjust all fertilizer openers to same depth.

Fertilizer opener down pressure can be adjusted from 250 lb (113.4 kg) to 640 lb (290.3 kg).

NOTICE	Do not operate HD single disc fertilizer openers at full down pressure tension on rocky ground or disc blades will chip.
---------------	---

NOTE: DO NOT adjust spring preset dimension less than 9½" (24.13 cm).

NOTE: Excessive down pressure can cause planter frame up-lift and affect machine performance. Planter frame should be 20" (50.8 cm) from ground in planting position. Excessive down pressure in loose soil conditions can cause openers to run too deep and push dirt ahead of opener and may stop soil press wheel and opener blade from turning.

Raise planter to remove weight from fertilizer opener. Turn spring preset nut clockwise to increase and counterclockwise to decrease down pressure. Adjust all rows to a similar setting. Minimal spring pressure for acceptable operation is recommended. See chart for spring length setting specifications.

Spring Preset	
Length	Down Pressure
11" (27.9 cm)	250 lb (113.4 kg)
10¾" (27.3 cm)	320 lb (145.1 kg)
*10½" (26.7 cm)	370 lb (167.8 kg)
10¼" (26 cm)	450 lb (204.1 kg)
10" (25.4 cm)	520 lb (235.8 kg)
9¾" (24.8 cm)	580 lb (263.1 kg)
9½" (24.1 cm)	640 lb (290.3 kg)
*Initial setting	

Adjust spring loaded dry fertilizer drop tube/scrapper periodically to maintain ⅛" (3 mm) gap between drop tube and opener blade. If this dimension is not maintained fertilizer may not drop in proper location.

Loosen scraper adjustment bolt. Slotted hole in scraper allows up or down adjustment.

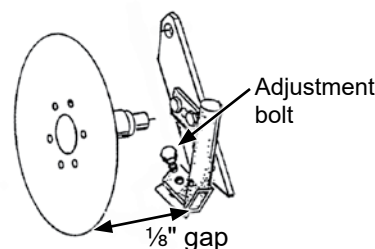

Adjust liquid drop tube/scrapper so there is slight contact between blade and scraper lower leading edge, and ¼" (0.6 cm) clearance between liquid drop tube trailing edge and blade. Blade should turn with minimum amount of drag.

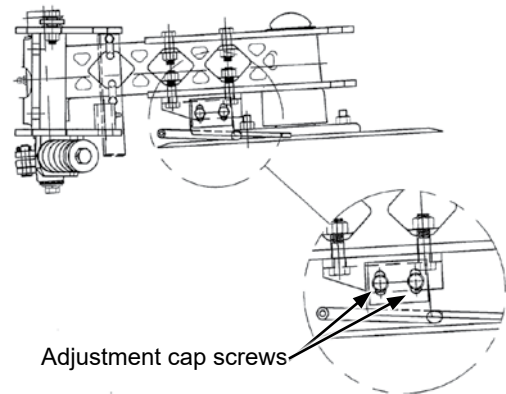

NOTE: Soil press wheel is not for gauging fertilizer opener operating depth.

Additional press wheel down pressure may be desirable in heavy moist soils. Turn press wheel spring adjustment bolt clockwise to increase down pressure.

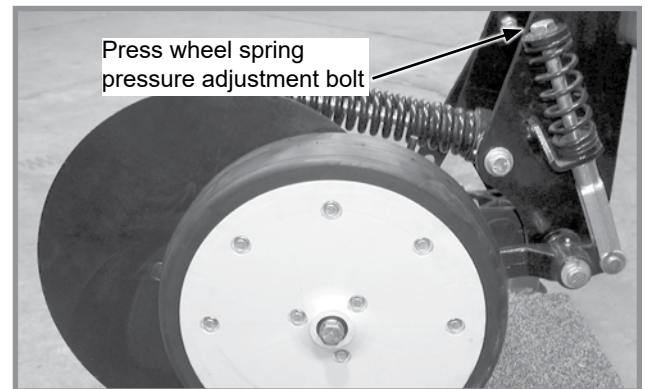



HD single disc fertilizer opener can be raised and locked up when fertilizer attachment is not used or during storage.

NOTE: A lockup bar automatically raises and locks soil press wheel when blade assembly is raised.

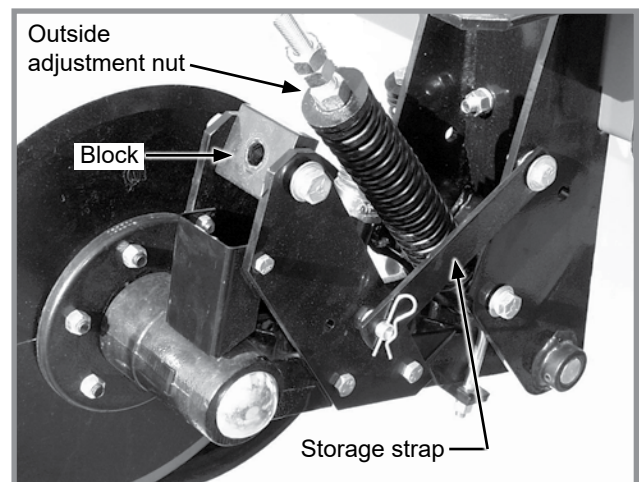
1. Place planter in planting position.
2. Remove outside blade depth adjustment.
3. Raise planter until adjustment bolt clears adjustment block.
4. Raise spring to clear blade assembly and raise blade assembly until storage strap can be positioned on lockup pin. Install hair pin clip.
5. Reinstall depth adjustment nut and tighten



DRY FERTILIZER ATTACHMENT

 <p>WARNING</p>	<p>Agricultural chemicals can cause death or serious injury to persons, animals, and plants or seriously damage soil, equipment, or property. Read and follow all chemical and equipment manufacturers labels and instructions.</p>
	

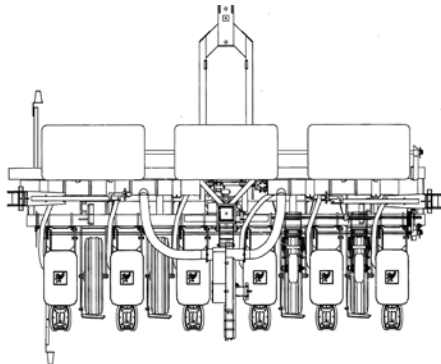

Dry fertilizer option installed

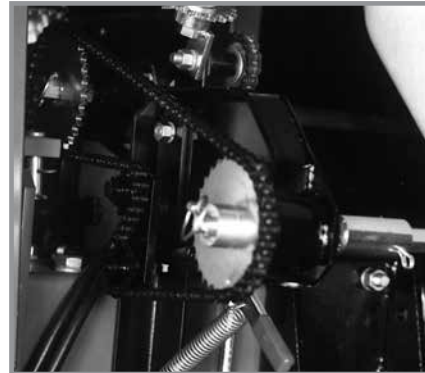

Fertilizer drive rate transmission

Rate of fertilizer application is determined by drive/driven sprocket combination on fertilizer drive rate transmission and auger position in the hoppers.



Augers positioned for high rate delivery



Augers positioned for low rate delivery

NOTE: Uneven delivery of fertilizer will occur if high rate auger position is used at too low a rate setting.

Remove 1/4" (0.6 cm) stainless steel cap screws holding augers in place on shaft and reposition augers to change delivery rate.

A fertilizer transmission is located directly ahead of row unit transmission on right side of planter and allows simple, rapid changes in sprockets to obtain desired fertilizer application rates. Chain tension is controlled by a spring loaded idler adjusted with a ratchet arm located to inside of transmission. Sprockets can be changed with those on the sprocket storage rod by removing hexagon shaft pins. Fertilizer rate charts in Rate Chart section will help you select correct sprocket combinations.

NOTE: Make a field check after each sprocket combination adjustment to be sure you are applying fertilizer at desired rate.

<p>NOTICE</p>	<p>Placing fertilizer too close to seeds or in excessive amounts can cause germination or seedling damage. Check with your fertilizer dealer or manufacturer for correct amount and placement.</p>
----------------------	--

Because dry fertilizer attachment meters granules by volume rather than weight, differences in brands, and fertilizer analysis, weight metered during actual application may vary considerably. Use chart for reference only. Use a container to catch and measure application for a better estimate.

Keep fertilizer dry during use and storage since most fertilizers easily absorb moisture. In addition to waste, deposits of fertilizer left in hopper can cause metal corrosion. Empty hoppers at end of each day.

CLEANING

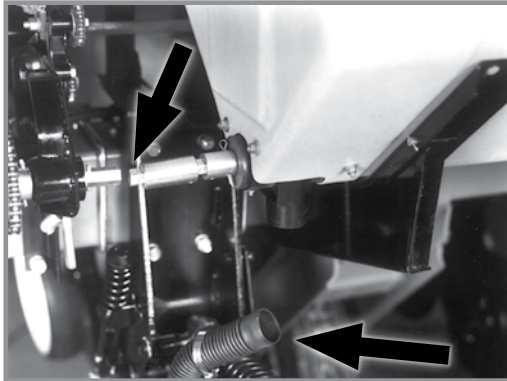

Disconnect drive shaft and hoses

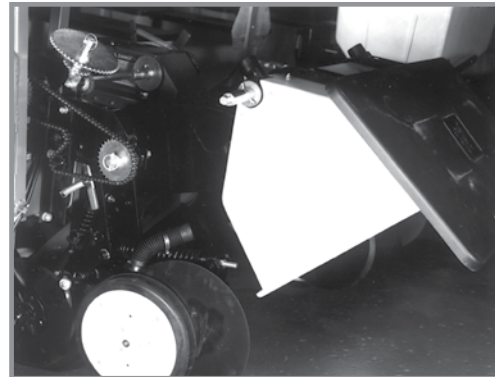

Rotate lid to back and rotate hopper forward

Dry fertilizer hoppers tip forward for dumping and ease of cleaning. Disconnect drive shaft from transmission and/or adjacent hopper. LOOSEN HOSE CLAMPS AND REMOVE HOSES FROM EACH HOPPER. Remove rear $\frac{1}{2}$ " x $\frac{1}{4}$ " cap screw from between each hopper saddle and hopper mount. Rotate each hopper lid to back side of hopper and carefully tip hopper forward. Flush all loose fertilizer from hoppers and hoses after dumping contents.

At end of planting season or when fertilizer attachment is not used for a period of time, hoppers should be disassembled, cleaned, and metal surfaces coated with a rust preventative. Remove $\frac{1}{4}$ " cotter pin and bearing from one end of shaft. Pull auger assembly from opposite end of hopper. Remove stainless steel cap screws from auger shaft and remove all auger components for cleaning. Coat all parts with rust preventative before reassembly. Reinstall auger halves in low or high rate position.

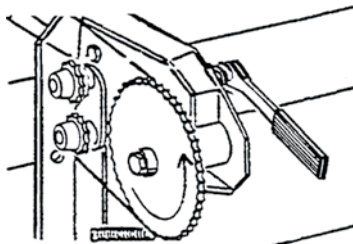

Transmission direction of rotation

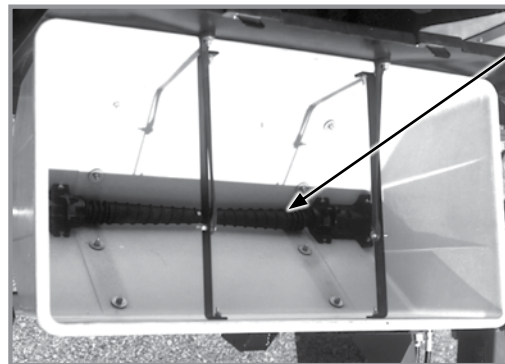

Flighting must move chemicals from center to outside of hopper.

Auger installation

NOTE: Install auger assembly so the flighting moves material to outer openings in hopper when augers rotate in direction they turn during operation.

Slide auger assembly through outlet housing into hopper. Secure in place by reinstalling bearing and cotter pin. Rotating shaft in direction shown to see if flighting (spirals) on auger move toward ends of hopper. If not, remove auger assembly, turn 180° , and reinstall.

NOTE: Frequent lubrication of auger bearings is critical to ensure augers turn freely. Check lubrication section for frequency.

Be certain augers turn freely. If not, loosen $\frac{5}{16}$ " carriage bolts in outlet housings, rotate auger several times, and retighten carriage bolts. This allows housings and augers to realign.

NOTE: Do not operate fertilizer attachment without auger baffles in place.

Install auger baffles over augers and secure in place with two hair pin clips in each hopper.

LIQUID FERTILIZER ATTACHMENT

WARNING



Agricultural chemicals can cause death or serious injury to persons, animals, and plants or seriously damage soil, equipment, or property. Read and follow all chemical and equipment manufacturers labels and instructions.

CAUTION

Overfilling tank can cause siphoning, tank collapse, personal injury, and damage to property and equipment. Do not overfill tank. Do not leave planter unattended when filling tank. Close fill valve and open tank lid if siphoning occurs. Follow all chemical manufacturers first aid, cleanup, and handling instructions.



Liquid fertilizer option installed



Repairable check valve

NOTE: Optional low rate check valves are available for in-line installation between liquid fertilizer squeeze or piston pump and openers to ensure equal distribution of product at low rates. Check valves also eliminate anti-siphon loops.

NOTICE

Placing fertilizer too close to seeds or in excessive amounts can cause germination or seedling damage. Check with your fertilizer dealer or manufacturer for correct amount and placement.

OPTIONAL PISTON PUMP

NOTE: Keep manuals shipped with pump and flow divider with this manual.

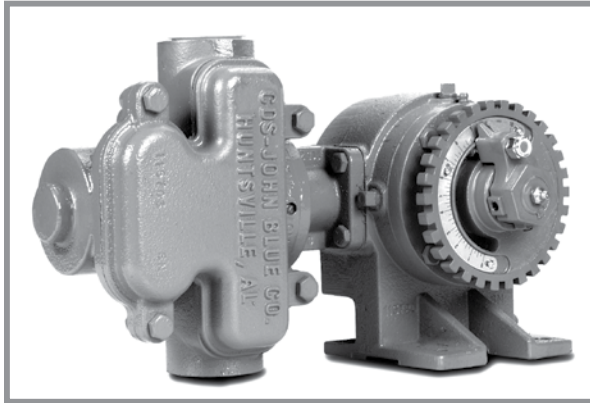

Piston pump

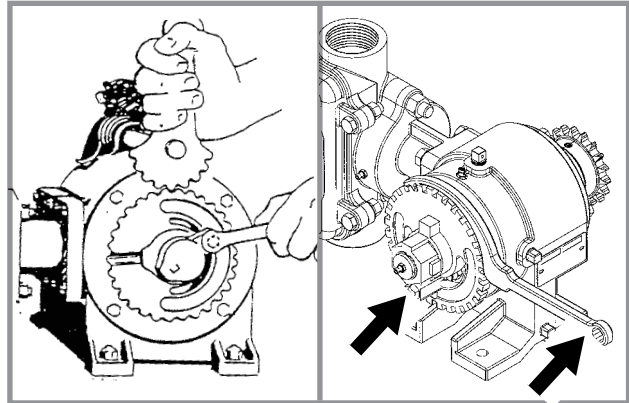

Adjusting delivery rate

NOTE: Delivery rate chart in Rate Chart section of this manual provides approximate application rate only. Delivery varies with temperature and fertilizer.

Loosen $\frac{3}{8}$ " lock nut that secures arm with pointer and rotate scale flange with adjustment wrench until pointer is over desired scale setting. Tighten $\frac{3}{8}$ " lock nut. DO NOT OVERTIGHTEN.

NOTE: Periodically check flow to all rows. Set rate is delivered to remaining rows if one or more lines are plugged.

CLEANING

Clean tanks, hoses, and metering pump thoroughly with water at end of planting season or prior to an extended period of non-use. Do not allow fertilizer to crystallize from cold temperature or evaporation.

On machines equipped with piston pump, take apart and clean strainer located between piston pump and ball valve daily. Remove the end cap to clean the screen. See Piston Pump Storage in Maintenance Section of this manual.

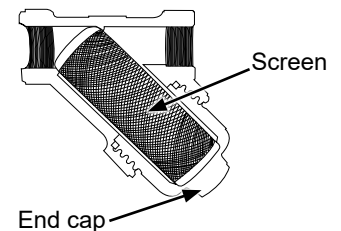

This page left blank intentionally.

GENERAL PLANTING RATE INFORMATION

NOTICE

Sprocket combinations in these charts are for average conditions. Changes in sprocket combinations may be required for desired planting population. **ALWAYS MAKE FIELD CHECKS TO BE SURE YOU ARE PLANTING AT THE DESIRED RATE.**

NOTICE

Seed additives added in the hopper may affect finger pickup seed meter performance and accelerate wear.

NOTE: Seed size and shape may affect planting rate.

NOTE: Not all row spacings listed apply to all size planters.

NOTE: Speeds above 6.0 MPH (10 KPH) can adversely affect seed spacing.

MECHANICAL

Finger Pickup Corn Meter

Larger grades generally plant more accurately at the high end of the ground speed range than smaller grades. Higher than optimum speeds may result in population rate increase or higher incidence of doubles, particularly with small seed. Medium round corn seed is most desirable for planting accuracy at optimum speed.

Finger Pickup Oil Sunflower Meter

Larger grades generally plant more accurately at the high end of the ground speed range than smaller grades. Higher than optimum speeds may result in population rate increase or higher incidence of doubles, particularly with small seed. No. 3 and/or No. 4 size oil sunflower seeds are recommended for use in finger pickup seed meters equipped with oil sunflower fingers. No. 1 and/or No. 2 size confectionery sunflower seeds are recommended for use in finger pickup seed meters equipped with corn fingers.

Brush-Type Seed Meter (Soybean, Milo/Grain Sorghum, Acid-Delinted Cotton)

Rate charts are given in seeds per acre as well as seed spacing in inches rounded to the nearest tenth of an inch. Because of the large range in seed size, pounds per acre is not a suggested method of selecting transmission settings. Smaller size seed pounds per acre may be below what was expected and large seed pounds per acre may appear above expectations. To determine pounds per acre, use the formula given in "Determining Pounds Per Acre (Brush-Type Seed Meter)" in "Check Seed Population" in Machine Operation section of this manual.

NOTE: Planting speed can affect actual seeding rate. Make a field check and adjust transmission setting to obtain desired seed drop.

Standard Rate (1 To 1) 17 Tooth Drive Sprocket

When planting 30"/36"/38" rows with brush-type seed meters using 17 tooth standard rate (1 to 1) sprocket, use charts on page 5-3, 5-5, and 5-6. When planting 15"/18"/19" rows using 17 tooth sprocket, use chart on page 5-4.

Half Rate (2 To 1) 34 Tooth Drive Sprocket

When using 34 tooth half rate (2 to 1) sprocket with brush-type seed meters, seeding rate is approximately 50% of chart readings. **Half rate (2 to 1) drive is recommended only when Split row push units are used and desired population falls below that shown on planting rate charts.**

VACUUM

NOTE: Contact wheel drive sprocket references are located in each chart title.

NOTE: DO NOT USE 44 tooth sprockets (60 cell soybean discs) with dry fertilizer.

NOTE: 15, 19, and 30 tooth drive sprockets are NOT applicable to all rate charts. Check chart titles to ensure proper rate chart is selected. 15 and 19 tooth sprockets requires 116 pitch No. 40 chain and 30 tooth sprocket requires 124 pitch No. 40 chain.

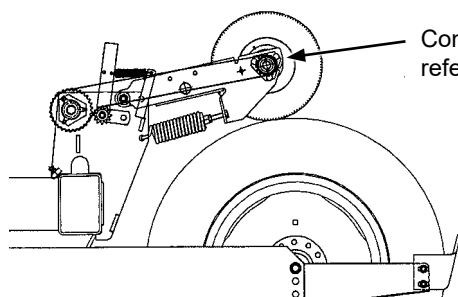

Reverser driven sprocket
referenced in rate chart title.

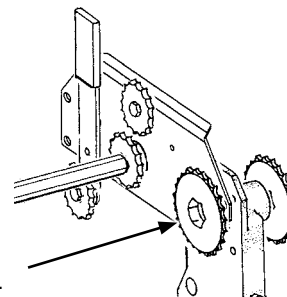

**PLANTING RATES FOR FINGER PICKUP SEED METER (STANDARD DRIVE)
APPROXIMATE SEEDS/ACRE FOR 30" ROW WIDTH**

30"Rows	Transmission Sprockets		Recommended Speed Range (MPH)	Average Seed Spacing In Inches
	Drive	Driven		
16,186	17	28	4 to 6	12.9
16,785	17	27	4 to 6	12.5
17,431	17	26	4 to 6	12.0
18,090	19	28	4 to 6	11.6
18,128	17	25	4 to 6	11.5
18,760	19	27	4 to 6	11.1
18,883	17	24	4 to 6	11.1
19,481	19	26	4 to 6	10.7
19,704	17	23	4 to 6	10.6
20,261	19	25	4 to 6	10.3
21,104	19	24	4 to 6	9.9
21,898	23	28	4 to 6	9.5
22,022	19	23	4 to 6	9.5
22,709	23	27	4 to 6	9.2
22,850	24	28	4 to 6	9.2
23,583	23	26	4 to 6	8.9
23,697	24	27	4 to 6	8.8
23,802	25	28	4 to 6	8.8
23,853	17	19	4 to 6	8.8
24,526	23	25	4 to 6	8.5
24,608	24	26	4 to 6	8.5
24,684	25	27	4 to 6	8.5
24,755	26	28	4 to 6	8.4
25,548	23	24	4 to 6	8.2
25,592	24	25	4 to 6	8.2
25,633	25	26	4 to 6	8.2
25,671	26	27	4 to 6	8.1
25,707	27	28	4 to 6	8.1
26,659	23	23	4 to 6	7.8
27,646	28	27	4 to 6	7.6
27,684	27	26	4 to 6	7.6
27,770	25	24	4 to 6	7.5
27,818	24	23	4 to 6	7.5
28,709	28	26	4 to 6	7.3
28,791	27	25	4 to 6	7.3
28,977	25	23	4 to 6	7.2
29,795	19	17	4 to 6	7.0
29,858	28	25	4 to 6	7.0
29,991	27	24	4 to 6	7.0
30,136	26	23	4 to 6	7.0
31,102	28	24	3 to 6	6.7
31,295	27	23	3 to 6	6.7
32,271	23	19	3 to 5.5	6.5
32,454	28	23	3 to 5.5	6.5
33,674	24	19	3 to 5.5	6.2
35,077	25	19	3 to 5	6.0
36,068	23	17	3 to 5	5.8
36,480	26	19	3 to 5	5.7
37,636	24	17	3 to 5	5.6
37,883	27	19	3 to 5	5.5
39,204	25	17	3 to 4.5	5.3
39,287	28	19	3 to 4.5	5.3
40,772	26	17	3 to 4.5	5.1
42,340	27	17	3 to 4.5	4.9
43,908	28	17	3 to 4.5	4.8

NOTE: See ["General Planting Rate Information" on page 5-1](#) and ["Check Seed Population" on page 2-31](#) for more information. Always field check seed population to verify planting rates.

**PLANTING RATES FOR BRUSH-TYPE SEED METERS (STANDARD DRIVE)
APPROXIMATE SEEDS/ACRE FOR 30" ROW WIDTH**

Transmission Sprockets		60 Cell Soybean Or High-Rate Milo/Grain Sorghum 30" Rows	Average Seed Spacing In Inches	48 Cell Specialty Soybean Or High-Rate Acid-Delinted Cotton 30" Rows	Average Seed Spacing In Inches	Speed Range (MPH)
Drive	Driven					
17	28	80,928	2.6	64,742	3.2	2 to 8
17	27	83,926	2.5	67,141	3.1	2 to 8
17	26	87,154	2.4	69,723	3.0	2 to 8
19	28	90,449	2.3	72,359	2.9	2 to 8
19	27	93,799	2.2	75,039	2.8	2 to 8
17	24	94,416	2.2	75,533	2.8	2 to 8
17	23	98,521	2.1	78,817	2.7	2 to 8
19	25	101,303	2.1	81,042	2.6	2 to 8
19	24	105,524	2.0	84,419	2.5	2 to 8
23	28	109,491	1.9	87,593	2.4	2 to 8
19	23	110,112	1.9	88,090	2.4	2 to 8
24	28	114,252	1.8	91,402	2.3	2 to 8
24	27	118,483	1.8	94,786	2.2	2 to 8
17	19	119,263	1.8	95,410	2.2	2 to 8
24	26	123,040	1.7	98,432	2.1	2 to 8
26	28	123,773	1.7	99,018	2.1	2 to 8
24	25	127,962	1.6	102,370	2.0	2 to 8
26	27	128,357	1.6	102,686	2.0	2 to 8
23	23	133,294	1.6	106,635	2.0	2 to 8
27	26	138,420	1.5	110,736	1.9	2 to 8
24	23	139,089	1.5	111,271	1.9	2 to 8
25	23	144,884	1.4	115,907	1.8	2 to 8
19	17	148,975	1.4	119,180	1.8	2 to 8
27	24	149,955	1.4	119,964	1.7	2 to 8
28	24	155,509	1.3	124,407	1.7	2 to 8
23	19	161,355	1.3	129,084	1.6	2 to 8
28	23	162,270	1.3	129,816	1.6	2 to 8
24	19	168,371	1.2	134,696	1.6	2 to 8
25	19	175,386	1.2	140,309	1.5	2 to 8
23	17	180,338	1.2	144,270	1.5	2 to 8
26	19	182,402	1.1	145,922	1.4	2 to 7
27	19	189,417	1.1	151,534	1.4	2 to 7
28	19	196,433	1.1	157,146	1.3	2 to 7
26	17	203,861	1.0	163,089	1.3	2 to 7
27	17	211,702	0.9	169,362	1.2	2 to 7
28	17	219,542	0.9	175,634	1.2	2 to 7

NOTE: ["General Planting Rate Information" on page 5-1](#) and ["Check Seed Population" on page 2-31](#) for more information.

NOTE: Rates are approximately 50% of given numbers when using the Half Rate (2 To 1) Drive Reduction Package.

NOTE: Always field check seed population to verify planting rates.

**PLANTING RATES FOR BRUSH-TYPE SEED METERS (STANDARD DRIVE)
APPROXIMATE SEEDS/ACRE FOR 15" ROW WIDTH**

Transmission Sprockets		60 Cell Soybean Or High-Rate Milo/Grain Sorghum 15" Rows	Average Seed Spacing In Inches	48 Cell Specialty Soybean Or High-Rate Acid-Delinted Cotton 15" Rows	Average Seed Spacing In Inches	Speed Range (MPH)
Drive	Driven					
17	28	161,856	2.6	129,484	3.2	2 to 8
17	27	167,852	2.5	134,282	3.1	2 to 8
17	26	174,308	2.4	139,446	3.0	2 to 8
19	28	180,898	2.3	144,718	2.9	2 to 8
19	27	187,598	2.2	150,078	2.8	2 to 8
17	24	188,832	2.2	151,066	2.8	2 to 8
17	23	197,042	2.1	157,634	2.7	2 to 8
19	25	202,606	2.1	162,084	2.6	2 to 8
19	24	211,048	2.0	168,838	2.5	2 to 8
23	28	218,982	1.9	175,186	2.4	2 to 8
19	23	220,224	1.9	176,180	2.4	2 to 8
24	28	228,504	1.8	182,804	2.3	2 to 8
24	27	236,966	1.8	189,572	2.2	2 to 8
17	19	238,526	1.8	190,820	2.2	2 to 8
24	26	246,080	1.7	196,864	2.1	2 to 8
26	28	247,546	1.7	198,036	2.1	2 to 8
24	25	255,924	1.6	204,740	2.0	2 to 8
26	27	256,714	1.6	205,372	2.0	2 to 8
23	23	266,588	1.6	213,270	2.0	2 to 8
27	26	276,840	1.5	221,472	1.9	2 to 8
24	23	278,178	1.5	222,542	1.9	2 to 8
25	23	289,768	1.4	231,814	1.8	2 to 8
19	17	297,950	1.4	238,360	1.8	2 to 8
27	24	299,910	1.4	239,928	1.7	2 to 8
28	24	311,018	1.3	248,814	1.7	2 to 8
23	19	322,710	1.3	258,168	1.6	2 to 8
28	23	324,540	1.3	259,632	1.6	2 to 8
24	19	336,742	1.2	269,392	1.6	2 to 8
25	19	350,772	1.2	280,618	1.5	2 to 8
23	17	360,676	1.2	288,540	1.5	2 to 8
26	19	364,804	1.1	291,844	1.4	2 to 7
27	19	378,834	1.1	303,068	1.4	2 to 7
28	19	392,866	1.1	314,292	1.3	2 to 7
26	17	407,722	1.0	326,178	1.3	2 to 7
27	17	423,404	0.9	338,724	1.2	2 to 7
28	17	439,084	0.9	351,268	1.2	2 to 7

NOTE: See ["General Planting Rate Information" on page 5-1](#) and ["Check Seed Population" on page 2-31](#) for more information.

NOTE: Rates are approximately 50% of given numbers when using the Half Rate (2 To 1) Drive Reduction Package.

NOTE: Always field check seed population to verify planting rates.

**PLANTING RATE FOR BRUSH-TYPE SEED METERS (STANDARD DRIVE)
APPROXIMATE SEEDS/ACRE FOR 30" ROW WIDTH**

Transmission Sprockets		36 Cell Acid-Delinted Large Cotton 30" Rows	Average Seed Spacing In Inches	30 Cell Milo/Grain Sorghum Or Acid-Delinted Cotton 30" Rows	Average Seed Spacing In Inches	Speed Range (MPH)
Drive	Driven					
17	28	48,557	4.3	40,464	5.2	2 to 8
17	27	50,356	4.2	41,963	5.0	2 to 8
17	26	52,292	4.0	43,577	4.8	2 to 8
19	28	54,269	3.9	45,225	4.6	2 to 8
19	27	56,279	3.7	46,900	4.5	2 to 8
17	24	56,650	3.7	47,208	4.4	2 to 8
17	23	59,113	3.5	49,261	4.2	2 to 8
19	25	60,782	3.4	50,652	4.1	2 to 8
19	24	63,314	3.3	52,762	4.0	2 to 8
23	28	65,695	3.2	54,746	3.8	2 to 8
19	23	66,067	3.2	55,056	3.8	2 to 8
24	28	68,551	3.0	57,126	3.7	2 to 8
24	27	71,090	2.9	59,242	3.5	2 to 8
17	19	71,558	2.9	59,631	3.5	2 to 8
24	26	73,824	2.8	61,520	3.4	2 to 8
26	28	74,264	2.8	61,886	3.4	2 to 8
24	25	76,772	2.7	63,981	3.3	2 to 8
26	27	77,014	2.7	64,178	3.3	2 to 8
23	23	79,976	2.6	66,647	3.1	2 to 8
27	26	83,052	2.5	69,210	3.0	2 to 8
24	23	83,453	2.5	69,544	3.0	2 to 8
25	23	86,930	2.4	72,442	2.9	2 to 8
19	17	89,385	2.3	74,488	2.8	2 to 8
27	24	89,973	2.3	74,978	2.8	2 to 8
28	24	93,305	2.2	77,755	2.7	2 to 8
23	19	96,813	2.2	80,678	2.6	2 to 8
28	23	97,362	2.1	81,135	2.6	2 to 8
24	19	101,023	2.1	84,185	2.5	2 to 8
25	19	105,232	2.0	87,693	2.4	2 to 8
23	17	108,233	1.9	90,169	2.3	2 to 8
26	19	109,441	1.9	91,201	2.3	2 to 7
27	19	113,650	1.8	94,709	2.2	2 to 7
28	19	117,860	1.8	98,216	2.1	2 to 7
26	17	122,317	1.7	101,930	2.1	2 to 7
27	17	127,021	1.6	105,851	2.0	2 to 7
28	17	131,725	1.6	109,771	1.9	2 to 7

NOTE: See ["General Planting Rate Information" on page 5-1](#) and ["Check Seed Population" on page 2-31](#) for more information.

NOTE: Rates are approximately 50% of given numbers when using the Half Rate (2 To 1) Drive Reduction Package.

NOTE: Always field check seed population to verify planting rates.

**PLANTING RATES FOR BRUSH-TYPE SEED METERS (STANDARD DRIVE)
APPROXIMATE HILLS/ACRE FOR 30" ROW WIDTH**

Due to variations in cotton seed size, meters equipped with the 12 cell acid-delinted hill-drop cotton discs will plant from 3 to 6 seeds per cell. Select proper disc for seed size range to be planted.

To determine planter transmission setting, determine desired hill spacing and select the transmission ratio closest to the hill spacing in inches on the chart. To decrease population increase spacing. To increase population decrease spacing.

To determine population per acre, determine average seeds per hill and hills per acre by doing a field check. Measure 1/1000 of an acre (1/1000 acre = Length of row 17' 5" for 30" row width). Multiply average seeds per hill by hills per acre.

EXAMPLE: 4 seeds per hill x (13 hills x 1000) = 52,000

Transmission Sprockets		NUMBER OF HILLS PER ACRE 12 Cell Hill-Drop Cotton, Acid-Delinted	Average Hill Spacing In Inches	Speed Range (MPH)
Drive	Driven	30" Rows		
17	28	16,186	12.9	2 to 8
17	27	16,785	12.5	2 to 8
17	26	17,431	12.0	2 to 8
19	28	18,090	11.6	2 to 8
19	27	18,760	11.1	2 to 8
17	24	18,883	11.1	2 to 8
17	23	19,704	10.6	2 to 8
19	25	20,261	10.3	2 to 8
19	24	21,105	9.9	2 to 8
23	28	21,898	9.5	2 to 8
19	23	22,022	9.5	2 to 8
24	28	22,850	9.2	2 to 8
24	27	23,697	8.8	2 to 8
17	19	23,853	8.8	2 to 8
24	26	24,608	8.5	2 to 8
26	28	24,755	8.4	2 to 8
24	25	25,592	8.2	2 to 8
26	27	25,671	8.1	2 to 8
23	23	26,659	7.8	2 to 8
27	26	27,684	7.6	2 to 8
24	23	27,818	7.5	2 to 8
25	23	28,977	7.2	2 to 8
19	17	29,795	7.0	2 to 8
27	24	29,991	7.0	2 to 8
28	24	31,102	6.7	2 to 8
23	19	32,271	6.5	2 to 8
28	23	32,454	6.5	2 to 8
24	19	33,674	6.2	2 to 8
25	19	35,077	6.0	2 to 8
23	17	36,068	5.8	2 to 8
26	19	36,480	5.7	2 to 7
27	19	37,883	5.5	2 to 7
28	19	39,287	5.3	2 to 7
26	17	40,772	5.1	2 to 7
27	17	42,340	4.9	2 to 7
28	17	43,908	4.8	2 to 7

NOTE: See ["General Planting Rate Information" on page 5-1](#) and ["Check Seed Population" on page 2-31](#) for more information.

NOTE: Rates are approximately 50% of given numbers when using the Half Rate (2 To 1) Drive Reduction Package.

NOTE: Always field check seed population to verify planting rates.

**PLANTING RATES FOR BRUSH-TYPE SEED METERS (STANDARD DRIVE)
APPROXIMATE SEEDS/ACRE FOR 15"/18"/19"/30"/36"/38" ROW WIDTHS**

Transmission Sprockets		54 Cell Soybean						Average Seed Spacing In Inches	Speed Range (MPH)
Drive	Driven	7.5" Rows or 15" Rows	18" Rows	19" Rows	30" Rows	36" Rows	38" Rows		
15	28	128,529	107,107	101,470	64,264	53,554	50,735	3.3	2 to 8
15	27	133,289	111,074	105,228	66,644	55,537	52,614	3.1	2 to 8
15	26	138,415	115,346	109,275	69,208	57,673	54,638	3	2 to 8
15	25	143,952	119,960	113,646	71,976	59,980	56,823	2.9	2 to 8
17	28	145,666	121,388	114,999	72,833	60,694	57,500	2.9	2 to 8
17	27	151,061	125,884	119,258	75,530	62,942	59,629	2.8	2 to 8
17	26	156,871	130,726	123,845	78,435	65,363	61,923	2.7	2 to 8
19	28	162,803	135,669	128,529	81,401	67,835	64,264	2.6	2 to 8
19	27	168,833	140,694	133,289	84,416	70,347	66,644	2.5	2 to 8
17	24	169,943	141,619	134,166	84,972	70,810	67,083	2.5	2 to 8
17	23	177,332	147,777	139,999	88,666	73,888	70,000	2.4	2 to 8
19	25	182,339	151,949	143,952	91,170	75,975	71,976	2.3	2 to 8
19	24	189,937	158,281	149,950	94,968	79,140	74,975	2.2	2 to 8
23	28	197,077	164,231	155,587	98,539	82,115	77,794	2.1	2 to 8
19	23	198,195	165,162	156,470	99,097	82,581	78,235	2.1	2 to 8
24	28	205,646	171,371	162,352	102,823	85,686	81,176	2	2 to 8
24	27	213,262	177,718	168,365	106,631	88,859	84,182	2	2 to 8
17	19	214,665	178,888	169,473	107,333	89,444	84,736	1.9	2 to 8
24	26	221,465	184,554	174,840	110,732	92,277	87,420	1.9	2 to 8
26	28	222,783	185,652	175,881	111,391	92,826	87,941	1.9	2 to 8
24	25	230,323	191,936	181,834	115,162	95,968	90,917	1.8	2 to 8
26	27	231,034	192,528	182,395	115,517	96,264	91,198	1.8	2 to 8
23	23	239,920	199,933	189,410	119,960	99,967	94,705	1.7	2 to 8
27	26	249,148	207,623	196,695	124,574	103,812	98,348	1.7	2 to 8
24	23	250,351	208,626	197,646	125,176	104,313	98,823	1.7	2 to 8
25	23	260,783	217,319	205,881	130,391	108,659	102,940	1.6	2 to 8
19	17	268,146	223,455	211,694	134,073	111,727	105,847	1.6	2 to 8
27	24	269,910	224,925	213,087	134,955	112,462	106,543	1.5	2 to 8
28	24	279,907	233,255	220,979	139,953	116,628	110,489	1.5	2 to 8
23	19	290,429	242,024	229,286	145,215	121,012	114,643	1.4	2 to 8
28	23	292,076	243,397	230,587	146,038	121,699	115,293	1.4	2 to 8
24	19	303,057	252,547	239,255	151,528	126,274	119,628	1.4	2 to 8
25	19	315,684	263,070	249,224	157,842	131,535	124,612	1.3	2 to 8
23	17	324,598	270,498	256,261	162,299	135,249	128,131	1.3	2 to 8
26	19	328,311	273,593	259,193	164,156	136,796	129,597	1.3	2 to 8
27	19	340,939	284,116	269,162	170,469	142,058	134,581	1.2	2 to 8
28	19	353,566	294,639	279,131	176,783	147,319	139,566	1.2	2 to 8
26	17	366,936	305,780	289,687	183,468	152,890	144,843	1.1	2 to 8
27	17	381,049	317,541	300,828	190,525	158,771	150,414	1.1	2 to 8
28	17	395,162	329,302	311,970	197,581	164,651	155,985	1.1	2 to 8

NOTE: See [“General Planting Rate Information” on page 5-1](#) and [“Check Seed Population” on page 2-31](#) for additional information.

NOTE: When using Half Rate (2 To 1) Drive Reduction Package, rates are approximately 50% of given numbers.

NOTE: Always field check seed population to ensure planting rates are correct.

**PLANTING RATES FOR (VACUUM) CORN/SUNFLOWER 40 CELL DISC
15 TOOTH CONTACT WHEEL DRIVE/23 TOOTH REVERSER DRIVEN SPROCKETS (SEE PAGE 5-1)
APPROXIMATE SEEDS/ACRE FOR VARIOUS ROW WIDTHS**

15" Rows	30" Rows	Transmission Sprockets		Recomm. Speed (MPH)	Average Spacing In Inches
		Drive	Driven		
47,604	23,802	15	28	4 to 6	8.8
49,367	24,683	15	27	4 to 6	8.5
51,266	25,633	15	26	4 to 6	8.2
53,316	26,658	15	25	4 to 6	7.8
53,951	26,975	17	28	4 to 6	7.7
55,537	27,769	15	24	4 to 6	7.5
55,949	27,974	17	27	4 to 6	7.5
57,952	28,976	15	23	4 to 6	7.2
58,101	29,050	17	26	4 to 6	7.2
60,298	30,149	19	28	4 to 6	6.9
60,425	30,212	17	25	4 to 6	6.9
62,531	31,266	19	27	4 to 6	6.7
62,943	31,472	17	24	4 to 6	6.6
64,936	32,468	19	26	4 to 6	6.4
65,679	32,840	17	23	4 to 6	6.3
67,533	33,767	19	25	4 to 6	6.2
70,153	35,076	15	19	4 to 6	5.9
70,348	35,173	19	24	4 to 6	5.9
72,992	36,496	23	28	4 to 6	5.8
73,406	36,704	19	23	4 to 6	5.7
75,695	37,848	23	27	4 to 6	5.6
76,166	38,083	24	28	4 to 6	5.5
78,406	39,203	15	17	4 to 6	5.4
78,987	39,493	24	27	4 to 6	5.3
79,507	39,753	17	19	4 to 6	5.3
81,752	40,876	23	25	4 to 6	5.1
82,513	41,256	26	28	4 to 6	5.1
85,158	42,578	23	24	4 to 6	4.9
85,306	42,653	24	25	4 to 6	4.9
85,686	42,843	27	28	4 to 6	4.9
88,861	44,430	23	23	4 to 6	4.7
92,152	46,076	28	27	4 to 6	4.6
92,278	46,138	27	26	4 to 6	4.5
92,724	46,362	24	23	4 to 6	4.5
95,695	47,848	28	26	4 to 6	4.4
95,969	47,985	27	25	4 to 6	4.4
96,587	48,293	25	23	4 to 6	4.3
99,314	49,657	19	17	4 to 6	4.2
99,968	49,984	27	24	4 to 6	4.2
100,450	50,226	26	23	4 to 6	4.2
103,670	51,835	28	24	4 to 6	4.0
104,314	52,157	27	23	4 to 6	4.0
107,567	53,784	23	19	4 to 6	3.9
108,177	54,089	28	23	4 to 6	3.9
112,244	56,122	24	19	4 to 6	3.7
116,921	58,461	25	19	4 to 6	3.6
120,223	60,112	23	17	4 to 6	3.5
121,598	60,799	26	19	4 to 6	3.4
125,449	62,725	24	17	4 to 6	3.3
126,275	63,137	27	19	4 to 6	3.3
130,677	65,338	25	17	4 to 6	3.2
130,952	65,476	28	19	4 to 6	3.2
135,904	67,952	26	17	4 to 6	3.1
136,252	68,126	23	15	4 to 6	3.0
141,131	70,565	27	17	4 to 6	2.9

NOTE: See ["General Planting Rate Information" on page 5-1](#) and ["Check Seed Population" on page 2-31](#) for more information. Always field check seed population to verify planting rates.

**PLANTING RATES FOR (VACUUM) CORN/SUNFLOWER 40 CELL DISC
19 TOOTH CONTACT WHEEL DRIVE/23 TOOTH REVERSER DRIVEN SPROCKETS (SEE PAGE 5-1)
APPROXIMATE SEEDS/ACRE FOR VARIOUS ROW WIDTHS**

15" Rows	30" Rows	Transmission Sprockets		Recomm. Speed (MPH)	Average Spacing In Inches
		Drive	Driven		
60,298	30,149	15	28	4 to 6	6.9
62,531	31,266	15	27	4 to 6	6.7
64,936	32,468	15	26	4 to 6	6.4
67,533	33,767	15	25	4 to 6	6.2
68,337	34,169	17	28	4 to 6	6.1
70,348	35,173	15	24	4 to 6	5.9
70,869	35,435	17	27	4 to 6	5.9
73,406	36,704	15	23	4 to 6	5.7
73,595	36,797	17	26	4 to 6	5.7
76,377	38,189	19	28	4 to 6	5.5
76,538	38,269	17	25	4 to 6	5.5
79,206	39,603	19	27	4 to 6	5.3
79,727	39,864	17	24	4 to 6	5.3
82,252	41,126	19	26	4 to 6	5.1
83,194	41,597	17	23	4 to 6	5.1
85,543	42,771	19	25	4 to 6	4.9
88,861	44,430	15	19	4 to 6	4.7
89,107	44,554	19	24	4 to 6	4.7
92,456	46,229	23	28	4 to 6	4.5
92,982	46,490	19	23	4 to 6	4.5
95,881	47,941	23	27	4 to 6	4.4
96,477	48,238	24	28	4 to 6	4.3
99,314	49,657	15	17	4 to 6	4.2
100,050	50,025	24	27	4 to 6	4.2
100,709	50,354	17	19	4 to 6	4.2
103,552	51,775	23	25	4 to 6	4.0
104,517	52,258	26	28	4 to 6	4.0
107,867	53,933	23	24	4 to 6	3.9
108,054	54,027	24	25	4 to 6	3.9
108,536	54,268	27	28	4 to 6	3.9
112,556	56,278	23	23	4 to 6	3.7
116,725	58,362	28	27	4 to 6	3.6
116,885	58,443	27	26	4 to 6	3.6
117,450	58,725	24	23	4 to 6	3.6
121,214	60,607	28	26	4 to 6	3.4
121,561	60,781	27	25	4 to 6	3.4
122,344	61,172	25	23	4 to 6	3.4
125,798	62,899	19	17	4 to 6	3.3
126,626	63,313	27	24	4 to 6	3.3
127,238	63,618	26	23	4 to 6	3.3
131,316	65,657	28	24	4 to 6	3.2
132,131	66,066	27	23	4 to 6	3.1
136,252	68,126	23	19	4 to 6	3.0
137,025	68,513	28	23	4 to 6	3.0
142,176	71,109	24	19	4 to 6	2.9
148,101	74,050	25	19	4 to 6	2.8
152,282	76,141	23	17	4 to 6	2.7
154,025	77,012	26	19	4 to 6	2.7
158,903	79,451	24	17	4 to 6	2.6
159,949	79,974	27	19	4 to 6	2.6
165,524	82,762	25	17	4 to 6	2.5
165,873	82,936	28	19	4 to 6	2.5
172,145	86,073	26	17	4 to 6	2.4
172,587	86,293	23	15	4 to 6	2.4
178,766	89,383	27	17	4 to 6	2.3

NOTE: See ["General Planting Rate Information" on page 5-1](#) and ["Check Seed Population" on page 2-31](#) for more information. Always field check seed population to verify planting rates.

**PLANTING RATES FOR (VACUUM) MILO / SUGAR BEET / SPECIALTY / SOYBEAN 60 CELL DISCS
15 TOOTH CONTACT WHEEL DRIVE/23 TOOTH REVERSER DRIVEN SPROCKETS (SEE PAGE 5-1)**

APPROXIMATE SEEDS/ACRE FOR VARIOUS ROW WIDTHS

15" Rows	30" Rows	Transmission Sprockets		Recomm. Speed (MPH)	Average Spacing In Inches
		Drive	Driven		
71,406	35,703	15	28	4 to 6	5.9
74,050	37,025	15	27	4 to 6	5.6
76,898	38,449	15	26	4 to 6	5.4
79,974	39,987	15	25	4 to 6	5.2
80,926	40,463	17	28	4 to 6	5.2
83,306	41,653	15	24	4 to 6	5.0
83,924	41,962	17	27	4 to 6	5.0
86,928	43,464	15	23	4 to 6	4.8
87,151	43,576	17	26	4 to 6	4.8
90,447	45,223	19	28	4 to 6	4.6
90,637	45,319	17	25	4 to 6	4.6
93,797	46,898	19	27	4 to 6	4.5
94,414	47,207	17	24	4 to 6	4.4
97,404	48,702	19	26	4 to 6	4.3
98,519	49,259	17	23	4 to 6	4.2
101,301	50,650	19	25	4 to 6	4.1
105,229	52,615	15	19	4 to 6	4.0
105,521	52,761	19	24	4 to 6	4.0
109,488	54,744	23	28	4 to 6	3.8
110,109	55,055	19	23	4 to 6	3.8
113,544	56,772	23	27	4 to 6	3.7
114,249	57,124	24	28	4 to 6	3.7
117,609	58,805	15	17	4 to 6	3.6
118,480	59,240	24	27	4 to 6	3.5
119,260	59,630	17	19	4 to 6	3.5
122,627	61,314	23	25	4 to 6	3.4
123,770	61,885	26	28	4 to 6	3.4
127,737	63,868	23	24	4 to 6	3.3
127,959	63,979	24	25	4 to 6	3.3
128,530	64,265	27	28	4 to 6	3.3
133,290	66,645	23	23	4 to 6	3.1
138,227	69,113	28	27	4 to 6	3.0
138,417	69,208	27	26	4 to 6	3.0
139,086	69,543	24	23	4 to 6	3.0
143,543	71,772	28	26	4 to 6	2.9
143,954	71,977	27	25	4 to 6	2.9
144,881	72,440	25	23	4 to 6	2.9
148,971	74,486	19	17	4 to 6	2.8
149,952	74,976	27	24	4 to 6	2.8
150,676	75,338	26	23	4 to 6	2.8
155,505	77,753	28	24	4 to 6	2.7
156,471	78,236	27	23	4 to 6	2.7
161,351	80,676	23	19	4 to 6	2.6
162,266	81,133	28	23	4 to 6	2.6
168,367	84,183	24	19	4 to 6	2.5
175,382	87,691	25	19	4 to 6	2.4
180,334	90,167	23	17	4 to 6	2.3
182,397	91,199	26	19	4 to 6	2.3
188,175	94,087	24	17	4 to 6	2.2
189,413	94,706	27	19	4 to 6	2.2
196,015	98,008	25	17	4 to 6	2.1
196,428	98,214	28	19	4 to 6	2.1
203,856	101,928	26	17	4 to 6	2.1
204,378	102,189	23	15	4 to 6	2.0
211,696	105,848	27	17	4 to 6	2.0

NOTE: See ["General Planting Rate Information" on page 5-1](#) and ["Check Seed Population" on page 2-31](#) for more information. Always field check seed population to verify planting rates.

**PLANTING RATES FOR (VACUUM) MILO / SUGAR BEET / SPECIALTY / SOYBEAN 60 CELL DISCS
19 TOOTH CONTACT WHEEL DRIVE/23 TOOTH REVERSER DRIVEN SPROCKETS (SEE PAGE 5-1)**

APPROXIMATE SEEDS/ACRE FOR VARIOUS ROW WIDTHS

15" Rows	30" Rows	Transmission Sprockets		Recomm. Speed (MPH)	Average Spacing In Inches
		Drive	Driven		
90,447	45,223	15	28	4 to 6	4.6
93,797	46,898	15	27	4 to 6	4.5
97,404	48,702	15	26	4 to 6	4.3
101,301	50,650	15	25	4 to 6	4.1
102,507	51,253	17	28	4 to 6	4.1
105,521	52,761	15	24	4 to 6	4.0
106,303	53,152	17	27	4 to 6	3.9
110,109	55,055	15	23	4 to 6	3.8
110,392	55,196	17	26	4 to 6	3.8
114,566	57,283	19	28	4 to 6	3.7
114,807	57,404	17	25	4 to 6	3.6
118,809	59,405	19	27	4 to 6	3.5
119,591	59,796	17	24	4 to 6	3.5
123,379	61,689	19	26	4 to 6	3.4
124,791	62,395	17	23	4 to 6	3.4
128,314	64,157	19	25	4 to 6	3.3
133,290	66,645	15	19	4 to 6	3.1
133,661	66,830	19	24	4 to 6	3.1
138,685	69,343	23	28	4 to 6	3.0
139,472	69,736	19	23	4 to 6	3.0
143,822	71,911	23	27	4 to 6	2.9
144,715	72,358	24	28	4 to 6	2.9
148,971	74,486	15	17	4 to 6	2.8
150,075	75,037	24	27	4 to 6	2.8
151,062	75,531	17	19	4 to 6	2.8
155,328	77,664	23	25	4 to 6	2.7
156,775	78,387	26	28	4 to 6	2.7
161,800	80,900	23	24	4 to 6	2.6
162,081	81,040	24	25	4 to 6	2.6
162,805	81,402	27	28	4 to 6	2.6
168,834	84,417	23	23	4 to 6	2.5
175,087	87,544	28	27	4 to 6	2.4
175,328	87,664	27	26	4 to 6	2.4
176,175	88,087	24	23	4 to 6	2.4
181,822	90,911	28	26	4 to 6	2.3
182,341	91,171	27	25	4 to 6	2.3
183,516	91,758	25	23	4 to 6	2.3
188,697	94,349	19	17	4 to 6	2.2
189,939	94,969	27	24	4 to 6	2.2
190,856	95,428	26	23	4 to 6	2.2
196,973	98,487	28	24	4 to 6	2.1
198,197	99,098	27	23	4 to 6	2.1
204,378	102,189	23	19	4 to 6	2.0
205,537	102,769	28	23	4 to 6	2.0
213,264	106,632	24	19	4 to 6	2.0
222,150	111,075	25	19	4 to 6	1.9
228,423	114,211	23	17	4 to 6	1.8
231,036	115,518	26	19	4 to 6	1.8
238,354	119,177	24	17	4 to 6	1.8
239,923	119,961	27	19	4 to 6	1.7
248,286	124,143	25	17	4 to 6	1.7
248,809	124,404	28	19	4 to 6	1.7
	129,109	26	17	4 to 6	1.6
	129,440	23	15	4 to 6	1.6
	134,074	27	17	4 to 6	1.6

NOTE: See ["General Planting Rate Information" on page 5-1](#) and ["Check Seed Population" on page 2-31](#) for more information. Always field check seed population to verify planting rates.

**PLANTING RATES FOR (VACUUM) SPECIALTY 60 CELL DISC
30 TOOTH CONTACT WHEEL DRIVE/17 TOOTH REVERSER DRIVEN SPROCKETS (SEE PAGE 5-1)
APPROXIMATE SEEDS/ACRE FOR VARIOUS ROW WIDTHS**

15" Rows	30" Rows	Transmission Sprockets		Recomm. Speed (MPH)	Average Spacing In Inches
		Drive	Driven		
193,217	96,608	15	28	4 to 6	2.2
200,373	100,186	15	27	4 to 6	2.1
208,079	104,040	15	26	4 to 6	2.0
216,403	108,201	15	25	4 to 6	1.9
218,979	109,489	17	28	4 to 6	1.9
225,419	112,710	15	24	4 to 6	1.9
227,089	113,545	17	27	4 to 6	1.8
235,220	117,610	15	23	4 to 6	1.8
235,823	117,912	17	26	4 to 6	1.8
244,741	122,371	19	28	4 to 6	1.7
245,256	122,628	17	25	4 to 6	1.7
	126,903	19	27	4 to 6	1.6
NOTE: Planting rates over 250,000 seeds/acre are not recommended with subject seed disc and/or drive ratio.	127,738	17	24	4 to 6	1.6
	131,784	19	26	4 to 6	1.6
	133,291	17	23	4 to 6	1.6
	137,055	19	25	4 to 6	1.5
	142,370	15	19	4 to 6	1.5
	142,766	19	24	4 to 6	1.5
	148,133	23	28	4 to 6	1.4
	148,973	19	23	4 to 6	1.4
	153,619	23	27	4 to 6	1.4
	154,573	24	28	4 to 6	1.4
159,120	15	17	4 to 6	1.3	
160,298	24	27	4 to 6	1.3	
161,353	17	19	4 to 6	1.3	
165,909	23	25	4 to 6	1.3	
167,454	26	28	4 to 6	1.2	
172,822	23	24	4 to 6	1.2	
173,122	24	25	4 to 6	1.2	
173,895	27	28	4 to 6	1.2	
180,336	23	23	4 to 6	1.2	
187,015	28	27	4 to 6	1.1	
187,272	27	26	4 to 6	1.1	
188,176	24	23	4 to 6	1.1	
194,207	28	26	4 to 6	1.1	
194,762	27	25	4 to 6	1.1	
196,017	25	23	4 to 6	1.1	
201,551	19	17	4 to 6	1.0	
202,877	27	24	4 to 6	1.0	
203,858	26	23	4 to 6	1.0	
210,391	28	24	4 to 6	1.0	
211,698	27	23	4 to 6	1.0	
218,301	23	19	4 to 6	1.0	
219,539	28	23	4 to 6	1.0	
227,792	24	19	4 to 6	0.9	
237,284	25	19	4 to 6	0.9	
243,983	23	17	4 to 6	0.9	
246,775	26	19	4 to 6	0.8	
		24	17	4 to 6	0.8
		27	19	4 to 6	0.8
		25	17	4 to 6	0.8
		28	19	4 to 6	0.8
		26	17	4 to 6	0.8
		23	15	4 to 6	0.8
		27	17	4 to 6	0.7

NOTE: See ["General Planting Rate Information"](#) on page 5-1 and ["Check Seed Population"](#) on page 2-31 for more information. Always field check seed population to verify planting rates.

**PLANTING RATES FOR (VACUUM) SOYBEAN 120 CELL DISC
15 TOOTH CONTACT WHEEL DRIVE/23 TOOTH REVERSER DRIVEN SPROCKETS (SEE PAGE 5-1)
APPROXIMATE SEEDS/ACRE FOR VARIOUS ROW WIDTHS**

15" Rows	30" Rows	Transmission Sprockets		Recomm. Speed (MPH)	Average Spacing In Inches
		Drive	Driven		
142,811	71,406	15	28	4 to 6	2.9
148,100	74,050	15	27	4 to 6	2.8
153,796	76,898	15	26	4 to 6	2.7
159,948	79,974	15	25	4 to 6	2.6
161,852	80,926	17	28	4 to 6	2.6
166,613	83,306	15	24	4 to 6	2.5
167,847	83,924	17	27	4 to 6	2.5
173,857	86,928	15	23	4 to 6	2.4
174,303	87,151	17	26	4 to 6	2.4
180,894	90,447	19	28	4 to 6	2.3
181,275	90,637	17	25	4 to 6	2.3
187,594	93,797	19	27	4 to 6	2.2
188,828	94,414	17	24	4 to 6	2.2
194,809	97,404	19	26	4 to 6	2.1
197,038	98,519	17	23	4 to 6	2.1
202,601	101,301	19	25	4 to 6	2.1
210,458	105,229	15	19	4 to 6	2.0
211,043	105,521	19	24	4 to 6	2.0
218,977	109,488	23	28	4 to 6	1.9
220,219	110,109	19	23	4 to 6	1.9
227,087	113,544	23	27	4 to 6	1.8
228,498	114,249	24	28	4 to 6	1.8
235,218	117,609	15	17	4 to 6	1.8
236,961	118,480	24	27	4 to 6	1.8
238,519	119,260	17	19	4 to 6	1.8
245,254	122,627	23	25	4 to 6	1.7
247,539	123,770	26	28	4 to 6	1.7
	127,737	23	24	4 to 6	1.6
	127,959	24	25	4 to 6	1.6
	128,530	27	28	4 to 6	1.6
	133,290	23	23	4 to 6	1.6
	138,227	28	27	4 to 6	1.5
	138,417	27	26	4 to 6	1.5
	139,086	24	23	4 to 6	1.5
	143,543	28	26	4 to 6	1.5
	143,954	27	25	4 to 6	1.5
	144,881	25	23	4 to 6	1.4
	148,971	19	17	4 to 6	1.4
	149,952	27	24	4 to 6	1.4
	150,676	26	23	4 to 6	1.4
	155,505	28	24	4 to 6	1.3
	156,471	27	23	4 to 6	1.3
	161,351	23	19	4 to 6	1.3
	162,266	28	23	4 to 6	1.3
	168,367	24	19	4 to 6	1.2
	175,382	25	19	4 to 6	1.2
	180,334	23	17	4 to 6	1.2
	182,397	26	19	4 to 6	1.1
	188,175	24	17	4 to 6	1.1
	189,413	27	19	4 to 6	1.1
	196,015	25	17	4 to 6	1.1
	196,428	28	19	4 to 6	1.1
	203,856	26	17	4 to 6	1.0
	204,378	23	15	4 to 6	1.0
	211,696	27	17	4 to 6	1.0

NOTE: See ["General Planting Rate Information" on page 5-1](#) and ["Check Seed Population" on page 2-31](#) for more information. Always field check seed population to verify planting rates.

**PLANTING RATES FOR (VACUUM) SOYBEAN 120 CELL DISC
19 TOOTH CONTACT WHEEL DRIVE/23 TOOTH REVERSER DRIVEN SPROCKETS (SEE PAGE 5-1)
APPROXIMATE SEEDS/ACRE FOR VARIOUS ROW WIDTHS**

15" Rows	30" Rows	Transmission Sprockets		Recomm. Speed (MPH)	Average Spacing In Inches
		Drive	Driven		
180,894	90,447	15	28	4 to 6	2.3
187,594	93,797	15	27	4 to 6	2.2
194,809	97,404	15	26	4 to 6	2.1
202,601	101,301	15	25	4 to 6	2.1
205,013	102,507	17	28	4 to 6	2.0
211,043	105,521	15	24	4 to 6	2.0
212,606	106,303	17	27	4 to 6	2.0
220,219	110,109	15	23	4 to 6	1.9
220,783	110,392	17	26	4 to 6	1.9
229,132	114,566	19	28	4 to 6	1.8
229,615	114,807	17	25	4 to 6	1.8
237,619	118,809	19	27	4 to 6	1.8
239,182	119,591	17	24	4 to 6	1.7
246,758	123,379	19	26	4 to 6	1.7
249,581	124,791	17	23	4 to 6	1.7
	128,314	19	25	4 to 6	1.6
NOTE: Planting rates over 250,000 seeds/acre are not recommended with subject seed disc and/or drive ratio.	133,290	15	19	4 to 6	1.6
	133,661	19	24	4 to 6	1.6
	138,685	23	28	4 to 6	1.5
	139,472	19	23	4 to 6	1.5
	143,822	23	27	4 to 6	1.5
	144,715	24	28	4 to 6	1.4
	148,971	15	17	4 to 6	1.4
	150,075	24	27	4 to 6	1.4
	151,062	17	19	4 to 6	1.4
	155,328	23	25	4 to 6	1.3
156,775	26	28	4 to 6	1.3	
161,800	23	24	4 to 6	1.3	
162,081	24	25	4 to 6	1.3	
162,805	27	28	4 to 6	1.3	
168,834	23	23	4 to 6	1.2	
175,087	28	27	4 to 6	1.2	
175,328	27	26	4 to 6	1.2	
176,175	24	23	4 to 6	1.2	
181,822	28	26	4 to 6	1.1	
182,341	27	25	4 to 6	1.1	
183,516	25	23	4 to 6	1.1	
188,697	19	17	4 to 6	1.1	
189,939	27	24	4 to 6	1.1	
190,856	26	23	4 to 6	1.1	
196,973	28	24	4 to 6	1.1	
198,197	27	23	4 to 6	1.1	
204,378	23	19	4 to 6	1.0	
205,537	28	23	4 to 6	1.0	
213,264	24	19	4 to 6	1.0	
222,150	25	19	4 to 6	0.9	
228,423	23	17	4 to 6	0.9	
231,036	26	19	4 to 6	0.9	
238,354	24	17	4 to 6	0.9	
239,923	27	19	4 to 6	0.9	
248,286	25	17	4 to 6	0.8	
248,809	28	19	4 to 6	0.8	
		26	17	4 to 6	0.8
		23	15	4 to 6	0.8
		27	17	4 to 6	0.8

NOTE: See ["General Planting Rate Information"](#) on page 5-1 and ["Check Seed Population"](#) on page 2-31 for more information. Always field check seed population to verify planting rates.

Wheat Disc Section

Use a 28 tooth Drive sprocket and a 27 tooth Driven sprocket

Drive	Driven	RPM/GS
27	28	3.671
15	15	3.807
28	27	3.948
27	26	3.953

FOR HYDRAULIC DRIVE (BRUSH-TYPE AND VACUUM) AND ELECTRIC DRIVE (VACUUM)

- a. Brush-Type: use the instructions found on page 5 to find the seeds per revolution (SDS/REV). The SDS/REV will be relatively constant at all speeds for the Brush-Type Meter
- b. Vacuum: use the instructions found on page 5 to find the seeds per revolution (SDS/REV) or look it up in Rate Chart on pages 3-4. The SDS/REV will decrease as the disc speed increases (less SDS/REV as ground speed increases) for the True Rate Vacuum Meter.
- c. Divide the SDS/REV by the number of Cells to get the SDS/CELL. Some display may not support 54 cells as an option for number of cells on a seed disc, in that case, substitute a useable number of cells (60 or 40) and use that Cell number in the calculation. DO NOT PHYSICALLY CHANGE THE DISC, THE CELL COUNT IS FOR THE MONITOR ONLY.
- d. Divide your target population by the SDS/CELL to get your Monitor Population.

Seed Meter Type	Target Population	SDS/REV	Cells	SDS/CELL	Monitor Population
Brush	800,000	465	54	8.611	92,903
Brush	1,200,000	465	54	8.611	139,355
Vacuum	808,755	891	54	16.500	49,015
Vacuum	1,195,655	771	54	14.278	83,742
Vacuum	808,755	891	60	14.85	54,461
Vacuum	1,195,655	771	60	12.85	93,047

PLANTING RATES FOR BRUSH-TYPE SEED METERS (HALF RATE DRIVE)
APPROXIMATE SEEDS/ACRE FOR 15" ROW WIDTH

Transmission Sprockets		Population Factor	Rye		Wheat		Speed Range (MPH)
Drive	Driven		400 SDS/REV, 35.9 SDS/GRAM	465 SDS/REV, 39.6 SDS/GRAM	Population (sds/acre)	Population (lbs/acre)	
15	28	1190.12	476,159	29	553,656	31	4 to 6
15	27	1234.20	493,795	30	574,163	32	4 to 6
15	26	1281.67	512,787	32	596,245	33	4 to 6
15	25	1332.94	533,298	33	620,095	35	4 to 6
17	28	1348.80	539,647	33	627,477	35	4 to 6
15	24	1388.48	555,519	34	645,932	36	4 to 6
17	27	1398.76	559,634	34	650,718	36	4 to 6
15	23	1448.84	579,672	36	674,017	38	4 to 6
17	26	1452.56	581,158	36	675,745	38	4 to 6
19	28	1507.49	603,134	37	701,298	39	4 to 6
17	25	1510.66	604,405	37	702,775	39	4 to 6
19	27	1563.32	625,473	38	727,272	41	4 to 6
17	24	1573.60	629,588	39	732,056	41	4 to 6
19	26	1623.45	649,530	40	755,244	42	4 to 6
17	23	1642.02	656,961	40	763,885	43	4 to 6
19	25	1688.39	675,511	42	785,454	44	4 to 6
15	19	1753.86	701,708	43	815,915	45	4 to 6
19	24	1758.74	703,658	43	818,181	46	4 to 6
23	28	1824.85	730,111	45	848,940	47	4 to 6
19	23	1835.20	734,251	45	853,754	48	4 to 6
23	27	1892.44	757,152	47	880,382	49	4 to 6
24	28	1904.19	761,855	47	885,850	49	4 to 6
15	17	1960.20	784,262	48	911,905	51	4 to 6
23	26	1965.23	786,273	48	914,242	51	4 to 6
24	27	1974.72	790,071	49	918,660	51	4 to 6
25	28	1983.54	793,598	49	922,761	51	4 to 6
17	19	1987.71	795,269	49	924,703	52	4 to 6
23	25	2043.84	817,724	50	950,813	53	4 to 6
24	26	2050.67	820,459	50	953,993	53	4 to 6
25	27	2057.00	822,991	51	956,937	53	4 to 6
26	28	2062.88	825,342	51	959,671	53	4 to 6
23	24	2128.99	851,795	52	990,429	55	4 to 6
24	25	2132.70	853,277	52	992,152	55	4 to 6
25	26	2136.11	854,644	53	993,742	55	4 to 6
26	27	2139.28	855,911	53	995,215	55	4 to 6
27	28	2142.22	857,087	53	996,582	56	4 to 6
15	15	2221.56	888,830	55	1,033,492	58	4 to 6
28	27	2303.84	921,750	57	1,071,769	60	4 to 6
27	26	2307.01	923,016	57	1,073,242	60	4 to 6
26	25	2310.42	924,384	57	1,074,832	60	4 to 6
25	24	2314.13	925,865	57	1,076,554	60	4 to 6
24	23	2318.15	927,475	57	1,078,426	60	4 to 6
28	26	2392.45	957,202	59	1,112,991	62	4 to 6
27	25	2399.28	959,937	59	1,116,171	62	4 to 6
26	24	2406.69	962,899	59	1,119,616	62	4 to 6
25	23	2414.74	966,120	59	1,123,361	63	4 to 6
19	17	2482.92	993,399	61	1,155,079	64	4 to 6

Continued on the next page.

**PLANTING RATES FOR BRUSH-TYPE SEED METERS (HALF RATE DRIVE)
APPROXIMATE SEEDS/ACRE FOR 15" ROW WIDTH**

Transmission Sprockets		Population Factor	Rye 400 SDS/REV, 35.9 SDS/GRAM		Wheat 465 SDS/REV, 39.6 SDS/GRAM		Speed Range (MPH)
Drive	Driven		Population (sds/acre)	Population (lbs/acre)	Population (sds/acre)	Population (lbs/acre)	
28	25	2488.15	995,490	61	1,157,511	64	4 to 6
27	24	2499.26	999,934	61	1,162,678	65	4 to 6
26	23	2511.33	1,004,765	62	1,168,295	65	4 to 6
17	15	2517.77	1,007,341	62	1,171,291	65	4 to 6
28	24	2591.82	1,036,969	64	1,205,741	67	4 to 6
27	23	2607.92	1,043,409	64	1,213,230	68	4 to 6
23	19	2689.26	1,075,952	66	1,251,069	70	4 to 6
28	23	2704.51	1,082,054	67	1,258,164	70	4 to 6
24	19	2806.18	1,122,733	69	1,305,464	73	4 to 6
19	15	2813.98	1,125,852	69	1,309,090	73	4 to 6
25	19	2923.10	1,169,513	72	1,359,857	76	4 to 6
23	17	3005.64	1,202,535	74	1,398,254	78	4 to 6
26	19	3040.03	1,216,294	75	1,414,252	79	4 to 6
24	17	3136.32	1,254,820	77	1,459,048	81	4 to 6
27	19	3156.95	1,263,075	78	1,468,647	82	4 to 6
25	17	3267.00	1,307,103	80	1,519,841	85	4 to 6
28	19	3273.88	1,309,855	81	1,523,041	85	4 to 6
26	17	3397.68	1,359,388	84	1,580,635	88	4 to 6
23	15	3406.39	1,362,873	84	1,584,687	88	4 to 6
27	17	3528.36	1,411,671	87	1,641,428	91	4 to 6
24	15	3554.50	1,422,128	87	1,653,587	92	4 to 6
28	17	3659.04	1,463,956	90	1,702,222	95	4 to 6
25	15	3702.60	1,481,384	91	1,722,487	96	4 to 6
26	15	3850.70	1,540,639	95	1,791,386	100	4 to 6
27	15	3998.81	1,599,895	98	1,860,286	104	4 to 6
28	15	4146.91	1,659,150	102	1,929,185	107	4 to 6

NOTE: Seed size and type affect the output rate of the meter. For a method to improve the population accuracy with your desired seed, please see the following pages.

NOTE: See "Mechanical Meter" in ["General Planting Rate Information" on page 5-1](#) and ["Check Seed Population" on page 2-31](#) for additional information.

NOTE: When using Half Rate (2 To 1) Drive Reduction Package, rates are approximately 50% of given numbers.

NOTE: Always field check seed population to ensure planting rates are correct.

To more accurately predict population when using the 54 Cell Wheat disc, two things are needed:

1. Seeds/gram
2. Grams/revolution of seed disc

Seeds per gram can be found by weighing a small sample of desired seed (a cup or less) and counting number of seeds in sample.

$$\frac{\text{Seeds}}{\text{Grams}} = \frac{\text{number of seeds in sample}}{\text{weight of sample in grams}} \quad \frac{396 \text{ Seeds}}{10 \text{ Grams}} = 39.6 \frac{\text{seeds}}{\text{gram}}$$

To find grams/revolution a gram scale, a stopwatch, a small container to catch seed, and a method for spinning the meter at a constant, known rpm (see your local Kinze dealer with a T4000 Seed Meter Test Stand) are needed.

1. Zero gram scale with the small container on it.
2. Load meter with correct disc.
3. Load meter with desired seed.
4. Start spinning meter at a known, constant rpm.
5. Start stopwatch as you place container under meter.
6. Catch seed with container for 10-30 seconds.
7. Stop the stopwatch as you remove container from underneath meter.
8. Weigh container.
9. Enter meter rpm, weight of sample, and duration of sample collection into the equation below:

$$\frac{\text{Grams}}{\text{Rev}} = \frac{\text{Sample Weight} * 60}{\text{Disc RPM} * \text{Sample Duration}}$$

EX: For a sample taken for 30 seconds with meter spinning at 50rpm and weighs 293 grams

$$\frac{293 \text{ Grams} * 60}{50 \text{ RPM} * 30 \text{ Seconds}} = 11.7 \frac{\text{Grams}}{\text{Rev}}$$

10. Find desired output rate. For seeds per acre, use seeds/rev. For pounds per acre, use lbs/rev.

a. Seeds/rev:

$$\frac{\text{Seeds}}{\text{Rev}} = \frac{\text{Seeds}}{\text{Grams}} * \frac{\text{Grams}}{\text{Rev}} \quad \left| \quad 39.6 \frac{\text{Seeds}}{\text{Grams}} * 11.7 \frac{\text{Grams}}{\text{Rev}} = 465 \frac{\text{Seeds}}{\text{Rev}} \right.$$

b. Lbs./rev:

$$\frac{\text{Pounds}}{\text{Rev}} = \frac{\frac{\text{Grams}}{\text{Rev}}}{453.6 \frac{\text{Grams}}{\text{Pound}}} \quad \left| \quad \frac{11.7 \frac{\text{Grams}}{\text{Rev}}}{453.6 \frac{\text{Grams}}{\text{Pound}}} = 0.0258 \frac{\text{Pounds}}{\text{Rev}} \right.$$

11. Find the correct population factor by dividing the desired population by the measured output rate.

Seeds/acre:

$$\frac{\text{Target Population}}{\text{Output Rate}} = \text{Population Factor} \quad \left| \quad \frac{1,000,000 \frac{\text{Seeds}}{\text{Acre}}}{465 \frac{\text{Seeds}}{\text{Rev.}}} = 2150.54$$

pounds/acre:

$$\frac{\text{Target Population}}{\text{Output Rate}} = \text{Population Factor} \quad \left| \quad \frac{56 \frac{\text{lbs}}{\text{Acre}}}{0.0258 \frac{\text{lbs}}{\text{rev}}} = 2170.54$$

12. Find the closest Population Factor in the Rate Chart to identify the correct transmission sprockets. For the examples list above, the closest Population Factor is 2142.22 which corresponds to a 27 tooth Drive sprocket and 28 tooth Driven sprocket.

NOTE: Multiple trials are recommended to increase the accuracy of the predicted rate.

**PLANTING RATES FOR (VACUUM) WHEAT 54 CELL DISC
(HALF RATE DRIVE [15 TOOTH])
APPROXIMATE SEEDS/ACRE FOR 15" ROW WIDTH**

Transmission Sprockets		RPM/GS (Seed Disc RPM To Ground Speed (MPH))	81NH2O, no sigulator		81NH2O, sigulator 3.3		Speed Range (MPH)
Drive	Driven		SDS/REV	Population	SDS/REV	Population	
15	28	2.039	909	744,562	554	453,298	5 to 7
15	27	2.115	903	764,594	551	465,585	5 to 7
15	26	2.196	897	785,948	547	478,707	5 to 7
15	25	2.284	891	808,755	543	492,751	5 to 7
17	28	2.311	888	815,760	542	497,071	5 to 7
15	24	2.379	883	833,164	539	507,816	5 to 7
17	27	2.397	882	837,650	539	510,588	5 to 7
15	23	2.483	876	859,343	535	524,013	5 to 7
17	26	2.489	875	860,943	535	525,004	5 to 7
19	28	2.583	868	884,424	531	539,571	5 to 7
17	25	2.589	868	885,771	530	540,408	5 to 7
19	27	2.679	861	907,980	527	554,221	5 to 7
17	24	2.697	860	912,286	526	556,903	5 to 7
19	26	2.782	854	932,998	522	569,822	5 to 7
17	23	2.814	852	940,653	521	574,605	5 to 7
19	25	2.893	846	959,608	518	586,466	5 to 7
15	19	3.006	838	986,010	513	603,032	5 to 7
19	24	3.014	837	987,957	513	604,256	5 to 7
23	28	3.127	829	1,014,147	508	620,748	5 to 7
19	23	3.145	828	1,018,206	508	623,310	5 to 7
23	27	3.243	821	1,040,464	504	637,378	5 to 7
24	28	3.263	819	1,044,993	503	640,247	5 to 7
15	17	3.359	813	1,066,386	499	653,818	5 to 7
23	26	3.368	812	1,068,291	499	655,029	5 to 7
24	27	3.384	811	1,071,881	498	657,311	5 to 7
25	28	3.399	810	1,075,206	497	659,426	5 to 7
17	19	3.406	809	1,076,779	497	660,427	5 to 7
23	25	3.502	803	1,097,745	493	673,790	5 to 7
24	26	3.514	802	1,100,276	493	675,407	5 to 7
25	27	3.525	801	1,102,616	493	676,902	5 to 7
26	28	3.535	801	1,104,786	492	678,288	5 to 7
23	24	3.648	793	1,128,951	488	693,762	5 to 7
24	25	3.655	792	1,130,291	487	694,622	5 to 7
25	26	3.661	792	1,131,527	487	695,416	5 to 7
26	27	3.666	792	1,132,671	487	696,150	5 to 7
27	28	3.671	791	1,133,732	487	696,831	5 to 7
15	15	3.807	782	1,162,044	482	715,055	5 to 7
28	27	3.948	772	1,190,735	476	733,619	5 to 7
27	26	3.953	772	1,191,825	476	734,326	5 to 7
26	25	3.959	772	1,193,001	476	735,089	5 to 7
25	24	3.966	771	1,194,273	476	735,915	5 to 7
24	23	3.973	771	1,195,655	475	736,812	5 to 7
28	26	4.100	762	1,220,871	471	753,227	5 to 7
27	25	4.112	762	1,223,163	470	754,723	5 to 7
26	24	4.124	761	1,225,641	470	756,341	5 to 7
25	23	4.138	760	1,228,328	469	758,097	5 to 7
19	17	4.255	752	1,250,825	465	772,837	5 to 7
28	25	4.264	752	1,252,531	465	773,957	5 to 7
27	24	4.283	750	1,256,146	464	776,334	5 to 7
26	23	4.304	749	1,260,061	463	778,909	5 to 7
17	15	4.315	748	1,262,143	463	780,280	5 to 7
28	24	4.442	740	1,285,788	458	795,893	5 to 7

Continued on next page.

**PLANTING RATES FOR (VACUUM) WHEAT 54 CELL DISC
(HALF RATE DRIVE [15 TOOTH])
APPROXIMATE SEEDS/ACRE FOR 15" ROW WIDTH**

Transmission Sprockets		RPM/GS (Seed Disc RPM To Ground Speed (MPH))	81NH20, no sigulator		81NH20, sigulator 3.3		Speed Range (MPH)
Drive	Driven		SDS/REV	Population	SDS/REV	Population	
27	23	4.469	738	1,290,855	457	799,250	5 to 7
23	19	4.609	729	1,316,059	452	816,013	5 to 7
28	23	4.635	728	1,320,711	451	819,119	5 to 7
24	19	4.809	717	1,351,123	445	839,524	5 to 7
19	15	4.822	716	1,353,411	445	841,067	5 to 7
25	19	5.009	704	1,384,810	438	862,343	5 to 7
23	17	5.151	695	1,407,761	433	878,034	5 to 7
26	19	5.210	692	1,417,121	431	884,470	5 to 7
24	17	5.375	682	1,442,697	426	902,174	5 to 7
27	19	5.410	680	1,448,057	425	905,906	5 to 7
25	17	5.599	668	1,475,915	419	925,450	5 to 7
28	19	5.610	668	1,477,616	418	926,651	5 to 7
26	17	5.823	655	1,507,414	412	947,862	5 to 7
23	15	5.837	654	1,509,452	411	949,325	5 to 7
27	17	6.046	642	1,537,193	405	969,410	5 to 7
24	15	6.091	640	1,542,943	403	973,616	5 to 7
28	17	6.270	630	1,565,254	398	990,094	5 to 7
25	15	6.345	625	1,574,226	395	996,797	5 to 7
26	15	6.599	611	1,603,300	388	1,018,868	5 to 7
27	15	6.853	598	1,630,167	381	1,039,830	5 to 7
28	15	7.106	584	1,654,826	374	1,059,683	5 to 7

1. Identify planting parameters and record in Table #1.
2. Weigh small sample of seeds and complete Table #2.
3. Use a device to spin the meter at a constant, measured RPM (Seed Meter Test Stand T4000). Set the RPM to settings in the table below (15, 20, 25, 30) and collect a sample of seed coming out of the meter. It is recommended to start with a Vacuum pressure of 8INH₂O and removing the singulator. Increasing the vacuum pressure will increase the SDS/REV while using the singulator will decrease the SDS/REV. Weigh the sample of seed and record the length of time the sample was collected in Table #3.
4. Complete Table #3 for each RPM setting using information from Tables 1 and 2. Variables with the subscript “[RPM]” uses the values in the same row in Table #3.
5. Choose the 2 closest populations to your desired target population and add them to Table #4 with their respective seeds per rev.
6. Complete Table #4 and calculate the approximate seeds per rev.
7. Calculate Seed Disc RPM/Ground Speed Ratio in Table #5.
8. Select the closest RPM/GS (Seed Disc RPM to Ground Speed (mph)) in the rate chart and use that Drive and Driven pair.

Table #1				Table #2	
Target Population [seeds/acre] (Pop_{TAR})				Number of Seeds (N)	
Ideal Planting Ground Speed [mph] (GS)				Weight of sample [grams] (W)	
Planter Row Spacing [in] (RS)				Seeds/ Gram = N/W (SG)	
Table #3					
			$SR_{RPM} = \frac{W_{RPM}}{t_{RPM}} \times \left(\frac{60}{RPM}\right) \times SG$		$Pop_{RPM} = \frac{SR_{RPM} \times RPM \times 5940}{GS \times RS}$
Vacuum Pressure	Disc RPM	Weight [grams] (W_{RPM})	Time [sec.] (t_{RPM})	Seeds/ Rev (SR_{RPM})	Population (Pop_{RPM})
	15				
Sing. Setting	20				
	25				
	30				
Table #4					
<i>Pop₁</i>		<i>Pop₂</i>		<i>Pop_{TAR}</i>	
<i>SR₁</i>		<i>SR₂</i>			
$SR_{TAR} = \left(\frac{SR_2 - SR_1}{Pop_2 - Pop_1}\right) \times (Pop_{TAR} - Pop_1) + SR_1$					
Table #5					
GS		$RPM_{TAR} = \frac{Pop_{TAR} \times GS \times RS}{5940 \times SR_{TAR}}$			
RS					
<i>Pop_{TAR}</i>		$\frac{RPM_{Tar}}{GS}$			
<i>SR_{TAR}</i>					

NOTE: Additional worksheets can be found on [page 5-24](#)

Example.

Table #1				Table #2	
Target Population [seeds/acre] (Pop_{TAR})	1,200,000			Number of Seeds (N)	259
Ideal Planting Ground Speed [mph] (GS)	6mph			Weight of sample [grams] (W)	10.01
Planter Row Spacing [in] (RS)	15 in.			Seeds/ Gram = N/W (SG)	25.88
Table #3					
			$SR_{RPM} = \frac{W_{RPM}}{t_{RPM}} \times \left(\frac{60}{RPM}\right) \times SG$		$Pop_{RPM} = \frac{SR_{RPM} \times RPM \times 5940}{GS \times RS}$
Vacuum Pressure	Disc RPM	Weight [grams] (W_{RPM})	Time [sec.] (t_{RPM})	Seeds/ Rev (SR_{RPM})	Population (Pop_{RPM})
8	15	$\frac{765}{90.43} \times \left(\frac{60}{15}\right) \times 25.88 = 875.7$		$\frac{875.7 \times 15 \times 5940}{6 \times 15} = 866,943$	
		765	90.43	875.7	866,943
Sing. Setting	20	$\frac{640}{60.55} \times \left(\frac{60}{20}\right) \times 25.88 = 820.6$		$\frac{820.6 \times 20 \times 5940}{6 \times 20} = 1,083,192$	
		640	60.55	820.6	1,083,192
removed	25	$\frac{1101}{90.1} \times \left(\frac{60}{25}\right) \times 25.88 = 759$		$\frac{759 \times 25 \times 5940}{6 \times 25} = 1,252,350$	
		1101	90.1	759	1,252,350
removed	30	$\frac{840}{60.58} \times \left(\frac{60}{30}\right) \times 25.88 = 717.7$		$\frac{717.7 \times 30 \times 5940}{6 \times 30} = 1,252,350$	
		840	60.58	717.7	1,421,046
Table #4					
Pop₁	1,083,192	Pop₂	1,252,350	Pop_{TAR}	1,200,000
SR₁	820.6	SR₂	756		
$SR_{TAR} = \left(\frac{SR_2 - SR_1}{Pop_2 - Pop_1}\right) \times (Pop_{TAR} - Pop_1) + SR_1$					776.0
$\left(\frac{756 - 820.6}{1,252,350 - 1,083,192}\right) \times (1,200,000 - 1,083,192) + 820.6 = 776.0$					
Table #5					
GS	6mph	$RPM_{TAR} = \frac{Pop_{TAR} \times GS \times RS}{5940 \times SR_{TAR}}$		23.4	
RS	15 in				
Pop_{TAR}	1,200,000	$\frac{1,200,000 \times 6 \times 15}{5940 \times 776} = 23.4$		23.4	
SR_{TAR}	776.0				
		$\frac{RPM_{Tar}}{GS} = \frac{23.4}{6} = 3.905$		3.905	

Additional Worksheet

Table #1				Table #2	
Target Population [seeds/acre] (Pop_{TAR})				Number of Seeds (N)	
Ideal Planting Ground Speed [mph] (GS)				Weight of sample [grams] (W)	
Planter Row Spacing [in] (RS)				Seeds/ Gram = N/W (SG)	
Table #3					
			$SR_{RPM} = \frac{W_{RPM}}{t_{RPM}} \times \left(\frac{60}{RPM}\right) \times SG$		$Pop_{RPM} = \frac{SR_{RPM} \times RPM \times 5940}{GS \times RS}$
Vacuum Pressure	Disc RPM	Weight [grams] (W_{RPM})	Time [sec.] (t_{RPM})	Seeds/ Rev (SR_{RPM})	Population (Pop_{RPM})
	15				
Sing. Setting	20				
	25				
	30				
Table #4					
<i>Pop₁</i>		<i>Pop₂</i>		<i>Pop_{TAR}</i>	
<i>SR₁</i>		<i>SR₂</i>			
$SR_{TAR} = \left(\frac{SR_2 - SR_1}{Pop_2 - Pop_1}\right) \times (Pop_{TAR} - Pop_1) + SR_1$					
Table #5					
GS		$RPM_{TAR} = \frac{Pop_{TAR} \times GS \times RS}{5940 \times SR_{TAR}}$			
RS					
<i>Pop_{TAR}</i>		$\frac{RPM_{Tar}}{GS}$			
<i>SR_{TAR}</i>					

DRY INSECTICIDE APPLICATION RATES
APPROXIMATE POUNDS/ACRE AT 5 MPH FOR 30" ROW
WIDTH

Meter Setting	30" Rows
CLAY GRANULES	
10	4.9
11	5.4
12	6.1
13	6.9
14	7.7
15	8.5
16	9.6
17	10.7
18	11.4
19	13.1
20	14.2
21	15.5
22	16.4
23	17.2
24	18.8
25	20.9
26	23.0
27	24.1
28	25.4
29	27.8
30	29.6
SAND GRANULES	
5	2.9
6	4.9
7	5.3
8	6.3
9	7.8
10	8.9
11	10.2
12	11.2
13	12.6
14	14.1
15	15.5
16	17.5
17	19.4
18	21.8
19	24.3
20	25.7
21	27.6
22	29.6
23	32.0
24	34.4
25	36.9

NOTE: Chart represents average values and should be used only as a starting point. Granular chemical flows through meter opening at a nearly uniform rate regardless of roller speed. Your actual rate will vary depending on insecticide, planting speed, and plant population. Planting speed/ground speed has the greatest effect on application rate.

Field check your actual rate with insecticide you are using at speed and population you will be planting. See ["Granular Chemical Application Field Check"](#) on page 2-33 page for more information.

**DRY HERBICIDE APPLICATION RATES
APPROXIMATE POUNDS/ACRE AT 5 MPH FOR 30" ROW WIDTH**

Clay Granules

Meter Setting	30" Rows
10	4.7
11	5.2
12	5.8
13	6.5
14	7.3
15	8.2
16	9.0
17	9.9
18	10.7
19	11.6
20	12.6
21	13.6
22	14.6
23	15.7
24	17.0
25	18.1
26	19.4
27	20.9
28	22.6
29	24.3
30	26.7

NOTE: Above chart represents average values and should be used only as a starting point. Granular chemical flows through given meter opening at a nearly uniform rate regardless of roller speed. Your actual rate will vary depending on specific herbicide, planting speed, and plant population. Planting speed/ground speed has the greatest effect on application rate.

Field check your actual rate with herbicide you are using at speed and population you will be planting. See ["Granular Chemical Application Field Check" on page 2-33](#) for more information.

DRY FERTILIZER APPLICATION RATES

APPROXIMATE RATE IN POUNDS PER ACRE

Drive Sprocket	Driven Sprocket	Low Rate Position 30" Rows	High Rate Position 30" Rows
15	35	32	94
15	33	36	109
15	30	39	120
19	33	45	135
19	30	50	153
15	19	58	174
30	35	61	188
30	33	67	200
33	35	69	206
35	33	76	214
33	30	81	241
19	15	93	278
30	19	116	347
33	19	127	382
35	19	133	402
30	15	146	440
33	15	161	482
35	15	168	510

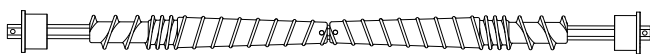

High rate setting

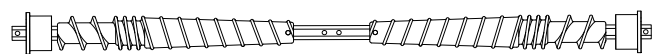

Low rate setting

NOTE: Uneven delivery may result from attempting to use lower rates than indicated by chart.

Chart is for planters equipped with contact drive. Check tires for correct operating pressure.

Chart calculated with a bulk density of 65 pounds per cubic foot.

NOTE: Fertilizer application rates can vary from weights calculated in above chart. Make field checks to be sure you are applying fertilizer at desired rate.

To check exact number of pounds your fertilizer attachment will actually deliver on a 30" row spacing:

1. Remove one spout from one fertilizer hopper and attach a container under opening.
2. Engage fertilizer attachment and drive forward 174'.
3. Weigh amount of fertilizer caught in container and multiply by 100. Result is pounds of fertilizer delivered per acre when planting in 30" rows.

LIQUID FERTILIZER PISTON PUMP APPLICATION RATES GALLONS PER ACRE

Applies to Model NGP-6055 Pumps With 50 Tooth Drive And 18 Tooth Driven Sprocket

Pump Setting	2	3	4	5	6	7	8	9	10
6 Row 30"	11.0	16.5	22.0	27.5	33.0	38.5	44.0	49.5	55.0
8 Row 30"	8.3	12.4	16.5	20.6	24.8	28.9	33.0	37.1	41.3

Chart is for planters equipped with contact drive. Check tires for correct operating pressure. Chart based on average wheel slippage and liquid viscosities.

Measure and weigh one gallon of actual fertilizer solution to determine exact application rate. Chart calculated based on a solution weighing ten pounds per gallon.

NOTE: Fertilizer application rates can vary from weights calculated in above chart. Make field checks to be sure you are applying fertilizer at desired rate.

NOTE: Periodically check flow to all rows. Desired rate is delivered to remaining rows keeping total application rate at desired rate if one or more lines are plugged.

To check exact number of gallons your fertilizer attachment delivers on a 30" row spacing:

1. Remove hose from one fertilizer opener and insert it into a collection container secured to planter frame.
2. Engage fertilizer attachment and drive forward for 174'.
3. Measure fluid ounces caught in container and multiply by 100. Divide that by 128. Result is gallons of fertilizer delivered per acre when planting in 30" rows.
4. Rinse collection container and repeat test on other rows if necessary.

LUBRICATION

Following pages show locations of all lubrication points. Proper lubrication of moving parts helps ensure efficient operation of your Kinze planter and prolongs the life of friction producing parts.

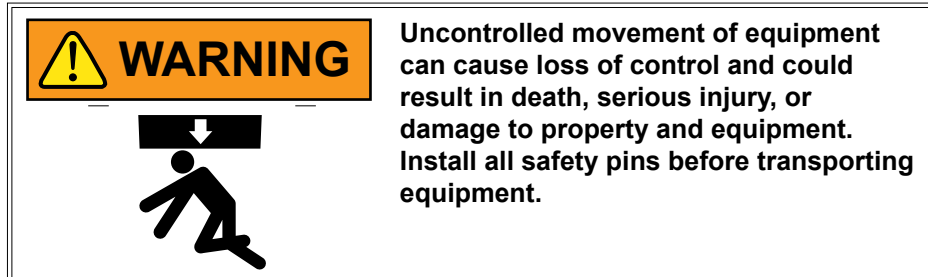

LUBRICATION SYMBOLS

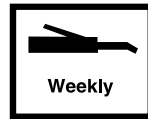
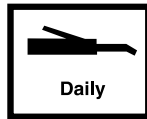

Lubricate at frequency indicated with SAE multipurpose grease.



Lubricate at frequency indicated with high quality SAE 10 weight oil or spray lubricant.

SEALED BEARINGS

Sealed bearings are used on your Kinze planter to provide trouble free operation.

These are located on drive shafts, row units, and transmission bearings. Sealed bearings are lubricated for life and are not serviceable.

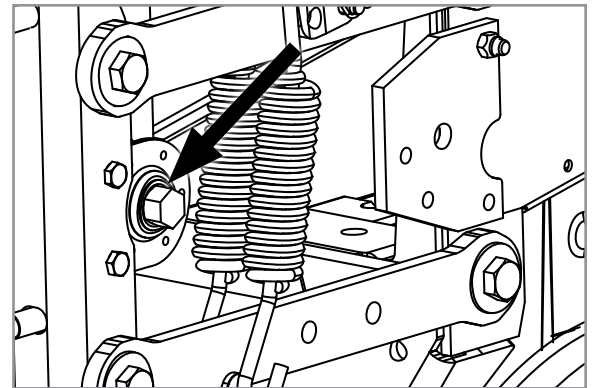

Sealed bearing (Typical)

WRAP SPRING WRENCH ASSEMBLY

1. Remove ¼"-20 x ½" cap screw securing idler assembly to wrap spring wrench tightener shaft and
2. Remove wrap spring wrench from planter.
3. Tip wrap spring wrench on its side and lubricate with a high quality spray lubricant. Lubricant must be absorbed into wrap spring area.
4. Reinstall wrap spring wrench on planter.



Wrap spring wrench lubrication

DRIVE CHAINS

Lubricate all transmission and drive chains daily with a high quality chain lubricant. Extreme operating conditions such as dirt, temperature, or speed may require more frequent lubrication. If a chain becomes stiff, it should be removed, soaked, and washed in solvent to loosen and remove dirt from joints. Soak chain in oil so lubricant can penetrate between rollers and bushings.

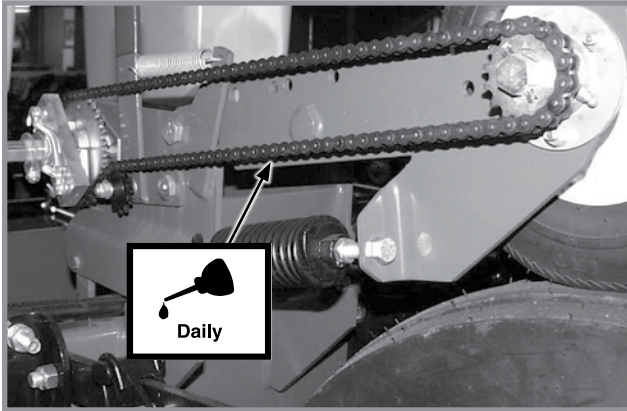

Contact Wheel Drive Chain

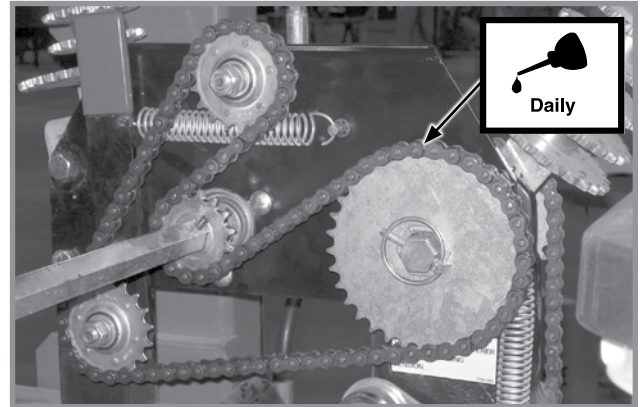

Reverser Plate Chain Drive

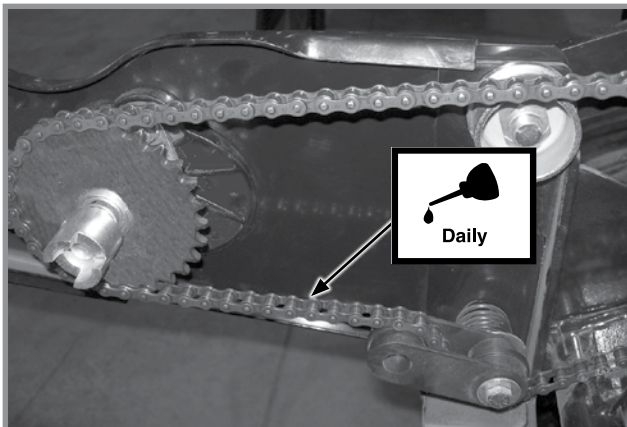

Pull Row Unit Drive Chain

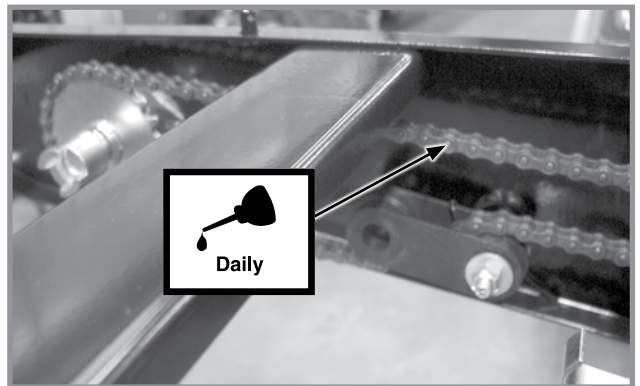

Row Unit Granular Chemical Drive Chains

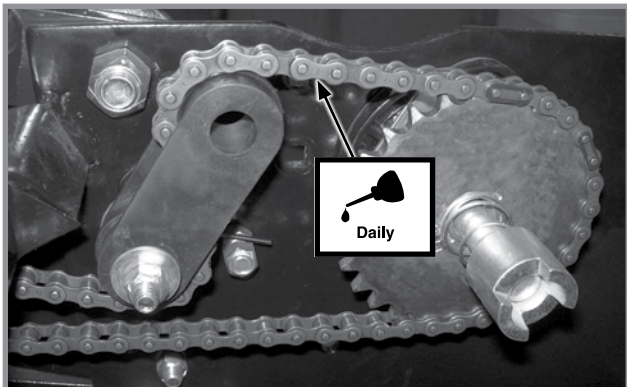

Push Row Unit Drive Chains

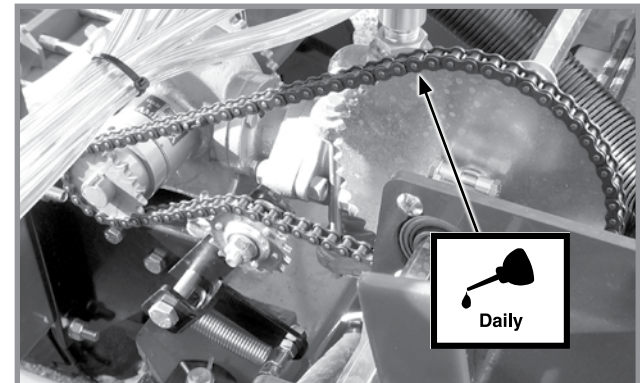

Liquid Fertilizer Piston Pump Drive Chain

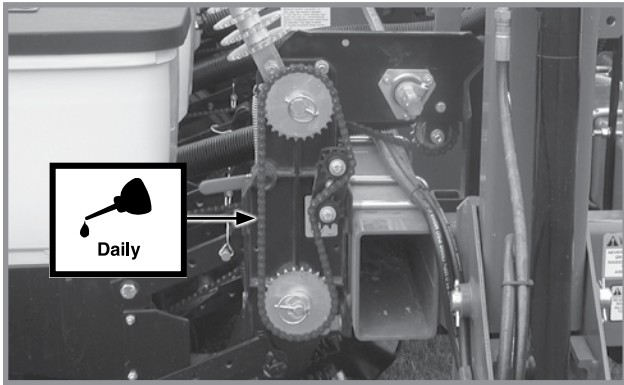

Planter Seed Rate Transmission Drive Chain

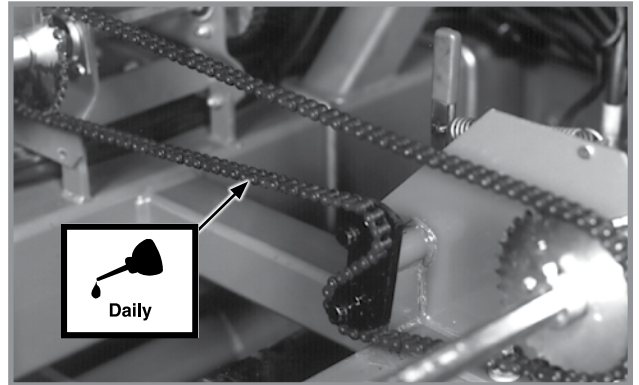

Liquid Fertilizer Squeeze Pump Drive Chain

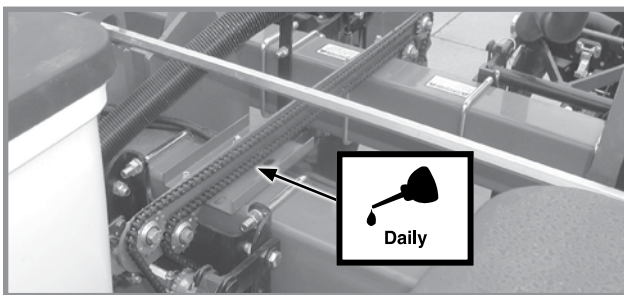

Split Row Package Drive Chain

SPLIT ROW PUSH ROW UNIT LOCKUPS



2 Per Row

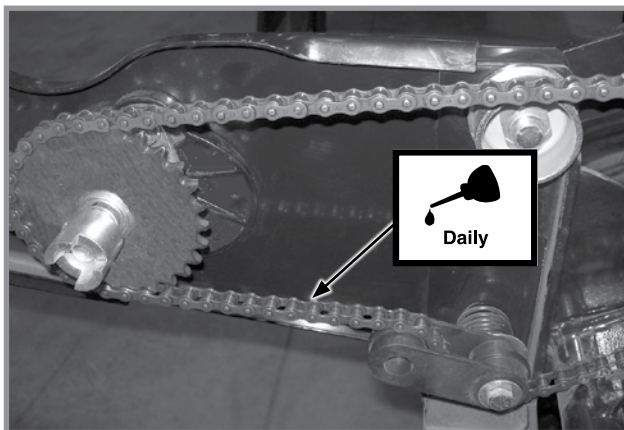

Pull Row Unit Drive Chain

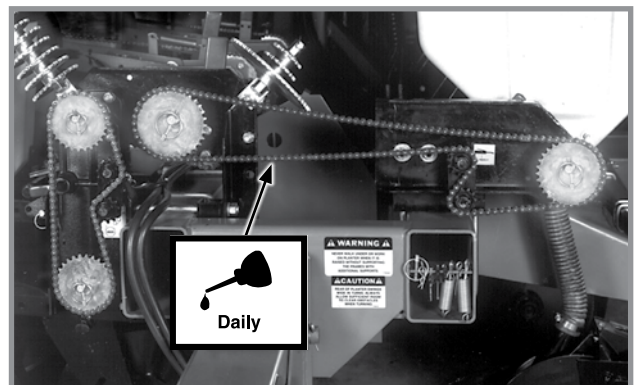

Dry Fertilizer Drive Chain

CENTER POST

NOTICE

Any oil or grease on center post and poly wear pads will attract dirt and accelerate wear. Do not lubricate center post and poly wear pads.

Center post is clad with stainless steel. Keep stainless steel surface clean and free of any lubrication to prolong service life.

See "Wear Pad Adjustment/Replacement" for more information.

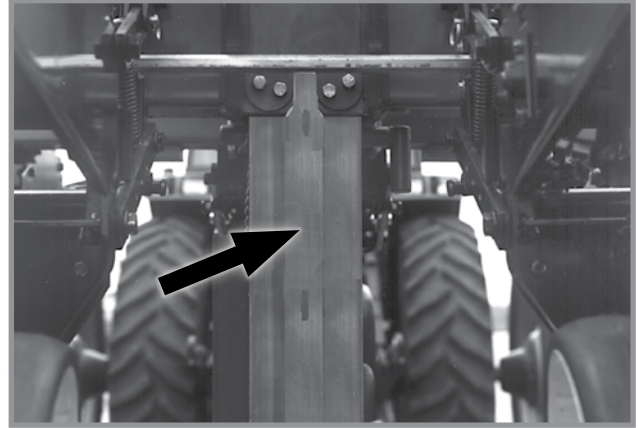

Center post

WHEEL BEARINGS

All drive, transport, and marker hub wheel bearings should be repacked annually and checked for wear.

1. Raise wheel off ground.
2. Check for bearing endplay by moving wheel side to side.
3. Rotate wheel to check for bearing roughness. If bearings sound rough, remove hub and inspect bearings.

NOTE: To repack wheel hubs, follow procedure outlined for wheel bearing replacement with exception that bearings and bearing cups are reused.

LIQUID FERTILIZER PISTON PUMP CRANKCASE OIL LEVEL

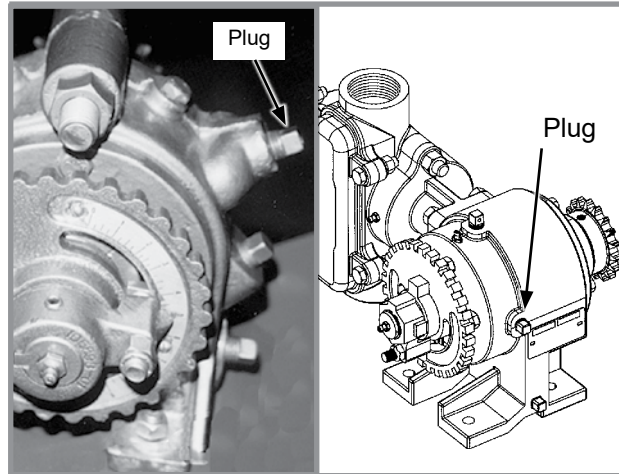

Piston pump oil fill plug location

Check crankcase oil daily and maintain at plug level. Fill as needed with EP 90 weight gear oil. Total oil capacity is approximately $\frac{3}{4}$ pint.

Refer to operator and instruction manual supplied with pump and flow divider for more information.

PTO PUMP SHAFT COUPLING (PTO PUMP DRIVE AND OIL COOLER OPTION)

NOTE: Clean and grease PTO shaft coupling each time pump is installed.

NOTE: Apply coating of high-speed industrial coupling grease, such as Chevron® Coupling Grease, that meets AGMA CG-1 and CG-2 Standards to extend shaft spline life.

Chevron® trademark is owned by Chevron Products Company. AGMA is the acronym for the American Gear Manufacturers Association.

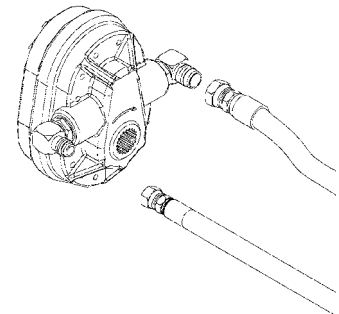

1 $\frac{3}{8}$ "-21 spline PTO pump shown

BUSHINGS

Lubricate bushings at frequency indicated.

Check each bolt for proper torque. If bolt is loose, removed it and inspect bushing for cracks and wear. Replace bushing if necessary. Use **only hardened flat washers**. Replace damaged flat washers with proper part. Torque hardware to 130 ft-lb (176.2 N-m).

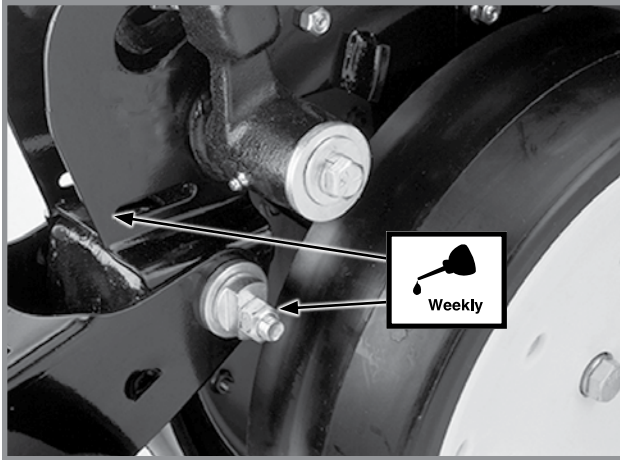

Row Unit “V” Closing Wheel, Covering Discs/
Single Press Wheel And/Or Drag Closing Wheel
Eccentric Bushings (2 Per Row)

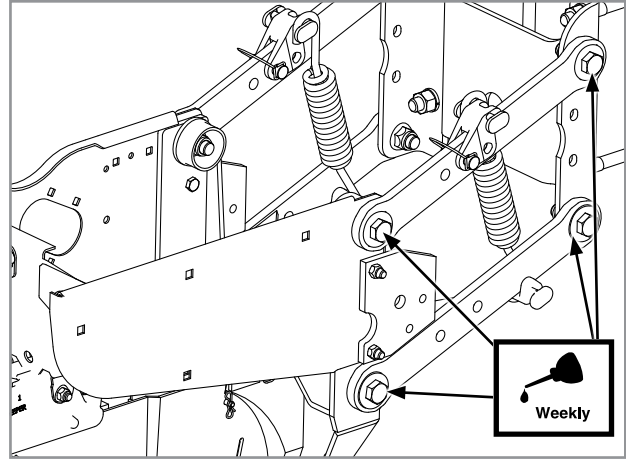

Pull Row Unit And/Or Push Row Unit Parallel
Linkages (8 Per Row)

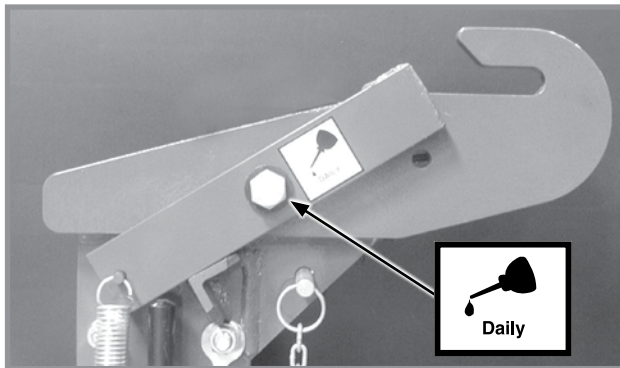

Transport Catch Pivot

GREASE FITTINGS

Lubricate parts with grease fittings at frequency indicated with an SAE multipurpose grease. Clean fitting thoroughly before using grease gun. Frequency of lubrication recommended is based on normal operating conditions. Severe or unusual conditions may require more frequent attention.

NOTE: Numbers on illustration below correspond to photos on following page showing lubrication frequencies.

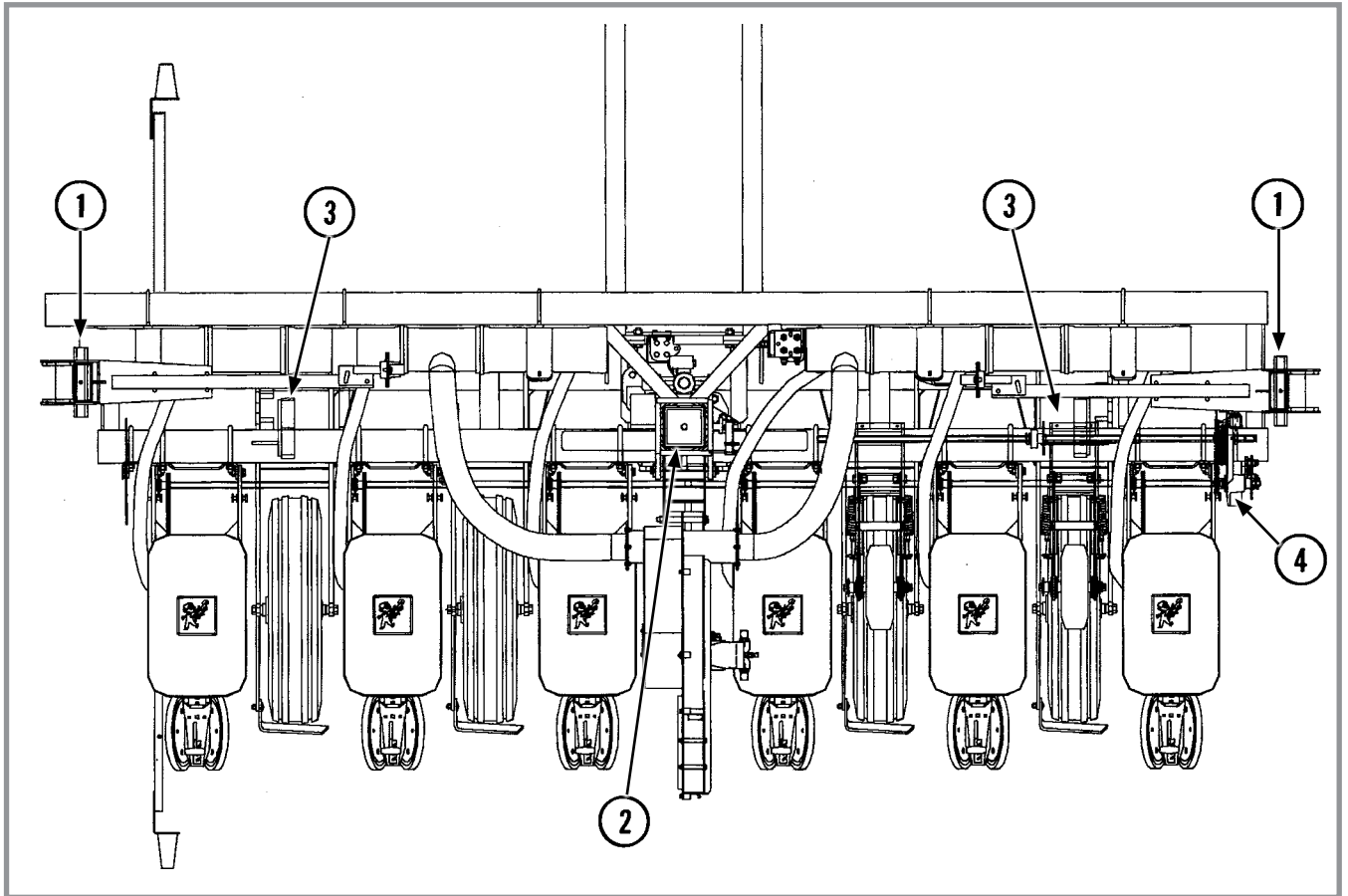

BASE MACHINE

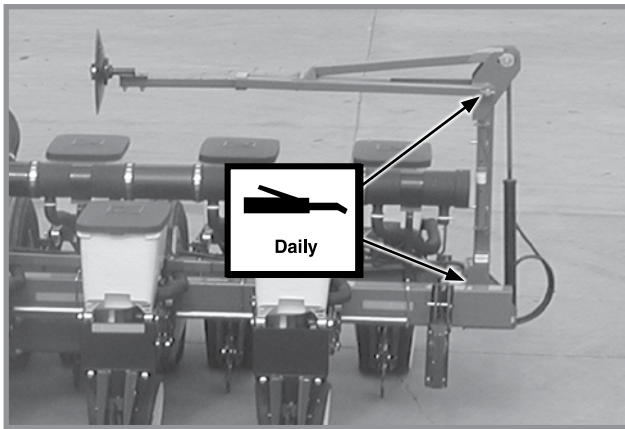

1. Row marker assembly - 2 per assembly

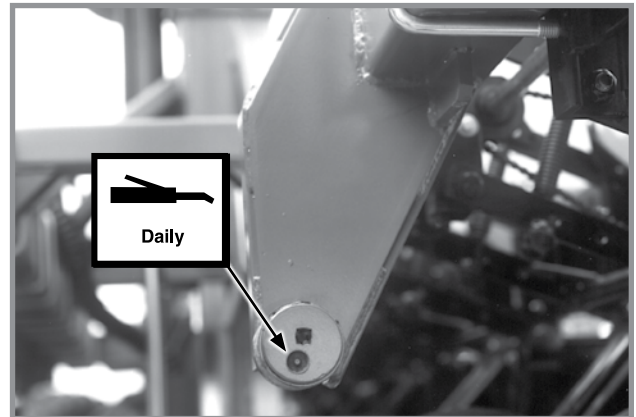

3. Cam follower - 1 per cam follower

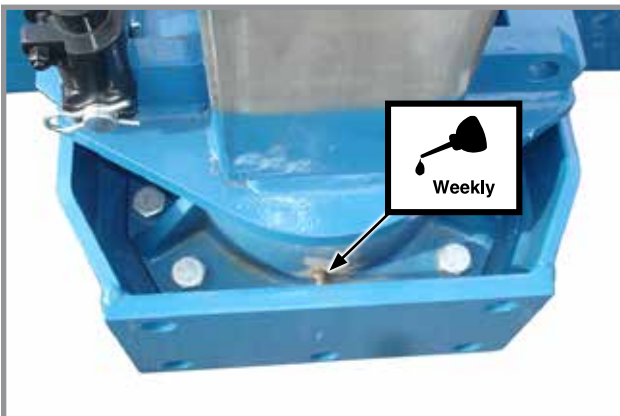

2. Center Pivot - 1

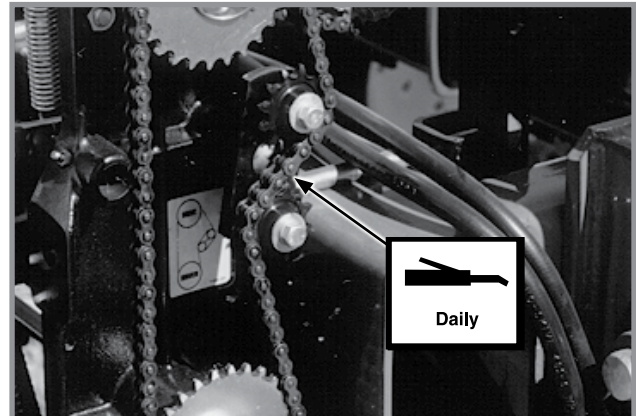

4. Seed rate transmission assembly - 1 (Idler)

ROW UNIT

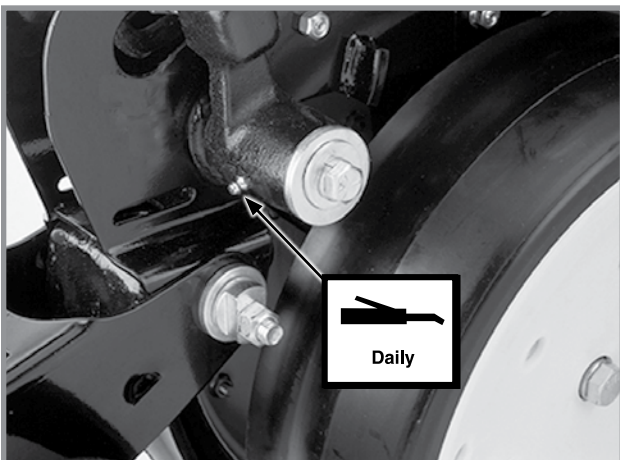

Gauge wheel arms - 1 per arm
 NOTE: Seals in gauge wheel arm are installed with lip facing out to allow grease to purge dirt away from seal. Pump grease into arm until fresh grease appears between washers and arm.)

FERTILIZER OPENERS

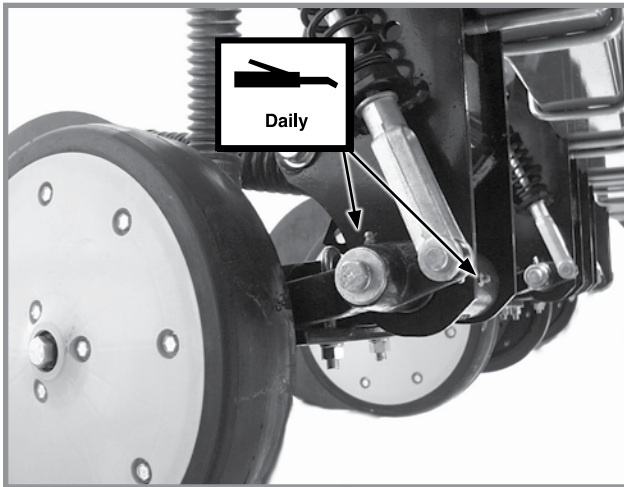

HD Single Disc Fertilizer Opener - 2
(Located On Wheel Arm And Opener Mount)

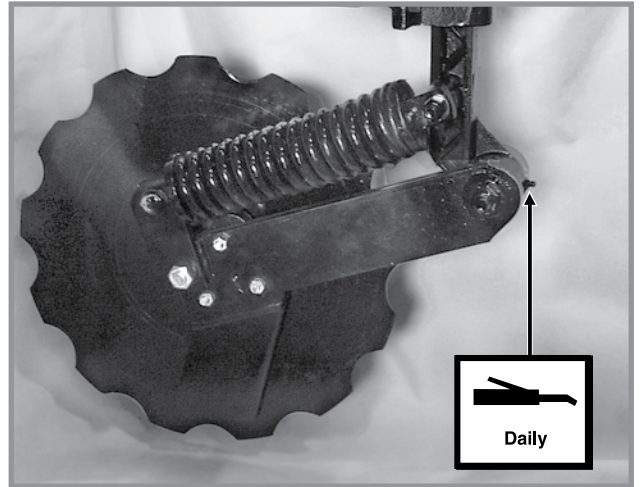

Notched Single Disc Fertilizer Opener - 1

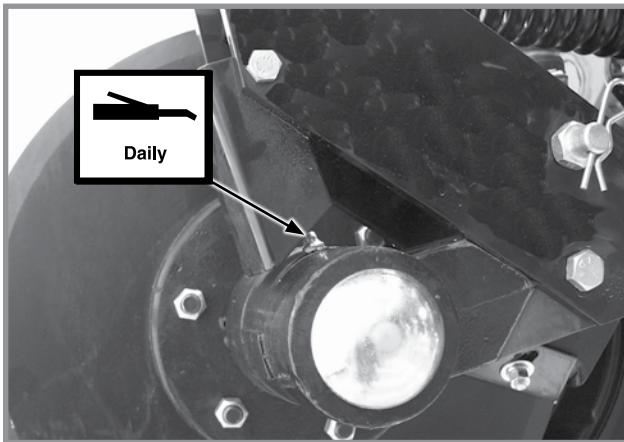

HD Single Disc Fertilizer Opener - 1
(Located On Disc Opener Spindle Hub)

DRY FERTILIZER ATTACHMENT

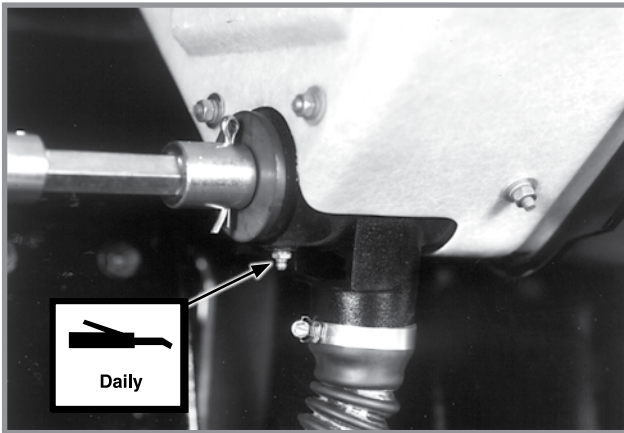

Fertilizer hopper - 2 per hopper

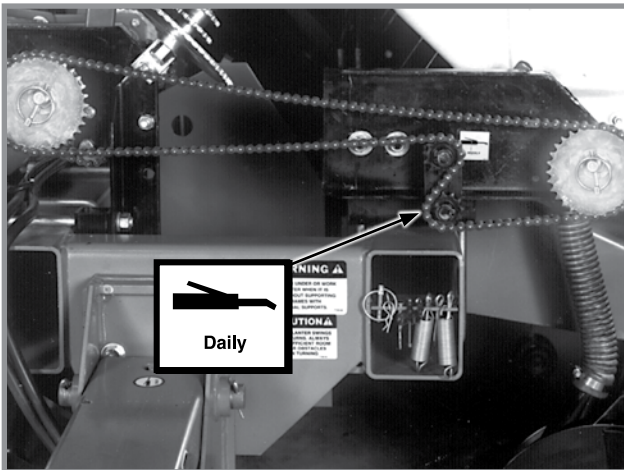

Fertilizer transmission - 1 per transmission (Idler)

LIQUID FERTILIZER PISTON PUMP

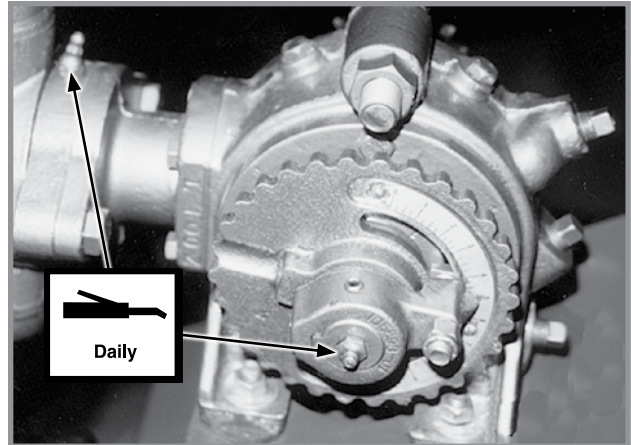

Piston Pump - 2

NOTE: Fill on outboard stuffing box until lubricant seeps out of drain hole in bottom.

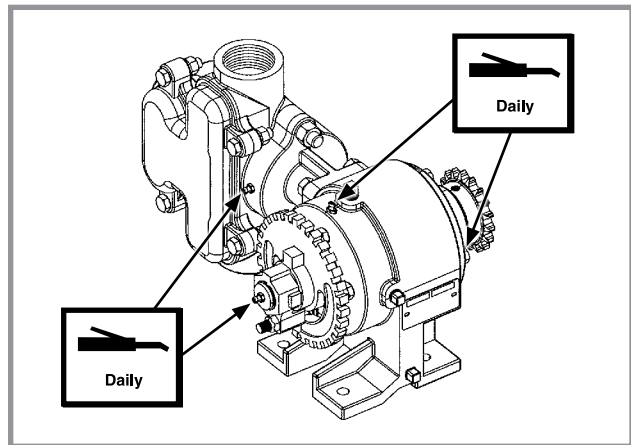

Liquid Fertilizer Piston Pump - 4

NOTE: Fill on outboard stuffing box until lubricant seeps out of drain hole in bottom.

MOUNTING BOLTS AND HARDWARE

Before operating planter for the first time, check all hardware is tight. Check all hardware again after first 50 hours of operation and beginning of each planting season.

All hardware used on the Kinze planter is Grade 5 (high strength) unless otherwise noted. Grade 5 cap screws are marked with three radial lines on the head. Hardware must be replaced with equal size, strength, and thread type.

WARNING

Loose transport wheel lug bolts can result in wheel separation from planter and result in death, serious injury, and damage to property and equipment. Check transport wheel lug nut torque before operating planter for the first time and periodically thereafter.

NOTICE

Over-tightening hardware can reduce its shock load capacity and cause equipment failure.

TORQUE VALUES CHART - PLATED HARDWARE

Diameter	Grade 2 (No marks)		Grade 5 (3 marks)		Grade 8 (6 marks)	
	Coarse	Fine	Coarse	Fine	Coarse	Fine
1/4"	50 in-lb	56 in-lb	76 in-lb	87 in-lb	9 ft-lb (12 N-m)	10 ft-lb (14 N-m)
5/16"	8 ft-lb (11 N-m)	9 ft-lb (12 N-m)	13 ft-lb (18 N-m)	14 ft-lb (19 N-m)	18 ft-lb (24 N-m)	20 ft-lb (27 N-m)
3/8"	15 ft-lb (20 N-m)	17 ft-lb (23 N-m)	23 ft-lb (31 N-m)	26 ft-lb (35 N-m)	33 ft-lb (45 N-m)	37 ft-lb (50 N-m)
7/16"	25 ft-lb (34 N-m)	27 ft-lb (37 N-m)	37 ft-lb (50 N-m)	41 ft-lb (56 N-m)	52 ft-lb (71 N-m)	58 ft-lb (79 N-m)
1/2"	35 ft-lb (48 N-m)	40 ft-lb (54 N-m)	57 ft-lb (77 N-m)	64 ft-lb (87 N-m)	80 ft-lb (108 N-m)	90 ft-lb (122 N-m)
9/16"	50 ft-lb (68 N-m)	60 ft-lb (81 N-m)	80 ft-lb (108 N-m)	90 ft-lb (122 N-m)	115 ft-lb (156 N-m)	130 ft-lb (176 N-m)
5/8"	70 ft-lb (95 N-m)	80 ft-lb (108 N-m)	110 ft-lb (149 N-m)	125 ft-lb (169 N-m)	160 ft-lb (217 N-m)	180 ft-lb (244 N-m)
3/4"	130 ft-lb (176 N-m)	145 ft-lb (197 N-m)	200 ft-lb (271 N-m)	220 ft-lb (298 N-m)	280 ft-lb (380 N-m)	315 ft-lb (427 N-m)
7/8"	125 ft-lb (169 N-m)	140 ft-lb (190 N-m)	320 ft-lb (434 N-m)	350 ft-lb (475 N-m)	450 ft-lb (610 N-m)	500 ft-lb (678 N-m)
1"	190 ft-lb (258 N-m)	205 ft-lb (278 N-m)	480 ft-lb (651 N-m)	530 ft-lb (719 N-m)	675 ft-lb (915 N-m)	750 ft-lb (1017 N-m)
1 1/8"	265 ft-lb (359 N-m)	300 ft-lb (407 N-m)	600 ft-lb (814 N-m)	670 ft-lb (908 N-m)	960 ft-lb (1302 N-m)	1075 ft-lb (1458 N-m)
1 1/4"	375 ft-lb (508 N-m)	415 ft-lb (563 N-m)	840 ft-lb (1139 N-m)	930 ft-lb (1261 N-m)	1360 ft-lb (1844 N-m)	1500 ft-lb (2034 N-m)
1 3/8"	490 ft-lb (664 N-m)	560 ft-lb (759 N-m)	1100 ft-lb (1491 N-m)	1250 ft-lb (1695 N-m)	1780 ft-lb (2413 N-m)	2030 ft-lb (2752 N-m)
1 1/2"	650 ft-lb (881 N-m)	730 ft-lb (990 N-m)	1450 ft-lb (1966 N-m)	1650 ft-lb (2237 N-m)	2307 ft-lb (3128 N-m)	2670 ft-lb (3620 N-m)

NOTE: Torque unplated hardware and bolts with lock nuts approximately 1/3 higher than above values. Torque bolts lubricated prior to installation to 70% of value shown in chart.

Torque Values - Pneumatic Down Pressure

Diameter	Torque Value
1/8" NPT	120 in-lb Maximum
1/2"-13	180 in-lb Maximum
3/4"-16	180 in-lb Maximum

NOTE: Use these torque values with pneumatic down pressure components.

Special Torque Values & Instructions

Row unit parallel linkage bushing hardware	130 ft-lb (176 Nm)
5/8" No till coulter spindle hardware	120 ft-lb (162 Nm)
Transport/ground drive lug bolts	125 ft-lb (169 Nm)
Vacuum/bulk fill fan impeller assembly to motor shaft 5/8"-18 hex jam nut (6 Row Only)	90 in-lb (10.1 Nm)
Vacuum fan impeller assembly to motor shaft 5/8"-18 hex jam nut (8 Row Only)	50 ft-lb (67.8 Nm)

Cylinder Rod Piston Retaining Nut Torque Chart

	Non-Nylock Nut	Nylock Nut
½"-20	55-70 ft-lb (75-95 N-m)	45-55 ft-lb (61-75 N-m)
¾"-16	115-125 ft-lb (156-169 N-m)	100-115 ft-lb (136-156 N-m)
7/8"-14	150-180 ft-lb (203-244 N-m)	130-150 ft-lb (176-203 N-m)
1"-14	275-330 ft-lb (373-447 N-m)	250-275 ft-lb (339-373 ft-lb)
1⅛"-12	300-375 ft-lb (407-508 N-m)	275-300 ft-lb (373-407 N-m)
1¼"-12	300-375 ft-lb (407-508 N-m)	275-300 ft-lb (373-407 N-m)

TIRE PRESSURE

WARNING

Explosive separation of rim and tire parts can cause death or serious injury. Overinflation, rim and tire servicing, improper use of rims and tires, or worn or improperly maintained tires could result in a tire explosion.

To prevent tire explosions:

- Maintain proper tire pressure. Inflating a tire above or below the recommended pressure can cause tire damage.
- Mount tires only by properly trained personnel using proper equipment.
- Replace tires with cuts or bubbles. Replace damaged rims. Replace missing lug bolts and nuts.
- Do not weld or heat wheel assembly. Heating increases tire pressure.

MODEL 3505 OPERATING TIRE PRESSURE

Transport/ground drive - 7.50" x 20" Inflate to 40 psi (275.7 kPa)

Contact drive - 4.10" x 6" Inflate to 50 psi (344.7 kPa)



CHAIN TENSION ADJUSTMENT

Drive chains are equipped with spring loaded idlers and are self-adjusting. The only adjustment needed is to shorten the chains if wear stretches the chains and reduces spring tension. The pivot point of these idlers should be checked periodically to ensure they rotate freely. See "Wrap Spring Wrench Assembly" in this section for more information.

Additional chain links can be found in the storage area located inside the front planter frame.

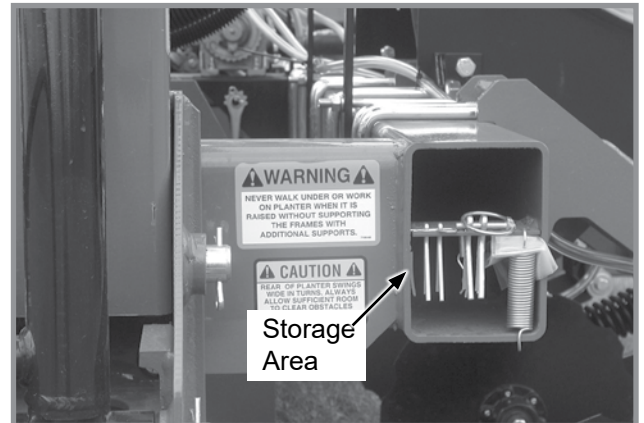

Spare chain link storage

PNEUMATIC DOWN PRESSURE AIR COMPRESSOR TANK

Moisture should be drained daily from the tank. Tank should be drained completely for storage.

To drain tank, locate drain plug on the bottom of tank. Stand off to the side of tank and pull cable attached to drain.

NOTE: If moisture is not drained from tank rust particles will form inside tank.

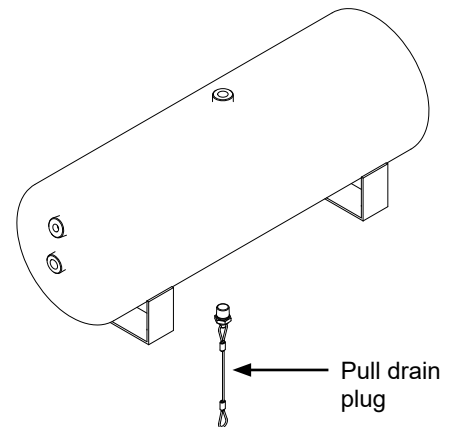

FINGER PICKUP SEED METER INSPECTION/ADJUSTMENT

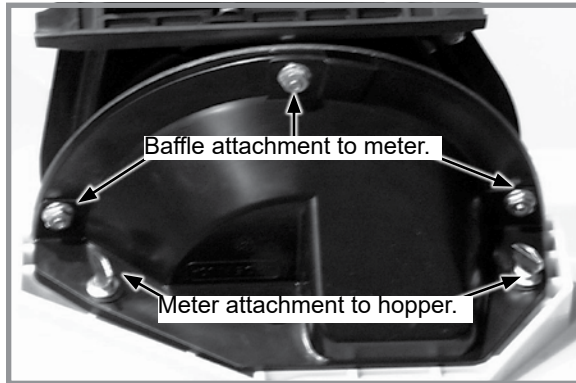

Removing meter and baffle

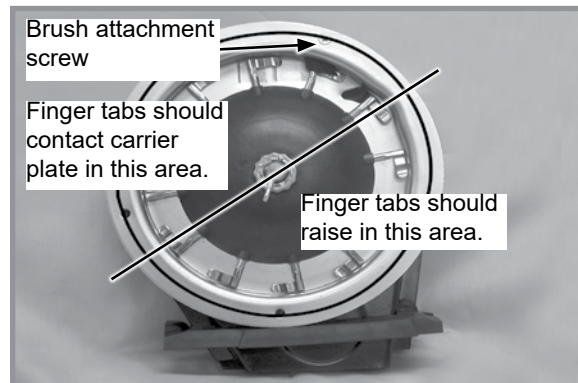

Proper finger operation

1. Remove two thumbscrews and meter from seed hopper and remove three cap screws and baffle from meter assembly.
2. Rotate seed meter drive by hand to ensure springs are holding tabs of fingers against carrier plat and fingers raise in correct area as shown in above photo.

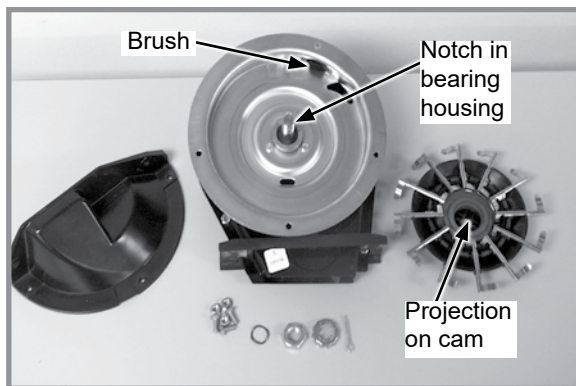

Finger pickup meter parts

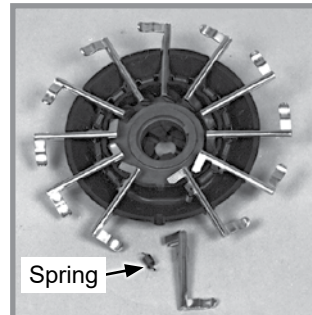

Corn Finger Assembly
(Position Spring Opening Toward Holder)



Oil Sunflower Finger Assembly

Buildup of debris or chaff may prevent proper finger operation and requires disassembly and cleaning of finger pickup meter.

1. Remove cotter pin, cover nut and adjusting nut and wave washer (If applicable) from drive shaft.
2. Carefully lift finger holder with fingers and cam off shaft and clean.
3. Check brush for wear and replace if necessary or after every 100 acres (41 hectares) per row of operation (Approximately 800 acres (324 hectares) of corn or sunflowers on a 8 row machine or 1200 acres (486 hectares) on an 12 row machine).

NOTE: It is not necessary to remove finger holder to replace brush.

4. Remove springs from fingers and remove finger from holder by lifting it out of friction fit slot. Life expectancy of these parts is about 600-900 acres (243-364 hectares) per row of operation under average conditions.
5. Reassemble meter in reverse order after cleaning and replacing defective parts. Make sure open end of spring loop is toward inside of finger holder when replacing fingers.
6. Install fingers in holder so holder is flush with carrier plate when assembled. A cam projection aligns with a mating notch in bearing housing to ensure proper operation when assembled.

7. Check indentations on carrier plate for wear before installing finger holder on carrier plate. Excessive wear of carrier plate at indentations will cause over planting especially with small sizes of seed. Inspect carrier plate annually. Life expectancy should be 250-300 acres (100-125 hectares) per row of operation under average conditions.
8. Install wave washer and adjusting nut with finger holder flush against carrier. Tighten adjusting nut to fully compress wave washer. Back off nut $\frac{1}{2}$ to 2 flats to obtain rolling torque of 22 to 25 inch pounds (2.5 N-m to 2.8 N-m).
9. Turn finger holder by hand to make sure it is firmly against carrier plate, but can be rotated with moderate force.
10. Install cover nut and cotter pin. Reinstall baffle.

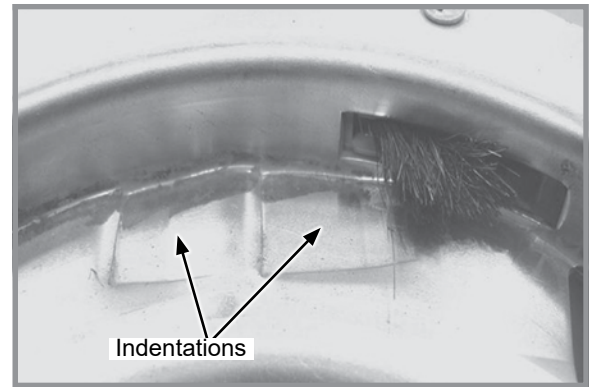

Worn carrier plate

NOTE: Check adjusting nut tightness on each unit after first day of use and periodically thereafter.

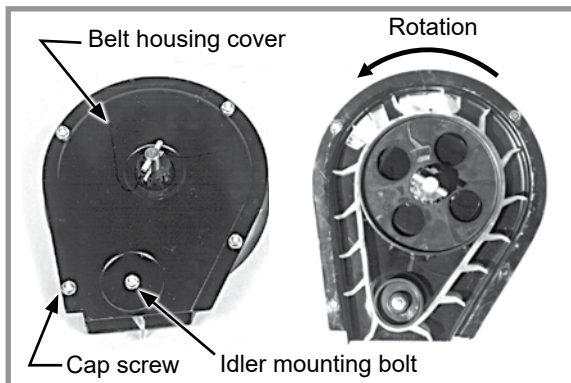

Belt idler

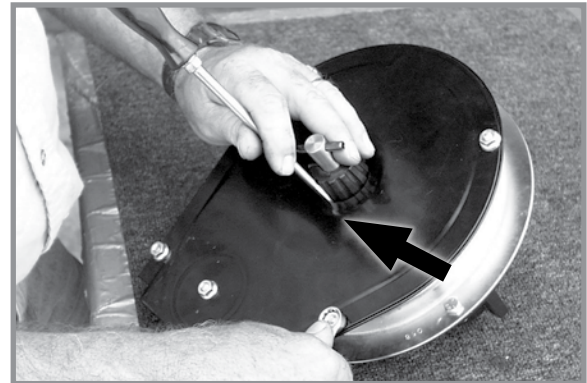

Centering belt housing cover

Remove four cap screws around edge of housing cover and nut from belt idler mounting bolt. Paddles must be correctly oriented as shown above. If belt is replaced. A diagram molded into drive sprocket shows correct orientation.

NOTICE

Do not over-tighten hardware or components may be damaged.

Reinstall housing cover. **DO NOT TIGHTEN** hardware. Wedge a screwdriver between sprocket hub and housing cover as shown above. Pry cover down until centered on belt housing and tighten hardware. Rotate meter drive shaft and check idler alignment. Seed belt should "run" centered on idler or with only slight contact with belt housing or cover.

CLEANING FINGER PICKUP SEED METER FOR STORAGE

1. Disassemble meter and blow out any foreign material.
2. Wash **ONLY** in mild soap and water. Do not use gasoline, kerosene, or any other petroleum based product. Dry thoroughly.
3. Coat lightly with a rust inhibitor.
4. Rotate finger assembly so finger does not touch brush.
5. Reassemble and store in a dry, rodent-free location.

BRUSH-TYPE SEED METER 2.0 MAINTENANCE

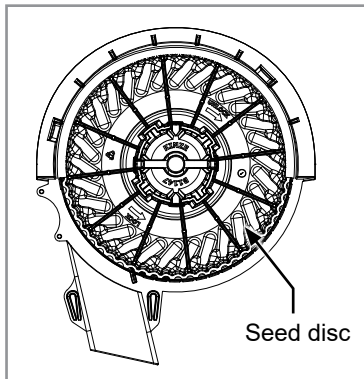

Brush-type seed meter seed disc installed

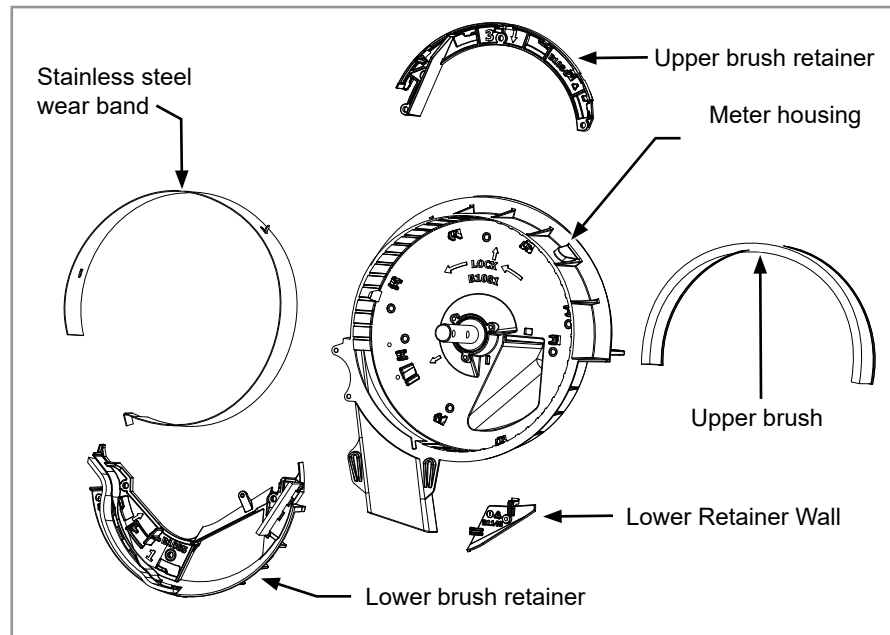

Brush-type seed meter 2.0 parts

Use clean, high quality seed. Damaged or cracked seed, hulls, or foreign materials can become lodged in upper brush and greatly reduce meter accuracy. Remove seed disc daily and check for buildup of foreign material on seed disc, particularly in seed loading slots. Clean disc by washing it with soap and water. Check for cracked seed, hulls, etc. lodged between brush retainer and stainless steel wear band which can greatly reduce accuracy of the meter because upper brush will not be able to retain seed in seed disc pocket. Thoroughly clean brush areas of meter housing.

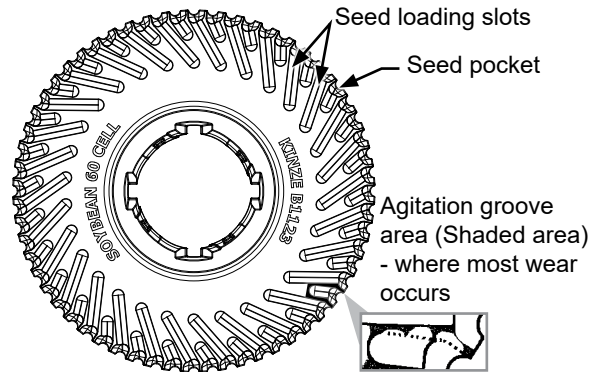

SEED DISC WEAR

Most seed disc wear is found in the agitation groove area (area between seed loading slots). Wear affects planting accuracy at high RPM. Lay a straight edge across disc surface at agitation groove area and measure gap between disc and straight edge. If agitation groove areas are worn in excess of .030" and accuracy starts to drop off at higher meter RPM, replace seed disc. Estimated seed disc life expectancy under normal operating conditions is approximately 200 acres per row. Severe operating conditions such as dust, lack of lubrication or abrasive seed coating could reduce seed disc life expectancy to under 100 acres per row.

STAINLESS STEEL WEAR BAND

NOTICE	If wear band wears through or if meter is used without wear band in place, meter housing may be damaged.
---------------	---

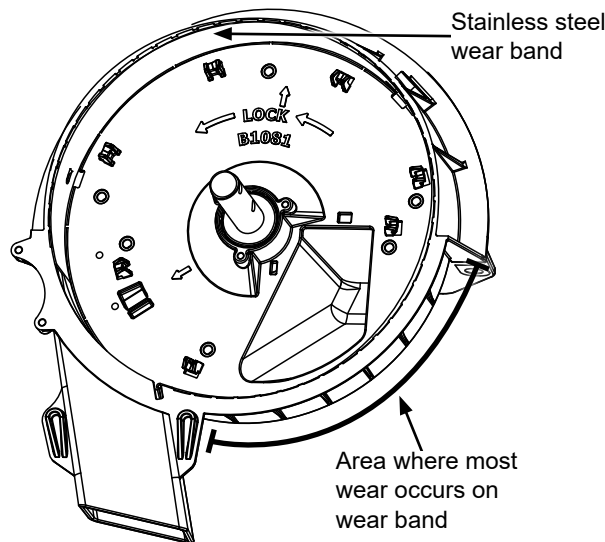

Stainless steel wear band

Stainless steel wear band protects meter housing from wear and is .030" thick. Replace wear band when there is approximately .020" of wear in primary wear area. Estimated life expectancy of stainless steel wear band is 240-800 acres per row.

ASSEMBLY

Assemble meter by putting parts back in the housing in the order they are numbered:

1. Lower brush retainer
2. Upper brush
3. Upper brush retainer

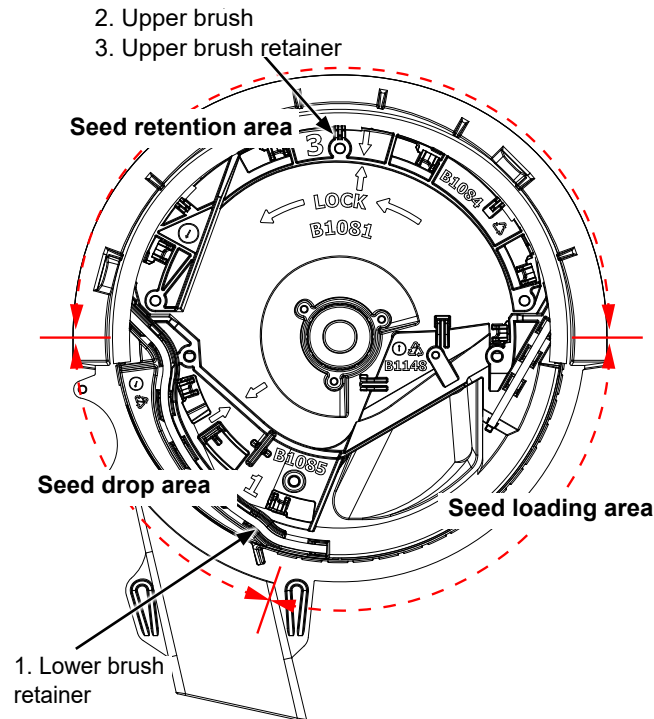

LOWER BRUSH

Lower brush moves seed down seed loading slots to seed pockets, isolates seed in reservoir from entering seed tube, and cleans seed loading slots. Estimated lower brush life expectancy is 240-800 acres per row. Replace lower brush if bristles are deformed or missing, or if there are cracks in brush retainer. Once all parts are properly in place, rotate to lock position.

UPPER BRUSH

Upper brush holds seed in seed disc pocket in seed retention area. Brush must apply enough pressure against seed in seed disc pocket as disc rotates through seed retention area to prevent seed from dropping out of disc pocket. A damaged spot, excessive brush wear, or foreign material lodged in brush may greatly reduce meter performance.

Replace upper brush at 120-400 acres per row of use or sooner if damage or excessive wear is found. Position upper brush into inner perimeter of seed retention area. Make sure base of brush is tight against bottom of meter housing. Install brush retainer. Once all parts are properly in place, rotate to lock position.

NOTE: Use P/N: GB1084 upper brush retainer for all seed discs. It is recommended for milo/grain sorghum to use P/N: GB1107 milo retainer for additional brush retention.

CLEANING BRUSH-TYPE SEED METER FOR STORAGE

1. Remove meter from seed hopper by removing two thumbscrews securing meter to hopper.
2. Remove seed disc and wash with soap and water and dry thoroughly.
3. Remove three hex head screws from brush retainer. Remove brush retainer and upper brush.
4. Remove three hex head screws from lower brush. Remove lower brush and stainless steel wear band.
5. Wash all parts and meter housing with soap and water and dry thoroughly.
6. Inspect all parts and replace worn parts.
7. Reassemble meter except for seed disc. Store meter in a dry, rodent-free space with seed disc removed.

VACUUM SEED METER MAINTENANCE

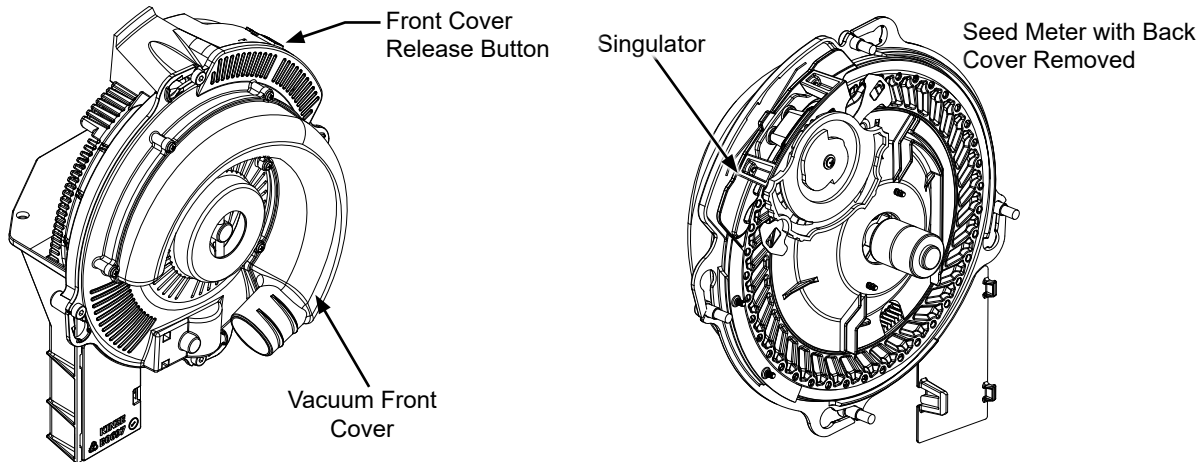

Before each planting season inspect seed discs and singulator and clean or replace as needed.

Use clean, high quality seed for maximum meter accuracy. Damaged or cracked seed, hulls, and foreign material may become lodged in seed disc orifices and greatly reduce meter accuracy.

Inspect and clean seed discs daily checking for any buildup of foreign material and blocked orifices. If seed disc orifices are plugged frequently with seed remnants, remnants ejector wheel may need to be replaced. Clean seed disc by washing it with soap and water. Dry thoroughly.

Inspect singulator blades and guide for wear after every 200 acres (81 hectares) per row of operation. If adjustment of singulator blade does not affect meter performance or if blades appear worn, singulator blade may need to be replaced.

Replace seed disc or vacuum seal if abnormally high vacuum is required or if consistent operation cannot be achieved.

See [“Preparation for Storage” on page 6-37](#) for additional Vacuum Seed Metering System maintenance.

NOTE: Remove seed discs from meters for annual storage and store them vertically on a dowel or pipe.

SEED METER CLEANOUT

NOTE: Use of damaged seed or seed containing foreign material will cause plugging of seed cell orifices and require more frequent seed meter cleanout to prevent underplanting.

Thorough seed meter cleanout is important to maintain genetic purity.

1. Disengage seed drive and remove seed hopper and meter.
2. Dump seed from right rear corner of hopper into a container.
3. Lay hopper on its right side. Push release button and rotate seed meter vacuum cover clockwise to align keyhole slots with bolt heads. Lift off cover.
4. Rotate seed disc hub clockwise to unlock and remove seed disc.
5. Empty meter.
6. Thoroughly inspect meter to ensure all seed is removed.
7. Replace seed disc. Install vacuum cover.

GAUGE WHEEL ADJUSTMENT

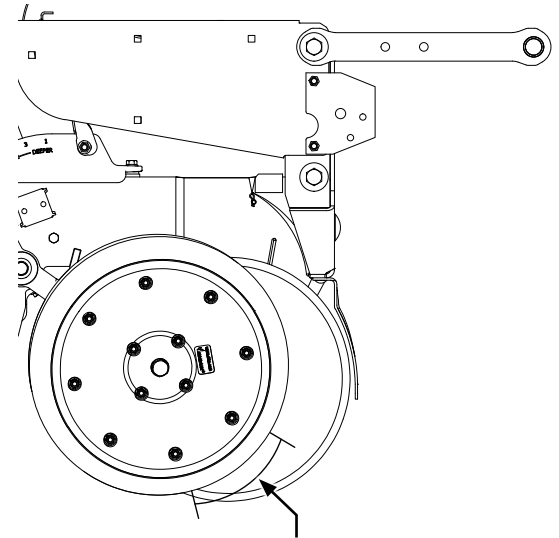
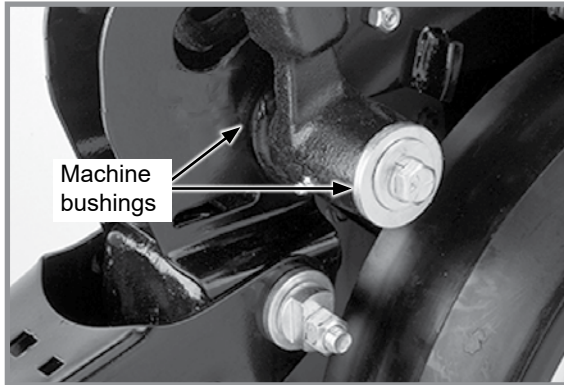

Shim gauge wheel to lightly contact opener disc blade in this area for 4" to 6". Check adjustment in operating position.

Gauge Wheel Adjustment

Add or remove machine bushings between shank and gauge wheel arm to adjust contact between gauge wheels and opener blades. Gauge wheels should lightly contact opener blades to prevent accumulation of dirt or trash. Gauge wheels and opener blades should turn with only slight resistance.

Store remaining machine bushings between gauge wheel arm and flat washer on outer side of gauge wheel arm.

Use the following guidelines:

NOTE: Set depth adjustment handle at 3x2 position and lift gauge wheel to stop one side at a time.

Contact should be no less than one half of the rotation of the wheel, while not sticking in any position (it does not have to be continuous). Wheel should rotate in the direction of travel of the row unit. Wheel can be held in position by supporting the spindle bolt head.

GAUGE WHEEL ARM BUSHING/SEAL REPLACEMENT

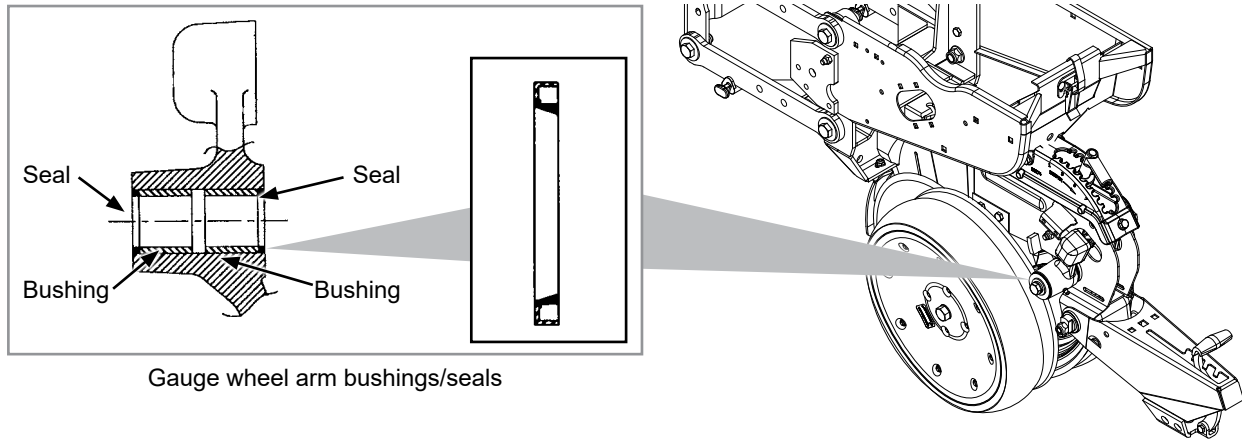

NOTE: Gauge Wheel Arm Bushing and Seal Driver Kit (G1K296) is available through your Kinze Dealer.

1. Remove gauge wheel from arm.
2. Remove gauge wheel arm from shank assembly.
3. Remove seal and bushing and discard. Clean and dry inner bore.
4. Drive/press replacement bushing inside bore of arm to a depth of .125" below flush.
5. Coat wiping edge of seal with grease.
6. Drive/press seal into place with lip to outside.

NOTE: Use extra care to protect the sealing lip during installation. Apply uniform pressure to assemble the seal into the bore of the arm. Never apply a direct hammer blow to the seal surface.

7. Inspect gauge wheel pivot spindle.
8. Reinstall gauge wheel arm assembly and gauge wheel.

NOTE: Use special machine bushing between gauge wheel arm and gauge wheel.

9. Shim for proper gauge wheel tire/disc blade clearance.
10. Lubricate with an SAE multipurpose grease.

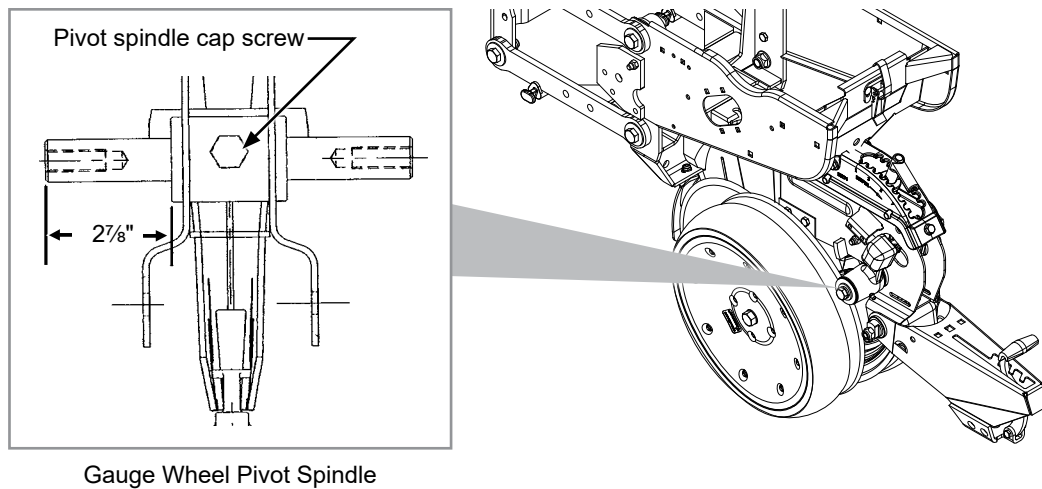
GAUGE WHEEL ARM PIVOT SPINDLE REPLACEMENT

1. Remove gauge wheel and arm assemblies from shank assembly.
2. Remove $\frac{1}{2}$ " x $\frac{3}{4}$ " cap screw that locks pivot spindle in place and remove spindle.
3. Install replacement spindle and position as shown. Exact centering is critical.
4. Install $\frac{1}{2}$ " x $\frac{3}{4}$ " cap screw and torque to lock pivot spindle in place.
5. Install gauge wheel and arm assemblies. Shim for proper gauge wheel tire/disc blade clearance.

15" SEED OPENER DISC BLADE/BEARING ASSEMBLY

Approximately $1" \pm \frac{1}{2}"$ ($3 \pm .5$ cm) of blade-to-blade contact should be maintained to properly open and form seed trench. As blade diameter decreases due to wear, it is necessary to relocate machine bushings from inside to outside to maintain $1" \pm \frac{1}{2}"$ ($3 \pm .5$ cm) of contact.

NOTE: Proper blade clearance is critical. Blades should have $1" \pm \frac{1}{2}"$ ($3 \pm .5$ cm) contact in this area. When blades are turned by hand in opposite directions against each other, there should be only light resistance to turning. Re-adjust blade scraper if necessary to center it between the blades.

NOTE: If proper blade-to-blade contact cannot be maintained after relocating machine bushings or if blade diameter wears below $14\frac{1}{2}"$ (37 cm), blades should be replaced.

NOTICE

Excessive blade contact may result in premature disc opener bearing/hub failures and excessive wear on seed tube guard/inner scraper. When properly adjusted, if one blade is held in fixed position, opposite blade should rotate with less than 5 pounds force (22 newtons) at outer edge of blade.

NOTICE

Left hand side of opener uses a left hand threaded cap screw. **DO NOT OVER TIGHTEN.** Damage to shank threads require replacement of row unit shank assembly.

REPLACE DISC BLADE/BEARING ASSEMBLY

1. Remove gauge wheel.
2. Remove scraper.
3. Remove bearing dust cap.
4. Remove cap screw, washer and disc blade/bearing assembly. Machine bushings between shank and disc blade are used to maintain approximate $1" \pm \frac{1}{2}"$ ($3 \pm .5$ cm) of blade-to-blade contact.
5. Install machine bushing(s), new disc blade bearing assembly, washer and cap screw. Torque $\frac{5}{8}"$ -11 Grade 5 cap screw to value shown in "Torque Values Chart".

NOTE: Replace disc blades only with disc blades of equal thickness.

6. Replace bearing dust cap.
7. Install scraper.
8. Install gauge wheel. It may be necessary to replace bearing only if there is excessive endplay or if bearing sounds or feels rough when disc blade is rotated.

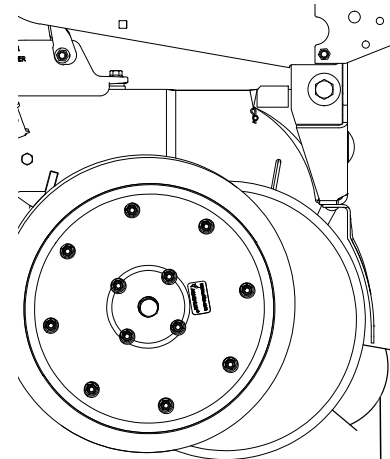

Approximately $1" \pm \frac{1}{2}"$ ($3 \pm .5$ cm) of blade-to-blade contact.

REPLACE BEARING ONLY

1. Remove gauge wheel, scraper, bearing cap, cap screw, washer and disc blade/bearing assembly.
2. Remove ¼" rivets from bearing housing to expose bearing.
3. After installing new bearing, install three evenly spaced ¼" cap screws into three of six holes in bearing housing to hold bearing and bearing housing in place. Install rivets in other three holes. Remove ¼" cap screws and install rivets in those three holes.
4. Reinstall disc blade/bearing assembly, washer and cap screw. Torque ⅝"-11 cap screw to value shown in "Torque Values Chart" at the beginning of this section.
5. Replace bearing dust cap.
6. Install scraper and gauge wheel.

SEED TUBE GUARD/INNER SCRAPER

Seed tube guard protects seed tube and acts as inner scraper for seed opener disc blades.

Remove seed tube and check for wear. Excessive wear on seed tube indicates a worn seed tube guard. Replace seed tube guard if it measures $\frac{5}{8}$ " (16 mm) or less at lower end. A new seed tube guard measures approximately $\frac{7}{8}$ " (22.2 mm).

NOTE: No till planting or planting in hard ground conditions, especially when planter is not equipped with no till coulters, and/or excessive blade-to-blade contact increases seed tube guard wear and requires more frequent inspection and/or replacement.

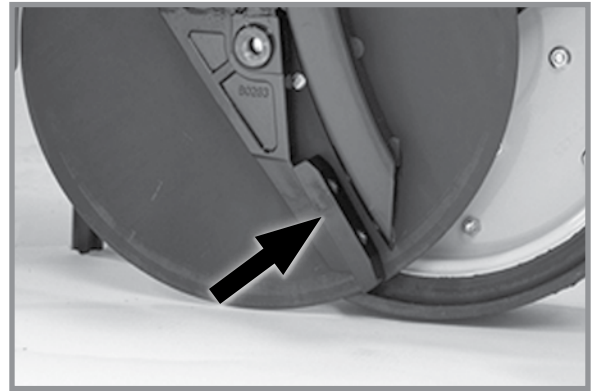

Seed tube guard/inner scraper
(Gauge wheel/seed opener disc blade removed)

NOTICE

Over tightening hex socket head cap screws may damage shank threads and require replacement of shank. An excessively worn seed tube guard may allow blades to wear into row unit shank, also requiring replacement of shank.

Remove seed tube and two hex socket head cap screws that attach seed tube guard. Hold replacement seed tube guard centered between seed opener disc blades. Install hex socket head cap screws. **DO NOT TIGHTEN.** Using a clamp or vise-grip, squeeze opener blades together in front of seed tube guard. Tighten seed tube guard retaining screws. Remove clamps. Distance between seed tube guard and opener blades should be equal on both sides. Reinstall seed tube.

ROW UNIT MOUNTED NO TILL COULTER



Check nuts and hardware periodically for proper torque.

NOTE: Torque $\frac{5}{8}$ " spindle hardware to 120 ft-lb (162 N-m).

Be sure coulters is positioned square with row unit and aligned in front of row unit disc opener.

Coulters blade can be adjusted to one of four settings. Initially blade is set in highest position. As blade wears it can be adjusted to one of three lower settings. See "Row Unit Mounted No Till Coulters" in Row Unit Operation section of this manual.

Replace 16" diameter coulters blade when worn to 14½" (37 cm).

COULTERS MOUNTED RESIDUE WHEELS



Wheel hubs are equipped with sealed bearings. If bearings sound or feel rough when wheel is rotated, replace them.

SPIKED CLOSING WHEEL

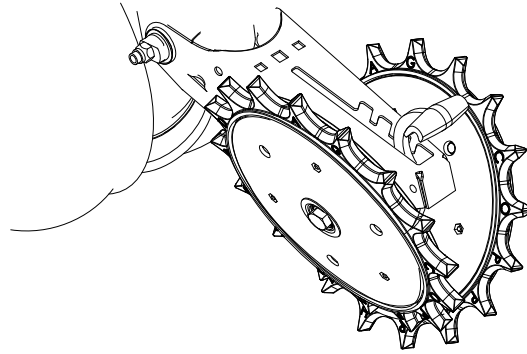

Row Unit Spiked Closing Wheel

Inner parts of spiked closing wheel will begin to wear at approximately 70% of life. Flip/reverse wheel to utilize remaining life of wheel.

GRANULAR CHEMICAL ATTACHMENT

Before storing planter, disengage granular chemical drive by rotating throwout knob $\frac{1}{4}$ turn counterclockwise. Remove drive chain and empty and clean all granular chemical hoppers. Clean drive chains and coat them with a rust preventive spray or submerge chains in oil. Inspect and replace worn or broken parts.

Install hoppers and chains. Check chain alignment.

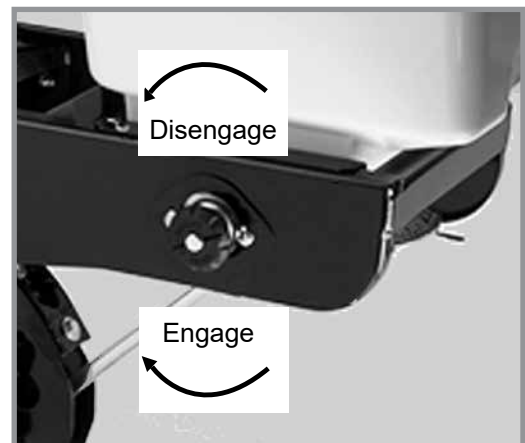

Granular chemical throwout knob

WEAR PAD ADJUSTMENT/REPLACEMENT

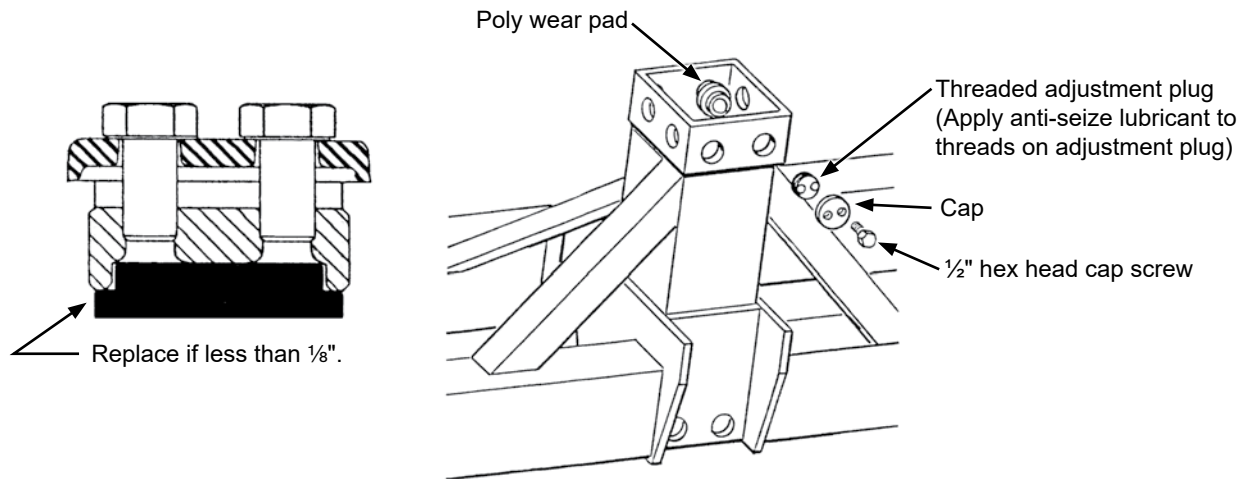

Planter center section consists of a steel tubular frame and 16 adjustable wear pad assemblies that travel up and down against a stainless steel clad center post. Each adjustable wear pad assembly consists of a poly wear pad, threaded adjustment plug, and cap. Assembly is held in place by the threaded adjustment plug and locked in place by the cap and two ½" hex head cap screws.

Check pad adjustment and wear annually on all wear pad assemblies.

1. Support frame with appropriate weight-rated safety stands at a comfortable working height with all row units off ground.
2. Level planter frame side to side and front to rear. with planter axle.
3. Remove two ½" hex head cap screws and cap. Reinstall hex head cap screws into adjustment pad and remove threaded adjustment plug and poly wear pad using hex head cap screws as a handle.
4. Replace poly wear pad if worn to less than ⅛".

NOTICE

Over tightening wear pads will cause premature wear and could damage hydraulic system. Do not over tighten wear pads.

5. Apply anti-seize lubricant to threads of adjustment plug ONLY. Hand tighten poly wear pad and adjustment plug until poly wear pad lightly contacts stainless steel clad center post. Maximum allowable gap is no more than .060".
6. Install cap with two ½" cap screws. Torque cap screws to 25-30 ft-lb (33.9 - 40.6 N-m).

ROW MARKER SEQUENCING/FLOW CONTROL VALVE INSPECTION



WARNING

Pressurized hydraulic fluid can penetrate body tissue and result in death, serious infection, or other injuries. Fluid injected under skin must be **IMMEDIATELY** removed by a surgeon familiar with this type of injury. Make sure connections are tight and hoses and fittings are not damaged before applying system pressure. Leaks can be invisible. Keep away from suspected leaks. Relieve pressure before searching for leaks or performing any system maintenance.

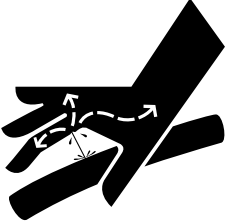

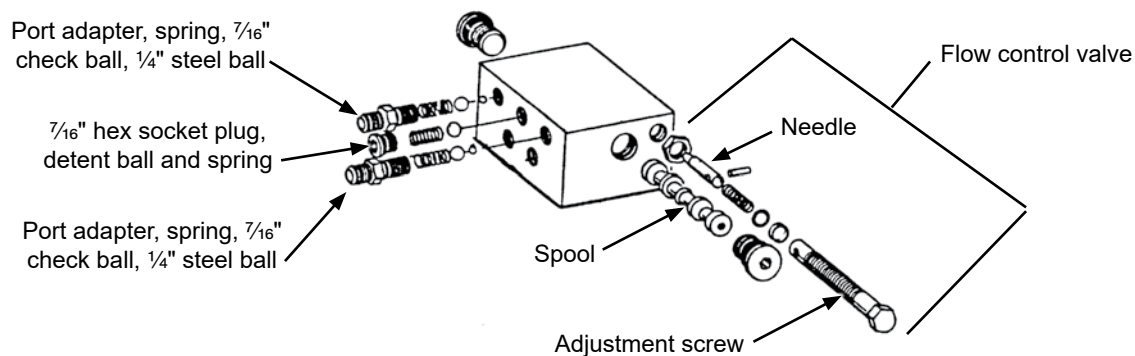

The valve block assembly consists of the row marker sequencing and flow control valves in one assembly. Sequencing valve portion consists of a chambered body containing a spool and series of check valves to direct hydraulic oil flow.

1. Remove valve block assembly from planter.
2. Remove detent assembly and port adapter assemblies from rear of valve block.

NOTICE

Damage to spool may occur if detent assembly and port adapter assemblies are not removed prior to removal of spool.

3. Remove plug from both sides of valve block and remove spool.
4. Inspect all parts for pitting, contamination, or foreign material. Check seating surfaces inside valve. Replace defective parts.
5. Lubricate spool with a light oil and reinstall. Check spool moves freely in valve body.

NOTE: Make sure correct check ball(s) and spring are installed in each valve bore upon reassembly.

A flow control valve is located on each side of block assembly. Adjust flow control valves for raise and lower speed as part of assembly procedure or upon initial operation. If valve fails to function properly or requires frequent adjustment, remove needle valve for inspection. Check for foreign material and contamination. Make sure needle moves freely in adjustment screw. Replace defective components.

NOTE: Hydraulics operate slowly when oil is cold. Make all adjustments with warm oil.

PTO PUMP DRIVE AND OIL COOLER OPTION

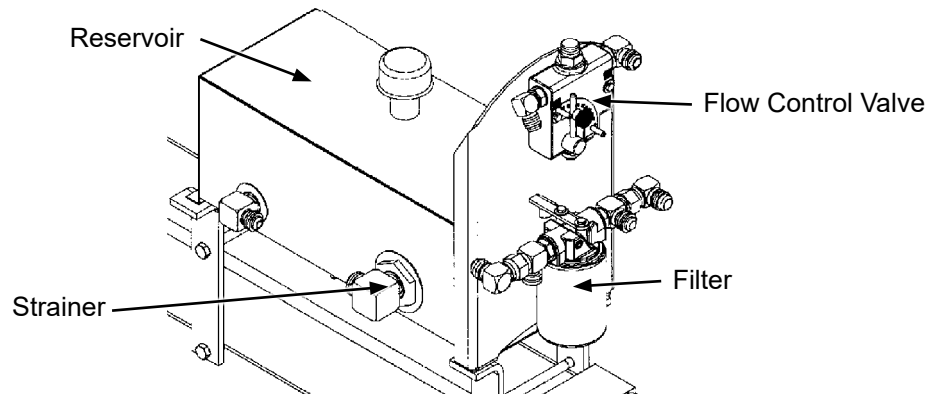

Drain reservoir, clean strainer and change filter annually.

1. Disconnect suction line (hose between reservoir and pump) from reservoir and drain. To fully drain tank, raise planter to field raised position.
2. Replace filter with good quality 10 micron filter.
3. Fill system with SAE 10W-20 multigrade wide temperature range transmission hydraulic fluid. Reservoir capacity is approximately 10 gallons.
4. Start system and run with tractor at idle and fan turned off for 1-2 minutes. Switch fan to full speed and run with tractor at idle for 1-2 minutes.
5. Check reservoir fluid level and fill as required. Hydraulic fluid level should be within 1"-2" (2.5 cm - 5 cm) from top of reservoir after pump has run and hydraulic hoses have been primed to allow fluid to expand when heated.
6. Bring tractor to PTO speed and adjust flow control to the desired vacuum level using the flow control valve lever.

High Pressure Filter

NOTE: Replace high pressure filter after first season and then check annually. If debris has collected on filter, replace filter.

1. Remove O-ring plug on top of filter.
2. Pull old filter straight out using handle.
3. Insert new filter.
4. Reinstall O-ring plug.

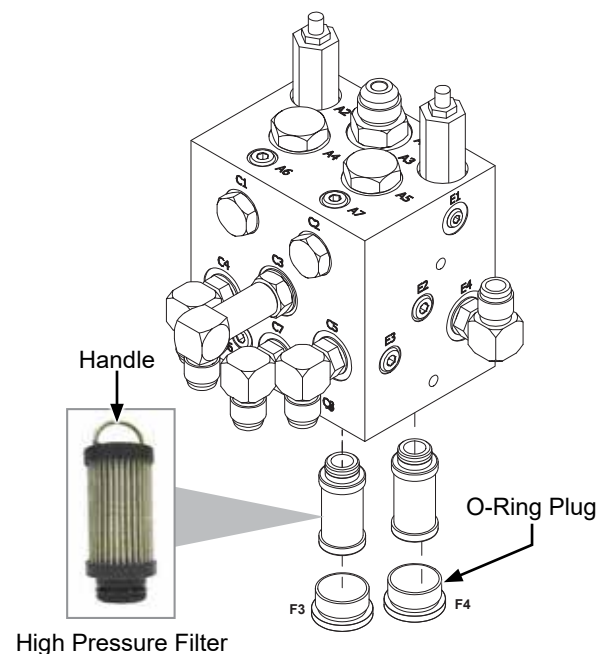

CHECK VALVE INSPECTION**(In valve block below vacuum fan motor assembly)**

Check valve return prevents reverse operation of vacuum fan motor. Remove and check for foreign material or if O-ring is leaking internally. Clean or replace if defective.

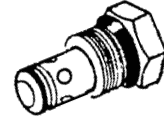
**RELIEF VALVE CARTRIDGE INSPECTION (6 ROW ONLY)****(In valve block below vacuum fan motor assembly)****NOTICE**

Connect hydraulic motor case drain to a case drain return line with zero pressure on tractor or hydraulic motor will be damaged. **DO NOT** connect hydraulic motor case drain to SCV outlet. Contact tractor manufacturer for specific details on “zero pressure return”.

Pressure relief valve helps prevent damage to vacuum fan motor by limiting pressure in motor case drain line. It is set to open at 35 PSI (241.21 kPa). Remove and check for foreign material and contamination on valve or seating area of valve body. Clean or replace if defective.

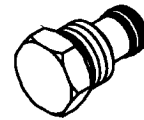

ROW MARKER BEARING LUBRICATION OR REPLACEMENT

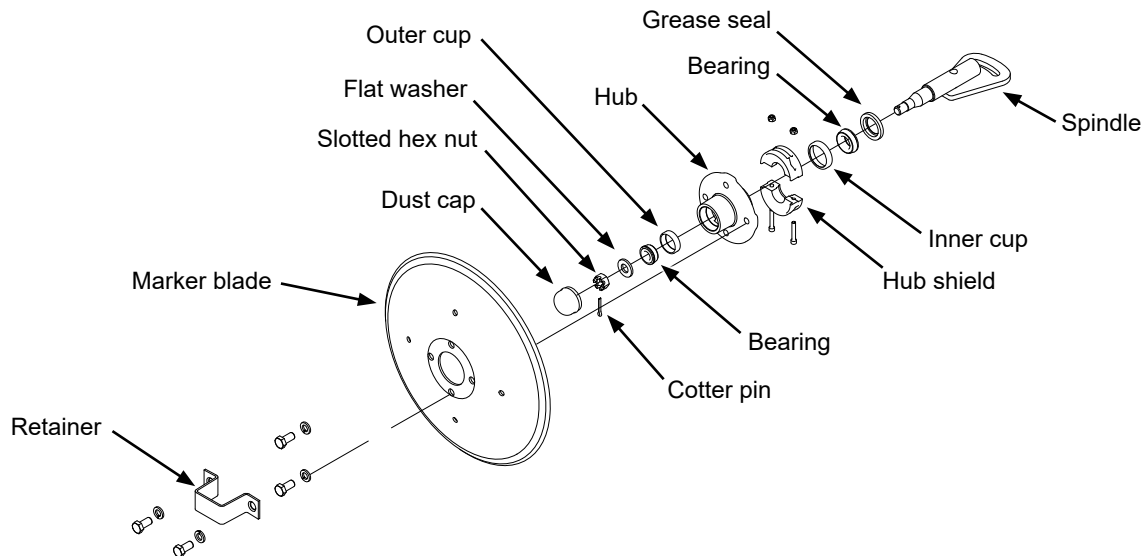

1. Remove retainer and marker blade.
2. Remove dust cap from hub.
2. Remove hub shield. Note direction of installation.
3. Remove cotter pin, slotted hex nut, and washer.
4. Slide hub from spindle.
5. Remove bearings and cups and discard if bearings are being replaced. Clean hub and dry. Remove bearings only and not cups if repacking.
6. Press in new bearing cups with thickest edge facing in. (Bearing replacement procedure only.)
7. Pack bearings with heavy duty wheel bearing grease thoroughly forcing grease between roller cone and bearing cage. Fill the space between the bearing cups in the hub with grease.
8. Install rubber seal into grease seal. Place inner bearing in place and press in new rubber seal/grease seal.
9. Clean spindle and install hub.
10. Install outer bearing, washer and slotted hex nut. Tighten slotted hex nut while rotating hub until there is some drag. This ensures all bearing surfaces are in contact. Back off slotted nut to nearest locking slot and install cotter pin.
11. Fill dust caps approximately $\frac{3}{4}$ full of wheel bearing grease and install on hub.
12. Install hub shield.
13. Install marker blade and retainer on hub. Tighten hardware evenly.

WHEEL BEARING REPACK OR REPLACEMENT

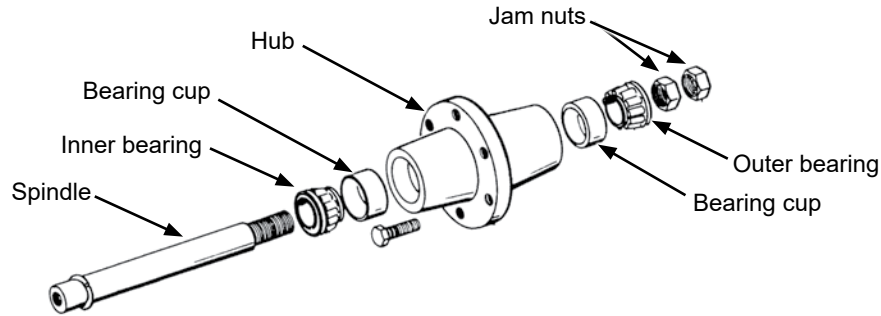

1. Raise tire clear of ground and remove wheel.
2. Remove double jam nuts and slide hub from spindle.
3. Remove bearings and cups and discard if bearings are being replaced. Clean hub and dry. Remove bearings only and not cups if repacking.
4. Press in new bearing cups with thickest edge facing in. (Bearing replacement procedure only.)
5. Pack bearings with heavy duty wheel bearing grease thoroughly forcing grease between roller cone and bearing cage. Fill space between bearing cups and hub with grease.
6. Place inner bearing in place.
7. Clean spindle and install hub.
8. Install outer bearing and jam nut. Tighten jam nut while rotating hub until there is some drag. This ensures all bearing surfaces are in contact. Back off jam nut $\frac{1}{4}$ turn or until there is only slight drag when rotating hub. Install second jam nut to lock against first.
9. Install wheel on hub. Tighten hardware evenly.

FERTILIZER CHECK VALVE CLEANING AND REPAIR

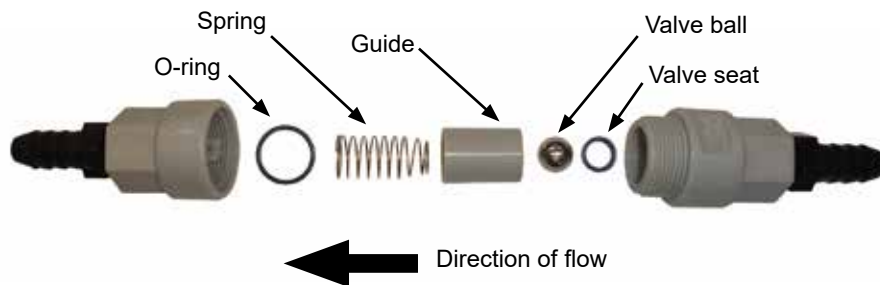

1. Unscrew valve body and separate halves. Note direction and location of parts.
2. Clean and inspect parts. Flush with clean water. Replace damaged parts.
3. Reassemble exactly as shown. O-ring and valve seat must be firmly in place inside each half of valve body.

BATTERY CARE

NOTICE

Read and follow all manufacturers labels and instructions.

Battery Specifications

Chemistry:	Wet lead acid (Low maintenance)
Voltage:	12.00
Milliamp Hours:	0 mAH
Capacity:	17.00 AH
Weight:	15.30 lb
Length:	7.72"
Width:	5.19"
Height:	7.30"
Termination:	Top post (auto type)

BEFORE PLANTING SEASON

- Check and clean all connections.
- Fully charge batteries before installing into the planter.
- Batteries more than two years old should be load checked.
- Reinstall batteries or connect the negative ground cables.

PREPARATION FOR STORAGE

Planter batteries that are stored for more than one month should be cared for as follows:

- Remove the batteries or disconnect the negative ground cables.
- Fully charge batteries before storing.
- Store in a cool dry location.
- Keep from freezing.

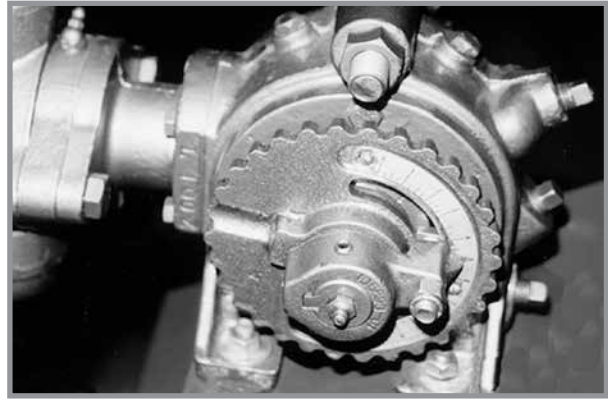
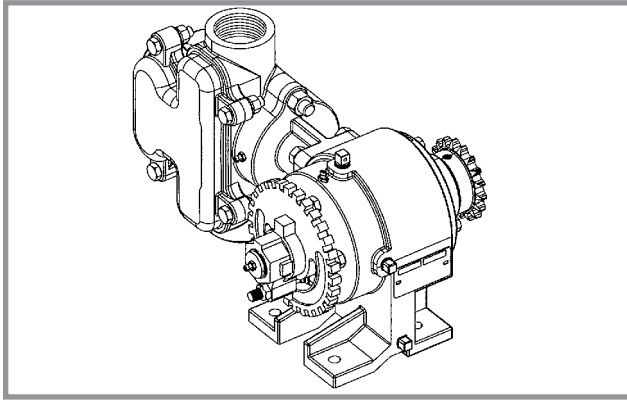

Liquid fertilizer piston pump

PISTON PUMP STORAGE

NOTICE

Entrance of air into pump will cause rapid and severe corrosion. **KEEP AIR OUT OF PUMP!**

NOTE: SUSPENSION FERTILIZER must be flushed from pump for ANY storage period.

1. Flush pump with 5 to 10 gallons (19 to 38 liters) of fresh water and circulate until all corrosive salts are dissolved in pump.
2. Set pump on 10. Draw in a mixture of half diesel fuel and 10 weight oil until discharge is clean. Plug inlet and outlet.

PREPARATION FOR STORAGE

Store planter in a dry sheltered area if possible.

Remove all trash wrapped on sprockets or shafts and remove dirt that can draw and hold moisture.

Clean all drive chains and coat with a rust preventative spray, or remove chains and submerge in oil.

Lubricate planter and row units at all lubrication points.

Inspect planter for parts that in need of replacement and order during “off” season.

Make sure all seed and granular chemical hoppers are empty and clean.

Remove seed discs from seed meters, clean and store meters in a rodent-free, dry area with discs removed. Store seed discs vertically on a dowel or pipe.

Remove vacuum hose from each seed meter. Operate vacuum fan at full hydraulic flow from tractor for two minutes to clear manifolds, hoses and fittings of dust and debris.

Clean breather on analog vacuum and pressure gauges.

Disassemble, clean and grease all U-joint slides.

Grease or paint disc openers/blades and row marker disc blades to prevent rust.

Flush liquid fertilizer tanks, hoses and metering pump with clean water. See “Piston Pump Storage” if applicable.

Empty dry fertilizer hoppers. Clean hoppers. Disassemble and clean metering augers. Reassemble, coating all metal parts with rust preventative.

See [“Battery Care” on page 6-35](#) if planters are equipped with batteries.

Bulk Fill System:

- Clean out bulk fill hopper, entrainment assembly, and delivery hoses.
- Disconnect delivery hoses from entrainer ports. Install small orange caps onto ports. Attach hoses to caps.
- Disconnect delivery hoses from air dissipator at each row unit. Install large orange caps. Attach hoses to caps.
- Check all bolts and fasteners used to assemble and attach entrainment device are tight (if applicable).
- Loosen knobs on entrainer cleanout doors to remove pressure from door gaskets.
- Inspect all seed delivery hoses and replace any that are worn, cut, or cracked.

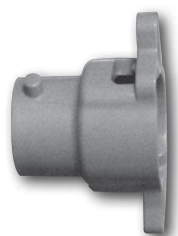

Entrainer Cap

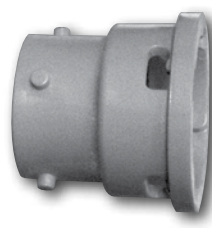

Row Unit Cap

ELECTRICAL WIRING DIAGRAM FOR LIGHT PACKAGE

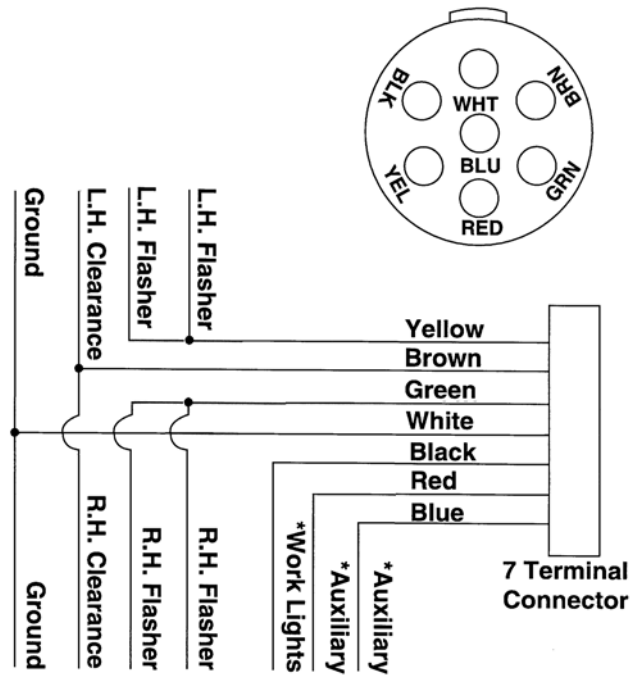

* Optional customer-supplied auxiliary lights and wires may be wired into existing plug terminals.

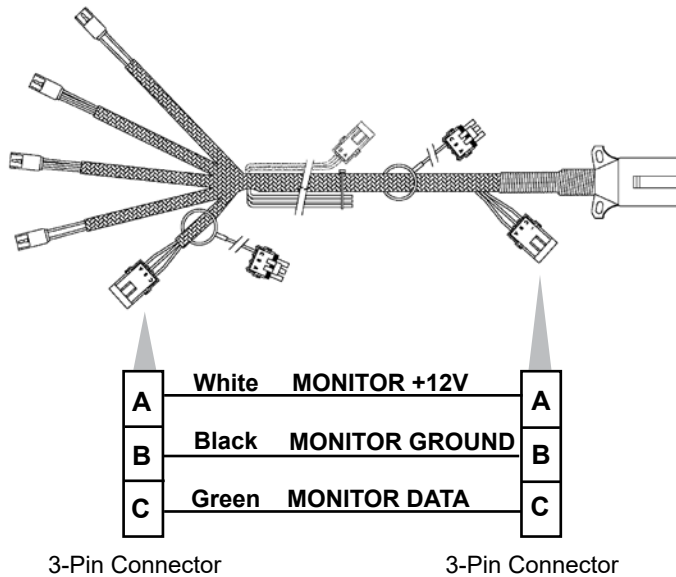

Light package meets ASABE Standards. For correct wiring harness to be wired into lights on your tractor, check with tractor manufacturer.

HYDRAULIC HOSE LIFE

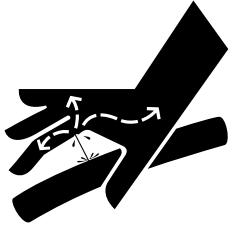
 WARNING	<p>Pressurized hydraulic fluid can penetrate body tissue and result in death, serious infection, or other injuries. Fluid injected under skin must be IMMEDIATELY removed by a surgeon familiar with this type of injury. Make sure connections are tight and hoses and fittings are not damaged before applying system pressure. Leaks can be invisible. Keep away from suspected leaks. Relieve pressure before searching for leaks or performing any system maintenance.</p>
	

Proper storage of hydraulic hoses can significantly increase the life of the hoses, for a period of three to five years. After this period, service life of hoses may decrease, depending on variables such as variances in rubber materials and storage environment. Refer to the guidelines below for best practices when storing.

- Store in a clean, cool and dry area
- Avoid direct sunlight or moisture
- Do not store near high power electrical equipment
- Avoid contact with corrosive chemicals
- Avoid ultraviolet light
- Avoid areas with obvious signs of insects or rodents

Unusually long periods of storage or poor storage environment may lead to performance issues or premature failure. Always inspect all hoses prior to use for extensive wear, cuts, or holes. If such flaws are identified, replace immediately to avoid potential failure, property damage or bodily injury.

HYDRAULIC DIAGRAM - PLANTER (6 ROW)

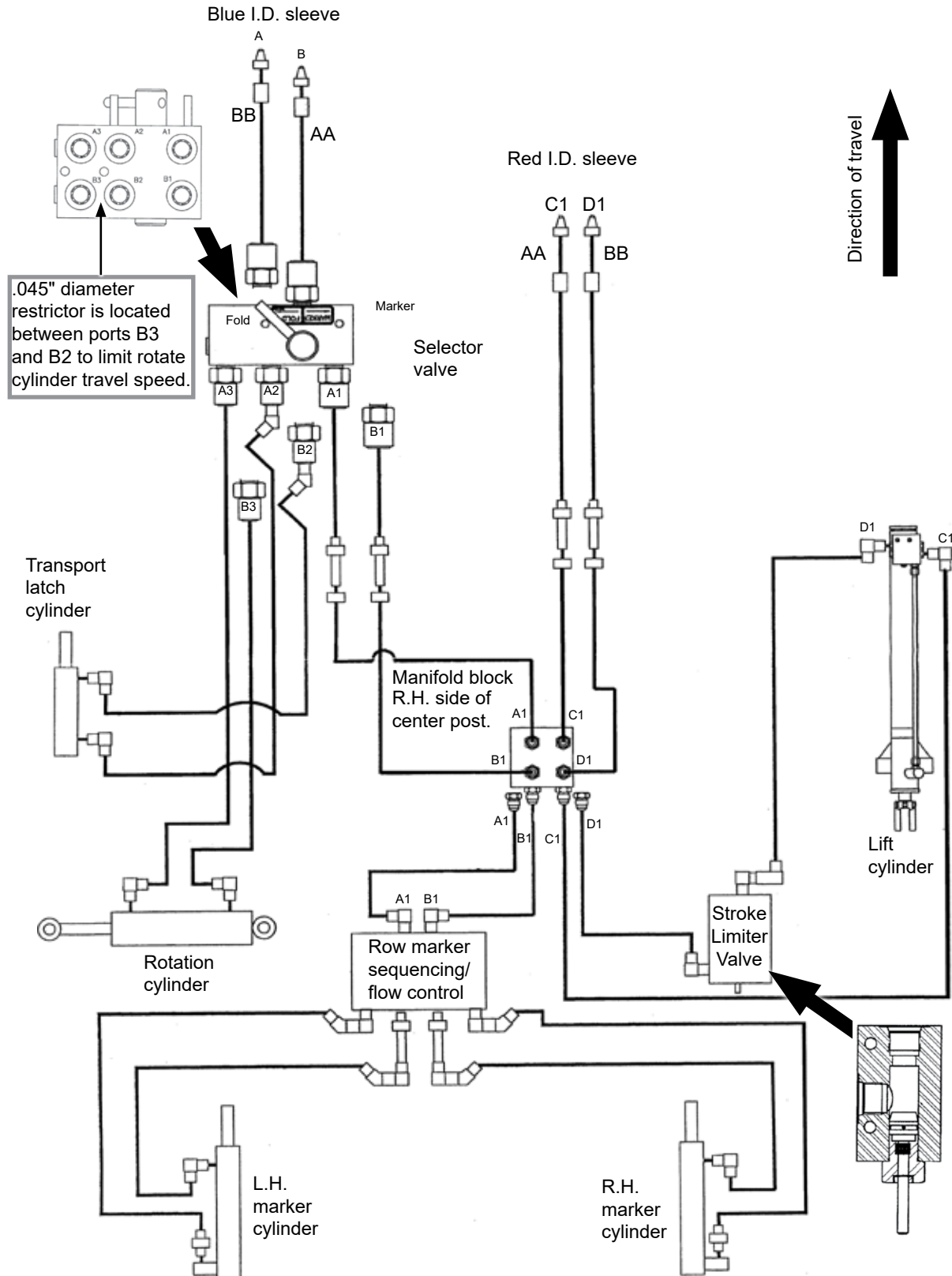

HYDRAULIC DIAGRAM - PLANTER (8 ROW CONVENTIONAL)

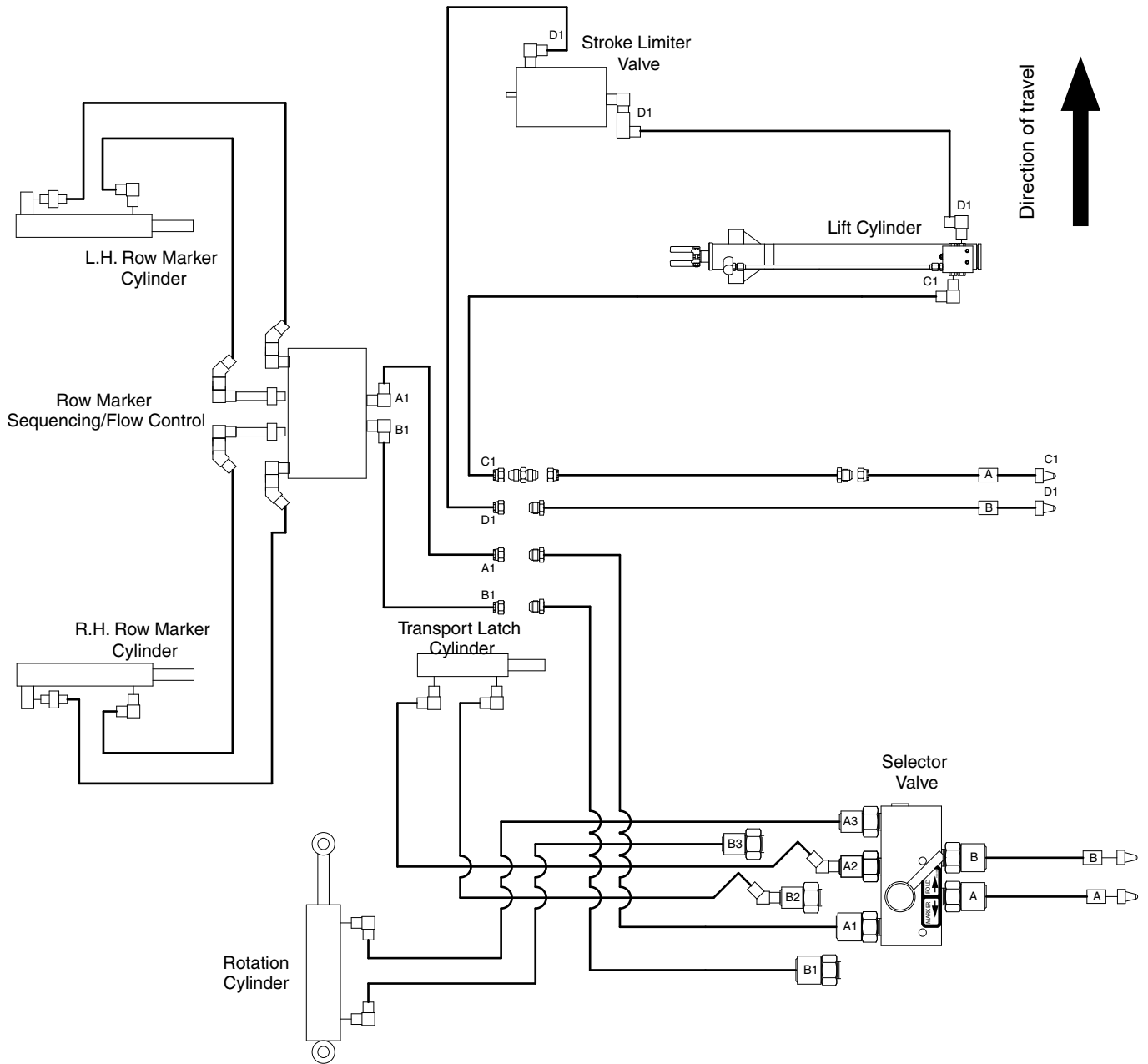

HYDRAULIC DIAGRAM - PLANTER (8 ROW BULK FILL)

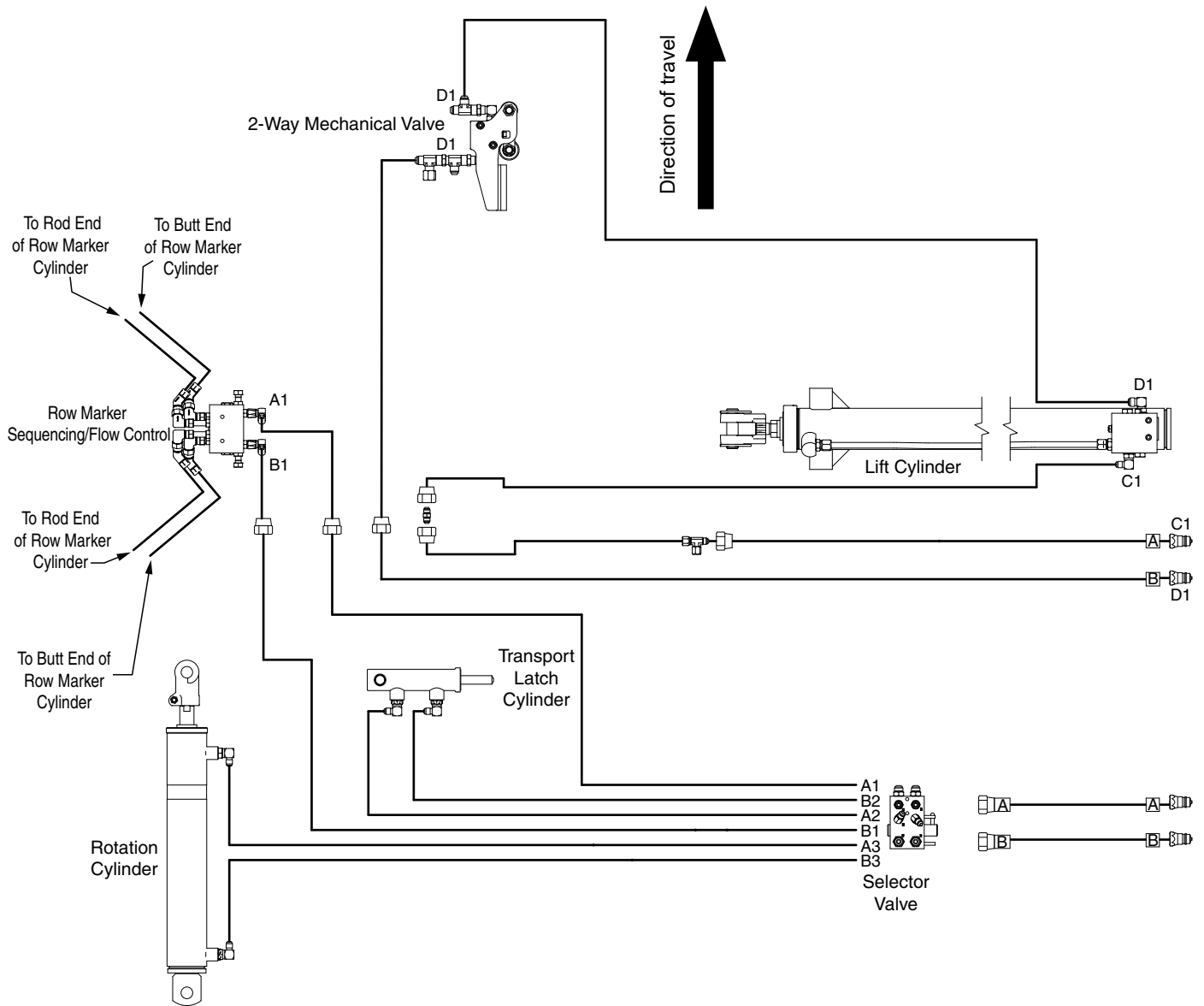

HYDRAULIC DIAGRAM - PLANTER (8 ROW CONVENTIONAL / BULK FILL)

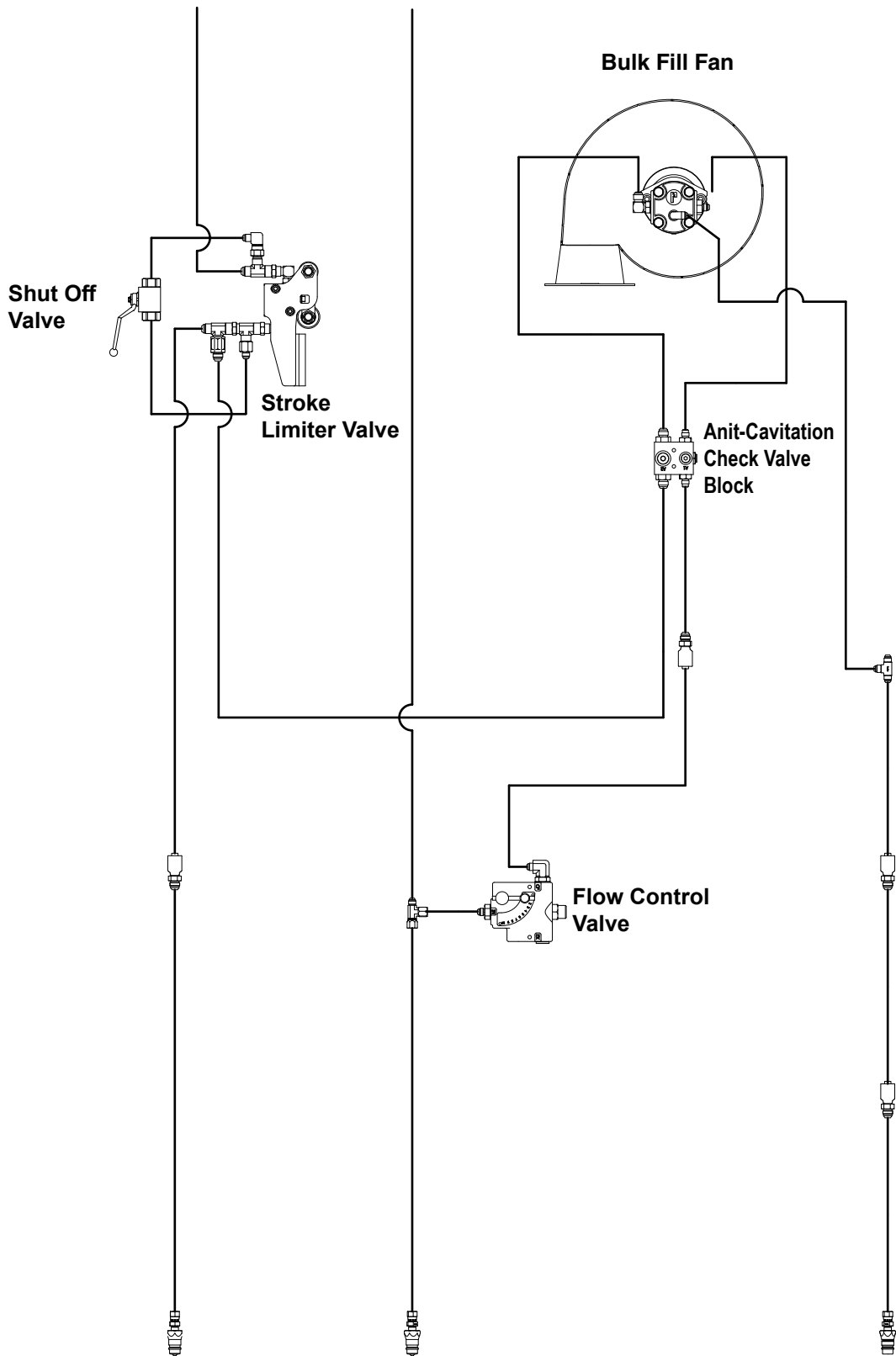

HYDRAULIC DIAGRAM - PLANTER (8 ROW VACUUM / BULK FILL)

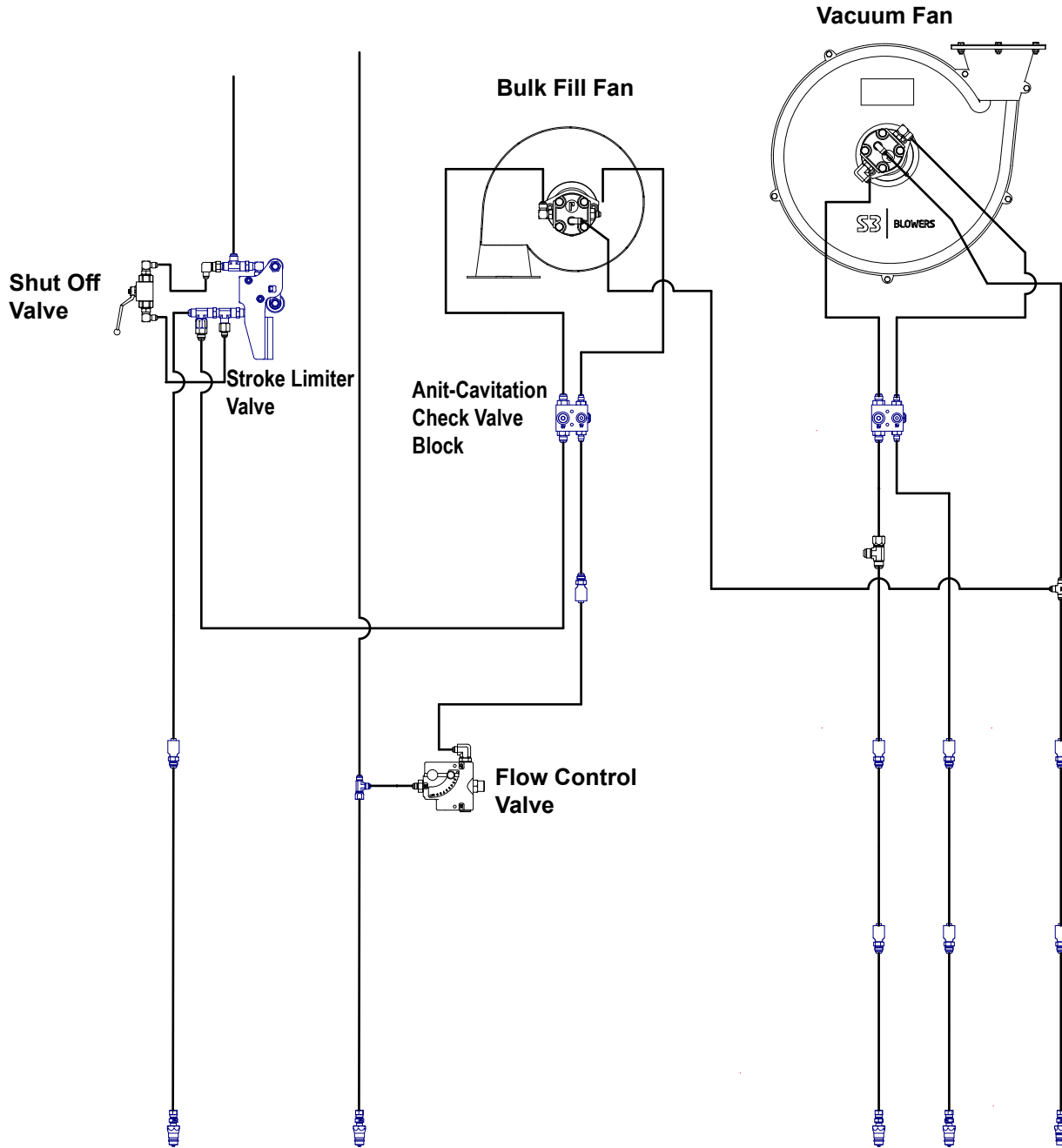

HYDRAULIC DIAGRAM - VACUUM FAN MOTOR SYSTEM (6 ROW)

NOTICE Connect hydraulic motor case drain to a case drain return line with zero pressure on tractor or hydraulic motor will be damaged. DO NOT connect hydraulic motor case drain to SCV outlet. Contact tractor manufacturer for specific details on "zero pressure return".

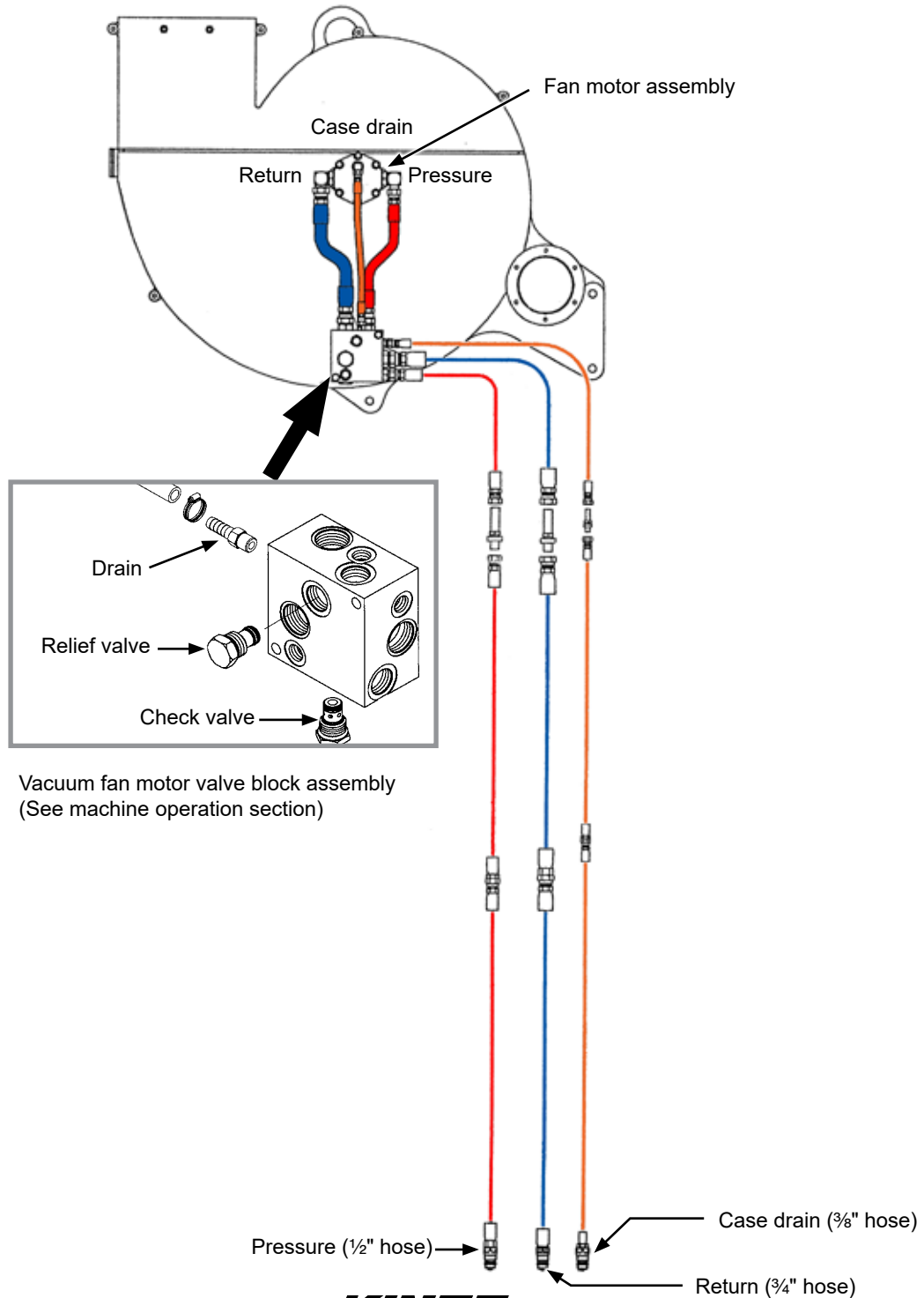

HYDRAULIC DIAGRAM - VACUUM FAN MOTOR SYSTEM (8 ROW)

NOTICE

Connect hydraulic motor case drain to a case drain return line with zero pressure on tractor or hydraulic motor will be damaged. DO NOT connect hydraulic motor case drain to SCV outlet. Contact tractor manufacturer for specific details on "zero pressure return".

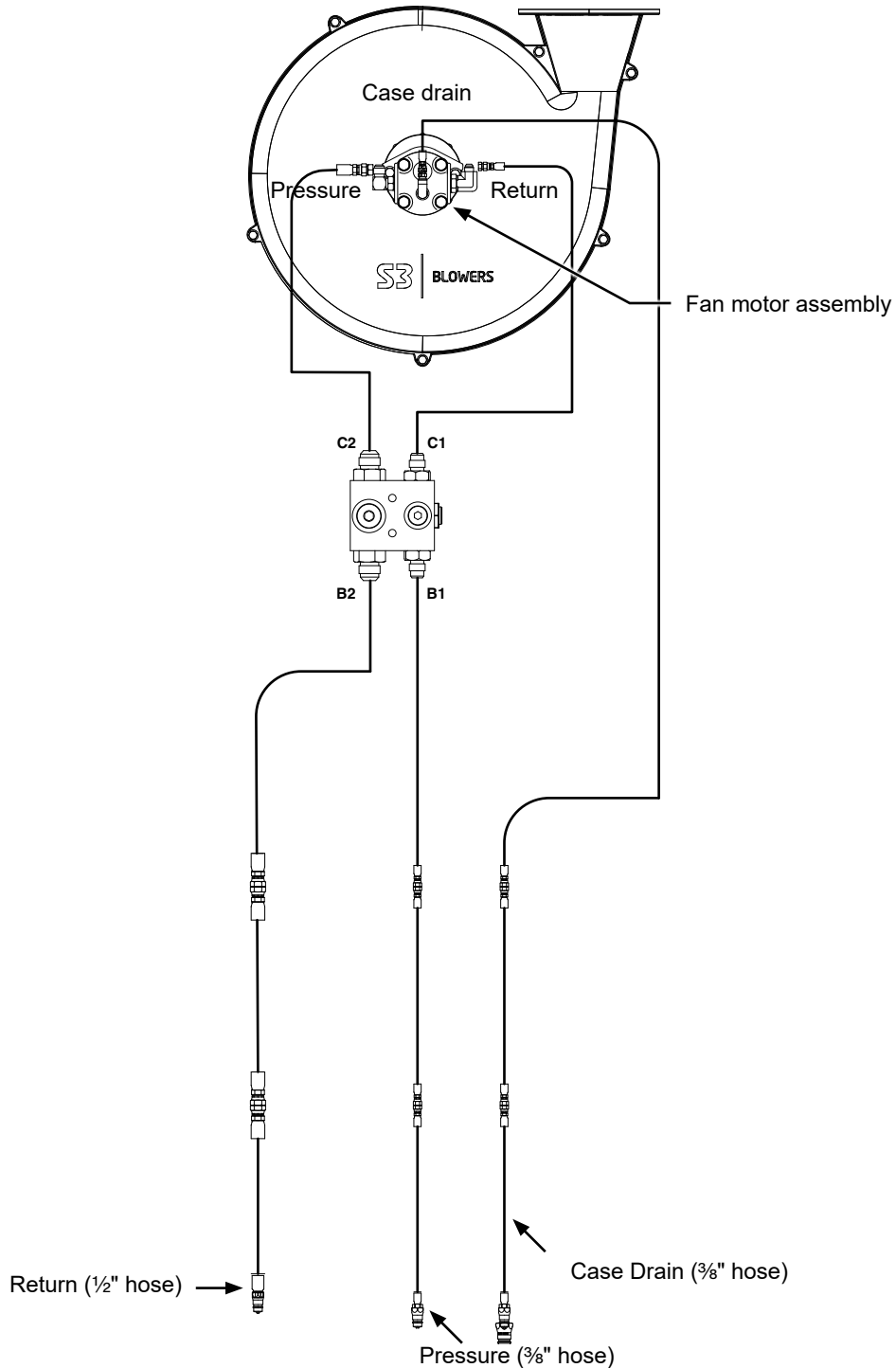

HYDRAULIC DIAGRAM - OPTIONAL PTO PUMP DRIVE AND OIL COOLER SYSTEM - 6 ROW

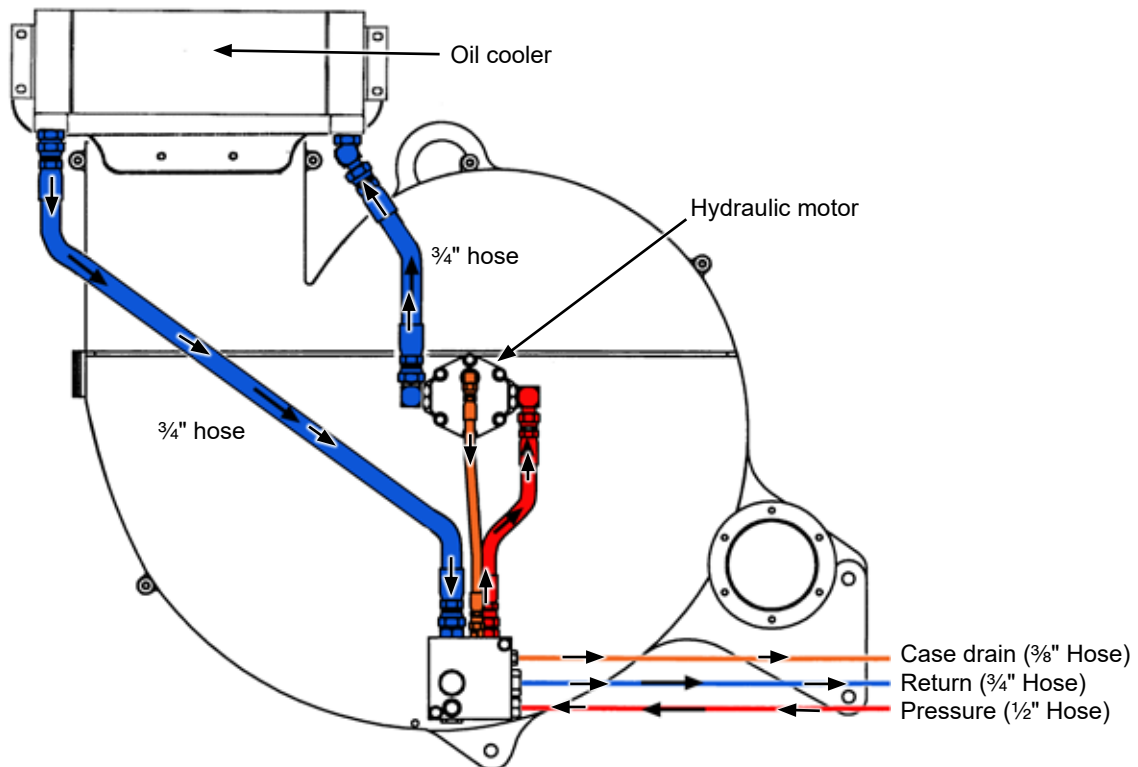
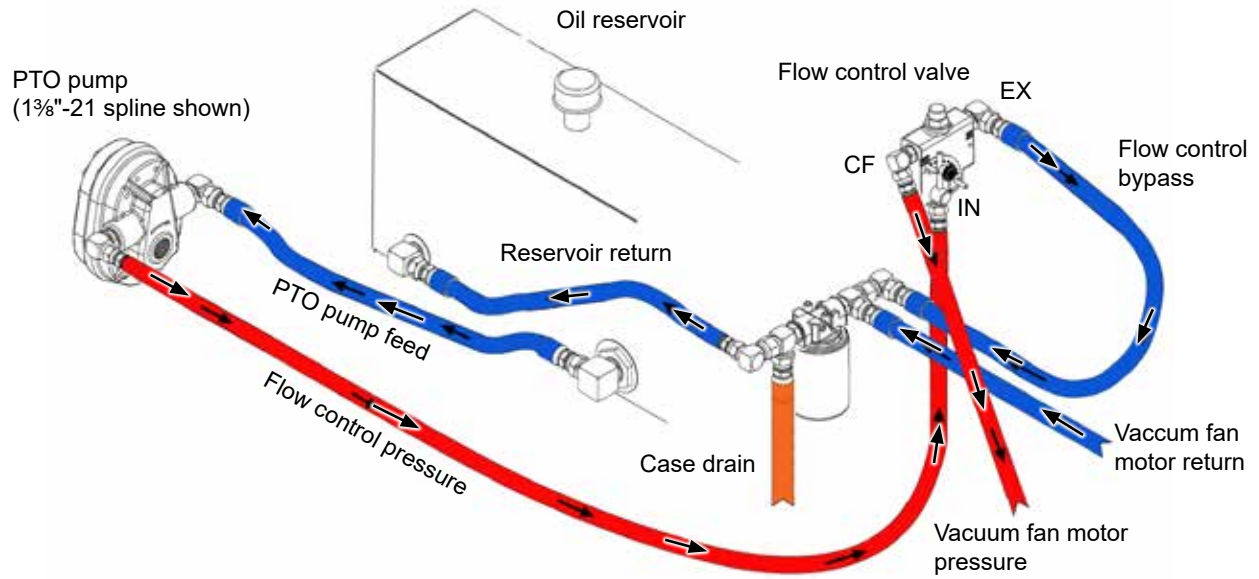

TRACTOR CONSOLE HARNESS (A25031)

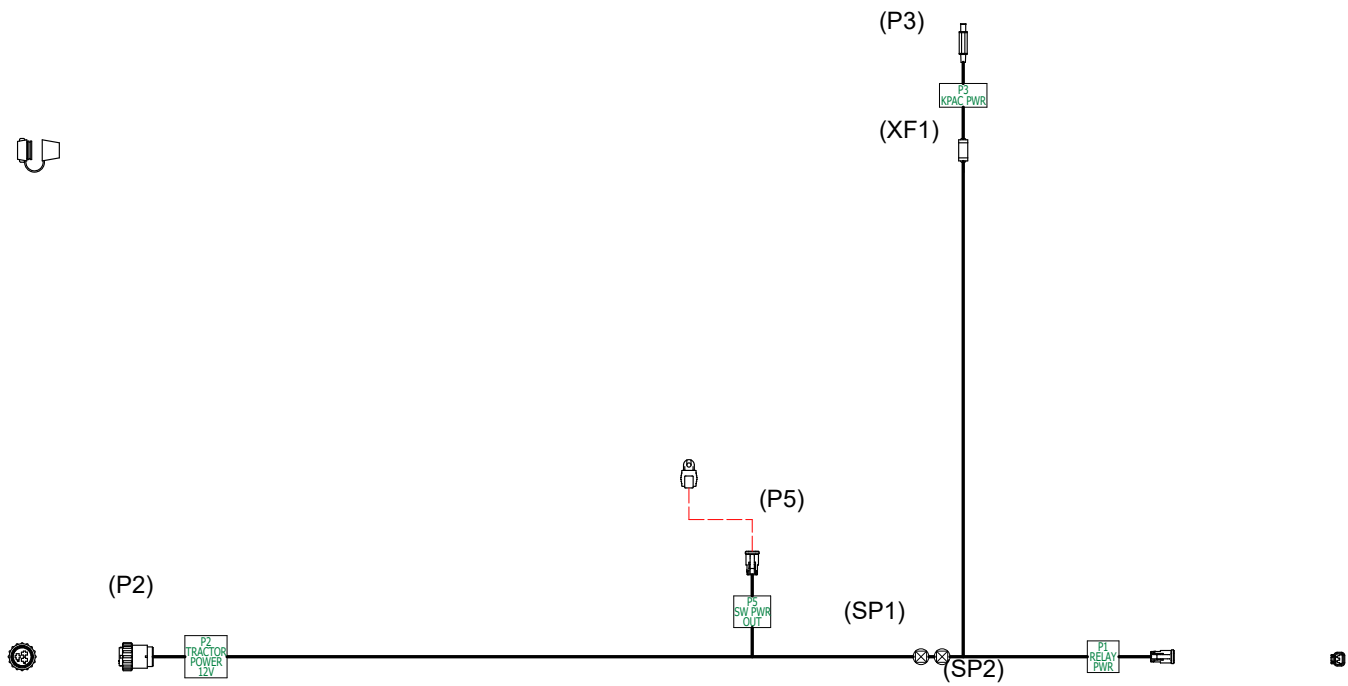

Signal	Wire Gauge	Color	FROM	TO
12V Switched (PWR)	16	RED	P2-1	SP1
Relay (PWR)	18	BLUE	SP1	P1-1
12V Switched (PWR)	18	RED	SP1	XF1-1
12V Switched (PWR)	18	ORN	SP1	P5-1
12V Switched (PWR)	18	RED	XF1-2	P3-1
12V Switched (PWR)	16	BLK	P2-3	SP2
12V Switched (PWR)	18	BLK	SP2	P1-2
12V Switched (PWR)	18	BLK	SP2	P3-2
12V Switched (PWR)	18	BLK	SP2	P5-2

TRACTOR POWER HARNESS (P/N: 10211901)

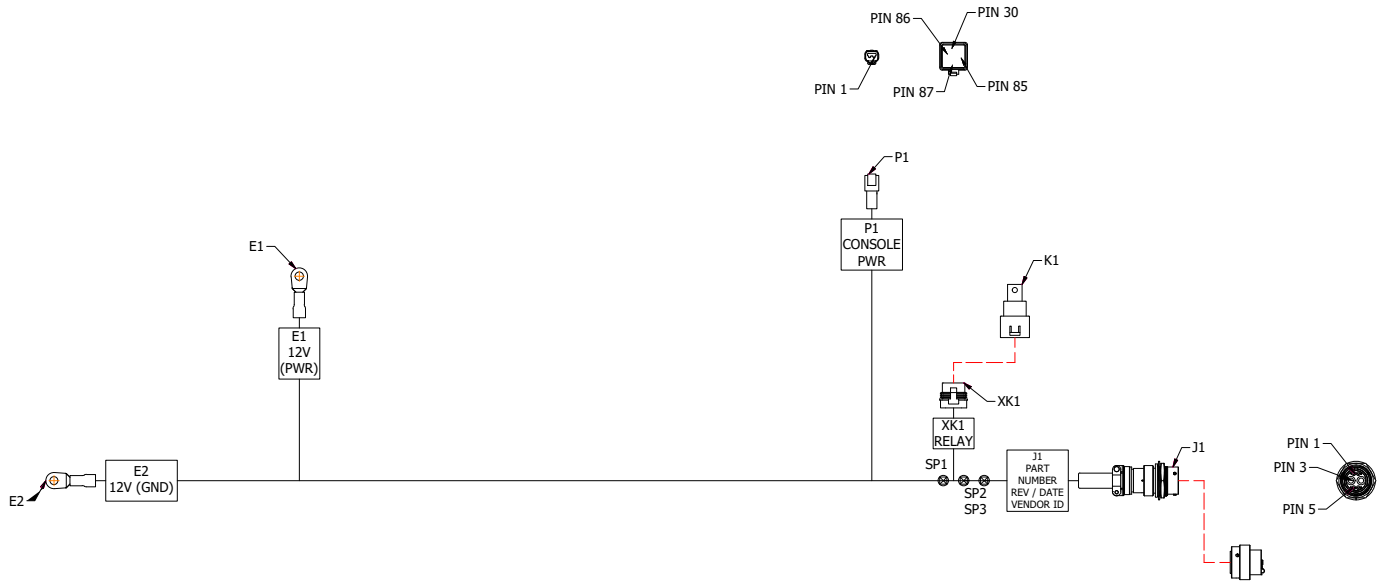

WIRE HOOKUP UP CHART							
REF DES	FROM	USED WITH ITEM	TO	USED WITH ITEM	GAUGE	COLOR	FUNCTION
W1	E1	---	SP1	---	2	RED	12V (PWR)
W2	SP1	---	XK1-30	13	10	RED	12V (PWR)
W3	XK1-87	13	SP2	---	10	RED	12V (PWR)
W4	SP2	---	J1-3	9	6	RED	12V (PWR)
W5	E2	---	SP3	---	2	BLK	12V (GND)
W6	SP3	---	J1-4	9	6	BLK	12V (GND)
W7	XK1-86	14	P1-1	11	18	BLU	SWITCH PWR (CONSOLE)
W8	XK1-85	14	P1-2	11	18	BLU	SWITCH GND (CONSOLE)

TRACTOR POWER HARNESS EXTENSION (P/N: 10060901/10060902)



WIRE HOOKUP CHART							
REF DES	FROM	USED W/ ITEM	TO	USED W/ ITEM	GAUGE	COLOR	FUNCTIO N
W1	P1-3	3	SP1	---	6	RED	12V PWR
W2	SP1	---	SP3	---	4	RED	12V PWR
W3	SP3	---	P2-3	3	6	RED	12V PWR
W4	P1-4	3	SP2	---	6	BLK	12V GND
W5	SP2	---	SP4	---	4	BLK	12V GND
W6	SP4	---	P2-4	3	6	BLK	12V GND

WORK LIGHT HARNESS (P/N: A26885)

WIRE HOOKUP CHART							
REF DES	FROM	USED WITH ITEM	TO	USED WITH ITEM	GAUGE	COLOR	FUNCTION
W1	J1-1	4	SP1	---	16	BLK	12V DC-
W2	J1-2	4	SP2	---	16	RED	12V DC+
W3	SP1	---	P1-1	3	16	BLK	WORKLIGHT (-)
W4	SP1	---	P2-1	3	16	BLK	WORKLIGHT (-)
W5	SP2	---	P1-2	3	16	RED	WORKLIGHT (+)
W6	SP2	---	P2-2	3	16	RED	WORKLIGHT (+)

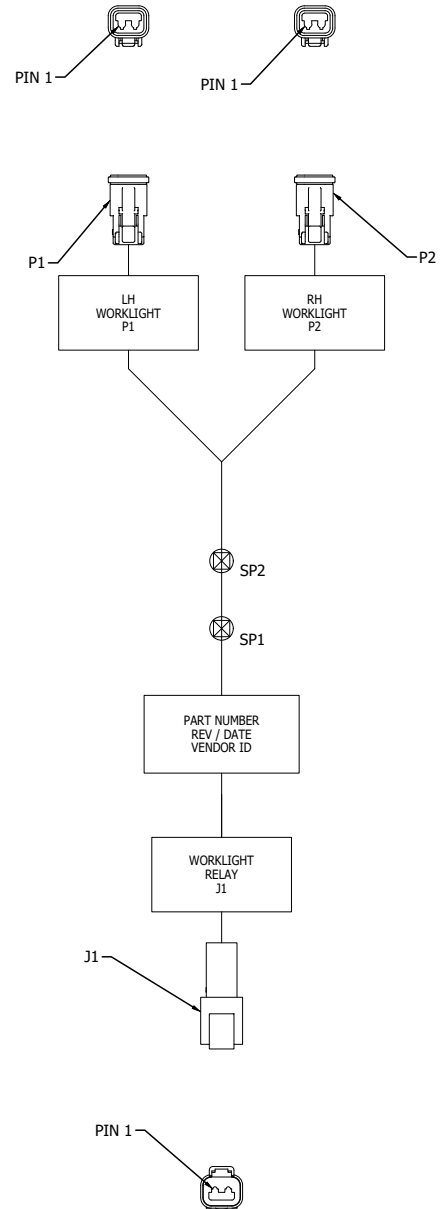

WORK LIGHT RELAY HARNESS (P/N: A22547)

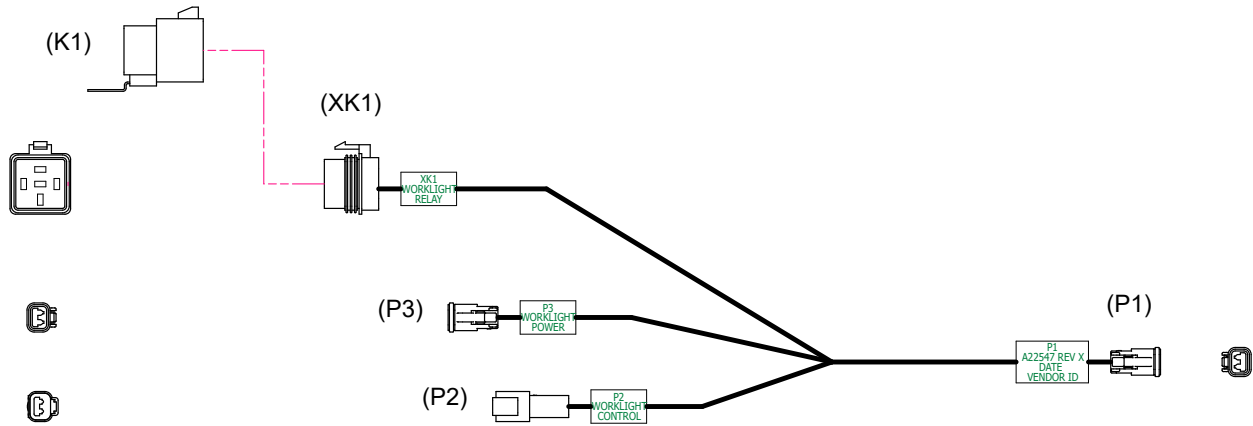

Signal	Wire Gauge	Color	FROM	TO
Work Light Power -	16	BLK	P3-1	P1-1
Work Light Power +	16	RED	P3-2	XK1-30
Relay Ground	16	BLK	P2-1	XK1-85
Relay 12V	16	BLU	P2-2	XK1-86
Worklight Power +	16	RED	XK1-87	P1-2

CAMERA POWER HARNESS (P/N: 10269201)

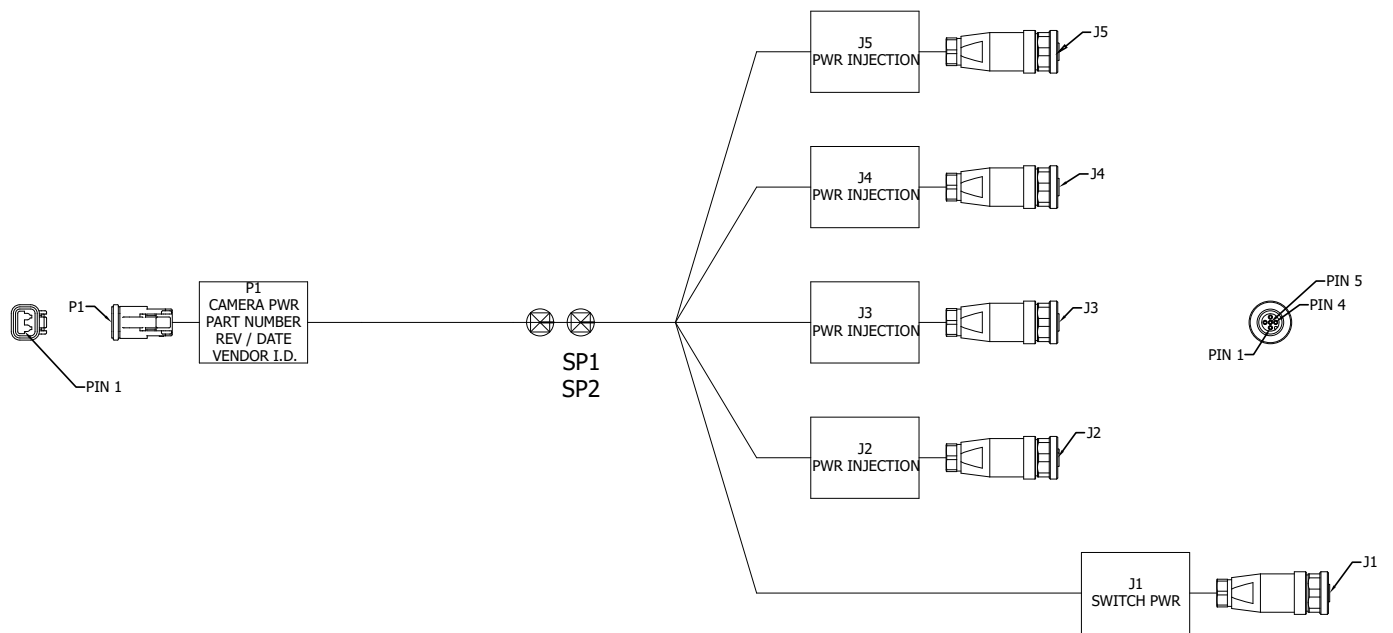

REF DES	FROM	USED W/ITEM	TO	USED W/ITEM	GAUGE	COLOR	FUNCTION
W1	P1-2	4	SP1	---	16	RED	PWR (+)
W2	SP1	---	J1-3	---	18	RED	SWITCH PWR (+)
W3	SP1	---	J1-4	---	18	RED	SWITCH PWR (+)
W4	SP1	---	J2-2	---	18	RED	CAMERA PWR (+)
W5	SP1	---	J2-3	---	18	RED	CAMERA PWR (+)
W6	SP1	---	J3-2	---	18	RED	CAMERA PWR (+)
W7	SP1	---	J3-3	---	18	RED	CAMERA PWR (+)
W8	SP1	---	J4-2	---	18	RED	CAMERA PWR (+)
W9	SP1	---	J4-3	---	18	RED	CAMERA PWR (+)
W10	SP1	---	J5-2	---	18	RED	CAMERA PWR (+)
W11	SP1	---	J5-3	---	18	RED	CAMERA PWR (+)
W12	P1-1	4	SP2	---	16	BLK	PWR (-)
W13	SP2	---	J1-1	---	18	BLK	SWITCH PWR (-)
W14	SP2	---	J1-2	---	18	BLK	SWITCH PWR (-)
W15	SP2	---	J2-1	---	18	BLK	CAMERA PWR (-)
W16	SP2	---	J2-4	---	18	BLK	CAMERA PWR (-)
W17	SP2	---	J3-1	---	18	BLK	CAMERA PWR (-)
W18	SP2	---	J3-4	---	18	BLK	CAMERA PWR (-)
W19	SP2	---	J4-1	---	18	BLK	CAMERA PWR (-)
W20	SP2	---	J4-4	---	18	BLK	CAMERA PWR (-)
W21	SP2	---	J5-1	---	18	BLK	CAMERA PWR (-)
W22	SP2	---	J5-4	---	18	BLK	CAMERA PWR (-)

MODEL 3505 AUX IPN 12 VOLT POWER HARNESS (P/N: 10331601)

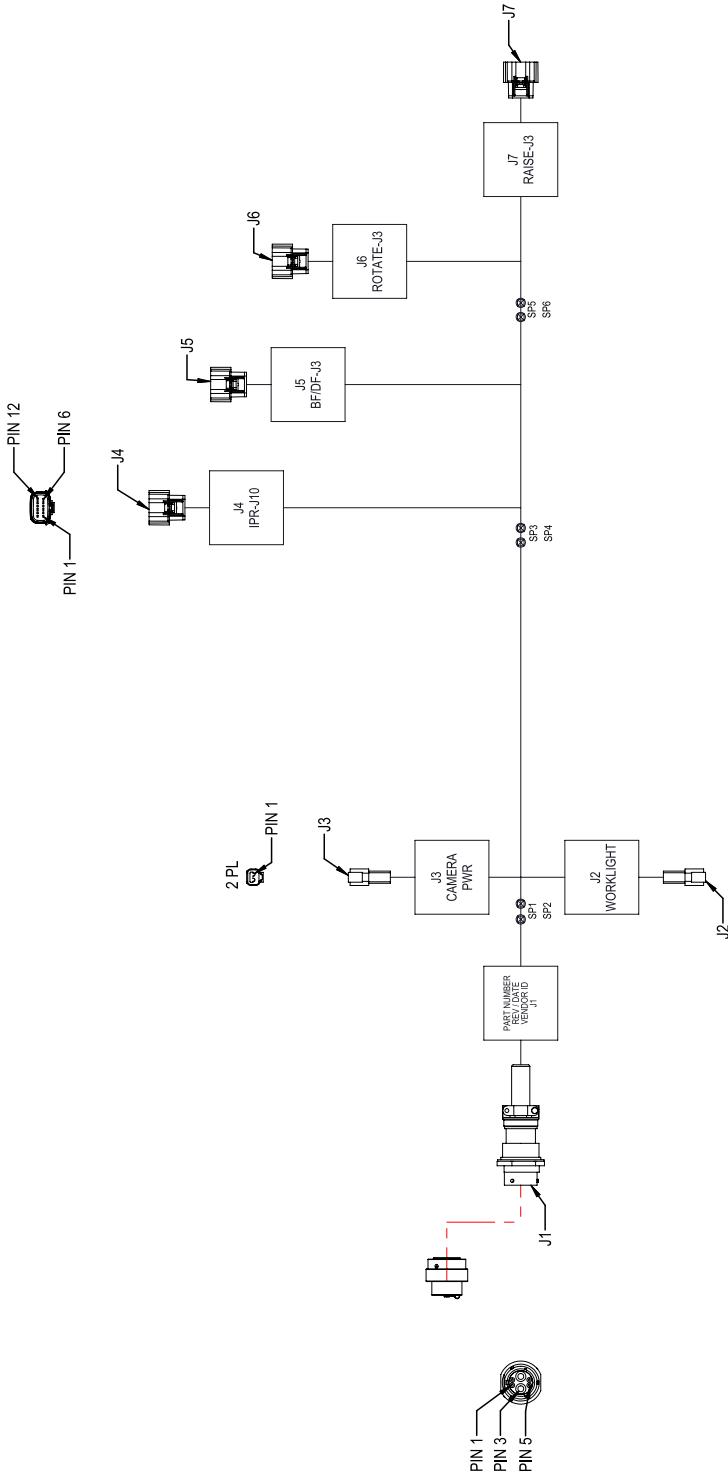

WIRE HOOKUP CHART						
REF DES	FROM	USED W/ ITEM	TO USED W/ ITEM	GAUGE	COLOR	FUNCTION
W1	J1-3	5	SP1	6	RED	12V DC (PWR)
W2	J1-4	5	SP2	6	BLK	12V DC (GND)
W3	SP1	7	J2-2	16	RED	WORKLIGHT (PWR)
W4	SP1	14	J3-2	14	RED	CAMERA (PWR)
W5	SP1	14	SP3	16	RED	12V DC (PWR)
W6	SP2	7	J2-1	16	BLK	WORKLIGHT (GND)
W7	SP2	14	J3-1	14	BLK	CAMERA (GND)
W8	SP2	16	SP4	16	BLK	12V DC (GND)
W9	SP3	6	J4-1	18	RED	IPR PWR
W10	SP3	8	J5-1	16	RED	BF/DF IPN (PWR)
W11	SP3	8	J6-3	16	RED	BF/DF IPN (PWR)
W12	SP3	12	SP5	12	RED	12V DC (PWR)
W13	SP4	6	J4-2	18	BLK	IPR GND
W14	SP4	6	J5-2	16	BLK	BF/DF IPN (GND)
W15	SP4	6	J6-4	16	BLK	BF/DF IPN (GND)
W16	SP4	12	SP6	12	GND	12V DC (GND)
W17	SP5	8	J6-1	16	RED	ROTATE IPN (PWR)
W18	SP5	8	J6-3	16	RED	ROTATE IPN (PWR)
W19	SP5	8	J7-1	16	RED	RAISE IPN (PWR)
W20	SP5	8	J7-3	16	RED	RAISE IPN (PWR)
W21	SP6	8	J6-2	16	BLK	ROTATE IPN (GND)
W22	SP6	8	J6-4	16	BLK	ROTATE IPN (GND)
W23	SP6	8	J7-2	16	BLK	RAISE IPN (GND)
W24	SP6	8	J7-4	16	BLK	RAISE IPN (GND)

STRAPPING TABLE 2			
CONNECTOR	PIN 10	PIN 11	PIN 12
J4	GND	---	GND

STRAPPING TABLE 1								
CONNECTOR	PIN 5	PIN 6	PIN 7	PIN 8	PIN 9	PIN 10	PIN 11	PIN 12
J5	GND	GND	GND	GND	GND	GND	GND	GND
J6	GND	---	GND	GND	GND	GND	---	GND
J7	---	GND	GND	GND	GND	GND	GND	GND

MODEL 3505 RAISE IPN HARNESS (P/N: 10331401)

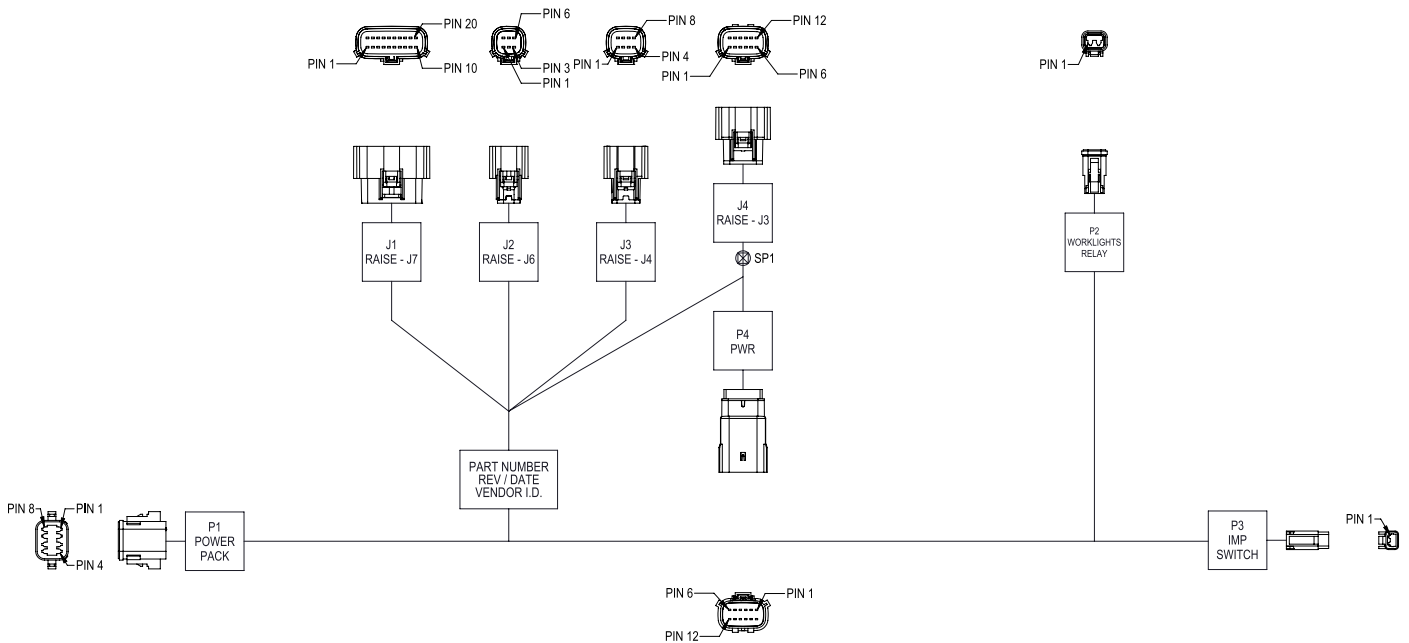

REF DES	FROM	USED W/ITEM	TO	USED W/ITEM	GAUGE	COLOR	FUNCTION
W1	J1-13	7	P1-4	8	20	YEL	RU PWR FEEDBACK
W2	J1-14	6	P1-7	9	14	ORN	BATTERY 1 VOLTAGE
W3	J1-16	6	P1-8	9	14	BLU	BATTERY 2 VOLTAGE
W4	J1-17	6	P1-2	8	16	BLK	RU PWR RELAY (GND)
W5	J1-18	6	P1-1	8	16	RED	RU PWR RELAY (PWR)
W6	J1-19	6	P2-1	8	16	BLK	WORKLIGHT RELAY (-)
W7	J1-20	6	P2-2	8	16	RED	WORKLIGHT RELAY (+)
W8	J3-5	7	P3-1	10	18	BRN	IMP SWITCH (PWR)
W9	J3-7	7	P3-2	10	18	GRN	IMP SWITCH (GND)
W10	J3-8	6	P1-3	8	16	BRN	ALTERNATOR SENSE (FREQ)
W11	J2-6	6	P1-6	8	16	GRN	BATTERY PACK RELAY (GND)
W12	P4-1	18	SP1	---	16	RED	RAISE IPN PWR (+)
W13	SP1	---	P1-5	8	16	RED	BATTERY PACK RELAY (PWR)
W14	SP1	---	J4	6	16	RED	RAISE IPN PWR (+)
W15	P4-2	18	J4	6	16	BLK	RAISE IPN PWR (-)
W16	P4-3	18	J4	6	16	RED	RAISE IPN PWR (+)
W17	P4-4	18	J4	6	16	BLK	RAISE IPN PWR (-)
W18	P4-5	18	J4	7	18	BLK	STRAPPING
W19	P4-6	18	J4	7	18	BLK	STRAPPING
W20	P4-7	18	J4	7	18	BLK	STRAPPING
W21	P4-8	18	J4	7	18	BLK	STRAPPING
W22	P4-9	18	J4	7	18	BLK	STRAPPING
W23	P4-10	18	J4	7	18	BLK	STRAPPING
W24	P4-11	18	J4	7	18	BLK	STRAPPING
W25	P4-12	18	J4	7	18	BLK	STRAPPING

COMPRESSOR HARNESS, 40' (P/N: A16391)

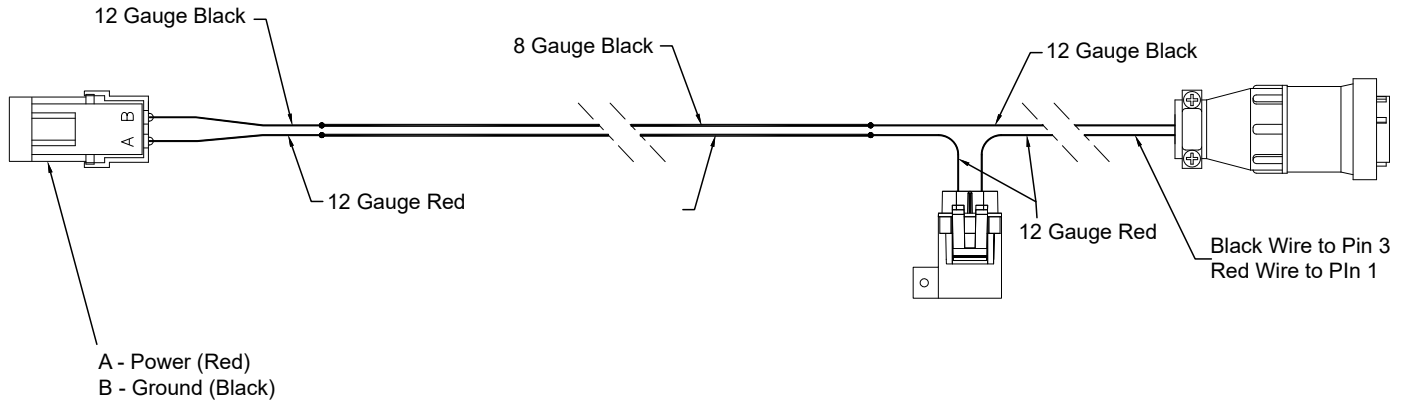

ROTATE HARNESS (P/N: 10074801)

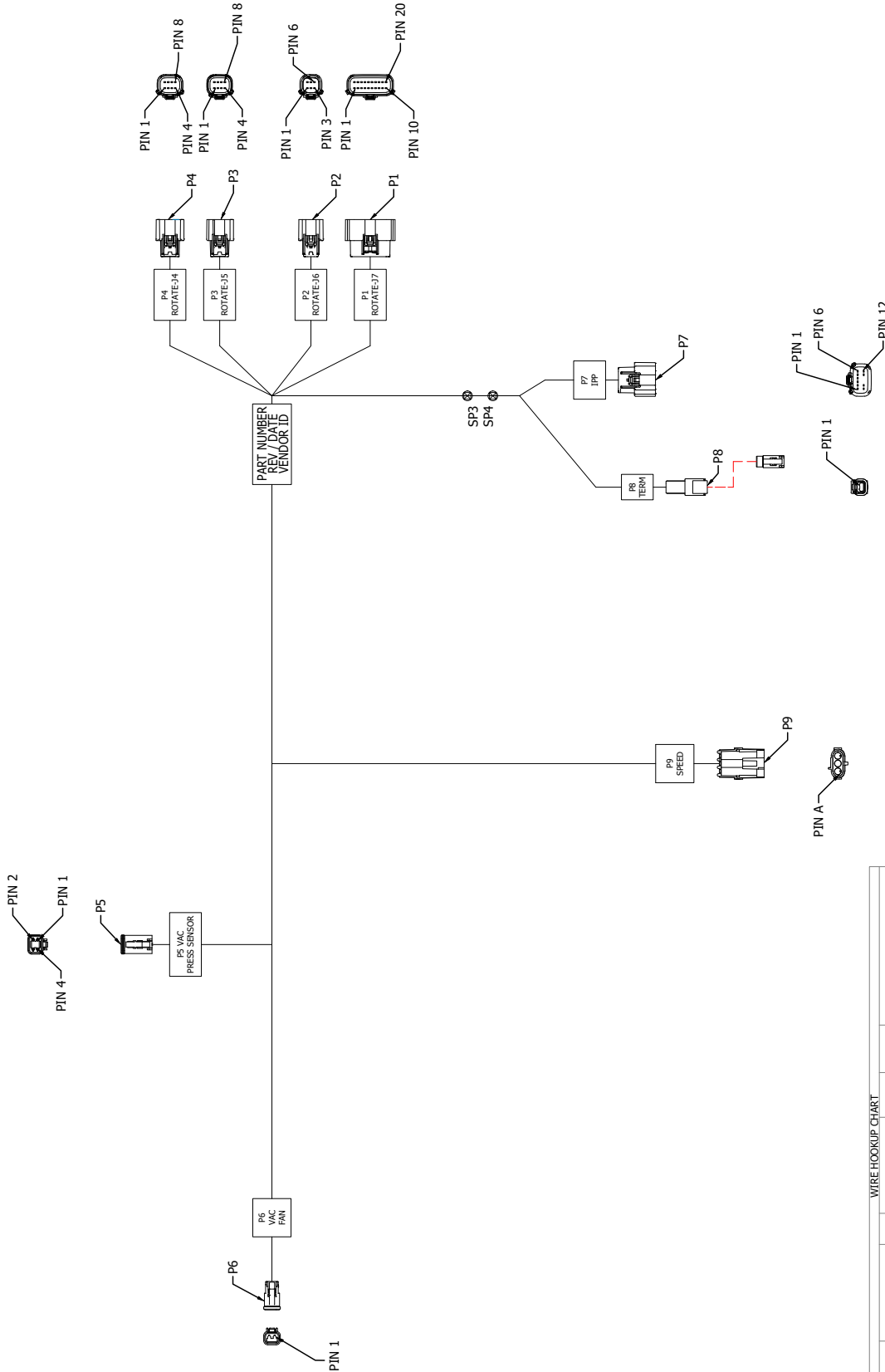

WIRE HOOKUP CHART

REF DES	FROM	USED WITH ITEM	TO	USED WITH ITEM	GAUGE	COLOR	FUNCTION
W1	P1-1	13	P7-1	13	18 (TP)	ORN	IPP RS232 RX
W2	P1-2	13	P7-2	13	18 (TP)	BRN	IPP RS232 TX
W3	P1-3	12	P6-1	15	16	RED	VAC SOLENOID (+)
W4	P1-4	12	P6-2	15	16	BLK	VAC SOLENOID (-)
W5	P2-1	13	SP3	15	18 (TP)	VEL	VAC PRESSURE SENSOR (SIG)
W6	P2-2	13	SP4	15	18 (TP)	GRN	IPP CAN HI
W7	P2-3	13	P7-12	12	16	RED	IPP CAN LO
W8	P2-4	12	P7-6	12	16	RED	IPP PWR +
W9	P2-5	12	P7-6	12	16	BLK	IPP PWR -
W10	P3-5	13	P7-11	13	18	BLU	IPP BOOT
W11	P3-5	13	P5-2	15	18	WHT	VAC PRESSURE SENSOR (PWR)
W12	P3-6	13	P5-1	15	18	BLK	VAC PRESSURE SENSOR (GND)
W13	P3-7	13	P9-C	15	18	WHT	WHEEL SPEED (RREQ)
W14	P4-6	13	P9-B	14	18	BLK	WHEEL SPEED (GND)
W15	P4-5	13	P9-A	14	18	RED	WHEEL SPEED (PWR)
W16	---	---	---	---	---	---	---
W17	SP3	13	P7-5	13	18 (TP)	VEL	IPP CAN HI
W18	SP4	13	P7-4	13	18 (TP)	GRN	IPP CAN LO
W19	SP3	16	---	---	---	VEL	CAN HI TERMINATOR
W20	SP4	16	P8-2	16	18 (TP)	GRN	CAN LO TERMINATOR

BULK FILL PDP HARNESS (P/N: A26884)

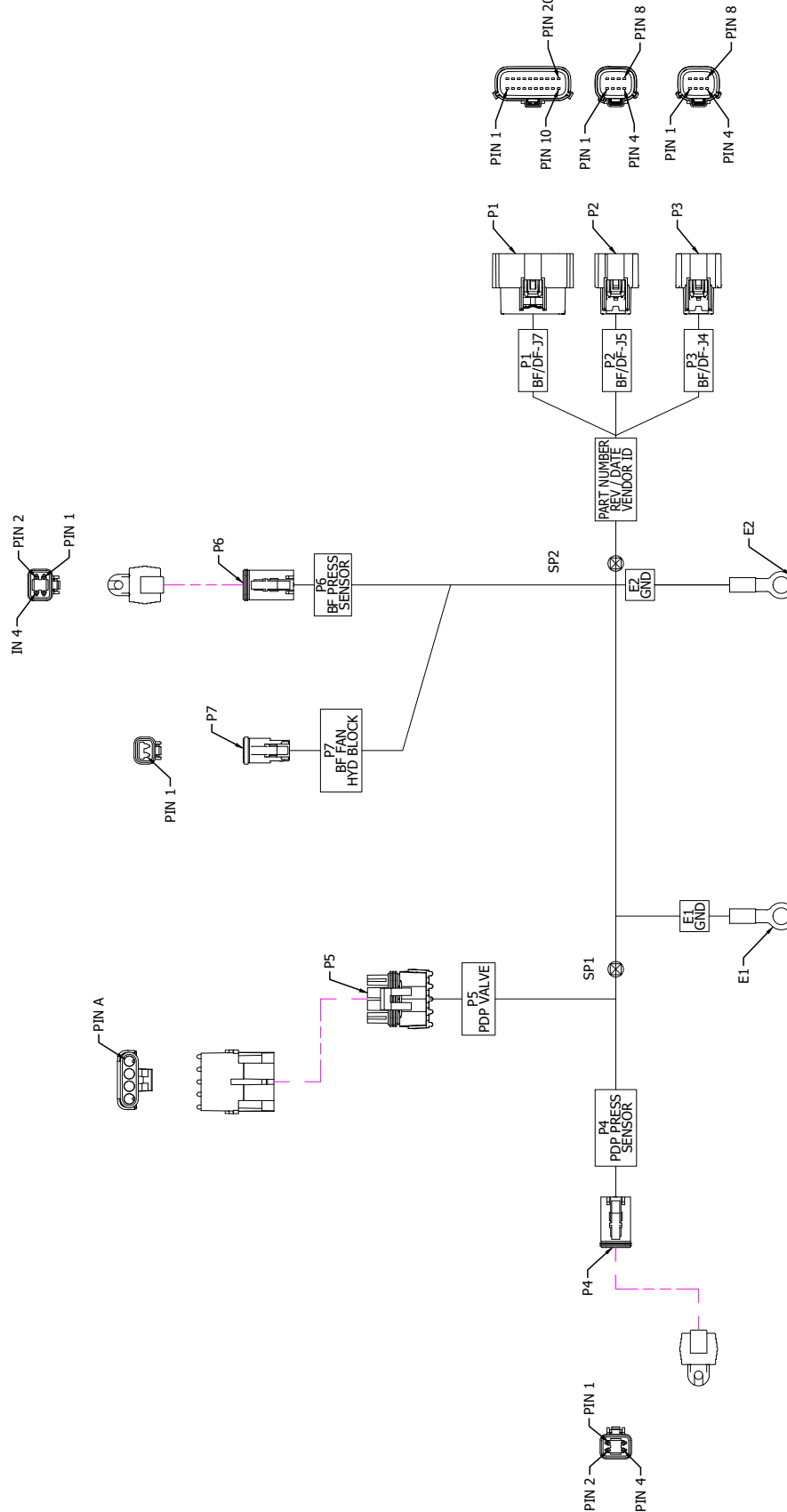

WIRE HOOKUP CHART

REFDES	FROM	USED WITH ITEM	TO	USED WITH ITEM	GAUGE	COLOR	FUNCTION
W1	P1-3	10	P5-C	14	16	V/LT	PDP DECREASE SOLENOID(+)
W2	P1-4	10	P5-D	14	16	BRN	PDP DECREASE SOLENOID(-)
W3	P1-16	8	P4-4	11	18	WHT	PDP SENSOR (ANALOG SIG)
W4	P1-19	8	SP1	---	18	BLK	PDP SENSOR (GND)
W5	P1-20	8	P4-2	11	18	BRN	PDP SENSOR (PWR)
W6	P2-1	10	P5-A	14	16	RED	PDP INCREASE SOLENOID (+)
W7	P2-2	10	P5-B	14	16	YEL	PDP INCREASE SOLENOID (-)
W8	P2-5	8	P6-2	11	18	WHT	BF PRESSURE SENSOR (PWR)
W9	P2-6	8	SP2	---	18	BLK	BF PRESSURE SENSOR (GND)
W10	P2-7	8	P6-4	11	18	YEL	BF PRESSURE SENSOR (ANALOG SIG)
W11	P3-1	10	P7-1	11	16	RED	BF FAN SOLENOID (+)
W12	P3-2	10	P7-2	11	16	BLK	BF FAN SOLENOID (-)
W13	SP1	---	P4-1	11	18	BLK	PDP SENSOR (GND)
W14	SP1	---	E1	---	18	BLK	GROUND
W15	SP2	---	P6-1	11	18	BLK	BF PRESSURE SENSOR (GND)
W16	SP2	---	E2	---	18	BLK	GROUND

IPP HARNESS, WING (P/N: A25214)

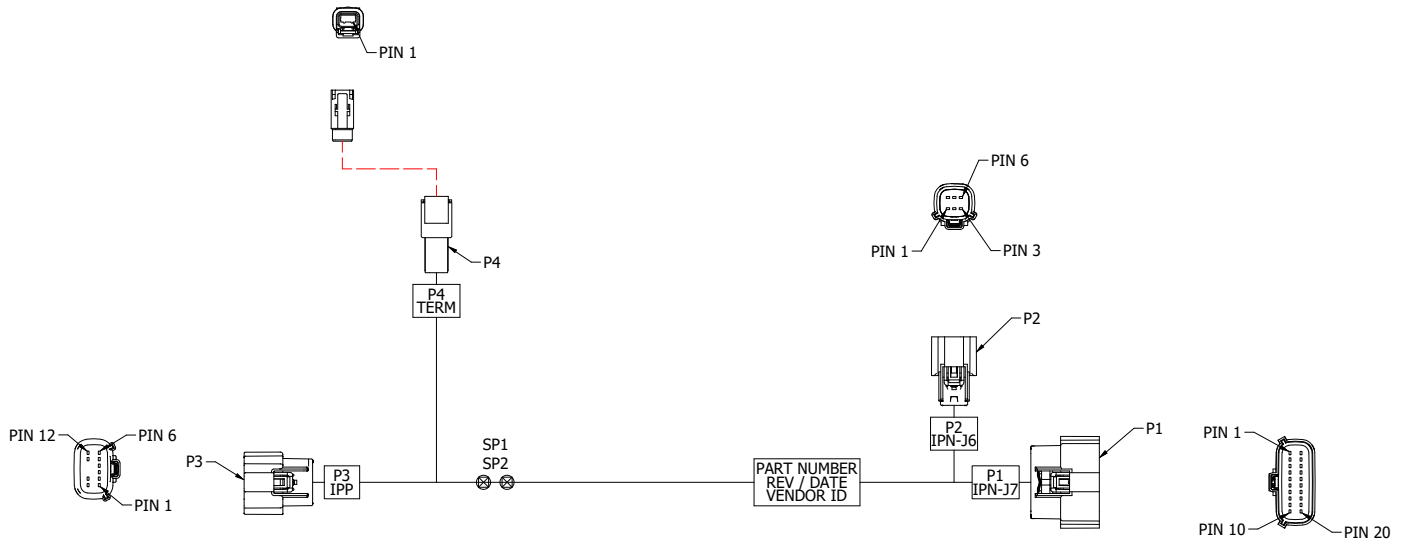

WIRE HOOKUP CHART							
REF DES	FROM	USED WITH ITEM	TO	USED WITH ITEM	GAUGE	COLOR	FUNCTION
W1	P1-1	5	P3-1	5	18(TP)	ORN	RS232 RX
W2	P1-2	5	P3-2	5	18(TP)	BRN	RS232 TX
W3	P2-1	5	SP1	---	18(TP)	YEL	CAN HI
W4	P2-2	5	SP2	---		GRN	CAN LO
W5	P2-3	7	P3-12	7	16	RED	PWR
W6	P2-4	7	P3-6	7	16	BLK	GND
W7	P2-5	5	P3-11	5	18	BLU	IPP SOFTWARE UPDATE
W8	SP1	---	P3-5	5	18(TP)	YEL	CAN HI
W9	SP2	---	P3-4	5	18(TP)	GRN	CAN LO
W10	SP1	---	P4-1	9	18(TP)	YEL	CAN HI
W11	SP2	---	P4-2	9		GRN	CAN LO

INSECTICIDE HARNESS (P/N: A22522)

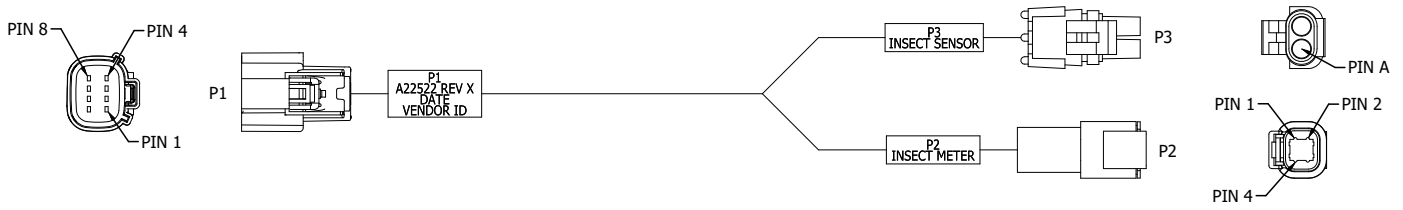

WIRE HOOKUP CHART							
REF DES	FROM	USED WITH ITEM	TO	USED WITH ITEM	GAUGE	COLOR	FUNCTION
W1	P1-1	5	P2-1	6	18	RED	INSECTICIDE METER MOTOR 1+
W2	P1-2	5	P2-2	6	18	WHT	INSECTICIDE METER MOTOR 1-
W3	P1-3	5	P2-4	6	18	BLK	INSECTICIDE METER MOTOR 2-
W4	P1-4	5	P2-3	6	18	GRN	INSECTICIDE METER MOTOR 2+
W5	P1-6	5	P3-B	8	18	BLK	INSECTICIDE SENSOR (GND)
W6	P1-7	5	P3-A	8	18	RED	INSECTICIDE SENSOR (PWR/SIGNAL)

SPLIT ROW ROW UNIT POWER HARNESS (P/N: 10331701)

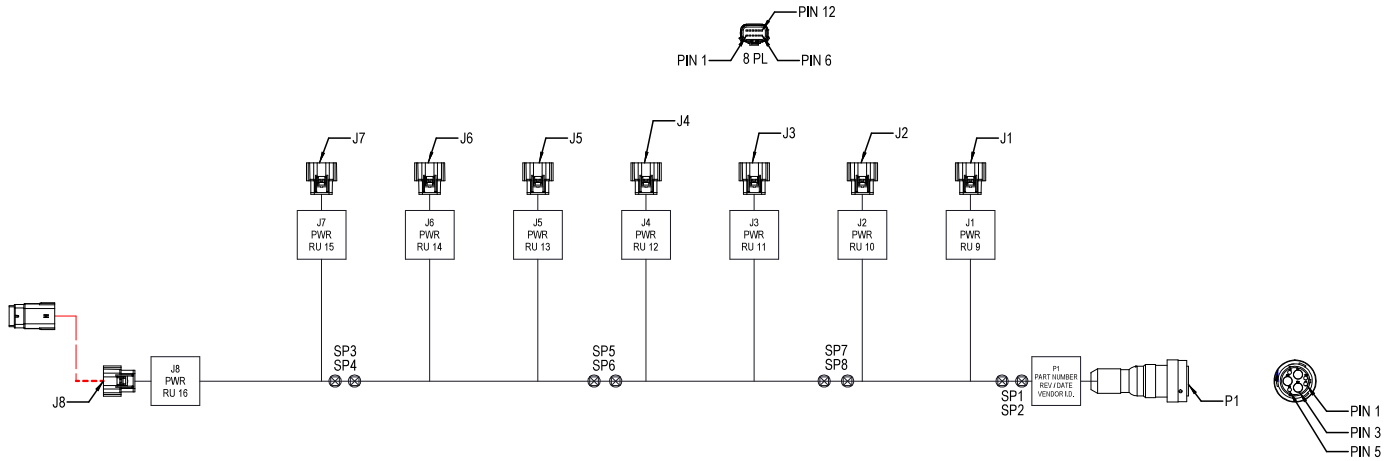

WIRE HOOKUP CHART

REF	DES	FROM	USE W/ITEM	TO	USE W/ITEM	GAUGE	COLOR	FUNCTION
W1		P1-6	5	SP1	---	6	RED	24V PWR (+)
W2		P1-4	5	SP2	---	6	BLK	24V PWR (-)
W3		SP1	---	J1-1	3	16	RED	RU PWR (+)
W4		SP1	---	J1-3	3	16	RED	RU PWR (+)
W5		SP1	---	J2-1	3	16	RED	RU PWR (+)
W6		SP1	---	J2-3	3	16	RED	RU PWR (+)
W7		SP1	---	SP7	---	10	RED	24V PWR (+)
W8		SP2	---	J1-2	3	16	BLK	RU PWR (-)
W9		SP2	---	J1-4	3	16	BLK	RU PWR (-)
W10		SP2	---	J2-2	3	16	BLK	RU PWR (-)
W11		SP2	---	J2-4	3	16	BLK	RU PWR (-)
W12		SP2	---	SP8	---	10	BLK	24V PWR (-)
W13		SP7	---	J3-1	3	16	RED	RU PWR (+)
W14		SP7	---	J3-3	3	16	RED	RU PWR (+)
W15		SP7	---	J4-1	3	16	RED	RU PWR (+)
W16		SP7	---	J4-3	3	16	RED	RU PWR (+)
W17		SP7	---	SP5	---	12	RED	24V PWR (+)
W18		SP8	---	J3-2	3	16	BLK	RU PWR (-)
W19		SP8	---	J3-4	3	16	BLK	RU PWR (-)
W20		SP8	---	J4-2	3	16	BLK	RU PWR (-)
W21		SP8	---	J4-4	3	16	BLK	RU PWR (-)
W22		SP8	---	SP6	---	12	BLK	24V PWR (-)
W23		SP5	---	J5-1	3	16	RED	24V PWR (+)
W24		SP5	---	J5-3	3	16	RED	RU PWR (+)
W25		SP5	---	J6-1	3	16	RED	RU PWR (+)
W26		SP5	---	J6-3	3	16	RED	RU PWR (+)
W27		SP5	---	SP3	---	14	RED	24V PWR (+)
W28		SP6	---	J5-2	3	16	BLK	RU PWR (-)
W29		SP6	---	J5-4	3	16	BLK	RU PWR (-)
W30		SP6	---	J6-2	3	16	BLK	RU PWR (-)
W31		SP6	---	J6-4	3	16	BLK	RU PWR (-)
W32		SP6	---	SP4	---	14	BLK	24V PWR (-)
W33		SP3	---	J7-1	3	16	RED	RU PWR (+)
W34		SP3	---	J7-3	3	16	RED	RU PWR (+)
W35		SP3	---	J8-1	3	16	RED	RU PWR (+)
W36		SP3	---	J8-3	3	16	RED	RU PWR (+)
W37		SP4	---	J7-2	3	16	BLK	RU PWR (-)
W38		SP4	---	J7-4	3	16	BLK	RU PWR (-)
W39		SP4	---	J8-2	3	16	BLK	RU PWR (-)
W40		SP4	---	J8-4	3	16	BLK	RU PWR (-)

STRAPPING TABLE

CONNECTOR	PIN 5	PIN 6	PIN 7	PIN 8	PIN 9	PIN 10	PIN 11	PIN 12
J1 (RU 9)	GND	---	---	GND	---	---	GND	GND
J2 (RU 10)	---	GND	---	GND	---	---	GND	GND
J3 (RU 11)	GND	GND	---	GND	---	---	---	GND
J4 (RU 12)	---	---	GND	GND	---	---	GND	GND
J5 (RU 13)	GND	---	GND	GND	---	---	---	GND
J6 (RU 14)	---	GND	GND	GND	---	---	---	GND
J7 (RU 15)	GND	GND	GND	GND	---	---	GND	GND
J8 (RU 16)	---	---	---	---	GND	---	---	GND

ROW UNIT SEED METER HARNESS (P/N: A25038)

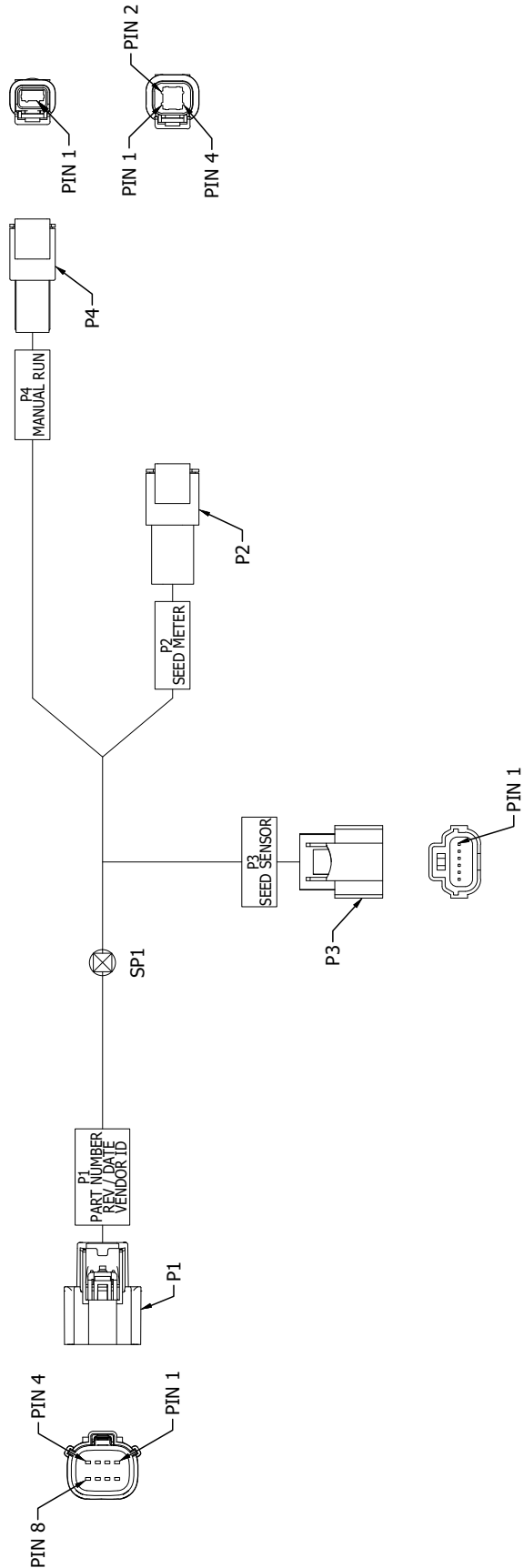

WIRE HOOKUP CHART

REF DES	FROM	USED WITH ITEM	TO	USED WITH ITEM	GAUGE	COLOR	FUNCTION
W1	P1-1	8	P2-1	5	18	RED	SEED METER MOTOR 1+
W2	P1-2	8	P2-2	5	18	WHT	SEED METER MOTOR 1-
W3	P1-3	8	P2-4	5	18	BLK	SEED METER MOTOR 2-
W4	P1-4	8	P2-3	5	18	GRN	SEED METER MOTOR 2+
W5	P1-5	8	P3-1	6	18 TXL	RED	SEED SENSOR (PWR)
W6	P1-6	8	SP1	---	18	BLK	GROUND
W7	P1-7	8	P3-2	6	18 TXL	BLU	SEED SENSOR (LIN)
W8	SP1	---	P3-6	6	18 TXL	BLK	SEED SENSOR (GND)
W9			P4-1	5	18	BLK	MANUAL RUN (GND)
W10	P1-8	8	P4-2	5	18	RED	MANUAL RUN (INPUT)

ROW UNIT POWER EXTENSION HARNESS (P/N: A25029)

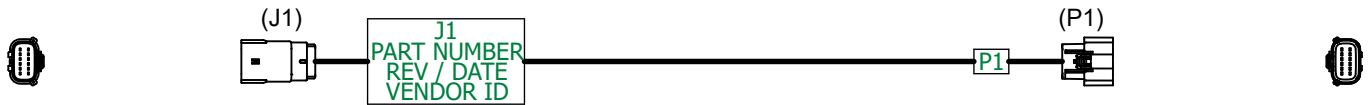

Signal	Wire Gauge	Color	FROM	TO
Power	16	Red	J1-1	P1-1
Ground	16	Black	J1-2	P1-2
Power	16	Red	J1-3	P1-3
Ground	16	Black	J1-4	P1-4
Strapping	20	Yellow	J1-5	P1-5
Strapping	20	Orange	J1-6	P1-6
Strapping	20	White	J1-7	P1-7
Strapping	20	Green	J1-8	P1-8
Strapping	20	Blue	J1-9	P1-9
Strapping	20	Violet	J1-10	P1-10
Strapping	20	Blue/Red	J1-11	P1-11
Strapping	20	Brown	J1-12	P1-12

LIGHT HARNESS (P/N: A25784)

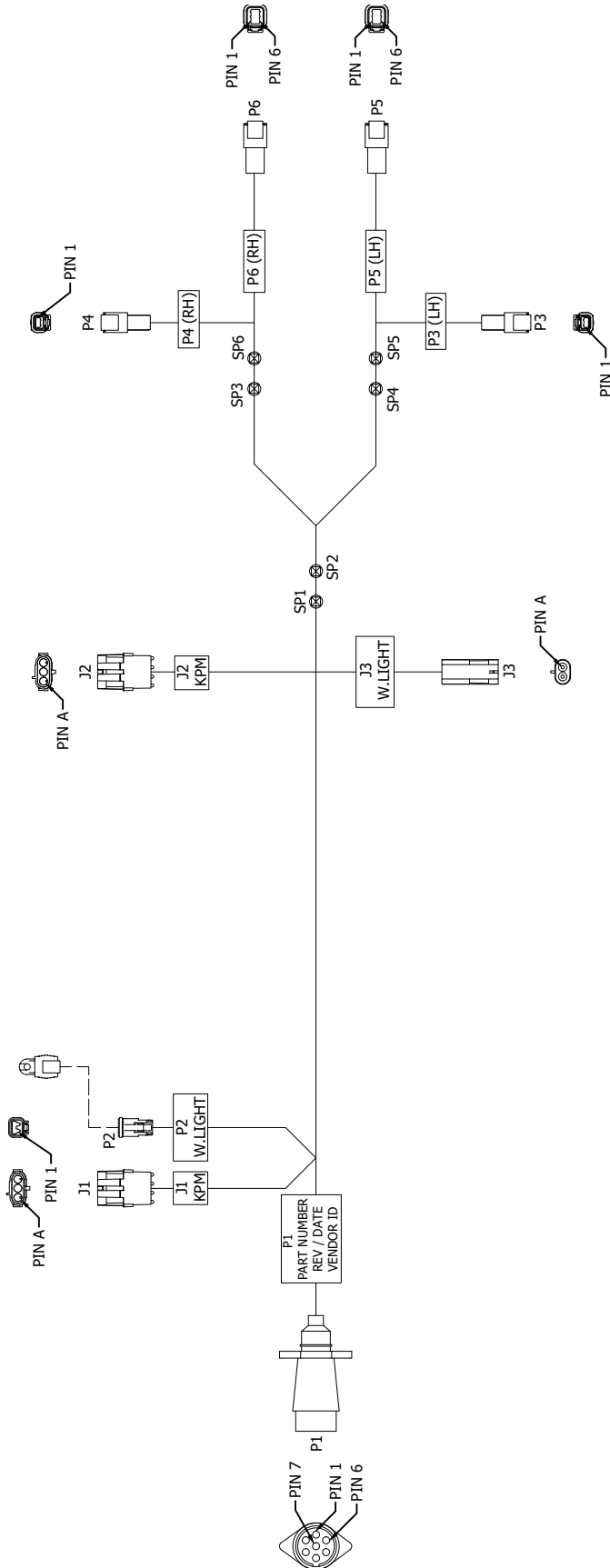

WIRE HOOKUP CHART

REF DES	FROM	USED W/	TO	USED W/	GAUGE	COLOR	FUNCTION
W001	J1-A	8	J2-A	8	14	WHT	MONITOR +12V (MUX)
W002	J1-B	8	J2-B	8	14	BLK	MONITOR GROUND (MUX)
W003	J1-C	8	J2-C	8	14	GRN	MONITOR DATA (MUX)
W004	P2-1	7	J3-B	8	14	WHT	WORK LIGHT +12V
W005	P2-2	7	J3-A	8	14	BLK	WORK LIGHT GROUND
W006	P1-1	---	P5-4	14	16	YEL	LH FLASH
W007	P1-4	---	P6-4	14	16	GRN	RH FLASH
W008	P1-2	---	P5-5	14	16	BLU	FOG
W009	P1-3	---	SP1	---	16	WHT	GND
W010	P1-6	---	SP2	---	16	RED	STOP LIGHTS
W011	P1-5	---	SP3	---	16	BRN	RH TAIL LIGHT PWR
W012	P1-7	---	SP4	---	16	BLK	LH TAIL LIGHT PWR
W013	SP1	---	SP5	---	16	WHT	GND (RH)
W014	SP1	---	SP6	---	16	WHT	GND (LH)
W015	SP2	---	P5-2	14	16	RED	STOP LIGHTS (LH)
W016	SP2	---	P6-2	14	16	RED	STOP LIGHTS (RH)
W017	SP3	---	P4-2	14	16	BRN	RH TAIL LIGHT WHITE PWR
W018	SP3	---	P6-3	14	16	BRN	RH TAIL LIGHT PWR
W019	SP4	---	P3-2	14	16	BLK	LH TAIL LIGHT WHITE PWR
W020	SP4	---	P5-3	14	16	BLK	LH TAIL LIGHT PWR
W021	SP5	---	P3-1	14	16	WHT	LH TAIL LIGHT WHITE GND
W022	SP5	---	P5-6	14	16	WHT	LH TAIL LIGHT GND
W023	SP6	---	P4-1	14	16	WHT	RH TAIL LIGHT WHITE GND
W024	SP6	---	P6-6	14	16	WHT	RH TAIL LIGHT GND

INTEGRATED TRUE DEPTH ROW UNIT HARNESS (P/N: A26709)

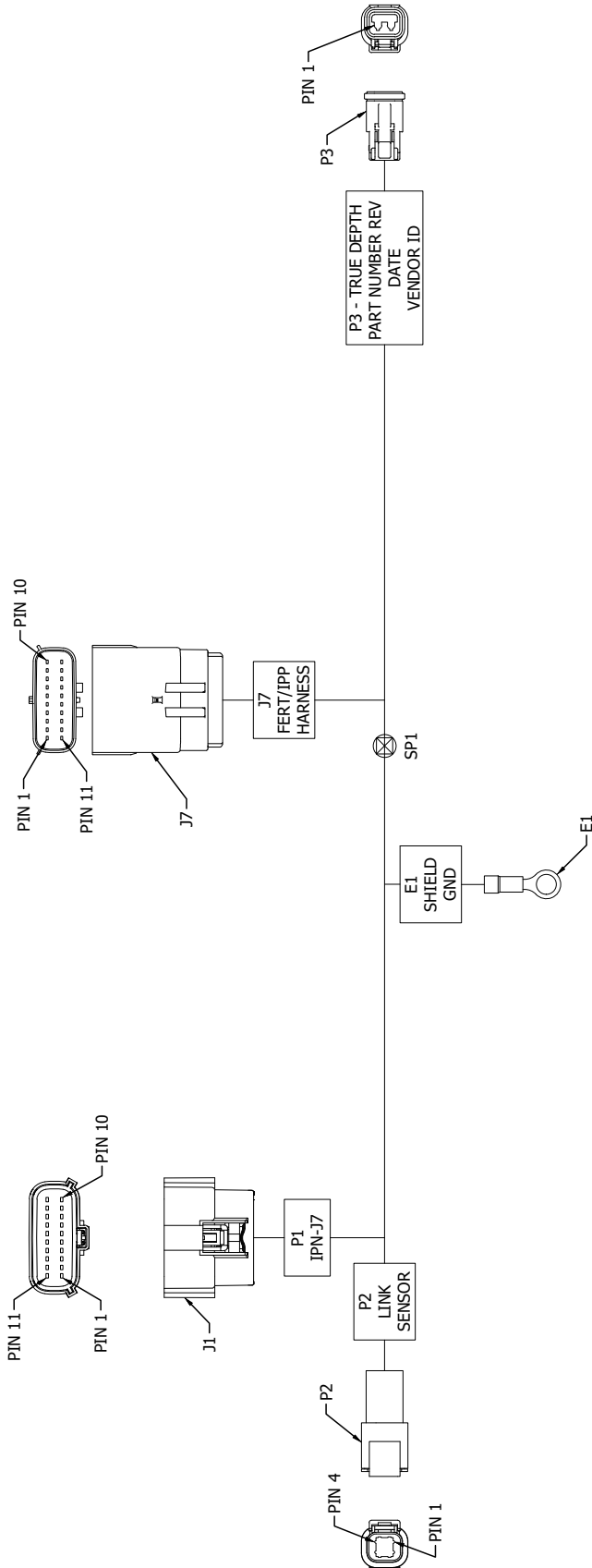

WIRE HOOKUP CHART

REF DLS	FROM	USED WITH ITEM	TO	USED WITH ITEM	GAUGE	COLOR	FUNCTION
W1	P1-1	2	J7-1	5	18 (TP-1)	ORN	RS232 RX
W2	P1-2	2	J7-2	5	18 (TP-1)	BRN	RS232 TX
W3	P1-3	2	J7-3	5	18	RED	FERT ROW CUTOFF VALVE (PWR)
W4	P1-4	2	J7-4	5	18	BLK	FERT ROW CUTOFF VALVE (GND)
W5	P1-7	2	P3-1	9	18	RED	TRUE DEPTH CYLINDER PWM+
W6	P1-8	2	P3-2	9	18	BLK	TRUE DEPTH CYLINDER PWM-
W7	P1-13	2	J7-13	5	18	RED	FERT FLOW SENSOR (PWR/SIGNAL)
W8	P1-16	2	P2-2	7	18	BLK	TRUE DEPTH LINK SENSOR (SIGNAL)
W9	P1-19	2	SP1	-	18	BLK	SENSOR (GND)
W10	SP1	-	J7-19	5	18	GND	FERT FLOW SENSOR (GND)
W11	SP1	-	P2-4	7	18	BLK	TRUE DEPTH LINK SENSOR (GND)
W12	P1-20	2	P2-1	7	18	RED	TRUE DEPTH LINK SENSOR (PWR)
W13	E1	-	P2-3	7	18	GRN	TRUE DEPTH LINK SENSOR (SHIELD)

IPP WING HARNESS (P/N: A26835)

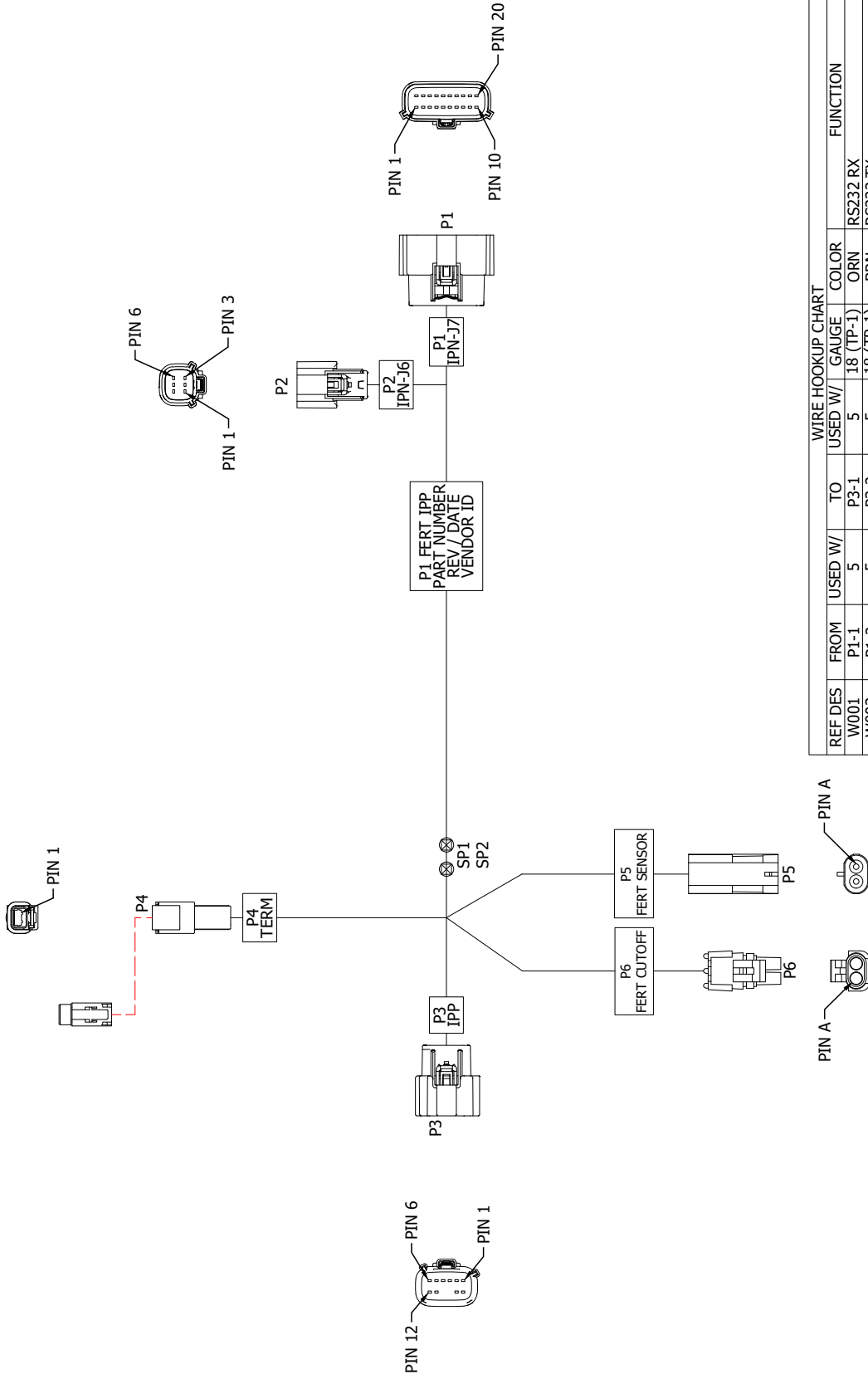

WIRE HOOKUP CHART

REF DES	FROM	USED W/	TO	USED W/	GAUGE	COLOR	FUNCTION
W001	P1-1	5	P3-1	5	18 (TP-1)	ORN	RS232 RX
W002	P1-2	5	P3-2	5	18 (TP-1)	BRN	RS232 TX
W003	P2-1	5	SP1	---	18 (TP-2)	YEL	CAN HI
W004	P2-2	5	SP2	---	18 (TP-2)	GRN	CAN LO
W005	P2-3	6	P3-12	6	16	RED	IPP PWR
W006	P2-4	6	P3-6	6	16	BLK	IPP GND
W007	P2-5	5	P3-11	5	18	BLU	IPP SOFTWARE UPDATE
W008	SP1	---	P3-5	5	18(TP-3)	YEL	CAN HI
W009	SP2	---	P3-4	5	18(TP-3)	GRN	CAN LO
W010	SP1	---	P4-1	11	18(TP-4)	YEL	CAN HI
W011	SP2	---	P4-2	11	18(TP-4)	GRN	CAN LO
W012	P1-3	5	P6-A	14	18	RED	FERT ROW CUTOFF VALVE (PWR)
W013	P1-4	5	P6-B	14	18	BLK	FERT ROW CUTOFF VALVE (GND)
W014	P1-13	5	P5-A	15	18	RED	FERT FLOW SENSOR (PWR/SIGNAL)
W015	P1-19	5	P5-B	15	18	BLK	FERT FLOW SENSOR (GND)

INTEGRATED TRUE DEPTH HARNESS (P/N: 10337001)

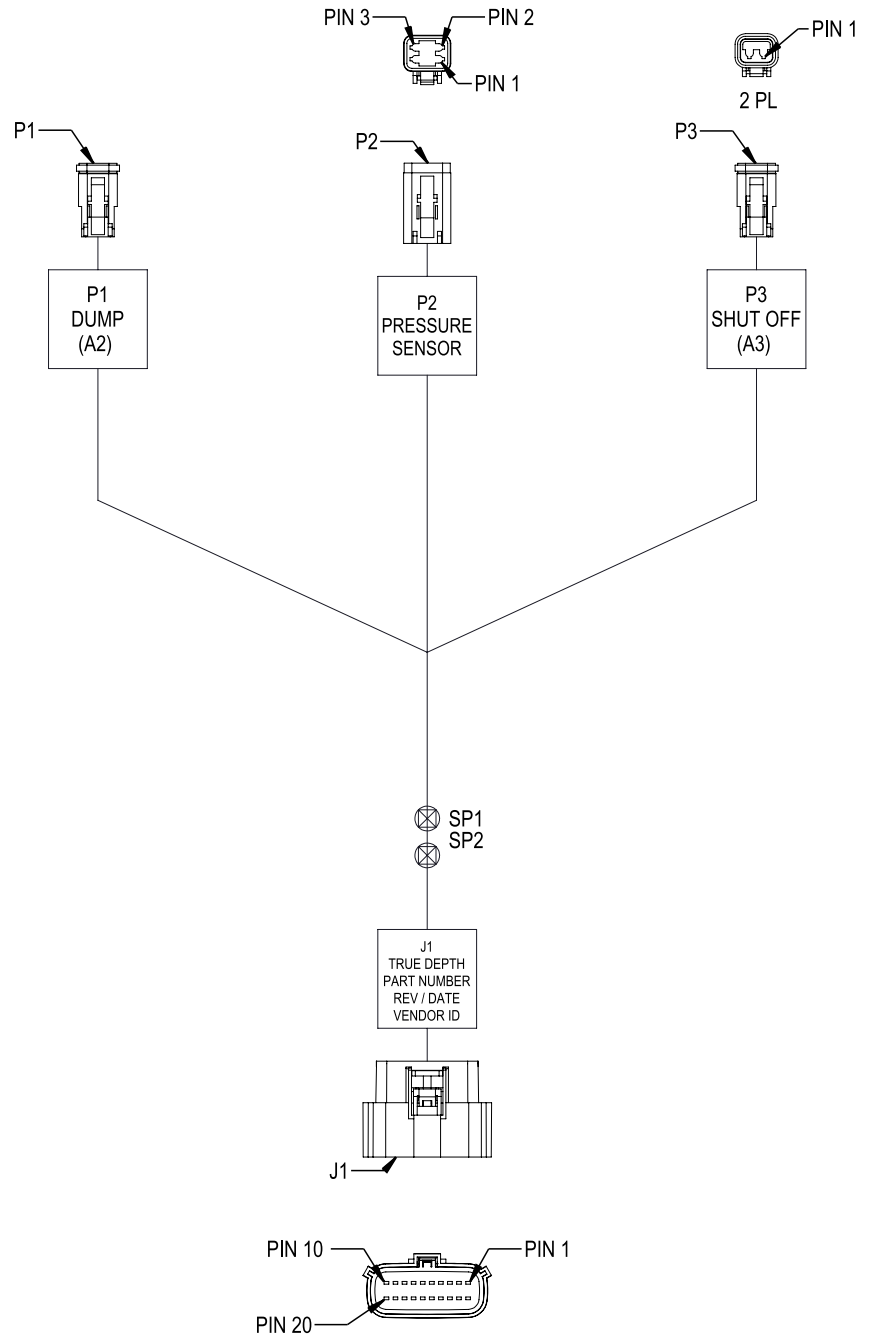

WIRE HOOKUP CHART							
REF DES	FROM	USED W/ ITEM	TO	USED W/ ITEM	GAUGE	COLOR	FUNCTION
W1	J1-3	8	SP1	---	16	VLT	HDP SOLE (+)
W2	J1-4	8	SP2	---	16	BRN	HDP SOLE (-)
W3	J1-16	8	P2-1	3	18	WHT	HDP SENSOR SIGNAL
W4	J1-19	8	P2-2	3	18	BLK	HDP SENSOR (GND)
W5	J1-18	8	P2-3	3	18	RED	HDP SENSOR (PWR)
W6	SP1	---	P1-1	3	16	VLT	HDP SOLE (+)
W7	SP1	---	P3-1	3	16	VLT	HDP SOLE (+)
W8	SP2	---	P1-2	3	16	BRN	HDP SOLE (-)
W9	SP2	---	P2-2	3	16	BRN	HDP SOLE (-)

ROW UNIT SEED METER HARNESS (P/N: A25203)

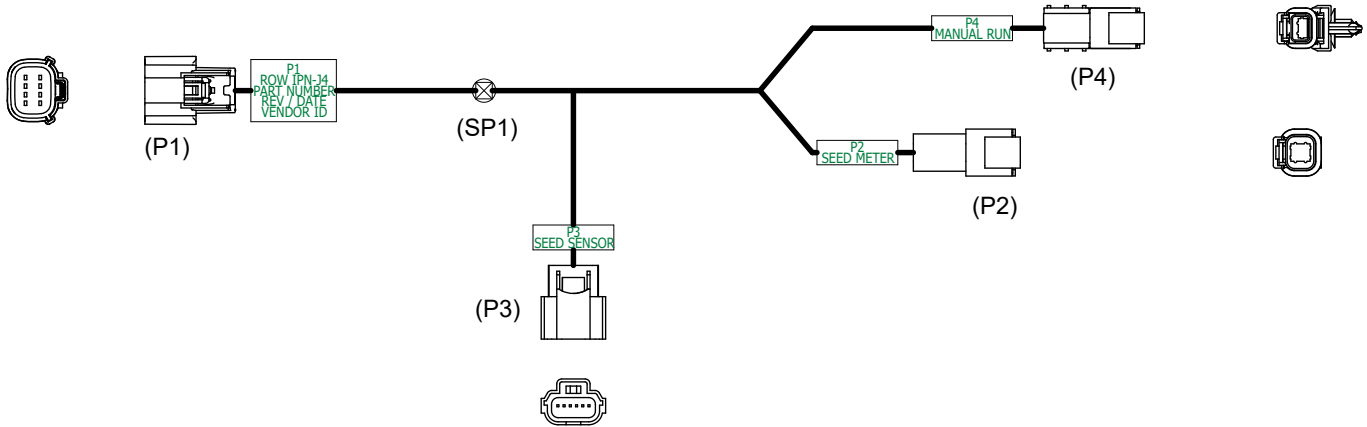

Signal	Wire Gauge	Color	From	To
Seed Meter Motor 1+	18	Red	P1-1	P2-1
Seed Meter Motor 1-	18	White	P1-2	P2-2
Seed Meter Motor 2-	18	Black	P1-3	P2-4
Seed Meter Motor 2+	18	Green	P1-4	P2-3
Seed Sensor (Power)	18 TXL	Red	P1-5	P3-1
Ground	18	Black	P1-6	SP1
Seed Sensor (Lin)	18 TXL	Blue	P1-7	P3-2
Seed Sensor (Ground)	18 TXL	Black	SP1	P3-6
Manual Run (Ground)	18	Black	SP1	P4-1
Manual Run (Input)	18	Red	P1-8	P4-2

BULK FILL

PROBLEM	POSSIBLE CAUSE	SOLUTION
Seed does not travel through delivery tubes.	System pressure set too low.	Increase system pressure.
Seed stops flowing to row unit during planting.	Seed surging.	Shut down bulk fill system and restart system from idle; seed should start flowing.
	Debris in system.	Insert shutoff door, open cleanout door. remove plug.
Seed does not move from entrainer at startup after exposure to water.	Seed swelled in entrainer.	Insert shutoff door, open cleanout door. remove swelled seed.

CLOSING WHEEL TROUBLESHOOTING

PROBLEM	POSSIBLE CAUSE	SOLUTION
Closing wheel(s) leave severe imprint in soil.	Too much closing wheel down pressure.	Adjust closing wheel pressure.
Closing wheel(s) not firming soil around seed.	Insufficient closing wheel down pressure.	Adjust closing wheel pressure. Severe no till conditions may require use of cast iron closing wheels.
"V" closing wheel running on top of seed furrow.	Improper centering.	Align. See "V" Closing Wheel Adjustment (Rubber or Cast Iron)" on page 3-1.

PISTON PUMP TROUBLESHOOTING

PROBLEM	POSSIBLE CAUSE	SOLUTION
Pump hard or impossible to prime.	Valves fouled or in wrong place.	Inspect and clean valves.
	Air leak in suction line.	Repair leak.
	Pump set too low.	Adjust pump setting.
	Packing washers worn out.	Replace.
Low metering.	Valves fouled or in wrong place.	Inspect and clean valves.
	Air leak in suction line.	Repair leak.
	Pump set too low.	Adjust pump setting.
	Broken valve spring.	Replace spring.
Over metering.	Broken discharge valve spring.	Replace spring.
	Trash under valves.	Inspect and clean valves.
	Improper rate setting.	Adjust pump setting.
Leaks through when stopped.	Broken discharge valve spring.	Replace spring.
	Trash under valves.	Inspect and clean valves.
Fertilizer solution leaking under stuffing box.	Packing washers worn out.	Replace.
Pump using excessive oil.	Oil seals or o-ring worn and leaking.	Replace.
Pump operates noisily.	Crankcase components worn excessively.	Inspect and replace if necessary.

PTO PUMP DRIVE AND OIL COOLER OPTION TROUBLESHOOTING

PROBLEM	POSSIBLE CAUSE	SOLUTION
Pump squealing.	Lack of oil to pump.	Check for plugged suction strainer.
	Air leak in suction line.	Check oil level.
Oil temperature is high.	Low oil level.	Check oil level and add as required.
Desired fan speed cannot be achieved.	Low oil level.	Check oil level and add as required.
	Plugged filter.	Check and change as required.
Vacuum level not displayed.	Digital vacuum gauge console power OFF.	Turn ON.
	Cable not plugged in.	Check connection.
	Digital vacuum gauge console has no power.	Check fuse.

ROW MARKER OPERATION TROUBLESHOOTING

PROBLEM	POSSIBLE CAUSE	SOLUTION
Both markers lowering and only one raising at a time.	Hoses from cylinders to valve connected backwards.	Check hosing diagram in manual and correct.
Same marker always operating.	Spool in sequencing valve not shifting.	Remove spool, inspect for foreign material, making sure all ports in spool are open. Clean and reinstall.
Both markers lower and raise at same time.	Foreign material under check ball in sequencing valve.	Remove hose fitting, spring and balls and clean. May be desirable to remove spool and clean as well.
	Check ball missing or installed incorrectly in sequencing valve.	Disassemble and correct. Refer to Lubrication and Maintenance section of this manual.
Marker (in raised position) settling down.	Damaged O-ring in marker cylinder or cracked piston.	Disassemble cylinder, inspect for damage, and repair.
	Spool in sequencing valve not shifting completely because detent ball or spring is missing.	Check valve assembly and install parts as needed.
	Spool in sequencing valve shifting back toward center position.	Restrict flow of hydraulic oil from tractor to sequencing valve.
Neither marker moves.	Flow control closed too far.	Loosen locking nut and turn flow control adjustment bolt out or counterclockwise until desired speed is set.
Markers moving too fast.	Flow control open too far.	Loosen locking nut and turn flow control adjustment bolt in or out until desired speed is set.
Sporadic marker operation speed.	Needle sticking open in flow control valve.	Remove flow control, inspect and repair, or replace.

SEED METER (BRUSH-TYPE) TROUBLESHOOTING

PROBLEM	POSSIBLE CAUSE	SOLUTION
Low count.	Meter RPM too high.	Reduce planting speed.
	Seed sensor not picking up all seeds dropped.	Clean seed tube. Switch meter to different row. If problem stays with same row, replace sensor.
	Lack of lubrication causing seeds not to release from disc properly.	Use graphite or talc as recommended.
	Seed size too large for seed disc.	Switch to smaller seed or appropriate seed disc. See "Brush-Type Seed Meter 2.0" on page 3-3 for proper seed disc for size of seed being used.
	Seed treatment buildup in meter.	Reduce amount of treatment used and/or thoroughly mix treatment with seed. Add talc.
Low count at low RPM and higher count at higher RPM.	Foreign material lodged in upper brush.	Remove seed disc and remove foreign material from between brush retainer and bristles. Clean thoroughly.
	Worn upper brush.	Replace. See "Lubrication and Maintenance" on page 6-1 .
Low count at higher RPM and normal count at low RPM.	Seed disc worn in the agitation groove area.	Replace disc. See "Lubrication and Maintenance" on page 6-1 .
High count.	Seed size too small for seed disc.	Switch to larger seed or appropriate seed disc.
	Incorrect seed rate transmission setting.	Reset transmission. Refer to proper rate chart in "Rate Charts" on page 5-1 .
	Upper brush too wide (fanned out) for small seed size.	Replace upper brush.
High count. (Milo/Grain Sorghum)	Incorrect brush retainer.	Make sure GB1107 brush retainer is installed to keep upper brush from fanning out.
Upper brush laid back.	Seed treatment buildup on brush.	Remove brush. Wash with soap and water. Dry thoroughly before reinstalling. See "Lubrication and Maintenance" on page 6-1 .
	Buildup of foreign material at base of brush.	Remove brush retainer and brush. Clean thoroughly. Reinstall.

SEED METER (FINGER PICKUP) TROUBLESHOOTING

PROBLEM	POSSIBLE CAUSE	SOLUTION
One row not planting seed.	Drive release not engaged.	Engage drive release mechanism.
	Foreign material in hopper.	Clean hopper and finger carrier mechanism.
	Seed hopper empty.	Fill seed hopper.
	Row unit drive chain off of sprocket or broken.	Check drive chain.
Drive release does not engage properly.	Drive release shaft is not aligned properly with meter drive shaft.	Align drive mechanism.
Unit is skipping.	Foreign material or obstruction in meter.	Clean and inspect.
	Finger holder improperly adjusted.	Adjust to specifications. (22 to 25 in. lbs. rolling torque)
	Broken fingers.	Replace fingers and/or springs as required.
	Planting too slowly.	Increase planting speed to within recommended range.
Planting too many doubles.	Planting too fast.	Stay within recommended speed range.
	Loose finger holder.	Adjust to specifications. (22 to 25 in. lbs. rolling torque)
	Worn brush in carrier plate.	Inspect and replace if necessary.
Overplanting.	Worn carrier plate.	Inspect and replace if necessary.
	Seed hopper additive being used.	Reduce or eliminate additive or increase graphite.
Underplanting.	Seed belt installed backwards.	Remove and install correctly.
	Weak or broken springs.	Replace.
	Spring not properly installed.	Remove finger holder and correct.
	Seed belt catching or dragging.	Replace belt.
	Brush dislodging seed.	Replace brush.
Irregular or incorrect seed spacing.	Driving too fast.	Check chart for correct speed.
	Wrong tire pressure.	Inflate tires to correct air pressure.
	Drive wheels slipping.	Reduce down pressure on row unit down force springs.
	Wrong sprockets.	Check seed rate charts for correct sprocket combinations.
Seed spacing not as indicated in charts.	Wrong tire pressure.	Inflate tires to correct air pressure.
	Inconsistent seed size.	Perform field check and adjust sprockets accordingly.
	Wrong sprockets.	Check chart for correct sprocket combination.
	Charts are approximate.	Slight variations due to wear in meter components and tire slippage due to field conditions may produce seed spacing variations.
	Stiff or worn drive chains.	Replace chains.
Scattering of seeds.	Planting too fast.	Reduce planting speed.
	Seed tube improperly installed.	Check seed tube installation.
	Seed tube worn or damaged.	Replace seed tube.
Seed tubes and/or openers plugging.	Allowing planter to roll backward when lowering.	Lower planter only when tractor is moving forward.
Inconsistent seed depth.	Rough seed bed.	Adjust down pressure springs. Reduce planting speed.
	Partially plugged seed tube.	Inspect and clean.
	Seed tube improperly installed.	Install properly.

VACUUM SEED METER

PROBLEM	POSSIBLE CAUSE	SOLUTION
Low seed count.	Meter RPM too high.	Reduce planting rate or planting speed.
	Singulator blade setting too aggressive.	Adjust singulator blade.
	Vacuum level too low.	Increase fan speed.
	Seed sensor not picking up all seeds dropped.	Clean seed tube. Move meter to different row.
	Seeds sticking to seed disc.	Use graphite or talc to aid release.
	Seed treatment buildup in seed disc recesses.	Reduce amount of treatment used and or mix thoroughly. Add talc.
	Seed size too large for disc used.	Use appropriate disc for seed size.
	Wrong seed disc.	Use appropriate disc for seed type and size.
	Failed/worn drive components.	Inspect and replace parts as required.
	Plugged orifices in seed disc.	Inspect and clean disc. Check remnant ejector.
	Loss of vacuum at meter.	Check for foreign material between vacuum cover and disc. Inspect parts for wear/damage. Clean or replace as required.
	Seed bridging in hopper.	Add graphite to improve seed flow.
	Faulty vacuum gauge reading.	Repair/replace gauge.
	Dirt in vacuum manifold.	Check vacuum manifold for dirt and clean.
	Seed baffle (If applicable) not allowing seed flow due to bridging of seed.	Mix talc thoroughly to coat all seeds. Remove seed baffle. See "Row Unit Operation" on page 3-1.
	Seed disc worn.	Replace.
Vacuum seal worn.	Replace.	
Not planting seed.	Seed hoppers empty.	Fill seed hopper.
	Seed tube plugged/damaged.	Clean or replace tube.
	Meter drive damaged.	Repair/replace drive components.
	Low/no vacuum.	Inspect vacuum system and repair as necessary.
	Singulator blade setting too aggressive.	Adjust singulator blade.
	Faulty vacuum gauge.	Repair/replace vacuum gauge.
	Seed bridging in hopper.	Add graphite to improve seed flow.
	Loss of vacuum at meter.	Check for foreign material between vacuum cover and disc. Inspect parts for wear/ damage. Clean and/ or replace as required.
	Wrong seed disc.	Use appropriate disc for seed type and size.
	Meter drive clutch not engaged.	Engage drive clutch.
	Fan not running.	Start fan.
	Dirt in vacuum manifold.	Check vacuum manifold for dirt and clean.

Continued on next page.

VACUUM SEED METER - Continued

PROBLEM	POSSIBLE CAUSE	SOLUTION
Not planting seed. (Continued)	Seed baffle (if applicable) not allowing seed flow due to bridging of seed.	Mix talc thoroughly to coat all seeds. Remove seed baffle. Row Unit Operation section.
	High vacuum.	Adjust vacuum level to appropriate level.
	Wrong seed disc.	Replace seed disc.
	Singulator setting not aggressive enough.	Adjust singulator.
	Faulty vacuum gauge.	Check gauge line for dirt/obstruction. Repair/replace vacuum gauge.
Poor seed spacing.	Obstruction in seed tube.	Clean seed tube.
	Dirty/damaged seed disc.	Inspect seed disc for damage, foreign material in orifices or seed treatment buildup in recesses. Clean or replace.
	Wrong vacuum setting.	Adjust vacuum to appropriate level.
	Excess foreign material in seed.	Inspect and clean meter and seed discs. Use clean, undamaged seed.
	Incorrect singulator setting.	Adjust singulator to appropriate setting.
	Inconsistent driveline.	Inspect drive components for rust, misalignment, worn or damaged parts. Replace/repair as required.
	Toolbar not level or wrong height.	Adjust hitch to level toolbar and row units.
	Planting too fast for conditions.	Reduce speed.
	Rough field conditions.	Reduce speed.
Irregular seed population.	Driving too fast.	Reduce speed.
Unable to achieve desired vacuum level.	Tractor hydraulic flow set too low.	Increase flow to fan motor.
	Incorrect hydraulic connections.	Check all hydraulic connections and hose routings.
	Damaged fan components.	Inspect motor and impeller for wear/damage and repair/replace as necessary.
	Vacuum hose pinched/kinked/blocked.	Inspect air lines for any damage or obstruction. Clean air lines and manifold by removing end cap from manifold and running fan at high speed.
	Vacuum hose loose/disconnected.	Inspect and reattach all air hoses.
	Tractor not producing required hydraulic flow/pressure.	Have tractor serviced by qualified technician.
	Dirt in vacuum gauge line.	Check gauge line for dirt/obstruction and clean.

This page left blank intentionally.