

# MODEL 3605 PIVOT FOLD PLANTER OPERATOR'S MANUAL

**M0303-01**

**Rev. 9/21**

This manual is for: Model 3605 Twin-Line Planters  
2021 Production and On

Record model number and serial number of your planter along with date purchased:

Model Number 3605

Serial Number \_\_\_\_\_

Date Purchased \_\_\_\_\_

Monitor Serial Number \_\_\_\_\_

Measured Pulses Per Mile/Km (Radar Distance Sensor) \_\_\_\_\_

Measured Pulses Per Mile/ Km (Magnetic Distance Sensor) \_\_\_\_\_

## SERIAL NUMBER

Record your serial number and purchase date above for quick reference.

The serial number provides important information about your planter and is required to obtain correct replacement parts. Always provide planter model and serial number to your Kinze Dealer when ordering parts or anytime correspondence is made with Kinze Manufacturing, Inc.



**Serial number plate location - R.H. Wing**

## **WARRANTY**

The Kinze Limited Warranty for your new machine is stated on the retail purchaser's copy of the Warranty And Delivery Receipt form. Additional copies of the Limited Warranty can be obtained through your Kinze Dealer.

Warranty, within the warranty period, is provided as part of Kinze's support program for registered Kinze products which have been operated and maintained as described in this manual. Evidence of equipment abuse or modification beyond original factory specifications will void the warranty. Normal maintenance, service and repair is not covered by Kinze warranty.

To register your Kinze product for warranty, a Warranty And Delivery Receipt form must be completed by the Kinze Dealer and signed by the retail purchaser, with copies to the Dealer, and to the retail purchaser. Registration must be completed and submitted to Kinze Manufacturing, Inc. within 5 business days of delivery of the Kinze product to the retail purchaser. Kinze Manufacturing, Inc. reserves the right to refuse warranty on serial numbered products which have not been properly registered.

If service or replacement of failed parts which are covered by the Limited Warranty are required, it is the user's responsibility to deliver the machine along with the retail purchaser's copy of the Warranty And Delivery Receipt to the Kinze Dealer for service. Kinze warranty does not include cost of travel time, mileage, hauling or labor. Any prior arrangement made between the Dealer and the retail purchaser in which the Dealer agrees to absorb all or part of this expense should be considered a courtesy to the retail purchaser.

*Kinze warranty does not include cost of travel time, mileage, hauling, or labor.*

## **GENERAL INFORMATION**

The Model 3605 Twin-Line Planter is available with vacuum or mechanical meters, conventional hoppers or Air Seed Delivery system (bulk fill), Interplant, and various other options. Liquid or dry fertilizer application equipment and various row unit attachments are also available.

Information used in these instructions was current at time of printing. However, due to Kinze's ongoing product improvement, production changes may cause your machine to appear slightly different in detail. Kinze Manufacturing, Inc. reserves the right to change specifications or design without notice and without incurring obligation to install the same on machines previously manufactured. To obtain the most recent version of your publication, please contact your Kinze dealer.

Right hand (R.H.) and left hand (L.H.), as used throughout this manual, are determined by facing direction machine travels in use unless otherwise stated.

**TO THE DEALER**

Predelivery service includes assembly, lubrication, adjustment and test. This service helps ensure planter is delivered to retail customer/end user ready for field use.

**PREDELIVERY CHECKLIST**

Use the following checklist after planter is completely assembled. Check off each item as it is found satisfactory or after proper adjustment is made.

- Center pivot base mounting and transport wheel spindle hex head cap screws torqued to 450 ft-lb (610.1 n-m).
- Row units properly spaced and optional attachments correctly assembled.
- Row marker assemblies installed and adjusted at each end of the planter.
- Vacuum and Bulk Fill components properly installed (as applicable).
- All grease fittings in place and lubricated.
- All working parts move freely, bolts are tight, and cotter pins are spread.
- Check all drive chains for proper tension and alignment.
- Check for oil leaks and proper hydraulic operation.
- Hydraulic hoses correctly routed to prevent damage.
- Inflate tires to specified air pressure and torque wheel lug bolts and lug nuts as specified in the manual.
- All safety decals correctly located and legible. Replace if damaged.
- All reflective decals and SMV sign correctly located and visible when the planter is in transport position.
- Safety/warning lights correctly installed and working properly.
- Paint all parts scratched during shipment or assembly.
- All safety lockup devices on the planter and correctly located.
- Auxiliary safety chain properly installed and hardware torqued to specification.
- Vacuum fan PTO-driven pump correctly attached to the tractor. Oil reservoir filled to capacity and system inspected for leaks (If Applicable).
- Control box properly installed in tractor. All cables correctly routed and secure.

***Planter has been thoroughly checked and to the best of my knowledge is ready for delivery to the customer.***

\_\_\_\_\_  
(Signature Of Set-Up Person/Dealer Name/Date)

**OWNER REGISTER**

Name \_\_\_\_\_ Delivery Date \_\_\_\_\_  
 Street Address \_\_\_\_\_ Model No. 3605 Serial No. \_\_\_\_\_  
 City, State/Province \_\_\_\_\_ Dealer Name \_\_\_\_\_  
 ZIP/Postal Code \_\_\_\_\_ Dealer No. \_\_\_\_\_

---

## DELIVERY CHECKLIST

Use the following checklist at time planter is delivered as a reminder of very important information which should be conveyed to retail customer/end user. Check off each item as it is fully explained.

- Check for proper operation of vacuum fan, Bulk Fill fan, and PTO-driven pump (If applicable) with tractor to be used with planter.
- Life expectancy of this or any other machine is dependent on regular lubrication as directed in the Operator Manual.
- All applicable safety precautions.
- Along with retail customer/end user, check reflective decals and SMV sign are clearly visible with planter in transport position and attached to tractor. Check safety/warning lights are in working condition. Tell retail customer/end user to check federal, state/provincial, and local regulations before towing or transporting on a road or highway.
- Give Operator Manual, Parts Manual, and all Instruction Sheets to retail customer/end user and explain all operating adjustments.
- Read warranty to retail customer/end user.
- Complete Warranty and Delivery Report form.

***To the best of my knowledge this machine has been delivered ready for field use and customer has been fully informed as to proper care and operation.***

---

(Signature Of Delivery Person/Dealer Name/Date)

## AFTER DELIVERY CHECKLIST

The following is a list of items we suggest to check during the first season of use of the equipment.

- Check planter performance with retail customer/end user.
- Check performance of vacuum or mechanical seed metering system with retail customer/end user.
- Review importance of proper maintenance and adherence to all safety precautions with retail customer/end user.
- Check for parts that may need to be adjusted or replaced.
- Check all safety decals, reflective decals, and SMV sign are correctly located as shown in the Parts Manual and that decals are legible. Replace if damaged or missing.
- Check safety/warning lights are working properly.

---

(Signature Of Follow-Up Person/Dealer Name/Date)

**All registrations must be submitted online at "[business.kinze.com](http://business.kinze.com)" within 5 business days of delivery.  
Retain a copy of this form for auditing purposes.**

*Tear Along Perforation*

**OVERVIEW**

To The Owner .....	1-1
Specifications .....	1-3
Tractor Hydraulic Requirements .....	1-4
General Safety Rules .....	1-5
Safety Precautions .....	1-6

**MACHINE OPERATION**

Manual Safety Lockup .....	2-1
Row Marker Safety Lockup .....	2-1
Tongue Safety Pin .....	2-2
Transport Latch Locking Pin .....	2-2
Initial Preparation .....	2-3
Tractor Requirements .....	2-4
Tractor Mounted PTO Pump And Oil Cooler Option .....	2-5
Tractor Preparation and Hookup .....	2-6
Level Planter .....	2-9
Ridge Planting .....	2-10
True Depth Hydraulic System Overview .....	2-11
True Depth Filter .....	2-12
Contact Wheel Spring Adjustment .....	2-13
Contact Wheel Drive Sprockets .....	2-13
Seed Rate Transmission Adjustment .....	2-14
Wrap Spring Wrench Operation .....	2-14
Ag Leader Electric Clutches .....	2-14
Hydraulic Seed Rate Drive .....	2-15
Hall Effect Sensor .....	
(Hydraulic Drive Only) .....	2-15
Hydraulic Weight Transfer Toolbar .....	2-15
Shear Protection .....	2-15
Hydraulic/Electric Operation .....	2-16
Transport to Field Sequence .....	2-17
Field Operation .....	2-20
Planting Speed .....	2-20
Field to Transport Sequence .....	2-21
Digital Vacuum Readout .....	2-23
Vacuum Fan Motor Valve Block Assembly .....	2-23
Vacuum Meter System .....	2-23
Analog Vacuum or Pressure Gauge .....	2-24
Bulk Fill System .....	2-24
Bulk Fill Entrainer Access .....	2-25
Bulk Fill Tanks - Clean Out .....	2-25
Bulk Fill Scale Package Option (2021 Production only) .....	2-26
Bulk Fill Scale Package Option (2022 Production and On) .....	2-29
Rock Guards .....	2-33

Auxiliary Work Lights Package .....	2-33
Ag Leader Monitoring Control Package (PMM) .....	2-34
Ag Leader InCommand 1200 Display .....	2-34
Kinze ISOBUS Option .....	2-34
Row Marker Operation .....	2-35
Row Marker Speed Adjustment .....	2-36
Even-Row Push Row Unit .....	2-36
Row Marker Adjustments .....	2-37
Row Marker Even-Row Length Adjustment .....	2-38
Offset Hitch Adjustment .....	2-38
Point Row Clutches .....	2-39
Auxiliary Hydraulic Option .....	2-40
Rear Trailer Hitch .....	2-41
Field Test .....	2-42
Field Check Seed Population .....	2-42
Determining Pounds Per Acre (Brush-Type Meter) .....	2-43
Determining Bushels Per Acre .....	2-43
Field Check Granular Chemical Application .....	2-44

**ROW UNIT OPERATION**

Planting Depth .....	3-1
"V" Closing Wheel Adjustment (Rubber or Cast Iron) .....	3-1
Closing Wheel Shield (Rubber or Cast Iron "V" Closing Wheels) .....	3-2
Brush-Type Seed Meter 2.0 .....	3-3
Finger Pickup Seed Meter .....	3-5
Vacuum Settings .....	3-6
Seed Meter Cleanout .....	3-11
Additives .....	3-12
Bayer Fluency Agent .....	3-13
Seed Hoppers .....	3-14
Seed Meter Drive Release .....	3-14
Row Unit Extension Brackets .....	3-14
Row Unit Chain Routing .....	3-15
Quick Adjustable Down Force Springs Option .....	3-16
Split row Push Row Unit Clutch Sprocket .....	3-18
Split Row Lockups .....	3-23
Split Row Push Row Unit Vacuum Hose Shutoff .....	3-25
Row Unit Mounted No Till Coulter .....	3-26
Coulter Mounted Residue Wheels .....	3-26
Granular Chemical Hopper and Drive .....	3-28
Granular Chemical Banding Options .....	3-29

**FERTILIZER**

Notched Single Disc Openers . . . . . 4-1  
 Depth/Gauge Wheel Attachment for  
     Notched Single Disc Fertilizer Opener . . . . . 4-3  
 HD Single Disc Fertilizer Opener . . . . . 4-4  
 Dry Fertilizer Attachment . . . . . 4-6  
 Liquid Fertilizer Attachment . . . . . 4-8

**RATE CHARTS . . . . . 5-1**

**LUBRICATION AND MAINTENANCE**

Lubrication . . . . . 6-1  
 Lubrication Symbols . . . . . 6-1  
 Sealed Bearings . . . . . 6-1  
 Wrap Spring Wrench Assembly . . . . . 6-1  
 Drive Chains . . . . . 6-2  
 Bushings . . . . . 6-4  
 Split Row Push Row Unit Lockups . . . . . 6-5  
 Center Post . . . . . 6-5  
 U-Joint Slides . . . . . 6-6  
 Liquid Fertilizer Piston Pump Crankcase Oil Level . . . . . 6-6  
 PTO Pump Shaft Coupling  
     (Tractor Mounted PTO Pump and Oil Cooler) . . . . . 6-7  
 Wheel Bearings . . . . . 6-7  
 Grease Fittings . . . . . 6-7  
 Mounting Bolts and Hardware . . . . . 6-11  
 Tire Servicing . . . . . 6-13  
 Finger Pickup Seed Meter Inspection/Adjustment . . . . . 6-14  
 Cleaning Finger Pickup Seed Meter For Storage . . . . . 6-15  
 Brush-Type Seed Meter 2.0 Maintenance . . . . . 6-16  
 Cleaning Brush-Type Seed Meter For Storage . . . . . 6-19  
 Vacuum Manifold Maintenance . . . . . 6-19  
 Vacuum Seed Meter Maintenance . . . . . 6-20  
 Vacuum Seed Meter Cleanout . . . . . 6-20  
 Chain Tension Adjustment . . . . . 6-21  
 Gauge Wheel Adjustment . . . . . 6-21  
 Gauge Wheel Arm Bushing/Seal Replacement . . . . . 6-22  
 Gauge Wheel Arm Pivot Spindle Replacement . . . . . 6-23  
 15" Seed Opener Disc Blade/Bearing Assembly . . . . . 6-24  
 Seed Tube Guard/Inner Scraper . . . . . 6-26  
 Row Unit Mounted No Till Coulter . . . . . 6-27  
 Coulter Mounted Residue Wheels . . . . . 6-27  
 Spiked Closing Wheel . . . . . 6-28  
 Granular Chemical Attachment . . . . . 6-28  
 Single Point Row Clutch Maintenance . . . . . 6-29  
 Check Valve (Lift System) . . . . . 6-31  
 Check Valve (Vacuum Fan) . . . . . 6-31  
 Flow Control Valve . . . . . 6-31  
 Pressure Relief Valve . . . . . 6-31  
 Pressure Reducing Relief Valve . . . . . 6-31

Relief Valve Cartridge . . . . . 6-31  
 Solenoid Valve . . . . . 6-31  
 Row Marker Bearing Lubrication or Replacement . . . . . 6-32  
 Row Marker Transport Stand Adjustment . . . . . 6-33  
 Wheel Bearing Repack or Replacement . . . . . 6-33  
 Wear Pad Field Replacement/Adjustment . . . . . 6-34  
 Tractor Mounted PTO Pump and Oil Cooler Option . . . . . 6-38  
 Fertilizer Check Valve Cleaning and Repair . . . . . 6-39  
 Piston Pump Storage . . . . . 6-39  
 Preparation for Storage . . . . . 6-40  
 Pneumatic Down Pressure Air Compressor Tank . . . . . 6-41  
 Electrical Wiring Diagram for Light Package . . . . . 6-42  
 Electrical Control Console Schematic . . . . . 6-43  
 Electrical Wiring Harness Schematic (On Tractor) . . . . . 6-44  
 Electrical Wiring Harness Schematic (On Planter) . . . . . 6-45  
 Valve Block - Located on Hitch . . . . . 6-46  
 Valve Block - Located on Rear Center Frame . . . . . 6-47  
 Hydraulic Hose Life . . . . . 6-48  
 Hydraulic System Schematic . . . . . 6-49  
 Wing Down Pressure Schematic  
     (Weight Transfer Mechanism) . . . . . 6-52  
 Electric Clutch Schematic . . . . . 6-53  
 Hydraulic Schematic - Vacuum Fan Motor System . . . . . 6-54  
 Hydraulic Schematic -  
     Tractor Mounted Single Stage PTO Pump . . . . . 6-55  
 ISOBUS Implement Cable . . . . . 6-56  
 ISOBUS CAN Jumper Cable . . . . . 6-56  
 Product Control Module Cable . . . . . 6-57  
 Implement Switch Extension Cable . . . . . 6-58  
 Section Adapter Cable - 12 Row . . . . . 6-59  
 Section Adapter Cable - 16 Row . . . . . 6-59  
 Clutch Cable - 12 Row . . . . . 6-60  
 Clutch Cable - 16 Row . . . . . 6-61  
 True Depth Option- Interconnect . . . . . 6-62  
 True Depth Option - Hydraulic Schematic . . . . . 6-63

**TROUBLESHOOTING**





Bulk Fill . . . . . 7-1  
 Closing Wheel . . . . . 7-1  
 Lift Circuit . . . . . 7-2  
 Piston Pump . . . . . 7-3  
 PTO Pump Drive and Oil Cooler Option . . . . . 7-3  
 Point Row Clutch . . . . . 7-4  
 Row Marker Operation . . . . . 7-5  
 Rotation Circuit . . . . . 7-6  
 Seed Meter (Brush-Type) . . . . . 7-6  
 Vacuum Seed Meter . . . . . 7-7  
 Seed Meter (Finger Pickup) . . . . . 7-9  
 Solenoid Valve . . . . . 7-9  
 Tongue Cylinder Circuit . . . . . 7-10

Kinze Manufacturing, Inc. thanks you for your patronage. We appreciate your confidence in Kinze farm machinery. Your Kinze planter has been carefully designed to provide dependable operation in return for your investment.

**This manual has been prepared to aid you in the operation and maintenance of the planter. It should be considered a permanent part of the machine and remain with the machine when you sell it.**

It is the responsibility of the user to read and understand the Operator Manual in regards to safety, operation, lubrication and maintenance before operation of this equipment. It is the user's responsibility to inspect and service the machine routinely as directed in the Operator Manual. We have attempted to cover all areas of safety, operation, lubrication and maintenance; however, there may be times when special care must be taken to fit your conditions.

Throughout this manual the symbol  and the words **DANGER**, **WARNING**, and **CAUTION** are used to call attention to safety information that if not followed, will or could result in death or injury. **NOTICE** and **NOTE** are used to call your attention to important information. The definition of each of these terms follows:

	Indicates an imminently hazardous situation that, if not avoided, will result in death or serious injury. This signal word is to be limited to the most extreme situations, typically for machine components which, for functional purposes, cannot be guarded.
	Indicates a potentially hazardous situation that, if not avoided, could result in death or serious injury, and includes hazards that are exposed when guards are removed. It may also be used to alert against unsafe practices.
	Indicates a potentially hazardous situation that, if not avoided, may result in minor or moderate injury. It may also be used to alert against unsafe practices.
	Used to address safety practices not related to personal injury.

**NOTE:** Special point of information or machine adjustment instructions.

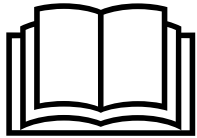
**WARNING**

Improperly operating or working on this equipment could result in death or serious injury. Read and follow all instructions in Operator Manual before operating or working on this equipment.

**WARNING**

Some photos in this manual may show safety covers, shields, or lockup devices removed for visual clarity. **NEVER OPERATOR OR WORK ON** machine without all safety covers, shields, and lockup device in place as required.

**NOTE:** Some photos in this manual may have been taken of prototype machines. Production machines may vary in appearance.

**NOTE:** Some photos and illustrations in this manual show optional attachments installed. Contact your Kinze Dealer for purchase of optional attachments.



Specification	Conventional Hoppers		
	12R N 30 Y	12R W 36-38 Y	16R N 30 Y
Number of Rows			
Weight Empty (Mechanical)	12,822 lb (5,815.96 kg)	13,522 lb (6133.47 kg)	15,975 lb (7,246.13 kg)
Weight Empty (Vacuum)	12,780 lb (5,796.91 kg) - 13,185 lb (5,980.62 kg)	---	15,730 lb (7,135.00 kg) - 16,210 lb (7,352.73 kg)
*Weight based off typical configuration of a complete machine.			
Transport Height	11' 5" (3.5M)	11' 5" (3.5M)	11' 5" (3.5M)
Planting Length	21' 0" (6.4M)	22'0" (6.7M)	24' 0" (7.4M)
Transport Length	36' 10" (11.3M)	45'10" (14M)	46' 10" (14.3M)
Planting Width	31' 2" (9.5M)	37'2" (11.4M)	41' 2" (12.6M)
Transport Width	11' 2" (3.5M)	13'4" (4.1M)	11' 2" (3.5M)
Seed Capacity	1.75 bu. (Vacuum/Hopper); 1.90 bu. (Mechanical/Hopper)		
Transport Tire Size	Four 255 - 70R 22.5 radial load range 'H' tubeless rib implement w/o center groove.		
Field Tire Size	7.50" x 20" 8 ply rib implement tires w/o center groove.		
Field Lift	Two master/two slave rephasing cylinders.		
Row Markers	Independently controlled, three stage, low profile, w/disk blade depth bands.		



Specification	Bulk Fill		
	12R N 30 Y	16R N 30 Y	16 R 7.5" Y
Number of Rows			
Weight Empty (Mechanical)	14,590 lb (6,617.91 kg) - 15,242 lb (6,913.65 kg)	15,600 lb (7,076.04 kg) - 17,048 lb (7,732.84 kg)	19,620 lb (8,899.48 kg) - 21,140 lb (9,588.94 kg)
Weight Empty (Vacuum)	14,590 lb (6,617.91 kg) - 15,242 lb (6,913.65 kg)	15,600 lb (7,076.04 kg) - 17,048 lb (7,732.84 kg)	19,620 lb (8,899.48 kg) - 21,140 lb (9,588.94 kg)
*Weight based off typical configuration of a complete machine.			
Transport Height	12' 6" (3.9M)	12' 6" (3.9M)	12' 6" (3.9M)
Planting Length	21' 0" (6.4M)	24' 0" (7.4M)	24' 0" (7.4M)
Transport Length	36' 10" (11.3M)	46' 10" (14.3M)	46' 10" (14.3M)
Planting Width	31' 2" (9.5M)	41' 2" (12.6M)	41' 2" (12.6M)
Transport Width	11' 2" (3.5M)	11' 2" (3.5M)	11' 2" (3.5M)
Seed Capacity	80 bu.		
Bulk Fill Fill Height (planting position)	8' 2" (2.5M)		
Transport Tire Size	Four 255 - 70R 22.5 radial load range 'H' tubeless rib implement w/o center groove.		
Wing/Lift Tire Size	7.50" x 20" 8 ply rib implement tires w/o center groove.		
Field Lift	Two master/two slave rephasing cylinders.		
Row Markers	Independently controlled, three stage, low profile, w/disk blade depth bands.		



Configuration	Requirements		Description
<b>Mechanical Metering Configuration</b>			
Base Machine W/Mechanical Meters	2 SCV	15 gpm	#1 SCV: Planter Lift #2 SCV: Markers/Fold (W/12v Control Console)
Base Machine W/Mechanical Meters <i>Hydraulic Drive</i>	3 SCV	20 gpm	#1 SCV: Planter Lift #2 SCV: Markers/Fold (W/12v Control Console) #3 SCV: Hydraulic Drive
Base Machine W/Mechanical Meters <i>Bulk Fill system</i> →External case drain required for Bulk Fill hydraulic circuit. →Use of a Tractor-mounted PTO hydraulic pump supplies oil flow for the vacuum hydraulic circuit reducing the required SCVs by 1 and the gpm by 10	3 SCV	25 gpm	#1 SCV: Planter Lift #2 SCV: Markers/Fold (W/12v Control Console) #3 SCV: Bulk Fill System
Base Machine W/Mechanical Meters <i>Bulk Fill system Hydraulic drive</i> →External case drain required for Bulk Fill hydraulic circuit. →Use of a Tractor-mounted PTO hydraulic pump supplies oil flow for the vacuum hydraulic circuit reducing the required SCVs by 1 and the gpm by 10	4 SCV	30 gpm	#1 SCV: Planter Lift #2 SCV: Markers / Fold (with 12v Control Console) #3 SCV: Hydraulic Drive #4 SCV: Bulk Fill Delivery System
<b>Vacuum Metering Configuration</b>			
Base Machine W/Vacuum Meters →External case drain required for Vacuum hydraulic circuit. →Use of a Tractor-mounted PTO hydraulic pump supplies oil flow for the vacuum hydraulic circuit reducing the required SCVs by 1 and the gpm by 15	3 SCV	30 gpm	#1 SCV: Planter Lift #2 SCV: Markers/Fold (W/12v Control Console) #3 SCV: Vacuum Fan
Base Machine W/Vacuum Meters <i>Hydraulic Drive</i> →External case drain required for Vacuum hydraulic circuit. →Use of a Tractor-mounted PTO hydraulic pump supplies oil flow for the vacuum hydraulic circuit reducing the required SCVs by 1 and the gpm by 15	4 SCV	40 gpm	#1 SCV: Planter Lift #2 SCV: Markers/Fold (W/12v Control Console) #3 SCV: Hydraulic Drive #4 SCV: Vacuum Fan
Base Machine W/Vacuum Meters <i>Bulk Fill System</i> →External case drain required for bulk fill vacuum hydraulic circuit. →Use of a Tractor-mounted PTO hydraulic pump supplies oil flow for the vacuum hydraulic circuit reducing the required SCVs by 1 and the gpm by 10	4 SCV	40 gpm	#1 SCV: Planter Lift #2 SCV: Markers/Fold (W/12v Control Console) #3 SCV: Vacuum Fan #4 SCV: Bulk Fill Delivery System

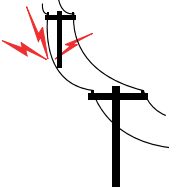

1. Read and understand instructions provided in this manual and warning labels. Review these instructions frequently!
2. This machine is designed and built with your safety in mind. Do not make any alterations or changes to this machine. Any alteration to design or construction may create safety hazards.
3. A large portion of farm accidents happen from fatigue or carelessness. Safe and careful operation of tractor and planter will help prevent accidents.
4. Never allow planter to be operated by anyone unfamiliar with operation of all functions of the unit. Operators must read and thoroughly understand all instructions given in this manual before operating or working on equipment.
5. Be aware of bystanders, particularly children! Always look around to make sure it is safe to start tow vehicle engine or move planter. This is particularly important with higher noise levels and quiet cabs, as you may not hear people shouting.
6. Make sure planter weight does not exceed towing capacity of tractor, or bridge and road limits. This is critical to maintain safe control and prevent death or injury, or property and equipment damage.
7. Never ride or allow others to ride on planter.
8. Store planter in an area away from human activity. DO NOT permit children to play on or around the stored unit.
9. Keep hands, feet, and clothing away from moving parts. Do not wear loose-fitting clothing which may catch in moving parts.
10. Always wear protective clothing, shoes, gloves, hearing, and eye protection applicable for the situation.
11. Do not allow anyone to stand between tongue or hitch and towing vehicle when backing up to planter.
13. Prevent electrocution, other injuries, or property and equipment damage. Watch for obstructions such as wires, tree limbs, etc. when operating machine. Be aware of clearances during turns and when folding/unfolding planter.
14. Reinstall all guards removed for maintenance activities. Never leave guards off during operation.
15. Use of aftermarket hydraulic, electric, or PTO drives may create serious safety hazards to you and people nearby. If you install such drives, follow all appropriate safety standards and practices to protect you and others near this planter from injury.
16. Follow all federal, state/provincial, and local regulations when towing farm equipment on a public highway. Use safety chain (not an elastic or nylon/plastic tow strap) to retain connection between towing and towed machines in the event of primary attaching system separation.
17. Make sure all safety/warning lights, SMV sign, and reflective decals are in place and working properly before transporting the machine on public roads.
18. Limit towing speed to 15 MPH. Tow only with farm tractor of a minimum 90 HP. Allow for unit length when making turns.
19. Reduce speed prior to turns to avoid the risk of overturning. Always drive at a safe speed relative to local conditions and ensure your speed is slow enough for a safe emergency stop.
20. Chemical application is often an integral part of planting. Follow label instructions for proper chemical mixing, handling and container disposal methods.
21. Be familiar with safety procedures for immediate first aid should you accidentally contact chemical substances.
22. Use the proper protective clothing and safety equipment when handling chemicals.
23. Chemicals are supplied with Material Safety Data Sheets (MSDS) that provide full information about the chemical, its effects on exposure, and first aid needs in the event of an emergency. Keep your MSDS file up-to-date and available for first responders in case of emergency.
24. When servicing ground engaging components such as opening disks and firming points, use special care to avoid points and edges worn sharp during use.
25. Use professional help if you are unfamiliar with working on hydraulic systems. Pressurized hydraulic fluid can penetrate body tissue and result in death, serious infection, or other injuries.
26. Transporting planter with hoppers over half full or unevenly loaded can cause loss of control and could result in death, serious injury, or damage to property and equipment.

Following are some common hazard warnings associated with this equipment. Pay close attention to all safety, operating, and maintenance information in this manual and decals applied to your equipment.

 <b>DANGER</b>	<p>Contacting or coming close to power lines or other high energy sources will cause death or serious injury.</p>
	<p>Keep away from power lines or high energy sources at all times.</p>

 <b>WARNING</b>	<p>Improperly operating or working on this equipment could result in death or serious injury. Read and follow all instructions in Operator Manual before operating or working on this equipment.</p>
	

 <b>WARNING</b>	<p>Falling equipment can cause death or serious injury. Install all lockup devices or lower planter to ground before working on equipment.</p>
	

 <b>WARNING</b>	<p>Explosive separation of rim and tire parts can cause death or serious injury. Overinflation, rim and tire servicing, improper use of rims and tires, or worn or improperly maintained tires could result in a tire explosion.</p>
	

## SAFETY SIGNS AND DECALS

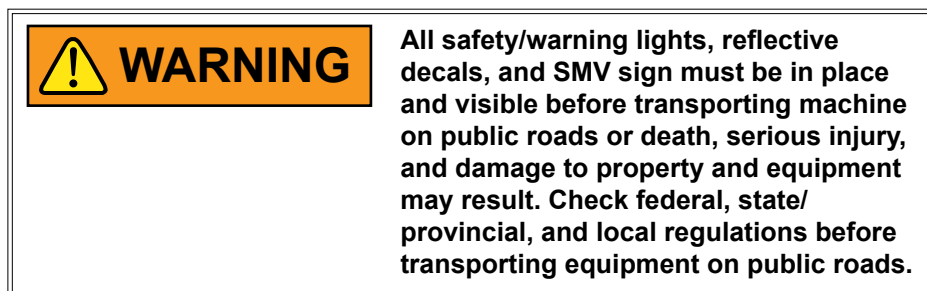

Safety signs and decals are placed on the machine to warn of hazards and provide important operating and maintenance instructions. Information on these signs are for your personal safety and the safety of those around you. FOLLOW ALL SAFETY INSTRUCTIONS!



- **Keep signs clean so they can be easily seen. Wash with soap and water or cleaning solution as required.**
- **Replace safety signs if damaged, painted over, or missing.**
- **Check reflective decals and SMV sign periodically. Replace if they show any loss of reflective properties.**
- **When replacing decals, clean machine surface thoroughly with soap and water or cleaning solution to remove all dirt and grease.**

**NOTE:** Safety sign and decal locations are shown in the Parts Manual for this machine.

**NOTE:** Style and locations of SMV sign, reflective decals, and safety/warning lights conform to ANSI/ASABE S279.14 JUL 2008 and ANSI/ASABE S276.6 JAN 2005.

**This page left blank intentionally.**

### MANUAL SAFETY LOCKUP

 <b>WARNING</b>	<p>Uncontrolled movement of equipment can cause loss of control and could result in death, serious injury, or damage to property and equipment. Install all safety pins before transporting equipment.</p>
	



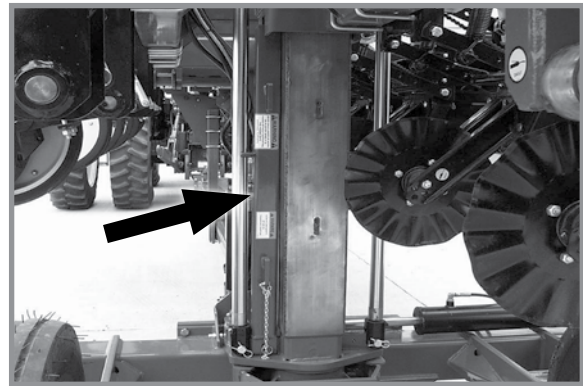

Manual safety lockup in storage position



Manual safety lockup in transport position

Remove manual safety lockup and store on L.H. side of transport axle for field operation.

### ROW MARKER SAFETY LOCKUP



 <b>WARNING</b>	<p>Row marker can lower at any time and could cause death or serious injury. Stay away from row markers! Install safety lockup device when not in use.</p>
	

Always install row marker lockups when working or transporting planter.

Connect chain between marker stand and second stage of marker assembly.



Row marker safety lockup installed

 <b>WARNING</b>	<p>Uncontrolled movement of equipment can cause loss of control and could result in death, serious injury, or damage to property and equipment. Install all safety pins before transporting equipment.</p>
	

**TONGUE SAFETY PIN**

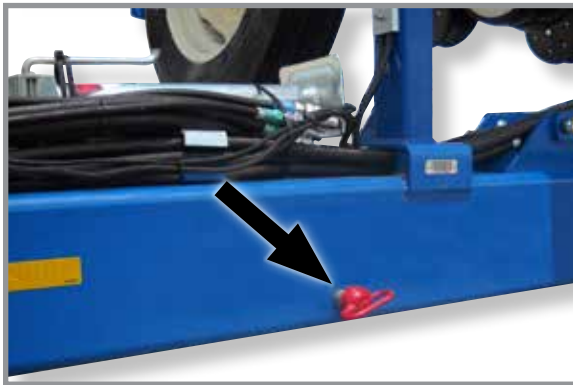

**Tongue safety pin installed for transport**

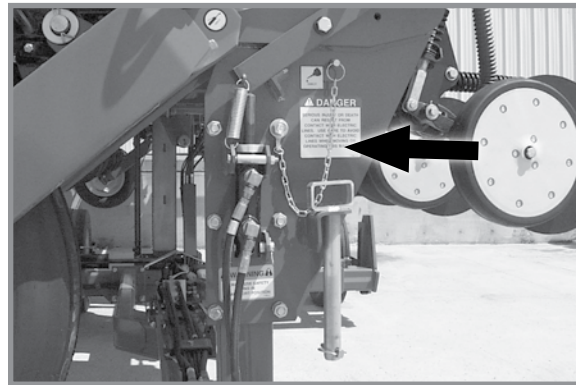

**Tongue safety pin stored for field operation**

Never transport planter without installing tongue safety pin. Tongue safety pin prevents tongue cylinder from retracting should hydraulic failure occur or a sudden stop be made when transporting planter.

Remove tongue safety pin and store in bracket on transport latch post at center of planter for field operation.

**TRANSPORT LATCH LOCKING PIN**

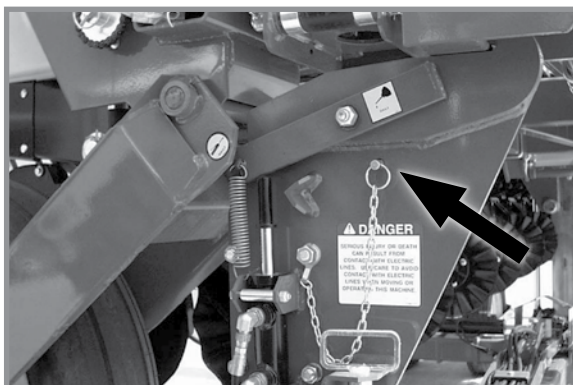

**Transport latch locking pin stored for field operation**

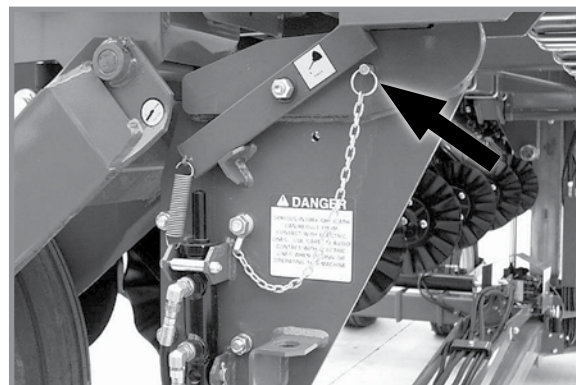

**Transport latch locking pin installed for transport**



Never transport planter without installing transport latch locking pin. Transport latch locking pin prevents latch bar from disengaging and allowing planter frame to swing away.



Remove transport latch locking pin and store in location provided on latch post for field operation.





## INITIAL PREPARATION

Following information is general in nature to aid in preparation of tractor and planter for use, and to provide general operating procedures. Operator experience, familiarity with the machine, and the following information should combine for efficient planter operation and good working habits.

 <b>WARNING</b> 	<p>Improperly operating or working on this equipment could result in death or serious injury. Read and follow all instructions in Operator Manual before operating or working on this equipment.</p>
---	--

 <b>WARNING</b> 	<p>Loose transport wheel lug bolts can result in wheel separation from planter and cause death, serious injury, and damage to property and equipment. Torque transport wheel lug bolts before operating planter for the first time and periodically after.</p>
---	--

 <b>WARNING</b> 	<p>Explosive separation of rim and tire parts can cause death or serious injury. Overinflation, rim and tire servicing, improper use of rims and tires, or worn or improperly maintained tires could result in a tire explosion.</p>
---	--

 <b>WARNING</b>	<p>Folding or towing planter with outer transport wheel on left side of machine removed can cause death, serious injury, or damage to property and equipment. Tipping may occur because of narrow wheel base. Outer transport wheel on left side of machine is shipped removed on non-bulk fill planters (not bolted on) to allow narrower width truck shipment. <b>DO NOT REMOVE THIS ASSEMBLY AFTER PLANTER IS ASSEMBLED FOR USE.</b></p>
--	---

 <b>WARNING</b>	<p>Transporting planter with hoppers over half full or unevenly loaded can cause loss of control and could result in death, serious injury, or damage to property and equipment. Properly load planter when transporting. Be aware of extra transport weight, and road conditions and limits.</p>
--	---

1. Torque transport wheel  $\frac{5}{8}$ "- 18 lug nuts to 200 ft-lb (271 N-m).

2. Inflate tires to the following specifications:

Transport (center section) 255-70R 22.5" □□□□□□□  
75 psi (517.1 kPa) recommended/100 psi (689.4 kPa) max.

Ground drive (wings) 7.50" x 20" 40 psi (275.7 kPa)

Contact drive 50 psi (344.7 kPa).

Liquid fertilizer piston pump 7.60" x 15" 40 psi (275.7 kPa)

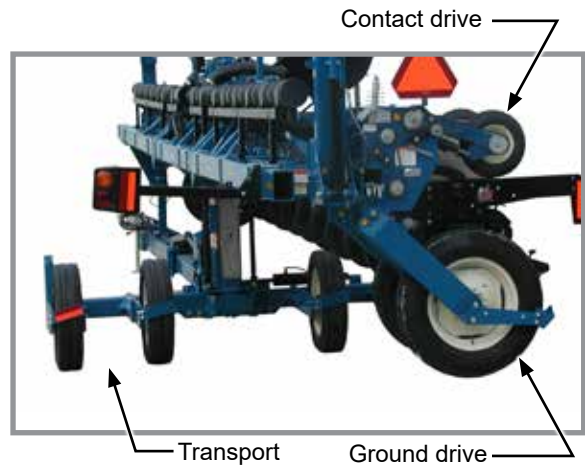

**Tire locations (not all tires shown)**

3. Lubricate planter and row units following instructions in lubrication and Maintenance section of this manual.

4. Check all drive chains for proper tension, alignment, and lubrication.

## TRACTOR REQUIREMENTS

Consult your dealer for information on horsepower requirements and tractor compatibility. Requirements vary with planter options, tillage, and terrain.

A 12 volt DC electrical system is required on all sizes.

A minimum of two SCV remote hydraulic outlets are required on all sizes. One SCV is used for field lift and with a control console switch operates raise to transport function. A second SCV using control console operates row markers fold/unfold functions. Additional SCV's with a zero pressure case drain are needed for vacuum fan motor for seed metering system, Hydraulic Drive, and Wing Down Pressure (if installed without vacuum or bulk fill).

Maximum hydraulic flow rate of 13 GPM @ 2000 PSI is required to operate vacuum fan motor.

**TRACTOR MOUNTED PTO PUMP AND OIL COOLER OPTION**

The tractor mounted PTO pump and oil cooler option is for tractors with less than required hydraulic output needed to operate hydraulic-driven vacuum fan and other planter hydraulic requirements.

A 1000 RPM PTO is required to operate the PTO-driven hydraulic pump.

PTO pump option consists of a 1 3/8"-21 or 1 3/4"-20 spline 13.5 GPM 2000 psi tractor mounted pump, planter mounted 10 gallon capacity hydraulic reservoir with spin-on 10-micron oil filter, vacuum fan mounted 15 GPM-rated oil cooler, and required hydraulic valves, fittings, and hoses.

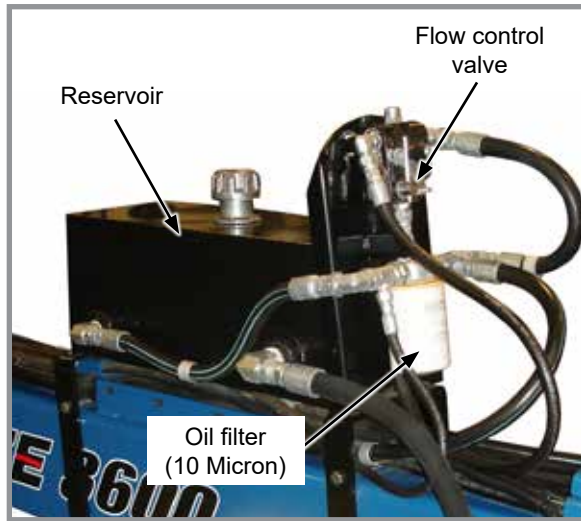

**Bulk Fill**

Hydraulic reservoir, flow control valve, and fittings

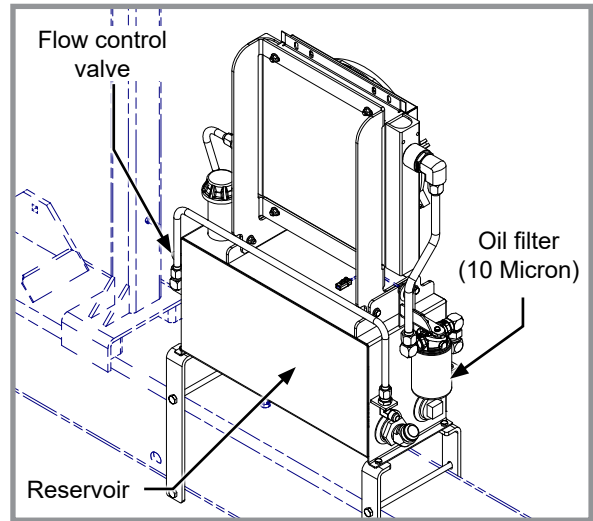

**Vacuum**

Hydraulic reservoir, flow control valve, and fittings

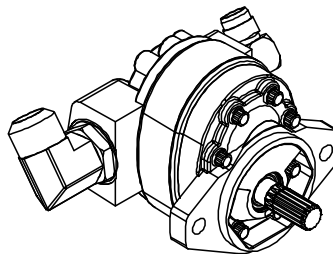

**PTO-driven hydraulic pump  
(1 3/8" spline PTO pump shown)**

---

## TRACTOR PREPARATION AND HOOKUP

1. Adjust tractor drawbar 13-17 inches above ground with hitch pin hole directly below PTO shaft center line. Make sure drawbar is in a stationary position.
2. Install control console on tractor in a convenient location within easy reach of operator and close to hydraulic controls. Mount control console securely and route power cord to power source. Control console operates on 12 volt DC only. If two 12 volt batteries are connected in series, ALWAYS make power connection on battery grounded to tractor chassis.

If two 6 volt batteries are connected in series, make sure power connection provides 12 volt DC across positive terminal on one battery and negative terminal of second battery.

3. Back tractor to planter and connect with 1¼" - 1½" diameter hitch pin. If tractor is not equipped with a hitch pin locking device, make sure hitch pin is secured with a locking pin or cotter pin.



**Drawbar and safety chain connection**

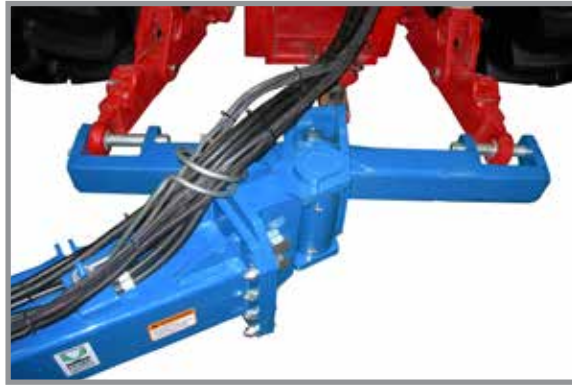

Optional 2-point hitch

4. Safety chain must be used to keep planter and tractor connected in case of a hitch pin/drawbar failure.

**NOTE: A 2-Point Hitch Option converts planter from drawn to semi-mounted and is available for use with Category 3N or 3 three-point hitch designs. Safety chain is not used with 2-point hitch.**

 **WARNING**



Pressurized hydraulic fluid can penetrate body tissue and result in death, serious infection, or other injuries. Fluid injected under skin must be **IMMEDIATELY** removed by a surgeon familiar with this type of injury. Make sure connections are tight and hoses and fittings are not damaged before applying system pressure. Leaks can be invisible. Keep away from suspected leaks. Relieve pressure before searching for leaks or performing any system maintenance.

**NOTICE**

Wipe hose ends to remove any dirt before connecting couplers to tractor ports or contamination may cause equipment failure.

5. Connect hydraulic hoses to tractor ports in a sequence familiar and comfortable to the operator.

<b>NOTICE</b>	<p>Connect hydraulic motor case drain to a case drain return line with zero PSI on tractor. Failure to connect to a return with zero PSI will cause hydraulic motor shaft seal damage. <b>DO NOT</b> connect hydraulic motor case drain to a SCV outlet or motor return circuit connection. Contact tractor manufacturer for specific details on “zero pressure return”.</p>
---------------	--

<b>NOTICE</b>	<p>Always connect hydraulic motor return hose to tractor motor return port. Do not connect to tractor SCV unless through a motor spool or hydraulic motor failure can occur. If a motor return port is not available on the tractor, the SCV controlling the bulk fill system <b>MUST</b> be in the float position before planter is moved in planting or field raised position when bulk fill system is not in use.</p>
---------------	--

PLANTER TO TRACTOR HYDRAULIC CONNECTIONS			
Color/Label	Machine Function	Hose Size	Function
Red AA	Field Lift	1/2"	Pressure
Red BB		1/2"	Return
Blue AA	Planter Fold & Row Marker	3/8"	Return
Blue BB		3/8"	Pressure
Black RR	Seed Rate Hydraulic Drive (Vacuum)	3/4"	Return
Black PP		1/2"	Pressure
Black RR	Seed Rate Hydraulic Drive (Mechanical)	1/2"	Return
Black PP		3/8"	Pressure
Green RR	Vacuum Fan	3/4"	Return
Green PP		1/2"	Pressure
Orange CD		3/8"	Case Drain
Yellow RR	Bulk Fill System Pressure Fan	3/4"	Motor Return
Yellow PP		1/2"	Pressure
Orange CD		1/4"	Case Drain

**NOTE:** Set adjustable flow outlet (SCV) to full flow position.

For tractors not equipped with a method for finite adjustment of hydraulic flow, Flow Control Needle Valve Kit G1K426 is available from Kinze Repair Parts through your Kinze Dealer.



G1K426 needle valve kit

6. Connect ASABE Standards 7 terminal connector for safety/warning lights on planter to ASABE Standards receptacle on tractor. If your tractor is not equipped with an ASABE Standards receptacle, check with your tractor manufacturer for availability. Check warning lights on planter work in conjunction with warning lights on tractor.

**NOTE: A 12 volt battery connection is required to power the vacuum fan digital gauge. Connect "red" wire to positive (+) battery terminal and "black" wire to negative (-) battery terminal.**

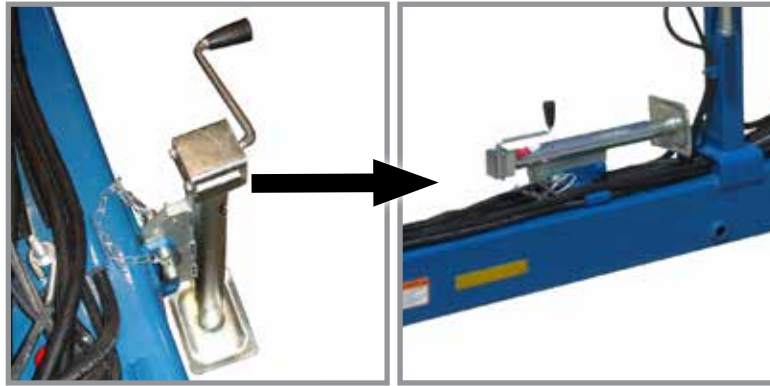

**Remove and store jack**

7. Raise jack stand and remount horizontally on storage bracket.

## LEVEL PLANTER

Lateral adjustment is maintained by tire pressure. Check tires are inflated to specification.

Front and rear level adjustment is maintained by hitch clevis position unless tractor drawbar is adjustable for height. Planter frame and row unit parallel arms must be level for proper planter and row unit operation. Bottom of toolbar should be 20" to 22" from planting surface.

1. Lower planter to planting position and check planter is level front to rear. Go to step 2 if hitch is too high or low.

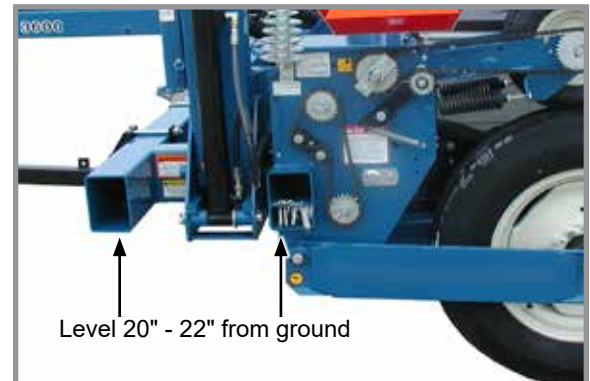

**Level planter toolbars**

**NOTE: DO NOT install safety chain using clevis hardware. Move safety chain location if necessary.**

2. Remove clevis hitch hex head cap screw and lock nut using a torque wrench. Replace if off-torque is below 75 ft-lb (101.6 N-m) or there is corrosion or damage.

**NOTE: Clevis must be free to move on hitch. DO NOT OVERTIGHTEN hardware.**

3. Align clevis to hitch holes at new location and install hex head cap screw and lock nut. Tighten lock nut until threads are fully engaged and hex head cap screw and lock nut are firmly against hitch bracket.

**NOTE: On planters with push row units and no till coulters, uplift from down force springs or air springs in pneumatic down pressure system may cause wings to rise slightly in planting position. Problem may be compounded if static pressure is trapped in planter's hydraulic lift system which can cause wing cylinders to extend slightly. Operating tractor's hydraulic system in float position or moving tractor's hydraulic lever to float position briefly to relieve pressure will help maintain proper toolbar height.**

4. Field check planter.

Field and actual planting conditions dictate which transport wheel setting to use so row unit parallel arms are parallel with ground. It may be necessary to lower ground drive wheels to ensure level lateral toolbar operation if transport wheels are set in one of the two lower sets of holes. Make a field check when planter is fully loaded with seed, granular chemicals, fertilizer, etc. to be sure wings are level with center frame. If wings are not level with center frame, drive wheels and/or transport wheels can be raised or lowered in wheel arms to increase or decrease planter toolbar height. Raise hitch to ensure level operation.

<b>NOTICE</b>	<b>Component interference can damage equipment. Check clearance between tires and drill shaft U-joint when using top hole setting.</b>
---------------	--

**NOTE:** To allow adequate drive force after lowering ground drive wheels, it may be necessary to lower contact drive wheel arms to lower sets of holes in wheel modules and lower down pressure springs to lower mounting rods on wheel modules.

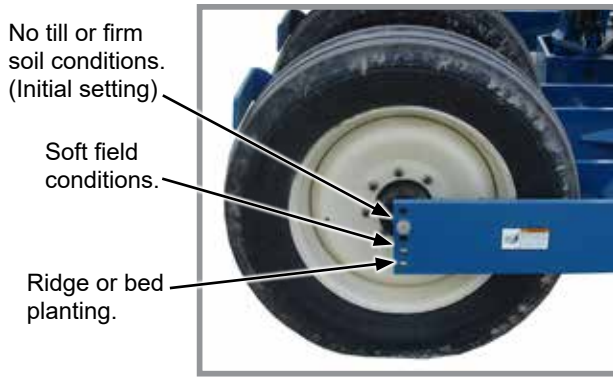

**Transport wheel adjustment**

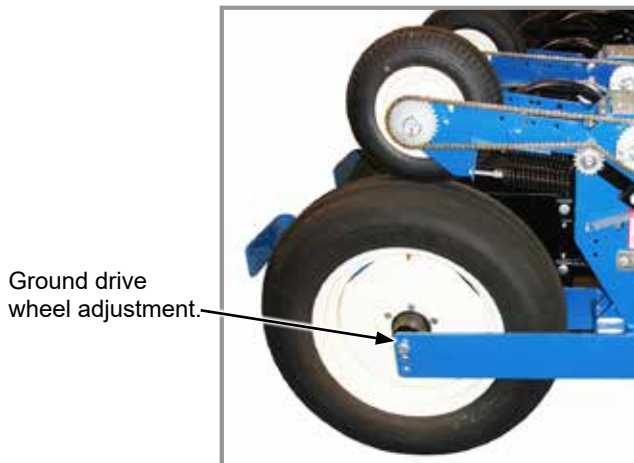
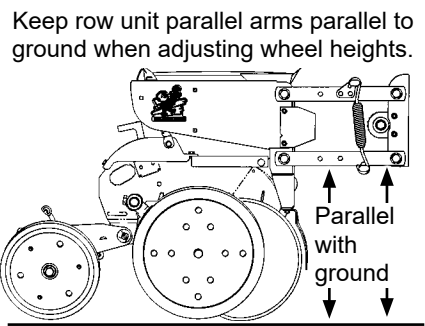

**Ground drive wheel adjustment**



**Contact drive wheel adjustment**

**NOTE:** If setting is changed see basic adjustment procedure under “Contact Wheel Spring Adjustment”

**RIDGE PLANTING**

Move drive and transport wheels 2" or 4" to lower mounting holes in wheel arms when ridge planting to increase planter toolbar height. Contact drive tire must also be moved to lower set of holes in wheel module and down pressure springs hooked on lower rod. Raise hitch height to ensure level operation.



**TRUE DEPTH HYDRAULIC SYSTEM OVERVIEW****True Depth Pressure Gauge****WARNING**

Remove all hydraulic power sources and verify True Depth pressure gauge reads zero before servicing.

**True Depth Cylinder****WARNING**

Flow out of the rod end port of the cylinder must not be restricted when pressurizing cap end port as 4.5:1 pressure intensification will occur on the rod end of the cylinder potentially resulting in failure of the cylinder and loss of containment of the piston rod assembly.



True Depth Filter

**TRUE DEPTH FILTER**

Replace filter cartridge annually, every 100 hours of operation, or when the clogging indicators point out the limit pressure drop created inside the filter.

To replace the cartridge:

1. Stop the system in "Machine Stopped" status
2. Secure any shut-off valves on the hydraulic circuit.
3. Unscrew the filter container (1).
4. Remove the clogged filtering cartridge (5), making sure no residual particles have settled in the bowl bottom.
5. Make sure the O-ring (2-4) and the anti-extrusion ring (3) are not damaged, otherwise replace them and consequently position the new ones correctly.
6. Insert the new filtering cartridge, lubricating the sealing O-ring beforehand.
7. Screw the container tight (1) making sure the threading is screwed correctly. Tighten to a tightening torque of 65 Nm.
8. Start the machine for a few minutes.
9. Make sure there are no leaks.

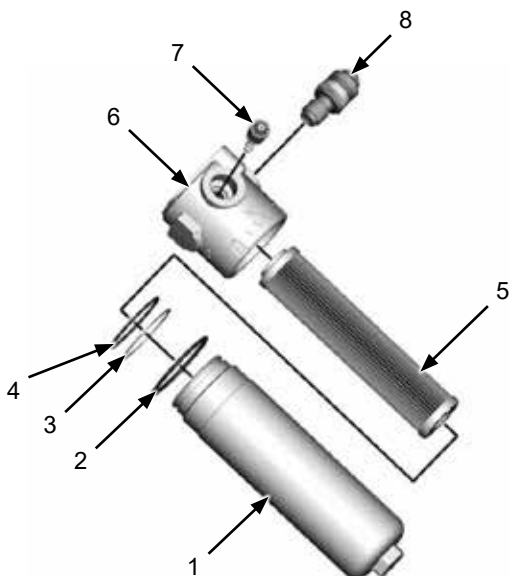

1. Filter Bowl
2. External O-Ring
3. Anti-extrusion ring
4. Sealing O-Ring
5. Filtering Element
6. Filter Head
7. By-pass valve
8. Visual differential indicator

True Depth Cylinder

## CONTACT WHEEL SPRING ADJUSTMENT

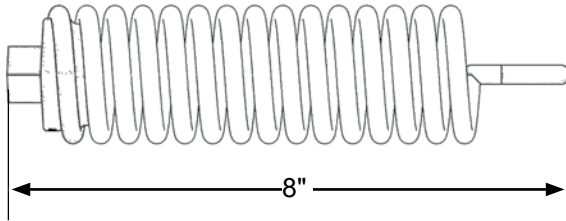

Spring length measurement (Factory setting)



Contact drive springs

There are two down pressure springs on each contact drive wheel. Spring tension is factory set to approximately 200 lb (90.7 kg) of down force at tire contact point and should require no further adjustment.

**NOTE:** Measurement must be taken in planting position with proper tire pressure.

## CONTACT WHEEL DRIVE SPROCKETS

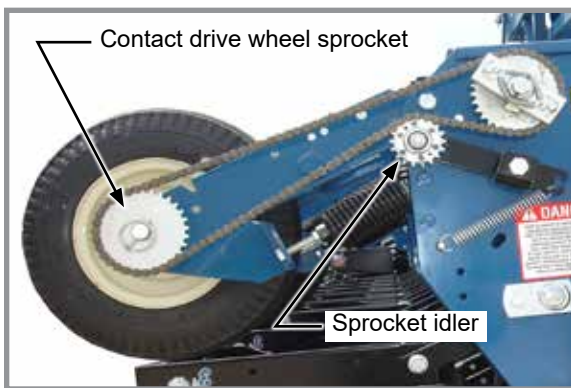

Contact wheel drive



Optional half-rate drive sprocket

Contact wheel drive works the same for mechanical or vacuum planters except for sprocket size. Chain tension is controlled by a spring-loaded sprocket idler. Planting rate charts in "Rate Chart" section help you select correct sprockets.

**NOTE:** Make a field test after each sprocket combination change to be sure you are planting at desired rate.

## VACUUM

22 tooth, 28 tooth or 44 tooth sprockets at each contact drive wheel can be exchanged with sprockets on storage rod bolted to wheel module on each side of planter chains.

**NOTE:** 22, 28 and 44 tooth drive sprockets do NOT apply to all rate charts. Check chart titles to make sure proper rate chart is selected. DO NOT USE 44 tooth drive sprockets (60 cell soybean discs) with Dry Fertilizer Package or Liquid Fertilizer Squeeze Pump Package.

## MECHANICAL

Seed planting rate charts are based on standard rate drive. Standard rate drive uses a 30 tooth sprocket and No. 40 118 pitch chain on each contact wheel.

Optional half-rate (2 to 1) drive is recommended only when population falls below planting rate charts. Replace 30 tooth sprocket on each contact wheel with a 15 tooth sprocket and shorter No. 40 110 pitch chain. This reduces planter transmission speed and planting and application rates by approximately 50%.

## SEED RATE TRANSMISSION ADJUSTMENT

Planting population rate changes are made using seed rate transmissions at each end of planter. Seed rate transmission allows quick and easy sprocket changes to obtain desired planting population. Sprockets are exchanged with those from sprocket storage rod bolted to transmission by removing lynch pins on hexagon shafts.

A decal positioned on transmission module illustrates proper chain routing. Planting rate charts found in “Rate Chart” section help you select correct sprocket combinations.

Chain tension is controlled by a spring-loaded dual-sprocket idler adjusted with an easy-release idler arm. This arm has a release position to remove spring tension for replacing sprockets. See “Wrap Spring Wrench Operation” below.

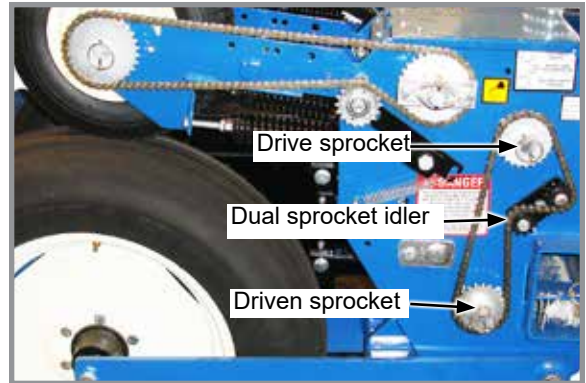

Seed rate transmission (R.H. shown)

## WRAP SPRING WRENCH OPERATION

Chain idlers are equipped with wrap spring wrenches. L.H. wrap spring wrenches have a blue release collar and R.H. wrap spring wrenches have a grey or black release collar.

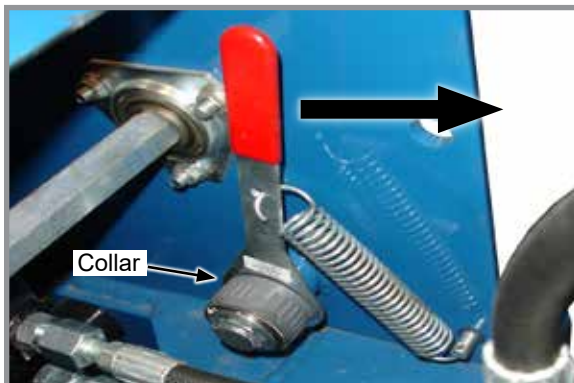

Wrap spring wrench (R.H. shown)



Chain idler tensioning

Rotate collar on wrap spring wrench and pull handle to release chain tension.

Rotate chain idler into chain and pull handle to tension idler spring.

## AG LEADER ELECTRIC CLUTCHES

Electric clutches along with GPS can stop seed flow by turning off seed meters (and planter sections) based on field mapping and previously planted areas.

## HYDRAULIC SEED RATE DRIVE

Refer to Ag Leader Integra or KINZE Cobalt operation manuals for information on setting and controlling hydraulic seed rate system.

## HALL EFFECT SENSOR (HYDRAULIC DRIVE ONLY)

Set Hall effect sensor within  $\frac{1}{8}$ " of pick-up disc.

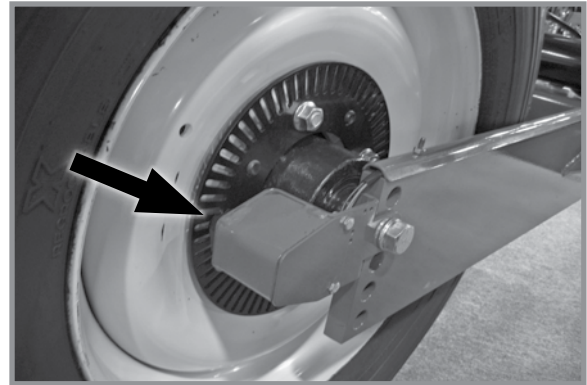

Hall effect sensor

## HYDRAULIC WEIGHT TRANSFER TOOLBAR

The hydraulic weight transfer is standard on bulk fill equipped machines and optional on conventional hopper machines. The bulk fill hydraulic system powers the hydraulic weight transfer system and conventional hopper system requires an additional SCV. Pressure is set from the factory and does not require additional adjustment.

## SHEAR PROTECTION

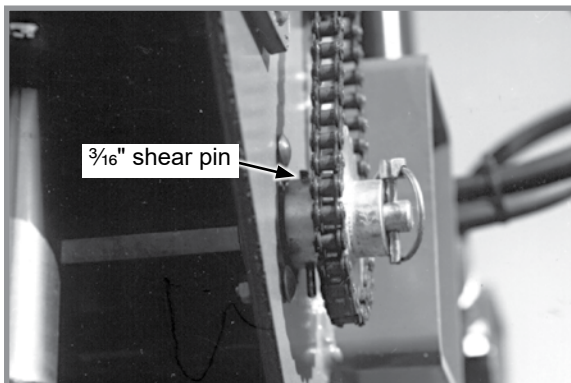

Transmission shaft

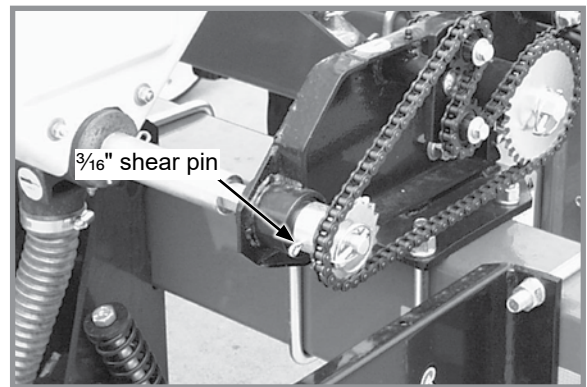

Dry fertilizer attachment transmission

Shear pins protect planter driveline and row unit components from damage.

1. Determine where binding has occurred before replacing a pin. Turn shaft by hand (with the aid of a wrench) and check for misalignment and seized parts.
2. When shaft can be turned by hand (with the aid of a wrench) replace shear pins with same size and type. Spare shear pins are stored inside ends of rear planter frame.

### NOTICE

Misaligned drill shaft/transmission coupler can cause equipment damage.

3. Check driveline alignment and follow prescribed lubrication schedules to prevent component binding or breakage.

## HYDRAULIC/ELECTRIC OPERATION

Control console switches and tractor's hydraulic system are used to raise planter to transport position, operate rotate and tongue extension functions, lock and release planter wings, and raise and lower row markers.

**NOTE: Turn console backlighting OFF during extended periods of non-use using push button switch on back of console.**



**Single point row clutch control box**

Model 3605 planters operate from three dual remote (SCV) hydraulic outlets and tractor mounted control console. One SCV and a control console switch operate raise to transport function. A second SCV and control console switches operate row markers and fold/unfold functions. A third SCV operates vacuum fan motor circuit.

Marker and point row selector switches are an ON-OFF-ON type. If planter is equipped with optional Two-Speed Point Row Clutch Package, point row switch and reduced rate switch operate independently from rest of control console.

Power to marker switch is fed through auxiliary switch and two transport function switches. Operating any lower row switch disables markers and turns off marker indicator light.

Raise/wing lock and rotate/tongue (fold function) switches are MOMENTARY ON-OFF-MOMENTARY ON type and must be held in position while operating tractor hydraulic SCV control. Activating a fold function switch disables marker circuit.



### WARNING

**Marker selector switch must be OFF (center position) when not in use to prevent accidental extension which could result in death or serious injury, or damage to property and equipment. An indicator light on control box panel is ON whenever marker circuits or point row clutch circuits are energized.**

Auxiliary switch is an ON-OFF type switch used with hydraulic marker/folding functions SCV control to operate optional attachments. Auxiliary switch must be OFF to enable other functions.

**NOTE: Activating auxiliary switch disables all other control console switches except point row clutch switch.**

**NOTE: Lift cylinders are (port type) rephasing cylinders. Cylinders must fully retract before they rephase in lowered position. Cylinder stops can not be used.**

A third SCV operates the vacuum fan. See "Digital Vacuum Gauge Operation".

## TRANSPORT TO FIELD SEQUENCE

Position planter in a relatively flat open area. Avoid an area with furrows, etc.

### SUMMARIZED TRANSPORT TO FIELD SEQUENCE

- Remove tongue safety pin.
- Remove transport latch locking pin.
- Remove manual safety lockup.
- Rotate planter to planting position.
- Raise planter slightly to release safety hook at top of center section.
- Lower planter to ground.
- Release wing locks.
- Rephase planter lift cylinders.
- Raise planter to raised field position and retract tongue.
- Remove row marker lockups.

NOTE: Read following information for detailed instructions.

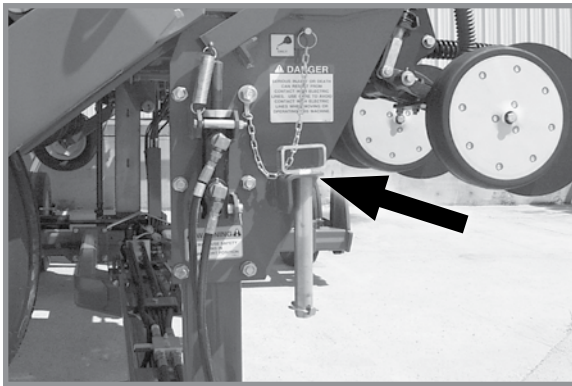

**Tongue safety pin in storage position**

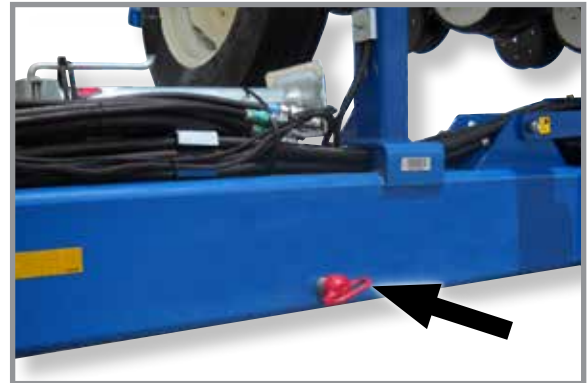

**Tongue safety pin in transport position.**

1. With tongue fully extended and planter in raised transport position, remove tongue safety pin and place it in storage position.

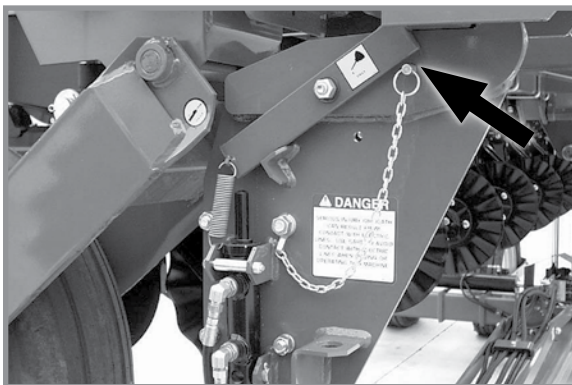

**Transport latch locking pin  
Locked transport position**

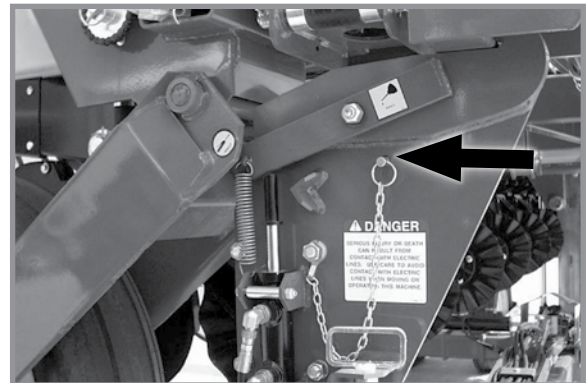

**Transport latch locking pin  
Storage position**

2. Remove transport latch locking pin from locked position and place it in storage location.

- Remove manual safety lockup from under front center lift cylinder and place it in storage location on left side of planter axle.

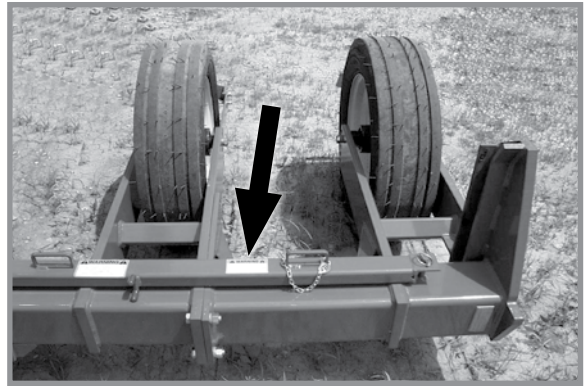

Storage position

- Hold control console “ROTATE/TONGUE” switch in “**ROTATE**” and operate hydraulic control to unfold planter. Transport latch automatically releases.



Rotate from transport to field

- Raise planter 1"-2". Safety hook will release and snap away from catch pin on top of pivot post.

**NOTE: Raising planter too high resets hook mechanism and sequence must be repeated.**

- Slowly lower planter to ground.

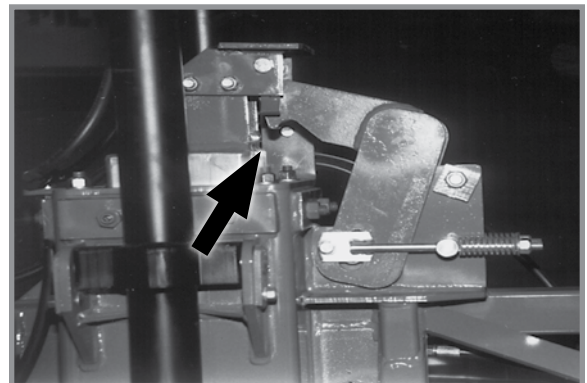

Safety hook release

- Hold control console “RAISE/WING LOCK” switch in “**WING LOCK**” position and operate hydraulic control to release wing locks.

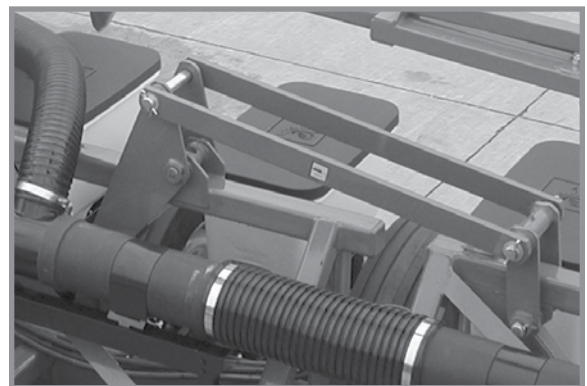

Wing lock



8. Hold hydraulic control (to lower planter) to rephase planter lift cylinders. Time to rephase system may vary due to tractor hydraulic flow and/or oil temperature. Normally 5 to 20 seconds is adequate to rephase system.
9. Raise planter to raised field position. Hold control console ROTATE/TONGUE switch in **TONGUE** and operate hydraulic control to retract tongue.



Retract tongue

10. Remove row marker lockups.



Row marker lockup

## FIELD OPERATION



**DANGER**

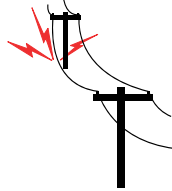

Contacting or coming close to power lines or other high energy sources will cause death or serious injury.

Keep away from power lines or high energy sources at all times.

**NOTICE**

Raise planter out of ground when making sharp turns or backing up or equipment damage may result.

There are two raised positions on planter. Transport position is when the planter is fully raised. Raised field position is when planter wing cylinders are fully extended and center lift cylinders are at mid-stroke. In “raised field position” row units are approximately 14 inches off ground. This position is used in making turns or passing over waterways during field operation.

An oil bypass solenoid is located on top side of valve blocks on rear R.H. side of center frame. This solenoid is not energized in raised field position so wing cylinders cannot bypass oil preventing planter from raising any higher.



**Raised field position**

## PLANTING SPEED

Planters are designed to operate in a speed range of 2 to 8 MPH. Higher ground speeds generally cause more variation in seed spacing. Speeds above 5.5 MPH are typically not recommended. See “Rate Charts”

## FIELD TO TRANSPORT SEQUENCE

Position planter in a relatively flat area. Avoid areas with furrows, etc.

### SUMMARIZED FIELD TO TRANSPORT SEQUENCE

- Install row marker lockups.
- Raise planter to raised field position.
- Extend tongue.
- Lock wings over center
- Raise planter to engage safety hook at top of center section into locking position.
- Lower planter onto safety hook.
- Rotate planter to transport position.
- Install tongue safety pin.
- Install transport latch locking pin.
- Install manual safety lockup.

**NOTE: Read following information for detailed instructions.**

1. Install row marker lockups.
2. Raise planter to raised field position using hydraulic control.



Row marker lockup

3. Hold "ROTATE/TONGUE" switch in "TONGUE" and operate hydraulic control until tongue is fully extended. Tongue lock latch automatically releases.

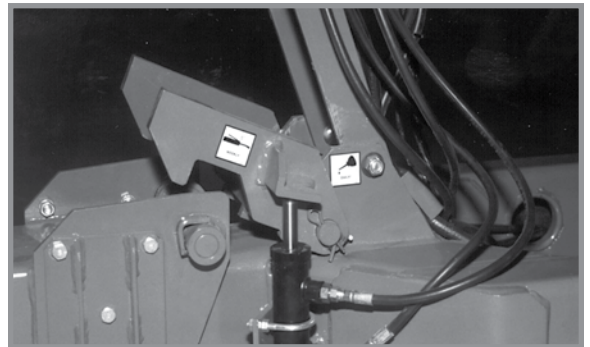

Tongue latch lock

4. Hold "RAISE/WING LOCK" switch in "WING LOCK" and operate hydraulic control until wing lock cylinders are fully extended and wing locks are locked over center.



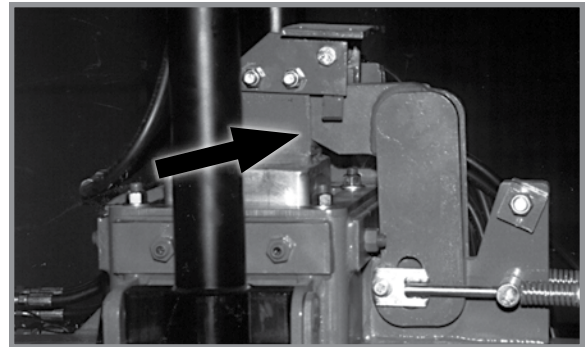

Wing lock

5. Hold control console “RAISE/WING LOCK” switch in “**RAISE**” and operate hydraulic control until two center lift cylinders are fully extended and safety hook at top of center section rotates into locking position.
6. Lower planter onto safety hook using hydraulic control.



Center section safety hook

 <b>WARNING</b>	<p>Uncontrolled movement of equipment can cause loss of control and could result in death, serious injury, or damage to property and equipment. Install all safety pins before transporting equipment.</p>
	

7. Hold control console “ROTATE/TONGUE” switch in “**ROTATE**” and operate hydraulic control to rotate planter until transport latch is engaged.
8. Install tongue safety pin.

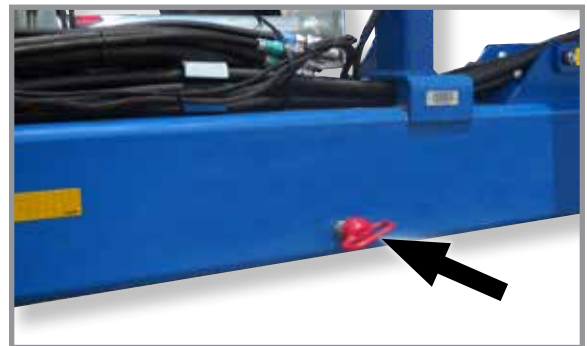

Tongue safety pin

9. Install transport latch locking pin.

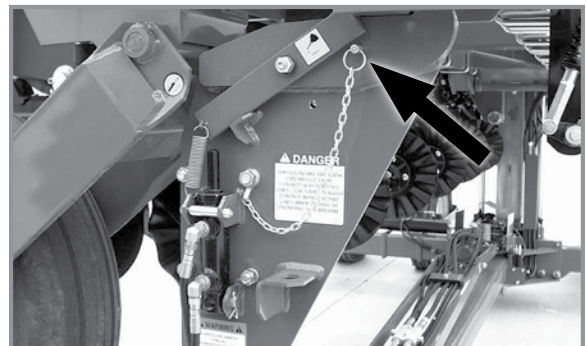

Transport latch locking pin installed

10. Remove manual safety lockup from storage location on left side of axle assembly and position it behind front center lift cylinder.

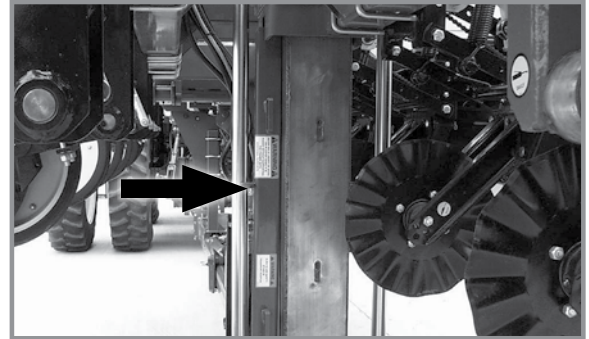

Manual safety lockup installed

## DIGITAL VACUUM READOUT

Digital vacuum readout is incorporated into in-cab display. Refer to the display operation manual for instructions.

## VACUUM FAN MOTOR VALVE BLOCK ASSEMBLY

A pressure relief valve in the hydraulic circuit prevents build up of oil pressure over 35 PSI in case drain line when vacuum fan motor is operating. This valve will vent oil outside valve block through a drain hole in the aluminum valve block. This can occur whenever case drain is improperly connected or pressure in motor circuit builds.



See “Hydraulic Diagram - Vacuum Fan Motor System” in Maintenance section.

Valve block contains a check valve that prevents vacuum fan from operating in wrong direction if pressure is applied to return side of motor and allows fan to coast to a stop when tractor hydraulic control is returned to neutral position.

**NOTE: Fan turns at a reduced speed if reverse pressure is applied.**

## VACUUM METER SYSTEM

Kinze vacuum meter seed metering system includes seed meters, seed discs, and an air system consisting of a hydraulic driven vacuum fan which draws air through manifolds, hoses, and seed meters on each row unit.

 <b>WARNING</b>	<p><b>Moving fan blades can cause amputation or severe injury. Never operate vacuum fan with cover removed.</b></p>
	

## ANALOG VACUUM OR PRESSURE GAUGE

Analog vacuum or pressure gauge connects directly to vacuum meter (vacuum) or bulk fill (pressure) manifold and is teed into digital sending units.

Only adjustment is to “zero” needle with no vacuum or pressure present. If there is a significant difference between gauge and a reading taken at meters, a different manifold location should be found to connect hose to gauge and digital sending unit.

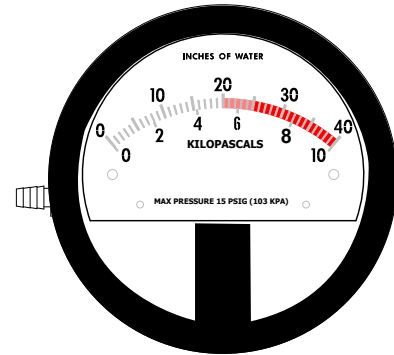

Analog Gauge

**NOTE:** Analog gauges are identical EXCEPT for plug and hose barb locations in side of gauge housing. DO NOT connect vacuum meter or bulk fill hose to wrong gauge. Check plug and hose barb installation if readout is erratic or appears inaccurate.

## BULK FILL SYSTEM



### CAUTION

Seed flying out of disconnected delivery tube at high velocity can cause injury. Do not disconnect delivery tubes when system is operating.

### NOTICE

Foreign materials can plug system. Make sure seed is clean and free of debris when filling bulk fill hoppers.

### NOTICE

Do not turn on system with tractor engine at full speed or system damage may occur.

### NOTICE

Do not operate bulk fill system above maximum system operating pressure of 20 inches of water or seed bridging may occur.

1. **Before filling hoppers refer to “Row Unit Operation” for additives information.** Fill hoppers with seed, latch lids, and secure with pin.
2. Start bulk fill system with tractor engine at idle.
3. Increase engine speed to full and set initial system pressure using flow control valve.
4. Allow system to warm up and adjust pressure if necessary.

Recommended pressures:

- Corn – 12 inches of water
- Soybeans – 10 inches of water
- Actual pressure needed is affected by seed size, shape, and coating.



**Bulk fill tank lid latch**

### BULK FILL ENTRAINER ACCESS

1. Shut down bulk fill system.
2. Remove pin holding shutoff door in its storage location.
3. Remove rubber plug closest to area in entrainer needing attention.
4. Insert shutoff door into open slot and push into entrainer at a slight upward angle.
5. When work is complete, remove shutoff door, return door to storage location, and plug open slot.

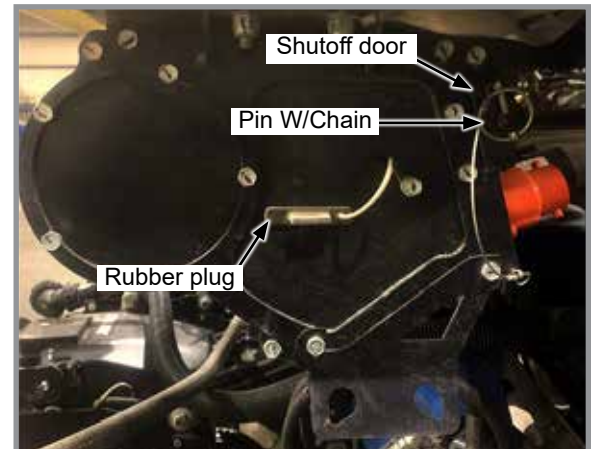

**Bulk fill entrainer (end view)**

### BULK FILL TANKS - CLEAN OUT

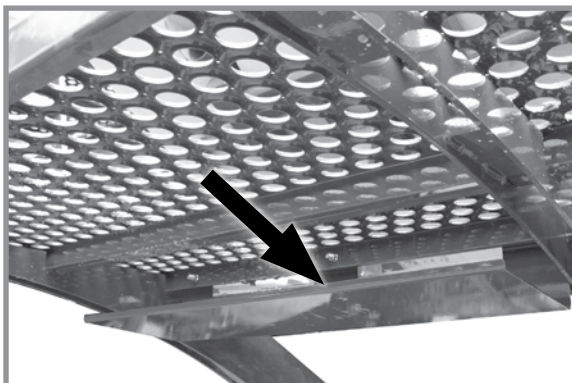

**Cleanout chute storage bracket**

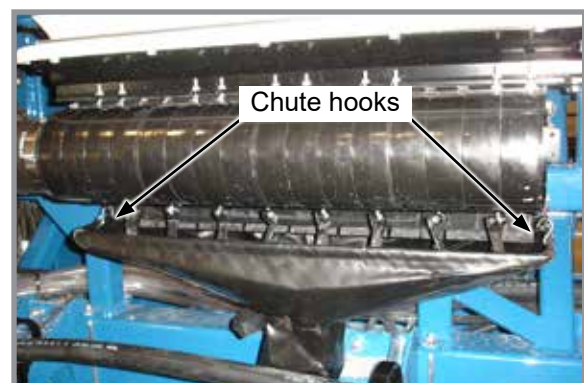

**Cleanout chute installed**

1. Remove bulk fill tank cleanout chute from storage location beneath catwalk.
2. Position tube of chute under entrainer and attach hooks on each end of entrainment assembly.
3. Open cleanout doors and empty tank.
4. Close all cleanout doors and return cleanout chute to storage location.

**BULK FILL SCALE PACKAGE OPTION (2021 PRODUCTION ONLY)****NOTICE**

High-pressure water can damage display. Remove display before power washing planter.

**NOTICE**

Remove and store display at end of planting season. Damage from sun and weather exposure may result.

- Provides seed weight or estimated acres remaining for each bulk fill hopper.
- Displays total (gross) seed weight or estimated acres remaining for both hoppers combined.
- Warns operator when seed goes below a pre-defined level (when using a Kinze Vision display).

**Operation of bulk fill scale package display is controlled by buttons located on its face:**

- Two screen-defined selection buttons.
- Backlight ON/OFF button.
- UP/DOWN arrow buttons.
- Screen position is changed by loosening thumb screw on mount at back of monitor and repositioning screen.

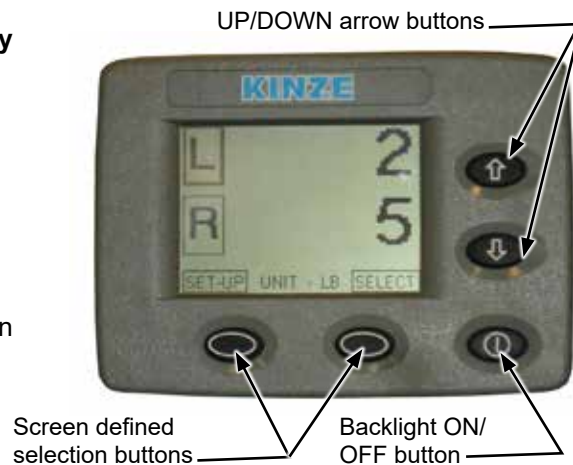



## SETUP BULK FILL SCALE PACKAGE DISPLAY

1. Press SET-UP button.
2. First setup screen displays and ALARM LEVEL box is highlighted.
3. Press SELECT button.
4. Press UP or DOWN arrows to change alarm weight level. Select BACK to save changes.
5. Press UP or DOWN arrows to highlight WEIGHT/ACRE MODE box. Press SELECT button.
6. Press UP or DOWN arrow buttons to toggle between weight or acre mode. This selection affects if values are displayed as pounds or estimated acres of seed remaining. Press BACK to save changes.
7. Press DOWN arrow to select second set-up screen.

**NOTE: CALIBRATION# and SETUP# are automatic and do not need to be changed.**

8. Select CONTRAST or BACKLIGHT. Use UP or DOWN arrow buttons to change levels. Press BACK to save changes.
9. Select BACK to return to main screen.



## MONITOR SEED LEVELS

1. Main screen displays information for left and right hoppers.
2. Select either L or R for individual hopper status information.
3. Select BACK to return to main screen.
4. Press down arrow once or twice to display GROSS screen. Combined status information for both hoppers is shown.
5. Press down arrow again to return to main screen.



ENTER SEED INFORMATION

1. Highlight and select either L (left) or R (right) for the appropriate input screen.
2. At input screen, L or R side is indicated at left side of screen and seed weight or acres remaining is on right side.



3. Press arrow keys to select desired box; press SELECT to darken and use arrow keys to change.

**NOTE: Seed information entered must be accurate for remaining estimated acres to calculate correctly.**

- SEEDS/ACRE is population rate.
- SEEDS/LB value comes from seed specifications.
- ZERO is selected to zero hopper that is selected.

4. Select BACK to return to main screen.



**BULK FILL SCALE PACKAGE OPTION (2022 PRODUCTION AND ON)****NOTICE**

High-pressure water can damage display. Remove display before power washing planter.

**NOTICE**

Remove and store display at end of planting season. Damage from sun and weather exposure may result.

**Bulk Fill Scale Package is capable of:**

- Displaying seed weights and estimated acres remaining for bulk fill hoppers separately.
- Setting alarm to warn operator when seed goes below a pre-defined level.

**NOTE: Operation of Bulk Fill Scale Package display is controlled by touchscreen.**

**NOTE: Screen position is changed by loosening the thumb screw on RAM™ mount.**

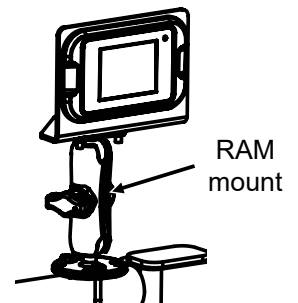

**To monitor seed levels (Main Screen):**

**NOTE: Only applicable to Ag Leader InCommand, refer to Blue Vantage manual for bulk fill scale user information.**

1. Main screen displays information for left and right hoppers.
2. Tap "Weight" to display left and right hopper weight.
3. Tap "Area to Empty" to display left and right acres to empty.



4. Tap either "L" or "R" to display detailed hopper screen.

**NOTE: "Zero" is selected to zero hopper that is selected. If hopper(s) is zeroed out with seed, weight in hopper will not be recognized. To reset hopper correctly seed must be emptied from hopper(s) and then zeroed to reset.**



5. Tap "Back" to return to main screen.
6. Tap "Planter Setup" to enter Seed information. See follow page for more information.

To enter seed information (Not applicable on Blue Vantage):

**NOTE:** Seed information entered must be accurate for remaining estimated acres to calculate correctly.

- SEEDS/ACRE is population rate.
- SEEDS/LB value comes from seed specifications.

1. From main screen, tap "Planter Setup".
2. From planter setup screen, tap "Seed Setup".

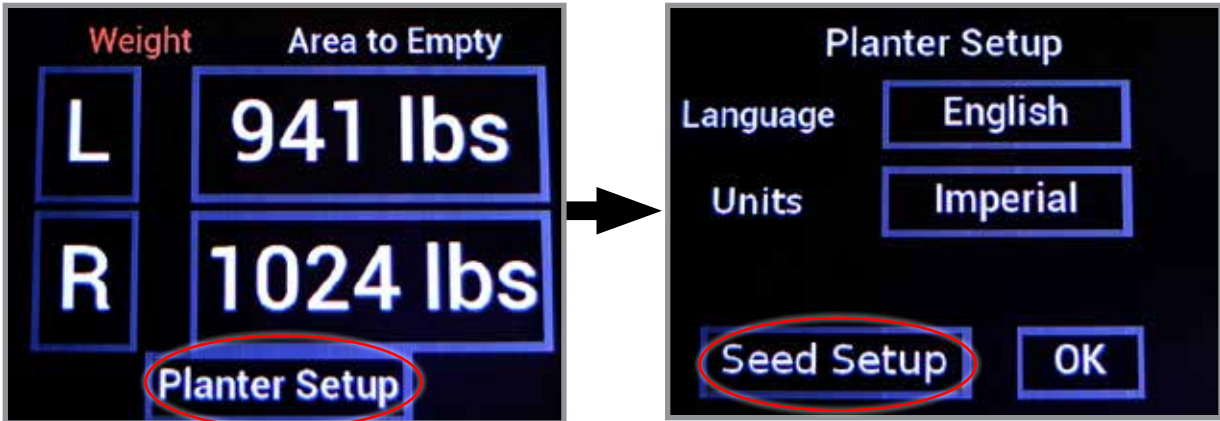

3. To change values in either "Seeds/Ac", "Seeds/lb", or "Alarm Level" tap in appropriate box.
4. At input screen, enter desired value. Tap "OK".

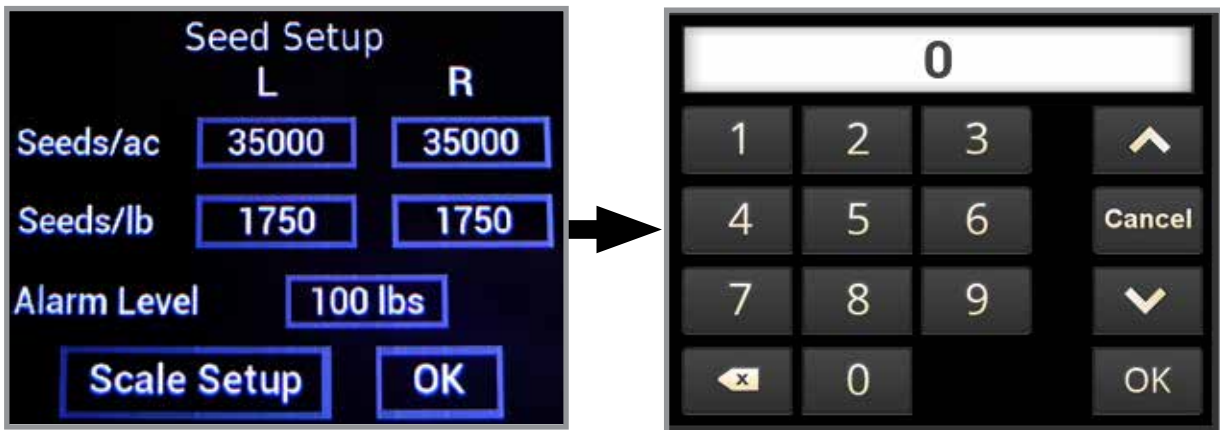

5. Once desired values have been entered tap "OK", to confirm changes tap "Accept" to return to main screen.

**NOTE:** It is NOT RECOMMENDED to make adjustments to setup in the "Scale Setup" screen.

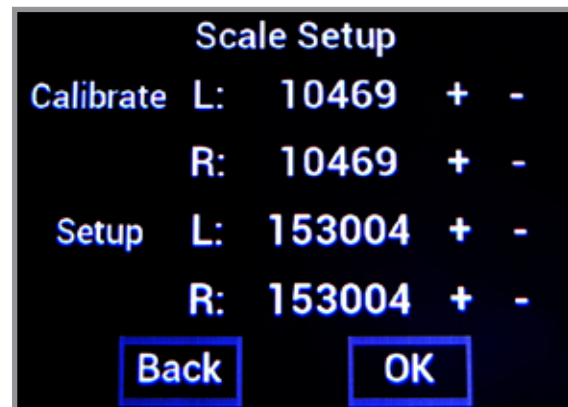

**Software Version:**

1. From main screen, tap "Planter Setup".
2. Tap on "English" to display software version.

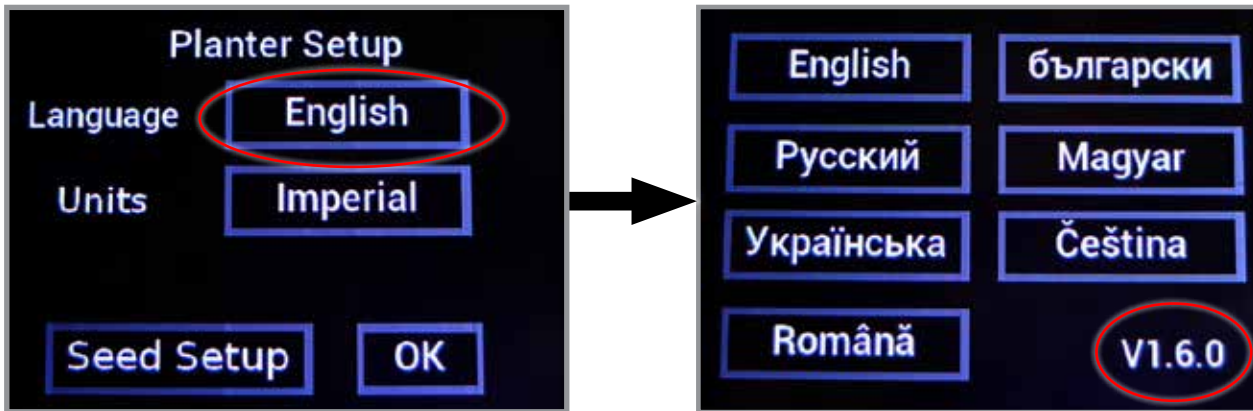

4. Tap "English" to return to planter setup screen.
3. Tap "OK" to return to main screen.

**Language/Units:**

**NOTE: English is the default language. Imperial is the default units.**

1. From main screen, tap "Planter Setup".
2. Tap on "English" to display language options.

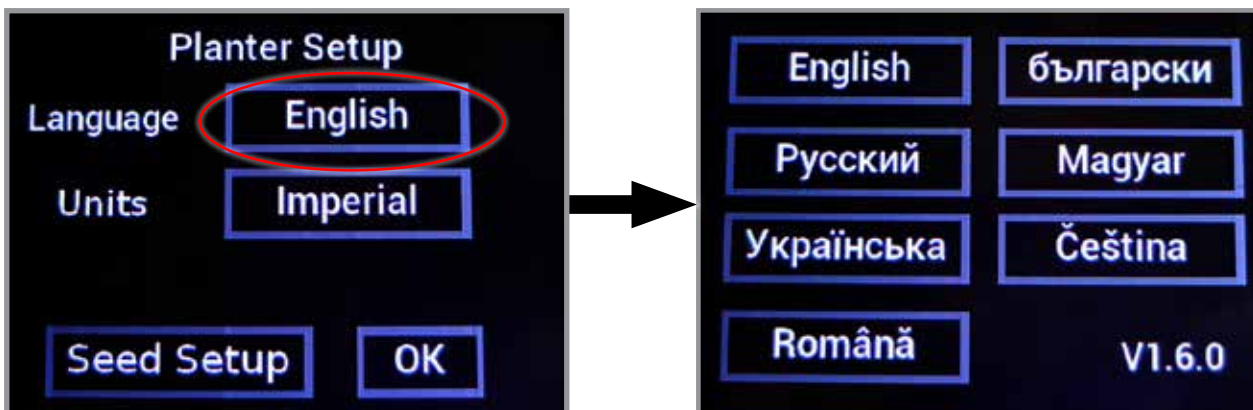

3. Tap on desired language to select and return to planter setup screen.
4. Tap on "Imperial" to switch to metric units and vice versa.

**NOTE: If units are switched back and forth between imperial and metric, measurements will round up each time.**

3. Tap "OK" to return to main screen.

## ROCK GUARDS

Transport wheel rock guards are used on both sides of each transport wheel when planter is used in rocky conditions.

Rock guards help prevent rocks from being picked up by wheels and damaging adjoining row units.



Rock guard

## AUXILIARY WORK LIGHTS PACKAGE

Auxiliary work lights package includes two 50 watt, 3" x 5" halogen flood lamps, mounting hardware, and a wiring harness to plug into existing planter light harness.

Mounting varies with bulk fill and conventional planters.



Auxiliary work lights

## AG LEADER MONITORING CONTROL PACKAGE (PMM)

The PMM Magnetic Distance Sensor Package includes a planter-mounted module enclosure with cover and mounting hardware, seed tubes w/sensors, planter harness, planter monitor cable, shaft rotation sensors and magnetic distance sensor components.

Ag Leader Integra display and associated cab harnesses are also required.



Planter monitor module (PMM)

## AG LEADER INCOMMAND 1200 DISPLAY

The InCommand 1200 is a full-featured display for any precision farming operation. A large, full-color 12.1" HD touchscreen display is easy to read and offers powerful, year-round precision farming tools. Mapping, planter and application control, yield monitoring, real-time data logging, and more – are all controlled from the cab using the InCommand display.

Four video camera inputs provide operators a better view of equipment operation and safety by allowing them to view live video on the display.

**NOTE: See InCommand operator manual for installation and programming.**



Ag Leader InCommand Display

## KINZE ISOBUS OPTION

Kinze ISOBUS option consists of a planter monitor module (PMM), and planter control module (PCM). Kinze planters will communicate directly with most ISO compatible monitors. See the Kinze ISOBUS manual for more information.



## ROW MARKER OPERATION

**DANGER**

Contacting or coming close to power lines or other high energy sources will cause death or serious injury.

Keep away from power lines or high energy sources at all times.

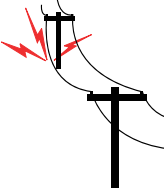



**Marker switch**

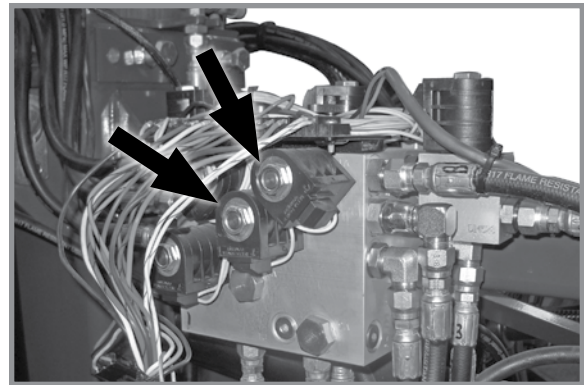

**Row marker solenoid valves (Cover removed)**

Two solenoid valves on valve block at rear R.H. side of center frame, and a three position selector switch on control console permit operator to lower or raise desired row marker.

**NOTICE**

**Marker position switch must be OFF when planter is not in use or tractor battery will drain.**

See "Row Marker Speed Adjustment".

1. Select which row marker to lower on control console.
2. Operate hydraulic control to lower row marker.
3. Move control switch to other side to operate opposite row marker.
4. Raise row marker at end of field using hydraulic control.
5. After turn, using the hydraulic control, lower the pre-selected row marker.
6. Continue to follow this procedure.

**NOTE: Both row markers can be lowered by operating switch in each position and hydraulic control twice. Row markers raise simultaneously with hydraulic control in raise position.**

If electrical system does not operate properly:

- Check fuse.
- Check wiring connections.
- Check control switch.
- Check solenoid. SOLENOID HOUSING IS MAGNETIZED WHEN ENERGIZED.

## ROW MARKER SPEED ADJUSTMENT

### NOTICE

Excessive row marker travel speed can damage row markers. Adjust flow controls before row markers are first used.

Marker hydraulic system includes two flow control valves. One flow control valve sets lowering speed and one sets raising speed of both markers. Flow controls determine amount of oil flow restriction through valves, varying marker travel speed.

Loosen jam nut and turn control clockwise, or IN to slow travel speed. Turn counterclockwise, or OUT to increase travel speed. Tighten jam nut after adjustments are complete.

**NOTE: Tractors with flow control valves. Make row marker speed adjustment with tractor flow controls in maximum position. After row marker speed is set, adjust tractor flow controls to allow hydraulic control to stay in detent during marker raise or lower cycle.**

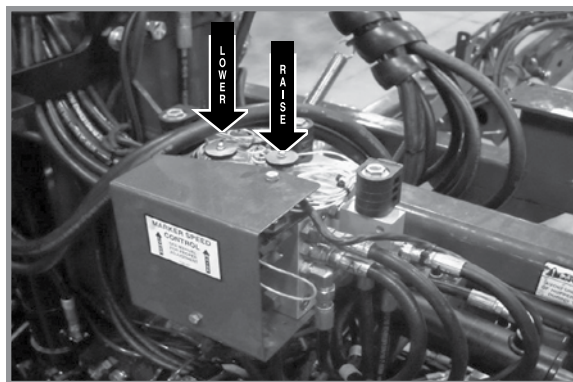

Row marker speed control adjustment

**NOTE: Hydraulics operate slowly when oil is cold. Make all adjustments with oil warm.**

**NOTE: On a tractor where oil flow cannot be controlled, tractor flow rate may be greater than rate marker cylinder can accept. Hold tractor hydraulic control lever until cylinder reaches end of its stroke. This occurs most often on tractors with an open center hydraulic system.**

## EVEN-ROW PUSH ROW UNIT

An Even-Row Push Row Unit Package is available to add one additional push row unit on outer L.H. side of front toolbar for use with Solid Row Interplant Package.

**NOTE: See "Row Marker Adjustment" for determining correct length to set row marker assemblies when planting with even-row push row unit option.**

**NOTE: install hitch onto 2-point hitch bar using R.H. hole if 2-Point Hitch Option is used. A 7½" offset mount is not needed. See "Offset Hitch Adjustment" for additional information.**

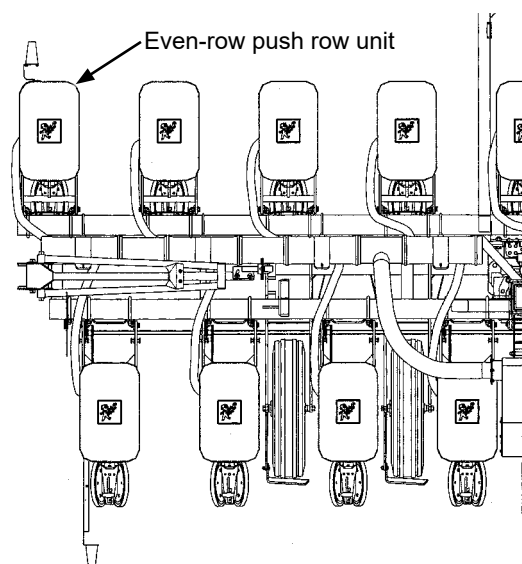

## ROW MARKER ADJUSTMENTS

1. Multiply number of rows by the average row spacing in inches to determine total planting width.

Row Marker Lengths	
12 Row 30"	360" (914.4 cm)
12 Row 36"	432" (1097.3 cm)
12 Row 38"	456" (1158.2 cm)
16 Row 30"	480" (1219.2 cm)

2. Lower planter and row marker assembly to ground.
3. Measure from planter center line to a point where blade contacts ground.
4. Adjust row marker extension so distance from marker disc blade to center line of planter is equal to total planting width. Adjust right and left row marker assemblies equally and securely tighten clamping bolts.

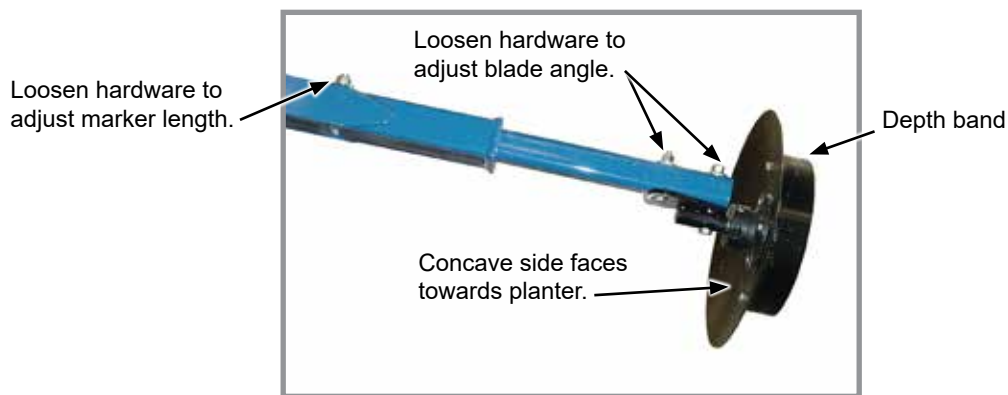

**Row marker disc blade angle adjustment**

### NOTICE

**Setting marker disc blade assembly at a sharper angle than needed adds stress to row marker assembly and shortens bearing and blade life. Set blade angle only as needed to leave a clear mark.**

Marker disc blade is installed with concave side facing inward. Spindle assembly is slotted so hub and blade can be angled to throw more or less dirt.

5. Loosen hardware and move assembly as required.
6. Tighten bolts to specified torque.
7. Do a field test to ensure markers are properly adjusted.

**NOTE: A notched marker blade is available from Kinze through your Kinze Dealer for use in more severe no till conditions.**

**ROW MARKER EVEN-ROW LENGTH ADJUSTMENT**

Adjust marker extensions as shown below when using even-row push row unit option.

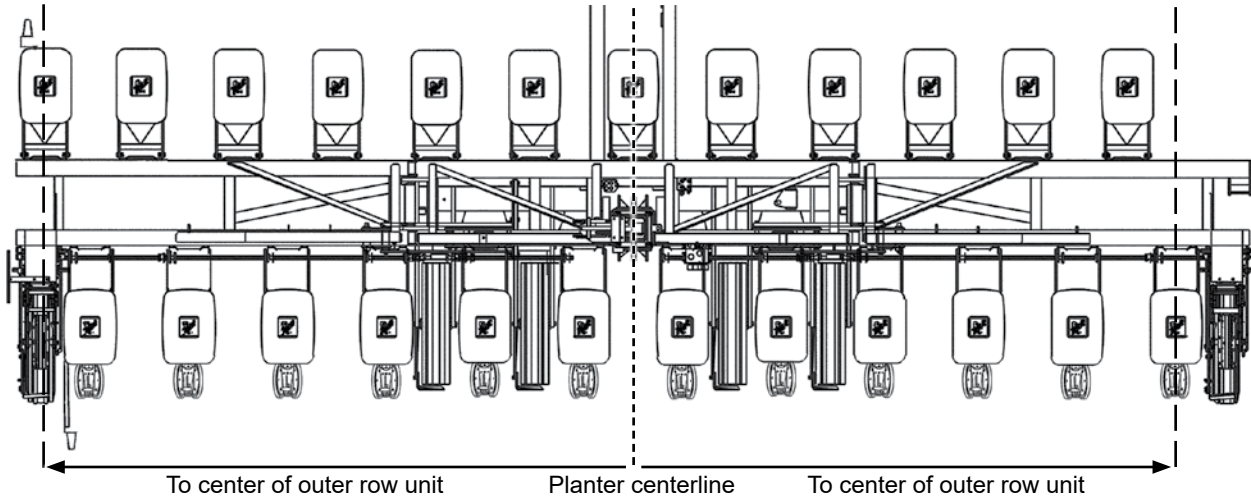

Center Of Planter To Center Of Outer Row Unit x 2 + 15" Row Spacing = Dimension Between Planter Center Line And Marker Blade

12 Row 30" With 12 Interplant Push Row Units  
 (L.H. Marker 180" x 2 + 15" = 375")  
 (R.H. Marker 165" x 2 + 15" = 345")

16 Row 30" With 16 Interplant Push Row Units  
 (L.H. Marker 240" x 2 + 15" = 495")  
 (R.H. Marker 225" x 2 + 15" = 465")

**NOTE: Readjust row markers when planting 30" rows.**

Number Of Rows x Row Spacing (Inches) = Dimension Between Planter Center Line And Marker Blade

12 Rows x 30" Spacing = 360" Marker Dimension  
 16 Rows x 30" Spacing = 480" Marker Dimension

**L.H. SIDE 30" - 7½" TWIN ROWS**

Number Of Rows x Row Spacing (Inches) + ¾" Hitch Offset = Dimension Between Planter Center Line And Marker Blade

12 Rows x 30" + ¾" = 363.75"  
 16 Rows x 30" + ¾" = 483.75"

**R.H. SIDE 30" - 7½" TWIN ROWS**

Number Of Rows x Row Spacing (Inches) - ¾" Hitch Offset = Dimension Between Planter Center Line And Marker Blade

12 Rows x 30" - ¾" = 356.25"  
 16 Rows x 30" - ¾" = 476.25"

**OFFSET HITCH ADJUSTMENT**

If tractor hitch is offset 7½" right of tractor center line, add 7½" to marker dimension on R.H. side of planter and subtract 7½" from marker dimension on L.H. side of planter.

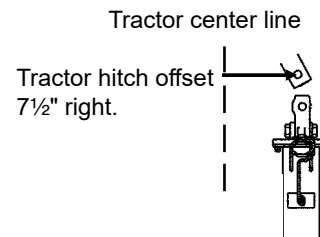

## POINT ROW CLUTCHES

L.H. point row clutch switch  
10 amp time delay fuse



Single point row clutch control box

R.H. point row clutch switch  
10 amp time delay fuse

Point row  
clutch switch

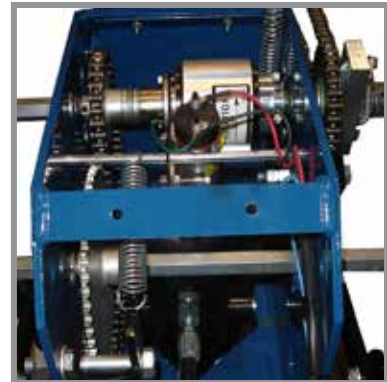

Point row clutch

Electric-activated clutches disengage drive on either half of planter for finishing up fields or for long point row situations. Clutch selector switch is located on tractor control box.

### NOTICE

Switch must be **OFF** when planter is not in use or tractor battery will be drained.

**NOTE:** Liquid fertilizer piston pump has its own drive wheel and is not affected by point row clutch.

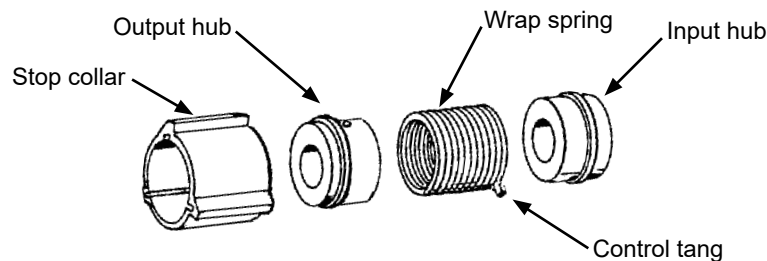

Clutch consists of a wrap spring riding on an input and output hub. Wrap spring is wrapped tightly over hubs during operation locking them together. Higher speeds create a tighter grip of spring on hubs.

Input end of spring is bent outward and is called the control tang. Control tang fits into a slot in stop collar located between input and output hubs over wrap spring. If stop collar is allowed to rotate with input hub, clutch is engaged. If stop collar is stopped from rotating, control tang connected to it is forced back and spring opens. This allows input hub to continue rotating without transmitting torque to output hub, stopping planter drive.

Stop collar is controlled by an electric solenoid and an actuator arm. When selector switch on tractor control box is OFF, solenoid coil is NOT ENERGIZED and actuator arm will not contact stop on stop collar, allowing it to rotate with hubs and drive planter.

When operational switch is in "DISENGAGE" (right or left) solenoid coil IS ENERGIZED and plunger in solenoid coil pulls actuator arm against stop on stop collar, disengaging wrap spring and stopping planter drive.

## AUXILIARY HYDRAULIC OPTION

A customer-supplied auxiliary hydraulic option provides 10 GPM of oil flow at rear of planter for powering fertilizer attachments, bulk seed handling equipment, etc. Two customer-supplied solenoid valve kits (G1K275) are required to activate auxiliary hydraulic option with control console auxiliary switch.



Auxiliary switch

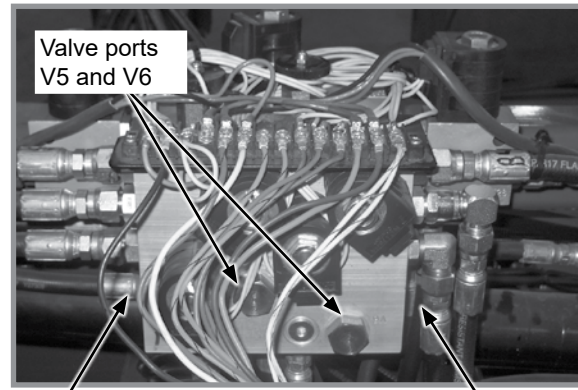

Hydraulic ports  
A9 and B9

Hydraulic ports  
A8 and B8

Valve block on rear center frame (Cover removed)



**WARNING**



**Pressurized hydraulic fluid can penetrate body tissue and result in death, serious infection, or other injuries. Fluid injected under skin must be IMMEDIATELY removed by a surgeon familiar with this type of injury. Make sure connections are tight and hoses and fittings are not damaged before applying system pressure. Leaks can be invisible. Keep away from suspected leaks. Relieve pressure before searching for leaks or performing any system maintenance.**

**NOTE: Place row markers in transport position and remove all pressure from hydraulic system.**

Remove cover from valve block on rear center frame of planter. Remove plugs from ports V5 and V6 and install solenoid valve assemblies following installation instruction supplied with each kit. Connect power to solenoid assemblies to orange/black wire located in wiring harness connection to L.H. side of valve block.

Remove plugs from 3/4"-16 O-ring ports A8 and B8 on R.H. side of valve block or ports A9 and B9 on L.H. side of valve block. Connect customer supplied hydraulic hoses.

Refer to "Hydraulic System Schematics" and "Electrical Wiring Schematics" in Lubrication and Maintenance section of this manual for additional information.

**NOTE: Auxiliary switch ON disables all other control console switches.**

Before operating auxiliary system make sure marker switch on control console is OFF. Move auxiliary switch to ON. Operate hydraulic control (marker/folding functions) to engage auxiliary system.

**REAR TRAILER HITCH**

Rear trailer hitch can tow a 3 or 4 wheel wagon behind planter. A spring, chain, and mounting bracket supports a 1¼" feed hose from hitch to piston pump. This extra length or loop is required to allow for planter to move into transport position without stretching hose.



Trailer hitch

<b>NOTICE</b>	<p>Rear trailer hitch is designed for use with piston pump only. Maximum allowable hitch weight is 200 lb (90.71 kg). Do not exceed 6,000 lb (2,721.55 kg) gross towing weight or the equivalent of a loaded 500 gal (1,892.7 L) tank and running gear or equipment can be damaged.</p>
---------------	---

**NOTE:** Periodically check feed hose for kinks to prevent restricted delivery rate.

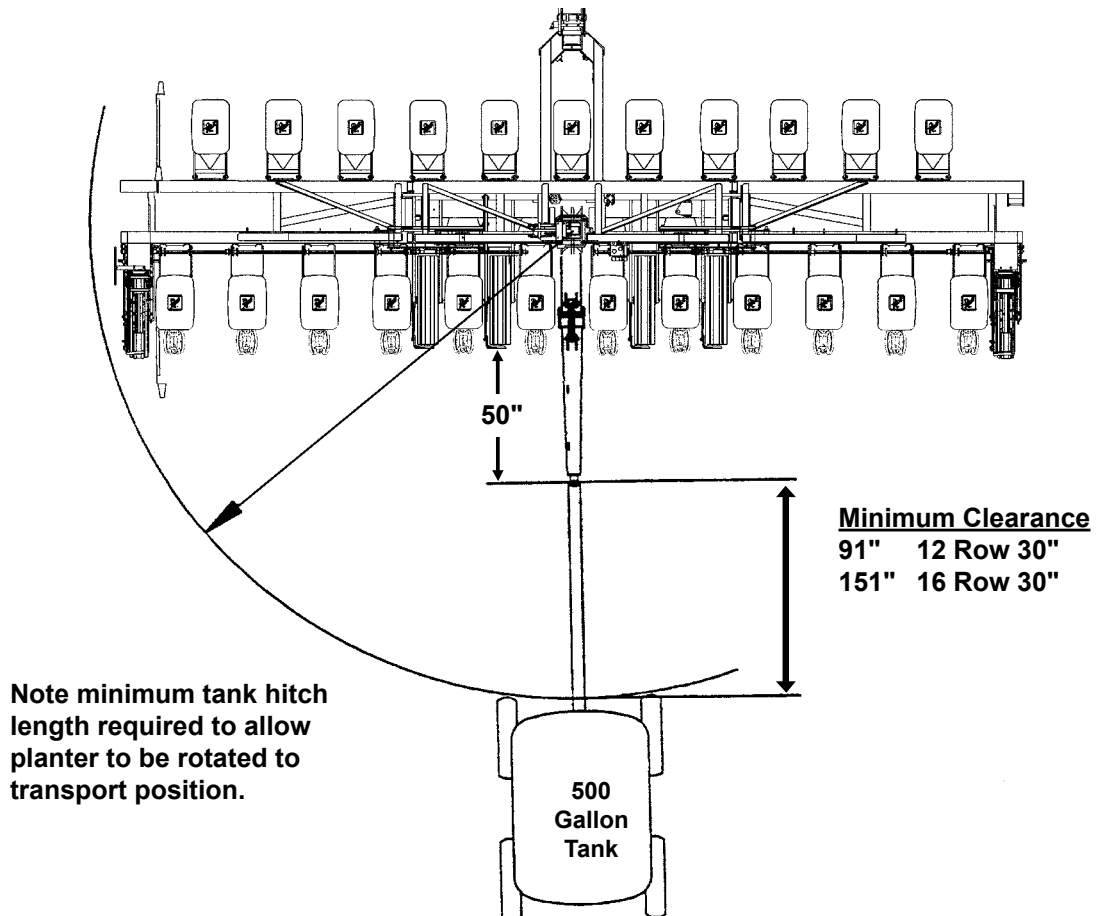

## FIELD TEST

Perform a field test with any change of field and/or planting conditions, seed size or planter adjustment to ensure proper seed placement and operation of row units.

- Check planter for front to rear and lateral level operation. See “Level Planter”.
- Check **all** row units to be certain they are running level. Row unit parallel arms should be approximately parallel to the ground when planting.
- Check row markers for proper operation and adjustment. See “Row Marker Adjustment” and “Row Marker Speed Adjustment”.
- Check for proper application rates and placement of granular chemicals on **all** rows. See “Field Check Granular Chemical Application”.
- Check for desired depth placement and seed population on **all** rows. See “Field Check Seed Population” and appropriate Rate Chart.
- Check for proper application rates of fertilizer on **all** rows. See proper “Fertilizer Application Rate Chart”.

Reinspect machine after field testing.

- Hoses And Fittings
- Bolts And Nuts
- Cotter Pins And Spring Pins
- Drive Chain Alignment

## FIELD CHECK SEED POPULATION

1. Tie up one or more sets of closing wheels by running a chain or rubber tarp strap between the hopper support panel and closing wheels. It may be necessary to decrease closing wheel arm spring tension.

Chain, rubber tarp strap, or similar.

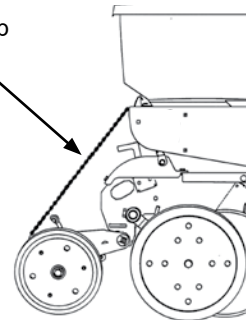

2. Plant a short distance and check to see if seed is visible in the seed trench. Adjust planting depth to a shallower setting if seed is not visible and recheck.

Planting depth adjustment handle

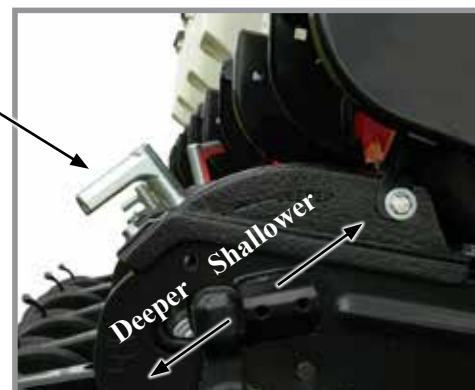

Planting depth adjustment



- Measure  $\frac{1}{1000}$  of an acre. See chart for correct distance for row width being planted. For example, if planting 30" rows  $\frac{1}{1000}$  of an acre would be 17' 5".

$\frac{1}{1000}$ Acre Seed Population Count Row Width/Distance						
Row Width	7.5"TR/15"	18"	19"	30"	36"	38"
Distance	34'10"	29'0"	27'8"	17'5"	14'6"	13'10"

**NOTE: Seeds may bounce or roll when planting with closing wheels raised and planting depth set shallow affecting seed spacing accuracy.**

- Count seeds in measured distance.
- Multiply number of seeds placed in  $\frac{1}{1000}$  of an acre by 1000. This gives total population.

EXAMPLE: With 30"-7 1/2" twin row spacing 17' 5" x 2 equals  $\frac{1}{1000}$  acre.

26 Seeds Counted x 1000 x 2 = 52,000 Seeds Per Acre

EXAMPLE: 30" row spacing 17' 5" equals  $\frac{1}{1000}$  acre.

26 seeds counted x 1000 = 26,000 seeds per acre

Seed count can be affected by drive wheel and seed meter drive ratio, tire pressure, and/or seed meter malfunction.

- If seed check shows average distance between seeds in inches is significantly different than seed rate chart indicates, first check drive ratio between drive wheel and seed meter. Check drive wheel air pressure, check for incorrect sprocket(s) in driveline and check drive and driven sprockets on transmission(s) for proper selection.
- Check for seed meter malfunction. For example, if spacing between kernels of corn at the transmission setting being used is 8" and a gap of 16" is observed, a finger has lost its seed and not functioned properly. If two seeds are found within a short distance of each other, finger has metered two seeds instead of one.
- See "Seed Meter (Finger Pickup) Troubleshooting" or "Seed Meter (Brush-Type) Troubleshooting" in Troubleshooting Section of this manual.

### DETERMINING POUNDS PER ACRE (BRUSH-TYPE METER)

Seeds per acre ÷ Seeds per pound (from label) = Pounds per acre

If seeds per pound information is not available use the following averages:

- 2,600 seeds per pound for medium size soybeans
- 15,000 seeds per pound for medium size milo/grain sorghum
- 4,500 seeds per pound for medium size cotton

### DETERMINING BUSHELS PER ACRE

Pounds per acre ÷ Seed unit weight = Bushels per acre



Average Unit Weight of:

- 1 Bushel Soybeans = 60 Pounds
- 1 Bushel Milo/Grain Sorghum = 56 Pounds
- 1 Bushel Cotton = 32 Pounds

If seed population check shows planting rate is significantly different than seed rate chart shows or if a particular meter is not planting accurately, see "Brush-Type Seed Meter Maintenance" and "Seed Meter (Brush-Type) Troubleshooting".

**FIELD CHECK GRANULAR CHEMICAL APPLICATION**

Temperature, humidity, speed, ground conditions, flowability of different material, or meter obstructions can affect granular chemical rate of delivery.

 <b>WARNING</b>	<p><b>Agricultural chemicals can cause death or serious injury to persons, animals, and plants or seriously damage soil, equipment, or property. Read and follow all chemical and equipment manufacturers labels and instructions.</b></p>
	

Perform a field check to determine application rates.

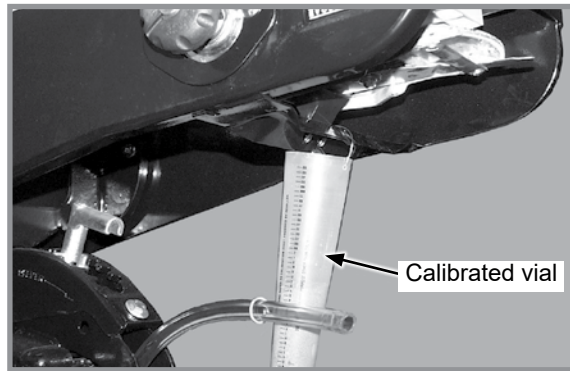

**Granular chemical field check**

1. Fill insecticide and/or herbicide hoppers.
2. Attach a calibrated vial to each granular chemical meter.

**NOTE: Disengage clutch to avoid dropping seed during test.**

3. Lower planter and drive 1320 feet at planting speed.
4. Weigh chemical in ounces caught in one vial.
5. Multiply that amount by factor shown to determine pounds per acre.

Pounds Per Acre	
Row Width	Factor
30"	.83
36"	.69
38"	.65

EXAMPLE: You are planting 30" rows. You have planted for 1320 feet at desired planting speed. You caught 12.0 ounces of chemical in one vial. 12.0 ounces times 0.83 equals 9.96 pounds per acre.

**NOTE: Check calibration of all rows.**

**METERING GATE**

Use metering gate setting as a starting point for distributing insecticide or herbicide. Charts are based on 5 mph (8 kph) planting speed. Use a higher gate setting for speeds faster than 5 mph (8 kph) and a lower setting for speeds slower than 5 mph (8 kph).

## PLANTING DEPTH

Planting depth is maintained by adjustable row unit gauge wheels. Depth adjustment range is approximately ½" to 3½" (1.2 to 8.8 cm).

1. Raise planter to remove weight from wheels.
2. Push down on depth adjustment handle and reposition it forward to decrease or rearward to increase planting depth. Initially adjust all units to the same setting.
3. Lower planter and check operation and planting depth of all row units. Readjust individual rows as needed for uniform operation.

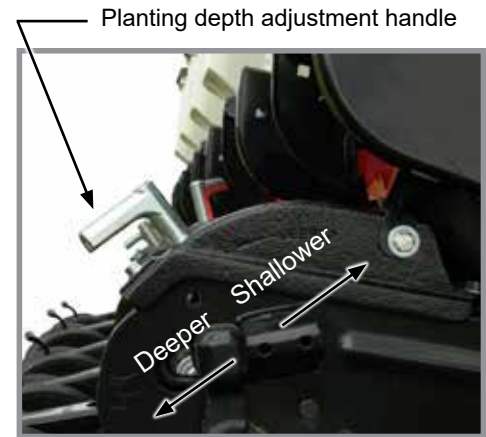

Planting depth adjustment

## “V” CLOSING WHEEL ADJUSTMENT (RUBBER OR CAST IRON)

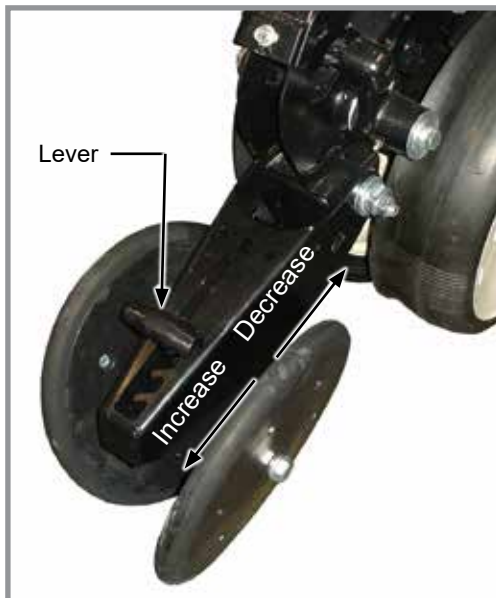

“V” Closing wheels installed offset

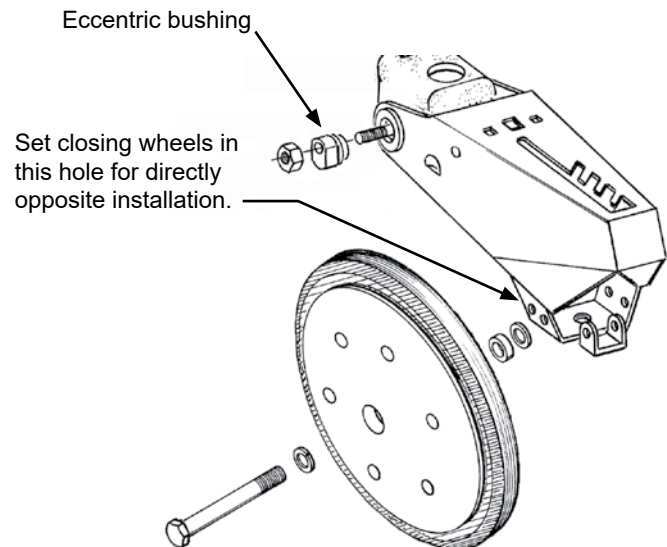

“V” closing wheels should have enough down pressure to close the seed trench and ensure good soil to seed contact. Move 5-position quick adjustable down force lever on the top of closing wheel arm to the rear to increase closing wheel spring pressure. Move lever forward to decrease pressure. Adjust all row units to a similar setting. Light soil usually requires less down force at average depth, approximately 2" (5 cm) while heavy soil requires increased down force.

Eccentric bushings in the wheel arm stop allow for lateral adjustment of the “V” closing wheel assembly. Use a ¾" wrench to loosen hardware attaching closing wheel arm to wheel arm stop. Use another ¾" wrench to turn eccentric bushings until **closing wheels are aligned with seed trench**. Tighten hardware.

Closing wheels can be installed “offset” (to improve residue flow) or “directly” opposite. Use forward installation holes if set “directly” opposite.





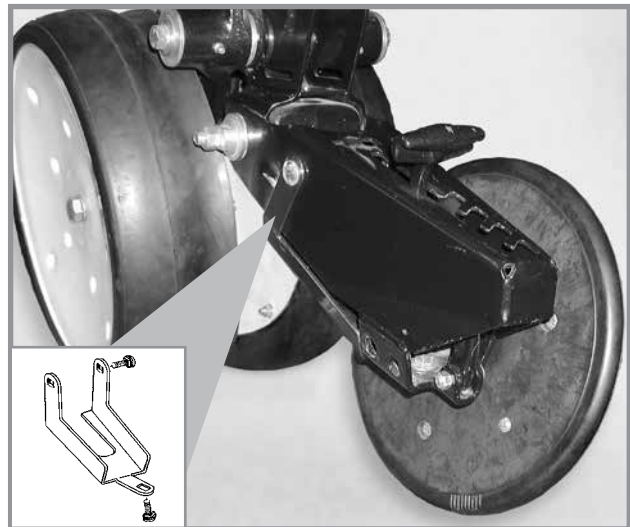



**CLOSING WHEEL SHIELD (RUBBER OR CAST IRON "V" CLOSING WHEELS)**

Optional closing wheel shield is installed on underside of closing wheel arm to help prevent root balls and stalks from clogging closing wheels.



**Closing wheel shield  
(Shown with closing wheel removed)**

**BRUSH-TYPE SEED METER 2.0**

Crop		Disc Color-Code (Disc Part No.)	Upper Brush Retainer	Cells	Seed Size Range	*Lubricant
	Soybean	Black (GB1123)	GB1084	60	2200 to 4000 seeds/lb.	<b>Graphite</b> Talc
	Soybean	Dark Gray (GB1171)	GB1084	54	2000 to 3000 seeds/lb.	<b>Graphite</b> Talc
	Specialty Soybean	Dark Blue (GB1124)	GB1084	48	1400 to 2200 seeds/lb.	<b>Graphite</b> Talc
	Small Milo/Grain Sorghum	Orange (GB1130)	GB1107	30	14,000 to 20,000 seeds/lb.	Talc
	Large Milo Grain Sorghum	Light Blue (GB1131)	GB1107	30	10,000 to 16,000 seeds/lb.	Talc
	High-Rate Small Milo/Grain Sorghum	Red (GB1132)	GB1107	60	12,000 to 18,000 seeds/lb.	Talc
	High-Rate Large Milo/Grain Sorghum	Yellow (GB1133)	GD8237	60	10,000 to 14,000 seeds/lb.	Talc
	Wheat	Purple (GB1134)	GB1084	54	N/A Volumetric	<b>Graphite</b> Talc

\*For More information on application rate see Additives section.

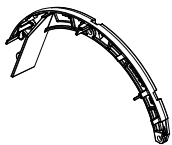

Use GB1084 upper brush retainer when using wheat and soybean discs.



Use GB1107 milo insert when using milo/ grain sorghum discs.

Turn seed disc counterclockwise when installing on meter hub while tightening two wing nuts that retain disc. Seed disc should have slight resistance when rotated counterclockwise after wing nuts are tight.

Brush-type seed meter attaches to seed hopper same as finger pickup seed meter. Secure to bottom of seed hopper with two  $\frac{5}{16}$ " thumbscrews. Tighten thumbscrews slightly with pliers. **DO NOT OVER TIGHTEN.**

Misalignment between drive coupler and seed meter input shaft may cause erratic seed spacing from momentary stoppage of seed disc. Check alignment and adjust as needed.

Refer to planting rate charts in this manual for recommended seed drive transmission sprocket combinations.

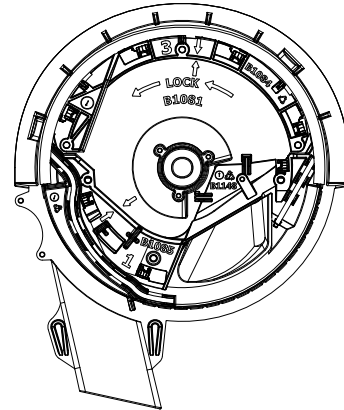

**Shown without seed disc installed**



## NOTICE

Replace hopper lids after hoppers are filled to prevent accumulation of dust or dirt in seed meter which will cause premature wear.

**NOTE:** Clean seed is required to ensure accurate seed metering from brush-type seed meters. Remove seed discs daily and check seed meter or brushes for buildup of foreign material, such as hulls, stems, etc.

**FINGER PICKUP SEED METER**

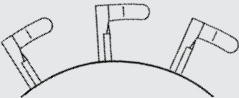
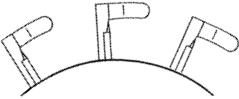
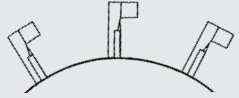









Crop	Fingers	*Lubricant
Corn	 Part No.: GR1848 - Finger Assembly, Corn	Graphite Talc
No. 1 and/or No. 2 size Confectionery Sunflower Seeds	 Part No.: GR1848 - Finger Assembly, Corn	Talc
No. 3 and/or No. 4 size Oil Sunflower Seeds	 Part No.: GR2154 - Finger Assembly, Oil	Talc
Blank fingers replace alternate fingers to reduce planting rate by half while allowing the finger wheel to maintain a minimum of 40 RPM when planting low rates.	 Part No.: GD11787 - Half Rate Blank Finger	Graphite Talc

**\*For More information on application rate see Additives section.**

**NOTE: Always field check seed population to verify planting rates.**

**NOTE: Refer to planting rate charts in this manual for recommended seed drive transmission sprocket combinations.**



**VACUUM SETTINGS**

Crop		**Seed Disc Kit	Seed Disc Part No.	Ejector Wheel (Color)	Cells	Seed Size Range	Singulator Zone Setting	Vacuum Setting Inches of Water (kPa)	Lubricant
	Corn ‡ Large Sweet Corn	G11043X	B1219 (Light Blue)	1 row 5 punches (Light Blue)	40	35-70 lbs/80k (2500-5000 seeds/kg)	2	18-20 (4.5-5.0)	<b>Graphite* Talc*</b> Bayer Fluency† (if mandated)
	Soybean	G11047X	B1232 (Black)	2 rows 6 punches (Black)	120	2200-4000 seeds/lb (4850-8820 seeds/kg)	0	10-14 (2.5-3.5)	<b>Graphite* Talc*</b> Bayer Fluency† (if mandated)
	Soybean Disc	G11048X	B1238 (Black)	1 row 6 punches (Green)	60	2200-4000 seeds/lb (4850-8820 seeds/kg)	0	10-14 (2.5-3.5)	<b>Graphite* Talc*</b> Bayer Fluency† (if mandated)
	Sugar Beet	G11045X	B1229 (Dark Orange)	1 row 6 punches (Dark Orange)	60	Pelletized	2	15 (3.75)	<b>Graphite* Talc*</b> Bayer Fluency† (if mandated)
	Milo	G11045X	B1229 (Dark Orange)	1 row 6 punches (Dark Orange)	60	10,000-20,000 seeds/lb (22000-44000 seeds/kg)	2	15 (3.75)	<b>Graphite* Talc*</b> Bayer Fluency† (if mandated)
	Sunflower ‡ Small Sweet Corn	G11044X	B1230 (Gray)	1 row 5 punches (Gray)	40	Oil seeds #2, 3, 4	2	12-18 (3.0-4.5)	<b>Graphite* Talc*</b> Bayer Fluency† (if mandated)
	Sunflower	G11044X	B1230 (Gray)	1 row 5 punches (Gray)	40	Oil seeds #5	2	5-8 (1.25-2.0)	<b>Graphite* Talc*</b> Bayer Fluency† (if mandated)
	Specialty Disc 1	G11039X	B1233 (Green)	1 row 6 punches (Green)	60	Cotton	2	15-20 (3.75-5.0)	<b>Graphite* Talc as needed*</b> Bayer Fluency† (if mandated)

Continued on next page.

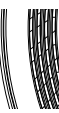

## VACUUM SETTINGS

Crop		**Seed Disc Kit	Seed Disc Part No.	Ejector Wheel (Color)	Cells	Seed Size Range	Singulator Zone Setting	Vacuum Setting Inches of Water (kPa)	Lubricant
	Specialty Disc 2	G11040X	B1235 (Brown)	1 row 6 punches (Green)	60	Black turtle & navy edible beans	2	15-20 (3.75-5.0)	<b>Graphite* Talc as needed*</b> Bayer Fluency <sup>†</sup> (if mandated)
	Specialty Disc 3	G11041X	B1234 (Dark Blue)	1 row 6 punches (Green)	60	Pinto & Great Northern edible beans & low-rate soybean	2	15-20 (3.75-5.0)	<b>Graphite* Talc as needed*</b> Bayer Fluency <sup>†</sup> (if mandated)
	Wheat Disc	G11042X	B1236 (Purple)	Brush Type	54	N/A Volumetric	0	6-16 (15-41)	<b>Graphite* Talc as needed*</b> Bayer Fluency <sup>†</sup> (if mandated)

Install selected seed disc. Position vacuum cover on meter by aligning keyhole slots over bolt heads. Push cover on meter and turn counter clockwise to lock in place.

\*For More information on application rate, ["Additives" on page 3-12](#) .

\*\*Includes seed disc, ejector wheel, and spring.

<sup>†</sup>Bayer Fluency Agent is only required to be used in place of graphite or talc lubricants on vacuum equipped planters that are sowing neonicotinoid treated seeds in Canada. Refer to ["Bayer Fluency Agent" on page 3-13](#) section for more information.

‡Conventional hoppers only, not applicable with bulk fill.

**NOTE:** See [“Field Check Seed Population” on page 2-42](#) for more information. Always field check seed population to ensure planting rates are correct.

**NOTE:** Singulator settings are marked from 0 - 3.

**NOTE:** Mixing seed sizes and shapes affects meter performance. Use consistent seed size and shape.

**NOTE:** Use 1 tablespoon powdered graphite with each standard hopper fill of seed. Seed treatment, foreign material, dirt or seed chaff may cause gradual reduction of seed disc fill (population). See “Additives” pages for more information.

**NOTE:** Excessive seed treatment, humidity, and light-weight seed can affect meter performance. Use ½ cup of talc with each standard hopper fill of seed and mix thoroughly to coat all seeds and adjust rates as needed. Use of talc aids seed flow into meter, singulation, and disc seed drop.

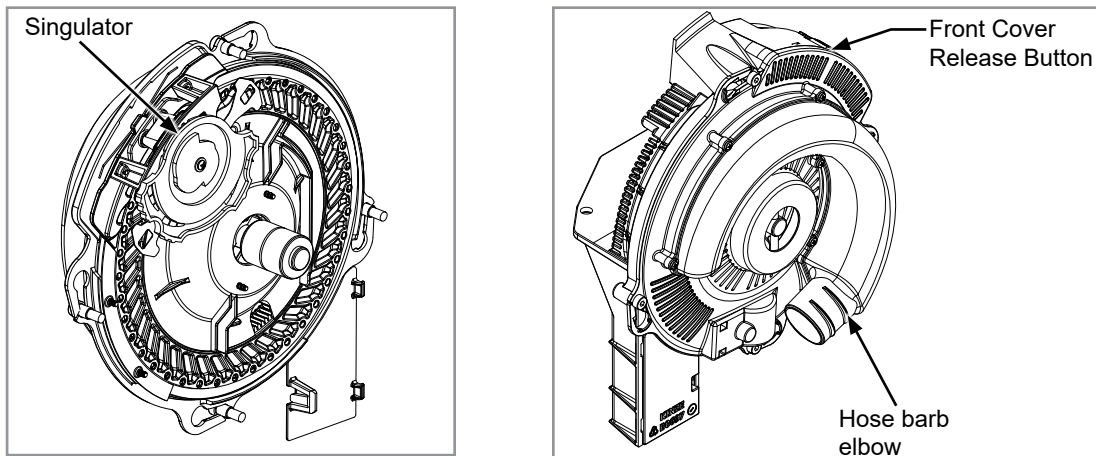

**NOTE:** Foreign material in seed disc orifices, such as seed chips, hulls, stems, etc., may affect seed delivery. Clean seed ensures accurate seed metering from vacuum seed meter. Remove Seed discs daily to check for buildup of foreign material in seed disc orifices.

Air inlet screens allow air to enter system and aids in keeping field residue or other foreign material out of meter.

See [“Vacuum Seed Meter Maintenance” on page 6-20](#) and [“Preparation for Storage” on page 6-40](#) in Lubrication and Maintenance section for more information.

**This page left blank intentionally.**

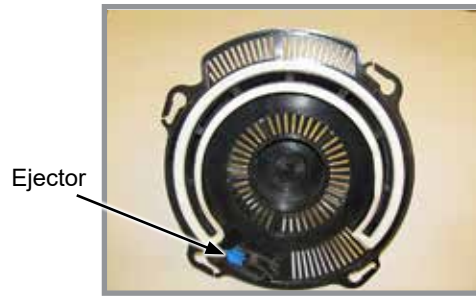

**NOTE: Damaged seed or seed containing foreign material will cause plugging of seed disc orifices and require more frequent seed meter cleanout to prevent underplanting.**

Wheel-Type Ejectors

Wheel-type ejectors expel seed remnants from seed disc orifices. These ejectors are disc specific and colored coded to match disc.

<b>NOTICE</b>	<b>Replace hopper lids after hoppers are filled to prevent accumulation of dust or dirt in seed meter which will cause premature wear.</b>
---------------	--

**NOTE: Seed size, seed shape, seed treatments, travel speed, and planting rate affect meter performance.**

1. Select seed disc and ejector to match crop and population.

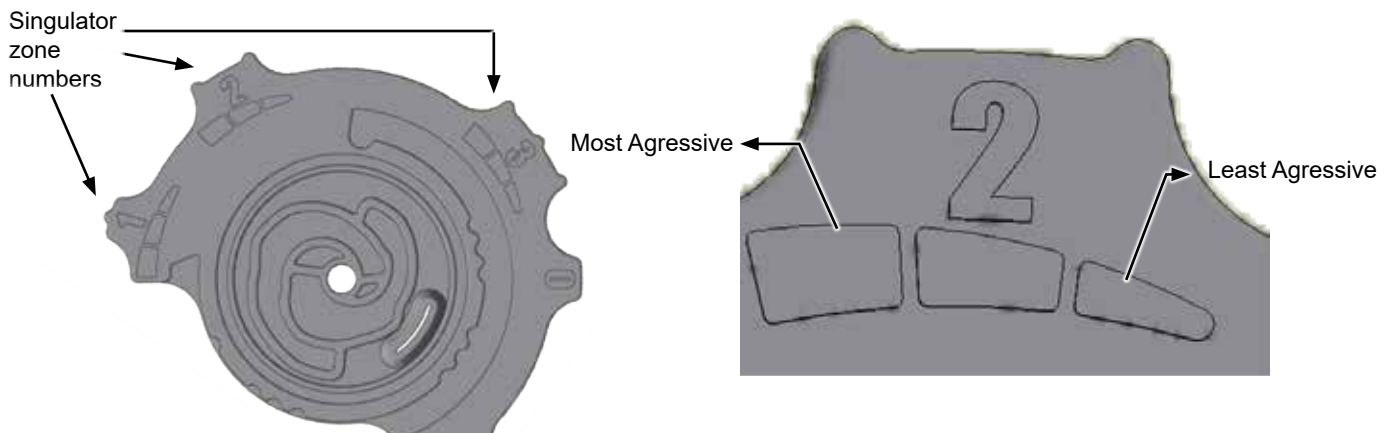

**Singulator Adjustment Wheel**

2. Adjust singulator wheel to initial setting. Seed size, seed shape, seed treatments, travel speed and planting rate all affect meter performance.
3. With vacuum fan running, lower planter to planting position and drive forward a short distance to load seed into seed disc cells.
4. Adjust vacuum level to initial setting according to tables on page.

**NOTE: Vacuum reading will be much lower when seed disc cells are empty. Load all seed cells before setting vacuum level.**

**NOTE: Operate vacuum fan 3-5 minutes to bring oil up to normal operating temperature prior to making final vacuum level adjustment.**

4. Adjust vacuum level to initial setting according to tables on page.

**NOTE: Vacuum reading will be much lower when seed disc cells are empty. Load all seed cells before setting vacuum level.**

**NOTE: Operate vacuum fan 3-5 minutes to bring oil up to normal operating temperature prior to making final vacuum level adjustment.**

## SEED METER CLEANOUT

**NOTE: Use of damaged seed or seed containing foreign material will cause plugging of seed cell orifices and require more frequent seed meter cleanout to prevent underplanting.**

Thorough seed meter cleanout is important to maintain genetic purity.

1. Disengage seed drive and remove seed hopper and meter.
2. Dump seed from right rear corner of hopper into a container.
3. Lay hopper on its right side. Push release button and rotate seed meter vacuum cover clockwise to align keyhole slots with bolt heads. Lift off cover.
4. Rotate seed disc hub clockwise to unlock and remove seed disc.
5. Empty meter.
6. Thoroughly inspect meter to ensure all seed is removed.
7. Replace seed disc. Install vacuum cover.

**ADDITIVES**

<b>Lubricant Application Rate</b>	
<b>Graphite</b>	
Conventional Hoppers	1 Tbs./Hopper Fill
Bulk Fill Hoppers	1 Pound Bottle/50 Unit Fill
<b>80/20 Talc-Graphite</b>	
Conventional Hoppers	½ C.**
Bulk Fill Hoppers	8 Pounds/50 Unit Fill**
**Must be evenly mixed during fill.	
<b>Talc</b>	
Conventional Hoppers	¼ C.*
Bulk Fill Hoppers	4 Pounds/50 Unit Fill*
*Double amount of talc for sunflowers.	

GRAPHITE

The use of graphite is the primary recommendation to promote seed flow, provide lubrication for the seed meter and to help dissipate static charge buildup. Among the available dry seed lubricants graphite is the most effective and easiest to use and it requires no mechanical agitation

Conventional Hoppers

Mix one tablespoon of **powdered graphite** with seed each time hoppers are filled. Regular graphite use prolongs life of the seed meter components, improves seed spacing, and may reduce buildup of seed treatments.

**NOTE: DO NOT apply graphite only in center of hopper. It will filter too quickly through the seed and not distribute as evenly as desired.**

Apply graphite around outer perimeter of hopper.

Bulk Fill Hoppers

Mix 1 pound of powdered graphite each time the bulk seed hopper is filled. Graphite should be added in layers as the bulk seed hoppers are filled. Regular graphite use prolongs life of the seed meter components, improves seed spacing, and may reduce buildup of seed treatments.



**Adding graphite to conventional hopper**



**Adding graphite bulk fill hopper**

**NOTE: Additional graphite may be required to retard buildup of seed treatments on meter components. More frequent cleaning of monitor seed tubes may be necessary due to use of additional graphite.**

### 80/20 TALC-GRAPHITE

Talc-Graphite lubricant is to be used for treated seed, providing benefits of both talc and graphite. It absorbs moisture to prevent bridging, minimizes static electricity for improved seed flow, and lubricates seed and meters.

#### Conventional Hoppers

Mix ½ C. of 80/20 talc-graphite evenly with seed each time hoppers are filled. Regular graphite use prolongs life of the seed meter components, improves seed spacing, and may reduce buildup of seed treatments.

**NOTE: Talc-Graphite lubricant MUST be mixed evenly during fill.**

#### Bulk Fill Hoppers

Mix 8 lbs. of 80/20 talc-graphite each time the bulk seed hopper is filled. Regular graphite use prolongs life of the seed meter components, improves seed spacing, and may reduce buildup of seed treatments.

**NOTE: Talc-Graphite lubricant MUST be mixed evenly during fill.**

### TALC

**Talc seed lubricant** may be used as a drying agent in addition to graphite lubrication. The drying agent may improve seed release and/or **to retard buildup of seed treatments on meter components.**

1. Fill hopper ½ full of seed, add ¼ cup (conventional); 2 pounds (Bulk Fill) of talc and **mix thoroughly.**
2. Finish filling hopper, add another ¼ cup (conventional); 2 pounds (Bulk Fill) of talc and **mix thoroughly.**
3. Adjust rate of talc use as needed so all seeds are coated, while avoiding a buildup of talc in bottom of hopper.

Humid conditions and/or small sized seeds with extra seed treatment may require additional talc to maintain meter performance.

**NOTE: Liquid seed treatments or inoculants may create buildup on the seed disc or brushes. Check frequently for proper population and/or seed delivery when using any liquid seed treatment.**

Completely mix all treatments with seed following manufacturers' recommendations. Seed treatment dumped on top of seed after hopper is filled may not mix properly and cause seed bridging, reducing population or stopping meter from planting.

## **BAYER FLUENCY AGENT**

Bayer Fluency Agent is an alternate seed lubricant by Bayer Crop Science. The intent of this product is to replace graphite and talc lubricants and to lower the amount of dust emissions from planter vacuum fans.

This product, as tested by Kinze, is compatible with Kinze's bulk fill system and vacuum meters. Due to limited testing, wear life characteristics of meters and bulk fill systems that use Bayer Fluency Agent are not yet known. Please follow Bayer Fluency Agent instructions for rates and mixing directions.

**NOTE: Presently, Bayer Fluency Agent is only required to be used in Canada with Bulk Fill or Vacuum planters that plant corn or beans treated with neonicotinoids. Farms outside of Canada, farms not using seed treated with neonicotinoids, and farms not using pneumatic metering devices do not need to use Bayer Fluency Agent. All planters not equipped with vacuums or fans are exempt from using Bayer Fluency Agent.**

**SEED HOPPERS**



**Seed hopper is retained by an over-center latch. Wear gloves to prevent injury to hands while releasing the latch.**

Mechanical seed hopper has a capacity of 1.9 bushels.

Vacuum seed hopper has a capacity of 1.75 bushels.

Use clean seed and make certain there are no foreign objects inside when filling seed hopper. **Replace hopper lids after hoppers are filled to prevent accumulation of dust or dirt in seed meter which can cause premature wear.** See “Finger Pickup Seed Meter” and/or “Brush-Type Seed Meter”.

Periodically empty hoppers completely to remove any foreign objects and to ensure proper seed meter operation.

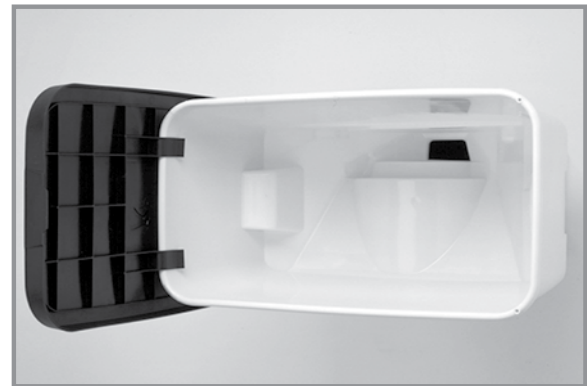

**Mechanical seed hopper**

Disengage meter drive and hopper latch and lift hopper off hopper support. See “Seed Meter Drive Release”.

**SEED METER DRIVE RELEASE**

A clutch release mechanism disengages seed meter drive from seed meter to remove seed hopper. Disconnecting drive allows operator to check granular chemical application rates without dropping seed. It also allows one or more rows to be disconnected when finishing fields.

Turn knob ¼ turn counterclockwise to disengage or ¼ turn clockwise to engage.

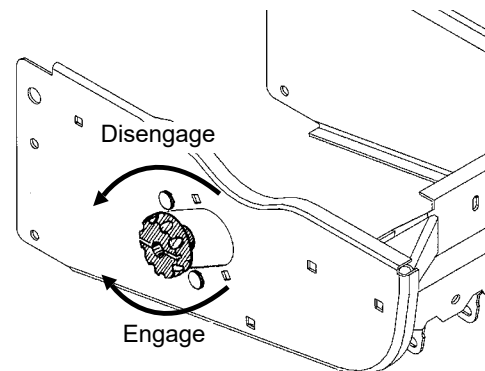

**Seed meter drive release**

**ROW UNIT EXTENSION BRACKETS**

Row unit extension brackets extend row units rearward 4" (10.1 cm) to provide clearance for coulter mounted residue wheels and HD single disc fertilizer openers.

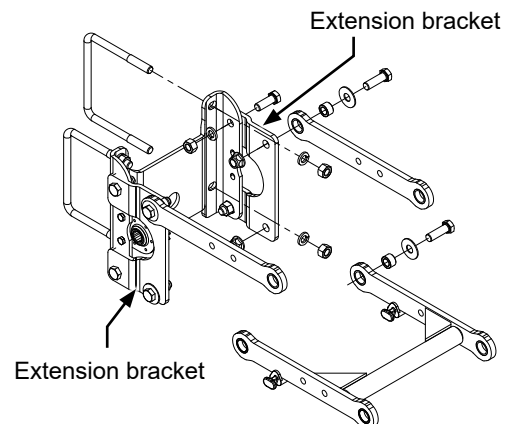

**Row unit extension brackets**



### ROW UNIT CHAIN ROUTING

Row unit drive chains must be properly tensioned and aligned for proper operation and to minimize wear.

Inspect and replace weak, worn or broken springs, idlers, and idler bushings.

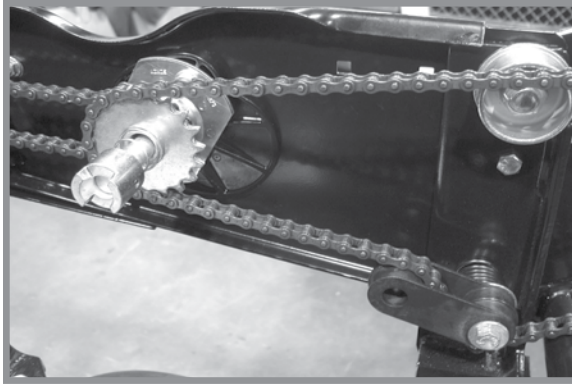

Mechanical pull row unit meter drive

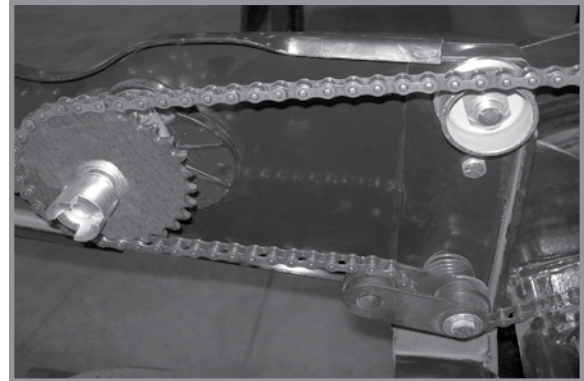

Vacuum pull row unit meter drive



Mechanical push row unit meter drive

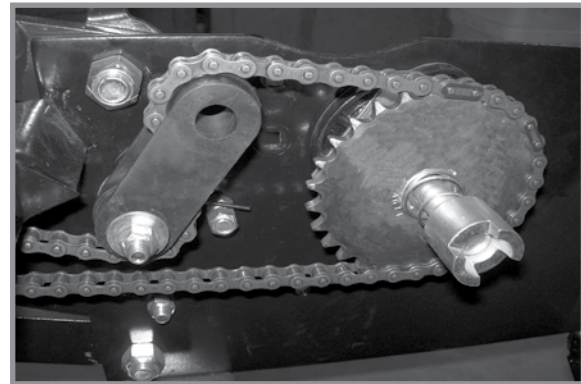

Vacuum push row unit meter drive

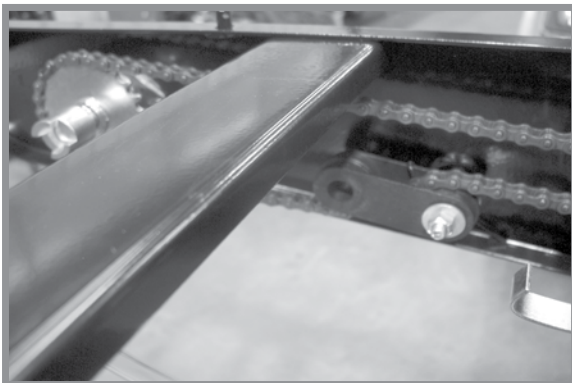

Row unit granular chemical drive

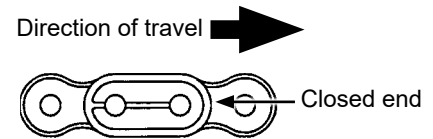

**NOTE:** Install connector link with closed end facing direction of travel.

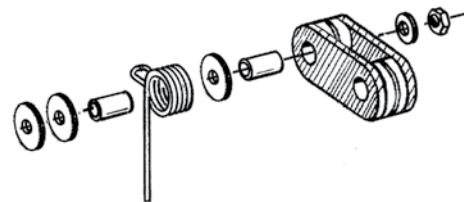

**NOTE:** Reverse idler when worn on one side for extended use.

**QUICK ADJUSTABLE DOWN FORCE SPRINGS OPTION**

Quick adjustable down force springs increase penetration in hard soil and keep row unit from bouncing in rough field conditions. Two springs per row, one on each side parallel arms, are used unless equipped with row unit mounted no till coulters. Four springs per row are used with row unit mounted no till coulters.

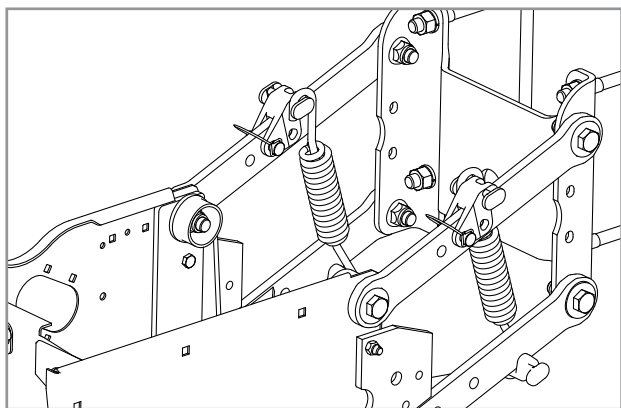

**Two Springs Per Row (Dual)**

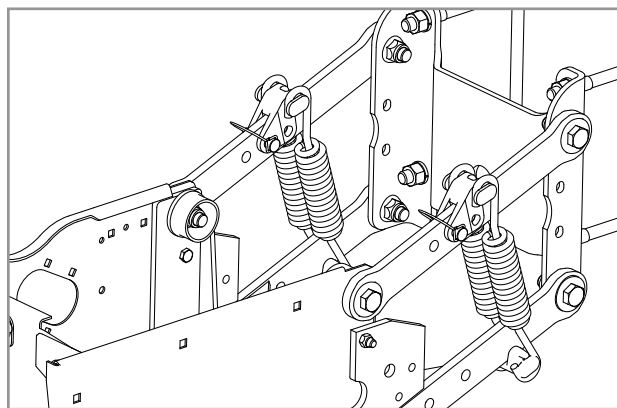

**Four Springs Per Row (Quad)  
(Row Unit Mounted No Till Coulters Only)**

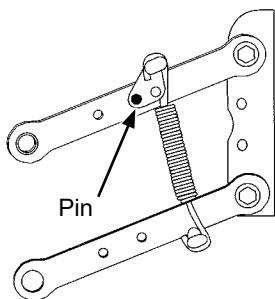

**Position 1 (Least)**

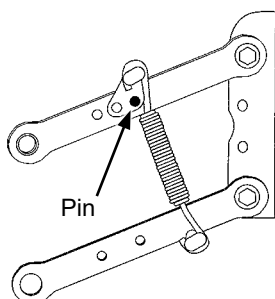

**Position 2**

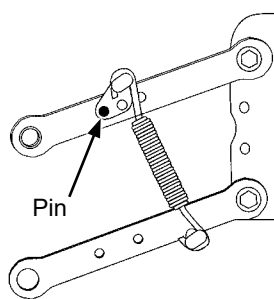

**Position 3**

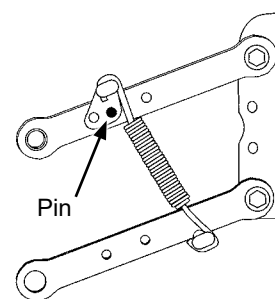

**Position 4 (Most)**

There are four positions to set down pressure spring tension.

**NOTICE**

Springs must be installed with open side of spring hooks toward seed hoppers to prevent binding on spring mount adjustment pins.

1. Raise planter and remove spring mount pin at top of spring.
2. Slide mount to desired position and install pin.

**NOTE: Adjust springs for field conditions. Too much down pressure in hard field conditions can cause row units to lift planter and keep drive wheels from making contact. Too much down pressure in soft field conditions can cause row unit to run too deep.**

Heavy Duty Spring Down Force Pressure*		
	2 Springs	4 Springs
Position	Heavy Duty P/N: D21337	Heavy Duty P/N: D21337
1	43 lb (19.5 kg)	80 lb (36.3 kg)
2	86 lb (39.0 kg)	144 lb (65.3 kg)
3	167 lb (75.7 kg)	307 lb (139.3 kg)
4	249 lb (113.0 kg)	470 lb (213.2 kg)

\*Pressure does not include weight of row unit, seed, or options.

## PNEUMATIC DOWN PRESSURE PACKAGE OPTION

Row unit down pressure can be adjusted on-the-go as field conditions change with pneumatic down pressure option. A cab-mounted control box adjusts pressure (Older models may have a digital readout). A planter-mounted 12 VDC air compressor with 3 gallon capacity air tank supplies air for the down pressure system.

Packages include upper and lower air spring mounting castings for pull row units (front and rear air spring mounting castings for push row units), 150 psi rated air springs,  $\frac{3}{8}$ " O.D. nylon hoses, dual solenoid air valve and stainless steel, 160 psi, 2" liquid-filled gauge and planter wiring harness.

Pneumatic down pressure row unit extension brackets are required in some applications.

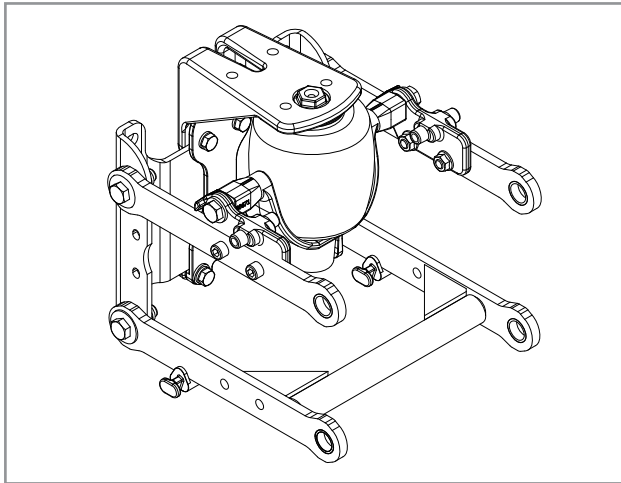

**Pull Row Unit Air Spring**

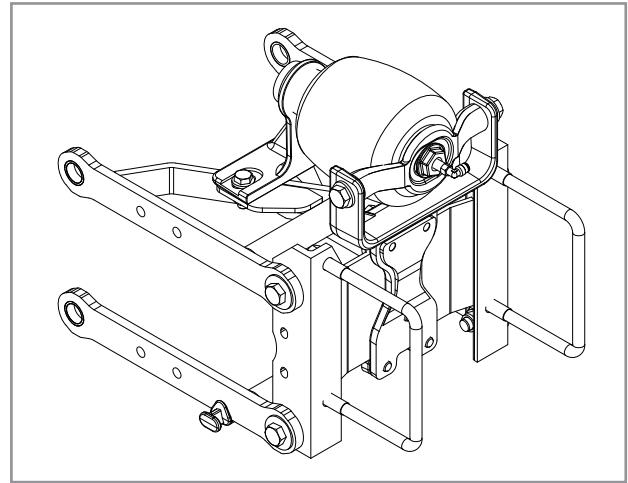

**Push Row Unit Air Spring**

**NOTE:** If additional down pressure is needed with the Pneumatic Down Pressure Package, assist springs are available through your Kinze dealer. One spring is installed on the outer side of the parallel arms on each side of the row unit as shown below.

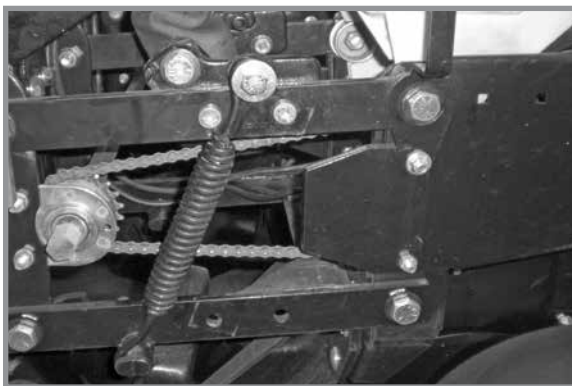

**Pull row unit assist springs**



**Push row unit assist springs**

## FIELD OPERATION

**NOTE: Adjust down pressure with planter lowered and row openers in ground for most accurate adjustment. Pressure can be adjusted from tractor using control console, or at planter using manual control valves on compressor assembly.**



Control console

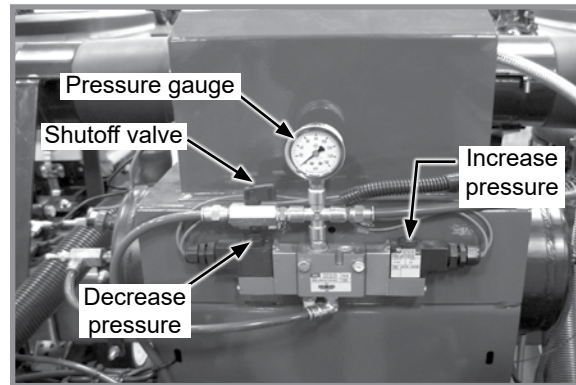

Air compressor assembly controls

## ADJUST DOWN PRESSURE FROM CAB

Push toggle switch left to increase or right to decrease pressure.

## ADJUST DOWN PRESSURE AT PLANTER

Push and hold decrease or increase button on compressor assembly to decrease or increase pressure.

**NOTE: Value on the air pressure gauge is NOT down pressure force. Multiply air pressure (psi) by four (4) to calculate down pressure.**

## LOCK UP PUSH ROW UNITS EQUIPPED WITH PNEUMATIC DOWN PRESSURE SPRINGS

1. Press and hold button on solenoid until pressure gauge reads 5 PSI.
2. Lock up units. See “Interplant Push Unit Lockup” for instructions.
3. Turn shutoff valve handle perpendicular to valve body to turn off push row unit air supply.

**SPLIT ROW PUSH ROW UNIT CLUTCH SPROCKET**

Push row unit clutch sprocket disengages interplant drive from push row unit drill shaft when only pull row units are used.

## DISENGAGE

Rotate knurled collar  $\frac{1}{4}$  turn. Rock drill shaft slightly using a  $\frac{7}{8}$ " wrench to take pressure off of spring loaded pins in clutch to allow pins to “pop” out, disengaging drive.

## ENGAGE

Rotate knurled collar  $\frac{1}{4}$  turn and turn drill shaft with a  $\frac{7}{8}$ " wrench until drive pins engage drive sprocket.

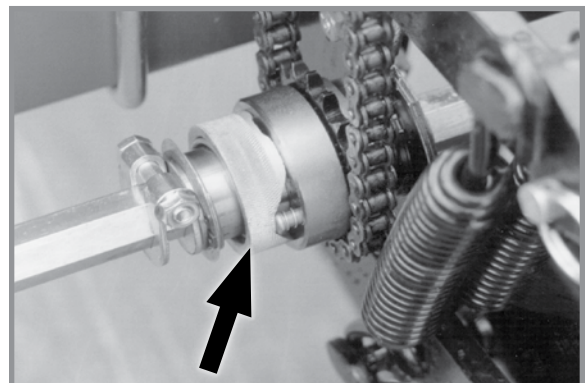

Interplant clutch sprocket

## TRUE DEPTH OPTION

True Depth provides on demand row by row hydraulic row unit down force ranging from 100 lbs. up force to 600 lbs. down force at 2350 psi. The system includes a 7" in cab standalone touchscreen display with antiglare screen protector and RAM mount, electronic control modules, harnesses, gauge wheel sensors, hydraulic cylinders, upper and lower cylinder mounts, and valves. See M0286 - Kinze True Depth Operator's Manual.



True Depth

## TRUE DEPTH CONSOLE INSTALLATION

### TRACTOR REQUIREMENTS

Consult your dealer for information on horsepower, hydraulic and electrical requirements, and tractor compatibility. Requirements vary with planter options, tillage, and terrain.

### TRACTOR INSTALLATION

Refer to Kinze Instruction Sheet IS1028 for installation of the True Depth down force system.

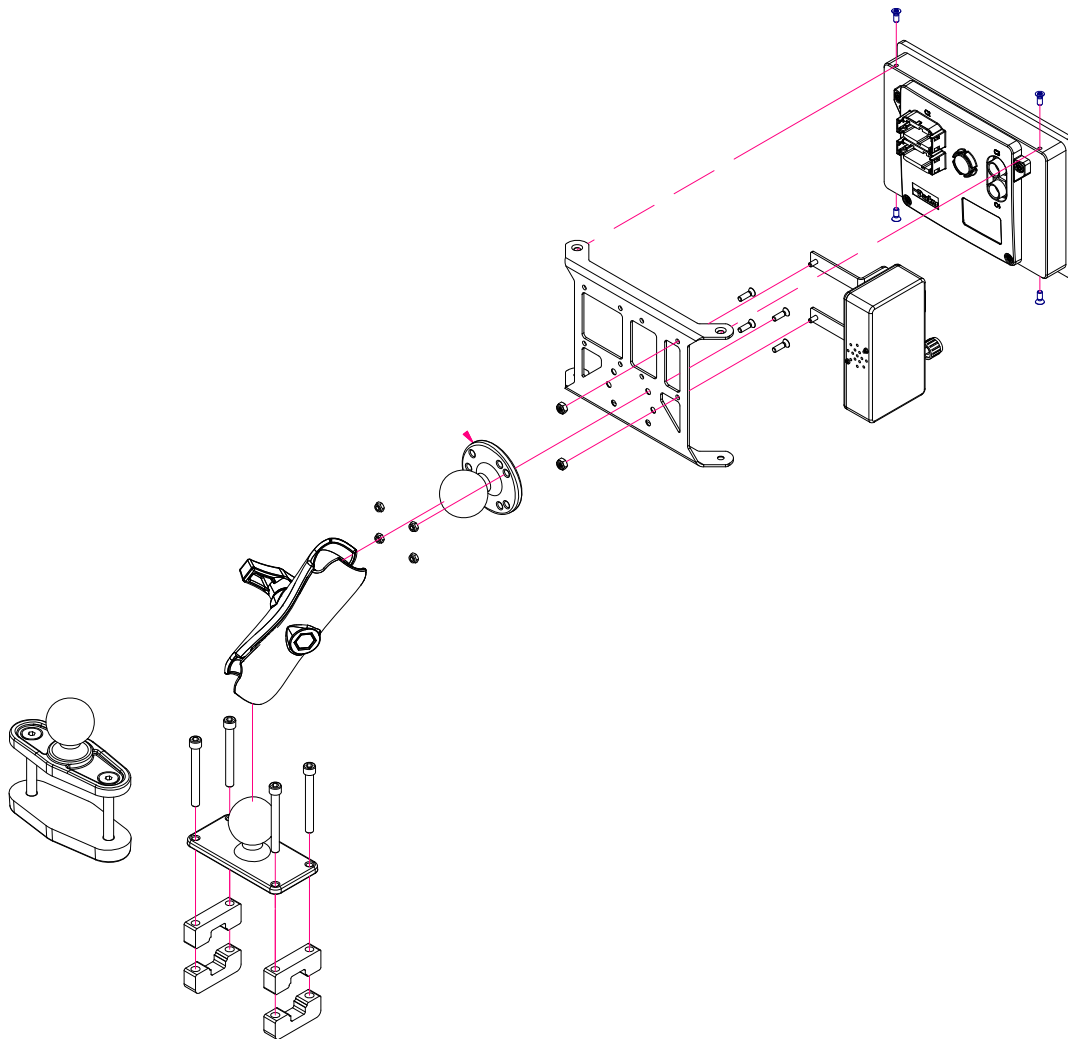

True Depth Console

**TRUE DEPTH HARNESS INSTALLATION**

Connect tractor power harness terminal E1 to positive battery terminal. Connect terminal E2 to negative battery terminal. Connect console harness P4 to display C1, and console harness P5 to display C2. Connect console harness P3 to the speaker box. Connect console harness P1 to tractor power harness J2. Connect the intermediate harness P1 to the tractor power harness J1.

**DANGER**

**ELECTRICAL SHOCK HAZARD**  
Disconnect (unplug) power before installing, inspecting, or servicing the unit.

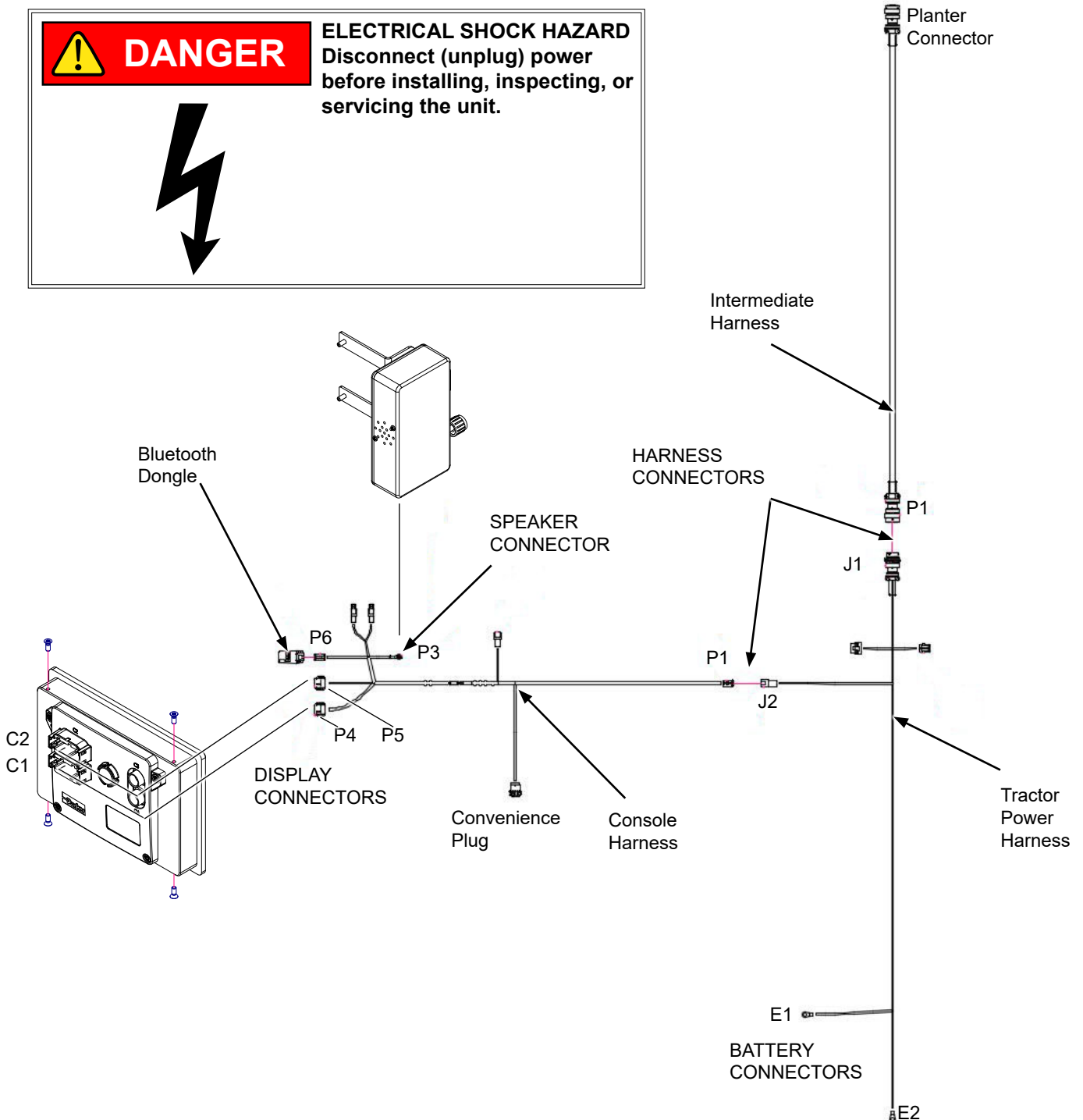



True Depth Harness Installation

**This page left blank intentionally.**



### SPLIT ROW LOCKUPS

Split row lockups are designed to allow the push row units to be locked in the raised position.

 <b>CAUTION</b>	<p>Improper lifting of row units can cause serious injury. An empty row unit requires minimum 84 lb (38.1 kg) lift. Set down pressure springs to minimum, lower planter to ground, and empty seed hopper before attempting to lift with this lever.</p>
	

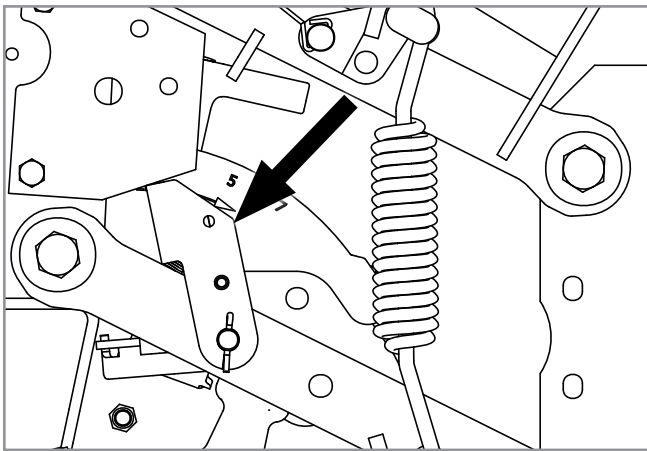

Push Row Unit Locked In Raised Position

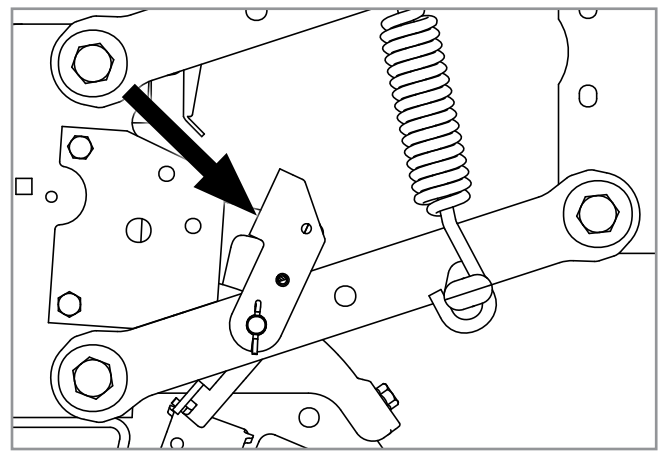

Lockup Released For Field Operation

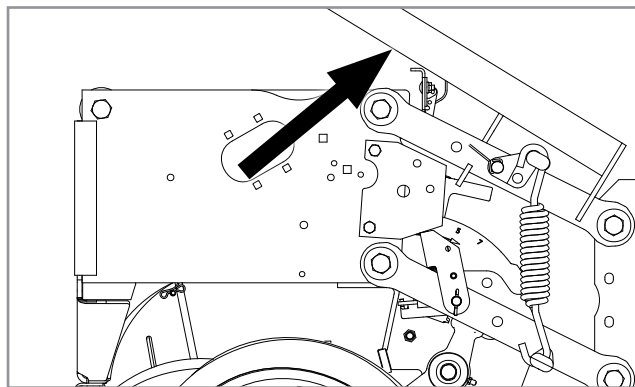

Lift lever positioned on push row unit

**To lock in raised position:**

1. Set row unit down pressure springs to minimum setting.
2. Lower the planter to the planting position.
3. Empty seed hoppers.
4. On each split row lockup, flip the spring tab forward.
5. Using the lift lever, raise the push row unit to allow the spring loaded lockups to snap into locked position under the row unit stops.
6. Repeat Steps 4 and 5 on remaining push row units.

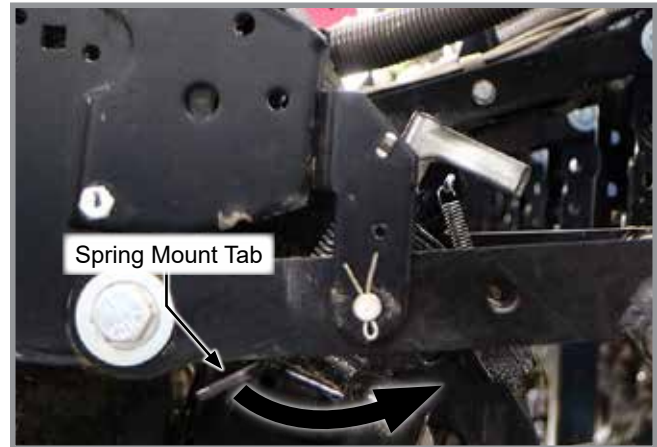
**To release lockups:**

1. Lower the planter to the planting position.
2. On each split row lockup, flip the spring tab rearward.
3. Using the lift lever, raise the push row unit to allow the spring loaded lockups to snap out of locked position. Lower row unit to the ground.
4. Repeat Step 3 on remaining push row units.

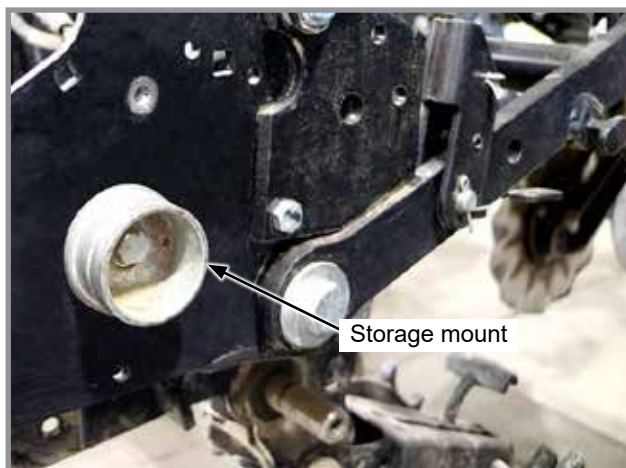

Lift lever in storage location

**SPLIT ROW PUSH ROW UNIT VACUUM HOSE SHUTOFF****Split Row vacuum hose shutoff**

When push row units are not used, move row unit end of 2" (5 cm) vacuum hose on each push row unit to storage mount located on side of shank.

## ROW UNIT MOUNTED NO TILL COULTER

Row unit mounted no till coulters with 1" bubbled, 1" fluted (8 flutes) or ¾" fluted (13 flutes) blades may be used on pull row units and push row units (¾" fluted shown). Four quick adjustable down force springs are required per row when using row unit mounted no till coulters. See "Quick Adjustable Down Force Springs Options".

Align coulters to row unit double disc openers. Adjust by loosening four attaching bolts, moving coulters, and tightening four attaching bolts. Coulters can be adjusted to one of four ½" incremental settings in the forked arm. Initial location is the top hole.

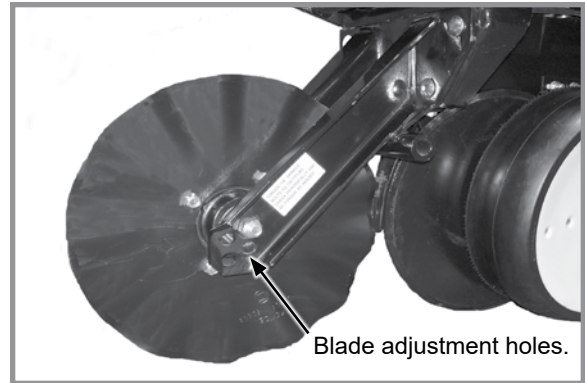

**Row Unit Mounted No Till Coulters**

Move blade as it wears to one of the three lower holes to maintain coulters at or slightly above opener discs as needed. Adjust coulters below depth of double disc opener blades in very hard soil conditions such as compacted wheel tracks to improve opener penetration and cutting of surface residue.

Check operating depth by setting planter down on a level concrete floor and checking relationship between coulters and row unit opener blade. Make sure planter is level and coulters are square with planter frame and aligned with row unit disc opener.

**NOTE: Torque 5/8" spindle hardware to 120 ft-lb (162.7 N-m).**

## COULTER MOUNTED RESIDUE WHEELS

Coulters mounted residue wheels are designed for use on pull row units and push row units. Row unit extension brackets are required on the four center pull row units if the planter is equipped with coulters mounted residue wheels.

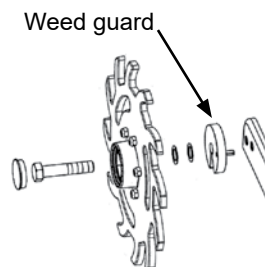

**NOTE: Opening in weed guard must face down.**



**Coulters mounted residue wheels**

Residue wheels attach to row unit mounted coulters with two cap screws and sleeves allowing unit to free-float. A 2-position spindle bolt mounting positions wheels interlocked or staggered. Depth adjustment is made with a spring-loaded cam and pin with 8 positions in 7/16" (6 mm) increments. A high point on the cam allows wheels to be locked up.

A weed guard on the inboard side of each wheel helps prevent weed wrap which can cause premature bearing failure.

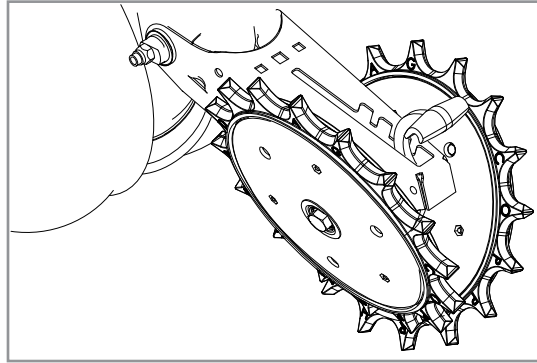

**SPIKED CLOSING WHEEL****Row Unit Spiked Closing Wheel**

Spiked closing wheels crumble the sidewall, allowing roots to penetrate soil. They can be used on pull row units and push row units.

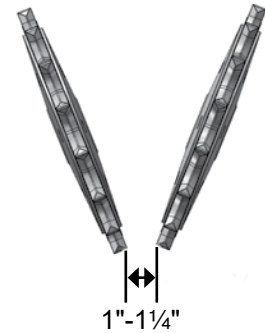
Align spiked closing wheels straight across from each other, in most forward holes on closing wheel arm. Set the wheels 1" - 1¼" (2.5 - 3.1 cm) apart at the closest point.



## GRANULAR CHEMICAL HOPPER AND DRIVE

 <b>WARNING</b>	<p>Agricultural chemicals can cause death or serious injury to persons, animals, and plants or seriously damage soil, equipment, or property. Read and follow all chemical and equipment manufacturers labels and instructions.</p>
	

The granular chemical hopper has a 1.4 cubic feet capacity.

Make sure no foreign objects get into hopper when it is being filled. Replace hopper lids after filling to prevent accumulation of dirt and moisture.

A metering gate on bottom of hopper regulates the application rate. See “Dry Insecticide and Dry Herbicide Application Rate Charts” in this manual. Calibrate using chemical manufacturers’ instructions.



**Granular chemical hopper**

Granular chemical clutch drive coupler and meter shaft can be disengaged and engaged by turning throwout knob at rear of hopper support panel.

Rotate knob  $\frac{1}{4}$  turn counterclockwise to disengage and  $\frac{1}{4}$  turn clockwise to engage.

Slotted holes in hopper support panel and clutch housing allow for alignment adjustment between clutch drive coupler and meter shaft.

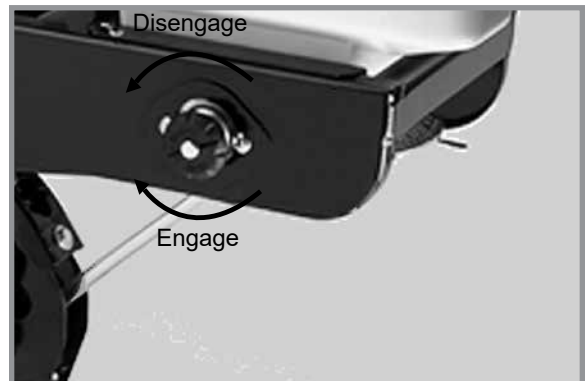

**Granular chemical drive release**

## GRANULAR CHEMICAL BANDING OPTIONS

Granular chemical banding options allow 4½" slope-compensating banding, straight drop in-furrow placement or 14" rear banding.

**NOTE: Granular chemical rear bander is not compatible with covering discs/single press wheel option.**

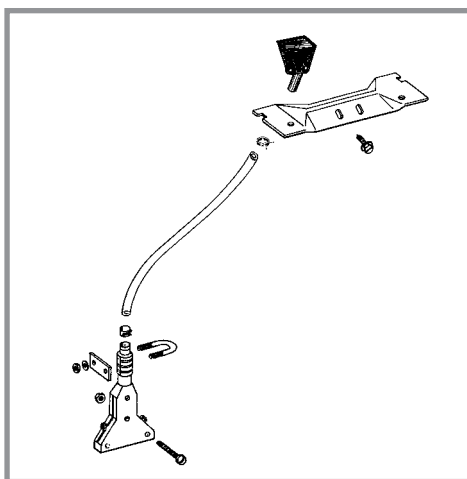

**4½" Slope-Compensating Bander**

**This page left blank intentionally.**



**NOTCHED SINGLE DISC OPENERS**

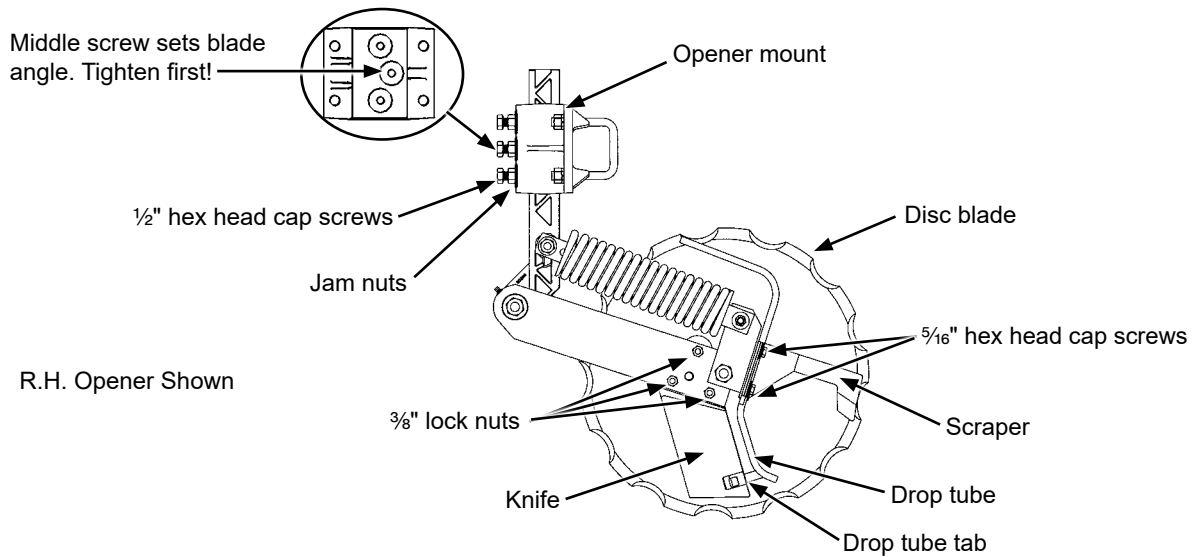

**Notched single disc opener adjustments**

 <b>CAUTION</b>	<p><b>Compressed spring may fly out of this assembly if attempting to disassemble and cause injury. Do not take apart this assembly.</b></p> <p><b>Disc blades are sharp and can cut causing serious injury. Wear gloves when working on or turning disc blades by hand.</b></p>
---	--

<b>NOTICE</b>	<p><b>Never strike knife with heavy object. Damage to knife will occur.</b></p> <p><b>If knife to disc blade clearance is too large, soil or residue can wedge between knife and blade, and blade will not turn.</b></p>
---------------	--

1. Adjust knife to disc blade contact. Loosen or tighten  $\frac{3}{8}$ " lock nuts to adjust knife's entire leading edge against disc blade. Turn blade and check for slight resistance without freewheeling. Readjust knife to blade's tight spot as needed.

**NOTICE**

**Adjust liquid drop tube out of path of soil flow across knife. Drop tube and tab wear quickly if not correctly adjusted.**

2. Adjust scraper and drop tube. Loosen two  $\frac{5}{16}$ " hex head cap screws. Adjust scraper until just touching disc blade. Adjust drop tube until it is centered between knife and disc blade. Tighten screws. Turn blade and check for slight resistance without freewheeling. Repeat as needed. Insert flat bladed pry bar or screwdriver between knife and drop tube above drop tube tab. Carefully bend tube until  $\frac{1}{4}$ "- $\frac{3}{8}$ " (6.35 - 9.5 mm) from disc blade.

**NOTE: Maximum disc blade depth 4" (10.2 cm).**

3. Adjust blade depth. Loosen three  $\frac{1}{2}$ " hex head cap screws and jam nuts in opener mount. Adjust opener assembly up or down to desired blade depth. Tighten center hex head cap screw and jam nut first to set proper disc blade angle. Tighten remaining hex head cap screws and jam nuts. Torque hex head cap screws and jam nuts to 57 ft-lb (77.29 N-m). Check fertilizer hose clearance and adjust as necessary.

---

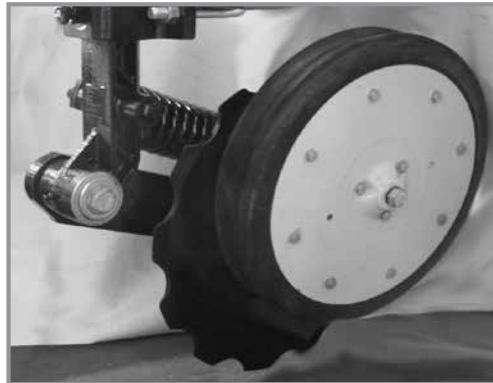
**DEPTH/GAUGE WHEEL ATTACHMENT FOR NOTCHED SINGLE DISC FERTILIZER OPENER**

**Notched single disc opener depth/gauge wheel**

Depth/gauge wheel attachment for notched single disc fertilizer opener is used where additional gauging is required to maintain desired fertilizer opener depth. Depth/gauge wheel is attached to notched single disc fertilizer opener using a mounting block fastened to the pivot arm with  $\frac{5}{8}$ " hardware through disc blade bearing.

Depth adjustment is made using 3 adjustment holes in depth/gauge wheel mounting block. Moving depth/gauge wheel increases/decreases depth in approximate 1" increments in relation to blade depth setting made at vertical mounting post.

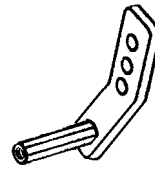

**HD SINGLE DISC FERTILIZER OPENER**

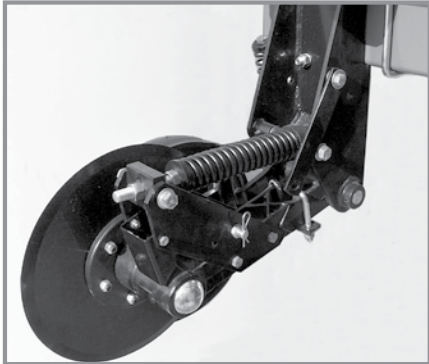

**HD single disc opener**

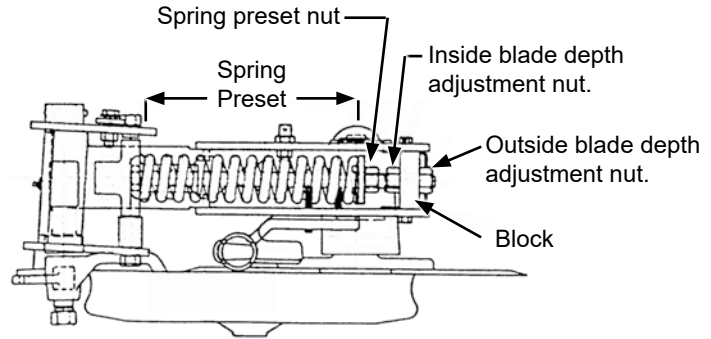

**R.H. configuration shown (Overhead view)**

Recommended placement of fertilizer with HD single disc fertilizer opener is 3½" - 4" (8.8 - 10.1 cm) from row.

<b>NOTICE</b>	<b>Never place fertilizer closer than 2" (5 cm) to row or seeds may be damaged.</b>
---------------	---

Maximum blade depth is approximately 5" (12.7 cm) with planter frame level and at 20" (50.8 cm) operating height. Soil conditions can affect depth slightly.

Raise planter to remove weight from fertilizer opener. Loosen inside adjustment nut with 1½" wrench. Turn outside nut clockwise to decrease or counterclockwise to increase blade depth. One full turn of blade depth adjustment nut changes blade depth ⅜". Tighten inside nut tight against block. Adjust all fertilizer openers to same depth.

Fertilizer opener down pressure can be adjusted from 250 lb (113.4 kg) to 640 lb (290.3 kg).

<b>NOTICE</b>	<b>Do not operate HD single disc fertilizer openers at full down pressure tension on rocky ground or disc blades will chip.</b>
---------------	---

**NOTE: DO NOT adjust spring preset dimension less than 9½" (24.13 cm).**

**NOTE: Excessive down pressure can cause planter frame up-lift and affect machine performance. Planter frame should be 20" (50.8 cm) from ground in planting position. Excessive down pressure in loose soil conditions can cause openers to run too deep and push dirt ahead of opener and may stop soil press wheel and opener blade from turning.**

Raise planter to remove weight from fertilizer opener. Turn spring preset nut clockwise to increase and counterclockwise to decrease down pressure. Adjust all rows to a similar setting. Minimal spring pressure for acceptable operation is recommended. See chart for spring length setting specifications.

Spring Preset	
Length	Down Pressure
11" (27.9 cm)	250 lb (113.4 kg)
10¾" (27.3 cm)	320 lb (145.1 kg)
<b>*10½" (26.7 cm)</b>	370 lb (167.8 kg)
10¼" (26 cm)	450 lb (204.1 kg)
10" (25.4 cm)	520 lb (235.8 kg)
9¾" (24.8 cm)	580 lb (263.1 kg)
9½" (24.1 cm)	640 lb (290.3 kg)
*Initial setting	

Adjust spring loaded dry fertilizer drop tube/scrapper periodically to maintain ⅛" (3 mm) gap between drop tube and opener blade. If this dimension is not maintained fertilizer may not drop in proper location.

Loosen scraper adjustment bolt. Slotted hole in scraper allows up or down adjustment.

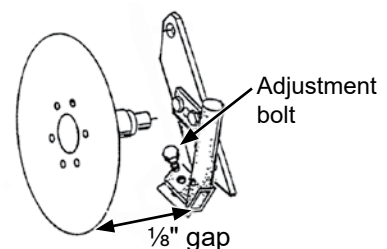

Adjust liquid drop tube/scrapper so there is slight contact between blade and scraper lower leading edge, and 1/4" clearance between liquid drop tube trailing edge and blade. Blade should turn with minimum amount of drag.

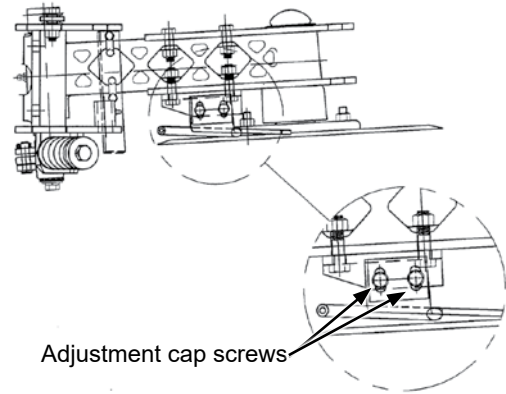

Adjustment cap screws

**NOTE: Soil press wheel is not for gauging fertilizer opener operating depth.**

Additional press wheel down pressure may be desirable in heavy moist soils. Turn press wheel spring adjustment bolt clockwise to increase down pressure.

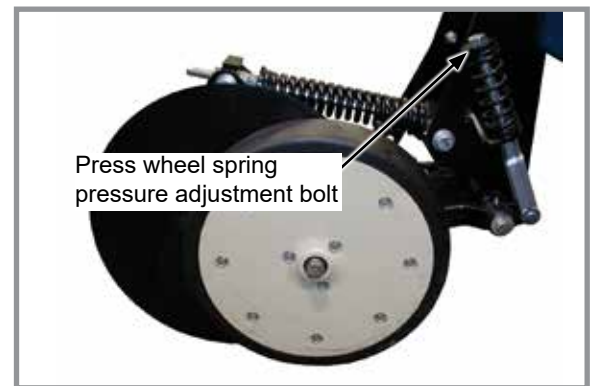

Press wheel down pressure adjustment

HD single disc fertilizer opener can be raised and locked up when fertilizer attachment is not used or during storage.

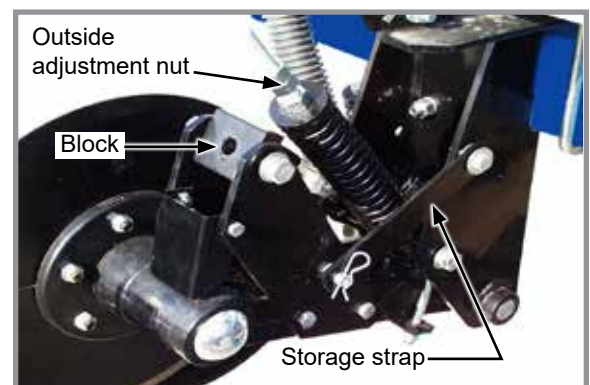

**NOTE: A lockup bar automatically raises and locks soil press wheel when blade assembly is raised.**

1. Place planter in planting position.
2. Remove outside blade depth adjustment.
3. Raise planter until adjustment bolt clears adjustment block.
4. Raise spring to clear blade assembly and raise blade assembly until storage strap can be positioned on lockup pin. Install hair pin clip.
5. Reinstall depth adjustment nut and tighten



HD opener lockup

**DRY FERTILIZER ATTACHMENT**

 <p><b>WARNING</b></p> 	<p>Agricultural chemicals can cause death or serious injury to persons, animals, and plants or seriously damage soil, equipment, or property. Read and follow all chemical and equipment manufacturers labels and instructions.</p>
---	---



**Dry fertilizer option installed**

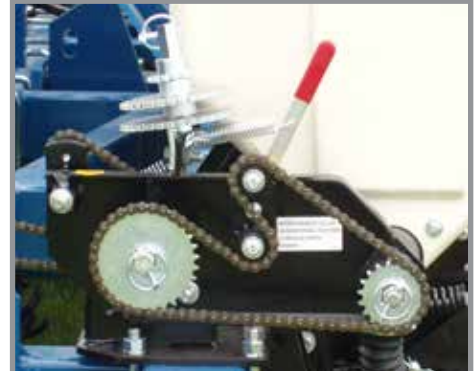

**Fertilizer drive rate transmission**

Rate of fertilizer application is determined by drive/driven sprocket combination on fertilizer drive rate transmission and auger position in the hoppers.



**Augers positioned for high rate delivery**



**Augers positioned for low rate delivery**

**NOTE: Uneven delivery of fertilizer will occur if high rate auger position is used at too low a rate setting.**

Remove ¼" stainless steel cap screws holding augers in place on shaft and reposition augers to change delivery rate.

A fertilizer transmission is located directly ahead of row unit transmission on right side of planter and allows simple, rapid changes in sprockets to obtain desired fertilizer application rates. Chain tension is controlled by a spring loaded idler adjusted with a ratchet arm located to inside of transmission. Sprockets can be changed with those on the sprocket storage rod by removing hexagon shaft pins. Fertilizer rate charts in Rate Chart section will help you select correct sprocket combinations.

**NOTE: Make a field check after each sprocket combination adjustment to be sure you are applying fertilizer at desired rate.**

<p><b>NOTICE</b></p>	<p>Placing fertilizer too close to seeds or in excessive amounts can cause germination or seedling damage. Check with your fertilizer dealer or manufacturer for correct amount and placement.</p>
----------------------	--

Because dry fertilizer attachment meters granules by volume rather than weight, differences in brands, and fertilizer analysis, weight metered during actual application may vary considerably. Use chart for reference only. Use a container to catch and measure application for a better estimate.

Keep fertilizer dry during use and storage since most fertilizers easily absorb moisture. In addition to waste, deposits of fertilizer left in hopper can cause metal corrosion. Empty hoppers at end of each day.

## CLEANING

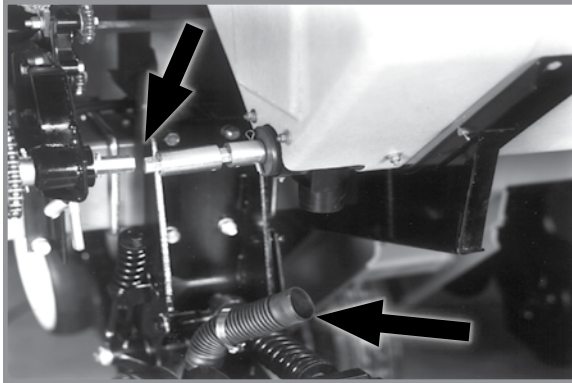
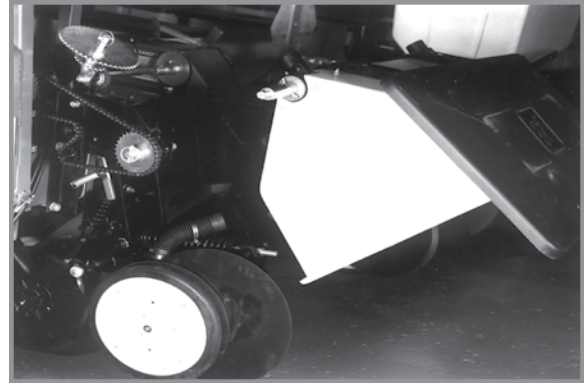
**Disconnect drive shaft and hoses****Rotate lid to back and rotate hopper forward**

Dry fertilizer hoppers tip forward for dumping and ease of cleaning. Disconnect drive shaft from transmission and/or adjacent hopper. **LOOSEN HOSE CLAMPS AND REMOVE HOSES FROM EACH HOPPER.** Remove rear  $\frac{1}{2}$ " x  $\frac{1}{4}$ " cap screw from between each hopper saddle and hopper mount. Rotate each hopper lid to back side of hopper and carefully tip hopper forward. Flush all loose fertilizer from hoppers and hoses after dumping contents.

At end of planting season or when fertilizer attachment is not used for a period of time, hoppers should be disassembled, cleaned, and metal surfaces coated with a rust preventative. Remove  $\frac{1}{4}$ " cotter pin and bearing from one end of shaft. Pull auger assembly from opposite end of hopper. Remove stainless steel cap screws from auger shaft and remove all auger components for cleaning. Coat all parts with rust preventative before reassembly. Reinstall auger halves in low or high rate position.

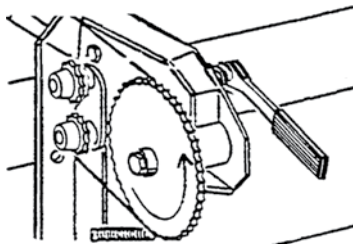
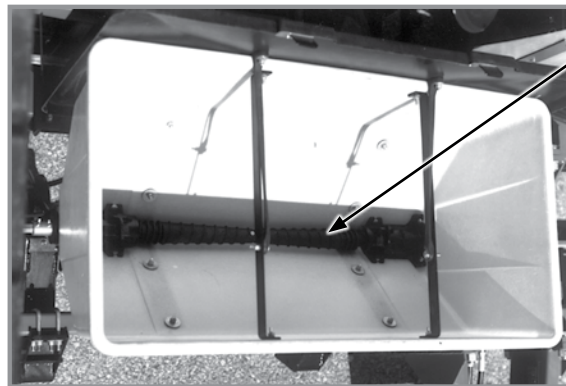
**Transmission direction of rotation**

Flighting must move chemicals from center to outside of hopper.

**Auger installation**

**NOTE: Install auger assembly so the flighting moves material to outer openings in hopper when augers rotate in direction they turn during operation.**

Slide auger assembly through outlet housing into hopper. Secure in place by reinstalling bearing and cotter pin. Rotating shaft in direction shown to see if flighting (spirals) on auger move toward ends of hopper. If not, remove auger assembly, turn  $180^\circ$ , and reinstall.

**NOTE: Frequent lubrication of auger bearings is critical to ensure augers turn freely. Check lubrication section for frequency.**

Be certain augers turn freely. If not, loosen  $\frac{5}{16}$ " carriage bolts in outlet housings, rotate auger several times, and retighten carriage bolts. This allows housings and augers to realign.

**NOTE: Do not operate fertilizer attachment without auger baffles in place.**

Install auger baffles over augers and secure in place with two hair pin clips in each hopper.

**LIQUID FERTILIZER ATTACHMENT**

**! WARNING**



Agricultural chemicals can cause death or serious injury to persons, animals, and plants or seriously damage soil, equipment, or property. Read and follow all chemical and equipment manufacturers labels and instructions.

**! CAUTION**

Overfilling tank can cause siphoning, tank collapse, personal injury, and damage to property and equipment. Do not overfill tank. Do not leave planter unattended when filling tank. Close fill valve and open tank lid if siphoning occurs. Follow all chemical manufacturers first aid, cleanup, and handling instructions.



Liquid fertilizer installed on 3605 bulk fill

**CHECK VALVES**



Reparable check valve

Optional low rate check valves are available for in-line installation between liquid fertilizer squeeze or piston pump and openers to ensure equal distribution of product at low rates. Check valves eliminate anti-siphon loops.



## PISTON PUMP

**NOTE: Keep manuals shipped with pump and flow divider with this manual.**

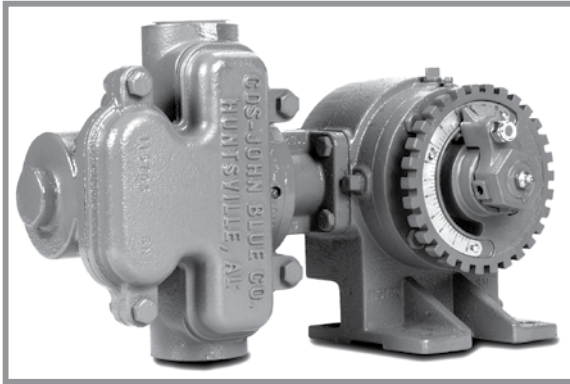

Piston pump

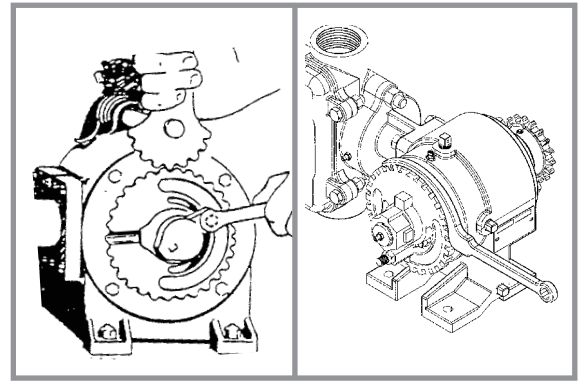

Adjusting delivery rate

**NOTE: Delivery rate chart in Rate Chart section of this manual provides approximate application rate only. Delivery varies with temperature and fertilizer.**

Loosen  $\frac{3}{8}$ " lock nut that secures arm with pointer and rotate scale flange with adjustment wrench until pointer is over desired scale setting. Tighten  $\frac{3}{8}$ " lock nut. **DO NOT OVERTIGHTEN.**

**NOTE: Periodically check flow to all rows. Set rate is delivered to remaining rows if one or more lines are plugged.**

## PISTON PUMP GROUND DRIVE WHEEL SPRING ADJUSTMENT

Initial down pressure spring tension on piston pump ground drive wheel, is set leaving  $12\frac{1}{4}$ " between the bottom of mounting plate and plug on top of spring. This dimension is taken with planter raised (tire not contacting the ground). Further adjustment can be made to fit conditions.

**NOTE: Piston pump ground drive wheel assembly can be locked in raised position when not in use. Remove two cap screws that attach upper end of spring to spring mount. Reattach spring using upper holes in spring mount. Reverse procedure to reset for field use.**

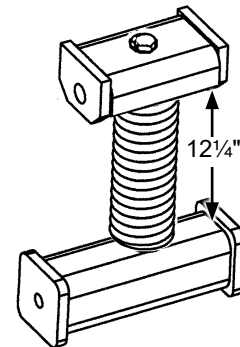

## CLEANING

Clean tanks, hoses, and metering pump thoroughly with water at end of planting season or prior to an extended period of non-use. Do not allow fertilizer to crystallize from cold temperature or evaporation.

On machines equipped with piston pump, take apart and clean strainer located between piston pump and ball valve daily. Remove the end cap to clean the screen. See Piston Pump Storage in Maintenance Section of this manual.

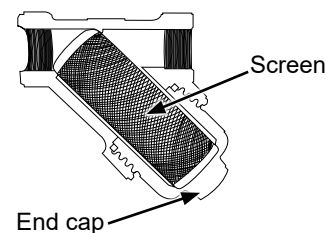

**This page left blank intentionally.**

## GENERAL PLANTING RATE INFORMATION

These planting rate charts are applicable to KINZE Model 3600 Twin-Line Planters.

### NOTICE

Sprocket combinations in these charts are for average conditions. Changes in sprocket combinations may be required for desired planting population. **ALWAYS MAKE FIELD CHECKS TO BE SURE YOU ARE PLANTING AT THE DESIRED RATE.**

### NOTICE

Seed additives added in the hopper may affect finger pickup seed meter performance and accelerate wear.

**NOTE:** Seed size and shape may affect planting rate.

**NOTE:** Not all row spacings listed apply to all size planters.

**NOTE:** Speeds above 6.0 MPH (10 KPH) can adversely affect seed spacing.

See [“Wheat Disc Section” on page 5-15](#) for brush meter and vacuum meter rate chart information.

### MECHANICAL SEED METERING

#### Finger Pickup Corn Meter

Larger grades generally plant more accurately at the high end of the ground speed range than smaller grades. Higher than optimum speeds may result in population rate increase or higher incidence of doubles, particularly with small seed. Medium round corn seed is most desirable for planting accuracy at optimum speed.

#### Finger Pickup Oil Sunflower Meter

Larger grades generally plant more accurately at the high end of the ground speed range than smaller grades. Higher than optimum speeds may result in population rate increase or higher incidence of doubles, particularly with small seed. No. 3 and/or No. 4 size oil sunflower seeds are recommended for use in finger pickup seed meters equipped with oil sunflower fingers. No. 1 and/or No. 2 size confectionery sunflower seeds are recommended for use in finger pickup seed meters equipped with corn fingers.

#### Brush-Type Seed Meter (Soybean, Milo/Grain Sorghum, Acid-Delinted Cotton)

Rate charts are given in seeds per acre as well as seed spacing in inches rounded to the nearest tenth of an inch. Because of the large range in seed size, pounds per acre is not a suggested method of selecting transmission settings. Smaller size seed pounds per acre may be below what was expected and large seed pounds per acre may appear above expectations. To determine pounds per acre, use the formula given in “Determining Pounds Per Acre (Brush-Type Seed Meter)” in “Check Seed Population” in Machine Operation section of this manual.

**NOTE:** Planting speed can affect actual seeding rate. Make a field check and adjust transmission setting to obtain desired seed drop.

#### Standard Rate (1 To 1) 30 Tooth Drive Sprocket

When planting 30"/36"/38" rows with brush-type seed meters using 30 tooth standard rate (1 to 1) sprocket, use charts on page 5-2 to 5-5.

#### Half Rate (2 To 1) 15 Tooth Drive Sprocket

When using 15 tooth half rate (2 to 1) sprocket with brush-type seed meters, seeding rate is approximately 50% of chart readings.

**NOTE:** Use of the Half Rate (2 To 1) Drive Reduction Package with brush-type seed meters will reduce planter transmission speed. Seeding rate will be approximately 50% of the chart reading when using Half Rate (2 To 1) Drive Reduction Package.

**EXAMPLE:** 30" row spacing using 60 cell seed discs in brush-type seed meters.  
 $80,928 \div 2 = 40,464$  Population (2.6" Seed Spacing x 2 = 5.2" Seed Spacing)

### VACUUM SEED METERING

**NOTE:** 15, 19, and 38 tooth drive sprockets are NOT applicable to all rate charts. Check chart titles to ensure proper rate chart is selected. 15 and 19 tooth sprockets requires 91 pitch No. 40 chain and 38 tooth sprocket requires 104 pitch No. 40 chain.

**NOTE:** Planting rates over 250,000 seeds/acre are not recommended.

**NOTE:** Contact wheel drive sprocket references in each rate chart title.

**PLANTING RATES FOR FINGER PICKUP SEED METERS (STANDARD DRIVE)  
APPROXIMATE SEEDS/ACRE FOR VARIOUS ROW WIDTHS**

Transmission Sprockets		7.5" Rows	30" Rows	36" Rows	38" Rows	Recomm. Speed Range (MPH)	Average Seed Spacing In Inches
Drive	Driven						
17	28	32,372	16,186	13,488	12,778	4 to 6	12.9
17	27	33,570	16,785	13,988	13,251	4 to 6	12.5
17	26	34,862	17,431	14,526	13,761	4 to 6	12.0
19	28	36,180	18,090	15,075	14,281	4 to 6	11.6
17	25	36,256	18,128	15,107	14,312	4 to 6	11.5
19	27	37,520	18,760	15,633	14,810	4 to 6	11.1
17	24	37,766	18,883	15,736	14,908	4 to 6	11.1
19	26	38,962	19,481	16,234	15,380	4 to 6	10.7
17	23	39,408	19,704	16,420	15,556	4 to 6	10.6
19	25	40,522	20,261	16,884	15,995	4 to 6	10.3
19	24	42,208	21,104	17,587	16,662	4 to 6	9.9
23	28	43,796	21,898	18,249	17,288	4 to 6	9.5
19	23	44,044	22,022	18,352	17,386	4 to 6	9.5
23	27	45,418	22,709	18,924	17,928	4 to 6	9.2
24	28	45,700	22,850	19,042	18,040	4 to 6	9.2
23	26	47,166	23,583	19,652	18,618	4 to 6	8.9
24	27	47,394	23,697	19,747	18,708	4 to 6	8.8
25	28	47,604	23,802	19,835	18,791	4 to 6	8.8
17	19	47,706	23,853	19,877	18,831	4 to 6	8.8
23	25	49,052	24,526	20,438	19,363	4 to 6	8.5
24	26	49,216	24,608	20,507	19,427	4 to 6	8.5
25	27	49,368	24,684	20,570	19,487	4 to 6	8.5
26	28	49,510	24,755	20,629	19,543	4 to 6	8.4
23	24	51,096	25,548	21,290	20,169	4 to 6	8.2
24	25	51,184	25,592	21,327	20,205	4 to 6	8.2
25	26	51,266	25,633	21,361	20,237	4 to 6	8.2
26	27	51,342	25,671	21,393	20,267	4 to 6	8.1
27	28	51,414	25,707	21,422	20,295	4 to 6	8.1
23	23	53,318	26,659	22,216	21,046	4 to 6	7.8
28	27	55,292	27,646	23,038	21,826	4 to 6	7.6
27	26	55,368	27,684	23,070	21,856	4 to 6	7.6
25	24	55,540	27,770	23,141	21,923	4 to 6	7.5
24	23	55,636	27,818	23,181	21,961	4 to 6	7.5
28	26	57,418	28,709	23,924	22,665	4 to 6	7.3
27	25	57,582	28,791	23,993	22,730	4 to 6	7.3
25	23	57,954	28,977	24,147	22,876	4 to 6	7.2
19	17	59,590	29,795	24,829	23,522	4 to 6	7.0
28	25	59,716	29,858	24,881	23,572	4 to 6	7.0
27	24	59,982	29,991	24,993	23,677	4 to 6	7.0
26	23	60,272	30,136	25,113	23,792	4 to 6	7.0
28	24	62,204	31,102	25,918	24,554	3 to 6	6.7
27	23	62,590	31,295	26,079	24,707	3 to 6	6.7
23	19	64,542	32,271	26,893	25,477	3 to 5.5	6.5
28	23	64,908	32,454	27,045	25,622	3 to 5.5	6.5
24	19	67,348	33,674	28,062	26,585	3 to 5.5	6.2
25	19	70,154	35,077	29,231	27,693	3 to 5	6.0
23	17	72,136	36,068	30,056	28,474	2 to 5	5.8
26	19	72,960	36,480	30,400	28,800	3 to 5	5.7
24	17	75,272	37,636	31,363	29,713	3 to 5	5.6
27	19	75,766	37,883	31,570	29,908	3 to 5	5.5
25	17	78,408	39,204	32,670	30,951	3 to 4.5	5.3
28	19	78,574	39,287	32,739	31,016	3 to 4.5	5.3
26	17	81,544	40,772	33,977	32,189	3 to 4.5	5.1
27	17	84,680	42,340	35,284	33,427	3 to 4.5	4.9
28	17	87,816	43,908	36,590	34,665	3 to 4.5	4.8

NOTE: See "Mechanical Seed Metering" in ["General Planting Rate Information" on page 5-1](#) and ["Field Check Seed Population" on page 2-42](#) for more information. Always field check seed population to verify planting rates.

**PLANTING RATES FOR BRUSH-TYPE SEED METERS (STANDARD DRIVE)**

**APPROXIMATE SEEDS/ACRE FOR 30"/36"/38" ROW WIDTHS**

Transmission Sprockets		60 Cell Soybean Or High-Rate Milo/Grain Sorghum			Average Seed Spacing In Inches	48 Cell Specialty Soybean Or High-Rate Acid-Delinted Cotton			Average Seed Spacing In Inches	Speed Range (MPH)
Drive	Driven	30" Rows	36" Rows	38" Rows		30" Rows	36" Rows	38" Rows		
17	28	80,928	67,440	63,891	2.6	64,742	53,952	51,113	3.2	2 to 8
17	27	83,926	69,938	66,257	2.5	67,141	55,950	53,006	3.1	2 to 8
17	26	87,154	72,628	68,805	2.4	69,723	58,102	55,044	3.0	2 to 8
19	28	90,449	75,374	71,407	2.3	72,359	60,299	57,126	2.9	2 to 8
19	27	93,799	78,166	74,052	2.2	75,039	62,533	59,242	2.8	2 to 8
17	24	94,416	78,680	74,539	2.2	75,533	62,944	59,631	2.8	2 to 8
17	23	98,521	82,101	77,780	2.1	78,817	65,681	62,224	2.7	2 to 8
19	25	101,303	84,419	79,976	2.1	81,042	67,535	63,981	2.6	2 to 8
19	24	105,524	87,937	83,309	2.0	84,419	70,350	66,647	2.5	2 to 8
23	28	109,491	91,243	86,440	1.9	87,593	72,994	69,152	2.4	2 to 8
19	23	110,112	91,760	86,931	1.9	88,090	73,408	69,545	2.4	2 to 8
24	28	114,252	95,210	90,199	1.8	91,402	76,168	72,159	2.3	2 to 8
24	27	118,483	98,736	93,539	1.8	94,786	78,989	74,831	2.2	2 to 8
17	19	119,263	99,386	94,155	1.8	95,410	79,509	75,324	2.2	2 to 8
24	26	123,040	102,534	97,137	1.7	98,432	82,027	77,710	2.1	2 to 8
26	28	123,773	103,144	97,715	1.7	99,018	82,515	78,172	2.1	2 to 8
24	25	127,962	106,635	101,023	1.6	102,370	85,308	80,818	2.0	2 to 8
26	27	128,357	106,964	101,334	1.6	102,686	85,571	81,067	2.0	2 to 8
23	23	133,294	111,078	105,232	1.6	106,635	88,862	84,186	2.0	2 to 8
27	26	138,420	115,350	109,279	1.5	110,736	92,280	87,423	1.9	2 to 8
24	23	139,089	115,907	109,807	1.5	111,271	92,726	87,846	1.9	2 to 8
25	23	144,884	120,737	114,382	1.4	115,907	96,590	91,506	1.8	2 to 8
19	17	148,975	124,146	117,612	1.4	119,180	99,317	94,090	1.8	2 to 8
27	24	149,955	124,963	118,386	1.4	119,964	99,970	94,709	1.7	2 to 8
28	24	155,509	129,591	122,770	1.3	124,407	103,673	98,216	1.7	2 to 8
23	19	161,355	134,463	127,386	1.3	129,084	107,570	101,909	1.6	2 to 8
28	23	162,270	135,225	128,108	1.3	129,816	108,180	102,483	1.6	2 to 8
24	19	168,371	140,309	132,924	1.2	134,696	112,247	106,339	1.6	2 to 8
25	19	175,386	146,155	138,463	1.2	140,309	116,924	110,770	1.5	2 to 8
23	17	180,338	150,282	142,372	1.2	144,270	120,226	113,898	1.5	2 to 8
26	19	182,402	152,001	144,001	1.1	145,922	121,601	115,201	1.4	2 to 7
27	19	189,417	157,878	148,540	1.1	151,534	126,278	118,832	1.4	2 to 7
28	19	196,433	163,694	155,078	1.1	157,146	130,955	124,062	1.3	2 to 7
26	17	203,861	169,884	160,943	1.0	163,089	135,907	128,754	1.3	2 to 7
27	17	211,702	176,418	167,133	0.9	169,362	141,134	133,706	1.2	2 to 7
28	17	219,542	182,952	173,323	0.9	175,634	146,362	138,658	1.2	2 to 7

**NOTE:** See "Mechanical Seed Metering" in ["General Planting Rate Information" on page 5-1](#) and ["Field Check Seed Population" on page 2-42](#) for additional information.

**NOTE:** When using Half Rate (2 To 1) Drive Reduction Package, rates are approximately 50% of given numbers.

**NOTE:** Always field check seed population to ensure planting rates are correct.

**PLANTING RATES FOR BRUSH-TYPE SEED METERS (STANDARD DRIVE)  
APPROXIMATE SEEDS/ACRE FOR 15"/18"/19" ROW WIDTHS**

Transmission Sprockets		60 Cell Soybean Or High-Rate Milo/Grain Sorghum			Average Seed Spacing In Inches	48 Cell Specialty Soybean Or High-Rate Acid-Delinted Cotton			Average Seed Spacing In Inches	Speed Range (MPH)
Drive	Driven	7.5" Rows or 15" Rows	18" Rows	19" Rows		7.5" Rows or 15" Rows	18" Rows	19" Rows		
17	28	161,856	134,880	127,782	2.6	129,484	107,904	102,226	3.2	2 to 8
17	27	167,852	139,876	132,514	2.5	134,282	111,900	106,012	3.1	2 to 8
17	26	174,308	145,256	137,610	2.4	139,446	116,204	110,088	3.0	2 to 8
19	28	180,898	150,748	142,814	2.3	144,718	120,598	114,252	2.9	2 to 8
19	27	187,598	156,332	148,104	2.2	150,078	125,066	118,484	2.8	2 to 8
17	24	188,832	157,360	149,078	2.2	151,066	125,888	119,262	2.8	2 to 8
17	23	197,042	164,202	155,560	2.1	157,634	131,362	124,448	2.7	2 to 8
19	25	202,606	168,838	159,952	2.1	162,084	135,070	127,962	2.6	2 to 8
19	24	211,048	175,874	166,618	2.0	168,838	140,700	133,294	2.5	2 to 8
23	28	218,982	182,486	172,880	1.9	175,186	145,988	138,304	2.4	2 to 8
19	23	220,224	183,520	173,862	1.9	176,180	146,816	139,090	2.4	2 to 8
24	28	228,504	190,420	180,398	1.8	182,804	152,336	144,318	2.3	2 to 8
24	27	236,966	197,472	187,078	1.8	189,572	157,978	149,662	2.2	2 to 8
17	19	238,526	198,772	188,310	1.8	190,820	159,018	150,648	2.2	2 to 8
24	26	246,080	205,068	194,274	1.7	196,864	164,054	155,420	2.1	2 to 8
26	28	247,546	206,288	195,430	1.7	198,036	165,030	156,344	2.1	2 to 8
24	25	255,924	213,270	202,046	1.6	204,740	170,616	161,636	2.0	2 to 8
26	27	256,714	213,928	202,668	1.6	205,372	171,142	162,134	2.0	2 to 8
23	23	266,588	222,156	210,464	1.6	213,270	177,724	168,372	2.0	2 to 8
27	26	276,840	230,700	218,558	1.5	221,472	184,560	174,846	1.9	2 to 8
24	23	278,178	231,814	219,614	1.5	222,542	185,452	175,692	1.9	2 to 8
25	23	289,768	241,474	228,764	1.4	231,814	193,180	183,012	1.8	2 to 8
19	17	297,950	248,292	235,224	1.4	238,360	198,634	188,180	1.8	2 to 8
27	24	299,910	249,926	236,772	1.4	239,928	199,940	189,418	1.7	2 to 8
28	24	311,018	259,182	245,540	1.3	248,814	207,346	196,432	1.7	2 to 8
23	19	322,710	268,926	254,772	1.3	258,168	215,140	203,818	1.6	2 to 8
28	23	324,540	270,450	256,216	1.3	259,632	216,360	204,966	1.6	2 to 8
24	19	336,742	280,618	265,848	1.2	269,392	224,494	212,678	1.6	2 to 8
25	19	350,772	292,310	276,926	1.2	280,618	233,848	221,540	1.5	2 to 8
23	17	360,676	300,564	284,744	1.2	288,540	240,452	227,796	1.5	2 to 8
26	19	364,804	304,002	288,002	1.1	291,844	243,202	230,402	1.4	2 to 7
27	19	378,834	315,756	297,080	1.1	303,068	252,556	237,664	1.4	2 to 7
28	19	392,866	327,388	310,156	1.1	314,292	261,910	248,124	1.3	2 to 7
26	17	407,722	339,768	321,886	1.0	326,178	271,814	257,508	1.3	2 to 7
27	17	423,404	352,836	334,266	0.9	338,724	282,268	267,412	1.2	2 to 7
28	17	439,084	365,904	346,646	0.9	351,268	292,724	277,316	1.2	2 to 7

NOTE: See ["General Planting Rate Information" on page 5-1](#) and ["Field Check Seed Population" on page 2-42](#) for additional information.

NOTE: When using Half Rate (2 To 1) Drive Reduction Package, rates are approximately 50% of given numbers.

NOTE: Always field check seed population to ensure planting rates are correct.

**PLANTING RATES FOR BRUSH-TYPE SEED METERS (STANDARD DRIVE)  
APPROXIMATE SEEDS/ACRE FOR VARIOUS ROW WIDTHS**

Transmission Sprockets		36 Cell Acid-Delinted Large Cotton			Average Seed Spacing In Inches	30 Cell Milo/Grain Sorghum Or Acid-Delinted Cotton			Average Seed Spacing In Inches	Speed Range (MPH)
Drive	Driven	30" Rows	36" Rows	38" Rows		30" Rows	36" Rows	38" Rows		
17	28	48,557	40,464	38,335	4.3	40,464	33,720	31,945	5.2	2 to 8
17	27	50,356	41,963	39,754	4.2	41,963	34,969	33,129	5.0	2 to 8
17	26	52,292	43,577	41,283	4.0	43,577	36,314	34,403	4.8	2 to 8
19	28	54,269	45,224	42,844	3.9	45,225	37,687	35,704	4.6	2 to 8
19	27	56,279	46,900	44,431	3.7	46,900	39,083	37,026	4.5	2 to 8
17	24	56,650	47,208	44,723	3.7	47,208	39,340	37,270	4.4	2 to 8
17	23	59,113	49,261	46,668	3.5	49,261	41,051	38,890	4.2	2 to 8
19	25	60,782	50,651	47,986	3.5	50,652	42,210	39,988	4.1	2 to 8
19	24	63,314	52,762	49,985	3.3	52,762	43,968	41,654	4.0	2 to 8
23	28	65,695	54,746	51,864	3.2	54,746	45,621	43,220	3.8	2 to 8
19	23	66,067	55,056	52,159	3.2	55,056	45,880	43,465	3.8	2 to 8
24	28	68,551	57,126	54,119	3.0	57,126	47,605	45,099	3.7	2 to 8
24	27	71,090	59,242	56,123	2.9	59,242	49,368	46,770	3.5	2 to 8
17	19	71,558	59,632	56,493	2.9	59,631	49,693	47,077	3.5	2 to 8
24	26	73,824	61,520	58,282	2.8	61,520	51,267	48,569	3.4	2 to 8
26	28	74,264	61,886	58,629	2.8	61,886	51,572	48,858	3.4	2 to 8
24	25	76,772	63,981	60,614	2.7	63,981	53,317	50,511	3.3	2 to 8
26	27	77,014	64,178	60,800	2.7	64,178	53,482	50,667	3.3	2 to 8
23	23	79,976	66,647	63,139	2.6	66,647	55,539	52,616	3.1	2 to 8
27	26	83,052	69,210	65,567	2.5	69,210	57,675	54,640	3.0	2 to 8
24	23	83,453	69,544	65,884	2.5	69,544	57,954	54,904	3.0	2 to 8
25	23	86,930	72,442	68,629	2.4	72,442	60,368	57,191	2.9	2 to 8
19	17	89,385	74,488	70,567	2.3	74,488	62,073	58,806	2.8	2 to 8
27	24	89,973	74,978	71,032	2.3	74,978	62,481	59,193	2.8	2 to 8
28	24	93,305	77,755	73,662	2.2	77,755	64,796	61,385	2.7	2 to 8
23	19	96,813	80,678	76,432	2.2	80,678	67,231	63,693	2.6	2 to 8
28	23	97,362	81,135	76,864	2.1	81,135	67,613	64,054	2.6	2 to 8
24	19	101,023	84,185	79,754	2.1	84,185	70,155	66,462	2.5	2 to 8
25	19	105,232	87,693	83,078	2.0	87,693	73,078	69,231	2.4	2 to 8
23	17	108,233	90,169	85,423	1.9	90,169	75,141	71,186	2.3	2 to 8
26	19	109,441	91,201	86,401	1.9	91,201	76,001	72,001	2.3	2 to 7
27	19	113,650	94,709	89,124	1.8	94,709	78,924	74,770	2.2	2 to 7
28	19	117,860	98,216	93,047	1.8	98,216	81,847	77,539	2.1	2 to 7
26	17	122,317	101,930	96,566	1.7	101,930	84,942	80,471	2.1	2 to 7
27	17	127,021	105,851	100,280	1.6	105,851	88,209	83,566	2.0	2 to 7
28	17	131,725	109,771	103,994	1.6	109,771	91,476	86,661	1.9	2 to 7

**NOTE:** See ["General Planting Rate Information" on page 5-1](#) and ["Field Check Seed Population" on page 2-42](#) for additional information.

**NOTE:** When using Half Rate (2 To 1) Drive Reduction Package, rates are approximately 50% of given numbers.

**NOTE:** Always field check seed population to ensure planting rates are correct.

**PLANTING RATES FOR BRUSH-TYPE SEED METERS (STANDARD DRIVE)  
APPROXIMATE HILLS/ACRE FOR VARIOUS ROW WIDTHS**

Due to variations in cotton seed size, meters equipped with 12 cell acid-delinted hill-drop cotton discs plant from 3 to 6 seeds per cell. Select proper disc for seed size range to be planted.

*To determine planter transmission setting, determine desired hill spacing and select the transmission ratio closest to the hill spacing in inches on the chart. To decrease population increase spacing. To increase population decrease spacing.*

*To determine population per acre, determine average seeds per hill and hills per acre by doing a field check. Measure 1/1000 of an acre (1/1000 acre = Length of row 17' 5" for 30" row widths, 14' 6" for 36" row widths and 13' 10" for 38" row widths). Multiply average seeds per hill by hills per acre. EXAMPLE: 4 seeds per hill x (13 hills x 1000) = 52,000*

Transmission Sprockets Drive Driven		NUMBER OF HILLS PER ACRE 12 Cell Hill-Drop Cotton, Acid-Delinted			Average Hill Spacing In Inches	Speed Range (MPH)
		30" Rows	36" Rows	38" Rows		
17	28	16,186	13,488	12,778	12.9	2 to 8
17	27	16,785	13,988	13,251	12.5	2 to 8
17	26	17,431	14,526	13,761	12.0	2 to 8
19	28	18,090	15,075	14,281	11.6	2 to 8
19	27	18,760	15,633	14,810	11.1	2 to 8
17	24	18,883	15,736	14,908	11.1	2 to 8
17	23	19,704	16,420	15,556	10.6	2 to 8
19	25	20,261	16,884	15,995	10.3	2 to 8
19	24	21,105	17,587	16,662	9.9	2 to 8
23	28	21,898	18,249	17,288	9.5	2 to 8
19	23	22,022	18,352	17,386	9.5	2 to 8
24	28	22,850	19,042	18,040	9.2	2 to 8
24	27	23,697	19,747	18,708	8.8	2 to 8
17	19	23,853	19,877	18,831	8.8	2 to 8
24	26	24,608	20,507	19,427	8.5	2 to 8
26	28	24,755	20,629	19,543	8.4	2 to 8
24	25	25,592	21,327	20,205	8.2	2 to 8
26	27	25,671	21,393	20,267	8.1	2 to 8
23	23	26,659	22,216	21,046	7.8	2 to 8
27	26	27,684	23,070	21,856	7.6	2 to 8
24	23	27,818	23,181	21,961	7.5	2 to 8
25	23	28,977	24,147	22,876	7.2	2 to 8
19	17	29,795	24,829	23,522	7.0	2 to 8
27	24	29,991	24,993	23,677	7.0	2 to 8
28	24	31,102	25,918	24,554	6.7	2 to 8
23	19	32,271	26,893	25,477	6.5	2 to 8
28	23	32,454	27,045	25,622	6.5	2 to 8
24	19	33,674	28,062	26,585	6.2	2 to 8
25	19	35,077	29,231	27,693	6.0	2 to 8
23	17	36,068	30,056	28,474	5.8	2 to 8
26	19	36,480	30,400	28,800	5.7	2 to 7
27	19	37,883	31,570	29,908	5.5	2 to 7
28	19	39,287	32,739	31,016	5.3	2 to 7
26	17	40,772	33,977	32,189	5.1	2 to 7
27	17	42,340	35,284	33,427	4.9	2 to 7
28	17	43,908	36,590	34,665	4.8	2 to 7

NOTE: See ["General Planting Rate Information" on page 5-1](#) and ["Field Check Seed Population" on page 2-42](#) for additional information.

NOTE: When using Half Rate (2 To 1) Drive Reduction Package, rates are approximately 50% of given numbers.

NOTE: Always field check seed population to ensure planting rates are correct.



**PLANTING RATES FOR BRUSH-TYPE SEED METERS (STANDARD DRIVE)  
APPROXIMATE SEEDS/ACRE FOR 15"/18"/19"/30"/36"/38" ROW WIDTHS**

Transmission Sprockets		54 Cell Soybean						Average Seed Spacing In Inches	Speed Range (MPH)
Drive	Driven	7.5" Rows or 15" Rows	18" Rows	19" Rows	30" Rows	36" Rows	38" Rows		
15	28	128,529	107,107	101,470	64,264	53,554	50,735	3.3	2 to 8
15	27	133,289	111,074	105,228	66,644	55,537	52,614	3.1	2 to 8
15	26	138,415	115,346	109,275	69,208	57,673	54,638	3	2 to 8
15	25	143,952	119,960	113,646	71,976	59,980	56,823	2.9	2 to 8
17	28	145,666	121,388	114,999	72,833	60,694	57,500	2.9	2 to 8
17	27	151,061	125,884	119,258	75,530	62,942	59,629	2.8	2 to 8
17	26	156,871	130,726	123,845	78,435	65,363	61,923	2.7	2 to 8
19	28	162,803	135,669	128,529	81,401	67,835	64,264	2.6	2 to 8
19	27	168,833	140,694	133,289	84,416	70,347	66,644	2.5	2 to 8
17	24	169,943	141,619	134,166	84,972	70,810	67,083	2.5	2 to 8
17	23	177,332	147,777	139,999	88,666	73,888	70,000	2.4	2 to 8
19	25	182,339	151,949	143,952	91,170	75,975	71,976	2.3	2 to 8
19	24	189,937	158,281	149,950	94,968	79,140	74,975	2.2	2 to 8
23	28	197,077	164,231	155,587	98,539	82,115	77,794	2.1	2 to 8
19	23	198,195	165,162	156,470	99,097	82,581	78,235	2.1	2 to 8
24	28	205,646	171,371	162,352	102,823	85,686	81,176	2	2 to 8
24	27	213,262	177,718	168,365	106,631	88,859	84,182	2	2 to 8
17	19	214,665	178,888	169,473	107,333	89,444	84,736	1.9	2 to 8
24	26	221,465	184,554	174,840	110,732	92,277	87,420	1.9	2 to 8
26	28	222,783	185,652	175,881	111,391	92,826	87,941	1.9	2 to 8
24	25	230,323	191,936	181,834	115,162	95,968	90,917	1.8	2 to 8
26	27	231,034	192,528	182,395	115,517	96,264	91,198	1.8	2 to 8
23	23	239,920	199,933	189,410	119,960	99,967	94,705	1.7	2 to 8
27	26	249,148	207,623	196,695	124,574	103,812	98,348	1.7	2 to 8
24	23	250,351	208,626	197,646	125,176	104,313	98,823	1.7	2 to 8
25	23	260,783	217,319	205,881	130,391	108,659	102,940	1.6	2 to 8
19	17	268,146	223,455	211,694	134,073	111,727	105,847	1.6	2 to 8
27	24	269,910	224,925	213,087	134,955	112,462	106,543	1.5	2 to 8
28	24	279,907	233,255	220,979	139,953	116,628	110,489	1.5	2 to 8
23	19	290,429	242,024	229,286	145,215	121,012	114,643	1.4	2 to 8
28	23	292,076	243,397	230,587	146,038	121,699	115,293	1.4	2 to 8
24	19	303,057	252,547	239,255	151,528	126,274	119,628	1.4	2 to 8
25	19	315,684	263,070	249,224	157,842	131,535	124,612	1.3	2 to 8
23	17	324,598	270,498	256,261	162,299	135,249	128,131	1.3	2 to 8
26	19	328,311	273,593	259,193	164,156	136,796	129,597	1.3	2 to 8
27	19	340,939	284,116	269,162	170,469	142,058	134,581	1.2	2 to 8
28	19	353,566	294,639	279,131	176,783	147,319	139,566	1.2	2 to 8
26	17	366,936	305,780	289,687	183,468	152,890	144,843	1.1	2 to 8
27	17	381,049	317,541	300,828	190,525	158,771	150,414	1.1	2 to 8
28	17	395,162	329,302	311,970	197,581	164,651	155,985	1.1	2 to 8

NOTE: See ["General Planting Rate Information" on page 5-1](#) and ["Field Check Seed Population" on page 2-42](#) for additional information.

NOTE: When using Half Rate (2 To 1) Drive Reduction Package, rates are approximately 50% of given numbers.

NOTE: Always field check seed population to ensure planting rates are correct.

**PLANTING RATES FOR (VACUUM) CORN//SUNFLOWER 40 CELL DISC  
22 TOOTH CONTACT WHEEL DRIVE SPROCKET  
APPROXIMATE SEEDS/ACRE FOR VARIOUS ROW WIDTHS**

Transmission Drive	Sprockets Driven	7.5" Rows or 15" Rows	18" Rows	19" Rows	30" Rows	36" Rows	38" Rows	Recomm. Speed Range (MPH)	Average Seed Spacing In Inches
15	28	47,604	39,670	37,582	23,802	19,835	18,791	4 to 6	8.8
15	27	49,367	41,139	38,973	24,683	20,569	19,487	4 to 6	8.5
15	26	51,266	42,721	40,473	25,633	21,361	20,236	4 to 6	8.2
15	25	53,316	44,430	42,091	26,658	22,215	21,046	4 to 6	7.8
17	28	53,951	44,959	42,593	26,975	22,480	21,296	4 to 6	7.7
15	24	55,537	46,281	43,845	27,769	23,141	21,923	4 to 6	7.5
17	27	55,949	46,625	44,170	27,974	23,312	22,085	4 to 6	7.5
15	23	57,952	48,293	45,752	28,976	24,147	22,876	4 to 6	7.2
17	26	58,101	48,417	45,869	29,050	24,208	22,934	4 to 6	7.2
19	28	60,298	50,248	47,604	30,149	25,124	23,802	4 to 6	6.9
17	25	60,425	50,354	47,704	30,212	25,177	23,852	4 to 6	6.9
19	27	62,531	52,110	49,367	31,266	26,054	24,683	4 to 6	6.7
17	24	62,943	52,452	49,691	31,472	26,226	24,846	4 to 6	6.6
19	26	64,936	54,114	51,266	32,468	27,056	25,633	4 to 6	6.4
17	23	65,679	54,732	51,852	32,840	27,366	25,926	4 to 6	6.3
19	25	67,533	56,278	53,316	33,767	28,139	26,658	4 to 6	6.2
15	19	70,153	58,461	55,384	35,076	29,231	27,692	4 to 6	5.9
19	24	70,348	58,623	55,537	35,173	29,312	27,769	4 to 6	5.9
23	28	72,992	60,827	57,626	36,496	30,413	28,812	4 to 6	5.8
19	23	73,406	61,172	57,952	36,704	30,586	28,976	4 to 6	5.7
23	27	75,695	63,080	59,760	37,848	31,539	29,880	4 to 6	5.6
24	28	76,166	63,472	60,131	38,083	31,735	30,066	4 to 6	5.5
15	17	78,406	65,338	61,899	39,203	32,669	30,950	4 to 6	5.4
24	27	78,987	65,823	62,358	39,493	32,911	31,179	4 to 6	5.3
17	19	79,507	66,255	62,768	39,753	33,128	31,385	4 to 6	5.3
23	25	81,752	68,126	64,541	40,876	34,063	32,271	4 to 6	5.1
26	28	82,513	68,761	65,142	41,256	34,381	32,571	4 to 6	5.1
23	24	85,158	70,965	67,230	42,578	35,482	33,615	4 to 6	4.9
24	25	85,306	71,088	67,347	42,653	35,544	33,674	4 to 6	4.9
27	28	85,686	71,405	67,647	42,843	35,703	33,824	4 to 6	4.9
23	23	88,861	74,050	70,153	44,430	37,025	35,076	4 to 6	4.7
28	27	92,152	76,793	72,751	46,076	38,396	36,375	4 to 6	4.6
27	26	92,278	76,898	72,851	46,138	38,449	36,426	4 to 6	4.5
24	23	92,724	77,270	73,203	46,362	38,635	36,601	4 to 6	4.5
28	26	95,695	79,747	75,549	47,848	39,873	37,774	4 to 6	4.4
27	25	95,969	79,974	75,765	47,985	39,987	37,882	4 to 6	4.4
25	23	96,587	80,489	76,253	48,293	40,245	38,126	4 to 6	4.3
19	17	99,314	82,762	78,406	49,657	41,381	39,203	4 to 6	4.2
27	24	99,968	83,307	78,922	49,984	41,653	39,461	4 to 6	4.2
26	23	100,450	83,709	79,304	50,226	41,854	39,651	4 to 6	4.2
28	24	103,670	86,392	81,845	51,835	43,196	40,922	4 to 6	4.0
27	23	104,314	86,928	82,353	52,157	43,465	41,176	4 to 6	4.0
23	19	107,567	89,640	84,922	53,784	44,819	42,461	4 to 6	3.9
28	23	108,177	90,148	85,403	54,089	45,074	42,702	4 to 6	3.9
24	19	112,244	93,537	88,614	56,122	46,768	44,307	4 to 6	3.7
25	19	116,921	97,435	92,307	58,461	48,717	46,153	4 to 6	3.6
23	17	120,223	100,186	94,913	60,112	50,092	47,456	4 to 6	3.5
26	19	121,598	101,331	95,999	60,799	50,666	47,999	4 to 6	3.4
24	17	125,449	104,542	99,039	62,725	52,271	49,520	4 to 6	3.3
27	19	126,275	105,229	99,691	63,137	52,614	49,845	4 to 6	3.3
25	17	130,677	108,897	103,166	65,338	54,417	51,583	4 to 6	3.2
28	19	130,952	109,126	103,383	65,476	54,563	51,691	4 to 6	3.2
26	17	135,904	113,253	107,292	67,952	56,627	53,646	4 to 6	3.1
23	15	136,252	113,544	107,567	68,126	56,771	53,784	4 to 6	3.0
27	17	141,131	117,609	111,419	70,565	58,804	55,710	4 to 6	2.9

**NOTE:** See ["General Planting Rate Information"](#) on page 5-1 and ["Field Check Seed Population"](#) on page 2-42 for additional information.

**PLANTING RATES FOR (VACUUM) CORN//SUNFLOWER 40 CELL DISC  
28 TOOTH CONTACT WHEEL DRIVE SPROCKET  
APPROXIMATE SEEDS/ACRE FOR VARIOUS ROW WIDTHS**

Transmission Sprockets		7.5" Rows or 15" Rows	18" Rows	19" Rows	30" Rows	36" Rows	38" Rows	Recomm. Speed Range (MPH)	Average Seed Spacing In Inches
Drive	Driven								
15	28	60,298	50,248	47,604	30,149	25,124	23,802	4 to 6	6.9
15	27	62,531	52,110	49,367	31,266	26,054	24,683	4 to 6	6.7
15	26	64,936	54,114	51,266	32,468	27,056	25,633	4 to 6	6.4
15	25	67,533	56,278	53,316	33,767	28,139	26,658	4 to 6	6.2
17	28	68,337	56,948	53,951	34,169	28,474	26,975	4 to 6	6.1
15	24	70,348	58,623	55,537	35,173	29,312	27,769	4 to 6	5.9
17	27	70,869	59,057	55,949	35,435	29,528	27,974	4 to 6	5.9
15	23	73,406	61,172	57,952	36,704	30,586	28,976	4 to 6	5.7
17	26	73,595	61,329	58,101	36,797	30,665	29,050	4 to 6	5.7
19	28	76,377	63,648	60,298	38,189	31,824	30,149	4 to 6	5.5
17	25	76,538	63,782	60,425	38,269	31,891	30,212	4 to 6	5.5
19	27	79,206	66,005	62,531	39,603	33,003	31,266	4 to 6	5.3
17	24	79,727	66,439	62,943	39,864	33,219	31,472	4 to 6	5.3
19	26	82,252	68,544	64,936	41,126	34,272	32,468	4 to 6	5.1
17	23	83,194	69,328	65,679	41,597	34,664	32,840	4 to 6	5.1
19	25	85,543	71,285	67,533	42,771	35,643	33,767	4 to 6	4.9
15	19	88,861	74,050	70,153	44,430	37,025	35,076	4 to 6	4.7
19	24	89,107	74,255	70,348	44,554	37,128	35,173	4 to 6	4.7
23	28	92,456	77,047	72,992	46,229	38,524	36,496	4 to 6	4.5
19	23	92,982	77,484	73,406	46,490	38,743	36,704	4 to 6	4.5
23	27	95,881	79,902	75,695	47,941	39,951	37,848	4 to 6	4.4
24	28	96,477	80,397	76,166	48,238	40,199	38,083	4 to 6	4.3
15	17	99,314	82,762	78,406	49,657	41,381	39,203	4 to 6	4.2
24	27	100,050	83,375	78,987	50,025	41,687	39,493	4 to 6	4.2
17	19	100,709	83,923	79,507	50,354	41,962	39,753	4 to 6	4.2
23	25	103,552	86,293	81,752	51,775	43,147	40,876	4 to 6	4.0
26	28	104,517	87,097	82,513	52,258	43,549	41,256	4 to 6	4.0
23	24	107,867	89,888	85,158	53,933	44,945	42,578	4 to 6	3.9
24	25	108,054	90,045	85,306	54,027	45,023	42,653	4 to 6	3.9
27	28	108,536	90,447	85,686	54,268	45,224	42,843	4 to 6	3.9
23	23	112,556	93,797	88,861	56,278	46,898	44,430	4 to 6	3.7
28	27	116,725	97,271	92,152	58,362	48,636	46,076	4 to 6	3.6
27	26	116,885	97,404	92,278	58,443	48,703	46,138	4 to 6	3.6
24	23	117,450	97,875	92,724	58,725	48,937	46,362	4 to 6	3.6
28	26	121,214	101,012	95,695	60,607	50,506	47,848	4 to 6	3.4
27	25	121,561	101,301	95,969	60,781	50,650	47,985	4 to 6	3.4
25	23	122,344	101,953	96,587	61,172	50,976	48,293	4 to 6	3.4
19	17	125,798	104,832	99,314	62,899	52,415	49,657	4 to 6	3.3
27	24	126,626	105,521	99,968	63,313	52,761	49,984	4 to 6	3.3
26	23	127,238	106,031	100,450	63,618	53,015	50,226	4 to 6	3.3
28	24	131,316	109,430	103,670	65,657	54,715	51,835	4 to 6	3.2
27	23	132,131	110,110	104,314	66,066	55,054	52,157	4 to 6	3.1
23	19	136,252	113,544	107,567	68,126	56,771	53,784	4 to 6	3.0
28	23	137,025	114,188	108,177	68,513	57,093	54,089	4 to 6	3.0
24	19	142,176	118,480	112,244	71,088	59,240	56,122	4 to 6	2.9
25	19	148,101	123,417	116,921	74,050	61,709	58,461	4 to 6	2.8
23	17	152,282	126,902	120,223	76,141	63,451	60,112	4 to 6	2.7
26	19	154,025	128,354	121,598	77,012	64,176	60,799	4 to 6	2.7
24	17	158,903	132,419	125,449	79,451	66,209	62,725	4 to 6	2.6
27	19	159,949	133,290	126,275	79,974	66,645	63,137	4 to 6	2.6
25	17	165,524	137,936	130,677	82,762	68,968	65,338	4 to 6	2.5
28	19	165,873	138,227	130,952	82,936	69,114	65,476	4 to 6	2.5
26	17	172,145	143,454	135,904	86,073	71,727	67,952	4 to 6	2.4
23	15	172,587	143,822	136,252	86,293	71,911	68,126	4 to 6	2.4
27	17	178,766	148,971	141,131	89,383	74,486	70,565	4 to 6	2.3

**NOTE:** See ["General Planting Rate Information"](#) on page 5-1 and ["Field Check Seed Population"](#) on page 2-42 for additional information.

**PLANTING RATES FOR (VACUUM) MILO / SUGARBEET / SPECIALTY / SOYBEAN 60 CELL DISCS  
22 TOOTH CONTACT WHEEL DRIVE SPROCKET**

**APPROXIMATE SEEDS/ACRE FOR VARIOUS ROW WIDTHS**

Transmission Sprockets		7.5" Rows or 15" Rows	18" Rows	19" Rows	30" Rows	36" Rows	38" Rows	Recomm. Speed Range (MPH)	Average Seed Spacing In Inches
Drive	Driven								
15	28	71,406	59,505	56,373	35,703	29,752	28,186	4 to 6	5.9
15	27	74,050	61,708	58,461	37,025	30,854	29,230	4 to 6	5.6
15	26	76,898	64,082	60,709	38,449	32,041	30,355	4 to 6	5.4
15	25	79,974	66,645	63,138	39,987	33,323	31,569	4 to 6	5.2
17	28	80,926	67,439	63,889	40,463	33,719	31,945	4 to 6	5.2
15	24	83,306	69,422	65,768	41,653	34,711	32,884	4 to 6	5.0
17	27	83,924	69,936	66,255	41,962	34,968	33,128	4 to 6	5.0
15	23	86,928	72,440	68,628	43,464	36,220	34,314	4 to 6	4.8
17	26	87,151	72,626	68,804	43,576	36,313	34,402	4 to 6	4.8
19	28	90,447	75,372	71,406	45,223	37,686	35,703	4 to 6	4.6
17	25	90,637	75,531	71,556	45,319	37,766	35,778	4 to 6	4.6
19	27	93,797	78,164	74,050	46,898	39,082	37,025	4 to 6	4.5
17	24	94,414	78,678	74,537	47,207	39,339	37,269	4 to 6	4.4
19	26	97,404	81,170	76,898	48,702	40,585	38,449	4 to 6	4.3
17	23	98,519	82,099	77,778	49,259	41,050	38,889	4 to 6	4.2
19	25	101,301	84,417	79,974	50,650	42,209	39,987	4 to 6	4.1
15	19	105,229	87,691	83,076	52,615	43,845	41,538	4 to 6	4.0
19	24	105,521	87,935	83,306	52,761	43,967	41,653	4 to 6	4.0
23	28	109,488	91,240	86,438	54,744	45,620	43,219	4 to 6	3.8
19	23	110,109	91,758	86,928	55,055	45,879	43,464	4 to 6	3.8
23	27	113,544	94,620	89,640	56,772	47,310	44,820	4 to 6	3.7
24	28	114,249	95,207	90,196	57,124	47,604	45,098	4 to 6	3.7
15	17	117,609	98,008	92,849	58,805	49,004	46,425	4 to 6	3.6
24	27	118,480	98,734	93,537	59,240	49,367	46,769	4 to 6	3.5
17	19	119,260	99,383	94,152	59,630	49,692	47,076	4 to 6	3.5
23	25	122,627	102,189	96,811	61,314	51,095	48,405	4 to 6	3.4
26	28	123,770	103,141	97,713	61,885	51,571	48,856	4 to 6	3.4
23	24	127,737	106,447	100,845	63,868	53,224	50,422	4 to 6	3.3
24	25	127,959	106,632	101,020	63,979	53,316	50,510	4 to 6	3.3
27	28	128,530	107,108	101,471	64,265	53,554	50,735	4 to 6	3.3
23	23	133,290	111,075	105,229	66,645	55,538	52,615	4 to 6	3.1
28	27	138,227	115,189	109,127	69,113	57,595	54,563	4 to 6	3.0
27	26	138,417	115,347	109,276	69,208	57,674	54,638	4 to 6	3.0
24	23	139,086	115,905	109,804	69,543	57,952	54,902	4 to 6	3.0
28	26	143,543	119,619	113,324	71,772	59,810	56,662	4 to 6	2.9
27	25	143,954	119,961	113,648	71,977	59,981	56,824	4 to 6	2.9
25	23	144,881	120,734	114,380	72,440	60,367	57,190	4 to 6	2.9
19	17	148,971	124,143	117,609	74,486	62,071	58,805	4 to 6	2.8
27	24	149,952	124,960	118,383	74,976	62,480	59,191	4 to 6	2.8
26	23	150,676	125,563	118,955	75,338	62,782	59,477	4 to 6	2.8
28	24	155,505	129,588	122,767	77,753	64,794	61,384	4 to 6	2.7
27	23	156,471	130,393	123,530	78,236	65,196	61,765	4 to 6	2.7
23	19	161,351	134,459	127,383	80,676	67,230	63,691	4 to 6	2.6
28	23	162,266	135,222	128,105	81,133	67,611	64,053	4 to 6	2.6
24	19	168,367	140,306	132,921	84,183	70,153	66,461	4 to 6	2.5
25	19	175,382	146,152	138,459	87,691	73,076	69,230	4 to 6	2.4
23	17	180,334	150,278	142,369	90,167	75,139	71,184	4 to 6	2.3
26	19	182,397	151,998	143,998	91,199	75,999	71,999	4 to 6	2.3
24	17	188,175	156,812	148,559	94,087	78,406	74,279	4 to 6	2.2
27	19	189,413	157,844	149,536	94,706	78,922	74,768	4 to 6	2.2
25	17	196,015	163,346	154,749	98,008	81,673	77,374	4 to 6	2.1
28	19	196,428	163,690	155,075	98,214	81,845	77,537	4 to 6	2.1
26	17	203,856	169,880	160,939	101,928	84,940	80,469	4 to 6	2.1
23	15	204,378	170,315	161,351	102,189	85,158	80,676	4 to 6	2.0
27	17	211,696	176,414	167,129	105,848	88,207	83,564	4 to 6	2.0

NOTE: See ["General Planting Rate Information"](#) on page 5-1 and ["Field Check Seed Population"](#) on page 2-42 for additional information.

**PLANTING RATES FOR (VACUUM) MILO / SUGAR BEET / SPECIALTY / SOYBEAN 60 CELL DISCS  
28 TOOTH CONTACT WHEEL DRIVE SPROCKET**

**APPROXIMATE SEEDS/ACRE FOR VARIOUS ROW WIDTHS**

Transmission Sprockets		7.5" Rows or 15" Rows	18" Rows	19" Rows	30" Rows	36" Rows	38" Rows	Recomm. Speed Range (MPH)	Average Seed Spacing In Inches
Drive	Driven								
15	28	90,447	75,372	71,406	45,223	37,686	35,703	4 to 6	4.6
15	27	93,797	78,164	74,050	46,898	39,082	37,025	4 to 6	4.5
15	26	97,404	81,170	76,898	48,702	40,585	38,449	4 to 6	4.3
15	25	101,301	84,417	79,974	50,650	42,209	39,987	4 to 6	4.1
17	28	102,507	85,422	80,926	51,253	42,711	40,463	4 to 6	4.1
15	24	105,521	87,935	83,306	52,761	43,967	41,653	4 to 6	4.0
17	27	106,303	88,586	83,924	53,152	44,293	41,962	4 to 6	3.9
15	23	110,109	91,758	86,928	55,055	45,879	43,464	4 to 6	3.8
17	26	110,392	91,993	87,151	55,196	45,997	43,576	4 to 6	3.8
19	28	114,566	95,472	90,447	57,283	47,736	45,223	4 to 6	3.7
17	25	114,807	95,673	90,637	57,404	47,836	45,319	4 to 6	3.6
19	27	118,809	99,008	93,797	59,405	49,504	46,898	4 to 6	3.5
17	24	119,591	99,659	94,414	59,796	49,830	47,207	4 to 6	3.5
19	26	123,379	102,816	97,404	61,689	51,408	48,702	4 to 6	3.4
17	23	124,791	103,992	98,519	62,395	51,996	49,259	4 to 6	3.4
19	25	128,314	106,928	101,301	64,157	53,464	50,650	4 to 6	3.3
15	19	133,290	111,075	105,229	66,645	55,538	52,615	4 to 6	3.1
19	24	133,661	111,384	105,521	66,830	55,692	52,761	4 to 6	3.1
23	28	138,685	115,571	109,488	69,343	57,786	54,744	4 to 6	3.0
19	23	139,472	116,227	110,109	69,736	58,113	55,055	4 to 6	3.0
23	27	143,822	119,852	113,544	71,911	59,926	56,772	4 to 6	2.9
24	28	144,715	120,596	114,249	72,358	60,298	57,124	4 to 6	2.9
15	17	148,971	124,143	117,609	74,486	62,071	58,805	4 to 6	2.8
24	27	150,075	125,062	118,480	75,037	62,531	59,240	4 to 6	2.8
17	19	151,062	125,885	119,260	75,531	62,943	59,630	4 to 6	2.8
23	25	155,328	129,440	122,627	77,664	64,720	61,314	4 to 6	2.7
26	28	156,775	130,646	123,770	78,387	65,323	61,885	4 to 6	2.7
23	24	161,800	134,833	127,737	80,900	67,416	63,868	4 to 6	2.6
24	25	162,081	135,067	127,959	81,040	67,534	63,979	4 to 6	2.6
27	28	162,805	135,670	128,530	81,402	67,835	64,265	4 to 6	2.6
23	23	168,834	140,695	133,290	84,417	70,348	66,645	4 to 6	2.5
28	27	175,087	145,906	138,227	87,544	72,953	69,113	4 to 6	2.4
27	26	175,328	146,107	138,417	87,664	73,053	69,208	4 to 6	2.4
24	23	176,175	146,812	139,086	88,087	73,406	69,543	4 to 6	2.4
28	26	181,822	151,518	143,543	90,911	75,759	71,772	4 to 6	2.3
27	25	182,341	151,951	143,954	91,171	75,975	71,977	4 to 6	2.3
25	23	183,516	152,930	144,881	91,758	76,465	72,440	4 to 6	2.3
19	17	188,697	157,248	148,971	94,349	78,624	74,486	4 to 6	2.2
27	24	189,939	158,282	149,952	94,969	79,141	74,976	4 to 6	2.2
26	23	190,856	159,047	150,676	95,428	79,523	75,338	4 to 6	2.2
28	24	196,973	164,145	155,505	98,487	82,072	77,753	4 to 6	2.1
27	23	198,197	165,164	156,471	99,098	82,582	78,236	4 to 6	2.1
23	19	204,378	170,315	161,351	102,189	85,158	80,676	4 to 6	2.0
28	23	205,537	171,281	162,266	102,769	85,641	81,133	4 to 6	2.0
24	19	213,264	177,720	168,367	106,632	88,860	84,183	4 to 6	2.0
25	19	222,150	185,125	175,382	111,075	92,563	87,691	4 to 6	1.9
23	17	228,423	190,352	180,334	114,211	95,176	90,167	4 to 6	1.8
26	19	231,036	192,530	182,397	115,518	96,265	91,199	4 to 6	1.8
24	17	238,354	198,629	188,175	119,177	99,314	94,087	4 to 6	1.8
27	19	239,923	199,935	189,413	119,961	99,968	94,706	4 to 6	1.7
25	17	248,286	206,905	196,015	124,143	103,452	98,008	4 to 6	1.7
28	19	248,809	207,340	196,428	124,404	103,670	98,214	4 to 6	1.7
26	17		215,181	203,856	129,109	107,591	101,928	4 to 6	1.6
23	15		215,733	204,378	129,440	107,866	102,189	4 to 6	1.6
27	17		223,457	211,696	134,074	111,729	105,848	4 to 6	1.6

**NOTE:** See ["General Planting Rate Information"](#) on page 5-1 and ["Field Check Seed Population"](#) on page 2-42 for additional information.

**PLANTING RATES FOR (VACUUM) SPECIALTY 60 CELL DISC  
44 TOOTH CONTACT WHEEL DRIVE SPROCKET  
APPROXIMATE SEEDS/ACRE FOR VARIOUS ROW WIDTHS**

Transmission Sprockets		7.5" Rows or 15" Rows	18" Rows	19" Rows	30" Rows	36" Rows	38" Rows	Recomm. Speed Range (MPH)	Average Seed Spacing In Inches
Drive	Driven								
15	28	142,811	119,009	112,746	71,406	59,505	56,373	4 to 6	2.9
15	27	148,100	123,417	116,921	74,050	61,708	58,461	4 to 6	2.8
15	26	153,796	128,164	121,418	76,898	64,082	60,709	4 to 6	2.7
15	25	159,948	133,290	126,275	79,974	66,645	63,138	4 to 6	2.6
17	28	161,852	134,877	127,778	80,926	67,439	63,889	4 to 6	2.6
15	24	166,613	138,844	131,536	83,306	69,422	65,768	4 to 6	2.5
17	27	167,847	139,873	132,511	83,924	69,936	66,255	4 to 6	2.5
15	23	173,857	144,881	137,255	86,928	72,440	68,628	4 to 6	2.4
17	26	174,303	145,252	137,607	87,151	72,626	68,804	4 to 6	2.4
19	28	180,894	150,745	142,811	90,447	75,372	71,406	4 to 6	2.3
17	25	181,275	151,062	143,112	90,637	75,531	71,556	4 to 6	2.3
19	27	187,594	156,328	148,100	93,797	78,164	74,050	4 to 6	2.2
17	24	188,828	157,357	149,075	94,414	78,678	74,537	4 to 6	2.2
19	26	194,809	162,341	153,796	97,404	81,170	76,898	4 to 6	2.1
17	23	197,038	164,198	155,556	98,519	82,099	77,778	4 to 6	2.1
19	25	202,601	168,834	159,948	101,301	84,417	79,974	4 to 6	2.1
15	19	210,458	175,382	166,151	105,229	87,691	83,076	4 to 6	2.0
19	24	211,043	175,869	166,613	105,521	87,935	83,306	4 to 6	2.0
23	28	218,977	182,481	172,876	109,488	91,240	86,438	4 to 6	1.9
19	23	220,219	183,516	173,857	110,109	91,758	86,928	4 to 6	1.9
23	27	227,087	189,239	179,279	113,544	94,620	89,640	4 to 6	1.8
24	28	228,498	190,415	180,393	114,249	95,207	90,196	4 to 6	1.8
15	17	235,218	196,015	185,699	117,609	98,008	92,849	4 to 6	1.8
24	27	236,961	197,467	187,074	118,480	98,734	93,537	4 to 6	1.8
17	19	238,519	198,766	188,305	119,260	99,383	94,152	4 to 6	1.8
23	25	245,254	204,378	193,622	122,627	102,189	96,811	4 to 6	1.7
26	28	247,539	206,283	195,426	123,770	103,141	97,713	4 to 6	1.7
23	24		212,894	201,689	127,737	106,447	100,845	4 to 6	1.6
24	25		213,264	202,040	127,959	106,632	101,020	4 to 6	1.6
27	28		214,217	202,942	128,530	107,108	101,471	4 to 6	1.6
23	23		222,150	210,458	133,290	111,075	105,229	4 to 6	1.6
28	27		230,378	218,253	138,227	115,189	109,127	4 to 6	1.5
27	26		230,695	218,553	138,417	115,347	109,276	4 to 6	1.5
24	23		231,809	219,609	139,086	115,905	109,804	4 to 6	1.5
28	26		239,239	226,647	143,543	119,619	113,324	4 to 6	1.5
27	25		239,923	227,295	143,954	119,961	113,648	4 to 6	1.5
25	23		241,468	228,759	144,881	120,734	114,380	4 to 6	1.4
19	17		248,286	235,218	148,971	124,143	117,609	4 to 6	1.4
27	24		249,919	236,766	149,952	124,960	118,383	4 to 6	1.4
26	23			237,909	150,676	125,563	118,955	4 to 6	1.4
28	24			245,535	155,505	129,588	122,767	4 to 6	1.3
27	23			247,060	156,471	130,393	123,530	4 to 6	1.3
23	19				161,351	134,459	127,383	4 to 6	1.3
28	23				162,266	135,222	128,105	4 to 6	1.3
24	19				168,367	140,306	132,921	4 to 6	1.2
25	19				175,382	146,152	138,459	4 to 6	1.2
23	17				180,334	150,278	142,369	4 to 6	1.2
26	19				182,397	151,998	143,998	4 to 6	1.1
24	17				188,175	156,812	148,559	4 to 6	1.1
27	19				189,413	157,844	149,536	4 to 6	1.1
25	17				196,015	163,346	154,749	4 to 6	1.1
28	19				196,428	163,690	155,075	4 to 6	1.1
26	17				203,856	169,880	160,939	4 to 6	1.0
23	15				204,378	170,315	161,351	4 to 6	1.0
27	17				211,696	176,414	167,129	4 to 6	1.0

**NOTE: Planting rates  
over 250,000 seeds/acre  
are not recommended  
with subject seed disc  
and/or drive ratio.**

**NOTE: See "General Planting Rate Information" on page 5-1 and "Field Check Seed Population" on page 2-42 for additional information.**

**PLANTING RATES FOR (VACUUM) SOYBEAN 120 CELL DISC  
22 TOOTH CONTACT WHEEL DRIVE SPROCKET  
APPROXIMATE SEEDS/ACRE FOR VARIOUS ROW WIDTHS**

Transmission Sprockets		15" Rows	18" Rows	19" Rows	30" Rows	36" Rows	38" Rows	Recomm. Speed Range (MPH)	Average Seed Spacing In Inches
Drive	Driven								
15	28	142,811	119,009	112,746	71,406	59,505	56,373	4 to 6	2.9
15	27	148,100	123,417	116,921	74,050	61,708	58,461	4 to 6	2.8
15	26	153,796	128,164	121,418	76,898	64,082	60,709	4 to 6	2.7
15	25	159,948	133,290	126,275	79,974	66,645	63,138	4 to 6	2.6
17	28	161,852	134,877	127,778	80,926	67,439	63,889	4 to 6	2.6
15	24	166,613	138,844	131,536	83,306	69,422	65,768	4 to 6	2.5
17	27	167,847	139,873	132,511	83,924	69,936	66,255	4 to 6	2.5
15	23	173,857	144,881	137,255	86,928	72,440	68,628	4 to 6	2.4
17	26	174,303	145,252	137,607	87,151	72,626	68,804	4 to 6	2.4
19	28	180,894	150,745	142,811	90,447	75,372	71,406	4 to 6	2.3
17	25	181,275	151,062	143,112	90,637	75,531	71,556	4 to 6	2.3
19	27	187,594	156,328	148,100	93,797	78,164	74,050	4 to 6	2.2
17	24	188,828	157,357	149,075	94,414	78,678	74,537	4 to 6	2.2
19	26	194,809	162,341	153,796	97,404	81,170	76,898	4 to 6	2.1
17	23	197,038	164,198	155,556	98,519	82,099	77,778	4 to 6	2.1
19	25	202,601	168,834	159,948	101,301	84,417	79,974	4 to 6	2.1
15	19	210,458	175,382	166,151	105,229	87,691	83,076	4 to 6	2.0
19	24	211,043	175,869	166,613	105,521	87,935	83,306	4 to 6	2.0
23	28	218,977	182,481	172,876	109,488	91,240	86,438	4 to 6	1.9
19	23	220,219	183,516	173,857	110,109	91,758	86,928	4 to 6	1.9
23	27	227,087	189,239	179,279	113,544	94,620	89,640	4 to 6	1.8
24	28	228,498	190,415	180,393	114,249	95,207	90,196	4 to 6	1.8
15	17	235,218	196,015	185,699	117,609	98,008	92,849	4 to 6	1.8
24	27	236,961	197,467	187,074	118,480	98,734	93,537	4 to 6	1.8
17	19	238,519	198,766	188,305	119,260	99,383	94,152	4 to 6	1.8
23	25	245,254	204,378	193,622	122,627	102,189	96,811	4 to 6	1.7
26	28	247,539	206,283	195,426	123,770	103,141	97,713	4 to 6	1.7
23	24		212,894	201,689	127,737	106,447	100,845	4 to 6	1.6
24	25		213,264	202,040	127,959	106,632	101,020	4 to 6	1.6
27	28		214,217	202,942	128,530	107,108	101,471	4 to 6	1.6
23	23		222,150	210,458	133,290	111,075	105,229	4 to 6	1.6
28	27		230,378	218,253	138,227	115,189	109,127	4 to 6	1.5
27	26		230,695	218,553	138,417	115,347	109,276	4 to 6	1.5
24	23		231,809	219,609	139,086	115,905	109,804	4 to 6	1.5
28	26		239,239	226,647	143,543	119,619	113,324	4 to 6	1.5
27	25		239,923	227,295	143,954	119,961	113,648	4 to 6	1.5
25	23		241,468	228,759	144,881	120,734	114,380	4 to 6	1.4
19	17		248,286	235,218	148,971	124,143	117,609	4 to 6	1.4
27	24		249,919	236,766	149,952	124,960	118,383	4 to 6	1.4
26	23			237,909	150,676	125,563	118,955	4 to 6	1.4
28	24			245,535	155,505	129,588	122,767	4 to 6	1.3
27	23			247,060	156,471	130,393	123,530	4 to 6	1.3
23	19				161,351	134,459	127,383	4 to 6	1.3
28	23				162,266	135,222	128,105	4 to 6	1.3
24	19				168,367	140,306	132,921	4 to 6	1.2
25	19				175,382	146,152	138,459	4 to 6	1.2
23	17				180,334	150,278	142,369	4 to 6	1.2
26	19				182,397	151,998	143,998	4 to 6	1.1
24	17				188,175	156,812	148,559	4 to 6	1.1
27	19				189,413	157,844	149,536	4 to 6	1.1
25	17				196,015	163,346	154,749	4 to 6	1.1
28	19				196,428	163,690	155,075	4 to 6	1.1
26	17				203,856	169,880	160,939	4 to 6	1.0
23	15				204,378	170,315	161,351	4 to 6	1.0
27	17				211,696	176,414	167,129	4 to 6	1.0

**NOTE: Planting rates over 250,000 seeds/acre are not recommended with subject seed disc and/or drive ratio.**

**NOTE: See "General Planting Rate Information" on page 5-1 and "Field Check Seed Population" on page 2-42 for additional information.**

**PLANTING RATES FOR (VACUUM) SOYBEAN 120 CELL DISC  
28 TOOTH CONTACT WHEEL DRIVE SPROCKET  
APPROXIMATE SEEDS/ACRE FOR VARIOUS ROW WIDTHS**

Transmission Sprockets		15" Rows	18" Rows	19" Rows	30" Rows	36" Rows	38" Rows	Recomm. Speed Range (MPH)	Average Seed Spacing In Inches
Drive	Driven								
15	28	180,894	150,745	142,811	90,447	75,372	71,406	4 to 6	2.3
15	27	187,594	156,328	148,100	93,797	78,164	74,050	4 to 6	2.2
15	26	194,809	162,341	153,796	97,404	81,170	76,898	4 to 6	2.1
15	25	202,601	168,834	159,948	101,301	84,417	79,974	4 to 6	2.1
17	28	205,013	170,844	161,852	102,507	85,422	80,926	4 to 6	2.0
15	24	211,043	175,869	166,613	105,521	87,935	83,306	4 to 6	2.0
17	27	212,606	177,172	167,847	106,303	88,586	83,924	4 to 6	2.0
15	23	220,219	183,516	173,857	110,109	91,758	86,928	4 to 6	1.9
17	26	220,783	183,986	174,303	110,392	91,993	87,151	4 to 6	1.9
19	28	229,132	190,944	180,894	114,566	95,472	90,447	4 to 6	1.8
17	25	229,615	191,346	181,275	114,807	95,673	90,637	4 to 6	1.8
19	27	237,619	198,016	187,594	118,809	99,008	93,797	4 to 6	1.8
17	24	239,182	199,318	188,828	119,591	99,659	94,414	4 to 6	1.7
19	26	246,758	205,632	194,809	123,379	102,816	97,404	4 to 6	1.7
17	23	249,581	207,984	197,038	124,791	103,992	98,519	4 to 6	1.7
19	25		213,857	202,601	128,314	106,928	101,301	4 to 6	1.6
15	19		222,150	210,458	133,290	111,075	105,229	4 to 6	1.6
19	24		222,768	211,043	133,661	111,384	105,521	4 to 6	1.6
23	28		231,142	218,977	138,685	115,571	109,488	4 to 6	1.5
19	23		232,453	220,219	139,472	116,227	110,109	4 to 6	1.5
23	27		239,703	227,087	143,822	119,852	113,544	4 to 6	1.5
24	28		241,192	228,498	144,715	120,596	114,249	4 to 6	1.4
15	17		248,286	235,218	148,971	124,143	117,609	4 to 6	1.4
24	27			236,961	150,075	125,062	118,480	4 to 6	1.4
17	19			238,519	151,062	125,885	119,260	4 to 6	1.4
23	25			245,254	155,328	129,440	122,627	4 to 6	1.3
26	28			247,539	156,775	130,646	123,770	4 to 6	1.3
23	24				161,800	134,833	127,737	4 to 6	1.3
24	25				162,081	135,067	127,959	4 to 6	1.3
27	28				162,805	135,670	128,530	4 to 6	1.3
23	23				168,834	140,695	133,290	4 to 6	1.2
28	27				175,087	145,906	138,227	4 to 6	1.2
27	26				175,328	146,107	138,417	4 to 6	1.2
24	23				176,175	146,812	139,086	4 to 6	1.2
28	26				181,822	151,518	143,543	4 to 6	1.1
27	25				182,341	151,951	143,954	4 to 6	1.1
25	23				183,516	152,930	144,881	4 to 6	1.1
19	17				188,697	157,248	148,971	4 to 6	1.1
27	24				189,939	158,282	149,952	4 to 6	1.1
26	23				190,856	159,047	150,676	4 to 6	1.1
28	24				196,973	164,145	155,505	4 to 6	1.1
27	23				198,197	165,164	156,471	4 to 6	1.1
23	19				204,378	170,315	161,351	4 to 6	1.0
28	23				205,537	171,281	162,266	4 to 6	1.0
24	19				213,264	177,720	168,367	4 to 6	1.0
25	19				222,150	185,125	175,382	4 to 6	0.9
23	17				228,423	190,352	180,334	4 to 6	0.9
26	19				231,036	192,530	182,397	4 to 6	0.9
24	17				238,354	198,629	188,175	4 to 6	0.9
27	19				239,923	199,935	189,413	4 to 6	0.9
25	17				248,286	206,905	196,015	4 to 6	0.8
28	19				248,809	207,340	196,428	4 to 6	0.8
26	17					215,181	203,856	4 to 6	0.8
23	15					215,733	204,378	4 to 6	0.8
27	17					223,457	211,696	4 to 6	0.8

**NOTE: Planting rates over 250,000 seeds/acre are not recommended with subject seed disc and/or drive ratio.**

**NOTE: See ["General Planting Rate Information"](#) on page 5-1 and ["Field Check Seed Population"](#) on page 2-42 for additional information.**



## WHEAT DISC SECTION

Use a 28 tooth Drive sprocket and a 27 tooth Driven sprocket

Drive	Driven	RPM/GS
27	28	3.671
15	15	3.807
28	27	3.948
27	26	3.953

### FOR HYDRAULIC DRIVE (BRUSH-TYPE AND VACUUM) AND ELECTRIC DRIVE (VACUUM)

- a. Brush-Type: use the instructions found on page 5 to find the seeds per revolution (SDS/REV). The SDS/REV will be relatively constant at all speeds for the Brush-Type Meter
- b. Vacuum: use the instructions found on page 5 to find the seeds per revolution (SDS/REV) or look it up in Rate Chart on pages 3-4. The SDS/REV will decrease as the disc speed increases (less SDS/REV as ground speed increases) for the True Rate Vacuum Meter.
- c. Divide the SDS/REV by the number of Cells to get the SDS/CELL. Some display may not support 54 cells as an option for number of cells on a seed disc, in that case, substitute a useable number of cells (60 or 40) and use that Cell number in the calculation. DO NOT PHYSICALLY CHANGE THE DISC. THE CELL COUNT IS FOR THE MONITOR ONLY.
- d. Divide your target population by the SDS/CELL to get your Monitor Population.

Seed Meter Type	Target Population	SDS/REV	Cells	SDS/CELL	Monitor Population
Brush	800,000	465	54	8.611	92,903
Brush	1,200,000	465	54	8.611	139,355
Vacuum	808,755	891	54	16.500	49,015
Vacuum	1,195,655	771	54	14.278	83,742
Vacuum	808,755	891	60	14.85	54,461
Vacuum	1,195,655	771	60	12.85	93,047

**PLANTING RATES FOR BRUSH-TYPE SEED METERS (HALF RATE DRIVE)  
APPROXIMATE SEEDS/ACRE FOR 15" ROW WIDTH**

Transmission Sprockets		Population Factor	Rye 400 SDS/REV, 35.9 SDS/GRAM		Wheat 465 SDS/REV, 39.6 SDS/GRAM		Speed Range (MPH)
Drive	Driven		Population (sds/acre)	Population (lbs/acre)	Population (sds/acre)	Population (lbs/acre)	
15	28	1190.12	476,159	29	553,656	31	4 to 6
15	27	1234.20	493,795	30	574,163	32	4 to 6
15	26	1281.67	512,787	32	596,245	33	4 to 6
15	25	1332.94	533,298	33	620,095	35	4 to 6
17	28	1348.80	539,647	33	627,477	35	4 to 6
15	24	1388.48	555,519	34	645,932	36	4 to 6
17	27	1398.76	559,634	34	650,718	36	4 to 6
15	23	1448.84	579,672	36	674,017	38	4 to 6
17	26	1452.56	581,158	36	675,745	38	4 to 6
19	28	1507.49	603,134	37	701,298	39	4 to 6
17	25	1510.66	604,405	37	702,775	39	4 to 6
19	27	1563.32	625,473	38	727,272	41	4 to 6
17	24	1573.60	629,588	39	732,056	41	4 to 6
19	26	1623.45	649,530	40	755,244	42	4 to 6
17	23	1642.02	656,961	40	763,885	43	4 to 6
19	25	1688.39	675,511	42	785,454	44	4 to 6
15	19	1753.86	701,708	43	815,915	45	4 to 6
19	24	1758.74	703,658	43	818,181	46	4 to 6
23	28	1824.85	730,111	45	848,940	47	4 to 6
19	23	1835.20	734,251	45	853,754	48	4 to 6
23	27	1892.44	757,152	47	880,382	49	4 to 6
24	28	1904.19	761,855	47	885,850	49	4 to 6
15	17	1960.20	784,262	48	911,905	51	4 to 6
23	26	1965.23	786,273	48	914,242	51	4 to 6
24	27	1974.72	790,071	49	918,660	51	4 to 6
25	28	1983.54	793,598	49	922,761	51	4 to 6
17	19	1987.71	795,269	49	924,703	52	4 to 6
23	25	2043.84	817,724	50	950,813	53	4 to 6
24	26	2050.67	820,459	50	953,993	53	4 to 6
25	27	2057.00	822,991	51	956,937	53	4 to 6
26	28	2062.88	825,342	51	959,671	53	4 to 6
23	24	2128.99	851,795	52	990,429	55	4 to 6
24	25	2132.70	853,277	52	992,152	55	4 to 6
25	26	2136.11	854,644	53	993,742	55	4 to 6
26	27	2139.28	855,911	53	995,215	55	4 to 6
27	28	2142.22	857,087	53	996,582	56	4 to 6
15	15	2221.56	888,830	55	1,033,492	58	4 to 6
28	27	2303.84	921,750	57	1,071,769	60	4 to 6
27	26	2307.01	923,016	57	1,073,242	60	4 to 6
26	25	2310.42	924,384	57	1,074,832	60	4 to 6
25	24	2314.13	925,865	57	1,076,554	60	4 to 6
24	23	2318.15	927,475	57	1,078,426	60	4 to 6
28	26	2392.45	957,202	59	1,112,991	62	4 to 6
27	25	2399.28	959,937	59	1,116,171	62	4 to 6
26	24	2406.69	962,899	59	1,119,616	62	4 to 6
25	23	2414.74	966,120	59	1,123,361	63	4 to 6
19	17	2482.92	993,399	61	1,155,079	64	4 to 6

Continued on the next page.

**PLANTING RATES FOR BRUSH-TYPE SEED METERS (HALF RATE DRIVE)  
APPROXIMATE SEEDS/ACRE FOR 15" ROW WIDTH**

Transmission Sprockets		Population Factor	Rye 400 SDS/REV, 35.9 SDS/GRAM		Wheat 465 SDS/REV, 39.6 SDS/GRAM		Speed Range (MPH)
Drive	Driven		Population (sds/acre)	Population (lbs/acre)	Population (sds/acre)	Population (lbs/acre)	
28	25	2488.15	995,490	61	1,157,511	64	4 to 6
27	24	2499.26	999,934	61	1,162,678	65	4 to 6
26	23	2511.33	1,004,765	62	1,168,295	65	4 to 6
17	15	2517.77	1,007,341	62	1,171,291	65	4 to 6
28	24	2591.82	1,036,969	64	1,205,741	67	4 to 6
27	23	2607.92	1,043,409	64	1,213,230	68	4 to 6
23	19	2689.26	1,075,952	66	1,251,069	70	4 to 6
28	23	2704.51	1,082,054	67	1,258,164	70	4 to 6
24	19	2806.18	1,122,733	69	1,305,464	73	4 to 6
19	15	2813.98	1,125,852	69	1,309,090	73	4 to 6
25	19	2923.10	1,169,513	72	1,359,857	76	4 to 6
23	17	3005.64	1,202,535	74	1,398,254	78	4 to 6
26	19	3040.03	1,216,294	75	1,414,252	79	4 to 6
24	17	3136.32	1,254,820	77	1,459,048	81	4 to 6
27	19	3156.95	1,263,075	78	1,468,647	82	4 to 6
25	17	3267.00	1,307,103	80	1,519,841	85	4 to 6
28	19	3273.88	1,309,855	81	1,523,041	85	4 to 6
26	17	3397.68	1,359,388	84	1,580,635	88	4 to 6
23	15	3406.39	1,362,873	84	1,584,687	88	4 to 6
27	17	3528.36	1,411,671	87	1,641,428	91	4 to 6
24	15	3554.50	1,422,128	87	1,653,587	92	4 to 6
28	17	3659.04	1,463,956	90	1,702,222	95	4 to 6
25	15	3702.60	1,481,384	91	1,722,487	96	4 to 6
26	15	3850.70	1,540,639	95	1,791,386	100	4 to 6
27	15	3998.81	1,599,895	98	1,860,286	104	4 to 6
28	15	4146.91	1,659,150	102	1,929,185	107	4 to 6

**NOTE: Seed size and type affect the output rate of the meter. For a method to improve the population accuracy with your desired seed, please see the following pages.**

**NOTE: See "Mechanical Seed Metering" in ["General Planting Rate Information" on page 5-1](#) and ["Field Check Seed Population" on page 2-42](#) for more information.**

**NOTE: When using Half Rate (2 To 1) Drive Reduction Package, rates are approximately 50% of given numbers.**

**NOTE: Always field check seed population to ensure planting rates are correct.**

To more accurately predict population when using the 54 Cell Wheat disc, two things are needed:

1. Seeds/gram
2. Grams/revolution of seed disc

Seeds per gram can be found by weighing a small sample of desired seed (a cup or less) and counting number of seeds in sample.

$$\frac{\text{Seeds}}{\text{Grams}} = \frac{\text{number of seeds in sample}}{\text{weight of sample in grams}} \quad \frac{396 \text{ Seeds}}{10 \text{ Grams}} = 39.6 \frac{\text{seeds}}{\text{gram}}$$

To find grams/revolution a gram scale, a stopwatch, a small container to catch seed, and a method for spinning the meter at a constant, known rpm (see your local Kinze dealer with a T4000 Seed Meter Test Stand) are needed.

1. Zero gram scale with the small container on it.
2. Load meter with correct disc.
3. Load meter with desired seed.
4. Start spinning meter at a known, constant rpm.
5. Start stopwatch as you place container under meter.
6. Catch seed with container for 10-30 seconds.
7. Stop the stopwatch as you remove container from underneath meter.
8. Weigh container.
9. Enter meter rpm, weight of sample, and duration of sample collection into the equation below:

$$\frac{\text{Grams}}{\text{Rev}} = \frac{\text{Sample Weight} * 60}{\text{Disc RPM} * \text{Sample Duration}}$$

EX: For a sample taken for 30 seconds with meter spinning at 50rpm and weighs 293 grams

$$\frac{293 \text{ Grams} * 60}{50 \text{ RPM} * 30 \text{ Seconds}} = 11.7 \frac{\text{Grams}}{\text{Rev}}$$

10. Find desired output rate. For seeds per acre, use seeds/rev. For pounds per acre, use lbs/rev.

a. Seeds/rev:

$$\frac{\text{Seeds}}{\text{Rev}} = \frac{\text{Seeds}}{\text{Grams}} * \frac{\text{Grams}}{\text{Rev}} \quad \left| \quad 39.6 \frac{\text{Seeds}}{\text{Grams}} * 11.7 \frac{\text{Grams}}{\text{Rev}} = 465 \frac{\text{Seeds}}{\text{Rev}} \right.$$

b. Lbs./rev:

$$\frac{\text{Pounds}}{\text{Rev}} = \frac{\frac{\text{Grams}}{\text{Rev}}}{453.6 \frac{\text{Grams}}{\text{Pound}}} \quad \left| \quad \frac{11.7 \frac{\text{Grams}}{\text{Rev}}}{453.6 \frac{\text{Grams}}{\text{Pound}}} = 0.0258 \frac{\text{Pounds}}{\text{Rev}} \right.$$

11. Find the correct population factor by dividing the desired population by the measured output rate.

Seeds/acre:

$$\frac{\text{Target Population}}{\text{Output Rate}} = \text{Population Factor} \quad \left| \quad \frac{1,000,000 \frac{\text{Seeds}}{\text{Acre}}}{465 \frac{\text{Seeds}}{\text{Rev.}}} = 2150.54$$

pounds/acre:

$$\frac{\text{Target Population}}{\text{Output Rate}} = \text{Population Factor} \quad \left| \quad \frac{56 \frac{\text{lbs}}{\text{Acre}}}{0.0258 \frac{\text{lbs}}{\text{rev}}} = 2170.54$$

12. Find the closest Population Factor in the Rate Chart to identify the correct transmission sprockets. For the examples list above, the closest Population Factor is 2142.22 which corresponds to a 27 tooth Drive sprocket and 28 tooth Driven sprocket.

**NOTE: Multiple trials are recommended to increase the accuracy of the predicted rate.**

**PLANTING RATES FOR (VACUUM) WHEAT 54 CELL DISC  
(HALF RATE DRIVE [15 TOOTH])  
APPROXIMATE SEEDS/ACRE FOR 15" ROW WIDTH**

Transmission Sprockets		RPM/GS (Seed Disc RPM To Ground Speed (MPH))	81NH2O, no sigulator		81NH2O, sigulator 3.3		Speed Range (MPH)
Drive	Driven		SDS/REV	Population	SDS/REV	Population	
15	28	2.039	909	744,562	554	453,298	5 to 7
15	27	2.115	903	764,594	551	465,585	5 to 7
15	26	2.196	897	785,948	547	478,707	5 to 7
15	25	2.284	891	808,755	543	492,751	5 to 7
17	28	2.311	888	815,760	542	497,071	5 to 7
15	24	2.379	883	833,164	539	507,816	5 to 7
17	27	2.397	882	837,650	539	510,588	5 to 7
15	23	2.483	876	859,343	535	524,013	5 to 7
17	26	2.489	875	860,943	535	525,004	5 to 7
19	28	2.583	868	884,424	531	539,571	5 to 7
17	25	2.589	868	885,771	530	540,408	5 to 7
19	27	2.679	861	907,980	527	554,221	5 to 7
17	24	2.697	860	912,286	526	556,903	5 to 7
19	26	2.782	854	932,998	522	569,822	5 to 7
17	23	2.814	852	940,653	521	574,605	5 to 7
19	25	2.893	846	959,608	518	586,466	5 to 7
15	19	3.006	838	986,010	513	603,032	5 to 7
19	24	3.014	837	987,957	513	604,256	5 to 7
23	28	3.127	829	1,014,147	508	620,748	5 to 7
19	23	3.145	828	1,018,206	508	623,310	5 to 7
23	27	3.243	821	1,040,464	504	637,378	5 to 7
24	28	3.263	819	1,044,993	503	640,247	5 to 7
15	17	3.359	813	1,066,386	499	653,818	5 to 7
23	26	3.368	812	1,068,291	499	655,029	5 to 7
24	27	3.384	811	1,071,881	498	657,311	5 to 7
25	28	3.399	810	1,075,206	497	659,426	5 to 7
17	19	3.406	809	1,076,779	497	660,427	5 to 7
23	25	3.502	803	1,097,745	493	673,790	5 to 7
24	26	3.514	802	1,100,276	493	675,407	5 to 7
25	27	3.525	801	1,102,616	493	676,902	5 to 7
26	28	3.535	801	1,104,786	492	678,288	5 to 7
23	24	3.648	793	1,128,951	488	693,762	5 to 7
24	25	3.655	792	1,130,291	487	694,622	5 to 7
25	26	3.661	792	1,131,527	487	695,416	5 to 7
26	27	3.666	792	1,132,671	487	696,150	5 to 7
27	28	3.671	791	1,133,732	487	696,831	5 to 7
15	15	3.807	782	1,162,044	482	715,055	5 to 7
28	27	3.948	772	1,190,735	476	733,619	5 to 7
27	26	3.953	772	1,191,825	476	734,326	5 to 7
26	25	3.959	772	1,193,001	476	735,089	5 to 7
25	24	3.966	771	1,194,273	476	735,915	5 to 7
24	23	3.973	771	1,195,655	475	736,812	5 to 7
28	26	4.100	762	1,220,871	471	753,227	5 to 7
27	25	4.112	762	1,223,163	470	754,723	5 to 7
26	24	4.124	761	1,225,641	470	756,341	5 to 7
25	23	4.138	760	1,228,328	469	758,097	5 to 7
19	17	4.255	752	1,250,825	465	772,837	5 to 7
28	25	4.264	752	1,252,531	465	773,957	5 to 7
27	24	4.283	750	1,256,146	464	776,334	5 to 7
26	23	4.304	749	1,260,061	463	778,909	5 to 7
17	15	4.315	748	1,262,143	463	780,280	5 to 7
28	24	4.442	740	1,285,788	458	795,893	5 to 7

Continued on next page.

**PLANTING RATES FOR (VACUUM) WHEAT 54 CELL DISC  
(HALF RATE DRIVE [15 TOOTH])  
APPROXIMATE SEEDS/ACRE FOR 15" ROW WIDTH**

Transmission Sprockets		RPM/GS (Seed Disc RPM To Ground Speed (MPH))	8INH2O, no sigulator		8INH2O, sigulator 3.3		Speed Range (MPH)
Drive	Driven		SDS/REV	Population	SDS/REV	Population	
27	23	4.469	738	1,290,855	457	799,250	5 to 7
23	19	4.609	729	1,316,059	452	816,013	5 to 7
28	23	4.635	728	1,320,711	451	819,119	5 to 7
24	19	4.809	717	1,351,123	445	839,524	5 to 7
19	15	4.822	716	1,353,411	445	841,067	5 to 7
25	19	5.009	704	1,384,810	438	862,343	5 to 7
23	17	5.151	695	1,407,761	433	878,034	5 to 7
26	19	5.210	692	1,417,121	431	884,470	5 to 7
24	17	5.375	682	1,442,697	426	902,174	5 to 7
27	19	5.410	680	1,448,057	425	905,906	5 to 7
25	17	5.599	668	1,475,915	419	925,450	5 to 7
28	19	5.610	668	1,477,616	418	926,651	5 to 7
26	17	5.823	655	1,507,414	412	947,862	5 to 7
23	15	5.837	654	1,509,452	411	949,325	5 to 7
27	17	6.046	642	1,537,193	405	969,410	5 to 7
24	15	6.091	640	1,542,943	403	973,616	5 to 7
28	17	6.270	630	1,565,254	398	990,094	5 to 7
25	15	6.345	625	1,574,226	395	996,797	5 to 7
26	15	6.599	611	1,603,300	388	1,018,868	5 to 7
27	15	6.853	598	1,630,167	381	1,039,830	5 to 7
28	15	7.106	584	1,654,826	374	1,059,683	5 to 7

1. Identify planting parameters and record in Table #1.
2. Weigh small sample of seeds and complete Table #2.
3. Use a device to spin the meter at a constant, measured RPM (Seed Meter Test Stand T4000). Set the RPM to settings in the table below (15, 20, 25, 30) and collect a sample of seed coming out of the meter. It is recommended to start with a Vacuum pressure of 8INH2O and removing the singulator. Increasing the vacuum pressure will increase the SDS/REV while using the singulator will decrease the SDS/REV. Weigh the sample of seed and record the length of time the sample was collected in Table #3.
4. Complete Table #3 for each RPM setting using information from Tables 1 and 2. Variables with the subscript “[RPM]” uses the values in the same row in Table #3.
5. Choose the 2 closest populations to your desired target population and add them to Table #4 with their respective seeds per rev.
6. Complete Table #4 and calculate the approximate seeds per rev.
7. Calculate Seed Disc RPM/Ground Speed Ratio in Table #5.
8. Select the closest RPM/GS (Seed Disc RPM to Ground Speed (mph)) in the rate chart and use that Drive and Driven pair.

Table #1				Table #2	
Target Population [seeds/acre] ( <b>Pop<sub>TAR</sub></b> )				Number of Seeds ( <b>N</b> )	
Ideal Planting Ground Speed [mph] ( <b>GS</b> )				Weight of sample [grams] ( <b>W</b> )	
Planter Row Spacing [in] ( <b>RS</b> )				Seeds/ Gram = <b>N/W (SG)</b>	
Table #3					
			$SR_{RPM} = \frac{W_{RPM}}{t_{RPM}} \times \left(\frac{60}{RPM}\right) \times SG$		$Pop_{RPM} = \frac{SR_{RPM} \times RPM \times 5940}{GS \times RS}$
Vacuum Pressure	Disc RPM	Weight [grams] ( <b>W<sub>RPM</sub></b> )	Time [sec.] ( <b>t<sub>RPM</sub></b> )	Seeds/ Rev ( <b>SR<sub>RPM</sub></b> )	Population ( <b>Pop<sub>RPM</sub></b> )
	15				
Sing. Setting	20				
	25				
	30				
Table #4					
<i>Pop<sub>1</sub></i>		<i>Pop<sub>2</sub></i>		<i>Pop<sub>TAR</sub></i>	
<i>SR<sub>1</sub></i>		<i>SR<sub>2</sub></i>			
$SR_{TAR} = \left(\frac{SR_2 - SR_1}{Pop_2 - Pop_1}\right) \times (Pop_{TAR} - Pop_1) + SR_1$					
Table #5					
GS		$RPM_{TAR} = \frac{Pop_{TAR} \times GS \times RS}{5940 \times SR_{TAR}}$			
RS					
<i>Pop<sub>TAR</sub></i>		$\frac{RPM_{Tar}}{GS}$			
<i>SR<sub>TAR</sub></i>					

**NOTE:** Additional worksheets can be found [“Additional Worksheet” on page 5-24](#)



Example.

Table #1				Table #2	
Target Population [seeds/acre] ( <b>Pop<sub>TAR</sub></b> )		1,200,000		Number of Seeds ( <b>N</b> )	
Ideal Planting Ground Speed [mph] ( <b>GS</b> )		6mph		Weight of sample [grams] ( <b>W</b> )	
Planter Row Spacing [in] ( <b>RS</b> )		15 in.		Seeds/ Gram = <b>N/W (SG)</b>	
				25.88	
Table #3					
		$SR_{RPM} = \frac{W_{RPM}}{t_{RPM}} \times \left(\frac{60}{RPM}\right) \times SG$		$Pop_{RPM} = \frac{SR_{RPM} \times RPM \times 5940}{GS \times RS}$	
Vacuum Pressure	Disc RPM	Weight [grams] ( <b>W<sub>RPM</sub></b> )	Time [sec.] ( <b>t<sub>RPM</sub></b> )	Seeds/ Rev ( <b>SR<sub>RPM</sub></b> )	Population ( <b>Pop<sub>RPM</sub></b> )
8	15	$\frac{765}{90.43} \times \left(\frac{60}{15}\right) \times 25.88 = 875.7$		$\frac{875.7 \times 15 \times 5940}{6 \times 15} = 866,943$	
		765	90.43	875.7	866,943
Sing. Setting	20	$\frac{640}{60.55} \times \left(\frac{60}{20}\right) \times 25.88 = 820.6$		$\frac{820.6 \times 20 \times 5940}{6 \times 20} = 1,083,192$	
		640	60.55	820.6	1,083,192
removed	25	$\frac{1101}{90.1} \times \left(\frac{60}{25}\right) \times 25.88 = 759$		$\frac{759 \times 25 \times 5940}{6 \times 25} = 1,252,350$	
		1101	90.1	759	1,252,350
removed	30	$\frac{840}{60.58} \times \left(\frac{60}{30}\right) \times 25.88 = 717.7$		$\frac{717.7 \times 30 \times 5940}{6 \times 30} = 1,252,350$	
		840	60.58	717.7	1,421,046
Table #4					
<i>Pop<sub>1</sub></i>	1,083,192	<i>Pop<sub>2</sub></i>	1,252,350	<i>Pop<sub>TAR</sub></i>	1,200,000
<i>SR<sub>1</sub></i>	820.6	<i>SR<sub>2</sub></i>	756		
$SR_{TAR} = \left(\frac{SR_2 - SR_1}{Pop_2 - Pop_1}\right) \times (Pop_{TAR} - Pop_1) + SR_1$					776.0
$\left(\frac{756 - 820.6}{1,252,350 - 1,083,192}\right) \times (1,200,000 - 1,083,192) + 820.6 = 776.0$					
Table #5					
GS	6mph	$RPM_{TAR} = \frac{Pop_{TAR} \times GS \times RS}{5940 \times SR_{TAR}}$		23.4	
RS	15 in				
<i>Pop<sub>TAR</sub></i>	1,200,000	$\frac{1,200,000 \times 6 \times 15}{5940 \times 776} = 23.4$		23.4	
<i>SR<sub>TAR</sub></i>	776.0				
		$\frac{RPM_{Tar}}{GS} = \frac{23.4}{6} = 3.905$		3.905	

**Additional Worksheet**

Table #1				Table #2	
Target Population [seeds/acre] ( <b>Pop<sub>TAR</sub></b> )				Number of Seeds ( <b>N</b> )	
Ideal Planting Ground Speed [mph] ( <b>GS</b> )				Weight of sample [grams] ( <b>W</b> )	
Planter Row Spacing [in] ( <b>RS</b> )				Seeds/ Gram = <b>N/W</b> ( <b>SG</b> )	
Table #3					
			$SR_{RPM} = \frac{W_{RPM}}{t_{RPM}} \times \left(\frac{60}{RPM}\right) \times SG$		$Pop_{RPM} = \frac{SR_{RPM} \times RPM \times 5940}{GS \times RS}$
Vacuum Pressure	Disc RPM	Weight [grams] ( <b>W<sub>RPM</sub></b> )	Time [sec.] ( <b>t<sub>RPM</sub></b> )	Seeds/ Rev ( <b>SR<sub>RPM</sub></b> )	Population ( <b>Pop<sub>RPM</sub></b> )
	15				
Sing. Setting	20				
	25				
	30				
Table #4					
<i>Pop<sub>1</sub></i>		<i>Pop<sub>2</sub></i>		<i>Pop<sub>TAR</sub></i>	
<i>SR<sub>1</sub></i>		<i>SR<sub>2</sub></i>			
$SR_{TAR} = \left(\frac{SR_2 - SR_1}{Pop_2 - Pop_1}\right) \times (Pop_{TAR} - Pop_1) + SR_1$					
Table #5					
GS		$RPM_{TAR} = \frac{Pop_{TAR} \times GS \times RS}{5940 \times SR_{TAR}}$			
RS					
<i>Pop<sub>TAR</sub></i>		$\frac{RPM_{Tar}}{GS}$			
<i>SR<sub>TAR</sub></i>					

**DRY FERTILIZER APPLICATION RATES (Mechanical)**  
**APPROXIMATE RATE IN POUNDS PER ACRE**

Drive Sprocket	Driven Sprocket	Low Rate Position			High Rate Position		
		30" Rows	36" Rows	38" Rows	30" Rows	36" Rows	38" Rows
15	35	29	24	23	86	71	68
15	33	33	27	26	98	82	78
15	30	36	30	28	109	90	86
19	33	41	34	33	124	104	98
19	30	45	38	36	138	114	108
15	19	52	43	41	158	132	125
30	35	56	47	44	172	143	136
30	33	60	50	47	182	152	144
33	35	63	53	50	189	158	149
35	33	70	58	56	212	177	168
33	30	73	60	57	220	184	174
19	15	84	70	66	272	227	215
30	19	104	87	82	316	263	250
33	19	115	96	91	347	290	275
35	19	122	102	97	368	307	291
30	15	132	110	104	400	334	316
33	15	145	121	115	440	367	348
35	15	154	129	122	467	389	369

See notes on following page.

**DRY FERTILIZER APPLICATION RATES (Vacuum)**  
**22 TOOTH CONTACT WHEEL DRIVE SPROCKET**  
**APPROXIMATE RATE IN POUNDS PER ACRE**

Drive Sprocket	Driven Sprocket	Low Rate Position			High Rate Position		
		30" Rows	36" Rows	38" Rows	30" Rows	36" Rows	38" Rows
15	35	29	24	23	86	71	68
15	33	33	27	26	98	82	78
15	30	36	30	28	109	90	86
19	33	41	34	33	124	104	98
19	30	45	38	36	138	114	108
15	19	52	43	41	158	132	125
30	35	56	47	44	172	143	136
30	33	60	50	47	182	152	144
33	35	63	53	50	189	158	149
35	33	70	58	56	212	177	168
33	30	73	60	57	220	184	174
19	15	84	70	66	272	227	215
30	19	104	87	82	316	263	250
33	19	115	96	91	347	290	275
35	19	122	102	97	368	307	291
30	15	132	110	104	400	334	316
33	15	145	121	115	440	367	348
35	15	154	129	122	467	389	369

See notes on following page.

**DRY FERTILIZER APPLICATION RATES (Vacuum)**  
**28 TOOTH CONTACT WHEEL DRIVE SPROCKET**  
**APPROXIMATE RATE IN POUNDS PER ACRE**

Drive Sprocket	Driven Sprocket	Low Rate Position			High Rate Position		
		30" Rows	36" Rows	38" Rows	30" Rows	36" Rows	38" Rows
15	35	37	30	29	109	90	86
15	33	42	34	33	124	104	99
15	30	46	38	35	138	114	109
19	33	52	43	42	157	132	124
19	30	57	48	46	175	144	137
15	19	66	54	52	200	167	158
30	35	71	60	56	218	181	172
30	33	76	63	60	231	193	182
33	35	80	67	63	239	200	189
35	33	89	73	71	269	224	213
33	30	92	76	72	279	233	220
19	15	106	89	84	345	288	272
30	19	132	110	104	400	333	317
33	19	146	122	115	440	367	348
35	19	155	129	123	466	389	369
30	15	167	139	132	507	423	400
33	15	184	153	146	557	465	441
35	15	195	163	155	592	493	467

**NOTE: (Vacuum ONLY) 22, 28 and 44 tooth drive sprockets are NOT applicable to all rate charts. Check title to ensure proper rate chart is selected. DO NOT USE 44 tooth drive sprockets (60 cell soybean discs) with Dry Fertilizer Package.**

**NOTE: Uneven delivery may result from attempting to use rates lower than indicated by chart.**

Direction  
Of Rotation

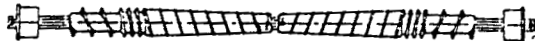

High Rate Position



Low Rate Position

Chart is for planters equipped with contact drive. See "Tire Pressure" for recommended tire pressures.

Chart calculated with a bulk density of 65 pounds per cubic foot.

**NOTE: Fertilizer application rates can vary from tweights calculated in chart. Make field checks to be sure you are applying fertilizer at desired rate.**

**NOTE: Optional two-speed point row clutch is located ahead of dry fertilizer drive. Activating two-speed point row clutch reduced rate switch will cause same percent of reduction in dry fertilizer application rates.**

To check exact number of pounds your fertilizer attachment actually delivers on a 30" row spacing, remove one spout from one fertilizer hopper and attach a container under opening. Engage fertilizer attachment and drive forward for 174'. Weigh amount of fertilizer caught in container and multiply that by 100. Result is pounds of fertilizer per acre when planting in 30" rows. To convert delivery rate for wider rows:

36" multiply by 0.83

38" multiply by 0.79

**LIQUID FERTILIZER SQUEEZE PUMP APPLICATION RATES (Mechanical)**

**GALLONS PER ACRE**

Drive	Driven	30" Rows	36" Rows	38" Rows	Drive	Driven	30" Rows	36" Rows	38" Rows
15	*62	6.1	5.1	4.8	46	*62	18.7	15.6	14.8
19	*62	7.7	6.4	6.1	15	19	19.9	16.6	15.7
15	46	8.2	6.9	6.5	32	34	23.7	19.8	18.7
19	46	10.4	8.7	8.2	34	32	26.8	22.3	21.1
15	34	11.1	9.3	8.8	19	15	31.9	26.6	25.2
15	32	11.8	9.8	9.3	46	34	34.1	28.4	26.9
32	*62	13.0	10.8	10.3	46	32	36.2	30.2	28.6
19	34	14.1	11.7	11.1	32	19	42.4	35.4	33.5
19	32	15.0	12.5	11.8	34	19	45.1	37.6	35.6
32	46	17.5	14.6	13.8	*62	34	45.9	38.3	36.3
34	46	18.6	15.5	14.7					

\*Optional sprocket.

Chart is for planters equipped with contact drive and based on a solution weighing ten pounds per gallon.. Check tires for correct operating pressure.

**NOTE:** Fertilizer application rates can vary from the above chart. To prevent application miscalculations, make field checks to be sure you are applying fertilizer at the desired rate.

**NOTE:** Optional two-speed point row clutch is located ahead of liquid fertilizer squeeze pump Activating two-speed point row clutch reduced rate switch will cause same percent of reduction in liquid fertilizer (squeeze pump) application rates.

To check exact number of gallons your fertilizer attachment will actually deliver on a 30" row spacing:

1. Remove hose from one fertilizer opener and insert it into a collection container secured planter frame.
2. Engage fertilizer attachment and drive forward for 174'.
3. Measure fluid ounces caught in container and multiply by 100. Divide that amount by 128. Result is gallons of fertilizer delivered per acre when planting in 30" rows.
4. Rinse collection container and repeat test on other rows if necessary. To convert delivery rate for wider rows, multiply by following conversion factors:

36" multiply by 0.83

38" multiply by 0.79

**LIQUID FERTILIZER SQUEEZE PUMP APPLICATION RATES (Vacuum)  
22 TOOTH CONTACT WHEEL DRIVE SPROCKET**

**GALLONS PER ACRE**

Drive	Driven	30" Rows	36" Rows	38" Rows	Drive	Driven	30" Rows	36" Rows	38" Rows
19	62	5.7	4.7	4.5	24	17	26.1	21.8	20.6
19	46	7.6	6.4	6.0	46	30	28.4	23.6	22.4
24	46	9.7	8.0	7.6	50	30	20.8	25.7	24.3
19	30	11.7	9.8	9.2	30	17	32.6	27.2	25.8
17	23	13.7	11.4	10.8	46	24	35.5	29.5	28.0
19	23	15.3	12.7	12.1	30	15	37.0	30.8	29.2
23	24	17.7	14.8	14.0	62	30	38.2	31.9	30.2
50	46	20.1	16.8	15.9	50	23	40.2	33.5	31.7
23	19	22.4	18.7	17.7	46	19	44.8	37.3	35.4
30	23	24.1	20.1	19.0	62	24	47.8	39.8	37.7

**LIQUID FERTILIZER SQUEEZE PUMP APPLICATION RATES (Vacuum)  
28 TOOTH CONTACT WHEEL DRIVE SPROCKET**

**GALLONS PER ACRE**

Drive	Driven	30" Rows	36" Rows	38" Rows	Drive	Driven	30" Rows	36" Rows	38" Rows
15	62	5.7	4.7	4.5	17	15	26.7	22.2	21.1
15	46	7.7	6.4	6.1	23	19	28.5	23.7	22.5
19	46	9.7	8.1	7.7	30	23	30.7	25.6	24.2
15	30	11.8	9.8	9.3	24	17	33.2	27.7	26.2
17	30	13.3	11.1	10.5	46	30	36.1	30.1	28.5
15	23	15.4	12.8	12.1	50	30	39.2	32.7	31.0
46	62	17.5	14.6	13.8	30	17	41.5	34.6	32.8
19	23	19.4	16.2	15.4	46	24	45.1	37.6	35.6
46	50	21.7	18.0	17.1	30	15	47.1	39.2	37.2
24	23	24.6	20.5	19.4	62	30	48.7	40.5	38.4

**NOTE: 22, 28 and 44 tooth drive sprockets are NOT applicable to all rate charts. Check title to ensure proper rate chart is selected. DO NOT USE 44 tooth drive sprockets (60 cell soybean discs) with Liquid Fertilizer Squeeze Pump Package.**

Chart is for planters equipped with contact drive and calculated based on a solution weighing ten pounds per gallon. Check tires for correct operating pressure.

**NOTE: Fertilizer application rates can vary from the above chart. To prevent application miscalculations, make field checks to be sure you are applying fertilizer at the desired rate.**

**NOTE: Optional two-speed point row clutch is located ahead of liquid fertilizer squeeze pump Activating two-speed point row clutch reduced rate switch will cause same percent of reduction in liquid fertilizer (squeeze pump) application rates.**

To check the exact number of gallons your fertilizer attachment will actually deliver on a 30" row spacing:

1. Remove hose from one fertilizer opener and insert it into a collection container secured planter frame.
2. Engage fertilizer attachment and drive forward for 174'.
3. Measure fluid ounces caught in container and multiply by 100. Divide that amount by 128. Result is gallons of fertilizer delivered per acre when planting in 30" rows. To convert this delivery rate for wider rows, multiply by the following conversion factors:

36" multiply by 0.83

38" multiply by 0.79

4. Rinse collection container and repeat test on other rows if necessary.

## LIQUID FERTILIZER PISTON PUMP APPLICATION RATES GALLONS PER ACRE

**Applies To Model NGP-7055 Pumps With 18 Tooth Sprocket  
And 7.60" x 15" Ground Drive Tire**

Pump Setting	2	3	4	5	6	7	8	9	10
8 Row 36"	9.2	13.9	18.5	23.1	27.6	32.0	36.8	41.5	46.1
8 Row 38"	8.8	13.1	17.5	21.9	26.1	30.5	34.9	39.3	43.7
12 Row 30"	7.4	11.1	14.8	18.5	22.1	25.8	29.5	33.2	36.9
12 Row 36"	6.2	9.3	12.3	15.4	18.4	21.5	24.6	27.7	30.8
12 Row 38"	5.8	8.8	11.7	14.6	17.4	20.4	23.3	26.2	29.1
16 Row 30"	5.5	8.3	11.1	13.9	16.6	19.4	22.2	24.9	27.7

Chart is for planters equipped with 7.60" x 15" ground drive tire, based on 91" forward travel per wheel revolution, 48 tooth drive sprocket and 18 tooth driven sprocket on metering pump. Check tires for correct operating pressure.

Chart calculated based on a solution weighing ten pounds per gallon.

**NOTE: Fertilizer application rates can vary from weights calculated in above chart. Make field checks to be sure you are applying fertilizer at desired rate.**

To check the exact number of gallons your fertilizer attachment will actually deliver on a 30" row spacing:

1. Remove hose from one fertilizer opener and insert it into a collection container secured planter frame.
2. Engage fertilizer attachment and drive forward for 174'.
3. Measure fluid ounces caught in container and multiply by 100. Divide that amount by 128. Result is gallons of fertilizer delivered per acre when planting in 30" rows. To convert this delivery rate for wider rows, multiply by the following conversion factors:

36" multiply by 0.83

38" multiply by 0.79

4. Rinse collection container and repeat test on other rows if necessary.

**DRY INSECTICIDE APPLICATION RATES  
APPROXIMATE POUNDS/ACRE AT 5 MPH FOR VARIOUS ROW WIDTHS**

Meter Setting	30" Rows	36" Rows	38" Rows
<b>CLAY GRANULES</b>			
10	4.9	4.1	3.9
11	5.4	4.5	4.3
12	6.1	5.1	4.8
13	6.9	5.7	5.4
14	7.7	6.4	6.0
15	8.5	7.1	6.7
16	9.6	8.0	7.6
17	10.7	8.9	8.4
18	11.4	9.5	9.0
19	13.1	10.9	10.3
20	14.2	11.8	11.2
21	15.5	12.9	12.3
22	16.4	13.7	12.9
23	17.2	14.3	13.6
24	18.8	15.7	14.9
25	20.9	17.4	16.5
26	23.0	19.2	18.1
27	24.1	20.0	19.0
28	25.4	21.2	20.1
29	27.8	23.2	22.0
30	29.6	24.7	23.4
<b>SAND GRANULES</b>			
5	2.9	2.4	2.3
6	4.9	4.0	3.8
7	5.3	4.4	4.2
8	6.3	5.3	5.0
9	7.8	6.5	6.1
10	8.9	7.4	7.0
11	10.2	8.5	8.0
12	11.2	9.3	8.8
13	12.6	10.5	10.0
14	14.1	11.7	11.1
15	15.5	12.9	12.3
16	17.5	14.6	13.8
17	19.4	16.2	15.3
18	21.8	18.2	17.2
19	24.3	20.2	19.1
20	25.7	21.4	20.3
21	27.6	23.0	21.8
22	29.6	24.7	23.4
23	32.0	26.7	25.3
24	34.4	28.7	27.2
25	36.9	30.7	29.1

**NOTE:** Chart represents average values and should be used only as a starting point. Granular chemical flows through meter opening at a nearly uniform rate regardless of roller speed. Your actual rate will vary depending on insecticide, planting speed, and plant population. Planting speed/ground speed has the greatest effect on application rate.

Field check your actual rate with herbicide you are using at speed and population you will be planting. See ["Field Check Granular Chemical Application"](#) on page 2-44 in Machine Operation section for more information.



**DRY HERBICIDE APPLICATION RATES  
APPROXIMATE POUNDS/ACRE AT 5 MPH FOR VARIOUS ROW WIDTHS**

**CLAY GRANULES**

<b>Meter Setting</b>	<b>30" Rows</b>	<b>36" Rows</b>	<b>38" Rows</b>
10	4.7	3.9	3.7
11	5.2	4.4	4.1
12	5.8	4.9	4.6
13	6.5	5.4	5.1
14	7.3	6.1	5.7
15	8.2	6.9	6.5
16	9.0	7.5	7.1
17	9.9	8.2	7.8
18	10.7	8.9	8.4
19	11.6	9.7	9.2
20	12.6	10.5	10.0
21	13.6	11.3	10.7
22	14.6	12.1	11.5
23	15.7	13.1	12.4
24	17.0	14.1	13.4
25	18.1	15.1	14.3
26	19.4	16.2	15.3
27	20.9	17.4	16.5
28	22.6	18.8	17.8
29	24.3	20.2	19.1
30	26.7	22.2	21.1

**NOTE:** Chart represents average values and should be used only as a starting point. Granular chemical flows through given meter opening at a nearly uniform rate regardless of roller speed. Your actual rate will vary depending on specific herbicide, planting speed, and plant population. Planting speed/ground speed has the greatest effect on application rate.

Field check your actual rate with herbicide you are using at speed and population you will be planting. See ["Field Check Granular Chemical Application" on page 2-44](#) in Machine Operation section for more information.

**Page intentionally blank.**

## LUBRICATION

Following pages show locations of all lubrication points. Proper lubrication of moving parts helps ensure efficient operation of your Kinze planter and prolongs the life of friction producing parts.

### LUBRICATION SYMBOLS

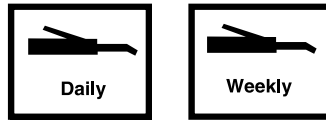

Lubricate at frequency indicated with SAE multipurpose grease.



Lubricate at frequency indicated with high quality SAE 10 weight oil or spray lubricant.

### SEALED BEARINGS

Sealed bearings are used on your Kinze planter to provide trouble free operation.

These are located on drive shafts, row units, and transmission bearings. Sealed bearings are lubricated for life and are not serviceable.

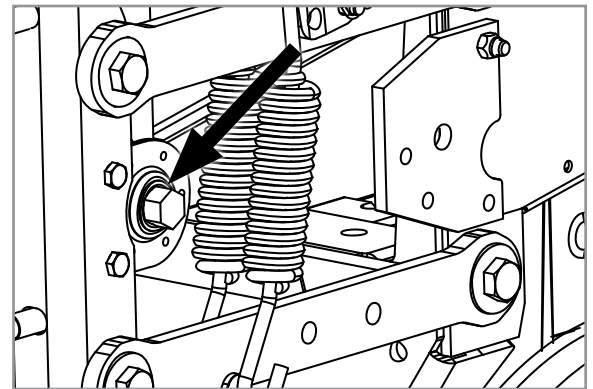

Sealed bearing (Typical)

### WRAP SPRING WRENCH ASSEMBLY

1. Remove ¼"-20 x ½" cap screw securing idler assembly to wrap spring wrench tightener shaft and
2. Remove wrap spring wrench from planter.
3. Tip wrap spring wrench on its side and lubricate with a high quality spray lubricant. Lubricant must be absorbed into wrap spring area.
4. Reinstall wrap spring wrench on planter.



Wrap spring wrench lubrication

### DRIVE CHAINS

Lubricate all transmission and drive chains daily with a high quality chain lubricant. Extreme operating conditions such as dirt, temperature, or speed may require more frequent lubrication. If a chain becomes stiff, it should be removed, soaked, and washed in solvent to loosen and remove dirt from joints. Soak chain in oil so lubricant can penetrate between rollers and bushings.

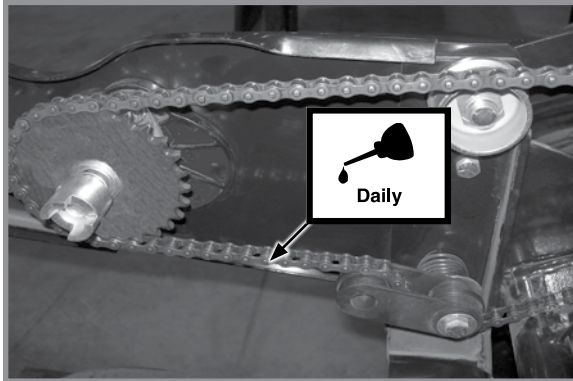

**Pull row unit drive chains**

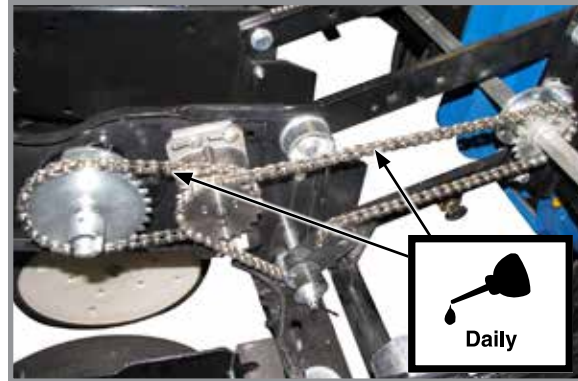

**Row Unit Electric Clutches**

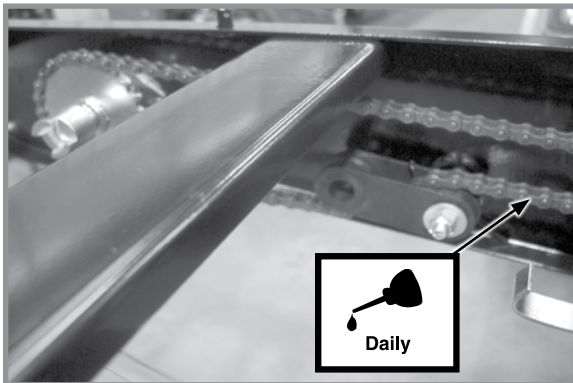

**Row unit granular chemical drive chains**

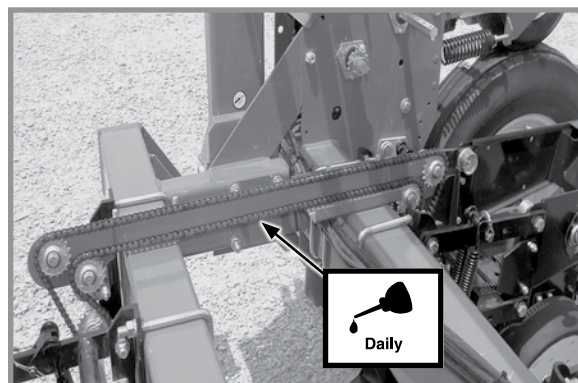

**Interplant package drive chains**

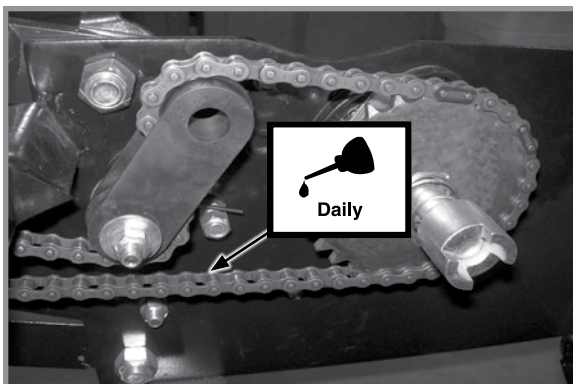

**Push row unit drive chains**

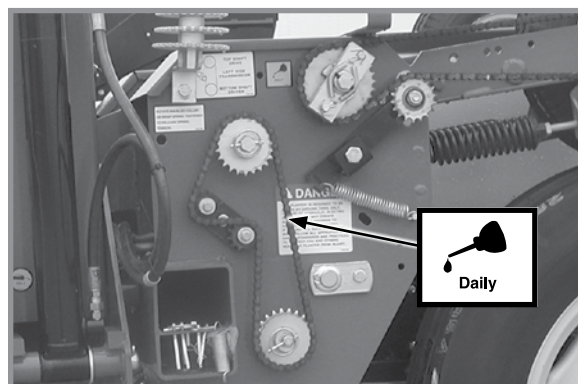

**Contact wheel drive chains  
Seed rate transmission drive chains**

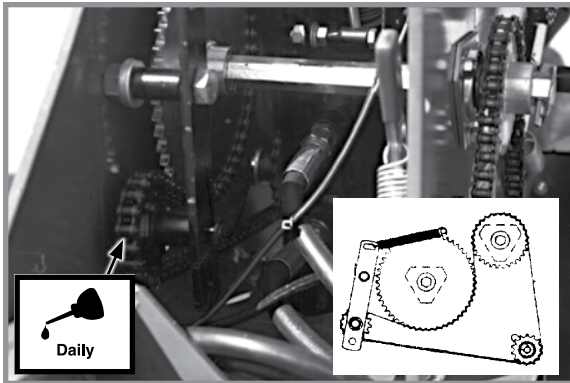

Inner wheel module drive chains

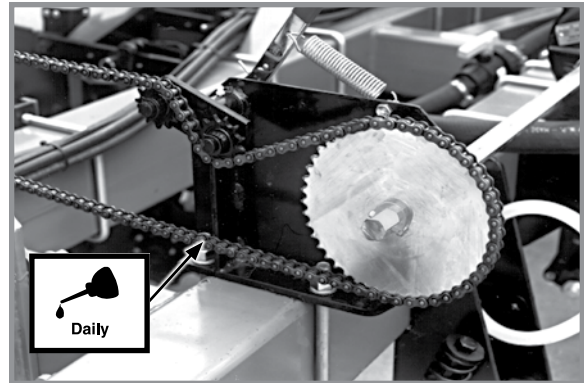

Liquid fertilizer drive chains (Squeeze pump)

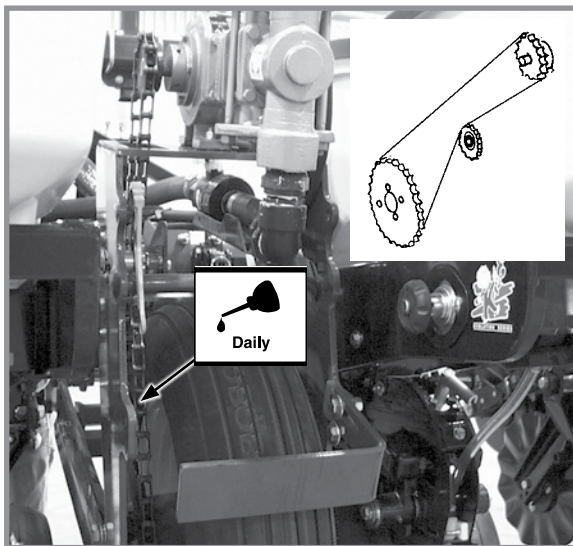

Piston pump ground drive chain

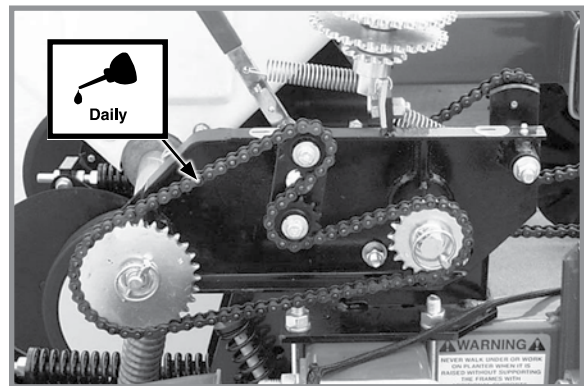

Dry fertilizer drive chains

## BUSHINGS

Lubricate bushings at frequency indicated.

Check each bolt for proper torque. If bolt is loose, removed it and inspect bushing for cracks and wear. Replace bushing if necessary. Use **only hardened flat washers**. Replace damaged flat washers with proper part. Torque hardware to 130 ft-lb (176.2 N-m).

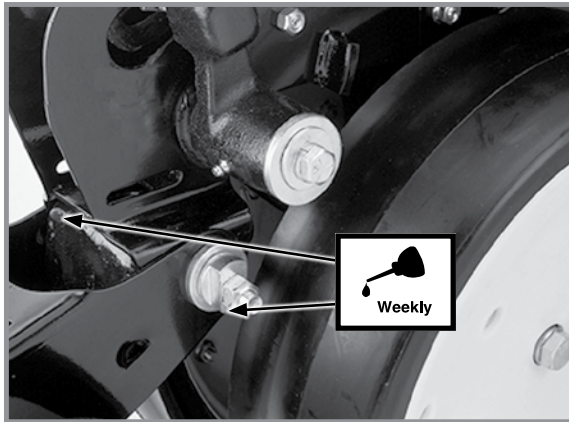

Row Unit “V” Closing Wheel, Covering Discs/ Single Press Wheel And/Or Drag Closing Wheel Eccentric Bushings (2 Per Row)

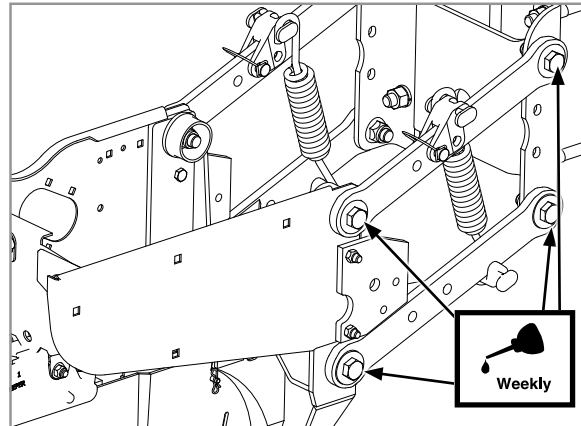

Pull Row Unit And/Or Push Row Unit Parallel Linkages (8 Per Row)

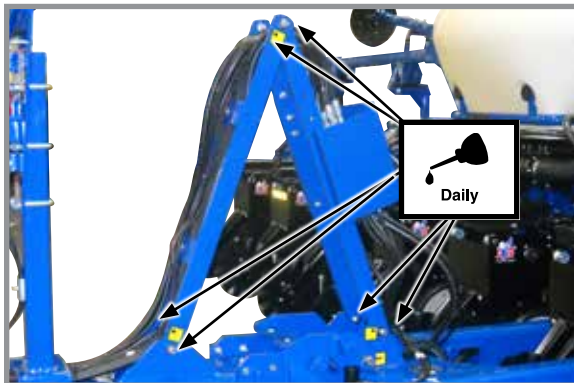

Hose take-up (6 locations)

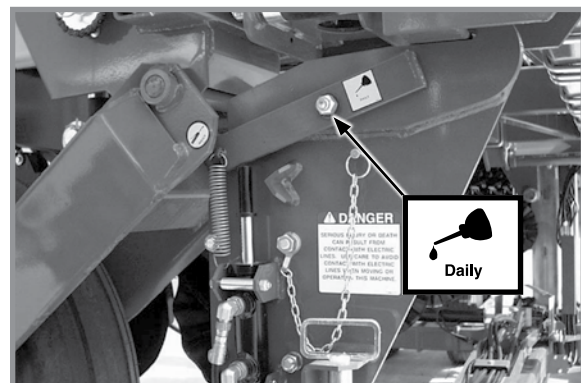

Transport latch (1 location)

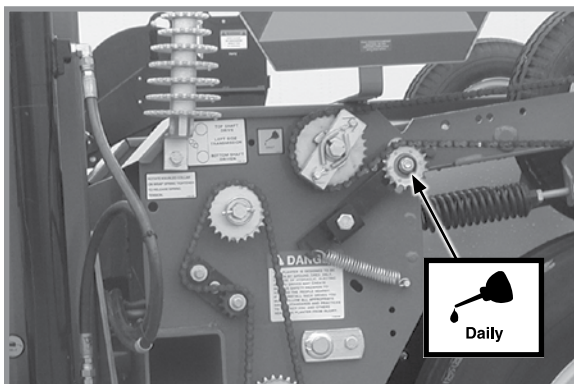

Contact wheel arm (2 per wheel assembly)

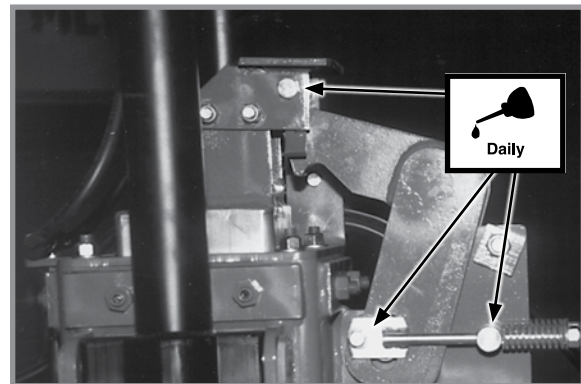

Safety hook at top of center section

## SPLIT ROW PUSH ROW UNIT LOCKUPS

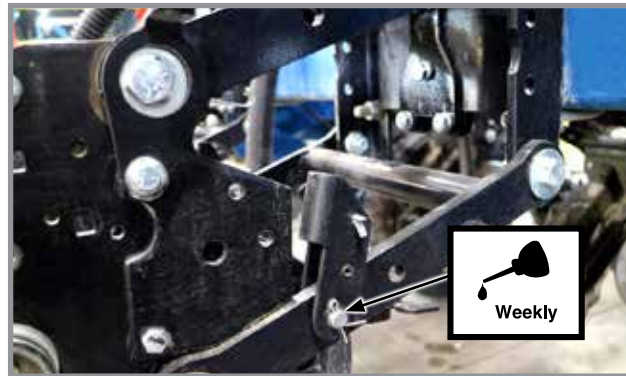

2 Per Row

## CENTER POST

### NOTICE

Any oil or grease on center post and poly wear pads will attract dirt and accelerate wear. Do not lubricate center post and poly wear pads.

Center post is clad with stainless steel. Keep stainless steel surface clean and free of any lubrication to prolong service life.

See ["Wear Pad Field Replacement/Adjustment" on page 6-34](#) for more information.

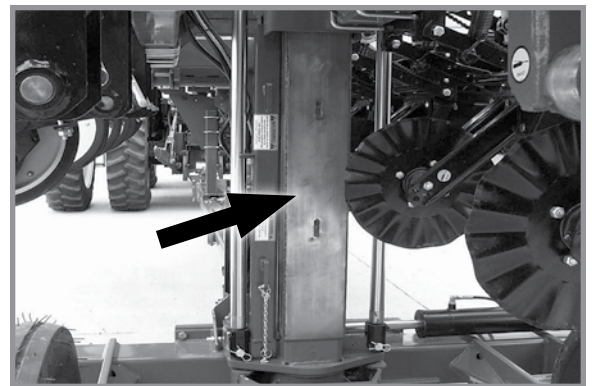

Center post

**U-JOINT SLIDES**

Lubricate all U-joint slides daily with a high quality lubricant.

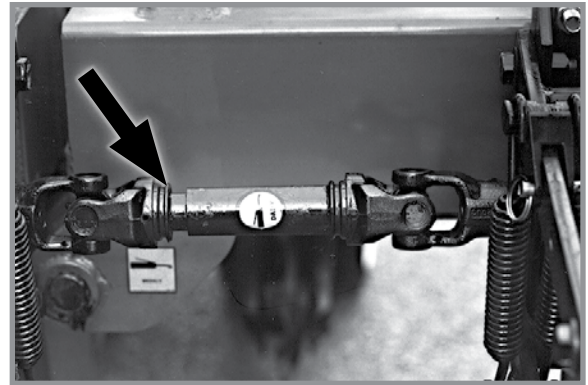

**U-joint slide**

**LIQUID FERTILIZER PISTON PUMP CRANK-CASE OIL LEVEL**

Check crankcase oil daily and maintain at oil level check plug. Fill as needed with EP 90 weight gear oil. Total oil capacity is approximately ¾ pint.

Refer to operator and instruction manual supplied with pump and flow divider for more information.

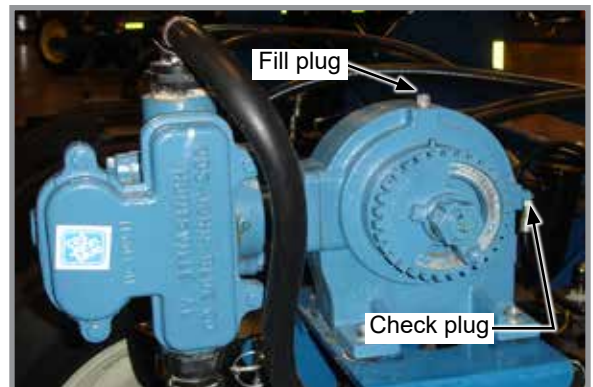

**Piston pump oil fill and check plug locations**



## PTO PUMP SHAFT COUPLING (TRACTOR MOUNTED PTO PUMP AND OIL COOLER)

**NOTE:** Clean and grease PTO shaft coupling each time pump is installed.

**NOTE:** Apply coating of high-speed industrial coupling grease, such as Chevron® Coupling Grease, that meets AGMA CG-1 and CG-2 Standards to extend shaft spline life.

*Chevron® trademark is owned by Chevron Products Company. AGMA is the acronym for the American Gear Manufacturers Association.*

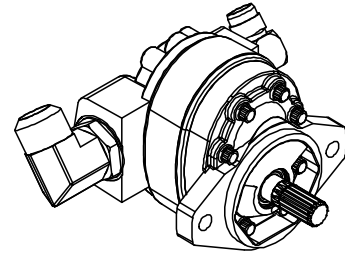

**PTO-driven hydraulic pump  
(1 $\frac{3}{8}$ " spline PTO pump shown)**

## WHEEL BEARINGS

All drive, transport, and marker hub wheel bearings should be repacked annually and checked for wear.

1. Raise wheel off ground.
2. Check for bearing endplay by moving wheel side to side.
3. Rotate wheel to check for bearing roughness. If bearings sound rough, remove hub and inspect bearings.

**NOTE:** To repack wheel hubs, follow procedure outlined for wheel bearing replacement except bearings and bearing cups are reused.

## GREASE FITTINGS

Parts equipped with grease fittings should be lubricated at frequency indicated with an SAE multipurpose grease. Clean fitting thoroughly before using grease gun. Frequency of lubrication recommended is based on normal operating conditions. Severe or unusual conditions may require more frequent attention.

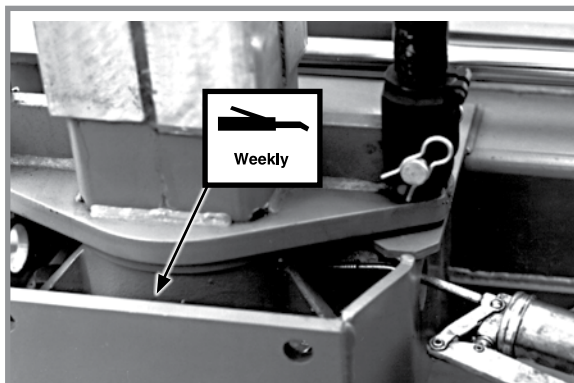

**Center Pivot - 1**



**Row marker assemblies - 3 per assembly**

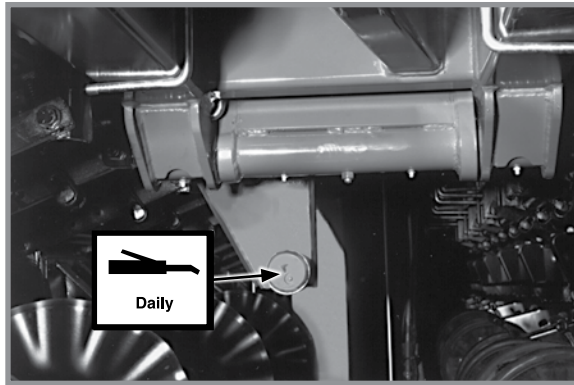

Cam follower - 1 per follower

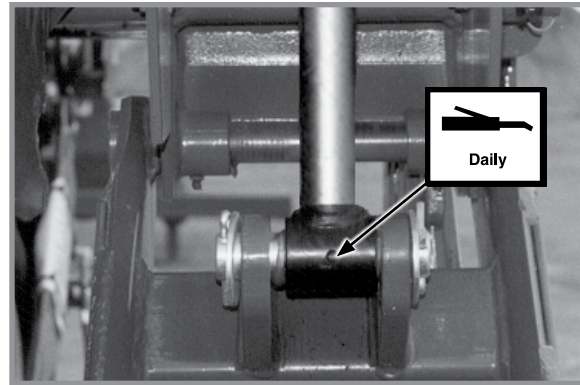

Wing lift cylinders - 1 per cylinder

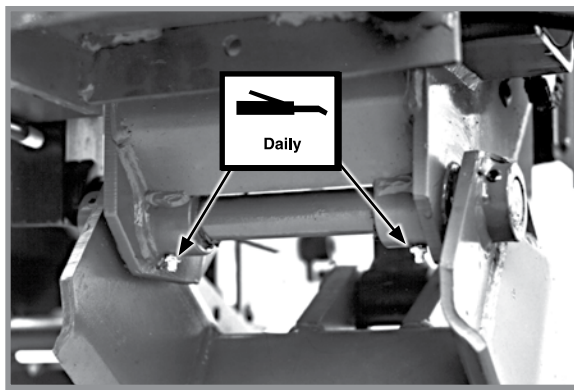

Wing wheel pivot - 2 per wheel module

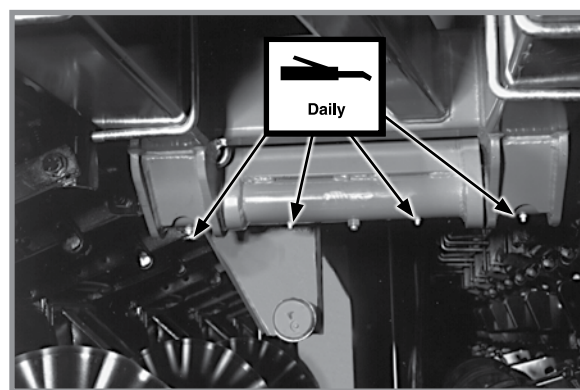

Wing hinges - 4 per wing

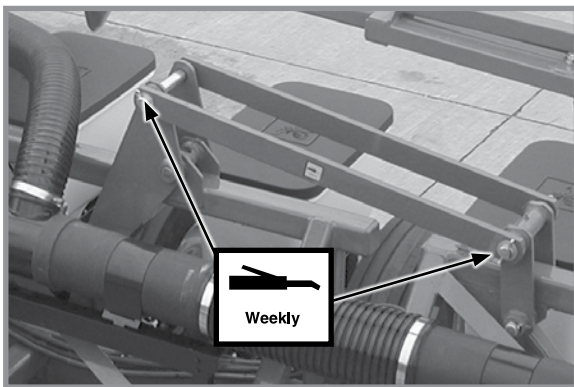

Wing locks - 3 per wing

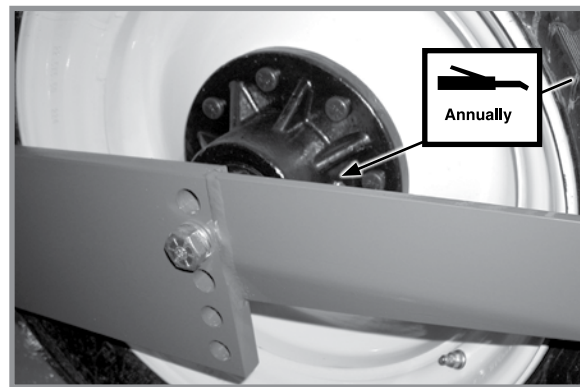

Transport wheel bearings - 1 per hub

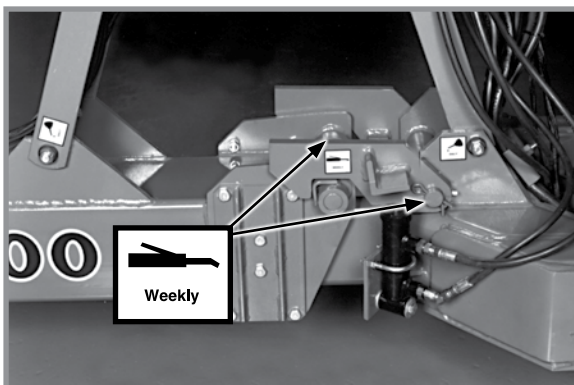

Tongue hook - 2

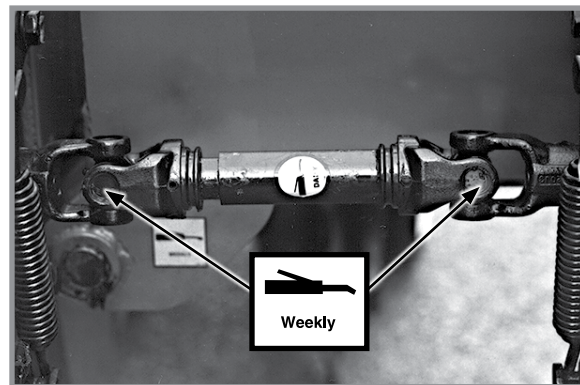

U-joints - 2 per hinge area

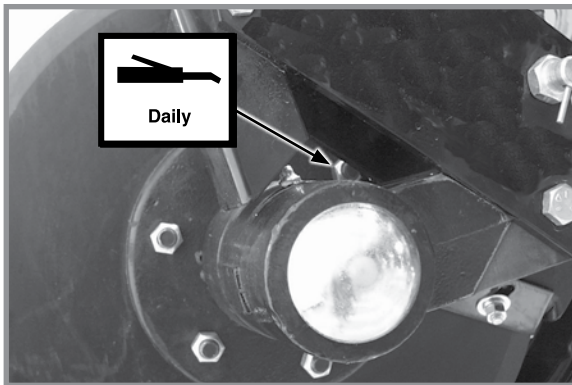

**HD single disc fertilizer opener - 1**  
(Located on disc opener spindle hub)

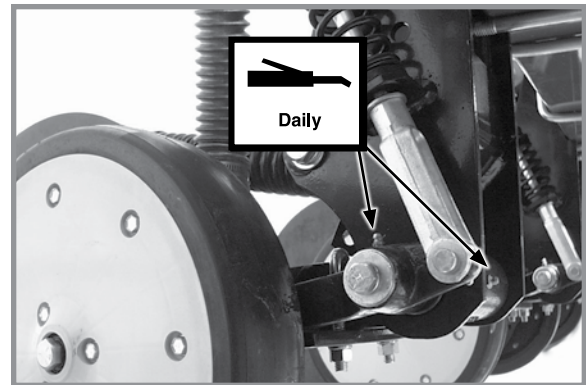

**HD single disc fertilizer opener - 2**  
(Located on wheel arm and opener mount)

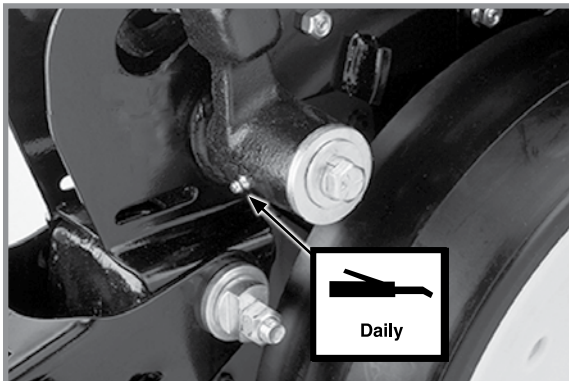

**Gauge wheel arms - 1 per arm**  
(Seals in gauge wheel arm are installed with lip facing out to allow grease to purge dirt away from seal. Pump grease into arm until fresh grease appears between washers and arm.)

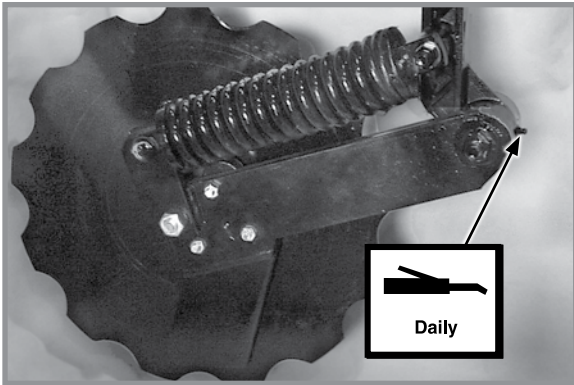

Notched single disc fertilizer opener - 1

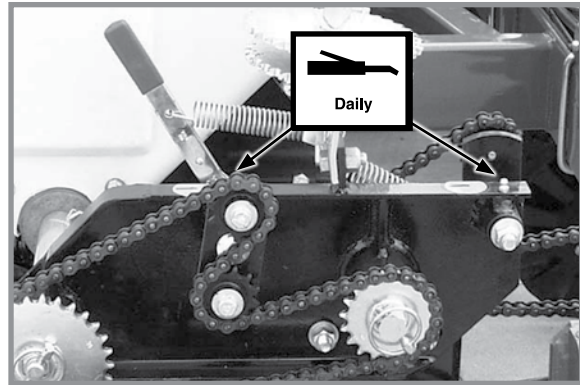

Dry fertilizer transmission - 2 per transmission

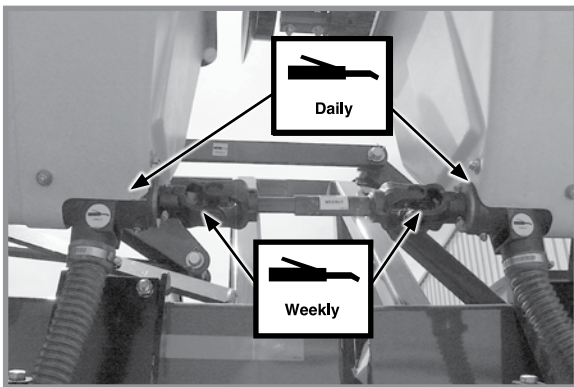

Dry fertilizer hopper - 2 per hopper  
U-joint - 1 per hinge area

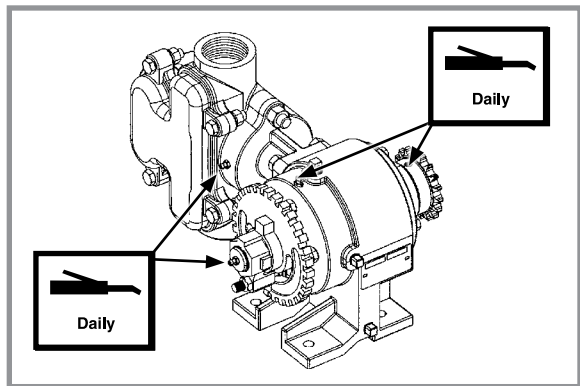

Liquid fertilizer piston pump - 4  
NOTE: Fill on outboard stuffing box until lubricant seeps out of drain hole in bottom.

**MOUNTING BOLTS AND HARDWARE**

Before operating planter for the first time, check all hardware is tight. Check all hardware again after first 50 hours of operation and beginning of each planting season.

All hardware used on the Kinze planter is Grade 5 (high strength) unless otherwise noted. Grade 5 cap screws are marked with three radial lines on the head. Hardware must be replaced with equal size, strength, and thread type.

**WARNING**

**Loose transport wheel lug bolts can result in wheel separation from planter and result in death, serious injury, and damage to property and equipment. Check transport wheel lug nut torque before operating planter for the first time and periodically thereafter.**

**NOTICE**

**Over-tightening hardware can reduce its shock load capacity and cause equipment failure.**

**TORQUE VALUES CHART - PLATED HARDWARE**

Diameter	Grade 2 (No marks)		Grade 5 (3 marks)		Grade 8 (6 marks)	
	Coarse	Fine	Coarse	Fine	Coarse	Fine
1/4"	50 in-lb	56 in-lb	76 in-lb	87 in-lb	9 ft-lb	10 ft-lb
5/16"	8 ft-lb	9 ft-lb	13 ft-lb	14 ft-lb	18 ft-lb	20 ft-lb
3/8"	15 ft-lb	17 ft-lb	23 ft-lb	26 ft-lb	33 ft-lb	37 ft-lb
7/16"	25 ft-lb	27 ft-lb	37 ft-lb	41 ft-lb	52 ft-lb	58 ft-lb
1/2"	35 ft-lb	40 ft-lb	57 ft-lb	64 ft-lb	80 ft-lb	90 ft-lb
9/16"	50 ft-lb	60 ft-lb	80 ft-lb	90 ft-lb	115 ft-lb	130 ft-lb
5/8"	70 ft-lb	80 ft-lb	110 ft-lb	125 ft-lb	160 ft-lb	180 ft-lb
3/4"	130 ft-lb	145 ft-lb	200 ft-lb	220 ft-lb	280 ft-lb	315 ft-lb
7/8"	125 ft-lb	140 ft-lb	320 ft-lb	350 ft-lb	450 ft-lb	500 ft-lb
1"	190 ft-lb	205 ft-lb	480 ft-lb	530 ft-lb	675 ft-lb	750 ft-lb
1 1/8"	265 ft-lb	300 ft-lb	600 ft-lb	670 ft-lb	960 ft-lb	1075 ft-lb
1 1/4"	375 ft-lb	415 ft-lb	840 ft-lb	930 ft-lb	1360 ft-lb	1500 ft-lb
1 3/8"	490 ft-lb	560 ft-lb	1100 ft-lb	1250 ft-lb	1780 ft-lb	2030 ft-lb
1 1/2"	650 ft-lb	730 ft-lb	1450 ft-lb	1650 ft-lb	2307 ft-lb	2670 ft-lb

**NOTE: Torque unplated hardware and bolts with lock nuts approximately 1/3 higher than above values. Torque bolts lubricated prior to installation to 70% of value shown in chart.**

**NOTE: Torque vacuum fan impeller assembly to motor shaft 1/2"-18 hex jam nut 50 ft-lb (67.8 N-m).**

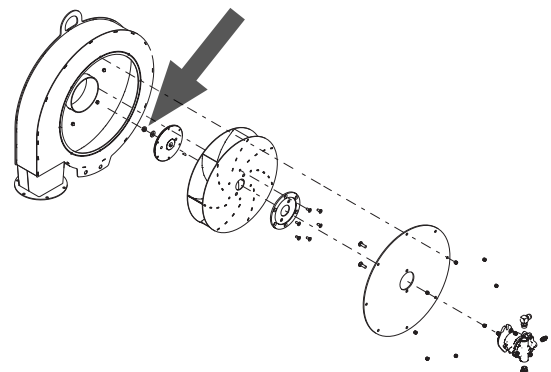

**CYLINDER ROD PISTON RETAINING NUT  
TORQUE CHART**

	<b>Non-Nylock Nut</b>	<b>Nylock Nut</b>
1/2"-20	55-70 ft-lb (75-95 Nm)	45-55 ft-lb (61-75 Nm)
3/4"-16	115-125 ft-lb (156-169 Nm)	100-115 ft-lb (136-156 Nm)
7/8"-14	150-180 ft-lb (203-244 Nm)	130-150 ft-lb (176-203 Nm)
1"-14	275-330 ft-lb (373-447 Nm)	250-275 ft-lb (339-373 Nm)
1 1/8"-12	300-375 ft-lb (407-508 Nm)	275-300 ft-lb (373-407 Nm)
1 1/4"-12	300-375 ft-lb (407-508 Nm)	275-300 ft-lb (373-407 Nm)

**TORQUE VALUES - PNEUMATIC DOWN PRESSURE**

Diameter	Torque Value
Torque Value	120 in-lb Maximum
1/2"-13	180 in-lb Maximum
3/4"-16	180 in-lb Maximum

**NOTE: Use these torque values with pneumatic down pressure components.**

**SPECIAL TORQUE VALUES**

Row unit parallel linkage bushing hardware	130 ft-lb (176 Nm)
5/8" No till coultter spindle hardware	120 ft-lb (169 Nm)
Center section transport tire lug nuts	180 ft-lb (244 Nm)
Wing ground drive tire lug bolts	125 ft-lb (122 Nm)

**TIRE SERVICING**

WARNING

**Explosive separation of rim and tire parts can cause death or serious injury. Overinflation, rim and tire servicing, improper use of rims and tires, or worn or improperly maintained tires could result in a tire explosion.**



To prevent tire explosions:

- Maintain proper tire pressure. Inflating a tire above or below the recommended pressure can cause tire damage.
- Mount tires only by properly trained personnel using proper equipment.
- Replace tires with cuts or bubbles. Replace damaged rims. Replace missing lug bolts and nuts.
- Do not weld or heat wheel assembly. Heating increases tire pressure.

**INFLATION SPECIFICATIONS**

WARNING

**Over-inflation of tires can result in explosive separation of rim and tire and cause death or serious injury. Different size rims are designed for different tire pressures. Inflate to correct pressure for specific rim size.**



Do not exceed the following maximum pressures:

- 100 psi (689.4 kPa) maximum pressure.

Transport (center section) 255-70R 22.5"  
75 psi (517.1 kPa) recommended/100 psi (689.4 kPa) max.

Ground drive (wings) 7.50" x 20". . . . .40 psi (275.7 kPa)

Contact drive - 4.80" x 8". . . . .50 psi (344.7 kPa)

Liquid fertilizer piston pump 7.60" x 15" . . . .40 psi (275.7 kPa)

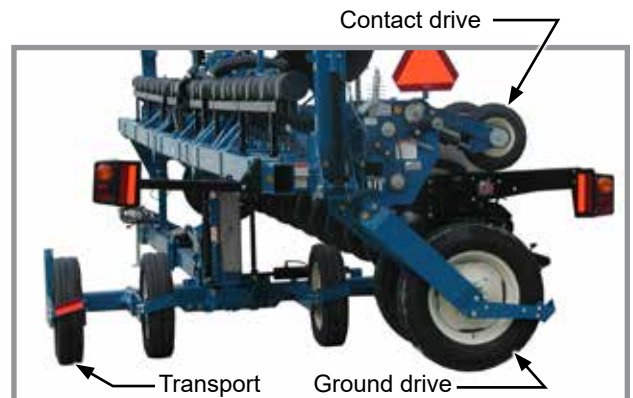

## FINGER PICKUP SEED METER INSPECTION/ADJUSTMENT

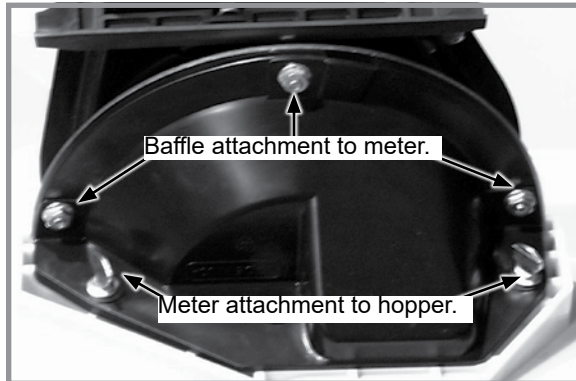

**Removing meter and baffle**

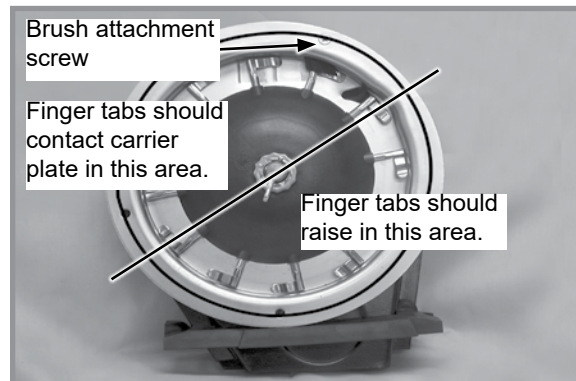

**Proper finger operation**

1. Remove two thumbscrews and meter from seed hopper and remove three cap screws and baffle from meter assembly.
2. Rotate seed meter drive by hand to ensure springs are holding tabs of fingers against carrier plate and fingers raise in correct area as shown in above photo.

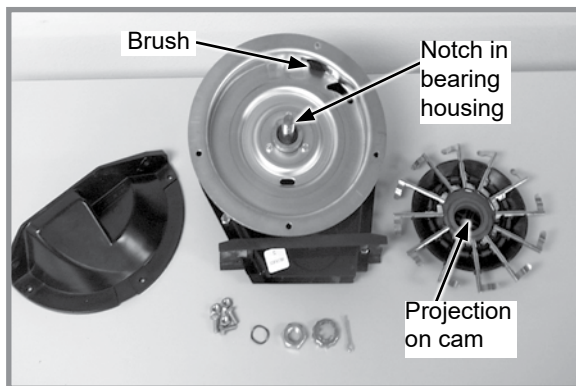

**Finger pickup meter parts**

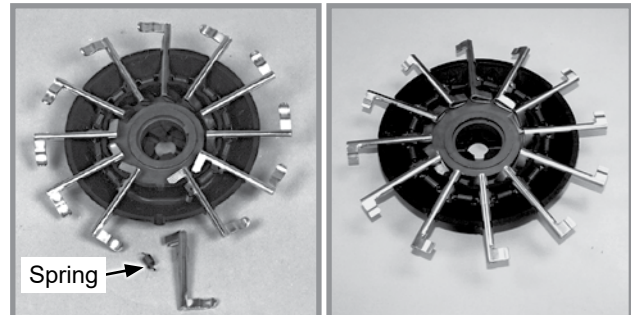

**Corn Finger Assembly**  
(Position Spring Opening  
Toward Holder)

**Oil Sunflower Finger  
Assembly**

Buildup of debris or chaff may prevent proper finger operation and requires disassembly and cleaning of finger pickup meter.

1. Remove cotter pin, cover nut and adjusting nut and wave washer (if applicable) from drive shaft.
2. Carefully lift finger holder with fingers and cam off shaft and clean.
3. Check brush for wear and replace if necessary or after every 100 acres per row of operation (Approximately 800 acres of corn or sunflowers on a 8 row machine or 1200 acres on an 12 row machine).

**NOTE: It is not necessary to remove finger holder to replace brush.**

4. Remove springs from fingers and remove finger from holder by lifting it out of friction fit slot. Life expectancy of these parts is about 600-900 acres per row of operation under average conditions.
5. Reassemble meter in reverse order after cleaning and replacing defective parts. Make sure open end of spring loop is toward inside of finger holder when replacing fingers.
6. Install fingers in holder so holder is flush with carrier plate when assembled. A cam projection aligns with a mating notch in bearing housing to ensure proper operation when assembled.

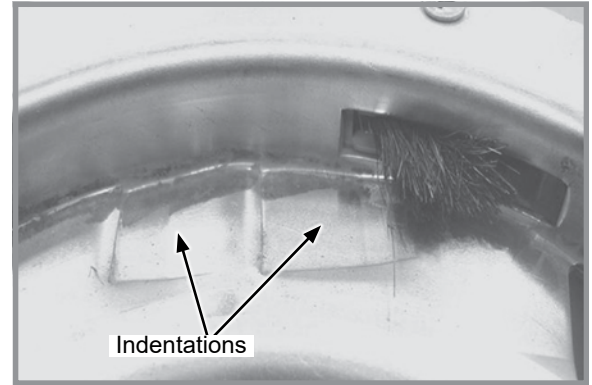

7. Check indentations on carrier plate for wear before installing finger holder on carrier plate. Excessive wear of carrier plate at indentations will cause over planting especially with small sizes of seed. Inspect carrier plate annually. Life expectancy should be 250-300 acres per row of operation under average conditions.
8. Install wave washer and adjusting nut with finger holder flush against carrier. Tighten adjusting nut to fully compress wave washer. Back off nut  $\frac{1}{2}$  to 2 flats to obtain rolling torque of 22 to 25 inch pounds.
9. Turn finger holder by hand to make sure it is firmly against carrier plate, but can be rotated with moderate force.
10. Install cover nut and cotter pin. Reinstall baffle.

**Worn carrier plate**

**NOTE: Check adjusting nut tightness on each unit after first day of use and periodically thereafter.**

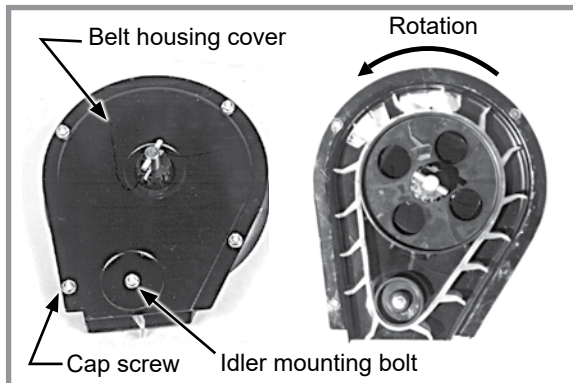
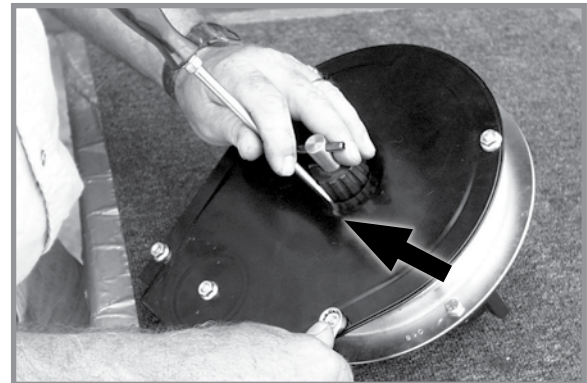
**Belt idler****Centering belt housing cover**

Remove four cap screws around edge of housing cover and nut from belt idler mounting bolt. Paddles must be correctly oriented as shown above. If belt is replaced. A diagram molded into drive sprocket shows correct orientation.

## NOTICE

**Do not over-tighten hardware or components may be damaged.**

Reinstall housing cover. **DO NOT TIGHTEN** hardware. Wedge a screwdriver between sprocket hub and housing cover as shown above. Pry cover down until centered on belt housing and tighten hardware. Rotate meter drive shaft and check idler alignment. Seed belt should "run" centered on idler or with only slight contact with belt housing or cover.

### **CLEANING FINGER PICKUP SEED METER FOR STORAGE**

1. Disassemble meter and blow out any foreign material.
2. Wash **ONLY** in mild soap and water. Do not use gasoline, kerosene, or any other petroleum based product. Dry thoroughly.
3. Coat lightly with a rust inhibitor.
4. Rotate finger assembly so finger does not touch brush.
5. Reassemble and store in a dry, rodent-free location.

**BRUSH-TYPE SEED METER 2.0 MAINTENANCE**

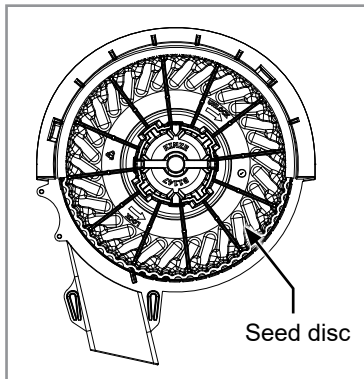

**Brush-type seed meter seed disc installed**

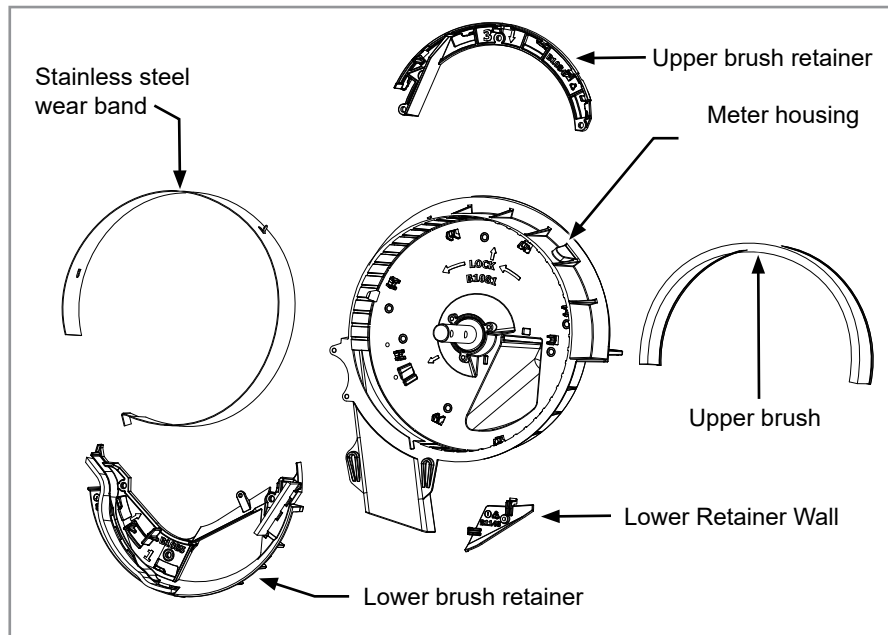

**Brush-type seed meter 2.0 parts**

Use clean, high quality seed. Damaged or cracked seed, hulls, or foreign materials can become lodged in upper brush and greatly reduce meter accuracy. Remove seed disc daily and check for buildup of foreign material on seed disc, particularly in seed loading slots. Clean disc by washing it with soap and water. Check for cracked seed, hulls, etc. lodged between brush retainer and stainless steel wear band which can greatly reduce accuracy of the meter because upper brush will not be able to retain seed in seed disc pocket. Thoroughly clean brush areas of meter housing.

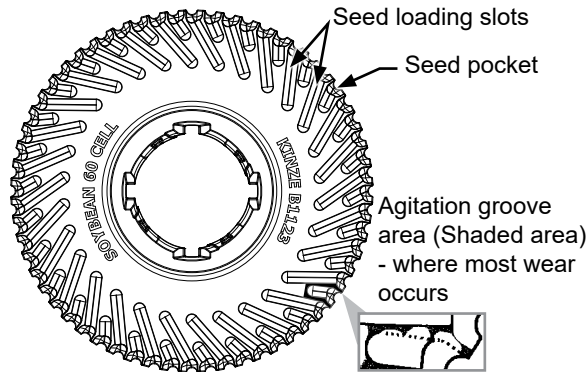

SEED DISC WEAR

Most seed disc wear is found in the agitation groove area (area between seed loading slots). Wear affects planting accuracy at high RPM. Lay a straight edge across disc surface at agitation groove area and measure gap between disc and straight edge. If agitation groove areas are worn in excess of .030" and accuracy starts to drop off at higher meter RPM, replace seed disc. Estimated seed disc life expectancy under normal operating conditions is approximately 200 acres per row. Severe operating conditions such as dust, lack of lubrication or abrasive seed coating could reduce seed disc life expectancy to under 100 acres per row.

STAINLESS STEEL WEAR BAND

<b>NOTICE</b>	<b>If wear band wears through or if meter is used without wear band in place, meter housing may be damaged.</b>
---------------	---

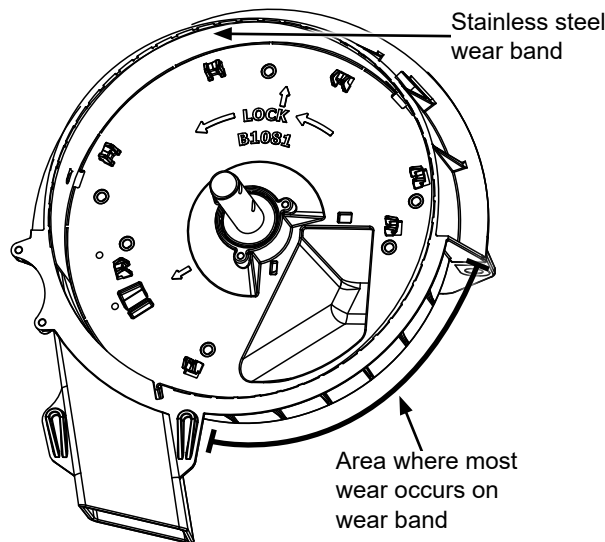

**Stainless steel wear band**

Stainless steel wear band protects meter housing from wear and is .030" thick. Replace wear band when there is approximately .020" of wear in primary wear area. Estimated life expectancy of stainless steel wear band is 240-800 acres per row.

## ASSEMBLY

Assemble meter by putting parts back in the housing in the order they are numbered:

1. Lower brush retainer
2. Upper brush
3. Upper brush retainer

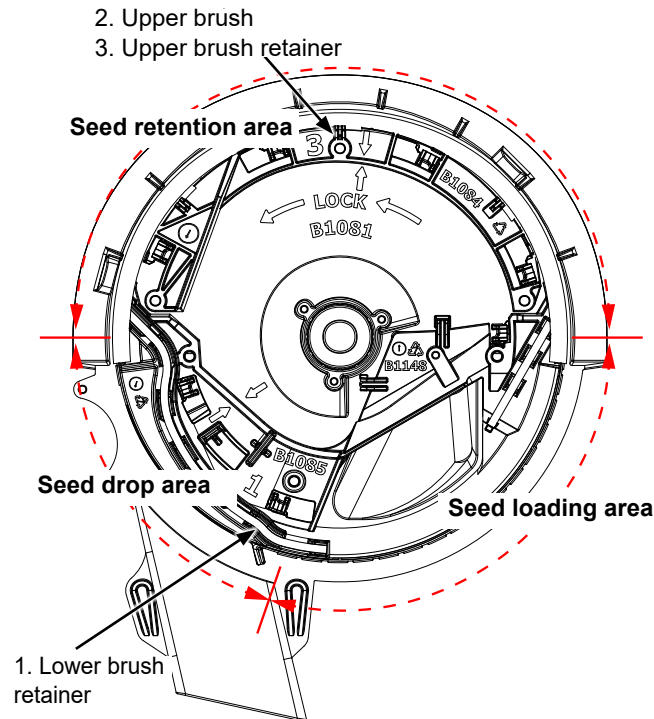

## LOWER BRUSH

Lower brush moves seed down seed loading slots to seed pockets, isolates seed in reservoir from entering seed tube, and cleans seed loading slots. Estimated lower brush life expectancy is 240-800 acres per row. Replace lower brush if bristles are deformed or missing, or if there are cracks in brush retainer. Once all parts are properly in place, rotate to lock position.

## UPPER BRUSH

Upper brush holds seed in seed disc pocket in seed retention area. Brush must apply enough pressure against seed in seed disc pocket as disc rotates through seed retention area to prevent seed from dropping out of disc pocket. A damaged spot, excessive brush wear, or foreign material lodged in brush may greatly reduce meter performance.

Replace upper brush at 120-400 acres per row of use or sooner if damage or excessive wear is found. Position upper brush into inner perimeter of seed retention area. Make sure base of brush is tight against bottom of meter housing. Install brush retainer. Once all parts are properly in place, rotate to lock position.

**NOTE: Use P/N: GB1084 upper brush retainer for all seed discs. It is recommended for milo/grain sorghum to use P/N: GB1107 milo retainer for additional brush retention.**

**CLEANING BRUSH-TYPE SEED METER FOR STORAGE**

1. Remove meter from seed hopper by removing two thumbscrews securing meter to hopper.
2. Remove seed disc and wash with soap and water and dry thoroughly.
3. Remove three hex head screws from brush retainer. Remove brush retainer and upper brush.
4. Remove three hex head screws from lower brush. Remove lower brush and stainless steel wear band.
5. Wash all parts and meter housing with soap and water and dry thoroughly.
6. Inspect all parts and replace worn parts.
7. Reassemble meter except for seed disc. Store meter in a dry, rodent-free space with seed disc removed.

**VACUUM MANIFOLD MAINTENANCE**

Dust accumulates in manifolds and hoses during normal operation. Clean manifolds annually. Abnormally dusty planting conditions may require more frequent cleaning.

1. Remove vacuum hose from each seed meter.
2. Operate vacuum fan at full hydraulic flow from tractor for two minutes to clear manifolds, hoses, and fittings of dust and debris.
3. Shut down fan and replace hoses

## VACUUM SEED METER MAINTENANCE

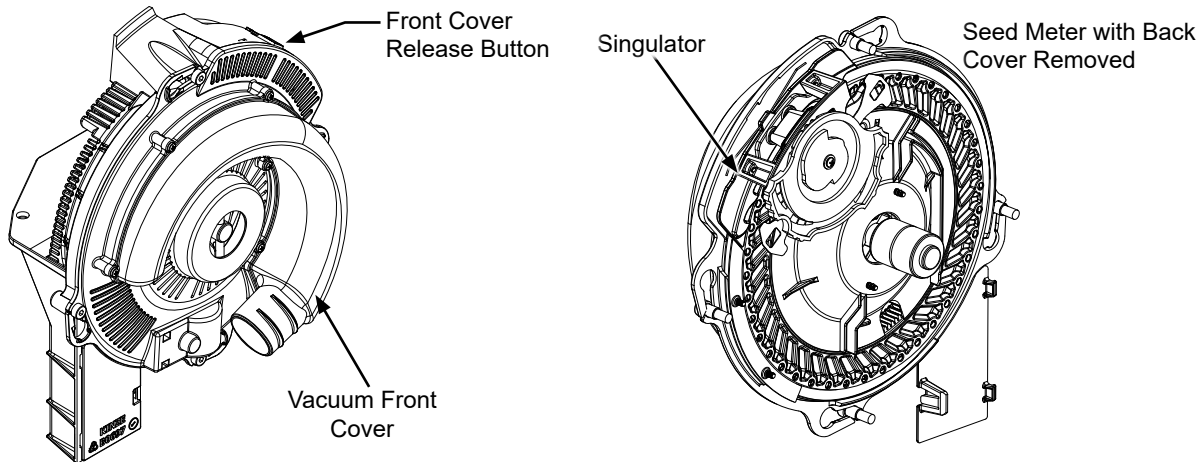

Before each planting season inspect seed discs and singulator and clean or replace as needed.

Use clean, high quality seed for maximum meter accuracy. Damaged or cracked seed, hulls, and foreign material may become lodged in seed disc orifices and greatly reduce meter accuracy.

Inspect and clean seed discs daily checking for any buildup of foreign material and blocked orifices. If seed disc orifices are plugged frequently with seed remnants, remnants ejector wheel may need to be replaced. Clean seed disc by washing it with soap and water. Dry thoroughly.

Inspect singulator blades and guide for wear after every 200 acres per row of operation. If adjustment of singulator blade does not affect meter performance or if blades appear worn, singulator blade may need to be replaced.

Replace seed disc or vacuum seal if abnormally high vacuum is required or if consistent operation cannot be achieved.

See ["Preparation for Storage" on page 6-40](#) additional Vacuum Seed Metering System maintenance.

**NOTE: Remove seed discs from meters for annual storage and store them vertically on a dowel or pipe.**

## VACUUM SEED METER CLEANOUT

Thorough seed meter cleanout is important to maintain genetic purity.

1. For electric seed meter, unplug meter drive motor and remove seed hopper and meter. Lay hopper on its right side.
2. Rotate vacuum cover clockwise to align key hole slots with bolt heads. Lift off cover.
3. Remove seed disc.
4. Empty meter and hopper by allowing seed to run out of meter.
5. Inspect meter to ensure all seed is removed.
6. Replace seed disc and install vacuum cover.

**NOTE: Use of damaged seed or seed containing foreign material will cause plugging of seed cell orifices and require more frequent seed meter cleanout to prevent underplanting.**

## CHAIN TENSION ADJUSTMENT

Drive chains have spring loaded idlers and are self-adjusting. Remove link to shorten chain if wear stretches chain and reduces spring tension. Check idler pivot points to make sure they rotate freely. See ["Wrap Spring Wrench Assembly" on page 6-1](#) in this section for additional information.

Additional chain links are stored inside planter frame.

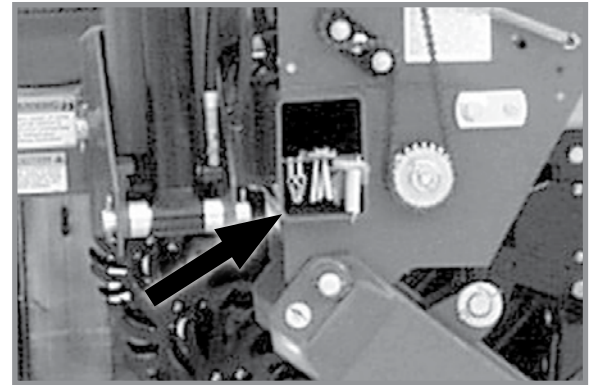

Additional chain links

## GAUGE WHEEL ADJUSTMENT

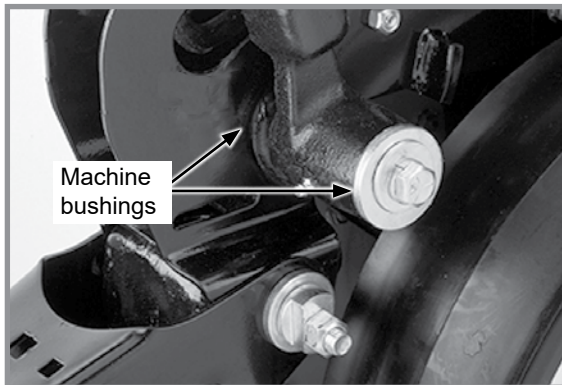

Machine bushings

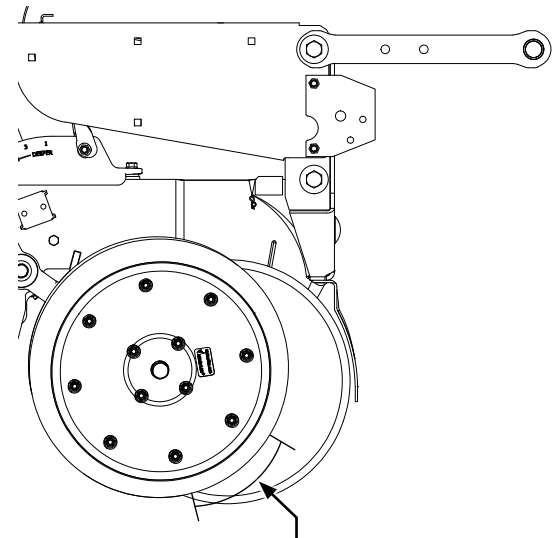

Shim gauge wheel to lightly contact opener disc blade in this area for 4" to 6". Check adjustment in operating position.

### Gauge Wheel Adjustment

Add or remove machine bushings between shank and gauge wheel arm to adjust contact between gauge wheels and opener blades. Gauge wheels should lightly contact opener blades to prevent accumulation of dirt or trash. Gauge wheels and opener blades should turn with only slight resistance.

Store remaining machine bushings between gauge wheel arm and flat washer on outer side of gauge wheel arm.

Use the following guidelines:

**NOTE: Set depth adjustment handle at 3x2 position and lift gauge wheel to stop one side at a time.**

Contact should be no less than one half of the rotation of the wheel, while not sticking in any position (it does not have to be continuous). Wheel should rotate in the direction of travel of the row unit. Wheel can be held in position by supporting the spindle bolt head.

## GAUGE WHEEL ARM BUSHING/SEAL REPLACEMENT

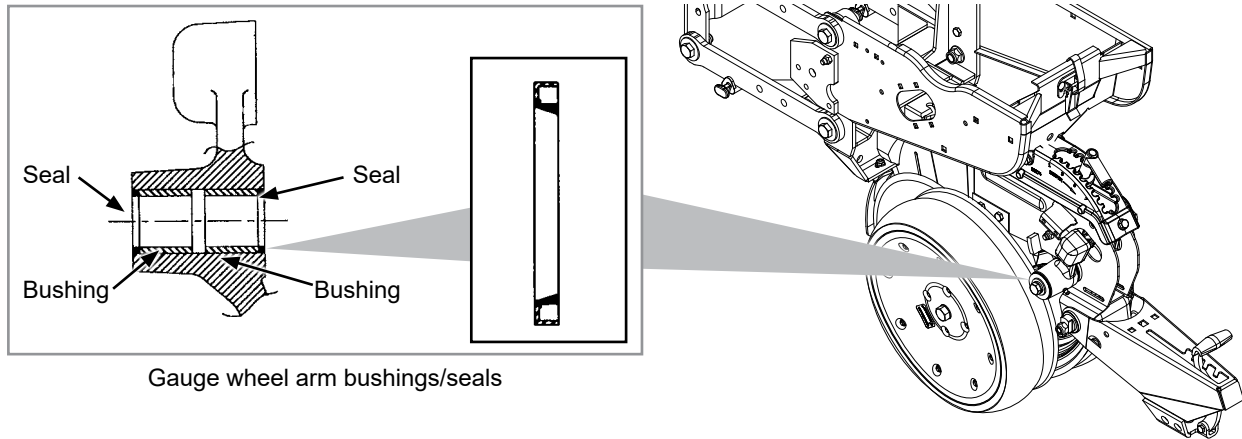

Gauge wheel arm bushings/seals

**NOTE: Gauge Wheel Arm Bushing and Seal Driver Kit (G1K296) is available through your Kinze Dealer.**

1. Remove gauge wheel from arm.
2. Remove gauge wheel arm from shank assembly.
3. Remove seal and bushing and discard. Clean and dry inner bore.
4. Drive/press replacement bushing inside bore of arm to a depth of .125" below flush.
5. Coat wiping edge of seal with grease.
6. Drive/press seal into place with lip to outside.

**NOTE: Use extra care to protect the sealing lip during installation. Apply uniform pressure to assemble the seal into the bore of the arm. Never apply a direct hammer blow to the seal surface.**

7. Inspect gauge wheel pivot spindle.
8. Reinstall gauge wheel arm assembly and gauge wheel.

**NOTE: Use special machine bushing between gauge wheel arm and gauge wheel.**

9. Shim for proper gauge wheel tire/disc blade clearance.
10. Lubricate with an SAE multipurpose grease.

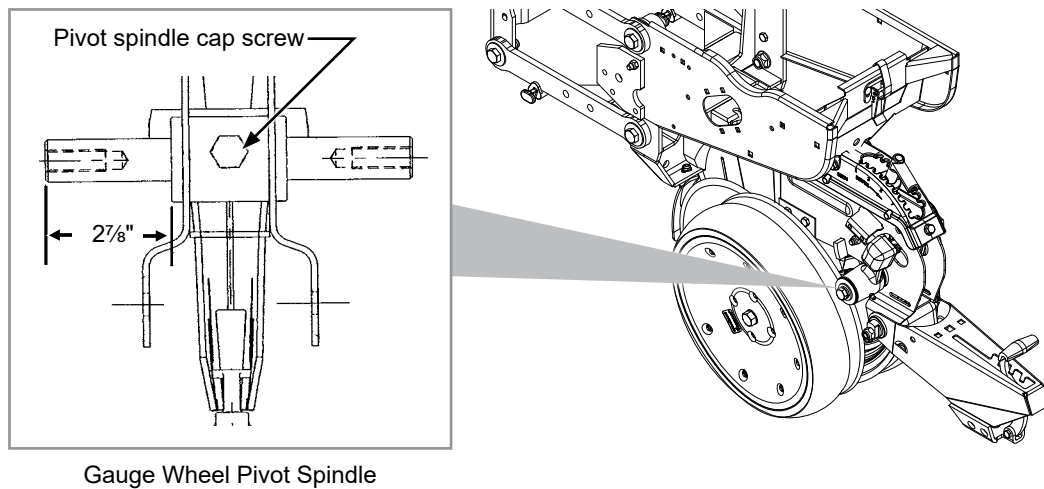

**GAUGE WHEEL ARM PIVOT SPINDLE REPLACEMENT**

Gauge Wheel Pivot Spindle

1. Remove gauge wheel and arm assemblies from shank assembly.
2. Remove  $\frac{1}{2}$ " x  $\frac{3}{4}$ " cap screw that locks pivot spindle in place and remove spindle.
3. Install replacement spindle and position as shown. Exact centering is critical.
4. Install  $\frac{1}{2}$ " x  $\frac{3}{4}$ " cap screw and torque to lock pivot spindle in place.
5. Install gauge wheel and arm assemblies. Shim for proper gauge wheel tire/disc blade clearance.

## 15" SEED OPENER DISC BLADE/BEARING ASSEMBLY

Approximately  $1" \pm \frac{1}{2}"$  ( $3 \pm .5$  cm) of blade-to-blade contact should be maintained to properly open and form seed trench. As blade diameter decreases due to wear, it is necessary to relocate machine bushings from inside to outside to maintain  $1" \pm \frac{1}{2}"$  ( $3 \pm .5$  cm) of contact.

**NOTE: Proper blade clearance is critical. Blades should have  $1" \pm \frac{1}{2}"$  ( $3 \pm .5$  cm) contact in this area. When blades are turned by hand in opposite directions against each other, there should be only light resistance to turning. Re-adjust blade scraper if necessary to center it between the blades.**

**NOTE: If proper blade-to-blade contact cannot be maintained after relocating machine bushings or if blade diameter wears below  $14\frac{1}{2}"$  (37 cm), blades should be replaced.**

### NOTICE

Excessive blade contact may result in premature disc opener bearing/hub failures and excessive wear on seed tube guard/inner scraper. When properly adjusted, if one blade is held in fixed position, opposite blade should rotate with less than 5 pounds force (22 newtons) at outer edge of blade.

### NOTICE

Left hand side of opener uses a left hand threaded cap screw. **DO NOT OVER TIGHTEN.** Damage to shank threads require replacement of row unit shank assembly.

### REPLACE DISC BLADE/BEARING ASSEMBLY

1. Remove gauge wheel.
2. Remove scraper.
3. Remove bearing dust cap.
4. Remove cap screw, washer and disc blade/bearing assembly. Machine bushings between shank and disc blade are used to maintain approximate  $1" \pm \frac{1}{2}"$  ( $3 \pm .5$  cm) of blade-to-blade contact.
5. Install machine bushing(s), new disc blade bearing assembly, washer and cap screw. Torque  $\frac{5}{8}"$ -11 Grade 5 cap screw to value shown in "Torque Values Chart".

**NOTE: Replace disc blades only with disc blades of equal thickness.**

6. Replace bearing dust cap.
7. Install scraper.
8. Install gauge wheel. It may be necessary to replace bearing only if there is excessive endplay or if bearing sounds or feels rough when disc blade is rotated.

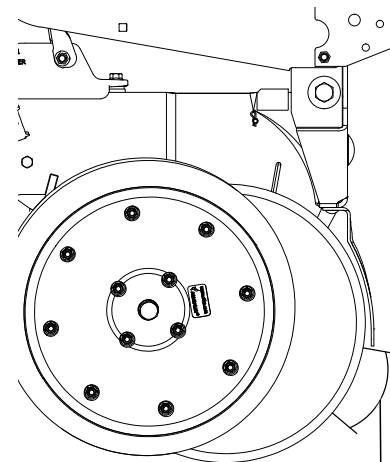

Approximately  $1" \pm \frac{1}{2}"$  ( $3 \pm .5$  cm) of blade-to-blade contact.

## REPLACE BEARING ONLY

1. Remove gauge wheel, scraper, bearing cap, cap screw, washer and disc blade/bearing assembly.
2. Remove ¼" rivets from bearing housing to expose bearing.
3. After installing new bearing, install three evenly spaced ¼" cap screws into three of six holes in bearing housing to hold bearing and bearing housing in place. Install rivets in other three holes. Remove ¼" cap screws and install rivets in those three holes.
4. Reinstall disc blade/bearing assembly, washer and cap screw. Torque ⅝"-11 cap screw to value shown in "Torque Values Chart" at the beginning of this section.
5. Replace bearing dust cap.
6. Install scraper and gauge wheel.

## SEED TUBE GUARD/INNER SCRAPER

Seed tube guard protects seed tube and acts as inner scraper for seed opener disc blades.

Remove seed tube and check for wear. Excessive wear on seed tube indicates a worn seed tube guard. Replace seed tube guard if it measures  $\frac{5}{8}$ " (16 mm) or less at lower end. A new seed tube guard measures approximately  $\frac{7}{8}$ " (22.2 mm).

**NOTE:** No till planting or planting in hard ground conditions, especially when planter is not equipped with no till coulters, and/or excessive blade-to-blade contact increases seed tube guard wear and requires more frequent inspection and/or replacement.

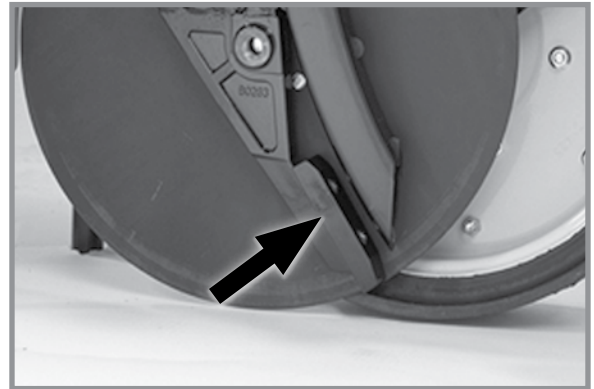

Seed tube guard/inner scraper  
(Gauge wheel/seed opener disc blade removed)

### NOTICE

Over tightening hex socket head cap screws may damage shank threads and require replacement of shank. An excessively worn seed tube guard may allow blades to wear into row unit shank, also requiring replacement of shank.

Remove seed tube and two hex socket head cap screws that attach seed tube guard. Hold replacement seed tube guard centered between seed opener disc blades. Install hex socket head cap screws. **DO NOT TIGHTEN.** Using a clamp or vise-grip, squeeze opener blades together in front of seed tube guard. Tighten seed tube guard retaining screws. Remove clamps. Distance between seed tube guard and opener blades should be equal on both sides. Reinstall seed tube.

## ROW UNIT MOUNTED NO TILL COULTER



Check nuts and hardware periodically for proper torque.

**NOTE: Torque  $\frac{5}{8}$ " spindle hardware to 120 ft-lb (162 N-m).**

Be sure coulters is positioned square with row unit and aligned in front of row unit disc opener.

Coulters blade can be adjusted to one of four settings. Initially blade is set in highest position. As blade wears it can be adjusted to one of three lower settings. See "Row Unit Mounted No Till Coulters" in Row Unit Operation section of this manual.

Replace 16" diameter coulters blade when worn to 14½" (37 cm).

## COULTERS MOUNTED RESIDUE WHEELS



Wheel hubs are equipped with sealed bearings. If bearings sound or feel rough when wheel is rotated, replace them.

## SPIKED CLOSING WHEEL

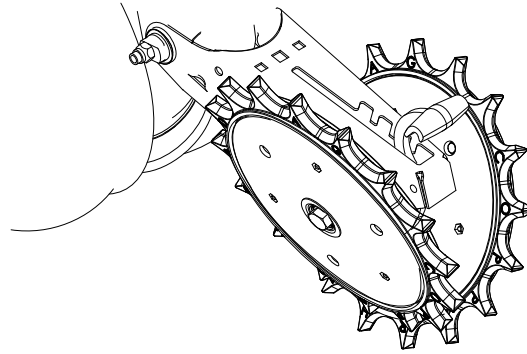

**Row Unit Spiked Closing Wheel**

Inner parts of spiked closing wheel will begin to wear at approximately 70% of life. Flip/reverse wheel to utilize remaining life of wheel.

## GRANULAR CHEMICAL ATTACHMENT

Before storing planter, disengage granular chemical drive by rotating throwout knob  $\frac{1}{4}$  turn counterclockwise. Remove drive chain and empty and clean all granular chemical hoppers. Clean drive chains and coat them with a rust preventive spray or submerge chains in oil. Inspect and replace worn or broken parts.

Install hoppers and chains. Check chain alignment.

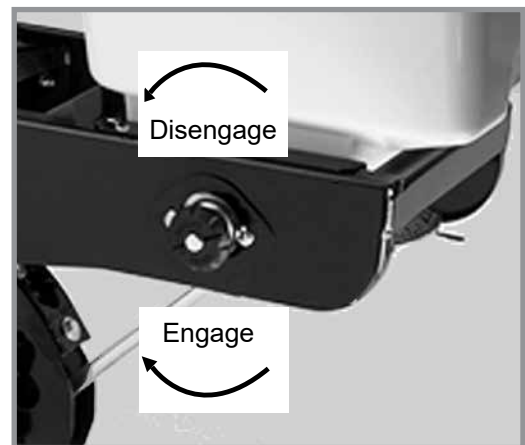

**Granular chemical throwout knob**

## SINGLE POINT ROW CLUTCH MAINTENANCE

Point row clutch is permanently lubricated and sealed and requires no periodic maintenance. Two-speed point row clutch is similar in design and operation to standard point row clutch except for two-speed function.

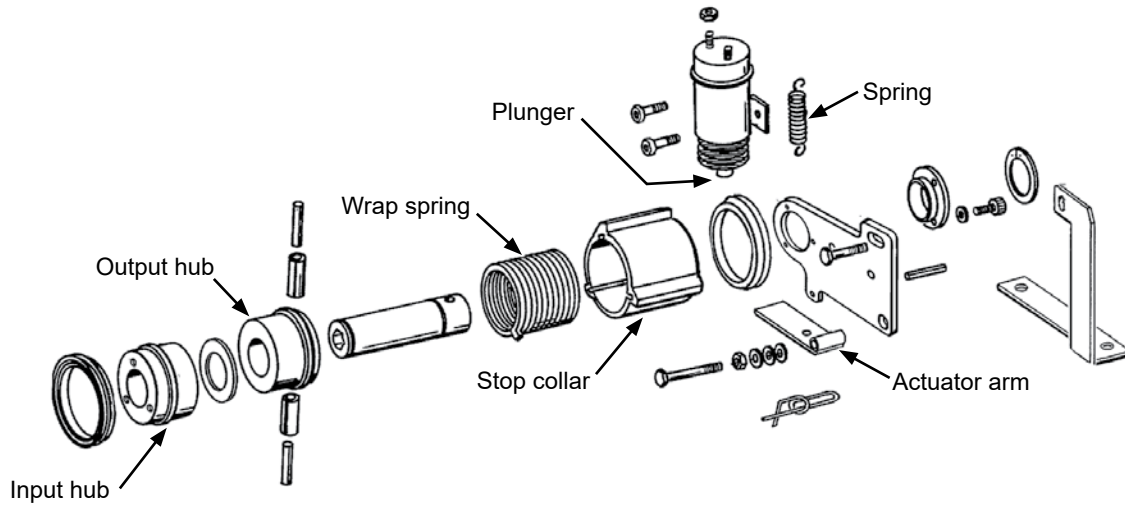

Single point row clutch main parts

TESTING AND FUSE REPLACEMENT

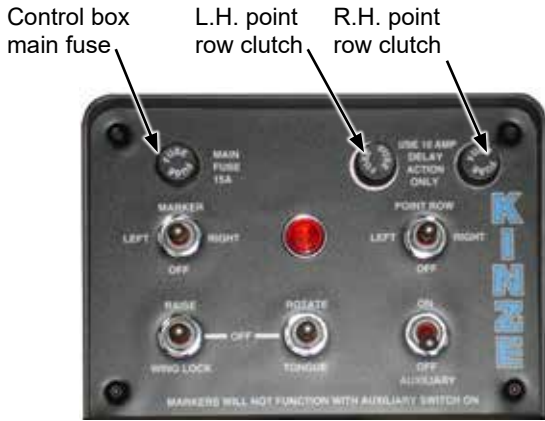

(Front View)

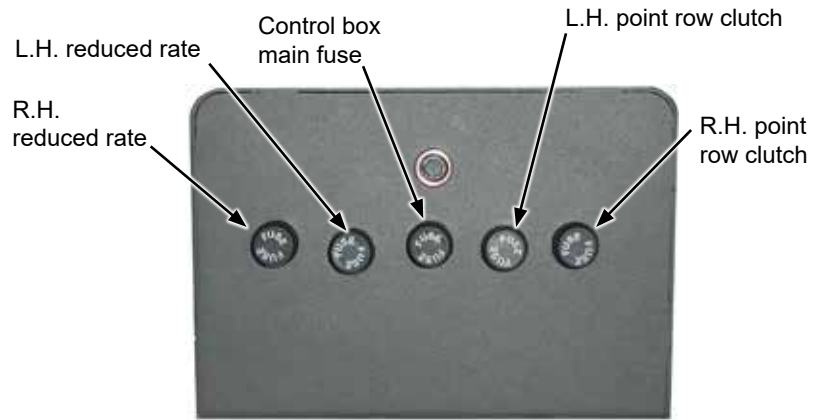

(Rear view)

**NOTE: Replace all point row fuses with MDL 10 amp slow blow fuses.**

If the clutch or clutches fail to operate, first determine if problem is electrical or mechanical.

Place operation switch in RIGHT or LEFT position. Solenoid plunger will retract causing a clicking sound if it is operating properly. Touch plunger with a metal object to check if it is electrically magnetized. Check clutch and wiring harness for power with a test light or volt meter.

**NOTE: R.H. clutch operates clockwise and L.H. clutch operates counterclockwise. Clutch parts such as the wrap spring are side specific. Use correct repair part if a clutch must be repaired.**

Also see "Point Row Clutch Troubleshooting" in Troubleshooting section.

ACTUATOR ARM ADJUSTMENT

Gap between actuator arm and stop on stop collar should be  $\frac{1}{8}"(\pm\frac{1}{32}"$ ) when solenoid is NOT engaged.

Loosen nut on mounting pin and move pin in slot until there is a  $\frac{1}{8}"(\pm\frac{1}{32}"$ ) gap between arm and stop on stop collar. Retighten nut.

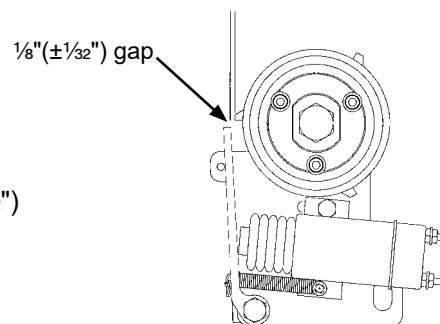



## CHECK VALVE (LIFT SYSTEM)

Check valves, located in valve block on right side of center post, trap oil flow in planter's lift system to keep toolbar level during field operation. Consult your Kinze Dealer for service.

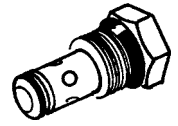

## CHECK VALVE (VACUUM FAN)

Check valve located in valve block below vacuum fan motor assembly operates as a return line check to prevent vacuum fan motor reverse operation. Remove and inspect valve. If it does not operate properly, check for foreign material and if O-ring is leaking internally. Replace if defective.

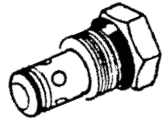

## FLOW CONTROL VALVE

Flow control valves should be adjusted for row marker raise and lower speed as part of assembly procedure or upon initial operation. If valve fails to function properly or requires frequent adjustment, it should be removed for inspection. Check for foreign material and contamination on valve and seating areas of valve body. Replace defective components.

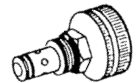

## PRESSURE RELIEF VALVE

If pressure relief valve does not release tongue lock or function properly, remove valve from valve block and check for foreign material or if O-ring is leaking internally. Replace if defective.

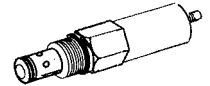

## PRESSURE REDUCING RELIEF VALVE

If wings do not properly stay to ground, plumb into butt end of cylinder to test psi. Proper setting is 750 PSI.

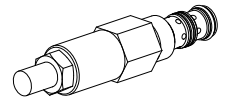

### NOTICE

Connect hydraulic motor case drain to a case drain return line with zero pressure on tractor or hydraulic motor will be damaged. DO NOT connect hydraulic motor case drain to SCV outlet. Contact tractor manufacturer for specific details on "zero pressure return".

## RELIEF VALVE CARTRIDGE

Pressure relief valve located in valve block below vacuum fan motor assembly helps prevent damage to vacuum fan motor by limiting pressure in the motor case drain line. It is set to open at 35 PSI. If valve fails to function properly, it should be removed for inspection. Check for foreign material and contamination on valve and the seating area of valve body. Replace if defective.

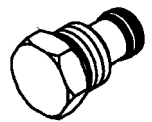

## SOLENOID VALVE

Solenoid valve consists of a chambered body with an electric coil actuated cartridge valve.

If solenoid or solenoids fail to operate, first determine if problem is electrical or hydraulic. If valve is working properly, a click will be heard when solenoid coil is energized and valve stem opens. If no sound is heard, check solenoid coil by touching top of coil housing with a metallic object such as a pliers or screwdriver. If coil is working properly, coil housing will be strongly magnetized when energized. If voltage to coil is low it will be weakly magnetized when energized and no click will be heard.

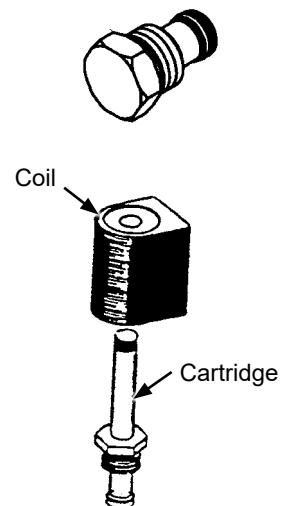

## ROW MARKER BEARING LUBRICATION OR REPLACEMENT

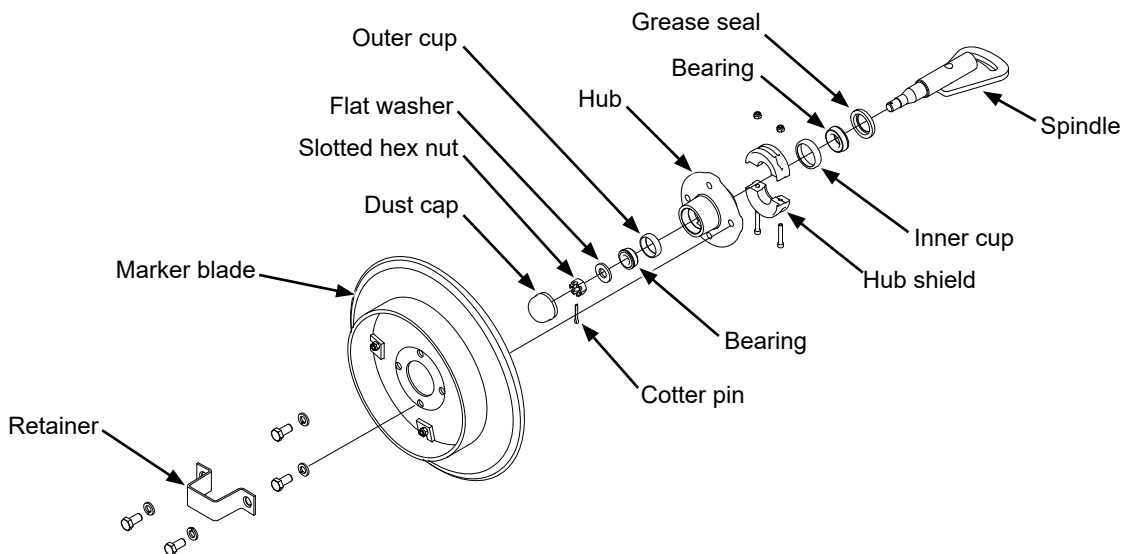

1. Remove retainer and marker blade.
2. Remove dust cap from hub.
2. Remove hub shield. Note direction of installation.
3. Remove cotter pin, slotted hex nut, and washer.
4. Slide hub from spindle.
5. Remove bearings and cups and discard if bearings are being replaced. Clean hub and dry. Remove bearings only and not cups if repacking.
6. Press in new bearing cups with thickest edge facing in. (Bearing replacement procedure only.)
7. Pack bearings with heavy duty wheel bearing grease thoroughly forcing grease between roller cone and bearing cage. Fill the space between the bearing cups in the hub with grease.
8. Install rubber seal into grease seal. Place inner bearing in place and press in new rubber seal/grease seal.
9. Clean spindle and install hub.
10. Install outer bearing, washer and slotted hex nut. Tighten slotted hex nut while rotating hub until there is some drag. This ensures all bearing surfaces are in contact. Back off slotted nut to nearest locking slot and install cotter pin.
11. Fill dust caps approximately  $\frac{3}{4}$  full of wheel bearing grease and install on hub.
12. Install hub shield.
13. Install marker blade and retainer on hub. Tighten hardware evenly.

## ROW MARKER TRANSPORT STAND ADJUSTMENT

Row marker transport stands must be correctly adjusted to allow marker cushion cylinders to function properly.

1. Raise markers to transport position.
2. Loosen mounting hardware to allow transport stands to drop down or remove transport stands.
3. With tractor engine shutoff, release hydraulic pressure on marker cylinders.
4. Locate transport stands so marker arm rests lightly on transport stand. When transport stands are correctly adjusted pin at rod end of cylinder should be loose enough to rotate and move back and forth in mounting slot.

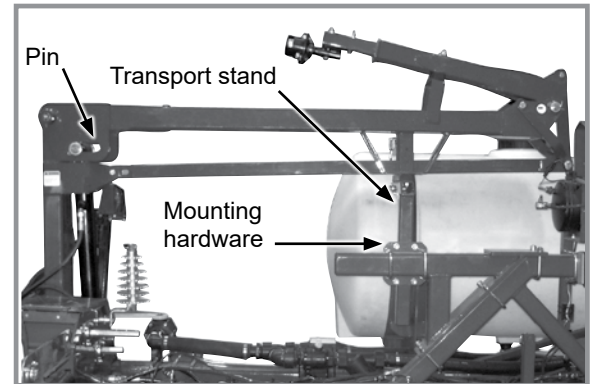

Row marker transport stand

## WHEEL BEARING REPACK OR REPLACEMENT

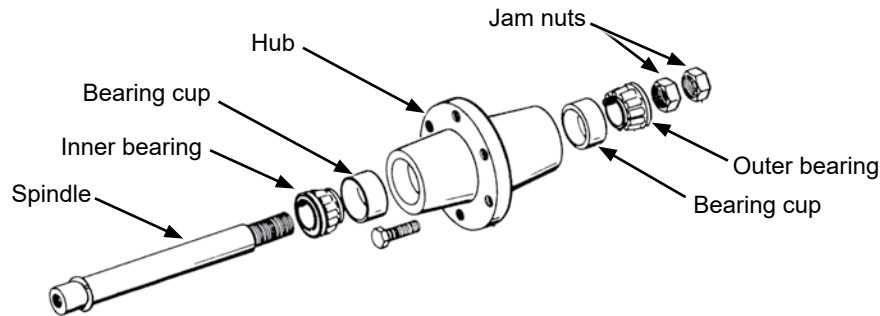

1. Raise tire clear of ground and remove wheel.
2. Remove double jam nuts and slide hub from spindle.
3. Remove bearings and cups and discard if bearings are being replaced. Clean hub and dry. Remove bearings only and not cups if repacking.
4. Press in new bearing cups with thickest edge facing in. (Bearing replacement procedure only.)
5. Pack bearings with heavy duty wheel bearing grease thoroughly forcing grease between roller cone and bearing cage. Fill space between bearing cups and hub with grease.
6. Place inner bearing in place.
7. Clean spindle and install hub.
8. Install outer bearing and jam nut. Tighten jam nut while rotating hub until there is some drag. This ensures all bearing surfaces are in contact. Back off jam nut  $\frac{1}{4}$  turn or until there is only slight drag when rotating hub. Install second jam nut to lock against first.
9. Install wheel on hub. Tighten hardware evenly.

## WEAR PAD FIELD REPLACEMENT/ADJUSTMENT

**NOTICE**

Over tightening wear pads will cause premature wear and excessive hydraulic lift pressures. Torque wear pads to 10 ft-lb (13.6 N-m). Do not over tighten wear pads.

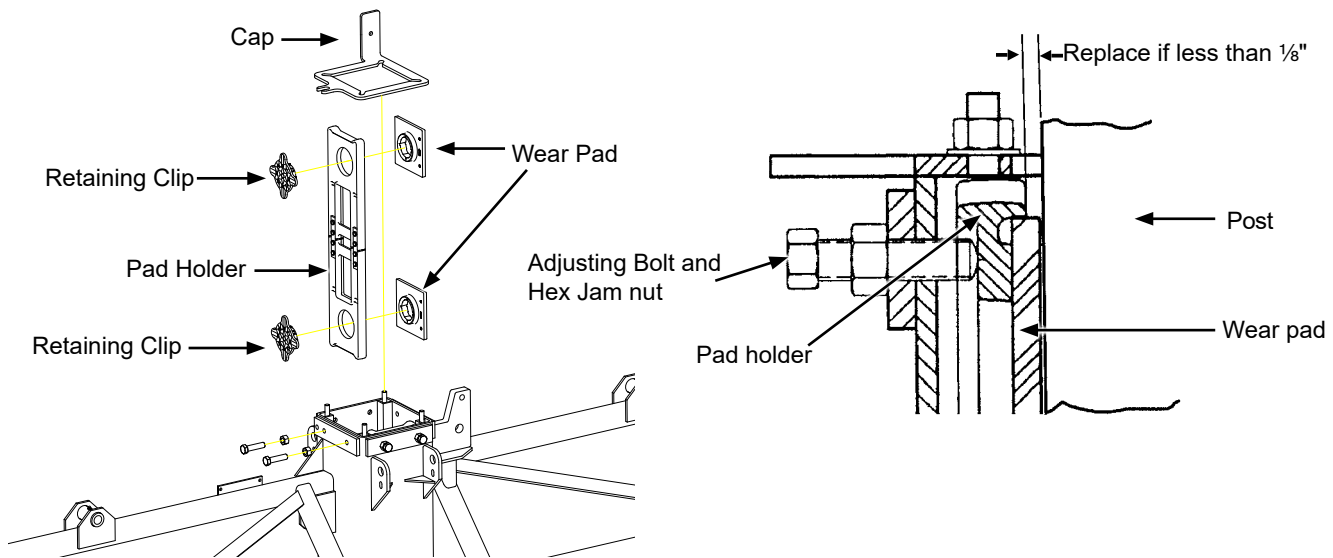

Planter center section is constructed around a steel tubular frame with four wear pad assemblies riding against a stainless steel clad center post. Two wear pads and retaining clips are held by a pad holder and locked in place by  $\frac{3}{4}$ " adjusting bolts and hex jam nuts. Inspect pads for wear and adjustment annually to ensure center section is stabilized and planter tracks properly. Pads should make full light contact with center post when properly adjusted. Too much preload on pads will cause hydraulic lift pressure to be higher than necessary or will not allow planter to raise when loaded.

1. Position planter on a level surface and place in raised field position.

**NOTE: Replace wear pad when worn to less than  $\frac{1}{8}$ ".**

2. Visually check four upper wear pads. Each wear pad should lightly contact stainless steel clad center post.
3. Place planter in raised transport position, install all safety lockups and visually check four lower wear pads for light contact.
4. Remove lockup and lower planter to field operation position. Loosen cap mounting nuts to allow wear pad adjustment. Loosen hex jam nuts as needed.

**NOTE: Cap mounting nuts MUST be loosened before adjusting wear pads.**

5. Tighten pad adjusting bolts, back off, and then torque wear pads to 10 ft-lb (13.6 N-m). Hold adjusting bolt from turning and torque hex jam nuts to 200 ft-lb (271.1 N-m).
6. Operate to full height on post and recheck for zero clearance.

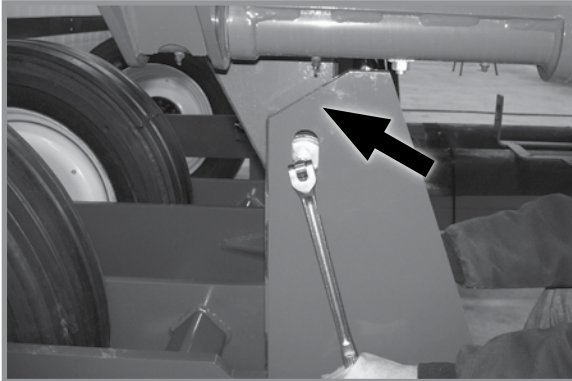
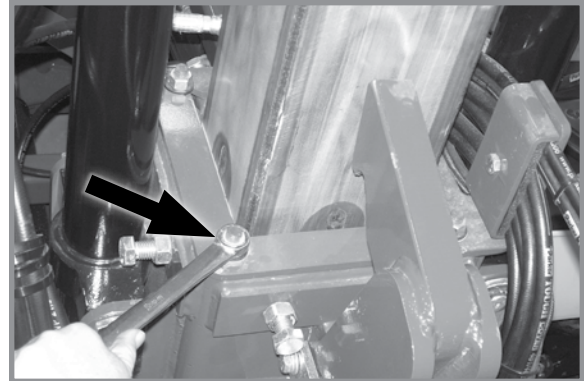
**MAJOR PAD ADJUSTMENT****Loosen cam rollers****Loosen four cap mounting nuts**

1. Loosen cam rollers so they move freely.
2. Lower planter to field operation position and release wing locks. Eliminate all uplift on planter frame by backing off row unit down pressure springs and uplift on any other planter attachments.
3. Check position of center frame to axle cam roller guides. Gap between guides and frame should be the same side to side. Gap on back sides of roller guide should be equal on both sides. Final adjustment will be done later.
4. Loosen four cap mounting nuts.

**NOTE: Cap mounting nuts MUST be loosened before adjusting wear pads.**



5. Loosen hex jam nuts and use pad adjusting bolts to position frame to center correctly.

**NOTICE**

**Over tightening wear pads will cause premature wear and excessive hydraulic lift pressures. Torque wear pads to 10 ft-lb (13.6 N-m). Do not over tighten wear pads.**

6. Tighten pad adjusting bolts, back off, and then torque wear pads to 10 ft-lb (13.6 N-m). Hold adjusting bolt from turning and torque hex jam nuts to 200 ft-lb (271.1 N-m).
7. Tighten cap mounting nuts.
8. Reset row unit down pressure and other attachments.

## PAD REPLACEMENT

 <b>WARNING</b>	<p>Improperly operating or working on this equipment could result in death or serious injury. Read and follow all instructions before operating or working on this equipment.</p>
	

- a. Loosen cam rollers so they move freely as shown.
- b. Lower planter to field operation position and release wing locks.
- c. Eliminate all uplift on planter frame by backing off row unit down pressure springs and uplift on any attachments.
- d. Remove safety hook.
- e. Disconnect hydraulic hose, remove nut on bulkhead fitting, and remove fitting from cap.
- f. Loosen four cap mounting nuts and remove pad holder cap.
- g. Loosen pad hex jam nuts, back pad bolts out, and remove four pad holder assemblies. Remove and discard old pads.

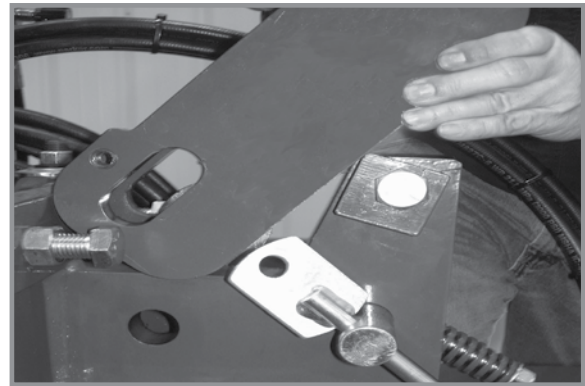

**Removing safety hook**

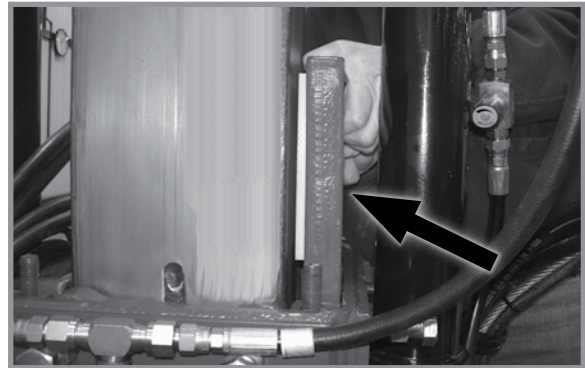

**Removing Pad Holder Assembly**

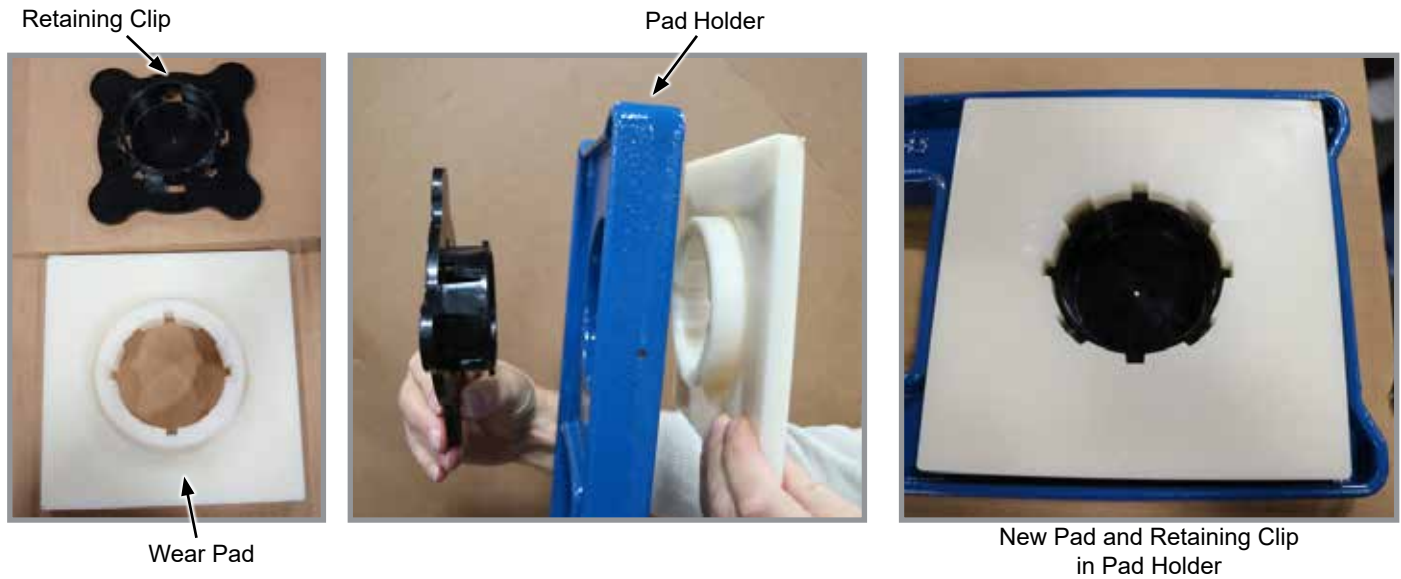

- h. Install new pad using retaining clip. Repeat for other side of pad holder.
- i. Reinstall pad holder in center section.

### NOTICE

Over tightening wear pads will cause premature wear and excessive hydraulic lift pressures. Torque wear pads to 10 ft-lb (13.6 N-m). Do not over tighten wear pads.

- j. Tighten pad adjusting bolts, back off, and then torque wear pads to 10 ft-lb (13.6 N-m). Hold adjusting bolt from turning and torque hex jam nuts to 200 ft-lb (271.1 N-m).
- k. Reinstall cap and tighten cap mounting nuts.
- l. Reinstall hydraulic hose, fittings, and safety hook.

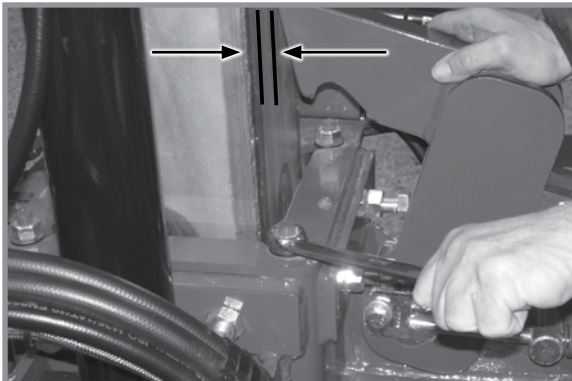

Adjust safety hook clearance to  $\frac{1}{4}$ "- $\frac{3}{8}$ "

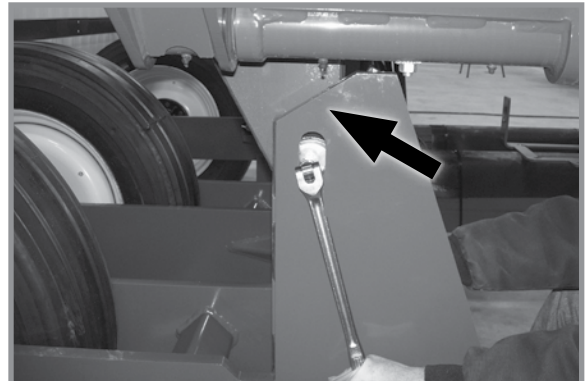

Adjust and tighten cam roller

- m. Adjust stop on safety hook to  $\frac{1}{4}$ "- $\frac{3}{8}$ " clearance.
- n. Rotate cam roller against front guide and tighten to 110 ft-lb (149.1 N-m). Make sure gap between roller guide and center frame are equal on both sides. Raise planter out of roller guides and lower back down into roller guides to be sure roller guides operate smoothly. Adjust rotation cylinder rod as needed.
- o. Reset row unit down pressure and other attachments.

**TRACTOR MOUNTED PTO PUMP AND OIL COOLER OPTION**

Drain reservoir, clean strainer and change filter annually.

1. Disconnect suction line (hose between reservoir and pump) from reservoir and drain. To fully drain tank, raise planter to field raised position.
2. Replace filter with good quality 10 micron filter.
3. Fill system with SAE 10W-20 multigrade wide temperature range transmission hydraulic fluid. Reservoir capacity is approximately 10 gallons.
4. Start system and run with tractor at idle and fan turned off for 1-2 minutes. Switch fan to full speed and run with tractor at idle for 1-2 minutes.
5. Check reservoir fluid level and fill as required. Hydraulic fluid level should be within 1"-2" from top of reservoir after pump has run and hydraulic hoses have been primed to allow fluid to expand when heated.
6. Bring tractor to PTO speed and adjust flow control to the desired vacuum level using the flow control valve lever.

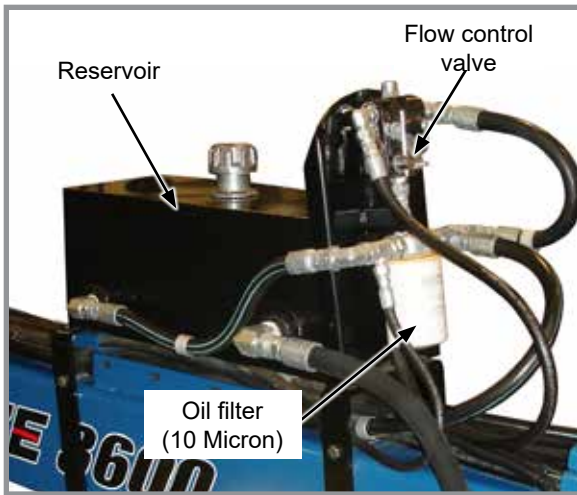

**Bulk Fill**

Hydraulic reservoir, flow control valve, and fittings

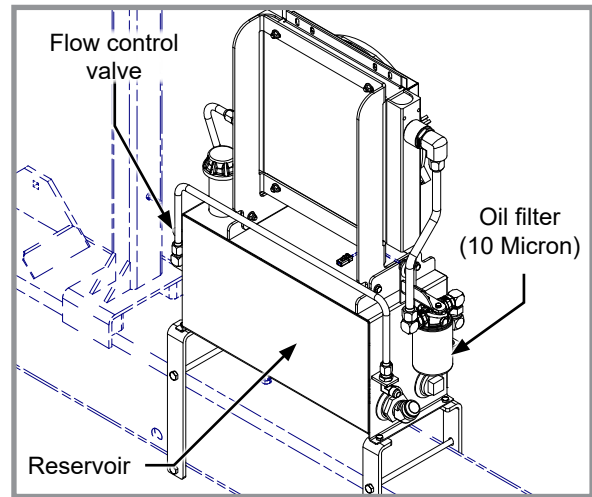

**Vacuum**

Hydraulic reservoir, flow control valve, and fittings

High Pressure Filter

**NOTE: Replace high pressure filter after first season and then check annually. If debris has collected on filter, replace filter.**

1. Remove O-ring plug on top of filter.
2. Pull old filter straight out using handle.
3. Insert new filter.
4. Reinstall O-ring plug.

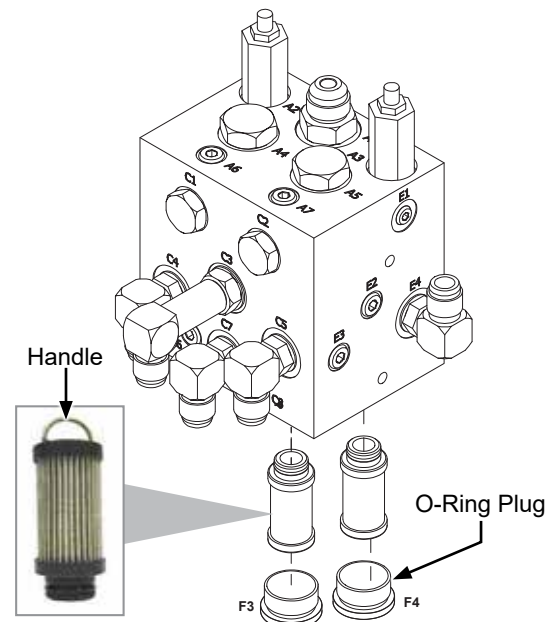

High Pressure Filter



## FERTILIZER CHECK VALVE CLEANING AND REPAIR

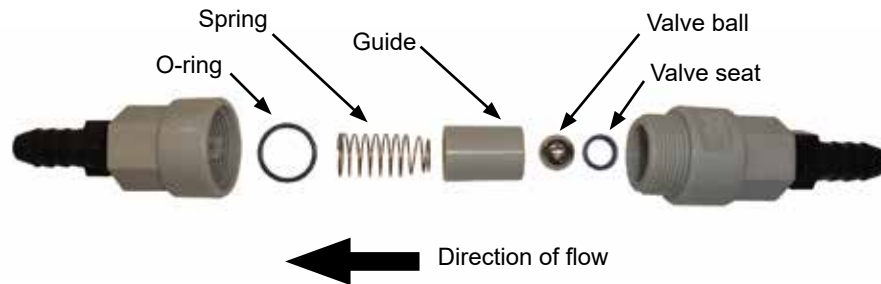

1. Unscrew valve body and separate halves. Note direction and location of parts.
2. Clean and inspect parts. Flush with clean water. Replace damaged parts.
3. Reassemble exactly as shown. O-ring and valve seat must be firmly in place inside each half of valve body.

## PISTON PUMP STORAGE

### NOTICE

Entrance of air into pump will cause rapid and severe corrosion. **KEEP AIR OUT OF PUMP!**

**NOTE: SUSPENSION FERTILIZER must be flushed from pump for ANY storage period.**

1. Flush pump with 5 to 10 gallons of fresh water and circulate until all corrosive salts are dissolved in pump.
2. Set pump on 10. Draw in a mixture of half diesel fuel and 10 weight oil until discharge is clean. Plug inlet and outlet.



**Liquid fertilizer piston pump**

---

## PREPARATION FOR STORAGE

Store planter in a dry sheltered area if possible.

Remove all trash wrapped on sprockets or shafts and remove dirt that can draw and hold moisture.

Clean all drive chains and coat with a rust preventative spray, or remove chains and submerge in oil.

Lubricate planter and row units at all lubrication points.

Inspect planter for parts that in need of replacement and order during “off” season.

Make sure all seed and granular chemical hoppers are empty and clean.

Remove seed discs from seed meters, clean and store meters in a rodent-free, dry area with discs removed. Store seed discs vertically on a dowel or pipe.

Remove vacuum hose from each seed meter. Operate vacuum fan at full hydraulic flow from tractor for two minutes to clear manifolds, hoses and fittings of dust and debris.

Clean breather on analog vacuum and pressure gauges.

Disassemble, clean and grease all U-joint slides.

Grease or paint disc openers/blades and row marker disc blades to prevent rust.

Flush liquid fertilizer tanks, hoses and metering pump with clean water. See “Piston Pump Storage” if applicable.

Empty dry fertilizer hoppers. Clean hoppers. Disassemble and clean metering augers. Reassemble, coating all metal parts with rust preventative.

Bulk Fill System:

- Clean out bulk fill hopper, entrainment assembly, and delivery hoses.
- Disconnect delivery hoses from entrainer ports. Install small orange caps onto ports. Attach hoses to caps.
- Disconnect delivery hoses from air dissipator at each row unit. Install large orange caps. Attach hoses to caps.
- Check all bolts and fasteners used to assemble and attach entrainment device are tight (if applicable).
- Loosen knobs on entrainer cleanout doors to remove pressure from door gaskets.
- Inspect all seed delivery hoses and replace any that are worn, cut, or cracked.

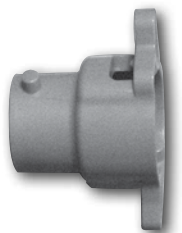

**Entrainer Cap**

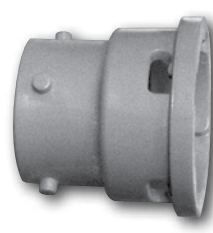

**Row Unit Cap**

## PNEUMATIC DOWN PRESSURE AIR COMPRESSOR TANK

Moisture should be drained daily from the tank. Tank should be drained completely for storage.

To drain tank, locate drain plug on the bottom of tank. Stand off to the side of tank and pull cable attached to drain.

**NOTE: If moisture is not drained from tank rust particles will form inside tank.**

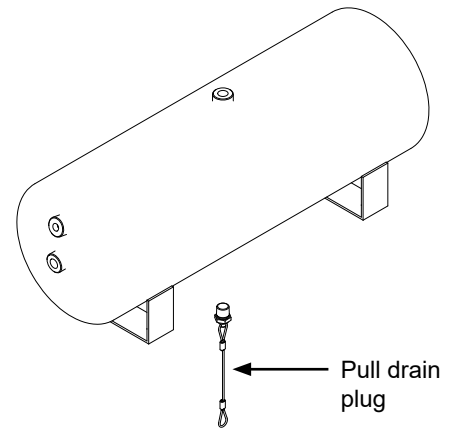

### ELECTRICAL WIRING DIAGRAM FOR LIGHT PACKAGE

#### Machines with double light assemblies

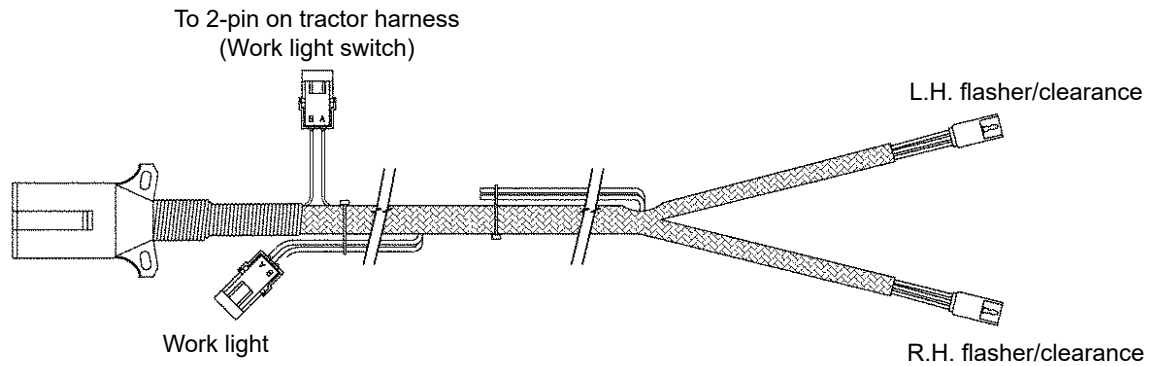
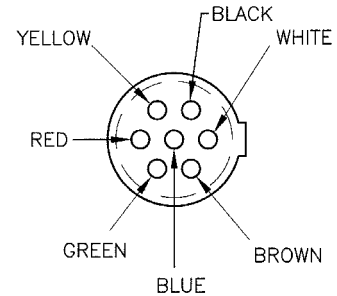
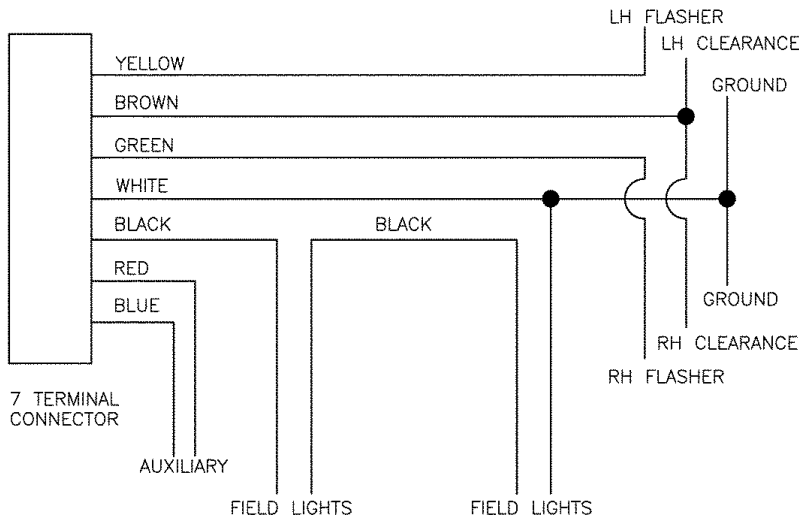

**\* Optional customer-supplied auxiliary lights and wires may be wired into existing plug terminals.**

Model 3605 Twin-Line Planter safety light package meets ASAE Standards. Check with your tractor manufacturer for proper connection to your tractor.

**ELECTRICAL CONTROL CONSOLE SCHEMATIC**

**NOTE: Disconnect control console from tractor battery before doing any electrical work. Keep wiring harnesses away from high temperature areas or sharp edges. DO NOT route wiring harnesses along battery cables. Use cable ties to keep wire harness away from moving parts on tractor and planter. Be sure tractor frame ground connections are clean to provide good electrical contact.**

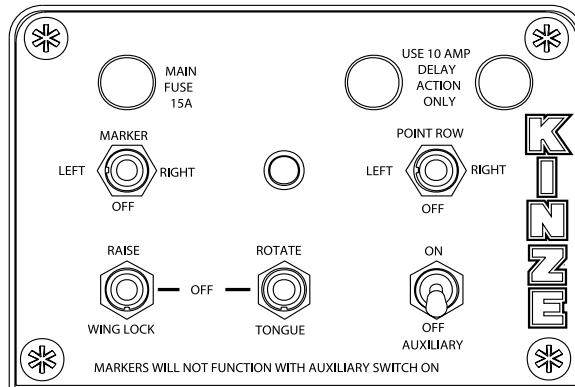
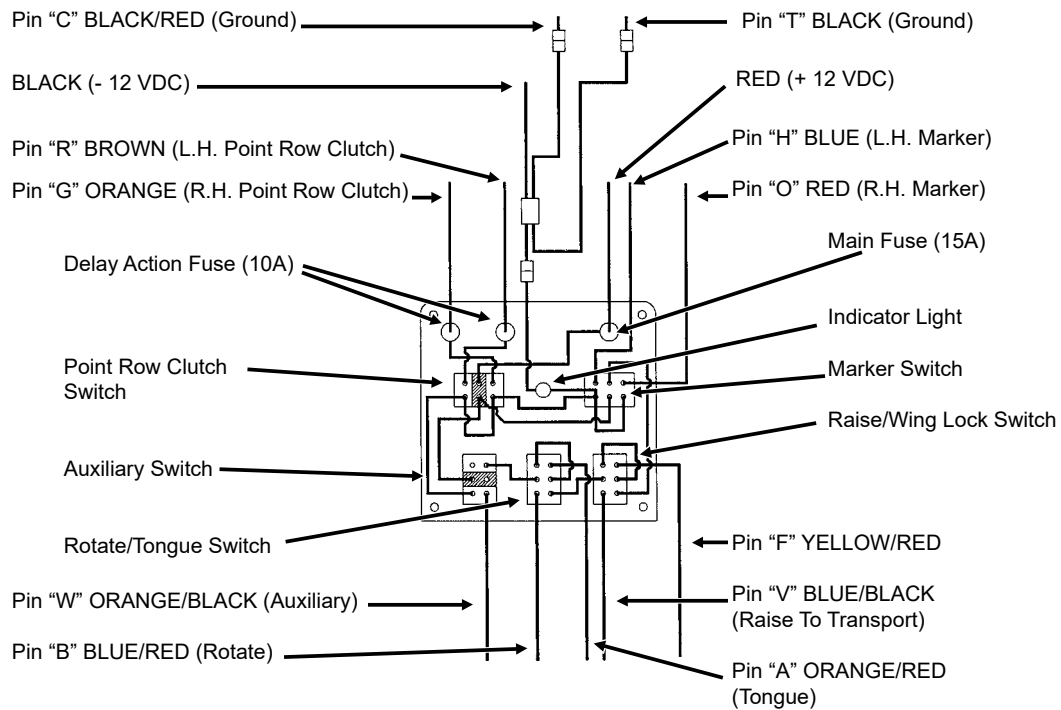

**NOTE 1. Operating marker or point row switch in either direction lights panel light.**

**NOTE 2. Point row clutch switch operates independently from rest of control box.**

**NOTE 3. Power to marker switch is fed through auxiliary switch and two transport function switches. Operating any switch in lower row disables marker function and turns off panel light. (If point row clutch switch is OFF.)**

See electrical control console schematic and wiring harness at two-speed point row clutch solenoids for planter equipped with optional Two-Speed Point Row Clutch Package in this section.

**ELECTRICAL WIRING HARNESS SCHEMATIC (On Tractor)**

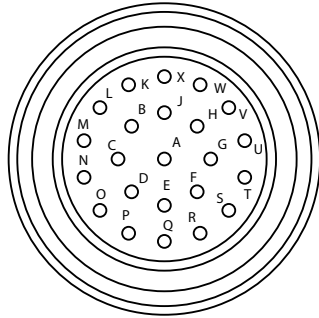

**23 Socket Capacity**

Pin No.	Wire Color	Function	Wire Ga.
A	Orange/Red	Tongue Raise	14
B	Blue/Red	Fold	14
C	Black/Red	Ground	14
D	White	Monitor B 12V	14
E	Green	Monitor B DATA	14
F	Yellow/Red	Wing Lock	14
G	Orange	Point Row - Right	12
H	Blue	Marker - Left	14
J	Black	Monitor B Ground	14
K	White	Monitor A 12V	14
L	Green	Monitor A Data	14
M	Black	Monitor A Ground	14
N	---	---	---
O	Red	Marker - Right	14
P	---	---	---
Q	---	---	---
R	Brown	Point Row - Left	12
S	Yellow	Reduced Rate - Left	12
T	Black	Ground	12
U	Red/Black	Reduced Rate - Right	12
V	Blue/Black	Raise to Transport	14
W	Orange/Black	Auxiliary	14
X	---	---	---

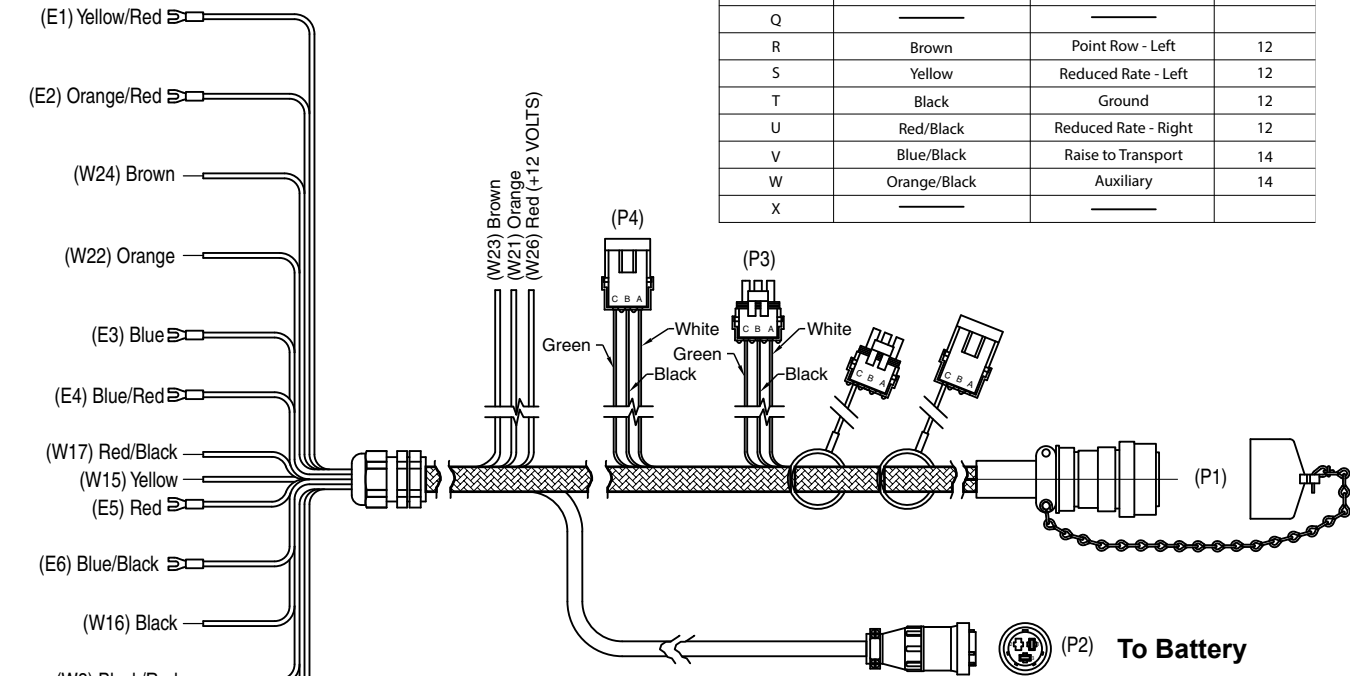

Wire No.	From	Used W/Item	To	Used W/Item	Gauge	Color	Function
W1	P1-A	3	E2		14	Orange/Red	Tongue Raise
W2	P1-B	3	E4		14	Blue/Red	Fold
W3	P1-C	3	---		14	Black/Red	Ground
W4	P1-D	3	P3-A		14	White	Monitor B 12V
W5	P1-E	3	P3-C		14	Green	Monitor B Data
W6	P1-F	3	E1		14	Yellow/Red	Wing Lock
W7	P1-G	3	SP1		12	Orange	Point Row - R.H.
W8	P1-H	3	E3		14	Blue	Marker - L.H.
W9	P1-J	3	P3-B		14	Black	Monitor B Ground
W10	P1-K	3	P4-A		14	White	Monitor A 12V
W11	P1-L	3	P4-C		14	Green	Monitor A Data
W12	P1-M	3	P4-B		14	Black	Monitor A Ground
W13	P1-O	3	E5		14	Red	Marker - R.H.
W14	P1-R	3	SP2		12	Brown	Point Row - L.H.
W15	P1-S	3	---		12	Yellow	Reduced Rate - L.H.
W16	P1-T	3	---		12	Black	Ground
W17	P1-U	3	---		12	Red/Black	Reduced Rate - R.H.
W18	P1-V	3	E6		14	Blue/Black	Raise to Transport
W19	P1-W	3	E7		14	Orange/Black	Auxiliary
W20W1	P2-1	---	SP3		12	Red	12 VDC+
W20W2	P2-3	---	---		12	Black	12 VDC-
W21	SP1	---	---		12	Orange	Point Row - R.H.
W22	SP1	---	---		12	Orange	Point Row - R.H.
W23	SP2	---	---		12	Brown	Point Row - L.H.
W24	SP2	---	---		12	Brown	Point Row - L.H.
W25	SP3	---	---		12	Red	12 VDC+
W26	SP3	---	---		12	Red	12 VDC-

**ELECTRICAL WIRING HARNESS SCHEMATIC (On Planter)**

23 Socket Capacity

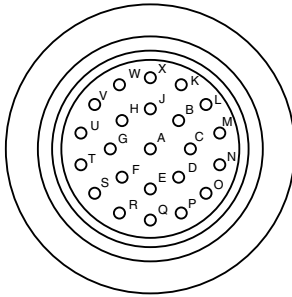

**VALVE BLOCK -  
Located on rear  
center frame**

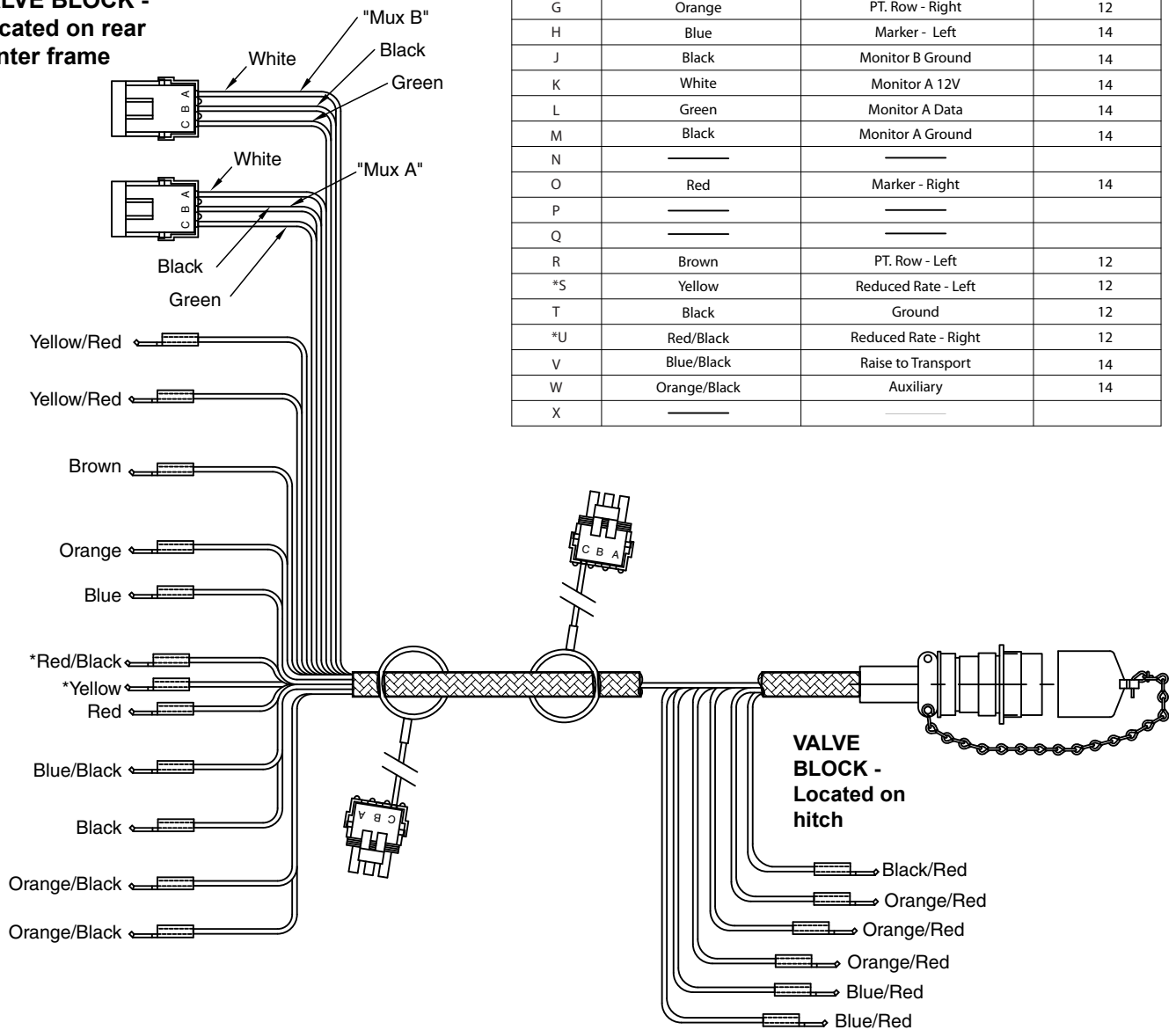

Pin No.	Wire Color	Function	Wire Ga.
A	Orange/Red	Tongue Retract/Extend	14
B	Blue/Red	Fold	14
C	Black/Red	Ground	14
D	White	Monitor B 12V	14
E	Green	Monitor B Data	14
F	Yellow/Red	Wing lock	14
G	Orange	PT. Row - Right	12
H	Blue	Marker - Left	14
J	Black	Monitor B Ground	14
K	White	Monitor A 12V	14
L	Green	Monitor A Data	14
M	Black	Monitor A Ground	14
N	---	---	---
O	Red	Marker - Right	14
P	---	---	---
Q	---	---	---
R	Brown	PT. Row - Left	12
*S	Yellow	Reduced Rate - Left	12
T	Black	Ground	12
*U	Red/Black	Reduced Rate - Right	12
V	Blue/Black	Raise to Transport	14
W	Orange/Black	Auxiliary	14
X	---	---	---

**VALVE BLOCK - LOCATED ON HITCH**

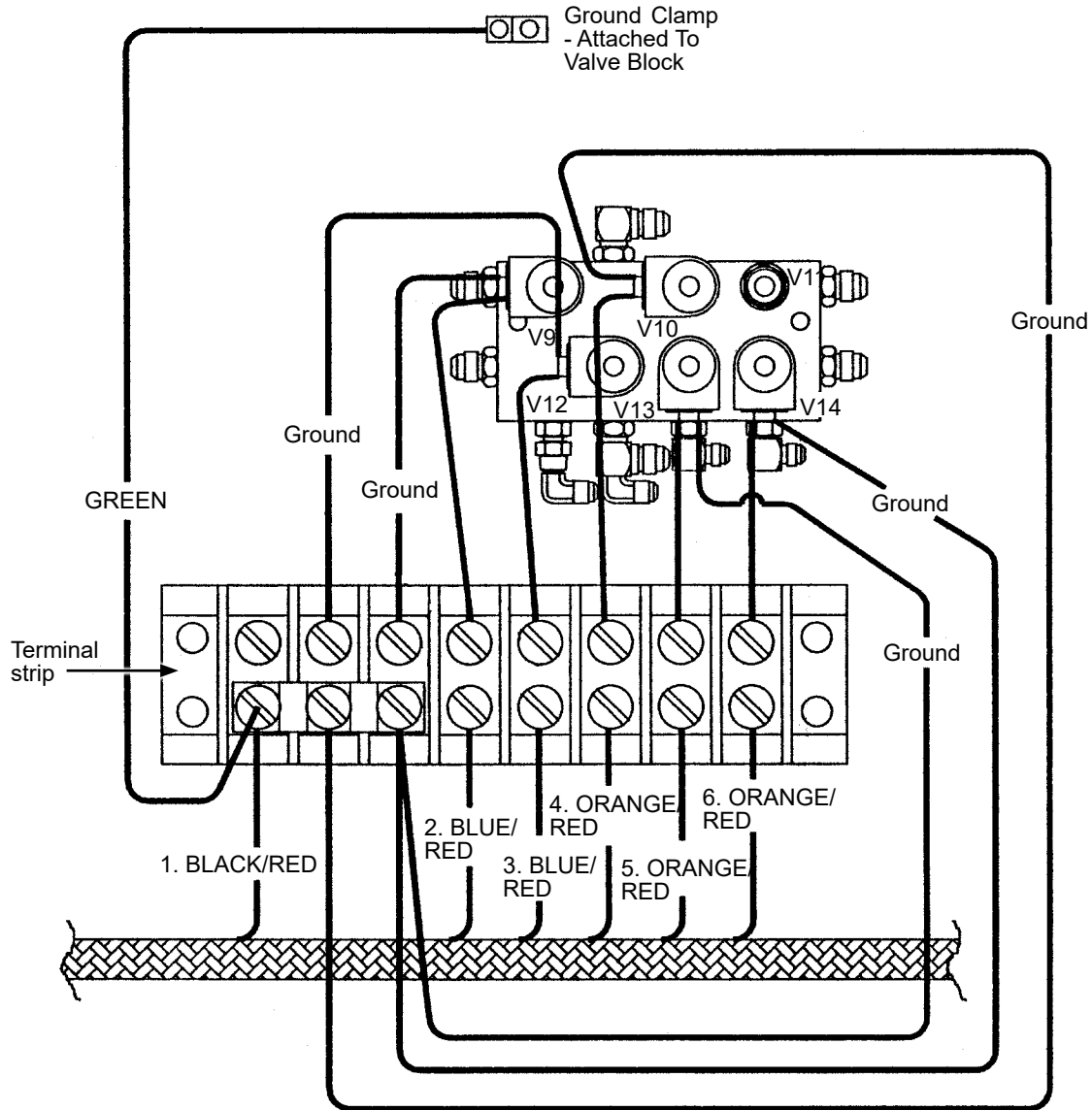

- 1. BLACK/RED - Pin "C" (Ground)
- 2. BLUE/RED - Pin "B" (Rotate) - Port V9
- 3. BLUE/RED - Pin "B" (Rotate) - Port V12
- 4. ORANGE/RED - Pin "A" (Tongue) - Port V10
- 5. ORANGE/RED - Pin "A" (Tongue) - Port V13
- 6. ORANGE/RED - Pin "A" (Tongue) - Port V14



## VALVE BLOCK - LOCATED ON REAR CENTER FRAME

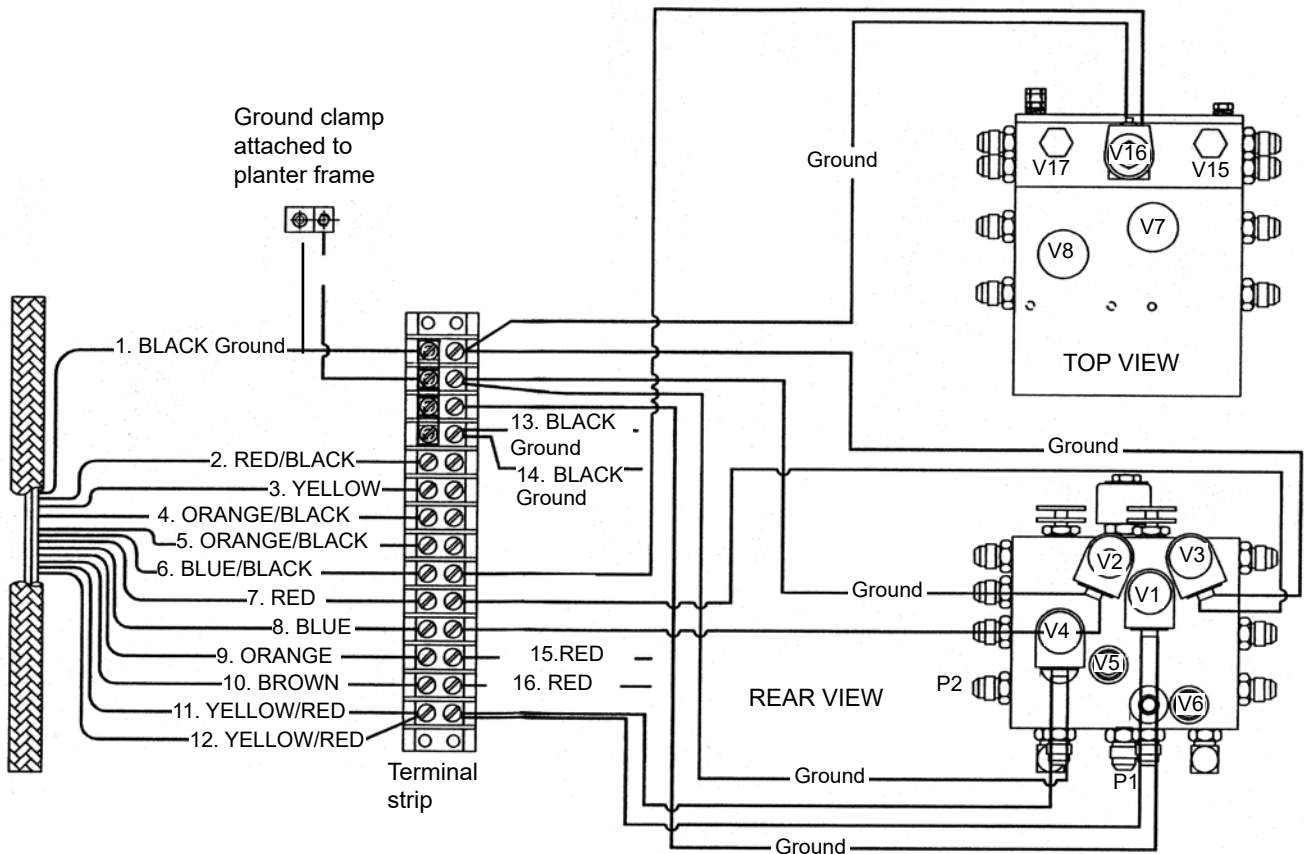

1. BLACK - Pin "T" (Ground)
2. RED/BLACK - Pin "U" (R.H. Two-Speed Clutch)\*
3. YELLOW - Pin "S" (Le.H.Two-Speed Clutch)\*
4. ORANGE/BLACK - Pin "W" (Auxiliary) - Ports V5 & V6
5. ORANGE/BLACK - Pin "W" (Auxiliary) - Ports V5 & V6
6. BLUE/BLACK - Pin "V" (Raise To Transport) - Port V16
7. RED - Pin "O" (R.H. Marker) - Port V1
8. BLUE - Pin "H" (L.H. Marker) - Port V2
9. ORANGE - Pin "G" (R.H. Point Row Clutch)
10. BROWN - Pin "R" (L.H. Point Row Clutch)
11. YELLOW/RED - Pin "F" (Wing Lock) - Ports V3 & V4
12. YELLOW/RED - Pin "F" (Wing Lock) - Ports V3 & V4
13. BLACK - (R.H. Point Row Ground)
14. BLACK - (L.H. Point Row Ground)
15. RED - (R.H. Point Row)
16. RED - (L.H. Point Row)

\* See page 7-40 if equipped with optional Two-Speed Point Row Clutch Package.

## HYDRAULIC HOSE LIFE

**WARNING**

Pressurized hydraulic fluid can penetrate body tissue and result in death, serious infection, or other injuries. Fluid injected under skin must be **IMMEDIATELY** removed by a surgeon familiar with this type of injury. Make sure connections are tight and hoses and fittings are not damaged before applying system pressure. Leaks can be invisible. Keep away from suspected leaks. Relieve pressure before searching for leaks or performing any system maintenance.



Proper storage of hydraulic hoses can significantly increase the life of the hoses, for a period of three to five years. After this period, service life of hoses may decrease, depending on variables such as variances in rubber materials and storage environment. Refer to the guidelines below for best practices when storing.

- Store in a clean, cool and dry area
- Avoid direct sunlight or moisture
- Do not store near high power electrical equipment
- Avoid contact with corrosive chemicals
- Avoid ultraviolet light
- Avoid areas with obvious signs of insects or rodents

Unusually long periods of storage or poor storage environment may lead to performance issues or premature failure. Always inspect all hoses prior to use for extensive wear, cuts, or holes. If such flaws are identified, replace immediately to avoid potential failure, property damage or bodily injury.

HYDRAULIC SYSTEM SCHEMATIC

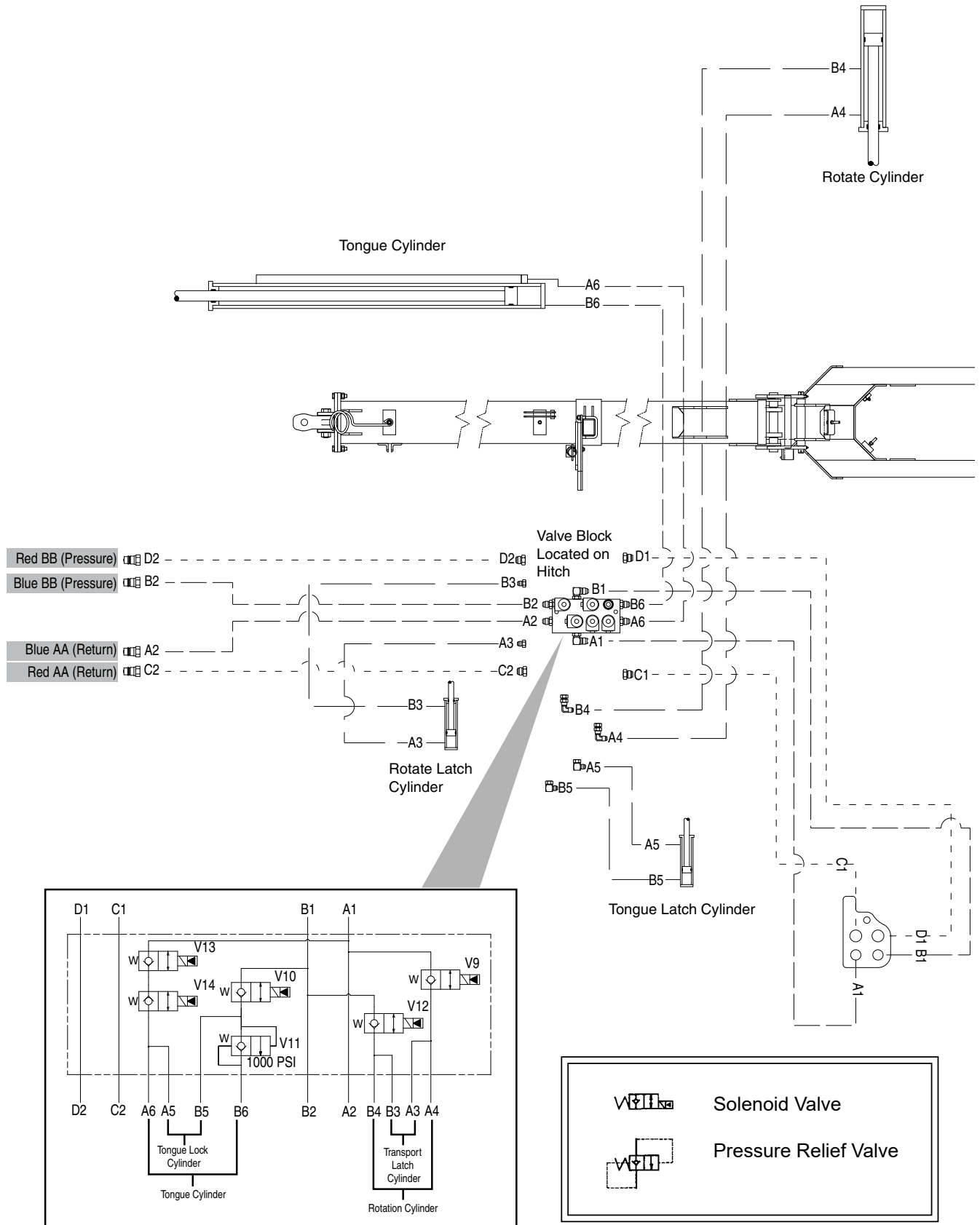

### Hydraulic System Schematic

12 Row (One Wing Lift Cylinder Per Wing) and 16 Row Shown (Two Wing Lift Cylinders Per Wing)

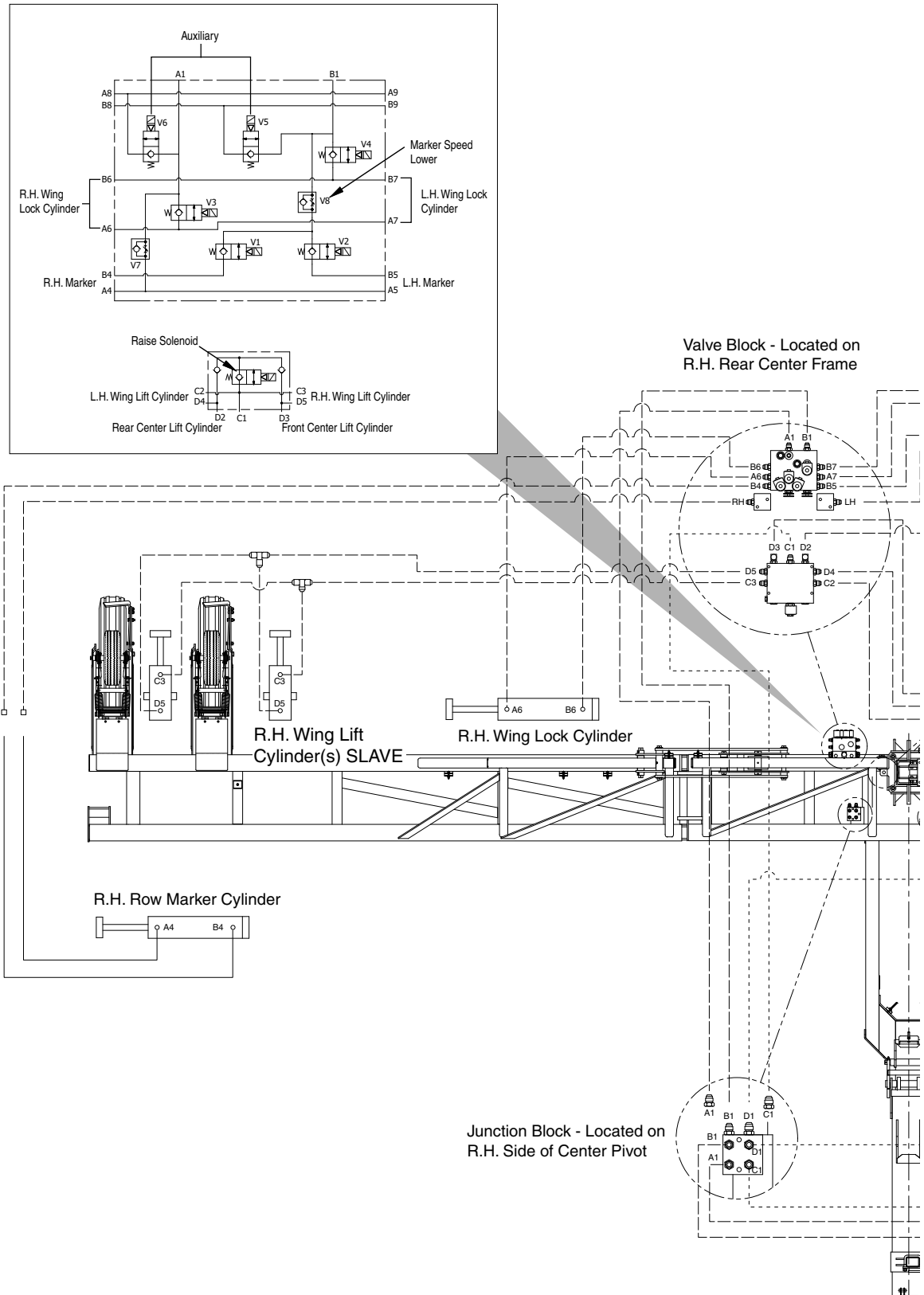

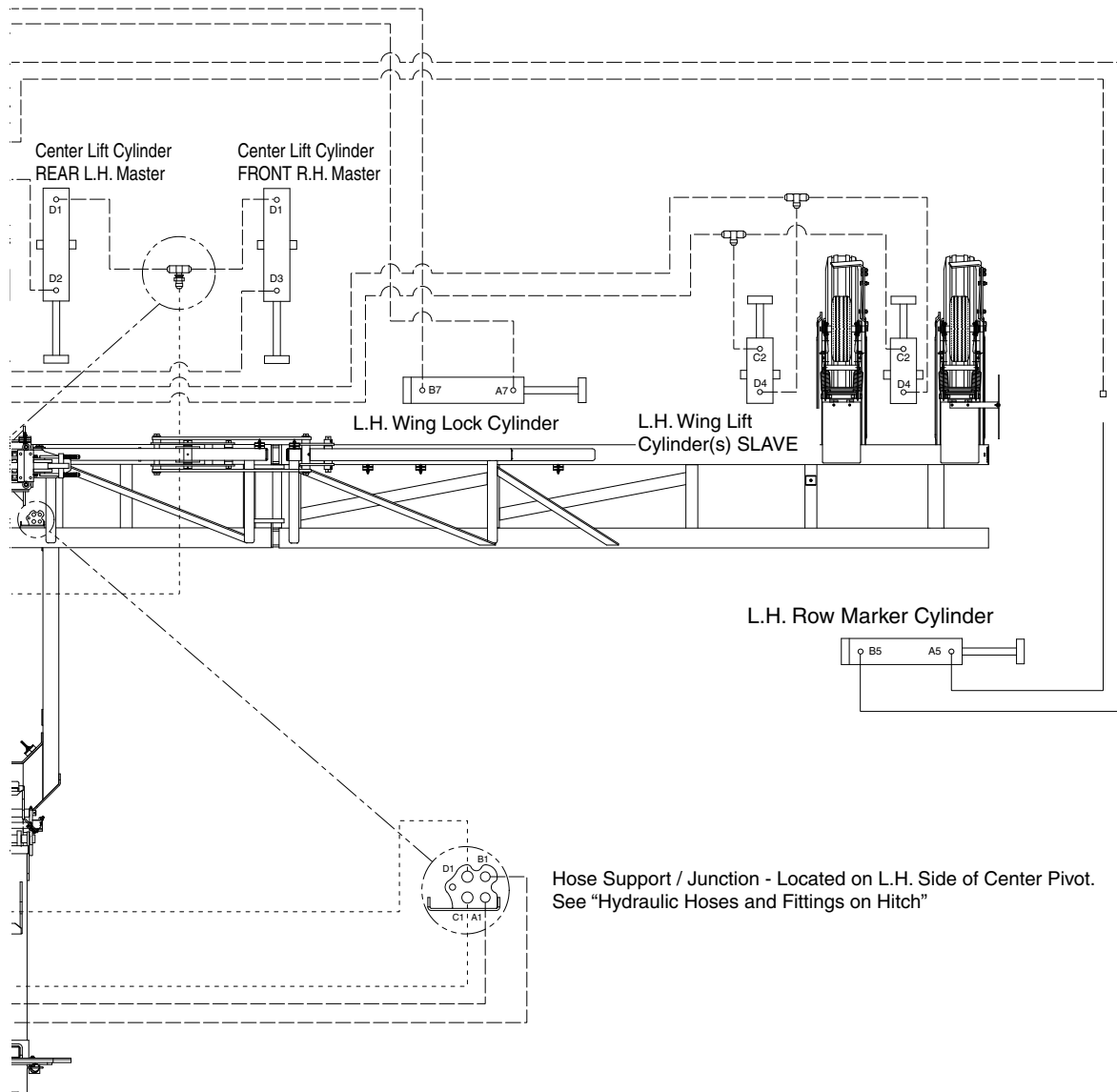
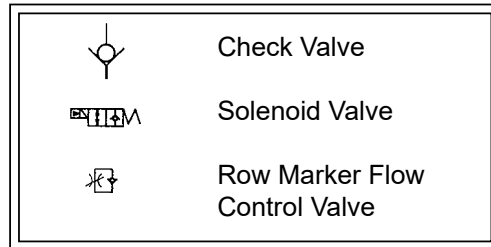

WING DOWN PRESSURE SCHEMATIC (WEIGHT TRANSFER MECHANISM)

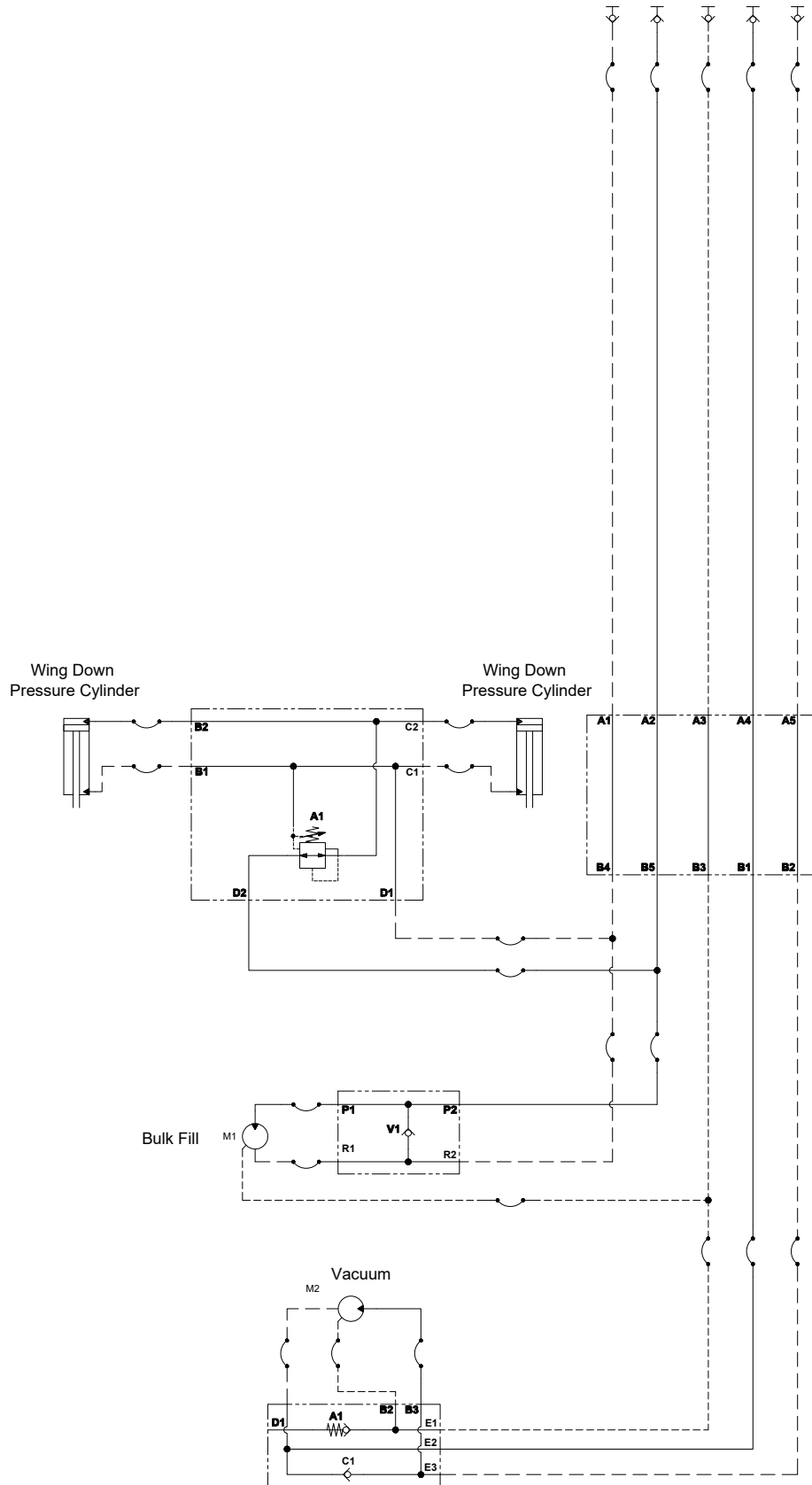

**ELECTRIC CLUTCH SCHEMATIC**

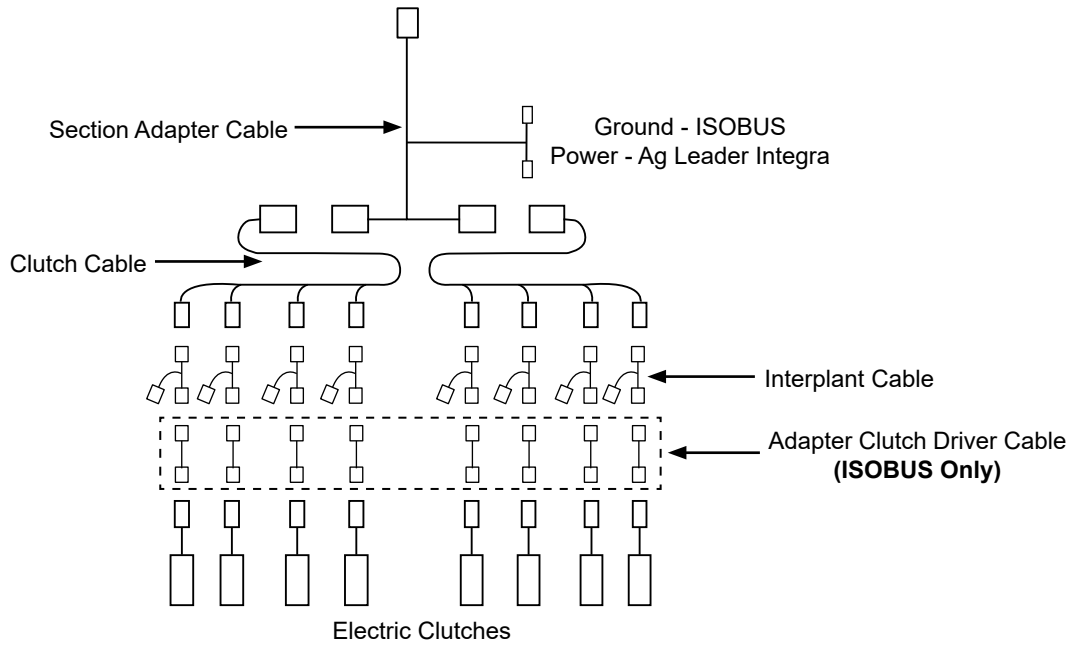

**HYDRAULIC SCHEMATIC - VACUUM FAN MOTOR SYSTEM**

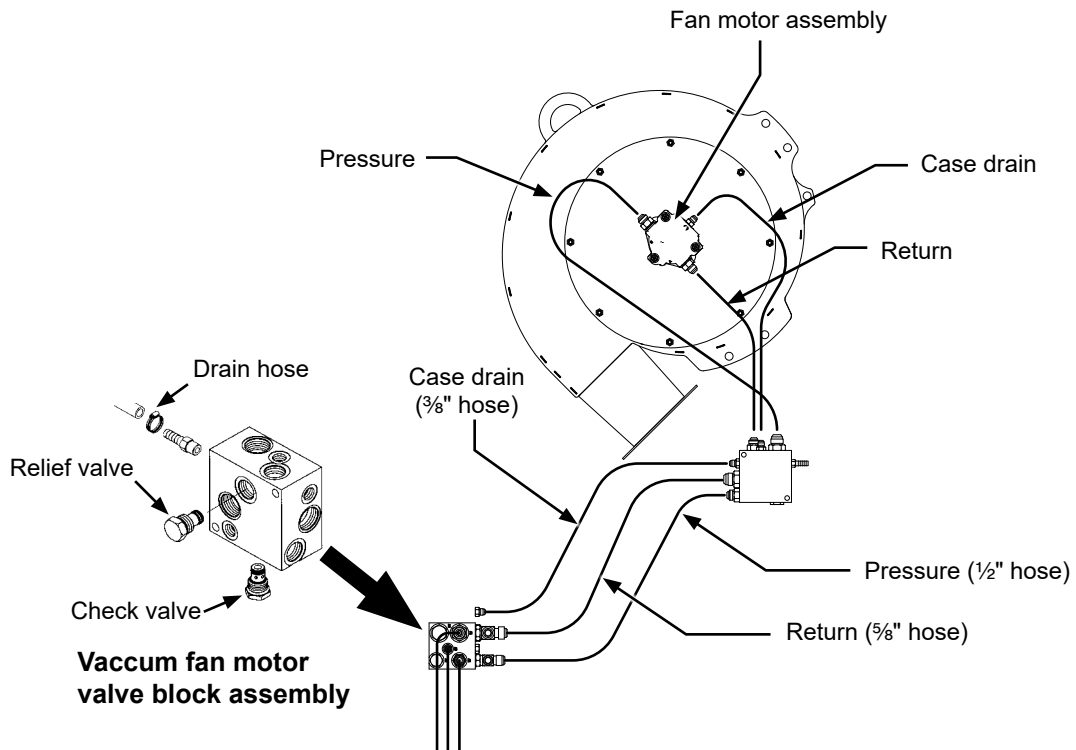

<b>NOTICE</b>	<p><b>Failure to connect to a return with zero pressure will damage hydraulic motor. Connect hydraulic motor case drain to a case drain return line with zero pressure on tractor. DO NOT connect hydraulic motor case drain to SCV outlet. Contact tractor manufacturer for specific details on "zero pressure return".</b></p>
---------------	--



HYDRAULIC SCHEMATIC - TRACTOR MOUNTED SINGLE STAGE PTO PUMP

**NOTICE**

Failure to connect to a return with zero pressure will damage hydraulic motor. Connect hydraulic motor case drain to a case drain return line with zero pressure on tractor. DO NOT connect hydraulic motor case drain to SCV outlet. Contact tractor manufacturer for specific details on "zero pressure return".

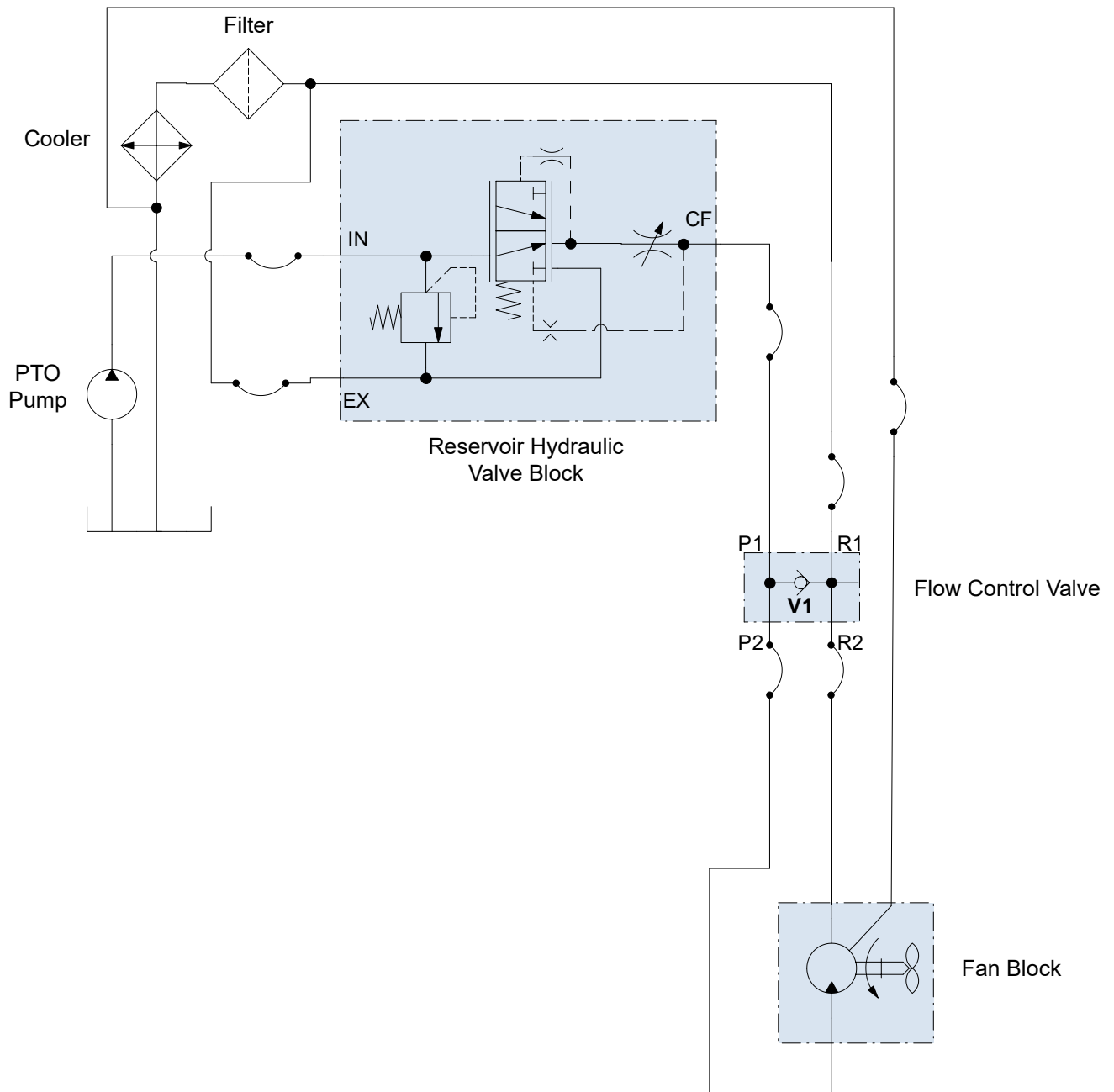

**ISOBUS IMPLEMENT CABLE**

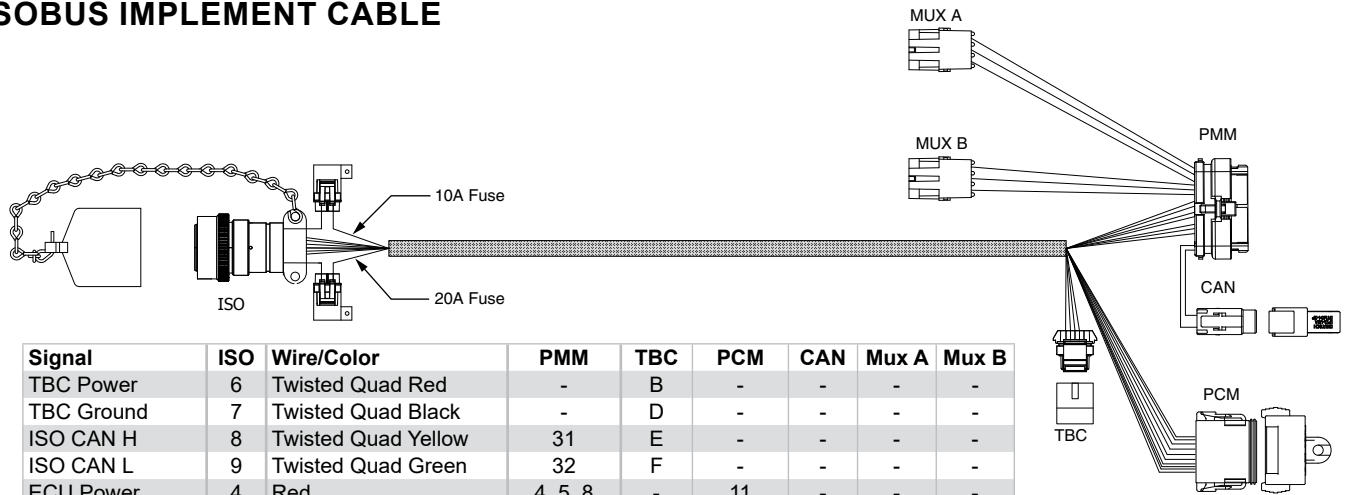

Signal	ISO	Wire/Color	PMM	TBC	PCM	CAN	Mux A	Mux B
TBC Power	6	Twisted Quad Red	-	B	-	-	-	-
TBC Ground	7	Twisted Quad Black	-	D	-	-	-	-
ISO CAN H	8	Twisted Quad Yellow	31	E	-	-	-	-
ISO CAN L	9	Twisted Quad Green	32	F	-	-	-	-
ECU Power	4	Red	4, 5, 8	-	11	-	-	-
ECU Ground	2	Black	14, 15	-	12	-	-	-
LOAD Power	3	Red	-	-	1, 2, 3, 4	-	-	-
LOAD Ground	1	Black	-	-	5, 6, 7, 8	-	-	-
MUX A Power	-	Jacketed 3-Cond White	12	-	-	-	A	-
MUX A Ground	-	Jacketed 3-Cond Black	3	-	-	-	B	-
MUX A Signal	-	Jacketed 3-Cond Green	28	-	-	-	C	-
PROP CAN H	-	Twisted Pair Yellow	34	-	-	1	-	-
PROP CAN L	-	Twisted Pair Green	35	-	-	2	-	-
MUX B Power	-	Jacketed 3-Cond White	23	-	-	-	-	A
MUX B Ground	-	Jacketed 3-Cond Black	26	-	-	-	-	B
MUX B Signal	-	Jacketed 3-Cond Green	7	-	-	-	-	C

**ISOBUS CAN JUMPER CABLE**

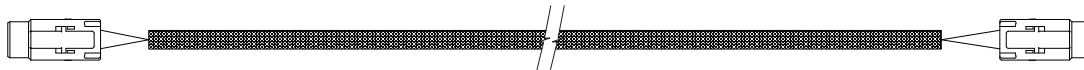

Signal	CAN	Wire/Color
CAN H	1	Twisted Pair Yellow
CAN L	2	Twisted Pair Green

**PRODUCT CONTROL MODULE CABLE**

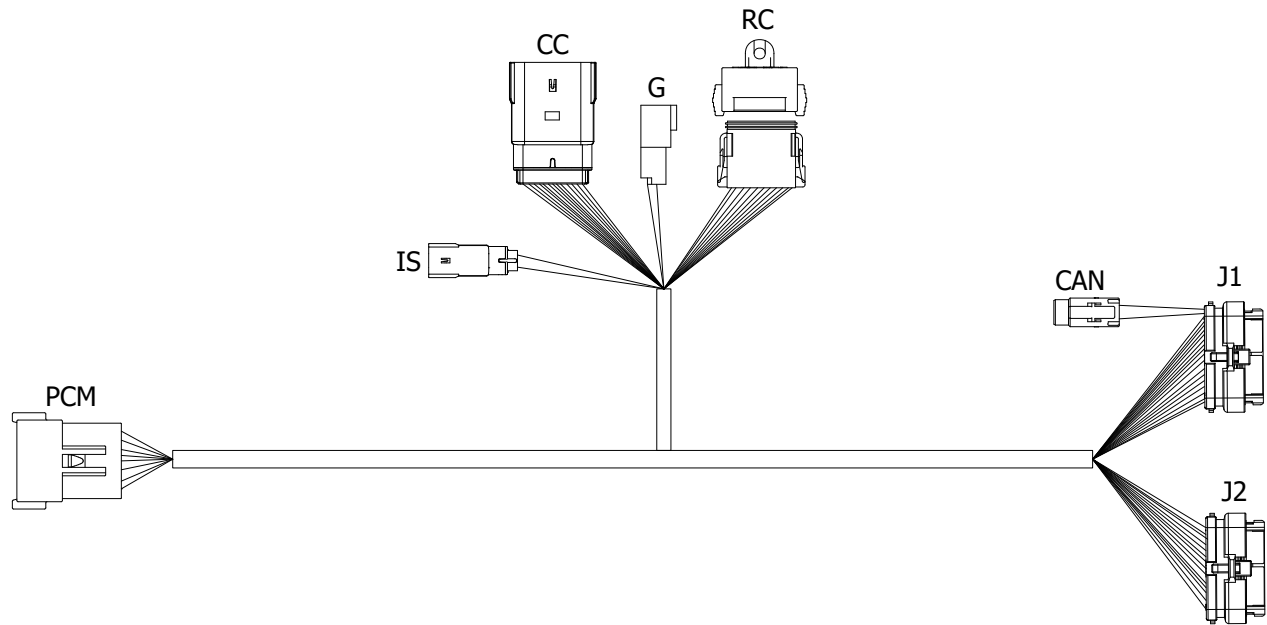

Signal	PCM	Wire/Color	J1	J2	CAN	RC	CC	IS	G
Load Power	1	Red	2	-	-	-	-	-	-
Load Power	2	Red	3	-	-	1	-	-	-
Load Power	3	Red	4	-	-	-	-	1	-
Load Power	4	Red	5	-	-	-	-	1	-
Load Ground	5	Black	-	-	-	-	-	-	1, 2
Load Ground	6	Black	14, 15	-	-	-	-	-	-
Load Ground	7	Black	16	-	-	2	-	-	-
Load Ground	8	Black	17	-	-	-	-	-	-
ECU Power	11	White/Red	11	-	-	-	-	-	-
CAN H	-	Twisted Pair Yellow	34	-	1	-	-	-	-
CAN L	-	Twisted Pair Green	33	-	2	-	-	-	-
Switch In	-	Red/Green	10	-	-	-	-	2	-
Section 1	-	White	24	-	-	-	1	-	-
Section 2	-	Green	25	-	-	-	2	-	-
Section 3	-	Orange	26	-	-	-	3	-	-
Section 4	-	Blue	27	-	-	-	4	-	-
Section 5	-	Brown	-	11	-	-	5	-	-
Section 6	-	Yellow	-	10	-	-	6	-	-
Section 7	-	Violet	-	9	-	-	7	-	-
Section 8	-	Gray	-	8	-	-	8	-	-
Section 9	-	Pink	-	7	-	-	9	-	-
Section 10	-	Tan	-	6	-	-	10	-	-
Section 11	-	Red/Green	-	5	-	-	11	-	-
Section 12	-	Black/Red	-	4	-	-	12	-	-
PWM 1 Power	-	Red/White	-	23	-	3	-	-	-
PWM 1 Ground	-	Black/White	35	-	-	4	-	-	-
PWM 2 Power	-	Red/Yellow	-	12	-	5	-	-	-
PWM 2 Ground	-	Black/Yellow	12	-	-	6	-	-	-
PWM 3 Power	-	Red/Blue	1	-	-	7	-	-	-
PWM 3 Ground	-	Black/Blue	-	24	-	8	-	-	-
Meter Speed 1	-	Green	30	-	-	9	-	-	-
Meter Speed 2	-	Green/White	29	-	-	10	-	-	-
Meter Speed 3	-	Green/Red	-	33	-	11	-	-	-

**IMPLEMENT SWITCH EXTENSION CABLE**

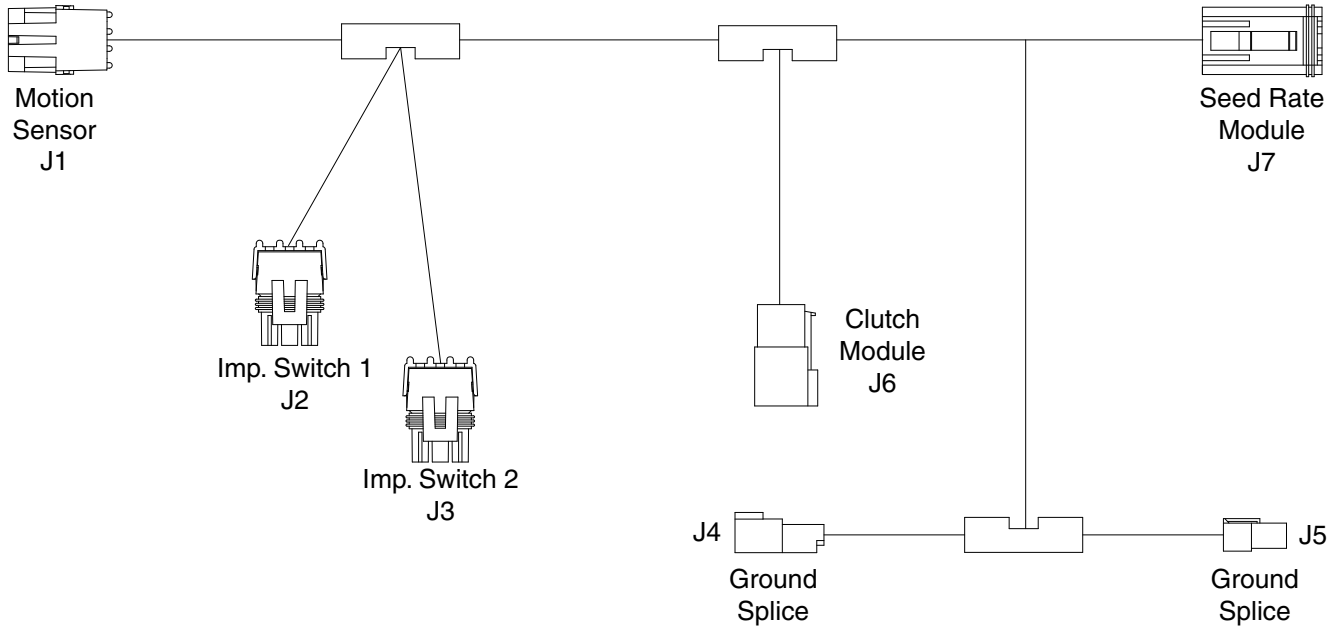

Signal	Imp. Switch 1 WP Tower 1	Imp. Switch 2 WP Tower 2	Motion Sensor WP Shroud	Color	Clutch Module Molex Recept	Seed Rate Module Deutsch Plug	Ground Splice 1	Ground Splice 2	Gauge
12V+ Power	A	A	-	Brown	1	12	-	-	16
Switch Signal	B	B	-	Green	2	10	-	-	16
Motion Signal	-	-	C	White	-	11	-	-	16
Ground	-	-	B	Black	-	6	-	-	16
12V+ Power	-	-	A	Red	-	1	-	-	16
Ground	C (Blue 16 AWG)	C (Blue 16 AWG)	-	Black	-	-	2	2	12
12V+ Power	-	-	-	Red	-	-	1	1	12

**SECTION ADAPTER CABLE - 12 ROW**

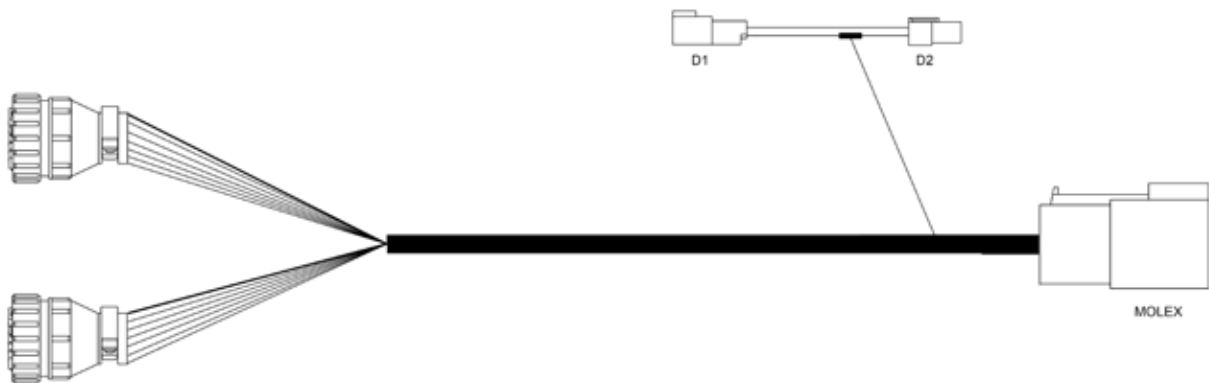

Signal	Color	AMP 1 (Left)	AMP 2 (Right)	Molex	D1	D2
High Current Power	Red	1 (16 Gauge)	1 (16 Gauge)	-	1 (12 Gauge)	1 (12 Gauge)
Ground	Black	-	-	-	2	2
Row 1, 2	Black	2, 3	-	1	-	-
Row 3, 4	Brown	4, 5	-	2	-	-
Row 5, 6	Orange	6, 7	-	3	-	-
Row 7, 8	Pink	-	6, 7	4	-	-
Row 9, 10	Green	-	4, 5	5	-	-
Row 11, 12	Yellow	-	2, 3	6	-	-

**SECTION ADAPTER CABLE - 16 ROW**

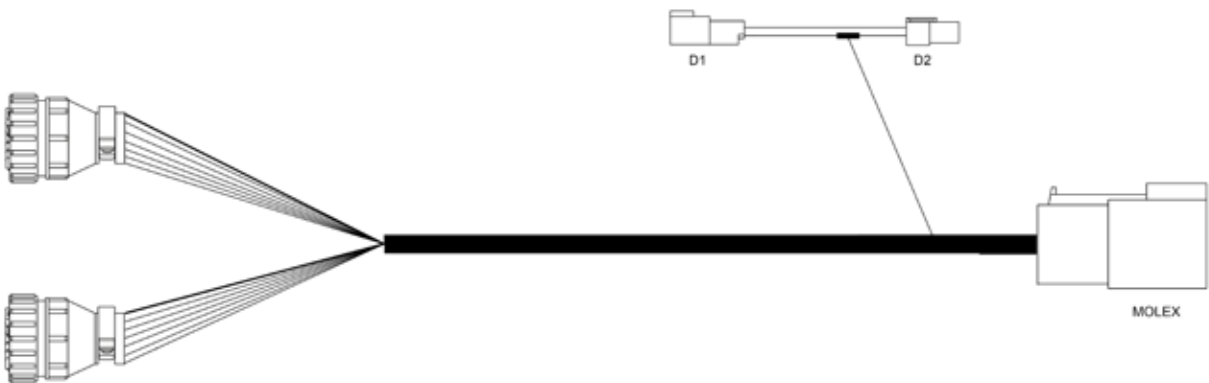

Signal	Color	AMP 1 (Left)	AMP 2 (Right)	Molex	D1	D2
High Current Power	Red	1 (16 Gauge)	1 (16 Gauge)	-	1 (12 Gauge)	1 (12 Gauge)
Ground	Black	-	-	-	2	2
Row 1, 2	Black	2, 3	-	1	-	-
Row 3, 4	Brown	4, 5	-	2	-	-
Row 5, 6	Orange	6, 7	-	3	-	-
Row 7, 8	Pink	8, 9	-	4	-	-
Row 9, 10	Green	-	8, 9	5	-	-
Row 11, 12	Yellow	-	6, 7	6	-	-
Row 13, 14	Blue	-	4, 5	7	-	-
Row 15, 16	Violet	-	2, 3	8	-	-

**CLUTCH CABLE - 12 ROW**

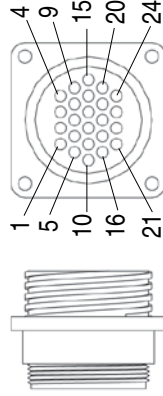
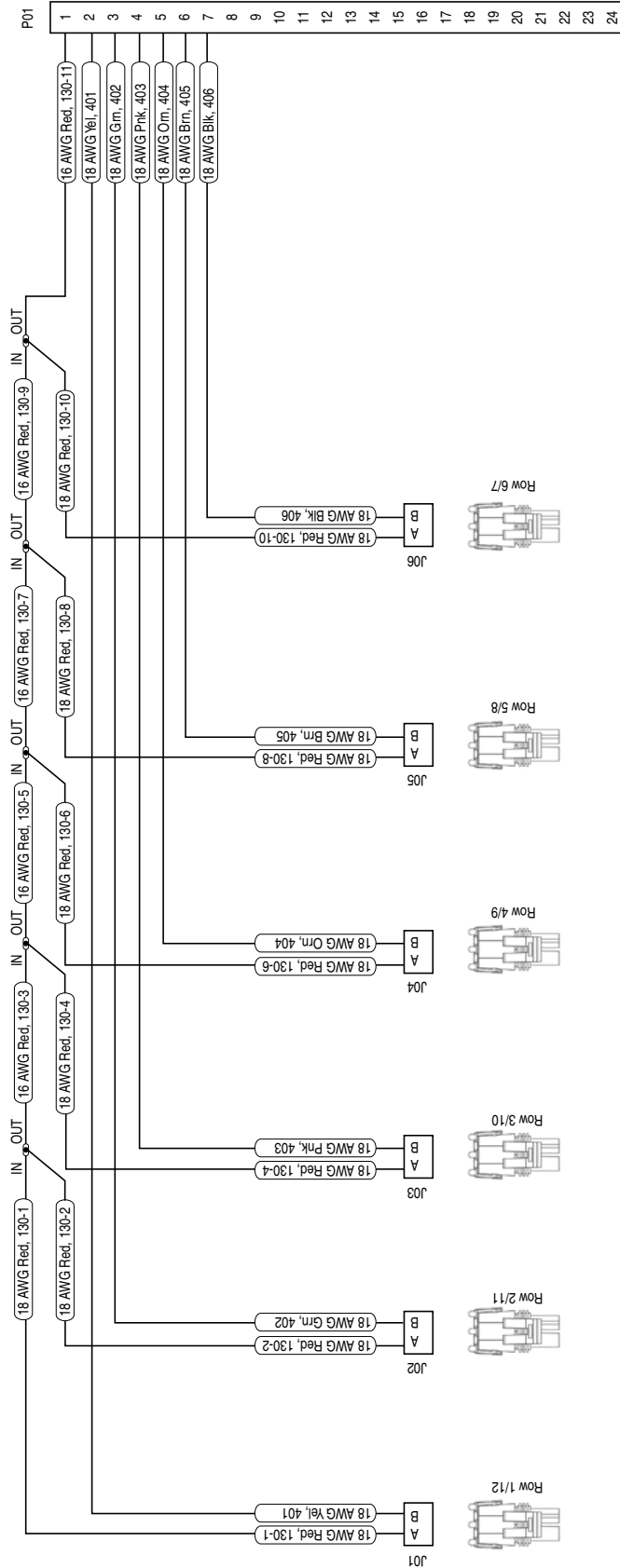

Clutch Module  
Left/Right

Signal	Clutch Cable	Row 8/9	Row 7/10	Row 6/11	Row 5/12	Row 4/13	Row 3/14	Row 2/15	Row 1/16
Power	1	A	A	A	A	A	A	A	A
Row 1/16	2	-	-	-	-	-	-	-	B
Row 2/15	3	-	-	-	-	-	B	-	-
Row 3/14	4	-	-	-	-	B	-	-	-
Row 4/13	5	-	-	-	B	-	-	-	-
Row 5/12	6	-	-	-	-	-	-	-	-
Row 6/11	7	-	-	B	-	-	-	-	-
Row 7/10	8	-	B	-	-	-	-	-	-
Row 8/9	9	B	-	-	-	-	-	-	-

**CLUTCH CABLE - 16 ROW**

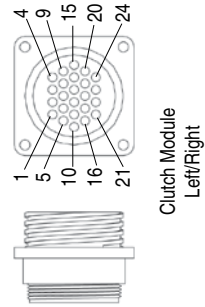
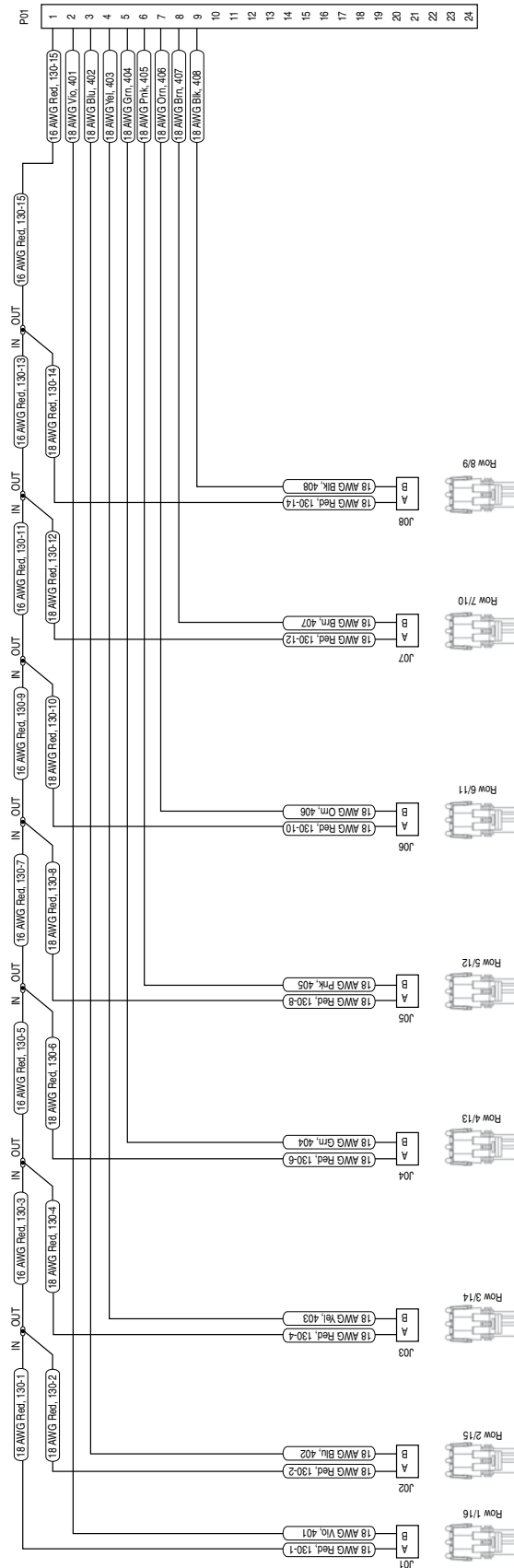

Signal	Clutch Cable	Row 8/9	Row 7/10	Row 6/11	Row 5/12	Row 4/13	Row 3/14	Row 2/15	Row 1/16
Power	1	A	A	A	A	A	A	-	-
Row 1/12	2	-	-	-	-	B	-	-	-
Row 2/11	3	-	-	-	-	-	B	-	-
Row 3/10	4	-	-	-	-	-	-	B	-
Row 4/9	5	-	-	B	-	-	-	-	-
Row 5/8	6	-	B	-	-	-	-	-	-
Row 6/7	7	B	-	-	-	-	-	-	-

TRUE DEPTH OPTION- INTERCONNECT

16 Row Shown

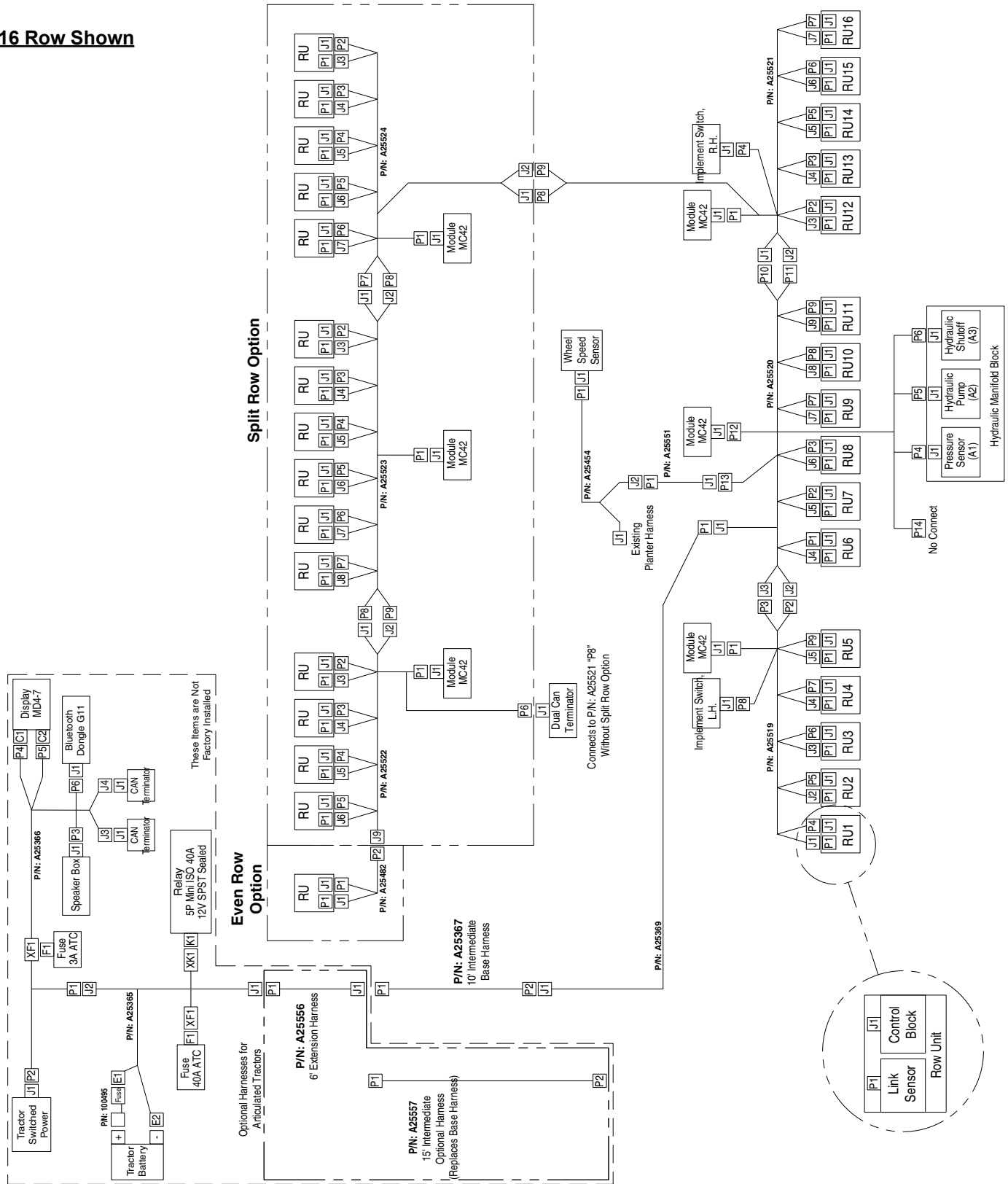



# TRUE DEPTH OPTION - HYDRAULIC SCHEMATIC

## 16 Row Shown

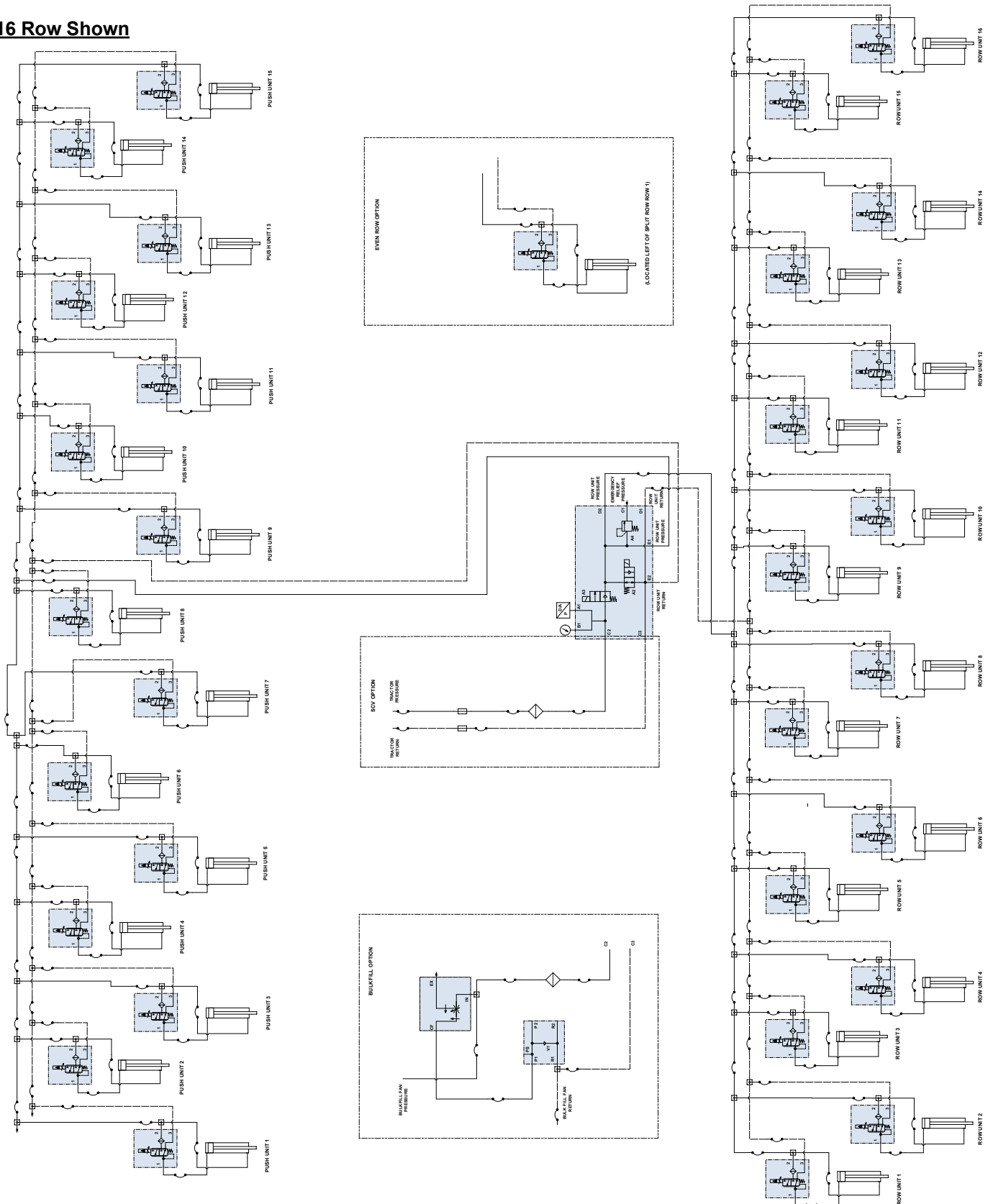

**This page left blank intentionally.**

**BULK FILL**

<b>PROBLEM</b>	<b>POSSIBLE CAUSE</b>	<b>SOLUTION</b>
Seed does not travel through delivery tubes.	System pressure set too low.	Increase system pressure.
Seed stops flowing to row unit during planting.	Seed surging.	Shut down bulk fill system and restart system from idle; seed should start flowing.
	Debris in system.	Insert shutoff door, open cleanout door. remove plug.
Seed does not move from entrainer at startup after exposure to water.	Seed swelled in entrainer.	Insert shutoff door, open cleanout door. remove swelled seed.

**CLOSING WHEEL**

<b>PROBLEM</b>	<b>POSSIBLE CAUSE</b>	<b>SOLUTION</b>
Closing wheel(s) leave severe imprint in soil.	Too much closing wheel down pressure.	Adjust closing wheel pressure.
Closing wheel(s) not firming soil around seed.	Not enough closing wheel down pressure.	Adjust closing wheel pressure. Severe no till conditions may require use of cast iron closing wheels.
"V" closing wheel running on top of seed furrow.	Improper centering.	Align. See <a href="#">"V" Closing Wheel Adjustment (Rubber or Cast Iron)"</a> on page 3-1.

**LIFT CIRCUIT**

<b>PROBLEM</b>	<b>POSSIBLE CAUSE</b>	<b>SOLUTION</b>
Right wing raises faster than left wing. Right wing may even raise completely before the center frame and left wing start to raise. If planter is loaded, the center frame and left wing may not be able to raise at all.	Master cylinder, located on front side of center post, leaking internally. NOTE: Make sure lift system is completely rephased.	Repair master cylinder.
Left wing raises faster than right wing. Left wing may even raise completely before the center frame and right wing start to raise. If the planter is loaded, the center frame and right wing may not be able to raise at all.	Master cylinder, located on rear side of center post, leaking internally. NOTE: Make sure the lift system is completely rephased.	Repair master cylinder.
Center frame raises, but wings do not.	Planter hydraulic circuit out of phase. Usually occurs when the planter is lowered from transport position.  Solenoid valve in port V16 leaking.	Hold hydraulic control in lowering position to give the hydraulic circuit more time to rephase.  Replace solenoid valve cartridge.
Center frame continues to raise after wing cylinders have reached full stroke when going to raised field position.	Solenoid valve in port V16 leaking.	Replace solenoid valve cartridge.
Planter raises to raised field position, but does not raise to transport position.	Solenoid valve coil in port V16 is not energized.	Be sure control console switch is in "raise" position to energize solenoid coil in port V16. Check control console fuse by moving auxiliary switch to ON position. If red light comes on the fuse is OK. Return auxiliary to OFF position. Check for poor wire connection or damaged wire and repair. Solenoid valve coil is defective. All solenoid valves used on the planter are the same. Switch the solenoid coil with one you know is working. If this cures the problem, replace defective coil.
	Solenoid valve cartridge in port V16 is stuck closed.	All solenoid valves used on the planter are the same. Switch the solenoid cartridge with one you know is working. If this cures the problem, replace defective cartridge.
Left wing lowering slower than center frame and right wing. If hydraulic lever is held in lowering position, left wing cylinder attempts to extend.	Check valve in port V17 leaking internally.	Remove check valve in port V17 and inspect for foreign material in valve and remove if possible. Replace check valve. If above fails, switch check valve in port V17 with check valve in port V15. If problem moves or switches to right wing, replace defective check valve.
Right wing lowering slower than center frame and left wing. If hydraulic control is held in lowering position, right wing cylinder attempts to extend.	Check valve in port V15 leaking internally.	Remove check valve in port V15 and inspect for foreign material in valve and remove if possible. Replace check valve. If above fails, switch check valve in port V15 with check valve in port V17. If problem moves or switches to right wing, replace defective check valve.
Planter does not raise or raises slowly.	Tractor may have hydraulic problem.	Switch remote outlets being used. Repair tractor hydraulics.
	Planter may be overloaded with hopper extensions and/or extra fertilizer tanks, coulters or other non-Kinze attachments.	Remove weight.
	Center pivot wear pads may be adjusted too tight and are binding on the post.	Adjust pads.
Planter will not rephase.	All cylinders not completely retracted. Caused by mechanical interference on or between planter frame and wheel lift module.	Remove interference.
	Center cylinders not retracting completely.	Lower planter and hold hydraulic lever in lower position to rephase system. Lower cylinder pins must be free to rotate in this position. If pins are tight, adjust cylinder clevises.

**PISTON PUMP**

<b>PROBLEM</b>	<b>POSSIBLE CAUSE</b>	<b>SOLUTION</b>
Pump hard or impossible to prime.	Valves fouled or in wrong place.	Inspect and clean valves.
	Air leak in suction line.	Repair leak.
	Pump set too low.	Adjust pump setting.
	Packing washers worn out.	Replace.
Low metering.	Valves fouled or in wrong place.	Inspect and clean valves.
	Air leak in suction line.	Repair leak.
	Pump set too low.	Adjust pump setting.
	Broken valve spring.	Replace spring.
Over meters.	Broken discharge valve spring.	Replace spring.
	Trash under valves.	Inspect and clean valves.
	Improper rate setting.	Adjust pump setting.
Leaks through when stopped.	Broken discharge valve spring.	Replace spring.
	Trash under valves.	Inspect and clean valves.
Fertilizer solution leaking under stuffing box.	Packing washers worn out.	Replace.
Pump using excessive oil.	Oil seals or O-ring worn and leaking.	Replace.
Pump operates noisily.	Crankcase components worn excessively.	Inspect and replace if necessary.

**PTO PUMP DRIVE AND OIL COOLER OPTION**

<b>PROBLEM</b>	<b>POSSIBLE CAUSE</b>	<b>SOLUTION</b>
Pump is squealing.	Lack of oil to pump.	Check for plugged suction strainer. Check oil level.
Oil temperature is high.	Low oil level.	Check oil level and add as required.
Desired fan speed cannot be achieved.	Low oil level.	Check oil level and add as required.
	Plugged filter.	Check and change as required.

**POINT ROW CLUTCH**

<b>PROBLEM</b>	<b>POSSIBLE CAUSE</b>	<b>SOLUTION</b>
No clutches disengage.	Main fuse blown in control console.	Replace defective fuse.
	Poor terminal connection in wiring harness.	Repair or replace.
	Wiring damage in wiring harness.	Repair or replace.
	Low voltage at coil. (12 volts required)	Check battery connections.
One section of planter will not re-engage.	Shear pin at seed drive transmission(s) sheared.	Replace pin with one of equal size and grade.
One clutch will not engage.	Fuses blown.	Replace defective fuses.
	Actuator arm and plunger stuck in disengaged position.	Remove, free up, and reinstall.
	Actuator arm out of adjustment.	Adjust actuator arm mounting pin in slot so that actuator arm clears stop on stop collar by approximately 1/8" when clutch is rotated.
	Wrap spring broken or stretched.	Disassemble clutch and replace spring.
	Something touching the stop collar.	Check to ensure collar is free to turn with clutch.
	Clutch assembled incorrectly.	Check clutch and diagram for correct assembly.
Clutch slipping.	Wrap spring stretched.	"Lock" clutch output shaft from turning. Place torque wrench on input shaft and rotate in direction of drive. After input shaft has rotated a short distance the wrap spring should tighten onto the input hub. If slippage occurs at less than 100 ft. lbs. replace spring. If spring still slips after installing new spring, replace input hub.
Planter section does not re-engage while planter is moving forward.	Spring in actuator arm not strong enough to push arm operational switch is turned to the ON position.	Remove spring from inside solenoid and stretch spring slightly or replace. Reinstall spring. If that fails, file the away from stop collar when stop on the stop collar slightly so that the stop is not as aggressive.
Frequent solenoid burnout.	Fuses too large.	Replace fuses on front panel with 10 amp slow blow fuses.
Frequent fuse burnout.	Low voltage (12 volts required).	Check power source voltage for partially discharged battery, etc.
	Damage to wiring harness.	Repair or replace harness.
Clutch or clutches will not disengage.	Input and output shafts out of alignment.	Align input and output shafts to prevent drag.
	Input or output shaft is pushed in too far creating a coupler.	Reposition input and output shafts.

### ROW MARKER OPERATION

PROBLEM	POSSIBLE CAUSE	SOLUTION
Right marker lowering slower than left marker.	Solenoid valve cartridge in port V1 not opening completely.	Switch with cartridge in port V2. If problem repeats, replace cartridge.
	Hose pinched or collapsed.	Inspect hose routing. Replace or repair hoses as required.
Left marker lowering slower than right marker.	Solenoid valve cartridge in port V2 not opening completely.	Switch with cartridge in port V1. If problem repeats, replace cartridge.
	Hose pinched or collapsed.	Inspect hose routing. Replace or repair hoses as required.
Both markers lowering.	Solenoid valve cartridge stuck open. If left marker switch is selected, right cartridge (V1) is defective. If right marker switch is selected, left cartridge (V2) is defective.	Replace solenoid valve cartridge.
Neither marker lowers.	Blown fuse.	Check red light on control console. It should be on if switch is on. If light is not on, switch to opposite marker position. If light comes on, switch may be defective. Replace switch. Otherwise replace fuse.
	Coils at V1 and V2 not energized.	Poor ground on wire, bad wire connection or damaged wire. Repair as required.
	Marker flow control valve closed too far.	See Operation Section for adjustment.
Neither marker will raise.	Marker flow control valve closed too far.	See Operation Section for adjustment.
Right marker will not lower.	Solenoid coil in port V1 not energized.	Check switch on control console. Replace if defective. Check coil ground wire. Check for poor connection or damaged wire.
	Solenoid cartridge in port V1 stuck closed.	Switch cartridge with one on the planter you know is operating properly. If right marker lowers, replace defective cartridge.
Left marker will not lower.	Solenoid coil in port V2 not energized.	Check switch on control console. Replace if defective. Check coil ground wire. Check for poor connection or damaged wire.
	Solenoid cartridge in port V2 stuck closed.	Switch cartridge with one on the planter you know is operating properly. If left marker lowers, replace defective cartridge.
Markers traveling too fast and damaging rubber stop on transport stands and/or damaging pivot at rod end of marker cylinders.	Marker transport stand not adjusted correctly to allow marker cushion cylinders to operate as designed.	See "Row Marker Transport Stand Adjustment".
	Marker flow control valve needs adjustment.	See Operation Section for adjustment.

**ROTATION CIRCUIT**

<b>PROBLEM</b>	<b>POSSIBLE CAUSE</b>	<b>SOLUTION</b>
Cylinder does not extend, but will retract.	Solenoid valve coil in port V12 defective.	Switch coil from port V12 with coil in port V9. If cylinder extends but will not retract, replace defective coil from port V12.
	Solenoid valve cartridge in port V12 stuck closed.	Switch cartridge from port V12 with cartridge in port V9. If cylinder extends but will not retract, replace defective cartridge from port V12.
Cylinder does not retract, but will extend.	Solenoid valve coil in port V9 defective.	Switch coil from port V9 with coil in port V12. If cylinder extends but will not retract, replace defective coil from port V9.
	Solenoid valve cartridge in port V9 stuck closed.	Switch cartridge from port V9 with cartridge in port V12. If cylinder extends but will not retract, replace defective cartridge from port V9.

**SEED METER (BRUSH-TYPE)**

<b>PROBLEM</b>	<b>POSSIBLE CAUSE</b>	<b>SOLUTION</b>
Low count.	Meter RPM too high.	Reduce planting speed.
	Seed sensor not picking up all seeds dropped.	Clean seed tube. Switch meter to different row. If problem stays in same row, replace sensor.
	Lack of lubrication causing seeds not to release from disc properly.	Use graphite or talc as recommended.
	Seed size too large for seed disc being used.	Switch to smaller seed or appropriate seed disc. See "Brush-Type Seed Meter" for proper seed disc for size of seed being used.
	Seed treatment buildup in meter.	Reduce treatment amount used. Thoroughly mix treatment with seed. Add talc.
Low count at low RPM and higher count at higher RPM.	Foreign material lodged in upper brush.	Remove seed disc and remove foreign material from between brush retainer and bristles. Clean thoroughly.
	Worn upper brush.	Replace. See "Maintenance".
Low count at higher RPM and normal count at low RPM.	Seed disc worn in agitation groove area.	Replace disc. See "Maintenance".
High count.	Seed size too small for seed disc.	Switch to larger or appropriate seed disc.
	Incorrect seed rate transmission setting.	Reset transmission. Refer to rate charts.
	Upper brush too wide (fanned out) for small seed size.	Replace upper brush.
High count. (Milo/Grain Sorghum)	Incorrect brush retainer being used.	Make sure GD8237 brush retainer is used to keep upper brush from fanning out.
Upper brush laid back.	Seed treatment buildup on brush.	Remove brush. Wash with soap and water. Dry thoroughly before reinstalling.
	Foreign material buildup at base of brush.	Remove brush retainer and brush. Clean thoroughly. Reinstall.



**VACUUM SEED METER**

<b>PROBLEM</b>	<b>POSSIBLE CAUSE</b>	<b>SOLUTION</b>
Low seed count.	Meter RPM too high.	Reduce planting rate or planting speed.
	Singulator blade setting too aggressive.	Adjust singulator blade.
	Vacuum level too low.	Increase fan speed.
	Seed sensor not picking up all seeds dropped.	Clean seed tube. Move meter to different row.
	Seeds sticking to seed disc.	Use graphite or talc to aid release.
	Seed treatment buildup in seed disc recesses.	Reduce amount of treatment used and or mix thoroughly. Add talc.
	Seed size too large for disc used.	Use appropriate disc for seed size.
	Wrong seed disc.	Use appropriate disc for seed type and size.
	Failed/worn drive components.	Inspect and replace parts as required.
	Plugged orifices in seed disc.	Inspect and clean disc. Check remnant ejector.
	Loss of vacuum at meter.	Check for foreign material between vacuum cover and disc. Inspect parts for wear/damage. Clean or replace as required.
	Seed bridging in hopper.	Add graphite to improve seed flow.
	Faulty vacuum gauge reading.	Repair/replace gauge.
	Dirt in vacuum manifold.	Check vacuum manifold for dirt and clean.
	Seed baffle (If applicable) not allowing seed flow due to bridging of seed.	Mix talc thoroughly to coat all seeds. Remove seed baffle. See Row Unit Operation section.
	Seed disc worn.	Replace.
Vacuum seal worn.	Replace.	
Not planting seed.	Seed hoppers empty.	Fill seed hopper.
	Seed tube plugged/damaged.	Clean or replace tube.
	Meter drive damaged.	Repair/replace drive components.
	Low/no vacuum.	Inspect vacuum system and repair as necessary.
	Singulator blade setting too aggressive.	Adjust singulator blade.
	Faulty vacuum gauge.	Repair/replace vacuum gauge.
	Seed bridging in hopper.	Add graphite to improve seed flow.
	Loss of vacuum at meter.	Check for foreign material between vacuum cover and disc. Inspect parts for wear/ damage. Clean and/or replace as required.
	Wrong seed disc.	Use appropriate disc for seed type and size.
	Meter drive clutch not engaged.	Engage drive clutch.
	Fan not running.	Start fan.
	Dirt in vacuum manifold.	Check vacuum manifold for dirt and clean.

Continued on next page.

**VACUUM SEED METER - Continued**

<b>PROBLEM</b>	<b>POSSIBLE CAUSE</b>	<b>SOLUTION</b>
Not planting seed. (Continued)	Seed baffle (if applicable) not allowing seed flow due to bridging of seed.	Mix talc thoroughly to coat all seeds. Remove seed baffle. Row Unit Operation section.
	High vacuum.	Adjust vacuum level to appropriate level.
	Wrong seed disc.	Replace seed disc.
	Singulator setting not aggressive enough.	Adjust singulator.
Poor seed spacing.	Faulty vacuum gauge.	Check gauge line for dirt/obstruction. Repair/replace vacuum gauge.
	Obstruction in seed tube.	Clean seed tube.
	Dirty/damaged seed disc.	Inspect seed disc for damage, foreign material in orifices or seed treatment buildup in recesses. Clean or replace.
	Wrong vacuum setting.	Adjust vacuum to appropriate level.
	Excess foreign material in seed.	Inspect and clean meter and seed discs. Use clean, undamaged seed.
	Incorrect singulator setting.	Adjust singulator to appropriate setting.
	Inconsistent driveline.	Inspect drive components for rust, misalignment, worn or damaged parts. Replace/repair as required.
	Toolbar not level or wrong height.	Adjust hitch to level toolbar and row units.
	Planting too fast for conditions.	Reduce speed.
Rough field conditions.	Reduce speed.	
Irregular seed population.	Driving too fast.	Reduce speed.
Unable to achieve desired vacuum level.	Tractor hydraulic flow set too low.	Increase flow to fan motor.
	Incorrect hydraulic connections.	Check all hydraulic connections and hose routings.
	Damaged fan components.	Inspect motor and impeller for wear/damage and repair/replace as necessary.
	Vacuum hose pinched/kinked/blocked.	Inspect air lines for any damage or obstruction. Clean air lines and manifold by removing end cap from manifold and running fan at high speed.
	Vacuum hose loose/disconnected.	Inspect and reattach all air hoses.
	Tractor not producing required hydraulic flow/pressure.	Have tractor serviced by qualified technician.
	Dirt in vacuum gauge line.	Check gauge line for dirt/obstruction and clean.

**SEED METER (FINGER PICKUP)**

<b>PROBLEM</b>	<b>POSSIBLE CAUSE</b>	<b>SOLUTION</b>
One row not planting seed.	Drive release not engaged.	Engage drive release mechanism.
	Foreign material in hopper.	Clean hopper and finger carrier mechanism.
	Seed hopper empty.	Fill seed hopper.
	Row unit drive chain off of sprocket or broken.	Check drive chain.
Unit is skipping.	Foreign material or obstruction in meter.	Clean and inspect.
	Finger holder improperly adjusted.	Adjust to specifications. (22 to 25 in. lbs. rolling torque)
	Broken fingers.	Replace fingers and/or springs as required.
	Planting too slowly.	Increase planting speed to within recommended range.
Planting too many doubles.	Planting too fast.	Stay within recommended speed range.
	Loose finger holder.	Adjust to specifications. (22 to 25 in. lbs. rolling torque)
	Worn brush in carrier plate.	Inspect and replace if necessary.
Overplanting.	Worn carrier plate.	Inspect and replace if necessary.
	Seed hopper additive being used.	Reduce or eliminate additive or increase graphite.
Underplanting.	Seed belt installed backwards.	Remove and install correctly.
	Weak or broken springs.	Replace.
	Spring not properly installed.	Remove finger holder and correct.
	Seed belt catching or dragging.	Replace belt.
	Brush dislodging seed.	Replace brush.
Irregular or incorrect seed spacing.	Driving too fast.	Check chart for correct speed.
	Wrong tire pressure.	Inflate tires to correct air pressure.
	Drive wheels slipping.	Reduce down pressure on row unit down force springs.
	Wrong sprockets.	Check seed rate charts for correct sprocket combinations.
Seed spacing not as indicated in charts.	Wrong tire pressure.	Inflate tires to correct air pressure.
	Inconsistent seed size.	Perform field check and adjust sprockets.
	Wrong sprockets.	Check chart for correct sprocket combination.
	Charts are approximate.	Slight variations due to wear in meter components and tire slippage due to field conditions may produce seed spacing variations.
	Stiff or worn drive chains.	Replace chains.
Scattering of seeds.	Planting too fast.	Reduce planting speed.
	Seed tube improperly installed.	Check seed tube installation.
	Seed tube worn or damaged.	Replace seed tube.
Seed tubes and/or openers plugging.	Allowing planter to roll backward when lowering.	Lower planter only when tractor is moving forward.
Inconsistent seed depth.	Rough seed bed.	Adjust down pressure springs. Reduce planting speed.
	Partially plugged seed tube.	Inspect and clean.
	Seed tube improperly installed.	Install properly.

**SOLENOID VALVE**

<b>PROBLEM</b>	<b>POSSIBLE CAUSE</b>	<b>SOLUTION</b>
No solenoids operate.	Low voltage.	Must be connected to 12 volt DC only. Negative ground.
	Blown fuse.	Replace control console fuse with AGC-15 amp.
	Battery connection.	Clean and tighten.
	Wiring harness damaged.	Repair or replace.
One solenoid valve will not operate.	Bad switch.	Replace on control panel.
	Cut wire in harness.	Locate and repair.
	Bad coil.	Replace.
	Poor connection at coil.	Check.
Valve operating when not energized.	Valve stem stuck open.	Replace cartridge.
	O-ring leaking.	Install new O-ring kit.
	Foreign material under poppet.	Remove and clean cartridge.

**TONGUE CYLINDER CIRCUIT**

<b>PROBLEM</b>	<b>POSSIBLE CAUSE</b>	<b>SOLUTION</b>
Tongue cylinder will not extend, but will retract.	No power to solenoid valve coil in port V10 and/or V14. Both must be energized.	Check wiring between control console and solenoid coils looking for damaged wires and poor connections.
	Solenoid valve coil defective.	Switch coil from port V13 with V10. If tongue still will not extend, switch coil from V14 with V13. It will not be necessary to remove any of the wire connections to the solenoid. All three of these solenoids are normally energized when the tongue switch is energized. Replace defective coil.
	Solenoid valve cartridges in port V10 and/or V14 stuck closed.	Switch cartridge from port V10 with cartridge in port V13. If tongue cylinder retracts, replace defective cartridge from port V10. If problem continues, switch cartridge from port V14 with cartridge in port V13. Replace defective cartridge.
Tongue cylinder will not extend but tongue lock cylinder extends.	Pressure relief valve in port V11 stuck closed or pressure setting too high. (Valve is factory set to open at 1000 PSI.)	Replace or adjust pressure relief valve. To adjust, loosen lock nut and turn counter clockwise to decrease pressure.
Tongue hook does not release before the tongue starts to extend.	Solenoid valve cartridge in port V11 stuck open or pressure setting too low. (Valve is factory set to open at 1000 PSI.)	Replace or adjust pressure relief valve. To adjust, loosen lock nut and turn clockwise to increase pressure.
Tongue cylinder will not retract, but will extend.	Solenoid valve coil in port V13 defective.	Switch coil from port V13 with coil from port V14. If coil from port V13 is bad, the tongue will extend but not retract. Replace defective coil.
	Solenoid valve cartridge in port V13 stuck closed.	Switch cartridge from port V13 with cartridge from port V14. If cartridge is bad, the tongue will extend but not retract. Replace defective cartridge.
Tongue extends with switch off.	Solenoid valve cartridge in port V10 and V14 stuck open.	Replace solenoid valve cartridge.
Tongue retracts with switch off.	Solenoid valve cartridge in port V13 stuck open.	Replace solenoid valve cartridge.
Tongue latch releases. Tongue extends slowly while planting.	Latch cylinder or tongue cylinder leaking internally.	Pressure check latch and tongue cylinders. Repair leaking cylinder(s).

**WING LOCK CYLINDER CIRCUIT**

<b>PROBLEM</b>	<b>POSSIBLE CAUSE</b>	<b>SOLUTION</b>
Cylinders will not extend or retract.	No power to the solenoid valve coils.	Auxiliary switch may be in the ON position. Must be in OFF position. Check fuse at control console. Replace fuse with 15 amp type AGC if blown. Check for poor wire connection or damaged wire. Repair as required.
Cylinders will not extend.	Solenoid valve coil in port V3 not energized.	Check for power to coil. Check coil ground wire. If OK, switch coil from port V3 with coil from port V4. If cylinders extend but will not retract, replace defective coil.
	Solenoid valve cartridge in port V3 stuck closed.	Switch cartridge in port V3 with cartridge in port V4. If cylinders extend but will not retract, replace defective cartridge.
Cylinders will not retract.	Solenoid valve coil in port V4 not energized.	Check for power to coil. Check coil ground wire. If OK, switch coil from port V4 with coil from port V3. If cylinders retract but will not extend, replace defective coil.
	Solenoid valve cartridge in port V4 stuck closed.	Switch cartridge in port V4 with cartridge in port V3. If cylinders retract but will not extend, replace defective cartridge.
Cylinders retract with the switch off.	Solenoid valve cartridge in port V4 stuck open.	Replace solenoid valve cartridge.
Cylinders extend with the switch off.	Solenoid valve cartridge in port V3 stuck open.	Replace solenoid valve cartridge.
	Internal cylinder leak.	Install new cylinder seal kit.