

MODEL 3665 PIVOT FOLD PLANTER OPERATOR MANUAL

M0304-01

Rev. 9/21

This manual is applicable to: Model 3665 Pivot Fold Planter
2021 Production Year and on

Record the model number and serial number of your planter along with date purchased:

Model Number 3665

Serial Number _____

Date Purchased _____

Monitor Serial Number _____
Measured Pulses Per Mile/Km (Radar Distance Sensor) _____
Measured Pulses Per Mile/ Km (Magnetic Distance Sensor) _____

SERIAL NUMBER

The serial number plate is located on the planter frame as shown below. The serial number provides important information about your planter and is needed to obtain correct replacement parts. Always provide model number and serial number to your Kinze Dealer when ordering parts or when contacting Kinze Manufacturing, Inc.



This page intentionally left blank.

TO THE DEALER

Predelivery service includes assembly, lubrication, adjustment and test. This service helps ensure planter is delivered to retail customer/end user ready for field use.

PREDELIVERY CHECKLIST

Use the following checklist after planter is completely assembled. Check off each item as it is found satisfactory or after proper adjustment is made.

- Center pivot base mounting and transport wheel spindle hex head cap screws torqued to 450 ft-lb (610.1 n-m).
- Row units properly spaced and optional attachments correctly assembled.
- Row marker assemblies installed and adjusted at each end of the planter.
- Vacuum and bulk fill components properly installed (as applicable).
- All grease fittings in place and lubricated.
- All working parts move freely, bolts are tight, and cotter pins are spread.
- Check all drive chains for proper tension and alignment (as applicable).
- Check for oil leaks and proper hydraulic operation.
- Hydraulic hoses correctly routed to prevent damage.
- Inflate tires to specified air pressure and torque wheel lug bolts and lug nuts as specified in the manual.
- All safety decals correctly located and legible. Replace if damaged.
- All reflective decals and SMV sign correctly located and visible when the planter is in transport position.
- Safety/warning lights correctly installed and working properly.
- Paint all parts scratched during shipment or assembly.
- All safety lockup devices on the planter and correctly located.
- Auxiliary safety chain properly installed and hardware torqued to specification.
- Vacuum fan PTO-driven pump correctly attached to tractor. Oil reservoir filled to capacity and system inspected for leaks (If applicable).
- Control box properly installed in tractor. All cables correctly routed and secure (hydraulic drive only).

Planter has been thoroughly checked and to the best of my knowledge is ready for delivery to the customer.

(Signature Of Set-Up Person/Dealer Name/Date)

OWNER REGISTER

Name _____ Delivery Date _____

Street Address _____ Model No. 3665 Serial No. _____

City, State/Province _____ Dealer Name _____

ZIP/Postal Code _____ Dealer No. _____

DELIVERY CHECKLIST

Use the following checklist at time planter is delivered as a reminder of very important information which should be conveyed to retail customer/end user. Check off each item as it is fully explained.

- Check proper operation of vacuum fan, bulk fill fan, and PTO-driven pump (If applicable) with tractor used with planter.
- (If applicable) Check for proper hitch clearance between tractor and PTO System.
- Life expectancy of this or any other machine is dependent on regular lubrication as directed in the Operator Manual.
- All applicable safety precautions.
- Along with retail customer/end user, check reflective decals and SMV sign are clearly visible with planter in transport position and attached to tractor. Check safety/warning lights are in working condition. Tell retail customer/end user to check federal, state/provincial, and local regulations before towing or transporting on a road or highway.
- Give Operator Manual, Parts Manual, and all Instruction Sheets to retail customer/end user and explain all operating adjustments.
- Read warranty to retail customer/end user.
- Complete Warranty and Delivery Report form.

To the best of my knowledge this machine has been delivered ready for field use and customer has been fully informed as to proper care and operation.

(Signature Of Delivery Person/Dealer Name/Date)

AFTER DELIVERY CHECKLIST

The following is a list of items we suggest to check during the first season of use of the equipment.

- Check planter performance with retail customer/end user.
- Check performance of vacuum or mechanical seed metering system with retail customer/end user.
- Review importance of proper maintenance and adherence to all safety precautions with retail customer/end user.
- Check for parts that may need to be adjusted or replaced.
- Check all safety decals, reflective decals, and SMV sign are correctly located as shown in the Parts Manual and that decals are legible. Replace if damaged or missing.
- Check safety/warning lights are working properly.

(Signature Of Follow-Up Person/Dealer Name/Date)

**All registrations must be submitted online at ["business.kinze.com"](http://business.kinze.com) within 5 business days of delivery.
Retain a copy of this form for auditing purposes.**

Tear Along Perforation

To The Owner	1-1
Warranty	1-3
General Information	1-3
Overview	1-3
Specifications	1-4
Tractor Hydraulic Requirements	1-5
General Safety Rules	1-7
Safety Precautions	1-8

MACHINE OPERATION

Planter Lift Safety Lockup	2-1
Row Marker Safety Lockup	2-1
Tongue Safety Pin	2-2
Transport Latch Locking Pin	2-2
Initial Preparation	2-3
Tractor Driven PTO Pump/Oil Cooler Option	2-5
Tractor Requirements	2-7
Tractor Preparation and Hookup	2-7
Level Planter	2-11
Ridge Planting	2-12
True Depth Hydraulic System Overview	2-13
True Depth Filter	2-14
Control Console Operation	2-15
Hydraulic Seed Rate Drive	2-16
Hall Effect Sensor (Hydraulic Drive Only)	2-16
Hydraulic Weight Transfer Toolbar	2-16
Ag Leader Electric Clutches	2-16
Transport to Field Sequence	2-17
Field Operation	2-19
Planting Speed	2-20
Field to Transport Sequence	2-20
Transport to Field Sequence Using Blue Vantage	2-23
Vacuum System	2-24
Digital Vacuum Readout	2-24
Vacuum Fan and Bulk Fill Motor Valve Block Assembly	2-24
Analog Vacuum or Pressure Gauge	2-24
Bulk Fill System	2-25
Bulk Fill Entrainer Access	2-26
Bulk Fill Tanks - Clean Out	2-26
Bulk Fill Scale Package Option (2021 Production only)	2-27
Bulk Fill Scale Package Option (2022 Production and On)	2-29
Ag Leader Monitoring Control (PMM)	2-33
Blue Drive Aux Mount	2-33
Ag Leader InCommand 1200 Display	2-33
Kinze ISOBUS Option	2-34

Auxiliary Work Lights Package	2-34
Kinze True Depth Display	2-34
Kinze Blue Vantage	2-34
Row Marker Operation (Hydraulic Drive Only)	2-35
Row Marker Speed Adjustment	2-36
Even-Row Push Row Unit	2-36
Row Marker Adjustments	2-37
Row Marker Even-Row Length Adjustment	2-38
Offset Hitch Adjustment	2-38
Point Row Clutches	2-39
Auxiliary Hydraulic Option	2-40
Rear Trailer Hitch	2-41
Field Test	2-42
Field Check Seed Population	2-42
Determining Pounds Per Acre (Brush-Type Meter)	2-43
Determining Bushels Per Acre	2-43
Field Check Granular Chemical Application	2-44

ROW UNIT OPERATION

Planting Depth	3-1
"V" Closing Wheel Adjustment (Rubber or Cast Iron)	3-1
Closing Wheel Shield (Rubber or Cast Iron "V" Closing Wheels)	3-2
Brush-Type Seed Meter 2.0	3-3
Finger Pickup Seed Meter	3-5
Vacuum Settings	3-6
True Speed Seed Meter	3-11
Seed Meter Cleanout	3-11
Additives	3-12
Bayer Fluency Agent	3-13
Seed Hoppers	3-14
Seed Meter Drive Release	3-14
Row Unit Extension Brackets	3-14
Row Unit Chain Routing	3-15
Quick Adjustable Down Force Springs Option	3-16
Split Row Lockups	3-22
Row Unit Mounted No Till Coulter	3-25
Coulter Mounted Residue Wheels	3-25
Granular Chemical Hopper and Drive	3-27
Granular Chemical Banding Options	3-28
Dry Insecticide Application Rates	3-29
Notched Single Disc Openers	4-1
Depth/Gauge Wheel Attachment for Notched Single Disc Fertilizer Opener	4-3
HD Single Disc Fertilizer Opener	4-4
Liquid Fertilizer Attachment	4-6

RATE CHARTS 5-1

LUBRICATION AND MAINTENANCE

Lubrication 6-1

Lubrication Symbols 6-1

Sealed Bearings 6-1

Wheel Bearings 6-1

Drive Chains 6-2

Bushings 6-3

Center Post 6-4

Liquid Fertilizer Piston Pump 6-4

Crankcase Oil Level. 6-4

PTO Pump Shaft Coupling
(Tractor Driven PTO Pump and Oil Cooler Option) 6-5

Grease Fittings 6-6

Mounting Bolts and Hardware 6-10

Tire Pressure 6-12

Transport Tires. 6-12

Inflation Specifications 6-12

Tractor Driven PTO Pump Drive and
Oil Cooler Option (Vacuum) 6-14

Tractor Driven PTO Pump and Oil Cooler Option
(Bulk Fill/Mechanical) 6-16

Finger Pickup Seed Meter Inspection/Adjustment. 6-17

Cleaning Finger Pickup Seed Meter For Storage 6-18

Brush-Type Seed Meter 2.0 Maintenance 6-20

Cleaning Brush-Type Seed Meter For Storage 6-23

Vacuum Manifold Maintenance 6-23

Vacuum Seed Meter Maintenance. 6-24

Seed Meter Cleanout. 6-24

Gauge Wheel Adjustment 6-25

Gauge Wheel Arm Bushing/Seal Replacement 6-26

Gauge Wheel Arm Pivot Spindle Replacement 6-27

15" Seed Opener Disc Blade/Bearing Assembly 6-28

Seed Tube Guard/Inner Scraper 6-30

Row Unit Mounted No Till Coulter 6-31

Coulter Mounted Residue Wheels 6-31

Spiked Closing Wheel 6-32

Granular Chemical Attachment 6-32

Check Valve (Lift System) 6-33

Check Valve (Vacuum Fan) 6-33

Flow Control Valve. 6-33

Pressure Relief Valve. 6-33

Pressure Reducing Relief Valve 6-33

Relief Valve Cartridge 6-33

Solenoid Valve 6-34

Hydraulic Down Force Proportional Pressure Reducing/
Relieving Valve (True Depth Option). 6-34

PWM Flow Control Valve 6-34

Compensator 6-34

Row Marker Bearing Lubrication or Replacement 6-35

Row Marker Transport Stand Adjustment 6-36

Wheel Bearing Repack or Replacement 6-36

Battery Care. 6-37

Center Frame Wear Pads 6-38

Rockshaft to Hitch Shim Adjustment 6-38

Center Frame Relation to Inner Hitch Adjustments 6-39

Triangulate and Set Planter Squareness 6-41

Install Rotation Stop Block. 6-42

Inspect and Adjust Rotation Cylinder Mount 6-43

Pneumatic Down Pressure Air Compressor Tank 6-43

Fertilizer Check Valve Cleaning and Repair 6-44

Piston Pump Storage. 6-44

Preparation for Storage 6-45

Electrical Wiring Diagram for Light Package 6-46

Electrical Control Console Schematic 6-47

Electrical Wiring Harness Schematic (On Tractor) 6-48

Electrical Wiring Harness Schematic (On Planter) 6-49

Valve Block - Located on Hitch 6-50

Valve Block - Located on Rear Center Frame 6-51

Tractor Power Harness (P/N: A25365) 6-52

Hydraulic Down Force Console harness Harness
(P/N: A25366) 6-53

Hydraulic Down Force intermediate harness
(P/N: A25367) 6-54

Hydraulic Down Force Extension harness, 6'
(P/N: A25556) 6-54

Hydraulic Down Force Extension harness, 15'
(P/N: A25557) 6-55

Fertilizer Flow Harness (P/N: A25714) 6-55

Integrated True Depth Row Unit Harness
(P/N: A26709) 6-56

Row Unit Seed meter harness (P/N: A25203) 6-57

Work Light harness (P/N: A22547) 6-57

Work Light harness (P/N: A22547) 6-58

Camera Power Harness (P/N: 10269201). 6-59

12V Power Harness, 12 Row (P/N: 10358301) 6-60

12V Power Harness, 16 Row (P/N: 10338901) 6-61

Rotate Harness, 12 Row (P/N: 10151601) 6-62

Rotate Harness, 16 Row (P/N: 10151901) 6-63

IPN Raise Harness, 12 Row (P/N: 10338901). 6-64

IPN Raise Harness, 16 Row (P/N: 10338801). 6-65

IPN Bulk Fill Harness (P/N: 10339001) 6-66

24V Row Unit Power Split Row Harness, 12 Row
(P/N: A25825) 6-67

24V Row Unit Power Split Row Harness, 16 Row
(P/N: A24484) 6-68

Row Unit Power Extension Harness (P/N: A25029)	6-69	Hydraulic System Schematic	6-104
Row Unit Seed Meter Harness (P/N: A25038)	6-70	Hydraulic Schematic - Vacuum Fan Motor System	6-108
24V Row Unit Seed Power Harness, 12 Row (P/N: A25819)	6-71	Hydraulic Schematic - Bulk Fill Motor System	6-109
24V Row Unit Seed Power Harness, 16 Row (P/N: A24483)	6-72	Hydraulic Schematic - Vacuum Fan Motor System with Bulk Fill System	6-110
IPP Harness, Wing (P/N: A25214)	6-73	(Blue Drive)	6-110
Integrated True Depth harness (P/N: A26713)	6-74	Blue Drive	7-10
CAN Stub Harness (P/N: 10286102)	6-75	Bulk Fill	7-1
Bulk Fill Scale CAN Cable PHD28 Harness (P/N: 10242801)	6-76	Closing Wheel	7-1
Battery Relay Excitation Harness (P/N: 10208501)	6-77	Hydraulic Schematic - Vacuum Fan Motor System with Bulk Fill System (Hydraulic Drive)	6-111
Active Hydraulic Weight Transfer Intercept Harness (P/N: 10496501)	6-78		
Tractor Power Harness (P/N: 10211901)	6-79	TROUBLESHOOTING	
Tractor Console Harness (P/N: A25031)	6-80	Lift Circuit Troubleshooting	7-2
Tractor Power harness Extension, 10'/16' (P/N: 10060901 and 10060902)	6-81	Piston Pump	7-3
True SPeed 3K Row Unit Harness W/IPP (P/N: 10210901)	6-82	PTO Pump Drive and Oil Cooler Option	7-3
True SPeed 3K Pull Row Unit Harness (P/N: 10210801)	6-83	Rotation Circuit	7-4
True Speed Row Unit Harness (P/N: 10210701)	6-84	Row Marker Operation	7-4
Row Unit Power SPliT Row Harness, 12 Row (P/N: 10010501)	6-85	Seed Meter (Brush-Type)	7-5
ISOBUS Implement Cable	6-86	Seed Meter (Finger Pickup)	7-8
ISOBUS CAN Jumper Cable	6-86	Solenoid Valve	7-9
Product Control Module Cable	6-87	Tongue Cylinder Circuit	7-9
Implement Switch Extension Cable	6-88	Vacuum Seed Meter	7-6
Section Adapter Cable - 12 Row	6-89	Wing Lock Cylinder Circuit	7-10
Section Adapter Cable - 16 Row	6-89		
Clutch Cable - 12 Row	6-90		
Clutch Cable - 16 Row	6-91		
True Depth - Interconnect	6-92		
True Depth Option- Hydraulic Schematic Main Down Force Valve Block	6-93		
True Depth Option - Hydraulic Schematic - Push Units 1-8	6-94		
True Depth Option - Hydraulic Schematic - Push Units 9-15	6-95		
True Depth Option - Hydraulic Schematic - Row Units 1-8	6-96		
True Depth Option - Hydraulic Schematic - Row Units 9-16	6-97		
True Depth Option - Hydraulic Schematic - SCV Input Option	6-98		
True Depth Option - Hydraulic Schematic - Battery Pack Input Option	6-99		
True Depth Option - Hydraulic Schematic - Bulk Fill Input Option	6-100		
True Depth Option - Hydraulic Schematic - Even Row Option	6-101		
Hydraulic Hose Life	6-103		





This page intentionally left blank.

Kinze Manufacturing, Inc. thanks you for your patronage. We appreciate your confidence in Kinze farm machinery. Your Kinze planter has been carefully designed to provide dependable operation in return for your investment.

This manual has been prepared to aid you in the operation and maintenance of the planter. It should be considered a permanent part of the machine and remain with the machine when you sell it.

It is the responsibility of the user to read and understand the Operator Manual in regards to safety, operation, lubrication and maintenance before operation of this equipment. It is the user's responsibility to inspect and service the machine routinely as directed in the Operator Manual. We have attempted to cover all areas of safety, operation, lubrication and maintenance; however, there may be times when special care must be taken to fit your conditions.

Throughout this manual the symbol  and the words **DANGER**, **WARNING**, and **CAUTION** are used to call attention to safety information that if not followed, will or could result in death or injury. **NOTICE** and **NOTE** are used to call your attention to important information. The definition of each of these terms follows:

	Indicates an imminently hazardous situation that, if not avoided, will result in death or serious injury. This signal word is to be limited to the most extreme situations, typically for machine components which, for functional purposes, cannot be guarded.
	Indicates a potentially hazardous situation that, if not avoided, could result in death or serious injury, and includes hazards that are exposed when guards are removed. It may also be used to alert against unsafe practices.
	Indicates a potentially hazardous situation that, if not avoided, may result in minor or moderate injury. It may also be used to alert against unsafe practices.
	Used to address safety practices not related to personal injury.

NOTE: Special point of information or machine adjustment instructions.

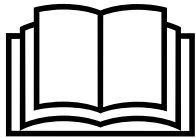

Improperly operating or working on this equipment could result in death or serious injury. Read and follow all instructions in Operator Manual before operating or working on this equipment.



Some photos in this manual may show safety covers, shields, or lockup devices removed for visual clarity. **NEVER OPERATOR OR WORK ON** machine without all safety covers, shields, and lockup device in place as required.

NOTE: Some photos in this manual may have been taken of prototype machines. Production machines may vary in appearance.

NOTE: Some photos and illustrations in this manual show optional attachments installed. Contact your Kinze Dealer for purchase of optional attachments.

Warranty

The Kinze Limited Warranty for your new machine is stated on the retail purchaser's copy of the Warranty And Delivery Receipt form. Additional copies of the Limited Warranty can be obtained through your Kinze Dealer.

Warranty, within the warranty period, is provided as part of Kinze's support program for registered Kinze products which have been operated and maintained as described in this manual. Evidence of equipment abuse or modification beyond original factory specifications will void the warranty. Normal maintenance, service and repair is not covered by Kinze warranty.

To register your Kinze product for warranty, a Warranty And Delivery Receipt form must be completed by the Kinze Dealer and signed by the retail purchaser, with copies to the Dealer, and to the retail purchaser. Registration must be completed and submitted to Kinze Manufacturing, Inc. within 5 business days of delivery of the Kinze product to the retail purchaser. Kinze Manufacturing, Inc. reserves the right to refuse warranty on serial numbered products which have not been properly registered.

If service or replacement of failed parts which are covered by the Limited Warranty are required, it is the user's responsibility to deliver the machine along with the retail purchaser's copy of the Warranty And Delivery Receipt to the Kinze Dealer for service. Kinze warranty does not include cost of travel time, mileage, hauling or labor. Any prior arrangement made between the Dealer and the retail purchaser in which the Dealer agrees to absorb all or part of this expense should be considered a courtesy to the retail purchaser.

Kinze warranty does not include cost of travel time, mileage, hauling, or labor.

General Information

The Model 3665 planter is available with vacuum or mechanical meters, conventional hoppers or bulk fill, Interplant, liquid fertilizer, and various other options. Contact your Kinze Dealer for available options and configurations. To obtain the most recent version of your publication, please contact your Kinze dealer.

Information used in these instructions was current at time of printing. However, due to Kinze's ongoing product improvement, production changes may cause your machine to appear slightly different in detail. Kinze Manufacturing, Inc. reserves the right to change specifications or design without notice and without incurring obligation to install the same on machines previously manufactured.

Right hand (R.H.) and left hand (L.H.), as used throughout this manual, are determined by facing direction machine travels in use unless otherwise stated.

Specification	Conventional Hoppers	
	12R N 30	16R N 30
Number of Rows	12R N 30	16R N 30
Weight Empty (Mechanical)	15,040 lb (6823 kg) - 18,400 (8346 kg)	18,460 lb (8374 kg) - 19,100 lb (8663.61 kg)
Weight Empty (Vacuum)	15,450 lb (7008 kg)	18,400 lb (8347 kg)
Transport Height	11' 11" (3.6M)	11' 11" (3.6M)
Planting Length	23' 9" (7.2M)	26'3" (8M)
Transport Length	39' 2" (12M)	49'2" (15M)
Planting Width	32' 11" (10M)	42'11" (13.1M)
Transport Width	11' 2" (3.4M)	11'2" (3.4M)
Seed Capacity	1.75 bu. (Vacuum / Hopper); 1.90 bu. (Mechanical / Hopper)	
Transport Tire Size	Four 41" x 11" R22.5 radial load range 'H' tubeless rib implement.	
Field Tire Size	7.50" x 20" 8 ply tubeless rib implement tires.	
Field Lift	Two master center rockshaft/four wing wheel slave rephasing cylinders.	
Row Markers	Independently controlled, three stage, low profile, w/disk blade depth bands.	

Specification	Bulk Fill	
	12R N 30	16R N 30
Number of Rows	12R N 30	16R N 30
Weight Empty (Mechanical)	17,120 lb (7766 kg) - 17,450 lb (7916 kg)	20,020 lb (9081 kg) - 21,400 lb (9707 kg)
Weight Empty (Vacuum)	17,120 lb (7766 kg) - 17,450 lb (7916 kg)	20,020 lb (9081 kg) - 21,400 lb (9707 kg)
Transport Height	12' 11" (4M)	12'11" (4M)
Planting Length	23' 9" (7.2M)	26'3" (8M)
Transport Length	39' 2" (12M)	49'2" (15M)
Planting Width	32' 11" (10M)	42'11" (13.1M)
Transport Width	11' 2" (3.4M)	11'2" (3.4M)
Seed Capacity	110 bu.	
Bulk Fill Fill Height (planting position)	8' 5" (2.6M)	
Transport Tire Size	Four 41" x 11" R22.5 radial load range 'H' tubeless rib implement.	
Field Tire Size	7.50" x 20" 8 ply tubeless rib implement.	
Field Lift	Two master center rockshaft/four wing wheel slave rephasing cylinders.	
Row Markers	Independently controlled, three stage, low profile, w/disk blade depth bands.	



Configuration	Requirements		Description
Mechanical Metering Configuration			
Base machine with mechanical meters Hydraulic drive	3 SCV	20 gpm	#1 SCV: planter lift
			#2 SCV: markers / fold (with 12v control console)
			#3 SCV: hydraulic drive / hydraulic weight transfer
Base machine with mechanical meters / True Depth (Hydraulic Down Force) Hydraulic drive	4 SCV	24 gpm	#1 SCV: planter lift
			#2 SCV: markers / fold (with 12v control console)
			#3 SCV: hydraulic drive / hydraulic weight transfer
			#4 SCV: True Depth™ (Hydraulic Down Force)
Base machine with mechanical meters Bulk Fill system Hydraulic drive →External case drain required for Bulk Fill hydraulic circuit. →Use of a Tractor-mounted PTO hydraulic pump supplies oil flow for the vacuum hydraulic circuit reducing the required SCVs by 1 and the gpm by 10	4 SCV	30 gpm	#1 SCV: planter lift
			#2 SCV: markers / fold (with 12v control console)
			#3 SCV: hydraulic drive / hydraulic weight transfer
			#4 SCV: bulk fill delivery system
Base machine with mechanical meters / True Depth (Hydraulic Down Force) Bulk Fill system Hydraulic drive →External case drain required for Bulk Fill hydraulic circuit. →Use of a Tractor-mounted PTO hydraulic pump supplies oil flow for the vacuum hydraulic circuit reducing the required SCVs by 1 and the gpm by 10	4 SCV	34 gpm	#1 SCV: planter lift
			#2 SCV: markers / fold (with 12v control console)
			#3 SCV: hydraulic drive / hydraulic weight transfer
			#4 SCV: bulk fill delivery system / True Depth (Hydraulic Down Force)



Configuration	Requirements		Description
Vacuum Metering Configuration			
Base Machine with Vacuum Meters Hydraulic Drive →External case drain required for vacuum hydraulic circuit. →Use of a Tractor-mounted PTO hydraulic pump supplies oil flow for the vacuum hydraulic circuit reducing the required SCVs by 1 and the gpm by 15	4 SCV	35 gpm	#1 SCV: planter lift
			#2 SCV: markers / fold (with 12v control console)
			#3 SCV: vacuum fan
			#4 SCV: hydraulic drive / hydraulic weight transfer
Base Machine with Vacuum Meters / True Depth (Hydraulic Down Force) Hydraulic Drive →External case drain required for vacuum hydraulic circuit. →Use of a Tractor-mounted PTO hydraulic pump supplies oil flow for the vacuum hydraulic circuit reducing the required SCVs by 1 and the gpm by 15 →Add 4 gpm for split row / even row	5 SCV	44 gpm	#1 SCV: planter lift
			#2 SCV: markers / fold (with 12v control console)
			#3 SCV: vacuum fan
			#4 SCV: hydraulic drive / hydraulic weight transfer
			#5 True Depth (Hydraulic Down Force)
Base Machine with True Rate™ Vacuum Meters Bulk Fill System Hydraulic Drive or Blue Drive →External case drain required for bulk fill vacuum hydraulic circuit. →Use of a Tractor-mounted PTO hydraulic pump supplies oil flow for the vacuum hydraulic circuit reducing the required SCVs by 1 and the gpm by 10	5 SCV	50 gpm	#1 SCV: planter lift
			#2 SCV: markers / fold (with 12v control console)
			#3 SCV: vacuum fan
			#4 SCV: hydraulic drive / hydraulic weight transfer
			#5 SCV: bulk fill delivery system
Base Machine with True Rate™ Vacuum Meters / True Depth (Hydraulic Down Force) Bulk Fill System Hydraulic Drive or Blue Drive →External case drain required for bulk fill vacuum hydraulic circuit. →Use of a Tractor-mounted PTO hydraulic pump supplies oil flow for the vacuum hydraulic circuit reducing the required SCVs by 1 and the gpm by 10 →Add 4 gpm for split row / even row	5 SCV	54 gpm	#1 SCV: planter lift
			#2 SCV: markers / fold (with 12v control console)
			#3 SCV: vacuum fan
			#4 SCV: hydraulic drive / hydraulic weight transfer
			#5 SCV: bulk fill delivery system / True Depth (Hydraulic Down Force)
NOTE: PTO pump is required for all machines equipped with Bulk Fill, Vacuum, Blue Drive and True Depth			

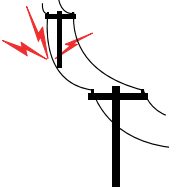

1. Read and understand instructions provided in this manual and warning labels. Review these instructions frequently!
2. This machine is designed and built with your safety in mind. Do not make any alterations or changes to this machine. Any alteration to design or construction may create safety hazards.
3. A large portion of farm accidents happen from fatigue or carelessness. Safe and careful operation of tractor and planter will help prevent accidents.
4. Never allow planter to be operated by anyone unfamiliar with operation of all functions of the unit. Operators must read and thoroughly understand all instructions given in this manual before operating or working on equipment.
5. Be aware of bystanders, particularly children! Always look around to make sure it is safe to start tow vehicle engine or move planter. This is particularly important with higher noise levels and quiet cabs, as you may not hear people shouting.
6. Make sure planter weight does not exceed towing capacity of tractor, or bridge and road limits. This is critical to maintain safe control and prevent death or injury, or property and equipment damage.
7. Never ride or allow others to ride on planter.
8. Store planter in an area away from human activity. DO NOT permit children to play on or around the stored unit.
9. Keep hands, feet, and clothing away from moving parts. Do not wear loose-fitting clothing which may catch in moving parts.
10. Always wear protective clothing, shoes, gloves, hearing, and eye protection applicable for the situation.
11. Do not allow anyone to stand between tongue or hitch and towing vehicle when backing up to planter.
13. Prevent electrocution, other injuries, or property and equipment damage. Watch for obstructions such as wires, tree limbs, etc. when operating machine. Be aware of clearances during turns and when folding/unfolding planter.
14. Reinstall all guards removed for maintenance activities. Never leave guards off during operation.
15. Use of aftermarket hydraulic, electric, or PTO drives may create serious safety hazards to you and people nearby. If you install such drives, follow all appropriate safety standards and practices to protect you and others near this planter from injury.
16. Follow all federal, state/provincial, and local regulations when towing farm equipment on a public highway. Use safety chain (not an elastic or nylon/plastic tow strap) to retain connection between towing and towed machines in the event of primary attaching system separation.
17. Make sure all safety/warning lights, SMV sign, and reflective decals are in place and working properly before transporting the machine on public roads.
18. Limit towing speed to 15 MPH. Tow only with farm tractor of a minimum 90 HP. Allow for unit length when making turns.
19. Reduce speed prior to turns to avoid the risk of overturning. Always drive at a safe speed relative to local conditions and ensure your speed is slow enough for a safe emergency stop.
20. Chemical application is often an integral part of planting. Follow label instructions for proper chemical mixing, handling and container disposal methods.
21. Be familiar with safety procedures for immediate first aid should you accidentally contact chemical substances.
22. Use the proper protective clothing and safety equipment when handling chemicals.
23. Chemicals are supplied with Material Safety Data Sheets (MSDS) that provide full information about the chemical, its effects on exposure, and first aid needs in the event of an emergency. Keep your MSDS file up-to-date and available for first responders in case of emergency.
24. When servicing ground engaging components such as opening disks and firming points, use special care to avoid points and edges worn sharp during use.
25. Use professional help if you are unfamiliar with working on hydraulic systems. Pressurized hydraulic fluid can penetrate body tissue and result in death, serious infection, or other injuries.

Following are some common hazard warnings associated with this equipment. Pay close attention to all safety, operating, and maintenance information in this manual and decals applied to your equipment.

 DANGER	<p>Contacting or coming close to power lines or other high energy sources will cause death or serious injury.</p>
	<p>Keep away from power lines or high energy sources at all times.</p>

 WARNING	<p>Improperly operating or working on this equipment could result in death or serious injury. Read and follow all instructions in Operator Manual before operating or working on this equipment.</p>
	

 WARNING	<p>Falling equipment can cause death or serious injury. Install all lockup devices or lower planter to ground before working on equipment.</p>
	

 WARNING	<p>Explosive separation of rim and tire parts can cause death or serious injury. Overinflation, rim and tire servicing, improper use of rims and tires, or worn or improperly maintained tires could result in a tire explosion.</p>
	

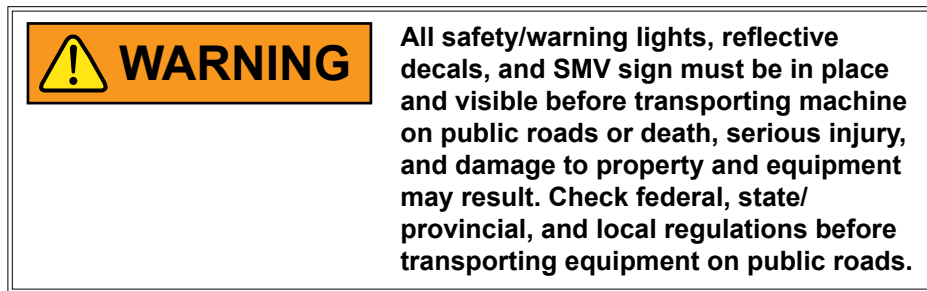
SAFETY SIGNS AND DECALS

Safety signs and decals are placed on the machine to warn of hazards and provide important operating and maintenance instructions. Information on these signs are for your personal safety and the safety of those around you. FOLLOW ALL SAFETY INSTRUCTIONS!



- **Keep signs clean so they can be easily seen. Wash with soap and water or cleaning solution as required.**
- **Replace safety signs if damaged, painted over, or missing.**
- **Check reflective decals and SMV sign periodically. Replace if they show any loss of reflective properties.**
- **When replacing decals, clean machine surface thoroughly with soap and water or cleaning solution to remove all dirt and grease.**

NOTE: Safety sign and decal locations are shown in the Parts Manual for this machine.

NOTE: Style and locations of SMV sign, reflective decals, and safety/warning lights conform to ANSI/ASABE S279.14 JUL 2008 and ANSI/ASABE S276.6 JAN 2005.

This page intentionally left blank.

PLANTER LIFT SAFETY LOCKUP

 WARNING	<p>Uncontrolled movement of equipment can cause loss of control and could result in death, serious injury, or damage to property and equipment. Install all safety pins before transporting equipment.</p>
	

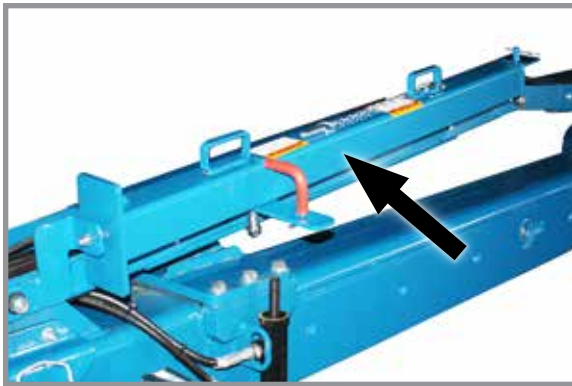



Safety lockup in storage position



Safety lockup in transport/maintenance position

Planter lift safety lockup is installed between center post and lift cylinder. It is held in place by a clevis pin near the base of the lift cylinder rod. Remove safety lockup and store on hose take-up for field operation.

ROW MARKER SAFETY LOCKUP

 WARNING	<p>Row marker can lower at any time and could cause death or serious injury. Stay away from row markers! Install safety lockup device when not in use.</p>
	

Always install row marker lockups when working or transporting planter.

Connect chain between marker stand and second stage of marker assembly.



Row marker safety lockup installed

WARNING

Uncontrolled movement of equipment can cause loss of control and could result in death, serious injury, or damage to property and equipment. Install all safety pins before transporting equipment.

TONGUE SAFETY PIN

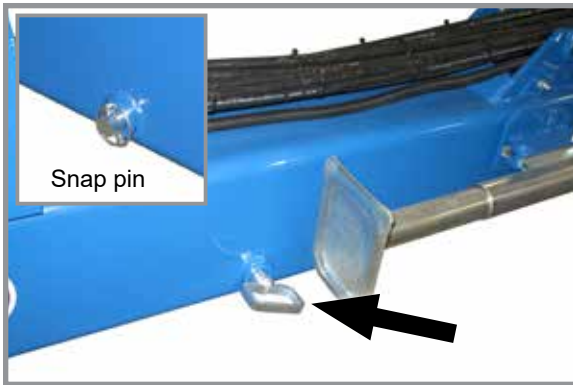

Tongue safety pin installed for transport



Tongue safety pin stored for field operation

Never transport planter without installing tongue safety pin. Tongue safety pin prevents tongue cylinder from retracting should hydraulic failure occur or a sudden stop be made when transporting planter.

Secure safety pin in hitch with snap pin. Remove tongue safety pin and store in bracket on transport latch post at center of planter for field operation.

TRANSPORT LATCH LOCKING PIN

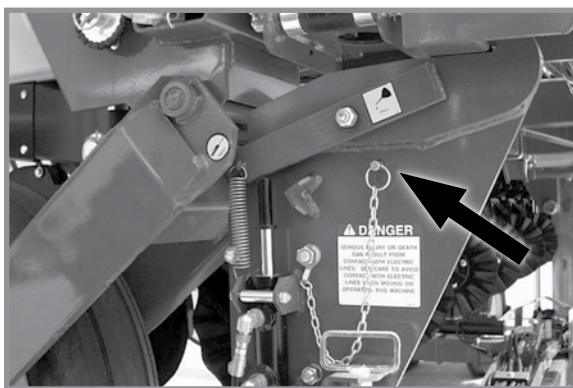

Transport latch locking pin stored

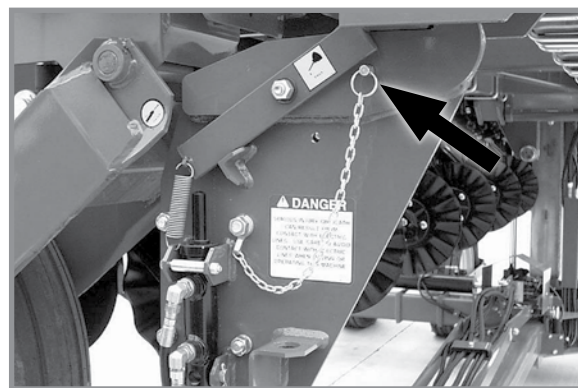



Transport latch locking pin installed



Never transport planter without installing transport latch locking pin. Transport latch locking pin prevents latch bar from disengaging and allowing planter frame to swing away.

Remove transport latch locking pin and store in location provided on latch post for field operation.

INITIAL PREPARATION

Following information is general in nature to aid in preparation of tractor and planter for use, and to provide general operating procedures. Operator experience, familiarity with the machine, and the following information should combine for efficient planter operation and good working habits.

 WARNING	<p>Uncontrolled movement of equipment can cause loss of control and could result in death, serious injury, or damage to property and equipment. Install all safety pins before transporting equipment.</p>
	

 WARNING	<p>Uncontrolled machine movement can crush or cause loss of control resulting in death, serious injury, or damage to property and equipment. Install all safety lockup devices before working under or transporting this equipment.</p>
	

 WARNING	<p>Transporting planter with hoppers over half full or unevenly loaded can cause loss of control and could result in death, serious injury, or damage to property and equipment. Properly load planter when transporting. Be aware of extra transport weight, and road conditions and limits.</p>
--	---

 WARNING	<p>To avoid unintended movement of axle during transport, return all SCV controls to the neutral position before transporting machine. DO NOT operate any hydraulic function while transporting machine. Doing so could result in death, serious injury, or damage to property and equipment.</p>
--	--

 WARNING	<p>Transport axle can lower from transport position without the use of any controller, causing death, serious injury, or damage to property and equipment. Do not operate any hydraulic function while transporting the planter. Make sure all transport safety lockups are installed on the four transport cylinders and all SCV controls are in their neutral state before transporting, storing and working on the planter.</p>
--	--

1. Torque transport wheel $\frac{5}{8}$ "- 18 lug nuts to 200 ft-lb (271 N-m).

2. Inflate tires to the following specifications:

Transport (center section) 255-70R 22.5"
 75 psi (517.1 kPa) recommended/100 psi (689.4 kPa) max.

Ground drive (wings) 7.50" x 20" 40 psi (275.7 kPa)

Liquid fertilizer piston pump 7.60" x 15" 40 psi (275.7 kPa)

3. Lubricate planter and row units following instructions in Lubrication and Maintenance section of this manual.

4. Check all row unit drive chains for proper tension, alignment, and lubrication.

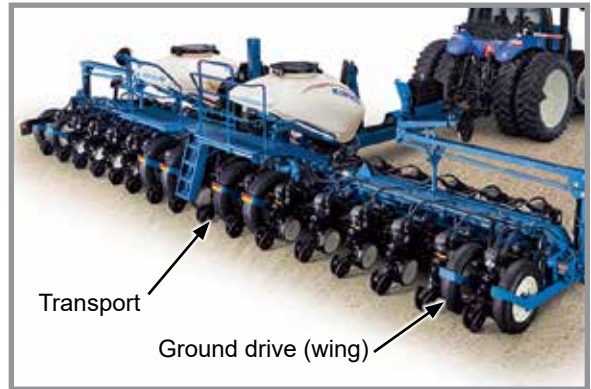

Tire locations

TRACTOR DRIVEN PTO PUMP/OIL COOLER OPTION

Tractor driven PTO pump and oil cooler option is for tractors with less than required hydraulic output needed to operate hydraulic-driven vacuum fan and other planter hydraulic requirements.

A 1000 RPM PTO is required to operate PTO-driven hydraulic pump.

Option consists of a 2-Bolt B SAE Pump Flange with $\frac{7}{8}$ "-13 tooth spline, 13.5 GPM 2000 PSI tractor mounted pump, 12 gallon (45.4L) capacity hydraulic reservoir, 15 GPM-rated oil cooler, spin-on 10-micron oil filter, and required hydraulic valves and fittings.

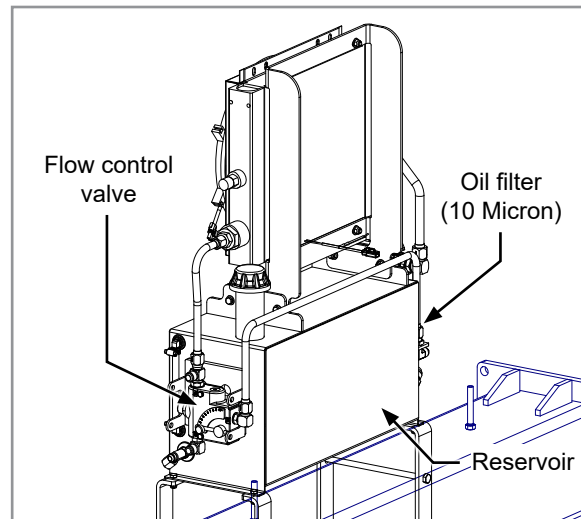

Single Stage - Vacuum or Bulk Fill/Mechanical

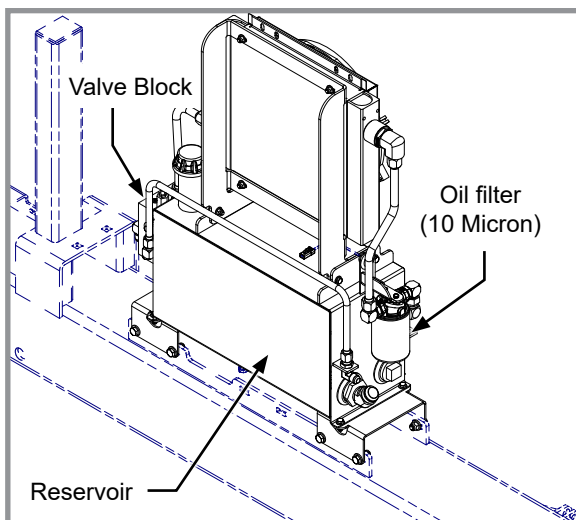

Single Stage - Bulk Fill/Blue Drive

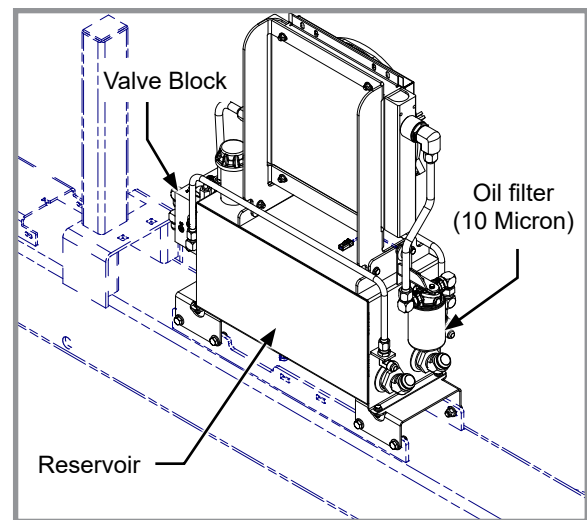

**Dual Stage - Bulk Fill/Mechanical or
Bulk Fill/Blue Drive**

* Electric Drive uses a relief valve rather than the flow control valve shown. Flow is controlled by Blue Drive System at the fan.

This page intentionally left blank.

TRACTOR REQUIREMENTS

Consult your dealer for information on horsepower requirements and tractor compatibility. Requirements vary with planter options, tillage, and terrain.

A 12 volt DC electrical system is required on all sizes.

TRACTOR PREPARATION AND HOOKUP

1. Adjust tractor drawbar 13-17 inches above ground with hitch pin hole directly below PTO shaft center line. Make sure drawbar is in a stationary position.
2. Install control console or Blue Vantage Display on tractor in a convenient location within easy reach of operator and close to hydraulic controls. Mount control console securely and route power cord to power source. Control console operates on 12 volt DC only. If two 12 volt batteries are connected in series, ALWAYS make power connection on battery grounded to tractor chassis.

If two 6 volt batteries are connected in series, make sure power connection provides 12 volt DC across positive terminal on one battery and negative terminal of second battery.

3. Back tractor to planter and connect with 1¼" - 1½" diameter hitch pin. If tractor is not equipped with a hitch pin locking device, make sure hitch pin is secured with a locking pin or cotter pin.



Kinze Blue Vantage

4. Safety chain must be used to keep planter and tractor connected in case of a hitch pin/drawbar failure.



NOTE: A 2-Point Hitch Option converts planter from drawn to semi-mounted and is available for use with Category 3N or 3 three-point hitch designs. Safety chain is not used with 2-point hitch.



Planter/safety chain hookup to tractor



Optional 2-point hitch

 WARNING	<p>Pressurized hydraulic fluid can penetrate body tissue and result in death, serious infection, or other injuries. Fluid injected under skin must be IMMEDIATELY removed by a surgeon familiar with this type of injury. Make sure connections are tight and hoses and fittings are not damaged before applying system pressure. Leaks can be invisible. Keep away from suspected leaks. Relieve pressure before searching for leaks or performing any system maintenance.</p>
	

NOTICE	<p>Wipe hose ends to remove any dirt before connecting couplers to tractor ports or contamination may cause equipment failure.</p>
---------------	--

5. Connect hydraulic hoses to tractor ports in a sequence familiar and comfortable to the operator.
6. (If applicable) Install PTO pump onto tractor PTO shaft. Make sure shaft rotation matches direction indicated on pump housing.

NOTICE	<p>Clean and grease PTO shaft coupling with high-pressure industrial coupling grease (Chevron® coupling grease or equivalent) meeting AGMA CG-1 and CG-2 Standards each time driveshaft is installed or premature wear and equipment failure can occur.</p>
---------------	---

NOTICE	<p>Check for proper hitch clearances between tractor and PTO system.</p>
---------------	--

NOTE: A tractor model-specific PTO mount kit is required and available from Ag Power Systems, LLC (319-646-2770 or www.agpowersystems.com) and Command Hydraulics (800-778-6200 or commandhydraulics.com).

NOTE: Follow instructions provided with PTO mount to ensure proper installation. The PTO pump requires a minimum of 1/8" between shafts and proper alignment to prevent premature pump failure.

7. (If applicable) Connect compressor harness.
8. If equipped with True Depth, attach the True Depth 6 pin connector.
9. If equipped with Blue Drive, attach the Blue Drive 6 pin connector and Ethernet cable to the Blue Vantage display.

NOTICE

Connect hydraulic motor case drain to a case drain return line with zero PSI on tractor. Failure to connect to a return with zero PSI will cause hydraulic motor shaft seal damage. **DO NOT** connect hydraulic motor case drain to a SCV outlet or motor return circuit connection. Contact tractor manufacturer for specific details on “zero pressure return”.

NOTICE

Always connect hydraulic motor return hose to tractor motor return port. Do not connect to tractor SCV unless through a motor spool or hydraulic motor failure can occur. If a motor return port is not available on the tractor, the SCV controlling the bulk fill system **MUST** be in the float position before planter is moved in planting or field raised position when bulk fill system is not in use.

PLANTER TO TRACTOR HYDRAULIC CONNECTIONS

Color/Label	Machine Function	Hose Size	Function
Red AA	Field Lift	1/2"	Pressure
Red BB		1/2"	Return
Blue AA	Planter Fold & Row Marker	3/8"	Return
Blue BB		3/8"	Pressure
Black RR	Seed Rate Hydraulic Drive (Vacuum)	3/4"	Return
Black PP		1/2"	Pressure
Black RR	Seed Rate Hydraulic Drive (Mechanical) Power Pack (Blue Drive)	1/2"	Return
Black PP		3/8"	Pressure
Green RR	Vacuum Fan	3/4"	Return
Green PP		1/2"	Pressure
Orange CD		3/8"	Case Drain
Yellow RR	Bulk Fill System Pressure Fan	3/4"	Motor Return
Yellow PP		1/2"	Pressure
Orange CD		3/8"	Case Drain
Purple RR	True Depth	5/8"	Return
Purple PP		1/2"	Pressure

NOTE: Set adjustable flow outlet (SCV) to full flow position.

For tractors not equipped with a method for finite adjustment of hydraulic flow, Flow Control Needle Valve Kit G1K426 is available from Kinze Repair Parts through your Kinze Dealer.

NOTE: Not to be used with Blue Drive Systems.



G1K426 needle valve kit

- Connect ASABE Standards 7 terminal connector for safety/warning lights on planter to ASABE Standards receptacle on tractor. If your tractor is not equipped with an ASABE Standards receptacle, check with your tractor manufacturer for availability. Check warning lights on planter work in conjunction with warning lights on tractor.

NOTE: A 12 volt battery connection is required to power the vacuum fan digital gauge. Connect “red” wire to positive (+) battery terminal and “black” wire to negative (-) battery terminal.



Jack in operating position



Jack in storage position

- Raise jack stand and remount horizontally on storage bracket on opposite side of hitch.

LEVEL PLANTER

Lateral adjustment is maintained by tire pressure. Check tires are inflated to specification.

Front and rear level adjustment is maintained by hitch clevis position unless tractor drawbar is adjustable for height. Planter frame and row unit parallel arms must be level for proper planter and row unit operation. Bottom of toolbar should be 20" to 22" from planting surface.

- Lower planter to planting position and check planter is level front to rear. Go to step 2 if hitch is too high or low.

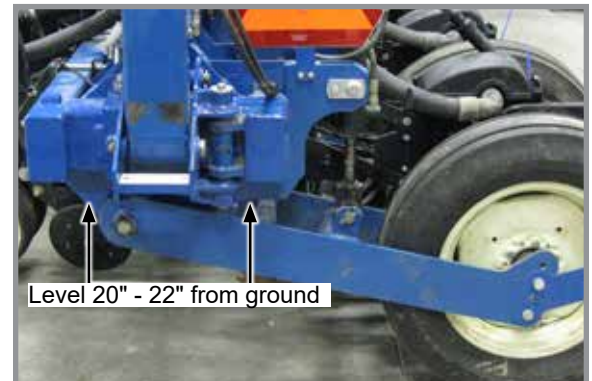

Level planter toolbars

NOTE: DO NOT install safety chain using clevis hardware. Move safety chain location if necessary.

- Remove clevis hitch hex head cap screw and lock nut using a torque wrench. Replace if off-torque is below 75 ft-lb (101.6 N-m) or there is corrosion or damage.

NOTE: Clevis must be free to move on hitch. DO NOT OVERTIGHTEN hardware.

- Align clevis to hitch holes at new location and install hex head cap screw and lock nut. Tighten lock nut until threads are fully engaged and hex head cap screw and lock nut are firmly against hitch bracket.

NOTE: On planters with push row units and no till coulters, uplift from down force springs or air springs in pneumatic down pressure system may cause wings to rise slightly in planting position. Problem may be compounded if static pressure is trapped in planter's hydraulic lift system which can cause wing cylinders to extend slightly. Operating tractor's hydraulic system in float position or moving tractor's hydraulic lever to float position briefly to relieve pressure will help maintain proper toolbar height.

4. Field check planter.

Field and actual planting conditions dictate which transport wheel setting to use so row unit parallel arms are parallel with ground. It may be necessary to lower ground drive wheels to ensure level lateral toolbar operation if transport wheels are set in one of the two lower sets of holes. Make a field check when planter is fully loaded with seed, granular chemicals, fertilizer, etc. to be sure wings are level with center frame. If wings are not level with center frame, drive wheels and/or transport wheels can be raised or lowered in wheel arms to increase or decrease planter toolbar height. Raise hitch to ensure level operation.

NOTICE Component interference can damage equipment. Check clearance between tires and drill shaft U-joint when using top hole setting.

NOTE: To allow adequate drive force after lowering ground drive wheels, it may be necessary to lower contact drive wheel arms to lower sets of holes in wheel modules and lower down pressure springs to lower mounting rods on wheel modules.

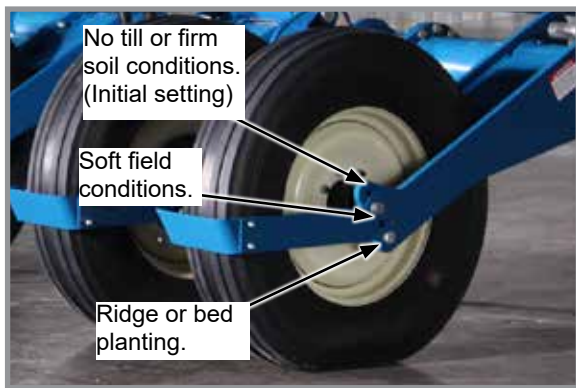

Transport wheel adjustment

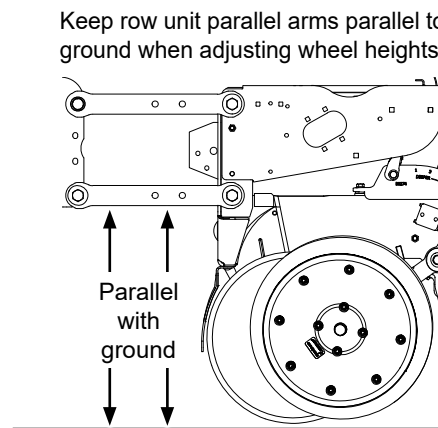

Field/wing wheel adjustment

RIDGE PLANTING

Move drive and transport wheels 2" or 4" to lower mounting holes in wheel arms when ridge planting to increase planter toolbar height. Raise hitch height to ensure level operation.

TRUE DEPTH HYDRAULIC SYSTEM OVERVIEW



True Depth Pressure Gauge

 WARNING	Remove all hydraulic power sources and verify True Depth pressure gauge reads zero before servicing.
--	--



True Depth Cylinder

 WARNING	Flow out of the rod end port of the cylinder must not be restricted when pressurizing cap end port as 4.5:1 pressure intensification will occur on the rod end of the cylinder potentially resulting in failure of the cylinder and loss of containment of the piston rod assembly.
--	---



True Depth Filter

TRUE DEPTH FILTER

Replace filter cartridge annually, every 100 hours of operation, or when the clogging indicators point out the limit pressure drop created inside the filter.

To replace the cartridge:

1. Stop the system in "Machine Stopped" status
2. Secure any shut-off valves on the hydraulic circuit.
3. Unscrew the filter container (1).
4. Remove the clogged filtering cartridge (5), making sure no residual particles have settled in the bowl bottom.
5. Make sure the O-ring (2-4) and the anti-extrusion ring (3) are not damaged, otherwise replace them and consequently position the new ones correctly.
6. Insert the new filtering cartridge, lubricating the sealing O-ring beforehand.
7. Screw the container tight (1) making sure the threading is screwed correctly. Tighten to a tightening torque of 65 Nm.
8. Start the machine for a few minutes.
9. Make sure there are no leaks.

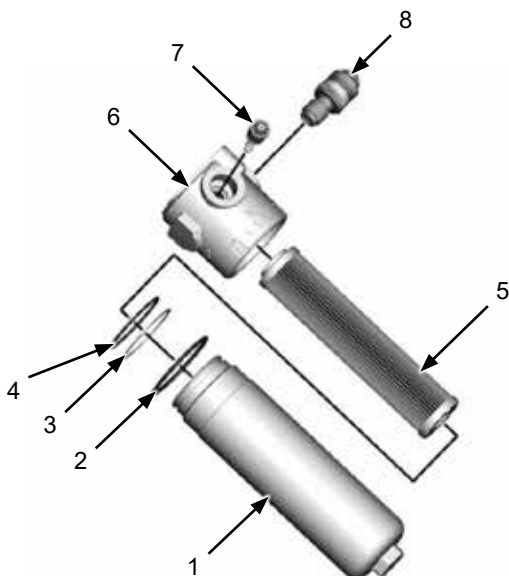

1. Filter Bowl
2. External O-Ring
3. Anti-extrusion ring
4. Sealing O-Ring
5. Filtering Element
6. Filter Head
7. By-pass valve
8. Visual differential indicator

True Depth Cylinder

CONTROL CONSOLE OPERATION

Tractor's hydraulic system and planter control console are used to raise and lower planter, rotate frame, extend and retract tongue, lock and release wings, and operate row markers.

DANGER

Contacting or coming close to power lines or other high energy sources will cause death or serious injury.

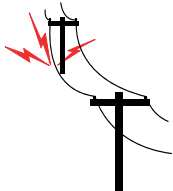

Keep away from power lines or high energy sources at all times.

WARNING

Being struck by a moving marker can cause death or serious injury. Markers can move unexpectedly when SCV controls are operated. Keep marker switch OFF when not in use.



NOTICE

Control console face is backlit with a power switch on back side. Turn off console when not in use or tractor battery will drain.

Marker switch is an ON/OFF/ON type to select right or left hand marker operation. It is disabled when a planter fold function is selected. An indicator light illuminates when switch is ON.

Raise/wing lock and rotate/tongue switches are MOMENTARY ON/OFF/MOMENTARY ON type to select a planter fold function. They must be held in position while operating tractor SCV control for desired function to operate.

Down pressure switch is a MOMENTARY ON/OFF/ MOMENTARY ON type used to increase or decrease row unit down pressure.



Model 3660 control box

Work light switch is on ON/OFF type to control optional planter mounted work lights.

Point row switches are not used on Model 3660 planter. This function is controlled by Kinze Vision or Cobalt planter controller.

A 50 amp main control box fuse and 20 amp delayed air compressor fuse are located on control box front lower left face.

NOTE: Hydraulic weight transfer toolbar operates when planter is in motion and hydraulic seed rate drive is operating.

Model 3660 planters operate using three to five dual remote (SCV) hydraulic outlets:

1. Raise and lower planter during field operation with axle rockshaft (field lift).
2. In conjunction with control console switches, controls row markers, center post, wing locks, rotation, and tongue extension.
3. Hydraulic seed rate drive.
4. Vacuum blower drive (optional).
5. Bulk fill blower drive (optional).

HYDRAULIC SEED RATE DRIVE

Refer to Ag Leader Integra or Kinze Cobalt operation manuals for information on setting and controlling hydraulic seed rate system.

HALL EFFECT SENSOR (HYDRAULIC DRIVE ONLY)

Set Hall effect sensor within $\frac{1}{8}$ " of pick-up disc.

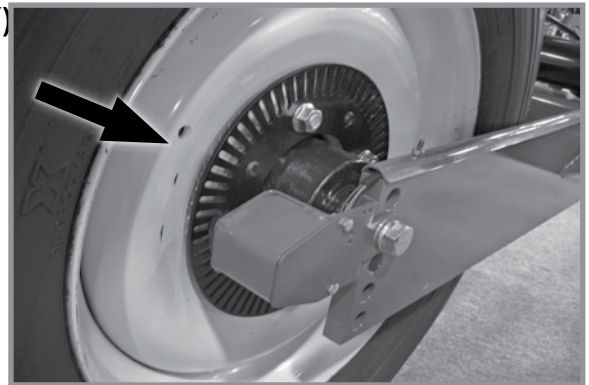

Hall effect sensor

HYDRAULIC WEIGHT TRANSFER TOOLBAR

The hydraulic weight transfer system is standard. The hydraulic drive system powers the hydraulic weight transfer system. Pressure is set from the factory and does not require additional adjustment.

AG LEADER ELECTRIC CLUTCHES

Electric clutches along with GPS can stop seed flow by turning off seed meters (and planter sections) based on field mapping and previously planted areas.

TRANSPORT TO FIELD SEQUENCE

Position planter in a relatively flat open area. Avoid an area with furrows, etc.

SUMMARIZED TRANSPORT TO FIELD SEQUENCE

1. Remove and store tongue safety pin.
2. Remove and store transport latch locking pin.
3. Remove and store safety lockup.
4. Rotate planter to field position.
5. Lower planter on center post.
6. Raise planter using field lift.
7. Release wing locks.
8. Retract tongue.
9. Lower planter to ground.
10. Remove row marker lockups.

NOTE: Read following information for detailed instructions.

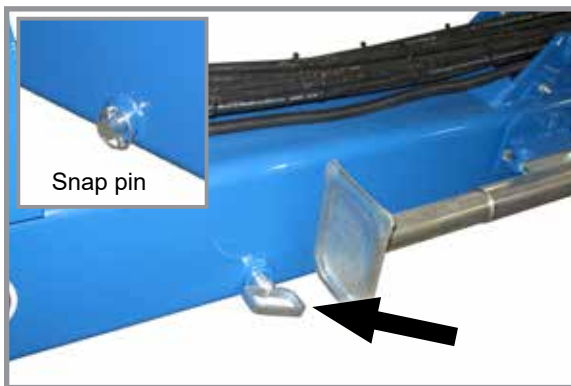

Tongue safety pin installed for transport



Tongue safety pin stored for field operation

1. With tongue fully extended, planter in transport position, and tractor shut down; remove tongue safety pin and place it in storage position.

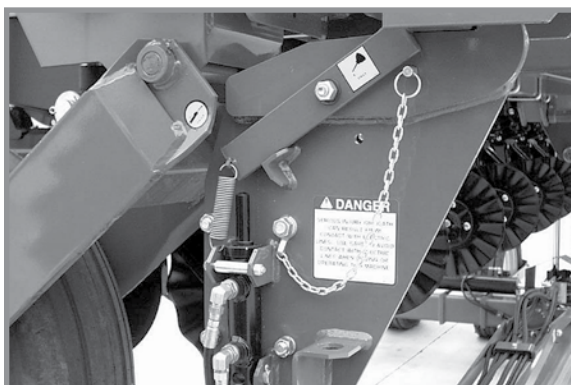

**Transport latch locking pin
Locked transport position**

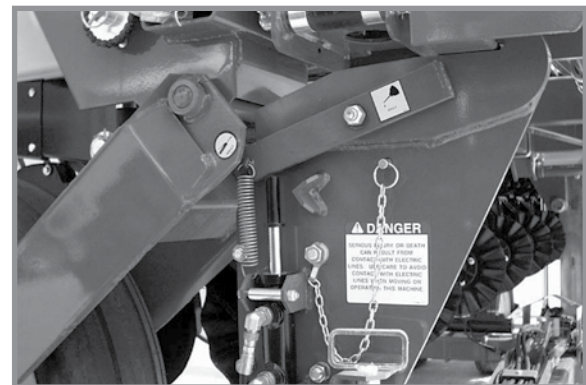

**Transport latch locking pin
Storage position**

2. Remove transport latch locking pin from locked position and place it in storage location.



Safety lockup in transport position

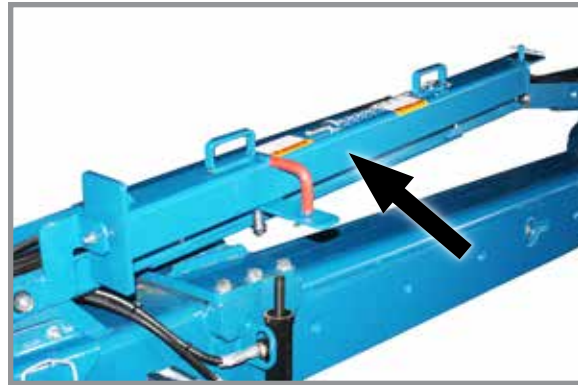

Safety lockup in storage position

3. Remove safety lockup from center lift cylinder and place in storage location on hose take-up.
4. Start up tractor. Hold rotate/tongue switch to ROTATE and operate hydraulic control to rotate planter to field position. Transport latch will automatically release.

NOTE: Center post lift is used only for folding or unfolding planter. Raising and lowering planter during field operation is performed using field lift (axle rockshaft).

5. Hold raise/wing lock switch to RAISE and operate hydraulic control to fully lower planter on center post.
6. Operate hydraulic control to raise planter using field lift.
7. Hold raise/wing lock switch to WING LOCK and operate hydraulic control to release wing locks.



Planter in field lift position



Wing lock release

- 8. Operate hydraulic control to raise planter using field lift.
- 9. Hold rotate/tongue switch to TONGUE and operate hydraulic control to fully retract tongue. Tongue latch automatically engages.



Field lift/tongue retraction

- 10. Remove row marker lockups.



Row marker lockup

FIELD OPERATION

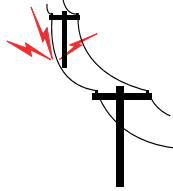
	<p>Contacting or coming close to power lines or other high energy sources will cause death or serious injury.</p>
	<p>Keep away from power lines or high energy sources at all times.</p>

	<p>Raise planter out of ground when making sharp turns or backing up or equipment damage may result.</p>
---	--

Raising and lowering planter is performed using field lift (axle rockshaft) during field operation.

NOTE: Field lift cylinders are rephasing cylinders and it is necessary to fully lower planter to rephase them. Cylinder stops can not be used.



Planting position

PLANTING SPEED

Planters are designed to operate in a speed range of 2 to 8 mph (3.2 - 12.9 kph). Higher ground speeds generally cause more variation in seed spacing. Speeds above 5.5 mph (8.8 kph) are typically not recommended.

FIELD TO TRANSPORT SEQUENCE

Position planter in a relatively flat area. Avoid areas with furrows, etc.

SUMMARIZED FIELD TO TRANSPORT SEQUENCE

1. Install row marker lockups.
2. Raise planter using field lift.
3. Extend tongue.
4. Engage wing locks.
5. Lower planter to ground.
6. Raise planter on center post.
7. Rotate planter to transport position.
8. Install safety lockup.
9. Install hitch safety pin.
10. Install transport latch locking pin.

NOTE: Read following information for detailed instructions.

1. Install row marker lockups.



Row marker lockup

2. Start tractor. Operate hydraulic control to raise planter using field lift.
3. Hold rotate/tongue switch to TONGUE and operate hydraulic control to fully extend tongue. Tongue latch automatically engages.



Field lift/tongue extension

4. Hold raise/wing lock switch to WING LOCK and operate hydraulic control to engage wing locks.
5. Operate hydraulic control to lower planter using field lift.



Wing lock engaged

6. Hold raise/wing lock switch to RAISE and operate hydraulic control to fully raise planter on center post.
7. Hold rotate/tongue switch to ROTATE and operate hydraulic control to rotate planter to transport position. Transport latch automatically engages.



Transport position



WARNING

Uncontrolled movement of equipment can cause loss of control and could result in death, serious injury, or damage to property and equipment. Install all safety pins before transporting equipment.

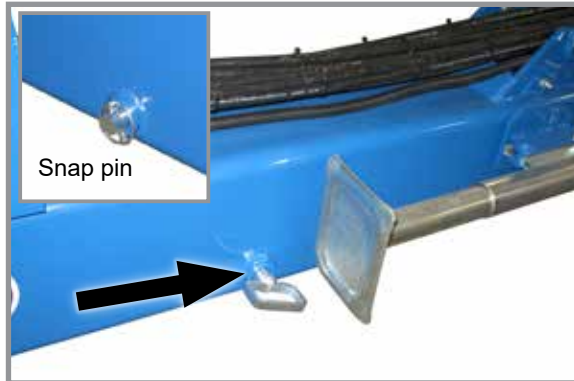

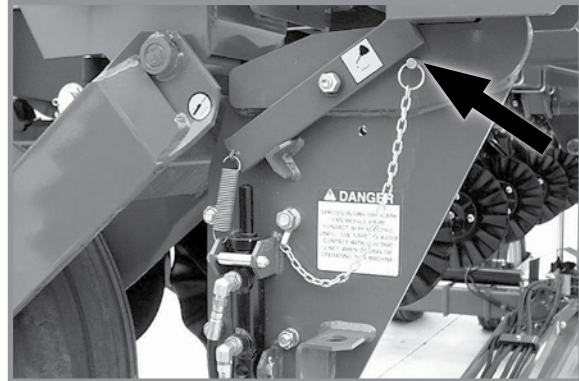

Tongue safety pin installed



Transport latch locking pin installed

8. Shut down tractor and remove safety lockup from storage location on hose take-up. Install safety lockup at center post as shown. Make sure top latch is around cylinder rod and fastened with safety pin, and that lower end is secured with detent pin.
9. Remove hitch safety pin from storage location and install in hitch.
10. Remove transport latch locking pin from storage location and install in transport latch.

TRANSPORT TO FIELD SEQUENCE USING BLUE VANTAGE**NOTICE**

Tractor must be in neutral and allowed to roll freely when unfolding to prevent equipment damage, especially in soft conditions or when loaded with seed. Use tractor assist as needed to aid in unfolding and to reduce stress on frame and transport components.

NOTICE

DO NOT fold or unfold planter without planter attached to a tractor. **DO NOT** unhitch planter from tractor unless fully folded for transport or fully unfolded with planting units lowered to ground.

**WARNING**

Improperly operating or working on this equipment could result in death or serious injury. Make sure there is no one in the area of the moving parts of the planter.

1. Remove lockups.
2. Press and hold "ROTATE TRANSPORT AXLE". Operate proper hydraulic tractor control to lower transport axle to field turnaround position.
3. Press and hold "LOWER WING WHEELS". Operate proper hydraulic tractor control to lower wing wheels into field turnaround position.
4. Press and hold "LOWER HITCH". Operate proper hydraulic tractor control to unhook the wings.
5. Press and hold "UNFOLD". Operate proper hydraulic tractor control to move wing out, away from tractor. Planter is completely unfolded when stub wings are latched into the H-frame.

Note: Place tractor in reverse and slowly reverse when unfolding to prevent damage to wheel arm.

6. Lower planter and hold hydraulic lever for an additional 30 seconds to rephase lift cylinders.
7. If equipped with row markers, remove lockups and place in storage position.
8. Lower hitch to level machine during planting.

VACUUM SYSTEM

Kinze vacuum seed metering system includes seed meters, seed discs, and an air system consisting of a hydraulic driven vacuum fan which draws air through manifolds, hoses, and seed meters on each row unit.

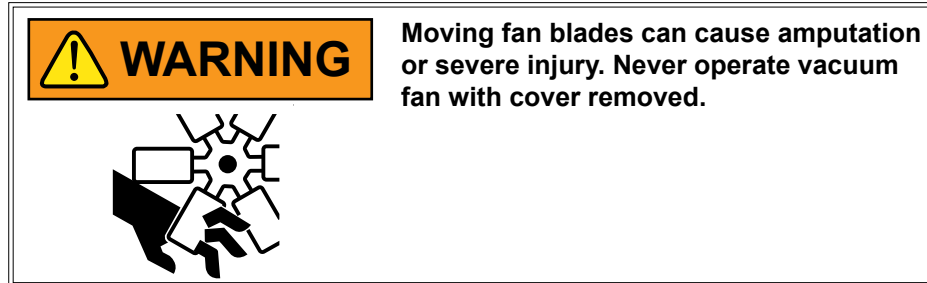

DIGITAL VACUUM READOUT

Digital vacuum readout is incorporated into in-cab display. Refer to the in-cab display operation manual for instructions.

VACUUM FAN AND BULK FILL MOTOR VALVE BLOCK ASSEMBLY

A PWM valve is incorporated into the vacuum system to control fan speed with Blue Drive equipped planters.

Refer to [“Hydraulic Schematic - Vacuum Fan Motor System” on page 6-108](#) in Lubrication and Maintenance section.

Valve block contains a check valve that prevents vacuum fan from operating in wrong direction if pressure is applied to return side of motor and allows fan to coast to a stop when tractor hydraulic control is returned to neutral position.

NOTE: Fan turns at a reduced speed if reverse pressure is applied.

ANALOG VACUUM OR PRESSURE GAUGE

Analog vacuum or pressure gauge connects directly to vacuum meter (vacuum) or bulk fill (pressure) manifold and is teed into digital sending units.

Only adjustment is to “zero” needle with no vacuum or pressure present. If there is a significant difference between gauge and a reading taken at meters, a different manifold location should be found to connect hose to gauge and digital sending unit.

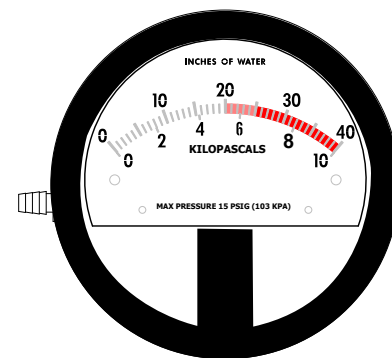

Analog Gauge

NOTE: Analog gauges are identical EXCEPT for plug and hose barb locations in side of gauge housing. DO NOT connect vacuum meter or bulk fill hose to wrong gauge. Check plug and hose barb installation if readout is erratic or appears inaccurate.

BULK FILL SYSTEM



Seed flying out of disconnected delivery tube at high velocity can cause injury. Do not disconnect delivery tubes when system is operating.

NOTICE

Foreign materials can plug system. Make sure seed is clean and free of debris when filling bulk fill hoppers.

NOTICE

Do not turn on system with tractor engine at full speed or system damage may occur.

NOTICE

Do not operate bulk fill system above maximum system operating pressure of 20 inches of water or seed bridging may occur.

1. **Before filling hoppers refer to [“Transport to Field Sequence Using Blue Vantage”](#) on page 2-23 for **additives information**.** Fill hoppers with seed, latch lids, and secure with pin.

2. Start bulk fill system with tractor engine at idle.

3. Increase engine speed to full and set initial system pressure using flow control valve.

Note: For models equipped with True Depth hydraulic down force tied into the bulk fill circuit, set the tractor’s control valve (SCV) to 100%. Then use the Flow Control Valve mounted on the RH front side of the tool bar to set the desired bulk fill pressure.

4. Allow system to warm up and adjust pressure if necessary.



Bulk Fill Lid



Flow Control Valve (True Depth)

Recommended pressures:

- Corn – 12 inches of water
- Soybeans – 10 inches of water
- Actual pressure needed is affected by seed size, shape, and coating.

BULK FILL ENTRAINER ACCESS

1. Shut down bulk fill system.
2. Loosen wing nut and turn retainer holding shutoff door in its storage location.
3. Remove rubber plug closest to area in entrainer needing attention.
4. Insert shutoff door into open slot and push into entrainer at a slight upward angle.
5. When work is complete, remove shutoff door, return door to storage location, and plug open slot.

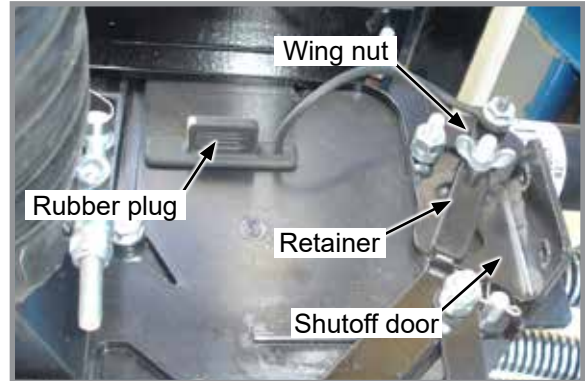

Bulk fill entrainer (end view)

BULK FILL TANKS - CLEAN OUT

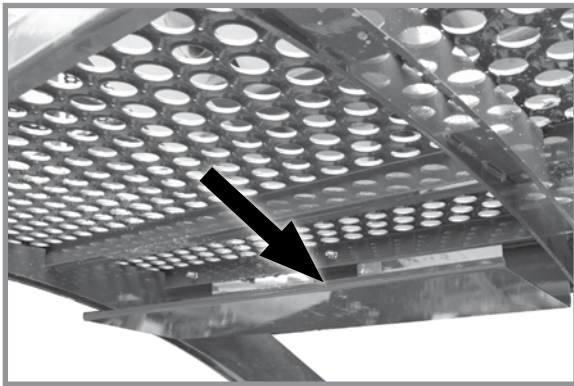

Cleanout chute storage bracket

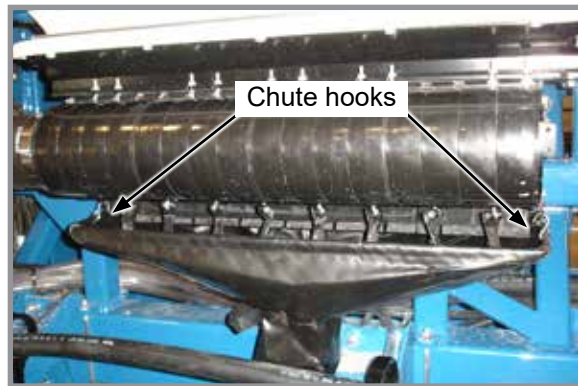

Cleanout chute installed

1. Remove bulk fill tank cleanout chute from storage location beneath catwalk.
2. Position tube of chute under entrainer and attach hooks on each end of entrainment assembly.
3. Open cleanout doors and empty tank.
4. Close all cleanout doors and return cleanout chute to storage location.

BULK FILL SCALE PACKAGE OPTION (2021 PRODUCTION ONLY)

NOTICE

High-pressure water can damage display. Remove display before power washing planter.

NOTICE

Remove and store display at end of planting season. Damage from sun and weather exposure may result.

- Provides seed weight or estimated acres remaining for each bulk fill hopper.
- Displays total (gross) seed weight or estimated acres remaining for both hoppers combined.
- Warns operator when seed goes below a pre-defined level (when using a Kinze Vision display).

Operation of bulk fill Scale Package display is controlled by buttons located on its face:

- Two screen-defined selection buttons.
- Backlight ON/OFF button.
- UP/DOWN arrow buttons.
- Screen position is changed by loosening thumb screw on mount at back of monitor and repositioning screen.

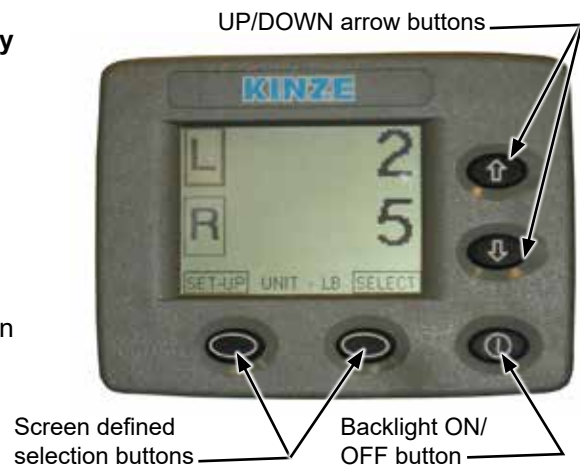

SETUP BULK FILL SCALE PACKAGE DISPLAY

1. Press SET-UP button.
2. First setup screen displays and ALARM LEVEL box is highlighted.
3. Press SELECT button.
4. Press UP or DOWN arrows to change alarm weight level. Select BACK to save changes.
5. Press UP or DOWN arrows to highlight WEIGHT/ACRE MODE box. Press SELECT button.
6. Press UP or DOWN arrow buttons to toggle between weight or acre mode. This selection affects if values are displayed as pounds or estimated acres of seed remaining. Press BACK to save changes.



- Press DOWN arrow to select second set-up screen.

NOTE: CALIBRATION# and SETUP# are automatic and do not need to be changed.

- Select CONTRAST or BACKLIGHT. Use UP or DOWN arrow buttons to change levels. Press BACK to save changes.
- Select BACK to return to main screen.



MONITOR SEED LEVELS

- Main screen displays information for left and right hoppers.
- Select either L or R for individual hopper status information.
- Select BACK to return to main screen.
- Press down arrow once or twice for GROSS screen to appear. This provides combined status information for both hoppers.
- Press down arrow again to return to main screen.



ENTER SEED INFORMATION

- Highlight and select either L (left) or R (right) for the appropriate input screen.
- At input screen, L or R side is indicated at left side of screen and seed weight or acres remaining is on right side.



- Press arrow keys to select desired box; press SELECT to darken and use arrow keys to change.

NOTE: Seed information entered must be accurate for remaining estimated acres to calculate correctly.

- SEEDS/ACRE is population rate.
- SEEDS/LB value comes from seed specifications.
- ZERO is selected to zero hopper that is selected.

- Select BACK to return to main screen.



BULK FILL SCALE PACKAGE OPTION (2022 PRODUCTION AND ON)**NOTICE**

High-pressure water can damage display. Remove display before power washing planter.

NOTICE

Remove and store display at end of planting season. Damage from sun and weather exposure may result.

Bulk Fill Scale Package is capable of:

- Displaying seed weights and estimated acres remaining for bulk fill hoppers separately.
- Setting alarm to warn operator when seed goes below a pre-defined level.

NOTE: Operation of Bulk Fill Scale Package display is controlled by touchscreen.

NOTE: Screen position is changed by loosening the thumb screw on RAM™ mount.

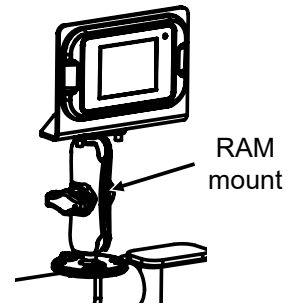

To monitor seed levels (Main Screen):

NOTE: Only applicable to Ag Leader InCommand, refer to Blue Vantage manual for bulk fill scale user information.

1. Main screen displays information for left and right hoppers.
2. Tap "Weight" to display left and right hopper weight.
3. Tap "Area to Empty" to display left and right acres to empty.



4. Tap either "L" or "R" to display detailed hopper screen.

NOTE: "Zero" is selected to zero hopper that is selected. If hopper(s) is zeroed out with seed, weight in hopper will not be recognized. To reset hopper correctly seed must be emptied from hopper(s) and then zeroed to reset.



5. Tap "Back" to return to main screen.
6. Tap "Planter Setup" to enter Seed information. See follow page for more information.

To enter seed information (Not applicable on Blue Vantage):

NOTE: Seed information entered must be accurate for remaining estimated acres to calculate correctly.

- SEEDS/ACRE is population rate.
- SEEDS/LB value comes from seed specifications.

1. From main screen, tap "Planter Setup".
2. From planter setup screen, tap "Seed Setup".

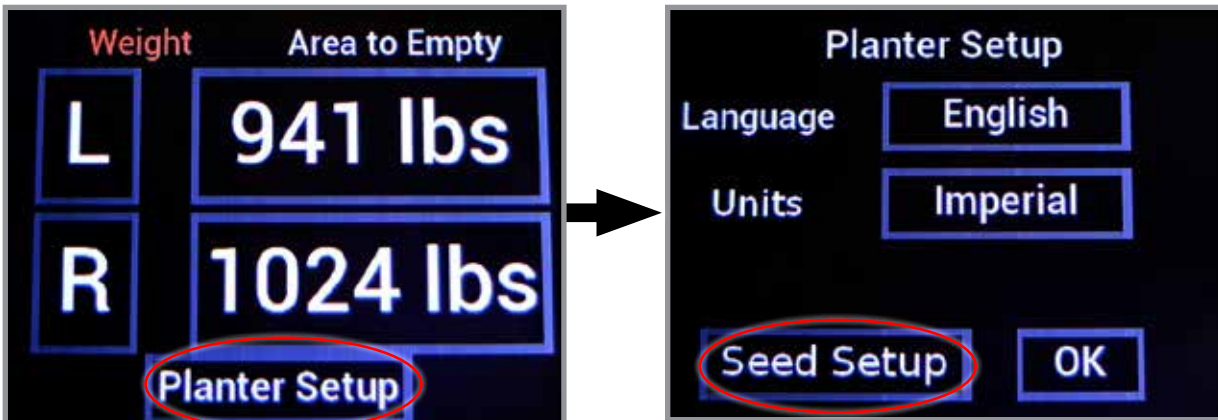

3. To change values in either "Seeds/Ac", "Seeds/lb", or "Alarm Level" tap in appropriate box.
4. At input screen, enter desired value. Tap "OK".



5. Once desired values have been entered tap "OK", to confirm changes tap "Accept" to return to main screen.

NOTE: It is NOT RECOMMENDED to make adjustments to setup in the "Scale Setup" screen.

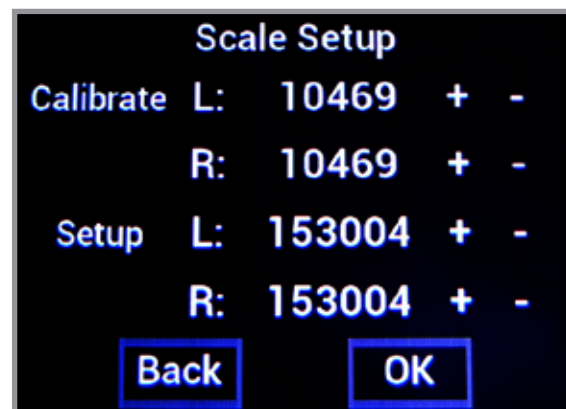

Software Version:

1. From main screen, tap "Planter Setup".
2. Tap on "English" to display software version.

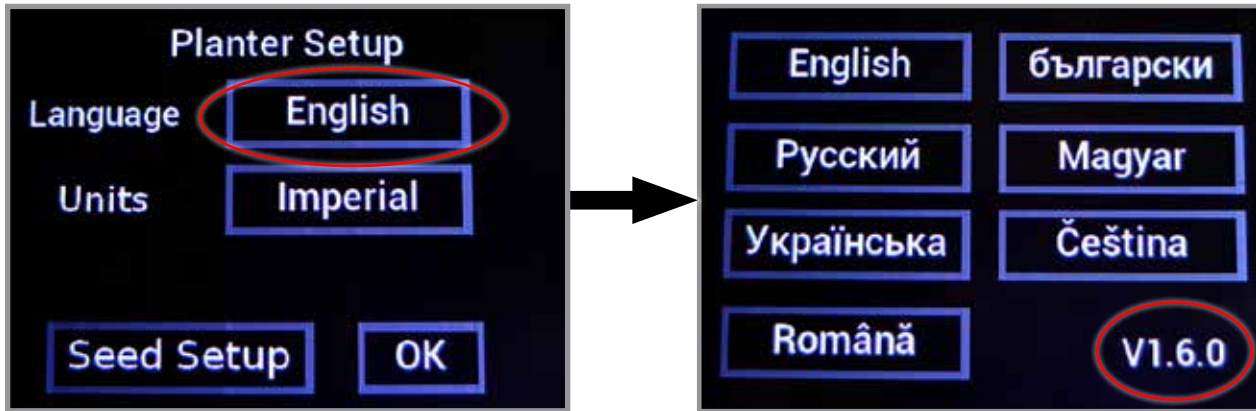

4. Tap "English" to return to planter setup screen.
3. Tap "OK" to return to main screen.

Language/Units:

NOTE: English is the default language. Imperial is the default units.

1. From main screen, tap "Planter Setup".
2. Tap on "English" to display language options.

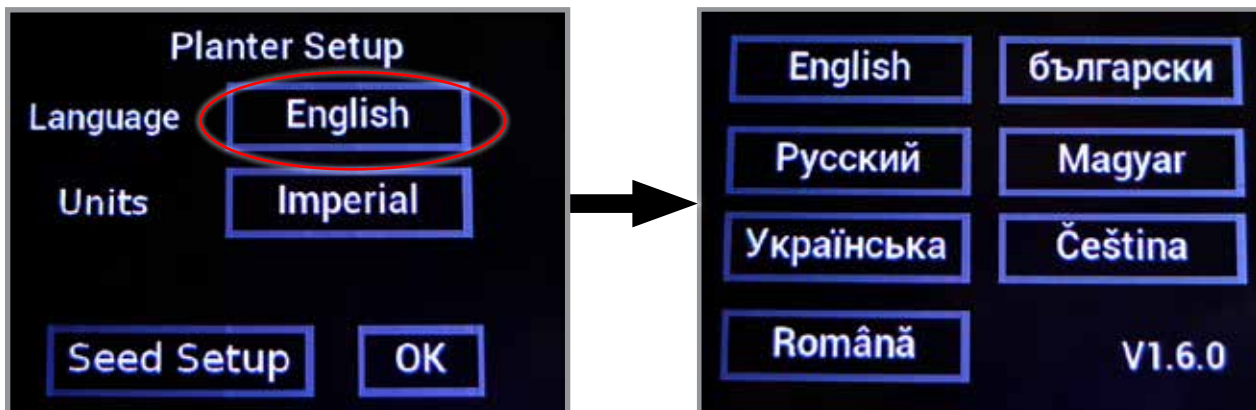

3. Tap on desired language to select and return to planter setup screen.
4. Tap on "Imperial" to switch to metric units and vice versa.

NOTE: If units are switched back and forth between imperial and metric, measurements will round up each time.

3. Tap "OK" to return to main screen.

AG LEADER MONITORING CONTROL (PMM)

The PMM Magnetic Distance Sensor Package includes a planter-mounted module enclosure with cover and mounting hardware, seed tubes w/sensors, planter harness, planter monitor cable, shaft rotation sensors and magnetic distance sensor components.

Ag Leader Integra display and associated cab harnesses are also required.



Planter monitor module (PMM)

BLUE DRIVE AUX MOUNT

The Blue Drive aux mount houses all modules for controlling vacuum, bulkfill, fold, and various sensors. The intelligent planter router is also housed at this location.



AG LEADER INCOMMAND 1200 DISPLAY

The InCommand 1200 is a full-featured display for any precision farming operation. A large, full-color 12.1" HD touchscreen display is easy to read and offers powerful, year-round precision farming tools. Mapping, planter and application control, yield monitoring, real-time data logging, and more – are all controlled from the cab using the InCommand display.

Four video camera inputs provide operators a better view of equipment operation and safety by allowing them to view live video on the display.

NOTE: See InCommand operator manual for installation and programming.



Ag Leader InCommand Display

KINZE ISOBUS OPTION

Kinze ISOBUS option consists of a planter monitor module (PMM), and planter control module (PCM). Kinze planters will communicate directly with most ISO compatible monitors. See the Kinze ISOBUS manual for more information.

AUXILIARY WORK LIGHTS PACKAGE

Auxiliary work lights package includes four LED lights with brackets and hardware to mount two lights on center lift cylinder and one on each wing. The provided wiring harness plugs into existing planter light harness.

Lights are controlled by the work light switch on control console.

If the planter is equipped with Blue Drive refer to M0288 - Kinze Blue Vantage Operator's Manual for work light control.

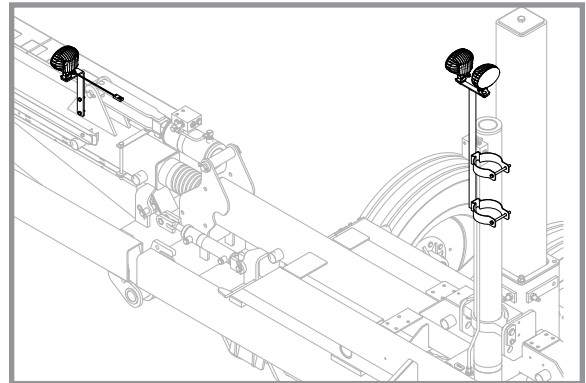

Auxiliary work lights
(Additional light mounted on opposite wing)

KINZE TRUE DEPTH DISPLAY

Kinze True Depth provides on demand row by row hydraulic row unit down force ranging from 100 lbs. up force to 600 lbs. down force at 2350 psi. The system includes a 7" in cab standalone screen display with antiglare screen protector and RAM mount, electronic control modules, harnesses, gauge wheel sensors, hydraulic cylinders, upper and lower cylinder mounts, and valves.

NOTE: See True Depth Operator's Manual for system operation and programming.



Kinze True Depth Display

KINZE BLUE VANTAGE

Blue Vantage can be ready to plant in three taps after proper setup. The health screen provides all critical planting parameters and controls. The grower can observe row-by-row planting performance in real-time.

NOTE: See Kinze Blue Vantage Operator's Manual for system operation and programming.



Kinze Blue Vantage

ROW MARKER OPERATION (HYDRAULIC DRIVE ONLY)

DANGER

Contacting or coming close to power lines or other high energy sources will cause death or serious injury.

Keep away from power lines or high energy sources at all times.

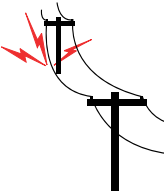



Marker switch



Row marker solenoid valves

Two solenoid valves on valve block at rear R.H. side of center frame, and a three position selector switch on control console permit operator to lower or raise desired row marker.

NOTICE

Marker position switch must be OFF when planter is not in use or tractor battery will drain.

See ["Row Marker Speed Adjustment" on page 2-36.](#)

If the planter is equipped with Blue Drive refer to M0288 - Kinze Blue Vantage Operator's Manual for marker control.

1. Select which row marker to lower on control console.
2. Operate hydraulic control to lower row marker.
3. Move control switch to other side to operate opposite row marker.
4. Raise row marker at end of field using hydraulic control.
5. After turn, using the hydraulic control, lower the pre-selected row marker.
6. Continue to follow this procedure.

NOTE: Both row markers can be lowered by operating switch in each position and hydraulic control twice. Row markers raise simultaneously with hydraulic control in raise position.

If electrical system does not operate properly:

- Check fuse.
- Check wiring connections.
- Check control switch.
- Check solenoid. SOLENOID HOUSING IS MAGNETIZED WHEN ENERGIZED.

ROW MARKER SPEED ADJUSTMENT

NOTICE

Excessive row marker travel speed can damage row markers. Adjust flow controls before row markers are first used.

Marker hydraulic system includes two flow control valves. One flow control valve sets lowering speed and one sets raising speed of both markers. Flow controls determine amount of oil flow restriction through valves, varying marker travel speed.

Loosen jam nut and turn control clockwise, or IN to slow travel speed. Turn counterclockwise, or OUT to increase travel speed. Tighten jam nut after adjustments are complete.

NOTE: Tractors with flow control valves. Make row marker speed adjustment with tractor flow controls in maximum position. After row marker speed is set, adjust tractor flow controls to allow hydraulic control to stay in detent during marker raise or lower cycle.

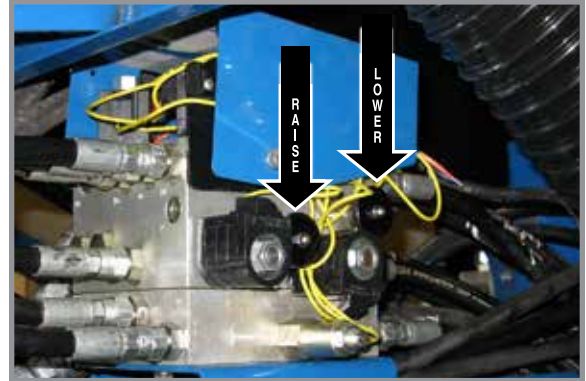

Row marker speed control adjustment

NOTE: Hydraulics operate slowly when oil is cold. Make all adjustments with oil warm.

NOTE: On a tractor where oil flow cannot be controlled, tractor flow rate may be greater than rate marker cylinder can accept. Hold tractor hydraulic control lever until cylinder reaches end of its stroke. This occurs most often on tractors with an open center hydraulic system.

EVEN-ROW PUSH ROW UNIT

An Even-Row Push Row Unit Package is available to add one additional push row unit on outer L.H. side of front toolbar for use with Solid Row Interplant Package.

NOTE: See [“Row Marker Adjustments” on page 2-37](#) for determining correct length to set row marker assemblies when planting with even-row push row unit option.

An inner hitch with a 7½" offset mount is available from Kinze through your Kinze Dealer to plant two 15" rows between last year's 30" rows and avoid tire damage from stalks by driving off row

NOTE: install hitch onto 2-point hitch bar using R.H. hole if 2-Point Hitch Option is used. A 7½" offset mount is not needed. See “Offset Hitch Adjustment” for additional information.

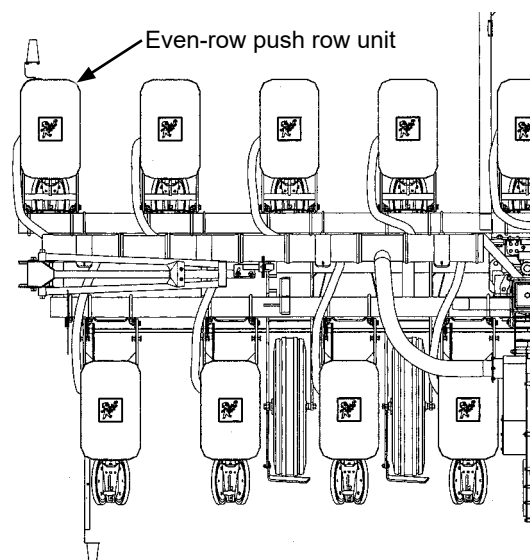

ROW MARKER ADJUSTMENTS

1. Multiply number of rows by the average row spacing in inches to determine total planting width.

Row Marker Lengths	
12 Row 30"	360" (914.4 cm)
16 Row 30"	480" (1219.2 cm)

2. Lower planter and row marker assembly to ground.
3. Measure from planter center line to a point where blade contacts ground.
4. Adjust row marker extension so distance from marker disc blade to center line of planter is equal to total planting width. Adjust right and left row marker assemblies equally and securely tighten clamping bolts.

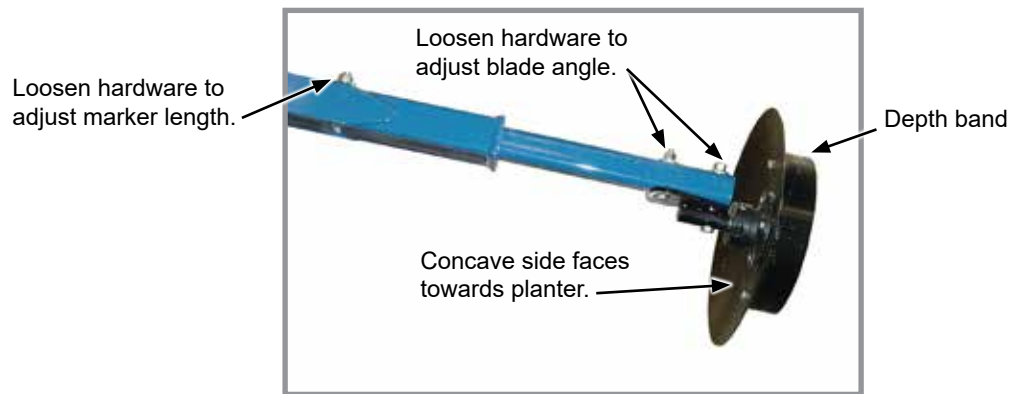

Row marker disc blade angle adjustment

NOTICE

Setting marker disc blade assembly at a sharper angle than needed adds stress to row marker assembly and shortens bearing and blade life. Set blade angle only as needed to leave a clear mark.

Marker disc blade is installed with concave side facing inward. Spindle assembly is slotted so hub and blade can be angled to throw more or less dirt.

5. Loosen hardware and move assembly as required.
6. Tighten bolts to specified torque.
7. Do a field test to ensure markers are properly adjusted.

NOTE: A notched marker blade is available from Kinze through your Kinze Dealer for use in more severe no till conditions.

ROW MARKER EVEN-ROW LENGTH ADJUSTMENT

Adjust marker extensions as shown below when using even-row push row unit option.

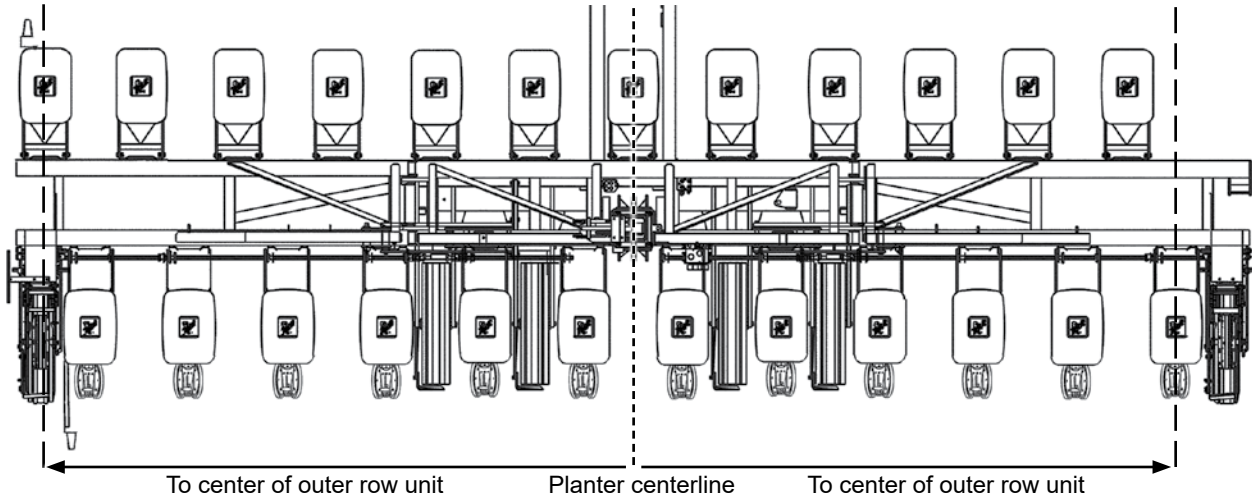

Center Of Planter To Center Of Outer Row Unit x 2 + 15" Row Spacing = Dimension Between Planter Center Line And Marker Blade

- 12 Row 30" With 12 Interplant Push Row Units
(L.H. Marker 180" x 2 + 15" = 375")
(R.H. Marker 165" x 2 + 15" = 345")
- 16 Row 30" With 16 Interplant Push Row Units
(L.H. Marker 240" x 2 + 15" = 495")
(R.H. Marker 225" x 2 + 15" = 465")

NOTE: Readjust row markers when planting 30" rows.

Number Of Rows x Row Spacing (Inches) = Dimension Between Planter Center Line And Marker Blade

12 Rows x 30" Spacing = 360" Marker Dimension
16 Rows x 30" Spacing = 480" Marker Dimension

OFFSET HITCH ADJUSTMENT

An offset hitch is available from Kinze through your Kinze Dealer. Offset hitch provides centered and offset mounting positions for hitch clevis.

If tractor hitch is offset 7½" right of tractor center line, add 7½" to marker dimension on R.H. side of planter and subtract 7½" from marker dimension on L.H. side of planter.

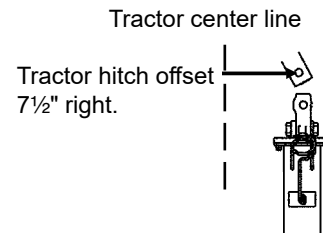

POINT ROW CLUTCHES

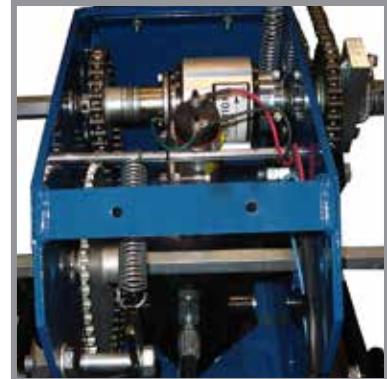
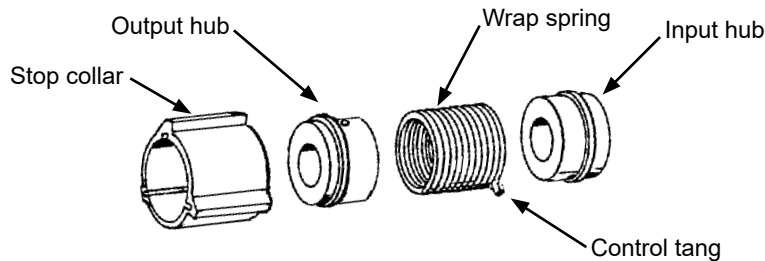

Point row clutch

Electric-activated clutches disengage drive on either half of planter for finishing up fields or for long point row situations. Clutch selector switch is located on tractor control box.

NOTE: Liquid fertilizer piston pump has its own drive wheel and is not affected by point row clutch.

Clutch consists of a wrap spring riding on an input and output hub. Wrap spring is wrapped tightly over hubs during operation locking them together. Higher speeds create a tighter grip of spring on hubs.



Input end of spring is bent outward and is called the control tang. Control tang fits into a slot in stop collar located between input and output hubs over wrap spring. If stop collar is allowed to rotate with input hub, clutch is engaged. If stop collar is stopped from rotating, control tang connected to it is forced back and spring opens. This allows input hub to continue rotating without transmitting torque to output hub, stopping planter drive.

Stop collar is controlled by an electric solenoid and an actuator arm. When selector switch on tractor control box is OFF, solenoid coil is NOT ENERGIZED and actuator arm will not contact stop on stop collar, allowing it to rotate with hubs and drive planter.

When "DISENGAGED" solenoid coil IS ENERGIZED and plunger in solenoid coil pulls actuator arm against stop on stop collar, disengaging wrap spring and stopping planter drive.

AUXILIARY HYDRAULIC OPTION

A customer-supplied auxiliary hydraulic option may be added to provide 10 gpm of oil flow at rear of planter. It is designed for powering bulk seed handling equipment when planter is not in motion and is controlled by the same tractor hydraulic control as the seed rate hydraulic drive.

 <p>WARNING</p>	<p>Pressurized hydraulic fluid can penetrate body tissue and result in death, serious infection, or other injuries. Fluid injected under skin must be IMMEDIATELY removed by a surgeon familiar with this type of injury. Make sure connections are tight and hoses and fittings are not damaged before applying system pressure. Leaks can be invisible. Keep away from suspected leaks. Relieve pressure before searching for leaks or performing any system maintenance.</p>
	

<p>NOTICE</p>	<p>Make sure MASTER switch is OFF on Kinze Vision or Cobalt display and planter is not in motion when using auxiliary hydraulic circuit.</p>
----------------------	--

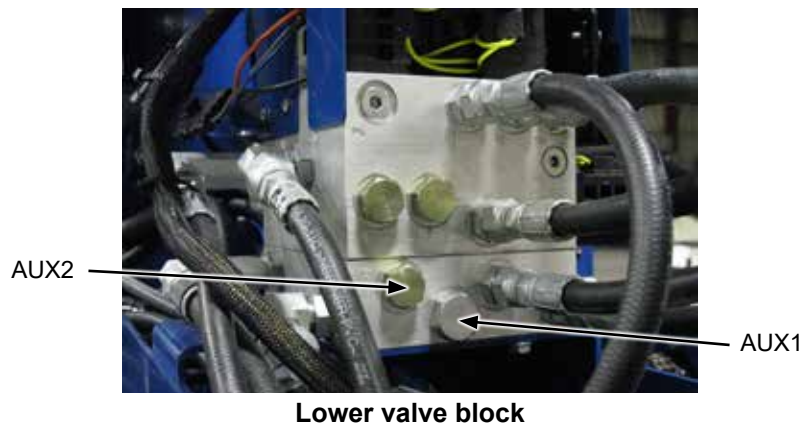

Customer-supplied hoses, fittings, and hydraulic outlets are added to ports AUX1 and AUX2 on lower valve block on back side of planter. Refer to “Hydraulic System Schematics” in the Lubrication and Maintenance section for additional information.

NOTE: The Auxiliary Hydraulic Option is not useable with True Depth System.

REAR TRAILER HITCH

Rear trailer hitch can tow a 3 or 4 wheel wagon behind planter. A spring, chain, and mounting bracket supports a 1¼" feed hose from hitch to piston pump. This extra length or loop is required to allow for planter to move into transport position without stretching hose.



Trailer hitch

NOTICE	<p>Rear trailer hitch is designed for use with piston pump only. Maximum allowable hitch weight is 200 lb (90.71 kg). Do not exceed 6,000 lb (2,721.55 kg) gross towing weight or the equivalent of a loaded 500 gal (1,892.7 L) tank and running gear or equipment can be damaged.</p>
---------------	---

NOTE: Periodically check feed hose for kinks to prevent restricted delivery rate.

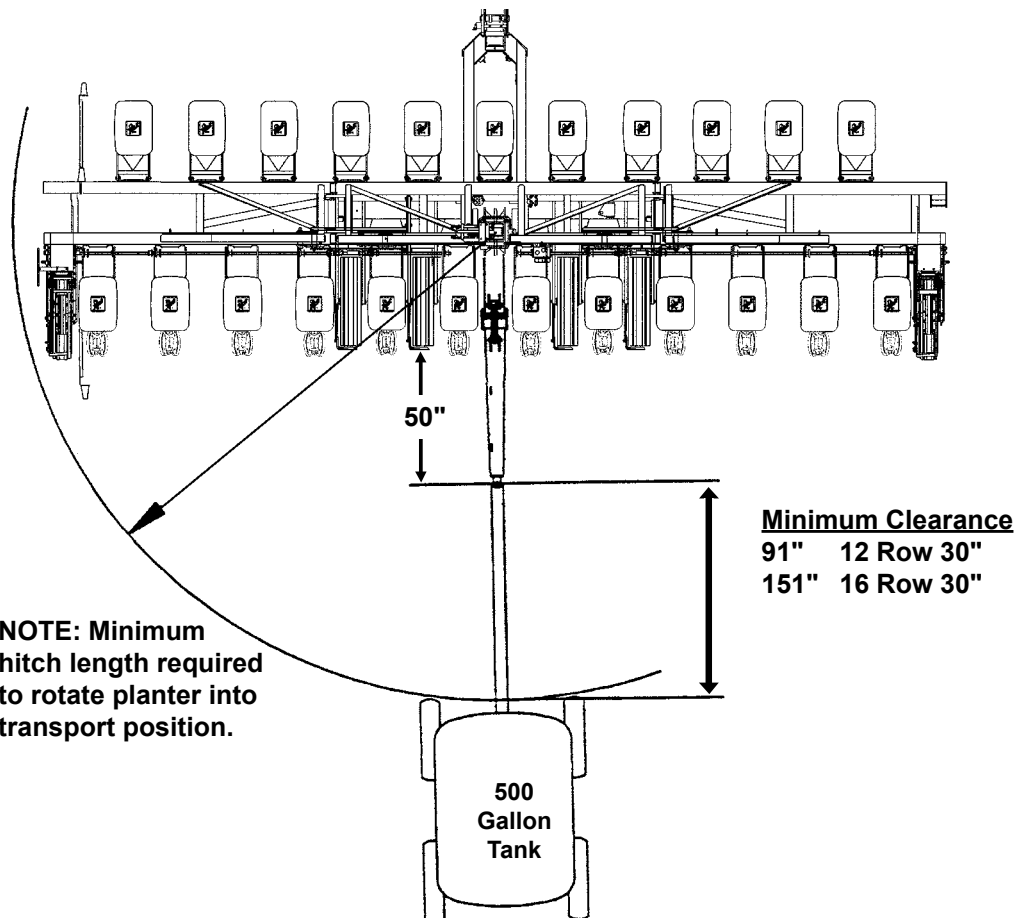

NOTE: Minimum hitch length required to rotate planter into transport position.

FIELD TEST

Perform a field test with any change of field and/or planting conditions, seed size or planter adjustment to ensure proper seed placement and operation of row units.

- Check planter for front to rear and lateral level operation. See “Level Planter”.
- Check **all** row units to be certain they are running level. Row unit parallel arms should be approximately parallel to the ground when planting.
- Check row markers for proper operation and adjustment. See “Row Marker Adjustment” and “Row Marker Speed Adjustment”.
- Check for proper application rates and placement of granular chemicals on **all** rows. See “Field Check Granular Chemical Application”.
- Check for desired depth placement and seed population on **all** rows. See “Field Check Seed Population”.
- Check for proper application rates of fertilizer on **all** rows. See “Fertilizer Application Rate Chart”.

Reinspect machine after field testing.

- Hoses And Fittings
- Bolts And Nuts
- Cotter Pins And Spring Pins
- Drive Chain Alignment

FIELD CHECK SEED POPULATION

1. Tie up one or more sets of closing wheels by running a chain or rubber tarp strap between the hopper support panel and closing wheels. It may be necessary to decrease closing wheel arm spring tension.

Chain, rubber tarp strap, or similar.

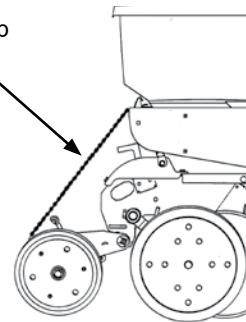

2. Plant a short distance and check to see if seed is visible in the seed trench. Adjust planting depth to a shallower setting if seed is not visible and recheck.

Planting depth adjustment handle

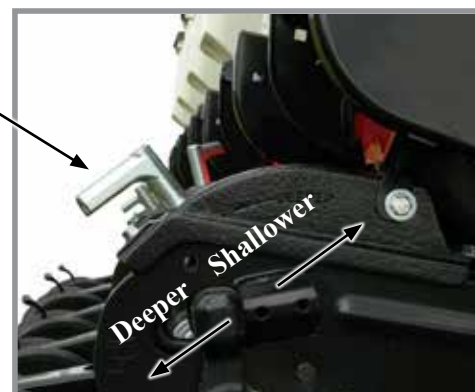

Planting depth adjustment

3. Measure $\frac{1}{1000}$ of an acre. See chart for correct distance for row width being planted. For example, if planting 30" rows $\frac{1}{1000}$ of an acre would be 17' 5".

$\frac{1}{1000}$ Acre Seed Population Count Row Width/Distance						
Row Width	15"	18"	19"	30"	36"	38"
Distance	34'10"	29'0"	27'8"	17'5"	14'6"	13'10"

NOTE: Seeds may bounce or roll when planting with closing wheels raised and planting depth set shallow affecting seed spacing accuracy.

4. Count seeds in measured distance.
5. Multiply number of seeds placed in $\frac{1}{1000}$ of an acre by 1000. This gives total population.

EXAMPLE: 30" row spacing 17' 5" equals $\frac{1}{1000}$ acre.
 26 seeds counted x 1000 = 26,000 seeds per acre

Seed count can be affected by drive wheel and seed meter drive ratio, tire pressure, and/or seed meter malfunction.

1. If seed check shows average distance between seeds in inches is significantly different than seed rate chart indicates, first check drive ratio between drive wheel and seed meter. Check drive wheel air pressure, check for incorrect sprocket(s) in driveline and check drive and driven sprockets on transmission(s) for proper selection.
2. Check for seed meter malfunction. For example, if spacing between kernels of corn at the transmission setting being used is 8" and a gap of 16" is observed, a finger has lost its seed and not functioned properly. If two seeds are found within a short distance of each other, finger has metered two seeds instead of one.
3. See ["Seed Meter \(Finger Pickup\)" on page 7-8](#) or ["Seed Meter \(Brush-Type\)" on page 7-5](#) in Troubleshooting Section of this manual.

DETERMINING POUNDS PER ACRE (BRUSH-TYPE METER)

Seeds per acre \div Seeds per pound (from label) = Pounds per acre

If seeds per pound information is not available use the following averages:

2,600 seeds per pound for medium size soybeans
 15,000 seeds per pound for medium size milo/grain sorghum
 4,500 seeds per pound for medium size cotton

DETERMINING BUSHELS PER ACRE

Pounds per acre \div Seed unit weight = Bushels per acre



Average Unit Weight of:

1 Bushel Soybeans = 60 Pounds
 1 Bushel Milo/Grain Sorghum = 56 Pounds
 1 Bushel Cotton = 32 Pounds

If seed population check shows planting rate is significantly different than seed rate chart shows or if a particular meter is not planting accurately, see "Brush-Type Seed Meter Maintenance" and "Seed Meter (Brush-Type) Troubleshooting".

FIELD CHECK GRANULAR CHEMICAL APPLICATION

Temperature, humidity, speed, ground conditions, flowability of different material, or meter obstructions can affect granular chemical rate of delivery.

 <p>WARNING</p>	<p>Agricultural chemicals can cause death or serious injury to persons, animals, and plants or seriously damage soil, equipment, or property. Read and follow all chemical and equipment manufacturers labels and instructions.</p>
	

Perform a field check to determine application rates.

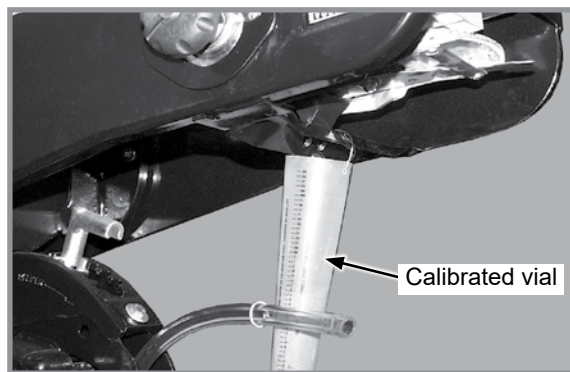

Granular chemical field check

1. Fill insecticide and/or herbicide hoppers.
2. Attach a calibrated vial to each granular chemical meter.

NOTE: Disengage clutch to avoid dropping seed during test.

3. Lower planter and drive 1320 feet at planting speed.
4. Weigh chemical in ounces caught in one vial.
5. Multiply that amount by factor shown to determine pounds per acre.

Pounds Per Acre	
Row Width	Factor
30"	.83
36"	.69
38"	.65

EXAMPLE: You are planting 30" rows. You have planted for 1320 feet at desired planting speed. You caught 12.0 ounces of chemical in one vial. 12.0 ounces times 0.83 equals 9.96 pounds per acre.

NOTE: Check calibration of all rows.

METERING GATE

Use metering gate setting as a starting point for distributing insecticide or herbicide. Charts are based on 5 mph (8 kph) planting speed. Use a higher gate setting for speeds faster than 5 mph (8 kph) and a lower setting for speeds slower than 5 mph (8 kph).

PLANTING DEPTH

Planting depth is maintained by adjustable row unit gauge wheels. Depth adjustment range is approximately ½" to 3½" (1.2 to 8.8 cm).

1. Raise planter to remove weight from wheels.
2. Push down on depth adjustment handle and reposition it forward to decrease or rearward to increase planting depth. Initially adjust all units to the same setting.
3. Lower planter and check operation and planting depth of all row units. Readjust individual rows as needed for uniform operation.

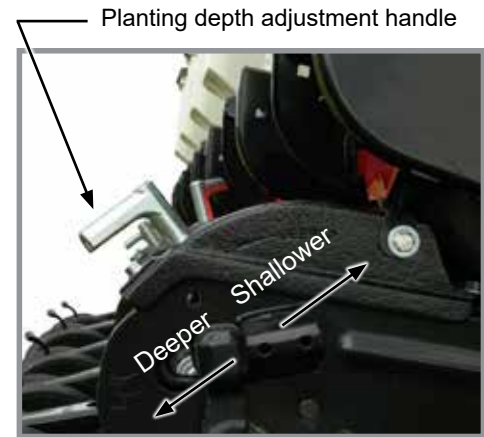

Planting depth adjustment

“V” CLOSING WHEEL ADJUSTMENT (RUBBER OR CAST IRON)

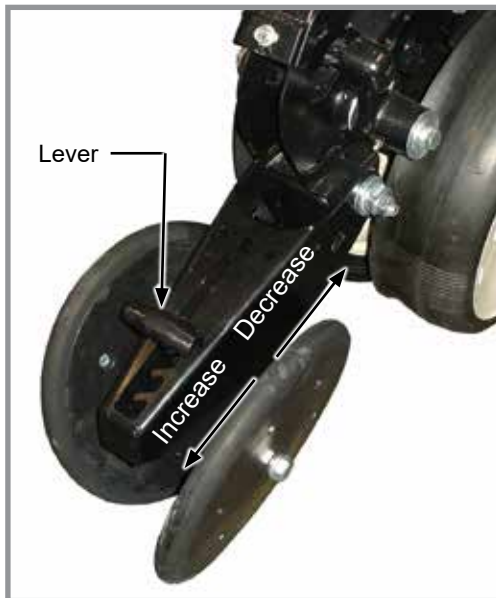

“V” Closing wheels installed offset

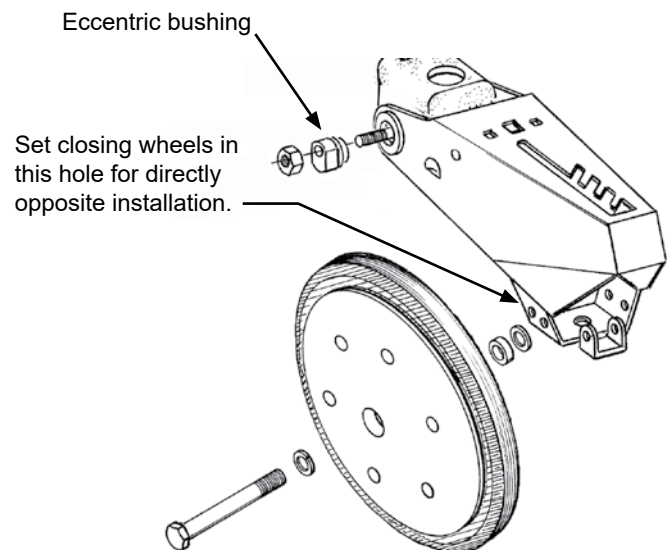

“V” closing wheels should have enough down pressure to close the seed trench and ensure good soil to seed contact. Move 5-position quick adjustable down force lever on the top of closing wheel arm to the rear to increase closing wheel spring pressure. Move lever forward to decrease pressure. Adjust all row units to a similar setting. Light soil usually requires less down force at average depth, approximately 2" (5 cm) while heavy soil requires increased down force.

Eccentric bushings in the wheel arm stop allow for lateral adjustment of the “V” closing wheel assembly. Use a ¾" wrench to loosen hardware attaching closing wheel arm to wheel arm stop. Use another ¾" wrench to turn eccentric bushings until **closing wheels are aligned with seed trench**. Tighten hardware.

Closing wheels can be installed “offset” (to improve residue flow) or “directly” opposite. Use forward installation holes if set “directly” opposite.





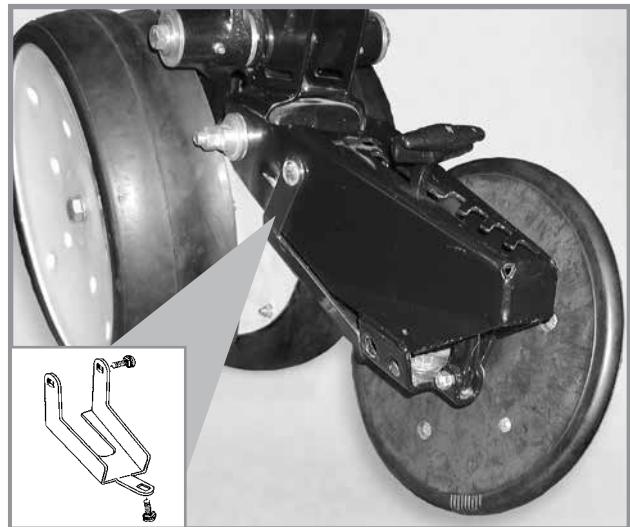



CLOSING WHEEL SHIELD (RUBBER OR CAST IRON "V" CLOSING WHEELS)

Optional closing wheel shield is installed on underside of closing wheel arm to help prevent root balls and stalks from clogging closing wheels.



**Closing wheel shield
(Shown with closing wheel removed)**

BRUSH-TYPE SEED METER 2.0

Crop		Disc Color-Code (Disc Part No.)	Upper Brush Retainer	Cells	Seed Size Range	*Lubricant
	Soybean	Black (GB1123)	GB1084	60	2200 to 4000 seeds/lb.	Graphite Talc
	Soybean	Dark Gray (GB1171)	GB1084	54	2000 to 3000 seeds/lb.	Graphite Talc
	Specialty Soybean	Dark Blue (GB1124)	GB1084	48	1400 to 2200 seeds/lb.	Graphite Talc
	Small Milo/Grain Sorghum	Orange (GB1130)	GB1107	30	14,000 to 20,000 seeds/lb.	Talc
	Large Milo Grain Sorghum	Light Blue (GB1131)	GB1107	30	10,000 to 16,000 seeds/lb.	Talc
	High-Rate Small Milo/Grain Sorghum	Red (GB1132)	GB1107	60	12,000 to 18,000 seeds/lb.	Talc
	High-Rate Large Milo/Grain Sorghum	Yellow (GB1133)	GD8237	60	10,000 to 14,000 seeds/lb.	Talc
	Wheat	Purple (GB1134)	GB1084	54	N/A Volumetric	Graphite Talc

*For More information on application rate see Additives section.

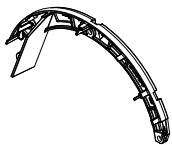

Use GB1084 upper brush retainer when using wheat and soybean discs.



Use GB1107 milo insert when using milo/ grain sorghum discs.

Turn seed disc counterclockwise when installing on meter hub while tightening two wing nuts that retain disc. Seed disc should have slight resistance when rotated counterclockwise after wing nuts are tight.

Brush-type seed meter attaches to seed hopper same as finger pickup seed meter. Secure to bottom of seed hopper with two $\frac{5}{16}$ " thumbscrews. Tighten thumbscrews slightly with pliers. DO NOT OVER TIGHTEN.

Misalignment between drive coupler and seed meter input shaft may cause erratic seed spacing from momentary stoppage of seed disc. Check alignment and adjust as needed.

Refer to planting rate charts in this manual for recommended seed drive transmission sprocket combinations.

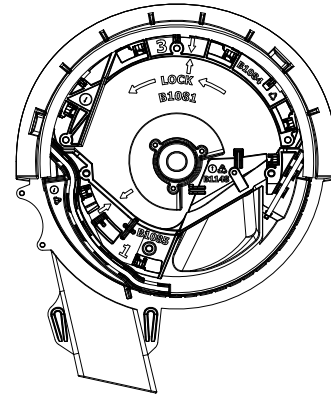

Shown without seed disc installed



NOTICE

Replace hopper lids after hoppers are filled to prevent accumulation of dust or dirt in seed meter which will cause premature wear.

NOTE: Clean seed is required to ensure accurate seed metering from brush-type seed meters. Remove seed discs daily and check seed meter or brushes for buildup of foreign material, such as hulls, stems, etc.

FINGER PICKUP SEED METER

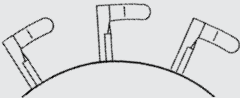
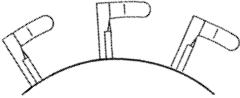
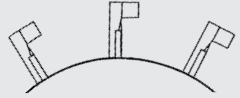









Crop	Fingers	*Lubricant
Corn	 Part No.: GR1848 - Finger Assembly, Corn	Graphite Talc
No. 1 and/or No. 2 size Confectionery Sunflower Seeds	 Part No.: GR1848 - Finger Assembly, Corn	Talc
No. 3 and/or No. 4 size Oil Sunflower Seeds	 Part No.: GR2154 - Finger Assembly, Oil	Talc
Blank fingers replace alternate fingers to reduce planting rate by half while allowing the finger wheel to maintain a minimum of 40 RPM when planting low rates.	 Part No.: GD11787 - Half Rate Blank Finger	Graphite Talc

***For More information on application rate see Additives section.**

NOTE: Always field check seed population to verify planting rates.



NOTE: Refer to planting rate charts in this manual for recommended seed drive transmission sprocket combinations.

VACUUM SETTINGS

Crop		**Seed Disc Kit	Seed Disc Part No.	Ejector Wheel (Color)	Cells	Seed Size Range	Singulator Zone Setting	Vacuum Setting Inches of Water (kPa)	Lubricant
	Corn ‡ Large Sweet Corn	G11043X	B1219 (Light Blue)	1 row 5 punches (Light Blue)	40	35-70 lbs/80k (2500-5000 seeds/kg)	2	18-20 (4.5-5.0)	Graphite* Talc* Bayer Fluency† (if mandated)
	Soybean	G11047X	B1232 (Black)	2 rows 6 punches (Black)	120	2200-4000 seeds/lb (4850-8820 seeds/kg)	0	10-14 (2.5-3.5)	Graphite* Talc* Bayer Fluency† (if mandated)
	Soybean Disc	G11048X	B1238 (Black)	1 row 6 punches (Green)	60	2200-4000 seeds/lb (4850-8820 seeds/kg)	0	10-14 (2.5-3.5)	Graphite* Talc* Bayer Fluency† (if mandated)
	Sugar Beet	G11045X	B1229 (Dark Orange)	1 row 6 punches (Dark Orange)	60	Pelletized	2	15 (3.75)	Graphite* Talc* Bayer Fluency† (if mandated)
	Milo	G11045X	B1229 (Dark Orange)	1 row 6 punches (Dark Orange)	60	10,000-20,000 seeds/lb (22000-44000 seeds/kg)	2	15 (3.75)	Graphite* Talc* Bayer Fluency† (if mandated)
	Sunflower ‡ Small Sweet Corn	G11044X	B1230 (Gray)	1 row 5 punches (Gray)	40	Oil seeds #2, 3, 4	2	12-18 (3.0-4.5)	Graphite* Talc* Bayer Fluency† (if mandated)
	Sunflower	G11044X	B1230 (Gray)	1 row 5 punches (Gray)	40	Oil seeds #5	2	5-8 (1.25-2.0)	Graphite* Talc* Bayer Fluency† (if mandated)
	Specialty Disc 1	G11039X	B1233 (Green)	1 row 6 punches (Green)	60	Cotton	2	15-20 (3.75-5.0)	Graphite* Talc as needed* Bayer Fluency† (if mandated)

Continued on next page.

VACUUM SETTINGS

Crop	**Seed Disc Kit	Seed Disc Part No.	Ejector Wheel (Color)	Cells	Seed Size Range	Singulator Zone Setting	Vacuum Setting Inches of Water (kPa)	Lubricant
 Specialty Disc 2	G11040X	B1235 (Brown)	1 row 6 punches (Green)	60	Black turtle & navy edible beans	2	15-20 (3.75-5.0)	Graphite* Talc as needed* Bayer Fluency [†] (if mandated)
 Specialty Disc 3	G11041X	B1234 (Dark Blue)	1 row 6 punches (Green)	60	Pinto & Great Northern edible beans & low-rate soybean	2	15-20 (3.75-5.0)	Graphite* Talc as needed* Bayer Fluency [†] (if mandated)
 Wheat Disc	G11042X	B1236 (Purple)	Brush Type	54	N/A Volumetric	0	6-16 (15-41)	Graphite* Talc as needed* Bayer Fluency [†] (if mandated)

Install selected seed disc. Position vacuum cover on meter by aligning keyhole slots over bolt heads. Push cover on meter and turn counter clockwise to lock in place.

*For More information on application rate, see ["Additives" on page 3-12.](#)

**Includes seed disc, ejector wheel, and spring.

[†]Bayer Fluency Agent is only required to be used in place of graphite or talc lubricants on vacuum equipped planters that are sowing neonicotinoid treated seeds in Canada. Refer to ["Bayer Fluency Agent" on page 3-13](#) section for more information.

‡Conventional hoppers only, not applicable with bulk fill.

NOTE: See [“Field Check Seed Population” on page 2-42](#) for more information. Always field check seed population to ensure planting rates are correct.

NOTE: Singulator settings are marked from 0 - 3.

NOTE: Mixing seed sizes and shapes affects meter performance. Use consistent seed size and shape.

NOTE: Use 1 tablespoon powdered graphite with each standard hopper fill of seed. Seed treatment, foreign material, dirt or seed chaff may cause gradual reduction of seed disc fill (population). See “Additives” pages for more information.

NOTE: Excessive seed treatment, humidity, and light-weight seed can affect meter performance. Use ½ cup of talc with each standard hopper fill of seed and mix thoroughly to coat all seeds and adjust rates as needed. Use of talc aids seed flow into meter, singulation, and disc seed drop.

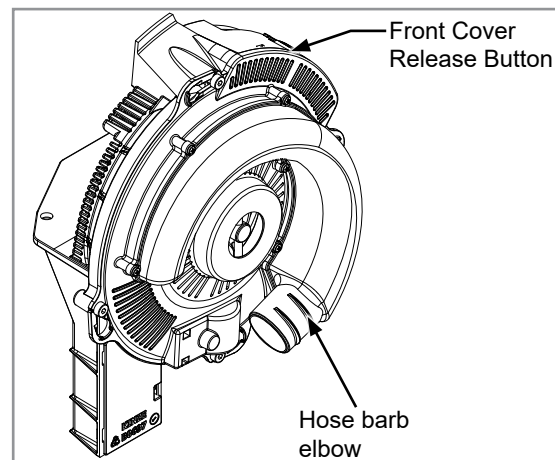
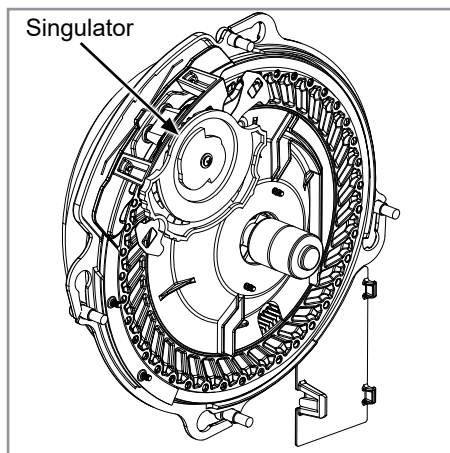

NOTE: Foreign material in seed disc orifices, such as seed chips, hulls, stems, etc., may affect seed delivery. Clean seed ensures accurate seed metering from vacuum seed meter. Remove Seed discs daily to check for buildup of foreign material in seed disc orifices.

Air inlet screens allow air to enter system and aids in keeping field residue or other foreign material out of meter.

See [“Vacuum Seed Meter Maintenance” on page 6-24](#) and [“Preparation for Storage” on page 6-45](#) in Lubrication and Maintenance section for more information.

This page intentionally left blank.

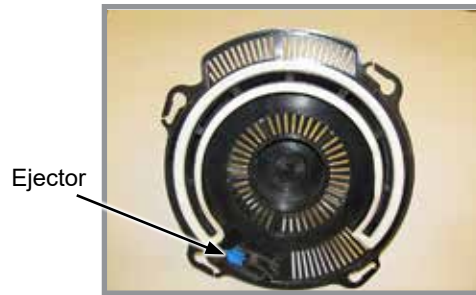

NOTE: Damaged seed or seed containing foreign material will cause plugging of seed disc orifices and require more frequent seed meter cleanout to prevent underplanting.

Wheel-Type Ejectors

Wheel-type ejectors expel seed remnants from seed disc orifices. These ejectors are disc specific and colored coded to match disc.

NOTICE	Replace hopper lids after hoppers are filled to prevent accumulation of dust or dirt in seed meter which will cause premature wear.
---------------	--

NOTE: Seed size, seed shape, seed treatments, travel speed, and planting rate affect meter performance.

1. Select seed disc and ejector to match crop and population.

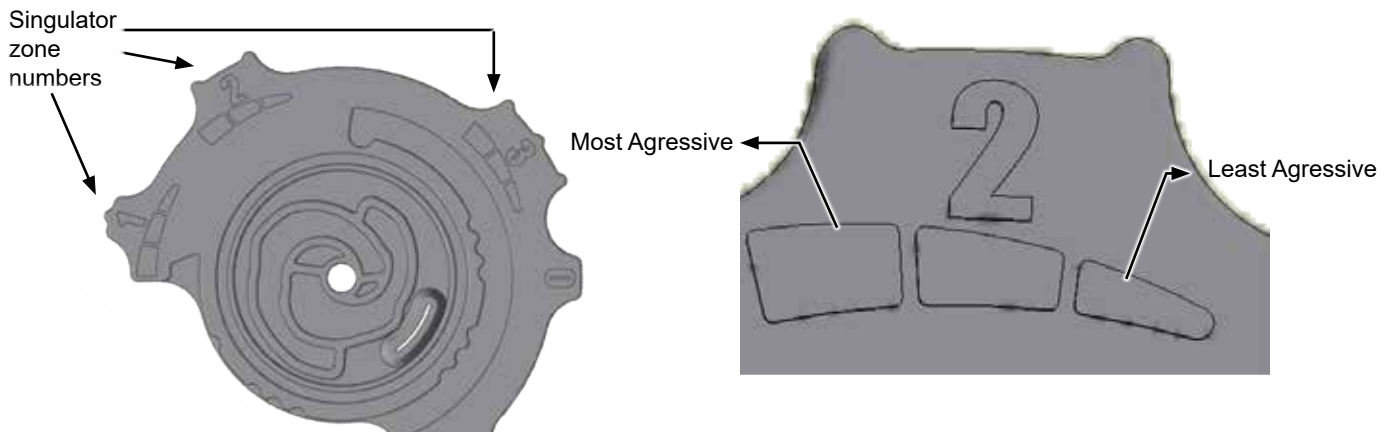

Singulator Adjustment Wheel

2. Adjust singulator wheel to initial setting. Seed size, seed shape, seed treatments, travel speed and planting rate all affect meter performance.
3. With vacuum fan running, lower planter to planting position and drive forward a short distance to load seed into seed disc cells.
4. Adjust vacuum level to initial setting according to tables on page.

NOTE: Vacuum reading will be much lower when seed disc cells are empty. Load all seed cells before setting vacuum level.

NOTE: Operate vacuum fan 3-5 minutes to bring oil up to normal operating temperature prior to making final vacuum level adjustment.

4. Adjust vacuum level to initial setting according to tables on page.

NOTE: Vacuum reading will be much lower when seed disc cells are empty. Load all seed cells before setting vacuum level.

NOTE: Operate vacuum fan 3-5 minutes to bring oil up to normal operating temperature prior to making final vacuum level adjustment.

TRUE SPEED SEED METER

See M0308 - True Speed Operator's Manual for all True Speed operation information.

SEED METER CLEANOUT

NOTE: Use of damaged seed or seed containing foreign material will cause plugging of seed cell orifices and require more frequent seed meter cleanout to prevent underplanting.

Thorough seed meter cleanout is important to maintain genetic purity.

1. Disengage seed drive (unplug meter with Blue Drive) and remove seed hopper and meter.
2. Dump seed from right rear corner of hopper into a container.
3. Lay hopper on its right side. Push release button and rotate seed meter vacuum cover clockwise to align keyhole slots with bolt heads. Lift off cover.
4. Rotate seed disc hub clockwise to unlock and remove seed disc.
5. Empty meter.
6. Thoroughly inspect meter to ensure all seed is removed.
7. Replace seed disc. Install vacuum cover.

ADDITIVES

Lubricant Application Rate	
Graphite	
Conventional Hoppers	1 Tbs./Hopper Fill
Bulk Fill Hoppers	1 Pound Bottle/50 Unit Fill
80/20 Talc-Graphite	
Conventional Hoppers	1/2 C.**
Bulk Fill Hoppers	8 Pounds/50 Unit Fill**
**Must be evenly mixed during fill.	
Talc	
Conventional Hoppers	1/4 C.*
Bulk Fill Hoppers	4 Pounds/50 Unit Fill*
*Double amount of talc for sunflowers.	

GRAPHITE

The use of graphite is the primary recommendation to promote seed flow, provide lubrication for the seed meter and to help dissipate static charge buildup. Among the available dry seed lubricants graphite is the most effective and easiest to use and it requires no mechanical agitation

Conventional Hoppers

Mix one tablespoon of **powdered graphite** with seed each time hoppers are filled. Regular graphite use prolongs life of the seed meter components, improves seed spacing, and may reduce buildup of seed treatments.

NOTE: DO NOT apply graphite only in center of hopper. It will filter too quickly through the seed and not distribute as evenly as desired.

Apply graphite around outer perimeter of hopper.

Bulk Fill Hoppers

Mix 1 pound of powdered graphite each time the bulk seed hopper is filled. Graphite should be added in layers as the bulk seed hoppers are filled. Regular graphite use prolongs life of the seed meter components, improves seed spacing, and may reduce buildup of seed treatments.



Adding graphite to conventional hopper



Adding graphite bulk fill hopper

NOTE: Additional graphite may be required to retard buildup of seed treatments on meter components. More frequent cleaning of monitor seed tubes may be necessary due to use of additional graphite.

80/20 TALC-GRAPHITE

Talc-Graphite lubricant is to be used for treated seed, providing benefits of both talc and graphite. It absorbs moisture to prevent bridging, minimizes static electricity for improved seed flow, and lubricates seed and meters.

Conventional Hoppers

Mix ½ C. of 80/20 talc-graphite evenly with seed each time hoppers are filled. Regular graphite use prolongs life of the seed meter components, improves seed spacing, and may reduce buildup of seed treatments.

NOTE: Talc-Graphite lubricant MUST be mixed evenly during fill.

Bulk Fill Hoppers

Mix 8 lbs. of 80/20 talc-graphite each time the bulk seed hopper is filled. Regular graphite use prolongs life of the seed meter components, improves seed spacing, and may reduce buildup of seed treatments.

NOTE: Talc-Graphite lubricant MUST be mixed evenly during fill.

TALC

Talc seed lubricant may be used as a drying agent in addition to graphite lubrication. The drying agent may improve seed release and/or **to retard buildup of seed treatments on meter components.**

1. Fill hopper ½ full of seed, add ¼ cup (conventional); 2 pounds (Bulk Fill) of talc and **mix thoroughly.**
2. Finish filling hopper, add another ¼ cup (conventional); 2 pounds (Bulk Fill) of talc and **mix thoroughly.**
3. Adjust rate of talc use as needed so all seeds are coated, while avoiding a buildup of talc in bottom of hopper.

Humid conditions and/or small sized seeds with extra seed treatment may require additional talc to maintain meter performance.

NOTE: Liquid seed treatments or inoculants may create buildup on the seed disc or brushes. Check frequently for proper population and/or seed delivery when using any liquid seed treatment.

Completely mix all treatments with seed following manufacturers' recommendations. Seed treatment dumped on top of seed after hopper is filled may not mix properly and cause seed bridging, reducing population or stopping meter from planting.

BAYER FLUENCY AGENT

Bayer Fluency Agent is an alternate seed lubricant by Bayer Crop Science. The intent of this product is to replace graphite and talc lubricants and to lower the amount of dust emissions from planter vacuum fans.

This product, as tested by Kinze, is compatible with Kinze's bulk fill system and vacuum meters. Due to limited testing, wear life characteristics of meters and bulk fill systems that use Bayer Fluency Agent are not yet known. Please follow Bayer Fluency Agent instructions for rates and mixing directions.

NOTE: Presently, Bayer Fluency Agent is only required to be used in Canada with Bulk Fill or Vacuum planters that plant corn or beans treated with neonicotinoids. Farms outside of Canada, farms not using seed treated with neonicotinoids, and farms not using pneumatic metering devices do not need to use Bayer Fluency Agent. All planters not equipped with vacuums or fans are exempt from using Bayer Fluency Agent.

SEED HOPPERS



Seed hopper is retained by an over-center latch. Wear gloves to prevent injury to hands while releasing the latch.

Mechanical seed hopper has a capacity of 1.9 bushels.

Vacuum seed hopper has a capacity of 1.75 bushels.

Use clean seed and make certain there are no foreign objects inside when filling seed hopper. **Replace hopper lids after hoppers are filled to prevent accumulation of dust or dirt in seed meter which can cause premature wear.** See “Finger Pickup Seed Meter” and/or “Brush-Type Seed Meter”.

Periodically empty hoppers completely to remove any foreign objects and to ensure proper seed meter operation.

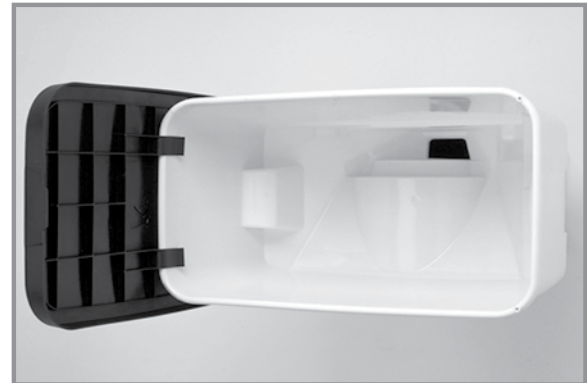

Mechanical seed hopper

Disengage meter drive and hopper latch and lift hopper off hopper support. See “Seed Meter Drive Release”.

SEED METER DRIVE RELEASE

A clutch release mechanism disengages seed meter drive from seed meter to remove seed hopper. Disconnecting drive allows operator to check granular chemical application rates without dropping seed. It also allows one or more rows to be disconnected when finishing fields.

Turn knob ¼ turn counterclockwise to disengage or ¼ turn clockwise to engage.

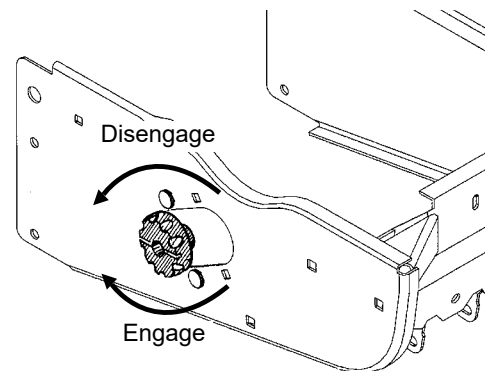

Seed meter drive release

ROW UNIT EXTENSION BRACKETS

Row unit extension brackets extend row units rearward 4" (10.1 cm) to provide clearance for coulter mounted residue wheels and HD single disc fertilizer openers.

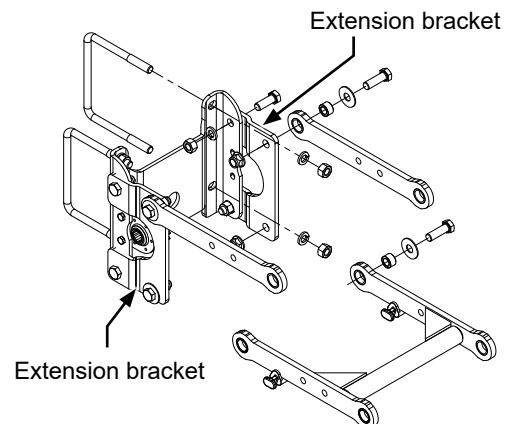

Row unit extension brackets

ROW UNIT CHAIN ROUTING

Row unit drive chains must be properly tensioned and aligned for proper operation and to minimize wear.

Inspect and replace weak, worn or broken springs, idlers, and idler bushings.

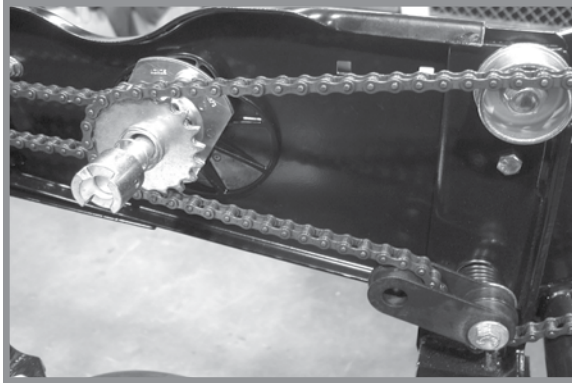

Mechanical pull row unit meter drive

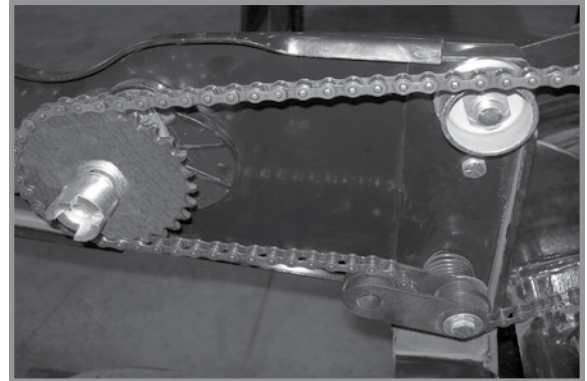

Vacuum pull row unit meter drive



Mechanical push row unit meter drive

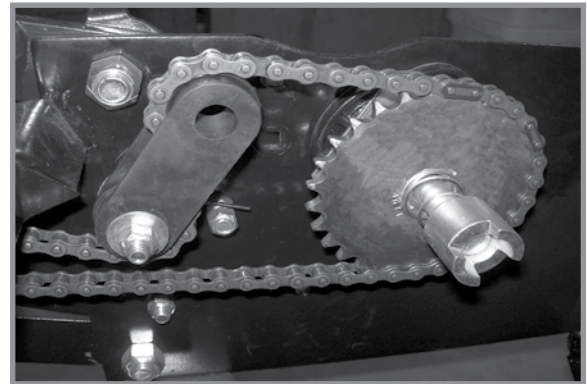

Vacuum push row unit meter drive

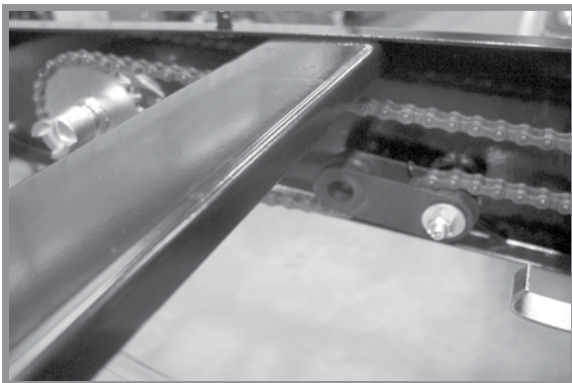

Row unit granular chemical drive

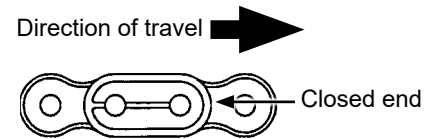

NOTE: Install connector link with closed end facing direction of travel.

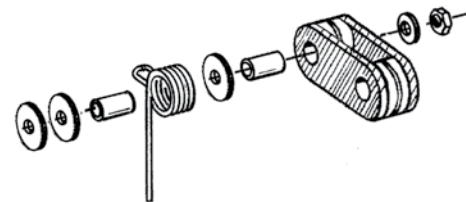

NOTE: Reverse idler when worn on one side for extended use.

QUICK ADJUSTABLE DOWN FORCE SPRINGS OPTION

Quick adjustable down force springs increase penetration in hard soil and keep row unit from bouncing in rough field conditions. Two springs per row, one on each side parallel arms, are used unless equipped with row unit mounted no till coulters. Four springs per row are used with row unit mounted no till coulters.

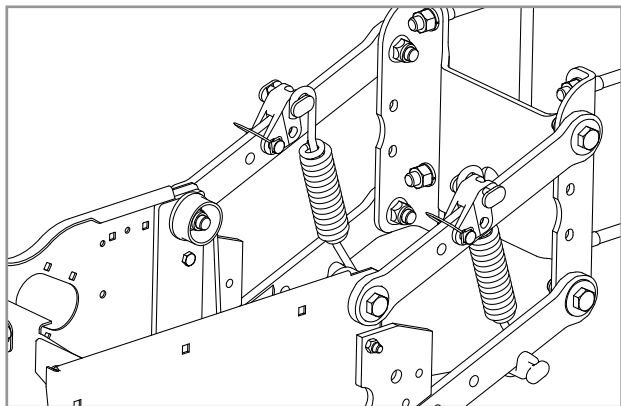

Two Springs Per Row (Dual)

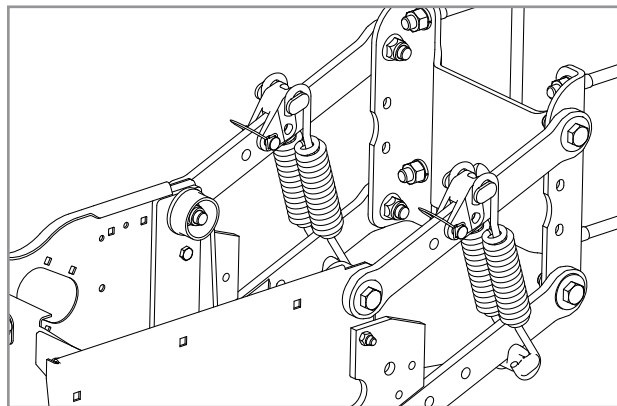

**Four Springs Per Row (Quad)
(Row Unit Mounted No Till Coulters Only)**

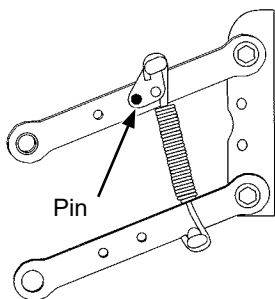

Position 1 (Least)

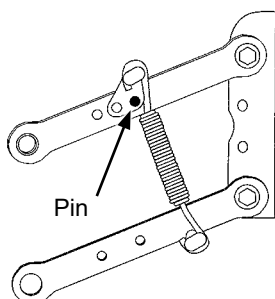

Position 2

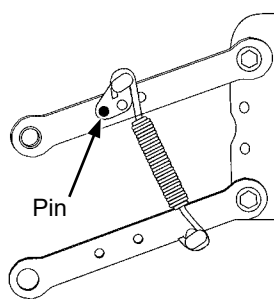

Position 3

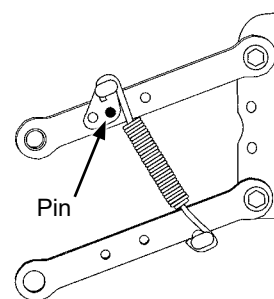

Position 4 (Most)

There are four positions to set down pressure spring tension.

NOTICE

Springs must be installed with open side of spring hooks toward seed hoppers to prevent binding on spring mount adjustment pins.

1. Raise planter and remove spring mount pin at top of spring.
2. Slide mount to desired position and install pin.

NOTE: Adjust springs for field conditions. Too much down pressure in hard field conditions can cause row units to lift planter and keep drive wheels from making contact. Too much down pressure in soft field conditions can cause row unit to run too deep.

Heavy Duty Spring Down Force Pressure*		
	2 Springs	4 Springs
Position	Heavy Duty P/N: D21337	Heavy Duty P/N: D21337
1	43 lb (19.5 kg)	80 lb (36.3 kg)
2	86 lb (39.0 kg)	144 lb (65.3 kg)
3	167 lb (75.7 kg)	307 lb (139.3 kg)
4	249 lb (113.0 kg)	470 lb (213.2 kg)

*Pressure does not include weight of row unit, seed, or options.

PNEUMATIC DOWN PRESSURE PACKAGE OPTION

Row unit down pressure can be adjusted on-the-go as field conditions change with pneumatic down pressure option. A cab-mounted control box adjusts pressure (Older models may have a digital readout). A planter-mounted 12 VDC air compressor with 3 gallon capacity air tank supplies air for the down pressure system.

Packages include upper and lower air spring mounting castings for pull row units (front and rear air spring mounting castings for push row units), 150 psi rated air springs, $\frac{3}{8}$ " O.D. nylon hoses, dual solenoid air valve and stainless steel, 160 psi, 2" liquid-filled gauge and planter wiring harness.

Pneumatic down pressure row unit extension brackets are required in some applications.

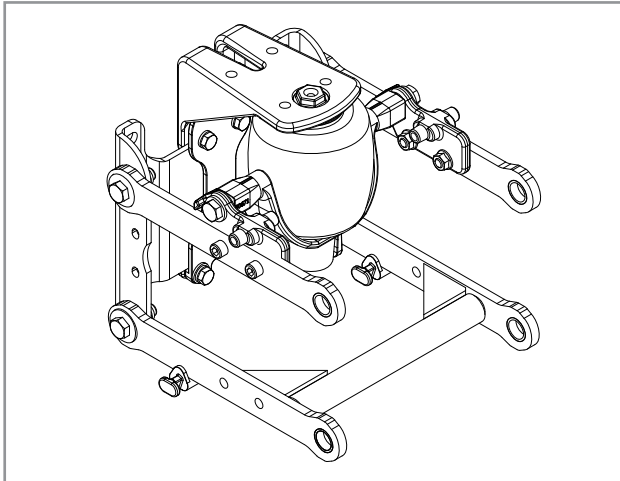

Pull Row Unit Air Spring

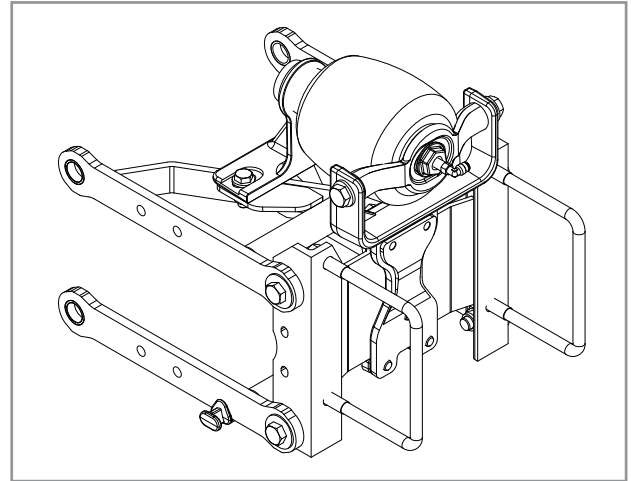

Push Row Unit Air Spring

NOTE: Assist springs are available through your Kinze dealer if additional down pressure is needed. One spring is installed on outer side of parallel arms on each side of row unit as shown below.

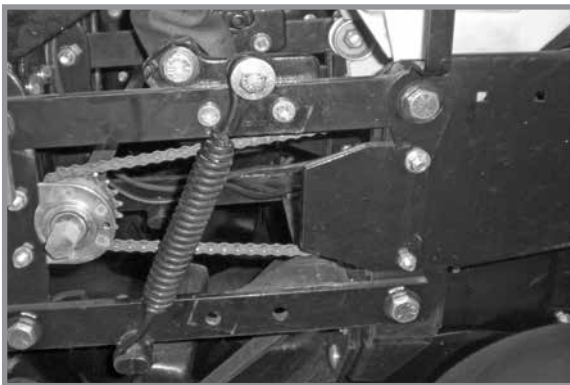

Pull row unit assist springs



Push row unit assist springs

FIELD OPERATION

NOTE: Adjust down pressure with planter lowered and row openers in ground for most accurate adjustment. Pressure can be adjusted from tractor using control console, or at planter using manual control valves on compressor assembly.



Control console

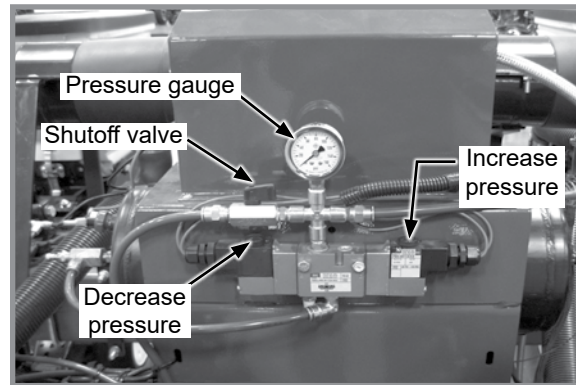

Air compressor assembly controls

ADJUST DOWN PRESSURE FROM CAB

Push toggle switch left to increase or right to decrease pressure.

ADJUST DOWN PRESSURE AT PLANTER

Push and hold decrease or increase button on compressor assembly to decrease or increase pressure.

NOTE: Value on the air pressure gauge is NOT down pressure force. Multiply air pressure (psi) by four (4) to calculate down pressure.

LOCK UP PUSH ROW UNITS EQUIPPED WITH PNEUMATIC DOWN PRESSURE SPRINGS

1. Disconnect electric power supply to compressor.
2. Press and hold button on solenoid until pressure gauge reads zero.
3. Lock up units. See "Interplant Push Unit Lockup" for instructions.
4. Turn shutoff valve handle perpendicular to valve body to turn off air supply to push row units.

NOTE: If control console is ON and pneumatic down force is not set to zero, compressor will start when electric power supply is reconnected.

5. Reconnect electric power supply to compressor.

Refer to M0288 - Kinze Blue Vantage Operator's Manual for pressure adjustment with Blue Vantage.

TRUE DEPTH OPTION

True Depth provides on demand row by row hydraulic row unit down force ranging from 100 lbs. up force to 600 lbs. down force at 2350 psi. The system includes a 7" in cab standalone touchscreen display with antiglare screen protector and RAM mount, electronic control modules, harnesses, gauge wheel sensors, hydraulic cylinders, upper and lower cylinder mounts, and valves. See M0286 - Kinze True Depth Operator's Manual.



True Depth

TRUE DEPTH CONSOLE INSTALLATION

TRACTOR REQUIREMENTS

Consult your dealer for information on horsepower, hydraulic and electrical requirements, and tractor compatibility. Requirements vary with planter options, tillage, and terrain.

TRACTOR INSTALLATION

Refer to Kinze Instruction Sheet IS1028 for installation of the True Depth down force system.

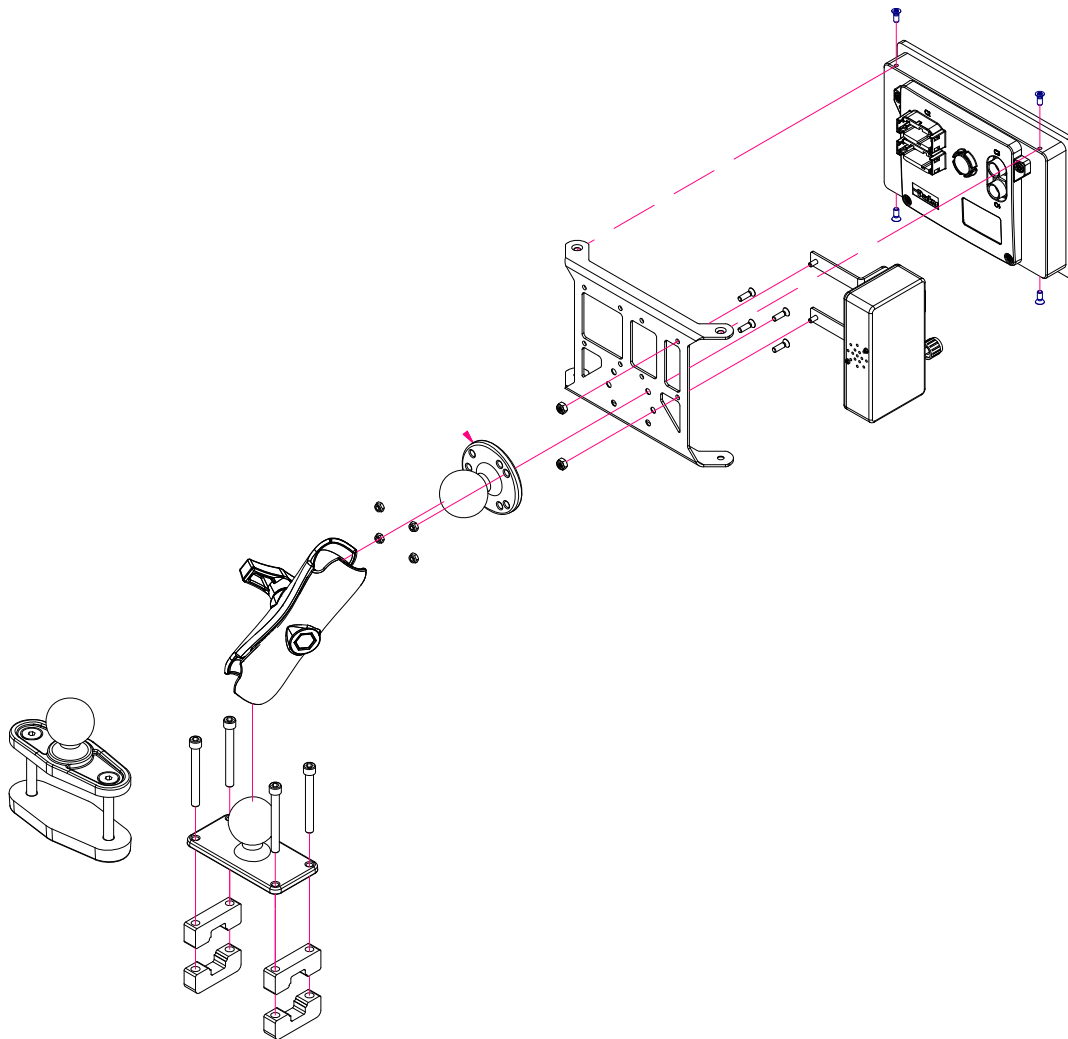

True Depth Console

TRUE DEPTH HARNESS INSTALLATION

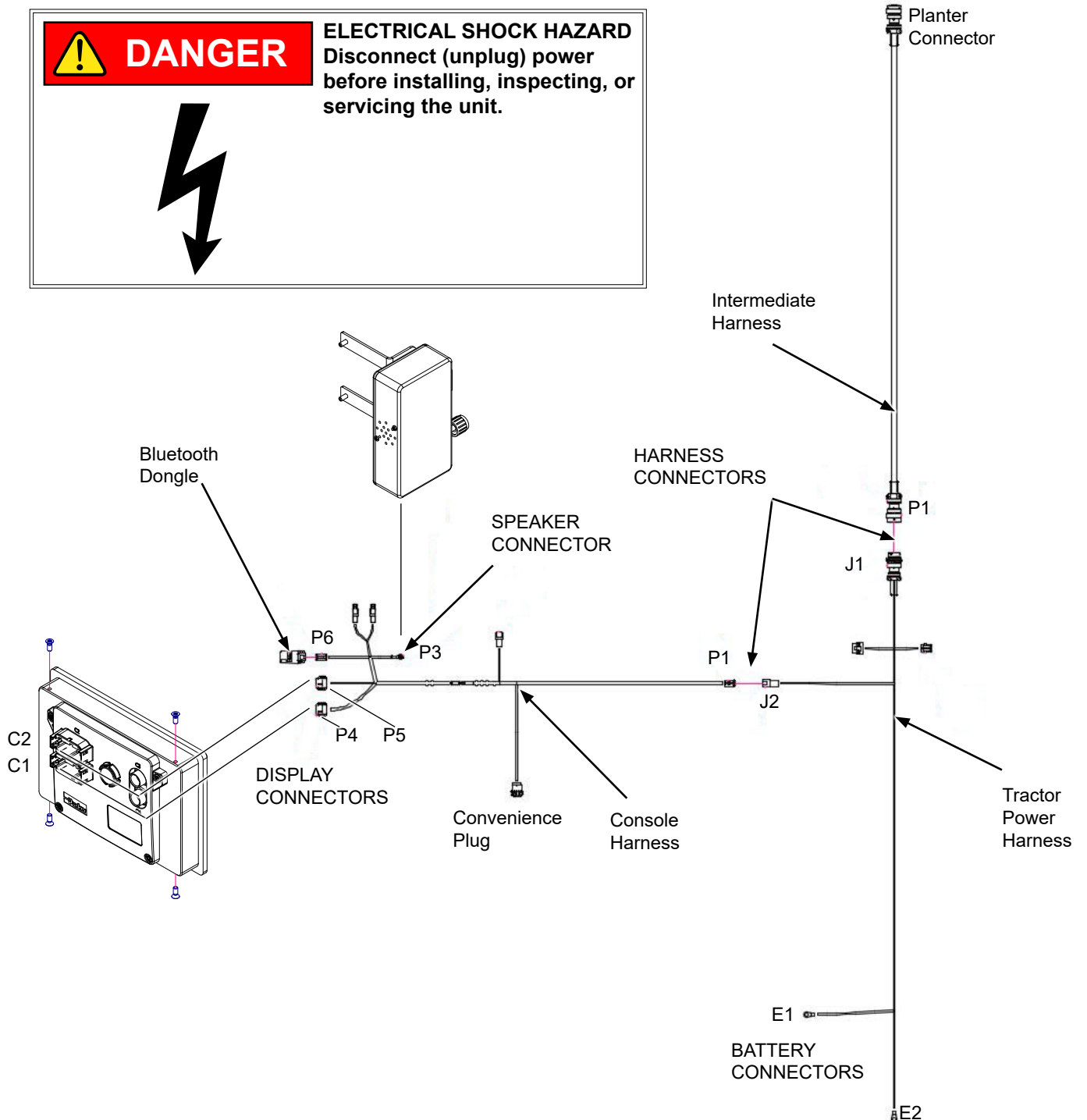
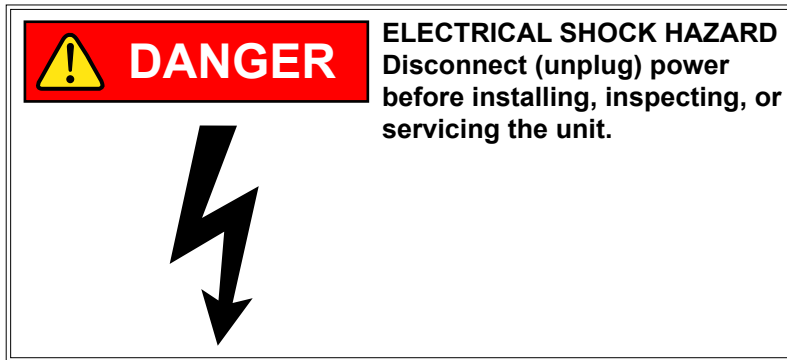

Connect tractor power harness terminal E1 to positive battery terminal. Connect terminal E2 to negative battery terminal. Connect console harness P4 to display C1, and console harness P5 to display C2. Connect console harness P3 to the speaker box. Connect console harness P1 to tractor power harness J2. Connect the intermediate harness P1 to the tractor power harness J1.



True Depth Harness Installation

SPLIT ROW LOCKUPS

Split row lockups are designed to allow the push row units to be locked in the raised position.

	<p>Improper lifting of row units can cause serious injury. An empty row unit requires minimum 84 lb (38.1 kg) lift. Set down pressure springs to minimum, lower planter to ground, and empty seed hopper before attempting to lift with this lever.</p>
	

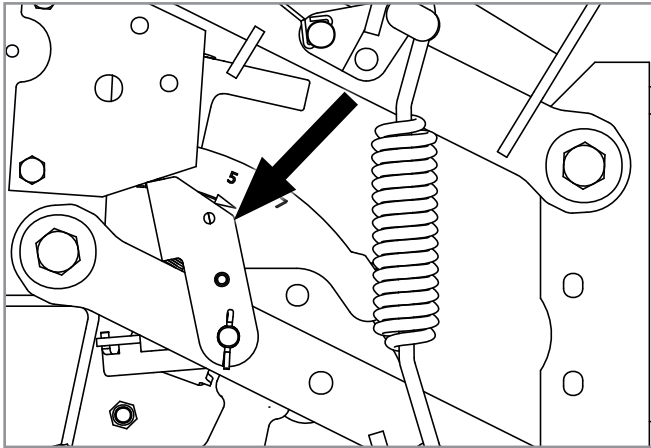

Push Row Unit Locked In Raised Position

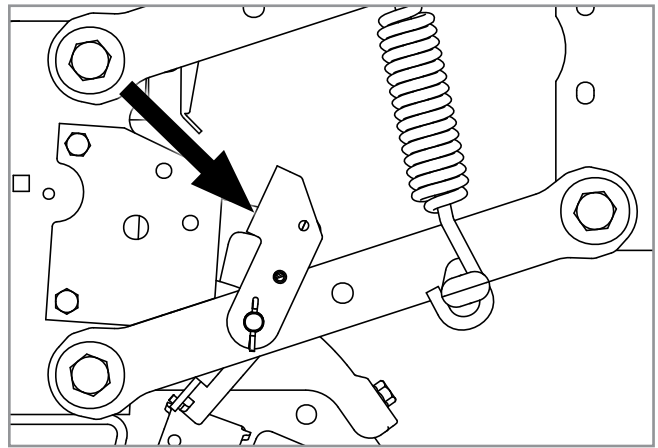

Lockup Released For Field Operation

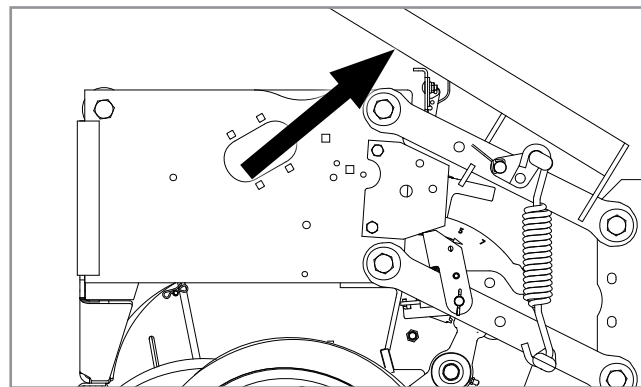

Lift lever positioned on push row unit

To Lock Row Unit in Raised Position:

1. Set row unit down pressure springs to minimum setting.
2. Lower the planter to the planting position.
3. Empty seed hoppers.

Note: If planter is equipped with True Depth, enable Lift Assist Mode with the True Depth Display. See M0286 - Kinze True Depth Manual, Page 18.

**WARNING**

Turning Lift Assist on or off may cause the planter to move or row units to fall causing injury or death.

4. On each push row unit lockup, flip the spring tab forward.

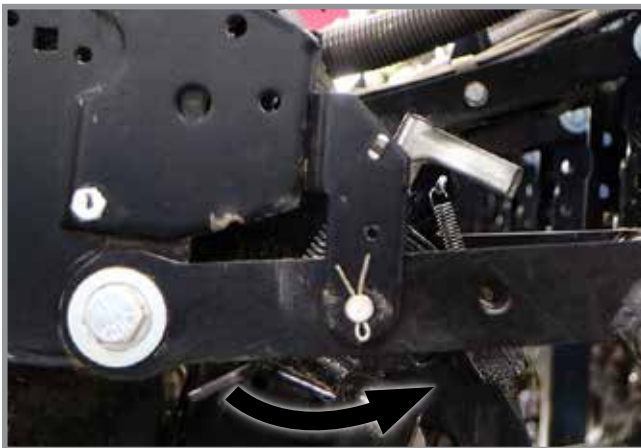
**DANGER**

Uncontrolled movement of equipment can cause loss of control and could result in death, serious injury, or damage to property and equipment. Keep clear of row unit while lowering it to the ground.

5. Using the lift lever, raise the push row unit to allow the spring loaded lockups to snap into locked position under the row unit stops.
6. Ensure that the row unit is lowered onto the stops.
7. Repeat Steps 4 through 6 on remaining push row units.



To Release Row Unit to Planting Position:



1. Lower the planter to the planting position.

Note: If planter is equipped with True Depth, enable Lift Assist Mode with the True Depth Display. See M0286 - Kinze True Depth Manual, Page 18.

 WARNING	Turning Lift Assist on or off may cause the planter to move or row units to fall causing injury or death. Please ensure that all row units are pushed down before exiting Lift Assist mode.
--	---

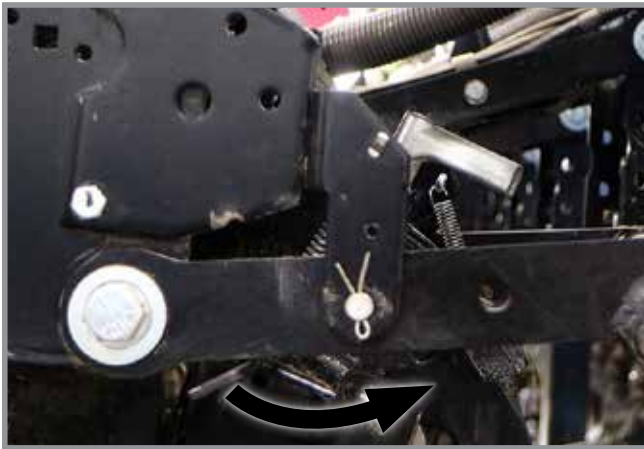
2. On each push row unit lockup, flip the spring tab rearward.



 DANGER	Uncontrolled movement of equipment can cause loss of control and could result in death, serious injury, or damage to property and equipment. Keep clear of row unit while lowering it to the ground.
	

3. Using the lift lever, raise the push row unit to allow the spring loaded lockups to snap out of locked position. Lower row unit to the ground.
4. Ensure that the row unit is lowered all the way to the ground.
5. Repeat Steps 2 and 4 on remaining push row units.



ROW UNIT MOUNTED NO TILL COULTER

Row unit mounted no till coulters with 1" bubbled, 1" fluted (8 flutes) or ¾" fluted (13 flutes) blades may be used on pull row units and push row units (¾" fluted shown). Four quick adjustable down force springs are required per row when using row unit mounted no till coulters. See "Quick Adjustable Down Force Springs Options".

Align coulters to row unit double disc openers. Adjust by loosening four attaching bolts, moving coulters, and tightening four attaching bolts. Coulters can be adjusted to one of four ½" incremental settings in the forked arm. Initial location is the top hole.

Move blade as it wears to one of the three lower holes to maintain coulters at or slightly above opener discs as needed. Adjust coulters below depth of double disc opener blades in very hard soil conditions such as compacted wheel tracks to improve opener penetration and cutting of surface residue.

Check operating depth by setting planter down on a level concrete floor and checking relationship between coulters and row unit opener blades. Make sure planter is level and coulters are square with planter frame and aligned with row unit disc opener.

NOTE: Torque 5/8" spindle hardware to 120 ft-lb (162.7 N-m).

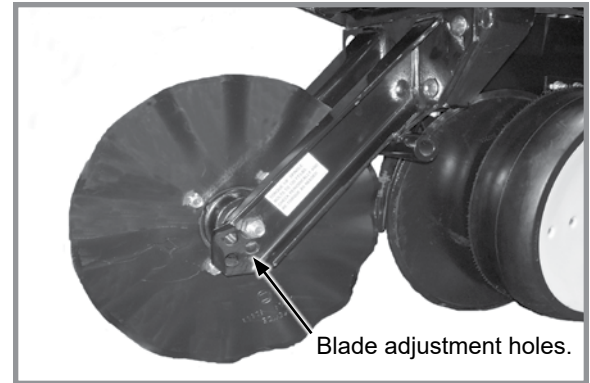

Row Unit Mounted No Till Coulters

COULTER MOUNTED RESIDUE WHEELS

Coulters mounted residue wheels are designed for use on pull row units and push row units. Row unit extension brackets are required on the four center pull row units if the planter is equipped with coulters mounted residue wheels.

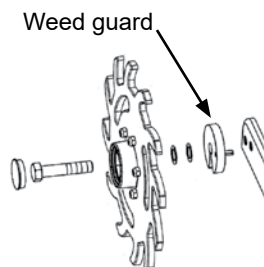

NOTE: Opening in weed guard must face down.



Coulters mounted residue wheels

Residue wheels attach to row unit mounted coulters with two cap screws and sleeves allowing unit to free-float. A 2-position spindle bolt mounting positions wheels interlocked or staggered. Depth adjustment is made with a spring-loaded cam and pin with 8 positions in 7/16" (6 mm) increments. A high point on the cam allows wheels to be locked up.

A weed guard on the inboard side of each wheel helps prevent weed wrap which can cause premature bearing failure.

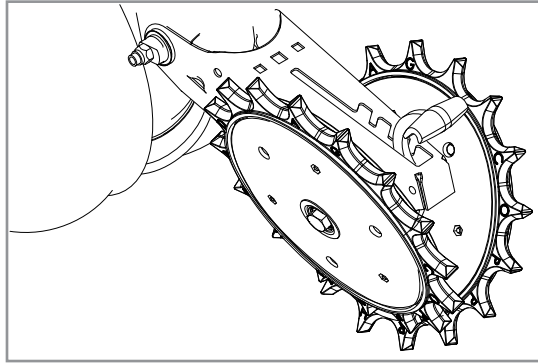

SPIKED CLOSING WHEEL**Row Unit Spiked Closing Wheel**

Spiked closing wheels crumble the sidewall, allowing roots to penetrate soil. They can be used on pull row units and push row units.

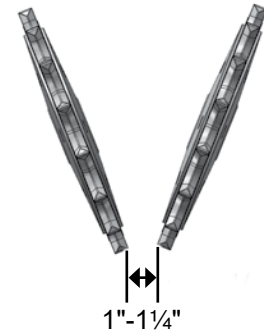
Align spiked closing wheels straight across from each other, in most forward holes on closing wheel arm. Set the wheels 1" - 1¼" (2.5 - 3.1 cm) apart at the closest point.



GRANULAR CHEMICAL HOPPER AND DRIVE

 WARNING	<p>Agricultural chemicals can cause death or serious injury to persons, animals, and plants or seriously damage soil, equipment, or property. Read and follow all chemical and equipment manufacturers labels and instructions.</p>
	

The granular chemical hopper has a 1.4 cubic feet capacity.

Make sure no foreign objects get into hopper when it is being filled. Replace hopper lids after filling to prevent accumulation of dirt and moisture.

A metering gate on bottom of hopper regulates the application rate. See [“Dry Insecticide Application Rates” on page 3-29](#) in this manual. Calibrate using chemical manufacturers’ instructions.



Granular chemical hopper

Granular chemical clutch drive coupler and meter shaft (not applicable to Blue Drive) can be disengaged and engaged by turning throwout knob at rear of hopper support panel.

Rotate knob $\frac{1}{4}$ turn counterclockwise to disengage and $\frac{1}{4}$ turn clockwise to engage.

Slotted holes in hopper support panel and clutch housing allow for alignment adjustment between clutch drive coupler and meter shaft.

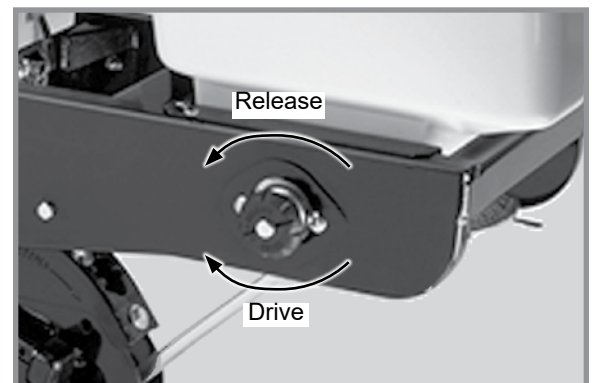

Granular chemical drive release

GRANULAR CHEMICAL BANDING OPTIONS

Granular chemical banding options allow 4½" slope-compensating banding, straight drop in-furrow placement or 14" rear banding.

NOTE: Granular chemical rear bander is not compatible with covering discs/single press wheel option.

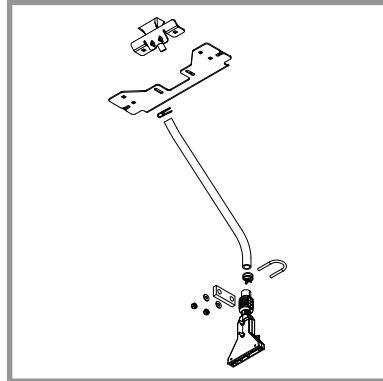

4½" slope-compensating bander

**DRY INSECTICIDE APPLICATION RATES
APPROXIMATE POUNDS/ACRE AT 5 MPH**

Meter Setting	30" Rows
CLAY GRANULES	
10	4.9
11	5.4
12	6.1
13	6.9
14	7.7
15	8.5
16	9.6
17	10.7
18	11.4
19	13.1
20	14.2
21	15.5
22	16.4
23	17.2
24	18.8
25	20.9
26	23.0
27	24.1
28	25.4
29	27.8
30	29.6
SAND GRANULES	
5	2.9
6	4.9
7	5.3
8	6.3
9	7.8
10	8.9
11	10.2
12	11.2
13	12.6
14	14.1
15	15.5
16	17.5
17	19.4
18	21.8
19	24.3
20	25.7
21	27.6
22	29.6
23	32.0
24	34.4
25	36.9

NOTE: Chart represents average values and should be used only as a starting point. Granular chemical flows through meter opening at a nearly uniform rate regardless of roller speed. Your actual rate will vary depending on insecticide, planting speed, and plant population. Planting speed/ground speed has the greatest effect on application rate.

Field check your actual rate with insecticide you are using at speed and population you will be planting. See ["Field Check Granular Chemical Application"](#) on page 2-44 in Machine Operation section for more information.

This page intentionally left blank.

NOTCHED SINGLE DISC OPENERS

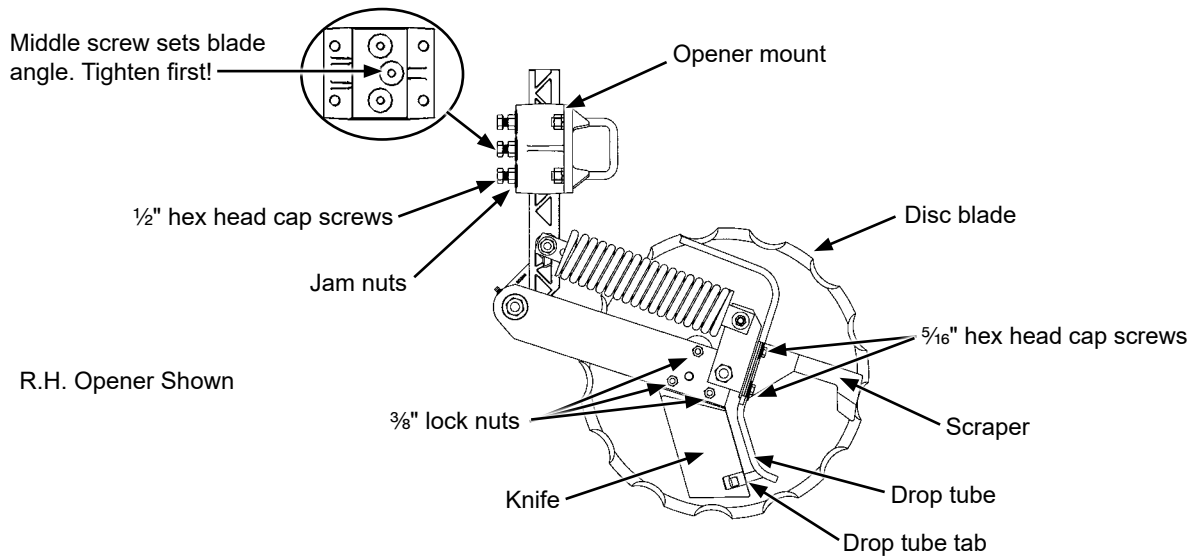

Notched single disc opener adjustments

 CAUTION	<p>Compressed spring may fly out of this assembly if attempting to disassemble and cause injury. Do not take apart this assembly.</p> <p>Disc blades are sharp and can cut causing serious injury. Wear gloves when working on or turning disc blades by hand.</p>
---	--

NOTICE	<p>Never strike knife with heavy object. Damage to knife will occur.</p> <p>If knife to disc blade clearance is too large, soil or residue can wedge between knife and blade, and blade will not turn.</p>
---------------	--

1. Adjust knife to disc blade contact. Loosen or tighten $\frac{3}{8}$ " lock nuts to adjust knife's entire leading edge against disc blade. Turn blade and check for slight resistance without freewheeling. Readjust knife to blade's tight spot as needed.

NOTICE

Adjust liquid drop tube out of path of soil flow across knife. Drop tube and tab wear quickly if not correctly adjusted.

2. Adjust scraper and drop tube. Loosen two $\frac{5}{16}$ " hex head cap screws. Adjust scraper until just touching disc blade. Adjust drop tube until it is centered between knife and disc blade. Tighten screws. Turn blade and check for slight resistance without freewheeling. Repeat as needed. Insert flat bladed pry bar or screwdriver between knife and drop tube above drop tube tab. Carefully bend tube until $\frac{1}{4}$ "- $\frac{3}{8}$ " (6.35 - 9.5 mm) from disc blade.

NOTE: Maximum disc blade depth 4" (10.2 cm).

3. Adjust blade depth. Loosen three $\frac{1}{2}$ " hex head cap screws and jam nuts in opener mount. Adjust opener assembly up or down to desired blade depth. Tighten center hex head cap screw and jam nut first to set proper disc blade angle. Tighten remaining hex head cap screws and jam nuts. Torque hex head cap screws and jam nuts to 57 ft-lb (77.29 N-m). Check fertilizer hose clearance and adjust as necessary.

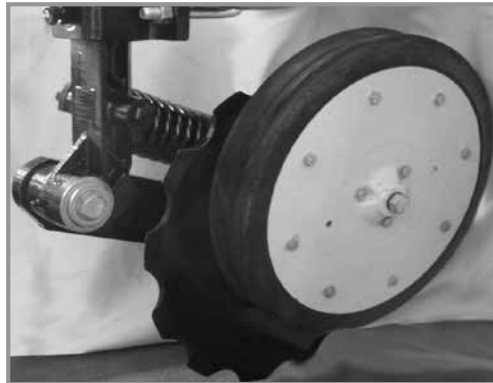
DEPTH/GAUGE WHEEL ATTACHMENT FOR NOTCHED SINGLE DISC FERTILIZER OPENER

Notched single disc opener depth/gauge wheel

Depth/gauge wheel attachment for notched single disc fertilizer opener is used where additional gauging is required to maintain desired fertilizer opener depth. Depth/gauge wheel is attached to notched single disc fertilizer opener using a mounting block fastened to the pivot arm with $\frac{5}{8}$ " hardware through disc blade bearing.

Depth adjustment is made using 3 adjustment holes in depth/gauge wheel mounting block. Moving depth/gauge wheel increases/decreases depth in approximate 1" increments in relation to blade depth setting made at vertical mounting post.

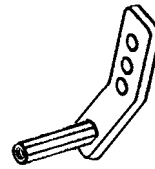

HD SINGLE DISC FERTILIZER OPENER

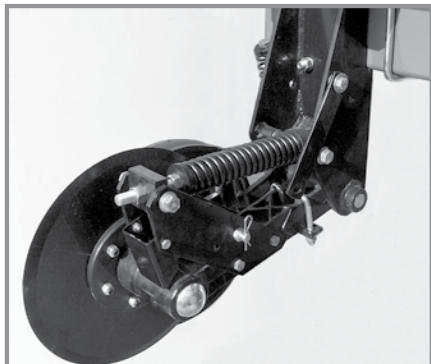

HD single disc opener

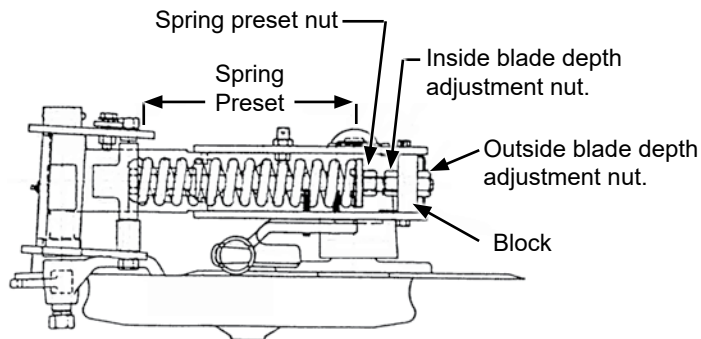

R.H. configuration shown (Overhead view)

Recommended placement of fertilizer with HD single disc fertilizer opener is 3½" - 4" (8.8 - 10.1 cm) from row.

NOTICE	Never place fertilizer closer than 2" (5 cm) to row or seeds may be damaged.
---------------	---

Maximum blade depth is approximately 5" (12.7 cm) with planter frame level and at 20" (50.8 cm) operating height. Soil conditions can affect depth slightly.

Raise planter to remove weight from fertilizer opener. Loosen inside adjustment nut with 1½" wrench. Turn outside nut clockwise to decrease or counterclockwise to increase blade depth. One full turn of blade depth adjustment nut changes blade depth ⅜". Tighten inside nut tight against block. Adjust all fertilizer openers to same depth.

Fertilizer opener down pressure can be adjusted from 250 lb (113.4 kg) to 640 lb (290.3 kg).

NOTICE	Do not operate HD single disc fertilizer openers at full down pressure tension on rocky ground or disc blades will chip.
---------------	---

NOTE: DO NOT adjust spring preset dimension less than 9½" (24.13 cm).

NOTE: Excessive down pressure can cause planter frame up-lift and affect machine performance. Planter frame should be 20" (50.8 cm) from ground in planting position. Excessive down pressure in loose soil conditions can cause openers to run too deep and push dirt ahead of opener and may stop soil press wheel and opener blade from turning.

Raise planter to remove weight from fertilizer opener. Turn spring preset nut clockwise to increase and counterclockwise to decrease down pressure. Adjust all rows to a similar setting. Minimal spring pressure for acceptable operation is recommended. See chart for spring length setting specifications.

Adjust spring loaded dry fertilizer drop tube/scrapper periodically to maintain ⅛" (3 mm) gap between drop tube and opener blade. If this dimension is not maintained fertilizer may not drop in proper location.

Loosen scraper adjustment bolt. Slotted hole in scraper allows up or down adjustment.

Spring Preset	
Length	Down Pressure
11" (27.9 cm)	250 lb (113.4 kg)
10¾" (27.3 cm)	320 lb (145.1 kg)
*10½" (26.7 cm)	370 lb (167.8 kg)
10¼" (26 cm)	450 lb (204.1 kg)
10" (25.4 cm)	520 lb (235.8 kg)
9¾" (24.8 cm)	580 lb (263.1 kg)
9½" (24.1 cm)	640 lb (290.3 kg)
*Initial setting	

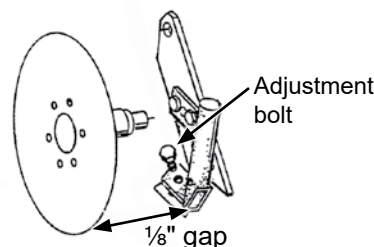

Adjust liquid drop tube/scrapper so there is slight contact between blade and scraper lower leading edge, and 1/4" clearance between liquid drop tube trailing edge and blade. Blade should turn with minimum amount of drag.

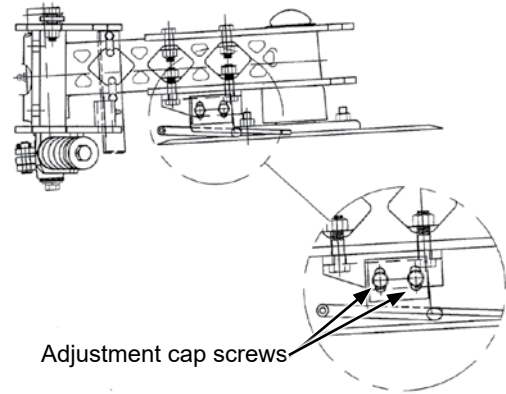

Adjustment cap screws

NOTE: Soil press wheel is not for gauging fertilizer opener operating depth.

Additional press wheel down pressure may be desirable in heavy moist soils. Turn press wheel spring adjustment bolt clockwise to increase down pressure.

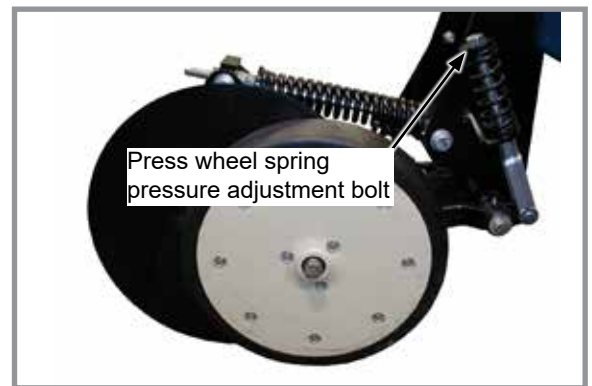

Press wheel down pressure adjustment

HD single disc fertilizer opener can be raised and locked up when fertilizer attachment is not used or during storage.

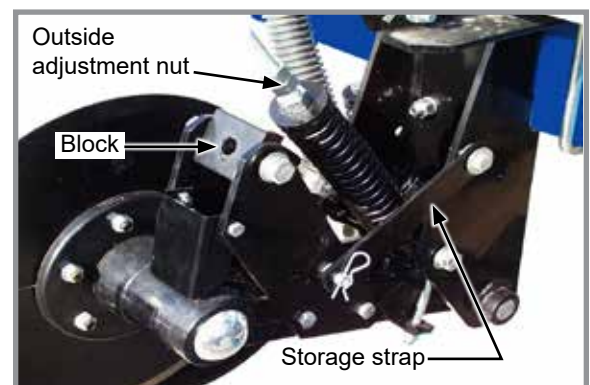

NOTE: A lockup bar automatically raises and locks soil press wheel when blade assembly is raised.

1. Place planter in planting position.
2. Remove outside blade depth adjustment.
3. Raise planter until adjustment bolt clears adjustment block.
4. Raise spring to clear blade assembly and raise blade assembly until storage strap can be positioned on lockup pin. Install hair pin clip.
5. Reinstall depth adjustment nut and tighten



HD opener lockup

LIQUID FERTILIZER ATTACHMENT

 WARNING	<p>Agricultural chemicals can cause death or serious injury to persons, animals, and plants or seriously damage soil, equipment, or property. Read and follow all chemical and equipment manufacturers labels and instructions.</p>
	

 CAUTION	<p>Overfilling tank can cause siphoning, tank collapse, personal injury, and damage to property and equipment. Do not overfill tank. Do not leave planter unattended when filling tank. Close fill valve and open tank lid if siphoning occurs. Follow all chemical manufacturers first aid, cleanup, and handling instructions.</p>
--	--

NOTICE	<p>Placing fertilizer too close to seeds or in excessive amounts can cause germination or seedling damage. Check with your fertilizer dealer or manufacturer for correct amount and placement.</p>
---------------	--



3660 conventional w/vacuum

CHECK VALVES



Repairable check valve

Optional low rate check valves are available for in-line installation between liquid fertilizer squeeze or piston pump and openers to ensure equal distribution of product at low rates. Check valves eliminate anti-siphon loops.

PISTON PUMP

NOTE: Keep manuals shipped with pump and flow divider with this manual.

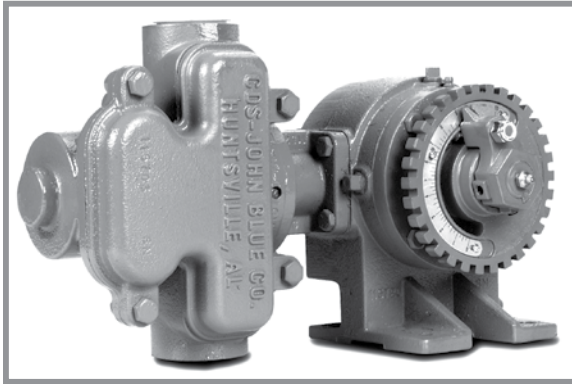

Piston pump

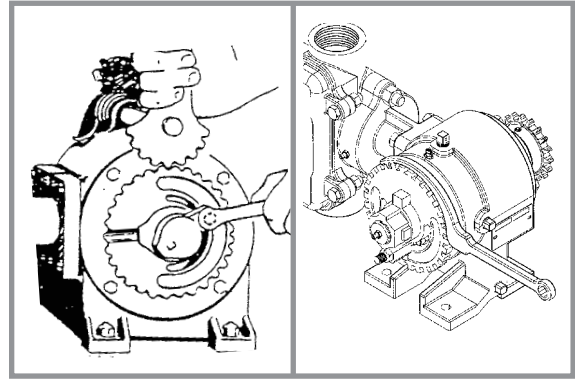

Adjusting delivery rate

NOTE: Delivery rate chart at back of this section provides approximate application rate only. Delivery varies with temperature and fertilizer.

Loosen $\frac{3}{8}$ " lock nut that secures arm with pointer and rotate scale flange with adjustment wrench until pointer is over desired scale setting. Tighten $\frac{3}{8}$ " lock nut. **DO NOT OVERTIGHTEN.**

NOTE: Periodically check flow to all rows. Set rate is still delivered to remaining rows if one or more lines are plugged.

PISTON PUMP GROUND DRIVE WHEEL SPRING ADJUSTMENT

Initial down pressure spring tension on piston pump ground drive wheel, is set leaving $12\frac{1}{4}$ " between the bottom of mounting plate and plug on top of spring. This dimension is taken with planter raised (tire not contacting the ground). Further adjustment can be made to fit conditions.

NOTE: Piston pump ground drive wheel assembly can be locked in raised position when not in use. Remove two cap screws that attach upper end of spring to spring mount. Reattach spring using upper holes in spring mount. Reverse procedure to reset for field use.

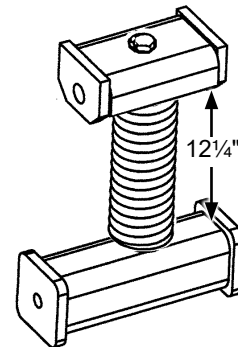

CLEANING

Clean tanks, hoses, and metering pump thoroughly with water at end of planting season or prior to an extended period of non-use. Do not allow fertilizer to crystallize from cold temperature or evaporation.

On machines equipped with piston pump, take apart and clean strainer located between piston pump and ball valve daily. Remove the end cap to clean the screen. See Piston Pump Storage in Maintenance Section of this manual.

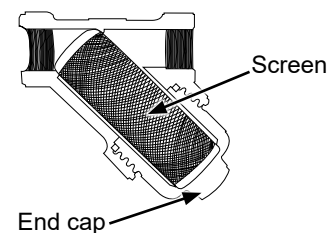

**LIQUID FERTILIZER PISTON PUMP APPLICATION RATES
GALLONS PER ACRE**

**Model NGP-6055 Piston Pump
With 18 Tooth Sprocket (Planter Equipped With One Piston Pump)**

Pump Setting	2	3	4	5	6	7	8	9	10
12 Row 30"	10.4	15.5	20.6	25.8	31.0	36.2	41.3	46.5	51.7
16 Row 30"	6.9	10.3	13.7	17.1	20.6	24.0	27.5	30.9	34.3

Chart is for planters equipped with contact drive. Check tires for correct operating pressure.

Chart calculated based on a solution weighing ten pounds per gallon.

NOTE: Fertilizer application rates can vary from weights calculated in above chart. Make field checks to be sure you are applying fertilizer at desired rate.

NOTE: Periodically check flow rates to all rows. Set flow rate is still delivered to remaining rows even if a lines are plugged.

To check the exact number of gallons your fertilizer attachment will actually deliver on a 30" row spacing:

1. Remove hose from one fertilizer opener and insert it into a collection container secured planter frame.
2. Engage fertilizer attachment and drive forward for 174'.
3. Measure fluid ounces caught in container and multiply by 100. Divide that amount by 128. Result is gallons of fertilizer delivered per acre when planting in 30" rows.
4. Rinse collection container and repeat test on other rows if necessary.

GENERAL PLANTING RATE INFORMATION**NOTICE**

Seed additives added in the hopper may affect finger pickup seed meter performance and accelerate wear.

NOTE: Seed size and shape may affect planting rate.

NOTE: Speeds above 5.5 MPH (8.8 KPH) can adversely affect seed spacing.

See [“Wheat Disc Section” on page 5-2](#) for brush meter and vacuum meter rate chart information.

MECHANICAL SEED METERINGFinger Pickup Corn Meter

Larger grades generally plant more accurately at the high end of the ground speed range than smaller grades. Higher than optimum speeds may result in population rate increase or higher incidence of doubles, particularly with small seed. Medium round corn seed is most desirable for planting accuracy at optimum speed.

Finger Pickup Oil Sunflower Meter

Larger grades generally plant more accurately at the high end of the ground speed range than smaller grades. Higher than optimum speeds may result in population rate increase or higher incidence of doubles, particularly with small seed. No. 3 and/or No. 4 size oil sunflower seeds are recommended for use in finger pickup seed meters equipped with oil sunflower fingers. No. 1 and/or No. 2 size confectionery sunflower seeds are recommended for use in finger pickup seed meters equipped with corn fingers.

Brush-Type Seed Meter (Soybean, Milo/Grain Sorghum, Acid-Delinted Cotton)

Rate charts are given in seeds per acre as well as seed spacing in inches rounded to nearest tenth of an inch. Because of large range in seed size, pounds per acre is not a suggested method of selecting transmission settings. Smaller size seed pounds per acre may be below what was expected and large seed pounds per acre may appear above expectations. To determine pounds per acre, use formula given in “Determining Pounds Per Acre (Brush-Type Seed Meter)” in “Check Seed Population” in Machine Operation section of this manual.

Wheat Disc Section

Drive	Driven	RPM/GS
27	28	3.671
15	15	3.807
28	27	3.948
27	26	3.953

Use a 28 tooth Drive sprocket and a 27 tooth Driven sprocket

FOR HYDRAULIC DRIVE (BRUSH-TYPE AND VACUUM) AND ELECTRIC DRIVE (VACUUM)

- a. Brush-Type: use the instructions found on page 5-9 to find the seeds per revolution (SDS/REV). The SDS/REV will be relatively constant at all speeds for the Brush-Type Meter
- b. Vacuum: use the instructions found on page 5-9 to find the seeds per revolution (SDS/REV) or see the Rate Charts. The SDS/REV will decrease as the disc speed increases (less SDS/REV as ground speed increases) for the True Rate Vacuum Meter.
- c. Divide the SDS/REV by the number of Cells to get the SDS/CELL. Some display may not support 54 cells as an option for number of cells on a seed disc, in that case, substitute a useable number of cells (60 or 40) and use that Cell number in the calculation. DO NOT PHYSICALLY CHANGE THE DISC, THE CELL COUNT IS FOR THE MONITOR ONLY.
- d. Divide your target population by the SDS/CELL to get your Monitor Population.

Seed Meter Type	Target Population	SDS/REV	Cells	SDS/CELL	Monitor Population
Brush	800,000	465	54	8.611	92,903
Brush	1,200,000	465	54	8.611	139,355
Vacuum	808,755	891	54	16.500	49,015
Vacuum	1,195,655	771	54	14.278	83,742
Vacuum	808,755	891	60	14.85	54,461
Vacuum	1,195,655	771	60	12.85	93,047

**PLANTING RATES FOR BRUSH-TYPE SEED METERS (HALF RATE DRIVE)
APPROXIMATE SEEDS/ACRE FOR 15" ROW WIDTH**

Transmission Sprockets		Population Factor	Rye 400 SDS/REV, 35.9 SDS/GRAM		Wheat 465 SDS/REV, 39.6 SDS/GRAM		Speed Range (MPH)
Drive	Driven		Population (sds/acre)	Population (lbs/acre)	Population (sds/acre)	Population (lbs/acre)	
15	28	1190.12	476,159	29	553,656	31	4 to 6
15	27	1234.20	493,795	30	574,163	32	4 to 6
15	26	1281.67	512,787	32	596,245	33	4 to 6
15	25	1332.94	533,298	33	620,095	35	4 to 6
17	28	1348.80	539,647	33	627,477	35	4 to 6
15	24	1388.48	555,519	34	645,932	36	4 to 6
17	27	1398.76	559,634	34	650,718	36	4 to 6
15	23	1448.84	579,672	36	674,017	38	4 to 6
17	26	1452.56	581,158	36	675,745	38	4 to 6
19	28	1507.49	603,134	37	701,298	39	4 to 6
17	25	1510.66	604,405	37	702,775	39	4 to 6
19	27	1563.32	625,473	38	727,272	41	4 to 6
17	24	1573.60	629,588	39	732,056	41	4 to 6
19	26	1623.45	649,530	40	755,244	42	4 to 6
17	23	1642.02	656,961	40	763,885	43	4 to 6
19	25	1688.39	675,511	42	785,454	44	4 to 6
15	19	1753.86	701,708	43	815,915	45	4 to 6
19	24	1758.74	703,658	43	818,181	46	4 to 6
23	28	1824.85	730,111	45	848,940	47	4 to 6
19	23	1835.20	734,251	45	853,754	48	4 to 6
23	27	1892.44	757,152	47	880,382	49	4 to 6
24	28	1904.19	761,855	47	885,850	49	4 to 6
15	17	1960.20	784,262	48	911,905	51	4 to 6
23	26	1965.23	786,273	48	914,242	51	4 to 6
24	27	1974.72	790,071	49	918,660	51	4 to 6
25	28	1983.54	793,598	49	922,761	51	4 to 6
17	19	1987.71	795,269	49	924,703	52	4 to 6
23	25	2043.84	817,724	50	950,813	53	4 to 6
24	26	2050.67	820,459	50	953,993	53	4 to 6
25	27	2057.00	822,991	51	956,937	53	4 to 6
26	28	2062.88	825,342	51	959,671	53	4 to 6
23	24	2128.99	851,795	52	990,429	55	4 to 6
24	25	2132.70	853,277	52	992,152	55	4 to 6
25	26	2136.11	854,644	53	993,742	55	4 to 6
26	27	2139.28	855,911	53	995,215	55	4 to 6
27	28	2142.22	857,087	53	996,582	56	4 to 6
15	15	2221.56	888,830	55	1,033,492	58	4 to 6
28	27	2303.84	921,750	57	1,071,769	60	4 to 6
27	26	2307.01	923,016	57	1,073,242	60	4 to 6
26	25	2310.42	924,384	57	1,074,832	60	4 to 6
25	24	2314.13	925,865	57	1,076,554	60	4 to 6
24	23	2318.15	927,475	57	1,078,426	60	4 to 6
28	26	2392.45	957,202	59	1,112,991	62	4 to 6
27	25	2399.28	959,937	59	1,116,171	62	4 to 6
26	24	2406.69	962,899	59	1,119,616	62	4 to 6
25	23	2414.74	966,120	59	1,123,361	63	4 to 6
19	17	2482.92	993,399	61	1,155,079	64	4 to 6

Continued on the next page.

**PLANTING RATES FOR BRUSH-TYPE SEED METERS (HALF RATE DRIVE)
APPROXIMATE SEEDS/ACRE FOR 15" ROW WIDTH**

Transmission Sprockets		Population Factor	Rye 400 SDS/REV, 35.9 SDS/GRAM		Wheat 465 SDS/REV, 39.6 SDS/GRAM		Speed Range (MPH)
Drive	Driven		Population (sds/acre)	Population (lbs/acre)	Population (sds/acre)	Population (lbs/acre)	
28	25	2488.15	995,490	61	1,157,511	64	4 to 6
27	24	2499.26	999,934	61	1,162,678	65	4 to 6
26	23	2511.33	1,004,765	62	1,168,295	65	4 to 6
17	15	2517.77	1,007,341	62	1,171,291	65	4 to 6
28	24	2591.82	1,036,969	64	1,205,741	67	4 to 6
27	23	2607.92	1,043,409	64	1,213,230	68	4 to 6
23	19	2689.26	1,075,952	66	1,251,069	70	4 to 6
28	23	2704.51	1,082,054	67	1,258,164	70	4 to 6
24	19	2806.18	1,122,733	69	1,305,464	73	4 to 6
19	15	2813.98	1,125,852	69	1,309,090	73	4 to 6
25	19	2923.10	1,169,513	72	1,359,857	76	4 to 6
23	17	3005.64	1,202,535	74	1,398,254	78	4 to 6
26	19	3040.03	1,216,294	75	1,414,252	79	4 to 6
24	17	3136.32	1,254,820	77	1,459,048	81	4 to 6
27	19	3156.95	1,263,075	78	1,468,647	82	4 to 6
25	17	3267.00	1,307,103	80	1,519,841	85	4 to 6
28	19	3273.88	1,309,855	81	1,523,041	85	4 to 6
26	17	3397.68	1,359,388	84	1,580,635	88	4 to 6
23	15	3406.39	1,362,873	84	1,584,687	88	4 to 6
27	17	3528.36	1,411,671	87	1,641,428	91	4 to 6
24	15	3554.50	1,422,128	87	1,653,587	92	4 to 6
28	17	3659.04	1,463,956	90	1,702,222	95	4 to 6
25	15	3702.60	1,481,384	91	1,722,487	96	4 to 6
26	15	3850.70	1,540,639	95	1,791,386	100	4 to 6
27	15	3998.81	1,599,895	98	1,860,286	104	4 to 6
28	15	4146.91	1,659,150	102	1,929,185	107	4 to 6

NOTE: Seed size and type affect the output rate of the meter. For a method to improve the population accuracy with your desired seed, please see the following pages.

NOTE: See "Mechanical Meter General Planting Rate Information" and "Check Seed Population" pages for additional information.

NOTE: When using Half Rate (2 To 1) Drive Reduction Package, rates are approximately 50% of given numbers.

NOTE: Always field check seed population to ensure planting rates are correct.

To more accurately predict population when using the 54 Cell Wheat disc, two things are needed:

1. Seeds/gram
2. Grams/revolution of seed disc

Seeds per gram can be found by weighing a small sample of desired seed (a cup or less) and counting number of seeds in sample.

$$\frac{\text{Seeds}}{\text{Grams}} = \frac{\text{number of seeds in sample}}{\text{weight of sample in grams}} \quad \frac{396 \text{ Seeds}}{10 \text{ Grams}} = 39.6 \frac{\text{seeds}}{\text{gram}}$$

To find grams/revolution a gram scale, a stopwatch, a small container to catch seed, and a method for spinning the meter at a constant, known rpm (see your local Kinze dealer with a T4000 Seed Meter Test Stand) are needed.

1. Zero gram scale with the small container on it.
2. Load meter with correct disc.
3. Load meter with desired seed.
4. Start spinning meter at a known, constant rpm.
5. Start stopwatch as you place container under meter.
6. Catch seed with container for 10-30 seconds.
7. Stop the stopwatch as you remove container from underneath meter.
8. Weigh container.
9. Enter meter rpm, weight of sample, and duration of sample collection into the equation below:

$$\frac{\text{Grams}}{\text{Rev}} = \frac{\text{Sample Weight} * 60}{\text{Disc RPM} * \text{Sample Duration}}$$

EX: For a sample taken for 30 seconds with meter spinning at 50rpm and weighs 293 grams

$$\frac{293 \text{ Grams} * 60}{50 \text{ RPM} * 30 \text{ Seconds}} = 11.7 \frac{\text{Grams}}{\text{Rev}}$$

10. Find desired output rate. For seeds per acre, use seeds/rev. For pounds per acre, use lbs/rev.

a. Seeds/rev:

$$\frac{\text{Seeds}}{\text{Rev}} = \frac{\text{Seeds}}{\text{Grams}} * \frac{\text{Grams}}{\text{Rev}} \quad \left| \quad 39.6 \frac{\text{Seeds}}{\text{Grams}} * 11.7 \frac{\text{Grams}}{\text{Rev}} = 465 \frac{\text{Seeds}}{\text{Rev}} \right.$$

b. Lbs./rev:

$$\frac{\text{Pounds}}{\text{Rev}} = \frac{\frac{\text{Grams}}{\text{Rev}}}{453.6 \frac{\text{Grams}}{\text{Pound}}} \quad \left| \quad \frac{11.7 \frac{\text{Grams}}{\text{Rev}}}{453.6 \frac{\text{Grams}}{\text{Pound}}} = 0.0258 \frac{\text{Pounds}}{\text{Rev}} \right.$$

11. Find the correct population factor by dividing the desired population by the measured output rate.

Seeds/acre:

$$\frac{\text{Target Population}}{\text{Output Rate}} = \text{Population Factor} \quad \left| \quad \frac{1,000,000 \frac{\text{Seeds}}{\text{Acre}}}{465 \frac{\text{Seeds}}{\text{Rev.}}} = 2150.54$$

pounds/acre:

$$\frac{\text{Target Population}}{\text{Output Rate}} = \text{Population Factor} \quad \left| \quad \frac{56 \frac{\text{lbs}}{\text{Acre}}}{0.0258 \frac{\text{lbs}}{\text{rev}}} = 2170.54$$

12. Find the closest Population Factor in the Rate Chart to identify the correct transmission sprockets. For the examples list above, the closest Population Factor is 2142.22 which corresponds to a 27 tooth Drive sprocket and 28 tooth Driven sprocket.

NOTE: Multiple trials are recommended to increase the accuracy of the predicted rate.

**PLANTING RATES FOR (VACUUM) WHEAT 54 CELL DISC
(HALF RATE DRIVE [15 TOOTH])
APPROXIMATE SEEDS/ACRE FOR 15" ROW WIDTH**

Transmission Sprockets		RPM/GS (Seed Disc RPM To Ground Speed (MPH))	81NH2O, no sigulator		81NH2O, sigulator 3.3		Speed Range (MPH)
Drive	Driven		SDS/REV	Population	SDS/REV	Population	
15	28	2.039	909	744,562	554	453,298	5 to 7
15	27	2.115	903	764,594	551	465,585	5 to 7
15	26	2.196	897	785,948	547	478,707	5 to 7
15	25	2.284	891	808,755	543	492,751	5 to 7
17	28	2.311	888	815,760	542	497,071	5 to 7
15	24	2.379	883	833,164	539	507,816	5 to 7
17	27	2.397	882	837,650	539	510,588	5 to 7
15	23	2.483	876	859,343	535	524,013	5 to 7
17	26	2.489	875	860,943	535	525,004	5 to 7
19	28	2.583	868	884,424	531	539,571	5 to 7
17	25	2.589	868	885,771	530	540,408	5 to 7
19	27	2.679	861	907,980	527	554,221	5 to 7
17	24	2.697	860	912,286	526	556,903	5 to 7
19	26	2.782	854	932,998	522	569,822	5 to 7
17	23	2.814	852	940,653	521	574,605	5 to 7
19	25	2.893	846	959,608	518	586,466	5 to 7
15	19	3.006	838	986,010	513	603,032	5 to 7
19	24	3.014	837	987,957	513	604,256	5 to 7
23	28	3.127	829	1,014,147	508	620,748	5 to 7
19	23	3.145	828	1,018,206	508	623,310	5 to 7
23	27	3.243	821	1,040,464	504	637,378	5 to 7
24	28	3.263	819	1,044,993	503	640,247	5 to 7
15	17	3.359	813	1,066,386	499	653,818	5 to 7
23	26	3.368	812	1,068,291	499	655,029	5 to 7
24	27	3.384	811	1,071,881	498	657,311	5 to 7
25	28	3.399	810	1,075,206	497	659,426	5 to 7
17	19	3.406	809	1,076,779	497	660,427	5 to 7
23	25	3.502	803	1,097,745	493	673,790	5 to 7
24	26	3.514	802	1,100,276	493	675,407	5 to 7
25	27	3.525	801	1,102,616	493	676,902	5 to 7
26	28	3.535	801	1,104,786	492	678,288	5 to 7
23	24	3.648	793	1,128,951	488	693,762	5 to 7
24	25	3.655	792	1,130,291	487	694,622	5 to 7
25	26	3.661	792	1,131,527	487	695,416	5 to 7
26	27	3.666	792	1,132,671	487	696,150	5 to 7
27	28	3.671	791	1,133,732	487	696,831	5 to 7
15	15	3.807	782	1,162,044	482	715,055	5 to 7
28	27	3.948	772	1,190,735	476	733,619	5 to 7
27	26	3.953	772	1,191,825	476	734,326	5 to 7
26	25	3.959	772	1,193,001	476	735,089	5 to 7
25	24	3.966	771	1,194,273	476	735,915	5 to 7
24	23	3.973	771	1,195,655	475	736,812	5 to 7
28	26	4.100	762	1,220,871	471	753,227	5 to 7
27	25	4.112	762	1,223,163	470	754,723	5 to 7
26	24	4.124	761	1,225,641	470	756,341	5 to 7
25	23	4.138	760	1,228,328	469	758,097	5 to 7
19	17	4.255	752	1,250,825	465	772,837	5 to 7
28	25	4.264	752	1,252,531	465	773,957	5 to 7
27	24	4.283	750	1,256,146	464	776,334	5 to 7
26	23	4.304	749	1,260,061	463	778,909	5 to 7
17	15	4.315	748	1,262,143	463	780,280	5 to 7
28	24	4.442	740	1,285,788	458	795,893	5 to 7

Continued on next page.

**PLANTING RATES FOR (VACUUM) WHEAT 54 CELL DISC
(HALF RATE DRIVE [15 TOOTH])
APPROXIMATE SEEDS/ACRE FOR 15" ROW WIDTH**

Transmission Sprockets		RPM/GS (Seed Disc RPM To Ground Speed (MPH))	8INH2O, no sigulator		8INH2O, sigulator 3.3		Speed Range (MPH)
Drive	Driven		SDS/REV	Population	SDS/REV	Population	
27	23	4.469	738	1,290,855	457	799,250	5 to 7
23	19	4.609	729	1,316,059	452	816,013	5 to 7
28	23	4.635	728	1,320,711	451	819,119	5 to 7
24	19	4.809	717	1,351,123	445	839,524	5 to 7
19	15	4.822	716	1,353,411	445	841,067	5 to 7
25	19	5.009	704	1,384,810	438	862,343	5 to 7
23	17	5.151	695	1,407,761	433	878,034	5 to 7
26	19	5.210	692	1,417,121	431	884,470	5 to 7
24	17	5.375	682	1,442,697	426	902,174	5 to 7
27	19	5.410	680	1,448,057	425	905,906	5 to 7
25	17	5.599	668	1,475,915	419	925,450	5 to 7
28	19	5.610	668	1,477,616	418	926,651	5 to 7
26	17	5.823	655	1,507,414	412	947,862	5 to 7
23	15	5.837	654	1,509,452	411	949,325	5 to 7
27	17	6.046	642	1,537,193	405	969,410	5 to 7
24	15	6.091	640	1,542,943	403	973,616	5 to 7
28	17	6.270	630	1,565,254	398	990,094	5 to 7
25	15	6.345	625	1,574,226	395	996,797	5 to 7
26	15	6.599	611	1,603,300	388	1,018,868	5 to 7
27	15	6.853	598	1,630,167	381	1,039,830	5 to 7
28	15	7.106	584	1,654,826	374	1,059,683	5 to 7

1. Identify planting parameters and record in Table #1.
2. Weigh small sample of seeds and complete Table #2.
3. Use a device to spin the meter at a constant, measured RPM (Seed Meter Test Stand T4000). Set the RPM to settings in the table below (15, 20, 25, 30) and collect a sample of seed coming out of the meter. It is recommended to start with a Vacuum pressure of 8INH2O and removing the singulator. Increasing the vacuum pressure will increase the SDS/REV while using the singulator will decrease the SDS/REV. Weigh the sample of seed and record the length of time the sample was collected in Table #3.
4. Complete Table #3 for each RPM setting using information from Tables 1 and 2. Variables with the subscript “ $[\text{RPM}]$ ” uses the values in the same row in Table #3.
5. Choose the 2 closest populations to your desired target population and add them to Table #4 with their respective seeds per rev.
6. Complete Table #4 and calculate the approximate seeds per rev.
7. Calculate Seed Disc RPM/Ground Speed Ratio in Table #5.
8. Select the closest RPM/GS (Seed Disc RPM to Ground Speed (mph)) in the rate chart and use that Drive and Driven pair.

Table #1				Table #2	
Target Population [seeds/acre] (Pop_{TAR})				Number of Seeds (N)	
Ideal Planting Ground Speed [mph] (GS)				Weight of sample [grams] (W)	
Planter Row Spacing [in] (RS)				Seeds/ Gram = N/W (SG)	
Table #3					
			$SR_{RPM} = \frac{W_{RPM}}{t_{RPM}} \times \left(\frac{60}{RPM}\right) \times SG$		$Pop_{RPM} = \frac{SR_{RPM} \times RPM \times 5940}{GS \times RS}$
Vacuum Pressure	Disc RPM	Weight [grams] (W_{RPM})	Time [sec.] (t_{RPM})	Seeds/ Rev (SR_{RPM})	Population (Pop_{RPM})
	15				
Sing. Setting	20				
	25				
	30				
Table #4					
Pop_1		Pop_2		Pop_{TAR}	
SR_1		SR_2			
$SR_{TAR} = \left(\frac{SR_2 - SR_1}{Pop_2 - Pop_1}\right) \times (Pop_{TAR} - Pop_1) + SR_1$					
Table #5					
GS		$RPM_{TAR} = \frac{Pop_{TAR} \times GS \times RS}{5940 \times SR_{TAR}}$			
RS					
Pop_{TAR}		$\frac{RPM_{Tar}}{GS}$			
SR_{TAR}					

NOTE: Additional worksheets can be found [“Additional Worksheet” on page 5-11](#)

Example.

Table #1				Table #2	
Target Population [seeds/acre] (Pop_{TAR})	1,200,000			Number of Seeds (N)	259
Ideal Planting Ground Speed [mph] (GS)	6mph			Weight of sample [grams] (W)	10.01
Planter Row Spacing [in] (RS)	15 in.			Seeds/ Gram = N/W (SG)	25.88
Table #3					
			$SR_{RPM} = \frac{W_{RPM}}{t_{RPM}} \times \left(\frac{60}{RPM}\right) \times SG$		$Pop_{RPM} = \frac{SR_{RPM} \times RPM \times 5940}{GS \times RS}$
Vacuum Pressure	Disc RPM	Weight [grams] (W_{RPM})	Time [sec.] (t_{RPM})	Seeds/ Rev (SR_{RPM})	Population (Pop_{RPM})
8	15	$\frac{765}{90.43} \times \left(\frac{60}{15}\right) \times 25.88 = 875.7$		$\frac{875.7 \times 15 \times 5940}{6 \times 15} = 866,943$	
		765	90.43	875.7	866,943
Sing. Setting	20	$\frac{640}{60.55} \times \left(\frac{60}{20}\right) \times 25.88 = 820.6$		$\frac{820.6 \times 20 \times 5940}{6 \times 20} = 1,083,192$	
		640	60.55	820.6	1,083,192
removed	25	$\frac{1101}{90.1} \times \left(\frac{60}{25}\right) \times 25.88 = 759$		$\frac{759 \times 25 \times 5940}{6 \times 25} = 1,252,350$	
		1101	90.1	759	1,252,350
removed	30	$\frac{840}{60.58} \times \left(\frac{60}{30}\right) \times 25.88 = 717.7$		$\frac{717.7 \times 30 \times 5940}{6 \times 30} = 1,252,350$	
		840	60.58	717.7	1,421,046
Table #4					
<i>Pop₁</i>	1,083,192	<i>Pop₂</i>	1,252,350	<i>Pop_{TAR}</i>	1,200,000
<i>SR₁</i>	820.6	<i>SR₂</i>	756		
$SR_{TAR} = \left(\frac{SR_2 - SR_1}{Pop_2 - Pop_1}\right) \times (Pop_{TAR} - Pop_1) + SR_1$					776.0
$\left(\frac{756 - 820.6}{1,252,350 - 1,083,192}\right) \times (1,200,000 - 1,083,192) + 820.6 = 776.0$					
Table #5					
GS	6mph	$RPM_{TAR} = \frac{Pop_{TAR} \times GS \times RS}{5940 \times SR_{TAR}}$		23.4	
RS	15 in				
<i>Pop_{TAR}</i>	1,200,000	$\frac{1,200,000 \times 6 \times 15}{5940 \times 776} = 23.4$		23.4	
<i>SR_{TAR}</i>	776.0				
		$\frac{RPM_{Tar}}{GS} = \frac{23.4}{6} = 3.905$		3.905	

Additional Worksheet

Table #1				Table #2	
Target Population [seeds/acre] (Pop_{TAR})				Number of Seeds (N)	
Ideal Planting Ground Speed [mph] (GS)				Weight of sample [grams] (W)	
Planter Row Spacing [in] (RS)				Seeds/ Gram = N/W (SG)	
Table #3					
			$SR_{RPM} = \frac{W_{RPM}}{t_{RPM}} \times \left(\frac{60}{RPM}\right) \times SG$		$Pop_{RPM} = \frac{SR_{RPM} \times RPM \times 5940}{GS \times RS}$
Vacuum Pressure	Disc RPM	Weight [grams] (W_{RPM})	Time [sec.] (t_{RPM})	Seeds/ Rev (SR_{RPM})	Population (Pop_{RPM})
	15				
Sing. Setting	20				
	25				
	30				
Table #4					
<i>Pop₁</i>		<i>Pop₂</i>		<i>Pop_{TAR}</i>	
<i>SR₁</i>		<i>SR₂</i>			
$SR_{TAR} = \left(\frac{SR_2 - SR_1}{Pop_2 - Pop_1}\right) \times (Pop_{TAR} - Pop_1) + SR_1$					
Table #5					
GS		$RPM_{TAR} = \frac{Pop_{TAR} \times GS \times RS}{5940 \times SR_{TAR}}$			
RS					
<i>Pop_{TAR}</i>		$\frac{RPM_{Tar}}{GS}$			
<i>SR_{TAR}</i>					

This page intentionally left blank.

NOTICE

Disconnect all electronic monitor and control modules prior to making any repairs or modifications to the planter or mounted attachments. Failure to do so will result in permanent damage to sensitive electronic components and could void your warranty.

NOTICE

Do not pressure wash any electronic modules directly. Direct pressure washing will result in permanent damage to sensitive electronic components and could void your warranty.

LUBRICATION

Following pages show locations of all lubrication points. Proper lubrication of moving parts helps ensure efficient operation of your Kinze planter and prolongs the life of friction producing parts.

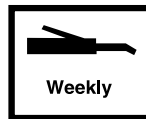
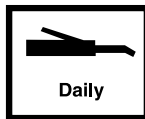
LUBRICATION SYMBOLS

Lubricate at frequency indicated with SAE multipurpose grease.

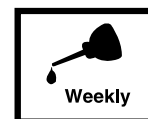

Lubricate at frequency indicated with high quality SAE 10 weight oil or spray lubricant.

SEALED BEARINGS

Sealed bearings are used on your Kinze planter to provide trouble free operation.

These are located on drive shafts, row units, and transmission bearings. Sealed bearings are lubricated for life and are not serviceable.

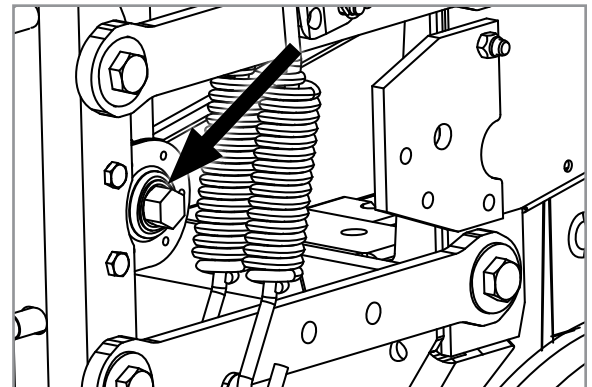

Sealed bearing (Typical)

WHEEL BEARINGS

All drive, transport, and marker hub wheel bearings should be repacked annually and checked for wear.

1. Raise wheel off ground.
2. Check for bearing endplay by moving wheel side to side.
3. Rotate wheel to check for bearing roughness. If bearings sound rough, remove hub and inspect bearings.

NOTE: To repack wheel hubs, follow procedure outlined for wheel bearing replacement in this section except bearings and bearing cups are reused.

DRIVE CHAINS

Lubricate all transmission and drive chains daily with a high quality chain lubricant. Extreme operating conditions such as dirt, temperature, or speed may require more frequent lubrication. If a chain becomes stiff, it should be removed, soaked, and washed in solvent to loosen and remove dirt from joints. Soak chain in oil so lubricant can penetrate between rollers and bushings.

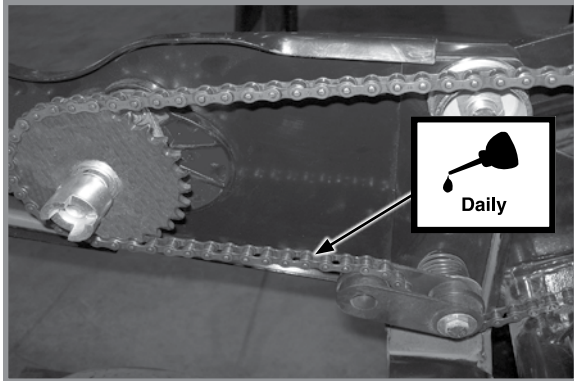

Pull row unit drive chains

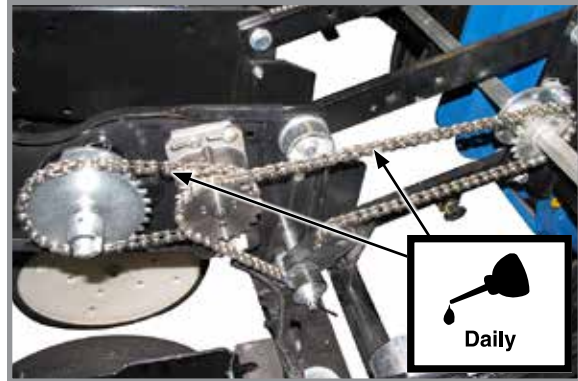

Row Unit Electric Clutches

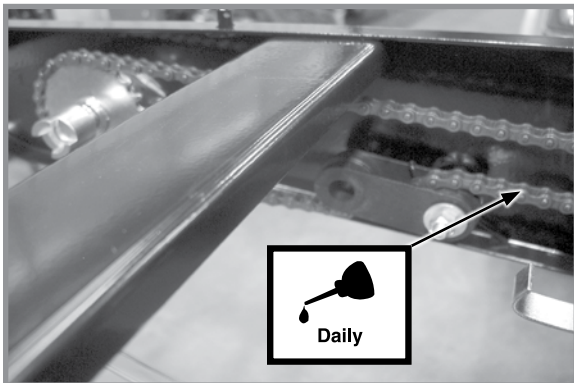

Row unit granular chemical drive chains

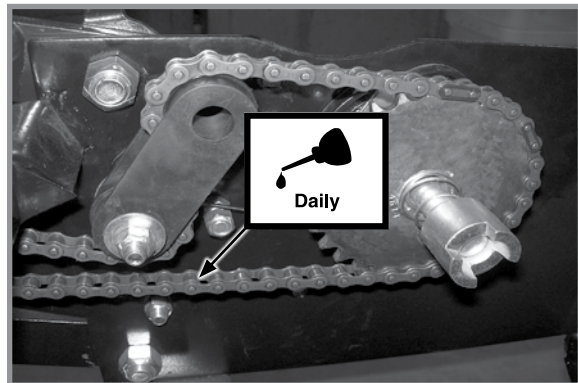

Push row unit drive chains

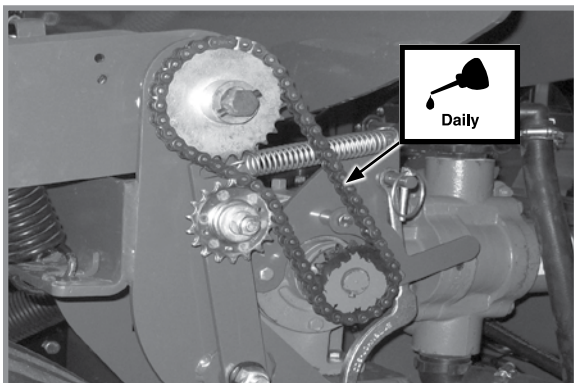

**Liquid fertilizer ground drive chains
(Piston pump)**

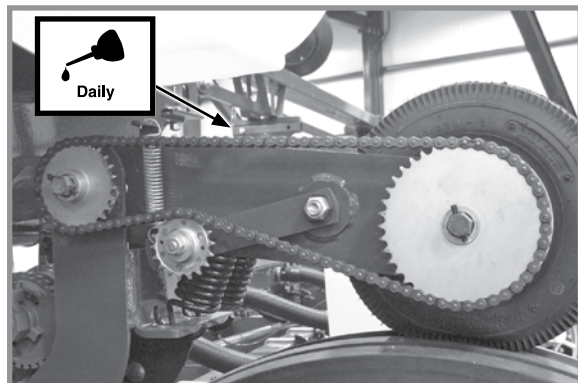

**Liquid fertilizer ground drive chains
(Piston pump)**

BUSHINGS

Lubricate bushings at frequency indicated.

Check each bolt for proper torque. If bolt is loose, removed it and inspect bushing for cracks and wear. Replace bushing if necessary. Use **only hardened flat washers**. Replace damaged flat washers with proper part. Torque hardware to **130 ft-lb (176.2 N-m)**.

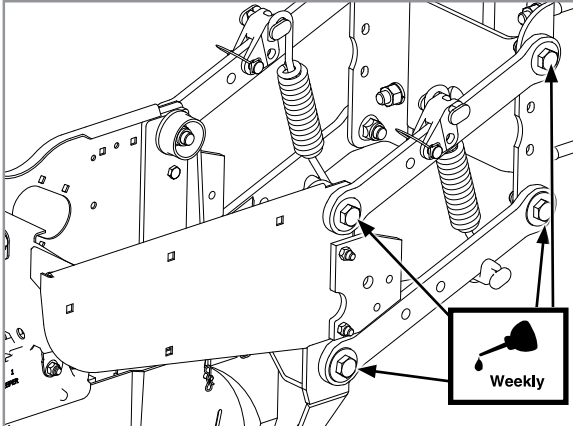

Pull Row Unit And/Or Push Row Unit Parallel Linkages (8 Per Row)

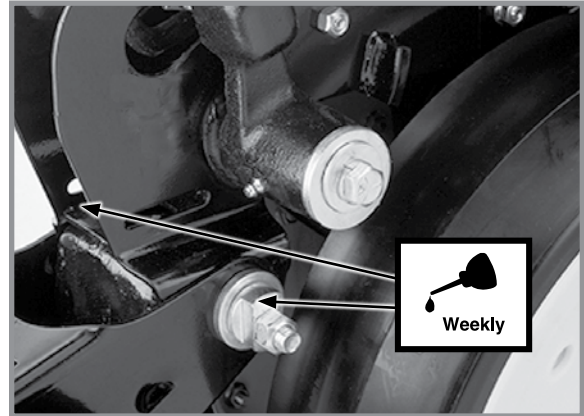

Row unit "v" closing wheel, covering discs/ single press wheel and/or drag closing wheel eccentric bushings (2 per row)

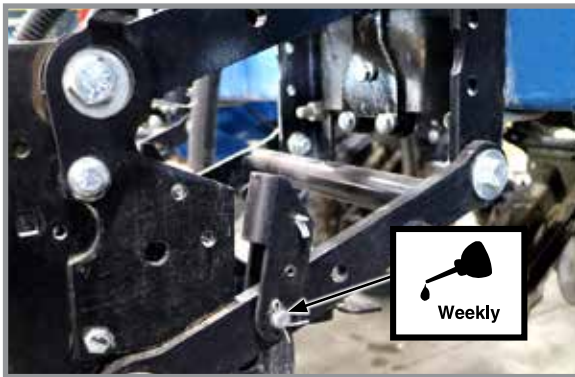

Split Row Push Row Unit Lockups (2 Per Row)

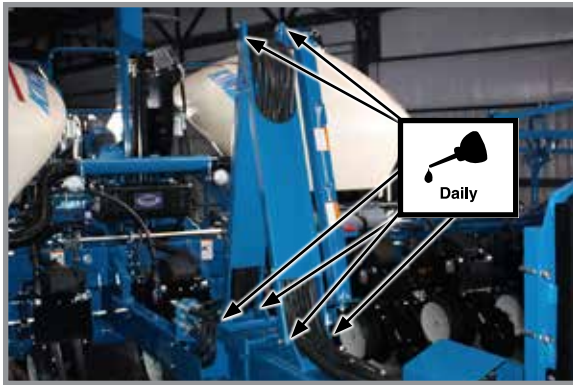

Hose take-up (6 locations)

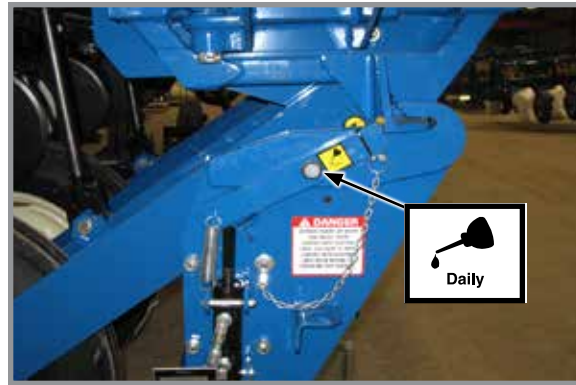

Transport latch (1 location)

CENTER POST

NOTICE

Any oil or grease on center post and poly wear pads will attract dirt and accelerate wear. Do not lubricate center post and poly wear pads.

Center post is clad with stainless steel. Keep stainless steel surface clean and free of any lubrication to prolong service life. See ["Center Frame Wear Pads" on page 6-38](#) for more information.

U-JOINT SLIDES

Lubricate all U-joint slides daily with a high quality lubricant.

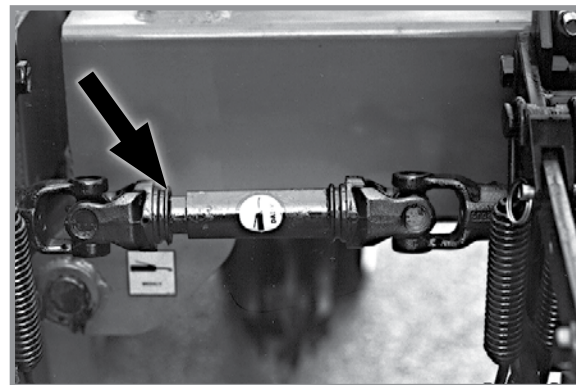

U-joint slide

LIQUID FERTILIZER PISTON PUMP CRANKCASE OIL LEVEL

Check crankcase oil daily and maintain at oil level check plug. Fill as needed with EP 90 weight gear oil. Total oil capacity is approximately ¾ pint.

Refer to operator and instruction manual supplied with pump and flow divider for more information.

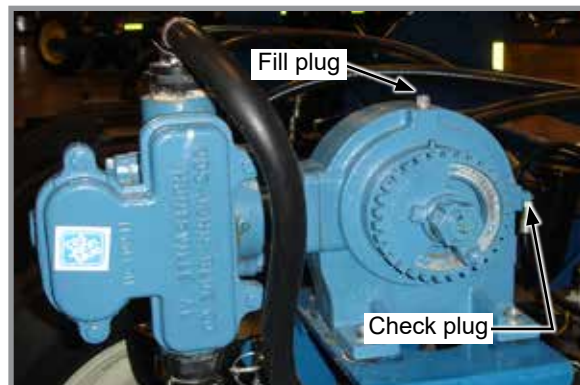

Piston pump oil fill and check plug locations

PTO PUMP SHAFT COUPLING (TRACTOR DRIVEN PTO PUMP AND OIL COOLER OPTION)

NOTE: Clean and grease PTO shaft coupling each time pump is installed.

NOTE: Apply coating of high-speed industrial coupling grease, such as Chevron Coupling Grease meeting AGMA CG-1 and CG-2 Standards, to extend shaft spline life.

NOTE: Keep cooler and fan free of debris buildup, performance may decrease if fan has debris buildup.

Chevron® trademark is owned by Chevron Products Company. AGMA is the acronym for the American Gear Manufacturers Association.

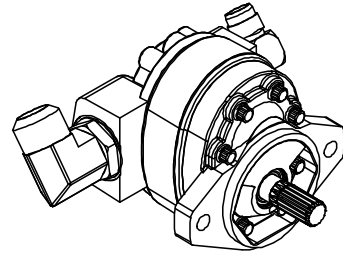

**PTO-driven hydraulic pump
($\frac{7}{8}$ "-13 tooth spline PTO pump shown)**

GREASE FITTINGS

Parts equipped with grease fittings should be lubricated at frequency indicated with an SAE multipurpose grease. Clean fitting thoroughly before using grease gun. Frequency of lubrication recommended is based on normal operating conditions. Severe or unusual conditions may require more frequent attention.

NOTE: Numbers on illustration below correspond to photos on following pages showing lubrication frequencies.

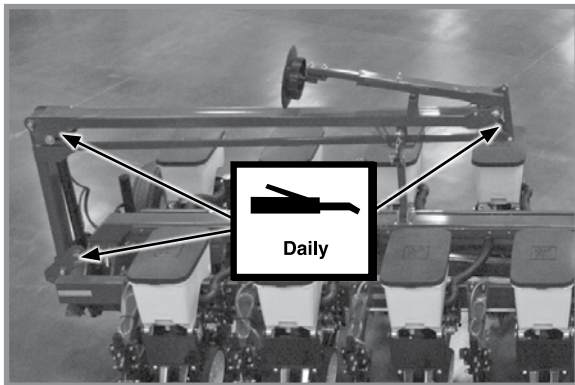
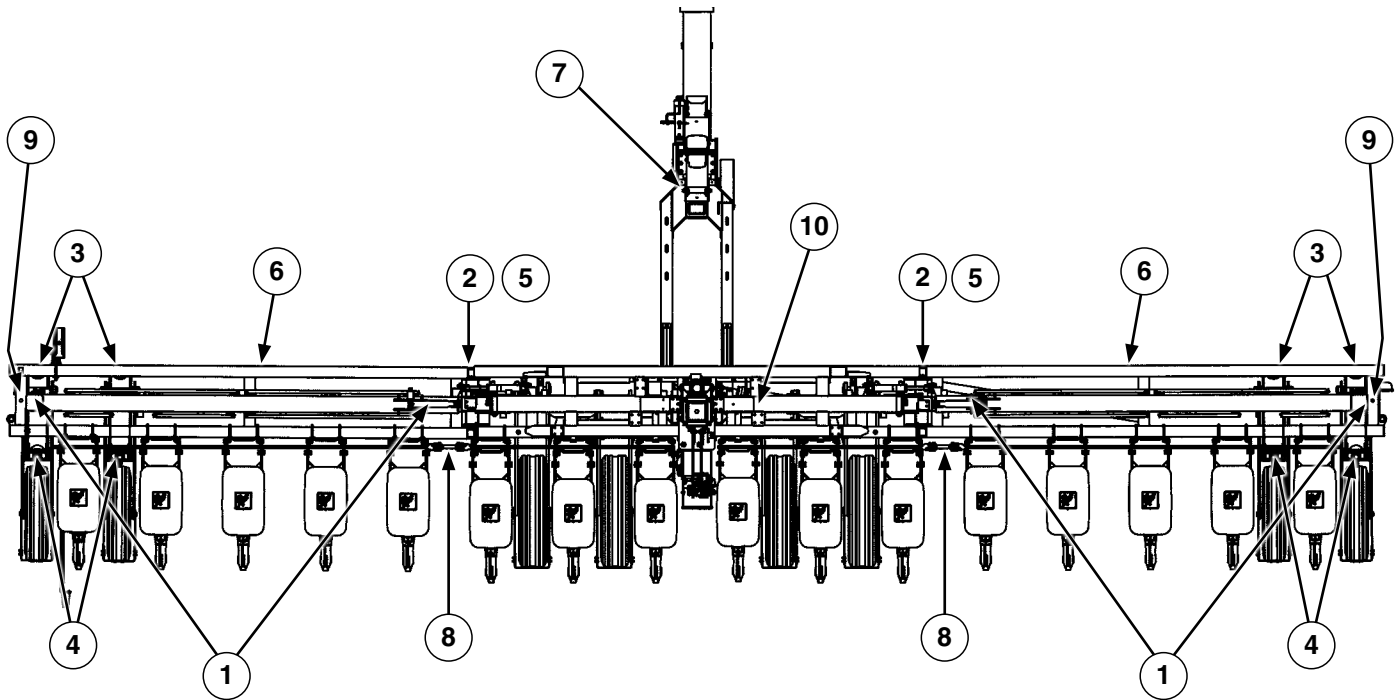

1. Row marker assemblies
3 fittings per assembly - 2 assemblies

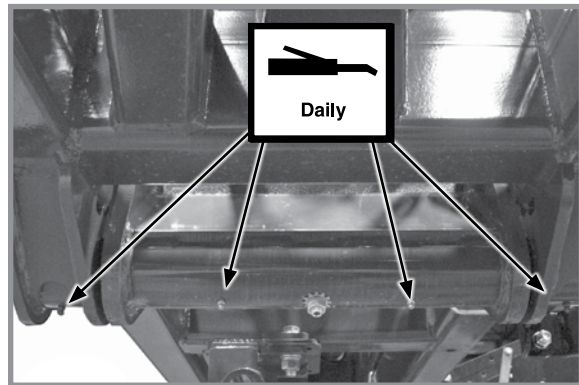

2. Wing hinges
4 fittings per hinge - 2 hinges

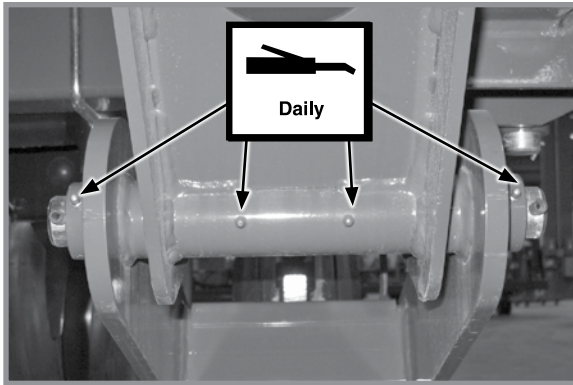

3. Wing wheel pivot
4 fittings per wing wheel - 4 wing wheels

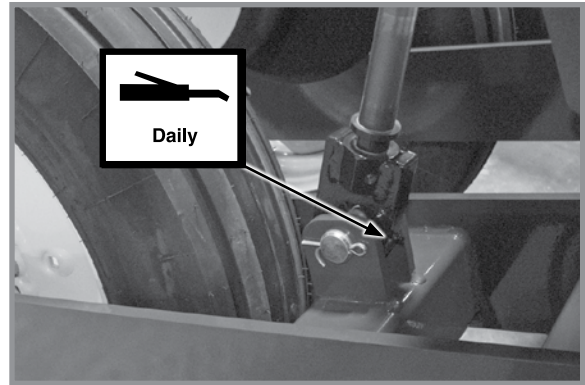

4. Wing lift cylinders
1 per cylinder - 4 cylinders

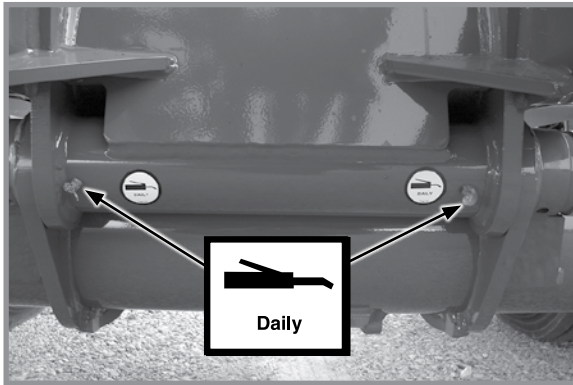

5. Rock shaft
2 fittings

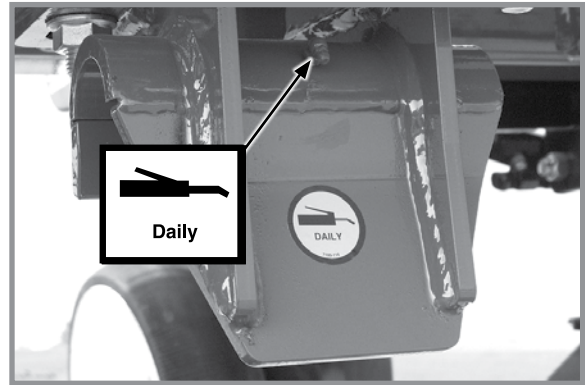

6. Field stabilizer
1 fitting per stabilizer - 2 stabilizers

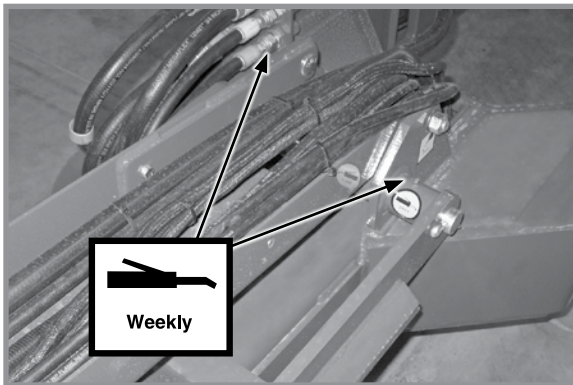

7. Tongue hook
2 fittings

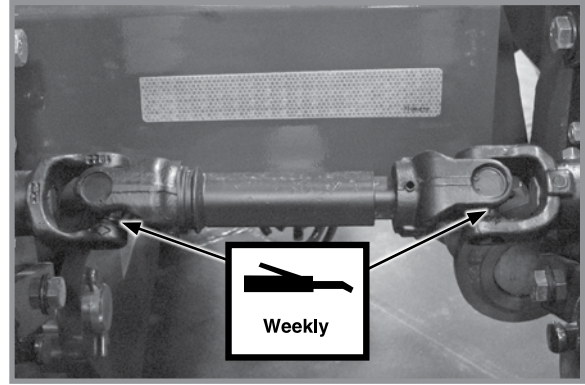

8. U-joints
2 fittings per U-joint - 2 U-joints w/out Interplant
4 U-joints w/Interplant

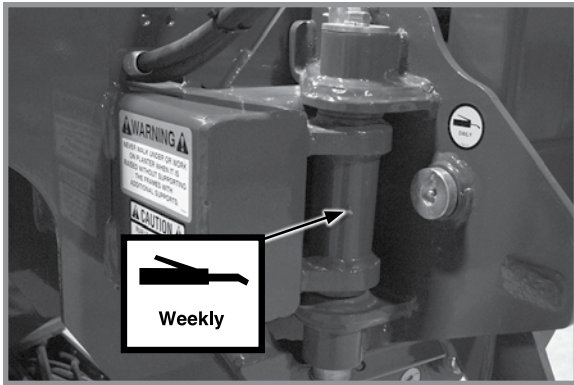

9. Row marker breakaway
1 fitting per breakaway - 2 breakaways

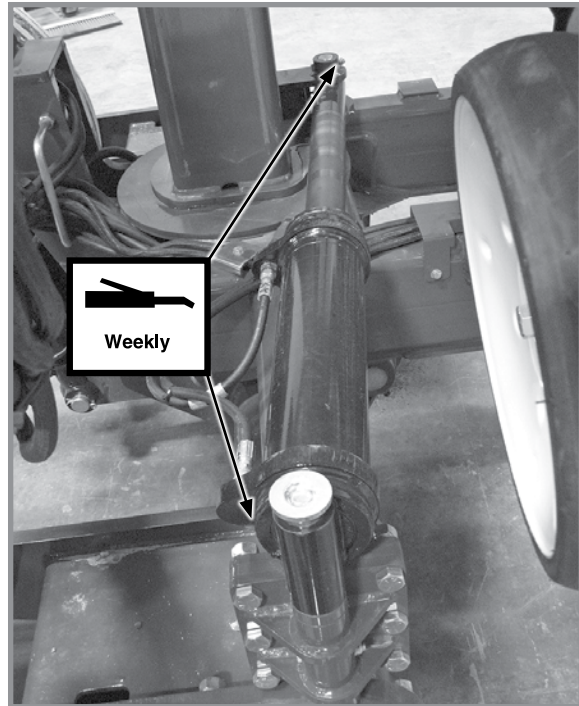

10. Rotate cylinder
2 fittings

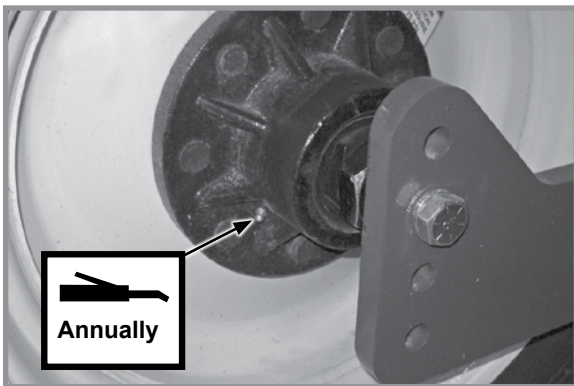

Transport wheel bearings
1 fitting per wheel - 4 wheels

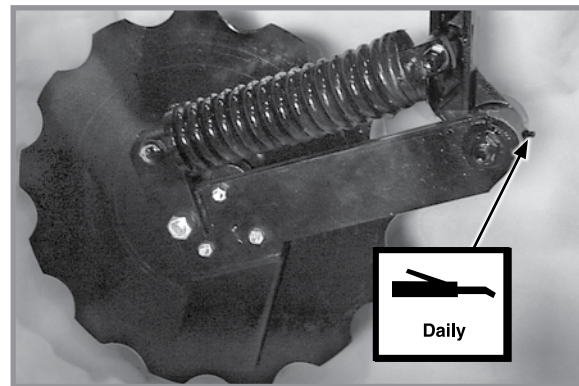

Notched single disc fertilizer opener - 1

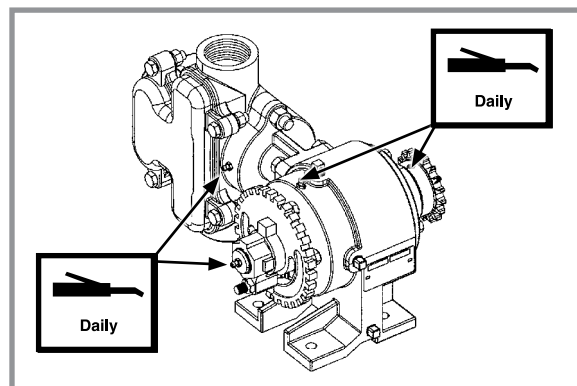

Liquid fertilizer piston pump - 4
NOTE: Fill on outboard stuffing box until lubricant seeps out of drain hole in bottom.

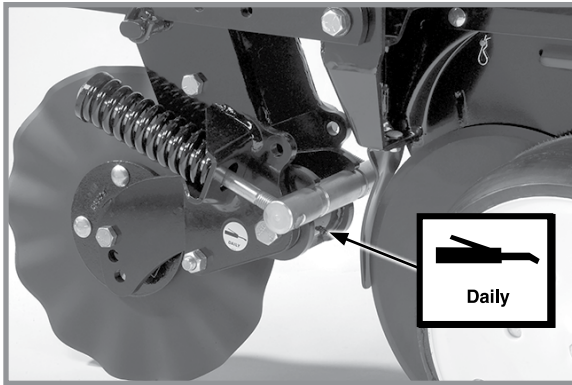

Frame Mounted Coulter - 1 Per Arm

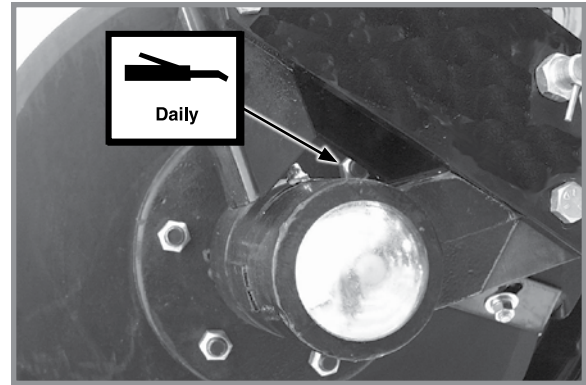

**HD single disc fertilizer opener - 1
(Located on disc opener spindle hub)**

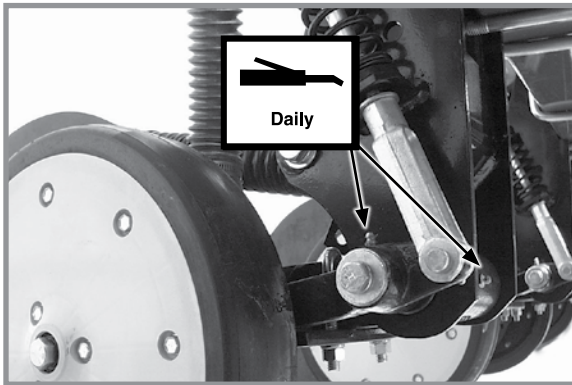

**HD Single Disc Fertilizer Opener - 2
(Located On Wheel Arm And Opener Mount)**

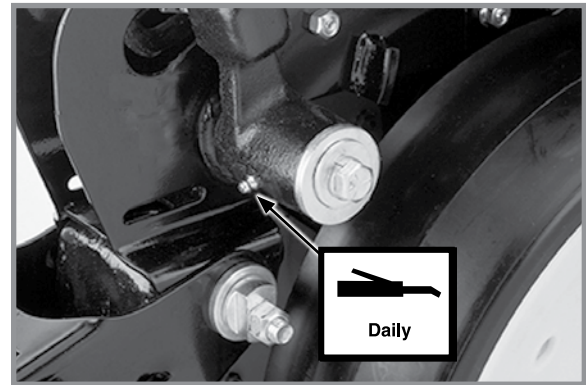

Gauge Wheel Arms - 1 Per Arm
(Seals in gauge wheel arm are installed with lip facing out to allow grease to purge dirt away from seal. Pump grease into arm until fresh grease appears between washers and arm.)

MOUNTING BOLTS AND HARDWARE

Before operating planter for the first time, check all hardware is tight. Check all hardware again after first 50 hours of operation and beginning of each planting season.

All hardware used on the Kinze planter is Grade 5 (high strength) unless otherwise noted. Grade 5 cap screws are marked with three radial lines on the head. Hardware must be replaced with equal size, strength, and thread type.

WARNING



Loose transport wheel lug bolts can result in wheel separation from planter and result in death, serious injury, and damage to property and equipment. Check transport wheel lug nut torque before operating planter for the first time and periodically thereafter.



NOTICE

Over-tightening hardware can reduce its shock load capacity and cause equipment failure.

TORQUE VALUES CHART - PLATED HARDWARE

Diameter	Grade 2 (No marks) 		Grade 5 (3 marks) 		Grade 8 (6 marks) 	
	Coarse	Fine	Coarse	Fine	Coarse	Fine
1/4"	50 in-lb	56 in-lb	76 in-lb	87 in-lb	9 ft-lb	10 ft-lb
5/16"	8 ft-lb	9 ft-lb	13 ft-lb	14 ft-lb	18 ft-lb	20 ft-lb
3/8"	15 ft-lb	17 ft-lb	23 ft-lb	26 ft-lb	33 ft-lb	37 ft-lb
7/16"	25 ft-lb	27 ft-lb	37 ft-lb	41 ft-lb	52 ft-lb	58 ft-lb
1/2"	35 ft-lb	40 ft-lb	57 ft-lb	64 ft-lb	80 ft-lb	90 ft-lb
9/16"	50 ft-lb	60 ft-lb	80 ft-lb	90 ft-lb	115 ft-lb	130 ft-lb
5/8"	70 ft-lb	80 ft-lb	110 ft-lb	125 ft-lb	160 ft-lb	180 ft-lb
3/4"	130 ft-lb	145 ft-lb	200 ft-lb	220 ft-lb	280 ft-lb	315 ft-lb
7/8"	125 ft-lb	140 ft-lb	320 ft-lb	350 ft-lb	450 ft-lb	500 ft-lb
1"	190 ft-lb	205 ft-lb	480 ft-lb	530 ft-lb	675 ft-lb	750 ft-lb
1 1/8"	265 ft-lb	300 ft-lb	600 ft-lb	670 ft-lb	960 ft-lb	1075 ft-lb
1 1/4"	375 ft-lb	415 ft-lb	840 ft-lb	930 ft-lb	1360 ft-lb	1500 ft-lb
1 3/8"	490 ft-lb	560 ft-lb	1100 ft-lb	1250 ft-lb	1780 ft-lb	2030 ft-lb
1 1/2"	650 ft-lb	730 ft-lb	1450 ft-lb	1650 ft-lb	2307 ft-lb	2670 ft-lb

NOTE: Torque unplated hardware and bolts with lock nuts approximately 1/3 higher than above values. Torque bolts lubricated prior to installation to 70% of value shown in chart.

**CYLINDER ROD PISTON RETAINING NUT
TORQUE CHART**

	Non-Nylock Nut	Nylock Nut
½"-20	55-70 ft-lb (75-95 N-m)	45-55 ft-lb (61-75 N-m)
¾"-16	115-125 ft-lb (156-169 N-m)	100-115 ft-lb (136-156 N-m)
7/8"-14	150-180 ft-lb (203-244 N-m)	130-150 ft-lb (176-203 N-m)
1"-14	275-330 ft-lb (373-447 N-m)	250-275 ft-lb (339-373 ft-lb)
1 1/8"-12	300-375 ft-lb (407-508 N-m)	275-300 ft-lb (373-407 N-m)
1 1/4"-12	300-375 ft-lb (407-508 N-m)	275-300 ft-lb (373-407 N-m)

TORQUE VALUES - PNEUMATIC DOWN PRESSURE

Diameter	Torque Value
1/8" NPT	120 in-lb Maximum
1/2"-13	180 in-lb Maximum
3/4"-16	180 in-lb Maximum

NOTE: Use these torque values with pneumatic down pressure components.

SPECIAL TORQUE VALUES

Row unit parallel linkage bushing hardware	130 ft-lb (176 Nm)
5/8" No till coultter spindle hardware	120 ft-lb (162 Nm)
Center section transport tire lug nuts	200 ft-lb (271 Nm)
Wing ground drive tire lug bolts	125 ft-lb (169 Nm)

**TORQUE VALUES - TRUE DEPTH HYDRAULIC
DOWN FORCE**

Cylinder Head to Body:	70 ft-lb
Cylinder Piston to Rod:	50 ft-lb
Row Unit Valve Cartridge to Line Body:	30 ft-lb
Row Unit Valve Solenoid to Valve:	4-6 ft-lb

NOTE:

- 1. A6-Pt Socket must be used to torque the cylinder head to the body.**
- 2. Apply blue threadlocker to cylinder head threads when reassembling.**
- 3. Replace piston to rod locknut with equivalent 7/16-20 locknut before reassembling.**

TIRE PRESSURE

WARNING

Explosive separation of rim and tire parts can cause death or serious injury. Overinflation, rim and tire servicing, improper use of rims and tires, or worn or improperly maintained tires could result in a tire explosion.

To prevent tire explosions:

- Maintain proper tire pressure. Inflating a tire above or below the recommended pressure can cause tire damage.
- Mount tires only by properly trained personnel using proper equipment.
- Replace tires with cuts or bubbles. Replace damaged rims. Replace missing lug bolts and nuts.
- Do not weld or heat wheel assembly. Heating increases tire pressure.

TRANSPORT TIRES

WARNING

Over-inflation of tires can result in explosive separation of rim and tire and cause death or serious injury. Different size rims are designed for different tire pressures. Inflate to correct pressure for specific rim size.

INFLATION SPECIFICATIONS

Transport (center section) 41x11 70R 22.5
75 psi (517.1 kPa) recommended/90 psi (620.5 kPa) max.

Ground drive (wings) 7.50" x 20"40 psi (275.7 kPa)

Liquid fertilizer piston pump 7.60" x 15"40 psi (275.7 kPa)

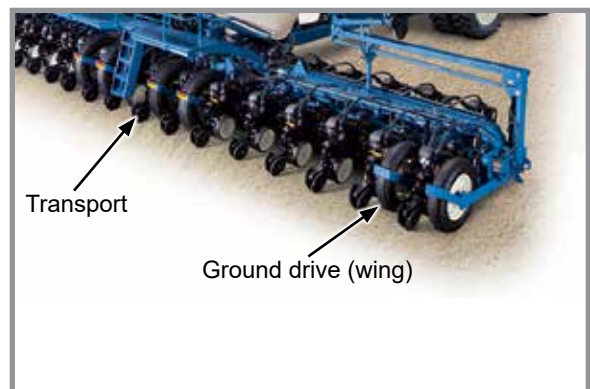

Tire locations

This page intentionally left blank.

TRACTOR DRIVEN PTO PUMP DRIVE AND OIL COOLER OPTION (VACUUM)

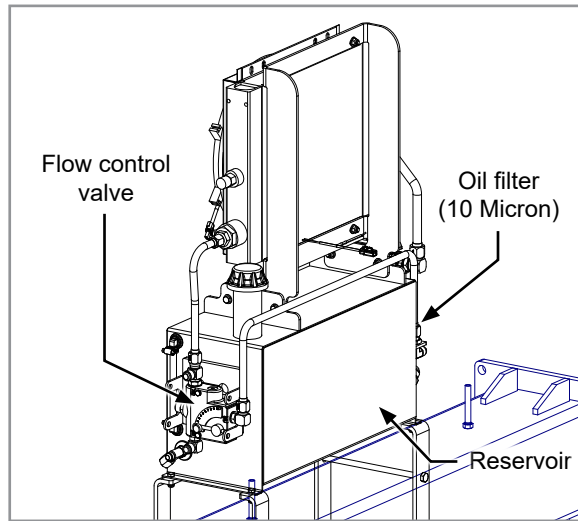

Single Stage - Vacuum or Bulk Fill/Mechanical

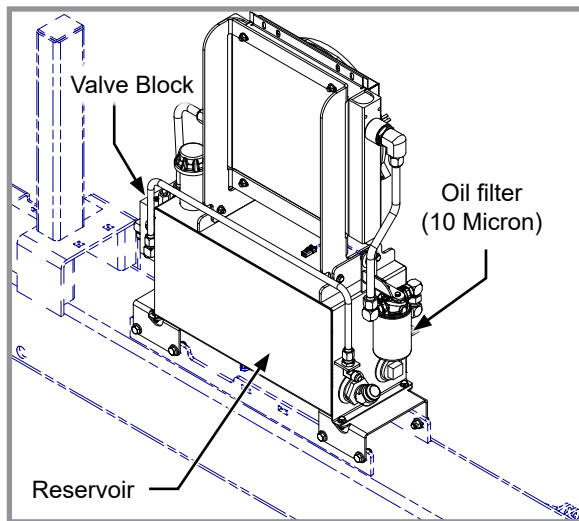

Single Stage - Bulk Fill/Blue Drive

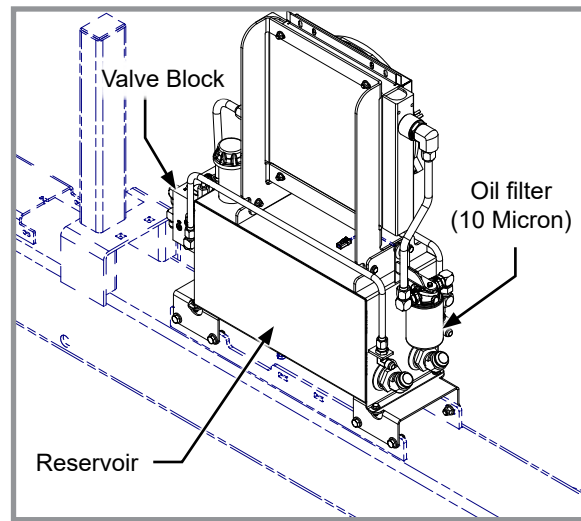

**Dual Stage - Bulk Fill/Mechanical or
Bulk Fill/Blue Drive**

NOTE: Clean and grease PTO shaft coupling with high-pressure industrial coupling grease (Chevron coupling grease or equivalent) meeting AGMA CG-1 and CG-2 Standards each time driveshaft is installed or premature wear and equipment failure can occur.

Chevron® trademark is owned by Chevron Products Company. AGMA is the acronym for American Gear Manufacturers Association.

Drain reservoir and change filter annually.

Fill system with SAE 10W-20 multigrade wide temperature range transmission hydraulic fluid. Reservoir capacity is approximately 12 gallon (45.4L).

Start up proceed after oil change:

1. Start system and run with tractor at idle and fan turned off for 1-2 minutes. Switch fan to full speed and run with tractor at idle for 1-2 minutes.
2. Check reservoir fluid level and fill as required. Hydraulic fluid level should be within 1"-2" from top of reservoir after pump has run and hydraulic hoses have been primed to allow fluid to expand when heated.
3. Bring tractor to full PTO speed and adjust flow control for desired system pressure.

NOTE: Periodically check and clean oil coolers.

High Pressure Filter

NOTE: Replace high pressure filter after first season and then check annually. If debris has collected on filter, replace filter.

1. Remove O-ring plug on top of filter.
2. Pull old filter straight out using handle.
3. Insert new filter.
4. Reinstall O-ring plug.

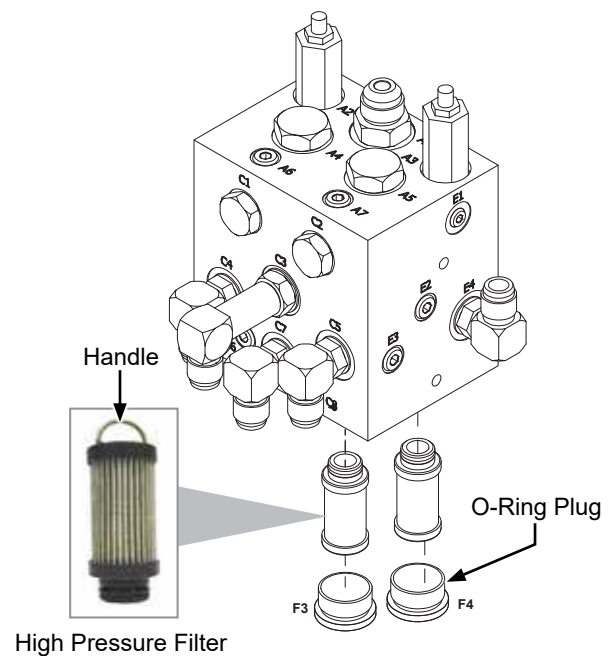

TRACTOR DRIVEN PTO PUMP AND OIL COOLER OPTION (BULK FILL/MECHANICAL)

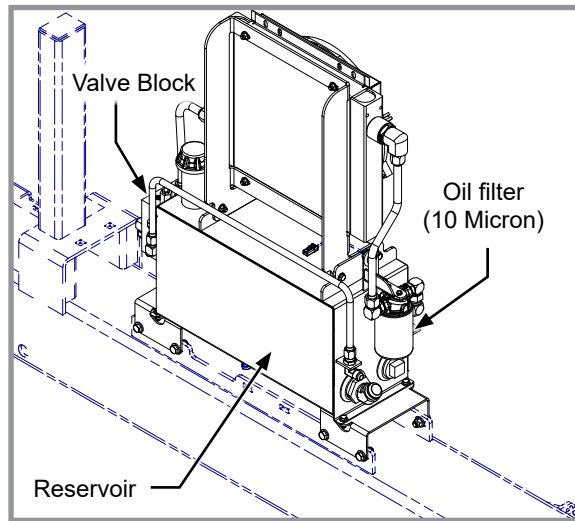

Single Stage - Bulk Fill/Mechanical

NOTE: Clean and grease PTO shaft coupling with high-pressure industrial coupling grease (Chevron coupling grease or equivalent) meeting AGMA CG-1 and CG-2 Standards each time driveshaft is installed or premature wear and equipment failure can occur.

Chevron® trademark is owned by Chevron Products Company. AGMA is the acronym for American Gear Manufacturers Association.

Drain reservoir and change filter annually.

Fill system with SAE 10W-20 multigrade wide temperature range transmission hydraulic fluid. Reservoir capacity is approximately 10 gal (37.8L).

Start up proceed after oil change:

1. Start system and run with tractor at idle and fan turned off for 1-2 minutes. Switch fan to full speed and run with tractor at idle for 1-2 minutes.
2. Check reservoir fluid level and fill as required. Hydraulic fluid level should be within 1"-2" from top of reservoir after pump has run and hydraulic hoses have been primed to allow fluid to expand when heated.
3. Bring tractor to full PTO speed and adjust flow control for desired system pressure.

NOTE: Periodically check and clean oil coolers.

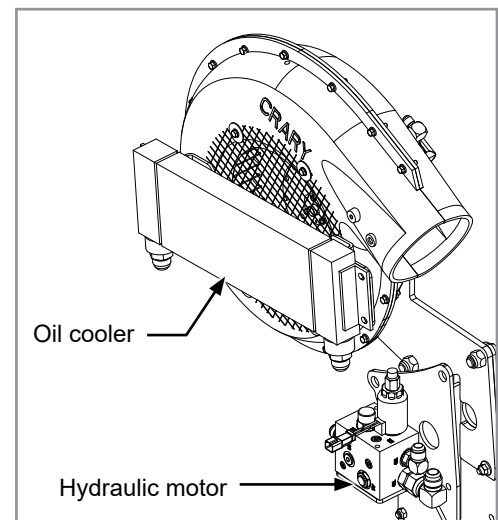

Bulk Fill Fan w/Oil Cooler

NOTE: Periodically check and clean oil cooler mounted on vacuum fan housing.

FINGER PICKUP SEED METER INSPECTION/ADJUSTMENT

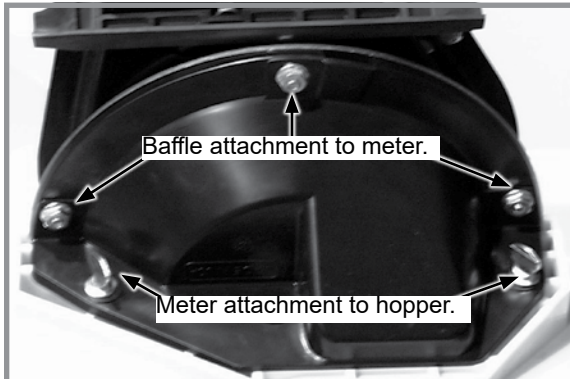

Removing meter and baffle

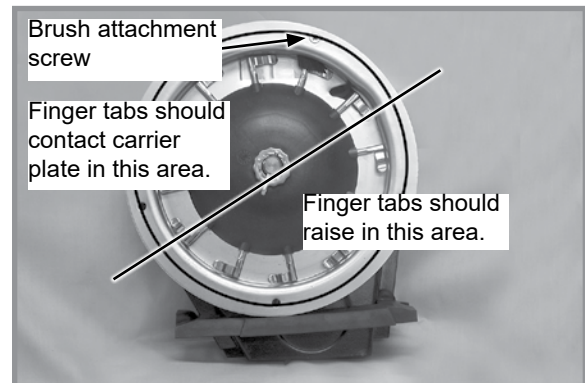

Proper finger operation

1. Remove two thumbscrews and meter from seed hopper and remove three cap screws and baffle from meter assembly.
2. Rotate seed meter drive by hand to ensure springs are holding tabs of fingers against carrier plate and fingers raise in correct area as shown in above photo.

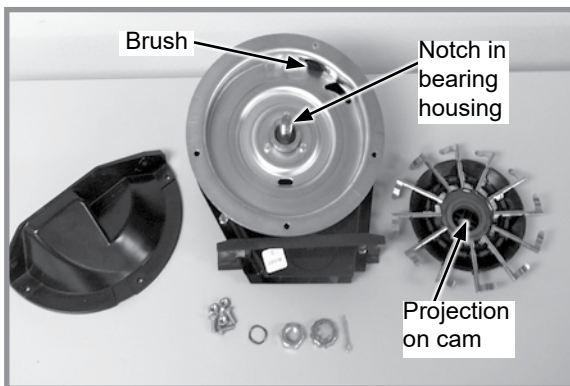

Finger pickup meter parts

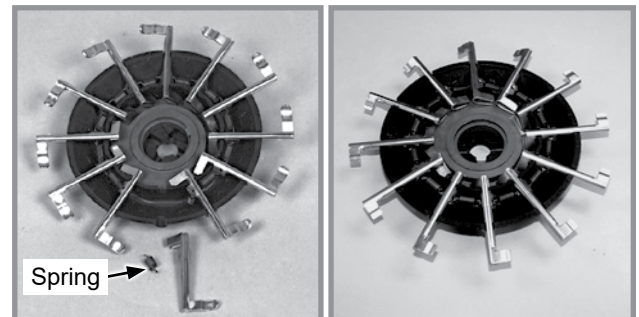

Corn Finger Assembly
(Position Spring Opening
Toward Holder)

**Oil Sunflower Finger
Assembly**

Buildup of debris or chaff may prevent proper finger operation and requires disassembly and cleaning of finger pickup meter.

1. Remove cotter pin, cover nut and adjusting nut and wave washer (If applicable) from drive shaft.
2. Carefully lift finger holder with fingers and cam off shaft and clean.
3. Check brush for wear and replace if necessary or after every 100 acres per row of operation (Approximately 800 acres of corn or sunflowers on a 8 row machine or 1200 acres on an 12 row machine).

NOTE: It is not necessary to remove finger holder to replace brush.

4. Remove springs from fingers and remove finger from holder by lifting it out of friction fit slot. Life expectancy of these parts is about 600-900 acres per row of operation under average conditions.
5. Reassemble meter in reverse order after cleaning and replacing defective parts. Make sure open end of spring loop is toward inside of finger holder when replacing fingers.
6. Install fingers in holder so holder is flush with carrier plate when assembled. A cam projection aligns with a mating notch in bearing housing to ensure proper operation when assembled.

7. Check indentations on carrier plate for wear before installing finger holder on carrier plate. Excessive wear of carrier plate at indentations will cause over planting especially with small sizes of seed. Inspect carrier plate annually. Life expectancy should be 250-300 acres per row of operation under average conditions.
8. Install wave washer and adjusting nut with finger holder flush against carrier. Tighten adjusting nut to fully compress wave washer. Back off nut $\frac{1}{2}$ to 2 flats to obtain rolling torque of 22 to 25 inch pounds.
9. Turn finger holder by hand to make sure it is firmly against carrier plate, but can be rotated with moderate force.
10. Install cover nut and cotter pin. Reinstall baffle.

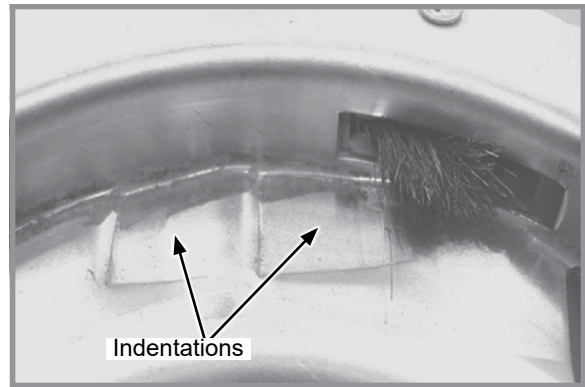
**Worn carrier plate**

NOTE: Check adjusting nut tightness on each unit after first day of use and periodically thereafter.

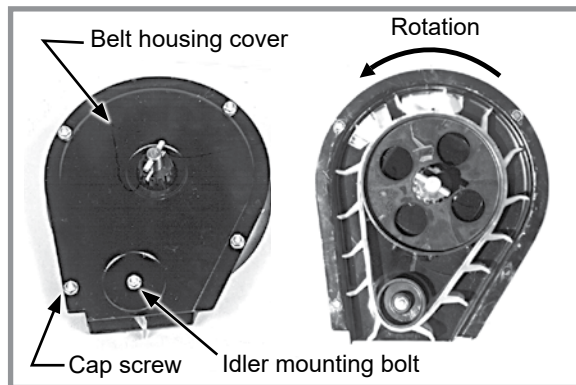
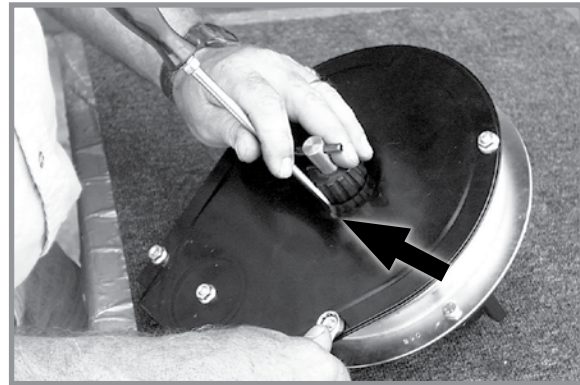
**Belt idler****Centering belt housing cover**

Remove four cap screws around edge of housing cover and nut from belt idler mounting bolt. Paddles must be correctly oriented as shown above if belt is replaced. A diagram molded into drive sprocket shows correct orientation.

NOTICE

Do not over-tighten hardware or components may be damaged.

Reinstall housing cover. **DO NOT TIGHTEN** hardware. Wedge a screwdriver between sprocket hub and housing cover as shown above. Pry cover down until centered on belt housing and tighten hardware. Rotate meter drive shaft and check idler alignment. Seed belt should "run" centered on idler or with only slight contact with belt housing or cover.

CLEANING FINGER PICKUP SEED METER FOR STORAGE

1. Disassemble meter and blow out any foreign material.
2. Wash **ONLY** in mild soap and water. Do not use gasoline, kerosene, or any other petroleum based product. Dry thoroughly.
3. Coat lightly with a rust inhibitor.
4. Rotate finger assembly so finger does not touch brush.
5. Reassemble and store in a dry, rodent-free location.

This page intentionally left blank.

BRUSH-TYPE SEED METER 2.0 MAINTENANCE

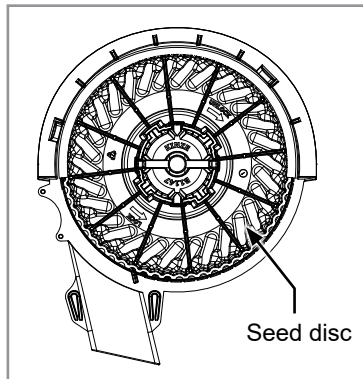

Brush-type seed meter seed disc installed

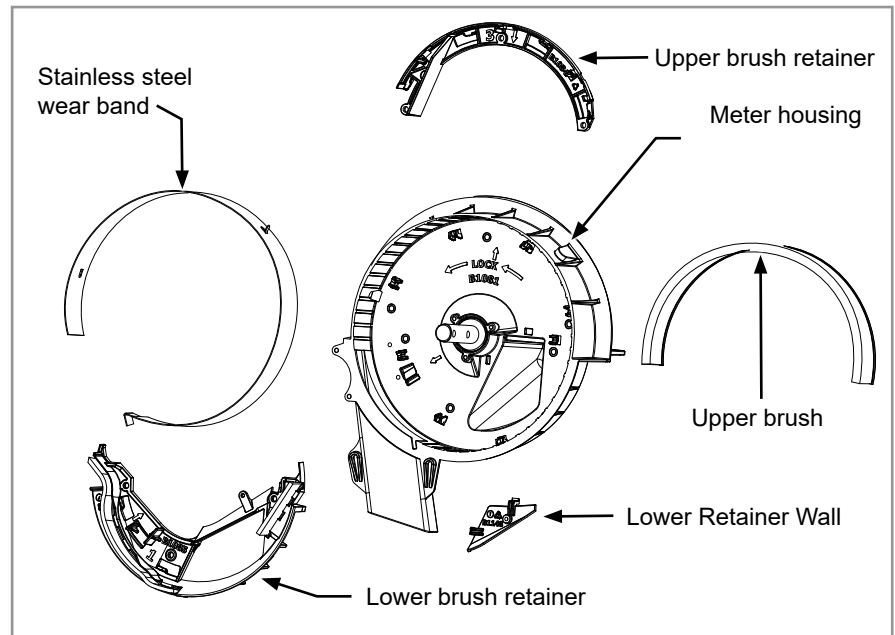

Brush-type seed meter 2.0 parts

Use clean, high quality seed. Damaged or cracked seed, hulls, or foreign materials can become lodged in upper brush and greatly reduce meter accuracy. Remove seed disc daily and check for buildup of foreign material on seed disc, particularly in seed loading slots. Clean disc by washing it with soap and water. Check for cracked seed, hulls, etc. lodged between brush retainer and stainless steel wear band which can greatly reduce accuracy of the meter because upper brush will not be able to retain seed in seed disc pocket. Thoroughly clean brush areas of meter housing.

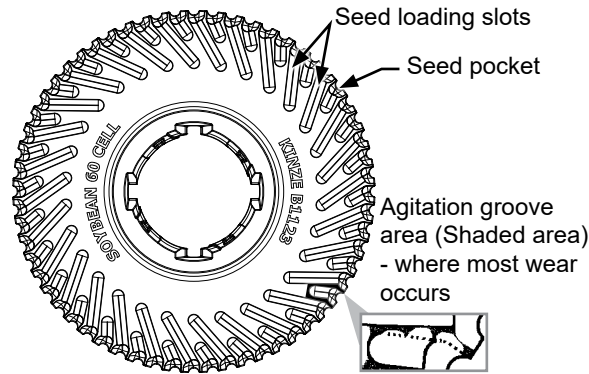

SEED DISC WEAR

Most seed disc wear is found in the agitation groove area (area between seed loading slots). Wear affects planting accuracy at high RPM. Lay a straight edge across disc surface at agitation groove area and measure gap between disc and straight edge. If agitation groove areas are worn in excess of .030" and accuracy starts to drop off at higher meter RPM, replace seed disc. Estimated seed disc life expectancy under normal operating conditions is approximately 200 acres per row. Severe operating conditions such as dust, lack of lubrication or abrasive seed coating could reduce seed disc life expectancy to under 100 acres per row.

STAINLESS STEEL WEAR BAND

NOTICE	If wear band wears through or if meter is used without wear band in place, meter housing may be damaged.
---------------	---

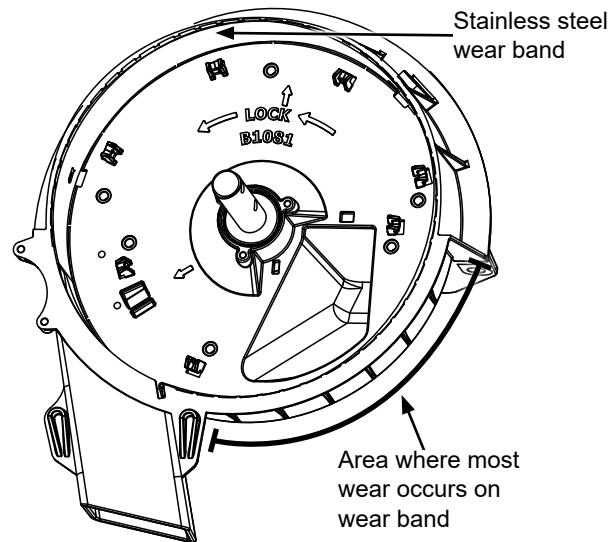

Stainless steel wear band

Stainless steel wear band protects meter housing from wear and is .030" thick. Replace wear band when there is approximately .020" of wear in primary wear area. Estimated life expectancy of stainless steel wear band is 240-800 acres per row.

ASSEMBLY

Assemble meter by putting parts back in the housing in the order they are numbered:

1. Lower brush retainer
2. Upper brush
3. Upper brush retainer

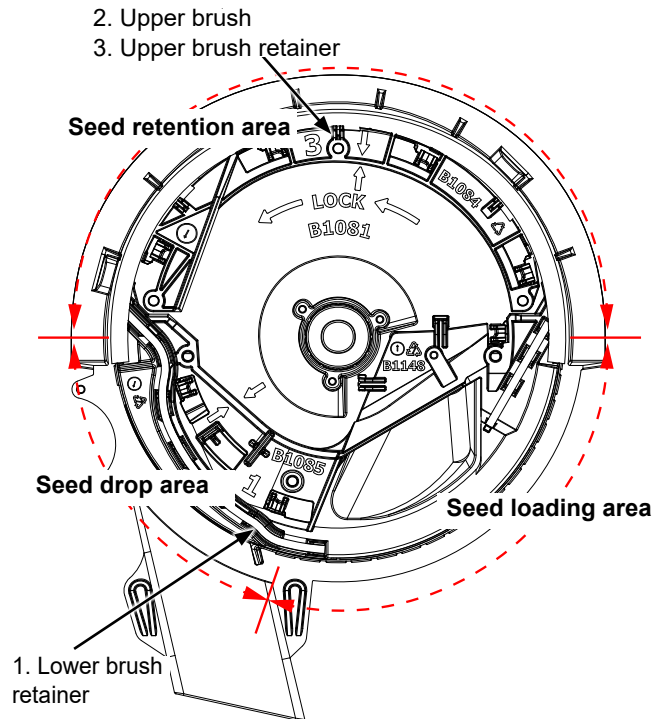

LOWER BRUSH

Lower brush moves seed down seed loading slots to seed pockets, isolates seed in reservoir from entering seed tube, and cleans seed loading slots. Estimated lower brush life expectancy is 240-800 acres per row. Replace lower brush if bristles are deformed or missing, or if there are cracks in brush retainer. Once all parts are properly in place, rotate to lock position.

UPPER BRUSH

Upper brush holds seed in seed disc pocket in seed retention area. Brush must apply enough pressure against seed in seed disc pocket as disc rotates through seed retention area to prevent seed from dropping out of disc pocket. A damaged spot, excessive brush wear, or foreign material lodged in brush may greatly reduce meter performance.

Replace upper brush at 120-400 acres per row of use or sooner if damage or excessive wear is found. Position upper brush into inner perimeter of seed retention area. Make sure base of brush is tight against bottom of meter housing. Install brush retainer. Once all parts are properly in place, rotate to lock position.

NOTE: Use P/N: GB1084 upper brush retainer for all seed discs. It is recommended for milo/grain sorghum to use P/N: GB1107 milo retainer for additional brush retention.

CLEANING BRUSH-TYPE SEED METER FOR STORAGE

1. Remove meter from seed hopper by removing two thumbscrews securing meter to hopper.
2. Remove seed disc and wash with soap and water and dry thoroughly.
3. Remove three hex head screws from brush retainer. Remove brush retainer and upper brush.
4. Remove three hex head screws from lower brush. Remove lower brush and stainless steel wear band.
5. Wash all parts and meter housing with soap and water and dry thoroughly.
6. Inspect all parts and replace worn parts.
7. Reassemble meter except for seed disc. Store meter in a dry, rodent-free space with seed disc removed.

VACUUM MANIFOLD MAINTENANCE

Dust accumulates in manifolds and hoses during normal operation. Clean manifolds annually. Abnormally dusty planting conditions may require more frequent cleaning.

1. Remove vacuum hose from each seed meter.
2. Operate vacuum fan at full hydraulic flow from tractor for two minutes to clear manifolds, hoses, and fittings of dust and debris.
3. Shut down fan and replace hoses

VACUUM SEED METER MAINTENANCE

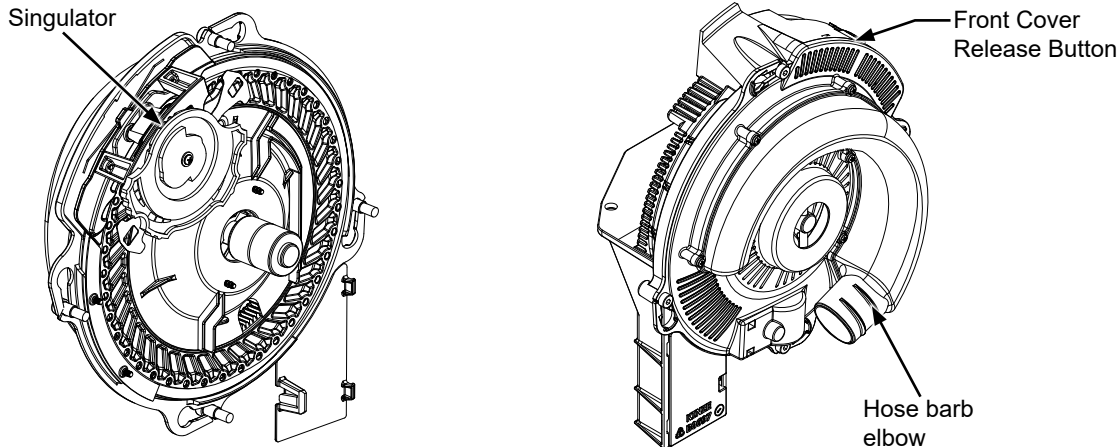

Before each planting season inspect seed discs and singulator and clean or replace as needed.

Use clean, high quality seed for maximum meter accuracy. Damaged or cracked seed, hulls, and foreign material may become lodged in seed disc orifices and greatly reduce meter accuracy.

Inspect and clean seed discs daily checking for any buildup of foreign material and blocked orifices. If seed disc orifices are plugged frequently with seed remnants, remnants ejector wheel may need to be replaced. Clean seed disc by washing it with soap and water. Dry thoroughly.

Inspect singulator blades and guide for wear after every 200 acres per row of operation. If adjustment of singulator blade does not affect meter performance or if blades appear worn, singulator blade may need to be replaced.

Replace seed disc or vacuum seal if abnormally high vacuum is required or if consistent operation cannot be achieved.

See [“Preparation for Storage” on page 6-45](#) for additional Vacuum Seed Metering System maintenance.

NOTE: Remove seed discs from meters for annual storage and store them vertically on a dowel or pipe.

SEED METER CLEANOUT

NOTE: Use of damaged seed or seed containing foreign material will cause plugging of seed cell orifices and require more frequent seed meter cleanout to prevent underplanting.

Thorough seed meter cleanout is important to maintain genetic purity.

1. Disengage seed drive and remove seed hopper and meter.
2. Dump seed from right rear corner of hopper into a container.
3. Lay hopper on its right side. Push release button and rotate seed meter vacuum cover clockwise to align keyhole slots with bolt heads. Lift off cover.
4. Rotate seed disc hub clockwise to unlock and remove seed disc.
5. Empty meter.
6. Thoroughly inspect meter to ensure all seed is removed.
7. Replace seed disc. Install vacuum cover.

GAUGE WHEEL ADJUSTMENT

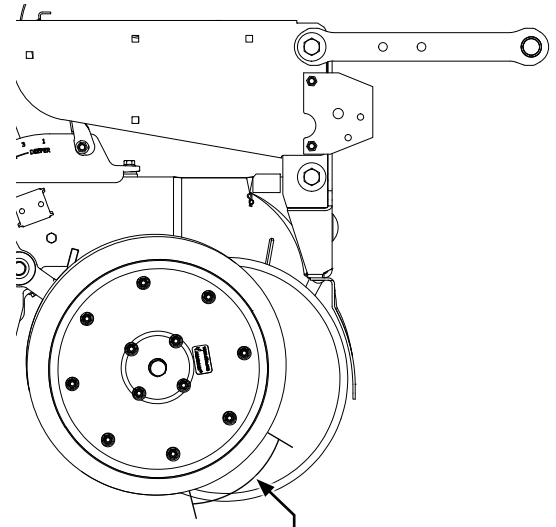
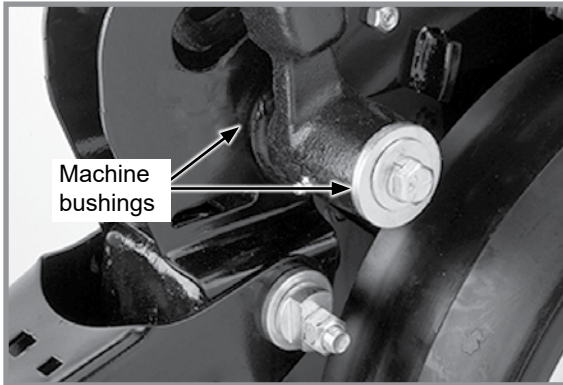

Shim gauge wheel to lightly contact opener disc blade in this area for 4" to 6". Check adjustment in operating position.

Gauge Wheel Adjustment

Add or remove machine bushings between shank and gauge wheel arm to adjust contact between gauge wheels and opener blades. Gauge wheels should lightly contact opener blades to prevent accumulation of dirt or trash. Gauge wheels and opener blades should turn with only slight resistance.

Store remaining machine bushings between gauge wheel arm and flat washer on outer side of gauge wheel arm.

Use the following guidelines:

NOTE: Set depth adjustment handle at 3x2 position and lift gauge wheel to stop one side at a time.

Contact should be no less than one half of the rotation of the wheel, while not sticking in any position (it does not have to be continuous). Wheel should rotate in the direction of travel of the row unit. Wheel can be held in position by supporting the spindle bolt head.

GAUGE WHEEL ARM BUSHING/SEAL REPLACEMENT

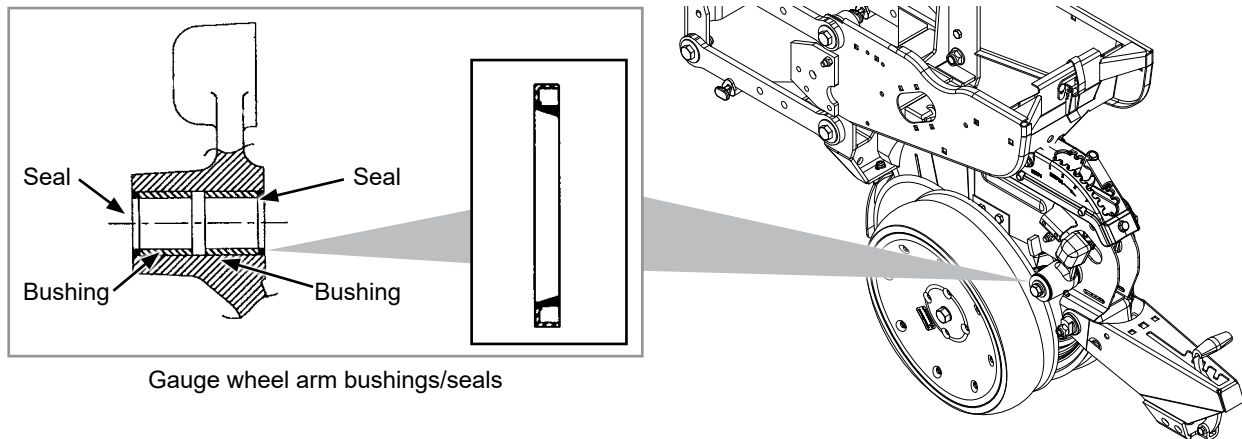

NOTE: Gauge Wheel Arm Bushing and Seal Driver Kit (G1K296) is available through your Kinze Dealer.

1. Remove gauge wheel from arm.
2. Remove gauge wheel arm from shank assembly.
3. Remove seal and bushing and discard. Clean and dry inner bore.
4. Drive/press replacement bushing inside bore of arm to a depth of .125" below flush.
5. Coat wiping edge of seal with grease.
6. Drive/press seal into place with lip to outside.

NOTE: Use extra care to protect the sealing lip during installation. Apply uniform pressure to assemble the seal into the bore of the arm. Never apply a direct hammer blow to the seal surface.

7. Inspect gauge wheel pivot spindle.
8. Reinstall gauge wheel arm assembly and gauge wheel.

NOTE: Use special machine bushing between gauge wheel arm and gauge wheel.

9. Shim for proper gauge wheel tire/disc blade clearance.
10. Lubricate with an SAE multipurpose grease.

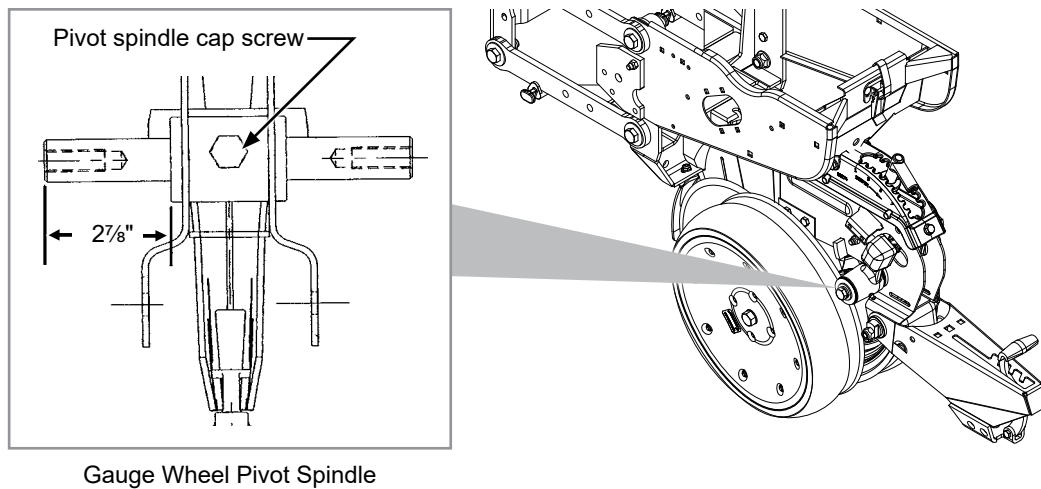
GAUGE WHEEL ARM PIVOT SPINDLE REPLACEMENT

Gauge Wheel Pivot Spindle

1. Remove gauge wheel and arm assemblies from shank assembly.
2. Remove $\frac{1}{2}$ " x $\frac{3}{4}$ " cap screw that locks pivot spindle in place and remove spindle.
3. Install replacement spindle and position as shown. Exact centering is critical.
4. Install $\frac{1}{2}$ " x $\frac{3}{4}$ " cap screw and torque to lock pivot spindle in place.
5. Install gauge wheel and arm assemblies. Shim for proper gauge wheel tire/disc blade clearance.

15" SEED OPENER DISC BLADE/BEARING ASSEMBLY

Approximately $1" \pm \frac{1}{2}"$ ($3 \pm .5$ cm) of blade-to-blade contact should be maintained to properly open and form seed trench. As blade diameter decreases due to wear, it is necessary to relocate machine bushings from inside to outside to maintain $1" \pm \frac{1}{2}"$ ($3 \pm .5$ cm) of contact.

NOTE: Proper blade clearance is critical. Blades should have $1" \pm \frac{1}{2}"$ ($3 \pm .5$ cm) contact in this area. When blades are turned by hand in opposite directions against each other, there should be only light resistance to turning. Re-adjust blade scraper if necessary to center it between the blades.

NOTE: If proper blade-to-blade contact cannot be maintained after relocating machine bushings or if blade diameter wears below $14\frac{1}{2}"$ (37 cm), blades should be replaced.

NOTICE

Excessive blade contact may result in premature disc opener bearing/hub failures and excessive wear on seed tube guard/inner scraper. When properly adjusted, if one blade is held in fixed position, opposite blade should rotate with less than 5 pounds force (22 newtons) at outer edge of blade.

NOTICE

Left hand side of opener uses a left hand threaded cap screw. **DO NOT OVER TIGHTEN.** Damage to shank threads require replacement of row unit shank assembly.

REPLACE DISC BLADE/BEARING ASSEMBLY

1. Remove gauge wheel.
2. Remove scraper.
3. Remove bearing dust cap.
4. Remove cap screw, washer and disc blade/bearing assembly. Machine bushings between shank and disc blade are used to maintain approximate $1" \pm \frac{1}{2}"$ ($3 \pm .5$ cm) of blade-to-blade contact.
5. Install machine bushing(s), new disc blade bearing assembly, washer and cap screw. Torque $\frac{5}{8}"$ -11 Grade 5 cap screw to value shown in "Torque Values Chart".

NOTE: Replace disc blades only with disc blades of equal thickness.

6. Replace bearing dust cap.
7. Install scraper.
8. Install gauge wheel. It may be necessary to replace bearing only if there is excessive endplay or if bearing sounds or feels rough when disc blade is rotated.

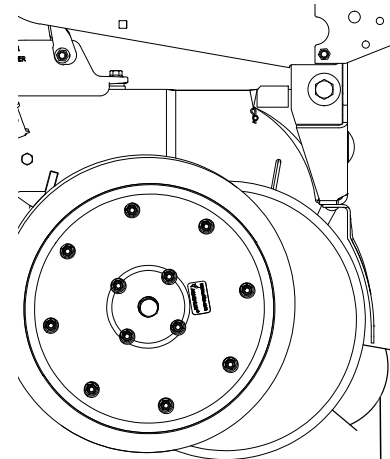

Approximately $1" \pm \frac{1}{2}"$ ($3 \pm .5$ cm) of blade-to-blade contact.

REPLACE BEARING ONLY

1. Remove gauge wheel, scraper, bearing cap, cap screw, washer and disc blade/bearing assembly.
2. Remove ¼" rivets from bearing housing to expose bearing.
3. After installing new bearing, install three evenly spaced ¼" cap screws into three of six holes in bearing housing to hold bearing and bearing housing in place. Install rivets in other three holes. Remove ¼" cap screws and install rivets in those three holes.
4. Reinstall disc blade/bearing assembly, washer and cap screw. Torque ⅝"-11 cap screw to value shown in "Torque Values Chart" at the beginning of this section.
5. Replace bearing dust cap.
6. Install scraper and gauge wheel.

SEED TUBE GUARD/INNER SCRAPER

Seed tube guard protects seed tube and acts as inner scraper for seed opener disc blades.

Remove seed tube and check for wear. Excessive wear on seed tube indicates a worn seed tube guard. Replace seed tube guard if it measures $\frac{5}{8}$ " (16 mm) or less at lower end. A new seed tube guard measures approximately $\frac{7}{8}$ " (22.2 mm).

NOTE: No till planting or planting in hard ground conditions, especially when planter is not equipped with no till coulters, and/or excessive blade-to-blade contact increases seed tube guard wear and requires more frequent inspection and/or replacement.

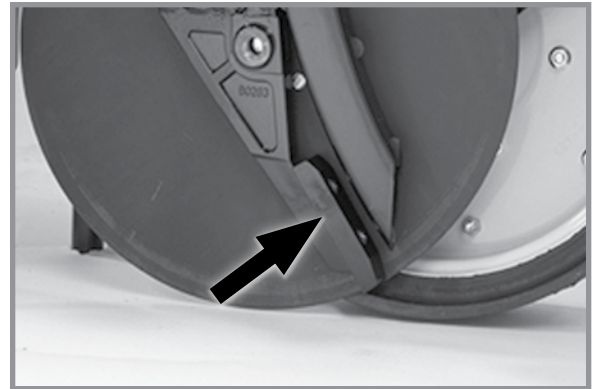

Seed tube guard/inner scraper
(Gauge wheel/seed opener disc blade removed)

NOTICE

Over tightening hex socket head cap screws may damage shank threads and require replacement of shank. An excessively worn seed tube guard may allow blades to wear into row unit shank, also requiring replacement of shank.

Remove seed tube and two hex socket head cap screws that attach seed tube guard. Hold replacement seed tube guard centered between seed opener disc blades. Install hex socket head cap screws. **DO NOT TIGHTEN.** Using a clamp or vise-grip, squeeze opener blades together in front of seed tube guard. Tighten seed tube guard retaining screws. Remove clamps. Distance between seed tube guard and opener blades should be equal on both sides. Reinstall seed tube.

ROW UNIT MOUNTED NO TILL COULTER



Check nuts and hardware periodically for proper torque.

NOTE: Torque $\frac{5}{8}$ " spindle hardware to 120 ft-lb (162 N-m).

Be sure coulters is positioned square with row unit and aligned in front of row unit disc opener.

Coulters blade can be adjusted to one of four settings. Initially blade is set in highest position. As blade wears it can be adjusted to one of three lower settings. See "Row Unit Mounted No Till Coulters" in Row Unit Operation section of this manual.

Replace 16" diameter coulters blade when worn to 14½" (37 cm).

COULTERS MOUNTED RESIDUE WHEELS



Wheel hubs are equipped with sealed bearings. If bearings sound or feel rough when wheel is rotated, replace them.

SPIKED CLOSING WHEEL

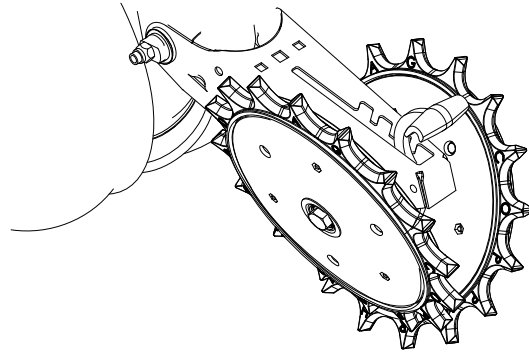

Row Unit Spiked Closing Wheel

Inner parts of spiked closing wheel will begin to wear at approximately 70% of life. Flip/reverse wheel to utilize remaining life of wheel.

GRANULAR CHEMICAL ATTACHMENT

Before storing planter, disengage granular chemical drive by rotating throwout knob $\frac{1}{4}$ turn counterclockwise. Remove drive chain and empty and clean all granular chemical hoppers. Clean drive chains and coat them with a rust preventive spray or submerge chains in oil. Inspect and replace worn or broken parts.

Install hoppers and chains. Check chain alignment.

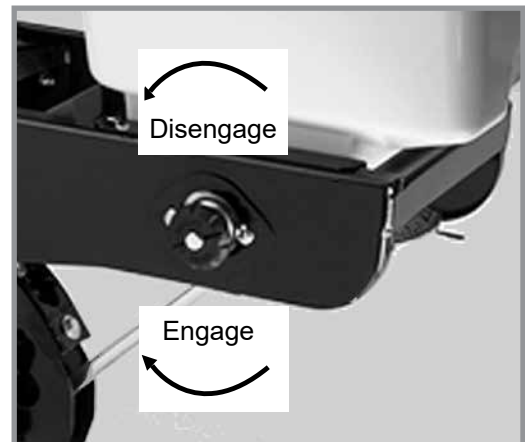

Granular chemical throwout knob

CHECK VALVE (LIFT SYSTEM)

Check valves, located in valve block on right side of center post, trap oil flow in planter's lift system to keep toolbar level during field operation. Consult your Kinze Dealer for service.

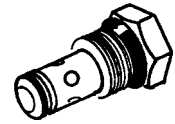

CHECK VALVE (VACUUM FAN)

Check valve located in valve block below vacuum fan motor assembly operates as a return line check to prevent vacuum fan motor reverse operation. Remove and inspect valve if it does not operate properly. Check for foreign material and if O-ring is leaking internally. Replace if defective.

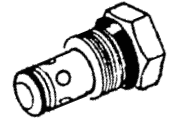

FLOW CONTROL VALVE

Flow control valves should be adjusted for row marker raise and lower speed as part of assembly procedure or upon initial operation. If valve fails to function properly or requires frequent adjustment, it should be removed for inspection. Check for foreign material and contamination on valve and seating areas of valve body. Replace defective components.

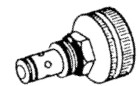

PRESSURE RELIEF VALVE

If pressure relief valve does not release tongue lock or function properly, remove valve from valve block and check for foreign material or if O-ring is leaking internally. Replace if defective.

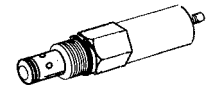

PRESSURE REDUCING RELIEF VALVE

If wings do not properly stay to ground, plumb into butt end of cylinder to test psi. Proper setting is 2000 PSI.

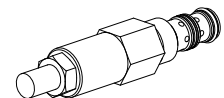

NOTICE

Connect hydraulic motor case drain to a case drain return line with zero pressure on tractor or hydraulic motor will be damaged. DO NOT connect hydraulic motor case drain to SCV outlet. Contact tractor manufacturer for specific details on "zero pressure return".

RELIEF VALVE CARTRIDGE

Pressure relief valve located in valve block below vacuum fan motor assembly helps prevent damage to vacuum fan motor by limiting pressure in the motor case drain line. It is set to open at 35 PSI. If valve fails to function properly, it should be removed for inspection. Check for foreign material and contamination on valve and the seating area of valve body. Replace if defective.



SOLENOID VALVE

Solenoid valve consists of a chambered body with an electric coil actuated cartridge valve.

If solenoid or solenoids fail to operate, first determine if problem is electrical or hydraulic. If valve is working properly, a click will be heard when solenoid coil is energized and valve stem opens. If no sound is heard, check solenoid coil by touching top of coil housing with a metallic object such as a pliers or screwdriver. If coil is working properly, coil housing will be strongly magnetized when energized. If voltage to coil is low it will be weakly magnetized when energized and no click will be heard.

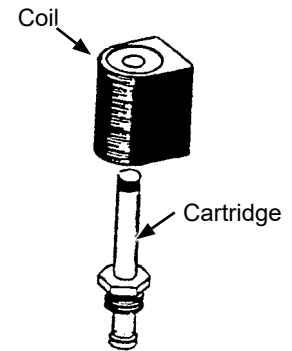

HYDRAULIC DOWN FORCE PROPORTIONAL PRESSURE REDUCING/RELIEVING VALVE (TRUE DEPTH OPTION)

Proportional pressure relief valves are located on each row of planters equipped with the True Depth hydraulic down force system. *These valves are factory set and should require no additional adjustment.* Each valve acts independently and controls the fluid pressure on the cap end of the down force cylinder. Consult your Kinze Dealer for service.



PWM FLOW CONTROL VALVE

PWM flow control valve is used to control the fans on the blue drive equipped planters. The Blue Vantage System controls the valve so no operator adjustment is required.

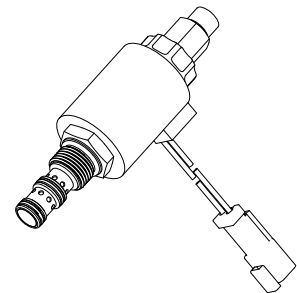

COMPENSATOR

The pressure compensator is used to maintain a constant pressure differential across the PWM Flow Control Valve to maintain the set flow rate regardless of system load pressure. It also bypasses excess flow when used with open center hydraulics systems such as the gear PTO pump by removing the internal bypass port plug.

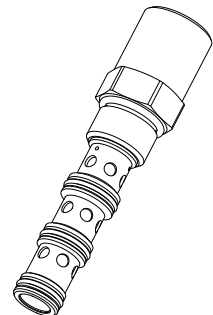

ROW MARKER BEARING LUBRICATION OR REPLACEMENT

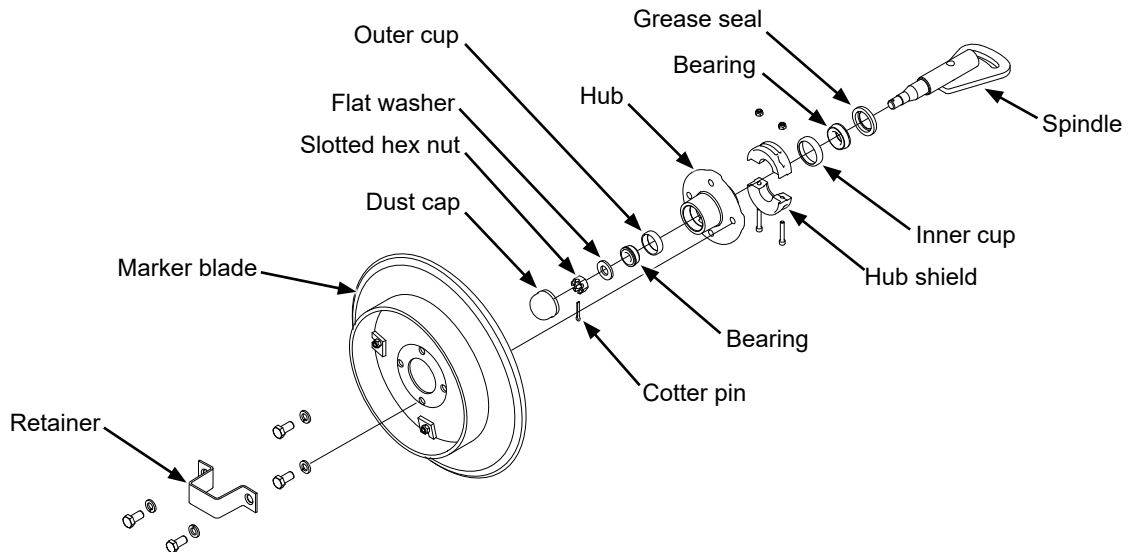

1. Remove retainer and marker blade.
2. Remove dust cap from hub.
2. Remove hub shield. Note direction of installation.
3. Remove cotter pin, slotted hex nut, and washer.
4. Slide hub from spindle.
5. Remove bearings and cups and discard if bearings are being replaced. Clean hub and dry. Remove bearings only and not cups if repacking.
6. Press in new bearing cups with thickest edge facing in. (Bearing replacement procedure only.)
7. Pack bearings with heavy duty wheel bearing grease thoroughly forcing grease between roller cone and bearing cage. Fill the space between the bearing cups in the hub with grease.
8. Install rubber seal into grease seal. Place inner bearing in place and press in new rubber seal/grease seal.
9. Clean spindle and install hub.
10. Install outer bearing, washer and slotted hex nut. Tighten slotted hex nut while rotating hub until there is some drag. This ensures all bearing surfaces are in contact. Back off slotted nut to nearest locking slot and install cotter pin.
11. Fill dust caps approximately $\frac{3}{4}$ full of wheel bearing grease and install on hub.
12. Install hub shield.
13. Install marker blade and retainer on hub. Tighten hardware evenly.

ROW MARKER TRANSPORT STAND ADJUSTMENT

Row marker transport stands must be correctly adjusted to allow marker cushion cylinders to function properly.

1. Raise markers to transport position.
2. Loosen mounting hardware to allow transport stands to drop down or remove transport stands.
3. With tractor engine shutoff, release hydraulic pressure on marker cylinders.
4. Locate transport stands so marker arm rests lightly on transport stand. When transport stands are correctly adjusted pin at rod end of cylinder should be loose enough to rotate and move back and forth in mounting slot.

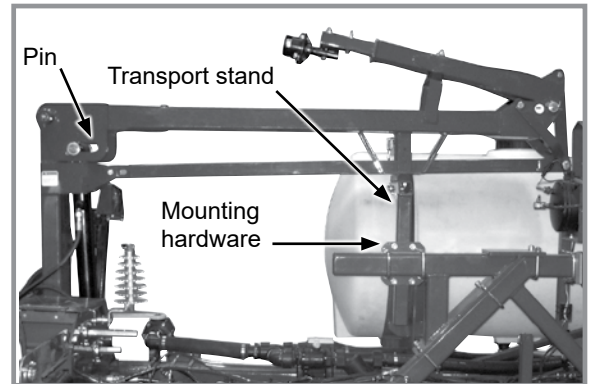

Row marker transport stand

WHEEL BEARING REPACK OR REPLACEMENT

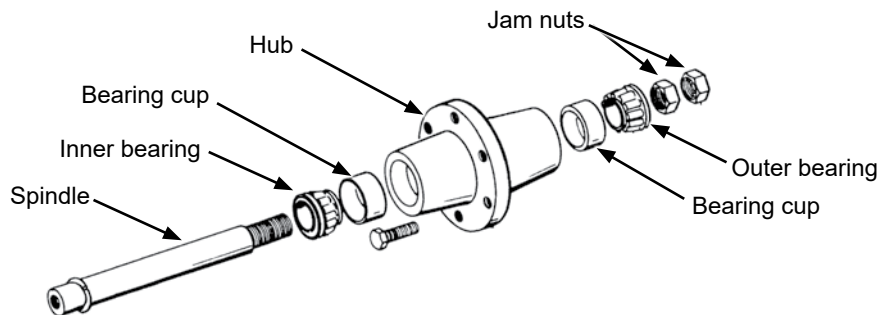

1. Raise tire clear of ground and remove wheel.
2. Remove double jam nuts and slide hub from spindle.
3. Remove bearings and cups and discard if bearings are being replaced. Clean hub and dry. Remove bearings only and not cups if repacking.
4. Press in new bearing cups with thickest edge facing in. (Bearing replacement procedure only.)
5. Pack bearings with heavy duty wheel bearing grease thoroughly forcing grease between roller cone and bearing cage. Fill space between bearing cups and hub with grease.
6. Place inner bearing in place.
7. Clean spindle and install hub.
8. Install outer bearing and jam nut. Tighten jam nut while rotating hub until there is some drag. This ensures all bearing surfaces are in contact. Back off jam nut $\frac{1}{4}$ turn or until there is only slight drag when rotating hub. Install second jam nut to lock against first.
9. Install wheel on hub. Tighten hardware evenly.

BATTERY CARE**NOTICE**

Read and follow all manufacturers labels and instructions.

Battery Specifications

Chemistry:	Wet lead acid (Low maintenance)
Voltage:	12.00
Milliamp Hours:	0 mAH
Capacity:	17.00 AH
Weight:	15.30 lb
Length:	7.72"
Width:	5.19"
Height:	7.30"
Termination:	Top post (auto type)

BEFORE PLANTING SEASON

- Check and clean all connections.
- Fully charge batteries before installing into the planter.
- Batteries more than two years old should be load checked.
- Reinstall batteries or connect the negative ground cables.

PREPARATION FOR STORAGE

Planter batteries that are stored for more than one month should be cared for as follows:

- Remove the batteries or disconnect the negative ground cables.
- Fully charge batteries before storing.
- Store in a cool dry location.
- Keep from freezing.

WARNING

Uncontrolled movement of equipment can cause loss of control and could result in death, serious injury, or damage to property and equipment. Install all safety pins before transporting equipment.



CENTER FRAME WEAR PADS

The 3660 planter includes a center frame section that slides up and down on a central 7" x 7" tube to move between transport and operation positions. Part of the center frame is a slide assembly consisting of four wear pad assemblies held in place by $\frac{3}{4}$ " set screws and jam nuts, riding against a powder coated center tube.

Inspect and adjust wear pads annually to ensure planter frame is stable and planter tracks correctly. Wear pads should lightly make full contact with center post when properly adjusted. Excessive preload on pads will cause increased hydraulic lift pressure and may fail to lift planter when fully loaded.

ROCKSHAFT TO HITCH SHIM ADJUSTMENT

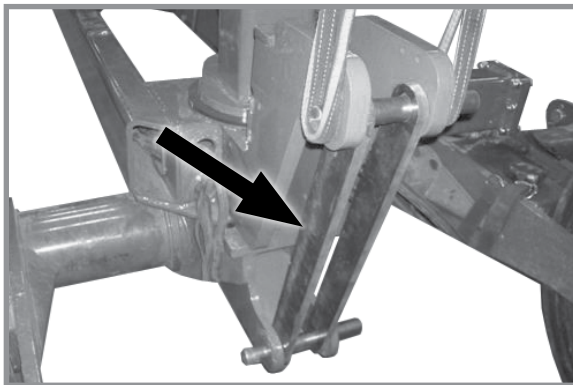

26" strap fixture

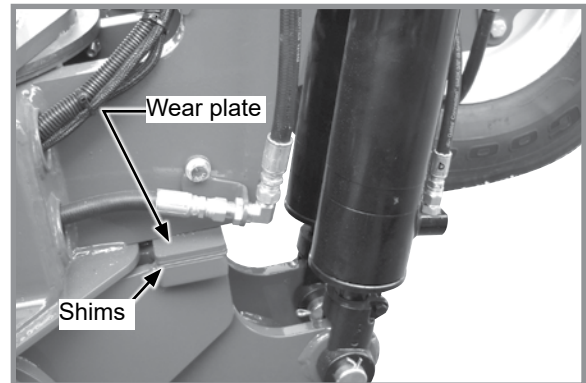

Wear plate and shim installation

1. Install strap fixture at rockshaft cylinder location to establish 26" center-to-center cylinder mount distance.
2. Place $\frac{1}{4}$ " thick wear plate between cylinder mount bracket and lower cylinder mount. Install a shims under wear plate using 16 and 10 gauge shims to maintain 26" distance.

CENTER FRAME RELATION TO INNER HITCH ADJUSTMENTS

NOTE: Planter must be in transport position with safety lockup installed and rock shaft cylinders fully retracted.

1. Lock wing frames for transport, fully raise planter, and install safety lockup. Make sure top latch is around cylinder rod and fastened with safety pin and that lower end is secured with detent pin.

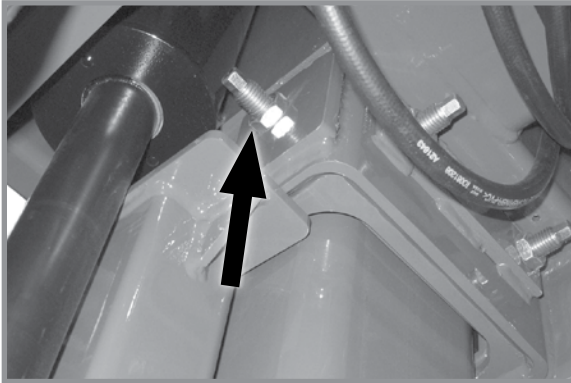

Lower front and side - six set screws

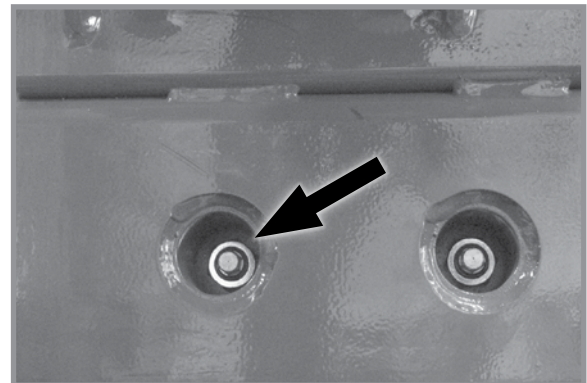

Lower rear side - two set screws

2. Adjust lower wear pads. Loosen jam nuts. Loosen and tighten set screws to move center frame slide tube until distance from outside of center tube to outside of slide tube is equal on all four sides - approximately 1½". Tighten all eight set screws.

NOTE: Perform Step 3 one set screw at a time.

3. Set contact pressure of lower wear pads. Loosen set screw, then tighten to 20 ft-lb (27.1 N-m). Hold set screw with a wrench to prevent it from turning and tighten jam nut to 75 ft-lb (101.6 N-m). Repeat with remaining set screws.
4. Remove safety lockup and lower planter frame until approximately 2' above top surface of outer hitch. Turn off hydraulic power source.

Top surface of outer hitch must be parallel to bottom of center frame. Distance between them is measured at four points:

- Top front of inner hitch to bottom of center sub-frame – left and right sides.
- Top rear of inner hitch to bottom of center frame – left and right sides.

NOTE: Subtract 8" from front measurement values before comparing to rear values.

5. Place a 2" x 2" x 36" tube or similar straight object on top of one leg of inner hitch, behind shim stack as shown at right.
6. Measure at points as shown at right.
7. Repeat on other leg of inner hitch.

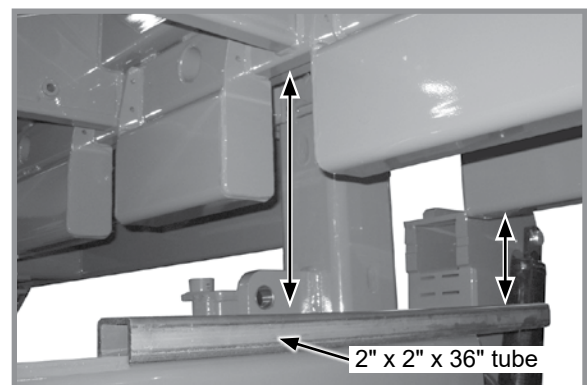

Measurement locations

8. Loosen jam nuts. Loosen and tighten set screws until all four measurements in Step 5 - 7 are equal.
9. Tighten all eight set screws.

NOTE: Perform Step 10 one set screw at a time.

10. Set contact pressure of upper wear pads. Loosen set screw, then tighten to 20 ft-lb (27.1 N-m). Hold set screw with a wrench to prevent it from turning and tighten jam nut to 75 ft-lb (101.6 N-m). Repeat with remaining set screws.

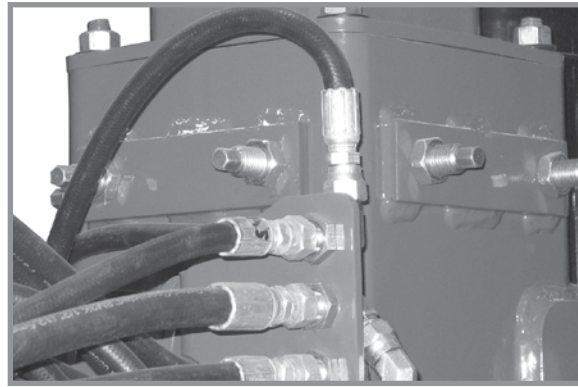

Upper set screws

Some shims must be removed to preventing pre-loading of planter frame in preparation of adjusting shim stack thicknesses.

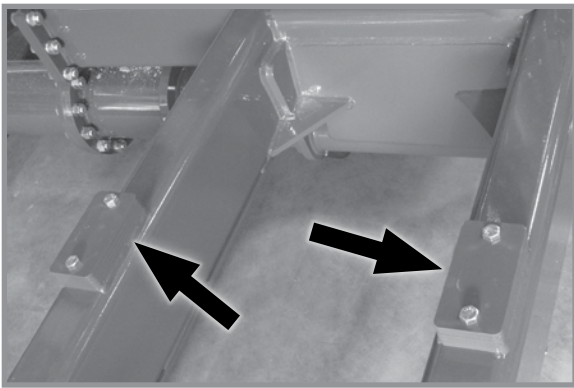

Inner hitch shim stacks

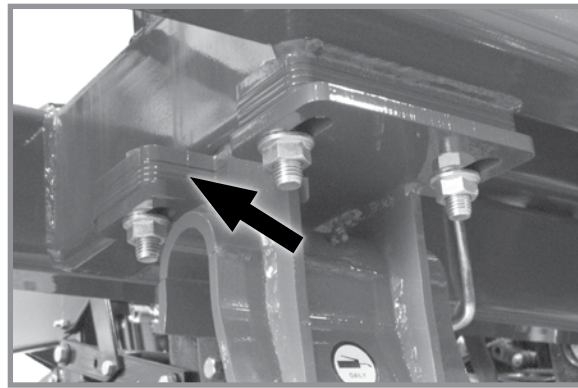

Field stabilizer shim stack

11. Loosen fasteners and remove one or two shims from the following locations:
 - Inner hitch shim stack – left and right sides.
 - Field stabilizer shim stack – left and right sides.
12. Replace fasteners at field stabilizers to keep shim stack in place.
13. Raise landing pad bolts to prepare for adjusting shim stack thickness. Loosen jam nuts and thread in bolts several turns.

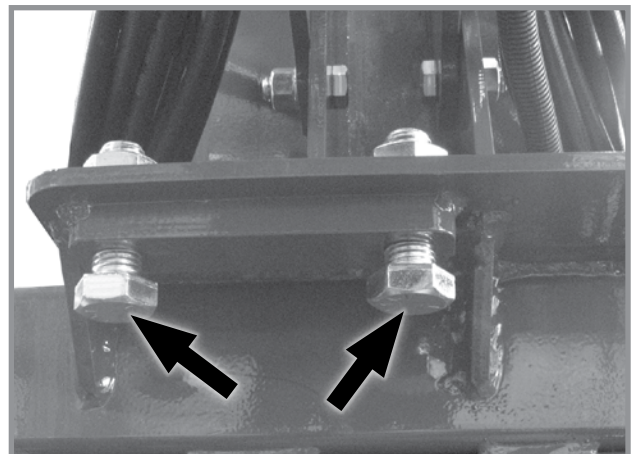

Landing pad bolts

14. Make two $\frac{3}{16}$ " x 2" x 1" shims out of bar stock or other suitable material.
15. Place one shim on left and one shim on right side of center post flange. Lower planter until center frame slide rests on them.

NOTE: When planter is lowered, no planter frame weight is to be supported at shim stacks or landing pad bolts – there must be space for adding shims and adjusting bolts downward.

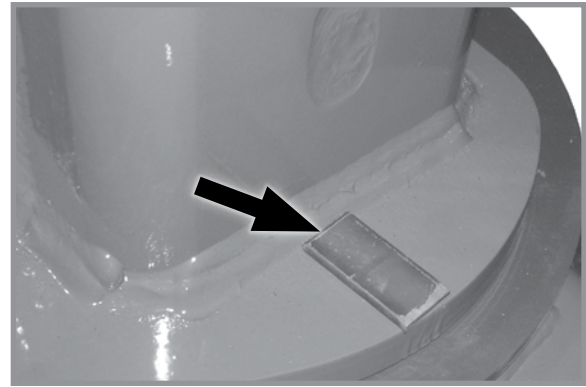

$\frac{3}{16}$ " x 2" x 1" shim

NOTE: Completely fill open space with appropriate combination of shims. Tolerance for filling open space is +0.030"/-0.000".

16. Add shims to fill open space at the following locations:
 - Inner hitch shim stack – left and right sides; make sure $\frac{1}{4}$ " thick wear plates remain on top.
 - Field stabilizer shim stack – left and right sides.
17. After adding shims, shim stack fasteners on inner hitch may be tightened. DO NOT fully tighten fasteners at field stabilizers.
18. Raise planter on center post. Remove temporary shims from beneath center frame slide and fully lower planter.
19. Lower landing pad bolts until they touch landing pad. Hold in place with wrench to prevent turning and tighten jam nuts.

TRIANGULATE AND SET PLANTER SQUARENESS

NOTICE

Planter frame must be square with hitch frame to ensure planter tracks correctly during operation.

1. Raise planter to transport position and install safety lockup.
2. Loosen fasteners and remove rotation stop tap block and shims.
3. Remove safety lockup and fully lower planter.

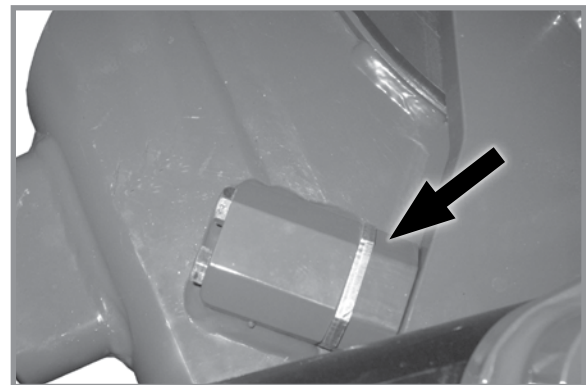

Rotation stop tap block and shims

4. Measure 67" from left side of inner hitch along lower frame member of center frame; place reference mark with an appropriate marker. Repeat on right side.
5. Measure width of inner hitch, divide value by 2, measure from one side of hitch, and place a centerline reference mark at that point on upper hitch cross member.
6. Measure from centerline to each of the reference marks on center frame (Y"). If measurements are NOT equal go to next step. If measurements are equal skip to Step 8.
7. Rotate center post or push on end of planter frame with shorter distance. Re-measure from centerline to reference marks. Repeat until measurements are equal.
8. Tighten field stabilizer fasteners when measurements are equal on both sides of planter.

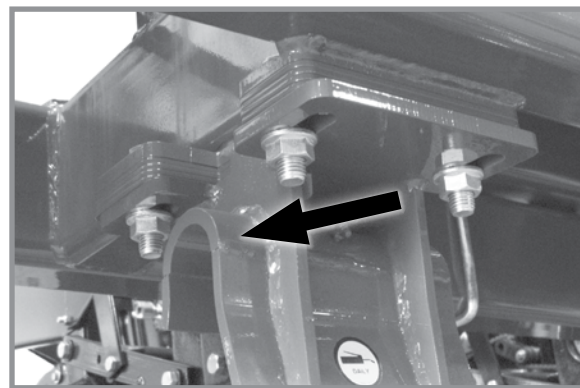
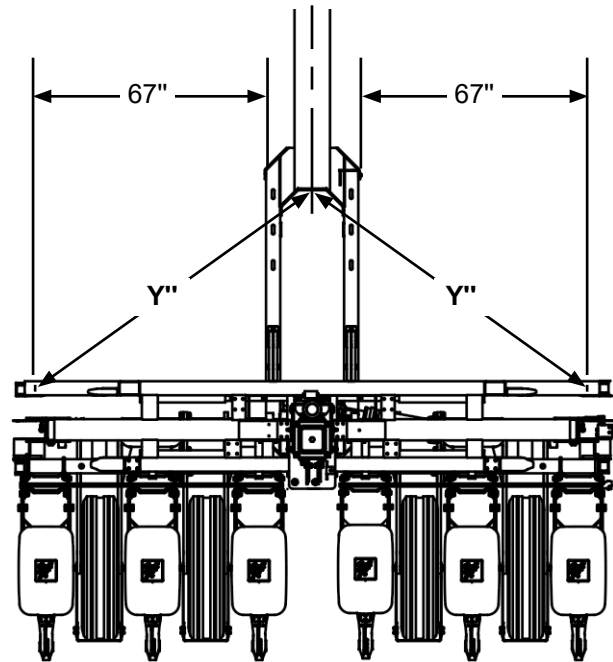

Field stabilizer

INSTALL ROTATION STOP BLOCK

1. Raise planter to transport position and install safety lockup.
2. Measure distance between stop mount on inner hitch and stop surface on center post. Include stop tap block to determine required combination of shims to completely fill this space. Tolerance for filling the space is $+1/16"/-0"$.

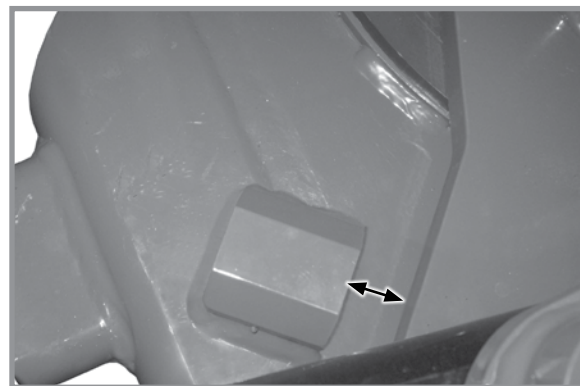

Stop block measurement

3. Rotate center post slightly to provide room to install shims.

NOTE: In situations where few shims are required, attachment cap screws may protrude beyond stop tap block. Install shims beneath cap screw heads to prevent them from protruding.

4. Attach required shims and stop tap block using two $\frac{3}{8}$ "-16 x 3" cap screws.
5. Rotate center post against stop tap block.

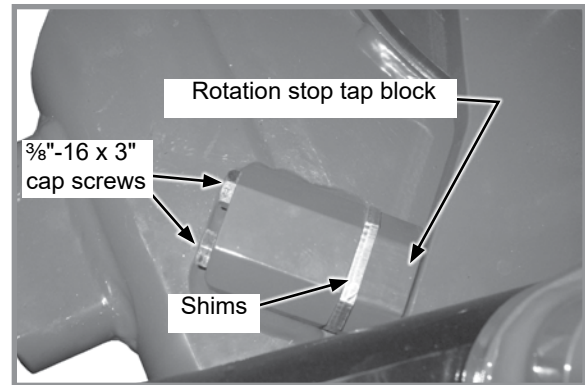

Stop tap block installation

INSPECT AND ADJUST ROTATION CYLINDER MOUNT

1. Make sure center post is rotated against stop block. Inspect rotation cylinder for correct amount of retraction.

A correctly retracted cylinder will have $\frac{1}{16}$ " or less exposed sliding surface on the rod .

If cylinder has more than $\frac{1}{16}$ " sliding surface exposed, shims will need to be removed from cylinder mount.

If cylinder has no slide surface exposed, AND center post cannot be fully rotated against stop block, shims will need to be added to cylinder mount.

2. Disconnect rod end of cylinder and remove six sets of fasteners from cylinder mount. Add or subtract shims as necessary.
3. Reassemble cylinder mount and connect rod end of cylinder. Inspect for correct amount of retraction.

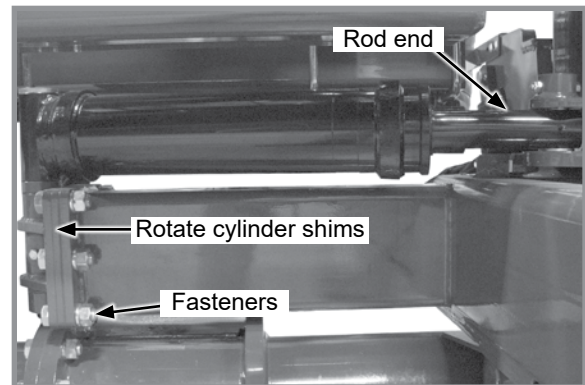

Rotate Cylinder mount adjustment

PNEUMATIC DOWN PRESSURE AIR COMPRESSOR TANK

The air tank is located in the frame. Moisture should be drained daily from the tank. Tank should be drained completely for storage.

To drain tank, locate drain plug on the bottom of tank . Stand off to the side of tank and pull cable attached to drain.

NOTE: If moisture is not drained from tank rust particles will form inside tank.

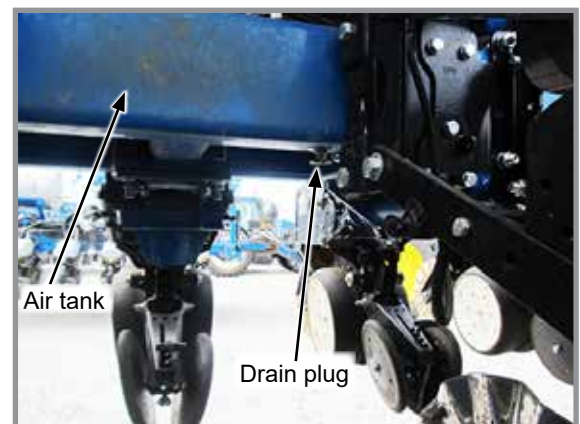

FERTILIZER CHECK VALVE CLEANING AND REPAIR

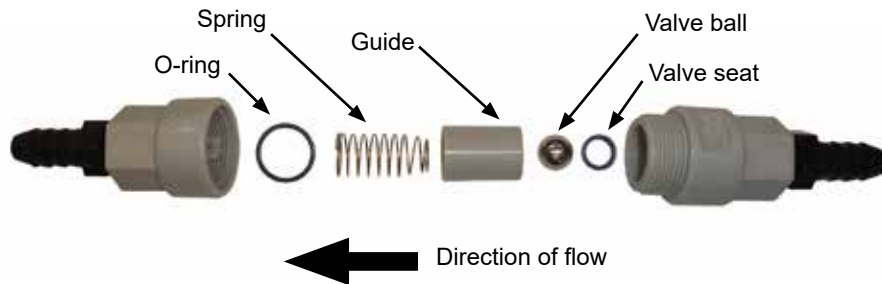

1. Unscrew valve body and separate halves. Note direction and location of parts.
2. Clean and inspect parts. Flush with clean water. Replace damaged parts.
3. Reassemble exactly as shown. O-ring and valve seat must be firmly in place inside each half of valve body.

PISTON PUMP STORAGE



Liquid fertilizer piston pump

NOTICE

Entrance of air into pump will cause rapid and severe corrosion. KEEP AIR OUT OF PUMP!

NOTE: SUSPENSION FERTILIZER must be flushed from pump for ANY storage period.

1. Flush pump with 5 to 10 gallons of fresh water and circulate until all corrosive salts are dissolved in pump.
2. Set pump on 10. Draw in a mixture of half diesel fuel and 10 weight oil until discharge is clean. Plug inlet and outlet.

PREPARATION FOR STORAGE

Store planter in a dry sheltered area if possible.

Remove all trash wrapped on sprockets or shafts and remove dirt that can draw and hold moisture.

Clean all drive chains and coat with a rust preventative spray, or remove chains and submerge in oil.

Lubricate planter and row units at all lubrication points.

Inspect planter for parts that in need of replacement and order during “off” season.

Make sure all seed and granular chemical hoppers are empty and clean.

Remove seed discs from seed meters, clean and store meters in a rodent-free, dry area with discs removed. Store seed discs vertically on a dowel or pipe.

Remove vacuum hose from each seed meter. Operate vacuum fan at full hydraulic flow from tractor for two minutes to clear manifolds, hoses and fittings of dust and debris.

Clean breather on analog vacuum and pressure gauges.

Disassemble, clean and grease all U-joint slides.

Grease or paint disc openers/blades and row marker disc blades to prevent rust.

Flush liquid fertilizer tanks, hoses and metering pump with clean water. See “Piston Pump Storage” if applicable.

Empty dry fertilizer hoppers. Clean hoppers. Disassemble and clean metering augers. Reassemble, coating all metal parts with rust preventative.

See [“Battery Care” on page 6-37](#) if planters are equipped with batteries.

Bulk Fill System:

- Clean out bulk fill hopper, entrainment assembly, and delivery hoses.
- Disconnect delivery hoses from entrainer ports. Install small orange caps onto ports. Attach hoses to caps.
- Disconnect delivery hoses from air dissipator at each row unit. Install large orange caps. Attach hoses to caps.
- Check all bolts and fasteners used to assemble and attach entrainment device are tight (if applicable).
- Loosen knobs on entrainer cleanout doors to remove pressure from door gaskets.
- Inspect all seed delivery hoses and replace any that are worn, cut, or cracked.

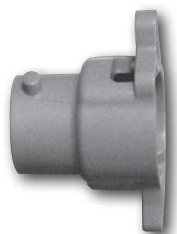

Entrainer Cap

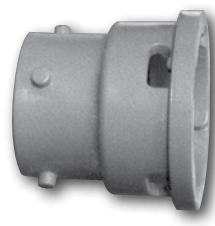

Row Unit Cap

ELECTRICAL WIRING DIAGRAM FOR LIGHT PACKAGE

Machines with double light assemblies

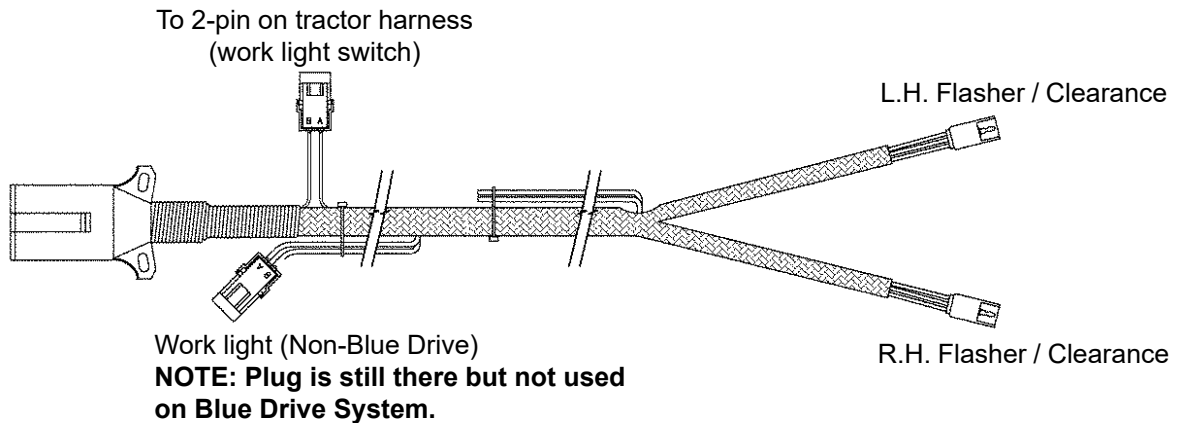
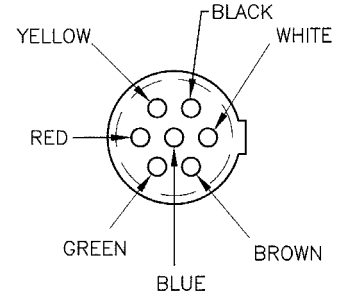
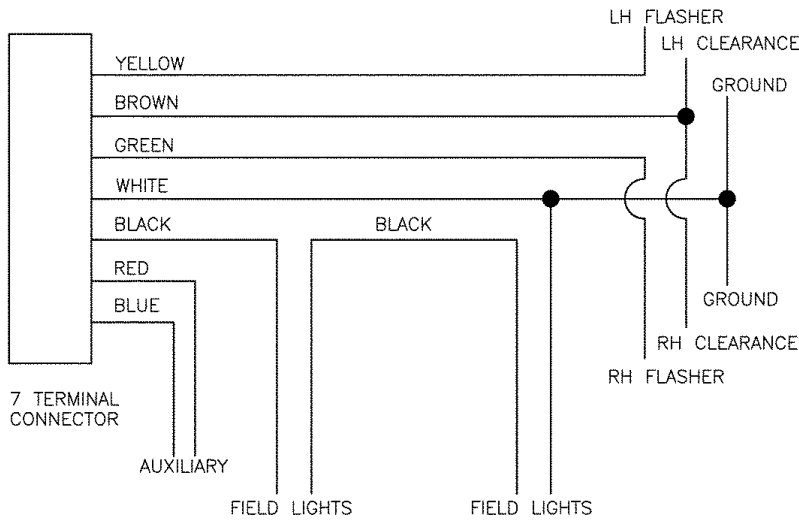

* Optional customer-supplied auxiliary lights and wires may be wired into existing plug terminals.

Model 3660 Twin-Line Planter safety light package meets ASAE Standards. Check with your tractor manufacturer for proper connection to your tractor.

ELECTRICAL CONTROL CONSOLE SCHEMATIC

NOTE: Not applicable to Blue Drive System.

NOTE: Disconnect control console from tractor battery before doing any electrical work. Keep wiring harnesses away from high temperature areas or sharp edges. **DO NOT** route wiring harnesses along battery cables. Use cable ties to keep wire harness away from moving parts on tractor and planter. Be sure tractor frame ground connections are clean to provide good electrical contact.

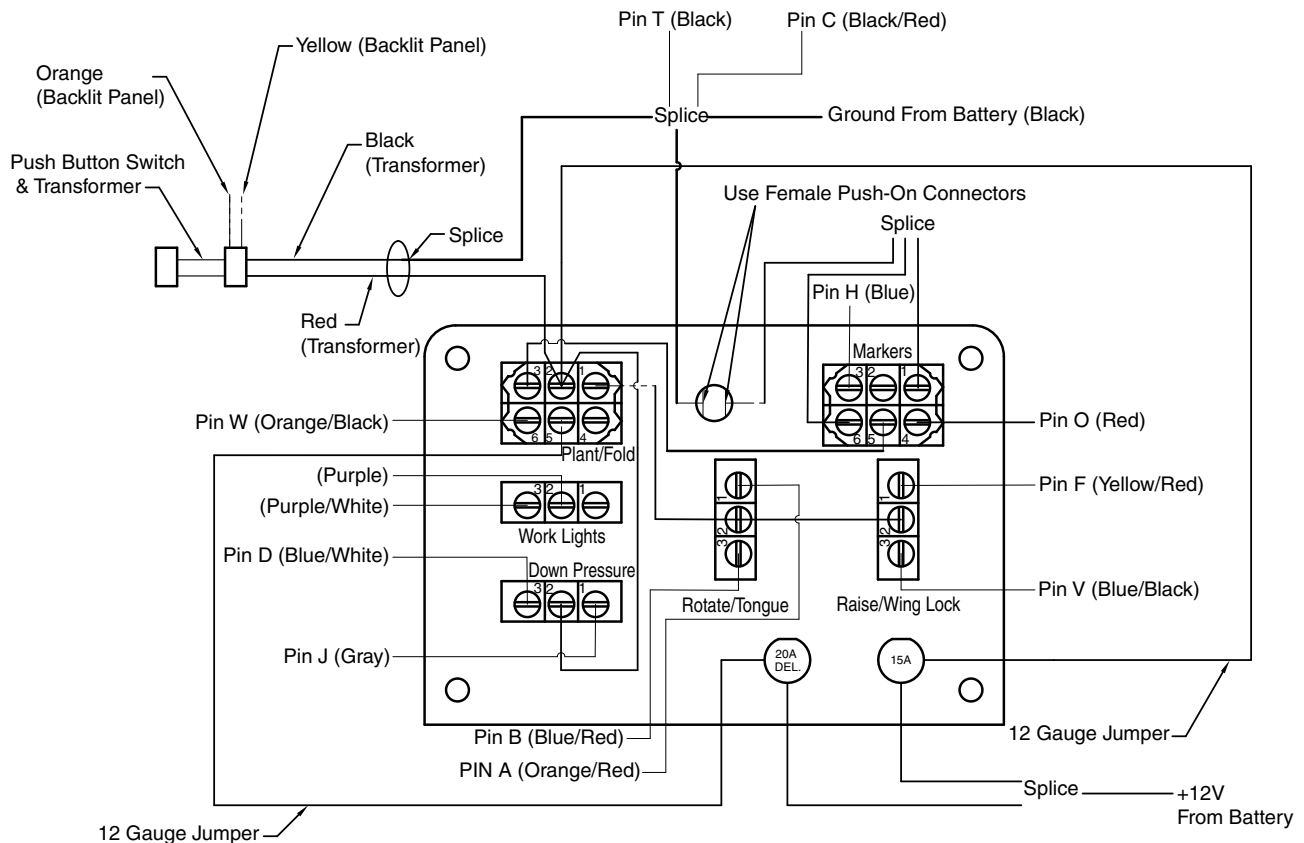
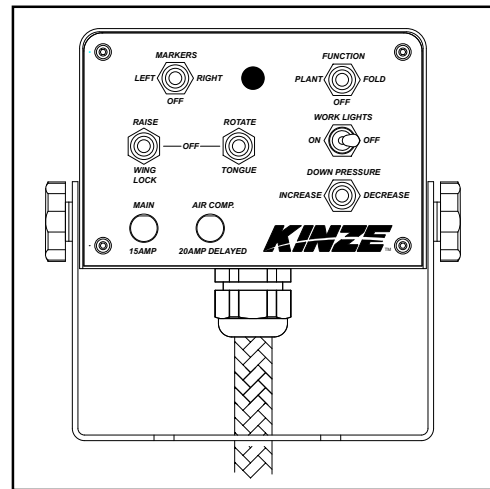

Rear View of Front Panel

ELECTRICAL WIRING HARNESS SCHEMATIC (On Tractor)

NOTE: Not applicable to Blue Drive System.

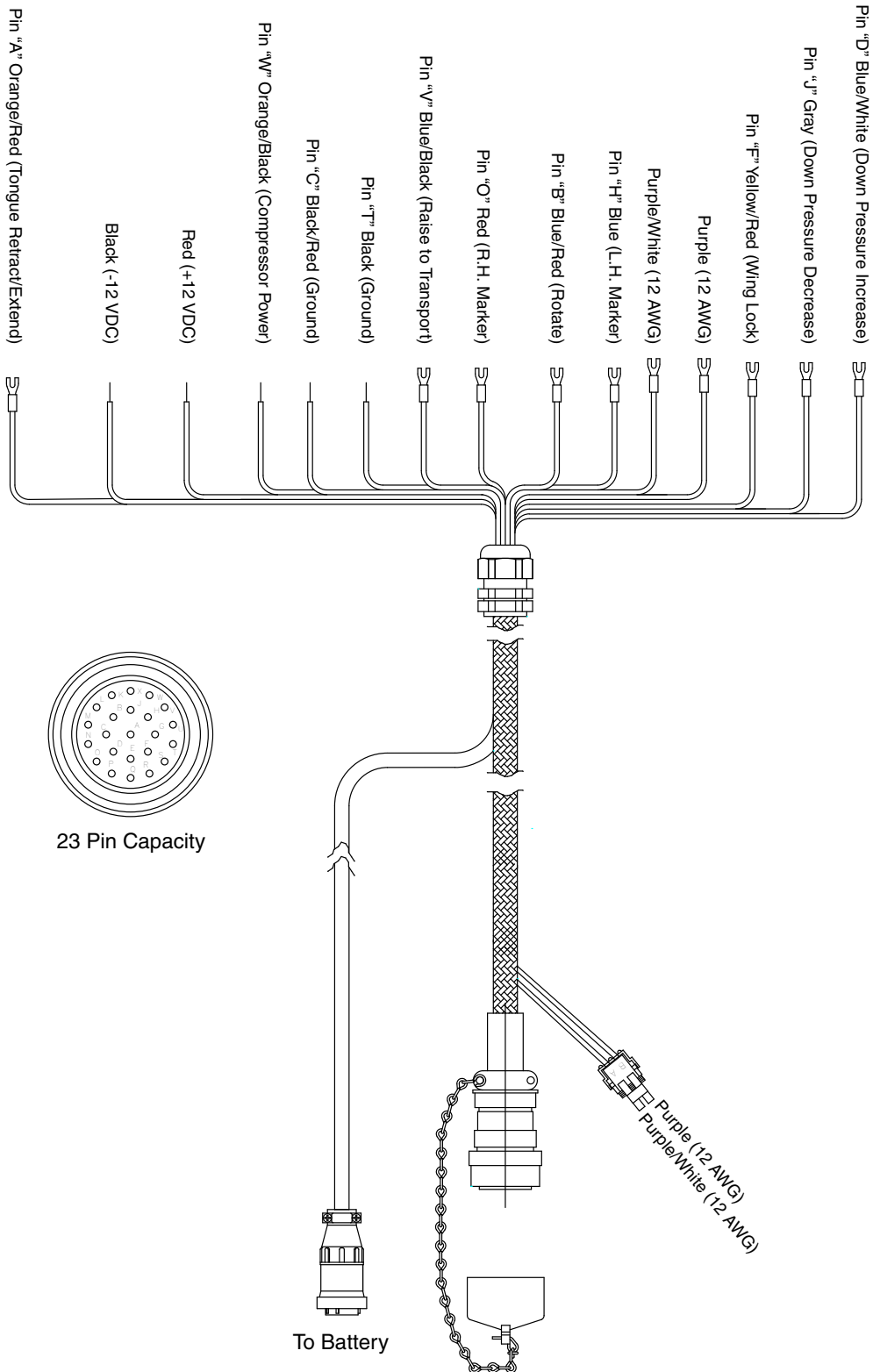

ELECTRICAL WIRING HARNESS SCHEMATIC (On Planter)

NOTE: Not applicable to Blue Drive System.

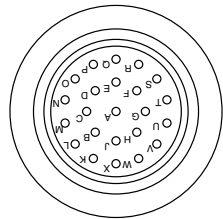

23 Pin Capacity

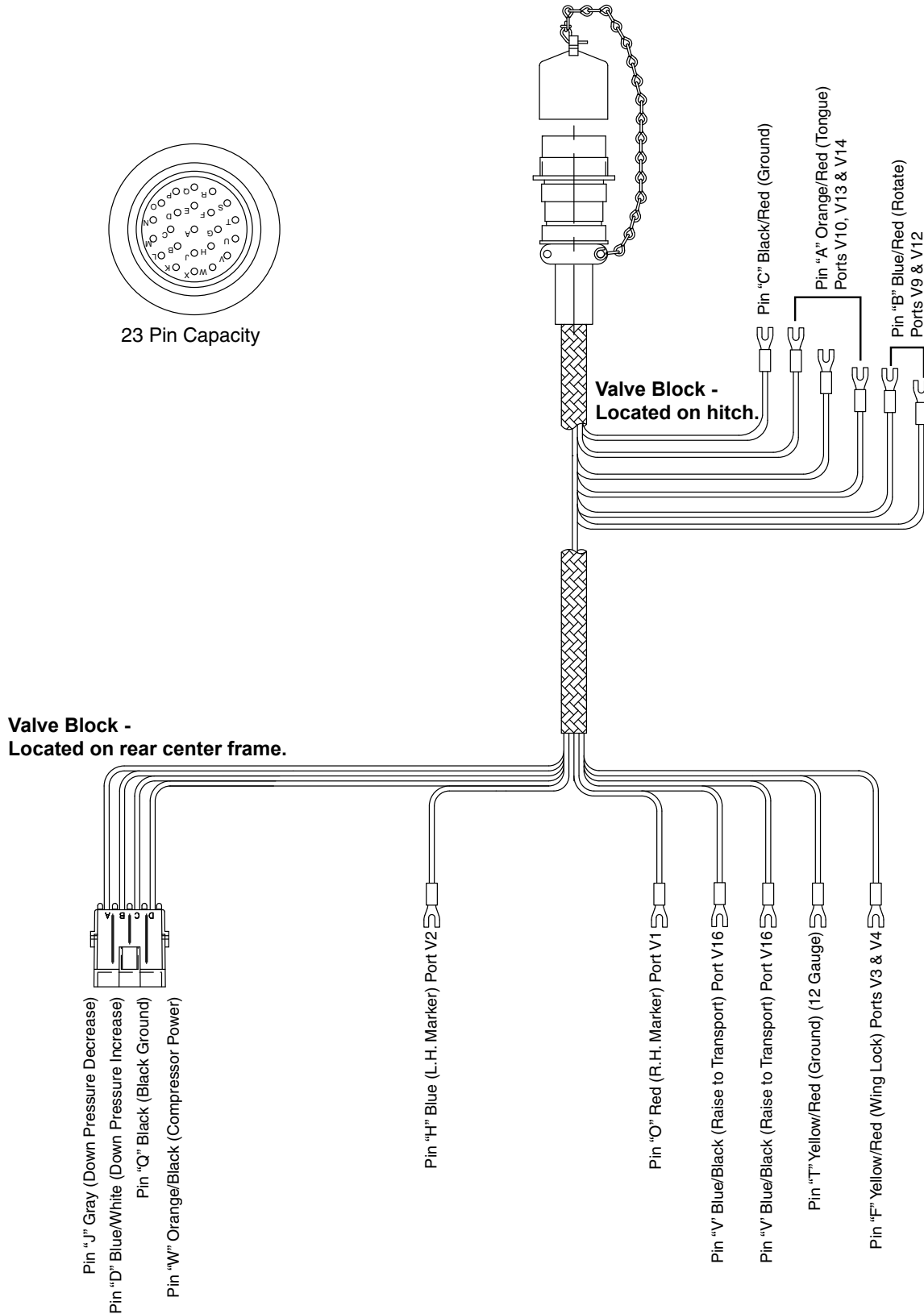

VALVE BLOCK - LOCATED ON HITCH

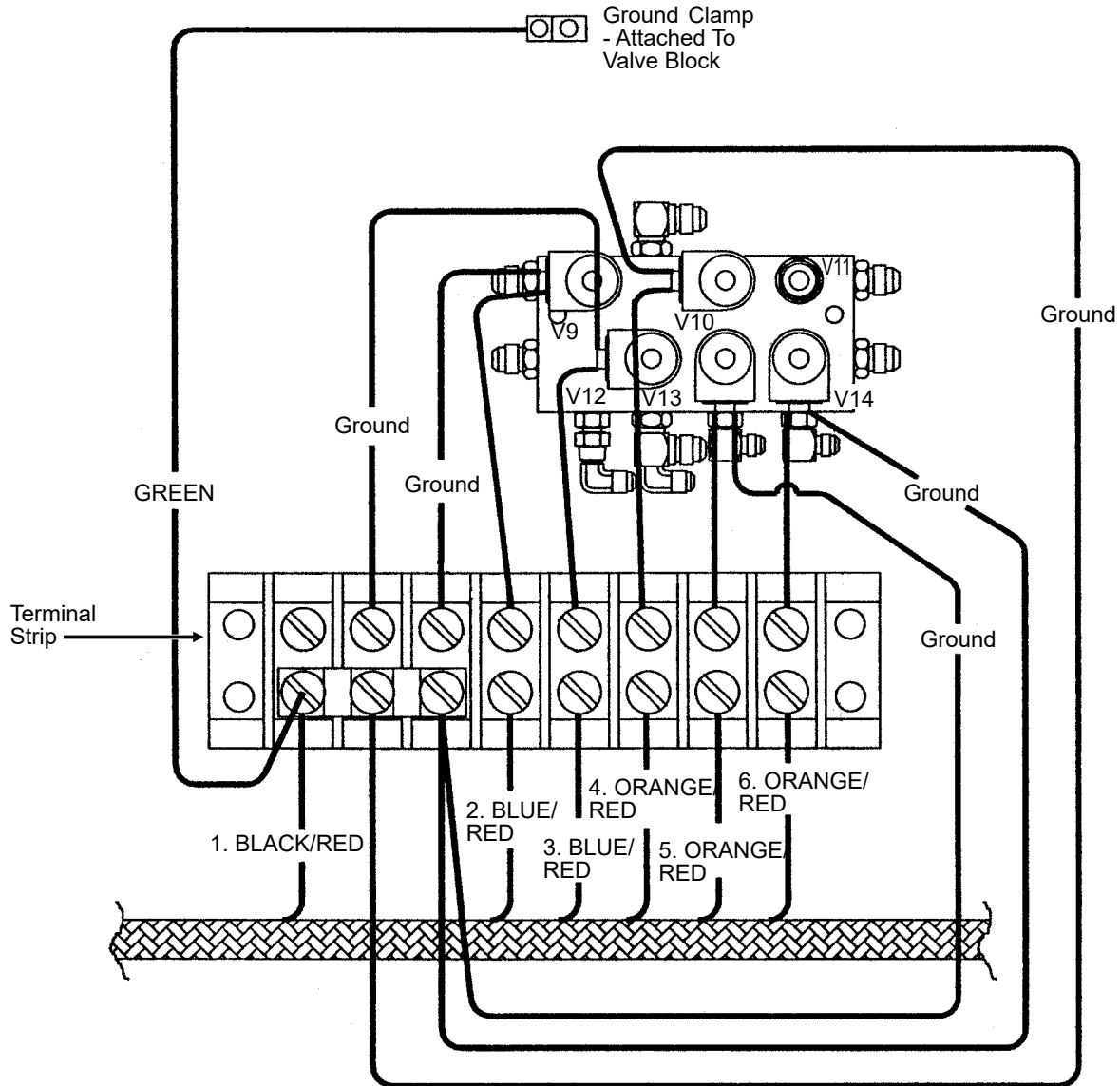

1. BLACK/RED - Pin "C" (Ground)
2. BLUE/RED - Pin "B" (Rotate) - Port V9
3. BLUE/RED - Pin "B" (Rotate) - Port V12
4. ORANGE/RED - Pin "A" (Tongue) - Port V10
5. ORANGE/RED - Pin "A" (Tongue) - Port V13
6. ORANGE/RED - Pin "A" (Tongue) - Port V14

VALVE BLOCK - LOCATED ON REAR CENTER FRAME

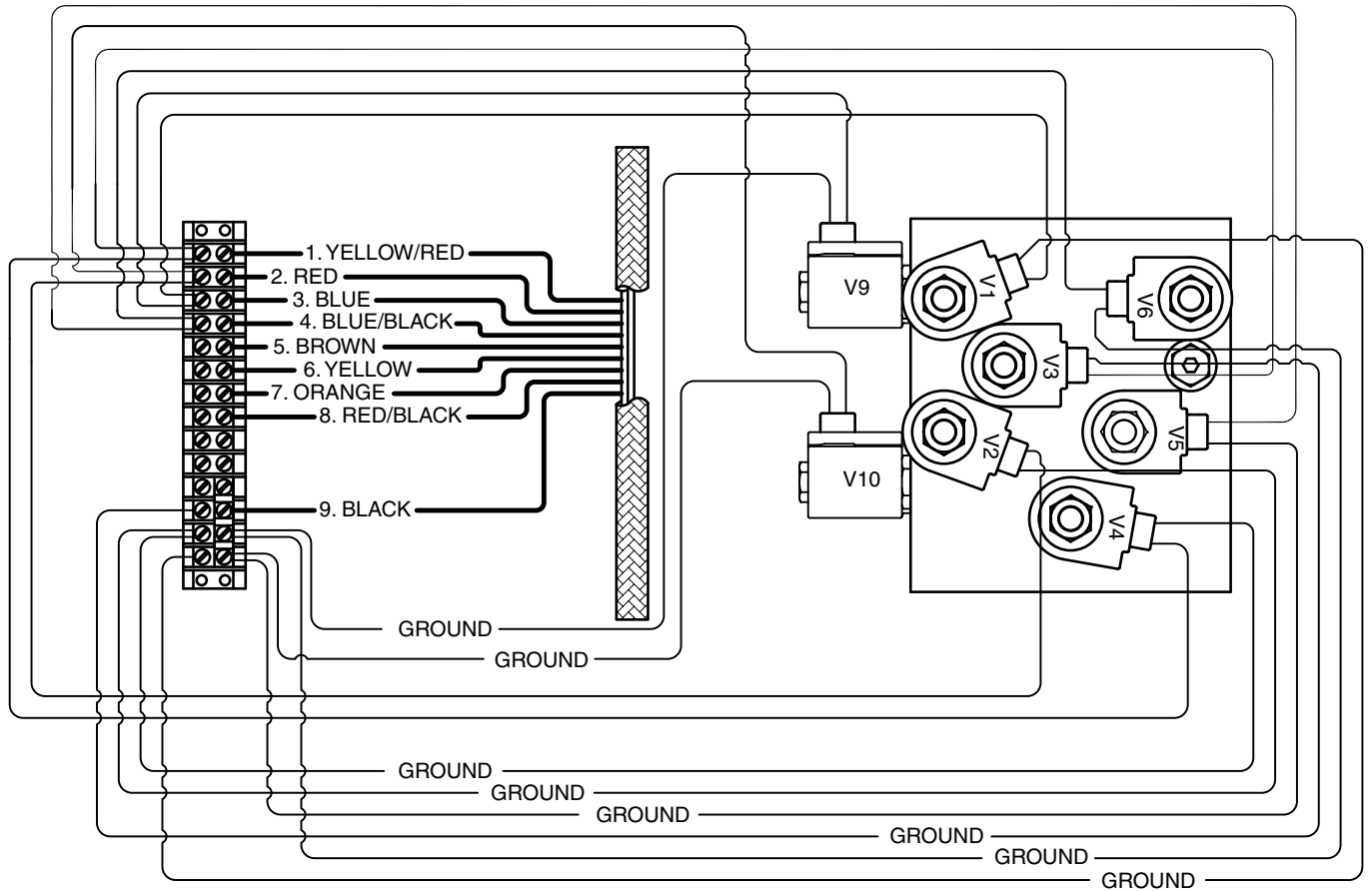

1. YELLOW/RED - Pin "F" (Wing Lock) - Ports V3 & V4
2. RED - Pin "O" (R.H. Marker) - Ports V2 & V10
3. BLUE - Pin "H" (L.H. Marker) - Ports V1 & V9
4. BLUE/BLACK - Pin "V" (Raise To Transport) - Ports V6 & V5
5. BROWN - Pin "R" (L.H. Point Row Clutch)
6. YELLOW - Pin "S" (L.H. Two-Speed Clutch)
7. ORANGE - Pin "G" (R.H. Point Row Clutch)
8. RED/BLACK - Pin "U" (R.H. Two-Speed Clutch)
9. BLACK - (Monitor Ground) - Port V3

TRACTOR POWER HARNESS (P/N: A25365)

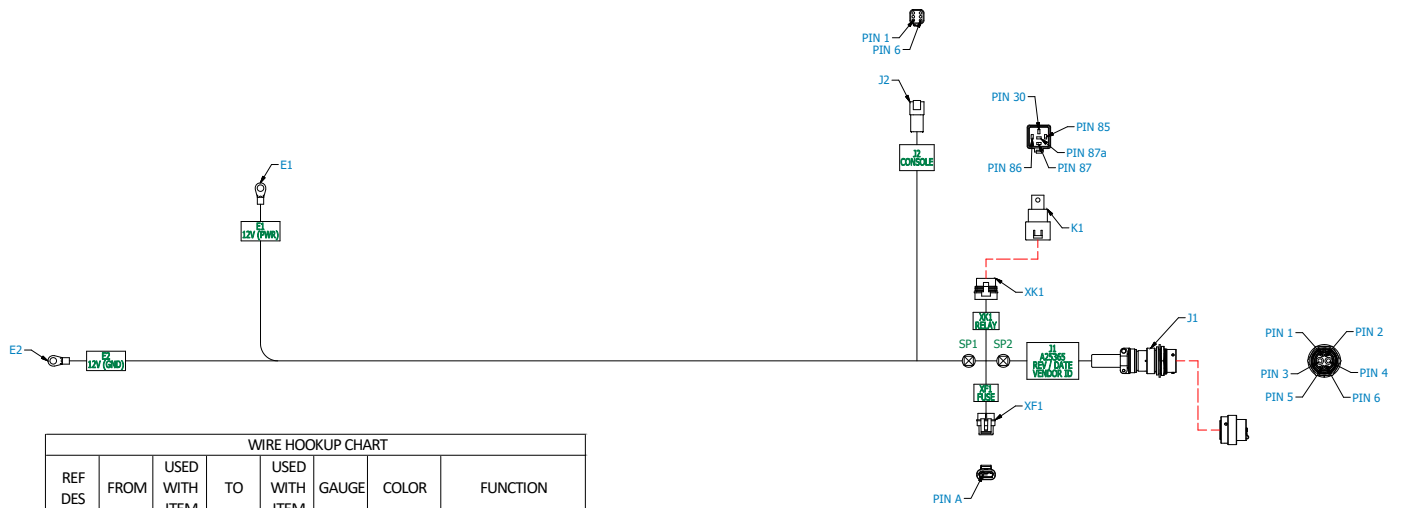

WIRE HOOKUP CHART

REF DES	FROM	USED WITH ITEM	TO	USED WITH ITEM	GAUGE	COLOR	FUNCTION
W1	E1	---	SP1	---	6	RED	BATTERY (12V+)
W2	SP1	---	XF1-A	6	12	RED	BATTERY (12V+)
W3	XF1-B	6	XK1-30	6	12	RED	BATTERY (12V+)
W4	XK1-87	6	SP2	---	12	RED	BATTERY (12V+)
W5	SP2	---	J1-3	15	6	RED	BATTERY (12V+)
W6	E2	---	J1-4	15	6	BLK	BATTERY (GND)
W7	J2-1	16	J1-1	16	18 (TP)	BLU	MASTER CAN LO
W8	J2-2	16	J1-2	16	18 (TP)	WHT	MASTER CAN HI
W9	J2-3	16	XK1-86	7	18	BLU	RELAY (PWR)
W10	J2-4	16	XK1-85	7	18	BLK	12V SWITCHED (GND)
W11	J2-5	16	J1-5	16	18 (TP)	GRN	J1939 CAN LO
W12	J2-6	16	J1-6	16	18 (TP)	YEL	J1939 CAN HI

HYDRAULIC DOWN FORCE CONSOLE HARNESS (P/N: A25366)

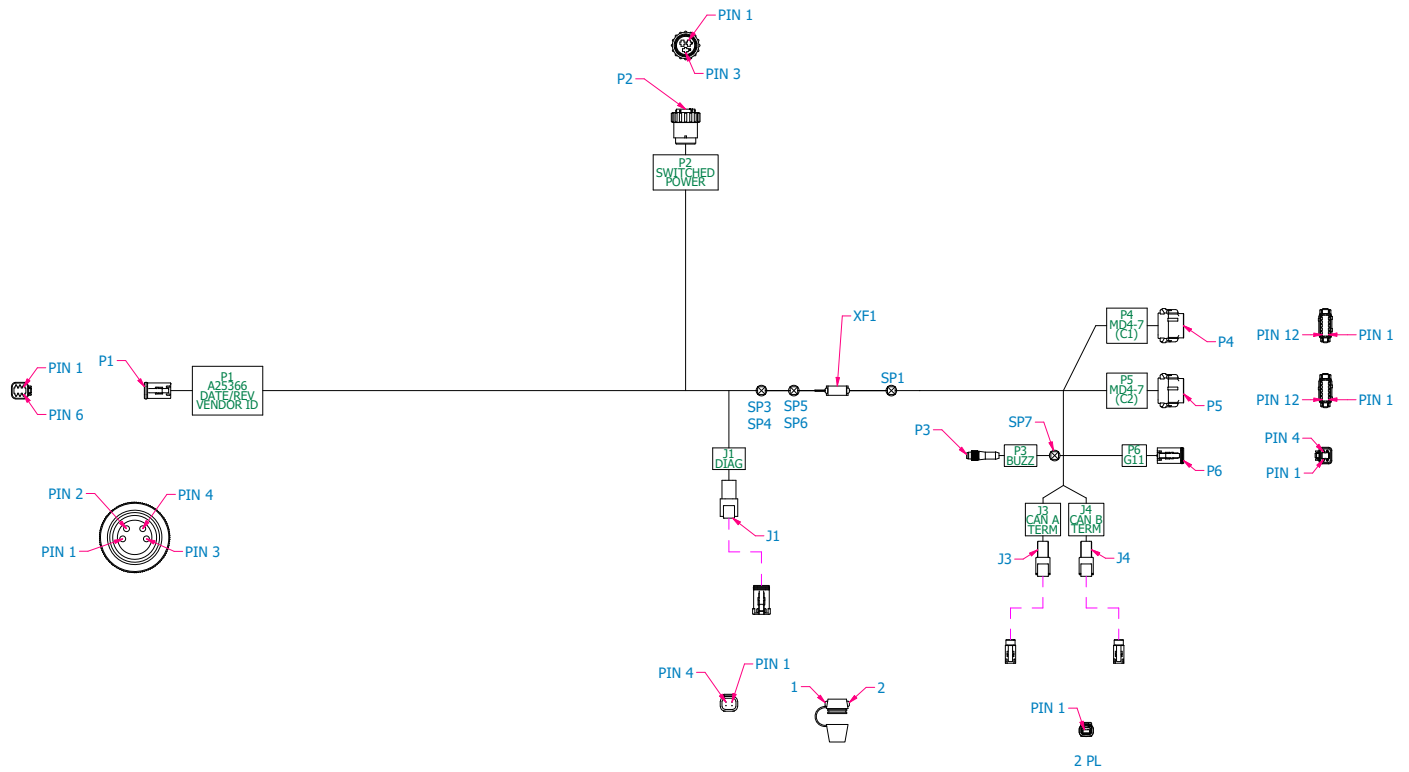

WIRE HOOKUP CHART							
REF DES	FROM	USED WITH ITEM	TO	USED WITH ITEM	GAUGE	COLOR	FUNCTION
W01	P2-1	22	XF1-1	---	16	RED	SWITCHED 12V+
W02	XF1-2	---	P3-2	---	16	RED	SWITCHED 12V+
W05	P2-3	22	SP1	---	16	BLK	GROUND
W06	SP1	---	P4-1	18	18	BLK	GROUND
W07	SP1	---	P6-1	17	18	BLK	GROUND
W08	SP1	---	P1-4	17	18	BLK	GROUND
W09	P5-3	18	P3-1	---	18	WHT	BUZZER
W10	P3-4	---	SP7	---	18	BRN	DISPLAY POWER 12V+
W11	SP7	---	P4-12	18	18	BRN	DISPLAY POWER 12V+
W12	SP7	---	P5-12	18	18	BRN	DISPLAY POWER 12V+
W13	SP7	---	P6-2	17	18	BRN	DISPLAY POWER 12V+
W14	P4-2	18	SP3	---	18 TP	BLUE	CAN A LO (MASTER)
W15	P4-11	18	SP4	---	18 TP	WHT	CAN A HI (MASTER)
W16	SP3	---	J1-1	19	18 TP	BLUE	CAN A LO (MASTER)
W17	SP4	---	J1-2	19	18 TP	WHT	CAN A HI (MASTER)
W18	SP3	---	P1-1	17	18 TP	BLUE	CAN A LO (MASTER)
W19	SP4	---	P1-2	17	18 TP	WHT	CAN A HI (MASTER)
W20	SP3	---	J3-1	16	18 TP	BLUE	CAN A LO (MASTER)
W21	SP4	---	J3-2	16	18 TP	WHT	CAN A HI (MASTER)
W22	SP3	---	P6-3	17	18 TP	BLUE	CAN A LO (MASTER)
W23	SP4	---	P6-4	17	18 TP	WHT	CAN A HI (MASTER)
W24	P4-3	18	SP5	---	18 TP	GRN	CAN B LO (J1939)
W25	P4-10	18	SP6	---	18 TP	YEL	CAN B HI (J1939)
W26	SP5	---	J1-3	19	18 TP	GRN	CAN B LO (J1939)
W27	SP6	---	J1-4	19	18 TP	YEL	CAN B HI (J1939)
W28	SP5	---	P1-5	17	18 TP	GRN	CAN B LO (J1939)
W29	SP6	---	P1-6	17	18 TP	YEL	CAN B HI (J1939)
W30	SP5	---	J4-1	16	18 TP	GRN	CAN B LO (J1939)
W31	SP6	---	J4-2	16	18 TP	YEL	CAN B HI (J1939)
W32	SP1	---	P3-3	---	18	BLK	GROUND
W33	SP7	---	P1-3	17	18	RED	DISPLAY POWER 12V+

HYDRAULIC DOWN FORCE INTERMEDIATE HARNESS (P/N: A25367)



WIRE HOOKUP CHART							
REF DES	FROM	USED WITH ITEM	TO	USED WITH ITEM	GAUGE	COLOR	FUNCTION
W1	P1-1	2	P2-1	2	18 (TP)	BLU	MASTER CAN LO
W2	P1-2	2	P2-2	2		WHT	MASTER CAN HI
W3	P1-3	3	P2-3	3	6	RED	BATTERY +
W4	P1-4	3	P2-4	3	6	BLK	BATTERY -
W5	P1-5	2	P2-5	2	18 (TP)	GRN	J1939 CAN LO
W6	P1-6	2	P2-6	2		YEL	J1939 CAN HI

HYDRAULIC DOWN FORCE EXTENSION HARNESS, 6' (P/N: A25556)



WIRE HOOKUP CHART							
REF DES	FROM	USED WITH ITEM	TO	USED WITH ITEM	GAUGE	COLOR	FUNCTION
W1	J1-1	3	P1-1	5	18 (TP)	BLU	MASTER CAN LO
W2	J1-2	3	P1-2	5		WHT	MASTER CAN HI
W3	J1-3	4	P1-3	6	6	RED	BATTERY +
W4	J1-4	4	P1-4	6	6	BLK	BATTERY -
W5	J1-5	3	P1-5	5	18 (TP)	GRN	J1939 CAN LO
W6	J1-6	3	P1-6	5		YEL	J1939 CAN HI

HYDRAULIC DOWN FORCE EXTENSION HARNESS, 15' (P/N: A25557)

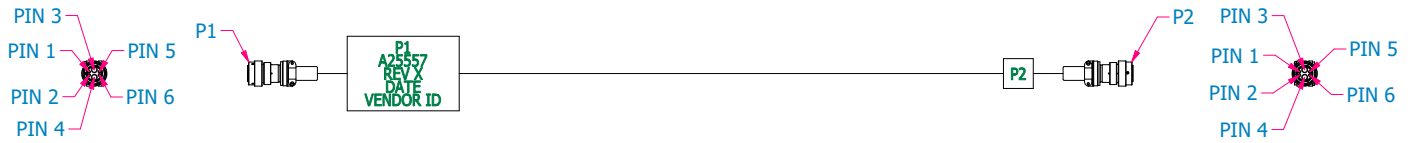

WIRE HOOKUP CHART							
REF DES	FROM	USED WITH ITEM	TO	USED WITH ITEM	GAUGE	COLOR	FUNCTION
W1	P1-1	2	P2-1	2	18 (TP)	BLU	MASTER CAN LO
W2	P1-2	2	P2-2	2		WHT	MASTER CAN HI
W3	P1-3	3	P2-3	3	6	RED	BATTERY +
W4	P1-4	3	P2-4	3	6	BLK	BATTERY -
W5	P1-5	2	P2-5	2	18 (TP)	GRN	J1939 CAN LO
W6	P1-6	2	P2-6	2		YEL	J1939 CAN HI

FERTILIZER FLOW HARNESS (P/N: A25714)

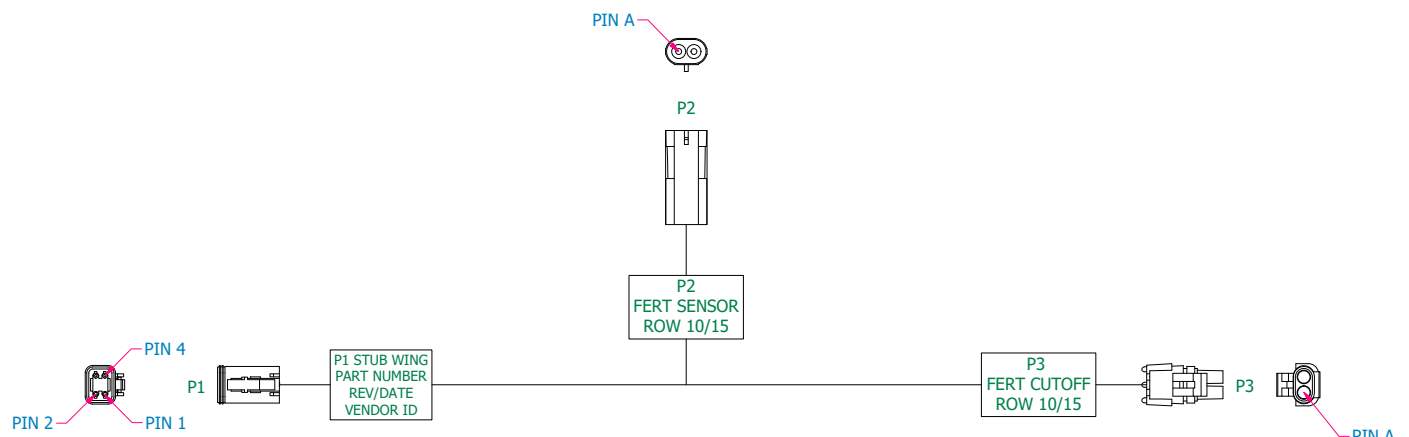

WIRE HOOKUP CHART							
REF DES	FROM	USED W/	TO	USED W/	GAUGE	COLOR	FUNCTION
W1	P1-1	7	P3-A	6	18	RED	FERT ROW CUTOFF VALVE (PWR)
W2	P1-2	7	P3-B	6	18	BLK	FERT ROW CUTOFF VALVE (GND)
W3	P1-3	7	P2-A	5	18	RED	FERT FLOW SENSOR (PWR/SIGNAL)
W4	P1-4	7	P2-B	5	18	BLK	FERT FLOW SENSOR (GND)

INTEGRATED TRUE DEPTH ROW UNIT HARNESS (P/N: A26709)

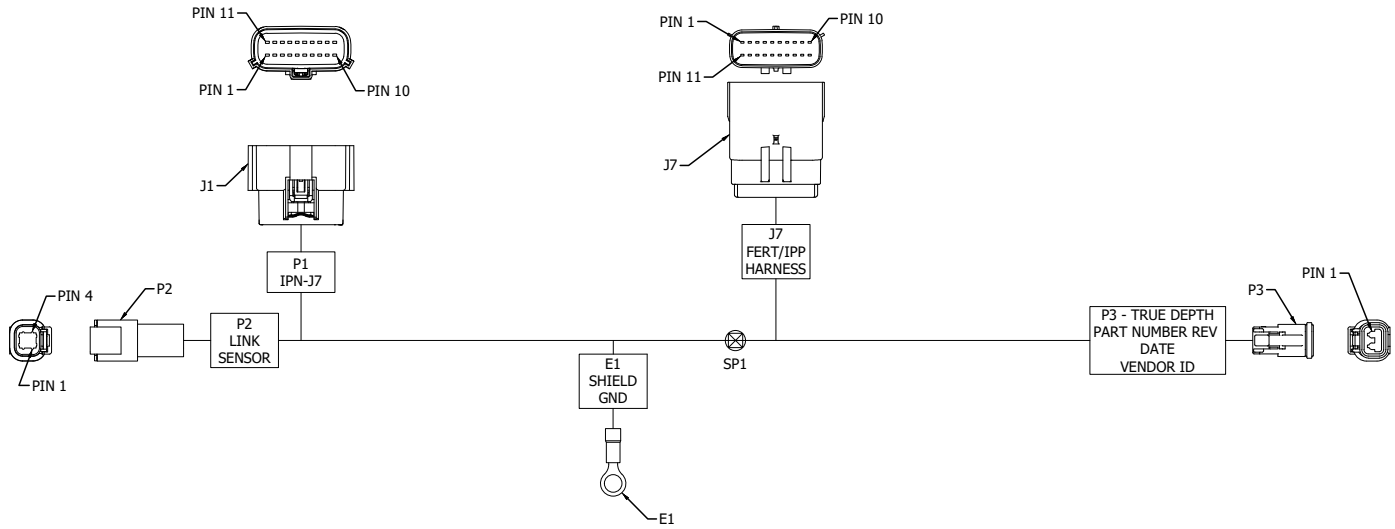

WIRE HOOKUP CHART							
REF DES	FROM	USED WITH ITEM	TO	USED WITH ITEM	GAUGE	COLOR	FUNCTION
W1	P1-1	2	J7-1	5	18 (TP-1)	ORN	RS232 RX
W2	P1-2	2	J7-2	5	18 (TP-1)	BRN	RS232 TX
W3	P1-3	2	J7-3	5	18	RED	FERT ROW CUTOFF VALVE (PWR)
W4	P1-4	2	J7-4	5	18	BLK	FERT ROW CUTOFF VALVE (GND)
W5	P1-7	2	P3-1	9	18	RED	TRUE DEPTH CYLINDER PWM+
W6	P1-8	2	P3-2	9	18	BLK	TRUE DEPTH CYLINDER PWM-
W7	P1-13	2	J7-13	5	18	RED	FERT FLOW SENSOR (PWR/SIGNAL)
W8	P1-16	2	P2-2	7	18	BLK	TRUE DEPTH LINK SENSOR (SIGNAL)
W9	P1-19	2	SP1	--	18	BLK	SENSOR (GND)
W10	SP1	--	J7-19	5	18	GND	FERT FLOW SENSOR (GND)
W11	SP1	--	P2-4	7	18	BLK	TRUE DEPTH LINK SENSOR (GND)
W12	P1-20	2	P2-1	7	18	RED	TRUE DEPTH LINK SENSOR (PWR)
W13	E1	--	P2-3	7	18	GRN	TRUE DEPTH LINK SENSOR (SHIELD)

ROW UNIT SEED METER HARNESS (P/N: A25203)

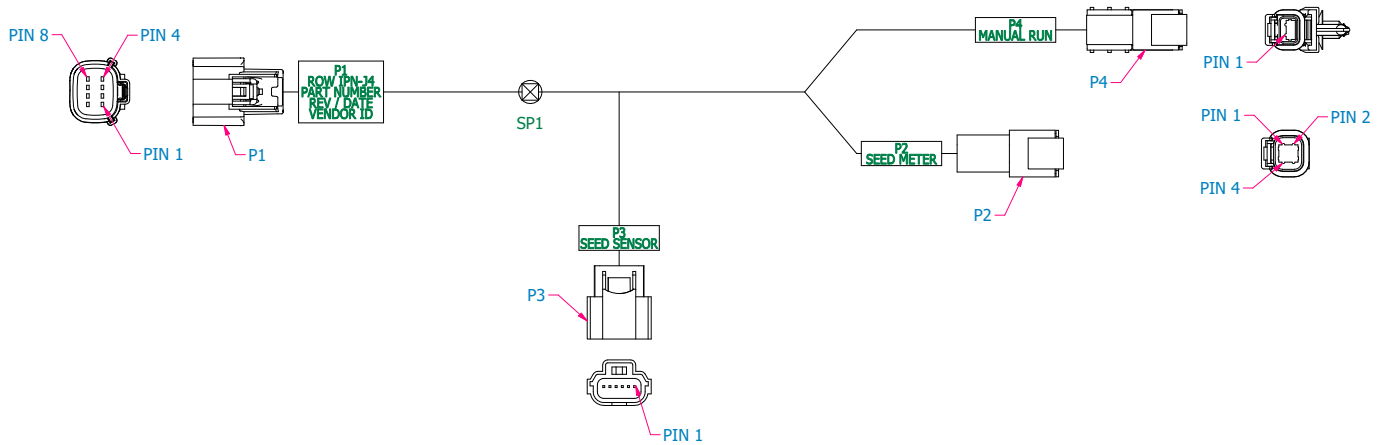

WIRE HOOKUP CHART							
REF DES	FROM	USED WITH ITEM	TO	USED WITH ITEM	GAUGE	COLOR	FUNCTION
W1	P1-1	8	P2-1	5	18	RED	SEED METER MOTOR 1+
W2	P1-2	8	P2-2	5	18	WHT	SEED METER MOTOR 1-
W3	P1-3	8	P2-4	5	18	BLK	SEED METER MOTOR 2-
W4	P1-4	8	P2-3	5	18	GRN	SEED METER MOTOR 2+
W5	P1-5	8	P3-1	6	18 TXL	RED	SEED SENSOR (PWR)
W6	P1-6	8	SP1	---	18	BLK	GROUND
W7	P1-7	8	P3-2	6	18 TXL	BLU	SEED SENSOR (LIN)
W8	SP1	---	P3-6	6	18 TXL	BLK	SEED SENSOR (GND)
W9			P4-1	5	18	BLK	MANUAL RUN (GND)
W10	P1-8	8	P4-2	5	18	RED	MANUAL RUN (INPUT)

WORK LIGHT HARNESS (P/N: A22547)

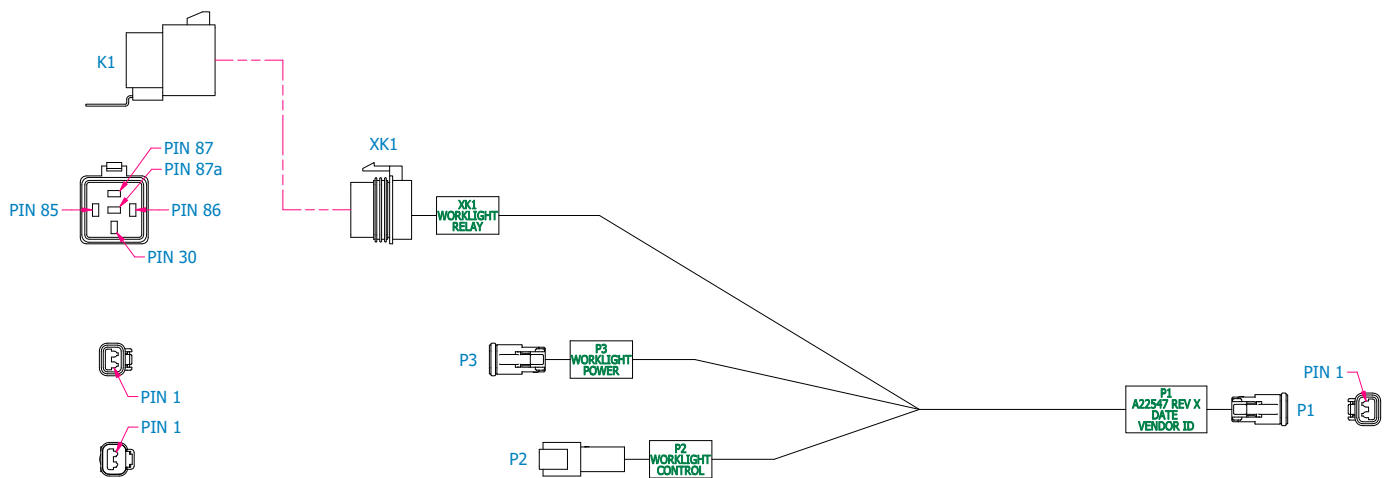

WIRE HOOKUP CHART							
REF DES	FROM	USED WITH ITEM	TO	USED WITH ITEM	GAUGE	COLOR	FUNCTION
W1	P3-1	7	P1-1	7	16	BLK	WORKLIGHT POWER -
W2	P3-2	7	XK1-30	---	16	RED	WORKLIGHT POWER +
W3	P2-1	8	XK1-85	---	16	BLK	RELAY GROUND
W4	P2-2	8	XK1-86	---	16	BLU	RELAY 12V
W5	XK1-87	---	P1-2	7	16	RED	WORKLIGHT POWER +

WORK LIGHT HARNESS (P/N: A22547)

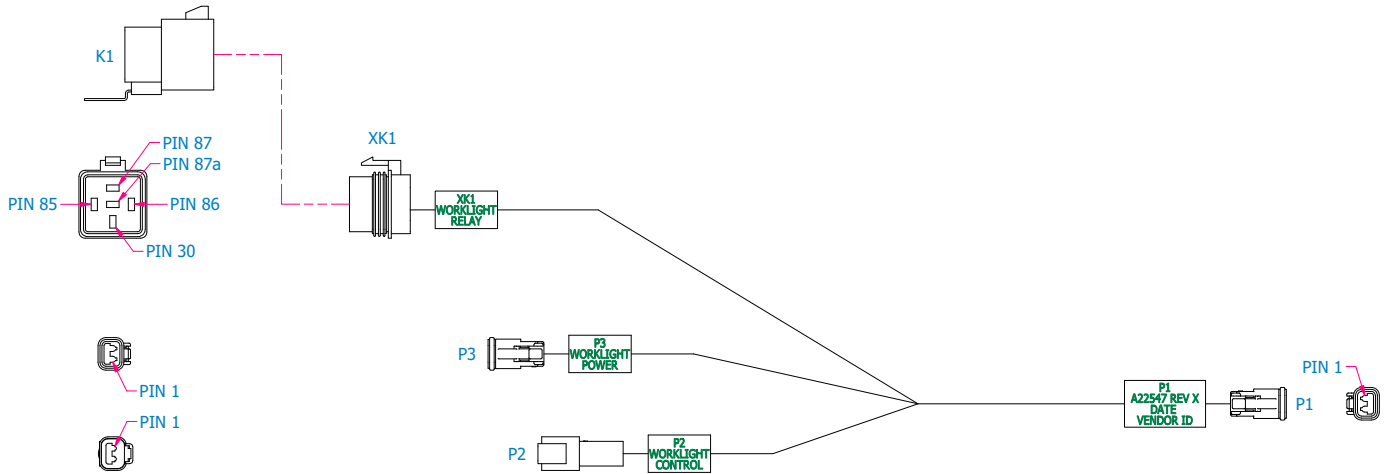

WIRE HOOKUP CHART							
REF DES	FROM	USED WITH ITEM	TO	USED WITH ITEM	GAUGE	COLOR	FUNCTION
W1	P3-1	7	P1-1	7	16	BLK	WORKLIGHT POWER -
W2	P3-2	7	XK1-30	---	16	RED	WORKLIGHT POWER +
W3	P2-1	8	XK1-85	---	16	BLK	RELAY GROUND
W4	P2-2	8	XK1-86	---	16	BLU	RELAY 12V
W5	XK1-87	---	P1-2	7	16	RED	WORKLIGHT POWER +

CAMERA POWER HARNESS (P/N: 10269201)

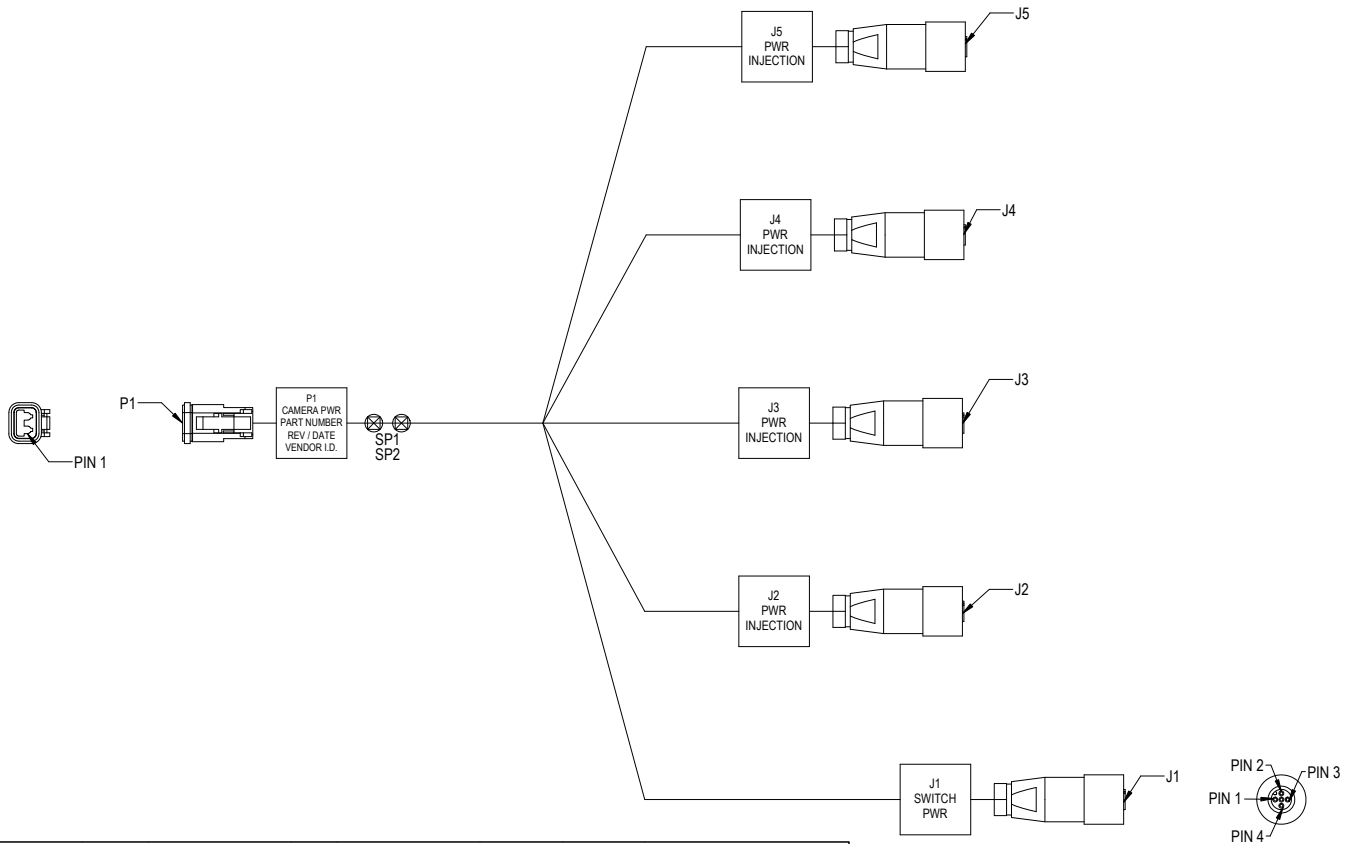

WIRE HOOKUP CHART							
REF DES	FROM	USED W/ ITEM	TO	USED W/ ITEM	GAUGE	COLOR	FUNCTION
W1	P1-2	4	XF1-1	7	16	RED	PWR (+)
W2	SP1	---	J1-3	---	18	RED	SWITCH PWR (+)
W3	SP1	---	J1-4	---	18	RED	SWITCH PWR (+)
W4	SP1	---	J2-2	---	18	RED	CAMERA PWR (+)
W5	SP1	---	J2-3	---	18	RED	CAMERA PWR (+)
W6	SP1	---	J3-2	---	18	RED	CAMERA PWR (+)
W7	SP1	---	J3-3	---	18	RED	CAMERA PWR (+)
W8	SP1	---	J4-2	---	18	RED	CAMERA PWR (+)
W9	SP1	---	J4-3	---	18	RED	CAMERA PWR (+)
W10	SP1	---	J5-2	---	18	RED	CAMERA PWR (+)
W11	SP1	---	J5-3	---	18	RED	CAMERA PWR (+)
W12	P1-1	4	SP2	---	16	BLK	PWR (-)
W13	SP2	---	J1-1	---	18	BLK	SWITCH PWR (-)
W14	SP2	---	J1-2	---	18	BLK	SWITCH PWR (-)
W15	SP2	---	J2-1	---	18	BLK	CAMERA PWR (-)
W16	SP2	---	J2-4	---	18	BLK	CAMERA PWR (-)
W17	SP2	---	J3-1	---	18	BLK	CAMERA PWR (-)
W18	SP2	---	J3-4	---	18	BLK	CAMERA PWR (-)
W19	SP2	---	J4-1	---	18	BLK	CAMERA PWR (-)
W20	SP2	---	J4-4	---	18	BLK	CAMERA PWR (-)
W21	SP2	---	J5-1	---	18	BLK	CAMERA PWR (-)
W22	SP2	---	J5-4	---	18	BLK	CAMERA PWR (-)
W23	XF1-2	7	SP1	--	16	RED	PWR (+)

12V POWER HARNESS, 12 ROW (P/N: 10358301)

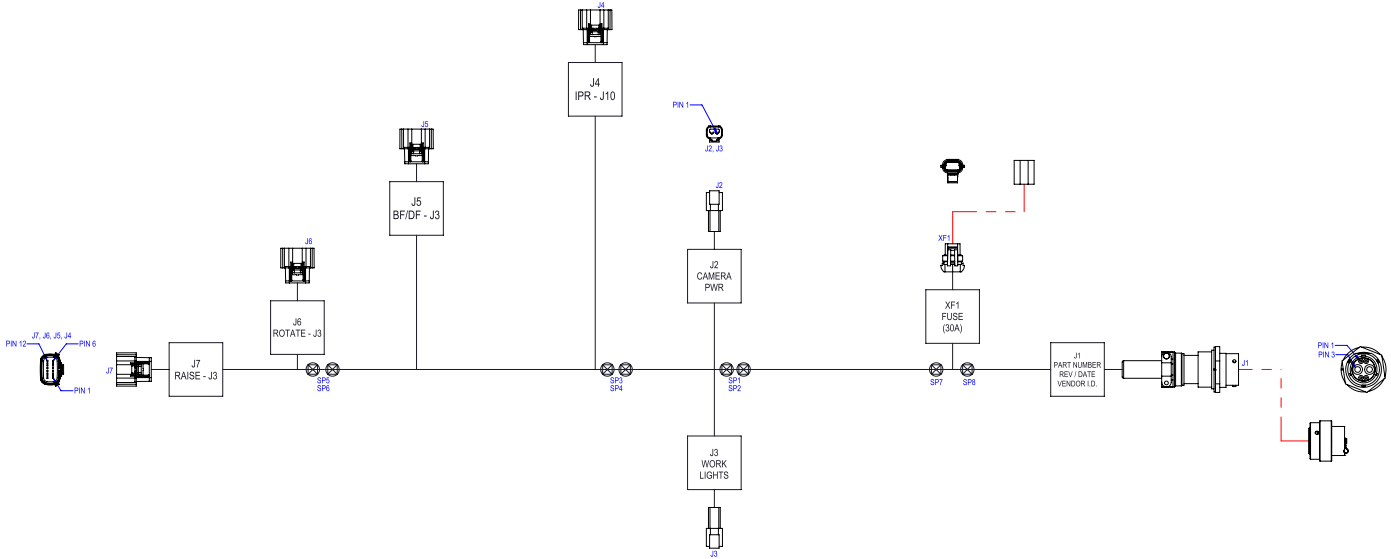

WIRE HOOKUP CHART						
REF DES	FROM	USED W/ ITEMS	TO	USED W/ ITEMS	GAUGE	FUNCTION
W1	J1-3	7	SP7	---	6	12V DC (+)
W2	SP7	---	XF1-1	16	12	12V DC (+)
W3	XF1-2	16	SP8	---	12	12V DC (+)
W4	SP8	---	SP1	---	6	12V DC (+)
W5	J1-4	7	SP2	---	6	12V DC (GND)
W6	SP1	---	J2-2	9	16	12V CAMERA (+)
W7	SP1	---	J3-2	9	16	12V WORKLIGHT (+)
W8	SP1	---	SP3	---	8	12V DC (+)
W9	SP2	---	J2-1	9	16	12V CAMERA (GND)
W10	SP2	---	J3-1	9	16	12V WORKLIGHT (GND)
W11	SP2	---	SP4	---	8	12V DC (-)
W12	SP3	---	J4-1	8	18	IPR (PWR)
W13	SP3	---	J5-1	10	16	BF / DF IPN (PWR)
W14	SP3	---	J5-3	10	16	BF / DF IPN (PWR)
W15	SP3	---	SP5	---	10	12V DC (+)
W16	SP4	---	J4-2	10	18	IPR (GND)
W17	SP4	---	J5-2	10	16	BF / DF IPN (GND)
W18	SP4	---	J5-4	10	16	BF / DF IPN (GND)
W19	SP4	---	SP6	---	10	12V DC (GND)
W20	SP5	---	J6-1	10	16	ROTATE IPN (PWR)
W21	SP5	---	J6-3	10	16	ROTATE IPN (PWR)
W22	SP5	---	J7-1	10	16	RAISE IPN (PWR)
W23	SP5	---	J7-3	10	16	RAISE IPN (PWR)
W24	SP6	---	J6-2	10	16	ROTATE IPN (GND)
W25	SP6	---	J6-4	10	16	ROTATE IPN (GND)
W26	SP6	---	J7-2	10	16	RAISE IPN (GND)
W26	SP6	---	J7-4	10	16	RAISE IPN (GND)

STRAPPING TABLE 2			
CONNECTOR	PIN 10	PIN 11	PIN 12
J4 (IPR)	GND	---	GND

STRAPPING TABLE 1								
CONNECTOR	PIN 5	PIN 6	PIN 7	PIN 8	PIN 9	PIN 10	PIN 11	PIN 12
J5 (BF / DF)	GND	GND	GND	GND	GND	GND	GND	GND
J6 (ROTATE)	GND	---	GND	GND	GND	GND	---	GND
J7 (RAISE)	---	GND	GND	GND	GND	GND	---	GND

12V POWER HARNESS, 16 ROW (P/N: 10338901)

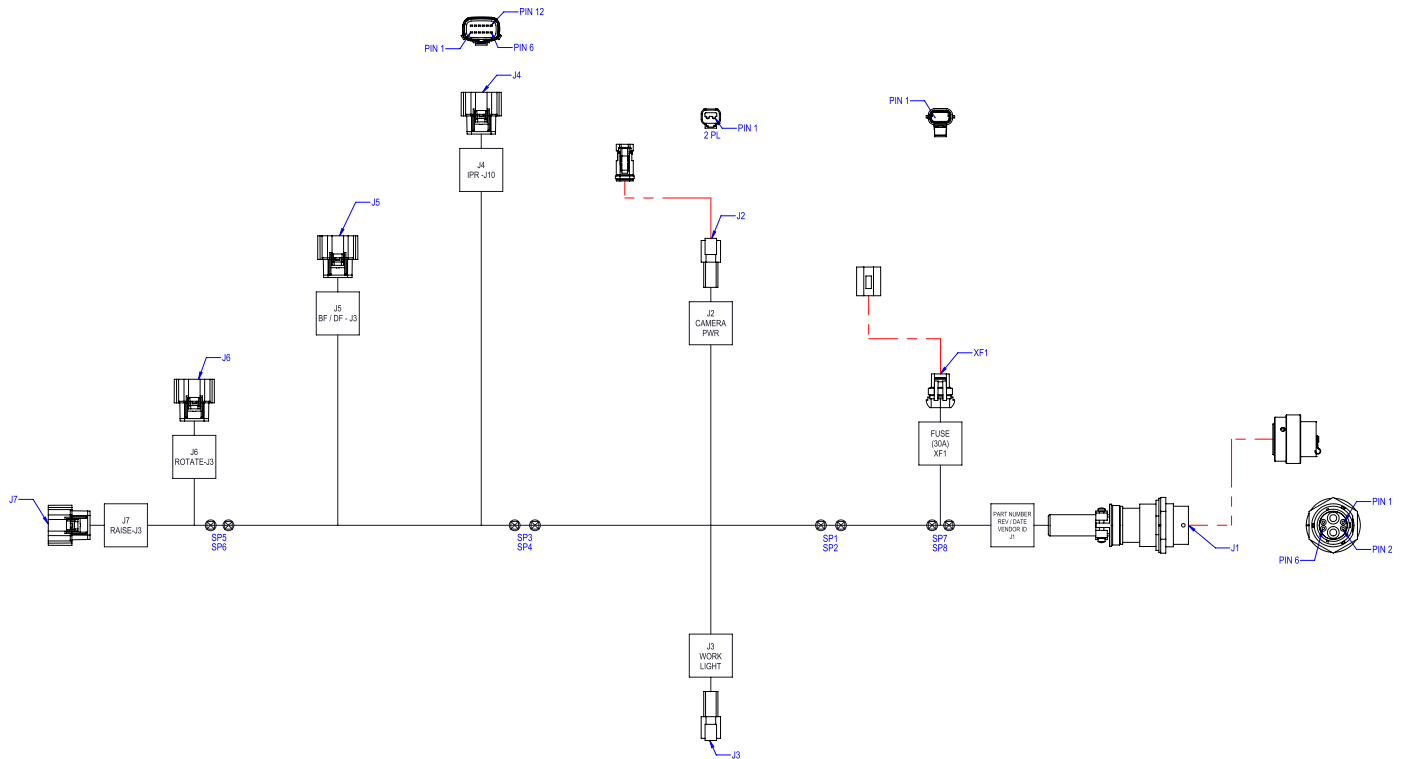

WIRE HOOKUP CHART							
REF DES	FROM	USED W/ ITEM	TO	USED W/ ITEM	GAUGE	COLOR	FUNCTION
W1	J1-3	17	SP7	---	6	RED	12V DC (PRE FUSE)
W2	SP7	---	XF1-1	14	12	RED	12V DC (PRE FUSE)
W3	XF1-2	14	SP8	---	12	RED	12V DC (PWR)
W4	SP8	---	SP1	---	6	RED	12V DC (PWR)
W5	J1-4	17	SP2	---	6	BLK	12V DC (GND)
W6	SP1	---	J2-2	6	16	RED	CAMERA (PWR)
W7	SP1	---	J3-2	6	16	RED	WORKLIGHT (PWR)
W8	SP1	---	SP3	---	12	RED	12V DC (PWR)
W9	SP2	---	J2-1	6	16	BLK	CAMERA (GND)
W10	SP2	---	J3-1	6	16	BLK	WORKLIGHT (GND)
W11	SP2	---	SP4	---	12	BLK	12V DC (GND)
W12	SP3	---	J4-1	5	18	RED	IPR (PWR)
W13	SP3	---	J5-1	7	16	RED	BF / DF (PWR)
W14	SP3	---	J5-3	7	16	RED	BF / DF (PWR)
W15	SP3	---	SP5	---	12	RED	12V DC (PWR)
W16	SP4	---	J4-2	5	18	BLK	IPR (GND)
W17	SP4	---	J5-2	7	16	BLK	BF / DF (GND)
W18	SP4	---	J5-4	7	16	BLK	BF / DF (GND)
W19	SP4	---	SP6	---	12	BLK	12V DC (GND)
W20	SP5	---	J6-1	7	16	RED	ROTATE (PWR)
W21	SP5	---	J6-3	7	16	RED	ROTATE (PWR)
W22	SP5	---	J7-1	7	16	RED	RAISE (PWR)
W23	SP5	---	J7-3	7	16	RED	RAISE (PWR)
W24	SP6	---	J6-2	7	16	BLK	ROTATE (PWR)
W25	SP6	---	J6-4	7	16	BLK	ROTATE (PWR)
W26	SP6	---	J7-2	7	16	BLK	RAISE (PWR)
W27	SP6	---	J7-4	7	16	BLK	RAISE (PWR)

STRAPPING TABLE 2			
CONNECTOR	PIN 10	PIN 11	PIN 12
J4 (IPR)	GND	---	GND

STRAPPING TABLE 1								
CONNECTOR	PIN 5	PIN 6	PIN 7	PIN 8	PIN 9	PIN 10	PIN 11	PIN 12
J5 (BF)	GND	GND	GND	GND	GND	GND	GND	GND
J6 (ROTATE)	GND	---	GND	GND	GND	GND	---	GND
J7 (RAISE)	---	GND	GND	GND	GND	GND	---	GND

ROTATE HARNESS, 12 ROW (P/N: 10151601)

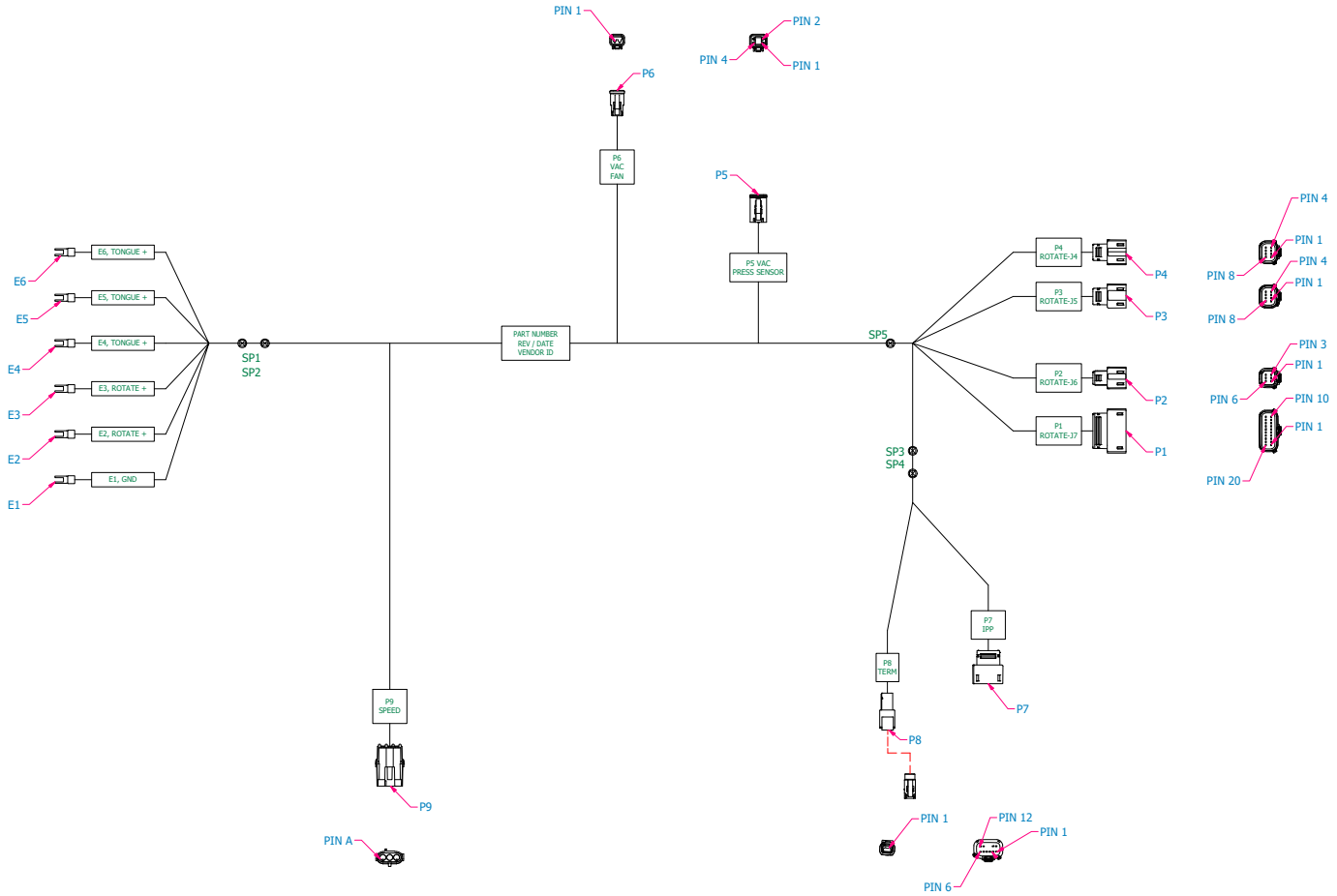

WIRE HOOKUP CHART							
REF DES	FROM	USED WITH ITEM	TO	USED WITH ITEM	GAUGE	COLOR	FUNCTION
W1	P1-1	14	P7-1	14	18 (TP)	ORN	IPP RS232 TX
W2	P1-2	14	P7-2	14	18 (TP)	BRN	IPP RS232 RX
W3	P1-3	13	P6-1	16	16	RED	VAC SOLENOID (+)
W4	P1-4	13	P6-2	16	16	BLK	VAC SOLENOID (-)
W5	P1-7	13	SP1	---	14	ORN/RED	TONGUE SOLENOID (+)
W6	P1-8	13	SP5	---	14	BLK/RED	TONGUE SOLENOID (-)
W7	P1-14	14	P5-4	16	18	YEL	VAC PRESSURE SENSOR (SIG)
W8	P2-1	14	SP3	---	18 (TP)	YEL	IPP CAN HI
W9	P2-2	14	SP4	---	18 (TP)	GRN	IPP CAN LO
W10	P2-3	13	P7-12	13	16	RED	IPP PWR +
W11	P2-4	13	P7-6	13	16	BLK	IPP PWR -
W12	P2-5	14	P7-11	14	18	BLU	IPP BOOT
W13	P3-5	14	P5-2	16	18	WHT	VAC PRESSURE SENSOR (PWR)
W14	P3-6	14	P5-1	16	18	BLK	VAC PRESSURE SENSOR (GND)
W15	P3-7	14	P9-C	16	18	WHT	WHEEL SPEED (FREQ)
W16	P4-1	13	SP2	---	14	BLU/RED	ROTATE SOLENOID (+)
W17	P4-2	13	SP5	---	14	BLK/RED	ROTATE SOLENOID (-)
W18	SP1	---	E4	---	14	ORN/RED	TONGUE SOLENOID (+)
W19	SP1	---	E5	---	14	ORN/RED	TONGUE SOLENOID (+)
W20	SP1	---	E6	---	14	ORN/RED	TONGUE SOLENOID (+)
W21	SP5	---	E1	---	14	BLK/RED	TERMINAL BLOCK (GND)
W22	SP2	---	E2	---	14	BLU/RED	ROTATE SOLENOID (+)
W23	SP2	---	E3	---	14	BLU/RED	ROTATE SOLENOID (+)
W24	P4-6	14	P9-B	15	18	BLK	WHEEL SPEED (GND)
W25	P4-5	14	P9-A	15	18	RED	WHEEL SPEED (PWR)
W28	SP3	---	P7-5	14	18(TP)	YEL	IPP CAN HI
W29	SP4	---	P7-4	14	18(TP)	GRN	IPP CAN LO
W30	SP3	---	P8-1	17	18(TP)	YEL	CAN HI TERMINATOR
W31	SP4	---	P8-2	17	18(TP)	GRN	CAN LO TERMINATOR

ROTATE HARNESS, 16 ROW (P/N: 10151901)

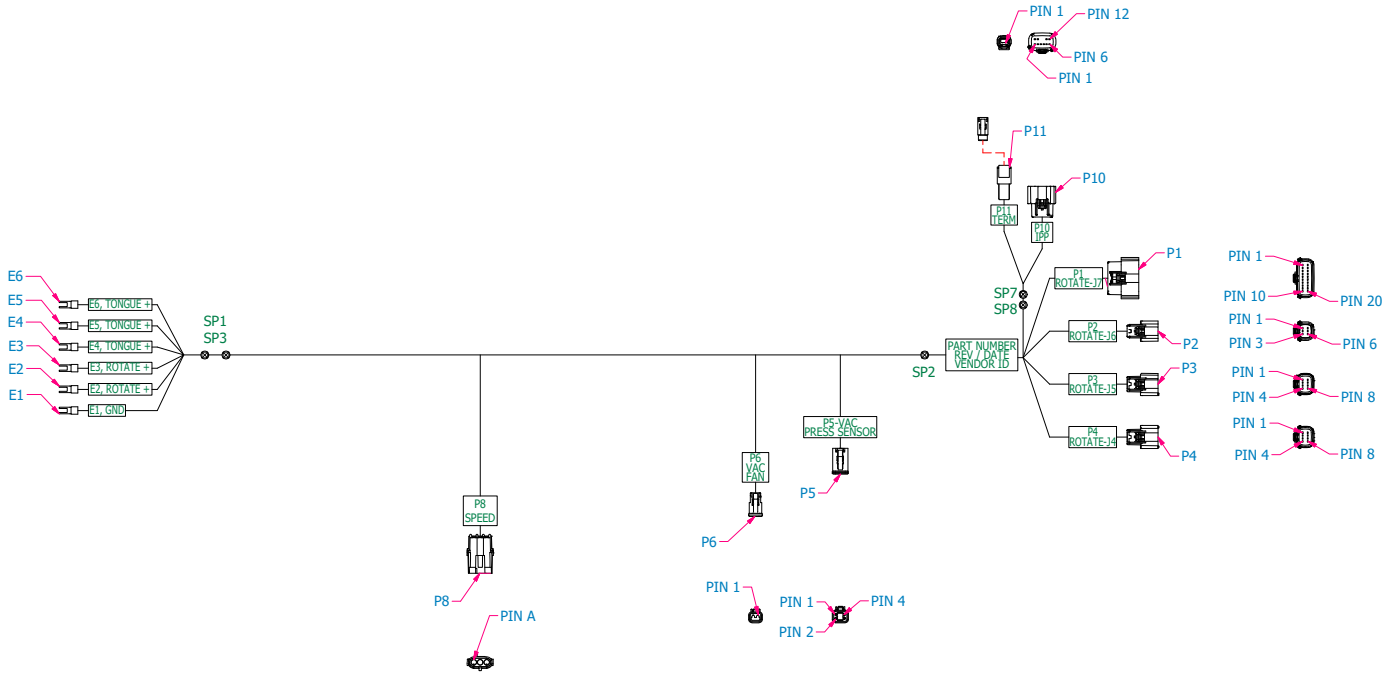

WIRE HOOKUP CHART

REF DES	FROM	USED WITH ITEM	TO	USED WITH ITEM	GAUGE	COLOR	FUNCTION
W1	P1-1	10	P10-1	10	18 (TP)	ORN	IPP RS232 RX
W2	P1-2	10	P10-2	10		BRN	IPP RS232 TX
W3	P1-3	9	P6-1	14	16	RED	VAC SOLENOID (+)
W4	P1-4	9	P6-2	14	16	BLK	VAC SOLENOID (-)
W5	P1-7	9	SP1	---	14	ORN/RED	TONGUE SOLENOID (+)
W6	P1-8	9	SP2	---	14	BLK/RED	TONGUE SOLENOID (-)
W7	P1-14	10	P5-4	14	18	YEL	VAC PRESSURE SENSOR (SIG)
W8	P2-1	10	SP7	---	18 (TP)	YEL	IPP CAN HI
W9	P2-2	10	SP8	---		GRN	IPP CAN LO
W10	P2-3	9	P10-12	9	16	RED	IPP PWR +
W11	P2-4	9	P10-6	9	16	BLK	IPP PWR -
W12	P2-5	10	P10-11	10	18	BLU	IPP BOOT
W13	P3-5	10	P5-2	14	18	WHT	VAC PRESSURE SENSOR (PWR)
W14	P3-6	10	P5-1	14	18	BLK	VAC PRESSURE SENSOR (GND)
W15	P3-7	10	P8-C	12	18	WHT	WHEEL SPEED (FREQ)
W16	P4-1	9	SP3	---	14	BLU/RED	ROTATE SOLENOID (+)
W17	P4-2	9	SP2	---	14	BLK/RED	ROTATE SOLENOID (-)
W18	SP1	---	E4	---	14	ORN/RED	TONGUE SOLENOID (+)
W19	SP1	---	E5	---	14	ORN/RED	TONGUE SOLENOID (+)
W20	SP1	---	E6	---	14	ORN/RED	TONGUE SOLENOID (+)
W21	SP2	---	E1	---	14	BLK/RED	TERMINAL BLOCK (GND)
W22	SP3	---	E2	---	14	BLU/RED	ROTATE SOLENOID (+)
W23	SP3	---	E3	---	14	BLU/RED	ROTATE SOLENOID (+)
W24	P4-6	10	P8-B	12	18	BLK	WHEEL SPEED (GND)
W25	P4-5	10	P8-A	12	18	RED	WHEEL SPEED (PWR)
W26	SP7	---	P10-5	10	18 (TP)	YEL	IPP CAN HI
W27	SP8	---	P10-4	10		GRN	IPP CAN LO
W28	SP7	---	P11-1	21	18 (TP)	YEL	CAN HI TERMINATOR
W29	SP8	---	P11-2	21		GRN	CAN LO TERMINATOR

IPN RAISE HARNESS, 12 ROW (P/N: 10338901)

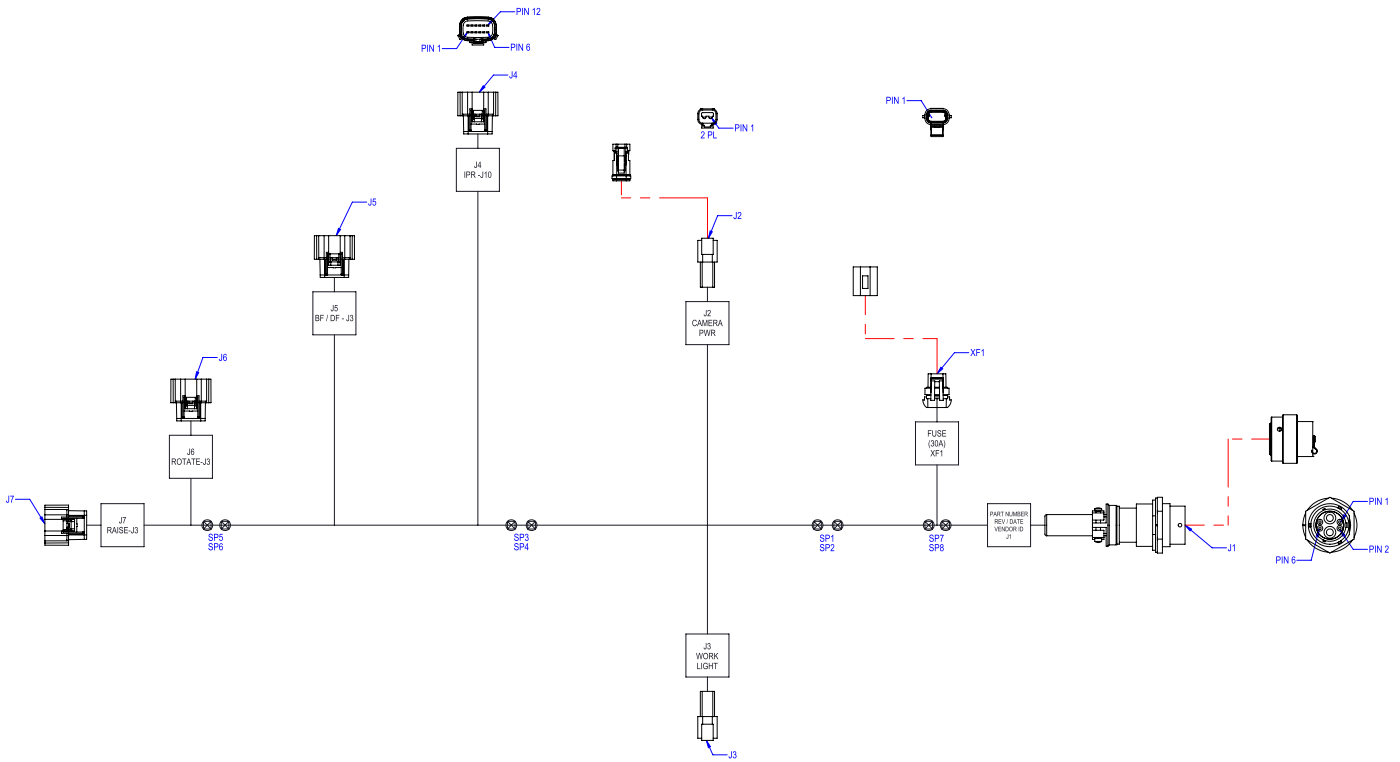

WIRE HOOKUP CHART							
REF DES	FROM	USED W/ ITEM	TO	USED W/ ITEM	GAUGE	COLOR	FUNCTION
W1	J1-3	17	SP7	---	6	RED	12V DC (PRE FUSE)
W2	SP7	---	XF1-1	14	12	RED	12V DC (PRE FUSE)
W3	XF1-2	14	SP8	---	12	RED	12V DC (PWR)
W4	SP8	---	SP1	---	6	RED	12V DC (PWR)
W5	J1-4	17	SP2	---	6	BLK	12V DC (GND)
W6	SP1	---	J2-2	6	16	RED	CAMERA (PWR)
W7	SP1	---	J3-2	6	16	RED	WORKLIGHT (PWR)
W8	SP1	---	SP3	---	12	RED	12V DC (PWR)
W9	SP2	---	J2-1	6	16	BLK	CAMERA (GND)
W10	SP2	---	J3-1	6	16	BLK	WORKLIGHT (GND)
W11	SP2	---	SP4	---	12	BLK	12V DC (GND)
W12	SP3	---	J4-1	5	18	RED	IPR (PWR)
W13	SP3	---	J5-1	7	16	RED	BF / DF (PWR)
W14	SP3	---	J5-3	7	16	RED	BF / DF (PWR)
W15	SP3	---	SP5	---	12	RED	12V DC (PWR)
W16	SP4	---	J4-2	5	18	BLK	IPR (GND)
W17	SP4	---	J5-2	7	16	BLK	BF / DF (GND)
W18	SP4	---	J5-4	7	16	BLK	BF / DF (GND)
W19	SP4	---	SP6	---	12	BLK	12V DC (GND)
W20	SP5	---	J6-1	7	16	RED	ROTATE (PWR)
W21	SP5	---	J6-3	7	16	RED	ROTATE (PWR)
W22	SP5	---	J7-1	7	16	RED	RAISE (PWR)
W23	SP5	---	J7-3	7	16	RED	RAISE (PWR)
W24	SP6	---	J6-2	7	16	BLK	ROTATE (PWR)
W25	SP6	---	J6-4	7	16	BLK	ROTATE (PWR)
W26	SP6	---	J7-2	7	16	BLK	RAISE (PWR)
W27	SP6	---	J7-4	7	16	BLK	RAISE (PWR)

STRAPPING TABLE 2			
CONNECTOR	PIN 10	PIN 11	PIN 12
J4 (IPR)	GND	---	GND

STRAPPING TABLE 1								
CONNECTOR	PIN 5	PIN 6	PIN 7	PIN 8	PIN 9	PIN 10	PIN 11	PIN 12
J5 (BF)	GND	GND	GND	GND	GND	GND	GND	GND
J6 (ROTATE)	GND	---	GND	GND	GND	GND	---	GND
J7 (RAISE)	---	GND	GND	GND	GND	GND	---	GND

IPN RAISE HARNESS, 16 ROW (P/N: 10338801)

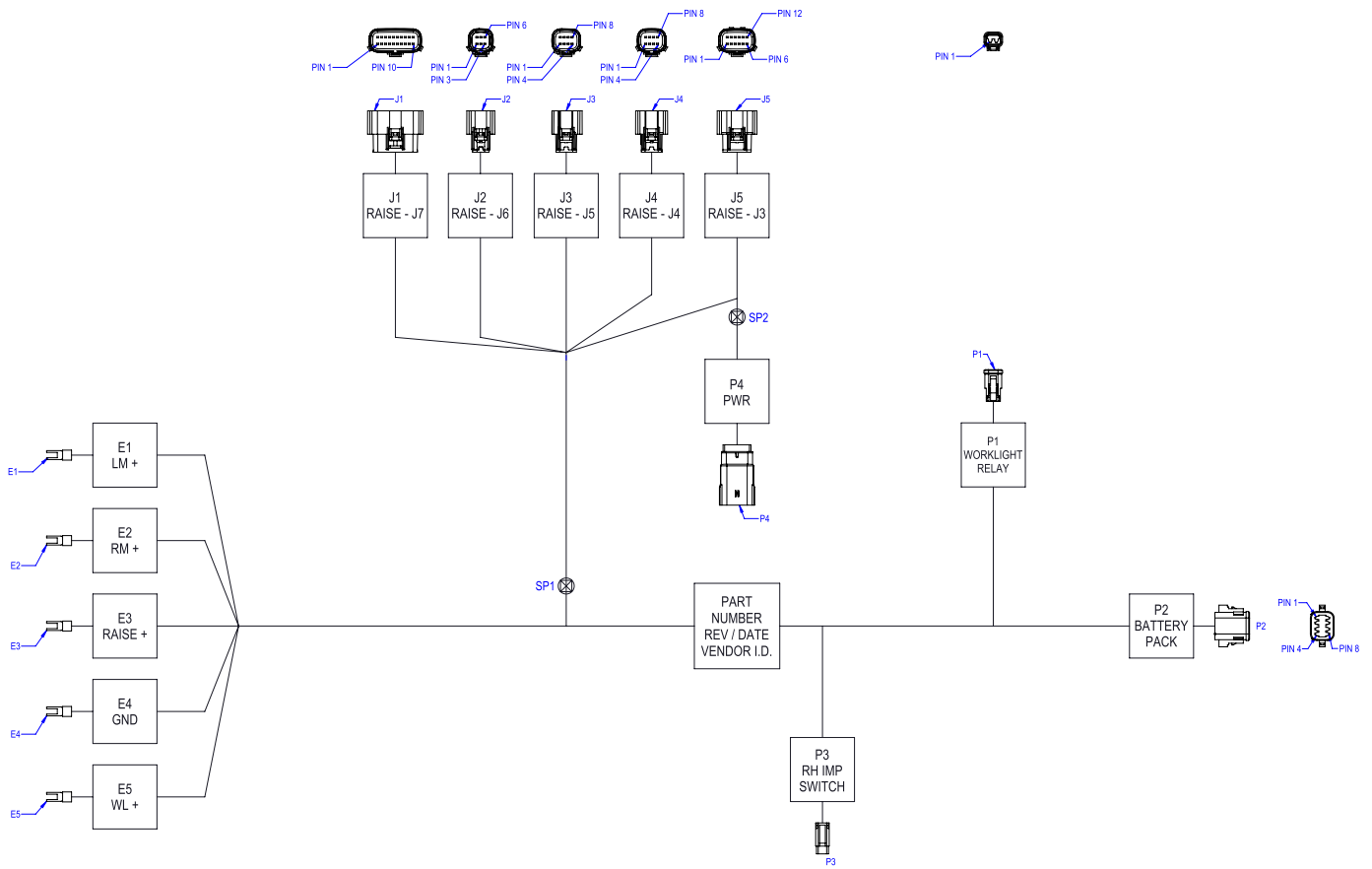

STRAPPING TABLE 1

RED DES	FROM	USED W/ ITEM	TO	USED W/ ITEM	GAUGE	COLOR	FUNCTION
W1	J1-3	14	E5	---	16	RED/ WHT	WING LOCK SOLENOID (+)
W2	J1-4	14	SP1	---	16	BLK	WING LOCK SOLENOID (-)
W3	J1-7	14	E1	---	16	BLU	LH MARKER SOLENOID (+)
W4	J1-8	14	SP1	---	16	BLK	LH MARKER SOLENOID (-)
W5	J1-13	9	P2-4	16	20	YEL	RU PWR FEEDBACK'
W6	J1-14	14	P2-7	16	14	ORN	BATTERY 1 VOLTAGE
W7	J1-16	14	P2-8	16	14	BLU	BATTERY 2 VOLTAGE
W8	J1-17	14	P2-2	16	16	BLK	RU PWR RELAY (GND)
W9	J1-18	14	P2-1	16	16	RED	PWR RELAY (PWR)
W10	J1-19	14	P1-1	16	16	BLK	WORKLIGHT RELAY (-)
W11	J1-20	14	P1-2	16	16	RED	WORKLIGHT RELAY (+)
W12	J3-1	14	E2	---	16	RED	RH MARKER SOLENOID (+)
W13	J3-2	14	SP1	---	16	BLK	RH MARKER SOLENOID (-)
W14	J3-5	9	P3-1	11	18	BRN	RH IMP SWITCH (PWR)
W15	J3-7	9	P3-2	11	18	GRN	TH IMP SWITCH (SIG)
W16	J4-1	14	E3	---	16	BLU/BLK	RAISE SOLENOID (+)
W17	J4-2	14	SP1	---	16	BLK	RAISE SOLENOID (-)
W18	J4-8	14	P2-3	16	16	BRN	ALTERNATOR SENSE (FREQ)
W19	SP1	---	E4	---	16	BKJ	TERMINAL BLOCK (GND)
W20	P4-1	19	SP2	---	16	RED	FOLD IPN PWR (+)
W21	SP2	---	P2-5	16	16	RED	BATTERY PACK RELAY (PWR)
W22	J2-6	14	P2-6	16	16	GRN	BATTERY PACK RELAY (GND)
W23	SP2	---	J5-1	15	16	RED	FOLD IPN PWR (+)
W24	P4-2	19	J5-2	15	16	BLK	FOLD IPN PWR (-)
W25	P4-3	19	J5-3	15	16	RED	FOLD IPN PWR (+)
W26	P4-4	19	J5-4	15	16	BLK	FOLD IPN PWR (-)
W27	P4-5	19	J5-5	9	18	BLK	STRAPPING
W28	P4-6	19	J5-6	9	18	BLK	STRAPPING
W29	P4-7	19	J5-7	9	18	BLK	STRAPPING
W30	P4-8	19	J5-8	9	18	BLK	STRAPPING
W31	P4-9	19	J5-9	9	18	BLK	STRAPPING
W32	P4-10	19	J5-10	9	18	BLK	STRAPPING
W33	P4-11	19	J5-11	9	18	BLK	STRAPPING
W34	P4-12	19	J5-12	9	18	BLK	STRAPPING

IPN BULK FILL HARNESS (P/N: 10339001)

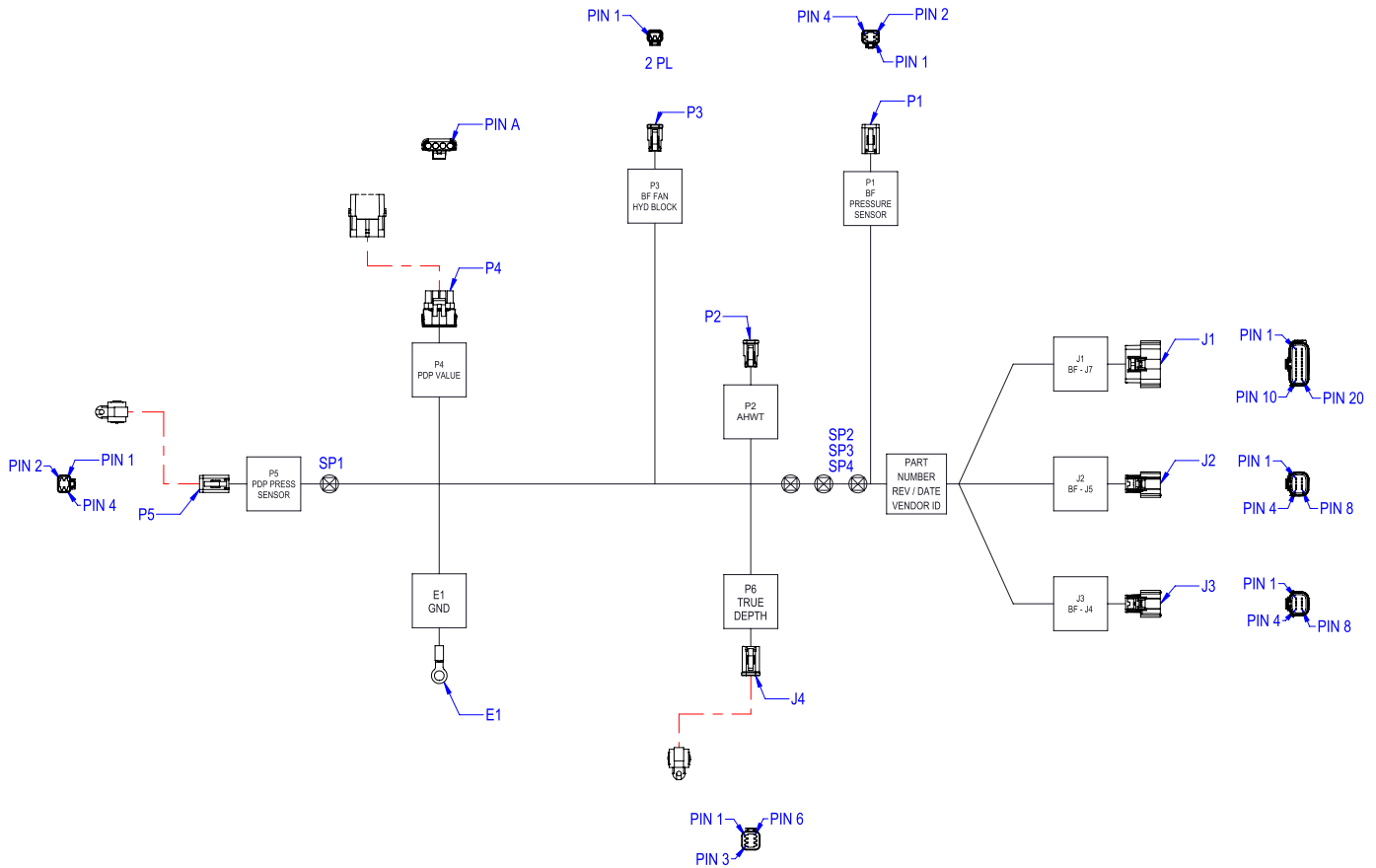

WIRE HOOKUP CHART							
REF DES	FROM	USE W/ ITEM	TO	USE W/ ITEM	GAUGE	COLOR	FUNCTION
W1	J1-3	9	SP4	---	16	VLT	PDP /HDP DECREASE SOLE (+)
W2	SP4	---	P4-C	13	16	VLT	PDP DECREASE SOLE (+)
W3	SP4	---	P6-4	10	18	VLT	HDP DECREASE SOLE (+)
W4	J1-4	9	SP3	---	16	BRN	PDP/HDP DECREASE SOLE (-)
W5	SP3	---	P4-D	13	16	BRN	PDP DECREASE SOLE (-)
W6	SP3	---	P6-5	10	18	BRN	HDP DECREASE SOLE (-)
W7	J1-16	7	SP2	---	18	WHT	PDP/HDP SENSOR ANALOG (SIGNAL)
W8	SP2	---	P5-4	10	18	WHT	PDP SENSOR (SIGNAL)
W9	SP2	---	P6-1	10	18	WHT	HDP SENSOR (SIGNAL)
W10	J1-19	7	SP1	---	18	BLK	PDP/HDP SENSOR (GND)
W11	J1-7	9	P2-1	10	16	RED	ELECTRONIC WEIGHT TRANSFER (+)
W12	J1-8	9	P2-2	10	16	BLK	ELECTRONIC WEIGHT TRANSFER (-)
W13	SP1	---	P5-1	10	18	BLK	PDP SENSOR (GND)
W14	SP1	---	P6-3	10	18	BLK	HDP SENSOR (GND)
W15	SP1	---	E1	---	18	BLK	GND
W16	J1-20	---	P5-2	10	18	ORN	PDP SENSOR (PWR)
W17	J1-18	---	P6-2	10	18	ORN	HDP SENSOR (PWR)
W18	J2-1	9	P4-A	13	16	RED	PDP INCREASE SOLENOID (+)
W19	J2-2	9	P4-B	13	16	YEL	PDP INCREASE SOLENOID (-)
W20	J2-5	7	P1-2	10	18	WHT	BF PRESSURE SENSOR (PWR)
W21	J2-6	7	P1-1	10	18	BLK	BF PRESSURE SENSOR (GND)
W22	J2-7	7	P1-4	10	18	YEL	BF PRESSURE SENSOR (ANALOG)
W23	J2-1	9	P3-1	10	16	RED	BF FAN SOLENOID (+)
W24	J2-2	9	P3-2	10	16	BLK	BF FAN SOLENOID (-)

24V ROW UNIT POWER SPLIT ROW HARNESS, 12 ROW (P/N: A25825)

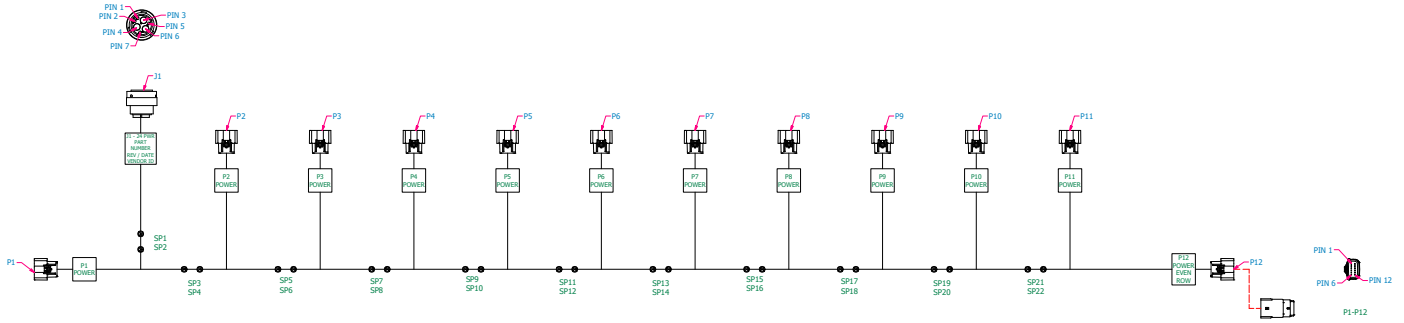

WIRE HOOKUP CHART								WIRE HOOKUP CHART							
REF DES	FROM	USED WITH ITEM	TO	USED WITH ITEM	GAUGE	COLOR	FUNCTION	REF DES	FROM	USED WITH ITEM	TO	USED WITH ITEM	GAUGE	COLOR	FUNCTION
W1	J1-4	3	SP1	---	4	RED	---	W33	SP11	---	SP13	---	10	RED	---
W2	J1-6	3	SP2	---	4	BLK	---	W34	SP11	---	P6-1	4	16	RED	RU 18 (PWR)
W3	SP1	---	SP3	---	10	RED	---	W35	SP11	---	P6-3	4	16	RED	RU 18 (PWR)
W4	SP1	---	P1-1	4	16	RED	RU 13 (PWR)	W36	SP12	---	SP14	---	10	BLK	---
W5	SP1	---	P1-3	4	16	RED	RU 13 (PWR)	W37	SP12	---	P6-2	4	16	BLK	RU 18 (GND)
W6	SP2	---	SP4	---	10	BLK	---	W38	SP12	---	P6-4	4	16	BLK	RU 18 (GND)
W7	SP2	---	P1-2	4	16	BLK	RU 13 (GND)	W39	SP13	---	SP15	---	10	RED	---
W8	SP2	---	P1-4	4	16	BLK	RU 13 (GND)	W40	SP13	---	P7-1	4	16	RED	RU 19 (PWR)
W9	SP3	---	SP5	---	10	RED	---	W41	SP13	---	P7-3	4	16	RED	RU 19 (PWR)
W10	SP3	---	P2-1	4	16	RED	RU 14 (PWR)	W42	SP14	---	SP16	---	10	BLK	---
W11	SP3	---	P2-3	4	16	RED	RU 14 (PWR)	W43	SP14	---	P7-2	4	16	BLK	RU 19 (GND)
W12	SP4	---	SP6	---	10	BLK	---	W44	SP14	---	P7-4	4	16	BLK	RU 19 (GND)
W13	SP4	---	P2-2	4	16	BLK	RU 14 (GND)	W45	SP15	---	SP17	---	10	RED	---
W14	SP4	---	P2-4	4	16	BLK	RU 14 (GND)	W46	SP15	---	P8-1	4	16	RED	RU 20 (PWR)
W15	SP5	---	SP7	---	10	RED	---	W47	SP15	---	P8-3	4	16	RED	RU 20 (PWR)
W16	SP5	---	P3-1	4	16	RED	RU 15 (PWR)	W48	SP16	---	SP18	---	10	BLK	---
W17	SP5	---	P3-3	4	16	RED	RU 15 (PWR)	W49	SP16	---	P8-2	4	16	BLK	RU 20 (GND)
W18	SP6	---	SP8	---	10	BLK	---	W50	SP16	---	P8-4	4	16	BLK	RU 20 (GND)
W19	SP6	---	P3-2	4	16	BLK	RU 15 (GND)	W51	SP17	---	SP19	---	10	RED	---
W20	SP6	---	P3-4	4	16	BLK	RU 15 (GND)	W52	SP17	---	P9-1	4	16	RED	RU 21 (PWR)
W21	SP7	---	SP9	---	10	RED	---	W53	SP17	---	P9-3	4	16	RED	RU 21 (PWR)
W22	SP7	---	P4-1	4	16	RED	RU 16 (PWR)	W54	SP18	---	SP20	---	10	BLK	---
W23	SP7	---	P4-3	4	16	RED	RU 16 (PWR)	W55	SP18	---	P9-2	4	16	BLK	RU 21 (GND)
W24	SP8	---	SP10	---	10	BLK	---	W56	SP18	---	P9-4	4	16	BLK	RU 21 (GND)
W25	SP8	---	P4-2	4	16	BLK	RU 16 (GND)	W57	SP19	---	SP21	---	10	RED	---
W26	SP8	---	P4-4	4	16	BLK	RU 16 (GND)	W58	SP19	---	P10-1	4	16	RED	RU 22 (PWR)
W27	SP9	---	SP11	---	10	RED	---	W59	SP19	---	P10-3	4	16	RED	RU 22 (PWR)
W28	SP9	---	P5-1	4	16	RED	RU 17 (PWR)	W60	SP20	---	SP22	---	10	BLK	---
W29	SP9	---	P5-3	4	16	RED	RU 17 (PWR)	W61	SP20	---	P10-2	4	16	BLK	RU 22 (GND)
W30	SP10	---	SP12	---	10	BLK	---	W62	SP20	---	P10-4	4	16	BLK	RU 22 (GND)
W31	SP10	---	P5-2	4	16	BLK	RU 17 (GND)	W64	SP21	---	P11-1	4	16	RED	RU 23 (PWR)
W32	SP10	---	P5-4	4	16	BLK	RU 17 (GND)								

WIRE HOOKUP CHART							
REF DES	FROM	USED WITH ITEM	TO	USED WITH ITEM	GAUGE	FUNCTION	
W64	SP21	---	P11-3	4	16	RED	RU 23 (PWR)
W65	SP22	---	P11-2	4	16	BLK	RU 23 (GND)
W67	SP22	---	P11-4	4	16	BLK	RU 23 (GND)
W68	SP21	---	P12-1	4	16	RED	RU 24 (PWR)
W69	SP21	---	P12-3	4	16	RED	RU 24 (PWR)
W70	SP22	---	P12-2	4	16	RED	RU 24 (GND)
W71	SP22	---	P12-4	4	16	RED	RU 24 (GND)

24V ROW UNIT POWER SPLIT ROW HARNESS, 16 ROW (P/N: A24484)

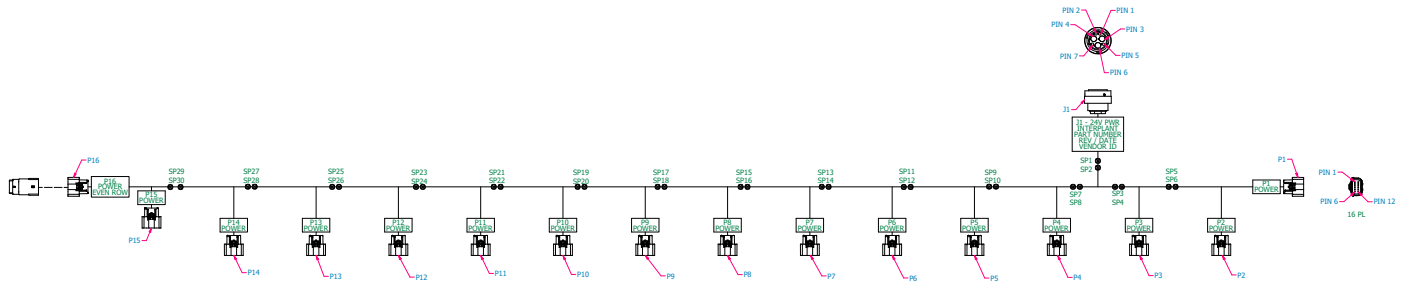

WIRE HITCHUP CHART						
REF DES	FROM	LEAD WITH ITEM	TO WITH ITEM	GALV	CONN	FUNCTION
W01	15-4	5	SP1	4	REL	---
W02	15-4	5	SP2	4	REL	---
W03	SP1	---	SP3	3	REL	---
W04	SP1	---	SP4	4	REL	---
W05	SP1	---	SP5	5	REL	---
W06	SP2	---	SP6	6	REL	---
W07	SP2	---	SP7	7	REL	---
W08	SP3	---	SP8	8	REL	---
W09	SP3	---	SP9	9	REL	---
W10	SP4	---	SP10	10	REL	---
W11	SP4	---	SP11	11	REL	---
W12	SP5	---	SP12	12	REL	---
W13	SP5	---	SP13	13	REL	---
W14	SP6	---	SP14	14	REL	---
W15	SP6	---	SP15	15	REL	---
W16	SP7	---	SP16	16	REL	---

WIRE HITCHUP CHART						
REF DES	FROM	LEAD WITH ITEM	TO WITH ITEM	GALV	CONN	FUNCTION
W17	SP8	---	SP17	17	REL	---
W18	SP8	---	SP18	18	REL	---
W19	SP9	---	SP19	19	REL	---
W20	SP9	---	SP20	20	REL	---
W21	SP10	---	SP21	21	REL	---
W22	SP10	---	SP22	22	REL	---
W23	SP11	---	SP23	23	REL	---
W24	SP11	---	SP24	24	REL	---
W25	SP12	---	SP25	25	REL	---
W26	SP12	---	SP26	26	REL	---
W27	SP13	---	SP27	27	REL	---
W28	SP13	---	SP28	28	REL	---
W29	SP14	---	SP29	29	REL	---
W30	SP14	---	SP30	30	REL	---
W31	SP15	---	SP31	31	REL	---
W32	SP15	---	SP32	32	REL	---
W33	SP16	---	SP33	33	REL	---
W34	SP16	---	SP34	34	REL	---
W35	SP17	---	SP35	35	REL	---
W36	SP17	---	SP36	36	REL	---
W37	SP18	---	SP37	37	REL	---
W38	SP18	---	SP38	38	REL	---
W39	SP19	---	SP39	39	REL	---
W40	SP19	---	SP40	40	REL	---
W41	SP20	---	SP41	41	REL	---
W42	SP20	---	SP42	42	REL	---
W43	SP21	---	SP43	43	REL	---
W44	SP21	---	SP44	44	REL	---
W45	SP22	---	SP45	45	REL	---
W46	SP22	---	SP46	46	REL	---

WIRE HITCHUP CHART						
REF DES	FROM	LEAD WITH ITEM	TO WITH ITEM	GALV	CONN	FUNCTION
W47	SP23	---	SP47	47	REL	---
W48	SP23	---	SP48	48	REL	---
W49	SP24	---	SP49	49	REL	---
W50	SP24	---	SP50	50	REL	---
W51	SP25	---	SP51	51	REL	---
W52	SP25	---	SP52	52	REL	---
W53	SP26	---	SP53	53	REL	---
W54	SP26	---	SP54	54	REL	---
W55	SP27	---	SP55	55	REL	---
W56	SP27	---	SP56	56	REL	---
W57	SP28	---	SP57	57	REL	---
W58	SP28	---	SP58	58	REL	---
W59	SP29	---	SP59	59	REL	---
W60	SP29	---	SP60	60	REL	---
W61	SP30	---	SP61	61	REL	---
W62	SP30	---	SP62	62	REL	---
W63	SP31	---	SP63	63	REL	---
W64	SP31	---	SP64	64	REL	---
W65	SP32	---	SP65	65	REL	---
W66	SP32	---	SP66	66	REL	---
W67	SP33	---	SP67	67	REL	---
W68	SP33	---	SP68	68	REL	---
W69	SP34	---	SP69	69	REL	---
W70	SP34	---	SP70	70	REL	---
W71	SP35	---	SP71	71	REL	---
W72	SP35	---	SP72	72	REL	---
W73	SP36	---	SP73	73	REL	---
W74	SP36	---	SP74	74	REL	---
W75	SP37	---	SP75	75	REL	---
W76	SP37	---	SP76	76	REL	---
W77	SP38	---	SP77	77	REL	---
W78	SP38	---	SP78	78	REL	---
W79	SP39	---	SP79	79	REL	---
W80	SP39	---	SP80	80	REL	---
W81	SP40	---	SP81	81	REL	---
W82	SP40	---	SP82	82	REL	---
W83	SP41	---	SP83	83	REL	---
W84	SP41	---	SP84	84	REL	---
W85	SP42	---	SP85	85	REL	---
W86	SP42	---	SP86	86	REL	---
W87	SP43	---	SP87	87	REL	---
W88	SP43	---	SP88	88	REL	---
W89	SP44	---	SP89	89	REL	---
W90	SP44	---	SP90	90	REL	---
W91	SP45	---	SP91	91	REL	---
W92	SP45	---	SP92	92	REL	---
W93	SP46	---	SP93	93	REL	---
W94	SP46	---	SP94	94	REL	---
W95	SP47	---	SP95	95	REL	---
W96	SP47	---	SP96	96	REL	---
W97	SP48	---	SP97	97	REL	---
W98	SP48	---	SP98	98	REL	---
W99	SP49	---	SP99	99	REL	---
W100	SP49	---	SP100	100	REL	---

CONNECTION	STRAPPING TABLE											
	PIN 5	PIN 6	PIN 7	PIN 8	PIN 9	PIN 10	PIN 11	PIN 12	PIN 13	PIN 14	PIN 15	PIN 16
P1	GRN	---	---	---	GRN	---	---	---	---	GRN	---	---
P2	---	GRN	---	---	---	GRN	---	---	---	---	---	GRN
P3	GRN	---	---	---	---	---	GRN	---	---	---	---	---
P4	---	---	GRN	---	---	---	---	GRN	---	---	---	---
P5	GRN	---	---	---	---	---	---	---	GRN	---	---	---
P6	---	---	---	GRN	---	---	---	---	---	GRN	---	---
P7	GRN	---	---	---	---	---	---	---	---	---	GRN	---
P8	---	---	---	---	GRN	---	---	---	---	---	---	GRN
P9	GRN	---	---	---	---	---	---	---	---	---	---	GRN
P10	---	---	---	---	---	GRN	---	---	---	---	---	---
P11	GRN	---	---	---	---	---	---	---	---	---	---	GRN
P12	---	---	---	---	---	---	GRN	---	---	---	---	---
P13	---	---	---	---	---	---	---	GRN	---	---	---	---
P14	GRN	---	---	---	---	---	---	---	---	---	---	GRN
P15	---	---	---	---	---	---	---	---	GRN	---	---	---
P16	---	---	---	---	---	---	---	---	---	GRN	---	---

ROW UNIT POWER EXTENSION HARNESS (P/N: A25029)



WIRE HOOKUP CHART							
REF DES	FROM	USED WITH ITEM	TO	USED WITH ITEM	GAUGE	COLOR	FUNCTION
W1	J1-1	3	P1-1	4	16	RED	PWR
W2	J1-2	3	P1-2	4	16	BLK	GND
W3	J1-3	3	P1-3	4	16	RED	PWR
W4	J1-4	3	P1-4	4	16	BLK	GND
W5	J1-5	3	P1-5	5	20	YEL	STRAPPING
W6	J1-6	3	P1-6	5	20	ORN	STRAPPING
W7	J1-7	3	P1-7	5	20	WHT	STRAPPING
W8	J1-8	3	P1-8	5	20	GRN	STRAPPING
W9	J1-9	3	P1-9	5	20	BLU	STRAPPING
W10	J1-10	3	P1-10	5	20	VLT	STRAPPING
W11	J1-11	3	P1-11	5	20	BLU/RED	STRAPPING
W12	J1-12	3	P1-12	5	20	BRN	STRAPPING

ROW UNIT SEED METER HARNESS (P/N: A25038)

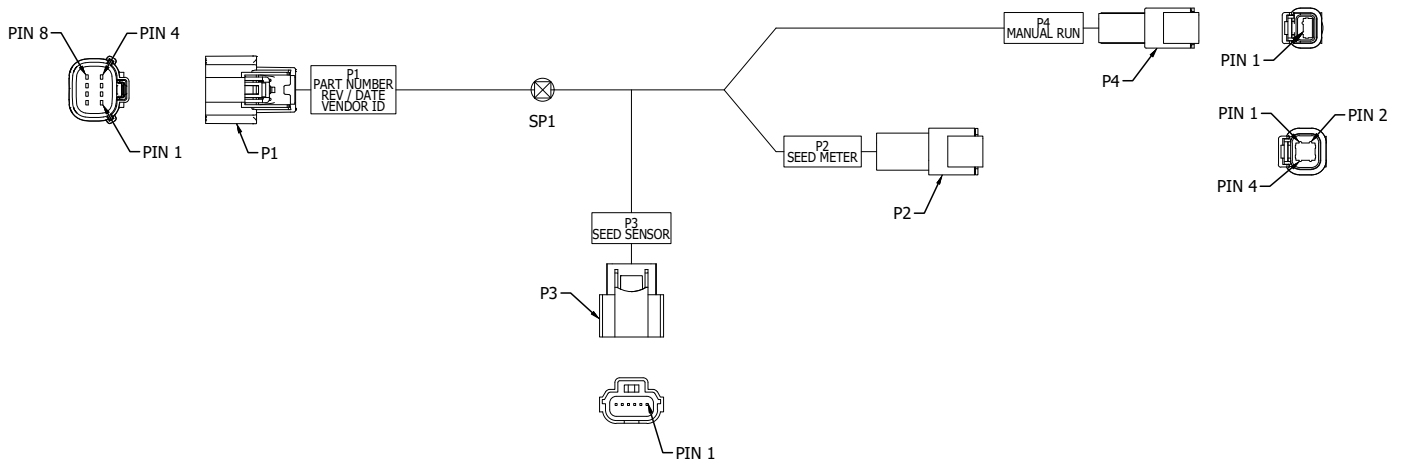

WIRE HOOKUP CHART

REF DES	FROM	USED WITH ITEM	TO	USED WITH ITEM	GAUGE	COLOR	FUNCTION
W1	P1-1	8	P2-1	5	18	RED	SEED METER MOTOR 1+
W2	P1-2	8	P2-2	5	18	WHT	SEED METER MOTOR 1-
W3	P1-3	8	P2-4	5	18	BLK	SEED METER MOTOR 2-
W4	P1-4	8	P2-3	5	18	GRN	SEED METER MOTOR 2+
W5	P1-5	8	P3-1	6	18 TXL	RED	SEED SENSOR (PWR)
W6	P1-6	8	SP1	---	18	BLK	GROUND
W7	P1-7	8	P3-2	6	18 TXL	BLU	SEED SENSOR (LIN)
W8	SP1	---	P3-6	6	18 TXL	BLK	SEED SENSOR (GND)
W9			P4-1	5	18	BLK	MANUAL RUN (GND)
W10	P1-8	8	P4-2	5	18	RED	MANUAL RUN (INPUT)

24V ROW UNIT SEED POWER HARNESS, 12 ROW (P/N: A25819)

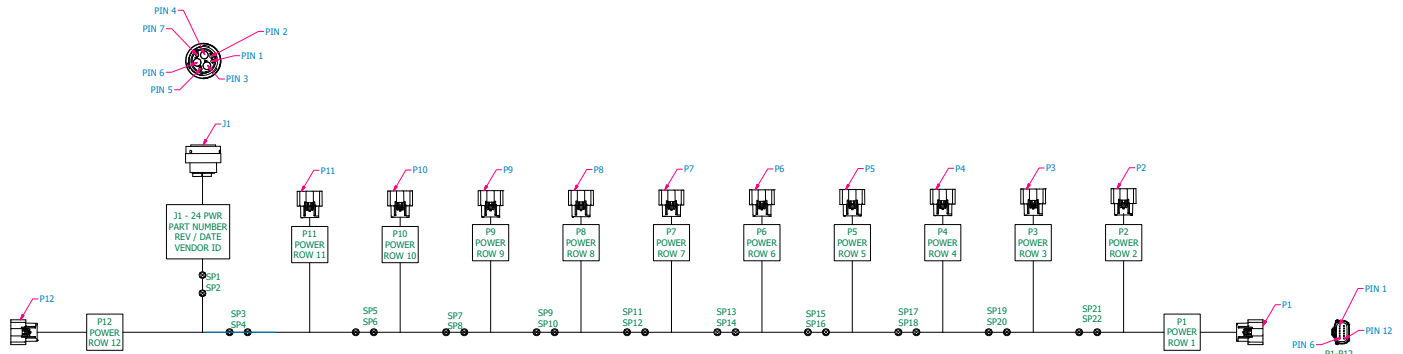

WIRE HOOKUP CHART								WIRE HOOKUP CHART							
REF DES	FROM	USED WITH ITEM	TO	USED WITH ITEM	GAUGE	COLOR	FUNCTION	REF DES	FROM	USED WITH ITEM	TO	USED WITH ITEM	GAUGE	COLOR	FUNCTION
W1	J1-6	5	SP1	---	4	RED	---	W33	SP11	---	SP13	---	10	RED	---
W2	J1-4	5	SP2	---	4	BLK	---	W34	SP11	---	P7-1	3	16	RED	RU 7(PWR)
W3	SP1	---	SP3	---	10	RED	---	W35	SP11	---	P7-3	3	16	RED	RU 7(PWR)
W4	SP1	---	P12-1	3	16	RED	RU 12(PWR)	W36	SP12	---	SP14	---	10	BLK	---
W5	SP1	---	P12-3	3	16	RED	RU 12(PWR)	W37	SP12	---	P7-2	3	16	BLK	RU 7(GND)
W6	SP2	---	SP4	---	10	BLK	---	W38	SP12	---	P7-4	3	16	BLK	RU 7(GND)
W7	SP2	---	P12-2	3	16	BLK	RU 12(GND)	W39	SP13	---	SP15	---	10	RED	---
W8	SP2	---	P12-4	3	16	BLK	RU 12(GND)	W40	SP13	---	P6-1	3	16	RED	RU 6(PWR)
W9	SP3	---	SP-5	---	10	RED	---	W41	SP13	---	P6-3	3	16	RED	RU 6(PWR)
W10	SP3	---	P11-1	3	16	RED	RU 11(PWR)	W42	SP14	---	SP16	---	10	BLK	---
W11	SP3	---	P11-3	3	16	RED	RU 11(PWR)	W43	SP14	---	P6-2	3	16	BLK	RU 6(GND)
W12	SP4	---	SP6	---	10	BLK	---	W44	SP14	---	P6-4	3	16	BLK	RU 6(GND)
W13	SP4	---	P11-2	3	16	BLK	RU 11(GND)	W45	SP15	---	SP17	---	10	RED	---
W14	SP4	---	P11-4	3	16	BLK	RU 11(GND)	W46	SP15	---	P5-1	3	16	RED	RU 5(PWR)
W15	SP5	---	SP7	---	10	RED	---	W47	SP15	---	P5-3	3	16	RED	RU 5(PWR)
W16	SP5	---	P10-1	3	16	RED	RU 10(PWR)	W48	SP16	---	SP18	---	10	BLK	---
W17	SP5	---	P10-3	3	16	RED	RU 10(PWR)	W49	SP16	---	P5-2	3	16	BLK	RU 5(GND)
W18	SP6	---	SP8	---	10	BLK	---	W50	SP16	---	P5-4	3	16	BLK	RU 5(GND)
W19	SP6	---	P10-2	3	16	BLK	RU 10(GND)	W51	SP17	---	SP19	---	10	RED	---
W20	SP6	---	P10-4	3	16	BLK	RU 10(GND)	W52	SP17	---	P4-1	3	16	RED	RU 4(PWR)
W21	SP7	---	SP9	---	10	RED	---	W53	SP17	---	P4-3	3	16	RED	RU 4(PWR)
W22	SP7	---	P9-1	3	16	RED	RU 9(PWR)	W54	SP18	---	P20	---	10	BLK	---
W23	SP7	---	P9-3	3	16	RED	RU 9(PWR)	W55	SP18	---	P4-2	3	16	BLK	RU 4(GND)
W24	SP8	---	SP10	---	10	BLK	---	W56	SP18	---	P4-4	3	16	BLK	RU 4(GND)
W25	SP8	---	P9-2	---	16	BLK	RU 9(GND)	W57	SP19	---	SP21	---	10	RED	---
W26	SP8	---	P9-4	---	16	BLK	RU 9(GND)	W58	SP19	---	P3-1	3	16	RED	RU 3(PWR)
W27	SP9	---	SP11	---	10	RED	---	W59	SP19	---	P3-3	3	16	RED	RU 3(PWR)
W28	SP9	---	P8-1	3	16	RED	RU 8(PWR)	W60	SP20	---	SP22	---	10	BLK	---
W29	SP9	---	P8-3	3	16	RED	RU 8(PWR)	W61	SP20	---	P3-2	3	16	BLK	RU 3(GND)
W30	SP10	---	SP12	---	10	BLK	---	W62	SP20	---	P3-4	3	16	BLK	RU 3(GND)
W31	SP10	---	P8-2	3	16	RED	RU 8(GND)	W63	SP21	---	P2-1	3	16	RED	RU 2(PWR)
W32	SP10	---	P8-4	3	16	RED	RU 8(GND)	W64	SP21	---	P2-3	3	16	RED	RU 2(PWR)
								W65	SP22	---	P2-2	3	16	BLK	RU 2(GND)
								W66	SP22	---	P2-4	3	16	BLK	RU 2(GND)
								W67	SP21	---	P1-1	3	16	RED	RU 1(PWR)
								W68	SP21	---	P1-3	3	16	RED	RU 1(PWR)
								W69	SP22	---	P1-2	3	16	BLK	RU 1(GND)
								W70	SP22	---	P1-4	3	16	BLK	RU 1(GND)

24V ROW UNIT SEED POWER HARNESS, 16 ROW (P/N: A24483)

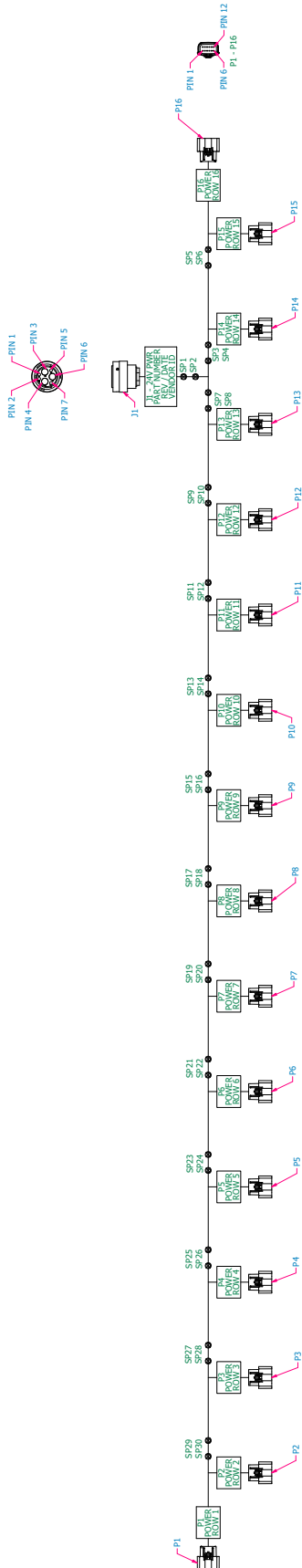

FUNCTION	PIN 1	PIN 2	PIN 3	PIN 4	PIN 5	PIN 6	PIN 7	PIN 8	PIN 9	PIN 10	PIN 11	PIN 12	PIN 13	PIN 14	PIN 15	PIN 16
P1	---	---	---	---	---	---	---	---	---	---	---	---	---	---	---	---
P2	---	---	---	---	---	---	---	---	---	---	---	---	---	---	---	---
P3	---	---	---	---	---	---	---	---	---	---	---	---	---	---	---	---
P4	---	---	---	---	---	---	---	---	---	---	---	---	---	---	---	---
P5	---	---	---	---	---	---	---	---	---	---	---	---	---	---	---	---
P6	---	---	---	---	---	---	---	---	---	---	---	---	---	---	---	---
P7	---	---	---	---	---	---	---	---	---	---	---	---	---	---	---	---
P8	---	---	---	---	---	---	---	---	---	---	---	---	---	---	---	---
P9	---	---	---	---	---	---	---	---	---	---	---	---	---	---	---	---
P10	---	---	---	---	---	---	---	---	---	---	---	---	---	---	---	---
P11	---	---	---	---	---	---	---	---	---	---	---	---	---	---	---	---
P12	---	---	---	---	---	---	---	---	---	---	---	---	---	---	---	---
P13	---	---	---	---	---	---	---	---	---	---	---	---	---	---	---	---
P14	---	---	---	---	---	---	---	---	---	---	---	---	---	---	---	---
P15	---	---	---	---	---	---	---	---	---	---	---	---	---	---	---	---
P16	---	---	---	---	---	---	---	---	---	---	---	---	---	---	---	---

REF ID	FRM	TO	UNIT	WTH	ITEM	GAUGE	COLOR	FUNCTION
W66	S722	---	S726	---	38	---	---	---
W67	S722	---	P6-2	3	36	---	---	---
W68	S722	---	P6-3	3	36	---	---	---
W69	S725	---	S725	---	38	---	---	---
W70	S725	---	P5-1	3	36	---	---	---
W71	S725	---	P5-2	3	36	---	---	---
W72	S724	---	S724	---	38	---	---	---
W73	S724	---	P5-2	3	36	---	---	---
W74	S724	---	P5-3	3	36	---	---	---
W75	S725	---	S727	---	38	---	---	---
W76	S725	---	P4-1	3	36	---	---	---
W77	S725	---	P4-3	3	36	---	---	---
W78	S726	---	S726	---	38	---	---	---
W79	S726	---	P4-2	3	36	---	---	---
W80	S727	---	S727	---	38	---	---	---
W81	S727	---	P3-1	3	36	---	---	---
W82	S727	---	P3-3	3	36	---	---	---
W83	S728	---	S728	---	38	---	---	---
W84	S728	---	P2-2	3	36	---	---	---
W85	S728	---	P2-3	3	36	---	---	---
W86	S729	---	S729	---	38	---	---	---
W87	S729	---	P3-1	3	36	---	---	---
W88	S729	---	P3-3	3	36	---	---	---
W89	S729	---	P2-2	3	36	---	---	---
W90	S729	---	P2-3	3	36	---	---	---
W91	S728	---	S728	---	38	---	---	---
W92	S728	---	P1-4	3	36	---	---	---

REF ID	FRM	TO	UNIT	WTH	ITEM	GAUGE	COLOR	FUNCTION
W93	S713	---	S713	---	38	---	---	---
W94	S713	---	P13-1	3	36	---	---	---
W95	S713	---	P13-2	3	36	---	---	---
W96	S713	---	S714	---	38	---	---	---
W97	S713	---	P13-4	3	36	---	---	---
W98	S713	---	P13-5	3	36	---	---	---
W99	S713	---	S713	---	38	---	---	---
W100	S713	---	P13-3	3	36	---	---	---
W101	S713	---	S713	---	38	---	---	---
W102	S714	---	S714	---	38	---	---	---
W103	S714	---	P14-1	3	36	---	---	---
W104	S714	---	P14-2	3	36	---	---	---
W105	S715	---	S717	---	38	---	---	---
W106	S715	---	P13-1	3	36	---	---	---
W107	S715	---	P13-3	3	36	---	---	---
W108	S716	---	S716	---	38	---	---	---
W109	S716	---	P12-2	3	36	---	---	---
W110	S716	---	P12-3	3	36	---	---	---
W111	S717	---	S717	---	38	---	---	---
W112	S717	---	P13-1	3	36	---	---	---
W113	S717	---	P13-3	3	36	---	---	---
W114	S718	---	S718	---	38	---	---	---
W115	S718	---	P14-1	3	36	---	---	---
W116	S718	---	P14-2	3	36	---	---	---
W117	S718	---	P14-3	3	36	---	---	---
W118	S718	---	P14-4	3	36	---	---	---
W119	S718	---	P14-5	3	36	---	---	---
W120	S718	---	P14-6	3	36	---	---	---
W121	S718	---	P14-7	3	36	---	---	---
W122	S717	---	P13-1	3	36	---	---	---
W123	S717	---	P13-3	3	36	---	---	---
W124	S718	---	P14-1	3	36	---	---	---
W125	S718	---	P14-2	3	36	---	---	---
W126	S718	---	P14-3	3	36	---	---	---
W127	S718	---	P14-4	3	36	---	---	---
W128	S718	---	P14-5	3	36	---	---	---
W129	S718	---	P14-6	3	36	---	---	---
W130	S718	---	P14-7	3	36	---	---	---

IPP HARNESS, WING (P/N: A25214)

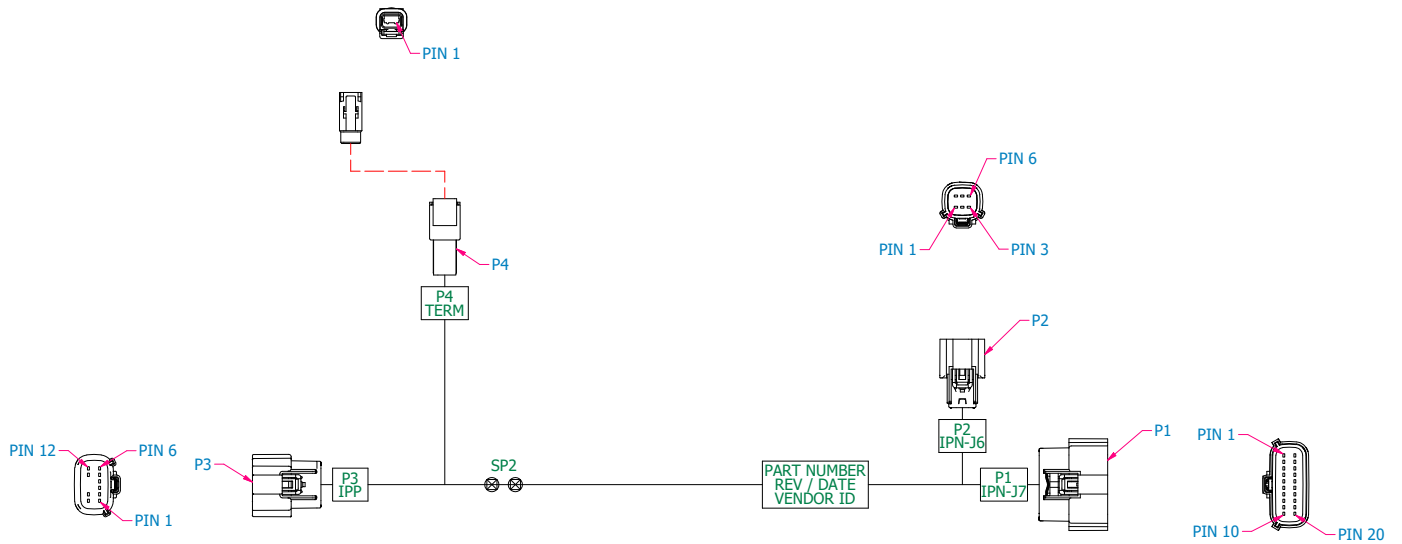

WIRE HOOKUP CHART							
REF DES	FROM	USED WITH ITEM	TO	USED WITH ITEM	GAUGE	COLOR	FUNCTION
W1	P1-1	5	P3-1	5	18(TP)	ORN	RS232 RX
W2	P1-2	5	P3-2	5		BRN	RS232 TX
W3	P2-1	5	SP1	---	18(TP)	YEL	CAN HI
W4	P2-2	5	SP2	---		GRN	CAN LO
W5	P2-3	7	P3-12	7	16	RED	PWR
W6	P2-4	7	P3-6	7	16	BLK	GND
W7	P2-5	5	P3-11	5	18	BLU	IPP SOFTWARE UPDATE
W8	SP1	---	P3-5	5	18(TP)	YEL	CAN HI
W9	SP2	---	P3-4	5		GRN	CAN LO
W10	SP1	---	P4-1	9	18(TP)	YEL	CAN HI
W11	SP2	---	P4-2	9		GRN	CAN LO

INTEGRATED TRUE DEPTH HARNESS (P/N: A26713)

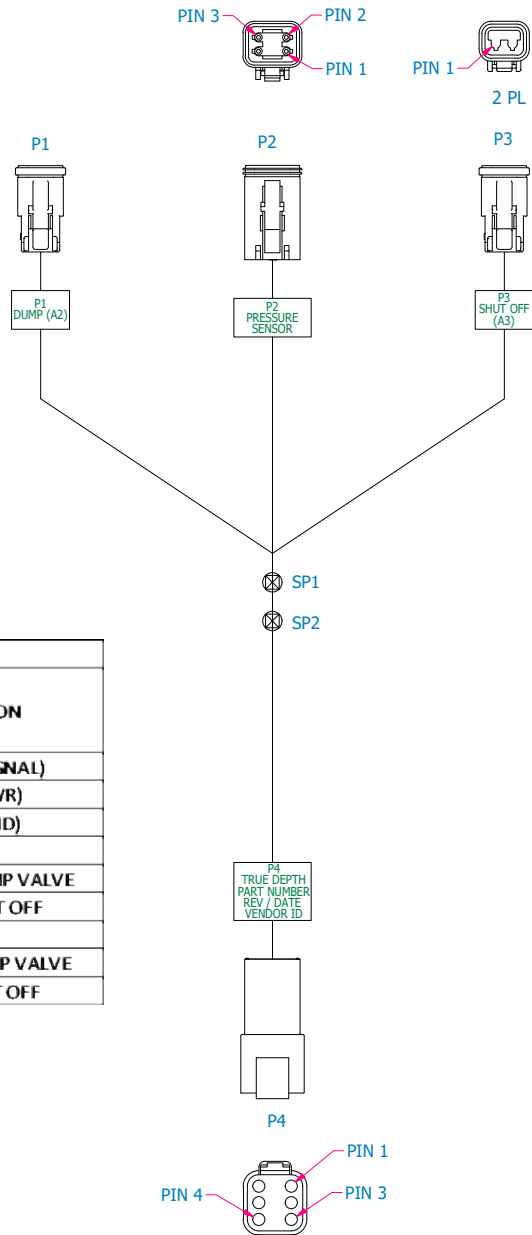

WIRE HOOKUP CHART							
REF DES	FROM	USED WITH ITEM	TO	USED WITH ITEM	GAUGE	COLOR	FUNCTION
W1	P4-1	8	P2-1	3	18	WHT	HDP SENSOR (SIGNAL)
W2	P4-2	8	P2-2	3	18	ORN	HDP SENSOR (PWR)
W3	P4-3	8	P2-3	3	18	BLK	HDP SENSOR (GND)
W4	P4-4	8	SP1	---	18	VLT	HDP PWM +
W5	SP1	---	P1-1	3	18	VLT	HDP PWM + DUMP VALVE
W6	SP1	---	P3-1	3	18	VLT	HDP PWM + SHUT OFF
W15	P4-5	8	SP2	---	18	BRN	HDP PWM -
W16	SP2	---	P1-2	3	18	BRN	HDP PWM - DUMP VALVE
W17	SP2	---	P3-2	3	18	BRN	HDP PWM - SHUT OFF

CAN STUB HARNESS (P/N: 10286102)



WIRE HOOKUP CHART							
REF DES	FROM	USED WITH ITEM	TO	USED WITH ITEM	GAUGE	COLOR	FUNCTION
W1	J1-3	7	J2-1	4	16	RED	PWR 12VDC
W2	J1-4	7	J2-2	4	16	BLK	GROUND
W3	J1-1	6	J2-3	4	18 TP	YEL	CAN HI
W4	J1-2	6	J2-4	4	18 TP	GRN	CAN LOW

BULK FILL SCALE CAN CABLE PHD28 HARNESS (P/N: 10242801)

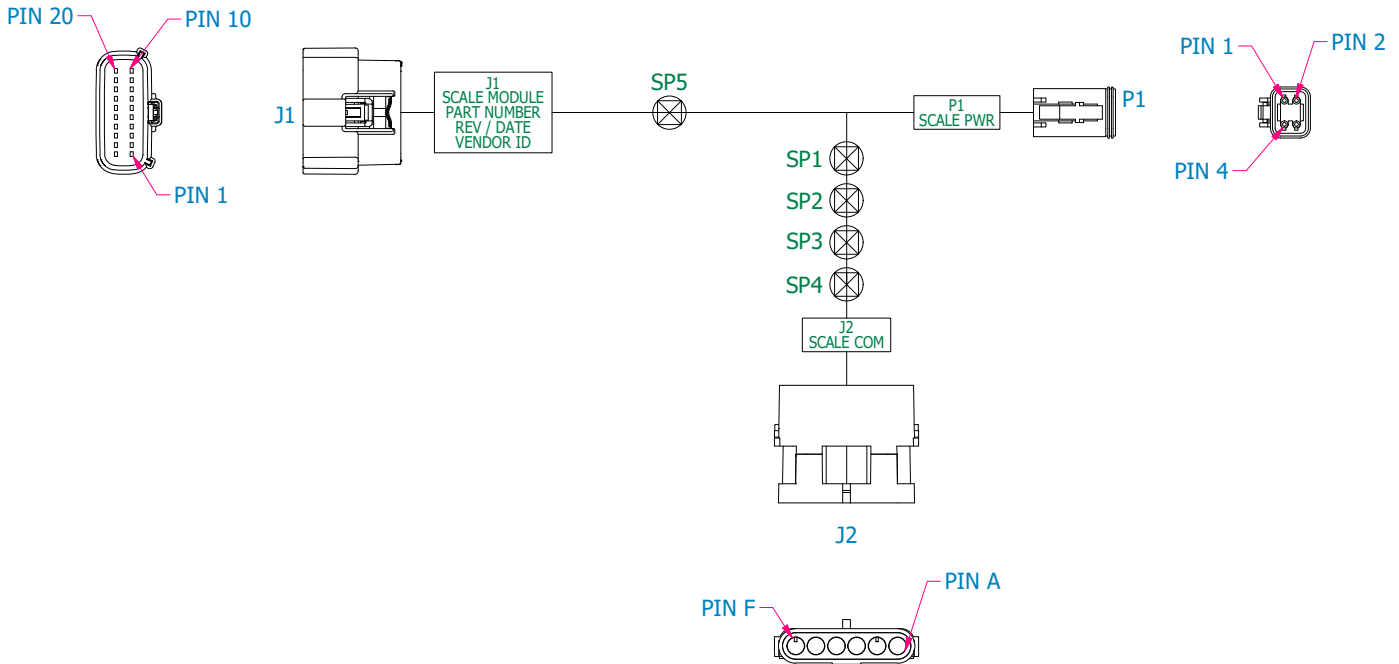

WIRE HOOKUP CHART

REF DES	FROM	USED WITH ITEM	TO	USED WITH ITEM	GAUGE	COLOR	FUNCTION
W1	J1-10	4	SP1	---	16	RED	PWR 12VDC
W2	SP1	---	P1-1	7	16	RED	PWR 12VDC
W3	SP1	---	J2-A	11	16	RED	PWR 12VDC
W4	J1-9	4	SP2	---	16	BLK	GROUND
W5	SP2	---	P1-2	7	16	BLK	GROUND
W6	SP2	---	J2-B	11	16	BLK	GROUND
W7	J1-8	5	SP5	---	18 TP	YEL	CAN HI
W8	SP3	---	P1-3	7	18 TP	YEL	CAN HI
W9	SP3	---	J2-E	12	18 TP	YEL	CAN HI
W10	J1-7	5	SP4	---	18 TP	GRN	CAN LOW
W11	SP4	---	P1-4	7	18 TP	GRN	CAN LOW
W12	SP4	---	J2-F	12	18 TP	GRN	CAN LOW
W13	SP5	---	SP3	---	18	YEL	CAN HI
W14	SP5	---	J1-5	5	18	YEL	CAN TERM

BATTERY RELAY EXCITATION HARNESS (P/N: 10208501)

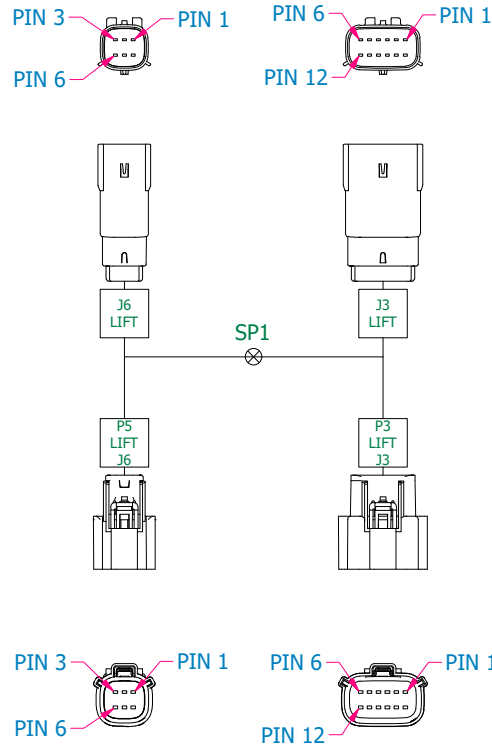

WIRE HOOKUP CHART							
REF DES	FROM	USED WITH ITEM	TO	USED WITH ITEM	GAUGE	COLOR	FUNCTION
W1	P5-6	6	J6-6	5	18	GRN	BATTERY BACK RELAY (GND)
W2	P3-1	6	SP1	-	18	RED	FOLD IPN 12V (PWR)
W3	SP1	-	J6-5	5	18	RED/WHT	BATTERY BACK RELAY (PWR)
W4	SP1	-	J3-1	5	18	RED	FOLD IPN 12V (PWR)
W5	P3-2	6	J3-2	5	18	BLK	FOLD IPN (GND)
W6	P3-3	6	J3-3	5	18	RED	FOLD IPN 12V (PWR)
W7	P3-4	6	J3-4	5	18	BLK	FOLD IPN (GND)
W8	P3-5	6	J3-5	5	18	BLK	STRAPPING
W9	P3-6	6	J3-6	5	18	BLK	STRAPPING
W10	P3-7	6	J3-7	5	18	BLK	STRAPPING
W11	P3-8	6	J3-8	5	18	BLK	STRAPPING
W12	P3-9	6	J3-9	5	18	BLK	STRAPPING
W13	P3-10	6	J3-10	5	18	BLK	STRAPPING
W14	P3-11	6	J3-11	5	18	BLK	STRAPPING
W15	P3-12	6	J3-12	5	18	BLK	STRAPPING

ACTIVE HYDRAULIC WEIGHT TRANSFER INTERCEPT HARNESS (P/N: 10496501)

WIRE HOOKUP CHART					
REF DES	FROM	TO	GAUGE	COLOR	DESCRIPTION
AHWT W1	P5:1	J5:1	18	WHT	PASSTHROUGH
AHWT W2	P5:2	J5:2	18	WHT	PASSTHROUGH
AHWT W3	P5:5	J5:5	18	WHT	PASSTHROUGH
AHWT W4	P5:6	J5:6	18	WHT	PASSTHROUGH
AHWT W5	P5:7	J5:7	18	WHT	PASSTHROUGH
AHWT W6	P5:8	P1:1	18	BLU	AHWT SENSOR SIG
AHWT W7	P7:3	J7:3	18	WHT	PASSTHROUGH
AHWT W8	P7:4	J7:4	18	WHT	PASSTHROUGH
AHWT W9	P7:7	J7:7	18	WHT	PASSTHROUGH
AHWT W10	P7:8	J7:8	18	WHT	PASSTHROUGH
AHWT W11	P7:9	J7:9	18	WHT	PASSTHROUGH
AHWT W12	P7:10	J7:10	18	WHT	PASSTHROUGH
AHWT W13	P7:11	J7:11	18	WHT	PASSTHROUGH
AHWT W14	P7:12	J7:12	18	WHT	PASSTHROUGH
AHWT W15	P7:13	J7:13	18	WHT	PASSTHROUGH
AHWT W16	P7:14	J7:14	18	WHT	PASSTHROUGH
AHWT W17	P7:15	J7:15	18	WHT	PASSTHROUGH
AHWT W18	P7:16	J7:16	18	WHT	PASSTHROUGH
AHWT W19	P7:17	SP1:IN	18	BLK	PASSTHROUGH
AHWT W20	SP1:OUT	J7:17	18	BLK	PASSTHROUGH
AHWT W21	SP1:OUT	P1:3	18	BLK	AHWT SENSO GND
AHWT W22	P7:18	SP2:IN	18	ORG	PASSTHROUGH
AHWT W23	SP2:OUT	J7:18	18	ORG	PASSTHROUGH
AHWT W24	SP2:OUT	P1:2	18	ORG	AHWT SENSO PWR
AHWT W25	P7:19	J7:19	18	WHT	PASSTHROUGH
AHWT W26	P7:20	J7:20	18	WHT	PASSTHROUGH

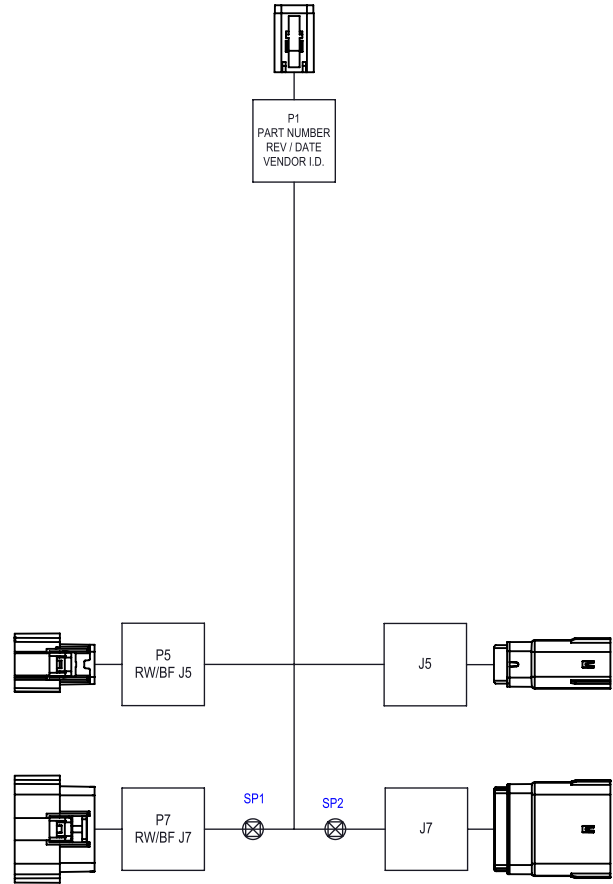

TRACTOR POWER HARNESS (P/N: 10211901)

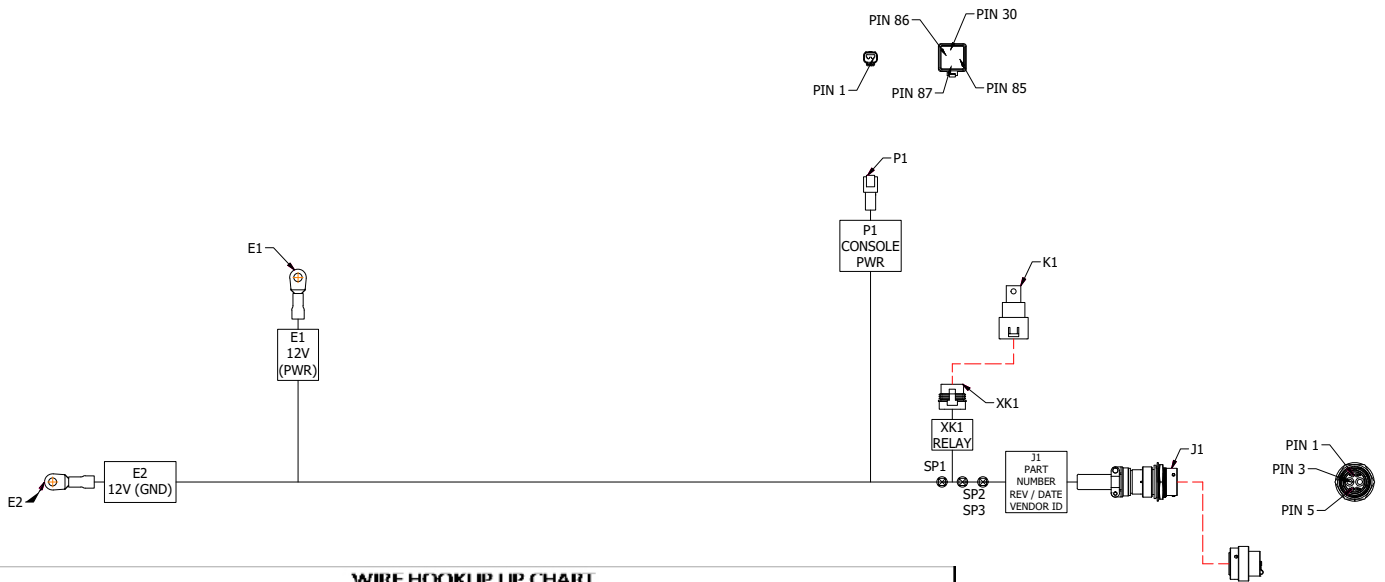

WIRE HOOKUP UP CHART

REF DES	FROM	USED WITH ITEM	TO	USED WITH ITEM	GAUGE	COLOR	FUNCTION
W1	F1	---	SP1	---	2	RFD	12V (PWR)
W2	SP1	---	XK1-30	13	10	RED	12V (PWR)
W3	XK1-87	13	SP2	---	10	RED	12V (PWR)
W4	SP2	---	J1-3	9	6	RFD	12V (PWR)
W5	F2	---	SP3	---	2	BLK	12V (GND)
W6	SP3	---	J1-4	9	6	BLK	12V (GND)
W7	XK1-86	14	P1-1	11	18	BLU	SWITCH PWR (CONSOLE)
W8	XK1-85	14	P1-2	11	18	BLU	SWITCH GND (CONSOLE)

TRACTOR CONSOLE HARNESS (P/N: A25031)

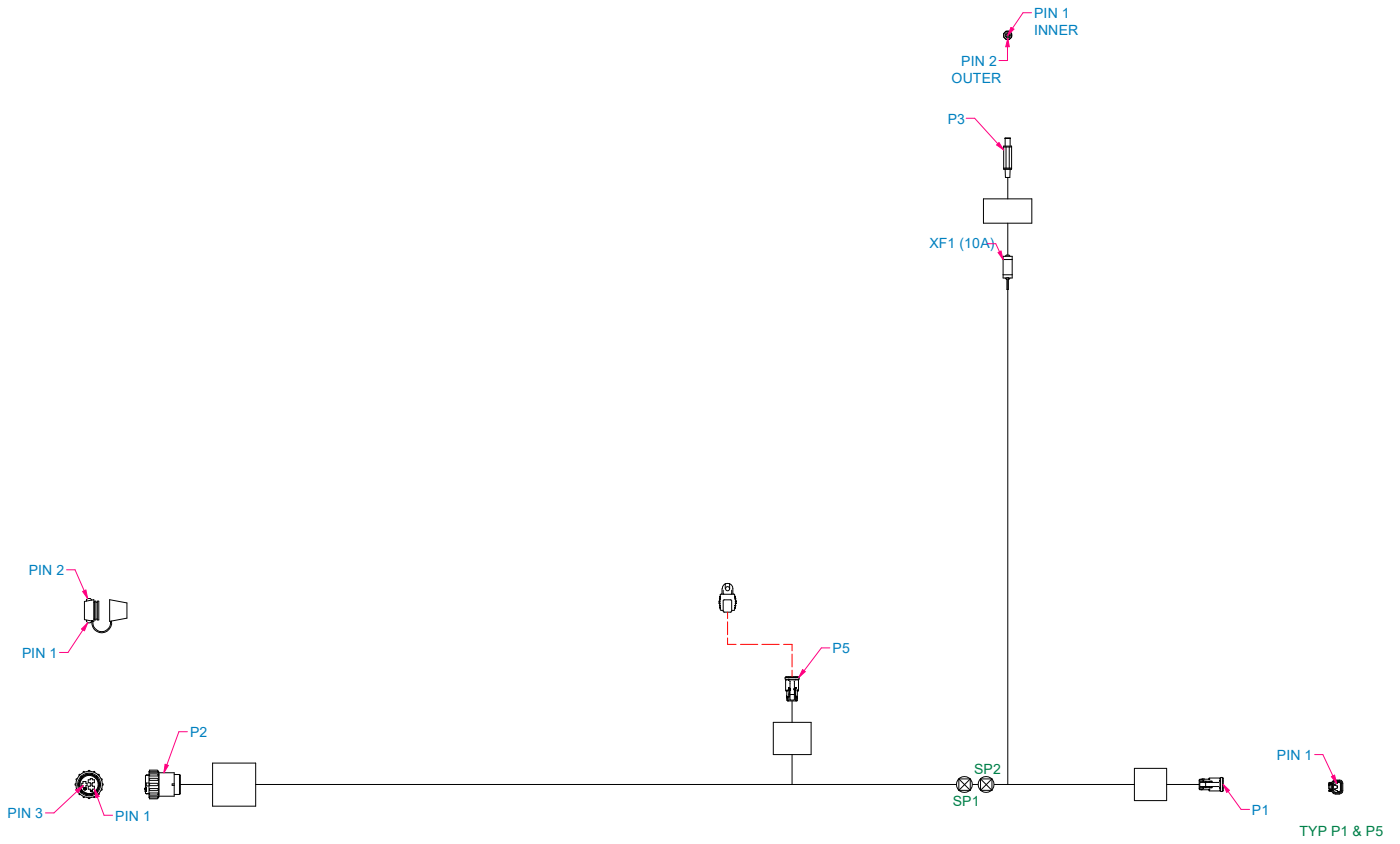

WIRE HOOKUP CHART							
REF DES	FROM	USED WITH ITEM	TO	USED WITH ITEM	GAUGE	COLOR	FUNCTION
W1	P2-1	10	SP1	---	16	RED	12V SWITCHED (PWR)
W2	SP1	---	P1-1	13	18	BLUE	RELAY (PWR)
W3	SP1	---	XF1-1	---	18	RED	12V SWITCHED (PWR)
W5	SP1	---	P5-1	13	18	ORN	12V SWITCHED (PWR)
W6	XF1-2	---	P3-1	SOLDER	18	RED	12V SWITCHED (PWR)
W8	P2-3	10	SP2	---	16	BLK	12V SWITCHED (GND)
W9	SP2	---	P1-2	13	18	BLK	12V SWITCHED (GND)
W10	SP2	---	P3-2	SOLDER	18	BLK	12V SWITCHED (GND)
W12	SP2	---	P5-2	13	18	BLK	12V SWITCHED (GND)

TRACTOR POWER HARNESS EXTENSION, 10'/16' (P/N: 10060901 AND 10060902)



WIRE HOOKUP CHART

REF DES	FROM	USED W/ ITEM	TO	USED W/ ITEM	GAUGE	COLOR	FUNCTIO N
W1	P1-3	3	SP1	---	6	RED	12V PWR
W2	SP1	---	SP3	---	4	RED	12V PWR
W3	SP3	---	P2-3	3	6	RED	12V PWR
W4	P1-4	3	SP2	---	6	BLK	12V GND
W5	SP2	---	SP4	---	4	BLK	12V GND
W6	SP4	---	P2-4	3	6	BLK	12V GND

TRUE SPEED 3K ROW UNIT HARNESS W/IPP (P/N: 10210901)

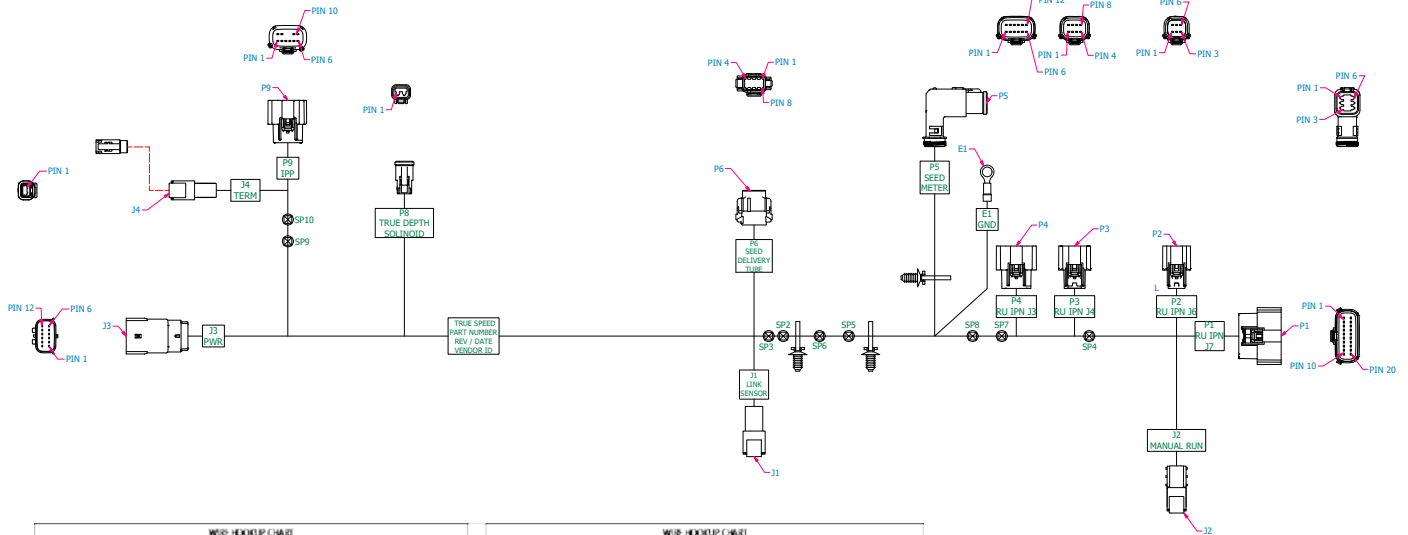

WIRE HOOKUP CHART							
REF DES	FROM	USED WITH ITEM	TO WITH ITEM	GAUGE	COLOR	FUNCTION	
W1	P1-1	19	P9-1	19	BRN	IS252 DC	
W2	P1-2	19	P9-2	19	BRN	IS252 DC	
W3	P1-7	19	P8-1	24	VLT	TRUE DEPTH CYLINDER PWR/M	
W4	P1-8	19	P8-2	24	BLU	TRUE DEPTH CYLINDER PWR/M	
W5	P1-16	19	J1-2	22	WHI	TRUE DEPTH LINK SENSOR (SIGNAL)	
W6	P1-19	19	J1-4	22	GRY	TRUE DEPTH LINK SENSOR (GND)	
W7	P1-20	19	J1-1	22	PNK	TRUE DEPTH LINK SENSOR (PWR)	
W8	P2-1	19	SP2	-	YEL	IPN (CAN H)	
W9	P2-2	19	SP3	-	GRN	IPN (CAN L)	
W10	SP2	-	P6-3	26	YEL	SEED SENSOR (CAN H)	
W11	SP3	-	P6-4	26	GRN	SEED SENSOR (CAN L)	
W12	SP2	-	P5-3	24	YEL	CAN H	
W13	SP3	-	P5-4	24	GRN	CAN L	
W14	P2-3	19	P9-12	19	RD/BLK	IPP PWR+	
W15	P2-4	19	P9-6	19	BLK/RED	IPP PWR-	
W16	P2-5	19	P9-11	19	BLU	IPP SOFTWARE UPDATE	
W17	P3-5	19	P6-5	26	PNK	SEED SENSOR (PWR)	
W18	P3-6	19	S4	-	GRY	SEED SENSOR/RUN BUTTON (GND)	
W19	S4	-	P6-6	26	GRY	SEED SENSOR (GND)	
W20	S4	-	J2-1	23	GRY	RUN BUTTON (GND)	
W21	P3-7	19	J2-2	23	BRN	RUN BUTTON (PWR)	
W22	P4-1	21	S5	-	RD	24V PWR	
W28	S5	-	J3-1	29	RD	24V IPN PWR	
W29	S5	-	P6-1	26	RD	BLU BLDC DRIVER (24V PWR)	
W30	P4-2	21	S6	29	BLK	24V GND	

WIRE HOOKUP CHART							
REF DES	FROM	USED WITH ITEM	TO WITH ITEM	GAUGE	COLOR	FUNCTION	
W31	S6	-	J3-2	29	BLK	24V IPN GND	
W32	S6	-	P6-2	26	BLK	BLU BLDC DRIVER (24V GND)	
W33	P4-3	21	S7	-	RD	24V PWR	
W34	S7	-	J3-3	29	RD	24V IPN PWR	
W35	S7	-	P5-1	24	RD	METER BLDC DRIVER (24V PWR)	
W36	P4-4	21	S8	-	BLK	24V IPN GND	
W37	S8	-	J3-4	29	BLK	24V IPN GND	
W38	S8	-	P5-2	24	BLK	METER BLDC DRIVER (24V GND)	
W39	S8	-	P5-6	24	BLK	METER BLDC DRIVER (STRAPPING x1)	
W40	P4-5	19	J3-5	29	YEL	IPN STRAPPING	
W41	P4-6	19	J3-6	29	ORN	IPN STRAPPING	
W42	P4-7	19	J3-7	29	WHI	IPN STRAPPING	
W43	P4-8	19	J3-8	29	GRN	IPN STRAPPING	
W44	P4-9	19	J3-9	29	BLU	IPN STRAPPING	
W45	P4-10	19	J3-10	29	VLT	IPN STRAPPING	
W46	P4-11	19	J3-11	29	GRY	IPN STRAPPING (PARTY)	
W47	P4-12	19	J3-12	29	BRN	IPN STRAPPING (GND)	
W48	P6-7	26	SP9	-	YEL	CAN H	
W49	P6-8	26	SP10	-	GRN	CAN L	
W50	SP9	-	J4-1	23	YEL	THRM (CAN H)	
W51	SP10	-	J4-2	23	GRN	THRM (CAN L)	
W52	SP9	-	P9-5	19	YEL	IPP (CAN H)	
W53	SP10	-	P9-4	19	GRN	IPP (CAN L)	
W54	J1-3	22	F1	-	GRN	TRUE DEPTH LINK SENSOR (SHIELD)	

TRUE SPEED 3K PULL ROW UNIT HARNESS (P/N: 10210801)

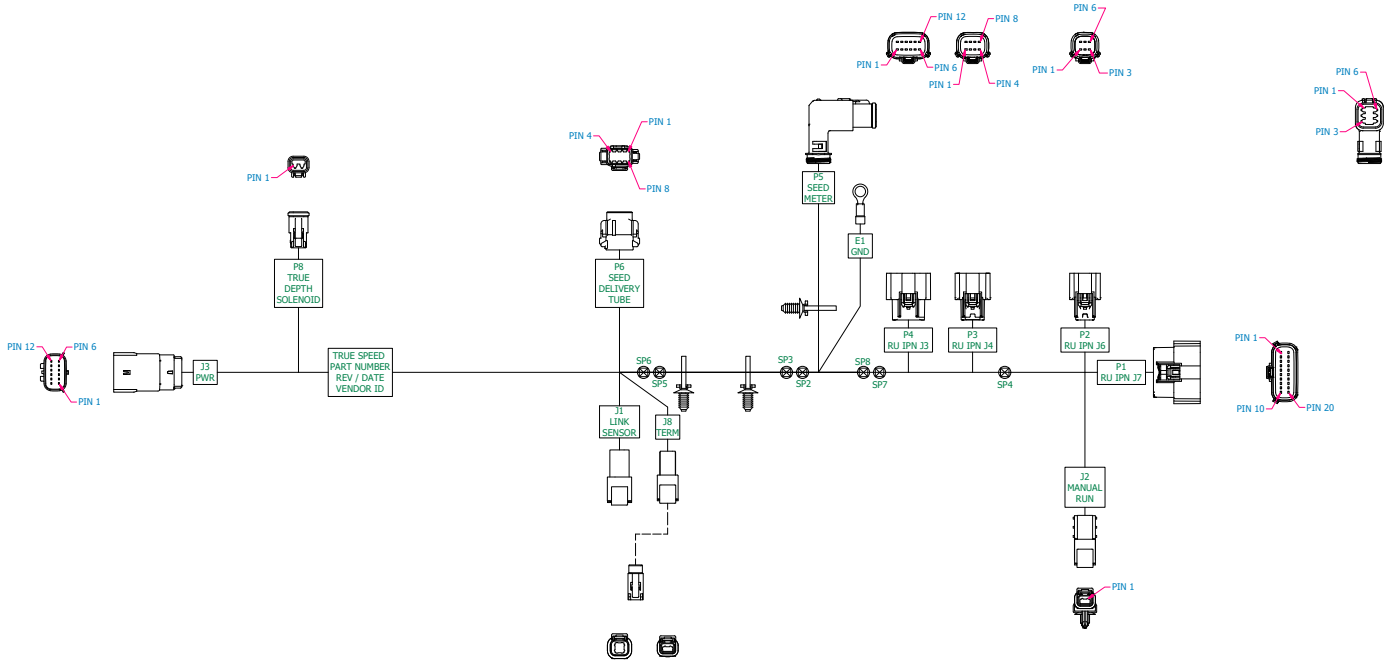

WIRE HOOKUP CHART							
REF DES	FROM	USED WITH ITEM	TO	USED WITH ITEM	GAUGE	COLOR	FUNCTION
W1	P1-7	19	P8-1	24	18	VLT	TRUE DEPTH CYLINDER PWM+
W2	P1-8	19	P8-2	24	18	BLU	TRUE DEPTH CYLINDER PWM-
W3	P1-16	19	I1-7	22	18	WHI	TRUE DEPTH LINK SENSOR (SIG/AL)
W4	P1-19	19	I1-4	22	18	GRY	TRUE DEPTH LINK SENSOR (GND)
W5	P1-20	19	I1-1	22	18	PNK	TRUE DEPTH LINK SENSOR (PWR)
W6	P2-1	19	SP2	-	18(1P)	YEL	CAN H
W7	P2-2	19	SP3	-	18(1P)	GRN	CAN L
W8	SP2	-	P6-3	26	-	YEL	SEED SENSOR (CAN H)
W9	SP3	-	P6-4	26	-	GRN	SEED SENSOR (CAN L)
W10	SP2	-	P5-3	24	-	YEL	CAN H
W11	SP3	-	P5-4	24	-	GRN	CAN L
W12	P3-5	19	P6-5	26	18	PNK	SEED SENSOR (PWR)
W13	P3-6	19	SP4	-	18	GRY	SEED SENSOR/RUN BUTTON (GND)
W14	SP4	-	P6-6	26	18	GRY	SEED SENSOR (GND)
W15	SP4	-	I2-1	23	18	GRY	RUN BUTTON (GND)
W16	P3-7	19	I2-7	23	18	BRN	RUN BUTTON (PWR)
W17	P4-1	21	SP5	-	16	RED	24V PWR
W18	SP5	-	I3-1	29	16	RED	24V IPN PWR
W19	SP5	-	P6-1	26	16	RED	BELT BLDC DRIVER (24V PWR)
W20	P4-2	21	SP6	-	16	BLK	24V GND

WIRE HOOKUP CHART							
REF DES	FROM	USED WITH ITEM	TO	USED WITH ITEM	GAUGE	COLOR	FUNCTION
W21	SP6	-	E3-7	29	16	BLK	24V IPN GND
W22	SP6	-	P6-7	26	16	BLK	BELT BLDC DRIVER (24V GND)
W23	P4-3	-	SP7	-	16	RED	24V PWR
W24	SP7	-	E3-4	29	16	RED	24V IPN PWR
W25	SP7	-	P5-1	24	16	RED	METER BLDC DRIVER (24V PWR)
W26	P4-4	21	SP8	-	16	BLK	24V IPN GND
W27	SP8	-	E3-4	29	16	BLK	24V IPN GND
W28	SP8	-	P5-2	24	16	BLK	METER BLDC DRIVER (24V GND)
W29	SP8	-	P5-6	24	16	BLK	METER BLDC DRIVER (STRAPPING G1)
W30	P4-5	19	E3-5	29	20	YEL	IPN STRAPPING
W31	P4-6	19	E3-6	29	20	GRN	IPN STRAPPING
W32	P4-7	19	E3-7	29	20	WHI	IPN STRAPPING
W33	P4-8	19	E3-8	29	20	GRN	IPN STRAPPING
W34	P4-9	19	E3-9	29	20	BLU	IPN STRAPPING
W35	P4-10	19	E3-10	29	20	VLT	IPN STRAPPING
W36	P4-11	19	E3-11	29	20	GRY	IPN STRAPPING (PARITY)
W37	P4-12	19	E3-12	29	20	BRN	IPN STRAPPING (GND)
W38	SP-7	26	B-1	23	-	YEL	TERM (CAN H)
W39	P6-8	26	B-2	23	-	GRN	TERM (CAN L)
W40	I1-3	22	E1	-	18	GRN	TRUE DEPTH LINK SENSOR (SHIELD)

TRUE SPEED LINK ROW UNIT HARNESS (P/N: 10210701)

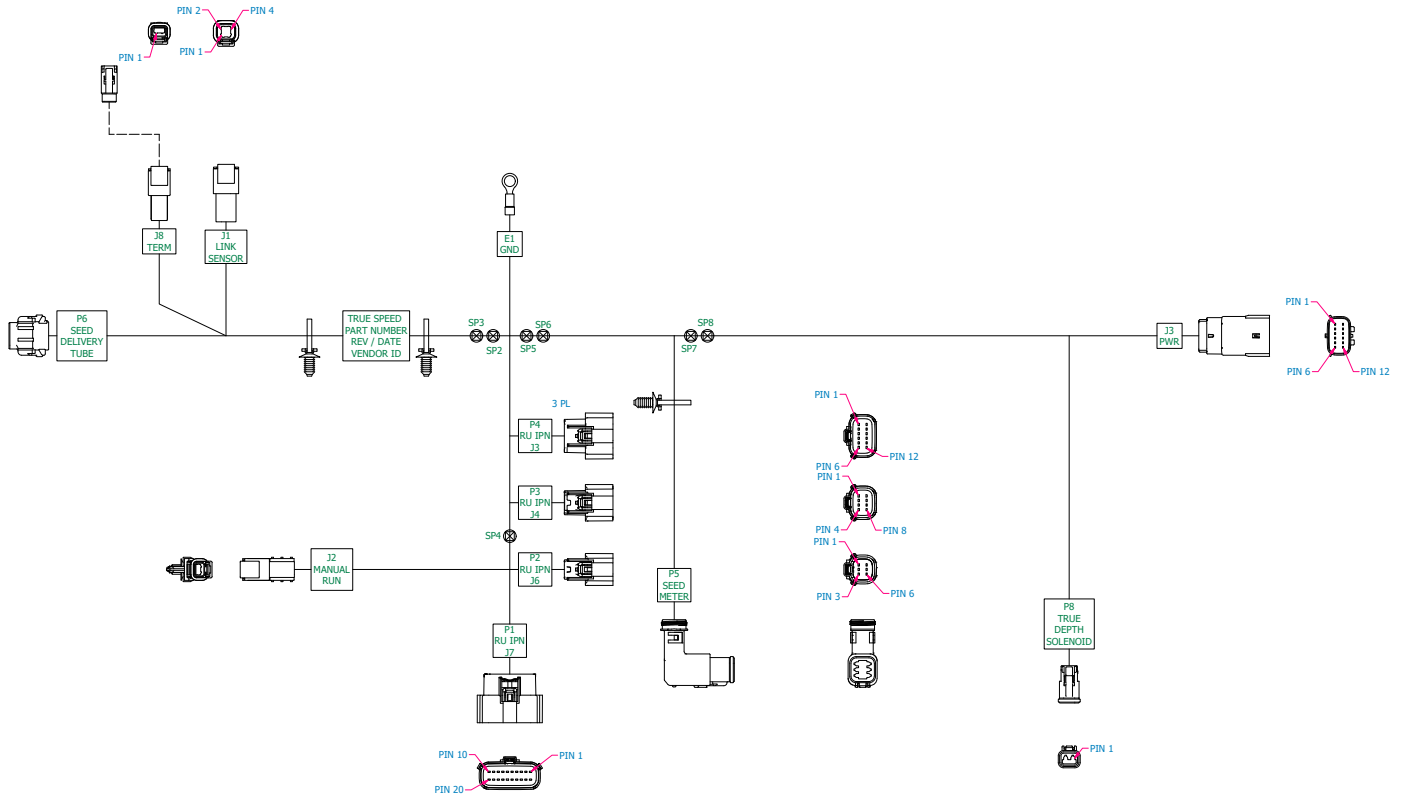

WIRE HOOKUP CHART							WIRE HOOKUP CHART								
REF DES	FROM	USED WITH ITEM	TO WITH ITEM	GALGE	COLOR	FUNCTION	REF DES	FROM	USED WITH ITEM	TO WITH ITEM	GALGE	COLOR	FUNCTION		
W1	P1-7	19	P8-1	24	18	YEL	TRUE DEPTH CYLINDER PWM+	W21	SP6	-	E3-2	29	16	BLK	24V IPN GND
W2	P1-8	19	P8-2	24	18	BLU	TRUE DEPTH CYLINDER PWM-	W22	SP6	-	P6-2	26	16	BLK	BLEE BLDC DRIVER (24V GND)
W3	P1-16	19	J1-2	22	18	WHI	TRUE DEPTH LINK SENSOR (SIGNAL)	W23	P4-3	21	SP7	-	16	RED	24V PWR
W4	P1-19	19	J1-4	22	18	GRY	TRUE DEPTH LINK SENSOR (GND)	W24	SP7	-	E3-3	29	16	RED	24V IPN PWR
W5	P1-20	19	J1-1	22	18	PNK	TRUE DEPTH LINK SENSOR (PWR)	W25	SP7	-	P5-1	24	16	RED	METER BLDC DRIVER (24V PWR)
W6	P2-1	19	SP2	-	-	YEL	CAN H	W26	P4-4	21	SP8	-	16	BLK	24V IPN GND
W7	P2-2	19	SP3	-	-	GRN	CAN L	W27	SP8	-	E3-4	29	16	BLK	24V IPN GND
W8	SP2	-	P6-3	26	-	YEL	SEED SENSOR (CAN H)	W28	SP8	-	P5-2	24	16	BLK	METER BLDC DRIVER (24V GND)
W9	SP5	-	P6-4	26	-	GRN	SEED SENSOR (CAN L)	W29	SP8	-	P5-6	24	16	BLK	METER BLDC DRIVER (STRAPPING DT)
W10	SP7	-	P5-1	24	-	YEL	CAN H	W30	P4-5	19	E3-5	29	20	YEL	IPN STRAPPING
W11	SP3	-	P5-4	24	-	GRN	CAN L	W31	P4-6	19	E3-6	29	20	BRN	IPN STRAPPING
W12	P1-5	19	P6-5	26	18	PNK	SEED SENSOR (PWR)	W32	P4-7	19	E3-7	29	20	WHI	IPN STRAPPING
W13	P1-6	19	SP4	-	-	GRY	SEED SENSOR/RUN BUTTON (GND)	W33	P4-8	19	E3-8	29	20	GRN	IPN STRAPPING
W14	SP4	-	P6-6	26	18	GRY	SEED SENSOR (GND)	W34	P4-9	19	E3-9	29	20	BLU	IPN STRAPPING
W15	SP4	-	J2-1	23	18	GRY	RUN BUTTON (GND)	W35	P4-10	19	E3-10	29	20	VLT	IPN STRAPPING
W16	P1-7	19	J2-2	23	18	BRN	RUN BUTTON (PWR)	W36	P4-11	19	J3-11	29	20	GRY	IPN STRAPPING (PARITY)
W17	P4-1	21	SP5	-	-	RED	24V PWR	W37	P4-12	19	J3-12	29	20	BRN	IPN STRAPPING (GND)
W18	SP5	-	J3-1	29	16	RED	24V IPN PWR	W38	P6-7	26	R8-1	23	-	YEL	TERM (CAN H)
W19	SP5	-	P6-1	26	16	RED	BLEE BLDC DRIVER (24V PWR)	W39	P6-8	26	R8-2	23	-	GRN	TERM (CAN L)
W20	P4-2	21	SP6	-	-	BLK	24V GND	W40	J1-3	22	E1	-	18	GRN	TRUE DEPTH LINK SENSOR (SHIELD)

ROW UNIT POWER SPLIT ROW HARNESS, 12 ROW (P/N: 10010501)

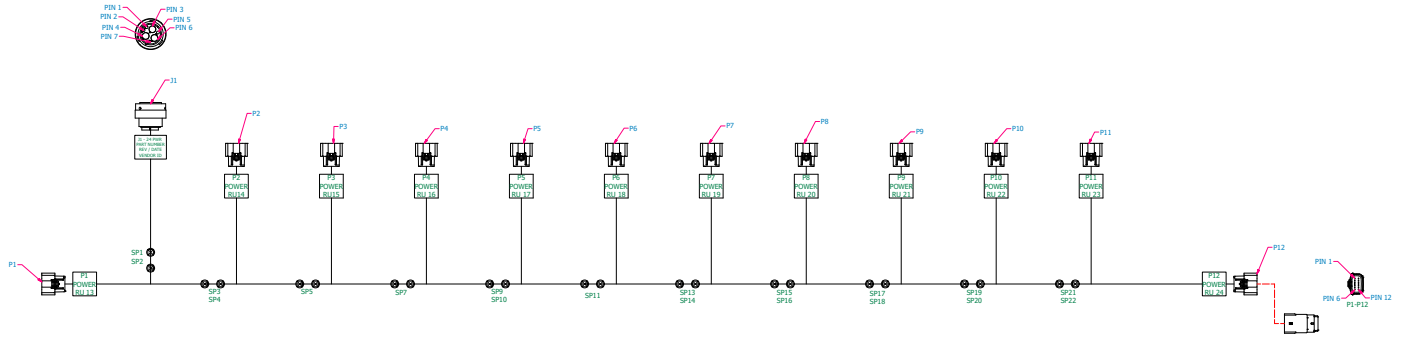

WIRE HOOKUP CHART							WIRE HOOKUP CHART							WIRE HOOKUP CHART									
REF DES	FROM	USED WITH ITEM	TO	USED WITH ITEM	GAUGE	COLOR	FUNCTION	REF DES	FROM	USED WITH ITEM	TO	USED WITH ITEM	GAUGE	COLOR	FUNCTION	REF DES	FROM	USED WITH ITEM	TO	USED WITH ITEM	GAUGE	COLOR	FUNCTION
W1	J1-6	3	SP1	---	4	RED	---	W33	SP11	---	SP13	---	10	RED	---	W64	SP21	---	P11-3	4	16	RED	RU 23 (PWR)
W2	J1-4	3	SP2	---	4	BLK	---	W34	SP11	---	P6-1	4	16	RED	RU 18 (PWR)	W65	SP22	---	P11-2	4	16	BLK	RU 23 (GND)
W3	SP1	---	SP3	---	10	RED	---	W35	SP11	---	P6-3	4	16	RED	RU 18 (PWR)	W66	SP22	---	P11-4	4	16	BLK	RU 23 (GND)
W4	SP1	---	P1-1	4	16	RED	RU 13 (PWR)	W36	SP12	---	SP14	---	10	BLK	---	W67	SP21	---	P12-1	4	16	RED	RU 24 (PWR)
W5	SP1	---	P1-3	4	16	RED	RU 13 (PWR)	W37	SP12	---	P6-2	4	16	BLK	RU 18 (GND)	W68	SP21	---	P12-3	4	16	RED	RU 24 (PWR)
W6	SP2	---	SP4	---	10	BLK	---	W38	SP12	---	P6-4	4	16	BLK	RU 18 (GND)	W71	SP22	---	P12-2	4	16	BLK	RU 24 (GND)
W7	SP2	---	P1-2	4	16	BLK	RU 13 (GND)	W39	SP13	---	SP15	---	10	RED	---	W72	SP22	---	P12-4	4	16	BLK	RU 24 (GND)
W8	SP2	---	P1-4	4	16	BLK	RU 13 (GND)	W40	SP13	---	P7-1	4	16	RED	RU 19 (PWR)								
W9	SP3	---	SP5	---	10	RED	---	W41	SP13	---	P7-3	4	16	RED	RU 19 (PWR)								
W10	SP3	---	P2-1	4	16	RED	RU 14 (PWR)	W42	SP14	---	SP16	---	10	BLK	---								
W11	SP3	---	P2-3	4	16	RED	RU 14 (PWR)	W43	SP14	---	P7-2	4	16	BLK	RU 19 (GND)								
W12	SP4	---	SP6	---	10	BLK	---	W44	SP14	---	P7-4	4	16	BLK	RU 19 (GND)								
W13	SP4	---	P2-2	4	16	BLK	RU 14 (GND)	W45	SP15	---	SP17	---	10	RED	---								
W14	SP4	---	P2-4	4	16	BLK	RU 14 (GND)	W46	SP15	---	P8-1	4	16	RED	RU 20 (PWR)								
W15	SP5	---	SP7	---	10	RED	---	W47	SP15	---	P8-3	4	16	RED	RU 20 (PWR)								
W16	SP5	---	P3-1	4	16	RED	RU 15 (PWR)	W48	SP16	---	SP18	---	10	BLK	---								
W17	SP5	---	P3-3	4	16	RED	RU 15 (PWR)	W49	SP16	---	P8-2	4	16	BLK	RU 20 (GND)								
W18	SP6	---	SP8	---	10	BLK	---	W50	SP16	---	P8-4	4	16	BLK	RU 20 (GND)								
W19	SP6	---	P3-2	4	16	BLK	RU 15 (GND)	W51	SP17	---	SP19	---	10	RED	---								
W20	SP6	---	P3-4	4	16	BLK	RU 15 (GND)	W52	SP17	---	P9-1	4	16	RED	RU 21 (PWR)								
W21	SP7	---	SP9	---	10	RED	---	W53	SP17	---	P9-3	4	16	RED	RU 21 (PWR)								
W22	SP7	---	P4-1	4	16	RED	RU 16 (PWR)	W54	SP18	---	SP20	---	10	BLK	---								
W23	SP7	---	P4-3	4	16	RED	RU 16 (PWR)	W55	SP18	---	P9-2	4	16	BLK	RU 21 (GND)								
W24	SP8	---	SP10	---	10	BLK	---	W56	SP18	---	P9-4	4	16	BLK	RU 21 (GND)								
W25	SP8	---	P4-2	4	16	BLK	RU 16 (GND)	W57	SP19	---	SP21	---	10	RED	---								
W26	SP8	---	P4-4	4	16	BLK	RU 16 (GND)	W58	SP19	---	P10-1	4	16	RED	RU 22 (PWR)								
W27	SP9	---	SP11	---	10	RED	---	W59	SP19	---	P10-3	4	16	RED	RU 22 (PWR)								
W28	SP9	---	P5-1	4	16	RED	RU 17 (PWR)	W60	SP20	---	SP22	---	10	BLK	---								
W29	SP9	---	P5-3	4	16	RED	RU 17 (PWR)	W61	SP20	---	P10-2	4	16	BLK	RU 22 (GND)								
W30	SP10	---	SP12	---	10	BLK	---	W62	SP20	---	P10-4	4	16	BLK	RU 22 (GND)								
W31	SP10	---	P5-2	4	16	BLK	RU 17 (GND)	W63	SP21	---	P11-1	4	16	RED	RU 23 (PWR)								
W32	SP10	---	P5-4	4	16	BLK	RU 17 (GND)																

ISOBUS IMPLEMENT CABLE

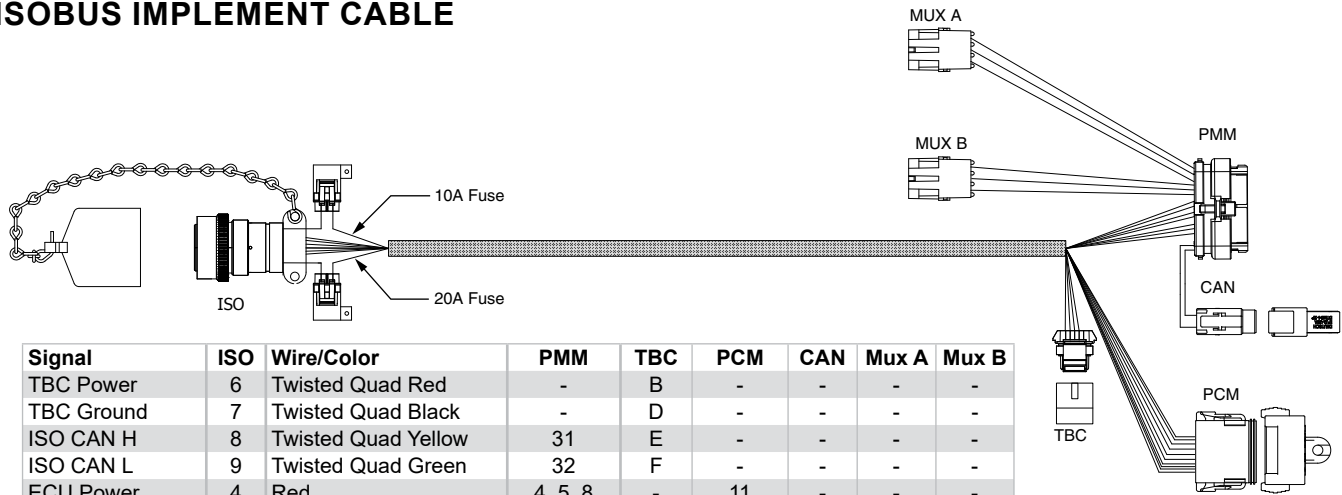

Signal	ISO	Wire/Color	PMM	TBC	PCM	CAN	Mux A	Mux B
TBC Power	6	Twisted Quad Red	-	B	-	-	-	-
TBC Ground	7	Twisted Quad Black	-	D	-	-	-	-
ISO CAN H	8	Twisted Quad Yellow	31	E	-	-	-	-
ISO CAN L	9	Twisted Quad Green	32	F	-	-	-	-
ECU Power	4	Red	4, 5, 8	-	11	-	-	-
ECU Ground	2	Black	14, 15	-	12	-	-	-
LOAD Power	3	Red	-	-	1, 2, 3, 4	-	-	-
LOAD Ground	1	Black	-	-	5, 6, 7, 8	-	-	-
MUX A Power	-	Jacketed 3-Cond White	12	-	-	-	A	-
MUX A Ground	-	Jacketed 3-Cond Black	3	-	-	-	B	-
MUX A Signal	-	Jacketed 3-Cond Green	28	-	-	-	C	-
PROP CAN H	-	Twisted Pair Yellow	34	-	-	1	-	-
PROP CAN L	-	Twisted Pair Green	35	-	-	2	-	-
MUX B Power	-	Jacketed 3-Cond White	23	-	-	-	-	A
MUX B Ground	-	Jacketed 3-Cond Black	26	-	-	-	-	B
MUX B Signal	-	Jacketed 3-Cond Green	7	-	-	-	-	C

ISOBUS CAN JUMPER CABLE

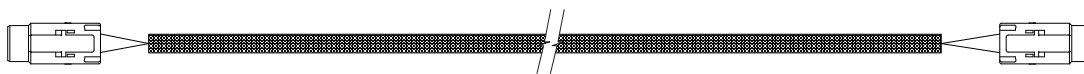

SIGNAL	CAN	WIRE/COLOR
CAN H	1	Twisted Pair Yellow
CAN L	2	Twisted Pair Green

PRODUCT CONTROL MODULE CABLE

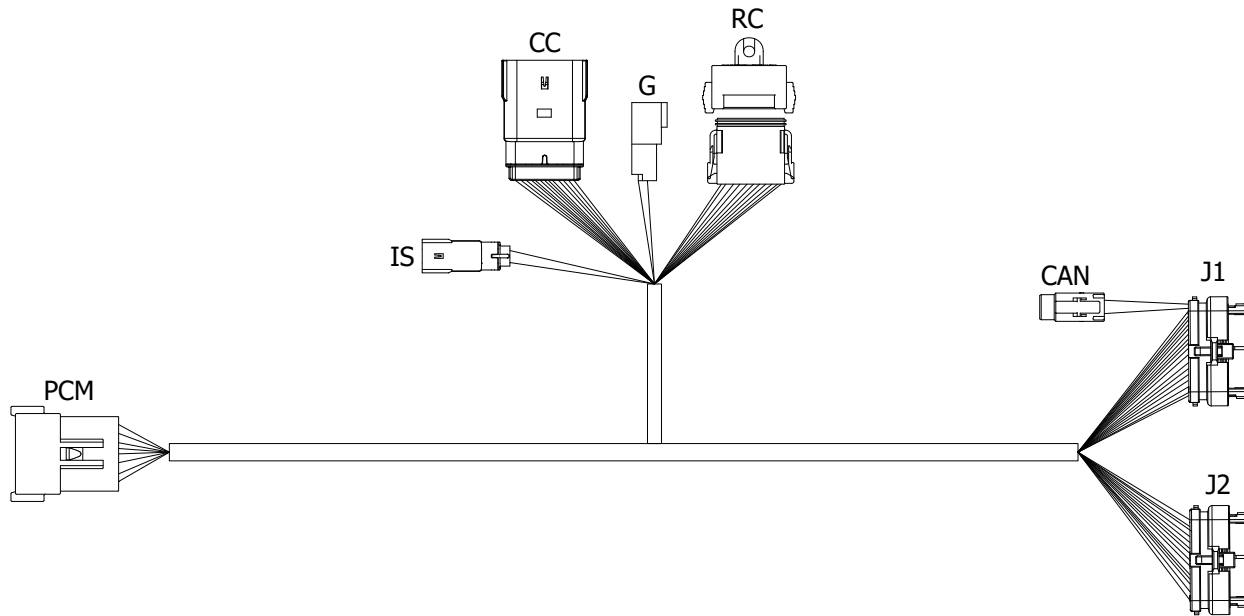

Signal	PCM	Wire/Color	J1	J2	CAN	RC	CC	IS	G
Load Power	1	Red	2	-	-	-	-	-	-
Load Power	2	Red	3	-	-	1	-	-	-
Load Power	3	Red	4	-	-	-	-	-	-
Load Power	4	Red	5	-	-	-	-	1	-
Load Ground	5	Black	-	-	-	-	-	-	1, 2
Load Ground	6	Black	14, 15	-	-	-	-	-	-
Load Ground	7	Black	16	-	-	2	-	-	-
Load Ground	8	Black	17	-	-	-	-	-	-
ECU Power	11	White/Red	11	-	-	-	-	-	-
CAN H	-	Twisted Pair Yellow	34	-	1	-	-	-	-
CAN L	-	Twisted Pair Green	33	-	2	-	-	-	-
Switch In	-	Red/Green	10	-	-	-	-	2	-
Section 1	-	White	24	-	-	-	1	-	-
Section 2	-	Green	25	-	-	-	2	-	-
Section 3	-	Orange	26	-	-	-	3	-	-
Section 4	-	Blue	27	-	-	-	4	-	-
Section 5	-	Brown	-	11	-	-	5	-	-
Section 6	-	Yellow	-	10	-	-	6	-	-
Section 7	-	Violet	-	9	-	-	7	-	-
Section 8	-	Gray	-	8	-	-	8	-	-
Section 9	-	Pink	-	7	-	-	9	-	-
Section 10	-	Tan	-	6	-	-	10	-	-
Section 11	-	Red/Green	-	5	-	-	11	-	-
Section 12	-	Black/Red	-	4	-	-	12	-	-
PWM 1 Power	-	Red/White	-	23	-	3	-	-	-
PWM 1 Ground	-	Black/White	35	-	-	4	-	-	-
PWM 2 Power	-	Red/Yellow	-	12	-	5	-	-	-
PWM 2 Ground	-	Black/Yellow	12	-	-	6	-	-	-
PWM 3 Power	-	Red/Blue	1	-	-	7	-	-	-
PWM 3 Ground	-	Black/Blue	-	24	-	8	-	-	-
Meter Speed 1	-	Green	30	-	-	9	-	-	-
Meter Speed 2	-	Green/White	29	-	-	10	-	-	-
Meter Speed 3	-	Green/Red	-	33	-	11	-	-	-

IMPLEMENT SWITCH EXTENSION CABLE

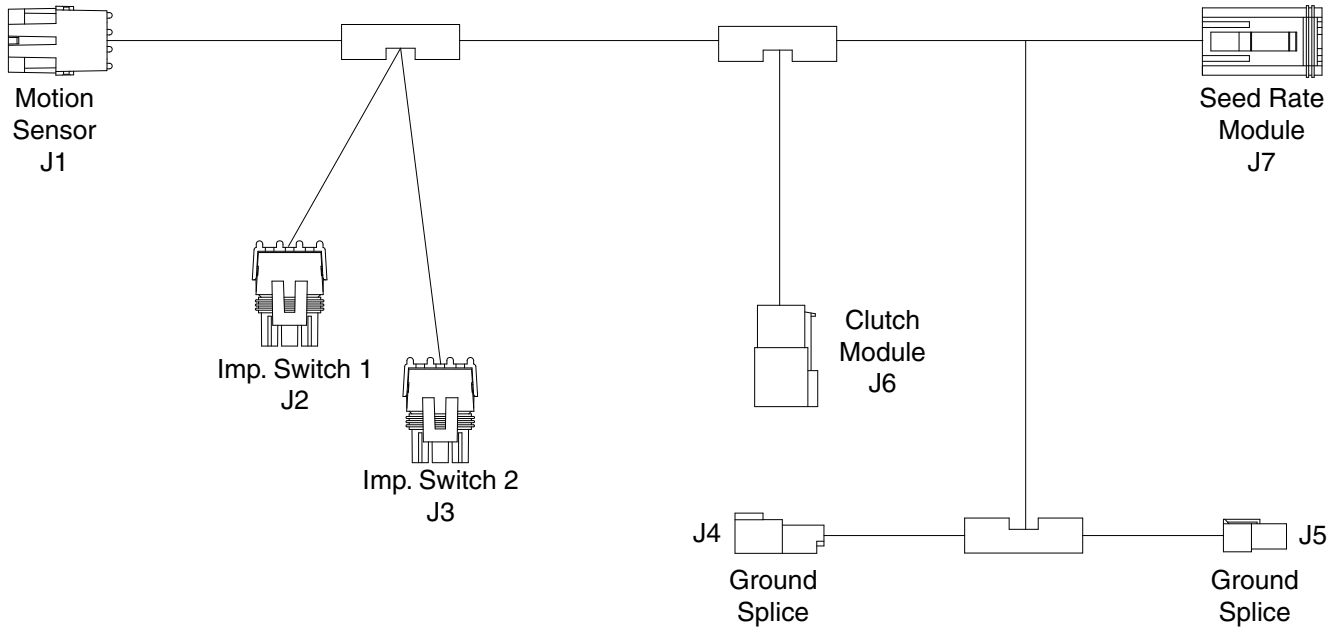

Signal	Imp. Switch 1 WP Tower 1	Imp. Switch 2 WP Tower 2	Motion Sensor WP Shroud	Color	Clutch Module Molex Recept	Seed Rate Module Deutsch Plug	Ground Splice 1	Ground Splice 2	Gauge
12V+ Power	A	A	-	Brown	1	12	-	-	16
Switch Signal	B	B	-	Green	2	10	-	-	16
Motion Signal	-	-	C	White	-	11	-	-	16
Ground	-	-	B	Black	-	6	-	-	16
12V+ Power	-	-	A	Red	-	1	-	-	16
Ground	C (Blue 16 AWG)	C (Blue 16 AWG)	-	Black	-	-	2	2	12
12V+ Power	-	-	-	Red	-	-	1	1	12

SECTION ADAPTER CABLE - 12 ROW

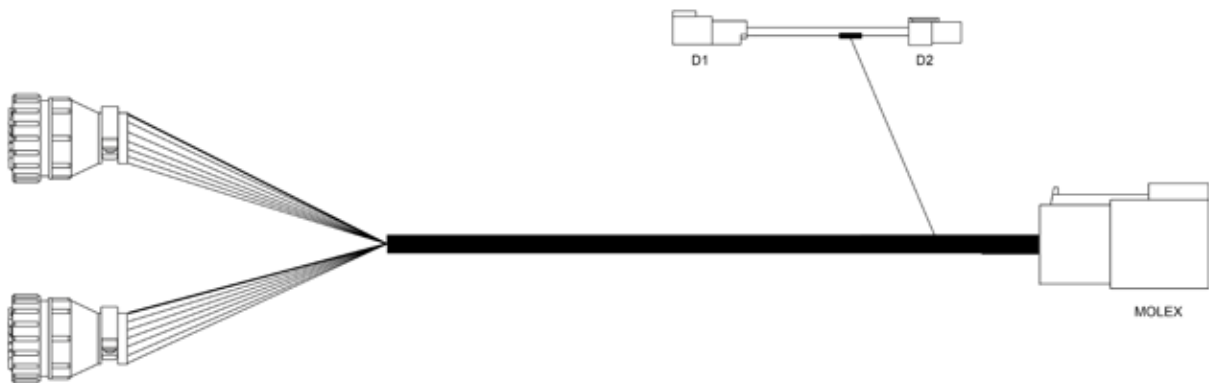

Signal	Color	AMP 1 (Left)	AMP 2 (Right)	Molex	D1	D2
High Current Power	Red	1 (16 Gauge)	1 (16 Gauge)	-	1 (12 Gauge)	1 (12 Gauge)
Ground	Black	-	-	-	2	2
Row 1, 2	Black	2, 3	-	1	-	-
Row 3, 4	Brown	4, 5	-	2	-	-
Row 5, 6	Orange	6, 7	-	3	-	-
Row 7, 8	Pink	-	6, 7	4	-	-
Row 9, 10	Green	-	4, 5	5	-	-
Row 11, 12	Yellow	-	2, 3	6	-	-

SECTION ADAPTER CABLE - 16 ROW

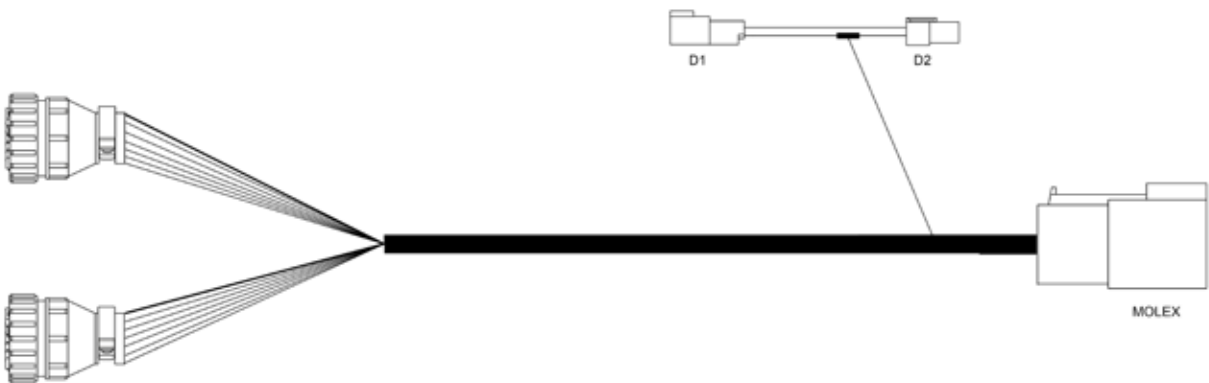

Signal	Color	AMP 1 (Left)	AMP 2 (Right)	Molex	D1	D2
High Current Power	Red	1 (16 Gauge)	1 (16 Gauge)	-	1 (12 Gauge)	1 (12 Gauge)
Ground	Black	-	-	-	2	2
Row 1, 2	Black	2, 3	-	1	-	-
Row 3, 4	Brown	4, 5	-	2	-	-
Row 5, 6	Orange	6, 7	-	3	-	-
Row 7, 8	Pink	8, 9	-	4	-	-
Row 9, 10	Green	-	8, 9	5	-	-
Row 11, 12	Yellow	-	6, 7	6	-	-
Row 13, 14	Blue	-	4, 5	7	-	-
Row 15, 16	Violet	-	2, 3	8	-	-

CLUTCH CABLE - 12 ROW

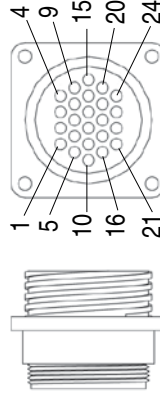
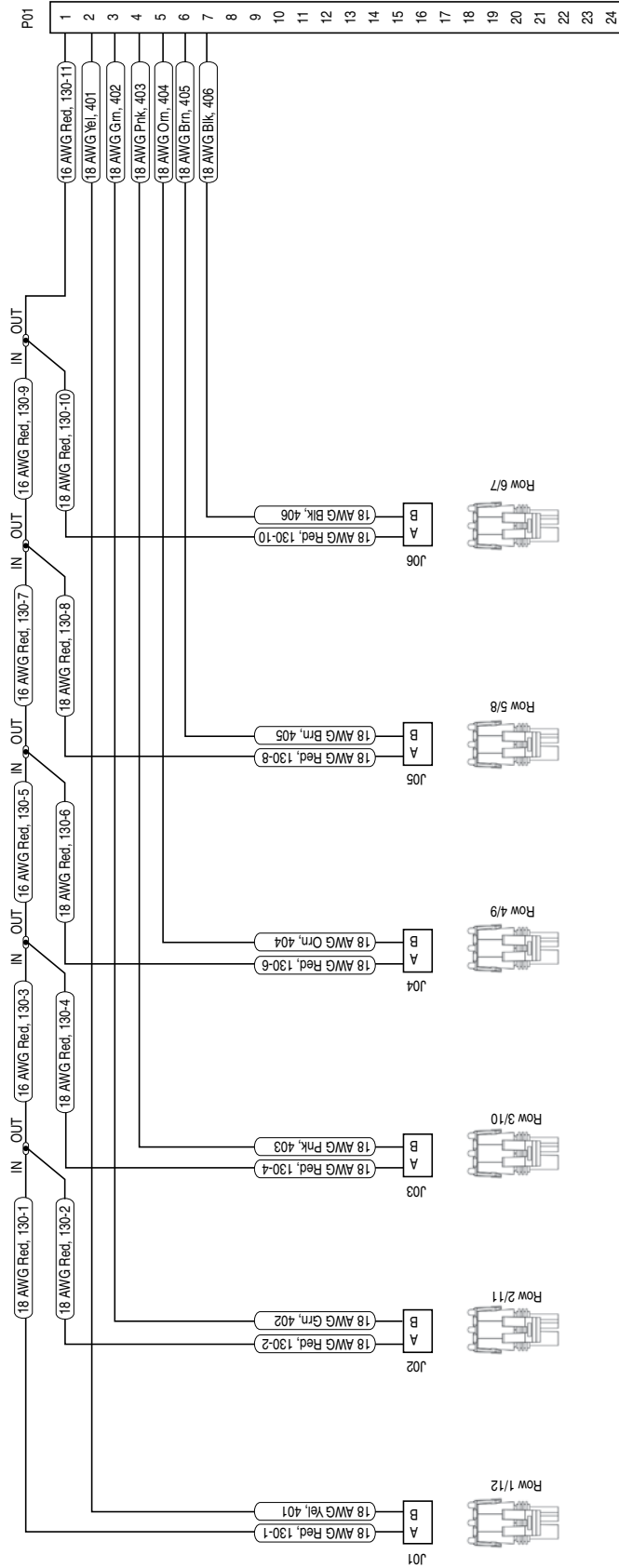

Clutch Module
Left/Right

Signal	Clutch Cable	Row 8/9	Row 7/10	Row 6/11	Row 5/12	Row 4/13	Row 3/14	Row 2/15	Row 1/16
Power	1	A	A	A	A	A	A	A	A
Row 1/16	2	-	-	-	-	-	-	-	B
Row 2/15	3	-	-	-	-	-	-	B	-
Row 3/14	4	-	-	-	-	-	B	-	-
Row 4/13	5	-	-	-	B	-	-	-	-
Row 5/12	6	-	-	-	-	-	-	-	-
Row 6/11	7	-	-	B	-	-	-	-	-
Row 7/10	8	-	B	-	-	-	-	-	-
Row 8/9	9	B	-	-	-	-	-	-	-

CLUTCH CABLE - 16 ROW

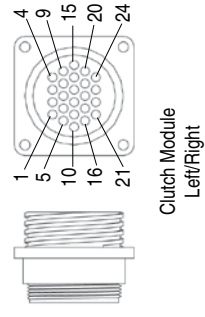
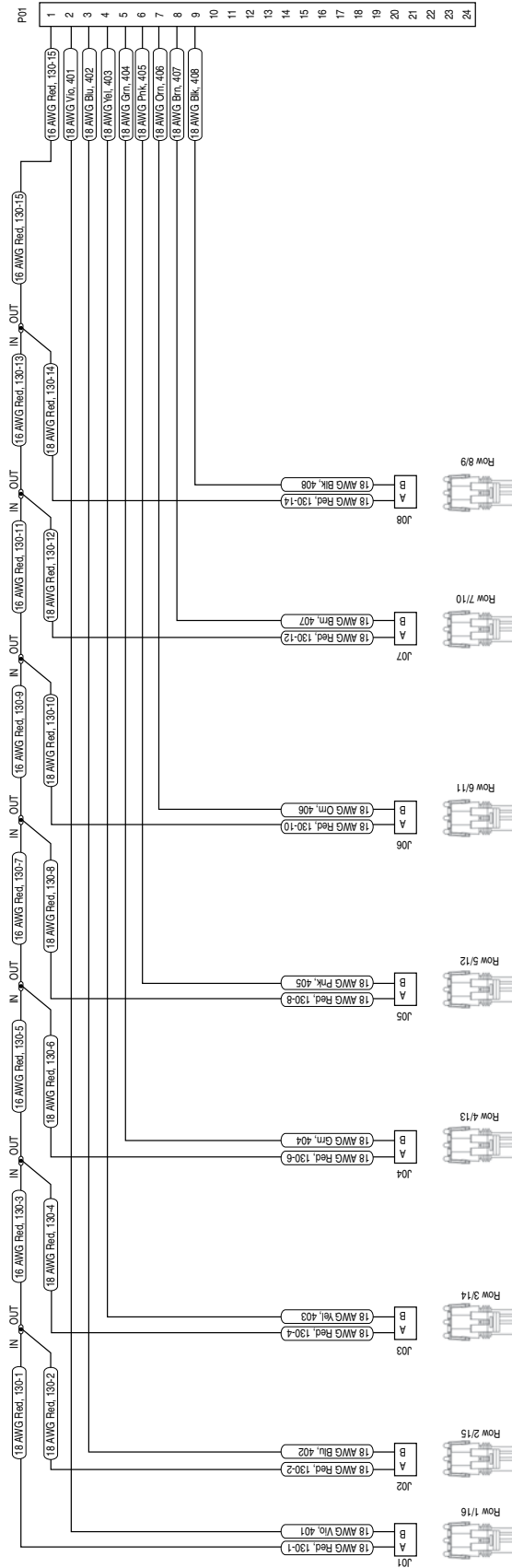

Signal	Clutch Cable	Row 8/9	Row 7/10	Row 6/11	Row 5/12	Row 4/13	Row 3/14	Row 2/15	Row 1/16
Power	1	A	A	A	A	A	A	-	-
Row 1/12	2	-	-	-	-	-	B	-	-
Row 2/11	3	-	-	-	-	B	-	-	-
Row 3/10	4	-	-	-	B	-	-	-	-
Row 4/9	5	-	-	B	-	-	-	-	-
Row 5/8	6	-	B	-	-	-	-	-	-
Row 6/7	7	B	-	-	-	-	-	-	-

TRUE DEPTH - INTERCONNECT

16 Row Shown

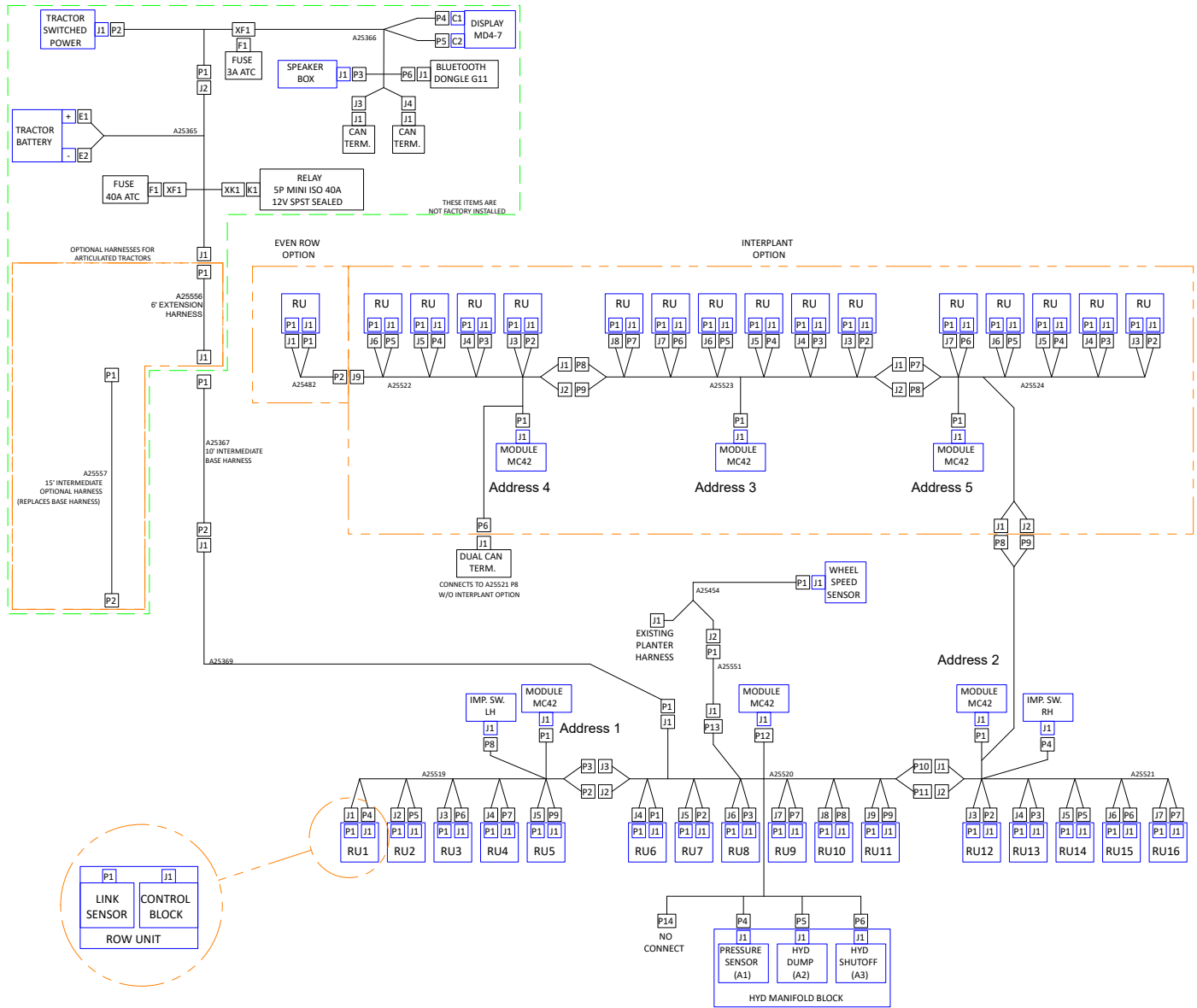

True Depth Interconnect

TRUE DEPTH OPTION- HYDRAULIC SCHEMATIC MAIN DOWN FORCE VALVE BLOCK

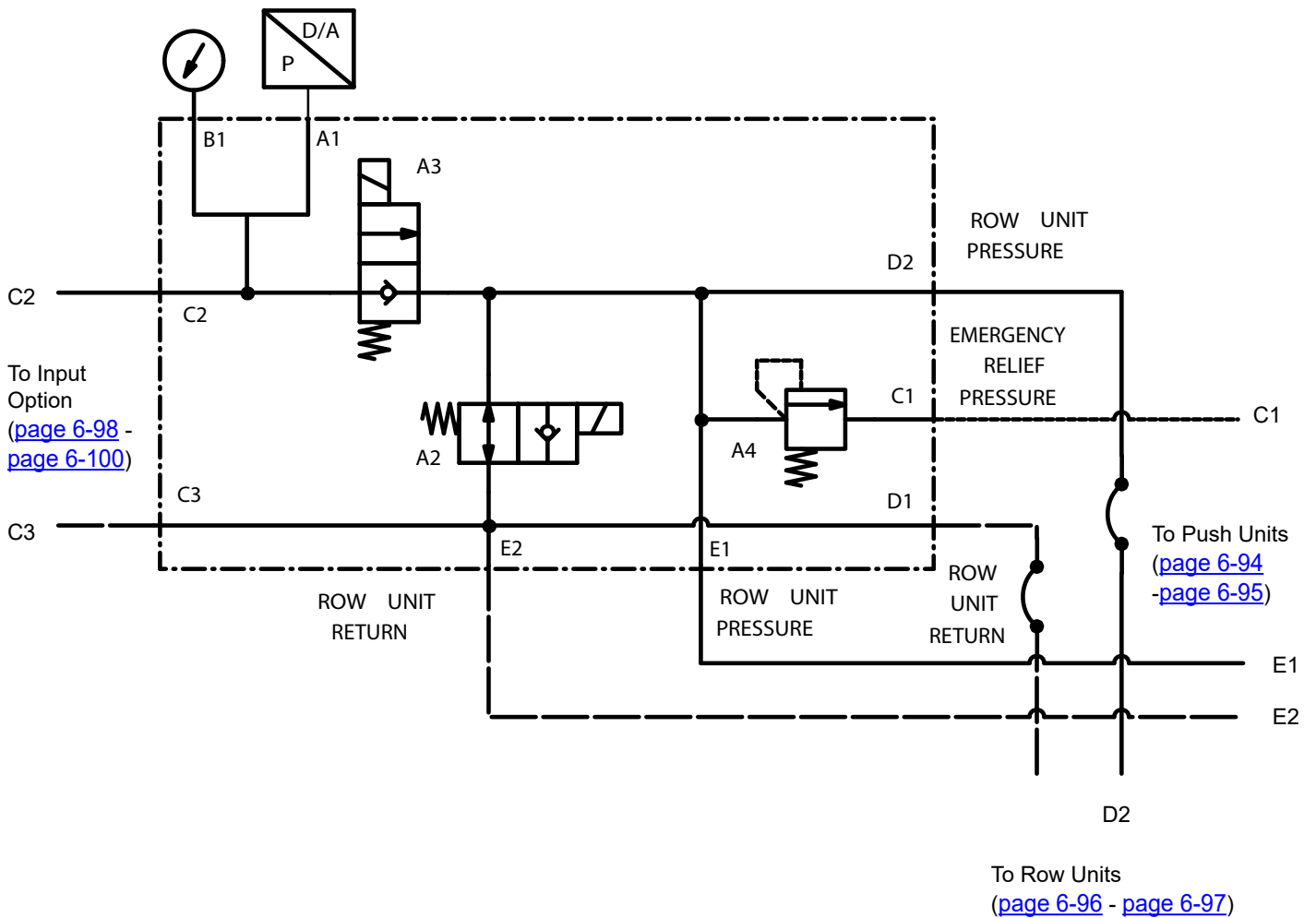

Main Down Force Valve Block

TRUE DEPTH OPTION - HYDRAULIC SCHEMATIC - PUSH UNITS 1-8

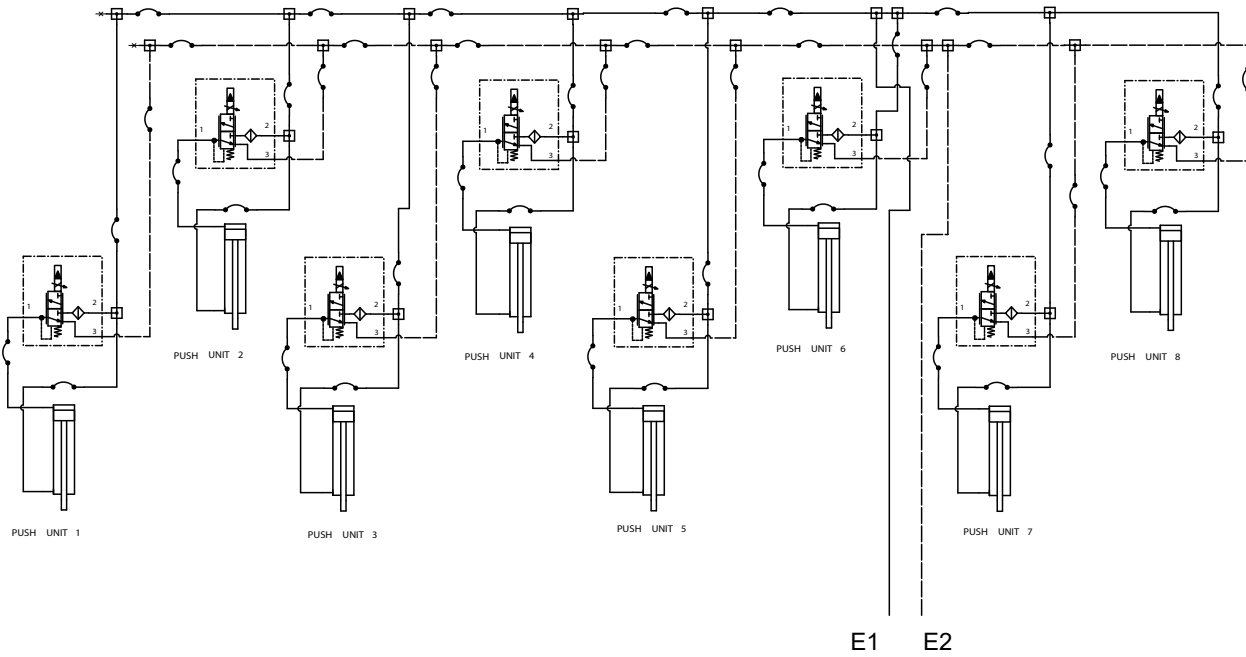

To Main Down Force Valve Block
([page 6-93](#))
Push Units 9-15
([page 6-95](#))

Push Units 1-8

TRUE DEPTH OPTION - HYDRAULIC SCHEMATIC - PUSH UNITS 9-15

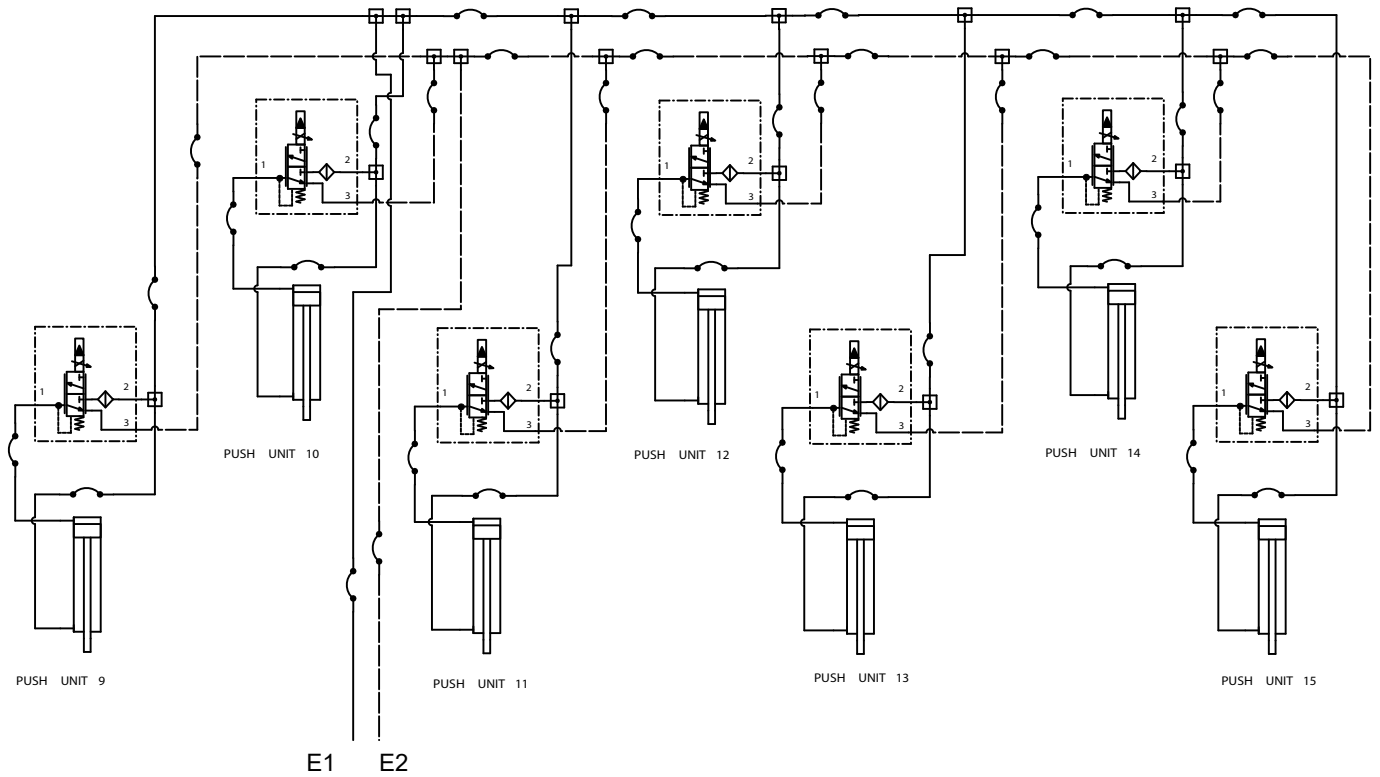

To Main Down Force Valve Block

[\(page 6-93\)](#)

Push Units 1-8

[\(page 6-94\)](#)

Push Units 9-15

TRUE DEPTH OPTION - HYDRAULIC SCHEMATIC - ROW UNITS 1-8

To Main Down Force Valve Block
([page 6-93](#))
Row Units 9-16
([page 6-97](#))

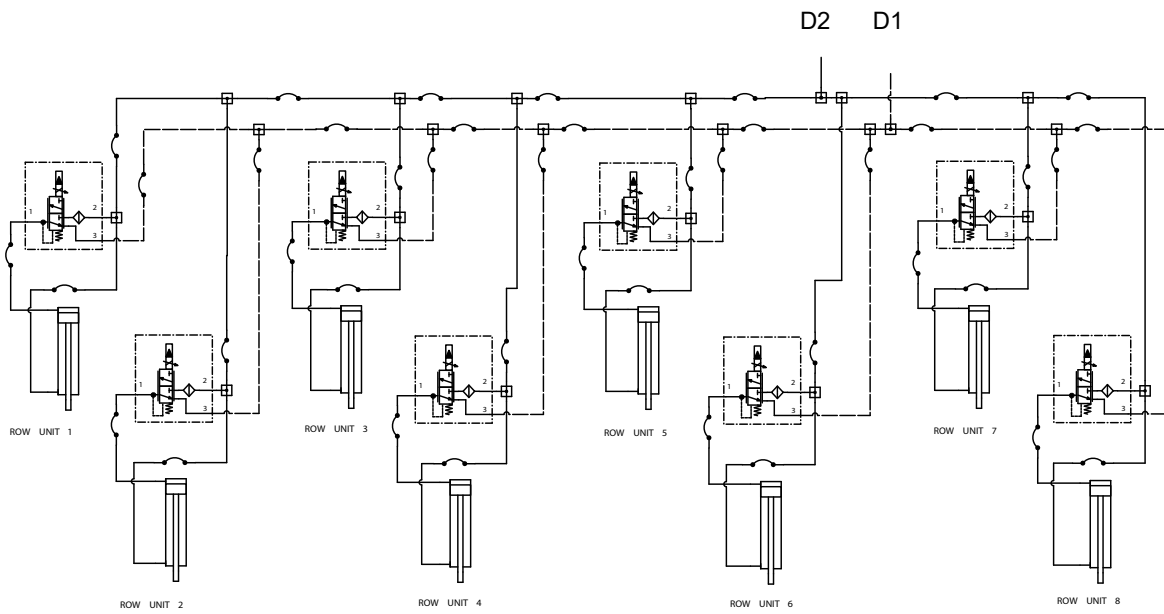

Row Units 1-8

TRUE DEPTH OPTION - HYDRAULIC SCHEMATIC - ROW UNITS 9-16

To Main Down Force Valve Block
([page 6-93](#))
Row Units 1-8
([page 6-96](#))

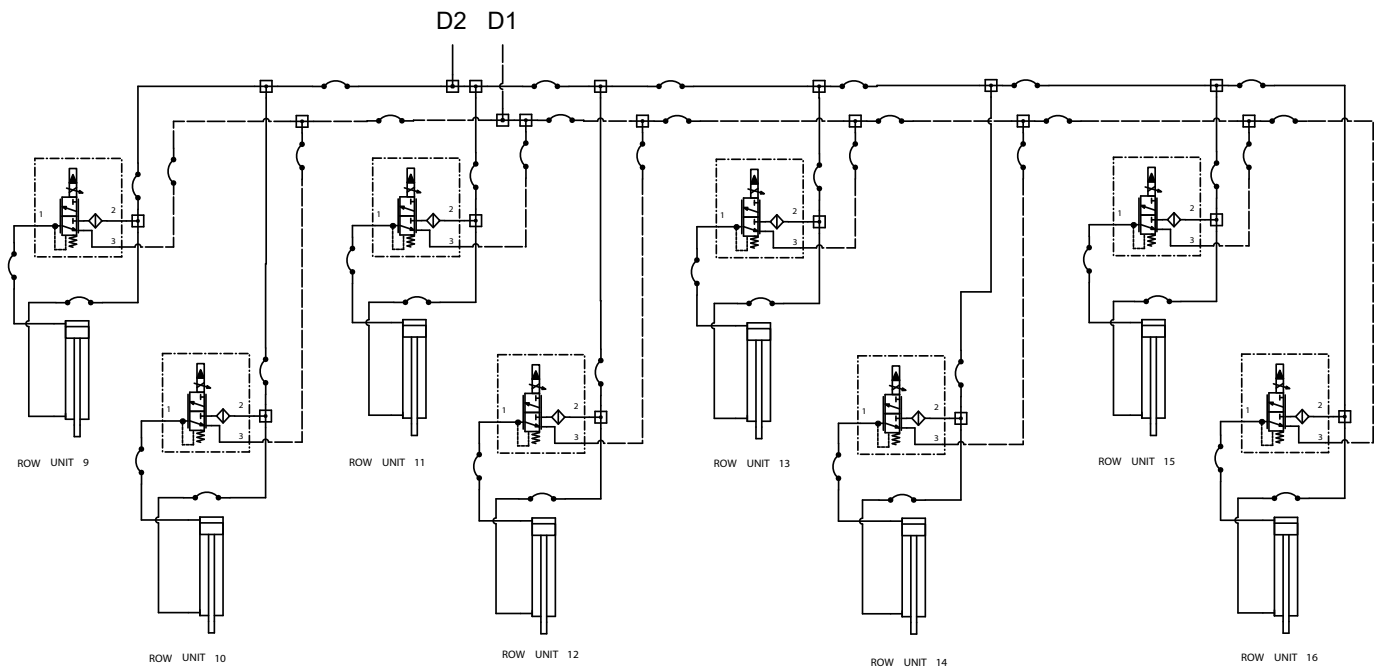

Row Units 9-16

TRUE DEPTH OPTION - HYDRAULIC SCHEMATIC - SCV INPUT OPTION

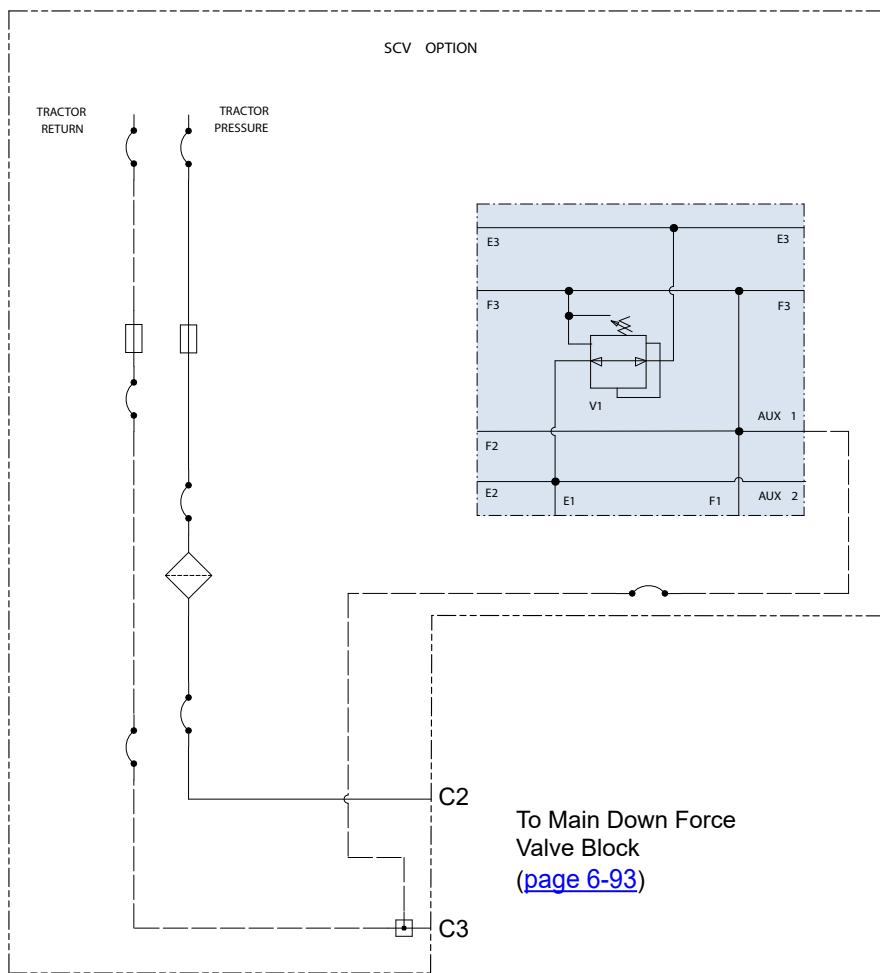

SCV Input Option

TRUE DEPTH OPTION - HYDRAULIC SCHEMATIC - BATTERY PACK INPUT OPTION

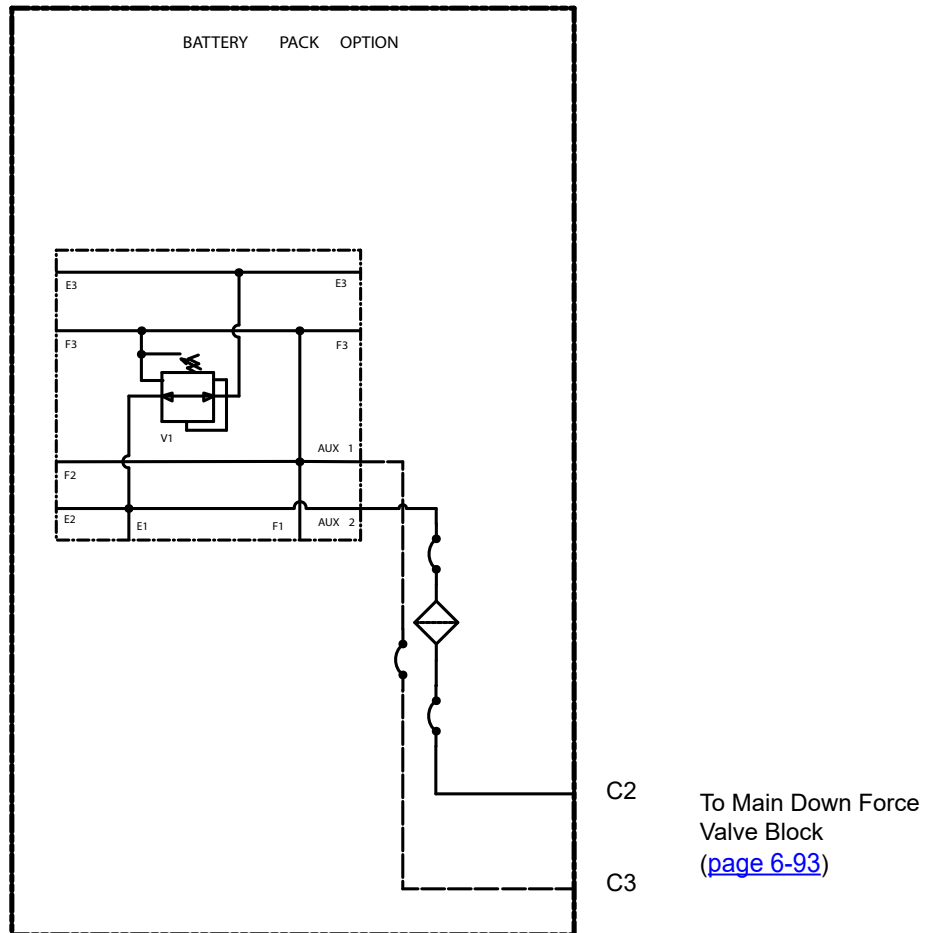

Battery Pack Input Option

TRUE DEPTH OPTION - HYDRAULIC SCHEMATIC - BULK FILL INPUT OPTION

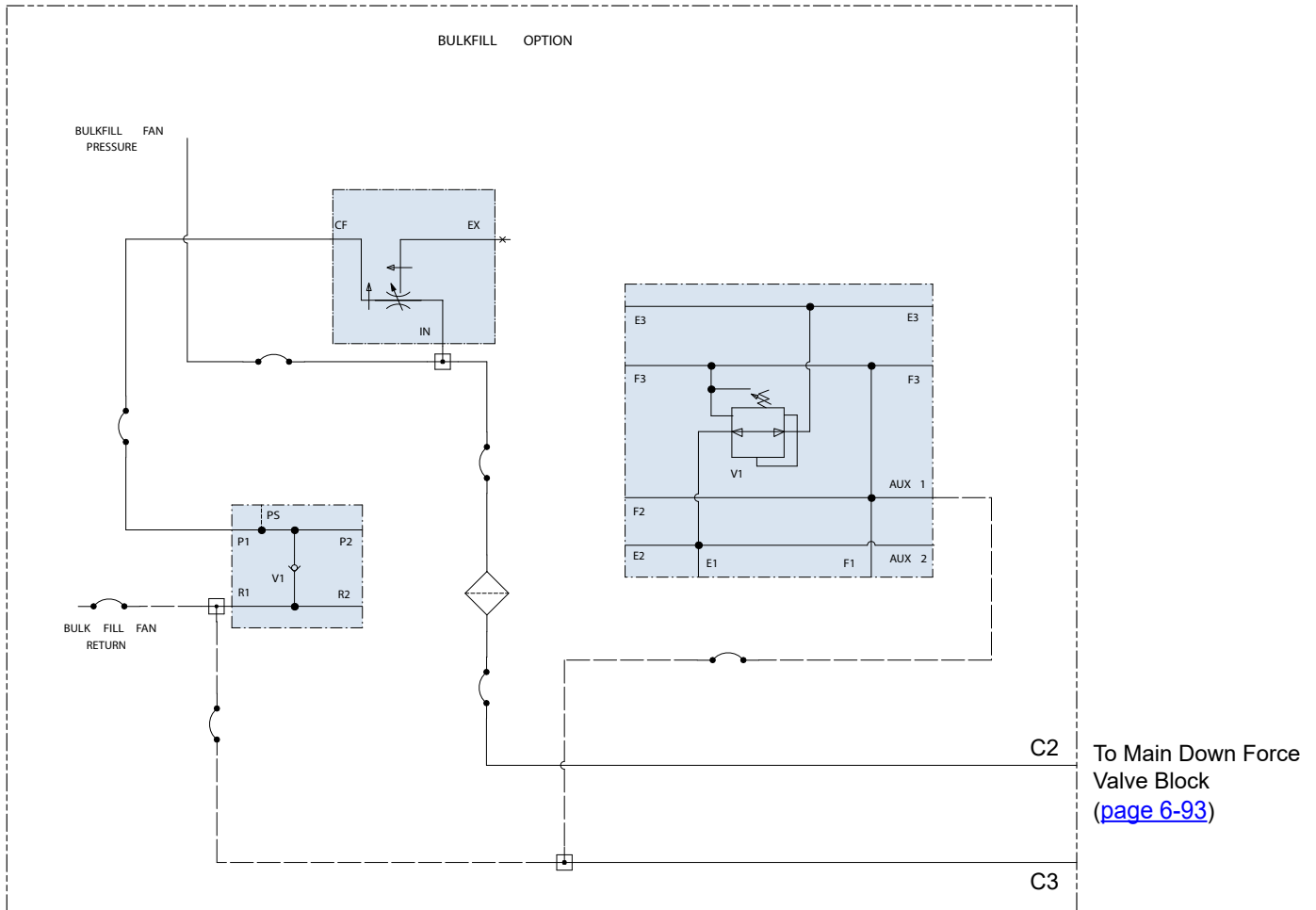

Bulk Fill Input Option

TRUE DEPTH OPTION - HYDRAULIC SCHEMATIC - EVEN ROW OPTION

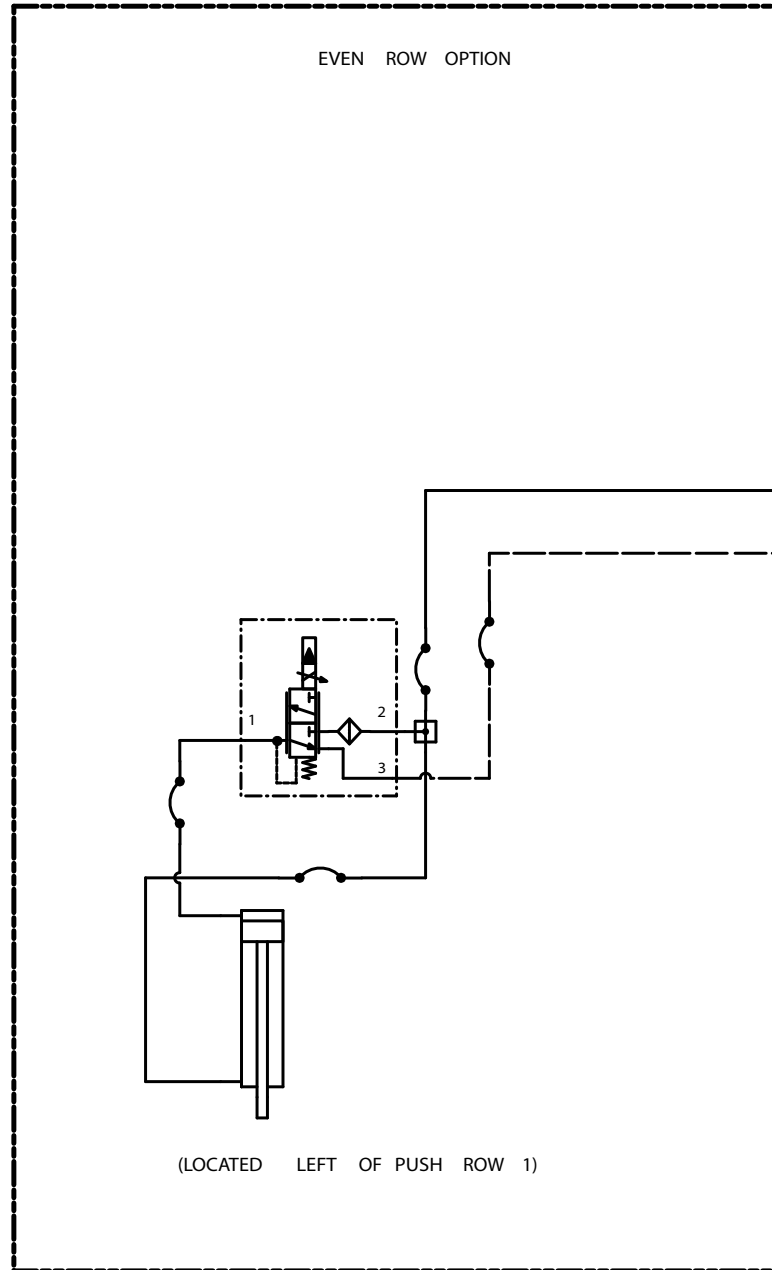



To Pressure and Return
Tees on Push Row Unit 1
([page 6-94](#))

Even Row Option

This page intentionally left blank.

HYDRAULIC HOSE LIFE

 WARNING	<p>Pressurized hydraulic fluid can penetrate body tissue and result in death, serious infection, or other injuries. Fluid injected under skin must be IMMEDIATELY removed by a surgeon familiar with this type of injury. Make sure connections are tight and hoses and fittings are not damaged before applying system pressure. Leaks can be invisible. Keep away from suspected leaks. Relieve pressure before searching for leaks or performing any system maintenance.</p>
	

Proper storage of hydraulic hoses can significantly increase the life of the hoses, for a period of three to five years. After this period, service life of hoses may decrease, depending on variables such as variances in rubber materials and storage environment. Refer to the guidelines below for best practices when storing.

- Store in a clean, cool and dry area
- Avoid direct sunlight or moisture
- Do not store near high power electrical equipment
- Avoid contact with corrosive chemicals
- Avoid ultraviolet light
- Avoid areas with obvious signs of insects or rodents

Unusually long periods of storage or poor storage environment may lead to performance issues or premature failure. Always inspect all hoses prior to use for extensive wear, cuts, or holes. If such flaws are identified, replace immediately to avoid potential failure, property damage or bodily injury.

HYDRAULIC SYSTEM SCHEMATIC

16 Row Shown (Two Wing Lift Cylinders Per Wing)

12 Row (One Wing Lift Cylinder Per Wing)

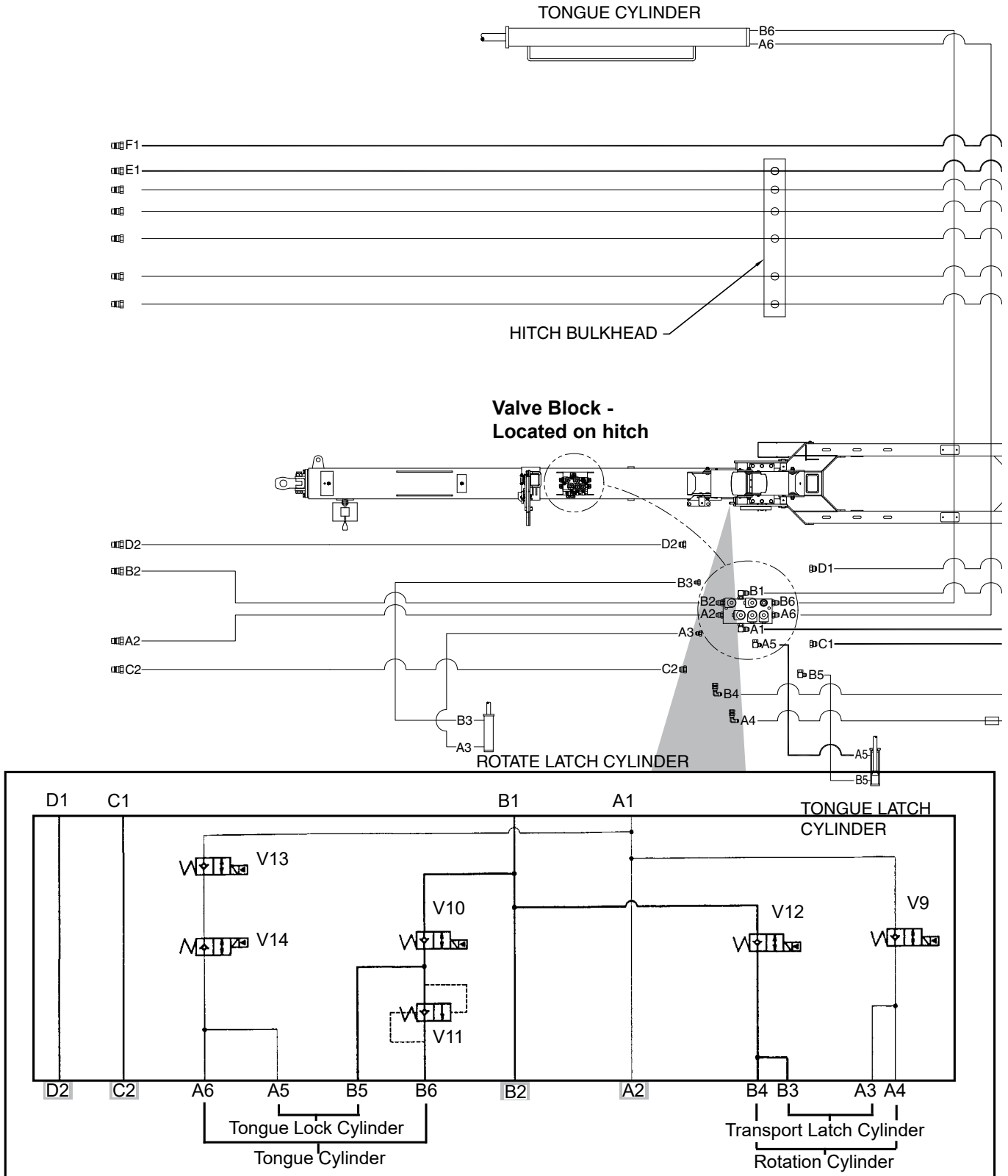

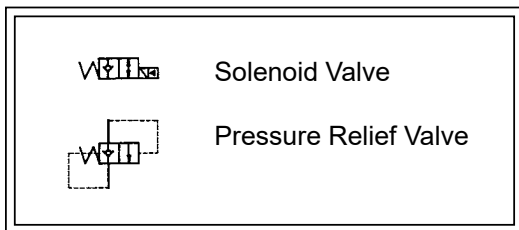
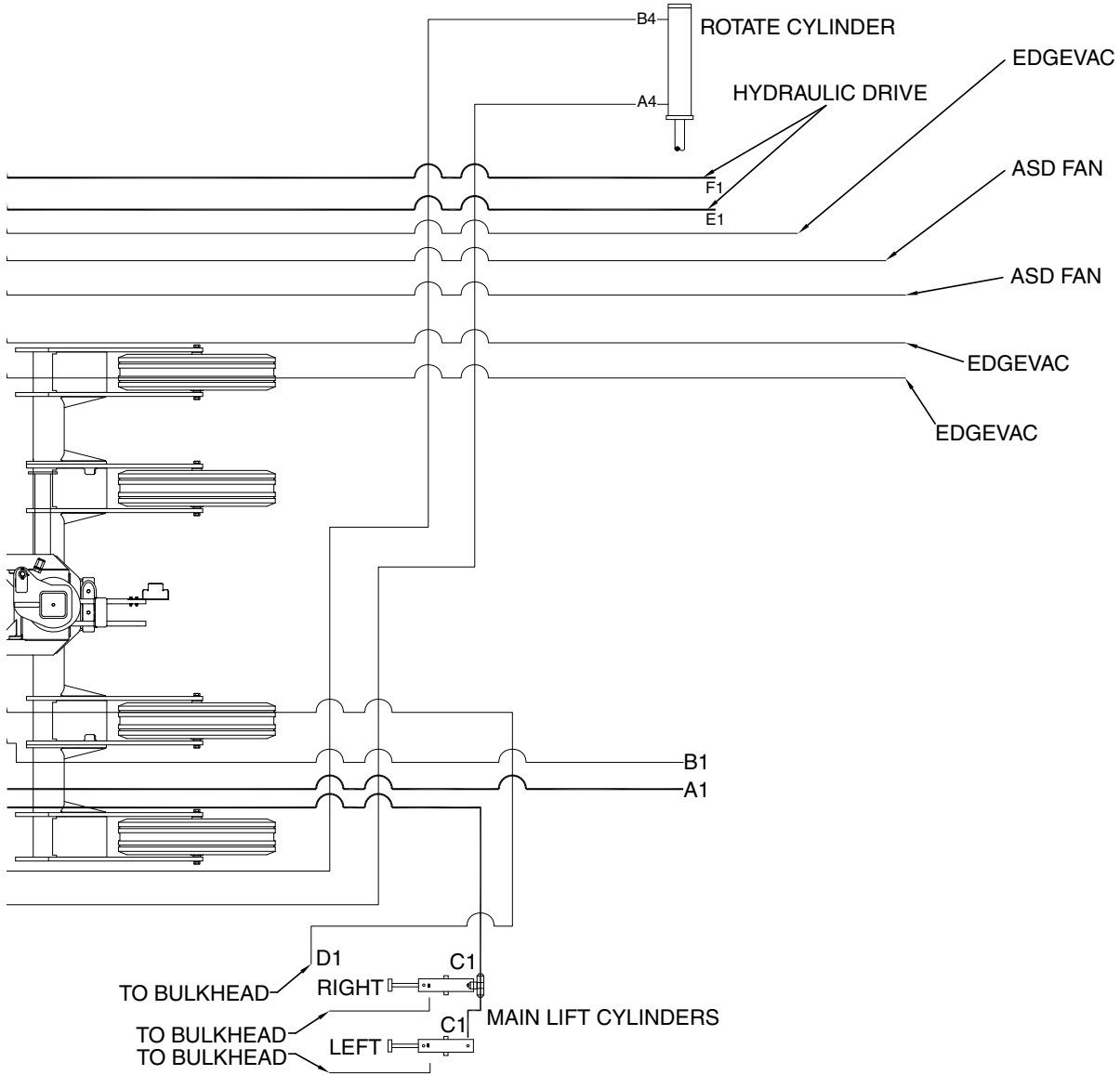

HYDRAULIC SYSTEM SCHEMATIC (Continued)

16 Row Shown (Two Wing Lift Cylinders Per Wing)

12 Row (One Wing Lift Cylinder Per Wing)

NOTE: See R.H. Marker Assembly for additional information.

RIGHT MARKER CYLINDER

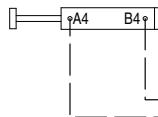

Valve Block - Located on rear center frame

TRANSPORT/LIFT CYLINDER



RIGHT DOWN PRESSURE CYLINDER

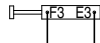

RIGHT WING LOCK CYLINDER

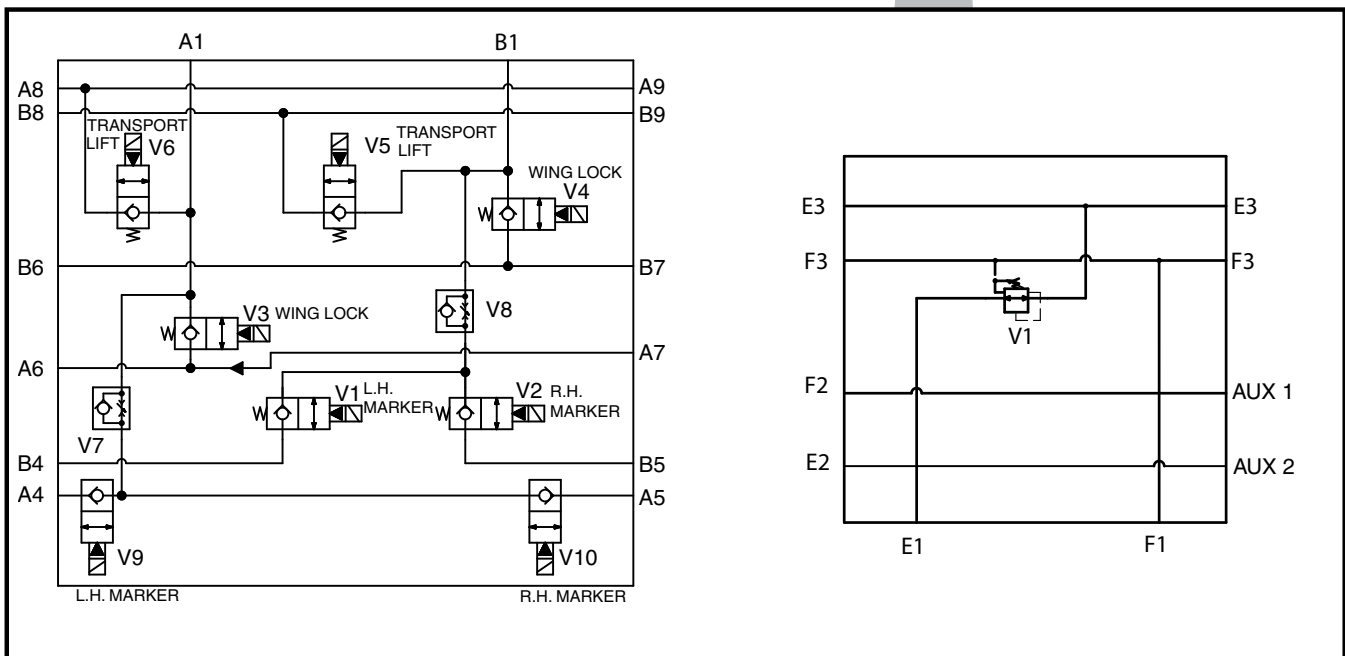
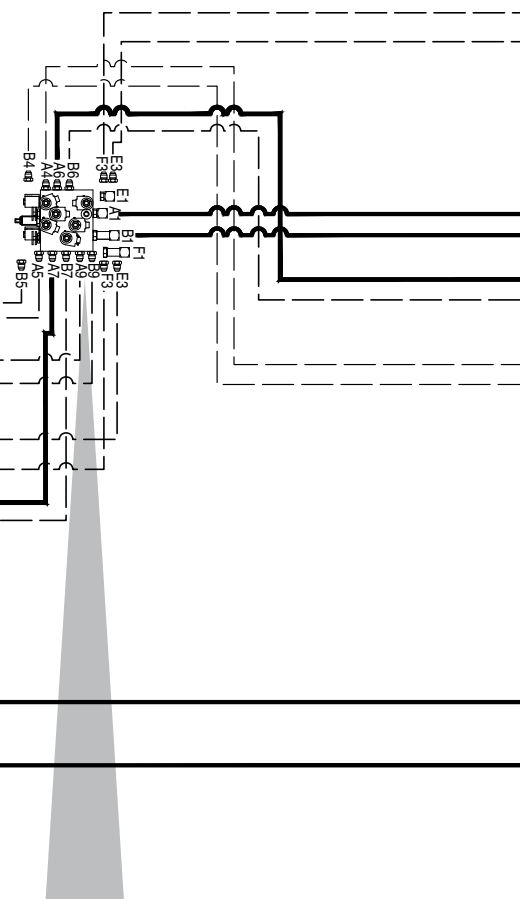
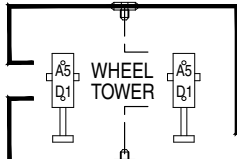

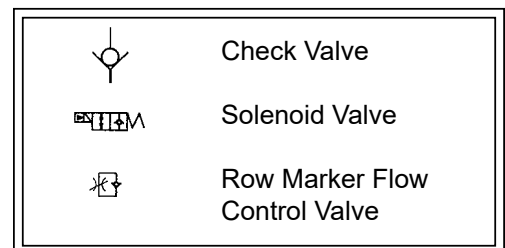
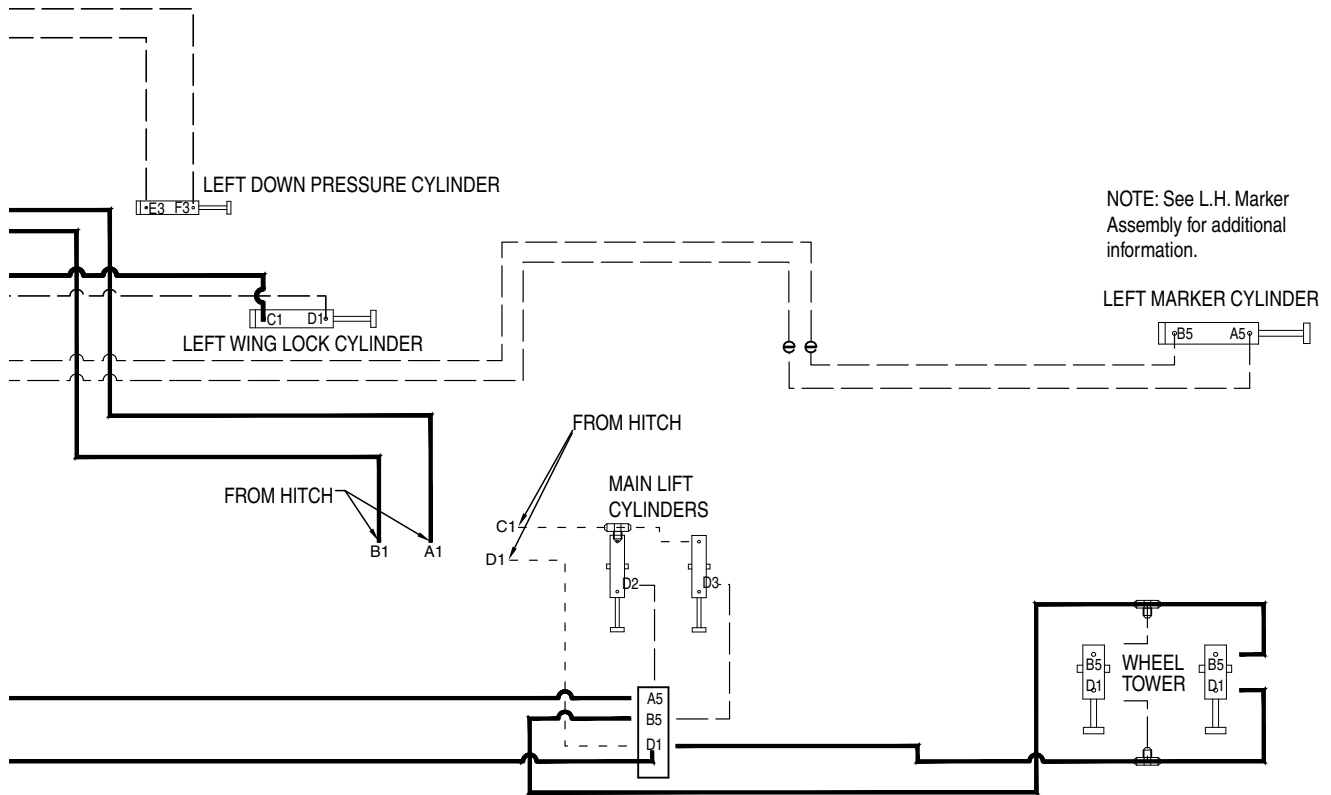

HYDRAULIC SCHEMATIC - VACUUM FAN MOTOR SYSTEM

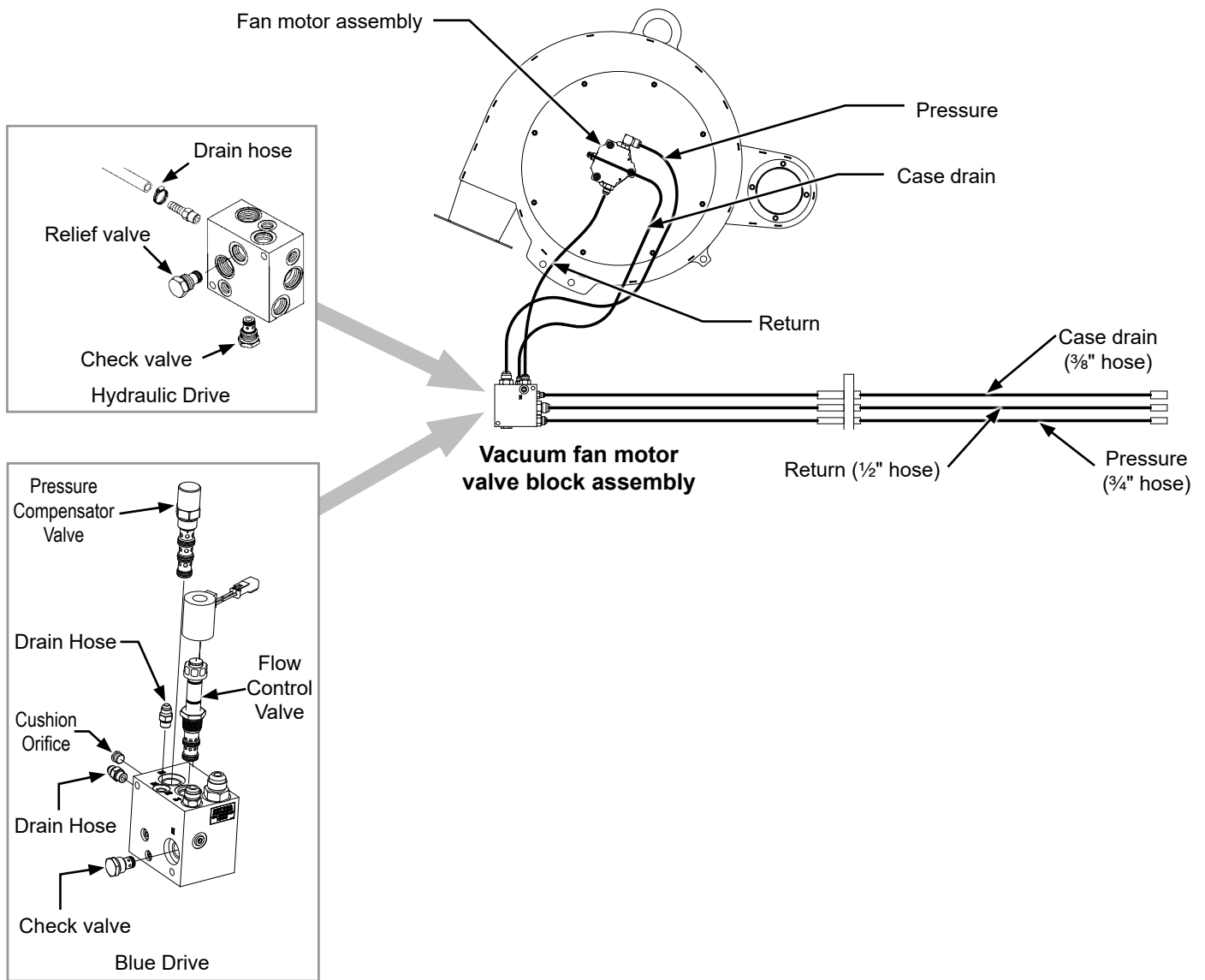

HYDRAULIC SCHEMATIC - BULK FILL MOTOR SYSTEM

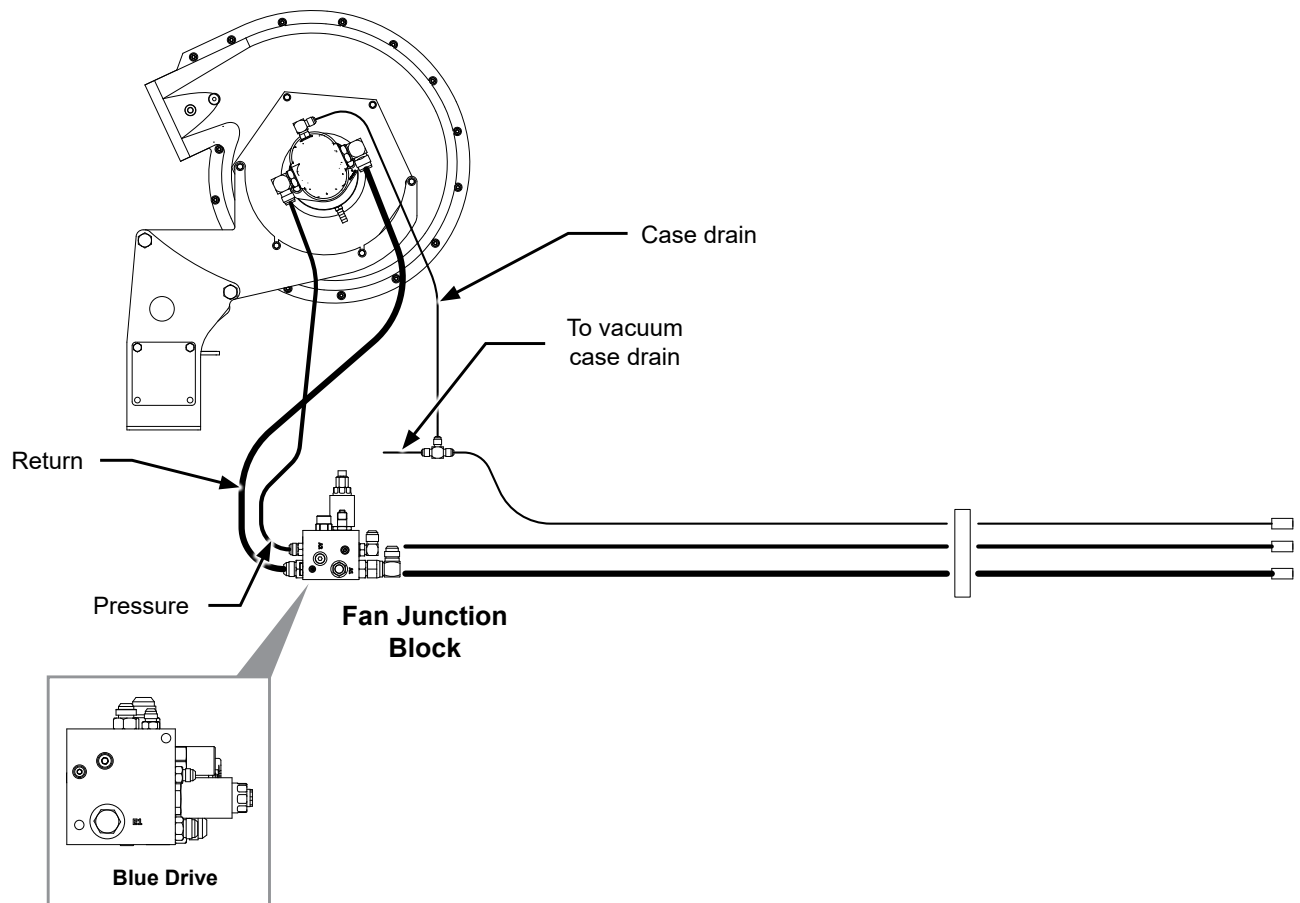

HYDRAULIC SCHEMATIC - VACUUM FAN MOTOR SYSTEM WITH BULK FILL SYSTEM (BLUE DRIVE)

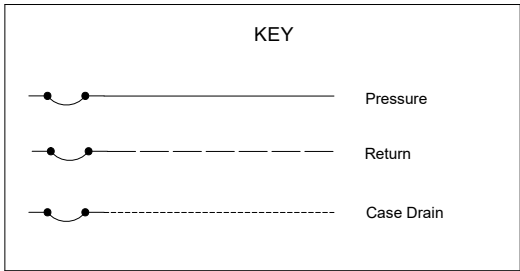
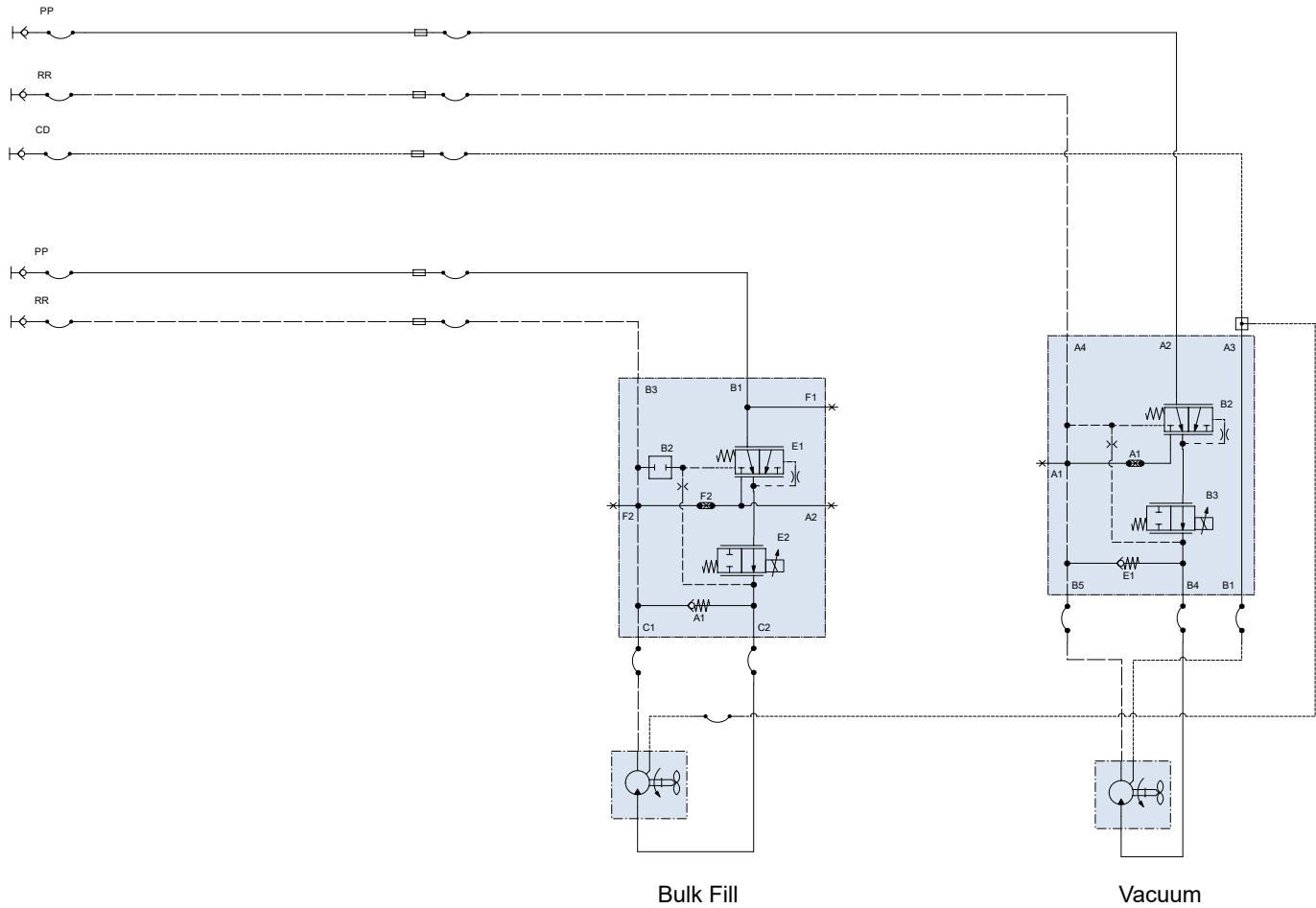

HYDRAULIC SCHEMATIC - VACUUM FAN MOTOR SYSTEM WITH BULK FILL SYSTEM (HYDRAULIC DRIVE)

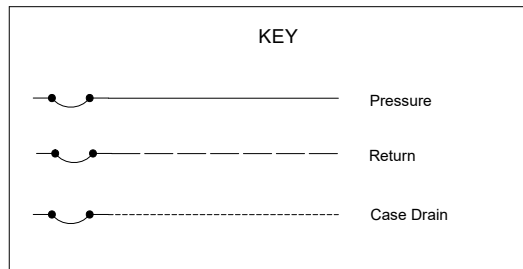
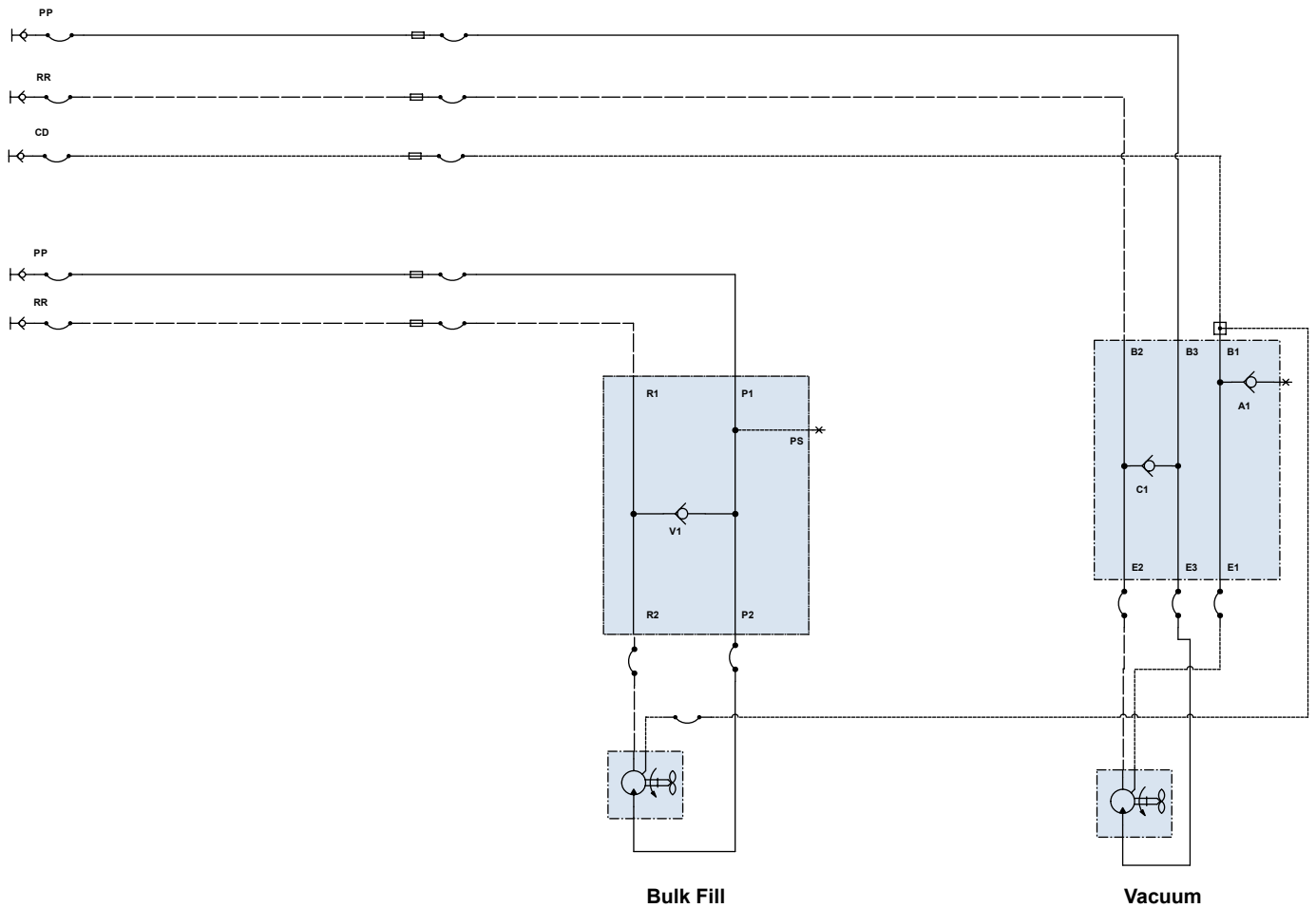

HYDRAULIC SCHEMATIC - OPTIONAL TRACTOR DRIVEN PTO PUMP AND OIL COOLER SYSTEM

NOTICE Failure to connect to a return with zero pressure will damage hydraulic motor. Connect hydraulic motor case drain to a case drain return line with zero pressure on tractor. DO NOT connect hydraulic motor case drain to SCV outlet. Contact tractor manufacturer for specific details on "zero pressure return".

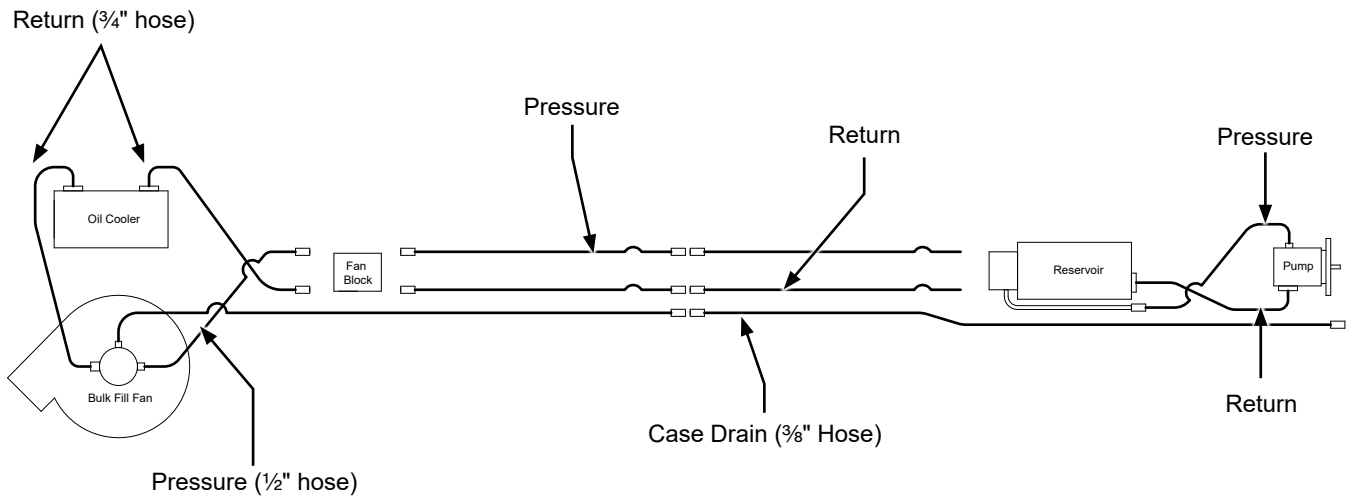

Single Stage
Bulk Fill/Mechanical
W/Fan Cooler

BULK FILL

PROBLEM	POSSIBLE CAUSE	SOLUTION
Seed does not travel through delivery tubes.	System pressure set too low.	Increase system pressure.
Seed stops flowing to row unit during planting.	Seed surging.	Shut down bulk fill system and restart system from idle seed should start flowing.
	Debris in system.	Insert shutoff door, open cleanout door. remove plug.
Seed does not move from entrainer at startup after exposure to water.	Seed swelled in entrainer.	Insert shutoff door, open cleanout door. remove swelled seed.

CLOSING WHEEL

PROBLEM	POSSIBLE CAUSE	SOLUTION
Closing wheel(s) leave severe imprint in soil.	Too much closing wheel down pressure.	Adjust closing wheel pressure.
Closing wheel(s) not firming soil around seed.	Not enough closing wheel down pressure.	Adjust closing wheel pressure. Severe no till conditions may require use of cast iron closing wheels.
"V" closing wheel running on top of seed furrow.	Improper centering.	Align. See "V Closing Wheel Adjustment".
Single closing wheel not directly over seed.	Improper centering.	Align. See "Covering Discs/Single Press Wheel Adjustment".

LIFT CIRCUIT TROUBLESHOOTING

PROBLEM	POSSIBLE CAUSE	SOLUTION
Right wing raises faster than left wing. Right wing may even raise completely before rock shaft and left wing start to raise. If planter is loaded, rock shaft and left wing may not be able to raise at all.	Master cylinder, located on right side of rock shaft, leaking internally. NOTE: Make sure lift system is completely rephased.	Repair master cylinder.
Left wing raises faster than right wing. Left wing may even raise completely before rock shaft and right wing start to raise. If planter is loaded, rock shaft and right wing may not be able to raise at all.	Master cylinder, located on left side of center post, leaking internally. NOTE: Make sure lift system is completely rephased.	Repair master cylinder.
Rock shaft will raise, but wings do not.	Planter hydraulic circuit out of phase. Usually occurs when planter is lowered from transport position.	Hold hydraulic control in lowering position to give hydraulic circuit more time to rephase.
Planter will not raise or raises slowly.	Tractor may have hydraulic problem.	Switch remote outlets being used. Repair tractor hydraulics.
	Planter may be overloaded with hopper extensions and/or extra fertilizer tanks, coulters or other non-Kinze attachments.	Remove weight.
Planter will not rephase.	All cylinders not completely retracted. Caused by mechanical interference on or between planter frame and wheel lift module.	Remove interference.
	Center cylinders not retracting completely.	Lower planter and hold hydraulic lever in lower position to rephase system. Lower cylinder pins must be free to rotate in this position. If pins are tight, adjust cylinder clevises.

PISTON PUMP

PROBLEM	POSSIBLE CAUSE	SOLUTION
Pump hard or impossible to prime.	Valves fouled or in wrong place.	Inspect and clean valves.
	Air leak in suction line.	Repair leak.
	Pump set too low.	Adjust pump setting.
	Packing washers worn out.	Replace.
Low metering.	Valves fouled or in wrong place.	Inspect and clean valves.
	Air leak in suction line.	Repair leak.
	Pump set too low.	Adjust pump setting.
	Broken valve spring.	Replace spring.
Over meters.	Broken discharge valve spring.	Replace spring.
	Trash under valves.	Inspect and clean valves.
	Improper rate setting.	Adjust pump setting.
Leaks through when stopped.	Broken discharge valve spring.	Replace spring.
	Trash under valves.	Inspect and clean valves.
Fertilizer solution leaking under stuffing box.	Packing washers worn out.	Replace.
Pump using excessive oil.	Oil seals or O-ring worn and leaking.	Replace.
Pump operates noisily.	Crankcase components worn excessively.	Inspect and replace if necessary.

PTO PUMP DRIVE AND OIL COOLER OPTION

PROBLEM	POSSIBLE CAUSE	SOLUTION
Pump is squealing.	Lack of oil to pump.	Check for plugged suction strainer. Check oil level.
Oil temperature is high.	Low oil level.	Check oil level and add as required.
	Debris build up.	Clean filter.
	Oil cooler is functional.	Ensure there is 12V power to cooler. Repair as necessary.
Desired fan speed cannot be achieved.	Low oil level.	Check oil level and add as required.
	Plugged filter.	Check and change as required.
Vacuum level not displayed.	Digital vacuum gauge console power OFF.	Turn ON.
	Cable not plugged in.	Check connection.

ROTATION CIRCUIT

PROBLEM	POSSIBLE CAUSE	SOLUTION
Cylinder does not extend, but will retract.	Solenoid valve coil in port V12 defective.	Switch coil from port V12 with coil in port V9. If cylinder extends but will not retract, replace defective coil from port V12.
	Solenoid valve cartridge in port V12 stuck closed.	Switch cartridge from port V12 with cartridge in port V9. If cylinder extends but will not retract, replace defective cartridge from port V12.
Cylinder does not retract, but will extend.	Solenoid valve coil in port V9 defective.	Switch coil from port V9 with coil in port V12. If cylinder extends but will not retract, replace defective coil from port V9.
	Solenoid valve cartridge in port V9 stuck closed.	Switch cartridge from port V9 with cartridge in port V12. If cylinder extends but will not retract, replace defective cartridge from port V9.

ROW MARKER OPERATION

PROBLEM	POSSIBLE CAUSE	SOLUTION
Right marker lowering slower than left marker.	Solenoid valve cartridge in port V1 not opening completely.	Switch with cartridge in port V2. If problem repeats, replace cartridge.
	Hose pinched or collapsed.	Inspect hose routing. Replace or repair hoses as required.
Left marker lowering slower than right marker.	Solenoid valve cartridge in port V2 not opening completely.	Switch with cartridge in port V1. If problem repeats, replace cartridge.
	Hose pinched or collapsed.	Inspect hose routing. Replace or repair hoses as required.
Both markers lowering.	Solenoid valve cartridge stuck open. If left marker switch is selected, right cartridge (V1) is defective. If right marker switch is selected, left cartridge (V2) is defective.	Replace solenoid valve cartridge.
Neither marker lowers.	Blown fuse.	Check red light on control console. It should be on if switch is on. If light is not on, switch to opposite marker position. If light comes on, switch may be defective. Replace switch. Otherwise replace fuse.
	Coils at V1 and V2 not energized.	Poor ground on wire, bad wire connection or damaged wire. Repair as required.
	Marker flow control valve closed too far.	See "Row Marker Speed Adjustment".
Neither marker will raise.	Marker flow control valve closed too far.	See "Row Marker Speed Adjustment".
Right marker will not lower.	Solenoid coil in port V1 not energized.	Check switch on control console. Replace if defective. Check coil ground wire. Check for poor connection or damaged wire.
	Solenoid cartridge in port V1 stuck closed.	Switch cartridge with one on the planter you know is operating properly. If right marker lowers, replace defective cartridge.
Left marker will not lower.	Solenoid coil in port V2 not energized.	Check switch on control console. Replace if defective. Check coil ground wire. Check for poor connection or damaged wire.
	Solenoid cartridge in port V2 stuck closed.	Switch cartridge with one on the planter you know is operating properly. If left marker lowers, replace defective cartridge.
Markers traveling too fast and damaging rubber stop on transport stands and/or damaging pivot at rod end of marker cylinders.	Marker transport stand not adjusted correctly to allow marker cushion cylinders to operate as designed.	See "Row Marker Transport Stand Adjustment".
	Adjust row marker flow control valve.	See "Row Marker Speed Adjustment".

SEED METER (BRUSH-TYPE)

PROBLEM	POSSIBLE CAUSE	SOLUTION
Low count.	Meter RPM too high.	Reduce planting speed.
	Seed sensor not picking up all seeds dropped.	Clean seed tube. Switch meter to different row. If problem stays in same row, replace sensor.
	Lack of lubrication causing seeds not to release from disc properly.	Use graphite or talc as recommended.
	Seed size too large for seed disc being used.	Switch to smaller seed or appropriate seed disc. See "Brush-Type Seed Meter" for proper seed disc for size of seed being used.
	Seed treatment buildup in meter.	Reduce treatment amount used. Thoroughly mix treatment with seed. Add talc.
Low count at low RPM and higher count at higher RPM.	Foreign material lodged in upper brush.	Remove seed disc and remove foreign material from between brush retainer and bristles. Clean thoroughly.
	Worn upper brush.	Replace. See "Brush-Type Seed Meter Maintenance".
Low count at higher RPM and normal count at low RPM.	Seed disc worn in agitation groove area.	Replace disc. Replace. See "Brush-Type Seed Meter Maintenance".
High count.	Seed size too small for seed disc.	Switch to larger or appropriate seed disc.
	Incorrect seed rate transmission setting.	Reset transmission. Refer to rate charts.
	Upper brush too wide (fanned out) for small seed size.	Replace upper brush.
High count. (Milo/Grain Sorghum)	Incorrect brush retainer being used.	Make sure GD8237 brush retainer is used to keep upper brush from fanning out.
Upper brush laid back.	Seed treatment buildup on brush.	Remove brush. Wash with soap and water. Dry thoroughly before reinstalling.
	Foreign material buildup at base of brush.	Remove brush retainer and brush. Clean thoroughly. Reinstall.

VACUUM SEED METER

PROBLEM	POSSIBLE CAUSE	SOLUTION
Low seed count.	Meter RPM too high.	Reduce planting rate or planting speed.
	Singulator blade setting too aggressive.	Adjust singulator blade.
	Vacuum level too low.	Increase fan speed.
	Seed sensor not picking up all seeds dropped.	Clean seed tube. Move meter to different row.
	Seeds sticking to seed disc.	Use graphite or talc to aid release.
	Seed treatment buildup in seed disc recesses.	Reduce amount of treatment used and or mix thoroughly. Add talc.
	Seed size too large for disc used.	Use appropriate disc for seed size.
	Wrong seed disc.	Use appropriate disc for seed type and size.
	Failed/worn drive components.	Inspect and replace parts as required.
	Plugged orifices in seed disc.	Inspect and clean disc. Check remnant ejector.
	Loss of vacuum at meter.	Check for foreign material between vacuum cover and disc. Inspect parts for wear/damage. Clean or replace as required.
	Seed bridging in hopper.	Add graphite to improve seed flow.
	Faulty vacuum gauge reading.	Repair/replace gauge.
	Dirt in vacuum manifold.	Check vacuum manifold for dirt and clean.
	Seed baffle (If applicable) not allowing seed flow due to bridging of seed.	Mix talc thoroughly to coat all seeds. Remove seed baffle. See Row Unit Operation section.
Seed disc worn.	Replace.	
Vacuum seal worn.	Replace.	
Not planting seed.	Seed hoppers empty.	Fill seed hopper.
	Seed tube plugged/damaged.	Clean or replace tube.
	Meter drive damaged.	Repair/replace drive components.
	Low/no vacuum.	Inspect vacuum system and repair as necessary.
	Singulator blade setting too aggressive.	Adjust singulator blade.
	Faulty vacuum gauge.	Repair/replace vacuum gauge.
	Seed bridging in hopper.	Add graphite to improve seed flow.
	Loss of vacuum at meter.	Check for foreign material between vacuum cover and disc. Inspect parts for wear/ damage. Clean and/ or replace as required.
	Wrong seed disc.	Use appropriate disc for seed type and size.
	Meter drive clutch not engaged.	Engage drive clutch.
	Fan not running.	Start fan.
	Dirt in vacuum manifold.	Check vacuum manifold for dirt and clean.

Continued on next page.

VACUUM SEED METER - Continued

PROBLEM	POSSIBLE CAUSE	SOLUTION
Not planting seed. (Continued)	Seed baffle (if applicable) not allowing seed flow due to bridging of seed.	Mix talc thoroughly to coat all seeds. Remove seed baffle. Row Unit Operation section.
	High vacuum.	Adjust vacuum level to appropriate level.
	Wrong seed disc.	Replace seed disc.
	Singulator setting not aggressive enough.	Adjust singulator.
	Faulty vacuum gauge.	Check gauge line for dirt/obstruction. Repair/replace vacuum gauge.
Poor seed spacing.	Obstruction in seed tube.	Clean seed tube.
	Dirty/damaged seed disc.	Inspect seed disc for damage, foreign material in orifices or seed treatment buildup in recesses. Clean or replace.
	Wrong vacuum setting.	Adjust vacuum to appropriate level.
	Excess foreign material in seed.	Inspect and clean meter and seed discs. Use clean, undamaged seed.
	Incorrect singulator setting.	Adjust singulator to appropriate setting.
	Inconsistent driveline.	Inspect drive components for rust, misalignment, worn or damaged parts. Replace/repair as required.
	Toolbar not level or wrong height.	Adjust hitch to level toolbar and row units.
	Planting too fast for conditions.	Reduce speed.
	Rough field conditions.	Reduce speed.
Irregular seed population.	Driving too fast.	Reduce speed.
Unable to achieve desired vacuum level.	Tractor hydraulic flow set too low.	Increase flow to fan motor.
	Incorrect hydraulic connections.	Check all hydraulic connections and hose routings.
	Damaged fan components.	Inspect motor and impeller for wear/damage and repair/replace as necessary.
	Vacuum hose pinched/kinked/blocked.	Inspect air lines for any damage or obstruction. Clean air lines and manifold by removing end cap from manifold and running fan at high speed.
	Vacuum hose loose/disconnected.	Inspect and reattach all air hoses.
	Tractor not producing required hydraulic flow/pressure.	Have tractor serviced by qualified technician.
	Dirt in vacuum gauge line.	Check gauge line for dirt/obstruction and clean.

SEED METER (FINGER PICKUP)

PROBLEM	POSSIBLE CAUSE	SOLUTION
One row not planting seed.	Drive release not engaged.	Engage drive release mechanism.
	Foreign material in hopper.	Clean hopper and finger carrier mechanism.
	Seed hopper empty.	Fill seed hopper.
	Row unit drive chain off of sprocket or broken.	Check drive chain.
Unit is skipping.	Foreign material or obstruction in meter.	Clean and inspect.
	Finger holder improperly adjusted.	Adjust to specifications. (22 to 25 in. lbs. rolling torque)
	Broken fingers.	Replace fingers and/or springs as required.
	Planting too slowly.	Increase planting speed to within recommended range.
Planting too many doubles.	Planting too fast.	Stay within recommended speed range.
	Loose finger holder.	Adjust to specifications. (22 to 25 in. lbs. rolling torque)
	Worn brush in carrier plate.	Inspect and replace if necessary.
Overplanting.	Worn carrier plate.	Inspect and replace if necessary.
	Seed hopper additive being used.	Reduce or eliminate additive or increase graphite.
Underplanting.	Seed belt installed backwards.	Remove and install correctly.
	Weak or broken springs.	Replace.
	Spring not properly installed.	Remove finger holder and correct.
	Seed belt catching or dragging.	Replace belt.
	Brush dislodging seed.	Replace brush.
Irregular or incorrect seed spacing.	Driving too fast.	Check chart for correct speed.
	Wrong tire pressure.	Inflate tires to correct air pressure.
	Drive wheels slipping.	Reduce down pressure on row unit down force springs.
	Wrong sprockets.	Check seed rate charts for correct sprocket combinations.
Seed spacing not as indicated in charts.	Wrong tire pressure.	Inflate tires to correct air pressure.
	Inconsistent seed size.	Perform field check and adjust sprockets.
	Wrong sprockets.	Check chart for correct sprocket combination.
	Charts are approximate.	Slight variations due to wear in meter components and tire slippage due to field conditions may produce seed spacing variations.
	Stiff or worn drive chains.	Replace chains.
Scattering of seeds.	Planting too fast.	Reduce planting speed.
	Seed tube improperly installed.	Check seed tube installation.
	Seed tube worn or damaged.	Replace seed tube.
Seed tubes and/or openers plugging.	Allowing planter to roll backward when lowering.	Lower planter only when tractor is moving forward.
Inconsistent seed depth.	Rough seed bed.	Adjust down pressure springs. Reduce planting speed.
	Partially plugged seed tube.	Inspect and clean.
	Seed tube improperly installed.	Install properly.

SOLENOID VALVE

PROBLEM	POSSIBLE CAUSE	SOLUTION
No solenoids operate.	Low voltage.	Must be connected to 12 volt DC only. Negative ground.
	Blown fuse.	Replace control console fuse with AGC-15 amp.
	Battery connection.	Clean and tighten.
	Wiring harness damaged.	Repair or replace.
One solenoid valve will not operate.	Bad switch.	Replace on control panel.
	Cut wire in harness.	Locate and repair.
	Bad coil.	Replace.
	Poor connection at coil.	Check.
Valve operating when not energized.	Valve stem stuck open.	Replace cartridge.
	O-ring leaking.	Install new O-ring kit.
	Foreign material under poppet.	Remove and clean cartridge.

TONGUE CYLINDER CIRCUIT

PROBLEM	POSSIBLE CAUSE	SOLUTION
Tongue cylinder will not extend, but will retract.	No power to solenoid valve coil in port V10 and/or V14. Both must be energized.	Check wiring between control console and solenoid coils looking for damaged wires and poor connections.
	Solenoid valve coil defective.	Switch coil from port V13 with V10. If tongue still will not extend, switch coil from V14 with V13. It is not necessary to remove any solenoid wire connections. All three solenoids are normally energized when tongue switch is energized. Replace defective coil.
	Solenoid valve cartridges in port V10 and/or V14 stuck closed.	Switch cartridge from port V10 with cartridge in port V13. If tongue cylinder retracts, replace defective cartridge from port V10. If problem continues, switch cartridge from port V14 with cartridge in port V13. Replace defective cartridge.
Tongue cylinder will not extend but tongue lock cylinder extends.	Pressure relief valve in port V11 stuck closed or pressure setting too high. (Valve is factory set to open at 1000 PSI.)	Replace or adjust pressure relief valve. To adjust, loosen lock nut and turn counter clockwise to decrease pressure.
Tongue hook does not release before tongue starts to extend.	Solenoid valve cartridge in port V11 stuck open or pressure setting too low. (Valve is factory set to open at 1000 PSI.)	Replace or adjust pressure relief valve. To adjust, loosen lock nut and turn clockwise to increase pressure.
Tongue cylinder will not retract, but will extend.	Solenoid valve coil in port V13 defective.	Switch coil from port V13 with coil from port V14. If coil from port V13 is bad, tongue will extend but not retract. Replace defective coil.
	Solenoid valve cartridge in port V13 stuck closed.	Switch cartridge from port V13 with cartridge from port V14. If cartridge is bad, tongue will extend but not retract. Replace defective cartridge.
Tongue extends with switch off.	Solenoid valve cartridge in port V10 and V14 stuck open.	Replace solenoid valve cartridge.
Tongue retracts with switch off.	Solenoid valve cartridge in port V13 stuck open.	Replace solenoid valve cartridge.
Tongue latch releases. Tongue extends slowly while planting.	Latch cylinder or tongue cylinder leaking internally.	Pressure check latch and tongue cylinders. Repair leaking cylinder(s).

WING LOCK CYLINDER CIRCUIT

PROBLEM	POSSIBLE CAUSE	SOLUTION
Cylinders will not extend or retract.	No power to solenoid valve coils.	Auxiliary switch may be ON. Must be OFF. Check fuse at control console. Replace fuse with 15 amp type AGC if blown. Check for poor wire connection or damaged wire. Repair as required.
Cylinders will not extend.	Solenoid valve coil in port V3 not energized.	Check for power to coil. Check coil ground wire. If OK, switch coil from port V3 with coil from port V4. If cylinders extend but will not retract, replace defective coil.
	Solenoid valve cartridge in port V3 stuck closed.	Switch cartridge in port V3 with cartridge in port V4. If cylinders extend but will not retract, replace defective cartridge.
Cylinders will not retract.	Solenoid valve coil in port V4 not energized.	Check for power to coil. Check coil ground wire. If OK, switch coil from port V4 with coil from port V3. If cylinders retract but will not extend, replace defective coil.
	Solenoid valve cartridge in port V4 stuck closed.	Switch cartridge in port V4 with cartridge in port V3. If cylinders retract but will not extend, replace defective cartridge.
Cylinders retract with switch off.	Solenoid valve cartridge in port V4 stuck open.	Replace solenoid valve cartridge.
Cylinders extend with switch off.	Solenoid valve cartridge in port V3 stuck open.	Replace solenoid valve cartridge.

BLUE DRIVE

Refer to M0288 - Kinze Blue Vantage Operator's manual for Blue Drive / Blue Vantage troubleshooting.