

# MODEL 4700 FRONT FOLDING PLANTER OPERATOR'S MANUAL

**M0295-01**

**3/20**

This manual is applicable to: Model 4700 Forward Folding Planters

Record the model number and serial number of your planter along with date purchased:

Model Number \_\_\_\_\_ 4700 \_\_\_\_\_

Serial Number \_\_\_\_\_

Date Purchased \_\_\_\_\_

Monitor Serial Number _____
Measured Pulses Per km (Radar Distance Sensor) _____
Measured Pulses Per km (Magnetic Distance Sensor) _____

## SERIAL NUMBER

The serial number plate is located on the planter frame as shown below. The serial number provides important information about your planter and is needed to obtain correct replacement parts. Always provide model number and serial number to your Kinze Dealer when ordering parts or when contacting Kinze Manufacturing, Inc.



**Serial Number Plate Location**

**This page intentionally left blank.**

**TO THE DEALER**

Predelivery service includes assembly, lubrication, adjustment and test. This service helps ensure planter is delivered to retail customer/end user ready for field use.

**PREDELIVERY CHECKLIST**

Use the following checklist after planter is completely assembled. Check off each item as it is found satisfactory or after proper adjustment is made.

- Row units properly spaced and optional attachments correctly assembled.
- Row marker assemblies installed and adjusted at each end of the planter.
- Vacuum meter and bulk fill components properly installed (as applicable).
- All grease fittings in place and lubricated.
- All working parts move freely, bolts are tight, and cotter pins are spread.
- Check all drive chains for proper tension and alignment.
- Check for oil leaks and proper hydraulic operation.
- Hydraulic hoses correctly routed to prevent damage.
- Inflate tires to specified air pressure and torque wheel lug bolts and lug nuts as specified in the Operator Manual.
- All safety decals correctly located and legible. Replace if damaged.
- All reflective decals and SMV sign correctly located and visible when the planter is in transport position.
- Safety/warning lights correctly installed and working properly.
- Paint all parts scratched during shipment or assembly.
- All safety lockup devices on the planter and correctly located.
- Auxiliary safety chain properly installed and hardware torqued to specification.
- Vacuum fan PTO-driven pump correctly attached to tractor. Oil reservoir filled to capacity and system inspected for leaks (If applicable).
- Bulkfill hoses remain in place with no belt slipping or hose pinching between stub wing and vacuum manifold.

***Planter has been thoroughly checked and to the best of my knowledge is ready for delivery to the customer.***

\_\_\_\_\_  
(Signature of Set-Up Person/Dealer Name/Date)

**OWNER REGISTER**

Name \_\_\_\_\_ Delivery Date \_\_\_\_\_

Street Address \_\_\_\_\_ Model No. 4700 Serial No. \_\_\_\_\_

City, State/Province \_\_\_\_\_ Dealer Name \_\_\_\_\_

ZIP/Postal Code \_\_\_\_\_ Dealer No. \_\_\_\_\_

---

## DELIVERY CHECKLIST

Use the following checklist at time planter is delivered as a reminder of very important information which should be conveyed to retail customer/end user. Check off each item as it is fully explained.

- Check proper operation of vacuum fan, bulk fill fan, and PTO-driven pump (If applicable) with tractor used with planter.
- Life expectancy of this or any other machine is dependent on regular lubrication as directed in the Operator Manual.
- All applicable safety precautions.
- Along with retail customer/end user, check reflective decals and SMV sign are clearly visible with planter in transport position and attached to tractor. Check safety/warning lights are in working condition. Tell retail customer/end user to check federal, state/provincial, and local regulations before towing or transporting on a road or highway.
- Give Operator Manual, Parts Manual, and all Instruction Sheets to retail customer/end user and explain all operating adjustments.
- Read warranty to retail customer/end user.
- Complete Warranty and Delivery Report form.

***To the best of my knowledge this machine has been delivered ready for field use and customer has been fully informed as to proper care and operation.***

---

(Signature of Delivery Person/Dealer Name/Date)

## AFTER DELIVERY CHECKLIST

The following is a list of items we suggest to check during the first season of use of the equipment.

- Check planter performance with retail customer/end user.
- Check performance of vacuum meter or mechanical seed metering system with retail customer/end user.
- Review importance of proper maintenance and adherence to all safety precautions with retail customer/end user.
- Check for parts that may need to be adjusted or replaced.
- Check all safety decals, reflective decals, and SMV sign are correctly located as shown in the Parts Manual and that decals are legible. Replace if damaged or missing.
- Check safety/warning lights are working properly.

---

(Signature of Follow-Up Person/Dealer Name/Date)

**All registrations must be submitted online at "[business.kinze.com](http://business.kinze.com)" within 5 business days of delivery.  
Retain a copy of this form for auditing purposes.**

*Tear Along Perforation*

**KINZE**

**OVERVIEW**

To The Owner . . . . . 1-1  
 Warranty . . . . . 1-3  
 General Information . . . . . 1-3  
 Specifications . . . . . 1-5  
 Specifications . . . . . 1-7  
 General Safety Rules . . . . . 1-8  
 Safety Precautions . . . . . 1-9  
 Safety Precautions . . . . . 1-10

**MACHINE OPERATION**

Row Marker Safety Lockup . . . . . 2-1  
 Transport Axle Cylinder Safety Lockup . . . . . 2-2  
 Drawbar Hitch Lockup . . . . . 2-3  
 Wing Latch Lockup . . . . . 2-4  
 Initial Planter Preparation . . . . . 2-4  
 Tractor Requirements . . . . . 2-6  
 Bulk fill Tractor Mounted PTO Pump and  
 Planter Mounted Hydraulics . . . . . 2-7  
 Tractor Preparation and Hookup . . . . . 2-8  
 True Depth Hydraulic System Overview . . . . . 2-11  
 True Depth Filter . . . . . 2-12  
 Transporting Planter . . . . . 2-13  
 Level Planter . . . . . 2-14  
 Field Operation . . . . . 2-15  
 Transport to Field Sequence Using Blue Vantage . . . . . 2-16  
 Field to Transport Sequence Using Control Box . . . . . 2-18  
 Row Marker Operation using Control Box . . . . . 2-20  
 Row Marker Speed Adjustment . . . . . 2-21  
 Row Marker Cable Adjustment . . . . . 2-22  
 Row Marker Length And Disc Blade Adjustment . . . . . 2-23  
 Vacuum Meter System . . . . . 2-24  
 Analog Vacuum or Pressure Gauge . . . . . 2-24  
 Bulk Fill System . . . . . 2-25  
 Bulk fill Entrainer Access . . . . . 2-26  
 Bulk Fill Tanks - Clean Out . . . . . 2-27  
 Bulk Fill Scale Package Option . . . . . 2-27  
 Monitor Seed Levels . . . . . 2-28  
 Field Test . . . . . 2-29  
 Field Check Seed Population . . . . . 2-29  
 Determining Pounds Per Acre . . . . . 2-30  
 Determining Bushels Per Acre . . . . . 2-30  
 Field Check Granular Chemical Application . . . . . 2-31

**ROW UNIT OPERATION**

Planting Depth . . . . . 3-1  
 "V" Closing Wheel Adjustment (Rubber or Cast Iron) . . . . . 3-1  
 Closing Wheel Shield  
 (Rubber or Cast Iron "V" Closing Wheels) . . . . . 3-1  
 Covering Discs/Single Press Wheel Adjustment . . . . . 3-2  
 Quick Adjustable Down Force Springs Option . . . . . 3-3  
 Pneumatic Down Pressure . . . . . 3-4  
 Field Operation . . . . . 3-5  
 Vacuum Settings . . . . . 3-6  
 Seed Meter Clean out . . . . . 3-9  
 Row Unit Mounted No Till Coulter . . . . . 3-12  
 Coulter Mounted Residue Wheels . . . . . 3-13  
 Granular Chemical Banding Options . . . . . 3-13  
 Granular Chemical Hopper and Drive . . . . . 3-14

**FERTILIZER**

System Overview . . . . . 4-1  
 Centrifugal Pump . . . . . 4-1

**LUBRICATION AND MAINTENANCE**

Lubrication . . . . . 5-1  
 Lubrication Symbols . . . . . 5-1  
 Wheel Bearings . . . . . 5-1  
 Grease Fittings . . . . . 5-2  
 PTO Shaft Coupling . . . . . 5-7  
 Mounting Bolts and Hardware . . . . . 5-8  
 Tire Pressure . . . . . 5-10  
 Transport Tires . . . . . 5-10  
 Inflation Specifications . . . . . 5-11  
 Vacuum Seed Meter Maintenance . . . . . 5-12  
 Seed Meter Cleanout . . . . . 5-12  
 Vacuum Manifold Maintenance . . . . . 5-13  
 Gauge Wheel Adjustment . . . . . 5-13  
 Gauge Wheel Arm Pivot Spindle Replacement . . . . . 5-14  
 Gauge Wheel Arm Bushing/Seal Replacement . . . . . 5-14  
 15" Seed Opener Disc Blade/Bearing Assembly . . . . . 5-15  
 Seed Tube Guard/Inner Scraper . . . . . 5-16  
 Row Unit Mounted No Till Coulter . . . . . 5-17  
 Coulter or Row Unit Mounted Residue Wheels . . . . . 5-17  
 Tractor Mounted Pump Drive and Oil Cooler . . . . . 5-18  
 Check Valve . . . . . 5-19  
 Flow Control Valves . . . . . 5-19  
 Pressure Relief Valves . . . . . 5-19  
 Pressure Compensated Flow Control Valves . . . . . 5-19  
 Solenoid Valve . . . . . 5-20  
 Pneumatic Down Pressure Air Compressor Tank . . . . . 5-20

Row Marker Bearing Lubrication or Replacement . . . . . 5-21

Transport and Lift/Ground Drive Wheel  
 Bearing Repack or Replacement . . . . . 5-22

Fertilizer Check Valve Cleaning and Repair. . . . . 5-23

Piston Pump Storage. . . . . 5-23

Preparation for Storage . . . . . 5-24

Electrical Wiring Diagram - Blue Drive Interconnect . . . 5-26

Electrical Wiring Diagram - Blue Drive Ethernet . . . . . 5-28

IPP Wing Harness . . . . . 5-30

Row Unit Power Extension Harness . . . . . 5-31

4K Row Unit Seed Meter Harness. . . . . 5-32

Fertilizer Flow Harness . . . . . 5-33

Extension Harness. . . . . 5-33

PDP Power Extension Harness, 18'. . . . . 5-34

PDP Power Extension Harness, 30'. . . . . 5-35

Drawbar Hitch Harness . . . . . 5-36

Left Wing Harness . . . . . 5-37

Right Wing Harness. . . . . 5-38

Tractor Power Harness. . . . . 5-39

Tractor Console Harness . . . . . 5-40

Draft Link Power harness. . . . . 5-41

IPN Power Harness . . . . . 5-42

Row Unit Power harness - Rows 1-18 . . . . . 5-43

Row Unit Power harness - Rows 19-36. . . . . 5-44

Bulk Fill Scale Harness . . . . . 5-45

Blue Drive PDP Harness . . . . . 5-46

12V Air Pump Harness . . . . . 5-47

BulkFill Harness. . . . . 5-48

Tail Light Harness . . . . . 5-49

Fertilizer Pump Harness . . . . . 5-50

Tail Light Extension Harness . . . . . 5-51

Work Light Relay Harness. . . . . 5-52

Tail Light Harness . . . . . 5-53

Fold Harness . . . . . 5-54

Vacuum Sensor Harness. . . . . 5-55

PTO Reservoir Fan Harness . . . . . 5-56

Hydraulic Hose Life . . . . . 5-57

Hydraulic Schematic . . . . . 5-58

Hydraulic Schematic - Row Markers. . . . . 5-60

**TROUBLESHOOTING**

Bulk Fill . . . . . 6-1

Closing Wheel . . . . . 6-1

Row Marker Operation. . . . . 6-2

Vacuum Seed Meter . . . . . 6-3

Solenoid Valve . . . . . 6-5





PTO Pump Drive and Oil Cooler Option . . . . . 6-5

Kinze Manufacturing, Inc. thanks you for your patronage. We appreciate your confidence in Kinze farm machinery. Your Kinze planter has been carefully designed to provide dependable operation in return for your investment.

**This manual has been prepared to aid you in the operation and maintenance of the planter. It should be considered a permanent part of the machine and remain with the machine when you sell it.**

It is the responsibility of the user to read and understand the Operator Manual in regards to safety, operation, lubrication and maintenance before operation of this equipment. It is the user's responsibility to inspect and service the machine routinely as directed in the Operator Manual. We have attempted to cover all areas of safety, operation, lubrication and maintenance; however, there may be times when special care must be taken to fit your conditions.

Throughout this manual the symbol  and the words **DANGER**, **WARNING**, and **CAUTION** are used to call attention to safety information that if not followed, will or could result in death or injury. **NOTICE** and **NOTE** are used to call your attention to important information. The definition of each of these terms follows:

	Indicates an imminently hazardous situation that, if not avoided, will result in death or serious injury. This signal word is to be limited to the most extreme situations, typically for machine components which, for functional purposes, cannot be guarded.
	Indicates a potentially hazardous situation that, if not avoided, could result in death or serious injury, and includes hazards that are exposed when guards are removed. It may also be used to alert against unsafe practices.
	Indicates a potentially hazardous situation that, if not avoided, may result in minor or moderate injury. It may also be used to alert against unsafe practices.
	Used to address safety practices not related to personal injury.

**NOTE:** Special point of information or machine adjustment instructions.

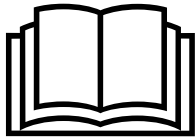

Improperly operating or working on this equipment could result in death or serious injury. Read and follow all instructions in Operator's Manual before operating or working on this equipment.



Some photos in this manual may show safety covers, shields, or lockup devices removed for visual clarity. **NEVER OPERATE OR WORK ON** machine without all safety covers, shields, and lockup device in place as required.

**NOTE:** Some photos in this manual may have been taken of prototype machines. Production machines may vary in appearance.

**NOTE:** Some photos and illustrations in this manual show optional attachments installed. Contact your Kinze Dealer for purchase of optional attachments.



## WARRANTY

The Kinze Limited Warranty for your new machine is stated on the retail purchaser's copy of the Warranty And Delivery Receipt form. Additional copies of the Limited Warranty can be obtained through your Kinze Dealer.

Warranty, within the warranty period, is provided as part of Kinze's support program for registered Kinze products which have been operated and maintained as described in this manual. Evidence of equipment abuse or modification beyond original factory specifications will void the warranty. Normal maintenance, service and repair is not covered by Kinze warranty.

To register your Kinze product for warranty, a Warranty And Delivery Receipt form must be completed by the Kinze Dealer and signed by the retail purchaser, with copies to the Dealer, and to the retail purchaser. Registration must be completed and submitted to Kinze Manufacturing, Inc. within 5 business days of delivery of the Kinze product to the retail purchaser. Kinze Manufacturing, Inc. reserves the right to refuse warranty on serial numbered products which have not been properly registered.

If service or replacement of failed parts which are covered by the Limited Warranty are required, it is the user's responsibility to deliver the machine along with the retail purchaser's copy of the Warranty And Delivery Receipt to the Kinze Dealer for service. Kinze warranty does not include cost of travel time, mileage or hauling. Any prior arrangement made between the Dealer and the retail purchaser in which the Dealer agrees to absorb all or part of this expense should be considered a courtesy to the retail purchaser.

*Kinze warranty does not include cost of travel time, mileage, hauling, or labor.*

## GENERAL INFORMATION

The Model 4700 Front Folding Planter is available with vacuum metering, bulk fill hopper, liquid fertilizer, and various other options. Contact your Kinze Dealer for additional details.



**Model 4700 24 Row Bulk Fill Planter with Liquid Fertilizer**

Information used in these instructions was current at time of printing. However, due to Kinze’s ongoing product improvement, production changes may cause your machine to appear slightly different in detail. Kinze Manufacturing, Inc. reserves the right to change specifications or design without notice and without incurring obligation to install the same on machines previously manufactured. To obtain the most recent version of your publication, please contact your Kinze dealer.

Right hand (R.H.) and left hand (L.H.), as used throughout this manual, are determined by facing direction machine travels in use unless otherwise stated.

**NOTE: Metric unit values in parentheses are approximate values and are to be used for reference only.**

**TOOLS REQUIRED**

Hardware Size / Tool Required			
1/4" = 7/16"	7/16" = 5/8" (nut for 7/16" hardware uses 11/16" tool)	3/4" = 1 1/8"	1 1/4" = 1 7/8"
5/16" = 1/2"	1/2" = 3/4"	7/8" = 1 5/16"	1 1/2" = 2 1/4"
3/8" = 9/16"	5/8" = 15/16"	1" = 1 1/2"	

**Specifications - Electric Drive**

<b>Specification</b>	<b>Bulk Fill</b>
Bulk Fill Hopper Capacity	120 bu.
Number of Rows	36
Row Spacing	20"
Width - Shipping	
Width - Transport	16' 2"
Width – Planting	62' 2"
Length – Transport	43' 2"
Length – Planting	30' 1"
Height – Transport	12' 4"
Height - Bulk Fill (In Planting Postion)	10' 4"
Weight - Hitch	8,000 lbs. - 10,000 lbs
Weight – Base Machine	32,000 - 37,400 lbs
Hydraulic Lift System	Two Master / Four Slave Hydraulics
Tires - Center (Transport and Field Operation)	four 445/50 R 22.5 tires
Tires – Wing (Field Operation)	four 380/55 R 16.5 150 A8/B (2 tires per wing)
Row Markers	Independently controlled, three stage fold, disk blade depth bands.

### ***Tractor Hydraulic Requirements and Use of Power Beyond***

The Power Beyond hydraulic system is used as a pressure/flow source for additional functions equipped with independent flow control valves; for example, bulk fill fan. Possible scenarios include:

- Tractor Selective Control Valve (SCV) control is not needed.
- No other SCV outlet is available.

The major difference between SCV and Power Beyond is that an SCV has built-in pressure/flow compensation whereas Power Beyond requires an external load signal.

Kinze suggests that if Power Beyond must be used, only the bulk fill circuit be connected using all three connections (Pressure, Return, Load Sense). Consult your tractor manufacturer to ensure proper connection, hydraulic flow, pressure and heat dissipation are met.

For more information on Power Beyond for remote hydraulic connections, refer to the tractor Operator's Manual.

### Selective Control Valve (SCV) Identification

#1 SCV: Planter Lift/Weight Distribution (Red Labels)

#2 SCV: Markers/Fold (Blue Labels)







#3 SCV: Power Pack/True Depth (Hydraulic Down Force) (Black Labels)

#4 SCV: Bulk Fill/Fertilizer Pump (Yellow Labels)

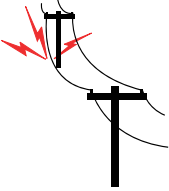
Configuration	Rows	Requirements		Description
Base Machine with Blue Drive / Bulk Fill / Vacuum Meters <b>with</b> PTO pump →PTO Hydraulic pump supplies oil flow for vacuum hydraulic circuit. →Add 4 GPM when using centrifugal fertilizer pump option. →External case drain required.	36R	4 SCV	44 gpm	#1 SCV: Planter Lift/Weight Distribution* (red labels) #2 SCV: Markers/Fold (blue labels) #3 SCV: Bulk Fill/Fertilizer (yellow labels) #4 SCV: Power Pack (black labels)
Base Machine with Blue Drive / Bulk Fill / Vacuum Meters / True Depth Hydraulic Down Force <b>with</b> PTO pump →PTO Hydraulic pump supplies oil flow for vacuum hydraulic circuit. →Add 4 GPM when using centrifugal fertilizer pump option. →External case drain required.	36R	4 SCV	52 gpm	#1 SCV: Planter Lift/Weight Distribution* (red labels) #2 SCV: Markers/Fold (blue labels) #3 SCV: Bulk Fill/Fertilizer (yellow labels) #4 SCV: Power Pack/True Depth (Hydraulic Down Force) (black labels)
<b>Notes:</b> →All SCVs should be set to max flow at all times →Tractor RPMs not recommended below 1750 RPMs →Consult your tractor manufacturer to ensure proper connection, hydraulic flow, pressure and heat dissipation →Power beyond will reduce the number of SCVs by 1. →PTO pump is required for all machines  *Only works when SCV is in detent.				

1. Read and understand instructions provided in this manual and warning labels. Review these instructions frequently!
  2. This machine is designed and built with your safety in mind. Do not make any alterations or changes to this machine. Any alteration to design or construction may create safety hazards.
  3. A large portion of farm accidents happen from fatigue or carelessness. Safe and careful operation of tractor and planter will help prevent accidents.
  4. Never allow planter to be operated by anyone unfamiliar with operation of all functions of the unit. Operators must read and thoroughly understand all instructions given in this manual before operating or working on equipment.
  5. Be aware of bystanders, particularly children! Always look around to make sure it is safe to start tow vehicle engine or move planter. This is particularly important with higher noise levels and quiet cabs, as you may not hear people shouting.
  6. Make sure planter weight does not exceed towing capacity of tractor, or bridge and road limits. This is critical to maintain safe control and prevent death or injury, or property and equipment damage.
  7. Never ride or allow others to ride on planter.
  8. Store planter in an area away from human activity. DO NOT permit children to play on or around the stored unit.
  9. Keep hands, feet, and clothing away from moving parts. Do not wear loose-fitting clothing which may catch in moving parts.
  10. Always wear protective clothing, shoes, gloves, hearing, and eye protection applicable for the situation.
  11. Do not allow anyone to stand between tongue or hitch and towing vehicle when backing up to planter.
  13. Prevent electrocution, other injuries, or property and equipment damage. Watch for obstructions such as wires, tree limbs, etc. when operating machine. Be aware of clearances during turns and when folding/unfolding planter.
  14. Reinstall all guards removed for maintenance activities. Never leave guards off during operation.
  15. Use of aftermarket hydraulic, electric, or PTO drives may create serious safety hazards to you and people nearby. If you install such drives, follow all appropriate safety standards and practices to protect you and others near this planter from injury.
  16. Follow all federal, state/provincial, and local regulations when towing farm equipment on a public highway. Use safety chain (not an elastic or nylon/plastic tow strap) to retain connection between towing and towed machines in the event of primary attaching system separation.
  17. Make sure all safety/warning lights, SMV sign, and reflective decals are in place and working properly before transporting the machine on public roads.
  18. Limit towing speed to 20 km/h. Tow only with a farm tractor equipped with a minimum of a Cat 4 hitch. Allow for unit length when making turns.
  19. Reduce speed prior to turns to avoid the risk of overturning. Always drive at a safe speed relative to local conditions and ensure your speed is slow enough for a safe emergency stop.
  20. Chemical application is often an integral part of planting. Follow label instructions for proper chemical mixing, handling and container disposal methods.
  21. Be familiar with safety procedures for immediate first aid should you accidentally contact chemical substances.
  22. Use the proper protective clothing and safety equipment when handling chemicals.
  23. Chemicals are supplied with Material Safety Data Sheets (MSDS) that provide full information about the chemical, its effects on exposure, and first aid needs in the event of an emergency. Keep your MSDS file up-to-date and available for first responders in case of emergency.
  24. When servicing ground engaging components such as opening disks and firming points, use special care to avoid points and edges worn sharp during use.
  25. Use professional help if you are unfamiliar with working on hydraulic systems. Pressurized hydraulic fluid can penetrate body tissue and result in death, serious infection, or other injuries.
  26. Disposing of waste improperly can threaten the environment. To dispose of your equipment properly contact your local environmental or recycling center.
- Never pour waste onto the ground, down a drain, or into any water source.
- When disposing of waste such as oil, use leakproof containers. Be sure to use containers that do not resemble food or beverage which may mislead someone into consuming them. Dispose of oil per your local, regional requirements.
- When disposing of any fertilizer chemicals used, contact the supplier of the chemicals.
- Model 4700 planter consists of 85% recyclable metals, 10% recyclable plastic and rubber, and 5% waste.

Following are some common hazard warnings associated with this equipment. Pay close attention to all safety, operating, and maintenance information in this manual and decals applied to your equipment.

 <p><b>DANGER</b></p> 	<p>Contacting or coming close to power lines or other high energy sources will cause death or serious injury.</p> <p>Keep away from power lines or high energy sources at all times.</p>
 <p><b>WARNING</b></p> 	<p>Improperly operating or working on this equipment could result in death or serious injury. Read and follow all instructions in Operator Manual before operating or working on this equipment.</p>
 <p><b>WARNING</b></p> 	<p>Falling equipment can cause death or serious injury. Install all lockup devices or lower planter to ground before working on equipment.</p>
 <p><b>WARNING</b></p> 	<p>Explosive separation of rim and tire parts can cause death or serious injury. Overinflation, rim and tire servicing, improper use of rims and tires, or worn or improperly maintained tires could result in a tire explosion.</p>

---

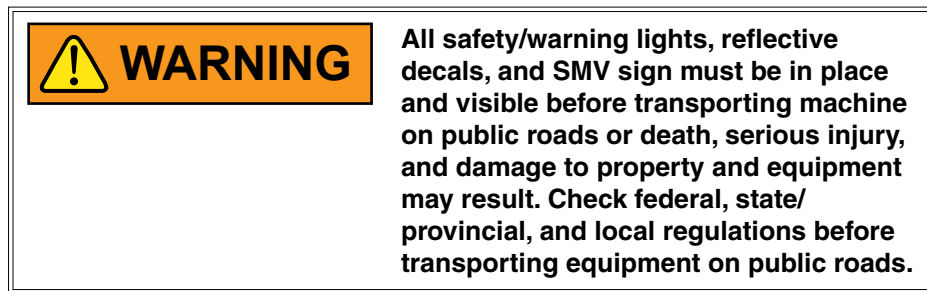
**SAFETY SIGNS AND DECALS**

Safety signs and decals are placed on the machine to warn of hazards and provide important operating and maintenance instructions. Information on these signs are for your personal safety and the safety of those around you. **FOLLOW ALL SAFETY INSTRUCTIONS!**



- **Keep signs clean so they can be easily seen. Wash with soap and water or cleaning solution as required.**
- **Replace safety signs if damaged, painted over, or missing.**
- **Check reflective decals and SMV sign periodically. Replace if they show any loss of reflective properties.**
- **When replacing decals, clean machine surface thoroughly with soap and water or cleaning solution to remove all dirt and grease.**

**NOTE:** Safety sign and decal locations are shown in the Parts Manual for this machine.

**NOTE:** Style and locations of SMV sign, reflective decals, and safety/warning lights conform to ANSI/ASABE S279.14 JUL 2008 and ANSI/ASABE S276.6 JAN 2005.



**ROW MARKER SAFETY LOCKUP**

 <b>WARNING</b>	Row marker can lower at any time and could cause death or serious injury. Stay away from row markers! Install safety lockup device when not in use.
	



**Row Marker Safety Lockup Stored**



**Row Marker Safety Lockup Installed**

Always install row marker lockups when working on, storing, or transporting planter. Hold in place with two clevis pins.

## TRANSPORT AXLE CYLINDER SAFETY LOCKUP



### WARNING

Transport axle can lower from transport position without the use of any controller, causing death, serious injury, or damage to property and equipment. Do not operate any hydraulic function while transporting the planter. Make sure all transport safety lockups are installed on the four transport cylinders and all SCV controls are in their neutral state before transporting, storing and working on the planter.



**Transport axle cylinder lockup installed**





**Cylinder lockup storage location**

Transport axle cylinder lockups are required on both transport cylinders on planter when working on, storing, or transporting planter.

Fully extend cylinder to raised position. Install transport axle cylinder lockups. Insert wire lock pin through holes on cylinder lockup and secure.

Store transport axle cylinder lockups in cylinder lockup storage location before operating planter.

 **WARNING**



Tanks must be empty when transporting to avoid death, serious injury, or damage to property or equipment. Do not pull planters in transport configuration with seed or fertilizer in tanks.

 **WARNING**

Planter hitch may raise uncontrollably during folding/unfolding and can cause death, serious injury, or damage property and equipment. DO NOT fold or unfold planter without planter attached to a tractor. DO NOT unhitch planter from tractor unless fully folded for transport or fully unfolded with planting units lowered to ground.

 **WARNING**



Uncontrolled movement of equipment can cause loss of control and could result in death, serious injury, or damage to property and equipment. Install all safety pins before transporting equipment.

### DRAWBAR HITCH LOCKUP



Place the drawbar hitch lockup pin in the hole on hitch when machine is in operation. Place pin in storage location while in operation.



### WING LATCH LOCKUP



Hitch Release from Wing Latch

 <b>WARNING</b>	<p>Improperly operating or working on this equipment could result in death or serious injury. Read and follow all instructions in Operator Manual before operating or working on this equipment.</p>
	

### INITIAL PLANTER PREPARATION

Following information is general in nature to aid in preparation of tractor and planter for use, and to provide general operating procedures. Operator experience, familiarity with the machine, and the following information should combine for efficient planter operation and good working habits.

 <b>WARNING</b>	<p>Explosive separation of rim and tire parts can cause death or serious injury. Overinflation, rim and tire servicing, improper use of rims and tires, or worn or improperly maintained tires could result in a tire explosion.</p>
	

 <b>WARNING</b>	<p>Wheel separation can cause loss of control resulting in death, serious injury, or damage to property and equipment. Check lug nuts on transport wheels are tight before operating planter for first time and periodically after.</p>
--	---

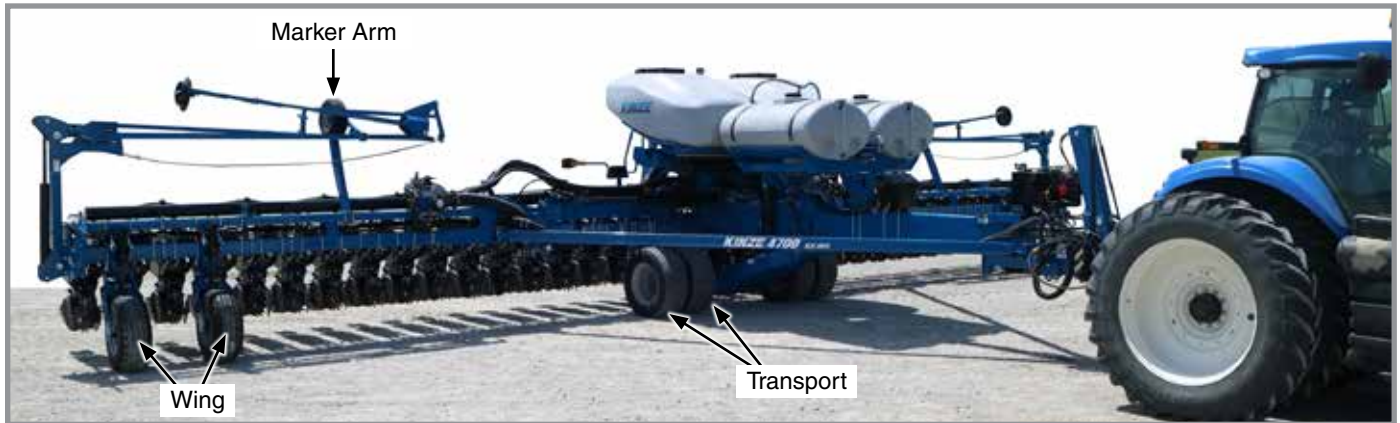

**Tire Locations (R.H. shown)**

1. Torque transport wheel  $\frac{3}{4}$ "- 16 lug nuts to 315 ft-lb.
2. Torque wing wheel  $\frac{5}{8}$ "-18 lug nuts to 200 ft-lb.
3. Inflate tires to the following specifications:

Transport Tire Size (4)	445/50R 22.5
Transport Tire Pressure	100 PSI
Wing (Field) Tire Size (4)	380/55R 16.5
Wing (Field) Tire Pressure	65 PSI
Marker Arm Tire Size (2)	16" x 6 $\frac{1}{2}$ " x 8"
Marker Arm Tire Pressure	14 PSI

4. Lubricate planter and row units per lubrication information in this manual.

**TRACTOR REQUIREMENTS****WARNING**

Loss of control of equipment during transport can result in death, serious injury, or damage to property and equipment. Tractor gross weight must be greater than planter gross weight with attachments and options.

**NOTICE**

Connect hydraulic motor case drain to a case drain return line with zero PSI on tractor. Failure to connect to a return with zero PSI will cause hydraulic motor shaft seal damage. **DO NOT** connect hydraulic motor case drain to a SCV outlet or motor return circuit connection. Contact tractor manufacturer for specific details on “zero pressure return”.

**NOTICE**

**All Hydraulic Requirements: Minimum Pressure 2350 PSI (16200 kPa); Maximum Pressure 3000 PSI (20700 kPa). Check tractor hydraulics to ensure that maximum pressure cannot be exceeded.**

Consult your dealer for information on horsepower requirements and tractor compatibility. Requirements vary with planter options, tillage, and terrain.

Four dual remote hydraulic outlets (SCV) are required on all sizes of bulk fill planters equipped with row markers. A 12 volt DC electrical system is required on all sizes.

---

**BULK FILL TRACTOR MOUNTED PTO PUMP AND PLANTER MOUNTED HYDRAULICS**



**Two-section PTO Hydraulic Pump**



**8 gal (30 L) Reservoir**

Bulk fill/vacuum meter equipped planters require a 1¼" (45 mm)-20 or 1½"(35 mm)-21 spline 1000 RPM PTO to operate PTO-driven two section hydraulic pump capable of supplying 26 gal/min to vacuum and bulk fill fans.

**NOTE: A tractor model-specific mount kit is required for the PTO-mounted pump.**

Contact Command Hydraulics (800-778-6200 or [www.commandhydraulics.com](http://www.commandhydraulics.com)) for your tractor pump mount requirements.

Vacuum Seed Metering System operates from a 8 gallon capacity oil reservoir.

**NOTE: Check that open center plug is removed from fan block before operating.**

Other dual fan system components include one oil cooler, one replaceable cartridge-type filter, and two pressure compensating flow-control valves.

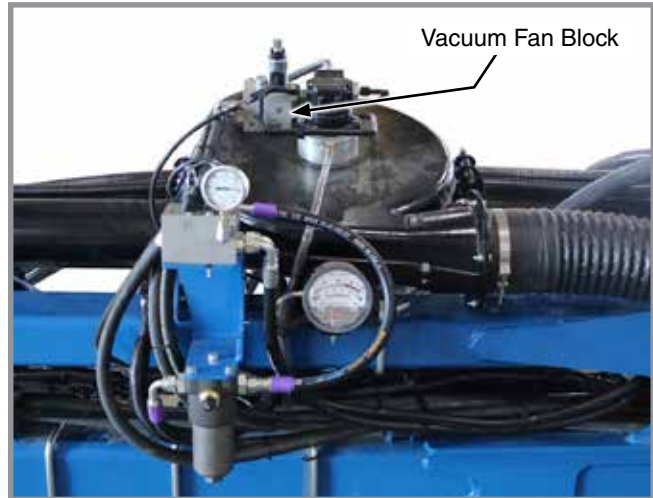

## TRACTOR PREPARATION AND HOOKUP

1. Back tractor to planter and connect with minimum 1¼" (32 mm) diameter hitch pin or 2 point hitch. Make sure hitch pin is secured with a locking pin or cotter pin if tractor is not equipped with a hitch pin locking device.

**NOTE: DO NOT install safety chain using clevis mounting hardware. Safety chain MUST be installed separately.**

2. For planters with drawbar hitch, safety chain must be used to keep planter and tractor connected in case of a hitch pin/drawbar failure. Attach safety chain at an unused clevis mounting hole on the planter hitch. Torque hardware to 840 ft-lb (1140 Nm).



**Tractor and Safety Chain Hookup  
for Drawbar Hitch**



**NOTICE**

Routing of hydraulic hoses from planter to tractor is very important. If done improperly, hoses can be pinched, cut or broken when planter is operated.

**WARNING**

Pressurized hydraulic fluid can penetrate body tissue and result in death, serious infection, or other injuries. Fluid injected under skin must be IMMEDIATELY removed by a surgeon familiar with this type of injury. Make sure connections are tight and hoses and fittings are not damaged before applying system pressure. Leaks can be invisible. Keep away from suspected leaks. Relieve pressure before searching for leaks or performing any system maintenance.

**NOTICE**

Wipe hose ends to remove any dirt before connecting couplers to tractor ports or contamination may cause equipment failure.

**NOTICE**

Always connect hydraulic motor return hose to tractor motor return port. Do not connect to tractor SCV unless through a motor spool or hydraulic motor failure can occur. If a motor return port is not available on the tractor, the SCV controlling the bulk fill system MUST be in the float position before planter is moved in planting or field raised position when bulk fill system is not in use.

3. Connect hydraulic hoses to tractor ports in a sequence familiar and comfortable to the operator. Refer to chart on the following page.

Color and Label	Machine Function	Hose Size	Hose Function
Red AA	Field Lift (Hydraulic Weight Transfer)	1/2"	Pressure/Return
Red BB		1/2"	Pressure/Return
Blue AA	Planter Fold & Row Marker	3/8"	Pressure/Return
Blue BB		3/8"	Pressure/Return
Black RR	Power Pack	5/8"	Return
Black PP		1/2"	Pressure
Yellow RR	Bulk Fill System Pressure Fan	5/8"	Return
Yellow PP		1/2"	Pressure
Orange CD	Power Pack/Bulk Fill System Pressure Fan	3/8"	Case Drain

<b>NOTICE</b>	<p><b>Clean and grease PTO shaft coupling with high-pressure industrial coupling grease (Chevron® coupling grease or equivalent) meeting AGMA CG-1 and CG-2 Standards each time driveshaft is installed or premature wear and equipment failure can occur.</b></p>
---------------	--

**NOTE: A tractor model-specific PTO mount kit for dual section pump option is required and available from Command Hydraulics (800-778-6200 or [www.commandhydraulics.com](http://www.commandhydraulics.com)).**

4. (If applicable) Install PTO pump onto tractor PTO shaft. Make sure shaft rotation matches direction indicated on pump housing.
5. If equipped with ISOBUS system, attach ISO connector.
6. For planters not equipped with ISOBUS, connect ASABE Standards 7 terminal connector for safety/warning lights on planter to ASABE Standards receptacle on tractor. If your tractor is not equipped with an ASABE Standards receptacle, check with your tractor manufacturer for availability. Check warning lights on planter work in conjunction with warning lights on tractor.
7. Completely raise parking stands, located behind drawbar hitch, to prevent damage to stands and equipment when moving planter.
8. (If applicable) Connect compressor harness.
9. (If applicable) Attach the True Depth 6-pin connector.
10. Attach Blue Drive 6-pin connector and ethernet cable to the Blue Vantage Display.

**TRUE DEPTH HYDRAULIC SYSTEM OVERVIEW**



**True Depth Pressure Gauge**

 <b>WARNING</b>	<p>Remove all hydraulic power sources and verify True Depth pressure gauge reads zero before servicing.</p>
--	---



**True Depth Cylinder**

 <b>WARNING</b>	<p>Flow out of the rod end port of the cylinder must not be restricted when pressurizing cap end port as 4.5:1 pressure intensification will occur on the rod end of the cylinder potentially resulting in failure of the cylinder and loss of containment of the piston rod assembly.</p>
--	--



True Depth Filter

**TRUE DEPTH FILTER**

Replace filter cartridge annually, every 100 hours of operation, or when the clogging indicators point out the limit pressure drop created inside the filter.

To replace the cartridge:



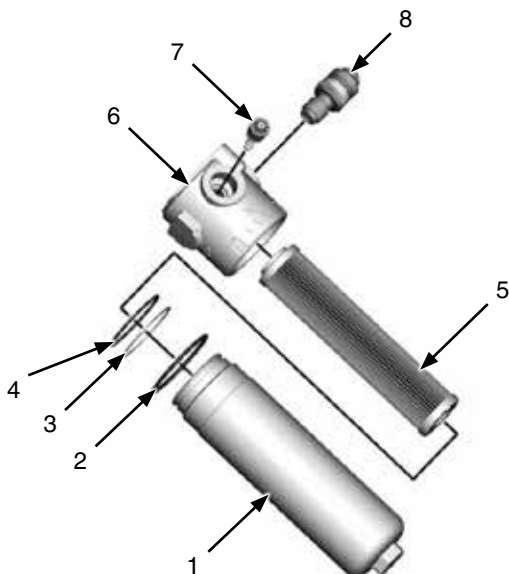



1. Stop the system in “Machine Stopped” status
2. Secure any shut-off valves on the hydraulic circuit.
3. Unscrew the filter container (1).
4. Remove the clogged filtering cartridge (5), making sure no residual particles have settled in the bowl bottom.
5. Make sure the O-ring (2-4) and the anti-extrusion ring (3) are not damaged, otherwise replace them and consequently position the new ones correctly.
6. Insert the new filtering cartridge, lubricating the sealing O-ring beforehand.
7. Screw the container tight (1) making sure the threading is screwed correctly. Tighten to a tightening torque of 65 Nm.
8. Start the machine for a few minutes.
9. Make sure there are no leaks.



1. Filter Bowl
2. External O-Ring
3. Anti-extrusion ring
4. Sealing O-Ring
5. Filtering Element
6. Filter Head
7. By-pass valve
8. Visual differential indicator

True Depth Cylinder

## TRANSPORTING PLANTER

- |   |  |
|---|--|
|  <b>WARNING</b><br> | <p>Uncontrolled movement of equipment can cause loss of control and could result in death, serious injury, or damage to property and equipment. Install all safety pins before transporting equipment.</p>   |
|  <b>WARNING</b><br> | <p>Uncontrolled machine movement can crush or cause loss of control resulting in death, serious injury, or damage to property and equipment. Install all safety lockup devices before working under or transporting this equipment.</p>  |
|  <b>WARNING</b>  | <p>Transporting planter with hoppers over half full or unevenly loaded can cause loss of control and could result in death, serious injury, or damage to property and equipment. Properly load planter when transporting. Be aware of extra transport weight, and road conditions and limits.</p>  |
|  <b>WARNING</b>  | <p>To avoid unintended movement of axle during transport, return all SCV controls to the neutral position before transporting machine. <b>DO NOT</b> operate any hydraulic function while transporting machine. Doing so could result in death, serious injury, or damage to property and equipment.</p>   |
|  <b>WARNING</b>  | <p>Transport axle can lower from transport position without the use of any controller, causing death, serious injury, or damage to property and equipment. Do not operate any hydraulic function while transporting the planter. Make sure all transport safety lockups are installed on the four transport cylinders and all SCV controls are in their neutral state before transporting, storing and working on the planter.</p> |

Make sure safety/warning lights, reflective decals, and SMV sign are in place and visible before transporting machine on public roads. It is your responsibility to check and comply with all federal, state/provincial, and local regulations.

Be aware of road and bridge weight limits. Allow for additional weight of added options and any additional material or substances that have been added to the machine.

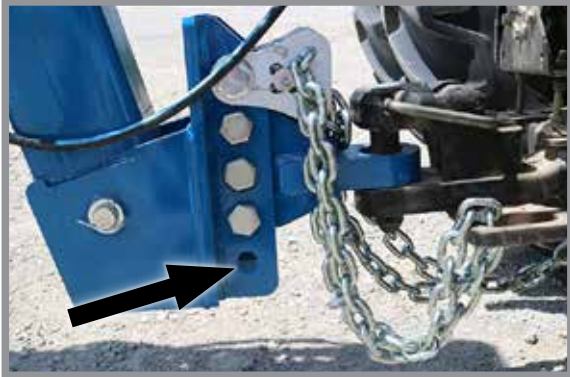
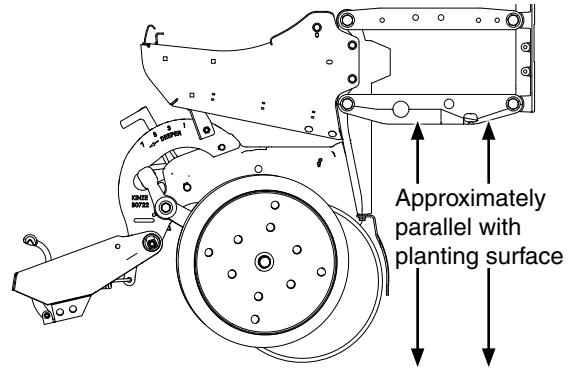
**LEVEL PLANTER****Clevis Adjustment Holes****Level Row Units**

Toolbar should operate at 23"-25" height from planting surface. Tire pressures must be maintained at pressures specified for planter to operate level laterally. Check toolbar and row unit parallel arms are level front to back with planter lowered to proper operating height.

Field and actual planting conditions determine which wheel settings to use to ensure row unit parallel arms are approximately parallel with planting surface. If planting in extremely soft soil conditions it may be necessary to move ground drive tires to lower sets of mounting holes. To allow adequate drive force after lowering the ground drive tires, it may be necessary to lower contact drive arms to lower set of holes in wheel module and relocate down pressure springs to lower mounting rod on wheel module.

If planter center is higher or lower than wings after rephasing, contact your Kinze Dealer for valve adjustment or maintenance.

**FIELD OPERATION**

Planters are designed to operate within a speed range of 2-8 mph. Higher ground speeds can cause more variation in seed spacing. Speeds above 6.5 mph are typically not recommended.

**NOTICE**

**Always raise planter out of ground when making sharp turns or backing up.**

Normal field planting operation requires use of tractor's hydraulic control to raise and lower planter frame when making field turnarounds.

**NOTICE**

**Operate row markers in float position to prevent damage to row markers.**

Operate row markers with Blue Vantage control W/tractor's hydraulics. After markers are lowered to ground, move hydraulic control to operate markers in float position. Marker speed is controlled with flow control valves located on both planter wings. One valve controls raise speed and other valve controls lower speed of both markers.

**Refer to Kinze Blue Vantage Operator's Manual for marker control.**

---

**TRANSPORT TO FIELD SEQUENCE USING BLUE VANTAGE**

Position planter in a relatively flat open area without furrows, etc.

**NOTICE**

Tractor must be in neutral and allowed to roll freely when unfolding to prevent equipment damage, especially in soft conditions or when loaded with seed. Use tractor assist as needed to aid in unfolding and to reduce stress on frame and transport components.

**NOTICE**

DO NOT fold or unfold planter without planter attached to a tractor. DO NOT unhitch planter from tractor unless fully folded for transport or fully unfolded with planting units lowered to ground.

**WARNING**

Improperly operating or working on this equipment could result in death or serious injury. Make sure there is no one in the area of the moving parts of the planter.



1. Remove lockups.
2. Press and hold "LOWER TRANSPORT AXLE". Operate proper hydraulic tractor control to lower transport axle to field turn around position. Axle will automatically stop in correct position.



3. Press and hold "LOWER HITCH". Operate proper hydraulic tractor control to lower hitch all the way down.



4. Press and hold "RAISE WING HOOKS". Operate proper hydraulic tractor control to disengage wing hooks.



5. Press and hold "UNFOLD". Operate proper hydraulic tractor control to fold wings outward until stub wing latch pins are sealed into H-frame receivers.



6. Lower the machine to rephase the cylinder. Raise hitch (if needed) to level machine during planting if necessary.



---

**FIELD TO TRANSPORT SEQUENCE USING CONTROL BOX**

Position planter in a relatively flat open area without furrows, etc.

**NOTICE**

Tractor must be in neutral and allowed to roll freely when unfolding to prevent equipment damage, especially in soft conditions or when loaded with seed. Use tractor assist as needed to aid in unfolding and to reduce stress on frame and transport components.

**NOTICE**

DO NOT fold or unfold planter without planter attached to a tractor. DO NOT unhitch planter from tractor unless fully folded for transport or fully unfolded with planting units lowered to ground.

**WARNING**

Improperly operating or working on this equipment could result in death or serious injury. Make sure there is no one in the area of the moving parts of the planter.

1. If equipped with row markers, remove lockups from storage and installation marker cylinder rods.
2. Place planter into field turnaround position.



3. Press and hold "Fold". Operate proper hydraulic tractor control to fold wings in toward tractor.



4. Press and hold "Lower Wing Hooks". Operate proper hydraulic tractor control to engage wing latches around the hitch tube to lock wings.



5. Press and hold "Raise Hitch". Operate proper hydraulic tractor control to raise hitch to transport height.



6. Press and hold "Raise Transport Axle". Operate proper hydraulic tractor control to raise transport axle to transport height.



7. Install lockups.

## ROW MARKER OPERATION USING CONTROL BOX

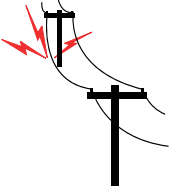
 <b>DANGER</b>	<p>Contacting or coming close to power lines or other high energy sources will cause death or serious injury.</p>
	<p>Keep away from power lines or high energy sources at all times.</p>

<b>NOTICE</b>	<p>When marker option is installed, a CAT 5 hitch must be used. A CAT 4 hitch will be overloaded.</p>
---------------	---

Two solenoid valves on valve block at rear L.H. side of center frame, and a three position selector switch on control console permit operator to lower or raise desired row marker.

**NOTE: See row marker adjustments on following pages.**

1. Place FUNCTION switch in PLANT position.
2. Place MARKERS switch in LEFT or RIGHT position.
3. Toggle switch to other side to operate opposite row marker.
4. Raise row marker at end of field.
5. After turn, lower the pre-selected row marker.
6. Continue to follow this procedure.



**Row Marker Solenoid Valves**

**NOTE: Both row markers can be lowered by operating switch in each position and hydraulic control twice. Row markers raise simultaneously with hydraulic control in raise position.**

If electrical system does not operate properly:

- Check fuse.
- Check wiring connections.
- Check control switch.
- Check solenoid. SOLENOID HOUSING IS MAGNETIZED WHEN ENERGIZED.

## ROW MARKER SPEED ADJUSTMENT

### NOTICE

Excessive row marker travel speed can damage row markers. Adjust flow controls before row markers are first used.

Marker hydraulic system includes two flow control valves. One flow control valve sets lowering speed and one sets raising speed of both markers. Flow controls determine amount of oil flow restriction through valves, varying marker travel speed.

Loosen jam nut and turn control clockwise, or IN to slow travel speed. Turn counterclockwise, or OUT to increase travel speed. Tighten jam nut after adjustments are complete.

**NOTE: Tractors with flow control valves. Make row marker speed adjustment with tractor flow controls in maximum position. After row marker speed is set, adjust tractor flow controls to allow hydraulic control to stay in detent during marker raise or lower cycle.**

**NOTE: Hydraulics operate slowly when oil is cold. Make all adjustments with oil warm.**

**NOTE: On a tractor where oil flow cannot be controlled, tractor flow rate may be greater than rate marker cylinder can accept. Hold tractor hydraulic control lever until cylinder reaches end of its stroke. This occurs most often on tractors with an open center hydraulic system.**



Row Marker Speed Control Adjustment

## ROW MARKER CABLE ADJUSTMENT

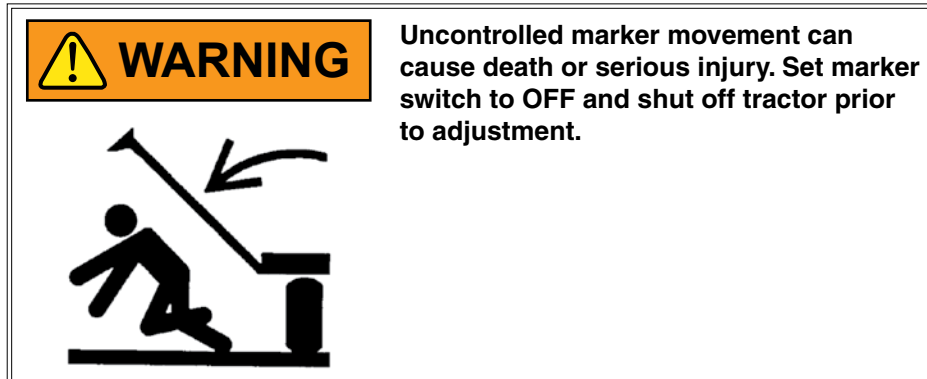

**NOTE:** Operate two-fold or three-fold row markers with the tractor's hydraulic valve in float position.

**NOTE:** A cable or chain may be used. For continuity, cable will be used in this manual.

Cable adjustment is critical. Adjust with second stage of marker in vertical position and first stage in horizontal position.

Cable must be adjusted so third stage of marker is pulled out as soon as second stage begins outward travel. Cable stretches with use and needs routine adjustment. It may be necessary to twist for a finer adjustment.

Marker cable is PROPERLY ADJUSTED if marker blade pushes dirt 12" or less as marker completes fold into field operating position. Cable should have some slack when marker is in field operating position.

Marker cable is TOO LOOSE and should be adjusted if marker blade pushes dirt more than 12" as it completes the fold into field operating position.

Marker cable is TOO TIGHT if it will not allow marker blade to follow ground contour and cable is tight when marker is in field operating position.

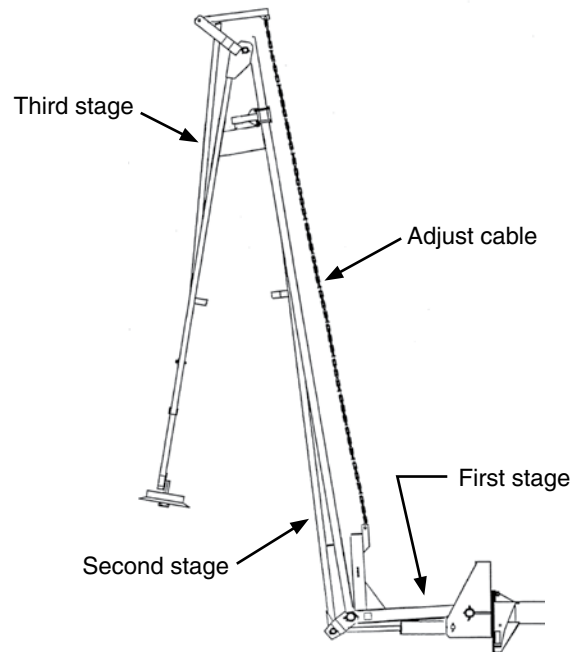

## ROW MARKER LENGTH AND DISC BLADE ADJUSTMENT

1. Multiply number of rows by the average row spacing to determine total planting width.

Row Marker Lengths	
36 Row 20	720"

2. Lower planter and row marker assembly to ground.
3. Measure from planter center line to a point where blade contacts ground.
4. Adjust row marker extension so distance from marker disc blade to center line of planter is equal to total planting width. Adjust right and left row marker assemblies equally and securely tighten clamping bolts.

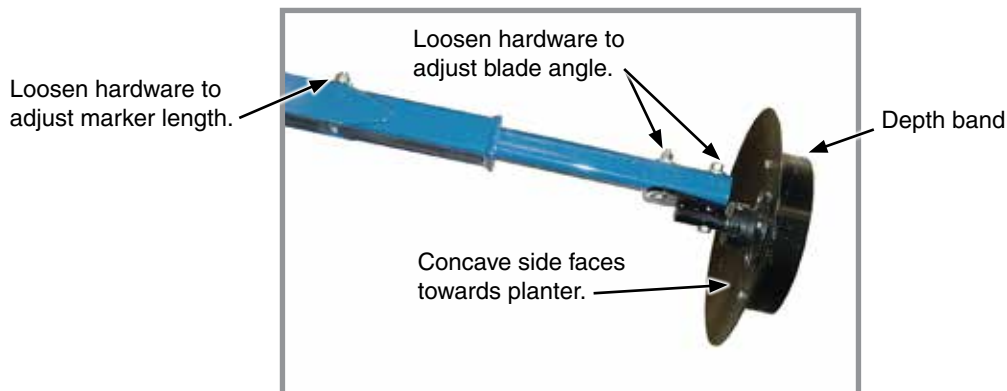

**Row Marker Disc Blade Angle Adjustment**

### NOTICE

Setting marker disc blade assembly at a sharper angle than needed adds stress to row marker assembly and shortens bearing and blade life. Set blade angle only as needed to leave a clear mark.

Marker disc blade is installed with concave side facing inward. Spindle assembly is slotted so hub and blade can be angled to throw more or less dirt.

5. Loosen hardware and move assembly as required.
6. Tighten bolts to specified torque.
7. Do a field test to ensure markers are properly adjusted.

**NOTE: A notched marker blade is available from Kinze through your Kinze Dealer for use in more severe no till conditions.**

## VACUUM METER SYSTEM

Kinze vacuum meter seed metering system includes seed meters, seed discs, and an air system consisting of a hydraulic driven vacuum fan which draws air through manifolds, hoses, and seed meters on each row unit.

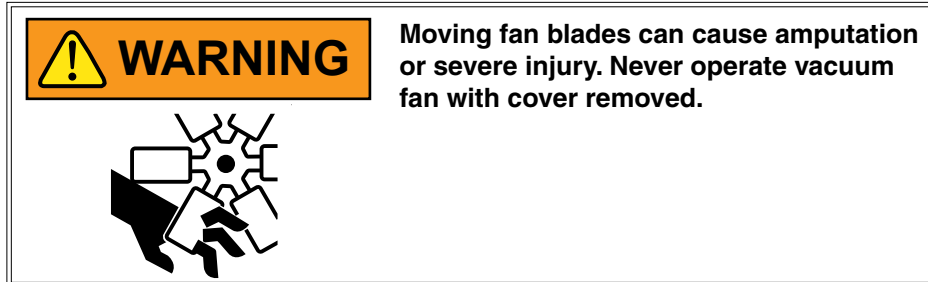

## ANALOG VACUUM OR PRESSURE GAUGE

Analog vacuum or pressure gauge connects directly to vacuum manifold (vacuum) or bulk fill (pressure) manifold and is tied into digital sending units.

Only adjustment is to “zero” needle with no vacuum or pressure present. If there is a significant difference between gauge and a reading taken at meters, a different manifold location should be found to connect hose to gauge and digital sending unit.

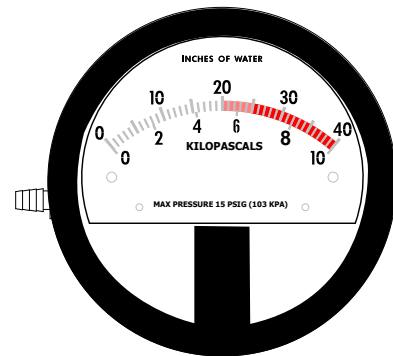

**Analog Gauge**

**NOTE: Analog gauges are identical EXCEPT for plug and hose barb locations in side of gauge housing. DO NOT connect vacuum meter or bulk fill hose to wrong gauge. Check plug and hose barb installation if readout is erratic or appears inaccurate.**



**BULK FILL SYSTEM****WARNING**

Do not remove lid during machine operation. Contents are pressurized and could result in death, serious injuries or equipment damage.

Review operator manual for proper filling procedure.

**CAUTION**

Seed flying out of disconnected delivery tube at high velocity can cause injury. Do not disconnect delivery tubes when system is operating.

**DANGER**

**DO NOT ENTER.** Hazardous conditions inside will result in death or serious injury. Follow OSHA confined space procedures.

**NOTICE**

Foreign materials can plug system. Make sure seed is clean and free of debris when filling bulk fill hoppers.

**NOTICE**

Do not turn on system with tractor engine at full speed or system damage may occur.

**NOTICE**

Do not operate bulk fill system above maximum system operating pressure of 20 inches of water or seed bridging may occur.

**WARNING**

Transporting planter with hoppers over half full or unevenly loaded can cause loss of control and could result in death, serious injury, or damage to property and equipment. Properly load planter when transporting. Be aware of extra transport weight, and road conditions and limits.

1. **Before filling hoppers, refer to “Row Unit Operation” on page 3-1 for additives information.** Fill hoppers with seed, then twist lid clockwise to close.
2. Start bulk fill delivery system with tractor engine at idle.
3. Increase engine speed to full and set initial system pressure using flow control valve.
4. Allow system to warm up and adjust pressure if necessary.



Bulk Fill Lid

Recommended pressures:

- Corn – 18-20 inches of water
- Soybeans – 10 inches of water
- Actual pressure needed is affected by seed size, shape, and coating.

## BULK FILL ENTRAINER ACCESS

1. Shut down bulk fill system.
2. Loosen wing nut and turn retainer holding shutoff door in its storage location.
3. Remove rubber plug closest to area in entrainer needing attention.
4. Insert shutoff door into open slot and push into entrainer at a slight upward angle.
5. When work is complete, remove shutoff door, return door to storage location, and plug open slot.

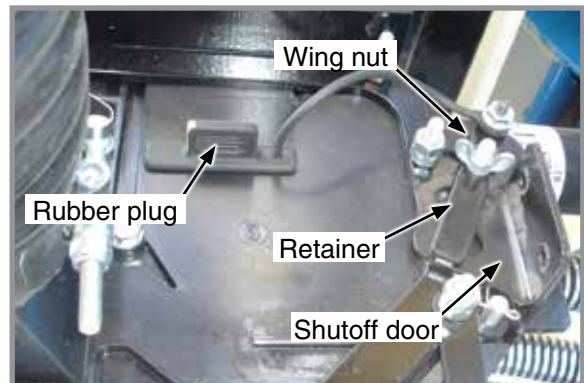

Bulk Fill Entrainer (End View)

## BULK FILL TANKS - CLEAN OUT



**Cleanout Chute Storage Location**

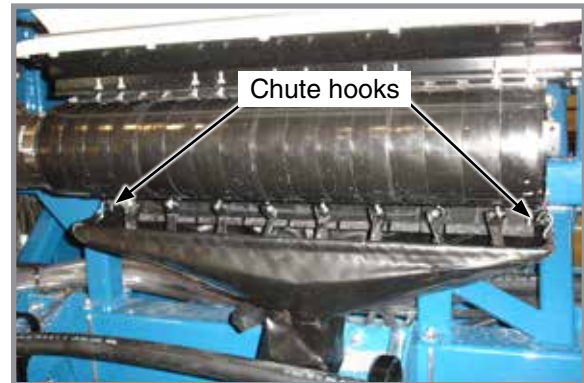

**Cleanout Chute Installed**

1. Remove bulk fill tank cleanout chute from storage location under L.H. bulk fill tank.
2. Position tube of chute under entrainer and attach hooks on each end of entrainment assembly.
3. Open cleanout doors and empty tank.
4. Close all cleanout doors and return cleanout chute to storage location.

## BULK FILL SCALE PACKAGE OPTION

### NOTICE

High-pressure water can damage display. Remove display before power washing planter.

### NOTICE

Remove and store display at end of planting season. Damage from sun and weather exposure may result.

- Provides seed weight or estimated acres remaining for each bulk fill hopper.
- Displays total (gross) seed weight or estimated acres remaining for both hoppers combined.
- Warns operator when seed goes below a pre-defined level (ISO display).

Operation of Bulk Fill Scale Package display is controlled by buttons located on its face:

- Two screen-defined selection buttons.
- Backlight ON/OFF button.
- UP/DOWN arrow buttons.
- Screen position is changed by loosening thumb screw on mount at back of monitor and repositioning screen.

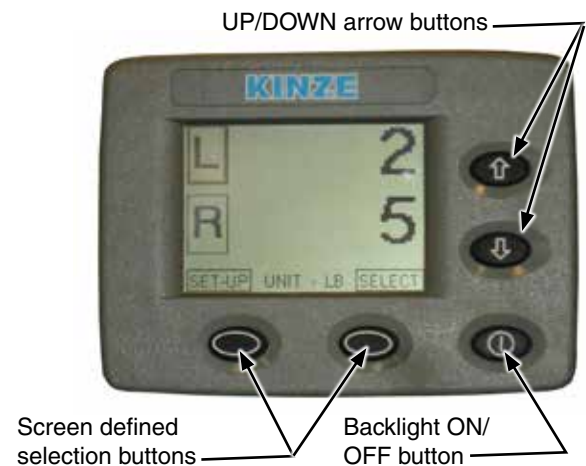

## MONITOR SEED LEVELS

1. Main screen displays information for left and right hoppers.
2. Select L or R for individual hopper status information.
3. Select BACK to return to main screen.
4. Press down arrow once or twice for GROSS screen to appear.  
This provides combined status information for both hoppers.
5. Press down arrow again to return to main screen.



## FIELD TEST

Perform a field test with any change of field and/or planting conditions, seed size or planter adjustment to ensure proper seed placement and operation of row units.

- Check planter for front to rear and lateral level operation. See [“Level Planter” on page 2-14](#)
- Check **all** row units to be certain they are running level. Row unit parallel arms should be approximately parallel to the ground when planting.
- Check row markers for proper operation and adjustment. See [“Row Marker Speed Adjustment” on page 2-21](#), [“Row Marker Cable Adjustment” on page 2-22](#), [“Row Marker Length And Disc Blade Adjustment” on page 2-23](#)
- Check for desired depth placement and seed population on **all** rows. See [“Field Check Seed Population” on page 2-29](#)
- Check for proper application rates of fertilizer on **all** rows.

Reinspect machine after field testing.

- Hoses And Fittings
- Bolts And Nuts
- Cotter Pins And Spring Pins
- Drive Chain Alignment
- Confirm ASD and dry fertilizer hoses were not crushed during fold/unfold operation.

## FIELD CHECK SEED POPULATION

1. Tie up one or more sets of closing wheels by running a chain or rubber tarp strap between the hopper support panel and closing wheels. It may be necessary to decrease closing wheel arm spring tension.
2. Plant a short distance and check to see if seed is visible in the seed trench. Adjust planting depth to a shallower setting if seed is not visible and recheck.

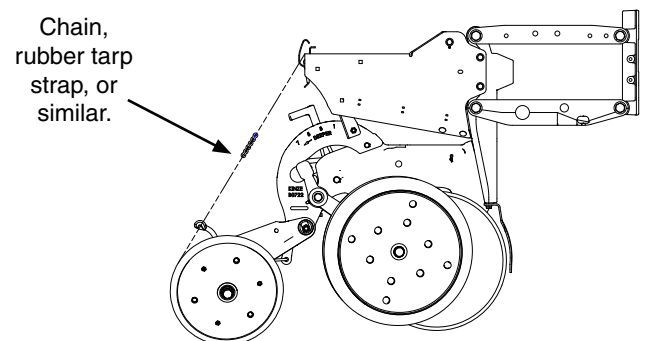

Planting depth adjustment handle



Planting Depth Adjustment

3. Measure  $\frac{1}{1000}$  of an acre. See chart for correct distance for row width being planted. For example, if planting 20" rows  $\frac{1}{1000}$  of a acre would be 26' 2".

$\frac{1}{1000}$ Hectare Seed Population Count Row Width/ Distance	
Row Width	20"
Distance	26' 2"

**NOTE: Seeds may bounce or roll when planting with closing wheels raised and planting depth set shallow affecting seed spacing accuracy.**

4. Count seeds in measured distance.  
 5. Multiply number of seeds placed in  $\frac{1}{1000}$  of an acre by 1000. This gives total population.

EXAMPLE: 20" row spacing 26' 2" equals  $\frac{1}{1000}$  acre.  
 26 seeds counted x 1000 = 26,000 seeds per acre

**DETERMINING POUNDS PER ACRE**

Seeds per acre ÷ Seeds per pound (from label) = Pounds per acre

If seeds per pound information is not available use the following averages:

- 2,600 seeds per pound for medium size soybeans
- 15,000 seeds per pound for medium size milo/grain sorghum
- 4,500 seeds per pound for medium size cotton

**DETERMINING BUSHELS PER ACRE**



Pounds per acre ÷ Seed unit weight = Bushels per hectare

Average Unit Weight of:

- 1 Bushel Soybeans = 60 Pounds
- 1 Bushel Milo/Grain Sorghum = 56 Pounds
- 1 Bushel Cotton = 32 Pounds

## FIELD CHECK GRANULAR CHEMICAL APPLICATION

Temperature, humidity, speed, ground conditions, flowability of different material, or meter obstructions can affect granular chemical rate of delivery.

 <b>WARNING</b>	<p><b>Agricultural chemicals can cause death or serious injury to persons, animals, and plants or seriously damage soil, equipment, or property. Read and follow all chemical and equipment manufacturers labels and instructions.</b></p>
	

Perform a field check to determine application rates.

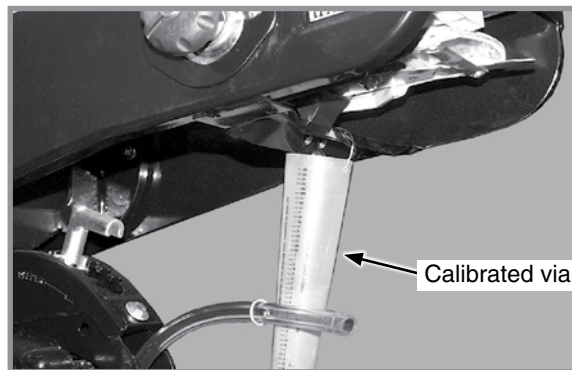

**Granular chemical field check**

1. Fill insecticide and/or herbicide hoppers.
2. Attach a calibrated vial to each granular chemical meter.

**NOTE: Disengage clutch to avoid dropping seed during test.**

3. Lower planter and drive 1320 feet at planting speed.
4. Weigh chemical in grams caught in one vial.
5. Multiply that amount by factor shown to determine pounds per hectare.

Pounds Per Acre	
Row Width	Factor
20"	1.25

**EXAMPLE:** You are planting 30" rows. You have planted for 1320 feet at desired planting speed. You caught 12.0 ounces of chemical in one vial. 12.0 ounces times 0.83 equals 9.96 pounds per acre.

**NOTE: Check calibration of all rows.**

### METERING GATE

Use metering gate setting as a starting point for distributing insecticide or herbicide. Charts are based on 5 mph planting speed. Use a higher gate setting for speeds faster than 5 mph and a lower setting for speeds slower than 5 mph.

**This page intentionally left blank.**



## PLANTING DEPTH

Planting depth is maintained by adjustable row unit gauge wheels. Depth adjustment range is approximately ½" to 3½".

1. Raise planter to remove weight from wheels.
2. Push down on depth adjustment handle and reposition it forward to decrease or rearward to increase planting depth. Initially adjust all units to the same setting.
3. Lower planter and check operation and planting depth of all row units. Readjust individual rows as needed for uniform operation.



Planting Depth Adjustment

## “V” CLOSING WHEEL ADJUSTMENT (RUBBER OR CAST IRON)

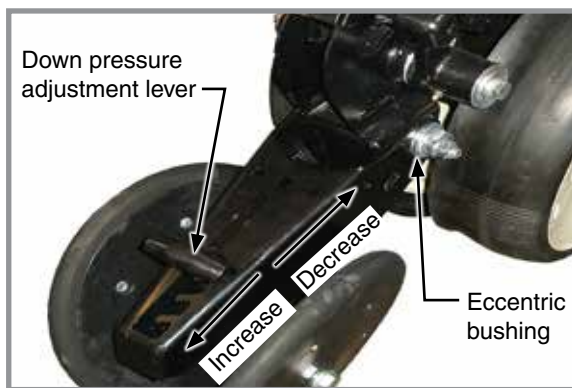

“V” Closing Wheel Adjustments

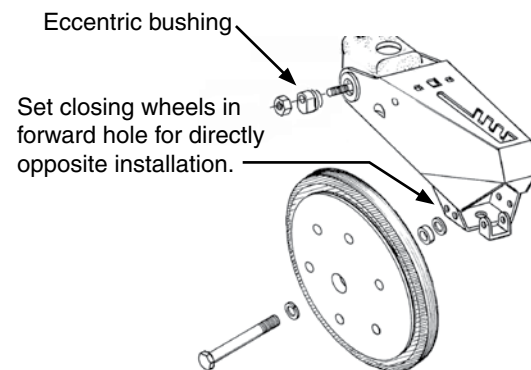

“V” closing wheels should have enough down pressure to close the seed trench and ensure good soil to seed contact. Move 5-position quick adjustable down force lever on the top of closing wheel arm to the rear to increase closing wheel spring pressure. Move lever forward to decrease pressure. Adjust all row units to a similar setting. Light soil usually requires less down force at average, depth approximately 2" while heavy soil requires increased down force.

Eccentric bushings in the wheel arm stop allow for lateral adjustment of the “V” closing wheel assembly. Use a ¾" wrench to loosen hardware attaching closing wheel arm to wheel arm stop. Use another ¾" wrench to turn eccentric bushings until **closing wheels are aligned with seed trench**. Tighten hardware.

Closing wheels can be installed “offset” (to improve residue flow) or “directly” opposite. Use forward installation holes if set “directly” opposite.

## CLOSING WHEEL SHIELD (RUBBER OR CAST IRON “V” CLOSING WHEELS)

Optional closing wheel shield is installed on underside of closing wheel arm to help prevent root balls and stalks from logging closing wheels.

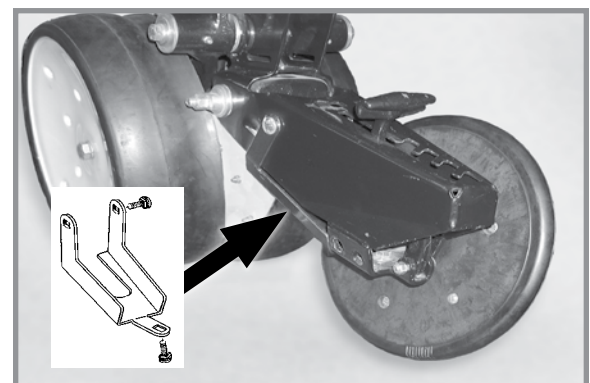

Closing Wheel Shield (closing wheel removed)

**COVERING DISCS/SINGLE PRESS WHEEL ADJUSTMENT**

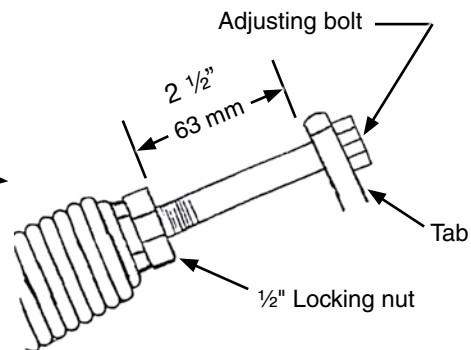
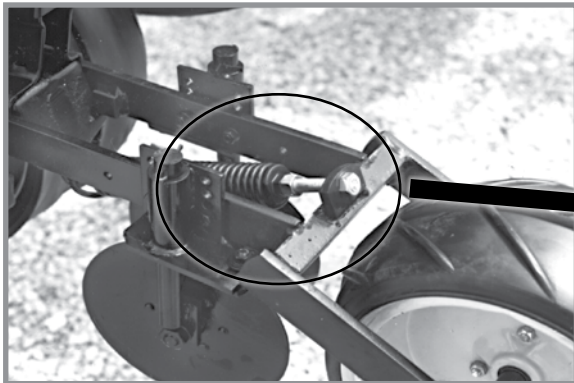

**Press Wheel Down Force Adjustment**

Check operation of covering discs/single press wheels after adjusting planting depth. Initial press wheel down force spring setting is 2 1/2" (63 mm) between mounting arm tab and locking nut. Loosen 1/2" locking nut and turn adjusting bolt in to increase down force or out to decrease down force. Tighten locking nut against spring plug. Adjust all row units to a similar setting.

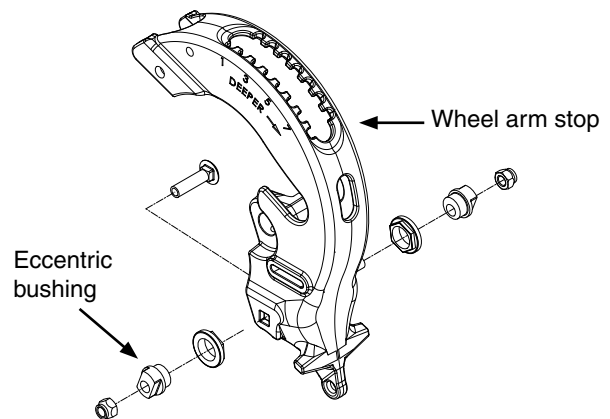
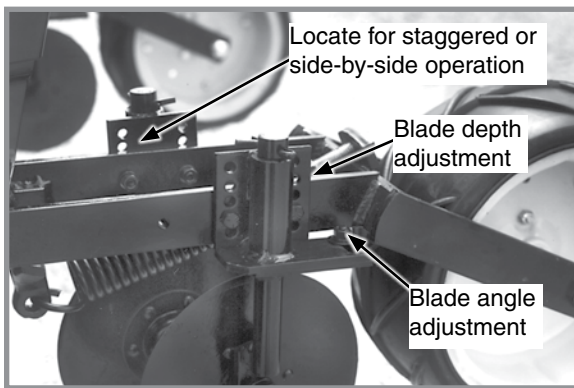

**Covering Disc Adjustments**

Eccentric bushings in the wheel arm stop allow for lateral adjustment of covering discs/single press wheel assembly. Use a 3/4" wrench to loosen hardware attaching closing wheel arm to wheel arm stop. Use another 3/4" wrench to turn eccentric bushings until covering discs/single press wheel assembly is aligned with seed trench. Tighten hardware. Two sets of holes in mounting arm locate covering discs for staggered or side-by-side operation. Five sets of holes in each disc bracket allow 13 mm incremental blade depth adjustment. Slotted holes in disc mount and bracket allow for 0° - 15° blade angle adjustment. Adjust covering discs on all row units to similar settings.

**QUICK ADJUSTABLE DOWN FORCE SPRINGS OPTION**

Standard and heavy duty quick adjustable down force springs are available to increase penetration in hard soil and keep row unit from bouncing in rough field conditions. Two springs per row, one on each side parallel arms, are used unless equipped with row unit mounted no till coulters. Row unit mounted no till coulters require four springs per row.



**Two Springs per Row (Dual)**



**Four Springs per Row (Quad)**

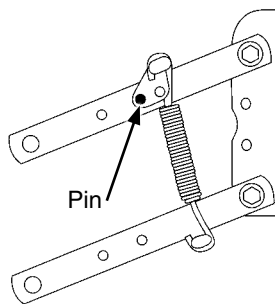

**Position 1 (Least)**

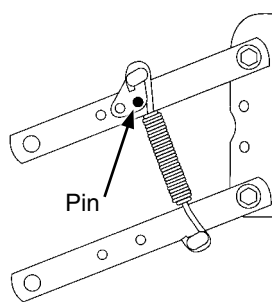

**Position 2**

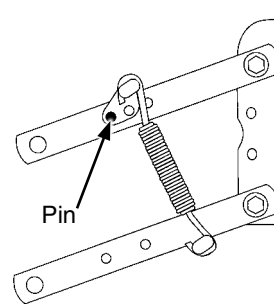

**Position 3**

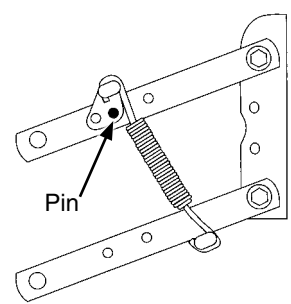

**Position 4 (Most)**

There are four positions to set down pressure spring tension.

Standard and Heavy Duty Spring Down Force Pressure*				
Position	2 Springs		4 Springs	
	Standard D8249	Heavy Duty D21337	Standard D8249	Heavy Duty D21337
1	41lb (18.6 kg)	43 lb (19.5 kg)	74 lb (33.6 kg)	80 lb (36.3 kg)
2	73 lb (33.1 kg)	86 lb (39.0 kg)	120 lb (54.4 kg)	144 lb (65.3 kg)
3	136 lb (61.7 kg)	167 lb (75.7 kg)	255 lb (115.7 kg)	307 lb (139.3 kg)
4	207 lb (93.9 kg)	249 lb (113.0 kg)	369 lb (167.4 kg)	470 lb (213.2 kg)

\*Pressure does not include weight of row unit, seed, or options.

<b>NOTICE</b>	<b>Springs must be installed with open side of spring hooks toward seed hoppers to prevent binding on spring mount adjustment pins.</b>
---------------	---

1. Raise planter and remove spring mount pin at top of spring.
2. Slide mount to desired position and install pin.

**NOTE: Adjust springs for field conditions. Too much down pressure in hard field conditions can cause row units to lift planter and keep drive wheels from making contact. Too much down pressure in soft field conditions can cause row unit to run too deep.**

## PNEUMATIC DOWN PRESSURE

Row unit down pressure can be adjusted on-the-go as field conditions change. ISOBUS monitor adjusts pressure (Older models may have a digital readout). One planter-mounted 12 V DC air compressor with 3-gallon capacity air tank supplies air for the down pressure system.



**Row Unit Air Spring**

Packages include upper and lower air spring mounting castings for pull row units, 150 psi rated air springs,  $\frac{3}{8}$ " O.D. nylon hoses, dual solenoid air valve and stainless steel, 160 psi, 2" liquid-filled gauge and planter wiring harness.

**NOTE: Assist springs are available through your Kinze dealer if additional down pressure is needed.**

---

**FIELD OPERATION**

**NOTE:** Adjust down pressure with planter lowered and row openers in ground for most accurate adjustment. Pressure can be adjusted using your Blue Vantage monitor. Refer to the Blue Vantage manual for more information.











**Air Compressor**

**ADJUST DOWN PRESSURE FROM CAB**

For models equipped with an Blue Vantage monitor, use the monitor to adjust down pressure. Refer to your Blue Vantage manual for more information.

## VACUUM SETTINGS

Crop		**Seed Disc Kit	Seed Disc Part No.	Ejector Wheel (Color)	Cells	Seed Size Range	Singulator Zone Setting	Vacuum Setting Inches of Water (cm)	Lubricant
	Corn ‡ Large Sweet Corn	G9040X	B0678 (Light Blue)	1 row 5 punches (Light Blue)	40	35-70 lbs/80k (2500-5000 seeds/kg)	2	18-20 (46-51)	<b>Graphite* Talc*</b> Bayer Fluency† (if mandated)
	Soybean	G9041X	B0848 (Black)	2 rows 6 punches (Black)	120	2200-4000 seeds/lb (4850-8820 seeds/kg)	0	10-14 (25-36)	<b>Graphite* Talc*</b> Bayer Fluency† (if mandated)
	Sugar Beet	G9043X	B0683 (Dark Orange)	1 row 6 punches (Dark Orange)	60	Pelletized	2	15 (38)	<b>Graphite* Talc*</b> Bayer Fluency† (if mandated)
	Milo	G9043X	B0683 (Dark Orange)	1 row 6 punches (Dark Orange)	60	10,000-20,000 seeds/lb (22000-44000 seeds/kg)	2	15 (38)	<b>Graphite* Talc*</b> Bayer Fluency† (if mandated)
	Sunflower ‡ Small Sweet Corn	G9042X	B0684 (Gray)	1 row 5 punches (Gray)	40	Oil seeds #2, 3, 4	2	12-18 (30-46)	<b>Graphite* Talc*</b> Bayer Fluency† (if mandated)
	Sunflower	G9042X	B0684 (Gray)	1 row 5 punches (Gray)	40	Oil seeds #5	2	5-8 (13-20)	<b>Graphite* Talc*</b> Bayer Fluency† (if mandated)
	Specialty Disc 1	G9272X	B0912 (Green)	1 row 6 punches (Green)	60	Cotton	2	15-20 (38-51)	<b>Graphite* Talc as needed*</b> Bayer Fluency† (if mandated)
	Specialty Disc 2	G9273X	B0914 (Brown)	1 row 6 punches (Green)	60	Black turtle & navy edible beans	2	15-20 (38-51)	<b>Graphite* Talc as needed*</b> Bayer Fluency† (if mandated)
	Specialty Disc 3	G9308X	B0913 (Dark Blue)	1 row 6 punches (Green)	60	Pinto & Great Northern edible beans & low-rate soybean	2	15-20 (38-51)	<b>Graphite* Talc as needed*</b> Bayer Fluency† (if mandated)

Install selected seed disc. Position vacuum cover on meter by aligning keyhole slots over bolt heads. Push cover on meter and turn counter clockwise to lock in place.

\*For More information on application rate, see Additives section.

\*\*Includes seed disc, ejector wheel, and spring.

†Bayer Fluency Agent is only required to be used in place of graphite or talc lubricants on vacuum equipped planters that are sowing neonicotinoid treated seeds in Canada. Refer to the Bayer Fluency Agent section for more information.

‡Conventional hoppers only, not applicable with bulk fill.

**NOTE:** See ["Field Check Seed Population" on page 2-29](#) for more information. Always field check seed population to ensure planting rates are correct.

**NOTE:** Singulator settings are marked from 0 - 3.

**NOTE:** Mixing seed sizes and shapes affects meter performance. Use consistent seed size and shape.

**NOTE:** Use 1 tablespoon powdered graphite with each standard hopper fill of seed. Seed treatment, foreign material, dirt or seed chaff may cause gradual reduction of seed disc fill (population). See "Additives" pages for more information.

**NOTE:** Excessive seed treatment, humidity, and light-weight seed can affect meter performance. Use  $\frac{1}{2}$  cup of talc with each standard hopper fill of seed and mix thoroughly to coat all seeds and adjust rates as needed. Use of talc aids seed flow into meter, singulation, and disc seed drop.

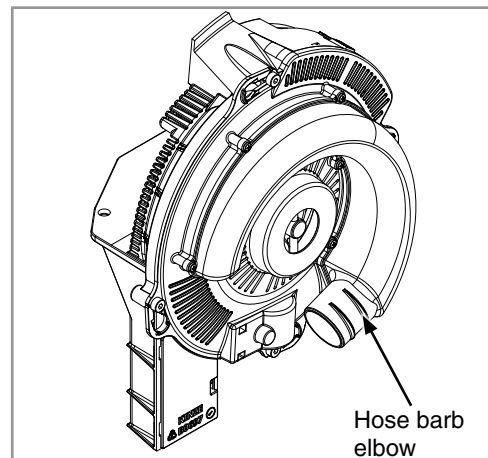
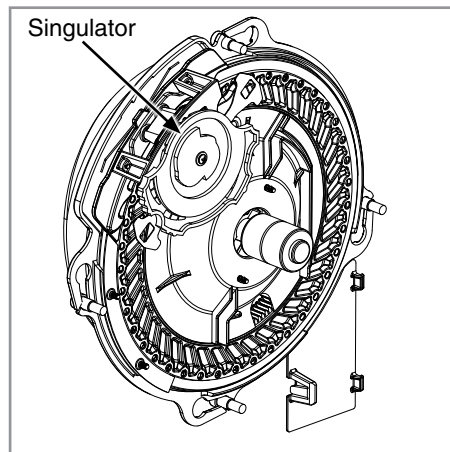

**NOTE:** Foreign material in seed disc orifices, such as seed chips, hulls, stems, etc., may affect seed delivery. Clean seed ensures accurate seed metering from vacuum seed meter. Remove Seed discs daily to check for buildup of foreign material in seed disc orifices.

Air inlet screens allow air to enter system and aids in keeping field residue or other foreign material out of meter.

See ["Vacuum Seed Meter Maintenance" on page 5-12](#) and ["Preparation for Storage" on page 5-24](#) in Lubrication and Maintenance section for more information.

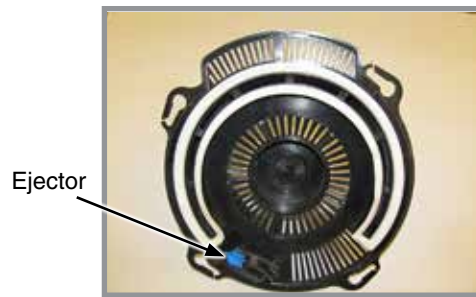

**NOTE: Damaged seed or seed containing foreign material will cause plugging of seed disc orifices and require more frequent seed meter clean out to prevent underplanting.**

#### Wheel-Type Ejectors

Wheel-type ejectors expel seed remnants from seed disc orifices. These ejectors are disc specific and colored coded to match disc.

### NOTICE

Reinstall hopper lids after hoppers are filled to prevent accumulation of dust or dirt in seed meter which will cause premature wear.

**NOTE: Seed size, seed shape, seed treatments, travel speed, and planting rate affect meter performance.**

1. Select seed disc and ejector to match crop and population.

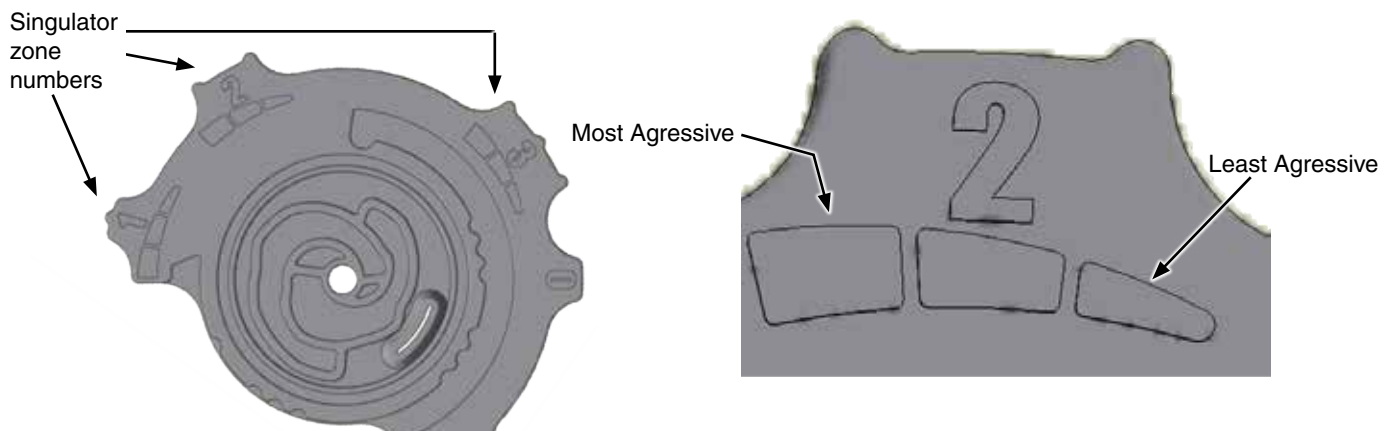

#### **Singulator Adjustment Wheel**

2. Adjust singulator wheel to initial setting. Seed size, seed shape, seed treatments, travel speed and planting rate all affect meter performance.
3. With vacuum fan running, lower planter to planting position and drive forward a short distance to load seed into seed disc cells.
4. Adjust vacuum level to initial setting according to tables on page.

**NOTE: Vacuum reading will be much lower when seed disc cells are empty. Load all seed cells before setting vacuum level.**

**NOTE: Operate vacuum fan 3-5 minutes to bring oil up to normal operating temperature prior to making final vacuum level adjustment.**



## SEED METER CLEAN OUT

**NOTE: Use of damaged seed or seed containing foreign material will cause plugging of seed cell orifices and require more frequent seed meter clean out to prevent underplanting.**

Thorough seed meter clean out is important to maintain genetic purity.

1. Disengage seed drive and remove seed hopper and meter.
2. Dump seed from right rear corner of hopper into a container.
3. Lay hopper on its right side. Push release button and rotate seed meter vacuum cover clockwise to align keyhole slots with bolt heads. Lift off cover.
4. Rotate seed disc hub clockwise to unlock and remove seed disc.
5. Empty meter.
6. Thoroughly inspect meter to ensure all seed is removed.
7. Replace seed disc. Install vacuum cover.

**ADDITIVES**

<b>Lubricant Application Rate</b>	
<b>Graphite</b>	
Conventional Hoppers	1 Tbs./Hopper Fill
Bulk Fill Hoppers	1 Pound Bottle/50 Unit Fill
<b>80/20 Talc-Graphite</b>	
Conventional Hoppers	½ C.**
Bulk Fill Hoppers	8 Pounds/50 Unit Fill**
**Must be evenly mixed during fill.	
<b>Talc</b>	
Conventional Hoppers	¼ C.*
Bulk Fill Hoppers	4 Pounds/50 Unit Fill*
*Double amount of talc for sunflowers.	

GRAPHITE

The use of graphite is the primary recommendation to promote seed flow, provide lubrication for the seed meter and to help dissipate static charge buildup. Among the available dry seed lubricants graphite is the most effective and easiest to use and it requires no mechanical agitation

Conventional Hoppers

Mix one tablespoon of **powdered graphite** with seed each time hoppers are filled. Regular graphite use prolongs life of the seed meter components, improves seed spacing, and may reduce buildup of seed treatments.

**NOTE: DO NOT apply graphite only in center of hopper. It will filter too quickly through the seed and not distribute as evenly as desired.**

Apply graphite around outer perimeter of hopper.

Bulk Fill Hoppers

Mix 1 pound bottle of powdered graphite each time the bulk seed hopper is filled. Graphite should be added in layers as the bulk seed hoppers are filled. Regular graphite use prolongs life of the seed meter components, improves seed spacing, and may reduce buildup of seed treatments.



Adding graphite to conventional hopper



Adding graphite bulk fill hopper

**NOTE: Additional graphite may be required to retard buildup of seed treatments on meter components. More frequent cleaning of monitor seed tubes may be necessary due to use of additional graphite.**

### 80/20 TALC-GRAPHITE

Talc-Graphite lubricant is to be used for treated seed, providing benefits of both talc and graphite. It absorbs moisture to prevent bridging, minimizes static electricity for improved seed flow, and lubricates seed and meters.

#### Conventional Hoppers

Mix ½ C. of 80/20 talc-graphite evenly with seed each time hoppers are filled. Regular graphite use prolongs life of the seed meter components, improves seed spacing, and may reduce buildup of seed treatments.

**NOTE: Talc-Graphite lubricant MUST be mixed evenly during fill.**

#### Bulk Fill Hoppers

Mix 8 lbs. of 80/20 talc-graphite each time the bulk seed hopper is filled. Regular graphite use prolongs life of the seed meter components, improves seed spacing, and may reduce buildup of seed treatments.

**NOTE: Talc-Graphite lubricant MUST be mixed evenly during fill.**

### TALC

**Talc seed lubricant** may be used as a drying agent in addition to graphite lubrication. The drying agent may improve seed release and/or **to retard buildup of seed treatments on meter components.**

1. Fill hopper ½ full of seed, add ¼ cup (conventional); 2 pounds (Bulk Fill) of talc and **mix thoroughly**.
2. Finish filling hopper, add another ¼ cup (conventional); 2 pounds (Bulk Fill) of talc and **mix thoroughly**.
3. Adjust rate of talc use as needed so all seeds are coated, while avoiding a buildup of talc in bottom of hopper.

Humid conditions and/or small sized seeds with extra seed treatment may require additional talc to maintain meter performance.

**NOTE: Liquid seed treatments or inoculants may create buildup on the seed disc or brushes. Check frequently for proper population and/or seed delivery when using any liquid seed treatment.**

Completely mix all treatments with seed following manufacturers' recommendations. Seed treatment dumped on top of seed after hopper is filled may not mix properly and cause seed bridging, reducing population or stopping meter from planting.

## **BAYER FLUENCY AGENT**

Bayer Fluency Agent is an alternate seed lubricant by Bayer Crop Science. The intent of this product is to replace graphite and talc lubricants and to lower the amount of dust emissions from planter vacuum fans.

This product, as tested by Kinze, is compatible with Kinze's bulk fill system and vacuum meters. Due to limited testing, wear life characteristics of meters and bulk fill systems that use Bayer Fluency Agent are not yet known. Please follow Bayer Fluency Agent instructions for rates and mixing directions.

**NOTE: Presently, Bayer Fluency Agent is only required to be used in Canada with Bulk Fill or Vacuum planters that plant corn or beans treated with neonicotinoids. Farms outside of Canada, farms not using seed treated with neonicotinoids, and farms not using pneumatic metering devices do not need to use Bayer Fluency Agent. All planters not equipped with vacuums or fans are exempt from using Bayer Fluency Agent.**

## SPIKED CLOSING WHEEL

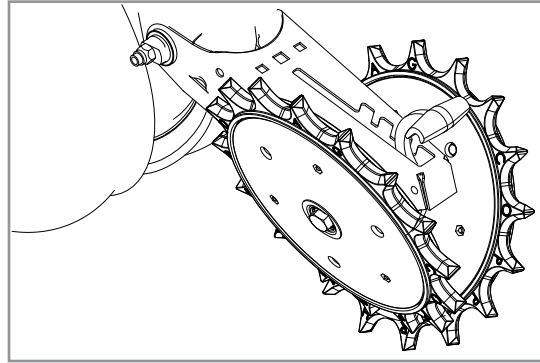

Row Unit Spiked Closing Wheel

Spiked closing wheels crumble the sidewall, allowing roots to penetrate soil. They can be used on pull row units and push row units.

Align spiked closing wheels straight across from each other, in most forward holes on closing wheel arm. Set the wheels 1" - 1¼" (2.5 - 3.1 cm) apart at the closest point.

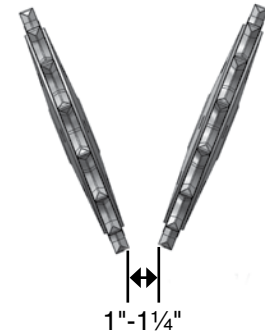

## ROW UNIT MOUNTED NO TILL COULTER

Row unit mounted no till coulters with 1" bubbled, 1" fluted (8 flutes) or ¾" (13 flutes) blades may be used on row units (¾" fluted shown). Four quick adjustable down force springs are required per row when using row unit mounted no till coulters. See "[Quick Adjustable Down Force Springs Option](#)" on page 3-3.

Coulter blade can be adjusted to one of four ½" (13 mm) incremental settings in the forked arm. Initial location is the top hole.

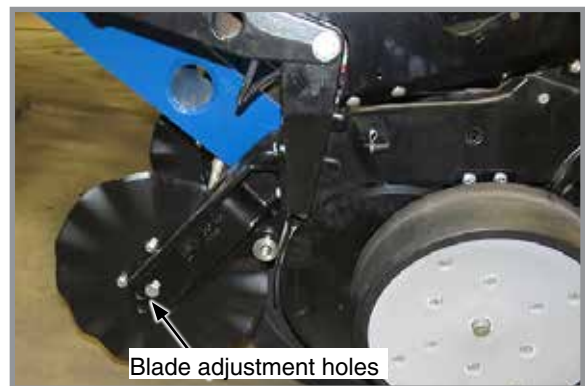

Row Unit Mounted No Till Coulters

Move blade as it wears to one of the three lower hole to maintain coulters blade at or slightly above opener discs. Adjust coulters below depth of double disc opener blades in very hard soil conditions such as compacted wheel tracks to improve opener penetration and cutting of surface residue.

Check operating depth by setting planter down on a level concrete floor and checking relationship between coulters blade and row unit opener blade. Make sure planter is level and coulters is square with planter frame and aligned with row unit disc opener.

**NOTE: Torque 5/8" spindle hardware to 120 ft-lb.**

## COULTER MOUNTED RESIDUE WHEELS

Coulter mounted residue wheels are designed for use on row units.

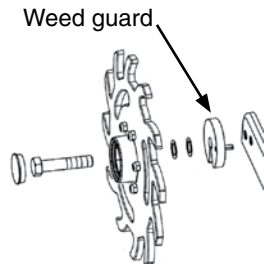

**NOTE: Opening in weed guard must face down.**



**Coulter Mounted Residue Wheels**

Residue wheels attach to row unit mounted coulter with two cap screws and sleeves allowing unit to free-float. A 2-position spindle bolt mounting positions wheels interlocked or staggered. Depth adjustment is made with a spring-loaded cam and pin with 8 positions in  $\frac{7}{16}$ " increments. A high point on the cam allows wheels to be locked up.

A weed guard on the inboard side of each wheel helps prevent weed wrap which can cause premature bearing failure.

## GRANULAR CHEMICAL BANDING OPTIONS

Granular chemical banding options allow  $4\frac{1}{2}$ " slope-compensating banding, straight drop in-furrow placement or 14" rear banding.

**NOTE: Granular chemical rear bander is not compatible with covering discs/single press wheel option.**

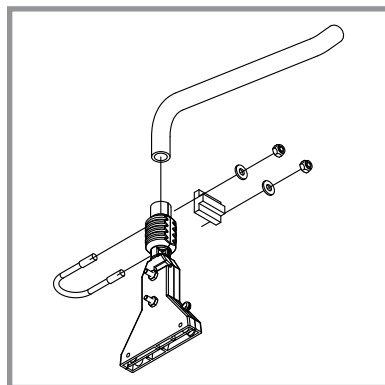

**$4\frac{1}{2}$ " Slope-compensating Bander**

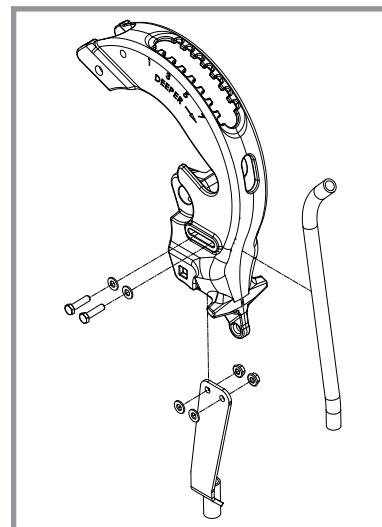

**Straight Drop In-furrow Placement**

**GRANULAR CHEMICAL HOPPER AND DRIVE****WARNING**

Agricultural chemicals can cause death or serious injury to persons, animals, and plants or seriously damage soil, equipment, or property. Read and follow all chemical and equipment manufacturers labels and instructions.

**NOTICE**

Do not store granular products in granular chemical hoppers. High humidity or rain may cause stored granular products to bind and block the product from flowing.

The granular chemical hopper has a 1.4 cubic feet capacity.

Make sure no foreign objects get into hopper when it is being filled. Replace hopper lids after filling to prevent accumulation of dirt and moisture.

A metering gate on bottom of hopper regulates the application rate. See “Dry Insecticide and Dry Herbicide Application Rate Charts” in this manual. Calibrate using chemical manufacturers’ instructions.



**Granular Chemical Hopper**

## SYSTEM OVERVIEW

Fertilizer is controlled through the Blue Vantage Display. You can increase or decrease fertilizer rate, turn fertilizer function on or off, and load a prescription. Refer to your Blue Vantage manual for more information.

## CENTRIFUGAL PUMP

**NOTE: Keep manuals shipped with centrifugal pump with this manual.**

The centrifugal pump operates off hydraulics from the bulk fill remote, which can be identified by yellow labeled hoses. It uses a common rail delivery system with orifice and control valve to achieve desired fertilizer rate. The fertilizer pump is factory set and has a hydraulic requirement of 4 gpm.

Operating pressure while operating in the field should be 30-40 psi. The orifice size installed at the factory is 0.037". If a different rate or travel speed is desired, use rate chart and install orifices for your rate.

The centrifugal pump should be running when:

- Bulk fill remote is on (identified by yellow hoses)
- Blue Vantage system must be in a task before pump will start.
- Fertilizer is turned on in the fertilizer section of your Blue Vantage system

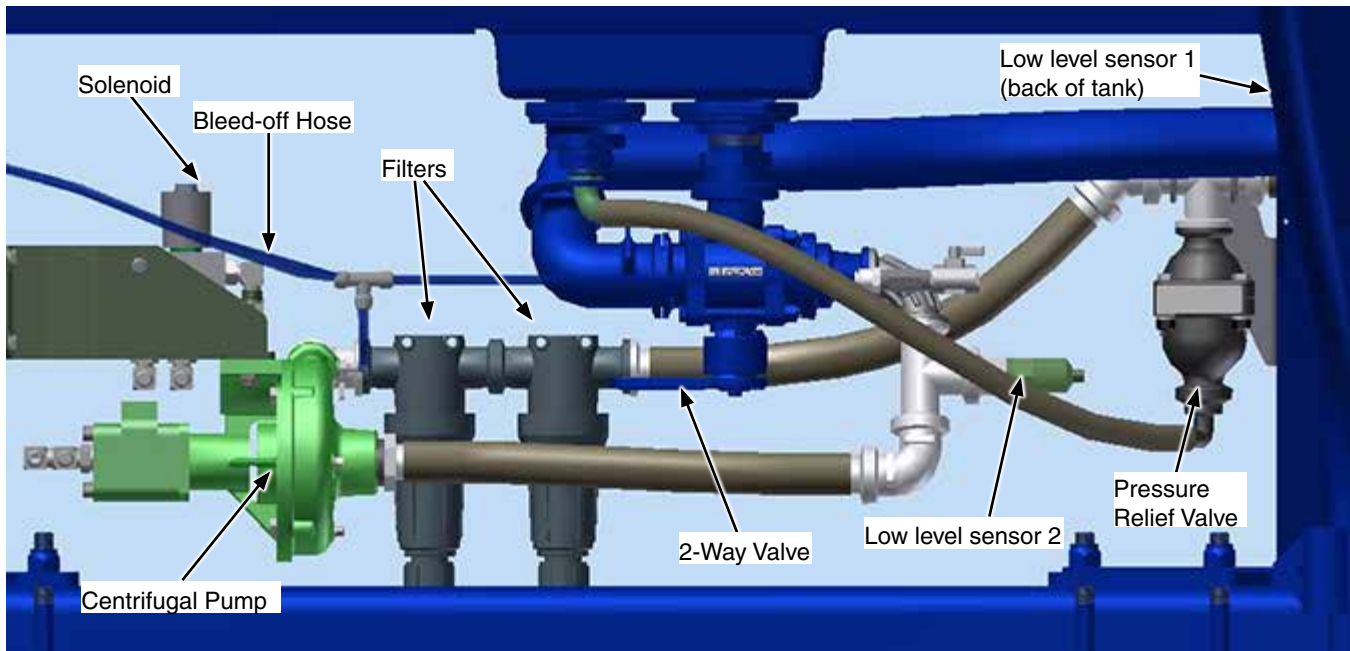

Underneath Fertilizer Tank

**Solenoid** allows oil to go to centrifugal pump and turn. It is controlled from the bulk fill IPN on the planter.

**Safety Relay** (not shown) shuts off the pump when no fluid is sensed in the lower Low Level Sensor.

**Low Level Sensor 1** is located on back of tank and signals in the cab when tank fluid level is low.

**Low Level Sensor 2** is located in the tee fitting after 2-way valve and prevents pump from running when fluid level in tank is too low.

**Centrifugal Pump** is hydraulically driven and pumps fertilizer to the manifold rail delivery system.

**2-Way Valve** has two positions for filling the tank. Use the "FILL/PUMP" position to fill the tank and while operating. "OFF" turns the tank off.

**Pressure Relief Valve** is a 75 psi relief valve that allows liquid to return to the tank when valves are shut off on all rows.

**Bleed-off Hose** is used for preventing or eliminating air-locking the centrifugal pump.



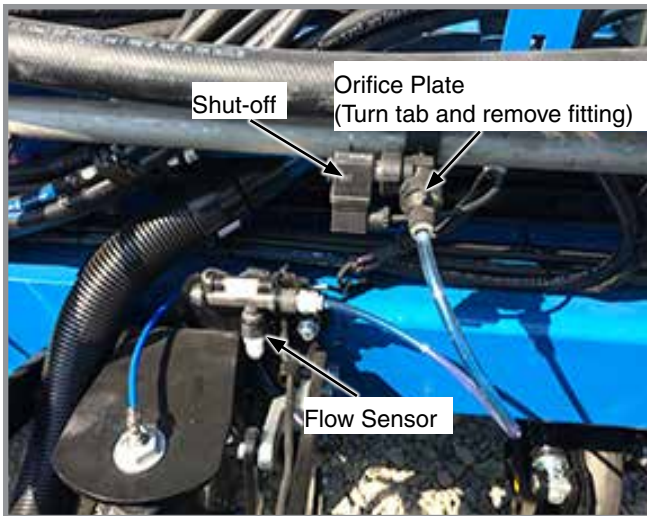

On Toolbar at Row

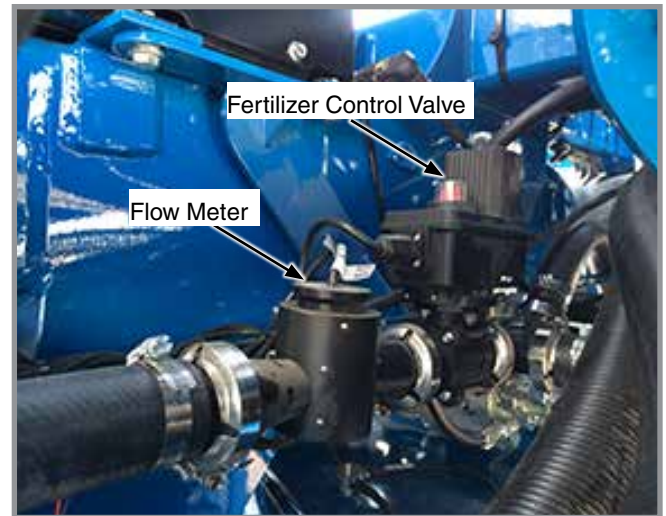

Underneath Bulk Fill Tank

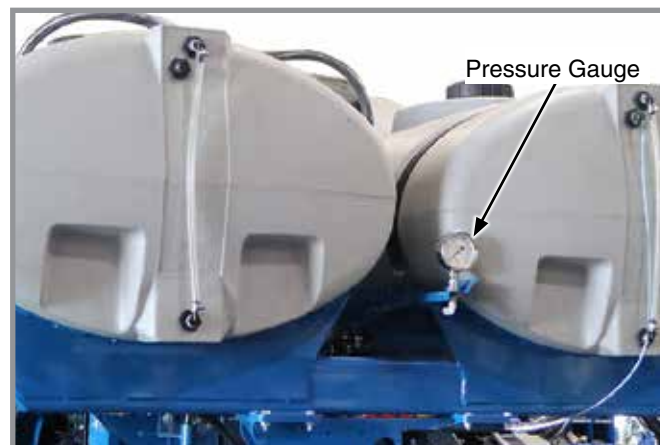

**Flow Meter** measures fertilizer rate when operating in the field and is displayed in the tractor cab.

**Fertilizer Control Valve** controls the fertilizer rate and changes rate with change in speed from input from the flow meter.

**Shut-off** 24 volt shut-off stops fertilizer when coming into a planted area.

**Flow Sensor** functions as a blockage sensor to signal operator when there is a blockage or no fertilizer flow when there should be. Flow sensor does not indicate rate.

**Orifice Plate** is factory installed with a 0.037" diameter. To access the orifice, turn the tab counterclockwise and remove the fitting and tube.

**Pressure Gauge** is located on the tank. On some models, the pressure gauge may be located on the end of the toolbar.

**This page left blank intentionally.**

**NOTICE**

Disconnect all electronic monitor and control modules prior to making any repairs or modifications to the planter or mounted attachments. Failure to do so will result in permanent damage to sensitive electronic components and could void your warranty.

**LUBRICATION**

The following pages show locations of all lubrication points. Proper lubrication of moving parts helps ensure efficient operation of your Kinze planter and prolongs the life of friction producing parts.

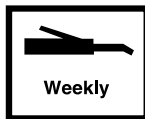
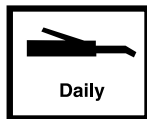
**LUBRICATION SYMBOLS**

Lubricate at frequency indicated with SAE multipurpose grease.

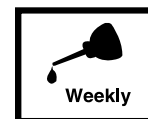

Lubricate at frequency indicated with high quality SAE 10 weight oil or spray lubricant.

**WHEEL BEARINGS**

All drive, transport, and marker hub wheel bearings should be repacked annually and checked for wear.

1. Raise wheel off ground.
2. Check for bearing endplay by moving wheel side to side.
3. Rotate wheel to check for bearing roughness. If bearings sound rough, remove hub and inspect bearings.

**NOTE: To repack wheel hubs, follow procedure outlined for wheel bearing replacement in this section except bearings and bearing cups are reused.**

**GREASE FITTINGS**

**WARNING**

Uncontrolled movement of equipment can cause loss of control and could result in death, serious injury, or damage to property and equipment. Install all safety lockup devices before transporting equipment.

Parts equipped with grease fittings should be lubricated at frequency indicated with an SAE multipurpose grease. Clean fitting thoroughly before using grease gun. Frequency of lubrication recommended is based on normal operating conditions. Severe or unusual conditions may require more frequent attention.

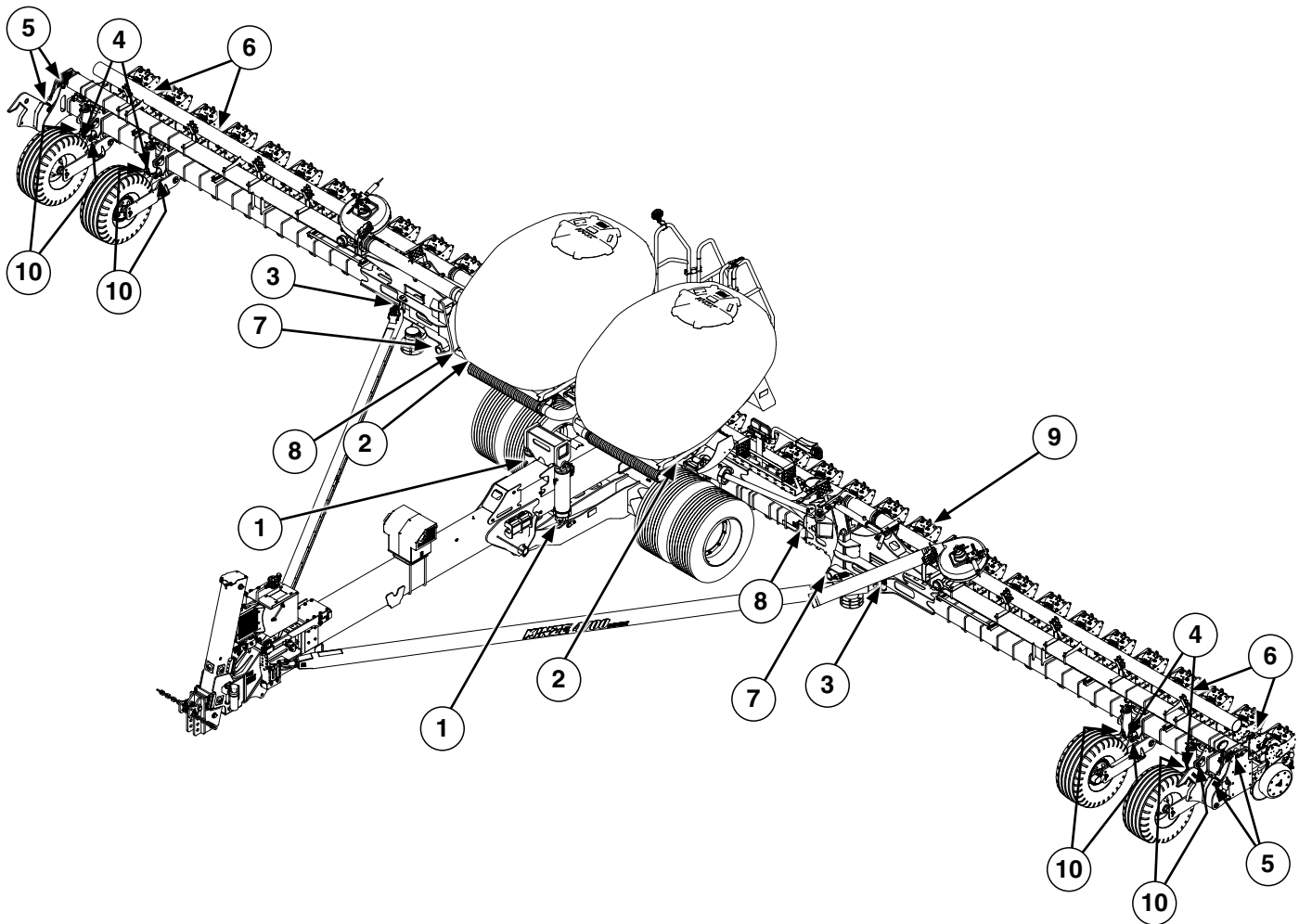

**NOTE:** Shown with no row markers.

**NOTE:** Numbers on illustration above correspond to photos on following pages showing lubrication frequencies.



1. Lift Cylinder, 2 per machine  
1 fitting per cylinder

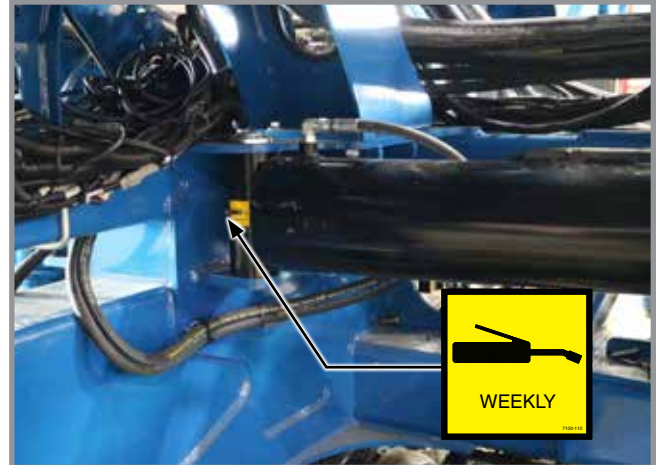

2. Fold cylinders, 2 per machine  
2 fittings per cylinder (one each end)

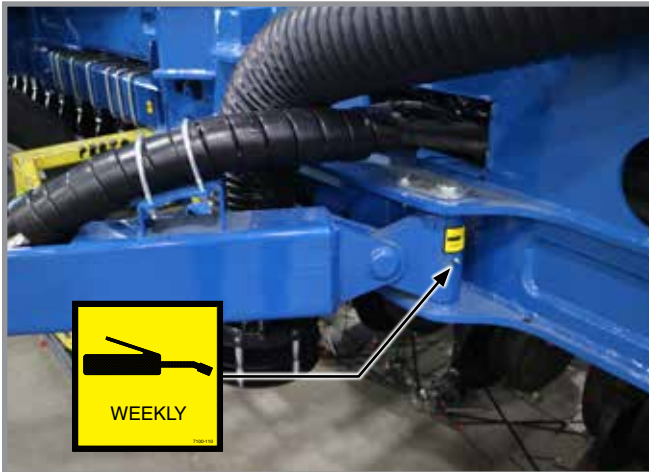

3. Draft Link, 2 per machine  
1 fitting per link



4. Lift Cylinders, 4 per machine  
1 fitting per cylinder

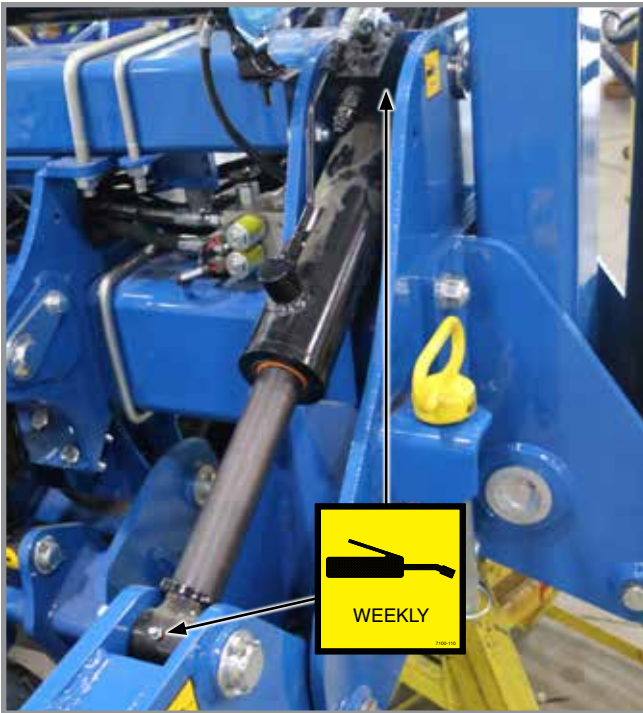

5. Wing Latch cylinders, 4 per machine  
2 fittings per cylinder (one each end)



6. Wheel modules, 4 per machine  
2 fittings per module

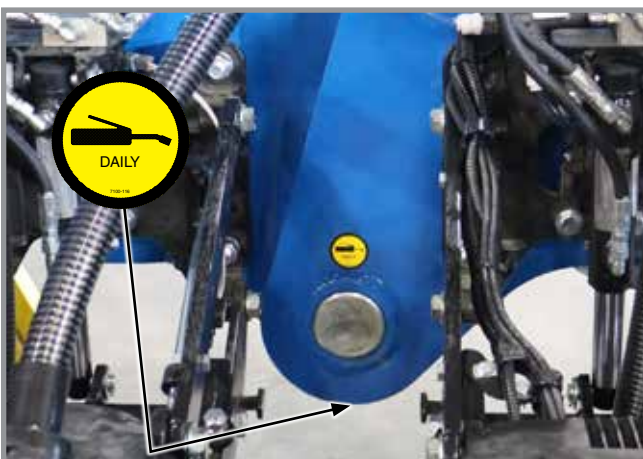

7. Wing pivot, 2 per machine  
2 fittings per pivot

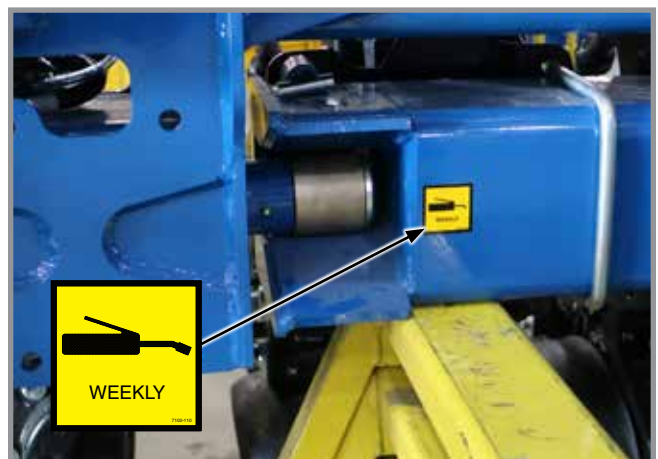

8. Stub Wing Roller, 2 per machine  
1 fittings per roller

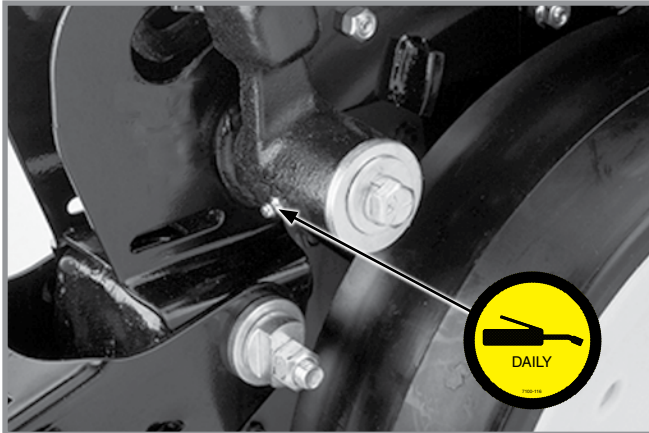
**9. Gauge wheel arms - 1 per arm**

(Seals in gauge wheel arm are installed with lip facing out to allow grease to purge dirt away from seal. Pump grease into arm until fresh grease appears between washers and arm.)

**10. Lift Cylinders, 8 per machine  
2 fittings per cylinder**

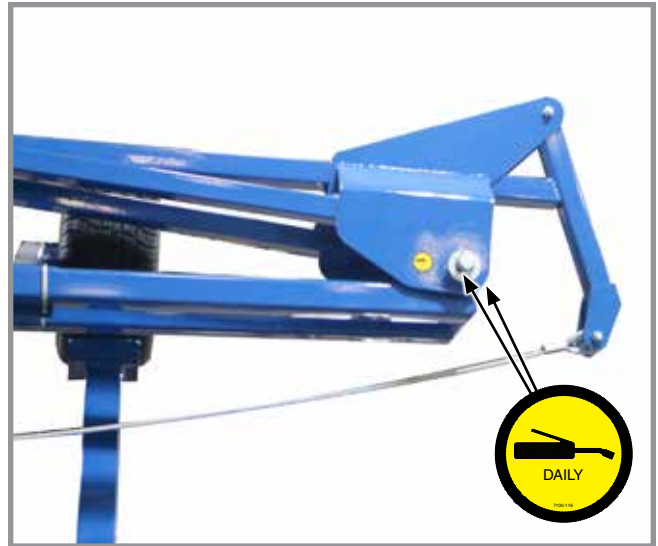
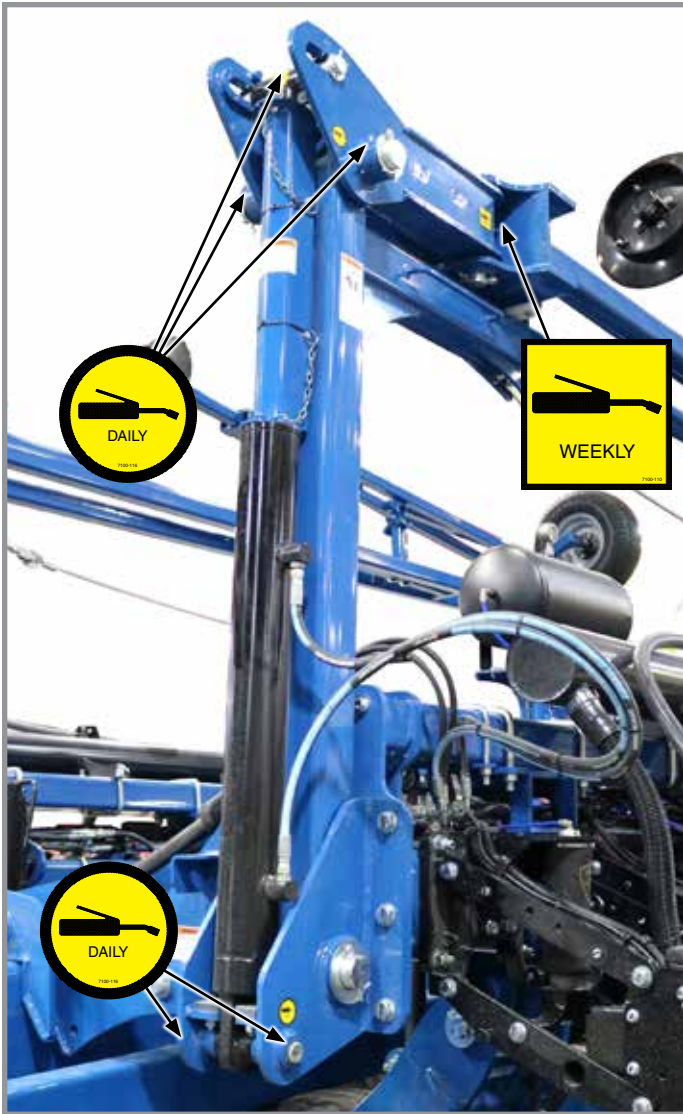

Row Markers



## PTO SHAFT COUPLING

Clean and grease PTO shaft coupling each time pump is installed.

Apply coating of high-speed industrial coupling grease, such as Chevron® Coupling Grease meeting AGMA CG-1 and CG-2 Standards to extend shaft spline life.



**PTO Pump Installed**

**MOUNTING BOLTS AND HARDWARE**

Before operating planter for the first time, check all hardware is tight. Check all hardware again after first 50 hours of operation and beginning of each planting season.

All hardware used on the Kinze planter is Grade 5 (high strength) unless otherwise noted. Grade 5 cap screws are marked with three radial lines on the head. Hardware must be replaced with equal size, strength, and thread type.

**WARNING**

**Loose transport wheel lug bolts can result in wheel separation from planter and result in death, serious injury, and damage to property and equipment. Check transport wheel lug nut torque before operating planter for the first time and periodically thereafter.**

**NOTICE**

**Over-tightening hardware can reduce its shock load capacity and cause equipment failure.**

**TORQUE VALUES CHART - PLATED HARDWARE**

Diameter	Grade 2 (No marks)		Grade 5 (3 marks)		Grade 8 (6 marks)	
	Coarse	Fine	Coarse	Fine	Coarse	Fine
1/4"	50 in-lb	56 in-lb	76 in-lb	87 in-lb	9 ft-lb	10 ft-lb
5/16"	8 ft-lb	9 ft-lb	13 ft-lb	14 ft-lb	18 ft-lb	20 ft-lb
3/8"	15 ft-lb	17 ft-lb	23 ft-lb	26 ft-lb	33 ft-lb	37 ft-lb
7/16"	25 ft-lb	27 ft-lb	37 ft-lb	41 ft-lb	52 ft-lb	58 ft-lb
1/2"	35 ft-lb	40 ft-lb	57 ft-lb	64 ft-lb	80 ft-lb	90 ft-lb
9/16"	50 ft-lb	60 ft-lb	80 ft-lb	90 ft-lb	115 ft-lb	130 ft-lb
5/8"	70 ft-lb	80 ft-lb	110 ft-lb	125 ft-lb	160 ft-lb	180 ft-lb
3/4"	130 ft-lb	145 ft-lb	200 ft-lb	220 ft-lb	280 ft-lb	315 ft-lb
7/8"	125 ft-lb	140 ft-lb	320 ft-lb	350 ft-lb	450 ft-lb	500 ft-lb
1"	190 ft-lb	205 ft-lb	480 ft-lb	530 ft-lb	675 ft-lb	750 ft-lb
1 1/8"	265 ft-lb	300 ft-lb	600 ft-lb	670 ft-lb	960 ft-lb	1075 ft-lb
1 1/4"	375 ft-lb	415 ft-lb	840 ft-lb	930 ft-lb	1360 ft-lb	1500 ft-lb
1 3/8"	490 ft-lb	560 ft-lb	1100 ft-lb	1250 ft-lb	1780 ft-lb	2030 ft-lb
1 1/2"	650 ft-lb	730 ft-lb	1450 ft-lb	1650 ft-lb	2307 ft-lb	2670 ft-lb

**NOTE: Torque unplated hardware and bolts with lock nuts approximately 1/3 higher than above values. Torque bolts lubricated prior to installation to 70% of value shown in chart.**

**CYLINDER ROD PISTON RETAINING NUT TORQUE CHART**

	Non-Nylock Nut	Nylock Nut
½"-20	55-70 ft-lb (75-95 N-m)	45-55 ft-lb (61-75 N-m)
¾"-16	115-125 ft-lb (156-169 N-m)	100-115 ft-lb (136-156 N-m)
7/8"-14	150-180 ft-lb (203-244 N-m)	130-150 ft-lb (176-203 N-m)
1"-14	275-330 ft-lb (373-447 N-m)	250-275 ft-lb (339-373 ft-lb)
1 1/8"-12	300-375 ft-lb (407-508 N-m)	275-300 ft-lb (373-407 N-m)
1 1/4"-12	300-375 ft-lb (407-508 N-m)	275-300 ft-lb (373-407 N-m)

**TORQUE VALUES- ALUMINUM**

Diameter	Torque Value
1/8"	180-220 in-lb
3/8"	350-380 in-lb
1/2"	350-400 in-lb
3/4"	350-400 in-lb

**NOTE: Use these torque values with pneumatic down pressure components.**

**SPECIAL TORQUE VALUES & INSTRUCTIONS**

Row unit parallel linkage bushing hardware	130 ft-lb (176 N-m)
5/8" No till coultter spindle hardware	120 ft-lb (162 N-m)
Row Unit Disc Opener Blade Bolt**	110 ft-lb (149 N-m) **Left hand side is left hand thread.
5/8" - 18 Wheel Lug Nuts and Lug Bolts	200 ft-lb (271 N-m)
9/16" - 18 Wheel Lug Nuts and Lug Bolts	125 ft-lb (169 N-m)
Row Unit Support (Face Plate)	90 ft-lb (122 N-m)
Notched Single Disc Opener - 3/4" L-bolts	160 ft-lb (217 N-m)
Notched Single Disc Opener - 5/8" Hex Head Cap Screws	90 ft-lb (122 N-m)
Notched Single Disc Opener - 3/4" Hex Set Screws	160 ft-lb (217 N-m)

**TORQUE VALUES - TRUE DEPTH HYDRAULIC DOWN FORCE**

Cylinder Head to Body:	70 ft-lb
Cylinder Piston to Rod:	50 ft-lb
Row Unit Valve Cartridge to Line Body:	30 ft-lb
Row Unit Valve Solenoid to Valve:	4-6 ft-lb

**NOTE:**

1. A 6-Pt Socket must be used to torque the cylinder head to the body.
2. Apply blue threadlocker to cylinder head threads when reassembling.
3. Replace piston to rod locknut with equivalent 7/16-20 locknut before reassembling.

## TIRE PRESSURE

**WARNING**

**Explosive separation of rim and tire parts can cause death or serious injury. Overinflation, rim and tire servicing, improper use of rims and tires, or worn or improperly maintained tires could result in a tire explosion.**



- Maintain proper tire pressure. Inflating a tire above or below the recommended pressure can cause tire damage.
- Mount tires only by properly trained personnel using proper equipment.
- Replace tires with cuts or bubbles. Replace damaged rims. Replace missing lug bolts and nuts.
- Do not weld or heat wheel assembly. Heating increases tire pressure.

## TRANSPORT TIRES

**WARNING**

**Overinflation of tires can result in explosive separation of rim and tire and cause death or serious injury. Different size rims are designed for different tire pressures. Inflate to correct pressure for specific rim size.**



## INFLATION SPECIFICATIONS



**Tire Locations (R.H. shown)**

1. Torque transport wheel  $\frac{3}{4}$ "- 16 lug nuts to 315 ft-lb.
2. Torque wing wheel  $\frac{5}{8}$ "-18 lug nuts to 200 ft-lb.
3. Inflate tires to the following specifications:

Transport Tire Size (4)	445/50R 22.5
Transport Tire Pressure	100 PSI
Wing (Field) Tire Size (4)	380/55R 16.5
Wing (Field) Tire Pressure	65 PSI
Marker Arm Tire Size (2)	16" x 6 $\frac{1}{2}$ " x 8"
Marker Arm Tire Pressure	14 PSI

4. Lubricate planter and row units per lubrication information in this manual.

## VACUUM SEED METER MAINTENANCE

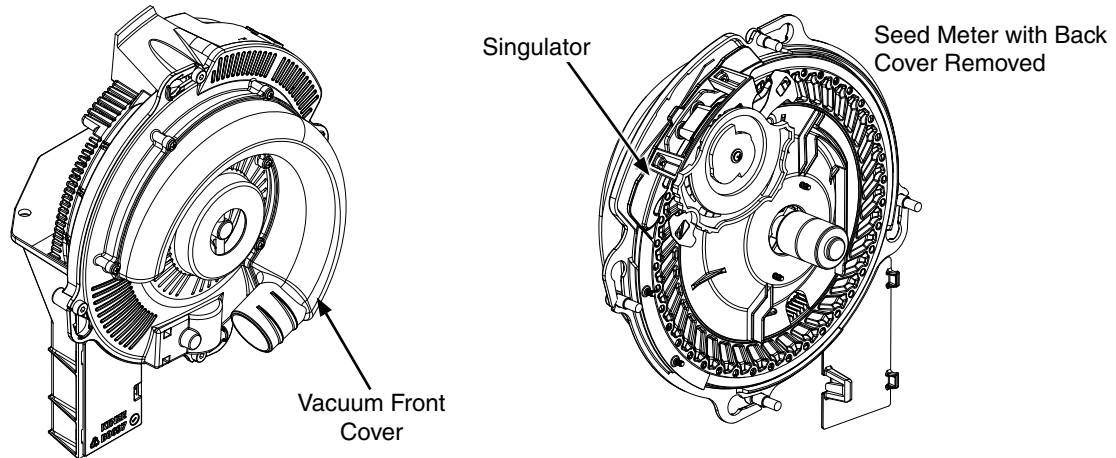

Before each planting season inspect seed discs and singulator and clean or replace as needed.

Use clean, high quality seed for maximum meter accuracy. Damaged or cracked seed, hulls, and foreign material may become lodged in seed disc orifices and greatly reduce meter accuracy.

Inspect and clean seed discs daily checking for any buildup of foreign material and blocked orifices. If seed disc orifices are plugged frequently with seed remnants, clean out brush with ball-type ejector (if applicable) may need to be replaced. Clean seed disc by washing it with soap and water. Dry thoroughly.

Inspect singulator blades and guide for wear after every 80 ha per row of operation. If adjustment of singulator blade does not affect meter performance or if blades appear worn, singulator blade may need to be replaced.

Replace seed disc or vacuum seal if abnormally high vacuum is required or if consistent operation cannot be achieved. See [“Preparation for Storage” on page 5-24](#) for additional Vacuum Seed Metering System maintenance.

**NOTE: Remove seed discs from meters for annual storage and store them vertically on a dowel or pipe.**

## SEED METER CLEANOUT

**NOTE: Use of damaged seed or seed containing foreign material will cause plugging of seed cell orifices and require more frequent seed meter cleanout to prevent underplanting.**

Thorough seed meter cleanout is important to maintain genetic purity.

1. Disengage seed drive and remove seed hopper and meter.
2. Dump seed from right rear corner of hopper into a container.
3. Lay hopper on its right side. Push release button and rotate seed meter vacuum cover clockwise to align keyhole slots with bolt heads. Lift off cover.
4. Rotate seed disc hub clockwise to unlock and remove seed disc.
5. Empty meter.
6. Thoroughly inspect meter to ensure all seed is removed.
7. Replace seed disc. Install vacuum cover.

## VACUUM MANIFOLD MAINTENANCE

Dust accumulates in manifolds and hoses during normal operation. Clean manifolds annually. Abnormally dusty planting conditions may require more frequent cleaning.

1. Remove vacuum hose from each seed meter.
2. Operate vacuum fan at full hydraulic flow from tractor for two minutes to clear manifolds, hoses, and fittings of dust and debris.
3. Shut down fan and replace hoses.

## GAUGE WHEEL ADJUSTMENT

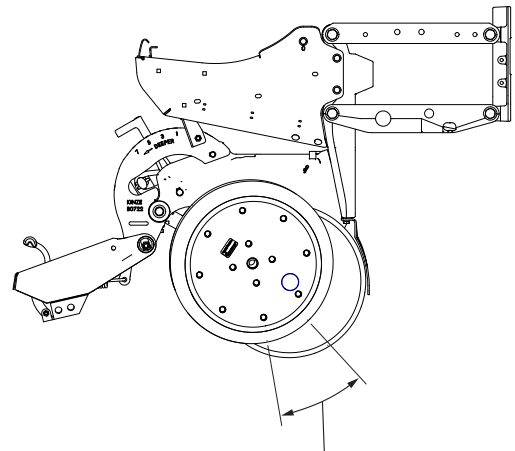
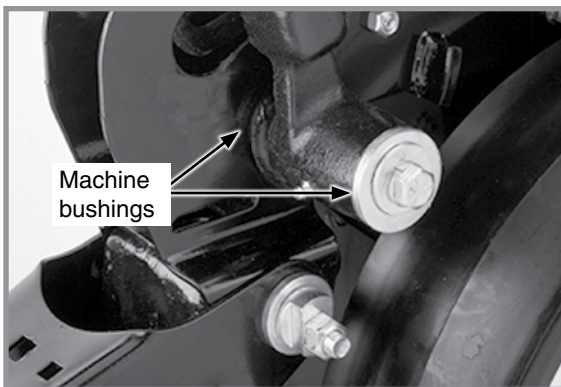

Shim gauge wheel to lightly contact opener disc blade in this area for 4" to 6". Check adjustment in operating position.

### Gauge Wheel Adjustment

Add or remove machine bushings between shank and gauge wheel arm to adjust contact between gauge wheels and opener blades. Gauge wheels should lightly contact opener blades to prevent accumulation of dirt or trash. Gauge wheels and opener blades should turn with only slight resistance.

Store remaining machine bushings between gauge wheel arm and flat washer on outer side of gauge wheel arm.

Use the following guidelines:

**NOTE: Set depth adjustment handle at 3x2 position and lift gauge wheel to stop one side at a time.**

Contact should be no less than one half of the rotation of the wheel, while not sticking in any position (it does not have to be continuous). Wheel should rotate in the direction of travel of the row unit. Wheel can be held in position by supporting the spindle bolt head.

## GAUGE WHEEL ARM PIVOT SPINDLE REPLACEMENT

1. Remove gauge wheel and arm assemblies from shank assembly.
2. Remove  $\frac{1}{2}$ " x  $\frac{3}{4}$ " cap screw that locks pivot spindle in place and remove spindle.
3. Install replacement spindle and position as shown. Exact centering is critical.
4. Install  $\frac{1}{2}$ " x  $\frac{3}{4}$ " cap screw and torque to lock pivot spindle in place.
5. Install gauge wheel and arm assemblies. Shim for proper gauge wheel tire/disc blade clearance.

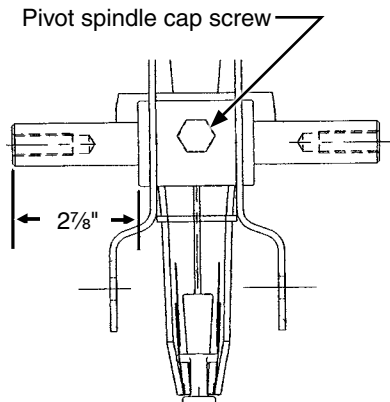

## GAUGE WHEEL ARM BUSHING/SEAL REPLACEMENT

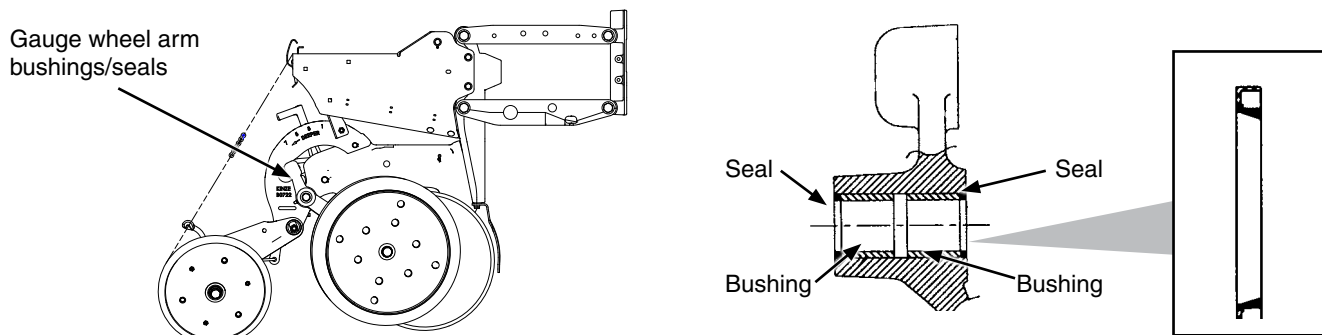

**NOTE: Gauge Wheel Arm Bushing and Seal Driver Kit (G1K296) is available through your Kinze Dealer.**

1. Remove gauge wheel from arm.
2. Remove gauge wheel arm from shank assembly.
3. Remove seal and bushing and discard. Clean and dry inner bore.
4. Drive/press replacement bushing inside bore of arm to a depth of .125" below flush.
5. Coat wiping edge of seal with grease.
6. Drive/press seal into place with lip to outside.

**NOTE: Use extra care to protect the sealing lip during installation. Apply uniform pressure to assemble the seal into the bore of the arm. Never apply a direct hammer blow to the seal surface.**

7. Inspect gauge wheel pivot spindle.
8. Reinstall gauge wheel arm assembly and gauge wheel.

**NOTE: Use special machine bushing between gauge wheel arm and gauge wheel.**

9. Shim for proper gauge wheel tire/disc blade clearance.
10. Lubricate with an SAE multipurpose grease.



## 15" SEED OPENER DISC BLADE/BEARING ASSEMBLY

### NOTICE

Excessive blade contact may result in premature disc opener bearing/hub failures and excessive wear on seed tube guard/inner scraper. When properly adjusted, if one blade is held in fixed position, opposite blade should rotate with less than 22 newtons force at outer edge of blade.

Maintain approximately  $1" \pm \frac{1}{2}"$  of blade-to-blade contact to properly open and form seed trench. As blade diameter decreases due to wear, it is necessary to relocate machine bushings from inside to outside to maintain  $1" \pm \frac{1}{2}"$  mm of contact.

**NOTE: Proper blade clearance is critical. Blades should have  $1" \pm \frac{1}{2}"$  contact in this area. When blades are turned by hand in opposite directions against each other, there should be only light resistance to turning. Re-adjust blade scraper if necessary to center it between the blades.**

**NOTE: Replace blades if proper blade-to-blade contact cannot be maintained after relocating machine bushings or if blade diameter wears below  $14\frac{1}{2}"$ .**

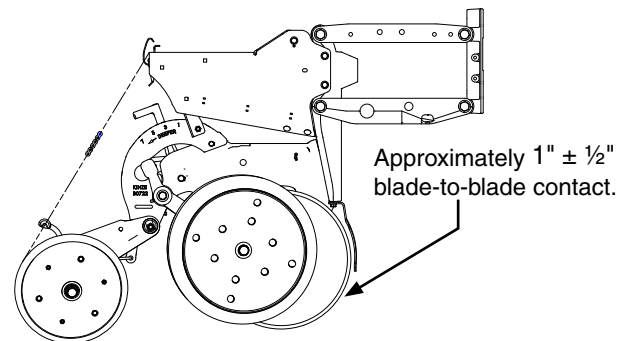

### REPLACE DISC BLADE/BEARING ASSEMBLY

**NOTE: Only bearing may need to be replaced if there is excessive endplay or if bearing sounds or feels rough when disc blade is rotated.**

1. Remove gauge wheel, scraper, and bearing dust cap.
2. Remove cap screw, washer and disc blade/bearing assembly. Machine bushings between shank and disc blade are used to maintain approximate  $1" \pm \frac{1}{2}"$  of blade-to-blade contact.

### NOTICE

Left hand side of opener uses a left hand threaded cap screw. **DO NOT OVER TIGHTEN.** Damage to shank threads require replacement of row unit shank assembly.

3. Install machine bushing(s), new disc blade bearing assembly, washer and cap screw. Torque  $\frac{5}{8}"$ -11 Grade 5 cap screw to 110 ft-lb.

**NOTE: Replace disc blades only with disc blades of equal thickness.**

4. Install bearing dust cap, scraper, and gauge wheel.

## 15" SEED OPENER DISC BLADE/BEARING ASSEMBLY (CONTINUED)

### REPLACE BEARING ONLY

1. Remove gauge wheel, scraper, bearing cap, cap screw, washer and disc blade/bearing assembly.
2. Remove  $\frac{1}{4}$ " rivets from bearing housing to expose bearing.
3. Installing new bearing. Install three evenly spaced  $\frac{1}{4}$ " cap screws into three of six holes in bearing housing to hold bearing and bearing housing in place. Install rivets in other three holes. Remove  $\frac{1}{4}$ " cap screws and install rivets in those three holes.
4. Reinstall disc blade/bearing assembly, washer and cap screw. Torque  $\frac{5}{8}$ "-11 cap screw to 110 ft-lb.
5. Install bearing dust cap, scraper, and gauge wheel.

## SEED TUBE GUARD/INNER SCRAPER

Seed tube guard protects seed tube and acts as inner scraper for seed opener disc blades.

Remove seed tube and check for wear. Excessive wear on seed tube indicates a worn seed tube guard. Replace seed tube guard if it measures  $\frac{5}{8}$ " or less at lower end. A new seed tube guard measures approximately  $\frac{7}{8}$ ".

**NOTE: No till planting or planting in hard ground conditions, especially when planter is not equipped with no till coulters, and/or excessive blade-to-blade contact increases seed tube guard wear and requires more frequent inspection and/or replacement.**

Remove gauge wheel and disc blade from one side of row unit. Lift up inner scraper approximately  $90^\circ$  to remove from slot when replacement is necessary.



**Seed Tube Guard/Inner Scraper  
(Gauge wheel/seed opener disc blade removed  
for easier identification of scraper)**

## ROW UNIT MOUNTED NO TILL COULTER

Check nuts and hardware periodically for proper torque.

**NOTE: Torque  $\frac{5}{8}$ " spindle hardware to 120 ft-lb.**

Be sure coulters are positioned square with row unit and aligned in front of row unit disc opener.

Coulters can be adjusted to one of four settings. Initially the blade is set in the highest position. As the blade wears, it can be adjusted to one of three lower settings. See "Row Unit Mounted No Till Coulters" in the Row Unit Operation section of this manual.

Replace 16" diameter coulters when worn to 14½".



Row Unit Mounted No Till Coulters

## COULTER OR ROW UNIT MOUNTED RESIDUE WHEELS



Coulters Mounted Residue Wheels

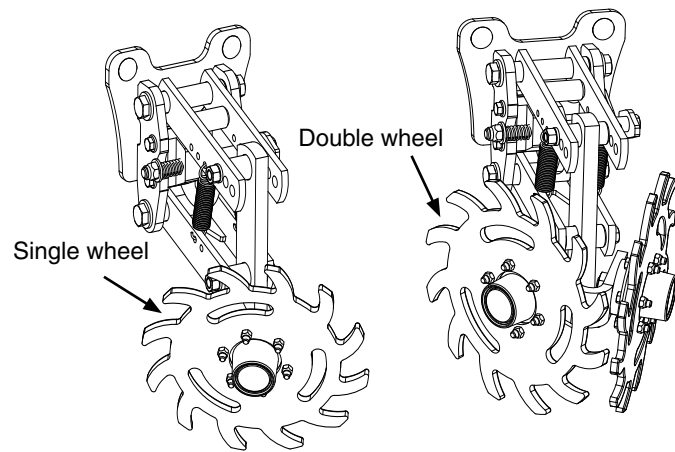

Row Unit Mounted Residue Wheels

Wheel hubs are equipped with sealed bearings. If a bearing sounds or feels rough when the wheel is rotated, replace them.

## SPIKED CLOSING WHEEL

Inner parts of the spiked closing wheel will begin to wear at approximately 70% of life. Flip/reverse the wheel to utilize the remaining life of the wheel.

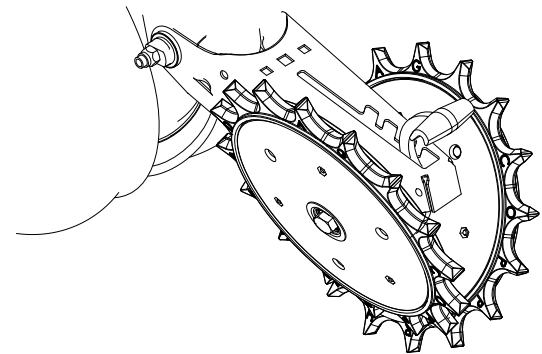

Row Unit Spiked Closing Wheel

**TRACTOR MOUNTED PUMP DRIVE AND OIL COOLER****NOTICE**

Clean and grease PTO shaft coupling with high-pressure industrial coupling grease (Chevron® coupling grease or equivalent) meeting AGMA CG-1 and CG-2 Standards each time driveshaft is installed or premature wear and equipment failure can occur.

**NOTE: Periodically check and clean oil coolers.**

1. Replace 10-micron spin-on filters on tank annually.
2. Fill system with SAE 10W-20 multigrade wide temperature range transmission hydraulic fluid. Reservoir capacity is approximately 30 L.
3. Start system and run with tractor at idle and fans turned off for 1-2 minutes. Switch fans to full speed and run with tractor at idle for 1-2 minutes.
4. Check reservoir fluid level and fill as required. Hydraulic fluid level should be within 1"- 2" from top of reservoir after pump has run and hydraulic hoses have been primed to allow fluid to expand when heated.

## CHECK VALVE

A check valve is located in each vacuum fan motor block assembly and operates as a return line check to prevent vacuum fan motor reverse operation. Remove and inspect valve. If it does not operate properly. Check for foreign material and if O-ring is leaking internally. Replace if defective.

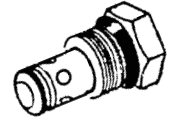

## FLOW CONTROL VALVES

Two flow control valves are located in valve block on both wings of planter. Flow control valves should be adjusted for row marker raise and lower speed as part of assembly procedure or upon initial operation. If valve fails to function properly or requires frequent adjustment, it should be removed for inspection. Check for foreign material and contamination on valve and seating areas of valve body. Replace defective components.

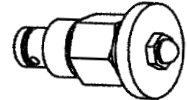

## PRESSURE RELIEF VALVES

Pressure relief valve in valve block on left wing of planter functions during lowering out of raised transport sequence. Valve is factory set and should require no additional adjustment. Pressure relief valve located in valve block on tongue functions during tongue extend cycle. This pressure relief valve ensures latch cylinder extends and releases prior to tongue extending. Valve is factory set and should require no additional adjustment. Contact your Kinze Dealer for service.

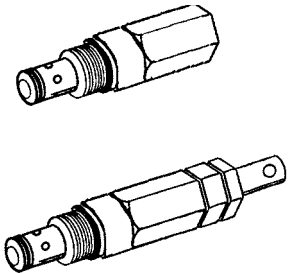

### NOTICE

Connect hydraulic motor case drain to a case drain return line with zero pressure on tractor or hydraulic motor will be damaged. DO NOT connect hydraulic motor case drain to SCV outlet. Contact tractor manufacturer for specific details on “zero pressure return”.

## PRESSURE COMPENSATED FLOW CONTROL VALVES

There are three pressure compensated flow control valves used on the planter. One is located on the vacuum fan block, on the ASD fan block and on the power pack block.

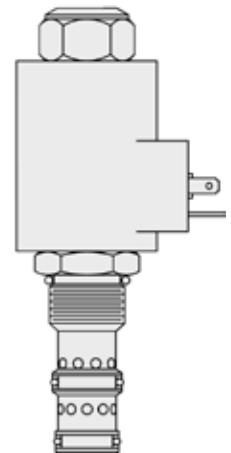

## SOLENOID VALVE

Solenoid valve consists of a chambered body with an electric coil actuated cartridge valve.

If solenoid or solenoids fail to operate, first determine if problem is electrical or hydraulic. If valve is working properly, a click will be heard when solenoid coil is energized and valve stem opens. If no sound is heard, check solenoid coil by touching top of coil housing with a metallic object such as a pliers or screwdriver. If coil is working properly, coil housing will be strongly magnetized when energized. If voltage to coil is low it will be weakly magnetized when energized and no click will be heard.

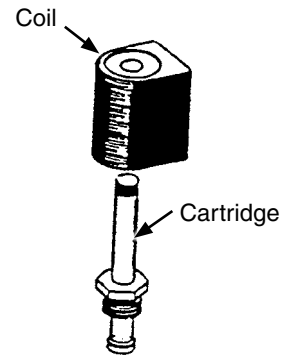

## PNEUMATIC DOWN PRESSURE AIR COMPRESSOR TANK

Moisture should be drained daily from the tank. Tank should be drained completely for storage.

To drain tank, locate drain plug on the bottom of tank. Stand off to the side of tank and pull cable attached to drain.

**NOTE: If moisture is not drained from tank rust particles will form inside tank.**

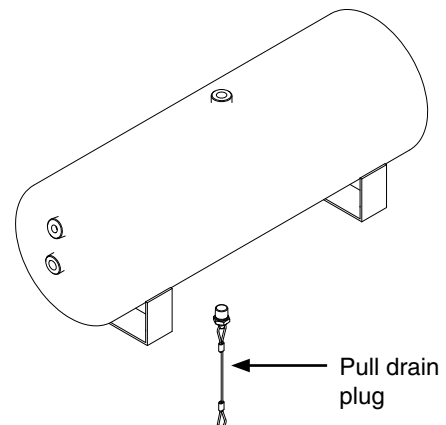

## ROW MARKER BEARING LUBRICATION OR REPLACEMENT

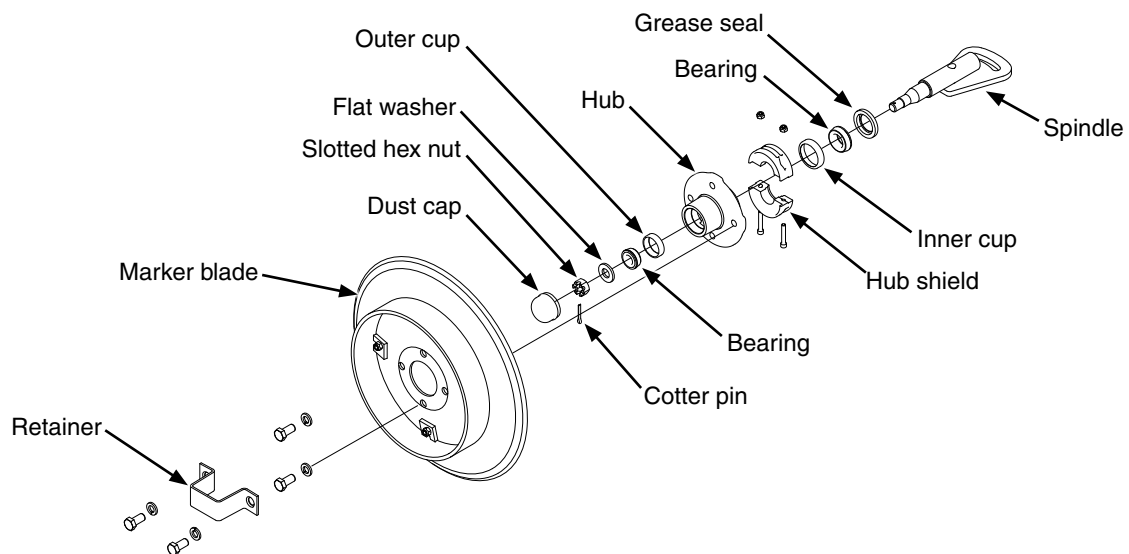

1. Remove retainer and marker blade.
2. Remove dust cap from hub.
3. Remove hub shield. Note direction of installation.
4. Remove cotter pin, slotted hex nut, and washer.
5. Slide hub from spindle.
6. Remove bearings and cups and discard if bearings are being replaced. Clean hub and dry. Remove bearings only and not cups if repacking.
7. Press in new bearing cups with thickest edge facing in. (Bearing replacement procedure only.)
8. Pack bearings with heavy duty wheel bearing grease thoroughly forcing grease between roller cone and bearing cage. Fill the space between the bearing cups in the hub with grease.
9. Install rubber seal into grease seal. Place inner bearing in place and press in new rubber seal/grease seal.
10. Clean spindle and install hub.
11. Install outer bearing, washer and slotted hex nut. Tighten slotted hex nut while rotating hub until there is some drag. This ensures all bearing surfaces are in contact. Back off slotted nut to nearest locking slot and install cotter pin.
12. Fill dust caps approximately  $\frac{3}{4}$  full of wheel bearing grease and install on hub.
13. Install hub shield.
14. Install marker blade and retainer on hub. Tighten hardware evenly.

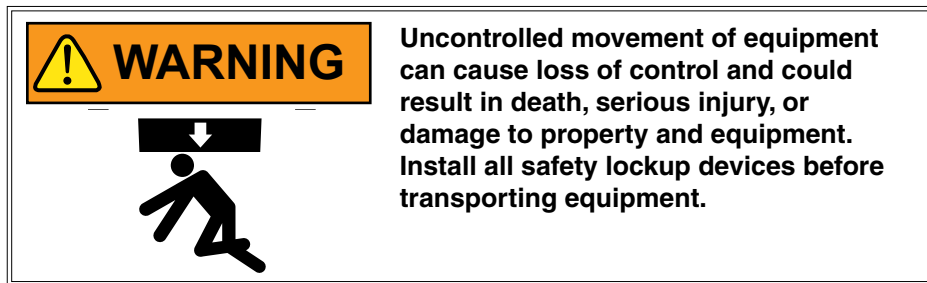

## TRANSPORT AND LIFT/GROUND DRIVE WHEEL BEARING REPACK OR REPLACEMENT

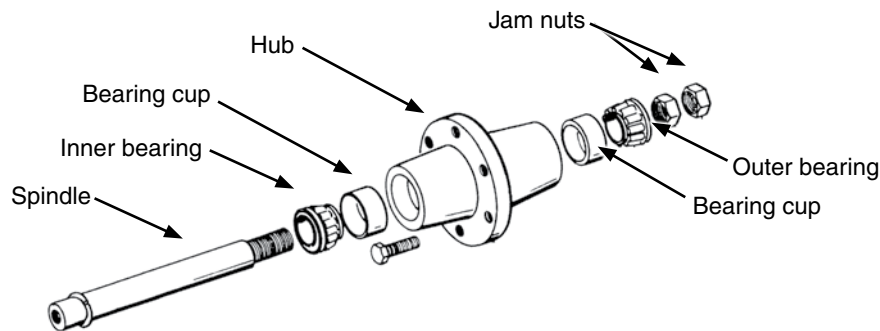

1. Raise tire clear of ground and remove wheel.
2. Remove double jam nuts and slide hub from spindle.
3. Remove bearings and cups and discard if bearings are being replaced. Clean hub and dry. Remove bearings only and not cups if repacking.
4. Press in new bearing cups with thickest edge facing in. (Bearing replacement procedure only.)
5. Pack bearings with heavy duty wheel bearing grease thoroughly forcing grease between roller cone and bearing cage. Fill space between bearing cups and hub with grease.
6. Place inner bearing in place.
7. Clean spindle and install hub.
8. Install outer bearing and jam nut. Tighten jam nut while rotating hub until there is some drag. This ensures all bearing surfaces are in contact. Back off jam nut  $\frac{1}{4}$  turn or until there is only slight drag when rotating hub. Install second jam nut to lock against first.
9. Install wheel on hub. Tighten hardware evenly. Refer to the torque chart information included previously in this section.

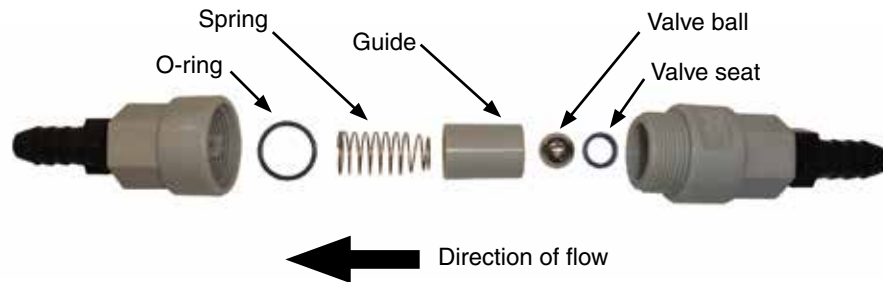

**FERTILIZER CHECK VALVE CLEANING AND REPAIR**

1. Unscrew valve body and separate halves. Note direction and location of parts.
2. Clean and inspect parts. Flush with clean water. Replace damaged parts.
3. Reassemble exactly as shown. O-ring and valve seat must be firmly in place inside each half of valve body.

**PISTON PUMP STORAGE****NOTICE**

Entrance of air into pump will cause rapid and severe corrosion. KEEP AIR OUT OF PUMP!

**NOTE: SUSPENSION FERTILIZER must be flushed from pump for ANY storage period.**

1. Flush pump with 5 to 10 gallons (19 to 38 L) of fresh water and circulate until all corrosive salts are dissolved in pump.
2. Set pump on 10. Draw in a mixture of half diesel fuel and 10 weight oil until discharge is clean. Plug inlet and outlet.

---

## PREPARATION FOR STORAGE

Store planter in a dry sheltered area if possible.

Remove all trash wrapped on sprockets or shafts and remove dirt that can draw and hold moisture.

Clean all drive chains and coat with a rust preventative spray, or remove chains and submerge in oil.

Lubricate planter and row units at all lubrication points.

Inspect planter for parts that in need of replacement and order during “off” season.

Make sure all seed and granular chemical hoppers are empty and clean.

Remove seed discs from seed meters, clean and store meters in a rodent-free, dry area with discs removed. Store seed discs vertically on a dowel or pipe.

Remove vacuum hose from each seed meter. Operate vacuum fan at full hydraulic flow from tractor for two minutes to clear manifolds, hoses and fittings of dust and debris.

Clean breather on analog vacuum and pressure gauges.

Disassemble, clean and grease all U-joint slides.

Grease or paint disc openers/blades and row marker disc blades to prevent rust.

Flush liquid fertilizer tanks, hoses and metering pump with clean water. See “Piston Pump Storage” if applicable.

Bulk Fill System:

- Clean out bulk fill hopper, entrainment assembly, and delivery hoses.
- Disconnect delivery hoses from entrainer ports. Install small orange caps onto ports. Attach hoses to caps.
- Disconnect delivery hoses from air dissipator at each row unit. Install large orange caps. Attach hoses to caps.
- Check all bolts and fasteners used to assemble and attach entrainment device are tight (if applicable).
- Loosen knobs on entrainer cleanout doors to remove pressure from door gaskets.
- Inspect all seed delivery hoses and replace any that are worn, cut, or cracked.

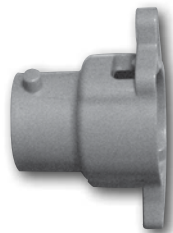

**Entrainer Cap**

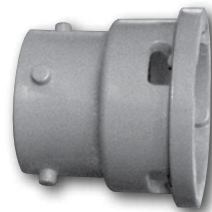

**Air Dissipator Cap**

**This page intentionally left blank.**

ELECTRICAL WIRING DIAGRAM - BLUE DRIVE INTERCONNECT

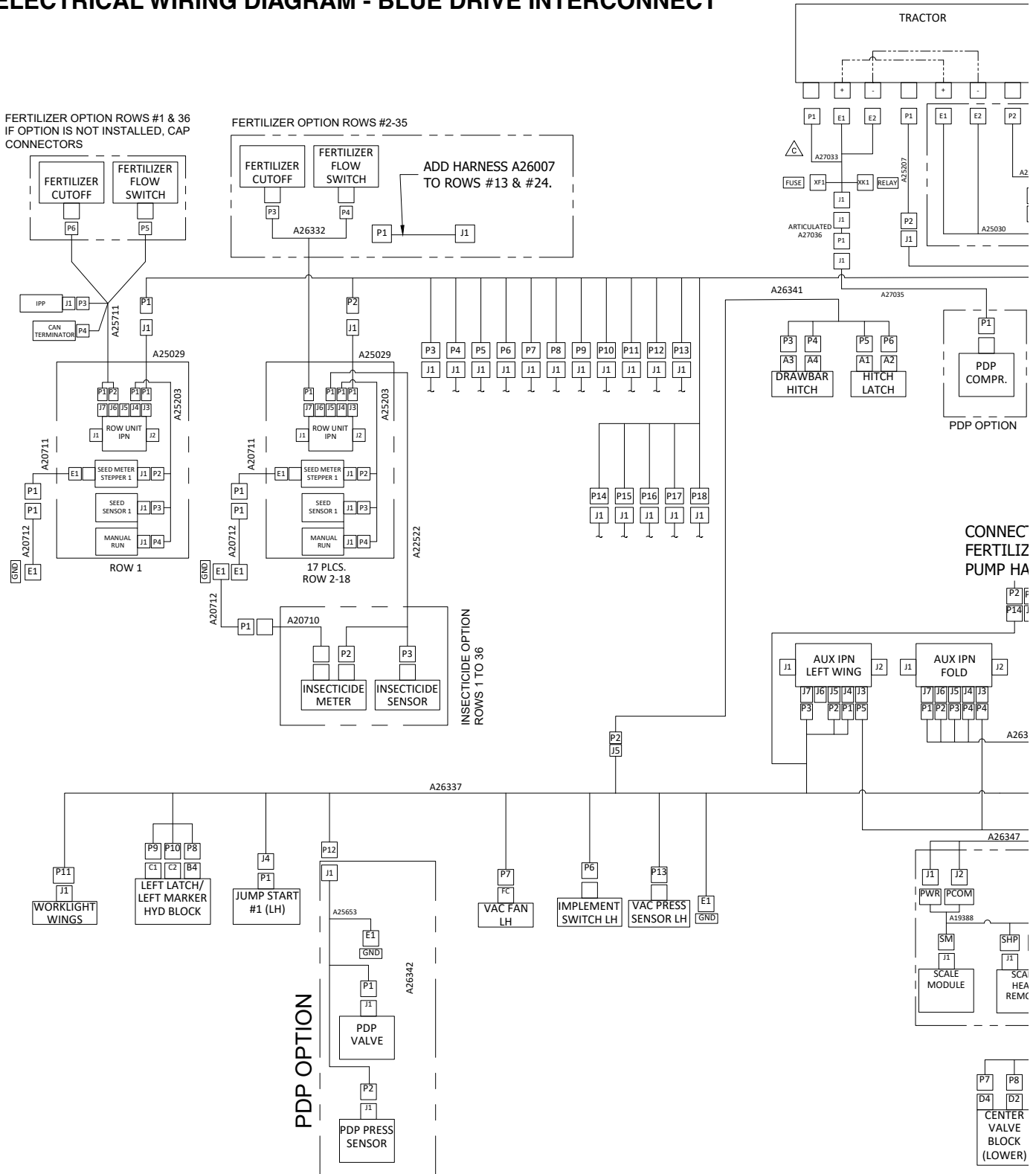

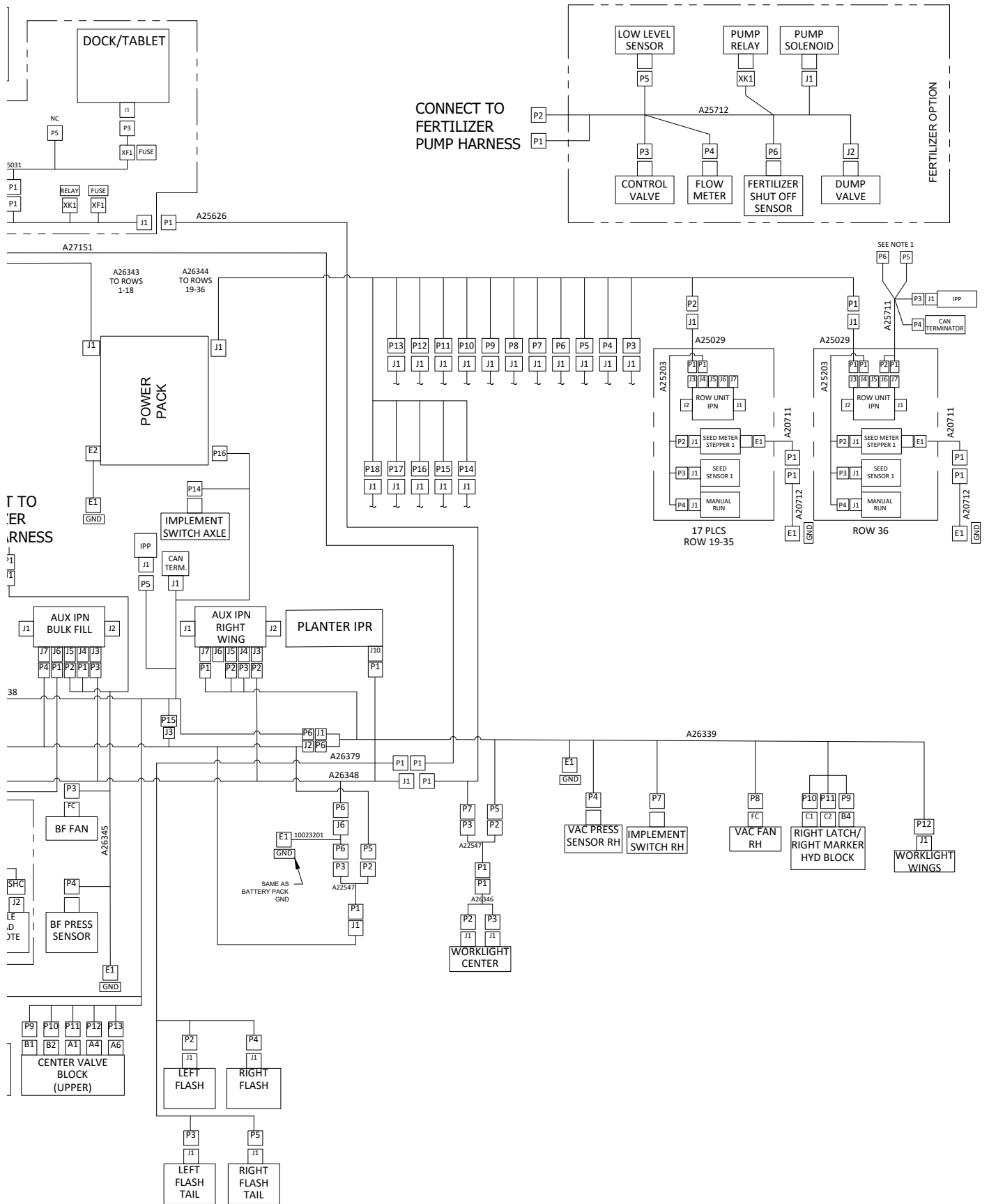

**ELECTRICAL WIRING DIAGRAM - BLUE DRIVE ETHERNET**

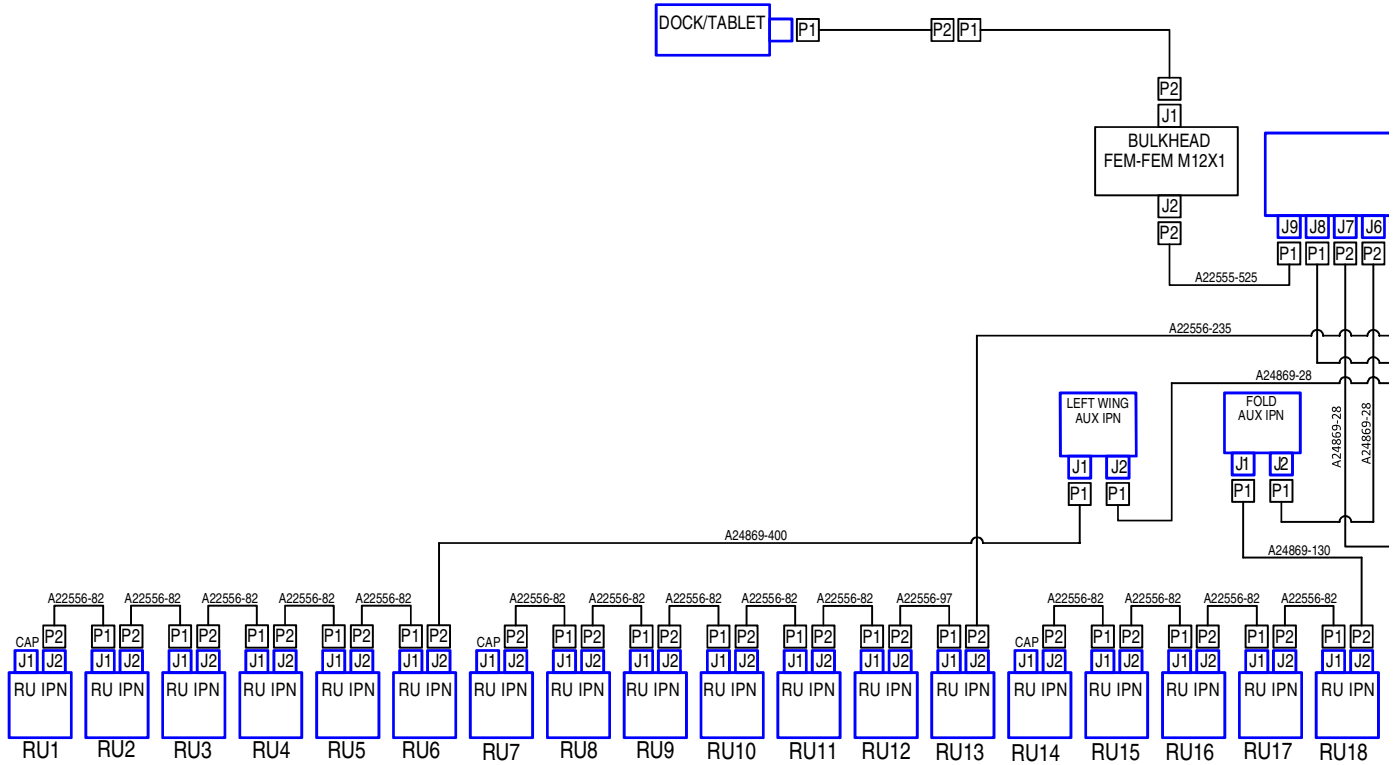

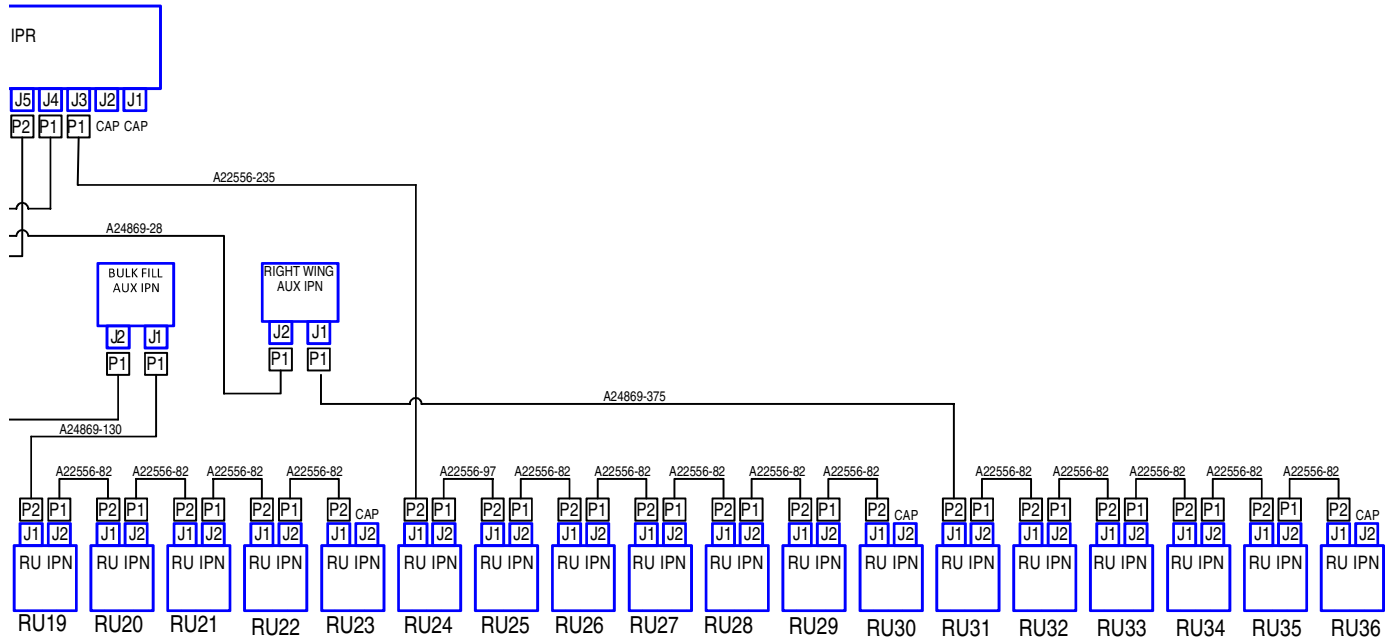

IPP WING HARNESS

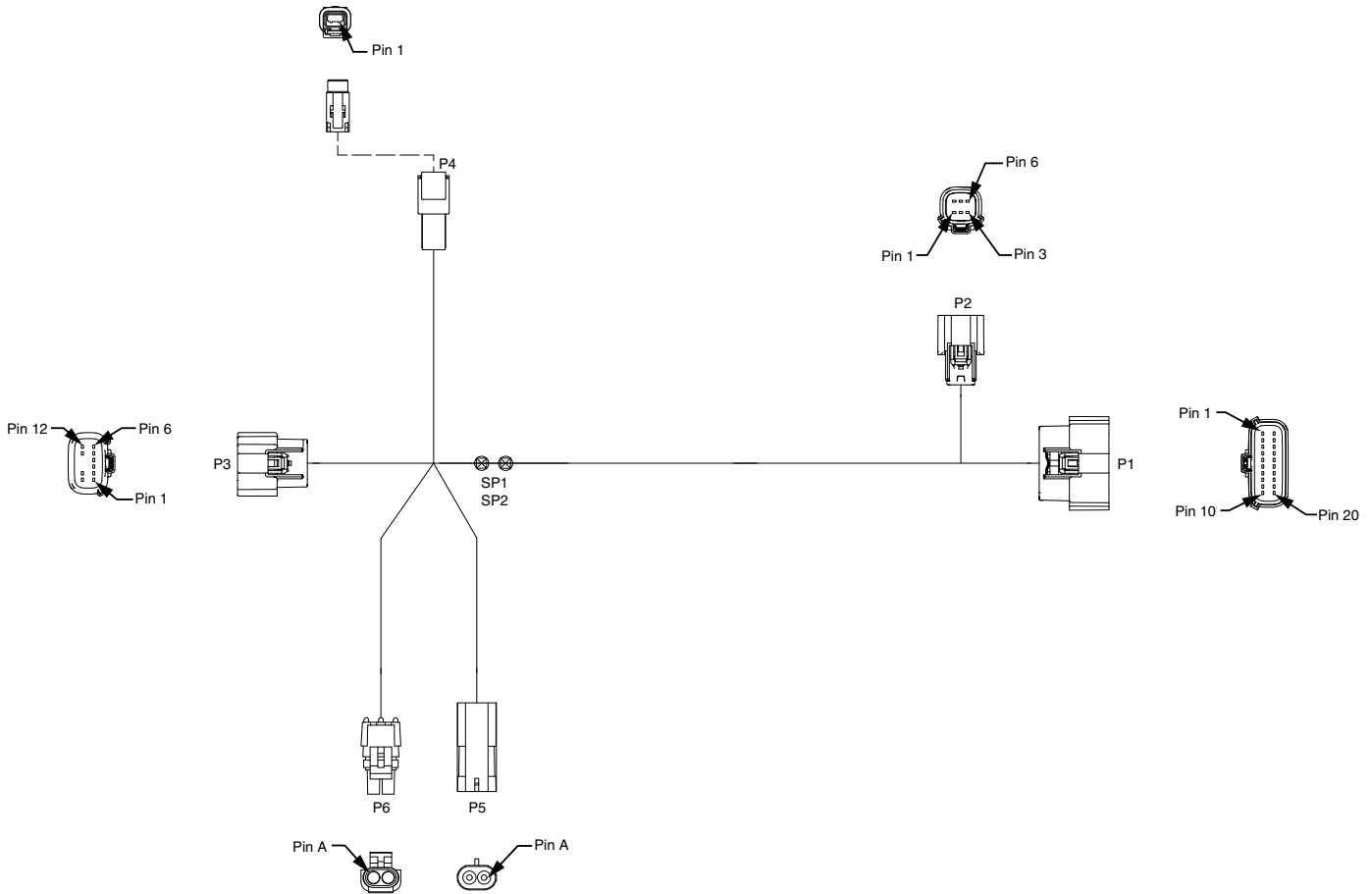

P/N A25711				
Signal	Wire Gauge	Color	From	To
RS232 RX	18(TP-1)	ORN	P1-1	P3-1
RS232 TX	18(TP-1)	BRN	P1-2	P3-2
CAN HI	18(TP-2)	YEL	P2-1	SP1
CAN LO	18(TP-2)	GRN	P2-2	SP2
IPP Power	16	RED	P2-3	P3-12
IPP Ground	16	BLK	P2-4	P3-6
IPP Software Update	18	BLU	P2-5	P3-11
CAN HI	18(TP-3)	YEL	SP1	P3-5
CAN LO	18(TP-3)	GRN	SP2	P3-4
CAN HI	18(TP-4)	YEL	SP1	P4-1
CAN LO	18(TP-4)	GRN	SP2	P4-2
Fertilizer Row Cut Off Valve (Power)	18	Red	P1-3	P6-A
Fertilizer Row Cut Off Valve (Ground)	18	Black	P1-4	P6-B
Fertilizer Flow Sensor (Power/Signal)	18	Red	P1-13	P5-A
Fertilizer Flow Sensor (Ground)	18	Black	P1-19	P5-B



**ROW UNIT POWER EXTENSION HARNESS**

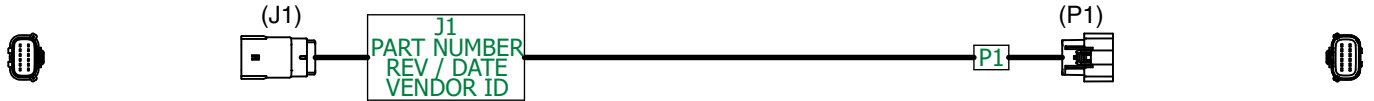

P/N A25029				
Signal	Wire Gauge	Color	FROM	TO
Power	16	Red	J1-1	P1-1
Ground	16	Black	J1-2	P1-2
Power	16	Red	J1-3	P1-3
Ground	16	Black	J1-4	P1-4
Strapping	20	Yellow	J1-5	P1-5
Strapping	20	Orange	J1-6	P1-6
Strapping	20	White	J1-7	P1-7
Strapping	20	Green	J1-8	P1-8
Strapping	20	Blue	J1-9	P1-9
Strapping	20	Violet	J1-10	P1-10
Strapping	20	Blue/Red	J1-11	P1-11
Strapping	20	Brown	J1-12	P1-12

4K ROW UNIT SEED METER HARNESS

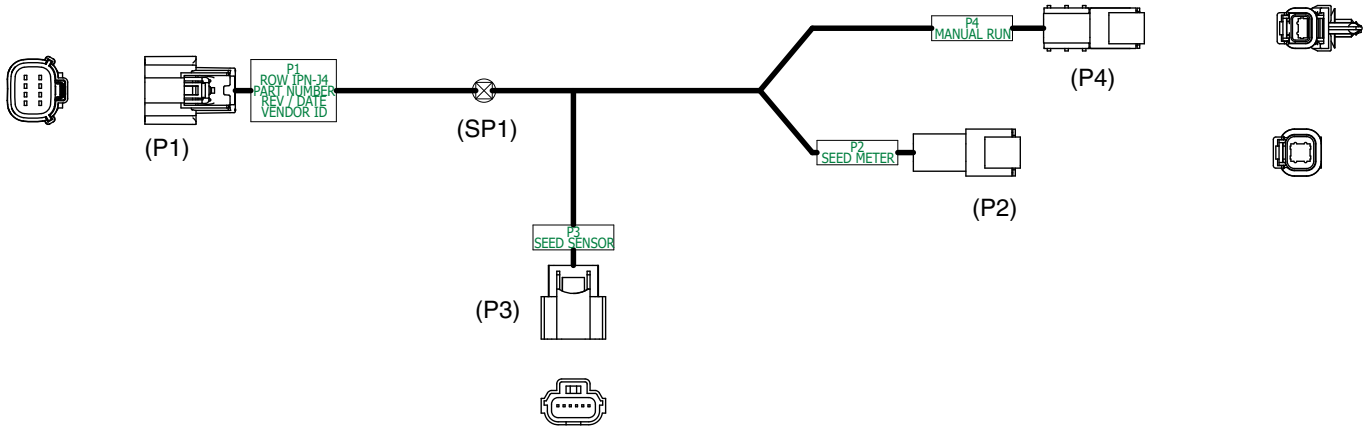

P/N A25203				
Signal	Wire Gauge	Color	From	To
Seed Meter Motor 1+	18	Red	P1-1	P2-1
Seed Meter Motor 1-	18	White	P1-2	P2-2
Seed Meter Motor 2-	18	Black	P1-3	P2-4
Seed Meter Motor 2+	18	Green	P1-4	P2-3
Seed Sensor (Power)	18 TXL	Red	P1-5	P3-1
Ground	18	Black	P1-6	SP1
Seed Sensor (Lin)	18 TXL	Blue	P1-7	P3-2
Seed Sensor (Ground)	18 TXL	Black	SP1	P3-6
Manual Run (Ground)	18	Black	SP1	P4-1
Manual Run (Input)	18	Red	P1-8	P4-2

**FERTILIZER FLOW HARNESS**



P/N A26332							
WIRE HOOKUP CHART							
REF DES	FROM	USED WITH ITEM	TO	USED WITH ITEM	GAUGE	COLOR	FUNCTION
W2	P1-3	4	P4-A	7	18	RED	FERT ROW CUTOFF VALVE (PWR)
W3	P1-4	4	P4-B	7	18	BLK	FERT ROW CUTOFF VALVE (GND)
W6	P1-13	4	P3-A	6	18	RED	FERT FLOW SENSOR (PWR/SIGNAL)
W7	P1-19	4	P3-B	6	18	BLK	FERT FLOW SENSOR (GND)

**EXTENSION HARNESS**



P/N A26007							
WIRE HOOKUP CHART							
REF DES	FROM	USED W/	TO	USED W/	GAUGE	COLOR	FUNCTION
W1	P1-A	3	J1-A	4	18	RED	FERT ROW CUTOFF VALVE (PWR)
W2	P1-B	3	J1-B	4	18	BLK	FERT ROW CUTOFF VALVE (GND)

**PDP POWER EXTENSION HARNESS, 18'**

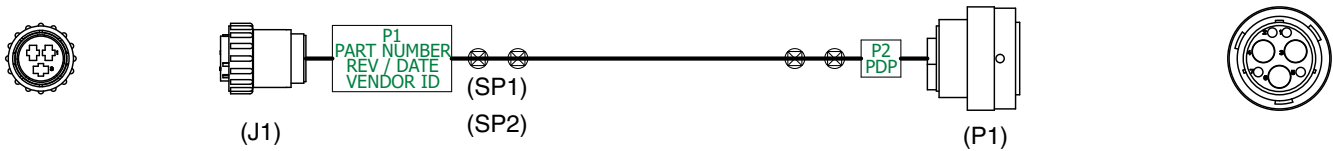

P/N A25209				
Signal	Wire Gauge	Color	From	To
PDP Power	10	RED	P1-1	SP1
PDP Ground	10	BLK	P1-3	SP2
PDP Power	8	RED	SP1	SP3
PDP Ground	8	BLK	SP2	SP4
PDP Power	4	RED	SP3	P2-3
PDP Ground	4	BLK	SP4	P2-4

**PDP POWER EXTENSION HARNESS, 30'**

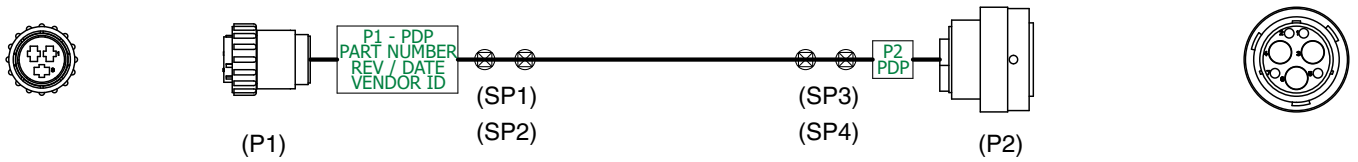

P/N A25210				
Signal	Wire Gauge	Color	From	To
PDP Power	10	RED	P1-1	SP1
PDP Ground	10	BLK	P1-3	SP2
PDP Power	8	RED	SP1	SP3
PDP Ground	8	BLK	SP2	SP4
PDP Power	4	RED	SP3	P2-3
PDP Ground	4	BLK	SP4	P2-4

**DRAWBAR HITCH HARNESS**

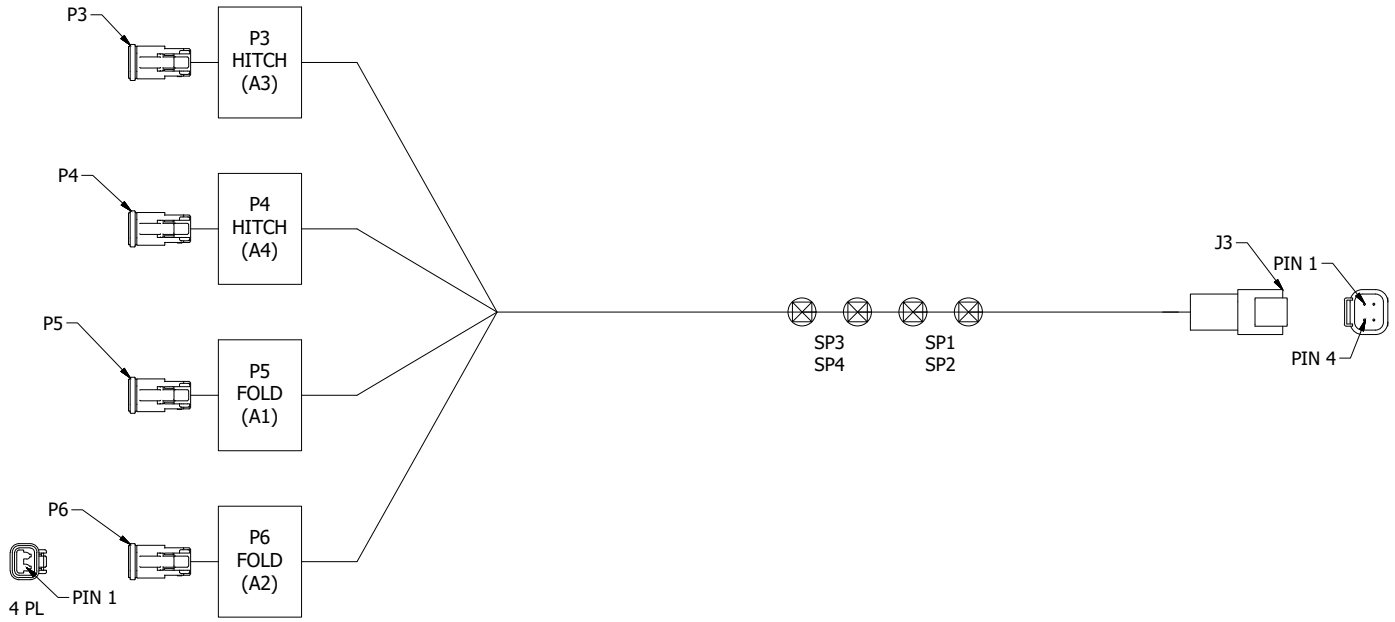

P/N A26341							
WIRE HOOKUP CHART							
REF DES	FORM	USED W/	TO	USED W/	GAUGE	COLOR	FUNCTION
W1	J3-1	4	SP1	—	16	WHT	DRAWBAR HITCH SOLENOID (+)
W2	J3-2	4	SP2	—	16	GRN	DRAWBAR HITCH SOLENOID (-)
W3	J3-3	4	SP3	—	16	RED	WING FOLD SOLENOID (+)
W4	J3-4	4	SP4	—	16	BLK	WING FOLD SOLENOID (-)
W5	SP1	—	P3-1	6	16	WHT	DRAWBAR HITCH SOLENOID (+)
W6	SP1	—	P4-1	6	16	WHT	DRAWBAR HITCH SOLENOID (+)
W7	SP2	—	P3-2	6	16	GRN	DRAWBAR HITCH SOLENOID (-)
W8	SP2	—	P4-2	6	16	GRN	DRAWBAR HITCH SOLENOID (-)
W9	SP3	—	P5-1	6	16	RED	WING FOLD SOLENOID (+)
W10	SP3	—	P6-1	6	16	RED	WING FOLD SOLENOID (+)
W11	SP4	—	P5-2	6	16	BLK	WING FOLD SOLENOID (-)
W12	SP4	—	P6-2	6	16	BLK	WING FOLD SOLENOID (-)

LEFT WING HARNESS

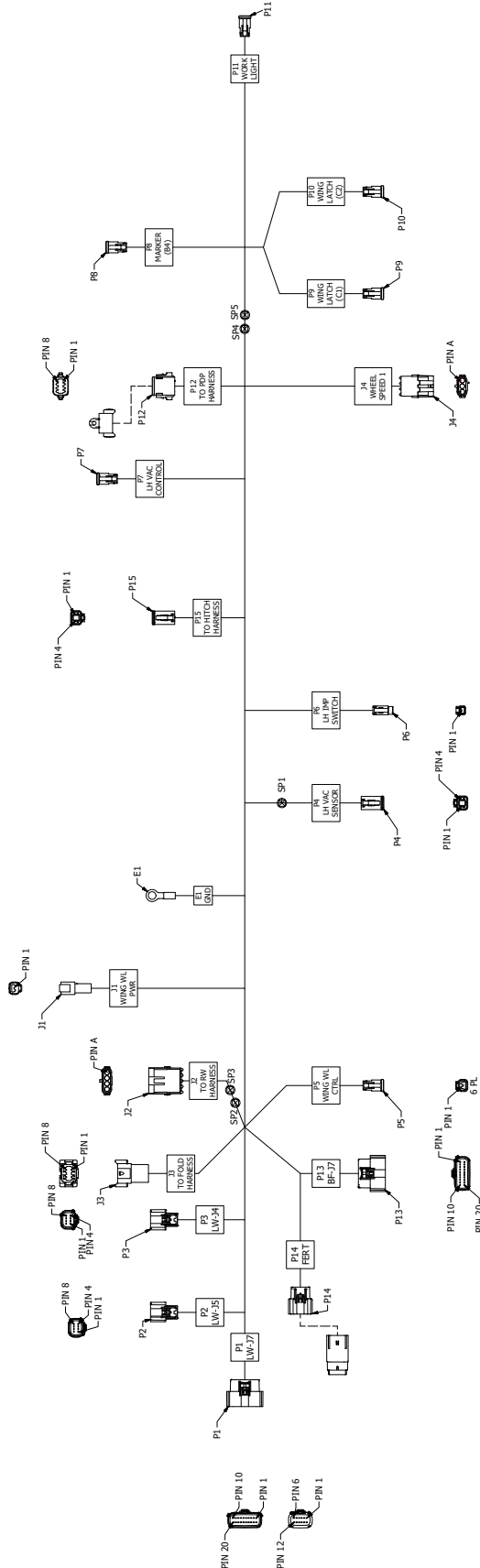

**PIN A26337**

REF DES	WIRE HOOKUP CHART				FUNCTION
	FROM	USED W/	TO	USED W/ GAUGE	
W1	P1-3	21	P12-3	22	VLT
W2	P1-4	21	P12-4	16	BKN
W3	P1-7	21	P5-2	16	RED
W4	P1-8	21	P5-1	22	BIK
W5	P1-16	25	P12-7	22	WHIT
W6	P1-19	25	P12-6	22	BIK
W7	P1-20	25	P12-5	22	ORN
W8	P2-1	21	P12-1	22	RED
W9	P2-2	21	P12-2	22	16
W10	P2-5	25	P4-2	22	ORN
W11	P2-6	25	SP1	18	BIK
W12	P2-7	25	P4-4	22	WHIT
W13	P3-1	21	P7-1	22	RED
W14	P3-2	21	P7-2	16	BIK
W15	P3-5	25	P6-1	23	BRN
W16	P3-7	25	P6-2	23	GRN
W17	SP1	---	P4-1	22	BIK
W18	SP1	---	E1	18	BIK
W19	J1-1	24	SP2	16	BIK
W20	J1-2	24	SP3	16	RED
W21	SP2	---	P11-1	22	BIK
W22	SP2	---	J7-B	14	BIK
W23	SP3	---	P11-2	22	16
W24	SP3	---	J2-A	14	RED
W25	J2-C	14	P8-1	22	RED
W26	J2-D	14	P8-2	22	16
W27	J3-1	24	J4-A	14	18
W28	J3-2	24	J4-B	14	18
W29	J3-3	24	J4-C	14	18
W30	J3-4	24	SP4	16	RED
W31	J3-5	24	SP5	16	BIK
W32	SP4	---	P9-1	22	RED
W33	SP4	---	P10-1	22	RED
W34	SP5	---	P9-2	22	BIK
W35	SP5	---	P10-2	22	16
W36	P13-3	21	P15-1	22	16
W37	P13-4	21	P15-2	22	16
W38	P13-7	21	P14-1	21	16
W39	P13-8	21	P14-2	21	16

WIRE HOOKUP CHART				FUNCTION	
REF DES	FROM	USED W/	TO USED W/ GAUGE		
W40	P13-13	25	P14-3	25	BLU
W41	P13-15	25	P14-5	25	18
W42	P13-16	25	P14-6	25	18
W43	P13-17	25	P14-7	25	18
W44	P13-18	25	P14-8	25	18
W45	P13-19	25	P14-9	25	18
W46	P13-20	25	P14-10	25	18
W47	J3-7	24	P15-3	22	16
W48	J3-8	24	P15-4	22	16

**RIGHT WING HARNESS**

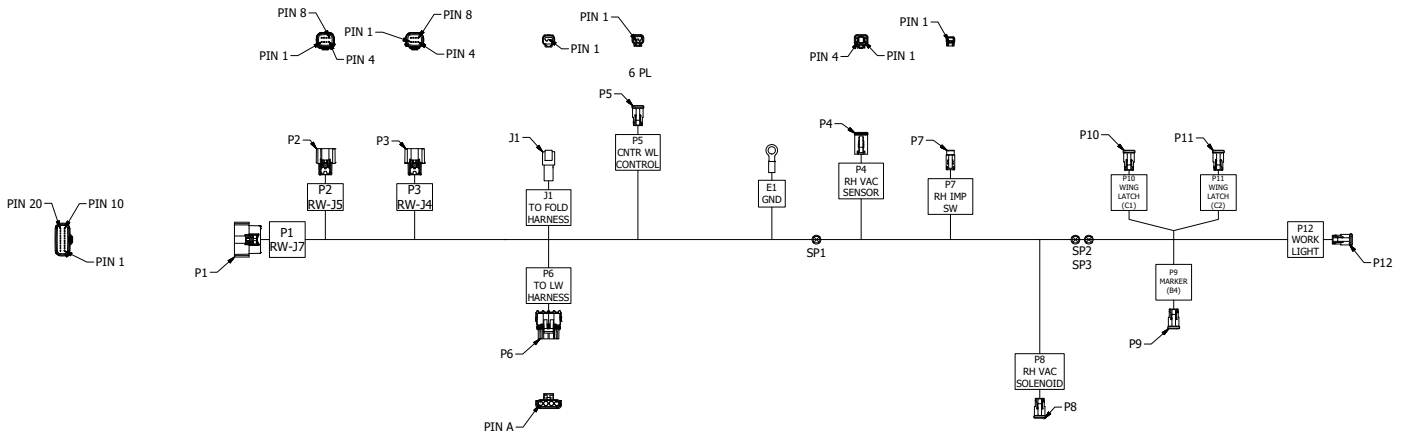

**P/N A26339**

WIRE HOOKUP CHART						
REF DES	FROM	USED W/	TO	USED W/	GAUGE	FUNCTION
W1	P1-3	10	P6-C	13	16	LEFT MARKER SOLENOID (+)
W2	P1-4	10	P6-D	13	16	LEFT MARKER SOLENOID (-)
W3	P1-7	10	P5-2	14	16	CENTER WORK LIGHT RELAY (+)
W4	P1-8	10	P5-1	14	16	CENTER WORK LIGHT RELAY (-)
W5	P2-1	10	P9-1	14	16	RIGHT MARKER SOLENOID (+)
W6	P2-2	10	P9-2	14	16	RIGHT MARKER SOLENOID (-)
W7	P2-5	11	P4-2	14	18	RIGHT VAC PRESS SENSOR (PWR)
W8	P2-6	11	SP1	---	18	RIGHT VAC PRESS SENSOR (GND)
W9	P2-7	11	P4-4	14	18	RIGHT VAC PRESS SENSOR (SIG)
W10	P3-1	10	P8-1	14	16	RIGHT VAC FAN SOLENOID (+)
W11	P3-2	10	P8-2	14	16	RIGHT VAC FAN SOLENOID (-)
W12	P3-5	11	P7-1	15	18	RIGHT IMP. SWITCH (PWR)
W13	P3-7	11	P7-2	15	18	RIGHT IMP. SWITCH (SIG)
W14	SP1	---	P4-1	14	18	RIGHT VAC PRESS SENSOR (GND)
W15	SP1	---	F1	---	18	PLANTER GROUND
W16	J1-1	12	SP2	---	16	RIGHT WING LATCH (+)
W17	J1-2	12	SP3	---	16	RIGHT WING LATCH (-)
W18	SP2	---	P10-1	14	16	RIGHT WING LATCH (+)
W19	SP2	---	P11-1	14	16	RIGHT WING LATCH (+)
W20	SP3	---	P10-2	14	16	RIGHT WING LATCH (-)
W21	SP3	---	P11-2	14	16	RIGHT WING LATCH (-)
W22	P6-A	13	P12-2	14	16	WING WORKLIGHT RH (+)
W23	P6-B	13	P12-1	14	16	WING WORKLIGHT RH (-)



TRACTOR POWER HARNESS

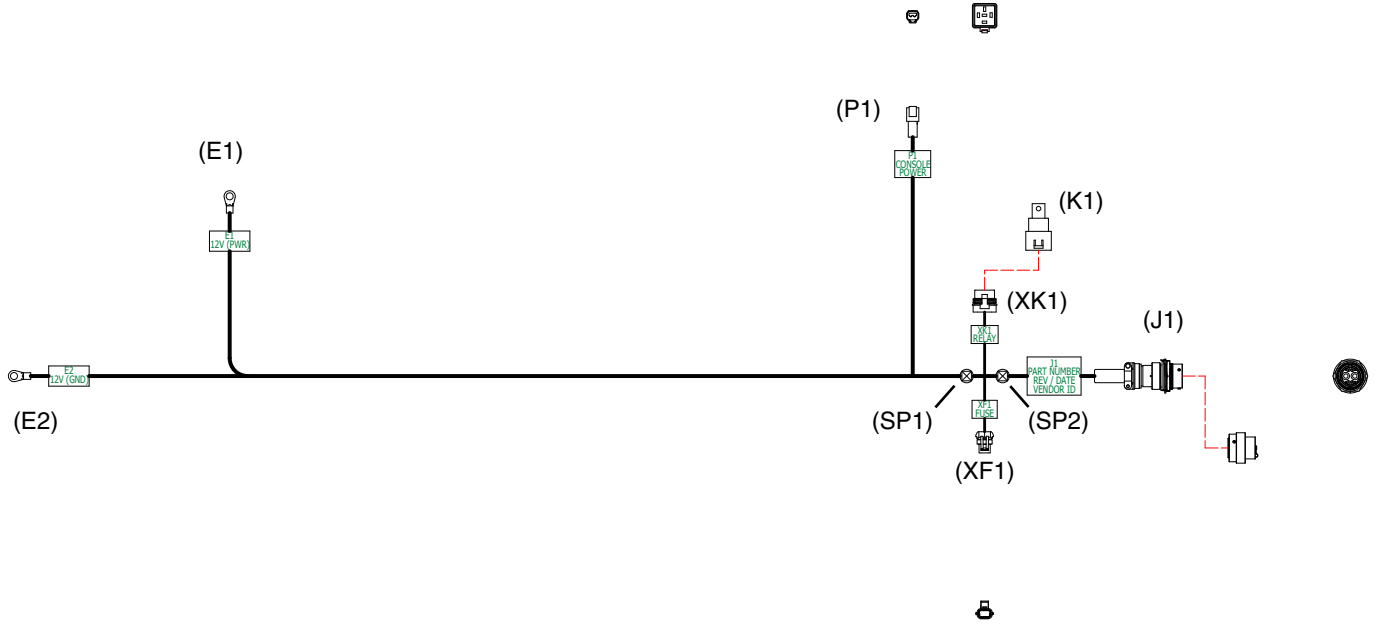

P/N A25030				
Signal	Wire Gauge	Color	FROM	TO
12V (PWR)	6	RED	E1	SP1
12V (PWR)	12	RED	SP1	XF1-A
12V (PWR)	12	RED	XF1-B	XK1-30
12V (PWR)	12	RED	XK1-87	SP2
12V (PWR)	6	RED	SP2	J1-3
12V (GND)	6	BLACK	E2	J1-4
Relay (PWR)	18	BLUE	P1-1	XK1-86
12V Switched (GND)	18	BLACK	P1-2	XK1-85

TRACTOR CONSOLE HARNESS

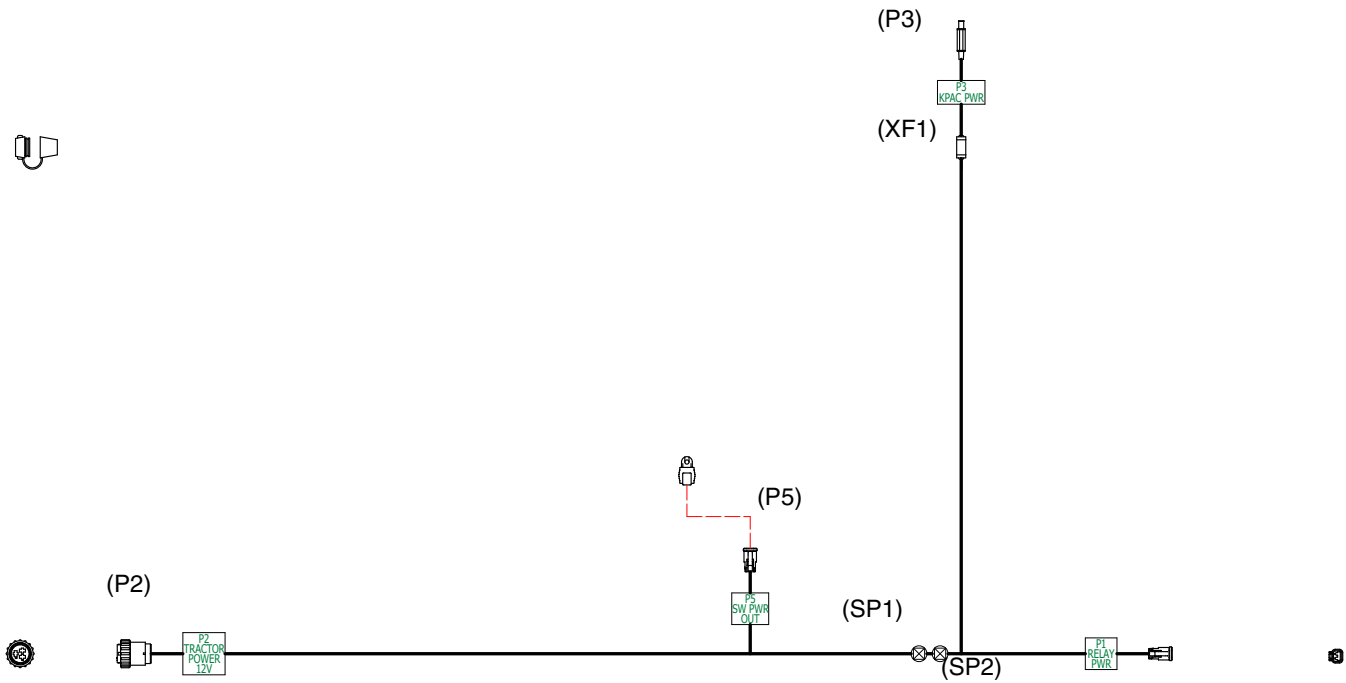

P/N A25031				
Signal	Wire Gauge	Color	FROM	TO
12V Switched (PWR)	16	RED	P2-1	SP1
Relay (PWR)	18	BLUE	SP1	P1-1
12V Switched (PWR)	18	RED	SP1	XF1-1
12V Switched (PWR)	18	ORN	SP1	P5-1
12V Switched (PWR)	18	RED	XF1-2	P3-1
12V Switched (PWR)	16	BLK	P2-3	SP2
12V Switched (PWR)	18	BLK	SP2	P1-2
12V Switched (PWR)	18	BLK	SP2	P3-2
12V Switched (PWR)	18	BLK	SP2	P5-2

**DRAFT LINK POWER HARNESS**



P/N A25626							
WIRE HOOKUP CHART							
REF DES	FROM	USED W/	TO	USED W/	GAUGE	COLOR	FUNCTION
W1	J1-3	7	P1-3	5	6	RED	12V DC+
W2	J1-4	7	P1-4	5	6	BLK	12V DC-

IPN POWER HARNESS

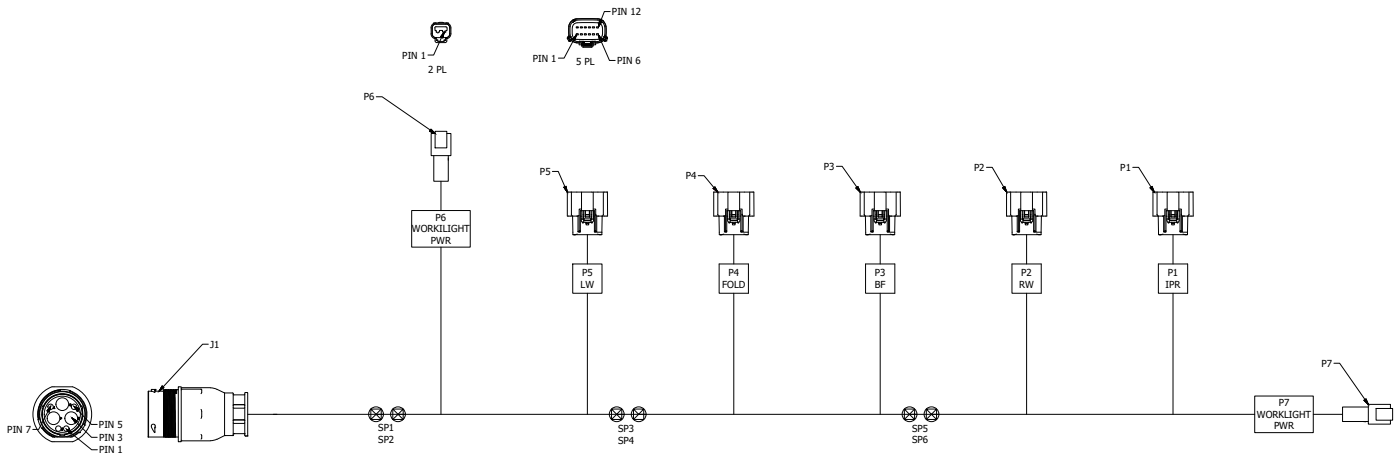

P/N A26348							
WIRE HOOKUP CHART							
REF DES	FROM	USED W/	TO	USED W/	GAUGE	COLOR	FUNCTION
W1	J1-3	12	SP1	---	6	RED	12V DC+
W2	J1-4	12	SP2	---	6	BLK	12V DC-
W3	SP1	---	P6-2	8	16	RED	WORKLIGHT (PWR)
W4	SP1	---	P5-1	9	16	RED	LW IPN (PWR)
W5	SP1	---	P5-3	9	16	RED	LW IPN (PWR)
W6	SP1	---	SP3	---	8	RED	PWR
W7	SP2	---	P6-1	8	16	BLK	WORKLIGHT (GND)
W8	SP2	---	P5-2	9	16	BLK	LW IPN (GND)
W9	SP2	---	P5-4	9	16	BLK	LW IPN (GND)
W10	SP2	---	SP4	---	8	BLK	GND
W11	SP3	---	P4-1	9	16	RED	FOLD IPN (PWR)
W12	SP3	---	P4-3	9	16	RED	FOLD IPN (PWR)
W13	SP3	---	P3-1	9	16	RED	BF IPN (PWR)
W14	SP3	---	P3-3	9	16	RED	BF IPN (PWR)
W14	SP3	---	SP5	---	8	RED	PWR
W15	SP4	---	P4-2	9	16	BLK	FOLD IPN (GND)
W16	SP4	---	P4-4	9	16	BLK	FOLD IPN (GND)
W17	SP4	---	P3-2	9	16	BLK	BF IPN (GND)
W18	SP4	---	P3-4	9	16	BLK	BF IPN (GND)
W19	SP4	---	SP6	---	8	BLK	GND
W20	SP5	---	P2-1	9	16	RED	RW IPN (PWR)
W21	SP5	---	P2-3	9	16	RED	RW IPN (PWR)
W22	SP5	---	P1-1	9	16	RED	IPR (PWR)
W23	SP5	---	P7-2	8	16	RED	WORKLIGHT (PWR)
W24	SP6	---	P2-2	9	16	BLK	RW IPN (GND)
W25	SP6	---	P2-4	9	16	BLK	RW IPN (GND)
W26	SP6	---	P1-2	9	16	BLK	IPR (GND)
W27	SP6	---	P7-1	8	16	BLK	WORKLIGHT (GND)

CONNECTOR	STRAPPING TABLE 1							
	PIN 5	PIN 6	PIN 7	PIN 8	PIN 9	PIN 10	PIN 11	PIN 12
P2 (R WING)	GND	GND	---	GND	GND	GND	---	GND
P3 (BULK FILL)	---	GND	---	GND	GND	GND	GND	GND
P4 (FOLD)	GND	---	---	GND	GND	GND	GND	GND
P5 (L WING)	---	---	GND	GND	GND	GND	GND	GND

CONNECTOR	STRAPPING TABLE 2		
	PIN 10	PIN 11	PIN 12
P1 (IPR)	GND	---	GND

ROW UNIT POWER HARNESS - ROWS 1-18

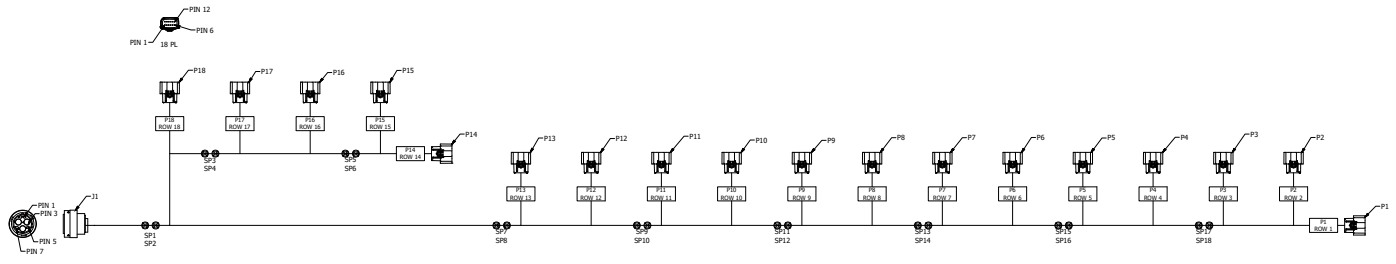

P/N A26343												
WIRE BOOKUP CHART												
REF DES	FROM	USED W/	TO	USED W/	GAUGE	COLOR	FUNCTION	REF DES	FROM	USED W/	TO	
W1	J3-6	6	SP1	---	4	RED	PAW	W40	SP9	---	SP13	---
W2	J3-4	6	SP2	---	4	BLK	GND	W40	SP9	---	P13-3	3
W3	SP1	---	SP3	---	14	RED	PAW	W41	SP9	---	P13-3	3
W4	SP1	---	P18-1	3	18	RED	RU 38 (PAW)	W42	SP9	---	P18-1	3
W5	SP1	---	P18-3	3	18	RED	RU 38 (PAW)	W43	SP9	---	P18-3	3
W6	SP1	---	SP7	---	6	RED	PAW	W44	SP10	---	SP12	---
W7	SP2	---	SP4	---	14	BLK	GND	W45	SP10	---	P11-2	3
W8	SP2	---	P18-2	3	18	BLK	RU 38 (GND)	W46	SP10	---	P11-4	3
W9	SP2	---	P18-4	3	18	BLK	RU 38 (GND)	W47	SP10	---	P18-2	3
W10	SP2	---	SP8	---	6	BLK	GND	W48	SP10	---	P18-4	3
W11	SP3	---	SP5	---	14	RED	PAW	W49	SP11	---	SP13	---
W12	SP3	---	P17-1	3	18	RED	RU 37 (PAW)	W50	SP11	---	P9-1	3
W13	SP3	---	P17-3	3	18	RED	RU 37 (PAW)	W51	SP11	---	P9-3	3
W14	SP3	---	P16-1	3	18	RED	RU 36 (PAW)	W52	SP11	---	P8-1	3
W15	SP3	---	P16-3	3	18	RED	RU 36 (PAW)	W53	SP11	---	P8-3	3
W16	SP4	---	SP6	---	16	BLK	GND	W54	SP12	---	SP14	---
W17	SP4	---	P17-2	3	18	BLK	RU 37 (GND)	W55	SP12	---	P9-2	3
W18	SP4	---	P17-4	3	18	BLK	RU 37 (GND)	W56	SP12	---	P9-4	3
W19	SP4	---	P16-2	3	18	BLK	RU 36 (GND)	W57	SP12	---	P8-2	3
W20	SP4	---	P16-4	3	18	BLK	RU 36 (GND)	W58	SP12	---	P8-4	3
W21	SP5	---	P15-1	3	18	RED	RU 35 (PAW)	W59	SP13	---	SP15	---
W22	SP5	---	P15-3	3	18	RED	RU 35 (PAW)	W60	SP13	---	P7-1	3
W23	SP5	---	P15-1	3	18	RED	RU 34 (PAW)	W61	SP13	---	P6-3	3
W24	SP5	---	P15-3	3	18	RED	RU 34 (PAW)	W62	SP13	---	P6-1	3
W25	SP6	---	P15-2	3	18	BLK	RU 35 (GND)	W63	SP13	---	P6-3	3
W26	SP6	---	P15-4	3	18	BLK	RU 35 (GND)	W64	SP14	---	SP16	---
W27	SP6	---	P14-2	3	18	BLK	RU 34 (GND)	W65	SP14	---	P7-2	3
W28	SP6	---	P14-4	3	18	BLK	RU 34 (GND)	W66	SP14	---	P7-4	3
W29	SP7	---	SP9	---	6	RED	PAW	W67	SP14	---	P6-2	3
W30	SP7	---	P13-1	3	18	RED	RU 33 (PAW)	W68	SP14	---	P6-4	3
W31	SP7	---	P13-3	3	18	RED	RU 33 (PAW)	W69	SP15	---	SP17	---
W32	SP7	---	P12-1	3	18	RED	RU 32 (PAW)	W70	SP15	---	P5-1	3
W33	SP7	---	P12-3	3	18	RED	RU 32 (PAW)	W71	SP15	---	P5-3	3
W34	SP8	---	SP8	---	6	BLK	GND	W72	SP15	---	P4-1	3
W35	SP8	---	P13-2	3	18	BLK	RU 33 (GND)	W73	SP15	---	P4-3	3
W36	SP8	---	P13-4	3	18	BLK	RU 33 (GND)	W74	SP16	---	SP18	---
W37	SP8	---	P12-2	3	18	BLK	RU 32 (GND)	W75	SP16	---	P5-2	3
W38	SP8	---	P12-4	3	18	BLK	RU 32 (GND)	W76	SP16	---	P5-4	3

STRAPPING TABLE							
CONNECTOR	PIN 5	PIN 6	PIN 7	PIN 8	PIN 9	PIN 10	PIN 11
P1	GND	---	---	---	---	---	GND
P2	---	GND	---	---	---	---	GND
P3	GND	GND	---	---	---	---	GND
P4	---	---	GND	---	---	---	GND
P5	GND	---	GND	---	---	---	GND
P6	---	GND	GND	---	---	---	GND
P7	GND	GND	GND	---	---	---	GND
P8	---	---	---	GND	---	---	GND
P9	GND	---	---	GND	---	---	GND
P10	---	GND	---	GND	---	---	GND
P11	GND	GND	GND	GND	---	---	GND
P12	---	---	GND	GND	---	---	GND
P13	GND	---	GND	GND	---	---	GND
P14	---	GND	GND	GND	---	---	GND
P15	GND	GND	GND	GND	---	---	GND
P16	---	---	---	GND	---	---	GND
P17	GND	---	---	GND	---	---	GND
P18	---	GND	---	GND	---	---	GND

ROW UNIT POWER HARNESS - ROWS 19-36

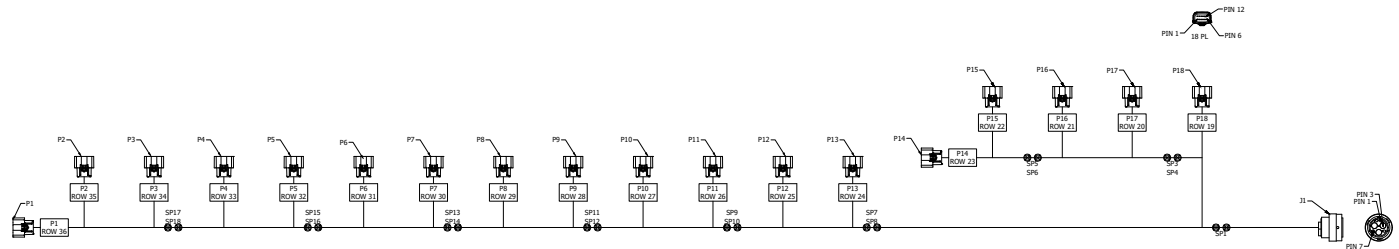

P/N A26344											
WIRE HOOKUP CHART											
REF DES	FROM	USED W/	TO	USED W/	GAUGE	COLOR	FUNCTION	REF DES	FROM	USED W/	TO
W1	J1-6	6	SP1	---	4	RED	PWR	W39	SP9	---	SP11
W2	J1-4	6	SP2	---	4	BLK	GND	W40	SP9	---	P11-1
W3	SP1	---	SP3	---	14	RED	PWR	W41	SP9	---	P11-3
W4	SP1	---	SP7	---	6	RED	PWR	W42	SP9	---	P10-1
W5	SP1	---	P18-1	3	18	RED	RU 19 (PWR)	W43	SP9	---	P10-3
W6	SP1	---	P18-3	3	18	RED	RU 19 (PWR)	W44	SP10	---	SP12
W7	SP2	---	SP4	---	14	BLK	GND	W45	SP10	---	P11-2
W8	SP2	---	SP8	---	6	BLK	GND	W46	SP10	---	P11-4
W9	SP2	---	P18-2	3	18	BLK	RU 19 (GND)	W47	SP10	---	P10-2
W10	SP2	---	P18-4	3	18	BLK	RU 19 (GND)	W48	SP10	---	P10-4
W11	SP3	---	SP5	---	18	RED	PWR	W49	SP11	---	SP13
W12	SP3	---	P17-1	3	18	RED	RU 20 (PWR)	W50	SP11	---	P9-1
W13	SP3	---	P17-3	3	18	RED	RU 20 (PWR)	W51	SP11	---	P9-3
W14	SP3	---	P16-1	3	18	RED	RU 21 (PWR)	W52	SP11	---	P8-1
W15	SP3	---	P16-3	3	18	RED	RU 21 (PWR)	W53	SP11	---	P8-3
W16	SP4	---	SP6	---	16	BLK	GND	W54	SP12	---	SP14
W17	SP4	---	P17-2	3	18	BLK	RU 20 (GND)	W55	SP12	---	P9-2
W18	SP4	---	P17-4	3	18	BLK	RU 20 (GND)	W56	SP12	---	P9-4
W19	SP4	---	P16-2	3	18	BLK	RU 21 (GND)	W57	SP12	---	P8-2
W20	SP4	---	P16-4	3	18	BLK	RU 21 (GND)	W58	SP12	---	P8-4
W21	SP5	---	SP5	---	18	RED	PWR	W59	SP13	---	SP15
W22	SP5	---	P15-1	3	18	RED	RU 22 (PWR)	W60	SP13	---	P7-1
W23	SP5	---	P14-1	3	18	RED	RU 23 (PWR)	W61	SP13	---	P7-3
W24	SP5	---	P14-3	3	18	RED	RU 23 (PWR)	W62	SP13	---	P6-1
W25	SP6	---	P15-2	3	18	BLK	RU 22 (GND)	W63	SP13	---	P6-3
W26	SP6	---	P15-4	3	18	BLK	RU 22 (GND)	W64	SP14	---	SP16
W27	SP6	---	P14-2	3	18	BLK	RU 23 (GND)	W65	SP14	---	P7-2
W28	SP6	---	P14-4	3	18	BLK	RU 23 (GND)	W66	SP14	---	P7-4
W29	SP7	---	SP9	---	6	RED	PWR	W67	SP14	---	P6-2
W30	SP7	---	P13-1	3	18	RED	RU 24 (PWR)	W68	SP14	---	P6-4
W31	SP7	---	P13-3	3	18	RED	RU 24 (PWR)	W69	SP15	---	SP17
W32	SP7	---	P12-1	3	18	RED	RU 25 (PWR)	W70	SP15	---	P5-1
W33	SP7	---	P12-3	3	18	RED	RU 25 (PWR)	W71	SP15	---	P5-3
W34	SP8	---	SP10	---	6	BLK	GND	W72	SP15	---	P4-1
W35	SP8	---	P13-2	3	18	BLK	RU 24 (GND)	W73	SP15	---	P4-3
W36	SP8	---	P13-4	3	18	BLK	RU 24 (GND)	W74	SP16	---	SP18
W37	SP8	---	P12-2	3	18	BLK	RU 25 (GND)	W75	SP16	---	P5-2
W38	SP8	---	P12-4	3	18	BLK	RU 25 (GND)	W76	SP16	---	P5-4

STRAPPING TABLE											
CONNECTOR	PIN 5	PIN 6	PIN 7	PIN 8	PIN 9	PIN 10	PIN 11	PIN 12			
P1	---	GND	---	---	---	GND	GND	GND			
P2	GND	GND	---	---	---	GND	GND	GND			
P3	---	GND	---	---	---	GND	GND	GND			
P4	GND	---	---	---	---	GND	GND	GND			
P5	---	---	---	---	---	GND	---	GND			
P6	GND	GND	GND	GND	---	---	---	---			
P7	---	GND	GND	GND	---	GND	GND	---			
P8	GND	---	GND	GND	---	GND	GND	---			
P9	---	GND	GND	GND	---	---	---	GND			
P10	GND	GND	GND	GND	---	GND	GND	---			
P11	---	GND	---	GND	---	---	---	---			
P12	GND	---	---	GND	---	GND	GND	---			
P13	---	---	---	GND	---	GND	GND	---			
P14	GND	GND	---	GND	---	GND	GND	---			
P15	---	GND	GND	GND	---	---	---	GND			
P16	GND	---	GND	---	---	GND	---	GND			
P17	---	GND	---	GND	---	GND	GND	---			
P18	GND	GND	---	---	---	GND	---	GND			

**BULK FILL SCALE HARNESS**

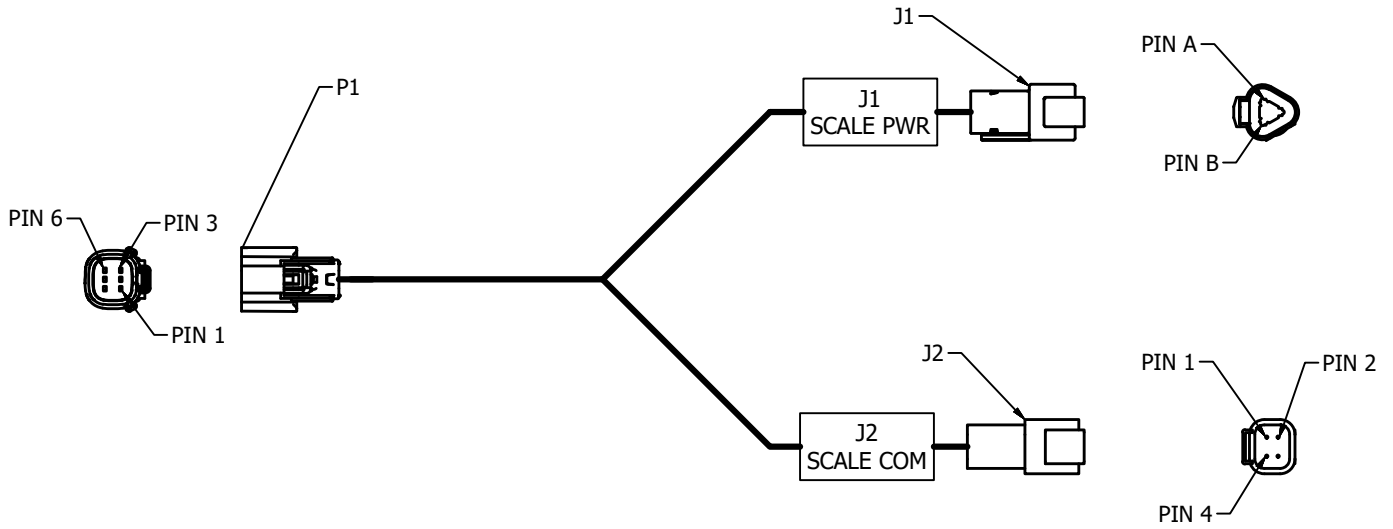

P/N A26347							
WIRE HOOKUP CHART							
REF DES	FROM	USED W/	TO	USED W/	GAUGE	COLOR	FUNCTION
W1	P1-1	4	J2-1	8	18 (TP)	YEL	BULKFILL SCALE (CAN H)
W2	P1-2	4	J2-2	8	18 (TP)	GRN	BULKFILL SCALE (CAN L)
W3	P1-3	4	J1-A	8	18	RED	BULKFILL SCALE HEAD (PWR+)
W4	P1-4	4	J1-B	8	18	BLK	BULKFILL SCALE HEAD (PWR-)

**BLUE DRIVE PDP HARNESS**

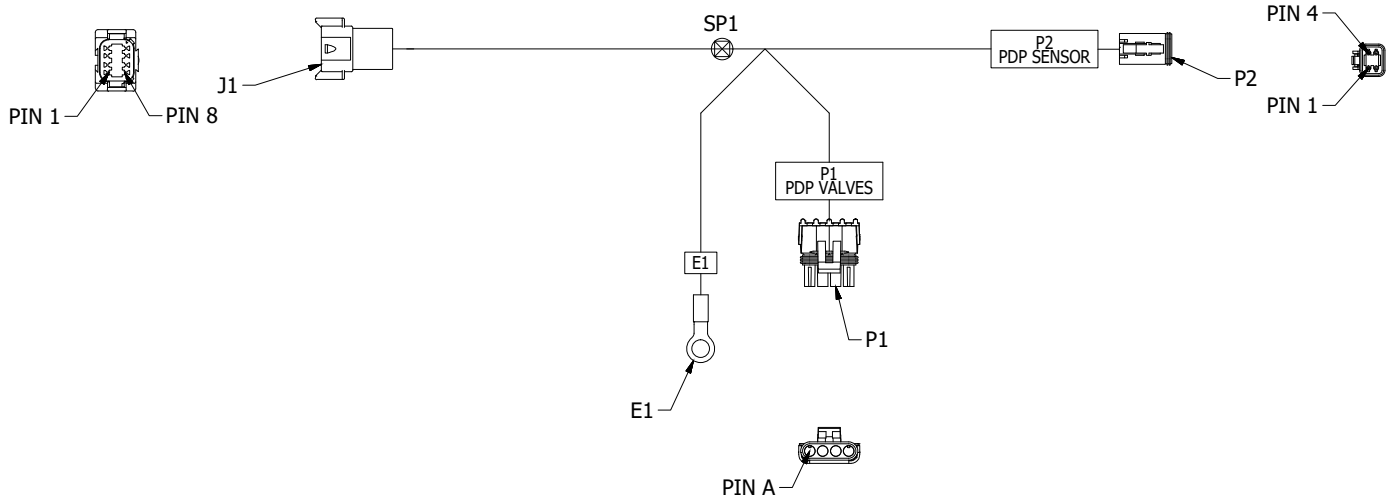

P/N A25653							
WIRE HOOKUP CHART							
REF DES	FROM	USED W/	TO	USED W/	GAUGE	COLOR	FUNCTION
W1	J1-1	11	P1-A	7	16	RED	PDP INCREASE (+)
W2	J1-2	11	P1-B	7	16	YEL	PDP INCREASE (-)
W3	J1-3	11	P1-C	7	16	VIO	PDP DECREASE (+)
W4	J1-4	11	P1-D	7	16	BRN	PDP DECREASE (-)
W5	J1-5	11	P2-2	10	18	ORN	PDP SENSOR (PWR)
W6	J1-6	11	SP1	10	18	BLK	PDP SENSOR (GND)
W7	J1-7	11	P2-4	---	18	WHT	PDP SENSOR (SIGNAL)
W8	SP1	---	E1	---	18	BLK	PDP SENSOR (GND)
W9	SP1	---	P2-1	10	18	BLK	PDP SENSOR (GND)



12V AIR PUMP HARNESS

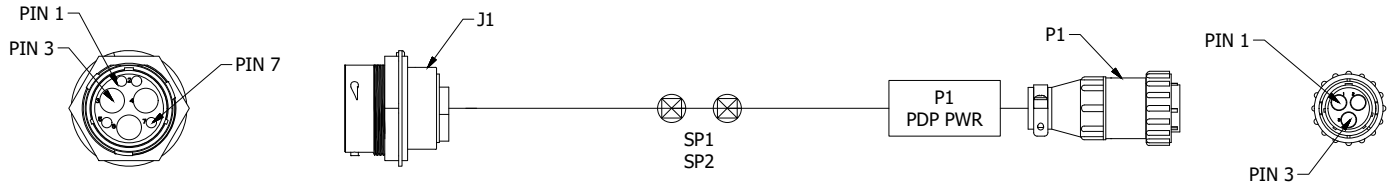

P/N A26342							
WIRE HOOKUP CHART							
REF DES	FROM	USED W/	TO	USED W/	GAUGE	COLOR	FUNCTION
W1	J1-3	5	SP1	---	4	RED	PDP PWR
W2	J1-4	5	SP2	---	4	BLK	PDP GND
W3	SP1	---	P1-1	4	8	RED	PDP PWR
W4	2P3	---	P1-2	4	8	BLK	PDP GND

**BULKFILL HARNESS**

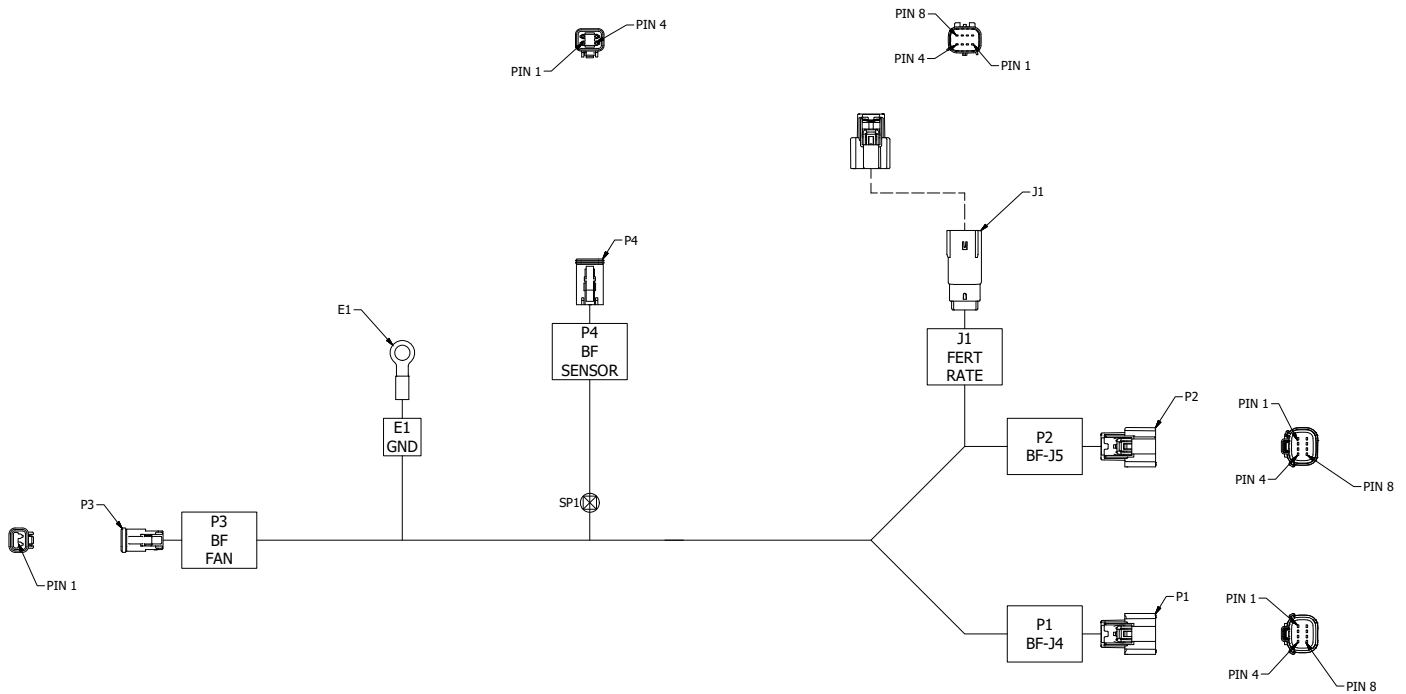

P/N A26345							
WIRE HOOKUP CHART							
REF DES	FROM	USED W/	TO	USED W/	GAUGE	COLOR	FUNCTION
W1	P1-1	12	P3-1	11	16	RED	BULK FILL FAN SOLENOID (+)
W2	P1-2	12	P3-2	11	16	BLK	BULK FILL FAN SOLENOID (-)
W3	P2-1	13	J1-1	15	18	YEL	FERTIZILER RATE INCREASE
W4	P2-2	13	J1-2	15	18	GRN	FERTIZILER RATE DECREASE
W5	P2-5	13	P4-2	11	18	ORN	BULK FILL PRESS SENSOR (PWR)
W6	P2-6	13	SP1	---	18	BLK	BULK FILL PRESS SENSOR (GND)
W7	P2-7	13	P4-4	11	18	WHT	BULK FILL PRESS SENSOR (SIG)
W8	SP1	---	P4-1	11	18	BLK	BULK FILL PRESS SENSOR (GND)
W9	SP1	---	E1	---	18	BLK	PLANTER GND

**TAIL LIGHT HARNESS**

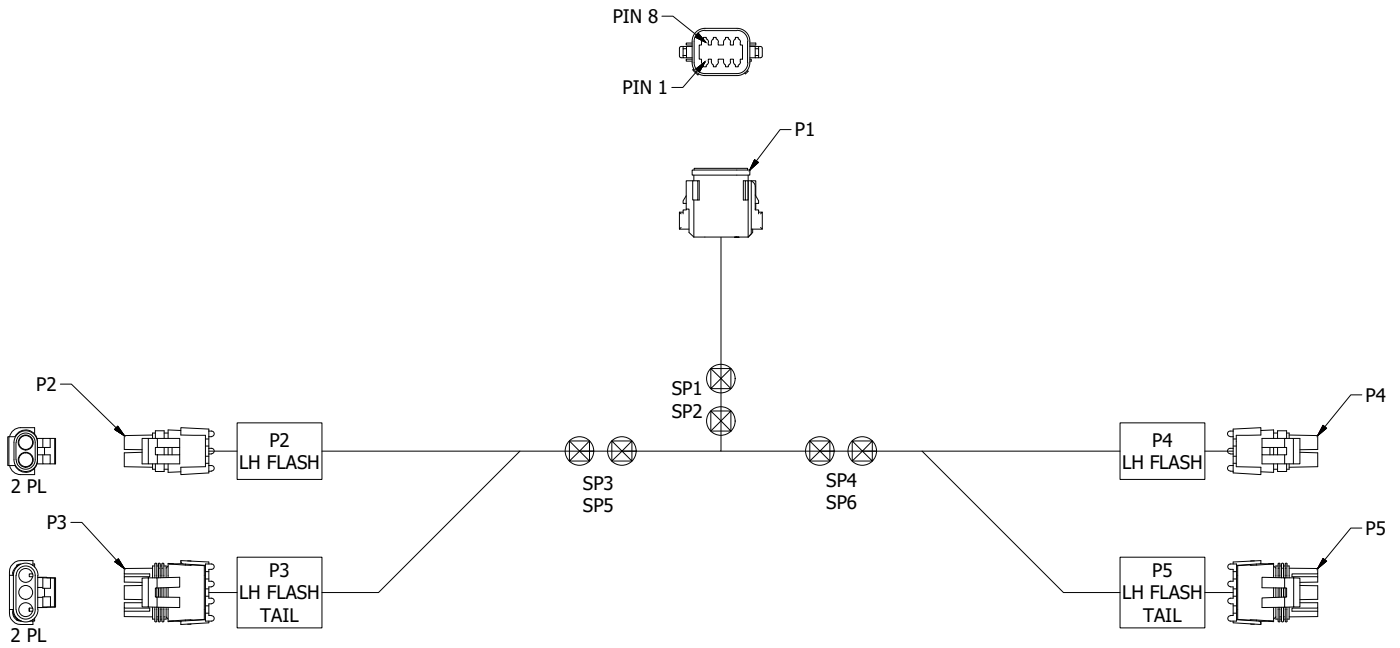

P/N A26379							
WIRE HOOKUP CHART							
REF DES	FROM	USED WITH ITEM	TO	USED WITH ITEM	GAUGE	COLOR	FUNCTION
W1	P1-1	4	SP1	---	18	WHT	GND
W2	P1-6	4	SP2	---	18	BRN	TAIL
W3	SP1	---	SP3	---	18	WHT	GND
W4	SP1	---	SP4	---	18	WHT	GND
W5	SP2	---	P3-C	5	18	BRN	TAIL
W6	SP2	---	P5-C	5	18	BRN	TAIL
W7	P1-3	4	SP5	---	18	YEL	LH TURN
W9	P1-5	4	SP6	---	18	GRN	RHTURN
W8	SP3	---	P2-A	5	18	WHT	GND
W10	SP3	---	P3-A	5	18	WHT	GND
W11	SP4	---	P4-A	5	18	WHT	GND
W11	SP4	---	P5-A	5	18	WHT	GND
W12	SP5	---	P2-B	5	18	YEL	LH TURN
W13	SP5	---	P3-B	5	18	YEL	LH TURN
W14	SP6	---	P4-B	5	18	GRN	RHTURN
W15	SP6	---	P5-B	5	18	GRN	RHTURN

FERTILIZER PUMP HARNESS

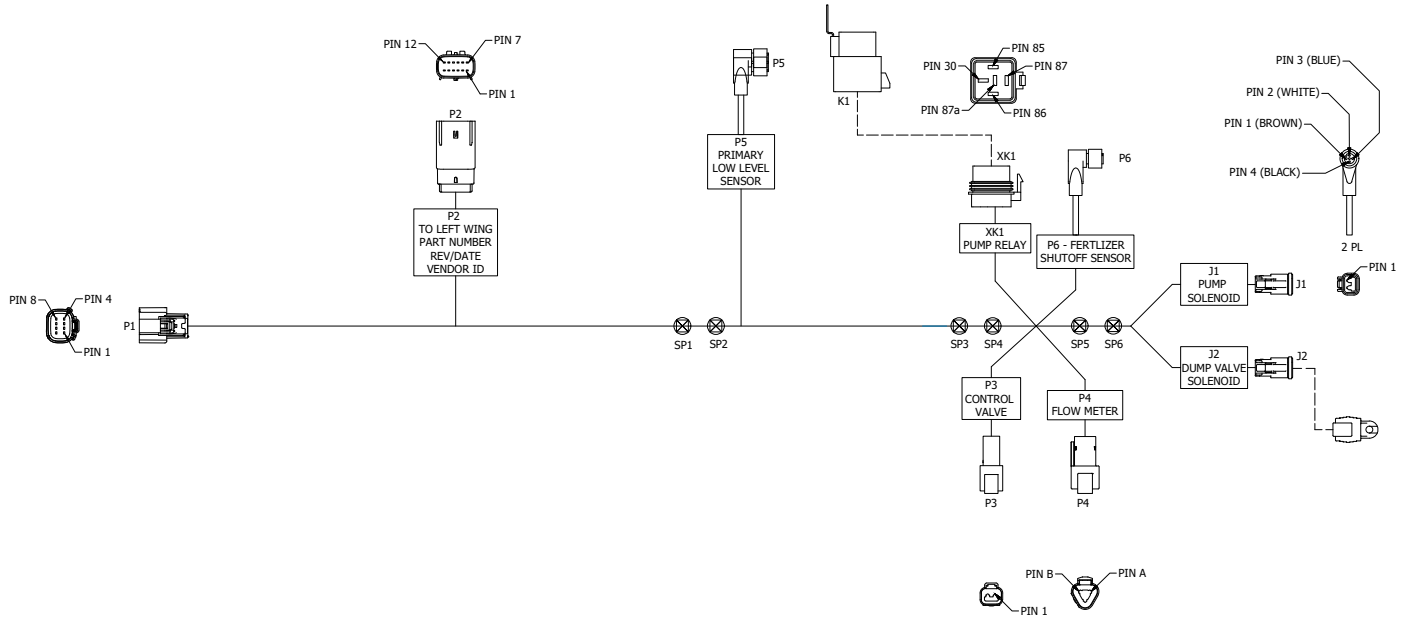

**P/N A25712**

WIRE HOOKUP CHART							
REF DES	FROM	USED W/	TO	USED W/	GAUGE	COLOR	FUNCTION
W1	P1-1	9	P3-1	12	18	YEL	FERTILIZER RATE INCREASE
W2	P1-2	9	P3-2	12	18	ORN	FERTILIZER RATE DECREASE
W3	P2-1	11	XK1-30	---	16	RED	FERT PUMP SOLENOID (12V)
W4	XK1-87	---	SP5	---	16	RED	FERT PUMP/DUMP VALVE SOLENOID (12V)
W5	P2-2	11	SP3	---	16	BLK	FERT PUMP SOLENOID (GND)
W6	P2-3	11	SP4	---	18	BLU	FERT PUMP SHUTOFF (SIG)
W7	P2-5	11	P4-B	12	18	WHT	FERT PUMP FLOW METER (REQ)
W8	P2-6	11	P5-4	---	18	YEL	FERT PRIMARY TANK LOW LEVEL (SIG)
W9	P2-7	11	SP2	---	18	BLK	FERT LOW LEVEL/PUMP SHUTOFF (GND)
W10	P2-8	11	SP1	---	18	RED	FERT LOW LEVEL/PUMP SHUTOFF (PWR)
W11	P2-9	11	P4-C	12	18	BLK	FERT PUMP FLOW METER (GND)
W12	P2-10	11	P4-A	12	18	ORN	FERT PUMP FLOW METER (PWR)
W13	SP3	---	SP6	---	16	BLK	FERT PUMP/DUMP VALVE SOLENOID (GND)
W14	SP3	---	XK1-85	---	18	BLK	FERT PUMP SOLENOID (GND)
W15	SP4	---	P6-4	---	18	BLU	FERT PUMP SHUTOFF (SIG)
W16	SP4	---	XK1-86	---	18	BLU	FERT PUMP SHUTOFF (SIG)
W17	SP2	---	P5-3	---	18	BLK	FERT LOW LEVEL/PUMP SHUTOFF (GND)
W18	SP2	---	P6-3	---	18	BLK	FERT LOW LEVEL/PUMP SHUTOFF (GND)
W19	SP1	---	P5-1	---	18	RED	FERT LOW LEVEL/PUMP SHUTOFF (PWR)
W20	SP1	---	P6-1	---	18	RED	FERT LOW LEVEL/PUMP SHUTOFF (PWR)
W21	SP5	---	J1-1	16	16	RED	FERT PUMP SOLENOID (12V)
W22	SP5	---	J2-1	16	16	RED	FERT DUMP VALVE SOLENOID (12V)
W23	SP6	---	J1-2	16	16	BLK	FERT PUMP SOLENOID (GND)
W24	SP6	---	J2-2	16	16	BLK	FERT DUMP VALVE SOLENOID (GND)

**TAIL LIGHT EXTENSION HARNESS**



P/N A25170							
WIRE HOOKUP CHART							
REF DES	FROM	USED WITH ITEM	TO	USED WITH ITEM	GAUGE	COLOR	FUNCTION
W1	P1-1	—	P2-1	4	16	YEL	LH FLASH
W2	P1-2	—	P2-2	4	16	BLU	FOG
W3	P1-3	—	P2-3	4	16	WHT	GND
W4	P1-4	—	P2-4	4	16	GRN	RH FLASH
W5	P1-5	—	P2-5	4	16	BRN	RH TAIL LIGHT
W6	P1-6	—	P2-6	4	16	RED	STOP LIGHTS
W7	P1-7	—	P2-7	4	16	BLK	LH TAIL LIGHT

**WORK LIGHT RELAY HARNESS**

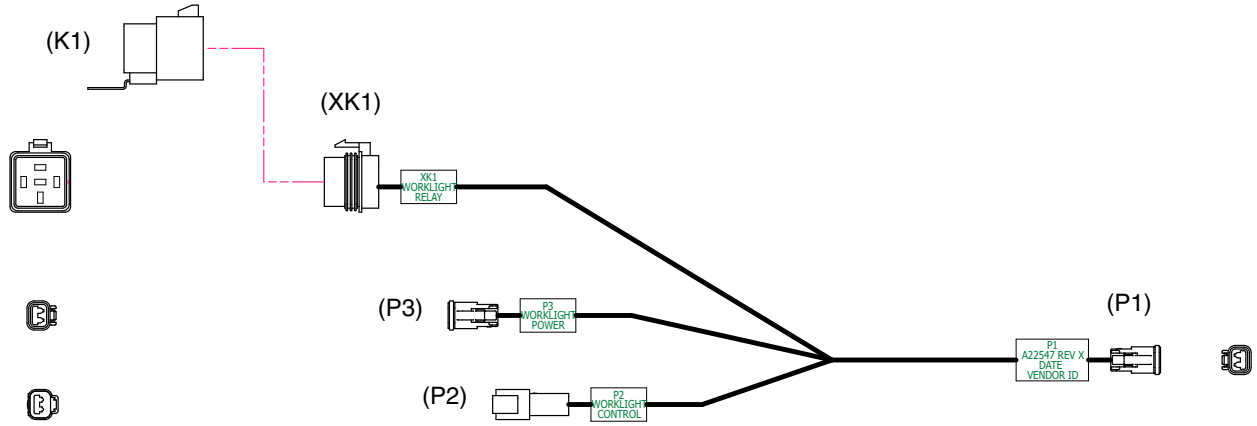

P/N A22547				
Signal	Wire Gauge	Color	FROM	TO
Work Light Power -	16	BLK	P3-1	P1-1
Work Light Power +	16	RED	P3-2	XK1-30
Relay Ground	16	BLK	P2-1	XK1-85
Relay 12V	16	BLU	P2-2	XK1-86
Worklight Power +	16	RED	XK1-87	P1-2

**TAIL LIGHT HARNESS**



P/N A27151							
WIRE HOOKUP CHART							
REF DES	FROM	USED W/	TO	USED W/	GAUGE	COLOR	FUNCTION
W1	J1-1	3	P1-1	3	16	WHT	GND
W2	J1-3	3	P1-3	3	16	YEL	LH TURN
W3	J1-5	3	P1-5	3	16	GRN	RH TURN
W4	J1-6	3	P1-6	3	16	BRN	TAIL

FOLD HARNESS

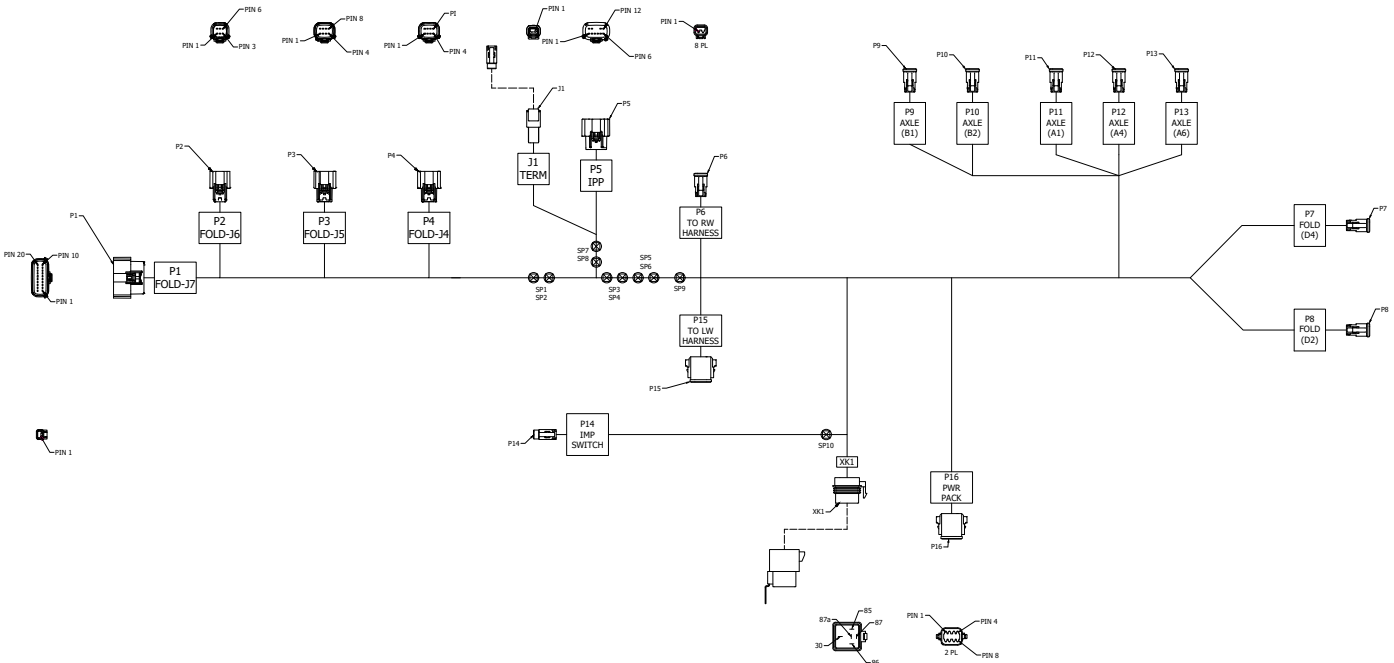

P/N A26338

WIRE HOODUP CHART

REF DIS	FROM	USED W/	TO	USED W/	GAUGE	COLOR	FUNCTION	REF DIS	FROM	USED W/	TO	USED W/	GAUGE	COLOR	FUNCTION
W1	P1-1	36	P5-1	18	18(TP)	ORN	IPP UPDATE/DEBUG (KS232 RX)	W27	SP30	—	XX1-30	—	36	RED	AXLE RELAY INPUT (+)
W2	P1-2	36	P5-2	18	18(TP)	BRN	IPP UPDATE/DEBUG (KS232 TX)	W28	SP5	—	P6-2	15	36	RED	RIGHT WING LATCH (+)
W3	P1-3	36	SP3	—	36	RED	FOLD (+)	W29	SP1	—	P9-1	15	36	RED	AXLE (+)
W4	P1-4	36	SP4	—	36	BLK	FOLD (-)	W30	SP1	—	P10-1	15	36	RED	AXLE (+)
W5	P1-7	36	SP10	—	36	RED	AXLE RELAY INPUT (+)	W31	SP5	—	P15-4	15	36	RED	LEFT WING LATCH (+)
W6	P1-8	36	SP9	—	36	BLK	AXLE RELAY (-)	W32	SP6	—	P6-1	15	36	BLK	RIGHT WING LATCH (-)
W7	P1-13	18	P36-4	15	20	YEL	REL PWR FEEDBACK FROM POWERPACK	W33	SP2	—	P9-2	15	36	BLK	AXLE (-)
W8	P1-14	36	P36-7	11	14	ORN	BATTERY 1 VOLTAGE	W34	SP2	—	P10-2	15	36	BLK	AXLE (-)
W9	P1-16	36	P36-8	11	14	BLU	BATTERY 2 VOLTAGE	W35	SP6	—	P15-5	15	36	BLK	LEFT WING LATCH (-)
W10	P1-19	36	P36-2	15	36	BLK	RLI POWER RELAY (GND)	W36	SP9	—	P13-2	15	36	BLK	AXLE RELAY (-)
W11	P1-20	36	P36-1	15	36	RED	RLI POWER RELAY (PWR)	W37	SP1	—	P11-1	15	36	RED	AXLE (+)
W12	P2-1	18	SP7	—	18(TP)	YEL	IPP CAN HI	W38	SP1	—	P12-1	15	36	RED	AXLE (+)
W13	P2-2	18	SP8	—	18(TP)	GRN	IPP CAN LO	W39	SP3	—	P15-7	15	36	RED	FOLD (+)
W14	P2-3	36	P5-12	36	36	RED	IPP PWR (+)	W40	SP2	—	P11-2	15	36	BLK	AXLE (-)
W15	P2-4	36	P5-6	36	36	BLK	IPP GND (-)	W41	SP2	—	P12-2	15	36	BLK	AXLE (-)
W51	P2-5	18	P5-11	18	18	BLU	IPP SOFTWARE UPDATE ENABLE	W42	SP4	—	P15-8	15	36	BLK	FOLD (-)
W16	P3-1	36	SP1	—	36	RED	AXLE (+)	W43	SP1	—	P7-1	15	36	RED	FOLD (+)
W17	P3-2	36	SP2	—	36	BLK	AXLE (-)	W44	SP3	—	P8-1	15	36	RED	FOLD (+)
W18	P3-5	36	P36-5	15	36	WHI	BATTERY PACK RELAY (PWR)	W45	SP4	—	P7-2	15	36	BLK	FOLD (-)
W19	P3-6	36	P36-6	15	36	GRN	BATTERY PACK RELAY (GND)	W46	SP4	—	P8-2	15	36	BLK	FOLD (-)
W20	P3-7	18	P15-3	15	18	WHI	SPEED WHEEL #1 (FRQ)	W47	XX1-30A	—	P13-1	15	36	RED	AXLE RELAY OUTPUT (+)
W21	P4-1	36	SP5	—	36	RED	WING LATCHES (+)	W48	SP7	—	P5-5	15	18(TP)	YEL	IPP CAN HI
W22	P4-2	36	SP6	—	36	BLK	WING LATCHES (-)	W49	SP8	—	P5-4	15	18(TP)	GRN	IPP CAN LO
W23	P4-5	18	P15-1	15	18	RED	SPEED WHEEL #1 (PWR)	W50	SP7	—	J1-1	17	18(TP)	YEL	CAN HI TERMINATOR
W24	P4-6	18	P15-2	15	18	BLK	SPEED WHEEL #1 (GND)	W51	SP8	—	J1-2	17	18(TP)	GRN	CAN LO TERMINATOR
W25	P4-8	36	P36-3	15	36	BRN	ALTERNATOR SENSE (FRQ)	W52	SP9	—	XX1-85	15	36	BLK	AXLE RELAY (-)
W26	SP10	—	P14-1	24	15	RED	AXLE RELAY INPUT (+)	W53	P14-3	24	XX1-86	—	36	BLU	SIGNAL



VACUUM SENSOR HARNESS

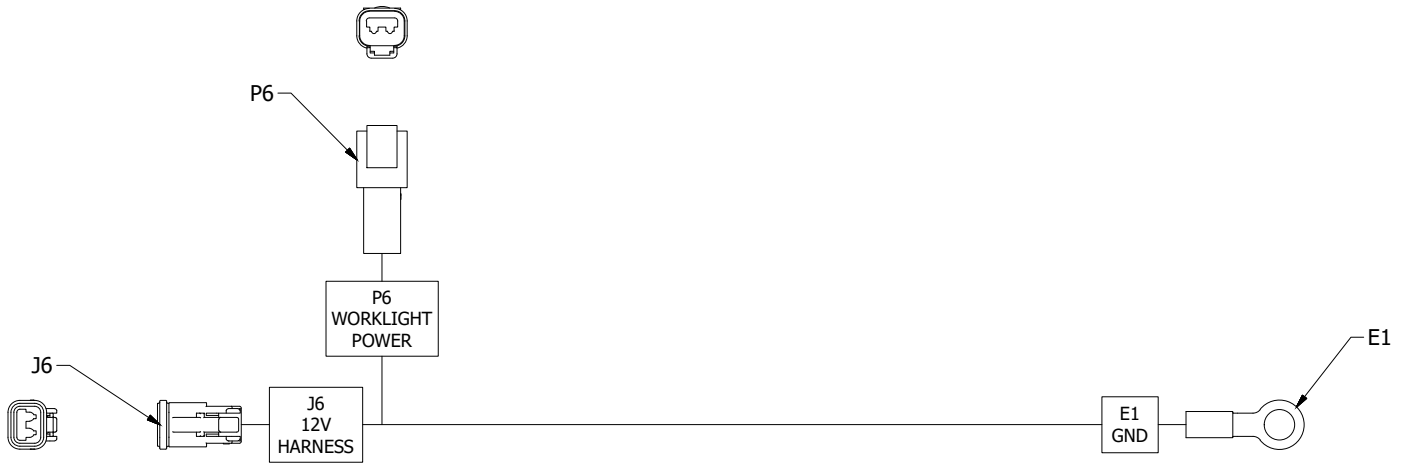

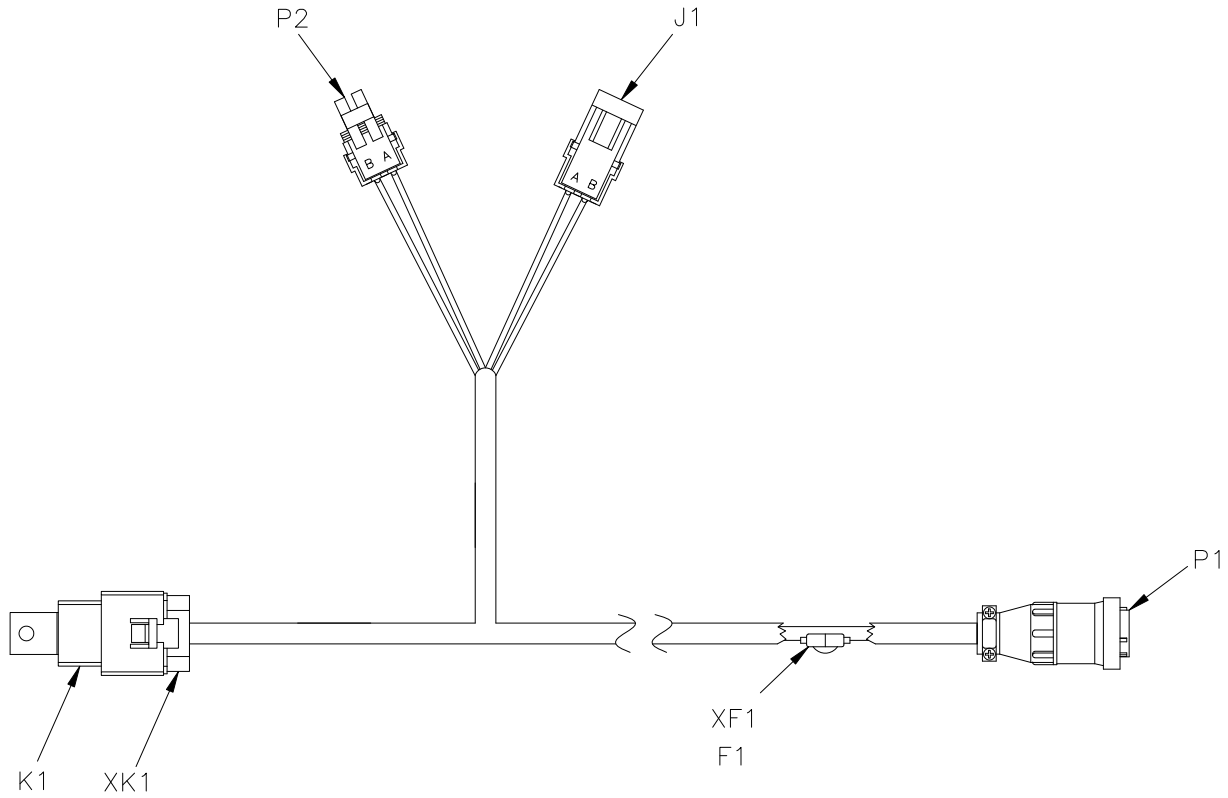

P/N 10023201							
WIRE HOOKUP CHART							
REF DES	FROM	USED WITH ITEM	TO	USED WITH ITEM	GAUGE	COLOR	FUNCTION
W1	J6-1	6	SP1	--	16	BLK	GND
W2	SP1	--	P6-1	7	16	BLK	GND
W3	SP1	--	E1	--	16	BLK	GND
W4	J6-2	6	P6-2	7	16	RED	GND

**PTO RESERVOIR FAN HARNESS**



P/N A20283					
WIRE HOOKUP CHART					
WIRE NO.	FROM	TO	GAUGE	COLOR	FUNCTION
W1	P1-2	XF1	14	RED	SWITCHED POWER
W2	XF1	XK1-4	14	RED	SWITCHED POWER
		P2-A			
W3	P1-3	XK1-5	14	BLK	GROUND
		J1-B			
W4	XK1-2	P2-B	14	BLU	TEMP SWITCH
W5	XK1-1	J1-A	14	RED	FAN POWER

**HYDRAULIC HOSE LIFE**

 <b>WARNING</b>	<p>Pressurized hydraulic fluid can penetrate body tissue and result in death, serious infection, or other injuries. Fluid injected under skin must be <b>IMMEDIATELY</b> removed by a surgeon familiar with this type of injury. Make sure connections are tight and hoses and fittings are not damaged before applying system pressure. Leaks can be invisible. Keep away from suspected leaks. Relieve pressure before searching for leaks or performing any system maintenance.</p>
	

Proper storage of hydraulic hoses can significantly increase the life of the hoses, for a period of three to five years. After this period, service life of hoses may decrease, depending on variables such as variances in rubber materials and storage environment. Refer to the guidelines below for best practices when storing.

- Store in a clean, cool and dry area
- Avoid direct sunlight or moisture
- Do not store near high power electrical equipment
- Avoid contact with corrosive chemicals
- Avoid ultraviolet light
- Avoid areas with obvious signs of insects or rodents

Unusually long periods of storage or poor storage environment may lead to performance issues or premature failure. Always inspect all hoses prior to use for extensive wear, cuts, or holes. If such flaws are identified, replace immediately to avoid potential failure, property damage or bodily injury.

HYDRAULIC SCHEMATIC

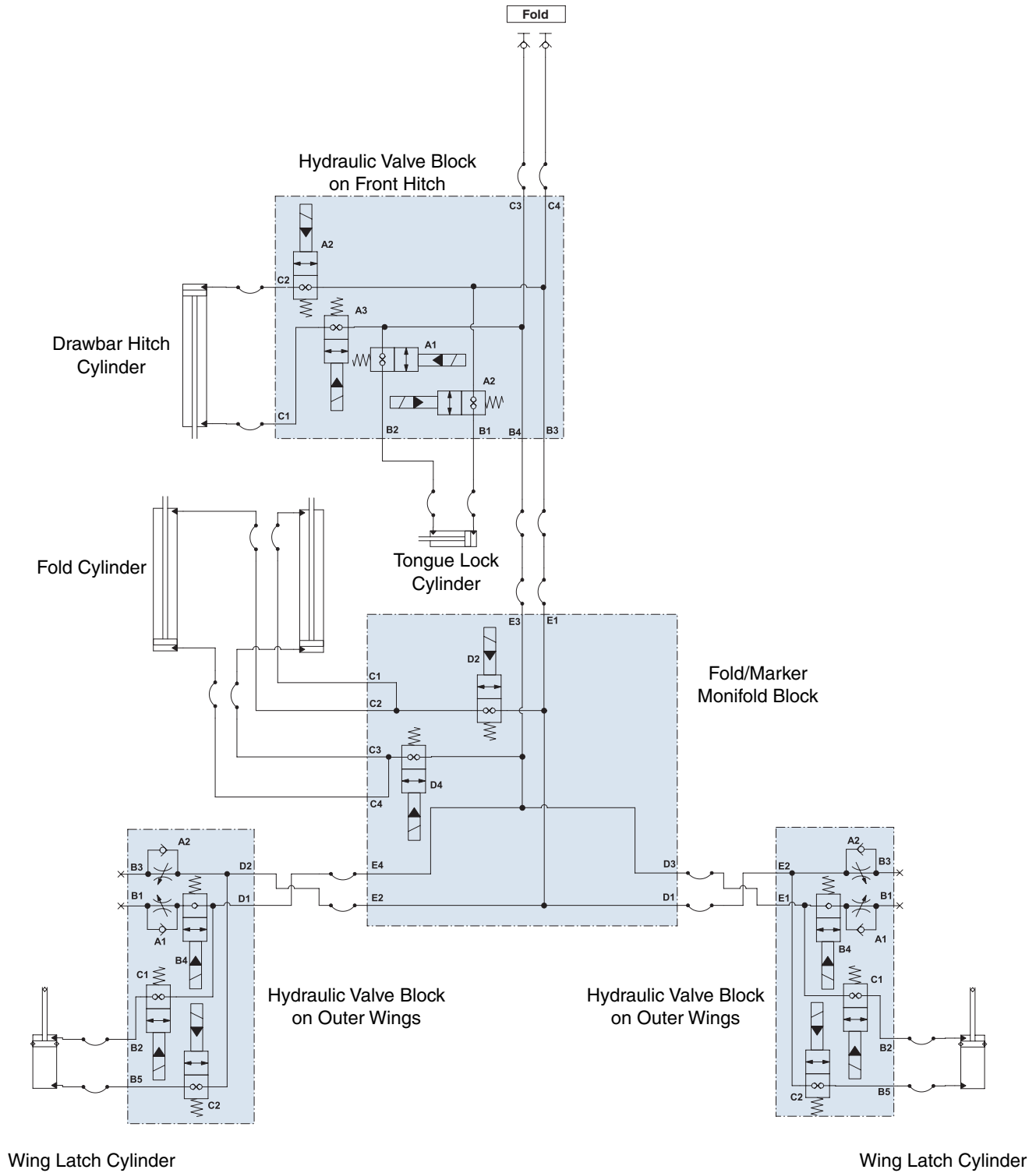

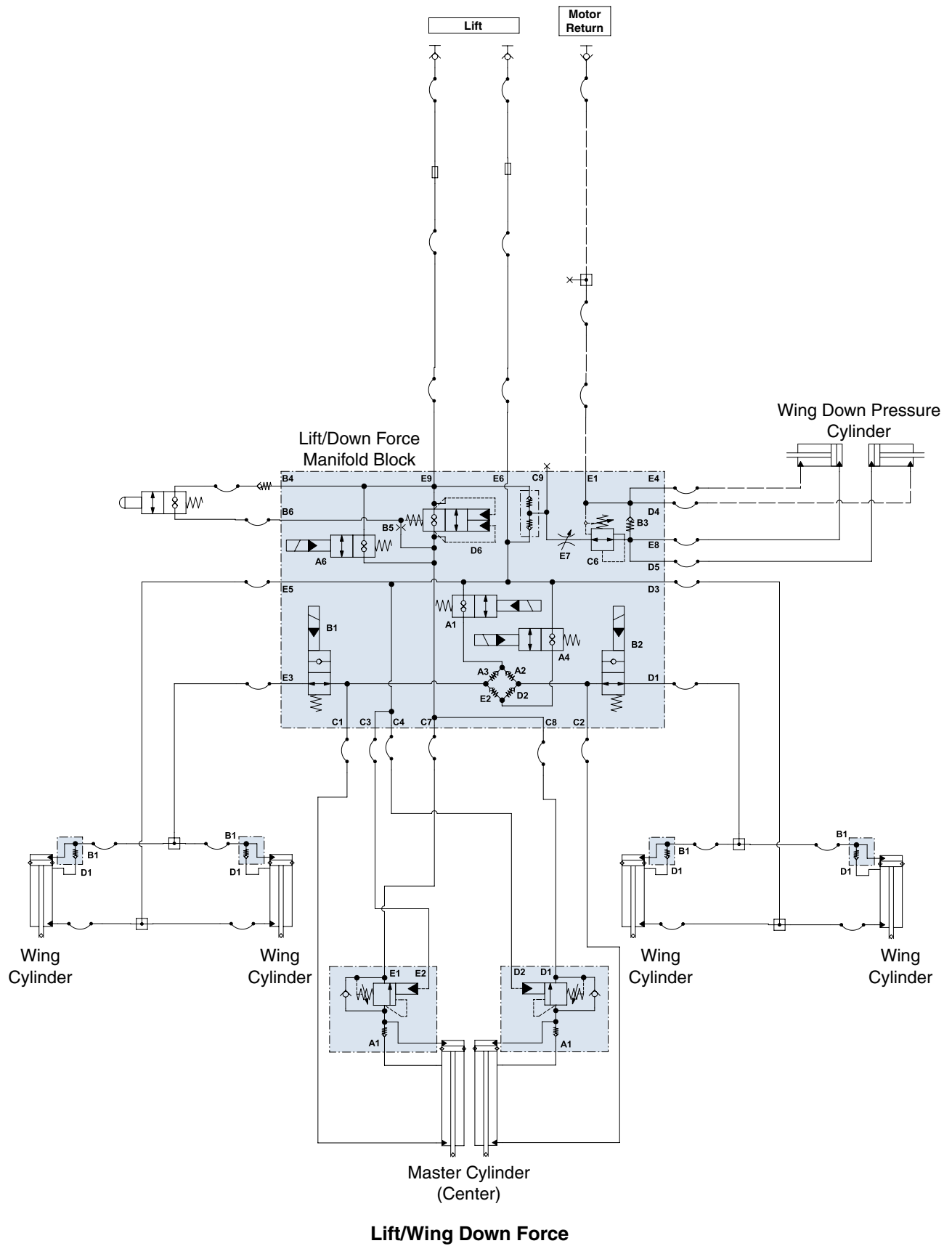

HYDRAULIC SCHEMATIC - ROW MARKERS

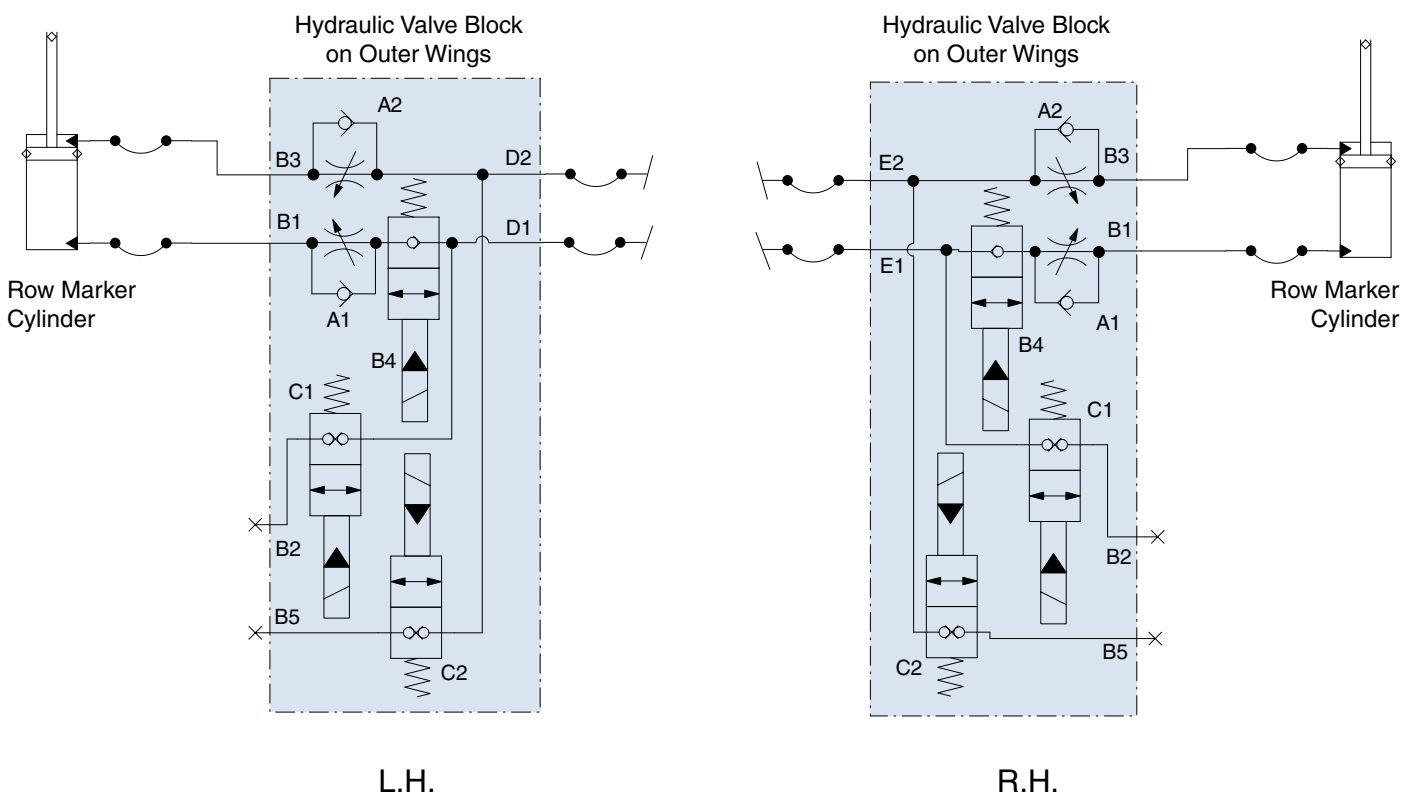

**BULK FILL**

<b>PROBLEM</b>	<b>POSSIBLE CAUSE</b>	<b>SOLUTION</b>
Seed does not travel through delivery tubes.	System pressure set too low.	Increase system pressure.
Seed stops flowing to row unit during planting.	Seed surging.	Shut down air seed delivery system and restart system from idle; seed should start flowing.
	Debris in system.	Insert shutoff door, open cleanout door. remove plug.
Seed does not move from entrainer at startup after exposure to water.	Seed swelled in entrainer.	Insert shutoff door, open cleanout door. remove swelled seed.
Seed bridging in entrainer.	System pressure too high.	Decrease system pressure to recommended pressures: <ul style="list-style-type: none"> <li>• Corn - 12" (30 cm) of water</li> <li>• Soybean - 10" (25 cm) of water</li> </ul> <p><b>NOTE: Actual pressure needed is affected by seed size, shape and coating.</b></p>

**CLOSING WHEEL**

<b>PROBLEM</b>	<b>POSSIBLE CAUSE</b>	<b>SOLUTION</b>
Closing wheel(s) leave severe imprint in soil.	Too much closing wheel down pressure.	Adjust closing wheel pressure.
Closing wheel(s) not firming soil around seed.	Not enough closing wheel down pressure.	Adjust closing wheel pressure. Severe no till conditions may require use of cast iron closing wheels.
"V" closing wheel running on top of seed furrow.	Improper centering.	Align. See <a href="#">"V" Closing Wheel Adjustment (Rubber or Cast Iron)"</a> on page 3-1
Single closing wheel not directly over seed.	Improper centering.	Align. See <a href="#">"Covering Discs/Single Press Wheel Adjustment"</a> on page 3-2

### ROW MARKER OPERATION

PROBLEM	POSSIBLE CAUSE	SOLUTION
Right marker lowering slower than left marker.	Solenoid valve cartridge in port V1 not opening completely.	Switch with cartridge in port V2. If problem repeats, replace cartridge.
	Hose pinched or collapsed.	Inspect hose routing. Replace or repair hoses as required.
Left marker lowering slower than right marker.	Solenoid valve cartridge in port V2 not opening completely.	Switch with cartridge in port V1. If problem repeats, replace cartridge.
	Hose pinched or collapsed.	Inspect hose routing. Replace or repair hoses as required.
Both markers lowering.	Solenoid valve cartridge stuck open. If left marker switch is selected, right cartridge (V1) is defective. If right marker switch is selected, left cartridge (V2) is defective.	Replace solenoid valve cartridge.
Neither marker lowers.	Blown fuse.	Check red light on control console. It should be on if switch is on. If light is not on, switch to opposite marker position. If light comes on, switch may be defective. Replace switch. Otherwise replace fuse.
	Coils at V1 and V2 not energized.	Poor ground on wire, bad wire connection or damaged wire. Repair as required.
	Marker flow control valve closed too far.	See <a href="#">"Row Marker Speed Adjustment" on page 2-21</a>
Neither marker will raise.	Marker flow control valve closed too far.	See <a href="#">"Row Marker Speed Adjustment" on page 2-21</a>
Right marker will not lower.	Solenoid coil in port V1 not energized.	Check switch on control console. Replace if defective. Check coil ground wire. Check for poor connection or damaged wire.
	Solenoid cartridge in port V1 stuck closed.	Switch cartridge with one on the planter you know is operating properly. If right marker lowers, replace defective cartridge.
Left marker will not lower.	Solenoid coil in port V2 not energized.	Check switch on control console. Replace if defective. Check coil ground wire. Check for poor connection or damaged wire.
	Solenoid cartridge in port V2 stuck closed.	Switch cartridge with one on the planter you know is operating properly. If left marker lowers, replace defective cartridge.
Markers traveling too fast and damaging rubber stop on transport stands and/or damaging pivot at rod end of marker cylinders.	Adjust row marker flow control valve.	See <a href="#">"Row Marker Speed Adjustment" on page 2-21</a>



**VACUUM SEED METER**

<b>PROBLEM</b>	<b>POSSIBLE CAUSE</b>	<b>SOLUTION</b>
Low seed count.	Meter RPM too high.	Reduce planting rate or planting speed.
	Singulator blade setting too aggressive.	Adjust singulator blade.
	Vacuum level too low.	Increase fan speed.
	Seed sensor not picking up all seeds dropped.	Clean seed tube. Move meter to different row.
	Seeds sticking to seed disc.	Use graphite or talc to aid release.
	Seed treatment buildup in seed disc recesses.	Reduce amount of treatment used and or mix thoroughly. Add talc.
	Seed size too large for disc used.	Use appropriate disc for seed size.
	Wrong seed disc.	Use appropriate disc for seed type and size.
	Failed/worn drive components.	Inspect and replace parts as required.
	Plugged orifices in seed disc.	Inspect and clean disc. Check remnant ejector.
	Loss of vacuum at meter.	Check for foreign material between vacuum cover and disc. Inspect parts for wear/damage. Clean or replace as required.
	Seed bridging in hopper.	Add graphite to improve seed flow.
	Faulty vacuum gauge reading.	Repair/replace gauge.
	Dirt in vacuum manifold.	Check vacuum manifold for dirt and clean.
	Seed baffle (If applicable) not allowing seed flow due to bridging of seed.	Mix talc thoroughly to coat all seeds. Remove seed baffle. See Row Unit Operation section.
	Seed disc worn.	Replace.
Vacuum seal worn.	Replace.	
Not planting seed.	Seed hoppers empty.	Fill seed hopper.
	Seed tube plugged/damaged.	Clean or replace tube.
	Meter drive damaged.	Repair/replace drive components.
	Low/no vacuum.	Inspect vacuum system and repair as necessary.
	Singulator blade setting too aggressive.	Adjust singulator blade.
	Faulty vacuum gauge.	Repair/replace vacuum gauge.
	Seed bridging in hopper.	Add graphite to improve seed flow.
	Loss of vacuum at meter.	Check for foreign material between vacuum cover and disc. Inspect parts for wear/ damage. Clean and/or replace as required.
	Wrong seed disc.	Use appropriate disc for seed type and size.
	Meter drive clutch not engaged.	Engage drive clutch.
	Fan not running.	Start fan.
Dirt in vacuum manifold.	Check vacuum manifold for dirt and clean.	

Continued on next page.

**VACUUM SEED METER - Continued**

<b>PROBLEM</b>	<b>POSSIBLE CAUSE</b>	<b>SOLUTION</b>
Not planting seed. (Continued)	Seed baffle (if applicable) not allowing seed flow due to bridging of seed.	Mix talc thoroughly to coat all seeds. Remove seed baffle. Row Unit Operation section.
	High vacuum.	Adjust vacuum level to appropriate level.
	Wrong seed disc.	Replace seed disc.
	Singulator setting not aggressive enough.	Adjust singulator.
Poor seed spacing.	Faulty vacuum gauge.	Check gauge line for dirt/obstruction. Repair/replace vacuum gauge.
	Obstruction in seed tube.	Clean seed tube.
	Dirty/damaged seed disc.	Inspect seed disc for damage, foreign material in orifices or seed treatment buildup in recesses. Clean or replace.
	Wrong vacuum setting.	Adjust vacuum to appropriate level.
	Excess foreign material in seed.	Inspect and clean meter and seed discs. Use clean, undamaged seed.
	Incorrect singulator setting.	Adjust singulator to appropriate setting.
	Inconsistent driveline.	Inspect drive components for rust, misalignment, worn or damaged parts. Replace/repair as required.
	Toolbar not level or wrong height.	Adjust hitch to level toolbar and row units.
	Planting too fast for conditions.	Reduce speed.
Irregular seed population.	Rough field conditions.	Reduce speed.
	Driving too fast.	Reduce speed.
Unable to achieve desired vacuum level.	Tractor hydraulic flow set too low.	Increase flow to fan motor.
	Incorrect hydraulic connections.	Check all hydraulic connections and hose routings.
	Damaged fan components.	Inspect motor and impeller for wear/damage and repair/replace as necessary.
	Vacuum hose pinched/kinked/blocked.	Inspect air lines for any damage or obstruction. Clean air lines and manifold by removing end cap from manifold and running fan at high speed.
	Vacuum hose loose/disconnected.	Inspect and reattach all air hoses.
	Tractor not producing required hydraulic flow/pressure.	Have tractor serviced by qualified technician.
	Dirt in vacuum gauge line.	Check gauge line for dirt/obstruction and clean.

**SOLENOID VALVE**

<b>PROBLEM</b>	<b>POSSIBLE CAUSE</b>	<b>SOLUTION</b>
No solenoids operate.	Low voltage.	Must be connected to 12 volt DC only. Negative ground.
	Blown fuse.	Replace control console fuse with AGC-15 amp.
	Battery connection.	Clean and tighten.
	Wiring harness damaged.	Repair or replace.
One solenoid valve will not operate.	Bad switch.	Replace on control panel.
	Cut wire in harness.	Locate and repair.
	Bad coil.	Replace.
	Poor connection at coil.	Check.
Valve operating when not energized.	Valve stem stuck open.	Replace cartridge.
	O-ring leaking.	Install new O-ring kit.
	Foreign material under poppet.	Remove and clean cartridge.

**PTO PUMP DRIVE AND OIL COOLER OPTION**

<b>PROBLEM</b>	<b>POSSIBLE CAUSE</b>	<b>SOLUTION</b>
Pump is squealing.	Lack of oil to pump.	Check for plugged suction strainer. Check oil level.
Oil temperature high.	Low oil level.	Check oil level and add as required.
Desired fan speed cannot be achieved.	Low oil level.	Check oil level and add as required.
	Plugged filter.	Check and change as required.

**This page intentionally left blank.**